

*Lever which
actuates locking
plunger*

HANDBOOK OF

MECHANICAL DESIGN

1942

*Locking
plunger*

*Shift
rod*

George F. Nordenholt
Joseph Kerr
John Sasso

*Shift lever keyed
to rod*
reprinted by Lindsay Publications Inc

HANDBOOK OF
**MECHANICAL
DESIGN**

1942

George F. Nordenholt
Joseph Kerr
John Sasso

reprinted by Lindsay Publications Inc

THIS PAGE IS BLANK
but this is not a printing or scanning
fault and no content is missing.

HANDBOOK
of
MECHANICAL DESIGN

BY

GEORGE F. NORDENHOLT
Editor of Product Engineering

JOSEPH KERR
Managing Editor of Product Engineering

AND

JOHN SASSO
Associate Editor of Product Engineering

McGRAW-HILL BOOK COMPANY, Inc.
NEW YORK AND LONDON
1942

Handbook of Mechanical Design

by George F. Nordenholt,
Joseph Kerr, and John Sasso

Originally published by
McGraw-Hill, New York

Original copyright 1942
by McGraw-Hill Book Company Inc

Reprinted by
Lindsay Publications Inc
Bradley IL 60915

All rights reserved.

ISBN 1-55918-154-X

1 2 3 4 5 6 7 8 9 0

1995

PREFACE

Many engineering departments, perhaps most, compile and keep up to date a manual which may be called the standards book, reference book, engineering department standards, or which may be given some other name. Also, many design engineers build their own book or manual. In such books will be found a vast fund of engineering data and many methods of design procedure not found in existing handbooks.

When *Product Engineering* was launched as a publication to serve the design engineers, it was obvious to the editors that a great service could be rendered to the profession by gathering and publishing data, information, and design procedures such as are contained in engineering department manuals. Thus, the first number of *Product Engineering* in January, 1930, contained a reference-book sheet for design calculations, a feature which has been continued in practically every number. Soon afterward, there was added to *Product Engineering's* editorial content another regular feature, a two-page spread illustrating standard constructions, possible variations by which to achieve a desired result, and similar design standards covering constructions, drives, and controls.

It was soon found impossible to meet all the requests for additional copies of reference-book sheets and design standards. The demand continued to increase and numerous readers suggested that the material be compiled into book form and published. It was in answer to this demand that the authors compiled this book.

Other than the major portion of the chapter on materials and a few other pages that have been added to round out the treatment of certain subjects, all the material in this book appeared in past numbers of *Product Engineering*, although some of it has been condensed or re-edited. Very little of the material in this book can be found in the conventional handbooks, for this *Handbook of Mechanical Design* contains practically no explanations of theoretical design. It confines itself to practical design methods and procedures that have been in use in engineering design departments.

The authors will welcome suggestions from users of this book and especially desire to be notified of any errors.

We wish to make special acknowledgment of the material on typical designs appearing in Chapters IV and VI, by Fred Firnhaber, now of Landis Tool Company; the nomograms by Carl P. Nachod, vice-president of Nachod & United Signal Co.; the standard procedure in the design of springs by W. M. Griffith of Atlas Imperial Diesel Engine Company; the spring charts by F. Franz; the methods for calculating belt drives and other nomograms by Emory N. Kemler, now associate professor of mechanical engineering at Purdue University; the nomograms for engineering calculations by M. G. Van Voorhis, now on the editorial staff of *Product Engineering*; and to S. A. Kilpatrick and O. J. Schaefer for their brilliant series of articles, which have

been included in slightly condensed form, on the design of formed thin-sheet aluminum-alloy sections. Acknowledgment is also made here of data on properties of materials contributed by the Aluminum Company of America, United States Steel Corporation, and the American Foundrymen's Association.

Other engineers whose contributions to *Product Engineering* have been incorporated in this book are H. M. Brayton, O. E. Brown, E. Cowan, C. Donaldson, R. G. N. Evans, C. H. Leis, A. D. McKenzie, G. A. Schwartz, A. M. Wasbauer, B. B. Ramey, J. W. Harper, H. M. Richardson, G. A. Ruehmling, T. H. Nelson, E. Touceda, W. S. Rigby, R. S. Elberty, Jr., and G. Smiley.

GEORGE F. NORDENHOLT,
JOSEPH KERR,
JOHN SASSO.

NEW YORK,
April, 1942.

CONTENTS

	PAGE
PREFACE	V
CHAPTER I	
CHARTS AND TABLES.	1
CHAPTER II	
MATERIALS.	33
CHAPTER III	
BEAMS AND STRUCTURES.	71
CHAPTER IV	
LATCHES, LOCKS, AND FASTENINGS.	95
CHAPTER V	
SPRINGS	121
CHAPTER VI	
POWER TRANSMISSION ELEMENTS AND MECHANISMS	151
CHAPTER VII	
DRIVES AND CONTROLS.	207
CHAPTER VIII	
DESIGN DATA ON PRODUCTION METHODS.	251

THIS PAGE IS BLANK
but this is not a printing or scanning
fault and no content is missing.

HANDBOOK OF MECHANICAL DESIGN

CHAPTER I

CHARTS AND TABLES

For General Arithmetical Calculations

The charts and nomograms in this chapter include only those pertaining to general arithmetical calculations, as listed below. Nomograms, charts, and tables for use in the design of specific machine elements or structures will be found in the chapters devoted to the design of those elements or structures.

<i>Length</i>		<i>Moment of Inertia, Radius of Gyration, and WR^2</i>	
	PAGE		PAGE
Arc Length vs. Central Angle.....	2	Prisms.....	16
Chordal Height and Length of Chord.....	3	Flywheels, Gears, and Armatures.....	17
Length of Material for Bends.....	4	Radii of Gyration.....	17
		Transferring to Parallel Axis.....	18
		WR^2 of Symmetrical Bodies.....	19
<i>Area</i>		<i>Force</i>	
Circular Segments.....	8	Centrifugal.....	26
		Forces in Toggle Joint.....	27
<i>Volume</i>		<i>Force, Velocity, and Acceleration</i>	
Tanks, Horizontal Round.....	9	Linear Motion.....	28
Tanks, Vertical Round.....	10	Rotary Motion.....	29
Volume, Weight, and Cost.....	11		
<i>Weight</i>		<i>Heat and Temperature</i>	
Cylindrical Pieces.....	12	Mean Cooling Temperature.....	30
Unit and Total Weight.....	14		
Weight and Volume.....	15	<i>Electrical</i>	
		Solution of Ohm's Equations.....	31
		Total Resistance of Parallel Circuits.....	32

ARC LENGTH VERSUS CENTRAL ANGLE
(Angle of Bend, Length, and Radius)

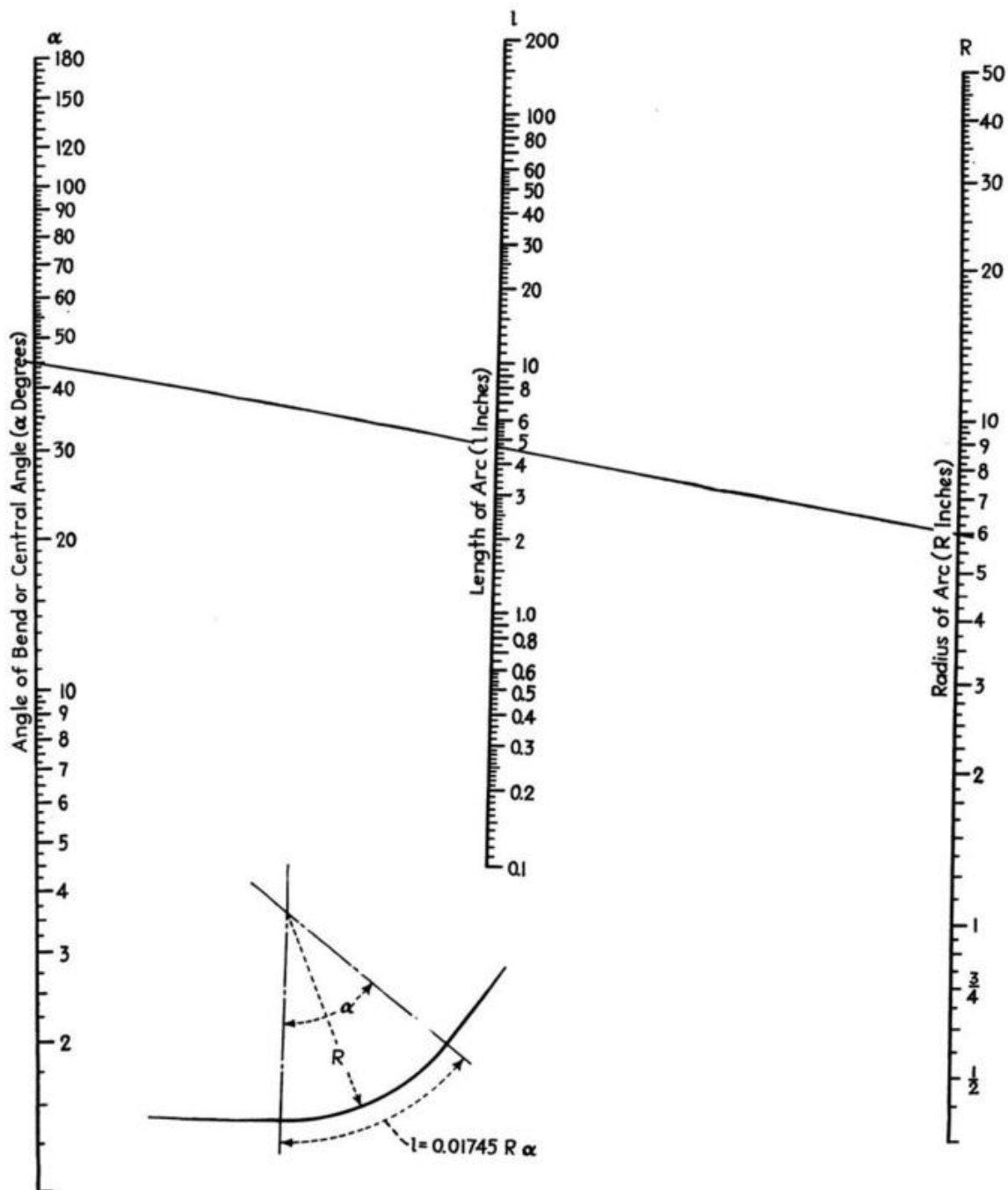

Draw a straight line through the two known points. The answer will be found at the intersection of this line with the third scale.

Example: For a 6-in. radius and 45-deg. bend, length of arc is 4.7 in.

CHORDAL HEIGHT AND LENGTH OF CHORD

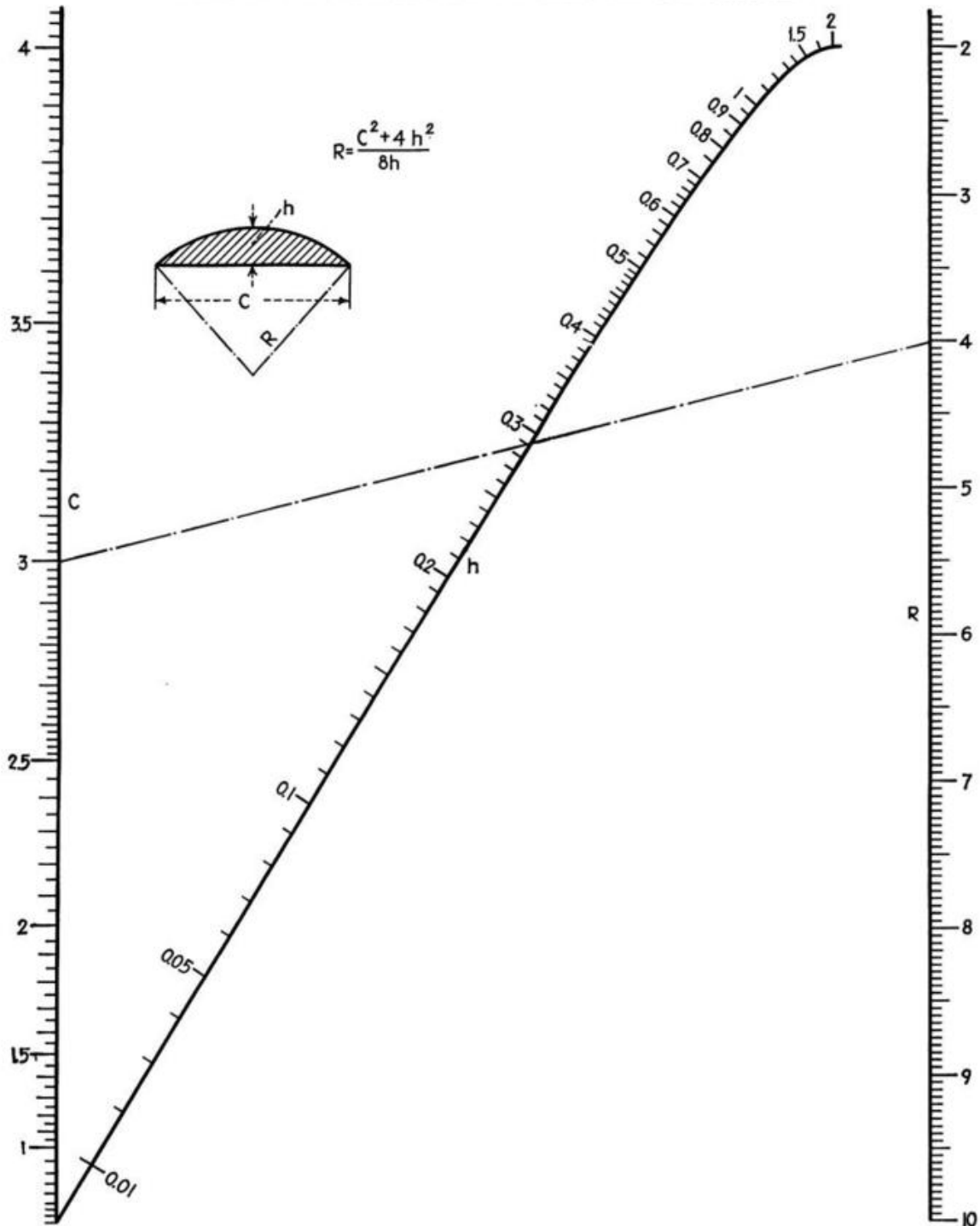

Draw a straight line through the two known points. The answer will be found at the intersection of this line with the third scale.

Example: Length of chord is 3 in., and radius of circle is 4 in. The height h of the chord is 2.9 in.

LENGTH OF MATERIAL FOR 90-DEG. BENDS

As shown in Fig. 1, when a sheet or flat bar is bent, the position of the neutral plane with respect to the outer and inner surfaces will depend on the ratio of the radius of bend to the thickness of the bar or sheet. For a sharp corner, the neutral plane will lie one-third the distance from the inner to the outer surface. As the radius of the bend is increased, the neutral plane shifts until it reaches a position midway between the inner and outer surfaces. This factor should be taken into consideration when calculating the developed length of material required for formed pieces.

The table on the following pages gives the developed length of the material in the 90-deg. bend. The following formulas were used to calculate the quantities given in the table, the radius of the bend being measured as the distance from the center of curvature to the inner surface of the bend.

1. For a sharp corner and for any radius of bend up to T , the thickness of the sheet, the developed length L for a 90-deg. bend will be

$$L = 1.5708 \left(R + \frac{T}{3} \right)$$

2. For any radius of bend greater than $2T$, the length L for a 90-deg. bend will be

$$L = 1.5708 \left(R + \frac{T}{2} \right)$$

3. For any radius of bend between $1T$ and $2T$, the value of L as given in the table was found by interpolation.

The developed length L of the material in any bend other than 90 deg. can be obtained from the following formulas:

1. For a sharp corner or a radius up to T :

$$L = 0.0175 \left(R + \frac{T}{3} \right) \times \text{degrees of bend}$$

2. For a radius of $2T$ or more:

$$L = 0.0175 \left(R + \frac{T}{2} \right) \times \text{degrees of bend}$$

For double bends as shown in Fig. 2, if $R_1 + R_2$ is greater than B :

$$X = \sqrt{2B(R_1 + R_2 - B/2)}$$

With R_1 , R_2 , and B known:

$$\cos A = \frac{R_1 + R_2 - B}{R_1 + R_2}$$

$$L = 0.0175(R_1 + R_2)A$$

where A is in degrees and L is the developed length.

If $R_1 + R_2$ is less than B , as in Fig. 3,

$$Y = B \operatorname{cosec} A - (R_1 + R_2)(\operatorname{cosec} A - \cotan A)$$

The value of X when B is greater than $R_1 + R_2$ will be

$$X = B \cot A + (R_1 + R_2)(\operatorname{cosec} A - \cotan A)$$

The total developed length L required for the material in the straight section plus that in the two arcs will be

$$L = Y + 0.0175(R_1 + R_2)A$$

To simplify the calculations, the table on this page gives the equations for X , Y , and the developed length for various common angles of bend. The table on following pages gives L for values of R and T for 90-deg. bends.

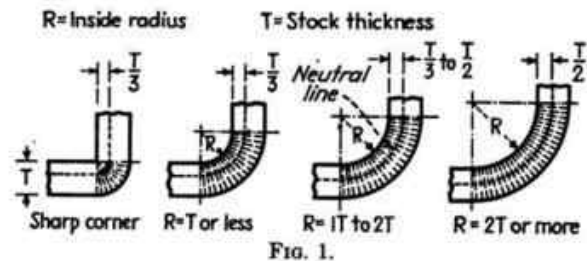

FIG. 1.

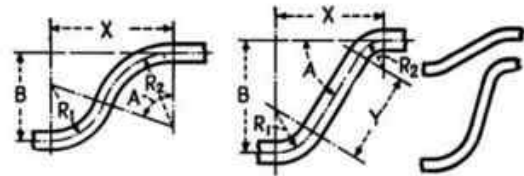

FIG. 2.

FIG. 3.

EQUATIONS FOR X, Y, AND DEVELOPED LENGTHS

Angle A , deg.	X	Y	Developed length
15	$3.732B + 0.132(R_1 + R_2)$	$3.864B - 0.132(R_1 + R_2)$	$3.864B + 0.130(R_1 + R_2)$
$22\frac{1}{2}$	$2.414B + 0.199(R_1 + R_2)$	$2.613B - 0.199(R_1 + R_2)$	$2.613B + 0.194(R_1 + R_2)$
30	$1.732B + 0.268(R_1 + R_2)$	$2.000B - 0.268(R_1 + R_2)$	$2.000B + 0.256(R_1 + R_2)$
45	$B + 0.414(R_1 + R_2)$	$1.414B - 0.414(R_1 + R_2)$	$1.414B + 0.371(R_1 + R_2)$
60	$0.577(B + R_1 + R_2)$	$1.155B - 0.577(R_1 + R_2)$	$1.155B + 0.470(R_1 + R_2)$
$67\frac{1}{2}$	$0.414B + 0.668(R_1 + R_2)$	$1.082B - 0.668(R_1 + R_2)$	$1.082B + 0.510(R_1 + R_2)$
75	$0.268B + 0.767(R_1 + R_2)$	$1.035B - 0.767(R_1 + R_2)$	$1.035B + 0.542(R_1 + R_2)$
90	$R_1 + R_2$	$B - R_1 - R_2$	$B + 0.571(R_1 + R_2)$

DEVELOPED LENGTH IN INCHES OF MATERIAL REQUIRED FOR 90-DEG. BEND

Thickness of material, in.	Inside radius of bend, in.															
	Sharp corner	0.005	0.010	1/4	0.020	0.025	1/2	0.040	3/4	0.050	1	1 1/4	1 1/2	0.100	1/2	1
0.004	0.002	0.011	0.0188	0.028	0.035	0.042	0.052	0.066	0.077	0.082	0.101	0.126	0.150	0.160	0.175	0.200
0.005	0.003	0.011	0.0196	0.028	0.035	0.043	0.053	0.067	0.077	0.083	0.102	0.127	0.151	0.161	0.176	0.200
0.007	0.004	0.012	0.020	0.030	0.037	0.045	0.055	0.068	0.079	0.084	0.104	0.128	0.153	0.163	0.177	0.202
0.008	0.004	0.012	0.0206	0.031	0.034	0.046	0.055	0.069	0.080	0.085	0.105	0.129	0.154	0.163	0.178	0.203
0.010	0.005	0.013	0.0213	0.031	0.039	0.047	0.057	0.071	0.081	0.086	0.106	0.131	0.155	0.165	0.180	0.204
0.012	0.006	0.014	0.022	0.032	0.040	0.049	0.058	0.072	0.083	0.088	0.108	0.132	0.157	0.167	0.181	0.206
0.014	0.007	0.015	0.023	0.032	0.040	0.049	0.060	0.074	0.085	0.090	0.109	0.134	0.158	0.168	0.183	0.207
0.016	0.008	0.016	0.024	0.033	0.041	0.050	0.061	0.075	0.085	0.091	0.110	0.135	0.159	0.169	0.184	0.209
0.016	0.008	0.016	0.024	0.033	0.041	0.051	0.062	0.075	0.086	0.091	0.111	0.135	0.160	0.170	0.184	0.209
0.018	0.009	0.017	0.025	0.034	0.042	0.052	0.062	0.077	0.088	0.093	0.112	0.137	0.161	0.171	0.186	0.211
0.020	0.011	0.018	0.026	0.035	0.043	0.052	0.063	0.079	0.089	0.094	0.114	0.138	0.163	0.173	0.187	0.212
0.022	0.012	0.019	0.027	0.036	0.043	0.053	0.063	0.079	0.096	0.096	0.116	0.140	0.165	0.174	0.189	0.214
0.025	0.013	0.021	0.029	0.038	0.045	0.053	0.064	0.080	0.092	0.098	0.118	0.142	0.167	0.177	0.191	0.216
0.028	0.015	0.023	0.030	0.039	0.046	0.054	0.065	0.081	0.092	0.099	0.120	0.145	0.169	0.179	0.194	0.218
0.031	0.016	0.024	0.032	0.041	0.048	0.056	0.065	0.081	0.093	0.100	0.123	0.147	0.172	0.182	0.196	0.221
0.032	0.017	0.025	0.032	0.041	0.048	0.056	0.066	0.082	0.094	0.100	0.123	0.148	0.172	0.182	0.197	0.222
0.035	0.018	0.026	0.034	0.043	0.050	0.058	0.067	0.082	0.095	0.101	0.124	0.150	0.175	0.185	0.199	0.224
0.038	0.020	0.028	0.035	0.044	0.051	0.059	0.069	0.083	0.096	0.102	0.125	0.152	0.177	0.185	0.201	0.226
0.040	0.021	0.029	0.037	0.045	0.052	0.060	0.070	0.084	0.097	0.102	0.126	0.153	0.179	0.189	0.203	0.228
0.042	0.022	0.030	0.038	0.047	0.053	0.061	0.071	0.085	0.097	0.103	0.126	0.154	0.180	0.190	0.205	0.229
0.044	0.023	0.031	0.039	0.047	0.054	0.062	0.072	0.086	0.097	0.103	0.127	0.154	0.182	0.191	0.206	0.231
0.045	0.024	0.031	0.039	0.048	0.055	0.063	0.073	0.086	0.099	0.104	0.127	0.154	0.183	0.192	0.207	0.232
0.049	0.026	0.034	0.041	0.050	0.057	0.065	0.075	0.088	0.099	0.105	0.128	0.155	0.183	0.196	0.210	0.235
0.051	0.027	0.034	0.042	0.051	0.058	0.066	0.076	0.083	0.100	0.105	0.129	0.155	0.184	0.196	0.212	0.236
0.057	0.030	0.038	0.046	0.054	0.061	0.069	0.079	0.093	0.103	0.108	0.130	0.156	0.185	0.198	0.214	0.241
0.058	0.030	0.038	0.046	0.055	0.062	0.070	0.079	0.093	0.104	0.109	0.130	0.157	0.185	0.198	0.215	0.242
0.063	0.033	0.041	0.048	0.057	0.064	0.072	0.082	0.096	0.106	0.111	0.131	0.158	0.186	0.199	0.216	0.245
0.064	0.034	0.041	0.049	0.058	0.065	0.073	0.083	0.096	0.107	0.112	0.132	0.159	0.187	0.200	0.217	0.246
0.065	0.034	0.042	0.050	0.058	0.065	0.073	0.083	0.097	0.107	0.113	0.132	0.159	0.187	0.200	0.218	0.246
0.072	0.038	0.046	0.053	0.062	0.069	0.077	0.087	0.100	0.111	0.116	0.136	0.161	0.189	0.202	0.220	0.248
0.078	0.041	0.049	0.057	0.065	0.072	0.080	0.090	0.104	0.114	0.119	0.139	0.163	0.190	0.204	0.223	0.250
0.081	0.042	0.050	0.058	0.067	0.074	0.082	0.091	0.105	0.116	0.121	0.140	0.165	0.191	0.205	0.224	0.250
0.083	0.043	0.051	0.059	0.068	0.075	0.083	0.092	0.106	0.117	0.122	0.141	0.166	0.192	0.205	0.225	0.251
0.091	0.047	0.055	0.063	0.072	0.080	0.087	0.096	0.110	0.121	0.126	0.146	0.170	0.194	0.207	0.227	0.254
0.094	0.049	0.057	0.065	0.074	0.080	0.088	0.098	0.112	0.123	0.128	0.147	0.172	0.196	0.208	0.227	0.255
0.095	0.050	0.058	0.065	0.074	0.081	0.089	0.099	0.113	0.123	0.128	0.148	0.172	0.197	0.209	0.228	0.256
0.102	0.053	0.061	0.069	0.078	0.085	0.092	0.102	0.116	0.127	0.132	0.151	0.176	0.200	0.210	0.230	0.258
0.109	0.057	0.065	0.073	0.082	0.088	0.096	0.106	0.120	0.131	0.136	0.155	0.180	0.204	0.214	0.232	0.261
0.120	0.063	0.071	0.079	0.087	0.094	0.102	0.112	0.126	0.136	0.141	0.161	0.186	0.210	0.220	0.235	0.265
0.125	0.065	0.073	0.081	0.090	0.097	0.105	0.114	0.128	0.139	0.144	0.164	0.188	0.213	0.222	0.237	0.267
0.141	0.074	0.081	0.089	0.098	0.105	0.113	0.123	0.136	0.147	0.152	0.172	0.196	0.221	0.231	0.245	0.270
0.156	0.082	0.090	0.097	0.106	0.113	0.121	0.131	0.145	0.155	0.160	0.180	0.204	0.229	0.239	0.253	0.278
0.172	0.090	0.098	0.106	0.114	0.121	0.129	0.139	0.153	0.163	0.168	0.188	0.213	0.237	0.247	0.262	0.286
0.188	0.098	0.106	0.114	0.123	0.130	0.137	0.147	0.161	0.172	0.177	0.196	0.221	0.245	0.255	0.270	0.295
0.203	0.106	0.114	0.122	0.131	0.138	0.146	0.155	0.169	0.180	0.185	0.204	0.229	0.253	0.263	0.278	0.303
0.219	0.115	0.122	0.130	0.139	0.146	0.154	0.163	0.177	0.188	0.193	0.213	0.237	0.262	0.272	0.286	0.311
0.234	0.123	0.130	0.138	0.147	0.154	0.162	0.172	0.185	0.196	0.201	0.221	0.245	0.270	0.280	0.294	0.319
0.250	0.131	0.139	0.147	0.155	0.162	0.170	0.180	0.194	0.204	0.209	0.229	0.254	0.278	0.288	0.303	0.327
0.281	0.147	0.155	0.162	0.172	0.178	0.186	0.196	0.209	0.221	0.225	0.245	0.270	0.294	0.304	0.319	0.345
0.313	0.164	0.171	0.179	0.188	0.195	0.203	0.213	0.226	0.237	0.242	0.262	0.286	0.311	0.321	0.335	0.360
0.344	0.180	0.188	0.196	0.204	0.211	0.219	0.229	0.243	0.253	0.258	0.278	0.303	0.327	0.337	0.352	0.376
0.375	0.196	0.204	0.212	0.221	0.228	0.236	0.245	0.259	0.270	0.275	0.295	0.319	0.344	0.353	0.368	0.393
0.438	0.229	0.237	0.245	0.254	0.260	0.268	0.278	0.292	0.303	0.308	0.327	0.352	0.376	0.386	0.401	0.425
0.500	0.262	0.270	0.277	0.286	0.293	0.301	0.311	0.325	0.335	0.340	0.360	0.384	0.409	0.419	0.433	0.458
0.563	0.295	0.302	0.310	0.319	0.326	0.334	0.344	0.357	0.368	0.373	0.393	0.417	0.442	0.452	0.466	0.491
0.625	0.328	0.335	0.343	0.352	0.359	0.367	0.377	0.390	0.401	0.406	0.426	0.450	0.475	0.484	0.499	0.524
0.688	0.360	0.368	0.376	0.384	0.391	0.399	0.409	0.423	0.433	0.438	0.458	0.483	0.507	0.517	0.532	0.556
0.750	0.393	0.400	0.408	0.417	0.424	0.432	0.442	0.456	0.466	0.471	0.491	0.515	0.540	0.550	0.564	0.589
0.813	0.425	0.433	0.441	0.450	0.457	0.465	0.474	0.488	0.499	0.504	0.524	0.548	0.573	0.583	0.597	0.622
0.875	0.458	0.465	0.473	0.483	0.489	0.497	0.507	0.520	0.532	0.538	0.556	0.581	0.605	0.615	0.630	0.654
0.938	0.491	0.499	0.507	0.515	0.522	0.530	0.540	0.554	0.564	0.569	0.589	0.614	0.638	0.648	0.663	0.687
1.000	0.524	0.531	0.539	0.548	0.555	0.563	0.573	0.586	0.597	0.602	0.622	0.646	0.671	0.681	0.695	0.720

DEVELOPED LENGTH IN INCHES OF MATERIAL REQUIRED FOR 90-DEG. BEND (Continued)

Thickness of material, in.	Inside radius of bend, in.													
	$\frac{1}{2}$	$\frac{1}{4}$	$\frac{3}{8}$	$\frac{1}{2}$	$\frac{5}{8}$	$\frac{3}{4}$	$\frac{7}{8}$	1	$1\frac{1}{4}$	$1\frac{1}{2}$	$1\frac{3}{4}$	2	$2\frac{1}{4}$	$2\frac{1}{2}$
0.004	0.249	0.298	0.347	0.396	0.494	0.592	0.690	0.789	0.985	1.181	1.376	1.574	1.967	2.359
0.005	0.249	0.299	0.348	0.397	0.495	0.593	0.691	0.789	0.986	1.182	1.378	1.575	1.967	2.360
0.007	0.251	0.300	0.349	0.398	0.496	0.595	0.693	0.791	0.987	1.184	1.380	1.576	1.969	2.362
0.008	0.252	0.301	0.350	0.399	0.497	0.595	0.694	0.792	0.988	1.184	1.381	1.577	1.970	2.362
0.010	0.253	0.302	0.351	0.401	0.499	0.597	0.695	0.793	0.990	1.186	1.382	1.579	1.971	2.364
0.012	0.255	0.304	0.353	0.402	0.500	0.599	0.697	0.795	0.991	1.188	1.384	1.580	1.973	2.366
0.014	0.256	0.306	0.355	0.404	0.502	0.600	0.698	0.796	0.993	1.189	1.385	1.582	1.974	2.367
0.016	0.258	0.307	0.356	0.405	0.503	0.601	0.699	0.798	0.994	1.190	1.387	1.583	1.976	2.368
0.018	0.258	0.307	0.356	0.405	0.503	0.602	0.700	0.798	0.994	1.191	1.387	1.583	1.976	2.369
0.018	0.260	0.309	0.358	0.407	0.505	0.603	0.701	0.800	0.996	1.192	1.389	1.585	1.978	2.370
0.020	0.261	0.310	0.359	0.408	0.507	0.605	0.703	0.801	0.998	1.194	1.390	1.587	1.979	2.372
0.022	0.263	0.312	0.361	0.410	0.508	0.608	0.705	0.803	0.999	1.195	1.392	1.588	1.981	2.373
0.025	0.265	0.314	0.363	0.412	0.511	0.609	0.707	0.805	1.001	1.198	1.394	1.590	1.983	2.376
0.028	0.267	0.317	0.366	0.415	0.513	0.611	0.709	0.807	1.004	1.200	1.396	1.593	1.985	2.378
0.031	0.270	0.319	0.368	0.417	0.515	0.614	0.712	0.810	1.006	1.203	1.399	1.595	1.988	2.381
0.032	0.271	0.320	0.369	0.418	0.516	0.614	0.712	0.811	1.007	1.203	1.400	1.596	1.989	2.381
0.035	0.273	0.322	0.371	0.420	0.518	0.617	0.715	0.813	1.009	1.206	1.402	1.598	1.991	2.384
0.038	0.275	0.324	0.373	0.422	0.520	0.619	0.717	0.815	1.011	1.208	1.404	1.600	1.993	2.386
0.040	0.277	0.326	0.375	0.424	0.522	0.621	0.719	0.817	1.013	1.210	1.406	1.602	1.995	2.388
0.042	0.278	0.328	0.377	0.426	0.524	0.622	0.720	0.818	1.015	1.211	1.407	1.604	1.996	2.389
0.044	0.280	0.329	0.378	0.427	0.525	0.623	0.722	0.820	1.016	1.212	1.409	1.605	1.998	2.391
0.045	0.281	0.330	0.379	0.428	0.526	0.624	0.723	0.821	1.017	1.213	1.410	1.606	1.999	2.392
0.049	0.284	0.333	0.382	0.431	0.529	0.628	0.726	0.824	1.020	1.217	1.413	1.609	2.002	2.395
0.051	0.285	0.334	0.383	0.433	0.531	0.629	0.727	0.825	1.022	1.218	1.414	1.611	2.003	2.396
0.057	0.290	0.339	0.388	0.438	0.536	0.634	0.732	0.830	1.027	1.223	1.419	1.616	2.008	2.401
0.058	0.291	0.340	0.389	0.438	0.536	0.635	0.733	0.831	1.027	1.224	1.420	1.616	2.009	2.402
0.063	0.294	0.344	0.393	0.442	0.540	0.638	0.736	0.834	1.031	1.227	1.423	1.620	2.013	2.405
0.064	0.296	0.345	0.394	0.443	0.541	0.639	0.738	0.836	1.032	1.228	1.425	1.621	2.014	2.406
0.065	0.296	0.346	0.395	0.444	0.542	0.640	0.738	0.837	1.033	1.229	1.426	1.622	2.015	2.407
0.072	0.302	0.351	0.400	0.449	0.547	0.646	0.744	0.842	1.038	1.235	1.431	1.627	2.020	2.413
0.078	0.306	0.356	0.405	0.454	0.552	0.650	0.749	0.847	1.043	1.239	1.436	1.632	2.025	2.417
0.081	0.307	0.358	0.407	0.456	0.554	0.653	0.751	0.849	1.045	1.242	1.438	1.634	2.027	2.420
0.083	0.308	0.360	0.409	0.458	0.556	0.654	0.752	0.851	1.047	1.243	1.440	1.636	2.029	2.421
0.091	0.312	0.366	0.415	0.464	0.562	0.660	0.758	0.857	1.053	1.249	1.446	1.642	2.035	2.427
0.094	0.313	0.368	0.417	0.466	0.564	0.663	0.761	0.859	1.055	1.252	1.448	1.644	2.037	2.430
0.095	0.314	0.369	0.418	0.467	0.566	0.664	0.762	0.860	1.056	1.253	1.449	1.645	2.038	2.431
0.102	0.316	0.370	0.424	0.473	0.571	0.669	0.767	0.865	1.062	1.258	1.454	1.651	2.043	2.436
0.109	0.319	0.371	0.429	0.478	0.577	0.675	0.773	0.871	1.067	1.264	1.461	1.656	2.049	2.442
0.120	0.322	0.371	0.433	0.487	0.585	0.683	0.782	0.880	1.076	1.272	1.469	1.665	2.058	2.450
0.125	0.324	0.373	0.434	0.491	0.589	0.687	0.785	0.884	1.080	1.276	1.473	1.669	2.062	2.454
0.141	0.328	0.378	0.439	0.495	0.601	0.700	0.798	0.896	1.092	1.289	1.485	1.681	2.074	2.467
0.156	0.332	0.384	0.444	0.500	0.614	0.712	0.810	0.908	1.104	1.301	1.497	1.693	2.086	2.479
0.172	0.335	0.389	0.449	0.505	0.619	0.724	0.822	0.920	1.117	1.313	1.509	1.706	2.098	2.491
0.188	0.344	0.394	0.454	0.510	0.624	0.736	0.834	0.933	1.129	1.325	1.522	1.718	2.111	2.503
0.203	0.352	0.401	0.459	0.515	0.627	0.741	0.847	0.945	1.141	1.338	1.534	1.730	2.123	2.516
0.219	0.360	0.409	0.463	0.519	0.633	0.746	0.859	0.957	1.153	1.350	1.546	1.742	2.135	2.528
0.234	0.368	0.417	0.466	0.524	0.638	0.751	0.864	0.969	1.166	1.362	1.558	1.755	2.147	2.540
0.250	0.376	0.425	0.474	0.529	0.643	0.756	0.869	0.982	1.178	1.374	1.571	1.767	2.160	2.553
0.281	0.393	0.442	0.491	0.540	0.652	0.766	0.879	0.992	1.202	1.399	1.595	1.792	2.184	2.577
0.313	0.409	0.458	0.507	0.556	0.662	0.776	0.889	1.002	1.227	1.423	1.620	1.816	2.209	2.602
0.344	0.425	0.474	0.523	0.573	0.671	0.786	0.899	1.012	1.238	1.448	1.644	1.841	2.233	2.626
0.375	0.442	0.491	0.540	0.589	0.687	0.797	0.909	1.022	1.247	1.473	1.669	1.865	2.258	2.651
0.438	0.474	0.524	0.573	0.622	0.720	0.818	0.928	1.043	1.266	1.492	1.718	1.914	2.307	2.700
0.500	0.507	0.556	0.605	0.654	0.753	0.851	0.949	1.061	1.285	1.511	1.737	1.964	2.356	2.749
0.563	0.540	0.589	0.638	0.687	0.785	0.884	0.982	1.090	1.304	1.529	1.755	1.982	2.405	2.798
0.625	0.573	0.622	0.671	0.720	0.818	0.916	1.014	1.113	1.323	1.548	1.774	2.001	2.454	2.847
0.688	0.605	0.654	0.703	0.753	0.858	0.949	1.047	1.145	1.342	1.566	1.793	2.019	2.472	2.896
0.750	0.638	0.687	0.736	0.785	0.884	0.982	1.080	1.178	1.374	1.585	1.812	2.038	2.491	2.945
0.813	0.671	0.720	0.769	0.818	0.916	1.014	1.113	1.211	1.407	1.603	1.831	2.056	2.510	2.964
0.875	0.703	0.753	0.802	0.851	0.949	1.047	1.145	1.243	1.440	1.636	1.850	2.075	2.529	2.983
0.938	0.736	0.785	0.834	0.884	0.982	1.080	1.178	1.276	1.473	1.669	1.865	2.094	2.547	3.002
1.000	0.769	0.818	0.867	0.916	1.014	1.113	1.211	1.309	1.505	1.702	1.898	2.112	2.566	3.021

DEVELOPED LENGTH IN INCHES OF MATERIAL REQUIRED FOR 90-DEG. BEND (Continued)

Thickness of material, in.	Inside radius of bend, in.													
	1½	2	2¼	2½	2¾	3	3¼	3½	3¾	4	4½	5	5½	6
0.004	2.752	3.145	3.537	3.930	4.323	4.716	5.108	5.501	5.894	6.286	7.072	7.857	8.643	9.428
0.005	2.753	3.146	3.538	3.931	4.324	4.716	5.109	5.502	5.894	6.287	7.073	7.858	8.643	9.429
0.007	2.754	3.147	3.540	3.932	4.325	4.718	5.111	5.503	5.896	6.289	7.074	7.859	8.645	9.430
0.008	2.755	3.148	3.541	3.933	4.326	4.719	5.111	5.504	5.897	6.289	7.075	7.860	8.646	9.431
0.010	2.757	3.149	3.542	3.935	4.328	4.720	5.113	5.506	5.898	6.291	7.076	7.862	8.648	9.433
0.012	2.758	3.151	3.544	3.936	4.329	4.722	5.115	5.507	5.900	6.293	7.078	7.863	8.649	9.434
0.014	2.760	3.153	3.545	3.938	4.331	4.723	5.116	5.509	5.901	6.294	7.080	7.865	8.650	9.436
0.016	2.761	3.154	3.547	3.939	4.332	4.725	5.117	5.510	5.903	6.295	7.081	7.866	8.652	9.437
0.016	2.761	3.154	3.547	3.940	4.332	4.725	5.118	5.510	5.903	6.296	7.081	7.867	8.652	9.437
0.018	2.763	3.156	3.548	3.941	4.334	4.727	5.119	5.512	5.905	6.297	7.083	7.868	8.654	9.439
0.020	2.765	3.157	3.550	3.943	4.335	4.728	5.121	5.514	5.906	6.299	7.084	7.870	8.655	9.441
0.022	2.766	3.159	3.552	3.944	4.337	4.730	5.122	5.515	5.908	6.300	7.086	7.871	8.657	9.442
0.025	2.769	3.161	3.554	3.947	4.339	4.732	5.125	5.517	5.910	6.303	7.088	7.874	8.659	9.444
0.028	2.771	3.164	3.556	3.949	4.342	4.734	5.127	5.520	5.912	6.305	7.091	7.876	8.661	9.447
0.031	2.773	3.166	3.559	3.952	4.344	4.737	5.130	5.522	5.915	6.308	7.093	7.879	8.664	9.449
0.032	2.774	3.167	3.559	3.952	4.345	4.738	5.130	5.523	5.916	6.308	7.094	7.879	8.665	9.450
0.035	2.775	3.169	3.562	3.954	4.347	4.740	5.133	5.525	5.918	6.311	7.096	7.881	8.667	9.452
0.038	2.779	3.171	3.564	3.957	4.350	4.742	5.135	5.527	5.920	6.313	7.098	7.883	8.669	9.454
0.040	2.780	3.173	3.566	3.958	4.351	4.744	5.137	5.529	5.922	6.315	7.100	7.885	8.671	9.456
0.042	2.782	3.175	3.567	3.960	4.353	4.745	5.138	5.531	5.923	6.316	7.102	7.887	8.672	9.458
0.044	2.783	3.176	3.569	3.961	4.354	4.747	5.139	5.532	5.924	6.318	7.103	7.888	8.674	9.459
0.045	2.784	3.177	3.570	3.962	4.355	4.748	5.140	5.533	5.926	6.319	7.104	7.889	8.675	9.460
0.049	2.787	3.180	3.573	3.965	4.358	4.751	5.144	5.536	5.929	6.322	7.107	7.892	8.678	9.463
0.051	2.789	3.181	3.574	3.967	4.360	4.752	5.145	5.538	5.930	6.323	7.109	7.894	8.679	9.465
0.057	2.794	3.186	3.579	3.972	4.365	4.757	5.150	5.543	5.935	6.328	7.113	7.899	8.684	9.470
0.058	2.794	3.187	3.580	3.973	4.365	4.758	5.151	5.543	5.936	6.329	7.114	7.900	8.685	9.470
0.063	2.798	3.191	3.583	3.977	4.369	4.761	5.154	5.547	5.940	6.332	7.118	7.903	8.688	9.474
0.064	2.799	3.192	3.585	3.977	4.370	4.763	5.155	5.548	5.941	6.333	7.119	7.904	8.690	9.475
0.065	2.800	3.193	3.585	3.978	4.371	4.763	5.156	5.549	5.942	6.334	7.120	7.905	8.690	9.476
0.072	2.805	3.198	3.591	3.984	4.376	4.769	5.162	5.554	5.947	6.340	7.125	7.911	8.696	9.481
0.078	2.810	3.203	3.596	3.988	4.381	4.774	5.166	5.559	5.952	6.344	7.130	7.915	8.701	9.486
0.081	2.812	3.205	3.598	3.990	4.383	4.776	5.169	5.561	5.954	6.347	7.132	7.917	8.703	9.488
0.083	2.814	3.207	3.599	3.992	4.385	4.778	5.170	5.563	5.956	6.348	7.134	7.919	8.705	9.490
0.091	2.820	3.213	3.605	3.998	4.391	4.784	5.176	5.569	5.962	6.354	7.140	7.925	8.711	9.496
0.094	2.822	3.215	3.608	4.001	4.393	4.786	5.179	5.571	5.964	6.357	7.142	7.928	8.713	9.498
0.095	2.824	3.216	3.609	4.002	4.394	4.787	5.180	5.572	5.965	6.358	7.143	7.929	8.714	9.499
0.102	2.829	3.222	3.614	4.007	4.400	4.792	5.185	5.578	5.971	6.363	7.149	7.934	8.719	9.505
0.109	2.835	3.227	3.620	4.013	4.405	4.798	5.191	5.583	5.976	6.369	7.154	7.940	8.725	9.510
0.120	2.843	3.236	3.629	4.021	4.414	4.807	5.199	5.592	5.985	6.377	7.163	7.948	8.734	9.519
0.125	2.847	3.240	3.632	4.025	4.418	4.811	5.203	5.596	5.989	6.381	7.167	7.952	8.738	9.523
0.1406	2.859	3.252	3.645	4.037	4.430	4.823	5.216	5.608	6.001	6.394	7.179	7.964	8.750	9.535
0.1562	2.872	3.264	3.657	4.050	4.442	4.835	5.228	5.620	6.013	6.406	7.191	7.977	8.762	9.547
0.1718	2.884	3.277	3.669	4.062	4.455	4.847	5.240	5.633	6.025	6.418	7.204	7.989	8.774	9.560
0.188	2.896	3.289	3.681	4.074	4.467	4.860	5.252	5.645	6.038	6.430	7.216	8.001	8.787	9.572
0.203	2.908	3.301	3.694	4.086	4.479	4.872	5.265	5.657	6.050	6.443	7.228	8.013	8.799	9.584
0.219	2.921	3.313	3.706	4.099	4.491	4.884	5.277	5.669	6.062	6.455	7.240	8.025	8.811	9.596
0.234	2.933	3.325	3.718	4.111	4.503	4.896	5.289	5.682	6.074	6.467	7.252	8.038	8.823	9.609
0.250	2.945	3.338	3.731	4.123	4.516	4.909	5.301	5.694	6.087	6.480	7.265	8.050	8.836	9.621
0.281	2.970	3.362	3.755	4.148	4.540	4.933	5.326	5.719	6.111	6.504	7.289	8.075	8.860	9.646
0.313	2.994	3.387	3.780	4.172	4.565	4.958	5.350	5.743	6.136	6.529	7.314	8.099	8.885	9.670
0.344	3.019	3.411	3.804	4.197	4.590	4.982	5.375	5.768	6.160	6.553	7.339	8.124	8.909	9.695
0.375	3.043	3.436	3.829	4.222	4.614	5.007	5.400	5.792	6.185	6.578	7.363	8.149	8.934	9.719
0.438	3.092	3.485	3.878	4.271	4.663	5.056	5.449	5.841	6.234	6.627	7.412	8.198	8.983	9.768
0.500	3.142	3.584	3.927	4.320	4.712	5.105	5.498	5.891	6.283	6.676	7.461	8.247	9.032	9.818
0.563	3.191	3.583	3.976	4.369	4.761	5.154	5.547	5.940	6.332	6.725	7.510	8.296	9.081	9.867
0.625	3.240	3.632	4.025	4.418	4.811	5.203	5.596	5.989	6.381	6.774	7.560	8.345	9.130	9.918
0.688	3.289	3.681	4.074	4.467	4.860	5.252	5.645	6.038	6.430	6.823	7.609	8.394	9.179	9.965
0.750	3.338	3.731	4.123	4.516	4.909	5.301	5.694	6.087	6.480	6.872	7.658	8.443	9.228	10.014
0.813	3.387	3.780	4.172	4.565	4.958	5.350	5.743	6.136	6.529	6.921	7.707	8.492	9.278	10.063
0.875	3.436	3.829	4.222	4.614	5.007	5.400	5.792	6.185	6.578	6.970	7.756	8.541	9.327	10.112
0.938	3.455	3.878	4.271	4.663	5.056	5.449	5.841	6.234	6.627	7.019	7.805	8.590	9.376	10.161
1.000	3.474	3.927	4.320	4.712	5.105	5.498	5.891	6.283	6.676	7.069	7.854	8.639	9.425	10.210

AREAS OF CIRCULAR SEGMENTS

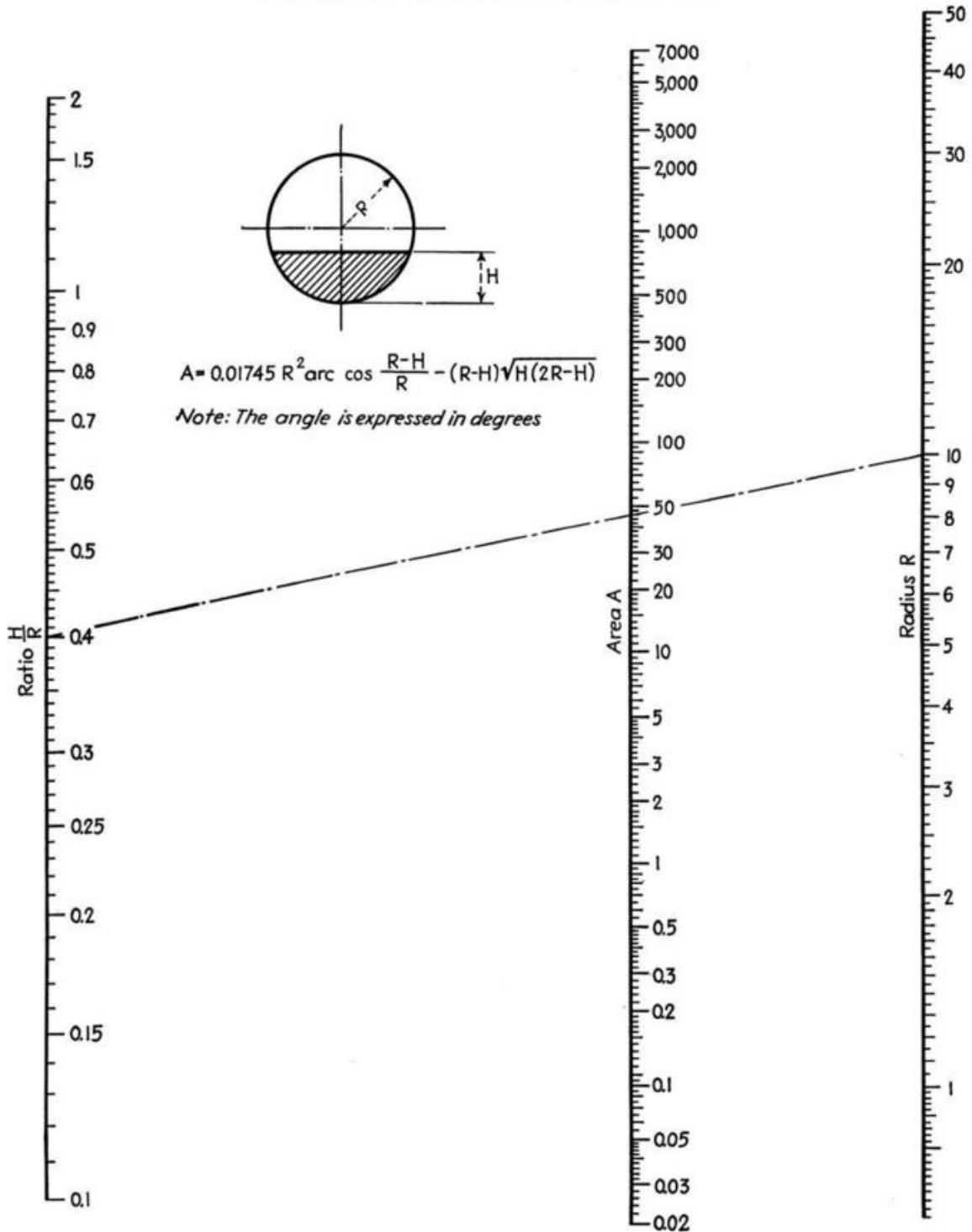

Draw a straight line through the two known points. The answer will be found at the intersection of this line with the third scale.

Example: For a 10-in. radius and $H = 4.0$ in., $H/R = 0.40$ in. Area $A = 46$ sq. in.

VOLUMES IN HORIZONTAL ROUND TANKS WITH FLAT ENDS

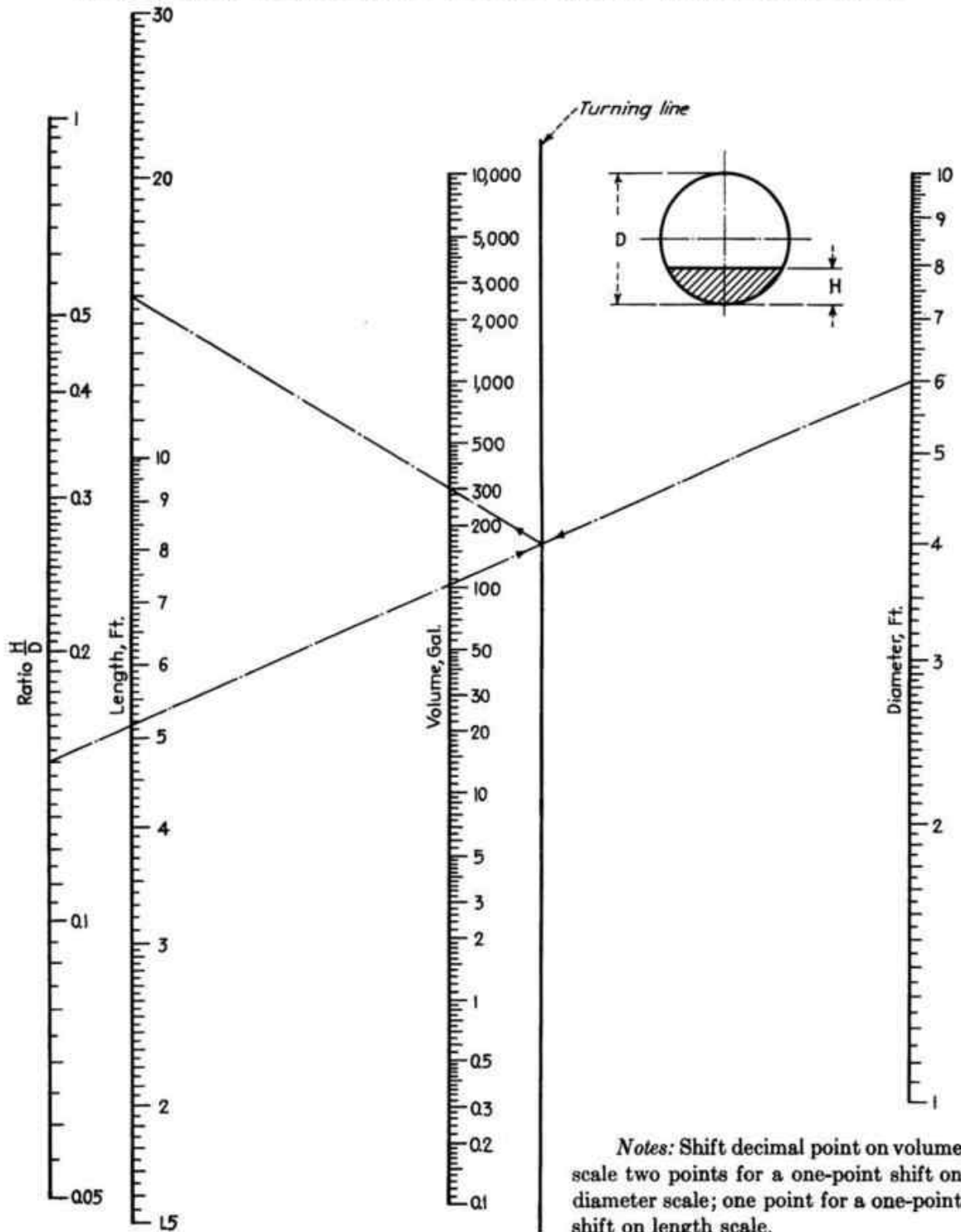

Notes: Shift decimal point on volume scale two points for a one-point shift on diameter scale; one point for a one-point shift on length scale.

VOLUMES IN VERTICAL ROUND TANKS WITH FLAT BOTTOMS

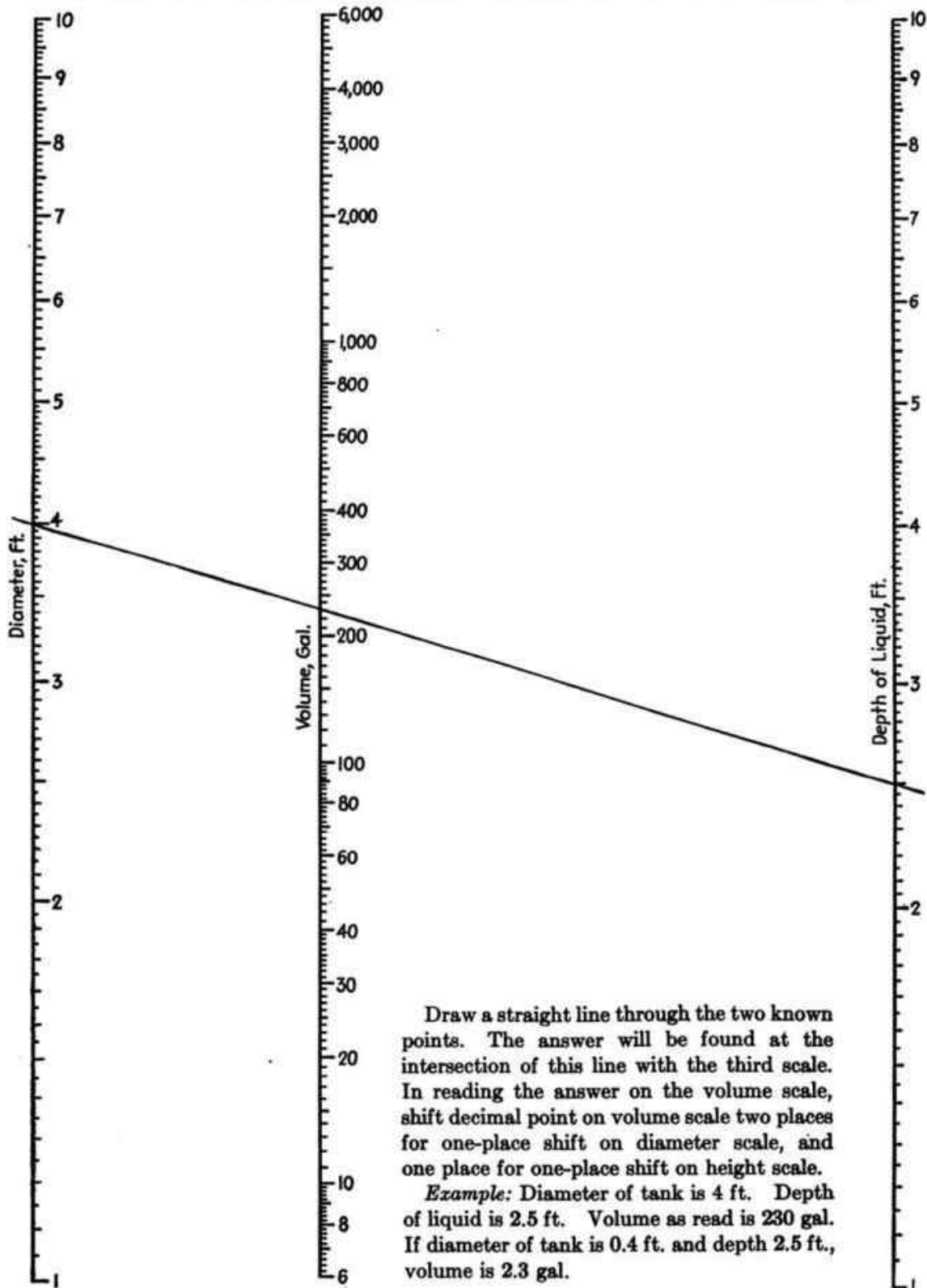

VOLUME, WEIGHT, AND COST CHART

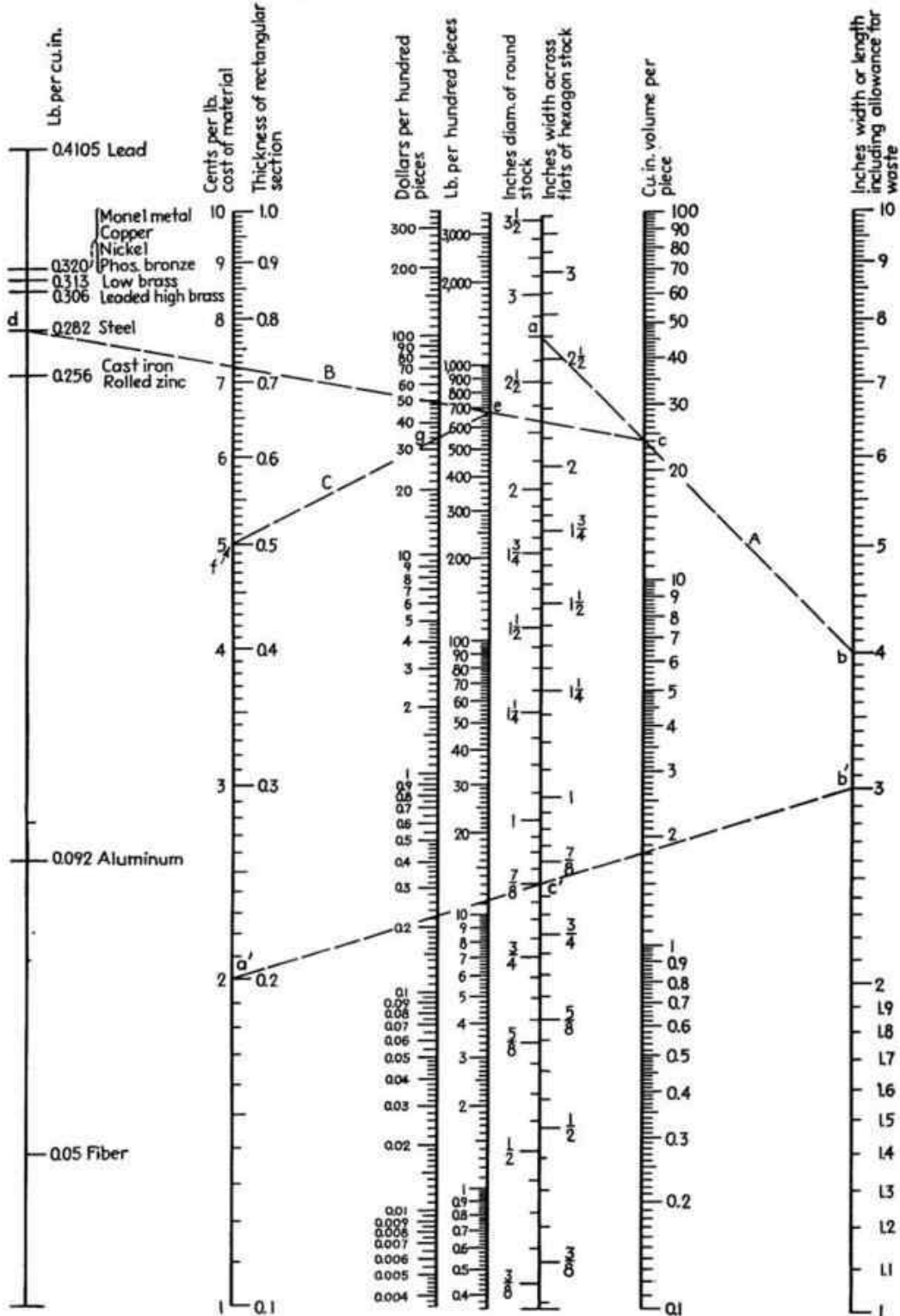

Example: For $2\frac{3}{4}$ in. round or $2\frac{5}{8}$ hex, pieces 4 in. long, draw lines A, B, and C, points a, b, c, d, e, f, and g being located in alphabetical order. For a rectangular section 0.2 in. thick by 3 in. wide, line a'b' gives equivalent circular or hex bar at c'. Then proceed as with round or hex bars.

WEIGHTS OF CYLINDRICAL PIECES

EXAMPLE OF PROCEDURE
CAST-IRON FLYWHEEL

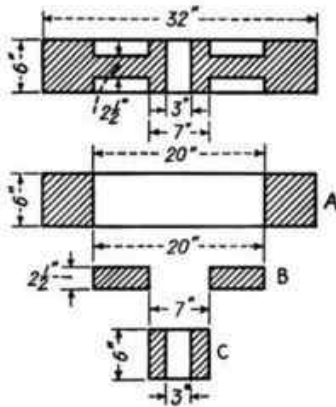

- A. Weights per inch of length, from table:
 32-in. diameter cylinder = 209.0 lb.
 20-in. diameter cylinder = 81.5 lb.
 Difference = 127.5 lb.
 Weight of element A = 127.5 × 6 = 765.0 lb.
- B. Weights per inch of length, from table:
 20-in. diameter cylinder = 81.5 lb.
 7-in. diameter cylinder = 10.0 lb.
 Difference = 71.5 lb.
 Weight of element B = 71.5 × 2½ = 143.0 lb.
- C. Weights per inch of length, from table:
 7-in. diameter cylinder = 10.0 lb.
 3-in. diameter cylinder = 1.8 lb.
 Difference = 8.2 lb.
 Weight of element C = 8.2 × 6 = 49.2 lb.
 Total weight of flywheel = 957.2 lb.

WEIGHTS OF CYLINDRICAL PIECES, POUNDS PER INCH OF LENGTH

Diam-eter	Cast iron	Wrought iron and steel	Common yellow brass	Bronze	Alumi-num	Diam-eter	Cast iron	Wrought iron and steel	Common yellow brass	Bronze	Alumi-num
1	0.204	0.220	0.237	0.251	0.072	11½	27.01	29.25	31.35	33.20	9.62
1¼	0.319	0.344	0.370	0.392	0.113	11¾	28.19	30.50	32.70	34.70	10.00
1½	0.459	0.497	0.533	0.565	0.163	12	29.41	31.85	34.15	36.20	10.47
1¾	0.625	0.677	0.725	0.768	0.222	12¼	30.64	33.15	35.50	37.70	10.90
2	0.817	0.885	0.948	1.005	0.291	12½	31.91	34.50	37.05	39.30	11.35
2¼	1.034	1.118	1.195	1.268	0.367	12¾	33.19	35.95	38.50	40.80	11.80
2½	1.276	1.380	1.480	1.570	0.454	13	34.51	37.35	40.00	42.45	12.27
2¾	1.544	1.672	1.790	1.895	0.550	13¼	35.85	38.80	41.60	44.10	12.75
3	1.837	1.988	2.130	2.260	0.654	13½	37.22	40.25	43.20	45.80	13.25
3¼	2.157	2.333	2.505	2.650	0.767	13¾	38.61	41.57	44.80	47.50	13.74
3½	2.501	2.701	2.900	3.075	0.890	14	40.02	43.30	46.40	49.30	14.23
3¾	2.871	3.105	3.330	3.530	1.022	14¼	41.47	44.80	48.00	51.00	14.74
4	3.287	3.548	3.800	4.020	1.163	14½	42.93	46.40	49.80	52.80	15.28
4¼	3.688	4.000	4.280	4.540	1.314	14¾	44.43	48.00	51.50	54.70	15.80
4½	4.135	4.470	4.790	5.090	1.471	15	45.95	49.70	53.30	56.50	16.35
4¾	4.607	4.980	5.350	5.670	1.640	15¼	49.06	53.00	56.80	60.30	17.45
5	5.105	5.530	5.930	6.280	1.820	16	52.3	56.4	60.6	64.3	18.6
5¼	5.628	6.080	6.540	6.925	2.000	16¼	55.5	60.0	64.5	68.3	19.8
5½	6.177	6.680	7.160	7.570	2.200	17	59.0	63.8	68.5	72.6	21.0
5¾	6.751	7.310	7.840	8.300	2.400	17¼	62.5	67.6	72.5	76.9	22.3
6	7.351	7.960	8.530	9.040	2.615	18	66.2	71.6	76.8	81.4	23.6
6¼	7.977	8.640	9.270	9.820	2.840	18¼	70.0	75.7	81.3	86.2	24.9
6½	8.627	9.340	10.000	10.611	3.070	19	73.6	79.5	85.5	90.6	26.2
6¾	9.304	10.067	10.792	11.444	3.315	19¼	77.7	84.0	90.3	95.6	27.7
7	10.000	10.820	11.600	12.300	3.560	20	81.5	88.2	94.5	101.0	29.0
7¼	10.733	11.613	12.400	13.150	3.820	20¼	85.7	92.7	99.6	106.3	30.5
7½	11.486	12.450	13.330	14.140	4.080	21	90.0	97.3	104.4	111.5	32.0
7¾	12.265	13.260	14.200	15.070	4.360	21¼	94.3	102.0	109.4	117.0	33.5
8	13.069	14.120	15.150	16.050	4.650	22	98.9	106.7	114.7	122.5	35.2
8¼	13.898	15.020	16.130	17.100	4.950	22¼	103.5	112.0	120.0	127.4	36.8
8½	14.754	15.960	17.130	18.300	5.260	23	108.0	116.7	125.3	133.0	38.5
8¾	15.634	16.900	18.100	19.200	5.570	23¼	112.7	121.5	130.7	138.5	40.0
9	16.540	17.900	19.200	20.350	5.880	24	117.5	127.0	136.3	144.6	41.8
9¼	17.472	18.900	20.300	21.500	6.220	24¼	122.5	132.4	142.0	150.7	43.6
9½	18.429	19.930	21.350	22.650	6.550	25	127.8	138.0	148.0	157.0	45.5
9¾	19.412	21.000	22.500	23.850	6.910	25¼	132.8	143.5	154.0	163.0	47.3
10	20.420	22.100	23.630	25.100	7.270	26	138.0	149.2	160.0	170.0	49.2
10¼	21.454	23.250	24.900	26.400	7.630	26¼	143.2	154.5	166.0	176.0	50.4
10½	22.513	24.350	26.100	27.700	8.000	27	149.0	161.0	173.0	183.2	53.0
10¾	23.598	25.550	27.400	29.000	8.400	27¼	154.2	166.5	178.7	189.5	54.8
11	24.708	26.750	28.650	30.500	8.780	28	160.0	173.0	185.7	197.0	57.0
11¼	25.845	27.950	29.950	31.800	9.200	28¼	166.0	179.5	192.5	204.0	59.2

WEIGHTS OF CYLINDRICAL PIECES, POUNDS PER INCH OF LENGTH (Continued)

Diam-eter	Cast iron	Wrought iron and steel	Common yellow brass	Bronze	Alumi-num	Diam-eter	Cast iron	Wrought iron and steel	Common yellow brass	Bronze	Alumi-num
29	172	186	199	211	61	61	760	822	882	935	270
29½	177	192	206	219	63	61½	773	836	897	952	275
30	183	199	213	226	65	62	785	848	912	967	279
30½	190	205	221	234	67	62½	798	863	927	983	284
31	196	212	227	241	69	63	810	875	940	997	288
31½	202	218	235	249	71	63½	823	891	955	1,013	293
32	209	228	243	257	74	64	836	904	970	1,028	298
32½	216	231	251	266	77	64½	850	919	987	1,046	303
33	222	240	257	273	79	65	863	934	1,000	1,062	307
33½	229	247	265	282	81	65½	877	949	1,017	1,078	312
34	236	255	274	290	84	66	890	963	1,033	1,095	317
34½	243	263	282	299	86	66½	903	977	1,047	1,111	322
35	250	270	290	307	89	67	917	992	1,064	1,128	327
35½	257	278	299	317	91	67½	932	1,007	1,080	1,146	332
36	264	286	307	325	94	68	944	1,020	1,095	1,162	336
36½	272	294	315	335	96	68½	958	1,036	1,111	1,179	341
37	279	302	324	344	99	69	972	1,050	1,127	1,196	346
37½	287	310	333	354	102	69½	986	1,065	1,144	1,213	351
38	295	319	342	363	105	70	1,000	1,080	1,160	1,230	356
38½	303	328	352	373	108	70½	1,014	1,097	1,177	1,247	362
39	311	336	361	382	111	71	1,030	1,114	1,195	1,267	367
39½	319	345	370	393	113	71½	1,044	1,130	1,213	1,285	372
40	327	354	380	403	116	72	1,058	1,144	1,228	1,302	377
40½	335	362	389	412	119	72½	1,074	1,162	1,247	1,322	382
41	343	371	398	422	122	73	1,088	1,177	1,262	1,340	387
41½	351	380	408	433	125	73½	1,102	1,191	1,276	1,354	392
42	360	389	418	443	128	74	1,117	1,207	1,296	1,375	398
42½	366	398	428	453	131	74½	1,132	1,224	1,313	1,392	403
43	377	408	437	464	134	75	1,150	1,243	1,334	1,415	410
43½	386	418	448	475	137	75½	1,165	1,260	1,351	1,433	415
44	396	428	460	487	141	76	1,181	1,277	1,370	1,452	420
44½	405	438	470	498	144	76½	1,195	1,293	1,386	1,470	425
45	414	448	481	510	147	77	1,210	1,308	1,404	1,490	431
45½	423	458	491	521	150	77½	1,226	1,325	1,423	1,508	436
46	433	468	503	533	154	78	1,243	1,345	1,442	1,530	442
46½	442	477	513	544	157	78½	1,258	1,360	1,460	1,548	448
47	451	488	523	555	160	79	1,274	1,377	1,477	1,567	454
47½	461	498	535	567	164	79½	1,290	1,395	1,496	1,587	459
48	471	509	546	579	167	80	1,307	1,413	1,516	1,608	466
48½	481	520	558	592	171	80½	1,323	1,430	1,536	1,627	471
49	491	531	570	604	174	81	1,340	1,448	1,555	1,648	477
49½	501	541	582	616	178	81½	1,356	1,465	1,572	1,667	483
50	511	552	593	628	182	82	1,372	1,483	1,590	1,689	488
50½	521	563	605	641	185	82½	1,389	1,500	1,610	1,709	494
51	531	574	616	654	189	83	1,406	1,520	1,630	1,730	500
51½	543	587	630	668	193	83½	1,422	1,537	1,650	1,750	506
52	554	599	643	682	197	84	1,440	1,557	1,670	1,770	512
52½	564	610	655	694	201	84½	1,458	1,576	1,690	1,792	519
53	574	620	666	707	204	85	1,475	1,595	1,710	1,815	525
53½	585	632	679	720	208	86	1,510	1,633	1,750	1,858	537
54	596	644	692	733	212	87	1,545	1,670	1,790	1,900	550
54½	607	656	705	747	216	88	1,581	1,710	1,835	1,945	562
55	617	667	716	760	219	89	1,616	1,745	1,874	1,987	575
55½	630	681	732	775	224	90	1,652	1,783	1,915	2,003	588
56	641	693	744	788	228	91	1,691	1,825	1,960	2,080	602
56½	652	705	756	803	233	92	1,730	1,870	2,008	2,130	616
57	664	717	770	817	236	93	1,766	1,905	2,049	2,170	628
57½	676	730	785	832	241	94	1,805	1,950	2,092	2,220	642
58	688	743	798	847	245	95	1,842	1,998	2,135	2,265	655
58½	700	757	812	862	249	96	1,882	2,030	2,180	2,310	669
59	712	768	825	876	253	97	1,920	2,070	2,228	2,360	684
59½	723	782	838	890	257	98	1,960	2,115	2,273	2,410	697
60	735	795	853	905	261	99	2,000	2,160	2,320	2,460	712
60½	748	808	869	920	266	100	2,040	2,202	2,367	2,510	726

UNIT AND TOTAL WEIGHTS

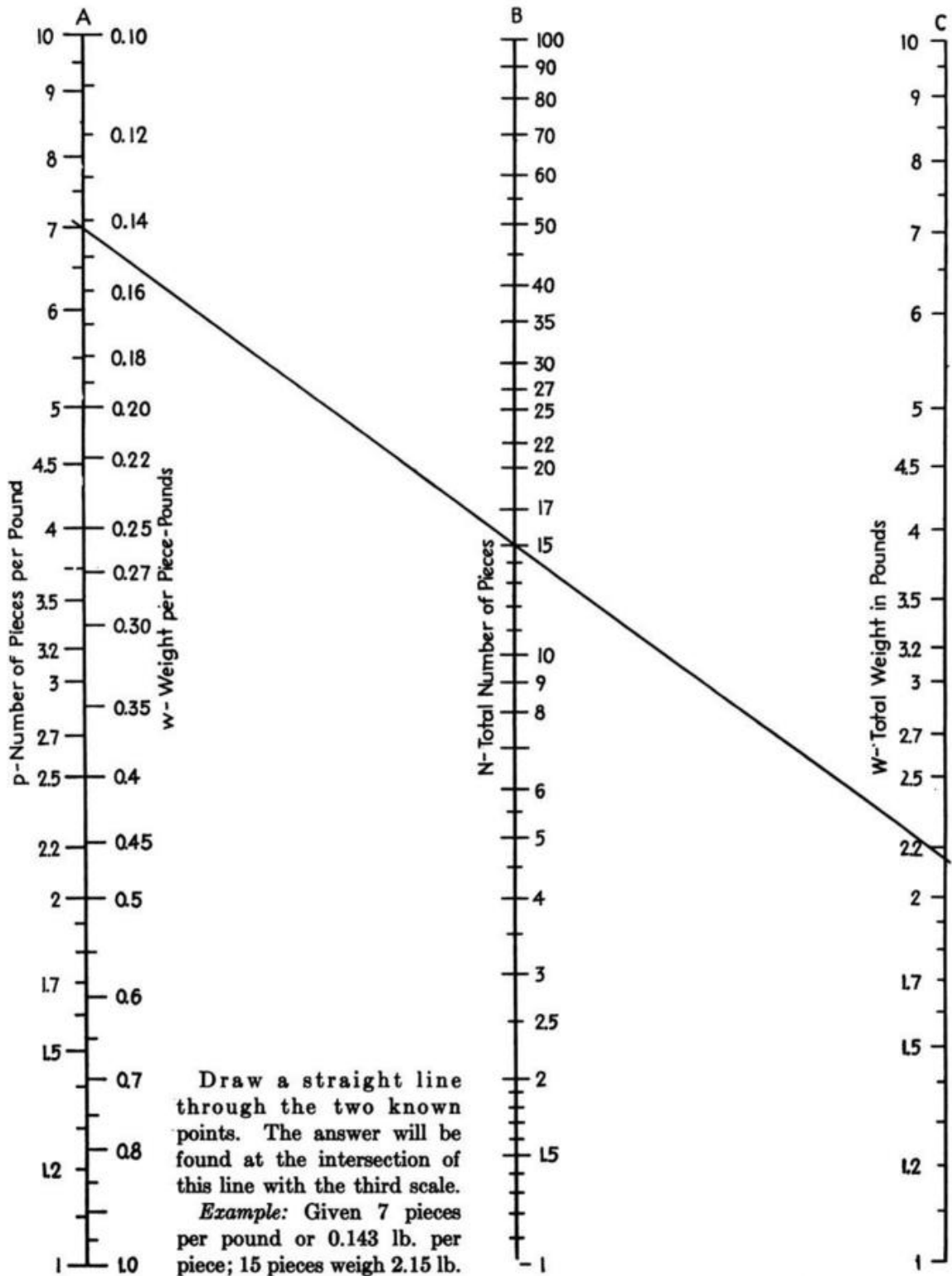

WEIGHT AND VOLUME

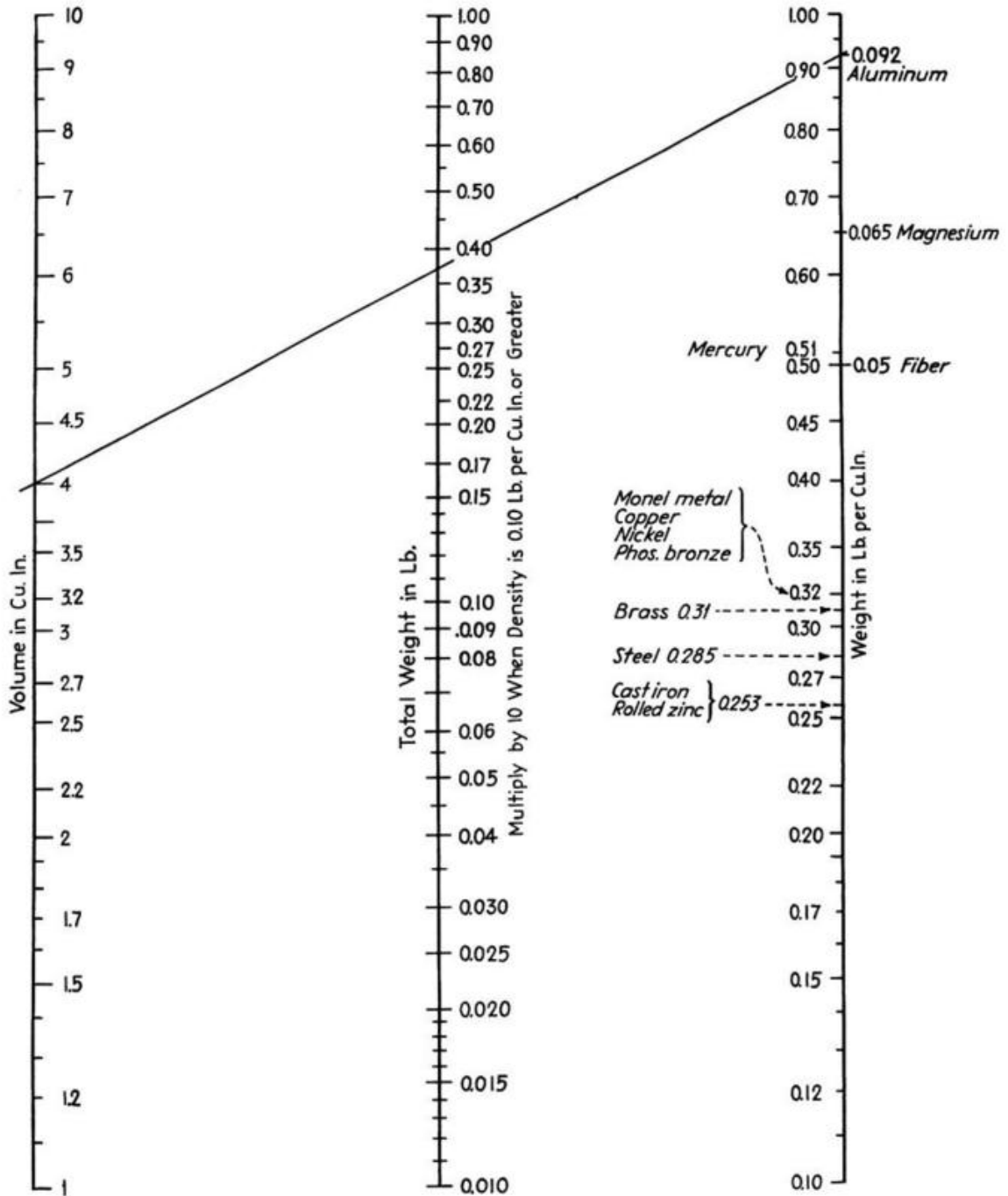



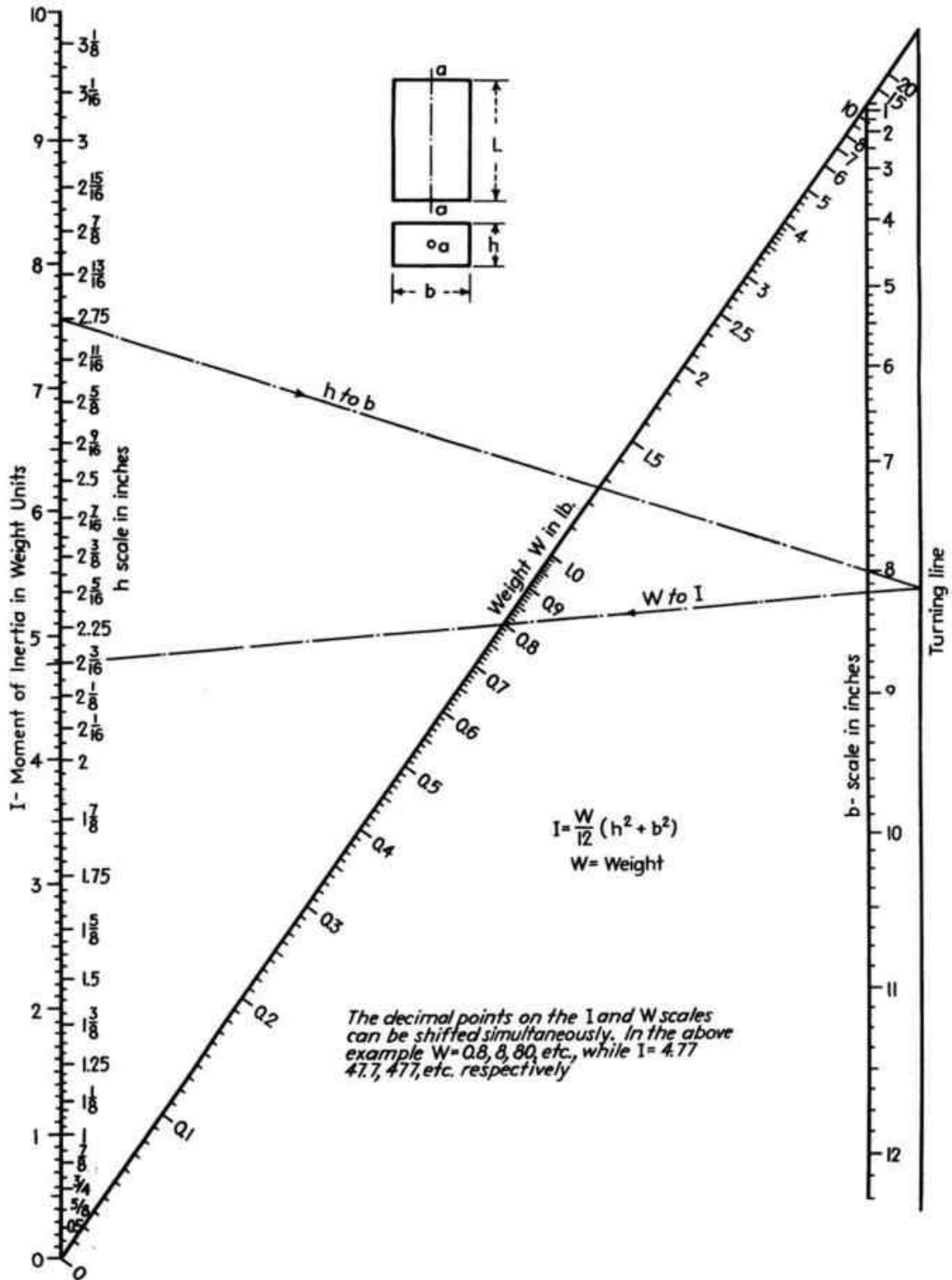

Draw a straight line through the two known points. The answer will be found at the intersection of this line with the third scale.

Example: 4 cu. in. of aluminum weighs 0.37 lb.

MOMENT OF INERTIA OF A PRISM ABOUT THE AXIS *aa*

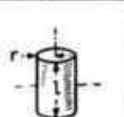

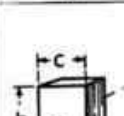
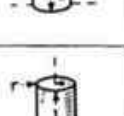
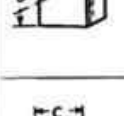
RADI OF GYRATION FOR ROTATING BODIES

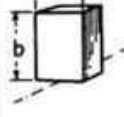
	Solid cylinder about its own axis	$R^2 = \frac{r^2}{2}$		Cylinder about axis through center	$R^2 = \frac{l + 3r^2}{12}$
	Hollow cylinder about its own axis	$R^2 = \frac{r_1^2 + r_2^2}{2}$		Cylinder about axis at one end	$R^2 = \frac{4l^2 + 3r^2}{12}$
	Rectangular prism about axis through center	$R^2 = \frac{b^2 + c^2}{12}$		Cylinder about outside axis	$R^2 = \frac{4l^2 + 3r^2 + 12dl + 12d^2}{12}$
	Rectangular prism about axis at one end	$R^2 = \frac{4b^2 + c^2}{12}$	<p>Any body about axis outside its center of gravity</p> $R^2_1 = R^2_0 + d^2$ <p>where R_0 = radius of gyration about axis through center of gravity</p> <p>R_1 = radius of gyration about any other parallel axis</p> <p>d = distance between center of gravity and axis of rotation</p> 		
	Rectangular prism about outside axis	$R^2 = \frac{4b^2 + c^2 + 12bd + 12d^2}{12}$			

APPROXIMATIONS FOR CALCULATING MOMENTS OF INERTIA

NAME OF PART	MOMENT OF INERTIA
Flywheels (not applicable to belt pulleys)	Moment of inertia equal to 1.08 to 1.15 times that of rim alone
Flywheel (based on total weight and outside diameter)	Moment of inertia equal to two-thirds of that of total weight concentrated at the outer circumference
Spur or helical gears (teeth alone)	Moment of inertia of teeth equal to 40 per cent of that of a hollow cylinder of the limiting dimensions
Spur or helical gears (rim alone)	Figured as a hollow cylinder of same limiting dimensions
Spur or helical gears (total moment of inertia)	Equal to 1.25 times the sum of that of teeth plus rim
Spur or helical gears (with only weight and pitch diameter known)	Moment of inertia considered equal to 0.60 times the moment of inertia of the total weight concentrated at the pitch circle
Motor armature (based on total weight and outside diameter)	Multiply outer radius of armature by following factors to obtain radius of gyration: Large slow-speed motor..... 0.75-0.85 Medium speed d-c or induction motor..... 0.70-0.80 Mill-type motor..... 0.60-0.65

CHART FOR TRANSFERRING MOMENT OF INERTIA

$$I = I_0 + WX^2$$

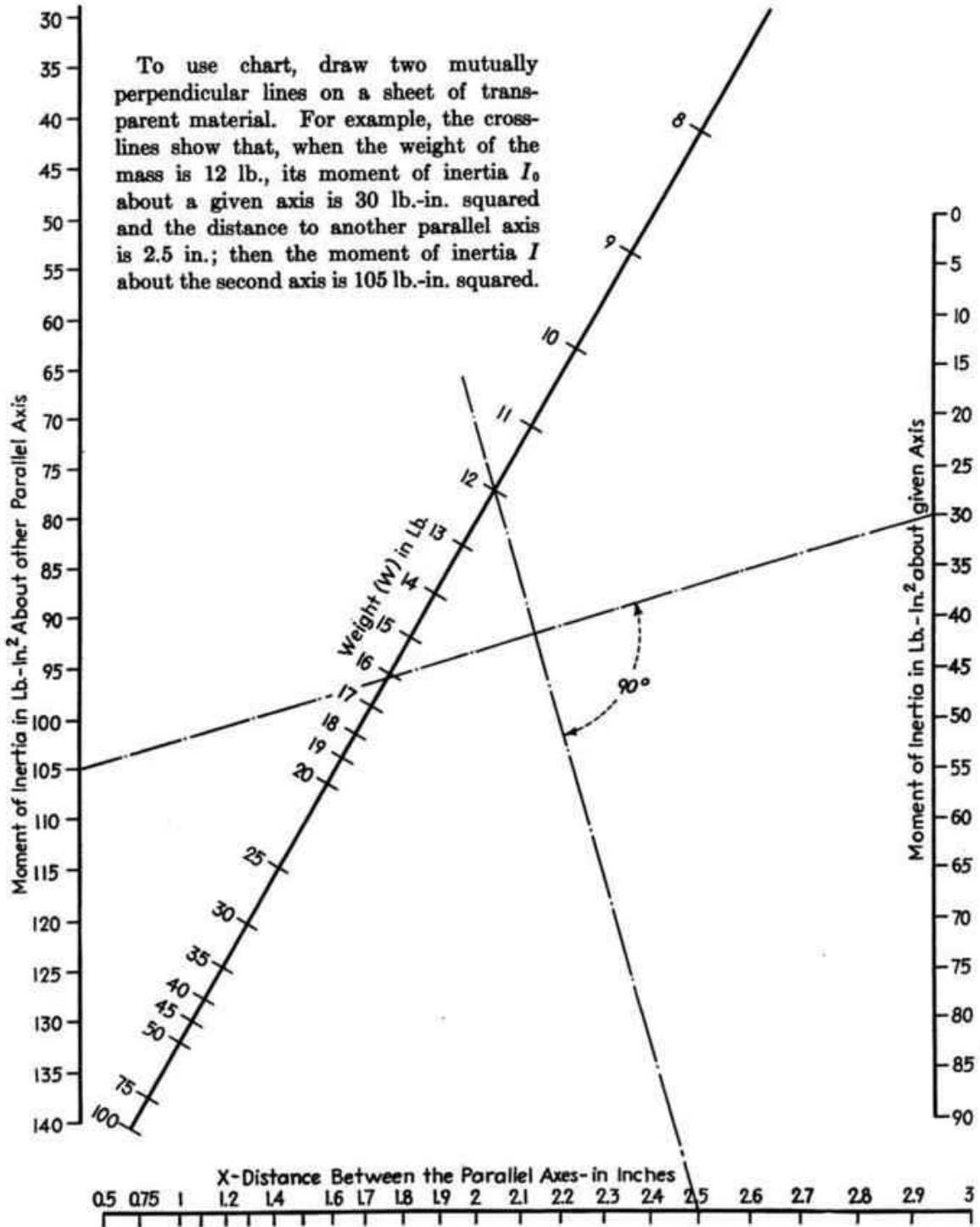

WR² OF SYMMETRICAL BODIES

For computing WR^2 of rotating masses by resolving the body into elemental shapes. See page 208 for effect of WR^2 on electric motor selection.

1. Weights per Unit Volume of Materials.

MATERIAL	WEIGHT, LB. PER CU. IN.
Cast iron.....	0.260
Cast-iron castings of heavy section i.e., flywheel rims.....	0.250
Steel.....	0.283
Bronze.....	0.319
Lead.....	0.410
Copper.....	0.318

Note: ρ in pounds per cubic inch and dimensions in inches give WR^2 in lb.-in. squared.

2. Cylinder, about Axis Lengthwise through the Center of Gravity.

$$\text{Volume} = \frac{\pi}{4} L(D^2_1 - D^2_2)$$

(a) For any material:

$$WR^2 = \frac{\pi}{32} \rho L(D^4_1 - D^4_2)$$

where ρ is the weight per unit volume.

(b) For cast iron:

$$WR^2 = \frac{L(D^4_1 - D^4_2)}{39.2}$$

(c) For cast iron (heavy sections):

$$WR^2 = \frac{L(D^4_1 - D^4_2)}{40.75}$$

(d) For steel:

$$WR^2 = \frac{L(D^4_1 - D^4_2)}{36.0}$$

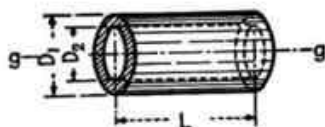

3. Cylinder, about an Axis Parallel to the Axis through Center of Gravity.

$$\text{Volume} = \frac{\pi}{4} L(D^2_1 - D^2_2)$$

(a) For any material:

$$WR^2_{x-x} = \frac{\pi}{4} \rho L(D^2_1 - D^2_2) \left(\frac{D^2_1 + D^2_2}{8} + y^2 \right)$$

(b) For steel:

$$WR^2_{x-x} = \frac{(D^2_1 - D^2_2)L}{4.50} \left(\frac{D^2_1 + D^2_2}{8} + y^2 \right)$$

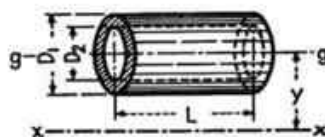

4. Solid Cylinder, Rotated about an Axis Parallel to a Line that Passes through the Center of Gravity and Is Perpendicular to the Center Line.

$$\text{Volume} = \frac{\pi}{4} D^2 L$$

(a) For any material:

$$WR^2_{x-x} = \frac{\pi}{4} D^2 L \rho \left(\frac{L^2}{12} + \frac{D^2}{16} + r^2 \right)$$

(b) For steel:

$$WR^2_{x-x} = \frac{D^2 L}{4.50} \left(\frac{L^2}{12} + \frac{D^2}{16} + r^2 \right)$$

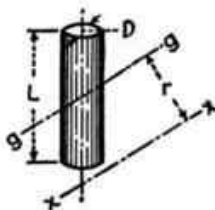

5. Rod of Rectangular or Elliptical Section, Rotated about an Axis Perpendicular to and Passing through the Center Line.

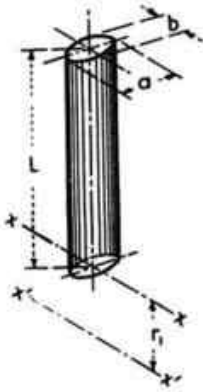

$$\text{Volume} = K_2 abL$$

For rectangular cross sections:

$$K_1 = \frac{1}{12}; \quad K_2 = 1$$

For elliptical cross sections:

$$K_1 = \frac{\pi}{64}; \quad K_2 = \frac{4}{\pi}$$

(a) For any material:

$$WR^2_{x'-x'} = \rho abL \left\{ K_2 \left[\frac{L^2}{3} + r_1(r_1 + L) \right] + K_1 a^2 \right\}$$

(b) For a cast-iron rod of elliptical section ($\rho = 0.260$):

$$WR^2_{x'-x'} = \frac{abL}{4.90} \left[\frac{L^2}{3} + r_1(r_1 + L) + \frac{a^2}{16} \right]$$

6. Elliptical Cylinder, about an Axis Parallel to the Axis through the Center of Gravity.

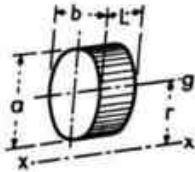

$$\text{Volume} = \frac{\pi}{4} abL$$

(a) For any material:

$$WR^2_{x-x} = \rho \frac{\pi}{4} abL \left(\frac{a^2 + b^2}{16} + r^2 \right)$$

(b) For steel:

$$WR^2_{x-x} = \frac{abL}{4.50} \left(\frac{a^2 + b^2}{16} + r^2 \right)$$

7. Cylinder with Frustum of a Cone Removed.

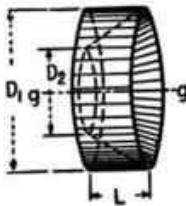

$$\text{Volume} = \frac{\pi L}{2(D_1 - D_2)} \left[\frac{1}{3} (D_1^3 - D_2^3) - \frac{D_2^2}{2} (D_1 - D_2) \right]$$

$$WR^2_{g-g} = \frac{\pi \rho L}{8(D_1 - D_2)} \left[\frac{1}{5} (D_1^5 - D_2^5) - \frac{D_2^2}{4} (D_1^4 - D_2^4) \right]$$

8. Frustum of a Cone with a Cylinder Removed.

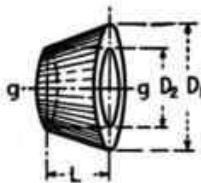

$$\text{Volume} = \frac{\pi L}{2(D_1 - D_2)} \left[\frac{D_1}{2} (D_1^2 - D_2^2) - \frac{1}{3} (D_1^3 - D_2^3) \right]$$

$$WR^2_{g-g} = \frac{\pi \rho L}{8(D_1 - D_2)} \left[\frac{D_1}{4} (D_1^4 - D_2^4) - \frac{1}{5} (D_1^5 - D_2^5) \right]$$

9. Solid Frustum of a Cone.

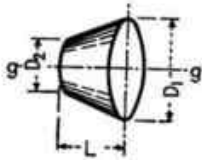

$$\text{Volume} = \frac{\pi L (D_1^3 - D_2^3)}{12 (D_1 - D_2)}$$

$$WR_{x-x}^2 = \frac{\pi \rho L (D_1^5 - D_2^5)}{160 (D_1 - D_2)}$$

10. Chamfer Cut from Rectangular Prism Having One End Turned about a Center.

Distance to center of gravity:

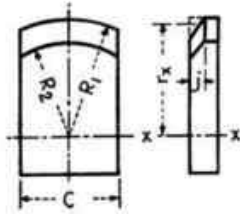

$$r_x = \frac{jR^3 B}{\text{volume} \times (1 - A)} \left[\frac{1}{3} (A^3 - 3A + 2) + \frac{B^2}{3} \left(1 - A - A \log_e \frac{1}{A} \right) + \frac{3}{40} \frac{B^4}{A} (A^2 - 2A + 1) + \frac{5}{672} \frac{B^6}{A^3} (3A^4 - 4A^3 + 1) \dots \right]$$

$$\text{Volume} = \frac{jR^2 B}{(1 - A)} \left\{ (A^2 - 2A + 1) + \frac{B^2}{3} \left[\log_e \frac{1}{A} - (1 - A) \right] + \frac{1}{40} \frac{B^4}{A^2} (2A^3 - 3A + 1) + \frac{1}{224} \frac{B^6}{A^4} (4A^5 - 5A^4 + 1) + \dots \right\}$$

where $A = R^2/R_1$ $B = C/2R_1$

$$WR_{x-x}^2 = - \frac{\rho j R^4 B}{6(1 - A)} \left\{ (A^4 - 4A + 3) + B^2 (A^2 - 2A + 1) + \frac{9}{10} B^4 \left[\log_e \frac{1}{A} - (1 - A) \right] + \frac{5}{56} \frac{B^6}{A^2} (2A^3 - 3A^2 + 1) + \dots \right\}$$

11. Complete Torus.

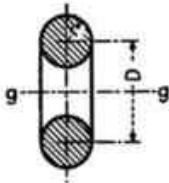

$$\text{Volume} = \pi^2 D r^2$$

$$WR_{x-x}^2 = \frac{\pi^2 \rho D r^2}{4} (D^2 + 3r^2)$$

12. Outside Part of a Torus.

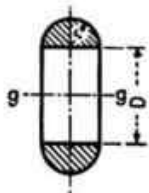

$$\text{Volume} = 2\pi r^2 \left(\frac{\pi D}{4} + \frac{2}{3} r \right)$$

$$WR_{x-x}^2 = \pi \rho r^2 \left[\frac{D^2}{4} \left(\frac{\pi D}{2} + 4r \right) + r^2 \left(\frac{3\pi}{8} D + \frac{8}{15} r \right) \right]$$

13. Inside Part of a Torus.

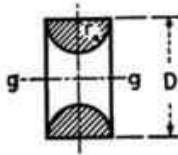

$$\text{Volume} = 2\pi r^2 \left(\frac{\pi D}{4} - \frac{2}{3} r \right)$$

$$WR^2_{g-g} = \pi \rho r^2 \left[\frac{D^2}{4} \left(\frac{\pi D}{2} - 4r \right) + r^2 \left(\frac{3\pi}{8} D - \frac{8}{15} r \right) \right]$$

14. Circular Segment about an Axis through Center of Circle.

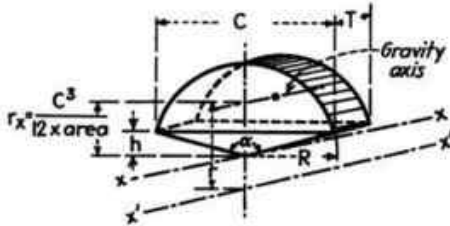

$$\alpha = 2 \sin^{-1} \frac{C}{2R} \text{ deg.}$$

$$\text{Area} = \frac{R^2 \alpha}{114.59} - \frac{C}{2} \sqrt{R^2 - \frac{C^2}{4}}$$

(a) Any material:

$$WR^2_{z-z} = \rho T \left[\frac{R^4 \alpha}{229.2} - \frac{1}{6} \left(3R^2 - \frac{C^2}{2} \right) \frac{C}{2} \sqrt{R^2 - \frac{C^2}{4}} \right]$$

(b) For steel:

$$WR^2_{z-z} = \frac{T}{3.534} \left[\frac{R^4 \alpha}{229.2} - \frac{1}{6} \left(3R^2 - \frac{C^2}{2} \right) \frac{C}{2} \sqrt{R^2 - \frac{C^2}{4}} \right]$$

15. Circular Segment about Any Axis Parallel to an Axis through the Center of the Circles. (Refer to 14 for Figure.)

$$WR^2_{z'-z'} = WR^2_{z-z} + \text{weight} (r^2 - r'^2)$$

16. Rectangular Prism about an Axis Parallel to the Axis through the Center of Gravity.

$$\text{Volume} = WLT$$

(a) For any material:

$$WR^2_{z-z} = \rho WLT \left(\frac{W^2 + L^2}{12} + y^2 \right)$$

(b) For steel:

$$WR^2_{z-z} = \frac{WLT}{3.534} \left(\frac{W^2 + L^2}{12} + y^2 \right)$$

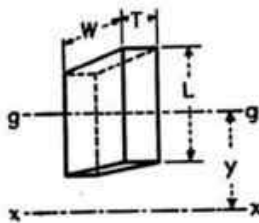

17. Isosceles Triangular Prism, Rotated about an Axis through Its Vertex.

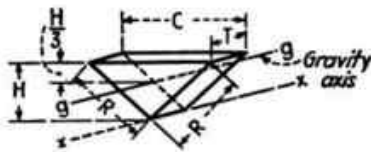

$$\text{Volume} = \frac{CHT}{2}$$

$$WR^2_{x-x} = \frac{\rho CHT}{2} \left(\frac{R^2}{2} - \frac{C^2}{12} \right)$$

18. Isosceles Triangular Prism, Rotated about Any Axis Parallel to an Axis through the Vertex.

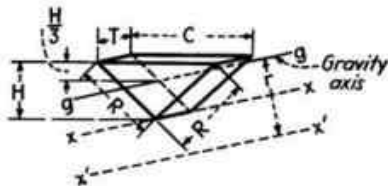

$$\text{Volume} = \frac{CHT}{2}$$

$$WR^2_{x'-x'} = \frac{\rho CHT}{2} \left(\frac{R^2}{2} - \frac{C^2}{12} - \frac{4}{9} H^2 + r^2 \right)$$

19. Prism with Square Cross Section and Cylinder Removed, along Axis through Center of Gravity of Square.

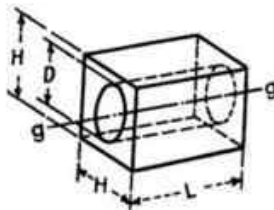

$$\text{Volume} = L \left(H^2 - \frac{\pi D^2}{4} \right)$$

$$WR^2_{g-g} = \frac{\pi \rho L}{32} (1.697 H^4 - D^4)$$

20. Any Body about an Axis Parallel to the Gravity Axis, When WR^2 about the Gravity Axis Is Known.

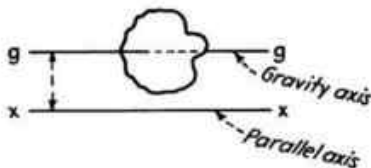

$$WR^2_{x-x} = WR^2_{g-g} + \text{weight} \times r^2$$

21. WR^2 of a Piston, Effective at the Cylinder Center Line, about the Crankshaft Center Line.

$$WR^2 = r^2 W_p \left(\frac{1}{2} + \frac{r^2}{8L^2} \right)$$

where r = crank radius

L = center-to-center length of connecting rod

W_p = weight of complete piston, rings, and pin

22. WR^2 of a Connecting Rod, Effective at the Cylinder Center Line, about the Crankshaft Center Line.

$$WR^2 = r^2 \left[W_1 + W_2 \left(\frac{1}{2} + \frac{r^2}{8L^2} \right) \right]$$

where r = crank radius

L = center-to-center length of connecting rod

W_1 = weight of the lower or rotating part of the rod = $[W_R(L - L_1)]/L$

W_2 = weight of the upper or reciprocating part of the rod = $W_R L_1/L$

$W_R = W_1 + W_2$, the weight of the complete rod
 L_1 = distance from the center line of the crankpin to the center of gravity of the connecting rod

23. Mass Geared to a Shaft.—The equivalent flywheel effect at the shaft in question is

$$WR^2 = h^2(WR^2)'$$

where h = gear ratio
 = $\frac{\text{r.p.m. of mass geared to shaft}}{\text{r.p.m. of shaft}}$

$(WR^2)'$ = flywheel effect of the body in question about its own axis of rotation

24. Mass Geared to Main Shaft and Connected by a Flexible Shaft.—The effect of the mass $(WR^2)'$ at the position of the driving gear on the main shaft is

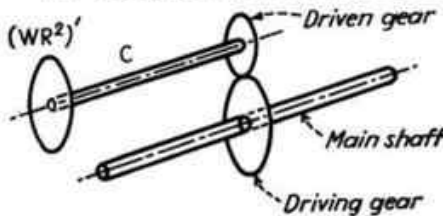

$$WR^2 = \frac{h^2(WR^2)'}{1 - \frac{(WR^2)'f^2}{9.775C}}$$

where h = gear ratio
 = $\frac{\text{r.p.m. of driven gear}}{\text{r.p.m. of driving gear}}$
 $(WR^2)'$ = flywheel effect of geared-on mass

f = natural torsional frequency of the shafting system, in vibrations per sec.
 C = torsional rigidity of flexible connecting shaft, in pound-inches per radian

25. Belted Drives.—The equivalent flywheel effect of the driven mass at the driving shaft is

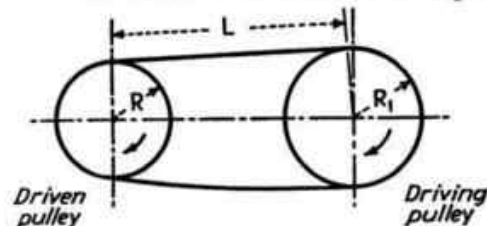

$$WR^2 = \frac{h^2(WR^2)'}{1 - \frac{(WR^2)'f^2}{9.775C}}$$

where $h = R_1/R$
 = $\frac{\text{r.p.m. of pulley belted to shaft}}{\text{r.p.m. of shaft}}$

$(WR^2)'$ = flywheel effect of the driven body about its own axis of rotation

f = natural torsional frequency of the system, in vibrations per sec.

$$C = R^2AE/L$$

A = cross-sectional area of belt, in sq. in.
 E = modulus of elasticity of belt material in tension, in lb. per sq. in.
 R = radius of driven pulley, in in.
 L = length of tight part of belt which is clear of the pulley, in in.

26. Effect of the Flexibility of Flywheel Spokes on WR^2 of Rim.—The effective WR^2 of the rim is

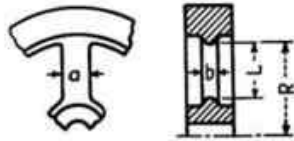

$$WR^2 = \frac{(WR^2)'}{1 - \frac{(WR^2)'}{9.775C}}$$

where $(WR^2)'$ = flywheel effect of the rim
 f = natural torsional frequency of the system of which the flywheel is a member, in vibrations per sec.
 C = torque required to move the rim through one radian relative to the hub

$C = \frac{12gEka^3bR}{L^2} \left(\frac{L}{3R} + \frac{R}{L} - 1 \right)$
 where g = number of spokes
 E = bending modulus of elasticity of the spoke material
 $k = \pi/64$ for elliptical, and $k = 1/12$ for rectangular section spokes
 All dimensions are in inches.

For cast-iron spokes of elliptical section:

$$E = 15 \times 10^6 \text{ lb. per sq. in.}$$

$$C = \frac{ga^3bR \times 10^6}{0.1132L^2} \left(\frac{L}{3R} + \frac{R}{L} - 1 \right) \frac{\text{lb.-in.}}{\text{radians}}$$

Note: It is found by comparative calculations that with spokes of moderate taper very little error is involved in assuming the spoke to be straight and using cross section at mid-point for area calculation.

TYPICAL EXAMPLE

The flywheel shown below is used in a Diesel engine installation. It is required to determine effective WR^2 for calculation of one of the natural frequencies of torsional vibration. The anticipated natural frequency of the system is 56.4 vibrations per sec.

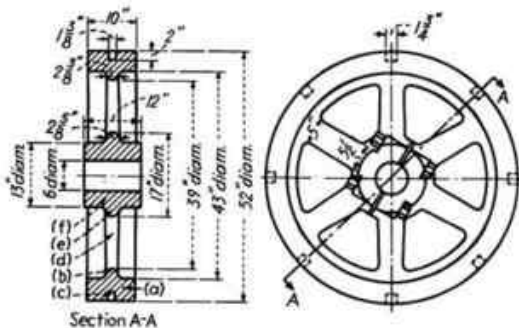

Note: Since the beads at the ends of the spokes comprise but a small part of the flywheel WR^2 , very little error will result in assuming them to be of rectangular cross section. Also, because of the effect of the clamping bolts, the outer hub will be considered a square equal to the diameter. The spokes will be assumed straight and of mid-point cross section.

Part of fly wheel	Formula	WR^2
(a)	2c	$\frac{10[(52)^4 - (43)^4]}{40.75} = 955,300$
(b)	2b	$\frac{2.375[(43)^4 - (39)^4]}{39.2} = 67,000$
(c)	16a neglecting $\left(\frac{W^2 + L^2}{12}\right)$	$-0.250 \times 1.75 \times 2 \times 1.375(25)^2 \times 8 = -6,000$
		Total for rim = 1,016,300 lb.-in. squared
(d)	5b	$6 \times \frac{5.25 \times 2.5 \times 11}{4.90} \left[\frac{(11)^2}{3} + 8.5(8.5 + 11) + \frac{(5.25)^2}{16} \right] = 36,800$
(e)	2b	$\frac{2.625[(17)^4 - (13)^4]}{39.2} = 3,700$
(f)	19	$\frac{\pi \times 0.250 \times 12}{32} [1.697 \times (13)^4 - (6)^4] = 13,900$
		Total for remainder of flywheel = 54,400 lb.-in. squared

From formula (26)

$$C = \frac{6 \times (5.25)^2 \times 2.5 \times 19.5 \times 10^6}{0.1132 \times (11)^2} \left(\frac{11}{3 \times 19.5} + \frac{19.5}{11} - 1 \right) = 2,970 \times 10^6 \frac{\text{lb.-in.}}{\text{radians}}$$

and $WR^2 = \frac{1,016,300}{1 - \frac{1,016,300 \times (56.4)^2}{9.775 \times 2,970 \times 10^6}} + 54,400 = 1,197,000 \text{ lb.-in. squared}$

CHART FOR DETERMINING CENTRIFUGAL FORCE

$$F = 0.000341WRn^2$$

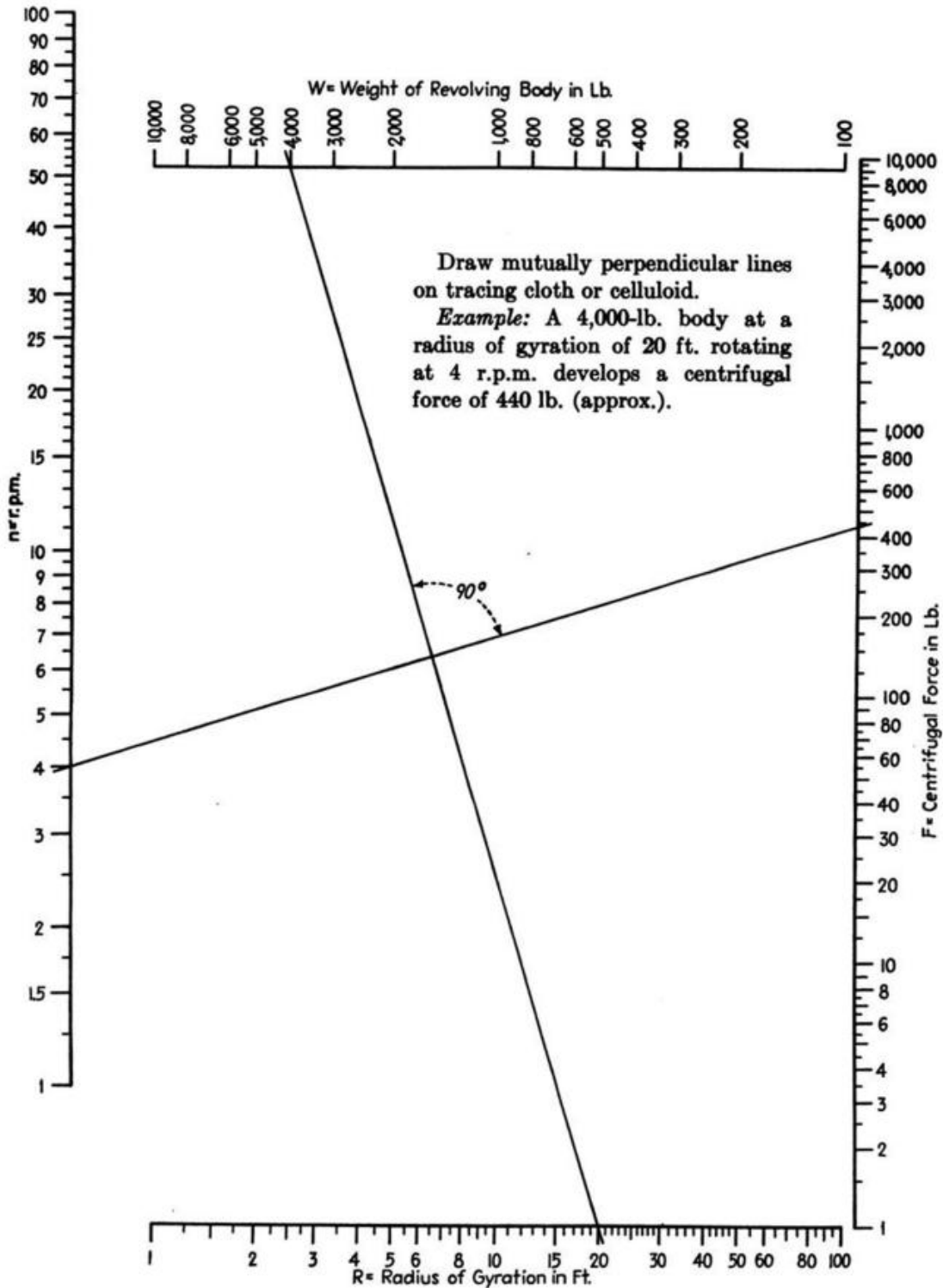

FORCES IN TOGGLE JOINT WITH EQUAL ARMS

$$\frac{P}{F} = \frac{S}{4h}$$

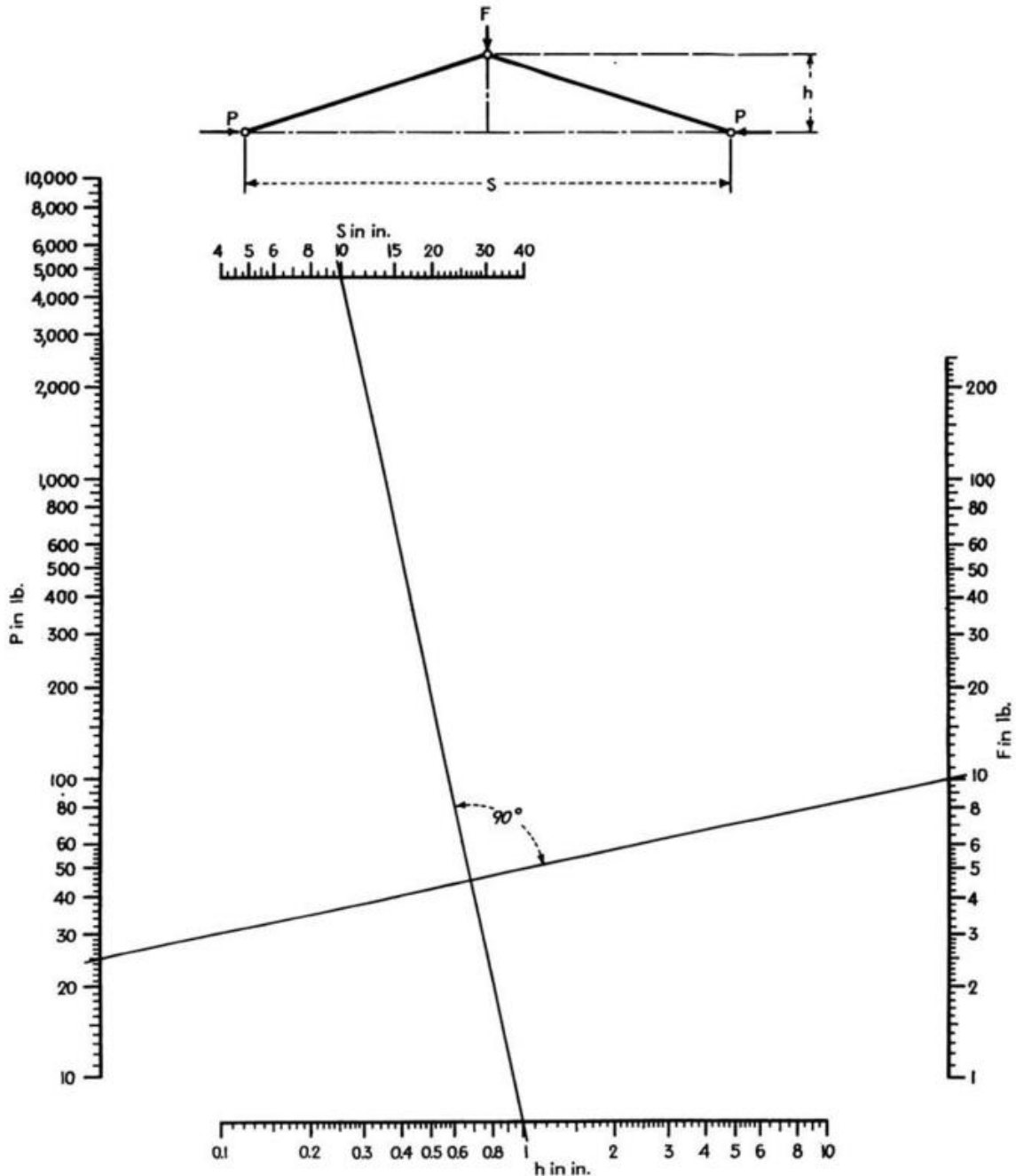

Example: Use mutually perpendicular lines drawn on tracing cloth or celluloid. In the example given for $S = 10$ in. and $h = 1$ in., a force F of 10 lb. exerts pressures P of 25 lb. each.

ACCELERATED LINEAR MOTION

$$\frac{2S}{T^2} = \frac{V}{2S} = \frac{V}{T} = \frac{32.16F}{W} = G$$

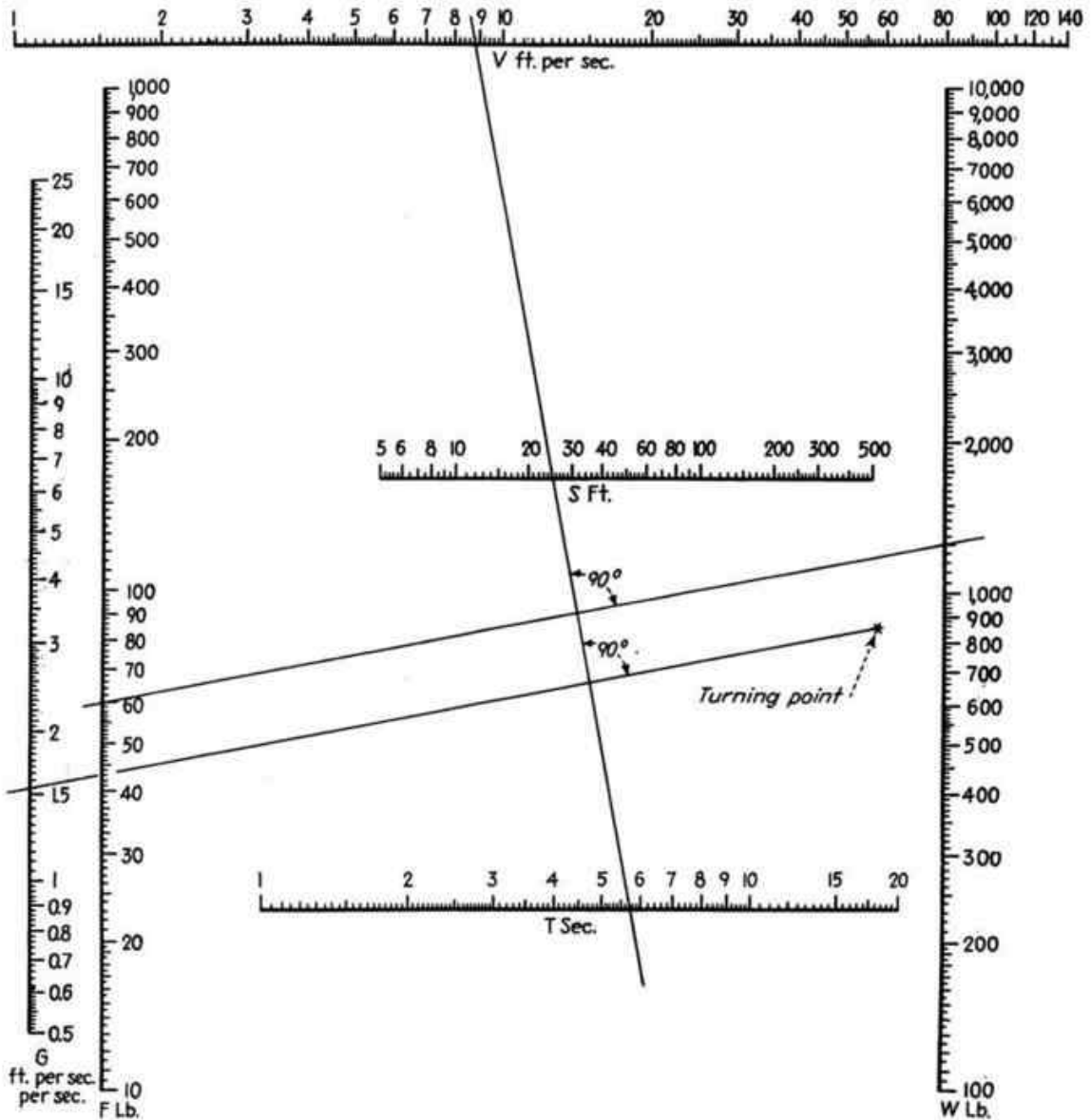

* = turning point

V = velocity at time T , in ft. per sec.

S = distance passed through, in ft.

T = time during which force acts, in sec.

F = accelerating force, in lb.

W = weight of moving body, in lb.

G = constant acceleration, in ft. per sec.

ROTARY MOTION

$$V = \frac{P}{F} = \frac{S}{T} = \frac{2\pi Rn}{12 \times 60}$$

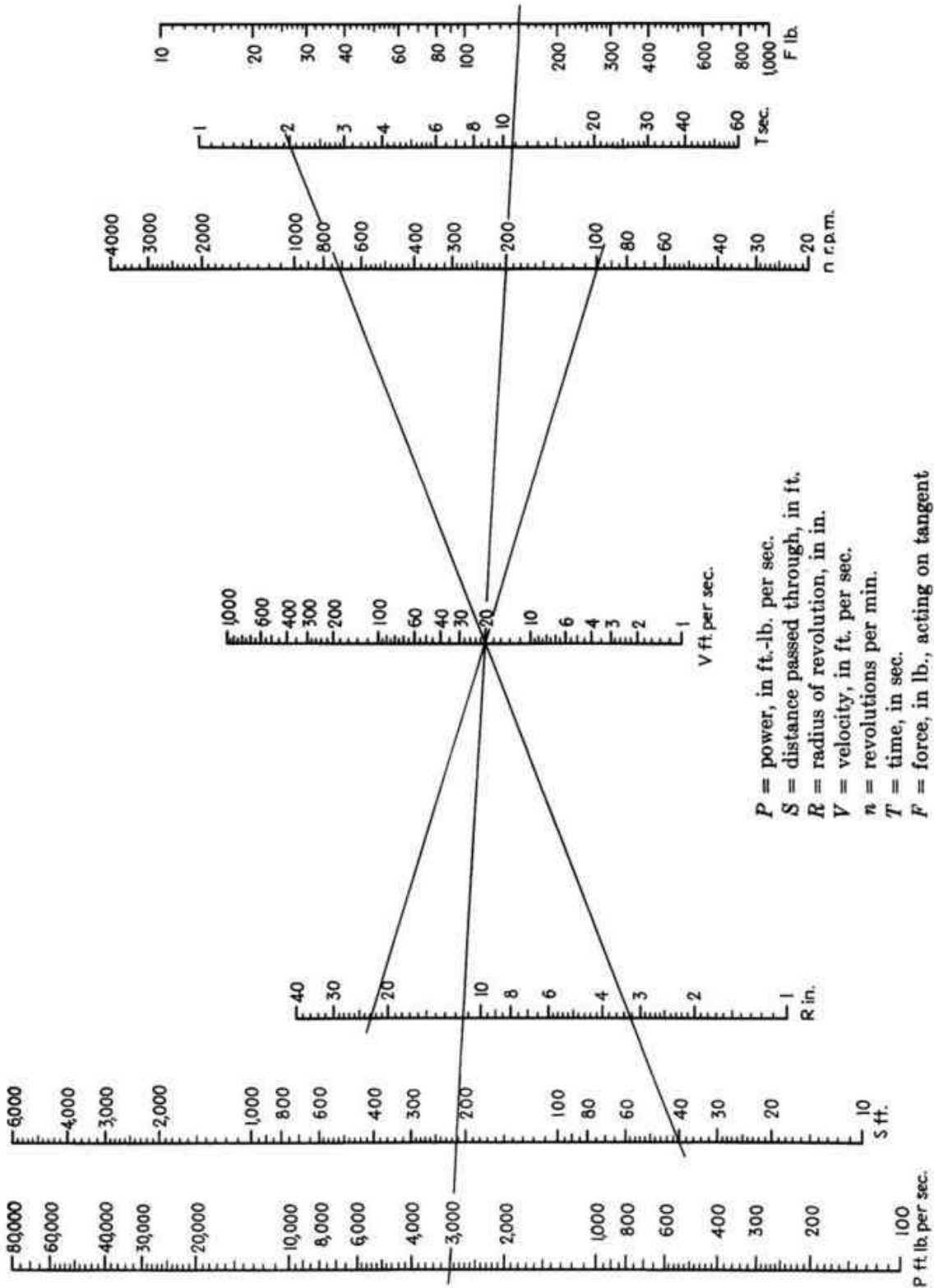

MEAN COOLING TEMPERATURE

Where Y_A and Y_B are any two ordinates to the curve $Y=ae^{-bx}$ the usual form of cooling curve, the mean value Y_M of all the ordinates between Y_A and Y_B is given by the relation

$$\text{Log mean } Y_M = \frac{Y_A - Y_B}{\text{Log } Y_A - \text{Log } Y_B}$$

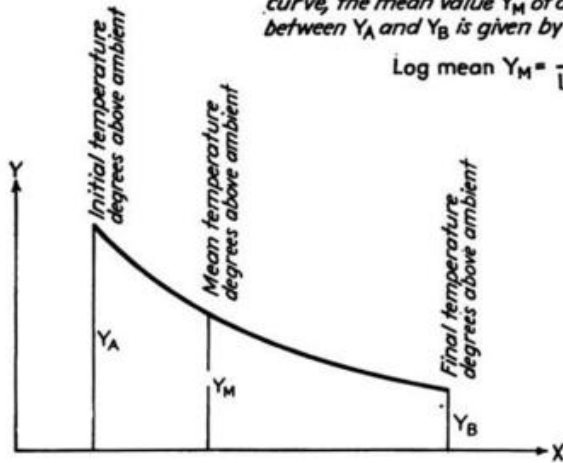

The dotted line shows that for a body cooling from 150 deg. F. to 70 deg. F. in air at 60 deg. F. the mean temperature difference is 36.3 deg. F. the mean temperature therefore is 96.3 deg. F.

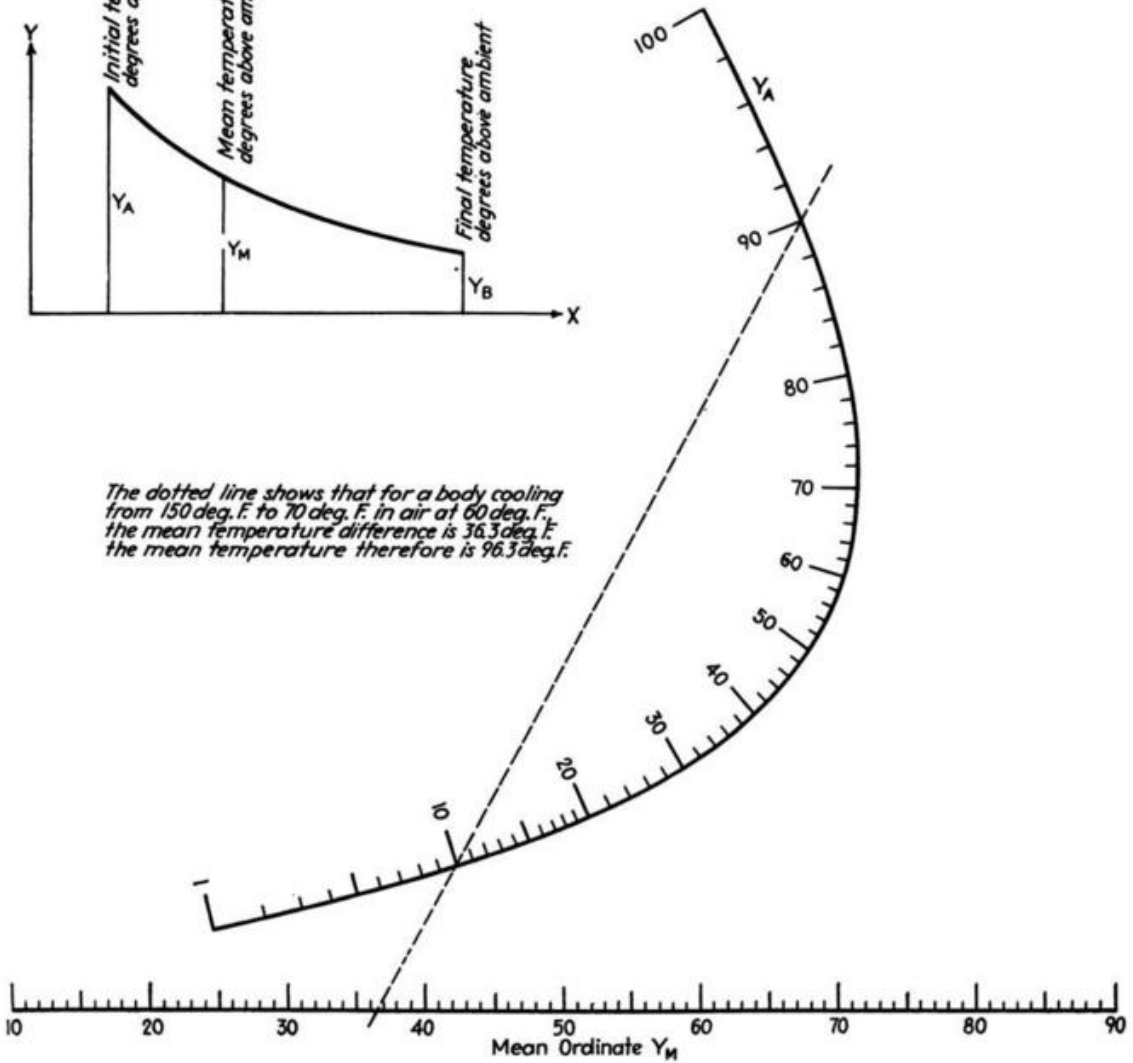

SOLUTION OF OHM'S EQUATIONS

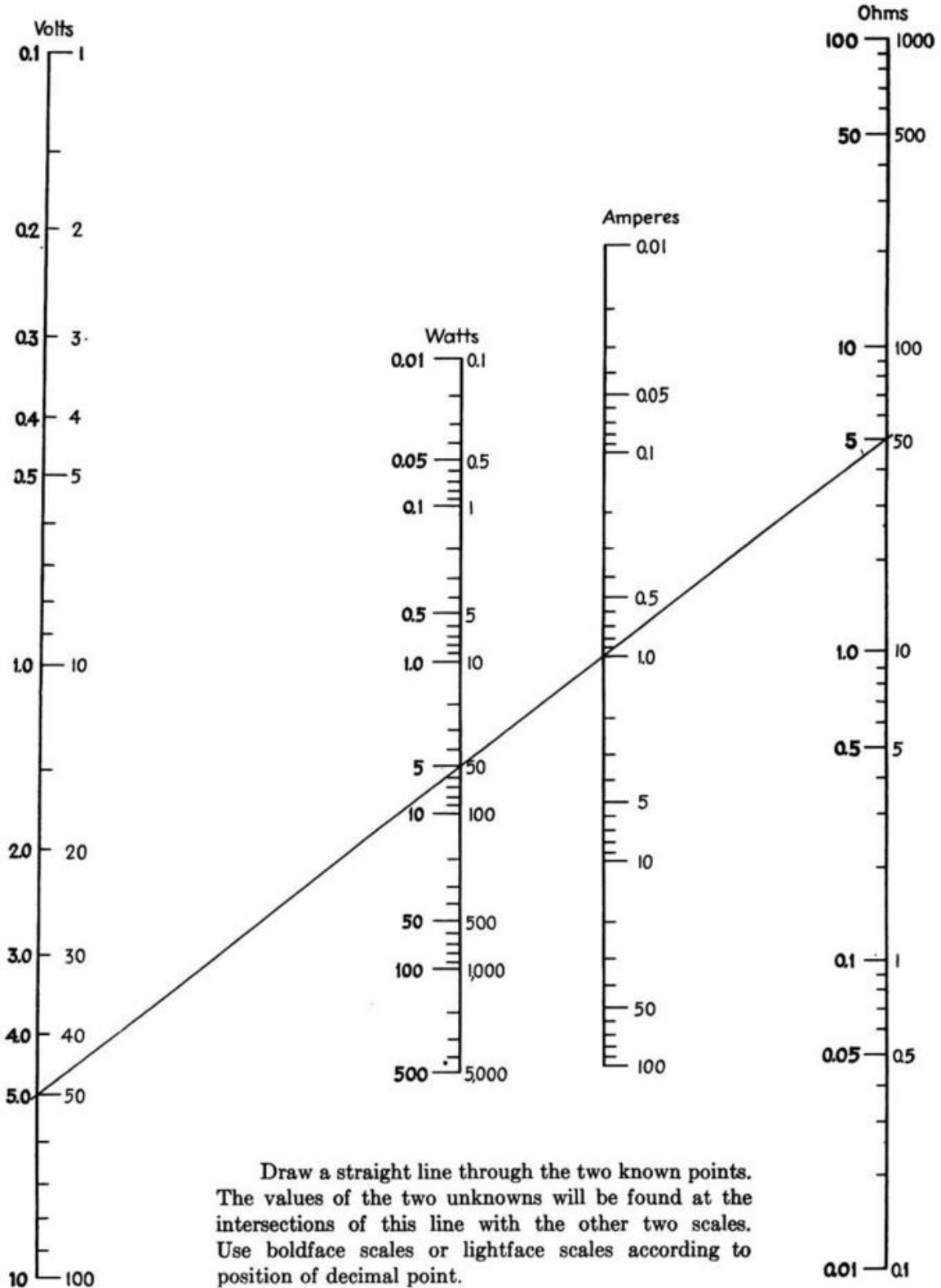

Draw a straight line through the two known points. The values of the two unknowns will be found at the intersections of this line with the other two scales. Use boldface scales or lightface scales according to position of decimal point.

TOTAL RESISTANCE OF PARALLEL CIRCUITS

$$R_t = \frac{1}{\frac{1}{R_1} + \frac{1}{R_2} + \frac{1}{R_3} + \frac{1}{R_4} + \dots}$$

For convenience, list the resistances of the different parallel circuits in descending order of magnitude. Locate R_1 on the diagonal scale and connect it with R_2 on the horizontal scale. The total resistance is found at the intersection with the Total Resistance diagonal. For more than two parallel circuits, project horizontally from the intersection point on the Total Resistance diagonal to the diagonal Resistance R_1 , draw a line to R_2 on the horizontal scale, and the answer will again be found at the intersection with the Total Resistance diagonal. Repeat successively for additional resistances R_3, R_4, \dots .

The light dashed lines indicate the procedure for finding the total resistance of five parallel circuits, $R_1 = 100, R_2 = 60, R_3 = 40, R_4 = 30, R_5 = 25$. The answer as given by the chart is 8.0.

Conversely, the resistances of individual parallel circuits to give a desired total resistance can be determined from this chart.

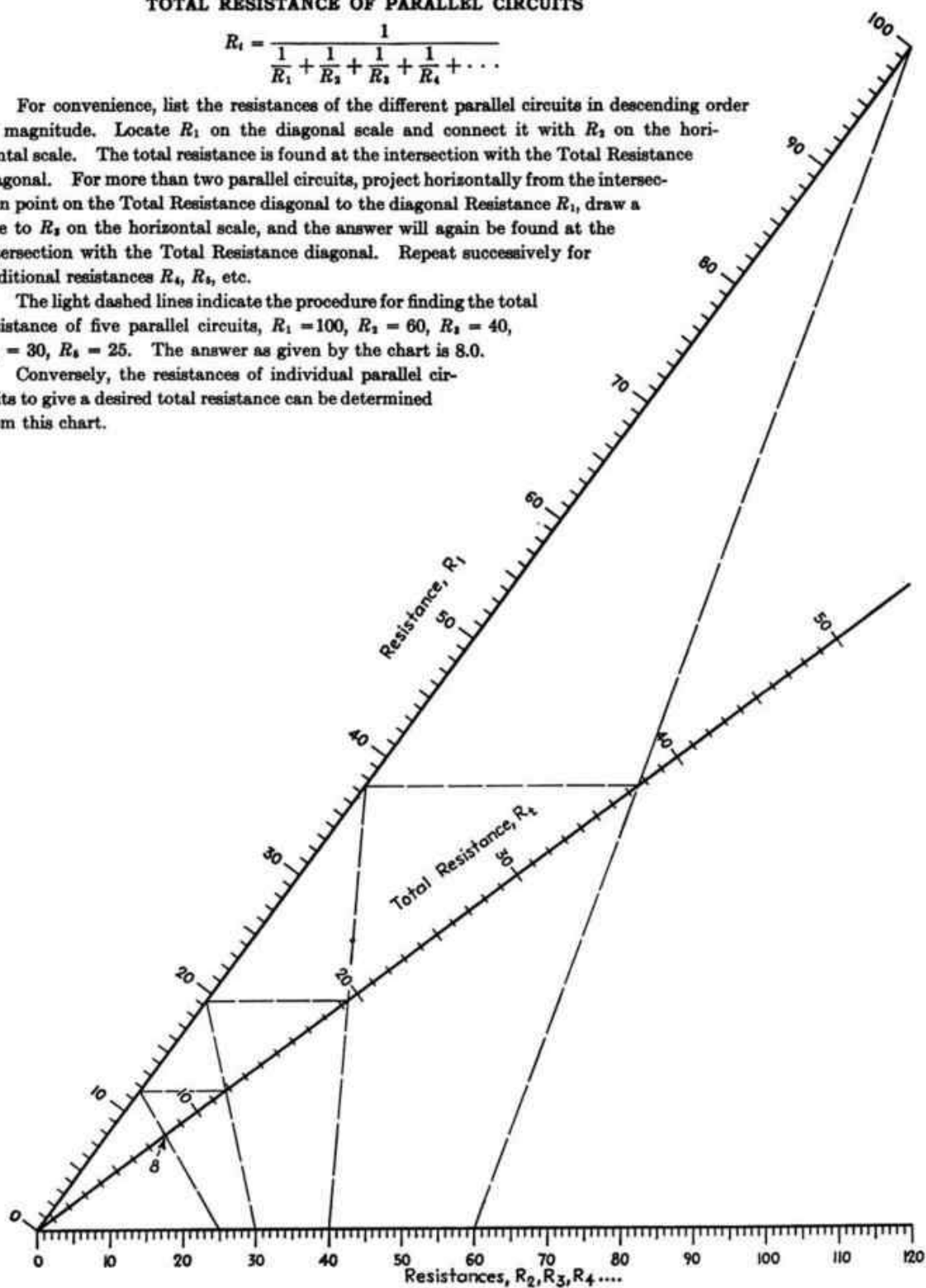

CHAPTER II
MATERIALS

	PAGE		PAGE
Selection of Materials.....	34	Properties of Stainless Steel.....	50
Cast Irons.....	35	Iron-Nickel-Chromium Alloys.....	52
Alloy Cast Irons.....	36	Wrought Brasses and Bronzes.....	54
Effect of Nickel and Chromium on Cast Iron.....	38	Corrosion-resisting Metals and Alloys.....	58
Malleable Iron Castings.....	39	Aluminum Base Alloys.....	60
Cast Carbon Steels.....	40	Magnesium Base Alloys.....	64
High Alloy Cast Steels.....	42	Insulating Materials.....	65
Low Alloy Cast Steels.....	44	Plastic Materials.....	66
Corrosion and Heat-resistant Cast Steels....	46	Phenolic Laminated Molded Materials.....	68
		Steels for Automotive Parts.....	70

SELECTION OF MATERIALS

The universal problem in engineering design is the selection of the materials from which the various parts of the device, machine, or product are to be made. It is also the first problem because the material selected will govern the allowable stresses, the types of construction that might be adopted, the manufacturing methods employed, the assembly operations, the finishes that might be applied, and, of greatest importance, the cost and sales appeal of the product. In many designs, the commercial success or failure will be determined definitely by the materials selected.

In practically every design, the physical and other properties required will determine which materials might be used. But the relative importance of the different properties will vary considerably for different types of design. The unit strength of the material is practically always a factor though often a minor one.

For constructions subjected to only a steady tension, the yield point on the stress-strain curve or the yield strength of the material, *i.e.*, the unit tension it can withstand with a specified elongation, will be the first consideration. But for a compression-loaded column, both the tensile strength and the elastic modulus must be considered. For vibratory or repeated stresses, the endurance limit of the material becomes the governing strength consideration, whereas for low-temperature service and shock loads the impact values are of great importance. And, of course, there is also to be considered the compressive strength or the shear strength, according to the type of stresses to which the member will be subjected.

In addition to the unit strength considerations, any one or a group of almost innumerable other properties must be considered. If, as in most machine tools, it is important to have little or no vibration, a material with a high vibration damping capacity, such as cast iron, might be considered first. Hardness, wear resistance, porosity, and ductility are some of the other properties that may be of major importance.

In addition to physical properties, corrosion resistance, heat conductivity, electrical conductivity, dielectric strength, frictional properties, and many others may enter into the problem.

There is no formula or equation by which the most suitable material from the standpoint of properties can be selected. Nor is it always advisable to use the material that has the highest values for the properties desired. Invariably the final selection must be a compromise largely because two other important factors enter into the problem, namely, the workability of the material and its cost.

When a number of different materials have been selected, each of which possesses the desired properties to a satisfactory degree, the next step toward the final selection is the determination of the manufacturing methods that might be employed. Aluminum, zinc, and many of the non-ferrous alloys naturally suggest die-casting, stamping, and forging. Iron, steel, aluminum, and some other metals offer great possibilities by virtue of their weldability. Casting is suitable for almost all metals and alloys. Plastics are mostly molded; some are sheet-laminated or are in the form of sheets; a few are extruded. To mention only a few other manufacturing processes, we have impact extrusion, die extrusion, drawn shapes and rolled shapes, and roll-formed sheet sections.

After it has been determined what types of construction might be used, the design must be analyzed with reference to such things as the use of inserts, consolidating different parts into one piece, use of standard purchased parts, and similar possibilities.

Hand in hand with the types of construction that might be employed are the costs of machining, grinding, and other operations, which will vary greatly. Included in this category may be punching, hand reaming, riveting, buffing, and polishing.

Not until all the factors discussed above have been studied closely and analyzed should any consideration be given to the cost per pound of the material. A complete analysis may often reveal that aluminum at 30 cts. per lb. or zinc at 10 cts. per lb. is cheaper to use than gray iron at 5 cts. per lb.

A complete analysis of all the items to be considered in the selection of materials and the associated problems of types of constructions and workability considerations would require volumes and even then would obscure the problem rather than clarify it. In the final analysis, nothing can be substituted for clear engineering thinking based on broad experience and knowledge.

CAST IRONS

GRAY IRON

CHEMICAL COMPOSITION	PER CENT BY WEIGHT
Graphitic carbon.....	2 - 3
Combined carbon.....	0.8 max.
Iron.....	93.7 -94.3
Silicon.....	0.25- 0.3
Manganese.....	0.5 - 1
Sulphur.....	0.07- 0.12
Phosphorus.....	0.10- 1.05
AVERAGE PHYSICAL PROPERTIES	LB. PER Sq. IN.
Tensile strength.....	21,000- 42,000
Shear strength.....	36,000- 60,000
Compressive strength.....	70,000-200,000
Modulus of elasticity.....	15,000,000

Gray iron ordinarily is easily machinable.

WHITE IRON

CHEMICAL COMPOSITION	PER CENT BY WEIGHT
Graphitic carbon.....	Trace
Combined carbon.....	3.30
Iron.....	94.93
Silicon.....	0.60
Manganese.....	0.52
Sulphur.....	0.15
Phosphorus.....	0.50
AVERAGE PHYSICAL PROPERTIES	LB. PER Sq. IN.
Tensile strength.....	20,000-70,000
Modulus of elasticity.....	20,000,000

White iron is difficult to machine. When not heat-treated, white iron has great resistance to wear by abrasion.

MOTTLED IRON

CHEMICAL COMPOSITION	PER CENT BY WEIGHT
Graphitic carbon.....	1.50
Combined carbon.....	1.80
Iron.....	95.07
Silicon.....	0.92
Manganese.....	0.36
Sulphur.....	0.13
Phosphorus.....	0.22

Mottled iron is a mixture of gray iron and white iron.

Chilled cast iron are those parts of castings which after pouring are cooled quickly by chills in order to retain the carbon in the iron carbide form found in white iron, whereas other parts of the casting cool slowly to form gray iron.

ALLOY CAST IRONS

To obtain exceptional properties such as high tensile strength, hardness, wear resistance, corrosion resistance, and heat resistance, many alloys of cast iron with other elements have been developed. The effect of various alloying additions are indicated in the accompanying table.

EFFECTS OF ALLOYING ADDITIONS ON CAST IRON

Addition	Effect on mechanical properties	Comments
Bismuth	Reduces tensile strength Lowers Brinell hardness in interior sections Low impact resistance	Improves machinability
Chromium	See page 38	
Cobalt	No useful results	Increases remnant magnetism and magnetic permeability
Copper	Increases tensile strength Increases Brinell hardness Increases wear resistance Increases antifriction properties Increases shock resistance where there is sliding friction Increases resistance to heat Increases resistance to corrosion	Increases remnant magnetism and coercive force
Manganese	Increases tensile strength Increases resistance to wear	Decreases machinability when in excess of 1.25 per cent May increase machinability within the limits of 0.40 and 1.00 per cent
Molybdenum	Increases tensile strength Increases hardness Improves impact resistance Improves fatigue characteristics Improves wear resistance Maintains strength of irons at elevated temperatures	Increases machinability by promoting structural uniformity
Nickel	See page 38	
Phosphorus	Small quantities do not affect the tensile strength. With increasing phosphorus, resilience and shock resistance decrease, but Brinell hardness and stiffness increase	One of five principal elements in cast iron Increase of phosphorus reduces machinability Phosphorus in pressure castings should be kept under 0.3 per cent
Silicon	Hardness increases with increased silicon With 4 per cent silicon, alloy becomes brittle with little ability to elongate without fracture, with tensile strength of about 90,000 lb. per sq. in. Large amounts of silicon make an alloy that is acid and corrosion resistant	Classified as a graphitizer and as a reducing agent
Titanium	Increases the tensile and bending strengths, also wear resistance More than 0.1 per cent increases acid resistance	Reducing and graphitizing agent. Improves machinability
Vanadium	Increases tensile strength, hardness, wear, and heat resistance. Heat-treating improves hardness	

EFFECT OF ALLOYS ON CAST IRON

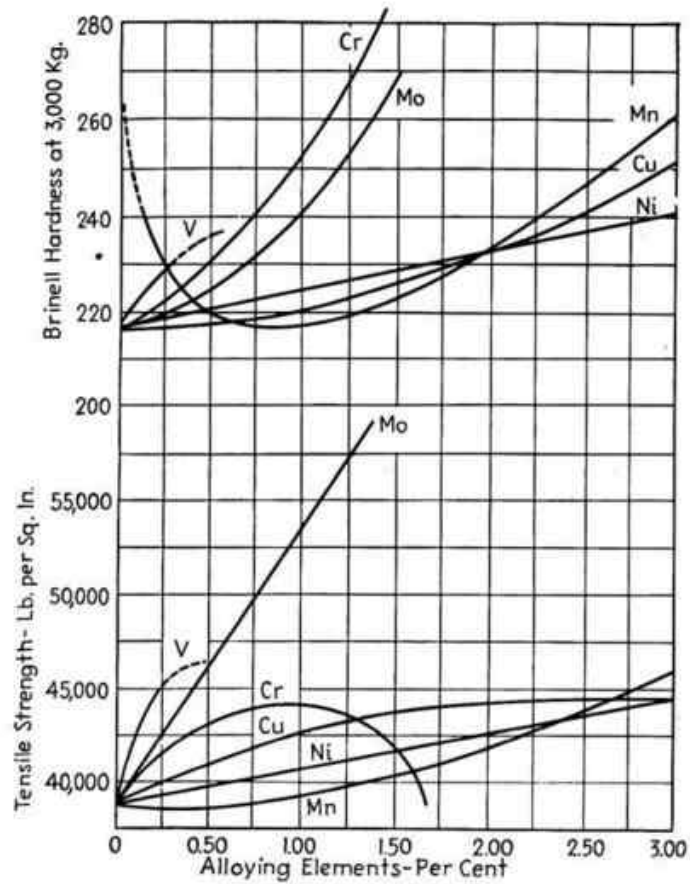

Effect of alloys on tensile strength and Brinell hardness of an electrically melted base iron containing 3.24 per cent total carbon, 0.67 per cent combined carbon, 2.57 per cent graphitic carbon, 0.71 per cent manganese, 1.88 per cent silicon, 0.17 per cent phosphorus, 0.09 per cent sulphur with an initial tensile strength of 39,000 lb. per sq. in., and Brinell hardness of 217. (*American Foundrymen's Association.*)

EFFECT OF NICKEL AND CHROMIUM ON CAST IRON

Addition of Nickel.

1. Increases strength and elasticity when composition of the iron is adjusted, especially the silicon content.
2. Refines the grain and reduces porosity.
3. Increases hardness.
4. Eliminates hard spots and thus improves machinability when nickel additions amount to $\frac{1}{2}$ to 4 per cent depending upon the silicon content and section thickness.
5. Decreases the amount of silicon needed to keep castings gray and machinable.
6. Increases wearing qualities.
7. Improves impact resistance.
8. Improves heat and corrosion resistance.
9. Raises electrical resistance.

Addition of Chromium.

1. Improves tensile strength.
2. Refines the grain.
3. Increases hardness. Produces hard spots when used alone or in excessive amounts.
4. Increases chilling power, depth of chill, and the combined carbon.
5. Increases heat resistance.
6. Increases wear resistance.
7. Increases corrosion resistance.
8. Decreases machinability.

Addition of Nickel and Chromium Together.

1. By using two or three parts of nickel to one of chromium, the chilling action of chromium is restrained and the beneficial effects of chromium are retained.
2. Increases strength and hardness. Amounts needed to obtain maximum machining qualities, and also hardness and strength, in castings of various section thickness are shown in the accompanying table.

Applications for Nickel and Nickel-chromium Cast Iron.

- Cylinders, cams, gears, hardware, bushings, machine frames, liners, and plates.

NICKEL AND CHROMIUM IN CAST IRON FOR MAXIMUM MACHINABILITY

Sections $\frac{1}{4}$ - $\frac{1}{2}$ in. thick		Sections 1-3 in. thick		Silicon, per cent
Nickel, per cent	Chromium, per cent	Nickel, per cent	Chromium, per cent	
1.50-3.00	0.75-3.00	0.20-0.60	1.00-1.50
0.50-2.00	0.00-0.30	0.75-3.00	0.40-1.00	1.50-2.00
0.50-1.50	0.00-0.40	0.75-3.00	0.50-1.10	2.00-2.50
0.50-1.25	0.20-0.50	0.75-3.00	0.60-1.25	2.50-3.00

MALLEABLE IRON CASTINGS**AVERAGE MECHANICAL PROPERTIES**

Tensile strength, lb. per sq. in.....	54,000
Yield point in tension, lb. per sq. in.....	36,000
Elongation in 2 in.....	18 per cent
Reduction in area (see note 1).....	19 per cent
Modulus of elasticity in tension, lb. per sq. in.....	25,000,000
Compressive strength (see note 2)	
Ultimate shearing strength, lb. per sq. in. (see note 3).....	48,000
Yield point in shear, lb. per sq. in.....	23,000
Modulus of elasticity in shear, lb. per sq. in.....	12,500,000
Yield point in torsion, lb. per sq. in.....	24,000
Modulus of rupture in torsion, lb. per sq. in.....	58,000
Brinell hardness number.....	100-140
Charpy impact value, ft.-lb. (see note 4).....	16.5
Wedge test for impact (see note 4)	
Fatigue endurance limit (no definite data, probably about 25,000 to 26,000 lb. per sq. in.)	
Effect of temperature (see note 5)	

PHYSICAL CONSTANTS

Specific gravity.....	7.15-7.45
Shrinkage allowance, in. per ft.....	$\frac{1}{8}$ - $\frac{3}{16}$
Coefficient of thermal expansion per deg. F.....	0.000066
Specific heat, c.g.s. units.....	0.122

ELECTRICAL AND MAGNETIC PROPERTIES

Resistivity, microhms per cc.....	28-37
Magnetization properties (see note 6)	
Magnetic hysteresis (see note 6)	

NOTES ON MALLEABLE IRON CASTINGS

1. *Reduction of Area.*—The elongation usually is spread quite evenly over the entire gage length, instead of being restricted locally. This may be construed to mean that cohesion is more uniform in malleable iron than in other ferrous metals.

2. *Compressive Strength.*—In ductile ferrous metals, the yield point in compression so closely approximates that in tension that testing for the latter, being much more easily determined, avoids the necessity of testing for the former. Also, it is impractical to determine the compressive strength of such products, because once the yield point has been passed the specimen flattens out, yielding no well-marked fracture.

3. *Shear and Torsion Tests.*—In determining shear by the "direct method," approximate results only can be secured because a certain amount of distortion caused by the combined effect of compression and bending during the test can not be avoided. Consequently, shearing properties are better studied from torsion tests. The number of twists per foot of length will furnish an estimate of the toughness of the material, and their distribution yields some indication of the variation in hardness which tends to cause an uneven localization of the twists, there being less distortion at planes of greater hardness.

4. *The wedge test* will furnish a more accurate idea of what can be expected of castings that are to be subjected to shock and occasional overload in service than will a notched bar test, wherein the stresses are concentrated at the root of the notch.

5. *Effect of Temperature.*—If malleable iron is heated to a temperature in excess of its critical range, the temper carbon will start to revert back to the combined form, and if heated to around 1600°F. practically all of it will be reverted. Malleable iron can be heated to around 800°F. without loss in tensile properties.

6. *Magnetization Properties.*—When high permeability is required in iron, the carbon should be in the form of temper carbon, whereas combined carbon or free cementite should be absent. Malleable iron possesses high induction and permeability and low hysteresis loss.

CAST CARBON STEELS

Chemical composition					Mechanical properties						Treatment of steel ^b
Carbon, per cent	Manganese, per cent	Silicon, per cent	Sulphur, per cent	Phosphorus, per cent	Tensile strength, lb. per sq. in.	Yield point, lb. per sq. in.	Elongation, per cent	Reduction of area, per cent	Impact values	Hardness numbers ^a	
0.11	0.73	0.27	0.027	0.028	56,000	33.0	36.0	Annealed in commercial furnace
					59,000	26,000	13.2	30.0	3.7 ^c	126B	As cast
0.11	0.60	0.40	0.035	0.030	57,000	24,000	28.2	53.0	2.1 ^c	119B	1475°F. (800°C.) (6), furnace cooled
					60,000	35,000	29.5	59.5	15.0 ^c	116B	1650°F. (900°C.) (6), furnace cooled
					60,000	35,000	31.0	54.0	13.7 ^c	126B	1825°F. (995°C.) (6), furnace cooled
0.15	0.81	0.20	62,000	34.0	52.5	Annealed
0.17	0.67	0.23	0.076	0.089	64,000	35,000	28.5	40.2	3.7 ^d	1650°F. (900°C.) (5), furnace cooled
0.18	0.83	0.30	73,000	34.0	49.0	Annealed
0.20-0.25	0.70-0.90	0.25-0.35	Under 0.03	Under 0.03	67,000	34,000	14.0	18.6	15 ^e	As cast
					70,000	37,000	26.5	31.6	36 ^e	1600°F. (870°C.), furnace cooled
0.19	0.60	0.44	0.031	0.028	70,000	36,500	33.0	51.2	16 ^f	137B	As cast
					71,500	46,500	34.0	58.0	24 ^f	139B	1650°F. (900°C.) (1), air cooled
					74,500	48,000	32.0	55.1	26 ^f	143B	1650°F. (900°C.) (1), furnace cooled
0.19	0.63	0.33	62,000	42,000	36.5	59.8	61 ^e	1650°F. (900°C.) (1), furnace cooled
					63,500	44,000	39.0	67.0	64 ^e	1700°F. (930°C.) (1), air cooled
											1600°F. (870°C.) (1), air cooled
											1200°F. (650°C.) (1), air cooled
0.22	0.70	0.32	0.030	0.024	71,000	37,000	33.0	53.5	149B	1650°F. (900°C.) (3), air cooled
0.22	0.68	0.28	0.030	0.025	72,000	43,000	32.5	52.4	149B	1650°F. (900°C.) (3), air cooled
0.22	0.67	0.34	0.029	0.024	73,500	43,500	33.0	49.7	156B	1650°F. (900°C.) (3), air cooled
0.24	0.78	0.28	71,000	28.6	47.8	1650°F. (900°C.), furnace cooled
					67,000	27,000	22.0	33.0	20.1 ^f	119B	As received
					77,000	44,000	30.5	51.0	32.6 ^f	136B	1650°F. (900°C.) (1), air cooled; 1525°F. (830°C.) (1), air cooled
0.25	0.68	0.32	0.032	0.012	77,000	43,000	31.5	52.0	32.0 ^f	136B	1650°F. (900°C.) (1), air cooled; 1525°F. (830°C.) (1), air cooled; 600°F. (315°C.) (1), air cooled
					76,000	43,000	31.7	56.0	34.0 ^f	133B	1650°F. (900°C.) (1), air cooled; 1525°F. (830°C.) (1), air cooled; 1000°F. (540°C.) (1), air cooled
0.26	0.84	0.37	75,000	33.0	54.2	Annealed, furnace cooled
0.27	0.71	0.41	72,000	32.9	57.6	35.5 ^e	1650°F. (900°C.) water quenched; 1300°F. (705°C.), furnace cooled
0.27	0.72	0.32	0.034	0.027	82,500	44,500	28.0	47.7	163B	1650°F. (900°C.) (3), air cooled
0.27	0.75	0.31	0.034	0.029	74,500	40,000	35.0	45.7	153B	1650°F. (900°C.) (3), air cooled
0.27	0.69	0.26	0.032	0.027	76,000	41,500	28.0	44.8	156B	1650°F. (900°C.) (3), air cooled
0.28	0.65	0.27	0.032	0.027	74,000	43,000	28.0	42.0	1550°F. (840°C.) (7), furnace cooled to 1000°F. (540°C.) air cooled
0.28	0.64	0.34	68,000	42,000	33.3	51.1	37.5 ^e	1650°F. (900°C.) (1), furnace cooled
					69,000	43,500	37.8	63.3	45.5 ^e	1700°F. (930°C.) (1), air cooled
											1600°F. (870°C.) (1), air cooled
											1200°F. (650°C.) (1), air cooled
					75,000	36,000	19.5	29.0	17 ^e	156B	As cast
					76,000	42,000	25.5	31.5	21 ^e	143B	Annealed
					84,000	57,000	30.0	65.0	44 ^e	160B	1650°F. (900°C.) water quenched, drawn 1300°F. (705°C.), air cooled
					95,000	68,000	24.0	57.0	192B	1650°F. (900°C.), water quenched, drawn 1100°F. (595°C.) air cooled
0.30	0.79	0.33	0.026	0.030	108,000	79,000	19.0	46.0	220B	1650°F. (900°C.), water quenched, drawn 900°F. (480°C.), air cooled
					119,000	90,000	14.0	33.0	238B	1650°F. (900°C.), water quenched, drawn 700°F. (370°C.), air cooled
					130,000	100,000	9.0	18.0	250B	1650°F. (900°C.), water quenched, drawn 500°F. (260°C.), air cooled

CAST CARBON STEELS (Continued)

Chemical composition					Mechanical properties							Treatment of steel ^h
Carbon, per cent	Manganese, per cent	Silicon, per cent	Sulphur, per cent	Phosphorus, per cent	Tensile strength, lb. per sq. in.	Yield point, lb. per sq. in.	Elongation, per cent	Reduction of area, per cent	Impact values	Hardness numbers ^a		
0.31	0.94	0.31	78,000	26.2	41.3	1650°F. (900°C.), furnace cooled	
0.31	0.75	0.42	0.029	0.034	85,500	54,500	29.5	53.4	21 ^f	146B	1650°F. (900°C.) (1), air cooled	
					92,500	66,500	26.0	61.8	32 ^f	164B	1650°F. (900°C.) (1), water quenched	
					77,000	43,500	28.7	44.5	14 ^f	134B	1200°F. (650°C.) (1), air cooled	
0.32	0.80	0.37	0.025	0.013	83,500	53,000	29.3	51.9	20 ^f	146B	1650°F. (900°C.) (1), furnace cooled	
					86,500	48,000	29.0	55.0	40 ^e	1650°F. (900°C.) (1), air cooled	
0.37	0.79	0.40	0.008	0.019	80,000	49,500	28.0	56.0	43 ^e	1600°F. (870°C.) (1), air cooled	
					84,000	23.9	32.9	5 ^e	1700°F. (930°C.) (1), air cooled	
					82,000	26.7	49.9	10 ^e	1600°F. (870°C.) (1), air cooled	
0.39	0.86	0.41	0.008	0.019	88,000	21.4	28.3	6 ^e	1700°F. (930°C.) (1), air cooled	
					82,000	21.4	28.3	6 ^e	1600°F. (870°C.) (1), air cooled	
					88,000	21.4	28.3	6 ^e	1200°F. (650°C.) (1), air cooled	
0.42	0.71	0.54	72,000	16.8	31.4	6.0 ^e	As received	
					86,000	23.5	38.7	24.5 ^e	1650°F. (900°C.) (4), water quenched; 1260°F. (680°C.) (6), air cooled	
					83,000	20.7	29.5	14.0 ^e	1650°F. (900°C.) (4), air cooled; 1290°F. (695°C.) (6), air cooled	
0.42	0.71	0.54	84,000	19.8	24.5	5.5 ^e	1650°F. (900°C.) (4) Furnace cooled	
					81,000	23.9	37.9	20.5 ^e	1650°F. (900°C.) (4), oil quenched; 1250°F. (675°C.) (6), furnace cooled	
0.42	0.71	0.54	82,000	26.4	44.2	17.7 ^e	1650°F. (900°C.) (4), water quenched; 1250°F. (675°C.) (6), furnace cooled	
					82,000	26.4	44.2	17.7 ^e	1650°F. (900°C.) (4), water quenched; 1250°F. (675°C.) (6), furnace cooled	
0.48	0.68	0.41	0.010	0.019	93,000	22.0	33.6	Annealed, furnace cooled	
					83,000	22.6	27.1	7 ^e	As received	
					88,000	24.9	41.9	10 ^e	1650°F. (900°C.) (4), water quenched; 1250°F. (675°C.) (6), air cooled	
0.50	0.59	0.54	91,000	21.3	29.5	8.5 ^e	1650°F. (900°C.) (4), air cooled; 1290°F. (695°C.) (6), air cooled	
					84,000	19.8	24.5	5.5 ^e	1650°F. (900°C.) (4), furnace cooled	
0.51	0.56	0.38	83,000	19.5	19.2	5.8 ^e	1650°F. (900°C.) (4), air cooled; 1400°F. (760°C.) (6), furnace cooled	
					84,000	22.5	26.6	5.9 ^e	1690°F. (920°C.) (5), air cooled; 1290°F. (695°C.) (6), furnace cooled	

Courtesy of American Foundrymen's Association.

^a The letter B designates Brinell hardness.

^b Numbers in parentheses following the temperature indicate number of hours at temperature.

^c Values in m.-kg. per sq. cm.

^d Specimen 30 × 30 × 160 mm. Cylindrical notch 4 mm. in diameter, 15 mm. deep. Values in meter-kilograms per square centimeter.

^e Isod, ft.-lb.

^f Charpy, ft.-lb.

^g Fremont, kg.-m.

HIGH ALLOY CAST STEELS

Manganese Steel.

1. Contains 10 to 14 per cent manganese with less than 1.5 per cent carbon.
2. Extremely hard, strong, and tough, with high resistance to wear.
3. Usually cast to form, but can be forged at a yellow heat.
4. Difficult to machine, can be partly softened by quenching from about 1830°F.
5. Hardness is restored by heating to about 1380°F. and cooling slowly in air.

Nickel Steel.

1. Contains ordinarily 0.52 to 3 per cent nickel with 0.15 to 0.60 per cent carbon.
2. Has high elastic limit and tensile strength.
3. Corrosion resistance increases with the nickel content.

Chrome Steel.

1. Contains usually 0.5 to 3.5 per cent of chromium with 0.2 to 0.6 per cent carbon.
2. Has high elastic limit, tensile strength, and hardness.
3. Up to 1 per cent of chromium has little effect on steel. With 1 per cent carbon and 2 per cent chromium, great toughness is attained.
4. Low-carbon chrome steels can be forged with as high as 12 per cent chromium present, but the alloy becomes brittle as the carbon increases.
5. Chrome steel attains great hardness when quenched in water.
6. Steels with about 15 per cent chromium are relatively corrosion resistant.

Vanadium Steel.

1. Small percentages of vanadium combined with chromium and manganese in steel result in an alloy that has high tensile strength and elastic limit.
2. Vanadium makes nickel steel more homogeneous and decreases the fragility; it is seldom used with more than 8 per cent nickel.
3. Additions of 0.15 to 0.25 per cent vanadium to chrome steel counterbalances the extreme hardness of chromium and produces an alloy with better machining properties.

Tungsten Steel.

1. Is very hard and brittle, difficult to forge, and cannot be welded when the tungsten exceeds 2 per cent.
2. Can be worked at a red heat, but is usually cast in the form of tools and ground to the desired form.
3. Addition of tungsten to steel produces a close and uniform structure.
4. High-carbon tungsten steel retains high magnetism.
5. Steel alloys with 5 to 8 per cent tungsten are self-hardening.

Molybdenum Steel.

1. Effect of molybdenum on steel is between that of tungsten and chromium.
2. Molybdenum in chrome steel improves the forging qualities.

High-speed Steels.

1. Derive their properties from selected combinations of the several metals listed above.
2. Cobalt, uranium, titanium, and silver are also used in high-speed steels.
- 3 A typical high-speed steel analysis is iron, 68.79 per cent; carbon, 0.51; manganese, 0.26; silicon, 0.14; phosphorus, 0.02; sulphur, 0.04; chromium, 7.08; tungsten, 22.68; and molybdenum, 0.48 per cent.

LOW-ALLOY CAST STEELS: ANALYSES AND PROPERTIES

Type of cast steel	Carbon, per cent	Manganese, per cent	Silicon, per cent	Nickel, per cent	Chromium, per cent	Molybdenum, per cent	Vanadium, per cent	Copper, per cent	Tensile strength, lb. per sq. in.	Yield point, lb. per sq. in.	Elongation in 2 in., per cent	Reduction of area, per cent	Brinell hardness	Impact value	Heat-treatment, deg. F.
Nickel.....	0.15	0.58	0.30	2.90	76,800	61,200	33.1	55.5	31†	Normalized 1750, normalized 1650, drawn 1200
	0.19	0.91	0.30	2.14	85,100	51,250	29.0	52.0	Normalized and drawn
	0.26	0.90	0.18	1.76	92,000	52,000	28.5	39.8	Annealed 1475
	0.30	1.05	1.95	104,550	63,550	25.0	54.8	Normalized 1850, drawn 1200
Medium manganese.....	0.40	0.52	2.39	145,900	128,000	20.0	58.6	268	Normalized 1500, oil quenched 1425, drawn 1100
	0.32	1.33	0.33	88,000	57,000	25.0	56.0	Normalized 1650, drawn 1250
	0.35	1.51	0.31	97,500	55,800	25.0	53.0	Annealed 1650, normalized 1550, drawn 700
	0.34	1.77	0.34	107,000	61,000	24.0	52.0	Annealed 1650, normalized 1550, drawn 700
Chromium.....	0.39	0.84	0.48	0.79	122,000	77,850	13.5	20.0	228	Normalized 1650, normalized 1550, drawn 700
	0.39	0.84	0.48	0.79	110,850	67,150	17.0	25.0	217	Normalized 1650, normalized 1550, drawn 1200
	0.28	0.47	0.81	3.05	150,000	125,000	13.0	32.0	Normalized 1650, normalized 1550, drawn 1000
	0.36	0.78	2.97	151,000	127,000	14.0	29.0	Water quenched 1650, drawn 1150
Molybdenum.....	0.41	0.67	2.56	142,000	117,000	19.0	39.0	285	Normalized 1650, drawn 1200
	0.36	0.74	0.41	0.83	95,000	55,000	18.0	31.0	213	Normalized 1650, drawn 1250
	0.30-0.40	0.70	0.40	0.30-0.40	83,200	58,100	21.0	33.0	208	Annealed, normalized, drawn
	0.24	0.64	0.36	0.50	73,550	46,400	33.0	46.0	153	Normalized 1650, drawn 1200
Vanadium.....	0.30	0.70	0.30	0.54	75,800	52,000	32.0	48.0	163	Normalized 1650, drawn 1200
	0.22	0.70	0.40	0.20	94,000	46,000	31.0	58.6	Double normalize, drawn
Silicon.....	0.38	0.87	0.32	0.20	79,100	54,900	24.0	53.9	30†
	0.17	1.11	1.11	71,000	45,000	27.0	54.0	Annealed
	0.13	0.62	70,000	50,000	31.0	54.1	143	Normalized 1600
	0.13	0.62	1.00	89,000	70,000	23.5	49.7	196	Normalized 1600, drawn 950
Copper.....	0.29	0.94	104,000	76,000	20.5	36.4	207	Normalized 1550, drawn 1000
	0.31	0.75	0.42	1.21	90,000	61,000	24.8	43.6	161	Annealed 1650
	0.31	0.75	0.42	1.21	110,500	82,500	21.0	45.8	201	Normalized 1650, drawn 930
	0.31	0.75	0.42	1.76	90,500	58,500	24.5	41.4	159	Annealed 1650
Medium manganese-nickel.....	0.31	0.75	0.42	1.76	116,500	89,500	18.8	38.8	215	Normalized 1650, drawn 930
	0.33	1.20	0.38	1.06	100,750	62,000	21.0	34.0	Annealed 1600
	0.33	1.20	0.38	1.06	99,000	63,500	23.5	48.0	187	Normalized 1600, drawn 1200
	0.28	1.56	1.27	96,000	63,000	26.0	58.5	Normalized 1600, drawn 1100
Nickel-chromium.....	0.29	1.44	1.41	102,000	65,000	26.7	58.9	Normalized 1600, drawn 1100
	0.39	0.86	0.37	1.78	0.67	112,000	66,500	19.0	32.0	Normalized 1600, drawn 1200
	0.40	0.52	0.37	2.39	1.00	145,900	101,500	20.0	58.6	268	Normalized 1600, oil quenched 1425, drawn 1100
	0.33	0.65	0.16	3.19	0.65	128,000	108,000	14.5	36.0	Oil quenched 1510, drawn 1100
Nickel-molybdenum.....	0.32	0.70	1.35	0.32	91,045	60,538	24.8	54.5	Annealed 1890, normalized 1700, drawn 1275
	0.29	1.02	0.31	1.49	0.13	93,000	65,000	29.0	57.8	Double normalized and drawn
Medium manganese-chromium.....	0.40	1.40	0.50	0.60	120,000	75,000	23.0	52.0	Annealed 1650, normalized 1650, drawn 700
	0.30	1.35	0.35	0.35	96,000	68,000	25.5	57.5	210	Normalized 1650, drawn 1250
Medium manganese-molybdenum.....	0.30	1.35	0.35	0.35	102,000	76,000	35.8	58.0	228	Oil quenched 1575, drawn 1250
	0.30	1.35	0.35	0.35	102,000	76,000	35.8	58.0	228	Oil quenched 1575, drawn 1250
Medium manganese-vanadium.....	0.30	1.65	0.10	101,000	67,000	27.0	55.0	Double normalized and draw
	0.30	1.68	0.43	0.042 (approx.)	108,000	78,000	28.0	59.0	Normalized 1600, drawn 1050

LOW-ALLOY CAST STEELS: ANALYSES AND PROPERTIES (Continued)

Type of cast steel	Carbon, per cent	Manganese, per cent	Silicon, per cent	Nickel, per cent	Chromium, per cent	Molybdenum, per cent	Vanadium, per cent	Copper, per cent	Tensile strength, lb. per sq. in.	Yield point, lb. per sq. in.	Elongation in 2 in., per cent	Reduction of area, per cent	Brinell hardness	Impact value	Heat-treatment, deg. F.
Chromium-molybdenum...	0.30	0.80	0.40	...	0.80	0.20	110,000	80,000	20.0	40.0	210	...	Normalized 1550, drawn 1250
	0.39	0.81	0.39	...	0.69	0.43	103,000	73,000	19.0	40.0	...	20½	Normalized and drawn
	0.90	0.45	0.41	...	1.36	0.30	156,000	95,000	9.0	9.0	Normalized 1325, drawn 1100
	0.22	0.71	0.50	...	4.02	0.46	121,000	91,000	19.0	51.0	Normalized 1650
Chromium-vanadium...	0.20	0.68	0.37	...	2.05	1.05	110,500	86,250	18.0	42.0	207	...	Double normalized and drawn
	0.30	0.80	0.40	...	1.00	...	0.10	...	94,300	64,850	27.5	57.1	Double normalized and drawn
Chromium-tungsten...	0.25	0.53	0.42	...	5.87	(W)0.80	125,000	100,000	18.0	45.0	Normalized 1750, drawn 1250
Medium manganese-chromium-silicon-vanadium...	0.42	1.45	0.80	...	0.38	...	0.16	...	116,000	74,000	19.0	43.0	Normalized 1650, drawn 1150
	0.37	0.80	0.40	1.75	0.75	0.40	149,000	90,000	17.0	25.1	262	27½	Normalized, drawn 1250
Nickel-chromium-molybdenum...	0.72	0.88	0.30	0.75	1.56	0.38	146,000	56,000	7.5	8.5	270	...	Annealed 1800
	0.34	1.19	0.96	0.34	115,800	82,450	21.0	55.0	227	...	Water quenched 1600, drawn 1300
Medium manganese-chromium-molybdenum...	0.28	1.34	0.39	1.72	0.11	...	103,050	71,500	23.0	40.4	...	43.3½	Annealed
Medium manganese-silicon-copper...	0.15	1.28	1.11	1.97	85,800	64,000	28.1	44.8	Annealed 1740
	0.23	1.11	1.58	1.51	92,200	69,200	29.5	44.2	Annealed 1740
Medium manganese-chromium-vanadium...	0.34	1.51	0.29	...	0.47	...	0.16	...	98,000	72,000	25.0	54.0	...	44½	Double normalized 1650-1650, drawn 1200
Medium manganese-copper-vanadium...	0.16	1.43	0.26	0.11	1.15	90,900	69,950	30.0	60.6	...	76.2½	Double normalized 1700-1550, drawn 750
	0.29	1.12	0.44	0.10	1.04	96,400	73,200	30.0	57.0	...	61.0½	Double normalized 1650-1600, drawn 750
Medium manganese-copper-titanium...	0.29	1.17	0.38	...	0.05 Ti	(approx.)	...	1.07	100,000	68,000	25.5	51.9	...	31.0½	Normalized 1600
Chromium-molybdenum-silicon...	0.30	0.68	1.05	2.15	...	0.52	120,500	89,600	19.0	39.0	197	...	1700, 4 hr., cool to 1500, hold 6 hr., air cool; 1250, 4 hr., furnace cool
	0.29	0.68	0.78	5.20	...	0.52	103,300	78,500	20.5	47.0	197	...	1700, 4 hr., cool to 1500, hold 6 hr., air cool; 1250, 4 hr., furnace cool

Courtesy of American Foundrymen's Association.
 * Titanium added: 5 lb. ferrocarbon-titanium per ton charge.
 † Charpy impact value in ft.-lb.
 ‡ Irod impact value in ft.-lb.

PROPERTIES OF CORROSION- AND HEAT-

Alloy	Chemical composition*					Physical properties							Machining behavior	Welding behavior		
	Carbon, per cent	Chromium, per cent	Nickel, per cent	Manganese, per cent	Silicon, per cent	At room temperature					At elevated temperature					
						Tensile strength, lb. per sq. in.	Yield point, lb. per sq. in.	Elongation in 2 in., per cent	Reduction of area, per cent	Isod impact strength, ft.-lb.	Temperature, deg. C.	Stress producing 1 per cent elongation in 10,000 hr.			Stress producing 1 per cent elongation in 100,000 hr.	
Iron-chromium Alloys																
A [†]	0.10	12.0	1.0	75,000-95,000	45,000-80,000	18-24	30-50	540† 595† 650†	13,000† 5,200† 2,100†	4,500-10,000† 2,000-4,000† 1,000-1,600†	About same as medium carbon steel	Satisfactory, if welds annealed and air cooled	
B [†]	0.12	19.0	1.0	75,000-110,000	45,000-70,000	10-20	15-35	3-10	425† 540† 595† 650†	8,500† 5,200† 2,100†	10,000† 4,200-7,000† 1,950-4,500† 900-1,600†	About same as medium carbon steel	Welding not recommended for other than very thin sections	
C [†]	0.50	28.0	1.0	40,000-80,000	30,000-45,000	0-2	0-5	1-5	540† 595† 650† 780†	4,550 1,950 750 150	About same as medium carbon steel	Satisfactory; slow cooling required to 600°C. then rapid cooling	
Iron-chromium-nickel Alloys																
D [†]	0.20	8.0	20.0	1.0	75,000-85,000	40,000-80,000	20-30	20-30	540† 595† 650† 705† 815†	20,500-25,000† 11,000-11,800† 5,600-6,000† 4,000† 1,100†	20,000† 9,500† 5,500† 3,600† 750†	Tough; intermediate between carbon steel and Monel metal	Satisfactory	
E [†]	0.15	18.0	8.0	1.0	70,000-80,000	25,000-40,000	40-75	40-75	50-105	480† 540† 595† 650† 705† 815† 17,000† 9,500-10,500† 7,000-9,500† 7,000† 800†	15,000-20,000† 10,000-15,000† 7,000-8,500† 4,000-5,500† 2,600-3,500† 650-750†	Tough; intermediate between carbon steel and Monel metal	Satisfactory if heat-treated after welding	
F [†]	0.06	18.0	8.0	1.0	70,000-80,000	25,000-30,000	40-75	40-75	60-105	480† 540† 595† 650† 705†	18,000-20,000† 12,000-15,000† 7,500-8,500† 4,500-5,500† 2,500-3,500†	Tough; intermediate between carbon steel and Monel metal	Satisfactory; desirable to heat-treat after welding	

Courtesy American Foundrymen's Association.

* Compositions given in this table differ slightly from the present nominal commercial compositions. The differences, however, are not significant in respect to the properties quoted.

† Data on the wrought alloy.

RESISTANT CAST STEELS

Coefficient of thermal expansion		Melting temperature, deg. C.	Specific gravity	Thermal conductivity		Specific heat	Specific electric resistance		Maximum temperature for safe use, deg. C.			Other media for which recommended	Typical applications	Alloy
Temperature range, deg. C.	Coefficient, per 1°C.			Temperature, deg. C.	Conductivity, c.g.s. units		Temperature, deg. C.	Resistance, microhms per cc.	Oxide gas	Fuel gas	Sulphur gas			
20-100†	0.000010†	1495-1385	7.6	20†	0.096†	0.15-0.16†	25†	62†	760†	760†	760†	Alkaline liquors, foodstuffs, oxidising acids, some organic acids, steam	Machine parts such as pump and valve bodies	A ¹
20-700†	0.000012†	100†	0.096†	700†	113†			
20-100†	0.000010†	1510-1370	7.6	20†	0.054-0.072†	20†	65†	870†	870†	815†	Oxidising acids, especially nitric, foodstuffs, sea water, alkaline liquors, steam	Nitric acid plant equipment, valve trim, steam pump valves, castings for moderate temperatures and low stresses, such as grate bars	B ²
20-900†	0.000013†	700†	117†			
20-100	0.000010	1450-1350	7.5	20	0.064	0.15	25†	68†	1035-1175	980-1150	980-1150	Foodstuffs and alkaline liquors, fumes of volatile heavy metals, oxidising acids, mine waters, and of especial value in sulphur-rich atmospheres at high temperatures	Annealing boxes, lead pots, roasting furnace rabble arms, cement chutes, pump and valve bodies	C ³
20-1000	0.000013	100	0.064	1000†	118†			
20-100†	0.000018†	1490-1430	8.0	20†	0.074†	20†	86†	760-980	760-980	Sea water, sulphuric acid in wide range of concentration and temperature, mine waters, steam, high-sulphur oils, alkaline liquors	Ship propellers, pump and valve bodies, impellers, rayon-producing equipment, oil still header-box plugs	D ⁴
20-800†	0.000019†			
20-100†	0.000016†	1470-1400	7.8	20	0.063	0.12†	25†	74†	870-925†	760-925†	150-700†	Sea water, alkaline liquors, hot dilute or cold concentrated sulphuric acid, acid sulphates, cold oxidising acids, mine waters, foodstuffs, organic acids	Pots, retorts, pump and valve bodies, equipment of chemical plants, paper mills and dairies, marine fittings, ornamental work	E ⁵
20-1000†	0.000020†	100	0.063	700†	118†			
20-100†	0.000016†	1470-1400	7.8	20†	0.058†	0.12†	20†	75†	870-925†	760-925†	150-700†	Alkaline liquors, hot dilute or cold concentrated sulphuric acid, acid sulphates, sea water, cold oxidising acids, mine waters, foodstuffs, organic acids	Pots, retorts, pump and valve bodies, equipment of chemical plants, paper mills and dairies	F ⁶
20-1000†	0.000020†	500-800†	112†			

¹ This class of alloys is covered by A.S.T.M. Tentative Specifications A168-35T.

² This class of alloys is covered by A.S.T.M. Tentative Specifications A169-35T.

³ This class of alloys is covered by A.S.T.M. Tentative Specifications A170-35T.

⁴ This class of alloys is covered by A.S.T.M. Tentative Specifications A198-38T.

PROPERTIES OF CORROSION- AND HEAT-

Alloy	Chemical composition*					Physical properties							Machining behavior	Welding behavior	
	Carbon, per cent	Chromium, per cent	Nickel, per cent	Manganese, per cent	Silicon, per cent	At room temperature					At elevated temperature				
						Tensile strength, lb. per sq. in.	Yield point, lb. per sq. in.	Elongation in 2 in., per cent	Reduction of area, per cent	Isod impact strength, ft.-lb.	Temperature, deg. C.	Stress producing 1 per cent elongation in 10,000 hr.			Stress producing 1 per cent elongation in 100,000 hr.
Iron-chromium-nickel Alloys (Cont.)															
G [‡]	0.50	22.0	22.0	1.5	60,000-70,000	45,000-60,000	5-10	3-10	540† 595† 650† 705† 735†	13,000-25,000† 8,000-16,000† 4,000-9,500† 2,000-5,000†	16,250† 2,300†	Tough; slightly easier than 18-8	Satisfactory
H [‡]	0.30	29.0	9.0	1.5	70,000-80,000	55,000-65,000	1-3	1-3	Tough; but more readily machined than 18-8	Satisfactory, if subsequently heat-treated
I [†]	0.30	28.0	16.0	1.5	Intermediate between 18-8 and 28-8 alloys	Satisfactory
J [‡]	0.50	18.0	36.0	2.0	60,000-70,000	40,000-55,000	1-8	3-10	Similar to annealed high-speed steel	Satisfactory
Nickel-rich Alloys															
K	0.60	13.0	62.0	1.0	1.5	60,000-75,000	35,000-45,000	1-5	1-5	540† 650† 780†	13,000† 9,000† 5,500†	Similar to annealed high-speed steel	Satisfactory
L	0.40	20.0	64.0	1.5	1.5	50,000-70,000	40,000-50,000	1-3	1-3	Similar to heat-treated simple steels but at lower speeds and feeds	Satisfactory

* Compositions given in this table differ slightly from the present nominal commercial compositions. The differences, however, are not significant in respect to the properties quoted.

† Data on the wrought alloy.

‡ Data on cast alloy containing 3 per cent tungsten.

RESISTANT CAST STEELS (Continued)

Coefficient of thermal expansion		Melting temperature, deg. C.	Specific gravity	Thermal conductivity		Specific heat	Specific electric resistance		Maximum temperature for safe use, deg. C.			Other media for which recommended	Typical applications	Alloy
Temperature range, deg. C.	Coefficient, per 1°C.			Temperature, deg. C.	Conductivity, c.g.s. units		Temperature, deg. C.	Resistance, microhms per cc.	Oxide gas	Fuel gas	Sulphur gas			
20-100 20-1000	0.000016 0.000019	1415	7.9	20	0.052	20	90	1150	1100	Grids, hearth plates, rollers, rails, chains, containers, etc. in heating furnaces not carrying gases with high sulphur content, apparatus for hydrogenation of refinery waste gases	G ⁴
20	0.000014	1500-1400	7.9	20	0.025	1100	1100	1000	Mine waters, sulphur-rich atmospheres at high temperatures, nitric and other oxidising acids	Roasting furnace rabble arms, oil still tube supports, pump parts for hot oil in refineries, steel mill soaking pit dampers	H ⁴
20-100 20-1000	0.000015 0.000018	7.9	20	0.039	0.14	20	80	1150	1150	180-1150	Mine waters, sulphurous acid and sulphite liquors, mixed acids, oxidising acids, high-temperature atmospheres of moderate sulphur content	Furnace hearth plates, cement kiln parts, recuperators, stack dampers, coal distillation retorts	I ¹
20-100 20-1000	0.000014 0.000018	1465-1400	8.0	20	0.027	0.11	20	118	1000-1100	1000-1100	Sulphuric acid in wide range of concentration and temperature, alkaline solutions, fused alkalis to 900°C.	Grids, hearth plates, rollers, rails, chains, containers, etc., in heating furnaces not carrying gases with even moderate sulphur content, rayon-producing equipment, ceramic furnace parts, carburising boxes	J ⁴
20-100 20-1000	0.000012 0.000016	1400-1260	8.1	20	0.033	0.14(20-1000°C.)	20	108	800-1150	800-1150	Synthesising ammonia, sulphuric and hydrochloric acid in some concentrations and temperatures	Carburising containers, oil-burner parts, special glass molds, chemical reaction chambers	K
20-100 20-1000	0.000013 0.000017	1440-1250	8.0	20	0.033	0.11	20	124	1100-1260	1100-1260	Fused alkalis and chlorides to 1000°C.	Carburising containers, oil-burner parts, containers for fused alkalis and cyanide, resistance grids, boiler baffles, enameling racks, pyrometer tubes	L

* This class of alloys is covered by A.S.T.M. Tentative Specification A173-35T.
 * This class of alloys is covered by A.S.T.M. Tentative Specification A173-35T.
 * This class of alloys is covered by A.S.T.M. Tentative Specification A171-35T.
 * This class of alloys is covered by A.S.T.M. Tentative Specification A173-35T.

PROPERTIES OF U.S.S. STAINLESS STEEL

Alloy	U.S.S. 18-8		U.S.S. stabilized 18-8	
	Type 302*	Type 304	Type 321	Type 347
Typical chemical composition				
Carbon.....	0.08/20	0.08 max.	0.10 max.	0.10 max.
Manganese.....	1.25 max.	2.00 max.	2.00 max.	2.00 max.
Phosphorus.....	0.03 max.	0.03 max.	0.03 max.	0.03 max.
Sulphur.....	0.03 max.	0.03 max.	0.03 max.	0.03 max.
Silicon.....	0.75 max.	0.75 max.	0.75 max.	0.75 max.
Chromium.....	18.0/20.0	18.0/20.0	17.0/20.0	17.0/20.0
Nickel.....	8.0/10.0	8.0/10.0	7.0/10.0	8.0/12.0
Titanium.....			4 X C min.	
Columbium.....				10 X C
Physical properties				
Density, lb. per cu. in.....	0.286	0.286	0.285	0.285
Specific electrical resistance at 68°F.:				
Microhms per cc.....	70 (cold worked, 70-82)	70 (cold worked, 70-82)	71	71
Microhms per cu. in.....	27.6 (cold worked, 27.6-32.3)	27.6 (cold worked, 27.6-32.3)	28	28
Low-carbon steel = 1.00.....	6.4	6.4	6.5	6.5
Melting range, deg. F.....	2550-2590	2550-2590	2550-2590	2550-2590
Structure.....	Austenitic	Austenitic	Austenitic	Austenitic
Magnetic permeability:				
As annealed.....	$\mu = 1.003$	$\mu = 1.003$	$\mu = 1.003$	$\mu = 1.003$
After 10 per cent reduction of area.....	$\mu = 1.10$	$\mu = 1.10$	$\mu = 1.10$	$\mu = 1.10$
Specific heat:				
B.t.u./deg. F./lb., at 32-212°F.....	0.12	0.12	0.12	0.12
Low-carbon steel = 1.00 (0-100°C.).....	1.1	1.1	1.1	1.1
Thermal conductivity:				
B.t.u./sq. ft./hr./deg. F./in., at 212°F.....	113	113	112	112
Low-carbon steel = 1.00, at 100°C.....	0.33	0.33	0.32	0.32
B.t.u./sq. ft./hr./deg. F./in., at 932°F.....	150	150	153	153
Coefficient of thermal expansion:				
Per deg. F. $\times 10^6$ (32-212°F.).....	9.6	9.6	9.3	9.3
Per deg. F. $\times 10^6$ (32-932°F.).....	10.2	10.2	10.3	10.3

Mechanical properties at room temperatures	U.S.S. 18-8		U.S.S. stabilized 18-8	
	Annealed	Cold worked	Annealed	Cold worked
Tensile strength, 10 ⁴ lb. per sq. in.....	80-95	105-300†	80-95	105-300†
Yield point, 10 ⁴ lb. per sq. in.....	35-45	60-250	35-45	60-250
Modulus of elasticity, 10 ⁶ lb. per sq. in.....	29	29-26	29	29-26
Elongation in 2 in., per cent.....	55-60	50-2	50-55	50-2
Reduction of area, per cent.....	55-65	65-30	55-65	65-30
Charpy impact strength, ft.-lb.....			77	
Izod impact strength, ft.-lb.....	75-110			77
Endurance limit (fatigue), 10 ⁴ lb. per sq. in.....	35	90-95	45	90-95
Brinell hardness number.....	135-185	170-460	135-185	170-460
Rockwell hardness number.....	B75-B90	C5-C47	B75-B90	C5-C47
Stress causing 1 per cent elongation (creep) in 10,000 hr.:				
At 1000°F., lb. per sq. in.....	17,000		17,000	17,000
At 1200°F., lb. per sq. in.....	7,000		7,000	7,000
At 1350°F., lb. per sq. in.....	3,000		3,000	3,000
At 1500°F., lb. per sq. in.....	850		850	850
Scaling temperature, deg. F. (approx.).....	1,650		1,650	1,650
Initial forging temperature, deg. F.....	2,200		2,200	2,200
Finishing temperature, deg. F.....	Not under 1600-1700		Not under 1600-1700	Not under 1600-1700
Annealing treatment.....	1900-2000°F. and quench		1900-2000°F. and quench	1900-2000°F. and quench
Cold forming, drawing, stamping.....	Excellent		Good	Good
Machinability.....	Fair tough		Fair tough	Fair tough
Welding (arc, gas, resistance, atomic hydrogen).....	Very good, anneal after welding for maximum corrosion resistance		Very good, not necessary to anneal	Very good, not necessary to anneal
Precautions (see notes)	(A)		(B)	(B)

* U.S.S. 18-8 free machining, Type 303, same as 302 except S or Se 0.07 min. or molybdenum 0.60 max.

† Commercial grades, thin gages of sheet and strip

1/4 Hard = 125,000 lb. per sq. in.
 1/2 Hard = 150,000 lb. per sq. in.
 3/4 Hard = 175,000 lb. per sq. in.
 Full hard = 185,000 lb. per sq. in.

PROPERTIES OF U.S.S. STAINLESS STEEL (Continued)

Alloy	U.S.S. 18-8 Mo	U.S.S. 25-12	U.S.S. 12	U.S.S. 17	U.S.S. 27
Typical chemical composition	Type 316	Type 309	Type 410†	Type 430	Type 446
Carbon.....	0.10 max.	0.20 max.	0.15 max.	0.12 max.	0.35 max.
Manganese.....	2.00 max.	2.00 max.	0.75 max.	0.75 max.	1.00 max.
Phosphorus.....	0.03 max.	0.03 max.	0.03 max.	0.03 max.	0.03 max.
Sulphur.....	0.03 max.	0.03 max.	0.03 max.	0.03 max.	0.03 max.
Silicon.....	0.75 max.	0.75 max.	0.75 max.	0.75 max.	0.75 max.
Chromium.....	16.0/18.0	22.0/26.0	10.0/14.0	14.0/18.0	23.0/30.0
Nickel.....	14.0 max.	12.0/14.0			
Molybdenum.....	2.00/3.00				
Physical properties					
Density, lb. per cu. in.....	0.291	0.283	0.276	2.273	0.270
Specific electrical resistance at 68°F.:					
Microhms per cc.....	72.3	78	57	59	67
Microhms per cu. in.....	28.5	30.7	22.4	23.2	26.4
Low-carbon steel = 1.00.....	6.6	7.1	5.2	5.4	6.1
Melting range, deg. F.....	2500-2550	2530-2570	2750-2790	2710-2750	2710-2750
Structure.....	Austenitic	Austenitic	Martensitic	Ferritic	Ferritic
Magnetic permeability:					
As annealed.....	$\mu = 1.003$	$\mu = 1.003$	Ferromagnetic	Ferromagnetic	Ferromagnetic
After 10 per cent reduction of area.....	$\mu = 1.10$	$\mu = 1.003$	Ferromagnetic	Ferromagnetic	Ferromagnetic
Specific heat:					
B.t.u./deg. F./lb. at 32-212°F.....	0.12	0.12	0.11	0.11	0.11
Low-carbon steel = 1.00 (0-100°C.).....	1.1	1.1	1.0	1.0	1.0
Thermal conductivity:					
B.t.u./sq. ft./hr./deg. F./in., at 212°F.....	108	87-116	173	169	145
Low-carbon steel = 1.00, at 100°C.....	0.31	0.25-0.34	0.50	0.49	0.42
B.t.u./sq. ft./hr./deg. F./in., at 932°F.....	145	125	199	181	169
Coefficient of thermal expansion:					
Per deg. F. $\times 10^6$ (32-212°F.).....	8.4	8.3	6.1	6.0	5.9
Per deg. F. $\times 10^6$ (32-932°F.).....	9.6	9.6	7.2	6.7	6.3

Mechanical properties at room temperatures	U.S.S. 18-8 Mo		U.S.S. 25-12		U.S.S. 12		U.S.S. 17		U.S.S. 27	
	Annealed	Cold worked	Annealed	Cold worked	Annealed	Quenched and drawn	Annealed	Cold worked	Annealed	Cold worked
Tensile strength, 10 ³ lb. per sq. in.....	80-95	105-300†	90-110	110-270	65-85	100-200	70-90	100-180	75-95	85-175
Yield point, 10 ³ lb. per sq. in.....	35-45	60-250	40-60	65-230	35-45	60-180	40-55	65-30	45-60	55-155
Modulus of elasticity, 10 ⁶ lb. per sq. in.....	29	29-26	29	29-26	28	28	29	29	29	29
Elongation in 2 in., per cent.....	50-55	50-2	35-50	25-2	35-25	25-10	30-20	25-2	30-20	25-2
Reduction of area, per cent.....	55-65	65-30	45-60	55-20	65-60	65-25	55-40	40-20	50-40	55-25
Charpy impact strength, ft.-lb.....	70-110									
Isod impact strength, ft.-lb.....					100-60	100-5	8-25			
Endurance limit (fatigue), 10 ³ lb. per sq. in.....	43	90-95	53				50		50	
Brinell hardness number.....	135-185	170-460	150-185	170-375	135-165	293-390	145-185	185-270	140-185	150-250
Rockwell hardness number.....	B75-B90	C5-C40	B80-B90	C5-C40	B75-B85	C30-C40	B80-B90	B90-B105	B80-90	C0-C25
Stress causing 1 per cent elongation (creep) in 10,000 hr.:										
At 1000°F., lb. per sq. in.....	25,000		17,000		13,000		8,500			
At 1200°F., lb. per sq. in.....	18,000		11,000		2,300		2,100		1,600	
At 1350°F., lb. per sq. in.....	8,000		3,400		1,400		1,200		400	
At 1500°F., lb. per sq. in.....	3,000		850							
Scaling temperature, deg. F. (approximate).....	1650		2100		1300		1550		2100	
Initial forging temperature, deg. F.....	2200		2150		2100		2000		2000	
Finishing temperature, deg. F.....	Not under 1600-1700		Not under 1600-1700		Not over 1450		Not over 1400		Not over 1400-1450	
Annealing treatment.....	1950-2050°F. and quench		1950-2050°F. and quench		Furnace cool from 1550-1100°F. or air cool from 1300-1400°F.		Air cool from 1500-1400°F.		Rapid cool from 1650-1550°F.	
Cold forming, drawing, stamping.....	Good		Good		Fair		Good		Poor	
Machinability.....	Fair tough		Fair tough		Fair		Fair		Fair	
Welding (arc, gas, resistance, atomic hydrogen)	Very good, anneal for maximum corrosion resistance		Very good, anneal for maximum corrosion resistance		Welding hardens. Anneal to restore ductility		Welds are brittle when cold. Slight response to anneal		Welds are brittle when cold. Slight response to anneal	
Precautions (see notes)	(A)		(A)		(C)		(D)		(D)	

† U.S.S. 12 free machining, Type 416, same as 410 except S or Se 0.07 min. or molybdenum 0.60 max.
 (A) Preheat slowly to 1600°F., then heat rapidly to the forging or annealing temperature. Exposure to temperatures between 800 to 1600°F. produces marked susceptibility to intergranular corrosion. If the metal is unattacked, this can be cured by repeating the annealing treatment.
 (B) For maximum corrosion resistance in high temperature service, use following stress relieving operations—heat 2 hr. at 1550°F., air cool.
 (C) Preheat slowly to 1450°F., then heat rapidly to 2100°F. for forging. Full corrosion resistance is developed only in the heat-treated condition. (Temper below 1000°F.)
 (D) In forging, preheat slowly to 1450°F. Excessive grain growth takes place above 2000°F. Expert welding is required to avoid excessive grain growth. Prolonged exposure at 850 to 950°F. produces cold brittleness. To prevent this, heat to 1650 to 1550°F. before cooling, and quench. Stainless steels cannot be forge hammer welded.

COMPOSITION AND PROPERTIES OF IRON-NICKEL-CHROMIUM ALLOYS

Group classification, typical composition of each type, per cent							Mechanical properties at normal temperatures (see note 1)						Ultimate and working stresses at elevated temperatures, (see note 2)					
Type	C	Si	Mn	S and P	Cr	Ni	Yield point, lb. per sq. in.	Ultimate stress, lb. per sq. in.	Elongation, per cent in 2 in.	Reduction of area, per cent	Impact, ft.-lb.	Hardness		1200° F.	1400° F.	1600° F.	1800° F.	2000° F.
												Bri-nell	Rock-well					
A-1	0.07	0.08	0.12	0.025	11.70	Tr	60,000	80,000	30	70	90	170	85-B	24,000	12,000	10,000		
							140,000	160,000	10	35	30	340	35-C					
A-2	0.09	1.25	0.35	0.025	18.50	Nil	50,000	75,000	35	75	0	140	80-B					
							80,000	95,000	25	60	12	200	95-B					
A-3	0.23	0.75	0.65	0.025	28.50	Tr	60,000	80,000	35	60	6	150	80-B	40,000	18,500	9,000	6,500	5,000
							80,000	120,000	25	40	2	210	95-B					

Castings from the above alloys have elongation and reduction in area from 5 to 20 per cent, much less than for the fabricated forms.

B-1	0.08	0.25	0.40	0.03	Nil	5.00	35,000	75,000	35	70	90	160	85-B					
							65,000	100,000	25	55	50	210	95-B					
B-2	0.15	0.20	0.43	0.03	Tr	36.10	30,000	70,000	35	65	110	160	85-B					
							45,000	90,000	25	55	60	170	85-B					

B-1 material, resistant to mild forms of corrosion, was extensively used for turbine blades; has been superseded by the low-carbon, 12 per cent chromium A-1 type.

C-1	0.07	0.30	0.40	0.03	18.00	8.00	30,000	80,000	65	75	120	130	75-B					
							45,000	100,000	50	65	90	160	85-B					
C-2	0.25	0.35	0.45	0.03	25.00	10.00	40,000	80,000	55	70	90	150	80-B	55,000	34,800	18,250	10,850	5,500
							60,000	110,000	35	50	50	200	95-B					
C-3	0.15	0.75	0.60	0.03	25.80	19.75	40,000	80,000	50	65	100	140	80-B	50,000	35,000	20,000	11,500	6,500
							45,000	95,000	30	50	60	180	90-B					

High silicon, copper, or molybdenum are often found in the C-group. Titanium, vanadium, and columbium are often added to retard or control carbide precipitation.

D-1	0.15	0.50-2.00	0.45	0.03	10.00	20.00	45,000	85,000	35	55	90	160	85-B	52,000	32,000	16,000		
							60,000	100,000	20	35	50	200	95-B					
D-2	0.35	0.03	12.00-20.00	35.00	45,000	80,000	35	60	60	160	85-B	55,000	40,600	23,400	13,250	7,500
							65,000	110,000	20	45	40	180	90-B					
D-3	0.45	W 2.00	0.03	20.00	60.00	35,000	60,000	35	60	100	140	80-B	55,000	35,250	22,500	15,250	9,250
							50,000	80,000	20	45	50	160	85-B					

D-1 type is obtainable in nearly all forms including seamless pierced and drawn tubes. D-2 type with modifications is available in various forms. Most of this material is used for heat resistance. For turbine blading, a lower chromium content is used for temperatures above 800°F. D-3 type is obtainable only in restricted forms. Modifications of this type are obtainable in certain forgings although it is difficult to fabricate. With the addition of 15 to 20 per cent molybdenum, this material becomes immune to hydrochloric and sulphuric acids.

Note 1: In columns headed yield point and ultimate stress, the first figure refers to the annealed condition; the second figure is for cold-worked or hardened material. Differences between these figures and other published data are accounted for by modifications of analysis or by variations in heat-treatment or work hardening during fabrication.

Note 2: The first figure is the ultimate stress obtained after 1 hr. at temperature; the second figure is considered by the author to be a conservative design stress for use at these temperatures. These working stresses are based on experience and have been used satisfactorily. But they should not be confused with creep strengths.

CHARACTERISTICS AND USES OF IRON-NICKEL-CHROMIUM ALLOYS

Type	Available forms							Forging, hardening, and annealing temperatures, deg. F.			General information	
	Castings	Forgings	Billets	Bars	Cold drawn or ground	Sheets, plate, strip	Seamless tubes	Forge	Hard-en	Anneal	Notations	Applications
A-1	✓	✓	✓	✓	✓	✓ Seldom used	✓	2100 1600	1750 1800	1550 1600	Magnetic Hardening type	General engineering purposes, turbine blading
	✓	✓	✓	✓	✓	?	No	2100 1600	1700 1750	1550 1600	Magnetic To soften draw at 1300-1400°F.	For general corrosion resistance where hardness is required. For cutlery, surgical instruments
A-2	✓	✓	✓	✓	✓	✓	✓	2000 1200	1450	Magnetic Nonhardening	General corrosion-resistant material for fabrication. Chemical equipment, nitric acid towers
A-3	✓	✓	✓	✓	✓	Plates	✓	2100 1400 1600	Magnetic Nonhardening	Special cases of corrosion resistance, temperatures up to 1800°F., for SO ₂ and SO ₃
B-1	✓	✓	✓	✓	✓	✓	✓	2000 1200	1500 1600	1450 1500	Magnetic Nonhardening	General engineering purposes, low temperature turbine blading
B-2	✓	✓	✓	✓	✓	✓	No	2000 1200	Quench Quench	Nonmagnetic Nonhardening	Resistant but not immune to hydrochloric and sulphuric acids. Nonmagnetic material for electrical parts

B-2 material is used where an austenitic material is required. This type of material with 10 to 12 per cent chromium is being used by turbine designers for higher temperatures than now prevailing.

C-1	✓	✓	✓	✓	✓	✓	✓	2100 1400	Air or water quench 1800 to 2000	Nonmagnetic Nonhardening	Chemical equipment; architectural, food, laundry, dyeing industries
	✓	✓	✓	✓	✓	✓	✓	2100 1400		Nonmagnetic Nonhardening	General fabrication; riveted and welded structures for chemical equipment
C-2	✓	✓	✓	✓	✓	✓	✓	2100 1400	Air or water quench 1800 to 2000	Nonmagnetic Nonhardening	General fabrication, resistant to sulphite solutions in paper processes
C-3	✓	✓	✓	✓	✓	✓	Hollow forged	2100 1400		Nonmagnetic Nonhardening	For mixed acid conditions in paper, dye, and general chemical processes. Resistant but not immune to hydrochloric and sulphuric acids

Selenium or zirconium sulphide may be added for free machining. When some of these elements are present the materials may become slightly magnetic.

D-1	✓	✓	✓	✓	✓	✓	✓	2000 1200	Air or water quench 1800-2000	Nonmagnetic Nonhardening	Resistant to salt water, cold dilute sulphuric acid. For oil refineries, naval equipment, and general chemical uses
D-2	✓	✓	✓	✓	✓	✓	Plates		Nonmagnetic Nonhardening	Low chrome, for high temperature turbine blading. High chrome, for heat resistant material for carburizing boxes and furnace parts
D-3	✓	?	?	?	?	?	No		Nonmagnetic Nonhardening	For temperatures up to 2000°F., for furnace parts, forgings, electrical equipment. Resistant but not immune to hydrochloric and sulphuric acids

COMPOSITION AND PROPERTIES OF WROUGHT BRASSES AND BRONZES

Item number	Material	Composition,* per cent				Ultimate strength,† 1,000 lb. per sq. in.				Yield strength,† 1,000 lb. per sq. in.				Elongation,† per cent in 2 in.				Thermal conductivity,‡ cal./sq. cm./sec./deg. at 20°C.	Relative suitability for being worked		Relative suitability for welding			
		Copper	Zinc	Tin	Lead	Others	Sheet	Hard	Soft	Sheet	Hard	Soft	Sheet	Hard	Soft	Cold	Hot		Gas	Carbon arc	Metallic arc	Resistance		
1	Gilding metal	95.0	5.0	55	35	...	34	11	...	5	38	...	A	A	C	B	B	D	20		
2	Commercial "brass"	90.0	10.0	67	37	...	47	11	...	3	40	...	A	A	B	B	C	D	20		
3	85 per cent red brass (rich low brass)	85.0	15.0	75	42	70	42	17	50	4	43	17.5	A	A	B	B	C	D	30		
4	80 per cent red brass (low brass)	80.0	20.0	75	43	70	45	15	60	4	50	15	A	B	B	C	D	D	30		
5	Shell head (bracing or special spring brass)	75.0	25.0	80	47	...	60	15	...	5	45	...	A	C	B	C	D	D	30		
6	Spring brass	72.0	28.0	76	47	...	35	15	...	4	55	...	A	C	B	C	D	C	30		
7	Seventy-thirty (cartridge, spinning, or eyelet) brass	70.0	30.0	76	45	...	65	15	...	4	50	...	A	C	B	C	D	C	30		
8	"Two-and-one" mixture (high, drawing, or yellow brass)	68.0	32.0	78	46	...	50	5	58	...	A	C	B	C	D	C	30		
9	Yellow brass (extruded rivet metal)	63.0	37.0	78	48	70	50	4	50	12	B	B	B	C	D	B	40		
10	Muntz metal	60.0	40.0	80	57	70	61	60	19	60	15	50	C	A	B	C	D	B	40		

Leaded Brass																						
Item number	Material	Copper	Zinc	Tin	Lead	Others	Sheet	Hard	Soft	Sheet	Hard	Soft	Sheet	Hard	Soft	Sheet	Hard	Soft	Sheet	Hard	Soft	
11	Free cutting or leaded commercial "brass"	89.0	9.0	...	2.0	0.432
		88.5	10.0	...	1.5	...	60	35	...	60	35
12	Free-cutting or leaded brass	69.0	29.5	...	1.5
13	Free-cutting high brass (bearing brass)	67.0	29.0	...	4.0
14	Tube brass	66.5	33.0	...	0.5
15	Free-cutting tube (lead high, semileaded, buff, matrix) brass	65.5	32.75	...	1.75	...	80	45	70	45	5	60	4
		64.0	35.0	...	1.0
16	Stamping brass	65.0	34.7	...	0.30
17	Engravers' brass	63.5	34.5	...	2.0
18	Free-cutting brass (free-cutting or riveting and turning rod, clock brass)	62.0	34.75	...	3.25
		61.5	37.0	...	1.80	...	80	45	80	45	4	40	4
19	Forging rod	60.0	38.25	...	1.75
		58.0	39.0	...	3.00
20	Architectural "brass" (typical)	56.0	41.5	...	2.50	...	70	50

COMPOSITION AND PROPERTIES OF WROUGHT BRASSES AND BRONZES (Continued)

Item number	Material	Composition, * per cent				Ultimate strength, † 1,000 lb. per sq. in.			Yield strength, † 1,000 lb. per sq. in.			Elongation, † per cent in 2 in.			Thermal conductivity, ‡ cal./sq. cm./sec./deg. at 20°C.		Relative suitability for being worked †		Relative suitability for welding			
		Copper	Zinc	Tin	Lead	Others	Hard	Soft	Hard	Soft	Hard	Soft	Hard	Soft	Cold	Hot	Gas	Carbon arc	Metallic arc	Resistance		
																					Sheet	Rod
Special Brasses																						
21	Silicon brass	78.0 77.0	20.0 22.0	2.0 Si 1.0 Si	110 96	83 12.5	A	A	A	A	30	
22	Aluminum brass	76.0	22.0	2.0 Al	83	62	75	62	A	C	B	D	30	
23	Admiralty brass	71.0	28.0	1.0	78	45	A	C	B	D	30	
24	Naval brass	60.0	39.25	0.75	90	45	75	54	62	24	55	24	4	40	25	50	50	50	30	
25	Leaded naval brass	60.0	37.75	0.75	1.5	55	D	B	C	D	70	
26	Die-casting brass	60.0	37.75	1.0	1.0	0.10 Al 0.15 Si	55	35	8	30	
Bronzes																						
27	Special phosphor bronzes	98.75 98.2	1.2 1.2	0.05 P 0.30 P	65 40	42	50	15	A	B	B	B	C	
28	5 per cent phosphor bronze	94.75	5.0	0.25 P	85	51	20	A	D	B	B	30	
29	Leaded phosphor bronze	93.75	5.0	1.0	0.25 P	85	51	B	D	D	C	50	
30	8 per cent phosphor bronze	91.75	8.0	0.25 P	93	60	20	B	D	B	B	20	
31	Free-cutting bronze (bushing)	88.0	4.0	4.0	4.0	45	65	C	D	D	C	100	
32	Silicon bronzes (typical)	97.75 96.25	0.25 0.50	2.0 Si 3.25 Si	100 110	45 60	110 125	95 100	22 24	97 120	65 65	10 65	65 65	10 65	A	A	A	A	30
33	Leaded silicon bronze	95.5	1.0	0.5	3.0 Si	93	A	A	A	A	30	
34	Aluminum bronze	95.0	5.0 Al	105	57	80	24	B	C	C	B	60	
35	Manganese bronze	59.0 57.5	39.0 40.45	0.75 1.0	1.25 Fe 0.05 Mn 1.25 Fe 0.05 Mn	75	60	50	15	D	A	B	C	30	

* Compositions given here are only approximate and represent only the major stock types. They are varied by the supplier to suit the individual problem of the designer.
 † Values are purely nominal as they represent results of tests of 0.040-in. sheet and 1.0-in. rod from several sources. Yield point strength is the stress that produces an extension of 0.50 per cent. Change in dimensions, temper, or manufacturing limitations will change these figures so that it is important that unusual or new problems be worked out in cooperation with the supplier.
 ‡ Coefficient applied up to 300°C. Tests were made on rod and reported in U. S. Bureau of Standards Scientific Paper 410. Fabrication characteristics are indicated by: A, excellent; B, good; C, fair; D, poor.

CHARACTERISTICS AND USES OF WROUGHT BRASSES AND BRONZES

Item	Material	Chief characteristics	Typical applications
1	Gilding metal	High ductility, corrosion resistant, reddish gold color	Drawn, stamped, and spun parts, primers, detonators, fuse caps
2	Commercial "bronze"	High ductility, corrosion resistant	Stamped, drawn, forged, and perforated parts, hardware, small shells, screen, screws, rivets, primer caps, kick plates, grillwork
3, 4	Red brass (rich low brass, low brass)	Ductility slightly less than first two items, corrosion resistant, yellow colors	Stamped, drawn, and formed parts, plumbing pipe, hardware, fasteners, flexible hose, screw shells, condenser tubes, sockets, conduit, radiator cores. The lower copper content material is also used for clock dials and bellows
5 6	Shell head (brazing or special spring brass) Spring brass	Easily brazed or soldered, corrosion resistant, can be cold worked readily, good physical properties for springs	Eyelets, springs, musical instruments, other drawn brazed and spun parts. The lower copper content material is best spring stock and is also used for turbine blades
7 8, 9	Seventy-thirty (cartridge, spinning, or eye-let brass) Lower copper-content grades are variously referred to as "two-and-one" mixture, high brass, spinning or drawing brass, yellow brass	Can be deep drawn, has high ductility, fair welding properties Lower copper content yellow brass is particularly good for cold heading	Stamped, spun, or deep-drawn parts, springs, cartridges, eyelets, screw shells, fasteners, bead chain, rivets, radiator tanks, corks and bins, pipe, reflectors. Some of the lower copper content materials also used for parts such as lamp fixtures and other ornamental work such as grilles. Item 9 is used for pins, rivets, and screws
10	Muntz metal (yellow metal)	Corrosion resistant (used for ship sheathing) readily worked by hot rolling, extruding, or hot-stamping	Valve stems, condenser tubes and heads, brazing rod, architectural trim, perforated metal
11	Free-cutting or leaded commercial "bronze"	Free machining, not suitable for deep drawing	Screw machine products, hardware, forgings, pickling crates
12	Free-cutting or leaded brass	Free machining, can be drawn or formed	For special shapes where a high lead content is detrimental to the bending or working of the part
13 15 17	Free-cutting high brass (bearing brass) Free-cutting tube (leaded high, semileaded, butt, matrix) brass Engraver's brass	Free machining, can be drawn moderately or formed by bending	Screw machine products, threaded parts, bushings, hinges, gears, clock and watch parts, stampings
14 16	Tube brass Stamping brass	Less machinable than above, better workability	Plumbing pipe and fixtures, pump liners, wind-shield tubing, flashlight shells, special shapes—stamped, drawn or formed parts, switch plates

CHARACTERISTICS AND USES OF WROUGHT BRASSES AND BRONZES (Continued)

Item	Material	Chief characteristics	Typical applications
18	Free-cutting brass (free-cutting rod, riveting and turning rod, clock brass)	Free machining. Item 18 can be cold worked, mills easily. Item 19 can be hot worked readily. Item 20 has strength and hardness	Hardware, screw machine products, pinions, gears, clock and meter parts—forgings, tire valve stems, faucet handles, shower heads—extruded shapes, forgings, hinges, lock bodies
19	Forging rod		
20	Architectural bronze		
21	Silicon brass	Low thermal and electrical conductivity, latter makes for good resistance welding. Resistant to corrosion	Special applications where high strength, stamping and electric welding is required, refrigerator evaporator shells, fire-extinguisher shells, hinges, kick plates, springs
22	Aluminum	Resistant to corrosion and erosion	Condenser tubes
23	Admiralty brass	Resistant to heat and salt-water corrosion	Condenser tubes, tube sheets, ferrules, filter wire
24	Naval brass	Resistant to salt-water corrosion. Leaded material can be hot worked	Marine hardware, propeller shafts, bolts, nuts, forgings—valve stems, screw machine products
25	Leaded naval brass		
27-31	Phosphor bronzes	High strength, good ductility, excellent corrosion resistance, fatigue resistance. Good hot workability up to about 2 per cent tin and phosphorus. Good cold workability. Leaded types possess fair to excellent machinability characteristics	Welding rod, rivets, screen cloth, springs, wire rope, fasteners, bridge bearing plates, screw machine products. Bearings, bushings, condenser tubes acid-resisting uses, thrust washers, diaphragms
32, 33	Silicon bronzes	High strength, resistance to corrosion comparable to copper, nonmagnetic, can be readily welded or heat-treated, when leaded possess good machining properties, can be cold worked	Corrosion-resistant tanks, pressure vessels, pipe fittings, piston rings, piston rod, propeller shaft, filters, condenser tubes, corrugated thermostat tubing, chain, evaporators, forgings, valve gates, bushings, structural shapes, screen wire and cloth, transmission line hardware
34	Aluminum bronze	High strength, resistant to corrosion, rich golden color, ductile	Stampings, condenser tubes, ornamental articles
35	Manganese bronze	Hard and resistant to wear	Structural purposes, perforated metals, welded or extruded parts, grillework, screens, wearing parts

CORROSION-RESISTING

Metal or alloy	Percentage composition	Condition	Ultimate strength, lb. per sq. in.	Percent elongation in 2 in.	Specific gravity	Scaling temperature, deg. F.	Annealing temperature, deg. F.
Silver	Ag 99.90	Annealed	25,000	60	10.49	1000-1150
Nickel	Ni 99.4	Hard Annealed	100,000 70,000	2-8 43-53	8.85	1200-1400	1200-1500
Copper	Cu 99.90	Hard Annealed	55,000 35,000	5 35	8.93	700-800	800-1100
Iron	Fe 99.95	Hard	44,000	25	7.86	1200-1500
Monel	Cu 28, Ni 69	Hard Annealed	110,000 70,000	2-8 35-50	8.80	900	1300-1600
Nickel silver	Ni 18, Cu 65, Zn 17	Hard Annealed	95,000 58,000	2 33	8.75	900	1100-1300
Sterling silver	Ag 92.5, Cu 7.5	Hard Annealed	63,000 40,000	8 35	10.3	1100-1250
Gilding metal	Cu 90, Zn 10	Hard Annealed	65,000 32,000	1 40	8.80	700	1000-1200
Bronze	Sn 2.0, Zn 7, Cu 91	Hard Annealed	130,000 51,000	1 50	8.60	1100-1250
Chromium steel	Cr 16, C 0.1	Hard Annealed	95,000 75,000	25 30	7.67	1450	1500 air cool
Chrome-nickel-steel	Cr 18.5, Ni 8.5, C 0.12	Hard Annealed	100,000 80,000	65 50	7.86	1700	2100 quench
White gold	Au 58.5, Cu 24, Zn 5.0, Ni 12.5	Hard Annealed	144,000 100,000	3 29	13.2	1250-1450
Yellow gold	Au 58.5, Cu 30, Ag 5.5, Zn 6.2	Hard Air quench Water quench	130,000 83,000 70,000	3 36 40	13.0		

METALS AND ALLOYS

Corrosion-resistant properties

Temp., deg. F.	Sulphuric acid		Nitric acid		Hydrochloric acid		Acetic acid		Sodium hydroxide		Ammonia		Sulphur dioxide	Fruit juice	Phosphoric acid	Sea water
	Dil.	Con.	Dil.	Con.	Dil.	Con.	Dil.	Con.	Dil.	Con.	Dil.	Con.				
68	No	No	No	No	✓	✓	✓	✓	✓	✓	✓	✓	No	✓	✓	✓
68	?	?	No	No	?	?	✓	✓	✓	✓	?	?	No	✓		
68	✓	?	No	No	No	No	✓	✓	✓	✓	No	No	No	✓	✓	✓
100	No	No	No	No	No	No	✓	✓	✓	✓	No	No	No			
68	No	No	✓	✓	No	No	No	No	?	?	No	No	No	No
68	No	No	No	No	No	No	?	?	✓	✓	✓	✓	No	?		
68	✓	No	No	No	No	No	✓	No	✓	?	No	No	No	?		
68	No	No	No	No	✓	✓	✓	✓	✓	✓	✓	✓	No	✓		
68	✓	No	No	No	No	No	✓	✓	✓	✓	No	No	No	✓
68	✓	?	No	No	No	No	✓	✓	✓	✓	No	No	No	✓
68	✓	?	✓	✓	No	No	✓	✓	✓	✓	✓	✓	✓	✓	✓	
68	✓	No	✓	✓	No	No	✓	No	✓	✓	✓	✓	✓	✓	✓	
68	✓	✓	✓	No	✓	✓	✓	✓	✓	✓	✓	✓	✓	✓	✓	✓
68	Resists all but aqua regia															

✓ = resistant. No = not resistant. ? = depending on conditions.

COMPOSITION AND PROPERTIES OF WROUGHT AND CAST ALUMINUM-BASE ALLOYS

S.A.E. alloy No.	Aluminum Co. of America Alloy No.	Approximate composition, per cent (balance aluminum)							Condition	Ultimate tensile strength, 1,000 lb. per sq. in.	Yield strength, 1,000 lb. per sq. in.	Elongation, per cent in 2 in.		Strength in compression		Fatigue endurance limit, 1,000 lb. per sq. in., 5×10^6 cycles	Brinell hardness, 500 lb. load on 10-mm. ball
		Copper	Magnesium	Manganese	Zinc	Nickel	Chromium	Lead				Iron	Sheet specimen, $\frac{3}{16}$ in. thick	Rod specimen, $\frac{3}{4}$ in. diam.	Yield strength in compression, 1,000 lb. per sq. in.		
Wrought Alloys																	
25	280	0.098	13	5	35	45	5	9.5	5.0	23
25	28H	0.098	24	21	5	15	5	13.0	8.5	44
29	380	1.2	0.099	16	6	30	40	6	11.0	7.0	28
29	38H	1.2	0.099	29	25	4	10	10	16.0	10.0	55
29	118T3	0.102	49	42	..	14	42	30.0	12.5	95
26	118T8	0.102	55	42	..	14	42	100
26	1780	4.0	0.5	0.101	26	10	20	22	10	18.0	11.0	45
26	178T	4.0	0.5	0.101	60	37	20	22	37	36.0	15.0	100
24	A178T	2.5	0.3	0.099	43	24	24	27	24	26.0	13.5	70
24	2480	4.6	1.5	0.100	26	10	20	22	10	18.0	12.0	42
24	248T	4.6	1.5	0.100	68	44	19	22	44	41.0	18.0	105
24	248RT	4.6	1.5	0.100	70	55	13	30	55	42.0	17.0	116
201	5280	0.096	29	14	25	30	14	18.0	11.0	45
201	528H	0.096	41	36	7	8	36	24.0	20.5	85
201	5380	0.097	16	7	25	35	7	11.0	7.5	26
...	538W	0.097	33	20	22	30	20	20.0	10.0	65
...	538T	0.7	1.3	0.097	39	33	14	20	33	24.0	11.0	80
...	6180	0.25	0.55	0.098	18	8	22	22	8	12.5	8.0	30
...	618W	0.25	0.55	0.098	35	21	12	22	21	24.0	12.5	65
...	618T	0.25	0.55	0.098	45	39	12	12	39	30.0	12.5	95
Forging Alloys																	
...	148T	4.4	0.8	0.4	0.101	65	60	10.0	10.0	60	45.0	16.0	130
...	178T	4.0	0.5	0.5	0.101	55	30	16.0	16.0	30	36.0	15.0	100
...	188T	0.103	55	35	10.0	10.0	35	35.0	15.0	100
27	268T	4.5	0.8	0.8	2.0	0.101	55	30	16.0	16.0	30	35.0	15.0	100
...	328T	0.8	12.0	0.8	0.8	0.097	52	40	5.0	5.0	40	38.0	14.0	115
280	A518T	0.25	0.097	41	34	14.0	14.0	34	32.0	10.5	90
...	538T	0.25	0.097	36	30	16.0	16.0	30	24.0	11.0	75
Sand-casting Alloys																	
35	43	0.096	19	9	6.0	6.0	10	14.0	6.5	40
37	47	12.5	0.096	26	11	8.0	8.0	11	18.0	6.0	50
33	108	4.0	3.0	0.099	21	14	2.0	2.0	14	20.0	8.5	55
33	112	7.5	0.103	23	14	1.5	1.5	17	25.0	9.0	70
34	122	10.0	0.2	2.0	0.103	26	21	0.5	0.5	..	20.0	9.5	85
34	122-T2	10.0	0.2	0.103	25	20	1.0	1.0	20	21.0	9.5	75
39	142	4.0	1.5	0.099	28	24	1.0	1.0	31	24.0	8.0	80
39	142-T61	4.0	1.5	0.099	37	32	0.5	0.5	47	32.0	8.0	100
...	142-T671	4.0	1.5	2.0	0.099	32	28	0.5	0.5	34	27.0	8.0	85
38	195-T4	4.0	0.100	31	16	8.5	8.5	16	24.0	8.0	65
38	195-T6	4.0	0.100	36	22	5.0	5.0	25	30.0	6.5	80
38	195-T62	4.0	0.100	40	31	2.0	2.0	36	31.0	7.0	95
38	212	8.0	1.2	0.102	22	14	2.0	2.0	14	20.0	8.0	65
38	214	...	3.8	0.095	25	12	9.0	9.0	12	30.0	7.0	50
324	220-T4	...	10.0	0.092	45	25	14.0	14.0	26	33.0	7.0	75

COMPOSITION AND PROPERTIES OF WROUGHT AND CAST ALUMINUM-BASE ALLOYS (Continued)

S. A. E. alloy No.	Aluminum Co. of America Alloy No.	Approximate composition, per cent (balance aluminum)							Condition	Ultimate tensile strength, 1,000 lb. per sq. in.	Yield strength, 1,000 lb. per sq. in.	Elongation, per cent in 2 in.		Strength in compression		Fatigue endurance limit, 1,000 lb. per sq. in., 5×10^6 cycles	Brinell hardness, 500 kg. load on 10-mm. ball
		Copper	Silicon	Manganese	Zinc	Nickel	Chromium	Lead				Iron	Sheet specimen, $\frac{1}{8}$ in. thick	Rod specimen, $\frac{1}{4}$ in. diam.	Yield strength in compression, 1,000 lb. per sq. in.		
Sand-casting Alloys																	
322	A334	3.0	4.0	0.3	As cast	25	16	2.0	22	24.0	8.5	85	
322	355-T4	1.3	5.0	0.5	Heat-treated	30	20	5.0	25	28.0	...	60	
322	355-T6	1.3	5.0	0.5	H.T. and aged	35	25	3.5	27	30.0	...	80	
	355-T51	1.3	5.0	0.5	Aged	28	23	1.5	24	32.0	7.0	60	
	A355-T51	1.4	5.0	0.8	0.8	Aged	28	24	1.5	24	32.0	7.0	65	
323	A355-T59	1.4	5.0	0.8	0.8	Aged	25	21	2.0	21	21.0	8.0	60	
323	356-T4	...	7.0	0.3	Heat-treated	16	16	4.0	18	22.0	...	55	
323	356-T6	...	7.0	0.3	H.T. and aged	32	22	6.0	22	27.0	8.0	70	
323	356-T51	...	7.0	0.3	Aged	25	20	2.0	22	18.0	6.0	60	
31	645	2.5	11.0	As cast	29	20	4.0	20	22.0	7.5	70	
Permanent Mold-casting Alloys																	
35	43	5.0	As cast	24	9	6.0	9	18.0	...	40	
	A108	4.5	5.5	As cast	28	16	2.0	16	25.0	...	60	
33	B113	7.0	1.7	2.0	As cast	27	19	1.5	19	23.0	...	55	
	C113	7.0	4.0	2.0	As cast	28	24	2.0	24	22.0	...	70	
34	122-T32	10.0	...	0.2	1.2 H.T. and aged	35	31	0.5	31	25.0	...	105	
	A132-T4	0.8	12.0	1.0	2.5	H.T. and aged	38	30	1.5	30	29.0	...	100	
	A132-T651	0.8	12.0	1.0	2.5	H.T. and aged	38	28	1.5	28	24.0	...	105	
	138	10.0	4.0	0.2	As cast	28	24	0.5	24	22.0	...	100	
30	142	4.0	...	1.5	2.0	As cast	34	24	1.0	26	24.0	...	105	
36	142-T61	4.0	...	1.5	2.0	H.T. and aged	47	42	0.5	46	31.0	9.5	110	
33	142-T571	4.0	...	1.5	2.0	H.T. and aged	40	32	0.5	34	24.0	...	105	
	B195-T4	4.5	3.0	H.T. and aged	36	25	7.0	25	30.0	...	105	
	B195-T6	4.5	3.0	H.T. and aged	39	32	5.0	32	32.0	9.5	105	
	A214	3.8	1.8	As cast	27	16	5.0	17	22.0	...	60	
322	355-T4	1.3	5.0	0.5	H.T. and aged	38	23	6.0	23	29.0	...	60	
322	355-T6	1.3	5.0	0.5	H.T. and aged	43	26	4.0	26	30.0	...	75	
Die-casting Alloys																	
305	13	...	12.0	As cast	33	18	1.8	18	...	15.0	...	
304	43	...	5.0	As cast	29	13	3.5	13	
312	81	7.0	3.0	As cast	32	24	1.3	24	...	16.0	...	
83	83	2.0	3.0	As cast	30	14	3.5	14	...	14.5	...	
85	85	4.0	5.0	As cast	33	19	2.7	19	...	17.0	...	
218	218	8.0	As cast	36	23	5.0	23	...	17.0	...	

For the wrought and cast alloys listed, the modulus of elasticity may be taken as 38×10^6 lb. per sq. in. Bearing strength for holes, where edge distance is more than twice the hole diameter, may be taken as 80 per cent greater than the tensile strength.

CHARACTERISTICS AND USES OF WROUGHT AND CAST ALUMINUM-BASE ALLOYS

Aluminum Co. of America Alloy number	Forms commonly available												Chief characteristics	Typical applications		
	Sheet and plate	Wire	Rod and bar	Rolled shapes	Extruded shapes	Tube and pipe	Rivets	Screw machine products	Forgings	Band castings	Permanent mold castings	Die castings			"Alclad" sheet	Heat-treatable alloy
28	•	•	•	•	•	•	•	•	•	•	•	•	•	•	Good forming qualities, resistant to corrosion, weldable Workability, weldability, and resistance to corrosion Good machinability, "free" cutting, good mechanical properties Highest strength and hardness of all aluminum alloys Excellent mechanical properties. (Duralumin-type alloy) Fair strength and cold-working properties Good strength at elevated temperatures High strength, sensitive to heat-treatment Excellent workability when hot, high strength Comparatively low coefficient of thermal expansion Excellent workability when hot, high strength Highest strength of non-heat-treatable aluminum alloys, good workability, and resistance to corrosion Fair mechanical properties, excellent resistance to salt-water corrosion Good strength and workability Excellent foundry characteristics, good mechanical properties, resistant to corrosion Good foundry characteristics, weldability, good resistance to corrosion, pressure tightness Good foundry characteristics, improved mechanical properties over Alcos 43 alloy Satisfactory foundry characteristics and mechanical properties for simple castings of moderate thickness Good foundry characteristics, good ductility Best combination of strength and ductility of the die-casting aluminum-base alloys Good foundry characteristics, pressure tightness Good foundry characteristics Widely used general casting alloy: good casting and machining characteristics Good foundry characteristics, good machining properties Modification of Alcoa B113 alloy with better pressure tightness	Sheet metal work, chemical equipment, cooking utensils Sheet metal work, decorative trim, gasoline tanks for aircraft Screw-machine products Heavy-duty forgings, power-ahovel balls, airplane fittings Structural applications in construction and transportation fields Rivets Forged aircraft-engine pistons Widely used in aircraft construction Complicated forgings Forged aircraft-engine pistons Intricate forgings, machine and automotive parts High-strength sheet metal work, marine and transportation applications Structures subject to severe corrosive conditions; naval, architectural, and industrial applications General-purpose casting alloy General-purpose alloy for large, intricate parts Castings that must be leakproof under pressure, architectural trim, sewage-disposal plants, pipe fittings High-strength intricate castings, leakproof castings Small, simple parts Parts requiring spinning or other forming operations Brackets, frames, levers with thick sections Manifolds, valves and other intricate castings requiring pressure tightness Ornamental grilles, general-purpose castings General-purpose castings, crankcases, oil pans, cylinder heads, differential carriers and other automotive applications Washing machine agitators, general-purpose castings Automotive-engine cylinder heads, general purpose castings
38	•	•	•	•	•	•	•	•	•	•	•	•	•	•		
118	•	•	•	•	•	•	•	•	•	•	•	•	•	•		
148	•	•	•	•	•	•	•	•	•	•	•	•	•	•		
178	•	•	•	•	•	•	•	•	•	•	•	•	•	•		
A178	•	•	•	•	•	•	•	•	•	•	•	•	•	•		
188	•	•	•	•	•	•	•	•	•	•	•	•	•	•		
248	•	•	•	•	•	•	•	•	•	•	•	•	•	•		
258	•	•	•	•	•	•	•	•	•	•	•	•	•	•		
328	•	•	•	•	•	•	•	•	•	•	•	•	•	•		
A318	•	•	•	•	•	•	•	•	•	•	•	•	•	•		
528	•	•	•	•	•	•	•	•	•	•	•	•	•	•		
538	•	•	•	•	•	•	•	•	•	•	•	•	•	•		
618	•	•	•	•	•	•	•	•	•	•	•	•	•	•		
13	•	•	•	•	•	•	•	•	•	•	•	•	•	•		
43	•	•	•	•	•	•	•	•	•	•	•	•	•	•		
47	•	•	•	•	•	•	•	•	•	•	•	•	•	•		
81	•	•	•	•	•	•	•	•	•	•	•	•	•	•		
83	•	•	•	•	•	•	•	•	•	•	•	•	•	•		
85	•	•	•	•	•	•	•	•	•	•	•	•	•	•		
108	•	•	•	•	•	•	•	•	•	•	•	•	•	•		
A108	•	•	•	•	•	•	•	•	•	•	•	•	•	•		
112	•	•	•	•	•	•	•	•	•	•	•	•	•	•		
B113	•	•	•	•	•	•	•	•	•	•	•	•	•	•		
C113	•	•	•	•	•	•	•	•	•	•	•	•	•	•		

CHARACTERISTICS AND USES OF WROUGHT AND CAST ALUMINUM-BASE ALLOYS (Continued)

Aluminum Co. of America alloy number	Forms commonly available												Heat-treatable alloy	Chief characteristics	Typical applications	
	Sheet and plate	Wire	Rod and bar	Rolled shapes	Extruded shapes	Tube and pipe	Rivets	Screw machine products	Forgings	Sand castings	Permanent mold castings	Die castings				"Alclad" sheet
122	●	High hardness, resistance to wear, usable at elevated temperatures	Auto engine pistons, camshaft bearings, valve tappet guides
A132	●	Low coefficient of thermal expansion, retains strength at high temperatures	Pistons for internal-combustion engines
138	Excellent hardness, which is retained at elevated temperatures	Flatiron sole plates
142	●	Retains strength at elevated temperatures, has good bearing characteristics	Pistons and cylinder heads
195	●	Good mechanical properties; resistant to salt-spray corrosion	Machine bases and parts, shop crane trucks, trolley parts, outboard motors, ship castings, aircraft-engine parts
B195	●	Widely used modification of Alcoa 195 alloy	Permanent-mold castings (products same as for Alcoa 195 alloy)
212	General-purpose casting alloy; has improved foundry characteristics over Alcoa 112 alloy	General-purpose castings of intricate design
214	Resistant to severe corrosive conditions, excellent mechanical properties	Carburetor cases, machine parts, pipe fittings
A214	●	Excellent mechanical properties, good resistance to corrosion and tarnishing	Cooking utensils
218	High mechanical properties, resistant to corrosion, easily finished	Marine fittings, hardware
220	●	Highest strength and shock resistance of casting alloys, good resistance to corrosion	Aircraft fittings, railroad car parts, heavy-duty castings, power-shovel dipper parts, marine applications
A334	Better tensile properties than Alcoa alloys No. 108, 112 and 212	Automotive-engine parts, air-brake valves
335	●	Good foundry characteristics, resistant to corrosion, strong at elevated temperatures	Cylinder heads and crankcases for Diesel and aircraft engines
A335	●	Modification of Alcoa 355 alloy	Same as Alcoa 355 alloy for operating temperatures above 400°F.
356	●	Good foundry characteristics, weldability, pressure tightness, and resistance to corrosion	High-strength, pressure-tight castings of intricate shape
645	●	Good mechanical properties, low resistance to corrosion	Machine parts not subjected to elevated temperatures or corrosive conditions

CAST AND WROUGHT MAGNESIUM-BASE ALLOYS

A.S.T.M. designation		Chemical composition in per cent* magnesium with				Form	Tensile strength, lb. per sq. in.	Yield point, lb. per sq. in.	Per cent elongation in 2 in.	Shear strength, lb. per sq. in.	Brinell hardness	Impact strength Isod, ft.-lb.				
Spec. No.	Alloy	Aluminum	Manganese, min.	Zinc	Silicon, max.											
Sand and permanent mold castings	2	9.0-11.0	0.10	0.3 max.	0.5	As cast	22,000	13,000	2	18,000	54	2				
						Heat-treated	35,000	12,000	9	20,000	52	4				
						H.T. and aged	36,000	19,000	2	22,000	69	2				
B80-38T	3	11.2-12.8	0.10	0.3 max.	0.5	As cast	19,000	14,000	0.5	17,000	65	0.4†				
						H.T. and aged	32,000	20,000	0.5	19,000	85	0.5†				
	4	5.3-6.7	0.15	2.5-3.5	0.5	As cast	27,000	12,000	6	18,000	55	3				
						Heat-treated	38,000	12,000	11	18,000	55	5				
B80-38T	14	9.0-11.0	0.10	0.5-1.5	0.5	H.T. and aged	36,000	22,000	1	20,000	77	1				
						Heat-treated	33,000	11,000	10	18,000	48	2.2†				
						As cast	24,000	9,000	6	14,000	44	2.0†				
						8.75-9.25	0.10	1.8-2.2	0.3	As cast	23,000	14,000	1	18,000	65	0.5†
										Heat-treated	39,000	14,000	10	20,000	63	2.0†
H.T. and aged	38,000	20,000	3	22,000	78	0.8†										
Die castings	B94-39T	9.0-11.0	0.10	0.3 max.	1.0	Die-cast	31,000	22,000	1	62	1				
Die-cast						34,000	21,000	5	50	2					
Die-cast						30,000	17,000	2.5	53					
Die-cast						27,000	17,000	4	50	3					
Forgings	B91-38T	7.8-9.2	0.15	0.3 max.	0.5	Pressed	42,000	24,000	5				
Forged						34,000	19,000	6					
Pressed						42,000	26,000	10					
B91-38T	9	7.8-9.2	0.15	0.2-0.8	0.5	Pressed	45,000	30,000	8	22,000	78	1.8†				
						Pressed and aged	46,000	33,000	6	82				
						15 15A	2.5-3.5	0.20	2.5-3.5	0.5	Forged	41,000	24,000	16	59
Forged and aged	42,000	28,000	14	62										
Extruded bars, rods, shapes, and tubing	B107-38T	3.3-4.7	0.20	0.3 max.	0.5	As extruded	40,000	29,000	16	20,000	47				
						As extruded	44,000	32,000	17	20,000	54	3.0				
						As extruded	47,000	35,000	12	20,000	61	2.2†				
						Extruded and aged	51,000	38,000	9	23,000	70	1.6†				
B107-38T	11 15 15A 2.5-3.5 2.5-3.5	1.20 0.20 0.20 2.5-3.5 2.5-3.5	0.3 0.5 0.5	As extruded	42,000	30,000	7	18,000	42	2.1†				
						As extruded	42,000	30,000	19	20,000	51				
						Extruded and aged	44,000	34,000	13	21,000	54				
						6	3.3-4.7	0.20	0.3 max.	0.5	Hard rolled	44,000	35,000	4	60
Annealed	36,000	22,000	10	18,000	50										
Hot rolled	40,000					
B90-38T	7	5.8-7.2	0.15	0.3 max.	0.5	Hard rolled	45,000	34,000	9	70				
						Annealed	39,000	20,000	15	57				
						11	1.20	0.3	Hard rolled	37,000	29,000	10	53
Annealed	32,000	16,000	16	17,000	48										
Hot rolled	34,000	19,000	13	47										

* Total impurities 0.3 per cent.

† Charpy, ft.-lb.

Notes: Physical properties for these alloys may be taken as: Weight, lb. per cu. in., 0.065; modulus of elasticity, 6,500,000 lb. per sq. in.; melting points from 1080 to 1200°F.

PROPERTIES OF INSULATING MATERIALS

Properties	Hard rubber	Vulcanized fiber	Laminated phenolic
Power factor, at radio frequencies	0.01-0.03	0.05	0.03-0.07
Dielectric constant, at radio frequencies	2.7-4.0	5	4.5-6
Dielectric strength (specimen 1/4 in. thick. Step by step test at 25°C.)	500-1,000 volts per mil	25-250 volts per mil	150-600 volts per mil
Tensile strength	3,000-5,000 lb. per sq. in.	9,000-16,000 lb. per sq. in.	6,000-20,000 lb. per sq. in.
Water absorption, per cent in 24 hr.	0.02	20-60	0.3-2.5
Specific gravity	1.2-1.5	1.2-1.4	1.3-1.4
Coefficient of linear expansion, per deg. C.	60-80 × 10 ⁻⁶	25 × 10 ⁻⁶	20-30 × 10 ⁻⁶
Effect of aging	Deteriorates slowly unless well vulcanized and protected from light	Improves	Improves
Effect of heat	Softens at 50 to 65°C. Melts at 200°C.	Will not melt; not readily inflammable, but chars and becomes brittle at high temperature. Burns at about 340°C.	Not readily inflammable. Temperatures from 60-150°C. tend to renew chemical reactions, resulting in shrinkage and loss in weight
Effect of sunlight	Discolors and disintegrates after a few months. Sulphate films formed on surface reduce surface resistivity	No effect	No visible effect
Effect of ultraviolet light	A few hours exposure is in its effects equivalent to many months exposure to sunlight	No data	Lowers surface resistivity
Effect of moist air	No effect	Absorbs water freely but without permanent injury; while saturated it becomes soft and flexible and swells; warps and twists upon drying	Absorbs slight amount of water, reducing dielectric properties
Effect of steam	The only effect is that resulting from the high temperature	Same as above, except absorption is more rapid	Best grades not affected beyond slight absorption of moisture; after a few days in steam the cheaper grades will swell appreciably and split; superheated steam tends to warp and blister all grades
Solvents	Affected by most organic solvents and mineral oils; unaffected by alkalies, weak acids, and certain concentrated acids	Organic solvents have no permanent effect; oils are slightly absorbed; affected by acids and alkalies	Not affected by most organic solvents, oils, or weak acids; attacked by alkalies and strong acids
Metallic inserts	Hard rubber is rapidly deteriorated by contact with iron or copper, the metals themselves also corroding. Inserts should be coated with tin, paper, unvulcanized rubber, or other mutually protecting medium	No effect	No effect
Machining qualities	Admits of a high-polish but machines less accurately than would be supposed, because of its great resiliency. It has tendency to warp, can be molded but not accurately to size	Admits of a fine finish; may be sawed, punched, drilled, stamped, embossed, turned, planed, bent, tapped	Admits of a good polish; can be sawed, punched, drilled, stamped, turned, planed, knurled, embossed, milled, tapped either with or against the grain, though not so easily as hard rubber and vulcanized fiber

MECHANICAL AND PHYSICAL PROPERTIES OF PLASTIC MATERIALS

Material	Specific gravity	Softening point, deg. F.	Specific heat, c.g.s.	Tensile strength, lb. per sq. in.	Burning rate	Heat resistant up to, deg. F.	Effect of light	Water absorption, per cent, 24-hr. immersion at 72°F.	Machining properties
Phenolic with wood flour filler.....	1.3-1.5	Infusible	0.30-0.40	5,000-10,000	Very low	480	Slight	0.1-0.6	Fair
Phenolic with asbestos filler.....	1.8-2.0	Infusible	0.30-0.40	5,000-10,000	Practically incombustible	475	Slight	0.1-0.3	Fair
Phenolic laminated with paper filler....	1.3-1.4	0.30-0.40	10,000-20,000	Very low	450	Slight	0.5-0.7	Good
Phenolic laminated with fabric filler....	1.3-1.8	8,000-10,000	Very low	320	Darkens	0.5-2.0	Good
Phenolic cast type....	1.31-1.33	212	3,000-10,000	Practically incombustible	150	Slight	0.1-0.7	Excellent
Urea formaldehyde....	1.48-1.50	5,000-13,000	Very low	200	Nil	1.0-2.0	Fair
Cellulose nitrate.....	1.35-1.60	160-195	0.34-0.38	5,000-10,000	Very high	Decomposes at 212	Becomes brittle	1.3-3.0	Excellent
Cellulose acetate....	1.26-1.60	158-240	0.31-0.45	3,000-9,000	Low	140	Slight	1.4-5	Good
Vinyl unfilled.....	1.34-1.36	160	0.24	8,000-10,000	Incombustible	140	Darkens	0.5-0.15	Good
Vinyl filled.....	1.35-2.50	150	6,000-12,000	Incombustible	158	Darkens	1.5-4.0	Good
Casein.....	1.34	7,500	Low	3.0-7.0	Good
Acrylate.....	1.19-1.20	131-203	0.45	8,000-9,000	Low	Decomposes above 390	0.3	Good
Styrene.....	1.05-1.07	150-200	6,000-7,000	Low	Nil	Nil	Good

CHARACTERISTICS AND USES OF PLASTIC MATERIALS

Material	Forms available	Characteristics after molding	Applications
Phenolic molding types.....	Powder, rods, sheets, tubes, molded parts, laminations	Thermosetting. Usually opaque, but some grades are transparent or mottled. Nonflammable, highly resistant to water and chemical attack	Electrical parts, closures, containers, instrument housings and parts, knobs, handles, and appliance parts
Phenolic casting type.....	Rods, sheets, tubes, cast parts	Thermosetting. Cast to form. Colors are bright. Easily machined and polished. Can be bent when heated	Containers, cases, housings, handles and knobs, frames, rods, sheets and tubes
Urea formaldehyde.....	Powder, molded parts, laminations	Thermosetting. Translucent or opaque	Table and kitchen ware, containers, cases, housings, fixture parts
Cellulose nitrate.....	Rods, sheets, films, tubes, molded parts	Thermoplastic. Highly inflammable, becomes brittle in sunlight. Can be molded and worked when hot	Laminated sheets. Sheets which are to be printed. Ornaments, toilet articles, pen and pencil barrels, handles
Cellulose acetate.....	Sheets, films, rods, tubes, granules, molded parts	Thermoplastic. Easily molded by injection processes. Becomes brittle when cold	Shatterproof windows and shields, instrument crystals, automotive accessories, radio and instrument parts, knobs, handles
Vinyl.....	Sheets, films, rods, tubes, moldings, insulation, powder	Thermoplastic. Nonflammable. Easily worked and molded. Easily printed	Thin sheets, laminated glass, wire insulation
Casein.....	Rods, sheets, formed articles	Thermoplastic. Can be dyed with colors readily	Buttons, buckles, and dress ornaments
Acrylate.....	Rods, sheets, tubes, molded and cast parts	Thermoplastic. Good transparency. Resistant to effects of atmospheric exposure	Window panels, cowlings, reflectors, lenses, instrument parts, decorative parts
Styrene.....	Rods, sheets, tubes, film, molded parts	Thermoplastic. Exceptional clarity. Can be cast as well as molded	Radio parts, lenses, and parts where clarity is desired

MECHANICAL AND PHYSICAL PROPERTIES OF PHENOLIC LAMINATED MOLDED MATERIALS

Item	N.E.M.A. classification	Water absorption at 30°C.			Compressive strength		Flexural strength, modulus of rupture	Tensile strength, lb. per sq. in.	Dielectric strength (short time), $\frac{1}{16}$ -in. thick at 25°C., volts per mil	Power factor at 1,000 kc. and 25°C.		Dielectric constant at 1,000 kc. and 21°C.	
		Size of sample, in.	After 24 hr., per cent	Saturation	Flat-wise, lb. per sq. in.	Edge-wise, lb. per sq. in.				As received	After 24 hr. in water	As received	After 24 hr. in water
1	X	1 × 3 × $\frac{1}{8}$	2.0	6.5	31,000	21,000	12,500	700	0.05	0.075	5.5	6.5
2	P	1 × 3 × $\frac{1}{8}$	3.0	12.0	23,500	15,000	8,000	600	0.06	0.09	5.5	6.5
3	XX	1 × 3 × $\frac{1}{8}$	1.3	6.0	35,000	16,000	8,000	700	0.045	0.060	5.5	6.0
4	XXX	1 × 3 × $\frac{1}{8}$	1.0	6.0	35,000	15,000	7,000	650	0.035	0.045	5.0	6.0
5	XX	2 × 2 × $\frac{1}{4}$	2.0	250 ($\frac{1}{4}$ in. thick)	0.007 (at 1 kc.)			
6	A	1 × 3 × $\frac{1}{8}$	0.5	25,000	15,000	8,000	150				
7	AA	1 × 3 × $\frac{1}{4}$	0.7	2.5									
8	D	1 × 3 × $\frac{1}{8}$	1.3	6.0	35,000	16,000	8,000					
9	LE	1 × 3 × $\frac{1}{4}$	0.7	4.0	37,000	25,000	19,000	9,000	500	0.045	0.065	5.0	6.0
10	LE	1 × 3 × $\frac{1}{4}$	0.50	3.0	37,000	25,000	19,000	9,000	500	0.045	0.065	5.0	6.0
11	CE	1 × 3 × $\frac{1}{4}$	1.5	6.0	36,000	25,000	19,000	9,500	425	0.055	0.10	5.5	6.5
12	CE	1 × 3 × $\frac{1}{4}$	0.75	4.0	36,000	25,000	19,000	9,500	425	0.055	0.10	5.5	6.5
13	L	1 × 3 × $\frac{1}{4}$	1.0	5.0	35,000	24,000	20,000	10,000	150	0.10	7.0	
14	C	1 × 3 × $\frac{1}{4}$	1.7	6.0	38,000	26,000	20,000	10,000	150	0.10	7.0	
15	L	1 × 3 × $\frac{1}{4}$	1.0	5.0	37,000	25,000	19,000	9,000					

CHARACTERISTICS AND USES OF PHENOLIC LAMINATED MOLDED MATERIALS

Item	N.E.M.A. classification	Base material	Colors	Finishes	Predominant characteristics	General uses
1	X	Paper	Natural tan, black; also black surface, natural core	High polish, satin	High mechanical strength—good machining qualities—can be satisfactorily punched while hot	These four grades have been developed primarily for insulation in the radio, electrical, and electronic fields. They offer insulating qualities in different values up to the most exacting requirements. Grade selection depends on the electrical and mechanical strength required by the application
2	P	Paper	Natural tan, black; also black surface, natural core	High polish, satin	Excellent cold-punching and shearing qualities, consistent with fair mechanical and electrical properties	
3	XX	Paper	Natural tan, black	High polish, satin	High insulating value, good machining and mechanical qualities	
4	XXX	Paper	Natural tan, black	Satin	Low dielectric losses and low power factor under high-humidity conditions	
5	XX	Paper	Natural tan	Ground	High insulating value. Tube form only	Any insulating purpose
6	A	Paper (asbestos)	Natural tan, black	Satin	Unusually high heat resistance	General insulation and mechanical uses where heat resistance is of primary importance
7	AA	Fabric (asbestos)	Natural tan, black	Satin	High heat resistance—mechanical strength—low moisture absorption	Similar to Grade A, but offering greater mechanical strength—used for valve disks in contact with steam, etc.
8	D	Paper	Red, green, etc.; also marble, mahogany, walnut, and others to order	High polish, satin dull	Decorative	Wall panelings, table tops, desk tops, and general decorative uses
9	LE	Fabric (fine-weave)	Natural tan, black	High polish, satin	Good electrical and machining qualities	Replaces other grades for electrical and radio insulation when greater toughness and resilience are also desired
10	LE	Fabric (fine-weave)	Natural tan	High polish, satin	Good electrical and machining qualities, plus low water absorption	Where exact dimensions must be maintained on machined parts and remain unchanged under temperature variations, and where resistance to water absorption is important, such as sleeve bearings in deep-well pumps and for gasoline-pump vanes
11	CE	Fabric (medium-weave)	Natural tan, black	High polish, satin	High mechanical strength with good machining and electrical properties	General mechanical uses
12	CE	Fabric (medium-weave)	Natural tan	High polish, satin	High mechanical strength with good machining and electrical properties, plus low water absorption	Similar to Grade CE, particularly where it must remain unaffected by water absorption
13	L	Fabric (fine-weave)	Natural tan	Satin	Tough, resilient, high mechanical strength and good machining qualities	Fine-pitch gears, intricate punchings, and for mechanical uses
14	C	Fabric (heavy-weave)	Natural tan	Satin	Excellent wearing qualities—greatest possible resistance to impact loads	For nonmetallic industrial gears and for mechanical uses where unusual toughness and a high ratio of strength to weight are required
15	L	Fabric (fine-weave graphite-impregnated)	Black	Satin	High mechanical strength, low water absorption—low coefficient of friction when lubricated	Water-lubricated bearings

TYPICAL STEELS USED IN FORD AUTOMOTIVE PARTS

Type	Part	Analysis	How cast	Heat-treatment, deg. F.	Elastic limit, 1,000 lb. per sq. in.	Tensile strength, 1,000 lb. per sq. in.	Elongation in 2 in., per cent	Reduction in area, per cent	Brinell hardness
A	Steering wheel hub, radius rod yoke	C 0.25-0.35 Mn 0.40-0.60 Cu 1.50-2.00 P 0.05 max. Si 0.90-0.80 S 0.08 max.	Sand	Normalized	53.8	71	18.5	33.0	163
B	Truck ring gears and parts to be carburised	C 0.18-0.25 Cr 0.10 max. Cu 0.50-1.50 P 0.05 max. Si 0.20-0.40 S 0.05 max. Mn 0.40-0.90 Ni 1.65-2.00 Mo 0.25-0.35	Various	Normalize-carburise, direct quench or reheat, and oil quench and draw to Rockwell C 58-62					
C	Centrifugal castings trans. countershaft and differential gear	C 0.30-0.38 Mo 0.10-0.20 Cu 0.50-1.50 P 0.90-1.00 Si 0.20-0.40 S 0.05 max. Mn 0.55-0.75 S 0.05 max.	Centrifugal Sand Centrifugal Sand Centrifugal Sand Centrifugal Sand Centrifugal Sand Centrifugal Sand	Normalized 1500 Oil quenched, 950 drawn 1500 Oil quenched, 950 drawn 1500 Oil quenched, 850 drawn 1500 Oil quenched, 800 drawn 1500 Oil quenched, 425 drawn 1500 Oil quenched, 355 drawn 1500 Oil quenched, 355 drawn	47 44 136 144 142 142 166 166 192 212 207	85 87 140 148 148 180 180 199 218 221	21.0 18.0 7.0 6.0 5.0 3.0 2.0 1.5 0.75 0.5	35.0 28.0 14.0 13.3 14.6 5.3 5.3 3.6 3.0 3.0	160 160 502 302 321 364 364 430 477 477
D	Tractor radius rods, tractor front axle, rear axle flange, plow beams, etc.	C 0.35-0.45 Mn 0.70-0.90 Cu 0.50-1.50 P 0.05 max. Si 0.20-0.40 S 0.05 max.	Sand Sand Sand Sand	Normalized 1470 Water quenched, 1125 drawn 1470 Water quenched, 1000 drawn 1470 Water quenched, 850 drawn 1470 Water quenched, 750 drawn	65.12 108.15 129.5 152.9 171.7	90.7 128.6 139.2 157.5 173.6	15.2 10.0 8.0 5.5 5.0	26.0 22.0 19.7 13.6 10.7	192 277 302 341 364
E	Truck rear axle housing—furrow wheel	C 1.35-1.65 Cr 0.08 max. Si 0.90-1.10 P 0.10 max. Mn 0.40-0.60 S 0.08 max.	Sand	Normalized	84	103	9.0	207
F	Crankshafts	C 1.35-1.60 Cr 0.40-0.50 Cu 1.50-2.00 P 0.10 max. Si 0.85-1.10 S 0.08 max. Mn 0.70-0.90	Sand	Normalized	95.08	120.2	6.5	235
G	Piston	C 1.40-1.60 Cr 0.15-0.20 Cu 2.00-2.50 P 0.10 max. Si 0.90-1.10 S 0.08 max. Mn 0.80-1.00	Sand	Normalized	85	104.7	7.5	220
Regular malleable				Annealed	38	52	15.7	110
Ford malleable				Annealed	43	60	14.0	140
Forged steel		C 0.30		Normalized	60	85	27.0	165
Forged steel		C 0.40		Normalized	80	110	20.0	225

CHAPTER III

BEAMS AND STRUCTURES

	PAGE		PAGE
Stress Calculations for Thin Aluminum		Hollow Girders.....	80
Sheet Sections.....	72	Box Sections Subjected to Torsion.....	85
Compression Members.....	72	Chart for Determining Bending Moments...	90
Angles in Compression.....	75	Deflection of Variously Loaded Beams.....	91
Shear Members.....	75	Stresses in Cantilever Beams.....	92
Vertical Stiffeners for Shear Resisting		Tensile Strength of Round Wires.....	93
Webs.....	77	Rectangular Moments of Inertia.....	94
Diagonal Tension Webs.....	77		

Stress Calculations for Thin Aluminum Sheet Sections

A condensation of the article by the same title by S. A. Kilpatrick and O. J. Schaefer, of The Glenn L. Martin Company, in *Product Engineering*, February, March, April, and May, 1936.

COMPRESSION MEMBERS

By the method presented here, compression members made of formed aluminum sheet for shapes as shown in the table below can be calculated for any length of member and any thickness of sheet.

L = length of the column, in in.	f = ultimate compressive stress of material, generally taken as yield point
ρ = radius of gyration	E = modulus of elasticity
t = thickness of the sheet, in in.	= 10,500,000 for 24 ST aluminum
K = shape factor at given L/ρ	C = coefficient for end restraint, as in the Rankine formula
K_o = shape factor for short columns at about $L/\rho = 20$	P/A = failing stress = load at failure divided by the section area
σ = allowable stress, in lb. per sq. in.	

$$\sigma = \frac{f}{1 + B} \quad (1)$$

In the preceding equation,

$$B = \frac{f}{C\pi^2 E} \left(\frac{L}{\rho}\right)^2 \quad (2)$$

For compact sections, tubing, corrugated sheet, and the simplest sections, use

$$\sigma = \frac{f(1 + B)}{1 + B + B^2}$$

First, calculate σ from the equation. Apply the shape factor K_o , given in the table, to the following equation:

$$K = K_o \left(\frac{f}{\rho}\right)^{1/2} \quad (3)$$

Then,

$$\frac{P}{A} = \sigma \tanh(Kt) \quad (4)$$

\tanh = hyperbolic tangent

Note: In general, for sections having a high shape factor, K_o , the shape factor, will be inversely proportional to the external dimensions. If the shape factor thus calculated is less than 10, as would obtain if the external dimensions of shape 1 were doubled, the value calculated should be squared and the value of t^2 should be used in place of t in Eq. (4).

If section such as shape 3 does not have ample fixity along one edge as represented by the wood block or as obtainable by closely spaced stiffeners, the section should be calculated as a simple angle.

As an example of the use of the table, a column of section similar to shape 2, shown in the table, is to be designed to be made of 24 ST aluminum sheet 0.051 in. thick and the length of the column is such that L/ρ is 50. The straight edges of the column are restrained.

From the table, for a short column of this section, for L/ρ less than 25, we get $K_o = 12$. The yield point of the material by test, or from figures given by material manufacturer, is $f = 50,000$, and $E = 10,500,000$ for 24 ST. The coefficient of end restraint C is 1.

SHAPE FACTORS FOR FORMED ALUMINUM COMPRESSION MEMBERS

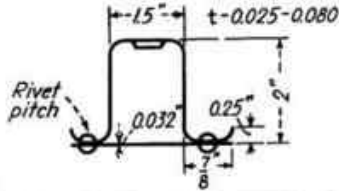
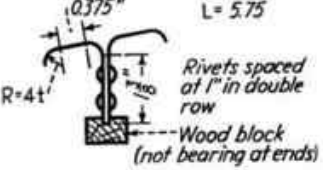
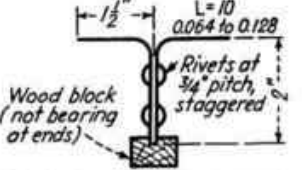
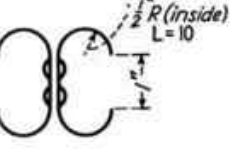
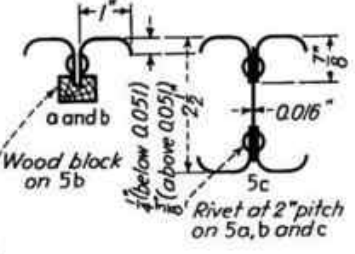
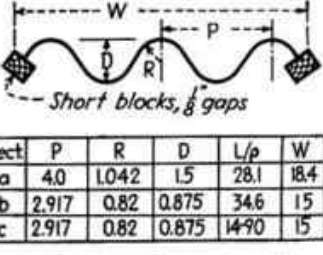
Shape	Material aluminum	Test L/p	End condition	K at test L/p	K_e	e , lb. per sq. in., at test L/p	Test, yield point, lb. per sq. in.																								
 <p>1</p>	24ST	12.6	Flat	15.6	15.6	48,000	48,000																								
 <p>2</p>	24ST	<25	Flat	12	12	59,800	50,000																								
 <p>3</p>	24ST	<25	Flat	10.8	10.8	50,000	50,000																								
 <p>4</p>	24ST	17.5	Flat	27	27	45,000	46,000																								
 <p>5</p>	24ST	<25 on 5a and 5b From 15 to 70 on 5c	Flat on 5a and 5b Knife on 5c	(a) 14.3 (b) 22.6 (c) 15.4 (at $L/p = 15$)	(a) 14.3 (b) 22.6 (c) 14.5	(a) 52,000 (b) 52,000 (c) 55,000 (at $L/p = 0$)	(a) 50,000 (b) 50,000 (c) 50,000 (avg.)																								
 <table border="1"> <thead> <tr> <th>Sect</th> <th>P</th> <th>R</th> <th>D</th> <th>L/p</th> <th>W</th> </tr> </thead> <tbody> <tr> <td>a</td> <td>4.0</td> <td>1.042</td> <td>1.5</td> <td>28.1</td> <td>18.4</td> </tr> <tr> <td>b</td> <td>2.917</td> <td>0.82</td> <td>0.875</td> <td>34.6</td> <td>15</td> </tr> <tr> <td>c</td> <td>2.917</td> <td>0.82</td> <td>0.875</td> <td>14.90</td> <td>15</td> </tr> </tbody> </table> <p>6</p>	Sect	P	R	D	L/p	W	a	4.0	1.042	1.5	28.1	18.4	b	2.917	0.82	0.875	34.6	15	c	2.917	0.82	0.875	14.90	15	24ST	Noted	(a) and (b) flat (c) knife	(a) 22.6 (b) 32.6 (c) 32.0 (at $L/p = 15$)	(a) 22.6 (b) 32.6 (c) 32.0	(a) 44,300 (b) 48,200 (c) 53,000	(a) 47,000 (b) 50,000 (c) 52,000
Sect	P	R	D	L/p	W																										
a	4.0	1.042	1.5	28.1	18.4																										
b	2.917	0.82	0.875	34.6	15																										
c	2.917	0.82	0.875	14.90	15																										

SHAPE FACTORS FOR FORMED ALUMINUM COMPRESSION MEMBERS (Continued)

Shape	Material aluminum	Test L/ρ	End condition	K at test L/ρ	K_s	σ , lb. per sq. in., at test L/ρ	Test. yield point, lb. per sq. in.
<p>7</p>	178T	26.6	Flat	15.3	15	45,000	40,000
<p>8</p> <p>$A(\text{effective}) = A - \frac{\pi D^2 t}{4P}$ A = Area without hole D = Diam. hole; P = pitch</p>	178T	27-55	Flat	23 at $L/\rho = 55$	19.0	30,000 at $L/\rho = 55$	44,000
<p>9</p>	178T	35.4	Flat	25	22.7	34,500	41,000
<p>10</p> <p>Bureau of Stds. tests</p>	178T	Length = 24 in.	Flat	$23/W$	$29.6^*/W$	32,000	About 40,000

$$* K_s = K \times \frac{33}{W} \sqrt{\frac{1}{40,000 - 32,000}}$$

Calculate B in Eq. (2) above, with $C = 1$.

Use this value of B to calculate σ in Eq. (1), from which $\sigma = 22,700$ lb. per sq. in.

From Eq. (3),

$$K = 12 \left(\frac{50,000}{22,700} \right)^{1/4} = 17.8$$

From Eq. (4),

$$\begin{aligned} \frac{P}{A} &= 22,700 \tanh (17.8 \times 0.051) \\ &= 22,700 \times 0.72 = 16,200 \text{ lb. per sq. in.} \end{aligned}$$

ANGLES IN COMPRESSION

For angles, the following table gives the value of σ for different values of L/ρ :

L/ρ	σ	L/ρ	σ
0	40,000	60	27,000
20	38,000	80	18,000
40	34,000		

For allowable stresses for angles,

$$\frac{P}{A} = \sigma \tanh K \left(\frac{t}{b} \right)^2$$

where t = thickness of angle

b = width of leg

$$K = 149.1 + 0.1 \left(\frac{L}{\rho} - 47 \right)^2$$

This equation holds only for $C = 1$.

SHEAR MEMBERS

Shear-resisting web designed to avoid buckling

$$f_s = \frac{K\pi^2 D}{b^2 t} \tag{5}$$

where f_s = critical shear stress or buckling stress

t = thickness of plate

b = depth of the panel or the distance between stiffeners, whichever may be the lesser

K = coefficient depending on value of the ratio b/a as given by the curve, Fig. 4

D = flexural stiffness factor

$$D = \frac{Et^2}{12 \left(1 - \frac{1}{m^2} \right)}$$

$E = 10,500,000$ lb. per sq. in. for 24 ST

$\frac{1}{m} =$ Poisson's ratio = 0.25 for 24 ST

Note: The accompanying Fig. 4 gives values of K , and Fig. 5 indicates the dimension a and b . If in a design problem b is greater than a , the terms should be transposed. In the equation below, b is always the smaller of the two dimensions.

Substituting in Eq. (1),

$$f_s = \frac{9,240,000K}{(b/t)^2} \tag{6}$$

Limitations of the equations:

1. Valid only for panels subjected to pure shear load.
2. If f_s exceeds the shear yield point of the material, shear yield point should be taken as the critical stress. For 24 ST, the shear yield point is 24,000,000 lb. per sq. in. approximately.
3. The equation does not give dependable results for sheets less than about 0.032 in. thick.

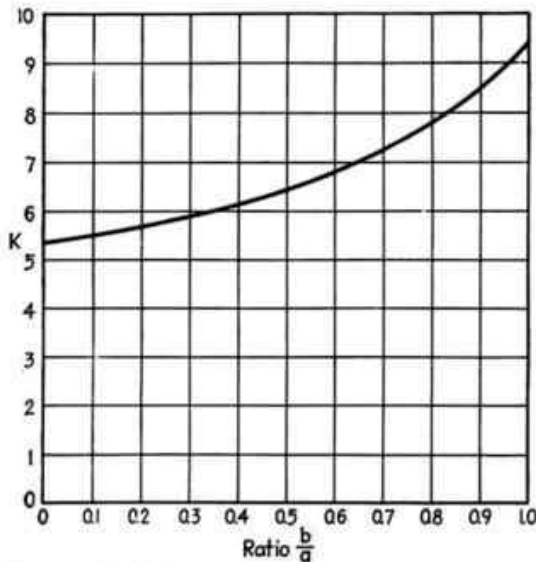

FIG. 4.—Coefficient K for calculating shear members, for different values of b/a or a/b .

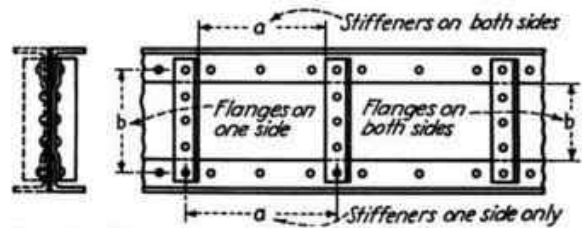

FIG. 5.—Dimensions a and b on a typical shear resisting web with chord and stiffener angles on one or both sides.

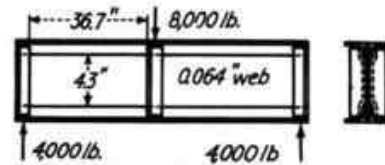

FIG. 6.—Example of a typical shear resisting web.

EXAMPLE

Dimensions of, and load on, a typical shear-resisting web are given in Fig. 6. Assume $Q/I = 0.1742$, where Q is the statical moment, *i.e.*, the summation of the various elementary areas above the neutral axis times their respective centroid distance from the neutral axis.

$$\begin{aligned} \text{Applied unit shearing stress} &= \frac{\text{shear load} \times Q/I}{\text{web thickness}} \\ &= 4000 \times \frac{0.1742}{0.064} \\ &= 10,900 \text{ lb. per sq. in.} \\ \left(\frac{b}{t}\right)^2 &= \left(\frac{4.3}{0.064}\right)^2 = 4,520 \\ \frac{b}{a} &= \frac{4.3}{36.7} = 0.117 \end{aligned}$$

From Fig. 4,

$$\begin{aligned} K &= 5.51 \text{ for } b/a = 0.117 \\ f_s &= \frac{9,240,000 \times 5.51}{4,520} \\ &= 11,250 \text{ lb. per sq. in.} \end{aligned}$$

Therefore, since the applied unit shearing stress of 10,900 lb. per sq. in. is less than the critical buckling stress of 11,250 lb. per sq. in., the web will carry the 4,000-lb. shear load without buckling.

VERTICAL STIFFENERS FOR SHEAR-RESISTING WEBS

An approximate formula for computing the required moment of inertia of the stiffener is

$$I_{st} = \frac{2.29d}{t} \left(\frac{Vh}{33E} \right)^{3/2}$$

For 24 ST aluminum, $E = 10,500,000$, this equation becomes

$$I_{st} = \frac{2.29d}{t} \left(\frac{Vh}{346,500,000} \right)^{3/2}$$

where d = distance between stiffeners h = distance between centroids of upper and lower chords
 t = thickness of stiffener

Note: Best practice is to make the stiffener thickness equal to that of the web and then compute the required moment of inertia by the above equation.

DIAGONAL TENSION WEBS

To determine when a web should be designed as a shear resisting web and when it is to be designed to carry the shear load in diagonal tension, calculate $\sqrt{V/h}$, where V is the applied shear, in pounds, and h is the depth of the beam, in inches. Usually, if this ratio is less than 7, the web should be designed as a diagonal tension member. If this ratio is more than 7, a shear resisting web should be used. If the ratio is 7, or nearly so, both types of web members should be investigated to determine which is the more economical.

The diagonal tension stress S_T in a tension field web is

$$S_T = \frac{2V}{ht \sin 2\alpha}$$

where h = distance between centroids of upper and lower chords

For $\alpha = 45$ deg.,

$$S_T = \frac{2V}{ht}$$

Theoretical maximum allowable S_T is equal to ultimate tensile strength of the material. An allowable S_T equal to about 0.7 ultimate tensile strength is recommended for calculations.

Vertical Stiffeners

Compression load P' in the stiffeners can be determined from

$$P' = -\left(\frac{Vb}{h} \right) \tan \alpha$$

For $\alpha = 45 \text{ deg.}$, $\tan \alpha = 1$,

$$P' = -\frac{Vb}{h}$$

Because the web in diagonal tension tends to hold the stiffeners straight, prevent bowing as a column, the stiffeners need not be designed for the full column length, but only to the equivalent column length as given by the curve in Fig. 7. The design of a vertical stiffener is the same as for any pin-ended compression member.

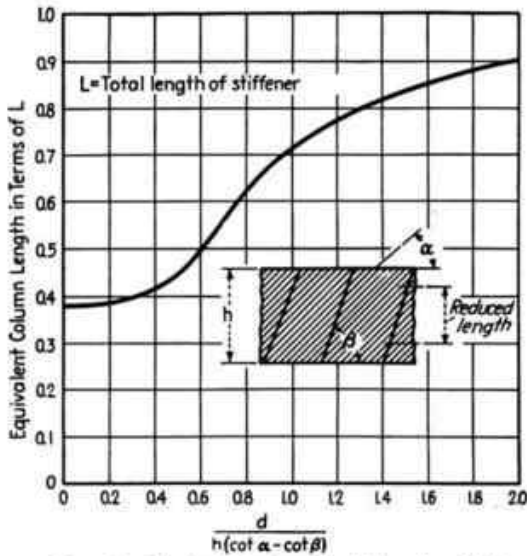

FIG. 7.—Equivalent free buckling length for tension field stiffeners is obtained by multiplying the total actual length by the factors from this curve.

Stiffeners must not be spaced farther apart than one-half the depth of the beam.

Chord Load

At any point distant X from the applied load (Fig. 8), the total chord load is

$$\pm \frac{M}{h} - \left(\frac{V}{2}\right) \cot \alpha$$

For $\alpha = 45 \text{ deg.}$, this reduces to

$$\pm \frac{M}{h} - \frac{V}{2}$$

where $M = XV$

The web is always neglected in computing the section modulus of the beam, for it has no resistance to compression.

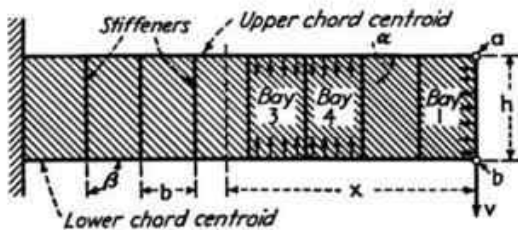

FIG. 8.—Diagonal lines represent the diagonal field tension in a thin web.

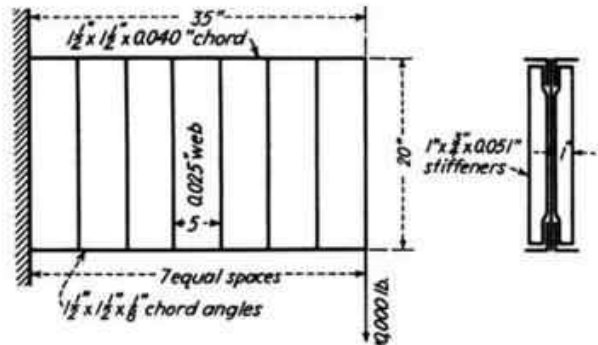

FIG. 9.—Example of a tension field web beam.

EXAMPLE

Assume two loads and dimensions as given in the accompanying Fig. 9,

$$S_r = \frac{2V}{ht \sin 2\alpha}$$

where $\alpha = 45 \text{ deg.}$
 $V = 10,000 \text{ lb.}$

$h = 20 \text{ in.}$
 $t = 0.025 \text{ in.}$

$$S_r = \frac{2 \times 10,000}{20 \times 0.025} = 40,000 \text{ lb. per sq. in.}$$

For 24 ST, allowable stress would be $0.7 \times 62,000 = 43,000$ lb. per sq. in.

To calculate lower chord:

$$\pm \frac{M}{h} - \frac{V}{2}$$

where $M = 10,000 \times 35$
 $h = 20$

$$V = 10,000$$

Maximum compression in lower chord = $-\frac{10,000 \times 35}{20} - \frac{10,000}{2} = -22,500$ lb.

Area of compression chord is 0.719 sq. in. Hence compressive stress developed is

$$\frac{P}{A} = \frac{-22,500}{0.719} = -31,300 \text{ lb. per sq. in.}$$

Maximum allowable stress, as calculated for compression member:

$\sigma = 45,000$, yield point of material, used in order to calculate crippling stress

$K = 10.8$ (assumed)

$t = 0.125$ in.

$$\frac{P}{A} = \sigma \tanh Kt$$

$$= 45,000 \tanh (10.8 \times 0.125)$$

$$= 39,300 \text{ lb. per sq. in.}$$

Hence, as this is greater than the 31,300 lb. per sq. in., stress developed, the chord is safe.

To calculate upper chord:

$$\begin{aligned} \text{Maximum tension} &= \pm \frac{M}{h} - \frac{V}{2} = \frac{10,000 \times 35}{20} - \frac{10,000}{2} \\ &= 17,500 - 5,000 = 12,500 \text{ lb.} \end{aligned}$$

Tension chord area = 0.237 sq. in.

$$\frac{P}{A} = \frac{12,500}{0.237} = 52,700 \text{ lb. per sq. in.}$$

Assuming 15 per cent reduction in area on account of rivets, and for an ultimate tensile strength of 62,000 lb. per sq. in., the allowable stress will be

$$0.85 \times 62,000 = 52,700 \text{ lb. per sq. in.}$$

which is not less than (and happens to be equal to) the actual stress. Hence tension chord is safe.

Stiffeners

Compression load by equation given above is

$$\begin{aligned} P' &= -\left(\frac{Vb}{h}\right) \tan \alpha \\ \alpha &= 45^\circ \quad \tan \alpha = 1 \end{aligned}$$

Stiffener load P' is therefore

$$P' = \frac{-10,000 \times 5}{20} = -2,500 \text{ lb.}$$

Stiffener area = 0.173 sq. in.

$$\frac{P}{A} = \frac{-2,500}{0.173} = -14,450 \text{ lb. per sq. in.}$$

$$\frac{d}{h} = 0.25$$

From the curve for equivalent column length (Fig. 7) for $d/h = 0.25$, equivalent length will be $0.39 \times 20 = 7.8$ in.

Radius of gyration of stiffener = 0.443

$$\frac{L}{\rho} = \frac{7.8}{0.443} = 17.6$$

$$\sigma = 45,000$$

$$K = 10 \text{ (assumed)}$$

$$t = 0.051 \text{ in.}$$

$$\frac{P}{A} = \sigma \tanh Kt$$

$$= 45,000 \tanh (10 \times 0.051)$$

$$= 45,000 \times 0.45$$

$$= 21,200 \text{ (approx.)}$$

DESIGN OF HOLLOW GIRDERS

Symmetrical Pure Monocoque Sections

The derivations of the equations for unsymmetrical sections for semimonocoque structures were developed by Guy L. Bryan, Jr., of The Glenn L. Martin Company.

In a monocoque structure, such as shown in Fig. 10, consisting of corrugated sheet sections for upper and lower chord sections and thin sheets for the web side skin, the maximum bending moment stresses can be approximated closely by the formula

$$f_b = \frac{My}{I_x} \quad (7)$$

where M = applied bending moment

y = distance from neutral axis to fibers in question

I_x = moment of inertia of the cross section about the neutral axis.

FIG. 10.—Symmetrical semi-monocoque structure consisting of corrugated-sheet chord sections, thin web side skin, and transverse frames.

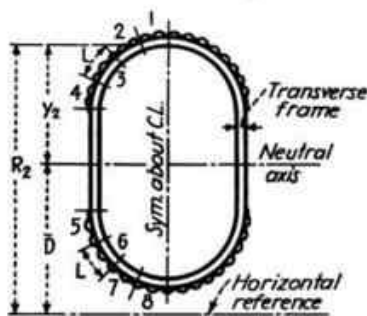

In calculations for this type of section, the thin side skin is neglected in all computations because it is incapable of resisting much compression. The sheet simply dimples. Also, the error resulting from ignoring the strength contributed by the portion of the side sheet in tension is negligible.

To determine the location of the neutral axis, proceed in the conventional manner, as follows:

1. Divide the corrugated sheet chord sections, upper and lower, into convenient short lengths L as indicated. L must be short enough so that the moment of inertia of the section of length L , about its own neutral axis, will be small compared with its moment of inertia about the neutral axis of the whole section of the structure.

2. Determine the areas A of the unit sections of length L , and locate the centroids or centers of gravity of these sections.

3. Choose any convenient horizontal reference line.

4. Determine the distance R from the centroids to the arbitrarily chosen horizontal reference line.

5. Tabulate in adjacent columns the areas A with their corresponding R , and calculate and tabulate the products AR .

6. Add all the AR values.

7. Divide the summation of AR values by A , and the result will be \bar{D} , which, as indicated in the figure, locates the neutral axis.

To calculate I_x , the moment of inertia, proceed as follows:

1. Determine and tabulate the y values, *i.e.*, the distances from the centroid of each short length element to the neutral axis. It is necessary to do this only for the elements lying to one side of the axis of symmetry.

2. Tabulate in the adjacent column the square of each y value.

3. Multiply each elemental area A by the square of its centroid distance y .

4. Add the Ay^2 values.

5. Multiply this summation by two if the elemental areas on only one side of the axis of symmetry have been tabulated.

6. The result $2\sum Ay^2$ will be the moment of inertia I_x of the section about the XX axis.

This method is applicable only when the section is symmetrical and the bending moment is normal to the neutral axis.

Unsymmetrical Pure Monocoque Sections

An example of an unsymmetrical box beam is shown in the accompanying Fig. 11. The fiber stress at any point on the beam cross section can be expressed by the equation

$$f_b = \frac{(M_y H - M_x I_y)y + (M_x H + M_y I_x)x}{I_x I_y - H^2} \quad (8)$$

XX and YY are any convenient set of rectangular axes passing through the centroid of the section, which is located by using the same method as described above for the symmetrical section.

I_x and I_y are calculated by the same method as used for the symmetrical section, I_x being the moment of inertia about the XX axis and I_y the moment of inertia about the YY axis.

M_x is the component of the bending moment perpendicular to the XX axis.

M_y is the component of moment perpendicular to YY axis.

M_x and M_y are obtained by resolving the applied bending moment, which may be at any angle to the XX axis, into its components about the XX axis and YY axis, respectively.

H is the summation of the product of each elemental area times both of its coordinates, *i.e.*, $H = \Sigma Axy$, the values of x and y being the distances from the centroid of the elemental areas to the YY axis and XX axis, respectively. Distances above the XX axis and distances to the right of the YY axis are positive. Distances below the XX axis and distances to the left of the YY axis are negative. Hence if XX and YY are principal axes, H is equal to zero.

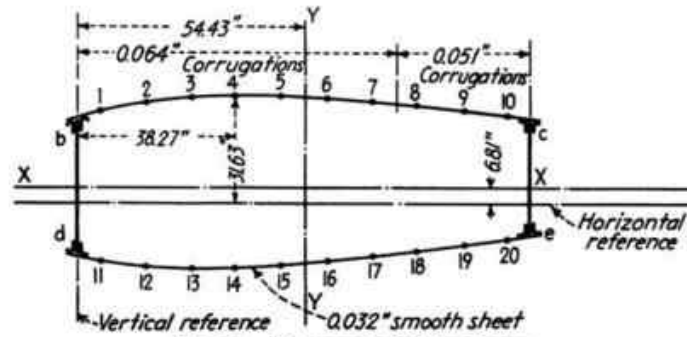

FIG. 11.—Unsymmetrical box beam.

From the preceding equation, the normal stress f_b at any point in the cross section can be calculated. When H is equal to zero, *i.e.*, XX and YY are the principal axes,

$$f_b = \frac{M_x y}{I_x} + \frac{M_y x}{I_y} \quad (9)$$

Further, if H is equal to zero and the section is symmetrical about one axis, at least, and the applied bending moment makes an angle of 90 deg. with the XX axis, and the reference axis is in the plane of the resulting bending moment,

$$f_b = \frac{My}{I_x} \quad (10)$$

As an example of the most general case of an unsymmetrical section such as shown in the figure and with the applied bending moment at an angle to the neutral axis, assume that f_b had been calculated from Eq. (8) and had been found to be

$$f_b = -1,086y + 85x \quad (11)$$

For the elemental or elementary area 4 in. Fig. 8,

$$\begin{aligned} x &= -54.43 + 38.27 = -16.16 \\ y &= 31.63 - 6.81 = 24.82 \\ &= 25.57 \text{ measured to extreme fiber of corrugation} \end{aligned}$$

from which

$$\begin{aligned} f_b &= -1,086 \times 25.57 - 85 \times 16.16 \\ &= -27,770 - 1,370 \\ &= -29,140 \text{ lb. per sq. in. compression} \end{aligned}$$

Allowable Stresses for Chord Sections

For chord sections consisting of corrugated sheets, determine allowable stresses as for columns as explained on pages 72–75. The column length of the corrugations is taken as the distance between the transverse frames of the semimonocoque construction. The coefficient of end restraint C is taken equal to one in the usual construction. If the corrugations are covered with thin sheet, a value of $C = 1.5$ is used.

Smooth Skin with Reinforcing Stringers

The foregoing equations cannot be used for calculating a semimonocoque structure with fore-and-aft stringers. Application of the equation $f_b = My/I_x$ would imply that the sheet and stringers were stressed the same. This is true only to the point of loading where the sheet begins to buckle. Beyond that load, the sheet con-

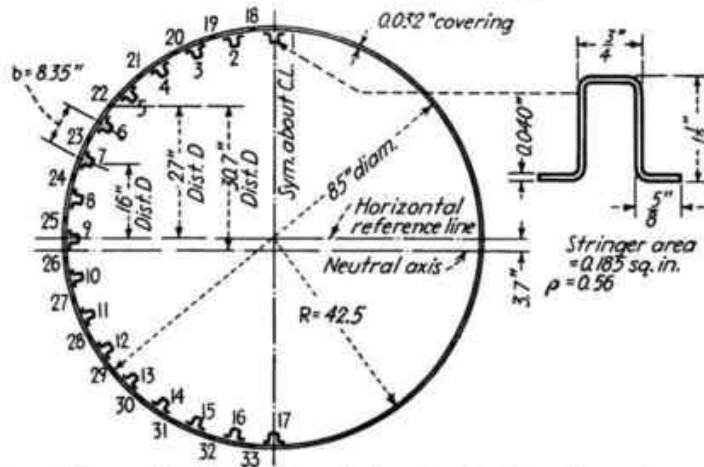

FIG. 12.—Typical section with smooth skin covering reinforced on inside with continuous fore and aft stringers. tributes no further resisting, holding only its buckling load, and only the stringers resist the further added load.

The accompanying Fig. 12 is a typical semimonocoque construction, a smooth skin covering reinforced on the inside with continuous fore-and-aft stringers of hat section. The allowable P/A for the stringers must first be calculated. For the section shown, the allowable P/A of the stiffener or stringer is calculated by the method explained under the heading Calculation of Compression Members, page 72. As an example, for the construction shown, assume

- Distance between transverse frames = 20 in.
- Coefficient of end restraint = 1.5
- Radius of gyration of hat section, $\rho = 0.56$

Calculations (see page 72) are as follows:

$$\frac{L}{\rho} = \frac{20}{0.56} = 35.7$$

$$B = \frac{45,000 \times 35.7^2}{1.5\pi^2 \times 10,500,000}$$

$$\sigma = \frac{45,000 \times 1.368}{1.368 + 0.368^2} = \frac{61,500}{1.504} = 41,000$$

$$K_o = 13 \text{ (assumed)}$$

$$K = 13 \left(\frac{45,000}{41,000} \right)^{1/2} = 13.6$$

$$\frac{P}{A} = S_{ST} = 41,000 \tanh 13.6 \times 0.040$$

$$= 20,200 \text{ lb. per sq. in. stiffener allowable}$$

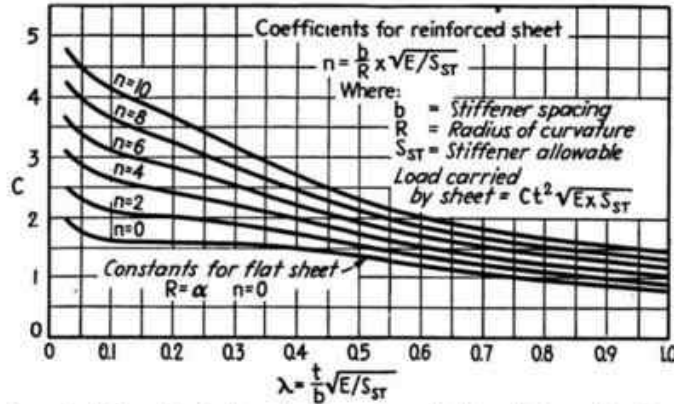

FIG. 13.—Curves for calculating the load carried by a curved skin reinforced by fore and aft stringers.

This is the allowable P/A of the stiffeners. The allowable load P that the curved sheet reinforced by the stringers can carry is equal to

$$P = Ct^2 \sqrt{ES_{ST}}$$

where E = modulus of elasticity = 10,500,000
 t = sheet thickness
 C = coefficient dependent upon the parameters n and λ

The value of C is obtained from the curves in Fig. 13 after n and λ have been calculated from the formulas (see Fig. 12 for the numerical values used for b , R and t)

$$n = \frac{b}{R} \sqrt{E/S_{ST}}$$

where b = stiffener spacing = 8.35 in.
 R = radius of curvature = 42.5 in.
 S_{ST} = 20,200 lb. per sq. in., from the preceding calculated stiffener allowable

$$n = \frac{8.35}{42.5} \sqrt{\frac{10,500,000}{20,200}} = 4.48$$

$$\lambda = \frac{t}{b} \sqrt{\frac{E}{S_{ST}}}$$

t = sheet thickness = 0.032 in.

$$\lambda = \frac{0.032}{8.35} \sqrt{\frac{10,500,000}{20,200}} = 0.088$$

From the curves, Fig. 13 for $n = 4.48$ and $\lambda = 0.088$,

$$C = 2.8$$

Hence, solving the equation for total load allowable on sheet,

$$P = Ct^2 \sqrt{ES_{ST}}$$

$$= 2.8 \times 0.032^2 \sqrt{10,500,000 \times 20,200}$$

$$= 2.8 \times 0.032^2 \times 3,245 \times 142.2$$

$$= 1,325 \text{ lb.}$$

$$\begin{aligned}\text{Allowable } \frac{P}{A} &= \frac{1,325}{b \times t} \\ &= \frac{1,320}{8.35 \times 0.032} = 4,860 \text{ lb. per sq. in.}\end{aligned}$$

This sheet value will not be realized unless the rivets are spaced closely enough so that the sheet cannot buckle between rivets. A rivet pitch not greater than forty times the sheet thickness is suggested as a safe limit.

Neutral axis and moment of inertia of the section are calculated in the usual manner except that a reduced area is used for the portion of the curved sheet which is under compression.

$$\text{Effective area} = A \times \frac{\text{sheet allowable}}{\text{stiffener allowable}} \times \frac{D}{d}$$

where D = distance from neutral axis to extreme fiber of section d = distance from centroid of the portion of sheet to neutral axis.

or

$$A_{EFF} = AK$$

Use $K = 1$ if K calculates greater than one.

Because a sheet on the compression side is only partly effective, the neutral axis shifts to slightly below the center of the circular section (Fig. 12). The error resulting therefrom is negligible.

For a bending moment of 3,300,000 in.-lb. in the preceding example, the maximum compression in the fibers is

$$f_s = \frac{-3,300,000 \times 45.9}{7,480} = 20,200 \text{ lb. per sq. in.}$$

This is equal to the allowable P/A calculated above; hence it is satisfactory.

BOX SECTIONS SUBJECTED TO TORSION

Closed tubular or box sections are the most efficient and hence most generally used. For a single-cell thin-walled box,

$$f_s = \frac{T}{2At} \quad (12)$$

where f_s = shearing stress, in lb. per sq. in. A = inclosed cross-sectional area in box, in sq. in.
 T = applied torsional moment, in in. lb. t = thickness of skin or covering

$$\theta = \frac{T}{GJ}$$

where θ = deflection in radians per in. of length J = torsion constant of the section
 G = torsional modulus of elasticity, generally taken as $0.4E$ for aluminum alloy $\frac{1}{J} = \frac{1}{4A^2} \int \frac{ds}{t}$

For the section in Fig. 14,

$$\int \frac{ds}{t} = \frac{s_1}{t_1} + \frac{s_1}{t_2} + \frac{s_2}{t_3} + \frac{s_2}{t_4} \tag{13}$$

When the sides of the box act as tension field members, in the preceding equation for θ the value of t used should be five-eighths the actual thickness, which will give a reasonably accurate value for θ , the angular deflection.

In the preceding equation for stress f_s the torsional moment is assumed to be applied so as to be distributed uniformly around the perimeter, an ideal condition which is approached by placing bulkheads or ribs at all points of application of load so as to transfer external loads directly to the walls of the box.

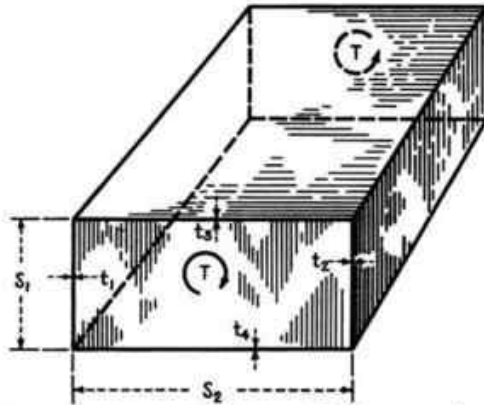

FIG. 14.—Single-cell thin-walled box section.

For a multicell section such as the wing section in Fig. 15 wherein sheets of different thicknesses are used, and if the trailing edge

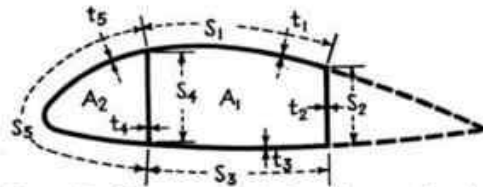

FIG. 15.—Unsymmetrical box beam wherein sheets of different thicknesses are used.

portion which resists only a small part of the torque is neglected,

$$T = 2(A_1h_1 + A_2h_2) \tag{14}$$

where h_1 = shear factor, in lb. per in. of portion of perimeter bounding area A_1 but not including front spar web h_2 = shear force, in lb. per in. of portion of perimeter, bounding area A_2 but not including front spar web

Note that the portion of the perimeter S_4 is omitted, *i.e.*, the front spar web, the shear per inch of which is given by

$$h_3 = h_1 - h_2$$

Shear per inch of the three sides of thickness t_1 , t_2 , and t_3 is

$$h_1 = \frac{T}{2K} [b_3(A_1 + A_2) + A_1b_2]$$

$$K = b_3(A_1 + A_2)^2 + A_2^2b_1 + A_1^2b_2$$

where $b_1 = s_4/t_4$

$b_2 = s_5/t_5$

Shear per inch for leading edge covering

$$h_2 = \frac{T}{2K} [b_3(A_1 + A_2) + A_2b_1]$$

wherein

$$b_1 = \frac{s_1}{t_1} + \frac{s_2}{t_2} + \frac{s_3}{t_3}$$

The shearing stress f_s in any part of the box is shear per inch divided by thickness, or

$$f_s = \frac{h}{t}$$

When any of the sides buckle to form diagonal tension fields, the wrinkles being assumed to make an angle of 45 deg., the tensile stress S_T is

$$S_T = \frac{2h}{t}$$

Torsional deflection in θ radians per in. of length is

$$\theta = \frac{T}{GJ} \tag{15}$$

where J is the torsion constant of the section corresponding to the moment of inertia I as commonly used in the formulas for beams under flexure. The equations for θ and for the shear loads per inch are strictly true only for shear resisting panels. If sides buckle to form diagonal tension fields, the values of t used in the equations for b_1 , b_2 , and b_3 should be multiplied by $\frac{5}{8}$. That is, use $\frac{5}{8}t$ instead of t . But for the stress calculations for f_s and S_T , always use for t , the actual thickness. However, if allowable buckling stress of tension field sides is high compared with actual stress, the use of an effective thickness $t_e = \frac{5}{8}t$ will not be accurate. For reasonable accuracy, proceed as follows:

Assume that the torsional moment causing buckling is 50,000 in.-lb. and the total applied torsional moment is 120,000 in.-lb. Calculate all stresses and deflections under a load of 50,000 in.-lb. as in a shear resisting section. Then calculate stresses and deflections under a load of 70,000 in.-lb. for the section as a tension field. Add the stresses and the deflections.

In a design as in Fig. 16, the front and rear spars are designed to resist all bending whereas the box is assumed to resist all torsional moments. To accomplish this, the proportion of the total bending moment resisted by each spar is proportional to the ratios of the moments of inertia of the respective spars, to the total moment of inertia, or

$$M_{F1} = \frac{ME_F I_F}{E_F I_F + E_R I_R} \tag{16}$$

$$M_{R1} = \frac{ME_R I_R}{E_F I_F + E_R I_R} \tag{17}$$

where M = total applied bending moment E_F and E_R = modulus of elasticity of material of the spars
 M_{F1} and M_{R1} = bending moments in front and rear spars I_F and I_R = moment of inertia of front and rear spars

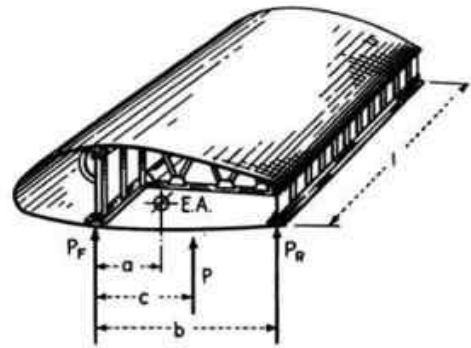

FIG. 16.—Front and rear spars are designed to resist all the bending, whereas the box is designed on the assumption that it resists all the torsion.

If the front and rear spars are of the same material, $E_R = E_F$, and cancel out. In Fig. 16, $E.A.$ is the center of resistance to bending, and in the figure

$$a = \frac{I_R b}{I_F + I_R} \quad (18)$$

The point $E.A.$ is called the elastic center, and the locus of these points is called the elastic axis. The torsional moment applied to the wing is the load times the distance of the center of gravity of the load to the elastic axis, *i.e.* $P(c - a)$ in Fig. 16. This will be the torsion that will be assumed resisted entirely by the box.

For two spars acting in bending and interconnected only by pin-ended ribs, the load P in Fig. 16 will be divided proportionally between the two spars, as follows:

$$P_{F2} = \frac{P(b - c)}{b} \quad (19)$$

$$P_{R2} = \frac{Pc}{b} \quad (20)$$

The root bending moments will be

$$M_{F2} = P_{F2}L \quad (21)$$

$$M_{R2} = P_{R2}L \quad (22)$$

This proportioning of the loads applies also when the spars offer but little resistance to torsion and the ribs are rigidly connected. If the spars have high torsional rigidity or if a box as in Fig. 13 is formed, the distribution approaches that given by Eqs. (16) and (17) for M_{R1} and M_{F1} .

If all torsion about $E.A.$ is resisted by the box in torsional shear, there is complete interaction between spars. If no torsion is resisted by the box, the interaction is zero. The amount of interaction is obtained from

$$C_i = \frac{B_o L^2}{A_o b^2} \quad (23)$$

where L = total length of uniform cross section of box

B_o = total of torsional stiffness of two spars plus box

$B_o = GJ$ when spars have relatively little resistance to torsion

$A_o = I_F I_R / (I_F + I_R)$, if E is same for both spars

Generally for a stressed skin box, ratio C_i is such that the moment would divide as in Eqs. (16) and (17), for all points along the span except the root. The difference between the moment obtained by the two methods is

$$M_{eF} = M_{F2} - M_{F1} \quad (24)$$

$$M_{eR} = M_{R2} - M_{R1} \quad (25)$$

For any degree of interaction C_R between spars, the final bending moment in each spar is

$$M_F = M_{F2} - C_R(M_{F2} - M_{F1}) \quad (26)$$

$$M_R = M_{R2} - C_R(M_{R2} - M_{R1}) \quad (27)$$

C_R approximates 0.70 at wing root for a trapezoidally loaded box wing, for which,

$$M_F = 0.7M_{F1} + 0.3M_{F2} \quad (28)$$

$$M_R = 0.7M_{R1} + 0.3M_{R2} \quad (29)$$

On the assumption that C_R increases linearly from 0.70 at the root to 1.00 at 20 per cent of the half span of the wing, Eqs. (16) and (17) apply from the wing tip to 80 per cent of the way inboard, and from this point inward to the root, Eqs. (26) and (27) will apply, with C_R varying from 1.0 at the 80 per cent distance to 0.7 at the root.

Allowable Stresses

These must be based on the combined shear stress and direct compressive stress. In the accompanying Fig. 17, f_c and f_s are the allowable compressive stress and allow-

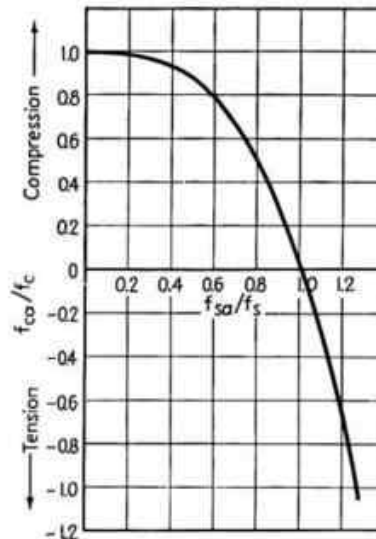
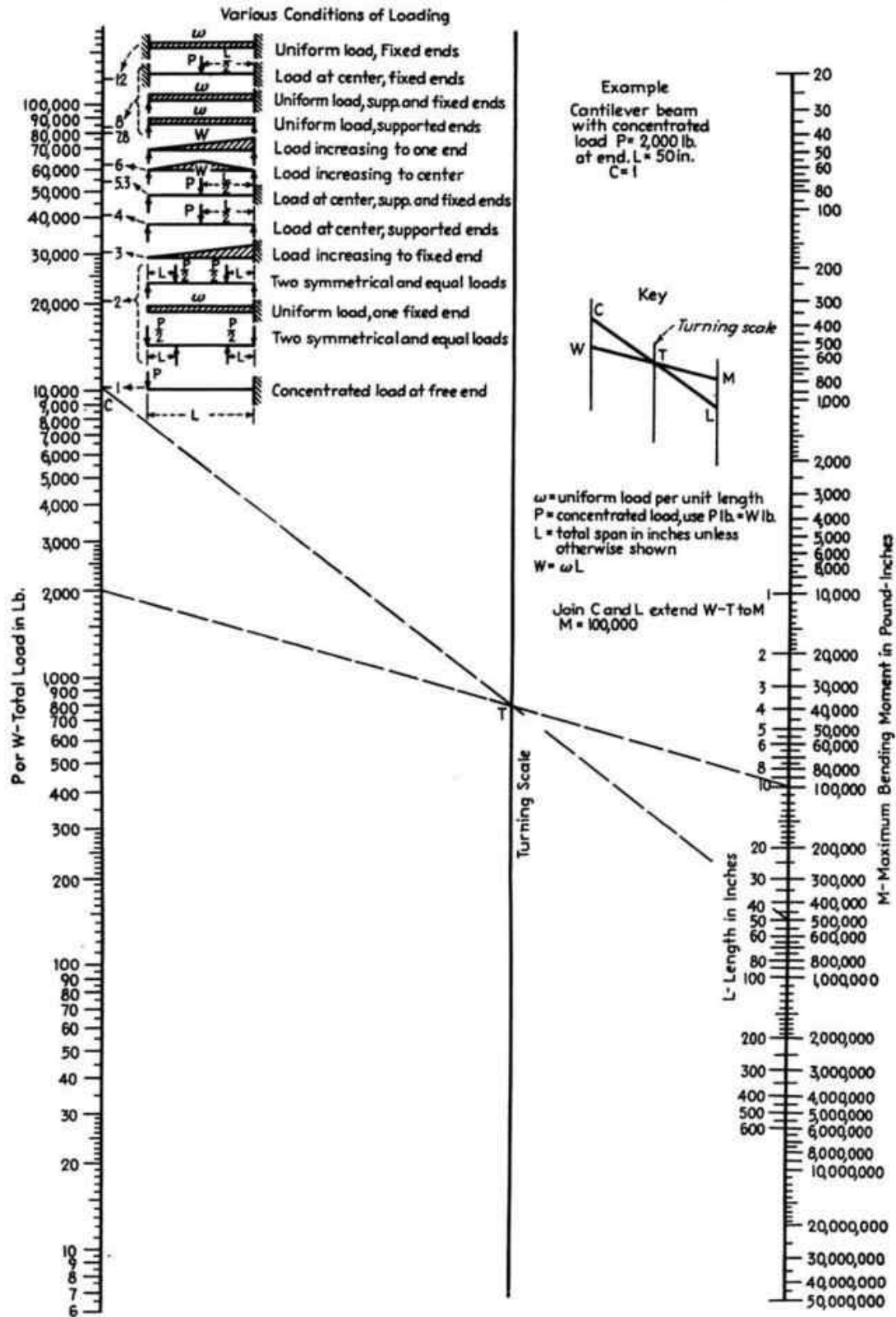

FIG. 17.—The combined stresses for axial and shear loads are obtained through the use of this curve plotted from the equation $1 - (f_{ca}/f_c) = (f_{sa}/f_s)^2$.

able shear stress, each acting alone. When shear stress of f_{sa} is acting together with a compressive or tensile stress, f_{ca} will be the allowable tensile or compressive stress. Similarly, f_{sa} will be the allowable shear stress when a compressive stress of f_{ca} is present. By means of the curve in Fig. 17, the allowable f_{ca} and f_{sa} are readily obtained for any ratio. This applies for curved sheet, flat sheet, or tubes and may be used for combined bending and torsion or shear combined with axial tension or compression.

CHART FOR DETERMINING BENDING MOMENTS



DEFLECTION OF VARIOUSLY LOADED BEAMS

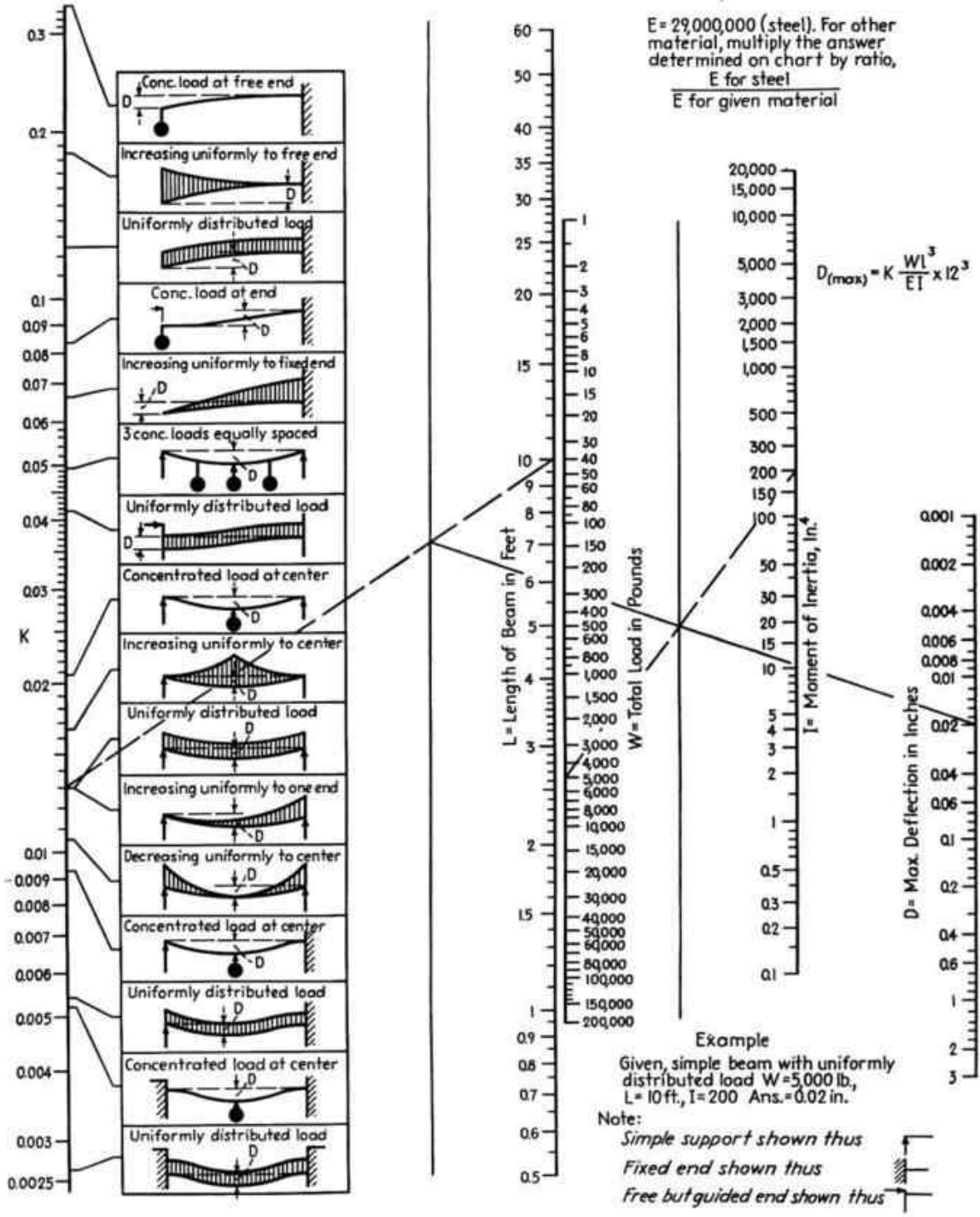

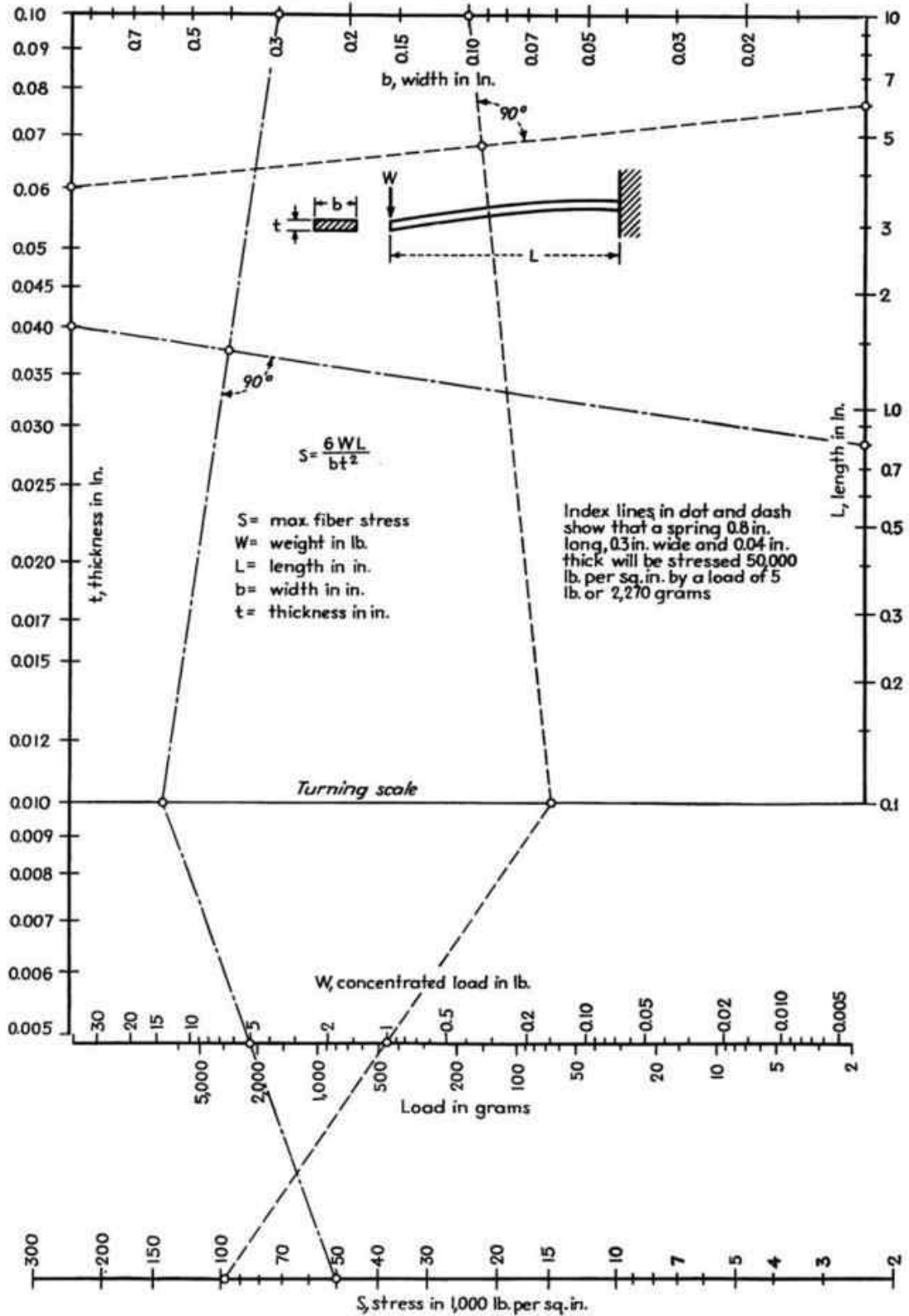

STRESSES IN CANTILEVER BEAMS

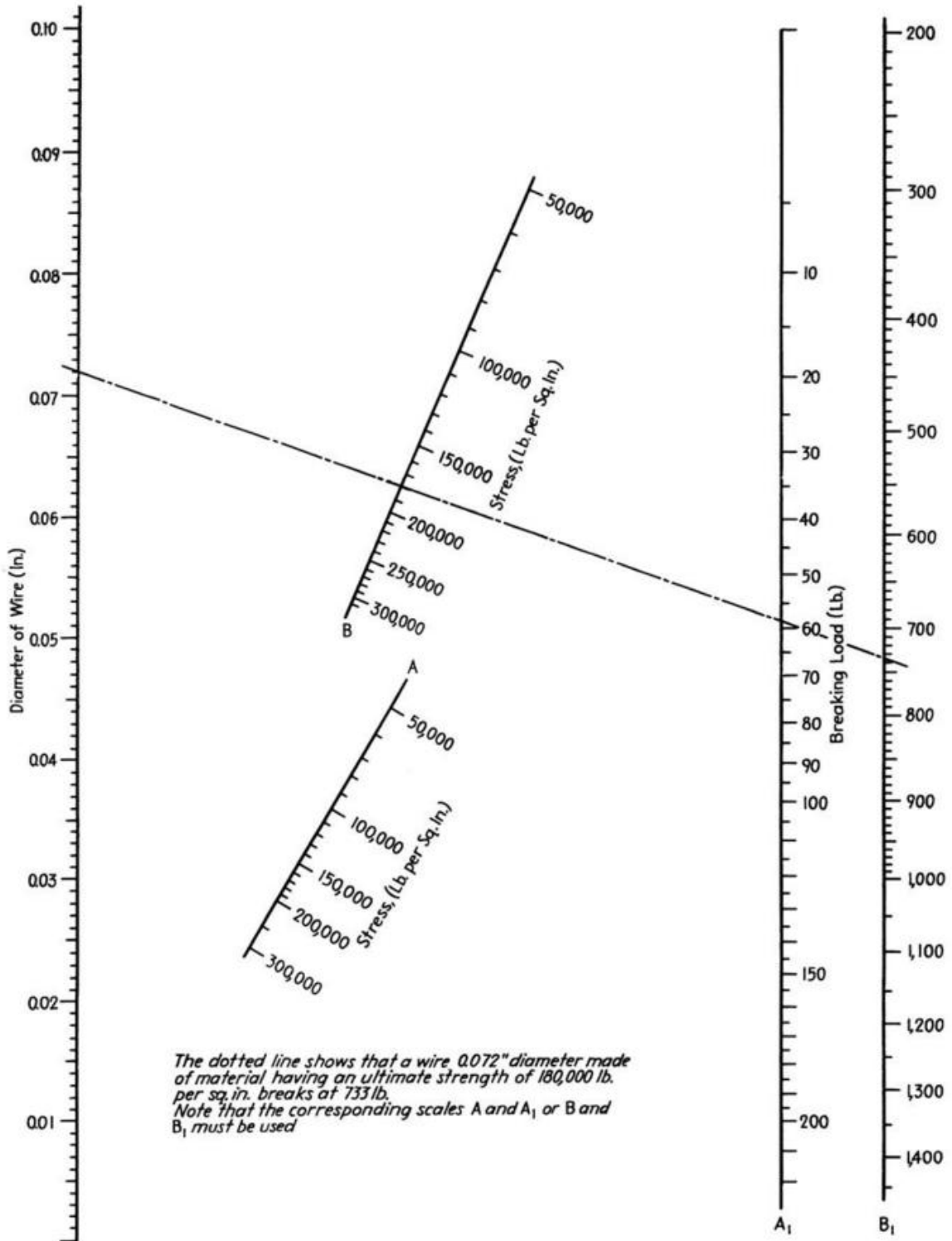

TENSILE STRENGTH OF ROUND WIRES

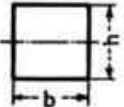
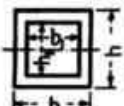

RECTANGULAR MOMENTS OF INERTIA AND SECTION MODULI

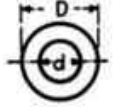
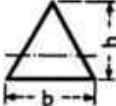
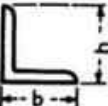
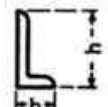
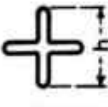
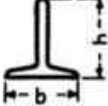
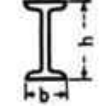
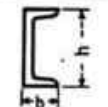
Shape of section $A = \text{area}$	Rectangular		
	Moment of inertia	Section modulus	
	Solid rectangle	$\frac{bh^3}{12}$	$\frac{bh^2}{6}$
	Hollow rectangle	$\frac{bh^3 - b_1h_1^3}{12}$	$\frac{bh^3 - b_1h_1^3}{6h}$
	Solid circle	$\frac{1}{64}\pi D^4 = 0.0491D^4$	$\frac{1}{32}\pi D^3 = 0.0982D^3$
	Hollow circle $A = \text{area of large section}$ $a = \text{area of small section}$	$\frac{AD^2 - ad^2}{16}$	$\frac{AD^2 - ad^2}{8D}$
	Solid triangle	$\frac{bh^3}{36}$	$\frac{bh^2}{24}$
	Angle with equal legs	$\frac{Ah^2}{10.2}$	$\frac{Ah}{7.2}$
	Angle with unequal legs	$\frac{Ah^2}{9.5}$	$\frac{Ah}{6.5}$
	Symmetrical cross	$\frac{Ah^2}{19}$	$\frac{Ah}{9.5}$
	Tee section	$\frac{Ah^2}{11.1}$	$\frac{Ah}{8}$
	I-beam	$\frac{Ah^2}{6.66}$	$\frac{Ah}{3.2}$
	Channel	$\frac{Ah^2}{7.34}$	$\frac{Ah}{3.67}$

CHAPTER IV

LATCHES, LOCKS, AND FASTENINGS

Typical methods of temporarily retaining, locking, or fastening one movable machine part with reference to another, including detents, snap rings, wire locks, and taper pins. Designs of indexing mechanisms, machine clamping methods and 23 examples of door and cover fastenings, all taken from actual designs, are included. A chart for computing bolt stress is given at the end of the chapter.

	PAGE		PAGE
Locking Devices.....	96	Clamping Shoes and Plugs.....	109
Retaining and Locking Detents.....	100	Lock Bolts and Indexing Mechanisms.....	111
Wire Locks and Snap Rings.....	103	Machine Clamps.....	115
Taper-Pin Applications.....	104	Door and Cover Fastenings.....	116
Hinges and Pivots.....	105	Bolt Diameter, Load, and Stress.....	119

LOCKING DEVICES

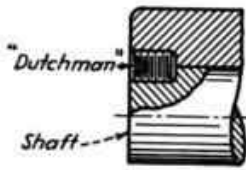

FIG. 18.

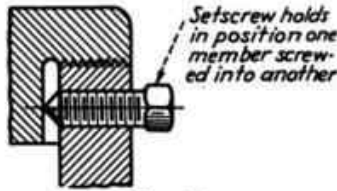

FIG. 19.

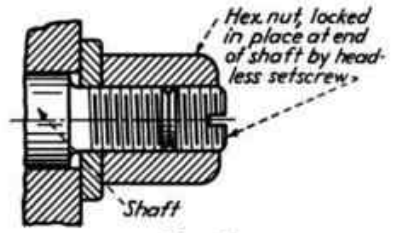

FIG. 20.

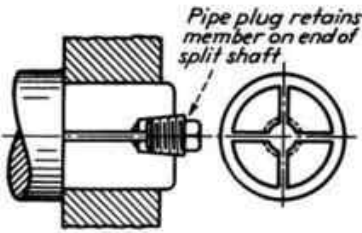

FIG. 21.

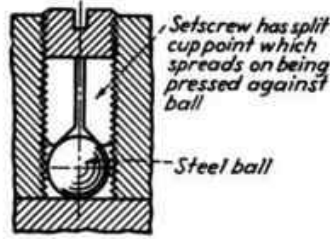

FIG. 22.

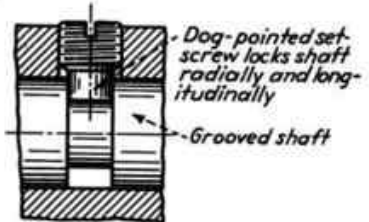

FIG. 23.

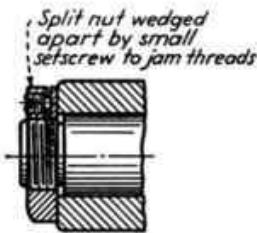

FIG. 24.

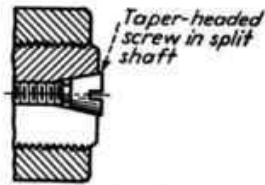

FIG. 25.

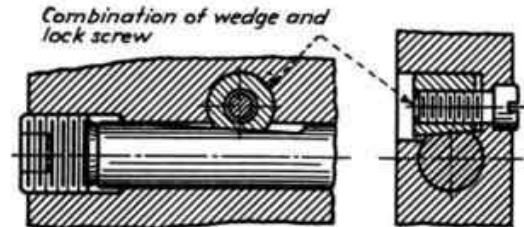

FIG. 26.

Cone-pointed screws contacting conical holes provide means for locking and adjustment.

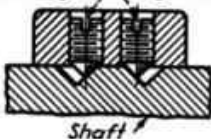

FIG. 27.

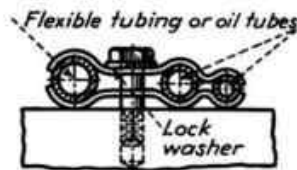

FIG. 28.

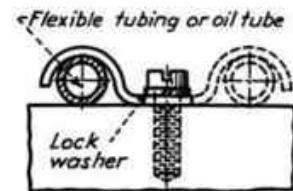

FIG. 29.

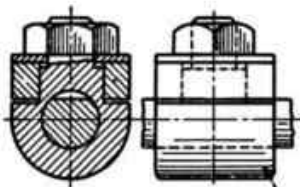

FIG. 30.

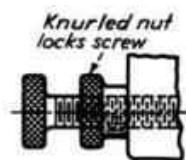

FIG. 31.

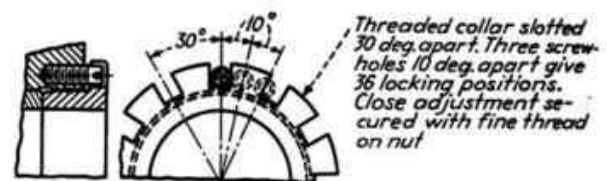

FIG. 32.

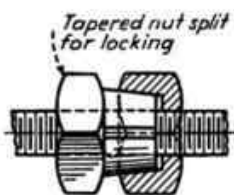

FIG. 33.

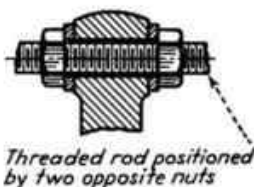

FIG. 34.

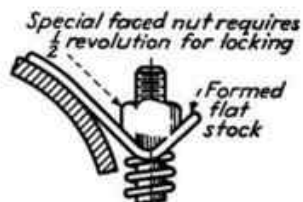

FIG. 35.

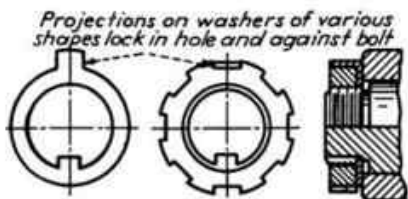

FIG. 36.

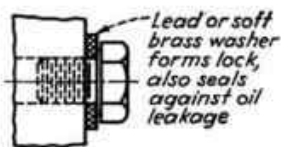

FIG. 37.

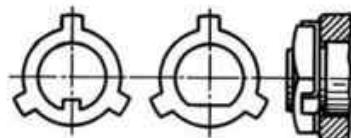

FIG. 38.

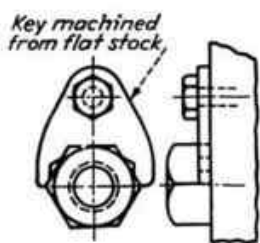

FIG. 39.

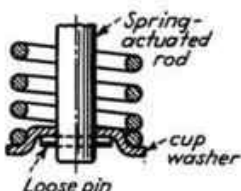

FIG. 40.

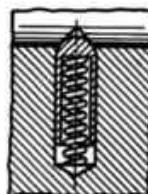

FIG. 41.



FIG. 42.

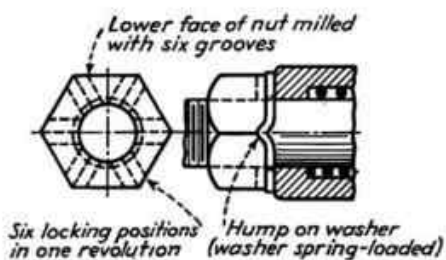

FIG. 43.

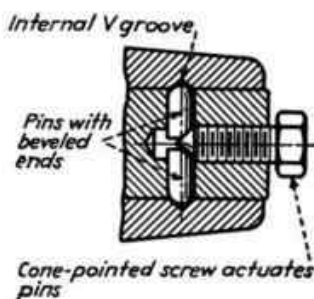

FIG. 44.

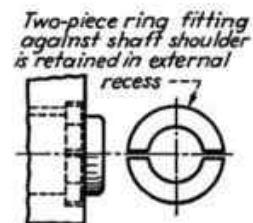

FIG. 45.

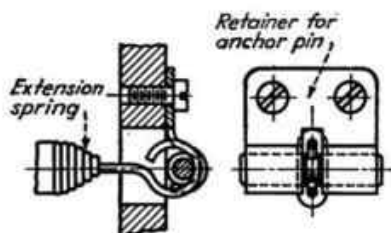

FIG. 46.

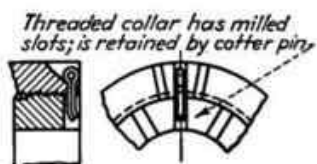

FIG. 47.

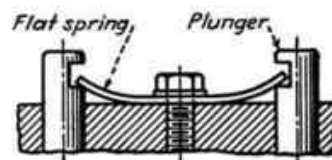

FIG. 48.

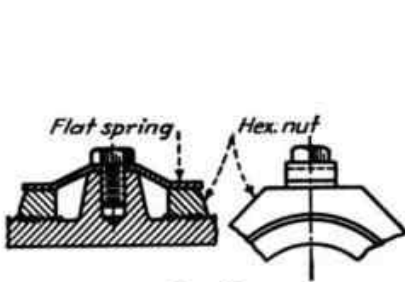

FIG. 49.

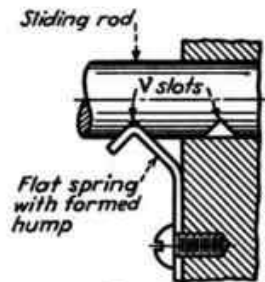

FIG. 50.



FIG. 51.

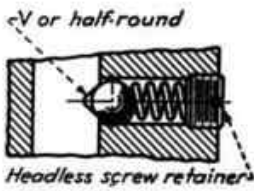

FIG. 52.

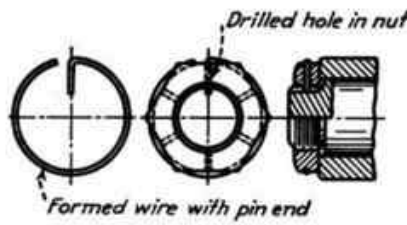

FIG. 53.

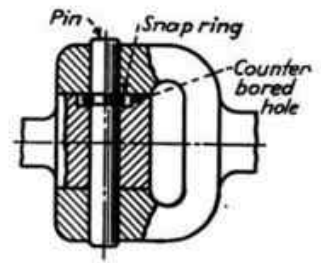

FIG. 54.

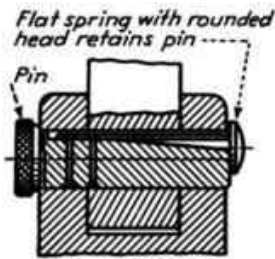

FIG. 55.

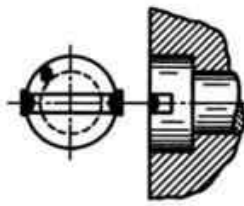

FIG. 56.

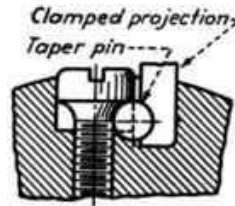

FIG. 57.

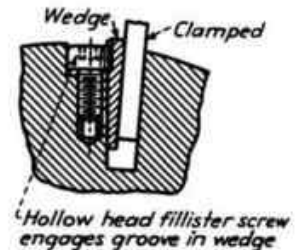

FIG. 58.

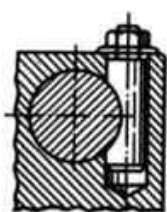

FIG. 59.

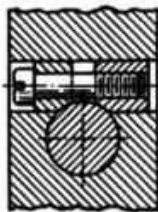

FIG. 60.

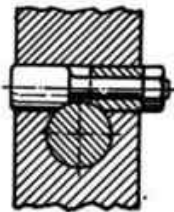

FIG. 61.

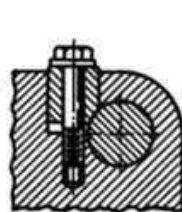

FIG. 62.

Figs. 59-62.—Round bars may be held singly or in multiple with one- or two-piece formed plugs and clamped either with screw or nut and washer. Clamping plugs may be reamed in place for accurate contact with round pieces.

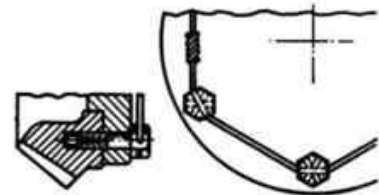

FIG. 63.—Soft flexible wire that withstands twisting offers an efficient retention of either slotted or drilled screws. This shows a method used extensively in automobile rear-axle design.

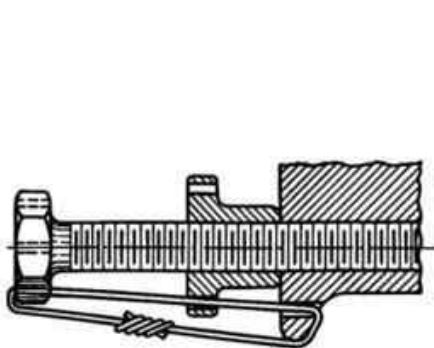

FIG. 64.

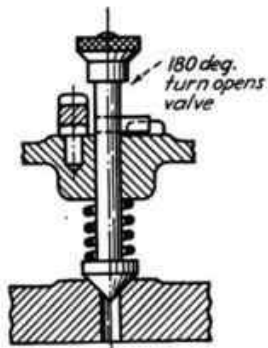

FIG. 65.

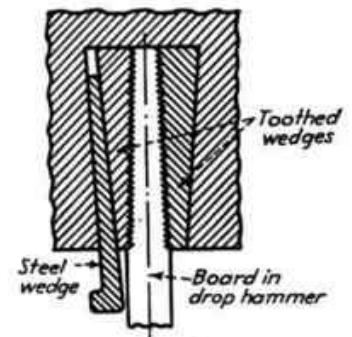

FIG. 66.

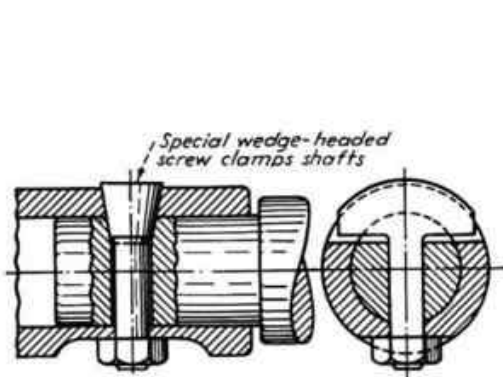

FIG. 67.

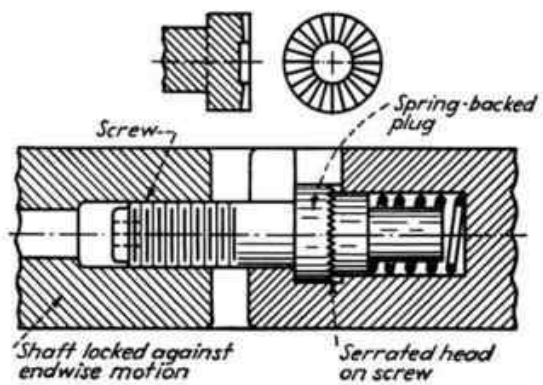

FIG. 68.

RETAINING AND LOCKING DETENTS

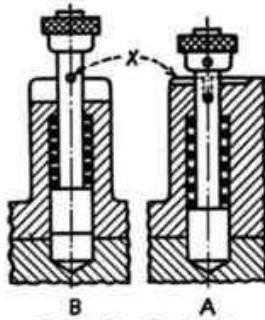

FIG. 69.—Driving plunger, shown in engagement at *A*, is pulled out and given a 90-deg. turn, pin *X* slipping into the shallow groove as shown at *B*, both members being thus disengaged.

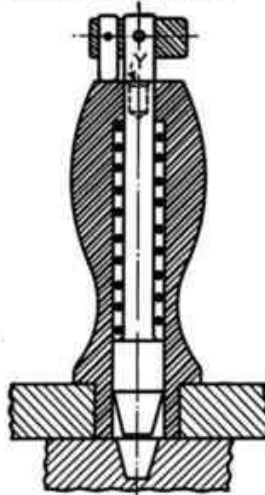

FIG. 70.—The pin in the collar attached to the plunger rides on the end of the handle when in the disengaged position and drops into the hole *Y* to allow engagement.



FIG. 71.—A long and a short slotted pin driven into the casting give two plunger positions.

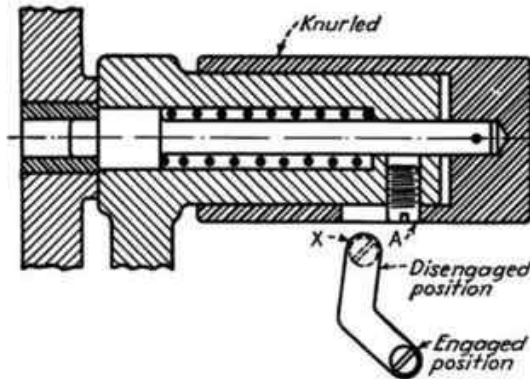

FIG. 72.—The plunger is pinned to the knurled handle, which is pulled out and twisted, the screw *A* dropping into the locked position at *X* in the bayonet slot.

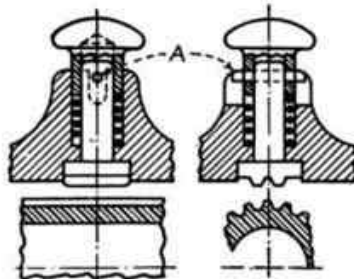

FIG. 73.—In this design, the pin *A* engaging in the slot prevents the plunger from turning. This detent is used as a temporary gear lock which is engaged for loosening a drawback rod through the gear.

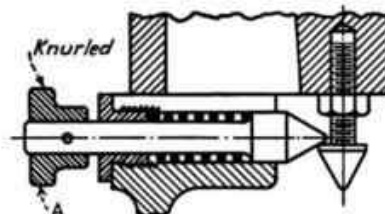

FIG. 74.—An adjustable gear cover lock. If the door is pushed shut, it is automatically latched, whereas pulling out the knurled knob *A* disengages the latch.

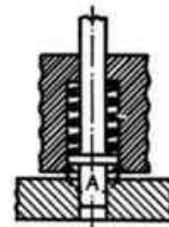

FIG. 75.—In this design, the plunger is retained by staking or spinning over the hole at *A*.

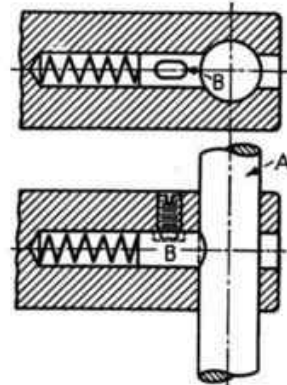

FIG. 76.—The end of the plunger *B* bearing against the hand lever *A* is concave and prevented from turning by the dog-point setscrew engaging the splined slot. Friction is the only thing that holds the adjustable hand lever *A* in position.

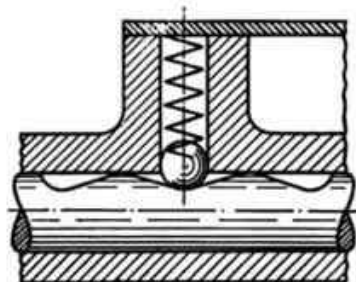

FIG. 77.—A spring-backed steel ball makes an inexpensive but efficient detent, the grooves in the rod having a long, easy riding angle. For economy, rejected or undersized balls can be purchased from manufacturers.

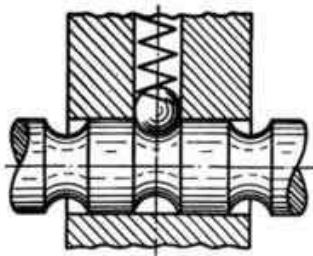

FIG. 78.—Another form, in which the grooves are cut all around the rod, which is then free to turn to any position.

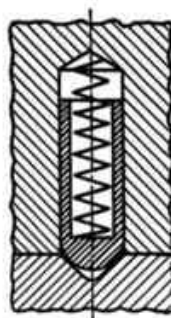

FIG. 82.—Instead of a ball, a hollow plunger is used which accommodates the spring. The end is hemispherical.

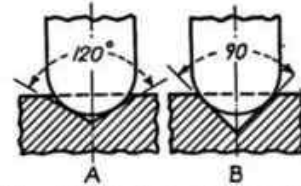

FIG. 83.—At *A* is shown the usual 120-deg. conical spot made with a drill. At *B* is shown a 90-deg. spot which gives a more positive seat, one which will not permit the plunger to disengage as readily and which is preferable when considerable vibration is encountered.

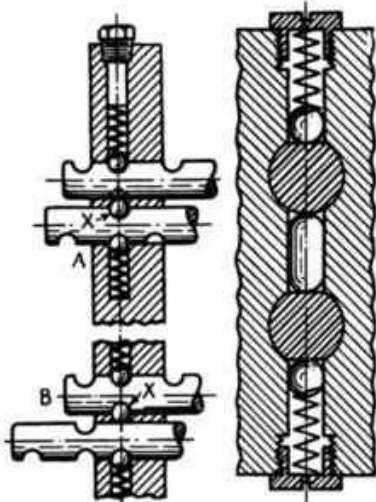

FIG. 79.

FIG. 80.

FIGS. 79 and 80.—A double-locking device for gear-shift yoke rods is shown in Fig. 79. At *A*, the neutral position is shown with ball *X* free in the hole. At *B*, the lower rod is shifted; ball *X* is forced upward, the upper rod being retained in a neutral position. The lower rod must also be in neutral position before the upper rod can be moved. A similar design is shown in Fig. 80, wherein a rod with hemispherical ends is used in place of ball *X*.

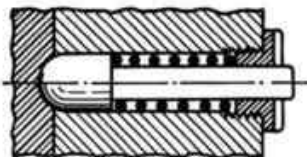

FIG. 84.—The plunger is turned down slightly smaller than the inside diameter of the spring which gets its other bearing against the threaded plug, the hole in the plug guiding the stem of the plunger.

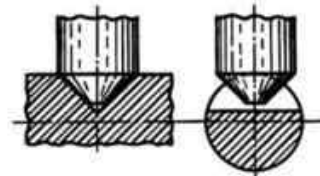

FIG. 85.—Instead of a hole, a slot is milled across the rod. Since the plunger is conical, it is obvious that only line contact is obtained.

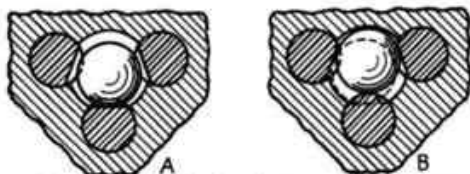

FIG. 81.—Without using a spring of any kind, three gear-shifting rods are locked by a large steel ball. At *A*, the neutral position is shown. At *B*, the lower rod has been shifted, forcing the ball upward, thereby locking the other two rods. The dashed circle shows the position of the ball when the right-hand rod has been shifted.

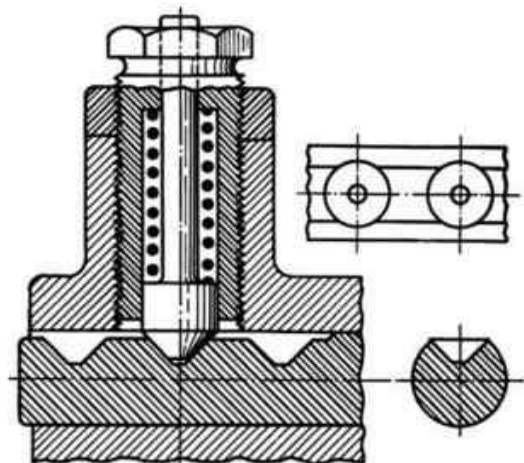

FIG. 86.—The spring tension may be increased or decreased as desired by the long hollow threaded plug, which is then locked in position by means of the check nut. In this design, the rod is flattened and the locating holes, which are truncated cones in shape, are machined into the flat surface.

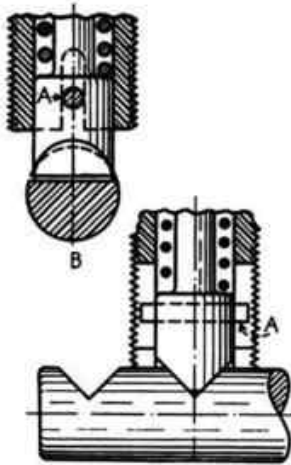

FIG. 87.—The round plunger is flat milled to a 90-deg. included angle and prevented from turning by pin *A* engaging milled slots in the threaded plug. In the end view shown at *B*, it can be seen that, if the spring tension is to be adjusted, at least a half turn must be given so that the flattened point will coincide with the slot in the rod.

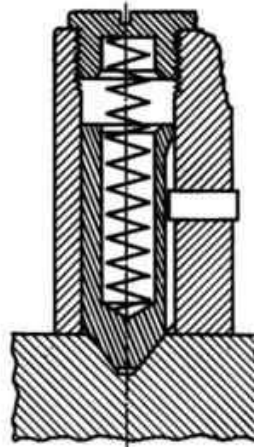

FIG. 88.—When the plunger diameter and the wall thickness are sufficiently large, a keyway can be milled into the plunger for engaging a pin, which prevents it from rotating.

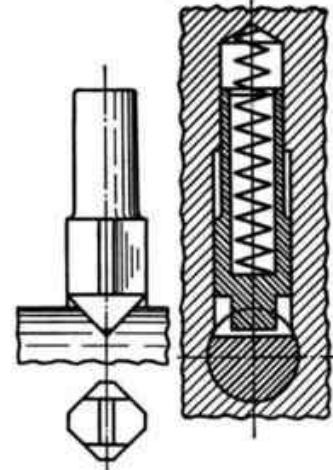

FIG. 89.—The plunger is milled square with round corners and the hole is partly broached; this does away with the necessity of a key. The point is flat milled.

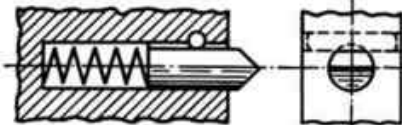

FIG. 90.—Sometimes the plunger can be milled with a flat which bears against a pin, as shown in the end view to the right; thus the plunger is prevented from turning in the hole. This design is particularly suitable for solid-type plungers.

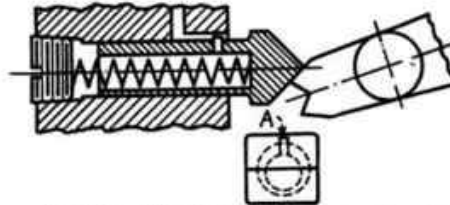

FIG. 91.—Here is shown a square-headed plunger with its body turned round to accommodate the spring in an eccentric hole, thereby giving a support to the pin *A*, which acts as a key.

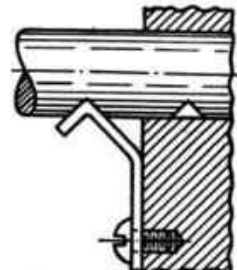

FIG. 92.—Probably one of the simplest yet most highly efficient forms of detent is merely a flat spring bent to a 90-deg. included angle and seating in V's milled in the rod.

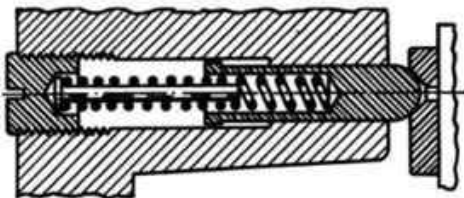

FIG. 93.—With a long spring and a fairly short plunger, a common flat-head wire nail can be used to support the spring against buckling. The spring also fits closely into the plunger hole to gain support, and the plunger is flanged at its upper end to prevent its slipping through the hole.

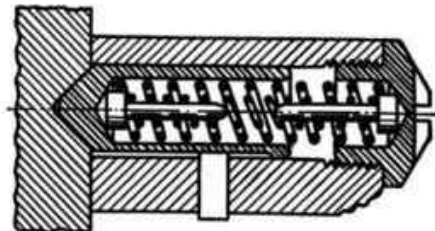

FIG. 94.—This design is similar to Fig. 88. When confined to a small diameter, a smaller spring is placed within the larger. By using a $\frac{3}{16}$ in. outside diameter outer spring, 25 per cent spring tension can be gained by the addition of the inner spring. The larger one has a sliding fit in the plunger and screw plug holes. Two guide pins, the heads fitting closely into the larger spring, keep the inner spring central and free from buckling.

WIRE LOCKS AND SNAP RINGS

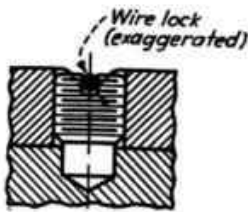

FIG. 95.

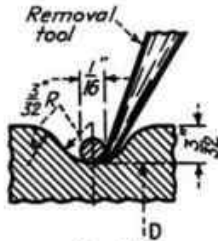

FIG. 96.

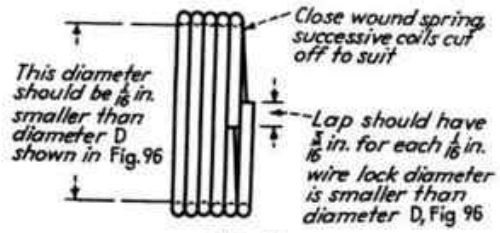

FIG. 97.

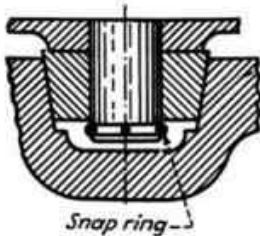

FIG. 98.

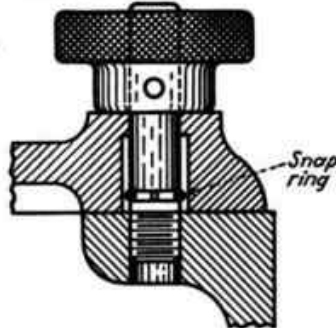

FIG. 99.

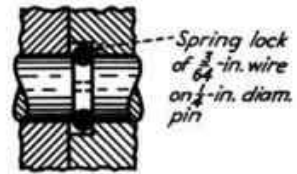

FIG. 100.

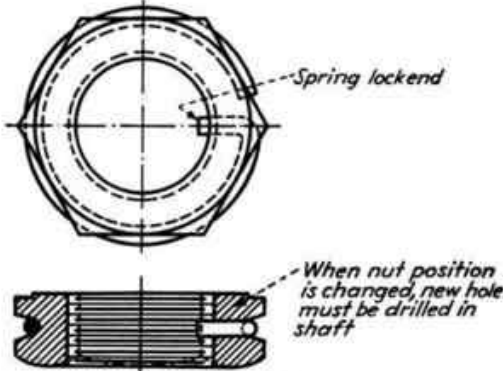

FIG. 101.

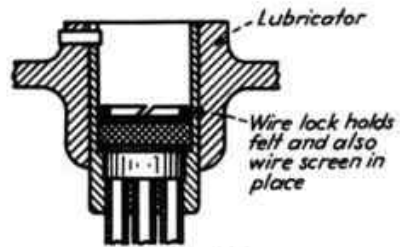

FIG. 102.

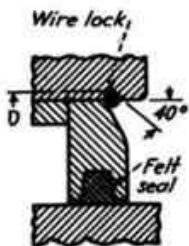

FIG. 103.

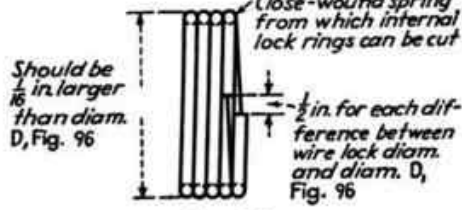

FIG. 104.



FIG. 105.



FIG. 106.

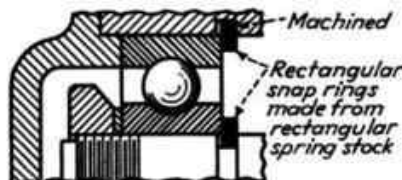

FIG. 107.

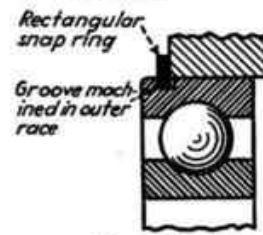

FIG. 108.

TAPER-PIN APPLICATIONS

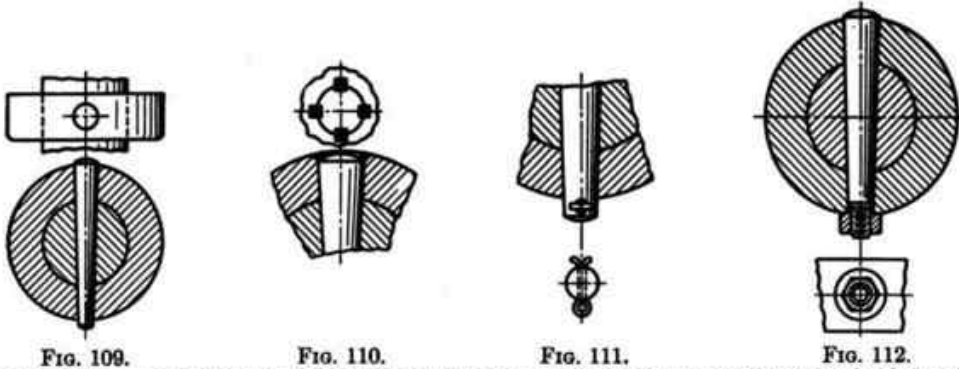

FIG. 109.—The conventional way of applying a taper pin, which depends upon friction to hold the pin in place. In gear boxes and other sealed mechanisms where it would be injurious for a pin to work loose, positive locking means must be provided.

FIG. 110.—The large end of the pin comes just below the surface of the external member it is holding and is staked as shown in the plan view. These little swellings, or burrs, straighten out or shear off if it is necessary to remove the pin, but usually will score the surface of the pin. It should be noted that cast iron does not stake readily as it is brittle and will not flow.

FIG. 111.—A small cotter pin retains but does not prevent loosening of the taper pin.

FIG. 112.—With this design, the taper pin is pulled tight with the hex nut which bears against a flat on the external member, although this flat is not necessary. Some engineers prefer to use a lock washer under the nut, in which case both the nut and the external member should not be hardened. Thus the lock washer can get a grip.

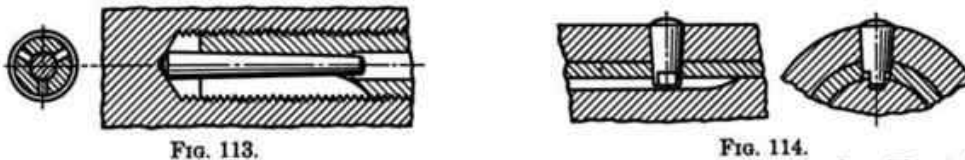

FIG. 113.—In this design, the screw stud is expanded and locked by the use of a taper pin. The stud is slitted as shown in the end view. The taper pin rests in the bottom of the hole, and the stud is screwed in until it can be turned no farther.

FIG. 114.—This shows a twofold purpose. The sawed-off taper pin acts as a holding device and as a key guide to the slidable inner member.

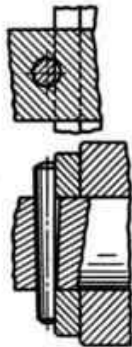
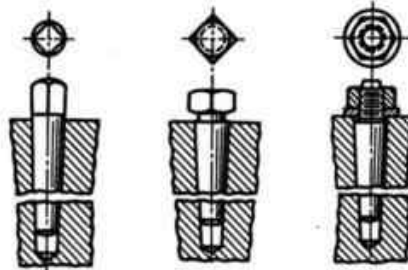

FIG. 115.—Here the pin is flattened off and used as a wedge. This method calls for accurate work, but, if the hole is reamed too large or wears too much, the next larger taper pin may be used.

FIGS. 116, 117, and 118.—When a taper pin is to be used in a blind hole, one of the three methods shown here can be used. To facilitate loosening the pin, a square may be milled at the large end as in Fig. 116. It is well to cyanide this squared end. Figure 117 shows a special form with a square head, the flat of which is equal to the large diameter. This type should be hardened all over and ground on the body. In Fig. 118, the pin is threaded and jacked out by a hex nut against a washer. The top end should be cyanided so it will not be pounded over during assembly. A fine thread should be used so as not to weaken the pin by too small a root diameter. For appearances, the washer and nut are left on, but this does not render it foolproof. This form is used as a dowel pin where the held member must be located accurately.



HINGES AND PIVOTS FOR COVERS AND FLEXIBLE JOINTS



FIG. 119.—Common cover hinge with pin tight in the cover and loose in the hinge lugs.



FIG. 120.—With the end peened, the pin can be made a loose fit in all lugs.



FIG. 121.—A plain pin with two cotters can be used in place of a peened rivet.

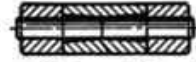

FIG. 122.—A double tapered hole in cover lugs with pin fitting tightly in outer lugs.



FIG. 123.—Sheet-metal cover bent around the hinge pin.

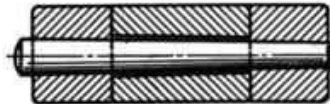

FIG. 124.—A tapered pin makes hinge adjustable.

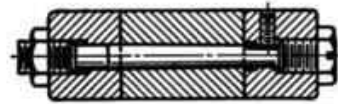

FIG. 125.—Combination straight and taper-pin hinge.

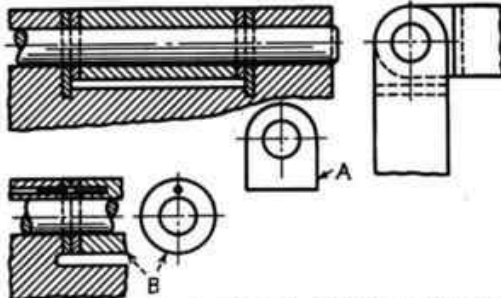

FIG. 126.—Hardened and ground washers to prevent wear. *A*, hinge lugs milled to prevent washers from turning. *B*, washers retained by a pin.

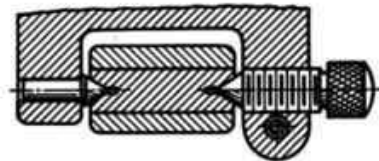

FIG. 127.—Pivot bearing with shouldered center pin and adjustable cone-pointed screw with lock.

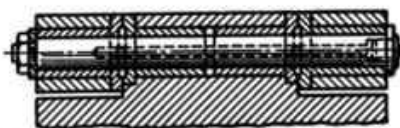

FIG. 128.—A design for severe duty and long life.

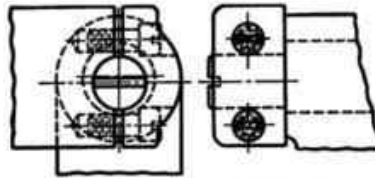

FIG. 129.—Capped eccentric pin bearing makes cover adjustable.

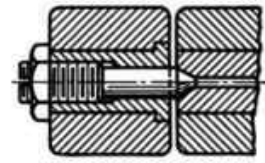

FIG. 130.—Pivot bearing with hardened conical-pointed pins.



FIG. 131.—Sheet-iron cover swinging on headed pin which is peened over at the opposite end.

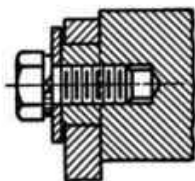

FIG. 132.—Lever arm pivoted on shouldered stud and retained by washer.

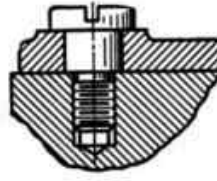

FIG. 133.—Light cast-iron cover pivoting on stud.

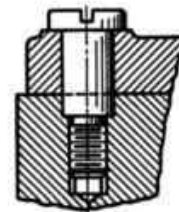

FIG. 134.—For heavier covers, the stud is shouldered and the casting counterbored.



FIG. 135.—Shouldered bushing centered in counterbored hole.
FIG. 136.—Bushing centered and held by stud screw.

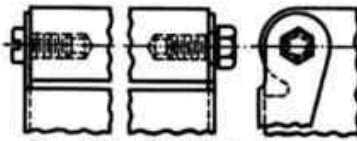
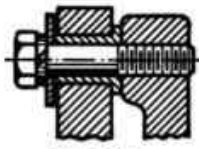

FIG. 137.—Sheet-iron cover with hinge ears fastened with shouldered hex head stud or fillister head screws.

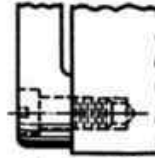

FIG. 138.—Poor design because screw tends to turn.

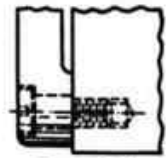

FIG. 139.—The hinge stud should screw in tightly, and head should have ample clearance.

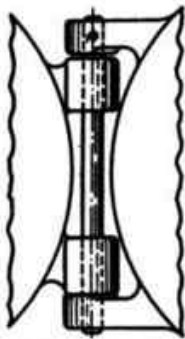

FIG. 140.—A poor design wherein all the thrust is taken on the lower case lug and the span of the cover lug is reduced.

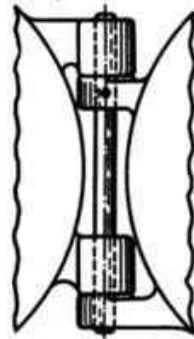

FIG. 141.—A conventional machine door hinge.



FIG. 142.—An improved design with lug drilled and reamed from opposite ends.

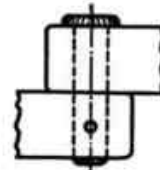

FIG. 143.—An incorrect design because it requires removal of the small pin for disassembling.

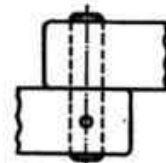

FIG. 144.—With a headless hinge pin, the cover can be lifted off.

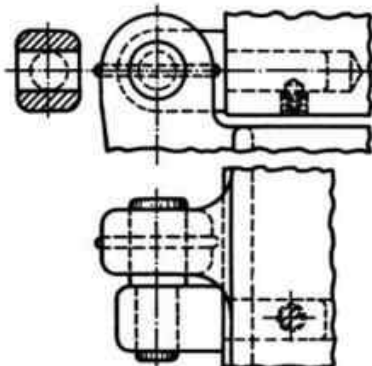

FIG. 145.—Separable lugs are used when the casting is too large for small lugs to cast satisfactorily.

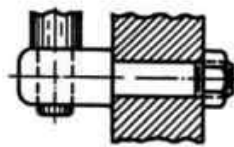

FIG. 146.—Another method of holding the steel lug.

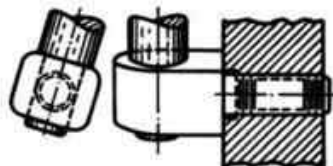

FIG. 147.—Wrong method of fastening steel lug, requiring cut and try. End view shows results.

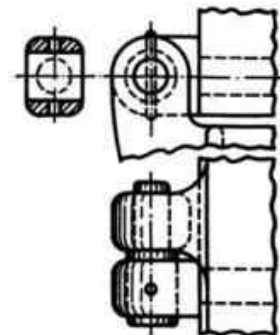

FIG. 148.—With inverted pin, the cover lug can be smaller. Studs are positioned before the final pinning.

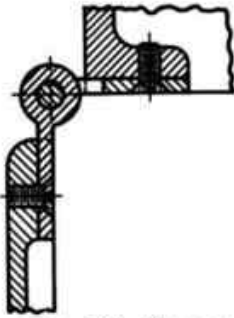

FIG. 149.—Common steel hinge applied to a machine-tool cover.

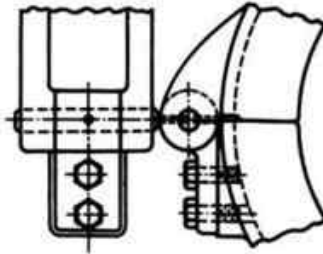

FIG. 150.—Cover lugs cast integrally, and pivot pins fastened in loose piece for greater span.

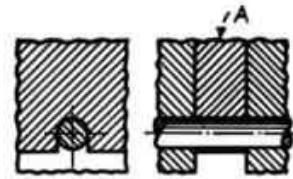

FIG. 151.—When swinging member *A* is to be removable, the bearing is cut as in the left view.

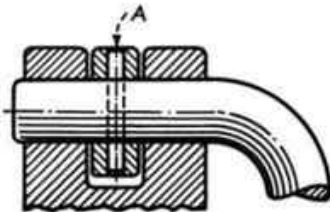

FIG. 152.—Swinging rod retained by pinned collar *A*. Both lugs are integral with the casting.

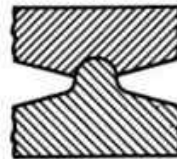

FIG. 153.—Pivot bearing as used on an adjustable vise jaw.

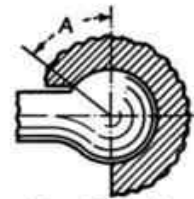

FIG. 154.—Toggle or pawl joint. Angle *A* should be 30 to 45 deg. to retain the member.

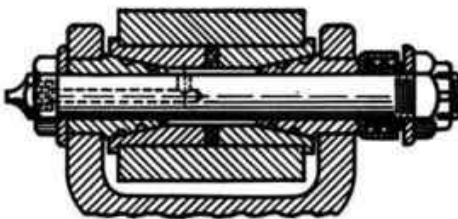

FIG. 155.—Radial and axial play are taken up by the hardened and ground bushings tapered to an included angle of $22\frac{1}{2}$ deg., sufficient to prevent sticking.

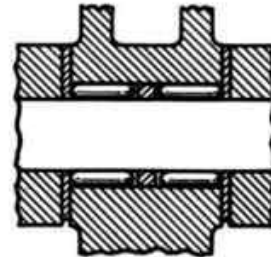

FIG. 156.—Needle-bearing pivot for either rotation or oscillation, with three hardened and ground washers for separating the rollers.

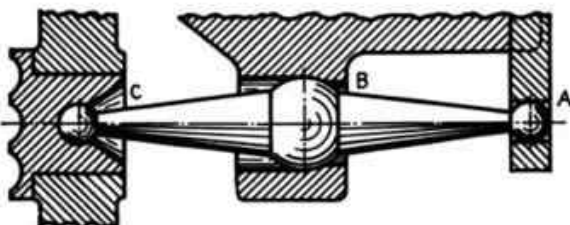

FIG. 157.—Three ball joints used in a gear-shift mechanism. Hole *A* is in shifting rod; *B* is the pivoting center, which is retained by the inserted locating plug at *C*.



FIG. 158.—Socket joint with hemispherical rod ends held in place by screw bushings.

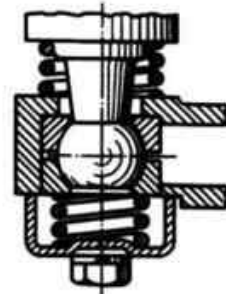

FIG. 159.—Self-adjusting socket joint. The sheet-metal spring cover is held in place by two screws.

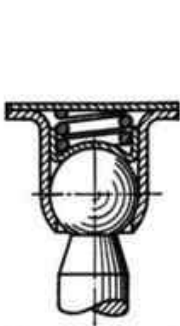

FIG. 160.—Sheet-metal ball-socket housing with cover fastened by spot welding.

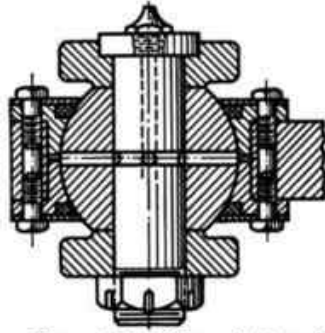

FIG. 161.—The flattened sphere is held by the center stud. Felt seals are used to retain the grease.

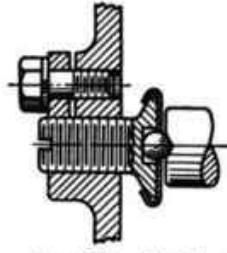

FIG. 162.—Combination pivot joint and end-thrust bearing, the ball being retained by the washer spun over the fixed screw.

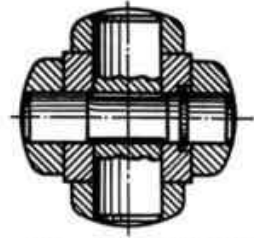

FIG. 163.—Universal joint, the smaller pin being retained by wire snap ring.

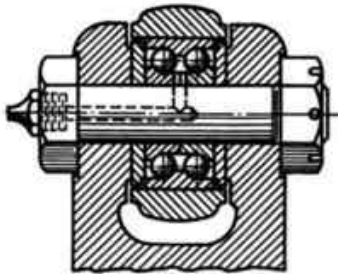

FIG. 164.—Rocker-arm bearing as used on an airplane.

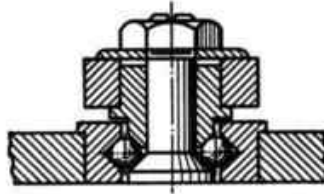

FIG. 165.—Arm joint of a pantograph machine, with center stud clamped without end play, stud head and bushing end forming the ball race.

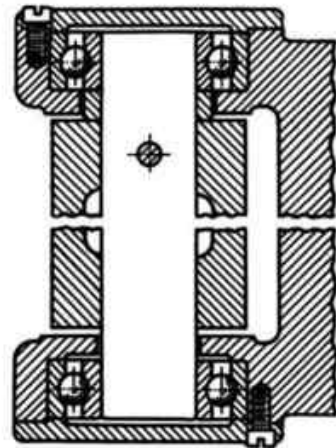

FIG. 166.—Arm joint designed for accuracy. Upper ball bearing takes all thrust caused by weight, and the spindle is pinned to the stationary member. The bearing has a light press fit.

CLAMPING SHOES AND PLUGS

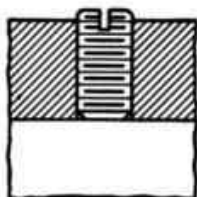

FIG. 167.—Plug may mar the shaft to the extent that disassembling might be impossible. The smooth surfaces of the hole are scored.

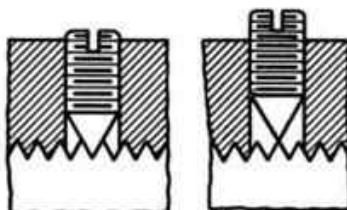

FIG. 168.—The 60-deg. point does not always line up with the bottom of the thread.



FIG. 169.—A flat filed or milled on the shaft is an improvement. But the cup point of the screw bites into the flat, and, once a ring is made into the flat, it is hard to get clear of it when the held member must be moved to either side.

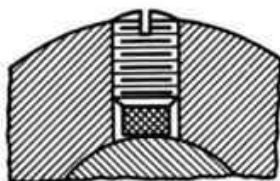

FIG. 170.—A further improvement is a brass plug making a loose fit with the inside diameter of the threaded hole.



FIG. 171.—A variation of the preceding construction is obtained by making the plug a press fit in the screw.



FIG. 172.—Here the side in contact with the shaft makes a full fit, achieved by inserting a reamer into the hub bore and constantly feeding the clamping screw while the reamer is turning.



FIG. 173.—This is similar to the construction shown in Fig. 172, a tap being used instead of a reamer.

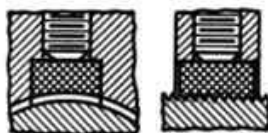

FIG. 174.—When a longer clamping surface is desired, a slot similar to a keyway is cut into the retaining member.

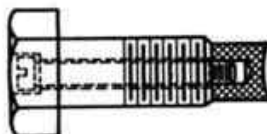

FIG. 175.—This construction facilitates the removal of the plug but can be used only when the diameter of the clamping screw is large enough. Freedom of the internal fillister head screw permits the plug to assume its natural position against the shaft.

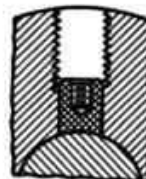

FIG. 176.—This shows another method of removing a plug, by first removing the clamping screw and then inserting a small screw to fit the tapped hole.

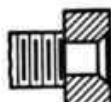

FIG. 177.



FIG. 178.



FIG. 179.

FIGS. 177-179.—In these modifications of the clamping plug, the shoe is assembled after the clamping screw is screwed through the hole. In Figs. 177 and 179, the shoe is retained by spinning or riveting, whereas in Fig. 178 a pin through the hub of the shoe engages the circular half-round groove near the end of the screw. In each case, the shoe bears against the shoulder of the screw.

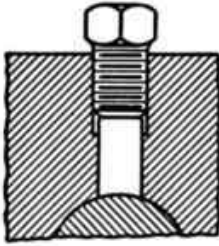

FIG. 180.—Here the plug is in the form of a rod, which allows the use of a short set-screw. This saves tapping a long hole and using a long screw.

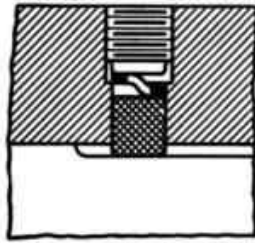

FIG. 181.—A lock washer under the hollow headless screw locks both the screw and plug in place.

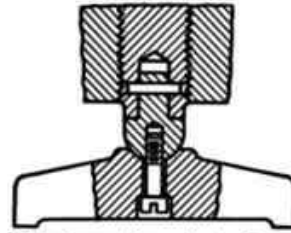

FIG. 182.—This is another adaptation of the methods used in Figs. 177-179. A ball end is pinned fast in the retaining screw, which acts like a swivel for the clamping shoe, the latter being held in place by a small fillister head screw in an oversized hole. The swiveling permits the shoe to accommodate itself to rough or uneven surfaces.

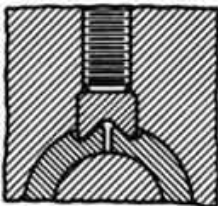

FIG. 183.—Here the shoe clamps the ring about the shaft. It is made in key form, i.e., a slot is cut in the external member to accommodate the shoe. The V in the shoe should be 90 deg.

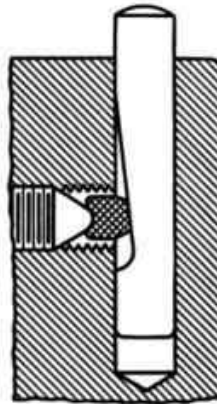

FIG. 184.—The round-pointed screw allows the plug to swivel 6 to 8 deg. The pin is for locating work in a level position, a number of them being used for this purpose. The flat is milled 6 to 8 deg. from the vertical, the feature being that the plug prevents lowering when weight is applied.

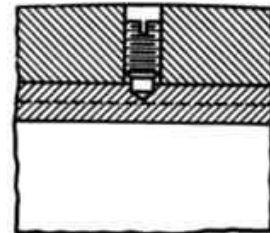

FIG. 185.—In this modified construction, the dog-point setscrew retains the key after the screw is loosened, the dog point fitting in the oversized hole in the key. This, of course, requires a key somewhat wider than the diameter of the dog point of the screw.

LOCK BOLTS AND INDEXING MECHANISMS



FIG. 186.

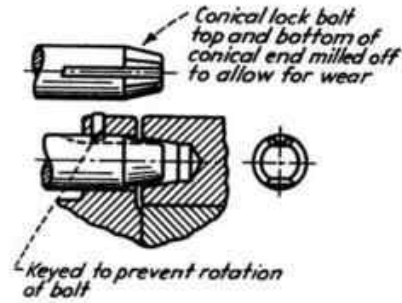

FIG. 187.

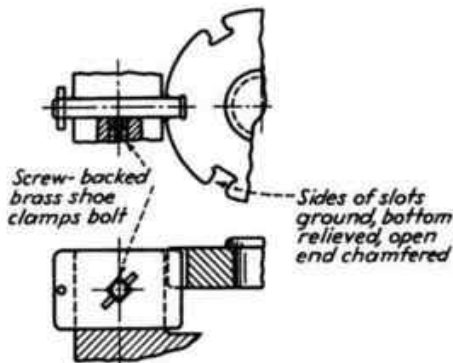

FIG. 188.

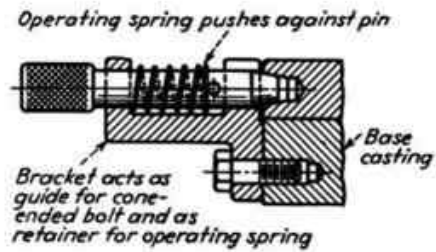

FIG. 189.

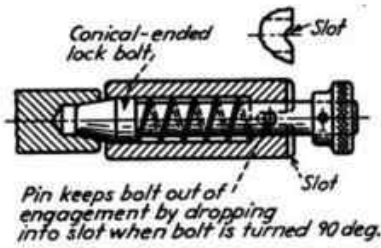

FIG. 190.

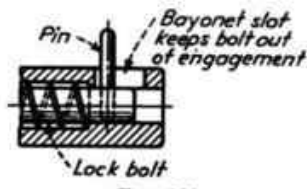

FIG. 191.

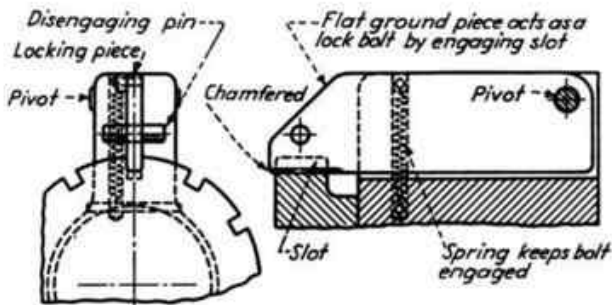

FIG. 192.

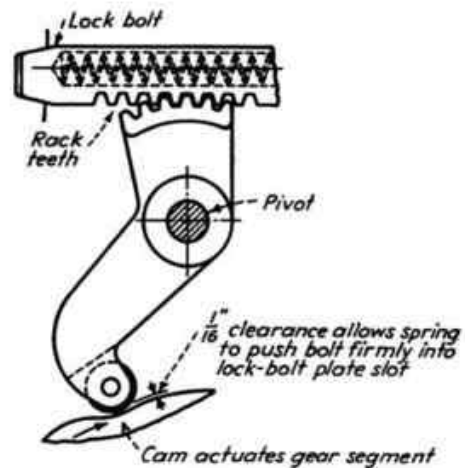

FIG. 193.

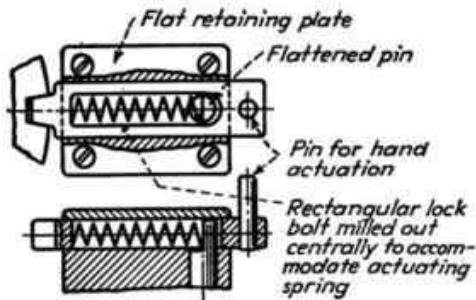

FIG. 194.—In this design the rectangular lock bolt is milled out centrally to accommodate actuating spring. A pin is provided for hand actuation when desired.

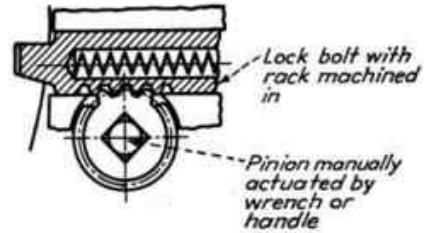

FIG. 195.—A rack is machined in the lock bolt. Pinion meshing with rack is manually actuated with wrench or handle.

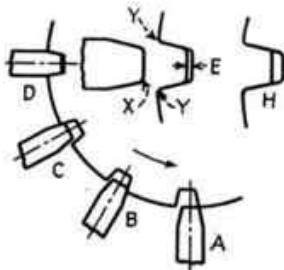

FIG. 196.—When indexing starts, the lock bolt is released and rides on the periphery of the plate. At point A, it starts to slide down the inclined slot. At B is shown the shearing or wearing action that takes place. In case the plate has overrun or indexed past its position as at C, the spring behind the lock bolt is required to turn the plate, together with the whole rotating mass attached to it, backward, resulting in wear on the side opposite to that shown at B. At D, complete engagement is shown. Rounded corners as at X and Y should be provided. There should be plenty of clearance as at E to allow for wear because of the small angle of the slot. At H is shown an improved form of gear. It assures clearance and provides for grinding of the angular surfaces if necessary. If the lock-bolt spring is not strong enough to seat the bolt by rotating the plate, vibration will usually complete the seating, causing chatter at the cutting tool or spindle and wear on the bolt and slot. In this type of bolt, the angular sides are alike, hence the direction may be opposite from that shown.

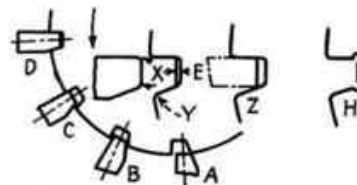

FIG. 197.—More accurate form of lock bolt, which is claimed by many to be the correct method for this type of design. The inclined surface gets the wear as it seats the the bolt, whereas the straight or radial side positions the bolt accurately. Positions A, B, C, and D correspond to those in Fig. 196, and indicate that the corners X and Y should be rounded. At H is shown how the groove is ground. Other notations are the same as given in Fig. 196.

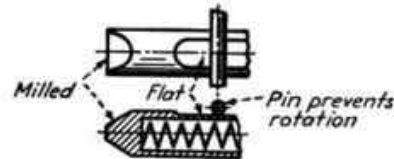

FIG. 198.

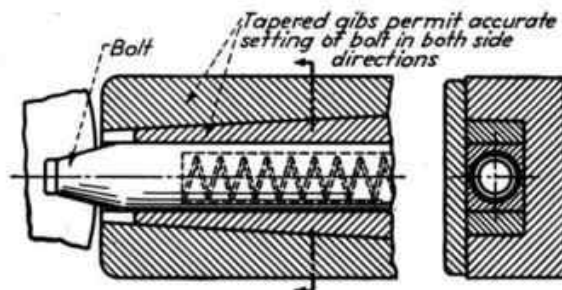

FIG. 199.

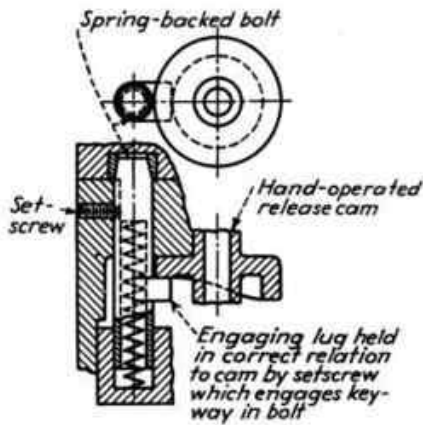

FIG. 200.

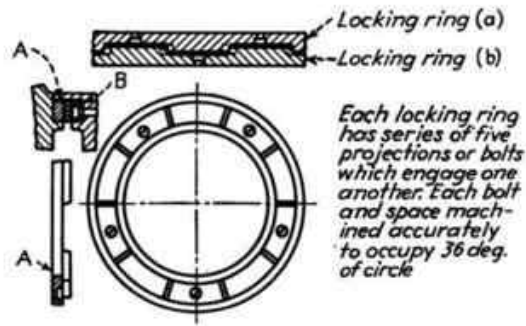

FIG. 201.

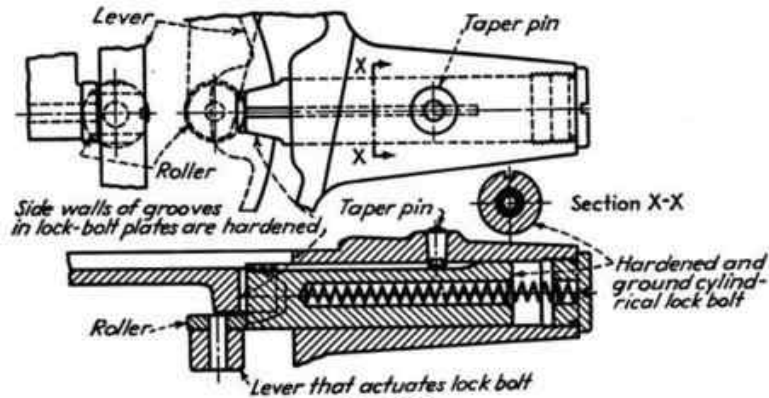

FIG. 202.

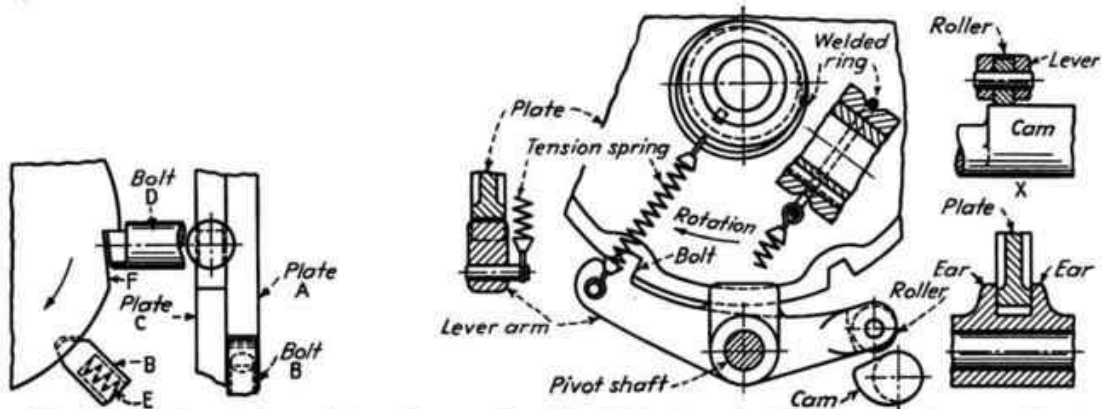

FIG. 203.—Plates A and C are fastened together, the former accommodating the bolt B, whereas plate C is positioned by bolt D. Rotated in direction of arrow, bolt B slides into slot in plate A, one side being milled to 20 deg. When indexing begins and bolt D is pulled away, 45-deg. slot in plate A pushes out the bolt B, both bolts then riding on periphery of respective plates, and bolt D sliding down the easy incline F to a predetermined depth.

FIG. 204.—Bolt integral with lever arm has ears directly above the pivot shaft fitting on either side of the plate. As the plate reciprocates, it pulls the bolt along with it. Cam contacts roller, the cam being long enough at X to accommodate the required travel of plate and bolt. The welded ring fits in groove in hub of plate and is connected to tension spring, the other end of which engages a pin in lever.

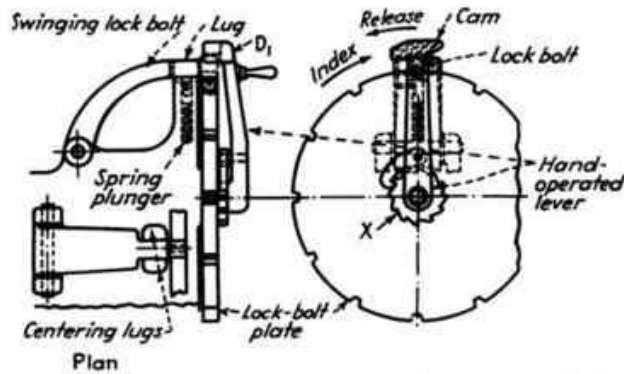
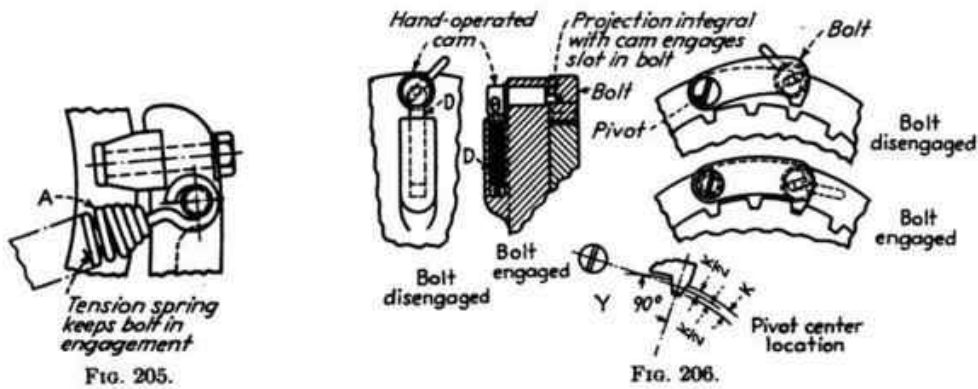

FIG. 207.—By using a lock-bolt plate larger than the work, the indexing error is diminished. The swinging lock bolt is released automatically by the spring plunger, which has a predetermined movement, when the hand-operated lever is moved to the left, as shown by the arrow marked Release, and the cam contacts the rounded top surface of the lock bolt. The ratchet is keyed with the lock-bolt plate to the spindle. As the lock bolt is released and the lever is rotated 30 deg. counterclockwise, the pawl engages the next tooth in the ratchet wheel at X. The lever is then pulled in the direction of the arrow marked Index, the cam moving the lock bolt downward into the next opening in the lock-bolt plate. The plan view of the bolt shows the two centering lugs between which the lock bolt is additionally supported.

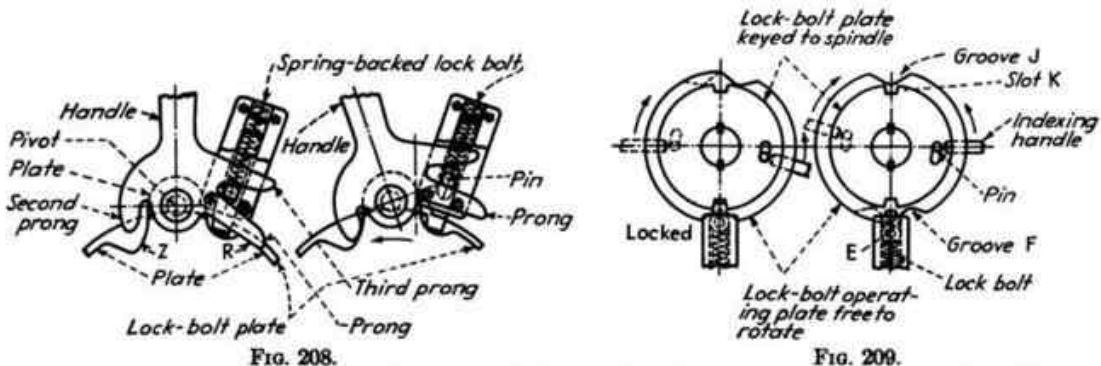

FIG. 208.—The handle is mounted on the plate and is independent of the lock-bolt plate. As the handle is pulled to the left, the prong pushes against the pin driven into the spring-backed lock bolt, thereby disengaging the bolt. At the same time, the second prong contacts the plate at Z. Both plates then move simultaneously, releasing the lock bolt, which rides on the periphery of the lock-bolt plate, and the bolt falls into the next slot. The handle is then pushed back again, clockwise, contacting the plate at R, upon which a third prong pushes against the pin-seating lock bolt in a locked position.

FIG. 209.—The plate is indexed through a half revolution in one direction and then back again in the opposite direction. The lock-bolt plate is keyed to the spindle. The lock-bolt operating plate is free to rotate on the spindle. When the indexing handle is pushed counterclockwise, as shown at the right, groove F in the plate forces the lock bolt out of engagement. The pin driven into the plate engages the slot in the plate, thereby lining up groove J with slot K. Upon further movement in a counterclockwise direction, the roller on the bolt may slide into groove J and the bolt may enter slot K. The dashed line in both views show the positions when indexing in the opposite directions.

MACHINE CLAMPS

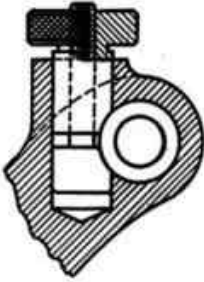

FIG. 210.—Clamping with bolt and bushing.

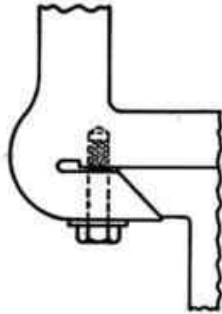

FIG. 211.—Clamping by spring dovetail.

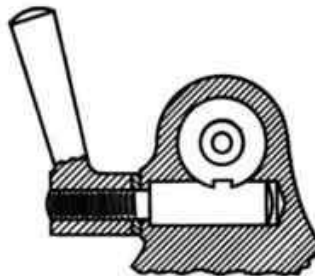

FIG. 212.—Spindle clamping bolt.

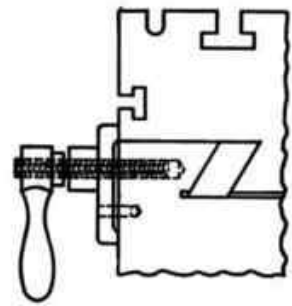

FIG. 213.—Clamping sliding table with plate and bolt.

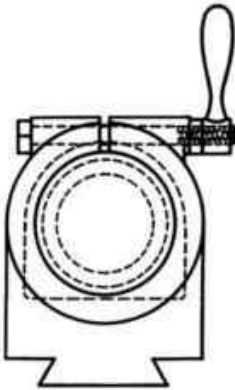

FIG. 214.—Clamping a spindle with a split bracket.

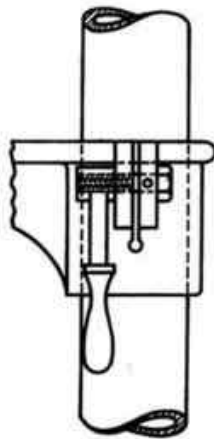

FIG. 215.—Sleeve split at ends for clamping.

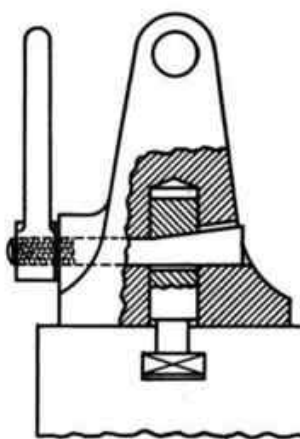

FIG. 216.—Example of wedge clamping.

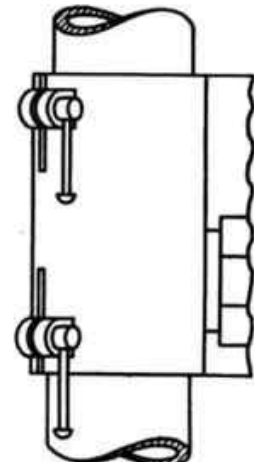

FIG. 217.—Clamping with a split bracket.

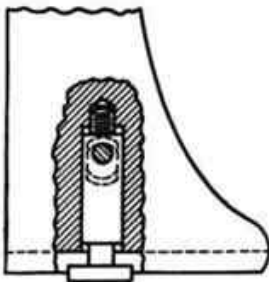

FIG. 218.—Clamping with an eccentric.

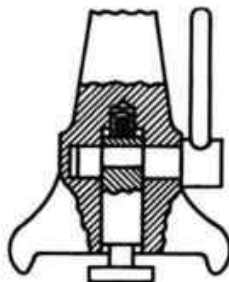
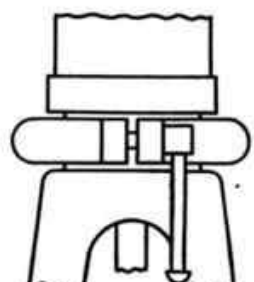
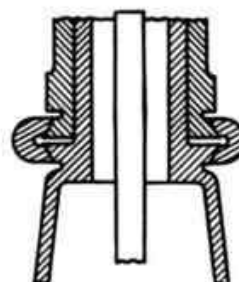

FIG. 219.—Clamping a swiveling column.



DOOR AND COVER FASTENINGS

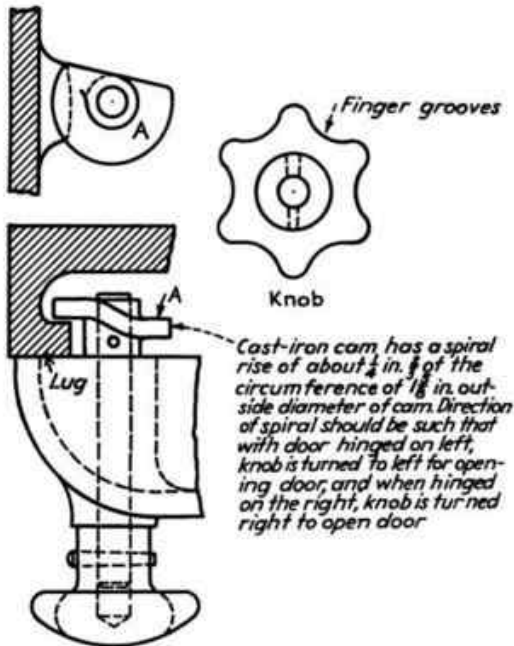

FIG. 220.

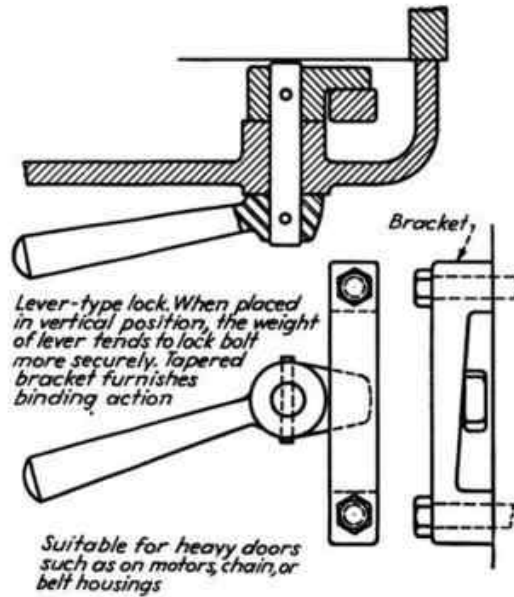

FIG. 222.

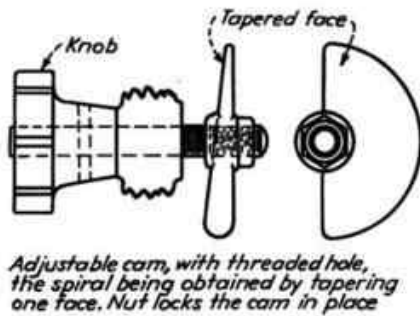

FIG. 221.

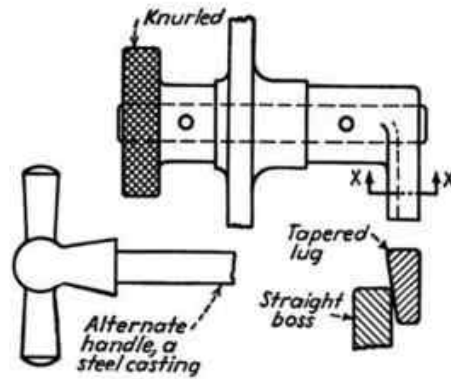

FIG. 223.

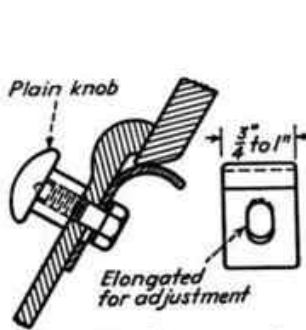

FIG. 224.—Snap-type fastener using a flat formed spring.

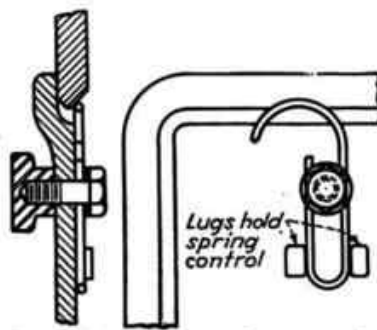

FIG. 225.—Snap-type fastener using round wire spring.

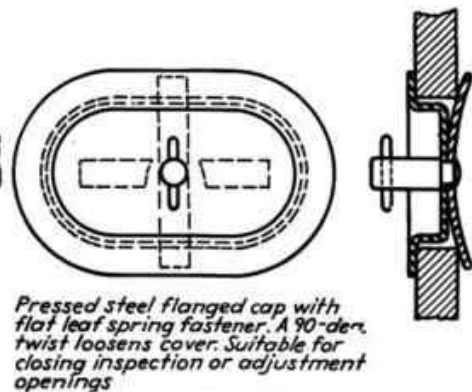

FIG. 226.

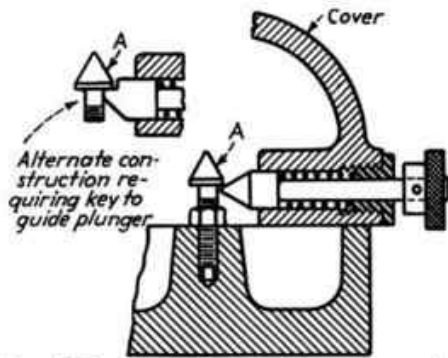

FIG. 227.—Spring-backed plunger type of automatic door lock, for light duty.

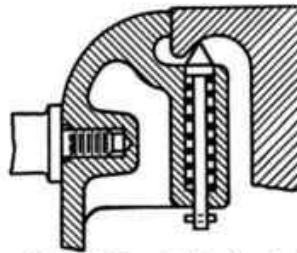

FIG. 228.—Spring-backed plunger engaging a cast lug on case, suitable for light duty.

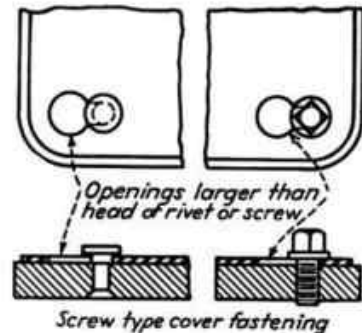

FIG. 229.

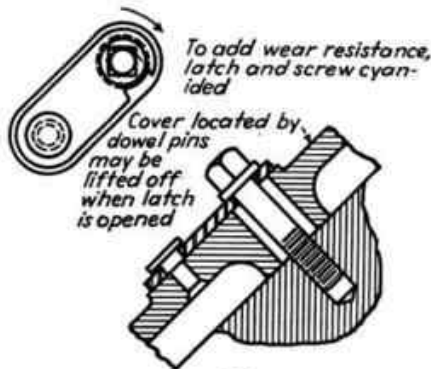

FIG. 230.

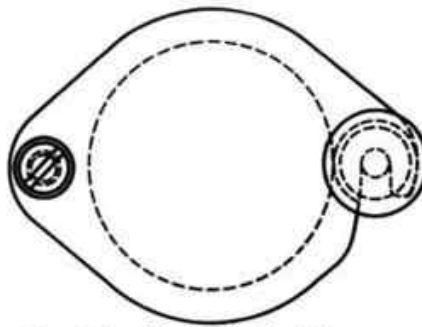

FIG. 231.—Simple cleaning-hole cover.

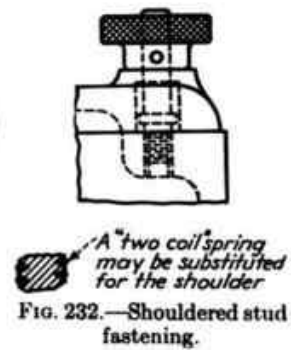

FIG. 232.—Shouldered stud fastening.

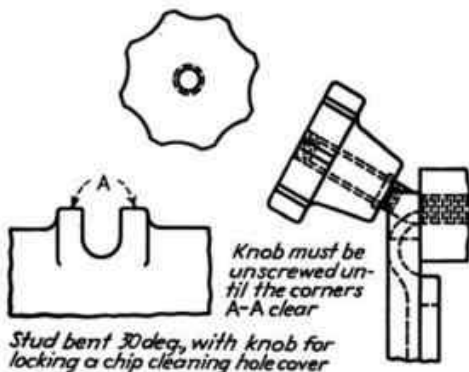

FIG. 233.

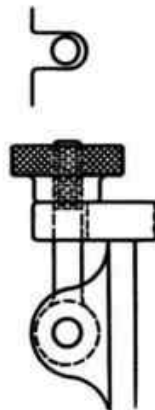

FIG. 234.—Simple swing bolt and open-end slot.

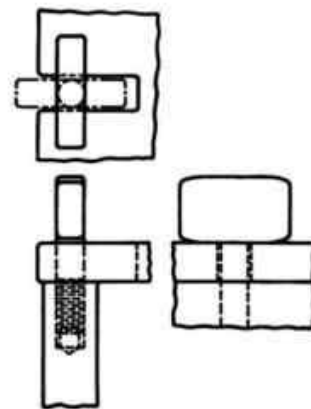

FIG. 235.—Tee-bolt type of fastening.

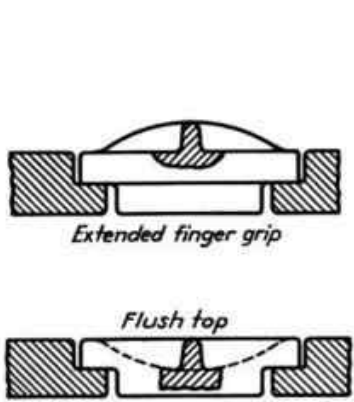

FIG. 236.—Stove-plate-type cover held by gravity.

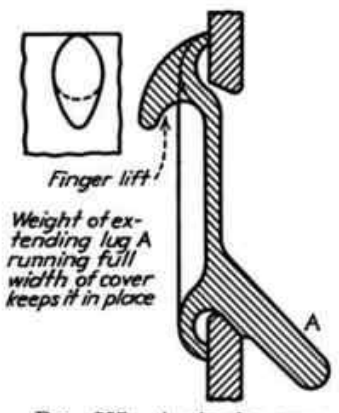

FIG. 237.—A simple cover held by gravity and requiring no machine work.



FIG. 238.—Pivoted oil-hole cover.



FIG. 239.—Vertical cover swung on a screw.

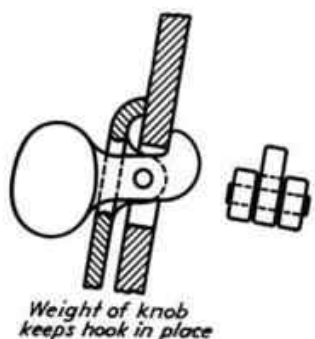

FIG. 240.

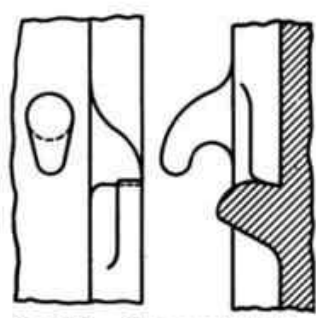

FIG. 241.—Plain gravity latch.

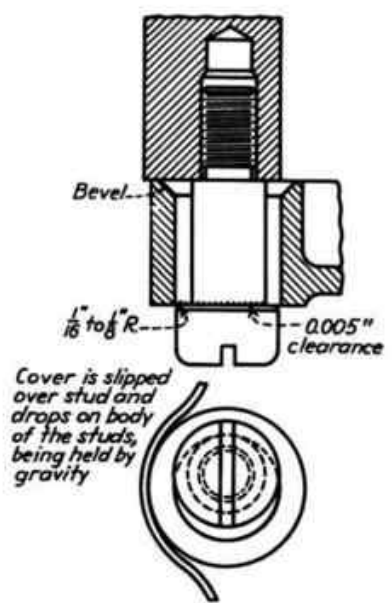
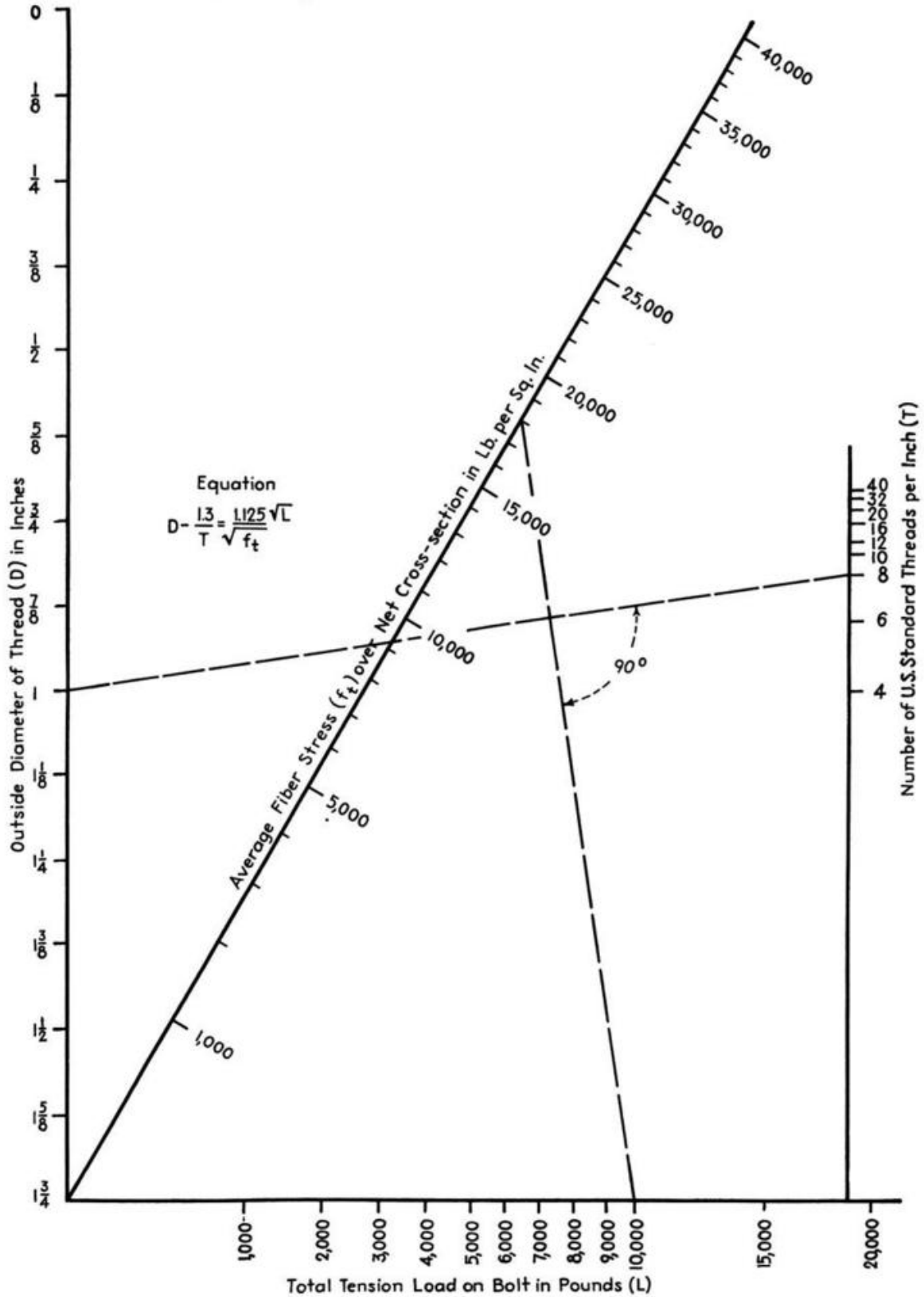

FIG. 242.—Positive type of gravity lock.

BOLT DIAMETER, LOAD, AND STRESS—U.S. STANDARD 60-DEG. V THREAD



THIS PAGE IS BLANK
but this is not a printing or scanning
fault and no content is missing.

CHAPTER V

SPRINGS

	PAGE		PAGE
Design of Helical Springs		Table of Wire Gages and Diameters, with Their Squares, Cubes, and Fourth Powers	138
Spring Wire Specifications.....	122	Inspection and Testing of Springs.....	139
Design Stresses.....	128	Graphical Solution of Helical Spring Formulas.....	140
Torsional Moduli.....	130	Helical Spring Charts for Specified Ratio of Loads and Lengths.....	141
Allowable Stresses Based on Endurance Limits.....	131	Designs of Tension Spring Ends.....	144
Natural Frequency.....	132	Flat Cantilever Springs, Graphical Design of.....	145
Formulas for Helical Springs.....	133	Semielliptic Laminated Springs, Graphical Design of.....	148
Permissible Manufacturing Tolerances...	134		
Form for Design Calculations.....	136		
Standard Drawings for Springs.....	137		

Design of Helical Springs

Condensation of the standard specifications and design procedure adopted by the Atlas Imperial Diesel Engine Company as set forth by W. M. Griffith, product engineer of that company, in March and April 1937, Product Engineering.

CLASSES OF SPRING SERVICE

- Class I.* Rapid, continuous deflection over a uniform stress range from zero to a maximum or from an intermediate stress to maximum—as in engine valve springs.
- Class II.* Rapid deflections over a variable stress range that may be from zero to intermediate, intermediate to maximum, or zero to maximum—but with only intermittent operation—as in springs for engine governors.
- Class III.* Statically loaded at maximum stress or infrequent deflections with stress range from zero to intermediate, intermediate to maximum, or zero to maximum—but with only infrequent operation—as springs for relief valves.

PURCHASE SPECIFICATIONS FOR SPRING WIRE

The minimum physical properties given in these specifications are 95 per cent of the average values determined by tests. Thus the minimum physical properties here specified are well within commercial limits.

SWEDISH STEEL SPRING WIRE SPECIFICATIONS

Generally used for Class I extension or compression springs and Class II and Class III extension springs, in wire diameters from 0.1055 in. up to 0.262 in. This material can be used for springs of larger or smaller wire diameter, but generally music wire is used for the smaller wire diameters and carbon steel for the larger wires.

1. Steel Manufacture

This steel is to be of Swedish manufacture according to approved practice by the acid open-hearth or electric-furnace process.

2. Chemical Composition

Carbon.....	0.60-0.70	Phosphorus.....	0.025 max.
Manganese.....	0.45-0.65	Sulphur.....	0.025 max.
Silicon.....	0.15-0.25		

3. Physical Properties

Range of wire diameter, in.	Minimum tensile strength, lb. per sq. in.		Minimum torsional strength, lb. per sq. in.	
	Ultimate	Elastic limit	Ultimate	Elastic limit
0.1055 and under.....	212,000	154,000	184,000	112,000
0.1205-0.1350.....	202,000	146,000	175,000	106,000
0.1483-0.1920.....	187,000	136,000	163,000	99,000
0.2070-0.2625.....	175,000	126,000	151,000	92,000
0.2812-0.3437.....	164,000	119,000	142,000	86,000
0.3625-0.4375.....	155,000	112,000	135,000	82,000
0.4615-0.5625.....	146,000	106,000	127,000	77,000

Reduction of area, 48 per cent minimum. Elongation in 10 in., 5 per cent minimum.

Twist Test: Samples taken from any part of the bundle of wire must withstand twisting seven revolutions forward and seven reverse, at a twisting speed not to exceed 25 r.p.m., for the number of times as given in the following table, and the ultimate break must be clean and square.

Length of wire between grips, 10 in.:

Diameter of wire, in..	0.1055	0.1205	0.1250	0.1350	0.1483	0.1563	0.1620	0.1770
Minimum twisting cycles.....	23	20	20	18	17	16	15	14

Length of wire between grips, 15 in.:

Diameter of wire, in..	0.1875	0.1920	0.2070	0.2188	0.2253	0.2437	0.2500	0.2625
Minimum twisting cycles.....	20	19	18	17	16	15	15	14

Length of wire between grips, 20 in.:

Diameter of wire, in.....	0.2813	0.2830	0.3065	0.3125	0.3310	0.3438	0.3625
Minimum twisting cycles.....	18	17	16	16	15	14	14

Length of wire between grips, 30 in.:

Diameter of wire, in.	0.3750	0.3938	0.4063	0.4305	0.4375	0.4615	0.4688	0.4900	0.500	0.5313	0.5625
Minimum twisting cycles.....	20	19	18	17	17	16	16	15	15	14	13

4. Surface Conditions

Upon etching with a hot solution of hydrochloric acid sufficiently to disclose surface defects, no hairline cracks, seams, pits, gouges, die marks, or other imperfections shall be revealed. Decarburization must be held to a minimum.

5. Limits of Variations in Diameter

- Wire diameter 0.162 in. and less—plus or minus 0.0015 in.
- Wire diameter 0.1770 in. and over—plus or minus 0.002 in.

6. Inspection, Rejections, and Replacements

All springs will be rigidly inspected at the plant as received. If more than a total of 10 per cent of the springs on any one purchase order are made of steel that fails to comply with the preceding specifications, or with the specifications on the detail drawing, the entire lot will be rejected. All springs rejected at the plant will be held at the seller's risk for a reasonable length of time, subject to his instructions, and shall be replaced by the seller without further cost to the purchaser.

CARBON-STEEL SPRING WIRE SPECIFICATIONS

Generally used for springs of wire diameter greater than 0.262 in. and also for square or rectangular wire ranging from $\frac{1}{32} \times \frac{1}{32}$ in. up to $\frac{1}{2} \times \frac{1}{2}$ in., advancing by $\frac{1}{32}$ in., and for sizes larger than $\frac{1}{2} \times \frac{1}{2}$ in., advancing by $\frac{1}{16}$ in.

1. Steel Manufacture

This steel is to be made according to approved practice by the electric-furnace or open-hearth process.

2. Chemical Composition

Carbon.....	0.60-0.70	Sulphur.....	0.025 max.
Manganese.....	0.45-0.65	Phosphorus.....	0.025 max.

3. Physical Properties

Range of wire diameter, in.	Minimum tensile strength, lb. per sq. in.		Minimum torsional strength, lb. per sq. in.	
	Ultimate	Elastic limit	Ultimate	Elastic limit
0.1055 and under.....	202,000	132,000	165,000	108,000
0.1205-0.1350.....	191,000	125,000	157,000	103,000
0.1483-0.1920.....	178,000	117,000	145,000	95,000
0.2070-0.2625.....	165,000	108,000	136,000	89,000
0.2813-0.3438.....	156,000	102,000	127,000	84,000
0.3625-0.4375.....	147,000	97,000	121,000	79,000
0.4615-0.5625.....	139,000	91,000	114,000	74,000

Reduction of area 48 per cent minimum. Elongation in 10 in., 5 per cent minimum.

4. Surface Conditions

Upon etching with a hot solution of hydrochloric acid sufficiently to disclose surface defects, no seams, hairline or otherwise, pits, gouges, die marks, or other imperfections shall be revealed. Decarburization must be held to a minimum.

5. Limits of Variation in Diameter

Wire diameter 0.1762 in. and less—plus or minus 0.0015 in.

Wire diameter 0.177 in. and over—plus or minus 0.002 in.

6. Inspection, Rejections, and Replacements

All springs will be rigidly inspected at the plants as received. If more than a total of 10 per cent of the springs on any one purchase order are made of steel that fails to comply with the above specifications, or with the specifications on the detail drawing, the entire lot will be rejected. All springs rejected at the plants will be held at the seller's risk for a reasonable length of time, subject to his instructions, and shall be replaced by the seller without further cost to the purchaser.

CHROME-VANADIUM-STEEL SPRING WIRE, S.A.E. 6150 SPECIFICATIONS

Generally used for same range of sizes of spring wire as covered by carbon-steel spring wire, and where the higher physicals of the chrome-vanadium-steel wire make its use specially desirable or necessary.

1. Steel Manufacture

This steel is to be made according to approved practice by the electric-furnace or open-hearth process.

2. Chemical Composition

Carbon.....	0.45-0.55	Sulphur.....	0.5 max.
Manganese.....	0.50-0.90	Phosphorus.....	0.04 max.
Chromium.....	0.80-1.10	Silicon.....	0.15-0.30
Vanadium.....	0.15 min.		

3. Physical Properties

Range of wire diameter, in.	Minimum tensile strength, lb. per sq. in.		Minimum torsional strength, lb. per sq. in.	
	Ultimate	Elastic limit	Ultimate	Elastic limit
0.1055 and under.....	212,000	195,000	158,000	116,000
0.1205-0.1350.....	202,000	184,000	149,000	111,000
0.1483-0.1920.....	187,000	171,000	139,000	103,000
0.2070-0.2625.....	174,000	160,000	130,000	95,000
0.2813-0.3438.....	163,000	150,000	122,000	89,000
0.3625-0.4375.....	155,000	143,000	116,000	84,500
0.4615-0.5625.....	146,000	134,000	109,000	80,000

Reduction of area, 48 per cent minimum. Elongation in 8 in., $3\frac{1}{2}$ per cent minimum. Rockwell C, 42-46.

4. Surface Conditions

Upon etching with a hot solution of hydrochloric acid sufficiently to disclose surface defects, no seams, hairline or otherwise, pits, gouges, die marks, or other imperfections shall be revealed. Decarburization must be held to a minimum.

5. Limits of Variation in Diameter

Wire diameter 0.1620 in. and less—plus or minus 0.0015

Wire diameter 0.177 in. and over—plus or minus 0.002

6. Inspection, Rejections, and Replacements

All springs will be rigidly inspected at the plants as received. If more than a total of 10 per cent of the springs on any one purchase order are made of steel that fails to comply with the above specifications, or with the specifications on the detail drawing, the entire lot will be rejected. All springs rejected shall be replaced by the seller without further cost to the purchaser.

MUSIC-WIRE SPRING STEEL SPECIFICATIONS

Generally used for Class I compression springs in wire sizes up to and including 0.105 in. wire diameter. Springs made of this wire should not be finished.

1. Steel Manufacture

This steel is to be of Swedish manufacture according to approved practice by the acid open-hearth or electric-furnace process.

2. Chemical Composition

Carbon.....	0.60-1.00	Sulphur.....	0.25 max.
Manganese.....	0.25-0.50	Phosphorus.....	0.25 max.
Silicon.....	0.10-0.20		

3. Physical Properties

Range of wire diameter, in.	Minimum tensile strength, lb. per sq. in.		Minimum torsional strength, lb. per sq. in.	
	Ultimate	Elastic limit	Ultimate	Elastic limit
0.008 and under.....	363,000	216,000	297,000	163,000
0.009-0.012.....	360,000	214,000	295,000	162,000
0.013-0.020.....	346,000	207,000	285,000	156,000
0.022-0.030.....	334,000	201,000	275,000	150,000
0.032-0.040.....	324,000	195,000	266,000	145,000
0.042-0.051.....	313,000	188,000	256,000	141,000
0.055-0.063.....	303,000	181,000	248,000	136,000
0.067-0.078.....	292,000	175,000	238,000	130,000
0.082-0.090.....	283,000	170,000	232,000	126,000
0.095-0.105.....	275,000	164,000	225,000	123,000

Reduction in area, 46 per cent minimum. Elongation in 8 in., 2 per cent minimum.

4. Surface Conditions

Upon etching with a hot solution of hydrochloric acid sufficiently to disclose surface defects, no seams, hairline or otherwise, pits, gouges, die marks, or other imperfections shall be revealed. Decarburization must be held to a minimum.

5. Limits of Variation in Diameter

Wire diameter 0.025 in. and under—plus or minus 0.00025 in.

Wire diameter 0.027 to 0.063 in.—plus or minus 0.0005 in.

Wire diameter 0.067 in. and over—plus or minus 0.001 in.

6. Inspection, Rejections, and Replacements

All springs will be rigidly inspected at the plants as received. If more than a total of 10 per cent of the springs on any one purchase order are made of steel that fails to comply with the above specifications, or with the specifications on the detail drawing, the entire lot will be rejected. All springs rejected shall be replaced by the seller without further cost to the purchaser.

PHOSPHOR BRONZE SPRING WIRE—S.A.E. 81

Used only for small springs, especially where resistance to moisture or other corrosion is essential. Can be used in Class I, Class II, or Class III service. Diameters are specified in Brown and Sharpe gage numbers. Square or rectangular material may be used from a minimum size of $\frac{1}{32} \times \frac{1}{32}$ in. to a maximum of $\frac{1}{2} \times \frac{1}{2}$ in., advancing by $\frac{1}{32}$ in.

1. Chemical Composition

Tin.....	4.00-6.00	Iron, max.....	0.10
Phosphorus.....	0.03-0.40	Lead, max.....	0.10
Zinc, max.....	0.20	Copper.....	remainder

2. Tensile Strength

RANGE OF WIRE DIAMETER, IN.	MINIMUM
	TENSILE STRENGTH, LB. PER SQ. IN.
Up to 0.0625	130,000
0.0625-0.1250	120,000
0.1250-0.2500	110,000
0.2500-0.3750	100,000

3. Bend Test

The wire should be capable of being bent through an angle of 180 deg. flat back on itself without fracture on the outside of the bent portion.

4. Appearance

The wire shall be uniform in quality and temper, cylindrical in shape, and smooth and free from injurious defects.

5. Dimensional Tolerances

The wire shall not vary from the specified diameter by more than the following:
 Sizes over 0.050 in., by plus or minus 1 per cent
 Sizes 0.050 to 0.025 in., by plus or minus 0.0005 in.
 Sizes under 0.025 in., by plus or minus 0.00025 in.

BRASS SPRING WIRE, S.A.E. 80

This material may be used for the same types and classes of springs for which phosphor bronze is suitable. It is available in two grades, as given below, Grade A for use where the requirements are especially severe and Grade B for use under ordinary conditions. Grade B will be furnished unless otherwise specified.

1. Chemical Composition

Constituents	Grade A	Grade B
Copper.....	70.00-74.00	64.00-68.00
Lead, maximum.....	0.10	0.10
Iron, maximum.....	0.06	0.07
Zinc.....	Remainder	Remainder

2. Physical Properties

This wire shall have a tensile strength of at least 100,000 lb. per sq. in. but should be capable of being bent through an angle of 180 deg. around a wire of the same diameter without breaking.

3. Appearance

The wire shall be uniform in quality and temper, cylindrical in shape, and smooth and free from injurious defects.

4. Dimensional Tolerances

The wire shall not vary from the specified diameter by more than the following:

- Sizes over 0.050 in., by plus or minus 1 per cent
- Sizes 0.050 to 0.025 in., by plus or minus 0.0005 in.
- Sizes under 0.025 in. by plus or minus 0.00025 in.

DESIGN CALCULATIONS

Class I springs, *i.e.*, springs subjected to rapid continuous deflections over a uniform stress range from zero to maximum or from an intermediate stress to maximum, as in engine valve springs, must be designed on the basis of the endurance limit of the material. Class II and Class III springs, respectively, springs that operate only intermittently or springs that are statically loaded are designed on the basis of the static strength of the material.

Because the static strength of wire of a given material increases with decreased wire diameter, as shown in Figs. 243 to 247, a larger permissible stress can be used for the smaller wires. The following table gives the maximum permissible working stresses for springs for Class II and Class III service.

MAXIMUM PERMISSIBLE STRESSES, POUNDS PER SQUARE INCH
For Class II and Class III Service

Type of steel	Compression springs		Extension springs		Torsion springs	
	0.1055- 0.2625 wire diameter	0.2812- 0.5625 wire diameter	0.1055- 0.2625 wire diameter	0.2812- 0.5625 wire diameter	0.1055- 0.2625 wire diameter	0.2812- 0.5625 wire diameter
Class II:						
Swedish.....	66,000	55,250	52,800	44,200	79,200	66,300
Carbon.....	63,750	53,500	51,000	42,800	76,500	64,200
Vanadium.....	76,000	64,250	60,800	51,400	91,200	77,100
Class III:						
Swedish.....	77,500	65,000	62,000	52,000	93,000	78,000
Carbon.....	75,000	63,000	60,000	50,400	90,000	75,600
Vanadium.....	89,500	75,500	71,600	60,400	107,400	90,600

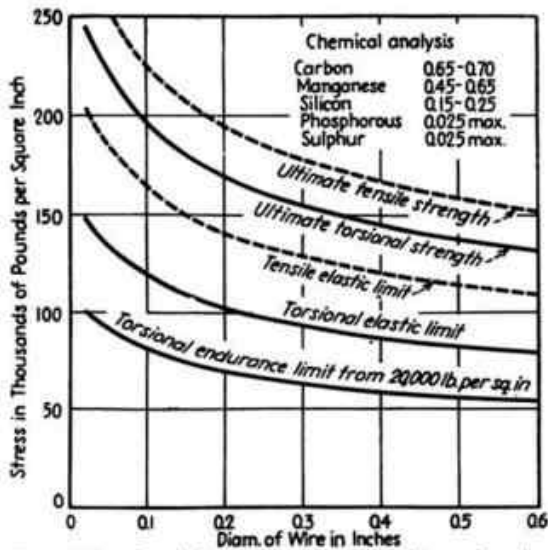

FIG. 243.—Swedish steel wire. Relation of wire diameter to physical properties.

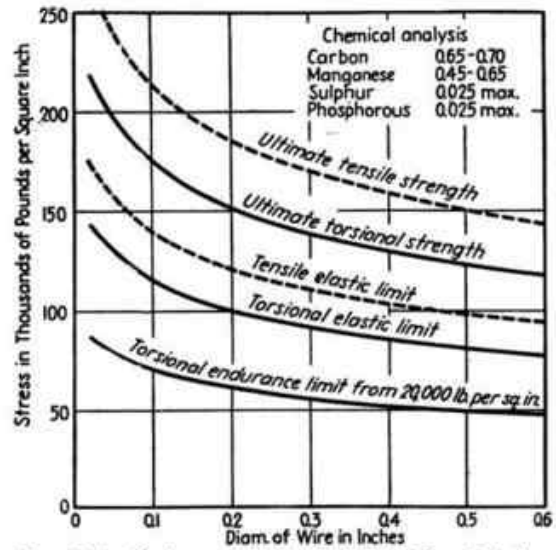

FIG. 244.—Carbon-steel wire, S.A.E. 1065. Relation of wire diameter to physical properties.

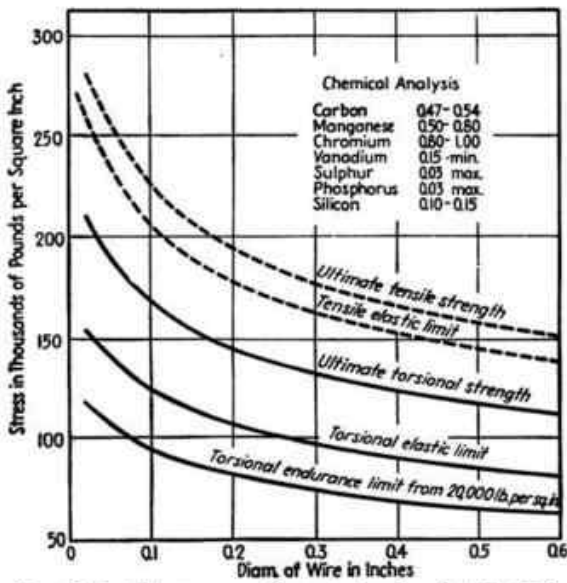

FIG. 245.—Chrome-vanadium-steel wire, S.A.E. 6150. Relation of wire diameter to physical properties.

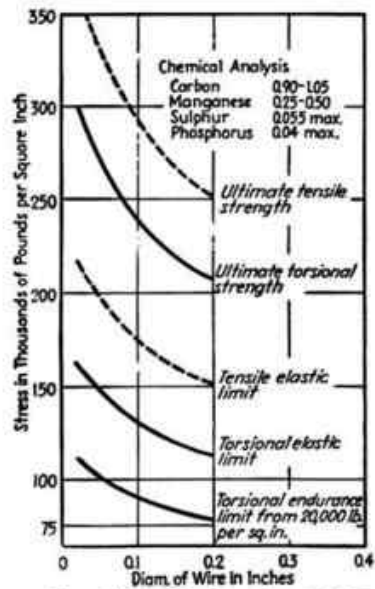

FIG. 246.—Music wire, S.A.E. 1095. Relation of wire diameter to physical properties.

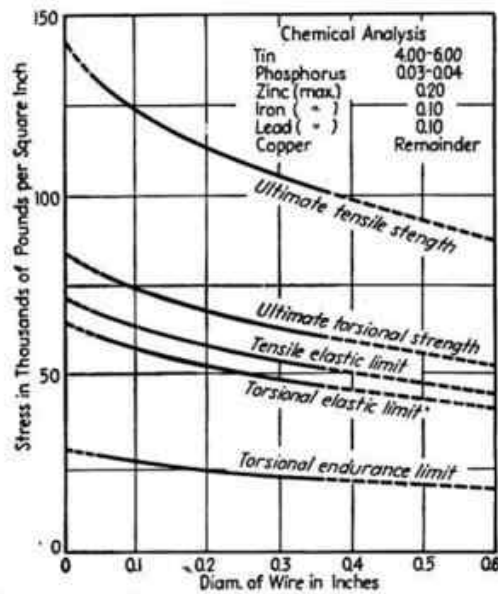

FIG. 247.—Phosphor bronze wire, S.A.E. 81. Relation of wire diameter to physical properties.

WAHL CORRECTION FACTOR

As the spring index, *i.e.*, the ratio of coil diameter to wire diameter, decreases, the maximum stress developed becomes increasingly greater than that as calculated by the conventional formulas. To compensate for this in the design calculations, the Wahl correction factor must be applied. The accompanying chart (Fig. 248)

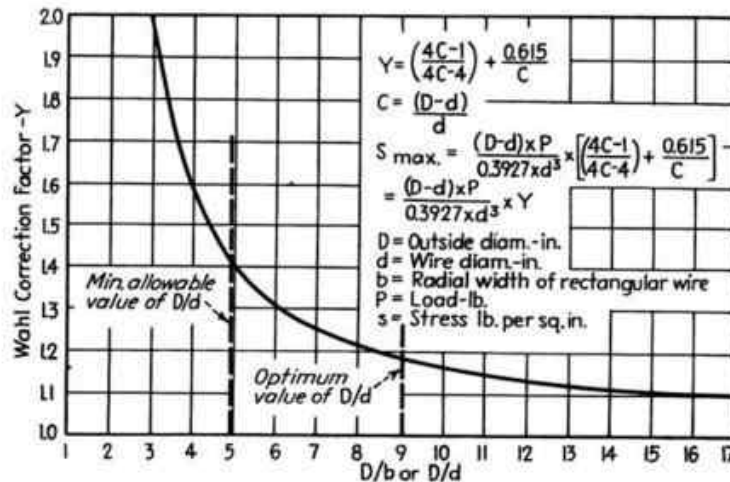

FIG. 248.—Wahl correction factor for different values of spring index.

gives this correction factor. The optimum value for the spring index is 9, the minimum value for practical purposes is 5. Below this figure, the stresses increase rapidly.

TORSIONAL MODULI

The torsional modulus of elasticity for Swedish steel, carbon steel, or vanadium steel can be taken as 11,500,000. For phosphor bronze and brass, a value of 6,000,000 can be taken. At high temperature, the value of *G* drops, as shown in Fig. 254 for steel.

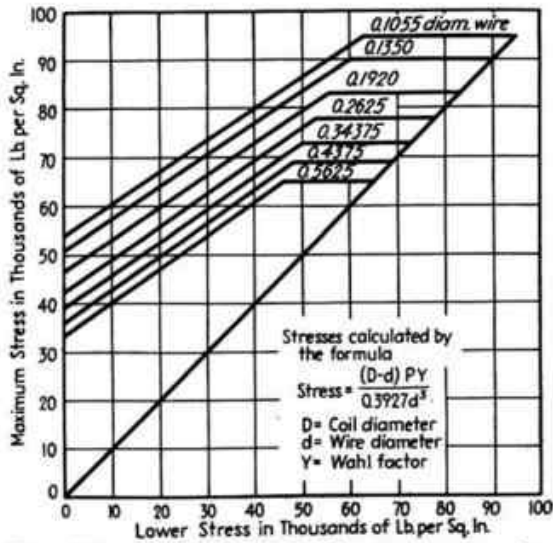

FIG. 249.—Allowable torsional stress range for Swedish steel wire.

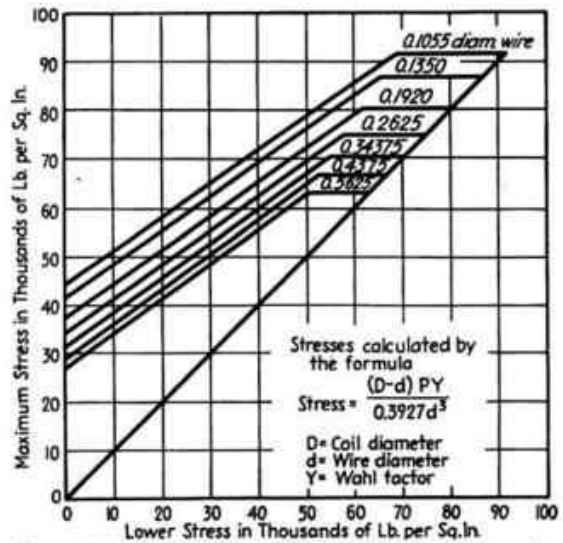

FIG. 250.—Allowable torsional stress range for ordinary carbon-steel wire.

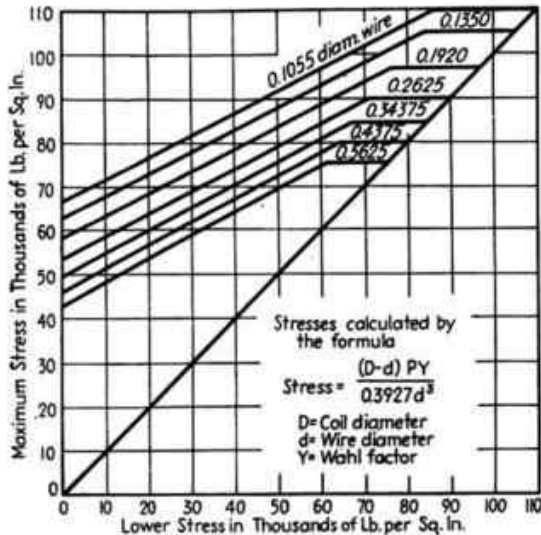

FIG. 251.—Allowable torsional stress range for chrome-vanadium-steel wire.

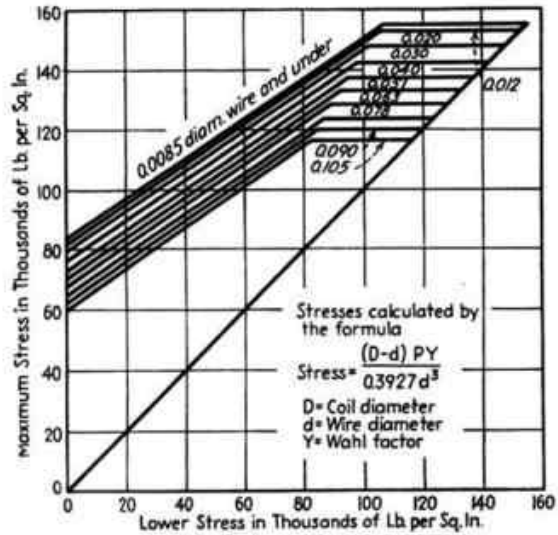

FIG. 252.—Allowable torsional stress range for music wire.

SPRING FORMULAS

In using the formulas given on pages 133 and 134 to design Class II and Class III springs, a trial value of D/d is assumed and the corresponding Wahl factor is obtained from the curve in Fig. 248. The material is selected and the allowable stress is taken from the table on page 128. The larger value is used if the estimated wire size is less than 0.2625 in. diameter. For larger wires the smaller value is used. With the outside diameter of the spring specified and the load W known, the wire diameter d can be calculated. The spring index must then be checked to see if it is on the safe side and approximates the index selected for the calculations. Likewise, the diameter of the wire must be checked against the permissible working stress selected.

In calculating Class I springs, the procedure is similar except that the permissible working stress must be based on the endurance value of the material. A tentative allowable stress is assumed, and the wire diameter is calculated by following the same procedure as outlined above for Class I and Class II springs. The calculated wire diameter is then checked against the endurance charts as given in Figs. 249 to 253 for the various materials.

As an example of the use of the endurance charts, assume a valve spring had been calculated to be made of Swedish steel wire 0.177 in. diameter and the wire calculated to be stressed to 62,000 lb. per sq. in. when the valve is closed and 81,000 lb. per sq. in.

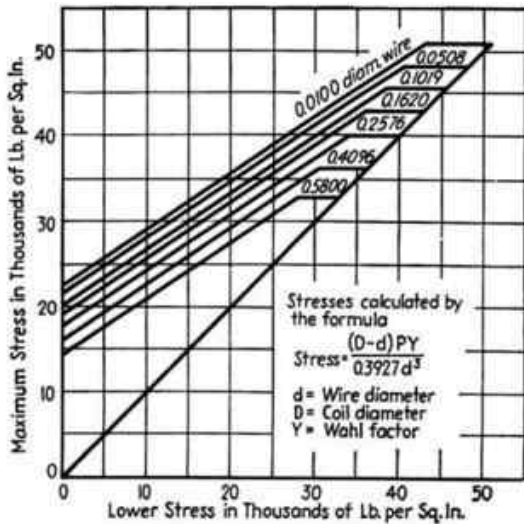

FIG. 253.—Allowable torsional stress range for phosphor-bronze wire.

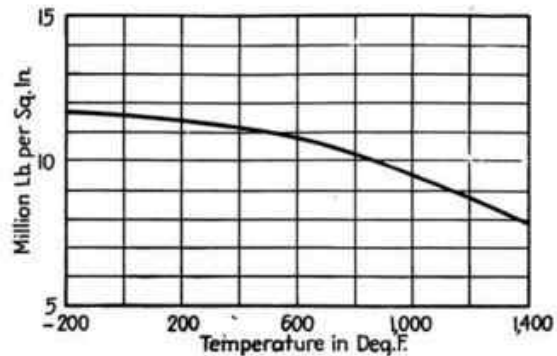

FIG. 254.—Value of torsional modulus of elasticity of steel at various temperatures.

when the valve is open. A check must then be made to see if this stress range is permissible. With reference to Fig. 249, from 62.0 on the lower-stress scale, representing 62,000 lb. per sq. in. stress, go up vertically on the chart to the curve representing the next larger wire diameter, namely, 0.1920. The maximum stress allowable as read from the scale on the left of the chart is 83.0, or 83,000 lb. per sq. in. Since this is greater than 81,000, the given stress range is therefore safe.

NATURAL FREQUENCY

Springs must be designed so that their natural frequency of vibration will not be close to their frequency of deflection in operation, in order to avoid resonance and resulting high stresses. If their natural frequency is sufficiently high to escape resonance with any harmonic below the twentieth order, resonance will be avoided. This will be assured if

$$\frac{250d \sqrt{G}/(D - d)^2 N}{\text{Deflection cycles per minute}} \text{ equals or exceeds } 20$$

The order of harmonic as calculated by this equation should be as much above 20 as possible. The order of harmonic, for a given spring material, decreases with the difference between the coil diameter and the diameter of the wire and is inversely

TABLES FOR CALCULATING HELICAL SPRINGS

COMPRESSION SPRING FORMULAS

Spring index = $\frac{D}{d}$ or $\frac{D}{b} = 5$ (minimum)

Round	Square	Rectangular
$W = \frac{0.3927Sd^3}{(D-d)Y}$ $N = \frac{MWL - (2.25d)}{1.10d}$ (maximum) $F = \frac{8P(D-d)^3}{Gd^4}$ $F_N = FN$ $FL = F_N + MWL$ Pitch = $\frac{FL - (2.25d)}{N}$ Load per inch of deflection = P/F_N Solid length = $(N + 2.25)d$ $MWL = (1.10dN) + (2.25d)$	$W = \frac{0.444Sd^3}{(D-d)Y}$ $N = \frac{MWL - \left[d \left(\frac{D}{D-d} + 1 \right) \right]}{0.53dz \left(\frac{D}{D-d} + 1 \right)}$ (maximum) $F = \frac{5.58P(D-d)^3}{Gd^4}$ $F_N = FN$ $FL = F_N + MWL$ Pitch = $\frac{FL - \left[d \left(\frac{D}{D-d} + 1 \right) \right]}{N}$ Load per inch of deflection = P/F_N Solid length = $\left[0.48d \left(\frac{D}{D-d} + 1 \right) N \right] + \left[d \left(\frac{D}{D-d} + 1 \right) \right]$ $MWL = \left[0.53d \left(\frac{D}{D-d} + 1 \right) N \right] + \left[d \left(\frac{D}{D-d} + 1 \right) \right]$	$W = \frac{Sbt \sqrt{b^2 + t^2}}{3.185(D-b)Y}$ $N = \frac{MWL - \left[t \left(\frac{D}{D-b} + 1 \right) \right]}{0.53t \left(\frac{D}{D-b} + 1 \right)}$ (maximum) $F = \frac{11.16P(D-b)^3}{Gbt(b^2 + t^2)}$ $F_N = FN$ $FL = F_N + MWL$ Pitch = $\frac{FL - \left[t \left(\frac{D}{D-b} + 1 \right) \right]}{N}$ Load per inch of deflection = P/F_N Solid length = $\left[0.48t \left(\frac{D}{D-b} + 1 \right) N \right] + \left[t \left(\frac{D}{D-b} + 1 \right) \right]$ $MWL = \left[0.53t \left(\frac{D}{D-b} + 1 \right) N \right] + \left[t \left(\frac{D}{D-b} + 1 \right) \right]$

EXTENSION SPRING FORMULAS

$F_N = F \times N$ Pitch = EL/N Load per inch deflection = P/F_N

Round	Square	Rectangular
$W = \frac{0.3927Sd^3}{(D-d)Y}$ $N = \frac{FL}{d}$ (maximum) $F = \frac{8P(D-d)^3}{Gd^4}$	$W = \frac{0.444Sd^3}{(D-d)Y}$ $N = \frac{FL}{0.48d \left(\frac{D}{D-d} + 1 \right)}$ $F = \frac{5.58P(D-d)^3}{Gd^4}$	$W = \frac{Sbt \sqrt{b^2 + t^2}}{3.185Y(D-b)}$ $N = \frac{FL}{0.48t \left(\frac{D}{D-b} + 1 \right)}$ $F = \frac{11.16P(D-b)^3}{Gbt(b^2 + t^2)}$

TABLES FOR CALCULATING HELICAL SPRINGS

TORSION SPRING FORMULAS

Pitch = FL/N

Round	Square rectangular
$W = \frac{0.098Sd^3}{R}$	$W = \frac{0.166Stb^3}{R}$
$F_N = \frac{20PIR^2}{Ed^4}$	$F_N = \frac{12PIR^2}{Eb^4l}$
$N = \frac{FL}{d}$ (maximum)	$N = \frac{FL}{0.48t \left(\frac{D}{D-b} + 1 \right)}$ maximum

 E = modulus of elasticity F = deflection of 1 turn, in in. F_N = total deflection, in in. FL = free length, in in. G = torsional modulus of elasticity l = length of rod (effective spring length uncoiled), in in. MWL = minimum working length, in in. N = number of effective turns P = load, in lb. R = length of arm, in in. S = stress, in lb. per sq. in. W = carrying capacity in lb. Y = Wahl factor

PERMISSIBLE MANUFACTURING TOLERANCES

Outside diameter, in.	Variation, in., plus or minus	Length, in.	Variation, in., plus or minus	Pitch	Variation, plus or minus	Load
Smaller than $\frac{1}{8}$	0.003	Less than 1	$\frac{1}{32}$	4 coils or less	$\frac{1}{4}$ coil	Plus or minus 10 per cent
$\frac{1}{8}$ - $\frac{1}{4}$	0.005	1 to 2	$\frac{1}{16}$			
$\frac{1}{4}$ - $\frac{1}{2}$	0.008	2 to 3	$\frac{3}{32}$	4-8 coils	$\frac{1}{2}$ coil	
		3 to 5	$\frac{1}{8}$			
$\frac{1}{2}$ -1	0.015	5 to 8	$\frac{5}{32}$	8-15 coils	$\frac{3}{4}$ coil	
		8 to 12	$\frac{1}{4}$			
1-2	$\frac{1}{32}$	12 to 18	$\frac{3}{8}$	15-25 coils	1 coil	
		18 to 24	$\frac{1}{2}$			
2-3	$\frac{1}{16}$	24 to 30	$\frac{3}{4}$	Over 25 coils	2 coils	
Over 3	$\frac{3}{32}$	Over 30	1			

proportional to the number of active turns. In a compression spring, the number of active turns will be the total number of turns less $2\frac{1}{2}$ turns, assuming $1\frac{1}{4}$ dead turns at each end of the spring.

DEFLECTION

Calculate the deflection per turn and total deflection by the formulas given in the tables on pages 133 and 134. For compression springs, the number of active or effective turns N will be the total number of turns less $2\frac{1}{2}$ turns.

GENERAL SPECIFICATIONS

Compression Springs.—Ends must be ground square. Minimum and maximum inside and outside diameters will be determined by the space restrictions imposed by the application. Both ends of the compression spring should be guided on either the outside or inside or both. All compression springs should be wound right hand except where they operate inside one another, in which case they should be wound oppositely. Minimum working length of the spring under compression should allow a minimum clearance between effective turns equal to 10 per cent of the wire diameter. Additional compression beyond this minimum working should not be permitted.

Extension Springs.—They may be close wound with or without initial tension, or they may be open wound. They should always be wound without initial tension when load capacity is an important factor. All extension springs should be wound right hand unless required otherwise. Maximum working length determines the position of the spring beyond which additional extension should not be permitted.

FINISHES

Steel springs to resist moisture or atmospheric corrosion should be cadmium plated. For appearance, they may be enameled, lacquered, or japanned. Springs made of nonferrous metals are usually not finished in any manner.

STANDARD DESIGN PROCEDURE

By using a form such as given on page 136, the procedure in designing springs can be standardized. The data relating to the actual dimensions and characteristics of the spring are obtained from the inspection or test department.

STANDARD DRAWINGS

Examples of standard drawings on sheets $8\frac{1}{2} \times 11$ in. for the three types of helical springs, compression, tension, and torsion, are shown on page 137. Drawing need not be to scale. Wire sizes should be specified in inches, not gage numbers. Use decimals for specifying wire diameters and fractions of inches for rectangular materials. Also dimension the thickness of rectangular wire so as to indicate how the wire is to be wound. Indicate finish, if any. In dimensioning the drawing, indicate the permissible manufacturing tolerances as given in table above, but tolerances as large as permissible should always be specified. Load tolerances should be indicated as plus or minus, the mean value to correspond with the specific rate.

The notations and dimensions as given in the drawings shown here should be given.

FORM FOR SPRING DESIGN CALCULATIONS

SPRING DESIGN						
Drg. No. <u>S-2494</u>	Class <u>1</u>	Rate <u>60</u>	Max. O.D. <u>2 ⁹/₃₂</u>	Min. I.D. <u>1 ³/₄</u>		
Pitch <u>0.550</u>	F.L. <u>6 ¹/₄</u>	M.W.L. <u>3.325</u>	Material <u>MS-12</u>	Size <u>0.2437 diam.</u>		
Length of arm _____	Length of rod _____	Max. def. _____				
CALCULATIONS						
$N = \frac{3.325 - 0.55}{0.268} = 10.35$	$(D-d) = \frac{\text{Max. O.D.} + \text{Min. I.D.}}{2} = 2.015$					
$F_N = FL - MWL = 2.925$	$P = \frac{G \times d^4 \times F_N}{8 \times (D-d)^3 \times N} = \frac{11,500,000 \times 0.003527^4 \times 2.925}{8 \times 8.2 \times 10.35} = 175$					
$\text{Rate} = \frac{P}{F_N} = \frac{175}{2.925} = 60$	$S = \frac{2.015 \times 175}{0.3927 \times 0.01447} \times 1.18 = 73,200$					
$\text{Pitch} = \frac{6.25 - 0.55}{10.35} = 0.550$	Solid length = $(10.35 + 2.25) \times 0.2437 = 3.07$					
ACTUAL VALUES						
F.L. <u>6 ⁹/₃₂</u>	N <u>10.5</u>	Load <u>58</u>	Def. <u>1"</u>	Solid length <u>3 ¹/₈</u>	O.D. <u>2 ⁹/₃₂</u>	d <u>0.24</u>
Set <u>1 ¹/₆₄</u>	Average of <u>10</u> Springs		Total turn <u>13</u>	Manufactured by <u>W. D. GIBSON</u>		
Solid line = Test Dotted line = Calculated						
Spring Part Number <u>S/S-E</u>						
Original by <u>GRE.</u>	Date <u>2-9-36</u>	Checked by <u>AND.</u>	Date <u>2-25-36</u>	Tested by <u>GAW.</u>	Date <u>3-25-36</u>	
APPROVED BY	DATE ISSUED <u>April 17, 1936</u>	SUPERSEDING	SUPERSEDED BY	REVISION DATES		

STANDARD DRAWINGS FOR SPRINGS

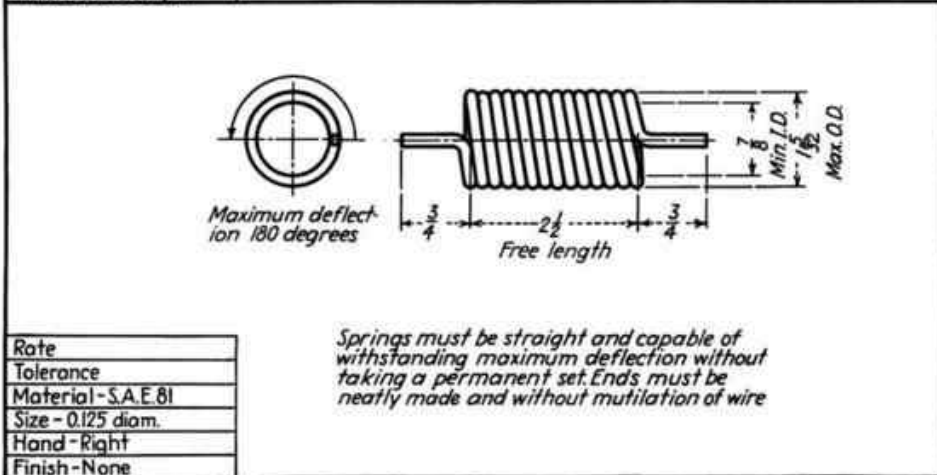
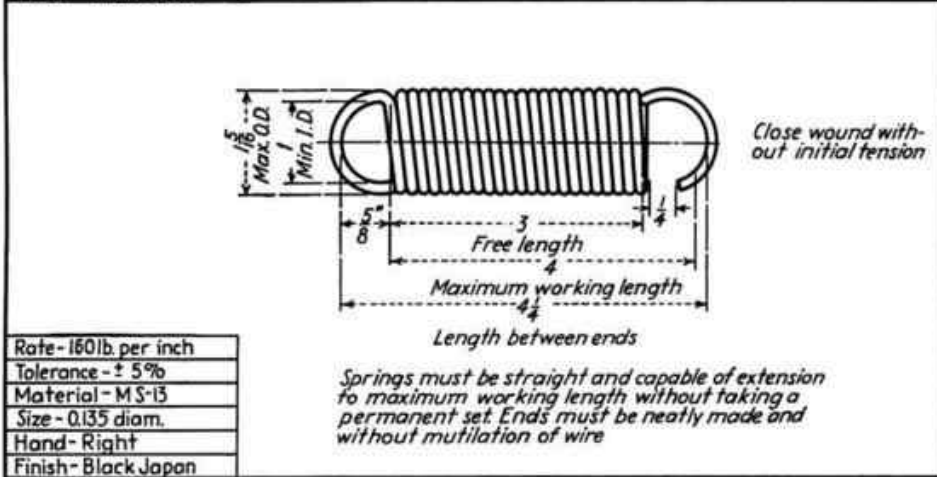
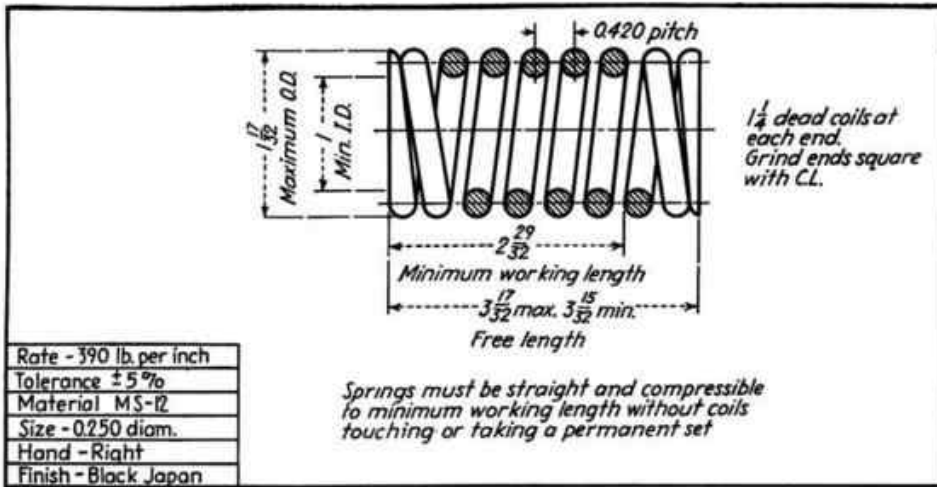

Examples of standard spring drawings. At the top is a compression spring; in the middle is shown an extension spring; at the bottom is a torsion spring.

Wire Gages, Diameters, and Their Squares, Cubes, and Fourth Powers

STEEL WIRE SIZES

(Washburn & Moen gage)

MONEL, BRONZE, AND BRASS WIRE

(Brown & Sharpe gage)

No.	Decimal	d ²	d ³	d ⁴	No.	Decimal	d ²	d ³	d ⁴
3/16	0.5625	0.3164	0.17798	0.10011	6-0	0.5800	0.3364	0.19511	0.11316
13/32	0.5313	0.2822	0.14993	0.07965	5-0	0.5165	0.2668	0.13779	0.07117
1/2	0.5000	0.2500	0.12500	0.06250	4-0	0.4600	0.2116	0.09734	0.04477
7-0	0.4900	0.2401	0.11765	0.05765	3-0	0.4096	0.16777	0.06872	0.02815
13/32	0.4688	0.2197	0.10300	0.04828	2-0	0.3648	0.13305	0.04855	0.01771
6-0	0.4615	0.2130	0.09829	0.04536	0	0.3249	0.10556	0.03430	0.01114
3/16	0.4375	0.19141	0.08374	0.03664	1	0.2893	0.08369	0.02421	0.00701
5-0	0.4305	0.18533	0.07978	0.03435	2	0.2576	0.06636	0.01709	0.00440
13/32	0.4063	0.16504	0.06705	0.02724	3	0.2294	0.05262	0.01207	0.00277
4-0	0.3938	0.15508	0.06107	0.02405	4	0.2043	0.04174	0.00853	0.00174
3/8	0.3750	0.14063	0.05273	0.01978	5	0.1819	0.03309	0.00602	0.00109
3-0	0.3625	0.13141	0.04763	0.01727	6	0.1620	0.02624	0.00425	0.00069
13/32	0.3438	0.11816	0.04062	0.01396	7	0.1443	0.02082	0.00301	0.00043
2-0	0.3310	0.10956	0.03626	0.01200	8	0.1285	0.01651	0.00212	0.00027
3/16	0.3125	0.09766	0.03052	0.00954	9	0.1144	0.01309	0.00150	0.00017
0	0.3065	0.09394	0.02879	0.00883	10	0.1019	0.01038	0.00106	0.00011
1	0.2830	0.08009	0.02267	0.00641	11	0.0907	0.00823	0.00075	0.00007
3/32	0.2813	0.07910	0.02225	0.00626	12	0.0808	0.00653	0.00053	0.00004
2	0.2625	0.06891	0.01809	0.00475	13	0.0720	0.00518	0.00037	0.00003
3/4	0.2500	0.06250	0.01563	0.00391	14	0.0641	0.00411	0.00026	0.00002
3	0.2437	0.05939	0.01447	0.00352	15	0.0571	0.00326	0.00019	0.00001
4	0.2253	0.05076	0.01144	0.00258	16	0.0508	0.00258	0.00013	0.000007
3/32	0.2188	0.04785	0.01047	0.00229	17	0.0453	0.00205	0.00009	0.000004
5	0.2070	0.04285	0.00887	0.00184	18	0.0403	0.00162	0.00006	0.000002
6	0.1920	0.03686	0.00708	0.00136	19	0.0359	0.00129	0.00005	0.000002
3/16	0.1875	0.03516	0.00659	0.00124	20	0.0320	0.00102	0.00003	0.000001
7	0.1770	0.03133	0.00554	0.00098	21	0.0285	0.00081	0.00002	0.000001
8	0.1620	0.02624	0.00425	0.00069	22	0.0253	0.00064	0.00002	0.0000004
3/32	0.1563	0.02441	0.00382	0.00059	23	0.0226	0.00051	0.00001	0.0000003
9	0.1483	0.02199	0.00326	0.00048	24	0.0201	0.00040	0.000008	0.0000002
10	0.1350	0.01823	0.00246	0.00033	25	0.0179	0.00032	0.000006	0.0000001
3/8	0.1250	0.01563	0.00195	0.00024	26	0.0159	0.00025	0.000004	0.00000006
11	0.1205	0.01452	0.00175	0.00021	27	0.0142	0.00020	0.000003	0.00000004
12	0.1055	0.01113	0.00117	0.00012	28	0.0126	0.00016	0.000002	0.00000003
3/32	0.0938	0.00879	0.00082	0.00008	29	0.0113	0.00013	0.000001	0.00000002
3/16	0.0625	0.00391	0.00024	0.00002	30	0.0100	0.00010	0.000001	0.00000001
3/32	0.0313	0.00098	0.00003	0.000001					

MUSIC WIRE SIZES

(Roebbling gage)

No.	Decimal	d ²	d ³	d ⁴	No.	Decimal	d ²	d ³	d ⁴
2	0.011	0.00012	0.000001	0.00000001	19	0.042	0.00176	0.000074	0.00000311
3	0.012	0.00014	0.000002	0.00000002	20	0.044	0.00194	0.000085	0.00000375
4	0.013	0.00017	0.000002	0.00000003	21	0.046	0.00212	0.000097	0.00000448
5	0.014	0.00020	0.000003	0.00000003	22	0.048	0.00230	0.000111	0.00000531
6	0.016	0.00026	0.000004	0.00000007	23	0.051	0.00260	0.000133	0.00000676
7	0.018	0.00032	0.000006	0.00000011	24	0.055	0.00303	0.000166	0.00000915
8	0.020	0.00040	0.000008	0.00000016	25	0.059	0.00348	0.000205	0.00001212
9	0.022	0.00048	0.000011	0.00000023	26	0.063	0.00397	0.000250	0.00001575
10	0.024	0.00058	0.000014	0.00000033	27	0.067	0.00449	0.000301	0.00002015
11	0.026	0.00068	0.000018	0.00000046	28	0.071	0.00504	0.000358	0.00002541
12	0.028	0.00078	0.000022	0.00000062	29	0.074	0.00548	0.000405	0.00002999
13	0.030	0.00090	0.000027	0.00000081	30	0.078	0.00608	0.000475	0.00003701
14	0.032	0.00102	0.000033	0.00000105	31	0.082	0.00672	0.000551	0.0000452
15	0.034	0.00116	0.000039	0.00000134	32	0.086	0.00740	0.000636	0.0000547
16	0.036	0.00130	0.000047	0.00000168	33	0.090	0.00810	0.000729	0.0000656
17	0.038	0.00144	0.000055	0.00000209	34	0.095	0.00903	0.000857	0.0000814
18	0.040	0.00160	0.000064	0.00000256	35	0.100	0.01000	0.001000	0.0001000

The spring end construction of tension and torsion springs should be given in detail by showing all necessary views. See page 144 for typical spring ends.

INSPECTION

All springs received shall be carefully inspected, tested, and marked, where required, for identification.

Inspection shall cover all specification requirements noted on the spring drawings and on the material specification sheets. Particular care should be exercised in inspecting the material to make certain all defects noted on the material specification sheets are absent. In case of doubt, one or two springs from the shipment in question should be etched in a 30 per cent solution of boiling hydrochloric acid for a sufficient length of time to reduce the diameter 0.002 to 0.003 in. After etching, all material or manufacturing defects are readily discernible.

A sufficient number of springs from each shipment shall be tested to determine if the spring rate is within the limits specified on the drawing. The amount of set, if any, when compressed to the minimum working length must also be determined.

All springs failing to meet the requirements referred to above shall be rejected. If more than 10 per cent of the springs on any one order are rejected, the entire shipment shall be rejected.

Springs constructed of music wire, Monel metal, phosphor bronze, or brass shall not be marked in any way for identification. Springs made of steel shall have one or two coils at one end painted a color corresponding to that indicated as follows: Swedish steel, blue; carbon steel, orange; chrome vanadium steel, red. The paint used shall be quick-drying, oilproof, heat-resisting lacquer.

GRAPHICAL SOLUTION OF HELICAL SPRING FORMULAS

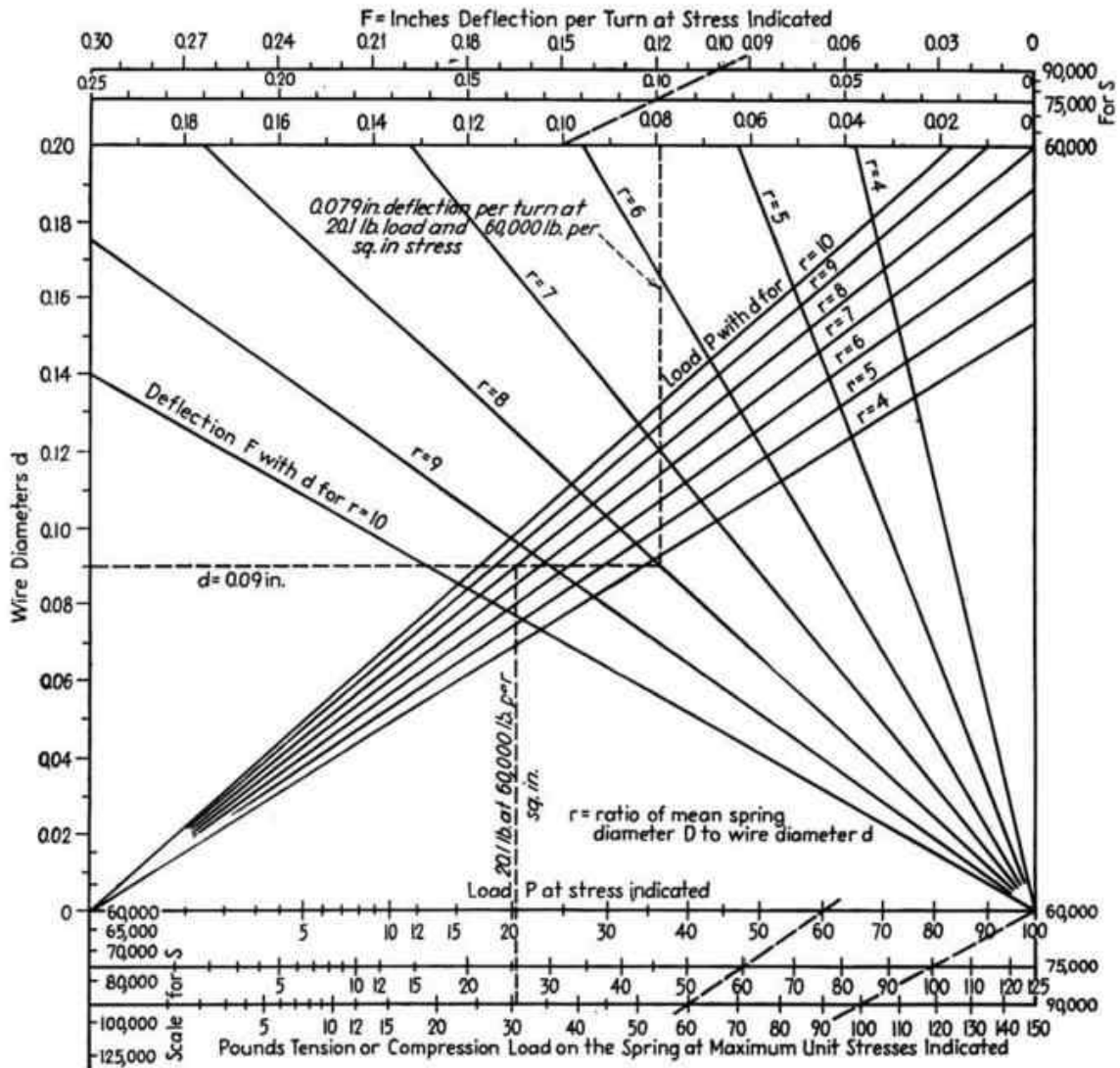

This chart, developed by Carl P. Nachod, of Nachod & United States Signal Co., can be used for the solution of the formulas for round-wire helical springs given on the preceding pages. The chart is based on G being 11,500,000. The Wahl factor is incorporated in the equation on which this chart is based.

To use the chart: Given a load P of 20.1 lb. and an allowable stress of 60,000 lb. per sq. in.; go vertically upward from the point representing 20.1 lb. on the lower 60,000 scale to the intersection with the load ray, extending upward to the right, corresponding to the spring index (D/d) selected, in this example $r = 8$. A horizontal line through the intersection point to the scale for wire diameters gives $d = 0.09$ in. Extend this horizontal line to the right to the "deflection" ray $r = 8$ of the group of rays extending upward to the left. From this point, trace vertically upward to the F scale corresponding to the value of S selected, and this gives the deflection F as 0.079 in. per turn at 60,000 lb. per sq. in. stress.

HELICAL SPRINGS OF GIVEN LOAD RATIO AND LENGTH RATIO

Graphical computation charts, developed by Frederick Franz, for springs for specified maximum load and length and specified minimum load and length based on

$$G = 11,500,000 \quad S = 50,000$$

Step 1. To determine spring index.

Compression Springs.—Divide specified initial load $P_{min.}$ on spring by maximum load $P_{max.}$, when compressed, to obtain load ratio. Similarly, calculate length ratio of compressed length $L_{min.}$ to initial length $L_{max.}$. The intersection of the vertical line representing load ratio and the horizontal line representing length ratio gives value of D/d , the ratio of outside diameter of coil to the diameter of the wire.

Tension Springs.—Divide initial tension on spring by final tension, to obtain load ratio. Divide initial length of spring by maximum length, to obtain length ratio. The intersection of the vertical line representing load ratio with the horizontal line representing length ratio gives D/d , the ratio of outside diameter of coil to the diameter of the wire.

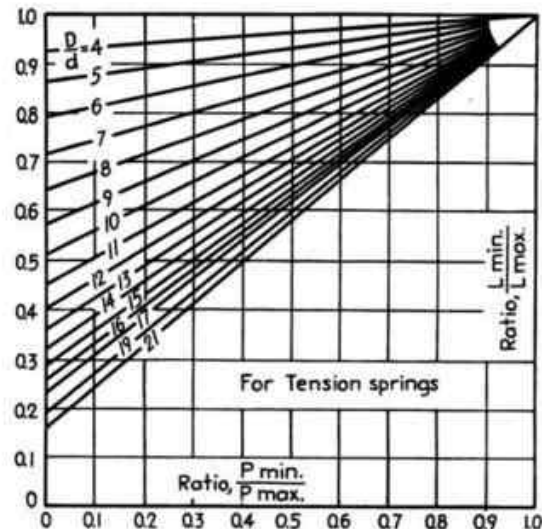
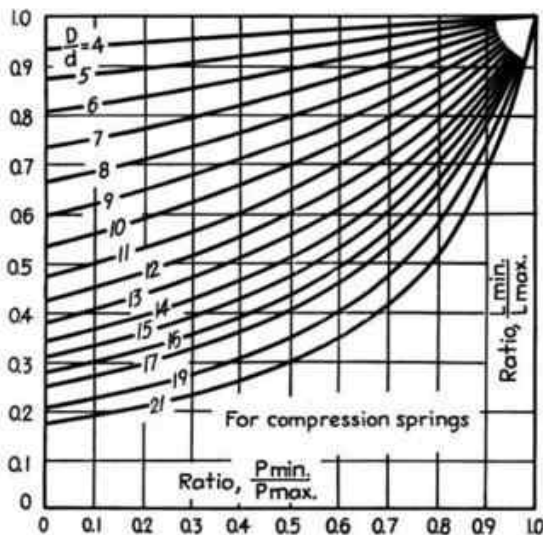

Length of a compression spring must be calculated as the length of active spring, *i.e.*, total length less length taken by inactive coils, namely, $1\frac{1}{4}$ dead turns at each end. For compression springs, a minimum clearance of $0.1d$ (wire diameter) must be allowed. For example, if the space available for a compression spring is 6 in. and a rough estimate indicates a wire diameter of $\frac{1}{4}$ in., and $1\frac{1}{4}$ dead turns on each end, the maximum length of spring will be 6 in. less the length equivalent of $2\frac{1}{2}$ turns which is $\frac{5}{8}$ in. Thus, $L_{max.}$ would be $5\frac{3}{8}$ in. If the minimum to which this spring is to be compressed is to be 5 in., the minimum active length will likewise be 5 in. less $\frac{5}{8}$ in., or $4\frac{3}{8}$ in. approximately.

Step 2. To determine maximum safe load, wire diameter, and mean coil diameter for helical round wire tension or compression springs; based on 50,000 lb. per sq. in. allowable stress.

When the value of D/d , ratio of outside diameter of spring to diameter of wire, has been determined, the chart below gives the maximum safe load, wire diameter, and mean coil diameter for values of D/d , the spring index.

MAXIMUM LOAD, WIRE DIAMETER, MEAN COIL DIAMETER, AND SPRING INDEX

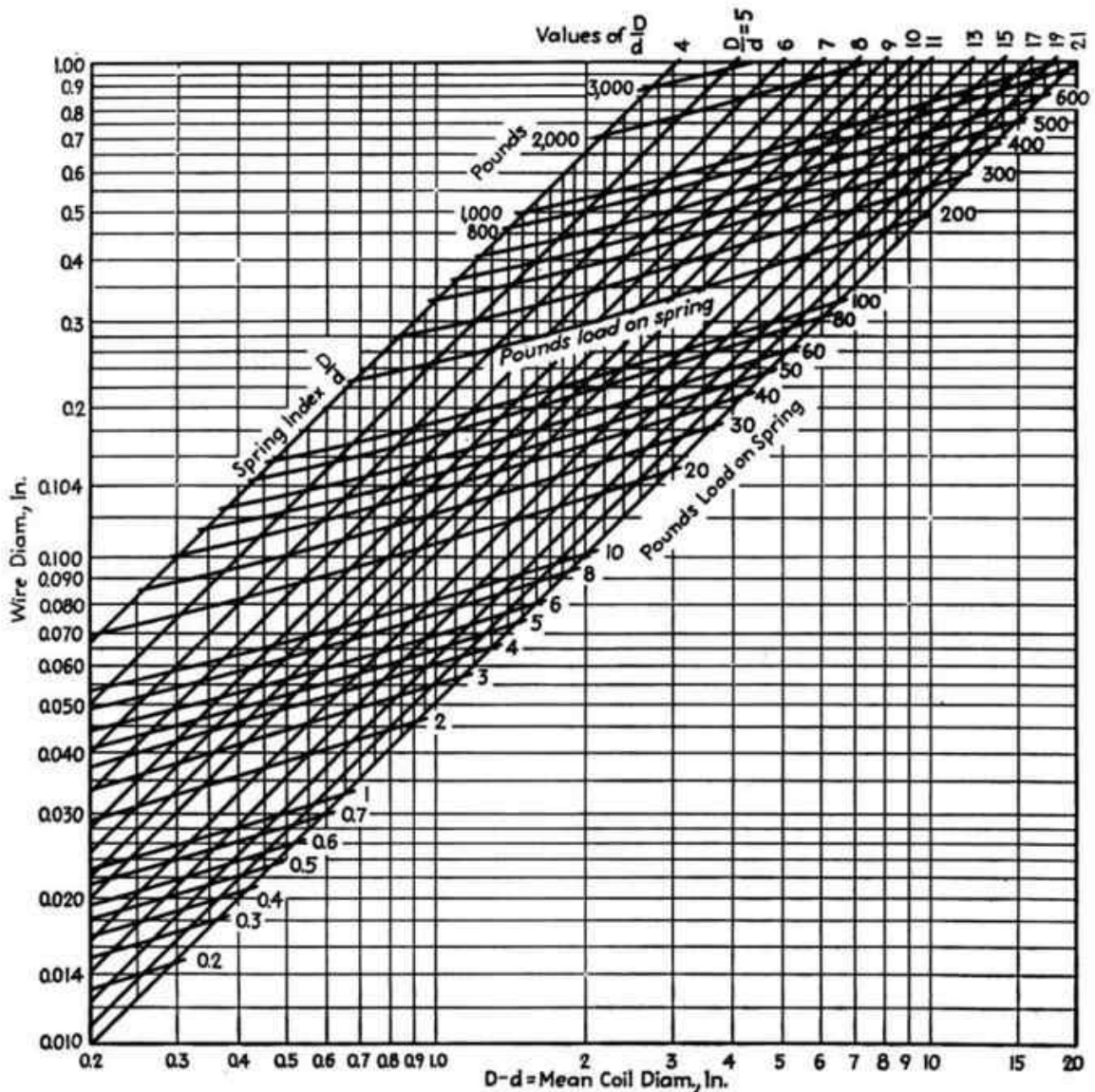

For example, for a spring index of 6, find the wire diameter required if the spring is to be loaded to 100 lb. maximum. Follow the diagonal for $D/d = 6$ (upper horizontal scale) down until it intersects with the diagonal Pounds Load on Spring representing 100-lb. load. By dropping down vertically from this intersection point, the bottom horizontal scale shows $D - d = 0.9$. On going horizontally from this intersection point to scale on left, $d = 0.175$ (approx.). Or d can easily be calculated from knowing that $D - d = 0.9$ and $D/d = 6$, from which $D = 6d$, hence $6d - d = 0.9$ or $d = 0.180$ (exact). This chart is based on 50,000 lb. per sq. in. fiber

stress. For any other fiber stress, divide the selected fiber stress by 50,000, take the square root of this ratio, and divide the diameter d obtained from the chart by this factor.

Step 3. To determine deflection per coil or per turn.

The chart is based on 50,000 lb. per sq. in. fiber stress and 11,500,000 for G , the modulus of elasticity in shear. For other values of maximum stress and modulus of

CHART TO DETERMINE DEFLECTION PER COIL

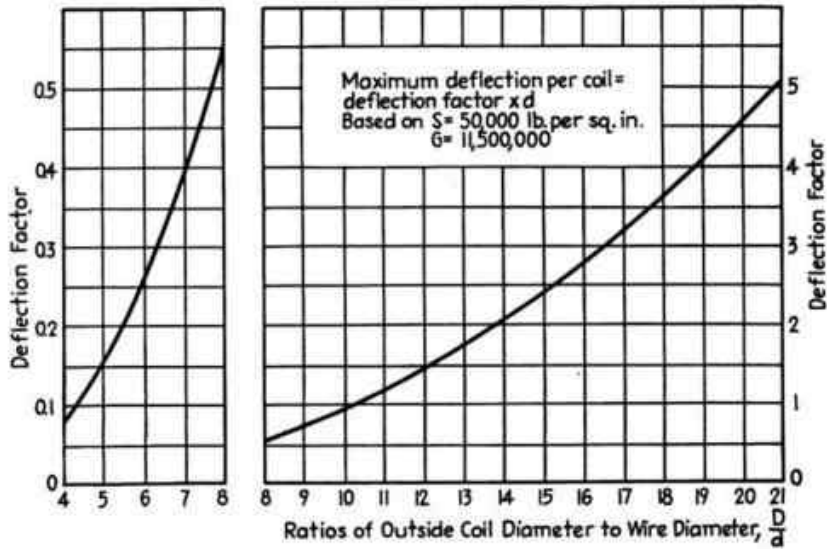

elasticity, the deflection factor will be directly proportional to the stress and inversely proportional to the modulus of elasticity.

Determine the deflection factor for given ratio D/d , correct for fiber stress and elastic modulus, multiply by d , the diameter of the wire.

DESIGNS OF TENSION SPRING ENDS

Dimensions X and Y should always be specified and are in the proportions shown.
See page 137 for standard spring drawings.

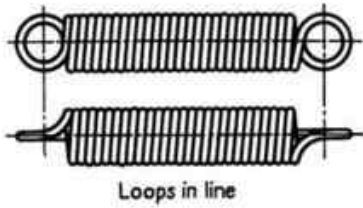

Loops in line

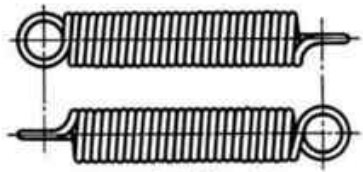
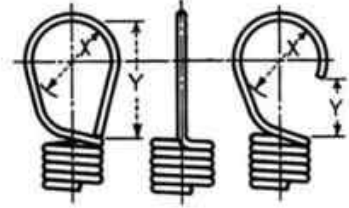
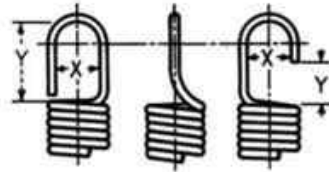

Loops at right angles

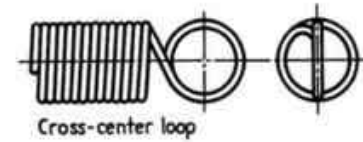
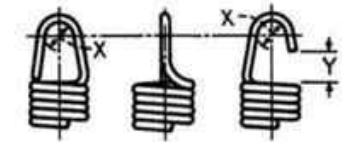
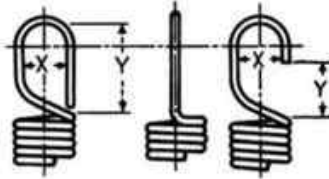

Cross-center loop

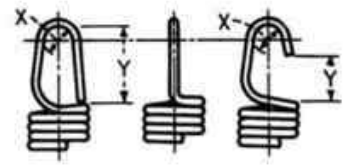
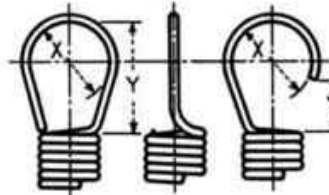

Regular loop

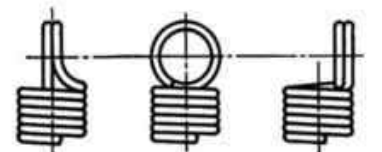
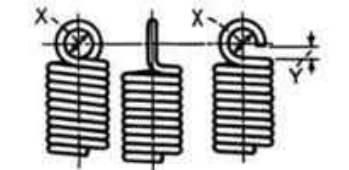
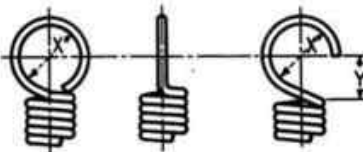
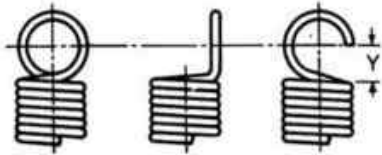
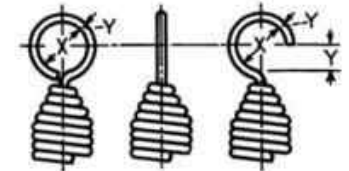
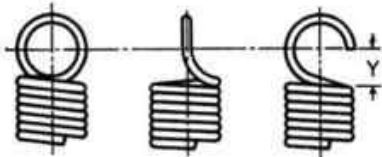
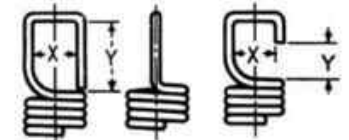
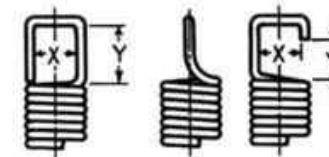

CANTILEVER SPRINGS—I

Maximum Fiber Stress, Length, Deflection, and Thickness

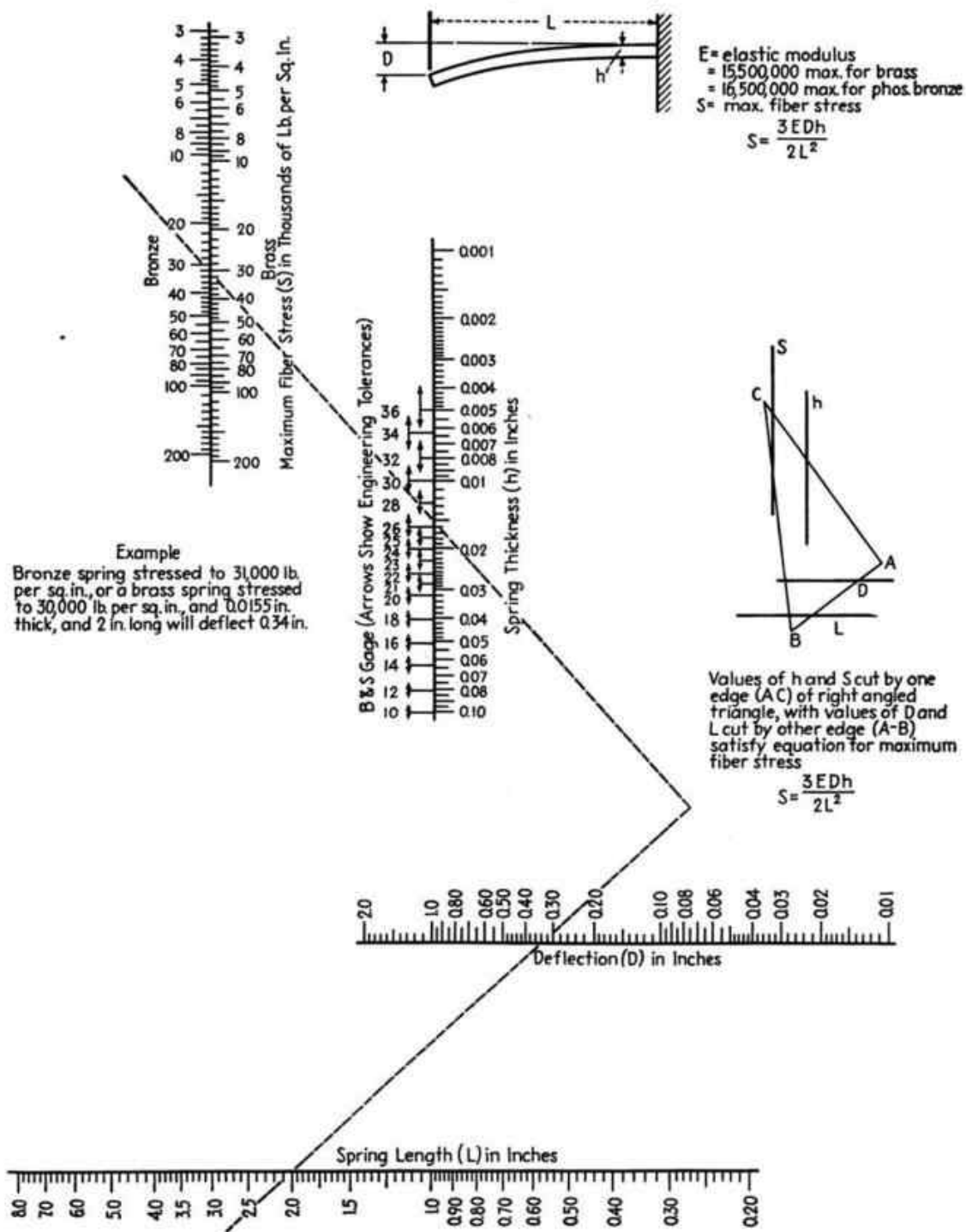

CANTILEVER SPRINGS—II
Maximum Fiber Stress for Given Loads

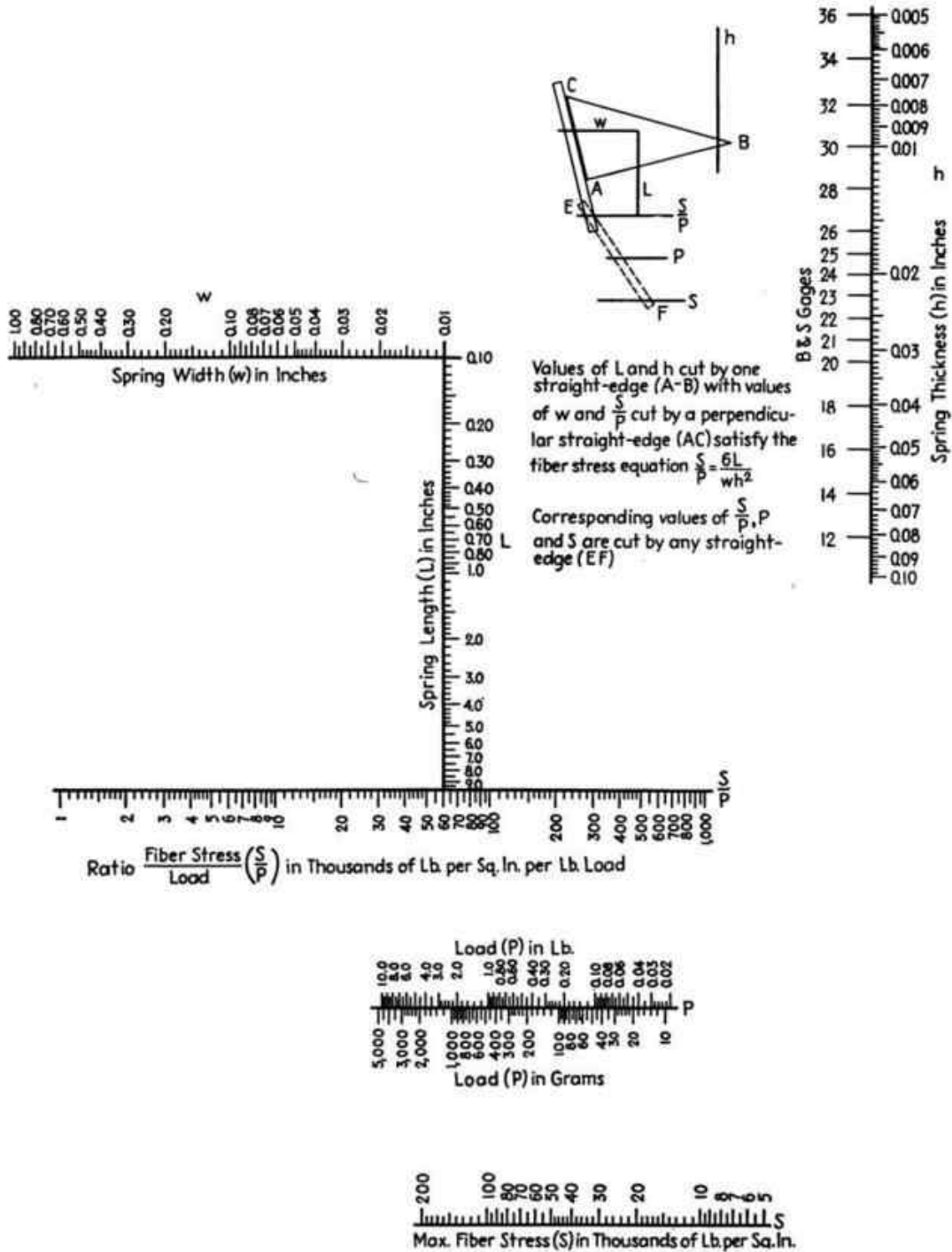

CANTILEVER SPRINGS—III

Load-deflection Ratio for Given Spring Dimensions

(Required thickness for given maximum deflection and fiber stress can be determined by use of Charts I and II, pages 145 and 146)

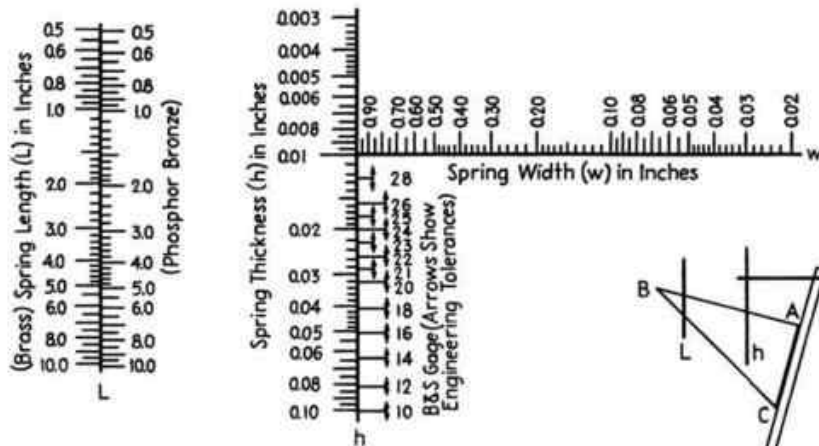

Deflections based on minimum of values of E, modulus of elasticity,
 For brass $E_{min.} = 13,000,000$
 For phos. bronze $= 14,000,000$

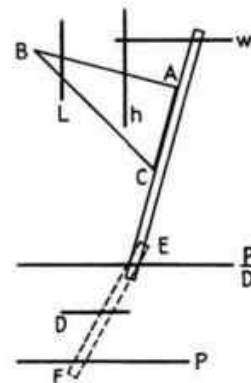

Values of h and L cut by one straight-edge (A-B), with values of w and $\frac{P}{D}$ cut by perpendicular edge (A-C) satisfy the load-deflection equation:

$$\frac{P}{D} = \frac{wh^3E}{4L^3}$$

Corresponding values of P, D and $\frac{P}{D}$ are cut by straight edge (EF)

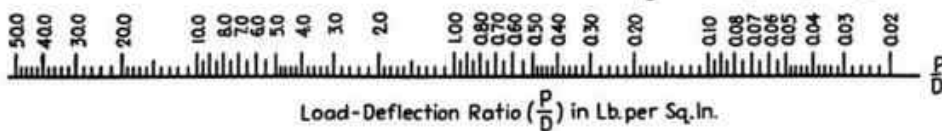

Brass ($E_{min.} = 13 \times 10^6$ p.s.i.)
 Phos. bronze ($E_{min.} = 14 \times 10^6$ p.s.i.)

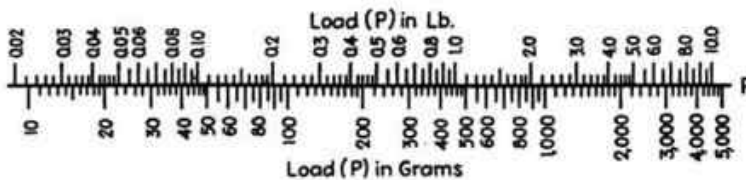

SEMIELLIPTIC LAMINATED SPRINGS

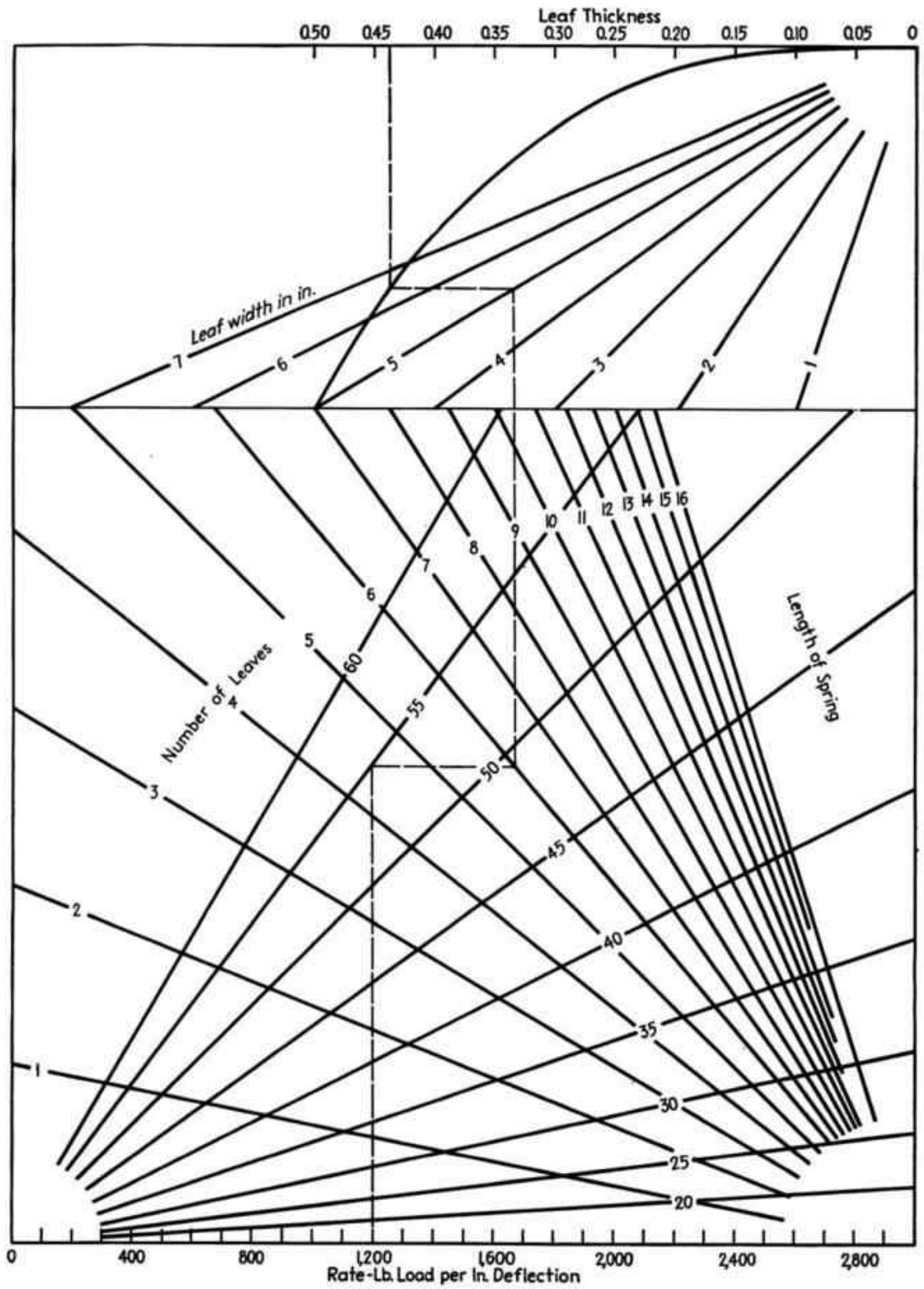

SEMIELLIPTIC LAMINATED SPRINGS

The chart on the facing page will facilitate the design of a semielliptic spring having graduated leaves of rectangular cross section. The chart is a graphical solution of the following formulas:

$$R = \frac{\Sigma I \times 32E}{K \times L^3} \quad (30)$$

$$I = \frac{WT^3}{12} \quad (31)$$

where R = rate of deflection, in lb. load per in. deflection
 E = modulus of elasticity, 28,000,000 lb. per sq. in.
 K = constant for semielliptic springs = 0.9
 L = full length of spring, in in.
 W = width of leaves, in in.
 T = thickness of leaves, in in.
 I = moment of inertia

The accompanying example shows how to use the chart. By starting with the desired rate of deflection, $R = 1,200$ lb. per in. deflection, read straight up to the length of spring, $L = 55$ in. Cross horizontally to the line representing the number of leaves, 6 leaves, then vertically to the line in the upper section of the chart corresponding to the width of the spring, $W = 5$ in. From this point, trace horizontally to the parabolic curve. The figure, 0.4375 in., directly above this last intersection, designates the thickness of each leaf in the spring. The spring has 1,200 lb. per in. rate of deflection, is 55 in. from eye to eye, has six leaves 5 in. wide, and each leaf is 0.4375 in. thick.

To find the safe load on the spring after the other values have been established from the chart,

$$S = \frac{4DET}{L^2} \quad \text{or} \quad D = \frac{SL^2}{4ET}$$

where S = unit fiber stress, in lb. per sq. in.
 D = total amount of deflection, in in.
 E = modulus of elasticity
 T = thickness of leaves, in in.
 L = full length of spring, in in.

The allowable working fiber stress will vary with the material used. Usually one-third of the elastic limit may be considered a safe working stress. For example, if the elastic limit is 180,000 lb. per sq. in., the safe unit stress will be 60,000 lb. per sq. in. By substituting this latter value for S in the formula, the amount of deflection D can then be solved. D multiplied by R (rate of deflection in pounds per inch) will give the full load capacity of the spring. In practice, the spring may be stressed to two-thirds of the elastic limit, but only under an occasional emergency load on the spring.

THIS PAGE IS BLANK
but this is not a printing or scanning
fault and no content is missing.

CHAPTER VI

POWER TRANSMISSION ELEMENTS AND MECHANISMS

Charts and nomograms for determining shaft and bearing sizes, horsepower transmitted by flat and V-belts, and typical examples of safety gear design, gear shifting mechanisms, bearing seals, gibs and guides, and cams. The final pages cover typical constructions of mechanical linkages.

	PAGE		PAGE
Flexible Couplings	152	Chart for Calculating Needle Bearings.....	178
Shaft Diameters for Torsion and Bending..	161	Thrust Bearing Friction Moments.....	179
Shaft Diameters for Torsional Deflection..	162	Bronze Bearing Alloys.....	180
Shaft Diameters for Lateral Deflection....	163	Shaft Seals.....	182
Shaft Diameters—A.S.M.E. code.....	164	Roller-bearing Seals.....	184
Two-bearing Shafts of Uniform Strength..	166	Sleeve-bearing Seals.....	186
Stress in Rotating Disk.....	167	Safety Gears.....	188
Velocity Chart for Gears and Pulleys.....	168	Shifting Mechanisms.....	190
Flat-belt Length and Pulley Diameter.....	169	Gibs and Guides.....	195
Flat-belt Speed-horsepower Charts.....	171	Cam Designs.....	198
Belt Horsepower Charts.....	172	Variable-speed Devices.....	199
Flat-belt Horsepower Charts.....	173	Transport Mechanisms.....	201
Flat and V-belt Horsepower Charts.....	174	Automatic Feed Hoppers.....	203
V-belt Lengths.....	175	Glue-applying Mechanisms.....	205
Short-center Belt Drives.....	176		

FLEXIBLE COUPLINGS

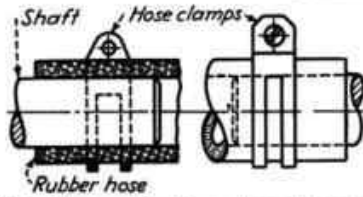

FIG. 255.—For applications where torque is low and slippage unimportant. It is easily assembled and disconnected without disturbing either machine element. It is adaptable to changes in longitudinal distance between machines. This coupling absorbs shocks, is not damaged by overloads, does not set up end thrusts, requires no lubrication, and compensates for both angular and offset misalignment.

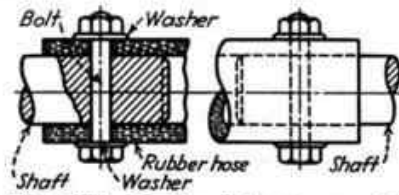

FIG. 256.—Positive drive is assured by bolting hose to shafts. This has the same advantages as the type in Fig. 255, except there is no over load protection other than the rupture of the hose.

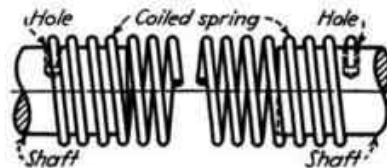

FIG. 257.—This type has excellent shock-absorbing qualities, but torsional vibrations are possible. It will allow end play in shafts, but sets up end thrust in so doing. Other advantages are the same as for the types shown in Figs. 255 and 256. This type compensates for misalignment in any direction.

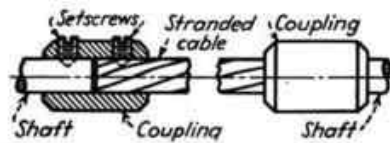

FIG. 258.—Coupling for low torques and unidirectional rotation. Inertia of rotating parts is low. This type is easily assembled and disconnected without disturbing either shaft. The cable can be encased and the length extended to allow for right-angle bends such as are used on dental drills and speedometer drives. The ends of the cable are soldered or bound with wire to prevent unraveling.

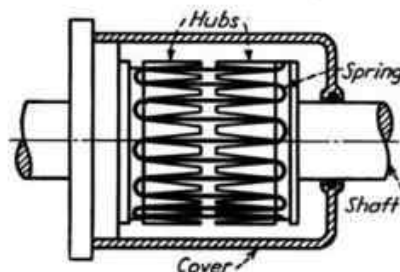

FIG. 259.—A type of Falk coupling that operates on the same principle as design shown in Fig. 260, but has a single flat spring in place of a series of coiled springs. A high degree of flexibility is obtained by use of tapered slots in hubs. Smooth operation is maintained by enclosing the working parts and packing with grease.

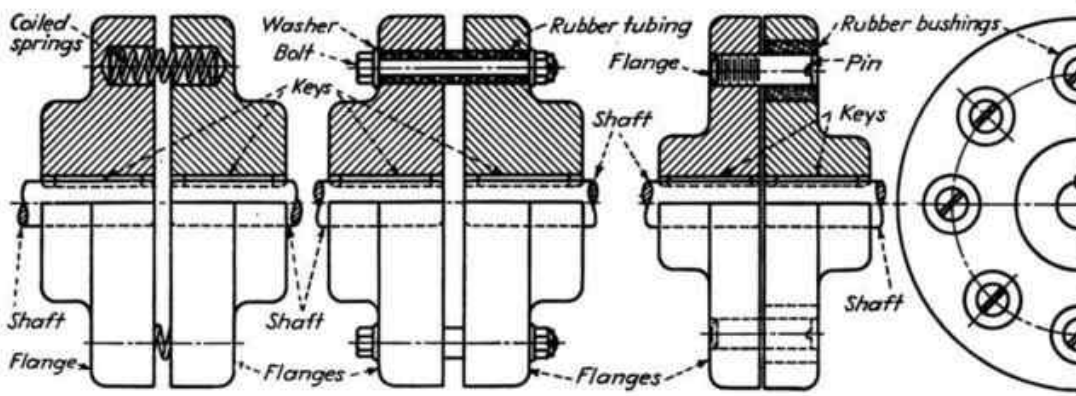

FIG. 260.

FIG. 261.

FIG. 262.

FIG. 260.—Two flanges and a series of coiled springs give a high degree of flexibility. This type is used only where the shafts have no free end play. It needs no lubrication, absorbs shocks, and provides protection against overloads, but will set up torsional vibrations. Springs can be of round or square wire with varying sizes and pitches to allow for any degree of flexibility.

FIG. 261.—Similar to Fig. 260, except that rubber tubing, reinforced by bolts, is used instead of coiled springs. Construction is sturdier but more limited in flexibility. This type has no overload protection other than shearing of the bolts. It has good antivibration properties if thick rubber tubing is used. It can absorb minor shocks. The connection can be quickly disassembled.

FIG. 262.—A series of pins engage rubber bushings cemented into flange. This type will allow minor end play in shafts and provides a positive drive with good flexibility in all directions.

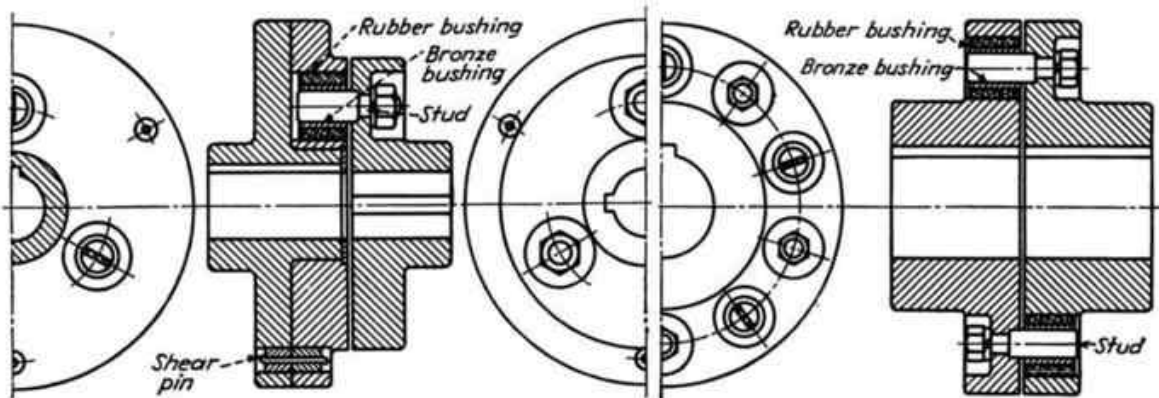

FIG. 263.—A Foote Gear Works flexible coupling which has shear pins in a separate set of bushings to provide overload protection. The principle is similar to that shown in Fig. 264. Replaceable shear pins are made of softer material than the shear-pin bushings.

FIG. 264.—A design made by the Ajax Flexible Coupling Company. Studs are firmly anchored with nuts and lock washers and bear in self-lubricating bronze bushings spaced alternately in both flanges. Thick rubber bushings cemented in flanges are forced over bronze bushings.

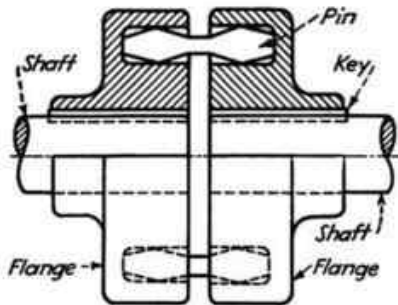

FIG. 265.—Another Foote Gear Works coupling. Flexibility is obtained by solid conically shaped pins of metal or fiber. This coupling provides positive drive of sturdy construction with flexibility in all directions.

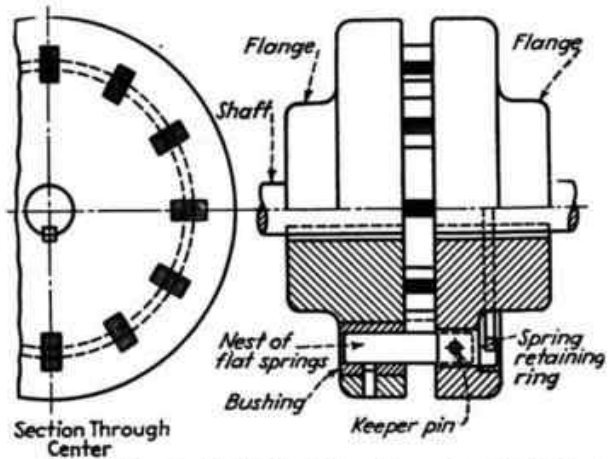

FIG. 266.—In this Smith & Serrell coupling, flexibility is obtained by laminated pins built up of tempered spring steel leaves. Spring leaves secured to holder by keeper pin. Phosphor bronze bearing strips are welded to outer spring leaves and bear in rectangular holes of hardened-steel bushings fastened in flange. Pins are free to slide endwise in one flange but are locked in the other flange by a spring retaining ring.

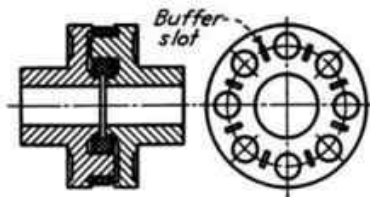

FIG. 267.—In this Brown Engineering Company coupling, flexibility is increased by addition of buffer slots in the laminated leather. These slots also aid in the absorption of shock loads and torsional vibration. Under parallel misalignment or shock loads, buffer slots will close over their entire width, but under angular misalignment, buffer slots will close only on one side.

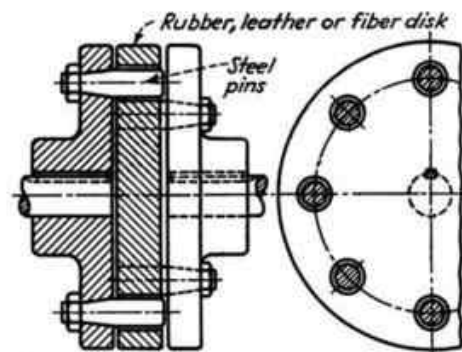

FIG. 268.—Flexibility is provided by resilience of a rubber, leather, or fiber disk in the W. A. Jones Foundry & Machine Company coupling. Degree of flexibility is limited to clearance between pins and holes in the disk plus the resilience of the disk. This type has good shock-absorbing properties, allows for end play, and needs no lubrication.

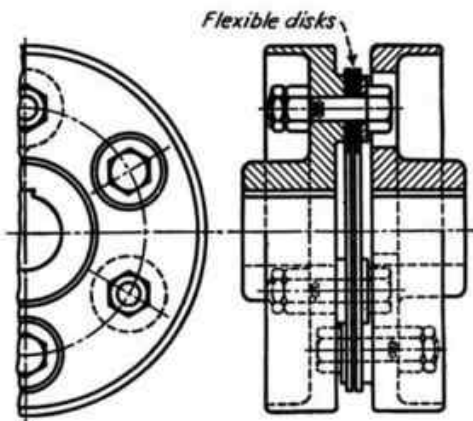

FIG. 269.—A coupling made by Aldrich Pump Company, similar to Fig. 268, except that bolts are used instead of pins. This coupling permits only slight endwise movement of the shaft and allows machines to be temporarily disconnected without disturbing the flanges. Driving and driven members are flanged for protection against projecting bolts.

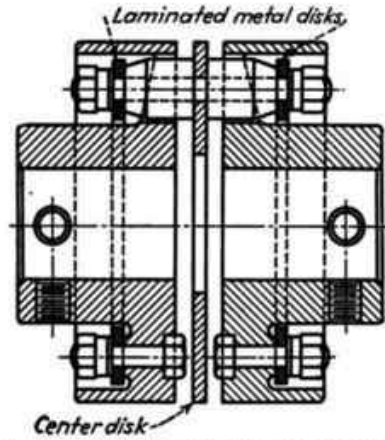

FIG. 270.—Laminated metal disks are used in this coupling made by Thomas Flexible Coupling Company. The disks are bolted to each flange and connected to each other by means of pins supported by a steel center disk. The spring action of the center ring allows torsional flexibility, and the two side rings compensate for angular and offset misalignment. This type of coupling provides a positive drive in either direction without setting up backlash. No lubrication is required.

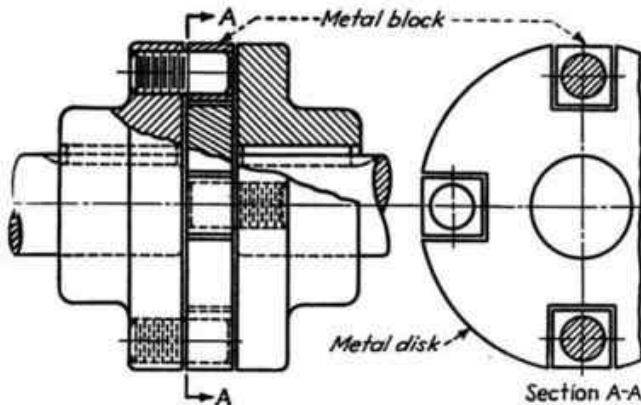

FIG. 271.—A design made by Palmer-Bee Company for heavy torques. Each flange carries two studs, upon which are mounted square metal blocks. The blocks slide in the slots of the center metal disk.

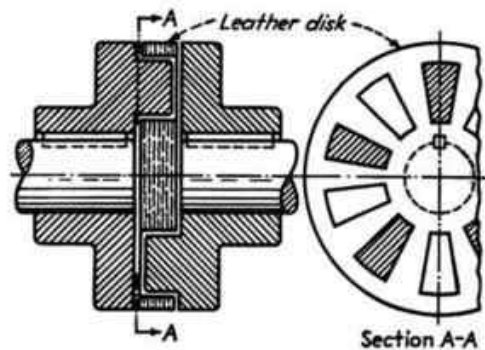

FIG. 273.—The principle of the T. B. Wood & Sons Company coupling is the same as Fig. 272, but the driving lugs are cast integrally with the metal flanges. The laminated leather disk is punched out to accommodate the metal driving lugs of each flange. This coupling has flexibility in all directions and does not require lubrication.

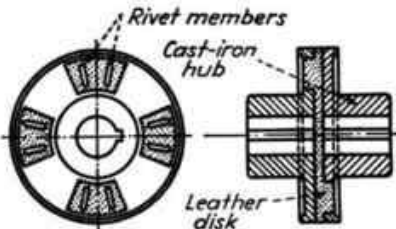

FIG. 272.—In this Charles Bond Company coupling, a leather disk floats between two identical flanges. Drive is through four laminated leather lugs cemented and riveted to the leather disk. This type compensates for misalignment in all directions, and sets up no end thrusts. The flanges are made of cast iron. Driving lug slots are cored.

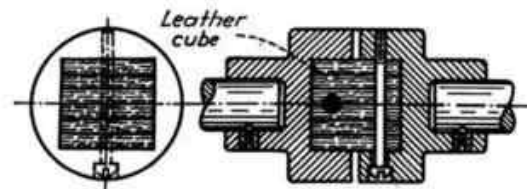

FIG. 274.—Another design made by Charles Bond Company. The flanges have square recesses into which a built-up leather cube fits. Endwise movement is prevented by through bolts used where low torque loads are to be transmitted.

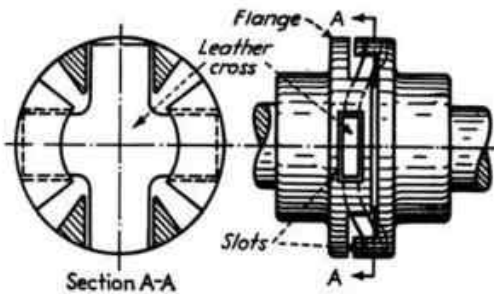

FIG. 275.—Similar to Fig. 274, being quiet in operation and used for low torques. This is also a design of Charles Bond Company. The floating member is made of laminated leather and is shaped like a cross. The ends of the intermediate member engage the two cored slots of each flange. The coupling will withstand a limited amount of end play.

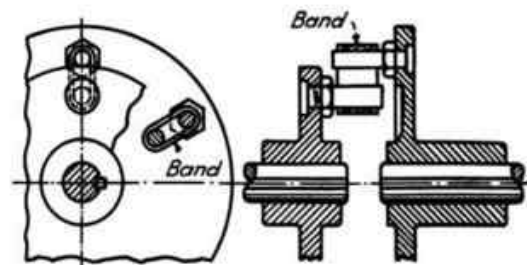

FIG. 276.—Pins mounted in flanges are connected by leather, canvas, or rubber bands. Coupling is used for temporary connections where large torques are transmitted, such as the driving of dynamometers by test engines. This type allows for a large amount of flexibility in all directions, absorbs shocks, but requires frequent inspection. Machines can be quickly disconnected, especially when belt fasteners are used on the bands. The driven member lags behind the driver when under load.

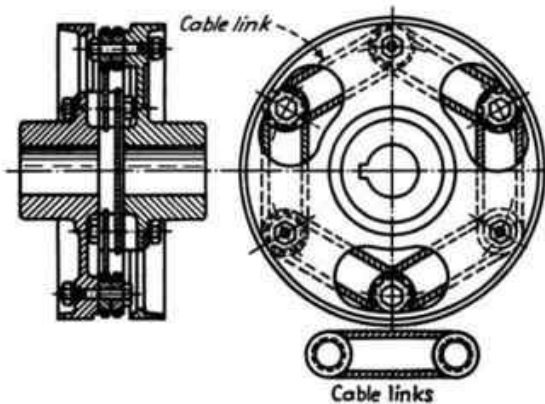

FIG. 277.—This Bruce-Macbeth Engine Company coupling is similar to that of Fig. 276, except that six endless wire cable links are used, made of plow-steel wire rope. The links engage small metal spools mounted on eccentric bushings. By turning these bushings, the links are adjusted to the proper tension. The load is transmitted from one flange to the other by direct pull on the cable links.

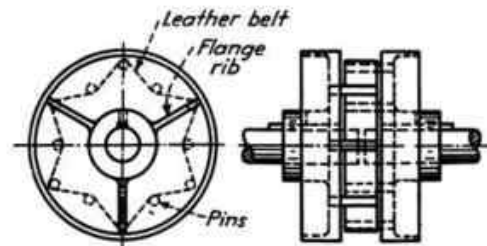

FIG. 278.—This Webster Manufacturing Company coupling uses a single endless leather belt instead of a series of bands, as in Fig. 276. The belt is looped over alternate pins in both flanges. This type has good shock-resisting properties because of belt stretch and the tendency of the pins to settle back into the loops of the belt.

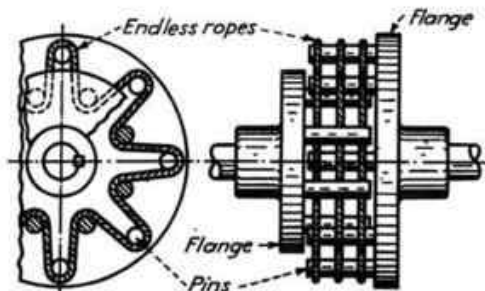

FIG. 279.—This coupling made by the Weller Manufacturing Company is similar to the design in Fig. 278, but instead of a leather belt uses hemp rope, made endless by splicing. The action under load is the same as in the endless-belt type.

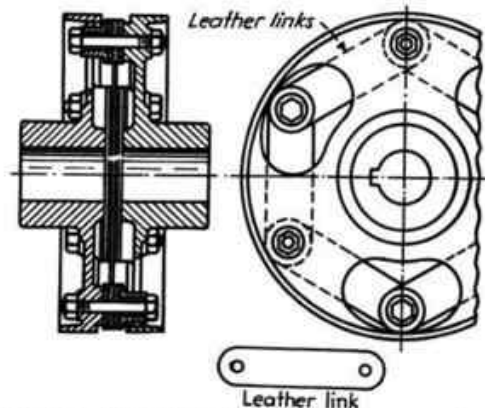

FIG. 280.—This Bruce-Macbeth design uses leather links instead of endless wire cables, as shown in Fig. 277. The load is transmitted from one flange to the other by direct pull of the links, which at the same time allows for the proper flexibility.

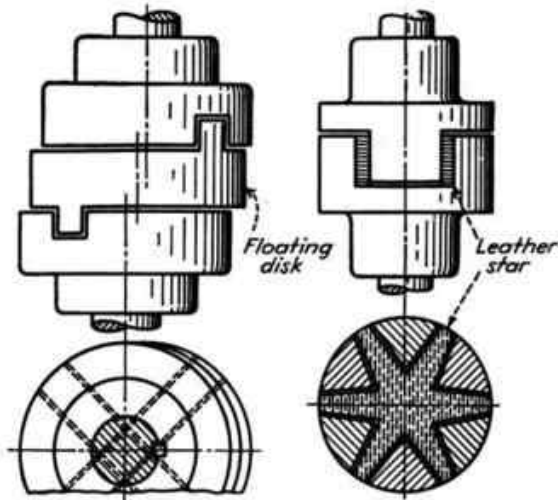

FIG. 281.

FIG. 281.—The Oldham form of coupling made by W. A. Jones Foundry and Machine Company is of the two-jaw type with a metal disk. Is used for transmitting heavy loads at low speed.

FIG. 282.

FIG. 282.—The Charles Bond Company star coupling is similar to the cross type shown in Fig. 275. The star-shaped floating member is made of laminated leather. It has three jaws in each flange. Torque capacity is thus increased over the two-jaw or cross type. The coupling takes limited end play.

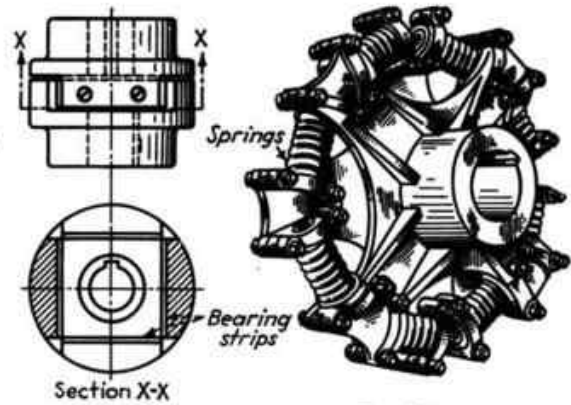

FIG. 284.

FIG. 284.—A metal block as a floating center is used in this American Flexible Coupling Company design. Quiet operation is secured by facing the block with removable fiber strips and packing the center with grease. The coupling sets up no end thrusts, is easy to assemble, and does not depend on flexible material for the driving action. It can be built in small sizes by using hardwood block without facings for the floating member.

FIG. 285.

FIG. 285.—This Westinghouse Nuttall Company coupling is an all-metal type having excellent torsional flexibility. The eight compression springs compensate for angular and offset misalignment. This type allows for some free endwise float of the shafts. It will transmit high torques in either direction. No lubrication is needed.

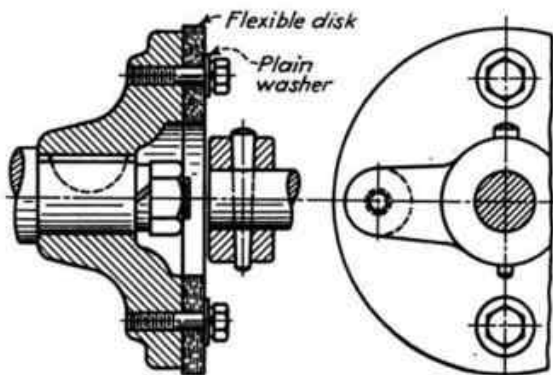

FIG. 283.—A combination rubber and canvas disk is bolted to two metal spiders. Extensively used for low torques where compensation for only slight angular misalignment is required. It is quiet in operation and needs no lubrication or other attention. Offset misalignment shortens disk life.

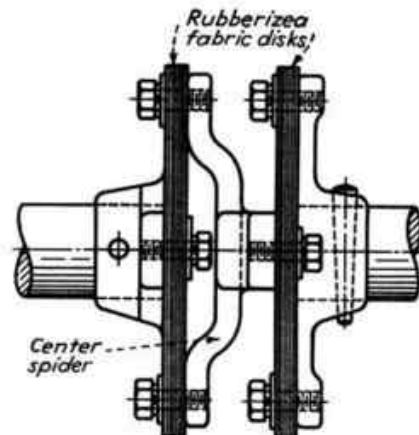

FIG. 286.—Similar to Fig. 283, but will withstand offset misalignment by addition of the extra disks. The center spider is free to float. By use of two rubber-canvas disks, as shown, the coupling will withstand a considerable angular misalignment.

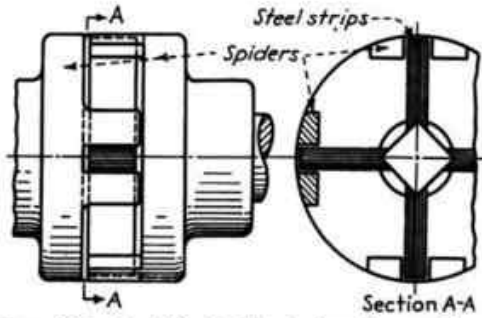

FIG. 287.—In this Smith & Serrell coupling, a flexible cross made of laminated-steel strips floats between two spiders. The laminated spokes, retained by four segmental shoes, engage lugs integral with the flanges. This coupling is intended for light loads only.

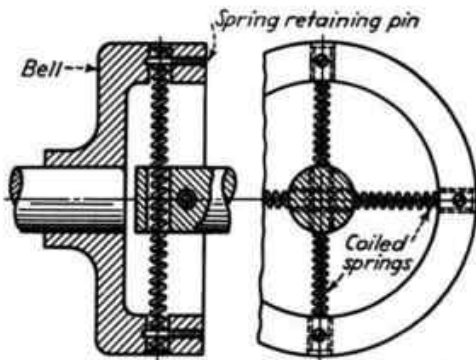

FIG. 288.—This coupling, made by Brown Engineering Company, is useful for improvising connections between apparatus in laboratories and similar temporary installations. It compensates for misalignment in all directions. It will absorb varying degrees of torsional shocks by changing the size of the springs. Springs are retained by threaded pins engaging the coils. Overload protection is possible by the slippage or breakage of replaceable springs.

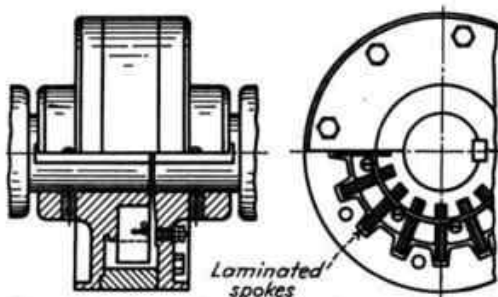

FIG. 289.—In another design by Brown Engineering Company, a series of laminated spokes transmit power between the two flanges without setting up end thrusts. This type allows free end play. Other advantages are the absorption of torsional shocks, no exposed moving parts, and good balance at all speeds. Wearing parts are replaceable and working parts are protected from dust.

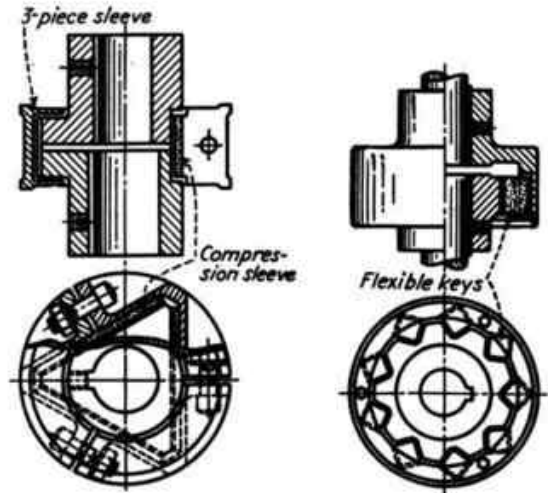

FIG. 290.—In this coupling of Falls Clutch & Machinery Company, two hubs with triangular heads and a three-piece sleeve are used. The sleeve is bolted together when assembling. Three pieces of compression lining provide the necessary flexibility. Misalignment is compensated for in all directions by compression of the linings.

FIG. 291.—This Medart Company flexible coupling uses square keys or pins of fiber, Textolite, or other flexible material which engage V slots. Clearance is provided in the V slots for flexibility. The pins are held in place by a retaining collar. Coupling can float endwise.

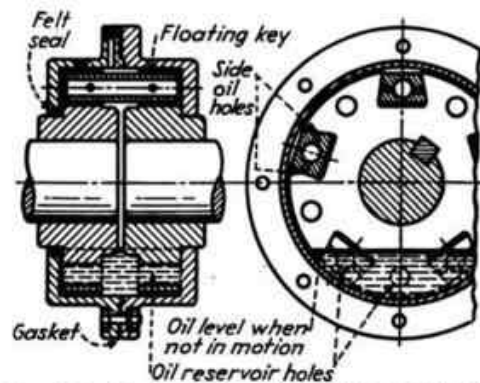

FIG. 292.—In the design of the W. H. Nicholson & Company flexible coupling, a series of floating steel keys slide in dovetail slots cut into each flange. The degree of misalignment compensated for depends on the clearance between the keys and slots. Wear is reduced, and cushioning is provided by operating keys in oil bath. Keys act noiselessly, centrifugal force keeping them against the slot surfaces.

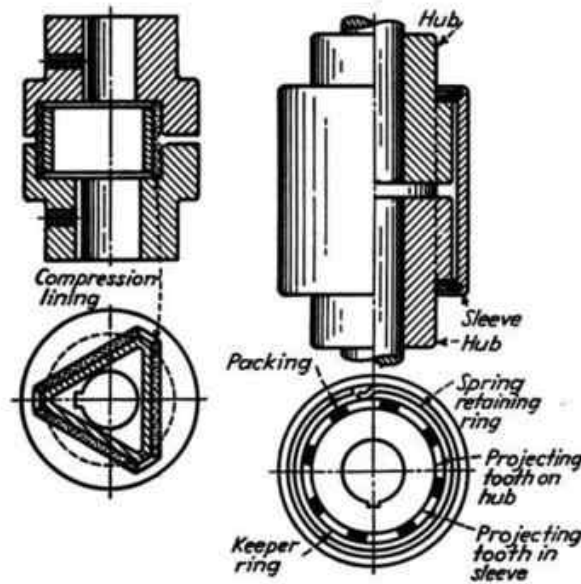

FIG. 293.

FIG. 294.

FIG. 293.—In another design made by Falls Clutch & Machinery Company, a triangular center floating member made of steel is placed inside two flanges. As in Fig. 290, three pieces of compression lining are used. Coupling flanges are triangularly recessed.

FIG. 294.—In this Clark Controller Company design, a splined hub mounted on each shaft is connected by a sleeve having internal projections. Power is transmitted through strips of packing fitted between the projecting teeth in the hubs and sleeve. Packing is retained at each end by keeper ring and snap ring. Compensates for misalignment in all directions without the use of flexing materials.

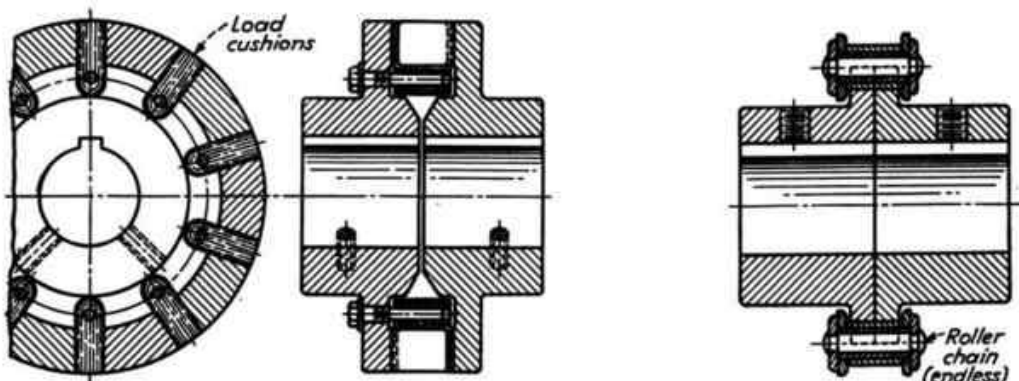

FIG. 295.—In one design of Lovejoy Tool Works flexible coupling, individual free-floating load cushions are hung between the flange jaws on removable studs. These replaceable cushions are made of brake-lining material, leather or rubber-duck fabric, depending on the loads sustained and the resilience required. No lubrication is needed.

FIG. 296.—The positive drive design of Diamond Chain & Manufacturing Company consists of two sprockets connected by a length of roller chain. Clearance between sprockets and chain side plates allows freedom to compensate for misalignment in all directions.

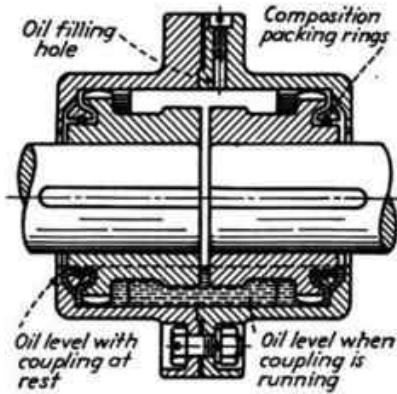

FIG. 297.—The Poole Engineering & Machine Company uses a two-piece floating sleeve with the internal gear teeth cut at each end, meshing with gear teeth on hubs. Toothed hubs are mounted at the end of each shaft. The hub teeth have spherically formed crowns. The teeth are in mesh around their entire circumference. Compensates for misalignment in all directions without the use of flexing materials. Bearing surfaces are lubricated in a bath of oil. Dust is excluded by packing ring at either end.

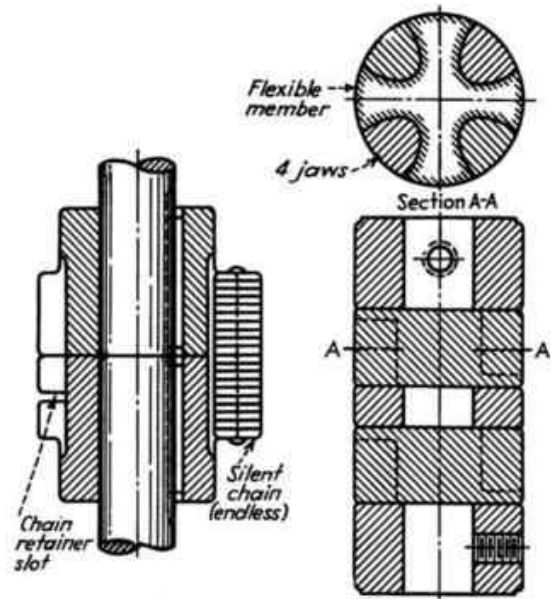

FIG. 298.

FIG. 299.

FIG. 298.—A silent chain is used as the flexible member in the Morse Chain Company coupling, the load being distributed over a number of teeth. A series of retaining links, running in the center of one sprocket, keep the chain in place. Flange covers enclose the chain when necessary.

FIG. 299.—Convex jaw surfaces that exert a rolling pressure when loaded are used in another Lovejoy Tool Works coupling design. The convex surfaces are so proportioned that the compression is uniform over the entire area of each spider arm. The floating spider is made of a resilient material which gives flexibility in all directions.

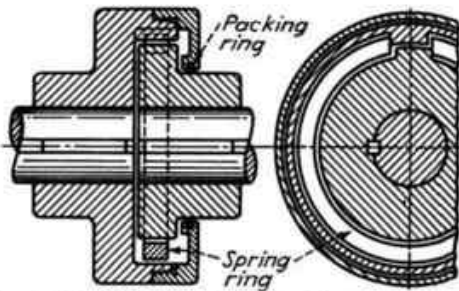

FIG. 300.—This T. L. Smith Company type of coupling has a flexible metal ring engaging projections integral with the outer and inner hubs. A packing ring protects the interior from dirt, yet compensates for angular misalignment. The coupling can drive in either direction.

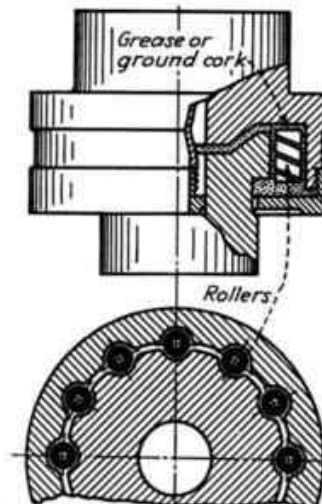

FIG. 301.—In this Meriam Company design, the internal and external hub is connected by a series of spring steel rollers fitted into semicircular recesses in each hub. The rollers are made of strip steel, wound spirally and ground on the periphery. Quiet operation is secured by packing the interior of the coupling with grease or ground cork.

SHAFT DIAMETERS FOR TORSION AND BENDING

$$D = \sqrt[3]{\frac{5.1}{f} \sqrt{M^2 + T^2}}$$

Example: Given $f = 6,000$ lb. per sq. in.
 Bending moment $M = 100,000$ in.-lb.
 Torsional moment $T = 50,000$ in.-lb.

- 1 Determine equivalent bending moment
 Join 100 on horizontal A scale to 50 on vertical A scale. This length scaled off on vertical A scale is the equivalent bending moment = 111,000 in.-lb.
- 2 Join 111,000 on B scale to 6,000 on f scale and extend line to read 4.6" diam. on left scale

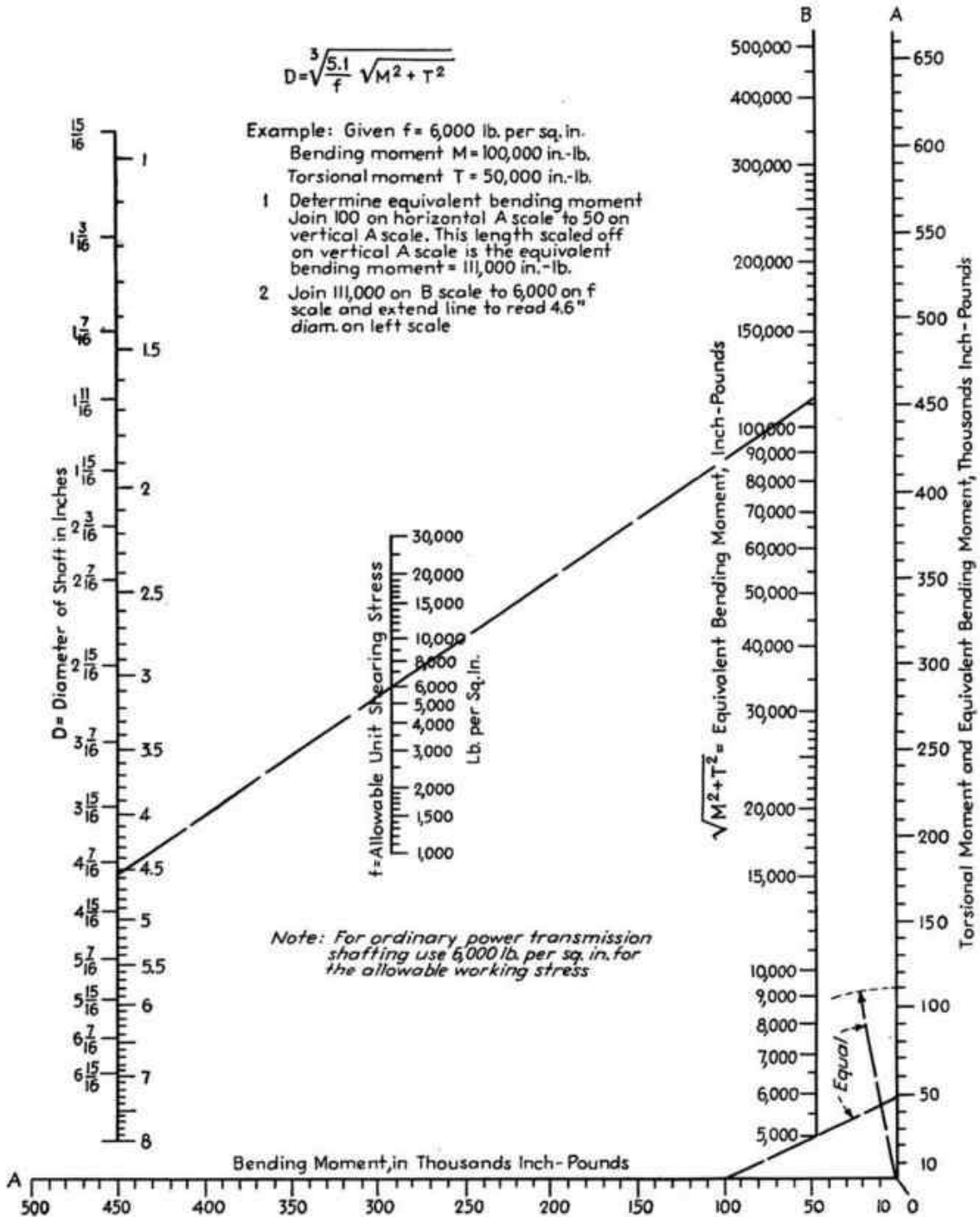

SHAFT DIAMETER FOR TORSIONAL DEFLECTION

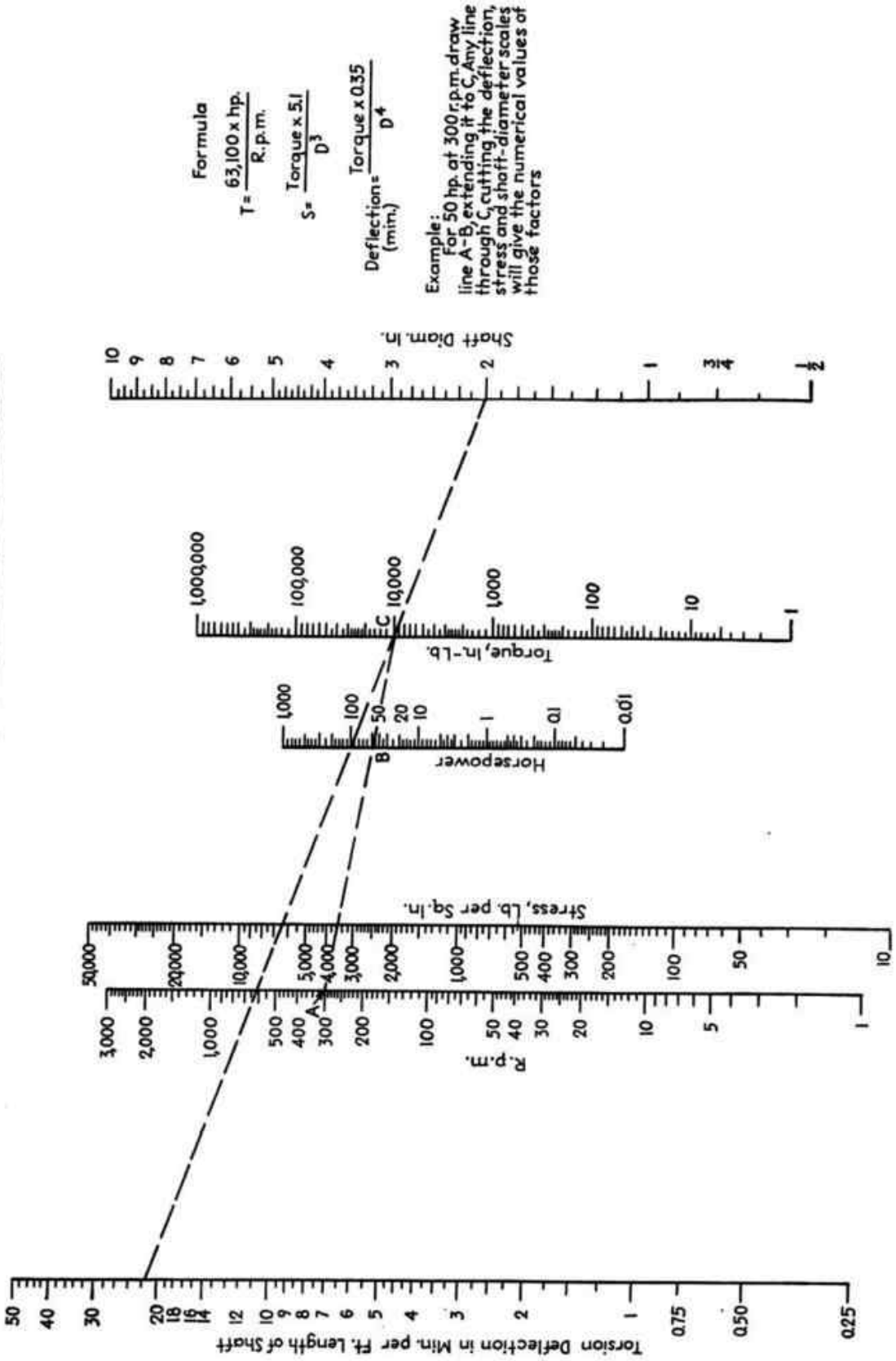

Formula

$$T = \frac{63,100 \times \text{hp.}}{R.p.m.}$$

$$S = \frac{\text{Torque} \times 5.1}{D^3}$$

$$\text{Deflection} = \frac{\text{Torque} \times 0.35}{D^4}$$

Example:
For 50 hp. at 300 r.p.m. draw line A-B, extending it to C. Any line through C, cutting the deflection, stress and shaft-diameter scales will give the numerical values of those factors

SHAFT DIAMETER FOR LATERAL DEFLECTION

(To use chart, follow in numerical order the notations referring to the line I, II, III, IV, and V)

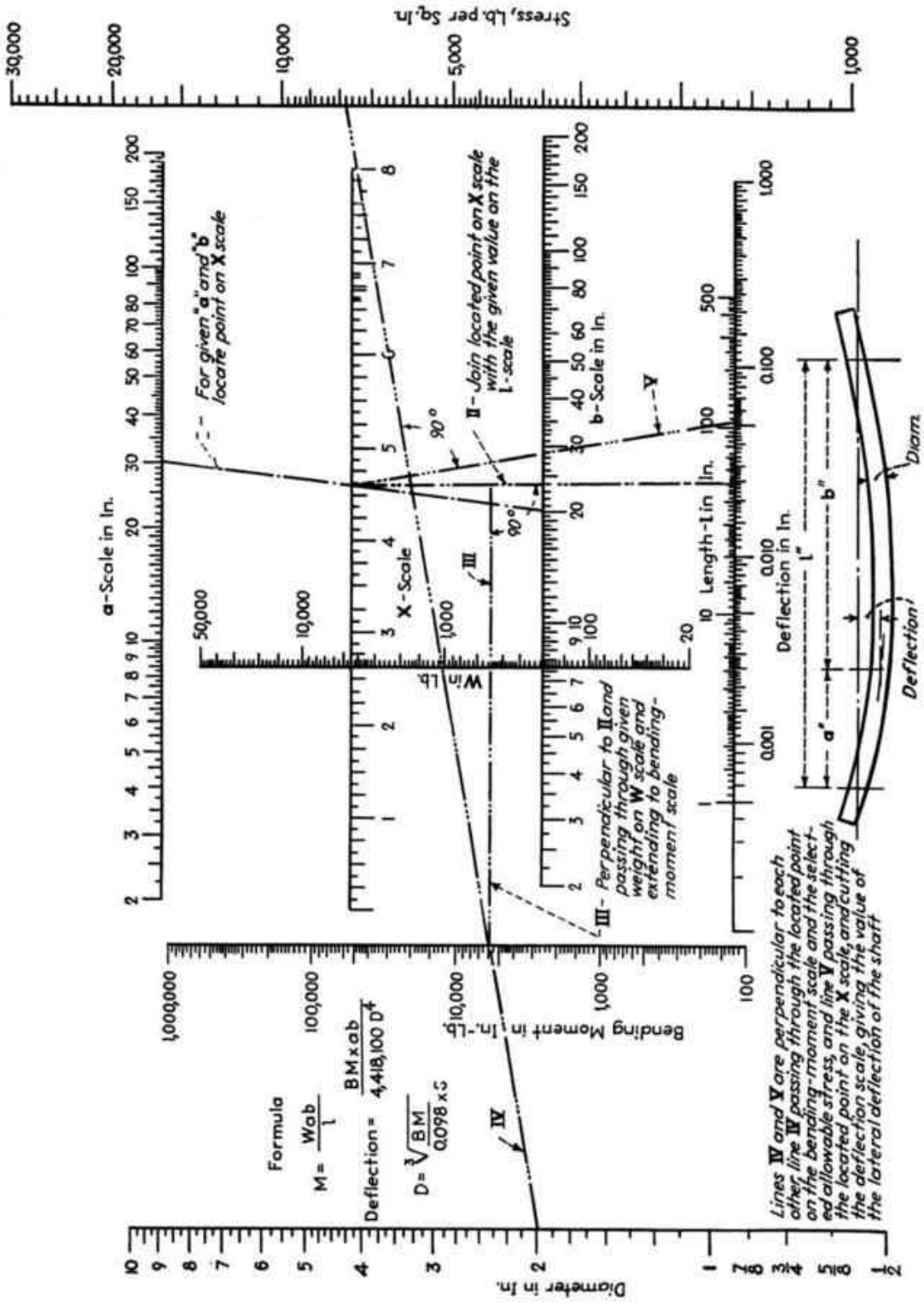

SHAFT DIAMETERS BASED ON THE A.S.M.E. CODE

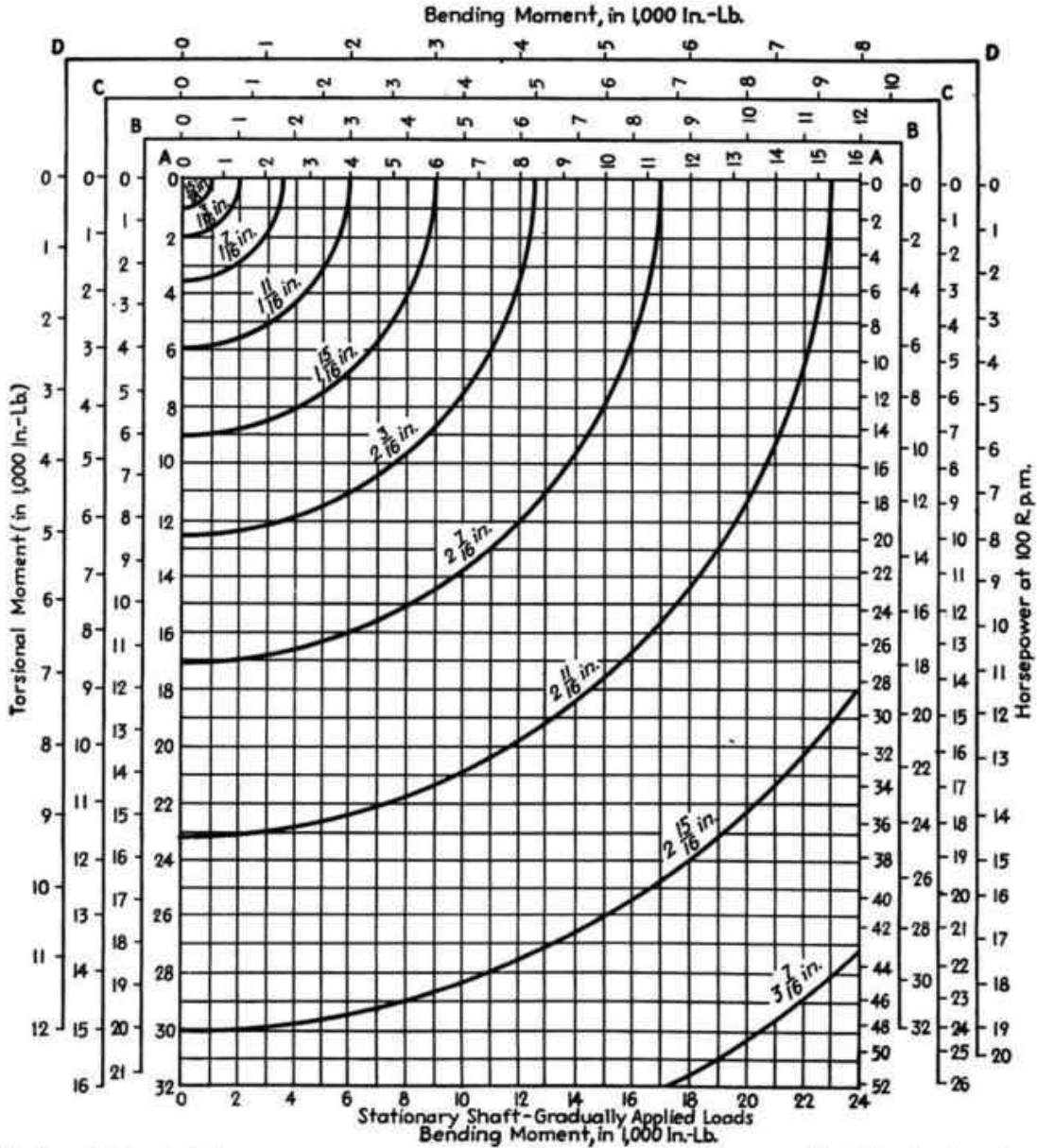

Scales (for rotating shafts):

- A. Gradually applied loads.
- B. Suddenly applied loads, minor shocks.
- C. Suddenly applied loads, heavy shocks.
- D. Severe operating conditions, high reliability.

Use of the Charts. Example.—Consider a shaft transmitting a steady load of 25 hp. at 200 r.p.m. and subjected to a bending moment of 10,000 in.-lb. If the shaft is made of ordinary cold-drawn shafting used for power transmission work and has a keyway at the point where the bending moment is maximum, a working stress of 6,000 lb. per sq. in. should be used. To find the

horsepower at 100 r.p.m., the following formula can be used:

$$\text{Hp. at 100 r.p.m.} = \frac{\text{hp. transmitted}}{\text{r.p.m. of shaft}} \times 100$$

For this problem, the horsepower at 100 r.p.m. is 12.5. Trace across from 12.5 to 10,000 in.-lb., bending moment line for the scale for steady loads. The shafting size is found to be $2\frac{1}{8}$ in. If there were no keyways, a working stress of 8,000 lb. per sq. in. could be used. The factor for this stress would be $2\frac{1}{8} \times 0.909 = 2.19$. Therefore a $\frac{3}{16}$ -in. shaft could be used if there were no keyway present.

SHAFT DIAMETERS BASED ON THE A.S.M.E. CODE (Continued)

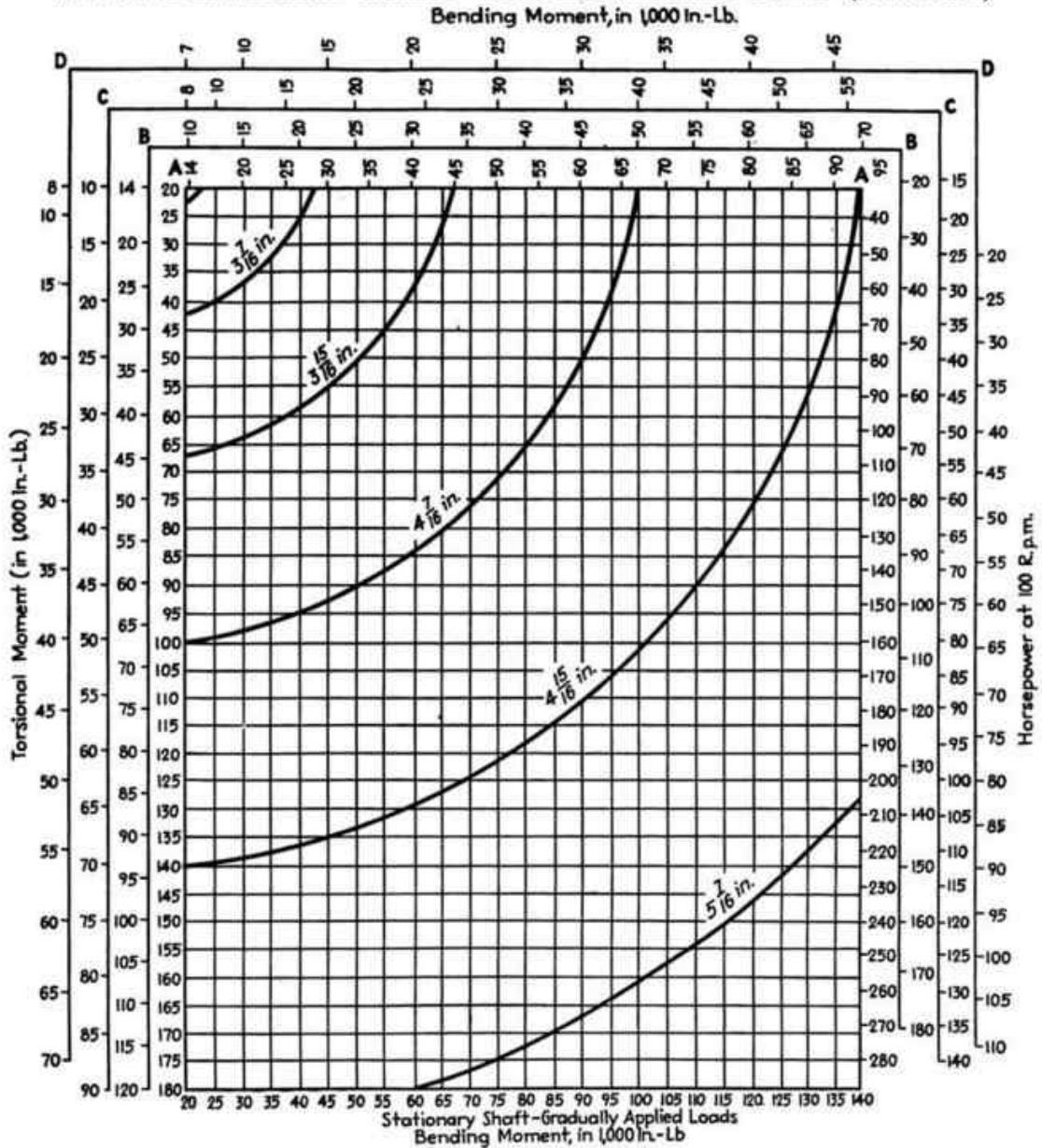

Scales (for rotating shafts):

- A. Gradually applied loads
- B. Suddenly applied loads, minor shocks
- C. Suddenly applied loads, heavy shocks
- D. Severe operating conditions—high reliability

Other Values of S_s .—In making the chart on this and the preceding page, the value of S_s was taken as 6,000 lb. per sq. in. For any other value of S_s , multiply the shaft diameter by a factor from the following table.

S_s	Factor	S_s	Factor
1,000	1.817	9,000	0.874
2,000	1.587	10,000	0.843
3,000	1.260	11,000	0.817
4,000	1.145	12,000	0.794
5,000	1.063	13,000	0.773
6,000	1.000	14,000	0.754
7,000	0.950	15,000	0.737
8,000	0.909	16,000	0.721

TWO-BEARING SHAFTS OF UNIFORM STRENGTH

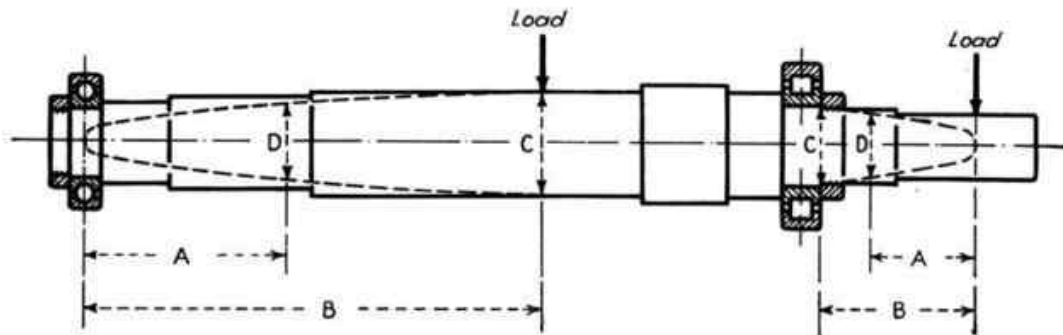
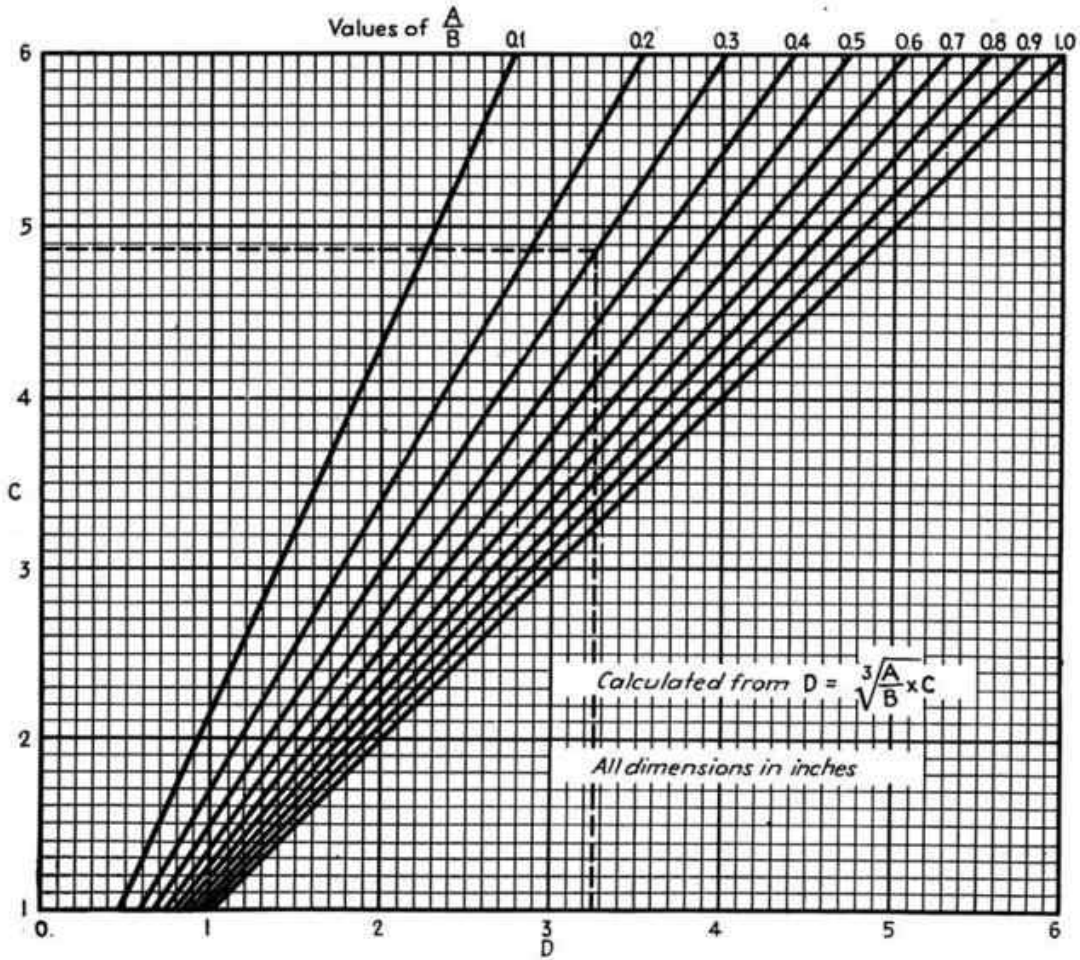

In designing a shaft with two bearings, the diameter at the point between the bearings where the load or resultant of loads is applied is calculated from considerations of deflection or stress. From the chart the minimum diameter at any other point a distance *A* from the center line of the bearing can be found. In the case of a shaft extension, the diameter at the bearing is calculated and the chart gives the minimum diameter at any other point a distance *A* from the load. These "minimum diameters" are shown plotted on the shaft, the points forming a curve. It will be apparent that the section of the shaft at the inside neck of the bearing or at the load must be sufficient to take care of shear and twisting moment. *Example:* Shown by dotted line: *A* = 4½ in.; *B* = 15 in.; *C* = 4⅞ in.; *D* = 3.26 in. from the chart.

STRESS IN A ROTATING DISK

Maximum tangential stress in a thin rotating disk is given by the relation

$$S = 71 w N^2 \times 10^{-6} [(3+m) R^2 + (1-m) r^2]$$

R and r are radii in in.

N = angular velocity in 1,000 r.p.m.

m = Poisson's ratio for the material

w = density in lb. per cu. in.

S = maximum tangential stress in 100,000 lb. per sq. in.

(If R exceeds 10 use light face scales for R, r and N)

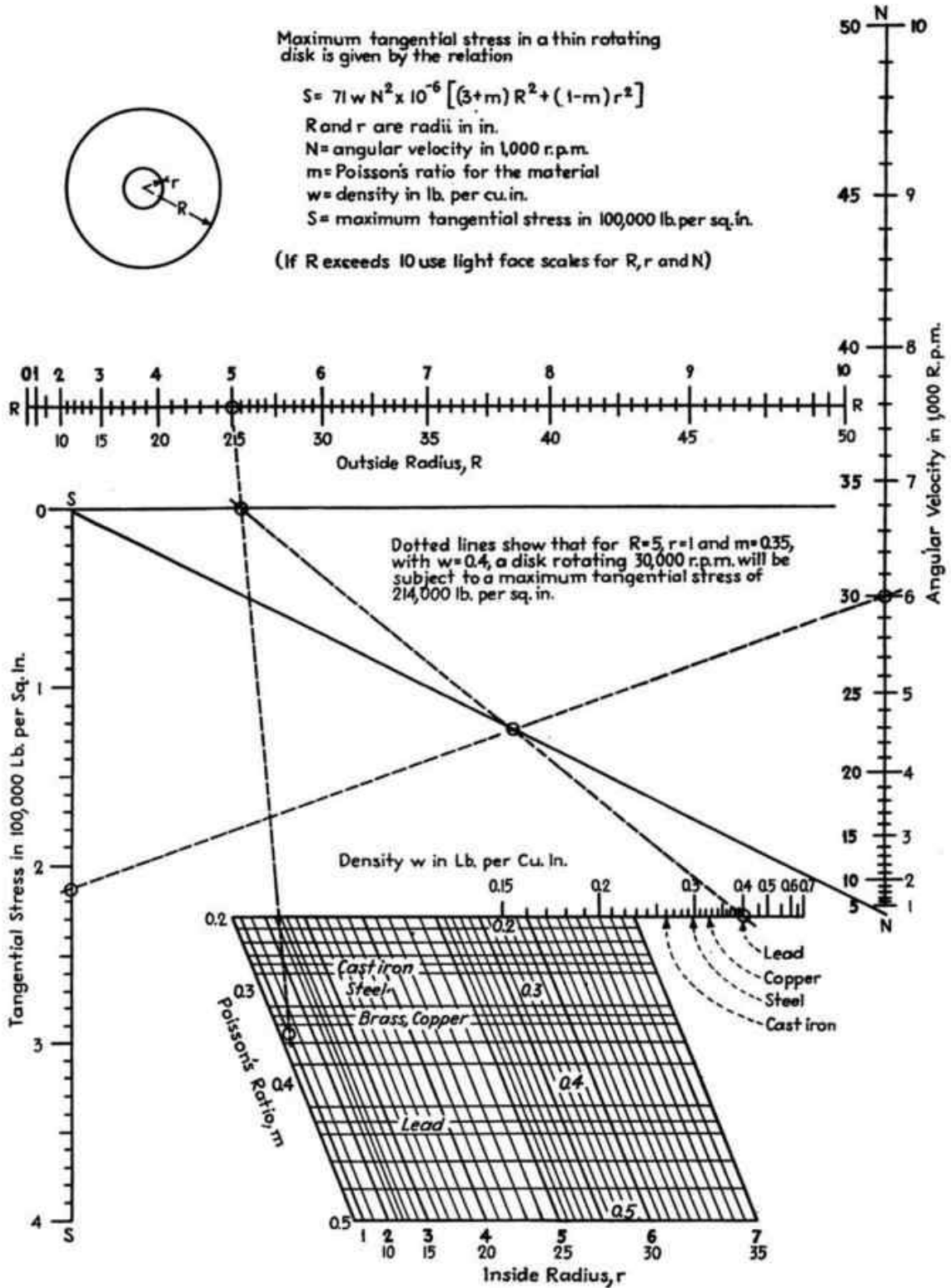

VELOCITY CHART FOR GEARS AND PULLEYS

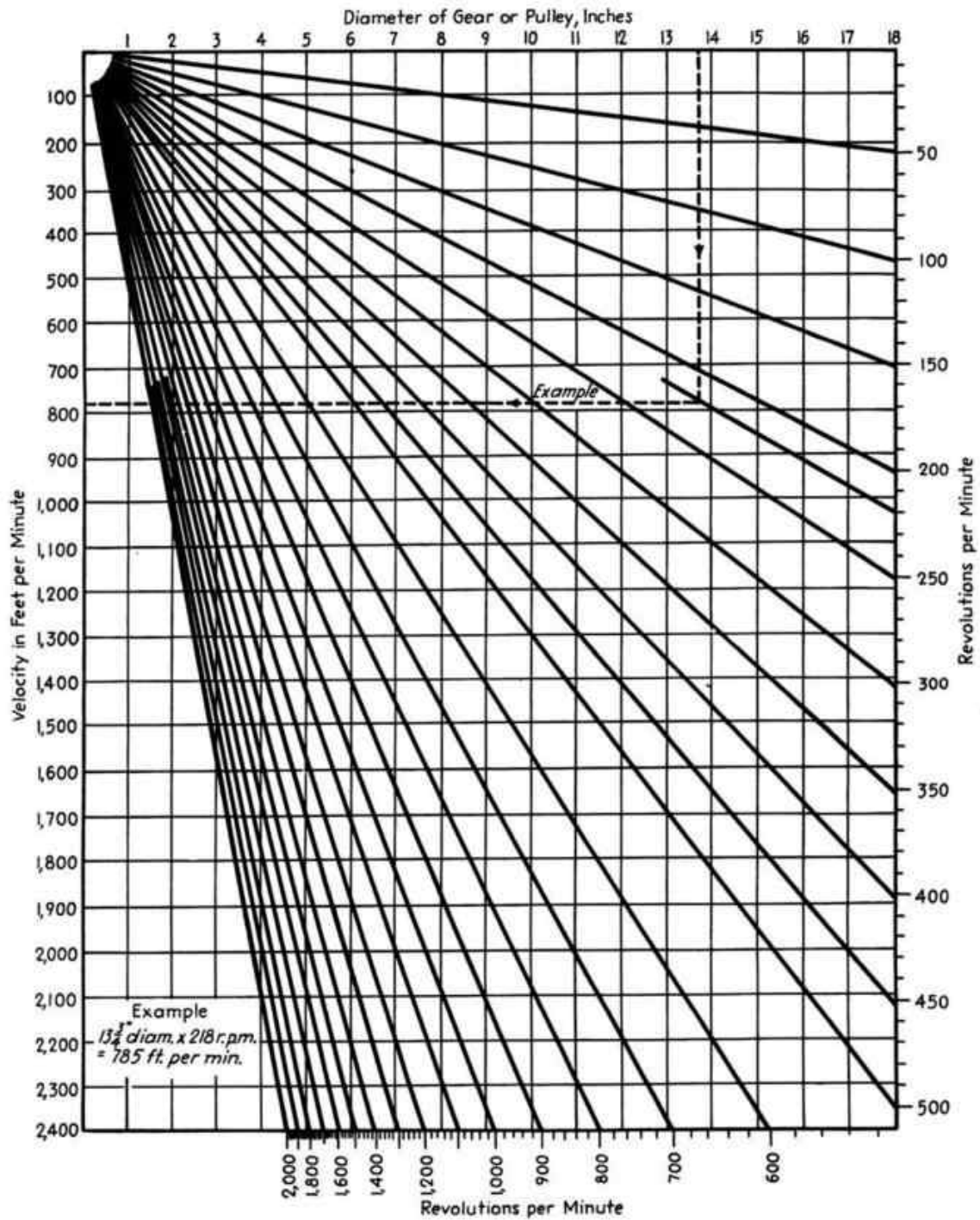

FLAT-BELT LENGTHS AND PULLEY DIAMETERS

The chart on the following page is used for the calculation of belt lengths for open belt drives, step cone pulley sizes for open belts, and pulley diameters on V-belt drives.

The length of a belt can be calculated with sufficient accuracy for all engineering problems from the formula

$$L = 2C + \frac{\pi}{2}d(n+1) + \frac{d^2(n-1)^2}{4C} \quad (32)$$

where L = belt length
 C = distance between pulley centers
 d = small pulley diameter
 n = speed ratio
 D = large pulley diameter
 $D = nd$

Any type of graphical solution of the equation is not simple in this form, because there are four variables in it and they cannot be shown in a simple chart. If the Eq. (32) is divided by C , it will take the form as follows:

$$\frac{L}{C} = 2 + \frac{\pi d}{2C}(n+1) + \frac{d^2}{C^2}(n-1)^2 \quad (33)$$

For further simplification, let $L/C = x$ and $d/C = y$. The equation will then become

$$x = 2 + \frac{\pi}{2}y(n+1) + y^2(n-1)^2 \quad (34)$$

Equation (34) contains only three variables, of which n , the speed ratio, is usually known. The equation can be plotted on ordinary coordinate paper as in the accompanying chart. The following examples show how to use it.

Belt Length for Open Drive

Example.—Assume the small pulley diameter $d = 5$ in., the speed ratio $n = 4$, and the distance between pulley centers $C = 50$ in. Then $d/C = \frac{5}{50} = 0.10$. From $d/C = 0.10$ on the chart, trace horizontally to the speed ratio $n = 4$ and follow vertically downward to read $L/C = 2.81$. Therefore

$$\begin{aligned} L &= C \times 2.81 \\ L &= 50 \times 2.81 = 140.5 \text{ in.} \end{aligned}$$

Substituting the numerical values given in this example in the Eq. (32), the solution will be

$$\begin{aligned} L &= 100 + \frac{\pi}{2}5(4+1) + \frac{5^2(4-1)^2}{4 \times 50} \\ &= 140.375 \text{ in.} \end{aligned}$$

Although there is $\frac{1}{8}$ in. difference in the belt length L as obtained from the chart figures and

by Eq. (32), the chart values are close enough for all ordinary belt length calculations.

Calculation of Step Cone Pulley Drives

Example.—A four-step cone pulley drive is required with speed ratios n of 2, 3, 4, and 5. Assume that one speed ratio, namely, $n = 4$, and that the diameter of the small pulley $d = 5$ in. is the same as in the preceding example. Center distance is $C = 50$ in., and the belt length is $L = 140.375$ in. The value of $L/C = 2.81$ will be the same in each instance.

For the speed ratio $n = 2$, read vertically from $L/C = 2.81$ to where this line intersects the ray of the speed ratio 2. Follow horizontally to d/C , and read 0.17. When $d/C = 0.17$, then

$$\begin{aligned} d &= 0.17 \times 50 \text{ in.} = 8.5 \text{ in.} \\ D &= 2 \times 8.5 \text{ in.} = 17 \text{ in.} \end{aligned}$$

For the speed ratio $n = 3$, $d/C = 0.126$ is obtained from the chart in a similar manner. Therefore:

$$\begin{aligned} d &= 0.126 \times 50 = 6.3 \text{ in.} \\ D &= 3 \times 6.3 \text{ in.} = 18.9 \text{ in.} \end{aligned}$$

For the speed ratio $n = 4$, as in the preceding example, $d/C = 0.10$ and $d = 5$ in. Then

$$D = 4 \times 5 \text{ in.} = 20 \text{ in.}$$

For the speed ratio $n = 5$, $d/C = 0.083$ on the chart so that

$$\begin{aligned} d &= 0.083 \times 50 = 4.15 \text{ in.} \\ D &= 5 \times 4.15 \text{ in.} = 20.75 \text{ in.} \end{aligned}$$

In this instance, the steps of the driven pulley will be 4.15, 5, 6.3, and 8.5 in. diameter, mating with steps on the driving pulley of 20.75, 20, 18.9, and 17 in. diameter, respectively.

Pulley Diameters for V-belt Drive

Example.—If the pitch length L of an endless V-belt is 120 in., the speed ratio $n = 4$, and the distance between centers $C = 40$ in., find the pitch diameters of the pulleys.

If $L/C = 3$, then $d/C = 0.1216$ is read at the intersection of the lines L/C and speed ratio $n = 4$. Therefore

$$\begin{aligned} d &= 0.1216 \times 40 = 4.864 \text{ in.} \\ D &= 4.864 \times 4 = 19.456 \text{ in.} \end{aligned}$$

A V-belt manufacturer's catalogue is then consulted to ascertain pulley outside diameters.

CHART FOR FLAT-BELT LENGTHS AND PULLEY DIAMETERS

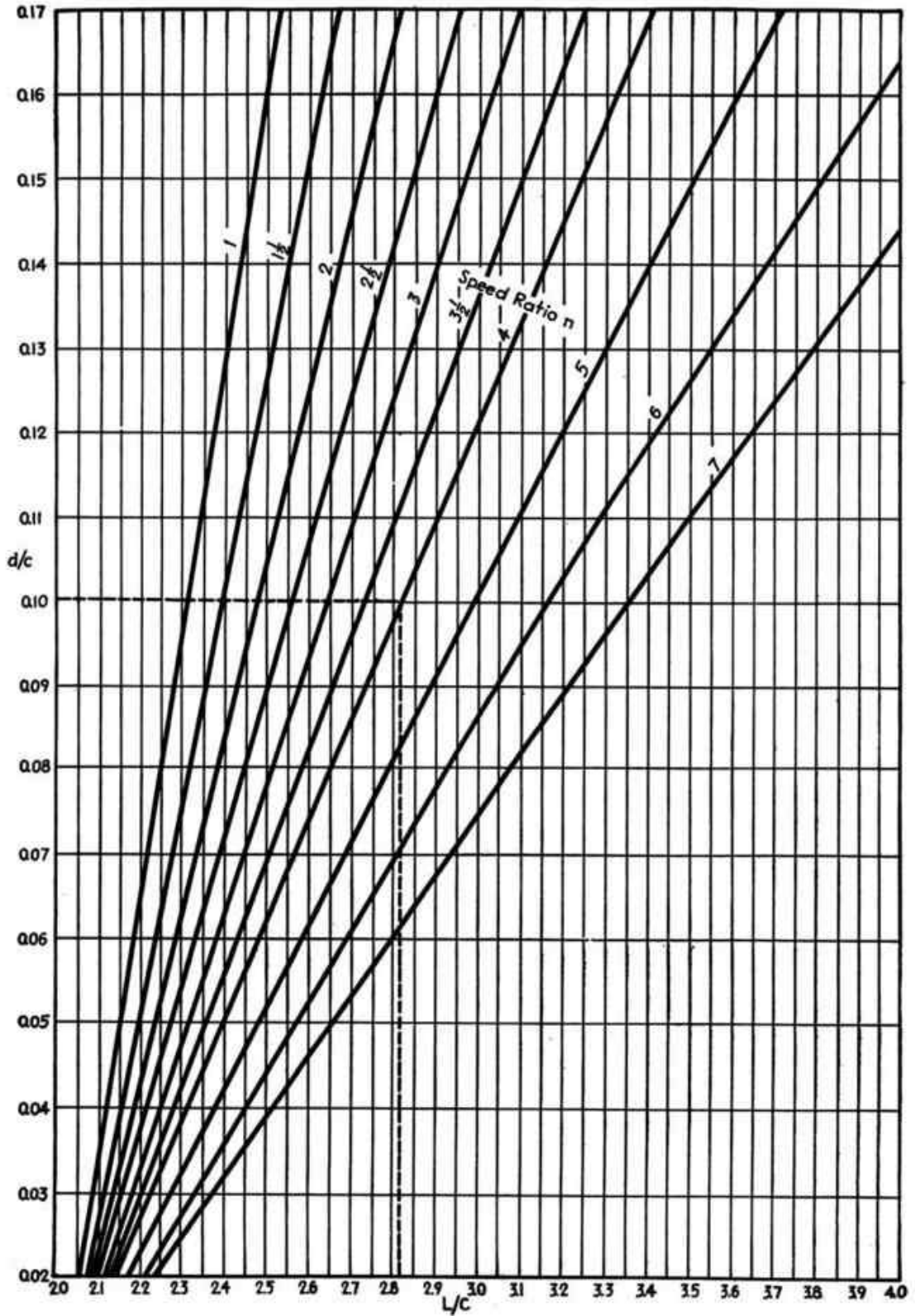

FLAT-BELT SPEED-HORSEPOWER CHARTS

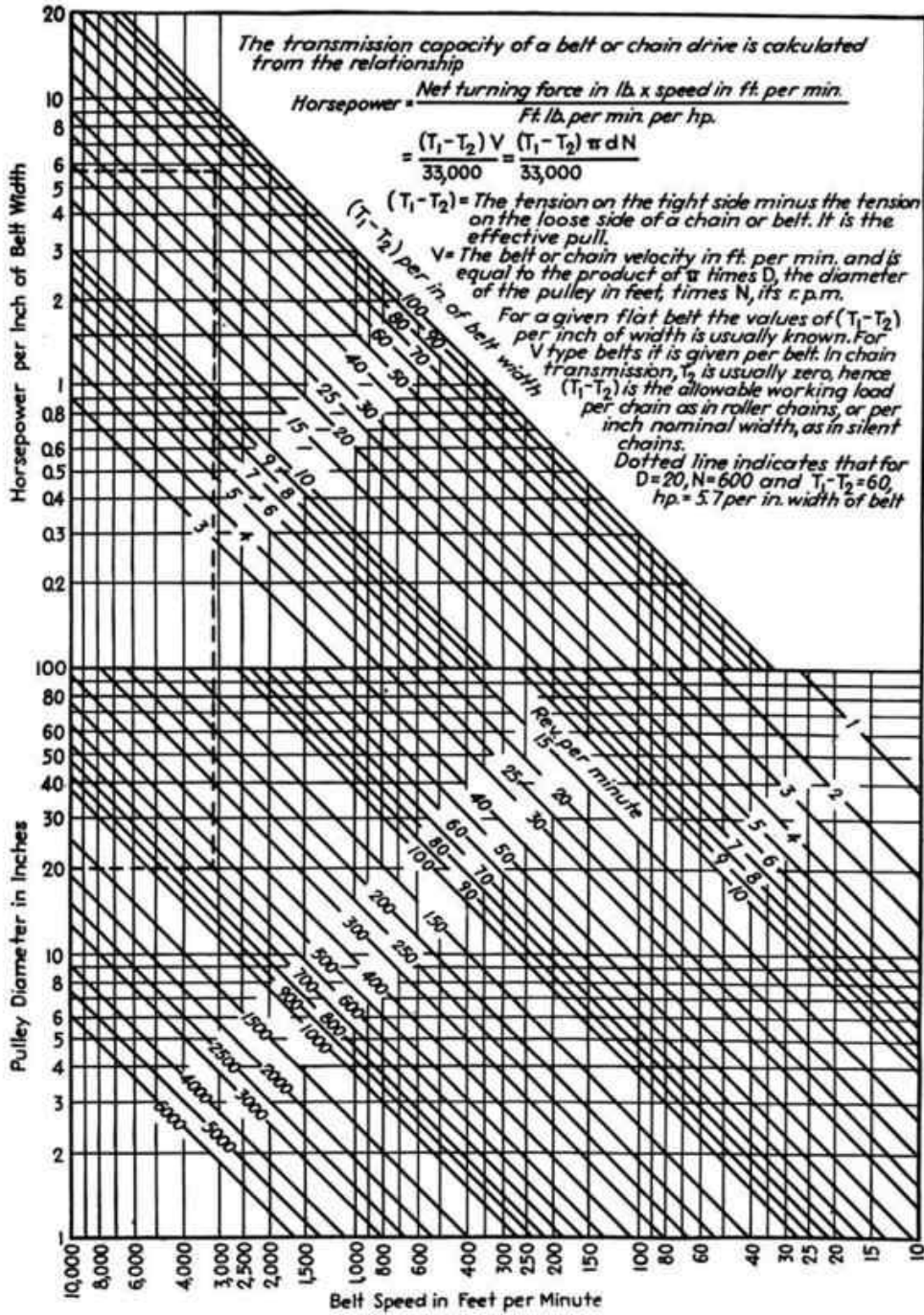

BELT HORSEPOWER CHARTS

Determining Belt Tension Resulting from Centrifugal Force

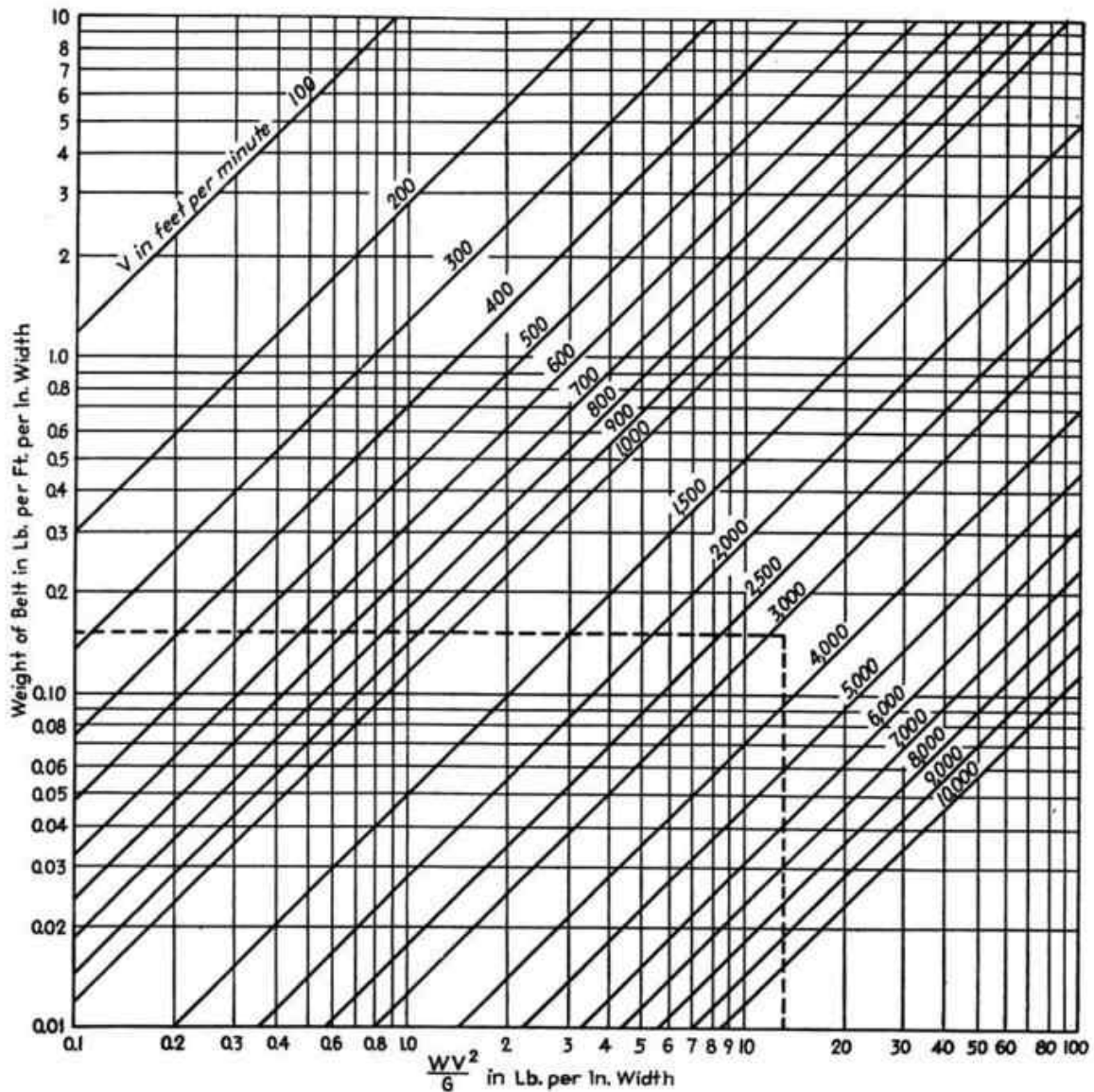

The flat-belt horsepower chart on the preceding page enables the designer to obtain the linear velocity of the belt in a given drive. In the illustrative example given with that chart, the linear velocity of the belt was shown to be 3,160 ft. per min. By assuming a belt whose unit weight is 0.15 lb. per ft. per in. width, the additional belt tension set up by centrifugal force can be obtained from the chart on this page.

From the point in the vertical scale designating 0.15 in. per ft. per in. width, trace horizontally to the right to the point representing a velocity of 3,160 ft. per min., as indicated by the diagonals. Then drop down vertically to the horizontal scale, which gives the value of WV^2/G as 13 lb. per in. width of belt.

FLAT-BELT HORSEPOWER CHARTS

Determining Arc of Contact for Open Belts

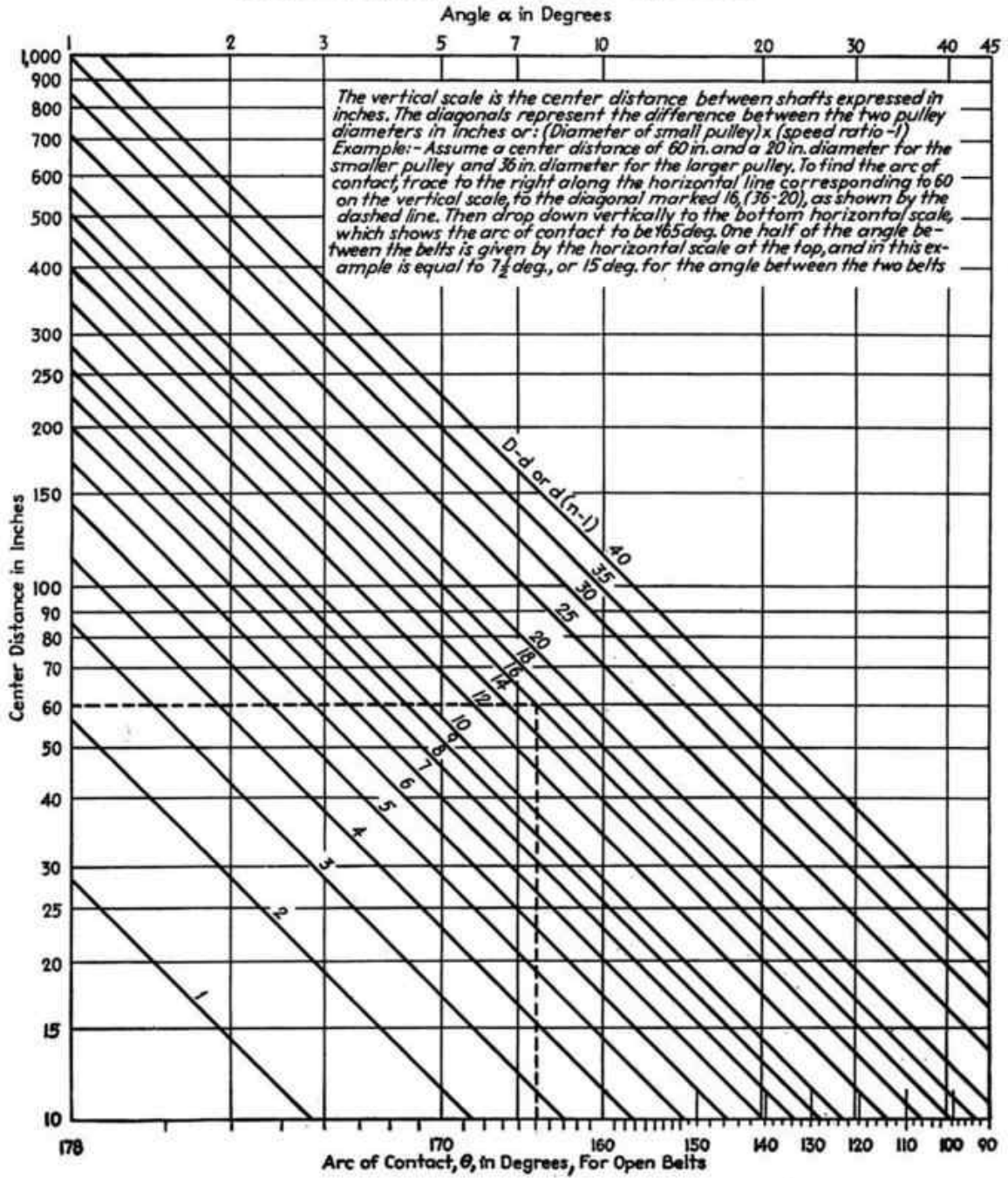

FLAT- AND V-BELT HORSEPOWER CHARTS

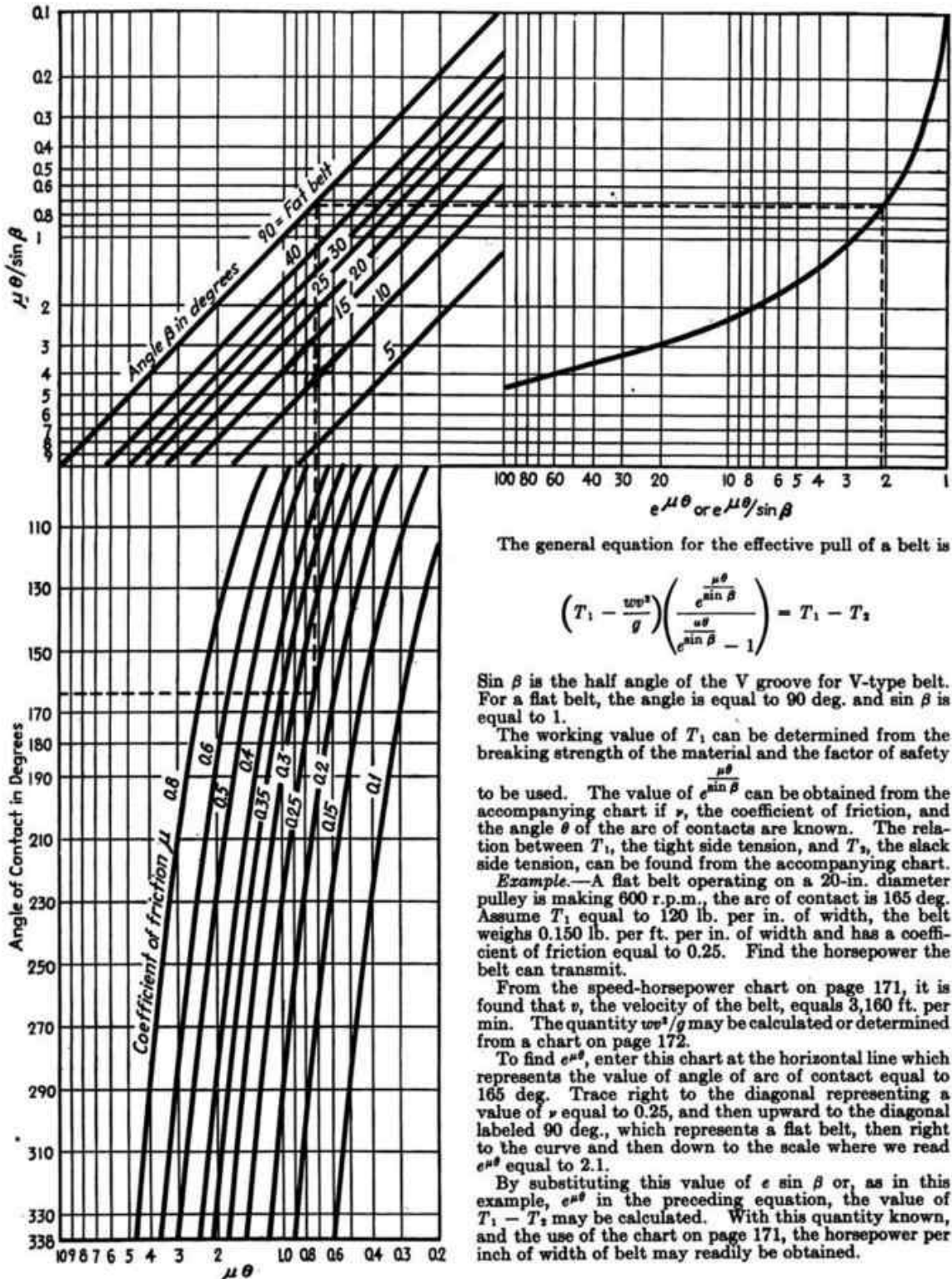

The general equation for the effective pull of a belt is

$$\left(T_1 - \frac{wv^2}{g}\right) \left(\frac{e^{\frac{\mu\theta}{\sin\beta}}}{e^{\frac{\mu\theta}{\sin\beta}} - 1}\right) = T_1 - T_2$$

$\sin\beta$ is the half angle of the V groove for V-type belt. For a flat belt, the angle is equal to 90 deg. and $\sin\beta$ is equal to 1.

The working value of T_1 can be determined from the breaking strength of the material and the factor of safety

to be used. The value of $e^{\frac{\mu\theta}{\sin\beta}}$ can be obtained from the accompanying chart if ν , the coefficient of friction, and the angle θ of the arc of contacts are known. The relation between T_1 , the tight side tension, and T_2 , the slack side tension, can be found from the accompanying chart.

Example.—A flat belt operating on a 20-in. diameter pulley is making 600 r.p.m., the arc of contact is 165 deg. Assume T_1 equal to 120 lb. per in. of width, the belt weighs 0.150 lb. per ft. per in. of width and has a coefficient of friction equal to 0.25. Find the horsepower the belt can transmit.

From the speed-horsepower chart on page 171, it is found that v , the velocity of the belt, equals 3,160 ft. per min. The quantity wv^2/g may be calculated or determined from a chart on page 172.

To find $e^{\mu\theta}$, enter this chart at the horizontal line which represents the value of angle of arc of contact equal to 165 deg. Trace right to the diagonal representing a value of ν equal to 0.25, and then upward to the diagonal labeled 90 deg., which represents a flat belt, then right to the curve and then down to the scale where we read $e^{\mu\theta}$ equal to 2.1.

By substituting this value of $e^{\mu\theta}$ in the preceding equation, the value of $T_1 - T_2$ may be calculated. With this quantity known, and the use of the chart on page 171, the horsepower per inch of width of belt may readily be obtained.

CHART FOR FINDING V-BELT LENGTHS

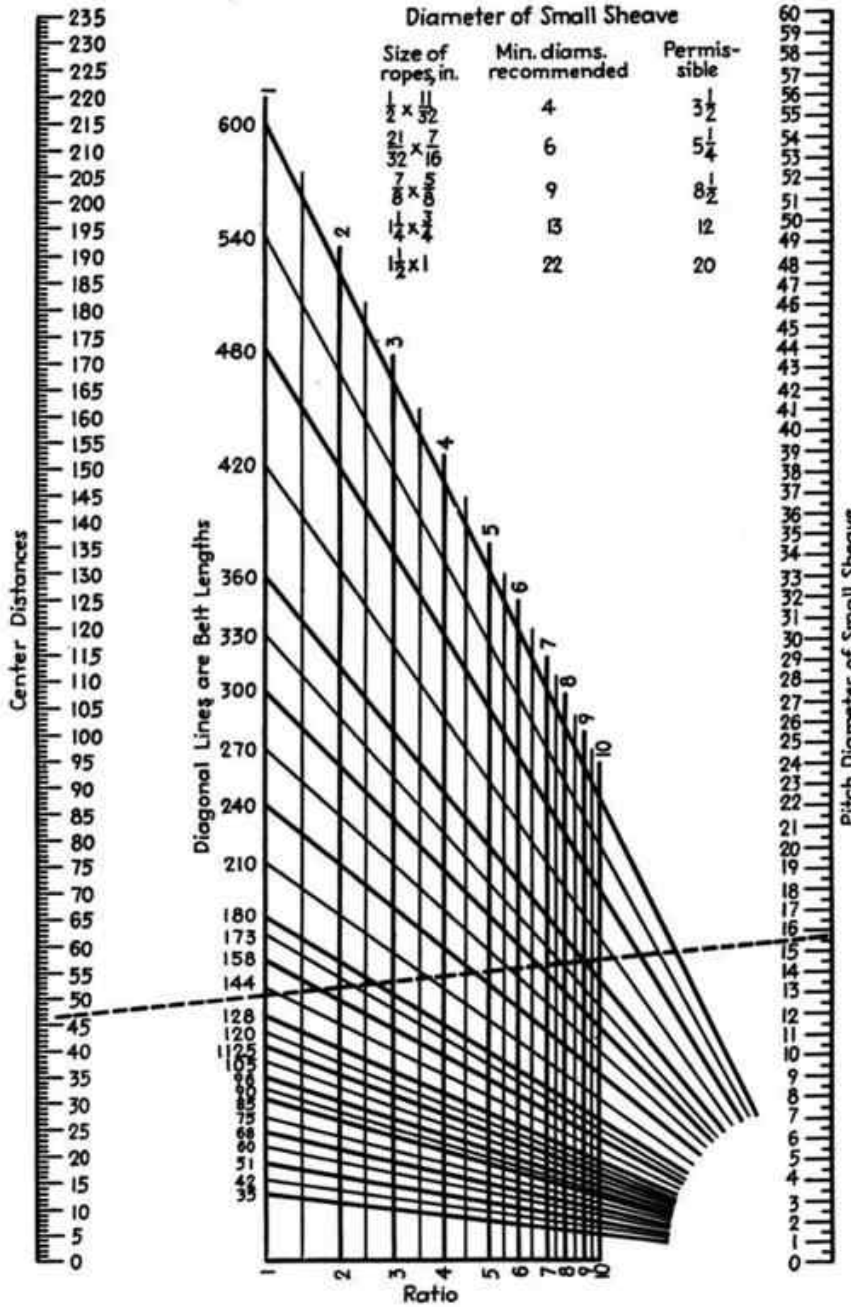

Given pitch diameter of the small sheave, center distance, and speed ratio: to find length of V belt, place straightedge on the given points of small sheave diameter (right) and center distance (left), and note intersection with ratio line (middle). Interpolate between diagonal belt length lines to obtain desired length.

Example: Dotted line drawn between points representing small sheave diameter of 15.65 in. and center distance 46 in. intersects ratio line 2.6 at diagonal line for 180 in. belt length.

The V-belt drive consists of a driving and driven sheave, grooved for a multiplicity of belts of trapezoidal cross section. Power is transmitted by the wedging contact between the belts and grooves. At maximum load, repeated tests show an efficiency of 99 per cent and a co-efficient of friction of 1.5. V-belt drives operate, therefore, with comparatively small tension on the slack side, without slippage and with little creep. In figuring loads, it is usually safe to take 1.5 times the torque to get the total belt pull. Manufacturer's ratings must be consulted for selection of number and size of belts for given load conditions.

A V-belt drive will usually be well proportioned when the center distance equals or is slightly greater than the large sheave diameter. On small ratios, the sheaves may be operated so closely together that the sheaves almost touch each other. Maximum center distance on $\frac{1}{2}$ -in. belts is 17 in., except on high ratios, where 25 in. is permissible.

In the accompanying chart, the sheave diameters are the pitch diameters, measured at the mid-point of the trapezoidal section of the belt when resting in the groove.

SHORT-CENTER BELT DRIVES

Calculations for the Arc of Contact and Length of Belts Having an Idler Pulley

When an idler pulley is used to increase the arc of belt contact on the driving pulley, it becomes necessary to calculate that increase to obtain the belt length. In the figure below, center lines are drawn connecting pulley centers.

Solving for the belt wrap θ on pulley d ,

$$X_1 + X_2 = \sqrt{A^2 + B^2} = \frac{d + D_2}{2 \sin(\phi + \Delta)}$$

$$X_1 = \frac{d}{2 \sin(\phi + \Delta)}$$

$$X_2 = \frac{D_2}{2 \sin(\phi + \Delta)}$$

$$\sin(\phi + \Delta) = \frac{(d + D_2)}{2 \sqrt{A^2 + B^2}}$$

$$\phi = \sin^{-1} \frac{(d + D_2)}{2 \sqrt{A^2 + B^2}} - \Delta$$

$$\Delta = \sin^{-1} \frac{A}{\sqrt{A^2 + B^2}}$$

$$\phi = \sin^{-1} \frac{d + D_2}{2 \sqrt{A^2 + B^2}} - \sin^{-1} \frac{A}{\sqrt{A^2 + B^2}}$$

The angle of belt contact on the driving pulley d will then be

$$\theta = 180 \text{ deg.} - \alpha + (\phi + \Delta) \pm \Delta$$

$$= 180 \text{ deg.} - \alpha + \phi$$

in which the angle of approach α is

$$\sin \alpha = \frac{D - d}{2C} \quad \text{or} \quad \alpha = \sin^{-1} \frac{D - d}{2C}$$

The angles ϕ and Δ can be found on the chart.

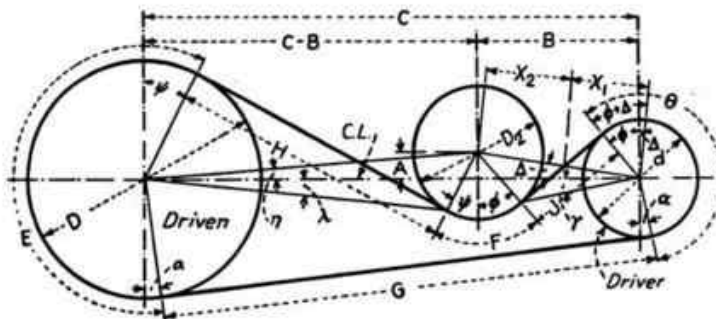

When A is above the center line, angle Δ will be minus, and, if A is below the center line, angle Δ will be plus. The scale A in the chart can be used for either plus or minus values but the sign preceding the angle Δ must be kept in mind. When values of A are less than 1, values of angle Δ must be interpolated. For example, when A is between ± 0.5 in., angle Δ is less than ± 2 deg. and is read on the scales "A" and "angle Δ in deg." by interpolating.

For the example shown on the chart on the next page, the arc of belt contact on pulley d will be

$$= 180 \text{ deg.} - \alpha + (\phi + \Delta) - \Delta$$

$$= 180 \text{ deg.} - 14.5 \text{ deg.} + 33 \text{ deg.} - (-4.5 \text{ deg.})$$

$$= 203 \text{ deg.}$$

Equation for the length L of belt is

$$L = E + \theta + F + G + H + J$$

where $E = \frac{D}{2} \frac{(180 \text{ deg.} + \alpha + \psi)}{57.3}$

$$\theta = \frac{d}{2} \frac{(180 \text{ deg.} - \alpha + \phi)}{57.3}$$

$$F = \frac{D_2}{2} \frac{(\psi + \phi)}{57.3}$$

$$G = C \cos \alpha$$

$$H = D \tan(90 \text{ deg.} - \psi + \lambda)$$

$$J = d \tan(90 \text{ deg.} - \phi + \gamma)$$

In the foregoing equations, values for the various symbols are calculated as follows:

$$\psi = \sin^{-1} \frac{D + d}{2 \sqrt{A + (C - B)^2}}$$

$$\alpha = \sin^{-1} \frac{D - d}{2C}$$

$$\phi = \sin^{-1} \frac{d + D_2}{2 \sqrt{A^2 + B^2}} - \tan^{-1} \frac{A}{B}$$

$$\lambda = \tan^{-1} \left(\frac{D_2/2 \cos \psi - A}{(C - B) - D_2/2 \sin \psi} \right)$$

$$\gamma = \sin^{-1} \left(\frac{D_2/2 \cos \phi - A}{B - D_2/2 \sin \phi} \right)$$

SHORT-CENTER BELT DRIVES

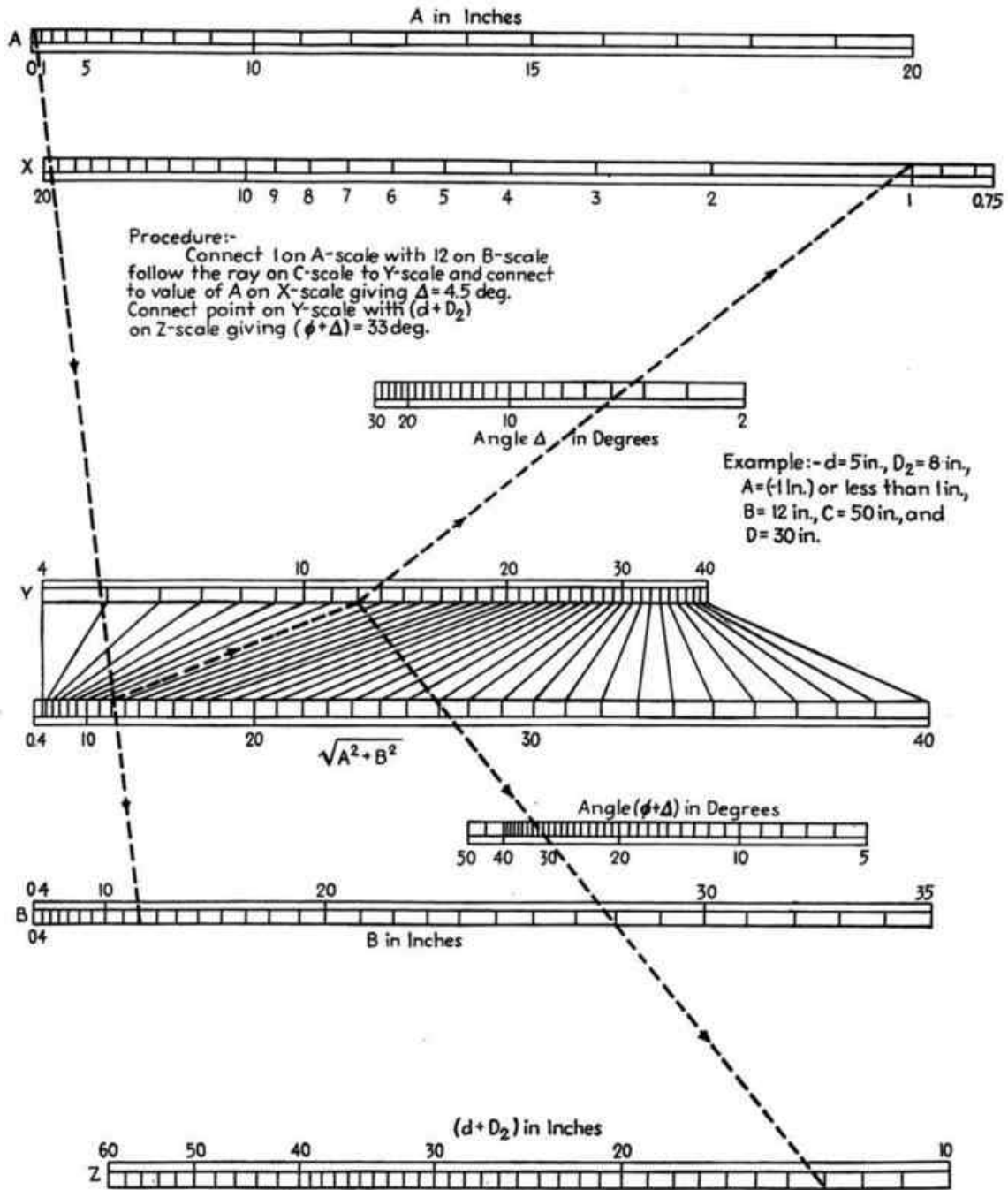
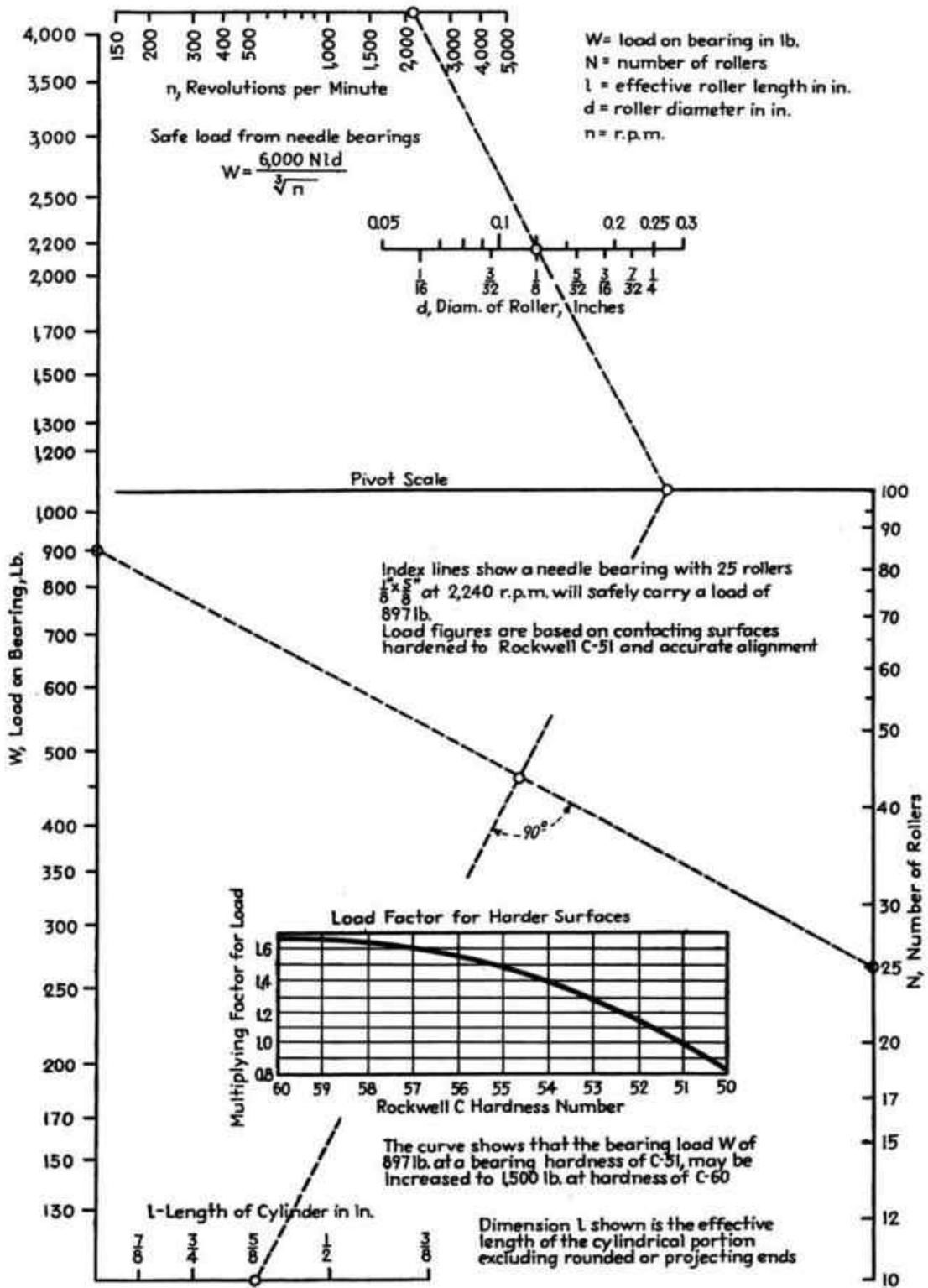
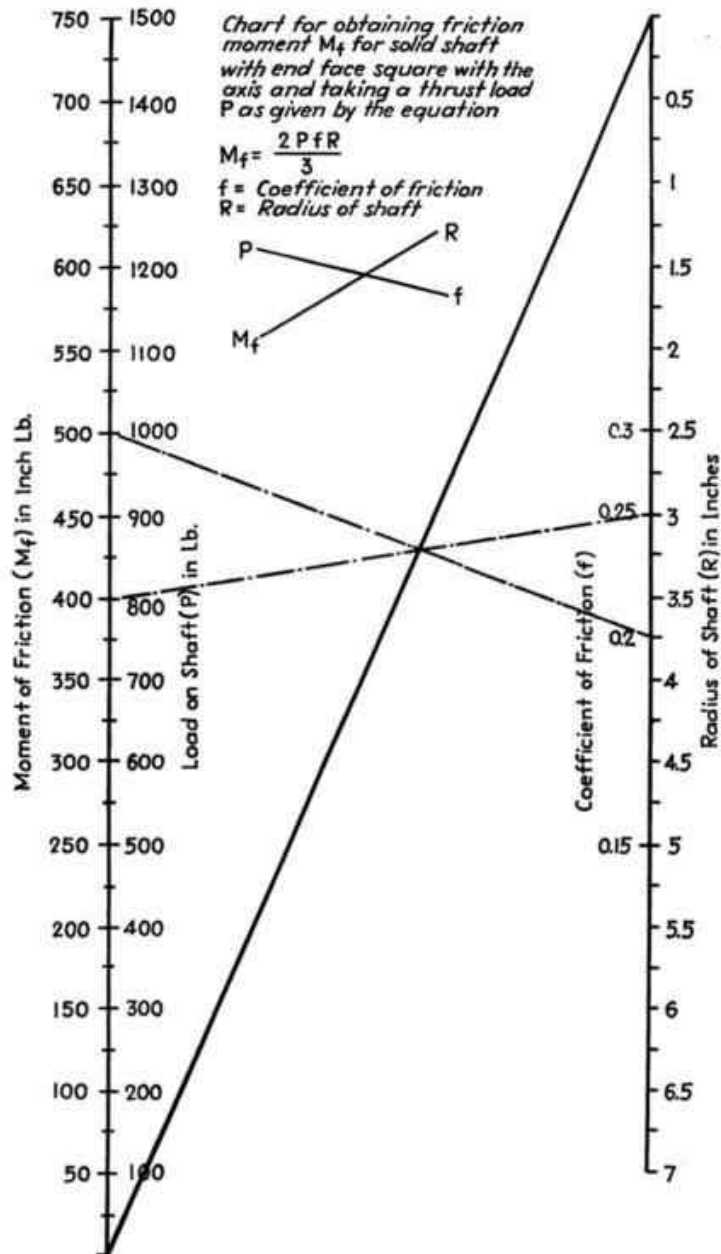

CHART FOR CALCULATING NEEDLE BEARINGS



THRUST BEARING FRICTION MOMENT DETERMINATIONS



For the rapid calculation of frictional resisting moments, a chart such as shown by the illustration on this page for a solid shaft with end face square with the axis may be constructed. In using this chart, it is merely necessary to connect the given values of P and f as found on their respective scales by a straight line. Where this line, shown dotted in the chart, crosses the diagonal, join this point with the given value of R as found on the scale, and extend to the left-hand scale where will be found the desired friction moment. If the friction moment and the speed of the shaft are known, the power lost in friction can be calculated.

CHEMICAL AND PHYSICAL PROPERTIES OF BRONZE BEARING ALLOYS

Johnson bronze alloy no.	Average chemical composition					Physical properties								
	Copper	Tin	Lead	Zinc	Nickel	Tensile, lb. per sq. in. $\pm 5,000$	Proportional limit $\pm 2,000$	Yield point, lb. per sq. in. $\pm 3,000$	Elongation, per cent in 2 in.	Brinell hardness no.	Wear rate* (dry)	Coefficient of friction † (dry)	Izod notch toughness ‡	Resistance to pounding §
19	70.0	11.0	19.0	27,500	7,800	20,700	8 \pm 4	62	0.24	0.16	3.4	54
25	75.0	5.0	19.0	...	1.0	22,500	6,900	16,750	11 \pm 4	44	0.36	0.14	5.2	22
27	80.0	10.0	10.0	30,000	9,700	19,000	10 \pm 5	58	0.32	0.19	4.4	63
29	78.0	7.0	15.0	24,000	7,600	16,400	9 \pm 4	52	0.35	0.16	5.6	40
51	87.0	10.0	1.0	2.0	...	36,500	12,500	18,500	15 \pm 5	67	0.63	0.25	8.3	81
53	88.0	10.0	2.0	...	36,000	13,000	19,000	18 \pm 4	69	0.62	0.26	8.5	86
55	86.0	12.0	2.0	...	39,200	13,600	21,000	10 \pm 5	74	0.53	0.29	3.9	109
66	85.0	5.0	9.0	1.0	...	26,000	7,800	14,500	12 \pm 5	48	0.50	0.19	8.4	20
71	85.0	5.0	5.0	5.0	...	29,000	8,200	16,500	20 \pm 7	49	0.64	0.18	12.1	20
72	83.0	7.0	7.0	3.0	...	29,000	8,600	14,600	17 \pm 5	56	0.41	0.19	8.6	38

* In grams per 10,000 revolutions—Amaler wear test machine—without lubrication.

† As determined on Amaler wear test machine.

‡ Foot-pounds of work required to break specimen 0.400 \times 0.400 in.

§ Number of blows of hammer weighing 7.5 lb. falling 2 in. required to deform specimen 5 per cent. Specimen diameter 0.394 in., length 0.788 in.

Note: Other alloys may be found, whose chemical and physical characteristics differ but little, and consequently their performance does not materially enhance their bearing value. Any operating condition can be met by the above 10 preferred bearing alloys. On page 181 is given a chart which indicates the field of application for bronzes of various percentages of copper, tin, and lead.

BEARING BRONZES GROUPED ACCORDING TO FIELDS OF USE

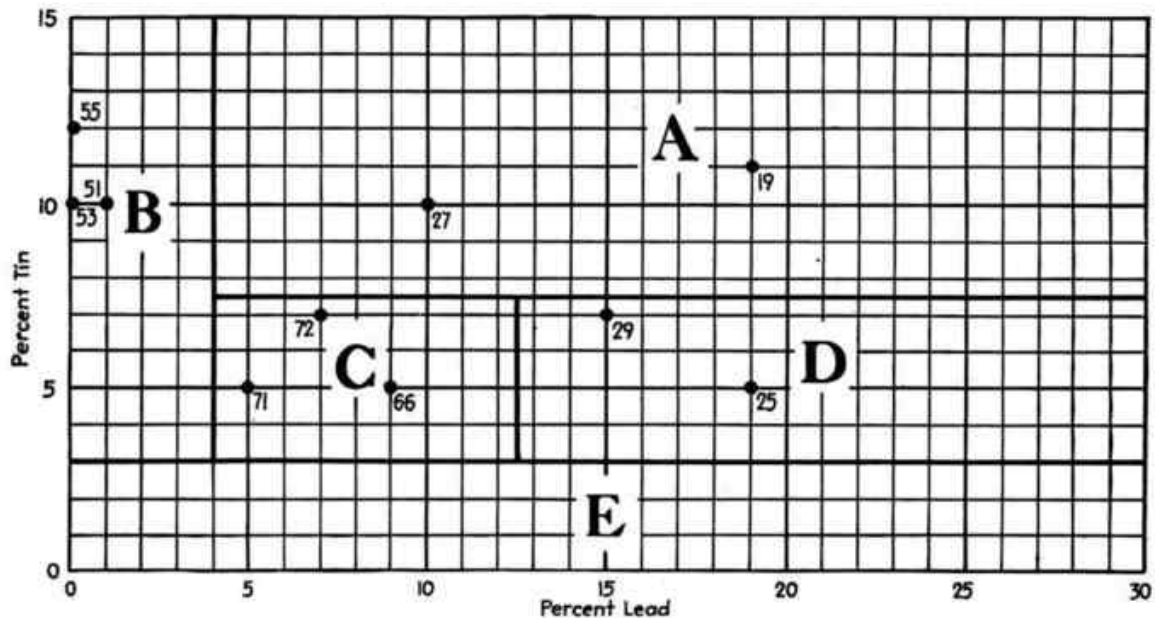

In this chart, the lead content and tin content of the alloy is as designated by the coordinates. The percentage of copper content will be 100 minus the total of percentage of tin plus percentage of lead. The numbers in the field of the chart are the Johnson bronze alloy numbers.

On the preceding page, will be found a table giving both the chemical compositions and physical properties of the alloys whose numbers appear in the field of this chart.

Refer to the article, *Bronze Bearing Alloys—Properties and Applications*, *Product Engineering*, page 202, June, 1934, wherein is set forth the reasons for the various bearing requirements and the effect of each of the various constituents in copper-tin-lead alloys. The characteristics of the 10 alloys included in the preceding chart and specific examples of their typical applications are also given.

Fields of Application of the Five Groups of Bronze Bearing Alloys.—A. This is the most useful range of copper-tin-lead alloys. All alloys in this group have good wear rates and resistance to pounding. Alloy 19 has the highest wear rate and has comparatively good resistance to pounding, but is somewhat brittle. Alloy 27 has a good wear rate and a correspondingly good resistance to pounding, it being moderately tough.

B. Alloys in this group are suitable for bearing installations only where adequate lubrication can be guaranteed at all times. They have valuable characteristics where exceptionally heavy impact loads are encountered as in the bearings of crushing machinery.

C. In this group are the alloys best suited for low loads and moderately high speeds. These alloys are often used as bearing backs.

D. Alloys in this group are suitable for high speeds and low loads, but should not be used where there is excessive pounding.

E. Alloys in this group, containing less than 3 per cent tin, are unsuited for general bearing service owing to their high wear rate and low resistance to pounding.

SHAFT SEALS

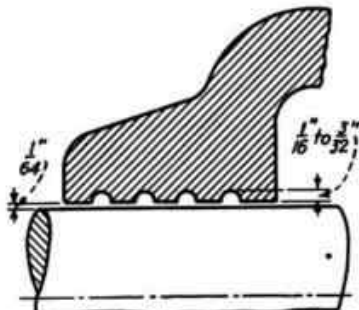

FIG. 302.—For grease lubrication, the half-round groove is used frequently, the effectiveness of the seal increasing with the number of grooves, of which there should be at least two.

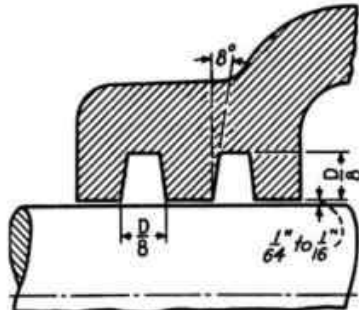

FIG. 303.—Sometimes this type is used without sealing rings.

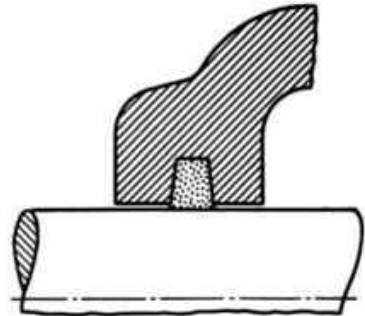

FIG. 304.—Usually only one groove with a cork or felt ring is depended upon to perfect the seal. The tapered walls tend to press the sealing ring against the shaft.

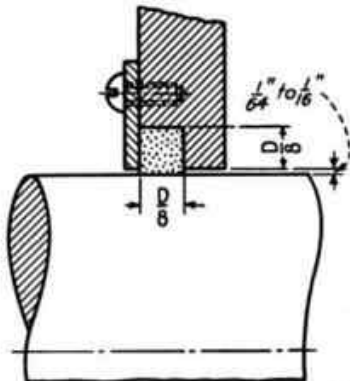

FIG. 305.—This design makes it easy to replace the cork or felt ring. In some instances, the depth of the counterbore is doubled and two rings are used.

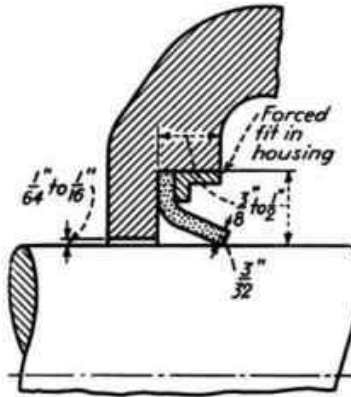

FIG. 306.—One method of applying a simple leather seal.

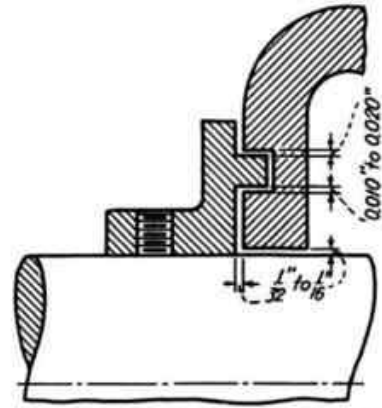

FIG. 307.—A simple design of labyrinth seal. Centrifugal force prevents the entrance of foreign particles while grease or oil lubricant on the shaft is thrown outward, thus filling the labyrinth opening.

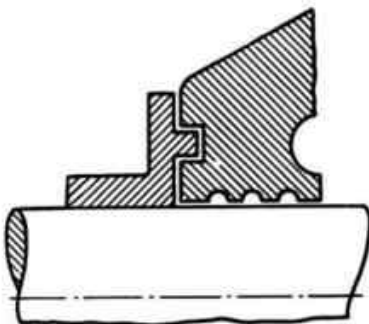

FIG. 308.

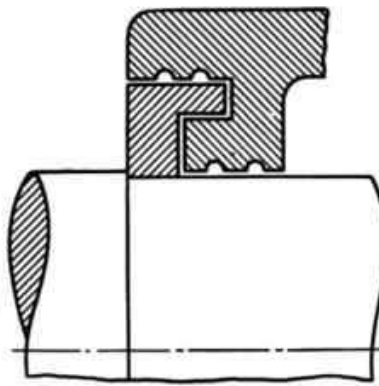

FIG. 309.

FIGS. 308 and 309.—Labyrinth and groove seals can be combined for greater effectiveness.

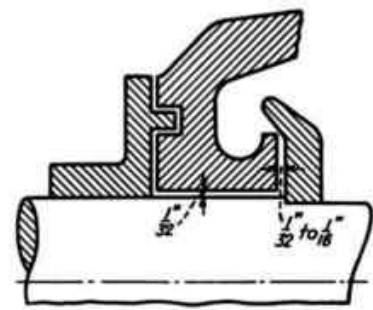

FIG. 310.—Addition of a slinger helps materially to prevent liquids finding their way through the seal.

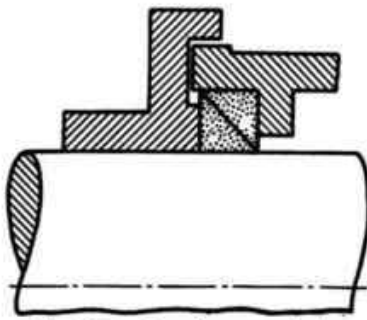

FIG. 311.—For slow speeds, two cork rings mounted as shown can be used. The set collar is sometimes counterbored and two small springs placed in the counterbore with a covering washer that bears against the sealing ring.

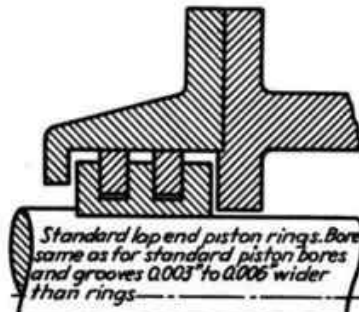

FIG. 312.—The common labyrinth shaft seal.

Standard lap end piston rings. Bore same as for standard piston bores and grooves 0.003" to 0.006" wider than rings—

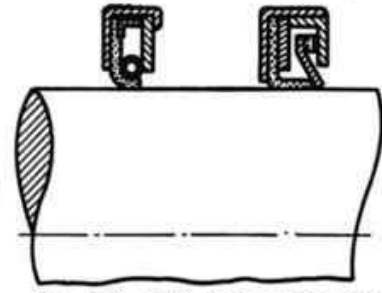

FIG. 313.—Left, Chicago Rawhide Company seal. Right, Gits Brothers Manufacturing Company seal. They can be used for sealing in either direction, the spring maintaining pressure between the leather and the shaft.

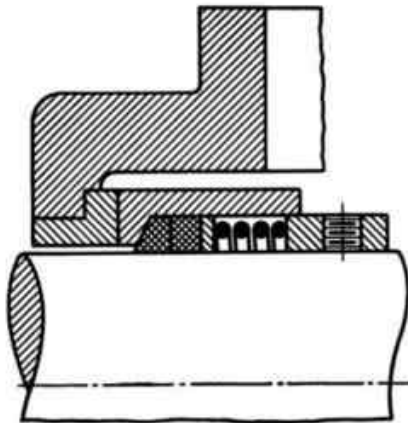

FIG. 314.—Cooke-type seal that embodies the patented principle of maintaining contact between the stationary and moving surfaces.

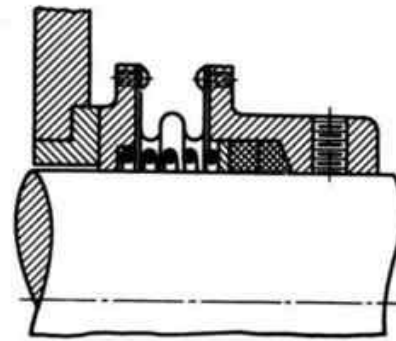

FIG. 315.—Another application of the Cooke seal. Metal bellows permit relative movement.

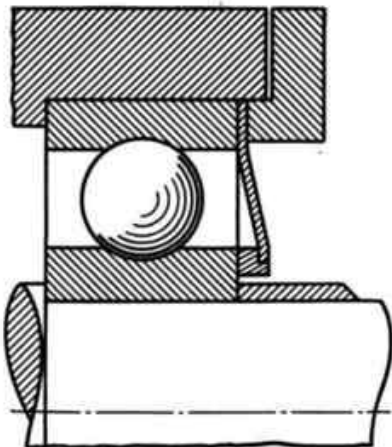

FIG. 316.—An effective ball or roller-bearing seal.

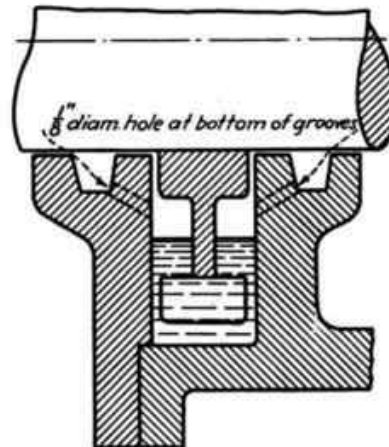

FIG. 317.—Illustrates the principle of the water seal.

ROLLER-BEARING SEALS

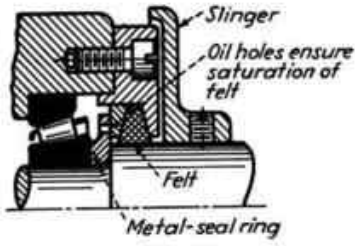

FIG. 318.

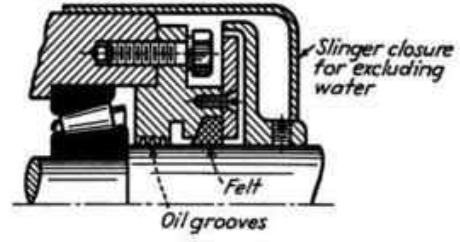

FIG. 319.



FIG. 320.

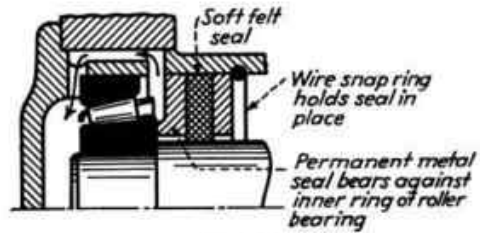

FIG. 321.

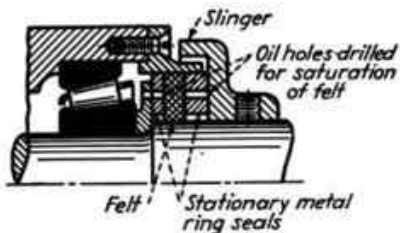

FIG. 322.

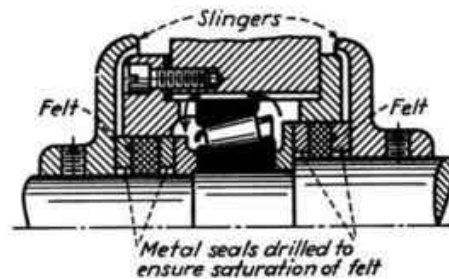

FIG. 323.

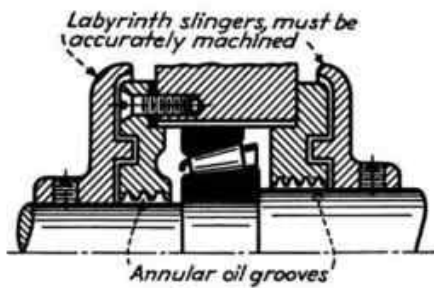

FIG. 324.

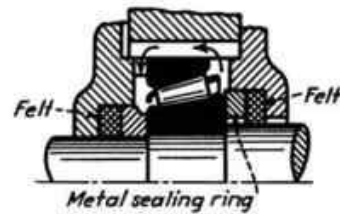
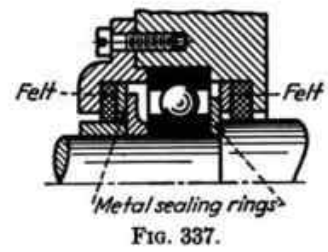
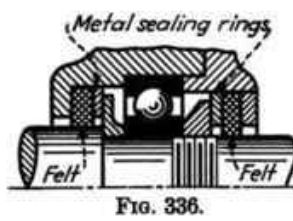
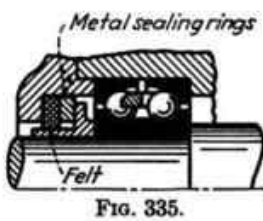
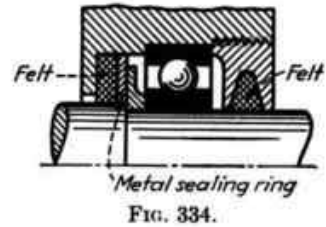
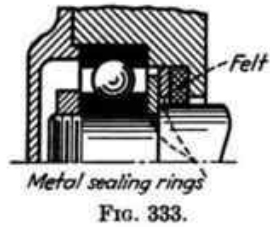
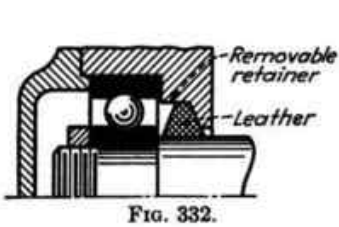
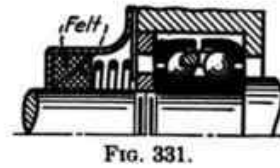
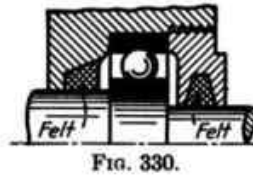
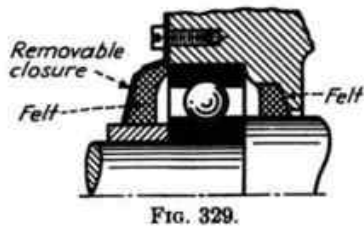
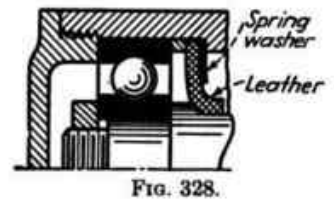
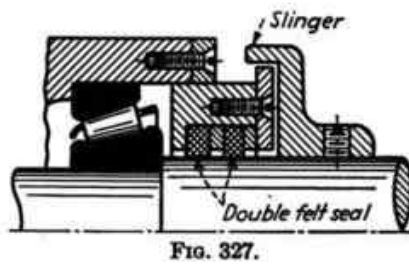
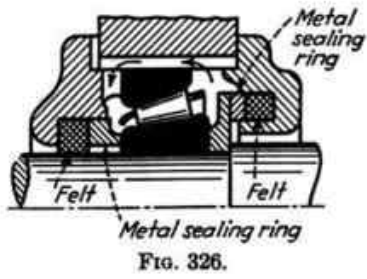

FIG. 325.



SLEEVE-BEARING SEALS

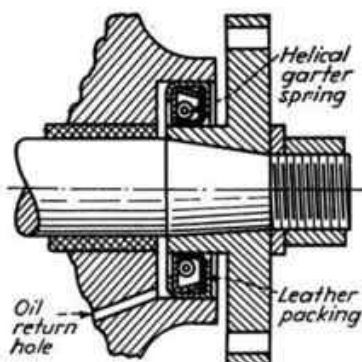

FIG. 338.

FIG. 338.—For retaining lubricant, the seal is assembled with the flanged leather projecting toward the bearing. The leather packing is clamped near the outer edge of the flange by the inner of two telescoping metal cups, a tight joint at the face being thereby assured. A garter-type spring compresses the leather about the shaft. Should misalignment occur, the seal is maintained by virtue of the flexibility of the leather and garter spring. To drain off the surplus oil passing the end of the bearing, a small hole is drilled in the casting connecting the reservoir.

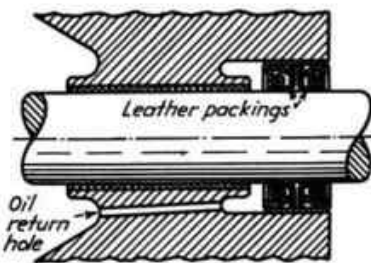

FIG. 339.

FIG. 339.—Installation of double seal unit for retaining lubricant in bearing recess and for guarding against entrance of foreign material. The seal is of the same general construction as shown in Fig. 338 except that two flanged leathers are mounted opposed to each other.

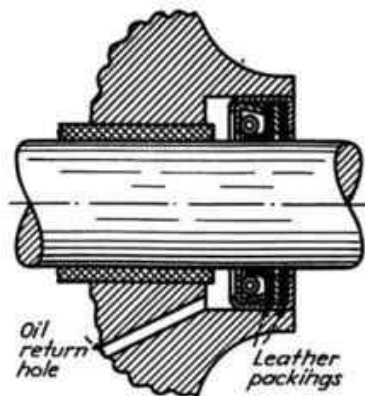

FIG. 340.

FIG. 340.—Used for the same general purposes as the arrangement shown in Fig. 339. The seal has but one garter spring for the oil-retention leather flange. The leather washer for dust exclusion shown at right has a beveled lip which contacts the shaft.

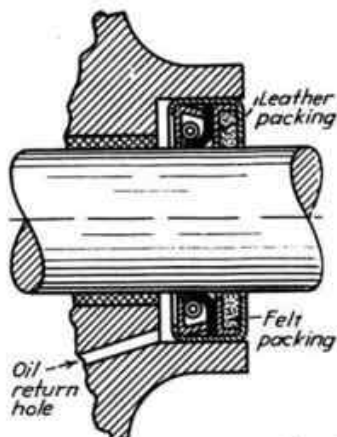

FIG. 341.—Sometimes felt is used on the dust-exclusion side of the seal in place of leather shown in Figs. 339 and 340. Both sealing materials are retained by spinning the outer casing over the leather clamping cup.

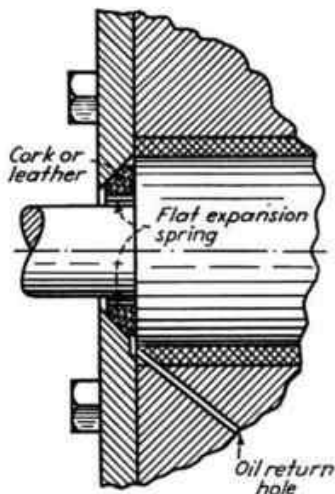
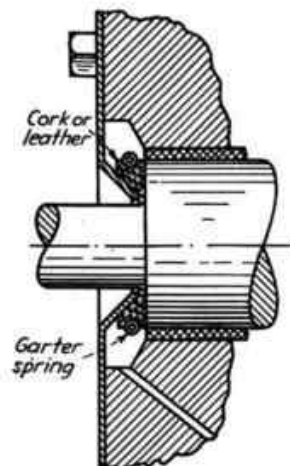
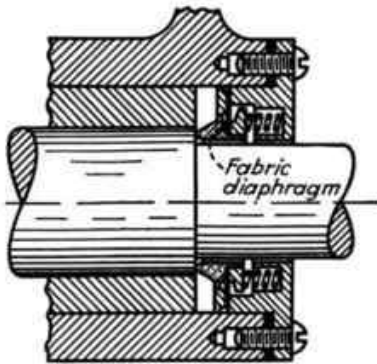

FIG. 342.—Where there is considerable difference in the diameters, the face of the shoulder thus formed can be utilized as the sealing surface. A soft ring of cork or leather is beveled at the outer surface as shown. A flat spiral spring, coiled to a greater diameter than the hole in the sealing material, expands the packing outward against the beveled ring and wedges it against the face of the shaft shoulder.



Figs. 338 to 343 incl.
Courtesy of Universal
Oil-Seal Company

FIG. 343.—Working on the same wedging principle as that shown in Fig. 342, except that the packing is beveled on the inner surface and is retained by a sheet metal flange. The cork or leather sealing material is compressed against the two bearing surfaces by a garter spring as shown. Seals shown here and in Fig. 342 are limited to approximately $\frac{1}{32}$ in. end play.



Courtesy Gits Bros. Manufacturing Co.

FIG. 344.—Another type of seal wherein a bronze ring bears against the shoulder of the shaft. The sealing material is in the form of a diaphragm of heat-resisting fabric which retains oil in the bearing and excludes dirt. In the flanged member that is screwed to the housing is a series of compression springs which hold the ring against the shaft shoulder. These springs not only take up wear but provide for end play of the shaft. To avoid torsional strain on the diaphragm, guide pins are used between the outer flange and spring bearing washer.

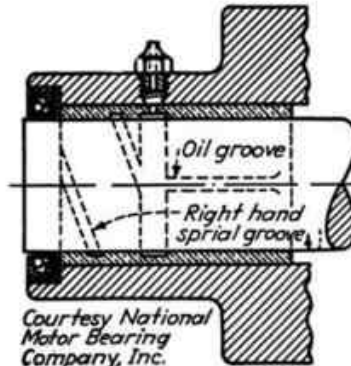

Courtesy National Motor Bearing Company, Inc.

FIG. 345.—When grease is used as a lubricant, it is sometimes desirable to assemble a single seal to keep dirt from reaching the bearing rather than retain the grease in the bearing. The illustration shows an installation wherein a right-hand spiral groove is cut in the bearing bore to lead the lubricant outward. Surplus grease is forced past the seal, thereby keeping the bearing clean.

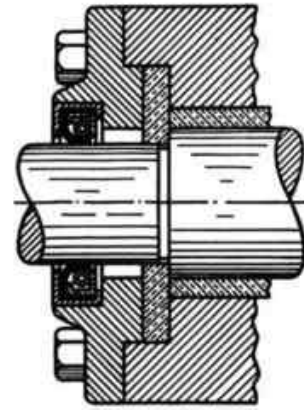

Courtesy of the Chicago Rawhide Manufacturing Co.

FIG. 346.—Leather flange seal with garter spring mounted in a flanged end plate. Spring tension is such as to give small area of contact between leather and shaft, thereby minimizing friction. A bronze thrust washer is between the bearing and the bearing housing.

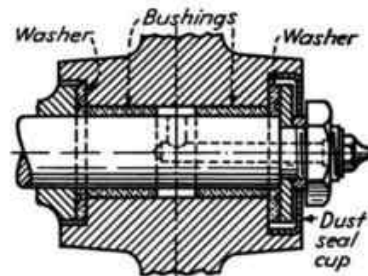
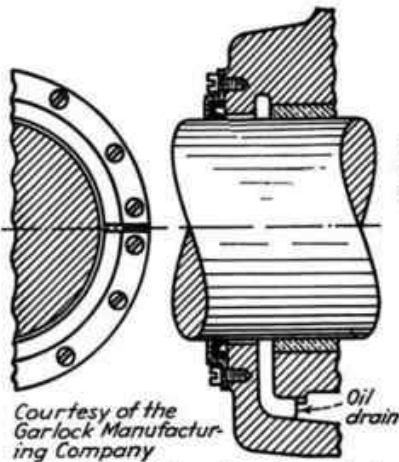

FIG. 347.—The labyrinth seal shown does not rely on nonmetallic materials but on the small clearances with the assembly. A steel washer contacting a bronze thrust washer is clamped against the shaft shoulder after the formed dust seal cup is pressed into the counterbored hole.



Courtesy of the Garlock Manufacturing Company

FIG. 348.—When oil seals are to be installed after a mechanism has been assembled or to preclude the necessity of disassembling heavy shafts and bearings when making seal renewals, split seals can be used in such installations. The spreader spring and packing ring are split, whereas the retaining cup is made in two halves. The packing is scarf-cut to form an oiltight joint when assembled.

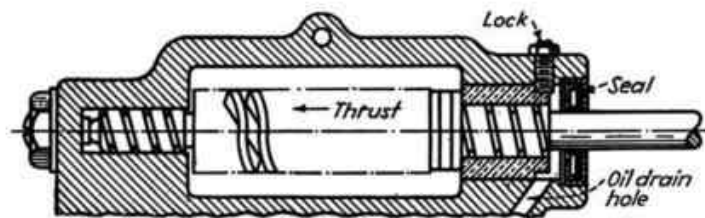
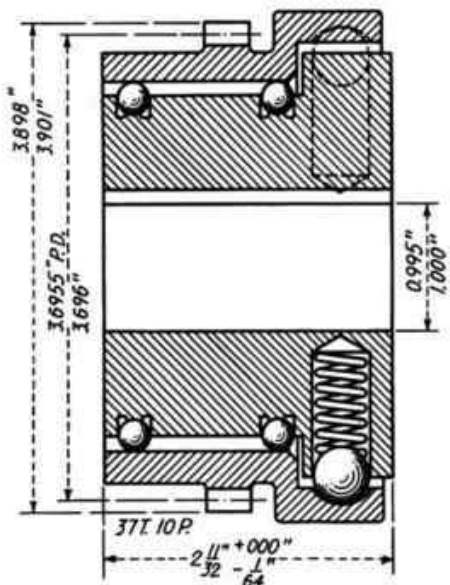
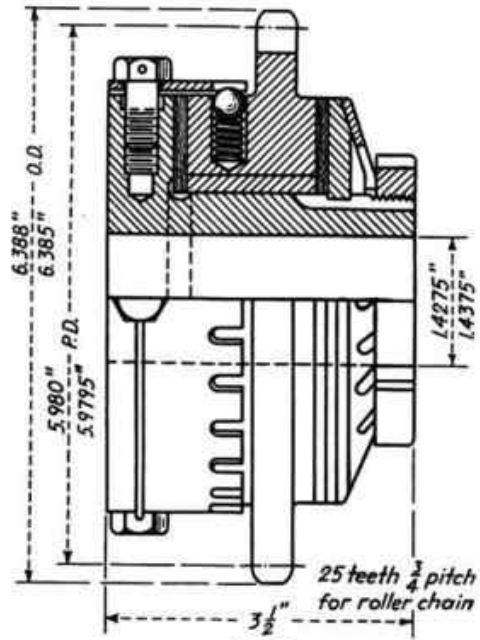

FIG. 349.—Another mounting of small worm-drive shaft for domestic washing machine and domestic stoker. The composition sealing material is held against the shaft by a V-formed spreader spring having serrated edges which nest into the sealing ring. The angle of the V in the spring is greater than the groove in the seal so that the fingers of the spring exert a light pressure on the sealing lip. An oil return hole is drilled outside the bearing to relieve built-up pressure against the seal.

SAFETY GEARS



9 springs
 $\frac{31}{64}$ " outside diameter
 0.109" diam. wire
 Load = 1100 lb. per in. travel per turn
 Test = load 35 to 40 lb. on 20 in. radius lever
FIG. 350.



2 springs
 $\frac{11}{32}$ " outside diameter
 0.040" diam. wire
 Load = 26 lb. per in. travel per turn, for noise maker only
 Test = load 25 to 28 lb. on a 57 in. radius lever
FIG. 351.

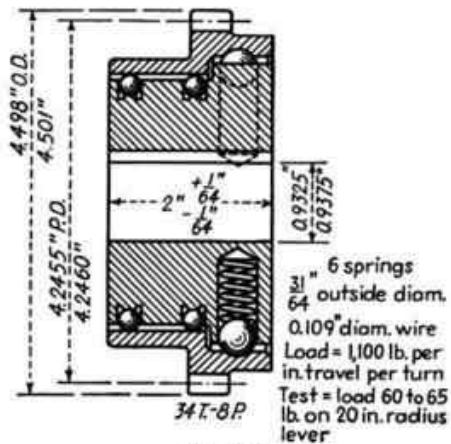

FIG. 352.

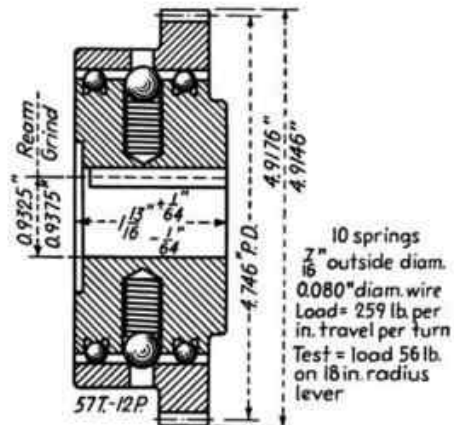
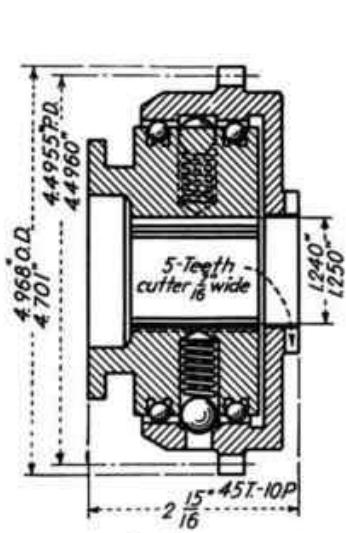
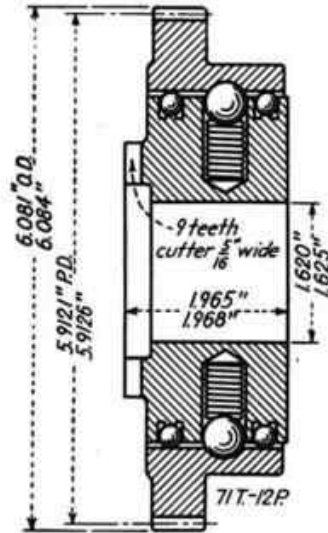

FIG. 353.



9 springs
 $\frac{13}{32}$ " outside diameter
 0.092" diam. wire
 Load = 814 lb. per in. travel per turn
 Test = load 50 to 60 lb. on 20 in. rad. lever
 FIG. 354.



12 springs
 $\frac{31}{64}$ " outside diameter
 0.109" diam. wire
 Load 1,100 lb. per in. travel per turn
 Test = load 65 to 75 lb. on 60 in. rad. lever
 FIG. 355.

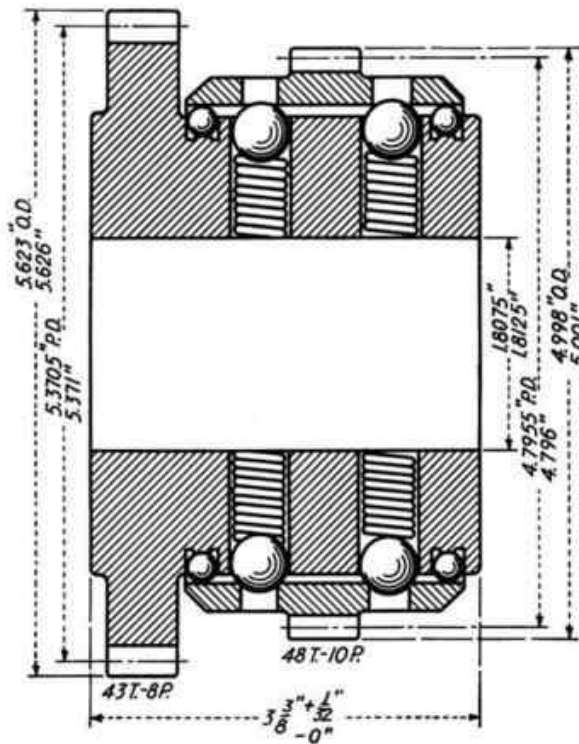

20 springs
 $\frac{31}{64}$ " outside diameter
 0.109" diam. wire
 Load 1,100 lb. per in. travel per turn
 Test = load 65 to 70 lb. on 60 in. radius lever
 FIG. 356.

SHIFTING MECHANISMS FOR GEARS AND CLUTCHES

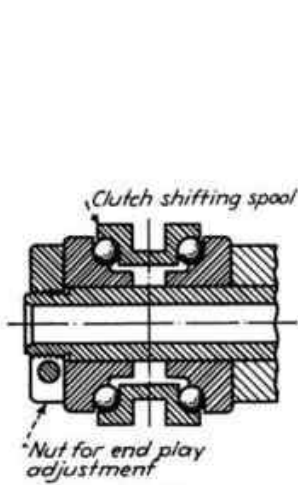

FIG. 357.

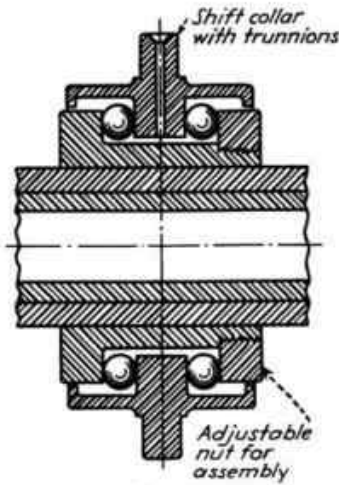

FIG. 358.

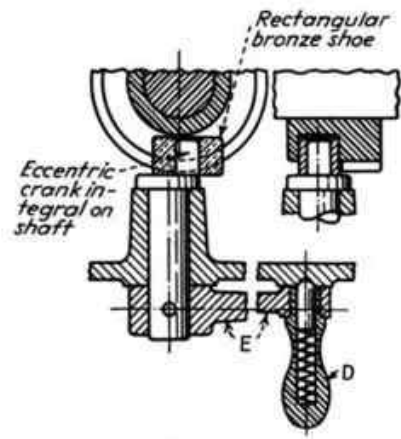

FIG. 359.

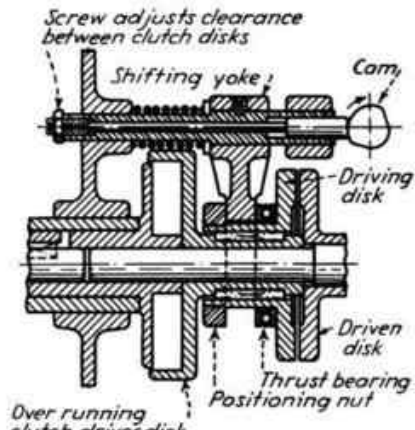

FIG. 360.

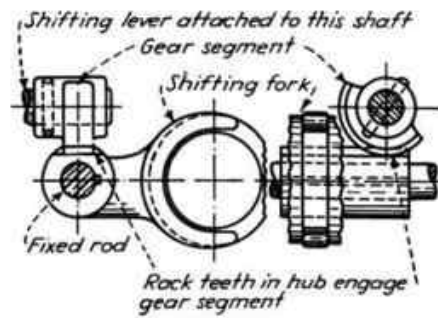

FIG. 361.

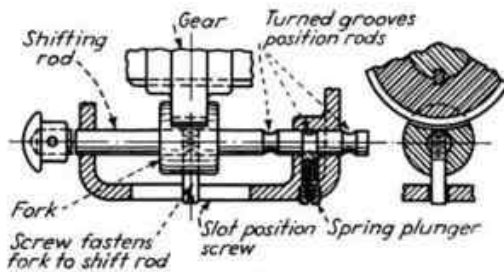

FIG. 362.

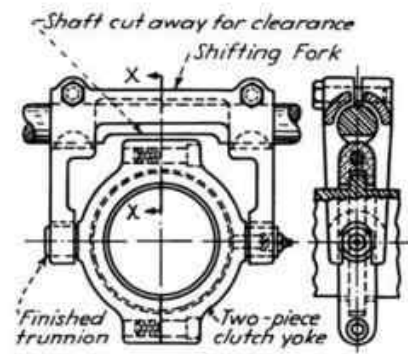

FIG. 363.

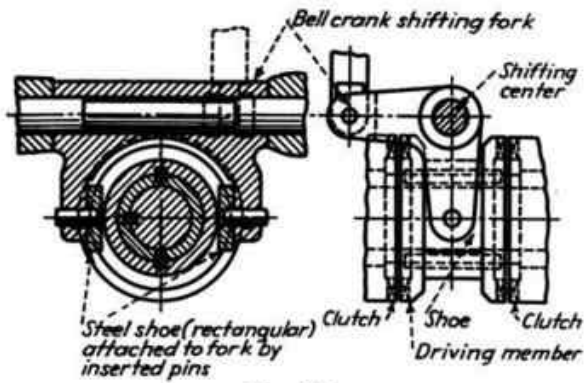

FIG. 364.

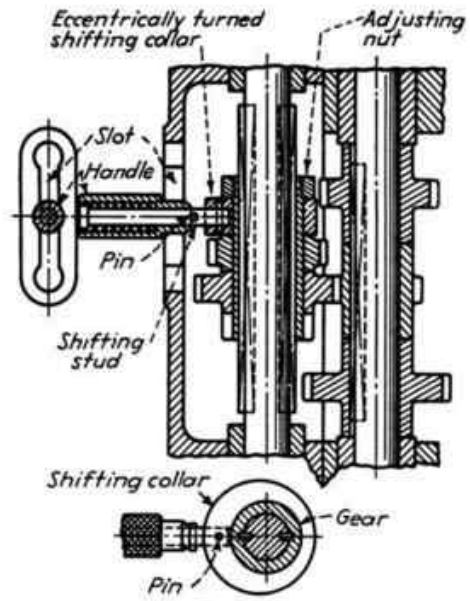

FIG. 365.

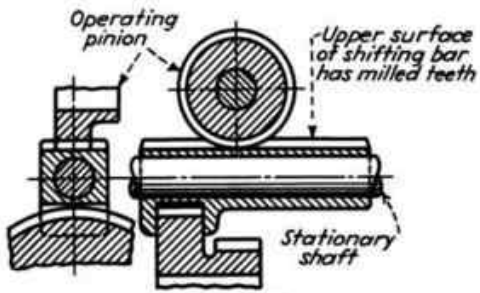

FIG. 366.

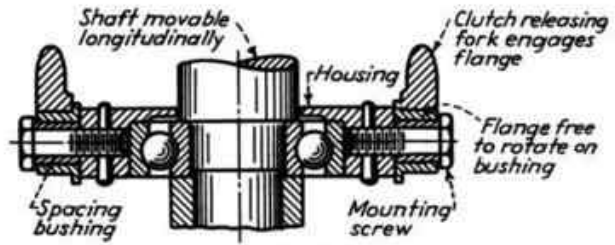

FIG. 367.

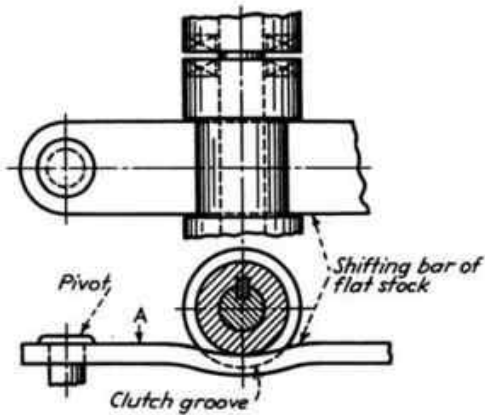

FIG. 368.

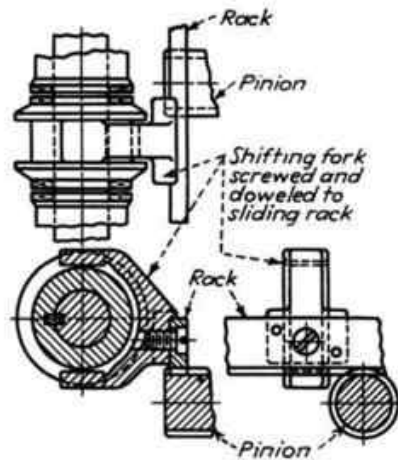

FIG. 369.

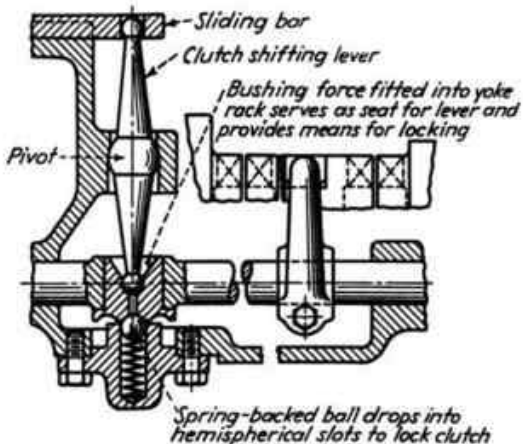

FIG. 370.

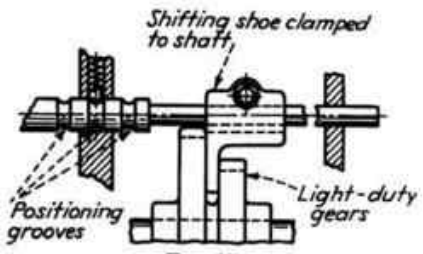

FIG. 374.

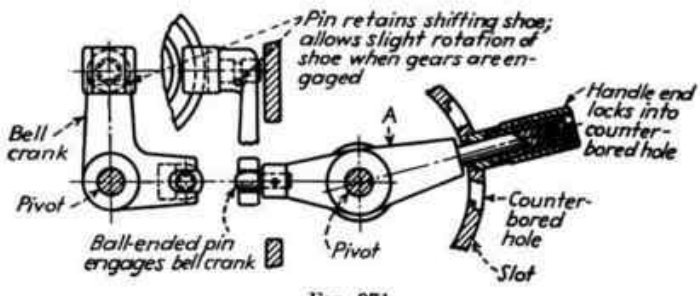

FIG. 371.

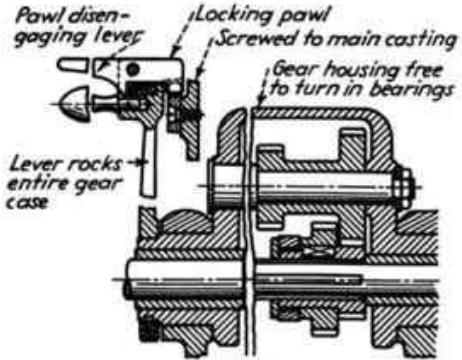

FIG. 375.

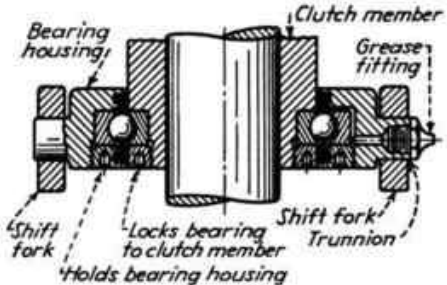

FIG. 372.

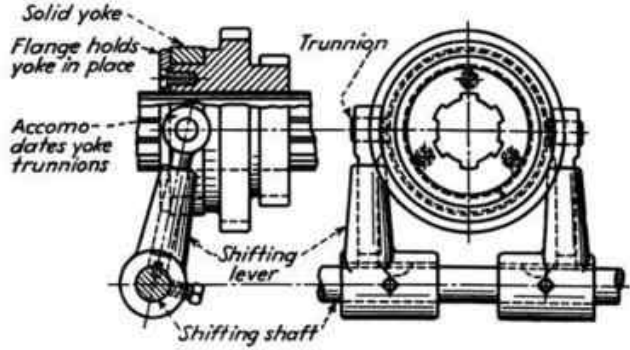

FIG. 373.

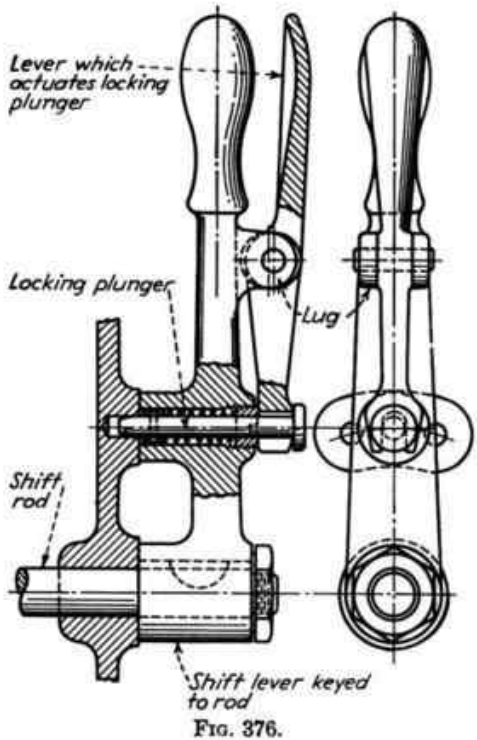

FIG. 376.

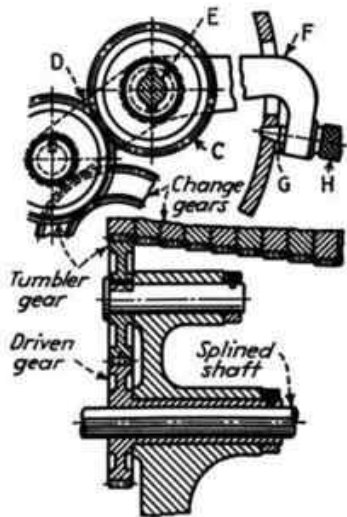

FIG. 377.

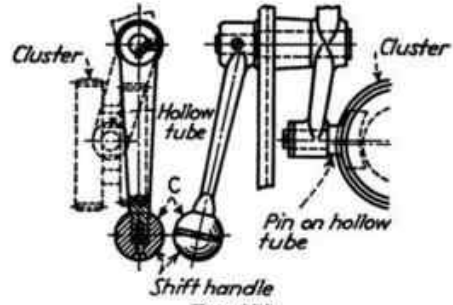

FIG. 378.

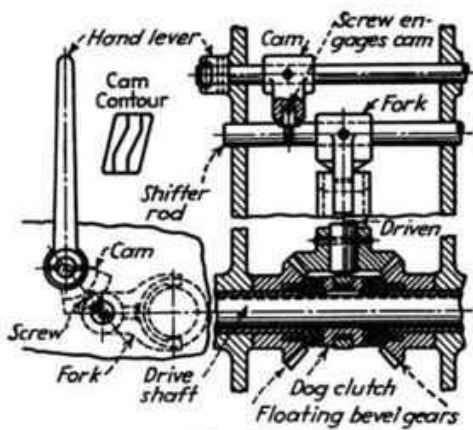

FIG. 379.

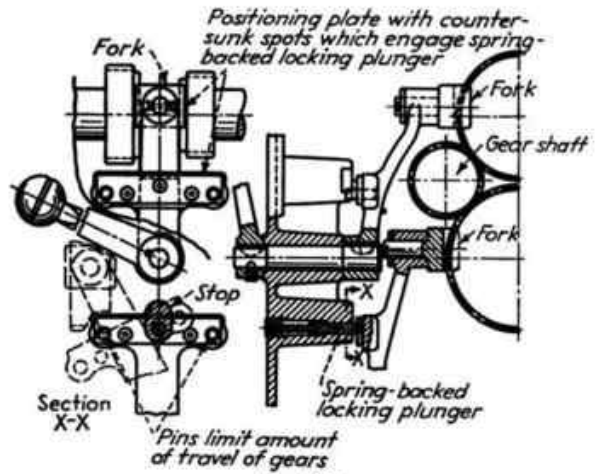

FIG. 380.

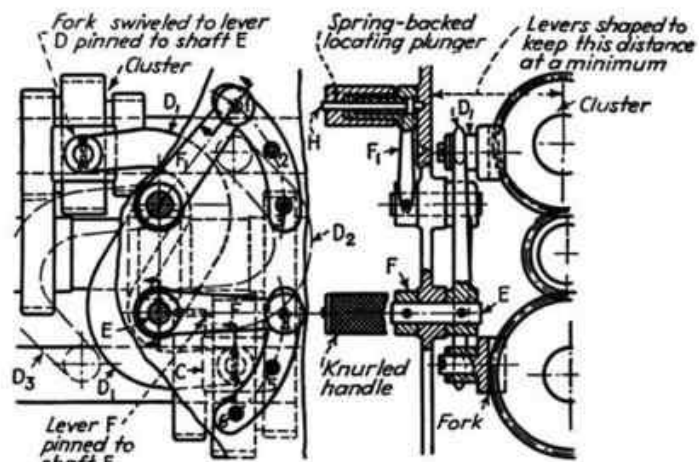

FIG. 381.

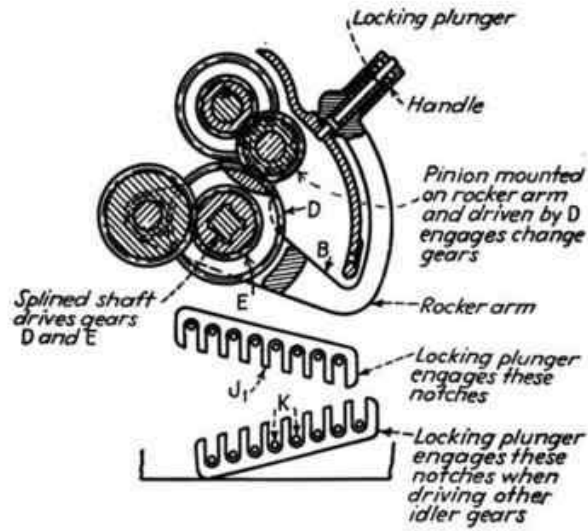

FIG. 382.

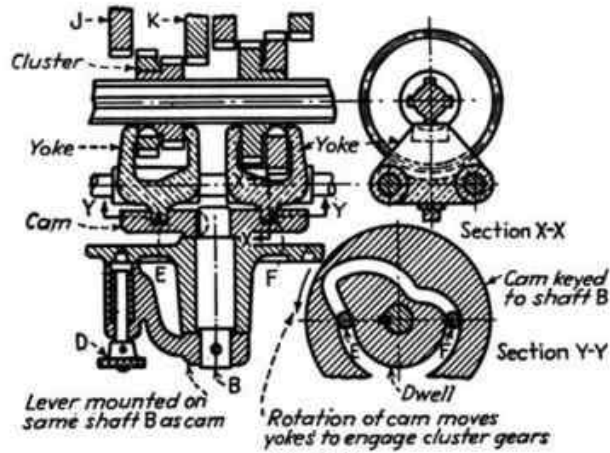

FIG. 383.

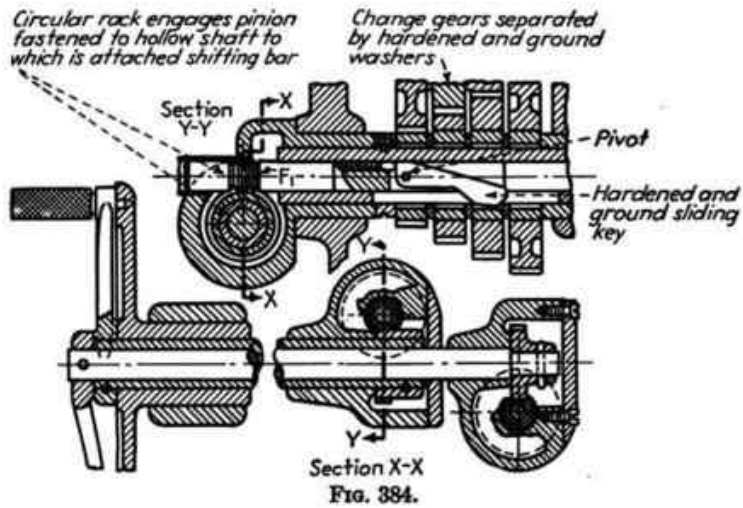
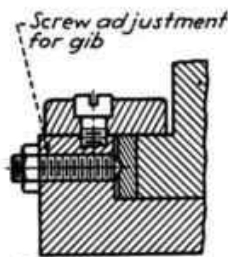

FIG. 384.

GIBS AND GUIDES



FIG. 385.



For light loads only
FIG. 386.

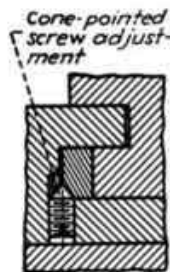

FIG. 387.

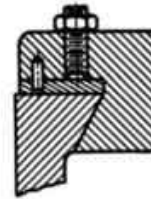

FIG. 388.

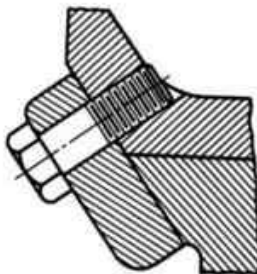

FIG. 389.

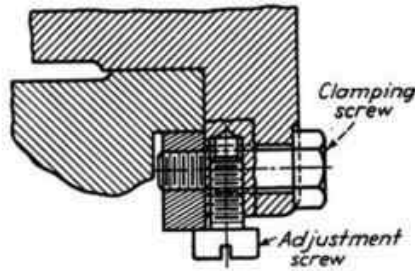

FIG. 390.

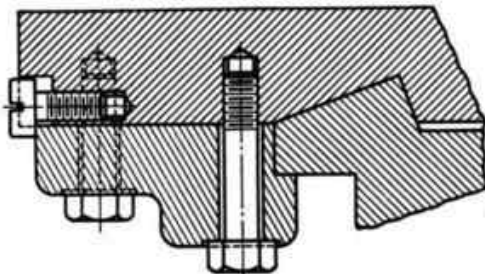
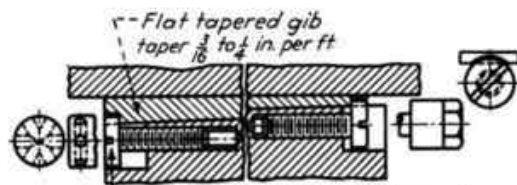

FIG. 391.



Adjustment and locking through screw engagement in counter-bored segment of gib
FIG. 392.

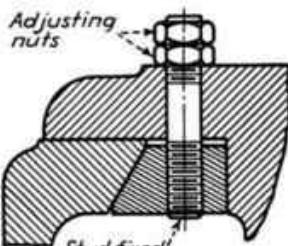

FIG. 393.

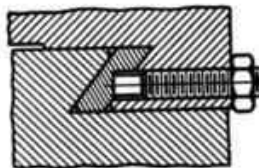

FIG. 394.

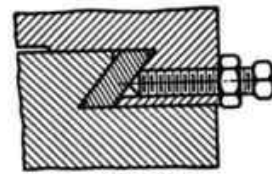

FIG. 395.

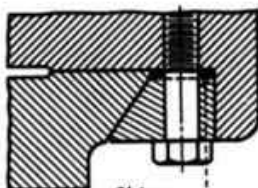

FIG. 396.

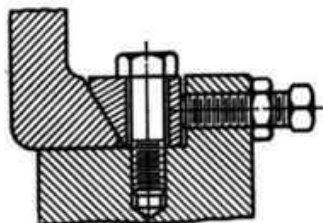

FIG. 397.

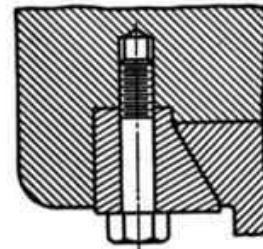

FIG. 398.

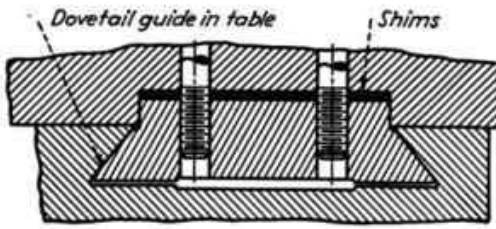

FIG. 399.

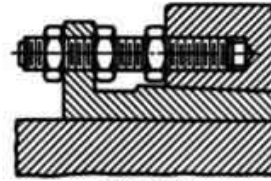

FIG. 400.

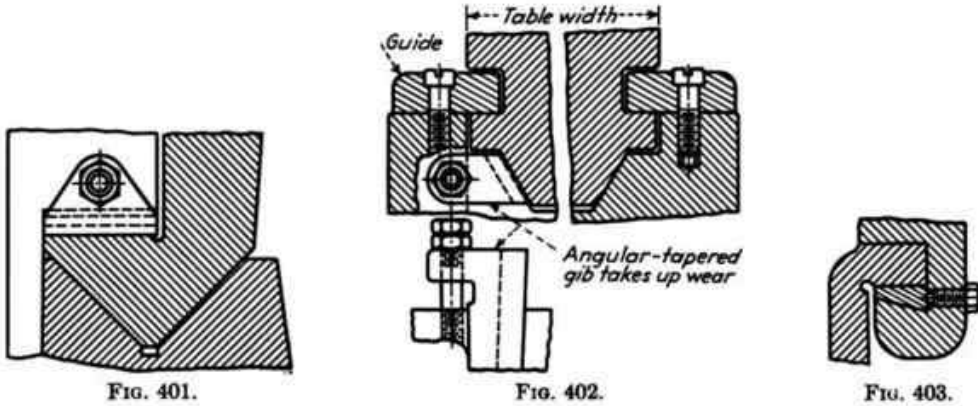

FIG. 401.

FIG. 402.

FIG. 403.

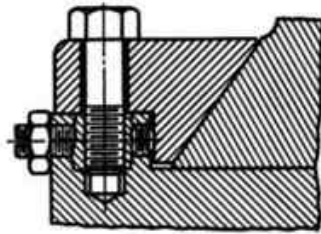

FIG. 404.

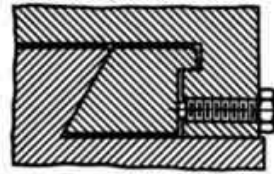

FIG. 405.

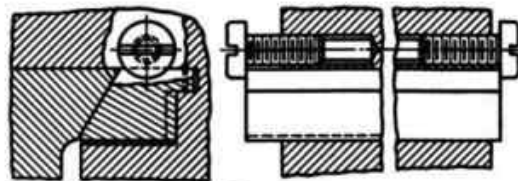

FIG. 406.

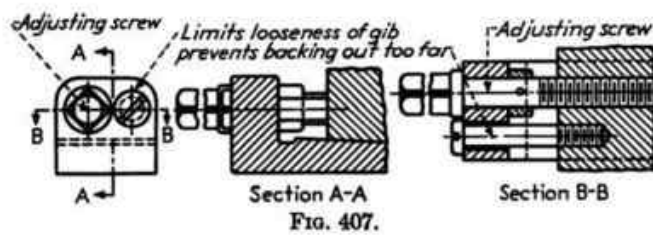

FIG. 407.

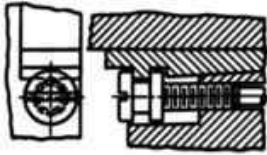

FIG. 408.

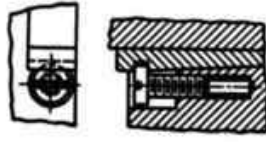

FIG. 409.

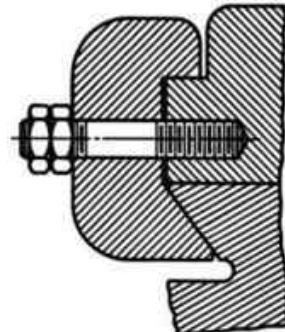

FIG. 410.

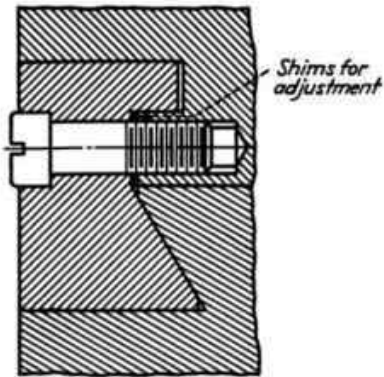

FIG. 411.

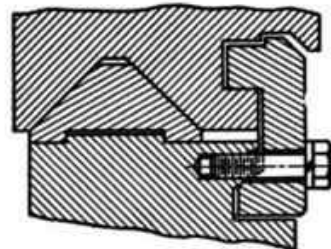

FIG. 412.

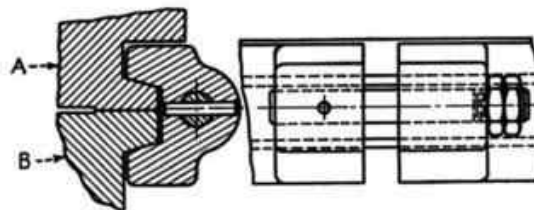

FIG. 413.

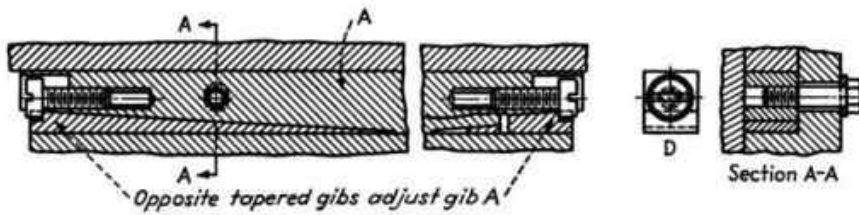
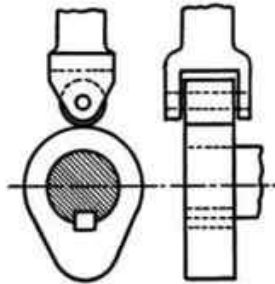

FIG. 414.

CAM DESIGNS

Typical Forms Used in Machine Design



Radial Cam with Roller Follower

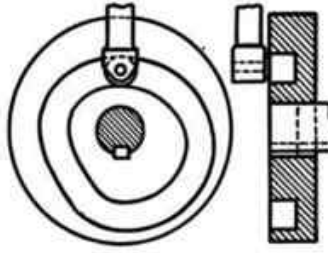

Face Cam

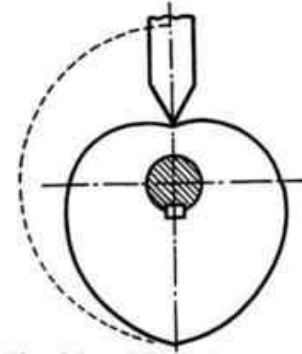

Heart Cam Sliding Contact

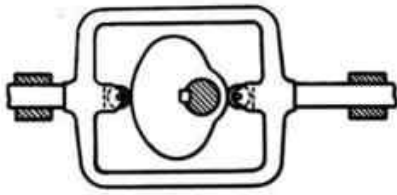

Yoke Cam

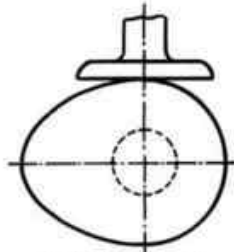

Radial Cam with Mushroom Follower

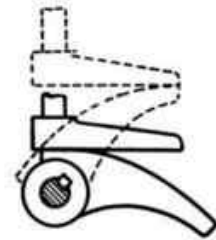

Toe and Wiper

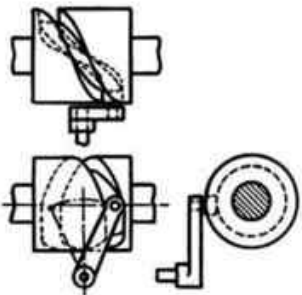

Cylindrical Cam with Swinging Follower

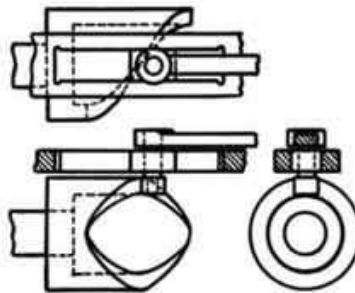

End Cam

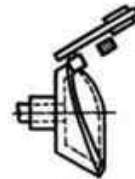

Conical Cam

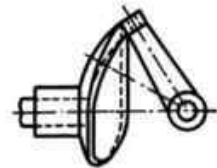

Spherical Cam

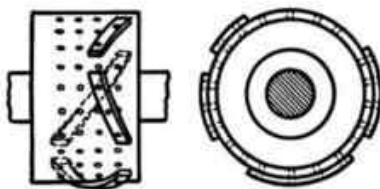

Barrel Cam

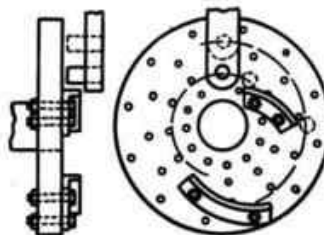
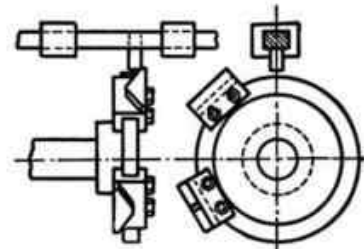

Plate Cam



Dog Cam

VARIABLE-SPEED DEVICES

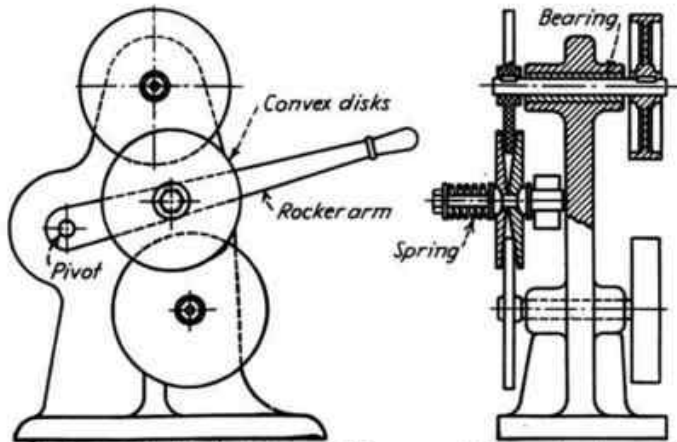

FIG. 415.—Device for transmitting power between fixed parallel shafts. Convex disks mounted freely on a rocker arm and pressing firmly against the flanges of the shaft wheels by a coiled spring form the intermediate sheave. Speed ratio changed by moving rocker lever. No reverse possible, but driven shaft may rotate above or below driver speed. Convex disk must be mounted on self-aligning bearings to ensure good contact at all positions.

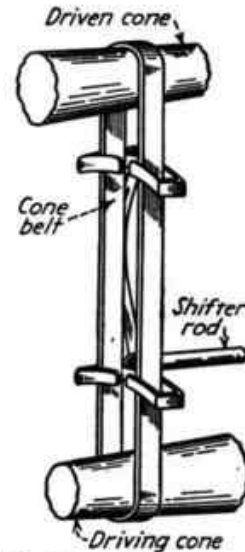

FIG. 416.—These speed cones are mounted at any convenient distance apart and connected by a belt, whose outside edges consist of an envelope of tough, flexible, wear-resisting rubberized fabric built to withstand the wear caused by the belt edge traveling at a slightly different velocity from the part of the cone in actual contact. Speed ratio changed by sliding the belt longitudinally.

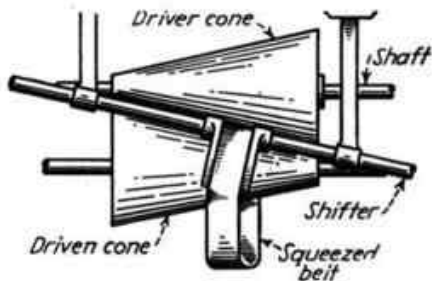

FIG. 417.—Two cones mounted close together and making actual contact through a squeezed belt. Speed ratio is changed by shifting the belt longitudinally. Taper on cones must be moderate in order to avoid excessive wear on the sides of the belt.

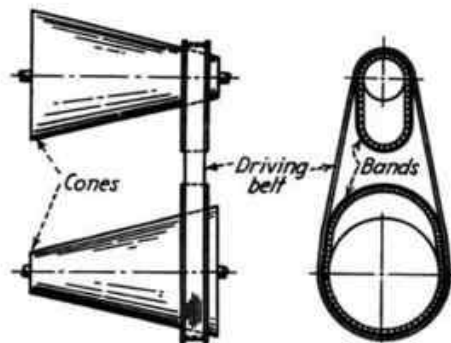

FIG. 418.—Another device to avoid belt "creep" and wear in speed-cone transmissions. The inner bands are tapered on the inside and present a flat or crowned surface to the belts in all positions. Speed ratio is changed by moving the inner bands rather than the main belts.

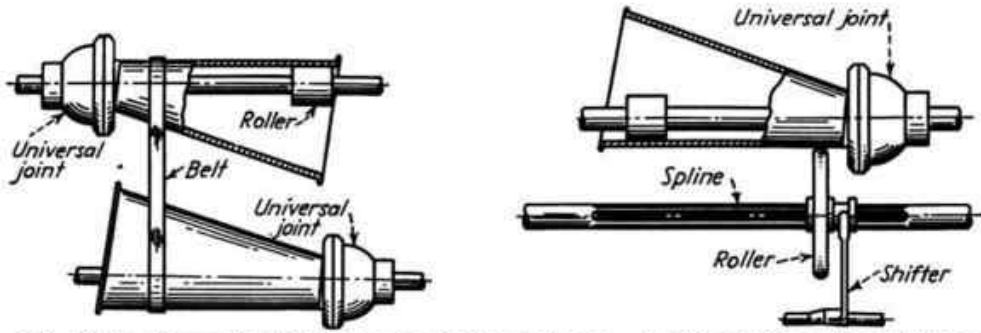

FIG. 419.—Devices for avoiding belt wear when using speed cones. At left, creeping acting of belt is not entirely eliminated, and universal joints present a problem of cost and maintenance. At right, a roller is substituted for the belt, giving more compactness.

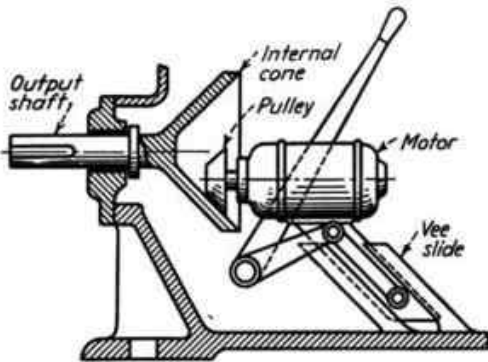

FIG. 420.—The main component of this drive is a hollow cone driven by a conical roller. Speed ratio changed by sliding driving unit in V guides. Note that when the roller is brought to the center of the hollow cone, the two run at identical speed with the same characteristics as a cone clutch. This feature makes the system attractive where heavy torque at motor speed is required in combination with lower speeds for light preliminary operations.

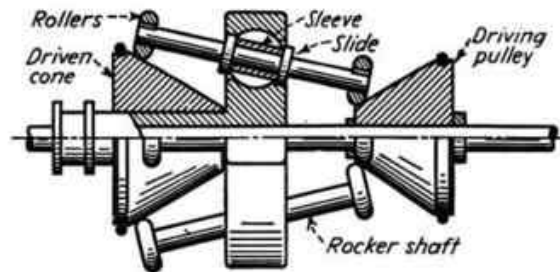

FIG. 421.—In this transmission, the cones are mounted in line and supported by the same shaft. One cone is keyed to the main shaft and the other is mounted on a sleeve. Power is transmitted by a series of rocking shafts and rollers. Pivoting rocking shafts and allowing them to slide change the speed ratio.

TRANSPORT MECHANISMS

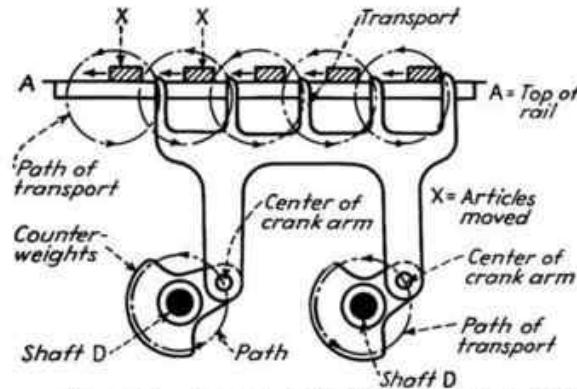

FIG. 422.—In this design, a rotary action is used. The shafts *D* rotate in unison and also support the main moving member. The shafts are carried in the frame of the machine and may be connected by either a link motion, a chain and sprocket, or by an intermediate idler gear between two equal gears keyed on the shafts. The rail *AA* is fixed rigidly on the machine. A pressure or friction plate may be used to hold the material against the top of the rail and prevent any movement during the period of rest.

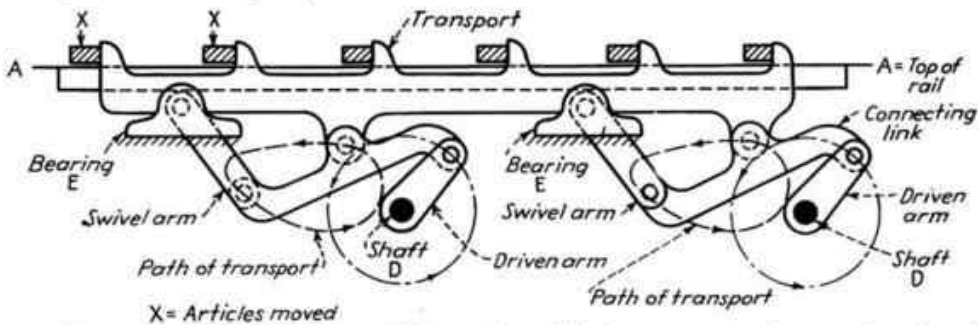

FIG. 423.—Here is shown a simple form of link motion which imparts a somewhat egg-shaped motion to the transport. The forward stroke is almost a straight line. The transport is carried on the connecting links. As in design in Fig. 422, the shafts *D* are driven in unison and are supported in the frame of the machine. Bearings *E* are also supported by the frame of the machine, and the rail *AA* is fixed. The details of operation can be understood readily from the figure.

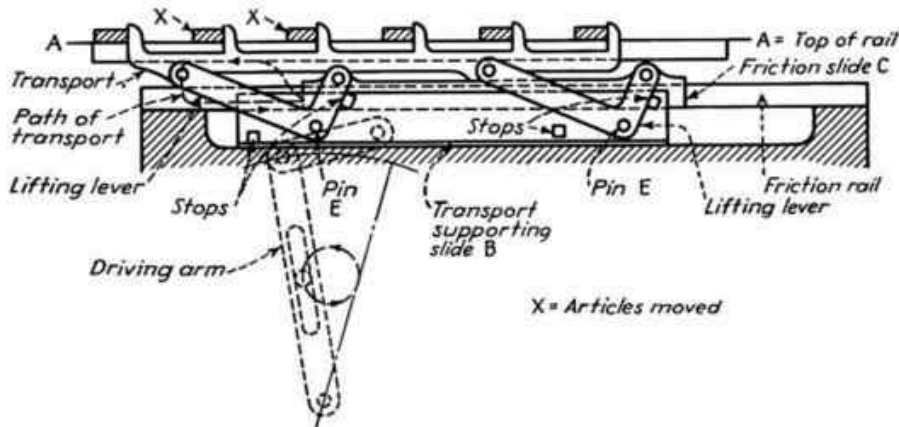

FIG. 424.—Another type of action. Here the forward and return strokes are accomplished by a suitable mechanism, whereas the raising and lowering is imparted by a friction slide. Thus it can be seen from a study of the figure that as the transport supporting slide *B* starts to move to the left, the friction slide *C*, which rests on the friction rail, tends to remain at rest. As a result, the lifting lever starts to turn in a clockwise direction. This motion raises the transport which remains in its raised position against stops until the return stroke starts at which time the reverse action begins. An adjustment should be provided for the amount of friction between the slide and its rail. It can readily be seen that this motion imparts a long straight path to the transport.

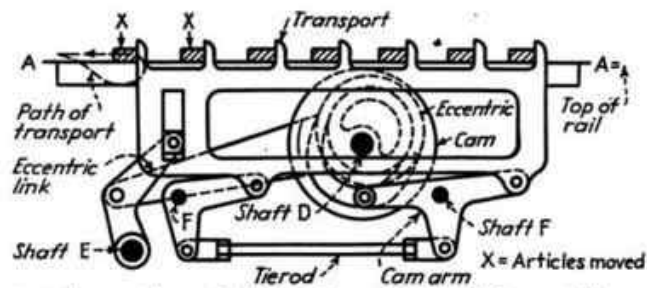

FIG. 425.—Here is illustrated an action such that the forward motion is imparted by an eccentric while the raising and lowering of the transport is accomplished by means of a cam. The shafts *F*, *E*, and *D* are located by the frame of the machine. Special bellcranks support the transport and are interconnected by means of a tie rod.

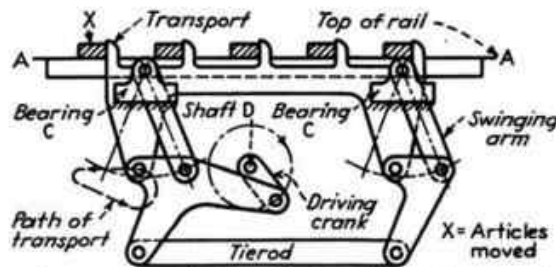

FIG. 426.—This is another form of transport mechanism wherein a link motion is used. The bearings *C* are supported by the frame, as is the driving shaft *D*.

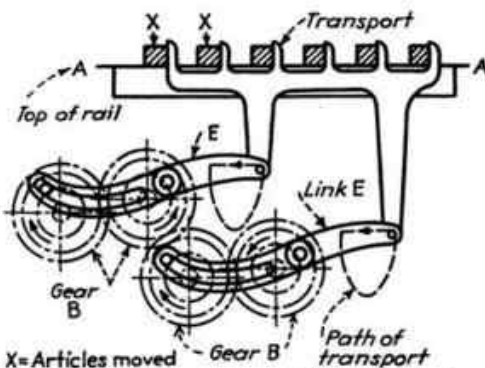

FIG. 427.—An arrangement of interconnected gears of equal diameters which will impart a transport motion to a mechanism, the gear and link mechanism imparting both the forward motion and the raising and lowering. The gear shafts are supported in the frame of the machine.

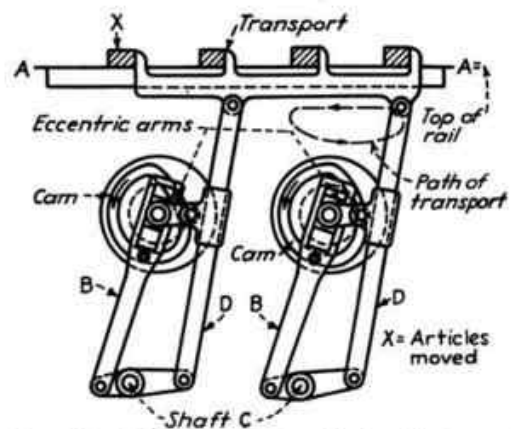

FIG. 428.—In this transport mechanism the forward and return strokes are accomplished by the eccentric arms, while the vertical motion is performed by the cams.

AUTOMATIC FEED HOPPERS

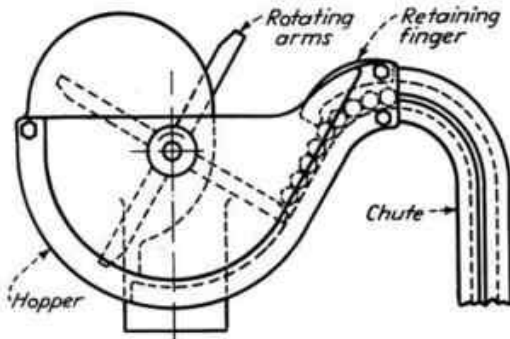

FIG. 429.—The rotating arms of the nut hopper push the nut blanks up the incline into the chute. The retaining finger holds several nuts and prevents them from sliding back into the hopper.

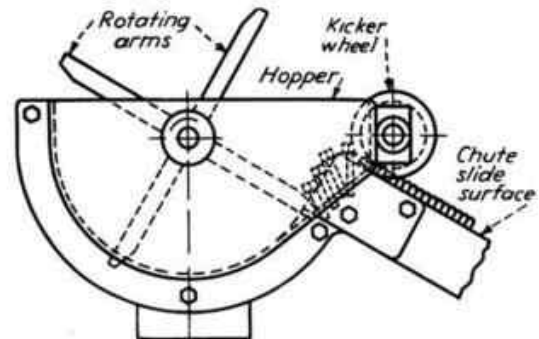

FIG. 430.—Same type hopper and rotating arms as in Fig. 429, but a different chute, designed to feed bolts. Kicker wheel at the mouth of the chute kicks back into the hopper the bolts that do not enter the chute properly.

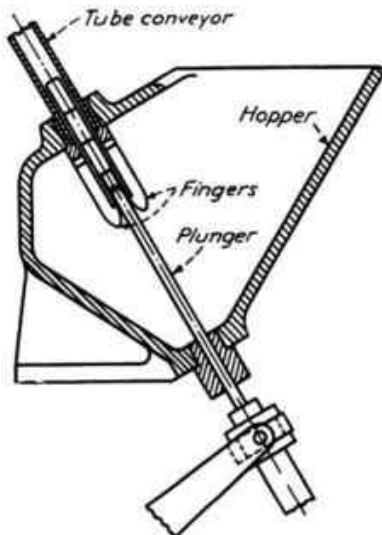

FIG. 431.—Hopper used for feeding shell-like pieces into a tube conveyor. A reciprocating plunger picks up the work at the lower end of the stroke and deposits it in snap fingers at the end of the conveyor tube.

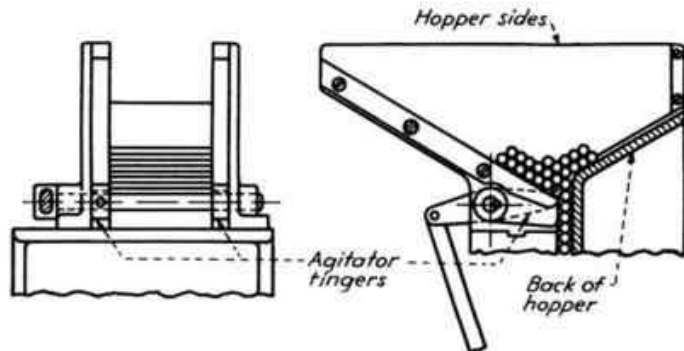

FIG. 432.—The hopper is adjustable for feeding various lengths and diameters of plain round stock, the pieces falling into the chute by gravity. The agitator finger at either end of the work prevents bridging or wedging of blanks over the chute opening.

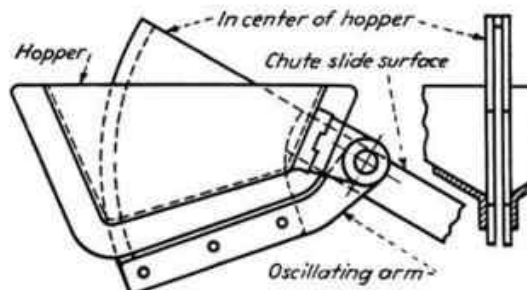

FIG. 433.—An oscillating arm carries the blade through the center of the bolt hopper and at the top of its stroke forms a continuation of the bolt chute. Sides of the hopper are inclined toward the center to feed bolts into the blade at a low position in the hopper. One blade is used for each diameter of stock handled, tapered spacers in hopper being adjustable to accommodate varying widths of blade.

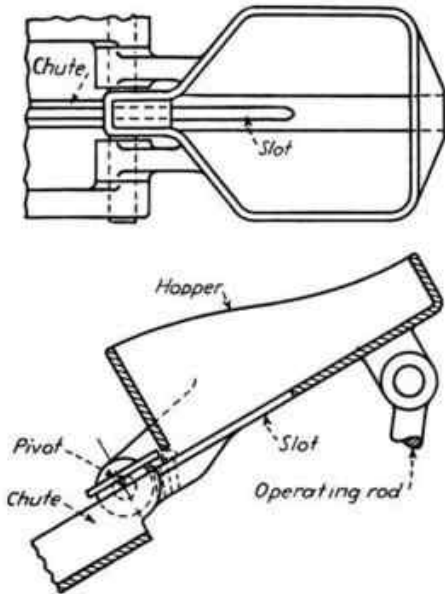

FIG. 434.—Tilting hopper for small rivets and screws, in which the work falls into a slot at the bottom center of the hopper, which is tilted to the same angle as the chute.

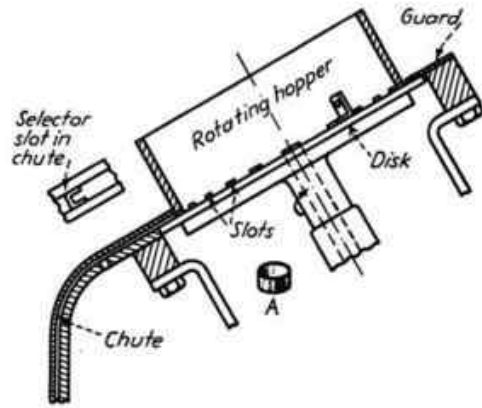

FIG. 435.—Rotating hopper set at angle is slotted at the lower face to feed into the chute small cup-shaped objects, as shown at A, positioning them with their open end up. Should cups enter chute open-end down, they will drop through selector slot in the chute; thus only those correctly positioned are allowed to proceed to the assembly point.

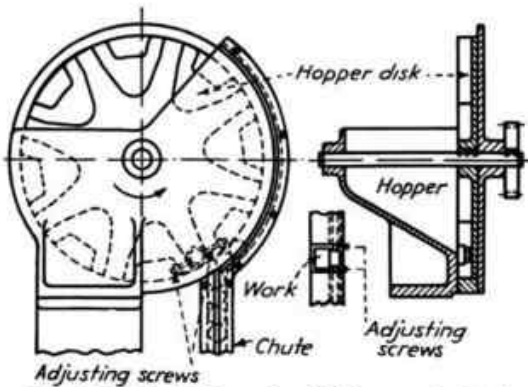

FIG. 436.—Vertical rotating disk hopper for feeding shouldered pieces to the chute. By adjusting the hardened dog-point screws, it is possible to feed pieces with a difference of only 0.010 in. on the diameter.

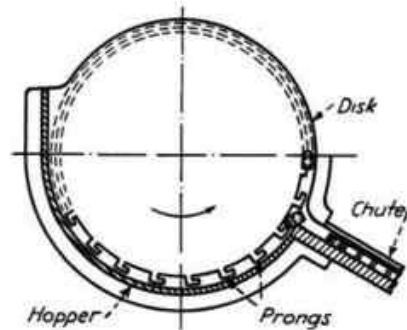

FIG. 437.—Another type of vertical rotating disk hopper for feeding hollow cylindrical pieces having a blind hole. Prongs are milled on the periphery of the disk; these prevent work from being fed open end up into the chute.

GLUE-APPLYING MECHANISMS

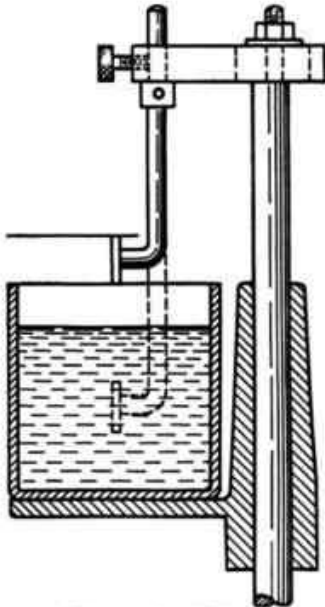

FIG. 438.—Direct glue dabbers such as this are inexpensive and simple, but can be used only when it is permissible for the quantity of glue to be applied to vary and when the application is to be made in strips or dots. The applicator, of any desired shapes, is held on the end of a bent rod, all parts that immerse in the glue being so shaped as to drain freely and not to splash when entering the glue. A collar on the rod serves as a stop to enable quick resetting after its removal for cleaning, whereas the linkage holding the applicator permits adjustment over a wide range of positions. The glue pot can be removed freely and usually requires no securing device other than means to prevent it from shifting.

In designing these mechanisms, the device must allow only a minimum of variation in the consistency of the glue at the point of application. Therefore the glue pot must be amply large so that evaporation of the solvent will affect the glue consistency but slightly. Even in transferring the glue, it should be exposed as little as possible to the atmosphere. In the device shown here, its directness of application and the simplicity of the parts in contact with the glue give it a high rating for continuous good performance.

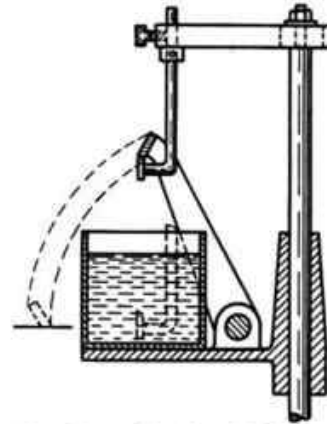

FIG. 439.—Example of an indirect type of gluing mechanism, similar in design to the direct type except for the addition of the transfer member. This makes it possible to apply glue to top surfaces and also to control in a certain measure the thickness of the layer of glue applied. This mechanism is also of the type that applies strips or dots rather than films. In all these designs, simplicity is of greatest importance in order that the device will be easy to keep clean, lubricated, and adjusted.

With reference to all types of gluing mechanisms, the practice of exposing the glue to the atmosphere after it has been applied and before the closing or uniting operation, in order to partly evaporate the solvent and thus make the glue more tacky, must be avoided. Such a practice usually is a serious source of troubles as many variable factors such as time, temperature, and atmospheric conditions enter in and will seriously affect the efficiency of the machine unless compensation can be made for the variation in these factors and the time element can be maintained constant by uninterrupted operation of the machine.

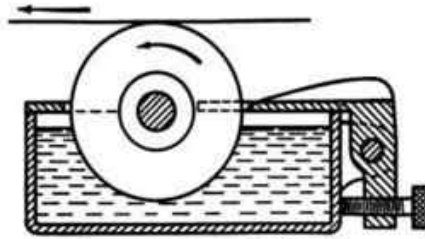

FIG. 440.—Film applicators are used much more extensively than those applying dabs, because they permit the application of a uniform film of glue of any selected thickness. A direct-acting type of this class of device is shown here. The material receiving the application runs in contact with the wheel that dips in the glue, the application being made to the under surface. Best results are obtained when the wheel runs at the same surface speed as the material passing over it. In this class of glue applicators, greatest attention must be given to the design of the trimmer blade. This blade must be adjustable, but it should be so constructed that in making the adjustment the blade will keep its proper relation to the wheel.

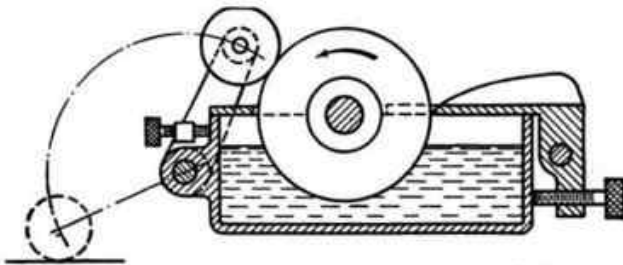

FIG. 441.—In the indirect types of film applicator, a transfer wheel receives glue from the main wheel and transfers it to the point of application. The clearance between the transfer wheel and the main wheel is usually made adjustable. On machines that must be stopped frequently, the drive to the glue wheels should be independent of the drive for the main machine so that the glue wheels can be kept revolving when the machine is stopped, thus preventing the glue from drying on the surface of the wheels.

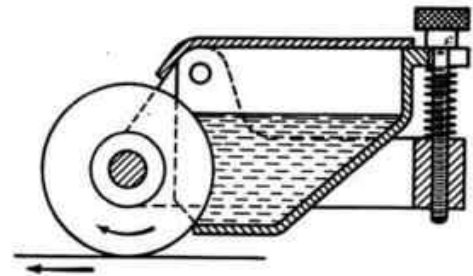

FIG. 442.—In this design of direct applicator, the film of glue is applied to the upper surface of the sheet. To keep the exact relation between the trimmer blade and wheel, there must be a complete elimination of lost motion. If a means for locking the trimmer blade in position is provided, it should be so designed that the act of locking will not disturb the setting. It should also be possible to remove the parts for cleaning without disturbing the setting. The drive of the glue wheel should be positive to ensure the proper speed. A belt drive is not to be recommended.

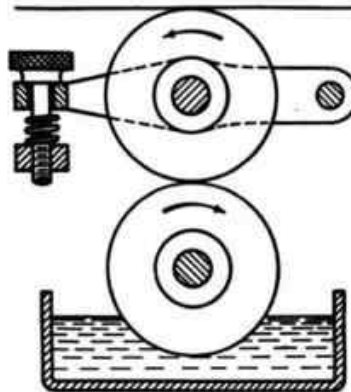

FIG. 443.—A type of trimming mechanism that is much in use in sheet-mounting machines and gumming machines. This type is easily cleaned and adjusted. When the rollers are long, consideration should be given to the deflection in the center of the rollers due to the pressure exerted in squeezing out glue. This deflection will result in a thicker film of glue in the center of the rollers than at the ends. This is usually compensated for by making the glue roller larger in diameter in the center than at the ends. The device has no trimmer blade, but thickness of glue film is regulated by adjusting the gap between the rollers.

CHAPTER VII
DRIVES AND CONTROLS

	PAGE		PAGE
Significance of WR^2	208	Electric Control Methods.....	224
Analysis of Motor Load.....	211	Electrically Operated Valves.....	231
Selection of Motor Type.....	214	Automatic Timers.....	234
Inquiry Form for Electric Motors.....	218	Trigger Switch Mountings.....	237
Winding Connection Diagrams for Multi- speed Motors.....	220	Thermostatic Mechanisms.....	242
		Automatic Stops.....	248

SIGNIFICANCE OF WR^2

In Drives for Machinery

Any moving body has stored in it kinetic energy, the magnitude of which is proportional to the mass of the body and to the square of its velocity. Whenever the speed of a body is changed, the amount of kinetic energy is increased, and the increase in energy must be supplied from a source within the system. If the speed is decreased, the kinetic energy of the body is decreased, and the energy lost must be absorbed by some other part of the system.

In a body of mass M moving with a linear velocity V ft. per sec., the kinetic energy E in foot-pounds is

$$E = \frac{1}{2} M V^2 = \frac{1}{2} \left(\frac{W}{g} \right) V^2 \quad (35)$$

where W is the weight of the body, in lb., and g is the acceleration of gravity, in ft. per sec. per sec.

In a body rotating at N r.p.m., the kinetic energy of the mass as actually distributed is the same as an equivalent mass concentrated at a point distant from the axis of rotation equal to the radius of gyration R of the body, the equivalent mass having the same speed of rotation N . The kinetic energy E in foot-pounds then becomes

$$E = \frac{WR^2N^2}{5,873} \quad (36)$$

Note that the term WR^2 is a physical term applying to a specific body; the term involves the weight W of the body and a radius of gyration R which is determined by the shape and dimensions of the body. The kinetic energy stored in a rotating body, therefore, is proportional to its WR^2 and to the square of N , its rotational speed.

Since Eq. (36) represents the kinetic energy stored in the body after speed N is attained, this equation also represents the energy that must be supplied from some source, to accelerate the body from rest to N r.p.m. In mechanical-drive problems, however, energy as such is of little interest; the major concern deals with the torque required to produce the acceleration. It can be easily demonstrated that the torque T in pound-feet required to accelerate a body from rest to a speed of N r.p.m. in t sec. is

$$T = \frac{WR^2N}{308t} \quad (37)$$

From Eq. (37), it is obvious that the term WR^2 is also an important factor in determining the torque required to produce a given acceleration.

By making use of the familiar equation

$$\text{Hp} = \frac{\text{torque} \times N}{5,250} \quad (38)$$

and Eq. (37), it is simple to determine the horsepower H required to accelerate uni-

formly the body from rest to a speed N r.p.m. in t sec., by using an average speed $N/2$

$$H = \frac{T \times N/2}{5,250} \quad (39a)$$

$$= \frac{WR^2N^2}{10,500 \times 308t} = \frac{WR^2N^2}{3,234 \times 10^3 \times t} \quad (39b)$$

In mechanical systems with a number of rotating parts, the energy E_s stored in the moving system is the sum of the energies stored in each part, or

$$E_s = \frac{W_1R_1^2N_1^2 + W_2R_2^2N_2^2 + W_3R_3^2N_3^2 + \dots + W_nR_n^2N_n^2}{5,873} \quad (40)$$

In power-drive and motor-application problems, it is advantageous to express the energy E_s in the system in terms of an "equivalent WR^2 ," which will be designated here as $W_sR_s^2$, at the drive or motor shaft having a speed of N_d , such that

$$E_s = \frac{W_sR_s^2N_d^2}{5,873} \quad (41)$$

By combining Eqs. (40) and (41), it will be seen that

$$W_sR_s^2 = W_1R_1^2 \left(\frac{N_1}{N_d}\right)^2 + W_2R_2^2 \left(\frac{N_2}{N_d}\right)^2 + W_3R_3^2 \left(\frac{N_3}{N_d}\right)^2 + \dots + W_nR_n^2 \left(\frac{N_n}{N_d}\right)^2 \quad (42)$$

The torque T_s necessary to accelerate uniformly a system at rest to a required speed in t sec. can be obtained by substituting $W_sR_s^2$ for WR^2 , and N_d for N in Eq. (37), which then becomes

$$T_s = \frac{W_sR_s^2N_d}{308t} \quad (43)$$

The horsepower H_s required to accelerate the system from the drive shaft at rest to a speed of N_d r.p.m. in t sec. can be determined by substituting $W_sR_s^2N_d^2$ for WR^2N^2 in Eq. (39), which then becomes

$$H_s = \frac{W_sR_s^2N_d^2}{3,234 \times 10^3 \times t} \quad (44)$$

or from Eq. (39a) by substituting N_d for N , and for T the value of T_s as given by Eq. (43) which then becomes

$$H_s = \frac{W_sR_s^2N_d}{308t} \times \frac{N_d}{5,250 \times 2} = \frac{W_sR_s^2N_d^2}{3,234 \times 10^3 \times t} \quad (45)$$

Sometimes complex systems are encountered involving both linear and rotating motion. The equivalent WR^2 of the linearly moving parts can also be reduced to the motor-shaft speed by the equation

$$\text{"Equivalent } WR^2\text{"} = W \left(\frac{V}{2\pi N_d}\right)^2 \quad (46)$$

where W = weight of the body

V = velocity, in feet per min

N_d = r.p.m. of the drive or motor shaft

This equation can be used only where the linear speed bears a continuous fixed relation to the rotating speed, as a rack driven by a gear. A more complex equation is necessary for systems involving reciprocating linear motion obtained by a crank arm.

By this method, it is possible to reduce the WR^2 of the individual parts of a complex system to an equivalent WR^2 at the drive or motor shaft speed. These values of equivalent WR^2 may be added directly, and the total equivalent WR^2 plus the WR^2 of the driving unit or the motor represents the WR^2 of the complete system which the motor must accelerate or decelerate. All further calculations may be made as though the system were a simple one of one element of WR^2 equal to the total equivalent WR^2 .

To simplify the calculation of the radius of gyration of various mechanical structures, see the tables on pages 17 and 19 to 25.

ANALYSIS OF MOTOR LOAD FOR TORQUE REQUIREMENTS

Starting Torque and Time Required to Start the Machine

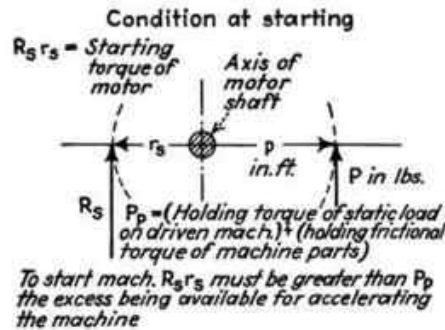

To start a machine, the motor torque must overcome all frictional resistances of bearings, sliding parts, and transmission elements, and also the resistance of any connected load. Where the load is not imposed until the machine has come up to working speed, the load resistance is zero. However, machines such as compressors, piston pumps, and hoists without unloading devices may be required to start under full load. With machines of these types, the resistance should be determined for the point of maximum starting torque in the machine cycle.

The motor torque delivered in excess of that required to overcome running friction at start plus starting load on the machine is used in bringing the machine up to speed.

Accelerating Torque and Time Required to Bring Machine Up to Speed

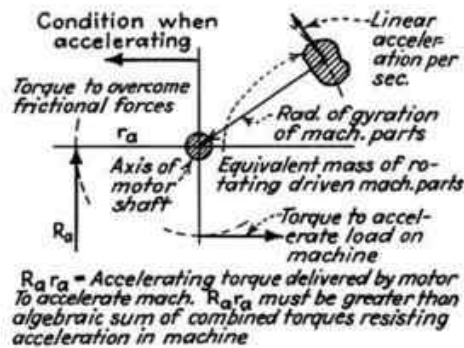

The amount of torque needed to accelerate the machine and the rate at which it should be delivered by the motor will depend upon the moments of inertia of the masses contained in the moving parts and their radii of gyration about or with reference to the motor axis. Flywheel members added to make the load on the motor uniform increase the WR^2 of the machine and, consequently, increase the accelerating torque which must be delivered by the motor. (For a discussion of these factors, see page 208.) Other factors that determine the torque needed are loads on machine that must be accelerated before full speed is attained. The time allowed for acceleration is an important factor in determining the heat developed in the motor windings.

Running Torque over Time Interval Required by Local Cycles on Machine

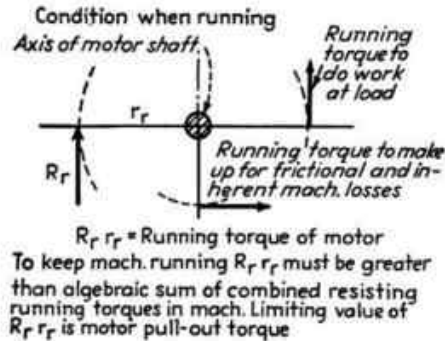

When operating at rated speed, the torque supplied by the motor is that required to do useful work and to make up for frictional and inherent machine losses.

In calculating the running torque required to keep the machine operating, it is desirable to add something on the safe side to take care of unexpected loads and circuit variations. It is poor practice to plan to use the excess torque that a motor can deliver over its nominal rating, because such overloads cause a rise in winding temperature with consequent depreciation in insulation properties and shortening of motor life.

Work Load Applied After Motor Is Running

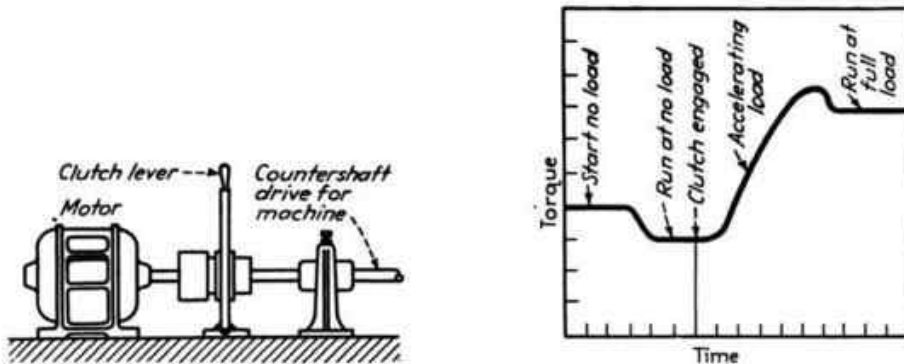

With a disengaged clutch or unloading device between motor and machine, the conditions at starting favor the motor since it is then free to start and to come up to speed against little resistance.

When clutch is engaged, the machine load imposed on the running motor may be applied almost instantaneously if the clutch is of the jaw or the magnetic types, or the load may be applied to the running motor gradually over a short time range if the clutch is of the frictional or the spring-separated plate type that permits slipping.

However, the ability of the running motor to start and accelerate the driven machine when the clutch is engaged is limited by the torque-value at which the motor will stall, usually called the break-down or pull-out torque.

If applying the machine load slows the motor, an accelerating torque will be required of the motor to bring the machine up to the desired speed. Thereafter, the machine load will determine the running torque required of motor.

Work Load Applied as Motor Speed Increases

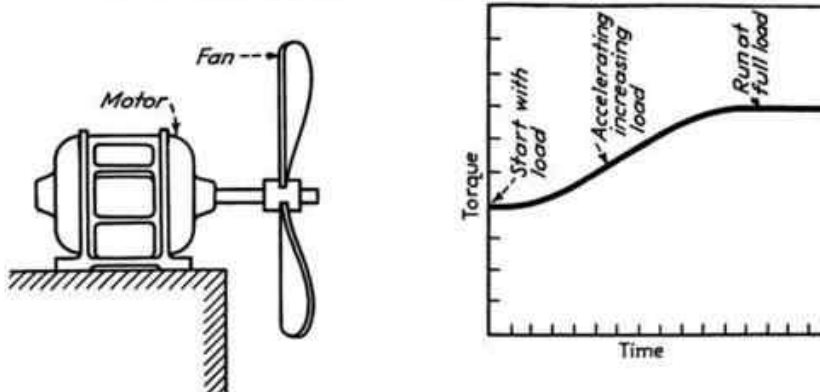

When the motor is directly connected to the driven machine, and the nature of the machine load is such that it increases as the machine speed increases from no load at rest to full load at full speed, as in fans, blowers, and centrifugal pumps, the motor is required to deliver an accelerating torque that can accelerate the increasing load plus the torque required to accelerate the revolving masses.

At the instant of starting, the inertia and holding torque of the machine may be small enough to be negligible. However, this fact should not be taken for granted, since dry bearings, cold lubricants, deflected shafting, and sprung parts are factors that may set up considerable resistance to starting.

After the machine has begun revolving, at any instant the rate at which the machine accelerates will depend upon the relation between the motor accelerating-torque versus the WR^2 of the moving machine parts, plus frictional resistance, plus the load that is on the machine at that instant.

The running torque required of the motor after coming up to speed is mainly determined by the useful work done and the efficiency of the machine.

Work Load Applied on the Motor When Starting

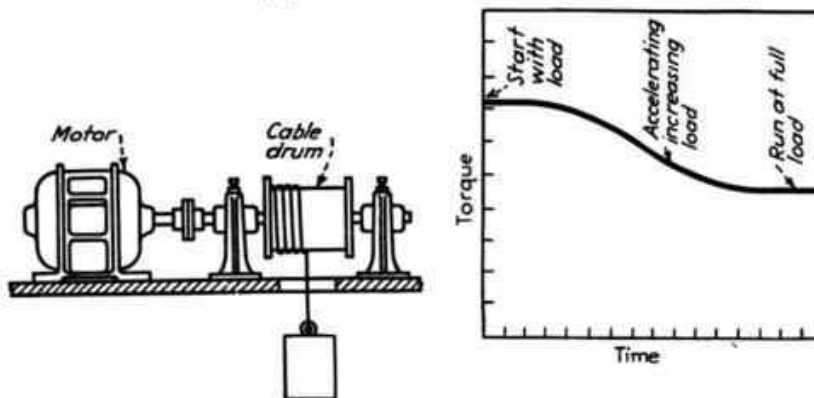

With the motor connected directly to a machine upon which a heavy work load must be encountered at instant of starting, such as in compressors and piston pumps without unloading devices, lifts, and hoists, the torque required to start and to accelerate may be many times greater than that needed to keep the machine in motion after the desired running speed has been reached.

Especially is this so when the mass of the machine parts is large and their radii of gyration is great. The motor may be able to deliver enough starting torque to turn the loaded machine over slowly, but if the motor is not capable of delivering sufficient accelerating torque to bring the machine and load up to speed in a short time, heating will probably occur.

When the motor has to start and stop frequently under full load, the length of time of motor operation as compared with the idle time in the work or duty cycle is an important consideration that governs the generation and dissipation of heat.

SELECTION OF MOTOR TYPE

Following the analysis of torque requirements and duty cycle of the driven machine, the next step in the selection of the motor is a matching of the torque characteristics of the load with torques that the various types of motors can be expected to deliver when starting, accelerating, and running.

The torques that motors can deliver are dependent upon the type of windings and the scheme of connections employed in the particular motor; the nature, uniformity, and magnitude of the voltage at the motor terminals; the capacity of the feed lines; and the physical conditions surrounding the motor.

Motors are designed primarily to deliver torque at specified speeds at definite voltages. Electrical current is supplied commercially as either a direct, *i.e.*, unidirectional potential, or as an alternating potential in which the voltage alternates in direction at definite frequencies or cycles per second. When the electrical service is alternating, a motor must be selected not only to suit the magnitude of the voltage as with direct current, but also to suit the frequency and the number of phases of current.

Although the frequency of alternating current as furnished by power companies is so nearly constant that variations in frequencies can be considered negligible the same is not true of voltage. Voltages do vary considerably especially at the end of a transmission line.

Variations in voltage are very important considerations in motor performance because the effective torque output of any motor will vary as the square of the change in applied voltage. Therefore, line voltages at the motor terminals should be known, and if a variation from rated motor voltage does exist the rated torque should be interpolated accordingly.

Feed-line capacity should be large enough to take care of the high inrush of current at starting without reducing the voltage and thus lowering the effective starting torque. The motor even though starting under subnormal voltage may be able to break the static load but have difficulty in accelerating the load up to speed; thus the accelerating time is lengthened, with attendant high current, which tends to cook the windings and in some types of motors to blow the condenser or burn the commutator.

Effect of Physical Conditions.—Extreme heat surrounding the motor, *i.e.*, high ambient temperatures, increases the operating temperature of the active iron and copper in the motor and thus limits the power output of the motor. Insulation will be affected and the life of the motor reduced if the temperature of the motor windings rises beyond safe limits.

Extreme cold around the motor and driven machine may cause the lubricating mediums to stiffen or harden. Stiff oil in the bearings, pistons, and packings of a machine will cause hard starting.

Extreme dampness, moisture, or corrosive acid fumes reduces the effectiveness of the insulation resulting in current leakage or actual puncture of the insulation. Special insulations are available for abnormal conditions.

Dirt, either falling or suspended in the atmosphere, and dripping water should not get into the motor: if these elements are present, an inclosed type of motor should be used.

DIRECT-CURRENT MOTORS

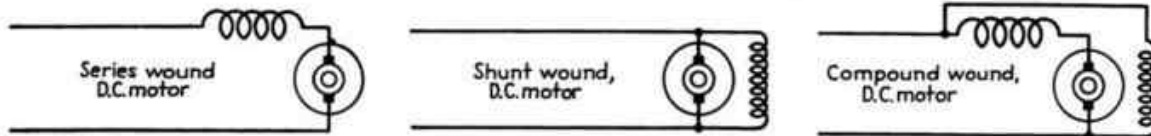

FIG. 444.—Wiring diagrams of typical winding schemes employed in direct-current series, shunt and compound motors.

In direct-current motors both the field and armature are excited directly from the power supply. A commutator and brushes are used to continuously commutate the armature currents to produce a rotating magnetic pull on the armature. The same electrical and magnetic reaction that is used to start the direct-current motor is also used for the running operation after the motor is brought up to speed.

The starting torque that direct-current motors can deliver is high, ranging as much as six and one-half times the full load torque. This type of motor will pull up or accelerate any load it can start.

When the driven machine is required to start frequently under heavy load, and it is not objectionable to have the operating speed vary inversely with the load, series motors can be used. The speed of a series motor will be constant only when the load is constant.

For operating conditions in which constant speed is desired with fluctuating loads and starting is not frequent, either shunt motors or compound motors can be considered. A shunt motor with field resistance control will give speed adjustments over a wide range. Compound motors can deliver higher starting torques than shunt motors, and if the high torque is needed only at starting the motor series field may be cut out after the driven machine is up to speed.

ALTERNATING-CURRENT MOTORS

In alternating-current motors a magnetic field is produced electrically which revolves at a speed equal to the frequency multiplied by 60 divided by the number of poles. The magnetic field as it rotates cuts and induces a current in the conductors of the short-circuited secondary winding. The secondary current in turn establishes secondary magnetic fields within the primary field and torque is thus produced. With rotor at standstill, *i.e.*, with a slip of 100 per cent, the maximum e.m.f. is induced in the secondary. Induction motors do not ever reach full synchronous speed because if there is no slip no secondary current is induced.

Maximum pull-up or accelerating torques that alternating-current motors, except the squirrel-cage type, can develop range from two to two and one-half times their full load torque.

Straight single-phase squirrel-cage type induction motors are not self-starting, and a supplementary means must be provided to give the motor the rotating effect required; however, the single-phase induction motor will run and provide torque after it is brought up to speed.

Repulsion-start induction-run motors develop a continuous rotating effect on the rotor because of induced currents in the rotor made continuously effective by commutation to produce torque during the starting period.

Repulsion-start induction-run motors have high starting and accelerating torques and when running as a single-phase induction motor with squirrel-cage rotor, or its equivalent, are very efficient. These motors at starting are repulsion motors, but on reaching a predetermined speed expanding governor weights push a device under the commutator which short circuits the commutator bars through a common ring; the same movement releases tension on the brushes with the result that the armature is short-circuited and is the equivalent of a squirrel-cage rotor in a poly-

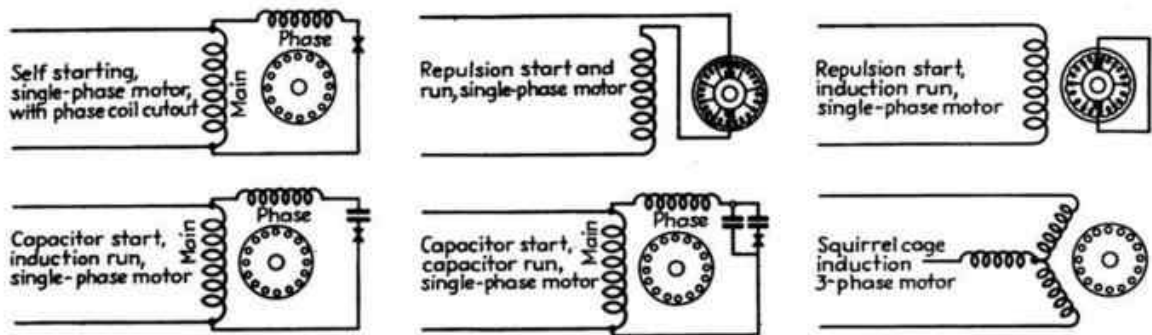

FIG. 445.—Wiring diagrams of winding schemes and starting devices used in typical alternating-current fractional horsepower motors.

phase induction motor. When the motor stops, the governor and mechanism return automatically to their original starting positions.

Repulsion-start induction-run type motors are suited for loads requiring high starting and accelerating torques. Repulsion-start induction-run type motors are furnished only for single speed applications.

The split-phase start induction motor develops its magnetic rotating effect by splitting the magnetic field of the stator winding into two separate windings displaced in space and having different electrical characteristics. One winding is a starting or phase winding, and the other is the main or running winding. When the motor starts, both windings are on the line. After accelerating up to a predetermined speed, a governor attached to the rotor acts to open a switch and cuts out the starting winding. The motor then continues to operate on the running winding as a single-phase induction motor.

Split-phase motors can be designed with high starting torque but only by using relatively high starting current. They are purposely designed with low starting torque so that the current and consequently the heating in the starting winding will be limited.

Equipment driven with split-phase motors should be easy to start. The inertia of the load should be small so that the motor can accelerate rapidly to avoid "cooking" the starting winding. Feed wires should have capacity great enough to carry the high starting current without reducing the voltage at the motor terminals with consequent reduction of the motor torque.

Capacitor motors are basically split-phase motors using split magnetic fields in starting. Improved starting characteristics are obtained by using a capacitor or condenser in connection with the starting winding. The electrical effect of the condenser increases the angle of the magnetic action to about 90 deg. between the two windings, approaching a true two-phase effect.

Capacitor-start and induction-run motors employ a centrifugal governor switch which cuts out both the starting winding and the condenser at a predetermined speed after which the motor operates as a straight single-phase squirrel-cage induction-type motor.

Capacitor-start induction-run motors will deliver starting torques that are approximately three and one-half to four and one-half times their full load torque with locked rotor currents approximately one and three-fourth times repulsion-start induction-run motor currents. Their operating characteristics when running are very similar to those of the repulsion start induction run type of motors.

Capacitor-start capacitor-run motors use a capacitor and also a transformer. The transformer acts to impress a high voltage on the capacitor for starting. Starting torque is three and one-half to four and one-half times full load torque, and starting current is of the same relative order as the capacitor-start induction-run type of motor.

Capacitor motors can be obtained for both single- and multispeed applications.

Fractional horsepower squirrel-cage induction polyphase motors have a field made up of polyphase windings and a squirrel-cage rotor made up of conductor bars. The starting torque is about two and one-half to three times the full load torque.

Squirrel-cage induction motors like direct-current motors will usually pull up any load they can start, *i.e.*, the maximum pull-up torque is about equal to the starting torque, and the rating of the motor should be selected to suit the greater torque as required by the load.

INQUIRY FORM FOR ELECTRIC MOTORS

1. Name of machine to be driven _____
2. Field of use _____
3. Estimated quantity, initial order _____
first year _____
4. Power supply:
 - (a) Direct current _____ volts
 - (b) Alternating current _____ volts,
_____ phase, _____ cycles
 - (c) Universal motor _____ volts
 - (d) Will power supply vary?
5. Motor speed and direction of rotation:
 - (a) Full-load running speed _____ r.p.m.
 - (b) Allowable variation \pm _____ per cent of full-load speed
 - (c) Direction of rotation, from end opposite shaft extension, clockwise _____, counter clockwise _____, reversible _____
 - (d) Is a multispeed motor required? Give speeds _____, _____, _____
 - (e) Adjustable speed motor, speed range _____ to _____
6. Running load requirements and conditions. Load determined by test _____, obtained from present practice _____, or estimated _____ (For multispeed motor give following data for each speed):
 - (a) Continuous load _____ hp.
 - (b) Intermittent load _____ hp.
 - (1) length of time at full load _____ min.
 - (2) idle running _____ min., time at rest _____ min.
 - (3) maximum momentary torque _____ lb. _____ in.
 - (c) Fluctuating load
 - (1) magnitude of overloads _____ hp.
 - (2) duration of overloads _____ min.
 - (3) frequency of occurrence _____
 - (d) Reversing service
 - (1) reversals per min. _____
 - (2) time intervals on _____ min., off _____ min.
 - (3) inertia of load _____
7. Starting load:
 - (a) Torque, starting _____, accelerating _____
 - (b) Is motor started under load? _____, or without load? _____
 - (c) Type of unloading device _____
 - (d) What is the inertia of the load including couplings, pulleys, gear drives, or fly-wheel? _____
 - (e) Speed of driven element _____ r.p.m.
 - (f) Drive: direct _____, gear _____, belt _____, chain _____ Type of coupling if direct drive _____
8. Space available for motor:
 - (a) Restricted to a maximum diameter of _____ in.
 - (b) Restricted to a maximum length of _____ in.
9. Motor mounting:
 - (a) Vertical _____, horizontal _____, oblique _____
 - (b) Foot mounting at end _____, below _____, above _____, flange mounting _____ Special (show by sketch)
 - (c) Resilient mounting _____
 - (d) Is mounting position of the motor changeable? _____
10. Motor housing:
 - (a) Motor exposure: outdoor _____, indoor _____
 - (b) Within machine or housing, partly inclosed _____, totally inclosed _____ (Give dimensioned sketch of housing and show ventilation provisions)
11. Condition of ventilating air:
 - (a) Presence of dust _____, grit _____, moisture _____, steam _____, corrosive gases _____, oil vapor _____, explosive gas _____, salt air _____, other contamination _____
 - (b) Maximum temperature of cooling air _____ deg. F.
12. Bearings and lubrication:
 - (a) Manufacturer's standard _____
 - (b) Motor to be lubricated at intervals of _____
 - (c) End play restricted _____; thrust loads present _____
 - (d) Type of bearing preferred
 - (1) Sleeve: lubricated by oil ring _____, waste _____
 - (2) Ball: lubricated by oil _____, or grease _____
13. Shaft extension: single _____ or both ends _____; if vertical, up _____ or down _____; straight _____ or tapered _____

- (a) Diameter _____ in., length _____ in.
 - (b) Pulley fastened by setscrew _____, key _____
 - (c) Keyway dimensions: standard _____, or special, width _____ in. depth _____ in. length _____ in.
 - (d) Can the design be made for standard shaft dimensions? _____
14. Weight limitations if any _____
15. Electrical control:
- (a) Hand _____, automatic _____, remote _____
 - (b) Motor protected against overload _____, under voltage _____
 - (c) Is limit switch used _____
 - (d) Are brakes used _____
16. Electrical leads:
- (a) Manufacturer's standard _____
 - (b) Special leads: number _____, length _____
 - (c) Attachment cord: length _____, plug _____
17. Give special requirements such as special insurance regulations, dynamically balanced rotor, quietness of operation, etc.

WINDING CONNECTION DIAGRAMS FOR MULTISPEED MOTORS

MULTISPEED MOTORS, CONSTANT HORSEPOWER, KEY DIAGRAMS

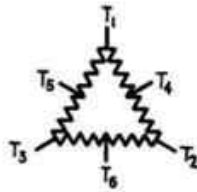

Single winding, two speed
N.E.M.A. MG. 6-41, Fig. 8, 1930

Speed	L ₁	L ₂	L ₃	
Low.....	T ₄	T ₅	T ₆	T ₁ , T ₂ , T ₃ together
High.....	T ₁	T ₂	T ₃	T ₄ , T ₅ , T ₆ open

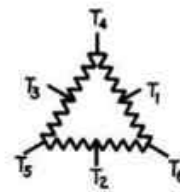

Single winding, two speed
A.S.A. C-6 3.720, 1938

Speed	L ₁	L ₂	L ₃	
Low.....	T ₁	T ₂	T ₃	T ₄ , T ₅ , T ₆ together
High.....	T ₄	T ₅	T ₆	T ₁ , T ₂ , T ₃ open

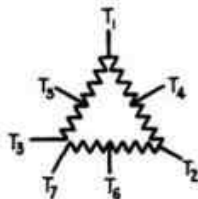

Two winding, three speed
N.E.M.A. MG. 6-41, Fig. 8, 1930

Speed	L ₁	L ₂	L ₃	
Low*.....	T ₄	T ₅	T ₆	T ₁ , T ₂ , T ₃ , T ₇ together
Second†.....	T ₁₁	T ₁₂	T ₁₃	
High*.....	T ₁	T ₂	T ₃ , T ₇	

Terminals not listed must be left open.
* Low speed half of high speed.
† Second speed between low and high.

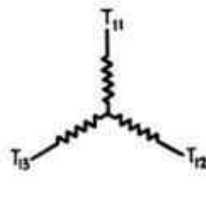

Two winding, three speed
A.S.A. C-6 3.720, 1938

Speed	L ₁	L ₂	L ₃	
Low*.....	T ₁	T ₂	T ₃	T ₄ , T ₅ , T ₆ , T ₇ together
Second†.....	T ₁₁	T ₁₂	T ₁₃	
High*.....	T ₄	T ₅ , T ₇	T ₆	

Terminals not listed must be left open.
* Low speed half of high speed.
† Second speed between low and high.

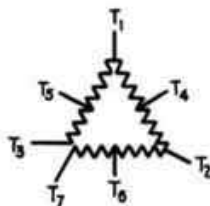

Two winding, four speed
N.E.M.A. MG. 6-41, Fig. 8, 1930

Speed	L ₁	L ₂	L ₃	Together
Low.....	T ₄	T ₅	T ₆	T ₁ , T ₂ , T ₃ , T ₇
Second ..	T ₁₄	T ₁₅	T ₁₆	T ₁₁ , T ₁₂ , T ₁₃ , T ₁₇
Third....	T ₁	T ₂	T ₃ , T ₇	None
High.....	T ₁₁	T ₁₂	T ₁₃ , T ₁₇	None

Terminals not listed must be left open.

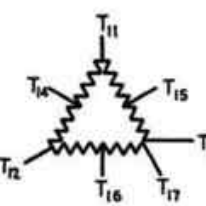

Two winding, four speed
A.S.A. C-6 3.720, 1938

Speed	L ₁	L ₂	L ₃	Together
Low.....	T ₁	T ₂	T ₃	T ₄ , T ₅ , T ₆ , T ₇ together
Second ..	T ₁₁	T ₁₂	T ₁₃	T ₁₄ , T ₁₅ , T ₁₆ , T ₁₇ together
Third....	T ₄	T ₅ , T ₇	T ₆	
High.....	T ₁₄	T ₁₅ , T ₁₇	T ₁₆	

Terminals not listed must be left open.

TWO WINDING, THREE SPEED, THREE PHASE, CONSTANT HORSEPOWER

N.E.M.A. Bul. 110, p, 612, 1926

A.S.A. C-6 3.725, 1938

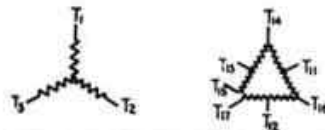
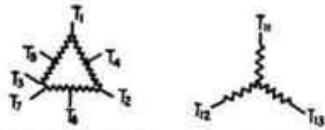

Speed	L ₁	L ₂	L ₃	Connect together
Low	T ₁₁	T ₁₂	T ₁₃	None
Second*	T ₄	T ₅	T ₆	T ₁ , T ₂ , T ₃ , T ₇
High*	T ₁	T ₂	T ₃ , T ₇	None

Speed	L ₁	L ₂	L ₃	Connect together
Low	T ₁	T ₂	T ₃	None
Second*	T ₁₁	T ₁₂	T ₁₃	T ₁₄ , T ₁₅ , T ₁₆ , T ₁₇
High*	T ₁₄	T ₁₅	T ₁₆ , T ₁₇	None

* Second speed half the high speed.

Terminals not listed must be left open.
* Second speed half the high speed.

TWO WINDING, THREE SPEED, THREE PHASE, CONSTANT TORQUE

N.E.M.A. Bul. 110, p, 612, 1926

A.S.A. C-6 3.725, 1938

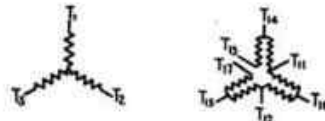
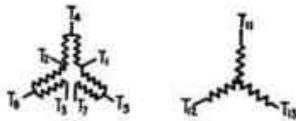

Speed	L ₁	L ₂	L ₃	Connect together
Low	T ₁₁	T ₁₂	T ₁₃	None
Second*	T ₁	T ₂	T ₃ , T ₇	None
High*	T ₄	T ₅	T ₆	T ₁ , T ₂ , T ₃ , T ₇

Speed	L ₁	L ₂	L ₃	Connect together
Low	T ₁	T ₂	T ₃	None
Second*	T ₁₁	T ₁₂	T ₁₃ , T ₁₇	None
High*	T ₁₄	T ₁₅	T ₁₆	T ₁₁ , T ₁₂ , T ₁₃ , T ₁₇

* Second speed half the high speed.

Terminals not listed must be left open.
* Second speed half the high speed.

TWO WINDING, TWO SPEED, THREE PHASE, CONSTANT TORQUE, VARIABLE TORQUE, CONSTANT HORSEPOWER

N.E.M.A. MG. 6-41, Fig. 3, 1930

A.S.A. C-6 3.725, 1938

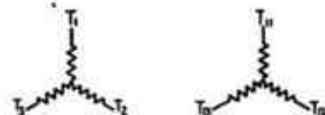
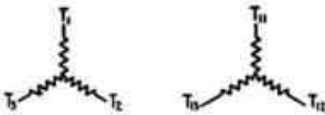

Speed	L ₁	L ₂	L ₃	
Low	T ₁	T ₂	T ₃	T ₁₁ , T ₁₂ , T ₁₃ open
High	T ₁₁	T ₁₂	T ₁₃	T ₁ , T ₂ , T ₃ open

Speed	L ₁	L ₂	L ₃	
Low	T ₁	T ₂	T ₃	T ₁₁ , T ₁₂ , T ₁₃ open
High	T ₁₁	T ₁₂	T ₁₃	T ₁ , T ₂ , T ₃ open

TWO WINDING, TWO SPEED, TWO PHASE, CONSTANT TORQUE, VARIABLE TORQUE, CONSTANT HORSEPOWER

N.E.M.A. MG. 6-41, Fig. 6, 1930

A.S.A. C-6 3.730, 1938

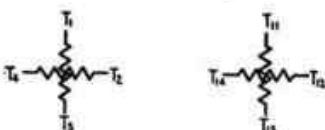
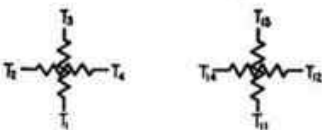

Speed	L ₁	L ₂	L ₃	L ₄	
Low	T ₁	T ₂	T ₃	T ₄	T ₁₁ , T ₁₂ , T ₁₃ , T ₁₄ open
High	T ₁₁	T ₁₂	T ₁₃	T ₁₄	T ₁ , T ₂ , T ₃ , T ₄ open

Speed	L ₁	L ₂	L ₃	L ₄	
Low	T ₁	T ₂	T ₃	T ₄	T ₁₁ , T ₁₂ , T ₁₃ , T ₁₄ open
High	T ₁₁	T ₁₂	T ₁₃	T ₁₄	T ₁ , T ₂ , T ₃ , T ₄ open

MULTISPEED MOTORS, CONSTANT TORQUE, KEY DIAGRAMS

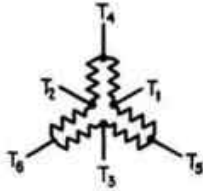

Single winding, two speed
N.E.M.A. MG 6-41, Fig. 7, 1930

Speed	L ₁	L ₂	L ₃	
Low.....	T ₁	T ₂	T ₃	T ₄ , T ₅ , T ₆ open
High.....	T ₄	T ₅	T ₆	T ₁ , T ₂ , T ₃ together

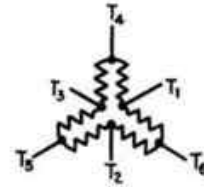

Single winding, two speed
A.S.A. C-6 3.720, 1938

Speed	L ₁	L ₂	L ₃	
Low.....	T ₁	T ₂	T ₃	T ₄ , T ₅ , T ₆ open
High.....	T ₄	T ₅	T ₆	T ₁ , T ₂ , T ₃ together

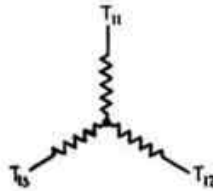
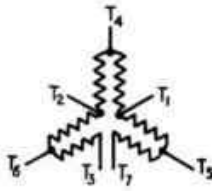

Two winding, three speed
N.E.M.A. MG 6-41, Fig. 7, 1930

Speed	L ₁	L ₂	L ₃	
Low*.....	T ₁	T ₂	T ₃ , T ₇	
Second†.....	T ₁₁	T ₁₃	T ₁₂	
High*.....	T ₄	T ₅	T ₆	T ₁ , T ₂ , T ₃ , T ₇ together

Terminals not listed must be left open.
* Low speed half of high speed.
† Second speed between low and high.

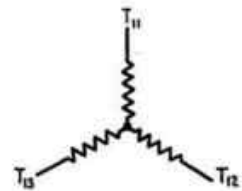
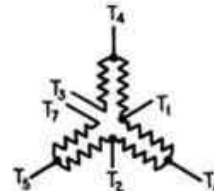

Two winding, three speed
A.S.A. C-6 3.720, 1938

Speed	L ₁	L ₂	L ₃	
Low*.....	T ₁	T ₂	T ₃ , T ₇	
Second†.....	T ₁₁	T ₁₃	T ₁₂	
High*.....	T ₄	T ₅	T ₆	T ₁ , T ₂ , T ₃ , T ₇ together

Terminals not listed must be left open.
* Low speed half of high speed.
† Second speed between low and high.

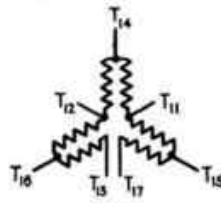
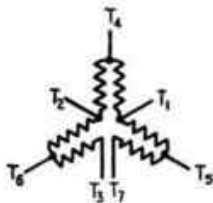

Two winding, four speed
N.E.M.A. MG 6-41, Fig. 7, 1930

Speed	L ₁	L ₂	L ₃	Together
Low....	T ₁	T ₂	T ₃ , T ₇	None
Second..	T ₁₁	T ₁₃	T ₁₂ , T ₁₇	None
Third...	T ₄	T ₅	T ₆	T ₁ , T ₂ , T ₃ , T ₇
High...	T ₁₄	T ₁₅	T ₁₆	T ₁₁ , T ₁₂ , T ₁₃ , T ₁₇

Terminals not listed must be left open.

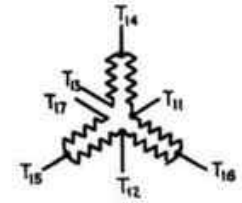
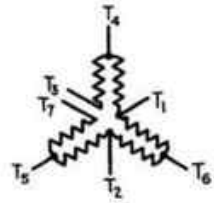

Two winding, four speed
A.S.A. C-6 3.720, 1938

Speed	L ₁	L ₂	L ₃	
Low....	T ₁	T ₂	T ₃ , T ₇	
Second..	T ₁₁	T ₁₃	T ₁₂ , T ₁₇	
Third...	T ₄	T ₅	T ₆	T ₁ , T ₂ , T ₃ , T ₇ together
High...	T ₁₄	T ₁₅	T ₁₆	T ₁₁ , T ₁₂ , T ₁₃ , T ₁₇ together

Terminals not listed must be left open.

MULTISPEED MOTORS, VARIABLE TORQUE, KEY DIAGRAMS

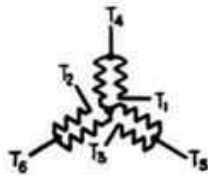

Single winding, two speed
N.E.M.A. MG 6-41, Fig. 4, 1930

Speed	L ₁	L ₂	L ₃	
Low	T ₁	T ₂	T ₃	T ₄ , T ₅ , T ₆ open
High	T ₄	T ₅	T ₆	T ₁ , T ₂ , T ₃ together

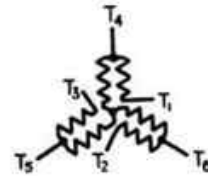

Single winding, two speed
A.S.A. C-6 3.720, 1938

Speed	L ₁	L ₂	L ₃	
Low	T ₁	T ₂	T ₃	T ₄ , T ₅ , T ₆ open
High	T ₄	T ₅	T ₆	T ₁ , T ₂ , T ₃ together

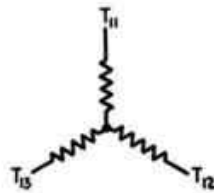
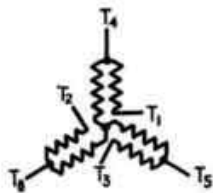

Two winding, three speed
N.E.M.A. MG 6-41, Fig. 4, 1930

Speed	L ₁	L ₂	L ₃	
Low*	T ₁	T ₂	T ₃	
Second†	T ₁₁	T ₁₂	T ₁₃	
High*	T ₄	T ₅	T ₆	T ₁ , T ₂ , T ₃ together

Terminals not listed must be left open.
* Low speed half of high speed.
† Second speed between low and high.

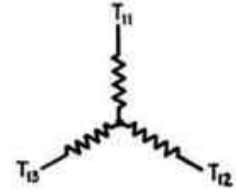
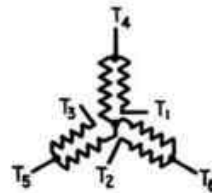

Two winding, three speed
A.S.A. C-6 3.720, 1938

Speed	L ₁	L ₂	L ₃	
Low*	T ₁	T ₂	T ₃	
Second†	T ₁₁	T ₁₂	T ₁₃	
High*	T ₄	T ₅	T ₆	T ₁ , T ₂ , T ₃ together

Terminals not listed must be left open.
* Low speed half of high speed.
† Second speed between low and high.

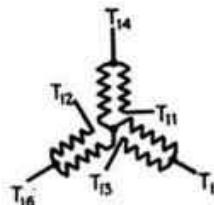
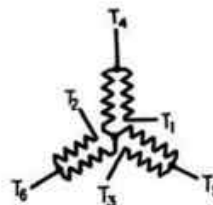

Two winding, four speed
N.E.M.A. MG 6-41, Fig. 4 1930

Speed	L ₁	L ₂	L ₃	Together
Low	T ₁	T ₂	T ₃	None
Second	T ₁₁	T ₁₂	T ₁₃	None
Third	T ₄	T ₅	T ₆	T ₁ , T ₂ , T ₃
High	T ₁₄	T ₁₅	T ₁₆	T ₁₁ , T ₁₂ , T ₁₃

Terminals not listed must be left open.

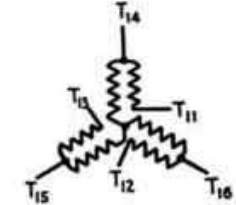
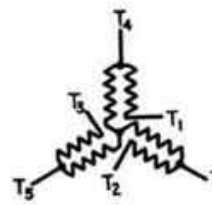

Two winding, four speed
A.S.A. C-6 3.720, 1938

Speed	L ₁	L ₂	L ₃	
Low	T ₁	T ₂	T ₃	
Second	T ₁₁	T ₁₂	T ₁₃	
Third	T ₄	T ₅	T ₆	T ₁ , T ₂ , T ₃ together
High	T ₁₄	T ₁₅	T ₁₆	T ₁₁ , T ₁₂ , T ₁₃ together

Terminals not listed must be left open.

ELECTRIC CONTROL METHODS

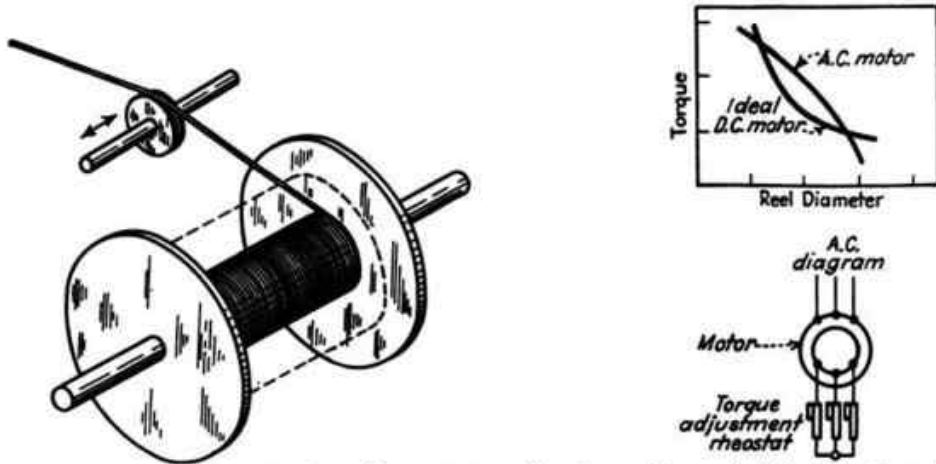

FIG. 446.—Constant tension with constant peripheral speed is required in this wire-reel application. The application can be used on wire-drawing machines, insulating machines, or any other reeling operation. As the reeling diameter increases, the reel speed decreases, and at the same time the reeling torque is increased. The required constant horsepower characteristic is obtained accurately with a direct-current motor and a regulator type of control on shunt field. An alternating-current wound rotor motor with secondary resistance control approximates ideal conditions.

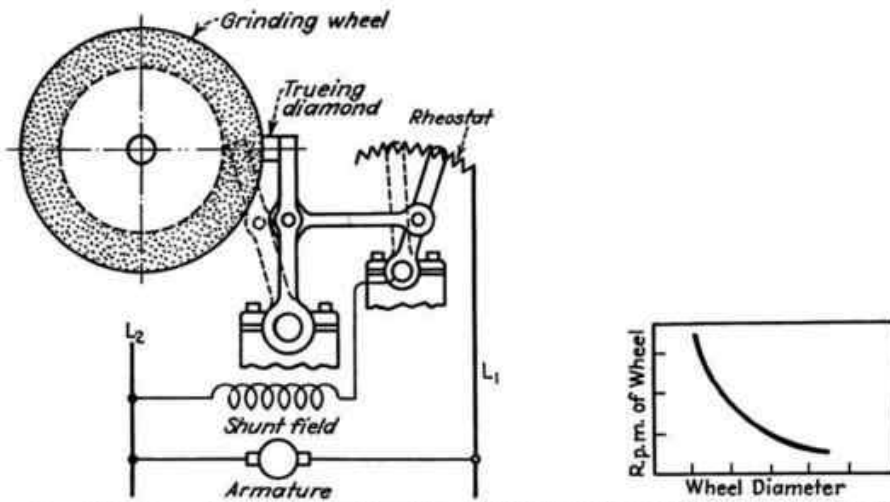

FIG. 447.—For automatically limiting the peripheral speed of a grinding wheel, the trueing diamond is mechanically interlocked with the wheel motor field rheostat. The wheel r.p.m. is increased as the wheel diameter decreases.

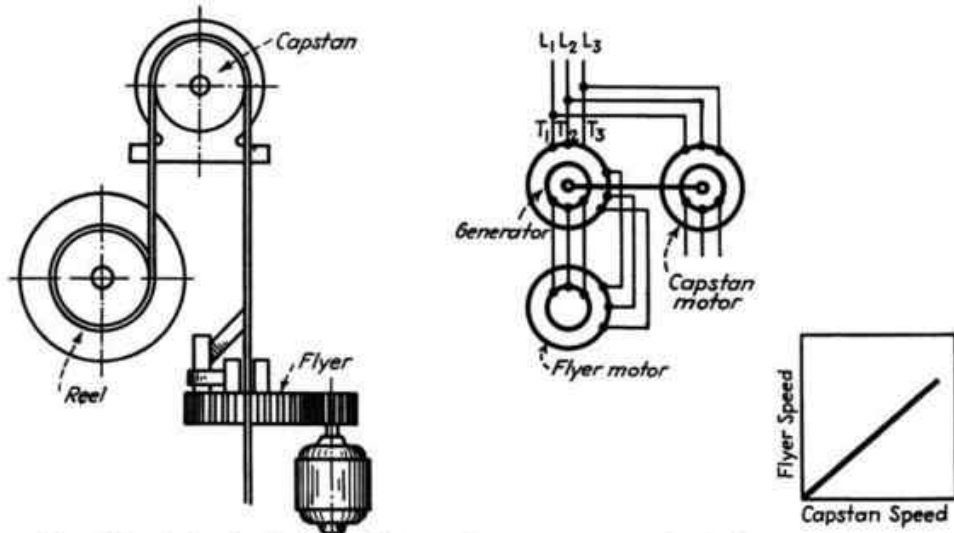

FIG. 448.—A wire-insulating machine requires a constant speed ratio between capstan motor and flyer for starting and running. The capstan motor drives a frequency changer or transmitter electrically connected to the synchronous motor of the flyer. The speed ratio between flyer and capstan is constant at all times.

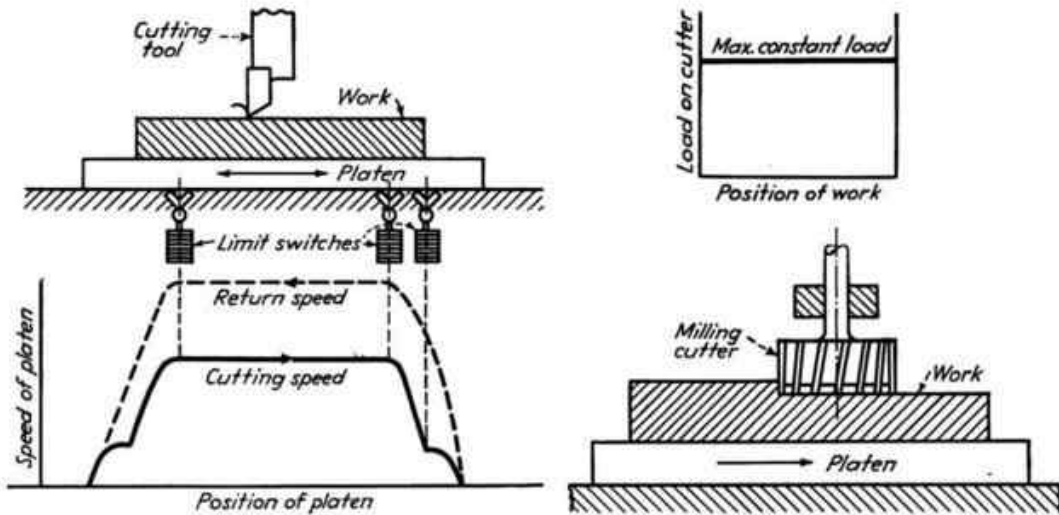

FIG. 449.

FIG. 450.

FIG. 449.—For high-speed cutting on a metal planer, the tool enters the work at a slow speed to prevent tool breakage, cutting speed is then increased, and near the end of the cut the cutting speed is reduced to prevent breaking out at edge of work. This speed control is accomplished by limit switches which put full field on the motor before the tool leaves work. After the return stroke, delayed acceleration keeps full field on motor until tool enters work; then the fast cutting speed is resumed.

FIG. 450.—To keep load constant on the cutter and spindle of a milling machine for maximum production, a relay controlled by the armature circuit of the direct-current spindle motor regulates the field of direct-current feed motor. This automatically controls the feed within limits to maintain a maximum constant load on the spindle motor.

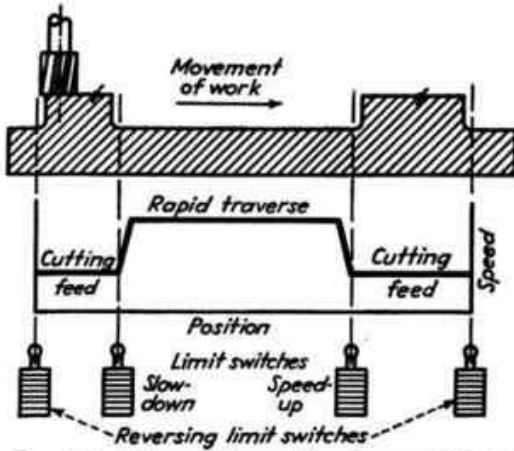

FIG. 451.—When milling work having a gap between machined surfaces, production is increased by rapid traverse between machining positions. Jump feed control is accomplished by means of adjustable limit switches, multispeed motors, and suitable magnetic controls.

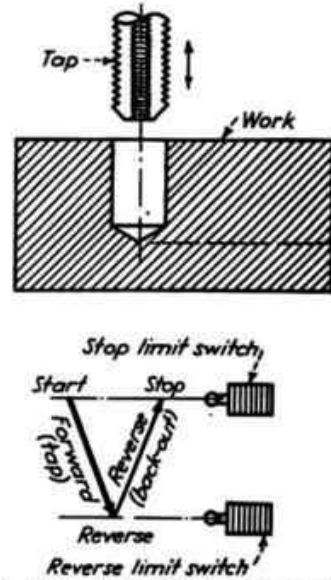

FIG. 452.—Accurate positioning of reversing and stop limits is necessary on tapping machines especially when tapping blind holes. Special alternating-current reversing motors for tapping service permit as many as 60 reversals per min. The use of two- or four-speed motors reduces the number of gear changes required. Accurate limit switches, quick-acting contactors, and high torque motors are used. A plug stop is used for braking at the "out" position.

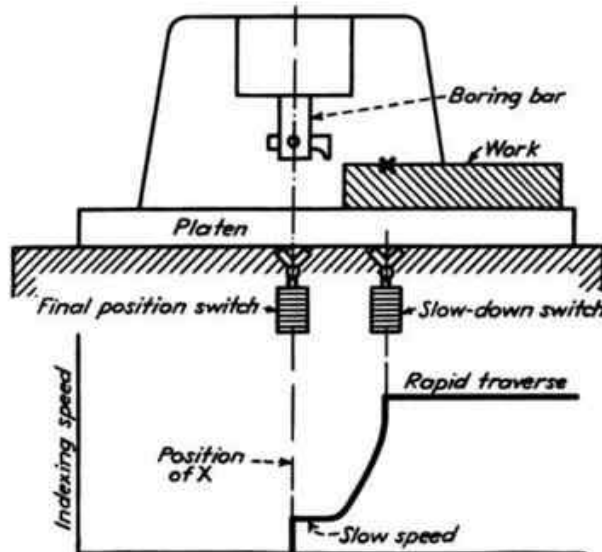

FIG. 453.—Accurate location of boring tools for indexing requires extremely slow speed of work table to prevent over-travel when stop limit is reached. A direct-current motor and control is used; heavy armature series resistance and armature parallel resistance provide for creep speeds for final positioning.

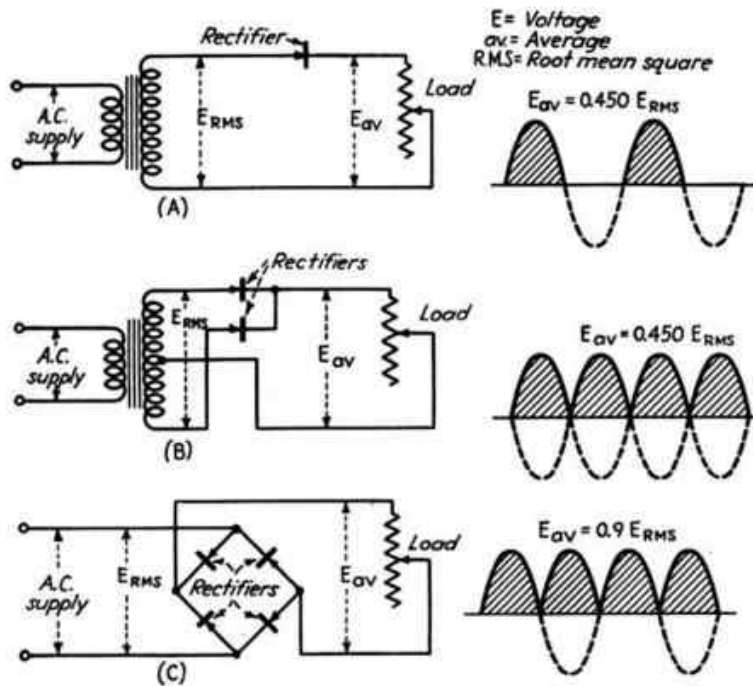

FIG. 454.—Single-phase rectifier circuits generally used. (A) Half-wave rectifier circuit used in radio, also in industrial equipment such as vibrating machinery or electric razors, requiring reciprocating motion. (B) Full-wave rectifier circuit used in radio work and magnetic chucks. (C) Full-wave rectifier circuit used in industrial applications to obtain direct-current from alternating-current source.

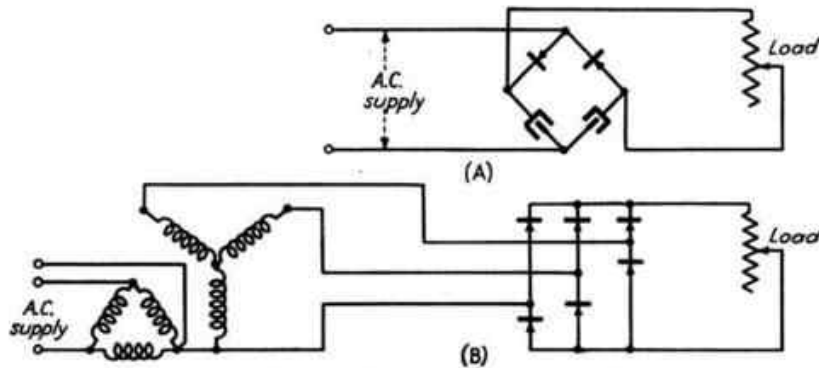

FIG. 455.—Other rectifier circuits. (A) Single-phase voltage-doubler rectifier circuit used in radio work to obtain higher than line voltage without transformer. (B) A three-phase full-wave rectifier circuit, one type of rectifier used to obtain a large amount of direct-current power for power circuit.

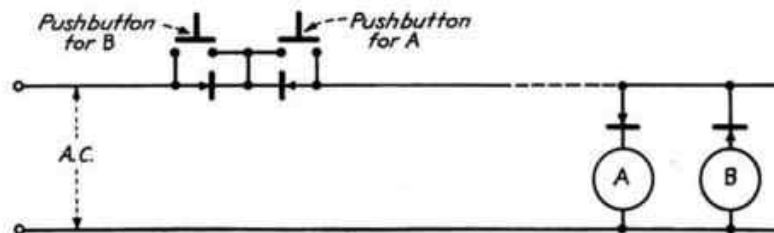

FIG. 456.—Illustrating the use of rectifiers in conjunction with magnetic control equipment on relays. Through the use of a rectifier in conjunction with direct-current relay, multiple control can be obtained over a single-control circuit.

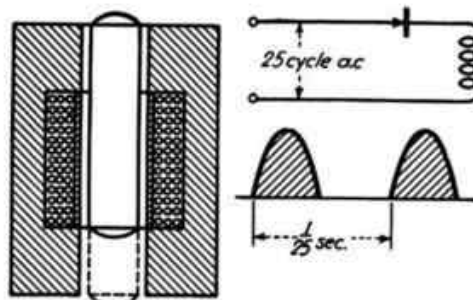

FIG. 457.—Showing the use of a pulsating direct current on a vibrating machine. In most instances, frequency of pulsations is important and on hammer shown 25-cycle alternating current is used with a single-wave rectifier.

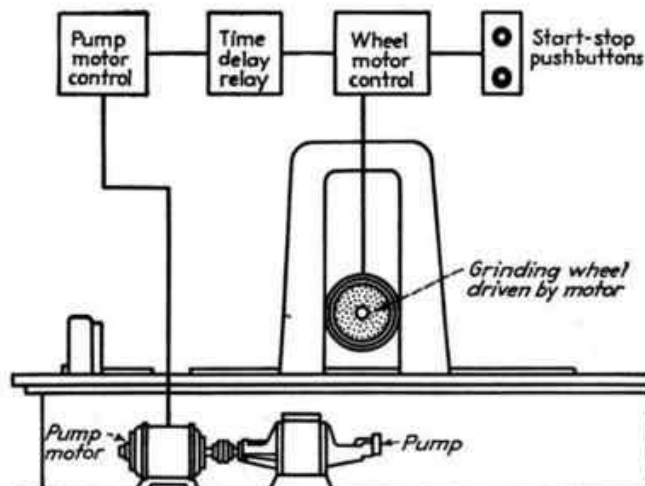

FIG. 458.—Large grinders use pumps driven by separate motors. Pump motor need not be in operation when grinding wheel is not running, but it is sometimes desirable to allow wheel motor to coast to rest before shutting down pump motor. This can be done electrically by means of time delay relay to permit pump motor to operate for pre-determined time after wheel motor is shut down. For the starting sequence, an arrangement similar to that in Fig. 462 may be used.

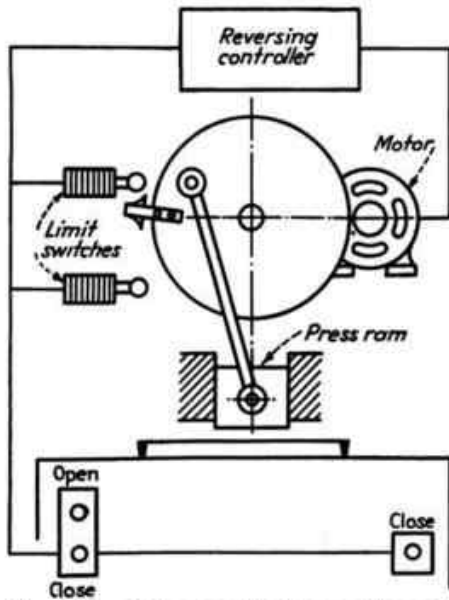

FIG. 459.—Motor-operated press with safety control requiring operator to use both hands to start press. In starting, if either "close" button is released, the motor stops. To guard against blocking in one close button, the control is wired so that both close buttons must be fully released or press will not operate. Limit switches are used.

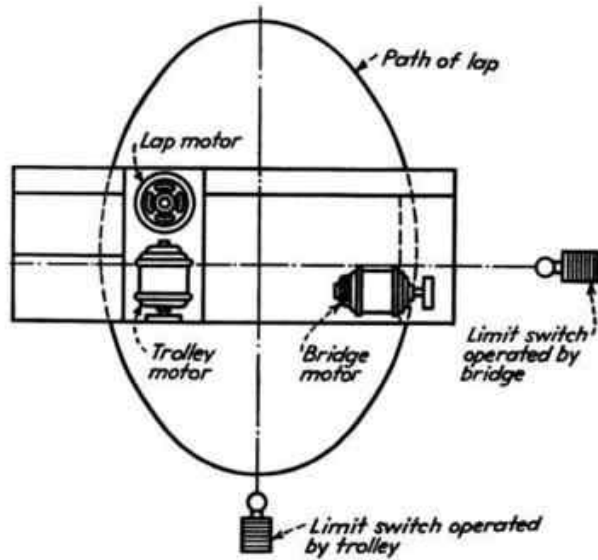

FIG. 460.—In a machine for polishing telescope mirrors, an elliptical motion of the polishing lap is sometimes required. Controls are arranged to reverse bridge motor at center of trolley motion and to reverse trolley motor at center of bridge motion.

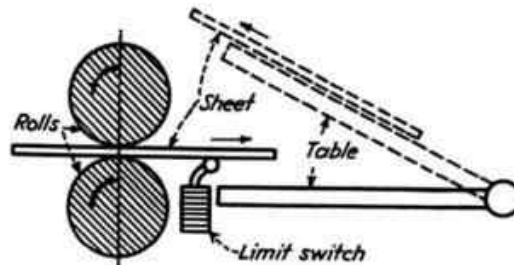

FIG. 461.—On a sheet catcher, the table must reverse and return the sheet as soon as it passes through the rolls. Since the length of the sheet varies, the sheet itself is used to operate the limit switch which reverses the table. This application requires specially designed motors and exceptional ruggedness in the control equipment.

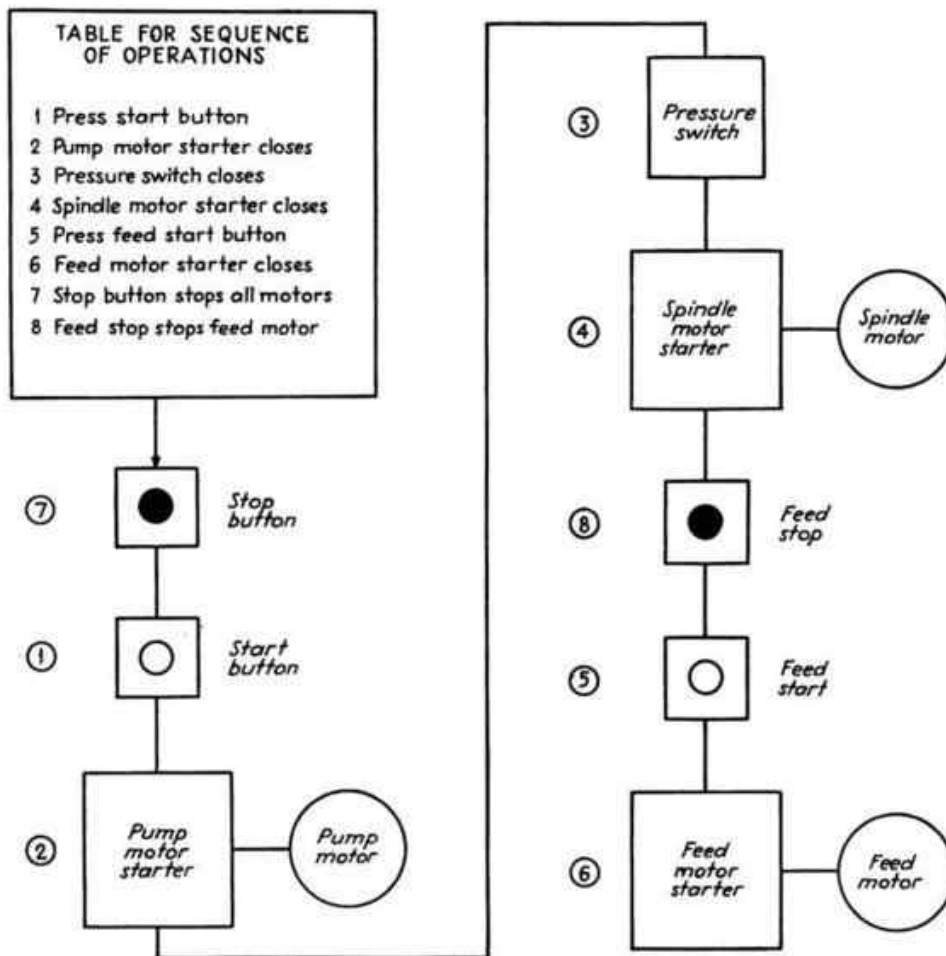

FIG. 462.—Electrical interlocking or sequencing of motors for large milling machine ensures that coolant pump motor is running and pressure obtained before spindle motor starts and that spindle motor is running before feed motor can be started. A master "stop" button dominates all controls.

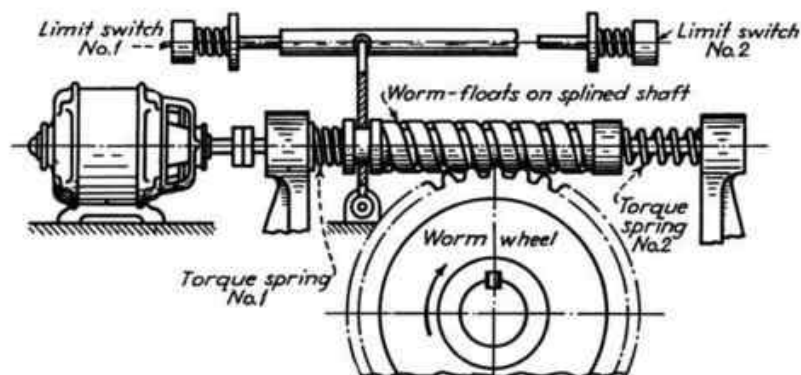

FIG. 463.—Combination mechanical and electrical torque or load limiting device for control of motor-operated valves, chucks, and clamps. When load becomes sufficiently high to stall wormwheel, the worm sliding on a splined shaft moves axially, similarly to a screw threading through a nut. This movement compresses a calibrated torque spring and opens a limit switch, thereby shutting off the motor.

ELECTRICALLY OPERATED VALVES

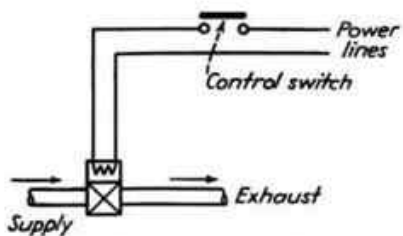

FIG. 464.—Straight-way solenoid valve as commonly connected for simple fluid control. Control switch energizes solenoid, opening valve, and permitting flow to begin.

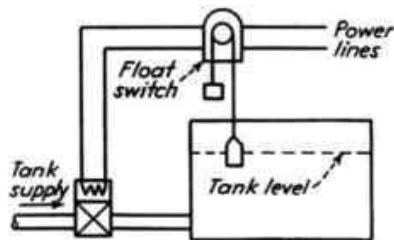

FIG. 465.—Straight-way valve applied to control automatically liquid level. Float switch used as pilot control device for valve.

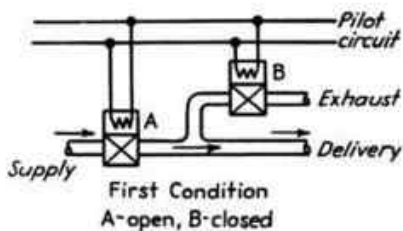

FIG. 466.—Two straight-way valves, A normally open and B normally closed, provide two-way fluid control. Energizing the solenoids cuts off supply and vents delivery through exhaust.

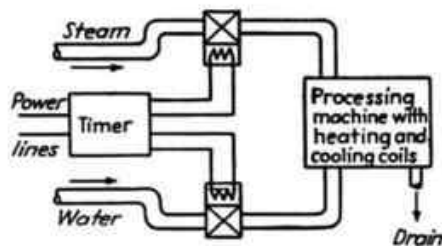

FIG. 467.—Two straight-way valves offer means of automatically controlling cycle of processing machine, such as plastic molding press, having heating and cooling coils.

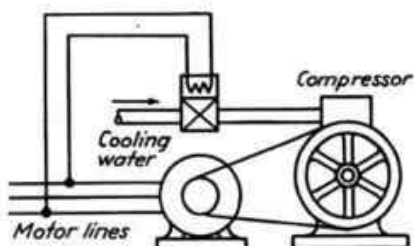

FIG. 468.—Single straight-way valve can be connected across one phase of motor winding to start flow of cooling water to compressor whenever motor starts.

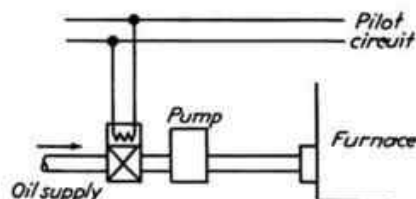

FIG. 469.—Straight-way valve of trip type interlocked with oil-furnace control system to cut off oil supply upon loss of current to motor-driven pump or to atomizing equipment, or upon occurrence of low water, low stack temperature, or similar conditions.

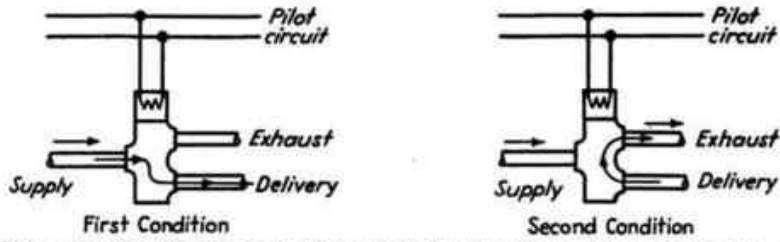

FIG. 470.—Single three-way solenoid valve cuts off supply and vents delivery through exhaust. Application similar to that, shown in Fig. 466, using two straight-way valves.

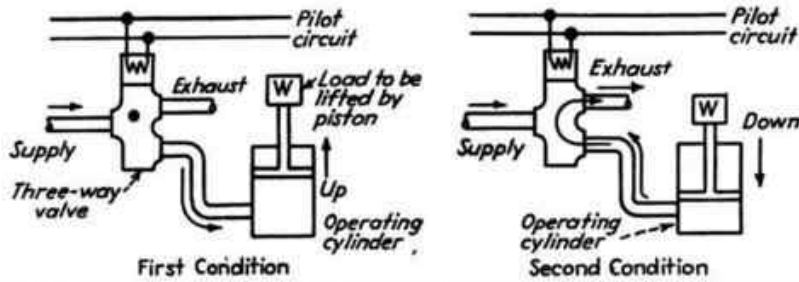

FIG. 471.—Three-way valve provides convenient means of controlling single-acting cylinders or diaphragms. By utilizing principle shown in Fig. 470, valve cuts off supply and vents delivery through exhaust, thus permitting return stroke of piston to take place.

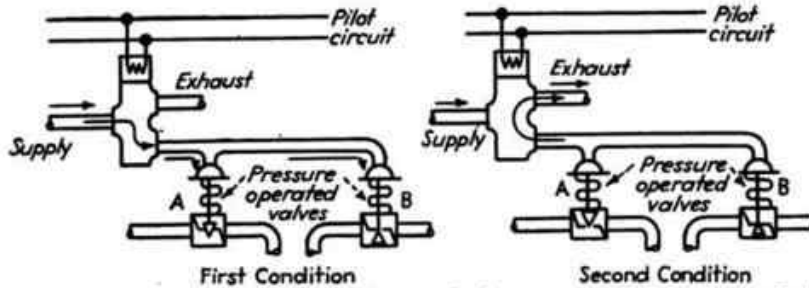

FIG. 472.—Three-way valve arranged for multiple control of pressure-operated valves. In the first condition, valve *A* is closed and valve *B* open. In the second condition, the reverse is true, with valve *A* open and valve *B* closed.



FIG. 473.—Three-way valve applied as convenient means of transferring one supply to either of two deliveries.

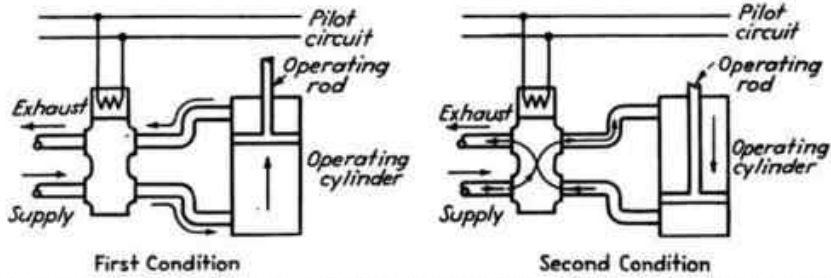

FIG. 474.—Four-way valve arranged to control double-acting cylinder. Upon energization of solenoid, operating rod of cylinder reverses direction.

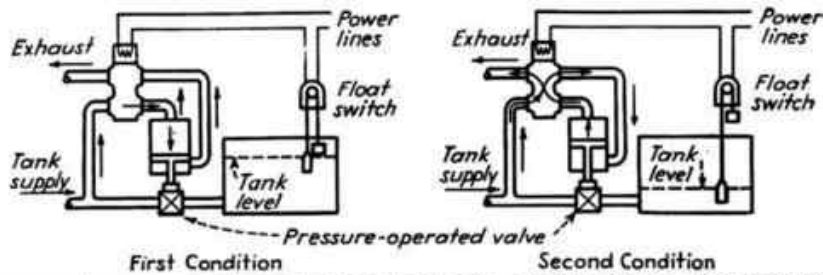

FIG. 475.—Four-way valve arrangement, employing principle shown in Fig. 474, provides automatic control of tank level through pressure-operated valve.

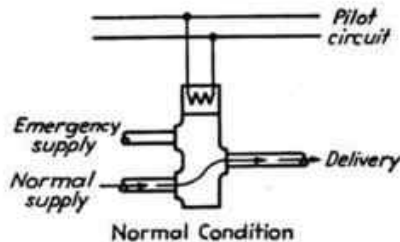

FIG. 476.—Three-way valve, utilizing inversion of principle shown in Fig. 473, offers means of transferring either of two supplies to a common delivery. Useful in applications where an emergency supply is provided.

AUTOMATIC TIMERS

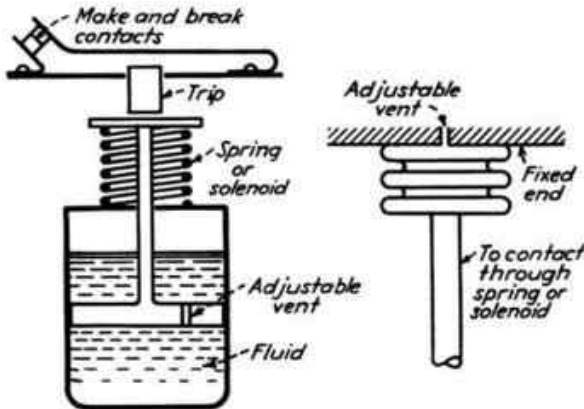

FIG. 477.—Dashpot principle. Simplest form consists of a piston or plunger operating in oil, mercury, or air. Adjustable small orifices or bleeders provide time adjustment. A by-pass may be provided near the end of the piston travel for snap action closing of the contact. Widely used because of its simplicity and low cost. When air is used, changing clearances caused by dust, gumming of lubricant, and leakage affect the timing. If oil is used, the temperature will change oil viscosity and affect the timing. Also subject to error because of clearance changes from wear.

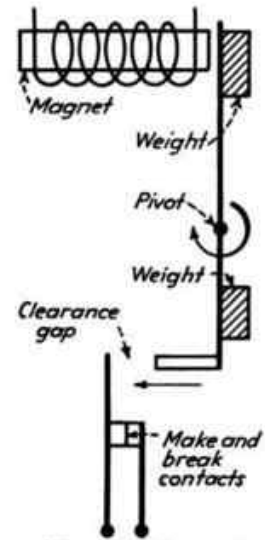

FIG. 478.—Inertia mechanism. Time delay is by virtue of the inertia of two weights mounted on a pivoted arm and the length of arc to be traversed before mechanical contact is made. Tilted by gravity, this device gives a relatively short interval and becomes clumsy for long time intervals.

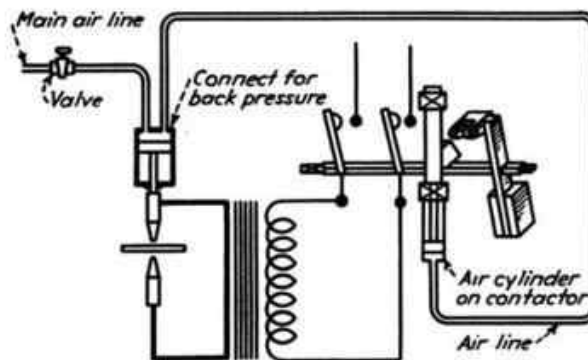

FIG. 479.—Contactor works on back pressure from the main cylinder on the welder, pressure being assured between the welding points before the welding contactor closes. When the back pressure has built up to a predetermined value, the plunger moves upward at a definite rate of speed and the hardened cam closes the main contacts. After a predetermined time, the cam moves by the roller that it engages and the main contacts open. One adjustment sets the back pressure at which the contactor plunger starts to move and therefore determines the lag in applying the current after pressure has been applied. A second adjustment changes the needle valve opening to the contactor air cylinder and thus times the upstroke. This determines the welding time. A third adjustment varies the time of the downstroke and is of importance only when used with a repeater.

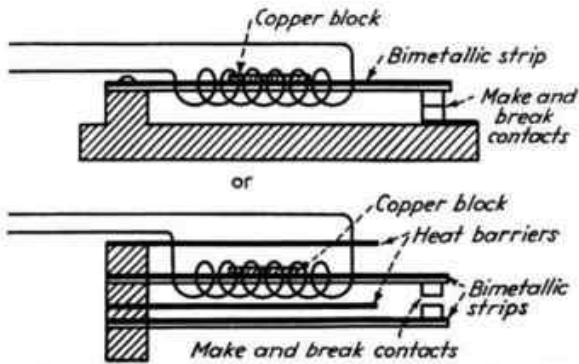

FIG. 480.—Thermal relays. Inexpensive time delay utilizing the effect of a heating coil around a bimetallic strip. Least accurate device. Has a slow make and break action. For longer time intervals, a copper block may be mounted to absorb some of the heat; the larger the block of copper, the longer the time interval. Time intervals ranging from $\frac{1}{2}$ sec. to 5 to 10 min. are possible with this device.

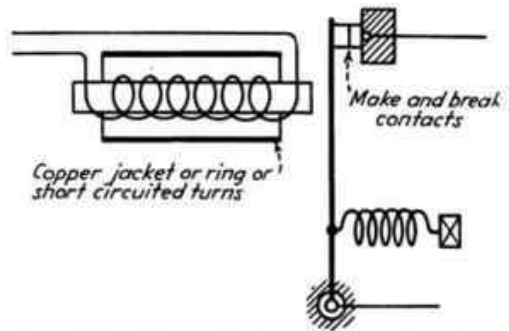

FIG. 481.—Magnetic time delay, used on direct current only. Relatively inexpensive, effects time delays up to 10 sec. by means of residual magnetism. Magnet may be copper jacketed, may have copper rings, or may have short-circuited turns around the magnet. Variation in the amount of copper or in the resistance of short-circuited turns will affect the time delay.

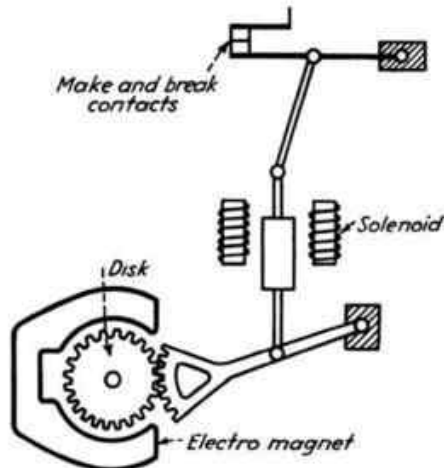

FIG. 482.—Magnetic-drag time delay. A small electromagnet is used, and the motion of the relay plunger is made to revolve a metal disk in the field of the magnet. The rotation of the disk is retarded by magnetic induction. Reliable device, trouble free, but relatively expensive.

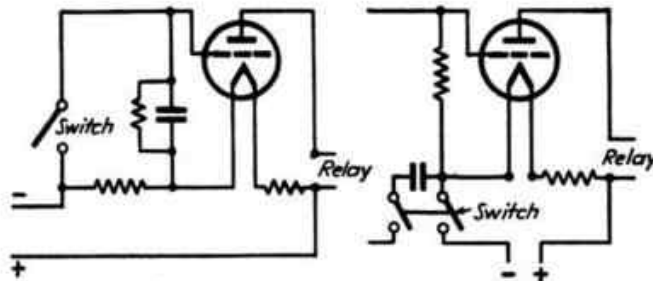

FIG. 483.—Vacuum tube. Condenser charged or discharged through a resistor closes a relay after definite time, using direct current. When switch is open, the condenser discharges slowly through shunt resistor. This lowers the negative potential on the grid, and at the critical value the plate current will rise enough to operate the relay. Full line voltage may be applied to the condenser to obtain longer time delay.

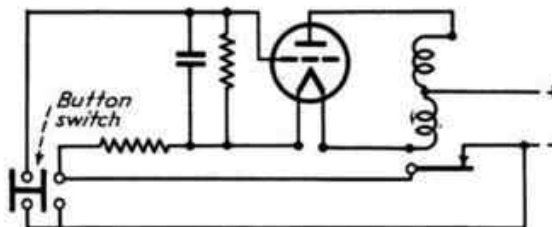

FIG. 484.—In this circuit, operation is maintained for a predetermined time after the starting impulse has stopped. When the button has been pressed, the filament gets current in series with relay winding 1, and the relay pulls up, locking in the circuit. The second contact charges the condenser negative, and no plate current flows. When button is released, the relay stays closed until condenser discharges. Then the plate current flows through the second relay winding in opposition to the first, releasing the armature. Applicable to direct current or rectified alternating current only.

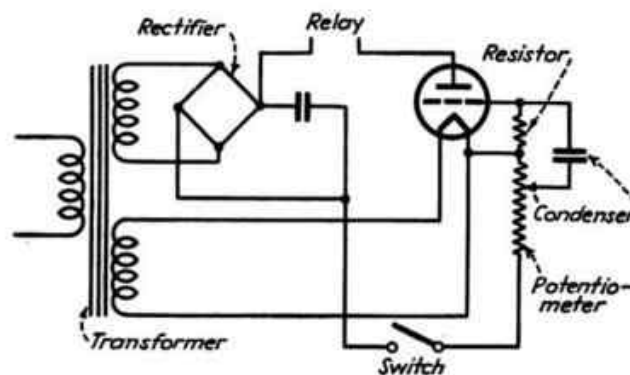

FIG. 485.—In the Westinghouse electronic relay, there is no temperature error, reset is instantaneous, adjustment is easy, and first cost is low. When the switch is closed, the tube passes current. As the current increases, the increasing IR drop from the potentiometer causes a charging current through condenser. The IR drop across the resistor because of this current applies the negative bias to the grid. Plate current cannot build up very rapidly, because the faster it increases, the more negative the grid becomes. After a time period, adjustable through potentiometer, the plate current will operate relay. The time delay is proportional to the product of resistance and capacitance. Long delays require large resistors, and short delays correspondingly small resistors. Maximum time delay with this device is about 3 min. About 0.05 sec. is the minimum.

TRIGGER SWITCH MOUNTINGS

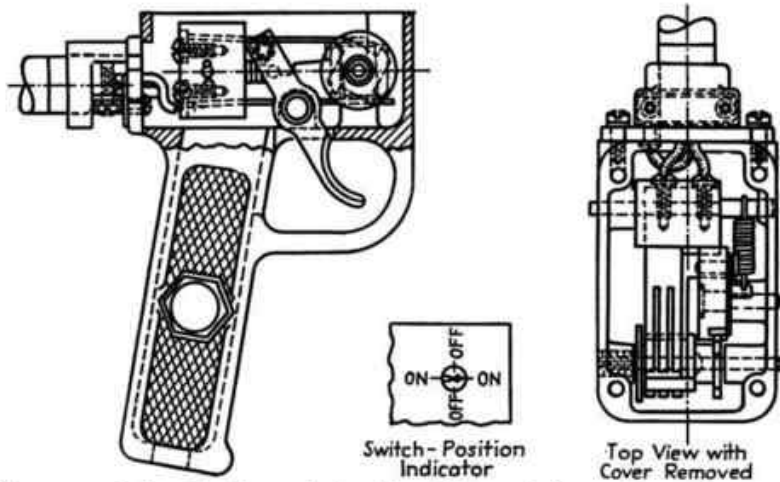

FIG. 486.—Trigger-operated ratchet-type single-pole switch, a design no longer in general use. An arrow stamped on the end of the shaft shows through a hole in the cover plate to indicate the position of the switch. Spring blades pressing on the faces of the square contact block give a snap action and hold the block in position.

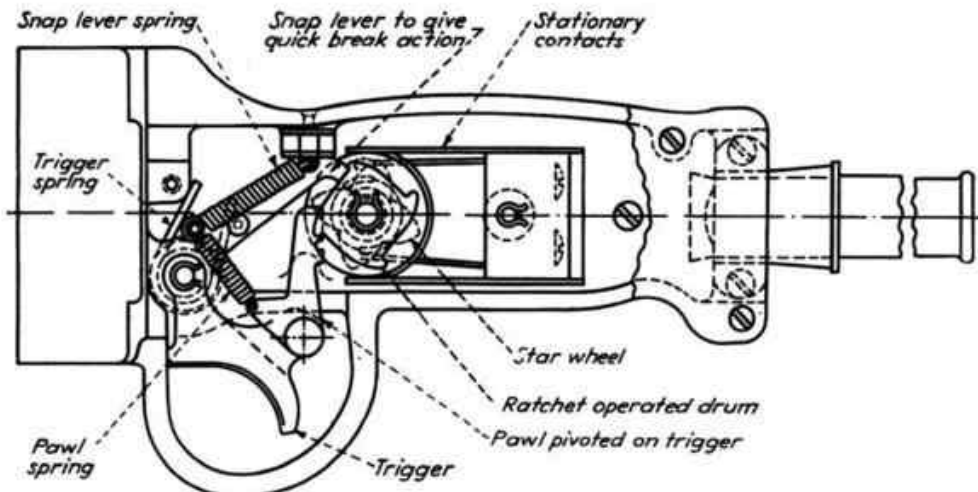

FIG. 487.—Ratchet-type switch with double pole for three phase. Can also be used for single phase. The word "on" is stamped on diametrically opposite points on the ratchet wheel. With switch in "on" position, the word shows through a hole in the cover plate. A spring lever snaps into the star wheel, giving quick snap action. To open the switch, a definite movement of the trigger is required.

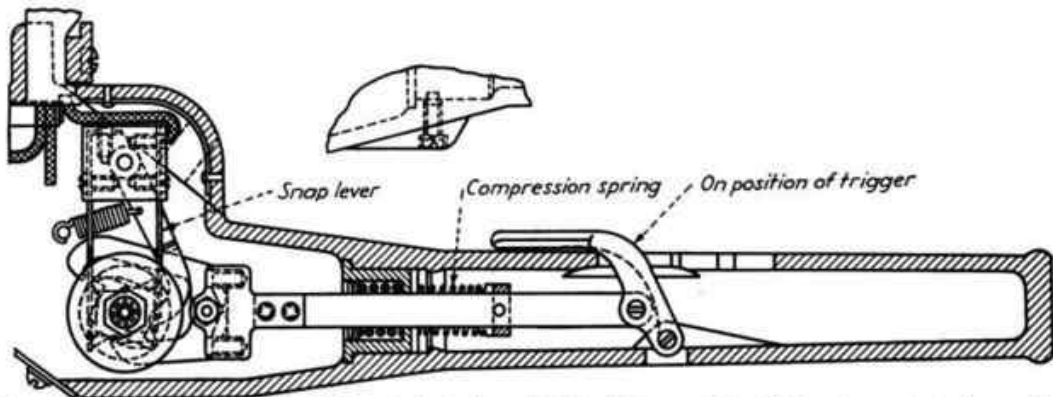

FIG. 488.—A design of switch similar to that shown in Fig. 486 except that it is a two-pole design and is self-opening when the trigger is released. It is shown here in the "on" position. As soon as the trigger is released, the compression spring opens the switch.

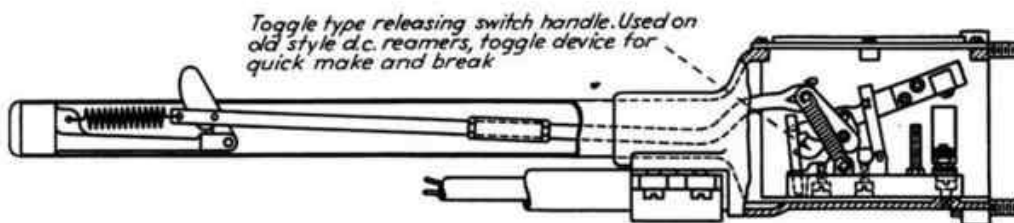

FIG. 489.—A toggle-type self-opening switch used on old-style direct-current reamers. The tripper is pushed forward until the line of pull of the spring passes the dead center of the link to which it is attached. The spring then pulls the switch closed. Upon releasing the trigger, the mechanism returns to the position shown, the switch snapping open when the toggle spring passes dead center.

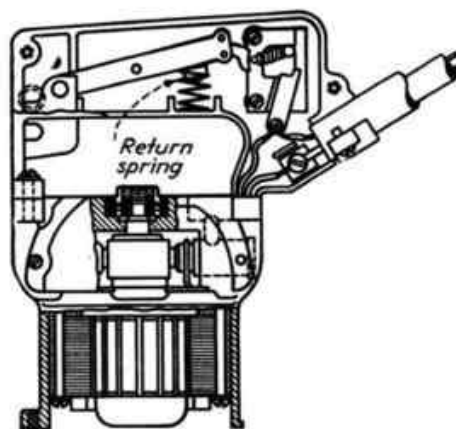

FIG. 490.—A conventional-type switch of old design that is self-opening when the trigger is released but can be held in the closed position by means of a locking pin. Common to all the switches shown in this group of designs, it is not dustproof.

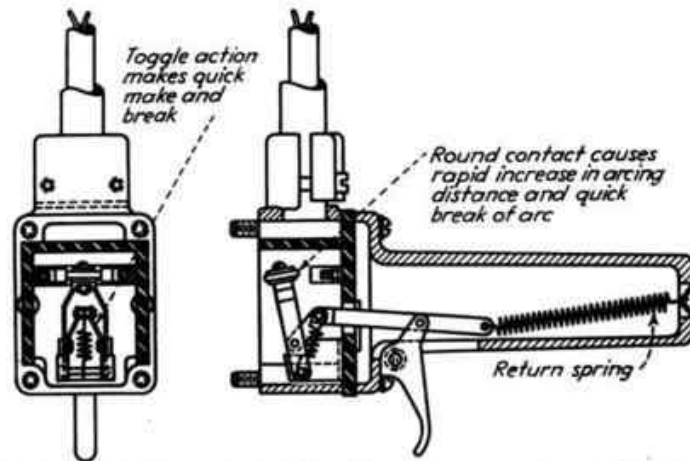

FIG. 491.—A special design of built-up switch of the self-opening type and provided with a locking pin, similar to that shown in Fig. 489. Common to all the designs shown here, the switch is now obsolete in favor of fully enclosed and easily replaceable switch units.

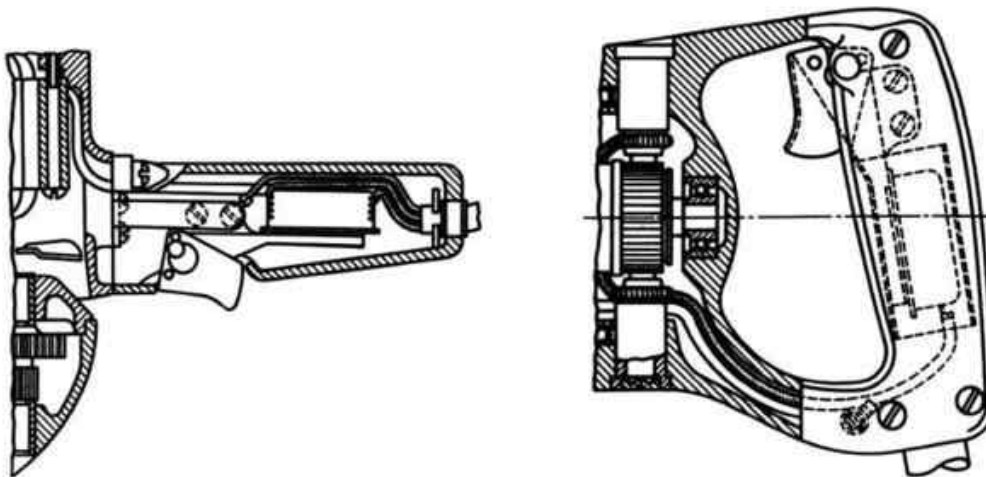

FIG. 492.

FIG. 493.

FIG. 492.—A modern-type commercial switch mounted in a side handle. Such switches are readily replaced as a unit, inexpensive, and sealed against the entrance of dirt. The switch opens as soon as the trigger is released unless the locking pin is set, in which case a slight pull on the trigger releases the locking pin and opens the switch.

FIG. 493.—Another example of a modern commercial switch mounted as a unit in a grip-type end handle.

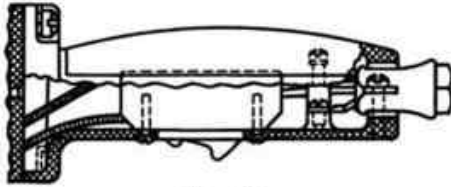

FIG. 494.

FIG. 494.—A rocker-type switch such as used on polishers and portable sanders. It is not self-releasing and is now being replaced by plunger-operated dusttight switches such as shown in Fig. 498.

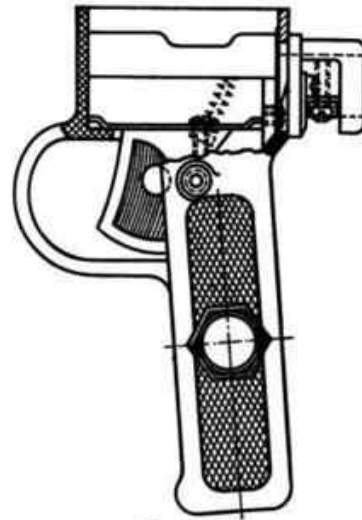

FIG. 495.

FIG. 495.—Another style of mounting a commercial-type switch in a side handle. The switch is replaceable as a unit and is self-opening, as soon as the trigger is released; the return spring being shown dotted.

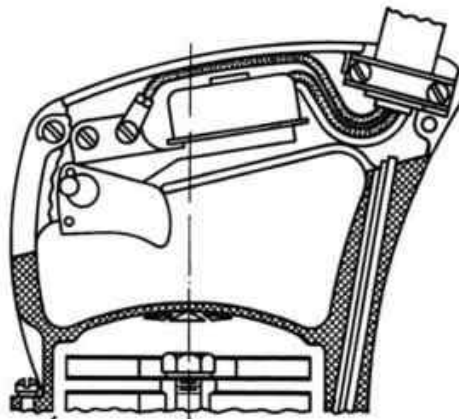

FIG. 496.—In this switch mounting, the trigger actuates the switch by means of a lift rod attached to the back of the trigger. A tension spring attached to the upper end of the lift rod and anchored to the lower end of the switch plate pulls the switch open as soon as the trigger is released. If the locking pin is depressed when the trigger is pulled back, it passes through the hole in the trigger which then cannot return to the open position. As soon as the trigger is pressed, the locking pin is released, snaps back, and releases the trigger.

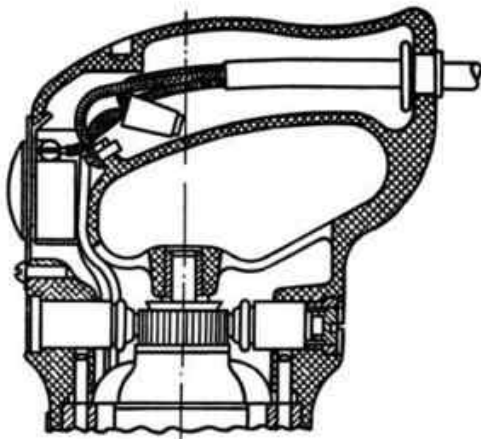

FIG. 497.—A slider-operated switch. The slider moves back and forth as indicated in the drawing. This switch is not provided with any release arrangement. It is used only on light model tools where no damage would be done if the tool were laid down with the power still on.

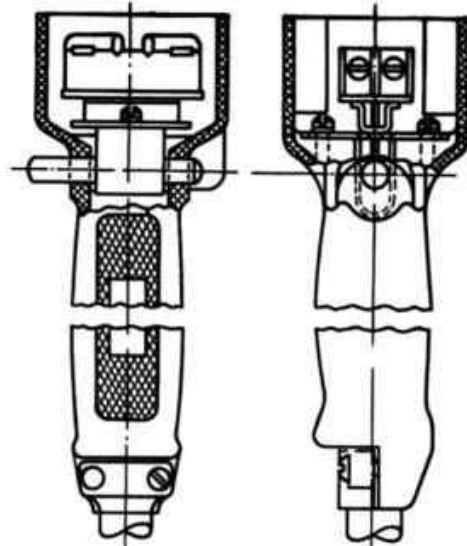

FIG. 498.—Latest type switch handle for polishers, sanders, and portable grinders. The switch is in a dust-tight chamber and is operated by a plunger instead of a trigger which eliminates the necessity of an opening such as is required when triggers or rockers are used. The plunger makes a close fit. Switch is not self-releasing, it being necessary to push the plunger for both on and off positions.

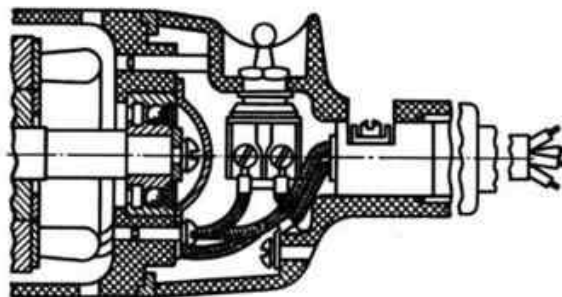

FIG. 499.—Latest design of switch arrangement for small die grinders and sanders. The toggle-operated switch unit is mounted in a dust-tight compartment and a dust seal is provided where the toggle comes through the case. This type of switch does not have a release arrangement that opens it automatically.

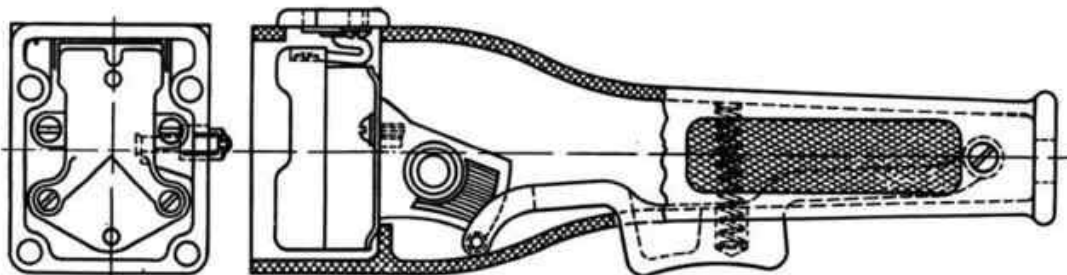

FIG. 500.—This switch is of the same type as shown in Fig. 495. It is mounted in a longer handle, being actuated by a remote trigger arrangement. It is provided with an additional return spring for quick action and also has a locking pin for holding the switch in the closed position when the trigger is released. A slight pull on the trigger releases the locking pin and opens the switch.

THERMOSTATIC MECHANISMS

Sensitivity or change in deflection for a given temperature change depends upon the combination of metals selected as well as the dimensions of the bimetal element. Sensitivity increases with the square of the length and inversely with the thickness. The force developed for a given temperature change also depends on the type of bimetal, whereas the allowable working load for the thermostatic strip increases with the width and the square of the thickness. Thus, the design of bimetal elements depends upon the relative importance of sensitivity and working load.

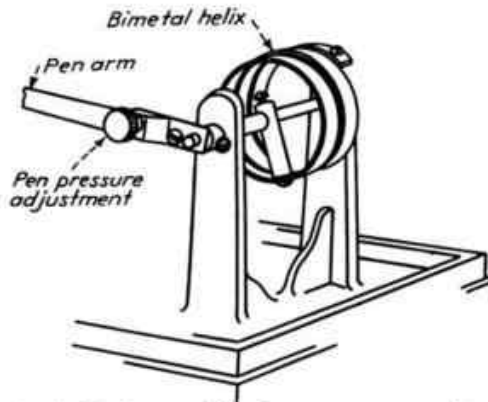

FIG. 501.—In the Taylor recording thermometer, a pen is moved vertically across a revolving chart by a brass-invar bimetal element. To obtain sensitivity, the long movement of the pen requires a long strip of bimetal, which is coiled into a helix to save space. For accuracy, a relatively large cross section gives stiffness, although the large thickness requires increased length to obtain the desired sensitivity.

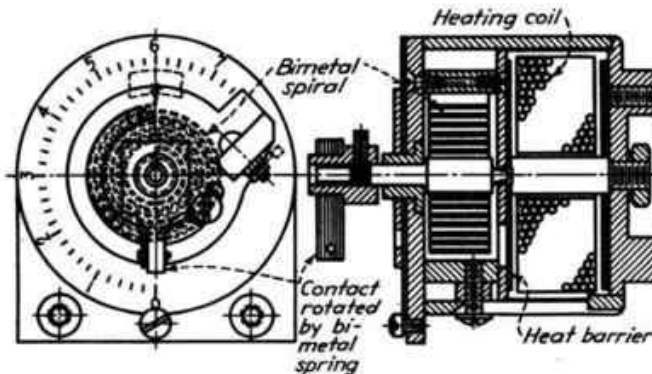

FIG. 503.—In this Westinghouse overload relay for large motors, a portion of the motor current is passed through a heating coil within the relay. Heat from the coil raises the temperature of a bimetal spiral which rotates a shaft carrying an electrical contact. To withstand the operating temperature, a heat-resistant bimetal is used, coiled into the spiral form for compactness. Because of the large deflection needed, the spiral is long and thin, whereas the width is made large to provide the required contact pressure.

By the use of heat barriers between the bimetal spiral and the heating coil, temperature rise of the bimetal can be made to follow closely the increase in temperature within the motor. Thus, momentary overloads do not cause sufficient heating to close the contacts, whereas a continued overload will in time cause the bimetal to rotate the contact arm around to the adjustable stationary contact, causing a relay to shut down the motor.

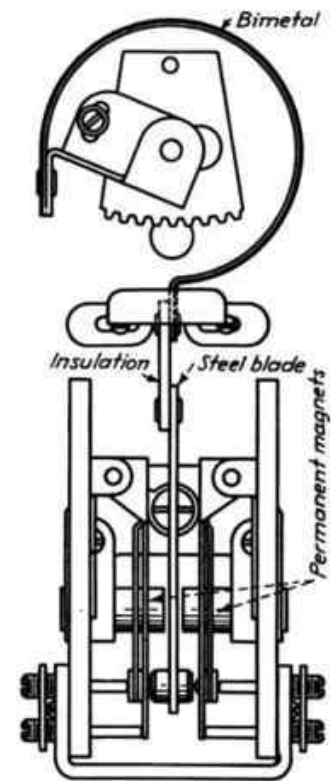

FIG. 502.—Room temperatures in summer as well as winter are controlled over a wide range by a single large-diameter coil of brass-invar in the Friez thermometer. To prevent chattering, a small permanent magnet is mounted on each side of the steel contact blade. The magnetic attraction on the blade, increasing inversely with the square of the distance from the magnet, gives a snap action to the contacts.

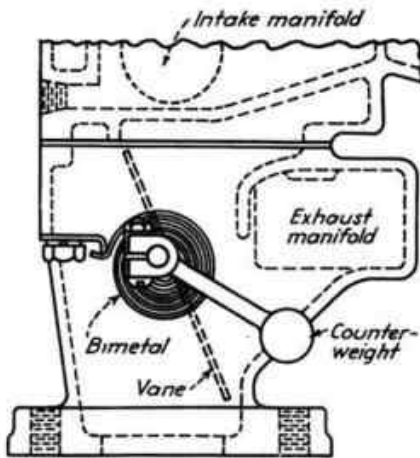

FIG. 504.

FIG. 504.—On the Dodge carburetor, when the engine is cold, a vane in the exhaust passage to the “hot spot” is held open by a bimetal spring against the force of a small counterweight. When the thermostatic spiral is heated by the outside air or by the warm air stream from the radiator, the spring coils up and allows the weight to close the vane. Since high accuracy is not needed, a thin, flexible cross section is used with a long length to give the desired sensitivity.

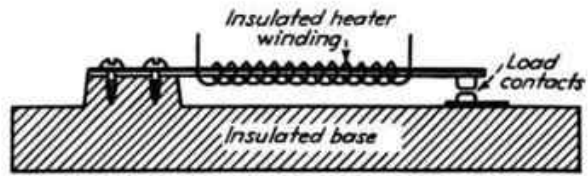

FIG. 505

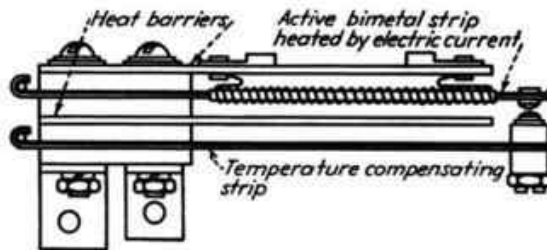

FIG. 506.

FIG. 505.—In the Friez relay, a constant current through an electrical heating coil around a straight bimetal strip gives a time-delay action. Since the temperature range is relatively large, high sensitivity is not necessary, hence a short straight strip of bimetal is suitable. Because of the relatively heavy thickness used, the strip is sufficiently stiff to close the contact firmly without chattering.

FIG. 506.—A similar type of bimetal element is used in the Ward Leonard time-delay relay for mercury-vapor rectifiers. This relay closes the potential circuit to the mercury tube only after the filament has had time to reach its normal operating temperature. To eliminate the effect of changes in room temperature on the length of the contact gap, and therefore the time interval, the stationary contact is carried by a second bimetal strip similar to the heated element. Barriers of laminated plastic on both sides of the active bimetal strip shield the compensating strip and prevent air currents from affecting the heating rate. The relatively high temperature range allows the use of a straight thick strip, whereas the addition of the compensating strip makes accurate timing possible with a short travel.

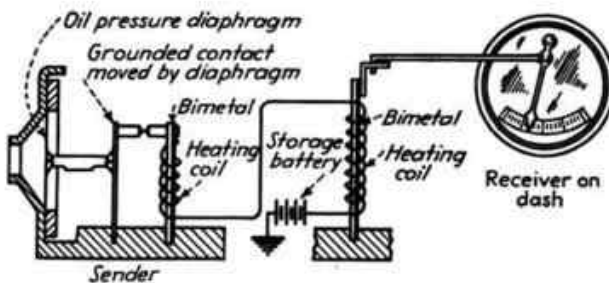

FIG. 507.

FIG. 507.—Oil pressure, engine temperature, or gasoline level are indicated electrically on automobile dashboard instruments built by King-Seeley in which a bimetal element is used in both the sender and receiver. A grounded contact at the sender completes an electric circuit through heaters around two similar bimetal strips. Since the same current flows around the two bimetal elements, their deflections are the same. But the sender element when heated will bend away from the grounded contact until the circuit is broken. Upon cooling, the bimetal again makes contact and the cycle continues, allowing the bimetal to follow the movement of the grounded contact. For the oil-pressure gage, the grounded contact is attached to a diaphragm; for the temperature indicator, the contact is carried by another thermostatic bimetal strip; in the gasoline-level device, the contact is shifted by a cam on a shaft rotated by a float. Deflections of the receiving bimetal are amplified through a linkage that operates a pointer over the scale of the receiving instrument. Since only small deflections are needed, the bimetal element is in the form of a short stiff strip.

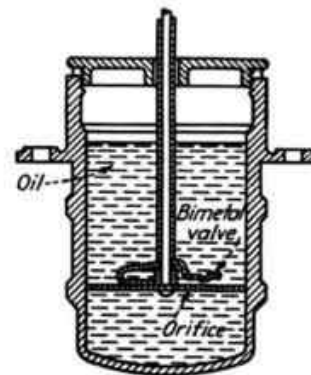

FIG. 508.

FIG. 508.—Oil dashpots used in heavy-capacity Toledo scales have a thermostatic control to compensate for changes in oil viscosity with temperature. A rectangular orifice in the plunger is covered by a swaged projection on the bimetal element. With a decrease in oil temperature, the oil viscosity increases, tending to increase the damping effect; but the bimetal deflects upward, enlarging the orifice enough to keep the damping force constant. A wide bimetal strip is used for stiffness so that the orifice will not be altered by the force of the flowing oil.

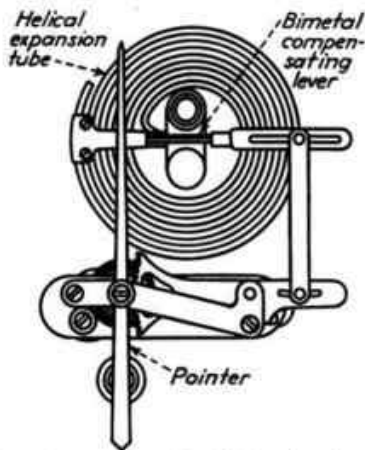

FIG. 509.—In mercury-filled indicating thermometers, expansion of the mercury in a bulb at the end of a capillary line causes the spiral tube in the gage to uncoil, the dial pointer being moved by means of a linkage. However, changes in the temperature of the mercury in the capillary and spiral also affect the movement of the linkage introducing an error in the reading. In the Taylor indicating thermometer, compensation for changes in gage temperature is obtained by a flat bimetal strip that forms a part of the pointer linkage. The strip is designed so that its deflections are equal but opposite to the effect caused by changes in gage temperature. Since little load is imposed on the thermostatic strip, the compensating action can be obtained with high accuracy.

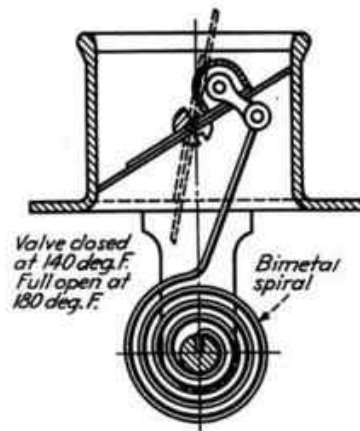

FIG. 510.—In cooling-water thermostats for automobile engines, the water flow imposes a load on the bimetal spiral, and in addition the overtravel caused by continued cooling after the valve is closed sets up stresses that increase as the temperature decreases. Sufficient strength and cross section to safely withstand these stresses without permanent deformation requires a long flexible element. High accuracy is not obtainable, but in this application a relatively large variation in operating temperature is permissible. In the Chase thermostat, the bimetal element is in the form of a tapered spiral spring which is connected to a rotating valve by a simple linkage. To stabilize the bimetal element, it is subjected to a series of hot and cold treatments at temperatures beyond the normal temperature range.

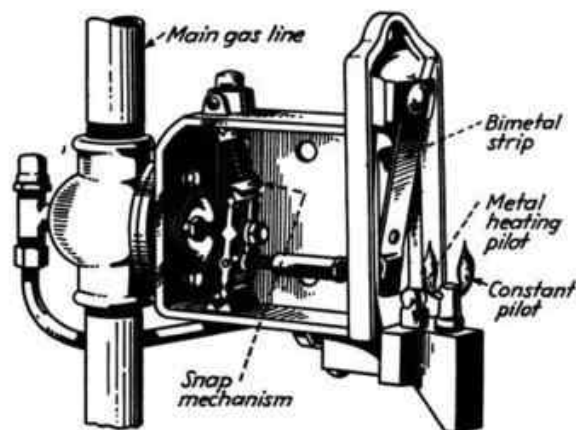

FIG. 511.—When the bimetal element in a gas pilot-light control is placed near the pilot flame, the bimetal is subjected to a temperature near its maximum operating range, and in service over long periods of time the valve may become corroded and fail to function when an emergency arises. In the pilot control made by the Patrol Valve Company, operating temperature of the bimetal is reduced and distortion from overheating is prevented by a dual pilot construction. The constant-burning pilot ignites a second pilot which heats the bimetal strip when the thermostatic control calls for heat. The bimetal strip upon heating opens the toggle-operated main burner valve, which, by means of a double-seat construction, reduces the supply of gas to the second pilot, just enough flame being left to keep the bimetal from closing the valve. Since relatively wide limits for temperature of operation are permissible, the bimetal element is designed to develop sufficient force to operate the toggle spring without the use of high working stresses.

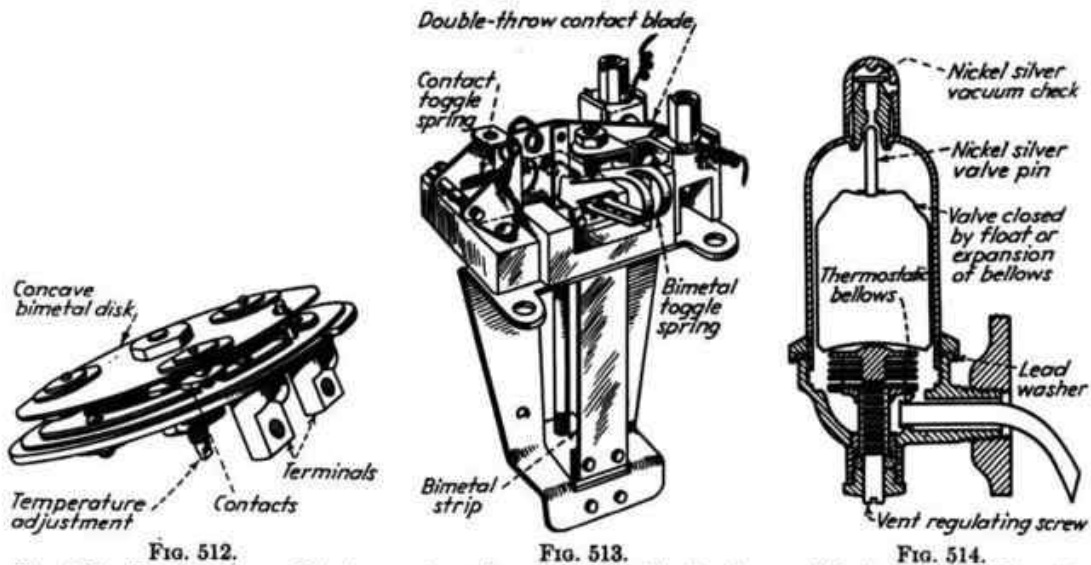

FIG. 512.—Toggle action, without separate springs, is obtained in the Spencer disk thermostat. The disk is a saucer-shaped piece of bimetal sheet which snaps itself from a concave to a convex shape at a predetermined temperature. Both the amount of movement and the temperature differential between opening and closing temperature depend on the design of the disk. For greater sensitivity, smaller differential and a larger movement than can be obtained with the plain disk, the bimetal disk is corrugated. Since the disk is small and stores but little heat, it warms or cools rapidly.

When used as an electrical control device, insulated silver contacts are mounted on the bimetal disk. In the cold position shown, each of the contacts bridges a gap in insulated plates connected to the heavy terminals. When heated, the disk snaps to a convex shape, the circuit opening through the device at three points.

FIG. 513.—In the Westinghouse thermostat for electric hot-water heaters, a small range of temperature difference between on and off is needed, and to eliminate the necessity for an intermediate relay, the contacts must break a relatively heavy current. These conflicting requirements are met by using a double-toggle mechanism. A light toggle spring on the contact blade keeps the contacts firmly seated until the stronger toggle on the bimetal strip comes into operation.

The bimetal blade is free to move nearly to the dead-center position, thereby storing energy in its toggle spring before any pressure is applied to the contact blade. Energy released by the toggle spring, when the bimetal blade passes dead center, delivers an impact to the contact blade, breaking loose any slight welding that may have occurred during the previous operation. This thermostat is used as a current-limiting switch, disconnecting one heater as another is connected. Because of the double-toggle design, the thermostat contacts will safely interrupt 5 kw. at 220 volts alternating current with a temperature differential of 5°F. or less.

FIG. 514.—In radiator air valves made by the Anderson Manufacturing Company, air forced into the valve passes around a small bellows partly filled with a liquid. When steam reaches the valve, the heat increases the vapor pressure within the bellows, and the resultant expansion raises the float, thereby closing the air-vent orifice.

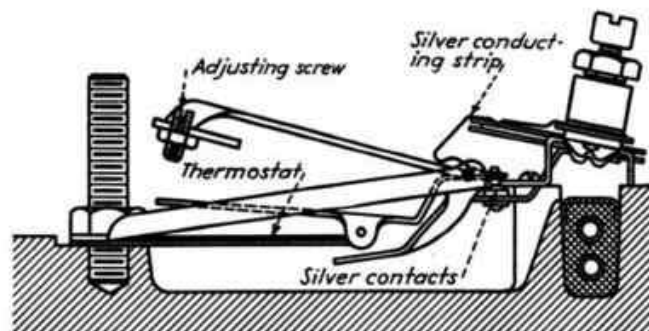

FIG. 515.—Electric irons require a convenient adjustment for the temperature at which the bimetal element opens the circuit. In the mechanism designed by Proctor & Schwartz, a double lever not only permits adjustment of the operating temperature, but also relieves the bimetal strip of any restriction when it cools to room temperature. Since the operating temperature range is high, a heat-resisting bimetal material is used in the form of a short stiff strip. Current is conducted to the bimetal contact through a flexible silver ribbon eliminating the effect of heat caused by current passing through the bimetal strip.

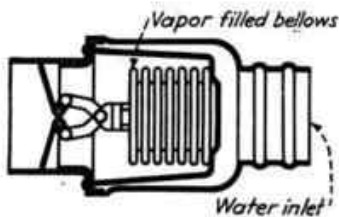

FIG. 516.—Automobile cooling water temperature is controlled by a self-contained bellows in the thermostat made by the Bridgeport Brass Company. As in the radiator air valve, the bellows itself is subjected to the temperature to be controlled. As the temperature of the water increases to about 140°F., the valve starts to open; at approximately 180°F., free flow is permitted. At intermediate temperatures, the valve opening is in proportion to the temperature.

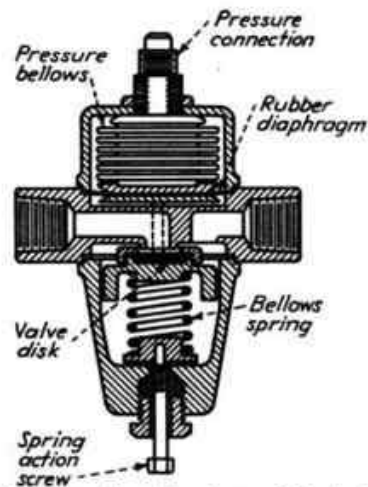

FIG. 517.—In a throttling type of circulating water control valve made by C. J. Tagliabue Manufacturing Company for use in refrigeration plants, the valve opening varies with the pressure on the bellows. This valve controls the rate of flow of the cooling water through the condenser, a greater amount of water being required when the temperature, and therefore the pressure, increases. The pressure in the condenser is transmitted through a pipe to the valve bellows thereby adjusting the flow of cooling water. The bronze bellows is protected from contact with the water by a rubber diaphragm.

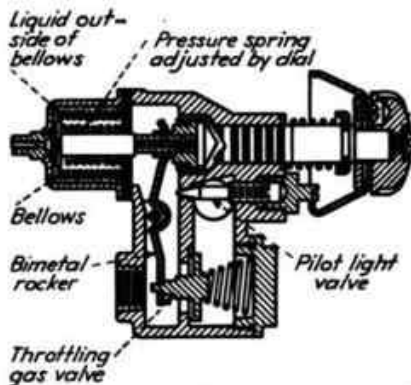

FIG. 518.—An automatic gas-range control made by the Wilcolator Company has a sealed thermostatic element consisting of a bulb, capillary tube, and bellows. As food is often placed near the bulb, a nontoxic liquid, chlorinated diphenyl, is used in the liquid expansion system. The liquid is also non-inflammable and has no corrosive effect upon the phosphor bronze bellows. By placing the liquid outside instead of inside the bellows, the working stresses are maximum at normal temperatures when the bellows bottoms on the cup. At elevated working temperatures, the expansion of the liquid compresses the bellows against the action of the extended spring which, in turn, is adjusted by the knob. Changes in calibration caused by variations in ambient temperature are compensated by making the rocker arm of bimetal suitable for high-temperature service.

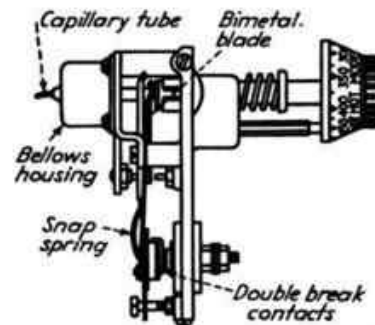

FIG. 519.—For electric ranges, the Wilcolator thermostat has the same bellows unit as is used on the gas-type control. But, instead of a throttling action, the thermostat opens and closes the electrical contacts with a snap action. To obtain sufficient force for the snap action, the control requires a temperature difference between "on" and "off" positions. For a control range from room temperature to 550°F., the differential in this device is plus or minus 10°F.; with a smaller control range, the differential is proportionately less. The snap-action switch is made of beryllium copper, giving high strength, better snap action, and longer life than obtainable with phosphor bronze, and because of its corrosion resistance the beryllium-copper blade requires no protective finish.

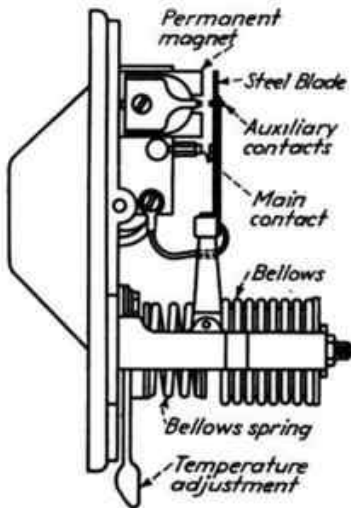

FIG. 520.

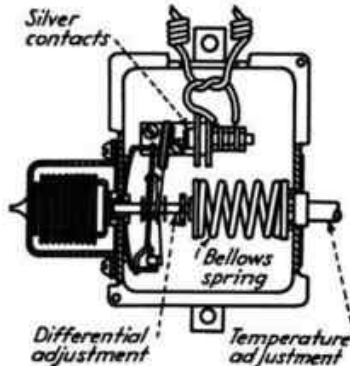

FIG. 521.

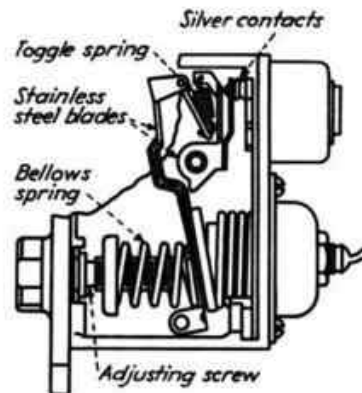

FIG. 522.

FIG. 520.—For heavy-duty room-temperature controls, the Penn thermostat uses a bellows mechanism that develops a high force with small changes in temperature. The bellows is partly filled with liquid butane, which at room temperatures is a gas having a large change in vapor pressure for small temperature differentials. Snap action of the electrical contact is obtained from a small permanent magnet that pulls the steel contact blade into firm contact when the bellows cools. Because of the firm contact, the device is rated at 20 amp. for noninductive loads. To avoid chattering or bounce under the impact delivered by the rapid magnetic closing action, small auxiliary contacts are carried on light spring blades. With the large force developed by the bellows, a temperature differential of only 2°F. is obtained.

FIG. 521.—Snap action in the Tagliabue refrigerator control is obtained from a bowed flat spring. The silver contacts carried on an extended end of the spring open or close rapidly when movement of the bellows actuates the spring. With this snap action, the contacts can control an alternating-current motor as large as 1½ hp. without the use of auxiliary relays. Temperature differential is adjusted by changing the spacing between two collars on the bellows shaft passing through the contact spring. For temperatures used in freezing ice, the bellows system is partly filled with butane.

FIG. 522.—In the General Electric refrigerator control, the necessary snap action is obtained from a toggle spring supported from a long arm moved by the bellows. With this type of toggle action, the contact pressure is a maximum at the instant the contacts start to open. Thermostatic action is obtained from a vapor-filled system using sulphur dioxide for usual refrigerating service or methyl chloride where lower temperatures are required. To reduce friction, the bellows makes point contact with the bellows cup. Operating temperature is adjusted by changing the initial compression in the bellows spring. For resistance to corrosion, levers and blades are stainless steel with bronze pin bearings.

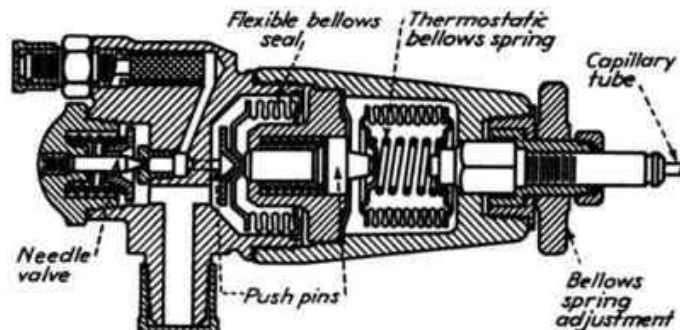

FIG. 523.—Two bellows units are used in the Fedders thermostatic expansion valve for controlling large refrigeration systems. A removable power bellows unit is operated by vapor pressure in a bulb attached to the evaporator output line. The second bellows serves as a flexible, gastight seal for the gas valve. A stainless steel spring holds the valve closed until opened by pressure transmitted from the thermostatic bellows through a molded push pin.

AUTOMATIC STOPS

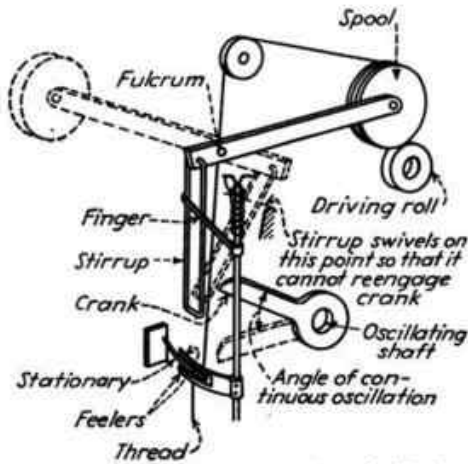

FIG. 524.—A mechanism used on the Barber-Colman spooler. When the thread breaks, the feelers are released and the spiral spring causes the spindle with finger to rotate. The latter throws the stirrup into the path of the oscillating crank, which on its downward stroke throws the spool into the position shown dotted, the stirrup then being thrown out of the path of the oscillating crank.

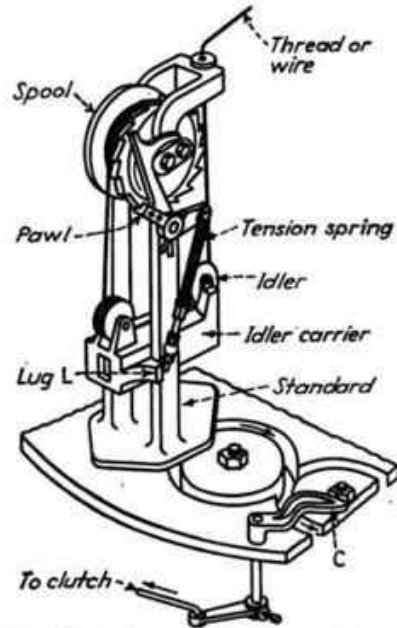

FIG. 525.—Mechanism used with variations on tubular braiding machines. When braiding, tension on the wire or thread lifts the idler carrier which thereby releases the pawl from the ratchet on spool flange and allows the spool to turn and unwind. When the machine stops, the tension on wire is decreased, allowing the idler carrier to fall so that the pawl can engage the ratchet. If the wire breaks while the machine is running, the unsupported idler carrier falls to the base of the standard, and when the standard arrives at the station in the raceway adjacent to the cam C, the lug L on idler carrier strikes the cam C, rotating it far enough to disengage a clutch on the driving shaft, thereby stopping the machine.

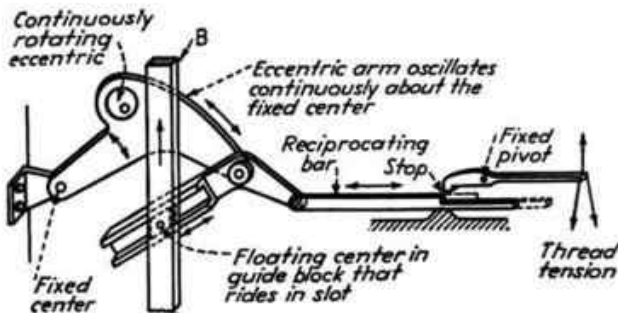

FIG. 526.—When the thread breaks, the stop drops and intercepts reciprocating bar. On the next counterclockwise oscillation of the eccentric arm, the bar B is raised. A feature of this design is that it permits the arm B to move up or down independently for a limited distance.

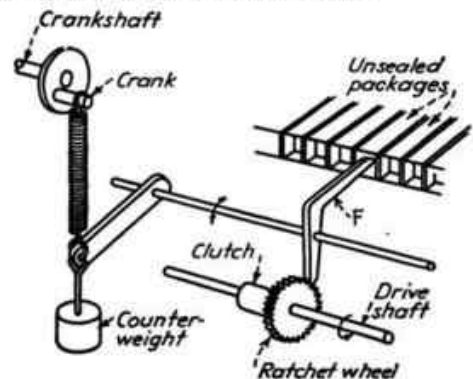

FIG. 527.—Arrangement used on some package-loading machines to stop the machine if a package should pass the loading station without receiving an insert. Pawl finger F has a rocking motion obtained from crankshaft, timed so that it enters the unsealed packages and is stopped against the contents. If the box is not filled, the finger enters a considerable distance and the pawl end at the bottom engages and holds a ratchet wheel on the driving clutch, which disengages the machine driving shaft.

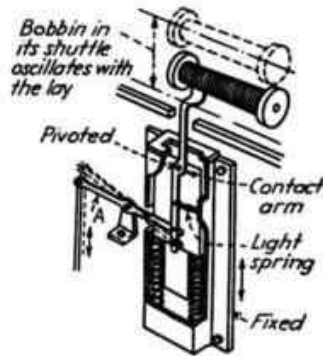

FIG. 528.—Schematic diagram of mechanism to cause bobbin changer to operate. If the contact arm does not slip on the bobbin, the lever *A* will rotate to the position shown. But if contact with the bobbin center slips, as it will do if the bobbin is empty, lever *A* will not rotate to the position indicated by the dashed line, thereby causing the bobbin changer to come into action.

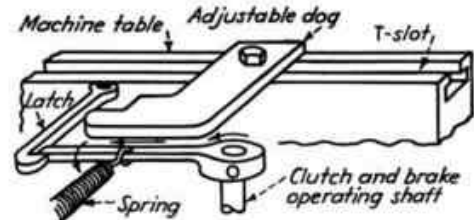

FIG. 529.—Simple type of stop mechanism for limiting the stroke of a reciprocating machine member. Arrows indicate the direction of movement.

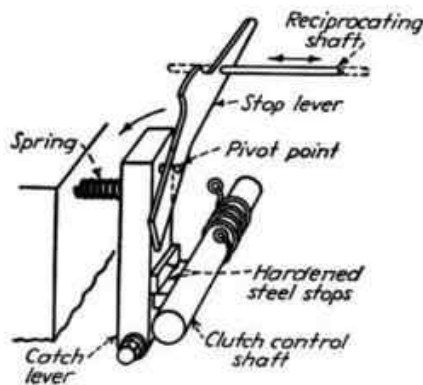

FIG. 530.—In this textile machine, any movement that will rotate the stop lever counterclockwise will bring it in the path of the continuously reciprocating shaft. This will cause the catch lever to be pushed counterclockwise and the hardened steel stop on the clutch control shaft will be freed. A spiral spring then impels the clutch-control shaft to rotate clockwise, which movement throws out the clutch and applies the brake. Initial movement of the stop lever may be caused by the breaking of a thread, a moving dog, or any other means.

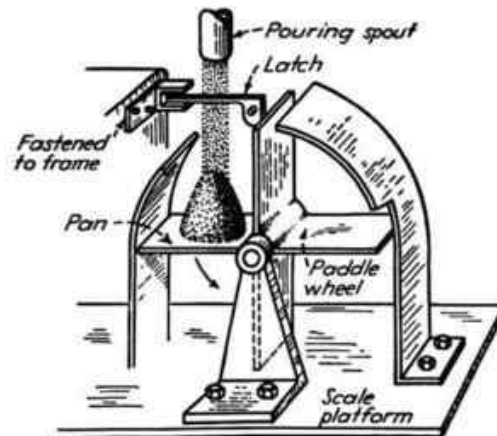

FIG. 531.—When the predetermined weight of material has been poured on the pan, the movement of the scale beam pushes the latch out of engagement, allowing the paddle wheel to rotate and thus dump the load. The scale beam drops, thereby returning the latch to the holding position and stopping the wheel when the next vane hits the latch.

THIS PAGE IS BLANK
but this is not a printing or scanning
fault and no content is missing.

CHAPTER VIII
**DESIGN DATA ON PRODUCTION
METHODS**

	PAGE		PAGE
Fusion Welding.....	252	Permanent Mold Casting.....	267
Resistance Welding.....	259	Die-casting.....	268
Furnace Brazing.....	264	Forging.....	270
Flame Hardening.....	266	Flame Cutting.....	275
Centrifugal Casting.....	267	Powdered Metal Pressings.....	276

BUILT-UP WELDED CONSTRUCTIONS

The details illustrated, taken from designs for sanitary and chemical processing equipment, represent utilization of diversified metal-working equipment—bending rolls, power presses, flangers and such—to fabricate functionally correct parts from simple sheet and fittings. Commercial shapes are used where practical; but parts are flame cut, forged, or rolled when such fabrication is more economical or design requirements dictate.

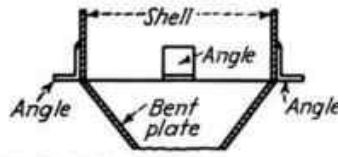
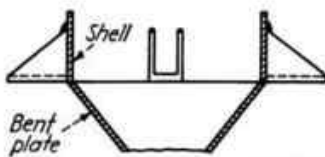
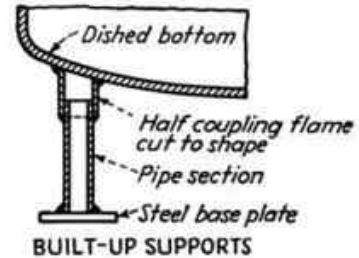
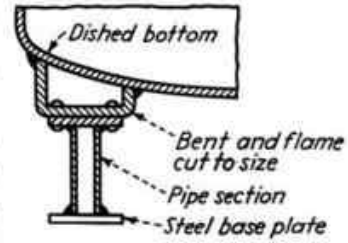

LIGHT TANK SUPPORTS

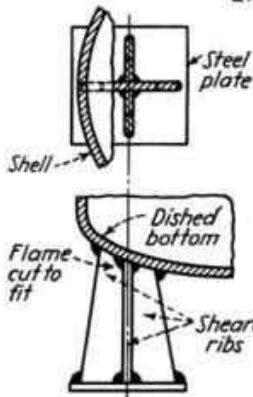

TANK SUPPORT

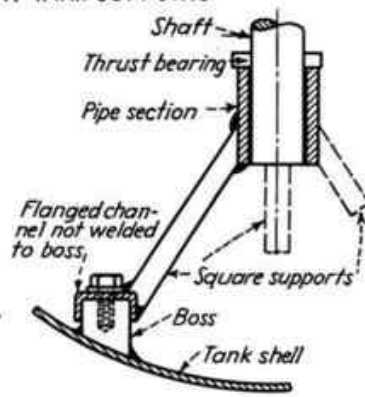

SHAFT SUPPORT

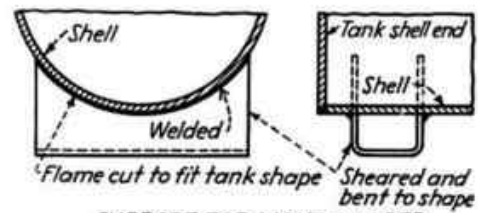

SUPPORT FOR LIGHT-LOADED LARGE DIAMETER TANKS

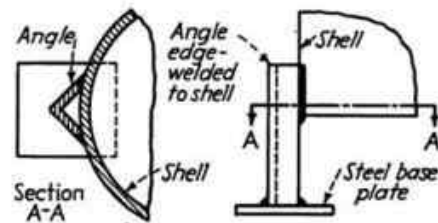

SIMPLE SUPPORT FOR CIRCULAR OR SQUARE TANKS



EDGE REINFORCEMENTS

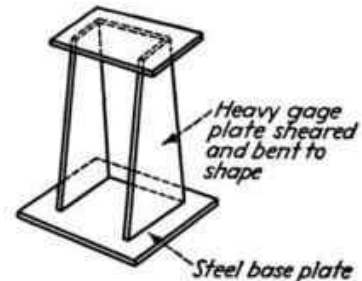

SIMPLE TANK SUPPORT

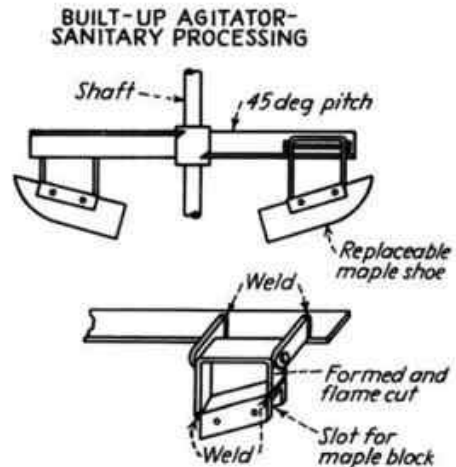
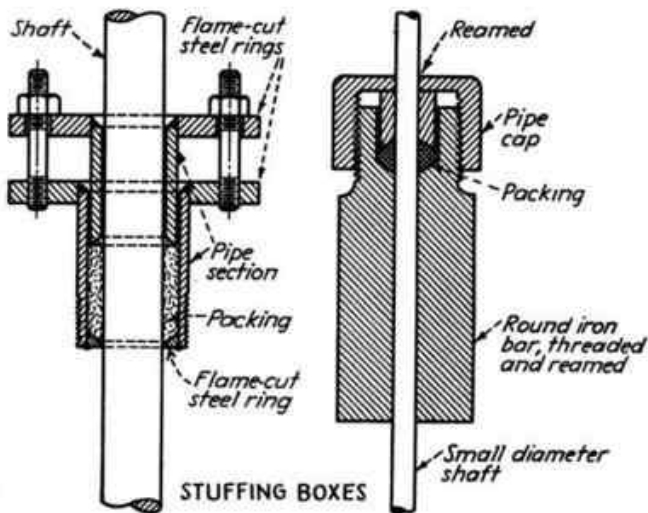
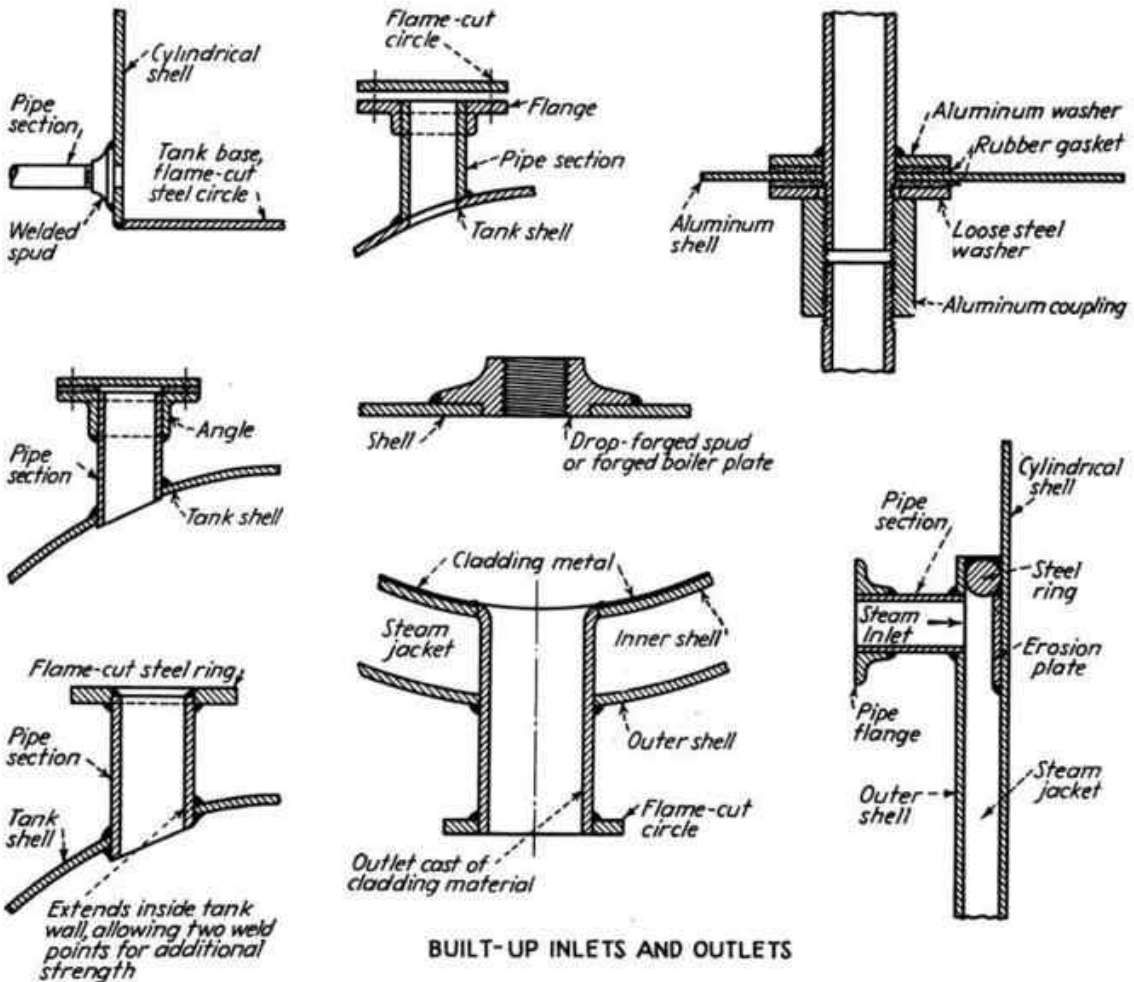

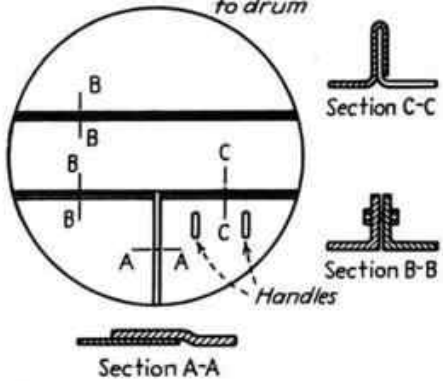
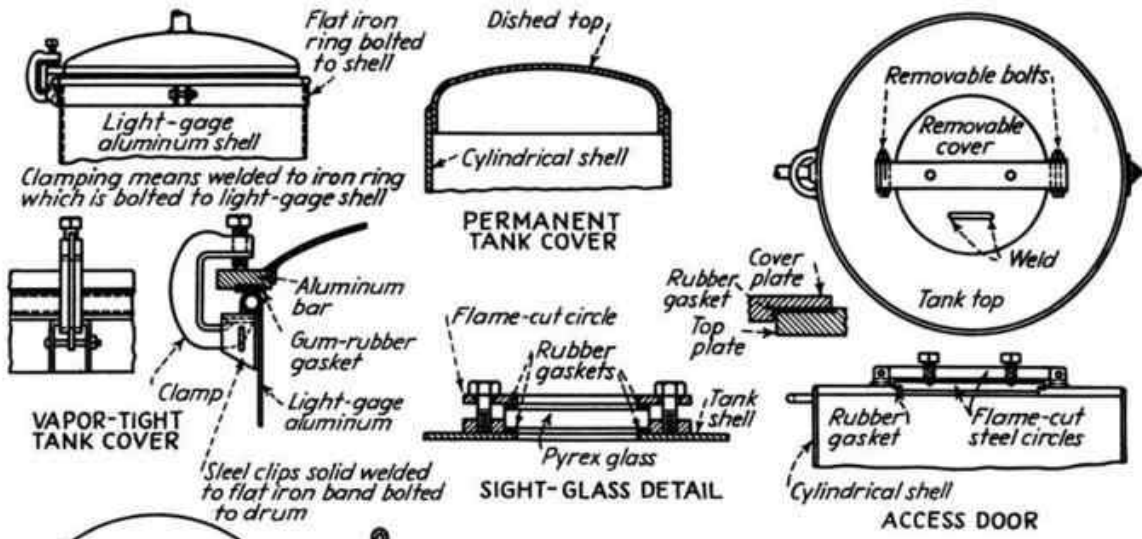

FOUR-SEGMENT DEMOUNTABLE TANK COVER

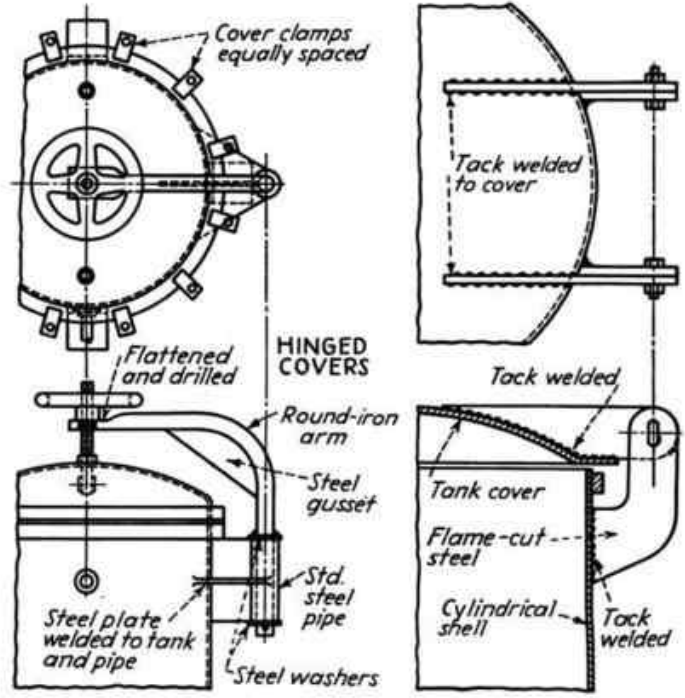
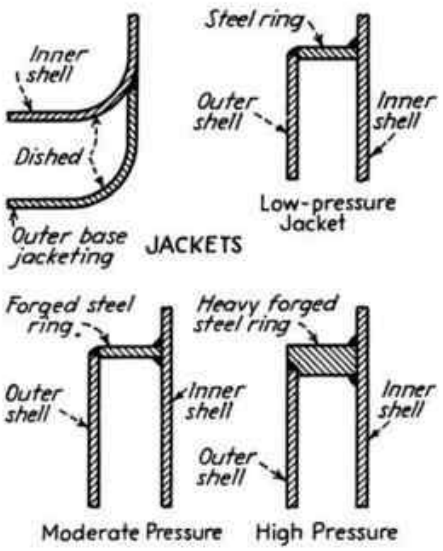
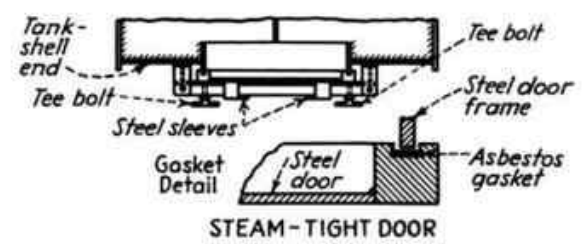

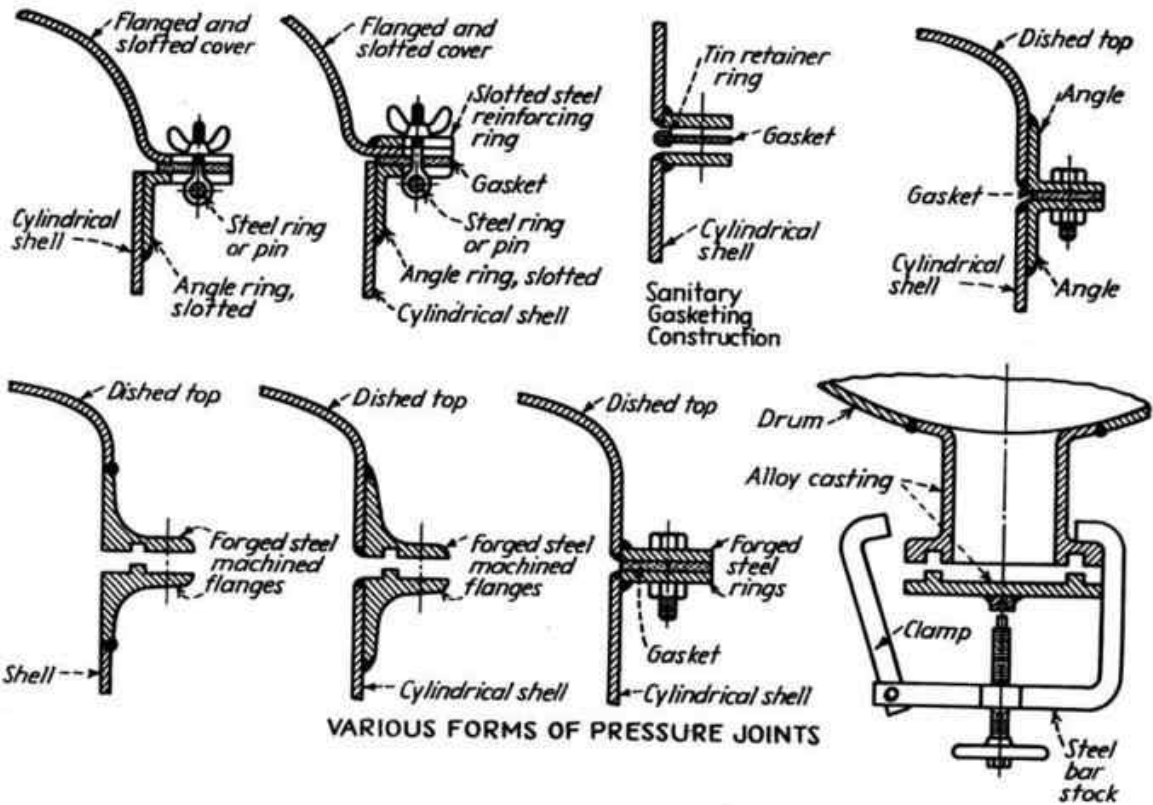

VARIOUS FORMS OF PRESSURE JOINTS

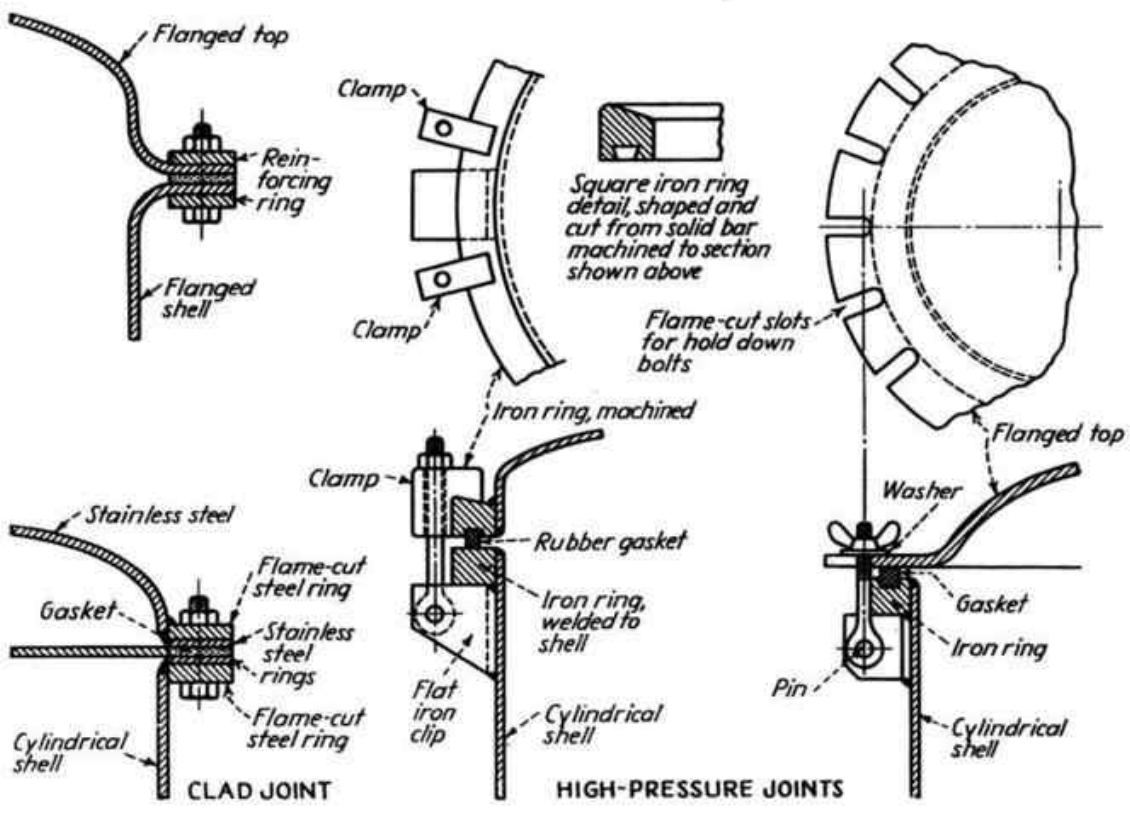

HIGH-PRESSURE JOINTS

WELDING S.A.E. 4340 STEEL

By welding, quenching, and tempering after gas welding, S.A.E. 4340 tubes can be butt-welded to give a tensile strength of more than 180,000 lb. per sq. in. with a Rockwell hardness of C 46. It is considered that a minimum tensile strength of 125,000 lb. per sq. in. can be safely specified for parts made by gas welding S.A.E. 4340 steel tubes and normalizing.

As shown in the accompanying table, butt-welded specimens of S.A.E. 4340 tubes can be heat-treated to develop a maximum tensile strength of 217,000 lb. per sq. in. as compared with a maximum tensile strength of 252,800 lb. per sq. in. for the unwelded tube. The gas-welding characteristics of this material are equal to or better than those of S.A.E. 4130 steel tubes.

RESULTS OF TENSION TESTS,
BUTT-WELDED 4340 STEEL TUBES
2¼ in. O.D. × 0.125-in. wall

Specimen No.	Tensile strength, lb. per sq. in.	Rockwell hardness, (base metal)
As Welded		
1	128,300	C 36.0
2	136,000	C 36.5
3	131,200	C 36.0
4	135,500	C 36.5
5	139,900	C 36.5
6	145,500	C 37.5
Average.....	136,000	C 36.5
Welded and Normalized		
7	135,000	C 40.5
8	125,700	C 36.5
9	130,800	C 42.5
10	133,900	C 38.0
11	134,800	C 43.5
12	137,500	C 38.5
Average.....	132,900	C 40.0
Welded, Quenched, and Tempered		
13	175,000	C 45.0
14	171,000	C 46.5
15	182,000	C 46.0
16	167,000	C 46.0
17	199,000	C 46.0
18	204,000	C 47.0
Average.....	183,000	C 46.0

Notes: Longitudinal bead welded on specimens 7 and 8. All specimens broke in the weld.

RESULTS OF TENSION TESTS,
BUTT-WELDED 4340 STEEL TUBES
1¾ in. O.D. × 0.65-in. wall

Specimen No.	Condition	Tensile strength, lb. per sq. in.	Rockwell hardness (base metal)
19 } 20 }	Annealed and welded	99,000	B 91.0
		98,700	B 91.5
Average.....		98,850	B 91.3
21 } 22 }	Welded "as received"	122,300	C 38.0
		138,700	C 38.0
Average.....		130,500	C 38.0
23 } 24 }	Welded "as received" and normalized	124,000	C 39.0
		134,000	C 37.0
Average.....		129,000	C 38.0
25 } 26 }	Welded "as received," oil quenched 1525°F., tempered 400°F.	217,000	C 51.0
		211,500	C 51.0
Average.....		214,250	C 51.0

Note: All specimens except 19 and 20 broke in or adjacent to the weld.

ARC WELDING THIN SHEETS

Uniformly good arc welds in sheets less than 0.050 in. (18 gage) thick can be made with generator-type welders with a minimum setting of 10 to 15 amp. with stable operation at 20 amp. and higher. Stainless steel and Monel exhaust stacks and manifolds for aircraft, which are of comparatively thin gage, are being fabricated by this method. Results of tests on two aircraft materials, S.A.E. 1025 and 4130, are shown in the following tables.

RESULTS OF TESTS ON WELDED THIN TUBES

Specimen	Material	Thickness	Current	Electrode diameter, in.	Failure*	Average unit tensile stress
Tubing (1 in. diameter).....	1025	0.035	18	$\frac{3}{64}$	O	81,950
		0.049	27	$\frac{1}{16}$	O	80,600
		0.065	32	$\frac{1}{16}$	I	75,200
	4130	0.035	18	$\frac{3}{64}$	I	94,250
		0.049	26	$\frac{1}{16}$	I	104,900
		0.065	32	$\frac{1}{16}$	I	82,600
Sheet..... (Specimen $\frac{3}{4}$ in. wide)	1025	0.187	73	$\frac{1}{8}$	I	57,260
	4130	0.035	23	$\frac{1}{16}$	O	113,500
		0.049	29	$\frac{1}{16}$	I	103,430
		0.187	65	$\frac{3}{32}$	I	57,260

* I, in weld; O, outside weld.

ROD SIZE AND AMPERAGE FOR WELDING THIN-GAGE MATERIAL
(Approximate)

Electrode diameter, in.	Welding current, amp.	Gage of material
$\frac{1}{32}$	5-10	32-26
$\frac{3}{64}$	10-20	26-20
$\frac{1}{16}$	20-40	20-14
$\frac{3}{32}$	40-60	14-10
$\frac{1}{8}$	60-75	10- $\frac{1}{4}$ in.

MINIMUM TENSILE STRENGTH OF WELDS FOR WELDER QUALIFICATION TESTS
(Air Corps Spec. 20013-B)

Carbon content of filler rod	Carbon-steel base metal	Alloy-steel base metal
Up to 0.06.....	45,000	55,000
0.07-0.12.....	50,000	65,000
Over 0.12.....	55,000	70,000

Tubular Section Formed of Thin-gage Stainless Steel.

A. Operations when plaster die formed parts are used:

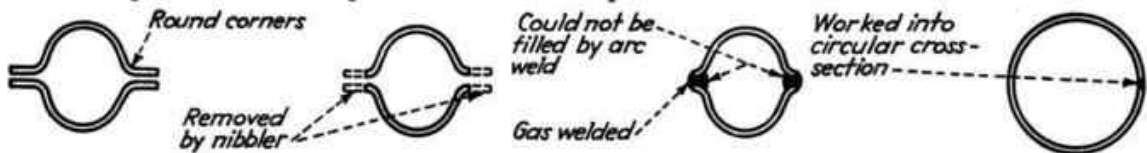

B. Operations when steel or hard aluminum-bronze dies are used:



By using metal dies, sharper corners can be formed and nibbling operation eliminated. By shearing off excess material, section can be arc welded in less time.

FUSION WELDING CHARACTERISTICS OF ALUMINUM ALLOYS

FIG. A.—Preparation of joints for torch welds.

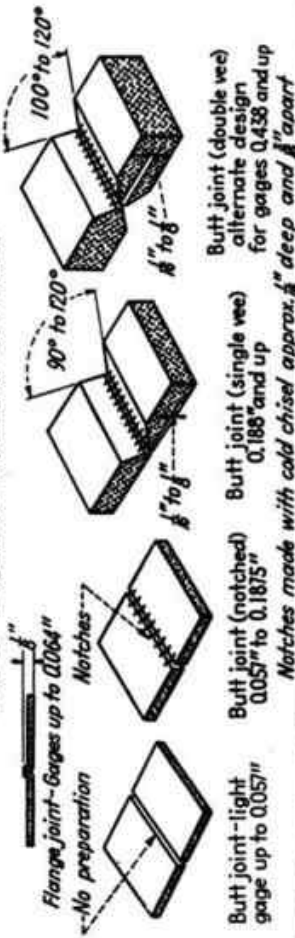

FIG. B.—Preparation of joints for arc welding.



Wrought alloys		Casting alloys	
Nonheat-treatable		Heat-treatable	
2A	3S	53S	61S
		Ale.	Ale.
		17S	24S
		43	214
		13214	406
			356

Gas welding with oxygen-acetylene or oxygen-hydrogen with No. 22 flux

1. Weldability.....	Good	Good	Good	Good	Poor	Poor	Good	Fair
2. Thickness weldable.....	Practical minimum 0.030 in.; maximum 1 in.							
3. Weld wire.....	2S	2S	43S	43S	43	43
4. Joint preparation.....	See Fig. A							
5. Max. preheat temperature.....	750	750	400	400	750	750
6. Finishing welds.....	Hammer	Hammer	Grind	Grind	Grind	Grind

Metallic arc welding with No. 43 flux-coated electrodes; for sheets 12 gage and thicker

1. Weldability.....	Good	Good	Good	Good	Poor	Poor	Good	Good
2. Joint preparation.....	None up to 1/4-in. sheet; see Fig. B							

Carbon arc with thin coat of No. 25 flux thoroughly dried on rods; for sheets 20 to 14 gage

1. Weldability.....	Good	Good	Good	Good	Poor	Poor	No applications have been made	
2. Type of joint.....	Well adapted to butt and simple lap joints							
3. Filler wire.....	2S	2S	43S	43S		
4. Maximum preheat temperature.....	400	400	400	400		
5. Joint preparation.....	None up to 1/8 in. (maximum for manual application)							

Atomic hydrogen with No. 22 flux; for sheets 0.040 in. and thicker

1. Weldability.....	Good	Good	Good	Good	Poor	Poor	Good	Good
2. Filler wire.....	2S	2S	43S	43S	43S	43S
3. Joint preparation.....	Same as for torch welding, see Fig. A							
4. Maximum preheat temperature.....	750	750	400	400	750	750

METALS THAT CAN BE RESISTANCE WELDED

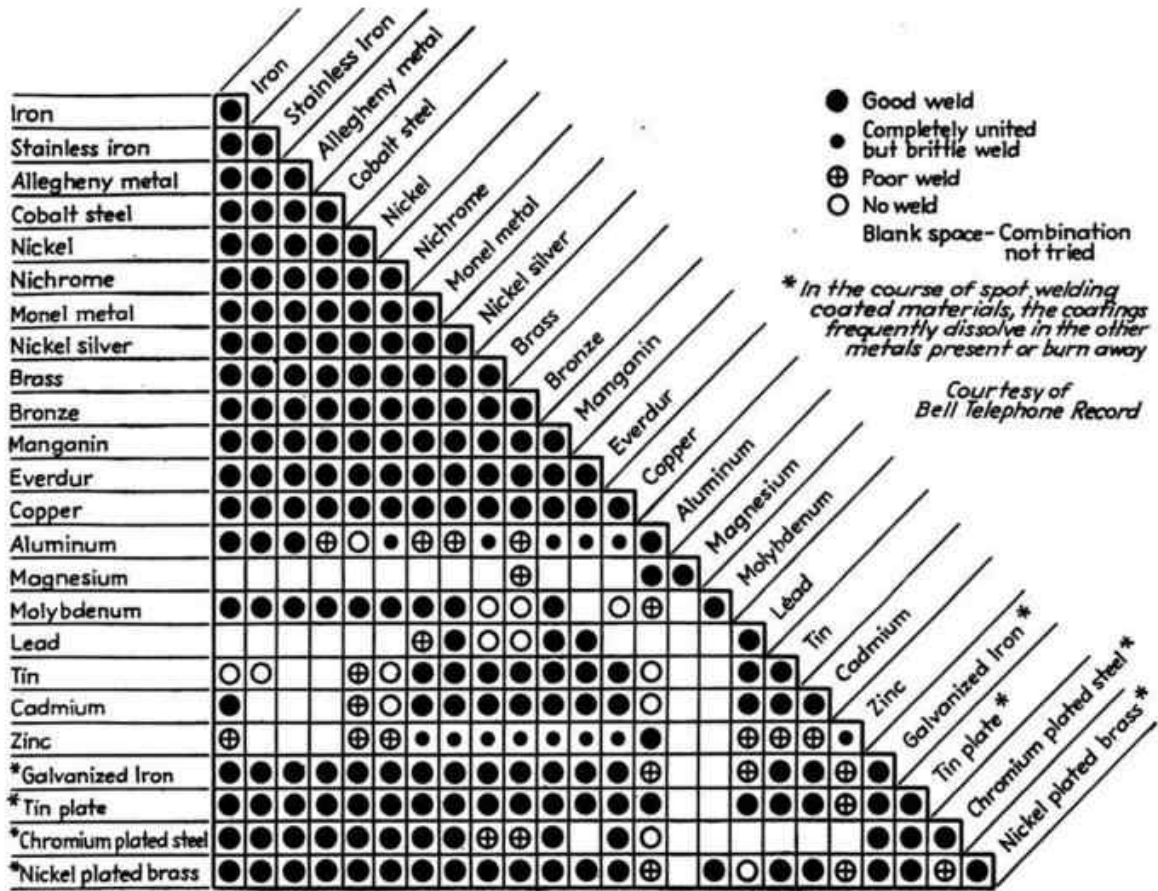

RESISTANCE WELDABILITY OF ALUMINUM ALLOYS

	Nonheat-treatable alloys				Heat-treatable alloys				Casting alloys		Remarks
	2S	3S	52S	61S	Alclad 17S	Alclad 24S	43	47			
1. Weldability.....	Good	Good	Fair	Good	Fair	Fair	Fair	Good		Hard tempers preferred to full annealed tempers. Permanent mold castings	
2. Thickness weldable, in.....	0.003-0.187	0.003-0.187	0.010-0.187	0.010-0.187	0.010-0.102 (see Note)	0.010-0.081	0.030-0.125	0.050-0.125		"Fair" welds subject to porosity, and cracks unless close control is exercised over all factors	
3. Maximum difference in thickness in two-ply joint in number of B & S gage numbers.....	8	8	8	8	6	6	6	6		Capacity of equipment may further limit thickness. Note: Brittle welds in greater thickness	
4. Number of plys that can be welded simultaneously.....	2-4	2-4	2-4	2-4	2-3	2-3	2	2		Larger difference permitted if domed tip is used against thinner member	
5. Suggested type of equipment.....	A.c.	A.c.	Inductance or condenser or a.c.	Inductance or condenser or a.c.	Inductance or condenser or a.c.	Inductance or condenser or a.c.	A.c.	A.c.		Depends somewhat on thickness and arrangement of plys	
6. Maximum variation in welding current, per cent.....	±5	±5	±5	±5	±2½	±2½	±5	±5			
7. Maximum variation in welding pressure, per cent.....	±5	±5	±5	±5	±2½	±2½	±5	±5			
8. Time control, for a.c. welding only.....	Contact- or ±1 cycle	Contact- or ±1 cycle	Contact- or ±1 cycle	Contact- or ±1 cycle	Syn-chronous control -0, +1 cycle	Syn-chronous control -0, +1 cycle	Contact- or ±1 cycle	Contact- or ±1 cycle		Better results with synchronous control of welding time	
9. Welding electrode material, R.W.M.A. specifications.....	Group A, Class 1	Group A, Class 1	Group A, Class 1	Group A, Class 1	Group A, Class 1	Group A, Class 1	Group A, Class 1	Group A, Class 1		Group A, Class 2, or Class 3 sometimes used to increase penetration of weld toward that electrode	
10. Recommended cleaning procedure for material to be welded.....	Remove oil and dirt	Remove oil and dirt	Cleaning method 1, 2, 3, or 4	Cleaning method 1, 2, 3, or 4	Cleaning method 1, 2, 3, or 4	Cleaning method 1, 2, 3, or 4	Remove flash and burrs	Remove flash and burrs		Cleaning by method 1, 2, 3, or 4 always produces sounder and more consistent welds	
11. Cleaning procedure after welding.....	None required	None required		Where invisible welds are required, spots must be sanded or rubbed with steel wool	
12. Cleaning of electrodes required after.....	10-40 welds	15-60 welds	8-30 welds	10-40 welds	10-40 welds	10-40 welds	8-15 welds	10-20 welds		Varies with different welding machines. Inductance or condenser welders will produce from three to ten times the number of welds before cleaning of electrodes is required	

FOUR SURFACE PREPARATIONS FOR SPOT WELDING ALUMINUM**Method I.**

1. Dip parts in 50 per cent HNO₃ cold for 15 sec.*
2. Rinse in cold water.*
3. Dip parts in 5 per cent NaOH + 4 per cent NaF at 160°F. for 30 sec.
4. Rinse in cold water.
5. Dip parts in 50 per cent HNO₃ cold for 15 to 30 sec. to remove black deposit from step 3.
6. Rinse in cold water.†
7. Rinse in boiling water.‡
8. Dry parts on steam coils or in sawdust.

Method II.

1. Dip parts in 50 per cent HNO₃ cold for 15 sec.*
2. Rinse in cold water.*
3. Dip parts in 10 per cent NaOH at 160°F. for 30 sec.
4. Rinse in cold water.
5. Dip parts in 50 per cent HNO₃ cold for 15 to 30 sec. to remove black deposit from step 3.
6. Rinse in cold water.†
7. Rinse in boiling water.‡
8. Dry parts on steam coil or in sawdust.

Method III.

1. Paint area to be welded with gum tragacanth HF acid paste and leave on for 30 sec.
2. Wash paste off with running cold water or with wet rags.
3. Dry off water with dry rags.

Gum tragacanth paste is prepared from:

3 lb. gum tragacanth
10 gal. hot water

Dissolve gum tragacanth in hot water, add one gallon of alcohol to water if necessary to dissolve gum tragacanth.

Add 10 lb. hydrofluoric acid to above solution.

Material must be stored in paraffin-lined containers.

Operators must wear rubber gloves and goggles to use this material. In partially assembled parts precautions should be taken to keep acid out of joint.

Method IV.

Area to be spot welded may be cleaned by mechanical means.

- a. Rub with steel wool.
- b. Rub with fine emery cloth.
- c. Use fine wire brush.

* Omit steps 1 and 2 for material relatively free from oil.

† Repeat steps 3 to 6 for material having very heavy heat-treating film not removed in steps 1 to 6.

‡ Final hot water should be thoroughly free of dissolved salts and of organic matter which would tend to stain the freshly cleaned parts.

PREPARATION OF MATERIALS FOR RESISTANCE WELDING



FIG. 532.

FIG. 533.

FIG. 534.

FIG. 535.

FIG. 532.—Round, embossed projections allow the use of flat electrodes. Several projection welds can be made simultaneously.

FIG. 533.—Pointed or cone-shaped projections are often used on light-gage materials, such as 22 and 24 gage.

FIG. 534.—Protruding punch out may help to locate parts preparatory to welding. Where great strength is not required, the punch out itself is sometimes electroforged down.

FIG. 535.—Prick punch marks made with round punch (one blow) used in welding thick plates to light-gage sheets to throw up a crater which localizes welding heat and pressure.

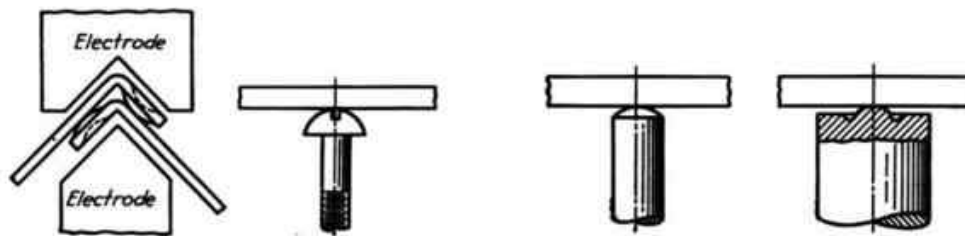

FIG. 536.

FIG. 537.

FIG. 538.

FIG. 539.

FIG. 536.—Design of embossed corners, formed over one another and welded between V-shaped electrodes.

FIG. 537.—Almost any form of screw, rivet, or specially headed part can be projection welded.

FIG. 538.—Slight radius on the end of the rod permits it to be welded to another part without throwing a fin or flash.

FIG. 539.—The crater or ringlike cavity is filled with the heated metal of the round projection, resulting in close mechanical contact over the whole surface.

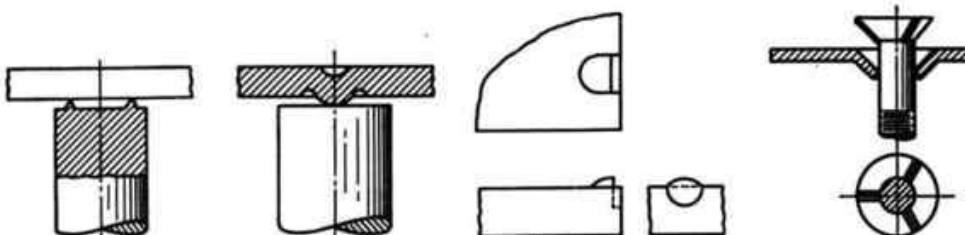

FIG. 540.

FIG. 541.

FIG. 542.

FIG. 543.

FIG. 540.—A ring projection can be turned or coined on the shaft in order to localize the welding area.

FIG. 541.—Similar to Fig. 539, except reversed.

FIG. 542.—Projection swaged on the edges of a piece, a method of embossing thick plates or strap stock.

FIG. 543.—Specially headed screws or studs prepared both to localize weld and to locate the screws without the necessity of using jigs or fixtures.

PREPARATION OF MATERIALS FOR RESISTANCE WELDING

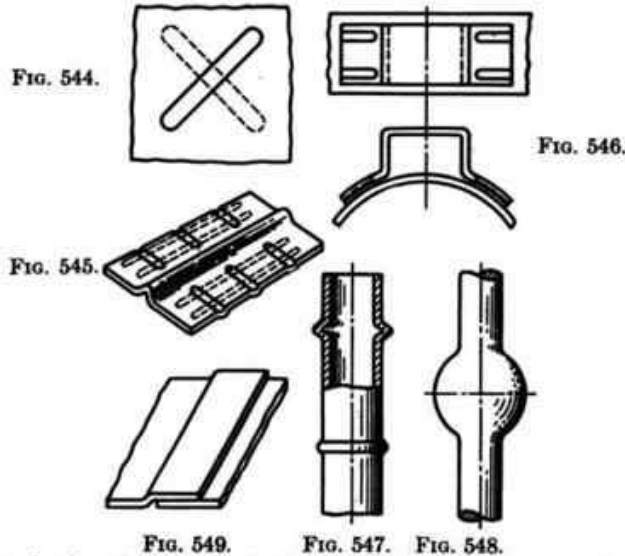

FIG. 544.—Elongated projections that cross each other are for the lightest gages and certain nonferrous combinations and where a good strong weld is imperative.

FIG. 545.—Elongated projections or a pattern of ribs that cross one another gives many points of small welded area. Should be used for thin sheet metal.

FIG. 546.—Elongated projection for welding to a curved surface. This assures ample contact surface in the direction in which movement is likely to occur.

FIG. 547.—Upsetting a tube to form bulges can be done by heating and upsetting on a butt welder.

FIG. 548.—Rods of almost any metal can be upset to provide increased sections or limiting rings.

FIG. 549.—Offsetting helps to locate the lap joint and also contributes to having one side smooth.

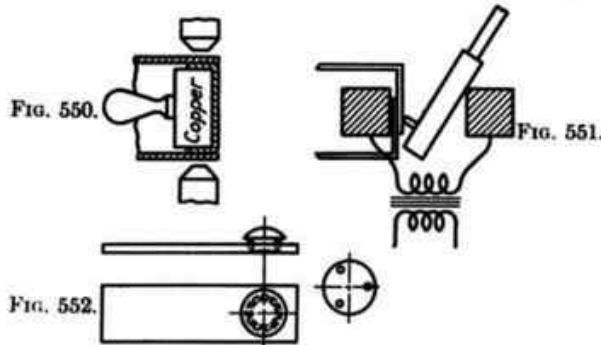

FIG. 550.—Welding both sides of a box form simultaneously, by employing a shunt-block device.

FIG. 551.—An example of "pry-bar" welding. Done by prying against parts backed up by dies.

FIG. 552.—Coined switch contacts having three conical projections that nest in a ring groove stamped in the blade.

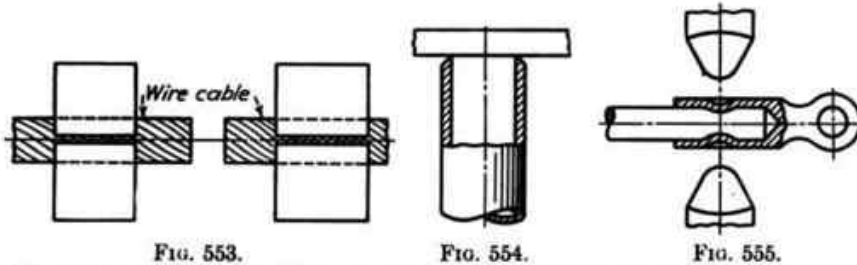

FIG. 553.—When wire cables are "cut" by clamping between the jaws of a welder and burning the cable in two, a globule of metal, formed on the ends, holds the wires together.

FIG. 554.—Pipe or heavy-walled tubes can be butted together or to other pieces. Chamfering the pipe ends keeps flash at a minimum.

FIG. 555.—Rods or cables can be economically welded into sleeves or ferrules.

FURNACE BRAZING

STRENGTH OF COPPER-BRAZED JOINTS

Material	Shear strength, lb. per sq. in.	
	Clearance 0.003 in.	Tight press fit
Mild steel.....	22,000	29,000
Alloy steel.....	30,000	50,000

Brazing Metal.—For steel parts, copper or brass in the form of wire, paste, or powder. For inaccessible surfaces, use copper-coated steel or make a spray consisting of copper or brass powder mixed with lacquer, and thin. This mixture is sprayed or brushed on the surfaces to be brazed.

For aluminum, a special flux and brazing metal is required. For inaccessible places, the aluminum sheet can be obtained with the brazing material rolled in along the edges.

Furnace Temperature.—For brass wire or powder, 1740 to 2000°F.; for copper brazing, about 2100°F. Furnace temperature can be anything reasonably higher that will not be detrimental to the parts.

Furnace Atmosphere.—Percentage composition carbon dioxide, 5.6; hydrogen, 11.9; carbon monoxide, 10.3; methane, 0.2; nitrogen, 72.0. No oxygen.

Heating for annealing or hardening can be simultaneous with the furnace brazing. All heating operations subsequent to the furnace brazing must be at temperatures below the melting temperatures of the brazing metal used.

Fit of Part.—Light press fits are desirable. Tight fits increase the flow of the brazing material into the joint, the tighter the joint the farther the molten metal will flow. Void spots or gaps are difficult to seal because clearance is too great to permit capillary attraction drawing the molten metal into the joints.

FURNACE BRAZING CHARACTERISTICS OF ALUMINUM ALLOYS

Factors involved	Wrought alloys							Casting alloys				Heat-treatable
	Nonheat-treatable			Heat-treatable				Nonheat-treatable				
	2S	3S	52S	53S	61S	Alc. 17S	Alc. 24S	43	214	B214	406	
1. Brazability.....	Good	Good	Poor	Fair	Good	Poor	Poor	Fair	Poor	Poor	Good	Poor
2. Filler material.....	13S	43S	X-716	X-716	X-716	43S
3. Flux.....	30	30	33	33	33	30
4. Brazing temperature, deg. F.....	1160	1160	1065	1065	1040	1160
	1185	1185	1090	1090	1050	1185

Note: Thickness range for alloys listed is 0.006 to $\frac{1}{2}$ in.

Design Precautions.—The brazing metals flow by virtue of capillary attraction, but if the gap between the surfaces to be brazed is greater than about 0.005 in., the capillary attraction is destroyed. Therefore, at no point in the path of intended flow of brazing metal should the gap between the surfaces to be brazed be more than about 0.005 in. as this would stop the further penetration of the brazing metal.

DESIGNS OF JOINTS FOR BRAZING

PARTS HELD TOGETHER BY THEIR OWN WEIGHT

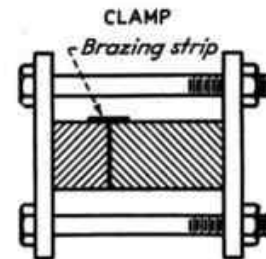
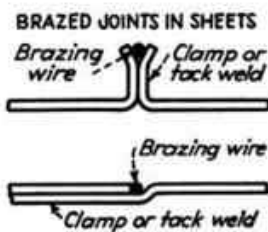
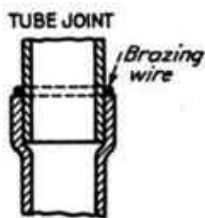
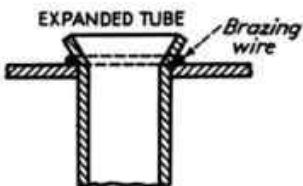
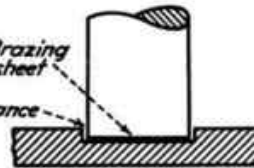
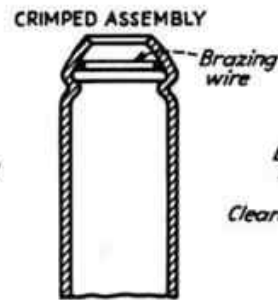
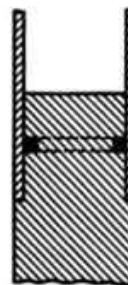
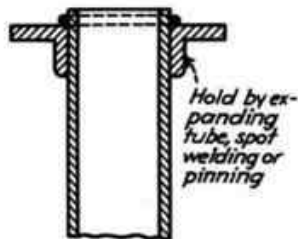
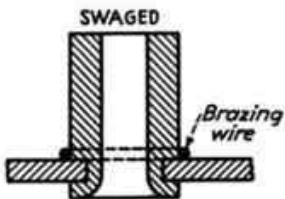
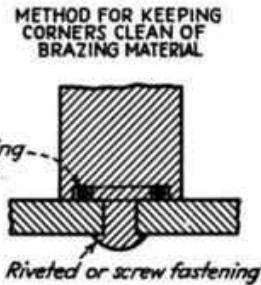
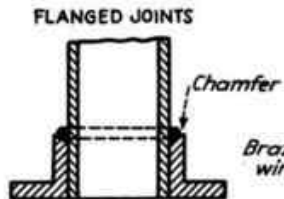
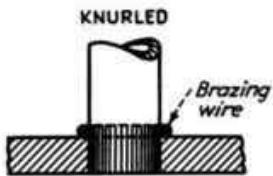
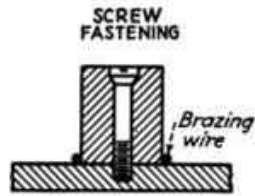
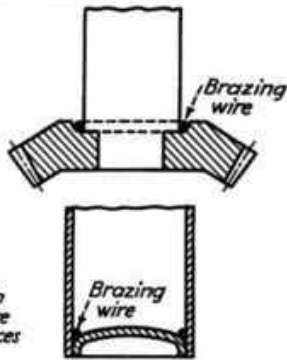
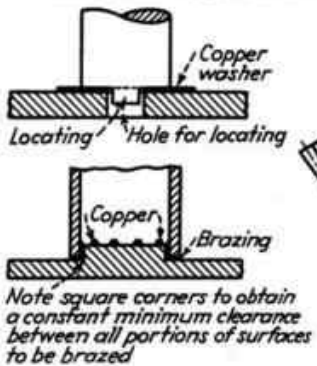

FLAME HARDENING DATA

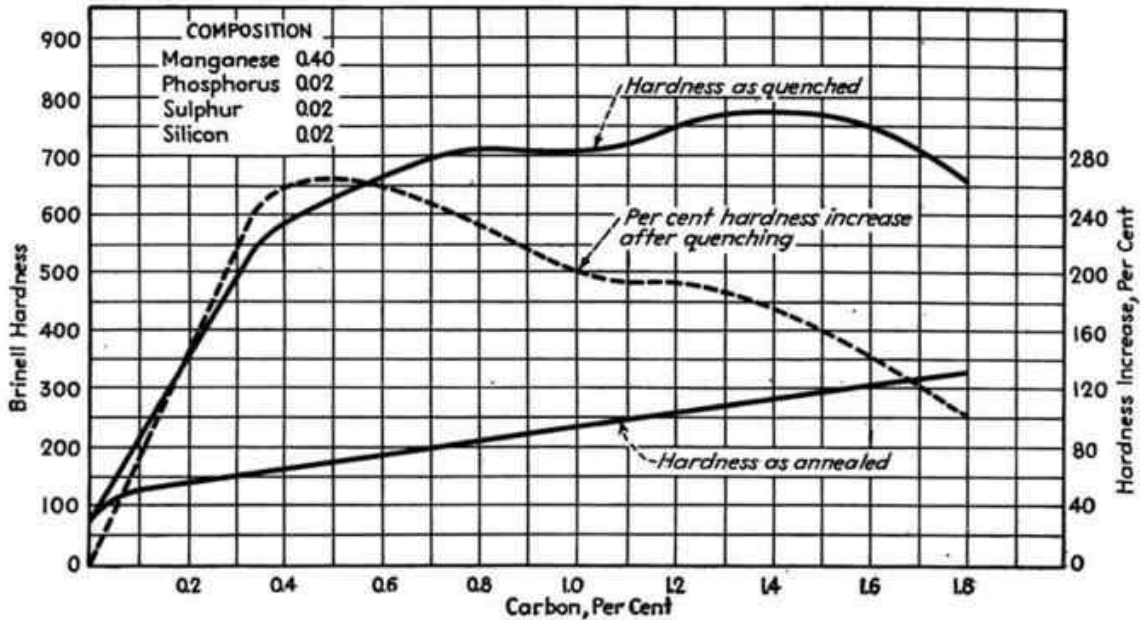

RELATION BETWEEN BRINELL HARDNESS AND CARBON CONTENT WHEN STEEL IS COOLED SLOWLY AND WHEN WATER QUENCHED

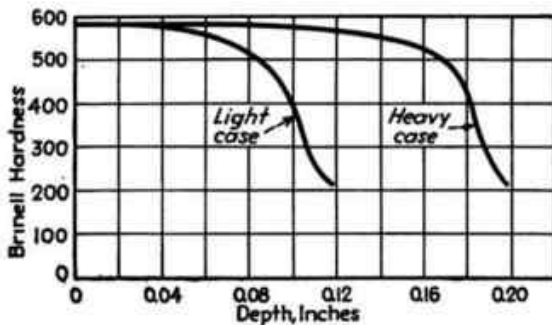

DEPTH HARDNESS CURVES OF FLAME HARDENED S.A.E. 4140 ANNEALED STEEL

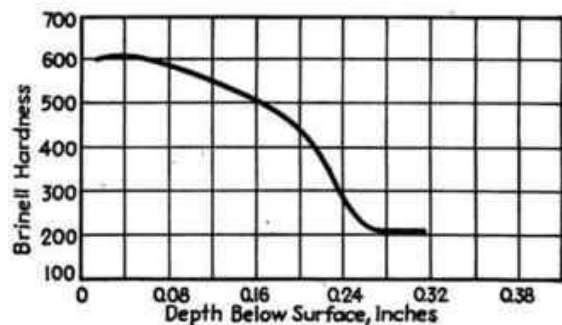

HARDNESS FROM SURFACE TO CORE OF FLAME HARDENED S.A.E. 1045 STEEL

Flame Hardening Specifications

Material.—Cast iron, malleable iron, and any alloy steels other than tool steels, with carbon content equal to S.A.E. 1040 or higher, depending on the hardness desired.

Preparation.—In order to assure freedom from surface cracking, the steel should be stress-relieved by annealing or normalizing before flame hardening.

Hardness Obtained.—Surface hardness of the case will depend on the carbon content of the steel, as shown by the accompanying curves.

Depth of Hardness.—Hardness varies with depth below the surface as shown by the curves.

Precautions.—Avoid overheating, which is one of the prime causes of surface checking and cracks.

Reference Literature.—“Flame Hardening by the Oxy-Acetylene Process,” published by the International Acetylene Association, 30 East 42nd Street, New York, N. Y.

CASTING DATA

Centrifugal Casting

Materials Suitable.—Aluminum, bronze, Monel, beryllium copper, iron, steels of various grades, stainless steel, copper, and other nonferrous materials.

Shapes.—Any combinations of cylindrical shapes such as wheels, gears, screw-down nuts, bushings with tapers, and parts with varying diameters.

Maximum Size.—Screw-down nuts, weighing approximately 3,600 lb. each, for a new continuous-type steel mill, have been centrifugally cast.

Finish Allowances.

Outside diameter, in.	Outside diameter allowance, in.	Inside diameter allowance, in.
2 or less.....	$\frac{1}{8}$	$\frac{1}{8}$
2 - $4\frac{1}{2}$	$\frac{1}{4}$	$\frac{1}{8}$
$4\frac{1}{2}$ - 6.....	$\frac{5}{16}$	$\frac{1}{8}$
6 -10.....	$\frac{3}{8}$	$\frac{1}{4}$
Over 10.....	$\frac{1}{2}$	$\frac{1}{4}$

Ford casting of both bevel and cluster gear blanks allows only $\frac{1}{32}$ to $\frac{1}{16}$ in. stock for machining.

Wall Thickness.—Practical minimum about $\frac{1}{4}$ in.

Relative Cost.—More costly in small quantities than sand castings in small quantities. However, as quantity increases to 20 or more, the cost is little if any more because of the material required for extra gates and risers in sand castings. Centrifugal mold cost is only about 15 per cent that of a comparable forging die. Generally the cost of a permanent metal die for centrifugal casting can be justified by as few as 10 or 12 pieces, although customarily such a die is not made for fewer than 25 or 30 pieces.

Typical Examples.—The bushings for Hamilton Standard propellers were formerly sand cast of beryllium copper with scrap running as high as 30 per cent. Permanent mold castings did not prove feasible. Scrap has been almost eliminated by use of aluminum bronze centrifugal castings of tapered hollow bushings.

In another case, several hundred bronze rings, about 45 in. outside diameter, and 20 in. inside diameter and 3 in. thick, originally specified as forgings were found to have satisfactory physical properties when centrifugally cast. Die costs would have been high for the comparatively few forgings required. Another gain was less time required to get delivery.

Permanent Mold Casting

Size limitations:

Largest permanent mold casting produced, 20 × 16 × 34 in., weighing more than 100 lb.

Smallest permanent mold casting produced weighed less than 1 oz.

Minimum tolerance, all dimensions:

Up to 5 in..... ±0.010 in.

Over 5 in..... Add 0.001 in. per in. of length

Undercuts:

Omit wherever possible, but, if unavoidable, they can be produced through use of collapsible metal core or, if that is impractical, by use of baked sand core.

Section thickness, minimum.....	0.085 in.
Cored holes, minimum diameter.....	0.25 in.
Draft angle, minimum.....	0.5 deg. per side
Inserts, steel or cast-iron inserts practical	
Cast threads, not practical	

Aluminum Die Casting**Size limitations:**

Maximum practical over-all dimensions..... 36 × 12 × 9 in.
(Few aluminum die castings exceed 25 in. in length)

Largest produced:

In size.....	84 × 12 × 1 in. (14 lb.)
(Die-cast dog used as trade-mark on Greyhound buses)	
By weight.....	19 lb. (12 × 19 × 20 in.)
(Die-cast cases for Leeds and Northrup instruments)	

Section thickness:

Large castings, minimum.....	0.085 to 0.10 in.
Small castings less than 6 in. length or width.....	0.050 to 0.065 in.
Avoid abrupt changes in wall thickness.	

Dimensional tolerances:

In any one dimension.....	±0.0015 in. per in.
(Frequently less by trial and error)	
Perpendicular to parting line:	
Large castings.....	-0.00 to +0.010 in.
Small castings.....	-0.00 to +0.003 in.
Between points formed by removable part and die, tolerances are the same as those across parting line.	

Cored holes:

Minimum diameter of cored holes.....	0.090 in. approx.
Length limit for through holes and blind holes:	

Diameter	Length limit	Diameter	Length limit
Under $\frac{3}{16}$ in.....	3 diameters	Over $\frac{1}{2}$ in.....	10 diameters
To $\frac{1}{2}$ in.....	6 diameters	Larger holes.....	No limit

Tolerances on through holes—small holes..... 0.001 in.

Closer tolerances on through holes must be obtained by reaming, the hole being cast 0.005 to 0.010 in. undersize.

Cores for internal threads—preferable to use threaded insert.

Draft allowances:

Outside walls, recommended.....	0.010 in./in.
Rectangular core, on each side.....	0.008 in./in.
Internal cores, in general, as in table below:	

**APPROXIMATE DIAMETER
OF HOLE**

APPROXIMATE DIAMETER OF HOLE	AMOUNT OF DRAFT
Less than $\frac{1}{8}$ in.....	0.015–0.020 in. on diameter
$\frac{1}{8}$ to 1 in.....	0.010–0.015 in. on diameter
More than 1 in.....	0.010–0.030 in. on diameter (depending on size and design)

If no draft is permissible, ream or, unless hole is shallow, use insert.

Small holes for tapping usually cast to root diameter of thread plus 15 per cent with standard draft added.

Inserts:

If strained, should be knurled on surfaces within casting.

Small pins, if subject to pull, should be both knurled and grooved.

Fillets:

Avoid sharp corners if possible.

Finishes:

Alumilite finish best on alloy 218. Colored alumilite best in darker shades. May be plated with common plating metals if desired.

Design to aid trimming:

Design part so that flashes will be in or parallel to main parting plane.

Cast threads:

Internal threads—best to cast threaded insert.

External threads—can be cast and need only light chasing to finish.

COMPARATIVE RATINGS FOR DIE CASTING ALLOYS

	Selection factor	Aluminum alloys, A.S.T.M. Nos. 5, 7, 12	Brass	Magnesium alloys, A.S.T.M. Nos. 12 and 13	Zinc alloys, A.S.T.M. Nos. 21, 23, 25
Mechanical properties	Tensile strength	3	1 (strongest)	3	2
	Impact strength	3	1 (toughest)	3	2
	Elongation	4	1 (most ductile)	3	2
	Dimensional stability	2	1 (most stable)	2	3*
	Resistance to cold flow	2	1 (most resistant)	2	3
	Brinell hardness	3	1 (hardest)	3	2
Physical constants	Electrical conductivity	1 (highest)	2	3	2
	Thermal conductivity	1 (highest)	2	4	3
	Melting point	2	1 (highest)	2	3
	Weight, per cu. in.	2	4	1 (lightest)	3
Casting characteristics	Ease, speed of casting	2	3	2	1 (easiest)
	Maximum feasible size	1 (largest feasible)	2	1 (largest feasible)	1 (largest feasible)
	Complexity of shape	1 (greatest possible)	2	1 (greatest possible)	1 (greatest possible)
	Dimensional accuracy	2	3	1	1 (most accurate)
	Minimum section thickness	2	3	2	1 (thinnest)
	Surface smoothness	2	3	2	1 (smoothest)
Cost	Die cost †	2	3	2	1 (lowest)
	Production cost	2	3	2	1 (lowest)
	Finishing cost ‡	3	2	3	1 (lowest)
	Cost per piece §	2	3	2	1 (lowest)

* Through the use of a low-temperature annealing treatment, alloy 23 can be made virtually stable in dimensions.

† Dies for casting the low melting point alloys are least expensive and have longest life.

‡ Includes polishing and buffing expense as well as ease of applying all types of commercial finishes, both electro-deposited and organic.

§ Based on die, material, and fuel costs, production speed, and machining and finishing costs.

THE DESIGN OF DROP FORGINGS

Most metal forgings are made from bar stock wherein the lines of the fibers run parallel to the axis. Best forging results are obtained when the forging pressure is applied along the axis of the bar, which will compel the metal to flow with least distortion of the fiber lines. When metal is compelled to flow in a direction perpendicular to the lines of the fiber by means of pressure applied perpendicular to the flow lines, as in raising a boss on a flat plate, the metal will not be as strong, especially in its resistance to impact loads. An even worse condition is created when the metal is compelled to flow at an angle to the direction across the grain.

The accompanying figures illustrate flow conditions in forging bars or plates.

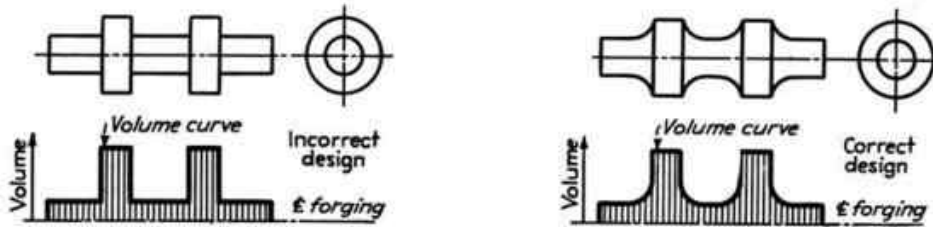
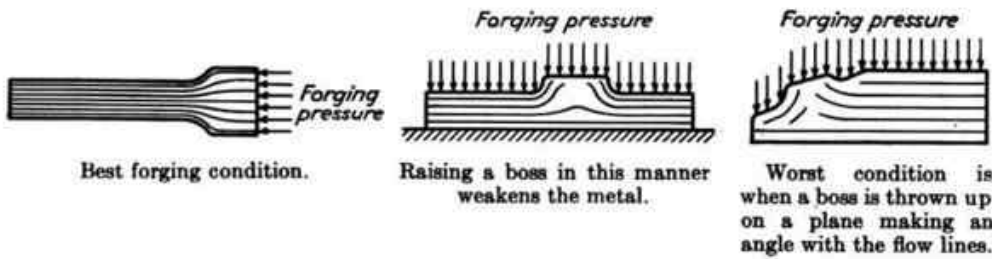

To assure best forging conditions, a curve of volumes, such as above, should be plotted. This enables the designer to visualize quickly and accurately the flow conditions that will exist in the forging operations. Thus to the left is the volume curve obtained from a poor design as indicated by the abrupt changes in volume. To the right is shown the same design corrected so that the volume curve changes smoothly. Smooth changes in volume also indicate a design that is most economical to forge. Poor flow conditions will cause an excessive amount of flash, thereby necessitating an excessive number of forging blows, which favors the formation of cold shuts, the metal not filling the die cavity. Cracks and other defects are also likely to result if the distribution of the metal around the neutral axis is unsymmetrical.

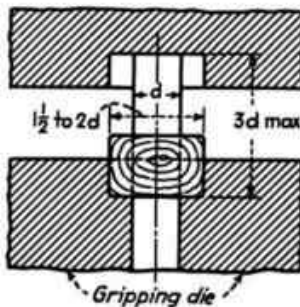

In making upset forgings, the bar stock is rough upset and is usually so proportioned that the upset ratio on the diameter will be $1\frac{1}{2}$ to 2, the length upset ratio usually 2 to $2\frac{1}{2}$, with 3 as a maximum. If it is greater than 3 diameters, the bar will usually buckle. However, length upset ratio may exceed 3 diameters, but the die and operation costs will be greatly increased.

STANDARD TOLERANCES FOR FORGINGS UNDER 100 LB. EACH*

Tolerances shall be either "special" or "regular." Special tolerances are those which are particularly noted in the specifications and may state any or all tolerances in any way as occasion may require. Special tolerances apply only to the particular dimension or thing noted. In all cases where special tolerances are not specified, regular tolerances shall apply.

Regular tolerances are divided into two divisions, "commercial standard" and "close standard." Commercial standard tolerances are for general forging practice, but when or where extra close work is desired involving additional expense and care in the production of forgings, close standard may be specified. Close standard may be specified for one or more of the following classes. When no standard is specified, commercial standard shall apply.

Classes

Regular tolerances are applicable to the following classes:

1. Thickness.
2. Width: (a) shrinkage and die wear; (b) mismatching; (c) trimmed size.
3. Draft angle.
4. Quantity.
5. Fillets and corners.

THICKNESS TOLERANCES
(Inches)

Net weights up to ___lb.	Commercial		Close	
	Minus	Plus	Minus	Plus
0.2	0.008	0.024	0.004	0.012
0.4	0.009	0.027	0.005	0.015
0.6	0.010	0.030	0.005	0.015
0.8	0.011	0.033	0.006	0.018
1	0.012	0.036	0.006	0.018
2	0.015	0.045	0.008	0.024
3	0.017	0.051	0.009	0.027
4	0.018	0.054	0.009	0.027
5	0.019	0.057	0.010	0.030
10	0.022	0.066	0.011	0.033
20	0.026	0.078	0.013	0.039
30	0.030	0.090	0.015	0.045
40	0.034	0.102	0.017	0.051
50	0.038	0.114	0.019	0.057
60	0.042	0.126	0.021	0.063
70	0.046	0.138	0.023	0.069
80	0.050	0.150	0.025	0.075
90	0.054	0.162	0.027	0.081
100	0.058	0.174	0.029	0.087

* Adopted by the Drop Forging Association, Feb. 11, 1937.

Class 1. Thickness Tolerances

Thickness tolerances shall apply to the over-all thickness of a forging. When applied to drop-hammer forgings, they shall apply to the thickness in a direction perpendicular to the main or fundamental parting plane of the die. When applied to upset forgings, they shall apply to the thickness in a direction parallel to the direction of travel of the ram, but only to such dimensions as are inclosed by the die.

Class 2. Width and Length Tolerances

Width and length tolerances shall be alike and shall apply to the width and/or length of a forging. When applied to drop-hammer forgings, they shall apply to the width or length in a direction parallel to the main or fundamental parting plane of the die, but only to such dimensions as are enclosed by and actually formed by the die. When applied to upset forgings, they shall apply to the width or length in a direction perpendicular to the direction of travel of the ram.

Width and length tolerances shall consist of three subdivisions:

- Class 2a. Shrinkage and die wear tolerance.
- Class 2b. Mismatching tolerance.
- Class 2c. Trimmed size tolerance.

Class 2a. Shrinkage and Die Wear

Shrinkage and die wear tolerances shall apply to that part of the forging formed by a single die block only. They shall not apply to any dimension crossing the parting plane. They shall be the sum of the shrinkage tolerances and the die wear tolerances as given in the following table. The shrinkage tolerances and die wear tolerances shall not be applied separately, but shall only be used as the sum of the two. They shall not be so applied as to include draft or variation thereof.

SHRINKAGE PLUS DIE WEAR
(Inches)

Lengths or widths up to__in.	Commercial, plus or minus	Close, plus or minus	Net weight up to__lb.	Commercial, plus or minus	Close, plus or minus
1	0.003	0.002	1	0.032	0.016
2	0.006	0.003	3	0.035	0.018
3	0.009	0.005	5	0.038	0.019
4	0.012	0.006	7	0.041	0.021
5	0.015	0.008	9	0.044	0.022
6	0.018	0.009	11	0.047	0.024
For each additional inch add	0.003	0.0015	For each additional 2 lb. add	0.003	0.0015
For example:			For example:		
12	0.036	0.018	21	0.062	0.031
18	0.054	0.027	31	0.077	0.039
24	0.072	0.036	41	0.092	0.046
36	0.108	0.054	51	0.107	0.054
48	0.144	0.072	71	0.137	0.069
60	0.180	0.090	91	0.167	0.084

Class 2b. Mismatching Tolerance

Mismatching is the displacement of a point in that part of a forging formed by one die block of a pair, from its desired position when located from the part of the forging formed in the other die block of the pair. Mismatching does not include any displacement caused by variation in thickness of the forging but is only the displacement in a plane parallel to the main or fundamental parting plane of the dies.

Mismatching tolerances are independent of, and in addition to, any other tolerances.

MISMATCHING TOLERANCE

Net weight up to—lb.	Inches tolerance	
	Commercial	Close
1	0.015	0.010
7	0.018	0.012
13	0.021	0.014
19	0.024	0.016
For each additional 6 lb. add	0.003	0.002
For example:		
37	0.033	0.022
55	0.042	0.028
79	0.054	0.036
97	0.063	0.042

Class 2c. Trimmed Size Tolerances

The trimmed size shall not be greater nor less than the limiting sizes at the parting plane imposed by the sum of the draft angle tolerances and the shrinkage and die wear tolerances.

Class 3. Draft Angle Tolerances

Draft angle tolerances are the permissible variations from the standard or nominal angle of draft.

DRAFT ANGLE TOLERANCES
For Drop-hammer Forgings
(Degrees)

	Nominal angle	Commercial limits	Close limits
Outside.....	7	0-10	0-8
Inside holes and depressions.....	10	0-13	
	7	0-8
For Upset Forgings			
	Nominal angle	Commercial limits	Close limits
Outside.....	3	0-5	0-4
Inside holes and depressions.....	5	0-8	0-7

Class 4. Quantity Tolerances

Quantity tolerances shall be the permissible over, or under, run allowed for each release or part shipment of an order. Any shipping quantity within the limits of over, and under, run shall be considered as completing the order. Commercial and close tolerances shall be the same amounts.

QUANTITY TOLERANCES

Number of pieces on order		Overrun pieces	Underrun pieces
1-	2	1	0
3-	5	2	1
6-	19	3	1
20-	29	4	2
30-	39	5	2
40-	49	6	3
50-	59	7	3
60-	69	8	4
70-	79	9	4
80-	99	10	5
		Per cent	Per cent
100-	199	10	5.0
200-	299	9	4.5
300-	599	8	4.0
600-	1,249	7	3.5
1,250-	2,999	6	3.0
3,000-	9,999	5	2.5
10,000-	39,999	4	2.0
40,000-	299,999	3	1.5
	300,000 up	2	1.0

Class 5. Fillet and Corner Tolerances

Fillet and corner tolerances apply to all meeting surfaces even though drawings and/or models indicate sharp corners, unless such drawings and/or models have or indicate (even though actual dimensions are not specified) fillet and/or corner dimensions of larger radii than the following standards, in which case such actual or indicated larger dimensions shall be considered as actually specified and the tolerances shall be special tolerances.

Fillet tolerances apply to inside corners and edges in all cases in which surfaces meet at an angle less than 180 deg.

Corner tolerances apply to outside corners and edges in all cases in which surfaces meet at an angle greater than 180 deg.

When a corner tolerance applies on the meeting of two drafted surfaces, the tolerance shall apply to the narrow end of such meeting and the radius will increase

toward the wide end. The total increase in the radius will equal the length of the drafted surface in inches, multiplied by the tangent of the nominal draft angle.

The radii of fillets and corners may be any value not greater than those given in the following table.

FILLET AND CORNER TOLERANCES
(Radii in Inches)

Net weights up to__lb.	Commercial	Close
0.3	$\frac{3}{32}$	$\frac{3}{64}$
1	$\frac{1}{8}$	$\frac{1}{16}$
3	$\frac{5}{32}$	$\frac{5}{64}$
10	$\frac{3}{16}$	$\frac{3}{32}$
30	$\frac{7}{32}$	$\frac{7}{64}$
100	$\frac{1}{4}$	$\frac{1}{8}$

FLAME-CUTTING DATA

Scope and Limitations

Thickness That Can Be Cut.—Any commercial thickness of steel plate and slabs up to about 12 in. thick.

Contours.—Straight lines, circles, or any irregular shapes, provided inside radii are not less than $\frac{1}{2}$ in., can be flame cut by machines.

Width of kerf, or metal removed, varies with thickness of plate as follows:

THICKNESS OF PLATE, IN.	APPROXIMATE WIDTH OF KERF, IN.
$\frac{1}{4}$ – $\frac{3}{8}$	$\frac{1}{16}$
$\frac{1}{2}$ –2	$\frac{3}{32}$
2–6	$\frac{1}{8}$
6–9	$\frac{3}{16}$
9–12	$\frac{1}{4}$

Effects of Flame Cutting

Steel containing less than 0.35 carbon can be cut without taking any special precautions. In general, steels that are satisfactory for fusion welding can be flame cut without causing any difficulties. Higher carbon steel will have a thin layer of hard steel formed on the flame cut surface. Preheating or reheating after flame cutting will prevent or eliminate the hardened surface.

Identical parts can be produced most economically by stack cutting or multiple cutting.

Cutting Speed.—Approximate cutting speeds range from 2 ft. per min. for sheets up to $\frac{1}{8}$ in. thick, to 21 in. per min. for $\frac{1}{2}$ in. thickness, 16 in. per min. for 1 in. thickness, 12 in. per min. for 2 in. thickness, to 3 in. per min. for 12 in. thickness.

Tolerances.—Squareness of cut can be held to $\frac{1}{32}$ in. for plates 6 in. thickness. This will be affected greatly by size of tip, gas pressure used, and other factors.

Reference Literature.—For a detailed discussion and data see Chap. 16, "Welding Handbook," 1938, published by the American Welding Society.

POWDERED METAL PRESSINGS

Design Factors

Formability.—Direct pressure must be applied to the entire cross section of the part when molding. The amount of pressure required to obtain a required density in the compressed compact depends upon the malleability of the metal powder used.

Powdered metal materials have almost no lateral flow in the mold in response to pressures applied axially, therefore reentrant angles cannot be molded in the compact. If reentrant angles are required at planes normal to the axis, they must be machined to shape by conventional methods.

Hot pressing may be resorted to as a means of obtaining solid, pore-free compacts. With this method, however, the operation is slow, also die and maintenance costs are higher.

Size and Shape Limitations.—Capacity of press available determines the maximum cross-sectional area that can be compacted. Pressures for compacting vary from 30 to 60 tons per sq. in.

The working stroke of the press, the compression ratio of the powder selected, and the density required all determine the length of part that can be compacted. Compression ratios range between 2 to 1 and 20 to 1 for various metal powders. Length is limited by minimum density desired because frictional losses prevent the compacting pressure from being uniformly transmitted throughout the depth of the mold.

Shapes are confined to simple contours without undercuts in surface parallel to the axis.

Dimensional Tolerances.—Possible to hold very close tolerances in cross-sectional dimensions.

Tolerances in axial dimensions must be more liberal than those in cross sections, because all the variables add up in the length of the briquette or the sintered piece.

Tolerances for concentricity depend largely upon the clearance that must be provided between the force and the mold, since this clearance is likely to be all on one side when the compacting pressure is applied. Eccentricity can be corrected by operations subsequent to sintering, such as swaging or rolling, but this means additional cost.

Physical Properties.—Tensile strengths depend upon unit pressures employed to briquette the powders, the length of heat-treatment, and the care exercised in control of powder.

With heat-treating and quenching, it is possible to produce from alloy powders, gears that have higher strength, wear, and impact resistance than case hardened low carbon steel.

Strength and density may also be improved by re-pressing or cold-working if the sintered piece is sufficiently malleable.

Design Advantages.—Parts having selected properties can be made. Two or more metal powders can be used to produce alloys which retain proportionately the individual characteristics of each constituent. Many special properties can be obtained by incorporating nonmetallic ingredients with the metal powder, but this reduces strength.

Economical for the production of parts which if made by other methods would involve considerable cost for machining operations in comparison with the cost of the material, or where scrap losses would be high. The more complicated the machining required by a piece made by other methods, the smaller the quantity that would have to be produced from metal powders in order to carry the expense for tools and equipment.

PARTS MADE FROM METAL POWDERS

These surfaces must be smooth and free from burrs
Sharp corners all others approx 0.005R

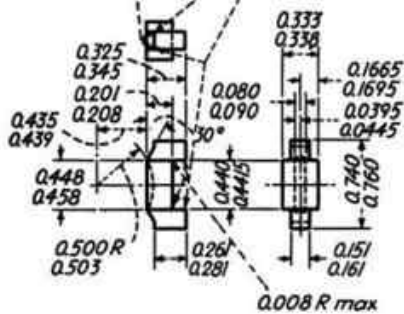

RADIO TUNING BRAKE

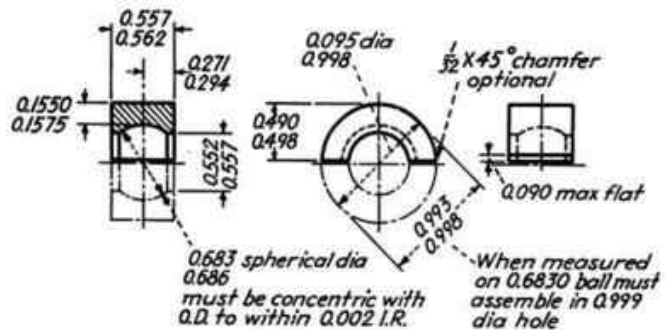

CLUTCH RELEASE SHAFT BEARING

Note: There can be no burr, ridge or seam at junction of cylindrical and flat outside surface

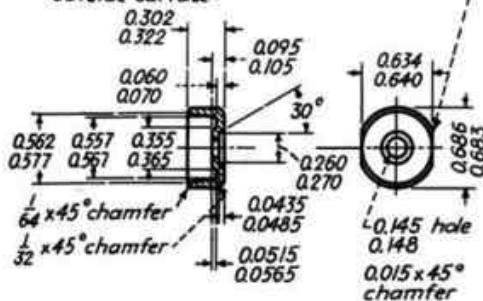

SPRING HOUSING

O.D. with I.D. 0.0015 I.R.-Pitch circle with I.D. 0.0025 I.R. Grind O.D.- Burnish tooth profile

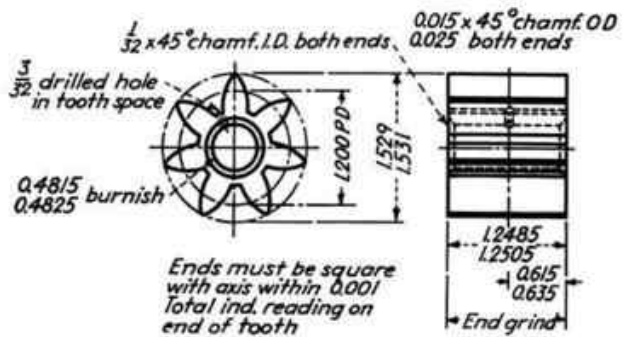

SPUR PINION

Note: fractional dimensions ± 0.010

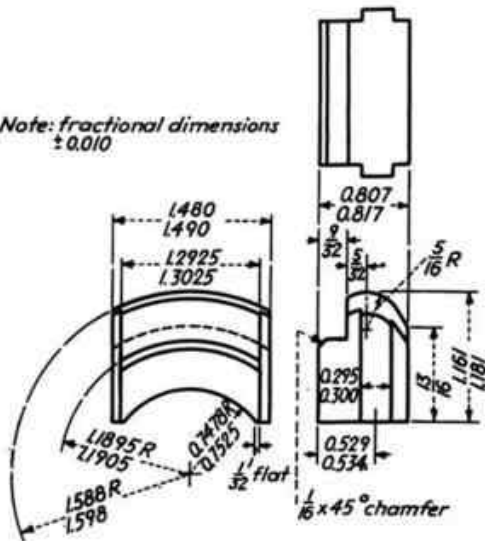

CLUTCH RELEASE BEARING

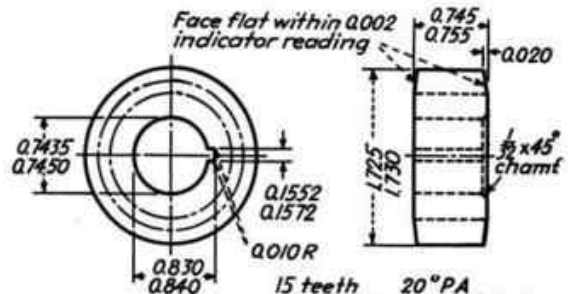

DRIVE GEAR FOR AGITATOR SHAFT ON WASHING MACHINE