

Mohamed A. El-Reedy



CONCRETE
and
STEEL
CONSTRUCTION

Quality Control and Assurance

CONCRETE
and
STEEL
CONSTRUCTION
Quality Control and Assurance

CONCRETE and STEEL CONSTRUCTION

Quality Control and Assurance

Mohamed A. El-Reedy



CRC Press

Taylor & Francis Group
Boca Raton London New York

CRC Press is an imprint of the
Taylor & Francis Group, an **informa** business

CRC Press
Taylor & Francis Group
6000 Broken Sound Parkway NW, Suite 300
Boca Raton, FL 33487-2742

© 2014 by Taylor & Francis Group, LLC
CRC Press is an imprint of Taylor & Francis Group, an Informa business

No claim to original U.S. Government works
Version Date: 20131029

International Standard Book Number-13: 978-1-4665-7796-1 (eBook - PDF)

This book contains information obtained from authentic and highly regarded sources. Reasonable efforts have been made to publish reliable data and information, but the author and publisher cannot assume responsibility for the validity of all materials or the consequences of their use. The authors and publishers have attempted to trace the copyright holders of all material reproduced in this publication and apologize to copyright holders if permission to publish in this form has not been obtained. If any copyright material has not been acknowledged please write and let us know so we may rectify in any future reprint.

Except as permitted under U.S. Copyright Law, no part of this book may be reprinted, reproduced, transmitted, or utilized in any form by any electronic, mechanical, or other means, now known or hereafter invented, including photocopying, microfilming, and recording, or in any information storage or retrieval system, without written permission from the publishers.

For permission to photocopy or use material electronically from this work, please access www.copyright.com (<http://www.copyright.com/>) or contact the Copyright Clearance Center, Inc. (CCC), 222 Rosewood Drive, Danvers, MA 01923, 978-750-8400. CCC is a not-for-profit organization that provides licenses and registration for a variety of users. For organizations that have been granted a photocopy license by the CCC, a separate system of payment has been arranged.

Trademark Notice: Product or corporate names may be trademarks or registered trademarks, and are used only for identification and explanation without intent to infringe.

Visit the Taylor & Francis Web site at
<http://www.taylorandfrancis.com>

and the CRC Press Web site at
<http://www.crcpress.com>

*This book is dedicated to my mother, to my father's spirit, and
to my wife and my children, Maey, Hisham, and Mayar*

Contents

Preface.....	xv
Author.....	xvii
1. Introduction.....	1
References	5
2. Effective Total Quality Management System.....	7
2.1 Introduction	7
2.2 Quality System	7
2.3 ISO 9000.....	8
2.4 Quality Management Requirements.....	9
2.4.1 Quality Manual.....	9
2.4.2 Quality Plan.....	9
2.4.3 Quality Control	10
2.4.3.1 Why Is Quality Control Important?	10
2.4.3.2 Submittal Data	11
2.4.3.3 How to Check Incoming Materials.....	12
2.4.3.4 Methods of Laying Out and Checking Work.....	12
2.4.3.5 Material/Equipment Compliance Tests	14
2.4.3.6 When to Inspect Work	15
2.4.3.7 Paperwork and Documentation.....	16
2.4.3.8 Quality Control Plans.....	17
2.4.4 Quality Assurance	18
2.4.4.1 Quality Assurance in ISO	19
2.4.4.2 Responsibility of Manufacturer	19
2.4.4.3 Responsibility of Owner	20
2.5 Project Quality Control in Various Stages.....	21
2.5.1 Feasibility Study Stage	21
2.5.2 Feed (Preliminary) Engineering.....	22
2.5.3 Detailed Studies	23
2.5.3.1 Design Quality Control.....	24
2.5.4 Execution Phase	25
2.5.4.1 ISO and Control Work	26
2.5.4.2 Inspection Procedures	26
2.5.4.3 Importance of Contracts in Assuring Project Quality	27
2.5.4.4 Checklists	27
2.6 Operational Phase.....	31
2.7 Total Building Commissioning System	32

2.7.1	Define Owner's Project Requirements.....	34
2.7.2	Design Stage	34
2.7.2.1	Review Owner's Project Requirements and Basis of Design.....	36
2.7.2.2	Issues Log and Role of CxA	36
2.7.2.3	Develop Commissioning Specifications	38
2.7.3	Written Test Procedures.....	39
2.7.4	Construction Stage.....	39
2.7.5	Oversee and Document Functional Performance Testing	40
2.7.6	Conduct Owner Training	41
2.7.7	Post-Construction Stage.....	42
2.7.7.1	Reinspect and Review Performance before End of Warranty Period.....	43
2.7.7.2	Complete Final Commissioning Report	44
2.7.7.3	Final Satisfaction Review with Customer Agency	44
	References	45
3.	Concrete Materials and Tests	47
3.1	Introduction	47
3.2	Concrete Materials Test.....	48
3.2.1	Cement.....	48
3.2.1.1	Cement Test by Sieve No. 170	49
3.2.1.2	Initial and Final Setting Times of Cement Paste Using Vicat Apparatus	50
3.2.1.3	Density of Cement.....	52
3.2.1.4	Define Cement Fineness Using Blaine Apparatus.....	54
3.2.1.5	Compressive Strength of Cement Mortars	56
3.2.2	Aggregate Tests	58
3.2.2.1	Sieve Analysis Test.....	58
3.2.2.2	Abrasion Resistance of Coarse Aggregates in Los Angeles Test	60
3.2.2.3	Determination of Clay and Other Fine Materials in Aggregates	61
3.2.2.4	On-Site Test	65
3.2.2.5	Aggregate Specific Gravity Test	68
3.2.2.6	Fine Aggregate Test.....	68
3.2.2.7	Define Specific Gravity for Coarse Aggregate	69
3.2.2.8	Bulk Density or Volumetric Weight Test for Aggregate	69
3.2.2.9	Percentage of Aggregate Absorption	70
3.2.2.10	Recycled Aggregate Concrete.....	70
3.2.3	Mixing Water Test.....	72

3.3	Admixtures.....	73
3.3.1	Samples for Testing.....	74
3.3.2	Chemical Tests to Verify Requirements	75
3.3.2.1	Chemical Tests	75
3.3.2.2	Ash Content.....	76
3.3.2.3	Relative Density.....	76
3.3.2.4	Define Hydrogen Concentration.....	77
3.3.2.5	Define Chloride Ion.....	77
3.3.3	Performance Tests.....	77
3.4	Steel Reinforcement Test	78
3.4.1	Weights and Measurement Test.....	78
3.4.2	Tension Test.....	81
	References	82
4.	Concrete Mix Design	85
4.1	Introduction	85
4.2	Essential Statistics Information.....	85
4.2.1	Arithmetic Mean.....	86
4.2.2	Standard Deviation.....	86
4.2.3	Coefficient of Variation	87
4.3	Basics of Concrete Mix Design.....	88
4.3.1	Normal Distribution.....	88
4.4	Egyptian Code.....	91
4.5	British Standard.....	94
4.6	American Specifications (American Concrete Institute).....	94
4.6.1	Acceptance and Refusal for Concrete Mix.....	95
4.6.2	Concrete Mix Procedure	96
4.6.2.1	Chemical Admixtures	98
4.6.2.2	Selection of Water:Cement Ratio.....	100
4.6.3	Mix Proportions	101
4.6.3.1	British Standard.....	102
4.7	Fresh Concrete Test.....	102
4.7.1	Cylinder and Cube Tests.....	102
4.7.1.1	Cube Test	103
4.7.1.2	Cylinder Test	103
4.7.2	Predicting Concrete Strength.....	105
4.8	Define Concrete Density	106
4.9	Defining Settlement for Fresh Concrete	108
4.10	Determining Compacting Factor for Fresh Concrete	112
4.11	High-Performance Concrete Mix.....	113
4.12	Pumped Concrete Mix	114
4.12.1	Basic Considerations.....	114
4.12.2	Coarse Aggregate.....	115
4.12.3	Fine Aggregate	115
4.12.4	Combined Normal Weight Aggregates.....	116

4.12.5	Water	116
4.12.6	Cementitious Materials	117
4.12.7	Admixtures	117
4.12.8	Field Practice	118
4.12.9	Field Control	118
4.13	Quality Control for Operation	119
4.13.1	Process Control Chart	119
4.13.2	Constructing X-R Chart	120
	References	123
5.	Construction Quality Control	125
5.1	Introduction	125
5.2	Create the Wooden Form	125
5.3	Formwork for High-Rise Buildings	132
5.3.1	Formwork	132
5.3.2	Delivery Systems	135
5.3.3	Allowable Tolerance in Dimensions	135
5.4	Detailing, Fabrication, and Installation of Steel Bar	135
5.4.1	Tolerance in Steel Bars in Egyptian Code	138
5.4.2	Allowable Tolerance in ACI 318	138
5.5	Concrete Cover and Its Specifications	138
5.5.1	British Standard	139
5.5.2	American Code	143
5.5.3	European Code	143
5.5.4	Special Specifications for Structures Exposed to Very Severe Conditions	145
5.5.5	Egyptian Code	148
5.5.6	Placing Concrete Cover	149
5.6	Concrete Pouring	151
5.6.1	Pouring Pumping Concrete	153
5.6.1.1	The Wrong Mix	156
5.6.1.2	Problems with Pipeline	157
5.6.1.3	Operator Error	158
5.6.2	Construction Joint	158
5.7	Compaction Procedure	159
5.8	Curing	160
5.8.1	Curing Process in ACI	164
5.8.2	Curing in British Standard	165
5.8.3	Protecting Special Structures	167
5.9	Hot Weather Concrete	167
5.9.1	Definition of Hot Weather Region	167
5.9.2	Problems of Concretes in Hot Climates	168
5.9.2.1	Fresh Concrete Problem	168
5.9.2.2	Harden Concrete Problem	168

5.9.2.3	Problems Due to Other Factors in Hot Climates	169
5.9.3	Effect of Hot Climate on Concrete Properties	169
5.9.3.1	Control Water Temperature in Mixing	170
5.9.3.2	Control Cement Temperature	173
5.9.3.3	Control Aggregate Temperature	173
5.9.3.4	Control Mixing Ratios	173
5.9.3.5	Control Concrete Mixing Process	174
5.9.3.6	Control Project Management	175
5.10	High-Strength Concrete Quality	176
5.10.1	Cement for High-Strength Concrete	177
5.10.2	Mineral Admixtures	178
5.10.2.1	Silica Fume	178
5.10.2.2	Fly Ash	181
5.10.2.3	Slag	185
5.10.2.4	Comparison of Mineral Additives	185
5.11	Self-Compacting Concrete (SCC)	186
5.11.1	Development of Prototype	187
5.12	Lightweight Aggregate Concrete	188
5.12.1	Lightweight Aggregate	190
5.12.2	Lightweight Coarse Aggregate or Structural Member	191
	References	192
6.	Nondestructive Testing for Concrete	195
6.1	Introduction	195
6.2	Core Test	195
6.2.1	Core Size	199
6.2.2	Sample Preparation	201
6.3	Rebound Hammer	203
6.3.1	Data Analysis	206
6.4	Ultrasonic Pulse Velocity	206
6.5	Load Test for Concrete Members	211
6.5.1	Test Preparation	212
6.5.2	Test Procedure	213
6.5.3	Results Calculations	214
6.5.4	Acceptance and Refusal Limits	214
6.6	Pullout Test	215
6.7	Define Chloride Content in Hardened Concrete	216
6.8	Concrete Cover Measurements	217
6.9	Comparison of Different Tests	220
	References	221
7.	Steel Structure Quality Control	223
7.1	Introduction	223

7.2	Steel Properties.....	223
7.2.1	Strength.....	224
7.2.2	Stress–Strain Behavior of Structural Steel	224
7.2.3	Steel Properties.....	225
7.2.4	Variability of Geometry	225
7.2.5	Ductility Requirements.....	227
7.3	Design Situations	229
7.4	Connection	230
7.4.1	Bolted Connection	230
7.4.2	Welding Connection.....	231
	7.4.2.1 Shielded Metal Arc Welding (SMAW)	232
	7.4.2.2 Gas Metal Arc Welding (GMAW)	234
7.5	Welding Types.....	234
7.5.1	Fillet Weld	234
7.5.2	Butt Weld.....	235
	7.5.2.1 Parts of Butt Weld.....	235
	7.5.2.2 Welding Groove Configurations.....	237
	7.5.2.3 Connection between Steel Plates	241
	7.5.2.4 Welding Groove.....	244
7.5.3	Problems in Welding.....	245
7.5.4	Welds and Welding Symbols	248
	7.5.4.1 Elements of Welding Symbols.....	250
	7.5.4.2 Fillet Weld Dimensions	257
7.6	Stud Weld	261
7.7	Quality Control on Site.....	263
	7.7.1 Quality of Human Resources.....	263
	7.7.2 Handling, Shipping, and Delivery	264
	7.7.3 Erection and Shop Drawings	264
	7.7.4 Inspection and Testing.....	265
	References	268
8.	Nondestructive Testing for Steel Structures.....	271
8.1	Introduction	271
8.2	Visual Test	271
8.3	Radiographic Test.....	274
	8.3.1 Principles.....	274
	8.3.2 Isotope Decay Rate (Half-Life)	274
	8.3.3 Radiographic Sensitivity.....	276
	8.3.4 Geometric Unsharpness.....	277
	8.3.5 Scatter Radiation	279
	8.3.6 Radio Isotope (Gamma) Sources.....	281
	8.3.7 Radiographic Film	283
	8.3.7.1 New Films	285
	8.3.8 General Welding Discontinuities	285
8.4	Ultrasonic Test	289

8.4.1	Wave Propagation	290
8.4.2	Attenuation of Sound Waves.....	292
8.4.3	Reflection in Sound Wave.....	293
8.4.4	Refraction of Sound Wave and Snell's Law	295
8.4.4.1	Angle Beams	296
8.4.5	Wave Interaction or Interference	298
8.4.6	Transducer Types.....	300
8.4.7	Calibration Methods.....	301
8.5	Penetration Test	302
8.5.1	Advantages and Disadvantages of Penetrant Testing	302
8.5.2	Penetrant Testing Materials.....	303
8.5.3	Penetrants.....	306
8.5.4	Developers	306
8.6	Magnetic Particle Test.....	307
8.6.1	Magnetic Field Characteristics.....	309
8.6.2	Electromagnetic Fields	310
8.6.3	Magnetic Field Orientation and Flaw Detectability	310
8.6.4	Tools for Testing.....	312
8.6.5	Magnetizing Current.....	314
8.6.6	Hysteresis Loop and Magnetic Properties	316
8.6.7	Examination Medium	318
	References	318

Preface

Nowadays there is huge competition among personnel and among companies as well. The main tools to make gains in the race are being aware and clearly understanding the principles of how to achieve high quality with lower costs. The construction industry in general is growing very fast, and due to globalization any company can gain a contract anywhere.

The aim of the book is to present up-to-date, effective quality techniques that can be used in the construction industry. This book provides practical and theoretical information about total quality management and all the quality tools that can be used during a project's life cycle.

This book can be used as a handbook by quality inspectors, junior and senior design engineers, the construction industry, and concrete and steel construction project management.

Construction quality control is the main way to achieve a competitive edge in the market, so this book is prepared for easy use by civil and structure engineers and any engineer working in project or construction management of concrete and steel projects. This book steers away from complicated statistics terms but a strong theoretical background is helpful for understanding concrete construction quality control criteria.

This book is comprised of eight chapters. The first two chapters provide the total quality management tools that can be applied during construction at any stage of a project—from the client idea to operation and maintenance. The next four chapters cover the principles of quality control for the concrete industry with the practical tests that can be used in fresh and hardened concrete including advanced concrete technology such as self-compacting concrete and high-strength concrete. Chapter 7 focuses on quality control for steel structures by focusing on welding terminology and procedures, and Chapter 8 presents the nondestructive tests for a steel structure and the proper way to achieve the best quality.

Author

Dr. Mohamed A. El-Reedy's background is in structural engineering. His main area of research is reliability of concrete and steel structures. He has provided consulting to engineering companies and oil and gas industries in Egypt, and to international companies including the International Egyptian Oil Company (IEOC) and British Petroleum (BP). He also provides different concrete and steel structure design packages for residential buildings, warehouses, telecommunication towers, and electrical projects with WorleyParsons Egypt. He has participated in liquefied natural gas (LNG) and natural gas liquid (NGL) projects with international engineering firms. Currently, El-Reedy is responsible for project management of green and brownfield projects for onshore concrete structures and offshore steel structure platforms.



Dr. El-Reedy has consulted with and trained executives at many organizations, including the Arabian American Oil Company (ARAMCO), BP, Apache, Abu Dhabi Marine Operating Company (ADMA), the Abu Dhabi National Oil Company, the Kingdom of Saudi Arabia's Interior Ministry, Qatar Telecom, the Egyptian General Petroleum Corporation, Saudi Arabia Basic Industries Corporation (SAPIC), the Kuwait Petroleum Corporation, and Qatar Petrochemical Company (QAPCO). He has taught technical courses worldwide about repair and maintenance for reinforced concrete structures and advanced materials in the concrete industry, especially in the Middle East.

Dr. El-Reedy has written numerous publications and presented many papers at local and international conferences sponsored by the American Society of Civil Engineers, the American Society of Mechanical Engineers, the American Concrete Institute, the American Society for Testing and Materials, and the American Petroleum Institute. He has published many research papers in international technical journals and has authored six books about corrosion of steel reinforcement and concrete repair, advanced materials in concrete structure, design and construction for onshore and offshore structures, for onshore and offshore structures, construction management for industrial projects, and the reliability of reinforced concrete structure. He earned his bachelor's degree in 1990, his master's degree in 1995, and his PhD in 2000, all from Cairo University.

Contact Dr. El-Reedy at elreedy@yahoo.com with any inquiries or to provide feedback. He often holds webinars educating others in his areas of expertise.

1

Introduction

The civilization of any country is measured by its construction projects such as bridges, high-rise buildings, and industrial projects. The development of these mega projects means that there were best quality management systems applied for these projects to be successful.

Concrete and steel are the main materials utilized in the construction industry. In ancient Egypt, they used concrete in their buildings and temples. They used crushed stone as an aggregate and clay as an adhesive. The Greeks used concrete in their buildings and called it *santorin tofa* (El-Arian and Atta 1974). The Romans used a material-like concrete called pozzolana.

After that, concrete disappeared for long time but then reappeared in the 18th century. Following are some of the famous scientists who worked with concrete:

- John Smeaton used it to construct Eddystone Lighthouse.
- Joseph Parker patented several cements.
- Odgar created an artificial cement from limestone and clay.
- Louis Vicat also used cement made from limestone and clay.
- Joseph Aspdin patented Portland cement.

At the end of 19th century and the beginning of 20th century, there were major changes to the shapes of buildings as architectural engineers and builders changed their point of view. They harkened to the ideas of the European Renaissance of using columns and arches and functional buildings. Concrete was best economical solution for architectural form and function.

Two of the tallest buildings in the world are the Dubai Tower (Figure 1.1) and the famous PETRONAS Twin Towers in Malaysia (Figure 1.2). Imagine how just one centimeter deviation would affect these buildings; *quality* is the secret word to achieving these big project. Indeed the trademarks of quality are the pyramids in Egypt as presented in Figure 1.3, which are more than 7000 years old.

Due to globalization, many contractors and international engineering companies have been founded recently. There is a critical need from clients to ensure that the product and services they receive from these companies are of high quality and these companies need to control the quality of their work for each of their branches worldwide. Therefore, ISO 9000 was established



FIGURE 1.1
Dubai Tower.

to guarantee that products or services comply with specifications. This type of quality management system also ensures that companies worldwide are working with the same level of quality. Variations in cultural, social, and economic levels make it difficult to use the same specifications and codes for every country as the loads affect the buildings and the loads depend on the way of life of people and the laws of each country. For example in some countries it is easy to convert residential buildings to commercial buildings, but other countries prohibit this conversion. Moreover, the dead load variations in value depend on the construction quality. Also, the competency of the engineers, supervisors, and laborers is different from country to country, affecting the quality of concrete and steel structures.



FIGURE 1.2
PETRONAS Twin Towers in Malaysia.



FIGURE 1.3
Pyramids in Egypt.

Therefore the target of the quality for the whole project and the construction onsite is to provide a system of quality assurance and quality control and to have projects match the requirements of the designer and the requested specifications. For example, in the case of a design done by the British Standard (BS), the quality control on site should follow BS, and if the design was done according to American Concrete Institute (ACI) code, the construction quality should comply with ACI. Although the construction crew on site was not involved in engineering design, they should follow the designers' specifications clearly. The main objective of managing the quality on site is to reduce the variation for all the phases of construction from receiving the materials that should be matched with the allowable deviation stated in the specification.

To achieve the complete project management in the construction project in a practical and professional matter, Chapter 2 details the process for auditing the suppliers, contractor, or the engineering firm in addition to presenting the procedure of internal auditing of the company.

The main problem in quality in construction project is the variation on the quality of the concrete itself. Concrete strength is measured by the concrete compressive strength test after 28 days and if you crushed many samples there will be a variation in the strength. In addition the concrete specimen is immersed in water for 28 days. Because this cannot be done for the whole building, we go through the curing process. The traditional way of curing is by spraying water for 7 days, hence the strength of the concrete specimen will be different from the concrete strength in the structure element. In addition, as noted by El-Reedy (2012), there are variations of the location of the concrete. So the target of the quality system as a whole for the project is to ensure that the processes of construction and receiving the materials are within the specification so the variation on strength and the load will be within the allowable limits of the safety factor in design.

The selection of concrete constitutes different materials, and the mixing design should comply with the standard and the technical practice corresponding to the available materials near the project site. It is worth mentioning that sand and aggregate are available in the Middle East, for example, but in some countries the coarse aggregate is rare so recycled concrete is used or the coarse aggregate is imported from nearby countries. However, even within the same country the raw materials from sand to coarse aggregate can vary from one location to another. Therefore the concrete component should comply with the standard specifications before it is used. Therefore, Chapter 3 discusses the concrete materials and different tests that control the quality of the concrete, and also presents the new materials that can be used to enhance the concrete strength and performance and aid the environment (e.g., recycled concrete). The quality control of the modern materials such as HPC, HSC, and SCC will be presented, as well as the required tests of steel reinforcement.

The concrete design mix is different from one code to another and every code has its requirements for calculating the required concrete strength. Chapter 4 presents concrete materials tests as well as onsite quality control tests for fresh concrete.

The main challenge of the project and construction manager is to control the quality during the execution phase. This will be discussed in Chapter 5 by illustrating the methods for receiving the wooden or steel form, and the steel detailing with the curing process in normal and hot climates.

The nondestructive test is performed for the hardened concrete to assure the quality of the concrete structures and in case if there is a debate between the contractors and the consultant engineers in case of a failed concrete compressive strength test after 28 days. All these tests with their advantages and disadvantages will be presented in Chapter 6 in addition to how to select the best method for your case.

The variation in steel structures is less than that in the concrete industry as the steel sections and plates are delivered from the mills under the control of the manufacturer, so the control of quality is very high. However, the quality inspector onsite should receive and accept these materials within the allowable limits of the code. Chapter 7 focuses on the quality control of the construction of the steel structures and explains terminology and precaution to be used during construction. The main problem in steel structure is in either bolted or welded connections. The quality control inspector should be familiar with all types of welding that are used in steel construction and the main issues that should be checked in reviewing and inspecting the welding.

Chapter 8 covers nondestructive tests for the steel structures, such as the visual inspection technique and tools, radiographic test, ultrasonic test, dye penetration, and magnetic penetration test.

References

- El-Arian, A. A., and Atta, A. M. 1974. *Concrete Technology*. World Book.
- El-Reedy, M. A. 2012. *Reinforced Concrete Structure Reliability*. Boca Raton, FL: CRC Press.
- Smith, B. S., and Coull, A. 1991. *Tall Building Structures: Analysis and Design*. New York: John Wiley & Sons.

2

Effective Total Quality Management System

2.1 Introduction

The process of controlling and assuring the quality of a product is a critical subject in most organizations and companies seeking to grow their businesses at the local and global levels. Essentially most of these companies are seeking to achieve total quality management (TQM). In this regard, we will focus on quality systems in construction projects and clarify the TQM responsibility of all parties, including the engineers, contractors, and suppliers, that share in the management of the project.

As mentioned earlier, the oil and gas business' concentration on low cost is important, but another focus is on the project time required to achieve quality and ensure that the materials will be effective for the life of a project.

2.2 Quality System

Due to globalization, you can purchase any machine or equipment or engineering services for your project from any place worldwide. However, clients need a system that gives them confidence in the products purchased, thus decreasing the level of the risk in their projects. On the flip side, multinational companies need assurance that they are providing consistent, quality services, whether they are servicing clients, for example, from their main offices in the United States or from their other offices in the Middle East, Asia, or Europe, or through a third-party vendor. Good quality protects a company's reputation.

For a long time there was no third party capable of providing the same confidence in good quality materials as the parent company. So there became a real need to have specifications in order to achieve the quality assurance. Some specifications have been developed that control all steps of execution and manufacturing.

Work on these specifications began in the United Kingdom through the British Standards Institute, and it has published a number of instructions on achieving BS 4891 quality assurance. After a short time, a number of acceptable documents were developed to meet the needs of manufacturers and suppliers. Specification BS 5750 was published in 1979 as guidance for internal quality management and quality assurance for users. The standards quickly became acceptable to manufacturers, suppliers, and customers and BS 5750 became the benchmark for quality in the UK.

At the same time, the United States prepared ANSI 90 specifications through the American National Standards Institute. Some European countries also began preparing similar specifications. The British specifications are considered the base points for European specifications.

2.3 ISO 9000

It is common to hear about ISO and its relation to quality. The International Organization for Standardization (ISO) was established in 1947 as an agent for the United Nations, and it consists of representatives from 90 countries including some from BSI and ANSI.

The activities of ISO increased over time and it published many specifications that have enjoyed widespread use due to the interest from manufacturers, their international agents, and customers. Manufacturers generate products intended to achieve customer satisfaction that will in turn increase production and sales. Modern equipment is designed and manufactured in conformity with international standards to guarantee acceptability for use in all countries in an effort to increase sales volumes.

The ISO 9000 specifications were released in 1987 and were very close to BS 5750, parts 1, 2, and 3. However the ISO became a general guide to illustrate the basic concepts and some applications. On December 10, 1987, the board of the European Committee for Standardization agreed to work on the ISO 9000 specifications. ISO 9000 is formally considered a standard specification for European countries without amendments or modifications, and it was published in the EN 29000 1987. The official languages of the European standards are English, French, and German, and the committee agreed to publish and translate these specifications for every country based on its language. The standards were revised in 1994 when about 250 articles were modified to clarify the specifications and make them easy to read. Over time, the number of countries working with these specifications increased.

ISO 9000 has been divided into several parts detailing quality assurance in the design, manufacture, and acceptance of the final product. These parts are 9001, 9002, and 9003, and they can be used by manufacturers and customers, and also be incorporated into contracts. ISO 9004 contains the basic rules for

the development of a total quality management system based on the nature of the product, market, production facility, and available technology. The specifications cover administrative regulations, manufacturing, customer needs, and management responsibilities.

2.4 Quality Management Requirements

The definition of quality management in ISO 9000 is an organizational structure of resources, activities, and responsibilities that provides procedures and means to ensure trust in the ability of a company or organization to achieve quality results.

2.4.1 Quality Manual

A company's quality manual is a formal record of its quality management system. It can contain the following:

- A rule book by which an organization functions
- A source of information from which the client derives confidence
- A vehicle for auditing, reviewing, and evaluating the company's quality management system
- A firm statement of the company policy toward quality control (QC)
- A quality assurance section and description of responsibilities

The manual should assure clients of the organization's ability to achieve quality and identify responsibilities and relationships of individuals in the organization. This manual is the driver of the process, review, and evaluation of the quality system in a company and must contain (1) models of documents, (2) models for recording test results; and (3) necessary documents for follow-up of quality lapses.

2.4.2 Quality Plan

The quality plan contains steps to achieve quality in a practical way and explains action steps to reach the required quality. A quality plan varies by project based on contract requirements. In general, the contract provides a plan of action to achieve the quality level requested by a client. The quality plan should detail the resources the company will use, staffing, and equipment required to achieve quality. It should also identify the responsibilities, methods, procedures, and work instructions along with a program of testing and examination.

It is worth mentioning that the quality plan must not be edited and should remain stable until a project is completed.

Some contracts require that the client specify the requirements needed to achieve the final product in the quality plan and detail steps that should be taken to produce what the client requires. The quality plan should be presented to the client to provide assurance of the ability of the contractor to achieve the quality of the desired product. The plan should include:

- All controls, processes, inspection equipment, manpower sources, and skills that a company must have to achieve the required quality
- Quality control inspection and testing techniques that have been updated
- Any new measurement technique required to inspect the product
- No conflict between inspection and operation
- Standards of acceptability for all features and requirement that have been clearly recorded
- Assurance of the compatibility of the design, manufacturing process, installation, inspection procedures, and applicable documentation well before production begins

2.4.3 Quality Control

The quality control definition in ISO is a group of operations, activities, or tests that should be done in a definite way to achieve the required quality for the final products. In construction projects, the final product is a building or structure that should function properly. The first step in quality control is to define the levels of supervision during all project phases to be sure that every phase is performed properly according to the required specifications so that the final product is compatible with the project specifications.

Note that the quality control is the responsibility of every level of worker from the manager to laborers. In reality management is accountable for quality control, but it should be clear that worker bears some responsibility for it.

2.4.3.1 Why Is Quality Control Important?

The improvement of quality provides many benefits. Quality control minimizes mistakes by ensuring that work is performed correctly. One result of eliminating corrective rework is reduced waste of project resources. Lower costs, higher productivity, and increased worker morale will put a company in a better competitive position.

For example, consider two crews. Assume that each crew has the same number of members, skill level, and work assignment. The first crew benefits from having an outside person perform quality control duties. As a result, any defective work can be corrected before correction becomes more difficult.

Any defect in the work of the second crew will probably be discovered after the work is completed. The defect may be torn down and corrected or ignored and left in place where it will cause further problems as construction progresses and cause customer dissatisfaction. The crew's employer may not be considered for future construction projects or may be responsible for a costly correction.

Defects are not free. The party that created the mistake was paid as will be the party who corrects the defective work. Additional material and equipment costs will also apply.

The effects of defective work can be demonstrated by the partial collapse of a parking garage in New York City. The absence of reinforcing steel in three of six cast-in-place column haunches supporting the main precast girders caused the accident. The project plans and rebar shop drawings showed that reinforcing steel to be installed at these locations was accidentally omitted. As a result, extra work had to be performed at the contractor's expense.

Another major quality blunder occurred during construction of a shopping mall in Qatar. After pouring the concrete for the columns and the slab, it was found that about 40% of the columns were of insufficient strength. The lack of concrete quality control on the site and the inexperienced staff meant huge repair costs and a lengthy project delay.

Quality is often sacrificed to save time and cut costs. However, quality work saves time money. Nothing saves more time and money than doing work correctly the first time and eliminating rework.

2.4.3.2 Submittal Data

The submittal data include shop drawings, samples, and performance data. Many deliverable materials also require data test results or letters of certification. The review of submittal data is one of the first steps in the quality control process. The information received from subcontractors and suppliers for items to be installed into the project must be verified to meet the standards set in the contract documents. Items such as dimensions (thickness, length, shape), ASTM standards, test reports, performance requirements, color, and coordination with other trades should be reviewed and verified carefully. Checking submittal information is important especially for shop drawings. Because contract drawings do not provide enough detailed information to fabricate material, vendors and suppliers must make their shop drawings. Materials that require shop drawings include concrete reinforcement, structural steel, cabinets and millwork, and elevators.

Basically, a shop drawing for any item fabricated off-site should be included in the submittal information. Fabricators use the information in approved shop drawings to custom-make their components. Therefore, each item on the shop drawings must be verified against the contract plans and specifications. After the submittal information is reviewed meticulously, the decision to approve or reject it must be made.

Submittals are reviewed by the general contractor and its consultant engineer for further review. If the data is incomplete or rejected, the originator must resubmit correct or additional information. A submittal for material or equipment that successfully completes the review process is used as the template by which the material is fabricated. Any mistakes not discovered in the submittal review process will lead to extra cost and additional time for correction.

The walkway collapse at the Kansas City Hyatt Regency Hotel in 1981 demonstrates how a poor shop drawing review can lead to disastrous consequences. A change in the details of structural connections that was left unchecked during the submittal process did not consider additional loads. The extra loads on the connections led to the collapse of the fourth floor suspended walkway onto the second floor walkway and then onto the ground floor below. This disaster led to 114 deaths and over 200 injuries.

2.4.3.3 How to Check Incoming Materials

After submittal information is checked against the contract requirements and approved, it is filed for future reference. Many companies file submittals by reference number.

Verifying that incoming material meets contract requirements is accomplished by using the data in the submittals. The information on delivery tickets or manufacturer's data provided with shipments is compared to the information in an approved submittal. If all information is correct, then the material can be approved for off-loading to the storage site.

Any rejected material stored on-site has the possibility of being used in construction and may lead to rework or other corrective action. Every item delivered to a site must be verified to comply with the contract requirements.

2.4.3.4 Methods of Laying Out and Checking Work

The layout of work and the verification of correct placement, orientation, and elevation are extremely important. Work that is not correctly placed will lead to extra costs for rework. For example, the misplacement of anchor bolts for the foundation will lead to expensive correction work and delays.

The proper layout of work is also required. The required tools for this function include a tape measure, plumb bob, carpenter's level, and chalk box. Proper layout and checking of work involve checking elevations at the heights of concrete footings during placement and finishing the grade and floor. Items to check for proper alignment of work in the field include manufacturer's recommendations for the layout of windows, overhead doors, and air-handling units.

Since quality control is the responsibility of everyone involved in the construction process, most engineers in construction positions will help manage

QC functions. Since defects are not always obvious, engineers should be instructed to watch for key items during inspection. QC items for steel door and frame installation would be as follow:

1. When delivered to the site, each door and frame should be checked for damage.
2. Ensure proper size and gauge of doors.
3. Doors and frames must be stored off the ground in a place that protects them from the weather.
4. Do not stack doors or lay doors flat. This will cause doors to warp. Doors must be stacked on the end of a carpet-covered rack or using other appropriate methods.
5. Check doors and frames for proper material, size, gauge, finish (satin, aluminum, milled), and anchorage requirements.
6. Verify door installation per door schedule shown in contract documents.
7. Fire-rated doors or frames must be used in fire-rated wall assemblies.
8. Fire-rated doors and frames must have a label attached or a certificate stating the fire-resistance rating.
9. Check for the proper location of the hinge side of the door and for proper swing of the door. (For example, per fire codes, the door swing for stairwells and other egress openings must open out, not into the stairwell.)
10. Door frames in masonry walls must be installed prior to starting masonry work (masonry must not be stepped back for future installation of door frame).
11. Is the door frame installation straight and plumb?
12. If wood blocking is required for door frame installation, make sure this activity is completed during the construction of the wall.
13. There is a uniform clearance between the door and frame (usually 1/8 inches).
14. Has adequate clearance been provided between the bottom of the door and the floor finish (carpet, tile) that will be installed?
15. Touch-up scratches and rust spots with approved paint primer.
16. Exterior doors must be insulated.
17. Check for weather-stripping requirements on exterior doors.
18. The intersection between the door frame and wall should be caulked. Check for missing caulking in hard-to-reach areas (for example, hinge side of door frame.)

2.4.3.5 Material/Equipment Compliance Tests

Every project owner requires testing of materials and equipment prior to placement and after installation. Engineers should be familiar with testing methods even if they will not perform the actual tests. Before construction starts, a list of all required tests should be prepared.

The list is for use by QC personnel and should note the types and frequencies of testing required for each segment of work. After tests are performed, reports documenting all results should be retained for future reference. A number of typical tests are performed during construction to ensure the quality of work completed.

2.4.3.5.1 Soils Testing

The foundation of a structure transfers loads from the structure into the ground below. The soil must be strong (dense) enough to withstand the loads that will be imposed. Additionally, the strength of soil must be uniform to avoid differential settlement of the structure that will lead to structural and weatherproofing problems. To ensure that minimal structure settlement takes place, soil compaction must be verified. Each excavation or soil back-fill operation must be checked to ensure compliance with the compaction requirements listed in the project specifications. These tests must be made before further work such as rebar placement is started.

2.4.3.5.2 Concrete Tests

Two types of concrete tests are used to evaluate concrete at a job site: (1) the slump test and (2) the concrete cylinder or cube test. The slump test, per ASTM C143, determines whether the desired workability of the concrete has been achieved without making the concrete too wet.

2.4.3.5.3 Mortar Testing

The project specifications will indicate that mortar must comply with ASTM C270 or ASTM C780. ASTM C270 states the required proportions of mortar ingredients (1 part Type S masonry cement to 3 parts masonry sand). ASTM C780 states the method of obtaining samples for compressive testing and the strength required for the mortar. Copies of these ASTM standards must be obtained to ensure full compliance with both the project specifications and industry standards.

2.4.3.5.4 Heating, Ventilation, and Air-Conditioning (HVAC) Testing

Although HVAC testing is performed by a professional testing agency, quality control personnel should know how and why these tests are performed to ensure that they are performed at appropriate times. The ductwork joint leakage test is performed after the ductwork is completed, before insulation is installed on the outside of the ductwork. The leakage test requires sealing of all openings in the ductwork. A high-powered fan is then used to pressurize the ductwork to a specified level. The project specifications will note the level or refer to the SMACNA (Sheet Metal and Air-Conditioning

Contractors National Association) *HVAC Air Duct Leakage Test Manual*. When proper test pressure is reached, the system will be monitored for drops in pressure. Any drop in pressure indicates a leaky joint in the ductwork. If this occurs, each joint must be corrected and retested until the proper pressure is maintained. HVAC system balancing adjusts the system to work properly and ensures that the actual air volume meets the designed air volume.

2.4.3.5.5 Plumbing Tests

All pipes in a structure must be checked for leaks. All pressurized pipes (supply and return pipes, fire sprinklers) must be subjected to hydrostatic pressure testing using a water pressure gauge. Usually, the test requires the pipes to hold 150% of the normal operating pressure for 2 hours. Any drop in pressure indicates a leak in the line. After any leaks are found and repaired, the test is restarted for 2 hours. Any leaky joints must be tightened or taken apart and corrected. The application of pipe sealant to pipe exteriors is not an approved correction.

2.4.3.5.6 Performance Tests

Performance tests are required for many of the complicated systems installed in a building. Examples are the fire alarm system, elevators, water chillers, and air handlers. These types of tests are performed by the installer of the system and must be witnessed and verified by QC personnel. Again, it is important for QC personnel to understand what is involved in testing these systems. The project specifications will state industry standards that must be followed.

2.4.3.6 When to Inspect Work

Knowing when to inspect work in progress is important to QC staff. The following is a summary of when and what to inspect at a work site.

2.4.3.6.1 Inspection before Commencement of Work

The U.S. Army Corps of Engineers calls this step the “preparatory inspection phase.” All major work components (materials, methods, workers) are inspected. Submittals and industry standards are used to verify that the work to be performed will comply with the project documents. The use of sample panels for work such as masonry or stucco finishes is a prime example of this type of inspection. The workmanship and materials are inspected and approved before installation. Corrections made as a result of this inspection will cost less and exert few impacts on the project schedule.

2.4.3.6.2 Inspection of Work in Progress

In some cases, the inspection of work-in-progress must be performed continuously. QC personnel must monitor work constantly until completion. It is critical for work to start correctly; otherwise, rework will be required to correct problems. It is easier and less expensive to correct work in progress instead of discovering defects after completion.

2.4.3.6.3 Inspection of Work after Completion

Each work activity must also be inspected upon completion to detect any deficient work before the next activity proceeds. A “punch list” detailing deficiencies discovered should be prepared and distributed to the parties responsible for the defective work. Verification that each deficiency has been corrected is required to eliminate any outstanding deficiencies. This stage of inspection will also require performance testing of installed materials and equipment.

2.4.3.7 Paperwork and Documentation

Keeping track of quality control activities is an important duty of QC personnel. QC documentation includes recording logs, pre-installation inspection reports, and punch lists.

2.4.3.7.1 Recording Logs

Recording logs are used to track items that have been completed or are still incomplete. Logs are used to keep track of the submittal flow during construction.

Each submittal is assigned a number for tracking purposes. The numbering can be consecutive or a number-letter combination may be used. For example, if 20 submittals have been received from subcontractors or suppliers since construction began, the next submittal received will then be #21. If it is sent to the reviewing architect or engineer and rejected, it must be resubmitted with the correct data. It will then be #21A.

Each submittal received is listed on a submittal log under its specific number. The log should provide spaces for a description of the submittal, number of shop drawings (if applicable), originator, and pertinent dates. A code column should be included to indicate whether a submittal is approved or rejected. The U.S. Army Corps of Engineers uses the following submittal action codes in the submittal review process:

- A—Approved as noted
- B—Approved, except as noted
- C—Approved except as noted; resubmission required
- D—Will be returned by separate correspondence
- E—Disapproved
- F—Receipt acknowledged
- FX—Receipt acknowledged; does not comply with contract requirements
- G—Other (specify)

Each construction deficiency discovered on a job must be documented to ensure that the proper correction is made. Construction deficiency logs are used in conjunction with notices of construction deficiencies to track the progress of all corrections.

A notice of construction deficiency states the details of the deficiency. The log tracks each deficiency until it is corrected. The forms should describe deficiencies, name the responsible parties, and explain corrective actions needed to ensure that no deficiencies remain unresolved.

A concrete placement log tracks dates, times, locations, amounts, and types of concrete pours at a job site. The log should also note testing laboratory information and cylinder data that is useful for matching concrete compressive test results with data on representative samples.

2.4.3.7.2 Pre-Installation Inspection Reports

Pre-installation inspection report forms are helpful for scheduling inspections for work in place before it is covered by the next phase of work. These forms are signed when the stated work is completed. The general contractor's quality control personnel perform their final inspection after all other parties have signed off on their tasks. Note that QC inspections must be continuous during construction. The pre-work installation forms are used for final inspection purposes, not for initial inspections.

2.4.3.7.3 Punch List Log

A punch list log provides a system for tracking deficiencies noted during project closeout. Blank copies of this form should be available at the site and used to note punch list items. The lists can be sorted by responsible parties and/or work types.

2.4.3.8 Quality Control Plans

Quality control should involve company executives and field personnel. Quality control plans serve as written references for implementation of a quality control program. The plan must explain the duties and activities of QC personnel as clearly and concisely as possible. The following writing suggestions may be helpful in drafting such a plan.

The plan should be based on inputs from all departments involved with the QC process, field office personnel, owners, engineers, subcontractors, and suppliers. Preparation and implementation of the QC plan must be more than a cosmetic exercise. The QC program may look good on paper, but it can only serve its intended purpose by strict adherence to the stated procedures. The plan must be easily understood by those who will implement the procedures. Items that should be included are organizational charts showing the chain of command, explanations of duties, lists of procedures, and examples of documents to be used.

The plan must be kept up to date by reflecting all changes required to maintain effective quality at the site and may include suggestions from the employees responsible for QC duties.

The following guidelines have been established by the U.S. Army Corps of Engineers for preparing an organizational chart for the QC department:

- Lines of authority
- QC resources
- Adequately sized staff
- Qualifications of QC personnel
- List of QC personnel duties
- Clearly defined duties, responsibilities, and authorities
- Deficiency identification, documentation, and correction
- Letter to QC personnel giving full authority to act on all quality issues
- Letter stating responsibilities and authorities addressed to each member of the QC staff
- Procedures for submittal management
- Submittals must be approved by the prime contractor before review by the owner's representative
- Log of required submittals showing scheduled dates by which submittals are needed
- Control testing plan
- Testing laboratories and qualifications
- Listing of all tests required as stated by contract documents
- Testing frequencies
- Reporting procedures
- Quality control reporting procedure addressed

2.4.4 Quality Assurance

The following example shows the importance of quality assurance. You decide to perform a sewage system project. About 7 years ago a contractor built you the same system—high quality, on time, and on budget. You alone are responsible for the contractor selection. Is it a good decision to go directly to this company or not? Why? (Please answer these questions before moving to the next paragraphs.)

Many construction companies now operate internationally. Globalization means that every company acts as a consumer, manufacturer, and/or service provider. For example, a contractor performs a service for a client and is also a client of manufacturers of plumbing and HVAC equipment, ceramic tiles, and other materials and equipment required for a project. The factory that makes ceramic tiles is also a client to the mechanical spare parts company that maintains its machines.

Any defect of any system will affect all the other systems. It is obvious that a quality system should apply to all vendors. Every company should build its own system to ensure that its products or services are based on specifications, requirements, and customer satisfaction. A strong quality system remains stable despite staff changes.

A small family operation may not be able to maintain the type quality program required for a large project. The chairmen of large multinational companies usually work far away from projects in progress and quality assurance follows a plan that may be reviewed in an external or internal audit. If a project owner complains about a company's work, the quality program should help solve the complaints. Quality assurance should:

- Ensure that the final product conforms to the specifications and that the workers are competent and able to achieve high performance and product quality through the administrative system.
- Apply the company's policies among all project sectors regardless of staff changes.
- Provide a finished product that meets the required specifications and reduces costs by reducing waste and defects. Quality exerts a major impact because the time factor is critical and may be the main driver of a project.

For example, on a hotel or refinery project, a delay of one day will create a significant impact. It is imperative not to waste time dealing with rejected products or repairing defective work. If a product meets standards, a good relationship is achieved between the seller and the client by reducing the number of complaints. In a case of repeated product complaints from a contractor that strongly impact a project, neither contractor nor suppliers may be called for similar projects. The reputation and quality of the final product affects clients, contractors, and materials suppliers. A quality assurance system is basic for any factory, construction company, or owner that wants to effectively compete.

2.4.4.1 Quality Assurance in ISO

ISO 9001 details the requirements of quality management systems and contracts between users and manufacturers through all states of design and manufacturing. ISO 9001 includes a model for quality assurance during the design, development, production, and use of the product.

2.4.4.2 Responsibility of Manufacturer

A manufacturer makes a product; it may also distribute the product and provide service. All areas of control and quality assurance have been identified. In the case of construction projects, the contractor is responsible

for implementation; an engineering office may be responsible for services relating to the design and preliminary engineering drawings.

It is clear that the first responsibility during the process of total quality management (TQM) falls on the manufacturer who must make sure that every product matches the specifications required by the owner or the agent of the owner.

Construction materials now move between countries and continents based on free trade. International trade agreements foster trade between countries and now impact the construction industries. The open market led to fierce competition among companies in the construction field and many have opened offices around the world. The competition among these companies arose from the need for quality assurance systems and led to the development of administrative regulations. Comprehensive quality control systems enable companies to operate effectively in many countries. Quality assurance systems should lead to customer satisfaction, increased revenues, and good reputations in world markets that allow companies to compete effectively.

Some basic steps are critical for improving quality. First, senior management must demonstrate the importance of quality control and quality assurance through comprehensive leadership. Second, management should provide a working environment that fosters quality assurance and ensures that all employees understand and follow the steps of quality assurance. Quality assurance should not be viewed as an administrative constraint. Senior management should pay close attention to training by organizing quality seminars for all employees.

2.4.4.3 Responsibility of Owner

Many problems arise because of poor quality of a final product or nonconformity of a project to the required specifications. This may be the fault of the owner who may not have defined the desired product clearly. For this reason, a contractor must demand all the necessary data and specifications from the owner.

Figure 2.1 shows the relationship of the owner, the contractor, and the consultant. It clearly indicates the exchanges of information and transactions. A breach by one party will affect all the other parties.

Based on the specifications, the contractor or manufacturer determines prices and scheduling based on the quality of the product. The owner is responsible for preparing detailed specifications of the project to ensure the final product achieves its objectives. The selection of a contractor or manufacturer is one of the most vital responsibilities of the owner or its agent.

First, the owner selects an engineering firm and then chooses a contractor. These selections are fundamental to the success of a project. Therefore, it is the responsibility of the owner or its agent to gather enough information about the engineer and contractor including their work experience

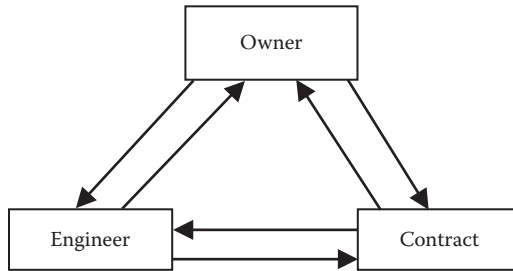
**FIGURE 2.1**

Relationship between owner, contractor, and engineering company.

on similar projects. The owner should review their financial data and ensure the contractor and engineer can fulfill their obligations to deliver the project.

2.5 Project Quality Control in Various Stages

A project is a set of activities that has a beginning and an end. The activities differ by project, depending on size and complexity. Examples of engineering projects are residences, offices, hospitals, industrial facilities, roads, bridges, railways, and irrigation systems.

Construction projects vary based on size and value. Therefore, the degree of quality control varies by project size and type, especially in developing countries. Quality control may be sufficient in small businesses, but the contracting companies or small engineering offices that are aimed at the international competition must increase their quality measures and thus increase project cost. Quality control must continue throughout all steps of construction.

2.5.1 Feasibility Study Stage

Each stage of a project is important and exerts a different impact on the whole project. The feasibility study phase followed by relevant preliminary studies set the goals of a project. The feasibility stage defines the goals and economic feasibility of a project. Feasibility studies require extensive research, discussions, deliberations, and compilations of economic data to determine whether a project will be accepted preliminarily.

The feasibility study phase is followed by further studies. Usually an owner will engage a consultant to study all aspects of a project after the feasibility study is completed.

2.5.2 Feed (Preliminary) Engineering

Feed engineering follows the completion of the feasibility study for the project. This phase is just as serious and far more dangerous. The success of the whole project depends on the engineering study and the engineering study depends on the engineer's experience with the specific type of project.

The quality level required depends on the size of the project. For example, for small projects such as apartment buildings, offices, and small factories, initial studies can determine the construction type. Will the project require reinforced, precise, or prestressed concrete? This decision determines the type of construction—solid or flat slabs, hollow blocks, columns, beams, frames, and shear walls. The choices are based on building size and use and the owner's requirements.

For major projects such as a stadium or oil refinery, the complexity of the feed engineering phase increases because of the need to consider spatial principles, for example, landscaping, foundation types, soil settlement, and other factors. Oil and gas projects require studies of the movements of products and materials in addition to normal construction considerations.

For any project, the feed engineering state requires experienced personnel and the owner must follow up on the initial studies to pursue the project and make decisions based on the results of civil, mechanical, electrical, and chemical engineering studies.

Generally, every project, regardless of size, must be based on an engineering document known as the statement of requirements (SOR). The SOR explains the objective of the project and the needs of the owner, and is an important component of the quality assurance system.

The SOR is required for all new or large-scale projects and is useful when a structure must be modified. In the case of a residential building, the owner should determine the number of floors required, the number of apartments on each floor, the number of shops, and other useful information.

Engineering studies are based on the SOR and presented in a document called the basis of design (BOD) or design criteria. Using this document, the engineering consultant should clarify the code and specifications needed for the design and the equations that will be used. The BOD should also specify the computer software to be used, the required number of copies of drawings, and the sizes of the drawings. Additional information about weather, ocean currents, and other data may be required. The BOD should be reviewed in detail by all parties and required revisions made. It is vital that both the owner and the engineering office have the same concept and agree fully on all technical issues.

Feed engineering staff should receive all drawings for review and preliminary work. The deadline for review should be determined in advance and drawings should be returned to the owner along with comments.

This phase may take months for a large project. The engineers and owner's staff should have experience in controlling costs and follow-up on time

according to the agreed schedule. The engineer is responsible for comparing estimated and expected costs with data in the feasibility study. The estimated cost accuracy will increase over time until the end of the preliminary study phase is reached.

It is imperative at this state not to lose sight of the future costs of maintaining the project based on the project lifetime. Future cost estimates should consider the use of the structure, type of construction, equipment, maintenance requirements, surrounding environment and weather conditions. An owner may choose a high-cost stainless steel material because of future savings based on minimal maintenance. Conversely, an owner may choose a system involving low initial cost and continuing maintenance over the life of a project. Factors to consider are the importance of the structure, its geographical location, and extent of maintenance required. This trade-off also applies to the initial selection of mechanical equipment such as machine turbines.

Manufacturers, operational details, maintenance requirements, and other aspects of the preliminary design must all be considered in the feed engineering phase. Decisions made at this stage will impact maintenance issues (repair or replacement) in the future. An error in this early phase may create a huge impact later in the project life cycle. It is possible to avoid heavy future expenses by carefully planning at the feed engineering stage.

2.5.3 Detailed Studies

It is assumed that complete construction drawings for the entire project will be available after feed engineering is complete. Construction drawings require extensive work, good coordination, and logical organization. A good manager allows freedom of communication among individual and continuous reviews. This stage also requires an affirmation of quality measures.

Engineers always believe in utopias of accuracy and teamwork but reality is somewhat different. Documents may arrive late; corrective actions may be needed, and procedures may change. All these issues result in lost time. The work environment must promote quality assurance through stable functioning of all departments despite personnel changes because the early phases of a project require intensive cooperation.

For example, strong relationships between departments and organizations with result in sharing of information. Periodic and productive meetings will ensure that the work proceeds smoothly. Quality assurance at this stage is important because it involves entire organizations. All participants should understand the quality goals and their responsibilities and all quality measures should be supported by documentation.

Documents are considered the operational arms of the quality application process and must reflect all amendments or corrections of the drawings. The drawings and any amendments must be received at a specific time for the owner to review.

Any changes may be canceled or approved, so there should be a quality system procedure to avoid confusion with the other copies of drawings and eliminate human errors. The modification revision number must be updated promptly until the final stage of the project when final drawings are ready for approval. Approve-for-construction drawings are prepared after the completion of the study phase and before the start of the execution phase. Projects may require hundreds of drawings.

Generally, designs are divided into five classifications and each should be covered by a quality assurance system:

1. Planning design and development—Determine who does what
2. Entrance design—Understand the client's needs and objectives
3. Troubleshooting design—Provide clarity for the final design
4. Verification of design—Review with the client to make sure that the design meets needs
5. Change design—Ensure that required changes in design are adopted

2.5.3.1 Design Quality Control

The goal of quality control during the operational phase of studies in ISO 9001 (Section 4.1) is to control the design at various stages as illustrated in Table 2.1. Requirements, design, development, planning, responsibilities, procedures and specifications, references, research marketing, safety features, and safety and health issues overlap among the technical teams and may change after an internal audit.

Input design concerns the technical information needed for the design process. Owner requirements must be identified and an SOR prepared to verify the accuracy of input design to ensure that the output of the process design is identical with the design required. Any information that is questionable or unclear must be resolved at this stage. Instructions to control operations are often stipulated in the contract. The owner may specify some specific control actions.

Marketing is an important factor in the design process and must be compatible with the design and marketing demands. This is the point at which the marketing team becomes active. The designer must consider the competitive products and the abilities of the owner.

TABLE 2.1

Design QC in ISO 9000

Design Input	Output Design
Instructions and control operations	Design review
Taking marketing materials into account	Design review process
Specifications and tolerances allowed	Verification of design
Health and safety and environment Computer	

Specifications and tolerances must be identical with the design specifications of the project, and the tolerances must be compatible with the specifications and requirements of the owner. The designer must also consider standards of health, safety, and environmental protection. Modifications and revisions or drawings have become easy with computer-aided design (CAD) programs that provide accurate information and access to various forms of tables and graphs.

Output design must conform to all requirements revealed by an internal audit. A change or modification in must be compatible with the health and safety requirements.

Design reviews must be scheduled in the early stages of design to ensure that the design meets the constraints of time and costs. All calculations must be reviewed for accuracy. Previous similar designs may serve as models for design and operations testing.

2.5.4 Execution Phase

The execution phase requires both quality assurance and quality control. In a reinforced concrete structure, concrete contains various materials such as cement, sand, gravel, water, additives, and perhaps steel reinforcement. The quality of each concrete mixture and structure must be assessed during the preparation of wooden forms, assembling the steel, casting, and processing.

The contractor should have a well organized administrative organization in order to achieve quality control and maintain sufficient documentation to show work progress, number of concrete samples, testing dates, procedures, and results, and other data.

Drawings may be changed as a result of problems at the site. Changes do not negate the requirement for quality assurance system throughout each construction phase. All changes must be documented completely to ensure their inclusion in the as-built drawings.

The owner and contractor have different organization methods, for example:

1. The owner may maintain a supervision team on site.
2. The owner may select a consulting engineer to perform the design and handles supervision.
3. In both cases, the contractor should have a strong organization because the organization controls quality. A knowledgeable contractor staff will understand quality assurance and control and the result will be little disagreement about the final quality of the project.

The construction phase reveals the strength of the contractor through quality assurance and customer satisfaction.

2.5.4.1 ISO and Control Work

Execution is covered by ISO 9001, Section 4.9. The implementation requirements to achieve the required quality include.

- Control the execution of special operations, environmental conditions, specifications, work instructions, procedures, control, and follow-up.
- Companies that operate through ISO should develop plans for execution processes, structures, and construction standards that affect the final quality of the project.
- All the actions of the execution process are registered and documented. Procedures should be in place to ensure that equipment works properly for the duration of the project without malfunctions affecting work flow.

2.5.4.2 Inspection Procedures

The execution phase requires deliveries of various materials from many locations, storage, and installation. The contractor's responsibility is to ensure that all materials for construction are handled and installed properly. Employees must receive adequate instructions for working with materials and equipment.

Inspection is the final quality process and involves materials supplied and finished work. Inspection of materials must be continuous and the following items should be documented:

- Substance to be tested
- Test procedure
- Equipment required for testing; inspection and calibration of such equipment
- Inspection method
- Environmental conditions required during operation, inspection, and testing
- Sampling method
- Defining limits of acceptance and rejection of samples tested

The following items from ISO 9000, Section 4.11 cover inspection and measurement tests:

- Control inspection
- Measurement and test equipment
- Calibration, maintenance, surrounding environment, storage, and documentation
- Registration and inspections

2.5.4.3 Importance of Contracts in Assuring Project Quality

Contracts between owners and contractors as well as between owners and engineering consultants are very diverse. A contract defines the parties, type of project, responsibilities, time lines and other factors. Omissions and ambiguous clauses in a contract will create a lot of problems, may lead to litigation, and cause delays that will impact the final cost of the project. Therefore, the number of contracts and reviews of the objectives should be controlled.

In general, the contract documents must contain the drawings and specifications for the materials, labor, and tools to be used. The documents must also cover skills needed, the relationships and responsibilities of the owner, contractor, engineer, and other parties, and a detailed material and equipment list showing quantities and prices.

Other essential items are the requirements for employee health and safety and environmental protection. The documents should specify how injuries and sicknesses are to be handled and which parties are responsible for the costs. Taxes and legal costs for resolving disagreements should also be included along with administrative items. Chapter 7 focuses on contracts.

2.5.4.4 Checklists

ISO 9000 specifies responsibilities for conducting reviews and some of the menus contain suggested questions about several important aspects of quality control at all project stages.

2.5.4.4.1 Checklists for Reviewers

1. Management Tasks

- Is a representative of the department responsible for achieving ISO 9000?
- Do all individuals involved in quality have specific responsibilities and authorities?
- Are the available resources adequate?
- Has skilled labor been engaged to perform certain skills?
- Are audits performed by independent auditors?

2. Quality Management System

- Is the quality management system documented adequately to ensure that the product will meet specifications?
- Will an audit review of all contracts be conducted to assure cooperation among the parties to implement the contract?

3. Control Design

- Are individuals capable of completing the work assigned to them?

- Are the design requirements reviewed by the owner?
 - Is the output compatible with the design input?
4. Control of Documents
- Is there a procedure to control document quality?
 - Are all documents reviewed and approved before use?
5. Purchases
- Do you buy products in conformity with the requirements of quality?
6. Product Suppliers
- Is there a procedure to verify the storage and maintenance of products received from suppliers?
7. Control of Manufacturing or Implementation
- Is the manufacturing process or implementation described in documents?
 - Do procedures control manufacturing and implementation of special operations?
8. Inspection and Testing
- Were products used?
 - Have they been tested or verified according to specifications?
 - Is there a procedure to verify conformity of products to specifications during manufacture?
 - Is there a procedure for final inspection tests?
9. Test Devices
- Is there a procedure to control the calibration and maintenance of test equipment?
10. Test Results
- Is there a procedure to ensure control of product nonconformity with specifications?
11. Corrective Steps
- Is there a procedure during inspection to determine the cause of incompatibility of product with customer requirements and specifications, and determine the steps necessary to fix the problem and prevent future recurrences?
12. Materials Storage
- Are there procedures and documentation for controlling contractors, storage, and handling?
13. Quality Recording
- Is there a procedure to identify, collect, and store all documents related to quality?

14. Review of Internal Quality

- Is there a system of internal audit documents?

15. Training

- Are procedures in place for identifying employee training needs to improve quality?

16. Service

- Are there procedures to monitor and improve service?

17. Statistical Processes

- Are there procedures to determine the statistical data needed to accept or reject products?

2.5.4.4.2 External Auditing

External auditing is performed by a team assigned by a contractor or service provider. A company that follows the ISO should manufacture materials and maintain safety standards that can be trusted. In reality, records covering these issues are not available in some countries; in other countries, companies may have ISOs but fail to apply systems to ensure quality control. The owner of a major project should formulate a team from its quality department to perform external audits of contractors, engineers, and other service providers.

If an external audit company is engaged, it should provide prequalification data. An in-house team should have strong skills and knowledge of quality and know how to audit in other countries.

First, the contractor or the service provider should present its quality manual for review by the quality team. The quality team will visit the site with a representative from the contractor or service provider to inspect the system in action. The process follows certain steps:

- Visit the supplier site to perform complete inspection.
- The supervisor will describe to the team exactly how the QC system works.
- The contractor provides examples of QC documentation.
- The team may request re-inspection of a previously inspected batch.
- The team will check regular maintenance of test equipment.
- The rejected products must be clearly marked and segregated to prevent their accidental inclusion with acceptable products.

After the site visit, there are three possible outcomes:

1. The contractor or service provider is registered on a company bidder list if the evaluation indicated that the contractor or provider has a satisfactory quality management system, demonstrated no deficiencies, met required standards, and provided assurance of quality.

2. Weak quality system—If the team finds several significant weaknesses in a supplier's system, the supplier must overcome the failures and improve its quality management system. The supplier can request another evaluation to demonstrate improvements in its quality system. However, improvements take time so it may be wise to not register the company and give it time to improve its systems.
3. Unacceptable quality system—The supplier must make radical changes to improve its overall quality management system. The actions required to achieve the quality management target will take more than one year, so it is best to not deal with this supplier.

ISO 9000 provides a checklist that is essential for an auditing team. Table 2.2 is a sample design checklist for auditing an engineering company. For the construction phase, the Table 2.3 checklist is tailored for auditing a contractor company.

TABLE 2.2

Design Checklist

Item	Questions	Yes/No	Remarks
1	Do they have a system to assure the client presents its needs clearly?		
2	Are client requirements clear to all design members?		
3	What international standard and specification do they use?		
4	Are the standards available in their office?		
5	Are the drawings and documents sent by the client registered?		
6	Do they have a document management system?		
7	Do they name the discipline lead?		
8	Are the activities clear to them?		
9	How can they select new engineers?		
10	Do the drawings have numbers?		
11	Is a strong numbering system used for drawings?		
12	Do they prepare a list of the drawings?		
13	Are they updating this list?		
14	What is the checking system for calculations?		
15	What is the checking system for drawings?		
16	Are employees familiar with CAD?		
17	Do they have a backup system for documents and drawings?		
18	Do they have antivirus systems?		
19	Do they use a subengineering office?		
20	What are the methods and criteria for selection?		
21	Is there a good relation between the design and supervision teams on site?		
22	Are they experienced with technical inquiries?		

TABLE 2.3

Construction Checklist

Item	Questions	Yes/No	Remarks
1	Is there a quality control procedure?		
2	Is the procedure understood by all members and how?		
3	Does the QC match the task?		
4	What is the way to assure test accuracy?		
5	Is test equipment calibrated?		
6	How they do the test piping, concrete, welding; what are the confidence levels?		
7	Is a third party used for the test?		
8	What are the criteria for choosing the third party?		
9	Do they use a subcontractor?		
10	What are the criteria for choosing subcontractors?		
11	Do they regularly maintain their equipment?		
12	Do they have certificate for cranes and wiring?		
13	Is there an on-site team that knows whether a project is time- or cost-driven?		
14	Does the team know the project objective and target?		
15	Do they control the documents and drawings on site?		
16	Do they have a document management system?		

All workers on a project must have very good technical skills and understand the quality system in accordance with ISO 9001, Section 4.18. They should be trained to increase their technical and managerial skills and follow total quality management procedures.

2.6 Operational Phase

In this phase, the owner gains full authority and responsibility to operate the project after commissioning and start-up. The start of operations may reveal a need to modify the facilities. This is common in the oil and gas industry that frequently must increase production or modify their production methods. Workshops may be required when changes are implemented. Most international companies that follow ISO have management change procedures.

First, the required modification is identified and approval is granted from all the engineering disciplines. For modification projects, it is preferable to request the original engineering office that performed the design to handle the modification.

An example of poor management of change (MOC) occurred in a hotel that converted a guest room to an entertainment facility. Without performing an MOC procedure, the hotel installed a clay floor. The heavy load collapsed

the floor and damaged cars in the basement garage. Many projects focus on profit goals and fail because they ignore input from engineers and operations managers.

In most oil and gas projects, the owner creates a separate team for a project, as described in Chapter 5. In most cases, a project falls under the responsibility of different departments and is supervised by operation engineers who simply request what they need and what is missing to cover all the operations departments requirements.

2.7 Total Building Commissioning System

The total building commissioning system is very important in oil and gas projects (El-Reedy 2012) and thus their engineers are familiar with commissioning and effectively link project and operations staffs. The United States applies this system for residential, administration, commercial, and public buildings to form teams responsible for commissioning from design through the operation phase.

Historically, *commissioning* was the process by which the HVAC systems of a building were tested and balanced according to established standards before acceptance by the owner. Current use of the term recognizes the integrated nature of the performance of all building systems that impact sustainability, productivity, occupant safety, and security.

The U.S. General Services Administration's Owner Engineering Team (OET), through its Public Buildings Service (PBS), manages buildings that house over a million federal associates and maintains an ongoing planning, design, and construction program to meet the government's needs for offices and other facilities. PBS' project delivery program is the vehicle for transforming agencies' visions into reality. The nation's public buildings include courthouses, office buildings, laboratories, border stations, and other structures. In a private construction project, the owner's engineering team fills the same responsible as the federal OET.

The National Conference on Building Commissioning defines total building commissioning as a "systematic process of assuring by verification and documentation, from the design phase to a minimum of one year after construction, that all facility systems perform interactively in accordance with the design documentation and intent, and in accordance with the owner's operational needs, including preparation of operation personnel." We need a wider definition that would cover all activities of all disciplines involved in a project.

My experience shows that during the engineering phase, the engineer worries about man-hours and approves bills. The on-site engineering disciplines focus on matching the design with standards and owner requirements. The owner or its engineering representative focuses on engineering deliverables

to ensure matches of standards and specifications and cost and time issues. In reality, every project needs a separate entity (OET) to ensure that work proceeds according to the owner's requirements.

An OET document should be prepared to explain the owner's needs for a project. First, it should define the owner's expectations for commissioning. It should detail all the owner's recommendations for each stage of the project (planning, design, construction, and post-construction). Appendices should include material samples, tool specifications, definitions of terms, and links to further sources of information about commissioning. The benefits of OET commissioning include:

- Improved facilities productivity and reliability
- Lower utility bills through energy savings
- Increased operations and owner satisfaction
- Enhanced environmental and health protection and occupant comfort
- Improved system and equipment functioning
- Improved facilities operation and maintenance
- Increased operations safety
- Better facilities documentation
- Shortened transition period from project to operation
- Significant extension of equipment and system life cycles

OET statistics indicate that on average the operating costs of a commissioned building range from 8 to 20% below those of noncommissioned buildings.

In general a total building commissioning system should apply to a project from preliminary engineering through the operation phase. The first step in the commissioning process is for the OET project manager (OET PM) to identify the commissioning team. The number and skills of the team will vary based on project type, size, and complexity. Most OET teams consist of:

- Project manager (team leader)
- Operating personnel
- Owner representative(s)
- Technical experts (structural, mechanical, electrical, fire protection, elevator, seismic, etc.)
- Construction manager (CM)
- Construction contractor and subcontractors
- Commissioning agent (CxA)
- Architect/engineer (A/E)

A responsibility matrix focusing on commissioning scope should be established for this project team.

2.7.1 Define Owner's Project Requirements

The objective of commissioning is to provide documented confirmation that a facility fulfills the functional and performance requirements of the occupants and operators. To attain this goal, it is necessary to establish and document the owner's requirements and criteria for system function, performance, and maintainability. The requirements will serve as the basis for all design, construction, acceptance, and operational decisions. Table 2.4 provides a framework for the types of requirements that must be considered.

2.7.2 Design Stage

Design stage commissioning activities should ensure that the owner's requirements for items such as energy efficiency, sustainability, indoor environmental quality, fire protection, and life safety are sufficiently defined and adequately reflected in the contract documents. During this stage, the commissioning team confirms that the building systems and equipment will function according to user expectations. Specific tests and procedures designed to verify the performance of systems and assemblies during the design should be incorporated into the contract documents. The commissioning team should:

1. Participate in documentation of owner's project requirements.
2. Document revisions to owner's requirements and obtain engineering team approval.
3. Document the basis of design.
4. Integrate commissioning process requirements and activities set by the CxA into the contract documents.
5. Attend commissioning team meetings (three design review meetings and monthly construction stage commissioning team meetings).
6. Verify that the operation and maintenance requirements of the systems are detailed adequately in the construction documents.
7. Review and incorporate as appropriate the CxA's comments into the contract documents.
8. Participate in training of operations and maintenance personnel as specified in training documentation.
9. Review test results submitted by the contractor.
10. Review and comment on the CxA's progress reports and issue logs.
11. Witness the functional testing of all commissioned systems and assemblies.
12. Review and accept all required documents.
13. Review and comment on final commissioning record.

TABLE 2.4**Owner Requirements**

Accessibility	Access and use by children, aged, and disabled persons
Acoustics	Control of internal and external noise and intelligibility of sound
Comfort	Identify and document comfort problems that caused past complaints and will be eliminated in this facility (e.g., glare, uneven air distribution, etc.)
Communications	Capacity to provide inter- and intra-telecommunications throughout facility
<i>Constructability transportation</i>	
Constructability	Transportation to site, erection of facility, and health and safety during construction
<i>Design</i>	
Excellence	Potential/objectives for design recognition
Durability	Retention of performance over required service life
Energy	Goals for energy efficiency (to the extent they are not cited in green building concepts)
<i>Fire protection and life</i>	
Safety	Fire protection and life safety systems
Flexibility	For future facility changes and expansions
<i>Green building</i>	
Concepts	Sustainability concepts including LEED certification goals
Health and hygiene	Protection from contamination from wastewater, garbage and other wastes, emissions and toxic materials
Indoor environment	Including hygrothermal, air temperature, humidity, condensation, indoor air quality, and weather resistance
Life Safety	Fire protection and life safety systems
Light	Including natural and artificial (i.e., electric, solar, etc.) illumination
<i>Maintenance</i>	
Requirements	Varied level of knowledge of maintenance staff and expected complexity of proposed systems
Security	Protection against intrusion (physical, thermal, sound, etc.) and vandalism and chemical/biological/radiological threats
<i>Standards</i>	
Integration	Integration of approved federal, state, and local as well as OET and customer
<i>Agency standards and requirements</i>	
Structural safety	Resistance to static and dynamic forces, impact and progressive collapse

14. Recommend final acceptance of systems to the engineering team.
15. Verify that systems are installed per specifications.

2.7.2.1 Review Owner's Project Requirements and Basis of Design

As described in previous sections, the owner's project requirements are developed through the OET project planning processes and established baseline criteria for facility function, performance, and maintainability.

The basis of design (BOD) is developed by the engineering office early in the design stage based on the owner's requirements. The BOD is the primary document that translates the OET's and owner's requirements into building components such as HVAC, envelope, security, and automation systems.

The BOD describes the technical approach planned for the project and the design parameters. The BOD is a technical document typically developed by the engineering office. The owner's requirements developed by OET are expressed in layman's terms.

Throughout the design process, a key role for the commissioning agent is to facilitate a clear understanding of the expectations of the design team. Periodic program review workshops offer all stakeholders the opportunity to indicate requirements for the next design submission. Commissioning documents identify work requirements by roles and responsibilities.

The CxA provides three focused reviews of the design documents. It is recommended that these reviews occur first at the end of design concepts (FEED), the second during design development (detail; 50%), and the third near the end of construction documents phase (95%). Additional meetings may be required to resolve outstanding issues.

The CxA compares the design with the interests and needs of the OET based on the owner's requirements. The CxA also compares the proposed design against OET design standards defined in the latest version of the PBS or company specifications for industrial projects.

The CxA identifies potential improvements in areas such as energy efficiency, indoor air quality, and operations and maintenance. While the CxA is responsible for reviewing the design from a commissioning perspective, he or she is not responsible for design concepts and criteria or compliance with regulatory federal codes (unless those tasks are included in his or her contract). See Table 2.5.

2.7.2.2 Issues Log and Role of CxA

All comments and issues identified must be tracked in a formal log in sufficient detail to allow tracking and future reference. The log shall contain the following at a minimum:

- Description of issue
- Cause
- Recommendation

TABLE 2.5**Commissioning Agent Focused Design Review Scope**

Certification facilitation	Review contract documents to facilitate project certification goals (i.e., does design meet Energy Star requirements; does commissioning meet LEED criteria, etc.)
Commissioning facilitation	Review contract documents to facilitate effective commissioning (sufficient accessibility, test ports, monitoring points, etc.)
Commissioning specifications	Verify that bid documents adequately specify building commissioning, including testing requirements by equipment type
Control system and control strategies	Review HVAC, lighting, fire control, emergency power, security control system, strategies, and sequences of operation for adequacy and efficiency
Electrical	Review electrical concepts/systems for enhancements
Energy efficiency	Review for adequacy the effectiveness of building layout and efficiency of system types and components for building shell, HVAC and lighting systems
Envelope	Review envelope design and assemblies for thermal and water integrity, moisture vapor control and assembly life, including impacts of interior surface finishes and impacts and interactions with HVAC systems (blast, hurricane, water penetration)
Fire protection and life safety	Review contract documents to facilitate effective commissioning of fire protection and life safety systems and aid fire protection engineer in system testing to obtain the OET occupancy permit
OET design guidelines and standards	Verify that the design complies with OET design guidelines and standards (i.e., OET P-100, Courts Design Guide, Border Station Guide, and Federal Facilities Council requirements)
Functionality	Ensure the design maximizes the functional needs of the occupants
Indoor environmental quality (IEQ)	Review to ensure that systems relating to thermal, visual acoustical, air quality comfort, air distribution maximize comfort and are in accordance with owner's project requirements
Life cycle costs	Review a life cycle assessment of the primary competing mechanical systems relative to energy efficiency, O&M, IEQ, functionality, sustainability.
Mechanical	Review for owner requirements that provide flexible and efficient operation as required in the P-100, including off peak chiller heating/cooling air heating unit (AHU) operations, and size and zoning of AHUs and thermostatted areas
Operations and maintenance (O&M)	Review for effects of specified systems and layout toward facilitating O&M (equipment accessibility, system control, etc.)
O&M documentation	Verify adequate building O&M documentation requirements
Owner's project requirements	Verify that contract documents meet owner's project requirements
Structural	Review structural concepts/design for enhancements (i.e., blast and progressive collapse)
Sustainability	Review to ensure that the building materials, landscaping, water and waste management create less of an impact on the environment, contribute to creating a healthful and productive workspace, and are in accordance with owner's project requirements; see also P-100 LEED requirements
Training	Verify adequate operator training requirements

- Cost and schedule implications (on design, construction, and facility operations)
- Priority
- Actions taken
- Final resolution

The issues log serves as a vehicle to track, critically review, and resolve all commissioning-related issues. The log is maintained by the CxA and becomes part of the final commissioning record.

The CxA leads design review meetings and works collaboratively with the commissioning team to present, discuss, and resolve design review comments. Upon resolution of the CxA's comments, the engineering firm is responsible to incorporate all approved changes into the design documents.

2.7.2.3 Develop Commissioning Specifications

The commissioning tasks for the contractors should be detailed in the commissioning specifications and include:

- General commissioning requirements common to all systems and assemblies
- Detailed descriptions of responsibilities of all parties
- Details of commissioning process (i.e., schedule and sequence of activities)
- Reporting and documentation requirements and formats
- Alerts about coordination issues
- Deficiency resolution
- Participation in commissioning meetings
- Preparation of submittals
- Preparation of O&M manuals
- Construction checklists
- All aspects of functional testing processes
- Meeting conditions and acceptance criteria
- Preparing as-built drawings
- Training

Specifications must clearly specify who should attend and document the start-up of each commissioned system. Specifications must also clearly indicate the party responsible for conducting and documenting functional tests. The CxA and the architect or engineer must work together to ensure that commissioning requirements are coordinated and fully integrated into project specifications.

2.7.3 Written Test Procedures

Written function test procedures must define the methods of conducting system and inter-system tests during the construction phase. The test procedures should be defined by the commissioning team during the design stage and incorporated into the contractor's scope of work. Test procedures will be refined early in the construction phase based on submittal data. Test procedures should cover the following items:

- Required parties (construction manager, contractor, relevant sub-contractors, designer, OET PM, OET operating personnel, OET technical experts, customer agency representatives). The roles of each party must be defined clearly.
- Prerequisites for performing the test, for example, completion of specific systems and assemblies. Prerequisites are critical during phased construction and/or phased occupancy. The CxA must coordinate tests with the construction according to the overall construction schedule and the anticipated completion times of relevant systems.
- List of instrumentation, tools, and supplies required for testing.
- Specific step-by-step instructions for systems and assemblies to be tested. This includes instructions for configuring the system before the test and returning it to normal operation after the test.
- Recording of observations and measurements and range of acceptable results.

2.7.4 Construction Stage

During the construction phase, the commissioning team works to verify that systems and assemblies operate in a manner that meets the owner's project requirements. The two overarching goals of the construction phase are to ensure the level of quality desired and ensure the requirements of the contracts are met.

The construction phase commissioning activities constituted a defined quality process that includes installation, start-up, functional performance testing, and training to ensure system performance in accordance with the owner's requirements. The tests and documentation serve as important benchmarks and baselines for future recommissioning.

As submittals for products and materials are received from contractors, copies of submittals critical to the commissioning process shall be forwarded to the CxA. In general, the CxA is responsible to review the following types of submittals:

- Coordination drawings
- Redlined as-builts

- Product data and key operations data submittals
- Systems manuals
- Training materials

Clearly, the CxA cannot review every project submittal. His or her reviews of submittals should be limited to items critical to the commissioning process. The limitation allows the CxA to check the submittals for adherence to the owner's requirements, the BOD, and the project specifications. The CxA should pay special attention to substitutions and proposed deviations from contract documents and the BOD and comment on submittals only to the extent they deviate from the owner's requirements.

Construction checklists are developed by the commissioning agent, maintained by the construction manager, and used by the construction contractor and subcontractors. The purpose of such checklists is to convey pertinent information to the installers about the owner's concerns related to installation and long-term operation of the facility and systems. The checklist should be short and simple and focus only on key elements. The checklist process should start when equipment is delivered to the job site and continue until systems are operational and cover testing, adjusting, and balancing installed systems. Specialized checklists:

Monitor deliveries and storage

- Document and track deliveries of equipment and materials
- Verify submittal information to prevent acceptance and installation of equipment that does not meet specifications
- Ensure equipment or materials remain free of contamination, moisture, and other foreign materials.
- Verify installation and start-up of equipment and components

The CxA will develop a checklist that identifies components and systems for which checklists are required. He or she is responsible for reviewing the owner's project requirements for key success criteria, specifications, and submittals for key requirements. The CxA develops sample checklists for OET PM and CM review, incorporates their feedback, and finalizes checklists for distribution.

2.7.5 Oversee and Document Functional Performance Testing

Functional performance testing begins when construction checklists are completed. Functional testing evaluates the ability of the components in a system to work together to achieve the owner's requirements. To obtain valid results, the individual components and systems must first operate properly have to be verified to be properly operating based on a specific checklist that covers start-up, testing, adjusting, and balancing (TAB).

The OET PM must coordinate start-up and installation activities with the operation team. The fire protection engineer must ensure compliance with

life safety and code requirements. Test data records capture results and detail procedures, observations, and measurements. Data may be recorded using photographs, forms, or other appropriate means. Test data records should contain:

- Test reference (number or other specific identifier) and test date
- Date and time of test
- First test or retest after correction of an issue
- Description of system, equipment, and/or assemblies tested including location and construction document designation
- Test conditions (i.e., ambient temperature, capacity, duration, occupancy, etc.); tests should be performed under steady-state conditions
- Expected performance
- Observed performance including decision to accept or reject the installation
- Issues revealed by testing
- Signatures of those performing and witnessing testing

Functional performance tests are critical to the commissioning process even though they are both difficult and time consuming. System troubleshooting is a critical function of the CxA. As inspections and testing proceed, the CxA may find items that do not appear to work as intended. This will necessitate system retesting. The OET PM should include time and money in the project budget to accommodate retesting.

If equipment or systems fail to function properly, the problems must be documented and added to the issues log for team resolution. The issues log must contain details of testing failures and correction measures. All contracts should clearly specify which parties are responsible for retesting costs.

2.7.6 Conduct Owner Training

An important step in the commissioning process is ensuring that OET operating personnel are properly trained in the required care, adjustment, maintenance, and operations of installed equipment and systems. It is critical that O&M personnel have the knowledge and skills required to operate the facility to meet the owner's requirements. Training should cover:

- Step-by-step procedures required for daily operation
- Adjustment instructions including information for maintaining operational parameters
- Troubleshooting procedures including instructions for diagnosing operating problems

- Maintenance and inspection procedures and schedules
- Repair procedures including disassembly, component removal, replacement, and reassembly
- Upkeep of maintenance documentation and logs
- Emergency instructions for operating the facility during nonstandard conditions and/or emergencies
- Key warranty requirements

Because of the CxA's in-depth knowledge of the design and building systems, he or she should be involved in training. The CxA is responsible for facilitating the entire owner training process that starts at the design stage and is based on training plans detailed in the project specifications.

The CxA should maintain a system-based (not component-based) focus on training to ensure that operating personnel understand the interrelationships of equipment, systems, and assemblies. The CxA should review contractors' agendas and training materials for quality, completeness, and accuracy and also attend key training sessions to evaluate effectiveness and suggest improvements.

Most training should be conducted during the construction phase, before substantial completion. Some systems and assemblies may require ongoing training during initial occupancy. The systems, subsystems, equipment, and assemblies that require training and the required number of hours of training should be specified in the project specifications. The construction manager must record attendance to verify the delivery of training.

Training should be conducted during regular work hours for all shifts on a schedule set by the OET PM. Videotaping of all training is highly recommended because it allows replay of the material for new employees. The team may also wish to consider DVDs recording for convenience. The contractor is required to provide the OET PM with an edited draft of taped training sessions (generally within seven days) that covers operation, inspection, testing, and maintenance of the systems. Technical experts should review all videotapes and provide comments to the contractor. The contractor will then resubmit a final version of the tape (generally within seven days of receipt of comments).

2.7.7 Post-Construction Stage

The conditions of systems, assemblies, equipment, and components will change over time. In addition, the needs and demands of facility users typically change as a facility is used. The post-construction stage allows continued adjustment, optimization, and modification of building systems to meet

specification requirements. The objective of this state is to maintain building performance throughout the useful life of the facility.

The active involvement of the commissioning agent and the commissioning team during initial facility operations is an integral aspect of commissioning. The commissioning activities during post-construction include issue resolution, seasonal testing, delivery of the final commissioning report, performance of a post-occupancy review with the owner, and developing a plan for recommissioning the facility throughout its life cycle.

Due to weather conditions, some systems may not be tested at or near full load during the construction phase. For instance, testing of a boiler system may be difficult in the summer, and testing of a chiller and cooling tower may be impossible in the winter. For these reasons, commissioning plans should cover off-season testing to provide the best possible conditions for critical equipment. In addition, testing of some systems may have been deferred for a number of reasons including phased occupancy issues and improper testing conditions. The commissioning team must ensure that all deferred testing is completed during post-construction.

2.7.7.1 Reinspect and Review Performance before End of Warranty Period

During the first year of a building's operation, it is important to assure that required performance levels are maintained, particularly before warranties expire. Ten months into a 12-month warranty period, the operation of system and components should be reviewed by the CxA, owner, and construction manager to identify any items that require repair or replacement under warranties to meet the owner's project requirements.

Discrepancies between predicted and actual performance and/or an analysis of complaints received may indicate a need for minor system modifications. The CxA must document any problems and forward recommendations to the owner and construction manager for resolution.

The OET PM should understand the impacts of a phased occupancy, if applicable, on warranty periods and make necessary adjustments for review and inspection. Proper maintenance programs, training, and understanding of the systems by the operating staff are important to support post-construction commissioning. For example, a standard method of recording and responding to complaints must be in place and used consistently.

As equipment and controls are replaced throughout the maintenance program, calibration and performance must be checked, documents must be revised, and any changes or new equipment data sheets included in the operations and maintenance manuals.

Ongoing training includes refresher sessions for existing personnel, training of new personnel, and training of all personnel on new equipment and revised operating procedures.

2.7.7.2 Complete Final Commissioning Report

During post-construction, the CxA is responsible for delivering a final commissioning report in addition to documents required for turnover commissioning. The final commissioning report should include:

- A statement that systems have been installed in accordance with the contract documents and are performing in accordance with the owner's final project requirements document
- Identification and discussion of any substitutions, compromises, or variances among the final design, contract documents, and as-built conditions
- Description of components and systems that exceed owner's project requirements and those that do not meet the requirements.
- A summary of all resolved and unresolved issues and recommendations for resolution
- Post-construction activities and results including deferred and seasonal testing data and reports and training documentation
- Lessons learned for future commissioning project efforts
- Recommendations for changes to OET standard test protocols and/or facility design standards

The final commissioning report will serve as a critical reference and benchmark document for future recommissioning of the facility. In addition, the CxA should ensure that the engineering office has complete and up-to-date as-built drawings.

2.7.7.3 Final Satisfaction Review with Customer Agency

The OET PM leads a final satisfaction review with the owner one year after occupancy and the commissioning team and other relevant parties should attend. The purpose of the review is to obtain honest, objective, and constructive feedback on what worked well throughout commissioning and what the commissioning team could have done better. The focus should be on identifying root causes and proposing corrective actions for future projects. Specific discussion topics may include:

- Owner's project requirements
- Systems selected for commissioning
- Coordination issues
- Commissioning budget and costs
- Commissioning schedule relative to project schedule
- Occupant comments and/or complaints

- Documentation issues
- Lessons learned

The OET PM should document the discussions in a formal lessons-learned report that will provide important input for future projects.

References

- El-Reedy, M.A. (2012). New Project Management Approach for Offshore Facilities Rehabilitation Projects, SPE-160794, ADIPEC Conference Proceedings, Abu Dhabi, UAE.
- Project Management Institute Standards Committee. (2004). *A Guide to the Project Management Body of Knowledge*. Upper Darby, PA: Project Management Institute.
- Tricker, R. (1997). *ISO 9000 for Small Business*. Oxford: Butterworth-Heinemann.
- U.S. General Services Administration. 2005. *The Building Commissioning Guide*.

3

Concrete Materials and Tests

3.1 Introduction

Concrete consists of two main parts: the first part is the aggregate (coarse and fine) and the other part is the adhesive, which is a mix of cement and water. So the main components are the coarse and fine aggregate, cement, water, and additives. These additives are added to the mix to improve the properties of concrete. They must be added in specific percentages to prevent negative impacts from incorrect preparations.

To obtain a concrete that conforms to the specifications, we must adjust the quality of each component in the concrete mix. In this chapter the main necessary tests of cement, aggregate, water, and additives to obtain high-quality concrete that matches international standards and project specifications will be illustrated.

It is known that the concrete itself is weak under tensile stress, so we use steel reinforcement in concrete to withstand the tensile stress, which increases the efficiency of concrete. Worldwide, reinforced concrete is an important element in the construction industry. It is cheaper in most cases than other alternatives and the ease of formation in the early stages allows for different architectural forms.

Steel is the most important element in reinforced concrete structures as it carries a large part of the stresses. Therefore, the production of the steel bars must be under a strict system of quality control to make sure that it follows the international standards and project specifications. These tests should be done in an appropriate way with valid calibration devices to give accurate results. The laboratory as a whole should follow a quality assurance system, and the equipment should be periodically calibrated. Moreover, the samples must be taken correctly according to standard specifications and pass all the necessary tests and reviews based on the quality system.

3.2 Concrete Materials Test

The following sections will describe the important field and laboratory tests for concrete materials. However, most civil engineers on site only focus on the compressive strength and slump tests. But the other tests are as important for testing concrete durability, strength, and performance.

3.2.1 Cement

The use of materials for adhesion is very old. The ancient Egyptians used calcined impure gypsum. The Greeks and the Romans used calcined limestone and later learned to add sand and crushed stone, or brick and broken tiles. This was the first concrete in history. Lime mortar does not harden underwater, and for construction underwater the Romans ground together lime and volcanic ash or finely ground burnt clay tiles. The active silica and alumina in the ash and the tiles combined with lime to produce what became known as pozzolanic cement from the village of Pozzuoli, near Mount Vesuvius, where the volcanic ash was first found. The name of pozzolanic cement is used to this day to describe cements obtained simply by the grinding of natural material at normal temperature.

At present, there are different types of cement to choose from and the different alternatives depend on the designer recommendation in the project specifications and the drawings based on the surrounding environmental conditions and the required strength.

The main types of cement, according to British Standards and ASTM, are shown in Table 3.1.

To ensure the cement quality, there are many tests to define the quality of the cement manufacturing or ensure the cement onsite is a match with the

TABLE 3.1

Cement Types

ASTM Description	British Description
Type I	Ordinary Portland cement
Type III	Rapid hardening Portland Extra rapid hardening Portland Ultra high early strength Portland
Type IV	Low heat Portland
Type II	Modified cement
Type V	Type V sulfate resisting Portland
Type IS	Portland blast furnace White Portland
Type IP & P	Portland pozzolana
Type S	Slag cement

specifications. There are some important tests described in many international standards, which define the limits of refusal and acceptance of the cement.

There are many ways to take a sample. Based on the procurement agreement loose cement or bags on site may be simple. It is very important to define in the agreement between the supplier and the customer the location and time to take the samples. There should be enough time allotted to take the sample to perform the required tests, obtain the results, and define the suitability of the cement to use. The tests should also be performed 28 days from the date of receiving the samples.

When taking the samples, they must be in conformity with the specifications agreed upon. The general requirement of the samples is that the weight of one sample is not less than 5 kg and that the sampling tools are dry and clean. The sample may be taken individually via digital sampling or through a number of samples at spaced intervals called composite sampling. In the case of bulk cement it is important to avoid the upper cement layer about 150 mm from the top.

Most sites receive the cement in sacks so the tests will be done by select random sacks, and the number of sacks will be according to the following equation:

$$\text{Number of samples} \geq (n)^{0.333}$$

3.2.1.1 Cement Test by Sieve No. 170

The fines of cement are important factors that affect the quality of concrete. If the cement particle is big it cannot completely react with water, as there will be a remaining cement core the water will be unable to reach. The water propagates through the cement particles and starts to dehydrate, causing an increase in temperature, which is the main reason hair cracks form, and the cement volume is not stabilized. Increasing the fines of cement will improve cohesion and durability, and decrease the water moving upward to the concrete surface. Figure 3.1 presents the relation between the concrete strength and concrete fines at different ages (Neville 1983).

To do the sieve test, take a sample of 50 grams of cement and shake it in closed glass bottle for 2 minutes and then revolve the sample gently using a dry bar. The sample will put in a closed bottle and left for 2 minutes. Put the sample in sieve No. 170 (90 microns), then shake the sieve horizontally and rotationally. The sieve test is complete when the rate of passing cement particles is not more than 0.5 g/min during the sieve. Carefully remove the fines from the bottom of the sieve with a smooth brush. Then collect and weigh what remains on the sieve (W1).

Repeat the same test again with another sample. Then residual weight for the second test is obtained (W2). Calculate the remaining samples using

$$R1 = (W1/50) \times 100$$

$$R2 = (W2/50) \times 100$$

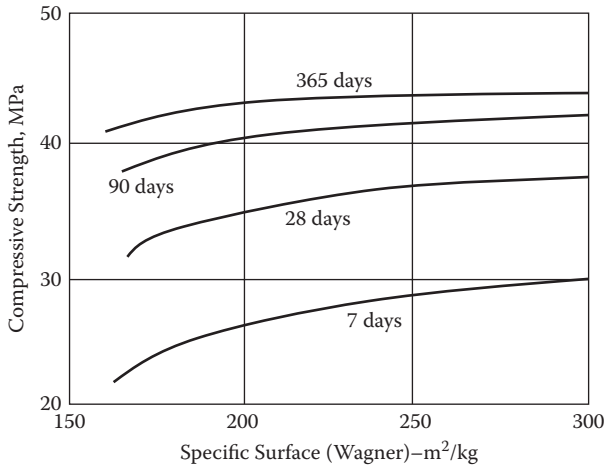

FIGURE 3.1

Relationship between cement fines and compressive strength.

The ratio (R) is calculated by taking the average of R1 and R2 to the nearest 0.1%. If the results of the two samples differ by more than 1%, do the test again for third time and take the average of the three results.

Therefore, you can accept or refuse the cement based on the following condition:

- For Portland cement the remainder must not exceed 10%.
- For rapid hardening Portland the remainder cement must not exceed 5%.

3.2.1.2 Initial and Final Setting Times of Cement Paste Using Vicat Apparatus

The objective of this test is to define the initial and final setting times for the paste of water and cement by using Vicat apparatus. This test determines if the cement is expired or can be used.

The initial setting is the required time for concrete set. After setting, the concrete cannot be poured or formed. The final setting time is the time required for the concrete to be hardened.

The Vicat apparatus (Figure 3.2) consists of a carrier with a needle acting under a prescribed weight. The parts move vertically without friction, weigh 300 ± 1 g, and are not subject to erosion or corrosion. The round paste mold on the bottom is made from a metal or hard rubber or plastic. The depth of 40 ± 2 mm and the internal diameter of the upper face 70 ± 5 mm and lower face 80 ± 5 mm. Under the mold is a larger sized, nonporous template of glass.

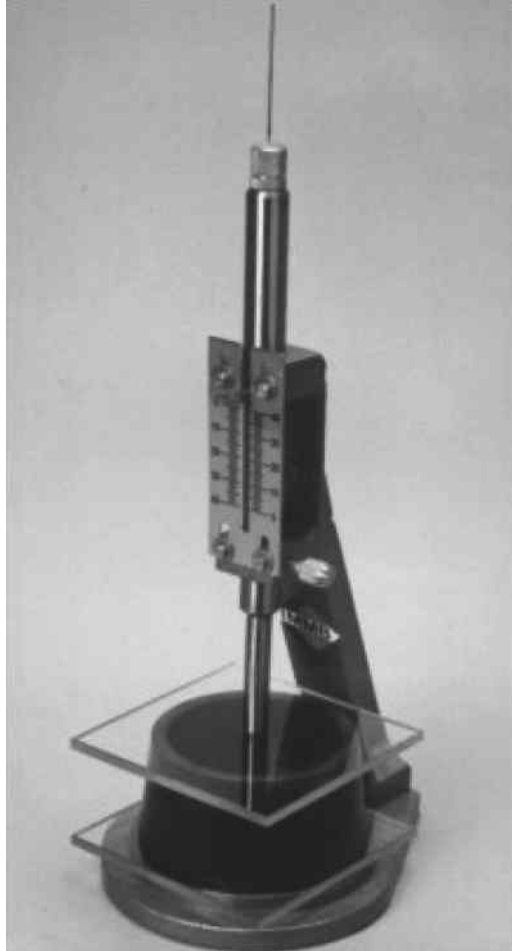

FIGURE 3.2
Vicat apparatus.

The needle used to determine the initial setting time is a steel cylinder with length of 50 ± 1 mm and diameter 1.13 ± 0.5 mm. The needle that measures final setting has length of 30 ± 1 mm and diameter 1.13 ± 0.5 mm, and a 5 mm diameter ring attachment at the free end. The distance between the end of the needle and the ring is 0.5 mm.

The test starts by taking a sample weighing about 400 grams, placing it on an impermeable surface, and then adding 100 mm of water. Record a zero measurement of the time of adding water to the cement and then mix for 240 ± 5 seconds on an impermeable surface.

To determine the initial setting time insert the Vicat needle and calibrate the device until the needle reaches the base of the mold, then

adjust the measuring device to zero and then return the needle to its original place.

Fill the mold with cement paste with standard consistency, trowel the surface, and put the mold for a short time in a place at the temperature and humidity required for the test.

Transfer the mold to the apparatus under the needle, and then move the needle slowly until it touches paste surface, stop it in place for a second or two to avoid impact of primary speed, leaving the moving parts to implement the needle vertically in the paste.

Grading is read when the needle stops penetration or after it has penetrated for 30 seconds, whichever is earlier. Record the reading of grading, which indicates the distance between the mold base and the end of the needle, as well as the time start from the zero level measurement.

Repeat the process of immersing the needle to the same paste in a different location with the distance between immersing and edge of the mold or between two immersing points not less 10 mm and after subsequent periods of time (about 10 minutes). Clean the needle immediately after each test.

Record time measured from zero to measure up to 5 ± 1 mm from the base of mold as the initial setting time to the nearest 5 minutes.

To determine the time of final setting, the needle is used to identify the final time of setting, follow the same steps for the initial setting time and increase the period between embedment tests to 30 minutes.

Record the time from zero measurement until embedment of the needle to a distance 0.5 mm and it will be the final setting time. To enhance the test accuracy reduce the time between tests and examine the fluctuation of these successive tests. Record the final setting time to nearest 5 min.

According to the Egyptian specifications the initial setting time must not be less than 45 minutes for all types of cement but for low heat cement the initial setting time should be not less than 60 minutes. The final setting time must be not more than 10 hours for all types of cement.

3.2.1.3 Density of Cement

The purpose of this test is to determine the density of cement by identifying weight and unit volume of material by using a Le Chatelier bottle. Determining the cement density is essential for concrete mix design and to control its quality. Use the specifications of ASTM C188-84.

The required shape of the Le Chatelier bottle is shown in Figure 3.3. The glass used in the Le Chatelier bottle is of high quality free from any defects, does not interact with chemicals, has high heat resistance, and is of appropriate thickness to resist crushing. Start measurements at the bottleneck. Measurement markings go from 0 to 1 ml and from 18 to 24 ml with accuracy 0.1 ml, and must be written on each bottle mark. Each bottle should be numbered on the cap. Any replacement parts must also have the

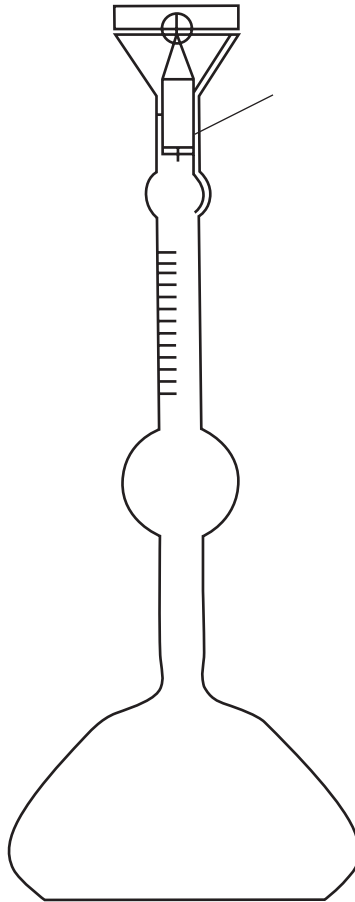

FIGURE 3.3
Le Chatelier bottle.

same number. Also note on the bottle the standard temperature and the capacity in millimeters over the highest point of grading.

The cement sample to be tested should weigh about 64 g to nearest 0.05 g according to the processing requirements of the cement samples.

Fill the bottle with kerosene free from water and oil, with density not less than 62 API. Up to a point between 0 and 1 ml, drying the inner surface of the bottle at the highest level of kerosene. If necessary use a rubber mat on the surface of the table when filling the bottle.

Vertically place the kerosene-filled bottle in a water bath and record the first reading to kerosene level.

Put a cement sample weighting 64 g inside the bottle with small batches at the same temperature of kerosene. When putting the cement inside the bottle avoid any spillage or adherence to the inside of the bottle. We can put

the bottle on the vibrating machine when filling to expedite the process and prevent cement from sticking to the inside of the bottle.

After putting the entire quantity of cement inside the bottle, put a cap on the bottle mouth. On an inclined rubber pallet on the surface, spin the bottle at a diagonal so as to expel the air between the granules of cement. Continue moving the bottle until air bubbles stop emerging from the kerosene surface inside the bottle.

Put the bottle in the water bath and then take the final reading. Record the reading at the lower surface of kerosene to avoid the surface tension effect. When taking the first and final readings ensure the bottle was placed in a water bath with constant temperature. The difference in temperature between the first and final reading should not be more than about 0.2°C.

The difference between the first and final reading is the volume of the moving liquid by the cement sample.

$$\text{Volume of the moving liquid} = \text{Final reading} - \text{First reading}$$

$$\text{Cement density} = \text{Cement weight (g)}/\text{Moving liquid volume (cm}^3\text{)}$$

The accuracy of the density calculation is to the nearest 0.01 g/cm³.

3.2.1.4 Define Cement Fineness Using Blaine Apparatus

This test is used to determine the surface area by comparing a test sample with a specific reference. The greater surface area increases the speed of concrete hardening and achieves early strength. This test defines the acceptance of the cement.

There are many tests to define the cement fineness and one of these tests is by using Blaine apparatus as suggested in many codes. This test depends on calculating the surface area by comparing the difference between the sample and the reference sample by using the Blaine apparatus (Figure 3.4), which measures the time required to pass a definite quantity of air inside the cement layer with defined dimensions and porosity.

The first step in testing is to determine the volume of the cement layer. Knowing the weight of the cement and the mercury density allow us to calculate the volume of cement layer:

$$V = W_1 - W_2/Dm$$

where

V = volume of cement layer (cm³)

W_1 = weight of mercury in grams that fill the device to nearest 0.0 g

W_2 = weight of mercury in grams that fill the device to level of cement to nearest 0.0 g

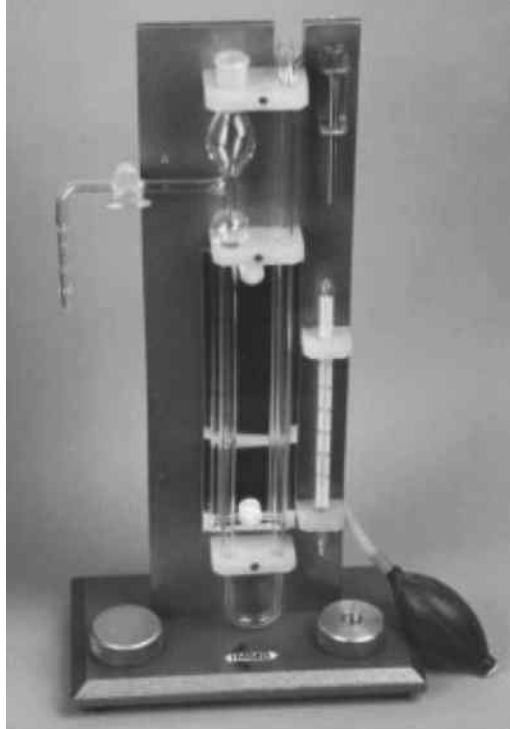

FIGURE 3.4
Blaine apparatus.

D_m = density of the mercury (g/cm^3); use tables to define the mercury density at the average temperature of the test and by the manometer

$$S_r = \frac{K}{D_r} \left(\frac{\sqrt{(P_r)^3 T_r}}{(1 - P_r) \sqrt{0.1 I_r}} \right)$$

where

S_r = reference cement surface area, (cm^2/g)

D_r = reference cement density (g/cm^3)

P_r = porosity of the cement layer

I_r = air viscosity in the average temperature for reference cement test

T_r = average time required for the manometer liquid to settle in two marks to nearest 0.2 s

K = Blaine apparatus constant factor defined by the previous equation by knowing the time need to pass the air in the sample

Calculate the sample surface area by using the following equation:

$$S_c = S_r (D_r/D_c) * (T_c/T_r)^{0.5}$$

TABLE 3.2

Cement Fineness Acceptance and Refusal Limits

Cement Type	Cement Fineness Not Less than cm ² /g
Ordinary Portland	2750
Rapid hardening Portland	3500
Sulfate resistance Portland	2800
Low heat Portland	2800
White Portland	2700
Mixing sand Portland	3000
4100 fineness	4100
Slag Portland	2500

According to the Egyptian code the acceptance and refusal of cement will be as shown in Table 3.2.

3.2.1.5 Compressive Strength of Cement Mortars

The cement mortar compressive strength test is performed with standard cubes of cement mortar. The cement mortar is mixed manually and compacted mechanically by a standard vibrating machine. This test is considered the refusal or acceptance test.

The compressive strength is one of the most important properties of concrete. The concrete gains its compressive strength from the presence of cement paste resulting from the interaction between the cement and water added to the mix. The test ensures that the cement used is of appropriate compressive strength and should be done to all types of cement.

The equipment needed for the test are sieves with standard square holes of the fabric of wires opened 850 microns, 650 microns. Nylon made of stainless steel does not react with cement and weighs about 210 grams.

The vibrating machine has a weight of about 29 kg and the speed of vibration is about (12000 vertical vibration + 400 RPM) and the moment of vibrating column is 0.016 Nm.

The mold of the test is a cube 70.7 ± 1 mm and the surface area for each surface is 500 mm². The acceptable tolerance in leveling is about 0.03 mm and the tolerance between paralleling for each face is about 0.06 mm.

The mold must be manufactured from materials that will not react with the cement mortar, and the base of the mold from steel that can prevent leak of the mortar or water from the mold, and the base should fit the vibrating machine.

The sand that will be used in the test must have a percentage of silica not less than 90% by weight, and must be washed and dried very well. Moreover, the humidity should be less than 0.1% by weight so the sand can pass through sieve opening 850 micron and the passing through the standard sieve size of 600 micron should not be more than 10% of sample weight. (Also see Tables 3.3 and 3.4.)

TABLE 3.3

One Cube Mixing Ratio

Cement Type	Materials	Ratios by Weight	Weight (g)
All types of cement	Cement	1.0	185 ± 1
	Sand	3.0	555 ± 1
	Water	0.4	74 ± 1
High alumina cement	Cement	1.0	190 ± 1
	Sand	3.0	570 ± 1
	Water	0.4	76 ± 1

TABLE 3.4

Allowable Deviation in Temperature and Humidity

Location	Temperature (°C)	Minimum Relative Humidity (%)
Mixing room	20 ± 2	65
Curing room		90
Water curing sink		–
Compression machine room		50

TABLE 3.5

Acceptance and Refusal Limits

Cement Type	Cube Compressive Strength (N/mm ²)			
	After 24 Hours ≥	After 3 Days ≥	After 7 Days ≥	After 28 Days ≥
Ordinary Portland	–	18	27	36
Rapid hardening Portland	–	24	31	40
Sulfate resistance Portland	–	18	27	36
Low heat Portland	–	7	13	27
White Portland	–	18	27	36
Mixing sand Portland	–	12	20	27
4100 fineness	10	25	32.5	40
Slag Portland	–	13	21	34
High alumina				
High Alumina 80	25			
High Alumina 70	30			

After performing the tests, the standard cubes will crush after 1 day which is about 24 ± 0.5 hours, and after 3 days within 72 ± 1 hour, and after 7 days within 168 ± 1 hour, and after 28 days within 672 ± 1 hour.

Table 3.5 illustrates the limits of acceptance and rejection based on the cement mortar compressive strength. Note from the table that there is more than one type of high-alumina cement, as high-alumina cements vary according to the percentage of oxide alumina. Also note that the

compressive strength after 28 days will not be considered for acceptance or rejection unless stated in the contract between the supplier and the client.

3.2.2 Aggregate Tests

3.2.2.1 Sieve Analysis Test

The main key to higher concrete strength is aggregate interaction. This interaction increases the density of concrete, which increases the compressive strength. The interaction between aggregates depends on the grading of coarse aggregate and sand. So this grading should be according to definite specifications. The sieve analysis test relies on a standard sieve of the specifications and dimensions as listed in Table 3.6.

The standard sieve is a metal cylinder frame with a square opening. The sieve is classified according to its opening length in millimeters and shape, as shown in Figure 3.5.

The test procedure starts by defining weight of the aggregate, and then drying it at a temperature of $105 \pm 5^\circ\text{C}$ for 24 hours until the weight proves to the nearest 0.1%.

Sieves are arranged according to size. The sample is placed in the largest sieve. Start shaking the sieve manually or mechanically for sufficient period but not less than 5 minutes so as to ensure that no more than 0.1% of the total weight of the sample passes through during 1 minute of manual shaking. You can take into granules aggregate that pass through sieve by applying hand pressure, but this can only be done for sieve size 20 mm and larger. (See Figure 3.6.)

Measure the weight of the remaining aggregate on the sieves separately, and then calculating that which passed through the sieves, as shown in Table 3.7.

The nominal maximum aggregate size is defined as the smallest sieve that passes at least 95% of the coarse aggregate or whole aggregate.

During this test do not impose excessive weight on the sieve. The maximum weight of the remaining aggregate on the sieve should not exceed the weights in Table 3.8, which is based on European Concrete Platform (ECP) code and BS 812-103.1:1985.

The above table is based on ISO 6274-1982. The acceptance and refusal limits for the coarse aggregate and sand, and the whole aggregate are based on ECP codes, BS 882:1992, and ASTM C33-93 as shown in Table 3.6 shows the grading requirement of coarse aggregate according to the BS 882:1992, which is similar with the ECP but with some modification. Tables 3.9 through 3.12 show acceptance and refusal limits for fine and coarse aggregates.

The acceptable grade requirement in BS 882:1973 is shown in Table 3.14.

The actual grading requirements depend to some extent on the shape and surface characteristics of the particles. For instance, sharp, angular particles with rough surfaces should have a slightly finer grading in order to reduce

TABLE 3.6

Standard Sieve Sizes for Aggregates Given by Various Standards (mm)

EC	BS 410:1986	BS 812: Section 103.1:1985	EN 993-2	ASTM E11-87
	125			125
				100
	90			
75		75		75
63	63.0	63.0	63.0	
50		50		
	45			
37.5		37.5		37.5
	31.5			
		28		
26.5				
				25
	22.4			
		20		
19				19
	16		16	
		14		
13.2				
				12.5
	11.2			
		10		
9.5				9.5
	8.0		8.0	
6.7				
		6.3		6.3
	5.6			
		5.0		
4.75				4.75
	4.0		4.0	
3.35		3.35		
	2.8			
2.36		2.36		2.36
	2.0		2.0	
1.7		1.7		
	1.4			
1.18		1.18		1.18
	1.00		1.00	
0.85		0.85		
	0.710			

(Continued)

TABLE 3.6 (Continued)

Standard Sieve Sizes for Aggregates Given by Various Standards (mm)

EC	BS 410:1986	BS 812: Section 103.1:1985	EN 993-2	ASTM E11-87
0.6		0.6		0.6
	0.5		0.5	
0.425				
	0.355			
0.3		0.30		0.30
	0.25		0.25	
0.212		0.212		
	0.18			
0.15		0.15		0.15
	0.125		0.125	
	0.090			
0.075		0.075		0.075
	0.063		0.063	
	0.045			
	0.032			

the interlocking and to compensate for the high friction between the particles. The actual grading of crushed aggregate is affected primarily by the type of crushing employed. A roll granulator usually produces fewer fines than other types of crushers, but the grading depends also on the amount of material fed into the crusher.

3.2.2.2 Abrasion Resistance of Coarse Aggregates in Los Angeles Test

From the Los Angeles test, one can define the abrasion factor, which is the percentage of weight loss due to abrasion. The Los Angeles device is a cylinder that is rotated manually. Inside it are balls made from cast iron or steel with a 48 mm diameter and the weight per ball ranges from 3.82 to 4.36 newtons.

This test begins by bringing a sample of big aggregate, weighing from 5 to 10 kg, and washing the sample with water and then drying it in a 105°C to 110°C oven until it reaches proved weight (Figure 3.7).

Separate the samples into different sizes through the sieves shown in Table 3.15. Then mix the weight of different sizes together.

Weigh the sample after remixing it. The weight is W_1 and the grading type is as per the table from A to G. By knowing the grading type, you can define the number of balls that will be put in the device, as shown in Table 3.16. Put the sample and the balls inside the Los Angeles machine and rotate the machine at 10 to 31 rpm so that the total number of rotations is 500 for sample gradients A, B, C, D, and F, and 1000 cycles for the rest of the grading.



FIGURE 3.5
Shapes of sieves.

Lift aggregate from the machine and put in sieve size 16 mm and then pass it through sieve size 1.7 mm. Wash the aggregates that remain on the two sieves, and then dry in 105°C to 110°C oven. This weight is W2.

$$\text{Percentage of abrasion} = (W1 - W2)/W1 \times 100$$

The acceptable aggregate that the percentage of abrasion by Los Angeles test is no more than 20% in aggregate and 30% for crushed stone.

3.2.2.3 Determination of Clay and Other Fine Materials in Aggregates

The clay and fine material that pass through micron-sized sieves are known as soft material. Therefore a test is conducted to make sure that aggregate is in conformity with the standard specifications. This will be done by taking a fine aggregate sample of at least 250 g. For coarse aggregate or whole aggregate the sample weight will be as in Table 3.17.



(a)



(b)

FIGURE 3.6

(a) Sand on the sieves. (b) Washing the aggregate.

TABLE 3.7

Percentage of Aggregate Remaining and Passing from Sieve Analysis

Sieve Size (mm)	Remaining Weight on Sieve	Total Remaining Weight on Sieve	Percentage of Remaining Aggregate	Percentage of Passing Aggregate
37.5	W_1	W_1	$R_1 = W_1/W$	$100 - R_1$
20	W_2	$W_1 + W_2$	$R_2 = (W_1 + W_2)/W$	$100 - R_2$
10	W_3	$W_1 + W_2 + W_3$	$R_3 = (W_1 + W_2 + W_3)/W$	$100 - R_3$
5	W_4	$W_1 + W_2 + W_3 + W_4$	$R_4 = (W_1 + W_2 + W_3 + W_4)/W$	$100 - R_4$

TABLE 3.8

Maximum Weight for Remaining Aggregate in Different Sieve Sizes

Sieve Opening Size (mm)	Maximum Weight (kg)		Sieve Opening Size (mm)	Maximum Weight (kg)	
	Sieve Diameter 450 mm	Sieve Diameter 300 m		Sieve Diameter 300 m	Sieve Diameter 200 m
50	14	5	5.00	750	350
37.5	10	4	3.35	550	250
28	8	3	2.36	450	200
20	6	2.5	1.80	375	150
14	4	2	1.18	300	125
10	3	1.5	0.85	260	115
6.3	2	1	0.6	225	100
5	1.5	0.75	0.425	180	80
3.35	1	0.55	0.300	150	65
			0.212	130	60
			0.15	110	50
			0.075	75	30

TABLE 3.9

Acceptance and Refusal Limits for Fine Aggregate

Sieve Opening Size (mm)	Percentage Passing the Sieve				ASTM C33-93
	ECP and BS 882:1992				
	General Grading	Coarse	Medium	Fine	
10.0	100	—	—	—	100
5.0	89-100	—	—	—	95-100
2.36	60-100	60-100	65-100	80-100	80-100
1.18	30-100	30-90	45-100	75-100	50-85
0.6	15-100	15-45	25-80	55-100	25-60
0.3	5-70	5-40	5-48	5-70	10-30
0.15	-15	—	—	—	2-10

TABLE 3.10

Acceptance and Refusal Limits for Coarse Aggregate in Egyptian Code

Sieve Opening Size (mm)	Percentage by Weight Passing Sieves						
	Nominal Size of Graded Aggregate (mm)				Nominal Size of Single-Sized Aggregate Size (mm)		
	5-40	5-20	5-10	40	20	14	10
50.0	100	-	-	100	-	-	-
37.5	90-100	100	-	85-100	100	-	-
20.0	35-70	90-100	100	0-25	85-100	100	-
14.0	-	-	90-100	-	-	85-100	-
10.0	10-40	30-60	50-58	0-5	0-25	0-50	100
5.0	0-5	0-10	0-10	-	0-5	0-10	50-100
2.36	-	-	-	-	-	-	0-30

TABLE 3.11

Acceptable and Refusal Limits for Coarse Aggregate in BS882:1992

Sieve Opening Size (mm)	Percentage by Weight Passing Sieves						
	Nominal Size of Graded Aggregate (mm)				Nominal Size of Single-Sized Aggregate Size (mm)		
	5-40	5-20	5-14	40	20	14	10
50.0	100	-	-	100	-	-	-
37.5	90-100	100	-	85-100	100	-	-
20.0	35-70	90-100	100	0-25	85-100	100	-
14.0	25-55	40-80	90-100	-	0-70	85-100	100
10.0	10-40	30-60	50-85	0-5	0-25	0-50	85-100
5.0	0-5	0-10	0-10	-	0-5	0-10	0-25
2.36	-	-	-	-	-	-	0-5

The test begins by drying the sample in an $110 \pm 5^\circ\text{C}$ oven until proved weight (W) is reached. Then immerse the sample in water and move it strongly. Remove the clay and fine materials from the aggregate sample by putting the wash water on two sieves, No. 75 micron and No. 141 micron. The No. 141 micron should be on the top and No. 75 on the bottom. Then repeat the washing several times until the washing water is pure.

Return the remaining materials on 141 and 75 micron sieves to the washed sample, then dry the remainder at the same oven temperature until weight W_1 . Then calculate the percentage of clay and fine materials by weight as follows:

$$\text{Percentage of fine materials and clay} = (W - W_1)/W \times 100$$

Based on the ECP, ASTM C142-78, and BS 882:1992 specifications, the maximum acceptable limits for clay and fine materials in aggregate are shown in Table 3.18.

TABLE 3.12

Grading Requirements for Coarse Aggregate According to ASTM C33-93

Sieve Opening Size (mm)	Percentage by Weight Passing Sieves				
	Nominal Size of Graded Aggregate (mm)			Nominal Size of Single-Sized Aggregate Size (mm)	
	37.5 to 4.75	19.0 to 4.75	12.5 to 4.75	63	37.5
75	–	–	–	100	–
63	–	–	–	90–100	–
50.0	100	–	–	35–70	100
38.1	95–100	–	–	0–15	90–100
25	–	100	–	–	20–55
19	35–70	90–100	100	0–5	0–15
12.5	–	–	90–100	–	–
9.5	10–30	20–55	40–70	–	0–5
4.75	0–5	0–10	0–15	–	–
2.36	–	0–5	0–5	–	–

TABLE 3.13

Acceptance and Refusal Limits of Whole Aggregate According to BS882:1992 and ECP2002

Sieve Opening Size (mm)	Percentage Passing Sieve		
	Nominal Maximum Aggregate Size	Nominal Maximum Aggregate Size	Nominal Maximum Aggregate Size
	40 mm	20 mm	10 mm
50.0	100	–	–
37.5	95–100	100	–
20.0	45–80	95–100	–
14.0	–	–	100
10.0	–	–	95–100
5.0	25–50	35–55	30–65
2.36	–	–	20–50
1.18	–	–	15–40
0.60	8–30	35–10	10–30
0.30	–	–	5–15
0.15	0–8*	0–8*	0–8*

*Increase to 10% for crushed rock fine aggregate.

3.2.2.4 On-Site Test

This simple test can be conducted on site with 50 cm³ of clean water filling a glass tube and then adding sand until the total volume is 100 cm³. Then add clean water until the total volume is 150 cm³ (Figure 3.8).

Strongly shake the glass tube until the fine materials and clay move to the top. Set the tube on a table for 3 hours. Then calculate the percentage

TABLE 3.14

Grading Requirement for Whole Aggregate Based on BS882:73

Sieve Size (mm)	Percentage by Weight Passing Sieves	
	Nominal Size 40 mm	Nominal Size 20 mm
75	100	–
37.5	95–100	100
20	45–80	95–100
5	25–50	35–55
600 μm	8–30	10–35
150 μm	0–6	0–6

**FIGURE 3.7**

Oven according to BS 1377.

of fine materials and clay by the volume that hangs on the top layer of the water with respect to the volume of the aggregate that has settled to the bottom.

So if you find a higher percentage of suspended clay and fine materials, the aggregate is not a match with the specification. Go to the previous laboratory test, which is the official test for accepting or refusing the aggregate.

TABLE 3.15

Sieve Analysis for Los Angeles Test

Passing from	Remaining on	A	B	C	D	E	F	G
75.00	63.00					1500		
63.00	50.00					1500		
50.00	37.5					1500	5000	
37.5	25.00	1250					5000	5000
25.00	19.00	1250						5000
19.00	12.5	1150	1500					
12.5	9.5	1150	1500					
9.5	6.3			1500				
6.3	4.75			1500				
4.75	2.38				5000			

TABLE 3.16

Relationship Between Sample Grade and Number of Balls

Sample Grades	Number of Abrasion Balls
A	13
B	11
C	8
D	6
E	11
F	11
G	11

TABLE 3.17

Sample Weight to Test Percentage of Clay and Fine Aggregate

Maximum Nominal Aggregate Size (mm)	Least Sample Weight (kg)
4.75–9.5	5
9.5–19	15
19–37.5	25
< 37.5	50

TABLE 3.18

Maximum Allowable Limits for Fine Aggregate in Concrete

Type of Aggregate	Percentage of Clay and Fine Materials by Weight (%)
Sand	3
Fine aggregate by crushing stone	5
Coarse aggregate	1
Coarse aggregate from crushed stone	3



FIGURE 3.8
Tubes for aggregate density test.

TABLE 3.19

Aggregate Specific Gravities

Type of Aggregate	Range of Specific Gravity
Sand	2.5–2.75
Coarse aggregate	2.5–2.75
Granite	2.6–2.8
Basalt	2.6–2.8
Limestone	2.6–2.8

3.2.2.5 Aggregate Specific Gravity Test

The specific gravity is obtained by dividing the weight of dry aggregate by water volume (Table 3.19).

3.2.2.6 Fine Aggregate Test

The test sample should not exceed 100 g. Dry it in a ventilated oven 100°C to 110°C. Cool the sample in the dryer, weigh it, return it to the drying process, and weigh it until it proves weight and measurement (W).

Add water at 15°C to 25°C to a graduated tube and then add the fine aggregate (W) and leave it submerged in water for an hour. Remove any bubbles by knocking on the tube. Leave it submerged in the water for an hour and remove the bubbles by tapping the tube.

One hour after adding the aggregates, read the level of the water in the tube. This defines the aggregate volume (V). Then calculate the specific gravity by the following equation:

$$\text{Specific gravity of aggregate} = W/V$$

3.2.2.7 Define Specific Gravity for Coarse Aggregate

Immerse the 2 kg sample in 15°C to 12°C water for 24 hours. Then take the aggregate and dry it manually with a piece of wool.

Fill a big bowl to its midpoint with water. This is volume (V1). Then add the aggregate to the bowl to fill to the same midpoint. Then add more water to fill the bowl completely. This identifies volume (V2). Then take the aggregate, dry it, and then measure its weight (W). Calculate the coarse aggregate specific gravity by the following equation:

$$\text{Coarse aggregate specific gravity (SG)} = W/(V2 - V1)$$

3.2.2.8 Bulk Density or Volumetric Weight Test for Aggregate

This test determines volumetric weight of the aggregate. By knowing the volumetric weight you can transform a given volume of aggregate and calculate the weight or vice versa. By knowing the volumetric weight and specific gravity you can calculate the percentage of voids between aggregate grains.

The definition of volumetric weight is the ratio of the weight of the aggregate to the volume that it occupies. The percentage of voids is the ratio between voids between the aggregate and the total volume of the aggregate.

Define the container base on Table 3.20. After determining its volume, measure the container when it is empty (W1). Fill the container with the aggregate and perform standard rod compaction 25 times. Perform compaction twice until the bowl is completely full, then measure the weight of the bowl with the compacted aggregate (W2).

TABLE 3.20

Sizes of Containers for Defining Aggregate Bulk Density

Maximum Nominal Aggregate Size (mm)	Bowl Volume (Liter)	Bowl Dimensions (mm)		
		Internal Diameter	Internal Height	Thickness
>40	30	360	293.6	5.4
40-5	15	360	282.4	4.1
<5	3	155	158.9	3.0

The volumetric weight and percentage can be calculated with the following equations:

$$\text{Volumetric weight } (V_w) = (W_2 - W_1)/V$$

$$\text{Void percentage} = (V_w - S_g)/V_w \times 100$$

3.2.2.9 Percentage of Aggregate Absorption

This test is used to identify the absorption of water by the aggregate with maximum nominal size higher than 5 mm. Table 3.21 shows the limits of absorbing aggregate to the water that should be followed in selecting the aggregate for the concrete mix, as it will affect the percentage of water in the concrete mix.

Begin the test by converting the maximum nominal aggregate size to millimeters. Wash the sample before testing on a 5-mm sieve remove the suspended materials.

Put the sample in a wire mesh of 1 to 3 mm, and then immerse in the container full of 15°C to 25°C water. In total immersion the distance between the highest point in the basket that is carrying the aggregate and surface water should be less than 50 mm.

After immersion remove the entrained air and leave the basket and sample immersed for 24 hours. Then remove the basket and the sample to remove the suspended water. Dry the surfaces of the sample gently and spread it on a piece of cloth. Let it air dry away from the sun or any source of heat. Then weigh it (W1). Then put the sample in a 105°C ± 5°C oven for 24 hours. Let it cool without exposure to any humidity, and weigh it again (W2).

$$\text{Absorption percentage} = (W1 - W2)/W2 \times 100$$

3.2.2.10 Recycled Aggregate Concrete

The idea of recycling of aggregates was introduced many years ago and from the beginning it had two environmental aspects: solving the growing waste disposal crisis and protection of depleted natural resources (Kasai 1988). In the last few decades it has also become an economical issue because the prices of good natural aggregates significantly increased in many regions.

TABLE 3.21

Maximum Allowable Limit of Absorption Water by Aggregate

Type of Aggregate	Percentage of Absorption (%)
Quartzite and crushed limestone	1–0.5–1%
Granite	0–1%
Stone	Not more than 2.5%

In the past the strength of aggregates derived from concrete structures was relatively low and consequently the applications were of secondary importance. At present the necessity of demolition of reinforced concrete (RC) or prestressed concrete (PC) structures like building frames, bridge beams, airport runways, or precast members creates sources of recycled aggregates that have different levels of quality.

Such a situation is typical for countries in Central and Eastern Europe where the programs of modernization have started for roads, in bridges; and municipal and industrial structures. Sometimes it is necessary to demolish relatively new structures, 10 years old or less, because the functional properties do not fit with the new projects. The best examples are road bridges for which the prefabricated prestressed concrete beams with spans 15 to 18 meters are not sufficient and have to be removed to widen the spans.

For such aggregates, apart from the obvious environmental aims of concrete recycling, there is a new economical aspect. Concrete originally mixed with large amount of cement retains some binding abilities, particularly when the carbonated zone is not too deep. It may be activated with silica fume or fly ash admixtures. Some savings in cement may be obtained in this way (Salem and Burdette 1998).

A pilot material test was undertaken to determine how to obtain good quality structural concrete using aggregates from demolished structures made from formerly medium- or high-strength concrete and to determine what properties could be obtained in such concrete by introduction of silica fume and superplasticizers. Basic results were presented by Ajdukiewicz and Kliszczewicz in 2000 during the PCI FHWA FIB Symposium in Orlando.

Many tests of recycled aggregates as the components of structural concrete have been undertaken in many countries since early 1980s. Despite serious differences in the original concrete the general conclusions are that recycled aggregate should be considered as a valuable material. These test have shown that such conclusions are also valid for high-strength, high-performance recycled concrete.

Nevertheless when properties of concrete with recycled aggregates are compared with properties of corresponding concrete with natural (new) aggregates the following differences have been noticed.

- Lower compressive strength from 10% to 30%
- Slightly lower tensile strength not more than 10%
- Lower elasticity modulus from 10% to 40% (depending on the origin of coarse aggregate)
- Substantially greater shrinkage from 20% to 55% but slightly smaller creep up to 10%

No significant differences were observed in bond (tested by the RILEM method) and in freezing resistance. Some changes in properties of fresh mix

of concrete were recorded, including shorter setting time and faster decrease of workability.

Up to the present the results of tests presented in different countries have been mainly concerned with properties obtained from testing concrete specimens prepared with various recycled aggregates. Mukai and Kikuchi (1988) and Di Niro et al. (1998) performed very few tests on structural members, particularly made from high-strength concrete. Such tests are necessary because it is difficult to predict the influence of the combination of differences in particular properties on the overall behavior of reinforced concrete members made from recycled aggregate concrete.

Ajdukiewicz and Kliszczewicz (2002) carried out tests on four series of beams with two concrete grades at about 40 MPa to 90 MPa. Behavior of reinforced concrete beams subjected to bending and shear depends on many properties of materials and constructional features. Taking into account similar elements made from concrete of the same mixture proportions but using different aggregates it is difficult to predict their failure, shape, load-bearing capacity deflection, and so on. Such a situation was found with the introduction of recycled aggregates. Despite complete tests on differences of properties of concrete from particular recycled aggregates the assessment of global result may be done more or less roughly only on the basis of standard methods of analysis.

Comparison of observations and results of tests made on four series of beams revealed that

- Differences in behavior of beams were relatively small within a particular series.
- Load-bearing capacity of beams made from concretes with various amounts of recycled aggregate differed relatively more with medium-strength concrete (30–60 MPa) than with high-strength concrete (80–90 MPa).
- Deflections (immediate) of beams made from recycled aggregate concrete were always greater than in comparable beams made with natural (new) aggregate but the range of differences varied from about 10% to 25% at failure load and as much as 30% to 50% at a probable service load.

3.2.3 Mixing Water Test

Water is very essential for mixing the concrete and the curing process, so the quality of water is essential to concrete durability and must follow the project specifications.

Table 3.22 illustrates the acceptable water specification for the mixing and curing process.

TABLE 3.22

Maximum Allowable Limits of Salt and Suspended Materials in Water

Type of Salt and Suspended Materials	Maximum Limit of Salt Content (g/L)
Total dissolved solid (TDS)	2.0
Chloride salt	0.5
Sulfate salt	0.3
Carbonate and bicarbonate salt	1.0
Sodium sulfate	0.1
Organic materials	0.2
Clay and suspended materials	3.0

The determination of soluble salts in water can be obtained by placing a sample of approximately 25 ml of water in a platinum dish, evaporating the sample and then transferring it to a drying oven at 105° degrees and again measuring the sample. By knowing size of the sample we can get the total content of dissolved salts in water (TDS) (g/L).

Chloride content in water is defined by performing a chemical analysis test to compare the content of chloride of water with the permissible content in the specifications as defined in Table 3.22.

3.3 Admixtures

Admixtures are now widely used in the concrete industry as they assist in increasing the concrete compressive strength, controlling the rate of hardening of fresh concrete, or increasing the concrete workability. Admixtures are powder or liquid materials that are produced from carbohydrate, melamine, condensate, naphthalene, and organic and nonorganic materials.

The type of admixture should be identified correctly as well as the dose required to achieve the target.

There are some tests that should be applied to the admixture before use. The results should be compared with the acceptable and refusal limits based on the project specification.

The types of admixtures are as follow:

1. Normal setting water reducer—This admixture increases the workability during concrete mixing without any change in water-to-cement ratio, or maintains the workability and decreases the water-to-cement ratio, so it will increase the concrete strength. This type will conform to ASTM C494, Type A-Normal Setting.
2. Retarder—These admixtures reduce the rate of reaction between cement and water and retard the concrete setting and hardening.

This type of admixture follows ASTM C494, Types B and D. This additive is usually used as a retarder in ready-mix concrete to achieve the required time to reach the site before setting.

3. Accelerators—These admixtures increase the rate of chemical reaction between cement and water, and thus increase the rate of setting and hardening concrete. This type of admixture follows ASTM C494, Types C and E. Accelerators are not normally used in concrete unless early form removal is critical to the project execution plan. Accelerators are added to concrete either to increase the rate of early strength development or to shorten the time of setting. The advantages are as follows:
 - a. Earlier removal of forms
 - b. Reduction of curing time
 - c. Early usage of the structure
 - d. Partial compensation for the effects of low temperature on rate of strength development.
 - e. Early finishing of surfaces
 - f. Reduction of pressure on forms
4. Admixture for water reducer and retarder—These admixtures reduce water content by increasing the workability and retarding the setting time.
5. Admixture for water reducer and accelerator—These admixtures reduce water content by increasing the workability and accelerating the setting time and hence we obtain two functions with the same additive.
6. High range water reducer—These modern water-reducing admixtures are much more effective than the aforementioned admixtures. Based on Neville (1983), at a given water-to-cement ratio, this dispersing action increases the workability of concrete. Typically by ranges the slump from 75 mm to 200 mm, with the mix remaining cohesive. The improvement in workability is smaller at high temperatures.
7. High range water reducer and retarder—These additives increase the durability by reducing the water-to-cement ratio to increase the concrete compressive strength and setting time.

3.3.1 Samples for Testing

Admixtures exist in liquid or powder form, so the sample should be taken in the proper manner to represent the deliverables quantity on site.

- a. Powder admixtures—The sample will be taken to represent no more than one ton. The samples are taken from six packs, or from 1% of the total number of packs, or from all packs if the number of packs is fewer than six. The samples should represent all the packs.

- b. Liquid admixtures—The samples will be taken from six drums or 1% fewer of all drums, whatever is larger; or from all the drums if six. Shake the drums to distribute the suspended materials and ignore the remaining sediments after shaking.

3.3.2 Chemical Tests to Verify Requirements

The chemical test should be performed to the admixtures to measure the criteria in Table 3.23.

3.3.2.1 Chemical Tests

The chemical test is performed to measure some parameters and compare results with the product data sheet to determine whether a sample matches manufacturer specifications.

1. For admixtures in the form of powder, the sample weight is three grams. The humidity will be removed first from it by weight of about 3 grams of the admixtures and remove the humidity and then determine of the percentage of the content of solid material.
2. For liquid admixtures:
 - a. Put 25 to 30 g of sand through No. 30 sieve into a glass bottle with rough surface opening and internal diameter 60 mm, height 30 mm and a cover.
 - b. Put the bottle and the cover in the drying oven at 105°C to 110°C and leave for 17 hours \pm 15 minutes.
 - c. Cover the bottle and place it in the dryer until it reaches room temperature, then weigh it to the nearest 0.001 g and record the weight.
 - d. Place about 4 ml from the sample inside the bottle over the sand and weigh it to the nearest 0.001 g (W_1).
 - e. Put the bottle in the dryer oven at the same temperature for 17 hours + 15 minutes.

TABLE 3.23

Admixture Characteristics

Characteristic	Requirement
Solid content	Not more than 5% of the weight on the value state by the manufacturer for solid and liquid admixtures
Ash content	Not more than 1% of weight for the value stated by the manufacturer
pH	Compare to value defined by manufacturer.
Chloride ion content	Not more that 5% of value stated by manufacturer or 0.2% of weight, whichever is higher

- f. The bottle cover and place in the dryer at room temperature and weigh to nearest 0.001 g (W_2).

The percentage of the solid materials will be calculated from the following equation:

$$\text{Percentage of solid content} = (W - W_2)/(W - W_1) \times 100$$

3.3.2.2 Ash Content

The purpose of this test is to determine the content of nonorganic materials through the analysis of ash content. This test is summarized in the following steps:

1. Heat the container with its cover at 600°C for 15 to 30 minutes and then transfer to dryer.
2. Let cool for 30 minutes and then weigh with the cover. The weight is W_1 .
3. Add about 1 g of the required admixture to test and then re-cover and measure this weight (W_2).
4. To reduce mechanical heat, spray the sample with water and then place in 90°C drying oven.
5. Heat the sample to 300°C for an hour and then increase heat to 600°C for 2 to 3 hours. Leave the sample at a temperature of 600°C for 16 ± 2 hours.
6. Transfer to drying oven and allow to cool with the cover. Weigh the content to the nearest 0.001 g after 30 minutes of cooling (W_3).

The ash content value will be calculated from the following equation:

$$\% \text{Ash content} = \frac{W_1 - W_3}{W_1 - W_2} \times 100$$

where

W_1 = weight of container and cover

W_2 = weight of container and cover and sample weight before burning

W_3 = weight of container and cover and sample weight after burning

3.3.2.3 Relative Density

In this test, put a sample at a temperature of $20^\circ\text{C} \pm 5^\circ\text{C}$ and then transferred the admixture sample to a tube with a capacity of 500 ml of the hydrometer immersed in the liquid inside tube. Then leave the hydrometer to reach the balance and then read the value hydrometer, then read the grading at

the base of the surface of contact with the liquid. Record the density to the nearest 0.002 ML.

3.3.2.4 Define Hydrogen Concentration

It will be sometimes useful to define admixture sample to determine a pH of a. In the case of admixtures in the form of powders to be prepared in the form of liquid, determine the pH by chemical tests and then compare with the specifications of the product.

3.3.2.5 Define Chloride Ion

In this test, prepare two equal solutions of sodium chloride and then add each sample solution to the admixtures sample. Estimate the proportion of chloride after each addition and calibrate it with a standard solution of silver nitrate using a pole of silver to determine the point of differential voltage.

One can assess the chloride ion content in the samples containing a very small percentage of chloride and at the same time estimate the standard silver nitrate and control the quantity of required sodium chloride.

Note that any method can be used to determine the chloride content and have the same accuracy.

3.3.3 Performance Tests

The purpose of these tests is to identify the performance of admixtures and the degree of influence on fresh and hardened concrete. To determine the performance of the admixtures, the test will be done for two mixtures meeting the same specification but one of them contains admixtures. The mixture without admixtures is the control specimen.

The admixtures samples to be tested are obtained in a liquid state or as powders, as mentioned earlier.

The control mixture consists of ordinary Portland cement. The coarse aggregate must be identical to the standard specifications, be fully dry by using the oven, and be clean and free of organic substances and impurities. The coarse aggregates have two sizes: 20-10 mm and 10-5 mm. The flakiness index must not exceed 35%.

The sand follows the same specifications of the coarse aggregate and also must be dried using the oven, and acid dissolved by no more than 5%.

1. Ratio of specimen control without admixture
 - Cement $300 \pm 5 \text{ kg/m}^3$
 - Cement-to-whole-aggregate ratio 1:6 by weight

- Percentage of coarse aggregate by weight: 45% for sizes 10-20 mm, 20% for sizes 10-5 mm, and 35% for sand
 - Water quantity to provide slump of 60 ± 1 mm or compaction ratio between 88% and 94%
 - Air entrained not to exceed 3%
2. Ratio of specimen control with admixture—Use the same ratios used for control but add the admixtures with the same ratio as specified by the manufacturer, taking into account the content of the water that makes concrete with the same mix as the control. The content of the air entrained in the control specimen should not be more than 2% and the total content of the air not more than 3%.

Table 3.24 presents a comparison between the performance of the concrete by adding admixtures and the control mix without admixtures. This table provides the guide to accept or refuse admixtures. For example, a retarder giving a retarding time of only 30 minutes should be refused as the retarding time must be from 1 to 3 hours according to the table.

The relation between the type of admixtures and the minimum acceptable limits to the concrete compressive strength as a percentage of the concrete compressive strength in the control mix without admixtures is shown in Table 3.25.

3.4 Steel Reinforcement Test

Steel reinforcement is an important element of reinforced concrete structures where the tensile loads are handled by reinforcing steel bars (rebar) in reinforced concrete. Therefore we must make sure that rebar meet specifications for the project. Some important tests for quality control for the rebar supplier to the project are presented next.

3.4.1 Weights and Measurement Test

This test requires a measuring tape as well as the relevant Vernier scale. Withdraw two samples of the same diameter of each consignment weighing less than 50 tons. Withdraw three samples if the consignment weighs more than 50 tons.

In each sample measure two perpendicular diameters in the same cross section by using a special measurement unit.

To ascertain the weight of a longitudinal meter, a sample with length not less than 500 mm with accuracy $\pm 0.5\%$ is required.

TABLE 3.24
Performance Requirements for Concrete with Admixtures

	Admixture Type					
	WR	Retarder	Accelerator	WR and Retarder	WR and Accelerator	HWR and Retarder
Maximum water content as percentage from mix control	95	-	-	95	95	88
Air content	Not increased more than 25 in concrete with admixture than the control specimen without admixtures and total air content must not be more than 3%					
Hardening time at penetration resistance	0.5 N/mm ² 1 hr from SC	-	-	1 hr more than SC as lower limit	More than 1 hr	-
penetration resistance	3.5 N/mm ² 1 hr from SC	-	-	-	1 hr lower than SC as lower limit	-
Setting time at penetration resistance*	3.5 N/mm ² 1 hr from SC	1 to 3 hr more than SC	1 to 3 hr lower than SC and not less than 45 min	1 to 3 hr more than SC	1 to 3 hrs lower than SC and not less than 45 min	1 to 3 hr more than SC
	27.6 N/mm ² 1 hr from SC	3 hr more than SC	1 hr less than SC and not less than 45 min	3 hr more than SC	1 hr less than SC and not less than 45 min	3 hr from SC

Notes: HWR, higher water reducer; SC, specimen control mix; WR, water reducer.
*Setting time according to ASTM C494-1996.

TABLE 3.25

Relationship of Type of Admixture and Minimum Limit to Concrete Strength as Percentage of Specimen Control Mix

Age (Days)	WR	Retarder	Accelerator	WR and Retarder	WR and Accelerator	HWR	HWR and Retarder
1	—	—	125	—	125	140	125
3	110	90	125	110	125	125	125
7	110	90	100	110	110	115	115
28	110	90	100	110	110	110	110
180	100	90	90	100	100	100	100

TABLE 3.26

Weight of Bar Per Unit Length

Nominal Diameter (mm)	Nominal Cross-Sectional Area (mm ²)	Weight (kg/m)	Tolerance Allowance (%)
6	28.3	0.222	±8
8	50.3	0.395	
10	78.5	0.618	±5
12	113	0.888	
13	133	1.04	
14	154	1.21	
16	201	1.58	
18	254	2.00	
19	283	2.22	
20	314	2.47	
22	380	2.98	
25	461	3.85	±4
28	616	4.83	
32	804	6.31	
36	1020	7.99	
40	1257	9.86	
50	1964	15.41	

The actual cross-sectional area, A , is calculated by taking into account the density of steel at 7.85 ton/m³. W is the weight to the nearest gram and L is the bar length (Table 3.26):

$$\text{Actual cross-sectional area} = W / (0.00785 L)$$

W = weight to nearest kilogram

L = length to nearest millimeter

3.4.2 Tension Test

This test is useful to define the mechanical properties of steel bars. The test sample with the standard dimensions is exposed to tensile stress until fracture. Figure 3.9 shows the tension machine and Figure 3.10 presents the elongation measurement. From this test one can define the yield stress or proof stress and the elongation percentage.

$$\text{Elongation percentage} = (L_2 - L_1)/L_1 \times 100$$



FIGURE 3.9
Steel bar in tension machine.



FIGURE 3.10
Elongation measurement.

TABLE 3.27

Acceptance and Refusal of Mechanical Properties

Steel Grade	Minimum Yield Strength (N/mm ²)	Minimum Tensile Strength (N/mm ²)	Elongation (%)
240	240	350	20
280	280	450	18
360	360	520	12
400	400	600	10

where

L_1 = original measured length

L_2 = final measured length

The length of the short sample $L_1 = 5D$ and the length of the long sample $L_1 = 10D$, where D is the diameter of the steel bar and the deviation for the measurement of sample dimensions is not more than $\pm 0.5\%$.

During sample preparation there can be some modification, but it is unacceptable to change the shape of the sample by increasing its temperature via exposure to heat.

Yield stress = yield force/actual cross-sectional area

Tension strength = maximum force/actual cross-sectional area

The Egyptian standard provides specifications to achieve at least 95% of the quantity tested values set in Table 3.27. Moreover, the result of any single test should not be less than 95% of the values mentioned in the table. The minimal acceptable limits for bars should be agreed between the supplier and customer to ensure that the values shown in Table 3.27 are met.

The ratio between the tension strength and yield strength for any sample should not be less than 1.1 and 1.05 for smooth and ripped bar, respectively. For steel that cannot define the yield point clearly, define the proof stress 0.02% instead of yield stress.

References

- ASTM C114-88, Chemical Analysis of Hydraulic Cement.
- ASTM C142-78, Test Method for Clay Lumps and Friable Particles in Aggregate.
- ASTM C183-88, Sampling and Amount of Testing of Hydraulic Cement.
- ASTM C188-84, Density of Hydraulic Cement.
- ASTM C349-82, Compressive Strength of Hydraulic Cement Mortars.
- ASTM C670-84, Testing of Building Materials.

- ASTM D1888-78 Standard Test Method for Particulate and Dissolved Matter, Solids, or Residue in Water.
- ASTM D512-85, Standard Test Method for Chloride Ion in Water.
- ASTM D516-82, Standard Test Method for Sulfate Ion in Water.
- ACI 228.1R89, In-Place Methods or Determination of Strength of Concrete. ACI Manual of Concrete Practice, Part 2: Construction Practices and Inspection of Pavements.
- Ajdkiewicz, A. B., and Kliszczewicz, A. T. 1999. *Utilization of Recycled Aggregates in HS/HPC*, 5th International Symposium on Utilization of High Strength/High Performance Concrete, Sandefjord, Norway, June, volume 2, pp. 973–980.
- Ajdkiewicz, A. B., and Kliszczewicz, A. T. 2000. *Properties and Usability of HPC with Recycled Aggregates*. Proceeding of PCI/FHWA/FIP International Symposium on High Performance Concrete, September, Orlando, Precast/Prestressed Concrete Institute, Chicago, pp. 89–98.
- Ajdkiewicz, A. B., and Kliszczewicz, A. T. 2002. *Behavior of RC Beams from Recycled Aggregate Concrete*. ACI Fifth International Conference, Cancun, Mexico.
- BS 410-1:1986, Specifications for Test Sieves of Metal Wire Cloth.
- BS 812 Part 103:1985, Sampling and Testing of Mineral Aggregate Sands and Fillers.
- BS 882:1992, Specification for Aggregates from Natural Sources for Concrete.
- BS EN933-1:1997, Tests for geometrical properties of aggregates, determination of particle size distribution. Sieving method.
- Kasai, Y. (editor). 1988. *Demolition and Reuse of Concrete and Masonry Reuse of Demolition Waste*. 2nd International RILEM Symposium, Building Research Institute and Nihon University, Tokyo. New York: Chapman & Hall.
- Di Niro, G., Dolara, E., and Cairns, R. 1998. *The Use of Recycled Aggregate Concrete for Structural Purposes in Prefabrication*. Proceedings of 13th FIP Congress “Challenges for Concrete in the Next Millennium,” Amsterdam, June. Balkema, Rotterdam-Brookfield, volume 2, pp. 547–550.
- Egyptian Code for Design and Execute Concrete Structures: Part 3 Laboratory Test for Concrete Materials, ECP203, 2003.
- Egyptian Standard Specification: 1947:1991, Method of Taking Cement Sample.
- Egyptian Standard Specification: 2421-1993, Natural and Mechanical Properties for Cement. Part 2: Define Cement Finening by Sieve No. 170.
- Egyptian Standard Specification: 2421-1993, Natural and Mechanical Properties for Cement. Part 2: Define Cement Finening by Using Blaine Apparatus.
- Egyptian Standard Specification: 2421-1993, Natural and Mechanical Properties for Cement. Part 1: Define Cement Setting Time.
- Egyptian Standard Specification: 1450-1979, Portland Cement with Fines 4100.
- Egyptian Standard Specification: 1109-1971, Concrete Aggregate from Natural Resources.
- Egyptian Standard Specification: 262-1999, Steel Reinforcement Bars.
- Egyptian Standard Specification: 76-1989, Tension Tests for Metal.
- ISO 6274-1982, Sieve Analysis of Aggregate.
- Mukai, T., and Kikuchi, M. 1988. Properties of reinforced concrete beams containing recycled aggregate. In Proceedings of 2nd International Symposium RILEM “Demolition and Reuse of Concrete and Masonry,” volume 2, London: Chapman & Hall, pp. 670–679.
- Murphy, W. E. 1977. Discussion on paper by V. M. Malhotra. Contract strength requirements: core versus in situ evaluation. *Journal American Concrete Institute*, volume 74, no. 10, pp. 523–525.

- Neville, A. M. 1983. *Properties of Concrete*, Great Britain: Pitman.
- Plowman, J. M., Smith, W. F., and Sheriff, T. 1974. Cores, cubes, and the specified strength of concrete. *The Structural Engineer*, volume 52, no. 11, pp. 421–426.
- Salem, R. M., and Burdette, E. G. 1998. role of chemical and mineral admixtures on physical properties and frost-resistance of recycled aggregate concrete. *ACI Materials Journal*, volume 95, no. 5, pp. 558–563.
- Van Acker, A. 1997. *Recycling of Concrete at a Precast Concrete Plant*. FIP Notes, part 1, no. 2, 1997, pp. 3–6; part 2, no. 4, pp. 4–6.
- Yuan, R. L., et al. 1991. Evaluation of core strength in high-strength concrete. *Concrete International*, volume 13, no. 5, pp. 30–34.

4

Concrete Mix Design

4.1 Introduction

Generally, every site location has special characteristics, depending on the aggregate materials available near the site. So the main task for designing the concrete mix is to obtain the required concrete characteristic strength after 28 days for standard cubes or cylinders according to the project specification. This is a very important factor in designing the concrete mix. The second factor is the workability and the concrete must be pourable, as in case of using a pump in the casting process, which needs a special concrete design mix.

On site, the quality control (QC) team has the authority to accept the concrete mix that they will receive; sometimes a third party can be hired to perform the quality control on the concrete. In any case, the QC staff should be well versed in visual inspection. But, they also should have the capability to do a fast fresh-concrete test and compare the results with the project specifications. The QC team is fully responsible for accepting or rejecting the concrete that is delivered or mixed on site.

The quality control team needs a basic understanding of concrete design mix based on different specifications and the capability to analyze the data using the essential statistics information presented in this chapter.

4.2 Essential Statistics Information

Some statistical knowledge is essential to the engineer who is responsible for the concrete quality control, as the quality control depends on studying the results of the concrete compressive strength tests. The test results can statistically define the acceptance and refusal limits. The concrete design mix specified in the Egyptian, American, and British codes depends on statistical information.

The essential statistics criteria that will be illustrated in the next section include the arithmetic mean, standard deviation, and coefficient of variation.

4.2.1 Arithmetic Mean

The arithmetic mean is the average of a group of results and is presented by the following equation:

$$\bar{X} = \frac{X_1 + X_2 + \dots + X_n}{n} \quad (4.1)$$

where n is the number of the results and X is the reading for each result.

As a practical example, assume three samples of standard cubes were taken after mixing and performing a compressive strength test after 28 days. We obtain the following results: 31 N/mm², 30 N/mm², and 29 N/mm². Using the preceding equation the arithmetic mean value is 30 N/mm².

From the second mixing, three samples of standard cubes and crushing were also taken after 28 days under the same conditions as the previous mix. We obtain the following results: 37 N/mm², 30 N/mm², and 23 N/mm². The mean is 30 N/mm².

The two mixes provide the same mean value. Does this mean the two mixes have the same quality? Can we accept the two mixes? From engineering sense there are differences between the two mixes but the arithmetic mean is the same. Therefore, it is important to define another statistical criterion to compare the two mixes.

4.2.2 Standard Deviation

The standard deviation is the second statistical parameter that concerns the distribution of the test results around the arithmetic mean and is presented by the following equation:

$$S = \sqrt{\frac{(X_1 - \bar{X})^2 + (X_2 - \bar{X})^2 + \dots + (X_n - \bar{X})^2}{n}} \quad (4.2)$$

If we apply the equation to the previous example for the first mix, the standard deviation will be

$$S = \sqrt{\frac{(31 - 30)^2 + (30 - 30)^2 + (29 - 30)^2}{3}}$$

The standard deviation for first mixing is 0.816 N/mm².

To calculate the standard deviation for the second mixing:

$$S = \sqrt{\frac{(37 - 30)^2 + (30 - 30)^2 + (23 - 30)^2}{3}}$$

The standard deviation for the second mix is 5.7 N/mm².

The standard deviation of the second mix has a higher value than the first mix, meaning that the result of cube concrete strength in the second mixture is far from the arithmetic mean. This means that it has a significant deviation from the arithmetic mean, which tells us that quality was very low.

Note that the standard deviation has units. Therefore, it must be conducted through the comparison with the same average value. In the previous example the two mixtures had the same required average concrete compressive strength at 28 days of 30 N/mm².

On the other hand, to compare two different locations with different concrete strength, another factor is required. Assume the first site required concrete strength is 30 N/mm² and the second site has concrete strength equal to 50 N/mm²; thus the standard deviation has no meaning as a comparison tool. So in this case we need another statistical tool, which is the coefficient of variation.

4.2.3 Coefficient of Variation

The coefficient of variation (C.O.V.) is the true measure of quality control as it determines the proportion of differences or the deviation of the readings from the arithmetic mean. This factor has no units, as it is the standard deviation divided by the mean. Therefore, this factor is the main factor for the quality control degree measurement.

$$\text{C.O.V} = \frac{S}{\bar{X}} \quad (4.3)$$

In another example, a third mixture from another site had a concrete compressive strength after 28 days equal to 50 N/mm². The values of compressive strength results of the three samples after 28 days are 51 N/mm², 50 N/mm², and 49 N/mm². The arithmetic mean is 50 N/mm² and the standard deviation is 0.816 N/mm². At this new site the arithmetic mean is identical with the requirements of the mixture design. In the previous example, the mean compressive strength was 30 N/mm² with the same value as the standard deviation. Therefore, comparison between the two sites should be through calculating the coefficient of variation for each.

$$\text{C.O.V for the first site} = 0.03$$

$$\text{C.O.V for the second site} = 0.02$$

The second site has a lower C.O.V than the first site, so the percentage of the standard deviation to arithmetic mean lowers in the second site. So the second site's concrete mixture has a higher quality than the first site. The closer the C.O.V is to zero, the better the quality control.

4.3 Basics of Concrete Mix Design

The strength results for 46 cube samples from a particular class of concrete delivered to a project are as follows:

305	340	422	298	340
267	297	382	320	356
349	366	340	312	355
404	382	368	306	311
350	448	322	350	326
303	365	346	384	358
344	339	298	306	398
360	360	320	282	378
352	325	326	341	367
				384

No.	Cell Boundaries	Midcell Values	Frequency
1	260–280	270	1
2	280–300	290	4
3	300–320	310	6
4	320–340	330	7
5	340–360	350	13
6	360–380	370	7
7	380–400	390	5
8	400–420	410	1
9	420–440	430	1
10	440–460	450	1
	Total		46

Table 4.1 is a frequency table of the numbers in descending order. Figure 4.1 is a frequency histogram and Figure 4.2 is a relation curve between frequency and concrete strength results. From the descending cumulative curve (Figure 4.3), one can find that 100% of the sampling results give compressive strength less than 45.9 N/mm². At the same time the results of previous tests results equal to or less than 28 N/mm² represent about 2% of the total tested samples.

4.3.1 Normal Distribution

Normal distribution is the most popular probability distribution curve. From the experimental test results and research on the concrete strength, the compressive concrete cube for standard tests follows the normal distribution.

TABLE 4.1

Descending Frequency Table

No.	Compressive Strength (kg/cm ²)	Number of Readings with Values Lower than Upper Boundary	Percentage of Readings Less than Lower Level Value
10	460	46	100
10	440	45	98
9	420	41	90
8	400	35	76
7	380	28	61
6	360	15	33
5	340	8	17
4	320	3	6
3	300	2	4
2	280	1	2
1	260	0	0

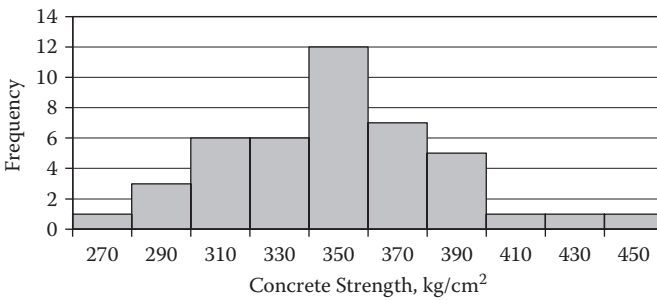

FIGURE 4.1

Frequency histogram.

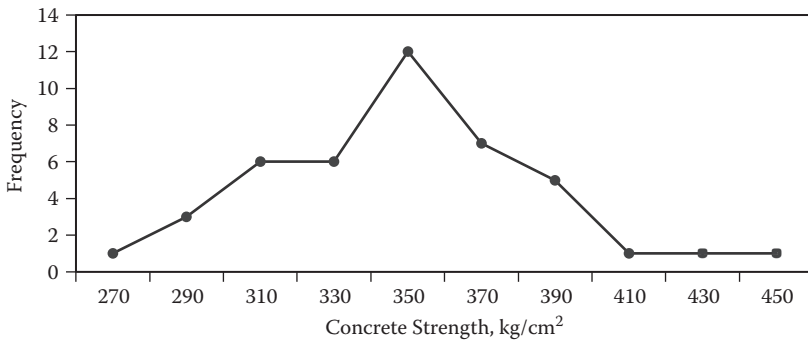

FIGURE 4.2

Relation curve between frequency and concrete strength results.

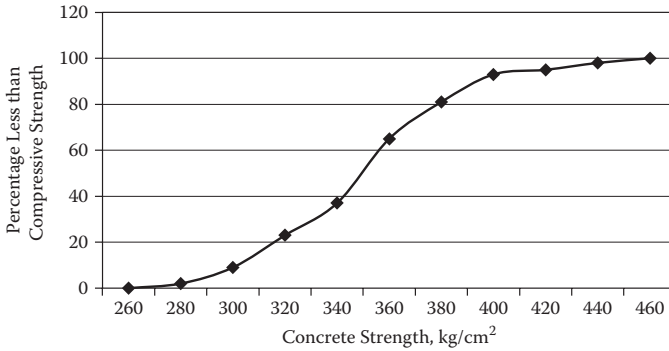

FIGURE 4.3
Descending curve for concrete compressive strength.

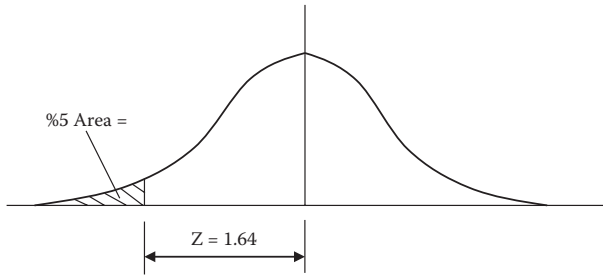

FIGURE 4.4
Normal distribution curve.

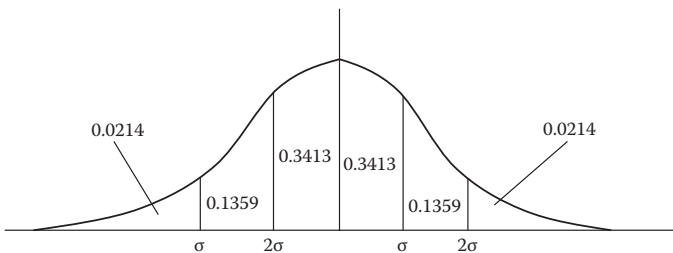

FIGURE 4.5
Dividing the area under the normal distribution curve.

The shape of the normal distribution is shown in Figure 4.4 and Figure 4.5 and it has the following special characteristics:

- Normal distribution is symmetrically distributed about the arithmetic mean. The arithmetic mean divides the curve to two equal parts.
- The arithmetic mean, median, and mode coincide.

- The area under the curve is equal to one since the sum for all probabilities must equal unity.
- The variable of the cube crushing results can take values from ∞ to $-\infty$ so the curve represents all the probability values of the concrete compressive strength.

The equation for probability distribution follows:

$$f(x) = \frac{1}{\sigma\sqrt{2\pi}} e^{-\frac{(x-\bar{x})^2}{2\sigma^2}} \quad (4.4)$$

where σ is the standard deviation and x is the mean.

The shape of the distribution depends on the mean and the standard deviation, and any variation in these two parameters affects the shape of the probability distribution. So the standard normal distribution is used to define the area under the curve. By knowing the standard deviation and the mean, we can obtain another parameter, which is Z :

$$z = \frac{x - \bar{x}}{\sigma} \quad (4.5)$$

Table 4.2 illustrates the values of the area under the curve by knowing, Z . For example, from the table one can find that the area under the curve at Z equal to 1.64 is 0.4495. So the area for values higher than Z is (0.5 to 0.4495), which is equal to 0.0505 or about 5%. This means that the probability that the results values are less than Z is 5%.

From Figure 4.5 one can see that the area from the mean to the first value of standard deviation is equal to 34.13% and for the area for the two standard deviations is equal to 47.72%.

4.4 Egyptian Code

The characteristic strength of concrete is defined as the strength below which not more than a prescribed percentage of the test results should fall. The Egyptian code adopts a percentage of 5%.

Hence, by knowing the required concrete characteristic strength, f_{cu} , we can define the target strength, f_m , to design the concrete mix as in the following equation:

$$f_m = f_{cu} + M \quad (4.6)$$

TABLE 4.2

Standard Normal Distribution

Z	0	0.01	0.02	0.03	0.04	0.05	0.06	0.07	0.08	0.09
0	0	0.004	0.008	0.012	0.016	0.0199	0.0239	0.0279	0.0319	0.0359
0.1	0.0398	0.0438	0.0478	0.0517	0.0557	0.0596	0.0636	0.0675	0.0714	0.0753
0.2	0.0793	0.0832	0.0871	0.091	0.0948	0.0987	0.1026	0.1064	0.1103	0.1141
0.3	0.1179	0.1217	0.1255	0.1293	0.1331	0.1368	0.1406	0.1443	0.148	0.1517
0.4	0.1554	0.1591	0.1628	0.1664	0.17	0.1736	0.1772	0.1808	0.1844	0.1879
0.5	0.1915	0.195	0.1985	0.2019	0.2054	0.2088	0.2123	0.2157	0.219	0.2224
0.6	0.2257	0.2291	0.2324	0.2357	0.2389	0.2422	0.2454	0.2486	0.2517	0.2549
0.7	0.258	0.2611	0.2642	0.2673	0.2704	0.2734	0.2764	0.2794	0.2823	0.2852
0.8	0.2881	0.291	0.2939	0.2967	0.2995	0.3023	0.3051	0.3078	0.3106	0.3133
0.9	0.3159	0.3186	0.3212	0.3238	0.3264	0.3289	0.3315	0.334	0.3365	0.3389
1	0.3413	0.3438	0.3461	0.3485	0.3508	0.3531	0.3554	0.3577	0.3599	0.3621
1.1	0.3643	0.3665	0.3686	0.3708	0.3729	0.3749	0.377	0.379	0.381	0.383
1.2	0.3849	0.3869	0.3888	0.3907	0.3925	0.3944	0.3962	0.398	0.3997	0.4015
1.3	0.4032	0.4049	0.4066	0.4082	0.4099	0.4115	0.4131	0.4147	0.4162	0.4177
1.4	0.4192	0.4207	0.4222	0.4236	0.4251	0.4265	0.4279	0.4292	0.4306	0.4319
1.5	0.4332	0.4345	0.4357	0.437	0.4382	0.4394	0.4406	0.4418	0.4429	0.4441
1.6	0.4452	0.4463	0.4474	0.4484	0.4495	0.4505	0.4515	0.4525	0.4535	0.4545
1.7	0.4554	0.4564	0.4573	0.4582	0.4591	0.4599	0.4608	0.4616	0.4625	0.4633
1.8	0.4641	0.4649	0.4656	0.4664	0.4671	0.4678	0.4686	0.4693	0.4699	0.4706
1.9	0.4713	0.4719	0.4726	0.4732	0.4738	0.4744	0.475	0.4756	0.4761	0.4767
2	0.4772	0.4778	0.4783	0.4788	0.4793	0.4798	0.4803	0.4808	0.4812	0.4817
2.1	0.4821	0.4826	0.483	0.4834	0.4838	0.4842	0.4846	0.485	0.4854	0.4857
2.2	0.4861	0.4864	0.4868	0.4871	0.4875	0.4878	0.4881	0.4884	0.4887	0.489
2.3	0.4893	0.4896	0.4898	0.4901	0.4904	0.4906	0.4909	0.4911	0.4913	0.4916
2.4	0.4918	0.492	0.4922	0.4925	0.4927	0.4929	0.4931	0.4932	0.4934	0.4936
2.5	0.4938	0.494	0.4941	0.4943	0.4945	0.4946	0.4948	0.4949	0.4951	0.4952
2.6	0.4953	0.4955	0.4956	0.4957	0.4959	0.496	0.4961	0.4962	0.4963	0.4964
2.7	0.4965	0.4966	0.4967	0.4968	0.4969	0.497	0.4971	0.4972	0.4973	0.4974
2.8	0.4974	0.4975	0.4976	0.4977	0.4977	0.4978	0.4979	0.4979	0.498	0.4981
2.9	0.4981	0.4982	0.4982	0.4983	0.4984	0.4984	0.4985	0.4985	0.4986	0.4986
3	0.4987	0.4987	0.4987	0.4988	0.4988	0.4989	0.4989	0.4989	0.499	0.499

After designing the concrete mix based on the target strength, the probability of the cube strength results falling under the values of the characteristic strength must be less than 5%.

M is the safety factor to verify that the percentage of the crushing cubes strength values less than f_{cu} will not be less than 5%. This safety factor is a function of the standard deviation as shown in the following equation (also see Table 4.3):

$$f_m = f_{cu} + 1.64 S \quad (4.7)$$

TABLE 4.3

Safety Margin Factor for Concrete Design Mix

Availability of Test Results	Margin Safety Factor (M) for Concrete Compressive Strength (f_{cu})		
	$f_{cu} < 200$	$200 \leq f_{cu} < 400$	$600 \geq f_{cu} \geq 400$
1—Forty results or more with similar materials and conditions	(1.64 S) and not less than 4 N/mm ²	(1.64 S) and not less than 6 N/mm ²	(1.64 S) and not less than 7.5 N/mm ²
2—No available data or Fewer than 40 test results with similar materials and conditions	Not less than 0.6 f_{cu}	Not less than 12 N/mm ²	Not less than 15 N/mm ²

Note: The test presents the average of three standard cubes taken from the same mix.

TABLE 4.4

Expected Standard Deviation Values

Quality Control Condition	Standard Deviation (N/mm ²)
Good QC with continuous supervision	4–5
Moderate QC with supervision sometimes	5–7
Poor QC with no supervision	7–9

TABLE 4.5

Classification of Standard of Concrete Based on ACI 214-77

Standard of Control	Overall Standard Deviation, MPa	
	In the Field	Laboratory Trial Mixes
Excellent	<3	<1.5
Very good	3–3.5	1.5
Good	3.5–4	1.5–2
Fair	4–5	2–2.5
Poor	>5	>2.5

Table 4.4 is a guideline to predict the standard deviation of the concrete after knowing the quality control (QC) of the site by visiting the site. Or one can make a test and calculate the standard deviation by auditing and categorizing the work and supervising activities as good, fair, or bad.

This is also a guide or QC indicator for a ready mix batch plant that supplies concrete.

Table 4.5 from ACI 214-77 presents the overall standard deviation for concrete in laboratory trial mixes and in the field on concrete strength 35 MPa.

4.5 British Standard

The European Concrete Platform (ECP) has requirements similar to BS 5328: Part 4: 1990. The British practice also uses cubes. The British approach is to use a characteristic strength, defined as the value of strength below which 5% of all possible test results are expected to fall. The margin between the characteristic strength and the mean strength is selected to verify this probability. The following criteria must be applied to achieve this probability:

1. The average value of any four consecutive test results exceeds the specified characteristic strength by 3 Mpa.
2. No test result falls below the specified characteristic strength by more than 3 Mpa.

Similar requirements are prescribed for the flexural test, however the values in the criteria are 0.3 Mpa.

4.6 American Specifications (American Concrete Institute)

The American Concrete Institute (ACI) code states that the concrete production facility must have records of at least 30 consecutive strength tests representing materials and conditions similar to those expected. The strength used as the basis for selecting concrete proportions must be the larger of

$$f_{cr} = f_c + 1.34S \quad (4.8)$$

or

$$f_{cr} = f_c + 2.33S - 500 \quad (4.9)$$

where f_{cr} is the required target strength in preparing the concrete mix and f_c is the concrete strength after 28 days.

If the standard deviation is unknown, the required average strength f_{cr} used as the basis for selecting concrete proportions must be determined from the following:

$$f_{cr} = f_c + 7 \text{ N/mm}^2; \quad f_c < 21 \text{ N/mm}^2$$

$$f_{cr} = f_c + 1000 \text{ psi}; \quad f_c < 3000 \text{ psi}$$

$$f_{cr} = f_c + 8.4 \text{ N/mm}^2; \quad f_c = 21 - 35 \text{ N/mm}^2$$

$$f_{cr} = f_c + 1200 \text{ psi}; \quad f_c = 3000 - 5000 \text{ psi}$$

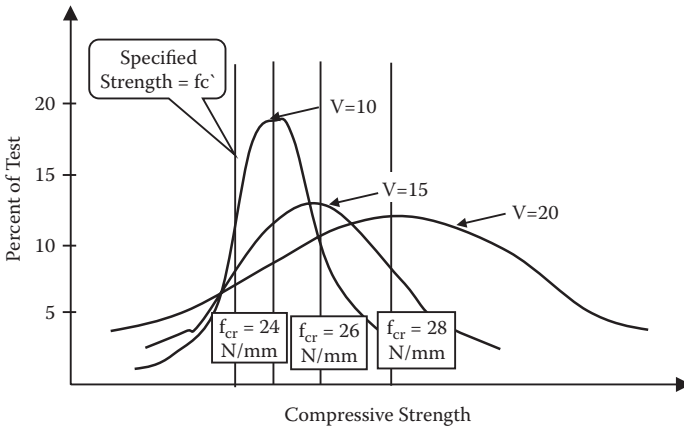

FIGURE 4.6

Normal Frequencies curve for C.O.V. 10, 15, 20 for different grades of concrete.

$$f_{cr} = f_c + 9.8 \text{ N/mm}^2; \quad f_c > 35 \text{ N/mm}^2$$

$$f_{cr} = f_c + 1400 \text{ psi}; \quad f_c > 5000 \text{ psi}$$

Formulas for calculating the required target strengths are based on the following criteria:

1. A probability of 1% that an average of three consecutive strength tests will be below the specified strength, f_c ($f_{cr} = f_c + 1.34S$).
2. A probability of 1% that an individual strength test will be more than 3.5 N/mm^2 (500 psi) below the specified strength f_c ($f_{cr} = f_c + 2.33S - 500$).

Criterion 1 will produce a higher required target strength than criterion 2 for low to moderate standard deviations, up to 500 psi. For higher standard deviations, criterion 2 will govern. The coefficient of variation for different concrete grades is presented in Figure 4.6.

4.6.1 Acceptance and Refusal for Concrete Mix

After a mix is approved for a proposed project, the concrete received on site will be acceptable if the result of the crushing standard cylinder test after 28 days meets both of the following criteria:

1. No single test strength or the average strengths of two cylinders from a batch shall be more than 3.5 N/mm^2 (500 psi) below the specified compressive strength f_c , that is, 21.1 N/mm^2 (3000 psi) for specified 24.6 N/mm^2 (3500 psi) concrete.
2. The average of any three consecutive test strengths must equal or exceed the specified compressive strength, f_c .

4.6.2 Concrete Mix Procedure

The mixing procedure is stated in ACI 211.1. Estimating the required batch weights for the concrete involves a sequence of logical, straightforward steps, which, in effect, fit the characteristics of the available materials into a mixture suitable for the work. The question of suitability is frequently not left to the individual selecting the proportions. The job specifications may dictate some or all of the following:

- Maximum water:cement or water:cementitious material ratio
- Minimum cement content
- Air content
- Slump
- Maximum size of aggregate
- Strength
- Other requirements relating to strength over design; admixtures; and special types of cement, other cementitious materials, or aggregate

Regardless of whether the concrete characteristics are prescribed by the specifications or left to the individual selecting the proportions, establishment of batch weights per cubic meter (m^3) of concrete can be best accomplished in the following sequence:

1. Choice of slump—If slump is not specified, a value appropriate for the work can be selected from Table 4.6. The slump ranges shown apply when vibration is used to consolidate the concrete. Mixes of the stiffest consistency that can be placed efficiently should be used. Noting that the values of the slump of in Table 4.6 can be increased when chemical admixtures are used.

TABLE 4.6

Recommended Slumps for Various Types of Construction

Types of Construction	Slump (mm)	
	Maximum	Minimum
Reinforced foundation, walls and footings	75	25
Plain footings, caissons, and substructure walls	75	25
Beams and reinforced walls	100	25
Building columns	100	25
Pavement and slabs	75	25
Mass concrete	50	25

Note: Slump may be increased when chemical admixtures are used, provided that the admixture-treated concrete has the same or lower water:concrete ratio and does not exhibit segregation potential or excessive bleeding.

2. Choice of maximum size of aggregate—Large nominal maximum sizes of well-graded aggregates have fewer voids than smaller sizes. Hence, concretes with the larger-sized aggregates require less mortar per unit volume of concrete. Generally, the nominal maximum size of aggregate should be the largest that is economically available and consistent with dimensions of the structure. In no event should the nominal maximum size exceed one-fifth of the narrowest dimension between sides of forms, one-third the depth of slabs, nor three-fourths of the minimum clear spacing between individual reinforcing bars, bundles of bars, or pretensioning strands. These limitations are sometimes waived if workability and methods of consolidation are such that the concrete can be placed without honeycomb or void.

In areas congested with reinforcing steel, posttension ducts or conduits, the design should specify a nominal maximum size of the aggregate so concrete can be placed without excessive segregation, pockets, or voids. When high strength concrete is desired, best results may be obtained with reduced nominal maximum sizes of aggregate since these produce higher strengths at a given water:cement ratio (w:c).

3. Estimation of mixing water and air content—The quantity of water per unit volume of concrete required to produce a given slump is dependent on the nominal maximum size, particle shape, and grading of the aggregates; the concrete temperature; the amount of entrained air; and use of chemical admixtures.

Slump is not greatly affected by the quantity of cement or cementitious materials within normal use levels (under favorable circumstances the use of some finely divided mineral admixtures may lower water requirements slightly).

Table 4.7 provides estimates of required mixing water for concrete made with various maximum sizes of aggregate, with and without air entrainment. Depending on aggregate texture and shape, mixing water requirements may be somewhat above or below the tabulated values, but they are sufficiently accurate for the first estimate. The differences in water demand are not necessarily reflected in strength since other compensating factors may be involved.

Rounded and angular coarse aggregates which both are well and similarly graded and of good quality, can be expected to produce concrete of about the same compressive strength for the same cement factor in spite of differences in w:c resulting from the different mixing water requirements.

Particle shape is not necessarily an indicator that an aggregate will be either above or below in its strength-producing capacity.

TABLE 4.7

Approximate Mixing Water (kg/m^3) for Different Slumps and Nominal Maximum Sizes of Aggregate for Non-Air-Entrained Concrete Based on ACI

Slump (mm)	Nominal Maximum Aggregate Size (mm)							
	10	12.5	19	25	37.5	50	75	152
25–50	206	198	186	177	162	153	130	112
75–100	227	215	201	192	177	168	145	124
152–178	242	227	212	201	185	177	159	—
<i>Approximate Amount of Entrapped Air in Non-Air-Entrained Concrete (%)</i>								
	3	2.5	2	1.5	1	0.5	0.3	0.2

Notes: Rounded aggregate will generally require 13.5 kg less water for non-air-entrained. The use of water-reducing chemical admixture, ASTM C494, may also reduce mixing water by 5% or more. The slump values of more than 178 mm are only obtained through the use of water-reducing chemical admixtures; they are for concrete containing nominal maximum size aggregate not larger than 25 mm.

4.6.2.1 Chemical Admixtures

Chemical admixtures are used to modify the properties of concrete to make it more workable, durable, or economical; increase or decrease the time of set; accelerate strength gain; or control temperature gain.

Chemical admixtures should be used only after an appropriate evaluation has been conducted to show that the desired effects have been accomplished in the particular concrete under the conditions of intended use. Be sure that water-reducing or set-controlling admixtures conforming to the requirements of ASTM C494, when used singularly or in combination with other chemical admixtures, will significantly reduce the quantity of water per unit volume of concrete.

The use of some chemical admixtures, even at the same slump, will improve such qualities as workability, finish ability, pumpability, durability, and compressive and flexural strength. A significant volume of liquid admixtures should be considered as part of the mixing water. The slumps shown in Table 4.6 from ACI, "Recommended Slumps for Various Types of Construction," may be increased when chemical admixtures are used, providing the admixture-treated concrete has the same or a lower water:cement ratio and does not exhibit segregation potential and excessive bleeding. When only used to increase slump, chemical admixtures may not improve any of the properties of the concrete.

Table 4.7 indicates the approximate amount of entrapped air to be expected in non-air-entrained concrete in the upper part of the table and shows the recommended average air content for air-entrained concrete in the lower part of the table. If air entrainment is needed or desired, three levels of air content

are given for each aggregate size depending on the purpose of the entrained air and the severity of exposure if entrained air is needed for durability.

1. Mild exposure—When air entrainment is desired for a beneficial effect other than durability, such as to improve both the workability and cohesion, or in low cement factor concrete to improve strength, air contents lower than those needed for durability can be used. This exposure includes indoor or outdoor service in a climate where concrete will not be exposed to freezing or to deicing agents.
2. Moderate exposure—Service in a climate where freezing is expected but where the concrete will not be continually exposed to moisture or free water for long periods prior to freezing and will not be exposed to deicing agents or other aggressive chemicals. Examples include exterior beams, columns, walls, girders, or slabs that are not in contact with wet soil and are so located that they will not receive direct applications of deicing salts.
3. Severe exposure—Concrete that is exposed to deicing chemicals or other aggressive agents or where the concrete may become highly saturated by continued contact with moisture or free water prior to freezing. For example, pavements, bridge decks, curbs, gutters, sidewalks, canal linings, or exterior water tanks or sumps. The use of normal amounts of air entrainment in concrete with a specified strength around 35 N/mm² (5000 psi) may not be possible due to the fact that each added percent of air lowers the maximum strength obtainable with a given combination of materials. In these cases the exposure to water, deicing salts, and freezing temperatures should be carefully evaluated. If a member is not continually wet and will not be exposed to deicing salts, lower air-content values such as those given in Table 4.7 for moderate exposure are appropriate even though the concrete is exposed to freezing and thawing temperatures.

However, for an exposure condition where the member may be saturated prior to freezing, the use of air entrainment should not be sacrificed for strength. In certain applications, it may be found that the content of entrained air is lower than that specified, despite the use of usually satisfactory levels of air-entraining admixture.

This happens occasionally, for example, when very high cement contents are involved. In such cases, the achievement of required durability may be demonstrated by satisfactory results of examination of air-void structure in the paste of the hardened concrete.

When trial batches are used to establish strength relationships or verify strength-producing capability of a mixture, the least favorable combination of mixing water and air content should be used. The air content should be the maximum permitted or likely to occur, and the concrete should be gauged to the highest permissible slump. This will avoid developing an overly optimistic

estimate of strength on the assumption that average rather than extreme conditions will prevail in the field. If the concrete obtained in the field has a lower slump or air content, the proportions of ingredients should be adjusted to maintain required yield. For additional information on air content recommendations, see ACI 201.2R, 301, and 302.1R.

4.6.2.2 Selection of Water:Cement Ratio

The required water:cement (w:c) ratio is determined not only by strength requirements but also by factors such as durability. Since different aggregates, cements, and cementitious materials generally produce different strengths at the same w:c, it is highly desirable to have or to develop the relationship between strength and w:c for the materials actually to be used. In the absence of such data, approximate and relatively conservative values for concrete containing type I Portland cement can be taken from Table 4.8 with typical materials, the tabulated w:c should produce the strengths shown, based on 28-day tests of specimens cured under standard laboratory conditions. The average strength selected must, of course, exceed the specific strength by a sufficient margin to keep the number of low tests within specific limits.

For severe conditions of exposure, the w:c ratio should be kept low even though strength requirements may be met with a higher value. Table 4.9 gives limiting values. When natural pozzolana, fly ash, ground granulated blast furnace (GGBF) slag, and silica fume, hereafter referred to as pozzolanic materials, are used in concrete, a water-to-cement plus pozzolanic materials

TABLE 4.8

Relation between Water:Cement Ratio and Concrete Compressive Strength

Compressive Strength at 28 Days (N/mm ²)	Non-Air-Entrained Concrete	Air-Entrained Concrete
42	0.41	—
35	0.48	0.40
28	0.57	0.48
21	0.68	0.59
14	0.82	0.74

Notes: Values are estimated average strengths for concrete that are not more than 2% air for non-air-entrained concrete and 6% total air content for air-entrained concrete. For a constant w:c, the strength of concrete is reduced as the air content is increased. Twenty-eight-day strength values may be conservative and may change when various cementitious materials are used. The rate at which the 28-day strength is developed may also change. Strength is based on 6 × 12 inch cylinders moist-cured for 28 days in accordance with the sections on "Initial Curing" and "Curing of Cylinders for Checking the Adequacy of Laboratory Mixture Proportions for Strength or as the Basis for Acceptance or for Quality Control" of ASTM method C 31 for making and curing concrete specimens in the field. The relationship in this table assumes a nominal maximum aggregate size of about 3/4 to 1 inch. For a given source of aggregate, strength produced at a given w:c will increase as nominal maximum size of aggregate decreases.

TABLE 4.9

Maximum Permissible Water:Cement Ratio for Concrete in Severe Exposures*

Type of Structure	Structure Wet Continuously or Frequently, and Exposed to Freezing and Thawing**	Structure Exposed to Sea Water or Sulfates
Thin sections (railings, curbs, sills, ledges, ornamental work) and sections with less than 25 mm cover over steel	0.45	0.40**
All other structures	0.50	0.45**

*Based on report of ACI Committee 201. Cementitious materials other than cement should conform to ASTM C618 and C989.

**If sulfate resisting cement (Type II or Type V of ASTM C 150) is used, water:cementitious materials ratio may be increased by 0.05.

ratio (or water-to-cement plus other cementitious materials ratio) by weight must be considered in place of the traditional water:cement ratio by weight.

4.6.3 Mix Proportions

The selection of the concrete mix depends on the available aggregate near the site. So the properties of these aggregate should be determined. The main factor in any engineering practice is the project cost so the selection of the mix proportion should consider the following:

- The required concrete compressive strength
- The durability of concrete, which is affected by the w:c ratio and cement content
- The availability of materials, performance, and economics

The following equation defines the concrete mix:

$$\frac{C}{1000\gamma_c} + \frac{A_f}{1000\gamma_f} + \frac{A_g}{1000\gamma_g} + \frac{W}{1000} = 1 \quad (4.10)$$

where

C = mass of cement

A_f = mass of fine aggregate

A_g = mass of coarse aggregate

\bar{W} = mass of water

$W = (w/c) \times C$

γ_c = cement specific gravity

γ_f = fine aggregate specific gravity

γ_g = coarse aggregate specific gravity

This equation calculates the quantities of ingredients to produce 1 cubic meter of concrete.

The cement content is based on the environmental conditions and the required concrete strength, which define the w:c. The cement to aggregate ratio is $[C/(A_f + A_g)]$ and the coarse-to-fine aggregate ratio is (A_f/A_g) . These ratios and the previous equation can define the mix proportions.

4.6.3.1 British Standard

The BS 8110 provides a guide for concrete mixes based on the environmental conditions (Table 4.10). The environmental conditions are classified to five categories.

After determining the environmental conditions based on BS 8110, go to Table 4.11, which provides the minimum concrete grade required, minimum cement content based on the maximum aggregate size, and the corresponding maximum w:c.

4.7 Fresh Concrete Test

4.7.1 Cylinder and Cube Tests

Three types of compression test specimens are used: cubes, cylinders, and prisms. Cubes are used in Great Britain, Germany, and many other countries in Europe. Cylinders are the standard in the United States, France and

TABLE 4.10

Classification of Environmental Conditions Based on BS 8110: Part 1: 1985

Environment	Exposure Conditions
Mild	Mild concrete surfaces protected against weather or aggressive conditions
Moderate	Exposed concrete surfaces but sheltered from severe rain or freezing while wet Concrete surfaces continuously under nonaggressive water Concrete in contact with nonaggressive soil Concrete subject to condensation
Severe	Concrete surfaces exposed to severe rain, alternate wetting and drying, or occasional freezing or severe condensation
Very severe	Concrete surfaces occasionally exposed to sea water spray or deicing salts (directly or indirectly) Concrete surfaces exposed to corrosive fumes or severe freezing conditions while wet
Most severe	Concrete surfaces frequently exposed to sea water spray or deicing salts (directly or indirectly) Concrete in sea water tidal zone down to 1 m below lowest low water
Abrasive	Concrete surfaces exposed to abrasive action, for example machinery, metal tiered vehicles, or water-carrying solids

Notes: For aggressive soil and water conditions, see 5.3.4 of BS 5328-1:1997. For marine conditions, see also BS 6349. For flooring, see BS 8204.

TABLE 4.11

Requirements of BS 8110: Part 1: 1985 to Ensure Durability under Specific Conditions of Exposure of Plain Concrete

Exposure Condition	Maximum w/c	Minimum Grade (MPa)	Minimum Content of Cement for Maximum Nominal Aggregate Size (kg/m ³)			
			40 mm	20 mm	14 mm	10 mm
Mild	0.80	20	150	180	200	220
Moderate	0.65	30	245	275	295	315
Severe	0.60	35	270	300	320	340
Very severe	0.55	35	295	325	345	365
Extreme	0.50	45	320	350	370	390

Canada, Australia, and New Zealand. In Scandinavia, tests are made on both cubes and prisms.

Fit present, especially in research, cylinders are preferable to cubes, but before comparing the types of specimens, the various tests should be considered in detail.

4.7.1.1 Cube Test

The specimens are cast in steel or cast-steel molds, generally 150 mm cubes. The standard practice prescribed by BS 1881: Part 3: 1970 is to fill the mold in three layers. Each layer of concrete is compacted by no less than 35 strokes of a 25-mm (1-inch) square steel rod. Ramming should continue until sufficient compaction has been achieved, for it is essential that the concrete in the cube be fully compacted if the compressive test is to represent the properties of fully compacted concrete.

After the top surface of the cube has been finished with a trowel, the cube is stored undisturbed for 24 hours at a temperature of 18°C to 22°C and relative humidity of not less than 90%. At the end of this period the mold is stripped and the cube is further cured in water at 19°C to 21°C.

The cube test is generally performed at 28 days, but also at 3 and 7 days. In a compression test, the cube is placed with the cast faces in contact with the platens of the testing machine. It is worth noting that, according to BS 1881: Part 4: 1970, the load on the cube should be applied at a constant rate of stress equal to 15 MPa/min (2200 psi/min).

The cube standard is 150 mm but there are other sizes.

4.7.1.2 Cylinder Test

The standard cylinder size is 150 mm diameter by 300 mm height or 100 mm diameter by 200 mm height. The mold cast is generally made of steel or cast steel. Use a 100 mm diameter cylinder in case of maximum nominal



FIGURE 4.7
Cylinder preparation.



FIGURE 4.8
Compressive strength and density machine test.

aggregate size not higher than 20 mm, and 40 mm in case of 150 mm diameter. The cylinder specimens are made in a similar way to the cubes but are compacted either in three layers using a 16 mm diameter rod or in two layers by means of an immersion vibrator. Details of the procedure are described in ASTM Standard C192-76. The preparation of the cylinder is as shown in Figure 4.7. Figure 4.8 shows the apparatus.

The top surface of the cylinder is finished with a float if not smooth enough for testing if it requires further preparation. This is the greatest disadvantage of this type of specimen.

The top surface can be prepared by two ways. The first method is by using mortar to the top by using a collar with a handle and filling with cement mortar. The second method prepares the surface top cover by adding sulfur and fine sand with small amount of carbons (1% to 2%) and this composition is heated to 130°C to 150°C, then slightly cooled.

The cylinder is placed on a layer of coverage material as thin as possible, making sure that the cylinder axis is vertical, and then the excess coverage materials are cut off after a few seconds. During the test must make sure that the cylinder cover will not slide or break before the collapse of the sample. The comprehensive strength and density machine tests are illustrated in Figure 4.8.

The cylinder test relies on sampling of concrete from the pouring process. The samples will be taken by standard shovel, manufactured from rest-resistant material, 0.8 mm thick. The amount of concrete taken by shovel at one time should be about 5 kg and the number of shovels is determined according to the type of test, taking into account whether sampling is from the mixer on site or from ready mix concrete that is delivered. If using delivered concrete, do not use the first or last parts of the shipment, as they are not good representative of the batch.

The comprehensive strength and density machines tests are illustrated in Figure 4.8.

In the case of casting, samples must be taken from the mixer or from the mixing truck using cranes or pumps.

4.7.2 Predicting Concrete Strength

Sampling to predict concrete strength is often done after 7 days and 28 days. The Egyptian code (Table 4.12) can be used to predict the concrete strength at 28 days by knowing the cube strength at 3 and 7 days. The number of cubes or cylinders tested at 3 and 7 days should be stated in project specifications. The specifications should also state the minimum strength acceptable at 3 or 7 days, and also define the reasonable time to remove the wood or the steel forms.

In the past, the gain in strength beyond 28 days was regarded merely as contributing to an increase in the safety of the structure but since 1957 the code of practice for reinforced and prestressed concrete allows the gain in strength to be taken into account in the design of structures that will not be subjected to load until a later age except when no-fines concrete is used. With some lightweight aggregates, verifying tests are advisable. The values of strength given in the British Code of Practice CP 110:1972, based on 28 day compressive strength, are given in Table 4.13. Note that Table 4.13 will not apply when accelerators are used.

TABLE 4.12

Correction Factor for Concrete Compressive Strength Test Results

Type of Cement	Concrete Age (Days)				
	3	7	28	90	360
Ordinary Portland cement	2.5	1.5	1.0	0.85	0.75
Fast hardening Portland cement	1.8	1.2	1.0	0.9	0.85

TABLE 4.13

British Code of Practice CP 110:1972 Factors for Increase in Compressive Strength of Concrete with Age (Average Values)

Minimum Age of Member When Full Design Load Is Applied (Months)	Age Factors for Concrete with a 28-Day Strength (MPa)		
1	1.00	1.00	1.00
2	1.10	1.09	1.07
3	1.16	1.12	1.09
6	1.20	1.17	1.13
12	1.24	1.23	1.17

TABLE 4.14

Correction Factor for Concrete Strength for Different Molds

Cube	Mold Dimensions (mm)	Correction Factor
Cube	100 × 100 × 100	0.97
Cube	150 × 150 × 150	1.00
	158 × 158 × 158	
Cube	200 × 200 × 200	1.05
Cube	300 × 300 × 300	1.12
Cylinder	100 × 200	1.20
Cylinder	150 × 300	1.25
Cylinder	250 × 500	1.30
Prism	150 × 150 × 300	1.25
	158 × 158 × 316	
Prism	150 × 150 × 450	1.30
	158 × 158 × 474	
Prism	150 × 150 × 600	1.32

Table 4.14 defines the relation between cube and cylinder test values, so if you have the values of cylinder compressive strength value they can be converted to cube values and vice versa.

4.8 Define Concrete Density

Concrete density is an important factor for determining the dead loads to do an accurate structure analysis. By knowing the concrete density one can predict the concrete compressive strength and the permeability. Figure 4.9 depicts a vibration table.

Figure 4.9 presents the vibrating table used in the test. In some special structures, the main factor is the concrete density. A heavy concrete

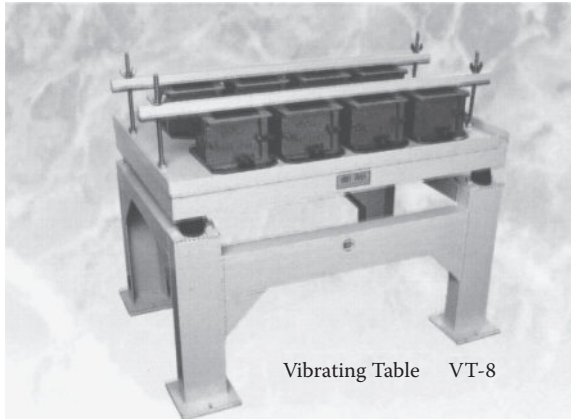

FIGURE 4.9
Vibration table.

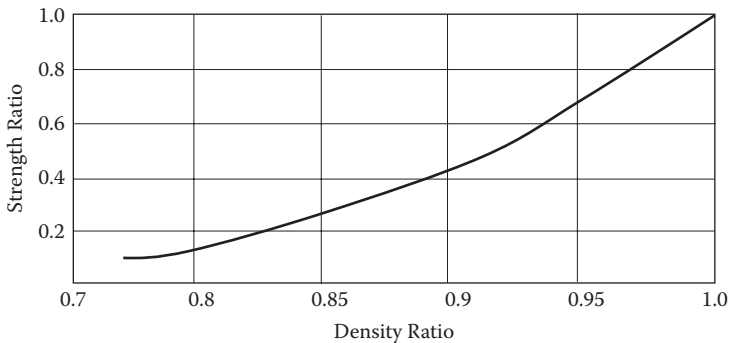

FIGURE 4.10
Relation between density and compressive strength. (Adapted from Neville, A. M., 1983, *Properties of Concrete*, London: Pitman.)

structure is affected by floating force so producing dense concrete is very critical. The relation between the density and compressive strength is shown in Figure 4.10.

Sample size should be not less than $50 s^3$, where, s is the nominal maximum aggregate size. In any case the sample size should not be less than 0.001 m^3 . Often the sample is in the form of a cube or cylinder, and the volume (V) should be determined accurately to the nearest millimeter.

The sample weight (W_1) is the weight upon arrival to the laboratory.

Measure the weight of the sample after immersion in water at $20^\circ\text{C} \pm 2^\circ\text{C}$. Then measure the weight again after 24 hours. The two readings should

TABLE 4.15

First Estimation of Fresh Concrete Density

Maximum Size of Aggregate (mm)	Non-Air Entrained (kg/m ³)	Air Entrained
10	2285	2190
12.5	2315	2235
20	2355	2280
25	2375	2315
40	2420	2355
50	2445	2375
70	2465	2400
150	2505	2435

be approximately the same; any change should not exceed 0.02%. This weight is W_2 .

Measure the weight of the sample (W_d) in dry condition by drying it in a $105^\circ\text{C} \pm 5^\circ\text{C}$ oven. Measure the weight after removal from the oven and again after 24 hours. The change in weight should not exceed 0.02%.

Calculate density in the three cases:

$$D_1 = W_1/V \quad (\text{Laboratory sample})$$

$$D_2 = W_2/V \quad (\text{Immersed sample})$$

$$D_3 = W_d/V \quad (\text{Dry sample})$$

Based on ACI 211.1-91, estimate the density of fresh concrete for different maximum aggregate sizes in air entrained and non-air-entrained cases (Table 4.15).

4.9 Defining Settlement for Fresh Concrete

The slump test is one of the easiest tests of concrete and gives good information on the concrete before casting. It is considered one of the key means to control the quality of concrete at the site. It is therefore widely used. The slump test is described by ASTM C143-90a and BS 1881: Part 102: 1983.

The tools used in this test are a metal template cone with a steel flat plate and the steel rod for compaction. The materials of these tools are not affected by the cement paste. The materials are not less than 1.5 mm and the surfaces are smooth and free from any nails or juts profile. The tools are shown in

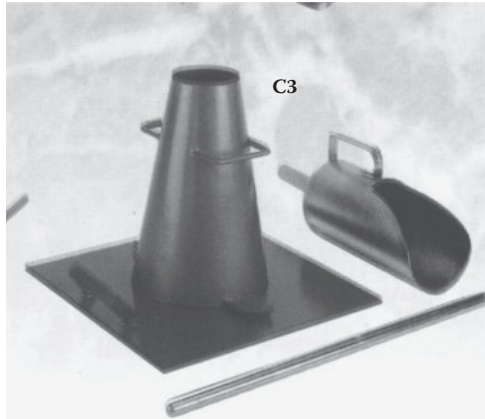

FIGURE 4.11
Slump test tools.



FIGURE 4.12
Pouring concrete in slump.

Figure 4.11, Figure 4.12 demonstrates pouring the concrete in slump. The dimensions of the slump cone are as follows (Figure 4.13):

Top diameter = 100 ± 2 mm

Bottom diameter = 200 ± 2 mm

Height = 300 ± 2 mm

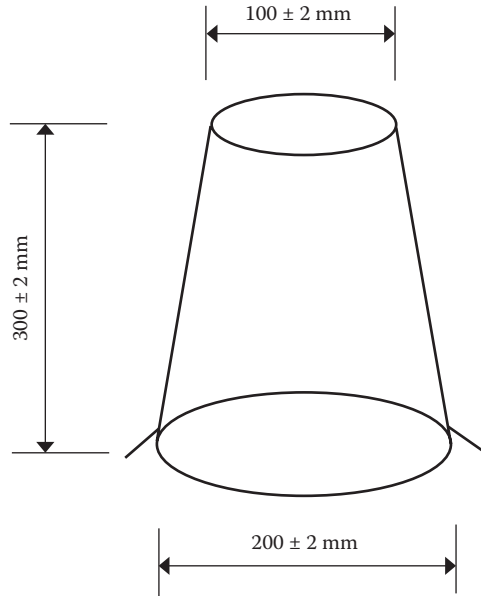

FIGURE 4.13
Slump cone dimensions.

The basin for preparing the sample is flat with dimensions of 1.2 m \times 1.2 m, depth equal to 50 mm, and thickness equal to 1.6 mm. The round steel rod for compaction has 16 mm diameter and is 600 mm long with semispherical ends.

The settlement test is performed after mixing the concrete. During pouring, three cubic meters are taken by six shovels, poured into the flat basin, and mixed by shovels twice. The next step is to prepare the horizontal surface to be clean and flat for the cone.

Pour concrete inside the cone up to a third of the cone height (Figure 4.12) and compact it with the rod 25 times to distribute equally and to compact it flat inside the mold. Take into account that only the first floor bar compaction meets a horizontal surface. Then pour the second layer and perform compaction the same way. Finally, pour the last third using the same technique, and finish the surface by troweling.

After 5 to 10 seconds remove the mold vertically, slowly, and carefully. The entire process from pouring the concrete until full lifting of the template should not be more than about 150 seconds. If the sample collapses, repeat the test.

Put the steel rod on the top horizontal to the converted cone and measure the settlement of the concrete, as shown in Figure 4.13. Compare the measurements to what is stipulated in the project specifications (Figure 4.14). See the Egyptian code for allowable settlement values by type of structure



FIGURE 4.14
Measuring the slump settlement.

TABLE 4.16

Required Slump Values for Different Concrete Members

Element Type	Slump (mm)	Type of Compaction
Concrete blocks	0–25	Mechanical compaction
Concrete foundation with light reinforcement and medium reinforcement and concrete section with light reinforcement	25–50	Mechanical compaction
Concrete section with medium or high reinforcement	50–100	Mechanical compaction, manual compaction
Concrete sections with dense reinforcement	100–125	Light compaction
Deep foundation and pumped concrete	125–200	Light compaction

TABLE 4.17

Allowable Tolerance to Define the Maximum Settlement

Maximum Amount of Settlement (mm)	Allowable Tolerance (mm)
75 or less	35
>75	60

(Table 4.16) and the allowable tolerance for maximum allowable slump settlement (Table 4.17) and required settlement (Table 4.18).

The slump test is very useful on site for monitoring the concrete quality variation in the materials fed into the mixer daily or hour by hour. For example, too high or too low slump gives immediate warning and enables the

TABLE 4.18

Allowable Tolerance to Define the Required Settlement

Required settlement value, mm	Allowable tolerance, mm
50 or less	±10
50–100	±20
>100	±30

TABLE 4.19

Compaction Factor and Workability Degree

Concrete Workability Degree	Compaction Factor
Very low	0.8
Low	0.87
Moderate	0.935
High	0.96

mixer operator to remedy the situation. This application of the slump test, as well as its simplicity, is the reason for its widespread use.

4.10 Determining Compacting Factor for Fresh Concrete

The compacting factor test is described in BS 1881: Part103; 1993 and in ACI 211.3-75 (revised 1987 and reapproved 1993). This test will be to appoint a working compaction of concrete interoperability with a low, medium, and apply to regular concrete manufactured with air entrained for aggregate with normal, light, or heavy weight (Table 4.19). Therefore, the nominal maximum aggregate size is 40 mm, and often this test is only performed in pre-cast concrete or large work sites.

The apparatus consists of two cones atop a cylinder fixed on a steel support (Figure 4.15). The dimensions of the cylinder, cone, and the distance between them are based on BS 1881.

Gently place a sample of concrete in the upper cone and fill to the top. Then open the gate of the upper cone to let concrete fall on the lower cone, and then open the gate of the lower cone to drop the concrete down into the cylinder.

Measure the weight of the partially compacted concrete to the nearest 10 g (W_1) within 150 seconds of the start time of the test.

Then refill cylinder with the same type of concrete to be fully compacted and weigh the concrete to the nearest 10 g (W_2).

$$\text{Compaction factor} = W_1/W_2$$

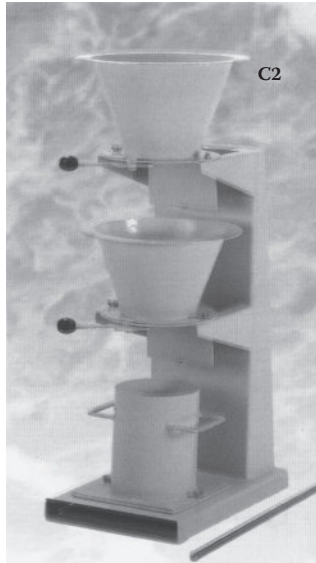

FIGURE 4.15
Compaction factor apparatus.

Table 4.19 demonstrates the relation between the concrete workability degree versus the compaction factor value from the test.

4.11 High-Performance Concrete Mix

Based on ACI 211.4 (93), high-strength concrete is defined as concrete that has a specified compressive strength f'_c of 42 N/mm² (6000 psi) or greater.

This guide is intended to cover field strengths up to 84 N/mm² (12,000 psi) as a practical working range, although greater strengths may be obtained. Recommendations are based on current practice and information from contractors, concrete suppliers, and engineers who have been involved in projects dealing with high-strength concrete.

ACI 318 allows concrete mixtures to be proportioned based on field experience or laboratory trial batches. To meet the specified strength requirements, the concrete must be proportioned in such a manner that the averages of compressive strength results of field tests exceed the specified design compressive strength f'_c by an amount sufficiently high to make the probability of low test results small. When the concrete producer chooses to select high-strength concrete mixture proportions based upon field experience, it is recommended that the required average strength f'_c serve as

the basis for selection of concrete proportions as the larger value calculated from the following:

- The average of all sets of three consecutive strength test results equals or exceeds the required f'_c .
- No individual strength test (average of two cylinders) falls below $0.90 f'_c$.

Note that this is different from the ACI 318 requirement. The latter criterion differs from the 3.4 MPa (500 psi) under strength criterion in ACI 318, because a deficiency of 3.4 MPa (500 psi) may not be significant when high-strength concrete is used.

High-strength concretes may continue to gain significant strength after the acceptance test age, especially if fly ash or ground granulated blast furnace slag is used.

Experience has shown that strength tested under ideal field conditions attains only 90% of the strength measured by tests performed under laboratory conditions. To assume that the average strength of field production concrete will equal the strength of a laboratory trial batch is not realistic, since many factors can influence the variability of strengths and strength measurements in the field. Initial use of a high-strength concrete mixture in the field may require some adjustments in proportions and proper selection for its component. Once sufficient data have been generated from the job, mixture proportions should be reevaluated using ACI 214 and adjusted accordingly.

For the high-strength concrete or high-performance concrete there is no standard or typical mix proportion, Table 4.20 presents the results of several successful mixes (Neville). The table lists different HPC mixing ratios for different countries: A and D are from the United States; B, C, E, F, and I from Canada; G from Morocco; and H from France.

4.12 Pumped Concrete Mix

4.12.1 Basic Considerations

Concrete pumping is so established in most areas that most ready-mixed concrete producers can supply a mixture that will pump readily if they are informed of the concrete pump volume and pressure capability, pipeline diameter, and horizontal and vertical distance to be pumped.

The shape of the coarse aggregate, whether angular or rounded, has an influence on the required mixture proportions, although both shapes can be pumped satisfactorily. The angular pieces have a greater surface area per

TABLE 4.20
Mix Proportions for High-Performance Concrete

Component (kg/m ³)	A	B	C	D	E	F	G	H	I
Portland cement	534	500	315	513	163	228	425	450	460
Silica fume	40	30	36	43	54	46	40	45	
Fly ash	59	—	—	—	—	—	—	—	—
GGBS	—	—	137	—	325	182	—	—	—
Fine aggregates	623	700	745	685	730	800	755	736	780
Coarse aggregates	1069	1100	1130	1080	1100	1110	1045	1118	1080
Total water	139	143	150	139	136	138	175*	143	138
w:c + b	0.22	0.27	0.31	0.25	0.25	0.30	0.38	0.29	0.30
Slump	255	—	—	—	200	220	230	230	110
<i>Cylinder Strength (MPa)</i>									
1	—	—	—	—	13	19	—	35	36
2	—	—	—	65	—	—	—	—	—
7	—	—	67	91	72	62	—	68	—
28	—	93	83	119	114	105	95	111	83
56	124	—	—	—	—	—	—	—	—
91	—	107	93	145	126	121	105	—	89
365	—	—	—	—	136	126	—	—	—

*It is suspected that the high water content was caused by a high ambient temperature in Morocco.

unit volume as compared with rounded pieces and thus require more mortar to coat the surface for pumpability.

4.12.2 Coarse Aggregate

The maximum size of angular or crushed coarse aggregate is limited to 1/3 of the smallest inside diameter of the pump or pipeline. For well-rounded aggregate, the maximum size should be limited to 2/5 of these diameters. The principles of proportioning are covered in ACI 211.1 and ACI 211.2.

Whereas the grading of sizes of coarse aggregate should meet the requirements of ASTM C 33, it is important to recognize that the range between the upper and lower limits of this standard is broader than ACI Committee 304 recommends for producing a pumpable concrete.

4.12.3 Fine Aggregate

The properties of the fine aggregate have a much more prominent role in the proportioning of pumpable mixtures than do those of the coarse aggregate. Together with the cement and water, the fine aggregate provides the mortar or fluid that conveys the coarse aggregates in suspension, thus rendering a mixture pumpable.

Particular attention should be given to those portions passing the finer screen sizes. At least 15% to 30% should pass the No. 50 screen and 5% to 10% should pass the No. 100 screen. ACI 211.1 states that for more workable concrete, which is sometimes required when placement is by pump, it may be desirable to reduce the estimated coarse aggregate content by up to 10% based on 304R-30 ACI Committee report.

Exercise caution to ensure that the resulting slump, w:c, and strength properties of the concrete meet applicable project specification requirements.

4.12.4 Combined Normal Weight Aggregates

The combined coarse and fine aggregates occupy about 67% to 77% of the mixture volume. For gradation purposes, the fine and coarse aggregates should be considered together even though they are usually proportioned separately.

ACI 304.2R includes an analysis worksheet for evaluating the pumpability of a concrete mixture by combining the fine and coarse aggregate with nominal maximum-sized aggregate from 3/4 to 1½ inches (19 to 38 mm). The worksheet makes provision for additional coarse and fine aggregate that can be added to a mixture to improve the overall gradation and recognizes possible overlap of some coarse and fine aggregate components. If a mixture known to be pumpable is evaluated and plotted first, the curve representing its proportions provides a useful reference for determining the pumpability of a questionable mixture.

Those pumps with powered valves exerting higher pressure on the concrete, and allowing the most gradual and smallest reduction from concrete tube diameter can pump the most difficult mixtures.

Concrete containing lightweight fines and coarse aggregate can be pumped if the aggregate is properly saturated. You can refer to ACI 304.2R for more detailed information and procedures.

4.12.5 Water

Water requirements and slump control for pumpable normal weight concrete mixtures are interrelated and extremely important considerations. The amount of water used in a mixture will influence the strength and durability (for a given amount of cement) and will affect the slump or workability. Mixing water requirements vary for different maximum sizes of aggregate as well as for different slumps.

To establish the optimum slump resulting from water content for a pump mixture and to maintain control of that particular slump through the course of a job are both extremely important factors. Slumps from 2 to 6 inches (50 to 150 mm) are most suitable for pumping. In mixtures with higher slump, the coarse aggregate can separate from the mortar and paste and can cause

pipeline blockage. Slumps obtained using superplasticizers, however, are usually pumped without difficulty.

There are several reasons why the slump of concrete can change between initial mixing and final placement. If the slump at the end of the discharge hose can be maintained within specification limitations, it may be satisfactory for the concrete to enter the pump at a higher slump to compensate for slump loss, if the change is due simply to aggregate absorption.

4.12.6 Cementitious Materials

The determination of the cementitious materials content follows the same basic principles used for any concrete. In establishing the cement content, remember the need for overstrength proportioning in the laboratory to allow for field variations. The use of extra quantities of cementitious materials as the only means to correct pumping difficulties is shortsighted and uneconomical. Correcting any deficiencies in the aggregate gradation is more important.

4.12.7 Admixtures

Any admixture that increases workability in both normal weight and light-weight concretes will usually improve pumpability. Admixtures used to improve pumpability include regular and high-range, water-reducing admixtures; air-entraining admixtures; and finely divided mineral admixtures.

Increased awareness of the need to incorporate entrained air in concrete to minimize freezing and thawing damage to structures has coincided with increased use of concrete pumps, as well as the development of longer placement booms. This has resulted in considerable research and testing, which established that the effectiveness of the air-entraining agent (AEA) in producing a beneficial air-void system depends on many factors. The more important factors are:

- The compatibility of the AEA and other admixtures as well as the order in which they are introduced into the batch
- The mixture proportions and aggregate gradation
- Mixing equipment and procedures
- Mixture temperatures
- Slump

AEA effectiveness and the resulting dosage of AEA also depends on the cement fineness, cement factor, and water content, and the chemistry of cement and water, as well as the characteristics of other chemical and mineral admixtures used in the concrete. Refer to ACI 304.2R for more detailed information on air content and admixtures.

4.12.8 Field Practice

It is essential to perform preplanning for concrete pumping for successful placements, with increasing detail and coordination required as the size of the placement and the project increases. This planning should provide for the correct amount and type of concrete for the pump used, provision for the necessary pipeline, and agreement as to which personnel will provide the labor necessary to complete the placement operation.

Any trailer- or truck-mounted concrete pump can be used for pipeline concrete placement. The limiting factor in this method is the ability to spread the concrete as needed at the end of the pipeline. Generally, this is done by using a rubber hose at the end of a rigid placement line.

The discharge of powered placement booms can be positioned at almost any point within the radius of the boom and at elevations achieved with the boom from near vertical (up or down) to horizontal. Their use generally reduces the number of workers required for a given placement.

4.12.9 Field Control

Pumped concrete does not require any compromise in quality. A high level of quality control, however, should be maintained to ensure concrete uniformity.

Concrete has been pumped successfully during both hot and cold weather. Precautions may be necessary to provide adequate protection during extreme conditions.

The concrete that is to be pumped must be well mixed before feeding into the pump. A slump between 50 and 150 mm is generally recommended.

Aggregate grading recommendations for pumping concrete can be found in ACI 304.2R-91 (Table 4.21).

TABLE 4.21
Recommended Aggregate Grading

Size (mm)	Cumulative Percentage Passing	
	Maximum Size 25 mm	Maximum Size 20 mm
25	100	—
20	80–88	100
13	64–75	75–82
9.50	55–70	61–72
4.75	40–58	40–58
2.36	28–47	28–47
1.18	18–35	18–35
0.6	12–25	12–25
0.3	7–14	7–14
0.15	3–8	3–8
0.075	0	0

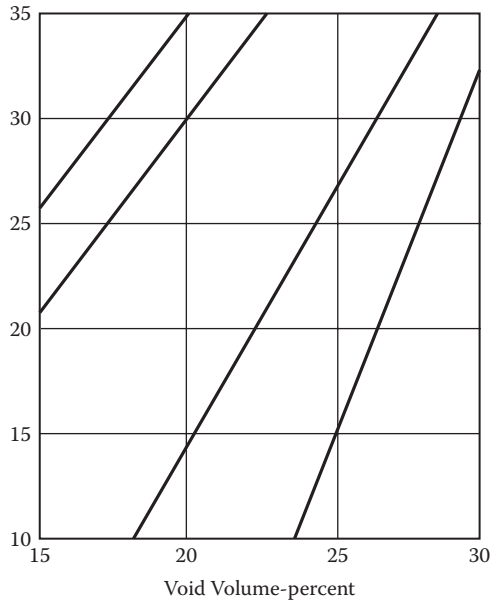
**FIGURE 4.16**

Pumpability of concrete in relation to cement content and void content of aggregate.

Johansson and Tuutti (1976) studied the relation between the cement content and the void content to determine whether a concrete could be pumped.

Generally, any mix selection of concrete to be pumped must be subjected to a test. Although laboratory pumps have been used to predict the pumpability of concrete, the performance of any given mix also depends on the distance through which the concrete is to be pumped.

Figure 4.16 shows the relation between cement content and aggregate void content and, excessive frictional resistance on segregation and bleeding.

4.13 Quality Control for Operation

This type of quality control is going through the manufacturing process on an hourly or daily basis, as in the case of ready-mix concrete, management should monitor the quality over the operation time.

4.13.1 Process Control Chart

The control chart provides a graphic tracking method whereby measurements and samples taken can be laid out against the time variable for the data-collection period (Figure 4.17 and Figure 4.18).

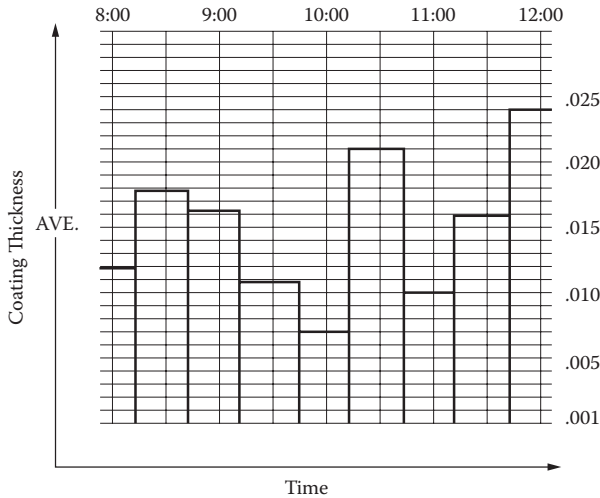

FIGURE 4.17
Histogram presenting the coating thickness measuring time.

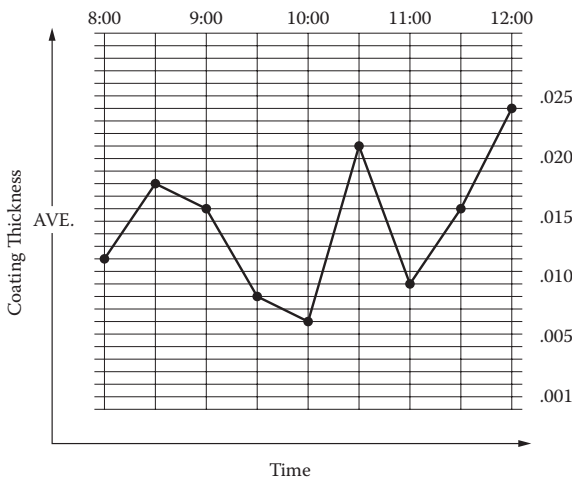

FIGURE 4.18
Curve presenting the coating thickness measurement over time.

4.13.2 Constructing X-R Chart

- Step 1—Prepare the blank chart and distribute it to all team members.
- Step 2—Take samples and place the numbers on the chart. (The period of samples is 1 working day.)
- Step 3—Calculate the average of each sample.

- Step 4—Calculate the overall average. (An example of this can be found in Figure 4.20)
- Step 5—Find the range ($X_{max}-X_{min}$).
- Step 6—Calculate the average range.
- Step 7—Calculate the graph scale from the largest and smallest averages and ranges.
- Step 8—Plot the data.
- Step 9—Draw the total average values and range as calculated before.
- Step 10—Analyze the data and obtain the observation.

See Figure 4.19 and Figure 4.20. Figure 4.21 plots the results.

Process capability index

Define

$$C_p = (USL-LSL)/(6 \sigma) \text{ where,}$$

USL: Upper specification limit

LSL: Lower Specification Limit

Where: s is the standard deviation of the test

$\sigma = R/d_2$, where d_2 is a constant that depends on subgroup size, as presented in Table 4.21.

PART NAME (PRODUCT)					OPERATION (PROCESS)					SPECIFICATION LIMITS					
OPERATOR			MACHINE			GAGE			UNIT OF MEASURE			ZERO EQUALS			
DATE															
TIME															
SAMPLE MEASUREMENTS	1														
	2														
	3														
	4														
	5														
SUM															
AVERAGE, \bar{X}															
RANGE, R															
NOTES															
AVERAGES	1														
	2														
	3														
	4														
	5														
	6														
	7														
	8														
	9														
	10														
	11														
	12														
	13														
	14														
	15														
	16														
	17														
	18														
	19														
	20														
	21														
	22														
	23														
	24														
	25														
RANGES	1														
	2														
	3														
	4														
	5														
	6														
	7														
	8														
	9														
	10														
	11														
	12														
	13														
	14														
	15														
	16														
	17														
	18														
	19														
	20														
	21														
	22														
	23														
	24														
	25														

X and R chart form as constructed by the American Society for Quality Control (ASQC).

FIGURE 4.19 Variable control chart. (X-R chart)

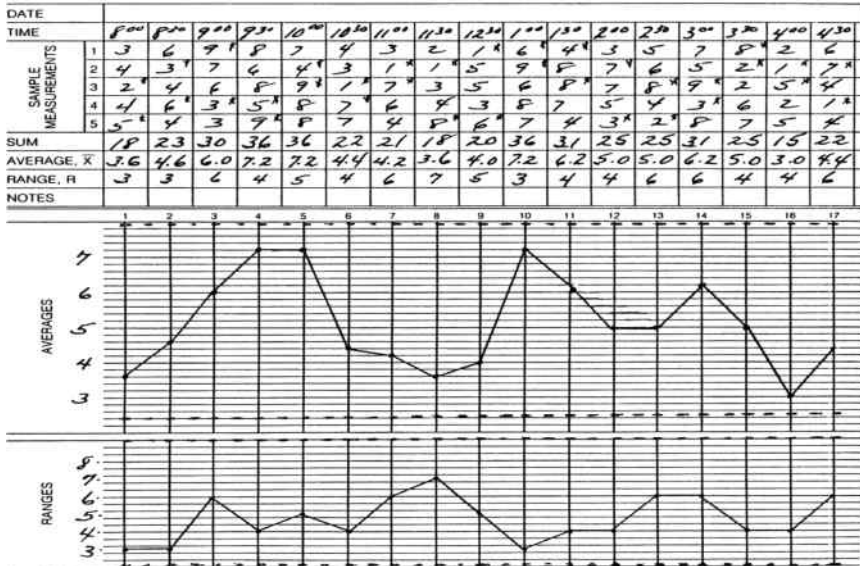

FIGURE 4.20 Process chart.

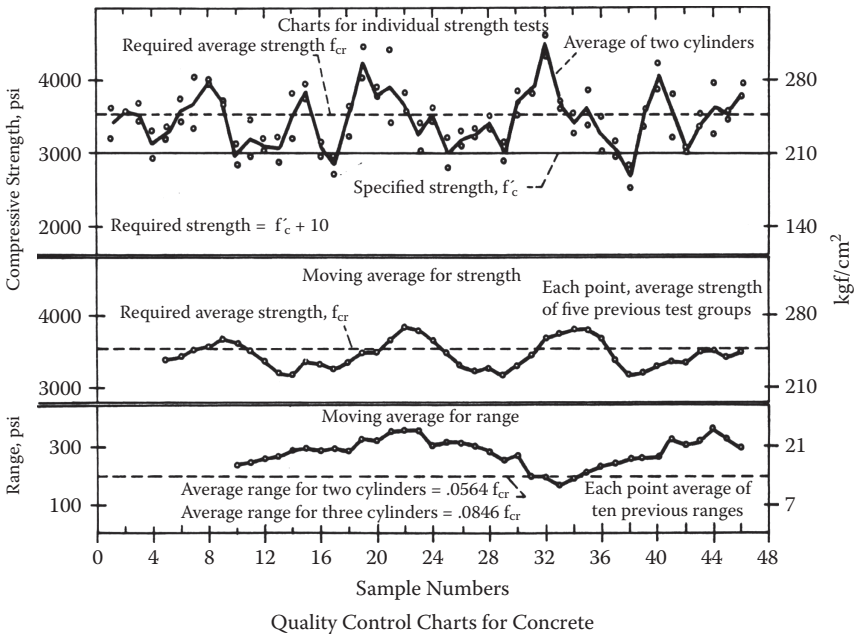

FIGURE 4.21 Concrete quality control chart.

$$\sigma = 4.71/2.326 = 2.02$$

$$C_p = (7-3)/(12.12) = 0.33$$

$$C_{pK} = \min(C_{pl}, C_{pu}) = 0.31$$

$$C_{pu} = (USL-X)/3s = 0.35$$

$$C_{pl} = (LSL-X)/3s = 0.31$$

References

- ACI 211.3-75, revised 1987, reapproved 1992, Standard Practice for Selecting Proportions or No-Slump Concrete, ACI Manual of Concrete Practice, part 1 Materials and General Properties of Concrete (Detroit, Michigan, 1994).
- ACI 228-89-R1, In-Place Methods for Determination of Strength of Concrete.
- ACI Monograph No. 9, Testing Hardened Concrete: Nondestructive Methods.
- Aitcin, P. C., and Neville, A. 1993. High-performance concrete demystified. *Concrete International*, vol. 15, no.1, pp. 21–26.
- ASTM C188-84, Density of Hydraulic Cement.
- ASTM C114-88, Chemical Analysis of Hydraulic Cement.
- ASTM C183-88, Sampling and Amount of Testing of Hydraulic Cement.
- ASTM C349-82, Compressive Strength on Hydraulic Cement Mortars.
- ASTM C670-84, Testing of Building Materials.
- ASTM C142-78, Test Method for Clay Lumps and Friable Particles in Aggregate.
- Baalbaki, M., Sarker, S. L., Aitcin, P. C., and Isabelle, H. 1992. Properties and microstructure or high-performance concretes containing silica fume, slag, and fly ash, in *Fly-Ash Silica Fume and Natural Pozzolans in Concrete*, vol. 2, Ed. V. M. Malhotra, ACI, SP-132, pp. 921–942. Detroit, MI: ACI.
- Best, J. F., and Lane, R. O. 1980. Testing or optimum pumpability of concrete. *Concrete International*, vol. 2, no. 10, pp. 9–17.
- BS 1881:Part 5:1970, Methods for Testing Hardened Concrete for Other Than Strength.
- BS 1881:Part 6:1971, Methods of Testing Concrete, Analysis of Hardened Concrete.
- BS 812:Part 103:1985, Sampling and Testing of Mineral Aggregate Sands and Fillers.
- BS 1881:Part 108:1983, Method for Making Test Cubes from Fresh Concrete.
- BS 1881:Part 109:1983, Testing Concrete: Methods for Making Test Beams from Fresh Concrete.
- BS 1881:Part 110:1983, Testing Concrete: Methods for Making Test Cylinders from Fresh Concrete.
- BS 1881:Part 114:1983, Testing Concrete: Methods for Determination of Density of Hardened Concrete.
- BS 1881:Part 116:1983, Testing Concrete: Methods for Determination of Compressive Strength of Concrete Cubes.
- BS 1881:Part 119:1983, Methods for Determination of Compressive Strength Using Portions of Beams Broken in Flexure (Equivalent Cube Method).
- Cadoret, G., and Richard, P. 1992. Full use of high performance concrete in building and public works, in *High Performance Concrete: From Material to Structure*, Ed. Y. Malier, pp. 379–411. London: E&FN Spon.

- Causse, G., and Montents, S. 1992. The Roize Bridge, in *High Performance Concrete: From Material to Structure*, Ed. Y. Malier, pp. 525–536. London: E&FN Spon.
- Johansson, A., and Tuutti, K. 1976. Pumped Concrete and Pumping of Concrete, CBI Research Reports, 10:76 (Swedish Cement and Concrete Research Institute).
- Lessard, M., et al. 1994. High-performance concrete speeds reconstruction for McDonald's, *Concrete International*, vol. 16, no. 9, pp. 47–50.
- Neville, A. M. 1983. *Properties of Concrete*. London: Pitman.

5

Construction Quality Control

5.1 Introduction

The aim of this chapter is to illustrate the traditional and modern techniques to deliver a high concrete quality match with the current standards. Ready-mix concrete is most popular in some countries, whereas other countries mix on site. Based on a study by El-Reedy, ready-mix concrete can provide high quality so it can be match with less conservative design. However in some countries, a more conservative and restricted code is needed to cover the uncertainty of concrete mixed on-site.

The concrete industry works in a stepwise fashion. Every step has different alternatives and selection of these alternatives depends on the project itself and its economics. Every stage needs the same care to obtain good quality for the final products. In summary these steps are preparing the wood or steel forms, preparing and installing the steel bars, pouring concrete, compaction, and curing. This chapter provides the traditional and alternative techniques for each step based on the American, British, and Egyptian standards.

5.2 Create the Wooden Form

The design of wooden formwork depends on the structure system since each structure system has a particular shape. For example, a solid slab and beam system is different from the flat slab with no beam and also different from the hollow block system. Therefore, the design of the formwork is an important factor that must be subject to engineer design review since the form will have to carry loads resulting from the concrete in its early stages during the casting and curing in addition to labor and equipment movement on the slab during concrete pouring. Any error in design will result in many problems in the structure.

However, one can find that poor design or execution can result in many critical problems. For example, if there is movement to the form in the beam

side during concrete pouring, then longitudinal cracks to the concrete can result, affecting the integrity of the total structure.

Based on American Concrete Institute (ACI) 318 there are some precautions in designing the form:

- Forms shall result in a final structure that conforms to shapes, lines, and dimensions of the members as required by the design drawings and specifications.
- Forms shall be substantial and sufficiently tight to prevent leakage of mortar.
- Forms shall be properly braced or tied together to maintain position and shape.
- Forms and their supports shall be designed so as not to damage previously placed structures.
- Design of formwork shall consider rate and method of placing concrete.
- Formwork design should consider precisely, the construction loads, including vertical, horizontal, and impact loads.
- There should be special form requirements for construction of shells, folded plates, domes, architectural concrete, or similar types of elements.

On the following pages, some pictures of the wooden forms were taken from projects published in the International Network on the Internet. Figure 5.1 shows the wooden form of reinforced concrete wall, as well as all the vertical struts to support it. Figure 5.2 shows the shape of the vertical, horizontal, and inclined struts from steel tube. The concrete form is of plywood to produce a smooth face to the bridge girder. Figure 5.3 shows the shape of the forms and struts and column boxes. Moreover, the wooden walkway provides easy access and safety for the laborers. Figure 5.4 shows the shape of the wooden form for reinforced concrete slab that will be poured in the ground. The side shutter, strap, and strut are also shown.

Figure 5.5 is different as it shows the metal form for a big reinforced concrete foundation and the metal for it is traditionally used in reinforced concrete pipes for sanitary or sewage work and also for precast buildings.

Sometimes steel sheet is used as a shuttering to the concrete slab. Do not remove the shuttering after construction, as shown in Figure 5.6.

Figure 5.7 illustrates the other shape of wood form and support, which is traditionally plywood with steel supports. The last photo of Figure 5.7 shows that the cantilever is supported by a cantilever steel section to support the plywood form.

Note that the use of wood or metal form must be constructed in accordance with relevant codes. The formwork design depends on the discretion



FIGURE 5.1
Formwork for reinforced concrete wall.



FIGURE 5.2
Bridges and slab form support.



FIGURE 5.3
Wood form for concrete columns.



FIGURE 5.4
Strengthening wood form for ground slab.



FIGURE 5.5
Steel form for raft foundation.

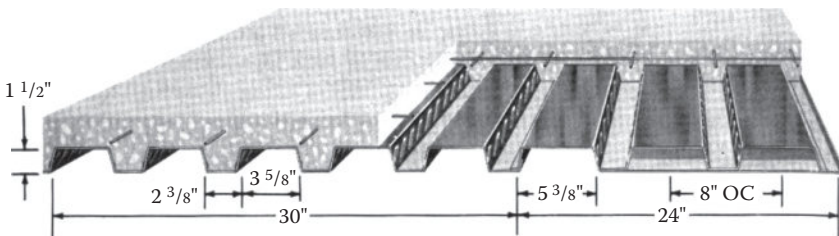

FIGURE 5.6
Steel sheet slab shuttering.

of the designer, who will approve the formwork. The engineer supervising the receipt of the forms should receive the formwork before the casting process and approve it. The process of review and audit must be conducted by an on-site authority who will issue documents to show that the form is sound.

One must be aware when designing the forms that they will be exposed to strong vibration during casting and compaction of concrete in addition to the movement of labor, equipment, and tools. The following are some general observations that must be taken into account:

- The form should be solid and strong provisions taken to prevent the leakage of mortar or the slurry, which is a mixture of cement and water, during the casting of concrete and compaction. This leakage is the main reason for honeycombs.



FIGURE 5.7
Steel supports with marine plywood.



FIGURE 5.7 (Continued)

- When the wood or metal form is exposed to the sun for a long time before pouring, concrete will be deformed. The supervisor should make sure that there are no changes of the dimensions or torsion in the wood form.
- The bottom of the beam and slabs will camber according to the project specifications or the standard codes the projects follow. In Egypt, if the span is equal or larger than 8 m, the camber will be 1/300 to 1/500 from the span; on the other side, if the cantilever has a length higher than 1.5 m, the camber will be 1/150 from the cantilever length.

5.3 Formwork for High-Rise Buildings

Much of the technological change in concrete construction occurred in the first half of the 20th century. Advances in formwork, mixing of concrete, techniques for pumping, and types of admixtures to improve quality have all contributed to the ease of working with concrete in high-rise construction.

5.3.1 Formwork

The most efficient construction coordination plan for a tall building allows formwork to be reused multiple times. Traditionally, formwork was made of wood but as technology has advanced, the forms have become a combination of wood, steel, aluminum, fiberglass, and plastic, to name only a few materials. Each set may be self-supporting with trusses attached to the exterior or may need additional shoring to support it in appropriate locations. New additions to the family of forms include flying forms, slip forms, and jump forms.

Flying forms or table forms are rental items (Figure 5.8). They are built in typical span lengths in order to provide continual reuse in a variety of jobs. The assemblage is made of fiberglass pan forms, steel trusses and purlins, and plywood, which are moved as a unit providing the base for a floor slab. After concrete placement and the strength of concrete has reached an appropriate maturity, the forms are removed, cleaned, and “flown” with a crane to the next level of a building for reuse.

Slip forms are another type of early removal system using materials, which are continuously reemployed as shown in Figure 5.9. Three types of jacks—hollow screw jack, hydraulic jack, and pneumatic jack—are used worldwide to “slip” formwork for a wall section to higher levels as the concrete cures. The screw jack is manually operated and used in areas of the world where mechanization is limited. The hydraulic and pneumatic jacks are fully automated, moving continuously as concrete is pumped into place.



FIGURE 5.8
Flying form.



FIGURE 5.9
Slip form.

Jump forms are another type of concrete formwork, which moves as concrete cures to create a reusable, economic system. Jump forms also have a lifting mechanism but it is used differently from that of the continuous pours made with slip forming. These are designed to swing away from the structure (like a door opening) for cleaning and oiling with subsequent reattaching to the wall as it increases in height.

Lift slab is another system, as shown in Figure 5.10 (top). Basically this system works by pouring the slabs on the ground, lifting with a jack, and anchoring to the column, as shown in Figure 5.10 (bottom).



FIGURE 5.10

Top: Lift slabs. Bottom: Anchoring lift slab.

5.3.2 Delivery Systems

While the history of concrete is long, its use in tall buildings was partially curtailed because of difficult delivery systems. For the construction of the Ingalls Building (Cincinnati, Ohio), the ingredients of concrete were brought to the site and stored on the basement floor. Blending of materials was accomplished mechanically by power-driven, on-site mixers, which had been developed in the 1880s. When transport of concrete began in 1913, it was executed using open trucks. Since segregation occurred on the way to the site, remixing was always necessary. In 1947, the first hydraulically driven truck-mixers were introduced.

Delivery of concrete had been an issue for tall buildings and other large projects. Another concern was the challenge of material placement in large quantities. Technology remained primitive and stagnant in this area until the 1960s when hydraulically powered and controlled pumps were first developed and mounted on trucks for mobile service. From here, techniques improved continually until now when pumping of concrete is considered even for small jobs.

5.3.3 Allowable Tolerance in Dimensions

Any project specification must contain tolerances in specific dimensions to be followed by workers on site. Table 5.1 illustrates the allowable tolerances in the dimensions in the Egyptian code in 2003 and these tolerance values allow the site engineer to accept or refuse the work. Table 5.2 shows the tolerance levels according to the ACI code. For high-rise buildings there will be other specifications for acceptance and refusal, as the designer must state the tolerance limits in the specifications of the project.

5.4 Detailing, Fabrication, and Installation of Steel Bar

There was a study performed by a research team to compile more than 150 cases of collapse and cracks in reinforced concrete buildings. The team found the lack of sufficient thickness to the concrete cover concrete on the steel bars in beams and slabs during the pouring of concrete, causing corrosion in the steel reinforcement, and falling of concrete cover while installing the steel bars on the forms. The site engineer supervising the work should monitor the thickness of the concrete cover during the receipt of steel reinforcement work.

The steel reinforcement bars are important elements in reinforced concrete projects as the location of the steel bars can change the state of structure from safe to hazardous since the shape of the steel bars, their numbers, and distribution locations are the main elements in designing the reinforced concrete structure.

TABLE 5.1

Allowable Dimension Tolerances in Egyptian Code

Item	Description	Tolerance (mm)
1	Maximum tolerance to columns, beams and walls dimensions	
	In any span or every 6 m in any direction	±13
	Total structure dimensions	+25
2	Vertical alignment for column and wall surfaces and line of surface intersection	
	Every 6 m height	6
	Whole building height (max. 30 m)	25
3	Surface of corner column and vertical expansion joint	
	Every 6 m height	6
	Whole building height (max. 30 m)	15
4	Columns and walls executed by sliding form	
	Every 1.5 m height	3
	Every 15 m height	25
	Whole building height (max. 180)	75
5	Allowable tolerance for slab and beam bottom level	
	Every 3 m in horizontal distance	+5
	Every span or every 6 m horizontal distance	±10
	Whole building length and width	±20
6	Allowable tolerance in points of level that define slab and inclined beam leveling	
	Every span or every 6 m horizontal distance	±10
	Whole building length and width	±20
7	Allowable tolerance for columns, beam, slab, tie beam and walls	
	Dimensions to 400 mm	+10 or -5 mm
	More than 400 mm	+15 or -10
8	Reinforced concrete foundation	
	Horizontal dimensions	-15 or +50
	Dimensions between axes	±50
	Foundation thickness	Without maximum or -2%
	Foundation top level	+15 or -5
9	Stairs	
	Height for one rise	±3
	Horizontal distance for one rise	±6
	Height for one flight or group of flight for one story	±5
	Horizontal dimensions for one flight or group of flight for one story	±10

TABLE 5.2

Allowable Dimension Tolerances in ACI Code

Item	Description	Tolerance (mm)
1	Maximum tolerance to columns, beams and walls dimensions	
	In any span or every 6 m in any direction	+13
	Whole building dimensions	±25
2	Vertical alignment for column and wall surfaces and line of surface intersection	
	Every 3 m height	6
	Whole building height (max. 30 m)	25
3	Surface of corner column and vertical expansion joint	
	Every 6 m height	6
	Whole building height (max. 30 m)	13
4	Columns and walls executed by sliding form	
	Every 1.5 m height	3
	Every 15 m height	25
	Whole building height (max. 180)	75
5	Allowable tolerance for slab and beam bottom level	
	Every 3 m in horizontal distance	+6
	Every span or every 6 m horizontal distance	±10
	Whole building length and width	±19
6	Allowable tolerance in points of level that define slab and inclined beam leveling	
	Every span or every 6 m horizontal distance	±10
	Whole building length and width	±19
7	Allowable tolerance for columns, beam, slab, tie beam and walls	
	Dimensions to 304 mm	+10 or -6 mm
	More than 304 mm	+13 or -10
8	Reinforced concrete foundation	
	Horizontal dimensions	-13 or +50
	Dimensions between axes	±50
	Eccentricity of column to foundation	2% of foundation length in deviation direction and not more than 50 mm
	Foundation thickness	Without maximum or -2%
9	Stairs	
	Foundation top level	+13 or -50
	Height for one rise	±3
	Horizontal distance for one rise	±6
	Height for one flight or group of flight for one story	±3
	Horizontal dimensions for one flight or group of flight for one story	±6

Therefore, the quality control team or the supervising engineer is fully responsible to ensure the steel bars in the drawings totally match those on the form before pouring and any change should be approved by the designer. This audit and review will be from the contractor QC team followed by approval from the client representative. Any amendment must be submitted to the technical office for approval. The designer also must change the drawings in accordance with the quality procedures and documents. It is preferable to avoid any change in the engineering drawings, because change causes time loss.

The most common error is to move the steel bars during compaction and pouring. Reviewing the drawings is very important step and there should be a checklist to avoid forgetting any items. For example, a weak review process would not note insufficient space between steel bars. A good reviewing system would easily avoid this mistake.

Figures 5.11 to 5.15 show the installation for the steel bars in different projects. Figure 5.11 shows the installation of reinforcing steel bars by using a crane due to the huge slab on the ground. Figure 5.12 illustrates the form of steel and how to lift it on the ground. Figure 5.13 presents the shape of the sleeve and the shape of reinforcement around it. The reinforced steel bars that are connected to the concrete foundation as the retaining wall are seen in Figure 5.14. In Figure 5.15 shows the arrangement of the steel reinforcement in the raft foundation.

5.4.1 Tolerance in Steel Bars in Egyptian Code

The tolerance in reinforcing steel depends on the shape of the bar. Figure 5.11 shows the most common forms of steel reinforcement bars and Table 5.3 and Table 5.4 identify the allowable tolerances.

5.4.2 Allowable Tolerance in ACI 318

ACI states the allowable tolerances during steel bar fabrication or installation in the form and we can see that it is approximately similar to the Egyptian code. The allowable tolerance in the ACI code is presented in Table 5.5 and Figure 5.16. Table 5.6 shows that the distance between bars higher than 25 mm (1 inch) in any case must be higher than three-fourths the maximum nominal aggregate size.

5.5 Concrete Cover and Its Specifications

The concrete cover is the first line of defense to protect the steel reinforcement from corrosion and therefore the thickness of the concrete cover must meet all specifications. So, the thickness of the concrete cover must



FIGURE 5.11
Distributing steel bars for ground slab.

not exceed a certain limit, according to the types of the structure members and surrounding environmental conditions. Many codes are devoted to specifications of the thickness of concrete cover, according to the nature of structure, method of construction, and quality of concrete used, as well as weather factors.

5.5.1 British Standard

In the British standard the efficiency of the concrete cover to protect the reinforcement steel bars from corrosion depends on the thickness of the concrete cover and the quality of the concrete.

Moreover, when we talk about quality control of concrete and concrete cover, we mean that the concrete has no cracks and its compaction is good



FIGURE 5.12
Steel bars for raft foundation.



FIGURE 5.13
Wall steel bars with pipe sleeve.



FIGURE 5.14
Steel bars between foundation and wall.



FIGURE 5.15
Distributing steel reinforcement in concrete raft.

TABLE 5.3

Allowable Tolerances in Depth Concrete Cover

Effective Depth	Tolerance in Effective Depth (mm)	Tolerance in Concrete Cover (mm)
Effective depth (d) ≤ 250 mm	± 10	-6
Effective depth (d) > 250 mm	± 15	-8

TABLE 5.4

Allowable Tolerances in Egyptian Code

Item	Member Description	Allowable Tolerance (mm)
1	Distance between bars	
	Beam	-5
	Slabs and walls	± 20
	Stirrups	± 20
2	Bending location and ends for longitudinal bars	
	Continuous beam and slabs	± 25
	Ends of bars in beam and external slabs	± 15
3	Decrease of bar splice length	-25
4	Reduce splice length inside concrete	
	For bar diameters 10 to 32 mm	-25
	For bar diameters exceeding 32 mm	-50

TABLE 5.5

Allowable Tolerances in Depth and Concrete Cover

Effective Depth	Allowable in Effective Depth	Tolerance in Concrete Cover
Effective depth (d) ≤ 8 in	± 0.375 in	-0.375 in
Effective depth (d) > 8 in	+0.5 in	-0.5 in

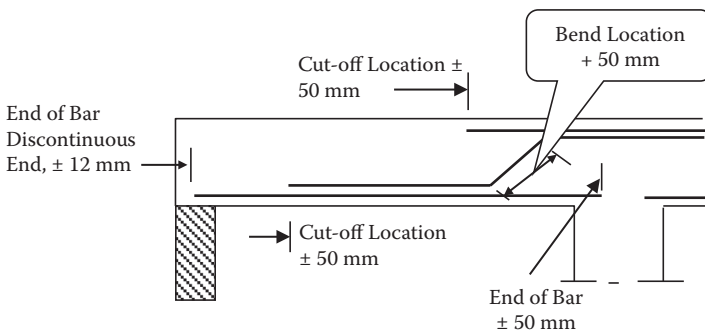
**FIGURE 5.16**

Tolerance in steel bars.

TABLE 5.6

Tolerances in Steel Bars Based on ACI

Item	Member Type	Allowable Tolerance (inches)
1	Distance between bars	
	Min. distance between bars in a beam	-0.25
	Slabs and walls in case of equal space	±2
	Stirrups	±1
2	Bending location and ends for longitudinal bars	
	Continuous beam and slabs	+2
	Ends of bars in beam and external slabs	+0.5
3	Reduce bar splice	-1.5
4	Reduce splice length inside concrete	
	For bar diameters #3 to #11	-1
	For bar diameters #14 to #18	-2

since it will have a high density and low water-to-cement (w:c) ratio, which works to prevent the permeability of the water into the concrete or any other material that will cause corrosion. Therefore it is logical that concrete cover thickness is a function of the expected concrete quality. For example in the case of a high-quality concrete, there is little need for thick cover. This principle depends on BS 8110.

The specifications of the concrete cover thickness in the British code indicated in Table 5.7 depend on the weather factors as well as the concrete strength and its quality based on the cement content and w:c.

5.5.2 American Code

The ACI code does not give the exact details as does the British code. But it does provide the minimum thickness cover for concrete that has been poured at the site (Table 5.8).

To get good concrete exposed to water with high salinity ratio such as sea water, the American code sets the maximum ratio of w:c equal to 0.4 and the minimum thickness of the concrete cover is 50 mm.

Because of the mistakes that can occur during construction, it is preferred that the design of the concrete cover thickness be 65 mm so that after execution the minimum cover will be 50 mm.

The American code allows lower thickness of the concrete cover than shown in Table 5.8.

5.5.3 European Code

The European Union code gives precise and detailed recommendations and defines the degree of concrete strength required based on the weather conditions.

TABLE 5.7

Properties and Thickness of Concrete Cover in BS 8110

	Concrete Cover Thickness				
	30	35	40	45	50
Concrete grade (MPa)	30	35	40	45	50
w:c	0.65	0.65	0.55z	0.50	0.45
Minimum cement content (kg/m ³)	275	300	325	350	400
Environmental conditions					
Moderate: Concrete surface protected from external weather or hard condition	25	20	20	20	20
Moderate: Concrete surface protected from rain or freezing and the concrete under water or concrete adjacent to unaffected soil		35	30	25	20
Hard: Concrete surface exposed to rain and dry conditions			40	30	25
Very hard: Concrete exposed to sea water spray or melting ice by salt or freezing			50	40	30
Maximum condition: Concrete surface exposed to abrasion from solid particles or moving water with pH 4.5, or machines or cars				60	50

TABLE 5.8

Minimum Cover Thickness for Cast-in-Place Concrete as per ACI Committee 301

Type of Structure	Minimum Cover (mm)
Concrete Deposited against the Ground	75
<i>Formed Surfaces Exposed to Weather or in Contact with Ground</i>	
No. 6 bar or greater	50
No. 5 bar or smaller	38
<i>Formed Surfaces Not Exposed to Weather or Not in Contact with Ground</i>	
Beams, girders and columns	38
Slabs and walls, No. 11 bar or smaller	19
Slabs and walls, No. 14 and 18 bars	38

The European code ENV 206 in 1992 set a w:c, as well as the lower content of the cement in concrete and the concrete cover corresponds to the concrete strength according to weather conditions (Table 5.9). This code has set specifications for reinforced concrete structures and prestressed concrete. Note that the last column in Table 5.9 determines the concrete strength characteristics in set value units (MPa). The first number is the value of the strength characteristics of cubic and the second number is the equivalent of the cylinders, for example, C30/37 mean concrete characteristics cube compressive strength of 30 MPa and concrete characteristic cylinder compressive strength is 37 MPa.

TABLE 5.9

Concrete Durability Under European Code ENV 206 [1992] and British Recommendation DDENV 206

Exposure Condition	Maximum w/c	Minimum Cement Content (kg/m ³)	Minimum Concrete Cover (mm)	Concrete Grade
Dry	0.65	260	15	C30/37
Humid				
• No frost	0.60	280	20	C30/37
• Frost	0.55	280	25	C35/45
Deicing salts	0.5	300	40	C35/45
Sea water				
• No frost	0.55	300	40	C35/45
• Frost	0.50	300	40	C35/45
Aggressive chemical exposure				
• Slight	0.55	280	25	
• Moderate	0.50	300	30	
• High	0.45	300	40	

It is preferred to use cement resistant to sulfate sulfur if the sulfate content is more than 500 mg/kg in water or more than 3000 mg/kg in the soil. In both cases it is recommended to use additional painting on the concrete surface.

We must bear in mind that during construction the concrete cover thickness often depends less on design because of the many factors during construction discussed by Brown et al. (1993). They found that the average thickness of the concrete cover is about 13.9 mm, which is about half the value stated in the design of 25 mm.

Van Daveer (1975) did a survey on the thickness of the concrete cover in the design of bridges. If the design stated that the concrete cover thickness was to be about 38 mm, it was found that the standard deviation of the thickness of the concrete cover is very high, up to 9.5 mm. Arnon Bentur in 1998 suggested that if we are to obtain a concrete cover 50 mm thick at a site we must revise the thickness of the cover in the construction drawings and specifications to about 70 mm.

The European code identified deviation during construction as the minimum concrete cover increased by the allowable deviation and its value is from zero to 5 mm for precast concrete and from 5 to 10 mm for concrete cast in situ.

5.5.4 Special Specifications for Structures Exposed to Very Severe Conditions

These are offshore structures that are directly exposed to sea water, such as ports and offshore concrete platforms used in the oil industry. ACI Committee 357 set specifications for these structures.

TABLE 5.10

ACI Committee 357 Recommendation for Concrete Strength and Cover Thickness in Offshore Structures

Location	Maximum w:c	Minimum Concrete Strength at 28 Days	Cover Thickness	
			Reinforced Steel	Prestressed
Air	0.4	35	50	75
Splash zone	0.4	35	65	90
Immersed in water	0.45	35	50	75

TABLE 5.11

Comparison of Different Specifications for Concrete Design in Splash Zone

Code	Concrete Cover Thickness (mm)	Maximum Crack Width (mm)	Maximum w:c	Minimum Cement Content (kg/m ³)	Permeability Factor (m/s)
DNV	50		0.45	400	10–12
FIP	75	0.004x thickness or 0.3	0.45	400	
BS6235	75	0.004x thickness or 0.3	0.40	400	
ACI	65		0.40	360	

The concrete cover thickness is defined based on the construction method for reinforced concrete structure or prestressed concrete. In addition the concrete strength and the water-to-cement ratio are stated (Table 5.10).

The area in a structure most vulnerable to corrosion is the splash zone, the region periodically exposed to sea water but not completely submerged in water and also exposed to air. So, there are several specifications of reinforced concrete in that particular region, as shown in Table 5.11.

British specifications have identified more detail for concrete cover thickness and concrete specifications required for private structures. Also considered are concrete mix, chloride diffusion factor in the concrete, and the life expectancy of structure, as indicated in Table 5.12.

The ability of the concrete cover to protect steel from corrosion depends on the thickness of the cover, but also on the w:c ratio, the content of cement in the mix, and the degree of quality control. While those factors are the most important influences, also considered are the method of mixing, coarse aggregate, sand sieve analysis, compaction, and curing of concrete after pouring.

TABLE 5.12
 British Code Requirement and Expected Diffusion Values Deff and Expected Time of the Beginning of Corrosion (Ci = 0.4 by wt% of cement) and Corrosion Propagation (per unit of mass = 1% by wt of cement)

Source	Exposed Degree	Chloride Exposed Condition	Concrete Mix Detail					Diffusion Coefficient (m ² /s)	Age (years)	
			Cement Content (kg/m ³)	Maximum w:c	Minimum Slump (mm)	Minimum Concrete Cover (mm)	Ci = 0.4%		Cp = 1%	
All structures BS 8110	Very severe	Spray sea water or deicing	325	0.55	40	50	3.93 × 10 ⁻¹²	3.1	5.6	
			400	0.45	50	30	3.18 × 10 ⁻¹²	2.6	4.6	
Bridges BS 5400 Part 4	Severe	Abrasion and sea water contain solids	350	0.5	45	60	2.57 × 10 ⁻¹²	1.9	3.7	
			400	0.45	50	50	3.18 × 10 ⁻¹²	5.8	10.4	
Offshore structure BS 6349 Part 1	Very severe	Deicing or sea water pray	360	N/A	40	50	2.57 × 10 ⁻¹²	5.4	10.2	
			330	0.45	50	40	3.93 × 10 ⁻¹²	3.3	6.1	
Sea water ENV 06	Severe	Abrasive by sea water	360	N/A	40	50	2.57 × 10 ⁻¹²	3.0	5.5	
			330	0.45	50	40	3.93 × 10 ⁻¹²	5.5	10.3	
Chlorides	Submerged always	Below sea level by 1 m	350	0.5	n/a	>50 prefer 75	2.57 × 10 ⁻¹²	5.7	10.3	
			400	0.45	N/A	>50 prefer 75	3.18 × 10 ⁻¹²	3.3	7.2	
Sea water ENV 06	Tidal/splash	Less than lowest level by 1 m	400	0.45	N/A	>50 prefer 75	3.18 × 10 ⁻¹²	7.4	16.2	
			330	0.5	40	35	2.57 × 10 ⁻¹²	5.4	10.2	
Chlorides	XS1	Air saturated by water	330	0.5	40	40	2.57 × 10 ⁻¹²	12.0	22.9	
			350	0.45	45	40	3.93 × 10 ⁻¹²	1.5	2.7	
Chlorides	XS2	Submerged in water	300	0.55	40	40	3.93 × 10 ⁻¹²	2.0	3.6	
			330	0.50	40	40	3.18 × 10 ⁻¹²	2.1	4.6	
Chlorides	XS3	Wet and rarely dry	300	0.55	40	40	3.93 × 10 ⁻¹²	2.0	3.4	
			330	0.50	40	40	3.93 × 10 ⁻¹²	2.0	3.6	

5.5.5 Egyptian Code

In the Egyptian code, the concrete cover thickness depends on the surface of concrete that has tension stresses. The effects of environmental factors have been divided into four sections, as in Table 5.13. From this table one can accurately determine the structure under any type of element and by the strength of the concrete construction and the type of element, as shown in Table 5.14.

The Egyptian code states that in the thickness of the concrete cover should not be less than the largest used bar diameter.

TABLE 5.13

Structure Element Based on the Environmental Condition

Element Type	Degree of Exposed Tension Surface to Environmental Factor
• Tension surface is protected	<ul style="list-style-type: none"> • All internal members in building • Contant immersion in water without any aggressive materials • The last floor isolated against humidity and rain
• Tension surface is not protected	<ul style="list-style-type: none"> • All structure exposed to weather; bridges and last floor not isolated • Structure protected but near coast • Element exposed to humidity such as open hall or parking area
• Tension surface exposed to aggressive environment	<ul style="list-style-type: none"> • Element exposed to higher relative humidity • Element exposed periodically to relative humidity • Water tanks • Structure exposed to vapor, gases or chemicals
• Tension surface exposed to oxides cause corrosion	<ul style="list-style-type: none"> • Chemical vapor causes corrosion • Structure exposed to sea water

TABLE 5.14

Minimum Concrete Cover Thickness

Type of Element	Concrete Cover Thickness (mm)			
	For All Elements Except Slab		Walls and Solid Slab	
	$f_{cu} \leq 250$	$f_{cu} > 250$	$f_{cu} \leq 250$	$f_{cu} > 250$
Tension surface is protected	20	15	15	10
Tension surface is not protected	25	20	20	15
Tension surface exposed to aggressive environment	30	25	25	20
Tension surface exposed to oxides that cause corrosion	40	35	35	30

5.5.6 Placing Concrete Cover

From the previous sections, we can see the importance of concrete cover and there are several practical methods to maintain the thickness of concrete cover during the construction process. A popular method is using pieces of cuboids of concrete called “biscuits” about 50 mm × 100 mm. The thickness depends on the required cover thickness.

With the cuboid concrete, a steel wire is inserted during pouring to tie the steel bars with these pieces to maintain the spacing between the bars. The disadvantage of this method is that when moving the steel bars to pour concrete or to do any other tasks such as inspection or supervision, the load puts concentrated pressure on concrete pieces and leads to cracks and damage. Therefore, after construction in many cases you will see that the cover is very thin. The advantage of this method is that it is cheap, as concrete used is the same as that used on site and the workers are already available on site.

However it is more practical to use plastic pieces to maintain the concrete cover. The plastic pieces are inexpensive, strong, and help maintain the accuracy of the cover thickness. Figure 5.17 shows pieces of plastic forms that are used to stabilize the steel bars. The shapes of the pieces vary according to size and form of bars; whether they are used on a column, slab, or beam; and concrete cover thickness to be preserved. Figure 5.18 shows the plastic pieces carrying the chairs that are also useful also in protecting steel from being exposed to the concrete outer surface.

More than 30 years ago, aggregates were placed under the steel bars to cover the concrete but the method is now prohibited in some countries. It is important to highlight that this method is still used in some low-cost residential buildings in developing countries because it is very cheap. However, costs will be incurred in the future for repairing the deterioration from corrosion of steel bars.

The British Standards require concrete cover measurement in accordance with BS 1881, Part 204. An electromagnetic device estimates position depth and the size of the reinforcement. Then engineer in charge of the project determines locations for checking cover and the frequency of measurement.

Reinforcement should be secured to prevent displacement outside the specified limits, unless noted otherwise:

1. The actual concrete cover should be not less than the required nominal cover minus 5 mm.
2. Where reinforcement is located in relation to only one face of a member, for example, on a straight bar in a slab.

The actual concrete cover should be not more than the required nominal cover plus:

1. 5 mm on bars up to and including 12 mm
2. 10 mm on bars over 12 mm up to and including 25 mm
3. 15 mm on bars over 25 mm



FIGURE 5.17
Different kinds of plastic pieces.

Nominal cover should be specified for all steel reinforcement including links. Spacers between the links (or the bars where no links exist) and the formwork should be of the same size as the nominal cover.

Spacers, chairs, and other supports detailed on drawings, together with such other supports as may be necessary, should be used to maintain the specified nominal cover to the steel reinforcement. Spacers and chairs should be placed in accordance with the requirements of BS 7973-2.

Spacers and/or chairs should conform to BS 7973-1. Concrete spacer blocks made on the construction site should not be used.

The position of reinforcement should be checked before and during concreting, with particular attention to ensuring that the nominal cover is maintained within the given limits, especially in the case of cantilever sections. The importance of cover in relation to durability justifies the regular use of a cover meter to check the position of the reinforcement in the hardened concrete.

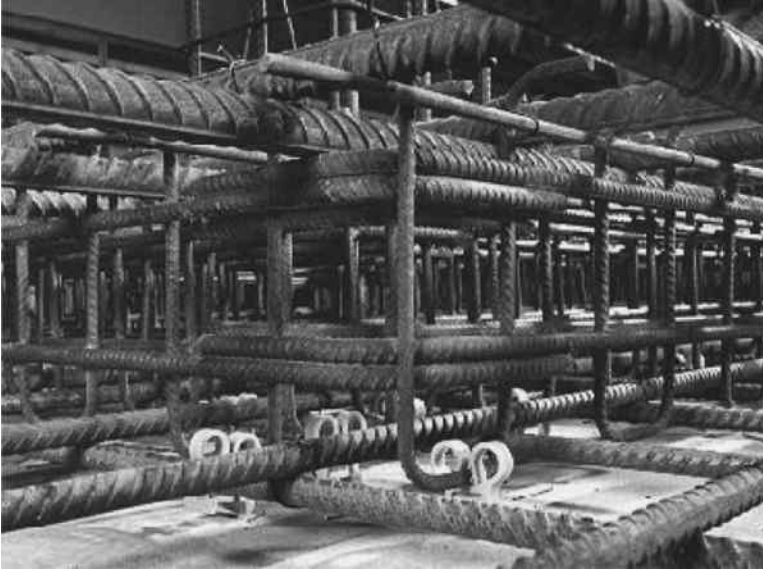

FIGURE 5.18
Plastic pieces carrying chairs.

5.6 Concrete Pouring

One critical process that needs attention and competent workers on-site is concrete pouring.

All the codes and standards advise avoiding concrete segregation and specify the time between adding water to dry mix. Pouring should not be more than 30 minutes in normal weather conditions; the temperature should not exceed 30°C in the shade. In hot weather, pouring should not take longer than 20 minutes. This time period can be increased if needed by using admixtures noted in the project specifications.

If the pouring is to be done in special situations such as heights (e.g., columns and retaining walls), it should be cast in layers 300 to 500 mm thick, and a vibrator should be used. The time between layers should not exceed 30 minutes in normal weather or 20 minutes in hot weather. These time periods can be extended by adding admixtures if there is enough steel reinforcement to bond the casting layers.

When pouring concrete into columns, there is the issue of heights that are more than 2.5 m high. Concrete can be poured in one step but for the side of the form you can only pour concrete every 25 m. Close the opening the open the one above, and so on until you finish the column height.

ACI has a correct way to pour concrete to avoid segregation and honeycomb in the column or the walls. Figures 5.19 and 5.20 present the proper

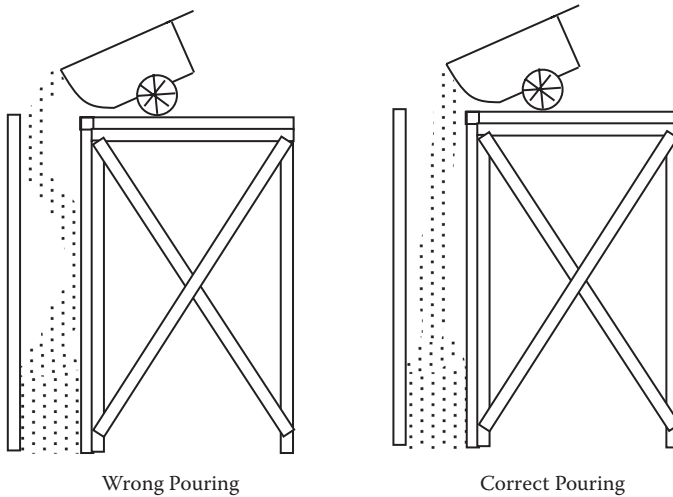

FIGURE 5.19
Pouring concrete wall.

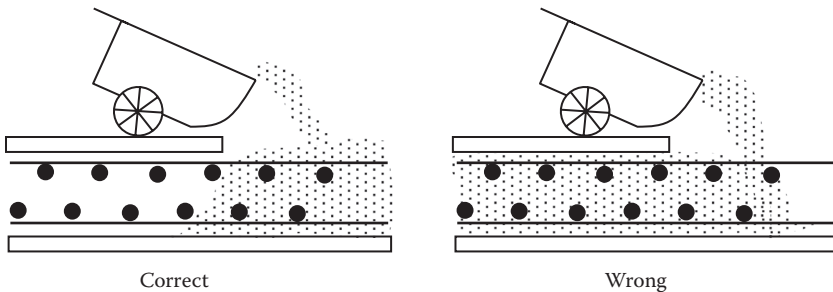

FIGURE 5.20
Pouring ground slab.

way to pour the concrete in the columns and the retaining walls. Figure 5.21 illustrates the proper way to pour the concrete for inclined slabs to avoid the segregation of the aggregate. Figure 5.22 and Figure 5.23 present the right way for pouring the concrete by pump for a curve beam or wall and retaining walls or columns, respectively.

Environmental conditions must be taken into consideration during concrete pouring. In hot climates with temperatures more than 36°C in shade, during mixing or pouring the coarse aggregate and sand should be stored in shaded areas and the aggregate can be cooled by sprinkling water. Loose cement can be stored in silos, but the silos must be painted in a color reflecting the sun from outside. If the cement is in sacks, the sacks should be stored under a slab or shaded area. The water can be cooled during pouring. With precast concrete the pouring should be done in a shaded area.

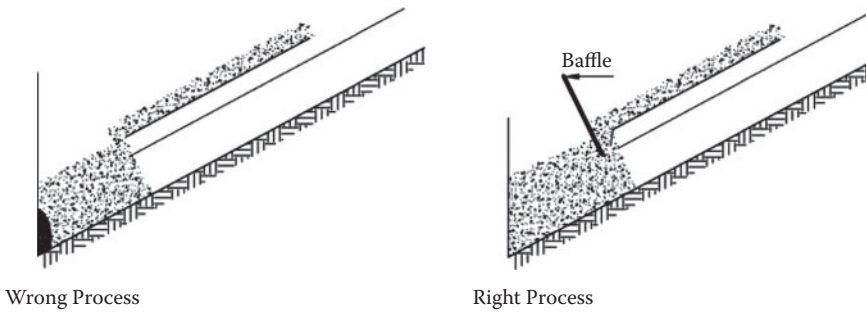

FIGURE 5.21
Pouring inclined concrete slab.

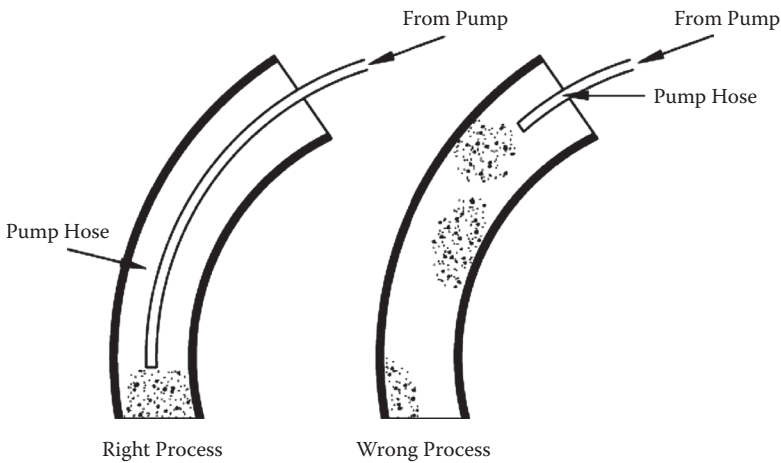

FIGURE 5.22
Pouring concrete in curvature wall.

In some cases we can use a caisson to pour the concrete instead of a hose. The caisson collects the concrete on the ground level and lifts it with a lifting tool. The caisson has a gate to open to pour the concrete.

5.6.1 Pouring Pumping Concrete

In modern countries the concrete pump is the usual method for pouring concrete, especially for high-rise buildings. As shown in Figures 5.24 to 5.26, the concrete can be poured into a raft foundation by using a pump.

The first concrete pump was used in America in 1913. By 1930 other countries were pouring concrete using special valve design with a sliding door. From 1950 to 1960 the concrete pump was used widely in Germany, and

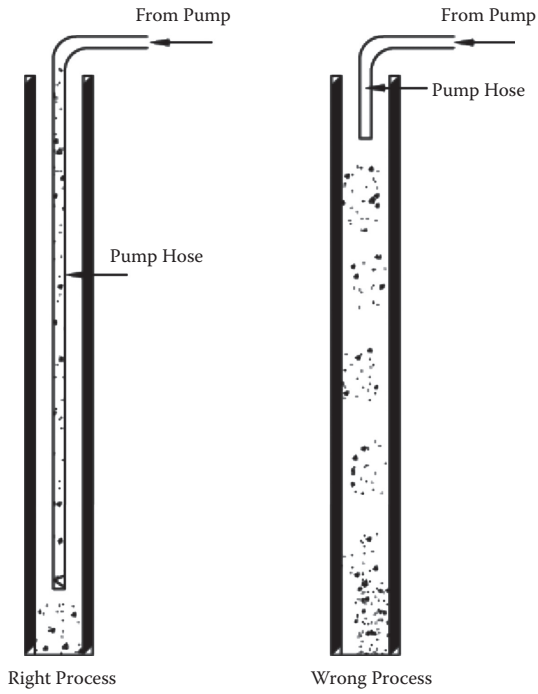

FIGURE 5.23
Pouring concrete by pump.



FIGURE 5.24
Pouring raft foundation by using pump.



FIGURE 5.25
Pump concrete in pouring a slab.



FIGURE 5.26
Pump concrete in pouring a slab.



FIGURE 5.27
Pouring beam by using caisson.

about 40% of concrete pouring was performed by the pumps. Companies in Germany, including Schwing, Putzmeister, and Elba, competed to develop new pumps and valves. Figure 5.27 demonstrates pouring a beam by using a caisson, and Figure 5.28 shows the start compaction and surface preparation after pouring by pump.

The builders for the Jin Mao Building in Shanghai, China, boast of pumping high-strength concrete as high as 1200 ft (366 m). Pumping is limited by the plastic qualities of concrete, the type of pump available, and the piping needed to carry the product up to the desired level. For such great heights, a high-pressure unit is needed. Thought must be given to the properties of concrete and how it will react when pressure is applied in a pipe. All these factors demanded innovations in concrete technology.

Sometimes a pump is the only way of placing concrete in a certain location, such as a high rise building, or large slabs where the chutes of the concrete truck cannot reach the height where the concrete is needed.

Other times, the ease and speed make pumping concrete the most economical method of placement.

5.6.1.1 The Wrong Mix

The most common mix problem is failure to retain mixing water. Concrete can bleed due to poorly graded sand that allows water to bleed through the small channels formed due to voids in the sand or too much water.



FIGURE 5.28
Preparing concrete surface.

Insufficient mixing can cause segregation in the mix. For successful pumping, aggregate must have a full coating of cement grout to lubricate the mix as it is pumped.

A delay in placing the concrete due to traffic or job site problems, as well as hot weather conditions, may cause the concrete to begin to set prematurely. This creates a mix that may be too stiff to pump, because it will not fill the pumping cylinders, causing excessive pumping pressures.

5.6.1.2 Problems with Pipeline

The entire pumping system must be evaluated for the job. A project requires a properly sized system including pump capacity and motor horsepower to move the concrete through the full length of the pipeline.

Pipes must be properly cleaned, because a dirty pipe may cause blockages where old concrete has set, and may cause bleeding and segregation. Defective couplings, gaskets, or weld collars also can result in the loss of grout.

Also, bends that are too short, too sharp, or too numerous increase concrete pumping pressure. Variations of pipeline diameter, such as when a larger diameter hose is coupled with a smaller one, may cause blockages or rock jams because the concrete cannot flow as quickly through the smaller diameter pipeline.

5.6.1.3 Operator Error

The most common error from inexperienced operators is setting up the pumping system improperly. Operators must know to set up each job so that pipe or hose only needs to be removed, not added on. If the placing crew has to add hose after a pour is in progress, the dry conditions inside the added hose are likely to cause a blockage.

Careless handling of flexible rubber discharge hoses can also be a problem, since kinking can occur. A rock jam is likely to be the result of a kinked hose, as the inside hose diameter is reduced, which restrains the aggregate in the line while the lubricating grout is allowed to pass. Premature localized wear and eventual rupture of the hose, may also occur at the point where the hose is kinked. The concrete surface is finished using a tool called a “helicopter” is shown in Figure 5.29.

5.6.2 Construction Joint

The location of the construction joints should be known and agreed among all the concerned engineers. The contractor will document the construction



FIGURE 5.29
Finishing the concrete surface.

joints before work and the locations will be based on equipment and manpower availability.

Generally, it is preferred to have no construction joints. However if they are needed, they should be defined before the day of pouring because they will weak points.

The construction joints in beam and slabs are located at the point of zero bending moment, or at the location of minimum shear force. A joint should be perpendicular to the affected internal forces so the location of the construction joints should be shown in the workshop drawings that will be accepted by the designer and supervisor engineer. The steel bars will transfer tension and shear force in the joints. The designer may use dowels in construction joints.

On the second day, before pouring the concrete, the surface of the concrete should be cleaned by blowing air to remove any loose materials and spraying water on the surface. Then there are two methods. The old one is to use slurry, which is a mix of water and cement, and painting the surface before pouring the concrete. The new and preferable method is to use epoxy to bond the new concrete to the old concrete.

5.7 Compaction Procedure

The compaction is very important stage as it enhances the concrete strength. During the compaction process be sure that there is no high vibration on the concrete poured earlier and no change in the forms or dimensions or location of the steel bars. The compaction must be performed by a competent person who can use the vibrator perpendicular to the concrete as recommended by ACI (Figures 5.30 and 5.31). The compaction will stop when there are no more air bubbles.



FIGURE 5.30
Concrete vibrator.

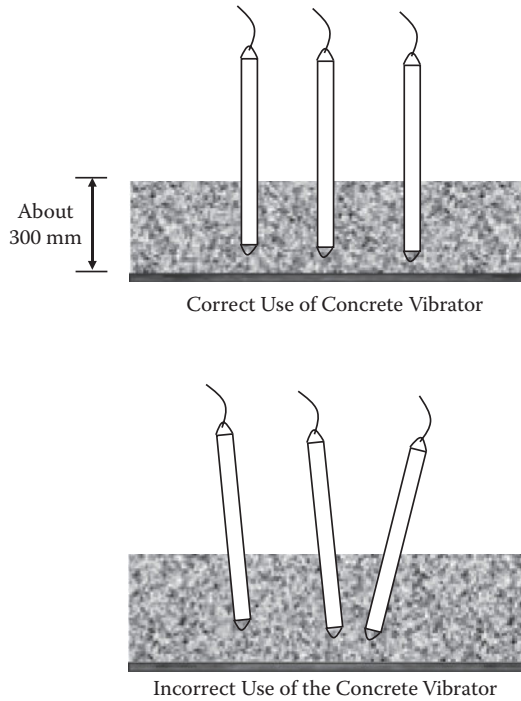

FIGURE 5.31
Correct and wrong use of concrete vibrator.

In modern construction, additives and silica fume and self-compacting concrete can be used instead. The self-compacting concrete is discussed in Chapter 6. Self-compacting concrete is beneficial in that it reduces work on site.

5.8 Curing

Recently poured concrete must be prevented from drying fast as a result of the warm or dry air and protected from rain. The protection will be done by covering the cast concrete with a suitable coating system after finishing the pouring process until the time for final hardening and then proceeding with the curing process stated in the project specification document.

Figures 5.32 to 5.34 illustrate the impact of relative humidity and air temperature with wind speed on concrete drying.

The purpose of the curing process is to maintain the wetness of the concrete for no less than 7 days for ordinary Portland cement and no less than 4 days for fast hardening concrete or with the use of additives to accelerate the setting time. There are many ways of curing.

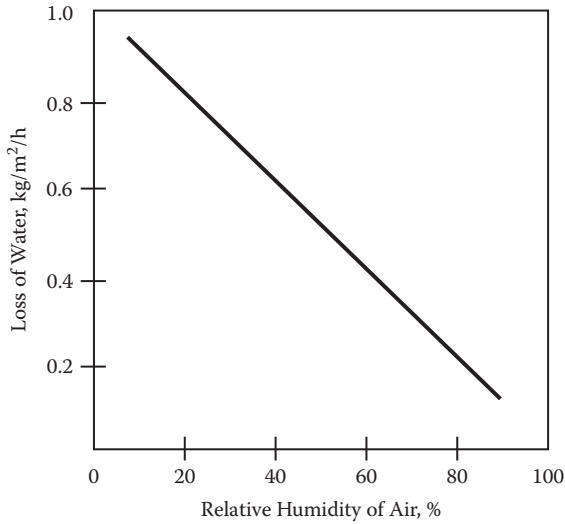

FIGURE 5.32 Relationship between loss of water and concrete temperature. Relation between relative humidity and loss of water. (From Neville, A. M., 1975, *Properties of Concrete*, London: Pittman. With permission.)

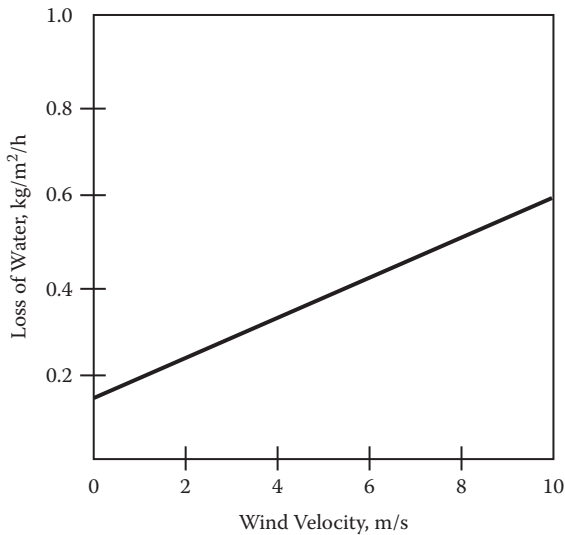
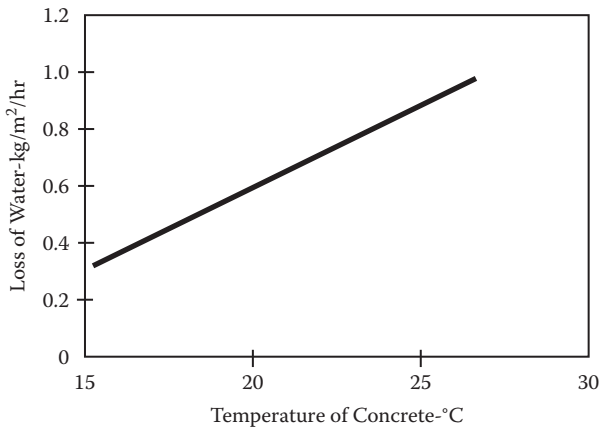

FIGURE 5.33 Relation between wind speed and loss of water. (From Neville, A. M., 1975, *Properties of Concrete*, London: Pittman. With permission.)

**FIGURE 5.34**

Relation between temperature and loss of water. (From Neville, A. M., 1975, *Properties of Concrete*, London: Pittman. With permission.)

- Spraying water free from salt and any harmful substances
- Covering the concrete surface by rough sand or wood manufacturer wastes, and keep it wet by regularly spraying water on it
- Covering the concrete surface with high-density polyethylene sheets
- Spraying additives on the concrete surface
- Using steam for curing in some special structures

Figures 5.35 to 5.37 represent different types of curing. The most common curing method is spraying water on the concrete member in the early morning and at night. Avoid spraying water in the afternoon, as it will produce some cracks on the surface due to evaporation. Figure 5.35 shows the second most common method of curing by covering the slab with moist textile. The aforementioned methods are used for normal environmental conditions, but in some areas as in the Middle East where the temperature in the summer could reach 55°C, chemicals are sprayed on the surface to prevent evaporation of the water in the concrete mix, as shown in Figure 5.36. Another curing method is covering the concrete member with special plastic sheet to avoid the evaporation of water (Figure 5.37).

Other curing methods include spraying the remnants of wood manufacturing and distributing them on the slab. A similar idea is to distribute sand on the slab and spray it by water. Be aware that the wet sand has a high dead weight that can affect the structure.

The curing process is considered an important issue, as it costs little compared to the cost of concrete as a whole, but it increases the resistance of concrete in a very significant way. Figure 5.38 shows that the concrete strength increases clearly when the curing process takes 7 days rather than



FIGURE 5.35
Curing by using textile.



FIGURE 5.36
Spraying chemical.

3 days. The effect will be stronger when the duration of curing is 14 days and this increase in strength of concrete will be continuous throughout the structure's existence. Moreover, the increase of concrete strength due to curing after 28 days has no more effect than curing for 14 days. The specifications of the project should provide a method of curing and exactly define



FIGURE 5.37
Plastic sheet to protect from evaporation.

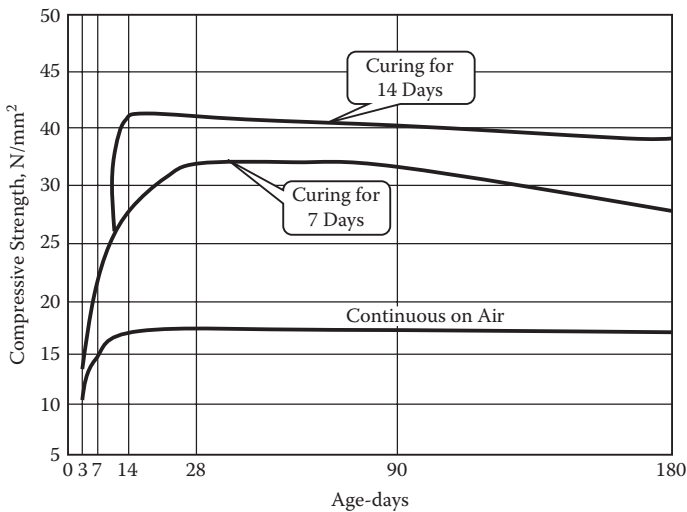

FIGURE 5.38
Relation between curing time and compressive strength.

the required curing time, as conditions differ from project to project according to the weather factors of the area and according to the concrete members.

5.8.1 Curing Process in ACI

According to ACI 5.11 the curing of concrete shall be maintained above 50°F and in a moist condition for at least the first 7 days after placement.

For high-early-strength concrete the temperature should be above 50°F and in a moist condition for at least the first 3 days.

Curing can be accelerated with high-pressure steam, steam at atmospheric pressure, heat and moisture, or other accepted processes. Accelerated curing shall provide a compressive strength of the concrete at the load stage considered at least equal to required design strength at that load stage.

The curing process shall produce concrete with durability at least equivalent to that required by the engineer or architect. Strength tests shall be performed to assure that curing is satisfactory.

The compressive strength of steam-cured concrete is not as high as that of similar concrete continuously cured under moist conditions at moderate temperatures. Also the elastic modulus, E_c , of steam-cured specimens may vary from that of specimens moist-cured at normal temperatures. When steam curing is used, it is advisable to base the concrete mixture proportions on steam-cured test cylinders.

Accelerated curing procedures require careful attention to obtain uniform and satisfactory results. Preventing moisture loss during the curing is essential.

In addition to requiring a minimum curing temperature and time for normal- and high-early-strength concrete, tests should be done for judging the adequacy of field curing. At the test age for which the strength is specified (usually 28 days), field-cured cylinders should produce strength not less than 85% of that of the standard, laboratory-cured cylinders. For a reasonably valid comparison to be made, field-cured cylinders and companion laboratory-cured cylinders should come from the same sample. Field-cured cylinders should be cured under conditions identical to those of the structure. If the structure is protected from the elements, the cylinder should be protected.

5.8.2 Curing in British Standard

Curing is the process of preventing the loss of moisture from the concrete while maintaining a satisfactory temperature regime. The curing regime should prevent the development of high temperature gradients within the concrete.

The rate of strength development at early ages of concrete made with supersulfated cement is significantly reduced at lower temperatures. Supersulfated cement concrete is seriously affected by inadequate curing and the surface has to be kept moist for at least 4 days.

Curing and protection should start immediately after the compaction of the concrete to protect it from the following:

- Premature drying out, particularly by solar radiation and wind
- Leaching out by rain and flowing water
- Rapid cooling during the first few days after placing

- High internal thermal gradients
- Low temperature or frost
- Vibration and impact that may disrupt the concrete and interfere with its bond to the reinforcement

Where members are of considerable bulk or length, the cement content of the concrete is high, the surface finish is critical, or special or accelerated curing methods are to be applied, the method of curing should be specified in detail.

BS 1881 states that the surfaces should normally be cured for a period not less than that given in Table 5.15. Depending on the type of cement, the ambient conditions and the temperature of the concrete, the appropriate period is taken from Table 5.15 or calculated from the last column of that table. During this period, no part of the surface should fall below a temperature of 5°C.

The surface temperature is lowest at sunrise and depends upon several factors, including the size and shape of the section, the cement class and cement content of the concrete, the insulation provided by the formwork or other covering, the temperature of the concrete at the time of placing, and the temperature and movement of the surrounding air. If not measured or calculated, the surface temperature should be assumed equal to the temperature of the surrounding air (see CIRIA Report No. 43).

The most common methods of curing as specified by British specifications are as follows:

- Maintaining formwork in place
- Covering the surface with an impermeable material such as polyethylene, which should be well sealed and fastened
- Spraying the surface with an efficient curing membrane

TABLE 5.15

Minimum Periods of Curing and Protection As in BS8110

Type of Cement	Condition after Casting	Minimum Period of Curing (Days)	
		5°C to 10°C	Any Temperature between 10°C and 25°C
Portland cement and sulfate-resisting Portland cement	Average	$60/(t + 10)$	4
	Poor	$80/(t + 10)$	6
All cement except the above and super sulfated cement	Average	$80/(t + 10)$	6
	Poor	$140/(t + 10)$	10
All	Good	No special requirements	

Notes: Good, damp and protected (relative humidity greater than 80%; protected from sun and wind); average, intermediate between good; poor, dry or unprotected (relative humidity less than 50%; not protected from sun and wind).

5.8.3 Protecting Special Structures

The code and specifications requirements in the design and execution of concrete structures to preserve the structure from corrosion are not sufficient in some structures exposed to a extreme atmospheric factors, such as offshore structures, and exposed to moving water (splash zone), or in parking garages or bridges where salt is used to melt ice.

Some modern commercial or residential buildings adjacent to the sea water, may not be exposed to sea water directly and but are exposed to chlorides in marine areas with a warm atmosphere, such as the Middle East, especially the Gulf area.

In structures located on islands or peninsulas, which are surrounded by water and subject to high temperature such as Singapore and Hong Kong, the start time of corrosion is early and the corrosion rate can be very high. Therefore, the control of corrosion through determining the exact content of the cement and the specific w:c ratio, and using the proper curing process are key factors for protecting the reinforced concrete structures from corrosion and the first line of defense against corrosion.

5.9 Hot Weather Concrete

Frequently, concrete mixing is studied under moderate air temperature conditions, that is, about $27^{\circ}\text{C} \pm 2^{\circ}\text{C}$, and most of the specifications base their recommendations on these circumstances. Moderate air temperature conditions are ideal in the preparation of the concrete mixture or casting or curing.

Unfortunately, we cannot control nature or high temperatures. Nowadays because of the competitive real estate business it is not profitable to stop construction because of hot weather. ACI Committee 305R devised recommendations and requirements for all phases of concrete industry to accommodate hot weather. The project contractor or the manufacturer of ready-mix concrete carries out the recommendations.

5.9.1 Definition of Hot Weather Region

Multiple factors affect fresh and hardened concrete quality by increasing the setting time and decreasing moisture:

- Higher weather temperature
- Higher concrete temperature
- Lower relative humidity
- High wind speed
- Sun rays

A hot weather region is any region where the air temperature is continuously high, over 35°C, especially in the summer.

The project specification document should define if relevant. A hot climate, To be precise most projects specifications stipulate that the contractor follow the specifications for hot weather when the temperature is equal to or higher than 35°C in the shade for 3 consecutive days.

The contractor should have a thermometer on site and frequently perform calibration of the thermometer to ensure its accuracy.

5.9.2 Problems of Concretes in Hot Climates

Many problems can occur with fresh and hardened concrete in hot climates.

5.9.2.1 Fresh Concrete Problem

There are many problems in hot climates for fresh concrete including:

- Increased water in the mix
- The rate of concrete slump settlement will decrease and complicate the transportation operation so more water is needed to increase slump settlement
- The setting time will decrease and affect pouring, compaction and finishing surface operation
- Increased probability of plastic cracking
- Inability to control air entrained inside the concrete

5.9.2.2 Harden Concrete Problem

Hot climates affect the performance of concrete after hardening, which is very dangerous since it affects the performance of concrete with age. In fact, this affects the economics of the project as a whole. The problems caused by high temperature can be summarized in the following points:

- Concrete strength reduces a result of increasing the water or increase in the temperature of the concrete or both during pouring or in the early days
- Increase the likelihood of shrinkage cracks as a result of the difference in temperature between the casting concrete and temperature of the building or due different temperatures in the same sections
- Decreased durability over time due to these cracks
- Difference in the color of outer concrete as a result of various hydration rates or different water-to-cement ratios

- A greater probability of corrosion for reinforcing bars due to concrete cracks
- Concrete voids caused by excess water or poor curing that increase permeability

5.9.2.3 Problems Due to Other Factors in Hot Climates

There are other factors involving design and materials that can cause problems in hot climates:

- Using cement with a high dehydration rate
- Using a high strength concrete that requires a large quantity of cement, thus causing problems in hot weather
- Slender design with high reinforcement ratio that impacts compaction in hot climates
- Economics of the project that necessitate working in high temperatures

5.9.3 Effect of Hot Climate on Concrete Properties

Concrete has some characteristics that distinguish it from other materials used in construction. They may be affected by hot climate unless controlled. If precautions are not taken, we will obtain weak concrete with high permeability, which will affect the lifelong performance of the structure.

The factors that must be controlled are the appropriate choice of components of concrete mixtures, defining the concrete mixing ratios accurately, and performing the required tests. We must also note the temperature of concrete, wind speed, solar radiation, atmospheric temperature, and humidity during the stages of mixing, pouring, and curing.

In general, concrete that is mixed, poured, and cured in high atmospheric temperature gives a higher compressive strength in the early days than concrete processed in low air temperature, but at 28 days or more, it gives the least compressive strength result.

From Figure 5.39, it is noted that with the increase in atmospheric temperature in the curing process the reduction will occur in the concrete compressive strength at 28 days and the concrete strength is increased on the first day (Klieger 1958; Verbeck and Helmuth 1968).

Low temperature during mixing or curing helps with cement dehydration, which significantly increases the concrete strength.

Plastic shrinkage cracks are more likely in hot climates when pouring concrete for large surfaces such as concrete slabs, and in some cases can weaken beams and foundations. These cracks are presented due to drying the surface when the rate of evaporation of water from the concrete surface exceeds the rate of bleeding, which is moving water inside the concrete by capillary

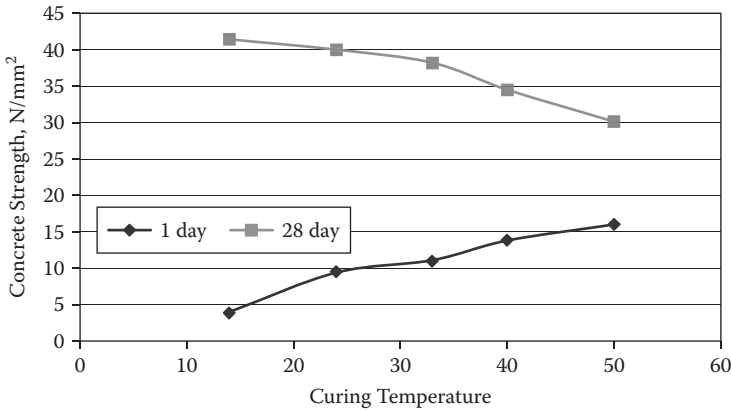

FIGURE 5.39
Effect of curing temperature on concrete strength.

action. It is worth mentioning that the rate of evaporation increases due to an increase in atmospheric temperature, high wind speed, or low humidity. The rate of bleeding depends on the concrete components of the mixture, mixing ratios, and the thickness of the concrete section, compaction, and process of surface finishing. That is why the cracks of plastic shrinkage occur when increasing the rate of evaporation of water from the surface due to the weather conditions or lack of bleeding rate due to the concrete components such as high-strength concrete. With the use of silica fume or fly ash or cement with very small particles the rate of bleeding will be reduced. Therefore in this type of mixing the probability of seeing plastic shrinkage cracking is high even in normal weather conditions.

Note that plastic shrinkage cracking usually happens in hot climates. Table 5.16 from ACI presents different relative humidity and different air temperatures and concrete temperatures that cause high evaporation rate. Table 5.16 is based on a wind speed of 16 km/h and atmospheric temperature lower than the temperature of concrete by about 6 degrees.

However, the rate of evaporation of water is due to the air temperature of concrete and other factors such as wind speed and humidity. Therefore the maximum temperature of the atmosphere or of concrete may be correct in a region and not suitable for another area.

Therefore, each project must define the maximum concrete temperature based on climate conditions. In general if the atmospheric temperature is higher than 20°C to 30°C, experimental work in accordance with ASTM C192 is required.

5.9.3.1 Control Water Temperature in Mixing

Water is an essential component of concrete and has an impact on the properties of fresh concrete and hardening concrete.

TABLE 5.16

Concrete Temperature and Corresponding Relative Humidity That Cause Plastic Shrinkage

Concrete Temperature (°C)	Air Temperature (°C)	Critical Evaporation Rate (kg/m ² /hr)			
		1	0.75	0.5	0.25
41	35	85	100	100	100
38	32	80	95	100	100
35	29	75	90	100	100
32	27	60	85	100	100
29	24	55	80	95	100
27	21	35	60	85	100
24	19	20	55	80	100

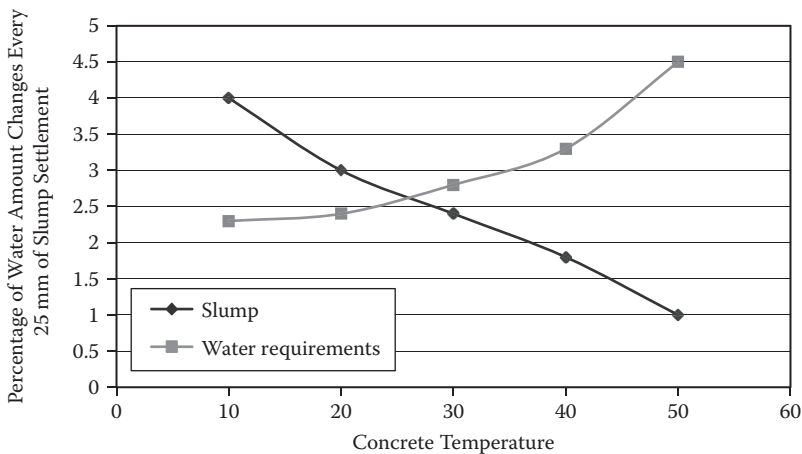

FIGURE 5.40 Effect of concrete temperature on concrete slump and water quantity.

When increasing the temperature of the water, the concrete temperature will simultaneously increase. When increasing the temperature of concrete, the required amount of water for mixing will increase to obtain the same concrete slump as illustrated in Figure 5.40 and Figure 5.41.

The specific heat is the number of calories necessary to raise the temperature of one gram of the material one degree Celsius. The specific heat of water is about four to five times the specific heat of cement and aggregate. Therefore, mixing water temperature has a very important impact on the temperature of concrete. Fortunately, the water temperature can be more easily controlled than other components of concrete.

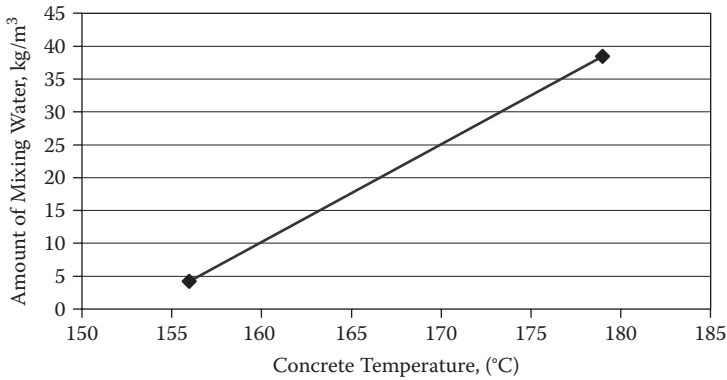

FIGURE 5.41

Effect of increasing concrete temperature on water amount and slump settlement of 75 mm and maximum aggregate size of 38 mm.

The use of cooling water can reduce the temperature of concrete at about 4.5°C and the amount of cold water does not increase the quantity of water for mixing design. Reducing the temperature of water to about 2°C to 2.2°C reduces the temperature of concrete about 0.5°C. The contractor should obtain cold water and maintain the water temperature during the process. The means of transporting the water, such as pipes, storage tanks, and transporting trucks, should be well insulated.

One can cool water up to 1°C using ice or chilled water or advanced technology. The ice is used frequently in areas of hot weather. The ice should not be melted before mixing it with the concrete component to obtain the most benefit, but the ice must melt at the end of the mixing process and before pouring starts.

The temperature of concrete can be estimated from the following equation:

$$T = \frac{0.22(T_a W_a - T_c W_c) T_w W_w + T_a W_{wa} + (-W_i)(79.6 - 0.5T_i)}{0.22(W_a + W_c) + W_w + W_i + W_{wa}}$$

where

T_a = aggregate temperature

T_c = cement temperature

T_w = temperature of mixing water without ice

T_i = ice temperature

W_a = weight of dry aggregate

W_c = cement content

W_w = quantity of water mixing

W_{wa} = quantity of water absorbed by aggregate

5.9.3.2 Control Cement Temperature

Increasing the concrete temperature will increase the cement dehydration rate, which will cause the concrete to set in less time. This requires more water during mixing to maintain the workability and increasing the water can cause many problems as discussed earlier. A solution is to use types of cement that increase the setting time and these types of cement, according to ASTM, are C595 Type II Portland cement or Type IP or Type IS.

Generally, a concrete that has less cement content decreases the concrete setting time, and the concrete shrinkage cracking will be less. We can use some sort of cement that slows the rate of dehydration and this reduces the temperature caused by the dehydration, which reduces the overall concrete temperature. This will reduce the occurrence of cracks due to thermal expansion and the likelihood of cracks will be less with other methods to cool concrete. In general, low heat cement is very important when pouring mass concrete for slabs and retaining walls or bridge supports.

Cement temperature affects the temperature of concrete. Cement constitutes 10 to 15% of concrete which is why the temperature of concrete increases 0.5°C if the cement temperature increases about 4°C .

5.9.3.3 Control Aggregate Temperature

Aggregate is present in 60% to 80% of concrete mixes and the aggregate properties directly affect the concrete properties. The size, shape, and the aggregate sieve analysis have direct effects on the required amount of water in the concrete mix to achieve the necessary concrete slump in the project specifications.

The aggregate grading and particle shape are important to reduce the amount of the water. Notice that the aggregate from crushed stone needs more water and it resists more cracks than the round aggregate particles.

Reducing the aggregate temperature is very important to reduce the concrete temperature, as the percentage of aggregate in concrete is high. Reducing the temperature of the aggregate from 0.8°C to 1.1°C reduces the temperature of concrete about 0.5°C , but reducing the temperature of the aggregate is very costly. But we can use simple precautions to reduce the aggregate temperature or maintain its temperature at acceptable limits. These precautions include storing the aggregate in a shaded area or continuously spraying the aggregate with water.

5.9.3.4 Control Mixing Ratios

The concrete mixture in a hot climate country must reach appropriate strength after 28 days in accordance with ACI 318/318R, and requires a trial mixing based on the air temperature in the project site location.

According to previous discussions, the suitable mixing design will be based on using the lowest cement content that provides the required strength and maintains the concrete performance over time.

In other words, one can use another material such as fly ash or slag to reduce the setting time, but this will reduce the heat resulting from dehydration.

Moreover, one can use different types of additives that reduce the water in mixing to increase the concrete workability and reduce water content at the same time.

To obtain reasonable workability to easily perform compaction, it is preferred the concrete slump to be not less than 75 mm.

5.9.3.5 Control Concrete Mixing Process

Manufacturing reinforced concrete in a country with a hot climate needs special attention and expertise of individuals who work at the site or in a ready-mix factory. The production facilities should be able to meet the required specifications for a hot weather condition.

The concrete temperature with the normal mixing ratio can decrease by 0.5°C in the following cases:

- Reduce cement temperature by 4°C
- Reduce water temperature by 2°C
- Reduce the aggregate temperature by 1°C

In the concrete mixing process the mixer should be painted white to reduce the effect of sun heat. In some cases the mixer can be covered with a wet sheet.

The mixing speed must be less at the start of mixing to reduce the heat produced due to friction as per ACI 207.4R recommendation. Once the mix becomes homogeneous, reduce the mixer speed to its lower rate which is one revolution per minute for a total of 300 revolutions. The project specification can be defined or modified based on the following cases:

- Using water reducer and retarder admixtures
- Using nitrogen to reduce the temperature
- Determine whether the concrete can maintain its workability without adding water

Nitrogen is used in some hot climate countries during the mixing process to reduce the concrete temperature. Figure 5.42 shows the nitrogen in a mixing truck.



FIGURE 5.42
Using nitrogen for cooling.

Figure 5.43 shows the addition of a block of ice in the concrete mix to reduce the concrete temperature, which is considered a most effective technique to reduce the temperature.

5.9.3.6 Control Project Management

Concrete projects in hot climates require personnel and equipment ready to deal with the temperatures, and also sufficient experienced supervisors to control the site and find a quick solution to any problem.

The time period between the start of mixing and the start of concrete pouring must be reduced. There must be good management between the mixing plant center that sends the mixing truck to the site and the execution speed on site to avoid any delay.

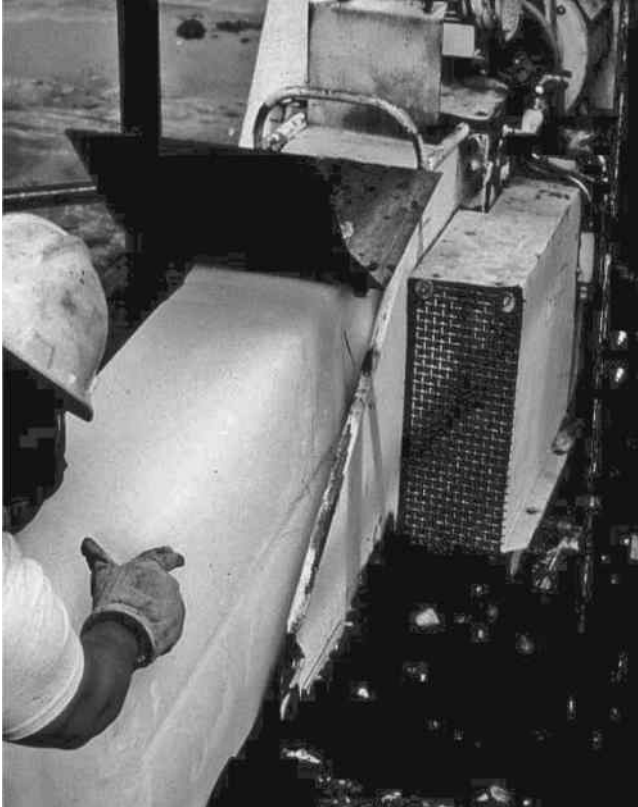

FIGURE 5.43
Using ice in concrete mixing.

It is preferred to set the pouring time away from the rush hour and prepare the site location carefully so the mixer trucks can easily maneuver without delay.

5.10 High-Strength Concrete Quality

The concrete industry strives 1950s to achieve concrete with greater compressive strength. Over time, the definition of “high-strength” concrete has changed. In the 1950s a concrete compressive crushing strength at 28 days of 34 N/mm^2 was considered high-strength concrete. In the beginning of the 1960s commercially produced concrete reached 41 to 52 N/mm^2 compressive strength. By the 1970s concrete strength was up to about

62 N/mm². Recently, concrete compressive strength up to 138 N/mm² was reached for concrete pouring on site.

Now because of urban growth, especially vertical growth, the use of high-strength concrete has increased significantly. Moreover, there are some buildings that would have been difficult to construct without high concrete strength. Examples include the water tower in Chicago and bridges with large spans, such as East Huntington Bridge over the Ohio River.

Contractors in Australia are using high-strength concrete that gives compressive strength of 65 to 70 N/mm². Concrete that gives strength of about 100 N/mm² is available (Lloyd and Rangan 1995).

The evolution in the use of concrete is very important in economic terms because increasing the concrete strength will reduce the dead load on the building as a whole, reducing the cost of structure significantly. There are also economic benefits for owners. Due to overcrowding in some cities, space is at a premium and sellers can charge per meter. The use of high-strength concrete reduces concrete area.

High-strength concrete also has the ability to enhance the concrete performance during the structure lifetime, reducing costs for maintenance and regular inspections.

The American Concrete Institute specifies that 40 N/mm² or more is considered high-strength concrete, noting that this concrete will not contain from polymer or epoxy. The committee also recommended that the definition of high-strength concrete varies according to geographical location because of the nature of the aggregate. For example, in Hurghada and Aswan, Egypt, they use crushed granite. It gives concrete strength to 45 N/mm² without any additions or enhancing mixing ratios. However when using the aggregate in Cairo under the same conditions with the same concrete mix, the highest value of compressive strength was 25 N/mm².

The ACI committee also notes that for commercial concrete the strength is 62 N/mm², and high-strength concrete is defined as 83 to 100 N/mm².

The Australian Society stipulates that concrete that gives compressive strength after 28 days of more than 50 N/mm² is a high-strength concrete.

5.10.1 Cement for High-Strength Concrete

The nature of high-strength concrete requires accuracy in choosing the components and quality control procedures. The cement is one of the basic components that needs quality control tests to identify strength to break through the cement mortar cubes at 7, 28, 56, and 91 days, according to the specifications of ASTM C109 without rapid hardening Portland cement Type III. The properties of cement and fines follow the specification ASTM C150.

Increasing the cement content increases the temperature of concrete. For example in the case of a 1.2 m² column in a water tower containing 502 kg/m³ cement, concrete reached 66°C although the initial temperature was 24°C

during the process of dehydration. These temperatures decreased within 6 days and there were no problems.

In case of expected problems due to the rise in temperature, it is preferable to use low heat cement (Type II) to give the required strength after 28 days.

5.10.2 Mineral Admixtures

Mineral admixtures, such as silica fume, fly ash, and furnace slag, form the basic material for high-strength concrete and self-compacting concrete. It is important that the following simple questions are answered:

- What is carrying the load aggregate or cement?
- What is the function of the coarse aggregate?
- What is the function of the sand?
- What is the function of the cement?

Simply, the coarse aggregate is responsible for carrying the load on the concrete, and fine aggregate (e.g., sand) fills the voids between the aggregates. Cement and water act as an adhesive between the coarse and fine aggregate. To obtain high-strength concrete we need to reduce the voids as much as we can.

When the voids are filled, the concrete can reach its highest strength. This is the advantage of mineral additives, such as silica fume, fly ash, and slag. These materials have very small sized grains that can fill the voids in the concrete mixture.

The absence of voids diminishes the force of water inside the concrete and also reduces the penetration of oxygen, protecting the steel bars from corrosion and extending the life of a structure. Therefore, high-strength concretes sometimes called high-performance concrete.

5.10.2.1 Silica Fume

Silica fume, or microsilica, is widely used in the production of high-strength concrete. Silica fume is a very fine and dense powder. The rounded particles contain 85% silicon dioxide. The average size of grains of silica fume is about 0.1 to 0.2 microns and the surface area is about 1500 m²/kg.

Figure 5.44 is a microscopic photo of cement particles on the left and the much smaller silica fume particles on the right.

According to the ASTM C1240, the specifications of silica fume are as follows:

- Content of SiO₂ is not less than 85%
- Loss due to ignition is not more than 6%

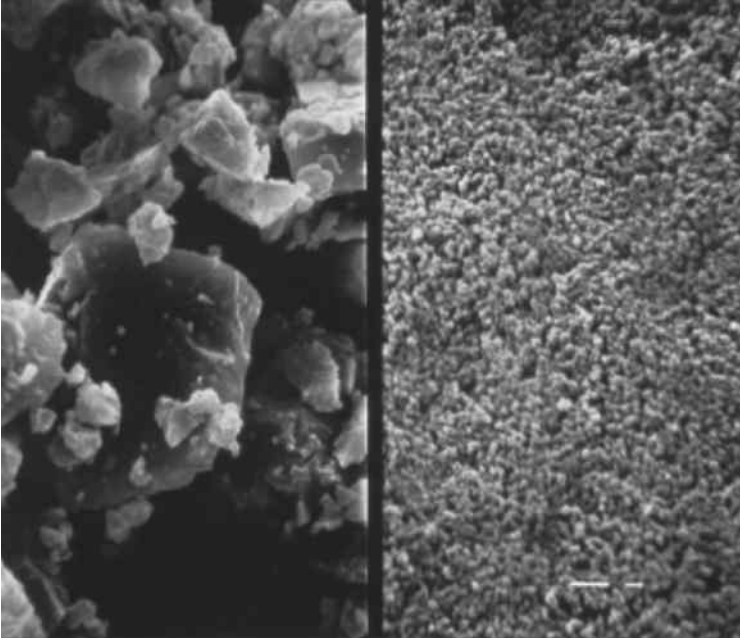

FIGURE 5.44
The difference in size between silica fume and cement particles.

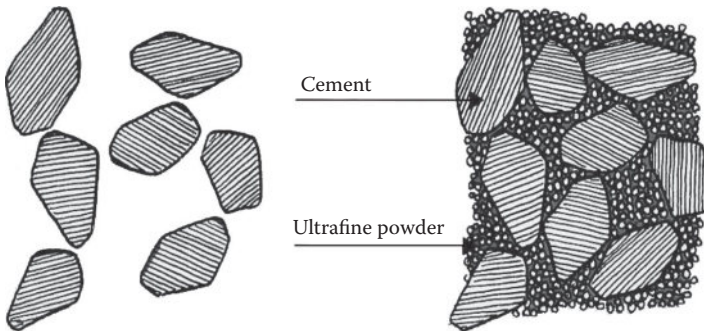

FIGURE 5.45
Shape of cement particles and silica fume.

- Maximum remaining percentage in 45 micron sieve is 10%
- Minimum value of the surface area is 15 m²/g

Due to the small particle size of silica fume, it can fill voids in the concrete mix. Figure 5.45 presents the shape of the cement particle on the right and the shape of mix after adding the silica fume as it fill the voids in the concrete mix on the left.



FIGURE 5.46
Storage of silica fume in sacks.

For any successful project, the supervisors should take into account environmental impacts and employee health. Employees should cover their faces when working with silica fume. Precautions should be taken for storing silica fume on-site. It can be stored in silos (Figure 5.45) or in closed sacks (Figure 5.46). The way to open sacks of the silica fume is presented in Figure 5.47.

The main disadvantages of the silica fume is when pouring concrete in hot climate conditions, as the silica fume fill the voids which prevent the concrete permeability. So the evaporation rate from the surface is higher than the bleeding so the curing process is critical when using silica fume in concrete (Figure 5.48). Figure 5.49 presents the spraying of water to increase the humidity on the concrete surface.

In most specifications, the minimum curing period is 7 days (Table 5.17). Early during the curing process, as shown in Figure 5.50, the concrete is sprayed with chemical compounds to increase the concrete strength and then wrapped in a wet plastic sheet.

One consequence of the high early reactivity of silica fume is that the mix water is rapidly used up; in other words, self-desiccation takes place (Hotoon 1993) and the dense microstructure of the hydrated cement paste makes it difficult for water from outside, if available, to penetrate the unhydrated remnants of Portland cement or silica fume particles. In consequence, strength development increases much earlier than with Portland cement alone; some experimental data are shown in Table 5.18. There was no increase in strength beyond 56 days. The data in Table 5.18 refer to mixes with a total content of cementitious materials of 400 kg/m^3 ; sulfate-resisting Portland (Type V); cement; silica fume contents of 10%, 15%, and 20% by mass of total



FIGURE 5.47
Putting sacks of silica fume in truck mixer.

cementitious materials; and a water:cement ratio of 0.36. The concrete specimens were maintained under moist conditions.

5.10.2.2 Fly Ash

One of the most successful fine aggregates is fly ash. Fly ash comes primarily from coal-fired, electricity-generating power plants. The plants grind coal to powder before it is burned. Fly ash is the mineral residue produced by

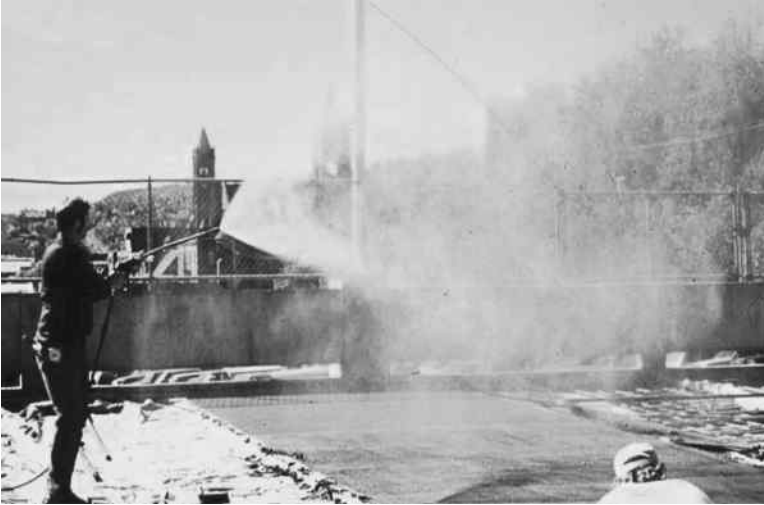

FIGURE 5.48
Curing concrete with silica fume.



FIGURE 5.49
Spraying chemical compound on the surface.

TABLE 5.17

Minimum Curing Times (in Days) Recommended in ENV

Rate of Gain of Strength of Concrete	Rapid*			Medium			Slow		
Temperature of concrete	5	10	15	5	10	15	5	10	15
No sun, RH ≥80	2	2	1	3	3	2	3	3	2
Medium sun or medium wind or RH ≥50	4	3	2	6	4	3	8	5	4
Strong sun or high wind or RH <50	4	3	2	8	6	5	10	8	5

Source: Hootom (1993).

Note: RH, relative humidity in percent.

*Low water/cement ratio and rapid-hardening cement.



FIGURE 5.50

Curing by using plastic sheet.

burning coal, which is captured from the plant’s exhaust gases and collected for use.

The particle of the fly ash is round (Figure 5.51) and its volume is much less than the volume of a cement particle, so it fills the voids in concrete mix and provides plasticity (Table 5.19).

Additionally, when water is added to Portland cement, it creates two products: a durable binder that glues concrete aggregates together and free lime. Fly ash reacts with this free lime to create more of the desirable binder.

TABLE 5.18

Strength Development of Test Cylinders of Concretes Containing Silica Fume

Age	Compressive Strength (MPa) of Mixes with Silica Fume Content			
	0%	10%	15%	20%
1 day	26	25	28	27
7 days	45	60	63	65
28 days	56	71	75	74
56 days	64	74	76	73
91 days	63	78	73	74
182 days	73	73	71	78
1 year	79	77	70	80
2 years	86	82	71	82
3 years	88	90	85	88
5 years	86	80	67	70

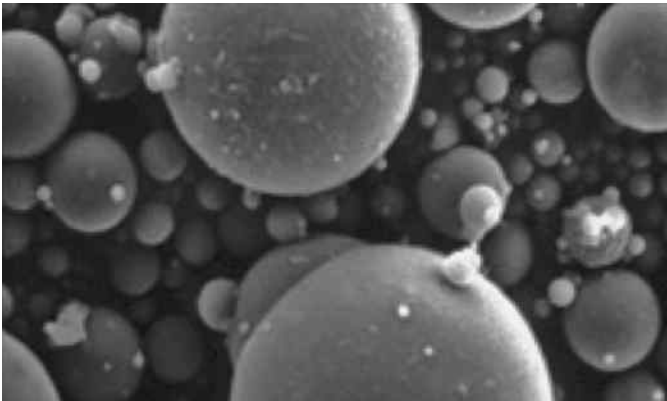
**FIGURE 5.51**
Shape of fly ash particle.**TABLE 5.19**

Typical Compressive Strength of Fly Ash Concrete

Cementitious Material	Compressive Strength, MPa at Age (Days)						
	1	3	7	14	28	91	365
Portland cement	12.1	21.2	28.6	33.9	40.1	46	51.2
Class F fly ash (25%)	7.1	13.9	19.4	24.3	30.3	39.8	47.3
Class C fly ash (25%)	8.9	19.0	24.1	28.5	29.4	40.5	45.6

The spherical shape of fly ash creates a “ball bearing” effect in the mix, improving workability without increasing water requirements. Fly ash also improves the pumpability of concrete by making it more cohesive and less prone to segregation. The spherical shape improves the pumpability by decreasing the friction between the concrete and the pump line.

The American standard specification places fly ash into two classes:

- Class F, which is normally produced by burning bituminous coal, which has less than 5% CaO
- Class C, which is normally produced by burning lignite or subbituminous coal, and has CaO in excess of 10%

Gebler and Klieger (1986) compared 100% Portland cement with two mixes with class C and class F with 25% of the cement weight. All the mixes had a total cementitious materials content of 307 kg/m³ with a 25% content of fly ash. The water/cement ratio was 0.4 to 0.45, and the mix slump was 75 mm. In this study the maximum size of the aggregate was 9.5 mm. The beneficial effect of the fly ash with respect to packing around the coarse aggregate was smaller than with conventional concrete mix.

From a durability point of view the fly ash prevents the permeability. But fly ash contains carbon, so it is recommended to not use it in case of a high probability of steel corrosion in some countries. As per the 1991 CUR report fly ash was prohibited in prestressed concrete.

5.10.2.3 Slag

Slag is another successful material that is used to obtain the high-strength concrete. Iron is manufactured using a blast furnace. The furnace is continuously charged from the top with oxides, fluxing material, and fuel. Two products, slag and iron, are collected in the bottom of the hearth. Molten slag floats on top of the molten iron; both are tapped separately. The molten iron is sent to the steel-producing facility, while the molten slag is diverted to a granulator. This granulation process is the rapid quenching with water of the molten slag into a raw material called granules. Rapid cooling prohibits the formation of crystals and forms glassy, non-metallic, silicates and aluminosilicates of calcium. These granules are dried and then ground to a suitable fineness, the result of which is slag. The granules can also be incorporated as an ingredient in blended Portland cement.

5.10.2.4 Comparison of Mineral Additives

Every mineral additive has advantages and disadvantages, and their availability should be considered in the design mix. Table 5.20 summarizes a comparison of cement, two classes of fly ash, slag, and silica fume.

TABLE 5.20

Comparison of Chemical and Physical Characteristics Portland Cement, Fly Ash, Slag Cement, and Silica Fume

Property	Portland Cement	Class (F) Fly Ash	Class (C) Fly Ash	Slag Cement	Silica Fume
SiO ₂ content (%)*	21	52	35	35	85 to 97
Al ₂ O ₃ content (%)*	5	23	18	12	
Fe ₂ O ₃ content (%)*	3	11	6	1	
CaO content (%)*	62	5	21	40	<1
Fineness as surface area (m ² /kg)**	370	420	420	400	15000 to 30000
Specific gravity	3.15	2.38	2.65	2.94	2.22
General use in concrete	Primary binder	Cement replacement	Cement replacement	Cement replacement	Property enhancer

*Note that these are approximate values; values for a specific material may vary from what is shown.

**Surface area measurements for silica fume by nitrogen adsorption method, others by air permeability method (Blaine).

The benefits of mineral additives are:

- Better concrete workability
- Easier finishability
- Higher compressive and flexural strengths
- Lower permeability
- Improved resistance to aggressive chemicals
- More consistent plastic and hardened properties
- Lighter color

Table 5.21 shows the experimental results from different mixing ratios of silica fume and compares the concrete compressive strength until 56 days age. Table 5.22 presents different mixture ratios and the corresponding slump test values and compressive strength at 28 days.

5.11 Self-Compacting Concrete (SCC)

Beginning in the 1980s, the durability of concrete structures was a major topic of interest in Japan. To make durable concrete structures, sufficient compaction by skilled workers is required. However, the gradual reduction in the number of skilled workers in Japan's construction industry has led

TABLE 5.21

Strength Development of Several Concrete Mixtures Containing Silica Fume

Mixtures	Cement (kg/m ³)	Fly Ash (kg/m ³)	SF (kg/m)	SF (%)*	w/cm
1***	475	104	74	11	0.23
2**	390	71	48	9	0.37
3***	475	59	24	4	0.29
4**	390		27	6	0.35
5**	362		30	8	0.39
6**	390		30	7	0.37

*Silica fume as a percentage of total cementitious materials, by mass.

**Data provided by Elkem.

***Data from Burg and Ost (1994).

TABLE 5.22

Types of Concrete Mixes

Concrete Composition	Mix 1	Mix 2	Mix 3	Mix 4	Mix 5
w:c	0.3	0.3	0.3	0.3	0.25
Water (kg/m ³)	127	128	129	131	128
Cement (kg/m ³)	450	425	365	228	168
SF (kg/m ³)	—	45	—	45	54
Fly ash (kg/m ³)	—	—	95	—	—
Slag (kg/m ³)	—	—	—	183	320
Coarse aggregate (kg/m ³)	1100	1110	1115	1100	1100
Fine aggregate (kg/m ³)	815	810	810	800	730
Superplasticizer (L/m ³)	15.3	14	13	12	13
Slump after 45 minutes (mm)	110	180	170	220	210
Strength at 28 day (MPa)	99	110	90	105	114

to a similar reduction in the quality of construction work. One solution for the achievement of durable concrete structures independent of the quality of construction work is the employment of self-compacting concrete (SCC), which can be compacted into every corner of a formwork, purely by means of its own weight and without the need for vibrating compaction.

The necessity of this type of concrete was proposed by Okamura in 1986. Studies to develop self-compacting concrete, including a fundamental study on the workability of concrete, were carried out by Ozawa and Maekawa at the University of Tokyo. Figure 5.52 represents the difference between the SCC mix and the traditional concrete mix.

5.11.1 Development of Prototype

The prototype of self-compacting concrete was first completed in 1988 using materials already on the market. The prototype performed satisfactorily

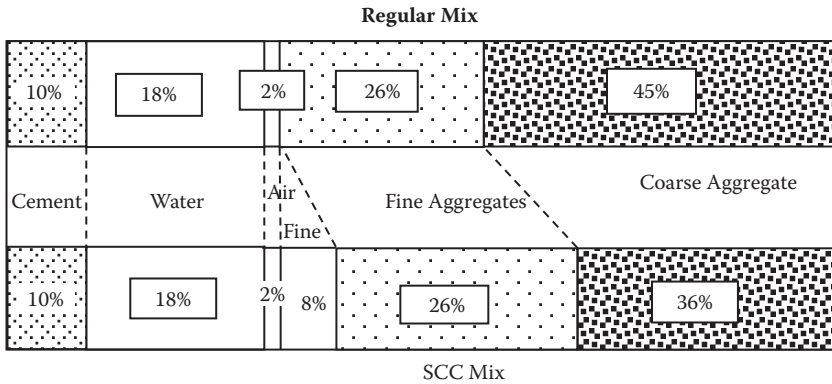

FIGURE 5.52
Comparison of SCC and regular concrete mix.

with regard to drying and hardening shrinkage, heat of hydration, density after hardening, and other properties. The product was named “high-performance concrete.”

At almost the same time, high-performance concrete was defined by Professor Aitcin as a concrete with high durability due to low water:cement ratio. Since then, high-performance concrete has been known around the world as high-durability concrete. Okamura changed the name to “self-compacting high-performance concrete.”

Since the development of the prototype of self-compacting concrete in 1988, the use of self-compacting concrete in structures has gradually increased. The main reasons for the employment of self-compacting concrete can be summarized as follows:

1. To shorten construction period
2. To assure compaction in the structure, especially in confined zones where vibrating compaction is difficult
3. To eliminate noise due to vibration, especially at concrete product plants

5.12 Lightweight Aggregate Concrete

The main disadvantage of normal concrete is the high self weight, as the concrete density is about 2200 to 2600 kg/m³. This high self weight has an effect on the dimensions for concrete sections and foundations and a direct

impact on project costs. Therefore, many attempts to reduce the self weight of concrete to increase efficiency have been made.

The practical range of densities of lightweight concrete is between about 300 and 1850 kg/m³. Basically there is only one method to produce lightweight concrete by the inclusion of air and this can be achieved in the following three ways:

1. Replacing the usual mineral aggregate by cellular porous or light-weight aggregate
2. Introducing gas or air bubbles in mortar resulting in aerated concrete
3. Creating no-fines concrete, by omitting sand fraction from aggregate

Table 5.23 presents the materials that are used in different ways.

There are three categories of lightweight aggregate concrete. Structural lightweight concrete has a density between 1350 and 1900 kg/m³, and as its name implies, this concrete is used for structural purposes. It has a minimum compressive strength of 17 Mpa. Low density concrete has a density between 300 and 800 kg/m³. This concrete is used for nonstructural purposes, mainly for thermal insulation. Its compressive strength, measured on standard cylinders, is between 7 and 17 Mpa. The thermal insulation characteristics are between those of low density concrete and structural lightweight concrete (Table 5.24).

For strength up to 41 MPa, ACI expresses the modulus of elasticity of concrete, E_c , in GPa as

TABLE 5.23

Groups of Lightweight Concrete

No-Fines Concrete	Lightweight Aggregate Concrete	Aerated Concrete	
		Chemical	Foaming Mixture
Gravel	Clinker	Aluminum powder method	Preformed foam
Crushed stone	Foamed slag	Hydrogen peroxide and bleaching powder method	Air-entrained foam
Coarse clinker	Expanded clay		
Sintered pulverized fuel ash	Expanded shale		
Expanded clay or shale	Expanded slate		
Expanded slate	Sintered pulverized fuel ash		
Foamed slag	Exfoliated vermiculite		
	Expanded perlite		
	Pumice		
	Organic aggregate		

TABLE 5.24

Approximate Relation between Strength of Lightweight Aggregate Concrete and Cement Content

Compressive Strength (MPa)	Cement Content	
	With Lightweight Fine Aggregate (kg/m ³)	With Normal Weight Fine Aggregate (kg/m ³)
17	240–300	240–300
21	260–330	250–330
28	310–390	290–390
34	370–450	360–450
41	440–500	420–500

$$E_c = 43 \times 10^{-6} \rho^{1.5} \sqrt{f_c}$$

where

f_c = standard cylinder strength in MPa

ρ = density of concrete in kg/m³

This expression is valid for densities between 1440 and 2480 kg/m³, but the actual modulus of elasticity may deviate from the calculated value by up to 20%.

The third type is lightweight aggregate concrete with a compressive strength in the range of 60 to 100 MPa. The relation of the modulus of the compressive strength seems to be best described by a Norwegian standard expression reported by Zhang and Gjorv as:

$$E_c = 9.5 f_c^{0.3} x \left(\frac{\rho}{2400} \right)^{1.5}$$

where

E_c = modulus of elasticity in GPa

f_c = compressive strength of 100 by 200 mm cylinders in MPa

ρ = density of the concrete in kg/m³

It can be noted that the lower modulus of elasticity of lightweight aggregate concrete allows the development of a higher ultimate strain, compared with normal weight concrete of the same strength. The values of 3.3×10^{-3} to 4.6×10^{-3} have been reported.

5.12.1 Lightweight Aggregate

The lightweight aggregates have high porosity, and low specific gravity.

The main types of the natural lightweight aggregates are diatomite, pumice, scoria, volcanic cinders, and tuff; except for diatomite, all are of volcanic origin.

There is another type of lightweight aggregate produced in factories and is often known by a trade name.

The lightweight aggregate that is used in structural concrete is manufactured from the natural materials of expanded clay, shale, and slate.

5.12.2 Lightweight Coarse Aggregate or Structural Member

The requirements for lightweight aggregate are given in ASTM C330-89 (Table 5.25) and BS3797:1990 (Table 5.26). Note that the quality control on manufactured aggregate grading is easier than control for natural aggregate.

Lightweight aggregate concrete has a higher moisture movement than normal weight concrete. It has a high initial drying shrinkage about 5% to 40% higher than conventional concrete, but the total shrinkage with some lightweight aggregates may be even higher. Concretes made from expanded clay, shale, or slag are in the lower shrinkage range.

TABLE 5.25

Grading Requirement of Lightweight Coarse Aggregate According to ASTM C330-89

Sieve Size	Percentage of Mass Passing Sieves			
	Nominal Size of Graded Aggregate			
	25 to 4.75	19 to 4.75	12.5 to 4.75	9.5 to 2.36
25	95–100	100	—	—
19	—	90–100	100	—
12.5	2560	—	90–100	100
9.5	—	10–50	40–80	80–100
4.75	0–10	0–15	0–20	5–40
2.36	—	—	0–10	0–20

TABLE 5.26

Grading Requirement of Lightweight Coarse Aggregate According to BS 3797:1990

Sieve Size	Percentage of Mass Passing Sieves		
	Nominal Size of Graded Aggregate		
	20 to 5	14 to 5	10 to 2.36
20	95–100	100	—
14	—	95–100	100
10	30–60	50–95	85–100
6.3	—	—	—
5.0	0–10	0–15	10–35
2.36	—	—	5–25

The voids in the lightweight aggregate facilitate the diffusion of the carbon dioxide so it is recommended to increase the cover thickness.

References

- ACI Committee 201. 1994. Guide to Durable Concrete, Manual of Concrete Practice, Part 1. Detroit, MI: American Concrete Institute.
- ACI Committee 222. 1994. Corrosion of Metals in Concrete, Manual of Concrete Practice, Part 1. Detroit, MI: American Concrete Institute.
- ACI Committee 301. 1994. Specification for Structural Concrete for Building. Manual of Concrete Practice, Part 3. Detroit, MI: American Concrete Institute.
- ACI Committee 318. 1994. Building Code Requirements for Reinforced Concrete (ACI 318-89) and Commentary (ACI 318R-89), Manual of Concrete Practice, Part 3. Detroit, MI: American Concrete Institute.
- ACI Committee 357. 1994. Guide for Design and Construction of Fixed Off-Shore Concrete. Detroit, MI: American Concrete Institute.
- Bamforth, P. B. 1994. Specification and design of concrete for the protection of reinforcement in chloride-contaminated environments. Paper presented at UK Corrosion & Eurocorr '94, Bournemouth International Center, October 31–November 3.
- Beeby, A. W. 1979. Concrete in the Oceans: Cracking and Corrosion. Tech. Rep. No. 2 CIRIA/UEG, Cement and Concrete Association, UK.
- Bentur, A., S. Diamond, and N.S. Berke. 1998. Steel Corrosion in Concrete: Fundamental in Civil Engineering Practice. London: E&FN SPON.
- British Standard 8110:1985, Structural Use of Concrete, Part 1. Code of Practice for Design and Construction.
- British Standard PD 6534:1993, Guide to Use in the UK of DD ENV 206:1992. Concrete: Performance, Production, Placing and Compliance Criteria.
- Browne, R. D., Geoghegan, M. P., and Baker, A. F. 1993. Analysis of structural condition from durability results. In *Corrosion of Reinforcement in Concrete Construction*, ed. A. P. Crane, Society of Chemical Industry (Great Britain), pp. 193–222.
- Burg, R.G., and Ost, B., 1994, Engineering Properties of Commercially Available High Strength Concrete, Research and Development Bulletin RD104T, Portland Cement Association, Skokie, IL.
- CUR report 144: fly ash as addition to concrete. 1991. Gouda, the Netherlands: Center of Civil Engineering Research and Codes, 99.
- Egyptian Code of Practice. 2003.
- European Prestandard ENV 206. 1992. Concrete—Performance, Production, Placing and Compliance Criteria.
- Gebler, S. H., and P. Klieger. 1986. Effect of fly ash on physical properties of concrete. In *Fly ash, silica fume, slag, and natural pozzolans in concrete*, vol. 1, V. M. Malhotra, ed., 1–50. Detroit, Michigan: ACI SP-91.
- Hooton, R. D. 1993. Influence of silica fume replacement of cement on physical properties and resistance to sulfate attack, freezing and thawing, and alkali-silica reactivity. *ACI Materials Journal* 90(2):143–51.

- Klieger, P. 1958. Effect of Mixing and Curing Temperature on Concrete Strength, *ACI JOURNAL, Proceedings* V. 54, No. 12, June, pp. 1063–1081. Also, *Research Department Bulletin 103*, Portland Cement Association.
- Lloyd, N. A., and Rangan, B. V., High-Strength Concrete Columns under Eccentric Compression, Research Report No. 1/95, School of Civil Engineering, Curtin University of Technology, Perth, Western Australia, January 1995.
- Neville, A. M. 1975. *Properties of Concrete*. London: Pittman.
- Van Daveer, J.R. 1975. *Techniques for evaluating reinforced concrete bridge decks*, *ACI Journal*, 72(12), 697–704.
- Verbeck, G. J., and Helmuth, R. H., 1968, *Structure and Physical Properties of Cement Pastes, Proceedings*, Fifth International Symposium on the Chemistry of Cement, Tokyo, V. III, pp. 1–32.

6

Nondestructive Testing for Concrete

6.1 Introduction

Poured concrete will begin to harden and we may need to conduct some tests and measurements to ascertain the quality of concrete, to settle any disagreement between the contractor and the owner or the consultant, or to verify parts of the construction. The quality control inspector should be able to detect the quality of hardened concrete through the use of nondestructive testing. The inspector should choose the method that is economically feasible, based on the structure condition and system. The tests should be selected based on the condition of the structure and the location of the member that will be tested and the test should provide accurate results (Table 6.1).

6.2 Core Test

The core test is a semidestructive test. This test is very important for studying safety of a structure as a result of changing the system of loading, deterioration of the structure as a result of accidents (e.g., fire or weather factors), or a need for temporary support for a repair when there is no accurate data about concrete strength.

The test is not too expensive and it is the most accurate test for determining actual strength of the concrete.

The core test is done by cutting cylinders from the concrete member, which could affect the integrity of structure. Therefore only the required samples must be taken according to the standard, as the required number will provide adequate results without weakening the building.

In our case for the deteriorated structure due to corrosion of steel bars, the structure lost most of its strength due to reduction on the steel cross-section

TABLE 6.1
 Nondestructive Test Methods for Determining Material Properties of Hardened Concrete and Assessing Condition in Existing Construction (ACI 228.2)

Property	Possible Methods		Comment
	Primary	Secondary	
Compressive strength	Cores for compression testing (ASTM C42 and C39)	Penetration resistance (ASTM C803; drilled in pullout test)	Strength of in-place concrete; comparison of strength in different locations; and drilled in pullout test not standardized
Relative compressive strength	Rebound number (ASTM C805); ultrasonic pulse velocity (ASTM C597)	—	Rebound number influenced by near surface properties; ultrasonic pulse velocity gives average result through thickness
Tensile strength	Splitting-tensile strength of core (ASTM C496)	In-place pulloff test (ACI 503R; BS 1881; Part 207)	Assess tensile strength of concrete
Density	Specific gravity of samples (ASTM C642)	Nuclear gage	—
Moisture content	Moisture meters	Nuclear gage	—
Static modulus of elasticity	Compression test of cores (ASTM C469)	—	—
Dynamic modulus of elasticity	Resonant frequency testing of sawed specimens (ASTM C215)	Ultrasonic pulse velocity (ASTM C597); impact echo; spectral analysis of surface waves (SASW)	Requires knowledge of density and Poisson's ratio (except ASTM C215); dynamic elastic modulus is typically greater than static elastic modulus
Shrinkage/expansion	Length change of drilled or sawed specimens (ASTM C341)	—	Measure of incremental potential length change
Resistance to chloride penetration	90-day ponding test (AASHTO-T-259)	Electrical indication of ability to resist chloride ion penetration (ASTM C1202)	Establishes relative susceptibility of concrete to chloride ion intrusion; assesses effectiveness of chemical sealers, membranes, and overlays

Air content; cement content; and aggregate properties (scaling, alkali-aggregate reactivity, freezing and thawing susceptibility)	Petrographic examination of concrete samples removed from structure (ASTM C856, ASTM C457); cement content (ASTM C1084)	Petrographic examination of aggregates (ASTM C294, ASTM C295)	Assist in determination of cause(s) of distress; degree of damage; quality of concrete when originally cast and current
Alkali-silica reactivity	Cornel VSHRP rapid test	—	Establish in field if observed deterioration is due to alkali-silica reactivity
Carbonation, pH	Phenolphthalein (qualitative indication); pH meter	Other pH indicators (for example, litmus paper)	Assess corrosion protection value of concrete with depth and susceptibility of steel reinforcement to corrosion; depth of carbonation
Fire damage	Petrography; rebound number (ASTM C805)	Ultrasonic pulse velocity; impact-echo; impulse-response	Rebound number permits demarcation of damaged concrete
Freezing and thawing damage	Petrography	SASW; impulse response	—
Chloride ion content	Acid-soluble (ASTM C1152) and water-soluble (ASTM C1218)	Specific ion probe	Chloride ingress increases susceptibility of steel reinforcement to corrosion
Air permeability	SHRP surface airflow method (SHRP-S-329)	—	Measures in-place permeability index of near-surface concrete (15 mm)
Electrical resistance of concrete	AC resistance using four-probe resistance meter	SHRP surface resistance test (SHRP-S-327)	AC resistance useful for evaluating effectiveness of admixtures and cementitious additions; SHRP method useful for evaluating effectiveness of sealers
Reinforcement location	Cover meter; ground penetrating radar (GPR) (ASTM D4748)	X-ray and y-ray radiography	Steel location and distribution; concrete cover
Local or global strength and behavior	Load test, deflection or strain measurements	Acceleration, strain, and displacement measurements	Ascertain acceptability without repair or strengthening; determine accurate load rating
Corrosion potentials	Half-cell potential (ASTM C876)	—	Identification of location of active reinforcement corrosion

(Continued)

TABLE 6.1 (Continued)
 Nondestructive Test Methods for Determining Material Properties of Hardened Concrete and Assessing the Condition in Existing Construction (ACI 228.2)

Property	Possible Methods		Comment
	Primary	Secondary	
Corrosion rate	Linear polarization (SHRP-S-324 and S-330)	—	Corrosion rate of embedded steel; rate influenced by environmental conditions
Locations of delaminations, voids, and other hidden defects	Impact-echo; infrared thermography (ASTM D4788); impulse-response; radiography; GPR	Sounding (ASTM D4580); pulse-echo; SASW; intrusive drilling and borescope	Assessment of reduced structural properties; extent and location of internal damage and defects; sounding limited to shallow delamination
Concrete component thickness	Impact-echo (I-E); GPR (ASTM D4748)	Intrusive probing	Verify thickness of concrete; provide more certainty in structural capacity calculations; I-E requires knowledge of wave speed, and GPR of dielectric constant
Steel area reduction	Ultrasonic thickness gage (requires direct contact with steel)	Intrusive probing; radiography	Observe and measure rust and area reduction in steel; observe corrosion of embedded posttensioning components; verify location and extent of deterioration; provide more certainty in structural capacity calculations

TABLE 6.2

Number of Cores and Deviation in Strength

Number of Cores	Deviation Limit between Expected Strength and Actual Strength (Confidence Level 95%)
1	+12%
2	+6%
3	+4%
4	+3%

area. Therefore more caution should be taken when performing this test and when selecting the proper concrete member to perform this test on.

The codes and specifications provide some guides to the number of cores to test and these values are as follows:

- Volume of concrete member (V) ≤ 150 m³ — 3 cores
- Volume of concrete member (V) > 150 m³ — [3 + (V - 150/50)] cores

The degree of confidence of the core test depends on the number of tests that you can take, which must be minimal. The relation between number of cores and confidence is shown in Table 6.2.

Before you choose the location of the sample, first you must define the location of the steel bars. Select a sample away from the steel bars to avoid taking a sample that contains steel reinforcement bars. Because of the accuracy needed when selecting a sample, the test should be performed by an experienced engineer. Moreover, the laboratory test must be certified and the test equipment must be accompanied by a certificate of calibration from a certified company.

Figure 6.1 and Figure 6.2 present the process of taking the core from a reinforced concrete bridge girder.

6.2.1 Core Size

Note that the permitted diameter is 100 mm in the case of maximum aggregate size of 25 mm, and 150 mm in the case the maximum aggregate size of 40 mm. It is preferable to use 150 mm diameter whenever possible, as it gives more accurate results. Table 6.3 represents the relationship between the dimensions of the sample and potential problems. So this table should be considered when choosing correct core size.

Some researchers state that the core test can be done with core diameter of 50 mm for an aggregate size no larger than 20 mm. However, small core sizes give different results than large sizes.

Cores taken from concrete serve as samples; every country has specific size requirements. The cylinders use to remove the cores are treated with a special mixture containing diamond powder to aid rotation of the cylinder

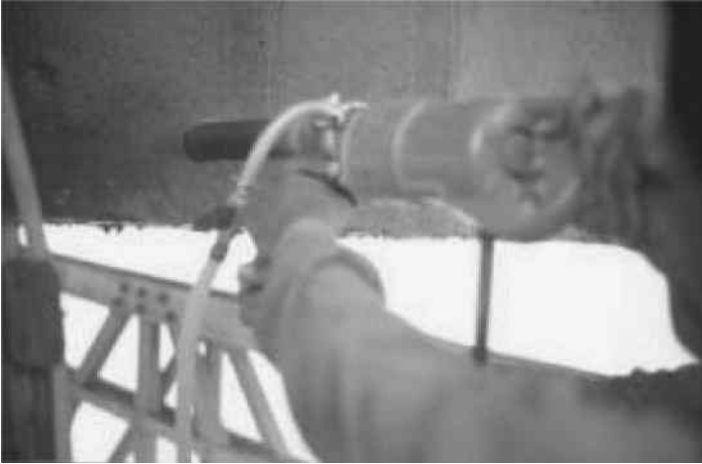

FIGURE 6.1
Taking a core sample.



FIGURE 6.2
How to take a core.

through the body of the concrete. The operator should maintain consistent pressure on the cylinder during sampling.

After the core is removed, the hole in the concrete should be filled with a material of appropriate strength such as grout, epoxy, or more concrete.

The filling must be done soon after taking the sample.

TABLE 6.3
Core Sizes and Possible Problems

Test	Diameter (mm)	Length (mm)	Possible problem
1	150	150	May contain steel reinforcement
2	150	300	May cause more cutting depth to concrete member
3	100	100	Not allowed if the maximum aggregate size is 25 mm; may cut with depth less than required
4	100	200	Less accurate data

The lab sample must be examined and every core photographed. Gaps are small voids if measured between 0.5 and 3 mm, average voids if between 3 mm to 6 mm, and large voids, if measured more than 6 mm. The core is also examined to determine the shape, kind, and color gradient of aggregates and qualities of the sand as well.

In the laboratory the dimensions, weight of each core, density, steel bar diameter, and distance between the bars are also measured.

6.2.2 Sample Preparation

After cutting the core from the concrete element, process the sample by leveling the surface of the core, then prepare a core that has a length not less than 95% of the diameter and not more than double the diameter.

Figure 6.3 shows the shape of the core sample after cutting from the concrete structure member.

For leveling the surface use a chainsaw or steel cutting disk, then prepare the two ends of the sample by covering them with mortar or sulfide, and then submerge the sample in 20°C ± 2°C water for at least 48 hours before testing the sample.

The sample is put in a testing machine. A load is gradually applied at the regular rate and a continuous range of 0.2 to 0.4 N/mm² until it reaches the maximum load at which the sample has been crushed.

To determine the estimated actual strength for a cube by knowing the crushing stress that is obtained from the test, use the following equation.

For the horizontal core the strength calculation will be as follow:

$$\text{Estimated actual strength for cube} = 2.5/(1/\lambda) + 1.5 \times \text{core strength}$$

where λ is core length/core diameter.

For the vertical core, the strength calculation will be as follows:

$$\text{Estimated actual strength for cube} = 2.3/(1/\lambda) + 1.5 \times \text{core strength} \quad (6.1)$$



FIGURE 6.3
Shape of core sample.

If the existing steel in the core is perpendicular to the core axis, multiply the previous equations with the following correction factor:

$$\text{Correction factor} = 1 + 1.5 (S \phi)/(LD) \quad (6.2)$$

where

L = core length

D = core diameter

S = distance from steel bar to edge of core

ϕ = steel bar diameter

Cores should be free of steel, but if steel is found, you must use the correction factor only in the event that the value ranges from 5 to 10%. If the correction factor is more than 10%, the results of the cores cannot be trusted and you should take another core.

The cores are often taken after 28 days, and should show higher strength than the standard used Yuan et al. (1991) found the opposite situation

TABLE 6.4

Relation between Standard Cylinder and Cores

Age (Days)	Standard Cylinder Strength (MPa)	Core Strength (MPa)	F_c (core)/ f_c (cylinder at 28)
7	66	57.9	0.72
28	80.4	58.5	0.73
56	86.0	61.2	0.76
180	97.9	70.6	0.88
365	101.3	75.4	0.94

(Table 6.4). They compared the standard cylinders and cores taken from a column cured using a sealing compound. It can be seen that in situ concrete often gained little strength after 28 days.

When examining the test results, the following points must be taken into account:

- Before testing, submerge the sample in water. This leads to a decrease in strength of about 15%.
- The equation to calculate the expected actual concrete strength does not take into account any differences in direction between the core and the standard cube.
- The concrete is acceptable if the average strength of the cores is at least 75% of the required strength and the calculated strength for any core is less than 65% of the required strength.

For prestressed concrete, the strength is acceptable if the average strength of the cores was at least 80% of the required strength and the calculated strength for any core was less than 75% of the required strength.

6.3 Rebound Hammer

The rebound hammer nondestructive test is the most common as it is easy to do. However, it gives less precise results. This test relies on measuring the concrete strength by measuring the hardening from the surface. It measures the strength using calibration curves of the relationship between the concrete hardening and concrete compressive strength. Figure (6.4) and Figure (6.5) present different type of rebound (Schmidt) hammers. The most common hammer gives an impact energy of 2.2 N/mm. In some cases the reading will be analog or digital or the device may record the readings. Figures 6.4 through 6.1 show various types of Schmidt (rebound) hammers.



FIGURE 6.4
Rebound hammer.



FIGURE 6.5
Another type of rebound hammer.

Inspect the device before using it by using the calibration tool that is attached. The calibration should be within the allowable limit based on the manufacturer's recommendation.

First the 300 mm × 300 mm concrete testing area should be clean and smooth (Figure 6.6). Test a surface that has not changed after casting or has not received any smoothing during the casting process.

On the surface to be tested draw a net of perpendicular lines in both directions about 2 to 5 cm apart. The intersection points will be the points where to take the test. The test point must be about 2 cm away from the edge. See Figure 6.7.

The following recommendations should be followed during the test:

- The hammer must be perpendicular to the surface (Figure 6.6 and Figure 6.7) that will be tested because the direction of the hammer affects the value of the rebound number as a result of the impact of hammer weight.



FIGURE 6.6
Rebound hammer test.



FIGURE 6.7
Another type of hammer device.

- The wet surface gives a reading on the rebound hammer less than reading a dry surface by up to 20%.
- The tested concrete member must be fixed and not vibrate.
- Do not use the curves for the relationship between concrete compressive strength and rebound number as given by the manufacturer.

You must calibrate the hammer by taking the reading on concrete cubes and crushing the concrete cubes to obtain the calibration of the curves. This calibration is important from time to time as the spring inside the rebound hammer loses some of its stiffness with time.

- Only use one hammer when you making a comparison between the quality of concrete in different sites.
- The type of cement affects the readings. For example, for concrete with high alumina cement can yield higher results than concrete with ordinary Portland cement by about 100%. Concrete with sulfate-resistant cement can yield results about 50% less than that of ordinary Portland cement.
- Concrete with higher cement content gives lower readings than concrete with less cement content; the gross error is 10%.

6.3.1 Data Analysis

The number of readings must be high enough to give reasonably accurate results. The minimum number of readings is 10 but usually 15 are taken. The extreme values are excluded; take the average for the remaining values to determine the compressive strength. Compare the results with the required concrete strength.

6.4 Ultrasonic Pulse Velocity

The ultrasonic pulse velocity test measures the speed of transmission of ultrasonic pulses through a construction member. It measures the time required for the transmission of impulses and by knowing the distance between the sender and receiver, the pulse velocity can be calculated.

Once these velocities are known, the concrete strength and its mechanical characteristics can be determined. The same procedure to identify compressive strength, the dynamic and static modulus of elasticity, and the Poisson ratio.

The equipment must have the capability to record time for the tracks with lengths ranging from 100 mm to 3000 mm within 1%.

The manufacturer should define how to work with the equipment in different temperatures and humidities. The sender and the receiver should be able to handle natural frequency vibrations between 20 to 150 kHz, bearing in mind that the frequency appropriate for most practical applications in the field of concrete is 50 to 60 kHz.

There are different ways for wave transmission to occur. One is surface transmission (Figure 6.8). Semidirect transmission is shown in Figure (6.9), and the third is direct transmission as shown in Figure (6.10).

The ultrasonic test equipment consists of two rods of metal with lengths of 250 mm and 1000 mm. The first is used in the determination of zero of the measurement and the second is used in the calibration. Each rod measures the time of the passage of waves through it. The operator connects

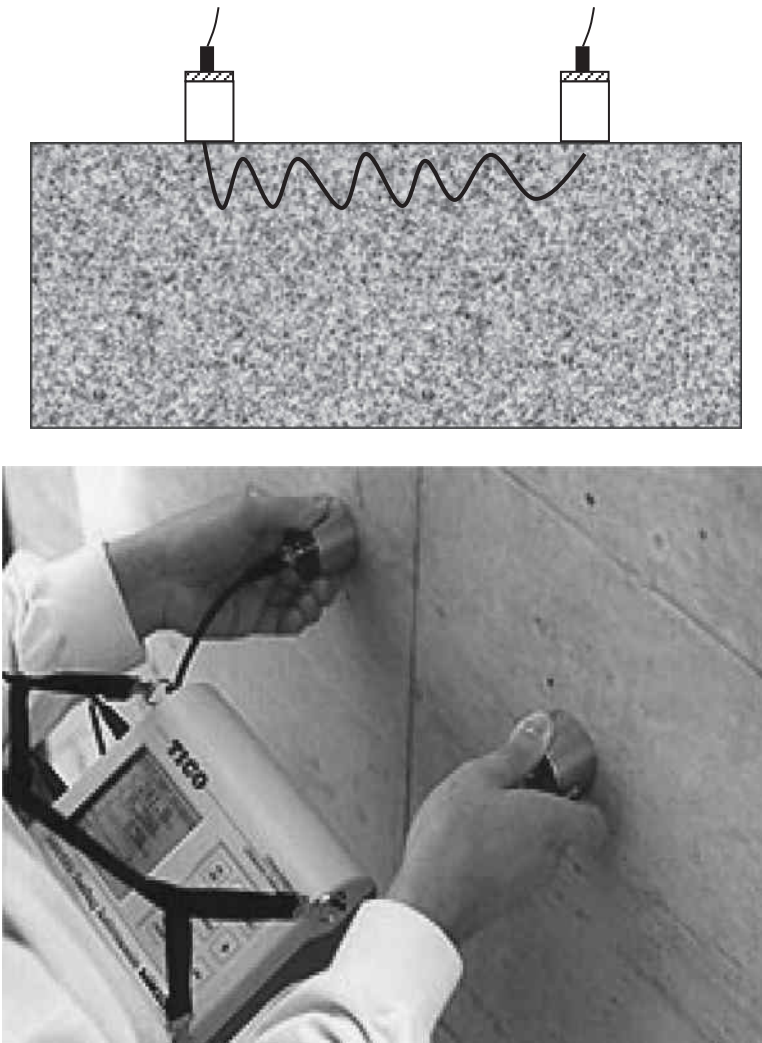

FIGURE 6.8
Top: Sketch of surface transmission concept. Bottom: Test in progress using UT machine.



FIGURE 6.9
Semi direct transmission in progress.

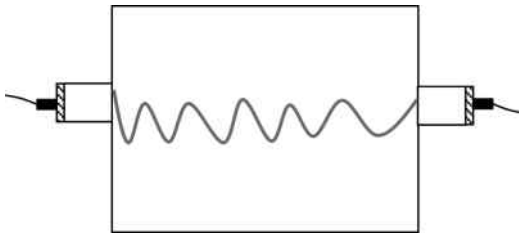

FIGURE 6.10
(a) Direct transmission concept. (b) Direct transmission setup.

the ends of the rod to the sender and receiver, then measures the time for pulse transmission and compares it with the known reading.

A long bar is used in the same way to define the result. However the difference between the two readings should not be more than $\pm 0.5\%$.

It is worth mentioning that the wave transmission velocity value in steel is twice the value in concrete, so steel bars in the concrete member will influence the accuracy of the reading. Therefore the location of the steel reinforcement must be defined with respect to the path of the ultrasonic pulse velocity.

If the steel bars are parallel to the pulse wave (Figure 6.11), the calculation of the pulse velocity will be as in the following equation:

$$V_c = K.V_m \tag{6.3}$$

$$K = \gamma + 2(a/L)(1 - \gamma^2)^{0.5} \tag{6.4}$$

$$L_s = (L - 2b) \tag{6.5}$$

where

V_m = pulse velocity from transmission time from the equipment

V_c = pulse velocity in concrete

γ = a factor whose value varies according to steel bar diameter

The effect of the steel bar can be ignored if the diameter is 6 mm or less or if the between the steel bar and end of the equipment is far.

If steel reinforcement bars are perpendicular to the direction of pulse transmission as shown in Figure (6.12), the effect of steel on the reading will be less. The effect can be considered zero if we use a transmission source of 54 KHZ and

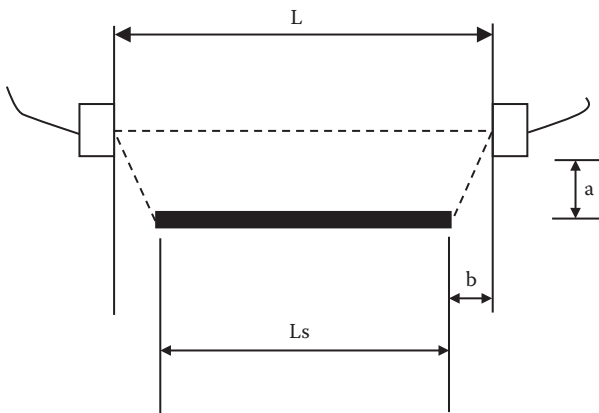

FIGURE 6.11
Ultrasonic wave parallel to steel bars.

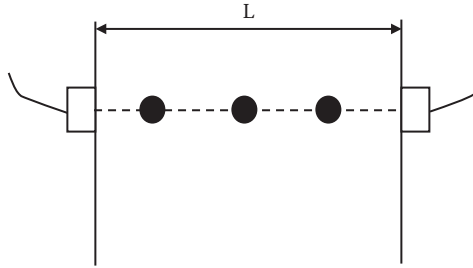

FIGURE 6.12
Ultrasonic wave perpendicular to steel bars.

TABLE 6.5
Temperature Effect on Pulse Transmission Velocity

Temperature (°C)	Percentage Correction of Velocity Reading (%)	
60	+5	+4
40	+2	+1.7
20	0	0
0	-0.5	-1
-4	-1/5	-7.5

the steel bar diameter is less than 20 mm. The above equation is used in case of less frequency and a diameter higher than 20 mm. Change the value of gamma according to the bar diameter in the data that is delivered with the equipment.

There are other factors that influence the measurement, such as the temperature (Table 6.5), thawing, and concrete humidity. Some of the more common errors are:

- Ignoring the reference bar to adjust zero.
- The concrete surface, which is level and smoothed after pouring, may have properties different from the concrete in the core of the member. If testing the concrete surface cannot be avoided, take into account the impact of the surface.
- Temperature affects the transmission ultrasonic velocity so note an increase or decrease in temperature of 30°C.
- When comparing the quality of concrete between the various components of the same structure, similar circumstances should be considered, such as the composition of concrete and moisture content and age, temperature, and type of equipment used. There is a relationship between the quality of concrete and the pulse velocity (Table 6.6).

TABLE 6.6

Relation between Concrete Quality and Pulse Velocity

Pulse Velocity (km/s)	Concrete Quality Degree
>4.5	Excellent
4.5–3.5	Good
3.5–3.0	Fair
3.0–2.0	Poor
<2.0	Very poor

TABLE 6.7

Relation between Elastic Modulus and Pulse Velocity

Pulse Velocity (km/s)	Elastic Modulus (Mega N/mm ²)	
	Dynamic	Static
3.6	24000	13000
3.8	26000	15000
4.0	29000	18000
4.2	32000	22000
4.4	36000	27000
4.6	42000	34000
4.8	49000	43000
5.0	58000	52000

The static and dynamic modulus of elasticity can be defined by knowing the transmission pulse velocity in the concrete (Table 6.7). Figure 6.13 depicts a reading.

6.5 Load Test for Concrete Members

The load test is done under the following conditions:

- When the core test gives concrete compressive strength results lower than characteristic concrete strength defined in design.
- When this test is included in the project specifications.
- When there is a doubt in the ability of the concrete structure member to withstand design loads.

This test is usually done to the slabs and in some cases to beams. The purpose of this test is to expose the concrete slab to a certain load and then remove the load and measure the deformation on the concrete member.

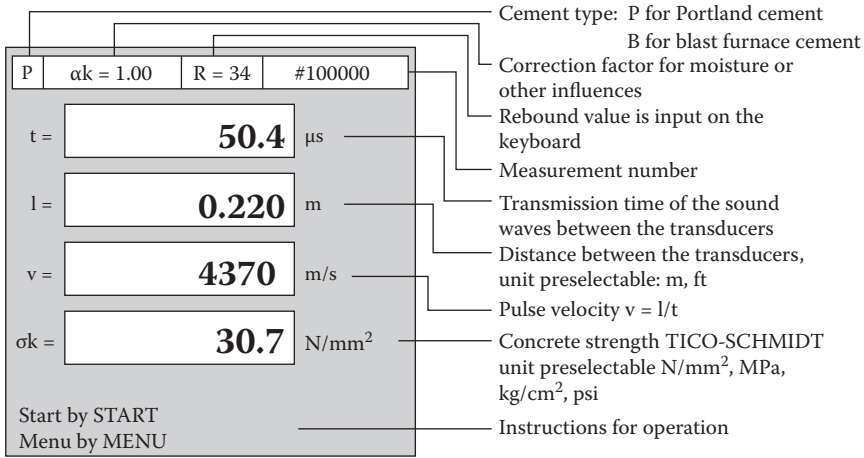

FIGURE 6.13
Ultrasonic pulse display.

The deformations could be deflections or cracks. Compare the results with the allowable limit in the specifications.

6.5.1 Test Preparation

The load test is done by loading the concrete member with a load equal to the following:

$$\text{Load} = 0.85 (1.4 \text{ dead load} + 1.6 \text{ live load}) \quad (6.6)$$

The load is applied using sacks of sand or concrete blocks. If sand sacks are used there should be 10 sacks at least for every span of 15 m^2 . Take into consideration the vertical distance between sacks to prevent an arch effect. With concrete blocks take into account the horizontal distance to avoid the arch effect.

It is important to identify the adjacent elements that may have an impact on the structure element to be loaded to obtain the maximum possible deformation for the test member.

Also consider the location of the test by identifying the locations for gauges. Calculate the actual dead load on the concrete member, through the identification weight of the same member in addition to coverage such as tiles, plastering or the weight of any kind of finishing work.

The location of the measurement unit for a slab test is shown in Figure 6.14 with the following specifications:

- Place one device in middle of the span and another beside it as backup, as shown in the figure.

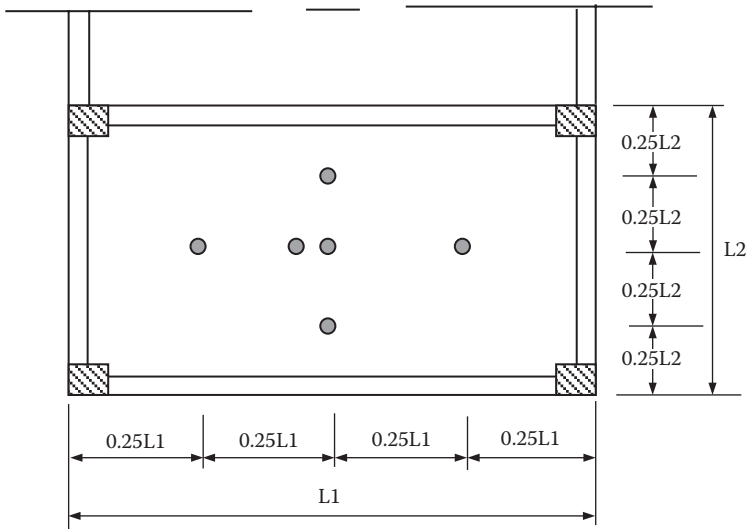

FIGURE 6.14
Location of measurement devices.

- Put other measurement devices as shown. The consultant engineer must define the other locations for measurement.
- The measurement devices must be calibrated before use for sensitivity of 0.01 mm and its scale about 50 mm.
- The device must have an accuracy of 0.01 mm and be capable of measuring crack widths.

6.5.2 Test Procedure

1. Test load = $0.85(1.4DL + 1.6LL)$, where DL is the dead load already affect the member and LL is the design live load value.
2. Take the reading of the deflection before starting the test (R1).
3. Start with 25% of the test load to avoid the arch effect or any impact load.
4. Read the measurement for the effect of 25% of the load and visually inspect the member for cracks. If cracks are present measure its width.
5. Repeat this procedure three times for each 25% increase of the load.
6. Record the time for the last load and the last deflection reading and crack thickness.
7. After 24 hours of the load, draw the locations of the cracks. Note the maximum thickness and the deflection reading (R2), and then remove the load gradually and avoid any impact load.

8. After removing all the load, measure the deflection reading and crack width.
9. After 24 hours from removing the load, record the measurement and the reading (R3), and record the crack width.

6.5.3 Results Calculations

The maximum deflection after 24 hours from load effect is calculated as:

$$\begin{aligned} \text{Maximum deflection} = & (\text{First measurement after passing 24 hours} \\ & \text{from load effect} - \text{reading before load effect}) \\ & \times \text{device sensitivity} \end{aligned} \quad (6.7)$$

$$\text{Maximum deflection} = (R2 - R1) \times \text{device sensitivity} \quad (6.8)$$

In case of any problem in the first device, use the second device reading. If the two devices have similar readings, take the average of the two readings.

The remaining maximum deflection after 24 hours of completely removing the load will be from the following equation:

$$\begin{aligned} \text{Maximum remaining deflection} = & (\text{Reading 24 hours after removing the} \\ & \text{load} - \text{reading before load effect}) \times \\ & \text{device sensitivity} \end{aligned} \quad (6.9)$$

$$\text{Maximum remaining deflection} = (R3 - R2) \times \text{device sensitivity} \quad (6.10)$$

The maximum recovery deflection will be calculated as follow:

$$\text{Maximum deflection recovery} = \text{Maximum deflection} - \text{maximum remaining deflection} \quad (6.11)$$

The maximum deflection 24 hours after loading and the recovery maximum deflection are shown in Figure 6.14.

Calculate the relation between the load and maximum deflection in case of loading and unloading.

Note the maximum crack thickness after 24 hours from load effect and 24 hours after removing the load.

6.5.4 Acceptance and Refusal Limits

Calculate the maximum allowable deflection for the member as follows:

$$\text{Maximum allowable deflection} = L^2/2t \text{ cm} \quad (6.12)$$

where

L = span of the member in meters for the shorter span of a flat slab and short direction for a solid slab. For a cantilever it will be twice the distance from the end of cantilever and the support face.

t = thickness of the concrete member in centimeters.

Compare the maximum deflection recorded after 24 hours from load effect and the allowable maximum deflection and you will have three outcomes:

1. If the maximum deflection after 24 hours from load effect is less than the allowable maximum deflection from the previous equation, the test is a success and the member can safely carry loads.
2. If the maximum deflection after 24 hours from load effect is higher than the allowable maximum deflection, the recovery deflection after 24 hours from removing load must be equal to or higher than 75% of maximum deflection. If this condition is verified, the member is considered adequate.
3. If the recovery is less than 75% of the maximum deflection, repeat the test by the same procedure 72 hours after removing the load from the first test.

After repeating the test a second time, this concrete structure member most refused if it does not meet the following two conditions:

1. If the recover deflection in the second test is less than 75% of the maximum deflection after 24 hours from load effect in second test
2. If the recorded maximum crack thickness is not permissible.

6.6 Pullout Test

The pullout test is widely used in European countries. (It is called the Lok-Test in Denmark.) This test measures the concrete strength by means of a special jack. The pullout force is the force required to pull a metal insert cast from hardened concrete against a circular counter pressure placed on the concrete surface (Figure 6.15).

The pullout force is related to the compressive strength of concrete (Figure 6.16).

The method of the pullout test is prescribed by ASTM C900-87 (reapproved 1993) and by BS 1881: Part 207: 1992. The ASTM states that the depth of the concrete above the enlarged end of the insert is to be equal to the diameter of the enlarged end. The apex angle of the frustum of the cone lies between 54 and 70 degrees.

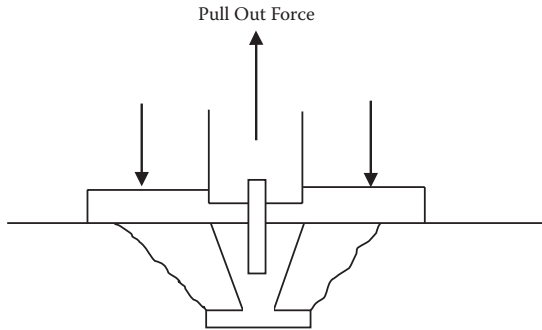

FIGURE 6.15
Sketch for pullout test.

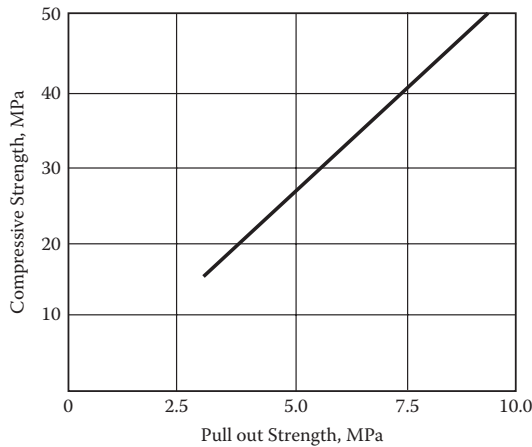

FIGURE 6.16
Sketch of the relation between pullout strength and concrete compressive strength.

6.7 Define Chloride Content in Hardened Concrete

Determination of the maximum chloride content in concrete is an important factor in protecting the reinforced concrete structure from the corrosion of the steel bars. Table 6.8 shows the limits of the chloride content of ions dissolved in the concrete.

The ACI codes state the limits for chloride ions in ACI 318R-89 and ACI 201, 357, and 222 as dissolved ions, as components of concrete, or in water used in concrete mixtures. ACI Committee 357 recommends that water used in reinforced concrete contain no more than 0.07 chloride and water used in prestressed concrete contain 0.04% (Table 6.9).

TABLE 6.8

Maximum Allowable Dissolved Chloride Ions

Condition around Concrete	Maximum Dissolved Chloride Ions in Concrete Water (% from Cement Weight)
Reinforced concrete exposed to chloride	0.15
Dry reinforced concrete totally protected from humidity during use	1.0
Different structure members	0.3

TABLE 6.9

ACI Recommendations for Maximum Acceptable Chloride Ions

Type of Member	Dissolved (in Water) ^a	Total ^b	Dissolved (in Acid) ^c	Total ^d
Prestressed concrete	0.06		0.06	0.08
Reinforced concrete exposed to chloride during use	0.15	0.1	0.1	0.2
Dry reinforced concrete	1.0			
Different structure members	0.3	0.15		

^a ACI 318R-89 ACI Building Code.

^b ACI Committee 202.

^c ACI Committee 357.

^d ACI Committee 222.

European code ENV 206 states the limits of chlorides in concrete according to the type of application. These limits are 0.01% of the weight of cement for plain concrete, 0.04% of the weight of cement of reinforced concrete, and 0.02% of the weight of cement concrete for prestressed concrete.

The EU specifications prevent the use of any additives containing chloride or calcium chloride in reinforced concrete or prestressed concrete.

6.8 Concrete Cover Measurements

The thickness of the concrete cover is measured in to ensure that it conforms to the specifications. The process of measuring the thickness of the concrete cover in structures was begun when corrosion, from inadequate cover increased. The chlorides or carbonation where it propagated inside the concrete causing the speeding of steel corrosion. Also, the lack of cover thickness propagated of moisture and oxygen, which are the main factors in the corrosion process.

The measurement of the concrete cover thickness explains the causes of corrosion and identifies areas that have the capability to corrode faster.

The measurement of the concrete cover thickness is defined as axis y , x . The equipment that measures the thickness of the concrete cover is simple but high tech (Figure 6.17); one can obtain numerical measurement readings. Radiographs can be used in but at high cost (Cadry and Gamnon 1992; Bungey 1993).

The magnetic cover method is simple but can be affected by the distance between steel bars, and the thickness of the concrete cover can influence the readings significantly. Because this method depends on the supply of electricity through the 9-volt battery, while the second side of the equipment measures the potential voltage envelope when the electrical circuit close by the steel bar, is buried in concrete, as seen in Figure 6.18.

Figure 6.19 illustrates the magnetic cover test device on the concrete surface and Figure 6.20 presents the direction of the device from which one can obtain the maximum and minimum signals.

The British Standard 1881, Part 204 is the only standard that considers the measurement of concrete cover after construction. In 1993, Alldred studied the accuracy of the measurement of the cover when there were more steel bars close to each other. He suggested using more than one head of



FIGURE 6.17

Concrete cover thickness measurement machine.

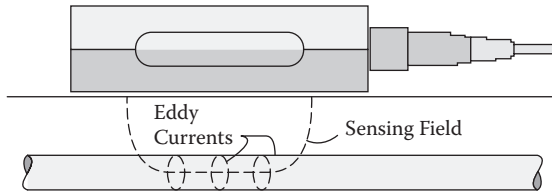

FIGURE 6.18
Magnetic cover test.

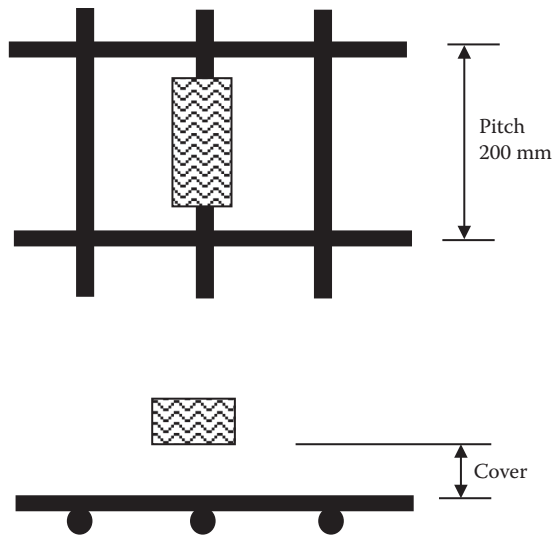

FIGURE 6.19
Device location on concrete surface.



FIGURE 6.20
Direction of device for maximum and minimum signals.

measurement as that would increase the accuracy of the reading and the small heads affected the accuracy of the equipment.

Therefore, the problem with this method is that dense steel reinforcement in a concrete section will give inaccurate data. The equipment should be calibrated based on the existing steel bars as the result can be affected by the

type of steel. The operator of this equipment must be competent and aware of factors that can affect the reading, such as bolts and steel wires.

6.9 Comparison of Different Tests

The different methods to determine the hardened concrete strength have advantages and disadvantages, which are summarized Table 6.10.

Moreover, these tests differ in their costs, their effects on the concrete member, and accuracy (Table 6.11).

After you obtain the results of the tests, you may find that the data of strength is lower than the concrete strength specified in the drawings or project specifications. The value of concrete strength in the drawing is the standard cube (cylinder) compressive strength after 28 days. Noting that the cubes or the cylinder will be poured and compacted based on the standard and the curing process was for 28 days, conditions at the site will be different. Curing times will vary. Laboratory and site temperatures vary. In addition the concrete pouring and compaction method is different for the cubes or cylinder than on site. All these variations should be considered in the design codes. Concrete, strength should be measured only after complete hardening.

TABLE 6.10

Comparison of Test Methods

Test Method	Probable Damage	Precaution Requirement
Overload test	Possible member loss	Member must be isolated or allow distribution of load to adjacent members; extensive safety precautions in case of collapse
Cores	Hole repairs good	Limitations of core size and numbers; safety precaution for critical member
Ultrasonic	None	Needs two smooth surfaces
Rebound hammer	None	Needs smooth surface

TABLE 6.11

Performance Comparison of Methods

Test Method	Damage to Concrete	Impact on Concrete	Accuracy	Speed	Cost
Overload test	Variable	Good	Good	Slow	High
Cores	Moderate	Moderate	Good	Slow	High
Ultrasonic	None	Good	Moderate	Fast	Low
Rebound hammer	Unlikely	Surface only	Poor	Fast	Very low

References

- ACI 228.1R89. 1994. In-place methods for determination of strength of concrete, ACI Manual of Concrete Practice, Part 2: Construction Practices and Inspection Pavements. Detroit, Michigan: American Concrete Institute.
- Ajdkiewicz A. B., and Kliszczewicz, A. T. 2002. Behavior of RC beams from recycled aggregate concrete. ACI Fifth International Conference, Cancun, Mexico.
- Ajdkiewicz, A. B., and Kliszczewicz, A. T. 1999. Utilization of recycled aggregates in HS/HPC, in *5th International Symposium on Utilization of High Strength/High Performance Concrete, Sandefjord, Norway*, June, vol. 2, pp. 973–980.
- Ajdkiewicz, A. B., and Kliszczewicz, A. T. 2000. Properties and usability of HPC with recycled aggregates, in *Proceedings of PCI/FHWA/FIP International Symposium on High Performance Concrete, September 2000, Orlando*. Chicago: Precast/Prestressed Concrete Institute, pp. 89–98.
- Allred, J. C. 1993. Quantifying the losses in cover-meter accuracy due to congestion of reinforcement. *Proceedings of the Fifth International Conference on Structural Faults and Repair 2*:125–130.
- ASTM C114-88, Chemical Analysis of Hydraulic Cement.
- ASTM C142-78, Test Method for Clay Lumps and Friable Particles in Aggregate.
- ASTM C183-88, Sampling and Amount of Testing of Hydraulic Cement.
- ASTM C188-84, Density of Hydraulic Cement.
- ASTM C349-82, Compressive Strength of Hydraulic Cement Mortars.
- ASTM C670-84, Testing of Building Materials.
- ASTM D1888-78, Standard Test Method for Particulate and Dissolved Matter, Solids or Residue in Water.
- ASTM D512-85 Standard Test Method for Chloride Ion in Water.
- ASTM D516-82 Standard Test Method for Sulfate Ion in Water.
- BS 410-1:1986 (2000), Specification for Test Sieves of Metalwire Cloth.
- BS 812 Part 103:1985, Sampling and Testing of Mineral Aggregate Sands and Fillers.
- BS 882:1992, Specification for Aggregates from Natural Sources for Concrete.
- BS EN933-1 1997, Tests for Geometrical Properties of Aggregates, Determination of Particle Size Distribution. Sieving Method.
- Bungey, J. H. ed. 1993. Non-destructive testing in civil engineering. International Conference of the British Institute of Non-Destructive Testing, Liverpool University. Cady, P. D., and E. J. Gannon. 1992. Condition evaluation of concrete bridges relative to reinforcement corrosion. Vol. 1: State of the art of existing methods. National Research Council, Washington, D.C.: SHRP-S-330.
- Di Niro, G., Dolara, E., and Cairns, R. 1998. The use of recycled aggregate concrete for structural purposes in prefabrication, in *Proceedings of the 13th FIP Congress "Challenges for Concrete in the Next Millennium," Amsterdam, June*. Rotterdam-Brookfield: Balkema, vol. 2, pp. 547–550.
- Egyptian Code for Design and Execute Concrete Structures: Part 3 Laboratory Test for Concrete Materials, ECP203, 2003.
- Egyptian Standard Specification: 1109-1971, Concrete Aggregate from Natural Resources.
- Egyptian Standard Specification: 1450-1979 Portland Cement with Fines 4100.
- Egyptian Standard Specification: 1947:1991, Method of Taking Cement Sample.

- Egyptian Standard Specification: 2421-1993. Natural and Mechanical Properties for Cement. Part 2: Define Cement Finening by using Blaine Apparatus.
- Egyptian Standard Specification: 2421-1993. Natural and Mechanical Properties for Cement. Part 1: Define Cement Setting Time.
- Egyptian Standard Specification: 2421:1993, Natural and Mechanical Properties for Cement. Part 2: Define Cement Finening by Sieve No.170.
- Egyptian Standard Specification: 262-1999, Steel Reinforcement Bars.
- Egyptian Standard Specification: 76-1989, Tension Tests for Metal.
- ISO 6274-1982, Sieve Analysis of Aggregate.
- Kasai, Y. (ed.). 1988. *Demolition and Reuse of Concrete and Masonry Reuse of Demolition Waste, 2nd International Symposium RILEM, Building Research Institute and Nihon University, Tokyo, November*. London: Chapman & Hall.
- Mukai, T., and Kikuchi, M. 1988. Properties of reinforced concrete beams containing recycled aggregate. *Proceedings of the 2nd International Symposium RILEM "Demolition and Reuse of Concrete and Masonry," Tokyo, November*. London: Chapman & Hall, vol. 2, pp. 670-679.
- Murphy, W. E. (discussion on paper by V. M. Malhotra). 1977. Contract strength requirements—core versus in situ evaluation. *Journal of American Concrete Institute*, vol. 74, no. 10, pp. 523-525.
- Neville, A. M. 1983. *Properties of Concrete*. London: Pitman.
- Plowman, J. M., Smith, W. F., and Sheriff, T. 1974. Cores, cubes, and the specified strength of concrete. *The Structural Engineer*, vol. 52, no. 11, pp. 421-426.
- Salem, R. M., and Burdette, E. G. 1998. Role of chemical and mineral admixtures on physical properties and frost—Resistance of recycled aggregate concrete. *ACI Materials Journal*, vol. 95, no. 5, pp. 558-563.
- Van Acker, A. 1997. Recycling of concrete at a precast concrete plant. *FIP Notes*, part 1: no 2, pp. 3-6; part 2: no. 4, pp. 4-6.
- Yuan, R. L., Ragab, M., Hill, R. E., and Cook, J. E. 1991. Evaluation of core strength in high-strength concrete. *Concrete International*, vol. 13, no. 5, pp. 30-34.

7

Steel Structure Quality Control

7.1 Introduction

The steel structures are the most common in industrial projects and also in as bridges and high-rise buildings. Steel has the following advantages:

- High strength in tension and compression, which gives small cross section and is critical for long spans.
- Elasticity: steel is a good example of materials that follow Hook's law.
- Ductility: Steel has good elongation before breaking so it can withstand overload without sudden failure.
- It is easy to strengthen steel without using complex technology.
- Consistent quality control.
- Easy and quick to erect.
- Recoverable from scrap.
- Salvage Value.

As for the disadvantages of steel, it needs periodic maintenance.

7.2 Steel Properties

The starting point of controlling the quality of steel structures is understanding the properties of steel. Steel delivered to the site should be checked and tested to match the project specification.

7.2.1 Strength

The variability of the structural material is reflected in variations in strength of the components of the structure. For structural steel, the most important property in this context is the yield strength. The characteristic yield strength is normally defined as that value below which only a small proportion of all values would be expected to fall. For practical reasons a nominal value corresponding to the specified minimum yield strength is generally used as the characteristic value for structural design purposes. This is the case in Eurocode 3, which tabulates nominal values of yield strength for different grades of steel.

The design value for the strength of steel is defined as the characteristic value divided by the appropriate partial safety factor.

7.2.2 Stress–Strain Behavior of Structural Steel

Structural steel is an important construction material. It possesses attributes such as strength, stiffness, toughness, and ductility that are very desirable in modern constructions.

Strength is the ability of a material to resist stresses. It is measured in terms of yield strength, F_y , and ultimate or tensile strength, F_u . For steel, the ranges of F_y and F_u ordinarily used in constructions are 248 to 345 MPa and 400 to 483 MPa, respectively, although higher strength steels are becoming more common. Stiffness is the ability of a material to resist deformation. It is measured as the slope of the material's stress–strain curve. With reference to Figure 7.1 in which uniaxial engineering stress–strain curves obtained from tests for various grades of steels are shown, the modulus of elasticity, E ,

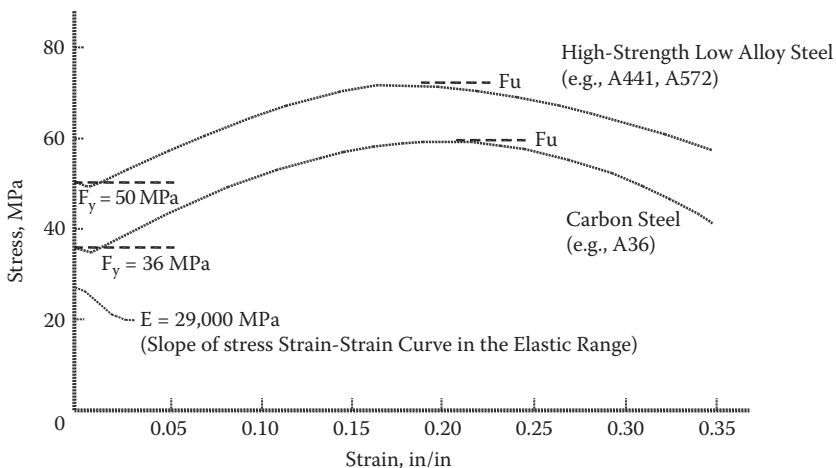

FIGURE 7.1

Uniaxial stress–strain behavior of steel.

does not vary appreciably for the different steel grades. Therefore, a value of 200 GPa is often used for design.

Toughness is the ability of a material to absorb energy before failure. It is measured as the area under the material's stress–strain curve. The lower grade steels possess high toughness, which is suitable for both static and seismic applications. Ductility is the ability of a material to undergo large inelastic, or plastic, deformation before failure. It is measured in terms of percent elongation or percent reduction in the area of the specimen tested in uniaxial tension.

Nominal values of yield strength, F_y , and ultimate tensile strength for rolled hot steel in Eurocode standards are presented in Table 7.1.

7.2.3 Steel Properties

Other material properties, notably modulus of elasticity, shear modulus, Poisson's ratio, coefficient of linear thermal expansion and density, are much less variable than strength, and their design values are typically quoted as deterministic with no partial safety factor applied.

In addition to the quantified values used directly in structural design, certain other material properties are normally specified by codes to ensure the validity of the design. For instance, Eurocode 3 stipulates minimum requirements for the ratio of ultimate to yield strength, elongation at failure, and ultimate strain if plastic analysis is to be used.

The material coefficients to be adopted in calculations for the structural steels covered by this Eurocode should be taken as follows:

- Modulus of elasticity, $E = 210000 \text{ N/mm}^2$
- Shear modulus, 81000 N/mm^2
- Poisson's ratio in elastic stage, $\nu = 0.3$
- Coefficient of linear thermal expansion, $\alpha = 12 \times 10^{-6}$ per K (for $T \leq 100^\circ\text{C}$)

When calculating the structural effects of unequal temperatures in composite concrete–steel structures to EN 1994, the coefficient of linear thermal expansion is taken as $\alpha = 10 \times 10^{-6}$ per K.

7.2.4 Variability of Geometry

Geometrical data are generally represented by their nominal values and used for design purposes. The variability, for instance, in cross-section dimensions, is accounted for in partial safety factors applied elsewhere. Other imperfections such as lack of verticality, lack of straightness, lack of fit, and unavoidable minor eccentricities present in practical connections should be considered. They may influence the global structural analysis, the analysis of the bracing system, or the design of individual structural elements, and are generally accounted for in the design rules.

TABLE 7.1

Nominal Values of Yield Strength f_y and Ultimate Strength f_u for Hot Rolled Structural Steel

Standard and Steel Grade	Nominal Thickness of Element t (mm)			
	$t \leq 40$ mm		$40 \text{ mm} < t \leq 80$ mm	
	f_y (N/mm ²)	f_u (N/mm ²)	f_y (N/mm ²)	f_u (N/mm ²)
<i>En 10025-2</i>				
S 235	235	360	215	360
S 275	275	430	255	410
S 355	355	510	335	470
S 450	440	550	410	550
<i>En 10025-3</i>				
S 275 N/NL	275	390	255	370
S 355 N/NL	355	490	335	470
S 420 N/NL	420	520	390	520
S 460 N/NL	460	540	430	540
<i>En 10025-4</i>				
S 275 N/NL	275	370	255	360
S 355 N/NL	355	470	335	450
S 420 N/NL	420	520	390	500
S 460 N/NL	460	540	430	530
<i>En 10025-5</i>				
S 235 W	235	360	215	340
S 355 W	355	510	335	490
<i>En 10025-6</i>				
S 460 Q/QL/QL 1	460	570	440	550
<i>En 10210-1</i>				
S 235 H	235	360	215	340
S 275 H	275	430	255	410
S 355 H	355	510	335	490
S 275 NH/NLH	275	390	255	370
S 355 NH/NLH	355	490	335	470
S 420 NH/NLH	420	540	390	520
S 460 NH/NLH	460	560	430	550
<i>En 10219-1</i>				
S 235 H	275	390		
S 275 H	355	490		
S 355 H	420	520		
S 275 NH/NLH	275	370		
S 355 NH/NLH	355	470		

TABLE 7.1 (Continued)

Nominal Values of Yield Strength f_y and Ultimate Strength f_u for Hot Rolled Structural Steel

Standard and Steel Grade	Nominal Thickness of Element t (mm)			
	$t \leq 40$ mm		$40 \text{ mm} < t \leq 80$ mm	
	f_y (N/mm ²)	f_u (N/mm ²)	f_y (N/mm ²)	f_u (N/mm ²)
S 460 NH/NLH	460	550		
S 275 MH/MLH	275	360		
S 355 MH/MLH	355	470		
S 420 MH/MLH	420	500		
S 460 MH/MLH	460	530		

The geometry parameters and axes for hot rolled sections in Eurocode 3 are presented in Figure 7.2.

There are difference in the axes between the American Institute of Steel Construction (AISC), BS 5950, and the Eurocodes. The comparison between the British Standard and Eurocodes for the direction of the axis and frequently used symbols is presented in Table 7.2 and Table 7.3, respectively.

7.2.5 Ductility Requirements

The main benefit of the steel structure is its ductility. The codes and standards include the limits of ductility based on a reasonable factor of safety and there are limits of deformation and side sway for the steel frames based on that ductility. Therefore, the steel for a project should match the codes cited in the design. In general, for steels a minimum ductility is required that should be expressed in terms of limits for:

- The ratio f_u/f_y of the specified minimum ultimate tensile strength, f_u , to the specified minimum yield strength, f_y
- The ultimate strain is ϵ_u , where ϵ_u corresponds to the ultimate strength f_u . The limiting values of the ratio f_u/f_y , the elongation at failure and the ultimate strain ϵ_u may be defined in the National Annex. The following values are recommended:
 - $f_u/f_y \geq 1,10$
 - Elongation at failure not less than 15%
- $\epsilon_u \geq 15\epsilon_y$, where ϵ_y is the yield strain ($\epsilon_y = f_y/E$)

Steel conforming to one of the steel grades listed in Table 7.1 should be accepted as satisfying these requirements.

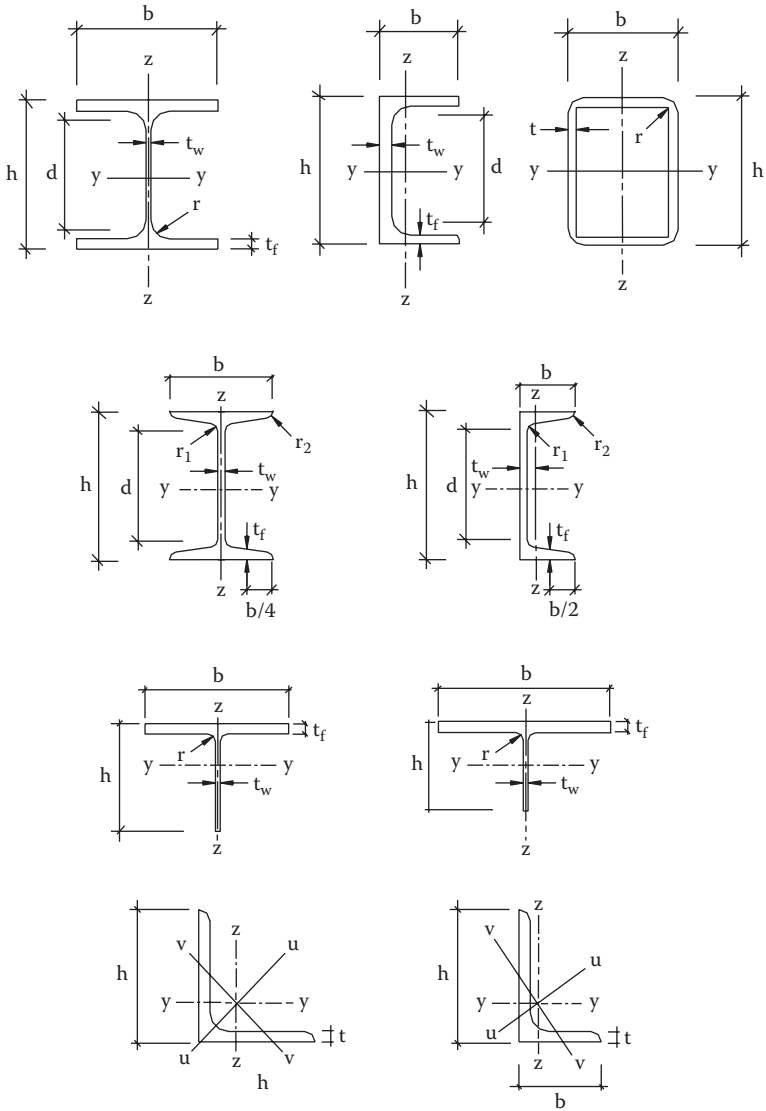

FIGURE 7.2
Geometry for rolled section based on Eurocode.

TABLE 7.2

Differences in Axes under BS and Eurocodes

Axes	AISC and BS 5950-1	Eurocodes
Along member		X
Major axis	X	Y
Minor axis	Y	Z

TABLE 7.3

Comparison of Frequency Used in BS5950-1 and Eurocodes

	AISC and BS 5950-1	Eurocodes
Area	A	A
Elastic modulus	Z	W_{ef}
Plastic modulus	S	W_{pt}
Inertia about major axis	I_x	I_y
Inertia about minor axis	I_y	I_z
Warping constant	H	I_w
Torsion constant	J	I_t
Radius of gyration	r	I
Applied axial force	F	N
Resistance to axial force	P	N_{Rd}
Bending moment	M	M
Applied shear force	F_v	V
Shear resistance	P_v	V_{Rd}
Yield stress	P_y	f_y
Bending strength	P_b	$X_{LT} f_y$
Compressive strength	P_c	$X f_y$

7.3 Design Situations

The relevant design situations based on Eurocode 3 (EC3) should consider the circumstances under which the structure is required to function.

Design situations classified as follows:

- Persistent design situations are conditions of normal use.
- Transient design situations are temporary conditions applicable to the structure, during execution or repair.
- Accidental design situations are exceptional conditions applicable to the structure or to its exposure to fire, explosion, impact, or the consequences of localized failure.
- Seismic design situations are conditions applicable to effects on a structure from seismic events.

The selected design situations shall be sufficiently severe and varied so as to encompass all conditions that can reasonably be foreseen to occur during the execution or along the structure lifetime.

7.4 Connection

A very important part of a steel structure is the connection system as from 45% to 50% of the project cost for steel relates to connection. The safety of the steel structure mainly depends on controlling the quality of the connection from the design and drafting stage, and the quality control and quality assurance should be implemented by the engineering firm designing the steel structure. When a steel structure fails, about 50% is due to the connection design, construction, or poor maintenance.

In steel structures there are two main types of connections: the bolted connection and welding connection.

7.4.1 Bolted Connection

Bolted connections are used in most steel structures (Figure 7.3). Bolting has the following advantages:



FIGURE 7.3

Using torque wrench to fix high strength bolt.

TABLE 7.4

Properties and Strength of High Strength Bolt (Grade 10.9)

Bolt Diameter (mm)	Bolt Area (mm ²)	Stress Area (cm ²)	Penetration Force (ton)	Required Torque (kg/m)
M12	113	84	5.29	12
M16	201	157	9.89	31
M20	314	245	15.43	62
M22	380	303	19.08	84
M24	452	353	22.23	107
M27	573	459	28.91	157
M30	706	561	35.34	213
M36	1018	817	51.47	372

Note: For Grade 8.8 bolts, the above values are reduced by 30%.

- Bolting is generally a faster operation than welding.
- Bolting does not have the temperature and weather condition requirements that are associated with welding.
- Unexpected weather changes may delay welding operations.

The properties of high strength bolts are presented in Table 7.4.

7.4.2 Welding Connection

Welding is used in most steel structures. The welding design will be performed by the structural engineer and its quality will be covered during quality control in the engineering phase. In addition, the drawings should be reviewed by the construction team for constructability.

In general there are two types of welding: fillet weld and butt weld. The fillet weld should be designed by defining the welding thickness and length. In contrast the butt weld in most cases will not be designed as the strength of the weld is the same as the strength of the original steel strength of the structure member, hence if the steel member can carry the forces the welding can carry the forces too. The butt weld will vary based on the groove needed for the welding. A fillet weld requires no groove.

The types of welding processes are shielded metal arc welding (SMAW), gas metal arc welding (GMAW) (also called metal inert gas [MIG] welding), flux cored arc welding (FCAW), gas tungsten arc welding (GTAW) (also known as tungsten inert gas [TIG] welding), submerged arc welding (SAW), and plasma arc welding (PAW).

Most steel structure projects use SMAW. In the case of welding a similar type of joint for mass production in workshop one can use GMAW.

The main code of welding for the steel structure is the AWS D1.1, of the American Welding Society. This code covers the design of welded connections, prequalification requirements, and fabrication and inspection.

7.4.2.1 Shielded Metal Arc Welding (SMAW)

The main method of welding for the steel structure is SMAW. It is also known as stick welding. The process of welding is shown in Figure 7.4, and involves creating an arc between the electrode and the steel workpiece as a result of flow of electricity. The arc will produce heat to melt the base metal of the electrode. The electrode coating will provide a shielding during the welding process. Welding leaves a solidified weld metal covered by a layer of converted flux, which is a slag that tends to float outside the metal in case

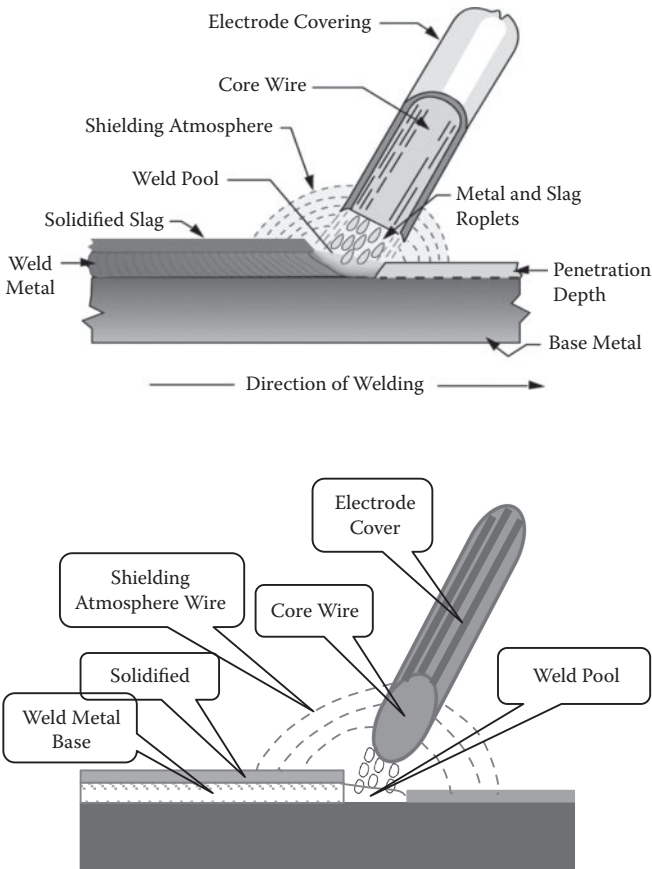

FIGURE 7.4
SMAW welding process.

of a poor weld. The flux may exist on the welding and should be determined by a nondestructive test.

The SMAW electrode has the symbol EXXXX E, and the first two or three digits refer to the minimum tensile strength of the weld metal in thousands of pounds per square inch. E70 indicates 70,000 psi (482 MPa). The next number refers to the position in which the electrode can be used. These numbers are 1, 2, and 4 (3 is no longer used).

- A 1 means that the electrode can be used in any position.
- A 2 indicates the molten metal is so fluid that the electrode can be used in the flat position for all welding types and in the horizontal position for fillet welds only.
- A 4 means that the electrode is suitable for the downhill welding position.

The last number describes the composition of the coating on the electrode, which correspond to the electrical current: alternative current (AC), direct current with positive electrode (DCEP), or direct current with negative electrode (DCEN). Electrodes that end with 5, 6, or 8 are classified as low hydrogen types.

The equipment used in SMAW is shown in Figure 7.5.

Quality control inspection of SMAW welding should consider hat discontinuities may be present in welds. The welding inspector may ignore or reject the following discontinuities:

- Porosity
- Slag inclusions

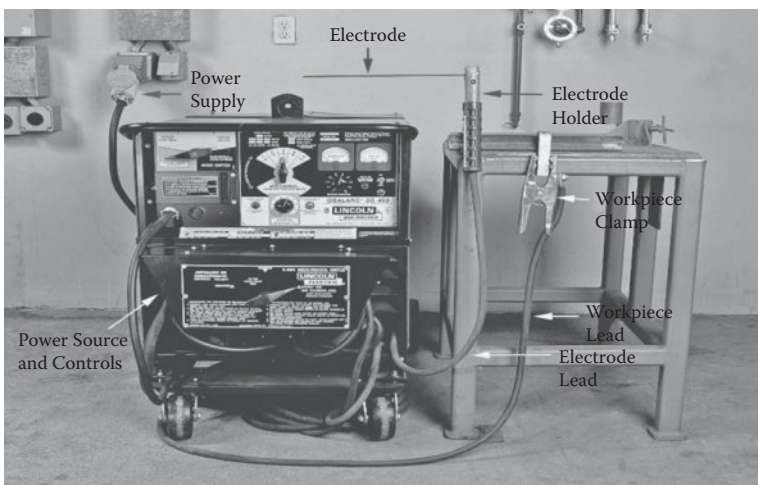

FIGURE 7.5
SMAW welding tools.

- Spatter
- Incomplete joint penetration
- Incomplete fusion

7.4.2.2 Gas Metal Arc Welding (GMAW)

GMAW is mainly used in the workshop as it needs special equipment and there are some limitations:

- Unsuitable for windy conditions
- Little tolerance for contamination
- Usually limited to shop welding
- Equipment is more complex
- Consumables—liners, contact tips

The discontinuities that are usually present in the GMAW process are:

- Porosity
- Incomplete fusion
- Incomplete joint penetration

7.5 Welding Types

In general, there are two types of weldings used in steel structures: fillet weld and butt weld.

7.5.1 Fillet Weld

The two types of fillets are convex and concave. Note that the design of the welding by the structure engineer defines the leg length so maintaining the leg length is very important.

Figure 7.6 and Figure 7.7 present the fillet weld in convex and concave fillet welds, respectively. The following terminology is used in the drawings.

- Leg and size
- Convexity or concavity
- Actual throat
- Effective throat
- Theoretical throat

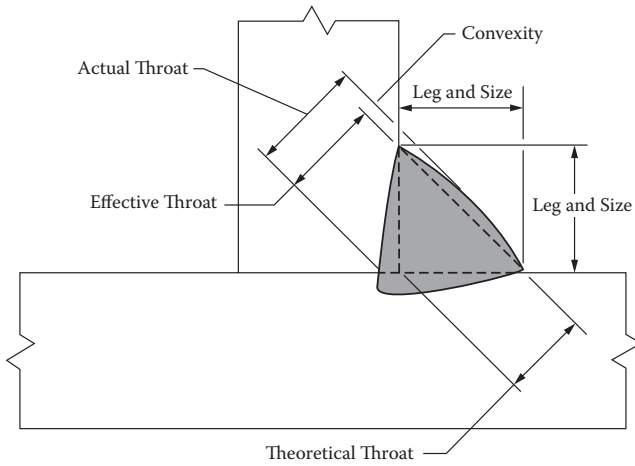

FIGURE 7.6
Fillet weld convex shape.

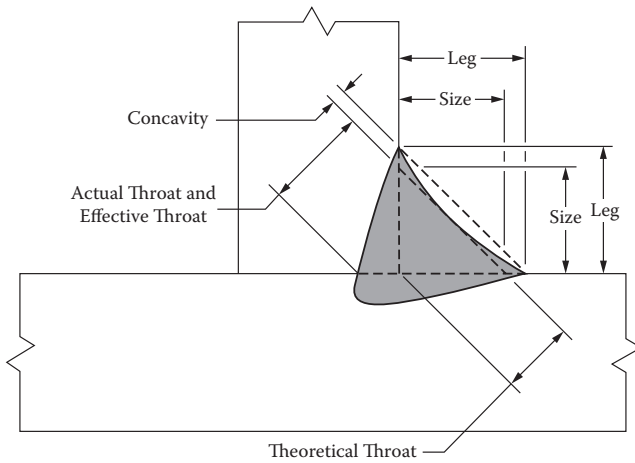

FIGURE 7.7
Fillet weld concave shape.

7.5.2 Butt Weld

7.5.2.1 Parts of Butt Weld

The butt weld consists of the following parts (Figure 7.8):

- Toe
- Face
- Face reinforcement

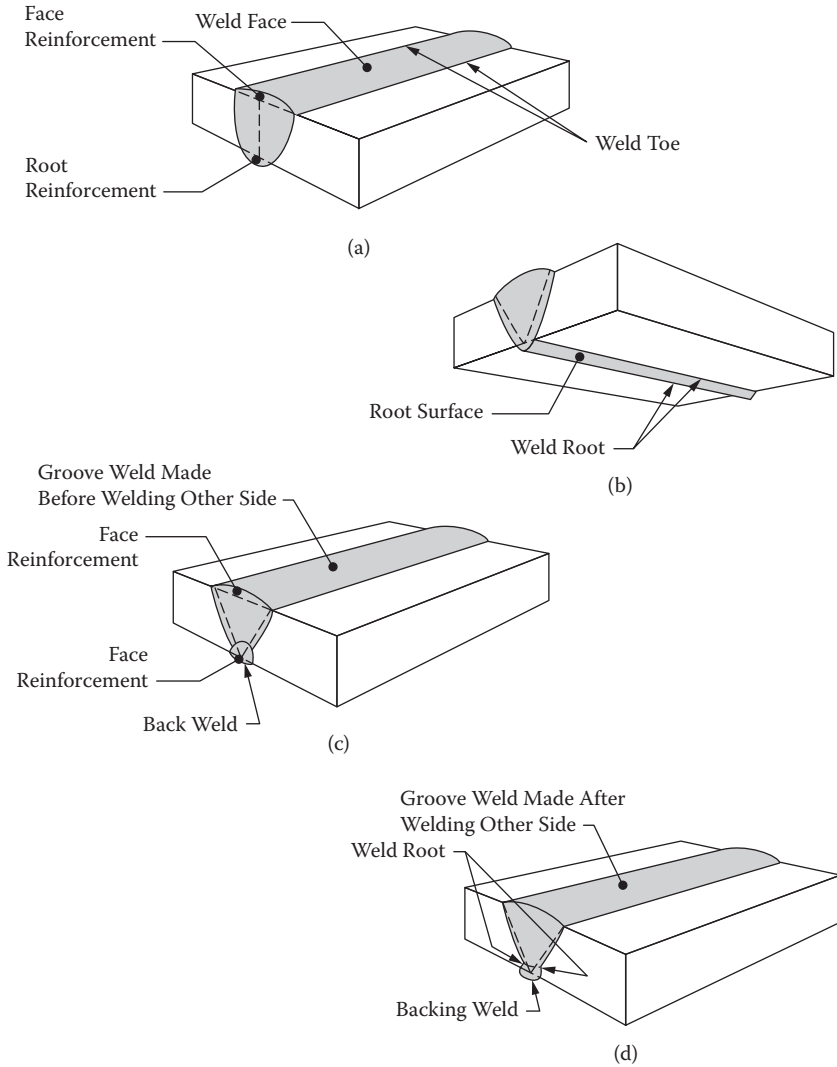

FIGURE 7.8
Butt weld.

- Root reinforcement
- Root surface
- Weld root
- Bead
- Back weld
- Backing weld

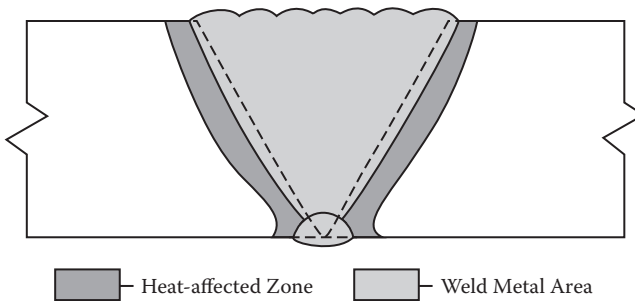

FIGURE 7.9
Heat-affected zone.

- Spacer
- Heat-affected zone (HAZ)

The heat-affected zone, which is the very critical and dangerous part of the integrity for any steel member welding, and the weld metal are shown in Figure 7.9. As the microscopic structure of the steel will be changed due to the effect of heat, the corrosion in most cases starts in this part.

7.5.2.2 Welding Groove Configurations

The following describes the main configurations for welding plates. There are different types of grooves and every type of groove has a different symbol notation:

- Square groove—As per AISC the base metal thickness is 0.25 inches maximum and the root opening is half the base metal thickness. The shape of square groove is as shown in Figure 7.10.
- Single V-groove—This weld can be used for any thickness of the base metal (Figure 7.11). The root opening depends on the groove angle. For 45° , 30° , 20° , the corresponding root openings are 0.25, 3/8, 0.5 inches (6, 9.5, 13 mm), respectively.
- Double V-groove—The double groove has the same root opening with respect to groove angle as discussed for the single V-groove (Figure 7.12).
- Single-bevel groove—This type is also applied for all base metal thickness and the root openings are 6 mm, 9.5 mm (0.25, 0.375 inches) corresponding to 45° and 30° groove angles, respectively (Figure 7.13).
- Double-bevel groove—The double bevel groove and its welding symbol are shown in Figure 7.14.

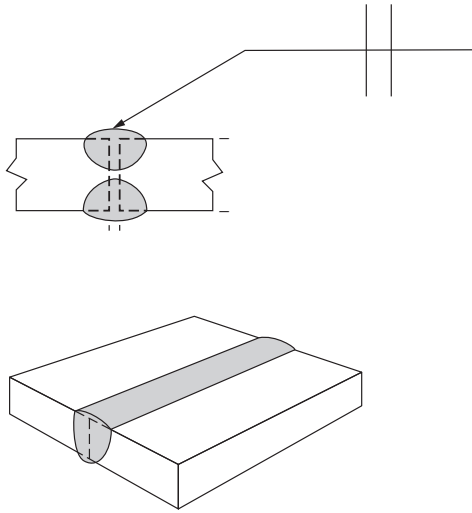

FIGURE 7.10
Square groove.

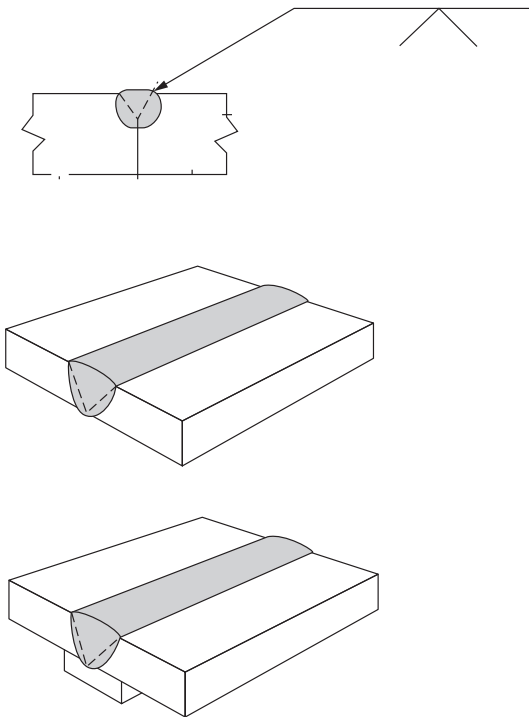

FIGURE 7.11
Single V-groove.

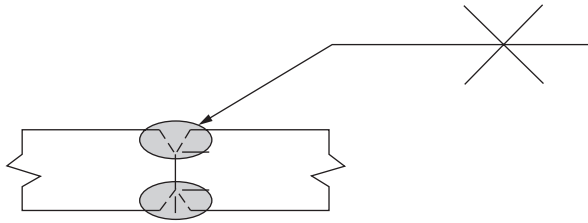

FIGURE 7.12
Double V-groove.

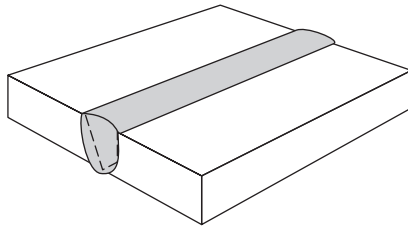
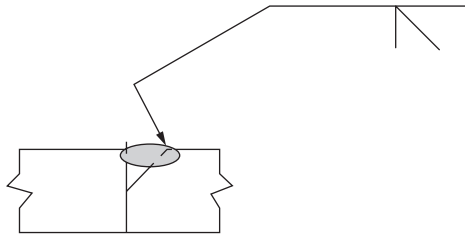

FIGURE 7.13
Single-bevel groove.

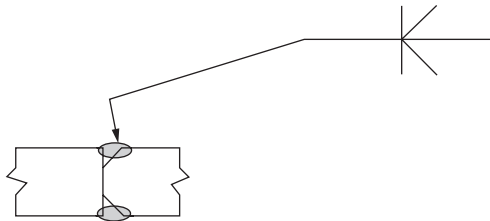

FIGURE 7.14
Double-bevel groove.

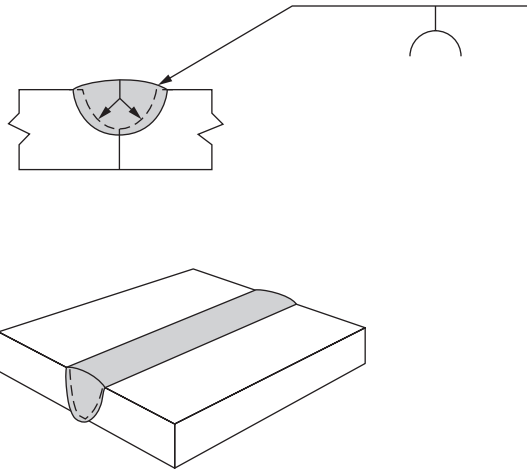

FIGURE 7.15
Single-U groove.

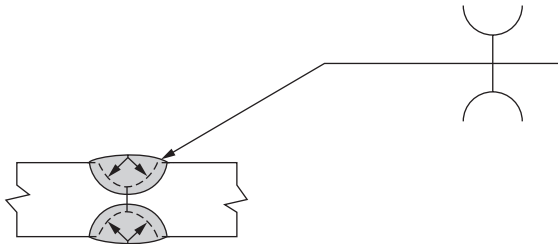

FIGURE 7.16
Double-U groove.

- Single-U groove—The root opening is from 0 to 3 mm (0 to 0.125 inches) and the groove angle in most cases is 45° or 20° . This type of welding can be applied for all thicknesses of base metal as shown in Figure 7.15.
- Double-U groove—In most cases the groove angle is 45° and can be applied for all metal thicknesses, with root opening of 0.25 inches (6 mm). The double-U groove is presented in Figure 7.16.
- Single-J groove—Single- and double-J grooves see Figure 7.17 and Figure 7.18 are applied for any base metal thickness with root openings from 0 to 0.125 inches and the groove angle is 45° .
- Double-J groove—This groove is presented in Figure 7.18 with its welding symbol.
- Flare-bevel groove—The root opening is zero. Its symbol is shown in Figure 7.19.

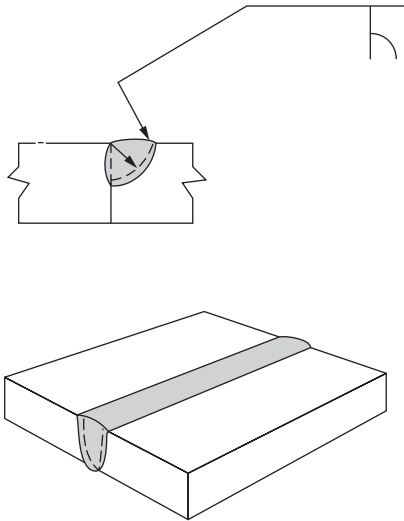

FIGURE 7.17
Single-J groove.

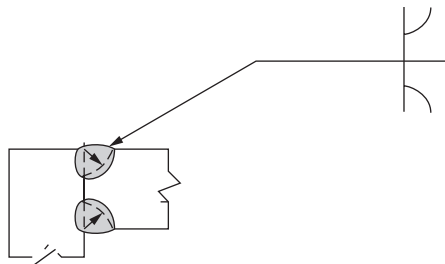

FIGURE 7.18
Double-J groove.

All the groove shapes are presented in Figure 7.20.

7.5.2.3 Connection between Steel Plates

There are different positions of the welding of the steel plates. Every position has a special welding groove type.

Back to back—A welding between two steel plates is aligned approximately in the same plane (Figure 7.21). This position of the two plates allows application of a fillet weld and the following types of grooves can be used in the welding:

- Bevel groove
- Flare-bevel groove

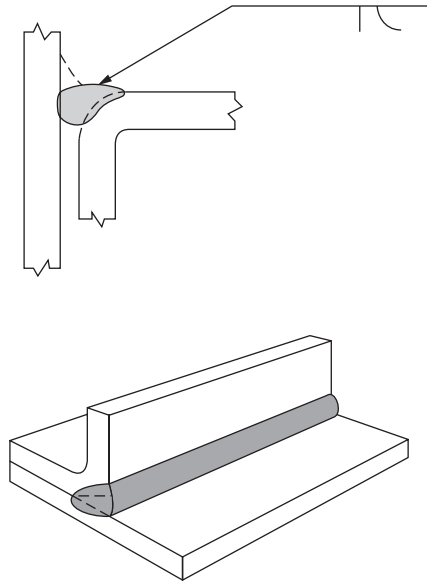
**FIGURE 7.19**

Flare bevel.

- Flare-V groove
- J-groove
- Square-groove
- U-groove
- V-groove
- Edge flange

Corner joint—A welding between the steel plates at right angles to each other in the form of an L is shown in Figure 7.22. The following types of grooves can be used in corner joint welding:

- Fillet
- Bevel groove
- Flare-bevel groove
- Flare-V groove
- J-groove
- Square groove
- U-groove
- V-groove

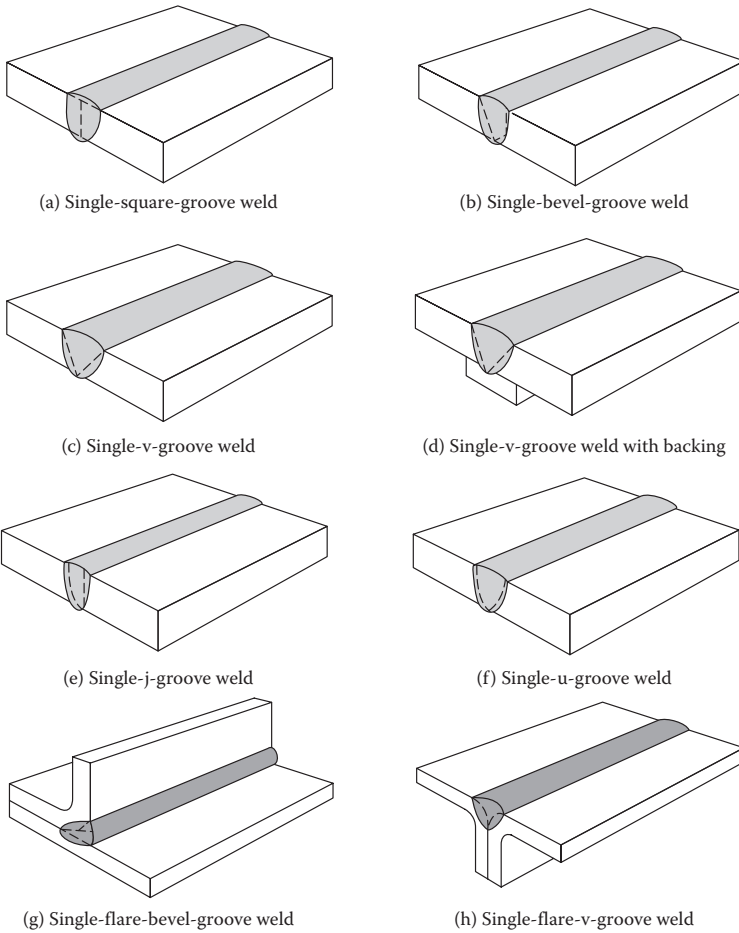

FIGURE 7.20
Different groove shapes.

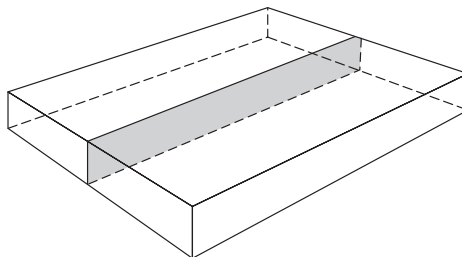

FIGURE 7.21
Face-to-face plates.

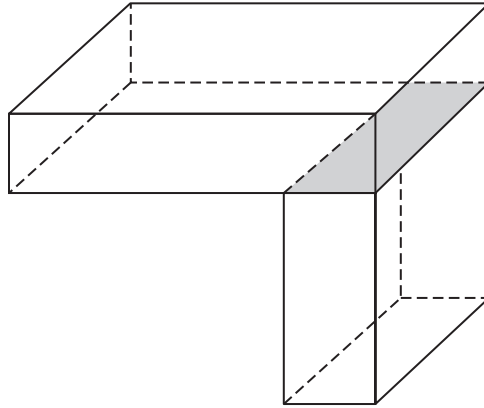

FIGURE 7.22
Corner plates.

T-joint—A joint between two members at approximately right angles to each other forms a T (Figure 7.23). The following grooves can be used in the welding:

- Fillet
- Bevel-groove
- Flare-bevel groove
- J-groove
- Square groove

Lap joint—The two steel plates overlap as shown in Figure 7.24. The following grooves can be used in lap joint welding:

- Bevel-groove
- Flare-bevel-groove
- Flare-V groove
- J-groove
- Square groove
- U-groove
- V-groove
- Edge
- Seam

7.5.2.4 Welding Groove

The welding groove symbols and terminology should be known very well to the team members who are responsible for the quality control on site as

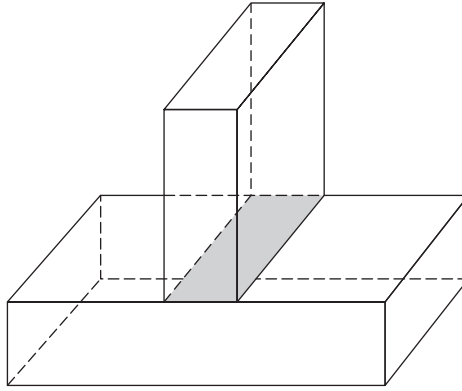

FIGURE 7.23
T-connection.

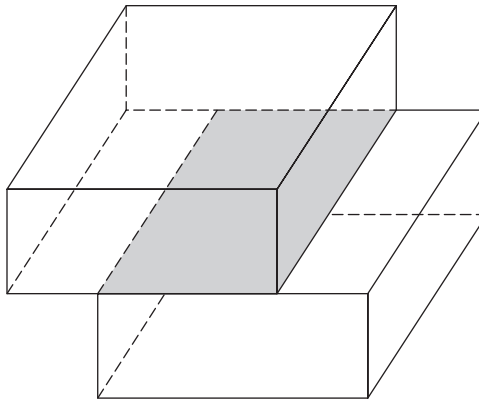

FIGURE 7.24
Lap joint.

shown in Figure 7.25. The data of the bevel angle, depth of bevel, root opening, and other information should be presented in the workshop drawings. The workshop drawings should be reviewed and approved by the owner or the consultant engineer who represents the owner.

7.5.3 Problems in Welding

There are many potential welding problems, but they can be avoided with excellent quality control and quality assurance systems.

Incomplete joint penetration is one of the main problems in the welding process. Incomplete penetration in a butt weld is shown in Figure 7.26 and

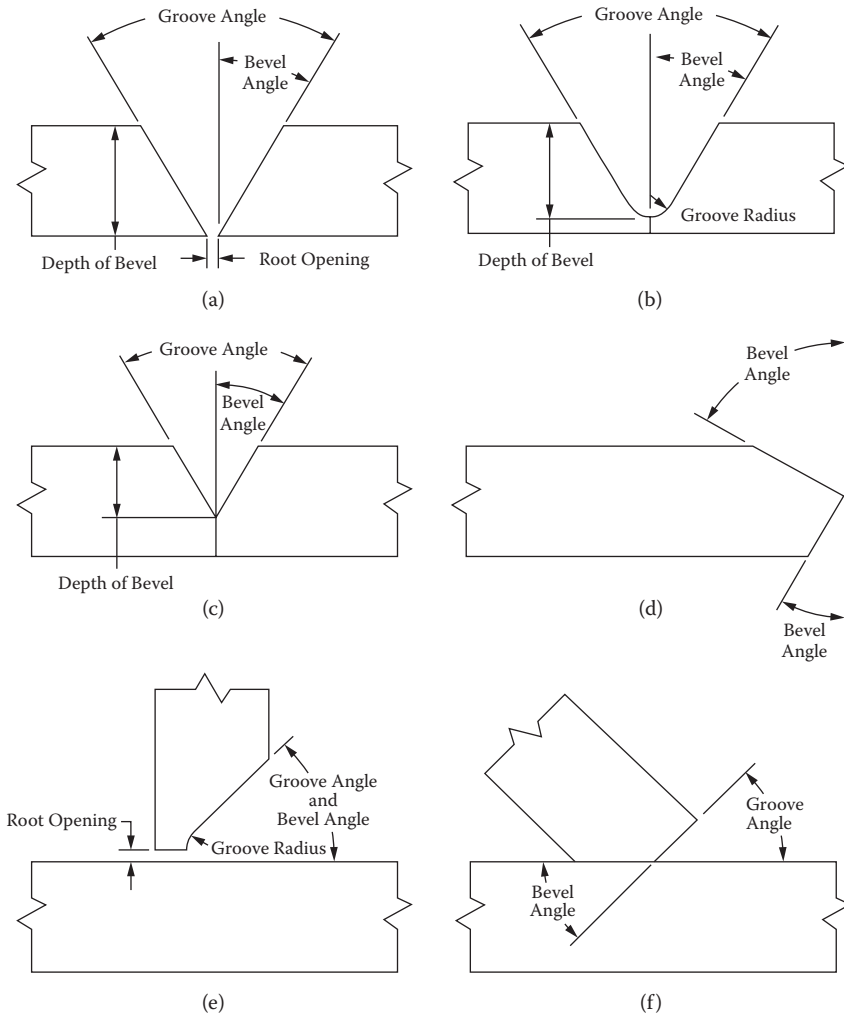

FIGURE 7.25
Welding groove dimension requirement.

incomplete penetration in a fillet weld is presented in Figure 7.27. Fusion faces are shown in Figure 7.28 (butt weld) Figure 7.29 (fillet weld). Incomplete fusion of a butt weld is shown in Figure 7.30. Figure 7.31 depicts incomplete fusion of a fillet weld. Examples of welding discontinuities are:

- Cracks undercut
- Overlap
- Underfill

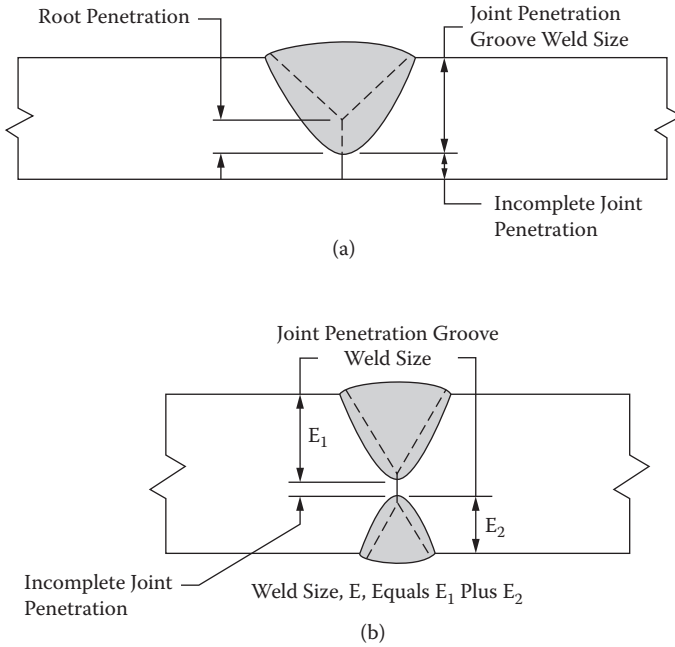

FIGURE 7.26
(a, b) Butt weld: incomplete penetration.

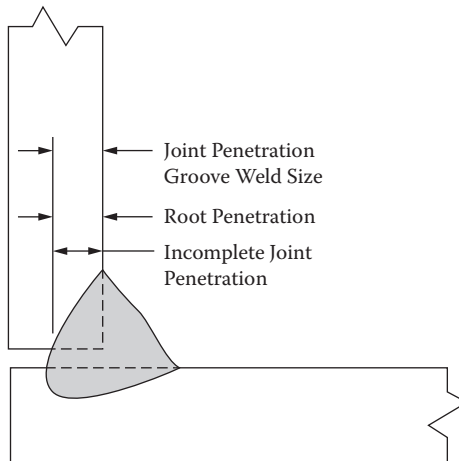

FIGURE 7.27
Fillet weld: incomplete penetration.

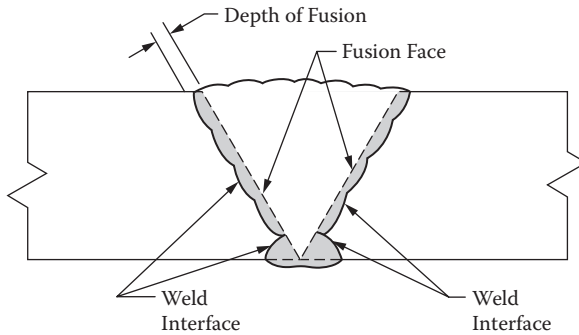

FIGURE 7.28
Fusion faces in butt weld.

7.5.4 Welds and Welding Symbols

A weld symbol indicates the type of weld. A welding symbol provides complete welding information to all parties, including the welder. The table below shows several symbols.

Groove							
Square	Scarf	V	Bevel	U	J	Flare-V	Flare-Bevel

Fillet	Plug or Slot	Stud	Spot or Projection	Seam	Back or Backing	Surfacing	Edge

AWS D1.1 notes that a symbol with a perpendicular leg should have the perpendicular leg drawn on the left side of the symbol (fillet, bevel groove, J-groove, and flare-bevel groove). The symbols for stud and surfacing welds should always be drawn below the reference line.

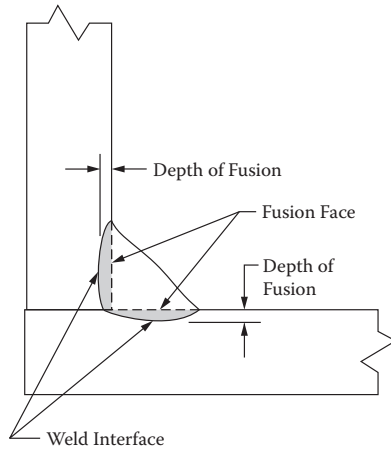

FIGURE 7.29
Fusion faces in fillet weld.

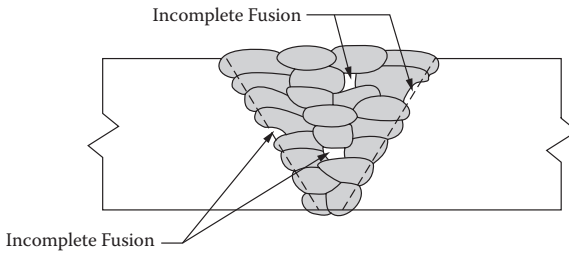

FIGURE 7.30
Incomplete fusion in butt weld.

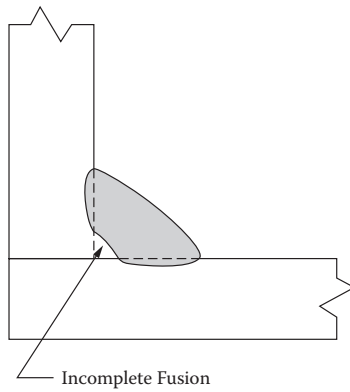

FIGURE 7.31
Incomplete fusion in fillet weld.

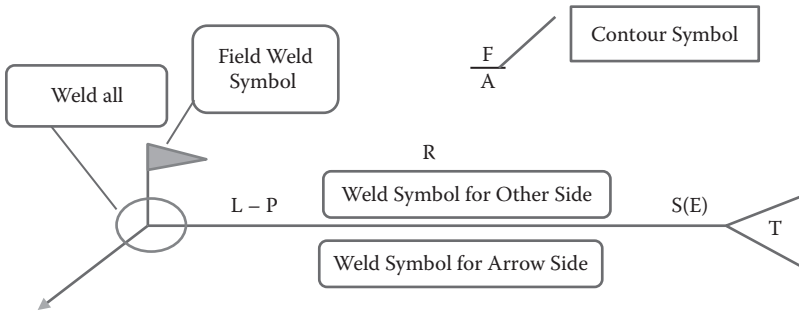

FIGURE 7.32 Welding arrow configuration. L, weld length; F, finish symbol; P, pitch center to center spacing; A, groove angle; S, depth of bevel; R, root opening; E, groove weld size; T, welding symbol or supplementary information.

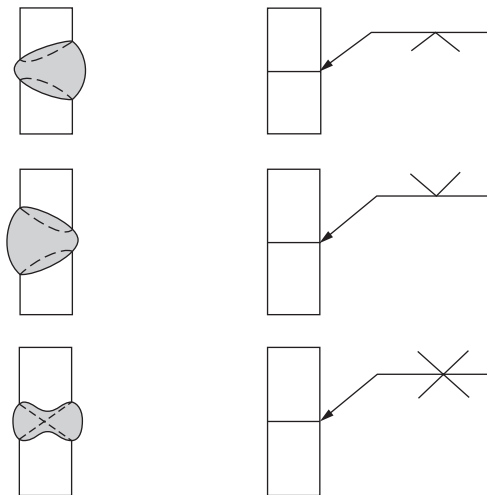

FIGURE 7.33 Welding symbol direction.

Figure 7.32 shows the welding arrow configuration. The directions of welding symbol with respect to a steel plate are shown in Figure 7.33.

7.5.4.1 Elements of Welding Symbols

The structural engineer in the design phase and the construction engineer on site should be familiar with welding symbols in the table below and understand them clearly.

Weld All Around	Field Weld	Melt Through	Consumable Insert (square)	Backing or Spacer (Rectangle)	Contour		
					Flush or Flat	Convex	Concave

The elements of welding are as follow:

1. Required elements

- Reference line, always horizontal
- Arrow

2. Optional elements

- Multiple reference lines
- Tail
- Weld symbol
- Dimensions
- Supplementary symbols
- Finish
- Specification, process

3. Arrow notation

- Information applicable to the arrow side of the joint is placed below the reference line
- Information applicable to the other side of a joint is placed above the reference line

Figure 7.34 presents the arrow side weld symbols.

The weld symbol straddles the reference line when there is no side significance:

- Resistance spot weld
- Resistance seam weld
- Flash weld

A break in the arrow line signifies that the member to which the arrow points is the member receiving the edge preparation.

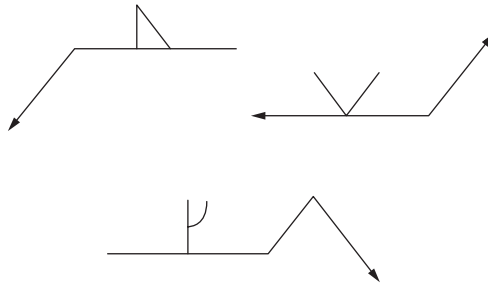

FIGURE 7.34
Arrow side weld symbols.

A welding drawing with symbols is shown in Figure 7.35 and Figure 7.36. For joints requiring more than one weld type, a weld symbol should specify each weld (Figure 7.37).

Two or more arrows may be used for a single reference line to denote locations where identical welds are specified.

Two or more reference lines may be used to indicate a sequence of operations. The first operation is always on the reference line nearest to the object.

The field weld symbol is a solid flag (Figure 7.38), and is always located at junction of the arrow and reference line. The weld all-around symbol is a circle and is located at the junction of the arrow and reference line. This symbol is very important as it defines the working procedure, test requirement during construction, what part will be weld in the workshop and what part will be welded on-site.

Figure 7.39 illustrates the tail that is used to specify welding process information or other such welding details. Weld contours and finishing are presented in Figure 7.40, and are usually present in the workshop drawings and should depict:

- Weld surfaces can be contoured to several shapes: convex, concave, flush, or flat.
- Finishing methods are abbreviated as shown in Figure 7.40.
- U denotes the contour method is unspecified.
- Contour symbol without finish symbol means as-welded.
- Tolerances, if required, are to be placed in the tail.
- Welding symbols are usually drawn without dimension units, such as inches or millimeters (Figure 7.41).
- Welding symbols to be used for publications or those requiring high precision should be dimensioned and have the dimensional tolerances noted within the tail.

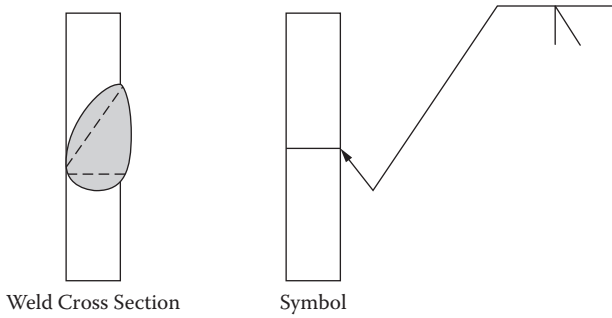

FIGURE 7.35
Arrow line.

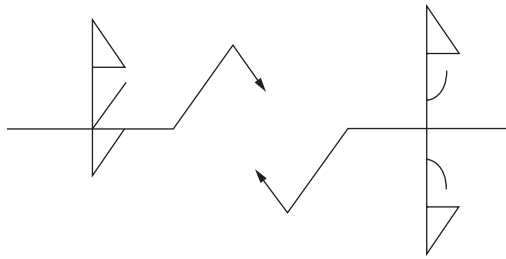

FIGURE 7.36
Two and more arrow symbols.

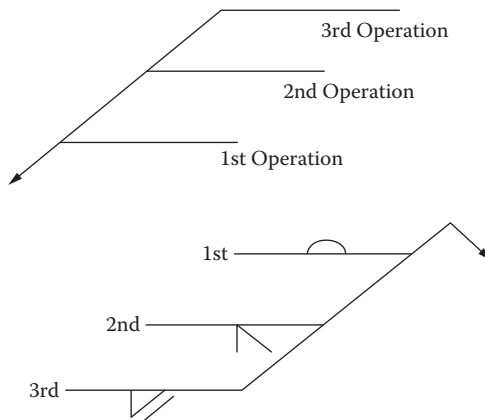

FIGURE 7.37
Operation sequence.

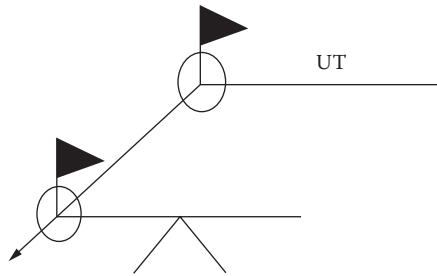

FIGURE 7.38
Nondestructive testing (NDT) symbol.

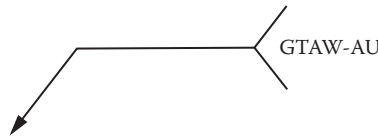

FIGURE 7.39
Arrow indicating weld direction.

- C - Chipping
- G - Grinding
- H - Hammering
- M - Machining
- R - Rolling

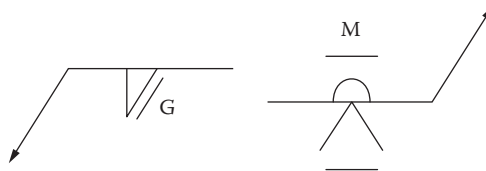

FIGURE 7.40
Finishing symbol.

A single-bevel groove, double fillet is shown in Figure 7.42. The weld all-around symbol is a very useful symbol (Figure 7.43). Figure 7.44 shows a square-groove butt with melt-through.

The groove weld dimensions are as shown in Figure 7.45. Depth of bevel (S) and size of weld (E) are placed to the left of the symbol. An example for a 6 mm (1/4 inch) bevel with a 10 mm (3/8 inch) weld is shown in Figure 7.46.

The example for a symbol with the dimension present is in Figure 7.47.

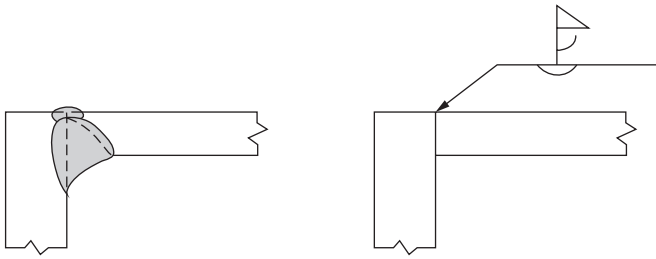

FIGURE 7.41
Finishing symbol.

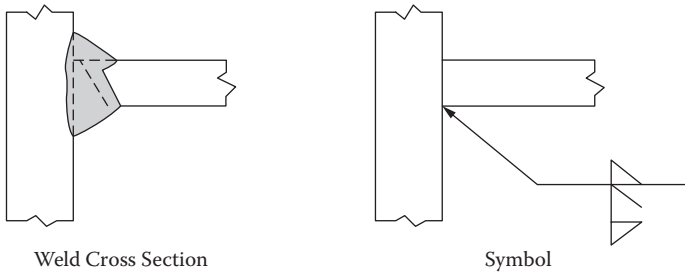

FIGURE 7.42
Single-bevel groove, double fillet.

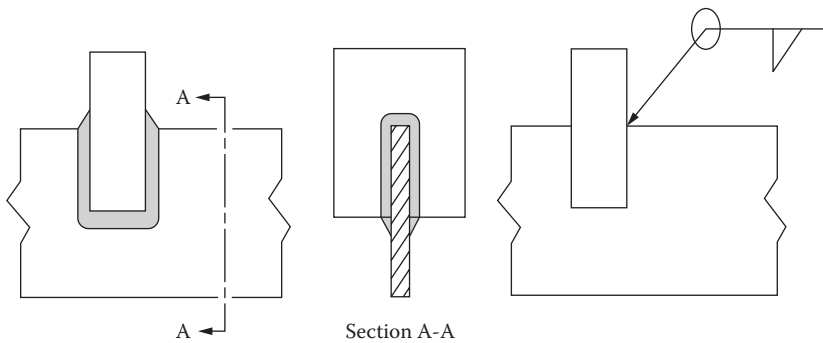

FIGURE 7.43
Weld all around.

The root opening is placed within the weld symbol or just outside, and only on one side of the reference line and noted in inches or millimeters per shop practice. The symbol of root opening is shown in Figure 7.48.

The groove angle is placed just outside the weld symbol as shown in Figure 7.49. The length of the weld should be placed to the right of the weld

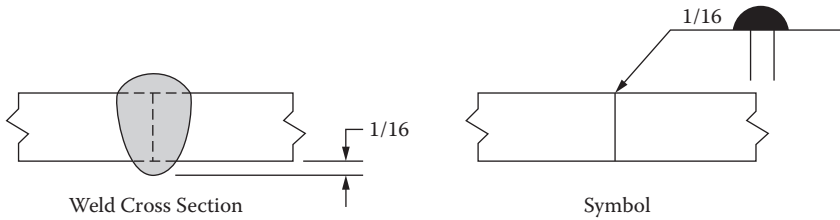

FIGURE 7.44
Square-groove butt with melt-through.

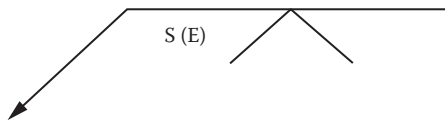

FIGURE 7.45
Dimensions on arrow.

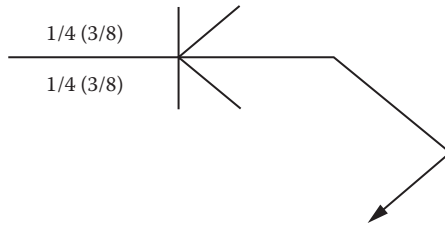

FIGURE 7.46
Dimension example.

symbol. No dimension is required if a weld is continuous for the full length of the joint.

Pitch is the distance between centers of adjacent weld segments. Pitch length is shown to the right of the weld length dimension following a hyphen as presented in Figure 7.50.

Chain intermittent weld dimensions are to be placed on both sides of reference line, and opposite each other. Staggered intermittent weld dimensions are to be placed on both sides of the reference line, and offset from each other as shown in Figure 7.51.

The back and backing weld symbols are identical. The sequence of welding determines which designation applies. Back welds are made after the groove weld; backing welds are made before groove welds. The back weld symbol is placed on the reference line opposite the groove weld using a single reference line with note in the tail. Or use multiple reference lines as shown in Figure 7.52.

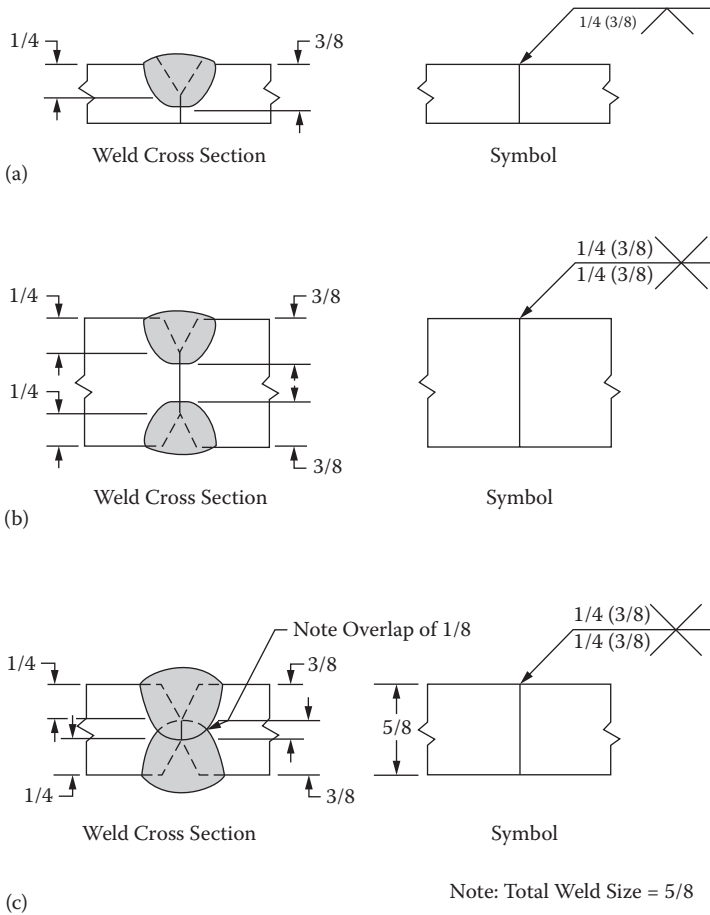

FIGURE 7.47
Dimensions for different configurations.

The backing weld symbol is placed on the reference line opposite the groove weld using a single reference line with a note in the tail or use multiple reference lines.

The backing symbol is placed on the reference line opposite the weld symbol. The R refers to removing the backing after welding is completed.

The backing weld symbol is presented in Figure 7.53 and Figure 7.54.

7.5.4.2 Fillet Weld Dimensions

The fillet weld size is shown to the left of the symbol as shown in Figure 7.55. For double fillets, each is dimensioned. The fillet weld size for unequal leg fillets is shown to the left of the symbol, with clarifying information in the tail.

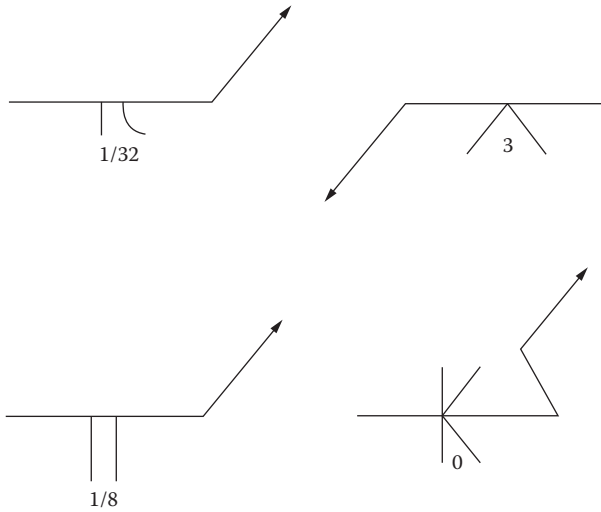

FIGURE 7.48
Root opening dimension.

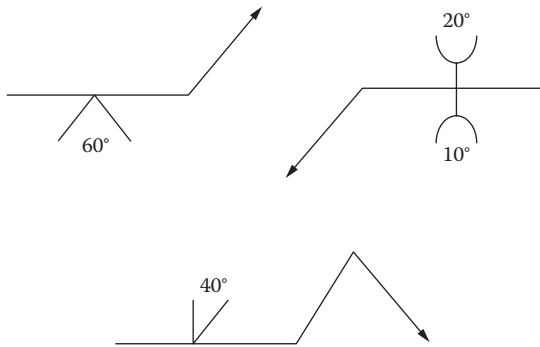

FIGURE 7.49
Groove angle.

Nondestructive examination (NDE) symbols are presented in many textbooks for use in workshop drawings, but in practical use they do not exist as the nondestructive tests will be defined in the quality control process plan. All conventions used are similar, if not identical to welding symbols. The inspector must be familiar with NDE abbreviations for test methods noting that the supplementary symbols have slightly different meanings (Figure 7.56). and the number of tests and the extent of testing must be specified.

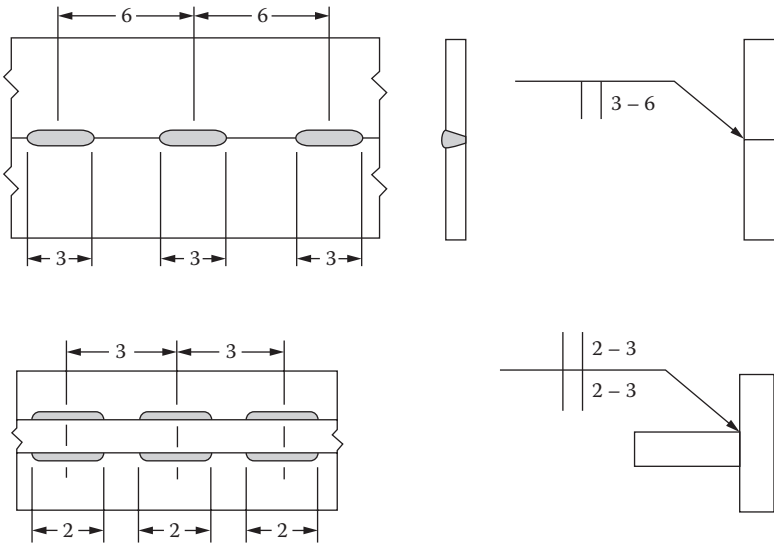

FIGURE 7.50
Symbol for pitch distance.

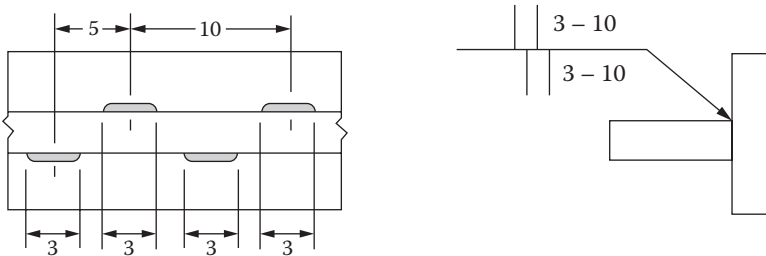

FIGURE 7.51
Staggered pitch symbol.

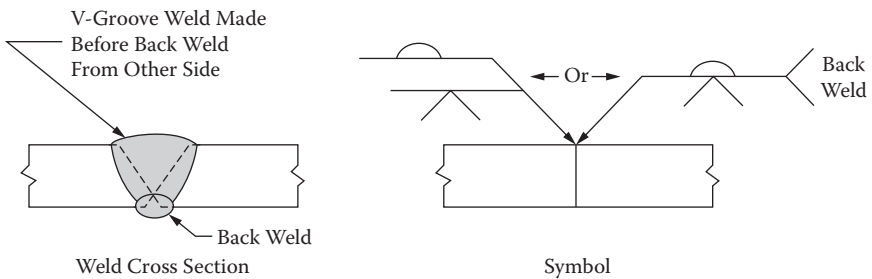

FIGURE 7.52
Back weld symbol.

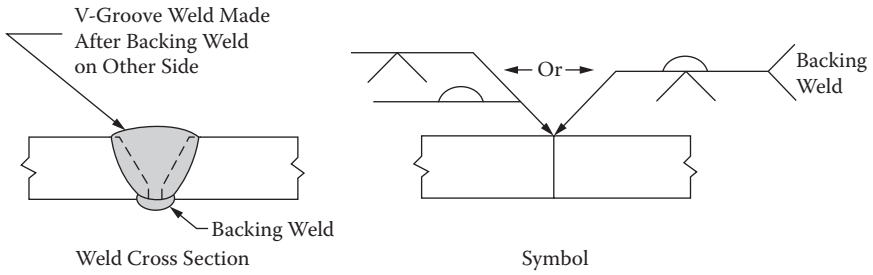

FIGURE 7.53
Backing weld symbol I.

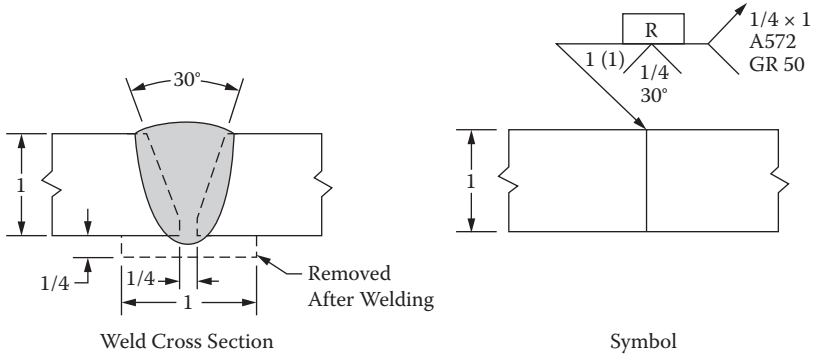

FIGURE 7.54
Backing weld symbol II.

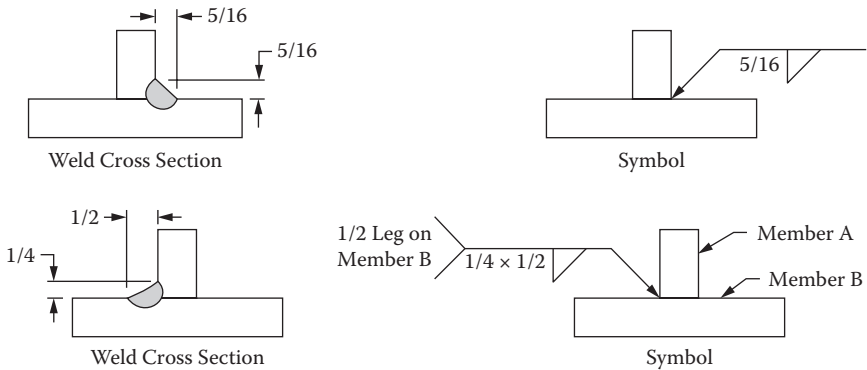

FIGURE 7.55
Examples for fillet weld dimensions.

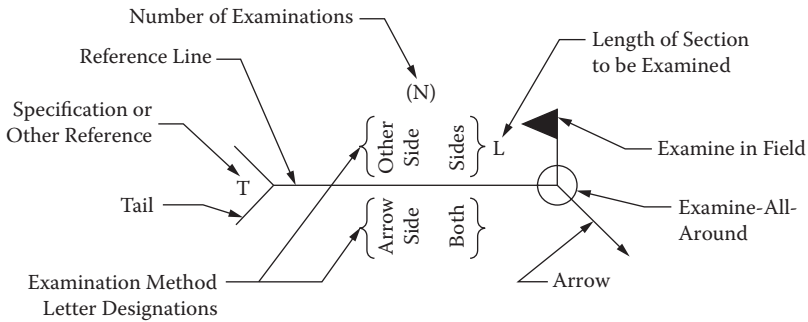

FIGURE 7.56
Arrow for welding inspector.

Non-destructive evaluation (NDE) abbreviations include:

- AET, Acoustic emission testing
- ET, Electromagnetic testing
- LT, Leak testing
- MT, magnetic test
- NRT, Newton radiographic testing
- PT, penetration test
- RT, radiographic test
- UT, ultrasonic test
- VT, visual test

Welding and NDE symbols can be combined on the same reference line or on separate lines. Combining welding and NDE symbols on multiple reference lines often clarifies the exact sequence of operations required.

7.6 Stud Weld

A stud weld is used with composite sections. The stud is placed on the steel deck and then the concrete is poured with light reinforcement.

Stud welding is considered to be an arc welding process because the heat for welding is generated by an arc between the stud and the metal. The process is performed by a mechanical gun to a power supply through a control

panel. The arc will quickly melt the stud end and a spot on the workpiece beneath the stud.

The stud bolts are as shown in Figure 7.57 and Figure 7.58.

Figure 7.59 illustrates the stud welding symbol drawings. The stud weld symbol is always on the arrow side, the size (diameter of stud) to the left of the symbol, and the pitch to the right. The number in parentheses is just outside the symbol.



FIGURE 7.57
Stud bolts.



FIGURE 7.58
Stud bolts in roof slab.

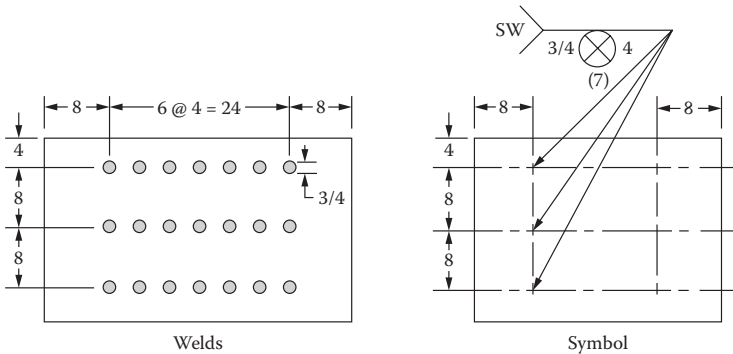

FIGURE 7.59
Stud weld symbol.

7.7 Quality Control on Site

7.7.1 Quality of Human Resources

Welding is the main element impacting/over structure safety and its integrity along its lifetime. The welding inspector who is responsible for the quality of welding on site should be competent and certified to do this job, such as a Certified Welding Inspector (CWI), designation the American Welding Society or a Certification Scheme for Welding and Inspection Personnel (CSWIP) in the United Kingdom. Based on the American Welding Society the welding inspectors should have the following qualifications:

- Ability to understand drawings and specifications
- Knowledge of welding terms and processes
- Knowledge of testing methods
- Professional attitude
- Training in engineering and metallurgy
- Welding experience
- Adequate Safety education
- Good physical condition and good vision

Communication skills are also very essential. The inspector will be the contact person for the fabricator and all persons involved in the welding so he or she should have the ability to transfer ideas clearly.

One of the main tasks of the inspector is to select qualified welders based on work history and passing the qualifications related to AWS D1.1 Section 4, based on groove and fillet weld tests in the four positions: flat, horizontal, vertical, and overhead.

7.7.2 Handling, Shipping, and Delivery

Delivery of steel to the site should follow the order cited in the erection plan.

The delivery sequence for fabricated steel, unless otherwise noted in the contract documents or arranged by the client representative, shall be as follows: anchor bolts, loose base plates, steel embedded in concrete, erection bolts, first tier columns and framing for all levels (including stairs and handrails), second tier columns and framing, and so on.

All bolts, washers and nuts should be packaged and delivered in rigid, weatherproof containers. Cardboard containers are not acceptable.

Railcars or trucks shall be loaded and cribbed so that others can readily unload them. Loading should ensure that continuous drainage will occur.

The fabricator should ensure that all steel and its coatings are protected from any damage caused by handling, storage, or shipping prior to receipt by the buyer. The fabricator should ensure that adequate protection is provided for threads on sag rods, anchor bolts, and any other threaded components to prevent damage during shipping and handling. Care shall be taken that holes and surfaces prepared for connection and the threads of bolts, anchors, mortises, and so forth, stay clean and undamaged. The bottoms of base plates should be clean and free of any rust or corrosion.

The fabricator is responsible for delivering all materials and documentation to the job site in good condition. All material and documentation will be inspected immediately upon receipt by the buyer to determine that all items included in the bill of materials have been supplied, to ensure that all documentation has been received, and to check for any damage.

All materials designated for the care, custody, and control of the contractor should be received, unloaded, stored, and otherwise handled in a manner that will prevent distortion, deterioration, or damage.

7.7.3 Erection and Shop Drawings

In general, shop drawings and erection drawings should be prepared in accordance with the AISC documents listed in the specification. When reviewing the shop drawings, the following criteria should be checked:

- Erection drawings shall reference the corresponding design drawings. Every steel piece on the shop drawings should reference the appropriate erection drawing.

- Erection and shop drawings should be grouped in sets and identified separately for each structure or yard area.
- Erection drawings should clearly show the mark number and position for each member.
- All fabricated steel sections shall be match-marked for field assembly with designating numbers or letters corresponding to the field erection drawings. Match-marking of steel should be done with suitable paint, waterproof ink, or with pressed metal tags.
- In addition to the fabricator's identification marks, each item or bundle of walkways and platforms should be marked with a unique tag number to clearly indicate associated equipment. Each item or bundle of walkways and platforms should also be indicated on the erection drawings.
- The shop drawings should state the welding procedure to be used.
- Shop drawings should clearly show the specification and grade of steel to be used.
- Surface preparation and shop-applied coatings, including areas to be masked, should be noted on the shop drawings.
- The fabricator should provide a bolt list and a list of other fasteners showing the number, grade, size, and length of field bolts for each connection. These lists may be shown on either the shop drawings or on separate sheets.
- In the event that drawing revisions are necessary, the fabricator should clearly flag all revisions on the shop drawings.

7.7.4 Inspection and Testing

All NDT procedures shall be submitted to the inspection department for the client or the consultant engineer of the owner. The inspector should have American Society for Nondestructive Testing (ASNT) Level III designation before starting work.

The quality control inspector has the right to inspect all materials and workmanship, and should have unrestricted entry to the shop of the fabricator at all times while work is being performed. The owner may reject improper, inferior, defective, or unsuitable materials and workmanship. All materials and workmanship rejected should be repaired or replaced by the fabricator as directed by the owner.

The inspection test plan (ITP) should be provided for review and approval by the inspector.

Welding procedures and individual welders should be qualified in accordance with the requirements of ANSI/AWS D1.1/D1.1M or ANSI/

AWS D1.3 as appropriate. All welding procedures and welding performance qualification records should be made available to the owner's inspector for review.

Inspection of welding should be performed in accordance with the Structural Welding Code, ANSI/AWS D1.1/D1.1M. Ultrasonic testing may be substituted for radiography if approved by the inspector. In most cases the following criteria should be considered:

- All welds should have 100% visual inspection performed per ANSI/AWS D1.1. In addition, any strikes, gouges, and other indications of careless workmanship (such as surface porosity) should be removed by grinding.
- Pipes used as piling (circumferential welds) and tubular structures shall be randomly radiographed at the rate of 10% (one weld of each ten welds should be 100% radiographed). The specified amount of random radiography should include x-ray samples from each welder's daily production.
- The butt-welded flange sections for all primary load-bearing members should be 100% radiographed at the welds. Primary load-bearing members should be defined as the main frames and any members that are parts of the lateral load carrying system.
- For secondary members such as purlins, girts, or rafters that are not part of the main sway frame, 10% of the butt welds of each day's production (randomly selected) should have radiographic tests performed.
- All lifting lug connections should be 100% radiographed. Procedures and operator qualifications should meet ANSI/AWS D1.1 and be submitted to the inspector for review and approval. For skid-mounted equipment with a total lift weight less than 3000 kg, it is acceptable to use fillet-welded lugs with dye penetrant inspection.
- The minimum percent coverage of the specified NDT method may be increased (at any level up to 100%) if, in the opinion of the inspector, the welds are of questionable workmanship or NDT indicates an excessive number of defects. Additional or alternative NDT methods may be used at the discretion of the inspector in order to assist in determining the type or extent of defects.

Material test reports for structural steel, high-strength, and ASTM A307 bolts should be available for review by the quality control inspector. Material test reports should conform to EN 10204, Type 3.1.

The owner's representative may require representative samples of bolt assemblies, which the fabricator shall supply for testing. Testing

in accordance with ASTM F606 or ASTM F606M will be at the owner’s expense.

If any damage is discovered, or any parts, components, or documentation are missing or otherwise defective, the occurrence shall be immediately reported to the buyer in writing.

Shop inspection may include but not be limited to the following issues.

Verification of conformance of materials with this specification and the drawings: the limits of acceptability and repair of surface imperfections for structural steel should be in accordance with ASTM A6/ASTM A6M.

Inspection of high-strength bolted connections should be in accordance with AISC specification for structural joints using ASTM A325 or ASTM A490 Bolts.

The quality control inspector has the right to inspect and reject all galvanized steel in accordance with ASTM A123 and ASTM E376.

Any test or inspection should be as per a checklist that is included in the quality manual for the project. An example of a checklist for steel structure alignment is shown in Table 7.5 and inspection for the foundation to start steel erection is presented in Table 7.6.

TABLE 7.5

Example Checklist for Steel Structure Alignment Report

Project Name:		
Construction Manager:		
Contractor or Subcontractor:		
Floor Number:		
Layout Drawing Number:		
Revision Number:		
Item and/or Location	Test Date	QC Number
Horizontal alignment		
Vertical alignment		
Horizontal misalignment		
Vertical misalignment		
Approvals		
Party	Signature	Date
Contractor		
Technician Performing Test		
QC Inspector		
QC Supervisor		
Owner’s Representative		
Construction Manager		

TABLE 7.6

Example Checklist for Foundation Concrete Inspection Report*

Project Name:
 Construction Manager:
 Contractor or Subcontractor:
 Floor Number:
 Layout Drawing Number:
 Revision Number:

Acceptance Criterion	Pass/Fail	Date	QC Number
Check foundation and connections To confirm locations, orientations, Elevations, and conditions (readiness, anchor bolts, curing, cleanliness, etc.) Top of concrete must be minimum of 150 mm above finished grade. Concrete must be cured before release for structural steel installation. Design compressive strength shall be 27.6 MPa (4000 psi) at 28 days. Minimum thickness of group must be 25 mm.			
Approving Party	Signature	Date	
Contractor Technician Performing Test QC Inspector QC Supervisor Owner's Representative Construction Manager			

*Inspection to be completed satisfactorily before steel is erected.

References

- American Institute of Steel Construction (AISC)-ASD. 1989. *Specification for Structural Steel Buildings: Allowable Stress Design and Plastic Design*, 9th ed. Chicago: American Institute of Steel Construction.
- American Welding Society. 1972. *AWS D1.1, Structural Welding Code*, 1st ed. American Welding Society.
- ASTM A123/A123M – 12. Standard Specification for Zinc (Hot-Dip Galvanized) Coatings on Iron and Steel Products.
- ASTM A307 – 12. Standard Specification for Carbon Steel Bolts, Studs, and Threaded Rod 60 000 PSI Tensile Strength.
- ASTM A325 – 10. Standard Specification for Structural Bolts, Steel, Heat Treated, 120/105 ksi Minimum Tensile Strength.
- ASTM A490 – 12. Standard Specification for Structural Bolts, Alloy Steel, Heat Treated, 150 ksi Minimum Tensile Strength.

- ASTM A6/A6M – 12a. Standard Specification for General Requirements for Rolled Structural Steel Bars, Plates, Shapes, and Sheet Piling.
- ASTM E376 – 11. Standard Practice for Measuring Coating Thickness by Magnetic-Field or Eddy-Current (Electromagnetic) Testing Methods.
- ASTM F606 – 11a. Standard Test Methods for Determining the Mechanical Properties of Externally and Internally Threaded Fasteners, Washers, Direct Tension Indicators, and Rivets.

8

Nondestructive Testing for Steel Structures

8.1 Introduction

Nondestructive testing is a very essential technique for the steel industry. The main construction activity is the welding which should be based on the standards and project specifications. The technicians who perform these tests should be certified based on the American Society for Nondestructive Testing (ASNT) Level 3 certification.

8.2 Visual Test

ASME V states precautions that should be followed when doing a visual inspection. Direct visual examination is usually made when access is sufficient to place the eye within 24 inches (600 mm) of the surface to be examined and at an angle not less than 30 degrees to the surface to be examined. Mirrors may be used to improve the angle of vision, and aids such as a magnifying lens may be used to assist examinations.

Illumination (natural or supplemental white light) for the specific part, component, vessel, or section examined is required. The minimum light intensity at the examination surface should be 100 foot candles (1000 lux). The light source, technique used, and light level verification is required to be demonstrated one time, documented, and maintained on file.

The visual inspection is usually performed by an experienced inspector. In addition to that there are some tools that can be used on the site to check whether the welding matches the standard and project specifications.

One such tool it is the fillet weld set, which is a rectangular piece of metal in the shape of the fillet weld (Figure 8.1). The inspector will move the fillet weld set over the piece of the steel to determine whether the welding thickness matches the value on the gage.



FIGURE 8.1
Fillet weld thickness test.



FIGURE 8.2
Butt weld thickness test.

Other tools are used to measure the fillet weld for concavity and convexity, and to measure the butt weld reinforcement (Figure 8.2). The Vernier caliper (Figure 8.3) measures the thickness of the base metal and weld. The Vernier caliper is an extremely precise measuring instrument; the reading error is $1/20 \text{ mm} = 0.05 \text{ mm}$.



FIGURE 8.3
Vernier caliper.

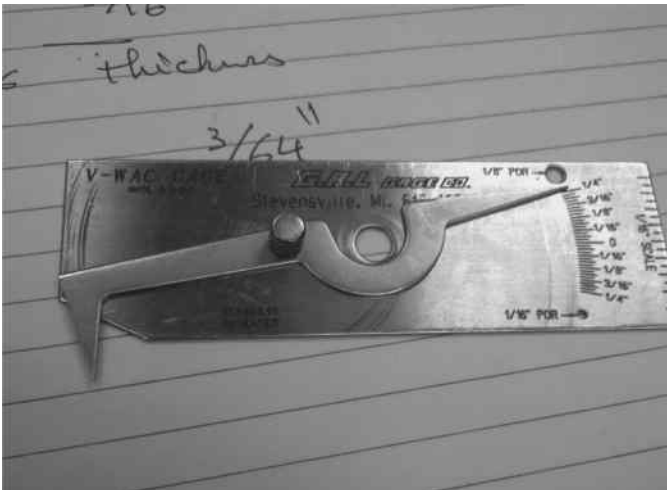

FIGURE 8.4
Corrosion pitting measurement tool.

If there is pitting in the base metal due to corrosion, or between the base metal and the weld due to poor welding, the undercut and the pit measurement tools will be used (Figure 8.4).

Figure 8.5 shows a tool that can measure the angle of preparation, excess weld metal, depth of undercut, depth of pitting, weld throat size, and more.



FIGURE 8.5
Multifunction tool for inspecting welding.

8.3 Radiographic Test

8.3.1 Principles

The most important technique in nondestructive testing (NDT) is the radioactive test because it is very accurate. The bad news is that it is harmful if the user does not follow the safety precautions and restrictions. The basis of this test is to use the short wavelength electromagnetic radiation with high-energy photons to penetrate through the materials.

Either an x-ray machine, as shown in Figure 8.6, or a radioactive source such as Ir-192, Co-60, or in rare cases Cs-137, can be used as a source of photons (Figure 8.7). In most steel structures the gamma radiation is used because the system is portable.

The main principle of the radiographic test is to apply gamma or x-ray to the part of steel and the material will absorb the radiation depending on its thickness, so this intensity will be reflected on a film placed on the other side of the test specimen (Figure 8.8). Therefore, the specimen must be accessible from two sides. The latent image produced in the film becomes a shadow picture of the specimen when the film is processed.

Penetrating radiations are restricted to that part of the electromagnetic spectrum of wavelength below 10.

8.3.2 Isotope Decay Rate (Half-Life)

The curie is the basic unit for radioactive material. The specific activity of any radioactive source is defined as the activity in curies per gram. The curie

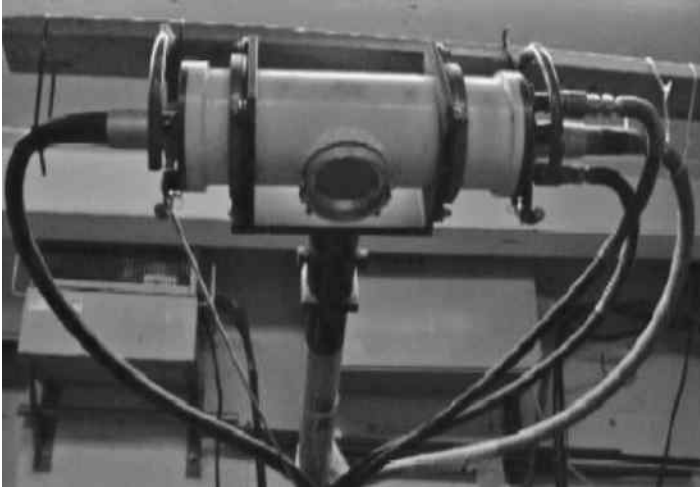
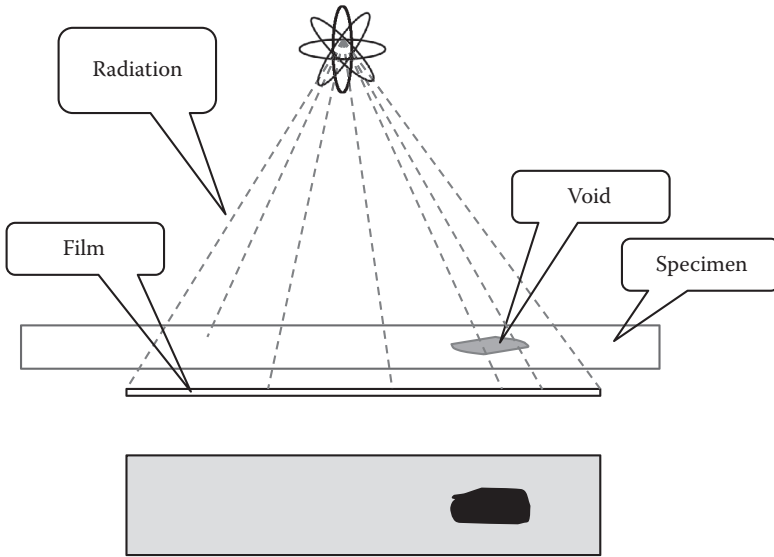

FIGURE 8.6
X-ray machine.



FIGURE 8.7
Radiographic test by gamma ray.

was originally defined as that amount of any radioactive material that disintegrates at the same rate as one gram of pure radium. The curie has since been defined more precisely as a quantity of radioactive material in which 3.7×10^{10} atoms disintegrate per second. The specific activity is defined as the concentration of radioactivity, or the relationship between the mass of radioactive material and the activity, and expressed as the number of curies

**FIGURE 8.8**

Top: Radiographic test concept. Bottom: Discontinuity on film.

per unit mass or volume. For example, each gram of cobalt-60 will contain approximately 50 curies. Iridium-192 will contain 350 curies for every gram of material. The shorter the half-life, the less material required to produce a given activity or curie level. The radioactive source decays over with time. The definition of half-life of an isotope is the time it takes for 0.5 of the atom to decay or disintegrate.

The half-lives of some common radioisotopes are shown in Table 8.1. As shown in the table, each radionuclide decays at its own unique rate, which cannot be altered by any chemical or physical process. A useful measure of this rate is the half-life of the radionuclide. Half-life is defined as the time required for the activity of any particular radionuclide to decrease to one-half of its initial value.

For selecting the suitable isotope use Table 8.2.

8.3.3 Radiographic Sensitivity

The measure of accuracy of a radiograph is called sensitivity. The sensitivity is a function of the contrast and definition of the radiograph contrast. Contrast is the comparison between densities for different areas of the radiographic film. The definition is the line of demarcation between areas of different densities (Figure 8.9). For example a clear and sharp image on the film means that the radiographic film shows good definition.

TABLE 8.1
Half-Lives of Radio Isotopes

Radioactive	Time
Radium 226 (Ra-226)	1620 years
Cesium 137 (Cs-137)	30 years
Cobalt 60 (Co-60)	5.3 years
Thulium 170 (Tm-170)	130 days
Iridium 192 (Ir-192)	75 days

TABLE 8.2
Properties for Different Isotope Materials

Factors	Cobalt	Radium	Cesium	Iridium	Thulium
Half-life	5.3 years	1600 years	30 years	75 days	130 days
Radiation level ^a	14.5	9.0	4.2	5.9	0.03
Half value layer (lead)	0.5 in	0.5 in	0.3 in	0.2 in	0.05 in
Source size	Small	Radium large, Radon small	Relatively large	Very small	Small
Specific activity	Medium	Very low	Low	Very high	Highest
Cost	Low	High to buy low to rent	Medium	Relatively low	High

^a Expressed as curies or RHF units.

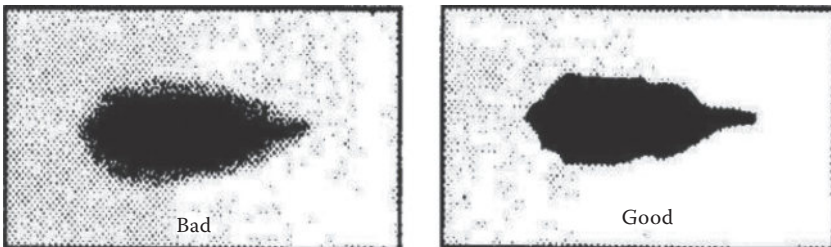

FIGURE 8.9
Good and bad definition.

8.3.4 Geometric Unsharpness

Geometric unsharpness occurs if the basic principles of shadow formation are not followed. One cause of geometric unsharpness relates to the size or shape of the radiographic source. The image cast is not perfectly sharp and the fuzzy edges of the image are called the penumbra. Penumbra cannot be completely eliminated.

Geometric unsharpness is the loss of definition that is the result of geometric factors of the radiographic equipment and setup. It occurs because the radiation does not originate from a single point but rather over an area. Consider the images in Figure 8.9, which show two sources of different sizes, the paths of the radiation from each edge of the source to each edge of the feature of the sample, the locations where this radiation will expose the film, and the density profile across the film. In the first image, the radiation originates at a very small source. Since all of the radiation originates from basically the same point, very little geometric unsharpness is produced in the image. In the second image, the source size is larger and the different paths that the rays of radiation can take from their point of origin in the source cause the edges of the notch to be less defined.

There are three factors that affect the unsharpness; they are source size, source to object distance, and object to detector distance. The source size will be given by the manufacturer's specifications. Noting that, when the source size decreases, the geometric unsharpness also decreases. For a given size source, the unsharpness can also be decreased by increasing the source to object distance, but this comes with a reduction in radiation intensity.

In most cases, the object to detector distance is kept as small as possible to help minimize unsharpness. However, there are situations, such as when using geometric enlargement, when the object is separated from the detector, which will reduce the definition. The area of varying density at the edge of a feature that results due to geometric factors is called the penumbra (Figure 8.10). The figure shows the relation between the unsharpness and the

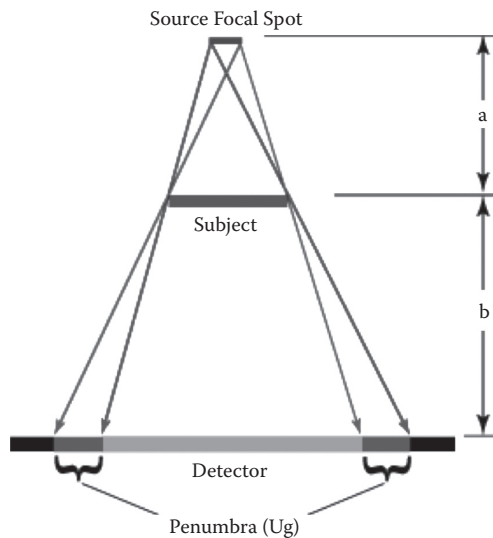

FIGURE 8.10
Causes of penumbra.

source focal spot size and the distance between the source and the specimen and between the specimen and the film. When the distance between the film and the specimen is less the penumbra will be reduced.

Codes and standards used in industrial radiography require that geometric unsharpness be limited. In general, the allowable amount is 1/100 of the material thickness up to a maximum of 0.040 inch. These values refer to the degree of penumbra shadow.

8.3.5 Scatter Radiation

Another problem that should be considered in radiographic testing is the scatter radiation. The scattered photons cause a loss of contrast and definition. The scattered radiation is usually described with reference to its origin:

1. Internal scatter—The internal scatter is shown in Figure 8.11. In the right side of the figure the definition is very poor. This is caused by free electrons that are generated by the radiographic ray as it passes through the film.
 - The scattering of free electrons through the film causes the film to be exposed whenever the electron travels.
 - The scattering causes some degree of fuzzy edges on the image that cannot be avoided.
2. Side scatter—The side scatter is shown in Figure 8.12. The scatter is due to walls or any other object near to the path of the radiation ray.
3. Backscatter—Backscatter is often identified by placing letter B on the backside of the film cassette. This is due to any object such as walls, floor, table, or any similar object located in the back of the film, as shown in Figure 8.13.

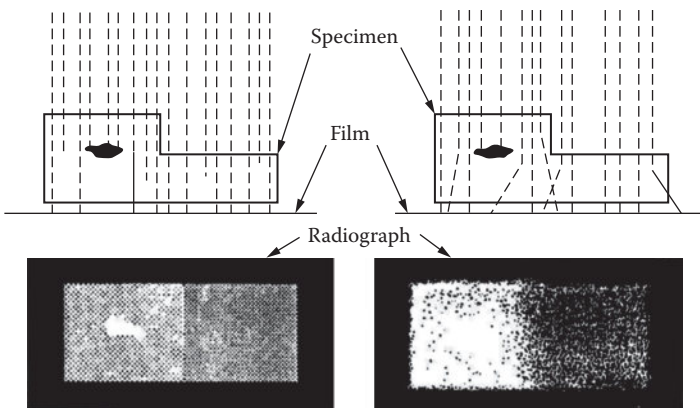

FIGURE 8.11
Internal scatter.

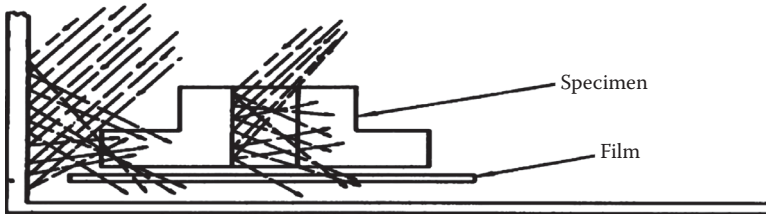

FIGURE 8.12
Side scatter.

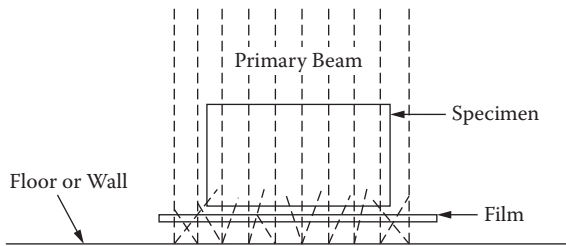

FIGURE 8.13
Backscatter.

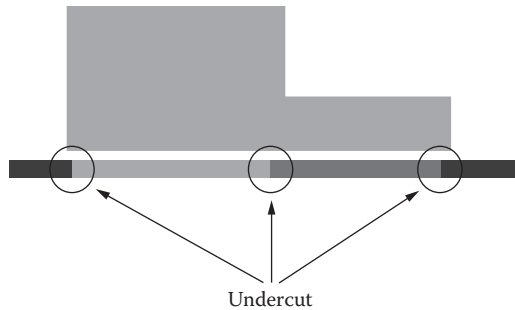

FIGURE 8.14
Locations of undercut.

4. Undercut—The undercut phenomenon (Figure 8.14) should be controlled when producing a radiograph. Parts with holes, hollow areas, or abrupt thickness changes are likely to suffer from undercut if controls are not put in place. Undercut appears as a darkening of the radiograph in the area of the thickness transition. This results in a loss of resolution or blurring at the transition area. The undercut occurs due to scattering within the film. At the edges of a part or

areas where the part transitions from thick to thin, the intensity of the radiation reaching the film is much greater than in the thicker areas of the part.

The high level of radiation intensity reaching the film results in a high level of scattering within the film. It should also be noted that the faster the film speed, the more undercut that is likely to occur. Scattering from within the walls of the part also contributes to undercut, but research has shown that scattering within the film is the primary cause. Masks are used to control undercut. Sheets of lead cut to fill holes or surround the part and metallic shot and liquid absorbers are often used as masks.

A comparison of the high and low energy radiation on the thinness or thickness of the radiographic image is presented in Figure 8.15.

8.3.6 Radio Isotope (Gamma) Sources

For the gamma ray source the physical size of isotope materials varies between manufacturers, but generally an isotope material is a pellet that measures 1.5 mm × 1.5 mm. Depending on the level of activity desired, a pellet or pellets are loaded into a stainless steel capsule and sealed by welding. The capsule is attached to a short flexible cable called a pigtail (Figure 8.16).

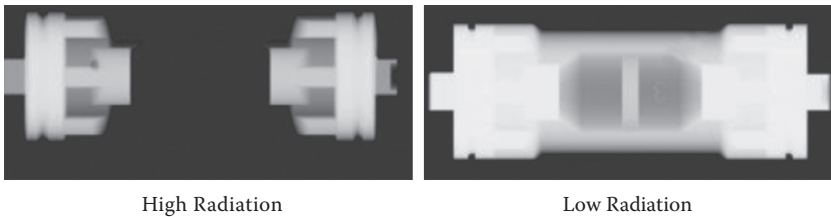

FIGURE 8.15
Effects of high and low energy radiation on image.

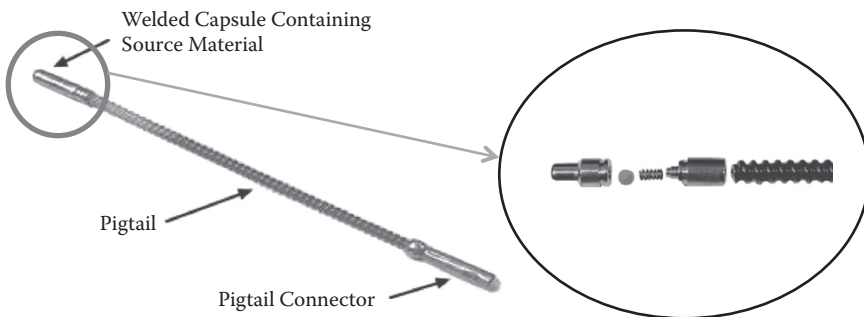

FIGURE 8.16
Location of isotope source.

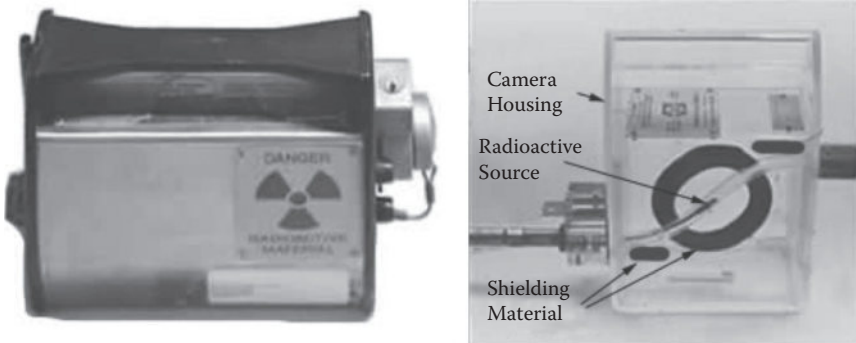

FIGURE 8.17
Radio active source and placement.



FIGURE 8.18
Maintaining distance between operator and source.

All precautions should be taken that the source should be away from the operator (Figure 8.17). So the source is located in shielding materials and the exposure device for iridium-192 and cobalt-60 sources will contain 45 pounds and 500 pounds of shielding materials, respectively. The location of the inspector in relation to the vessel is shown in Figure 8.18.

Cobalt cameras are often fixed to a trailer and transported to and from inspection sites. When the source is not being used to make an exposure, it is locked inside the exposure device.

The main principle is the safety of the personnel; therefore a crank-out mechanism and a guide tube are attached to opposite ends of the exposure device (Figure 8.19). The guide tube often has a collimator at the end to shield the radiation except in the direction necessary to make the exposure. The end of the guide tube is secured in the location where the radiation source needs

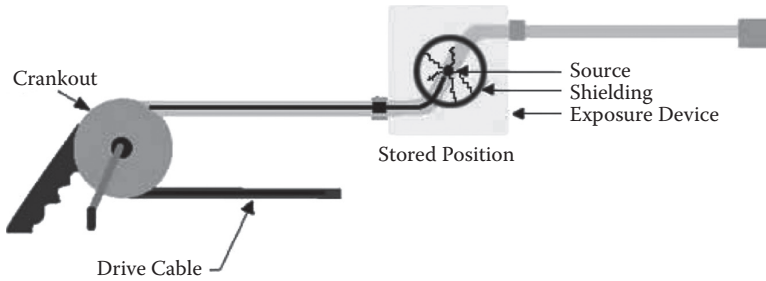

FIGURE 8.19
Isotope in stored position.

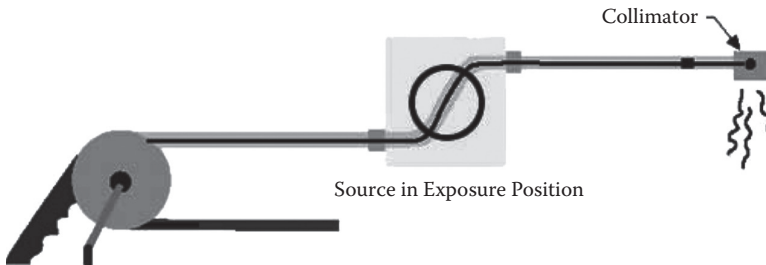

FIGURE 8.20
Isotope in end position.

to be to produce the radiograph. The crank-out cable is stretched as far as possible to put as much distance as possible between the exposure device and the inspector. The isotope in the stored position and at the end position is shown in Figure 8.19 and Figure 8.20, respectively.

8.3.7 Radiographic Film

Radiographic film consists of five layers: the core is a film sheet and a lead screen on the front and back, and cardboards on both sides. The lead screen is required to filter out the low energy radiation and to increase the photographic action on the film.

The film contains radiation-sensitive silver halide crystals, such as silver bromide or silver chloride, and a flexible, transparent, blue-tinted base. The emulsion is different from those used in other types of photography films to account for the distinct characteristics of gamma rays and x-rays, but x-ray films are sensitive to light. Usually, the emulsion is coated on both sides of the base in layers about 0.0005 inches thick. Putting emulsion on both sides of the base doubles the amount of radiation-sensitive silver halide, and thus increases the film speed.

Radiographic film is available in different packaging options. The most basic form is as individual sheets in a box. In preparation for use, each sheet must be loaded into a cassette or film holder in the darkroom to protect it from exposure to light.

A rip strip makes it easy to remove the film in the darkroom for processing. This form of packaging has the advantage of eliminating the process of loading the film holders in the darkroom to the shape of the film (Figure 8.21). The film should be protected from finger marks and dirt until it is removed from the envelope for processing.

The packaged film is also available in rolls, which allows the radiographer to cut the film to any length. The ends of the packaging are sealed with electrical tape in the darkroom. In applications such as the radiography of circumferential welds and the examination of long joints on an aircraft fuselage, long lengths of film offer great economic advantage. The film is wrapped around the outside of a structure and the radiation source is positioned on the axis inside, allowing for examination of a large area with a single exposure.

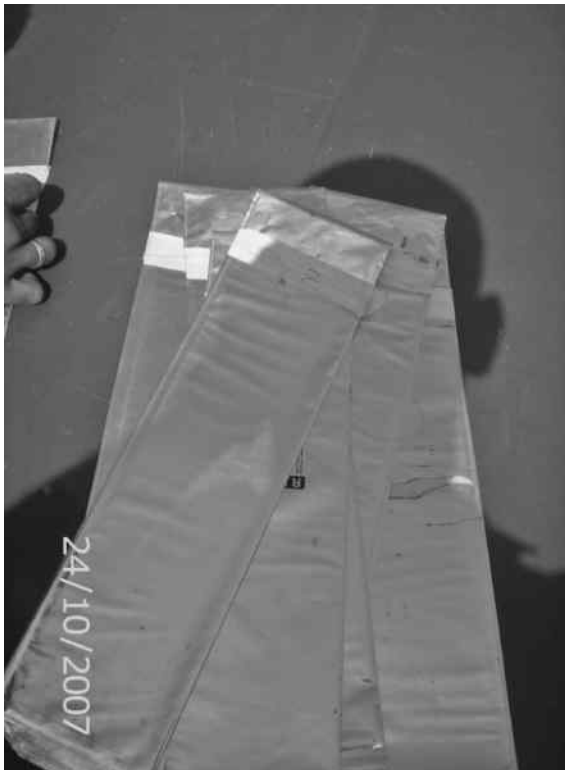

FIGURE 8.21
Film samples.



FIGURE 8.22
Fixing identification number.

Envelope-packaged film can be purchased. The film is sandwiched between two lead oxide screens that reduce scatter radiation at energy levels below 150 keV and act as intensification screens above 150 keV.

The radiographic film should be handled carefully to avoid pressure, creasing, buckling, friction, or other sources of film deterioration. There are numbers and words in lead as shown in Figure 8.22 that are used to indicate the date and film number.

To define the sensitivity of the film, ASTM and ASME recommend penetrometers (devices that measure the ease of penetration of an object) have an identification number that represent the thickness of the penetrometer. Three holes are drilled into the penetrometer representing the diameters of 1, 2, and 4 times the thickness of the penetrometer.

8.3.7.1 New Films

A new type of film is packaged with a memory stick. Photos will be converted directly to the computer. The computer files are easy to handle and transfer via e-mail. The film and all the calculation, precaution and constraints are the same as conventional film.

Scanners on the market convert the conventional photo to a computer file for easy use.

8.3.8 General Welding Discontinuities

A cold lap occurs when the weld filler metal does not properly fuse with the base metal or the previous weld pass material. This results because the arc does not melt the base metal sufficiently and causes the slightly molten

puddle to flow into the base material without bonding. Figure 8.23 presents a cold lap sketch and radiographic film.

As discussed in Chapter 7, the porosity problem is due to the gas entrapment in the solidifying metal. Porosity can take many shapes on a radiograph but often appears as dark round or irregular spots or specks appearing singularly, as shown in Figure 8.24. Sometimes, porosity is elongated and may appear to have a tail. This is the result of gas attempting to escape while the metal is still in a liquid state and is called wormhole porosity. A porosity is a void in a material and it will have a higher radiographic density than the surrounding area.

Figure 8.25 presents a cluster porosity, which happened when flux-coated electrodes were contaminated with moisture. The moisture turns into a gas when heated and becomes trapped during the welding process. The shape of cluster porosity appears the same as the regular porosity in the radiograph, but the indications are grouped close together.

Slag inclusions are nonmetallic solid materials entrapped in weld metal or between weld and base metal. In a radiograph, dark, jagged asymmetrical shapes within the weld or along the weld joint areas are indicative of slag inclusions (Figure 8.26).

As discussed in Chapter 7, incomplete penetration occurs when the weld metal fails to penetrate the joint. It is one of the most objectionable weld

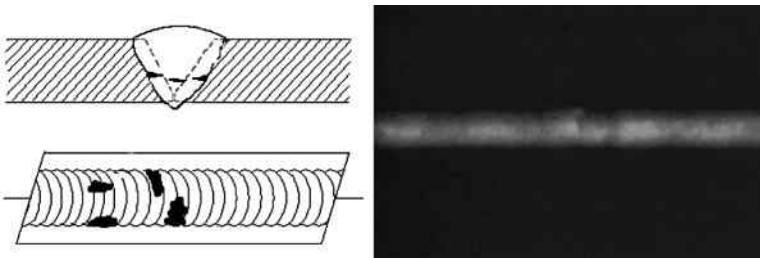

FIGURE 8.23
Cold lap.

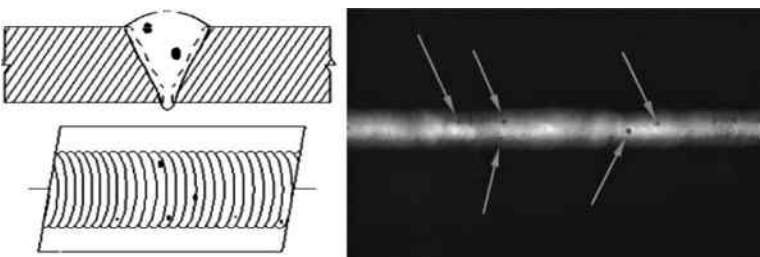

FIGURE 8.24
Porosity.

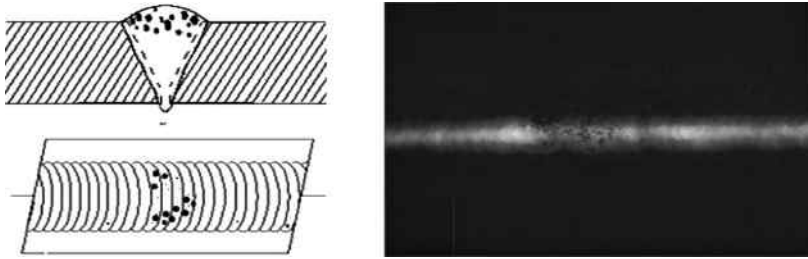

FIGURE 8.25
Cluster porosity.

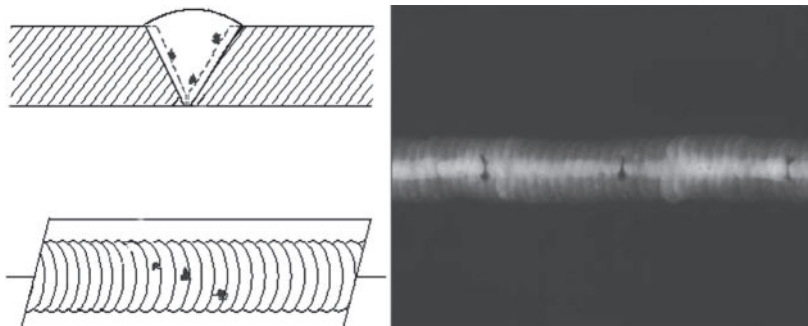

FIGURE 8.26
Slag inclusions.

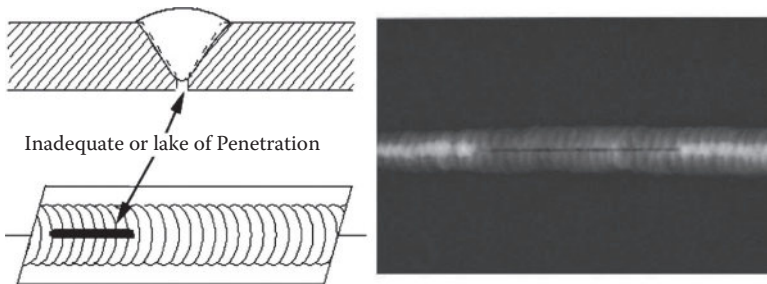

FIGURE 8.27
Incomplete penetration.

discontinuities. Lack of penetration allows a natural stress riser from which a crack may propagate. The appearance on a radiograph is a dark area with well-defined, straight edges that follows the land or root face down the center of the weldment (Figure 8.27).

Incomplete fusion is shown in Figure 8.28. It occurs when the weld filler metal does not properly fuse with the base metal. Appearance on radiograph

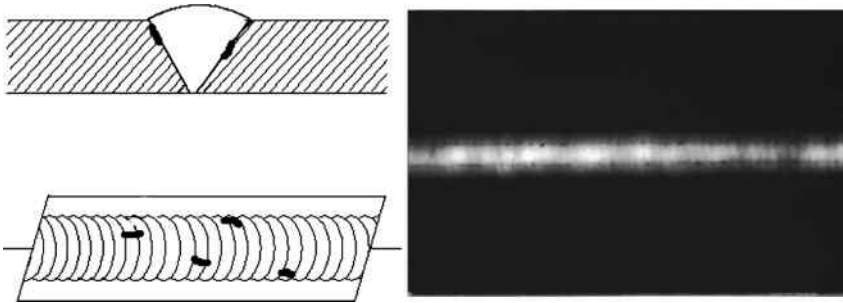

FIGURE 8.28
Incomplete fusion.

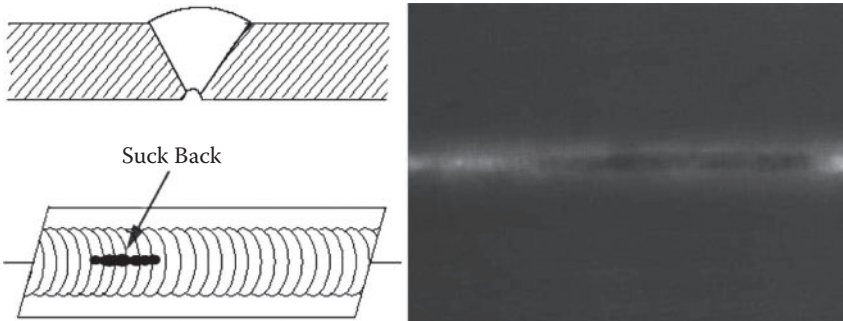

FIGURE 8.29
Internal concavity.

is usually a dark line or lines oriented in the direction of the weld seam along the weld preparation or joining area.

Internal concavity or suck-back happens when the weld metal contracts as it cools and has been drawn up into the root of the weld (Figure 8.29). On a radiograph it looks similar to a lack of penetration but the line has irregular edges and it is often quite wide in the center of the weld image.

Undercut near the crown or the root is shown in Figure 8.30.

Offset or mismatch between two plates that are welded is shown in Figure 8.31. The radiographic image shows a noticeable difference in density between the two pieces. The difference in density is caused by the difference in material thickness. The dark, straight line is caused by the failure of the weld metal to fuse with the land area.

Inadequate and excess weld reinforcement are shown in Figure 8.32a and Figure 8.32. The thickness of weld metal deposited is less than the thickness of the base material or more than required in the engineering drawings.

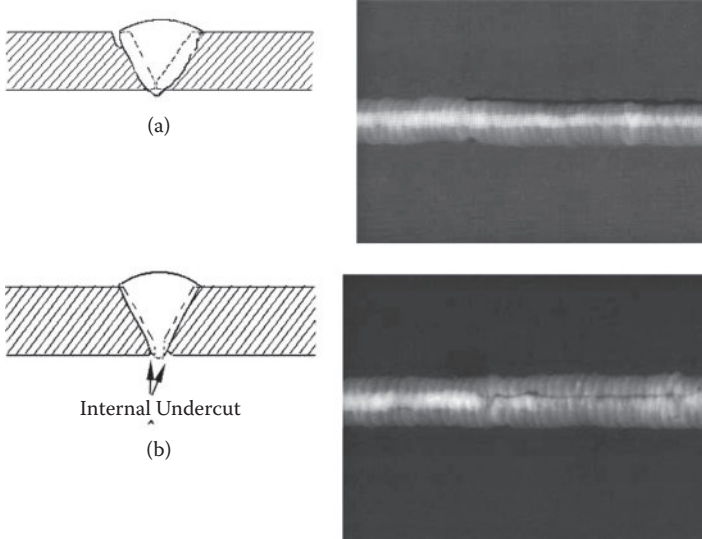

FIGURE 8.30
Undercut for (a) crown and (b) root.

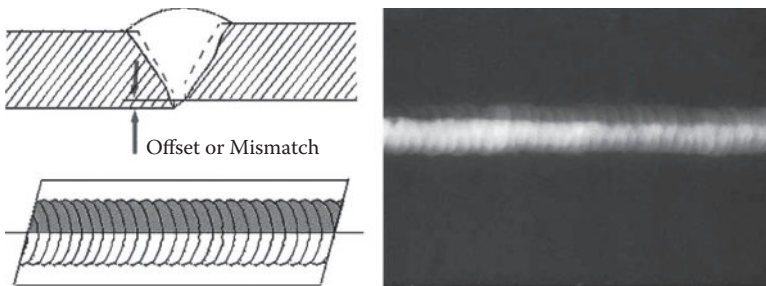

FIGURE 8.31
Offset between two plates.

8.4 Ultrasonic Test

The main principle of the ultrasonic test is to send sound waves through materials and analyze the received waves to find cracks and calculate steel thickness. Ultrasonic testing (UT) uses very short ultrasonic pulse waves with center frequencies ranging from 0.1 to 15 MHz and occasionally up to 50 MHz penetrating into materials to detect internal flaws or characterize the materials. A common example is ultrasonic thickness measurement of webs and flanges in an existing steel structure.

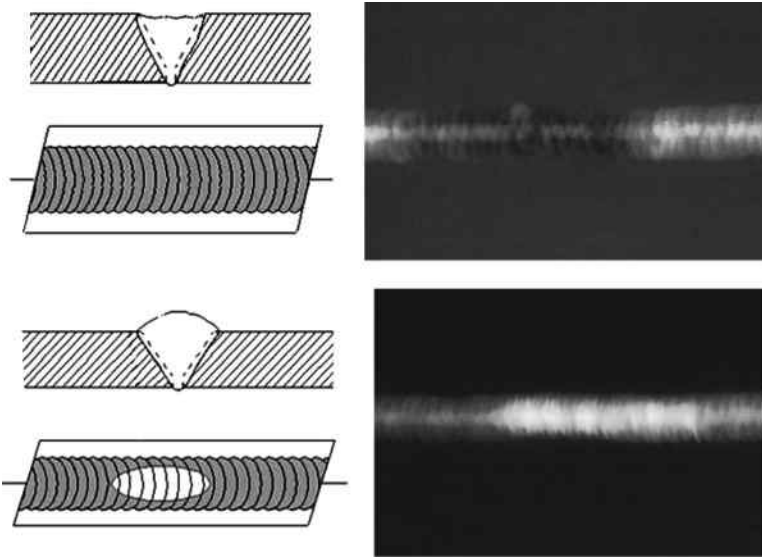

FIGURE 8.32
Inadequate (top) and excess (bottom) welding reinforcement.

In 1929 and 1935, Sokolov studied the use of ultrasonic waves in detecting metal objects. Mulhauser, in 1931, obtained a patent using two transducers to detect flaws in solids. Firestone (1940) and Simons (1945) developed pulsed ultrasonic testing using a pulse-echo technique.

8.4.1 Wave Propagation

Ultrasonic testing is based on time-varying vibrations (acoustic properties) in materials. By applying ultrasonic sound to a specimen can determine its soundness, thickness or other physical properties.

There are various types of waves of sound, including longitudinal waves, shear waves, surface waves, and in thin materials, plate waves. The longitudinal and shear waves are the two modes of propagation most widely used in ultrasonic testing.

As shown in Figure 8.33, longitudinal waves propagate in the longitudinal direction. For the transverse or shear wave, the particles oscillate at a right angle or transverse to the direction of propagation. Shear waves require an acoustically solid material for effective propagation, and are not effectively propagated in materials such as liquids or gasses. Shear waves are relatively weak when compared to longitudinal waves. In fact, shear waves are usually generated in materials using some of the energy from longitudinal waves.

The sending and receiving of waves in steel structures are different than in concrete. The receiving and sending is done by one transducer (Figure 8.34).

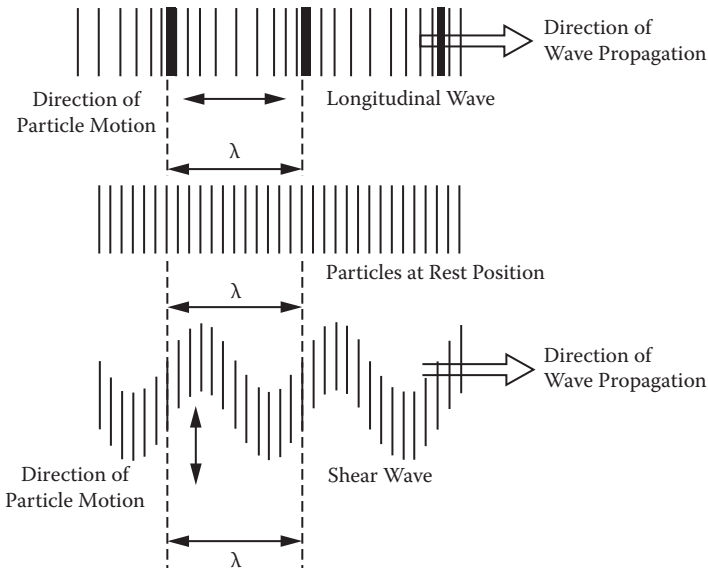

FIGURE 8.33
Types of waves.

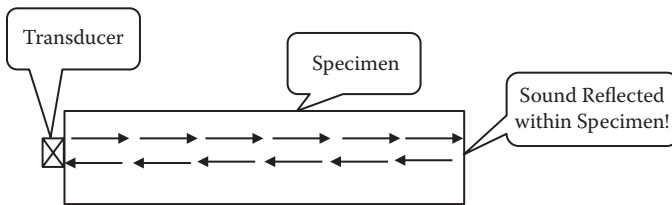

FIGURE 8.34
Sound propagation.

Among the properties of waves propagating in isotropic solid materials are wavelength, frequency, and velocity. The wavelength is directly proportional to the velocity of the wave and inversely proportional to the frequency of the wave. The relation of wave length, sound velocity, and frequency is as follows:

$$\text{Wavelength } (\lambda) = \text{Velocity } (V) / \text{Frequency } (f)$$

The wavelength can be obtained by changing the frequency, as the wave velocity is a fixed value depending on the specimen materials. Based on ASNT, the smallest discontinuity you can detect by UT is about half the wavelength (0.5λ). Note that the frequency value must be kept between

0.1 to 1 MHz (one million cycles per second) and the wave velocity must be between 0.1 and 0.7 cm/ μ sec.

8.4.2 Attenuation of Sound Waves

When sound travels through a medium, its intensity reduces with distance. In ideal materials, sound pressure (signal amplitude) is only reduced by the spreading of the wave. Natural materials, however, produce an effect that further weakens the sound. This further weakening results from scattering and absorption. Scattering is the reflection of the sound in directions other than its original direction of propagation. Absorption is the conversion of the sound energy to other forms of energy. The combined effect of scattering and absorption is called attenuation. Ultrasonic attenuation is the decay rate of the wave as it propagates through material, as shown in Figure 8.35.

The beam of sound energy spreads as it moves through the specimen (Figure 8.36). A high frequency transducer provides narrower sound beams

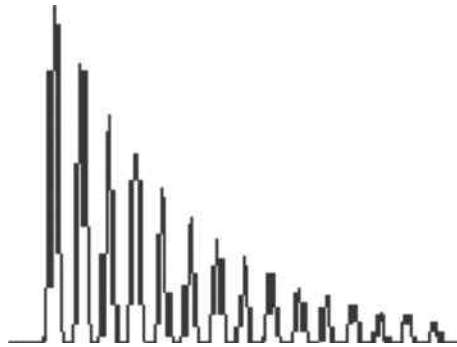

FIGURE 8.35
Attenuation in sound wave.

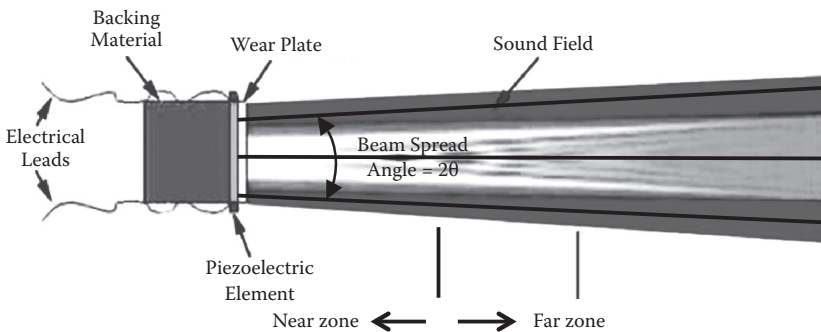

FIGURE 8.36
Beam spread for ultrasonic wave.

than a low frequency transducer of identical size. As shown in Figure 8.36, the near zone varies irregularly due to sound wave interaction close to the transducer and this prevents reliable detection of discontinuities near the surface. In the far zone the intensity decreases steadily due to both the attenuation and beam spread.

The primary reasons for attenuation are absorption and scattering of the ultrasonic energy.

The beam spread may be calculated as a function of the transducer diameter (D), frequency (F), and the sound velocity (V) in a liquid or solid medium. The following equation can be used to calculate the spread angle:

$$\sin \theta = 1.2 \frac{V}{DF}$$

where

θ = beam divergence angle from centerline to point where signal is at half strength.

V = sound velocity in the material (inch/sec or cm/sec).

D = diameter of the transducer (inch or cm).

F = frequency of the transducer (cycles/second).

8.4.3 Reflection in Sound Wave

The wave velocity is constant through a given medium. There is a parameter called the acoustic impedance, which multiplies the wave velocity for a certain medium with the density of that medium. Table 8.3 presents the velocity, density and impedance in different media.

Acoustic impedance is important in the determination of acoustic transmission and reflection at the boundary of two materials having different impedances. It is required for design of ultrasonic transducers and assessing absorption of sound in a medium.

Ultrasonic waves are reflected at boundaries where there is a difference in acoustic impedances of the materials on each side. This difference in impedance is commonly referred to as the impedance mismatch. The greater the impedance mismatch, the greater the percentage of energy that will be

TABLE 8.3
Recommended Current

Prod Spacing (inches)	Thickness of Plate in Inches	
	Under ¼ inch	¼ inch and over
2 to 4	200 to 300 amperes	300 to 400 amperes
4 to 6	300 to 400 amperes	400 to 600 amperes
6 to 8	400 to 600 amperes	600 to 800 amperes

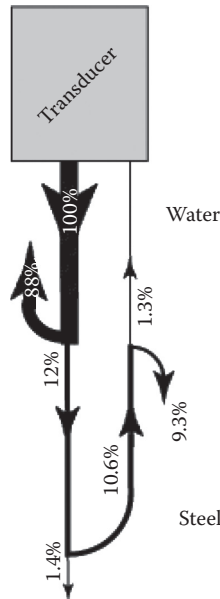

FIGURE 8.37
Reflection.

reflected at the interface or boundary between one medium and another. In our cases we have two media, which are steel and air.

The reflection is clearly shown in Figure 8.37. If reflection and transmission at interfaces is followed through the component, only a small percentage of the original energy makes it back to the transducer, even when loss by attenuation is ignored. For example, consider an immersion inspection of a steel block. The sound energy leaves the transducer, travels through the water, encounters the front surface of the steel, encounters the back surface of the steel, and reflects back through the front surface on its way back to the transducer. At the water–steel interface (front surface), 12% of the energy is transmitted. At the back surface, 88% of the 12% that made it through the front surface is reflected. This is 10.6% of the intensity of the initial incident wave. As the wave exits the part back through the front surface, only 12% of 10.6 or 1.3% of the 10.6 will return.

The reflection factor can be calculated from the following equation:

$$\text{Reflection factor } (R) = \left(\frac{Z_1 - Z_2}{Z_1 + Z_2} \right)$$

where Z is the acoustical impedance. If we apply the equation for the water–steel interface, the reflection value will be 88%.

8.4.4 Refraction of Sound Wave and Snell’s Law

When an ultrasonic wave passes through an interface between two materials at an oblique angle, and the materials have different indices of refraction, both reflected and refracted waves are produced. This also occurs with light, which is why objects seen across an interface appear to be shifted relative to where they really are. For example, if you look straight down at an object at the bottom of a glass of water, it looks closer than it really is. A good way to visualize how light and sound refract is to shine a flashlight into a bowl of slightly cloudy water noting the refraction angle with respect to the incident angle.

Refraction of sound waves and Snell’s law are presented in Figure 8.38. V_{L1} is the longitudinal wave velocity in material (1) and V_{L2} is the longitudinal wave velocity in material (2).

The velocity of sound in each material is determined by its properties (elastic modulus and density). Therefore, when the wave encounters the interface between these two materials, the portion of the wave in the second material is moving faster than the portion of the wave in the first material and this causes the wave to bend.

Snell’s law describes the relationship between the angles and the velocities of the waves. Snell’s law equates the ratio of material velocities V_1 and V_2 to the ratio of the sines of incident (θ_1) and refracted (θ_2) angles, as shown in the following equation:

$$\frac{\sin \theta_1}{V_{L1}} = \frac{\sin \theta_2}{V_{L2}}$$

Note that the wave is reflected at the same angle as the incident wave because the two waves are traveling in the same material, and hence have the same velocities. This reflected wave is unimportant in our explanation

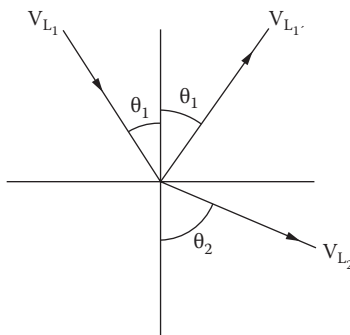

FIGURE 8.38
Reflection angles.

of Snell's law, but it should be remembered that some of the wave energy is reflected at the interface.

When a longitudinal wave moves from a slower to a faster material, there is an incident angle that makes the angle of refraction for the wave 90° . This is known as the first critical angle. The first critical angle can be found from Snell's law by using 90° for the angle of the refracted ray (Figure 8.38). At the critical angle of incidence, much of the acoustic energy is in the form of an inhomogeneous compression wave, which travels along the interface and decays exponentially with depth from the interface. This wave is sometimes referred to as a "creep wave." Because of their inhomogeneous nature and the fact that they decay rapidly, creep waves are not used as extensively as Rayleigh surface waves in NDT. However, creep waves are sometimes more useful than Rayleigh waves because they suffer less from surface irregularities and coarse material microstructure due to their longer wavelengths.

8.4.4.1 Angle Beams

Angle beam transducers and wedges are typically used to introduce a refracted shear wave into the test material (Figure 8.39). An angled sound path allows the sound beam to come in from the side, thereby improving detectability of flaws in and around welded areas.

The location of the crack can be obtained from its surface distance and the depth by knowing the sound path. These data can be obtained by the following equations:

$$\text{Surface distance} = \text{Sound path} \times \sin \theta$$

$$\text{Depth} = \text{Sound path} \times \cos \theta$$

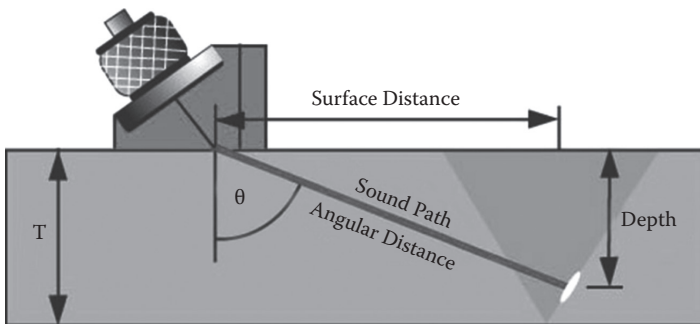

FIGURE 8.39

Angle beam. θ is the angle of refraction and T is the specimen test thickness.

Angle beam transducers and wedges are typically used to introduce a refracted shear wave into the test material. The geometry of the sample, as shown in Figure 8.40, allows the sound beam to be reflected from the back wall to improve detectability of flaws in and around welded areas.

The leg length, the skip distance, and the V-path are calculated from the following equations:

$$\text{Leg} = T/\text{Cos } \theta$$

$$\text{Skip distance} = 2T(\tan \theta)$$

$$\text{V-path} = 2T/\text{Cos } \theta$$

To check the welding move the transducer as shown in Figure 8.41.

The skip distance will be calculated from the aforementioned equation. From that you can define the distance of movement to check all the weld thicknesses.

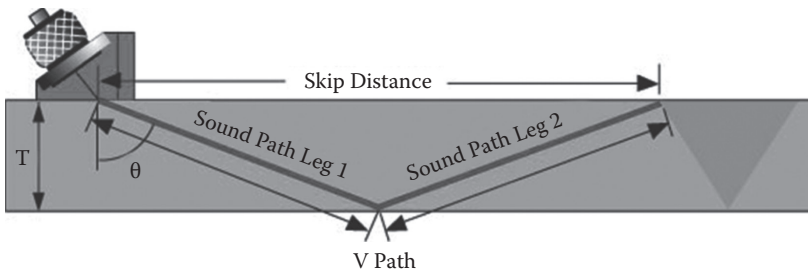

FIGURE 8.40
Inclined probe measurement.

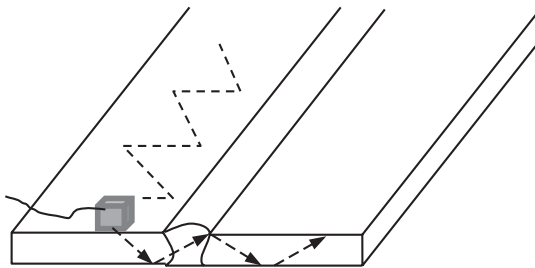

FIGURE 8.41
Angle beam path.

8.4.5 Wave Interaction or Interference

The inspector should be understand everything about the discontinuities on the steel plate from the UT screen. Figure 8.42 depicts the echo on a UT screen.

There are three basic types of visual display: A-scan, B-scan, and C-scan. A-scan is the time versus amplitude display, which reveals a discontinuity using a PIP on a cathode ray tube (Figure 8.43). The B-scan utilizes a cross-sectional view of the testing materials. The C-scan is similar to the x-ray

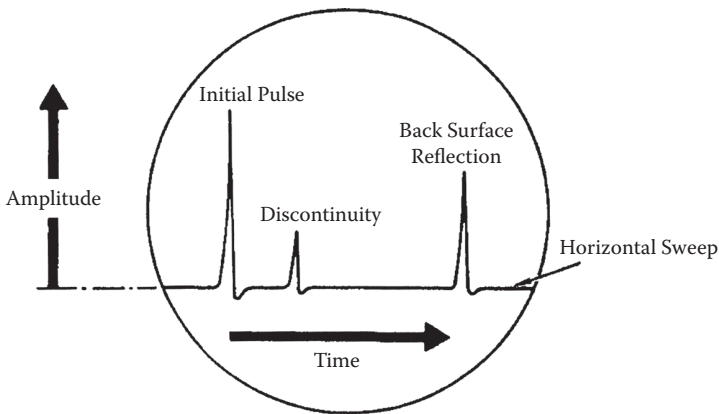

FIGURE 8.42
Echo pattern for discontinuity.



FIGURE 8.43
Peak of first echo.

picture, which provides a plane view but the depth cannot be obtained. In most cases an A-scan is used.

The A-scan presentation displays the amount of received ultrasonic energy as a function of time. The relative amount of received energy is plotted along the vertical axis and the elapsed time is presented on the x-axis (Figure 8.44). The location of cracks B and C and the reduction of thickness in A is presented in the echo in the UT screen in Figure 8.44. Note that BW, indicates the back wall echo.

For different patterns of cracks, the pulses on the UT screen will be different and should be known very well by the inspector. Examples of different discontinuities with different echo shapes are presented in Figure 8.45.

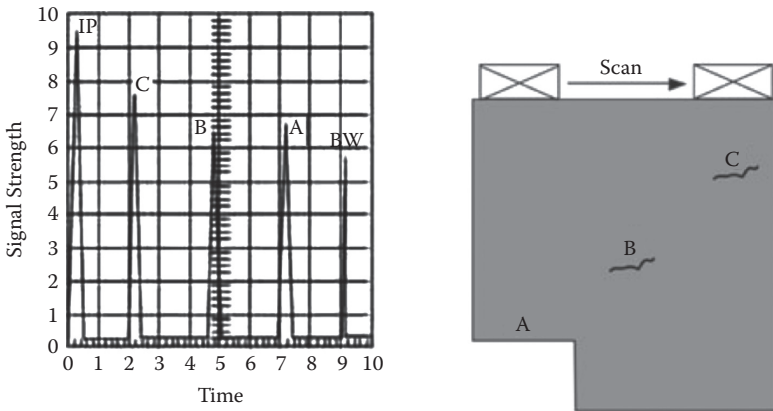

FIGURE 8.44 Left: Plot of signal versus time. Right: Echo on UT screen.

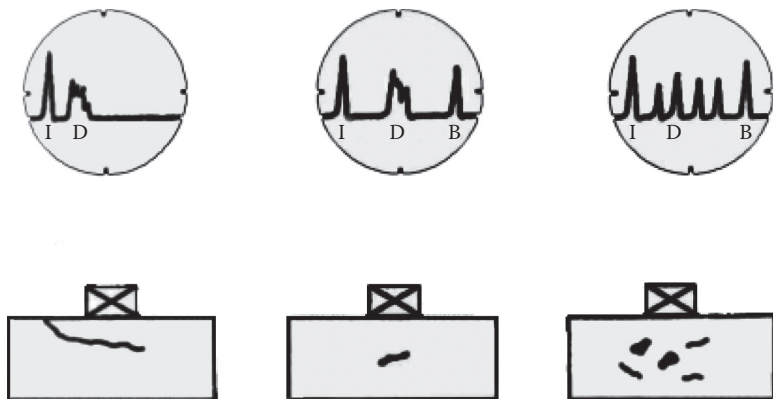

FIGURE 8.45 Discontinuity patterns.

8.4.6 Transducer Types

The transducer is the main part of the ultrasonic test equipment. There are many types of transducers manufactured for a variety of applications (Figure 8.46) and can be custom fabricated when necessary.

The main part of the transducer is the piezoceramic, which converts electrical pulses to mechanical vibrations. The conversion of returned mechanical vibrations back into electrical energy is the basis for ultrasonic testing. The transducer must be protected from damage.

The contact between the transducer and the test specimen is by the couplant (Figure 8.47). A couplant is a liquid or grease such as oil, glycerin or water, which is placed between the transducer and the test specimen. The couplant is generally necessary because the acoustic impedance mismatch between air and solids (i.e., such as the test specimen) is large. The couplant displaces the air and makes it possible to get more sound energy into the test specimen so that a usable ultrasonic signal can be obtained.



FIGURE 8.46
Types of transducers.

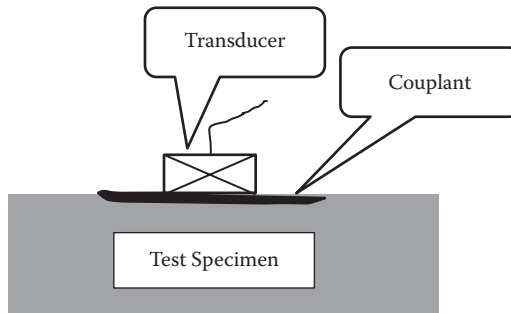

FIGURE 8.47
Location of couplant.

8.4.7 Calibration Methods

Calibration should be done for the straight beam transducer and also for the angle beam transducer. See Figure 8.48.

Calibration is required for evaluating and adjusting the precision and accuracy of measurement equipment. In ultrasonic testing, several forms of calibration must occur. First, the electronics of the equipment must be calibrated to ensure that they are performing as designed.

In ultrasonic testing, there is also a need for reference standards to establish a general level of consistency in measurements, and to help interpret and quantify the received signal. Reference standards are used to validate that the equipment and the setup provide similar results from one day to the next and that similar results are produced by different systems. Reference standards also help the inspector to estimate the sizes of flaws. In a pulse-echo setup, signal strength depends on both the size of the flaw and the distance between the flaw and the transducer. The inspector can use a reference standard with an artificially induced flaw of known size at approximately the same distance away for the transducer to produce a signal. By comparing the signal from the reference standard to that received from the actual flaw, the inspector can estimate the flaw size.

Calibration and reference standards for ultrasonic testing come in many shapes and sizes. The type of standard used is dependent on the nondestructive examination (NDE) application and the form and shape of the object evaluated. The material of the reference standard should be the same as the material to be inspected and the artificially induced flaw should closely resemble that of the actual flaw. This requirement is a major limitation of most standard reference samples.

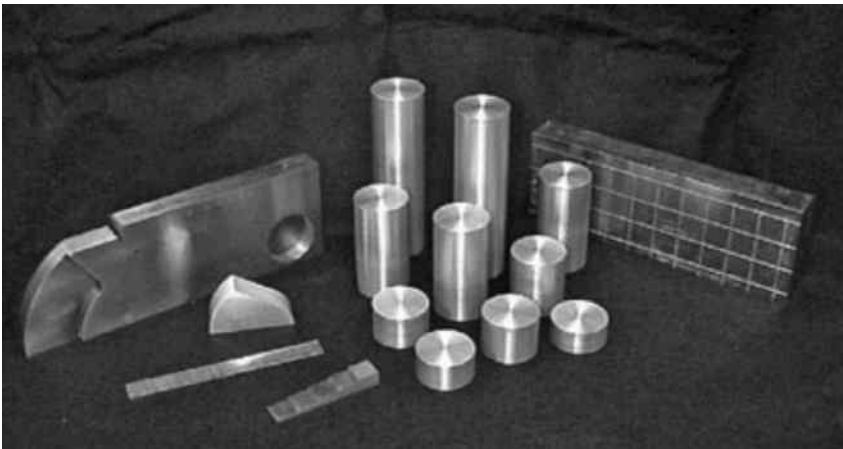

FIGURE 8.48
Calibration tools.

8.5 Penetration Test

This is the lowest cost and easiest technique to define the discontinuities on the surface of steel and in the welding zone. This test depends on penetration of a liquid to reveal surface-breaking flaws by bleed-out of a colored or fluorescent dye from the flaw.

The time after spraying the liquid on the steel surface is called the *dwell*. Excess penetrant is removed and a developer applied. Contrast penetrants require good white light. Fluorescent penetrants must be used in darkened conditions under ultraviolet (“black”) light but they are not used to examine steel structures.

Surface penetration is a critical step. The surface must be free of oil, grease, water, and other contaminants that may prevent the penetrant from entering flaws. A sample may require etching if it has been subjected to machining, sanding, or grit blasting operations that clog openings and prevent the penetrant from entering flaws. Once the surface has been thoroughly cleaned and dried, the penetrant liquid is applied by spraying, brushing or immersing the part in a penetrant bath.

The penetrant is left on the surface for a sufficient time period to allow as much penetrant as possible to be drawn from or to seep into a defect. Penetrant dwell time is the total time that the penetrant is in contact with the part surface. Dwell times are usually recommended by the penetrant producers. The times vary depending on the application, penetrant materials used, the material, and the type of defect being inspected for. Minimum dwell times typically range from 5 to 60 minutes. Generally, there is no harm in using a longer penetrant dwell time as long as the penetrant is not allowed to dry. The ideal dwell time is often determined by experimentation and may be very specific to a particular application.

After that a thin layer of developer is applied to the sample to draw penetrant trapped in flaws back to the surface where it will be visible. Developers come in a variety of forms that may be applied by dusting (dry powdered), dipping, or spraying (wet developers).

The developer is allowed to stand on the part surface for a period sufficient to permit the extraction of the trapped penetrant from surface flaws. This development time is usually a minimum of 10 minutes. Significantly longer times may be necessary for tight cracks.

Finally the inspection is then performed under appropriate lighting to detect indications from any flaws that may be present. The last step is to remove the developer from the parts that were found to be acceptable.

8.5.1 Advantages and Disadvantages of Penetrant Testing

When deciding whether to use penetrant testing, it is important to clearly know the advantages and disadvantages. The primary advantages and

disadvantages as described in the dry penetrate method in ASTM (1980) are summarized below.

Primary Advantages

- The liquid penetration test is highly sensitive to small surface discontinuities.
- The method has few material limitations, that is, metallic and nonmetallic, magnetic and nonmagnetic, and conductive and nonconductive materials may be inspected.
- Large areas and large volumes of parts or materials can be inspected rapidly and at low cost.
- Parts with complex geometric shapes can be routinely inspected.
- Indications are produced directly on the surface of the part and constitute a visual representation of the flaw.
- It is very portable when aerosol spray is used as a penetrant material.
- Penetrant materials and associated equipment are relatively inexpensive.

Primary Disadvantages

- Only surface breaking defects can be detected.
- It can be used only on materials with relatively nonporous surfaces can be inspected, so it is recommended for steel structures.
- The surface precleaning is critical since contaminants can mask defects.
- The inspector must have direct access to the surface to be inspected.
- Surface finish and roughness can affect sensitivity.
- Multiple process operations must be performed and controlled.
- Postcleaning of acceptable materials after inspection is essential.
- Chemical handling and proper disposal are required.

8.5.2 Penetrant Testing Materials

The penetrants are made to produce the level of sensitivity desired by the inspector. The following are the penetrant characteristics important:

- It should spread easily over the surface of the material being inspected to provide complete and even coverage.
- It should be drawn into surface breaking defects by capillary action.

- It remains in the defect but removes easily from the surface of the part.
- It remains fluid so it can be drawn back to the surface of the part through the drying and developing steps.
- It can be highly visible or fluoresce brightly to produce easy-to-see indications.
- It will not be harmful to the material being tested or the inspector.

Figure 8.49 presents the shape of a discontinuity after applying the penetrant.

Penetrant manufacturers have developed different formulations to address a variety of inspection applications. Some applications call for the detection of the smallest defects possible and have smooth surfaces so that the penetrant is easy to remove. In other applications, the rejectable defect size may be larger and a penetrant formulated to find larger flaws can be used. The penetrants that are used to detect the smallest defect will also produce the largest numbers of irrelevant indications.

Penetrant materials are classified in the various industry and government specifications by their physical characteristics and their performance. Aerospace Material Specification (AMS) 2644, Inspection Material, Penetrant, is now the primary specification used in the United States to control penetrant materials. Historically, Military Standard 25135, Inspection Materials, Penetrants, has been the primary document for specifying penetrants, but this document is slowly being replaced by AMS 2644. Other specifications

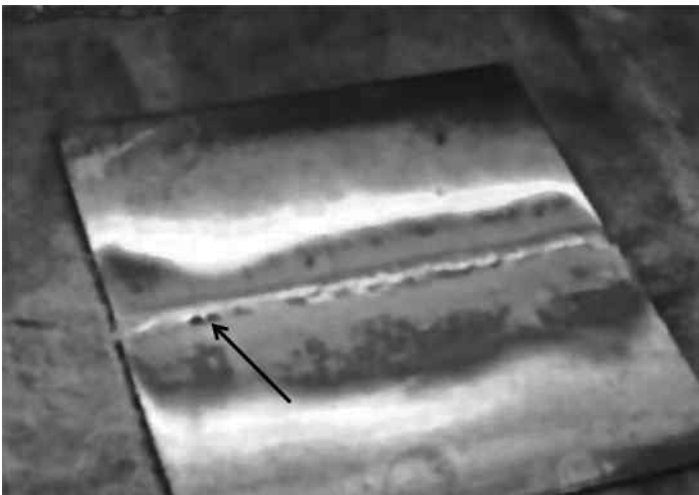

FIGURE 8.49

The shapes of discontinuities after liquid penetration.

such as ASTM 1417, Standard Practice for Liquid Penetrant Examinations, may also contain information on the classification of penetrant materials, but readers are generally referred back to MIL-I-25135 or AMS 2644.

Penetrant materials come in two basic types: (1) fluorescent penetrants and (2) visible penetrants. Fluorescent penetrants contain a dye or several dyes that fluoresce when exposed to ultraviolet radiation. Visible penetrants contain a red dye that provides high contrast against the white developer background. Visible penetrants are also less vulnerable to contamination from chemicals such as cleaning fluid that can significantly reduce the strength of a fluorescent indication.

Penetrants are also classified by the method used to remove the excess penetrant from the part. The four types are:

- Water washable
- Postemulsifiable, lipophilic
- Solvent removable
- Postemulsifiable, hydrophilic

Water washable penetrants can be removed by rinsing with water alone. These penetrants contain an emulsifying agent (detergent) that makes it possible to wash the penetrant from the part surface with water alone. Water washable penetrants are sometimes referred to as self-emulsifying systems. Postemulsifiable penetrants come in two varieties, lipophilic and hydrophilic. In lipophilic systems, the penetrant is oil soluble and interacts with the oil-based emulsifier to make removal possible. Hydrophilic systems use an emulsifier that is a water-soluble detergent that lifts the excess penetrant from the surface of the part with a water wash. Solvent removable penetrants require the use of a solvent to remove the penetrant from the part.

Penetrants are then classified based on the strength or detectability of very small and tight fatigue cracks. The five sensitivity levels are:

- Level ½, ultralow sensitivity
- Level 1, low sensitivity
- Level 2, medium sensitivity
- Level 3, high sensitivity
- Level 4, ultrahigh sensitivity

The major U.S. government and industry specifications currently rely on the U.S. Air Force Materials Laboratory at Wright-Patterson Air Force Base to classify penetrants into one of the five sensitivity levels. This procedure uses titanium and Inconel specimens with small surface cracks produced in low cycle fatigue bending to classify penetrant systems. The brightness of the indication produced is measured using a photometer. The sensitivity levels and

the test procedure used can be found in Military Specification MIL-I-25135 and Aerospace Material Specification 2644, Penetrant Inspection Materials.

An interesting note about the sensitivity levels is that only four levels were originally planned. However, when some penetrants were judged to have sensitivities significantly lower than most others in the level 1 category, the ½ level was created.

8.5.3 Penetrants

The industry and military specifications that control penetrant materials and their use all stipulate certain physical properties that must be met. Some of these requirements address the safe use of the materials, such as toxicity, flash point, and corrosiveness, and other requirements address storage and contamination issues. Still others delineate properties that are thought to be primarily responsible for the performance or sensitivity of the penetrants. The properties of penetrant materials that are controlled by AMS 2644 and MIL-I-25135E include flash point, surface wetting capability, viscosity, color, brightness, ultraviolet stability, thermal stability, water tolerance, and removability.

8.5.4 Developers

The developer objective is to trapped penetrant material out of defects and spread it out on the surface so an inspector can see it. The fine developer particles both reflect and refract the incident ultraviolet light, allowing more of it to interact with the penetrant, causing more efficient fluorescence. The developer also allows more light to be emitted through the same mechanism. This is why indications are brighter than the penetrant itself under UV light. Another function that some developers perform is to create a white background so there is a greater degree of contrast between the indication and the surrounding background.

AMS 2644 and Mil-I-25135 classify developers into six standard forms:

1. Form a—Dry powder
2. Form b—Water soluble
3. Form c—Water suspendable
4. Form d—Nonaqueous Type 1 fluorescent (solvent based)
5. Form e—Nonaqueous Type 2 visible dye (solvent based)
6. Form f—Special applications

The developer classifications are based on the method by which the developer is applied. The developer can be applied as a dry powder, or dissolved or suspended in a liquid carrier. Each of the developer forms has advantages and disadvantages.



FIGURE 8.50
Using spray to develop, penetrate, and clean test surface.

Nonaqueous developer is the most traditional technique to be used specifically in steel structure projects. Figure 8.50 presents the spray of nonaqueous developer. Nonaqueous developers are commonly distributed in aerosol spray cans for portability. The solvent tends to pull penetrant from the indications by solvent action. Since the solvent is highly volatile, forced drying is not required. A nonaqueous developer should be applied to a thoroughly dried part to form a slightly translucent white coating.

When it is not practical to conduct a liquid penetrant examination within the temperature range of 40°F to 125°F (5°C to 52°C), the examination procedure at the proposed lower or higher temperature range requires qualification of the penetrant materials and procedure.

8.6 Magnetic Particle Test

Magnetic particle inspection (MPI) is a nondestructive testing method used for defect detection. MPI is fast and relatively easy to apply, and part surface preparation is not as critical as it is for some other NDT methods. These characteristics make MPI one of the most widely utilized nondestructive testing methods.

The MPI uses magnetic fields and small magnetic particles (i.e., iron filings) to detect discontinuities on the surfaces of materials. The only requirement from an inspectability standpoint is that the component being inspected must be made of a ferromagnetic material such as iron, nickel, cobalt, or some of their alloys. Ferromagnetic materials can be magnetized to a level that will allow the inspection to be effective.

In theory, MPI is a relatively simple concept. It can be considered as a combination of two nondestructive testing methods: magnetic flux leakage

testing and visual testing. Consider the case of a bar magnet that has a magnetic field. Any place that a magnetic line of force exits or enters the magnet is called a pole. A pole where a magnetic line of force exits the magnet is called a north pole and a pole where a line of force enters the magnet is called a south pole (Figure 8.51).

When a magnetic part has a crack, as shown in Figure 8.52, it will formulate two different magnetic poles; a north and south pole will form at each edge of the crack. The magnetic field exits the north pole and reenters at the south pole. The magnetic field spreads when it encounters the small air gap created by the crack because the air cannot support as much magnetic field per unit volume as the magnet can. When the field spreads, it appears to leak from the material and, thus is called a flux leakage field.

If iron particles are sprinkled on a cracked magnet, the particles will be attracted to and cluster at the poles at the ends of the magnet and also at the poles at the edges of the crack. This cluster of particles is much easier to see than the actual crack and this is the basis for magnetic particle inspection.

The first step in a magnetic particle inspection is to magnetize the component that is to be inspected. If any defects on or near the surface are present,

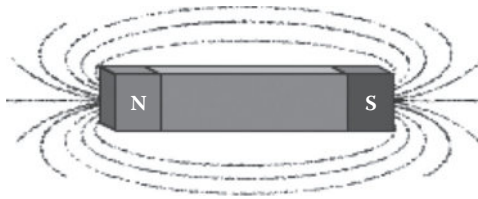

FIGURE 8.51
Magnet poles.

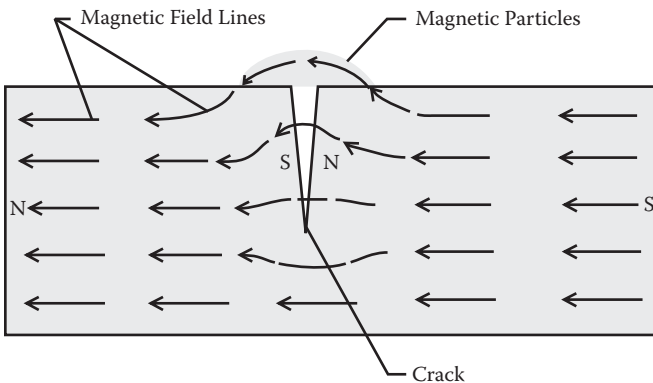

FIGURE 8.52
Magnet poles in metal cracks.

the defects will create a leakage field. After the component has been magnetized, iron particles, in a dry or wet suspended form, are applied to the surface of the magnetized part. The particles will be attracted and cluster at the flux leakage fields, thus forming a visible indication that the inspector can detect.

8.6.1 Magnetic Field Characteristics

Magnets come in a different shapes and the horseshoe (U) magnet (Figure 8.53) is one of the more common. The horseshoe magnet has north and south poles just like a bar magnet but the magnet is curved so the poles lie in the same plane. The magnetic lines of force flow from pole to pole just like in the bar magnet. However, since the poles are located closer together and a more direct path exists for the lines of flux to travel between the poles, the magnetic field is concentrated between the poles.

If a bar magnet was placed across the end of a horseshoe magnet or if a magnet was formed in the shape of a ring, the lines of magnetic force would not even need to enter the air. The value of such a magnet is probably limited. However, it is important to understand that the magnetic field can flow in a loop within a material.

Magnetic lines of force have a number of important properties, which include:

- They seek the path of least resistance between opposite magnetic poles. In a single bar magnet, they attempt to form closed loops from pole to pole.
- They never cross one another.

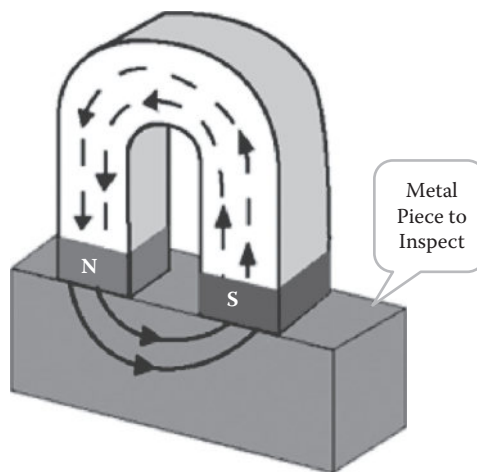

FIGURE 8.53

Direction of propagation in magnetic field.

- They all have the same strength.
- Their density decreases (they spread out) when they move from an area of higher permeability to an area of lower permeability.
- Their density decreases with increasing distance from the poles.
- They are considered to have direction although no actual movement occurs.
- They flow from the south pole to the north pole within a material and north pole to south pole in air.

8.6.2 Electromagnetic Fields

The magnetic field will formulate in circular form around the wire and the intensity of the field is directly proportional to the amount of current carried by the wire (Figure 8.54). The strength of the field is strongest next to the wire and diminished with distance from the conductor until it could no longer be detected. In most conductors, the magnetic field exists only as long as the current is flowing. In ferromagnetic materials, the electric current will cause some or all of the magnetic domains to align and a residual magnetic field will remain.

The direction of the magnetic field is dependent on the direction of the electrical current in the wire. A three-dimensional representation of the magnetic field is shown in Figure 8.55. There is a simple rule known as the right-hand rule, for remembering the direction of the magnetic field around a conductor. For the right-hand rule to work it must be remembered that current flows from the positive terminal to the negative terminal.

A coil called a solenoid can be used to generate a nearly uniform magnetic field similar to that of a bar magnet. The concentrated magnetic field inside a coil is very useful in magnetizing ferromagnetic materials for inspection using the magnetic particle testing method. The field outside the coil is weak and is not suitable for magnetizing ferromagnetic materials.

8.6.3 Magnetic Field Orientation and Flaw Detectability

To properly inspect a component for cracks or other defects, it is important to understand that the orientation between the magnetic lines of force and the flaw is very important. There are two general types of magnetic fields that can be established within a component. A longitudinal magnetic field has magnetic lines of force that run parallel to the long axis of the part. Longitudinal magnetization of a component can be accomplished using the longitudinal field set up by a coil or solenoid. It can also be accomplished using permanent magnets or electromagnets. A circular magnetic field has magnetic lines of force that run circumferentially around the perimeter of a part. A circular magnetic field is induced in an article by either passing

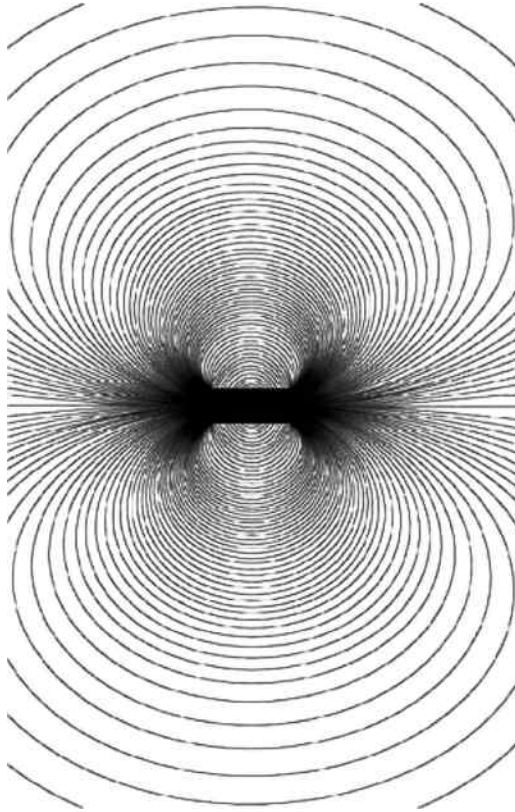

FIGURE 8.54
Magnetic field in horizontal plane.

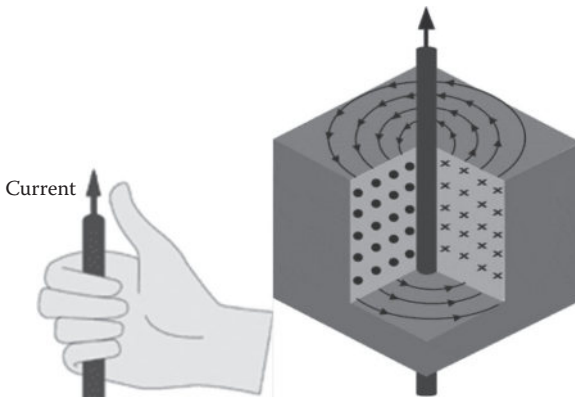

FIGURE 8.55
Right-hand rule.

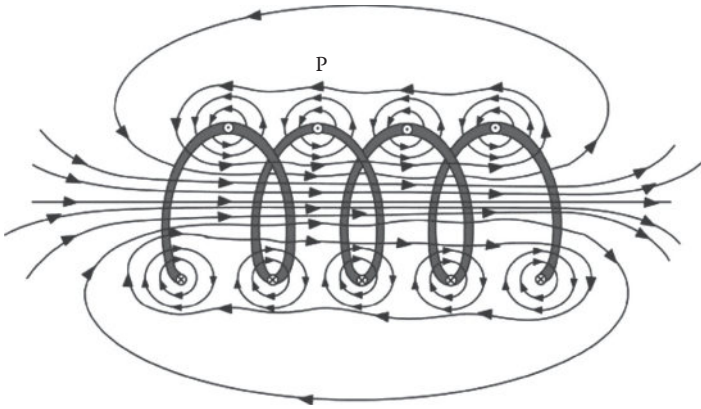

FIGURE 8.56
Direction of magnet flow.

current through the component or by passing current through a conductor surrounded by the component.

The type of magnetic field established is determined by the method used to magnetize the specimen. Being able to magnetize the part in two directions is important because the best detection of defects occurs when the lines of magnetic force are established at right angles to the longest dimension of the defect. This orientation creates the largest disruption of the magnetic field within the part and the greatest flux leakage at the surface of the part. As can be seen in Figure 8.56, if the magnetic field is parallel to the defect, the field will see little disruption and no flux leakage field will be produced.

An orientation of 45 to 90 degrees between the magnetic field and the defect is necessary to form an indication. Since defects may occur in various and unknown directions, each part is normally magnetized in two directions at right angles. If the component below is considered, it is known that passing current through the part from end to end will establish a circular magnetic field that will be 90 degrees to the direction of the current. Therefore, defects that have a significant dimension in the direction of the current (longitudinal defects) should be detectable. Alternately, transverse-type defects will not be detectable with circular magnetization.

There are a variety of methods that can be used to establish a magnetic field in a component for evaluation using magnetic particle inspection. It is common to classify the magnetizing methods as either direct or indirect.

8.6.4 Tools for Testing

For steel structure sections it is normal to use probe magnetization (Figure 8.57). By applying the hand rule theory the direction of magnetization is as illustrated in the figure parallel to the welding line.

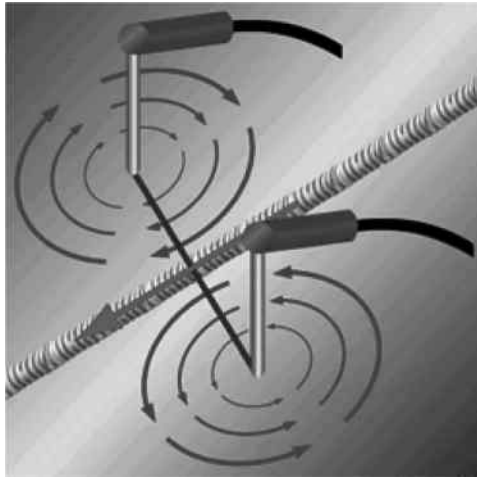

FIGURE 8.57
Magnet probes.

TABLE 8.4

Sound Penetration Parameters

Material	Velocity (cm/sec)	Density (gm/cm ³)	Impedance (gm/cm ² -sec)
Air	0.33×10^5	0.001	0.000033×10^6
Water	1.49×10^5	1.00	0.149×10^6
Aluminum	6.35×10^5	2.71	1.72×10^6
Steel	5.85×10^5	7.8	4.56×10^6

As a guideline from ASTN, Table 8.4 shows penetration parameters of various materials.

The half-wave direct current (DC) provides a better power mobility than AC. It also consumes less power and correspondingly produces a lower heat effect at the probe contact point. As per ASME V recommendation to avoid arcing, a remote control switch, which may be built into the prod handles, shall be provided to permit the current to be applied after the probes have been properly positioned.

The other method in the market is the yoke. This machine is used to magnetize a specimen longitudinally (Figure 8.58). There is a coin around the horseshoe magnet that is made of soft, low-retentivity iron, which is magnetized by a small coil wound around its horizontal bar. The machine also follows the right-hand rule to demonstrate the current flow. As per ASME V, this method shall only be applied to detect discontinuities that are open to the surface of the part.

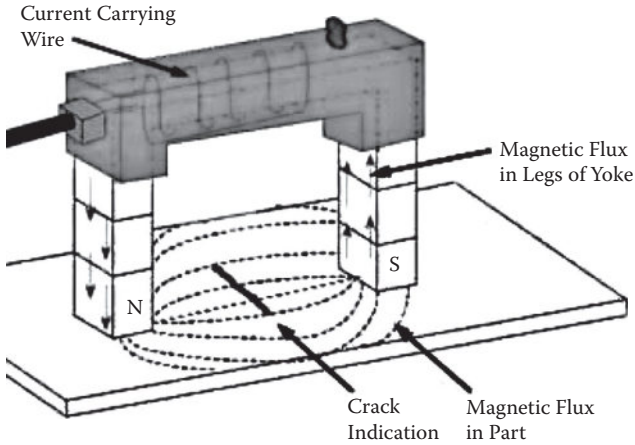

FIGURE 8.58
Yoke tool for MPI.

Calibrate the yoke machine by applying the maximum lifting force of the alternating current (AC) yoke. This should be determined at the actual leg separation to be used in the examination as per ASME V. This may be accomplished by holding the yoke with a 10 lb (4.5 kg) ferromagnetic weight between the legs of the yoke and adding additional weights, calibrated on a scale, until the ferromagnetic weight is released. The lifting power of the yoke should be the combined weight of the ferromagnetic material and the added weights, before the ferromagnetic weight was released. Other methods may be used such as a load cell.

8.6.5 Magnetizing Current

The alternating current is the most widely used for conducting magnetic particle testing. Because AC is continuously reversing its direction, the magnetic field has a tendency to agitate the iron particles and make them more mobile.

Currents from single phase 110 volts to three phase 440 volts are used when generating an electric field in a component. Current flow is often modified to provide the appropriate field within the part. The type of current used can have an effect on the inspection results, so the types of currents commonly used will be briefly reviewed.

AC reverses in direction at a rate of 50 or 60 cycles per second. In the United States, a 60-cycle current is the commercial norm but a 50-cycle current is common in many countries. Since AC is readily available in most facilities, it is convenient to make use of it for magnetic particle inspection. However, when AC is used to induce a magnetic field in ferromagnetic materials, the magnetic field will be limited to a narrow region at the surface of

the component. This phenomenon is known as the “skin effect” and occurs because induction is not a spontaneous reaction and the rapidly reversing current does not allow the domains below the surface time to align. Therefore, it is recommended that AC be used only when the inspection is limited to surface defects.

A better choice is single phase AC, which can be rectified to produce half-wave alternative current (HWAC), commonly called half-wave direct current (HWDC).

When single-phase alternating current is passed through a rectifier, current is allowed to flow in only one direction. The reverse half of each cycle is blocked out so that a one-directional, pulsating current is produced. The current rises from zero to a maximum and then returns to zero. No current flows during the time when the reverse cycle is blocked out. The HWAC repeats at the same rate as the unrectified current. Since half of the current is blocked out, the amperage is half of the unaltered AC (Figure 8.59). This type of current is often referred to as half-wave DC or pulsating DC. The pulsation of the HWAC helps magnetic particle indications form by vibrating the particles and giving them added mobility. This added mobility is especially important when using dry particles. The pulsation is reported to significantly improve inspection sensitivity. HWAC is most often used to power electromagnetic yokes.

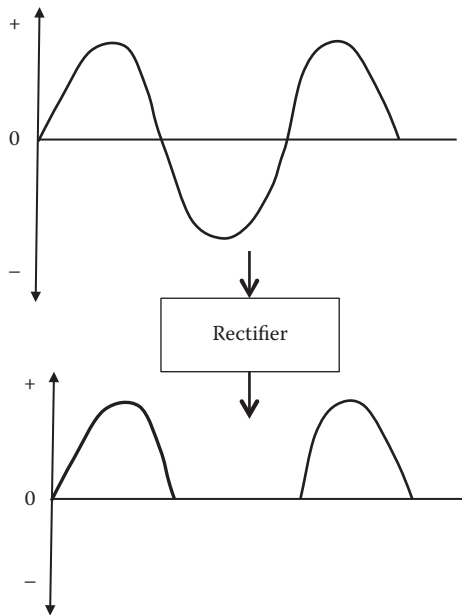

FIGURE 8.59
AC and HWAC.

8.6.6 Hysteresis Loop and Magnetic Properties

The hysteresis loop (Figure 8.60) depends on the electric current that magnetize the materials. This curve can be drawn by placing pieces of metal in coils through which alternating current is passed and we can plot the relation between magnetizing current in x-axis and the flux density on the y-axis.

It is worth mentioning that the permeability of a material can be determined by increasing the magnetizing force, which has a direct relation to the electric current density until the material reaches its saturation point. Every material has a point of maximum saturation or maximum flux density.

The dashed line from the zero origin to the positive maximum saturation at point *a* is as shown in Figure 8.60. It is known as the virgin curve. When the magnetizing force increases, the flux density increases until it reaches a saturation point at which any increase in magnetizing force produces no increase in flux density. After that the current will be reduced and the flux density will reduce slowly until the magnetizing force reaches zero at point *b*, which is the retentively point where there is a residual magnetism, which is the value from zero to *b*. After that there will be a corrective force, which is the reverse magnetizing force required to remove residual magnetism from the material as shown in the figure at point *c* with zero flux density and this point is called coercivity. A hardened steel would require a stronger reverse magnetizing force to remove the residual magnetism. After point *c* the reverse magnetizing force increases until it reaches the saturation point

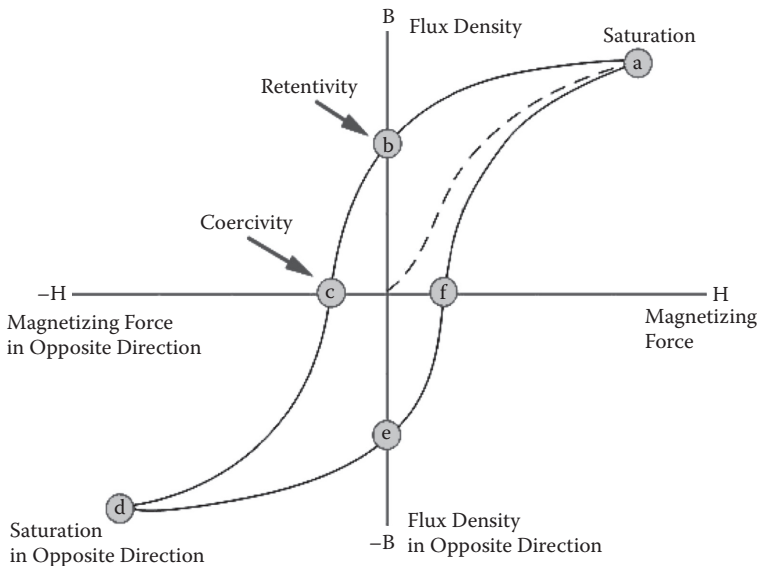

FIGURE 8.60
Hysteresis loop.

at d and then reduces the magnetizing force to decrease the flux density until it reaches the other retentivity point at point e . Under the same principle, the required force to remove this residual field is as shown between point zero and f .

From the hysteresis loop, a number of primary magnetic properties of a material can be determined.

1. Retentivity—A measure of the residual flux density corresponding to the saturation induction of a magnetic material. In other words, it is a material's ability to retain a certain amount of residual magnetic field when the magnetizing force is removed after achieving saturation (the value of B at point b on the hysteresis curve).
2. Residual magnetism or residual flux—The magnetic flux density that remains in a material when the magnetizing force is zero. Note that residual magnetism and retentivity are the same when the material has been magnetized to the saturation point. However, the level of residual magnetism may be lower than the retentivity value when the magnetizing force did not reach the saturation level.
3. Coercive force—The amount of reverse magnetic field that must be applied to a magnetic material to make the magnetic flux return to zero (the value of H at point c on the hysteresis curve).
4. Permeability, μ —A property of a material that describes the ease with which a magnetic flux is established in the component.
5. Reluctance—The opposition that a ferromagnetic material shows to the establishment of a magnetic field. Reluctance is analogous to the resistance in an electrical circuit.

A hard steel would have the following qualities and produce a wide hysteresis loop.

- Low permeability so it is hard to magnetize.
- High retentivity so it retains a strong residual magnetic field.
- High coercive force so it requires a high reverse magnetizing force to remove the residual magnetism.
- High reluctance so it will be highly resistant to magnetizing force.
- High residual magnetism so it retains a strong residual magnetic field.

Soft or low carbon steel would provide the following characteristics:

- High permeability so it is easy to magnetize.
- Low retentivity so it retains a weak residual magnetic field.
- Low coercive force so it requires a low reverse magnetizing force to remove the residual magnetism.

- Low reluctance so it will be of low resistance to magnetizing force.
- Low residual magnetism so it retains a weak residual magnetic field.

8.6.7 Examination Medium

The iron particle that will indicate the location and shape of the discontinuities should have a special specification, but some precaution should be taken during in selection. ASME V states that ferromagnetic particles used for the examination shall meet the following requirements. Particle types should be treated to impart color such as fluorescent pigments, nonfluorescent pigments, or both in order to be highly visible with contrast against the background of the surface being examined. The particles should be used within the temperature range limitations set by the manufacturer.

References

- American Society of Nondestructive Testing. 1980. *Dry Penetrant Training Manual*.
American Society of Nondestructive Testing. 1980. *Magnetic Particle Test Training Manual*.
American Society of Nondestructive Testing. 1980. *Radiographic Method Manual*.
American Society of Nondestructive Testing. 1980. *Ultrasonic Method Training Manual*.

CONCRETE and STEEL CONSTRUCTION

Starting with the receipt of materials and continuing all the way through to the final completion of the construction phase, *Concrete and Steel Construction: Quality Control and Assurance* examines all the quality control and assurance methods involving reinforced concrete and steel structures. This book explores the proper ways to achieve high-quality construction projects, and also provides a strong theoretical and practical background. It introduces information on quality techniques and quality management, and covers the principles of quality control.

The book presents all of the quality control and assurance protocols and non-destructive test methods necessary for concrete and steel construction projects, including steel materials, welding and mixing, and testing. It covers welding terminology and procedures, and discusses welding standards and procedures during the fabrication process, as well as the welding codes. It also considers the total quality management system based on ISO 9001, and utilizes numerous international and industry building standards and codes.

- Covers AISC, ACI, BS, and AWS codes
- Examines methods for concrete quality control in hot and cold weather applications, as well as material properties
- Illustrates methods for non-destructive testing of concrete and for steel welding—radiographic, ultrasonic, and penetration and other methods.
- Addresses ISO 9001 standards—designed to provide organizations better quality control systems
- Includes a checklist to be considered as a QA template

Developed as a handbook for industry professionals, this book also serves as a resource for anyone who is working in construction and on non-destructive inspection testing for concrete and steel structures.

K16818

