

McGRAW-HILL

ELECTRICIAN'S

POCKET MANUAL

SECOND EDITION

- The electrician's at-a-glance job site companion
- Provides answers in 60 seconds or less

REX MILLER

Electrician's Pocket Manual

Rex Miller

*Professor Emeritus
State University College
Buffalo, New York*

Second Edition

McGraw-Hill

New York Chicago San Francisco Lisbon London Madrid
Mexico City Milan New Delhi San Juan Seoul
Singapore Sydney Toronto

Copyright © 2005 by The McGraw-Hill Companies, Inc. All rights reserved. Manufactured in the United States of America. Except as permitted under the United States Copyright Act of 1976, no part of this publication may be reproduced or distributed in any form or by any means, or stored in a database or retrieval system, without the prior written permission of the publisher.

0-07-158915-5

The material in this eBook also appears in the print version of this title: 0-07-145887-5.

All trademarks are trademarks of their respective owners. Rather than put a trademark symbol after every occurrence of a trademarked name, we use names in an editorial fashion only, and to the benefit of the trademark owner, with no intention of infringement of the trademark. Where such designations appear in this book, they have been printed with initial caps.

McGraw-Hill eBooks are available at special quantity discounts to use as premiums and sales promotions, or for use in corporate training programs. For more information, please contact George Hoare, Special Sales, at george_hoare@mcgraw-hill.com or (212) 904-4069.

TERMS OF USE

This is a copyrighted work and The McGraw-Hill Companies, Inc. (“McGraw-Hill”) and its licensors reserve all rights in and to the work. Use of this work is subject to these terms. Except as permitted under the Copyright Act of 1976 and the right to store and retrieve one copy of the work, you may not decompile, disassemble, reverse engineer, reproduce, modify, create derivative works based upon, transmit, distribute, disseminate, sell, publish or sublicense the work or any part of it without McGraw-Hill’s prior consent. You may use the work for your own noncommercial and personal use; any other use of the work is strictly prohibited. Your right to use the work may be terminated if you fail to comply with these terms.

THE WORK IS PROVIDED “AS IS.” MCGRAW-HILL AND ITS LICENSORS MAKE NO GUARANTEES OR WARRANTIES AS TO THE ACCURACY, ADEQUACY OR COMPLETENESS OF OR RESULTS TO BE OBTAINED FROM USING THE WORK, INCLUDING ANY INFORMATION THAT CAN BE ACCESSED THROUGH THE WORK VIA HYPERLINK OR OTHERWISE, AND EXPRESSLY DISCLAIM ANY WARRANTY, EXPRESS OR IMPLIED, INCLUDING BUT NOT LIMITED TO IMPLIED WARRANTIES OF MERCHANTABILITY OR FITNESS FOR A PARTICULAR PURPOSE. McGraw-Hill and its licensors do not warrant or guarantee that the functions contained in the work will meet your requirements or that its operation will be uninterrupted or error free. Neither McGraw-Hill nor its licensors shall be liable to you or anyone else for any inaccuracy, error or omission, regardless of cause, in the work or for any damages resulting therefrom. McGraw-Hill has no responsibility for the content of any information accessed through the work. Under no circumstances shall McGraw-Hill and/or its licensors be liable for any indirect, incidental, special, punitive, consequential or similar damages that result from the use of or inability to use the work, even if any of them has been advised of the possibility of such damages. This limitation of liability shall apply to any claim or cause whatsoever whether such claim or cause arises in contract, tort or otherwise.

DOI: 10.1036/0071458875



Professional



Want to learn more?

We hope you enjoy this McGraw-Hill eBook! If you'd like more information about this book, its author, or related books and websites, please [click here](#).

CONTENTS

Preface / vii

Acknowledgments / ix

1. Special Equipment / 1
 2. Troubleshooting / 11
 3. Troubleshooting Electric Motors / 25
 4. Alarm Systems / 47
 5. Lamps and Lighting Systems / 71
 6. Electric Motors / 103
 7. Power Sources / 121
 8. Wires and Wiring / 147
 9. Hazardous Locations Equipment / 203
 10. Programmable Controllers / 229
 11. Wiring for Telephone Installation / 233
 12. Basic Mathematics and Measurement Conversion / 269
 13. Estimating a Job / 279
 14. Electrical and Electronic Formulas / 283
 15. Basic Electronics / 305
 16. How to Measure / 323
- Appendix 1.** Rules of Safety / 333
- Appendix 2.** Codes, Standards and Regulations / 349
- Appendix 3.** National Electrical Code Tables
Measurement / 357

Index / 387

ABOUT THE AUTHOR

Rex Miller is Professor Emeritus of Industrial Technology at State University College at Buffalo and has taught technical curriculum at the college level for more than four decades. Mr. Miller is the co-author of McGraw-Hill's bestselling *Carpentry & Construction*, Third Edition, as well as more than 75 texts for vocational and industrial arts programs. He resides in Round Rock, Texas.

PREFACE

This new edition of a popular pocket reference contains much new material. The pocket size has much new information inserted where needed to bring it up to date.

The value of the new edition has been enhanced by its more compact format that allows you to locate your information more quickly. Information in this edition has been updated to reflect changes in the latest edition of the *National Electrical Code* (also known as the Code).

The purpose of this book is to aid you in your everyday tasks and keep you updated with the latest facts, figures, and devices in this important trade.

Many illustrations are included, which show a variety of parts and techniques found in present day practice in the field. Obviously, not all related problems can be presented here, since there is a great deal of ingenuity required by the worker on the job. For standard procedure, however, the *National Electrical Code* handbook does give a guide to the number of wires and types of equipment that is safe to install in a given location. This handbook should be a part of your tool kit.

Rex Miller

ACKNOWLEDGMENTS

The author would like to thank the following manufacturers for their generous efforts. They furnished photographs, drawings, and technical assistance. Without their valuable time and effort this book would not have been possible. We hope this acknowledgment of some of the contributors will let you know that the field you are working in or are about to enter is one of the best. Individuals, too numerous to mention, have also played a role in this book. I would like to take this opportunity to also thank them for their contributions.

Arrow Fastener Co., Inc.	*National Electrical Code®
Automatic Switching Co.	National Electrical Contractors Association
Bodine Electric Co.	NEMA (National Electrical Manufacturers Association)
Bryant Electric Co.	Niagara-Mohawk Power Corp.
Canadian Standards Association	NuTone®, Inc.
Carlton®	Square D®, Inc.
Clauss Tools, Division of Ripley Tools	Stanley Tools, Division of The Stanley Works
Crouse-Hinds Electric Contractor Materials	Star Industries
ITW Linx	Underwriters' Laboratories, Inc.
M.M. Rhodes & Sons, Co.	Wiremold® Tools & Raceways
Motorola®, Inc.	

* National Electrical Code® and NEC® are registered trademarks of the National Fire Protection Association, Quincy, Massachusetts.

1

Special Equipment

Certain jobs or particular locations in which routine jobs must be done require the use of special equipment for gaining access in hard-to-reach places. Other types of jobs, especially industrial and commercial settings, may also require the use of special or large, heavy-duty equipment. Not every electrician needs to have these tools in the toolbox. Most large, expensive, and complicated tools are provided by the electrical contractor for whom the electrician works. However, the apprentice electrician should have familiarity with the more common special tools and their use.

BENDERS

There are cable benders for large cables that cannot be bent by hand and there are conduit benders.

Cable Bender. A cable bender is used to bend cable in close quarters with a minimum of effort. Most cable benders have insulated handles for the user's comfort. Figure 1-1 shows a typical cable bender. This one can handle cable up to 750 MCM.

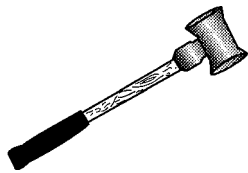


FIGURE 1-1. Cable bender.

2 CHAPTER ONE

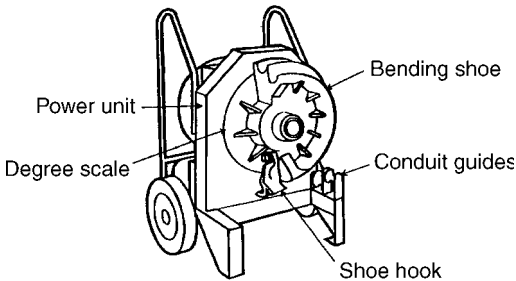


FIGURE 1-2. Electric bender.

Electric Bender. An electric bender can handle large rigid-steel and aluminum conduit easily. Bending shoes are sized to fit the conduit. Figure 1-2 shows a typical electric bender with different shoes and support rollers for various sizes of conduit.

Hydraulic Bender. A hydraulic bender is used to end conduit. A steel box houses the bender unit that can be used with two electric pumps or a manual pump. Figure 1-3 shows a typical hydraulic bender. Become familiar with its parts so that you are able to use it on the job.

CABLE GUIDE

A cable guide is used to keep cable where it is supposed to be while it is being pulled through conduit, along trays, or underground through manholes in the street. Some models have an adjustable radius that permits cable of different diameters to be guided. Figure 1-4 shows a cable guide with a radius that can be adjusted from $19\frac{1}{2}$ to 36 inches.

CABLE ROLLERS

Cable rollers are designed to reduce the problems associated with pulling cable over trays and ladders and to prevent snags. There

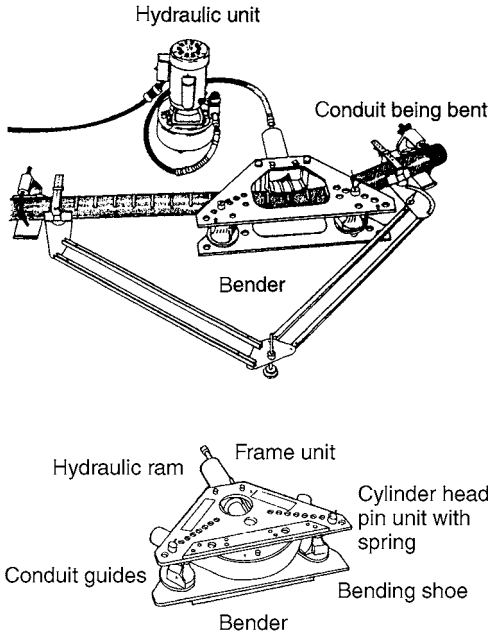


FIGURE 1-3. Hydraulic bender.

are several types of cable rollers, each designed for a specific purpose. See Figure 1-5.

Straight Rollers. Straight cable rollers, designed to be mounted on trays of common widths, or bottom-mounted. In most ladder configurations, they are used flat or vertically.

Radius Rollers. Radius rollers can be used alone or in combination with pulling off-sets for turns of less than 90° . They can be

4 CHAPTER ONE

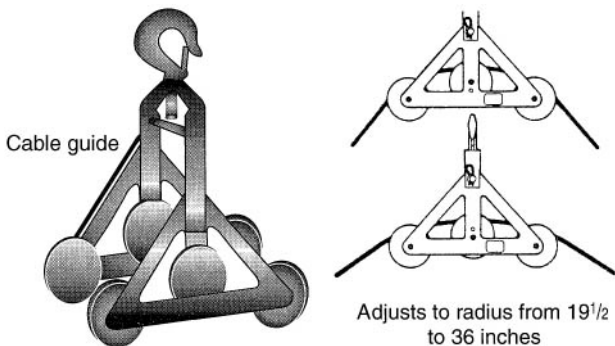


FIGURE 1-4. Cable guide.

top-mounted or bottom-mounted. When bottom mounting, allow a 5 $\frac{1}{2}$ -inch minimum clearance between rungs. Radius rollers have two J-bolts and mounting hardware similar to that on straight rollers.

Right Angle Rollers. Right-angle rollers handle even the heaviest cables. A combination of horizontal and vertical ball-bearing

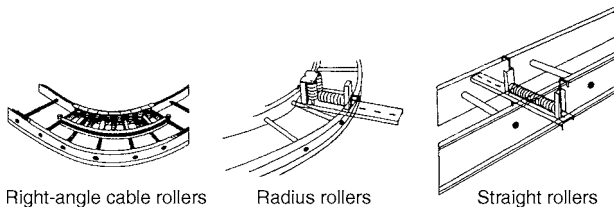


FIGURE 1-5. Types of rollers.

rollers will ensure easy pulling and added control at all points of contact in 90° turns. They can be top-mounted or inside-mounted on any manufacturer's tray or ladder.

CONNECTOR TOOLS FOR ALUMINUM WIRE OR CABLE

Hydraulic pumps are used to ensure that all sizes of aluminum conductors can be properly terminated. They are also used in bending aluminum cable when it is of such diameter as to require the extra pressure afforded by a hydraulic device.

A hydraulic pump for aluminum connector tools exerts high pressure to crimp or squeeze lugs onto aluminum cable. Before compression, a typical cross section of cable and connector consists of about 75% metal and 25% air. After compression, the cross section is hexagonal and, with the force provided by a hydraulic compressor tool, 100% of the metal makes contact with the wire with no air spaces between the cable wires and the lug or terminal. See Figure 1-6.

An aluminum connector and tool consist of a pump to which is attached different sizes of heads. If a source of electric power is available, an electric motor is used to drive the hydraulic pump. If power is not available, a portable generator is used to supply power, or a hand-operated pump is used.

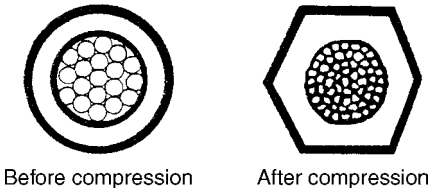
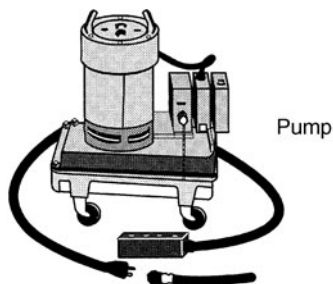


FIGURE 1-6. Cross section of cable.



12-ton head 15-ton head

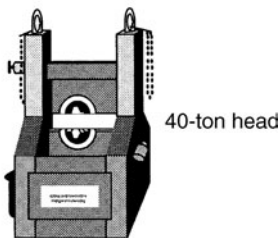


FIGURE 1-7. Aluminum connector tool.

PUMP

Hydraulic pumps for aluminum connector tools come in many sizes. Figure 1-7 illustrates a typical pump. It weighs only 95 pounds and operates on 120 volts AC. It has a 1-horsepower motor that can pump 115 cubic inches of hydraulic fluid per minute at 2500 pounds per square inch or 57 cubic inches per minute at 10,000 pounds per square inch. Foot- and hand-operated switches are used to control the motor, which, in turn, drives the pump. The high pressure generated provides the force to crimp the aluminum cable.

HEADS

The heads are the tools that actually do the work of compressing the cable and lugs to make good, tight fits. Heads are available in different sizes to fit the requirements of particular jobs. They are identified by the amount of pressure they are able to exert on a connection. Three common types of heads are shown in Figure 1-7.

Twelve-Ton Head. The 12-ton head is a versatile tool designed for field or bench work. The small size of the compression head and the fact that it can be operated by a switch located nearby but not on the pump, allows the pump to be in one area where there is space, and the head in a confined area where the connection has to be made.

The 12-ton head, shown in Figure 1-7, is made from forged steel. It weighs 7½ pounds. When in use, it can apply 12 tons of pressure, or 24,000 pounds per square inch. The dies that fit into the head are color-coded to match color-coded connectors. A 12-ton head installs aluminum lugs and splices wire from 12 to 750 MCM.

Fifteen-Ton Head. The 15-ton head can apply 30,000 pounds per square inch of pressure. It is used to install aluminum lugs, taps, and splices for #12 AWG to 1000 MCM. The 15-ton head shown in Figure 1-7, weighs 15½ pounds and can be operated up to 100 feet from the electric hydraulic pump. Compression dies are available in two types: one that fits directly into the head and is used for large cables; and one that is used in combination with an adaptor for small conductors. All dies are color-coded to match the color-coded connectors.

Forty-Ton Head. The 40-ton head makes connections with cable up to 2000 MCM with its 80,000 pounds per square inch of pressure.

PUMPS, MANUAL (HAND- OR FOOT-OPERATED)

A manual pump aids in getting a number of jobs done in the field. These pumps can be used to bend conduit and apply pressure on connectors for taps and lugs as well as splices. See Figures 1-8 and 1-9. Figure 1-10 shows channel hole punch.



FIGURE 1-8. Hydraulic pump.

8 CHAPTER ONE

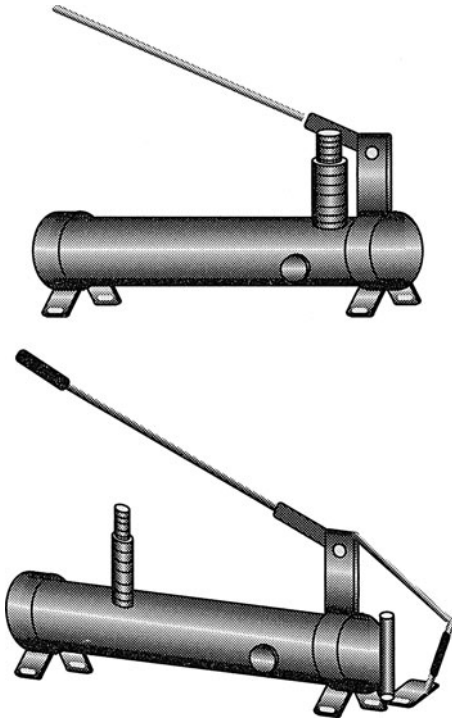


FIGURE 1-9. Hand-operated hydraulic pump.

Manual pumps can be used in vertical or horizontal positions. The long handle on most models makes it possible to apply a great deal of pressure on the pumping apparatus and obtain the needed squeezing power to make a good electrical connection. In some cases, a hand- or foot-operated hydraulic pump can also be used to make punches for circuit breaker boxes, metal studs, or other steel boxes.

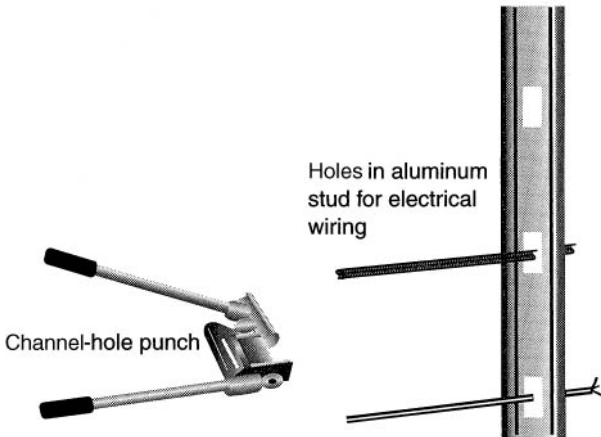


FIGURE 1-10. Channel hole punch.

USING A MANUAL PUMP

There are a number of operations to perform or observe before operating the manual-type pump.

- Before using the pump, check all hoses for leaks and cracks.
 - Check that all safety valves are operating.
 - Always wear goggles when using a manual pump.
-

WIRE DISPENSER

A wire dispenser is a device that holds and dispenses wire. One common type is shown in Figure 1-11. This wire dispenser handles six 2500-foot spools of wire up to 18 inches in diameter. The dispenser itself can be passed through a standard 30-inch doorway. The front wheel is swivel-mounted to allow feeding in any

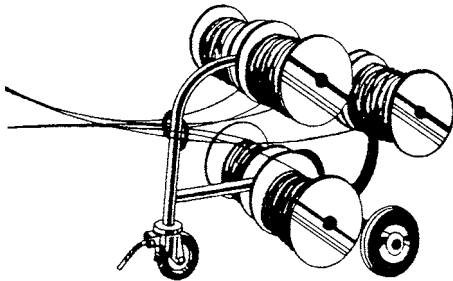


FIGURE 1-11. Wire trolley.

direction from a central location and can be locked to prevent movement. Wire is paid out easily, and there is automatic braking. There are less expensive models. They are available with the ability to handle spools of 500 feet of wire. They do not usually have automatic braking.

2

Troubleshooting

Troubleshooting tests the electrician's ability to observe and understand how things work. Electrical problems are many: every connection and every device is a potential problem. One of the best ways to prevent trouble is to check certain items as a routine procedure—to catch trouble before it becomes serious and causes fires, other damage, or even death.

This chapter presents some general troubleshooting techniques, concentrating on common problems and causes of troubles, and then focuses on troubleshooting electric motors. Remember, though, that troubleshooting hints apply only to common problems and their probable causes and remedies. They cannot give specific solutions, since on the scene facts may alter a situation. It takes a trained observer to ferret out the facts in a specific situation and make a diagnosis. Once a problem is identified, it is easily corrected.

GENERAL TROUBLESHOOTING

Several problems occur frequently in electrical work. Among them are:

- Handling wet and damp areas
- Removing a ground

12 CHAPTER TWO

- Preventing accidental shock
- Checking wiring installations

HANDLING DAMP AREAS

One factor that can cause problems in any wiring system is dampness. Watertight equipment should be installed wherever there is a danger of water contacting live wires. Three things that can cause trouble are:

- condensation
- rust
- corrosion.

CONDENSATION

One major problem is the condensation of moisture inside panel boards. Moisture condenses when warm moist air in the basement moves up and contacts cold air outside, thus making the riser cold. See Figure 2-1. In areas where this is a problem, an underground entrance should be made, or an outside riser should be mounted alongside the house, making its entry only when it reaches the panel board. An entrance as low as possible is preferred so that any moisture that does condense will easily drain out at the bottom of the panel board without contacting the hot side of the distribution panel. See Figure 2-2. This problem can occur in farm buildings that house livestock because the animals generate a lot of humidity.

RUST AND CORROSION

Another problem with electrical installations can be the presence of rust and corrosion. Each can be a source of trouble.

Rust. Rust is another problem. There is the possibility of rust with exposed steel surfaces and water. Rust can cause problems with the ground system. Paint helps prevent rust. Touch up scratched surfaces frequently.

Corrosion. Corrosion can be a problem when dissimilar metals make contact with moisture. Use galvanized panels or conduit and in some cases use plastic boxes, panels, and conduit. Some metals may also be coated with an anticorrosion agent. Check (National Electrical Code) NEC regulations for safe applications to prevent corrosion.

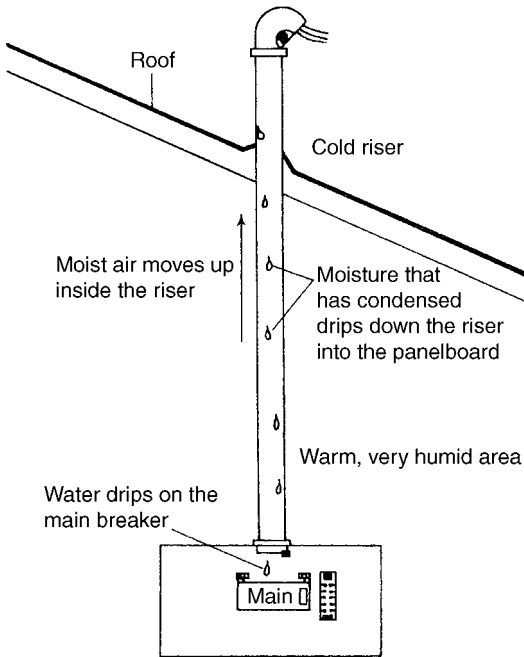


FIGURE 2-1. Condensation inside a panel board.

HANDLING GROUNDS AND PREVENTING ACCIDENTAL SHOCK

Removing a ground produces a potentially hazardous situation. In a properly installed 120/240-volt system, the current on the neutral line carries the difference between the current flowing on the hot lines. If rust or corrosion prevents contact with the proper grounding lugs, the ground becomes open—in effect, it is removed. See Figure 2-3.

14 CHAPTER TWO

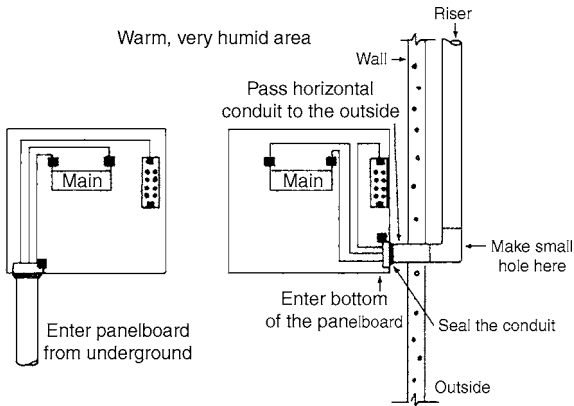


FIGURE 2-2. An underground entrance prevents condensation from contacting hot distribution panel.

One of the indications of this open-ground situation in a house is that some of the lights in the house will appear very bright and others very dim. If this occurs, turn off the main switch and locate the open or corroded ground connection before doing anything else. A situation like this is dangerous for anyone who touches any of the conductors. That person or animal then completes the ground circuit and a fatal shock may occur.

GROUND FAULT INTERRUPTER

The ground fault circuit interrupter (GFCI) is one device used to prevent accidental shock. However, the use of a GFCI should never be a substitute for good grounding practices. Rather, it should test for and support a well-maintained grounding system.

Several types of GFCI devices are used to check grounding systems and thus prevent accidental shock. Figure 2-4 shows some of these devices. A, B, C, D, and E indicate the various devices. Some plug-in testers check polarity and grounding (A). Some check the continuity of a ground path (B). This is very important with many

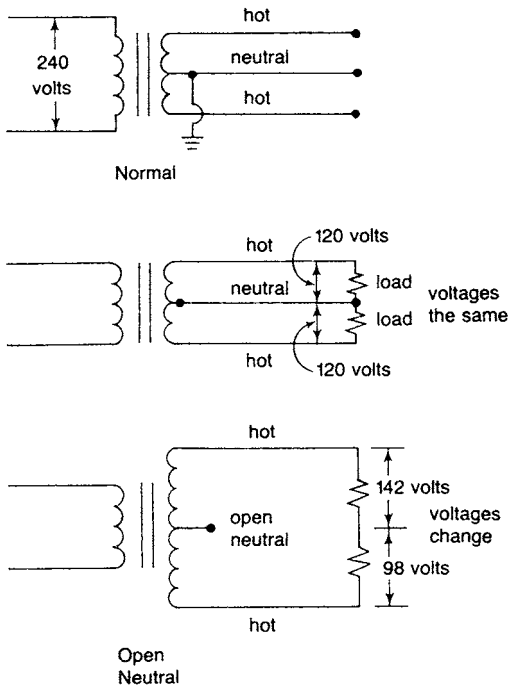


FIGURE 2-3. Removing a ground.

tools, especially those with metal handles. Another type is a ground loop tester (C). It measures the ground loop impedance of live circuits. Others check the 500-volt and 1000-volt direct current (DC) installation resistance of de-energized circuits and electrical equipment (D). It also checks the continuity in low-resistance circuits. Still others provide insurance against a tool developing a fault while being used (E), possibly causing serious personal injury by ensuring that any current leaking is below a hazard level.

16 CHAPTER TWO

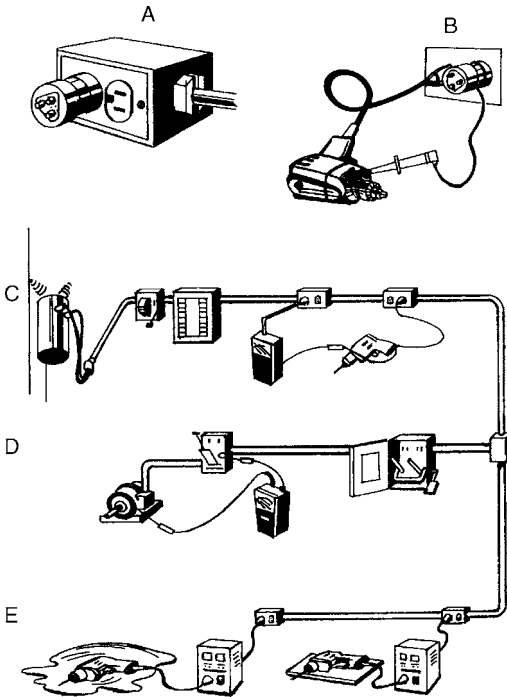


FIGURE 2-4. These devices check the grounding system and thus prevent shock.

One problem associated with ground fault circuit interrupters is nuisance tripping. Keep in mind that even a few drops of moisture or flecks of dust can trip the GFCI. One way to avoid this problem is to use watertight plugs and connectors on extension cords.

NOTE

The 2005 NEC has added requirements for GFCI protection.

GROUND FAULT RECEPTACLES

A ground fault receptacle (GFR) is a ground fault circuit interrupter with a receptacle. A GFR may be wired to protect its own outlet—terminal installation—or it may be wired to protect its outlet and other downstream receptacles. A typical wiring diagram for terminal installation is shown in Figure 2-5. One way to check for terminal installation is to check the red and gray wires. If they are capped with a wire nut, then you know that the GFR does not service any other outlets.

When a GFR that protects more than one outlet is tripped, it takes all of the outlets it services off the line. This can lead to some problems. For example, a GFR located in an upstairs bathroom may also protect an outside outlet and a downstairs bathroom outlet. If someone tries to use the outside outlet and it doesn't work, he or she may not relate this malfunction to the GFR in the upstairs bathroom and may call the electrician unnecessarily. All that needs to be done in such a situation is to push the test (T) button on the GFR upstairs and then the reset (R) button to make sure the fault does not still exist; this puts the outlets back on line. Figure 2-6 shows typical wiring for a GFR that protects more than one outlet.

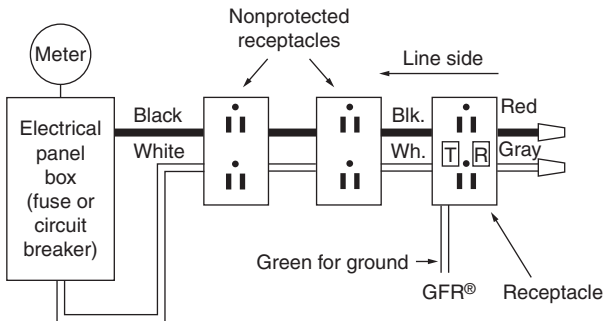


FIGURE 2-5. Wiring diagram for GFR that is also a receptacle with service for only one outlet.

18 CHAPTER TWO

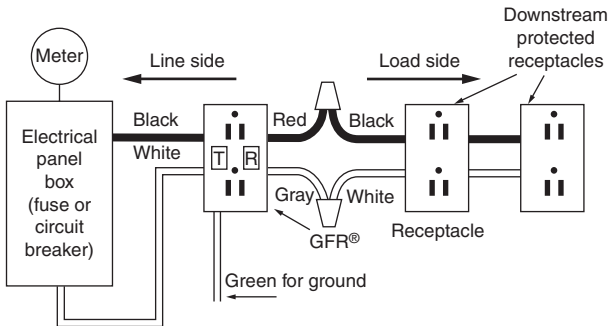


FIGURE 2-6. Wiring diagram for GFR that protects other downstream receptacles.

WIRING PROBLEMS

Some problems with wiring systems can be traced to the use of improper materials in the wiring devices. Therefore, the use of proper materials in the installation stage is a form of preventive maintenance, decreasing the likelihood of problems later.

Shock hazards should be minimized by the dielectric strength of the material used for the molded interior walls and the individual wire pocket areas. Each molded piece has to support adjacent molded pieces to result in good resiliency and strength. Nylon seems to be the best for this job. Nylon devices withstand high impact in heavy-duty neoprene, urea, or phenolic materials. Damage can be invisible and cause direct shorts and other hazards. Nylon also has the ability to withstand high voltages without breaking down. Tables 2-1 and 2-2 detail the properties of materials commonly used in wiring devices.

In troubleshooting wiring problems, it is important to check that switches have been wired properly. Figure 2-7 shows wiring diagrams for switches in various systems. Plugs and connectors must also be wired and grounded correctly. Figure 2-8 shows the grounding systems used in connecting various plugs to a circuit.

TABLE 2-1
Chemical Resistance of Materials Commonly Used in Wiring Devices

Chemical	Nylon	Melamine	Phenolic	Urea	Polyvinyl Chloride	Polycarbonate	Rubber
Acids	C	B	B	B	A	A	B
Alcohol	A	A	A	A	A	A	B
Caustic bases	A	B	B	B	A	C	C
Gasoline	A	A	A	C	A	A	B
Grease	A	A	A	A	A	A	B
Kerosene	A	A	A	A	A	A	A
Oil	A	A	A	A	A	A	A
Solvents	A	A	A	A	C	C	C
Water	A	A	A	A	A	A	B

A—Completely resistant; good-to-excellent, recommended for general use.

B—Resistant; fair-to-good limited service.

C—Prone to slow attack; not recommended for use.

TABLE 2-2
Mechanical and Electrical Properties of Material Commonly Used in Wiring Devices

	Nylon	Melamine	Phenolic	Urea	Polyvinyl Chloride	Polycarbonate
Tensile strength (psi)	900–12,000	7000–13,000	6500–10,000	5500–13,000	5000–9000	8000–9500
Elongation (percent)	60–300	0.6–0.9	0.4–0.8	0.5–1.0	2.0–4.0	60–100
Tensile modulus (10 ⁵ psi)	1.75–4.1	12–14	8–17	10–15	3.5–6	3.5
Compressive strength (psi)	6700–12,500	25,000–45,000	22,000–36,000	25,000–45,000	8000–13,000	12,500
Flexural strength (psi)	No break	10,000–16,000	8500–12,000	10,000–18,000	10,000–16,000	13,500
Impact strength (ft-lb/in.)	1.0–2.0	0.24–0.35	0.24–0.60	0.25–0.40	0.4–20	12–16
Rockwell hardness	R109–R118	M110–M125	M96–M120	M110–M120	70–90 shore	M70–R116
Continuous temperature resistance (°F)	180–200	210	350–360	170	150–175	250
Heat distortion psi (°F)	360–365	*	*	*	179	285
Dielectric strength (volt/mil)	385–470	300–400	200–400	300–400	425–1300	400
Arc resistance (sec) ASTM D495	100–105	110–180	0–7	110–150	60–80	10–120
Burning rate (in./min)	Self-extinguishing	Self-extinguishing	Very low	Self-extinguishing	Self-extinguishing	Self-extinguishing

*Not applicable, because these are thermosetting materials.

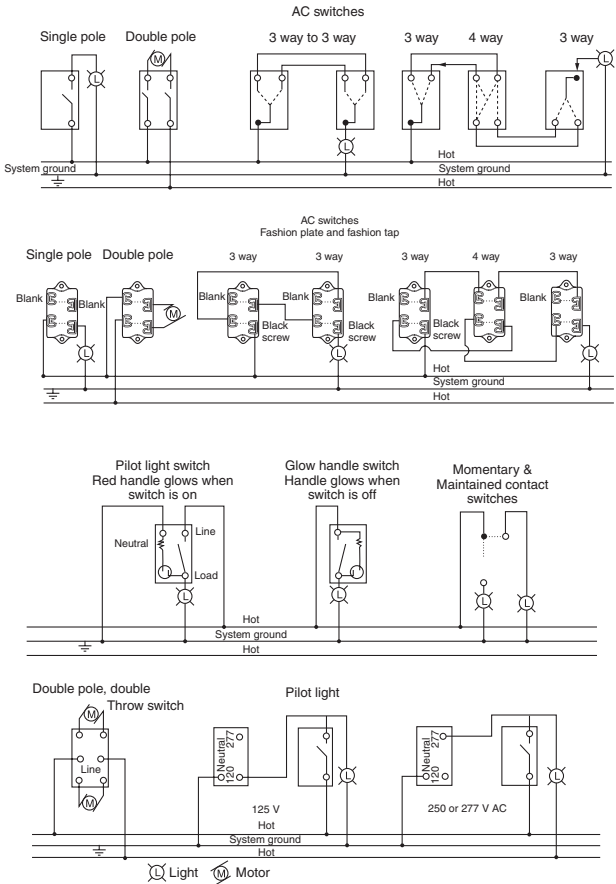


FIGURE 2-7. Wiring diagrams for switches in various systems.

22 CHAPTER TWO

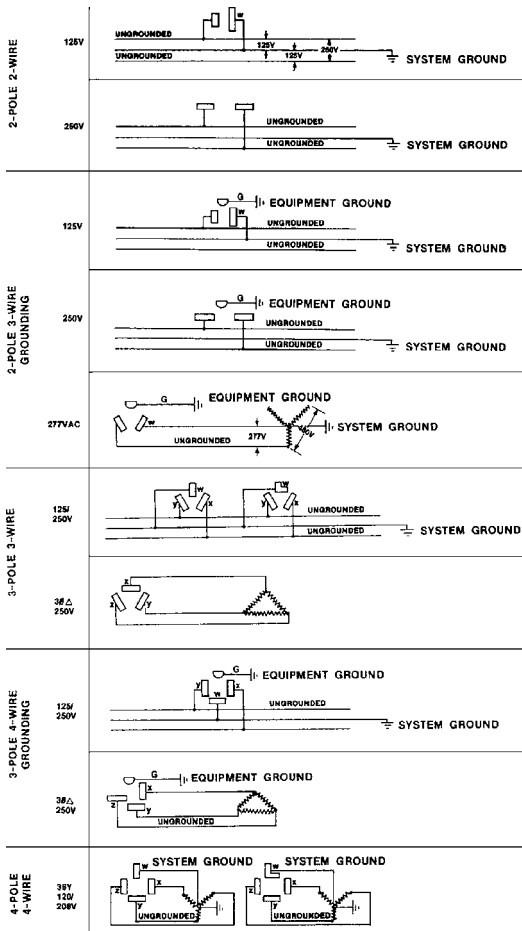


FIGURE 2-8. Grounding systems used by connecting various plugs to a circuit.

In some troubleshooting situations, the electrician will be called upon to trace wires. Most multi-wire cables have color-coded conductors. Follow the color code to identify the same conductor at each end of the installation. When installing a wiring system, make a list of the color-coded conductors and where each terminates. This makes future troubleshooting easier.

Test for wire pairs using an ohmmeter. Short two wires together on one location and use an ohmmeter at the other end to test for continuity. Then mark with colored tape or a number label.

This page intentionally left blank

3

Troubleshooting Electric Motors

Electric motors should be installed and maintained by electricians. There are millions of motors in use in homes, offices, stores, and industrial plants. One major concern is choosing the right motor for a given job. The choice depends on

- The intended use of the motor
- The availability of power
- The location
- Other factors

Once installed, the motor must be properly maintained to prevent problems. The electrician and apprentice should ensure proper motor maintenance, and if problems do occur, they should be able to pinpoint the source and cause of the problem and correct it. This chapter discusses preventive maintenance of electric motors and danger signals to recognize in motors, and hints for correcting common problems.

PREVENTIVE MAINTENANCE

Small motors usually operate with so little trouble that they are apt to be neglected. However, they should be thoroughly inspected twice a year to detect wear and to remove any conditions that

26 CHAPTER THREE

might lead to further wear or cause trouble. Special care should be taken to inspect motor bearings, cutouts, and other parts subject to wear. Also, be sure that dirt and dust are not interfering with ventilation or clogging moving parts.

CHECKING AND MAINTAINING SMALL MOTORS

- *Be sure there is adequate wiring.* After a motor has been installed or transferred from one location to another, check the wiring. Be sure that adequate wire sizes are used to feed electric power to the motor; in many cases, replacing wires is all that is needed to prevent future breakdowns. Adequate wiring also helps to prevent overheating and reduces electric power costs.
- *Check internal switches.* Although switches usually give little trouble, regular attention will make them last longer. Use fine sandpaper to clean contacts. Be sure sliding members on a shaft move freely, and check for loose screws.
- *Check load conditions.* Check the driven load regularly. Sometimes additional friction develops gradually within a machine and after a period imposes an overload on the motor. Watch motor temperatures and protect motors with properly rated fuses or overload cutouts.
- *Provide extra care in lubrication.* Motors should be lubricated according to manufacturer's recommendations. A motor running three times more than usual needs three times more attention to lubrication. Provide enough oil, but don't overdo it.
- *Keep commutators clean.* Do not allow a commutator to become covered with dust or oil. Wipe it occasionally with a clean, dry cloth or one moistened with a solvent that does not leave a film. If it is necessary to use sandpaper to clean the commutator, use No. 0000 or finer.
- *Replace worn brushes.* Inspect brushes at regular intervals. Whenever a brush is removed for inspection, be sure to replace it in the same axial position—that is, it should not be turned around in the brush holder when it is put back in the

motor. If the contact surface that has been worn in to fit the commutator is not replaced in the same position, excessive sparking and loss of power will result.

- *Brushes naturally wear down.* They should be replaced before they are less than $\frac{1}{4}$ inch long.
 - *Be sure that the motor has a proper service rating.* Whenever a motor is operated under different conditions or used in a different way, be sure it is rated properly. Take, for example, a motor rated for intermittent duty because the temperature rise within the motor will not be excessive when it is operated for a short period. Putting such a motor on continuous duty will result in excessive temperature increases that will lead to burnout or at least to deterioration of the insulation.
-

LUBRICATION

As stated in the list in the previous section, extra care in lubrication is essential in maintaining all motors. The exact function of the lubricant and the choice of lubricant depend somewhat on the type of motor.

Lubricating Ball-Bearing Motors. Ball-bearing motors are motors that have rollers or ball bearings supporting the rotor at each end. The lubricants in ball-bearing motors serve to:

- Dissipate heat caused by friction of bearing members under load
- Protect bearing members from rust and corrosion
- Provide protection against the entrance of foreign matter into the bearings.

Lubricating Sleeve-Bearing Motors. Sleeve-bearing motors are quieter than ball-bearing motors. They operate by having a small tube-like (brass, bronze, or alloy) sleeve support the rotor shaft at each end. The lubricant used with sleeve bearings must actually provide a film that completely separates the bearing surfaces from the rotating shaft member and ideally eliminates all metal-to-metal contact.

28 CHAPTER THREE

Choice of Lubricant. Good lubricants are essential to low-maintenance costs. Oil that provides the most effective bearing lubrication and does not require frequent renewal should be selected. In general, low-viscosity oils are recommended for fractional horsepower motors because they offer low friction, permit fuller realization of the motors' efficiency, and minimize the operating temperature of the bearing. Top-grade oils are recommended, since they are

- Refined from pure petroleum
- Substantially noncorrosive to metal surfaces
- Free from sediment, dirt, or other foreign materials
- Stable in the presence of heat and moisture encountered in the motor

In terms of performance, the higher-priced oils often prove to be cheaper.

If extremes in bearing temperatures are expected, special care should be exercised in selecting the proper lubricant. Special oils are available for motor applications at high temperatures and low temperatures. Standard-temperature-range oils should not be used in situations with high ambient temperatures and high motor-operating temperatures because there will be

- Decrease in viscosity
- Increase in corrosive oxidation products, and
- Usually a reduction in the quantity of lubricant in contact with the bearing

This, in turn, will cause an increase in bearing temperature and a damaging effect on bearing life and motor performance.

PREVENTION OF WEAR

Sleeve-bearing motors are less susceptible to wear than ball-bearing motors because the relatively soft surface of the sleeve bearing can absorb hard particles of foreign materials. Therefore, there is less abrasion and wear. However, good maintenance procedures for both types of motors require that the oil and bearings be kept clean. How often the oil should be changed depends on local conditions, such as the severity and continuity of service and operating temperatures. A conservative lubrication maintenance

program should call for inspection of the oil level and cleaning and refilling with new oil every 6 months.

WARNING

Overlubrication should be avoided at all times. Excess motor lubricant is a common cause of the failure of motor winding insulation in both sleeve and ball-bearing motors.

DANGER SIGNALS

There are danger signals that usually appear before a motor overheats or burns out. At first appearance of these signs, the electrician or apprentice should make every effort to correct and improve maintenance procedures and remedy any other problems to try to avoid permanent damage to the bearings or motor.

Major Danger Signals in Ball-Bearing Motors

- A sudden increase in the temperature differential between the motor and bearing temperatures—usually indicates malfunction of the bearing lubricant.
- A temperature higher than that recommended for the lubricants—warns of a reduction in bearing life. (A good rule of thumb is that grease life is halved for each 25° increase in operating temperature.)
- An increase in bearing noise, accompanies an increase in bearing temperature—indicating a serious bearing malfunction.

Major Causes of Ball-Bearing Failure

- Foreign matter in the bearing from dirty grease or ineffective seals
- Deterioration of grease because of high temperatures or contamination
- Overheating caused by too much grease

Major Danger Signals in Sleeve-Bearing Motors

- Rumbling noise
- High-pitched whistling sound

30 CHAPTER THREE

COMMON MOTOR TROUBLES AND THEIR CAUSES

When troubleshooting an electric motor, it is advisable to keep in mind the most common problems associated with a particular type of motor.

With a fractional-horsepower motor, easy-to-detect symptoms indicate exactly what is wrong in many cases. However, at times, several types of problems have similar symptoms, and it becomes necessary to check each symptom separately to diagnose the overall problem. Table 3-1 lists some of the more common problems of small motors along with suggestions of possible causes.

Most common motor troubles can be checked by some tests or by visual inspection. The order in which to conduct these tests rests with the troubleshooter, but it is natural to conduct the simplest tests first. For instance, when a motor fails to start, you first inspect the motor connections, since this is an easy and a simple thing to do. In some cases, a combination of symptoms will provide a clue to the source of trouble and eliminate some possibilities. For example, in the case cited previously—a motor will not start—if heating occurs, this fact suggests that a short or ground exists in one of the windings and eliminates the likelihood of an open circuit, poor line connection, or defective starter switch.

Centrifugal starting switches, found in many types of fractional horsepower motors, are occasionally a source of trouble. If the mechanism sticks in the run position, the motor will not start once it is turned off. On the other hand, if the switch sticks in the closed position, the motor will not attain speed and the start winding quickly heats up. The motor may also fail to start if the contact points of the switch are out of adjustment or coated with oxide. It is important to remember, however, that any adjustment of the switch or contacts should be made only at the factory or at an authorized service station.

Knowing the arrangement of coils aids in checking for possible

- Shorts
- Grounds
- Opens

in any type of alternating current (AC) or direct current (DC) motor. Figure 3-1 shows these motor connections.

TABLE 3-1
Guide to Probable Causes of Motor Troubles

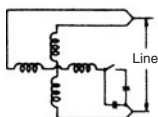
Motor Type	AC Single Phase				AC Polyphase (2 or 3 Phase)	Brush Type (Universal, Series, Shunt, or Compound)
	Split Phase	Capacitor Start	Permanent-Split Capacitor	Shaded Pole		
Trouble	*Probable Causes					
Will not start	1, 2, 3, 5	1, 2, 3, 4, 5	1, 2, 4, 7, 17	1, 2, 7, 16, 17	1, 2, 9	1, 2, 12, 13
Will not always start, even with no load, but will run in either direction when started manually	3, 5	3, 4, 5	4, 9		9	
Starts but heats rapidly.	6, 8	6, 8	4, 8	8	8	8
Starts but runs too hot.	8	8	4, 8	8	8	8
Will not start but will run in either direction when started manually—overheats.	3, 5, 8	3, 4, 5, 8	4, 8, 9		8, 9	
Sluggish—sparks severely at the brushes.						10, 11, 12, 13, 14
Abnormally high speed—sparks severely at the brushes					15	
Reduction in power—motor gets too hot.	8, 16, 17	8, 16, 17	8, 16, 17	8, 16, 17	8, 16, 17	13, 16, 17
Motor blows fuse, or will not stop when switch is turned to off position.	8, 18	8, 18	8, 18	8, 18	8, 18	18, 19
Jerky operation—severe vibration.						10, 11, 12, 13, 19

*Probable causes

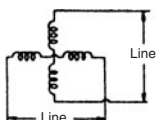
- | | | |
|--|---|--|
| 1. Open in connection to line | 8. Winding short-circuited or grounded | 14. Oil-soaked brushes |
| 2. Open circuit in motor winding | 9. One or more windings open | 15. Open circuit in the shunt winding |
| 3. Contacts of centrifugal switch not closed | 10. High mica between commutator bars | 16. Sticky or tight bearings |
| 4. Defective capacitor | 11. Dirty commutator or commutator is out of round | 17. Interference between stationary and rotating members |
| 5. Starting winding open | 12. Worn brushes and/or annealed brush springs | 18. Grounded near switch end of winding |
| 6. Centrifugal starting switch not opening | 13. Open circuit or short circuit in the armature winding | 19. Shorted or grounded armature winding |
| 7. Motor overloaded | | |

Source: Courtesy of Bodine Electric Company, Chicago.

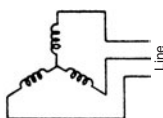
CONNECTION DIAGRAMS



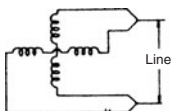
RELUCTANCE SYNCHRO-
NOUS TWO-VALUE
CAPACITOR—Reversible
only from rest (by trans-
posing leads).



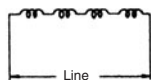
RELUCTANCE SYNCHRO-
NOUS TWO-PHASE—4-
LEAD—Reversible by
transposing either phase
leads with line.



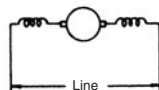
RELUCTANCE SYNCHRO-
NOUS THREE-PHASE—
Reversible by transposing
any two leads.



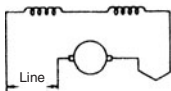
HYSTERESIS
SYNCHRONOUS
PERMANENT-SPLIT
CAPACITOR—Reversible
by transposing leads.



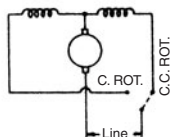
SHADED POLE—Non-
reversible.



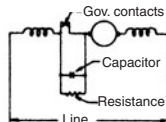
SERIES-WOUND—
2-LEAD—Non-reversible.



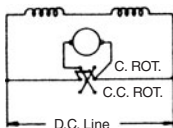
SERIES-WOUND—4-LEAD
Reversible by transposing
armature leads.



SERIES-WOUND SPLIT
FIELD—Reversible by
connecting either field
lead to line.

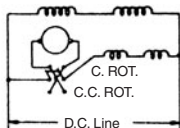


ELECTRIC GOVERNOR
CONTROLLED SERIES-
WOUND—Non-reversible.



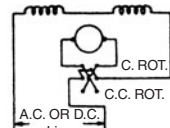
(a)

SHUNT MOTOR
4-WIRE REVERSIBLE



(b)

COMPOUND MOTOR
5-WIRE REVERSIBLE

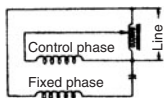


(c)

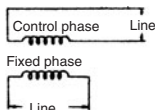
SERIES MOTOR
4-WIRE REVERSIBLE

FIGURE 3-1. Connection diagrams showing the arrangement of coils in various types of motors.

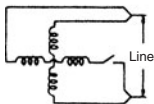
CONNECTION DIAGRAMS



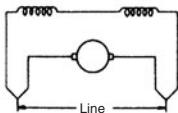
TWO-PHASE SERVO TYPE CONTROL—Reversible.



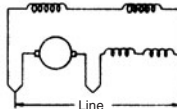
(Bodine Electric Co.)



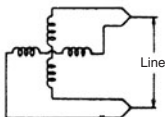
SPLIT-PHASE—Reversible only from rest (by transposing leads).



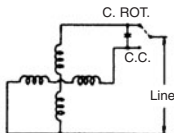
SHUNT-WOUND—Reversible by transposing leads.



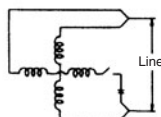
COMPOUND-WOUND—Reversible by transposing armature leads.



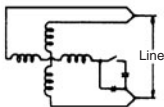
PERMANENT-SPLIT CAPACITOR 4-LEAD—Reversible by transposing leads.



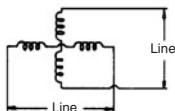
PERMANENT-SPLIT CAPACITOR 3-LEAD—Reversible by connecting either side of capacitor to line.



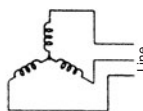
CAPACITOR-START—Reversible only from rest (by transposing leads).



TWO-VALUE CAPACITOR—Reversible only from rest (by transposing leads).



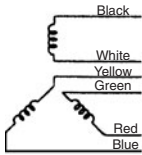
TWO-PHASE 4-LEAD—Reversible by transposing either phase leads with line.



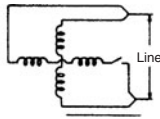
THREE-PHASE-SINGLE VOLTAGE—Reversible by transposing any two leads.

FIGURE 3-1. (continued)

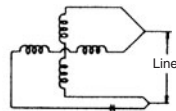
34 CHAPTER THREE



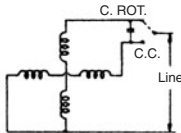
3-PHASE, STAR-DELTA, 6-LEAD REVERSIBLE—For 440 volts connect together white, yellow and green: Connect to line black, red and blue. To reverse rotation, transpose any two line leads. For 220 volts connect white to blue, black to green, and yellow to red: Then connect each junction point to line. To reverse rotation, transpose any two junction points with line.



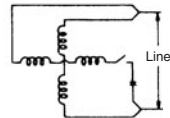
RELUCTANCE SYNCHRONOUS SPLIT-PHASE—Reversible only from rest (by transposing leads).



RELUCTANCE SYNCHRONOUS PERMANENT-SPLIT-CAPACITOR 4-LEAD—Reversible by transposing lead.



RELUCTANCE SYNCHRONOUS PERMANENT-SPLIT-CAPACITOR 3-LEAD—Reversible by connecting either side of capacitor to line.



RELUCTANCE SYNCHRONOUS CAPACITOR-START—Reversible only from rest (by transposing leads).

FIGURE 3-1. (continued)

Knowing the current expected to be drawn in the normal operation of a motor also aids in troubleshooting. Then it is possible to use a clamp-on ammeter, check the current drawn by the motor, and compare it with the standards to see if it is excessive or otherwise incorrect. Table 3-2 shows these ampere ratings of AC motors that operate on three-phase power. Remember, however, that these are average ratings and that the rating on the specific motor could be higher or lower. Therefore, the selection of heater coils on this basis alone involves some risk. For fully reliable motor protection, check the motor's nameplate and select heater coils based on the full-load current rating given in this section.

ANALYZING SYMPTOMS

Table 3-3 presents a comprehensive guide to troubleshooting three-phase motors. Find the symptoms you are dealing with in a particular motor, study the possible causes listed, eliminate any

TABLE-3-2
Ampere Rating of Three-Phase, 60 Hertz, AC Induction Motors

Hp	Syn. Speed RPM	Current in Amperes					
		115 V	230 V	380 V	460 V	575 V	2200 V
1/4	1800	1.90	0.95	0.55	0.48	0.38	—
	1200	2.80	1.40	0.81	0.70	0.56	—
	900	3.20	1.60	0.93	0.80	0.64	—
1/3	1800	2.38	1.19	0.69	0.60	0.48	—
	1200	3.18	1.59	0.92	0.80	0.64	—
	900	3.60	1.80	1.04	0.90	0.72	—
1/2	1800	3.44	1.72	0.99	0.86	0.69	—
	1200	4.30	2.15	1.24	1.08	0.86	—
	900	4.76	2.38	1.38	1.19	0.95	—
3/4	1800	4.92	2.46	1.42	1.23	0.98	—
	1200	5.84	2.92	1.69	1.46	1.17	—
	900	6.52	3.26	1.88	1.63	1.30	—
1	3600	5.60	2.80	1.70	1.40	1.12	—
	1800	7.12	3.56	2.06	1.78	1.42	—
	1200	7.52	3.76	2.28	1.88	1.50	—
900	900	8.60	4.30	2.60	2.15	1.72	—
	3600	8.72	4.36	2.64	2.18	1.74	—
	1800	9.71	4.86	2.94	2.43	1.94	—
1200	1200	10.5	5.28	3.20	2.64	2.11	—
	900	11.2	5.60	3.39	2.80	2.24	—
	3600	11.2	5.60	3.39	2.80	2.24	—
1800	1800	12.8	6.40	3.87	3.20	2.56	—
	1200	13.7	6.84	4.14	3.42	2.74	—
	900	15.8	7.90	4.77	3.95	3.16	—
3	3600	16.7	8.34	5.02	4.17	3.34	—
	1800	18.8	9.40	5.70	4.70	3.76	—
	1200	20.5	10.2	6.20	5.12	4.10	—
900	900	22.8	11.4	6.90	5.70	4.55	—
	3600	27.1	13.5	8.20	6.76	5.41	—
	1800	28.9	14.4	8.74	7.21	5.78	—
1200	1200	31.7	15.8	9.59	7.91	6.32	—
	900	31.0	15.5	9.38	7.75	6.20	—
	3600	39.1	19.5	11.8	9.79	7.81	—
1800	1800	43.0	21.5	13.0	10.7	8.55	—
	1200	43.7	21.8	13.2	10.9	8.70	—
	900	46.0	23.0	13.9	11.5	9.19	—
10	3600	50.8	25.4	15.4	12.7	10.1	—
	1800	53.8	26.8	16.3	13.4	10.7	—

(continued)

TABLE-3-2

Ampere Rating of Three-Phase, 60 Hertz, AC Induction Motors (continued)

Hp	Syn. Speed RPM	Current in Amperes					
		115 V	230 V	380 V	460 V	575 V	2200 V
15	1200	56.0	28.0	16.9	14.0	11.2	—
	900	61.0	30.5	18.5	15.2	12.2	—
	3600	72.7	36.4	22.0	18.2	14.5	—
	1800	78.4	39.2	23.7	19.6	15.7	—
20	1200	82.7	41.4	25.0	20.7	16.5	—
	900	89.0	44.5	26.9	22.2	17.8	—
	3600	101.1	50.4	30.5	25.2	20.1	—
	1800	102.2	51.2	31.0	25.6	20.5	—
25	1200	105.7	52.8	31.9	26.4	21.1	—
	900	109.5	54.9	33.2	27.4	21.9	—
	3600	121.5	60.8	36.8	30.4	24.3	—
	1800	129.8	64.8	39.2	32.4	25.9	—
30	1200	131.2	65.6	39.6	32.8	26.2	—
	900	134.5	67.3	40.7	33.7	27.0	—
	3600	147	73.7	44.4	36.8	29.4	—
	1800	151	75.6	45.7	37.8	30.2	—
40	1200	158	78.8	47.6	39.4	31.5	—
	900	164	81.8	49.5	40.9	32.7	—
	3600	193	96.4	58.2	48.2	38.5	—
	1800	202	101	61.0	50.4	40.3	—
50	1200	203	102	61.2	50.6	40.4	—
	900	209	105	63.2	52.2	41.7	—
	3600	241	120	72.9	60.1	48.2	—
	1800	249	124	75.2	62.2	49.7	—
60	1200	252	126	76.2	63.0	50.4	—
	900	260	130	78.5	65.0	52.0	—
	3600	287	143	86.8	71.7	57.3	—
	1800	298	149	90.0	74.5	59.4	—
75	1200	300	150	91.0	75.0	60.0	—
	900	308	154	93.1	77.0	61.5	—
	3600	359	179	108	89.6	71.7	—
	1800	365	183	111	91.6	73.2	—
100	1200	368	184	112	92.0	73.5	—
	900	386	193	117	96.5	77.5	—
	3600	461	231	140	115	92.2	—
	1800	474	236	144	118	94.8	23.6
	1200	478	239	145	120	95.6	24.2
	900	504	252	153	126	101	24.8

TABLE-3-2

Ampere Rating of Three-Phase, 60 Hertz, AC Induction Motors (*continued*)

Hp	Syn. Speed RPM	Current in Amperes					
		115 V	230 V	380 V	460 V	575 V	2200 V
125	3600	583	292	176	146	116	—
	1800	584	293	177	147	117	29.2
	1200	596	298	180	149	119	29.9
150	900	610	305	186	153	122	30.9
	3600	687	343	208	171	137	—
	1800	693	348	210	174	139	34.8
	1200	700	350	210	174	139	35.5
200	900	730	365	211	183	146	37.0
	3600	904	452	274	226	181	—
	1800	915	458	277	229	184	46.7
	1200	920	460	266	230	184	47.0
250	900	964	482	279	241	193	49.4
	3600	1118	559	338	279	223	—
	1800	1136	568	343	284	227	57.5
	1200	1146	573	345	287	229	58.5
300	900	1200	600	347	300	240	60.5
	1800	1356	678	392	339	274	69.0
	1200	1368	684	395	342	274	70.0
400	1800	1792	896	518	448	358	91.8
500	1800	2220	1110	642	555	444	116.

Note: Ampere ratings of motors vary somewhat. The values given here are for drip-proof, Class B insulated (T frame) where available, 1.15 service factor, NEMA Design B motors. The values represent an average full-load motor current that was calculated from the motor performance data published by several motor manufacturers. In the case of high-torque squirrel cage motors, the ampere ratings will be at least 10% greater than the values shown.

Source: Courtesy of Bodine Electric Company, Chicago.

that you can because of the presence or absence of other identifying signs, and then try the recommended corrections.

Be sure that in searching for symptoms and analyzing possible causes, you have correct and complete information. That means the measurements—for example, of volts or amperes—must be made with accurate meters. All other information from visual inspection or any other test should also be done firsthand and carefully.

TABLE 3-3
Motor Troubleshooting Guide

Symptom	Possible Causes	Correction
<p>High Input Current (all three phases) Running Idle (disconnected from load)</p>	<p>Accuracy of ammeter readings.</p> <p>High line voltage 5% to 10% over nameplate.</p>	<p>First, check accuracy of ammeter readings on all three phases. Consult power company—possibly decrease by using lower transformer tap.</p>
<p>Running Loaded</p>	<p>Motor overloaded. Motor voltage rating does not match power system voltage.</p>	<p>Reduce load or use larger motor. Replace motor with one of correct voltage rating. Consult power company—possibly correct by using a different transformer tap.</p>
<p>Unbalanced Input Current (5% or more deviation from the average input current)</p>	<p>Unbalanced line voltage due to:</p> <p>(a) Power supply. (b) Unbalanced system loading. (c) High resistance connection. (d) Undersized supply lines. Defective motor.</p>	<p>Carefully check voltage across each phase <i>at the motor terminals</i> with good, properly calibrated voltmeter.</p>
<p>Note: A small voltage imbalance* will produce a large current imbalance. Depending on the magnitude of imbalance and the size of the load, the input current in one or more of the motor input lines may greatly exceed the current rating of the motor.</p>		<p>If there is doubt as to whether the trouble lies with the power supply or the motor, check per the following: Rotate <i>all three input power lines</i> to the motor by one position—i.e., move line 1 to 2 motor lead, line 2 to 3 motor lead, and line 3 to 1 motor lead.</p>

Excessive Voltage Drop

(more than 2% or 3% of nominal supply voltage)

Excessive starting or running load.
Inadequate power supply.
Undersized supply lines.
High-resistance connections.

Each phase lead run in separate conduits.

Overload Relays Tripping

Upon starting (Also see "Slow Starting")

Slow starting. (10–15 seconds or more) due to high inertia Load.
Low voltage at motor terminals.

- (a) If the unbalanced current pattern follows the *input power lines*, the problem is in the power supply.
- (b) If the unbalanced current pattern follows the *motor leads*, the problem is in the motor.

Correct the voltage balance of the power supply or replace the motor, depending on answer to (a) & (b) listed earlier.

Reduce load.

Consult power company.

Increase line sizes.

Check motor leads and eliminate poor connections.

All three-phase leads shall be in a single conduit, per National Electrical Code. (This applies only to metal conduit with magnetic properties.)

Reduce starting load,

Increase motor size if necessary.

Improve power supply and/or increase line size.

Note: *Imbalance is the proper word. However, in technical usage unbalance is commonly used!

(continued)

TABLE 3-3
Motor Troubleshooting Guide (continued)

Symptom	Possible Causes	Correction
Running Loaded	<p>Overload. Unbalanced input current. Single phasing. Excessive voltage drop. Too frequent starting or intermittent overloading. High ambient starter temperatures.</p> <p>Wrong size relays.</p>	<p>Reduce load or increase motor size. Balance supply voltage. Eliminate. Eliminate (see above). Reduce frequency of starts and overloading or increase motor size. Reduce ambient temperature or provide outside source of cooler air. Correct size per nameplate current of motor. Relays have built-in allowances for service factor current. Refer to National Electrical Code.</p>
Motor Runs Excessively Hot	<p>Overloaded.</p> <p>Blocked ventilation: (a) TFECs (b) ODPs</p> <p>High ambient temperature over 40°C (104°F) Unbalance input current.</p> <p>Single phased.</p>	<p>Reduce load or load peaks and number of starts in cycle and increase motor size. Clean external ventilation system—check fan. Blow out internal ventilation passages. Eliminate external interference to motor ventilation. Reduce ambient temperature or provide outside source of cooler air. Balance supply voltage. Check motor leads for tightness. Eliminate single-phase condition.</p>

Won't Start (Just hums and heats up)	Single phased.	Shut power off. Eliminate single phasing. Check motor leads for tightness.
	Rotor or bearings locked.	Shut power off. Check shaft for freeness of rotation. Be sure proper sized overload relays are in <i>each of three phases</i> of starter Refer to National Electrical Code.
Runs Noisy Under Load (excessive electrical noise or chatter under load)	Single phased.	Shut power off. If motor cannot be restarted, it is single phased. Eliminate single phasing. Be sure proper sized overload relays are in <i>each of the three phases</i> of the starter. Refer to National Electrical Code.
Slow Starting (10 or more seconds on small motors—15 or more seconds on large motors) Across the Line Start	Excessive voltage drop (5–10% voltage drop causes 10–20% or more drop in starting torque).	Consult power company. Check system. Eliminate voltage drop.
	High-inertia load.	Reduce starting load or increase motor size.

(continued)

TABLE 3-3
Motor Troubleshooting Guide (continued)

Symptom	Possible Causes	Correction
Reduced Voltage Start	Excessive voltage drop. Loss of starting torque.	Check and eliminate.
Y-Delta	Starting torque reduced to 33%.	Reduce starting load or increase motor size.
PWS	Starting torque reduced to 50%.	Choose type of starting with higher starting torque.
Auto. Transformer	Starting torque reduced—25–64%.	Reduce time delay between 1st and 2nd step on starter—get motor across the line sooner.
Load Speed Appreciably Below Nameplate Speed	Overload. Excessively low voltage.	Reduce load or increase voltage. Note: A reasonable overload or voltage drop of 10–15% will reduce speed only 1–2%. A report of any greater drop would be questionable.
Excessive Vibration (mechanical)	Inaccurate method of measuring RPM. Out of balance: (a) Motor mounting. (b) Load.	Check meter using another device or method. Be sure motor mounting is tight and solid. Disconnect belt or coupling—restart motor—if vibration stops, the imbalance was in load.

Noisy Bearings

(Listen to bearings)

Smooth mid-range hum

High whine

Low rumble

Rough clatter

(c) Sheaves or coupling.

Remove sheave or coupling—securely tape 1/2 key in shaft keyway and restart motor—if vibration stops, the imbalance was in the sheave or coupling.

(d) Motor.

If the vibration does not stop after checking (a), (b), and (c) listed previously, the imbalance is in the motor—replace the motor.

(e) Misalignment on close coupled application.

Check and realign motor to the driven machine.

Normal fit.

Bearing OK.

Internal fit of bearing too tight.

Replace bearing—check fit.

Internal fit of bearing too loose.

Replace bearing—check fit.

Bearing destroyed.

Replace bearing—avoid:

(a) Mechanical damage.

(b) Excessive greasing.

(c) Wrong grease.

(d) Solid contaminants.

(e) Water running into motor.

(f) Misalignment or closecoupled-application.

(g) Excessive belt tension.

(continued)

TABLE 3-3
Motor Troubleshooting Guide (*continued*)

Symptom	Possible Causes	Correction
Mechanical Noise	Driven machine or motor noise. Motor noise amplified by resonant mounting. Driven machine noise transmitted to motor through drive. Misalignment on close-coupled application	Isolate motor from driven machine—check difference in noise level. Cushion motor mounting or dampen source of resonance. Reduce noise of driven machine or dampen transmission to motor. Improve alignment.

SAFETY PRECAUTIONS

When working with motors, it is important that certain safety procedures be followed at all times.

- Be sure that all motor installation, maintenance, and repair work is performed only by qualified people.
- Disconnect and lock all input power before doing any work on motors or any electrical equipment.
- Whenever equipment is to be lifted, follow the specific procedures for using the lift bail.
- Follow the National Electrical Code (NEC) rules and all local codes when installing any electrical equipment.
- Be sure that all equipment is properly grounded in accordance with the NEC.
- Keep hands, hair, clothing, and tools away from all moving parts when operating or repairing equipment.
- Provide proper safeguards to prevent contact with rotating parts.
- Be familiar with and adhere to recommendations outlined in Safety Standards for Construction and Guide for Selection, Installation and Use of Electric Motors and Generators (NEMA MG-2).

WARNING: WHEN USING LIFT BAIL

Do not use the lift bail on the motor to lift the motor along with additional equipment, such as

- Pumps
- Compressors
- Other driven machinery

In the case of assemblies on a common base, do not lift the motor by the lift bail, but rather use a sling around the base or the lifting means provided on the base. In all cases, take care to ensure lifting only in the direction intended in the design of the lifting means. Also, be careful to avoid hazardous overloads due to deceleration, acceleration, or shock forces.

This page intentionally left blank

4

Alarm Systems

There are many specific functions and jobs with which an electrician and apprentice should be familiar. It is impossible in a book such as this to explain and discuss all of them. We, however, discuss the major topics that include most of the tasks an electrician may be called on to do. These are

1. Installation and repair (if necessary)
2. Alarm systems
3. Lighting systems
4. Motors
5. Power systems
6. Programmable controllers
7. General wiring systems

There are a number of different types of alarm systems. Some are hand-wired, with wires running from switches to a central location where a relay is energized or de-energized to cause an alarm to be sounded. However, some types of alarm systems require less wiring. They rely on electronics for sensing and sending signals to central units. They may be digitized, with programmed codes that disable the system temporarily to allow entry into the premises and to allow zone changes from time to time.

A TYPICAL HARD-WIRED SYSTEM

In a typical hard-wired system, fire and security systems are wired together. Figure 4-1 shows the wiring diagram of a house with such a system. A detailed diagram of the wiring for the security or fire system is given in Figure 4-2. Notice the closed-loop intruder-detection circuit and how the switches work. Then examine the fire detection circuit and how it is wired into the system. Except for the 120-volt line to the power supply, the rest of the wiring is low voltage.

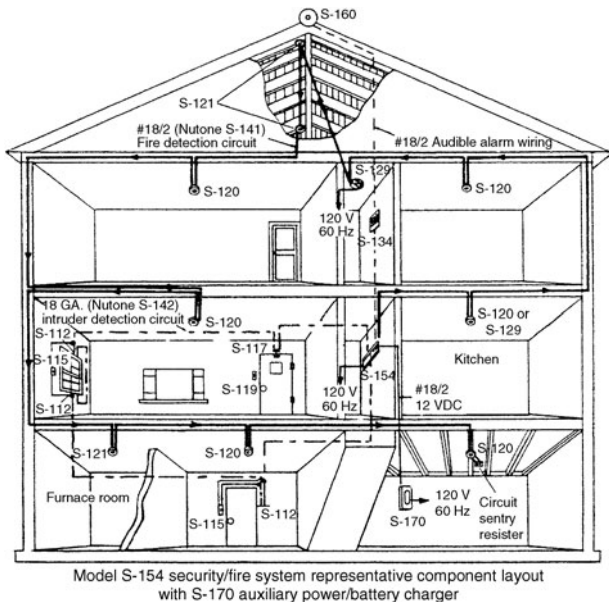


FIGURE 4-1. A typical hard-wired system with fire and security systems wired together (NuTone).

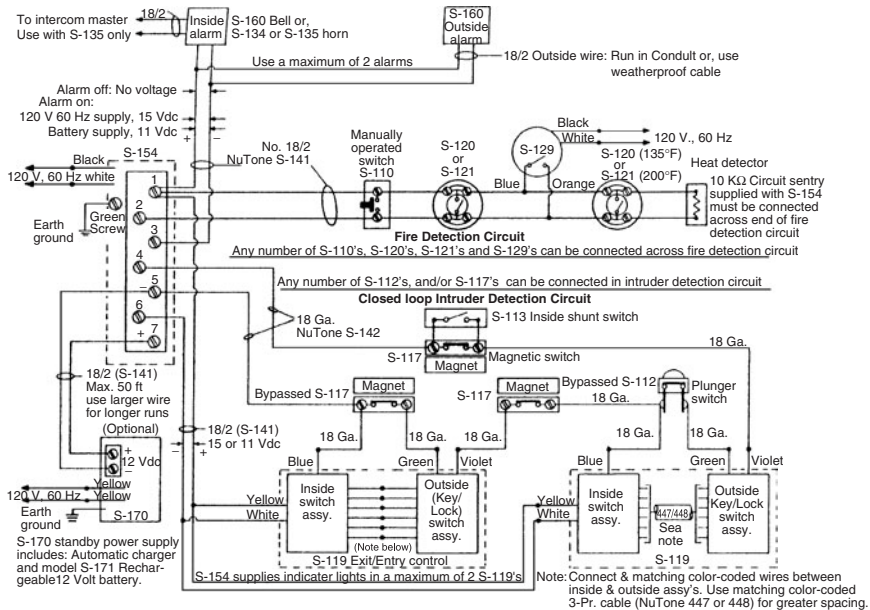


FIGURE 4-2. Wiring for a typical security or fire system.

50 CHAPTER FOUR

The control unit should be mounted between studs in a location with easy access from all rooms in the house; this is usually in a hallway. The control box should be mounted out of the reach of small children and not readily accessible to casual visitors. See Figure 4-3.

When possible, the control unit, the smoke or heat detectors and the auxiliary power or battery charger (if used) should be connected to an individually fused 120-volt, 60-hertz power source, according to local code requirement.

PARTS OF THE SYSTEM

Different hard-wired systems are available with various components in addition to the usual smoke or heat and security parts. The choice of which parts and system to use depends on

- Purpose of the system
- Type of building it is in
- Location
- Other factors

A discussion of the common parts in a typical hard-wired system follows.

Motion Detectors. A motion detector operates on ultrasonic frequencies. An ultrasonic frequency is above the human hearing range. The receiver transducer and transmitter are approximately the size of a quarter. Any motion within the range of the unit causes a slight change in frequency that is reflected back to the receiving unit. This difference in frequency causes a relay or a transistor circuit to energize and complete the circuit to the alarm control center.

Ultrasound motion detectors are quite sensitive. They can be activated by the movements of a dog or cat or even by a hot air furnace causing curtains to move. These units need little or no maintenance if wired into a household circuit.

Heat or Smoke Detectors. Heat detectors sense heat above a certain temperature—usually 136°F—and activate an alarm. Most heat detectors contain bimetallic switches that remain open below

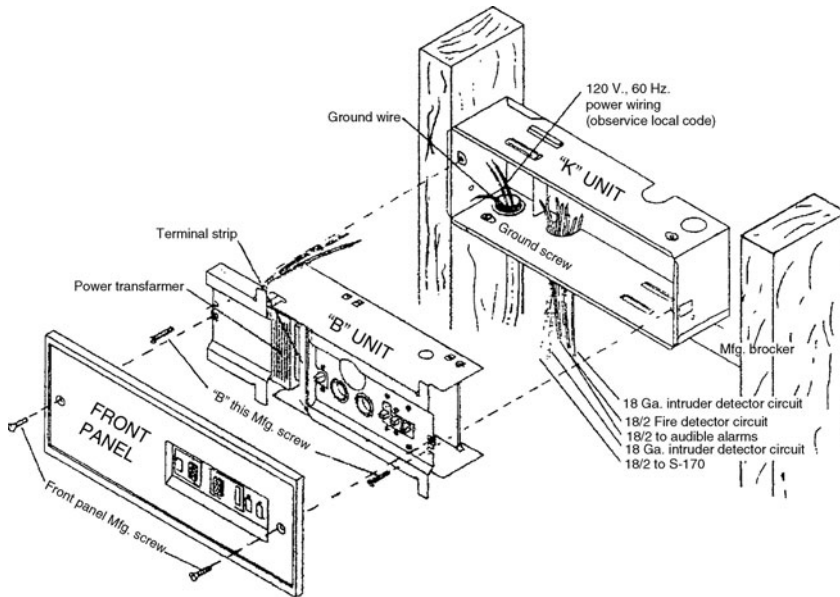


FIGURE 4-3. The control unit should be mounted between studs.

52 CHAPTER FOUR

a temperature of 135°F but close above that temperature, triggering an alarm. Some are activated by higher temperatures of 200°F—and the switches should be used in areas with higher-than-normal temperatures, such as boiler rooms and attics.

With most smoke detectors, a concentration of less than 4% smoke in the air will sound the alarm. What is 4%? Examine a cigarette smoking in an ashtray. The plume of smoke rises, coils, and spreads. It diffuses into the air. Somewhere above the cigarette is a region where the smoke is drawn out and wispy, but barely visible. That concentration is close to 4%. If that amount of smoke were concentrated in the chamber of a smoke detector, it would set off the alarm. However, under normal conditions, even a roomful of people smoking won't trigger an alarm because smoke spreads out so that the concentration is very low. Figure 4-4 shows how the detector is wired to the control unit.

There are two types of smoke detectors. In the photoelectric smoke detector, the smoke is detected as it interrupts a small light from a bulb inside the unit. This type is best at detecting thick smoke because that kind of smoke causes the light beam to be interrupted. This type of detector is used primarily in the home, since house fires are usually of the smoldering type with thick smoke.

Less dense smoke triggers the radioactive detector. This type of detector contains a dime-sized capsule of the radioactive element *americium*. Smoke interrupts the beam of ions produced by the low-level radiation and thus triggers the alarm. This type is best for detecting the kind of smoke generated in business or commercial fires. It however, is more susceptible to false alarms than the photoelectric type.

For maximum protection, heat or smoke detectors should be placed in every enclosed area, including bathrooms and closets. If any single dimension of a room exceeds 20 feet, additional detectors should be installed. For unfinished attic spaces with gable roofs, detectors should be installed 10 feet from the end and 20 feet apart on the bottom of the ridgepole. Figure 4-5 shows how to locate heat sensors.

Heat detectors should be installed on the ceiling but, when necessary, may be mounted on a sidewall. When installed on a smooth ceiling, each detector will protect a 20-square-foot area. When installed on a wall, detectors should be at least 6 inches and no more than 12 inches below the ceiling and at least 12 inches from any corner.

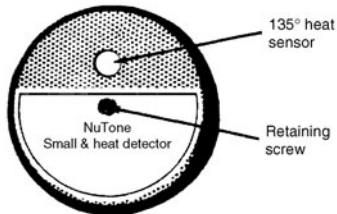
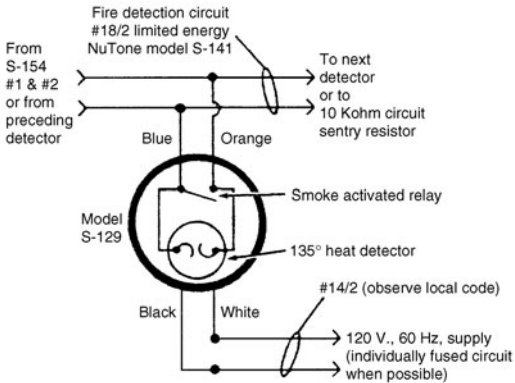
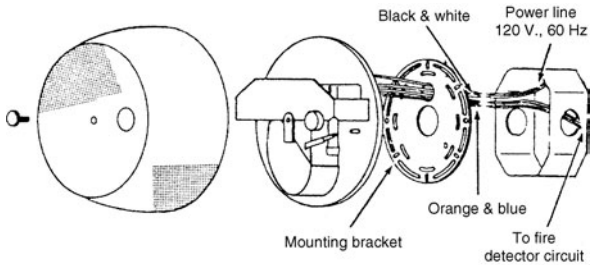


FIGURE 4-4. How the smoke or heat detector is wired to the control unit.

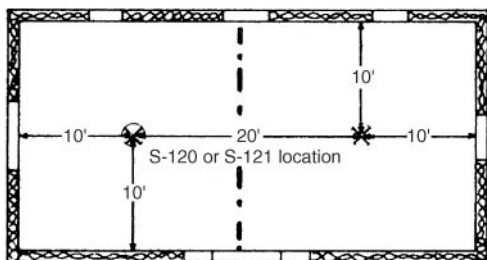
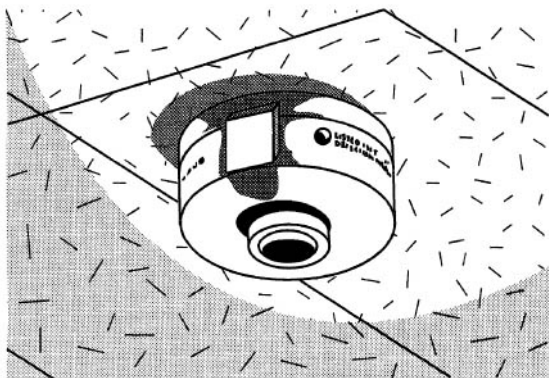


FIGURE 4-5. How to locate heat sensors.

Intruder Detectors. A motion detector functions as an intruder detector, but other intruder-detecting systems are also available. A typical intruder-detection circuit is a closed-loop system, meaning that the entry-detection switches are connected in a series. When a protected door or window is opened, the circuit between the two terminals of the control unit is broken and the intruder alarm is activated. Several types of switches are available.

Plunger-type switches can be used in wooden doorframes or window sashes. The exact positioning of the switch depends on the type and design of the door or window. If possible, the switch should be installed in the frame on the hinge side of a door, and on double-hung windows, both top and bottom sections should be protected.

Remember, the mounting area must be large enough to accommodate the flange of the switch. See Figures 4-6 and 4-7.

Magnetic-operated reed switch assemblies are available for horizontal or vertical surface mounting on wood or metal doorframes or

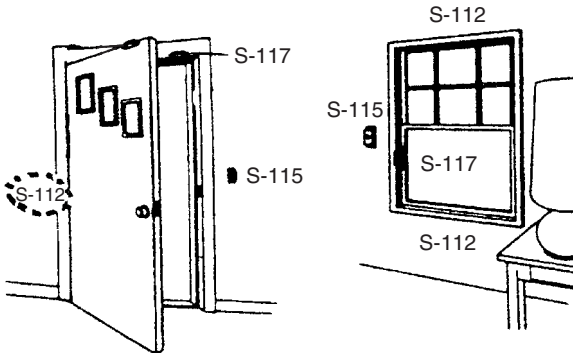


FIGURE 4-6. Plunger-type switches can be used on wooden door frames and window sashes.

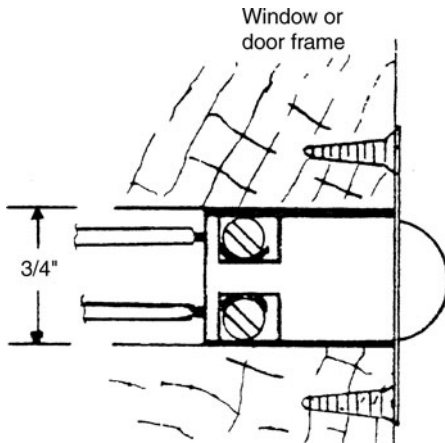


FIGURE 4-7. When mounting plunger-type switches, be sure the mounting area is large enough to accommodate the flange of the switch.

window sashes. Install the magnetic section on the door or window and the switch on the frame or sash. Use caution when installing reed switches because they are easily damaged if dropped, use shims if necessary to install them, and be sure they are parallel and flush. See Figure 4-8.

An inside shunt switch is used to bypass switches used in doors and windows. See Figure 4-9. This type of switch is surface-mounted and connected to bypass the entry detector switch, as previously shown in Figure 4-2.

Exit/entry control units include inside and outside switch plate assemblies to be installed on 2 $\frac{1}{2}$ -inch-deep single-gang wall boxes, above the reach of small children. The indicator lights will burn at a somewhat lower level when operating on the 12-volt DC power supply activated by failure of the 120-volt

supply. New models rely on a light-emitting diode (LED) for low power consumption. Figure 4-10 shows the location of inside-outside switches.

The wiring diagram in Figure 4-11 shows that changing the position of either S_1 or S_2 bypasses the entry detector switch and turns the indicator lights off so that the door can be opened without activating the alarm. The system can then be rearmed by changing the position of S_1 or S_2 .

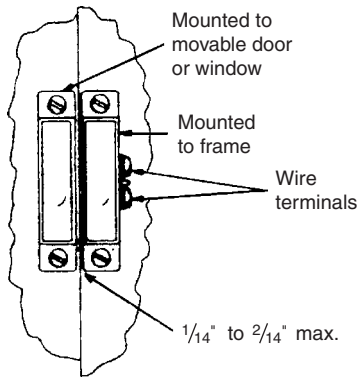
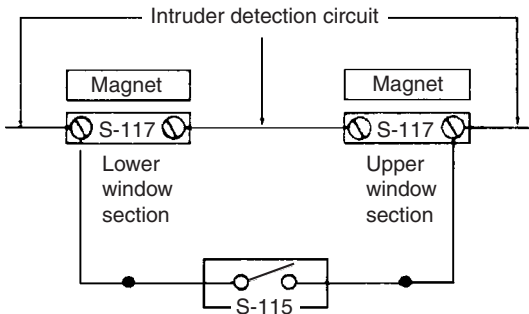


FIGURE 4-8. Magnetic reed switch mounted on a door or window.



S-115 bypassing 2 entry detector switches
(Double hung window installation)

FIGURE 4-9. A shunt switch used to bypass entry detector switches on a window.

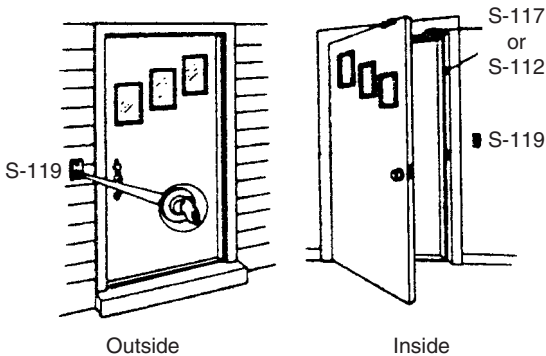


FIGURE 4-10. The location of inside-outside switches.

Pushbuttons for Emergencies. A manually operated pushbutton for emergency operation of the fire detection circuit should be installed near the outside (including basement) doors on the knob side at a height convenient for adults but out of the reach of small children. Such pushbuttons may also be installed in bedrooms or other areas where emergency operation of the alarm is desired.

Warning Devices. An alarm bell (see Figure 4-12) is a warning device. Surface-mounted units should be installed in a central area for greatest coverage throughout the house. The intercom can be connected so that the alarm is broadcast throughout the house when the speakers are on. Wiring to an outside bell should be hidden if possible. Wiring that is exposed should be run in a conduit, or a waterproof cable should be used. In the system illustrated, the alarm circuit to energize the bell is approximately 15-volts DC, with normal 120-volts AC supplied to the control unit. When there is no 120-volt supply, the emergency unit (e.g., an auxiliary power or battery charger) is in operation. This voltage will be about 11 volts from the battery. Therefore, any warning device, such as a bell, has to be able to operate on a 10- to 16-volt range See Figure 4-2.

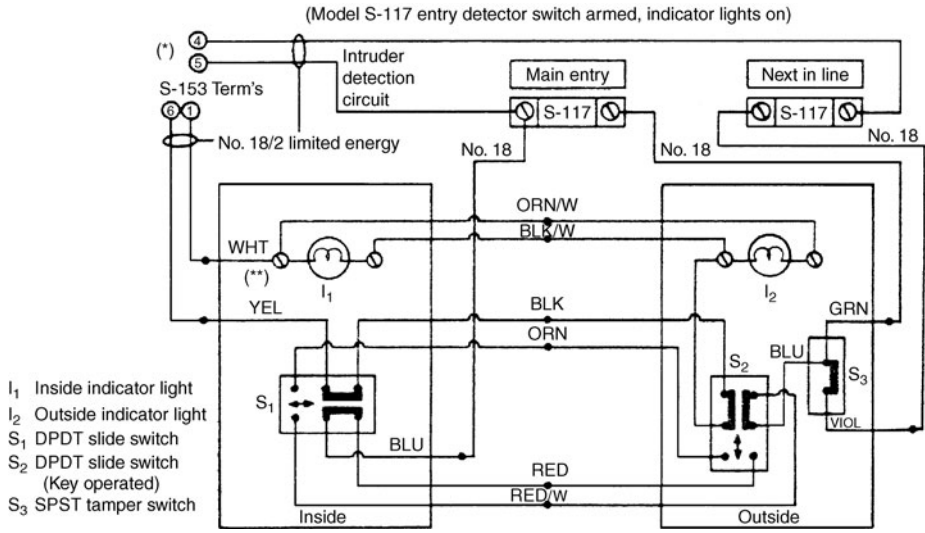


FIGURE 4-11. Wiring diagram showing how S_1 and S_2 changes can bypass the entry detector switch.



FIGURE 4-12. Typical alarm bell.

Auxiliary Power/Battery Charger. A complete alarm system should have an auxiliary power source or battery charger so that the system can operate in situations where the normal 120-volt power supply is cut off. See Figure 4-2.

A TYPICAL ELECTRONIC SECURITY SYSTEM

A number of electronic security systems are available. Most have standard parts that can be programmed to operate in a number of different configurations. The installation instructions that come with the system indicate how the system is to be wired.

PARTS OF THE SYSTEM

A typical microcomputer-based system has about eight fully programmable zones, plus keypad and fire, police, and medical emergency functions. Each installation may be custom-designed to meet specific requirements. These systems are nonvolatile electrically erasable read-only memory (EEROM) chips to store all data. This memory is retained even during complete power failures.

All programming is accomplished by entering data through remote digital keypads. These keypads are available in different styles, providing flexibility in system design. Some include a speaker that may be used as an indoor siren and/or an intercom station. See Figure 4-13.

The control panel houses the electronics for controlling the burglary or fire system and the digital communicator. The communicator itself is also keypad-programmable and may be programmed for most transmission formats. The control panel also contains a 12-volt DC, 1.5-ampere power supply that will provide 900 milliamperes of power for auxiliary devices.

Entry Delay Lines. Each zone in the system may be programmed for two entry times (from 000 to 225 seconds duration). After a time is programmed into each delay time's memory location, each separate zone may then be programmed for entry delay time #1 or #2. For example, a long delay time (#1) might be used for a garage door to allow sufficient time for car entry or exit, whereas a shorter delay time (#2) would be programmed for front door entry.

Loop Response Time. The system may also be programmed for fast or slow loop response times, or how long it takes for the switch on or off condition to be acted upon by the control unit. These range from 40 milliseconds to 10 seconds in 40-millisecond increments. After the fast and slow loop response times are programmed, each separate zone may then be programmed for slow or fast loop response time.

Keyswitch Zones. If the application calls for arm/disarm control from a keyswitch, the system may be programmed for a key-switch zone (a zone operated by using a key to turn a switch). Through keypad programming, the installer assigns one zone as a key-switch zone. This then can be controlled by a momentary normally open or a momentary normally closed key-switch. In some cases, a key-operated switch is desired for the garage door or a gate.



FIGURE 4-13. Remote digital keypad.

Bypassing Zones. Zones may be individually bypassed (shunted) with a two-keystroke operation at the remote control keypad. All manually bypassed zones are cleared when the system is disarmed. They must then be bypassed again before the system is armed. Zones cannot be bypassed once the system is armed. For special applications, fire zones may be programmed to be shuntable. The digital communicator can also be programmed to send a bypassed-zone-arming report to the central station.

Fire Zones and Day Zones. Both fire zones and day zones sound an audible pre-alarm for a trouble condition. The user can easily silence a fire pre-alarm at the keypad by pressing the CLEAR key, while an LED will remain blinking to remind the user that a trouble condition exists.

Alarm Outputs. A number of alarm outputs may be wired to operate two on-board auxiliary relays. The burglar alarm output can be programmed to be steady or pulsing. The auxiliary relay outputs can be connected to a self-contained siren, a two-tone siren driver, or an eight-tone siren driver.

Alarm outputs can be programmed to provide a 1-second siren or bell test upon arming the system. To extend the system's capability, the alarm outputs can be wired directly to a siren driver with "trigger inputs" (such as the eight-tone driver), freeing the on-board auxiliary relays for other tasks.

A typical electronic system can also be programmed for silent or audible alarms. There are separate outputs for burglary, fire, police, and medical. Each can be individually programmed for a cut-off time of 0.001 to 255 minutes or for continuous operation.

A lamp output terminal is activated for 2 minutes each time a key is pressed during entry and exit delay and during any alarm condition. It can be used as light control for a hall light or other applications.

Arm/Disarm Codes. Most systems have arm/disarm codes and a master programming code that can be changed by the user. The codes can be one to five digits long and digits may be repeated. Each of the arm/disarm codes in the system illustrated can be programmed to be

1. An arm/disarm code only.
2. An access code only. (The system includes an access control feature that can be used for an electric door release or oilier device. The access control output is timed. It is programmable for 1 to 254 seconds in duration)
3. An arm/disarm code if "1" is entered first; an access code if "0" is entered first.
4. Arm/disarm and access simultaneously.
5. Same as (4), plus just "0" and code allows access.
6. A duress code.

64 CHAPTER FOUR

The fourth code (4 listed earlier) can be programmed to function for a predetermined number of times (1 to 254). This code may be used to allow entry by housekeeping and service personnel, and the like. After the code is used the allowed number of times it will no longer work.

Most systems also include a programmable short-arming feature that allows one- or two-digit arming. If the first digit of an arm/disarm code is “0” then one-button arming is possible—just enter “1.” This feature also allows all other command keys to function simply by pressing the desired command key. However, the full code must be entered to disarm the system.

Burglary Alarms. A burglary causes an audible pre-alarm. An alarm causes the ARMED LED to flash. Entering the arm/disarm code silences the audible pre-alarm, but the flashing LED remains on. Pressing the CLEAR button resets the flashing LED. During an alarm, entry of an arm/disarm code will abort the digital communicator unless the code is a distress code. A fire or medical alarm can be silenced by pressing the CLEAR key.

Fire Alarms. Fire alarms can be silenced by entering an arm/disarm code by pressing the CLEAR key. The fire zone LED remains on for an alarm or remains blinking for a trouble condition. If a trouble condition clears itself, the FIRE LED automatically resets. The FIRE alarm LED can be cleared by entering the arm/disarm code.

When a fire alarm is silenced by pressing the CLEAR key, this does not reset the smoke detectors. After the smoke detector that caused the alarm has been identified (by viewing the alarm memory LEDs on the smoke detectors), pressing the SMOKE RESET key and the arm/disarm code interrupts power to the smoke detectors for 5 seconds, resetting them. SMOKE RESET also performs a battery test. It removes AC power from the control panel and dynamically tests the battery. If the battery fails the test, the POWER LED will flash. A low-battery condition will be reported to the central station. The flashing POWER LED can be reset only by a subsequent test that recognizes a good battery.

INSTALLING THE SYSTEM

The panel box of a typical electronic security system is easily mounted and contains the terminal strips required to complete all of the pre-wiring and terminal wiring connections (see Figure 4-14).

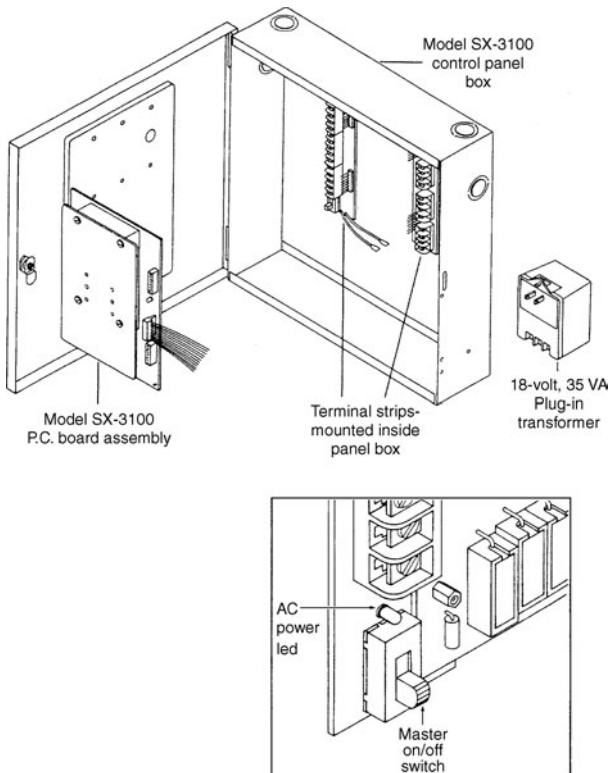


FIGURE 4-14. Exploded view of the panel box and master power switch location.

The terminal strips themselves are marked for identification. All input connections are made on one terminal strip. All output connections are made on the other. This arrangement allows the installer to complete the pre-wiring, make the terminal connections, and then safely lock the box.

66 CHAPTER FOUR

The main circuit board is a separate module. It is mounted with four hex screws. The board is mounted to the terminal strips and is simply plugged in with one connector. This arrangement allows for pre-wiring and protects the electronics from damage during wiring.

Once the installation and wiring are complete, power is supplied by a flip of the power switch. This eliminates the need to disconnect the power wiring during installation or service. When the system is powered up, the installer may program the system directly from digital remote control keypads. Programming worksheets (complete with zone identification, programming memory locations, and factory program values) are provided to aid the installer in programming. A detailed programming manual is also provided.

After the programming is complete, the installation can be checked out from the keypad. The installer simply uses the system status LEDs, the zone status command key, and the detector check key to verify the system installation. Then all user operations can be performed to verify the correctness of the program.

TROUBLESHOOTING THE SYSTEM

In a typical eight-zone system, the alarm memory function automatically reduces troubleshooting by one-eighth. Simply pressing the alarm memory command key reveals the zones last alarmed. Then, within that zone, the detector check command key may be used to troubleshoot specific detectors. For example, a typical system may contain 45 contacts, and the keypad can be used to troubleshoot the entire installation. With a conventional one-zone system, it would be necessary to troubleshoot most of the 45 contacts by trial and error. Figure 4-15 shows typical wiring for an eight-zone system.

PERSONAL ALARM SYSTEMS

There are a number of personal alarm systems today. Personal safety is of primary concern to everyone.

At the top of the security equipments list, whether it be personal security, home security, or industrial security, alarm systems are, in fact, everybody's concern. Some of the alarm systems can be

Factory
default
programming

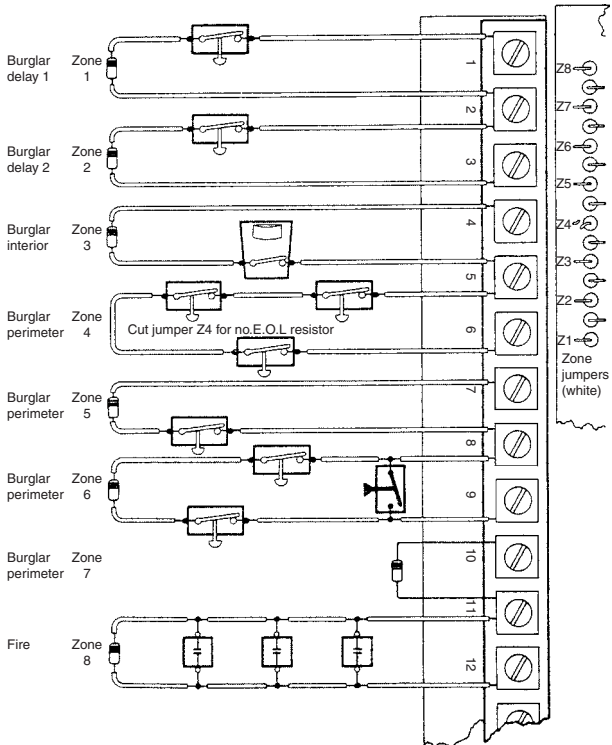


FIGURE 4-15. Typical eight-zone wiring.

68 CHAPTER FOUR

carried with you or installed easily on doors, windows, and sliding doors as well. Solid, state of the art designs make these alarm systems the most popular choice among effective security products.

Personal alarms are attractive, compact, and easy to carry. You can travel with these alarms on your belt or in your purse and use the accessories provided to turn them into portable door or window alarms. This is where the need for an electrician becomes necessary. Once the alarm has been installed as a permanent device located in a fixed position, there is usually the need for electrical power and proper set up to make it work properly. For instance, infrared motion alarms use passive infrared technology to produce an invisible barrier that cannot be penetrated without setting off the alarm. It is usually battery-operated and requires no wiring, no matter how many times you change its location. This variety of alarm system functions by detecting motion in any selected area. The electrician is called to do the job of installing it in a permanent home. The wiring and the testing for proper operation is the job of the electrician.

Magnetic door or window alarms are meant for use on any kind of door or window, even the sliding doors. Activated by opening the door or window, this alarm uses magnetic affinity to let off a loud siren. These are usually installed while the house is being built. In some cases, they have to be installed after the house is already framed and enclosed. This calls for some skill on the part of the person doing the installation.

Window glass breakage alarms are another important alarm system. This alarm has a very loud siren that is activated by the vibrations caused when someone breaks the glass. You can install it yourself on any window or have it permanently installed by an electrician.

The electronic barking dog alarms are used by utilizing microwave technology to “see” through walls. Like some police radar systems, it can sense if someone is approaching. When the person comes within a range of 20 feet, the alarm is activated and starts barking. It sounds as if a German shepherd is in the house.

ALARMS IN HAZARDOUS LOCATIONS

In the installation of alarms, it is necessary to follow the guidelines offered by the NEC’s latest edition. The National Electrical Code

includes the alarm system in a hazardous location under Article 501-14. Nearly all signaling, remote-control, and communication equipment involves make or break contacts: hence in Division 1 locations all devices must be explosion-proof, and the wiring must comply with the requirements for light and power wiring in such locations, including seals. The *Red Book* lists signal devices that include fire alarms and fire detectors.

This page intentionally left blank

Lamps and Lighting Systems

The installation, troubleshooting, and repair of lighting systems are some of the most common tasks of an electrician. Familiarity with the basic types of lamps and lighting fixtures and with systems for controlling lighting is essential for any electrician or apprentice.

The National Electric Code (NEC) classifies lamps as incandescent or electric discharge. Incandescent lamps have a filament that glows white-hot. Lamps that produce light without a filament are classified as electric discharge lamps.

- Fluorescent lamps
- Mercury vapor lamps
- Metal halide lamps
- Some other types of lamps

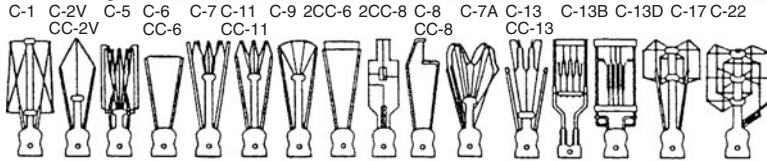
are classified as discharge types. Electric discharge lamps operate by passing current through a gas-filled envelope. In some cases, they may have a filament to get started.

INCANDESCENT LAMPS

An incandescent lamp has a filament made of tungsten. When the tungsten becomes white hot, or incandescent, it gives off light and heat. Incandescent lamp filaments are available in a number of sizes and shapes. See Figure 5-1.

Incandescent lamps differ in their output, bases, wattage, and life expectancy.

Filament designations



Filament designations consist of a letter or letters to indicate whether the wire is straight or coiled, and an arbitrary number sometimes followed by a letter to indicate the arrangement of the filament on the supports. Prefix letters include: S (straight)– wire is straight or slightly corrugated; C (coil)– wire is wound into a helical coil or it may be deeply fluted; CC (coiled coil) – wire is wound into a helical coil and this coiled wire again wound into a helical coil. Some of the more commonly used types of filament arrangements are illustrated.

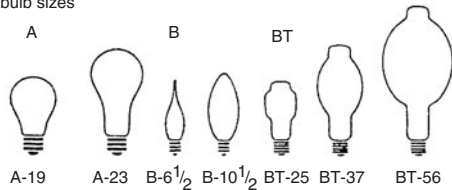
Bulb shapes
and bulb sizes

FIGURE 5-1. Incandescent lamp filaments.

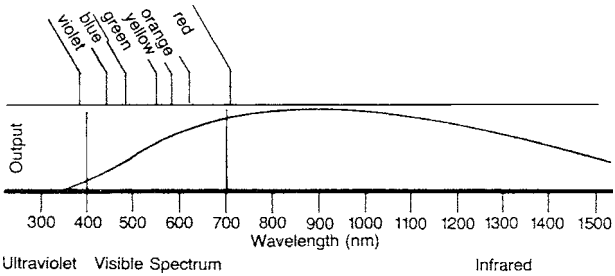


FIGURE 5-2. Electromagnetic spectrum.

OUTPUT

Most incandescent lamp output is in the infrared portion of the electromagnetic spectrum. See Figure 5-2. This means that larger amounts of light are available with incandescent lamps than with other light sources. See Figure 5-3.

Operation of light sources—
Colors present and amount of light available

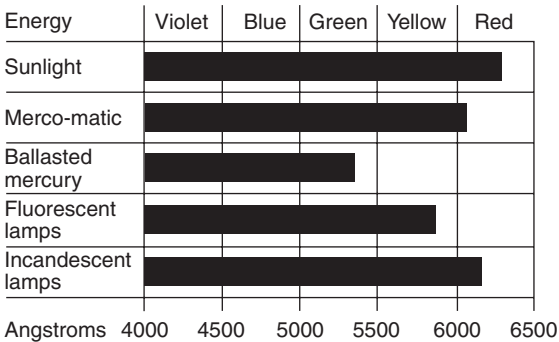


FIGURE 5-3. Amount of light available from the sun and different types of lamps.

74 CHAPTER FIVE

One type of incandescent lamp that has a very high output is the quartz bulb. This bulb has a filament that glows inside a quartz tube. It operates at extremely high temperatures. The main advantage of the quartz bulb is its constant light output over its entire operating life. Quartz bulbs are used in automobile headlights and for dome lights inside a car.

A quartz bulb cannot be touched when hot or cold because the quartz bulb will absorb any oil on the hand, and its surface will be damaged. So, remember to use gloves when handling quartz bulbs.

BASES

Most incandescent lamps for home use have a threaded base that is referred to as the *Edison base*. The threads on the base screw into matching threads on a socket. A base of the same shape but much larger in diameter is called a *mogul base*. It is usually found on bulbs that have high wattage capacity, draw high currents, and operate on 220 volts or higher. Mogul bases are also used on some mercury vapor lamps.

Some incandescent lamps have a bayonet base: two pins protruding on opposite sides of a smooth metal base. The socket into which bayonet-base lamps fit has a spring-metal contact at the bottom and two L-shaped channels on opposite sides of the socket wall that correlate to the pins on the lamp. The lamp is inserted by sliding the pins into the channels as far as they will go, which includes pushing against the spring-metal contact, and rotating one quarter turn. With this action, the pins then slide into the horizontal leg of the L-shaped channel, holding the lamp firmly against the spring-metal contact.

Figure 5-4 shows various bases, including miniature and other types of lamps. Each is designed to make good electrical contact and provide support for the bulb.

WATTAGE AND LIFE EXPECTANCY

The wattage rating of a bulb is directly related to its light output: the higher the wattage, the greater the light output. Wattage, in turn, is directly related to the voltage applied to the filament and changes with any increase or decrease in voltage. See Table 5-1. An increase in voltage over the rated wattage of the bulb decreases the operating life of the bulb. Lower voltage gives longer life—but less light.

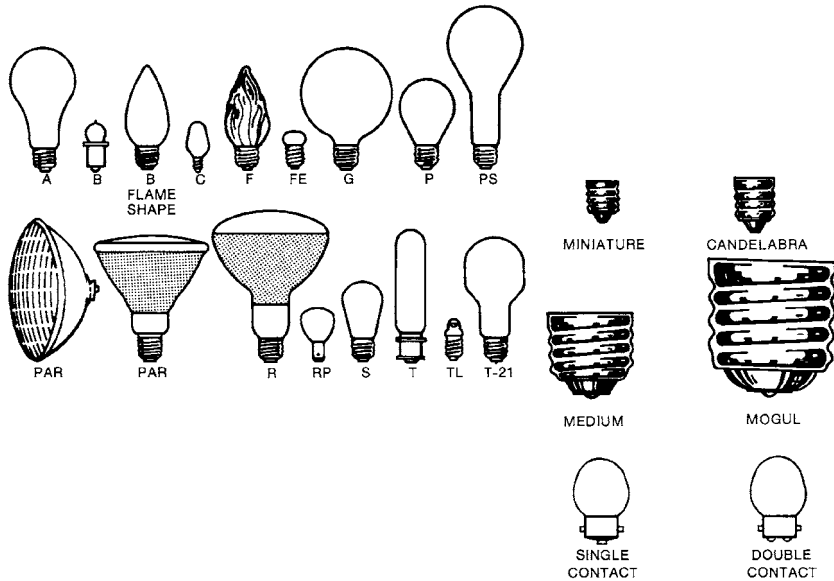


FIGURE 5-4. Popular incandescent lamp bases.

TABLE 5-1
An Ordinary 120-V, 100-W Incandescent Lamp Operating at Overvoltage
and Undervoltage

Voltage	Watts	Life (h)	Lumens	lm/W
110	88	2325	1250	14.2
115	94	1312	1450	15.2
120	100	750	1690	16.9
125	106	525	1960	18.5
130	112	375	2210	19.7

In an effort to increase the life expectancy of a bulb, some manufacturers have placed a diode in series with the filament. Some of these are washer-type diodes. They are designed for insertion in the base of a lamp to provide direct current (DC) to the lamp. This causes a change in the spectrum light and a loss in brilliance. In addition, engineers report that the diodes can inject a DC component into the power supply inside the house, and this can damage computers, videocassette recorders, and other sensitive electronic equipment. Considering the loss in brilliance and change in spectrum light, the addition of a diode to try to extend the life of a bulb is not worthwhile; the diode does not provide sufficient benefits to warrant its use.

INCANDESCENT FIXTURES

The 2002 NEC code changed the definition of fixture to *luminaire*. The term luminaire (lighting unit) was added throughout the NEC to replace the terms fixture(s) and lighting fixture(s). Since the NEC is international in scope, and used everywhere, the term was thought appropriate. However, it will appear in parenthesis in the code until it is more generally known.

Incandescent fixtures (luminaries) are usually mounted directly over a junction box. Be sure that there is proper support so that the weight is held in place without movement. Fixtures that weigh over 50 pounds have to be mounted by an independent box.

Incandescent fixtures can be recess-mounted, but these lamps generate a lot of heat and can cause a fire. For this reason insulation is not permitted within 3 inches of a fixture. This is to prevent

the insulation from trapping the heat and increasing the operating temperature of the fixture.

The wiring used in the recess-mounted incandescent lamp fixtures must be able to withstand higher-than-normal temperatures. Branch circuit wires cannot be mounted in the recessed fixture unless their temperature rating is sufficient to take the heat.

FLUORESCENT LAMPS

A fluorescent lamp is an arc-discharging device that has no inherent resistance. Therefore, unless it is controlled, current flow will rapidly increase until the lamp burns out. This problem is solved by the use of a device called ballast that is connected between the lamp and the power supply to limit the current to the correct value for proper lamp operation. (To “ballast” something is to stabilize or steady it; the ballast in a fluorescent lamp stabilizes, or limits, the amount of current flow.)

BALLAST

One of the most practical ways to limit current to a fluorescent lamp in an AC circuit is to use a coil or inductor. Simple inductive ballasts are coils of copper wire wound around iron cores. Alternating current passes through the turns of the copper wire, creating a strong magnetic field. The magnetic field reverses its polarity 120 times per second when operating on 60-hertz AC. The resulting reactance opposes a change in current flow and limits the current to the lamp. Only a few ballasts are this simple, but the basic principle of operation is the same in all ballasts. See Figure 5-5.

Ballast Life. The medium life expectancy of fluorescent ballasts is approximately 12 years. This means that 50% of the units installed will have failed after a period of 12 years. There are, however, several factors that affect ballast life, among them temperature, voltage, hours of use, and lamp condition.

The best way to ensure full ballast life is to apply the ballast or fixture combination properly so that ballast case temperatures do not exceed 90°C. Ballasts, like other electromagnetic devices such as motors and transformers, generate heat during operation. Ballast heat is transferred from the internal components to the ballast case through the filling medium. Once the heat reaches the

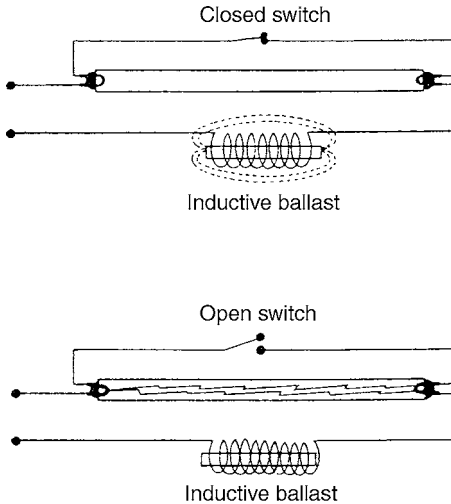


FIGURE 5-5. Simple ballast.

ballast case, it is dissipated by conduction, convection, and radiation to the surrounding air or mounting surfaces. If these normal means of heat dissipation are not adequate, the ballast may overheat. If this occurs, coil insulation may break down, resulting in internal short circuits and ballast or capacitor failure.

Applied voltage also affects the life of a ballast. A 1% increase in voltage over the nominal design voltage will cause the ballast's operating temperature to rise 1°C. If voltage increases continue, the ballast may overheat. Some ballasts (in Class P) now have an automatic resetting thermostat or ballast protector to prevent overheating. See Figure 5-6.

Duty cycle is also a consideration in the expected 12-year life expectancy. The 12-year expectancy is based on a duty cycle of 16 hours a day, 6 days a week, 50 weeks a year. This cycle, totaling 60,000 hours of operation, would cause half of the ballasts to wear out in 12 years. However, about 4 hours of each day's cycle are

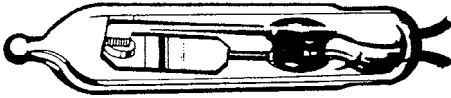


FIGURE 5-6. Automatic resetting thermostat ballast protector.

required to bring the ballast up to temperature, so the duty cycle described really totals only 12 hours a day, or about 45,000 hours, when the ballast is operating at full 90°C case temperature, during 12 years. Significant variations from the typical cycle will affect life expectancy, either increasing or decreasing it.

Failed lamps in most instant-start and preheat (switch-operated) fluorescent systems should not be allowed to remain in the fixture for extended periods of time because tins too will cause ballast overheating and result in significant reduction in ballast life. Ballasts are designed to withstand abnormal conditions resulting from a failed lamp for up to about 4 weeks, but not for extended periods. One type of ballast—rapid-start ballast—is not affected by failed lamps in a fixture.

Types of Ballasts. The overheating of fluorescent ballasts has caused a number of fires, and electrical codes now specify the use of thermally protected ballasts—Class P ballasts—in some situations. See NEC Section 410-73(e)(2) for detailed information. All ballasts installed indoors are now required to have thermal protection integral to the ballast itself. Previously installed, old ballasts without thermal protection must be replaced with ballasts that have thermal protection.

Ballast Role in Maintaining High Power Factor. High power factor means that the line current is almost in phase with the voltage. This means near unity or 100%. A resistive load presents a 100% (or unity) power factor, whereas the inductive load presented by the fluorescent lamp ballast is normally about 0.40 to 0.60 (53° to 66°). This can be corrected with the addition of a capacitor to within 5% or 0.95 or about 18° . It is advisable to correct the power factor when a large number of fluorescent lamps are used in a building. Buying high-power-factor ballasts also improves the efficiency and lowers operating costs.

Sound. The hum produced by ballasts varies with the way the ballast is mounted on or in the fixture. The sound is rated from A to F, A being the quietest. Factories can often use ballasts with an F-rating, but libraries need A-rated ballasts. The problem of ballast hum has been investigated extensively. By installing ballasts in accordance with sound-control recommendations provided by the manufacturer, it is possible to predict the likelihood of audible hum and try to reduce or eliminate sound problems

TYPES OF FLUORESCENT LAMPS

There are several types of fluorescent lamps available, among them rapid-start and instant-start cold-cathode lamps that do not require a starter and preheat lamps that do require a starter.

Preheat Fluorescent Lamp. The preheat or switch start circuit is the oldest one in use today. It is used with preheat or general-line lamps requiring starters and is particularly well suited for low-wattage, low-cost applications. Pushing the switch button causes the starting switch to close.

This allows the current to pass through the ballast, the starting switch, and the cathodes at each end of the lamp. The current heats the cathodes until electrons “boil off” and form clouds around each cathode. When the push button is released, the starting switch is opened. Then a higher-voltage inductive kick, caused by a sudden collapse of the ballast’s magnetic field, strikes the arc and lights the lamp. The ballast then limits, through its inductive reactance, the amount of current that flows through the circuit.

Instant-Start Cold-Cathode Fluorescent Lamp. Cold-cathode lamps do not have to be heated before starting. One type, the instant-start type, was developed in the 1940s. It requires no starter. The lamp is started by “brute force”; that means by applying a high starting voltage between the lamp cathodes—with no preheating it starts.

There are two types of two-lamp, instant-start circuits. One, called the series circuit, has a lower initial cost but does not provide independent lamp operation. The other type, the more expensive lead-lag circuit, provides not only independent lamp operation, but also reliable starting, even in low temperatures. See Figure 5-7.

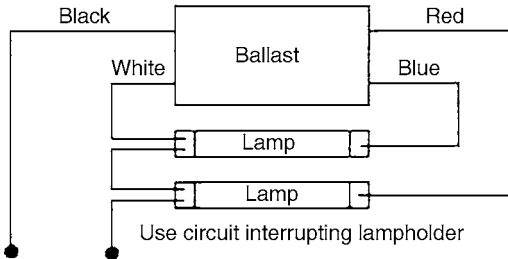


FIGURE 5-7. The lead-lag circuit is one type of instant-start cold cathode fluorescent lamp.

Rapid-Start Fluorescent Lamp. The rapid-start ballast circuit is the most popular in use today. It is used with rapid-start (430 mA), high-output (800 mA), and extra-high-output (1500 mA) lamps. Rapid start lamps use cathode heating continuously during lamp operation. No starter is required. The cathodes are designed to heat quickly once the switch is turned on. Current begins to flow through the tube almost instantly. Rapid-start fluorescent lamps require special ballast so that the lamp cathodes are quickly heated. See Figure 5-8.

STARTERS

A starter is needed to automatically start some preheat types of fluorescent lamps. They can be manually started if you use a switch or automatic if you use a sealed glow switch. See Figure 5-9. The glow switch consists of a can-covered glass envelope. Inside the envelope is a stationary post and a movable bimetallic post. Neon or argon gas under pressure is injected into the envelope and it is sealed. If it has an orange glow it is neon. When the lamp is turned on, the bimetallic strip begins to glow. When it glows, it heats up. As it heats up, the movable end begins to move toward the stationary contact pole. Once the bimetallic strip makes contact with the stationary pole, current travels through the cathode at each end of the tube, causing the cathodes to heat up.

Once the bimetallic strip makes contact with the stationary pole, the bimetallic strip begins to cool. As it cools, the movable end

82 CHAPTER FIVE

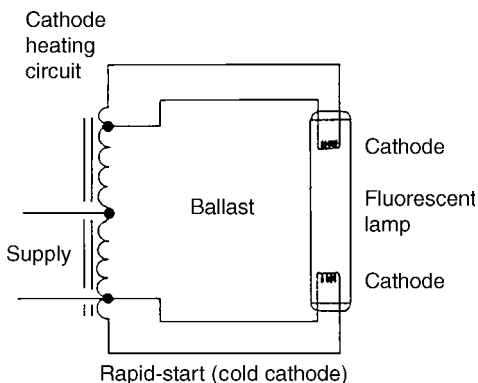


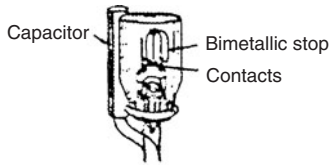
FIGURE 5-8. A rapid-start fluorescent circuit, the most popular type of ballast circuit.

moves away from the stationary post and the circuit is broken. By the time, the circuit is broken, the gas in the lamp has ionized and started to conduct and produce light, and there is no longer a need for the starter in the circuit. It is ready to be used again once the circuit has been turned off and then on again.

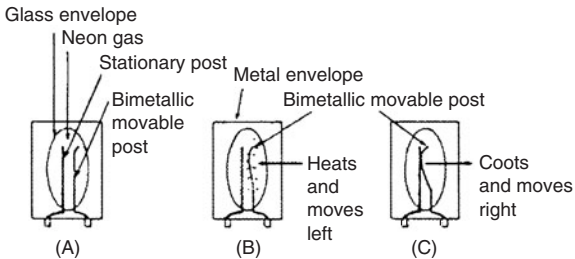
FLUORESCENT FIXTURES AND BASES

Fluorescent fixtures are usually sold by the manufacturer already wired, and they need to only be connected to a source of AC power, usually 120 volts. The rating of the wire used to serve these fixtures has to be such that it can withstand 90°C (194°F), or the wire cannot be placed within 3 inches of the ballast. (Type THW wire can be used for this purpose.)

Very little heat is generated by a fluorescent fixture, but it has to be taken into consideration whenever the fixture is mounted in hazardous environments. Special types of fixtures are available for use in spray-painting booths and similar environments, and fixtures to be used in explosive atmospheres or agricultural environments must meet special requirements set by the NEC. See Section 410-4.



Internal parts of fluorescent tube starter.



Operation of the glow-switch starter

Placing a starter in a preheat-type fluorescent lamp.

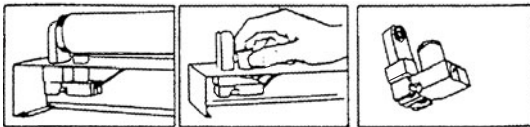


FIGURE 5-9. Starter for a fluorescent lamp.

Fluorescent fixtures may be flush-mounted or recessed. Fluorescent lamp fixtures that are flush-mounted to a box on the ceiling have to be arranged so that they cover the box completely. A hole in the fixture is needed to provide access to the junction box. If the hole is not located in the proper place, use a hole punch of some type to make a hole for access to the wiring. See NEC Sections 410-14(b) and 410-12 for further details.

84 CHAPTER FIVE

Special fixtures are made for a recessed installation. T-bars are used to fasten the fixture to the ceiling joists. In a commercial location, conduit usually feeds a junction box and flexible conduit or BX is used from the junction box to the fixture.

Fluorescent lamps that are installed in an industrial plant may be mounted to a raceway or to overhead pipes. In these cases, the lamps must be cord-connected to an overhead junction box directly in the fixture.

Fluorescent tubes are available with single-pin and bi-pin bases in different sizes. The type of base must be matched to the fixture installed. See Figure 5-10.

TROUBLESHOOTING FLUORESCENT LAMPS

Hints for troubleshooting fluorescent lamps are given in Table 5-2.

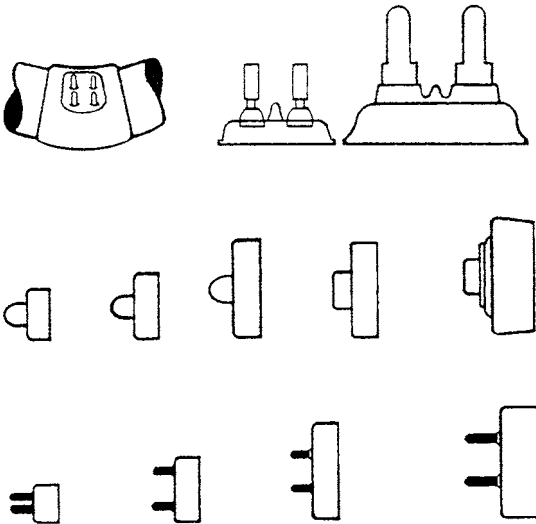


FIGURE 5-10. Typical fluorescent tube pin base.

TABLE 5-2
Troubleshooting Chart

Condition	Possible Causes to Investigate
(I) Lamps won't start.	<ol style="list-style-type: none"> (1) Lamp failure. (2) Poor lamp-to-lampholder contact. (3) Incorrect wiring. (4) Low voltage supply. (5) Dirty lamps or lamp pins. (6) Defective starters*. (7) Low or high lamp bulb-wall temperature. (8) High humidity. (9) Fixture not grounded. (10) Improper ballast application. (11) Ballast failure.
(II) Short lamp life	<ol style="list-style-type: none"> (1) Improper voltage. (2) Improper wiring. (3) Poor lamp-to-lampholder contact. (4) Extremely short duty cycles (greater than average number of lamp starts per day; check with lamp manufacturer). (5) Defective starters*. (6) Defective lamps. (7) Improper ballast application. (8) Defective ballast.
(III) Lamp flicker (spiraling or swirling effect)	<ol style="list-style-type: none"> (1) New lamps (should be operated 100 hours for proper seasoning). (2) Defective starters*. (3) Drafts on lamp bulb from air-conditioning system (lamp too cold). (4) Defective lamps. (5) Improper voltage. (6) Improper ballast application. (7) Defective ballast.
(IV) Audible ballast "hum"	<ol style="list-style-type: none"> (1) Loose fixture louvers, panels, or other parts. (2) Insecure ballast mounting. (3) Improper ballast selection. (4) Defective ballast.

(continued)

TABLE 5-2
Troubleshooting Chart (continued)

Condition	Possible Causes to Investigate
(V) Very slow starting	(1) Improper voltage—too low. (2) Inadequate lamp-starting-aid strip** (refer to fixture manufacturer). (3) Poor lamp-to-lampholder contact. (4) Defective starter*. (5) Defective lamp. (6) Improper circuit wiring. (7) Improper ballast application. (8) High humidity. (9) Bulb-Wall temperature too low or too high.
(VI) Excessive ballast heating over 90°C ballast case temperature	(1) Improper fixture design or ballast application (refer to fixture manufacturer). (2) High voltage. (3) Improper wiring or installation. (4) Defective ballast. (5) Poor lamp maintenance (instant-start and preheat systems). (6) Wrong type of lamps. (7) Wrong number of lamps.
(VII) Blinking	(1) Improper fixture design or ballast application (refer to fixture manufacturer). (2) High voltage. (3) Improper wiring or installation. (4) Defective ballast. (5) Poor lamp maintenance (instant-start and preheat systems). (6) Wrong type of lamps. (7) Wrong number of lamps. (8) High ambient temperature.

*Applies only to preheat (switch-start) circuits.

**Applies to only rapid-start and trigger-start circuits.

OTHER TYPES OF LAMPS

In addition to incandescent and fluorescent lamps, there are other sources of light; among them are mercury vapor lamps, metal halide lamps, and sodium lamps.

MERCURY VAPOR LAMPS

Mercury vapor lamps are commonly used in shopping centers, parking lots, in large farmyards, and along highways. A mercury vapor lamp is an arc-discharging, non-filament device. Once the arc is struck and the unit is emitting light, some type of ballast is usually required to limit the current flow to the device. There are two general types of mercury vapor lamps:

- Those that require the addition of a ballast some place on the fixture.
- Those that are self-ballasted.

The two types are similar in appearance, and you must be careful to screw the bulb only into a socket designed for its specific type. Figure 5-11 shows a typical screw-in mercury lamp that is not self-ballasted.

Many mercury vapor lamps mounted on poles in parking lots, in farm-yards, or along the highways have a photoelectric eye that turns the fixture on at dusk and off at dawn. Often the lamp needs time to warm up to full brilliance.

Possible problems with mercury vapor lamps include a burned-out lamp, a loose or broken wire, a bad photoelectric switch, and, if the lamp is not self-ballasted, a burned-out ballast. The more often the lamp is started, the shorter its life expectancy. The mercury vapor lamps used on farms and in commercial parking lots last about 24,000 hours, or 7 years when used with an automatic on-off switch for operation every night.

The best way to troubleshoot a mercury vapor lamp is with a meter. Check the bulb first to see if it is operational. Then check the on-off switch or photoelectric switch. To do this, short the two wires to the switch together. If light comes on, the switch is not defective. Remember, however, that it may take a few minutes for the lamp to begin to glow. If the bulb is not self-ballasted, disconnect the ballast and test it with an ohmmeter for shorts and opens.

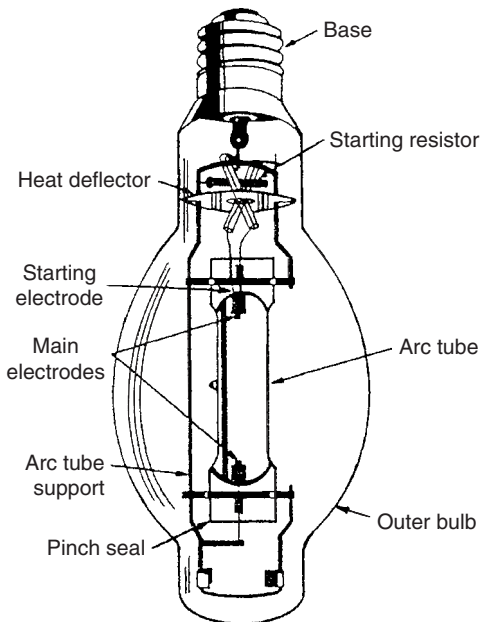


FIGURE 5-11. A mercury vapor lamp.

A cracked mercury vapor bulb can give off harmful radiation and damage the eyes and skin. Most, however, are safety bulbs, that will burn out almost immediately if the bulb is cracked.

METAL HALIDE LAMPS

The halide family of elements consists of mercury, sodium, thallium, indium, and iodine. The metal halide lamp contains many of these metals and puts out a better-quality light than a lamp containing only mercury. Colored objects appear their normal color

under this type of lamp—another advantage. Metal halide lamps are used for sports-lighting, outdoor-produce market lighting, and wherever a bright light with true colors is needed.

Metal halide lamps operate with the base up or down. However, you must know which. Otherwise, you can ruin the lamp because the starting switch inside the lamp will not operate properly unless it is mounted correctly. Do not place a metal halide lamp in a fixture designed for a mercury vapor lamp, and be sure the metal halide lamp will operate in the fixture that you have for it. (See Figure 5-12.)

Although the metal halide lamp provides bright, true-color light, there are some disadvantages associated with it. It is more expensive

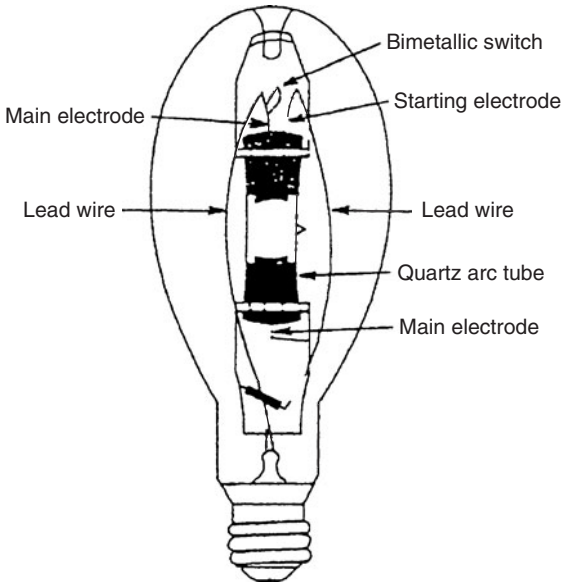


FIGURE 5-12. Metal halide lamp (for base-down mounting).

90 CHAPTER FIVE

than the mercury vapor lamp; lasts a shorter time, and produces a steadily decreasing amount of light with age.

SODIUM LAMPS, HIGH-PRESSURE

A high-pressure sodium lamp contains xenon gas, along with mercury and sodium. When the gases are vaporized by an electric arc, the glow gives a very intense light. The color of the light is somewhat yellowish-orange but objects under it appear almost their natural color. See Figure 5-13. High-pressure sodium lamps are

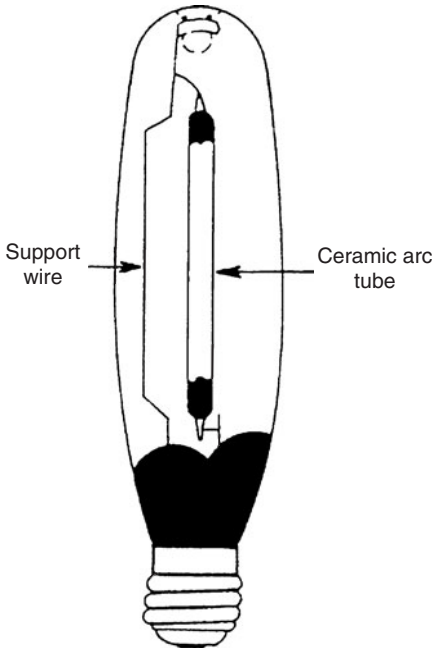


FIGURE 5-13. High-pressure sodium lamp.

used primarily as farm lights. They are more efficient than mercury lamps and give off about twice as much light for the same wattage, and can produce light much faster (within 2 minutes) than mercury vapor lamps. They do, however, cost more and need special ballast.

SODIUM LAMPS, LOW-PRESSURE

A low-pressure sodium lamp produces an orange color and gives objects under it an off-color cast. It can be used where high illumination is needed with little need for true color. A low-pressure sodium lamp makes a good security lamp. Lamp life is about 18,000 hours with special ballast and fixture.

OTHER TYPES OF LAMPS

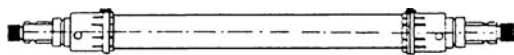
There are many other types of lamps, including ballasted mercury vapor lamps, compact-source iodide lamps, high-pressure mercury vapor lamps, repro-lamps, black light lamps, water-cooled, super-high-pressure mercury lamps, air-cooled, super-high-pressure mercury lamps, quartz tubes, pulsed xenon lamps, super actinic lamps, spectral lamps, and neon lamps. See Figure 5-14.

ANALYZING A LIGHTING SYSTEM

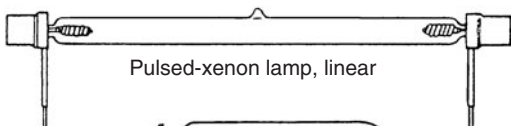
The type of lighting system needed depends on the facility—residential, commercial, recreational, or industrial—and on the activities of that facility. Use Table 5-3 as a guideline for determining the amount of light needed for various activities. Table 5-4 provides information on the color of light produced, the length of the lamp (in the case of fluorescent lamps), the initial lumens, the life expectancy, and the efficacy of different types of lamps. This information is essential for anyone working with lighting in any situation.

LIGHTING CONTROLS

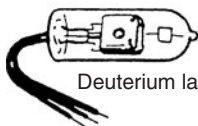
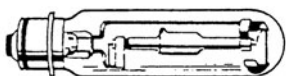
To make maximum use of available light, it is necessary to control it. Light may be controlled by turning lights on and off, either



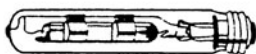
Light-printing lamp (copiers)



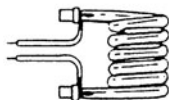
Pulsed-xenon lamp, linear



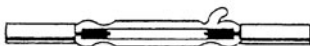
Deuterium lamp



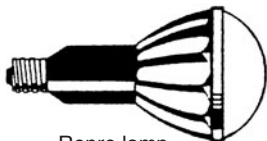
Spectral lamp



Pulsed-xenon lamp, loop design



Air-cooled, super high-pressure mercury lamp



Repro lamp

FIGURE 5-14. Some other types of lamps.

TABLE 5-3
Amount of Light Needed for Various Activities

10 fc		20 fc		30 fc		50 fc		70 fc		100 fc		150 fc		200 fc*		500 fc*																					
Concourses	Freight cars	Corridors	Stairways Elevators	Rough assembly— easy seeing	Reading good printed matter	Rest rooms	Ship fabricating	Rough assembly— difficult seeing	Rough bench and machine work	Bank lobbies	Ordinary inspection	Rough assembly— difficult seeing	Rough bench and machine work	Bank lobbies	Ordinary inspection	Rough assembly— difficult seeing	Rough bench and machine work	Bank lobbies	Ordinary inspection																		
Service station- entrance drive	Football field (recreational)	Baseball outfield (recreational)	Swimming	Exhibitions	Loading and freight docks	Active storage yard	Buildings— medium dark surfaces, bright surroundings	Tennis— tournament	Buildings—dark surfaces, bright surroundings	Reading hand- writing—pen or soft pencil	Intermittent	Filing	Folding	Textiles	Reading hand- writing—hard pencil	Active filing	Mail sorting	Medium bench and machine work	Indoor tennis	Car repairing	Fine painting	Store merchandise service areas	Football— major stadium	Major league baseball— infield	Bookkeeping	Accounting	Bank teller stations	Posting and keypunching	Reading—poor reproductions	Detailed drafting	Store merchandise— self-serve areas	Sheet metal scribing	Fine bench and machine work	Fine foundry inspection	Store feature displays	Jewelry and watch manufacturing	Fine automatic machines

*Often obtained with a combination of general and supplementary lighting.

**fc stands for footcandle (a unit of luminance).

TABLE 5-4
Lumens, Life, and Efficacy for the Lamps

Watts	Color	Length (ft)	Initial Lumens	Life (h)	Efficacy (lm/W)
Incandescent, standard inside frosted					
25			235	1000	9
40			480	1500	12
60			840	1000	14
75			1210	850	16
100			1670	750	17
150			2850	750	19
200			3900	750	19
300			6300	1000	21
500			10750	1000	21
1000			23100	1000	23
Incandescent PAR-38					
150 Spot			1100	2000	7
150 Flood			1350	2000	9
Quartz incandescent					
500			10550	2000	21
1000			21400	2000	21
1500			35800	2000	24
40	CW & WW	4	3150	20000	78
40	CWX	4	2200	20000	55
60	CW & WW	4	4300	12000	41
60	CWX	4	3050	12000	50
85	CW & WW	4	2850	20000	81
85	CWX	4	2000	20000	57
Fluorescent, U-line					
40	CW & WW	2	2850	12000	71
40	CWX	2	2020	12000	50
Fluorescent, instant start					
60	CW & WW	8	5600	12000	93
60	CWX	8	4000	12000	66
75	CW & WW	8	6300	12000	84
75	CWX	8	4500	12000	60
95	CW & WW	8	8500	12000	89
95	CWX	8	6100	12000	64
110	CW & WW	8	9200	12000	83
110	CWX	8	6550	12000	59
180	CW	8	12300	10000	68
215	CW	8	14500	10000	67
215	WW	8	13600	10000	63
Mercury-vapor					
40	Deluxe		1140	24000	28
50	Deluxe		1575	24000	31
75	Deluxe		2800	24000	37
100	Deluxe		4300	24000	43
175	Deluxe		8500	24000	48
175	Clear		7900	24000	45
250	Deluxe		13000	24000	52

TABLE 5-4
Lumens, Life, and Efficacy for the Lamps (continued)

Watts	Color	Length (ft)*	Initial Lumens	Life (h)	Efficacy (lm/W)
250	Clear		12100	24000	48
400	Deluxe		23000	24000	57
400	Clear		21000	24000	52
700	Deluxe		43000	24000	61
1000	Deluxe		63000	24000	63
Metal-halide					
175			14000	7500	80
250			20500	7500	82
400			34000	15000	85
1000			105000	10000	105
High-pressure sodium					
50			3300	20000	66
70			5800	20000	82
100			9500	20000	95
150			16000	24000	106
150†			12000	12000	80
200			22000	24000	110
215†			19000	12000	88
250			27500	24000	110
400			50000	24000	125
1000			140000	24000	140
Low-pressure sodium					
65			4800	18000	137
65			8000	18000	145
90			13500	18000	150
135			22500	18000	166
180			33000	18000	183

CW—cool white; WW—warm white; CWX—deluxe cool white; Deluxe—produces extra red light; Clear—produces very little red light.

*1 ft = 0.3048 meter.

†Suitable for use in a mercury-vapor fixture.

manually or with time clocks or photoelectric switches, and by controlling the level of illumination in a given area with dimmers and similar devices.

DIMMERS

Solid-state circuitry dimmer switches for incandescent lighting adjust lights from bright to candle-glow without causing a flicker. In some dimmers, a knob is turned to switch on the light and then

rotated until the brightness level desired is reached. Turning on a light with such a dimmer involves rotating the knob back and clicking the switch on. In other types of dimmers, the knob is pushed in to turn the lights on, and then the knob is rotated to the brightness level desired. The lights are turned off by pushing in on the knob. Push the knob again to turn the lights back on at the exact brightness level that was set when it was turned on. This type of dimmer has to have a filter to prevent problems with television and radio reception within the house, especially if they are all on the same circuit.

The 1000-, 1500-, and 2000-watt models of incandescent dimmers have break-off fins that permit close ganging of the switches, using minimum wall space. The 1500- and 2000-watt models have mounting holes for two-gang boxes.

Light control equipment comes in all sizes. Commercial-size units are usually transformers, and in some cases, such as stage lighting, saturable reactors are used. These reactors use a low-voltage DC to control the saturation level of the core of a transformer that, in turn, decreases or increases the available current from the secondary winding of the transformer that supplies the lights.

In most cases, a wall-mounted controller, mounted in a standard 4-inch wall box, is a continuously adjustable transformer. The rotating knob of the dimmer produces any light intensity from full bright to off or any level in between. It is a smooth, flickerless, stepless control process, suitable for either incandescent or 40-watt rapid-start fluorescent lamps.

Most newer models of dimmers are made with radio frequency interference (RFI) suppression to make sure that the dimmer does not interfere with the operation of a radio or television or any other electronic device on the same circuit or in the building. Triacs are made that can handle up to 4000 amperes. The high currents are controlled or triggered by diacs that are in turn controlled by low voltage.

Motor-driven units, composed of electronic circuits with RFI suppression, permit remote control. The dimmer can be installed in an out-of-the-way spot and the control station (knob) at a convenient location.

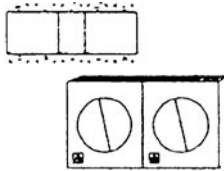
Dimmers are also available for use with fluorescent lamps. However, inasmuch as fluorescent lamps usually need about 100 volts to produce light, it is rare that anyone needs to dim them.

The electronic dimmers for fluorescent lamps that are now available permit gradual control of the entire dimming range from full intensity to completely off.

The dimmer can be mounted in a standard double-gang sectional switch box with a depth of at least 2½ inches. The dimmer comes with pigtails. When ganging dimmers horizontally, a single gang box is placed between double-gang boxes (Figure 5-15).

De-rating is not required when specifier series dimmers are ganged. Some dimmers handle from four to twenty 40-watt lamps; others will handle from four to forty 40-watt lamps, or 16.66 amperes. Figure 5-16 shows the installation circuits for fluorescent dimmers.

2-gang installation



Installation circuit diagram for 3-way control—incandescent

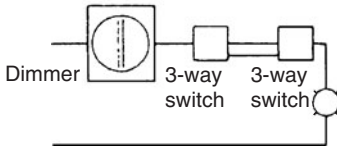
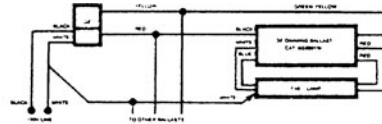


FIGURE 5-15. Dimmer installation for an incandescent lamp.

Installation circuit

With one-lamp GE dimming ballast Cat. 8G5001W



With two-lamp GE dimming ballast Cat. 8G5007W

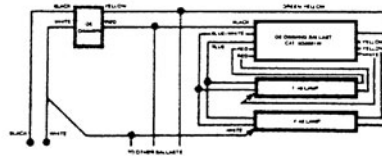
**Installation circuit**

Diagram for 3-way control—fluorescent

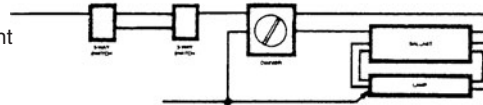


FIGURE 5-16. Installation circuit for fluorescent dimmers.

HIGH-TECH DIMMERS

Lights can be dimmed to vary light intensity in a room and to use the effect as part of a decorating scheme. Bright bathroom lights can be dimmed so that they are not such a problem at 3 a.m. Lights can be dimmed in the children's bedrooms to calm them and make it safer to go into the room when they are asleep without tripping over something. Bright lights are not exactly necessary when you are watching television, so the dimmer can be used to keep the room comfortable for viewing. Dining rooms can be made more suitable for dining, with dimmers used to create a relaxed and calm feeling rather than eat-and-run atmosphere. Dimmers are used to soften lights for reading, talking, and enjoying romance in the bedroom.

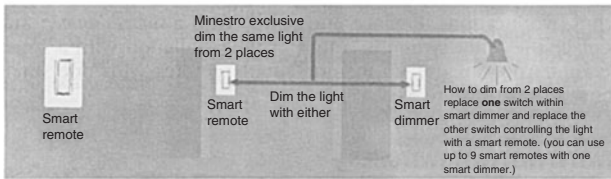
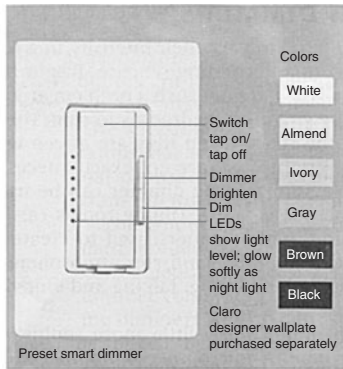
The high-tech dimmer is a little more sophisticated than the variable resistor type. A microprocessor is used to keep the light level where you want it. Some have a 10-second delay, and dynamic light-emitting diodes (LEDs). By adding a smart remote, you can dim the lights from two locations. Replace one switch with a *smart dimmer* and replace the other switch in a three-way installation with a smart remote. You can use up to nine smart remotes with one smart dimmer. See Figure 5-17.

PHOTOELECTRIC SWITCHES

Lighting can also be controlled by using photoelectric switches that detect the available sunlight and turn lamps on and off accordingly. There are many different types of photoelectric controls available—some to control indoor lighting and some to control outdoor lighting. They differ also in the sunlight level, measured in foot-candles, required to trigger lamp turn-on.

TIME CLOCKS

Time clocks can also be used to turn lights on and off. Time clocks can be obtained with a number of features. Some can be set to turn lights on and off at certain times each day; others permit longer or shorter operation periods for each individual day of the week as well as the possibility of omitting any day.



Lutron dimmers pay for themselves

Dimming your lights	Saves electricity	Makes your bulbs last longer
10%	10%	2 times longer
20%	20%	4 times longer
50%	40%	20 times longer
75%	60%	Greater than 20 times longer

*Dimmers can make bulbs last more than 20 times longer. They use far less electricity than switches

FIGURE 5-17. High-tech dimmers from Lutron Electronics.

This feature is necessary in many commercial lighting operations such as stores and shopping centers, where working hours vary from day to day.

In general, time clocks that can handle up to 40 amperes per contact in SPST, DPDT, 3PST, and SPDT configurations are available.

This page intentionally left blank

6

Electric Motors

Electric motors are available in many sizes, shapes, and types for every job imaginable. Characteristics, installation procedures, uses, and troubleshooting techniques differ somewhat among the motors.

There is some general information and basic characteristics of motors. Every electrician should be thoroughly familiar with both: the characteristics and information. Then, when called upon for installation, maintenance, and simple troubleshooting, the electrician will be able to use this basic information to interpret the specific details and manufacturer's instructions for the particular type of motor.

GENERAL CHARACTERISTICS AND NAMEPLATE INFORMATION

Fractional-horsepower motors may be single-phase or polyphase. These motors differ in starting torque, starting current, service factor, purpose (general or special), duty, reversibility, price, and other factors. These factors must be considered in choosing the right motor for a particular job and in maintaining and troubleshooting motors. Tables 6-1 and 6-2 list some important characteristics of fractional-horsepower alternating current (AC) motors.

TABLE 6-1
Typical Characteristics of AC Motors

Motor Types	Split-Phase General-Purpose	Split-Phase Special Service	Capacitor-Start Special Service	Start General-Purpose	Polyphase 1 hp & Below
Starting torque (% full load torque)	130%	175%	250%	350%	275%
Starting current service factor (% of rated load)	Normal 135%	High 100%	Normal 100%	Normal 135%	Normal 135%
Comparative price estimate (based on 100% per lowest cost motor)	110%	100%	135%	150%	150%
Remarks	Low starting torque. High service factor permits continuous loading—up to 35% over nameplate rating. Ideal for applications of medium starting duty.	Moderate starting torque, but has service factor of 1.0. Apply where load will not exceed nameplate rating for any extended duration of time. Because of higher starting current, use where starting is infrequent.	High starting torque but 1.0 service factor. Use only where load will not exceed nameplate rating for any extended duration of time. Starting current is normal.	Very high starting torque. High service factor permits continuous loading up to 35% over nameplate rating. Ideal for powering devices with heavy loads, such as conveyors.	Normal start current for poly phase is compared to single-phase motors. High factor permits continuous loading up to 35% over nameplate rating. Direct companion to general purpose capacitor-start motor.

Source: Courtesy of General Electric.

TABLE 6-2
Motor Characteristics

		Duty	Typical Reversibility	Speed Character	Typical Start Torque*
Polyphase	AC	Continuous	Rest/Rot.	Relatively constant	175% & up
Split phase synchronous	AC	Continuous	Rest only	Relatively constant	125–200%
Split phase nonsynchronous	AC	Continuous	Rest only	Relatively constant	175% & up
PSC nonsynchronous high slip	AC	Continuous	Rest/Rot.**	Varying	175% & up
PSC nonsynchronous norm. slip	AC	Continuous	Rest/Rot.**	Relatively constant	75–150%
PSC reluctance synchronous	AC	Continuous	Rest/Rot.**	Constant	125–200%
PSC hysteresis synchronous	AC	Continuous	Rest/Rot.**	Constant	125–200%
Shaded pole	AC	Continuous	Uni-directional	Constant	75–150%
Series	AC/DC	Int./Cont.	Uni-directional†	Varying‡	175% & up
Permanent magnet	DC	Continuous	Rest/Rot.§	Adjustable	175% & up
Shunt	DC	Continuous	Rest/Rot.	Adjustable	125–200%
Compound	DC	Continuous	Rest/Rot.	Adjustable	175% & up
Shell arm	DC	Continuous	Rest/Rot.	Adjustable	175% & up
Printed circuit	DC	Continuous	Rest/Rot.	Adjustable	175% & up
Brushless	DC	Continuous	Rest/Rot.	Adjustable	75–150%
DC stepper	DC	Continuous	Rest/Rot.	Adjustable	¶

Source: Courtesy of Bondine Electric.

*Percentages are relative to full-load rated torque. Categorizations are general and apply to small motors.

**Reversible while rotating under favorable conditions: generally when inertia of the driven load is not excessive.

†Usually unidirectional—can be manufactured bi-directional.

‡Can be adjusted but varies with load.

§Reversible down to 0°C after passing through rest.

¶Dependent upon load inertia and electronic driving circuitry.

NAMEPLATE READINGS

Each motor has a nameplate on which the manufacturer provides information to aid in motor selection, operation, maintenance, and troubleshooting. Although each manufacturer arranges the information in a different way, all provide the same data: the horsepower of the motor, the power required to operate the motor, and the frequency of that power. It also includes its voltage and current; the frame, serial number, and model number of the motor, the capacitor to be used (if needed); and the temperature required for normal operation.

OPERATING ACCORDING TO NAMEPLATE DIRECTIONS

- Do not operate motors at other than $\pm 10\%$ of the nameplate voltage.
 - Do not operate motors on nominal power source frequencies other than that indicated on the nameplate.
 - Do not overload the motor in excess of nameplate current rating.
 - Do not exceed the temperature of the nameplate insulation class.
 - Do not change the value of capacitance indiscriminately.
 - Do not subject the motor to duty cycles for which it was not designed.
-

Motor performance is adversely affected if it is operated under conditions that deviate from nameplate specifications. Table 6-3 lists some performance parameters adversely affected.

FACTORS TO CONSIDER IN SELECTING, OPERATING, AND MAINTAINING A MOTOR

Among the factors to consider in selecting a motor are the purpose for which the motor is to be used, whether some overload capacity is desired in the motor, the system voltage available, the power output needed, and the ease of reversibility in the motor.

TABLE 6-3
Performance Parameters Adversely Affected by Nameplate Deviations

Nameplate Parameters	Torque	Speed	Temperature	Noise	Vibration	Thermal O/L Protectors	Current Sensitive	Centrifugal Cutouts	Capacitor Life	Motor Life
Voltage	X	X	X	X	X	X	X		X	X
Frequency	X	X	X	X	X	X	X	X	X	X
Horsepower (torque)	—	X	X	X	X	X	X			X
Temperature	X	X	—	—	—	X	X		X	X
Capacitor Duty	X	X	X	X	X	X			X	X
	—		X	—	—	X	X	X	X	X

Source: Courtesy of Bodine Electric.

108 CHAPTER SIX

The electrician and apprentice must be familiar with all of these concepts to recognize the different types of motors available, understand nameplate data, and work efficiently on motors.

PURPOSE

Single-phase AC motors are available in two types: general purpose and special purpose. General-purpose motors can be used in many and widely varying situations. The choice of which motor to use depends on the particular situation.

Special-purpose motors include heavy-duty motors designed especially for severe farm duty. These are capacitor-start induction-run motors. They furnish high starting torque with normal current. These motors are gasketed throughout for protection from environmental hazards and have double-sealed ball bearings with a water flinger on the shaft end to protect the motor and bearings from contaminants.

An oversize conduit box makes wiring these types of motors easy. Grounding provision is usually included. Low-temperature thermal-overload protectors can also be used, but a manual-reset overload button (with a rubber weather boot) is standard on these motors, so there is maximum operator safety. Table 6-4 provides power ratings and other information about farm-duty motors.

TABLE 6-4
Farm-Duty Motors (Single-Phase)

hp	Speed (rpm)	Volts	NEMA Frame	Bearings	Therm. Protection	Full-Load Amps
1/4	1725	115	48	Ball	None	4.5
—	—	115	48	Ball	Auto	4.5
—	1140	115	56	Ball	None	5.3
—	—	115	56	Ball	Auto	5.3
1/3	1725	115	48	Ball	None	5.3
—	—	115	48	Ball	Auto	5.3
—	—	230	48	Ball	None	2.7
—	1140	115	56	Ball	None	7.0
1/2	1725	115	56	Ball	None	8.0

Source: Courtesy of General Electric.

SERVICE FACTOR

Service factor (SF) is a measure of the overload capacity designed into a motor. It varies for motors of different horsepower and speeds. A service-factor rating of 1.0 means that the motor should not be overloaded beyond its rated horsepower. A 1.15 SF means that the motor can deliver 15% more than the rated horsepower without injurious overheating.

Motors used on farms should have a service factor of at least 1.35 in order to take the abuse (overload) they often receive under various work conditions. Table 6-5 gives standard National Electrical Manufacturer's Association (NEMA) service factors for various horsepower motors and motor speeds.

POWER SUPPLY

The system voltage must be known in order to select the proper motor or check its operation. Usually the motor nameplate lists a voltage less than the nominal power system voltage. For example, the 120-volt line usually delivers between 110 and 120 volts depending on the location. The motor nameplate will usually list 115 volts, which is halfway between 110 and 120. A 240-volt system will usually have 230 volts on the nameplate. A joint committee of

TABLE 6-5
Service Factors

hp	Service Factor			
	Synchronous Speed			
	3600	1800	1200	900
1/20, 1/12, 1/8	1.40	1.40	1.40	1.40
1/6, 1/4, 1/3	1.35	1.35	1.35	1.35
1/2	1.25	1.25	1.25	1.15
3/4	1.25	1.25	1.15	1.15
1	1.25	1.15	1.15	1.15
1 1/2 and up	1.15	1.15	1.15	1.15

Source: Courtesy of General Electric.

TABLE 6-6
Power System Voltage Standards

Polyphase 60 Hz	
Nominal Power System, Volts	Motor Nameplate, Volts
208	200
240	230
480	440
600	575
Single-Phase 60 Hz	
Nominal Power System, Volts	Motor Nameplate, Volts
120	115
240	230

Source: Courtesy of General Electric.

the Edison Electric Institute and the NEMA has recommended standards for both power system voltage and motor nameplate voltage. See Table 6-6.

POWER OUTPUT

In some cases, it is necessary to compare the power output of various motors. Power output can be expressed in horsepower (English or customary measurement system) or in watts (SI system). To make comparisons, the electrician may need to convert from one system of measurement to another. In converting, remember

$$1 \text{ horsepower} = 746 \text{ watts}$$

$$1000 \text{ watts} = 1 \text{ kilowatt}$$

$$746 \text{ watts} = 0.746 \text{ kilowatts}$$

$$1 \text{ millihorsepower} = 0.001 \text{ horsepower}$$

TABLE 6-7
Motor Power Output Comparison

Watts Output	mhp*	hp†
0.746	1	1/1000
1.492	2	1/500
2.94	4	1/250
4.48	6	1/170
5.97	8	1/125
7.46	10	1/100
9.33	12.5	1/80
10.68	14.3	1/70
11.19	15	1/65
11.94	16	1/60
14.92	20	1/50
18.65	25	1/40
22.38	30	1/35
24.90	33	1/30
26.11	35	
29.80	40	1/25
37.30	50	1/20
49.70	—	1/15
60.17	—	1/12
74.60	—	1/10

Source: Courtesy of General Electric.

*Millihorsepower

†Fractional horsepower.

Note: Watts output is the driving force of the motor as calculated by the formula:

$$(TN/112.7) = WO$$

where T = torque (oz.ft), N = speed (rpm).

Table 6-7 lists the horsepower, millihorsepower, and watt equivalents for common sizes of motors. Table 6-8 provides horsepower-kilowatt equivalents. Table 6-9 provides horsepower-watt equivalents for different torques.

REVERSIBILITY

AC motors are not easily reversed. An AC induction motor will not always reverse while running. It may continue to run in the same

TABLE 6-8
Metric Motor Ratings

hp	kW
1/20	0.025
1/16	0.05
1/8	0.1
1/6	0.14
1/4	0.2
1/3	0.28
1/2	0.4
1 ¹ / ₂	0.8
1 ¹ / ₂	1.1
2	1.6
3	2.5
5	4.0
7.5	5.6
10	8.0

Source: Courtesy of Bodine Electric.

direction but at a reduced efficiency. Most motors that are classified as reversible while running will reverse with a non-inertial-type load. They may not reverse if they are under no-load conditions or if they have a light load or an inertial load. A permanent-split-capacitor motor that has insufficient torque to reverse a given load may just continue to run in the same direction.

One of the problems related to reversing a motor while it is running is the damage done to the transmission system connected to the load or to the load itself. One of the ways to avoid this is to make sure the right motor is connected to a load.

To reverse a squirrel-cage three-phase motor it is necessary to interchange only two leads—any two leads. On single-phase motors the connections between the power source and the run winding and start winding have to be reversed.

Wiring Diagrams for Reversing of Motors. To reverse electric motors you need to know how the windings are wired in relation to one another and the color code of the leads that are brought out to the terminals for connection to a power source. Figure 6-1

TABLE 6-9
Horsepower/Watts vs. Torque Conversion Chart

hp	Watts	@ 1125 r/min		@ 1200 r/min		@ 1425 r/min	
		Oz-in	mN-m	Oz-in	mN-m	Oz-in	mN-m
1/2000	0.373	0.4482	3.1649	0.4202	2.9670	0.3538	2.4986
1/1500	0.497	0.5976	4.2198	0.5602	3.9561	0.4718	3.3314
1/1000	0.746	0.8964	6.3297	0.8403	5.9341	0.7077	4.9971
1/750	0.994	1.1951	8.4396	1.1205	7.9121	0.9435	6.6628
1/500	1.49	1.7927	12.6594	1.6807	11.8682	1.4153	9.9943
1/200	3.73	4.4818	31.6485	4.2017	29.6705	3.5383	24.9857
1/150	4.97	5.9757	42.1980	5.6023	39.5606	4.7177	33.3142
1/100	7.46	8.9636	63.2970	8.4034	59.3409	7.0765	49.9713
1/75	9.94	11.9515	84.3960	11.2045	79.1212	9.4354	66.6284
1/70	10.70	12.8052	90.4243	12.0048	84.7727	10.1093	71.3876
1/60	12.40	14.9393	1054.4950	14.0056	98.9015	11.7942	83.2855
1/50	14.90	17.9272	126.5940	16.8068	118.6818	14.1531	99.9426
1/40	18.60	22.4090	158.2425	21.0085	148.3523	17.6913	124.9283
1/30	24.90	29.8787	210.9899	28.0113	197.8031	23.5884	166.5710
1/25	29.80	35.8544	253.1879	33.6135	237.3637	28.3061	199.8852
1/20	37.30	44.8180	316.4849	42.0169	296.7046	35.3827	249.8562
1/15	49.70	59.7574	421.9799	56.0225	395.6061	47.1769	333.1420
1/12	62.10	74.6967	527.4748	70.0282	494.5077	58.9711	416.4275
1/10	74.6	89.6361	632.9698	84.0338	593.4092	70.7653	499.7130
1/8	93.2	112.0451	791.2123	105.0423	741.7615	88.4566	624.4613
1/6	124.0	149.3934	1054.9497	140.0563	989.0153	117.9422	832.8550
1/4	186.0	224.0902	1582.4245	210.0845	1483.5230	176.9133	1249.2825
1/3	249.0	298.7869	2109.8994	280.1127	1978.0307	235.8844	1665.7101

(continued)

TABLE 6-9
Horsepower/Watts vs. Torque Conversion Chart (continued)

hp	Watts	@ 1500 r/min		@ 1725 r/min		@ 1800 r/min	
		Oz-in	mN-m	Oz-in	mN-m	Oz-in	mN-m
1/2000	0.373	0.3361	2.3736	0.2923	2.0640	0.2801	1.9780
1/1500	0.497	0.4482	3.1648	0.3897	2.7520	0.3735	2.6374
1/1000	0.746	0.6723	4.7473	0.5846	4.1281	0.5602	3.9561
1/750	0.994	0.8964	6.3297	0.7794	5.5041	0.7470	5.2747
1/500	1.490	1.3445	9.4945	1.1692	8.2561	1.1205	7.9121
1/200	3.730	3.3614	23.7364	2.9229	20.6403	2.8011	19.7803
1/150	4.97	4.4818	31.6485	3.8972	27.5204	3.7348	26.3737
1/100	7.46	6.722	47.4727	5.8458	41.2806	5.6023	39.5606
1/75	9.94	8.9636	63.2970	7.7944	55.0409	7.4697	52.7475
1/70	10.70	9.6039	67.8182	8.3512	58.9723	8.0032	56.5152
1/60	12.40	11.2045	79.1212	9.7431	68.8011	9.3371	65.9344
1/50	14.90	13.4454	94.9455	11.6917	82.5613	11.2045	79.1212
1/40	18.60	16.8068	118.6818	14.6146	103.2016	14.0056	98.9015
1/30	24.90	22.4090	158.2425	19.4861	137.6021	18.6742	131.8687
1/25	29.80	26.8908	185.8909	23.3833	165.1226	22.4090	158.2425
1/20	37.3	33.6135	237.3637	29.2292	206.4032	28.0113	197.8031
1/15	49.7	44.8180	316.4849	38.9722	275.2043	37.3484	263.7374
1/12	62.1	56.0225	395.6061	48.7153	344.0053	46.6854	329.6718
1/10	74.6	67.2270	474.7274	58.4583	412.8064	56.0025	395.6061
1/8	93.2	84.0338	593.4092	73.0729	516.0080	70.0282	494.5077
1/6	124.0	112.0451	791.2123	97.4305	688.0107	93.3709	659.3436
1/4	186.0	168.0676	1186.8184	146.1458	1032.0160	140.0563	989.0153
1/3	249.0	224.0902	1582.4245	194.8610	1376.0213	186.7418	1318.6871

hp	Watts	@ 3000 r/min		@ 3450 r/min		@ 3600 r/min	
		Oz-in	mN-m	Oz-in	mN-m	Oz-in	mN-m
1/2000	0.373	0.1681	1.1868	0.1461	1.0320	0.1401	0.9890
1/1500	0.497	0.2241	1.5824	0.1949	1.3760	0.1867	1.3187
1/1000	0.746	0.3361	2.3736	0.2923	2.0640	0.2801	1.3187
1/750	0.994	0.4482	3.1648	0.3897	2.7520	0.3735	1.9780
1/500	1.490	0.6723	4.7473	0.5846	4.1281	0.5602	2.6374
1/200	3.730	1.6807	11.8682	1.4615	10.3202	1.4006	3.9561
1/150	4.97	2.2409	15.8242	1.9486	13.7602	1.8674	9.8902
1/100	7.46	3.3614	23.7364	2.9229	20.6403	2.8011	13.1869
1/75	9.94	4.4818	31.6485	3.8972	27.5204	3.7348	19.7803
1/70	10.70	4.8019	33.9091	4.1756	29.4862	4.0016	26.3737
1/60	12.40	5.6023	39.5606	4.8715	34.4005	4.6685	28.2576
1/50	14.90	6.7227	47.4727	5.8458	41.2806	5.6023	39.5606
1/40	18.60	8.4034	59.3409	7.3073	51.6008	7.0028	49.4508
1/30	24.90	11.2045	79.1212	9.7431	68.8011	9.3371	65.9344
1/25	29.80	13.4454	94.9455	11.6917	82.5613	11.2045	79.1212
1/20	37.3	16.8068	118.6818	14.6146	103.2016	14.0056	98.9015
1/15	49.7	22.4090	158.2425	19.4861	137.0027	18.6742	131.8687
1/12	62.1	28.0113	197.8031	24.3576	172.0027	23.3427	164.8359
1/10	74.6	33.6135	237.3637	29.2292	206.4032	28.0113	197.8031
1/8	93.2	42.0169	296.7046	36.5364	258.0040	35.0141	247.2538
1/6	124.0	56.0225	395.6061	48.7153	344.0053	46.6854	329.6718
1/4	186.0	84.0338	593.4092	73.0729	516.0080	70.0282	494.5077
1/3	249.0	112.0451	791.2123	97.4305	688.0107	93.3709	659.3436

(continued)

TABLE 6-9
Horsepower/Watts vs. Torque Conversion Chart (continued)

hp	Watts	@ 1500 r/min		@ 1725 r/min		@ 1800 r/min	
		Oz-in	mN-m	Oz-in	mN-m	Oz-in	mN-m
1/2000	0.373	0.1008	0.7121	0.6721	0.4747	0.0504	0.3560
1/1500	0.497	0.1345	0.9495	0.0896	0.6330	0.0672	0.4747
1/1000	0.746	0.2017	1.4242	0.1345	0.9495	0.1008	0.7121
1/750	0.994	0.2689	1.8989	0.1793	1.2659	0.1345	0.9495
1/500	1.490	0.4034	2.8484	0.2689	1.8989	0.2017	1.4242
1/200	3.730	1.0084	7.1209	0.6723	4.7473	0.5042	3.5605
1/150	4.97	1.3445	9.4945	0.8964	6.3297	0.6723	4.7473
1/100	7.46	2.0168	14.2418	1.3445	9.4945	1.0084	7.1209
1/75	9.94	2.6891	18.9891	1.7927	12.6594	1.3445	9.4945
1/70	10.70	2.8812	20.3455	1.9208	13.5636	1.4406	10.1727
1/60	12.40	3.3614	23.7364	2.2409	15.8242	1.6807	11.8682
1/50	14.90	4.0336	28.4836	2.6891	18.9891	2.0168	14.2418
1/40	18.60	5.0420	35.6046	3.3614	23.7364	2.5210	17.8023
1/30	24.90	6.7227	47.4727	4.4818	31.6485	3.3614	23.7364
1/25	29.80	8.0672	56.9673	5.3782	37.9782	4.0336	28.4836
1/20	37.30	10.0841	71.2091	6.7227	47.4727	5.0420	35.6046
1/15	49.70	13.4454	94.9455	8.9636	63.2970	6.7227	47.4727
1/12	62.10	16.8068	118.6818	11.2045	79.1212	8.4034	59.3409
1/10	74.6	20.1681	142.4182	13.4454	94.9455	10.0841	71.2091
1/8	93.2	25.2101	178.0228	16.8068	118.6818	12.6051	89.0114
1/6	124.0	33.6135	237.3637	22.4090	158.2425	16.8068	118.6818
1/4	186.0	50.4203	356.0455	33.6135	237.3637	25.2101	178.0228
1/3	249.0	67.2270	474.7274	44.8180	316.4849	33.6135	237.3637

Source: Courtesy of Bodine Electric.

Note: Oz-in can also be in-Oz. Most people still refer to the torque of these motors as Oz-in.

AC SINGLE-PHASE

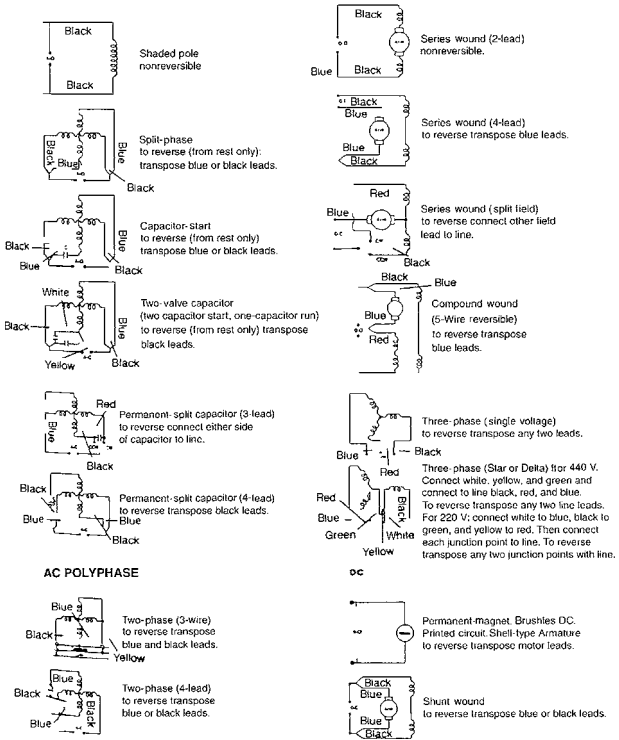


FIGURE 6-1. Wiring schematics and how to reverse different motors.

shows the wiring schematics and how to reverse the direction of rotation of the various types of motors.

CAPACITOR-START MOTORS

The capacitor-start motor is a modified form of the split-phase motor. It has a capacitor in series with the start winding. It uses a centrifugal switch to remove the start winding after it has come up to about 75% of rated speed. One advantage of the capacitor-start motor is its ability to start under load and develop high starting torque.

The capacitor-start motor can be reversed at rest or while rotating. The speed is relatively constant, while the starting torque is 75 to 150% of rated torque. The starting current is normal. Duty cycle for motor-starting capacitors is rated on the basis of twenty 3-second periods per hour. Sixty 1-second periods per hour should be one equivalent duty cycle. Table 6-10 lists the ratings and test limits for AC electrolytic capacitors.

WARNING

When you replace a defective capacitor, it is imperative that the new capacitor be of the same voltage and microfarad rating.

MOTOR ENCLOSURES

Enclosure is the term used to describe the motor housing, shell, or case. There are several common types of enclosures.

Drip-proof Enclosures. Drip-proof (DP) enclosures are usually used indoors in clean, dry locations. The ventilation openings in the end shields or bells and in the housing or shell are placed so that drops of liquid falling within an angle of 15° from the vertical will not affect performance.

Explosion-proof Enclosures. An explosion-proof (EXP-PRF) enclosure is designed to withstand an internal explosion of specified gases or vapors and not allow the internal flame or explosion

TABLE 6-10
Ratings and Test Limits for AC Electrolytic Capacitors

Capacity Rating, Microfarads			110-V Ratings		125-V Ratings		220-V Ratings	
Nominal	Limits	Average	Amps. at Rated Voltage, 60 Hz	Approx. Max. Watts	Amps. at Rated Voltage, 60 Hz	Approx. Max. Watts	Amps. at Rated Voltage, 60 Hz	Approx. Max. Watts
	25-30	27.5	1.04-1.24	10.9	1.18-1.41	14.1	2.07-2.49	43.8
	32-36	34	1.33-1.49	13.1	1.51-1.70	17	2.65-2.99	52.6
	38-42	40	1.56-1.74	15.3	1.79-1.98	19.8	3.15-3.48	61.2
	43-48	45.5	1.78-1.99	17.5	2.03-2.26	22.6	3.57-3.98	70
50	53-60	56.5	2.20-2.49	21.9	2.50-2.83	28.3	4.40-4.98	87.6
60	64-72	68	2.65-2.99	26.3	3.02-3.39	33.9	5.31-5.97	118.2
65	70-78	74	2.90-3.23	28.4	3.30-3.68	36.8	5.81-6.47	128.1
70	75-84	79.5	3.11-3.48	30.6	3.53-3.96	39.6	6.22-6.97	135
80	86-96	91	3.57-3.98	35	4.05-4.52	45.2	7.13-7.96	157.6
90	97-107	102	4.02-4.44	39.1	4.57-5.04	50.4	8.05-8.87	175.6
100	108-120	114	4.48-4.98	43.8	5.09-5.65	56.5	8.96-9.95	197
115	124-138	131	5.14-5.72	50.3	5.84-6.50	65	—	—
135	145-162	154	6.01-6.72	62.8	6.83-7.63	85.8	—	—
150	161-180	170	6.68-7.46	69.8	7.59-8.48	95.4	—	—
175	189-210	200	7.84-8.71	81.4	8.91-9.90	111.4	—	—
180	194-210	205	8.05-8.96	83.8	9.14-10.18	114.5	—	—
200	216-240	228	8.96-9.95	93	10.18-11.31	127.2	—	—
215	233-260	247	9.66-10.78	106.7	10.98-12.25	145.5	—	—
225	243-270	257	10.08-11.20	110.9	11.45-12.72	151	—	—
250	270-300	285	11.20-12.44	123.2	12.72-14.14	167.9	—	—
300	324-360	342	13.44-14.93	147.8	15.27-16.96	201.4	—	—
315	340-380	360	14.10-15.76	156	—	—	—	—
350	387-420	399	15.68-17.42	172.5	—	—	—	—
400	430-480	455	17.83-19.91	197.1	—	—	—	—

Source: Courtesy of General Electric.

120 CHAPTER SIX

to escape. If the motor is below 1/3 horsepower, the enclosure may be explosion-proof nonventilated (EPNV); if the motor is larger, an explosion-proof fan-cooled enclosure (EPFC) is usually used.

Open Enclosure. Open (OP) enclosures are used indoors in clean locations. Ventilation openings in end shields and/or in the shell permit the passage of cooling air over and around the windings. The location of the openings is not restricted.

Totally Enclosed. In a totally enclosed (TE) housing, there are no openings in the motor housing, but it is not airtight. This type of housing is used in locations that are dirty, oily, and the like. There are two types of totally enclosed housings: *totally enclosed fan-cooled* (TEFC), which have a fan to blow cooling air over the motor, and *totally enclosed non-ventilated* (TENV), which are not equipped with a fan and depend on convection air for cooling.

Power Sources

Most electrical power is generated commercially as three-phase. It is distributed from the generating plant to the substation near the community that uses it as three-phase. Then it is taken from the substation as single-phase and distributed locally to homes and farms. It is generated at 13,800 volts at the generating plant and then stepped up from 138,000 to as high as 750,000 volts to be distributed over long distances. See Figure 7-1.

THREE-PHASE (3 Φ) POWER

Three-phase power is available from electrical utilities. It can be brought to the farm, office, school, or industrial plant and used as three-phase, or it can be delivered as such and then broken down into single-phase for the equipment located on the premises. Three-phase power is expensive to install inasmuch as it uses different transformers and more wires than single-phase power. Most farms use three-phase only if the farm is located near a school or factory with that service. They are able to use single-phase since they don't usually have motors rated over 5 horsepower.

POLYPHASE GENERATORS

These generators are sometimes employed by hospitals and industries for emergency power. These generators are large units pulled

122 CHAPTER SEVEN

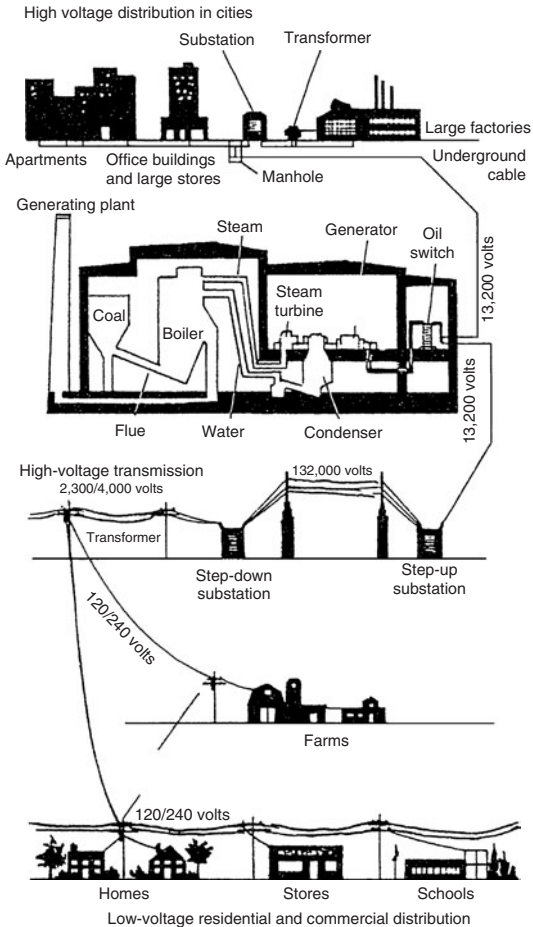


FIGURE 7-1. Generation and distribution of electricity.

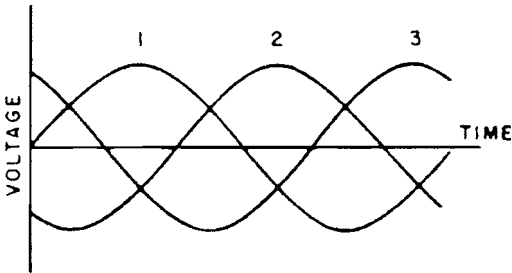


FIGURE 7-2. Output of the sine wave.

by engines generating up to 750 horsepower. They produce voltages from three different coils that are displaced 120° electrically.

The output of the sine wave is like that shown in Figure 7-2. The three windings are placed on the armature 120° apart. As the armature is rotated, the outputs of the three windings are equal, but out of phase by 120° . Three-phase windings are usually connected in delta or wye configuration. Each of these connections has definite electrical characteristics from which the designation “delta” and “wye” are derived. Figure 7-3 shows how the currents flow in the windings of a delta and a wye-connected coil.

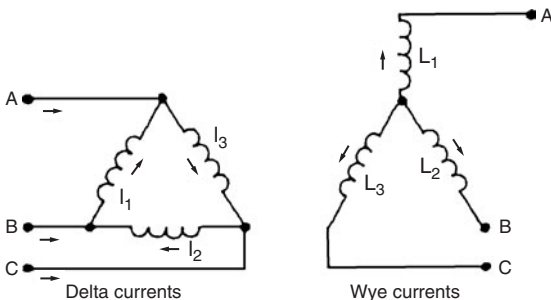


FIGURE 7-3. Current in delta-connected and wye-connected circuits.

VOLTAGES AND CURRENTS

To troubleshoot this type of service you have to understand some of the workings of the system.

In a balanced circuit, when the generators are connected in delta, the voltage between any two lines is equal to that of a single phase. The line voltage and voltage across any windings are in phase, but the line current is 30° or 150° out of phase with the current in any of the other windings. See Figure 7-3. In the *delta-connected* generator, the *line current* from any one of the windings is found by multiplying the phase current by $\sqrt{3}$ or 1.73.

In the *wye* connection, the current in the line is in phase with the winding current. The voltage between any two lines is not equal to the voltage of a single phase, but it is equal to the vector sum of the two windings between the lines. The current in line *A* of Figure 7-3 for instance, is current flowing through the winding L_1 ; that in line *B* is the current flowing through the winding L_2 ; and the current flowing in line *C* is that of the winding L_3 . Therefore, the current in any line is in phase with the current in the winding that it feeds. Since the line voltage is the vector sum of the voltages across any two coils the line voltage E_L and the voltage across the winding's three phases are 30° out of phase. The line voltage may be found by multiplying the voltage of any winding by the individual voltage across any winding by 1.73.

TRANSFORMERS

A transformer is used to step up or step down voltage. The three-phase transformer is used when large power outputs are required. A single transformer or three separate transformers may be used, generally connected in delta or wye. Commercial three-phase voltage from power lines is usually 208 volts. The standard values of single-phase voltage can be supplied for the line shown in Figure 7-4. This is a wye-connected transformer. The various types or combinations of three-phase transformer connections are shown in Figure 7-5. The main reason for selecting one type over another is the need for various voltages and currents. Delta has an advantage of greater current output. Figure 7-6 shows the voltages available from the two types of transformers.

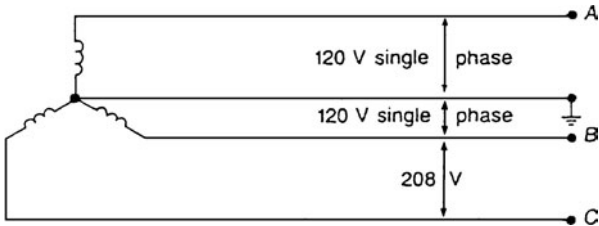


FIGURE 7-4. A wye-connected transformer that supplies standard value single-phase voltage.

WIRING

One of the electrician's important considerations when it comes to three-phase current is the grounding of the system. This is very important if the system is in a damp or wet location. Farms are usually considered wet and damp, and the grounding has to be very well done for the sake of animals and humans.

The National Electrical code has definite suggestions for the grounding of electrical systems. The various systems with voltages of 50 to 1000 volts are described in Section 250-5(b). Figure 7-7 describes the various types of electrical service and shows which of the transformer's secondary wires has to be grounded.

SINGLE PHASE (1 Φ) POWER

If power is being generated by a utility company, single-phase power is generated as three-phase and then broken down. If generated by local generators driven by diesel engines or gasoline engines, it is usually generated as single-phase since that is what is required for the equipment to be connected to it.

POWER DISTRIBUTION

Residential areas are served almost entirely by single-phase systems. Some utilities use radial primary systems, while others employ loop primaries. Other companies have both, the choice for a given area

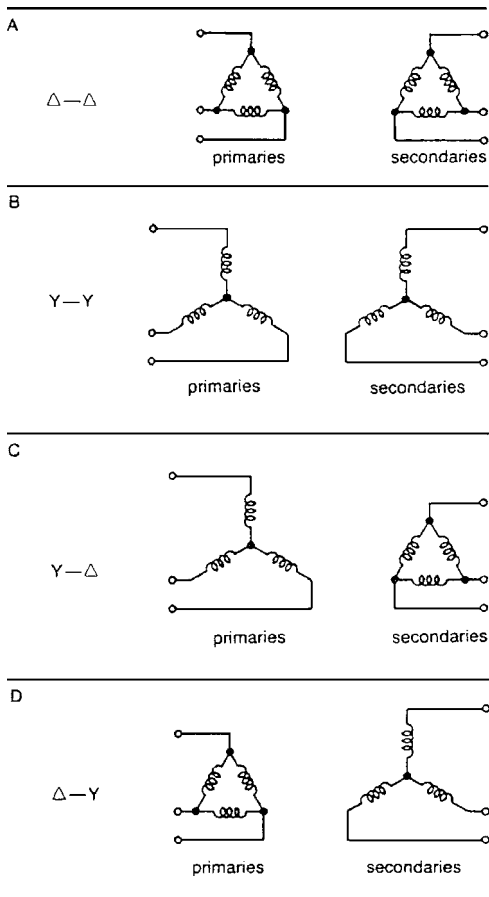


FIGURE 7-5. Methods of connecting three-phase transformer.

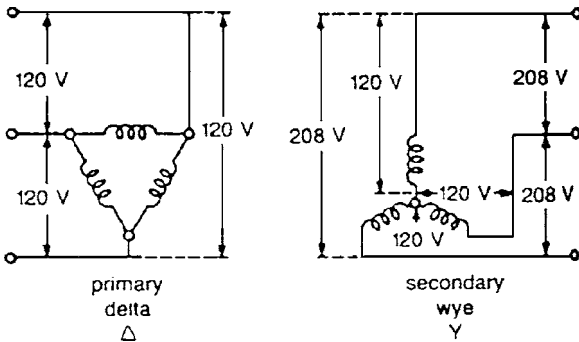


FIGURE 7-6. 39 voltages available from two types of transformers.

depending primarily on load density. In some instances, radial primaries are changed to loop primaries when the load reaches a higher level.

On some systems, a maximum number of 12 homes are served from a single transformer. There is a trend, however, toward fewer homes per transformer, especially in developments where homes are built with all-electric utilities and appliances. At present there is no strong trend concerning the location of service connections. Connections at the transformer compartment and in junction boxes below grade are methods preferred by utility companies. The use of pedestal and dome-type connections appears to be diminishing. Some companies are experimenting with a single transformer per house, with the service connection extending directly from a transformer that is either pad- or wall-mounted or installed in an underground vault.

Lightning Arresters. A majority of the utilities install *lightning arresters* on riser poles. In fact, many install arresters both on the poles and at the open point of a loop. Transformer primary protection is mostly by internal "weak links" or fuses; some companies use both. Various types of transformer switches are being used, but the use of "load-break elbows" for both transformer switching and sectionalizing is increasing.

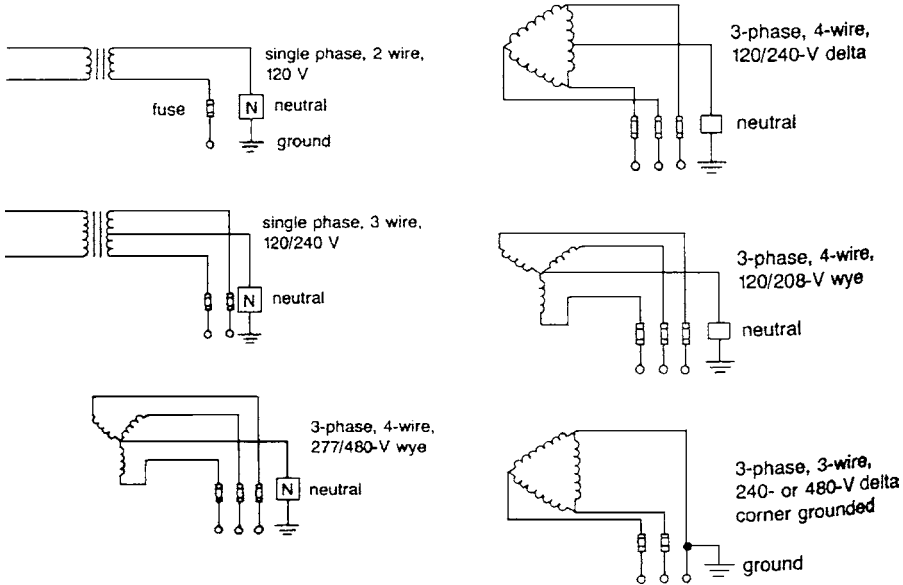


FIGURE 7-7. 40 various types of electrical service and transformer secondary wires to be grounded.

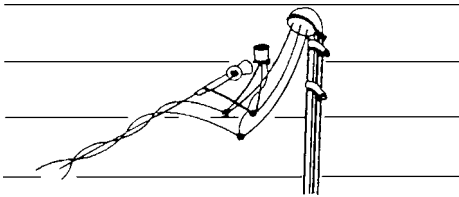


FIGURE 7-8. A lightning arrester connected to hot wires and the ground.

Lightning arresters used on the line after it leaves the transformer and reaches the house are very useful when the distance from the transformer to the house is long enough so that a high-voltage surge may be set up in the power line when it is struck by lightning or when the strike is near the wires. The lightning arrester shown in Figure 7-8 can be installed outside at the drip loop, or it can be installed on the load center or disconnect.

The arrester is connected to each hot wire entering the building and the ground wire. If a surge is detected, it will be diverted to the ground through the arrester. Surge protection is very important today with all of the surge sensitive electronic equipment such as computers installed in a typical home.

Surge Suppressors. Transient suppressors are available to protect electronic equipment. The larger devices can dissipate 8000 watts in 1 millisecond. Smaller diode-size devices have peak power dissipation of 600 watts. See Figure 7-9.

Meter Installation. The electrician is usually required to place the meter socket trough for the kilo-watt-hour (kWh) meter. It is usually supplied by the power company and installed by the customer. Figure 7-10 shows a typical 1-meter installation with a socket for plugging in the meter once the service has been connected. In the case of apartment houses, it is sometimes necessary to install two or more meters. Figure 7-11 shows proper installation of two to six meters for a single-phase three-wire, 120/240-volt, 150-ampere minimum service entrance.

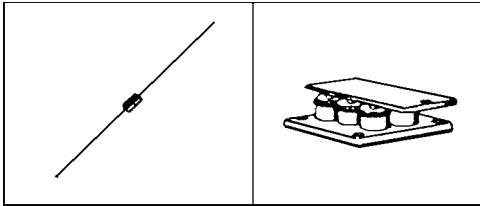


FIGURE 7-9. Two types of surge suppressors.

ENTRANCE INSTALLATION

The service entrance is very important inasmuch as it is the end of the distribution line for the utility. Once the power has reached the user, and enters the property, it is up to the owner to see to it that the wiring inside meets code requirements.

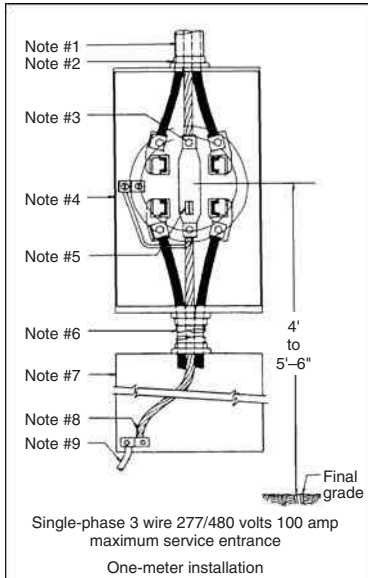
Figure 7-12 shows the attention given to the service entrance riser support on a low building. Note how far the meter is mounted above the ground. This work is usually done by the electrician; at least 24-inch service conductors are left for connection by the power company when it brings power up to the house or building.

In most suburban developments, the electrical service is brought in from the line to the house by underground cables. Figure 7-13 shows the requirements for such an installation. This service shows the pole in the rear of the house. Some localities also require that the entire electrical service to an area be underground. This eliminates poles in the rear of the house.

The standards for a farm meter pole by a local power company are shown in Figure 7-14. Note the division of ownership. Also, note the 5/8-inch by 8-foot ground rods at least 3 feet from the pole. This is a single-phase, three-wire 120/240-volt installation for loads exceeding 40-kilowatt demand.

INSTALLING THE LOAD CENTER

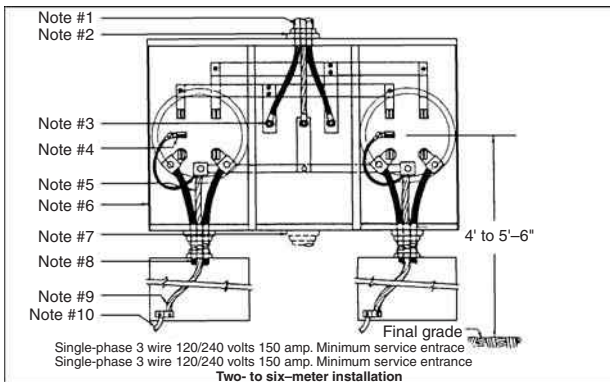
The load center is usually the largest metal box located outside the house and serves as the termination of the service line from the power



- Note 1 Service entrance cable or service entrance conductors in approved conduit. 100 amp maximum capacity
- Note 2 Watertight fitting
- Note 3 Grounded conductor connected to socket trough ground stud by customer
- Note 4 Meter socket trough supplied by company. Installed by customer
- Note 5 Neutral potential terminal required where service is single-phase 8 wire 277/480 volts connect to socket trough ground stud
- Note 6 Conductors to service equipment 100 amp. maximum capacity
- Note 7 Service equipment
- Note 8 Connect grounded conductor to service equipment ground block
- Note 9 Install grounding electrode conductor in accordance with NEC requirements

FIGURE 7-10. 1-meter installation.

132 CHAPTER SEVEN

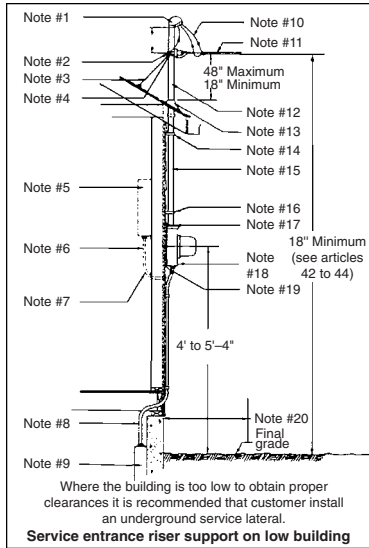


- Note 1 Service entrance cable or service entrance conductors in approved capacity—150-ampere minimum capacity
- Note 2 Watertight fitting
- Note 3 Preloaded compression for 3/8" stud size to be furnished and installed by contractors
- Note 4 Grounded terminal for potential code required only where service is single-phase 8 wire 120/208 volts. Connected to socket trough ground stud by customer.
- Note 5 Grounded conductor. Connected to socket trough ground stub by customer.
- Note 6 Meter socket troughs supplied by company. Installed by customer. Multimeter channel cannot be modified for additional positions.
- Note 7 Alternate service entrance location.
- Note 8 Conductors to service equipment. 150 ampere maximum per position
- Note 9 Connect grounded conductor to service equipment ground block
- Note 10 Install grounding electrode conductor in accordance with NEC requirements.

FIGURE 7-11. Installation of 2 to 6 meters.

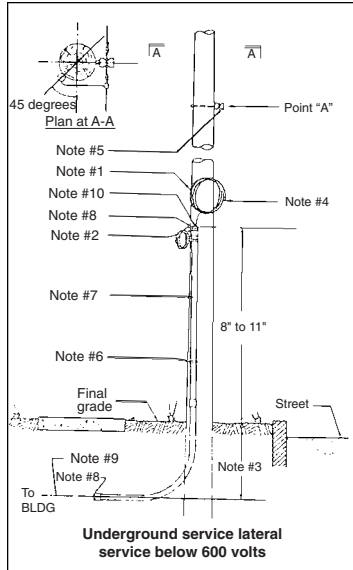
company. It may also be located inside the house or in the basement. In order to fit a specific wiring problem it may be necessary to remove some knockouts and insert connectors to prevent the wire from being damaged as it is inserted into the box.

The following information locates the knockouts and provides the dimensions of the box in both inches and millimeters.



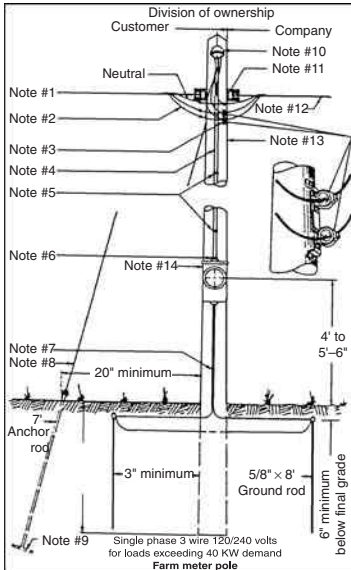
- Note 1 Raintight service head
 Note 2 Service bracket and, mounting strap furnished by company. Installed by customer
 Note 3 Back brace required for dimension greater than 24"
 Note 4 Bond riser to service neutral
 Note 5 Alternate service equipment
 Note 6 Alternate service entrance
 Note 7 Maximum length of unguarded service entrance conductors within wall shall be 12"
 Note 8 Service entrance
 Note 9 Service equipment
 Note 10 Leave 24" of service entrance conductors for service drop connection by company
 Note 11 Company's triplex service drop
 150 A—1000 lbs. strain
 200 A—1500 lbs. strain
 Note 12 The riser shall be capable of withstanding a horizontal pull at the service drop attached. Provide back brace where necessary.
 Note 13 Approved vent pipe flange
 Note 14 3/8" U bolt as close to roof as possible.
 Note 15 2" or 2 1/2" galvanized rigid steel conduit
 Note 16 3/8" U bolt riser support
 Note 17 Watertight fitting
 Note 18 Meter socket trough furnished by company. Installed by customer.
 Note 19 Provide treated wood backboard for mounting meter socket trough in a true vertical position. Fasten backboard to a structural member
 8' clear space to property line
 Note 20

FIGURE 7-12. Service entrance, riser support.



- Note 1 Service lateral cable to be furnished and installed by customer. It must be long enough to extend 8 feet above point "A" without a splice. If secondary rack is not on pole, ask company for its location. Pending connection by company, temporarily secure cable to pole to prevent damage.
- Note 2 Galvanized steel conduit and bend shall be grounded by bonding to an approved ground clamp 6" from the top of the conduit. A conductor of sufficient length shall be provided to extend 24" beyond the company's secondary neutral. The conductor shall be 14 copper minimum or larger as required by the national electrical code. Recommend use of corrosion-resistant bend in locations subject to highway salting. (Steel conduit not required where distance from pole to road is more than 25 ft.)
- Note 3 The burial depth shall be 24" minimum. If a continuous conduit is used, this depth may be 18" minimum.
- Note 4 Customer to seal cable ends to prevent entrance of moisture during construction. See article 62
- Note 5 Company's secondary rack point "A"
- Note 6 Pipe straps
- Note 7 Riser conduit furnished and installed by customer. Consult company for proper location on pole. See article 61
- Note 8 Insulating bushing
- Note 9 Customer's service lateral
- Note 10 Duct seal by customer

FIGURE 7-13. Underground service entrance.



- Note 1 Metered lines to customer's loads. Service equipment at each building.
- Note 2 Leave 24" of service entrance conductors for service drop connection by company
- Note 3 Two current transformers mounted on bracket furnished by company and installed by customer
- Note 4 Metering cable furnished by company
- Note 5 Straps at not more than 4-ft. intervals
- Note 6 Water tight
- Note 7 Continuous grounding conductor 14 insulated copper minimum
- Note 8 5/6" guy strand
- Note 9 130-sq.-inch metal anchor
- Note 10 Raintight service head
- Note 11 Service bracket furnished by company—installed by customer
- Note 12 Company's service drop
- Note 13 Customer's meter pole furnished and installed by customer. Consult company for pole and guy requirements.
Pole to be 5" minimum diameter at top 8" minimum diameter 6 feet from butt. Normally 35 foot pole except as otherwise needed for service drop height required
Pole to be pressure treated with pentachlorophenol in oil—see spec. to add or acceptable equivalent
- Note 14 Meter socket trough furnished by company—installed by customer in a true vertical position

FIGURE 7-14. Standards for a farm meter.

TABLE 7-1
Dimensions and Knockout Information for QC and Homeline Load Centers
(Square D)Dimensions

Box No.	W		H		D	
	in	mm	in	mm	in	mm
1	3.81	97	6.72	171	3.00	76
2	4.81	122	9.30	236	3.19	81
3	4.81	122	9.30	236	3.19	81
4	8.88	226	12.57	319	3.80	97
5	14.25	362	14.92	379	3.75	95
6	14.25	362	17.92	455	3.75	95
7	14.25	362	20.92	531	3.75	95
8	14.25	362	26.04	661	3.75	95
9	14.25	362	29.86	758	3.75	95
10	14.25	362	33.78	858	3.75	95
11	14.25	362	37.98	965	3.75	95
12	14.25	362	39.37	1000	3.75	95
13	5.88	149	13.12	333	3.38	86
14	14.25	362	20.92	531	3.75	95
15	20.00	508	50.00	1270	5.75	146
16	20.00	508	68.00	1727	5.75	146
17	20.00	508	53.00	1346	5.75	146
18	5.88	149	16.12	409	3.38	86
19	7.56	192	23.12	587	4.25	108
20	9.62	244	26.12	663	4.75	121
21	8.88	226	14.80	376	3.80	97
22	8.56	217	23.92	608	8.95	100

Table 7-1 shows the dimensions and Figure 7-15 shows the box number and the location of the knockouts.

LOW-VOLTAGE POWER

Most low-voltage systems use transformers from the 120-volt or 240-volt line and step down the voltage to either 16 volts or 24 volts to be used within a building as signaling or remote control circuits.

Chimes or doorbells use a step-down transformer to take 120 volts down to 16. The wiring is usually a two-conductor or three-conductor 18 wire. The low-voltage switching may be a number of pushbutton

Knockouts									
Symbol	A	B	C	D	E	F	G	H	I
Conduit size	1/2	3/4	1	1 1/4	1 1/2	2	2 1/2	3	3 1/2

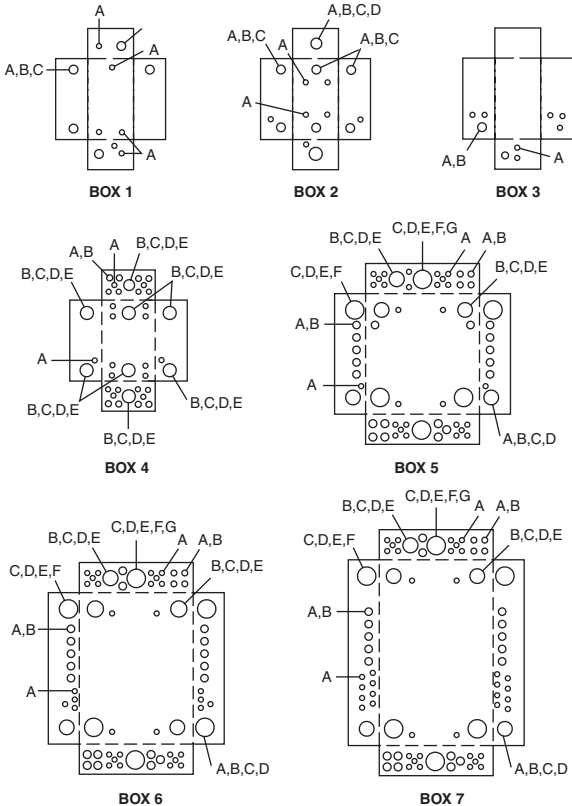
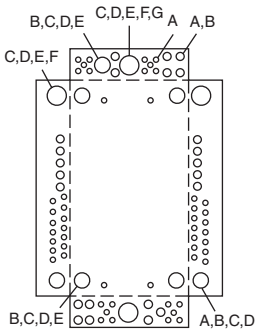
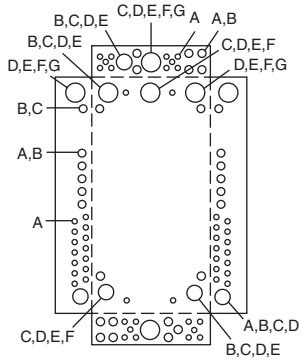


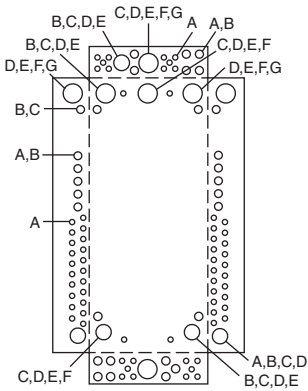
FIGURE 7-15. QO and Homeline Load Centers. Knockout information and enclosure dimensions (Square D).



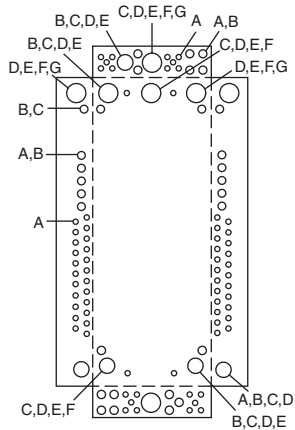
BOX 8



BOX 9



BOX 10



BOX 11

FIGURE 7-15. (Continued)

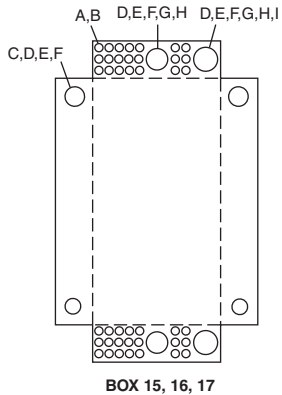
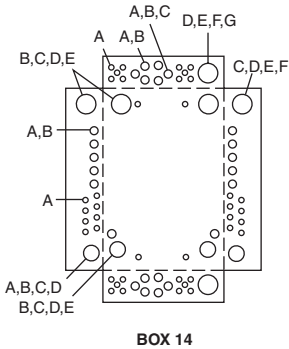
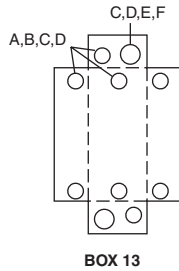
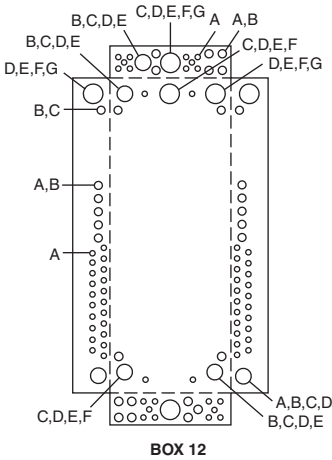


FIGURE 7-15. (Continued)

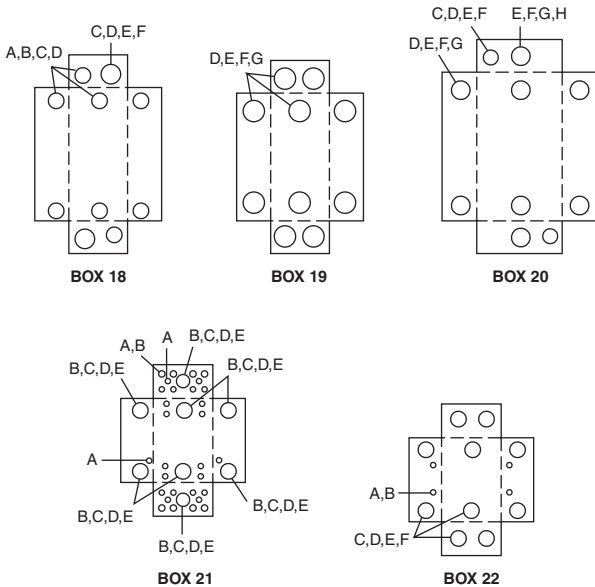


FIGURE 7-15. (Continued)

types. This same voltage may be used in control circuits for garage door openers and certain burglar alarm systems.

A low-voltage transformer is used to obtain 24 volts for use in controlling the hot-air furnace that heats the house or, in some-cases, stores and other commercial and industrial plants. The main advantage of these control circuits is that they can use 18 wire for short runs and then move up to 16 or 14 for longer distances.

Low-voltage signaling and remote control circuits are covered by the NEC Article 725. Class 1, Class 2, and Class 3 circuits are detailed as to voltages and currents allowed.

Low voltage is also used in modern construction and home lighting systems. General Electric makes a system that has found wide use. Inasmuch as it is low voltage and low current, the wiring

requirements for relay switching circuits are small, flexible wires that may be snaked in thin wall or steel partitions without the protection of metal raceways (except where local codes prohibit such installation). Wires can be dropped through hung ceilings into movable partitions as easily as rewiring telephones. In fact, wiring can be placed under rugs to switches located on desks and easily changed when required. The switches are modern in appearance and very compact.

The low-voltage *circuits* are simple, and one that can be easily followed is seen in Figure 7-16. It shows the basic circuit, one transformer, one relay, and one switch controlling a load. The red, white, and black wires from the switch to the relay and transformer are usually 20 AWG. This means they can be run longer distances for less cost than conventional wiring. Figure 7-17 shows the basic circuitry for a remote control system. The rectifier diode is used to change the 24 volts from alternating current (AC) to direct current (DC). This produces less noisy relays—no AC hum.

The power supply for the General Electric system (used here as an example—there are others) is a 24-volt transformer connected to a 120-volt line. It can also be obtained to operate from 277 volts. The *relays* in Figure 7-18 are the mechanical latching type. That means the switching circuits require only a momentary impulse. These relays have a coil design that resists burnout due to equipment or operational failure. They can control 20 amperes of tungsten, fluorescent, or inductive loads at 125-volt AC and 277-volt AC. They can also be used for $\frac{1}{2}$ -horsepower, 240-volt AC and $1\frac{1}{2}$ -horsepower, 125-volt AC motors. Some relays are available

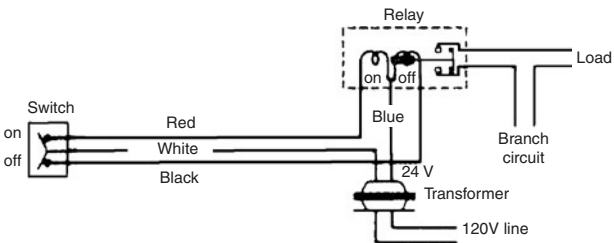


FIGURE 7-16. A simple low-voltage circuit.

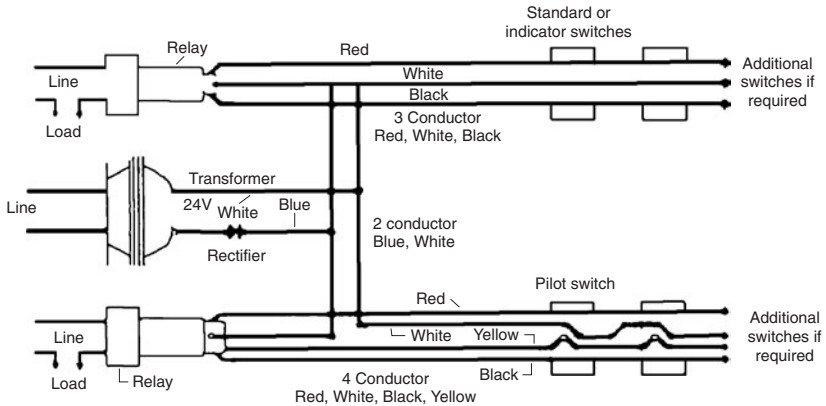


FIGURE 7-17. Basic circuitry for remote control system.

with a pilot light switch to indicate the on position in remote locations on a master panel.

Wiring can become a little more complicated, and the diagram has to be followed more closely when more stories are added to the system. See Figure 7-19. The

best way to troubleshoot such a system is to follow the manufacturer's checklist of possible troubles and their wiring diagrams, usually on file in the building where the wiring is installed.

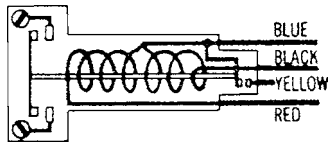


FIGURE 7-18. Internal wiring of a relay (schematically).

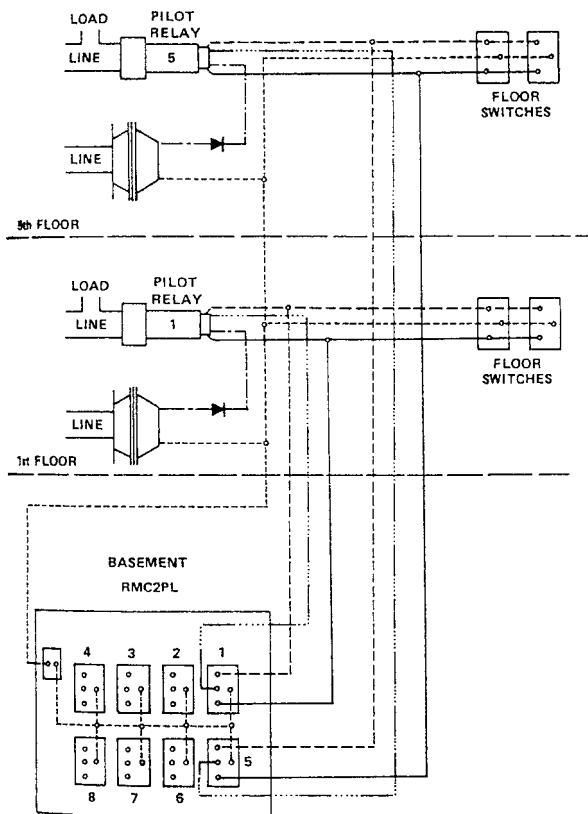
EMERGENCY POWER

Emergency power has always been needed in hospitals, public buildings, subways, schools, manufacturing plants, and on farms, not only for emergency lighting but also to run refrigerators, typewriters, kidney machines, manufacturing processes, cash registers, elevators, heating equipment, fire pumps, telephones, computers, alarms, and other applications. The need for emergency power sources has increased in recent years. More electrical loads are considered essential, and therefore additional backup power is required.

Figure 7-20 shows a basic system for automatic emergency power transfer. The accessory group (AG) monitors the level of voltage from the normal source (utility). If the normal source fails or drops below acceptable levels, the AG signals the automatic engine starting controls (AESC) to start and monitor the engine generator set. When the generator-set voltage and frequency are adequate, the AG causes the automatic transfer switch (ATS) to transfer the load to the generator. When the normal source is restored, the load is retransferred, and the engine generator is shut down after a cooling-off period. The controls then reset. The entire operation is automatic.

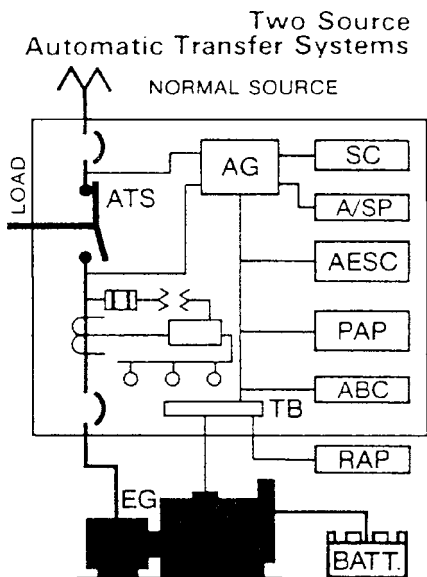
When normal power fails and emergency power is being used, it is important to make the most use of that power. Selective load transfer systems are effective, low-cost solutions to operating loads where only one or two out of a number of loads are operated from

144 CHAPTER SEVEN



Multistory, separate transformers. For master-selector control of individual relays on different floors, where separate floor transformers and floor switches are also used, this circuit diagram explains the necessary wiring requirements. This circuit is especially useful for lights controlled from a watchman's station, or for control of corridor lights from a superintendent's office.

FIGURE 7-19. Wiring on more than one story.



LEGEND

- ABC — Automatic Battery Charger
- AESC — Automatic Engine Starting Control
- AG — Accessory Group
- ATS — Automatic Transfer Switch
- EG — Engine Generator
- A/SP — Alarm/Status Panel
- PAP — Prealarm Panel
- RAP — Remote Alarm Panel
- SC — Special Circuitry
- TB — Terminal Block

FIGURE 7-20. A typical automatic emergency power transfer system.

146 CHAPTER SEVEN

the emergency source at any one time. A bank of elevators can be used as an example. A selective load transfer system allows one elevator at a time to be operated when normal power fails. This uses the minimum amount of auxiliary power for operation because the standby generator can be sized for the necessary emergency load plus only one elevator. Any number of elevators in any combination of sizes to suit the needs of the application can be accommodated. Moreover, the system can be interfaced with other emergency loads for expanded operation if it is found that certain loads no longer require emergency power.

Wires and Wiring

Without wire, there would be no electricity, where we want and need it. The type, size, and insulation of wire affects the safety of the electrical operation for long periods. In addition to wire, it also takes boxes, fixtures, switches, plugs, and other devices to wire any facility. In this section, we look at wire and some of the devices used in making an electrical wiring system operate without damage to people or buildings.

WIRE

A wire is a metal, usually in the form of a very flexible thread or slender rod that conducts an electric current.

CONDUCTING MATERIALS

Although silver is the best conductor, its use is limited because of its high cost. Two commonly used conductors are aluminum and copper. Each has advantages and disadvantages. Copper has high conductivity and is more ductile (can be drawn out thinner). It is relatively high in tensile strength and can be soldered easily. However, it is more expensive than aluminum.

Aluminum wire has about 60% of the conductivity of copper. It is used in high-voltage transmission lines and sometimes in commercial and industrial wiring. Its use has increased in recent years.

148 CHAPTER EIGHT

However, most electricians will *not* use it to wire a house today. There are a number of reasons for this, the most important being the safety of the installation and the possible deterioration of joints over the years due to expansion and contraction of the aluminum wire.

If copper and aluminum are twisted together in a wire nut, it is possible for moisture to get to the open metals over time. Corrosion will take place, causing a high-resistance joint. This can result in a dimmer light or a malfunctioning motor.

WIRE SIZE

The size of wire is given in numbers. The size usually ranges from 0000 (referred to as 4 aught) to No. 40. *The larger the wire, the smaller its number.*

Table 8-1 lists the size of standard annealed solid copper wire in relation to its number. Note the relation of circular mils to square inches. A mil is 0.001 inch. Circular mils are often expressed by Roman numerals; 212,000 circular mils is 212 MCM. The first M stands for thousand (as with Roman numerals) and the CM stands for circular mils. Wire larger than 0000 is usually referred to according to MCM (thousands of circular mils). A frequently used wire is 750 MCM (750,000 circular mils).

Figure 8-1 shows the various sizes of wire most often encountered by electricians. Note that. No. 6 and above consist of multi-strands of wire. This allows the wire to be bent by hand. The larger sizes sometimes require a conduit bender to bend them to smaller radii.

TYPES OF WIRE

Many types of wire are manufactured. Three major types are discussed here.

Branch Circuit Wiring. General-purpose circuits should supply all lighting and all convenience outlets through the house, except those convenience outlets in the kitchen, dining room or dining area of other rooms, breakfast room or nook, family room, and laundry areas. General-purpose circuits should be provided based on one 20-ampere circuit for not more than every 500 square feet

TABLE 8-1
Standard Annealed Solid Copper Wire

Gage Number*	Diameter (mils)	Cross Section	
		Circular (mils)	Square (in)
0000	460.0	212 000.0	0.166
000	410.0	168 000.0	0.132
00	365.0	133 000.0	0.105
0	325.0	106 000.0	0.0829
1	289.0	83 700.0	0.0657
2	258.0	66 400.0	0.0521
3	229.0	52 600.0	0.0431
4	204.0	41 700.0	0.0328
5	182.0	33 100.0	0.0260
6	162.0	26 300.0	0.0206
7	144.0	20 800.0	0.0164
8	128.0	16 500.0	0.0130
9	114.0	13 100.0	0.0103
10	102.0	10 400.0	0.00615
11	91.0	8 230.0	0.00647
12	81.0	6 530.0	0.00513
13	72.0	5 180.0	0.00407
14	64.0	4 110.0	0.00323
15	57.0	3 260.0	0.00258
16	51.0	2 580.0	0.00203
17	45.0	2 050.0	0.00161
18	40.0	1 620.0	0.00128
19	36.0	1 290.0	0.00101
20	32.0	1 020.0	0.000802
21	28.5	810.0	0.000636
22	25.3	642.0	0.000505
23	22.6	509.0	0.000400
24	20.1	404.0	0.000317
25	17.9	320.0	0.000252
26	15.9	254.0	0.000200
27	14.2	202.0	0.000158
28	12.6	160.0	0.000126
29	11.3	127.0	0.0000995
30	10.0	101.0	0.0000789
31	8.9	79.7	0.0000626
32	8.0	63.2	0.0000496
33	7.1	50.1	0.0000394
34	6.3	39.8	0.0000312
35	5.6	31.5	0.0000248
36	5.0	25.0	0.0000196
37	4.5	19.8	0.0000156
38	4.0	15.7	0.0000123
39	3.5	12.5	0.0000098
40	3.1	9.9	0.0000078

* American wire gage—B&S.



FIGURE 8-1. Common sizes of wire.

or one 15-ampere circuit for not more than every 375 square feet of floor area. Outlets supplied by these circuits should be equally divided among the circuits.

Feeder circuits should also be used. It is strongly recommended that consideration be given to the installation of branch circuit protective equipment served by appropriately sized feeders located throughout the house, rather than at a single location.

Small appliance branch circuits should also be installed. There should be in-home wiring service at least one three-wire, 120/240-volt, 20-ampere small-appliance branch circuit that is equipped with split-wired receptacles for all convenience outlets in the kitchen, breakfast and dining room, and family room. Two two-wire, 120-volt, 20-ampere branch circuits are equally acceptable.

Cable of several different types can be used for branch wiring.

Armored cable, commonly referred to as BX, is available in 250-foot rolls for use where local codes permit. BX is hard to work with and needs some attention to details once the metal shield has been cut. See Figures 8-2 and 8-3.

Armored Cable Fittings. Install armored cable fittings as follows:

- To protect wires, install antishort bushing in end of cable (754 series). Antishort bushings are not required when using screw-in connectors and couplings (044 and 045 series).
- Slip connector onto cable allowing 6 to 8 inches of wire to protrude from fitting.
- Tighten screw(s) (except 044 and 045 series).
- Remove locknut from fitting.

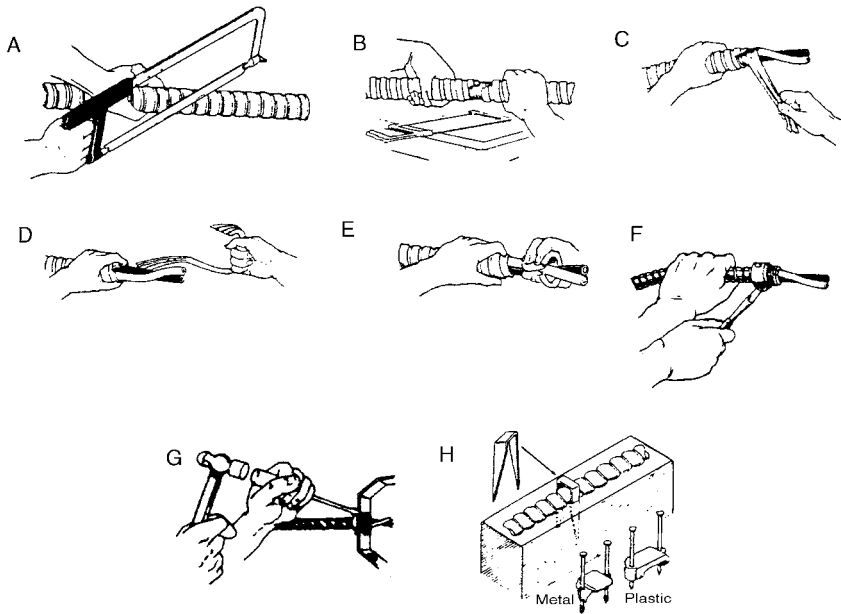
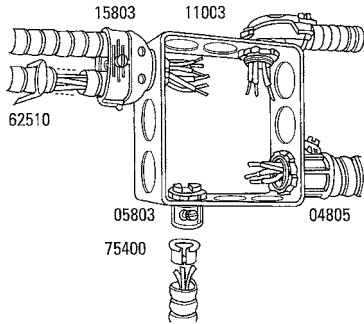


FIGURE 8-2. Installing armored cable.

fittings for armored cable



fittings for flexible metal conduit cable

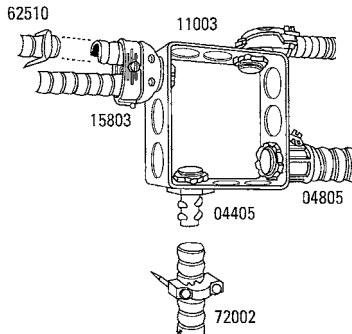


FIGURE 8-3. Installing fittings for armored or flexible metal conduit (Halex).

- Insert fitting (now with wires protruding) into knockout in outlet box.
- Turn locknut on fitting from inside the box and tighten by tapping with screwdriver blade until teeth bite into box.
- Tug on cable to test connection.

- Secure cable with staples (625, 720, and 730 series) within 12 inches of the box and one for every four 1/2 feet of cable run. Be careful not to damage cable insulation or conductors.

NOTE

- 044 and 045 screw-in series are used for flexible metal conduit only.
 - 05803 connector is to be used with armored cable only.
 - 153 series combination couplings can be used for EMT and flexible metal conduit only.
 - 15803 duplex connectors may be used on nonmetallic cable as well as armored and flexible metal conduit.
-

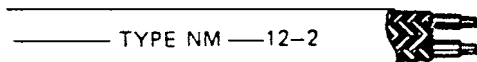
Romex cable is used for branch circuits and is easier to work with. A cable stripper is used to strip off the first coating of insulation.

Then, a knife or wire cutter is used to cut away any loose materials to expose the uninsulated copper wire and the black- and white-jacketed conductors, (In three-wire cable there is also found a red-jacketed conductor. See Figure 8-4.

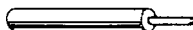
Figure 8-5 shows how Romex is used to wire a branch circuit with a receptacle. Figure 8-6 shows how to properly wire receptacles and switches in branch circuits. Figure 8-7 illustrates how branch circuits are loaded to balance the load on different phases. Single-phase and three-phase loading are shown. Of course, the proper wire should be used for each of the circuits.

Service Entrance Cable. Power is brought from the pole or transformer into the rear of the house (in some cases the lines are underground) by means of three wires—one black, one red, and one white or uninsulated. These wires may be three separate ones, or they may be twisted together to look like one cable.

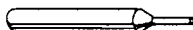
Once the cable is connected to the house, it is brought down to the meter by way of a sheathed cable with three wires: one red, one black, and one uninsulated (ground or neutral). The stranded, uninsulated wire is twisted at the end to make its connection. See Figure 8-8.



Romex cable, 12/2, for use in home circuits.



Wrong way



Right way

The right and wrong way to cut insulation from a piece of wire.

FIGURE 8-4. Romex cable is often used for branch circuits.

Wire size depends on the load to be applied to the line. The square footage of the house determines the amount of minimum service capacity needed (125 amperes, 150 amperes, or 200 amperes). From the outside, the cable enters the house and is connected to the distribution box located somewhere easily accessible, such as in the basement. From the distribution box, the branch circuits run to all parts of the house.

Underground Feeders and Branch Circuit Cable. This type of cable is for direct burial and is made with polyvinyl chloride

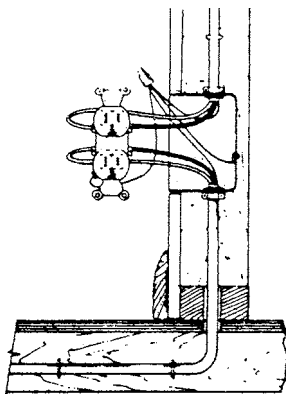
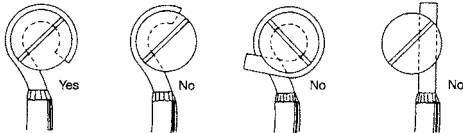
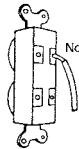


FIGURE 8-5. How Romex is used to wire a branch circuit with receptacle.

Always strip wire far enough back so the wire will go at least three-fourths of the distance around a binding screw. When stripping be careful not to nick the conductor. Use correctly sized stripping tool or strip with a knife as if sharpening a pencil. Wrap the wire at least three-fourths of the distance around a wire binding screw without overlapping—then tighten the screw as securely as possible.



Do not use push-in terminals for aluminum conductor or # 12 wire.



Never use electrical tape as a substitute for these connectors. Never use unlisted crimp-type clamps with twisted wire and tape.

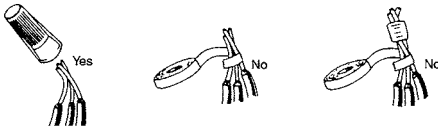


FIGURE 8-6. Proper wiring of receptacles and switches in branch circuits.

(PVC) insulation and jacket materials. See Figure 8-9. It is available in many sizes.

In multiple-conductor cables the two- or three-circuit conductors are individually insulated and are laid parallel under a jacket to form a flat construction. A multiple-conductor cable may have, in addition to the circuit conductors, an uninsulated or bare conductor of the same wire size for grounding purposes.

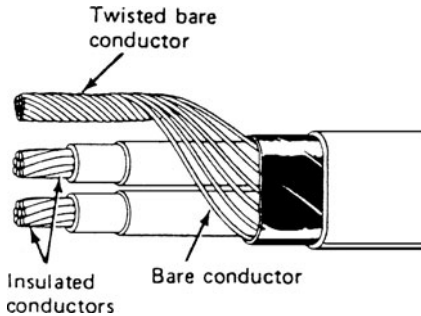


FIGURE 8-8. Connecting uninsulated wire in service entrance cable.

Multiple-conductor-type UF cable may be installed as nonmetallic sheathed cable. Once every 24 inches along the conductor jacket will appear “sunlight resistant UF, size of the wire, and the number of conductors plus 600 V UL.” See Figure 8-10.

CABLE

Cable is a general term often applied to large conductors. They may be single-strand conductors or a combination of conductors (wires) insulated from one another but encased together. Many types of cable are used, two of the most common being Romex cable and BX cable.

ROMEX CABLE

Romex cable is used to carry power from a distribution panel box to the individual outlets within the house. This nonmetallic sheathed cable has plastic insulation covering the wires to insulate them from all types of environments. Some types of Romex cable may be buried underground; underground Romex has UF stamped on its outside covering.

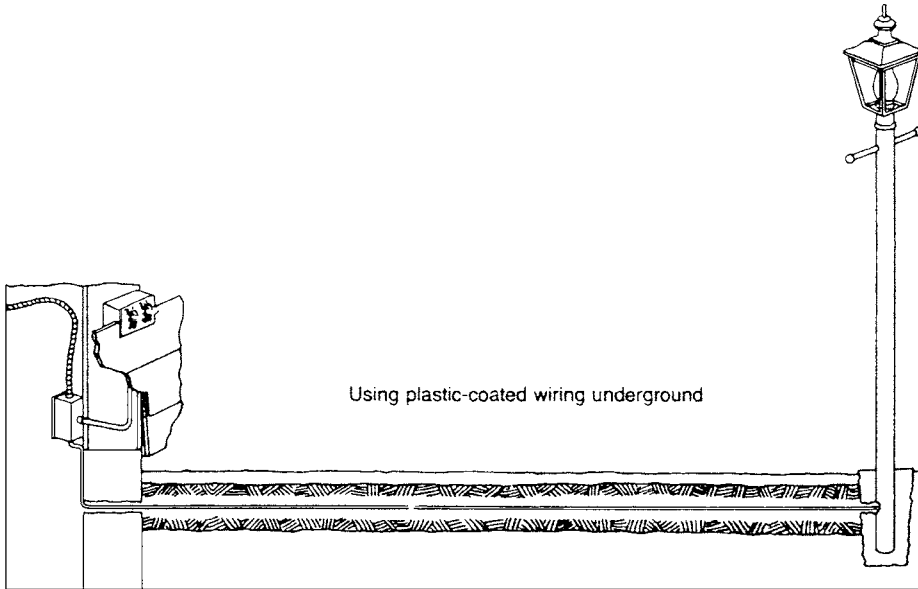


FIGURE 8-9. PVC covered cable for underground feeders.



FIGURE 8-10. UF cable.

BX CABLE

BX cable is the name applied to armored or metal-covered wiring. BX sometimes meets the need in home applications for flexible wiring. It is used to connect appliances, such as a garbage disposal unit, which vibrates or moves a great deal. BX cable has to have special fittings to make sure its metal covering does not cut through the insulation of the wire it houses.

CONDUIT

Conduit protects and carries wires. Conduit comes in many types: Thin-wall metal, plastic, or rigid. Rigid conduit is like pipe with thick walls and ends with screw threads.

ELECTRICAL METALLIC TUBING (THINWALL CONDUIT)

Electrical metallic tubing (EMT), often called thin-wall conduit, is commonly used. It is lightweight, thinner, and easier to bend than rigid conduit. Because it is metallic, it can handle physical abuse. It is used wherever physical protection is needed, but PVC cannot be used because of the presence of steam pipes or other sources of heat.

Conduit usually comes in 10-foot lengths. Couplings are used to extend the overall length of a piece of conduit. Thin-wall conduit couplings are electrical fittings used to attach or couple the length of one conduit to another. EMT does not require threads to be cut on the ends. It uses specially made connectors for the ends so that it can be attached to boxes, panels, and other devices. (Rain-tight fittings should be used outside.) Figure 8-11 shows how EMT is fitted into a conduit box, and Figure 8-12 shows how EMT fittings are installed:

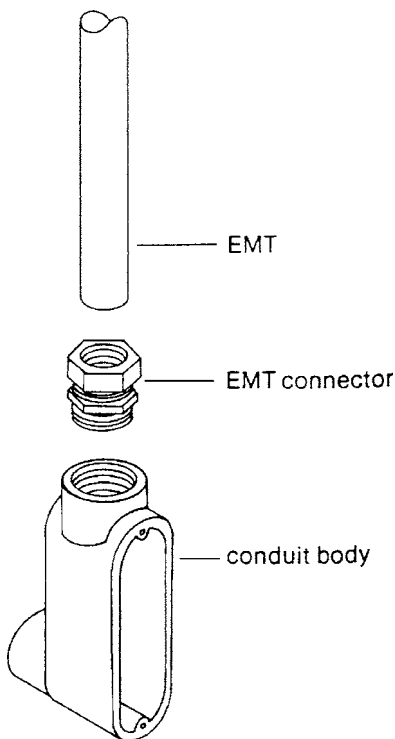


FIGURE 8-11. An EMT fitting into a conduit box.

1. To install connectors (set screw type 121 series; compression type 021 series):
 - a. Insert conduit into fitting.
 - b. Tighten screw on 121 series with screwdriver, or tighten compression nut on 021 series with wrench.

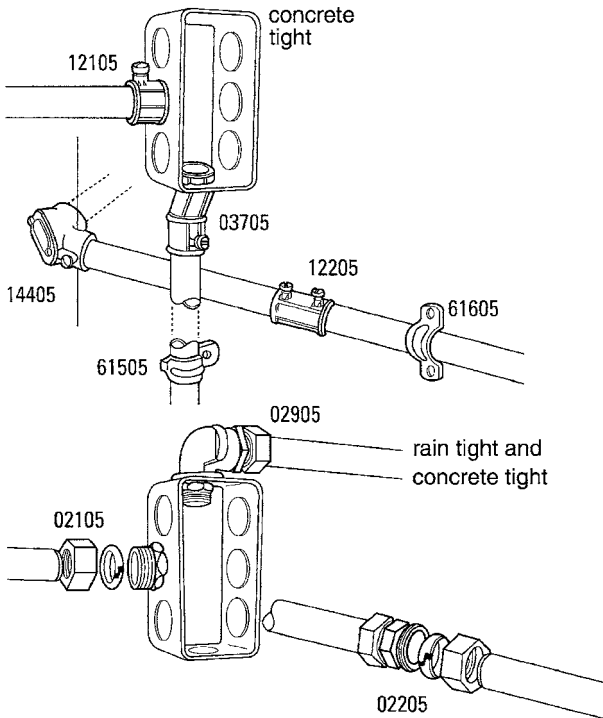


FIGURE 8-12. Installing fittings for EMT (Halex).

- c. Remove locknut from fitting.
- d. Insert fitting into knockout in outlet box.
- e. Turn locknut on fitting from inside box and tighten by lapping with a screwdriver blade until teeth bite into box.

162 CHAPTER EIGHT

2. To install couplings (122 series; 022 series):
 - a. Insert conduit into fitting.
 - b. Tighten screws on 122 series with screwdriver, or tighten compression nuts on 022 series with wrench.
3. Secure conduit with straps: (615, 616, 617 series)
 - a. Install minimum of one strap for every 10 feet of conduit run.
 - b. Always use a strap within 3 feet of a box.
4. Offset connectors (037 series) are used to connect conduit that is flat against wall with an outlet box without bending the conduit.
5. Pulling elbows (144 series) are made for corners and is installed onto conduit by tightening screws with screwdriver. Wires can be readily pulled through the fitting by simply removing the cover.

Figure 8-13 shows a variety of fittings used on EMT.

ELECTRICAL NONMETALLIC TUBING

Electrical nonmetallic tubing (ENMT) is also used as conduit. Made of the same material as PVC, ENMT is resistant to moisture and many atmospheric pollutants and is flame-retardant. Suitable for above-ground use, it is easily bent by hand but cannot be used where flexibility is needed, such as at motor terminations, to prevent noise and vibration. NEC Article 331 deals with ENMT and lists couplings, connectors, and fittings to be used with it. Exposed ENMT cannot be used in buildings more than three stories high. Changes to this article in 2002 NEC now allow it under certain conditions. It can be used in buildings of any height when concealed.

RIGID CONDUIT

Industrial and commercial wiring must, because of the large amounts of current and high voltages required, be enclosed in large pipe to protect the wires from damage by equipment operating around them.

This large pipe, called rigid conduit, presents a number of problems, most of which arise whenever a bend has to be made. (For conduit of smaller diameter, special hand benders, or “hickeys,” are used.) Dies are used to keep large pipe from collapsing as it is bent.

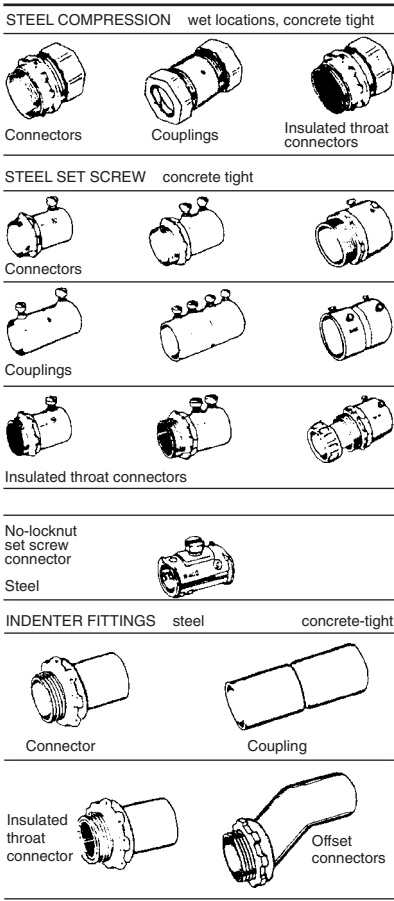


FIGURE 8-13. Variety of fittings used on EMT.

PRESSURE CAST COMPRESSION
WITH STEEL LOCKNUTS wet locations, concrete-tight



Couplings



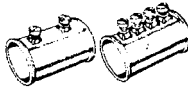
Connectors



Insulated throat
connectors

PRESSURE CAST SET SCREW
WITH STEEL LOCKNUTS concrete-tight

Couplings



Connectors



Insulated throat connectors

TWO-PIECE CONNECTORS

Die cast zinc



OFFSET CONNECTORS die cast zinc



Compression



Set screw



Indenter

90° SHORT-ANGLE CONNECTORS malleable iron



Malleable iron

Insulated
throat



FIGURE 8-13. (Continued)

HANDY ELLS

Pressure cast zinc
female-to-female
set screw



Male-to-female
Set screw


STRAPS

One-hole
push-on



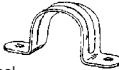
Stamped steel

One-hole



Malleable iron

Two-hole
push-on



Stamped steel

Nail-up



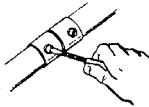
Stamped steel

APPLICATIONS AND FEATURES


Hardened steel,
extruded locknuts
on connectors
can't slip



Smooth throats
speed wire pulling.



Screw heads with deep
milled slots won't chew
off under pressure.

FIGURE 8-13. (Continued)

The inside part of the pipe is compressed as the outside portion is stretched. It is very easy to collapse the piece of pipe if proper care is not taken during the bending operation. That is why some very elaborate bending equipment is available. The skill associated with conduit bending comes with experience.

Threads have to be cut on the ends of rigid conduit for fittings. This can be done by hand tools in some cases, but in most instances, a thread-cutting machine is used. Cutting, threading, and bending rigid conduit takes a number of years to master. Rigid conduit has special types of boxes for switches and receptacles, known as FS boxes. See Figure 8-14 for fittings used on rigid conduit.

LOCKNUTS



Steel



Malleable iron



Steel
Not U/L listed

Bonding
locknuts



Sealing
locknuts

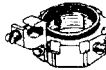


BUSHINGS

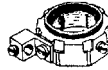


Insulated
throat

Insulated throat
with lay-in lug



Ground bushing with
ground lug



Bushings



105° C yellow
flame retardant



Capped
bushings

REDUCING BUSHINGS



Small Steel



Aluminum



Large cast iron

90° ELBOWS malleable iron



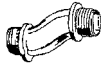
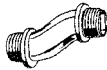
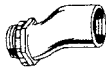
Short



Long

FIGURE 8-14. Fittings used on IMC and rigid conduit.

 OFFSETS die cast zinc

Standard 1/4"
nipplesOffset
connectorsSpecial 1-1/16"
nipples

 CONDUIT NIPPLES

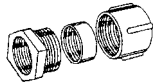


Die cast zinc

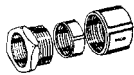
Insulated throat



 THREE-PIECE COUPLINGS



Malleable iron



Die cast zinc

 HUB pressure cast zinc wet locations



Insulated throat

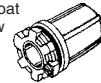
Insulated throat
ground screw

 FIGURE 8-14. (Continued)

When using rigid conduit, keep in mind that the entire conduit is not filled to capacity. The number of wires in the conduit is limited by NEC rules.

INTERMEDIATE METALLIC CONDUIT

This is a relatively new type of conduit with wall thickness less than that of rigid metal conduit but greater than that of ENMT. It uses the same threading methods and standard fittings as rigid

168 CHAPTER EIGHT

metal conduit and has the same general application rules as rigid metal conduit. Intermediate metallic conduit (IMC) is a light-weight rigid steel conduit that requires about 25% less steel than heavy-wall rigid conduit. Acceptance into the Code was based on a UL fact-finding report that showed, through research and comparative tests, that IMC performs as well as rigid steel conduit in many cases and surpasses rigid aluminum and EMT in more cases.

IMC may be used in any application for which rigid metal conduit is recognized by the NEC, including use in all classes and divisions of hazardous locations, as covered in Articles 501.4, 502.4, and 503.3. Its thinner wall makes it lighter and less expensive than standard rigid metal conduit. However, it has physical properties that give outstanding strength. It has the same outside diameter as rigid conduit and the same trade sizes. The rules for number of wires in IMC are the same as for rigid metal conduit,

See Figure 8-15 for fittings used on IMC and rigid conduit.

PVC CONDUIT SYSTEMS

PVC is also used in conduit systems. The use of this plastic conduit (pipe) in electrical wiring systems has decided advantages. Nonmetallic conduits weigh one-fourth to one-fifth as much as metallic systems. They can also be easily installed in less than half the time and are easily fabricated on the job. (Nonmetallic conduit and raceway systems are covered by Article 347 of the NEC.)

PVC has high impact resistance to protect wiring systems from physical damage. It is resistant to sunlight and approved for outdoor usage.

The use of expansion fittings allows the system to expand and contract with temperature variations. PVC conduit will expand or contract approximately four to five times as much as steel and two and one-fourth times as much as aluminum. Installations where the expected temperature exceeds 14°C (25°F) should use expansion joints. The manufacturer furnishes the formulas for figuring out the expansion joint size and how often it is needed in any given installation.

Any plastic conduit should always be installed away from steam lines and other sources of heat. Support straps should be tightened

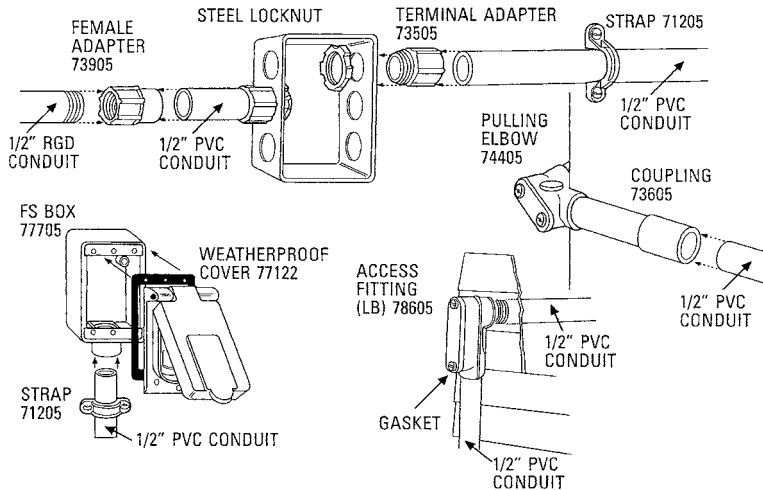


FIGURE 8-15. Installing fittings for PVC conduit (Halex).

170 CHAPTER EIGHT

only enough to allow for linear movement caused by expansion and contraction.

The PVC conduit that is widely used in the United States is called Plus 40. It is UL listed for use underground, encased in concrete or direct burial, and for exposed or concealed use in most conduit applications above ground.

Plus 80 is designed for above-ground and underground applications where PVC conduit with extra heavy wall is needed. It is frequently used in situations where severe abuse may occur, such as for pole risers, bridge crossings, and heavy traffic areas. Typical applications are around loading docks, in high-traffic areas, and where threaded connections are required.

PVC conduit and fittings are similar to those used on rigid conduit. See Figure 8-15. Installation of these is as follows:

1. To bond fittings to conduit:
 - a. Cut conduit to desired length and deburr ends.
 - b. Pipe any contaminant or shavings from end of conduit
 - c. Mate (unthreaded) end of fitting
 - d. Apply cement to clean end of conduit and fitting.
 - e. While making a one-quarter rotation, push conduit into fitting until it “bottoms.” Allow 10 minutes to set properly (more time is required in temperatures below 60°F).
2. To install terminal adapters (735 series):
 - a. Follow procedure in item 1 mentioned previously.
 - b. Insert threaded end of bonded terminal adapter through knockout into box.
 - c. Turn metallic locknut (019 or 619 series) onto terminal adapter threads from inside box and tighten by tapping with a screwdriver blade until locknut teeth bite into box.
3. To install couplings (736 series)—Follow procedure in item 1. (Note that special fittings, called expansion couplings, may be required if a PVC run is in an area subjected to drastic changes in temperature.)
4. Secure conduit with straps (712 series)
 - a. Install a minimum of one strap for every 10 feet of conduit run.
 - b. Always use a strap within 3 feet of box.
5. Pulling elbows (744 series) are made for corners and are installed onto conduit by following steps of item 1 mentioned previously.

6. To connect PVC conduit to a piece of rigid metallic pipe, use a PVC female adapter (739 series).
 - a. Follow item 1 mentioned previously to bond PVC female adapter to PVC conduit.
 - b. Turn female end of bonded PVC fitting onto rigid metallic threads.
 - c. Be certain that ground continuity is properly maintained.
7. An LB (786 series) fitting is used when running wires inside conduit through an outside building wall.
 - a. Open holes at each end will accept conduit.
 - b. Wires can be readily pulled through the fitting by simply removing the cover.
 - c. The gasket under the cover is designed to keep out moisture.
8. When installing FS-type boxes (767, 774, 777 series) follow procedure outlined in item 1 for bonding to conduit.
9. To mount a weatherproof cover (771 series) to a box, place the gasket and the cover together on the box and attach with screws provided.

NOTE

The purpose of the previous diagram and text is only to illustrate certain uses of PVC products. The manufacturer and publisher cannot be responsible for any actual electrical installation. The previous diagram and text are compiled on information that is current at the time of printing.

Recommendations for product use, as well as permissible applications, are subject to change.

Electrical equipment should be selected and be applied in accordance with the NEC or other local authority having jurisdiction over the installation.

WORKING WITH CONDUIT

Three types of conduit may need to be bent. This bending is in order to serve their intended purpose. That purpose is the protection of

172 CHAPTER EIGHT

electrical wiring against physical harm. Installation of rigid metal conduit, IMC, and EMT, sometimes referred to as thin-wall conduit, requires that provision for making changes of direction in the conduit runs—ranging from simple offsets at the point of termination at outlet boxes and cabinets to complicated angular offsets at columns, beams, cornices, and so forth.

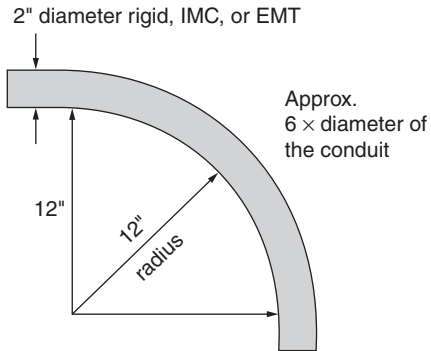
Sometimes contract specifications dictate otherwise, but changes in direction are made, particularly in the case of small diameter conduit, by bending the tubing as required. In the case of $1\frac{1}{4}$ inch and larger sizes, right-angle changes of direction are sometimes installed with the use of *factory* bent elbows or conduit bodies. In most cases, however, such changes in direction are made more economically by using conduit bent in the field.

A good reason for making on-the-job bends is multiple runs of the larger conduit sizes. This is because truer parallel alignment of multiple runs can be maintained by using on-the-job conduit bends rather than factory elbows. Such bends can all be made from the same center, using bends of the largest conduit in the turn as the pattern for all the other bends.

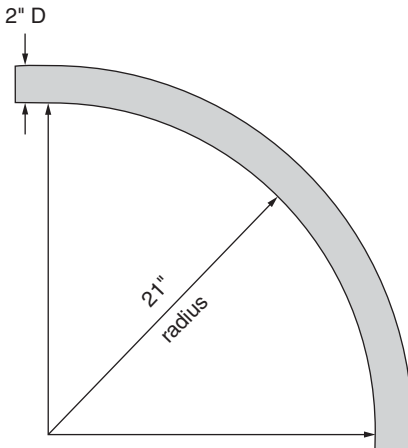
Most conduit and raceway systems are run exposed. Learning to install neat-looking conduit systems in an efficient and workman-like manner is the hallmark of a good electrician. Every electrician working on commercial and industrial electrical installations must learn how to calculate and fabricate conduit bends. That means the operation of both hand and power conduit benders take pride in performing the best work possible.

NATIONAL ELECTRICAL CODE

The NEC requires that metal conduit bends must be made so that the conduit will not be damaged during the installation and during operation. The Code also requires that the internal diameter of the conduit will not be effectively reduced in size. To accomplish this, the Code, further specifies that the minimum radius of the inner edge curve of a conduit bend be at least six times the internal diameter of the conduit when conductors without lead sheath are installed. See Fig. 8-16. The reason for this rule is: when the inside of an elbow is less than six times the inside diameter, wire pulling



A For conduit containing conductors without lead sheath



B For conduit containing lead-sheathed conductors

FIGURE 8-16. (A) 2-inches rigid, IMC or EMT bend radius.
(B) Radius of 90° bend.

174 CHAPTER EIGHT

becomes difficult. That means the insulation on the conductors may be damaged.

When lead sheath conductors are to be installed, the inside must be increased according to NEC Table 346-10. See Fig. 8-16B.

The NEC further states that no more than *four* bends (360°) total may be made in any one conduit run between boxes, cabinets, panels, or junction boxes. That is, between pull points.

CONDUIT TERMINOLOGY

In case you haven't seen them before, or need to refresh your memory, here are some of the terms encountered when working with conduit.

- **Circle**—a closed curve line point, the points of which are all the same distance from the center. The circumference of a circle is found by multiplying the diameter by the constant pi. Pi (π) has a value of 3.14159. Or, $C = \pi \times D$, where C is the circumference and D is the diameter.
- **Elbow**—an *ell* or a 90° bend that is made when a conduit must turn at a 90° angle. Factory elbows are available already bent. Figure 8-17 shows how factory elbows are used, and how on-the-job bends can be made for a neater look.
- **Gain**—the distance saved by the arc of a 90° degree bend. By knowing the gain you can pre-cut, ream, and pre-thread both ends of the conduit before the bend is actually made. A typical gain table is shown in Table 8-2.
- **Hickey**—designed for bending small sizes of rigid conduit. The hickey is not to be confused with a hand bender. See Figures 8-18A and Fig. 8-18B.
- **Kick**—a change in direction of the conduit, but at a small angle. The first bend in and offset is really a *kick*.
- **Little kicker**—a hand-operated device used to make offsets in EMT.
- **Offset**—when two 45 bends are used and when the conduit must run over, under, or around an obstacle. An offset is also used at outlet boxes, cabinets, panel boards, and pull boxes as can be seen in Fig. 8-19, and Table 8-3 and Table 8-4.
- **Right angle**—an angle that contains 90° . Remember that a circle has 360° .

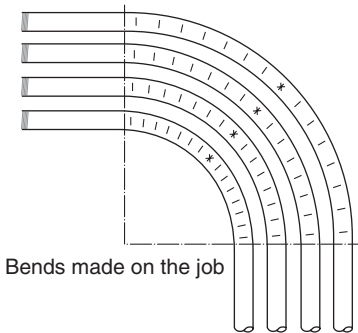
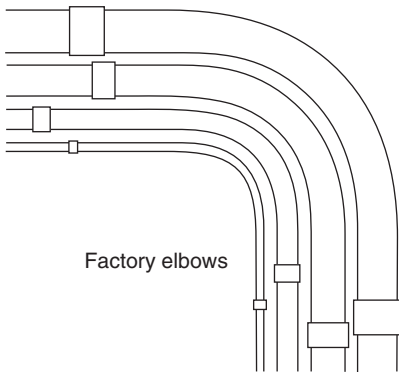


FIGURE 8-17. Bends of factory elbows compared with bends made on the job.

TABLE 8-2
Rigid Conduit—(90° Bends)

Rigid Conduit Size (in)	NEC Radius (in)	90° Gain (in)
1/2	4	2 ⁵ / ₈
3/4	5	3 ¹ / ₄
1	6	4
1 ¹ / ₄	8	5 ⁵ / ₈

- **Saddle**—when a small obstruction, such as a pipe, must be crossed by the conduit. It may be necessary to use two offsets to cross some larger objects. See Figure 8-20 and Table 8-5.
- **Stub-ups**—the short ends of the conduit that stick up after a bent See Table 8-6.
- **Take-up**—the amount of conduit the bender will use to form the bend. Bender manufacturers usually list their particular product’s take-up distances on the side of the device. See Table 8-7.

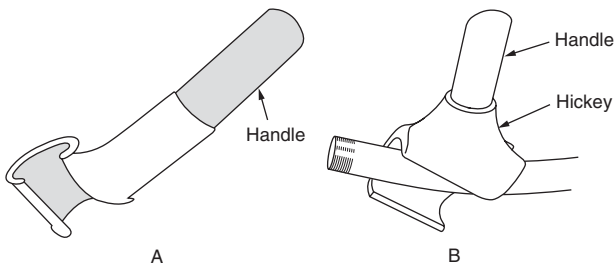
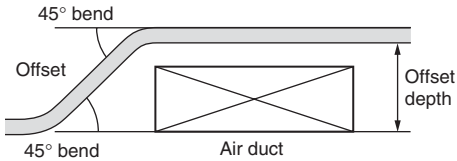
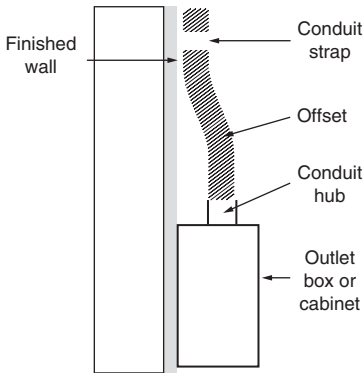


FIGURE 8-18. (A) Hickey for bending conduit. (B) Hickey in use.

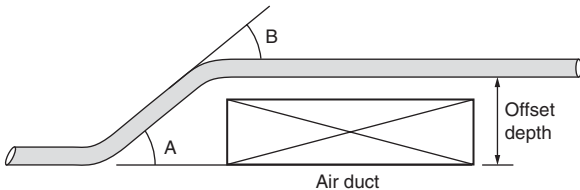


Note: If possible, always install conduit offsets and saddles over an object rather than under it. This avoids pockets in which water can settle

A



B



C

FIGURE 8-19. (A) Bends offsets over a heat or air duct. (B) Box or cabinet offset. (C) Closer look at bends for air duct.

TABLE 8-3
Conduit Offsets Measurements

Offset Depth (in)	Distance Between Bends (in)	Angle of Bends (degrees)	Conduit Length-Loss (in)
1	6	10	1/16
2	5 ^{1/4}	22 ^{1/2}	3/8
3	6	30	3/4
4	8	30	1
5	7	45	1 ^{7/8}
6	8 ^{1/2}	45	2 ^{1/4}
7	9 ^{3/4}	45	2 ^{5/8}
8	11 ^{1/4}	45	3
9	12 ^{1/2}	45	3 ^{3/8}
10	14	45	3 ^{3/4}

BOXES

Boxes are used to make connections of wiring or to mount switch boxes and fixtures. There are many types of metallic and nonmetallic boxes.

Nonmetallic PVC switch boxes and receptacle boxes are used in residential wiring. The roughing-in time can be reduced by using

TABLE 8-4
Typical Offset Multipliers—Various Angles

Angle (degrees)	Multiplier
10	5.76
15	3.86
22.5	2.61
30	2.00
45	1.41

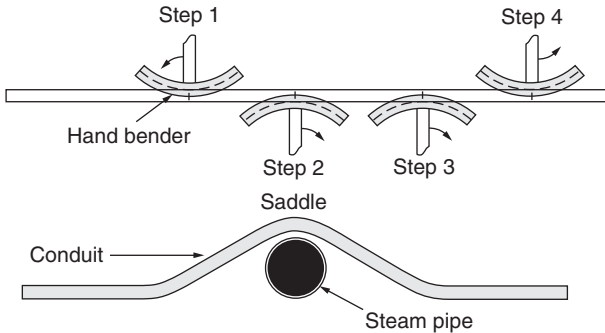


FIGURE 8-20. Steps in bending to have conduit go over or under a steam pipe.

these boxes, inasmuch as they have their own connectors molded into the box. They can also be used in remodeling old work. See Figure 8-24.

When you install an “old work” box into hollow walls, two arms swing out behind the wall. Tighten two screws and the arms draw

TABLE 8-5
Saddle Bending

Straight-Run Conduit (in)	Minimum Length (in)	Bend Spacing (in)	Bend Degrees	Bend Degrees	Bend Degrees
	E-C	C-C	No. 1	No. 2	No. 3
1	20	16	6	6	12
1 ¹ / ₄	20	16	7	7	14
1 ¹ / ₂	20	16	8	8	16
2	20	15 ⁷ / ₈	10	10	20
2 ¹ / ₂	20	15 ³ / ₄	12 ¹ / ₂	12 ¹ / ₂	25
3	20	15 ⁵ / ₈	15	15	30
3 ¹ / ₂	20	15 ¹ / ₂	18	18	36
4	20	15 ¹ / ₂	20	20	40

TABLE 8-6
Stub-ups Dimensions—Various Sizes of Conduit

Pipe and Conduit Size (in) Y (in)	Radius of Bend R (in)	Developed Length 90° (in)	Gain X (in)	1/2 Gain Y (in)
1/2	4	6 ⁵ / ₁₆	1 ¹¹ / ₁₆	7/ ₈
3/4	4 ¹ / ₂	7 ¹ / ₁₆	1 ¹⁵ / ₁₆	15/ ₁₆
1	5 ³ / ₄	9	2 ¹ / ₂	1 ¹ / ₄
1 ¹ / ₄	7 ¹ / ₄	11 ³ / ₈	3 ¹ / ₈	1 ⁹ / ₁₆
1 ¹ / ₂	8 ¹ / ₄	13	3 ¹ / ₂	1 ³ / ₄
2	9 ¹ / ₂	14 ¹⁵ / ₁₆	4 ¹ / ₁₆	2
2 ¹ / ₂	12 ¹ / ₂	19 ⁵ / ₈	5 ³ / ₈	2 ¹¹ / ₁₆
3	15	23 ⁵ / ₁₆	6 ⁷ / ₁₆	3 ³ / ₁₆
3 ¹ / ₂	17 ¹ / ₂	27 ¹ / ₂	7 ¹ / ₂	3 ³ / ₄
4	20	31 ⁷ / ₁₆	8 ⁹ / ₁₆	4 ¹ / ₄

tightly against the wall. Installation is completed with a few turns of the screwdriver. A template is included in the box to ensure an accurate cut in the wall. The swing-arm box can be used with wall material from 1/4-inch to 5/8-inch thick or from paneling to dry-wall. A cable clamp is molded into the box. Just push the wire in and pull back slightly to activate the clamping action.

TABLE 8-7
Conduit Take Up

EMT (in)	Rigid Conduit* (in)	Take-Up (in)
1/2	—	5
1/4	1/2	6
1	1/4	8
1 ¹ / ₄	11	11

Amount of take up for 90° bends with one-shot benders.

* IMC and Rigid will be the same.

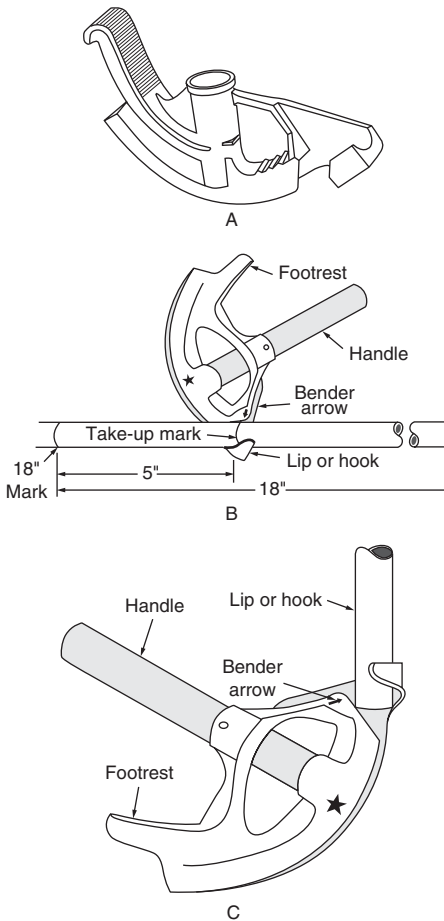


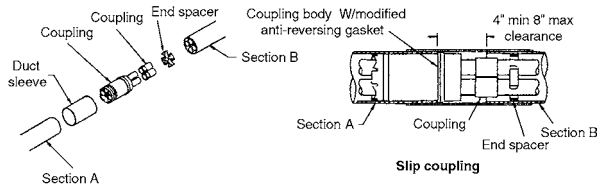
FIGURE 8-21. (A) Conduit bender. (B) Conduit bender—note the lip or hook placement. (C) Parts of the conduit bender.

Repairing vacant multi-gard

1 Cut out the damaged section and insert a belled short section (4" shorter than damaged section) of Multi-Gard onto either one of the ends (section A).

2 Apply 2" of cement on ends of spigots of coupling body, press couplings onto spigots.

3 Slide innerduct sleeve over Multi-Gard plain end (section A). Insert end spacer into Multi-Gard plain end (section B).

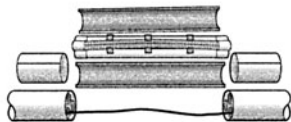


4 Insert female end of slip coupling into Multi-Gard plain end (section A). Align sections A and B. Apply cement to couplings. Slide slip coupling back onto innerducts in Multi-Gard (section B) until seated.

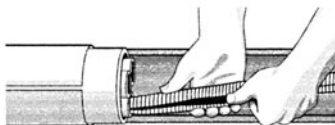
5 Apply cement to both plain ends of Multi-Gard and slide sleeve until centered on both sections.

FIGURE 8-22. Repairing multi-Gard PVC (Carlton).

Repairing multi-gard containing cables (s)



1 Carefully cut out damaged section up to 10 feet. Larger sections can be accommodated using multiple repair kits.



2 Install the 4" split sleeve couplings over the existing Multi-Gard. Slide the smaller split couplings onto the individual innerduct, fitting the cable into the split coupling. Repeat this process on opposite side. Carefully insert the cable(s) into the split corrugated innerduct.



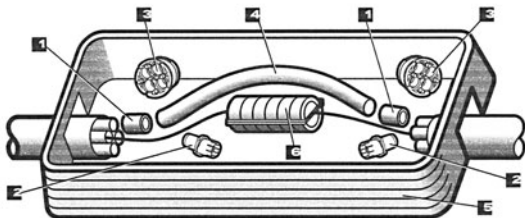
3 Install corrugated innerduct and remaining smooth innerduct into couplings by raising in the center and guiding them into their respective openings. Install the spacers to evenly support the innerduct.



4 Lay one piece of split duct under the repaired section. Install the other piece of split duct onto the first piece and strap or tape in place. Apply cement onto each end and slide the slip sleeves until centered on both sections. Backfill according to job specifications.

FIGURE 8-22. (Continued)

Repair kits



Repairing multi-gard with damaged cables

E E940F PVC Coupling

Couples PVC innerduct with solvent cement for empty cells (standard grade qt. cement #VC9962).

E MAFPG7 Fiber Optic Simplex Plug

(cable O.D. range .57 - .65) Seals innerduct with cable installed.

E MAQPG2 Quadplex Plug (4 holes each)

Seals outershell and innerduct.

4 48808DK PVC Pass-through Kit

(4 x 20' lengths) 20 foot lengths can be cut to length for continuous empty innerduct.

E Underground Vault & Lid needed

Choose size & construction based on dimensions of splice cases and weight requirements. (Allow 12" on either side of splice for bending innerduct)

E Splice Case**Repair Kit Instructions:**

1. Dig around break area enough to allow vault to drop over the repair area and rest level when the mouseholes have been cut away for the duct.
2. Cut away and remove outer shell and any damaged inner-ducts, being careful to protect any exposed cables.
3. Cut back the outer duct to allow approximately 6" of inner-duct exposed.
4. Install the splice case per manufacturer's or customer's specifications, allowing enough cable slack so no tension is felt.
5. Install the quad plugs (Item #3) and single plugs (Item #2) in duct containing cable.
6. Install pass-through ducts (Item #4) with coupling (Item #1) sealing with solvent cement.
7. Set the enclosure base over the entire package and place cover on enclosure.
8. Refill hole as required.

FIGURE 8-23. Repairing multigard damaged cables (Carlon).

PVC boxes are made for switches and ceiling installations. The ceiling boxes will support fixtures up to 50 pounds. Mounting posts have a pair of holes $\frac{3}{4}$ inches and $3\frac{1}{2}$ inches at the center to accept fixture canopies that require either of these spacings. Heavy-duty nails are already inserted. Just make sure you don't miss and hit the box with a hammer—the results can be disastrous. The plastic does crack when hit a hard blow with a hammer that missed its target. The PVC boxes are usually of bright color. They may be gold or blue, to name but two of the manufacturers' colors. However, the thermoset (hard plastic) boxes are black. They also have raised covers and reducers. Figure 8-25 shows some PVC boxes and thermoset boxes.

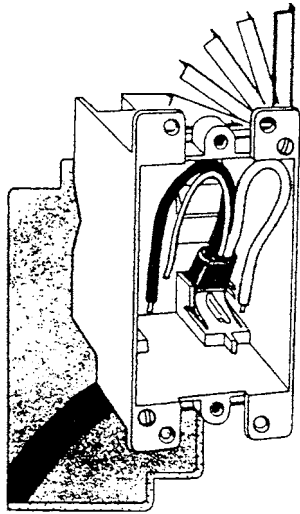
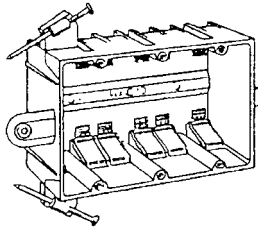
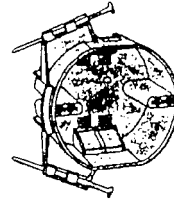


FIGURE 8-24. Nonmetallic box.

Boxes have been made of steel for years. There are many different manufacturers, but most of the boxes are made roughly to the same standards. Look for the CSA and UL labels before buying.

A wide variety of boxes is available. Each has its own identity and serves a specific purpose. Therefore, when, looking for an easy way to mount a box check all options. Many boxes come with brackets for specific types of mounting. See Figure 8-26. Plastic ears are included in many switch boxes. They are set forward $\frac{1}{16}$ inch in the "old work" position. Two screw ears are supplied with shallow boxes and one screw ear for deep boxes. See Figure 8-27. Clamps inside boxes are made for armored cable or nonmetallic cable (Romex). See Figure 8-28. Ground clips (Figure 8-29) are used to secure ground wires to the side of metal boxes.

Table 8-8 shows the volume needed per conductor so that a proper box can be chosen for a particular function. Remember that a clamp counts as a conductor.

3-GANG SWITCH BOX**4" DIA. CEILING BOX**

23.5 cubic inches

On 4" square boxes clamps are furnished on two sides

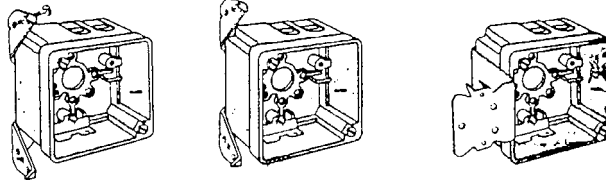
THERMOSET 4" SQUARE BOXES

FIGURE 8-25. PVC boxes and thermoset boxes.

With nonmetallic sheathed cable clamps

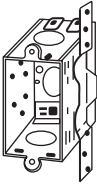
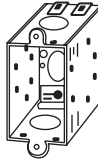
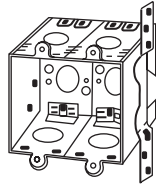
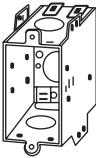
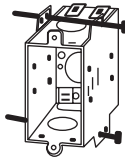
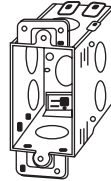
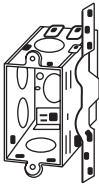
2-1/2" Deep, Welded
Bracket set back 3/4"2-1/2" Deep, Welded
Four nail holes
each side2-1/2" Deep, Welded
Bracket set back 3/4"2-1/2" Deep, Welded
External nail brackets2-1/2" Deep, Welded
Two 16 penny nails
in side2-3/4" Deep, gangable
plaster ears"

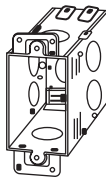
FIGURE 8-26. Boxes with brackets for different types of mounting.

PLUGS

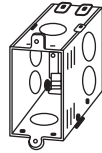
Plugs are made in a number of size and shapes for use with 125-, 250-, 277-, 480-, and 600-volt power sources. They are also made for three-phase as well as for single-phase power use. Current ratings are from 20 amperes up to 100 amperes. See Figure 8-30. General-purpose nonlocking plugs and receptacles are shown according to National Electrical Manufacturer's Association (NEMA) configurations in Figure 8-31. The plugs are easily removed or inserted into the receptacle. They too run the range from 125 volts to 600 volts with currents from 15 to 60 amperes.



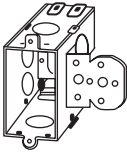
2-3/4" Deep, Gangable
Bracket set back 3/4"



3-1/2" Deep, Gangable
Two nail holes each side
Plaster ears*



3-1/2" Deep, Gangable
Two nail holes
each side

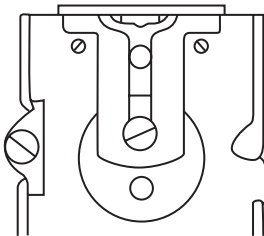


3-1/2" Deep, Gangable
Bracket set back 1/2"

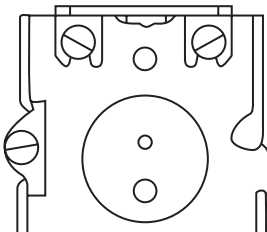


3-1/2" Deep, Gangable
Bracket set back 3/4"

FIGURE 8-26. (Continued)



One-screw ears



Two-screw ears

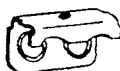
FIGURE 8-27. Boxes with screw ears for mounting.

CLAMPS

ARMORED CABLE

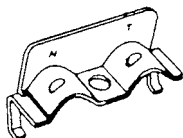


X CLAMP

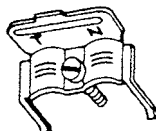


#12 CLAMP

NONMETALLIC CABLE



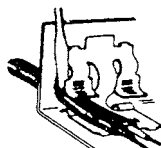
L CLAMP



N CLAMP



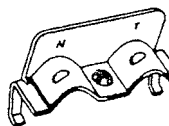
BN CLAMP



"Q" CLAMP



#9 CLAMP



#10 CLAMP

FIGURE 8-28. Clamps inside boxes.

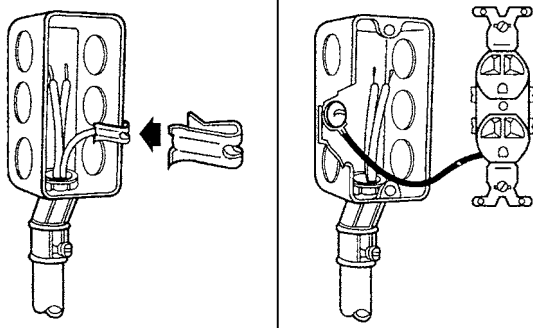


FIGURE 8-29. Grounding clip and screw on metal box.

TABLE 8-8
Volume Allowance Required per Conductor

Size of Conductor (AWG)	Free Space within Box for Each Conductor	
	cm ³	in ³
18	24.6	1.50
16	28.7	1.75
14	32.8	2.00
12	36.9	2.25
10	41.0	2.50
8	49.2	3.00
6	81.9	5.00

EQUIVALENT NEMA L6E	WIRING	COLOR CODE	AC VOLTAGE	20 AMPERE		30 AMPERE		60 AMPERE		100 AMPERE		AC VOLTAGE	EQUIVALENT NEMA L6E	WIRING	EQUIVALENT NEMA L6E
				RECEPTACLE CONNECTOR	PLUG INLET	RECEPTACLE CONNECTOR	PLUG INLET	RECEPTACLE CONNECTOR	PLUG INLET	RECEPTACLE CONNECTOR	PLUG INLET				
5	YELLOW		125	GE 220 R 4 GE 320 C 4	GE 320 P 4	GE 330 R 4 GE 330 C 4	GE 330 P 4	GE 360 R 4 GE 360 C 4	GE 360 P 4	GE 400 R 4 GE 400 C 4	GE 400 P 4	125	5	YELLOW	
6	BLUE		250	GE 360 R 6 GE 330 C 6	GE 320 P 6	GE 330 R 6 GE 330 C 6	GE 330 P 6	GE 360 R 6 GE 360 C 6	GE 360 P 6	GE 400 R 6 GE 400 C 6	GE 400 P 6	250	6	BLUE	
7	GRAY		277	GE 360 R 7 GE 330 C 7	GE 320 P 7	GE 330 R 7 GE 330 C 7	GE 330 P 7	GE 360 R 7 GE 360 C 7	GE 360 P 7	GE 400 R 7 GE 400 C 7	GE 400 P 7	277	7	GRAY	
8	RED		480	GE 420 R 8 GE 420 C 8	GE 420 P 8	GE 430 R 8 GE 430 C 8	GE 430 P 8	GE 460 R 8 GE 460 C 8	GE 460 P 8	GE 500 R 8 GE 500 C 8	GE 500 P 8	480	8	RED	
9	BLACK		600	RESERVED FOR FUTURE CONFIGURATIONS								600	9	BLACK	
14	ORANGE		125/250	GE 420 R 12 GE 420 C 12	GE 420 P 12	GE 430 R 12 GE 430 C 12	GE 430 P 12	GE 460 R 12 GE 460 C 12	GE 460 P 12	GE 500 R 12 GE 500 C 12	GE 500 P 12	125/250	14	ORANGE	
15	BLUE		250 3Ø	GE 430 R 9 GE 430 C 9	GE 430 P 9	GE 430 R 9 GE 430 C 9	GE 430 P 9	GE 460 R 9 GE 460 C 9	GE 460 P 9	GE 500 R 9 GE 500 C 9	GE 500 P 9	250 3Ø	15	BLUE	
16	RED		480 3Ø	GE 430 R 7 GE 430 C 7	GE 430 P 7	GE 430 R 7 GE 430 C 7	GE 430 P 7	GE 460 R 7 GE 460 C 7	GE 460 P 7	GE 500 R 7 GE 500 C 7	GE 500 P 7	480 3Ø	16	RED	
17	BLACK		600 3Ø	GE 500 R 10 GE 500 C 10	GE 500 P 10	GE 500 R 10 GE 500 C 10	GE 500 P 10	GE 500 R 10 GE 500 C 10	GE 500 P 10	GE 500 R 10 GE 500 C 10	GE 500 P 10	600 3Ø	17	BLACK	
21	BLUE		120/208 3Ø	GE 500 R 11 GE 500 C 11	GE 500 P 11	GE 500 R 11 GE 500 C 11	GE 500 P 11	GE 500 R 11 GE 500 C 11	GE 500 P 11	GE 500 R 11 GE 500 C 11	GE 500 P 11	120/208 3Ø	21	BLUE	
22	RED		277/480 3Ø	GE 500 R 11 GE 500 C 11	GE 500 P 11	GE 500 R 11 GE 500 C 11	GE 500 P 11	GE 500 R 11 GE 500 C 11	GE 500 P 11	GE 500 R 11 GE 500 C 11	GE 500 P 11	277/480 3Ø	22	RED	
23	BLACK		347/600 3Ø	GE 500 R 11 GE 500 C 11	GE 500 P 11	GE 500 R 11 GE 500 C 11	GE 500 P 11	GE 500 R 11 GE 500 C 11	GE 500 P 11	GE 500 R 11 GE 500 C 11	GE 500 P 11	347/600 3Ø	23	BLACK	

FIGURE 8-30. Plugs used with different current ratings.

192 CHAPTER EIGHT

	15 AMPERE		20 AMPERE		30 AMPERE		50 AMPERE		60 AMPERE	
	RECEPTACLE	PLUG	RECEPTACLE	PLUG	RECEPTACLE	PLUG	RECEPTACLE	PLUG	RECEPTACLE	PLUG
2-POLE/2-WIRE	125V	1-15R	1-15P							
	250V		2-15P	2-20R	2-20P	2-30R	2-30P			
	277V									(Reserved for Future Configurations)
	600V									(Reserved for Future Configurations)
2-POLE/3-WIRE GROUNDING	125V	5-15R	5-15P	5-20R	5-20P	5-30R	5-30P	5-50R	5-50P	
	Catalog No	5259-C* 5269-C-G	5266-P* 5286-P-HG	5369-C* 5369-CH-G	5306-P* 5306-PH-C					
	250V	6-15R	6-15P	6-20R	6-20P	6-30R	6-30P	6-50R	6-50P	
	Catalog No	5669-C*	5666-P*	5469-C*	5466-P*					
	277V AC	7-15R	7-15P	7-20R	7-20P	7-30R	7-30P	7-50R	7-50P	
	Catalog No	5769-C*	5766-P*							
347V AC	24-15R	24-15P	24-20R	24-20P	24-30R	24-30P	24-50R	24-50P		
480V AC									(Reserved for Future Configurations)	
600V AC									(Reserved for Future Configurations)	
3-POLE/3-WIRE	125/250V			10-20R	10-20P	10-30R	10-30P	10-50R	10-50P	
	3φ 250V	11-15R	11-15P	11-20R	11-20P	11-30R	11-30P	11-50R	11-50P	
	3φ 480V									(Reserved for Future Configurations)
3φ 600V									(Reserved for Future Configurations)	
3-POLE/4-WIRE GROUNDING	125/250V	14-15R	14-15P	14-20R	14-20P	14-30R	14-30P	14-50R	14-50P	14-60R
	3φ 250V	15-15R	15-15P	15-20R	15-20P	15-30R	15-30P	15-50R	15-50P	15-60R
	3φ 480V									(Reserved for Future Configurations)
	3φ 600V									(Reserved for Future Configurations)

FIGURE 8-31. General purpose nonlocking and locking plugs.

4-POLE/4-WIRE	3 ϕ 208Y/120V	18-13R	18-15P	18-20R	18-20P	18-30R	18-30P	18-50R	18-50P	18-60R	18-60P
	3 ϕ 480Y/277V					(Reserved for Future Configurations)					
	3 ϕ 600Y/347V					(Reserved for Future Configurations)					
4-POLE/5-WIRE GROUNDING	3 ϕ 208Y/120V					(Reserved for Future Configurations)					
	3 ϕ 480Y/277V					(Reserved for Future Configurations)					
	3 ϕ 600Y/347V					(Reserved for Future Configurations)					

FIGURE 8-31. (Continued)

194 CHAPTER EIGHT

Locking plugs and receptacles slip into the receptacle and are twisted to lock into place. A variety of single- and three-phase configurations are available to fit most requirements.

Plugs for hazardous locations are specially made to extinguish any sparks that may occur before the plug is pulled from the receptacle. Figure 8-32 shows how this is done.

SWITCHES

Canopy switches are used for lamps or small devices that require less than 6 amperes at 125 volts. Figure 8-33 shows several types:

- A. Pushbutton
- B. Pull-chain with a 3-foot cord
- C. Toggle with pigtails
- D. Four-position
- E. Two-circuit rotary

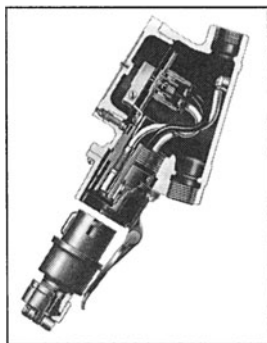
and a type that will handle only 1 ampere at 125 volts in a rotary action (item E given earlier).

Cord switches are used to turn on lamps, heating pads, and other small portable equipment that usually demand no more than 6 amperes at 125 volts. The switch is designed to fit onto the cord by removing one of the twin leads and cutting it to make contact inside the disassembled switch.

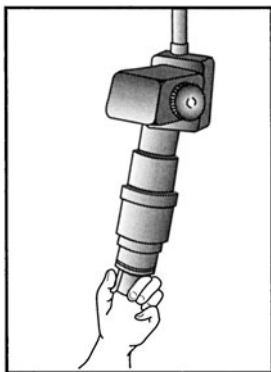
Electronic switches are now part of home, office, and industrial plant wiring. An electronic switch may be single-pole or three-way. It may allow manual override control, and at any time can be installed in a single-gang switch box. It also may be programmed to turn lights on and off up to eight times per day (with a minimum stay-on or -off time of 30 minutes). It comes with pigtail terminals for wire nuts, and can handle up to 500 watts.

Four-way switches have four screws. It takes two three-way switches with one four-way to be able to operate a device from three locations. If more than three locations are needed, it still takes two three-way switches plus whatever number of four-way switches are needed after that. See Figure 8-34.

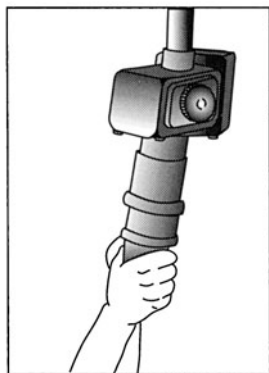
Snap switches with screw terminals are used most often. They also come with a push-in connection and a green screw for a ground wire connection. The switch without the grounding screw has the ground wire from the Romex grounded to the metal box.



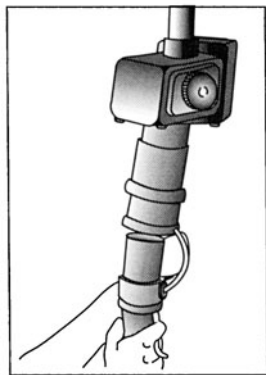
Receptacle constructed with an interlocked switch. Rotating the plug after insertion actuates this switch.



Plug partially withdrawn (delayed action stop in rotating sleeve prevents complete withdrawal). Contacts separated in explosion-proof chambers.



Plug about to be withdrawn.



Plug completely withdrawn.

FIGURE 8-32. Specially made plugs for hazardous locations.

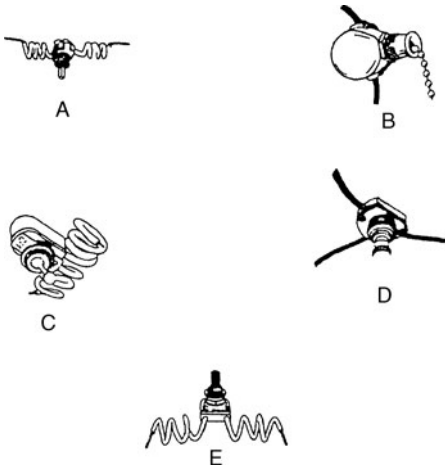


FIGURE 8-33. Canopy switches.

Then, when the metal part of the switch is mounted to the box, it completes the grounding of the switch. The single-pole switch is used for on-off operations in 120-volt circuits in most residential circuits. See Figure 8-35.

Three-way switches have three screws. The three screws are connected so that the *C* is common and the other two are travelers. That means that as the switch is operated it completes the circuit from one traveler to the other. They have to be used in pairs in order to operate properly. Three-way switches are necessary in order to have four-way switches operate. This type of switch is used to turn a light or device on or off from two different locations. See Figure 8-36.

Figure 8-37A shows how a notch in a stud is covered with a nail-plate to prevent the Romex wire from being damaged by a nail. A snap-in replacement for a knock out is shown in Figure 8-37B.

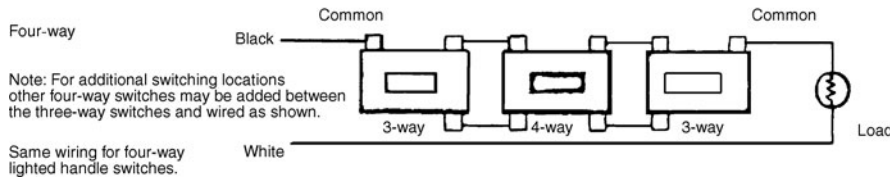
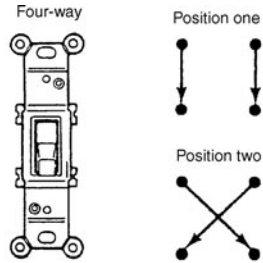
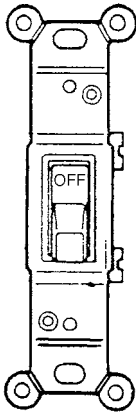


FIGURE 8-34. Four-way switches.

Single-pole switch



Position one



Position two

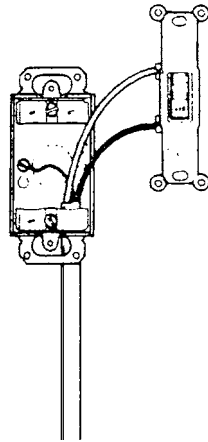


FIGURE 8-35. Snap switch.

Barrel locking switches provide maximum tamper resistance for demanding security needs. See Figure 8-38. This type of switch offers the best in pick-resistant switches. The six-point tumbler cylinder provides added security to supply override protection from unwarranted access.

Barrel locks have been commonly used for fire systems controls, limited access, and high security equipment for years. Now barrel-keyed switches limit access by any unauthorized personnel. This gives only authorized personnel access to the switches for lights and equipment. Light switches placed in public or semipublic areas play an important role in security and safety. Whether for schools, institutions, theaters, or public buildings good lighting provides safety. By using the proper switch, you can increase security.

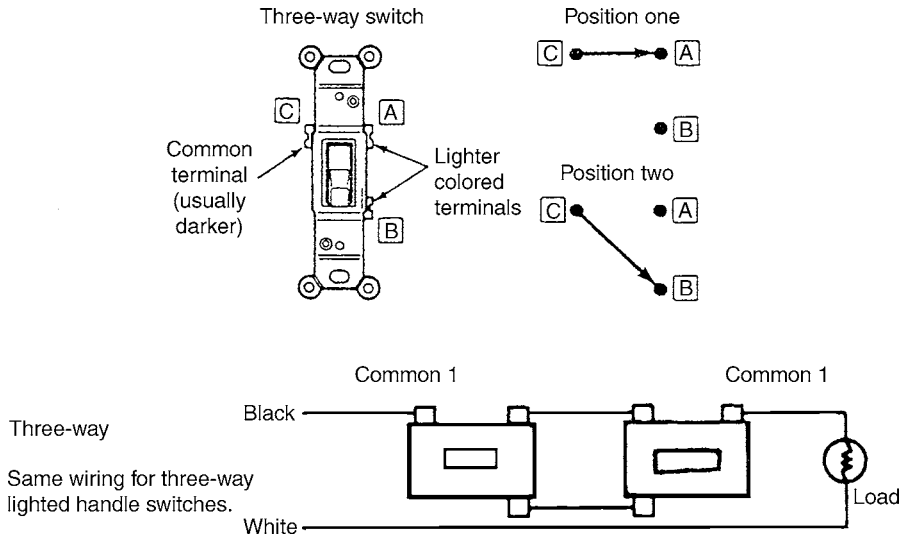


FIGURE 8-36. Three-way switch.

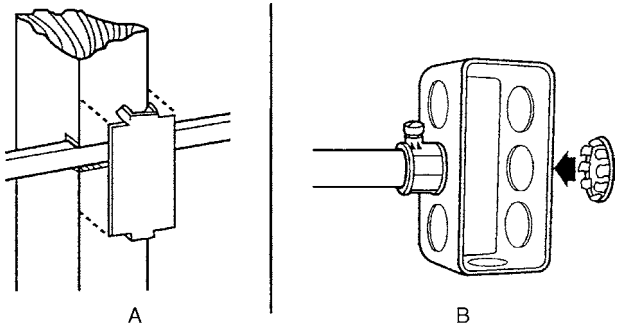


FIGURE 8-37. (A) Nail plate prevents nails into the 2 x 4 during drywall installation from penetrating the Romex cable. (B) Snap-in replacement for knockout in metal box.

The alternating current (AC) barrel keyed locking switch is one of the better lockouts. It can keep school kids from playing pranks. Its round key design renders knives, paper clips, and other flat objects virtually useless in obtaining access. The round barrel key is used to activate the cylindrical tumblers and it cannot be duplicated easily. Clearly marked stainless on/off wall plates in one- and two-gang configurations can be used to make it even more secure and tamper proof.

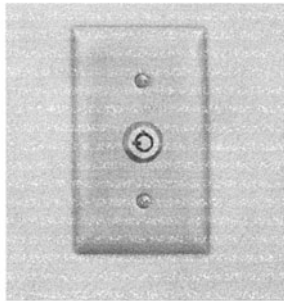
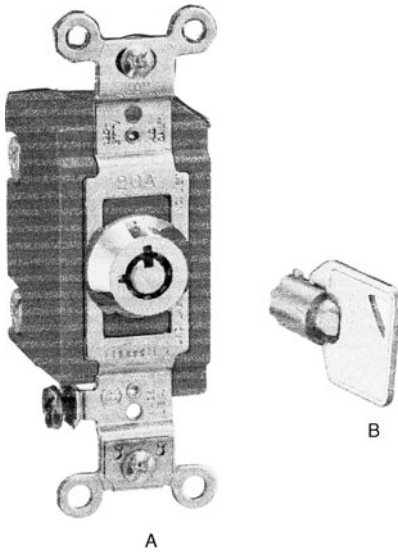


FIGURE 8-38. (A) Barrel-keyed locking switch. (B) Key to operate the switch. (C) Installed switch with a stainless steel switch plate or cover.

This page intentionally left blank

Hazardous Locations Equipment

Special fixtures and devices are made for electrical wiring in hazardous locations. The National Electrical Code (NEC) has extensive coverage of this type of wiring inasmuch as it is very dangerous. Only an experienced electrician should attempt wiring situations that are classified as hazardous. Check the NEC handbook for classes, groups, and divisions of hazardous materials (gases, vapors, dusts, and others) and hazardous locations. See Figure 9-1.

Sealed fittings, as specified in the code, are required in hazardous situations. Sealing fittings restrict the passage of gases, vapors, or flames from one portion of an electrical installation to another at atmospheric pressure and normal ambient temperatures. Sealed fittings limit explosions to the sealed-off enclosure and prevent precompression or “pressure piling” in conduit systems. Even though it is not a code requirement, many designers consider it good practice to minimize the effects of “pressure piling” through sectionalizing long conduit

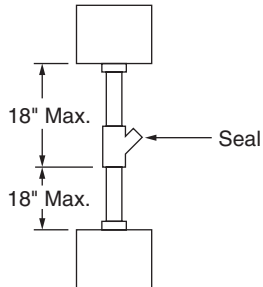


FIGURE 9-1. Placement of seals in a short run.

204 CHAPTER NINE

runs by inserting seals not more than 50 or 100 feet apart, depending on the conduit size.

Several electrical equipment makers offer a complete line of equipment for hazardous locations. The equipment is designed and produced in accordance with the requirements of the NEC. Some of this equipment needs conduit seals.

CONDUIT SEALS

The effectiveness of a conduit seal depends on properly filling the sealing fittings with a compound, following instructions furnished with the product. It should be noted that NEC Sections 501-5(c)(4) prohibits splices or taps in sealing fittings and states that no compound is to be used to fill any fittings in which splices or taps are made.

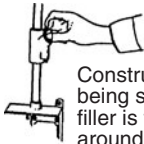
NOTE

The importance of careful workmanship cannot be overemphasized. The safe operation of the entire explosion-proof electrical system depends on properly made, correctly located seals.

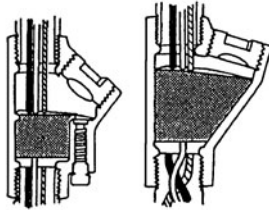
Sealing Compound. One of the most commonly used sealing compounds comes in a package with water in a plastic mixing pouch. The compound is easily mixed with water and then poured. It sets quickly. Setting takes place in 30 minutes, and it becomes hard within 60 to 70 minutes. It hardens to full compression strength within 2 days.

The compound is insoluble in water, is not attacked by petroleum products, and is not softened by heat. It is not injurious to any rubber or plastic wire insulation. In fact, continued cycling tests have shown that successive periods of heat, moisture, and freezing cold have no harmful effects on the seal after it has thoroughly hardened.

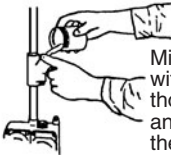
The compound expands slightly in setting; filling the sealing chamber completely. A properly made seal will withstand very high explosion pressure without crumbling or blowing out the seal fittings. See Figures 9-2 and 9-3.



Construct a dam in hub being sure the asbestos filler is tucked carefully around each conductor. Slightly dampen filler for easier use and to prevent shreds from forming leakage channels



Dams are important. Care and caution must be taken. Conductors should be separated and asbestos fiber packed tightly around them.



Mix proper proportion of water with sealing cement. Mix thoroughly in a clean container and pour directly into the sealing unilet.

Depth of sealing compound should be equal to the trade size of conduit. Having a minimum of 5/8 inch thickness. Close immediately after pouring.

FIGURE 9-2. Sealing the hub with a compound to assure explosion-proof operation.

The Mixing Pouch. The two-compartment plastic mixing pouch contains the compound and the precise amount of pure water needed for proper mixing. No mixing or measuring implements are required. A hard squeeze of the water compartment releases the water into the compound compartment. Mixing is completed by kneading the transparent pouch for 1 minute. A corner of the pouch is cut, and the mixture is then poured directly into the sealing fitting. No funnel is required.

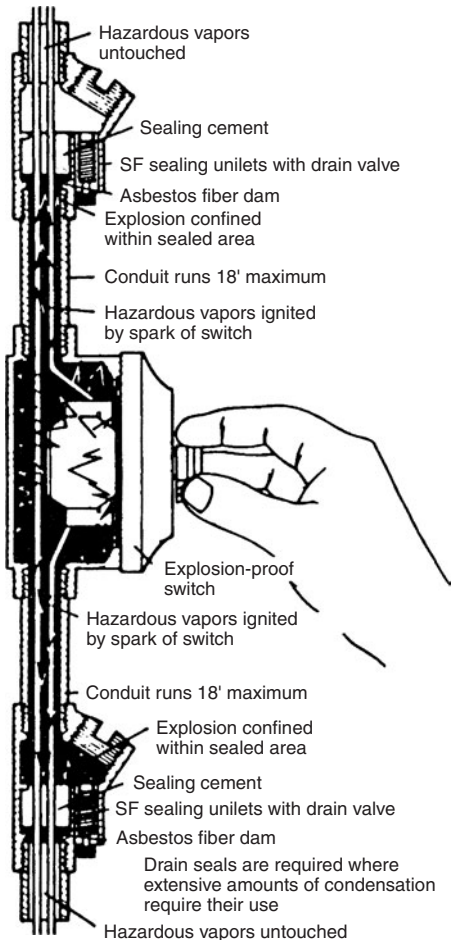


FIGURE 9-3. Sealing process.

HOW TO USE SEALING COMPOUND

1. Using a clean mixing vessel, mix two volumes of compound to each volume of clean, cold water. Warm water makes it set too quickly. Stir immediately and thoroughly.
 2. Pour mixed compound carefully into the sealing fittings, using a funnel for best results. Underwriters Laboratories standard for safety requires the depth of the seal to be equal to or greater than the trade size of the conduit, with a minimum of 5/8 inch. See Figure 9-4.
 3. Close the pouring opening immediately after pouring the compound.
 4. Do not mix more than will be used within 15 minutes because once the compound has started to set, it cannot be thinned without destroying its effectiveness.
 5. Do not mix and pour the compound in freezing temperatures as the water in the mixture will freeze before setting and curing, resulting in an unsafe seal. In addition, freezing water may expand sufficiently to damage the seal fittings.
-



FIGURE 9-4. Carefully pour compound into sealing fitting.

HOW TO USE SEALING FIBERS

To prevent sealing compound in its fluid state from leaking out, use sealing fiber to dam each conduit hub or sealing fitting in horizontal conduit and only the bottom hub in vertical conduit. See Figure 9-5. Figure 9-6 shows an explosion-proof installation for use in a hazardous location.

1. Pack the sealing fiber between and around the conductors in each conduit hub. If the conductors are stiff, temporary wooden wedges inserted between the conductors will be helpful. It is important that the conductors be permanently separated from one another and from sealing fitting walls so that the sealing compound will surround each conductor.
 2. Do not leave shreds of fiber clinging to the inside walls of the sealing chamber or to the conductors. Such shreds, when embedded in the compound, may form leakage channels. Dampening the fiber slightly will make its use easier and will help to prevent the shreds from clinging to the walls and wires.
-

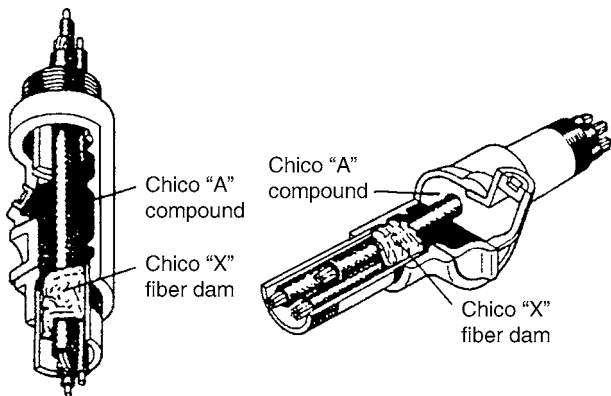


FIGURE 9-5. Sealing fiber used to dam sealing fittings.

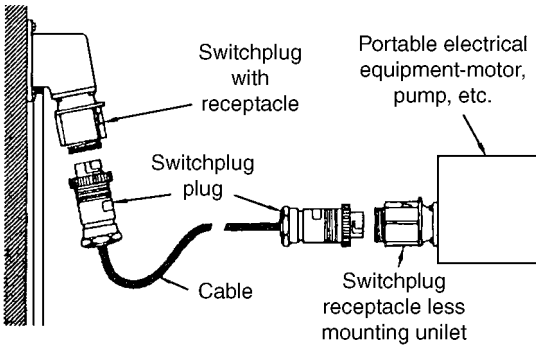


FIGURE 9-6. Explosion-proof receptacle and plug.

3. Be sure that the completed dam is even with the integral bushing. Remember that the dam has to be strong enough and tight enough to prevent a considerable weight of fluid sealing compound from seeping out.
4. If the fitting has a separate damming opening, close the cover before pouring the seal.

ISOLATED GROUND RECEPTACLES

With the increase in the number of pieces of sensitive electronic gear in the home, it has become necessary to improve on the quality of the electrical power these devices lap into. The computer and the videocassette recorder are very sensitive to variations in the power supply, especially to electromagnetic interference (EMI). One of the answers to this problem has been the isolated ground receptacle. See Figure 9-7A. Figure 9-7B shows the installation of ground clamps.

Transmitted electromagnetic radiation waves from other electrical equipment would normally induce interfering ground path noise on the equipment grounding conductor, but the isolated grounding conduit provides an electric noise shield.

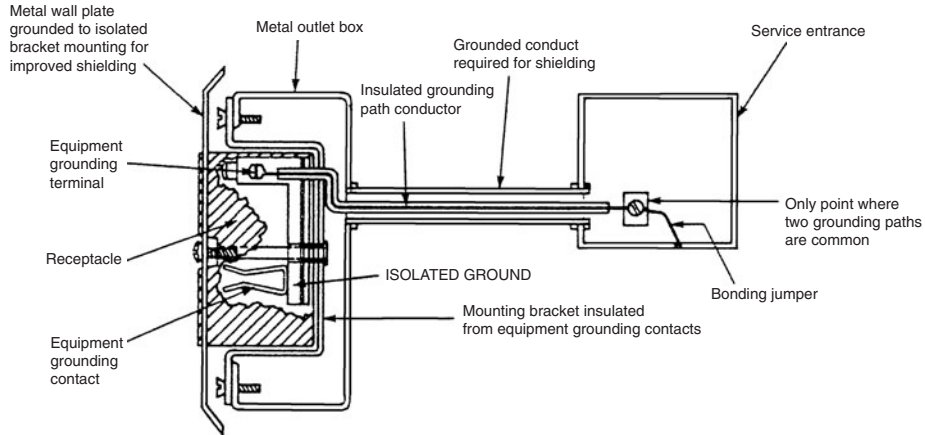


FIGURE 9-7A. Isolated ground receptacle.

NOTE:

Shut off electrical power before beginning installation or repair

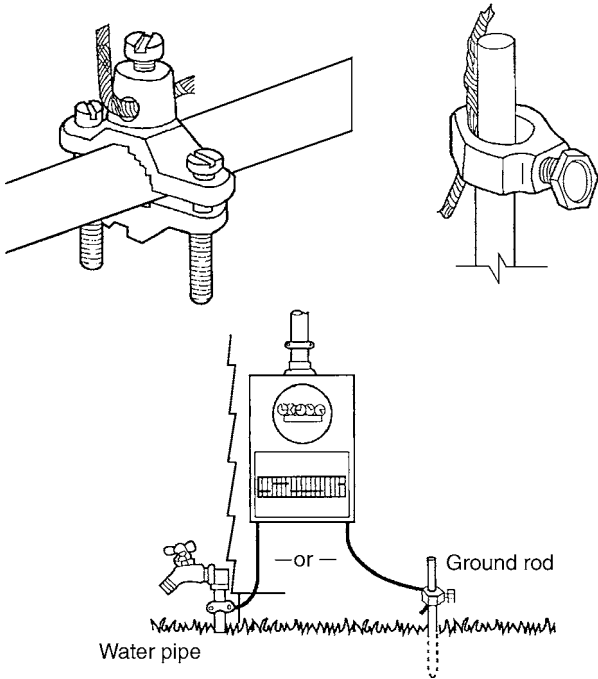


FIGURE 9-7B. Ground clamps.

FLEXIBLE NONMETALLIC CONDUIT

Carflex X-Flex is extra flexible nonmetallic conduit used for applications requiring extra strength and flexibility such as robotics where they are repeatedly flexing their arms. It comes in black only. The conduit is nonconductive, noncorrosive, and resistant to

212 CHAPTER NINE

oil, acid, ozone, and alkali. It is designed for use with standard fittings provided by the manufacturer to make a complete non-metallic system. Carflex X-Flex is lightweight for easier handling, transportation, and installation. See Figure 9-8. It has a smooth interior. This makes it ideal for pulling cable. In addition, since it has no jagged edges it is rated for continuous use at 60°C or 140°F ambient. It can be used for robotics, machine tools, and automatic moving machinery as well as control and motor wiring. Table 9-1 shows the specifications for conduit, which is available from 3/8 to 2 inches.

This type of liquid-tight nonmetallic conduit requires fittings to make it complete. Figure 9-9 shows the straight fittings, which are

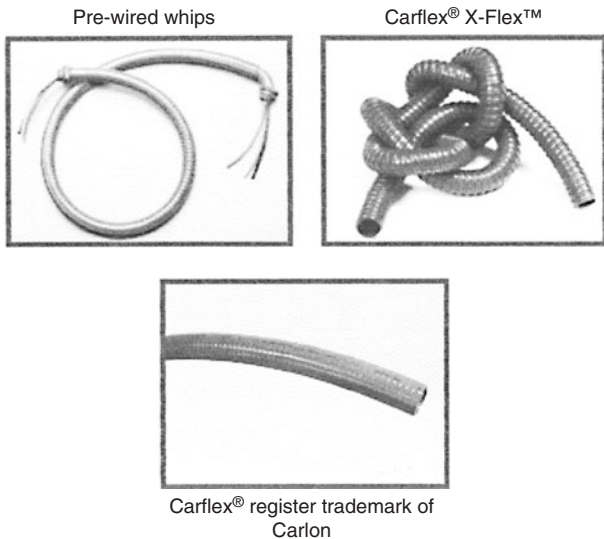


FIGURE 9-8. Carflex X-Flex extra-flexible nonmetallic conduit (Carlon).

TABLE 9-1
Coils of Carflex X-Flex (Available only in black)

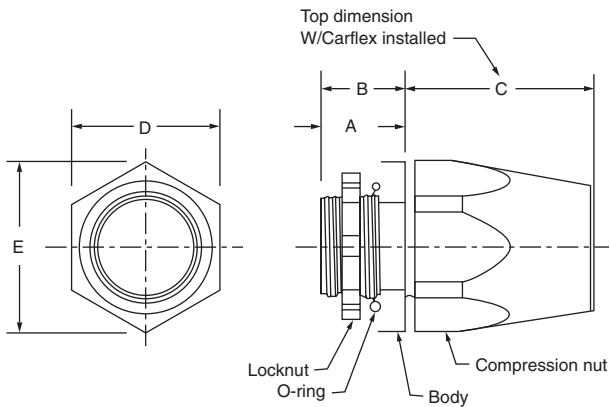
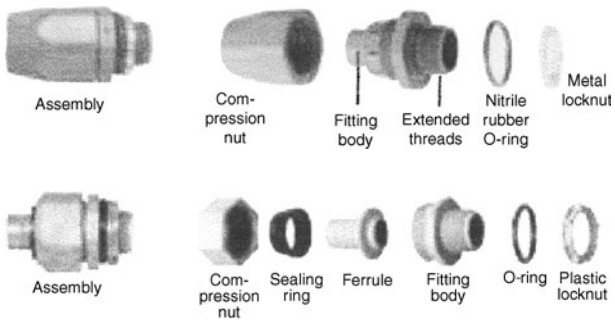
Part No.	Nom Size (in)	Length (ft)	Wt. Per 100 ft (lb)
15104-100	3/8	100	7.4
15105-100	1/2	100	10.7
15107-100	3/4	100	12.4
15108-100	1	100	20.5
15109-100	1 ¹ / ₄	100	31.0
15110-100	1 ¹ / ₂	100	38.0
15111-050	2	50	32.0

also nonconductive, noncorrosive, resistant to oil, acid, ozone, and alkali. They are easy to install and have a nitrile rubber "O" ring for a liquid-tight termination. Fittings can operate up to 115°F (107°C). Table 9-2 shows the specifications for straight fittings.

Figure 9-10 is another illustration of the fittings sometimes needed to complete a system. Note the use of the 90° fitting for the conduit is also nonconductive, noncorrosive, and resists the rugged environments used in many industrial and commercial locations. Specifications for the fitting are shown in Table 9-3.

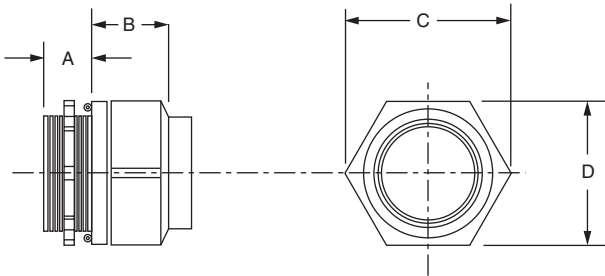
Figure 9-11 shows straight fittings and 90° fittings with a unique design. The simple, one-piece body design of the Carflex fitting requires no disassembly of components for installation. The system is so strong that there is no need for a compression nut. The PVC construction of the fitting and locknut provides protection from water, oil, and dust. Totally nonmetallic, the system is nonconductive and will not corrode or rust as well as operate at temperatures up to 140°F (60°C). Check the specifications of the fittings in Tables 9-4 and 9-5.

The straight omniconnector has been designed for conduit starting with 3/8 inches and running up to 1 inch. It has an all nylon construction and resists salt water, weak acids, gasoline, alcohol, oil, grease, and common solvents. It is suitable for indoor or outdoor use. The black connectors are provided with a nylon



LT43C-CAR, LT43D-NEW, LT43E-NEW, LT43F

FIGURE 9-9A. Straight fittings for Carflex conduits (Courtesy of Carlon).



LT43G, LT43H

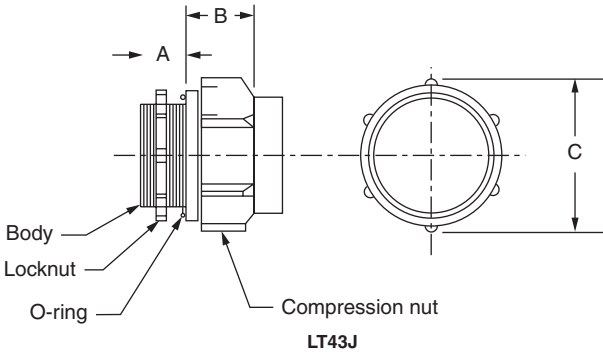


FIGURE 9-9B. Compression nut details (Carlton).

locknut. See Fig. 9-12. Specifications for the omniconnectors are given in Table 9-6. Figure 9-12B shows the features of the 90° connector. Note the two types—one with a sharp 90° and the other with a longer distance taken for the bend. Table 9-7 shows the specifications for the connectors.

TABLE 9-2
Specifications for Straight Fittings (Carlton)

Part No.	Size (in)	Std. Ctn. Qty.	Std. Ctn. Wt. (lb)	A (in)	B (in)	C (in)	D (in)	E (in)	Refer to Image
LT43C-CAR	3/8	15	1.2	0.55	7.5	1.60	1.30	1.40	1.2
LT43D-NEW	1/2	50	4.2	0.56	0.91	1.62	1.30	1.40	1.2
LT43E-NEW	3/4	50	6.6	0.56	0.91	1.88	1.61	1.71	1.2
LT43F	1	25	3.8	0.70	1.00	2.20	1.90	2.04	1.2
LT43G	1 ¹ / ₄	5	1.5	0.71	1.16	2.50	2.17	—	3.4
LT43H	1 ¹ / ₂	5	1.8	0.75	1.36	2.78	2.43	—	3.4
LT43I	2	5	2.5	1.00	1.45	3.33	—	—	3.4

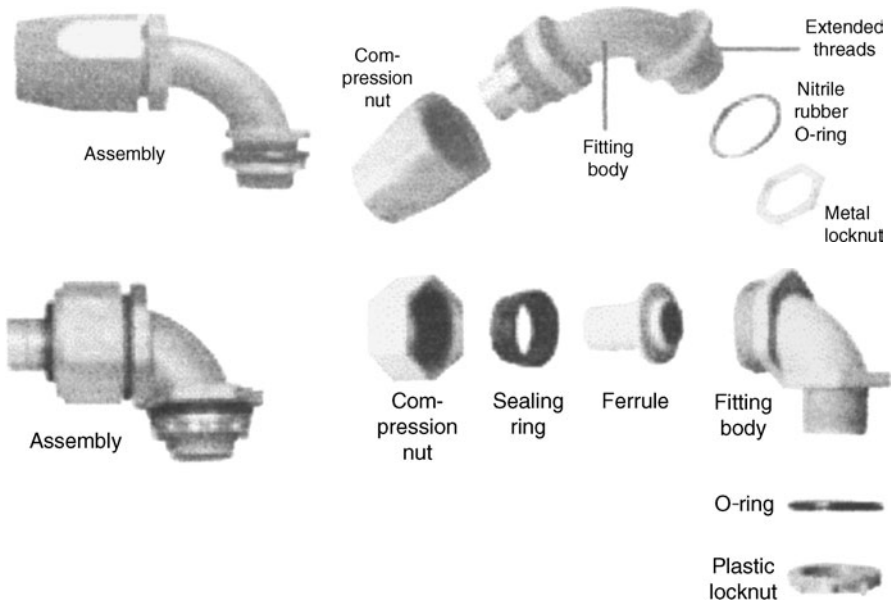
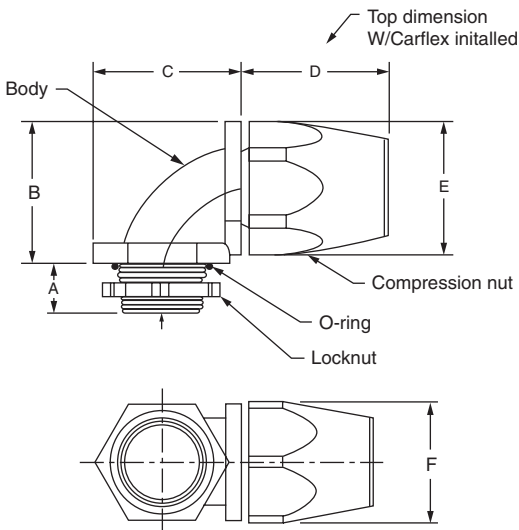


FIGURE 9-10. Straight fittings for use with Carflex conduit and Carflex X-Flex conduit (Carlon).



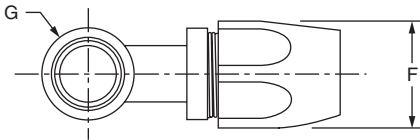
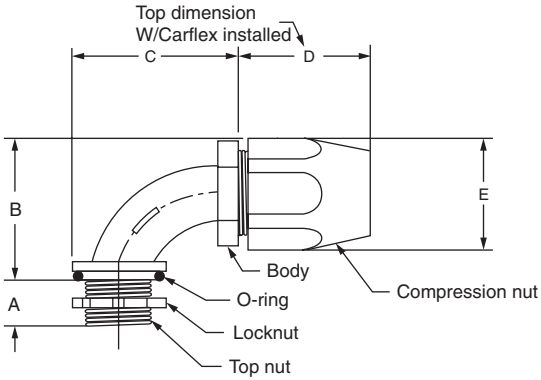
LT20C-CAR, LT20F-NEW

FIGURE 9-10. (Continued)

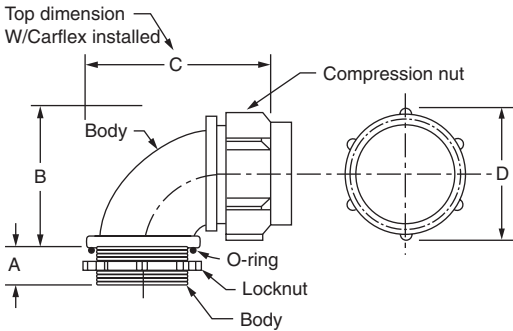
INSTALLATION OF CARFLEX FITTINGS

Installation of Carflex fittings may require some simple steps in their process of becoming a watertight system. For LT34C-CAR, LT43F thru J, LT20C-Car, LT20F thru J, there are a few suggestions: Cut the end of the Carflex conduit or Carflex X-Flex tubing square.

- Install compression nut and sealing gland ring over the end of the conduit or tubing.



LT20D-NEW, LT20E-NEW



LT20G, LT20H, LT 20J

FIGURE 9-10. (Continued)

TABLE 9-3
Specifications for 90° Fittings (Carlton)

Part No.	Size (in)	Std. Ctn. Qty.	Std. Ctn. Wt. (lb)	A (in)	B (in)	C (in)	D (in)	E (in)	F (in)	G (in)	Refer to Image
LT20C-CAR	3/8	15	1.6	0.56	1.44	1.44	1.56	1.39	1.26		3.4
LT20D-NEW	1/2	50	4.9	0.56	1.76	2.05	1.62	1.40	1.30	1.15	1.2
LT20E-NEW	3/4	50	8.8	0.56	2.04	2.35	1.88	1.71	1.61	1.50	1.2
LT20F	1	25	6.0	0.70	2.01	2.01	2.26	2.04	1.90	—	3.4
LT20G	1 ¹ / ₄	5	1.9	0.75	2.50	3.55	2.48	—	—	—	3.4
LT20H	1 ¹ / ₂	5	2.2	0.75	2.80	3.98	2.77	—	—	—	3.4
LT20I	2	5	3.0	0.94	3.48	4.56	3.33	—	—	—	3.4

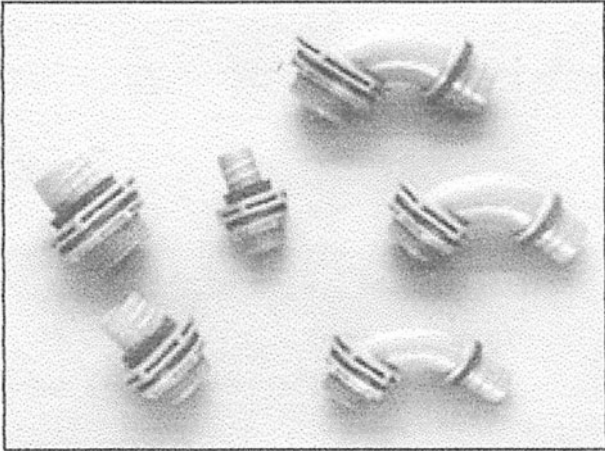


FIGURE 9-11. One-piece liquid tight nonmetallic fittings (Carlon).

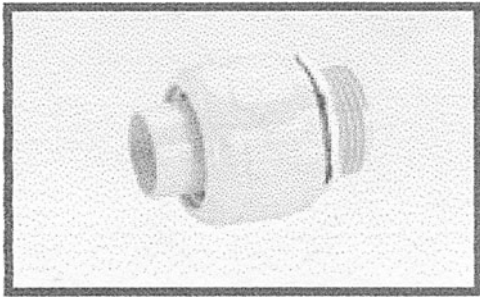
- Insert the ferrule end of the fitting into the conduit using a clockwise twisting action.
- Screw fitting body into compression nut.
- When installation is complete, use a wrench, tighten compression nut one quarter turn past hand-tight. Do not overtighten the fitting.

TABLE 9-4
Straight Fittings for Nonmetallic Liquid-Tight Conduit (Carlon)

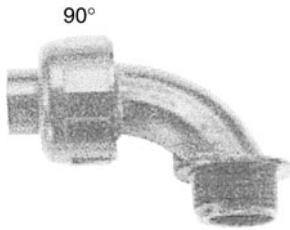
Part No.	Trade Size (in)	Std. Ctn. Qty.	Std. Ctn. Wt. (lb)	A (in)	D (in)	E (in)
LN43DA	7/8-14 NPT	100	2.0	0.56	1.34	1.19
LN43EA	7/8-14 NPT	50	3.2	0.56	1.63	1.44
LN43FA	1-11 1/2 NPT	25	4.8	0.69	1.99	1.75

TABLE 9-5
90° Fittings for Carflex (Carlton)

Part No.	Trade Size (in)	Std. Ctn. Qty.	Std. Ctn. Wt. (lb)	Thread Size	A (in)	B (in)	C (in)	D (in)	E (in)
LN20DA	1/2-14 NPT	100	4.3	1/2-14 NPT	0.56	1.50	1.99	1.34	1.19
LN20EA	3/4-14 NPT	50	6.6	3/4-14 NPT	0.56	1.73	2.25	1.63	1.44
LN20FA	1-11 ¹ / ₂ NPT	25	9.5	1-11 ¹ / ₂ NPT	0.69	1.86	2.58	1.99	1.75



A



B

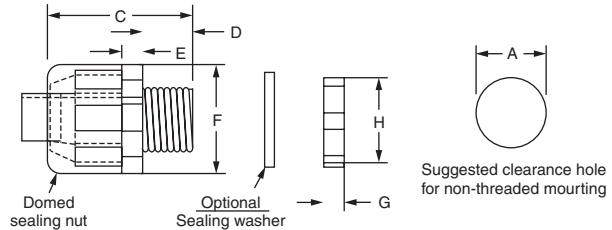
FIGURE 9-12. (A) Omniconnectors. (B) 90° omniconnector for Carflex (Carlton).

- To prevent damage to conductors, conduit, and fittings do not twist Carflex during installation.

There is a little difference in the procedure for LT43D-new, LT43E-new, LT20D-new, and LT20E-new.

- Cut the end of the Carflex conduit or Carflex X-Flex tubing square.
- Install compression nut over the end of the conduit or tubing.

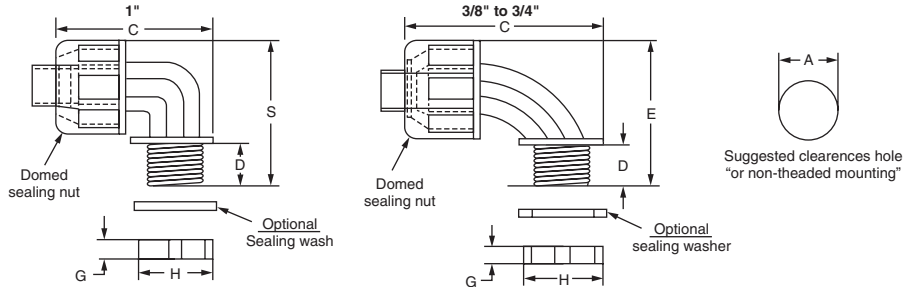
TABLE 9-6
Specifications for Omni Connectors (Carlton)



Size in (in.)	Part No. Black	Part No. Gray*	Description	Body and Sealing Unit					Locking Nut		Std. Ctn. Qty.
				A	C	D	E	F	G	H	
				Clearance Hole in (mm)	Max O.A. Length in (mm)	Thread Length in (mm)	Wrenching Nut Thickness in (mm)	Wrenching Flats in (mm)	Thickness in (mm)	Wrenching Flats in (mm)	
3/8	LT38	LT38G	Straight L/T fitting	0.875 (22.2)	2.000 (50.8)	0.625 (15.9)	0.250 (6.3)	1.328 (33.7)	0.266 (6.7)	1.062 (26.9)	50
1/2	LT50	LT50G	Straight L/T fitting	0.875 (22.2)	2.000 (50.8)	0.625 (15.9)	0.250 (6.3)	1.328 (33.7)	0.266 (6.7)	1.062 (26.9)	50
3/4	LT75	LT75G	Straight L/T fitting	1.109 (28.2)	2.031 (51.6)	0.625 (15.9)	0.250 (6.3)	1.562 (39.7)	0.266 (6.7)	1.312 (33.3)	25
1	LT100	LT100G	Straight L/T fitting	1.375 (34.9)	2.250 (57.1)	0.781 (19.8)	0.250 (6.3)	1.875 (47.6)	0.266 (6.7)	1.625 (41.3)	20

*Gray connectors provided with assembled o-ring and metal locknuts. Black connectors provided with nylon locknuts only.

TABLE 9-7
Specifications for 90° Connectors (Carlton)



Size in (in.)	Part No. Black	Part No. Gray	Description	Body and Sealing Unit				Locking Nut		Std. Ctn. Qty.
				A	B	C	D	G	H	
				Clearance Hole in (mm)	Max O.A. Height in (mm)	Max O.A. Length in (mm)	Thread Length in (mm)	Thickness in (mm)	Wrenching Flats in (mm)	
3/8	LT938	LT938G	90 degree L/T fitting	0.875 (22.2)	1.98 (50.3)	2.91 (73.9)	0.52 (13.2)	0.27 (6.8)	1.06 (26.9)	25
1/2	LT950	LT950G	90 degree L/T fitting	0.875 (22.2)	1.98 (50.3)	2.91 (73.9)	0.52 (13.2)	0.27 (6.8)	1.06 (26.9)	25
2/4	LT975	LT975G	90 degree L/T fitting	1.109 (28.2)	2.29 (58.2)	3.17 (80.5)	0.52 (13.2)	0.27 (6.8)	1.31 (33.3)	20
1	LT9100	LT9100G	90 degree L/T fitting	1.375 (34.9)	2.84 (72.1)	3.18 (80.8)	0.78 (19.8)	0.27 (6.8)	1.61 (40.9)	10

TABLE 9-8
Carflex Liquid-Tight Conduit Technical Information (Carlon)

Size of Conduit or Tubing		Radius to Center of Conduit of Tubing	
in	Metric Desgr.	in	mm
3/8	14	4	101.6
1/2	16	4	101.6
3/4	21	4 1/2	114.3
1	27	5 3/4	146.0
1 1/4	35	7 1/4	184.1
1 1/2	41	8 1/4	209.5
2	53	9 1/2	241.3

- Insert the ferrule end of the fitting into the conduit using a clockwise twisting action (be sure the conduit is fully inserted to the bottom of the fitting shoulder).
- Screw compression nut onto fitting body.
- Use a wrench and tighten compression nut one full turn past hand-tight. Do not overtighten fitting.
- To prevent damage to conductors, conduit, and fittings do not twist Carflex during installation.

Table 9-8 shows the size of the conductor or tubing in inches and in metric or mm.

- There should be no more than the equivalent of four 90° bends in the conduit and fittings.
- The radius of the curve of the center of the conduit or tubing shall not be less than that shown in Table 9-8.

Carflex watertight, nonmetallic conduit is UL listed for use as indicated in Article 356 of the NEC. It can be used for cellular metal floor raceways, connections to cabinets, and wall outlets.

- Class I, Div. 2, hazardous locations
- Class II, Div. 1, hazardous locations
- Class III, Div. 1, hazardous locations
- Computer room raised floor
- Concealed locations

- Intrinsically safe systems
- Lighting fixtures, connection to electric discharge fixture
- Nonmetallic boxes
- Recreational vehicle (RV) engine generator
- Swimming pool pump motor
- Tap conductors (fixture whips)
- Under-floor raceway, connection to cabinets, and wall outlets
- Wire-way, extensions, from wire-ways, and wiring methods
 - Agricultural buildings, flexible connections
 - Electric signs, 600 volts, nominal, or less
 - Electric signs, over 600 volts
 - Floating buildings
 - Marinas and boatyards
 - Service-entrance conductors
- Wiring on buildings, outside branch circuits and feeders
- Direct-burial applications.

Carflex is also available in prewired liquid-tight whips. They are complete so the electrician does not have to spend time looking for components. Since they are available, ready to install, they become very handy when installing swimming pool motors, hot tub spas, air conditioners, pumps, and outdoor lighting. The unit comes complete with moisture tight conduit, wire, one straight fitting and one 90° fitting. The assemblies are available in 1/2- and 3/4-inch diameters and 4- and 6-foot lengths. They are also available in special configurations including different fitting combinations, wire types and sizes, and metal fitting variations.

This page intentionally left blank

Programmable Controllers

Electricians who work in factories are called on to install and service programmable controllers. Programmable logic controllers (PLC) are electronic devices using integrated circuits and semiconductors for remote switching. Since they are made of solid-state electronics, they have no moving parts. These units have been very successful in automating machinery and working for long periods without maintenance or attention of any kind. They have largely replaced relays as the workhorses of industrial controls.

In many locations and for many jobs the programmable controller (PLC) is preferred over the robot. It is less expensive than the robot and can be relied on to do a specific job accurately and repeatedly without attention. The PLC manufacturer supplies installation and programming instructions for each type of PLC. Standard electrical wiring practices apply to the installation of these units. However, there are some particular concerns in troubleshooting these units. Since they use integrated circuits and semiconductors in their design, they are subject to the same problems as these devices.

The *output circuit* usually consists of a triac (in some instances, a silicon controlled rectifier). The triac is sensitive to applied voltages, current, and internal power dissipation and is limited to a maximum peak off-state voltage. Exceeding this alternating current (AC) peak causes a dielectric-type breakdown that may result in a permanent short-circuit failure. Often a semiconductor device,

a varistor (THY), is placed across the triac to limit the peak voltage to some value below the maximum rating; in other cases, an resistor-capacitor (RC) snubber (made up of a RC filter circuit) alone may adequately protect the triac from excess voltage. The direct current (DC) output consists of a power transistor protected against inductive loads by a diode.

Well-designed *input circuits* are less susceptible to damage than are output circuits using a triac. However, they do respond to transients (line surges) and noise on the input line. Special precautions must be taken to reduce the sources of interference. If an input circuit is damaged, the circuits can fail, and the control circuit senses it. The various outputs then respond accordingly and, depending on the application of the system, could place the system in a hazardous condition.

In situations involving such applications, an external means of monitoring the circuit inputs should be provided or redundant inputs should be used. Figure 10-1 shows a block diagram of a typical programmable controller system with its inputs and outputs.

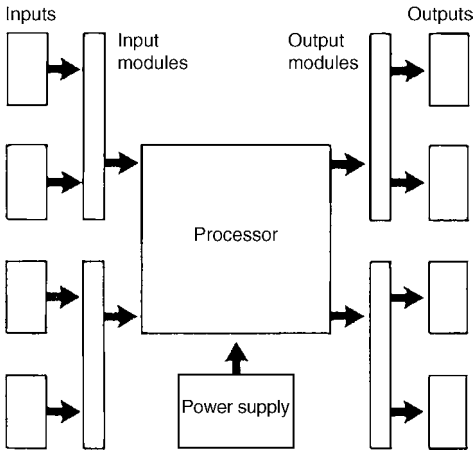


FIGURE 10-1 Block diagram of a programmable logic controller system.

SOURCES OF DAMAGE TO SEMICONDUCTORS

Semiconductors can be damaged by temperature and certain atmospheric contaminants, by shock and vibration, and by noise.

TEMPERATURE

Excessive temperature can cause semiconductor materials to malfunction. The failure rate increases rapidly with increase in temperature. Even when stored, the devices are subject to problems caused by excessive temperature. Elevated ambient temperature can also cause intermittent problems that disappear when the temperature is lowered again. Airflow should be maintained around semiconductors to keep temperatures within the limits stated for the device.

SHOCK AND VIBRATION

Semiconductor-type circuits are generally not very susceptible to shock and vibration. However, it is possible that shock and vibration can cause problems if there are loose connections or worn insulation on wiring.

NOISE

Noise is generated by a number of sources in an industrial setting. Noise is defined here as electrical energy of random amounts and frequencies that adversely affects the functioning of electronic circuits. Most noise-caused malfunctions are of the nuisance type, causing operating errors, but some can result in hazardous machine operation.

Noise enters the control circuits by a number of different means—through the input lines, the output lines, or the power supply lines. It may be coupled into the lines electrostatically through capacitance between these lines and the lines carrying the noise signals. In most industrial areas, a high potential is usually required, or long, closely spaced conductors are necessary. Noise caused by magnetic coupling is also quite common when control lines are close to lines carrying large current. The signals in this

232 CHAPTER TEN

case are coupled through mutual inductances, such as in a transformer. Electrostatic and magnetic noise may also be directly coupled into the control logic circuit. Programmable controllers have been designed to ignore problems created by noise. However, it is impossible to design for all situations. Therefore, filters, shielding circuitry, and insensitive circuitry have been placed in the design of the controllers for eliminating noise problems. It is also a good practice to make sure that no two PCs use the same grounding wire.

Wiring for Telephone Installation

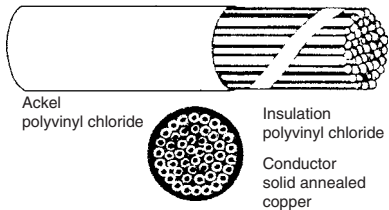
Inasmuch as the electrician is permitted to do telephone wiring of houses and other locations, the apprentice should be familiar with the types of wires used. Figure 11-1 shows different types of telephone wiring.

Station Wire. Station wire is designed for inside-outside use in station installations from the station protector to the telephone terminal block. It is designated SW with individual conductors and station wire twisted (SWT) with paired conductors that are twisted and then encased in polyvinyl chloride (PVC). The PVC jacket is tough, and weather and flame-resistant. It provides protection when exposed to weather conditions and inside cleaning products such as detergents, waxes, oils, and most solvents. The wire is installed with a stapling gun. See Figure 11-2.

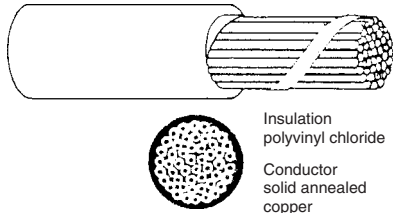
Insulated conductors are twisted together in two-, three- or four-conductor configurations and then jacketed. The PVC jacketed wire is available in beige or olive. It is packaged in 500-foot rolls or coils in a box.

PIC Building Systems inside Wiring Cables. Positive identification cables (PIC) are designed for inside use. The conductor is solid copper rated at 24 AWG. The main purpose for this type of semirigid polyvinyl cable is for use in private branch exchanges (PBX) and private attended branch exchanges (PABX) systems. The conductor insulation is color-coded with the telephone industry's standard colors. Each insulated conductor is band-stripped at

Fluoropolymer plenum telephone cables
ICPIP paired conductors

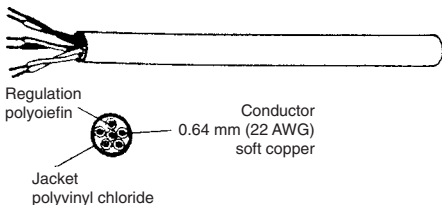


PIC building systems inside wiring cables



Classified by Underwriters Laboratories, Inc. as to smoke and frame characteristics only in accordance with section 800-3(d) of the National Electrical Code (NEC)

SWT paired conductors



SWTP paired conductors

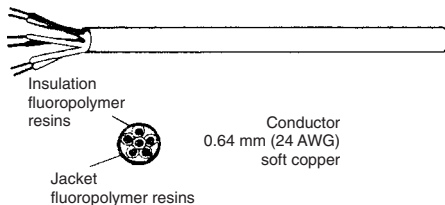


FIGURE 11-1. Types of telephone wire.

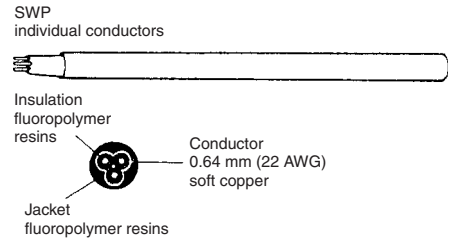
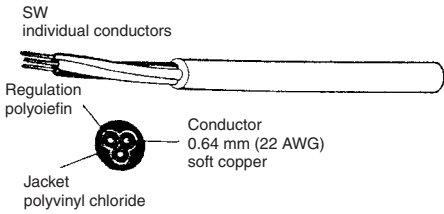


FIGURE 11-1. (Continued)

approximately 1-inch intervals with the color of the mating insulated conductor of the assembled pair. The individual conductors are mated in accordance with PI band stripes and twisted together into pairs. The pairs are assembled into a cylindrical core or into units and then formed into a core. If the cable contains more than 25 pairs, the pairs are molded into a 25-pair color group, each color group bound with a single color binder. (100-pair cable is available in either the standard makeup of four 25-pair units or five 20-pair units.) The jacket is flame-retardant and abrasion-resistant PVC. Jackets are available in olive or beige. Table 11-1.

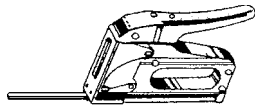


FIGURE 11-2. Staple gun used to attach station wire to wooden moldings or walls.

TABLE 11-1
Twisted-Pair Cable Color Code

Pair Codes for Pairs 1 to 25 within Binders			
Pair No.	Tip Color	Ring Color	Abbreviation
1	White	Blue	W-BL
2	White	Orange	W-O
3	White	Green	W-G
4	White	Brown	W-BR
5	White	Slate	W-S
6	Red	Blue	R-BL
7	Red	Orange	R-O
8	Red	Green	R-G
9	Red	Brown	R-BR
10	Red	Slate	R-S
11	Black	Blue	BK-BL
12	Black	Orange	BK-O
13	Black	Green	BK-G
14	Black	Brown	BK-BR
15	Black	Slate	BK-S
16	Yellow	Blue	Y-BL
17	Yellow	Orange	Y-O
18	Yellow	Green	Y-G
19	Yellow	Brown	Y-BR
20	Yellow	Slate	Y-S
21	Violet	Blue	V-BL

Station Wire Plenum, Individual Conductors. This type of wire is designed for use in air ducts and plenums without metal conduit in PBX and PABX, key system, and telephone instrument communications systems. (Key telephone systems [KTS], which can have 50 or more associated telephones, are similar to PBX systems. KTS has mostly outside calls. It is little used for internal calls. A PBX has a larger share of internal calls.) SWP is used in installations that require less station wiring or shorter direct runs, and it reduces station installation costs. It has a fully annealed, solid bare-copper conductor that is 22 AWG in size. Insulation is a fluoropolymer resin.

A two-conductor station wire has one conductor insulated with red and the other with green. A three-conductor wire has the third conductor insulated with yellow; in a four-conductor wire; the fourth conductor is black. The four-wire quad is made by spiraling the four wires together into the star quad configuration. The red and green conductors are placed diagonally across from each other to form pair 1, and the yellow and black conductors form pair 2. The insulated conductors are twisted in a two-, three- or four-conductor configuration and then jacketed. The jacket is made of fluoropolymer resin and is uncolored or olive in color. It is packaged in 500-foot coils in cartons. The cartons have a knock-out center to permit dispensing the wire directly from the carton.

Station Wire Twisted Plenum, Paired Conductors. This station wire is designed for use in air ducts and plenums without conduit in PBX, PABX, key system, and telephone instrument communication systems. It too is made of 22 AWG fully annealed, solid bare copper wire. Twisted pair color code is shown in Table 11-1. It varies slightly from the individual-conductors cable inasmuch as it has a color code for the four pairs:

1. Pair 1 is formed by a white and blue (tip) and a blue (ring) wire.
2. Pair 2 by a white and orange (tip) and an orange (ring) wire.
3. Pair 3 by a white and green (tip) and a green (ring) wire.
4. Pair 4 by a white and brown (tip) and a brown (ring) wire.

The tip (white) conductor insulation is band-stripped with the color of its mate to provide positive identification of each conductor.

ICPIP Pair Conductors. The individual conductors are mated in accordance with positive identification band stripes and then

TABLE 11-2
Binder Color Code

Binder No.	Binder Color	Abbreviation	Pairs in Binder
1	Blue-white	BL-W	1-25
2	Orange-white	O-W	26-50
3	Green-white	G-W	51-75
4	Brown-white	BR-W	76-100
5	Slate-white	S-W	101-125
6	Blue-red	BL-R	126-150
7	Orange-red	O-R	151-175
8	Green-red	G-R	176-200
9	Brown-red	BR-R	201-225
10	Slate-red	S-R	226-250
11	Blue-black	BL-BK	251-275
12	Orange-black	O-BK	276-300
13	Green-black	G-BK	301-325
14	Brown-black	BR-BK	326-350
15	Slate-black	S-BK	351-375
16	Blue-yellow	BL-Y	376-400
17	Orange-yellow	O-Y	401-425
18	Green-yellow	G-Y	426-450
19	Brown-yellow	BR-Y	451-475
20	Slate-yellow	S-Y	476-500
21	Blue-violet	BL-V	501-525
22	Orange-violet	O-V	526-550
23	Green-violet	G-V	551-575
24	Brown-violet	BR-V	576-600

twisted together into pairs. The pairs are assembled into a cylindrical core or into units and then formed into a core. If the cable contains more than 25 pairs, the pairs are coded into a 25-pair color group, each color group is bound with a unique color binder. See Table 11-2 and Table 11-3. The 100-pair cable is available in either the standard makeup of four 25-pair units or five 20-pair units.

COMMUNICATIONS WIRING

The electrician is generally expected to be able to install communications cable in a new building or in retrofits. Keeping the cable from damage and locating its pathway is important to maintaining

TABLE 11-3
Fiber-Optic Color Code Reference

Fiber No.	Blue Tube	Orange Tube	Green Tube	Brown Tube	Slate Tube	White Tube	Red Tube	Black Tube	Yellow Tube	Violet Tube	Rose Tube
Blue strand	1	13	25	37	49	61	73	85	97	109	121
Orange strand	2	14	26	38	50	62	74	86	98	110	122
Green strand	3	15	27	39	51	63	75	87	99	111	123
Brown strand	4	16	28	40	52	64	76	88	100	112	124
Slate strand	5	17	29	41	53	65	77	89	101	113	125
White strand	6	18	30	42	54	66	78	90	102	114	126
Red strand	7	19	31	43	55	67	79	91	103	115	127
Black strand	8	20	32	44	56	68	80	92	104	116	128
Yellow strand	9	21	33	45	57	69	81	93	105	117	129
Violet strand	10	22	34	46	58	70	82	94	106	118	130
Rose strand	11	23	35	47	59	71	83	95	107	119	131
Aqua strand	12	24	36	48	60	72	84	96	108	120	132

240 CHAPTER ELEVEN

the integrity of the cable and the signals it handles. Termination assignments for pairs of wire in the cable are set by various standards adapted by the telecommunications industry. Those shown here are typical of pin/pair assignments. Most modern buildings and retrofitted older buildings have a need for communication wiring that is terminated with various jacks and plugs. These jacks and plugs have various pin/pair assignments for terminating the wire according to the standard being used to guide the pin connections. The following illustrations indicate which colors are installed where in these jacks and plugs.

Commercial Building Telecommunications Cable Standard ANSI/TIA/EIA-568-A was produced by the Telecommunications Industry Association (TIA). See Figure 11-3.

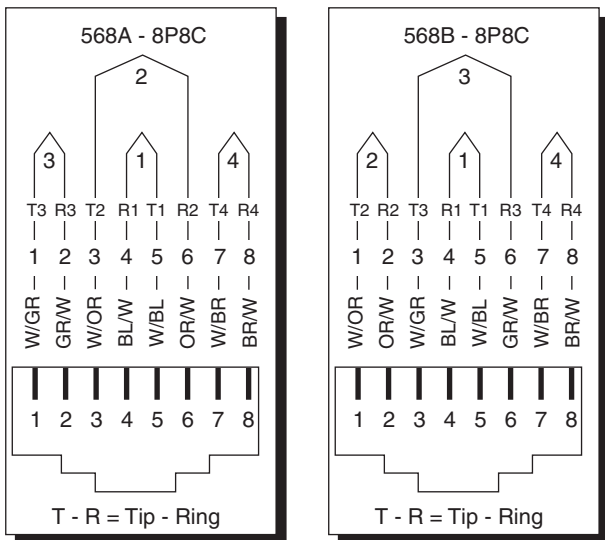


FIGURE 11-3. 568A/568/B pin/pair assignments. (Greenlee)

A modular plug is usually clear plastic and used on the end of patch cables. The connector uses insulation displacement to make contact with the conductors in the wire. No soldering and no twist nuts or twist-and-tape is required. The wire is crimped on the end of the cable, from which the jacket has been removed, but the insulation on the conductors is left intact. The modular plug can come in many varieties from a 4- to a 10-position handset. The plug used for residential phones is the 6-position, 4 or 6 conductor known in the trade as RJ11. The plug used for category 5 patch cables is the 8-position 8 conductor known as RJ45.

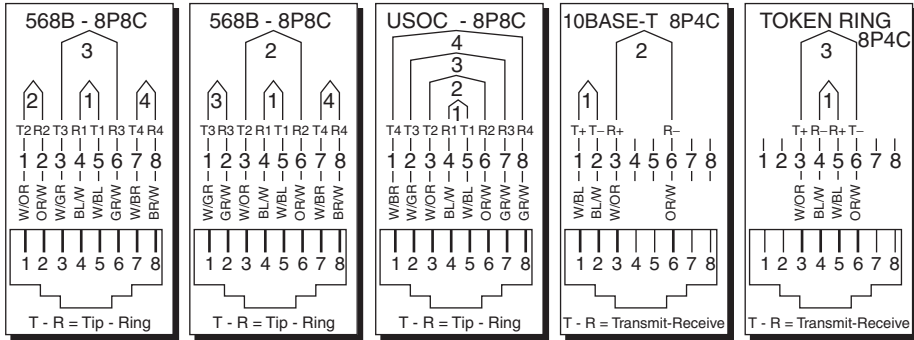
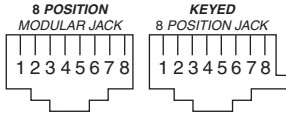
A patch panel is a rack-mount panel that is used in telecommunications closets as a point of cross connect. Typically, patch panels with the 110-style (insulation displacement) have connections on the back of the panel and modular jacks on the front. Specific conductors on the cable are assigned to specific pins on the modular jack, 110 connectors, and TELCO connectors. See Figures 11-4 to 11-7.

Horizontal cabling, also known as station cabling, consists of individual cables that run from the workstation outlets or wall plates back to the horizontal cross-connect or patch panel in the telecommunications closet. Keep in mind that if horizontal cabling is improperly installed or mistreated, there is the possibility of cross talk being produced by the untwisted cable. Cross talk occurs when an induced signal from a nearby or parallel transmitting pair imposes an unwanted conversation on the nearby circuit. Be careful with the cable tie. Do not pull the tie too tight, or it will crush the cable, deforming the pair twists and changing the performance characteristics of the cable. If pairs are untwisted too much at the termination point (not more than 1/2 inch), then attenuation and cross-talk performance characteristics of the cable are affected.

FIBER OPTICS

Fiber-optic communications is moving forward on both land and sea. For example, the latest fiber-optic submarine cables have amplifiers placed approximately 30 miles apart. The amplifiers are made by exciting a strand of coiled-up glass fibers containing a small percentage of the element erbium. An external, electrically powered laser beam bathes the fiber. The excited erbium atoms release their energy in step with the oncoming signal, sending the signal on its way stronger than before. Such optical amplifiers have

568B Wiring
is identical to
AT & T, WECCO, and
BELL 258A wiring



TIA/EIA STANDARD WIRING PATTERNS

FIGURE 11-4. Modular jack pin/pair assignments.

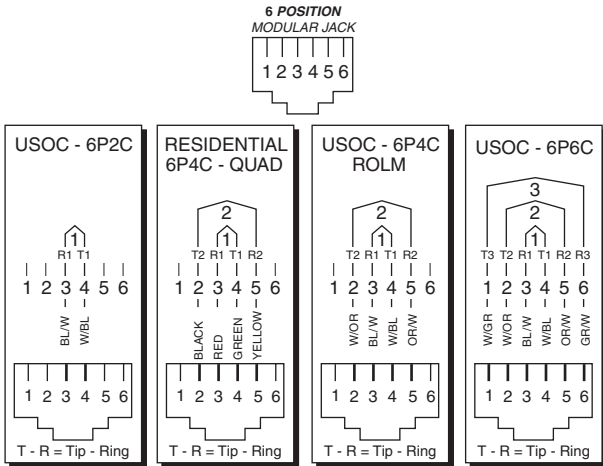


FIGURE 11-5. Modular jack pin/pair assignments.

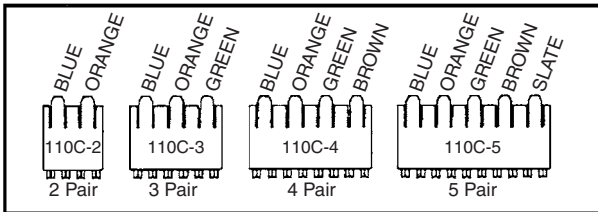


FIGURE 11-6. Connector pair assignments. (Greenlee-Textron)

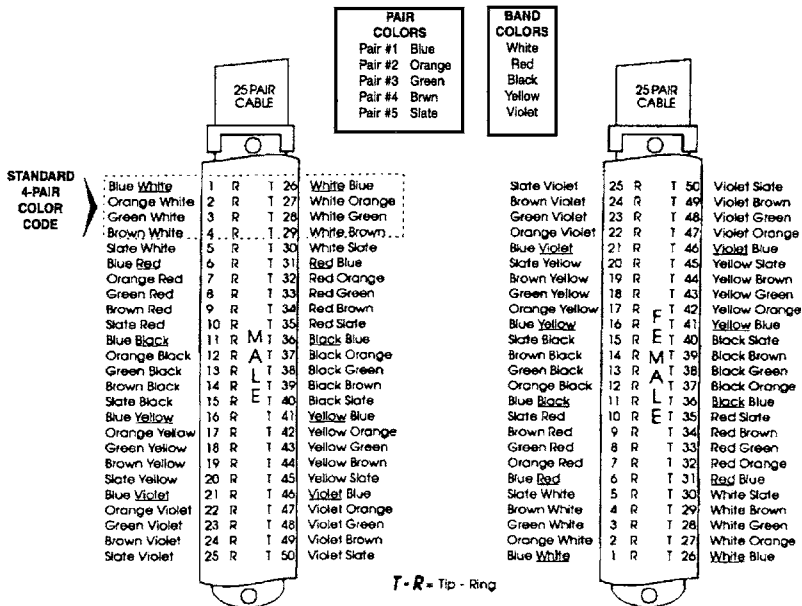


FIGURE 11-7. RJ25 Jelco connector pin/pair assignments. (Greenlee)

been in use since the early 1990s, replacing electronic amplifiers that were much slower.

It has now been learned that independent streams of information can be sent through a single fiber by using a different color for each channel. Researchers at Lucent Technology Bell Labs have announced that they have pushed 1.6 trillion bits, or terabits, of information through a single fiber. This was accomplished by splitting the light beam into 40 different colors, sufficient for sending 25 million conversations or 200,000 video signals at the same time. One cable may contain a dozen such fibers. Transmission speed has been doubling every year, and next year it is expected to double again and the year after that. See Table 11-1.

Fiber-optic cables are expensive when it comes to placing them under the sea or burying them underground, in just one project, Tyco paid US\$1 billion to add two new cables between Japan and the United States (West Coast). Project Oxygen, a rival network, raised US\$10 billion for a 100,000-mile network completed in 2003. There are 96 landing points in 75 countries and territories in the 100,000 miles of cable. An industry analyst who tracks the industry figures says, US\$31.8 billion was spent between 1999 and 2004.

Many schools and universities and some homes are being wired with fiber optics for future use. Electricians are being called on to make sure the cable is properly installed. That means it must be installed according to the local codes, and most of the local codes are based on the National Electrical Code (NEC). Article 770 of the NEC deals with the proper installation of fiber-optic cables and raceways. The main concern of the Code is the spread of fire and products of combustion. Ducts, plenums, and other air-handling spaces must be carefully taken into consideration when installation of the cable is proposed in any type of building. Most people will not have fiber-optic lines directly to their homes because of the installation cost.

National Electrical Code. Optical fiber cables and raceways are covered by the NEC in Article 770. The provisions of this article are in reference to optical fibers and raceways, but do not cover the construction of optical fiber cables or raceways. The circuits and equipment must comply with 770-2 (a) (b). Ducts, plenums, and other air-handling spaces are covered in Section 300-22, and 300-21 deals with the spread of fire or products of combustion as

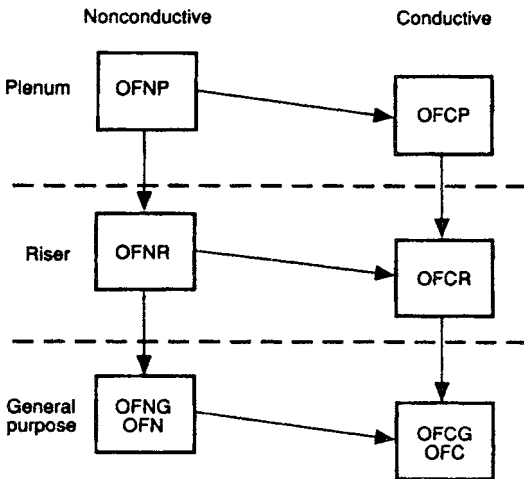
246 CHAPTER ELEVEN

related to optical fiber cables in raceways. A study of the information in 770-53 of the Code deals with the installation of the cable in raceways. See Table 11-4.

Cables. *Optical fiber cables* are made up of devices connected in a way that makes it possible to transmit light very efficiently through

TABLE 11-4
Cable Substitutions

Cable Type	Permitted Substitutions
OFNP	None
OFCP	OFNP
OFNR	OFNP
OFCR	OFNP, OFCP, OFNR
OFNG, OFN	OFNP, OFNR
OFCG, OFC	OFNP, OFCP, OFNR, OFCR, OFNG, OFN



[A] → **[B]** Cable A may be used in place of cable B.

them for the purposes of control, signaling, and communications. There are three types of optical fiber cables:

- *Nonconductive.* These cables contain no metallic members or other electrically conductive materials.
- *Conductive.* These are cables that contain non-current-carrying conductive members such as metallic strength members and metallic vapor barriers.
- *Composite.* Cables that contain both optical fibers and current-carrying electrical conductors are permitted to contain non-current-carrying conductive members such as metallic strength members and metallic vapor barriers.
 - Composite optical fiber cables are classified as *electrical cables* in accordance with the type of electrical conductors contained therein.

Raceways. With one exception, a raceway system designed for enclosing and routing only nonconductive optical cables must be of a type permitted in Chap. 3 of the Code and installed in accordance with Chap. 3. Cables are classified according to types. The use of letters to designate the cables makes it easier to refer to them accurately and with a minimum of space. For instance, Table 770-53 lists the types. See Table 11-5.

Cable Markings. Cables marked nonconductive optical fiber plenum (OFNP) and conductive optical fiber plenum OFCP, can be used in ducts, plenums, and other space carrying for environmental air. The cables must have adequate fire-resistant and low

TABLE 11-5
Cable Substitutions or Table 770.53 of NEC

Table 770.53 Cable Substitutions	
Cable Type	Permitted Substitutions
OFNP	None
OFCP	OFNP
OFNR	OFNP
OFCR	OFNP, OFCP, OFNR
OFNG, OFN	OFNP, OFNR
OFNG, OFC	OFNP, OFCP, OFNR, OFCR, OFNG, OFN

smoke-producing characteristics. Types OFNR and OFCR are designed for use in risers. They are suitable for use in a vertical run in a shaft or from floor-to-floor, and are listed as having fire-resistant characteristics capable of preventing the spread of fire from floor-to-floor.

Cables labeled OPNG and OFCG are cables that can be used for general purposes, with the exception of risers and plenums, and in situations where resistance to the spread of fire is desired. The OFN and OFC types of cables are suitable for general purpose use with the exception of risers, plenums, and other space that may be used for environmental air. See Table 770-50 of the Code or Table 11-6.

Section 770-52 of the Code deals exclusively with the installation of optical fibers and electrical conductors. Part (a) deals with conductors for electrical light and power circuits and class 1 circuits. Optical fibers may be used where the same composite cable for electrical light and power or class 1 circuits—operating at 600 volts or less—is used.

TABLE 11-6
Cable Markings or Table 770-50 of NEC

Code Table 770.50 Cable Markings		
Cable Marking	Type	Reference
OFNP	Nonconductive optical fiber plenum cable	770.51(a) and 770.53(a)
OFCP	Conductive optical fiber plenum cable	770.51(a) and 770.53(a)
OFNR	Nonconductive optical fiber riser cable	770.51(b) and 770.53(b)
OFCR	Conductive optical fiber riser cable	770.51(b) and 770.53(b)
OFNG	Nonconductive optical fiber general-purpose cable	770.51(c) and 770.53(c)
OFCG	Conductive optical fiber general-purpose cable	770.51(c) and 770.53(c)
OFN	Nonconductive optical fiber general-purpose cable	770.51(d) and 770.53(c)
OFC	Conductive optical fiber general-purpose cable	770.51(d) and 770.53(c)

Twisted_Pair Cable Color Code. This system has tip colors, ring colors, group colors, and binder colors. The twisted-pair color code is used to identify the number of a pair within a cable. For example, a pair in the orange-Yellow binder group that is Yellow-Green is pair 418 (O-Y+Y-O). The twisted-pair color code in our telephone network is shown in Table 11-1.

Binders. A binder is a plastic ribbon wrapped around 25 pairs of wire or 600 pairs of wire. Binder codes are identifying groups of 25 or 600. The binder code is the same as the pair code, only the group colors and the pair colors are reversed (e.g., white-blue becomes blue-white), so when the abbreviated colors are put together, they are easier to understand. Binder codes are good for 600 pairs of wire. After that, each group of 600 pairs gets an additional plastic binder. Table 11-2.

Large cable binders:

- Pair 1 to 600, surrounded by a white binder
- Pair 601 to 1200, surrounded by a red binder
- Pair 1201 to 1800, surrounded by a white binder.

Fiber-Optic Cables. Fiber-optic cables are made from concentric layers of glass. Each layer of glass has a slightly different *index of refraction* or density. The center rod is called the *core*, and the outer layers are called the *clad*. The core is a very thin strand of highly refined cylindrical glass. Approximately, 20 miles of a 0.010-inch diameter core can be drawn from a 4.5-inch cube of glass. A cable's glass core may have a diameter of 4.5 microns (0.0002 inch) or may be as large as 400 microns (0.016 inch). The clad is fused directly to the core. The naked eye cannot see the difference between the two materials. However, the clad has a different optical density than core material. Both core and clad may be made of glass or plastic materials of different densities, or core may be glass and the clad plastic.

Fiber optics work on the theory of reflection. That reflection results at the interface between two materials of different densities. For instance, in a metallic wave guide the radio frequency energy is reflected along the guide when one-half wavelength of energy is shorter than the width of the wave guide. However, in fiber optics, the energy is reflected down the glass wave guide when the *angle of reflection* remains smaller than a *critical angle*. The critical angle is determined by the ratio of the densities of the core and clad materials. See Figure 11-8.

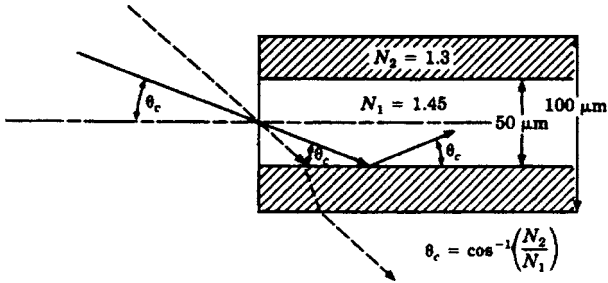


FIGURE 11-8. Critical angle θ_c .

Notice in Figure 11-8 that the diameter of the core is 50 microns whereas the clad adds another 50 microns to the overall diameter. Keep in mind that the core is only 0.002 inch in diameter. When light approaches the fiber core at an angle greater than the critical angle θ , away from the centerline of the core, then the core-clad interface will not reflect the light back into the core area. The light will pass through the clad—shown as a dashed line in Figure 11-8. Light passing through the clad is dissipated into the air outside the light cable.

Important to the proper operation of fiber-optic cables is the acceptance cone, which is formed as shown in Figure 11-9. Any approaching light coming near the cable from any direction at an

Cone of acceptance = $2\theta_c$

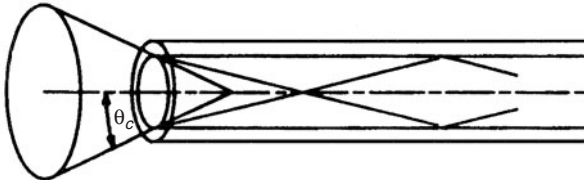


FIGURE 11-9. Cone of acceptance.

angle of 40° or less from the centerline of the cable will move down the core of the cable. A cone is formed by a boundary of 40° from the centerline in all directions. All light arriving at the core within the acceptance cone will enter the core and pass through the light guide.

Fiber-Optic Connectors. Fiber-optic connectors are important inasmuch as they serve as a means of splicing the fiber and causing it to continue the light beam with minimum of light (signal) loss. See Figure 11-10. Properly treated fiber ends are essential to a good installation. Figure 11-11 shows how the connectors are treated and how the fiber is polished with the proper equipment. Figure 11-12 shows some of the various alignments that produce losses, and Figure 11-13 illustrates the splicing of six individual fibers.

Cable Trays. Plastic *innerduct* commonly used for underground or outside plant construction may not have the appropriate fire safety characteristics required for optical fiber cable wiring in buildings. One reason for cable trays and raceways is to prevent the accumulation of wires and cables in front of electrical equipment located behind normally accessible panels. Cables should be supported by the building structure such that the cable will not be damaged by normal building use. The installation of fiber-optic cables should be done neatly and in a workmanlike manner.

Fiber-Optic Tools. If you are looking for tools to work with fiber-optics, the following is a listing of the specialized hand tools designed to work with this type of material. They have a tendency to eliminate most of the common defects produced by those not adequately skilled in making splices or installations. See Fig. 11-14 for fiber-optic tools.

There are a number of hand tools available for fiber-optic cabling needs. There is a wide variety of tools for fiber-optic termination, including strippers, tweezers, scribes, cleavers, and microscopes, polishing supplies, safety kits, and more.

Strippers for fiber-optic are accurate to -0 mm, $+0.0127$ mm with no adjustment necessary. It has back-up blades that support the cutting blades, nest positively, and "lock up" when the tool is closed. This maintains a perfect concentricity. The buffer being removed acts as a guide and provides protection for the fiber.

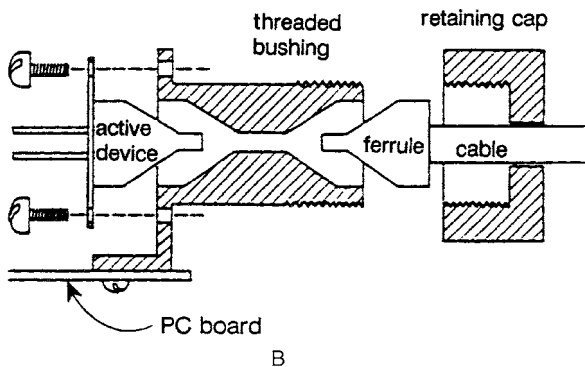
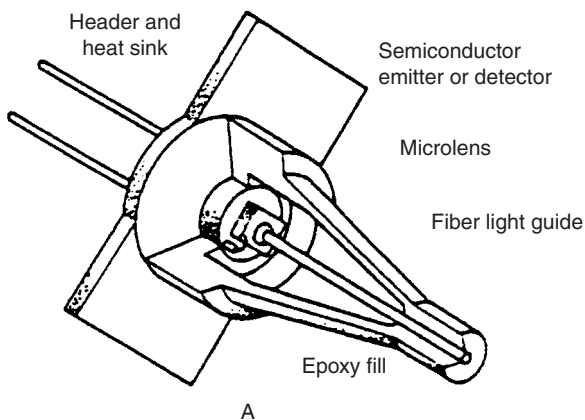


Figure 11-10. (A) Fiber-optic connectors. (B) PC board mounted connector.

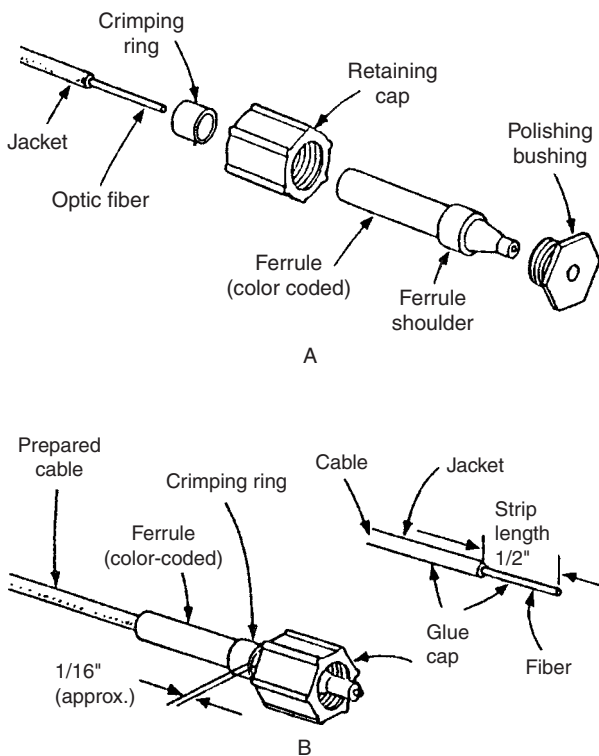


FIGURE 11-11. (A) Steps in polishing the end of a fiber conductor. (B) Strip length and crimping ring.

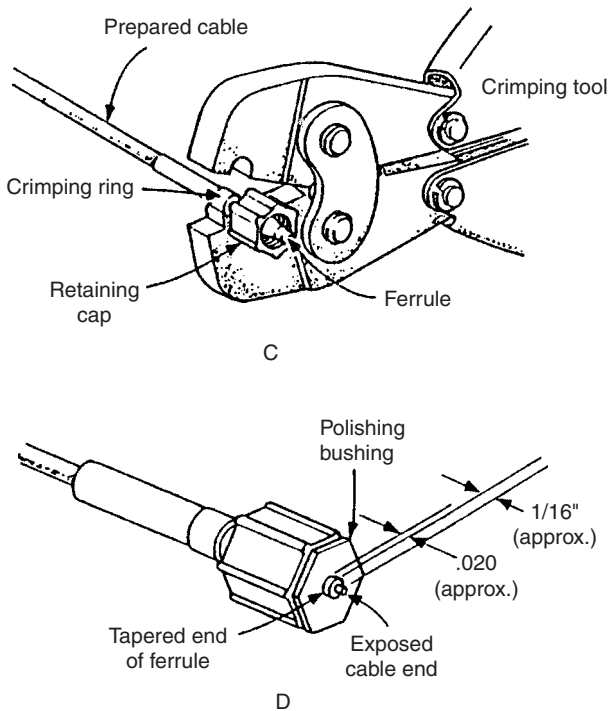


Figure 11-11. (C) Crimping operation. (D) Spacing in ferrule.

Strippers also are available in a three-piece kit in the most popular sizes, 203 microns (red handles), 245 microns, light blue handles, and 305 microns with white handles. The color-coded handles aid in quick identification. They come in a vinyl case that provides storage and protection.

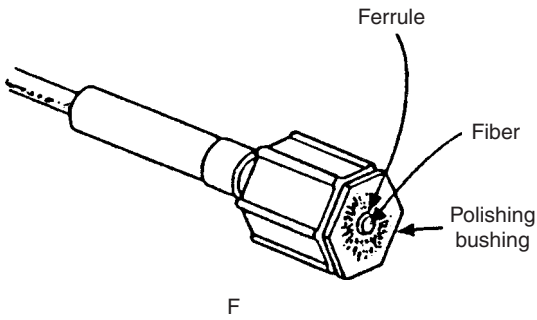
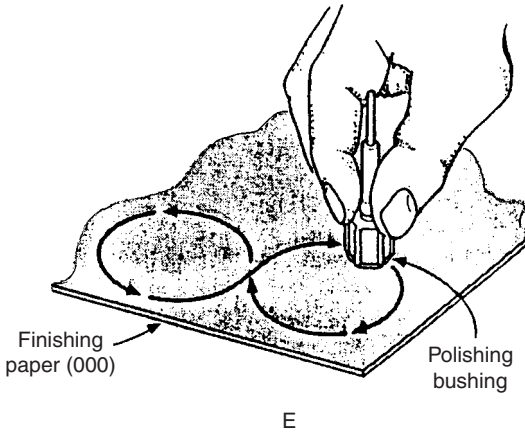


FIGURE 11-11. (E) Polishing bushing on sandpaper (000). (F) Locating the polishing bushing.

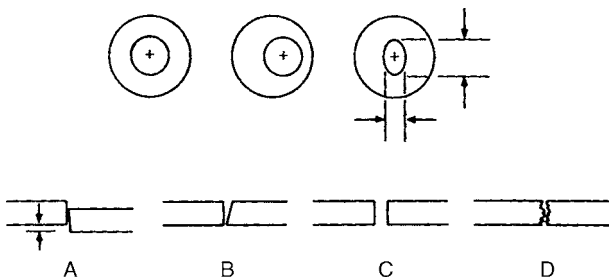


FIGURE 11-12. Alignment that can produce loss: a, b, d. End to end as in c is the preferred alignment. The end views of the fiber (shown above the alignment sequence) indicate how offset fibers can produce loss when spliced.

The fiber optic cleaver is designed for use with mechanical splices, with the newer “no-polish connections” and any other cleaves that require precise cleave lengths. It works well with 125-micron nominal cladding diameters and accommodates fibers in coated as well as cable form. It has a carbide-cleaving blade good for at least 5000 consistent cleaves. The cleave length is adjustable

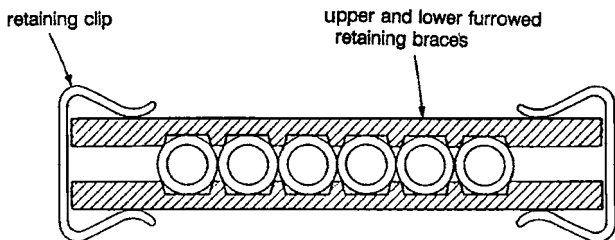
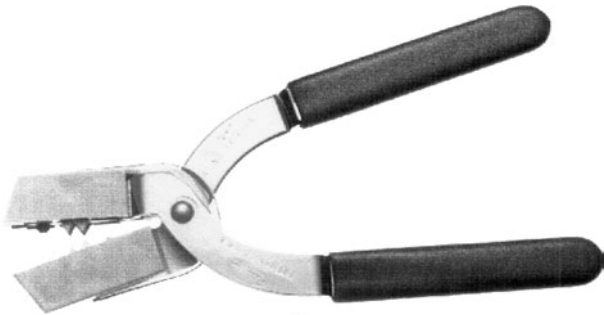
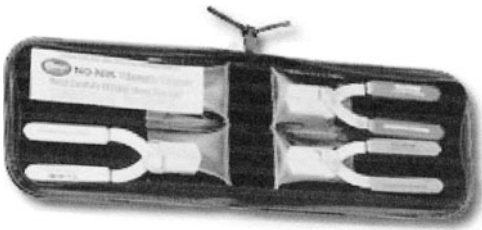


FIGURE 11-13. Multi-cable retaining assembly. This is a 6-fiber conductor assembly.



A



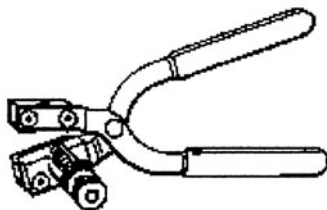
B

FIGURE 11-14. Tools for the fiber-optics trade. (Courtesy of Clauss Fiberoptics, now owned by Ripley Tools.) (A) Strippers for fiber-optics. (B) Strippers in a 3-piece kit in the most popular sizes, 203 microns (red handles), 245 microns, light blue handles, and 305 microns with white handles.

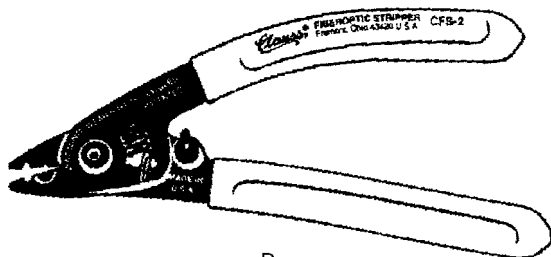
from 6.5 mm to 20 mm/0.25 inches to 0.75 inches. The cleave angle is $<1/2^\circ$ -50% of all cleaves, $<1^\circ$ -85% of all cleaves and $<2^\circ$ -100% of all cleaves.

This fiber-optic stripper has a 1.0-mm diameter-stripping hole at the tip of the tool so it can be used to strip the fiber jacket; and a

Fiberoptic cleaver

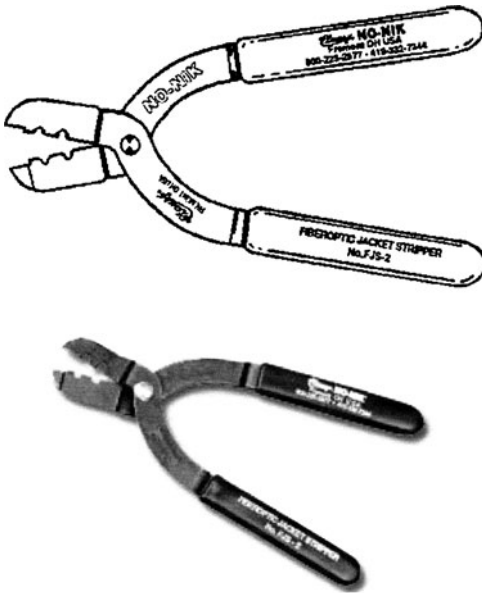


C



D

FIGURE 11-14. (C) The fiber-optic cleaver. (D) This is a fiber-optic stripper.



E

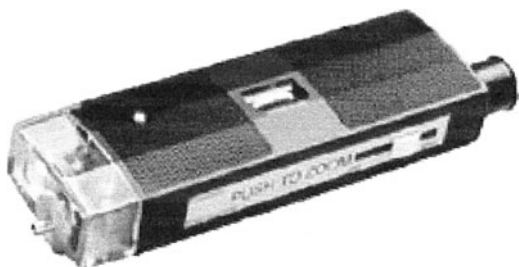
FIGURE 11-14. (E) The fiber-optic jacket stripper.

140- μm -diameter hole with a V-opening in the blade allows removal of 250-micron buffer coating from 125-micron fiber. This is preset at the factory with no adjustment needed. It will not scratch or nick the glass fiber.

The fiber-optic jacket stripper removes the outside jacket from the fiber-optic cable. The stripper has two stripping notches: one with a cutting diameter of 1.25 mm and the other with a cutting diameter of 1.5 mm, and can be used on 2.0-mm and 3.00-mm cable. The 1.5-mm notch works especially well on loose tube cable. It is easy to use and always leaves a clean strip.

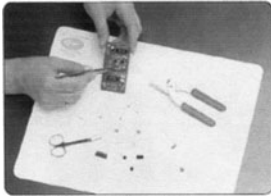


F



G

FIGURE 11-14. (F) The Kevlar shears. (G) The fiber-optic inspection microscope.



(1)



(2)



(3)



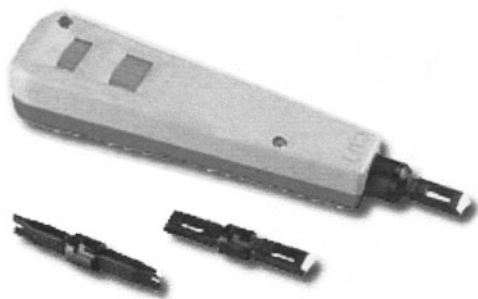
(4)

H

FIGURE 11-14. (H) Impact punch down tool.

The Kevlar shears has a nonslip serrated blade on each model and provides the solution for trimming back the DuPont Kevlar that serves as the central strength member in the optical fiber. The shears are made of hot-forged, high-carbon steel for longer life. The tool has a quick action spring release so the tool is ready when you are. The high leverage provides powerful cutting action.

The fiber-optic inspection microscope has three built-in magnifications: 150x, 175x, and 200x. The universal adapter accepts most ST, SC, and FC 2.5 mm connector ferrules. It has an on/off



Clauss Blade for 110/88-Type Blocks
(Model # PDB-110)



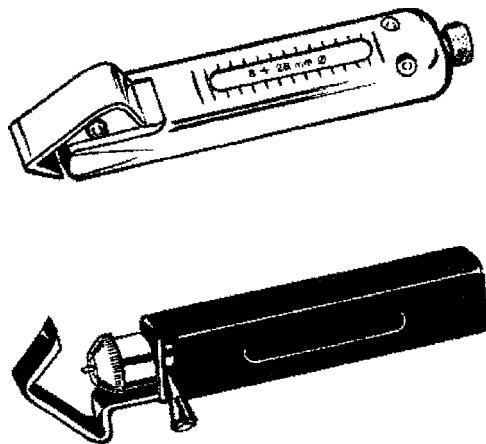
Clauss Blade for 66-Type Blocks
(Model # PDB-66)



I

FIGURE 11-14 (I) The rotary cable strippers.

switch, bulb rotation knob, and a focus wheel that is designed with a firm control dial to hold the focus. The eyepiece is so designed that it is unnecessary to remove conventional eyeglasses for safety eyewear.



J



K

FIGURE 11-14. (J) Wire strippers and cutters. (K) Wire strippers.

Tweezers for Access to Dense Areas

Clauss

Excellent for access to dense areas in micro-assembly work.

Features:

- Extra fine tips
- No. 4SA Anti-acid/Anti-magnetic stainless steel with a brushed satin finish
- No. 4C Carbon steel and chrome-plated for added protection
- 4-1/4" long

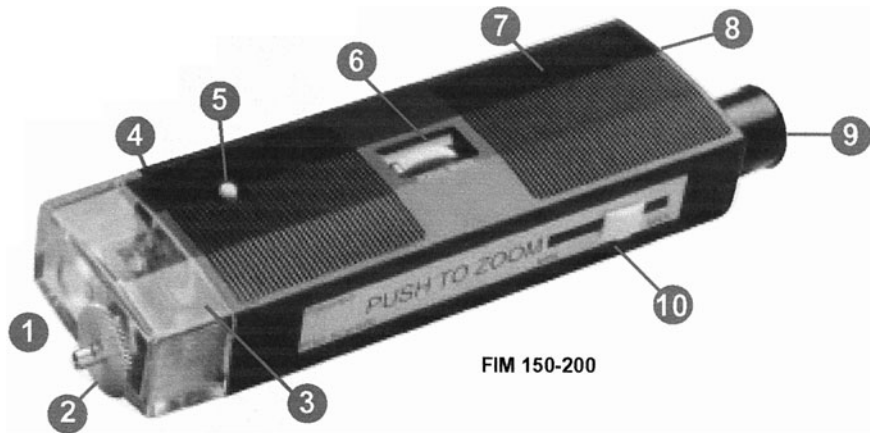


Fiberoptic Polishing Puck

1-1/2" diameter polishing puck for ST, SC, and FC connectors. Stainless steel for durability or disposable plastic.

L

FIGURE 11-14. (L) Other tools for efficient work.



FIM 150-200

M

FIGURE 11-14. (M) Fiberoptic inspection microscope.

There are various kits available for those working with fiber-optics. These include the polishing kit and the fiber-safe safety kit: The fiber-safe safety kit includes:

Polishing/work matt: The vinyl black work mat serves a dual purpose (14 inches \times 22 inches). Its primary function is to allow you to easily see the fiber scraps instead of trying to find them on a lighter colored work surface. It can also serve as a subsurface for some polishing applications. Instead of using a hard, nongiving surface, you have a resilient matt that depresses easily and allows you to quickly pick up the fibers you are working on.

Fiber scraps trashcan: The disposable fiber scraps trashcan gives you the safest method of disposing of glass fiber scraps because it can be incinerated when full.

Splinter removal tweezers: The splinter removal tweezers Teflon coating provides the cushioning you need to remove glass fibers splinters without shattering or breaking the glass.

Bifurcated cleaning swipes: The bifurcated (two-pronged) swipes put an end to working with messy bottles of alcohol and hand wipes to clean fiber ends before splicing, cleaving, or terminating fiber. The tube contains 99% isopropyl alcohol. Hand pressure breaks the seal, and the alcohol is dispensed only when you squeeze the tube, reducing evaporation and alcohol waste.

Safety glasses: They should always be worn when working with fiber. They have a single lens wrap-around feature to provide additional safety and the latest technology in safety glasses.

The spring-loaded adjustable, automatic impact punch down tool is used for terminating wires on 110/88 or 66-type connecting blocks. Precision hardened and interchangeable blades spread the termination prongs to allow fast and easy insertion of the wire into the contact, providing a tight termination that resists corrosion. The blade finishes the job in the same motion by neatly cutting off excess wire.

The rotary cable strippers are available for cable stripping the easy way. One stripper can strip cable with outer diameter of 8 mm to approximately 35 mm. The other strips cable with other diameter of 4 mm to approximately 25 mm. Replacement blades are available.

Wire strippers and cutters strip and cut commonly used wire, single or stranded, AWG or metric. Each tool will strip several different

wire sizes. The plier-nose is an extra feature along with custom grips and a spring release. The hardened pivoted joint produces a tool with a longer life. Good tools to have on the solder bench or in an assembly area.

Other tools and devices that make the job easier and more efficient.

DLC Cable Entries. In a conventional digital loop carrier (DLC) optic cable entry method, there can be problems. Figure 11-15 shows how a DLC can be interfaced with an outside plant fiber-optic cable. The cable is drawn into the closure, and then is grounded and exposed inside the case. The buffer tubes are attached to a splice tray inside the closure, and pigtails are spliced to the fibers contained in the buffer tube.

Disadvantages of this configuration, shown in Figure 11-15, are:

- If the DLC is at a junction splice, rather than at the end of a branch splice, several cables must be brought in, prepped, and spliced inside the box. This is sometimes difficult to accomplish, particularly if the copper splices have already been made.

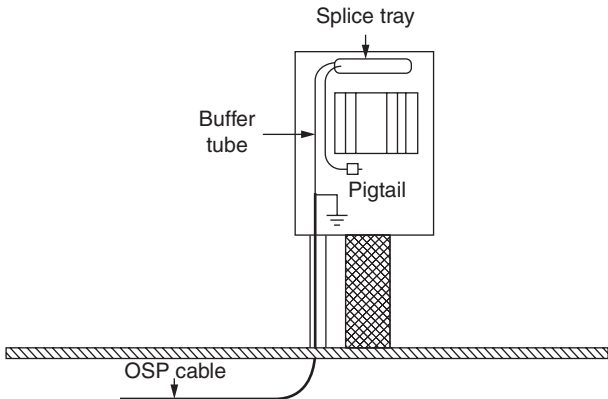


FIGURE 11-15. Direct entry with OSP cable into the DLC.

- If the DLC is at a junction splice, sometimes the cables are brought into a hand hole, then a length of cable is brought into the box, prepped, and pig tails are spliced onto the end of the extension cable. This creates another splice in the path, and still has the disadvantage of the inside preparation.
- In both instances, and at the end of a branch splice, a preparation of the cable inside the box means that a tent must be set up to prep the splice operation, and the fusion-splice must be made outside, rather than an arrangement that allows the splicing to be done inside a splicing trailer or van. Outside splicing is particularly difficult if the DLC is in a hard-to-reach area, such as on the side of a hill or off the road, where a level area to set a splicing table is difficult to find.
- When the cables are prepped inside the box, the fragile buffer tubes occupy space with the copper splices and power supply hookups. If attention is not paid to the clearance between the buffer tubing and the other activities, damage to the fiber patch will result.
- If the DLC must be replaced due to damage or vandalism, the splicing inside the DLC to be replaced must be cutoff and redone inside the new unit, increasing down time.

Some of the definitions you may want to put in your thinking space and use later.

Digital loop carrier (DLC). This is used to provide two dial tones over a single twisted copper pair. It is not always a good idea for use with fax machines and modems.

Open shortest path first (OSPF). This is a standard traffic control program used on routers. It was developed in 1970s for use with Internet applications.

Basic Mathematics and Measurement Conversion

Mathematics is a necessary tool for the electrician. Solving electrical formulas involves the use of basic arithmetic (addition, subtraction, multiplication, and division) and an understanding of squares and square roots, algebra, and trigonometry. Refer to a basic mathematics text if you need to review these subjects. In this chapter, we focus on several topics involving mathematics as it is encountered by the electrician and apprentice. Scientific notation is one of these topics, as is an understanding of the metric system of measurement and how to convert from U.S. customary to the SI (metric) system. We also discuss how an electrician can estimate a job and, finally, how the use of a calculator can make computation and problem solving easier.

SCIENTIFIC NOTATION

The multiplication and division of large numbers can be simplified by using scientific notation. Notation by powers of 10 is used to indicate the position of the decimal point. Multiples of 10 from 1 to 1,000,000, with their equivalents in powers of 10, are given in Table 12-1.

This notation provides for both positive and negative powers of 10.

TABLE 12-1
Powers of Ten

$1 = 10^0$
$10 = 10^1$
$100 = 10^2$
$1000 = 10^3$
$10000 = 10^4$
$100000 = 10^5$
$1000000 = 10^6$

Likewise, powers of 10 can be used to simplify decimal expressions. The submultiples of 10 from 0.1 to 0.000001, with their equivalents in powers of 10, are:

$0.1 = 10^{-1}$
$0.01 = 10^{-2}$
$0.001 = 10^{-3}$
$0.0001 = 10^{-4}$
$0.00001 = 10^{-5}$
$0.000001 = 10^{-6}$

When the power of 10 is positive, the decimal point of the number is moved to the right as many spaces as the exponent. When the power of 10 is negative, the decimal point is moved to the left.

Let's use the example 6.8759×10^4 —a number written in scientific notation—to illustrate this. This number 6.8759×10^4 equals 68759 because the decimal point is moved four places to the right. The notation 6.8759×10^{-3} equals 0.0068759 because the decimal point was moved three places to the left.

Scientific notation comes in handy for electricians when they need to solve problems dealing with frequency and capacitance.

THE SI SYSTEM

The metric system was originally based on a meter designed to be one-ten millionth of the earth's meridian at a particular spot in France. Later, this was found to be inaccurate and revisions were made.

In 1954, the *Conference Generale des Poids et Mesures* adopted a standard metric system of measure based on MKSA units: meter-kilogram-second-ampere. Later, the kelvin, candela, and mole were added for temperature, luminous intensity, and substance quality measures. This system of measurement was then named the *Systeme Internationale d'Unites*, abbreviated SI. It has been widely accepted throughout the world. Even in the United States and a few other nations where it is not commonly used, it is employed in many scientific and technical fields.

With the three principal SI units

- Meter, the unit of length
- Liter, unit of capacity
- Gram, the unit of weight

prefixes are used to indicate multiples and divisions.

Multiples of the units are expressed by adding the Greek prefixes *deka* (10), *hekto* (100), and *kilo* (1000). Divisions of the units are expressed by adding the Latin prefixes *deci* (0.1), *centi* (0.01), and *milli* (0.001). The prefixes are the same in all languages, thus improving communication. Table 12-2 lists the common prefixes, their symbols, and multiplying factors.

TABLE 12-2
SI Prefixes

Multiplying Factor	Prefix	Symbol
1 000 000 000 000 = 10 ¹²	Tera	T
1 000 000 000 = 10 ⁹	Giga	G
1 000 000 = 10 ⁶	Mega	M
1 000 = 10 ³	Kilo	k
100 = 10 ²	Hekto	h
10 = 10 ¹	Deka	da
0.1 = 10 ⁻¹	Deci	d
0.01 = 10 ⁻²	Centi	c
1.001 = 10 ⁻³	Milli	m
0.000 001 = 10 ⁻⁶	Micro	μ
0.000 000 001 = 10 ⁻⁹	Nano	n
0.000 000 000 001 = 10 ⁻¹²	Pico	p
0.000 000 000 000 001 = 10 ⁻¹⁵	Femto	f
0.000 000 000 000 000 001 = 10 ⁻¹⁸	Atto	a

We should point out here that there are some exceptions to the SI system and prefixes that the electrician may encounter in ordering supplies. In their catalogs, most electrical supply companies use the letter “C” to mean 100 units of an item and the letter “M” to mean 1000 units of an item.

In some cases, the electrician may need to convert from one system of measurement to another. Table 12-3 gives the conversion factors used to convert from the customary (U.S.) system of measurement to the metric system for measurement units that the electrician may encounter. Table 12-4A and B lists metric-U.S. equivalents for many common units. Table 12-5 gives common horsepower-kilowatt equivalents.

TABLE 12-3
Conversion Factors in Converting from Customary (U.S.) Units to Metric Units

To Find	Multiply	By
Microns	Mils	25.4
Centimeters	Inches	2.54
Meters	Feet	0.3048
Meters	Yards	0.9144
Kilometers	Miles	1.609344
Grams	Ounces	28.349523
Kilograms	Pounds	0.4539237
Liters	Gallons (U.S.)	3.7854118
Liters	Gallons (Imperial)	4.546090
Milliliters (cc)	Fluid ounces	29.573530
Milliliters (cc)	Cubic inches	16.387064
Square centimeters	Square inches	6.4516
Square meters	Square feet	0.09290304
Square meters	Square yards	0.83612736
Cubic meters	Cubic feet	2.8316847×10^{-2}
Cubic meters	Cubic yards	0.76455486
Joules	BTU	1054.3504
Joules	Foot-pounds (Pound feet)	1.35582
Kilowatts	BTU per minute	0.01757251
Kilowatts	(Pound feet) per minute	2.2597×10^{-5}
Kilowatts	Horsepower	0.7457
Radians	Degrees	0.017453293
Watts	BTU per minute	17.5725

**TABLE 12-4A
Metric-Customary Equivalents**

Measures of Length	
1 meter =	$\left\{ \begin{array}{l} 39.3 \text{ inches} \\ 3.28083 \text{ feet} \\ 1.0936 \text{ yards} \end{array} \right.$
1 centimeter =	0.3937 inch
1 millimeter =	0.03937 inch, or nearly 1/25 inch
1 foot =	0.3048 meter
1 inch =	$\left\{ \begin{array}{l} 2.54 \text{ centimeters} \\ 25.40 \text{ millimeters} \end{array} \right.$
Measures of Surface	
1 square meter =	$\left\{ \begin{array}{l} 10.764 \text{ square feet} \\ 1.196 \text{ square yards} \end{array} \right.$
1 square centimeter =	0.155 square inch
1 square millimeter =	0.00155 square inch
1 square yard =	0.836 square meter
1 square foot =	0.0929 square meter
1 square inch =	$\left\{ \begin{array}{l} 6.452 \text{ square centimeters} \\ 645.2 \text{ square millimeters} \end{array} \right.$
Measures of Volume and Capacity	
1 cubic meter =	$\left\{ \begin{array}{l} 35.314 \text{ cubic feet} \\ 1.308 \text{ cubic yards} \\ 264.2 \text{ U.S. gallons (231 cubic inches)} \end{array} \right.$
1 cubic decimeter =	$\left\{ \begin{array}{l} 61.0230 \text{ cubic inches} \\ 0.0353 \text{ cubic feet} \end{array} \right.$
1 cubic centimeter =	0.016 cubic inch
1 liter =	$\left\{ \begin{array}{l} 1 \text{ cubic decimeter} \\ 61.0230 \text{ cubic inches} \\ 0.0353 \text{ cubic foot} \\ 1.0567 \text{ quarts (U.S.)} \\ 0.2642 \text{ gallon (U.S.)} \\ 2.2020 \text{ lb of water at } 62^{\circ}\text{F} \end{array} \right.$
1 cubic yard =	0.7645 cubic meter
1 meter =	$\left\{ \begin{array}{l} 39.3 \text{ inches} \\ 3.28083 \text{ feet} \\ 1.0936 \text{ yards} \end{array} \right.$
1 cubic inch =	16.383 cubic centimeters
1 gallon (British) =	4.543 liters
1 gallon (U.S.) =	3.785 liters

(continued)

TABLE 12-4A
Metric-Customary Equivalents (*continued*)

Measures of Weight	
1 gram = 15,432 grains	
1 kilogram = 2,2046 pounds	
1 metric ton = {	0.9842 to of 2240 pounds
	19.68 cwts.
	2204.6 pounds
1 grain = 0.0648 grams	
1 ounce avoirdupois = 28.35 grams	
1 pound = 0.4536 kilogram	
1 ton of 2240 lb = 1.016 metric tons or 1016 kilograms.	

TEMPERATURE CONVERSION

Temperature may be expressed according to the Fahrenheit scale or the Celsius scale. Many motor and conductor temperatures are given in degrees Celsius and must be converted to the Fahrenheit scale if that is what the electrician is familiar with. The formulas for conversion are:

$$F = 1.8 \times C + 32$$

$$C = 0.55555555 \times F - 32.$$

Many times, however, the electrician may be able to refer to a table, such as Table 12-6 that provides the equivalent temperatures in both scales.

The numbers in italics in the center column refer to the temperature, in either degrees Celsius or degrees Fahrenheit that is to be converted to the other scale. If converting a Fahrenheit temperature to Celsius, find the number in the center column and then look to the left column for the Celsius temperature. If converting a Celsius temperature, find the number in the center column and look to the right for the Fahrenheit equivalent.

TABLE 12-4B
Metric Conversions

To Convert	Into-	Multiply By	Conversely Multiply By
Inches	Centimeters	2.54	0.3937
Inches	Mils	1000	0.001
Joules	Foot-pounds (pound feet)	0.7376	1.356
Joules	Ergs	10^7	10^{-7}
Kilogram-calories	Kilojoules	4.186	0.2389
Kilograms	Pounds (avoirdupois)	2.205	0.4536
Kg per sq meter	Pounds per sq foot	0.2048	4.882
Kilometers	Feet	3281	3.048×10^{-4}
Kilowatt-hours	Btu	3413	2.93×10^{-4}
Kilowatt-hours	Foot-pounds (Pound feet)	2.655×10^6	3.766×10^{-7}
Kilowatt-hours	Joules	3.6×10^6	2.778×10^{-7}
Kilowatt-hours	Kilogram-calories	860	1.163×10^{-3}
Kilowatt-hours	Kilogram-meters	3.671×10^5	2.724×10^{-6}
Liters	Cubic meters	0.001	1000
Liters	Cubic inches	61.02	1.639×10^{-2}
Liters	Gallons (liq U.S.)	0.2642	3.785
Liters	Pints (liq U.S.)	2.113	0.4732
Meters	Yards	1.094	0.9144
Meters per minute	Feet per minute	3.281	0.3048
Meters per minute	Kilometers per hour	0.06	16.67
Miles (nautical)	Kilometers	1.853	0.5396
Miles (statute)	Kilometers	1.609	0.6214
Miles per hour	Kilometers per minute	2.682×10^{-2}	37.28
Miles per hour	Feet per minute	88	1.136×10^{-2}
Miles per hour	Kilometers per hour	1.609	0.6214
Poundals	Dynes	1.383×10^4	7.233×10^{-5}
Poundals	Pounds (avoirdupois)	3.108×10^{-2}	32.17
Sq inches	Circular mils	1.273×10^6	7.854×10^{-7}
Sq inches	Sq centimeters	6.452	0.155
Sq feet	Sq meters	9.29×10^2	10.76
Sq miles	Sq yards	3.098×10^6	3.228×10^{-7}
Sq miles	Sq kilometers	2.59	0.3861
Sq millimeters	Circular mils	1973	5.067×10^{-4}
Tons, short (avoir 2000 lb)	Tonnes (1000 kg)	0.9072	1.102
Tons, long (avoir 2240 lb)	Tonnes (1000 kg)	1.016	0.9842

(continued)

TABLE 12-4B
Metric Conversions (continued)

To Convert	Into-	Multiply By	Conversely Multiply By
Tons, long (avoir 2240 lb)	Tons, short (avoir 2000 lb)	1.120	0.8929
Watts	Btu per minute	5.689×10^{-2}	17.58
Watts	Ergs per sec	10^7	10^{-7}
Watts	Ft-lb per minute	44.26	2.26×10^{-2}
Watts	Horsepower (550 ft-lb per sec)	1.341×10^{-3}	745.7
Watts	Horsepower (metric) (542.5 ft-lb per sec)	1.36×10^{-3}	735.5
Watts	Kg-calories per minute	1.433×10^{-2}	69.77

TABLE 12-5
Horsepower-Kilowatt Equivalents

Horsepower	Kilowatt (kW)
1/20	0.025
1/16	0.05
1/8	0.1
1/6	0.14
1/4	0.2
1/3	0.28
1/2	0.4
1	0.8
1 ¹ / ₂	1.1
2	1.6
3	2.5
5	4.0
7.5	5.6
10	8.0

Source: Courtesy of Bodine Electric.

TABLE 12-6

Temperature Conversions

The numbers in the center column refer to the temperature, either in degrees Celsius or degrees Fahrenheit, which is to be converted to the other scale. While converting a Fahrenheit temperature to Celsius, find the number in the center column and then look to the left column for the Celsius temperature. While converting a Celsius temperature, find the number in the center column and look to the right for the Fahrenheit equivalent.

-100 to 30			31 to 71			72 to 212			213 to 620		621 to 1000			
C	F		C	F		C	F		C	F	C	F		
-73	-100	-148	-0.6	31	87.8	22.2	72	161.6	104	220	428	332	630	1166
-68	-90	-130	0	32	89.6	22.8	73	163.4	110	230	446	338	640	1184
-62	-80	-112	0.6	33	91.4	23.3	74	165.2	116	240	464	343	650	1202
-57	-70	-94	1.1	34	93.2	23.9	75	167.0	121	250	482	349	660	1220
-51	-60	-76	1.7	35	95.0	24.4	76	168.8	127	260	500	354	670	1238
-46	-50	-58	2.2	36	96.8	25.0	77	170.6	132	270	518	360	680	1256
-40	-40	-40	2.8	37	98.6	25.6	78	172.4	138	280	536	366	690	1274
-34.4	-30	-22	3.3	38	100.4	26.1	79	174.2	143	290	554	371	700	1292
-28.9	-20	-4	3.9	39	102.2	26.7	80	176.0	149	300	572	377	710	1310
-23.32	-10	14	4.4	40	104.0	27.2	81	177.8	154	310	590	382	720	1328
-17.8	0	32	5.0	41	105.8	27.8	82	179.6	160	320	608	388	730	1346
-17.2	1	33.8	5.6	42	107.6	28.3	83	181.4	166	330	626	393	740	1364
-16.7	2	35.6	6.1	43	109.4	28.9	84	183.2	171	340	644	399	750	1382
-16.1	3	37.4	6.7	44	111.2	29.4	85	185.0	177	350	662	404	760	1400
-15.6	4	39.2	7.2	45	113.0	30.0	86	186.8	182	360	680	410	770	1418
-15.0	5	41.0	7.8	46	114.8	30.6	87	188.6	188	370	698	416	780	1436
-14.4	6	42.8	8.3	47	116.6	31.1	88	190.4	193	380	716	421	790	1454
-13.9	7	44.6	8.9	48	118.4	31.7	89	192.2	199	390	734	427	800	1472
-13.3	8	46.4	9.4	49	120.0	32.2	90	194.0	204	400	752	432	810	1490
-12.8	9	48.2	10.0	50	122.0	32.8	91	195.8	210	410	770	438	820	1508

(continued)

TABLE 12-6
Temperature Conversions (*continued*)

-100 to 30		31 to 71		72 to 212		213 to 620		621 to 1000						
C	F	C	F	C	F	C	F	C	F					
-12.2	10	50.0	10.6	51	123.8	33.3	92	197.6	216	420	788	443	830	1526
-11.7	11	51.8	11.1	52	125.6	33.9	93	199.4	221	430	806	449	840	1544
-11.1	12	53.6	11.7	53	127.4	34.4	94	201.2	227	440	824	454	850	1562
-10.6	13	55.4	12.2	54	129.2	35.0	95	203.0	232	450	842	460	860	1580
-10.0	14	57.2	12.8	55	131.0	35.6	96	204.8	238	460	860	466	870	1598
-9.4	15	59.0	13.3	56	132.8	36.1	97	206.6	243	470	878	471	880	1616
-8.9	16	60.8	13.9	57	134.6	36.7	98	208.4	249	480	896	477	890	1634
-8.3	17	62.6	14.4	58	136.4	37.2	99	210.2	254	490	914	482	900	1652
-7.8	18	64.4	15.0	59	138.2	37.8	100	212.0	260	500	932	488	910	1670
-7.2	19	66.2	15.6	60	140.0	43	110	230	266	510	950	493	920	1688
-6.7	20	68.0	16.1	61	141.8	49	120	248	271	520	968	499	930	1706
-6.1	21	69.8	16.7	62	143.6	54	130	266	277	530	986	504	940	1724
-5.6	22	71.6	17.2	63	145.4	60	140	284	282	540	1004	510	950	1742
-5.0	23	73.4	17.8	64	147.2	66	150	302	288	550	1022	516	960	1760
-4.4	24	75.2	18.3	65	149.0	71	160	320	293	560	1040	521	970	1778
-3.9	25	77.0	18.9	66	150.8	77	170	338	299	570	1058	527	980	1796
-3.3	26	78.8	19.4	67	152.6	82	180	356	304	580	1076	532	990	1814
-2.8	27	80.6	20.0	68	154.4	88	190	374	310	590	1094	538	1000	1832
-2.2	28	82.4	20.6	69	156.2	93	200	392	316	600	1112	—	—	—
-1.7	29	84.2	21.1	70	158.0	99	210	410	321	610	1130	—	—	—
-1.1	30	86.0	21.7	71	159.8	100	212	414	327	620	1148	—	—	—

Estimating a Job

All electricians have to do some estimating. People want to know what it will cost before contracting for a job. In electrical wiring, estimating requires a lot of time and effort. The electrician must charge the customer for the materials to be used (e.g., wires, switches, plugs), the cost of labor and supervision, overhead expenses (e.g., the cost of maintaining an office and operating trucks)—plus enough to make a profit.

If you bid on a commercial or industrial job, as the electrical contractor you must provide a detailed listing of what it will cost to do the job. A bid on residential wiring does not require so much detail. However, before preparing any bid, you should have a set of drawings that specify all of the materials to be used and what is to be done.

CHECKLIST FOR ESTIMATING

- Receptacles
- Light fixtures
- Switches: 3-way, 4-way, single-pole
- Receptacle cover plates
- Switch cover plates
- Boxes; square, octagonal, switch, receptacle
- Wire nuts, hangers, connectors, ground clips, staples

- 240-volt service
 - Wire
 - Receptacles
 - Oven
 - Surface burners
 - Dryer
 - Others
- Circuit breakers
- Circuit breaker box
- Wire (signal and Romex)
- Conduit
- Conduit fittings
- Labor
- Travel
- Overhead
- Miscellaneous

ESTIMATING THE COST OF MATERIALS

In determining the cost of materials to be figured in the overall estimate, one technique is to take the price paid for the material and double it. Most electrical supply houses have a list price and a net price. You, the electrician, will pay the net price, but you should use the list price in estimating. Estimates done this way provide enough leeway to allow you to offer the customer a discount for prompt payment—and still make a profit.

USING PAST EXPERIENCE AS A GUIDE IN ESTIMATING

After a job is complete, you can determine exactly what it cost to do it. You can figure what it cost to install a fixture, an outlet, a switch, or any other device. Then you can use this figure when preparing estimates for other, similar jobs. It will save much time if you have a reliable price to attach to specific jobs, such as the installation of a switch or dimmer. Then you simply count the number of switches, dimmers, outlets, or whatever is to be installed. Multiply by the per-unit installation price you have determined based on experience. This technique allows you to arrive at an accurate estimate for a job quickly.

TECHNIQUE FOR SAVING MONEY

One money-saving technique is buying in quantity. If, for example, you buy the supplies for two, three, or more jobs at one time, you can buy by the box or by 1000 feet of wire and obtain a better price than if you were buying by the unit or by smaller rolls of wire. Unit cost is lower this way, and you benefit from this by being able to bid lower on a job, thus increasing your chances of getting the job, and/or by being able to please customers by offering a discount for prompt payment.

USING A CALCULATOR

The hand-held calculator has become so inexpensive that almost everyone now has one. It is a valuable tool for the electrician and electronics technician inasmuch as it can speed up the problem solving and computation that is often a part of electrical and electronics work.

Many models of calculators are available. Some are complicated, with many formulas and other information stored on a chip. With simpler models, you must know the formula to be able to figure out the units you need for a particular problem. In general, electricians do not need complicated and expensive calculators. All that is needed is a basic calculator with at least one level of memory capable of performing the following functions:

Square root	$\sqrt{\quad}$
Reciprocals	$1/x$
Squares	x^2
Trig functions, especially cosine	cos
Addition	+
Subtraction	-
Division	\div
Multiplication	\times

A pi (π) key is also useful in some instances. In most cases, the calculator will take π out to eight decimal places. If, however π is rounded to 3.14 or 3.14159, a different answer will result.

Most calculators with memory and trigonometric tables also have the ability to do scientific notation. Many also are designed with U.S. metric conversion formulas already stored for easy use.

282 CHAPTER THIRTEEN

When you purchase a calculator, read the instructions carefully and practice how to use the calculator to solve different types of problems. Then, when you need to use it on the job, you will be thoroughly familiar with its capabilities and be able to solve problems quickly.

14

Electrical and Electronic Formulas

The electrician or apprentice is often called on to calculate the current on a line, the resistance in a circuit, or other factors. Mathematical formulas provide the means for doing this. The formulas can be solved with a basic knowledge of mathematics (addition, subtraction, multiplication, and division), algebra, and, in some cases, trigonometry.

The formulas most often used by an electrician are given in Table 14-1.

USING OHM'S LAW

Ohm's law is one of the most important and frequently used formulas. Georg Simon Ohm (1787–1854), an early experimenter with electrical phenomena, formulated the law. Doing a mathematical analysis of circuits, he found that the voltage, current, and resistance in any circuit have a definite mathematical relationship to one another. Specifically, he found that the current or intensity of electron flow I in any circuit was equal to the voltage or

TABLE 14-1
Electrical and Electronic Formulas

Resistance	
Series Resistors	Parallel Resistors
$R_T = R_1 + R_2 + R_3 + \dots$ $I_T = I_{R_1} = I_{R_2} = I_{R_3} \dots$ $E_A = E_{R_1} + E_{R_2} + E_{R_3} + \dots$	$R_T = \frac{R_1 \times R_2}{R_1 + R_2}$ (for two resistors only) $\frac{1}{R_T} = \frac{1}{R_1} + \frac{1}{R_2} + \frac{1}{R_3} + \dots$ $I_T = I_{R_1} + I_{R_2} + I_{R_3} + \dots$ $E_A = E_{R_1} = E_{R_2} = E_{R_3}$
Ohm's Law	
$E = I \times R$ $I = \frac{E}{R}$ $R = \frac{E}{I}$	
Power	
$P = E \times I$ $P = I^2 R$ $P = \frac{E^2}{R}$	
Time Constant	
$T = \frac{L}{R}$ inductive	$T = R \times C$ capacitive
Alternating Current	
Peak = rms \times 1.414 Average = peak \times 0.637	rms = peak \times 0.7071 Peak-to-peak = rms \times 2.828
Inductive Reactance $X_L = 2\pi FL$	
In series $X_{LT} = X_{L_1} + X_{L_2} + \dots$	In Parallel $X_{LT} = \frac{X_{L_1} \times X_{L_2}}{X_{L_1} + X_{L_2}}$ $\frac{1}{X_{LT}} = \frac{1}{X_{L_1}} + \frac{1}{X_{L_2}} + \frac{1}{X_{L_3}}$

TABLE 14-1
Electrical and Electronic Formulas (*continued*)

Transformers	
$\frac{E_p}{E_s} = \frac{I_s}{I_p} \quad \frac{T_p}{T_s} = \frac{E_p}{E_s}$	$I_p = \text{current, primary}$ $I_s = \text{current, secondary}$ $T_p = \text{turns, primary}$ $T_s = \text{turns, secondary}$
	$E_p = \text{voltage, primary}$ $E_s = \text{voltage, secondary}$
Capacitances	
Capacitors in series (all in the same unit of measurement)	Capacitors in parallel (all in the same unit of measurement)
$\frac{1}{C_T} = \frac{1}{C_1} + \frac{1}{C_2} + \frac{1}{C_3} + \dots$ $C_T = \frac{C_1 \times C_2}{C_1 + C_2} \text{ (two only)}$	$C_T = C_1 + C_2 + C_3 + \dots$
Capacitive Reactance	
$X_c = \frac{1}{2\pi f C}$	
In series $X_{C_r} = X_{C_1} + X_{C_2} + X_{C_3}$	In parallel $\frac{1}{X_{C_T}} = \frac{1}{X_{C_1}} + \frac{1}{X_{C_2}} + \frac{1}{X_{C_3}} + \dots$ $X_{C_T} = \frac{X_{C_1} \times X_{C_2}}{X_{C_1} + X_{C_2}} \text{ (for two only)}$
Ohm's Law for Alternating Current (AC) Circuits	
$E_L = I_L \times X_L$ $I_L = \frac{E_L}{X_L}$ $X_L = \frac{E_L}{I_L}$	$E_C = I_C \times X_C$ $I_C = \frac{E_C}{X_C}$ $X_C = \frac{E_C}{I_C}$

(continued)

TABLE 14-1
Electrical and Electronic Formulas (*continued*)

Series RL Circuits	Series RC Circuits
$Z = \sqrt{R^2 + X_L^2}$ $E_A = \sqrt{E_R^2 + E_L^2}$ $I_T = I_R = I_L$ $E_A = I_T Z$ <p>*PF = Cos $\angle\theta$</p> $\text{Cos } \angle\theta = \frac{R}{Z} = \frac{E_R}{E_A}$ <p>**TP = AP \times PF</p> <p>TP = Watts</p> <p>***AP = Volt-Amperes</p> <p>Phase $\angle = \angle\theta$</p> <p>*PF = Power factor</p> <p>**TP = True power</p> <p>***AP = Apparent power</p>	$Z = \sqrt{R^2 + X_C^2}$ $E_A = \sqrt{E_R^2 + E_C^2}$ $I_T = I_R = I_C$ $E_A = I_T Z$ <p>PF = Cos $\angle\theta$</p> $\text{Cos } \angle\theta = \frac{R}{Z} = \frac{E_R}{E_A}$ <p>PF = AP \times PF</p> <p>TP = Watts</p> <p>AP = Volt-Amperes</p> <p>Phase $\angle = \angle\theta$</p>
Series RLC Circuits	Series RC Circuits
$Z = \sqrt{R^2 + (X_L - X_C)^2}$ $F_A = \sqrt{E_R^2 + (E_L - E_C)^2}$ $I_T = I_R = I_L = I_C$ <p>Cos $\angle\theta$ = Power factor (PF)</p> $\text{Cos } \angle\theta = \frac{R}{Z} = \frac{E_R}{E_A}$ $E_A = I_T Z$ <p>TP = AP \times Cos $\angle\theta$</p> <p>AP = V \times A</p>	$X_L = X_C$ resonance $E_L = E_C$ resonance $I_T = \text{Maximum } (\infty)$ $Z = \text{Minimum } (0)$
Coil Merit (No Unit of Measurement)	
$Q = \frac{X_L}{R}$	

TABLE 14-1
Electrical and Electronic Formulas (*continued*)

Resonance	
$f_r = \frac{1}{2\pi\sqrt{LC}} \quad \text{or} \quad f_r = \frac{0.159}{\sqrt{LC}}$	
Parallel RL Circuits	Parallel RC Circuits
$Z = \frac{E_A}{I_T}$ $E_A = E_R = E_L$ $I_T = \sqrt{I_R^2 + I_L^2}$ $\text{Cos } \angle\theta = \frac{I_R}{I_T}$ $\text{PF} = \text{Cos } \angle\theta$ $\text{TP} = \text{AP} \times \text{PF}$ $\text{Phase } \angle = \angle\theta$	$Z = \frac{E_A}{I_T}$ $E_A = E_R = E_C$ $I_T = \sqrt{I_R^2 + I_C^2}$ $\text{Cos } \angle\theta = \frac{I_R}{I_T}$ $\text{PF} = \text{Cos } \angle\theta$ $\text{TP} = \text{AP} \times \text{PF}$ $\text{Phase } \angle = \angle\theta$
Parallel RCL Circuits	
$Z = \frac{E_A}{I_T}$ $E_A = E_R = E_L = E_C$ $I_T = \sqrt{I_R^2 + (I_L - I_C)^2}$ $\text{Phase } \angle = \angle\theta$	$\text{Cos } \angle\theta = \frac{I_R}{I_T}$ $\text{TP} = \text{AP} \times \text{PF} \text{ (Watts)}$ $\text{AP} = \text{V} \times \text{A} \text{ (Volt-Amperes)}$ $\text{PF} = \text{Cos } \angle\theta$
Antiresonance	
Parallel LC Circuits	or Tank Circuits
$X_L = X_C$ $Z = \text{maximum } (\infty)$ $I_{\text{line}} = \text{minimum } (0)$	$I_{\text{circulating}} = I_C \text{ or } I_L$ $I_C = \frac{E_A}{X_C} I_L = \frac{E_A}{X_L}$

288 CHAPTER FOURTEEN

electromotive force E divided by the resistance R . Or, in mathematical terms

$$I = \frac{E}{R} \quad (14-1)$$

Figure 14-1 shows how you can develop the formula for Ohm's law rather quickly and accurately. Let your finger cover the letter representing the value you are looking for, and the remaining two letters will show you the relationship between them by being situated either one on top of the other (division) or one next to the other (multiplication).

■ EXAMPLE 14-1

A resistor has a voltage of 120 volts applied to its 40 ohms of resistance. What is the current that will flow through the resistor?

Step 1. Decide which formula to use. Since the unknown is the current I , the formula to use is

$$I = \frac{E}{R} \quad (14-2)$$

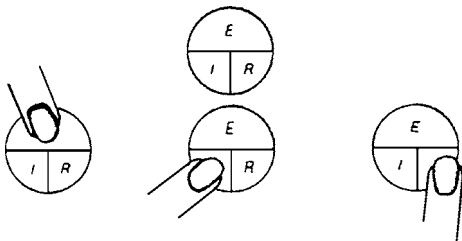


FIGURE 14-1. Graphic representation of Ohm's law.

Step 2. Substitute the known values—voltage E and resistance R —in the formula.

$$I = \frac{120}{40} \quad (14-3)$$

Step 3. Perform the mathematical operation—in this case, division.

$$I = 3 \text{ amperes}$$

■ EXAMPLE 14-2

How much voltage do you need to cause 2 amperes to flow through a resistance of 20 ohms?

Step 1. Decide which formula to use. Since the unknown is the voltage E , the formula to use is

$$E = I \times R$$

Step 2. Substitute the known values—the current I and resistance R —in the formula.

$$E = 2 \times 20$$

Step 3. Perform the mathematical operation—in this case, multiplication.

$$E = 40 \text{ volts}$$

■ EXAMPLE 14-3

What is the resistance of a circuit that has a voltage source of 24 volts pushing 6 amperes through a resistor?

Step 1. Determine the unknown and use the appropriate formula.

$$R = \frac{E}{I} \quad (14-4)$$

290 CHAPTER FOURTEEN

Step 2. Substitute the known values in the formula.

$$R = \frac{24}{6} \quad (14-5)$$

Step 3. Perform the mathematical operation.

$$R = 4 \text{ ohms}$$

USING POWER FORMULAS

A certain amount of power is expended whenever an electric current is passed through a load, such as a resistor. This energy is dissipated in the form of heat, which must be dissipated into the surrounding medium. The amount of heat that can be dissipated from the surface of the resistor determines its wattage rating, or power rating.

The unit of measure for electric power is the watt W. The watt was named for James Watt (1736–1819), a Scottish engineer and the inventor of the modern condensing steam engine, one of the first sources of mechanical power.

The watt is mathematically equal to the product of the voltage E and current I ,

$$P(\text{power in watts}) = E \times I$$

Many relationships between P , E , R , and I can be obtained by using simple algebra.

$$P = E \times I \quad P = \frac{E^2}{R} \quad (14-6)$$

$$I = \frac{P}{E} \quad P = I^2 R \quad (14-7)$$

■ EXAMPLE 14-4

What is the power consumed by an electric iron that has 120 volts at 10 amperes?

Step 1. Determine which formula to use. Since you know the voltage E and the current I , the formula to use is

$$P = E \times I$$

Step 2. Substitute the known values in the formula.

$$P = 120 \times 10$$

Step 3. Perform the mathematical computation.

$$P = 1200 \text{ watts}$$

■ EXAMPLE 14-5

How much current does a 120-volt, 60-watt light bulb pull?

Step 1. Determine which formula to use. Since you know the voltage E and the wattage, or power P , the formula to use is

$$I = \frac{P}{E} \quad (14-8)$$

Step 2. Substitute the known values in the formula.

$$I = \frac{60 \text{ W}}{120 \text{ V}} \quad (14-9)$$

Step 3. Perform the mathematical computation.

$$I = 0.5 \text{ ampere}$$

■ EXAMPLE 14-6

What is the current required to light a 120-volt, 15-watt light bulb to full brilliance?

Step 1. Use the appropriate formula—in this case

$$I = \frac{P}{E} \quad (14-10A)$$

TABLE 14-2
Current Drawn by Different Wattage Bulbs on a 120-Volt Circuit

Voltage 120	
Wattage	Current (amperes)
15	0.1250
25	0.2083
40	0.3330
60	0.5000
75	0.6250
100	0.8333
150	1.2500
200	1.6660
300	2.5000

Step 2. Substitute the known factors in the equation.

$$I = \frac{15}{120} \quad (14-10B)$$

Step 3. Perform the mathematical computation.

$$I = 0.125 \text{ amperes}$$

Power formulas can be developed, and the current that each wattage of light bulb will draw on a 120-volt circuit can be determined. (See Table 14-2) This type of table is handy when you need to compute how much current a circuit of so many light bulbs will draw, and it also helps in selecting the right size of wire for a job.

POWER FACTOR

The power factor (PF) is the ratio of true power (TP) to apparent power (AP), or

$$\text{PF} = \frac{\text{TP}}{\text{AP}} \quad (14-11)$$

where, true power is given in watts W and apparent power in volt-amperes VA . Therefore, the power factor relationship can also be expressed as

$$PF = \frac{W}{VA} \quad (14-12)$$

■ EXAMPLE 14-7

If true power is 100 watts and apparent power is 120 volt-amperes, what is the power factor?

Step 1. Use the correct formula.

$$PF = \frac{TP}{AP} = \frac{W}{VA} \quad (14-13)$$

Step 2. Substitute the known factors in the equation.

$$PF = \frac{100}{120} \quad (14-14)$$

$$PF = 0.8$$

Step 3. Perform the mathematical computation.

$$PF = 0.8$$

NOTE

An important fact to remember with power factors is that the ratio is never greater than 1. For estimating purposes, the power factor in any circuit can be assumed to be as follows:

Incandescent light circuit	0.95 to 1.0 PF
Lighting and motors	0.85 PF
Motors only	0.80 PF

The power factor formula can also be used to show other relationships. If, for example, in a direct-current circuit, true power

is expressed in kilowatts (kW) and apparent power as the product of kilovolts and amperes (kVA), then

$$\text{kW} = \frac{E \times I}{1000} = \frac{\text{kVA}}{1000} \quad (14-15)$$

For alternating current,

$$\text{kW} = \text{kVA} \times \text{PF}$$

DETERMINING DIFFERENT PHASE POWER

If the voltage E and current I are known, the power factor (PF) can be used to determine different phase power in kilowatts (kW). To determine three-phase power (3Φ) use the formula

$$\text{kW} = \frac{1.73 \times E \times I \times \text{PF}}{1000} \quad (14-16)$$

To determine two-phase power (2Φ), use the formula

$$\text{kW} = \frac{2 \times E \times I \times \text{PF}}{1000} \quad (14-17)$$

To determine single-phase power (1Φ), use the formula

$$\text{kW} = \frac{E \times I \times \text{PF}}{1000} \quad (14-18)$$

If you wish to have the answer in wattage, eliminate dividing by 1000, and then your answer will be in watts.

CONNECTIONS AND RESISTANCE IN THREE-PHASE POWER

Most commercial power is generated as three-phase. There are two types of three-phase hookups: delta *and* wye. Delta and wye connections are used in connecting transformers and in connecting the

loads to these power sources. A three-phase delta resembles the Greek letter delta (Δ) that is triangular in shape and the three-phase wye is shaped like the letter "Y."

WYE CONNECTION

The wye connection in Figure 14-2 has terminals labeled a , b , and c , and a common point called the neutral, shown at point 0. The terminal pairs, a - b , b - c , c - a , provide the three-phase supply.

In this connection, the line voltage is $\sqrt{3}$, which is 1.732050808 times the coil voltage, while the line current is the same as the coil current. The neutral point normally is grounded. It can be brought out to the power-consuming device by way of a four-wire power system for a dual voltage supply. This means it can produce a 120/208-volt system. If three wires are used and connected to points a , b , and c , then three-phase alternating current (AC) is available for use with motors and other loads. If you are using a 208-volt system, you know that you have a wye-connected transformer supplying the power. Single-phase AC is available if you connect from 0 to any one of the points a , b , or c . From 0 to a will produce 120 volts of single-phase AC. From 0 to b will produce

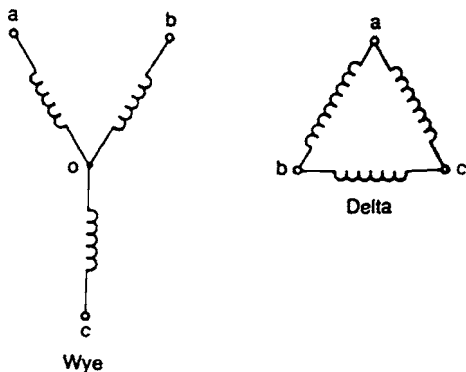


FIGURE 14-2. Wye and delta networks.

120 volts of single-phase AC, and from 0 to c will also produce 120 volts of single-phase AC.

DELTA CONNECTION

The delta connection has an advantage in current production because two of the coils are in series with each other and parallel with the third. A parallel arrangement produces better current availability. The voltage available from any two terminals, a to b , b to c , or c to a , is the same. This voltage is also single-phase. However if you wish to have 240 volts of three-phase AC, all you need to do is bring out three wires—one each from point a , point b , and point c . The current available in a three-phase delta connection is $\sqrt{3}$ times the current capability of any one coil.

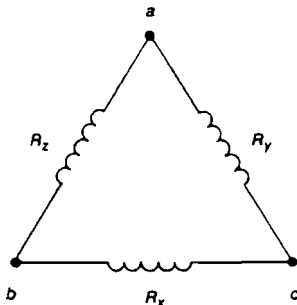


FIGURE 14-3. Delta network.

DELTA AND WYE RESISTOR CIRCUITS

In the delta network (See Figure 14-3) the resistance between terminals may be determined by combining the formulas for series and parallel resistances:

$$a \text{ to } b = \frac{R_z(R_x + R_y)}{R_z + (R_x + R_y)} \quad (14-19)$$

$$a \text{ to } c = \frac{R_y(R_x + R_z)}{R_y + (R_x + R_z)} \quad (14-20)$$

$$b \text{ to } c = \frac{R_x(R_z + R_y)}{R_x + (R_z + R_y)} \quad (14-21)$$

To simplify resistor networks for determining equivalent resistances, it is frequently necessary to convert a delta network to a wye (see Figure 14-4), or a wye to a delta. The mathematics for such conversions is simple and based on the formulas for series and parallel resistance.

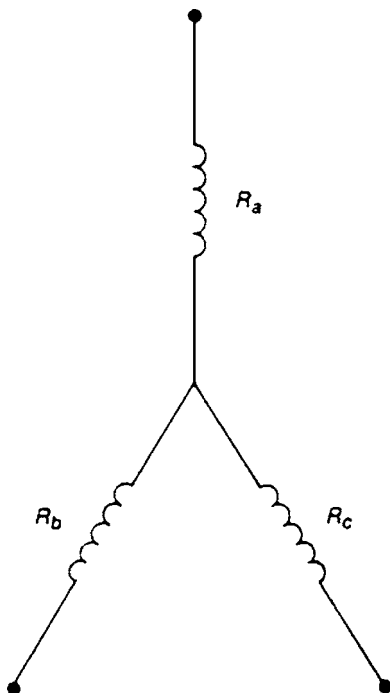


FIGURE 14-4. Wye network.

298 CHAPTER FOURTEEN

To convert from wye to delta, the formulas to use are

$$R_x = \frac{R_a R_b + R_b R_c + R_c R_a}{R_a} \quad (14-22)$$

$$R_y = \frac{R_a R_b + R_b R_c + R_c R_a}{R_b} \quad (14-23)$$

$$R_z = \frac{R_a R_b + R_b R_c + R_c R_a}{R_c} \quad (14-24)$$

To convert from delta to wye, the formulas to use are

$$R_a = \frac{R_x \times R_y}{R_x + R_y + R_z} \quad (14-25)$$

$$R_b = \frac{R_y \times R_z}{R_x + R_y + R_z} \quad (14-26)$$

$$R_c = \frac{R_x \times R_z}{R_x + R_y + R_z} \quad (14-27)$$

Simply put in the correct values, then multiply and add to obtain the desired results, using transformer formulas.

A transformer, you remember, is a device that increases or decreases voltage by inducing electrical energy from one coil to another through magnetic lines of force. The amount of voltage induced on either side (primary or secondary) of a transformer depends directly on the number of turns. The back electromotive force induced by the changing current in the primary is not equal to the electromotive force induced in the secondary unless the number of turns in the primary equals the number in the secondary. However, since the back electromotive force in the primary is equal to the applied voltage, a ratio may be set up to determine the electromotive force induced in the secondary in terms of applied voltage and the turns ratio of the two coils. The formula is

$$\frac{E_p}{T_p} = \frac{E_s}{T_s} \quad (14-28)$$

where

E_s is the voltage induced in the secondary

E_p is the voltage induced in the primary

T_p is the number of turns in the primary

T_s is the number of turns in the secondary.

The formula may also be written as

$$E_p T_s = E_s T_p$$

Another form of the formula is

$$E_s = \frac{E_p T_s}{T_p} \quad (14-29)$$

■ EXAMPLE 14-8

A transformer with 1000 turns in the secondary and 250 turns in the primary has a turn ratio of 4:1. If 120-volts AC is applied to the primary of this transformer, what is the voltage induced in the secondary?

Step 1. Decide which formula to use. Since you know the number of turns in the primary and secondary, the formula to use is

$$E_s = \frac{E_p T_s}{T_p} \quad (14-30)$$

Step 2. Substitute the known values and perform the mathematics computation.

$$E_s = \frac{120 \times 1000}{250} \quad (14-31)$$

$$E_s = \frac{120,000}{250} \quad (14-32)$$

$$E_s = 480 \text{ volts}$$

300 CHAPTER FOURTEEN

This means that the transformer in question is a step-up transformer because the secondary voltage is greater than the primary voltage, or in other words, the voltage has been stepped up.

The number of volts per turn in a transformer can also be determined using the formula

$$\left[\frac{\text{number of turns}}{\text{voltage}} \right]$$

If you have 675 turns for a 115-volt primary, then 675 divided by 115 means you have 5 turns per volt in the primary. Then, if you want to make a 12-volt secondary, you simply multiply the 5 turns-per-volt times the 12 volts you need in the secondary. This means you have to put 60 turns in the secondary to produce 12 volts of output. The correct number of turns in the secondary can be figured rather quickly using this method.

If you need to put 900 turns in the primary to increase the X_L of the transformer primary and have it draw less current while sitting idle on the line, then you divide the 900 turns by the 120 volts of the line and you get 7.5 turns per volt. Then, if you need 12 volts for the secondary voltage, take the 12 and multiply it by 7.5 to get the 90 turns needed to provide the voltage. Don't forget to add about 5% to make up for the inefficiency of the transformer.

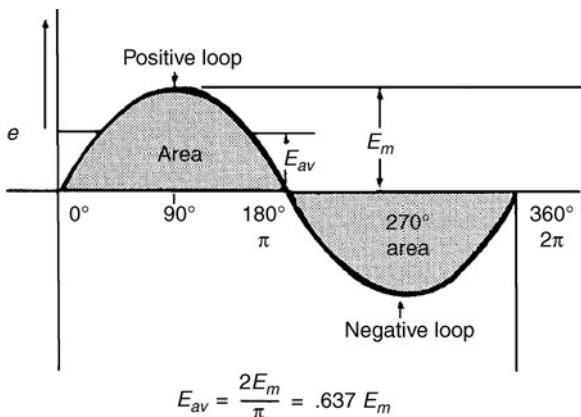
This is a step-down transformer, since the secondary voltage is lower than the primary voltage.

USING ALTERNATING CURRENT FORMULAS

A sine wave is the signature of AC. It has two alternations per hertz, or cycle. It is the alternation that is examined. This is to obtain the rms, the peak value E_m and the average values E_{av} of AC. See Figure 14-5.

RMS

The abbreviation *rms* means root-mean-square, the value used when a meter is calibrated to read voltage or current. When we say 120-volts AC, we really mean it is 120-volts rms. The rms is a way of equating AC and DC. It is the heating effect of AC compared to DC.



E_m = Peak voltage

E_{av} = Average voltage

FIGURE 14-5. A sine wave is the signature of alternating current.

A DC power source provides a steady voltage that rises almost instantaneously and stays at that level with no cooling period. AC varies, causing the resistor to heat up slowly and then cool down. This is why AC has only 70.71% of the heating value of an equal amount of DC. Remember this when comparing AC and DC systems.

PEAK VALUE

Peak is the maximum or highest point on the sine wave. To convert rms to peak, multiply by 1.414. A 120-volt rms thus has a 169.68-volt peak.

Peak-to-peak (p-p) is a term used to describe the signal voltage in television receivers. It is a term used more with electronics than with electrical work.

TABLE 14-3
Formulas for Motor Applications

<p> T = torque or twisting moment (force \times moment arm length) π = 3.1416 N = revolutions per minute HP = horsepower (33,000 lb-ft per min) applies to power output R = radius of pulley, in feet E = input voltage I = current in amperes P = power input in watts $\text{HP} = \frac{T(\text{lb-in}) \times N(\text{rpm})}{63,025}$ $\text{HP} = T(\text{oz-in}) \times N \times 9.917 \times 10^{-7}$ $= \text{approx } T(\text{oz-in}) \times N \times 10^{-6}$ $P = EI \times \text{power factor} = \frac{\text{HP} \times 746}{\text{motor efficiency}}$ </p>
Power to Drive Pumps
<p> $\text{HP} = \frac{\text{gal per min} \times \text{total head (including friction)}}{3960 \times \text{eff of pump}}$ </p> <p>where</p> <p> $\text{Approx friction head (ft)} = \frac{\text{pipe length (ft)} \times [\text{velocity of flow (fps)}]^2 \times 0.02}{5.367 \times \text{diameter (in)}}$ </p> <p>Eff = Approx 0.50 to 0.85</p>
Time to Change Speed of Rotating Mass
<p> $\text{Time (sec)} = \frac{WR^2 \times \text{change in rpm}}{308 \times \text{torque (lb-ft)}}$ </p> <p>where</p> <p> $WR^2(\text{disc}) = \frac{\text{Weight (lb)} \times [\text{radius (ft)}]^2}{2}$ </p> <p> $WR^2(\text{rim}) = \frac{\text{Wt. (lb)} \times [(\text{outer radius in ft})^2 + (\text{inner radius in ft})^2]}{2}$ </p>
Power to Drive Fans
<p> $\text{HP} = \frac{\text{Cu ft air per min} \times \text{water gage pressure (in)}}{6.350 \times \text{eff}}$ </p>

AVERAGE VALUE

The average value of a sine wave function is defined as the area under one loop divided by the base of the loop. It is the average value of AC being delivered. The base of one loop is 180° or pi (π) radians in length. However, in order to find the area of such an irregular surface as a sine loop, the figure must be broken down into a series of small rectangles, the areas of which can be easily determined. The sum of all these small areas will then be the area of the loop.

To convert from peak to average, multiply by 0.637. The 169.68-volt peak (given earlier) would then have an average of 108.

FORMULAS USED WITH MOTORS

Working with motors sometimes requires the use of special formulas—for example, to figure the horsepower of a motor or to determine the power needed to drive a pump or a fan. Table 14.3 gives abbreviations used in dealing with motors and useful formulas.

This page intentionally left blank

Basic Electronics

Electronics got its start with the invention of the vacuum tube. A vacuum tube has the ability to rectify and to amplify. Edison was experimenting with his first electric lamp when he discovered that the frequent burning out of the carbon filament near the positive end produced a black deposit inside the bulb and a shadow on the positive leg of the lamp filament. He tried to remedy the condition by placing a metal plate inside the lamp near the filament and connecting it through a galvanometer to the filament battery. When the positive terminal was connected to the metal plate, a deflection of the galvanometer was observed. When the plate was connected to the negative terminal, there was no deflection of the galvanometer. Edison recorded these effects in his notebook but did not pursue the phenomenon.

Sir J. J. Thomson, an English physicist, discovered the electron around the turn of the century. Once the electron was discovered and defined, it was an easy task to describe what happened during the “Edison effect.” Electrons escaped from the heated carbon filament and, being negatively charged, moved freely through the vacuum to the plate when it was connected to the positive battery terminal. However, when the plate was negative, the electrons were repelled, and no deflection was observed on the galvanometer.

The vacuum tube diode was the first device to take advantage of the Edison effect. It was made to *rectify* alternating current (AC)—that is, to change the AC to direct current (DC).

DIODES

There are two types of diodes. One is the vacuum tube diode, and the other is the semiconductor diode. Both types possess two elements: a cathode and an anode. These elements have polarity. A cathode in a vacuum tube is labeled negative (-), and the anode positive (+). In a semiconductor device, the cathode is positive, which is indicated by a ring around one end of the diode. Both types of diode serve the same functions: They rectify current and they are used for switching operations.

Diodes can also be broken down into two other groups—power diodes and signal diodes. Power diodes handle large power requirements in power supplies and they are used to change AC to pulsating DC. They can be either vacuum tubes or semiconductors. Signal diodes are smaller than power diodes and may be either vacuum tubes or semiconductors. As semiconductors, they are very small and encapsulated in plastic or glass.

RECTIFIER DIODES

The actual size of these semiconductor diodes is small, but they can handle up to 6 amperes at 400 volts and are very inexpensive. When properly used in circuits that do not exceed their ratings, they will last for many years. Rectifier diodes are identified by three or four numbers with a 1N or MR prefix. See Figure 15-1 for the wide range of currents and voltages available, and see how the characteristic numbers are used to identify them.

BRIDGE RECTIFIERS

Bridge rectifiers are made up of four diodes. They produce a full-wave rectification so that both halves of the wave are utilized in power supplies. They are found in many devices from battery chargers to meters. Many electrical power supplies have bridge rectifiers. They are packaged in a variety of forms. See Figure 15-2.

DIACS

This device [diode (two-element) AC switch] is used in switching-amplifier control systems. It is used in combination with a triac to



Description	Industry Part No.
1 AMP 50V	1N4001
1 AMP 500V	1N4002
1 AMP 200V	1N4003
1 AMP 400V	1N4004
1 AMP 400V	1N4004
1 AMP 600V	1N4005
1 AMP 100V	1N4007
1 AMP 100V	1N4007
3 AMPS 100V	1N5401
3 AMPS 200V	1N5402
3 AMPS 300V	1N5403
3 AMPS 400V	1N5404
3 AMPS 600V	1N5406
6 AMPS 200V	MR751
6 AMPS 200V	MR752
6 AMPS 400V	MR754
3 AMPS 100V FAST RECOVERY	MR851
3 AMPS 400V FAST RECOVERY	MR854
1 AMP 50V FAST RECOVERY	1N4933
1 AMP 100V FAST RECOVERY	1N4934
1 AMP 600V FAST RECOVERY	1N4937

FIGURE 15-1. Rectifier diodes are available in a wide range of currents and voltages.

serve as a light dimmer and to regulate the speed of electric motors. The diac is made specifically to trigger triacs, but is also useful in conjunction with silicon-controlled rectifiers. It will trigger with either positive or negative pulses. See Figure 15-3.

SILICON CONTROLLED RECTIFIERS (SCRs)

These are also called thyristors. They have many uses, such as for speed controls, light dimmers, and many other control circuits. See Figure 15-4.

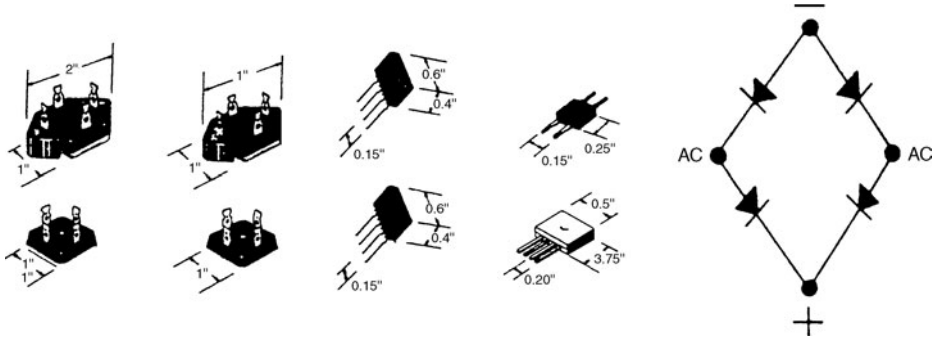


FIGURE 15-2. Bridge rectifiers, packaged in many forms, are found in a variety of different devices.

TRIACS

The triac [standing for triode (three-element) AC switch] can be triggered by positive and negative gate signals and conducts during both halves of the AC cycle. This device is used in level controls, light dimmers, and speed controls for motors. See Figure 15-5.

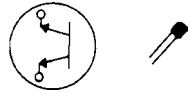


FIGURE 15-3. A diac, or diode AC switch, is used with triacs and SCRs.

SWITCHING AND SIGNAL DIODES

These diodes are for small currents and voltages less than 100. They can be found in many older devices of the germanium type. Switching diodes are used for computer and control circuits. See Table 15-1.

ZENER DIODES

This type of diode is used for voltage regulation and is found in almost every piece of industrial and commercial electronics equipment or control device. The zener is also prefixed with a 1N designation. Wattage ratings are from 400 milliwatts to 5 watts. Be sure to obtain the right wattage rating if you want the diode to operate without burning up. Zener diodes resemble the standard rectifier diode in appearance. However, the symbol for the zener is slightly different, so it can be spotted on a schematic. See Table 15-2.

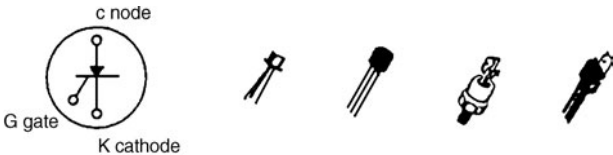


FIGURE 15-4. A silicon-controlled rectifier (SCR), also called a thyristor, is used in many control circuits.

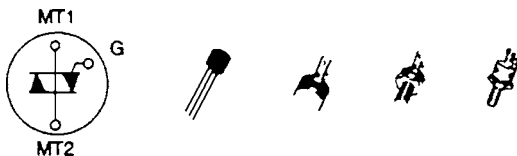


FIGURE 15-5. A triac, or triode AC switch, is used in level controls and speed control devices.

INTEGRATED CIRCUITS (ICS)

A single, monolithic chip of semiconductor was developed in 1958. J S. Kilby was responsible for its fabrication. Active and passive circuit elements were successively diffused and deposited on a single chip. Shortly afterward, Robert Noyce made a complete circuit in a single chip. This led the way to the modern, inexpensive integrated circuits.

Resistors, capacitors, and transistors, as well as diodes, can be placed on a chip. Diodes can be arranged in many groups to do different things. Photolithography, a combination of photographic advertisement printing techniques, has been used to aid in the layout of the diode arrangement and has made it possible to mass-produce sophisticated devices with high reliability.

TABLE 15-1
Switching and Signal Diodes

Description	Industry Part No.	Description	Industry Part No.
5MA 60V germanium signal	1N34A	200 mA 50V switching	1N4150
200 mA 100V switching	1N270	100 mA 25V switching	1N4154
200 mA 75V switching	1N914B	200 mA 70V switching	1N4446
200 mA 75V switching	1N4148	200 mA 75V switching	1N4448

TABLE 15-2
Zener Diodes Quick Reference Guide Low Power 500 mW

Nominal Voltage V_2	400 mW DO-35	500 mW DO-35	400 mW DO-7		500 mW DO-7	250 & 400 mW DO-7	250 mW DO-7
1.8 2.0 2.2 2.4 2.5		1N5985	1N4370		1N5221 1N5222	1N4614 1N4615 1N4616 1N4617	1N4678 1N4679 1N4680 1N4681
2.7 2.8 3.0 3.3 3.6		1N5986 1N5987 1N5988 1N5989	1N4371 1N4372 1N746 1N747		1N5223 1N5224 1N5225 1N5226 1N5227	1N4618 1N4619 1N4620 1N4621	1N4682 1N4683 1N4683 1N4684 1N4685
3.9 4.3 4.7 5.1 5.6	 1N5728B 1N5729B 1N5730B	1N5990 1N5991 1N5992 1N5993 1N5994	1N748 1N749 1N750 1N751 1N752		1N5228 1N5229 1N5230 1N5231 1N5232	1N4622 1N4623 1N4624 1N4625 1N4626	1N4686 1N4687 1N4688 1N4689 1N4690
6.0 6.2 6.8 7.5 8.2	 1N5731B 1N5732B 1N5733B 1N5734B	1N5995 1N5996 1N5997 1N5998	1N753 1N754 1N755 1N756	 1N957 1N958 1N959	1N5233 1N5234 1N5235 1N5236 1N5237	1N4627 1N4099 1N4100 1N4101	1N4691 1N4692 1N4693 1N4694

(continued)

TABLE 15-2
Zener Diodes Quick Reference Guide Low Power 500 mW (continued)

Nominal Voltage V_2	400 mW DO-35	500 mW DO-35	400 mW DO-7		500 mW DO-7	250 & 400 mW DO-7	250 mW DO-7
8.7					1N5238	1N4102	1N4695
9.1	1N5735B	1N5999	1N757	1N960	1N5239	1N4103	1N4696
10	1N5736B	1N6000	1N757	1N961	1N5240	1N4104	1N4697
11	1N5737B	1N6001		1N962	1N5241	1N4105	1N4698
12	1N5738B	1N6002	1N758	1N963	1N5242	1N4106	1N4699
13	1N5739B	1N6003		1N964	1N5243	1N4107	1N4700
14					1N5244	1N4108	1N4701
15	1N5740B	1N6004		1N965	1N5245	1N4109	1N4702
16	1N5741B	1N6005		1N966	1N5246	1N4110	1N4703
17					1N5247	1N4111	1N4704
18	1N5742B	1N6006		1N967	1N5248	1N4112	1N4705
19					1N5249	1N4113	1N4706
20	1N5743B	1N6007		1N968	1N5250	1N4114	1N4707
25					1N5253	1N4117	1N4710
27	1N5746B	1N6010		1N971	1N5254	1N4118	1N4711
28					1N5255	1N4119	1N4712
30	1N5747B	1N6011		1N972	1N5256	1N4120	1N4713
33	1N5748B	1N6012		1N973	1N5257	1N4121	1N4714
36	1N5749B	1N6013		1N974	1N5258	1N4122	1N4715
39	1N5750B	1N6014		1N975	1N5259	1N4123	1N4716
43	1N5751B	1N6015		1N976	1N5260	1N4124	1N4717
47	1N5752B	1N6016		1N977	1N5261	1N4125	1N4718
51	1N5753B			1N978	1N5262	1N4126	

56			1N979	1N5263	1N4127	
60				1N5264	1N4128	
62			1N980	1N5265	1N4129	
68			1N981	1N5266	1N4130	
75			1N982	1N5267	1N4131	
82			1N983	1N5268	1N4132	
87				1N5269	1N4133	
91			1N984	1N5270	1N4134	
100			1N985	1N5271	1N4135	
110			1N986	1N5272		
120			1N987	1N5273		
130			1N988	1N5274		
140				1N5275		
150			1N989	1N5276		
160			1N990	1N5277		
170				1N5278		
180			1N991	1N5279		
190				1N5280		
200			1N992	1N5281		

(continued)

TABLE 15-2
Medium Power 1 through 5 Watts (continued)

Nominal Voltage V_2	1 Watt DO-41	1 Watt DO-13	1 Watt Case J	2 Watt Case J	3 Watt Case J	5 Watt Case T-18
3.3	1N4728A	1N3821	1N4728			1N5333
3.6	1N4729A	1N3822	1N4729	2EZ3.6D5		1N5334
3.9	1N4730A	1N3823	1N4730	2EZ3.9D5	3EZ3.9D5	1N5335
4.3	1N4731A	1N3824	1N4731	2EZ4.3D5	3EZ4.3D5	1N5336
4.7	1N4732A	1N3825	1N4732	2EZ4.7D5	3EZ4.7D5	1N5337
5.1	1N4733A	1N3826	1N4733	2EZ5.1D5	3EZ5.1D5	1N5338
5.6	1N4734A	1N3827	1N4734	2EZ5.6D5	3EZ5.6D5	1N5339
6.0						1N5340
6.2	1N4735A	1N3828	1N4735	2EZ6.2D5	3EZ6.2D5	1N5341
6.8	1N4736A	1N3829	1N3016 1N4736	2EZ6.8D5	3EZ6.8D5	1N5342
7.5	1N4737A	1N3830	1N3017 1N4737	2EZ7.5D5	3EZ7.5D5	1N5343
8.2	1N4738A		1N3018 1N4738	2EZ8.2D5	3EZ8.2D5	1N5344
8.7						1N5345
9.1	1N4739A		1N3019 1N4739	2EZ9.1D5	3EZ9.1D5	1N5346
10	1N4740A		1N3020 1N4740	2EZ10D5	3EZ10D5	1N5347
11	1N4741A		1N3021 1N4741	2EZ11D5	3EZ11D5	1N5348
12	1N4742A		1N3022 1N4742	2EZ12D5	3EZ12D5	1N5349
13	1N4743A		1N3023 1N4743	2EZ13D5	3EZ13D5	1N5350
14				2EZ14D5	3EZ14D5	1N5351
15	1N4744A		1N3024 1N4744	2EZ15D5	3EZ15D5	1N5352

16	1N4745A	1N3025	1N4745	2EZ16D5	3EZ16D5	1N5353
17				2EZ17D5	3EZ17D5	1N5354
18	1N4746A	1N3026	1N4746	2EZ18D5	3EZ18D5	1N5355
19				2EZ19D5	3EZ19D5	1N5356
20	1N4747A	1N3027	1N4747	2EZ20D5	3EZ20D5	1N5357
22	1N4748A	1N3028	1N4748	2EZ22D5	3EZ22D5	1N5358
24	1N4749A	1N3029	1N4749	2EZ24D5	3EZ24D5	1N5359
25						1N5360
27	1N4750A	1N3030	1N4750	2EZ27D5	3EZ27D5	1N5361
28						1N5362
30	1N4751A	1N3031	1N4751	2EZ30D5	3EZ30D5	1N5363
33	1N4752A	1N3032	1N4752	2EZ33D5	3EZ33D5	1N5364
36	1N4753A	1N3033	1N4753	2EZ36D5	3EZ36D5	1N5365
39	1N4754A	1N3034	1N4754	2EZ39D5	3EZ39D5	1N5366
43	1N4755A	1N3035	1N4755	2EZ43D5	3EZ43D5	1N5367
47	1N4756A	1N3036	1N4756	2EZ47D5	3EZ47D5	1N5368
51	1N4757A	1N3037	1N4757	2EZ51D5	3EZ51D5	1N5369
56		1N3038	1N4758	2EZ56D5	3EZ56D5	1N5370
60					3EZ60D5	1N5371
62		1N3039	1N4759	2EZ62D5	3EZ62D5	1N5372
68		1N3040	1N4760	2EZ68D5	3EZ68D5	1N5373
75		1N3041	1N4761	2EZ75D5	3EZ75D5	1N5374
82		1N3042	1N4762	2EZ82D5	3EZ82D5	1N5375
87						1N5376
91		1N3043	1N4763	2EZ91D5	3EZ91D5	1N5377
100		1N3044	1N4764	2EZ100D5	3EZ100D5	1N5378
110		1N3045	1EZ110D5	2EZ110D5	3EZ110D5	1N5379
120		1N3046	1EZ120D5	2EZ120D5	3EZ120D5	1N5380
130		1N3047	1EZ130D5	2EZ130D5	3EZ130D5	1N5381
140			1EZ140D5	2EZ140D5	3EZ140D5	1N5382

(continued)

TABLE 15-2
Medium Power 1 through 5 Watts (*continued*)

Nominal Voltage V_2	1 Watt DO-41	1 Watt DO-13	1 Watt Case J	2 Watt Case J	3 Watt Case J	5 Watt Case T-18
150		1N3048	1EZ150D5	2EZ150D5	3EZ150D5	1N5383
160		1N3049	1EZ160D5	2EZ160D5	3EZ160D5	1N5384
170			1EZ170D5	2EZ170D5	3EZ170D5	1N5385
180		1N3050	1EZ180D5	2EZ180D5	3EZ180D5	1N5386
190			1EZ190D5	2EZ190D5	3EZ190D5	1N5387
200		1N3051	1EZ200D5	2EZ200D5	3EZ200D5	1N5388

Integrated circuits are packaged in a number of types of ceramic and plastic cases. They may have four or as many as 48 pins. The identification of the pins starts with the notch in the top of the case. Usually it will also have a dot on top to indicate the No. 1 pin. See Figure 15-6.

Integrated circuits are relatively standardized. This is partly to take advantage of mass-production techniques. Standard components and connections are needed if the finished electronic equipment is to be low in cost.

Large numbers of ICs are used in computers and calculators, as well as in television and other communication equipment. They are small and very reliable, and they consume little power. It is possible to obtain ICs with large memory capacities. Thousands of

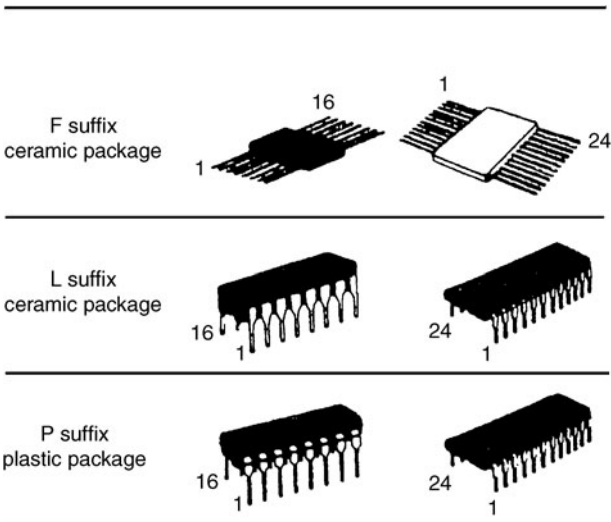


FIGURE 15-6. Integrated circuits with from 4 to as many as 48 pins are packaged in a variety of ceramic and plastic cases.

electronic elements may be placed on a single chip; this is done through a method known as large-scale integration (LSI).

Robotics uses electronics. Electricians wire the installations and are responsible for getting power to the control consoles. Inside the consoles are many types of ICs. Their identification may be very useful. See Figure 15-6. Check catalogs for the right ones for the particular job. In some cases, an IC has been created and manufactured for a specific piece of equipment. Manufacturers' numbers, have to be obtained from the top of the chip in order to replace it with the correct substitute.

OPTOELECTRONIC DEVICES

Optoelectronics has been used in many industrial and commercial operations. Displays are used everywhere to indicate calculator results, cash register amounts, weights on digital scales, and readouts on digital meters. Photo diodes, infrared-emitting diodes, and photo detectors, as well as phototransistors, reflective object sensors, and infrared light-emitting diodes (LEDs) are used in industry in control devices. Many of these are also used in fiber optics through which telephone messages are transmitted and received.

DISPLAYS

The seven-element LED display comes in five sizes. This type of display produces light and can be used where there is no ambient light. It usually glows red. Optoelectronic displays are used wherever a sturdy readout is needed. They can be replaced if soldered in place or in sockets. The right size is important when trying to locate a replacement.

Liquid crystal displays (LCDs) need ambient light in order to be seen. They do not use much energy, working with microwatts of power, whereas the LED display that glows brightly enough to be seen in the dark or daylight draws more energy in terms of milliwatts.

Light-emitting diodes are available with either common cathodes or common anodes. In the former (common cathode) case, particular segments are energized when a positive voltage is applied to them, with the remainder "down." In the latter (common anode)

case, energized portions are “high,” and those portions to be energized are “low,” i.e., at 0 volts. A 7447 decoder is needed to illuminate the appropriate segments of the display.

LIGHT-EMITTING DIODES (LEDS)

The light-emitting diode is used for indicator lights, calculator numerical displays, and computer display systems. The LED is a PN junction diode, operating in a forward-biased mode. Recombinations of electrons and holes release the stored energy in the excited electrons. The P-type gallium arsenide LED must be made very thin for efficient light output. Electrons are pumped up by an externally supplied direct current.

LEDs are used as infrared sources for many sensing operations in industry. Along with reflective object sensors, they can be used to count and do quality control operations. The photo sensor responds to infrared radiation from the LED only when a reflective object is within its field of view.

OPTICAL COUPLERS

The triac-driven opto-couplers each contain a gallium arsenide or gallium aluminum arsenide infrared-emitting diode coupled to a photodiode and a zero-voltage bidirectional triac driver mounted in a standard six-pin dual in-line package (DIP), the type ICs use. These devices are intended to be used for low-power DC control of power triacs, which in turn control resistive, inductive, or capacitive loads powered from the 120-volt AC or 220-volt AC with required LED drive currents of 30, 15, 10, or 5 milliamperes. Zero-voltage crossing ensures that the device will not turn on until the line voltage reduces to 15 volts for the 120-volt devices and 25 volts for the 220-volt devices.

TRANSISTORS

Transistors are semiconductor devices made from N- and P-type crystals. Once joined, the two different types of crystal produce junctions. Transistors are identified according to emitter junction and collector junction.

320 CHAPTER FIFTEEN

A PNP transistor is formed by a thin N region between two P regions. The center N region is called the base. This base is usually 0.001 inch thick. A collector junction and an emitter junction are also formed.

NPN and PNP transistors (see Figure 15-7) are the two most popular types. The main difference between the two transistors is in polarity. Polarity can be recognized by pin locations on transistors. Pin designations for specific transistors are found in a transistor handbook.

The important thing to remember in transistor circuits is polarity and voltage. The polarity of the voltage is very important in the proper operation of the transistor. NPN and PNP types differ only in their polarity.

Surface-mounted technology has increased efficiency and lowered the cost of integrated circuits for control circuits and computers. See Figure 15-8.

Transistors

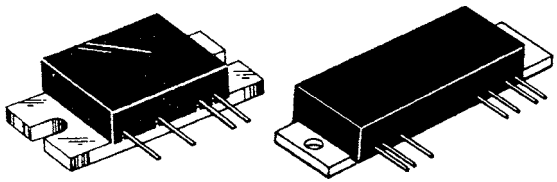
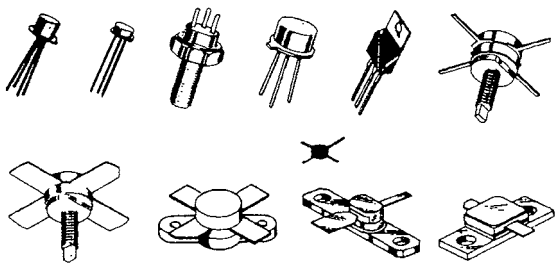
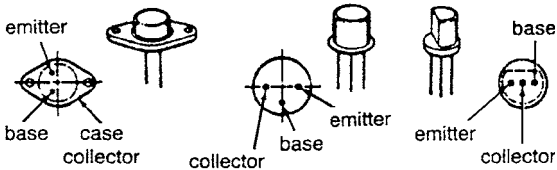
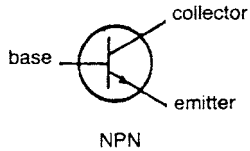
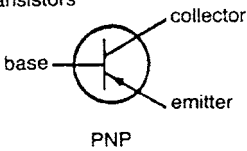
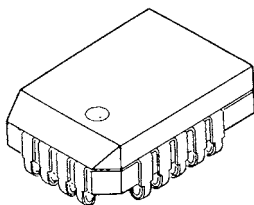
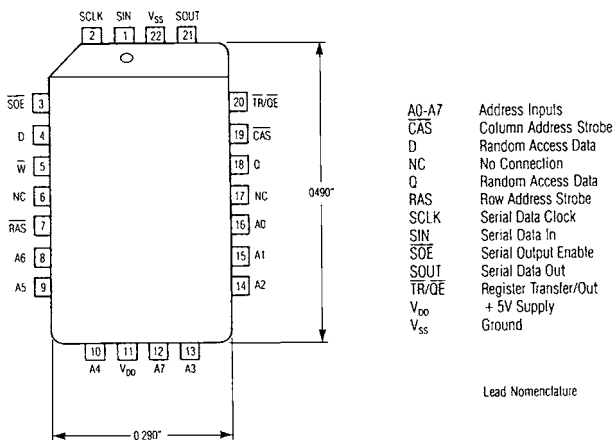
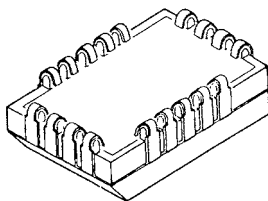


FIGURE 15-7. The two most popular types of transistors, PNP and NPN, come in a wide variety of pin designations.

322 CHAPTER FIFTEEN



A Top View



B Bottom View

FIGURE 15-8. Surface-mount components represent the latest in integrated circuits. The unit can be surface mounted or soldered in place easier and more quickly than previously.

How to Measure

The electrician frequently needs to measure when on the job. The measurements may be linear—for example, measuring lines on a blueprint and understanding what they represent or measuring lengths of wire or distances between switches or outlets. Measurements may also be of wire diameter or of electrical phenomena such as current, voltage, or resistance.

Devices and tools are available for all of these and other types of measurement the electrician may be called on to do. Some of these were discussed earlier. Here we discuss how to use some of the most frequently employed measuring devices. However, before doing this, we should point out there are many terms and abbreviations used in measuring electrical phenomena—terms not used in other fields and often not familiar to the layperson. The electrician and apprentice must be thoroughly familiar with all of these terms.

USING SCALES AND RULES

The engineer uses several types of scales and rules on the job. These are used to read blueprints, to

- Measure the length of wire
- Locate switch boxes
- Do many other things

ARCHITECT'S SCALE

The architect's scale is most often used by the electrician when reading blueprints, which allows the use of the same scale as that used to make the drawing.

Figure 16-1 shows how the architect's scale is used to measure to scale. Figure 16-1a shows a scale that is 12 inches long (see top part of drawing). A 1/8 -inch scale is visible at the top edge. This means that 1/8-inch is equal to 1 foot, unless otherwise noted on the drawing. Figure 16-1b shows the same scale, extended to 24 inches. Notice that units are numbered at intervals of 4. Remember, however, that each long line equals 1 foot. If, for example, you read between 0 and 23 on the scale, you have 23 feet. Then, if the line you are measuring is a little more than 23 feet but not 24 feet, read backward from 0 on the graduated scale. You are measuring halfway between 0 and the end of the scale. The halfway mark is

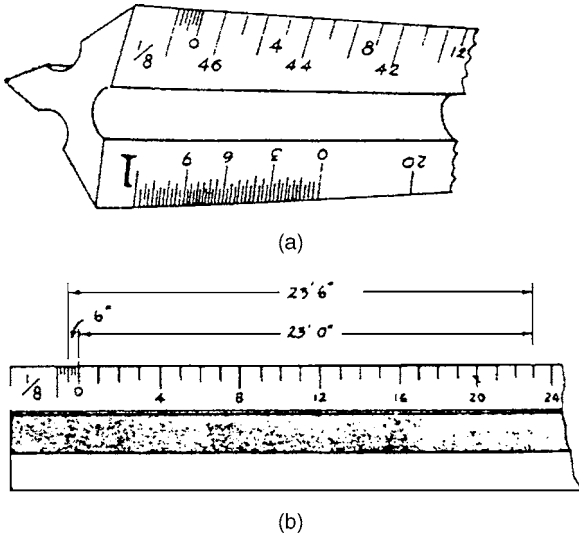


FIGURE 16-1. Architect's scale.



FIGURE 16-2. Flat rulers.

1/2 foot, or 6 inches. (Each of the small lines in the portion between the 1/8 scale marking and 0 represents 2 inches.) The line you have measured, therefore, represents 23 feet 6 inches.

FLAT RULE

The flat 6-inch rule is used the same way as any scale if it is calibrated the same way. See Figure 16-2. The top rule is divided into 1/16 of an inch and 1/32 of an inch. This type of rule comes in handy in a machine shop and in reading a map scale where, for example, 1/32 inch equals 50 miles. An electrician may use this type of ruler when studying a large map showing where a building is to be erected.

The bottom rule in Figure 16-2 is a 6-inch ruler that is divided into four spaces per 1 inch and eight spaces per 1 inch. This type of ruler can be used to make accurate measurements on blueprints.

FOLDING RULE

The 6-foot folding rule is easily carried in the pocket; it is rugged and can take the abuse it is subjected to, on the job. Electricians need this type of measuring device to estimate wire lengths and to measure the height of boxes off the floor and the locations of switch boxes, among other uses. See Figure 16-3.

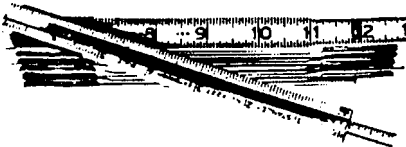


FIGURE 16-3. Folding rule.

USING WIRE GAGES

A wire gage is a tool used to measure the size of a wire. The wire being checked is pushed from the outside to the inside of the gage slot. The size of the slot is the actual size of the wire. However, if the wire is covered with insulation or other covering, you must allow for the thickness of the covering. For example, an insulated wire that reads No. 13 on the gage is really a No. 14 wire with a one-size coating.

One commonly used wire gage is the American standard wire gage. It is especially useful for measuring sheets, plates, and wire made from nonferrous metals, such as aluminum, brass, and copper. This gage has a table on the back that gives the diameter of the various wires in decimal form. See Figure 16-4.

Another wire gage commonly used is the Stub's iron wire gage, commonly known as the Birmingham gage. This gage is used to measure drawn steel wire or drill rod and gives the sizes in Stub's soft-wire sizes.

Table 16-1 shows dimensions of wire in decimal parts of an inch for different sizes of wire on several commonly used wire gages.

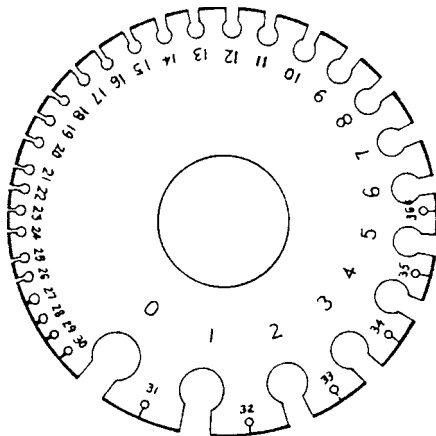


FIGURE 16-4. Wire gage.

TABLE 16-1
Standards for Wire Gages (Dimensions of Sizes in Decimal Parts of an inch)

No. of Wire	American or Brown & Sharpe for Nonferrous Metals	Birmingham or Stub's Iron Wire	American S. & W.'s (Washburn & Moen) Std. Steel Wire	American S. & W.'s Music Wire	Imperial Wire	Stub's Steel Wire	U.S. Std. Gage for Sheet & Plate Iron & Steel	No. of Wire
7-0's	0.651354	—	0.4900	—	0.500	—	0.500	7-0's
6-0's	0.580049	—	0.4615	0.004	0.464	—	0.46875	6-0's
5-0's	0.516549	0.500	0.4305	0.005	0.432	—	0.4375	5-0's
4-0's	0.460	0.454	0.3938	0.006	0.400	—	0.40625	4-0's
000	0.40964	0.425	0.3625	0.007	0.372	—	0.375	000
00	0.3648	0.380	0.3310	0.008	0.348	—	0.34375	00
0	0.32486	0.340	0.3065	0.009	0.324	—	0.3125	0
1	0.2893	0.300	0.2830	0.010	0.300	0.227	0.28125	1
2	0.25763	0.284	0.2625	0.011	0.276	0.219	0.265625	2
3	0.22942	0.259	0.2437	0.012	0.252	0.212	0.250	3
4	0.20431	0.238	0.2253	0.013	0.232	0.207	0.234375	4
5	0.18194	0.220	0.2070	0.014	0.212	0.204	0.21875	5
6	0.16202	0.203	0.1920	0.016	0.192	0.201	0.203125	6
7	0.14428	0.180	0.1770	0.018	0.176	0.199	0.1875	7
8	0.12849	0.165	0.1620	0.020	0.160	0.197	0.171875	8
9	0.11443	0.148	0.1483	0.022	0.144	0.194	0.15625	9
10	0.10189	0.134	0.1350	0.024	0.128	0.191	0.140625	10
11	0.090742	0.120	0.1205	0.026	0.116	0.188	0.125	11
12	0.080808	0.109	0.1055	0.029	0.104	0.185	0.109375	12
13	0.07196	0.095	0.0915	0.031	0.092	0.182	0.09375	13
14	0.064084	0.083	0.0800	0.033	0.080	0.180	0.78125	14

USING ELECTRICAL METERS

There are many types of meters used to measure electrical quantities:

- Clamp-on meter
- Digital readout meter
- Volt-ohm-milliammeter (VOM)

AC CLAMP-ON METERS

The alternating current (AC) clamp-on meter is inserted over a wire carrying AC. The magnetic field around the wire induces a small amount of current in the meter. Because the wire is run through the large loop extending past the meter movement, it is possible to read the current without removing the insulation from the wire. These meters are very useful when working with AC motors and other high-current devices. Volts can be measured by using test leads and probes that fit into holes on the side of the meter. See Figure 16-5.

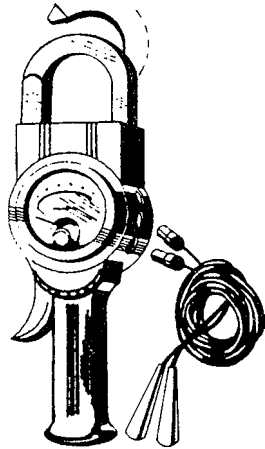


FIGURE 16-5. AC clamp-on meter.

DIGITAL METER

The digital meter is a portable, self-contained, battery-powered meter that is electronic. It uses printed circuits and integrated circuit chips to measure and calculate voltage, resistance, or current. There are no coils or magnets. The digital reading is indicated on a liquid crystal display (LCD). See Figure 16-6.

Most digital meters have a number of voltage ranges, and you must select the range each time you measure. Others are auto-ranging, selecting the proper range and measuring the voltage without the need for such preselections. The operator must indicate if volts, ohms, or amps are to be measured.

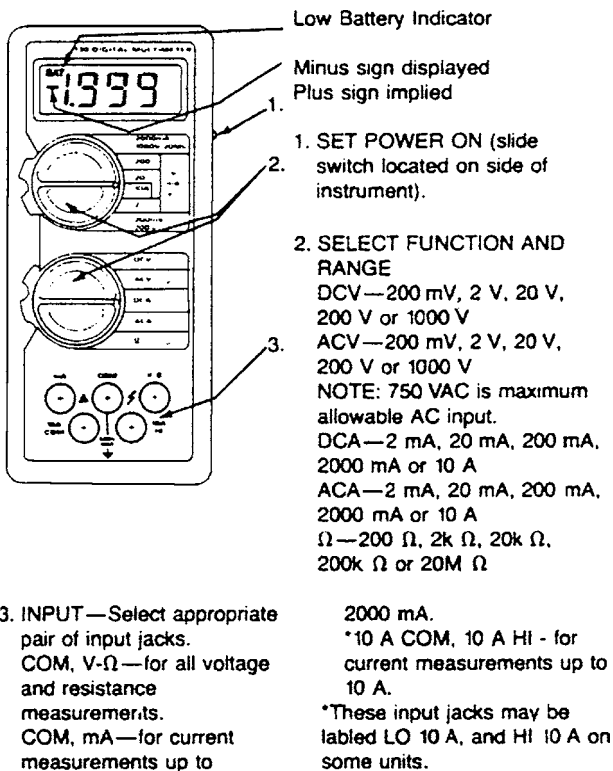


FIGURE 16-6. Digital meter.

VOM

The VOM is a multi-range, multi-purpose meter that has been around for a long time. It serves many useful functions for electricians and electronic technicians.

330 CHAPTER SIXTEEN

A VOM has its own batteries for measuring ohms on a number of ranges and shunts to increase the range for measuring amperes as well as milliamperes. The voltage scale is extended by using multipliers that allow measuring DC voltage and small diodes that allow the reading of AC volts. See Figure 16-7.

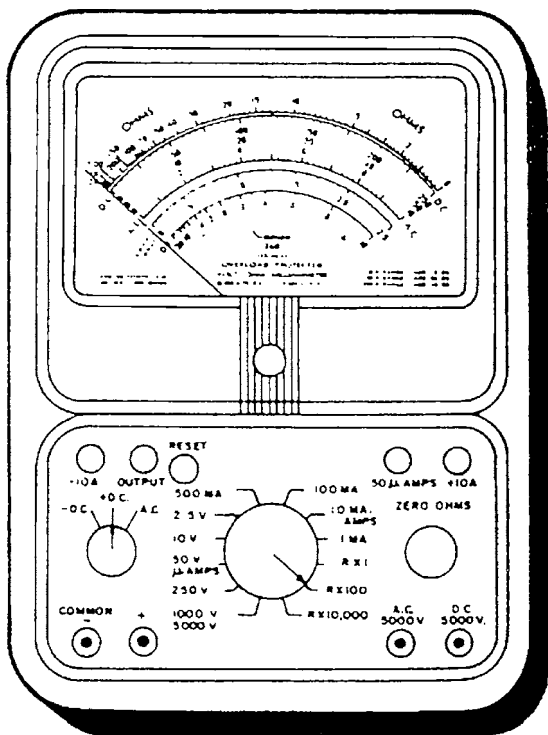


FIGURE 16-7. Volt-ohm-milliammeter (VOM).

The main thing to keep in mind when using a VOM is to be sure the meter is set to measure the unit you wish to measure. In other words, if you wish to measure ohms, be sure the meter is set to measure ohms, not voltage. If, for example, you try to measure voltage when the meter is set to measure resistance (ohms), the meter resistors may burn out and the meter may be rendered inoperative for other uses. Another caution: be sure the proper range is set for reading amperes so that the meter movement is not destroyed by too much current.

This page intentionally left blank

Appendix 1

Rules of Safety

Strange as it may seem, most fatal electrical shocks happen to people who should know better. Some electromedical facts will make you think twice before taking chances.

It's not the voltage but the current that kills. People have been killed by 100 volts AC in the home and with as little as 42 volts DC. Any electrical device used on a house wiring circuit can under certain conditions, transmit a fatal amount of current.

Currents between 100 and 200 milliamperes (0.1 and 0.2 amperes) are fatal. Anything in the neighborhood of 10 milliamperes (0.01 amperes) is capable of producing painful to severe shock. See Table A1-1.

As the current rises, the shock becomes more severe. Below 20 milliamperes, breathing becomes labored; it ceases completely even at values below 75 milliamperes. As the current approaches 100 milliamperes ventricular fibrillation occurs. This is an uncoordinated twitching of the walls of the heart's ventricles.

Since you don't know how much current went through the body, it is necessary to perform artificial respiration to try to get the person breathing again; or if the heart is not beating, cardiopulmonary resuscitation (CPR) is necessary.

FIRST AID FOR ELECTRIC SHOCK

Shock is a common occupational hazard associated with working with electricity. A person who has stopped breathing is not

TABLE A1-1
Physiological Effects of Electric Currents

	Readings	Effects
Safe current values	1 mA or less	Causes no sensation—not felt.
	1 to 8 mA	Sensation of shock, not painful; individual can let go at will since muscular control is not lost.
	8 to 15 mA	Painful shock; individual can let go at will since muscular control is not lost.
Unsafe current values	15 to 20 mA	Painful shock; control of adjacent muscles lost; victim cannot let go.
	50 to 100 mA	Ventricular fibrillation—a heart condition that can result in instant death—is possible.
	100 to 200 mA	Ventricular fibrillation occurs.
	200 and over	Severe burns, severe muscular contractions—so severe that chest muscles clamp the heart and stop it for the duration of the shock. (This prevents ventricular fibrillation.)

Source: Information provided by National Safety Council.

necessarily dead but is in immediate danger. Life is dependent on oxygen, which is breathed into the lungs and then carried by the blood to every body cell. Since body cells cannot store oxygen and since the blood can hold only a limited amount (and only for a short time), death will surely result from continued lack of breathing. However, the heart may continue to beat for some time after breathing has stopped, and the blood may still be circulated to the body cells, since the blood will, for a short time, contain a small supply of oxygen, the body cells will not die immediately. For a very few minutes, there is some chance that the person's life may be saved.

The process by which a person who has stopped breathing can be saved is called artificial ventilation (respiration). The purpose of artificial respiration is to force air out of the lungs and into the

lungs, in rhythmic alternation, until natural breathing is reestablished. Records show that seven out of 10 victims of electric shock were revived when artificial respiration was started in less than 3 minutes. After 3 minutes, the chances of revival decrease rapidly.

Artificial ventilation should be given only when the breathing has stopped. Do not give artificial ventilation to any person who is breathing naturally. You should not assume that an individual who is unconscious due to electrical shock has stopped breathing. To tell if someone suffering from an electrical shock is breathing, place your hands on the person's sides at the level of the lowest ribs. If the victim is breathing, you will usually be able to feel movement.

Once it has been determined that breathing has stopped, the person nearest the victim should start the artificial ventilation immediately and send others for assistance and medical aid. The only logical, permissible delay is that required to free the victim from contact with the electricity in the quickest, safest way. This step, while it must be taken quickly, must be done with great care otherwise there may be two victims instead of one.

In the case of portable electric tools, lights, appliances, equipment, or portable outlet extensions, the victim should be freed from contact with the electricity by turning off the supply switch or by removing the plug from its receptacle, if the switch or receptacle cannot be quickly located, the suspected electrical device may be pulled free of the victim. Other persons arriving on the scene must be clearly warned not to touch (the suspected equipment until it is de-energized).

The injured person should be pulled free of contact with stationary equipment (such as a bus bar) if the equipment cannot be quickly de-energized or if the survival of others relies on the electricity and prevents immediate shutdown of the circuits. This can be done quickly and easily by carefully applying the following procedures:

- Protect yourself with dry insulating material.
- Use a dry board, belt, clothing, or other available nonconductive material to free the victim from electrical contact.
- Do *not* touch the victim until the source of electricity has been removed.

Once the victim has been removed from the electrical source, it should be determined whether the person is breathing. If the person is not breathing, a method of artificial respiration is used.

CARDIOPULMONARY RESUSCITATION

Sometimes victims of electrical shock suffer cardiac arrest or heart stoppage as well as loss of breathing. Artificial ventilation alone is not enough in cases where the heart has stopped. A technique known as CPR has been developed to provide aid to a person who has stopped breathing and suffered a cardiac arrest. Because you are working with electricity, the risk of electrical shock is higher than in other occupations. You should at the earliest opportunity, take a course to learn the latest techniques used in CPR. The techniques are relatively easy to learn and are taught in courses available through the American Red Cross.

NOTE

A heart that is in fibrillation cannot be restarted by closed-chest cardiac massage. A special device called a defibrillator is available in some medical facilities and ambulance services. Muscular contractions at 200 milliamperes are so severe that the heart is forcibly clamped during the shock. This clamping prevents the heart from going into ventricular fibrillation, making the victim's chances for survival better.

SAFETY MEASURES

Working with electricity can be dangerous. However, electricity can be safe if properly respected.

USING GROUND FAULT CIRCUIT INTERRUPTERS

Some dangerous situations have been minimized by using ground fault circuit interrupters (GFCIs). See Figure A1-1. Since 1975, the National Electrical Code (NEC) has required installation of GFCIs in outdoor and bathroom outlets in new construction, but most homes built before 1975 have no GFCI protection.

Retrofit GFCIs that can protect one outlet or an entire circuit with multiple outlets can be installed in older homes to reduce the danger. One of the simplest ways to achieve this protection in an

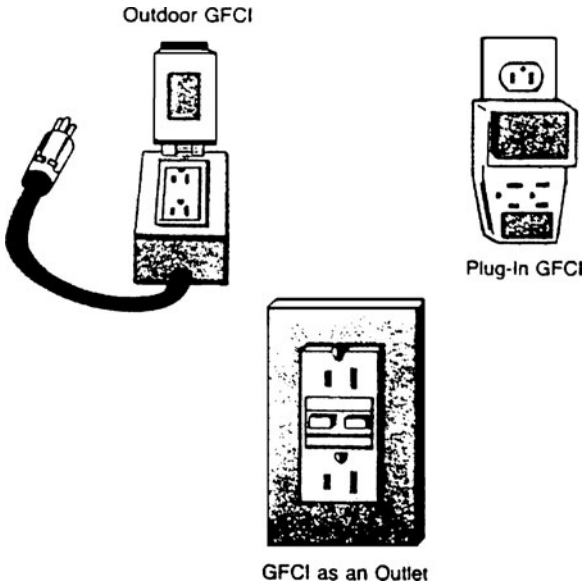


FIGURE A1-1. A ground fault circuit interrupter (GFCI) is now required by the NEC in all outdoor and bathroom outlets.

outdoor outlet or other outlets in which shock dangers are high is to use a plug-in GFCI.

Two kinds of plug-ins are available. One has contact prongs attached to the housing, and it is simply plugged into a grounded outlet. The device to be used is plugged into a receptacle in the housing of the GFCI.

Another GFCI, more suitable for outdoor use, has a heavy-duty housing attached to a short extension cord. The extension cord type of GFCI is easily plugged into an outdoor outlet without its becoming entangled in the outlet's lid or cover.

Back in 2002 the NEC code changed and the Panel decided it was safer to require an *in-use weatherproof cover* to be installed for

all outdoor applications regardless if it is a GFCI or a standard receptacle or whether or not it is attended.

Keep in mind that GFCIs are not foolproof. However, they do switch off the current in less than 0.025 second if a leakage is detected. They can detect as little as 2 milliamperes, although most operate at a threshold of 5 milliamperes—well below the level that would affect a person.

FOLLOWING CODE REQUIREMENTS FOR GROUNDING CONDUCTORS

The National Electrical Code requires a system-grounding conductor be connected to any local metallic water-piping system which is available on the premises. That is provided the length of the buried water piping is a minimum of 10 feet. If the system is less than 10 feet, or if the electrical continuity is broken by either disconnection or nonmetallic fittings, then it should be supplemented by the use of an additional electrode of a type specified by the NEC.

AVOIDING HAZARDOUS SITUATIONS

Ground fault circuit interrupters are not always effective, especially under wet conditions. Fatal shocks are most likely under damp or wet conditions or if the user of an electrical device is touching a metal object such as a ladder or pipe. See Figure A1-2. In such a situation the person completes the circuit to ground and the ground fault circuit interrupter detects the leakage of current through the circuit, which includes the person. See Figure A1-3.

It is impractical to list all of the electrical shock hazards that might exist on the job, but those listed in Table A1-2 may be helpful in locating hazardous situations.

EXTENSION CORDS

Extension cords are used on the job for many purposes. However, if not carefully chosen for the job and properly cared for, they too can be hazardous.

The main concern is the insulation and the wire size needed to carry the current. Table A1-3 shows the current-carrying capacity

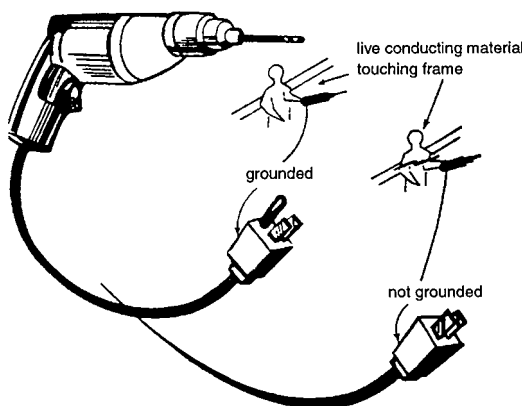


FIGURE A1-2. A person using a tool with an ungrounded plug may receive a shock, especially if he or she is touching a grounded metal object.

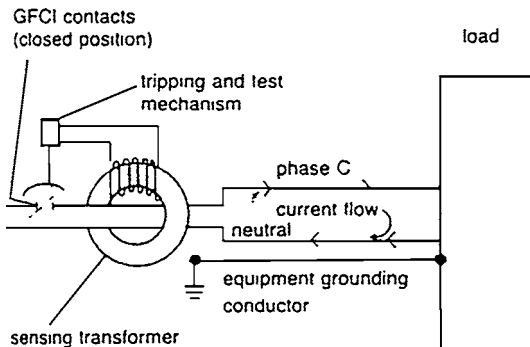


FIGURE A1-3. A GFCI detects any leakage of current in a circuit and thus prevents shock.

TABLE A1-2
Common Electrical Shock Hazards in Industry

Unsafe Physical Conditions	Control Measures
Worn insulation on extension and drop cords splices on cords.	Install a system of inspection and preventive maintenance to uncover dangerous conditions and to correct them. Use UL-approved materials only. Spliced cords should be removed from service.
Exposed conductors at rear of switchboard.	Enclose rear of switchboard to prevent exposure of unauthorized persons. Provide rubber mats for workers who must enter the enclosure.
Open switches and control apparatus on panel and switchboards, location of machine switches.	Provide enclosed safety switches. Insulate with rubber mats in front of switch and control equipment. Locate machine switches so as not to create hazard to the operator.
Unsafe wiring practices such as using wires too small for the current being carried, open wiring not in conduit, temporary wiring, and wiring improperly located.	Comply with recognized electrical code. Remove temporary wiring as soon as it has served its purpose.
The accidental energizing of non-current-carrying parts of machines and tools by means of short circuit, breaks in insulation, etc.	Properly ground all non-current-carrying parts of machines, tools, and frames of control equipment.

Unsafe Actions

Control Measures

Working on “live” low-voltage circuits in the belief that they are not hazardous. Working on live circuits that are thought to be “dead.”	Educate and train workers in the hazards of low-voltage circuits.
Replacing fuses by hand on live circuits. Using 120-volt lighting circuits for work in boiler or other similar enclosures. Overloading circuits beyond their capacity. Abusing electrical equipment and poor housekeeping about electrical equipment.	Require that switches on all circuits being worked on be locked open and properly tagged. Use protective equipment such as rubber gloves and blankets. Open switch before replacing fuses. Use fuse pullers. Use low-voltage circuits: 6 volts for lighting, not over 30 volts for power. Lock fuse boxes to prevent bridging or replacing with heavier fuse. Institute safe work practices, with inspection and preventive maintenance of equipment. Improve housekeeping practices.

Source: Courtesy of the National Safety Council.

*Tinsel cord.

†Elevator cables only.

‡7 amperes for elevator cables only, 2 amperes for other types.

Note: The allowable currents under Column A apply to three-conductor cords and other multiconductor cords connected to utilization equipment so that only three conductors are current carrying. The allowable currents under Column B apply to two-conductor cords and other multiconductor cords connected to utilization equipment so that only two conductors are current carrying.

Source: Reprinted with permission from NFPA, National Electrical Code, Copyright 2005. National Fire Protection Association, Quincy, MA 02269. This reprinted material is not the complete and official position of the NFPA on the referenced subject which is represented only by the standard in its entirety.

344 APPENDIX ONE

of flexible cords. If the wrong length of cord is selected for a particular tool, then it is possible to reduce the voltage available at the piece of equipment, relying on the power source to supply the correct voltage. Table A1-4 shows the size of extension cords that should be used for portable electric tools.

PLUGS AND RECEPTACLES

Plugs and receptacles must match the job at hand. Each type of receptacle is designed to handle a specific amount of voltage and current. Figure A1-4 shows how this is done by simply looking up the circuit requirements. The figure shows which receptacle to install for the current and voltage requirements of the circuit or device. Some plug-in electrical devices are designed to reduce the danger of electrical shock and have plastic housings, double insulation, and other safety features.

HAZARDOUS LOCATIONS

Hazardous locations are classified into three main classes, which are further broken down into divisions. The classes and divisions of hazardous locations established by the National Electrical Code are listed in Table A1-5.

SAFETY EQUIPMENT AND CLOTHING

Electricians who work on lines must wear the proper clothing and safety equipment. However, most of this work is done by persons trained by local utilities. The lineman's equipment includes an electrician's safety belt and gloves. Proper headgear, eyeglasses, shoes, and outer clothing should be chosen for the job.

At increased voltages, the line worker has a special equipment checklist to follow and routines to use in making sure the equipment is in good condition and that the gloves have not become infected with bacterial growths that could cause electrical conduction.

TABLE A1-4
Size of Extension Cords for Portable Electric Tools

For 115-Volt Tools						
Full-Load Ampere Rating of Tool	Wire Size (AWG)					
	0 to 2 A	2.1 to 3.4 A	3.5 to 5 A	5.1 to 7 A	7.1 to 12 A	12.1 to 16 A
Length of Cord	Wire Size (AWG)					
25 feet	18	18	18	16	14	14
50 feet	18	18	18	16	14	12
75 feet	18	18	16	14	12	10
100 feet	18	16	14	12	10	8
200 feet	16	14	12	10	8	6
300 feet	14	12	10	8	6	4
400 feet	12	10	8	6	4	4
500 feet	12	10	8	4	6	2
600 feet	10	8	6	4	2	2
800 feet	10	8	6	4	2	1
1000 feet	8	6	4	2	1	0

Note: If the voltage is already low at the source (outlet), increase to standard voltage or use a much larger cable than listed in order to prevent any further loss in voltage.

Source: Reprinted with permission from NFPA, National Electrical Code, Copyright 2005. National Fire Protection Association, Quincy, MA 02269. This reprinted material is not the complete and official position of the NFPA on the referenced subject that is represented only by the standard in its entirety.

346 APPENDIX ONE

Wiring Diagram	NEMA ANSI	Receptacle Configuration	Rating		Rating	Receptacle Configuration	NEMA ANSI	Wiring Diagram
	5-15 C73.11		15A 125V	2 POLE 3 WIRE	3P3W	30A 3 ϕ 250V	11-30 C73.56	
	5-20 C73.12		20A 125V			50A 3 ϕ 250V	11-50 C73.57	
	5-30 C73.45		30A 125V			15A 125/250V	14-15 C73.49	
	5-50 C73.46		50A 125V			20A 125/250V	14-20 C73.50	
	6-15 C37.20		15A 250V			30A 125/250V	14-30 C73.16	
	6-20 C73.51		20A 250V			50A 125/250V	14-50 C73.17	
	6-30 C73.52		30A 250V			60A 125/250V	14-60 C73.18	
	6-50 C73.53		50A 250V			15A 3 ϕ 250V	15-15 C73.58	
	7-15 C73.28		15A 277V			20A 3 ϕ 250V	15-20 C73.59	
	7-20 C73.63		20A 277V			30A 3 ϕ 250V	15-30 C73.60	
	7-30 C73.64		30A 277V	50A 3 ϕ 250V	15-50 C73.61			
	7-50 C73.65		50A 277V	60A 3 ϕ 250V	15-60 C73.62			
	10-20 C73.23		20A 125/250V	3 POLE 3 WIRE	4 POLE 4 WIRE	15A 3 ϕ Y 120/208V	18-15 C73.15	
	10-30 C73.24		30A 125/250V			20A 3 ϕ Y 120/208V	18-20 C73.26	
	10-50 C73.25		50A 125/250V			30A 3 ϕ Y 120/208V	18-30 C73.47	
	11-15 C73.54		15A 3 ϕ 250V			50A 3 ϕ Y 120/208V	18-50 C73.48	
	11-20 C73.55		20A 3 ϕ 250V			60A 3 ϕ Y 120/208V	18-60 C73.27	

FIGURE A1-4. Voltage and current ratings for plugs and receptacles.

Rating	Receptacle Configuration	NEMA ANSI	Wiring Diagram	Wiring Diagram	NEMA ANSI	Receptacle Configuration	Rating
3P3W	30A 3 ϕ 480V		L12-30 C73.102			ML2 C73.44	15A 125V
	30A 3 ϕ 600V		L13-30 C73.103			L5-15 C73.42	15A 125V
3 POLE 4 WIRE	20A 125/250V		L14-20 C73.83			L5-20 C73.72	20A 125V
	30A 125/250V		L14-30 C73.84			L5-30 C73.73	30A 125V
	20A 3 ϕ 250V		L15-20 C73.85			L6-15 C73.74	15A 250V
	30A 3 ϕ 250V		L15-30 C73.86			L6-20 C73.75	20A 250V
	20A 3 ϕ 480V		L16-20 C73.87			L6-30 C73.76	30A 250V
	30A 3 ϕ 480V		L16-30 C73.88			L7-15 C73.43	15A 277V
	30A 3 ϕ 600V		L17-30 C73.89			L7-20 C73.77	20A 277V
	20A 3 ϕ Y 120/208V		L18-20 C73.104			L7-30 C73.78	30A 277V
4 POLE 4 WIRE	30A 3 ϕ Y 120/208V		L18-30 C73.105			L8-20 C73.79	20A 480V
	20A 3 ϕ Y 277/480V		L19-20 C73.106			L8-30 C73.80	30A 480V
	30A 3 ϕ Y 277/480V		L19-30 C73.107			L9-20 C73.81	20A 600V
	20A 3 ϕ Y 347/600V		L20-20 C73.108			L9-30 C73.82	30A 600V
	30A 3 ϕ Y 347/600V		L20-30 C73.109			ML3 C73.30	15A 125/250V
	20A 3 ϕ Y 120/208V		L21-20 C73.90			L10-20 C73.96	20A 125/250V
	30A 3 ϕ Y 120/208V		L21-30 C73.91			L10-30 C37.97	30A 125/250V
	20A 3 ϕ Y 277/480V		L22-20 C73.92			L11-15 C73.98	15A 3 ϕ 250V
4 POLE 5 WIRE	30A 3 ϕ Y 277/480V		L22-30 C73.93			L11-20 C73.99	20A 3 ϕ 250V
	20A 3 ϕ Y 347/600V		L23-20 C73.94			L11-30 C73.100	30A 3 ϕ 250V
	30A 3 ϕ Y 347/600V		L23-30 C73.95			L12-20 C73.101	20A 3 ϕ 480V

FIGURE A1-4. (Continued).

TABLE A1-5
Hazardous Location Classifications

Class I— Highly Flammable Gases or Vapors		Class II— Combustible Dusts		Class III— Combustible Fibers or Flyings	
Division 1	Division 2	Division 1	Division 2	Division 1	Division 2
Locations where hazardous concentrations are probable or accidental occurrence should be simultaneous with failure of electrical equipment.	Locations where flammable concentrations are possible, but only in the event of process closures rupture, ventilation failure, etc.	Locations where hazardous concentrations are probable, existence would be simultaneous with electrical equipment failure, or where electrically conducting dusts are involved.	Locations where hazardous concentrations are not likely, but it is where deposits of the dust might interfere with heat dissipation from electrical equipment, or be ignited by electrical equipment.	Locations in which easily ignitable fibers or materials and combustible flyings are handled, manufactured, or used.	Locations in which such fibers or flyings are stored or handled, except in the process of manufacture.

Groups:

- A- Atmospheres containing acetylene
- B- Atmospheres containing hydrogen or gases or vapors of equivalent hazard
- C- Atmospheres containing ethyl ether vapors, ethylene, or cyclopropane
- D- Atmospheres containing gasoline, hexane, naphtha, benzene, butane, propane, alcohol, acetone, benzol, or natural gas
- E- Atmospheres containing metal dust, including aluminum, magnesium, and other metals or equally hazardous characteristics
- F- Atmospheres containing carbon black, coke, or coal dusts
- G- Atmospheres containing flour, starch, or grain dusts

Appendix 2

Codes Standards and Regulations

Since the inception of the electric utility industry, research has made it possible for electricity to transform the way we live at home, on the farm, and in the factory. Research has also transformed the industry.

Thomas Edison's first electric station could transmit electricity only 5000 feet while modern power plants enable a customer to use electricity produced in a power plant many states away. Early generators had a power-producing capacity of only 100 kilowatts, but generators with the ability to produce millions of kilowatts are now in operation. Since 1900, transmission voltages have increased from 30,000 to 500,000 volts, and lines of up to 765,000 volts are now in operation.

In the early 1800s, the New York Board of Fire Underwriters became concerned with the new method of electric lighting proposed by Thomas Edison. Although Edison did not realize the danger of the giant force that he was helping to harness, the New York Board recognized that unless proper precautions were followed the new method of lighting could prove to be as hazardous as the open flame that it was replacing. In 1881, one man was appointed to inspect every electrical installation before power was turned on. This was the beginning of the electrical department of the New York Board. It was necessary for the inspector to check not only the installation within the building but also to carry his investigation back to the power station, which was then only one or two blocks distant. The board at that time investigated the

350 APPENDIX TWO

safety of the entire power system and required the power companies to make weekly tests for grounds and open circuits and to report to the board the results of their tests. In 1882, the committee or surveys drew up a set of safeguards, which was the forerunner of the present *National Electrical Code* for arc and incandescent lighting.

NATIONAL ELECTRICAL CODE

The National Electrical Code (NEC) is the most widely adopted code in the world. Over one million copies of the code are sold each time it is published, which is once every three years. The NEC is a nationally accepted guide for the safe installation of electrical conductors and equipment and is, in fact, the basis for all electrical codes used in the United States. It is also used extensively outside the United States, particularly where American-made equipment are installed. No electrician is without a copy in his or her toolbox.

The code is purely advisory as far as the National Fire Protection Association (NFPA) and American National Standards Institute (ANSI) are concerned, but it is offered for use in law and for regulatory purposes in the interest of life and property protection. Anyone noticing any errors is asked to notify the NFPA Executive Office, the Chairman and the Secretary of the Committee.

CODE BOOK

The *National Electrical Code Handbook* is published by the National Fire Protection Association to assist those concerned with electrical safety in understanding the intent of the code. A verbatim reproduction of the 2005 NEC is included, and comments, diagrams, and illustrations are added where necessary to clarify some of the intricate requirements of the code.

The NEC may be bought in paperback or as a hardcover book. It contains much of the information needed by an electrician on the job. It has definitions of electrical terms; chapters on wiring design and protection, wiring methods and materials, equipment for general use, and special occupancies, equipment, and conditions; sections on communications and tables; an index; and an appendix.

A copy of the book can be obtained from a local bookstore or by writing directly to

National Fire Protection Association (NFPA)
P.O. Box 9101 Batterymarch Park
Quincy, MA 02269-9101

UNDERWRITERS LABORATORIES

William Henry Merrill started the Underwriters Laboratories, Inc. (UL) in 1894. He was called to Chicago to test the installation of Thomas Edison's new incandescent electric lights at the Columbian Exposition. The display had a nasty habit of setting itself on fire. Merrill started the UL to test products for electric and fire hazards for insurance companies. It continued as a testing laboratory for insurance underwriters until 1917. Then it became an independent, self-supporting safety-testing laboratory. The National Board of Fire Underwriters continued as sponsors of the UL until 1968. At that time, sponsorship and membership were broadened to include representatives of consumer interests, governmental bodies or agencies, education, public-safety bodies, public utilities, and the insurance industry, in addition to safety and standardization experts.

The UL has offices in Chicago and Northbrook, Illinois; Melville, New York; and Santa Clara, California.

UL LABEL

The UL label, Figure A2-1, tells you that the product on which the label appears is reasonably free from fire, electric shock, and related accident hazards.

The UL's engineers test products that are voluntarily submitted by manufacturers to see whether the products meet the UL's requirements for safety. A product is tested and analyzed for all reasonably foreseeable hazards.

The UL label is placed on products as they come off the assembly line. The issuance of the label is firmly controlled by the UL and can be obtained only through them. The label should be on the body of the product or on the carton.

The electrician is especially interested in the label on metal boxes for electrical wiring systems. The UL label will be stamped on the

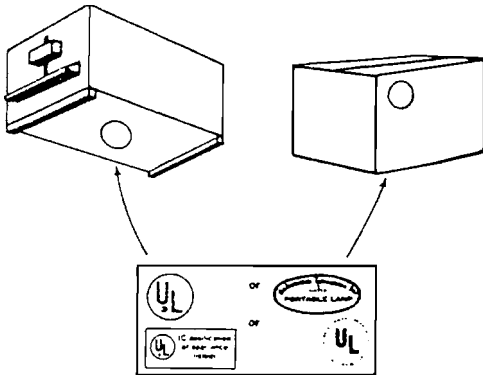


FIGURE A2-1. UL symbol.

side of the metal box so that it cannot be removed. It is indented into the metal. The UL label is placed on cords for lamps, drills, and other electrical equipment if the cord (not necessarily the product it serves) meets the standards of the UL. In some instances, the cord may be approved and not the product it serves. Make sure the electrical device also has the UL label attached for safe operation.

UL ELECTRICAL DEPARTMENT

The electrical department of the UL is the largest of the organization's six engineering departments. Safety evaluations are made on hundreds of different types of appliances for use in the home, commercial buildings, schools, and factories. The scope of the work in this department also includes electrical construction materials used within buildings to distribute electrical power from the meter location to the electrical outlet.

CANADIAN STANDARDS ASSOCIATION

The Canadian Standards Association (CSA) has more authority as an agency than the UL does. The UL program is strictly voluntary.

If an electrical product (or in some cases other type of product used in Canada) is connected in any way with the consumption of power from the electrical power sources owned by the provinces, the product must have CSA approval. The basic objectives of the CSA are

- To develop voluntary national standards
- To provide certification services for national standards
- To represent Canada in international standards activities

CSA headquarters are in Rexdale, Ontario. Professional engineers and skilled lab technicians work with a management team to keep the standards current. Regional offices and test facilities are located in Montreal and Vancouver. A branch office is located in Edmonton, and executive offices are located in the capital city of Ottawa.

STANDARDS DEVELOPMENT

An early role of the CSA was directed toward safety in the operation of electrical appliances and equipment. *The Canadian Electrical Code* was first published by the CSA in 1927. Its recommendations soon became mandatory requirements in every province and the CSA established testing and inspection facilities that enable manufacturers to obtain certification of products that conform to the code. This early example has been followed in many fields—fuel-burning equipment, plumbing products, and plastics, to name a few.

CERTIFICATION PROGRAM

A manufacturer, who may be from any part of the world, may file an application with the CSA. The CSA engineers and technicians inspect and test the product for compliance with an applicable standard. If the product meets the standard (modification may be required), the manufacturer may apply a CSA mark to the product indicating certification. (See Figure A2-2.)

The CSA is the safety testing authority that is accepted by inspection authorities in Canada. Inspectors may drop in unannounced at factories to inspect the quality of the product. See Figure A2-2.



FIGURE A2-2.
CSA symbol.

354 APPENDIX TWO

The CSA symbol on electrical equipment you purchase is an assurance that such equipment has passed rigid inspection. Many electrical wiring devices made in the United States will have the CSA emblem stamped or tagged on them next to the UL label.

STATE AND LOCAL CODES

Some states have prepared special codes and ordinances of their own. These usually apply to electrical systems in public buildings. In most cases, the local rules and regulations are taken from the NEC. Many municipalities adopt the NEC verbatim. This provides some degree of authority to the code, and, in most instances, the municipality will appoint electrical inspectors to check all new construction to make sure it conforms to the code.

In some localities, the soil may be a little different, and special standards have to be established for grounding conductors. There may also be differences in weather conditions that call for some special rules and regulations. The rules have to be adopted by the city, town, county, or state in order for inspection to have any meaning.

Before any building is begun in a community, it is best to check with local regulations for electrical installations.

UTILITY COMPANIES

In most instances, the local utility will have information available that deals with its suggestions for hookup to the utility's lines. Most electric companies have an Adequate Wiring Bureau that you will want to consult before trying to wire a building. If the building does not meet the bureau's standards, the electric company can refuse to connect the building to the company's lines.

WIRING-DEVICE STANDARDS AND REGULATORY AGENCIES

Standards for the manufacture of electrical equipment have to be established in order for the equipment to be used in the wiring of buildings. The important part is to standardize the devices so that

they will still be able to fit regardless of who manufactures the devices. There are agencies that develop standards, rules, and regulations that govern the manufacture of electrical boxes, switches, and wire. Most of these standards are incorporated into the NEC and made law by federal, state, and local governments.

The agencies that have the most to do with establishing these regulations and standards follow.

American Institute of Architects (AIA)

17335 New York Avenue, NW

Washington, DC 20006

www.aiaonline.com

American National Standards Institute, Inc. (ANSI)

1819 L Street, NW

Washington, DC 20036

www.ansi.org

ASTM

100 Barr Harbor Drive

West Conshohocken, PA 19428-2959

(Standard Practices for Security Engineer Symbols)

www.astm.org

Canadian Standards Association (CSA)

178 Rexdale Boulevard

Rexdale, Ontario, Canada

M9W 1R3

General Services Administration (GSA)

Federal Supply Service

Crystal Mall, Bldg. 4

Washington, DC 20406

www.gsa.gov

Illuminating Engineering Society of North America (IESNA)

120 Wall Street

New York; NY 10005-4001

www.iesna.org

National Electrical Contractors Association (NECA)

3 Bethesda Metro Center, Suite 1100

Bethesda, MD 20814

(National Electrical Installation Standards)

www.nec.org

National Electrical Manufacturers Association (NEMA)

1300 North 17th Street, Ste. 1847

356 APPENDIX TWO

Rosslyn, VA 22209

www.nema.org

National Fire Protection Association (NFPA)

P.O. Box 9101 Batterymarch Park

Quincy, MA 02269-9101

www.nfpa.org

Occupational Safety and Health Administration (OSHA)

U.S. Department of Labor

200 Constitution Ave., NW

Washington, DC 20210

www.osha.gov

Underwriter's Laboratories, Inc. (UL)

333 Pfingsten Road

Northbrook, IL 60062

www.ul.com

Standards can take many forms, dictated by the particular object under consideration. For instance, the National Electrical Manufacturers Association (NEMA) has a standard, WD-1. It deals with the definition of terms used in the wiring industry.

Standards are extensively used in the design and installation of the electrical system for any building. It is the responsibility of the electrician to keep informed and updated in terms of changes and equipment available to do the job correctly.

Appendix 3

National Electrical Code Tables

The National Electrical Code provides many tables that present information useful to the electrician in a concise and convenient way. All of the tables are found in the code, *a copy of which every electrician should have in the toolbox at all times*. Remember, the code is updated every three years, and you can obtain new copies from

The National Fire Protection Association
P.O. Box 9101
Quincy, MA 02269-9101.

For your convenience, several of the most frequently used National Electrical Code tables are reprinted here. The table numbers appearing in the actual Code have been retained.

TABLE 210-21 (b)(2)
Maximum Cord- and Plug-Connected Load to Receptacle

Circuit Rating (A)	Receptacle Rating (A)	Maximum Load (A)
15 or 20	15	12
20	20	16
30	30	24

Source: Reprinted with permission from NFPA, National Electrical Code, Copyright 2005. National Fire Protection Association, Quincy, MA 02269. This reprinted material is not the complete and official position of the NFPA on the referenced subject, which is represented only by the standard in its entirety.

TABLE 210-21 (b)(3)

Circuit Rating (A)	Receptacle Rating (A)
15	Not over 15
20	15 or 20
30	30
40	40 or 50
50	50

Source: Reprinted with permission from NFPA, National Electrical Code, Copyright 2005. National Fire Protection Association, Quincy, MA 02269. This reprinted material is not the complete and official position of the NFPA on the referenced subject, which is represented only by the standard in its entirety.

TABLE 210-24
Summary of Branch-Circuit Requirements

Circuit Rating	15 A	20 A	30 A	40 A	50 A
Conductors (Min. Size)					
Circuit wires*	14	12	10	8	6
Taps	14	14	14	12	12
Fixture wires and cords	Refer to Section 240-4				
Overcurrent protection	15 A	20 A	30 A	40 A	50 A
Outlet devices:					
Lampholders	Any	Any	Heavy	Heavy	Heavy
Permitted	Type	Type	Duty	Duty	Duty
Receptacle	15 Max.	15 or 20	30	40 or 50	50
Rating [†]	A	A	A	A	A
Maximum load	15 A	20 A	30 A	40 A	50 A
Permissible load	Refer to Section 210-23 (a)	Refer to Section 210-23 (a)	Refer to Section 210-23 (b)	Refer to Section 210-23 (c)	Refer to Section 210-23 (c)

*These gages are for copper conductors.

[†]For receptacle rating of cord-connected electric-discharge lighting fixtures, see Section 410-30(c).

Source: Reprinted with permission from NFPA, National Electrical Code, Copyright 2005. National Fire Protection Association, Quincy, MA 02269. This reprinted material is not the complete and official position of the NFPA on the referenced subject, which is represented only by the standard in its entirety.

TABLE 220-54
Demand Factors for Household Electric Clothes Dryers

Number of Dryers	Demand Factor (Percent)
1-4	100%
5	85%
6	75%
7	65%
8	60%
9	55%
10	50%
11	47%
12-22	% = 47 - (number of dryers - 11)
23	35%
24-42	% = 35 - [0.5 × (number of dryers - 23)]
43 and over	25%

FPN No. 1: See Example D5 (A) in Annex D.

FPN No. 2: See Table 220.56 for commercial cooking equipment.

FPN No. 3: See the example in Annex D.

Engineering Supervision. Under engineering supervision, conductor ampacities shall be permitted to be calculated by means of the following general formula:

$$I = \sqrt{\frac{TC - (TA + \Delta TD)}{RDC(1 + YC)RCA}}$$

where TC = conductor temperature in degrees Celsius (°C)

TA = ambient temperature in degrees Celsius (°C)

ΔTD = dielectric loss temperature rise

RDC = DC resistance of conductor at temperature TC

YC = component AC resistance resulting from skin effect and proximity effect

RCA = effective thermal resistance between conductor and surrounding ambient

TABLE 220-55

Demand Factors and Loads for Household Electric Ranges, Wall-Mounted Ovens, Counter-Mounted Cooking Units, and Other Household Cooking Appliances over $1\frac{3}{4}$ kW Rating (Column C to be used in all cases except as otherwise permitted in Note 3.)

Number of Appliances	Demand Factor (Percent) (See Notes)		Column C Maximum Demand (kW) (See Notes) (Not over 12 kW Rating)
	Column A (Less than $3\frac{1}{2}$ kW Rating)	Column B ($3\frac{1}{2}$ kW to $8\frac{3}{4}$ kW Rating)	
1	80	80	8
2	75	65	11
3	70	55	14
4	66	50	17
5	62	45	20
6	59	43	21
7	56	40	22
8	53	36	23
9	51	35	24
10	49	34	25
11	47	32	26
12	45	32	27
13	43	32	28
14	41	32	29
15	40	32	30
16	39	28	31
17	38	28	32
18	37	28	33
19	36	28	34
20	35	28	35
21	34	26	36
22	33	26	37
23	32	26	38
24	31	26	39
25	30	26	40

TABLE 220-55

Demand Factors and Loads for Household Electric Ranges, Wall-Mounted Ovens, Counter-Mounted Cooking Units, and Other Household Cooking Appliances over 1³/₄ kW Rating (Column C to be used in all cases except as otherwise permitted in Note 3.) (continued)

Number of Appliances	Demand Factor (Percent) (See Notes)		Column C Maximum Demand (kW) (See Notes) (Not over 12 kW Rating)
	Column A (Less than 3 ¹ / ₂ kW Rating)	Column B (3 ¹ / ₂ kW to 8 ³ / ₄ kW Rating)	
26–30	30	24	15 kW + 1 kW for each range
31–40	30	22	
41–50	30	20	25 kW + 3/4 kW for each range
51–60	30	18	
61 and over	30	16	

Notes: 1. Over 12 kW through 27 kW ranges all of same rating. For ranges individually rated more than 12 kW but not more than 27 kW, the maximum demand in Column C shall be increased 5% for each additional kilowatt of rating or major fraction thereof by which the rating of individual ranges exceeds 12 kW.

2. Over 8³/₄ kW through 27 kW ranges of unequal ratings. For ranges individually rated more than 8³/₄ kW and of different ratings, but none exceeding 27 kW, an average value of rating shall be calculated by adding together the ratings of all ranges to obtain the total connected load (using 12 kW for any range rated less than 12 kW) and dividing by the total number of ranges. Then the maximum demand in Column C shall be increased 5% for each kilowatt or major fraction thereof by which this average value exceeds 12 kW.

3. Over 1³/₄ kW through 8³/₄ kW. In lieu of the method provided in Column C, it shall be permissible to add the nameplate ratings of all household cooking appliances rated more than 1³/₄ kW but not more than 8³/₄ kW and multiply the sum by the demand factors specified in Column A or B for the given number of appliances. Where the rating of cooking appliances falls under both Column A and Column B, the demand factors for each column shall be applied to the appliances for that column, and the results added together.

4. *Branch-Circuit Load.* It shall be permissible to calculate the branch-circuit load for one range in accordance with Table 220.55. The branch-circuit load for one wall-mounted over or one counter-mounted cooking unit shall be the nameplate rating of the appliance. The branch-circuit load for a counter-mounted cooking unit and not more than two wall-mounted ovens, all supplied from a single branch circuit and located in the same room, shall be calculated by adding the nameplate rating of the individual appliances and treating this total as equivalent to one range.

5. This table also applies to household cooking appliances rated over 1³/₄ kW and used in instructional programs.

TABLE 220-84
Optional Calculation—Demand Factors for Three or More Multifamily Dwelling Units

Number of Dwelling Units	Demand Factor Percentage
3–5	45
6–7	44
8–10	43
11	42
12–13	41
14–15	40
16–17	39
18–20	38
21	37
22–23	36
24–25	35
26–27	34
28–30	33
31	32
32–33	31
34–36	30
37–38	29
39–42	28
43–45	27
46–50	26
51–55	25
56–61	24
62 & over	23

Source: Reprinted material is not the complete and official position of the NFPA on the referenced subject, which is represented only by the standard in its entirety.

FPN: See Annex B of the Code book for examples of formula applications.

Fixed Bends. Where FMT is bent for installation purposes and is not flexed or bent as required by use after installation, the radii of bends measured to the inside of the bend shall not be less than specified in Table 360-24(B).

TABLE 230-51(c)

Supports

Maximum Volts	Maximum Distance Between Supports		Minimum Clearance			
			Between Conductors		From Surface	
	M	ft	mm	in	mm	in
600	2.7	9	150	6	50	2
600	4.5	15	300	12	50	2
300	1.4	4 ^{1/2}	75	3	50	2
600*	1.4*	4 ^{1/2} *	65*	2 ^{1/2} *	25*	1*

*Where not exposed to weather.

TABLE 310-15(b)(6)

Conductor Types and Sizes for 120/240-Volt, 3-Wire, Single-Phase Dwelling Services and Feeders. Conductor Types: RHH, RHW, RHW-2, THHN, THHW, THW, THW-2, THWN, THWN-2, XHHW, XHHW-2, SE, USE, USE-2

Conductor (AWG or kcmil)		
Copper	Aluminum or Copper-Clad Aluminum	Service or Feeder Rating (A)
4	2	100
3	1	110
2	1/0	125
1	2/0	150
1/0	3/0	175
2/0	4/0	200
3/0	250	225
4/0	300	250
250	350	300
350	500	350
400	600	400

364 APPENDIX THREE

Boxes and Fittings. Fittings shall effectively close any openings in the connection.

Splices and Taps. Splices and taps shall be made in accordance with 300.15.

Grounding. FMT Shall be permitted as an equipment grounding conductor where installed in accordance with 250.118(7).

Bends—Number in One Run. There shall not be more than the equivalent of four quarter bends (360 degrees total) between termination points.

Trimming. For termination, the conduit shall be trimmed away from the conductors or cables using an approved method that will not damage the conductor or cable insulation or jacket. All conduit ends shall be trimmed inside and out to remove rough edges.

Bushings. Where the NUCC enters a box, fitting, or other enclosure, a bushing or adapter shall be provided to protect the conductor or cable from abrasion unless the design of the box, fitting, or enclosure provides equivalent protection.

FPN: See 300.4(F) for the protection of conductors size 4 AWG or larger.

Joints. All joints between conduit, fittings, and boxes shall be made by an approved method.

Conductor Terminations. All terminations between the conductors or cables and equipment shall be made by an approved method for that type of conductor cable.

Splices and Taps. Splices and taps shall be made in junction boxes or other enclosures.

FPN No. 1: Table 1 is based on common conditions of proper cabling and alignment of conductors where the length of the pull and the number of bends are within reasonable limits. It should be

TABLE 360-24(a)
Minimum Radii for Flexing Use

Metric Designator	Trade Size	Minimum Radii for Flexing Use	
		mm	in
12	3/8	25.4	10
16	1/2	317.5	12 ¹ / ₂
21	3/4	444.5	17 ¹ / ₂

TABLE 360-24(b)
Minimum Radii for Fixed Bends

Metric Designator	Trade Size	Minimum Radii for Flexed Bends	
		mm	in
12	3/8	88.9	3 ¹ / ₂
16	1/2	101.6	4
21	3/4	127.0	5

TABLE 344-30(b)(2)
Supports for Rigid Metal Conduit

Conduit Size		Maximum Distance Between Rigid Metal Conduit Supports	
Metric Designator	Trade size	m	ft
16–21	1/2–3/4	3.0	10
27	1	3.7	12
35–41	1 ¹ / ₄ –1 ¹ / ₂	4.3	14
53–63	2–2 ¹ / ₂	4.9	16
78 and larger	3 and larger	6.1	20

TABLE 352-3(b)
Support of Rigid Nonmetallic Conduit (RNC)

Conduit Size (in)	Maximum Spacing Between Supports (ft)
1/2–1	3
1 1/4–2	5
2 1/2–5	6
3 1/2–5	7
6	8

For SI units: (Supports) 1 foot = 0.3048 meter.

TABLE 354-24
Minimum Bending Radius for Nonmetallic Underground
Conduit with Conductors (NUCC)

Conduit Size		Minimum Bending Radius	
Metric Designator	Trade Size	mm	in
16	1/2	250	10
21	3/4	300	12
27	1	350	14
35	1 ¹ / ₄	450	18
41	1 ¹ / ₂	500	20
53	2	650	26
63	2 ¹ / ₂	900	36
78	3	1200	48
103	4	1500	60

recognized that under certain conditions a larger size conduit or a lesser conduit fill should be considered.

FPN No. 2: When pulling three conductors or cables into a raceway, if the ratio of raceway (inside diameter) to the conductor or cable (outside diameter) is between 2.8 and 3.2, jamming can occur. While jamming can occur when pulling four or more conductors or cables into a raceway, the probability is very low.

FPN—A change bar in the margins of the NEC handbook that indicates that a change in the NEC has been made since the last edition.

TABLE 1
Percent of Cross Section of Conduit and Tubing for Conductors

Number of Conductors	All Conductor Types
1	53
2	31
Over 2	40

TABLE 2
Radius of Conduit and Tubing Bends

Conduit or Tubing Size		One Shot and Full Shoe Benders		Other Bends	
Metric Designator	Trade Size	mm	in	mm	in
16	1/2	101.6	4	101.6	4
21	3/4 ^{3/4}	114.3	4 ^{1/2}	127	5
27	1	146.05	5 ^{3/4}	152.4	6
35	1 ^{1/4}	184.15	7 ^{1/4}	203.2	8
41	1 ^{1/2}	209.55	8 ^{1/4}	254	10
53	2	241.3	9 ^{1/2}	304.8	12
63	2 ^{1/2}	266.7	10 ^{1/2}	381	15
78	3	330.2	13	457.2	18
91	3 ^{1/2}	381	15	533.4	21
103	4	406.4	16	609.6	24
129	5	609.6	24	762	30
155	6	762	30	914.4	36

Notes to Tables These notes are referenced to the National Electrical Code handbook. Keep in mind that the NEC code book is changed every three years and these references may have to be located by searching the changes. It all depends on when you are using this reference. This Handbook is updated to the 2005 edition of the NEC codebook.

1. See Annex C for the maximum number of conductors and fixture wires, all of the same size (total cross-sectional area including insulation) permitted in trade sizes of the applicable conduit or tubing.
2. Table 1 applies only to complete conduit or tubing systems and is not intended to apply to sections of conduit or tubing used to protect exposed wiring from physical damage.
3. Equipment grounding or bonding conductors, where installed, shall be included when calculating conduit or tubing fill. The actual dimensions of the equipment grounding or bonding conductor (insulated or bare) shall be used in the calculation.

368 APPENDIX THREE

4. Where conduit or tubing nipples having a maximum length not to exceed 600 millimeters (24 inches) are installed between boxes, cabinets, and similar enclosures, the nipples shall be permitted to be filled to 60% of their total cross-sectional area, and 310-15(b)(2)(a) adjustment factors need not apply to this condition.
5. For conductors not included in Chapter 9, such as multiconductor cables, the actual dimensions shall be used.
6. For combinations of conductors of different sizes, use Table 5 and Table 5A for dimensions of conductors and Table 4 for the applicable conduit or tubing dimensions.
7. When calculating the maximum number of conductors permitted in a conduit or tubing, all of the same size (total cross-sectional area including insulation), the next higher whole number shall be used to determine the maximum number of conductors permitted when the calculation results in a decimal of 0.8 or larger.
8. Where bare conductors are permitted by other sections of the *code*, the dimensions for bare conductors in Table 8 shall be permitted.
9. A multi-conductor cable of two or more conductors shall be treated as a single conductor for calculating percentage conduit fill area. For cables that have elliptical cross sections, the cross-sectional area calculation shall be based on using the major diameter of the ellipse as a circle diameter.

TABLE 4
Dimensions and Percent Area of Conduit and Tubing (Areas of Conduit or Tubing
for the Combinations of Wires Permitted in Table 1)

Article 358—Electrical Metallic Tubing (EMT)													
Metric Designator	Trade Size	Nominal Internal Diameter		Total Area 100%		60%		1 Wire 53%		2 Wires 31%		Over 2 Wires 40%	
		mm	in	mm ²	in ²	mm ²	in ²	mm ²	in ²	mm ²	in ²	mm ²	in ²
16	1/2	15.8	0.622	196	0.304	118	0.182	104	0.161	61	0.094	78	0.122
21	3/4	20.9	0.824	343	0.533	206	0.320	182	0.283	106	0.165	137	0.213
27	1	26.6	1.049	556	0.864	333	0.519	295	0.458	172	0.268	222	0.346
35	1 ¹ / ₄	35.1	1.380	968	1.496	581	0.897	513	0.793	300	0.464	387	0.598
41	1 ¹ / ₂	40.9	1.610	1314	2.036	788	1.221	696	1.079	407	0.631	526	0.814
53	2	52.5	2.067	2165	3.356	1299	2.013	1147	1.778	671	1.040	866	1.342
63	2 ¹ / ₂	69.4	2.731	3783	5.858	2270	3.515	2005	3.105	1173	1.816	1513	2.343
78	3	85.2	3.356	5701	8.846	3421	5.307	3022	4.688	1767	2.742	2280	3.538
91	3 ¹ / ₂	97.4	3.834	7451	11.545	4471	6.927	3949	6.119	2310	3.579	2980	4.618
103	4	110.1	4.334	9521	14.753	5712	8.852	5046	7.819	2951	4.573	3808	5.901

(continued)

TABLE 4
Dimensions and Percent Area of Conduit and Tubing (Areas of Conduit or Tubing
for the Combinations of Wires Permitted in Table 1) (continued)

Article 362—Electrical Nonmetallic Tubing (ENT)													
Metric Designator	Trade Size	Nominal Internal Diameter		Total Area 100%		60%		1 Wire 53%		2 Wires 31%		Over 2 Wires 40%	
		mm	in	mm ²	in ²	mm ²	in ²	mm ²	in ²	mm ²	in ²	mm ²	in ²
16	1/2	14.2	0.560	158	0.246	95	0.148	84	0.131	49	0.076	63	0.099
21	3/4	19.3	0.760	293	0.454	176	0.272	155	0.240	91	0.141	117	0.181
27	1	25.4	1.000	507	0.785	304	0.471	269	0.416	157	0.243	203	0.314
35	1 ¹ / ₄	34.0	1.340	908	1.410	545	0.846	481	0.747	281	0.437	363	0.564
41	1 ¹ / ₂	39.9	1.570	1250	1.936	750	1.162	663	1.026	388	0.600	500	0.774
53		51.3	2.020	2067	3.205	1240	1.923	1095	1.699	641	0.993	827	1.282
63	2 ¹ / ₂	—	—	—	—	—	—	—	—	—	—	—	—
78	3	—	—	—	—	—	—	—	—	—	—	—	—
91	3 ¹ / ₂	—	—	—	—	—	—	—	—	—	—	—	—

Article 348—Flexible Metal Conduit (FMC)

Metric Designator	Trade Size	Nominal Internal Diameter		Total Area 100%		60%		1 Wire 53%		2 Wires 31%		Over 2 Wires 40%	
		mm	in	mm ²	in ²	mm ²	in ²	mm ²	in ²	mm ²	in ²	mm ²	in ²
12	3/8	9.7	0.384	74	0.116	44	0.069	39	0.061	23	0.036	30	0.046
16	1/2	16.1	0.635	204	0.317	122	0.190	108	0.168	63	0.098	81	0.127
21	3/4	20.9	0.824	343	0.533	206	0.320	182	0.283	106	0.165	137	0.213
27	1	25.9	1.020	527	0.817	316	0.490	279	0.433	163	0.253	211	0.327
35	1 ¹ / ₄	32.4	1.275	824	1.277	495	0.766	437	0.677	256	0.396	330	0.511
41	1 ¹ / ₂	39.1	1.538	1201	1.858	720	1.115	636	0.985	372	0.576	480	0.743
53	2	51.8	2.040	2107	3.269	1264	1.961	1117	1.732	653	1.013	843	1.307
63	2 ¹ / ₂	63.5	2.500	3167	4.909	1900	2.945	1678	2.602	982	1.522	1267	1.963
78	3	76.2	3.000	4560	7.069	2736	4.241	2417	3.746	1414	2.191	1824	2.827
91	3 ¹ / ₂	88.9	3.500	6207	9.621	3724	5.773	3290	5.099	1924	2.983	2483	3.848
103	4	101.6	4.000	8107	12.566	4864	7.540	4297	6.660	2513	3.896	3243	5.027

(continued)

TABLE 4
Dimensions and Percent Area of Conduit and Tubing (Areas of Conduit or Tubing
for the Combinations of Wires Permitted in Table 1) (continued)

Article 342—Intermediate Metal Conduit (IMC)													
Metric Designator	Trade Size	Nominal Internal Diameter		Total Area 100%		60%		1 Wire 53%		2 Wires 31%		Over 2 Wires 40%	
		mm	in	mm ²	in ²	mm ²	in ²	mm ²	in ²	mm ²	in ²	mm ²	in ²
12	3/8	—	—	—	—	—	—	—	—	—	—	—	—
16	1/2	16.8	0.660	222	0.342	133	0.205	117	0.181	69	0.106	89	0.137
21	3/4	21.9	0.864	377	0.586	226	0.352	200	0.311	117	0.182	151	0.235
27	1	28.1	1.105	620	0.959	372	0.575	329	0.508	192	0.297	248	0.384
35	1 ¹ / ₄	36.8	1.448	1064	1.647	638	0.988	564	0.873	330	0.510	425	0.659
41	1 ¹ / ₂	42.7	1.683	1432	2.225	859	1.335	759	1.179	444	0.690	573	0.890
53	2	54.6	2.150	2341	3.630	1405	2.178	1241	1.924	726	1.125	937	1.452
63	2 ¹ / ₂	64.9	2.557	3308	5.135	1985	3.081	1753	2.722	1026	1.592	1323	2.054
78	3	80.7	3.176	5115	7.922	3069	4.753	2711	4.199	1586	2.456	2046	3.169
91	3 ¹ / ₂	93.2	3.671	6822	10.584	4093	6.351	3616	5.610	2115	3.281	2729	4.234
103	4	105.4	4.166	8725	13.631	5235	8.179	4624	7.224	2705	4.226	3490	5.452

Article 356—Liquid tight Flexible Nonmetallic Conduit (LFNC-B*)													
Metric Designator	Trade Size	Nominal Internal Diameter		Total Area 100%		60%		1 Wire 53%		2 Wires 31%		Over 2 Wires 40%	
		mm	in	mm ²	in ²	mm ²	in ²	mm ²	in ²	mm ²	in ²	mm ²	in ²
12	3/8	12.5	0.494	123	0.192	74	0.115	65	0.102	38	0.059	49	0.077
16	1/2	16.1	0.632	204	0.314	122	0.188	108	0.166	63	0.097	81	0.125
21	3/4	21.1	0.830	350	0.541	210	0.325	185	0.287	108	0.168	140	0.216
27	1	26.8	1.054	564	0.873	338	0.524	299	0.462	175	0.270	226	0.349
35	1 ¹ / ₄	35.4	1.395	984	1.528	591	0.917	522	0.810	305	0.474	394	0.611
41	1 ¹ / ₂	40.3	1.588	1276	1.981	765	1.188	676	1.050	395	0.614	510	0.792
53	2	51.6	2.033	2091	3.246	1255	1.948	1108	1.720	648	1.006	836	1.298

(continued)

TABLE 4
Dimensions and Percent Area of Conduit and Tubing (Areas of Conduit or Tubing
for the Combinations of Wires Permitted in Table 1) (continued)

Article 356—Liquid tight Flexible Nonmetallic Conduit (LFNC-A*)													
Metric Designator	Trade Size	Nominal Internal Diameter		Total Area 100%		60%		1 Wire 53%		2 Wires 31%		Over 2 Wires 40%	
		mm	in	mm ²	in ²	mm ²	in ²	mm ²	in ²	mm ²	in ²	mm ²	in ²
12	3/8	12.6	0.495	125	0.192	75	0.115	66	0.102	39	0.060	50	0.077
16	1/2	16.0	0.630	201	0.312	121	0.187	107	0.165	62	0.097	80	0.125
21	3/4	21.0	0.825	346	0.535	208	0.321	184	0.283	107	0.166	139	0.214
27	1	26.5	1.043	552	0.854	331	0.513	292	0.453	171	0.265	221	0.342
35	1 ¹ / ₄	35.1	1.383	968	1.502	581	0.901	513	0.796	300	0.466	387	0.601
41	1 ¹ / ₂	40.7	1.603	1301	2.018	781	1.211	690	1.070	403	0.626	520	0.807
53	2	52.4	2.063	2157	3.343	1294	2.006	1143	1.772	669	1.036	863	1.337

Article 350—Liquid tight Flexible Metal Conduit (LFMC)

Metric Designator	Trade Size	Nominal Internal Diameter		Total Area 100%		60%		1 Wire 53%		2 Wires 31%		Over 2 Wires 40%	
		mm	in	mm ²	in ²	mm ²	in ²	mm ²	in ²	mm ²	in ²	mm ²	in ²
12	3/8	12.5	0.494	123	0.192	74	0.115	65	0.102	38	0.059	49	0.077
16	1/2	16.1	0.632	204	0.314	122	0.188	108	0.166	63	0.097	81	0.125
21	3/4	21.1	0.830	350	0.541	210	0.325	185	0.287	108	0.168	140	0.216
27	1	26.8	1.054	564	0.873	338	0.524	299	0.462	175	0.270	226	0.349
35	1 ¹ / ₄	35.4	1.395	984	1.528	591	0.917	522	0.810	305	0.474	394	0.611
41	1 ¹ / ₂	40.3	1.588	1276	1.981	765	1.188	676	1.050	395	0.614	510	0.792
53	2	51.6	2.033	2091	3.246	1255	1.948	1108	1.720	648	1.006	836	1.298
63	2 ¹ / ₂	63.3	2.493	3147	4.881	1888	2.929	1668	2.587	976	1.513	1259	1.953
78	3	78.4	3.085	4827	7.475	2896	4.485	2559	3.962	1497	2.317	1931	2.990
91	3 ¹ / ₂	89.4	3.520	6277	9.731	3766	5.839	3327	5.158	1946	3.017	2511	3.893
103	4	102.1	4.020	8187	12.692	4912	7.615	4339	6.727	2538	3.935	3275	5.077
129	5	—	—	—	—	—	—	—	—	—	—	—	—
155	6	—	—	—	—	—	—	—	—	—	—	—	—

(continued)

TABLE 4
Dimensions and Percent Area of Conduit and Tubing (Areas of Conduit or Tubing
for the Combinations of Wires Permitted in Table 1) (continued)

Article 344—Rigid Metal Conduit (RMC)													
Metric Designator	Trade Size	Nominal Internal Diameter		Total Area 100%		60%		1 Wire 53%		2 Wires 31%		Over 2 Wires 40%	
		mm	in	mm ²	in ²	mm ²	in ²	mm ²	in ²	mm ²	in ²	mm ²	in ²
12	3/8	—	—	—	—	—	—	—	—	—	—	—	—
16	1/2	16.1	0.632	204	0.314	122	0.188	108	0.166	63	0.097	81	0.125
21	3/4	21.2	0.836	353	0.549	212	0.329	187	0.291	109	0.170	141	0.220
27	1	27.0	1.063	573	0.887	344	0.532	303	0.470	177	0.275	229	0.355
35	1 ¹ / ₄	35.4	1.394	984	1.526	591	0.916	522	0.809	305	0.473	394	0.610
41	1 ¹ / ₂	41.2	1.624	1333	2.071	800	1.243	707	1.098	413	0.642	533	0.829
53	2	52.9	2.083	2198	3.408	1319	2.045	1165	1.806	681	1.056	879	1.363
63	2 ¹ / ₂	63.2	2.489	3137	4.866	1882	2.919	1663	2.579	972	1.508	1255	1.946
78	3	78.5	3.090	4840	7.499	2904	4.499	2565	3.974	1500	2.325	1936	3.000
91	3 ¹ / ₂	90.7	3.570	6461	10.010	3877	6.006	3424	5.305	2003	3.103	2584	4.004
103	4	102.9	4.050	8316	12.882	4990	7.729	4408	6.828	2578	3.994	3326	5.153
129	5	128.9	5.073	13050	20.212	7830	12.127	6916	10.713	4045	6.266	5220	8.085
155	6	154.8	6.093	18821	29.158	11292	17.495	9975	15.454	5834	9.039	7528	11.663

Article 352—Rigid PVC Conduit (RNC), Schedule 80

Metric Designator	Trade Size	Nominal Internal Diameter		Total Area 100%		60%		1 Wire 53%		2 Wires 31%		Over 2 Wires 40%	
		mm	in	mm ²	in ²	mm ²	in ²	mm ²	in ²	mm ²	in ²	mm ²	in ²
12	3/8	—	—	—	—	—	—	—	—	—	—	—	—
16	1/2	13.4	0.526	141	0.217	85	0.130	75	0.115	44	0.067	56	0.087
21	3/4	18.3	0.722	263	0.409	158	0.246	139	0.217	82	0.127	105	0.164
27	1	23.8	0.936	445	0.688	267	0.413	236	0.365	138	0.213	178	0.275
35	1 ¹ / ₄	31.9	1.255	799	1.237	480	0.742	424	0.656	248	0.383	320	0.495
41	1 ¹ / ₂	37.5	1.476	1104	1.711	663	1.027	585	0.907	342	0.530	442	0.684
53	2	48.6	1.913	1855	2.874	1113	1.725	983	1.523	575	0.891	742	1.150
63	2 ¹ / ₂	58.2	2.290	2660	4.119	1596	2.471	1410	2.183	825	1.277	1064	1.641
78	3	72.7	2.864	4151	6.442	2491	3.865	2200	3.141	1287	1.997	1660	2.577
91	3 ¹ / ₂	84.5	3.326	5608	8.688	3365	5.213	2972	4.605	1738	2.693	2243	3.475
103	4	96.2	3.786	7268	11.258	4361	6.755	3852	5.967	2253	3.490	2907	4.503
129	5	121.1	4.768	11518	17.855	6911	10.713	6105	9.463	3571	5.535	4607	7.142
155	6	145.0	5.709	16513	25.598	9908	15.359	8752	13.567	5119	7.935	6605	10.239

(continued)

TABLE 4
Dimensions and Percent Area of Conduit and Tubing (Areas of Conduit or Tubing
for the Combinations of Wires Permitted in Table 1) (continued)

Article 352 and 353—Rigid PVC Conduit (RNC), Schedule 40, and HDPE Conduit														
Metric	Designator	Trade Size	Nominal Internal Diameter		Total Area 100%		60%		1 Wire 53%		2 Wires 31%		Over 2 Wires 40%	
			mm	in	mm ²	in ²	mm ²	in ²	mm ²	in ²	mm ²	in ²	mm ²	in ²
	12	3/8	—	—	—	—	—	—	—	—	—	—	—	—
	16	1/2	15.3	0.602	184	0.285	110	0.171	97	0.151	57	0.088	74	0.114
	21	3/4	20.4	0.804	327	0.508	196	0.305	173	0.269	101	0.157	131	0.203
	27	1	26.1	1.029	535	0.832	321	0.499	284	0.441	166	0.258	214	0.333
	35	1 ¹ / ₄	34.5	1.360	935	1.453	561	0.872	495	0.770	290	0.450	374	0.581
	41	1 ¹ / ₂	40.4	1.590	1282	1.986	769	1.191	679	1.052	397	0.616	513	0.794
	53	2	52.0	2.047	2124	3.291	1274	1.975	1126	1.744	658	1.020	849	1.316
	63	2 ¹ / ₂	62.1	2.445	3029	4.695	1817	2.817	1605	2.488	939	1.455	1212	1.878
	78	3	77.3	3.042	4693	7.268	2816	4.361	2487	3.852	1455	2.253	1877	2.907
	91	3 ¹ / ₂	89.4	3.521	6277	9.737	3766	5.842	3327	5.161	1946	3.018	2511	3.895
	103	4	101.5	3.998	8091	12.554	4855	7.532	4288	6.654	2508	3.892	3237	5.022
	129	5	127.4	5.016	12748	19.761	7649	11.856	6756	10.473	3952	6.126	5099	7.904
	155	6	153.2	6.013	18433	28.567	11060	17.140	9770	15.141	5714	8.856	7373	11.427

Article 352—Type A, Rigid PVC Conduit (RNC)													
Metric Designator	Trade Size	Nominal Internal Diameter		Total Area 100%		60%		1 Wire 53%		2 Wires 31%		Over 2 Wires 40%	
		mm	in	mm ²	in ²	mm ²	in ²	mm ²	in ²	mm ²	in ²	mm ²	in ²
16	1/2	17.8	0.700	249	0.385	149	0.231	132	0.204	77	0.119	100	0.154
21	3/4	23.1	0.910	419	0.650	251	0.390	222	0.374	130	0.202	168	0.260
27	1	29.8	1.175	697	1.084	418	0.651	370	0.575	216	0.336	279	0.434
35	1 ¹ / ₄	38.1	1.500	1140	1.767	684	1.061	604	0.937	353	0.548	456	0.707
41	1 ¹ / ₂	43.7	1.720	1500	2.324	900	1.394	795	1.231	465	0.720	600	0.929
53	2	54.7	2.155	2350	3.647	1410	2.188	1245	1.933	728	1.131	940	1.459
63	2 ¹ / ₂	66.9	2.635	3515	5.453	2109	3.272	1863	2.890	1090	1.690	1406	2.181
78	3	82.0	3.230	5281	8.194	3169	4.916	2799	4.343	1637	2.540	2112	3.278
91	3 ¹ / ₂	93.7	3.690	6896	10.694	4137	6.416	3655	5.668	2138	3.315	2758	4.278
103	4	106.2	4.180	8858	13.723	5315	8.234	4695	7.273	2746	4.254	3543	5.489
129	5	—	—	—	—	—	—	—	—	—	—	—	—
155	6	—	—	—	—	—	—	—	—	—	—	—	—

(continued)

TABLE 4
Dimensions and Percent Area of Conduit and Tubing (Areas of Conduit or Tubing
for the Combinations of Wires Permitted in Table 1) (continued)

Article 352—Type EB, PVC Conduit (RNC)													
Metric Designator	Trade Size	Nominal Internal Diameter		Total Area 100%		60%		1 Wire 53%		2 Wires 31%		Over 2 Wires 40%	
		mm	in	mm ²	in ²	mm ²	in ²	mm ²	in ²	mm ²	in ²	mm ²	in ²
16	1/2	—	—	—	—	—	—	—	—	—	—	—	—
21	3/4	—	—	—	—	—	—	—	—	—	—	—	—
27	1	—	—	—	—	—	—	—	—	—	—	—	—
35	1 ¹ / ₄	—	—	—	—	—	—	—	—	—	—	—	—
41	1 ¹ / ₂	—	—	—	—	—	—	—	—	—	—	—	—
53	2	56.4	2.221	2498	3.874	1499	2.325	1324	2.053	774	1.201	999	1.550
63	2 ¹ / ₂	—	—	—	—	—	—	—	—	—	—	—	—
78	3	84.6	3.330	5621	8.709	3373	5.226	2979	4.616	1743	2.700	2248	3.484
91	3 ¹ / ₂	96.6	3.804	7329	11.365	4397	6.819	3884	6.023	2272	3.523	2932	4.546
103	4	108.9	4.289	9314	14.448	5589	8.669	4937	7.657	2887	4.479	3726	5.779
129	5	135.0	5.316	14314	22.195	8588	13.317	7586	11.763	4437	6.881	5726	8.878
155	6	160.9	6.336	20333	31.530	12200	18.918	10776	16.711	6303	9.774	8133	12.612

TABLE 314.16(a)
Metal Boxes

Box Trade Size			Minimum Volume		Maximum Number of Conductors*						
mm	in		cm ³	in ³	18	16	14	12	10	8	6
100 × 32	(4 × 1 ¹ / ₄)	Round/octagonal	205	12.5	8	7	6	5	5	5	2
100 × 38	(4 × 1 ¹ / ₂)	Round/octagonal	254	15.5	10	8	7	6	6	5	3
100 × 54	(4 × 2 ¹ / ₈)	Round/octagonal	353	21.5	14	12	10	9	8	7	4
100 × 32	(4 × 1 ¹ / ₄)	Square	295	18.0	12	10	9	8	7	6	3
100 × 38	(4 × 1 ¹ / ₂)	Square	344	21.0	14	12	10	9	8	7	4
100 × 54	(4 × 2 ¹ / ₈)	Square	497	30.3	20	17	15	13	12	10	6
120 × 32	(4 ¹¹ / ₁₆ × 1 ¹ / ₄)	Square	418	25.5	17	14	12	11	10	8	5
120 × 38	(4 ¹¹ / ₁₆ × 1 ¹ / ₂)	Square	484	29.5	19	16	14	13	11	9	5
120 × 54	(4 ¹¹ / ₁₆ × 2 ¹ / ₈)	Square	689	42.0	28	24	21	18	16	14	8
75 × 50 × 38	(3 × 2 × 1 ¹ / ₂)	Device	123	7.5	5	4	3	3	3	2	1
75 × 50 × 50	(3 × 2 × 2)	Device	164	10.0	6	5	5	4	4	3	2
75 × 50 × 57	(3 × 2 × 2 ¹ / ₄)	Device	172	10.5	7	6	5	4	4	3	2
75 × 50 × 65	(3 × 2 × 2 ¹ / ₂)	Device	205	12.5	8	7	6	5	5	4	2
75 × 50 × 70	(3 × 2 × 2 ³ / ₄)	Device	230	14.0	9	8	7	6	5	4	2
75 × 50 × 90	(3 × 2 × 3 ¹ / ₂)	Device	295	18.0	12	10	9	8	7	6	3

TABLE 314.16(a)
Metal Boxes (continued)

Box Trade Size			Minimum Volume		Maximum Number of Conductors*						
mm	in		cm ³	in ³	18	16	14	12	10	8	6
100 × 54 × 38	(4 × 2 ¹ / ₈ × 1 ¹ / ₂)	Device	169	10.3	6	5	5	4	4	3	2
100 × 54 × 48	(4 × 2 ¹ / ₈ × 1 ⁷ / ₈)	Device	213	13.0	8	7	6	5	5	4	2
100 × 54 × 54	(4 × 2 ¹ / ₈ × 2 ¹ / ₈)	Device	238	14.5	9	8	7	6	5	4	2
95 × 50 × 65	(3 ³ / ₄ × 2 × 2 ¹ / ₂)	Masonry box/gang	230	14.0	9	8	7	6	5	4	2
95 × 50 × 90	(3 ³ / ₄ × 2 × 3 ¹ / ₂)	Masonry box/gang	344	21.0	14	12	10	9	8	7	4
Min. 44.5 depth	FS—single cover/ gang (1 ³ / ₄)		221	13.5	9	7	6	6	5	4	2
Min. 60.3 depth	FD—single cover/ gang (2 ³ / ₈)		295	18.0	12	10	9	8	7	6	3
Min. 44.5 depth	FS—multiple cover/ gang (1 ³ / ₄)		295	18.0	12	10	9	8	7	6	3
Min. 60.3 depth	FD—multiple cover/ gang (2 ³ / ₈)		395	24.0	16	13	12	10	9	8	4

*Where no volume allowances are required by 314-16(b)(2) through (b)(5) of the Code.

TABLE 314.16(b)
Volume Allowance Required per Conductor

Size of Conductor (AWG)	Free Space within Box for Each Conductor	
	cm ³	in ³
18	24.6	1.50
16	28.7	1.75
14	32.8	2.00
12	36.9	2.25
10	41.0	2.50
8	49.2	3.00
6	81.9	5.00

Abbreviations

Abbreviation	Description	Abbreviation	Description
1P	One pole	AT	AMP trip
1P1W	One pole, one wire	ATS	Automatic transfer switch
1P2W	One pole, two wire	AUD	Audiometer box connection
2P	Two pole	BLDG	Building
2P2W	Two pole, two wire	C	Conduit (Generic term for raceway. Provide as specified.)
2P3W	Two pole, three wire	C.T.	Current transformer
3P	Three pole	CAM	Camera
3P2W	Three pole, two wire	CAT	Catalog
3P3W	Three pole, three wire	CATV	Cable television
3P4W	Three pole, four wire	CB	Circuit breaker
4P	Four pole	CKT	Circuit
4P4W	Four pole, four wire	COL	Column
A	Ampere	☉	Centerline
A/V	Audio visual	CU	Copper
AC	Alternating current	DC	Direct current
AF	AMP frame	Δ	Delta
AFF	Above finished floor	DISC	Disconnect
AFG	Above finished grade	DT	Dust tight*
AIC	Ampere interrupting capacity	DWG	Drawing
AL	Aluminum		
ARCH	Architect		
AS	AMP switch		

(continued)

Abbreviations (*continued*)

Abbreviation	Description	Abbreviation	Description
E	Wired on emergency circuit	KCMIL	Thousand circular mils
EC	Electrical contractor	KVA	Kilovolt ampere
EMT	Electric metallic tubing	KVAR	Kilovolt ampere reactive
EOL	End of line	KW	Kilowatt
EWC	Electric water cooler	LFMC	Liquid tight flexible metallic conduit
EXIST.	Existing	LFNC	Liquid tight flexible nonmetallic conduit
EXIST.	Existing		
F	Flush	LP	Lighting panelboard
FA	Fire alarm	LS	Limit switch
FBO	Furnished by others	ITG	Lighting
FC	Fire protection contractor	LV	Low voltage
FDN	Foundation	MC	Metal clad cable
FLA	Full load amps	MCB	Main circuit breaker
FMC	Flexible metallic conduit	MCC	Motor control center
FRE	Fiberglass-reinforced epoxy conduit	MDP	Main distribution panel
GC	General contractor	MISC	Miscellaneous
GFCI	Ground fault circuit interrupter	MLO	Main lugs only
GFPE	Ground fault protection equipment	MOD	Motor-operated disconnect switch
GND	Grounded	MTD	Mounted
GRC	Galvanized rigid conduit	MTG	Mounting
HP	Horsepower	MTS	Manual transfer switch
HV	High voltage	N/A	Not applicable
HVAC	Heating, ventilating, and air conditioning	NC	Normally closed
Hz	Hertz (cycle) per second	NEC	National Electrical Code
IAM	Individual addressable module	NIC	Not in contract
IG	Isolated ground	NL	Night light
IMC	Intermediate metal conduit	NM	Nonmetallic sheathed cable
JB	Junction box	NO	Normally open
K/O	Knockout	#	Number
		NRTL	Nationally recognized testing lab
		NTS	Not to scale

Abbreviations (*continued*)

Abbreviation	Description	Abbreviation	Description
P	Pole	SWBD	Switchboard
PB	Pull box	TC	Telephone cabinet
PC	Plumbing system contractor	TCI	Telecommunications cabling installer
PH ϕ	Phase	TEL	Telephone
PIV	Postindicating valve	TEL/DATA	Telephone/data
PNL	Panel (board)	TERM	Terminal(s)
PP	Power panel	TYP	Typical
PR	Pair	U.O.I.	Unless otherwise indicated
PRI	Primary	UG	Underground
PT	Potential transformer	UTP	Unshielded twisted pair
PVC	Polyvinyl chloride conduit	V	Volt
PWR	Power	VT	Vaportight*
REC	Recessed	W	Watt
RSC	Rigid steel conduit	WH	Watt-hour
RT	Raintight*	WP	Weatherproof
S	Surface mounted	WT	Watertight*
SEC	Secondary	XFMR	Transformer
SIG	Signal	XP	Explosion proof*
SN	Solid neutral	Y	Wye
SP	Spare	ZAM	Zone adapter module
SPL	Splice	+72	Mounting units to centerline above finished floor or grade
SS	Stainless steel		
STL	Carbon steel		
STP	Shielded twisted pair		
SUSP	Suspended		
SW	Switch		

*It is recommended that the appropriate NEMA designation be used in place of this abbreviation.

This page intentionally left blank

INDEX

A

Abbreviations, 383–385

AC

- clamp-on meters, 329
- electrolytics, 119
- formulas, 300

Alarms

- burglary, 64
- outputs, 63
- systems, 47
 - personal, 66, 68
- control unit, 51
- parts of the system, 50
- in hazardous
 - locations, 68

Aluminum connector, 5

Arm/disarm codes, 63

Armored cable

- fittings, 150
- installing, 151

Arresters, lightning, 127

Artificial ventilation, 335

Automatic braking, 10

Average value, 302

B

Ballast, 77

- life, 78
- power factor, 79
- sound, 79
- types of, 79

Ball-bearing motors, 27, 29

Bender, 1

- cable, 1
- electric, 2
- hydraulic 2, 3

Bends

- factory, 175

fixed, 362, 365

offset, 177

rigid conduit, 365

rigid nonmetallic
conduit, 365

Bending (conduit),
radius, 366

Bifurcated cleaning wipes, 266

Binders cable, 249

Boxes, 178

- and fittings, 364
- metal, 381, 382
- PVC nonmetallic, 178
- with brackets, 187
- with screws, 188

Branch circuit

- loading, 156
- wiring, 148
- requirements, 358

Bridge rectifiers, 306, 308

Brush, wear, 27

Brushes, 26

Building systems, inside wiring,
233

Bushings, 364

C

Cable, 157

- binders, 249
- branch circuit, 154
- cross section, 5
- entries, DLC, 267
- fiber optics, 246
 - composite, 247
 - conductive, 247
- markings, 247, 248
- multi-conductor, 155, 368
- nonconductive, 247

388 INDEX

- Cable (*Cont.*)
 - rollers, 2
 - Romex, 153, 154, 157
 - service entrance, 153
 - substitutions, 246
 - table, 247
 - trays, 251
 - UF, 159
 - Calculator, using, 281
 - Cardiopulmonary resuscitation, 336
 - Carflex, 227
 - fittings, 222, 223
 - installation, 218, 219
 - Certification program, 353
 - Characteristics, motors, 103–105
 - Charger, auxiliary
 - power/battery, 60
 - Checklist for estimating, 279, 280
 - Chemical resistance of materials, 19
 - Clamps
 - ground, 211
 - inside boxes, 189
 - Classifications, hazardous locations, 348
 - Cleaver, 256
 - Clocks, time, 99
 - Code book, 350
 - Codes, 349
 - state and local, 354
 - Color code
 - binder, 238
 - cable, 236
 - fiber optic, 239
 - Communications wiring, 238
 - Commutators, 26
 - Compound, sealing, 204
 - Condensation, 12, 13
 - Conducting materials, 147
 - Conductor
 - aluminum, 155
 - types, 363
 - volume required, 383
 - Conduit, 159
 - 90° bends, 173
 - bender, 181
 - box, 160
 - cross section, 366, 367
 - flexible metal, 348
 - flexible nonmetallic, 211
 - liquid tight, 226
 - offsets, 178
 - plastic (PVC), 168, 352, 378–380
 - rigid, 162, 376
 - seals, 204
 - take up, 180
 - terminology, 174
 - working with, 171, 172
 - Connection diagrams, motors, 32, 33, 34
 - Connector tools, 5
 - Connectors, Carflex, 225
 - Control
 - equipment, light, 96
 - measures, 341
 - panel box, exploded view, 65
 - Controllers,
 - programmable, 229
 - Conversion factors
 - U.S.-metric, 272
 - Convert wye to delta, 298
 - Copper wire, annealed, 149
 - Cords, extension, 338
 - Core of acceptance, 250
 - Corrosion, 12
 - Corrosive oxidation, 28
 - Crimping operation, 254
 - Critical angle, 250
 - CSA symbol, 353
 - CSA, Canadian Standards Association, 352
 - CSA, UL labels, 185
 - Current drawn for light bulbs, 292
- D**
- Demand factors, 359–364
 - Delta and wye resistor circuits, 296

- Delta
 - connection, 296
 - currents, 123
- Detectors, intruder, 55
- Diacs, 306, 307
- Digital meter, 329, 330
- Dimensions for
 - knockouts, 136
- Dimmer, 95, 96
 - high tech, 99, 100
 - installation, 97
 - smart, 99
- Diodes, 306
- Displays, 318
- Distribution of electricity, 122
- Distribution panel, 12
- DLC, 268
- Drip proof enclosures, 118

- E**
- Effects of electric current, 334
- Elbow, 174
- Electric motors, 25, 103
- Electric ranges, 360, 361
- Electric shock, 333
- Electrical formulas, 283
- Electronic formulas, 283
- Electronics, basic, 305
- Emergency power, 143
 - automatic transfer, 145, 146
 - push button, 58
- EMT, 159
- Engineering supervision, 359
- Entrance installation, 130
- Entry delay lines, 61
- Equipment
 - hazardous locations, 203
 - special, 1
- Estimating
 - a job, 279
 - cost of materials, 280
- Exit/entry control units, 56

- Explosion-proof
 - enclosures, 118
- Extension cords, 338
 - size, 345

- F**
- Farm meter standards, 135
- Fiber alignments, 256
- Fiber optics, 241
 - cables, 249
 - cleaver, 258
 - connectors, 251–253
 - jacket stripper, 259
 - stripper, 257
 - tools, 251
- Fire alarms, 64
- First aid, shock, 333
- Fittings
 - EMT, 160
 - installing, 161
 - armored cable, 150, 152
 - Carflex conduit, 214
 - flexible metal conduit cable, 152
 - IMC, 166, 167
 - installing, 169
 - specifications, 220
 - straight, 216–218
 - variety of, 163–165
- Fixtures
 - fluorescent, 83
 - incandescent, 76
- Flat rule, 325
- Flexible cords
 - ampacity, 342, 343
- Fluorescent
 - bases, 83
 - dimmers, 98
 - lamp, cold-cathode, 80
 - instant start, 80
 - preheat, 80
 - rapid start, 81
 - lamps, 71
 - troubleshooting, 84–86
- Folding rule, 325

390 INDEX

Foreign matter, 29
Formulas, motor, 303
Fractional horsepower, 111
FS boxes, 165

G

Gain, 174
Galvanized panels, 12
Ganged boxes, 186
GFCIs, 14
 protection, 16
 tools, 339
 types, 337
 using, 336

GFR, 17

Ground

 clamps, 211
 fault receptacles, 17
 removing a, 11, 15
 clips, 190
 conductors, 338
 system, 16, 22
Grounding, 364
 systems, 22

Grounds, handling, 13

Guide

 cable, 2, 4
 estimating, 280
 probable causes of motor
 troubles, 31

H

Hard-wired alarm system, 48, 49

Hazardous

 locations, 344
 situations, 338

Hazards, shock, 340

Head

 fifteen-ton, 7
 forty-ton, 7

Heads, for pumps, 6

Heat detectors, 50, 52
 locating, 54

Hickey, 174

 bending, 176

Horsepower/watts vs. torque,
 113–116

Horsepower-kilowatt
 equivalents, 276

Hub, sealing the, 205

I

ICPIP pair conductors, 237

ICS, integrated circuits, 310

IMC, 167

Impact punch-down tool, 261

Incandescent lamps, 71

Inspection microscope, 265

Installation of multiple meters, 132

Installing the load center, 130

Integrated circuits, 317, 322

Internal switches, 26

Internet connection, 268

J

Jacks and plugs, 240–244

Joints, 364

Junction splice, 267

K

Kevlar shears, 260

Key-switch zones, 61

L

Lamp bases, 74

 incandescent, 75

Lamp

 filaments, 72
 deuterium, 92
 light printing, 92
 mercury, 92
 pulsed-xenon, 92
 repro, 92
 spectral, 92

Lamps

 and lighting systems, 71
 fluorescent, 76
 types of, 79–82
 mercury vapor, 87, 88
 other types, 91

LED, 318, 319
 Life expectancy, bulbs, 74
 Lift bail, 45
 Light for activities, 93
 Light sources, lamps, 73
 Lighting controls, 91
 Lightning arresters, 127, 129
 Liquid-tight conduit, 226, 373, 375
 Little kicker, 174
 Load centers, 137–140
 Loop response time, 61
 Low voltage power, 136
 Lubricate, choice of, 28
 Lubrication, 26, 27
 Lumens, life, and efficacy for lamps, 94, 95

M

Magnetic reed switch, 57
 Maintaining a motor, 106
 Measuring
 a surface, 273
 volume and capacity, 273
 Mechanical and electrical properties of materials, 20
 Mercury vapor lamps, 71
 Metal halide lamps, 71, 88, 89
 Meter installation, 129, 131
 Meters, using, 328
 Metric
 conversions, 275, 276
 motor ratings, 112
 customary equivalents, 273, 274
 Milli-horsepower, 110
 Mixing pouch, 205
 MKSA units, 271
 Monolithic chip, 310
 Motion detectors, 50
 Motor
 enclosures, 118
 formulas, 302, 303
 grounds, 30
 opens, 30

power output, 111
 safety precautions, 45
 troubles
 causes, 30
 common, 30
 troubleshooting guide, 38–44

Motors

capacitor-start, 118
 danger signals, 29
 farm-duty, 108
 single phase, 108

Multi-cable retaining assembly, 256

Multi-gard, repairing, 182–184

N

Nail plate, 200
 Nameplate (motor)
 information, 103
 operating according to, 106
 readings, 106
 National Electrical Code, 245, 172, 350
 National Fire Protection Association, 357
 NEC, 16
 Neutral, open, 15
 Noise (motor), 231, 232
 Nonmetallic
 box, 185
 conduit, 212
 fittings, 221
 tubing, 162
 Nut, compression, 215
 Nylon devices, 18

O

Offset, 174
 multipliers, 178
 Ohm's law
 graphic, 288–290
 using, 283–287

392 INDEX

- Ohmmeter, use of, 23
- Omni connectors, 224
- Open enclosure, 120
- Operating a motor, 106
- Optical couplers, 319
- Opto-electronic devices, 318
- OSP cable, 267
- OSPF, 268
- Over-lubrication, 29
- Over-voltage, 75

- P**
- Panel board, 13
- Peak value, 301
- Performance parameters, motors,
 - 107
- Photoelectric switches, 99
- PLC, 229
- Plenum, station wire, 237
- Plug, explosion proof, 209
- Plugs, 187
 - and receptacles, 344,
 - 346, 347
 - different current ratings, 191
 - hazardous locations, 195
 - locking and non-locking,
 - 192, 193
- Polishing
 - bushing, 255
 - mat, 266
 - puck, 264
- Polyphase generators, 121
- Power
 - distribution, 125
 - factor, 292, 293
 - formulas, using, 290, 291
 - output, 109
 - phase, 294
 - sources, 121
 - supply, 109
 - system, voltage
 - standards, 110
- Powers of ten, 270
- Preventive maintenance,
 - electric motors, 25
- Process, sealing, 206
- Programmable logic
 - controller, 230
- Pump, 6
 - foot operated, 7
 - hand-operated, 7, 8
 - hydraulic, 5–8
 - manual, 7–9
- Punch, channel hole, 9
- Pure petroleum, 28
- PVC, 155
 - boxes, 185, 186
 - conduit, 168–170
 - covered cable, 158

- R**
- Raceways, 247
- Receptacle, 155
 - explosion-proof, 209
 - isolated ground, 209, 210
- Rectifier diodes, 306
- Red Book*, 69
- Regulations, 349
- Regulatory agencies, 354, 355,
 - 356
- Remote
 - control system, 142
 - digital keypad, 62
- Repair kits, 184
- Resetting thermostat
 - ballast, 78
- Resuscitation, 336
- Reversibility, motors, 111
- Right angle, 174
- Rigid conduit, 162, 176
- Riser, 13
- RMS, 300
- Rollers, 2
 - radius, 3, 4
 - right angle, 4
 - straight, 3, 4
 - types of, 4
- Rotary cable strippers, 262
- Rumbling noise, 29
- Rust, 12

S

- Saddle, 176, 179
 - bending, 179
- Safety
 - clothing, 344
 - equipment, 344
 - glasses, 266
 - measures, 336
 - rule of, 333
- Saving money, 281
- Scale, architect's, 324
 - and rules, 323
- Scientific notation, 269
- SCRs, 307, 309
- Sealing compound, 204
 - how to use, 207
- Sealing fiber
 - used to dam, 208
 - how to use, 208
- Sealing process, 206
- Seals, conduit, 204
- Secondary wires
 - to ground, 128
- Security system
 - electronic, 60
 - parts of, 61
- Selecting a motor, 106
- Semiconductors, damaged, 231
- Service
 - entrance, 133
 - factor, 109
 - rating, 27
- Shock
 - and vibration, 231
 - hazards, 18, 340
 - preventing, 12, 13
- Shunt switch, 57
- SI
 - prefixes, 271
 - system, 270
- Signal diodes, 309, 310
- Sine wave, 123
 - signature, 301
- Single-phase power, 125
- Sleeve-bearing motors, 27

- Small motors
 - checking, 26
 - maintaining, 26
- Smoke detectors, 50, 52, 53
- Snap-in, 200
- Sodium lamps
 - high pressure, 90
 - low-pressure, 91
- Spectrum, electromagnetic, 73
- Splices and taps, 364
- Standards, 349
 - development, 353
- Staple gun, 236
- Starters, 81–83
- Station wire, 233
- Straight fittings, 221
- Strippers, 254
- Stub-ups, 176, 180
- Surge suppressors, 129, 130
- Supports, 363
- Switch
 - barrel locking, 198, 201
 - canopy, 194, 196
 - cord, 194
 - four-way, 197
 - plunger type, 55
 - mounting, 56
 - snap, 198
 - three-way, 196, 199
- Symptoms, analyzing, 34
- System
 - installing, 64
 - lighting, 91
 - troubleshooting, 66

T

- Take-ups, 176
- Tamper proof, 200
- Telephone wire, types of, 234, 235
- Temperature conversion, 274, 277, 278
- Temperature, 231
- Thermoset boxes, 186
- Thin-wall conduit, 159

394 INDEX

Three-phase
motors, amp rating, 35, 36, 37
power, 121
power connections, 294
transformer, connecting, 126,
127

Thyrister, 230

TIA, 240

Time clocks, 99

Tool, aluminum connector, 6

Tools for fiberoptics, 257

Totally enclosed enclosure, 120

Transformer, three-phase, 298

Transformers 124

Transistors, 319–321

Triacs, 309

Trimmings, 364

Troubleshooting

electric motors, 25

general, 11

Tube pin base, fluorescent, 84

Tweezers, 264

Twisted plenum station

wire, 237

Twisted-pair cable color

code, 236

Type UF cable, 156

UL

electrical department, 352

label, 351, 352

Underwriter's Laboratories, Inc.,

351

Underground

entrance, 14

feeders, 154

service entrance, 134

Under-voltage, 75

Unsafe actions, 341

Utility companies, 354

V

Viscosity, 28

Voltages and currents, 124

Volume allowance, 190

VOM, 329–331

W

Warning devices, 58

Wear prevention, 28

Wet and damp areas, 11

Whistling sound (motors), 29

Wire, 147

cutters, 263, 266

dispenser, 9

gages, 326

permitted, 369, 370, 372

size, 148, 150

standard, 327

stripper, 263, 266

trolley, 10

types of, 148

Wiring diagram

eight zone alarm, 67

entry detector switch, 59

GFR, 17

for switches, 21

motor reversing, 112

Wiring, 125, 144

communications, 238

device standards, 354

installations, checking, 12

problems, 18

schematics, reversing motors, 117

telephone installation, 233

Wye

and delta networks, 295

connection, 295

currents, 123

network, 297

X

X-flex, 212

X-flex, coils, 212

Z

Zener diodes, 309

tables, 311–316

Zones

bypassing, 62

day, 63

fire, 63