

NEW AGE

# MECHANICAL SCIENCE-II

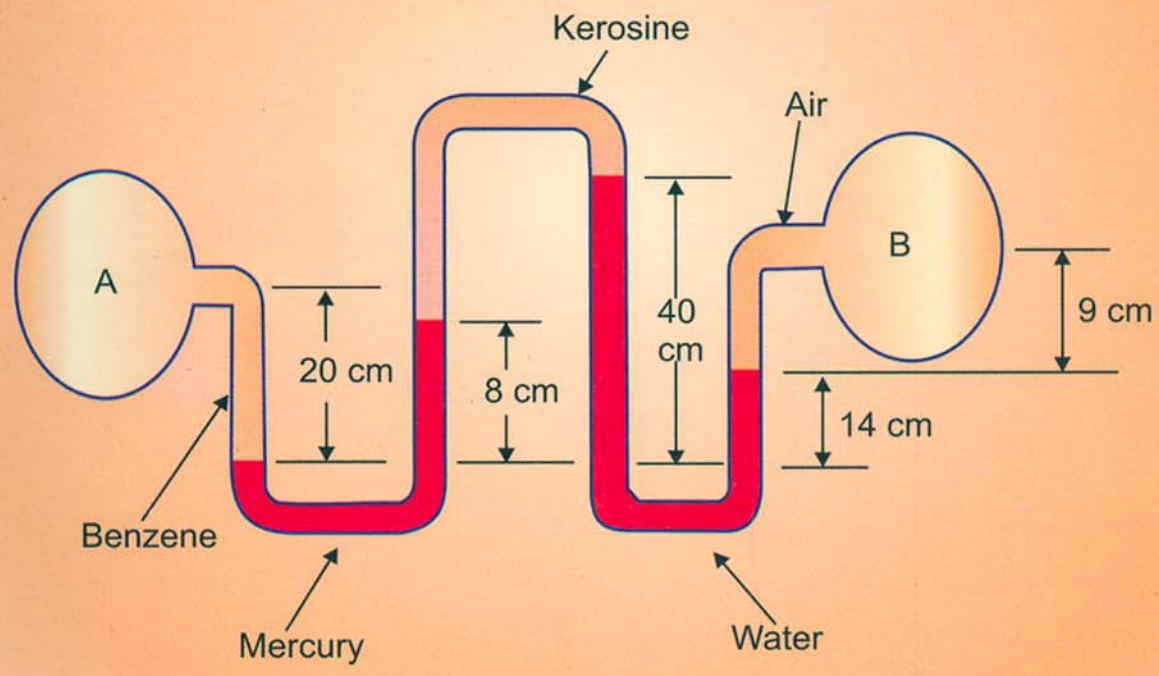

B. Bhattacharyya  
S.C. Bera



NEW AGE INTERNATIONAL PUBLISHERS

# **MECHANICAL SCIENCE-II**

**This page  
intentionally left  
blank**

# MECHANICAL SCIENCE-II

**Dr. Basudeb Bhattacharyya**

*Department of Applied Mechanics  
Bengal Engineering and Science University, Shibpur,  
Howrah – 711103*

**Prof. Subal Chandra Bera**

*Narula Institute of Technology  
Agarpara, Kolkata – 700109*

*Previously  
Department of Applied Mechanics  
Bengal Engineering and Science University, Shibpur  
Howrah – 711103*



PUBLISHING FOR ONE WORLD

**NEW AGE INTERNATIONAL (P) LIMITED, PUBLISHERS**

New Delhi • Bangalore • Chennai • Cochin • Guwahati • Hyderabad  
Jalandhar • Kolkata • Lucknow • Mumbai • Ranchi

Visit us at [www.newagepublishers.com](http://www.newagepublishers.com)

Copyright © 2009, New Age International (P) Ltd., Publishers  
Published by New Age International (P) Ltd., Publishers

---

All rights reserved.

No part of this ebook may be reproduced in any form, by photostat, microfilm, xerography, or any other means, or incorporated into any information retrieval system, electronic or mechanical, without the written permission of the publisher.  
*All inquiries should be emailed to [rights@newagepublishers.com](mailto:rights@newagepublishers.com)*

**ISBN (13) : 978-81-224-2871-1**

**PUBLISHING FOR ONE WORLD**

**NEW AGE INTERNATIONAL (P) LIMITED, PUBLISHERS**

4835/24, Ansari Road, Daryaganj, New Delhi - 110002

Visit us at [www.newagepublishers.com](http://www.newagepublishers.com)

**Dedicated**  
**to**  
*the student community who will use*  
*this book*

**This page  
intentionally left  
blank**

# PREFACE

---

Mechanical Sciences-II, within the purview of WBUT syllabus, deals the fundamental aspects of thermodynamics and fluid mechanics. Both of thermodynamics and fluid mechanics have separate identity as full-fledged subjects. Hence to study both of them, the students of WBUT may need to separate books. Here in a single book these two subjects' matters are compiled for the good of students. To achieve an in-depth knowledge of these two basic subjects, it needs very lucid elaboration of the text and also presentation of numerous worked out examples for complete understanding of the topic. Keeping these basic requirements in mind, we have tried to exert our best to come up with a most useful book.

In this newly revised edition, we have tried to rectify the errors and omissions detected earlier. The present version mainly features

- ❖ Thorough discussion of the topic in basic level, avoiding much detailing and critical discourse.
- ❖ Inclusion of multiple choice questions relevant to the topic.
- ❖ Provision of number of useful numerical examples for holistic understanding of the topic.

The forbearance as well as the active support of our family members and the useful suggestions by our colleagues and the commendable support from the editorial team of the publishing house consorted successfully to bloom this project. Though proper care has been adopted to make the book error free, any unintended mistake or error or omission noticed may be directly communicated to the publisher or the author(s).

**Dr. Basudeb Bhattacharya**  
**Prof. Subal Chandra Bera**

**This page  
intentionally left  
blank**

**This page  
intentionally left  
blank**

**This page  
intentionally left  
blank**

# CONTENTS

---

<i>Preface</i>	<i>vii</i>
<i>Syllabus</i>	<i>ix</i>

## Group–A: Thermodynamics

<b>CHAPTER 1: BASIC CONCEPT AND SOME DEFINITIONS</b>	<b>3–31</b>
1.1 Introduction	3
1.2 Macroscopic and Microscopic Approach	3
1.3 Thermodynamic System	4
1.4 Classification of Thermodynamic Systems	4
1.5 Control Mass and Control Volume	6
1.6 Thermodynamic Co-ordinates	7
1.7 State of a System	7
1.8 Properties of a System	7
1.9 Classification of Properties of a System	7
1.10 Phase	8
1.11 Thermodynamic Equilibrium	8
1.12 Path	9
1.13 Process	9
1.14 Cyclic Process or Thermodynamic Cycle	10
1.15 Point Function and Path Function	12
1.16 Unit	13
1.17 Systems of Units	15
1.18 Mass (M)	15
1.19 Weight (W)	16
1.20 Force (F)	16
1.21 Specific Weight ( $W_s$ )	17
1.22 Specific Volume ( $v_s$ )	17

1.23	Pressure	17
1.24	Absolute, Gauge and Vacuum Pressure	17
1.25	Pressure Measurement by Manometer	18
1.26	Normal Temperature and Pressure (N.T.P)	20
1.27	Standard Temperature and Pressure (S.T.P)	20
1.28	Energy	20
1.29	Types of Stored Energy	20
1.30	Law of Conservation of Energy	21
1.31	Power	21

## **CHAPTER 2: ZEROTH LAW AND TEMPERATURE**

**33–57**

2.1	Temperature	33
2.2	Zerorth Law of Thermodynamics	33
2.3	Measurement of Temperature	33
2.4	Constant Volume Gas Thermometer and Temperature Scale	34
2.5	Heat and Heat Transfer	37
2.6	Specific Heat	38
2.7	Thermal or Heat Capacity of a Substance	38
2.8	Water Equivalent of a Substance	39
2.9	Mechanical Equivalent of Heat	39
2.10	Work	39
2.11	Sign Convention of Work	41
2.12	Work Done During a Quasi-Static or Quasi-Equilibrium Process	41
2.13	Work and Heat Transfer—A Path Function	43
2.14	Comparison of Heat and Work	44
2.15	Example of Work	45
2.16	Work in Non-flow Process Versus Flow Process	50

## **CHAPTER 3: PROPERTIES AND THERMODYNAMIC PROCESSES OF GAS**

**59–102**

3.1	Introduction	59
3.2	General Gas Equation	59
3.3	Equation of State and Characteristic Equation of Gas	60
3.4	Universal Gas Constant or Molar Gas Constant	60
3.5	Specific Heat of Gas	61
3.6	Linear Relation Between $C_p$ and $C_v$	62
3.7	Ratio of $C_p$ and $C_v$	62
3.8	Enthalpy of a Gas	63
3.9	Thermodynamic Processes	63
3.10	Classification of Thermodynamic Process	64
3.11	Heating and Expansion of Gases in Non-flow Process	64
3.12	Constant Volume or Isochoric Process	64
3.13	Constant Pressure or Isobaric Process	66
3.14	Hyperbolic Process	68
3.15	Constant Temperature or Isothermal Process	69

---

3.16	Adiabatic Process	71
3.17	Polytropic Process	74
3.18	General Laws for Expansion and Compression	75
3.19	Real Gas	76
3.20	Real Gas and Compressibility Factor	76
3.21	Law of Corresponding State and Generalized Compressibility Chart	77
<b>CHAPTER 4: FIRST LAW OF THERMODYNAMICS AND ITS APPLICATION</b>		<b>103–131</b>
4.1	Introduction	103
4.2	Joule's Experiment	103
4.3	First Law of Thermodynamics for a System Undergoing a Thermodynamics Cycle	104
4.4	The Important Consequences of the First Law of Thermodynamics	105
4.5	Limitations of First Law of Thermodynamics	108
4.6	Application of First Law Thermodynamics to a Non-flow Process	109
4.7	Application of First Law of Thermodynamic to a Steady Flow Process	111
4.8	Mass Balance (Continuity Equation)	113
4.9	Work Done in a Steady Flow Process	113
4.10	Work Done Various Steady Flow Process	114
4.11	Throttling Process	115
4.12	Application of Steady Flow Energy Equation to Engineering System	115
<b>CHAPTER 5: SECOND LAW OF THERMODYNAMICS</b>		<b>133–155</b>
5.1	Introduction	133
5.2	The Second Law of Thermodynamics	135
5.3	Equivalence of Kelvin-Planck and Clausius of Second Law of Thermodynamics	137
5.4	Reversible Cycle	138
5.5	Irreversible Cycle	138
5.6	Reversibility and Irreversibility of Thermodynamic Process	138
5.7	Carnot Cycle	139
5.8	Reversed Carnot Cycle	142
5.9	Carnot Theorem	142
<b>CHAPTER 6: ENTROPY</b>		<b>157–182</b>
6.1	Introduction	157
6.2	Importance of Entropy	157
6.3	Units of Entropy	158
6.4	Clausius Theorem	158
6.5	Entropy—A Point Function or a Property of a System	161
6.6	Clausius Inequality	162
6.7	Principle of Increase of Entropy	162
6.8	Entropy and Temperature Relation	163
6.9	General Expression for Change of Entropy of a Perfect Gas	164
6.10	Change of Entropy of Perfect Gas During Various Thermodynamic Process	165
6.11	Irreversibility	167

<b>CHAPTER 7: PROPERTIES OF PURE SUBSTANCES</b>	<b>183–227</b>
7.1 Introduction	183
7.2 Phase Equilibrium of a Pure Substance on T-V Diagram	183
7.3 Temperature and Total Heat Graph During Steam Formation	185
7.4 Phase Equilibrium at Higher Pressure	185
7.5 Phase Equilibrium at Lower Pressures	187
7.6 Thermodynamic Surface	187
7.7 $p$ - $v$ Diagram of a Pure Substances	188
7.8 Important Terms of Steam	189
7.9 Entropy of Steam	213
7.10 Entropy of Water	213
7.11 Entropy Increases During Evaporation	213
7.12 Entropy of Wet and Dry Steam	214
7.13 Entropy for Superheated Steam	214
7.14 External Work of Evaporation	215
7.15 Internal Latent Heat	215
7.16 Internal Energy of Steam	215
7.17 Temperature-Entropy Diagram of Water and Steam	216
7.18 Isothermal Lines on T-S Diagram	216
7.19 Isentropic Lines	216
7.20 Enthalpy-Entropy (h-s) Diagram for Water and Steam or Mollier Chart	217
7.21 Dryness Fraction Lines on h-s Diagram	219
7.22 Constant Volume Line	219
7.23 Constant Pressure Line	219
7.24 Isothermal Line	219
7.25 Isentropic Line on (h-s) Diagram	220
7.26 Throttling Lines on h-s Diagram	220
 <b>CHAPTER 8: THERMODYNAMIC AIR STANDARD CYCLES</b>	 <b>229–248</b>
8.1 Introduction	229
8.2 Assumptions in Thermodynamic Cycles	229
8.3 Classification of Thermodynamic Cycles	230
8.4 Important Parameters in Air Standard Cycle Analysis	230
8.5 Important Terms used in Thermodynamic Cycles	230
8.6 Types of Thermodynamic Cycles	232
8.7 Carnot Cycle	232
8.8 Otto Cycle	232
8.9 Joule's Cycle	234
8.10 Diesel Cycle	235
8.11 Comparison between the Efficiency of Otto and Diesel Cycle for same Compression Ratio	237
 <b>CHAPTER 9: STEAM POWER CYCLE</b>	 <b>249–258</b>
9.1 Introduction	249
9.2 Rankine Cycle	249
9.3 Vapour Compression Refrigeration Cycle	251
 <b>BIBLIOGRAPHY</b>	 <b>259</b>

## Group–B: Fluid Mechanics

<b>CHAPTER 1: INTRODUCTION AND FUNDAMENTAL CONCEPTS</b>	<b>263–288</b>
1.1 Definition of Fluid	263
1.2 Fluid Mechanics and its Perview	263
1.3 Fluid as a Continuum	263
1.4 Properties of Fluid	264
<b>CHAPTER 2: FLUID STATICS</b>	<b>289–327</b>
2.1 Forces on Fluid Element	289
2.2 Equilibrium of Static Fluid Element	290
2.3 Solution of Euler’s Equations	291
2.4 Gauge Pressure and Absolute Pressure	294
2.5 Measurement of Pressure	295
2.6 Manometer	296
2.7 Hydrostatic Force on Submerged Plane Surface	298
2.8 Hydrostatic Force on Submerged Curved Surface	300
2.9 Buoyancy and Archimedes Law	301
2.10 Equilibrium and Metacentre	302
<b>CHAPTER 3: KINEMATICS OF FLUID FLOW</b>	<b>329–355</b>
3.1 Introduction	329
3.2 Scalar and Vector Field	329
3.3 Description of Fluid Flow	329
3.4 Classification of Flow	330
3.5 Description of Flow Patterns	333
3.6 Conservation of Mass	335
<b>CHAPTER 4: DYNAMICS OF FLUID FLOW</b>	<b>357–392</b>
4.1 Introduction	357
4.2 Equation of Steady Motion Along Streamline	358
4.3 Bernoulli’s Equation	359
4.4 Different Heads	360
4.5 Hydraulic Grade Line (HGL) and Energy Grade Line (EGL)	360
4.6 Major and Minor Head Loss	361
4.7 Absolute and Relative Roughness	361
4.8 Reynold’s Number	361
4.9 Application of Bernoulli’s Equation	362
4.10 Static Pressure and Stagnation Pressure	365
4.11 Pitot Tube	366
<b>BIBLIOGRAPHY</b>	<b>393</b>
<b>QUESTIONS PAPER</b>	<b>395–408</b>
<b>INDEX</b>	<b>409–416</b>

**This page  
intentionally left  
blank**

**Group–A**  
*Thermodynamics*

**This page  
intentionally left  
blank**

CHAPTER
1

# BASIC CONCEPT AND SOME DEFINITIONS

---

## 1.1 INTRODUCTION

Thermodynamics is the science of the conversion of energy, in terms of heat and work and their mutual relationship along with properties of the system. It also can be defined as the science of Energy and Entropy. The principles of energy conversion have been formulated into different thermodynamic laws, which are known as *Zerth Law*, *First*, *Second* and *Third Law* of Thermodynamics.

The field of Engineering Science which deals with the applications of thermodynamics and its laws to energy conversion devices, in order to understand their function and improve their performance, is known as *Thermal Engineering*.

A system, which converts heat into mechanical works or vice versa, is known as *Heat Engine*. In the heat engine, heat is generated by the combustion of fluid, which may be solid, liquid or gas. In *external combustion engines* (i.e., steam engines or steam turbines) solid fuel is used as working substance and combustion takes place outside of the engine. In *internal combustion engine* a mixture of air and fuel is used as working substance and combustion takes place inside the engine's cylinder.

## 1.2 MACROSCOPIC AND MICROSCOPIC APPROACH

There are two point of views to study a thermodynamics problem from which the behaviour of matter can be studied. They are known as *macroscopic approach* and *microscopic approach*.

In the *macroscopic approach*, we study the gross or time averaged effects of the particles which may be observable and measurable by instruments. The macroscopic approach is used in *Classical Thermodynamics* which is the subject matter of the text. In this point of view we deal with volumes that are considerably large compared to molecular dimensions. It is not concerned with the behaviour of individual molecules. Therefore, it treats the matter as continuous, or the whole of this as a *Continuum*.

For example, when a container contains gas, the gas exerts pressure on the walls of its container. The pressure results from the change in momentum of the gas molecules as they collide against the wall of the container. In this approach, it is not concerned with the collisions of the molecules, but with the time averaged value of force exerted on the unit area of the surface of the container, which can be measured by a pressure gauge.

In *microscopic approach*, we make an attempt to analyse system by considering it as comprising of discrete particles which are its atoms and molecules. It is difficult to adopt it in practice. The *modified microscopic approach* is employed to simplify this problem in which we deal with average value for all particles under consideration making use of the *theory of probability*. This modified approach is employed in statistical thermodynamics and kinetic theory of gases. It is particularly helpful, when dealing with the system in which the mean free path of the molecules is large compared with the dimension of the system such as in high vacuum technology.

### 1.3 THERMODYNAMIC SYSTEM

Thermodynamics dealing with the energy transfer within a definite quantity of matter of fixed mass or definite area or region in space or control volume which is bounded by a closed surface upon which attention is focused is known as system. The systems are shown in Venn diagram in figure 1.1.

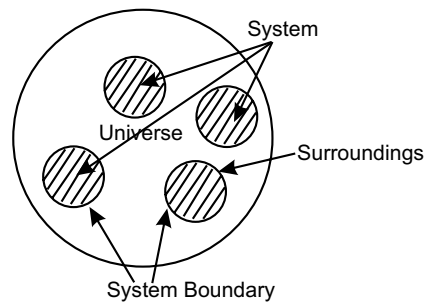

Fig. 1.1

- (a) **Boundary:** Thermodynamic system (or simply known as system) is bounded by a closed surface which separates it from the other systems and universe. This closed surface is known as boundary or system boundary. These boundaries may be fixed or movable. A tank of certain mass of compressed fluid and a certain volume of water in a pipe/line are examples of fixed and movable boundary, respectively. Boundary may be real or imaginary in nature.
- (b) **Surrounding:** The space or anything outside the system boundaries is known as surrounding.
- (c) **Universe:** Systems and surroundings together is known as universe.

### 1.4 CLASSIFICATION OF THERMODYNAMIC SYSTEMS

The thermodynamic systems may be classified into three groups:- (a) Closed system, (b) Open system, and (c) Isolated system.

#### 1.4.1 Closed System

In this system, a definite quantity of matter of fixed mass and identity is considered whose boundaries are determined by the space of the matter occupied in it. A closed system is shown in figure 1.2(a). In this system energy can cross its boundary but the system does not permit any mass transfer along its boundary. In other words, the heat and work energy can cross the boundary of the system during the process, but during the process there is no addition or loss of the original mass of the working substance. Hence, the mass of the working substance which occupies in the control volume of the system, is fixed.

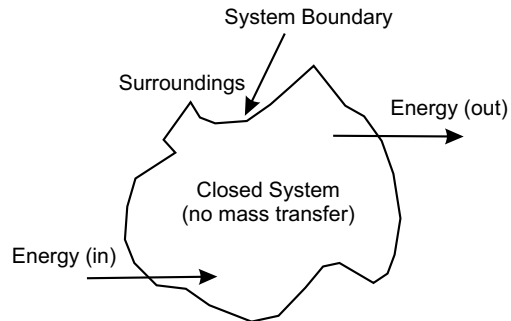

Fig. 1.2 (a)

### 1.4.2 Open System

In this system, both energy (heat and work energy) and mass of the working substance can cross the boundary of the system, during the process. The mass of the working substance within the control volume of system may not be constant. It is shown in figure 1.2(b).

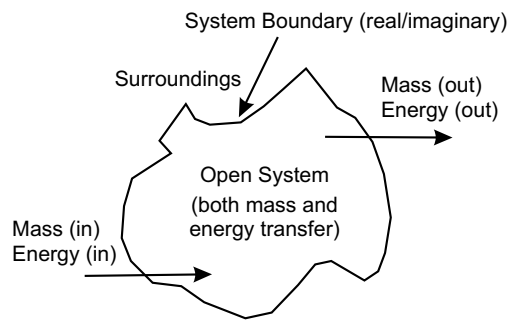

Fig. 1.2 (b)

### 1.4.3 Isolated System

In this system, neither energy (heat energy & work energy) nor mass of the working substance can cross the system boundary during the process. During the process ongoing, there is no addition or loss of the energy and mass of working substance which occupy within the control volume. It is shown in figure 1.2.(c).

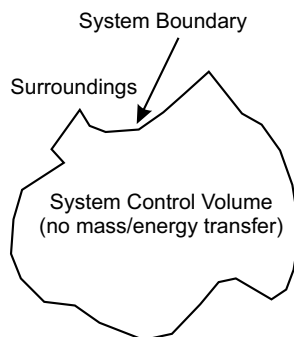

Fig. 1.2 (c)

### 1.5 CONTROL MASS AND CONTROL VOLUME

The region in space of definite quantity of matter of fixed mass and identity is bounded by a closed surface (boundary), upon which attention is focused for study. Mass inside the system boundary is known as control mass as shown in figure 1.3(a). In closed system the mass does not cross the system boundary, so mass of system is fixed, though its volume can change against a flexible boundary. Therefore fixed mass of closed system is called control mass.

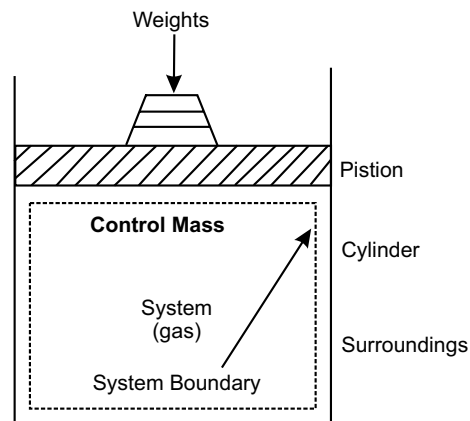

Fig. 1.3 (a)

A control volume is a region in space bounded by a closed envelope on which attention is focused for energy analysis. The control volume bounded by a prescribed boundary is known as control surface as shown in figure 1.3(b). The control volume need not be fixed in size as well as shape. It may not be fixed in position also. However, in most of the applications we deal with control volume which are fixed in size and shape as well as fixed in position relative to the observer. An open system is equivalent in every respect to a control volume.

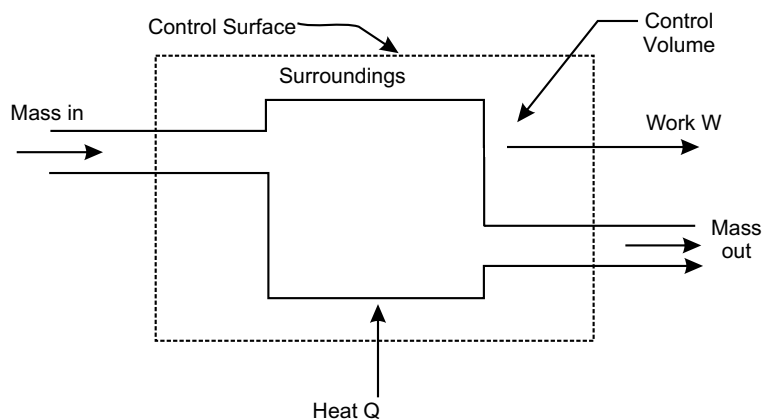

Fig. 1.3 (b)

### 1.5.1 Comparison of Properties of a Control Mass and a Control Volume

Control mass	Control volume
1. Refers to a definite quantity of matter on which attention is focused.	1. Refers to a defined region of space on which attention is focused.
2. Bounded by a closed boundary which may be real or imaginary.	2. Enclosed by a control surface which may be real or imaginary.
3. Matter does not cross the boundaries of a control mass.	3. Matter continuously flows in and out of the control volume.
4. Heat and work interaction are present across the system boundary.	4. Control volume can exchange heat and work through control surface.

### 1.6 THERMODYNAMIC CO-ORDINATES

Every system has certain observable characteristics by which its physical condition may be described. Such characteristics like location, pressure, volume, temperature etc are called properties. Properties are the co-ordinates to describe the state of the system. These co-ordinates for locating thermodynamic state points are defined as the thermodynamic co-ordinates.

### 1.7 STATE OF A SYSTEM

The state of a system is the configuration of the system at any particular moment which can be identified by the statement of its properties, such as pressure, volume, temperature etc., so that one state point may be distinguished from the other states.

### 1.8 PROPERTIES OF A SYSTEM

Properties of a system are thermodynamic co-ordinates of the system which describe its physical condition such as location, volume, pressure, temperature etc., So any observable characteristics of the system is a property. A sufficient number of independent properties exist to represent the state of a system. A property of the system depends only upon the state of the system and not upon how that state may have been reached. The properties are measurable quantities in terms of numbers and units of measurements.

Mathematically it can be explained whether any quantity is a property or not as follows.

If  $x$  and  $y$  are two properties of a system, then  $dx$  and  $dy$  are their exact differentials. In general,

if the differential is of the form of  $(Mdx + Ndy)$ , the test for exactness is  $\left(\frac{\partial M}{\partial y}\right)_x = \left(\frac{\partial N}{\partial x}\right)_y$ .

### 1.9 CLASSIFICATION OF PROPERTIES OF A SYSTEM

The thermodynamic properties of a system may be classified into the following two groups:  
(a) Extensive properties and (b) Intensive properties.

### 1.9.1 Extensive Properties

The properties of a system, whose values for the entire system depending on the mass of the system are equal to the sum of their values for the individual parts of the system are called extensive properties. Total volume, total energy and total mass of the system are extensive properties of the system.

The ratio of an extensive property to the mass is called the specific property or the property per unit mass. For example

$$\text{Specific volume } (v_s) = \frac{\text{total volume}}{\text{total mass}} = \frac{V}{m} \text{ m}^3/\text{kg}$$

The ratio of an extensive property to the mole number is called the molar property, like

$$\text{Molar volume } (v_m) = \frac{\text{total volume}}{\text{mole number}} = \frac{V}{n} \text{ m}^3/\text{kg}$$

### 1.9.2 Intensive Properties

The properties of a system where value do not depend upon the mass of the system are called intensive properties, such as temperature of the system. It does not depend on the mass of the system and whatever remains the mass of the system it is same for the entire system. It is also true for specific volume, density and pressure of the system.

### 1.9.3 Difference between Extensive and Intensive Properties with an Example

The properties which depend on the mass of a system are called extensive properties, whereas the properties which do not depend on the mass of a system are called intensive properties. So intensive properties are independent of the mass of the properties. At normal temperature and pressure i.e., at 0°C and 1 standard atmospheric pressure (at NTP) one mole of a gas occupies a volume of 22.4 litres. Consider two systems  $P$  and  $Q$  such that system  $P$  contains 1 mole of oxygen at NTP and system  $Q$  contains 5 moles of oxygen at NTP. If the volume occupied by the systems  $P$  and  $Q$  can be measured, it will be found that the system  $Q$  occupies a volume of  $22.4 \times 5 = 112.0$  litres which is equal to five times the volume occupied by system  $P$ . So the volume occupied by a system depends on the mass of the system and hence volume is an extensive thermodynamic property. Measurement of temperature and pressure show that systems  $P$  and  $Q$  will have the same temperature (0°C) and pressure (one standard atmospheric pressure). Hence, the properties pressure and temperature do not depend on the mass of the system and so are called intensive properties.

### 1.10 PHASE

When a quantity of matter is homogeneous throughout in terms of chemical composition and physical structure is called a phase. There are three phases, solid, liquid and gas. A system consisting of a single phase is called a *homogeneous system*, while a system consisting of more than one phase is known as a *heterogeneous system*.

### 1.11 THERMODYNAMIC EQUILIBRIUM

A system is said to be in thermodynamic equilibrium, when no change in any one of the properties do occur. A system will be in a state of thermodynamic equilibrium, if it satisfies the following three

requirements of equilibrium (a) Mechanical equilibrium, (b) Chemical equilibrium (c) Thermal equilibrium.

### 1.11.1 Mechanical Equilibrium

The system is said to be in mechanical equilibrium, when there is no unbalanced force within the system.

### 1.11.2 Chemical Equilibrium

The system is said to be in chemical equilibrium, if there is no chemical reaction and no transfer of matter from one part of the system to another.

### 1.11.3 Thermal Equilibrium

When a system is in contact with its surroundings across a diathermal wall (wall through which heat can flow) and if there is no spontaneous change in any of the properties of the system, the system is said to exist in thermal equilibrium with its surroundings. Also, a system may exist in thermal equilibrium with another system. Adjacent figure 1.4 illustrates thermal equilibrium between two systems or between a system and its surroundings, temperature being one property must be the same.

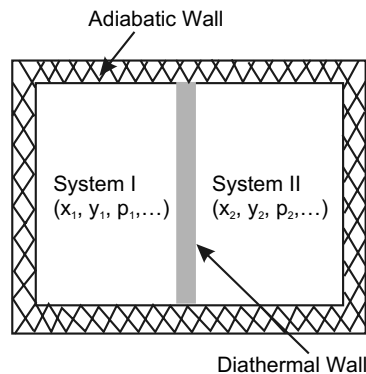

Fig. 1.4

## 1.12 PATH

Properties are the thermodynamic co-ordinates of the state of a system. So the properties are state-variable of the system. When any one or more of the properties of a system change, it is called a change of state. When a system passes through a series of states during a change of state from the initial state to the final state, it is called the path of the change of state.

## 1.13 PROCESS

When a system passes through a successive states during a change of state from the initial state to the final state, with a completely specified path for each successive change in states, the change of state is defined as a process, e.g., a constant volume process, constant pressure process. It is shown in figure 1.5, where 1-2 is a constant volume process and 2-3 is a constant pressure process.

A process is designated by the path followed by the system in reaching the final equilibrium state from the given initial state.

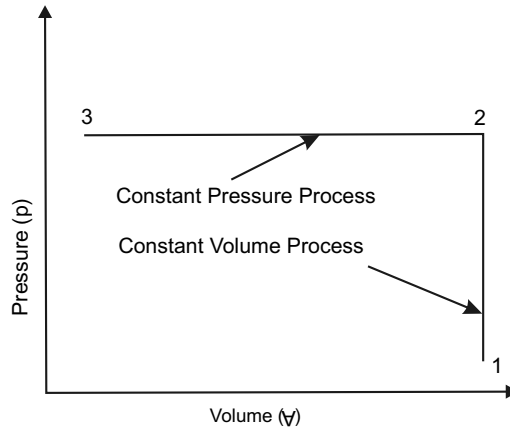

Fig. 1.5

### 1.14 CYCLIC PROCESS OR THERMODYNAMIC CYCLE

When a process or processes are performed on a system in such a way that the initial and the final states will be same, then the process is called thermodynamic cycle or cyclic process. In figure 1.6 1-A-2 and 2-B-1 are two simple processes whereas 1-A-2-B-1 is a cyclic process, whose final and initial states are the same.

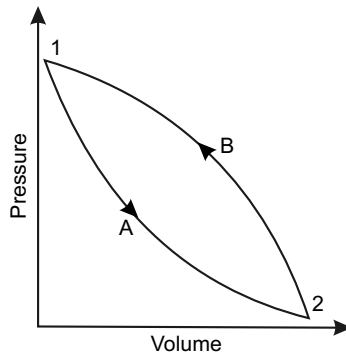

Fig. 1.6

#### 1.14.1 Quasi-static Process or Quasi-equilibrium Process

Quasi-static process is a process carried out in such a way that at every instant, the deviation of the state from the thermodynamic equilibrium will be infinitesimally small. Every state passing through the system will be in closely approximating succession of equilibrium state. The locus of all these equilibrium points passed through the system is a quasi-static process. A quasi-static process is shown in figure 1.7.  $AB$  is a quasi-static process and at the successive states (shown by the points at 1, 2, 3 etc..) the system is very nearly of thermodynamic equilibrium. Only Quasi-static process can be represented on a thermodynamic plane.

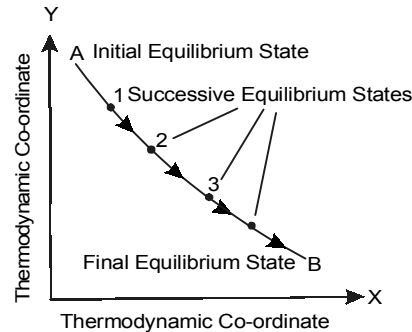

Fig. 1.7

### 1.14.2 Non-equilibrium Process

Non-equilibrium process is a process carried out in such a way that the initial state-point and the final state-point are in equilibrium but the intermediate state-points, through which the system is passing, are in non-equilibrium state. Figure 1.8 shows the non-equilibrium process whose initial and final equilibrium states are joined by a dotted line which has got no-meaning otherwise.

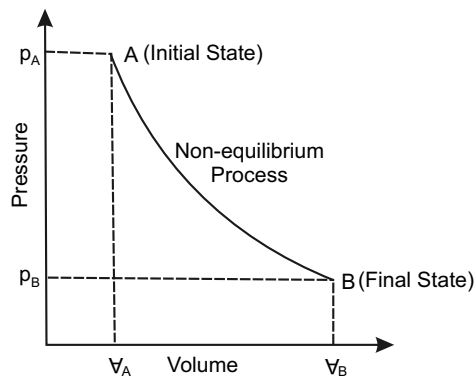

Fig. 1.8

### 1.14.3 Reversible Process

Reversible process is a process carried out in such a way that at every instant, the system deviation is only infinitesimal from the thermodynamic state, and also which can be reversed in direction and the system retraces the same equilibrium states. Thus in reversible process, the interactions between the system and the surroundings are equal and opposite in direction. The Quasi-static or Quasi-equilibrium process is also known as reversible process. In reversible process the work done could be written in the form  $W = \int p dV$  When there is a change in system boundaries.

### 1.14.4 Irreversible Process

A process is said to be irreversible, while initial and final states both being in equilibrium, when reversed, the system and the surroundings do not come to the original initial state and a trace of history of the forward process is left. In actual practice, most of the processes are irreversible, due

to turbulence in the system, temperature gradients in the system and due to friction. In irreversible processes, the network output is less than  $\int pdv$  and is given by  $W_{\text{net}} = \int pdv - W_{\text{dissipated}}$

Reversible and Irreversible processes are shown in figure 1.9.

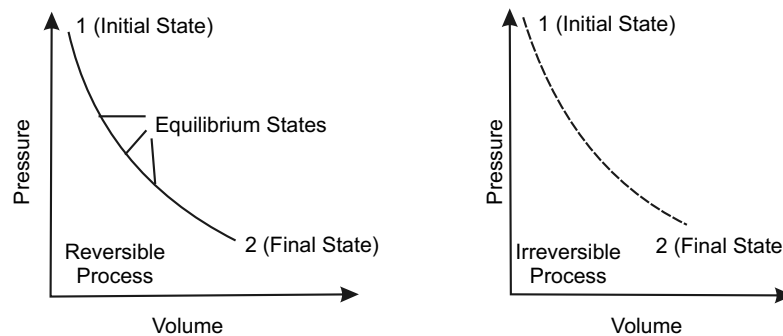

Fig. 1.9

### 1.14.5 Flow Process

The process occurring in the control volume of open system which permits the transfer of mass to and from the system is known as flow process. The working substance, in flow processes, enters the system and leaves after doing the work. The flow processes may be classified as (1) steady flow processes and (2) unsteady flow processes. The conditions which must be satisfied for a steady flow process are as following:

- (i) The mass flow rate through the system remains constant.
- (ii) The rate of heat transfer is constant.
- (iii) The rate of work transfer is constant.
- (iv) The characteristics of the working substance, like velocity, pressure, density etc., at any point do not change with time.

If any one of these conditions are not satisfied, then the flow process is said to be an unsteady flow process.

### 1.14.6 Non-flow Process

The process in which mass of working substance is not permitted to cross the boundary of the control volume of the system, is called non-flow process. Generally non-flow processes occur in the closed system.

### 1.15 POINT FUNCTION AND PATH FUNCTION

The values of properties of a system in a given state are independent of the path followed to reach that final state from initial state. Because of this characteristics, the state is a point function. Consider the change of state of a system from an initial equilibrium state 1 to a final equilibrium state 2 by following many different paths such as 1-A-2 or 1-B-2 or 1-C-2 or 1-D-2 etc, as shown in figure 1.10. The values of properties of states 1 and 2 are  $p_1, v_1$  and  $p_2, v_2$ , respectively. The state 2, whether is reached via 1-A-2 or 1-B-2 or 1-C-2 etc, will have the same values of properties  $p_2$  and  $v_2$ . So the change in the value of a property between any two given states is the same irrespective of the path

between the two states. Thus in the present illustration, the differences of values of properties, i.e.,  $\int_1^2 dp = p_2 - p_1$  and  $\int_1^2 dV = V_2 - V_1$  are always the same between the states 1 and 2 whether the path followed is 1-A-2 or 1-B-2 or any other one. It is also true for any quantity being a point function, the change of which is independent of path.

The path followed to reach the final state from a initial state is called the process. The quantity, the value of which depends on the path followed during a change of state is a path function. For example, in the above figure, the areas under 1-A-2, 1-B-2 etc., are different i.e.,

$$\int_1^2 dA \neq A_2 - A_1$$

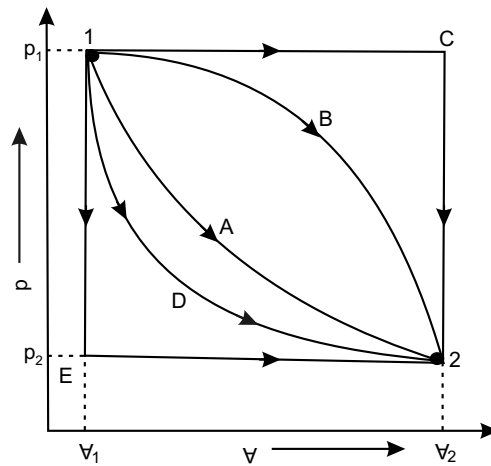

Fig. 1.10

Where initial value  $A_1$  and the final value  $A_2$  have no meaning. The integral value of such quantities as

$$\int_1^2 dA = {}_1A_2 \text{ or } A_{12}$$

The area for process between state 1 and 2 can only be determined, when the path followed is known.

## 1.16 UNIT

The primary quantities are measured in terms of the basic or fundamental units and the secondary quantities are measured in terms of derived units.

### 1.16.1 Fundamental Units

Fundamentals units are the basic unit normally which are unit of mass ( $M$ ), unit of length ( $L$ ) and unit of time ( $T$ ), but in the International System of units, there are seven fundamental units and two supplementary units, which cover the entire field of science and engineering. These units are shown in the Table 1.1.

**Table: 1.1. Fundamental and Supplementary Units***Fundamental Unit:*

Sl.No.	Physical Quantity	Unit	Symbol
1.	Mass (M)	kilogram	kg
2.	Length (L)	metre	m
3.	Time (t)	second	s
4.	Temperature (T)	kelvin	K
5.	Electric current (I)	ampere	A
6.	Luminous intensity ( $I_v$ )	candela	Cd
7.	Amount of substance (n)	mole	mole

*Supplementary Unit:*

1.	Plane angle ( $\alpha, \beta, \theta, \phi$ )	radian	rad
2.	Solid angle ( $\Omega$ )	steradian	Sr

**1.16.2 Derived Units**

Some units expressed in terms of other basic units, which are derived from fundamental units are known as derived units. The derived units, which will be commonly used in this book, are given in the following table.

**Table: 1.2. Derived Units**

Sl.No.	Physical Quantity	Unit	Symbol
1.	Area	$m^2$	A
2.	Angular velocity	rad/s	$\omega$
3.	Angular acceleration	$rad/s^2$	$\alpha$
4.	Linear velocity	m/s	V
5.	Linear acceleration	$m/s^2$	a
6.	Mass density	$kg/m^3$	$\rho$
7.	Force, weight	N	F, W
8.	Work, energy, enthalpy	J	W, E, H
9.	Pressure	$N/m^2$	p
10.	Power	Watt	P
11.	Absolute or dynamic viscosity	$N\cdot s/m^2$	$\mu$
12.	Kinematic viscosity	$m^2/s$	$\nu$
13.	Characteristic gas constant	J/kg·K	R

*Contd..*

14.	Universal gas constant	J/kgmol.K	$R_m$
15.	Frequency	Hz, 1Hz = 1cps	f
16.	Thermal conductivity	W/mK	k
17.	Specific heat	J/kg.K	C
18.	Molar mass or molecular mass	kg/mol	M
19.	Sp. weight or wt. density	kgf/m <sup>3</sup>	$w_s$
20.	Sp. volume	m <sup>3</sup> /kg	$v_s$
21.	Volume	m <sup>3</sup>	$\nabla$

### 1.17 SYSTEMS OF UNITS

There are only four systems of units, which are commonly used and universally recognized. These are known as:

(1) C.G.S systems (2) F.P.S systems (3) M.K.S systems (4) S.I (System Internationale or International system of units). The internationally accepted prefixes in S.I to express large and small quantities are given below in the table.

**Table: 1.3. Prefix Factors**

Factor of Multiplication	Prefix	Symbol
$10^{12}$	tera	T
$10^9$	giga	G
$10^6$	mega	M
$10^3$	kilo	k
$10^2$	hecto	h
$10^1$	deca	da
$10^{-1}$	deci	d
$10^{-2}$	centi	c
$10^{-3}$	milli	m
$10^{-6}$	micro	$\mu$
$10^{-9}$	nano	n
$10^{-12}$	pico	p

### 1.18 MASS (M)

Mass is the amount of matter contained in a given body and it does not vary with the change in its position on the earth's surface.

### 1.19 WEIGHT (W)

The weight is the amount of force of attraction, which the earth exerts on a given body. The weight of the body will vary with its position on the earth's surface, because force of attraction vary with variation of distance between the two bodies.

### 1.20 FORCE (F)

Force may be defined as an agent which produces or tends to produce, destroy or tends to destroy the motion. According to Newton's Second Law of Motion, the applied force or impressed force is directly proportional to the rate of change of momentum

$$\text{Hence,} \quad F \propto \frac{mv - mu}{t}$$

$$\Rightarrow \quad F \propto m \left( \frac{v - u}{t} \right)$$

$$\Rightarrow \quad F \propto m a$$

$$\therefore \quad F = k \cdot m \cdot a$$

Where  $k$  is the constant of proportionality. If the unit of force adopted so that it produces unit acceleration to a body of unit mass, then

$$\therefore \quad 1 = k \cdot 1 \cdot 1$$

$$\Rightarrow \quad k = 1$$

$$\Rightarrow \quad F = ma$$

**or, Force = mass  $\times$  acceleration**

In S.I the unit is newton(N) and  $1\text{N} = 1 \text{ kg m/s}^2$ .

There are two types of units of force, absolute and gravitational. When a body of mass 1 kg is moving with an acceleration of  $1 \text{ m/s}^2$ , the force acting on the body is 1 newton(N). This is the absolute unit of force.

When a body of mass 1 kg is attracted towards the earth with an acceleration of  $9.81 \text{ m/s}^2$ , the force acting on the body is 1 kilogram-force, briefly written as 'kgf' or kg-wt. The unit of force in kgf is called gravitational or engineers, unit of force or metric unit of force. From the Newton's Second Law of Motion

$$F = k \cdot m \cdot a = m \cdot \frac{g}{g_c} = \text{weight}$$

Where  $a = g$  (acceleration due to gravity), and

$$k = \frac{1}{g_c}, \text{ while}$$

$$g_c = 9.80665 \text{ kg} \frac{\text{m}}{\text{s}^2} \approx 9.81 \text{ kg} \cdot \frac{\text{m}}{\text{s}^2} \cdot \frac{1}{\text{kgf}}$$

and 
$$1 \text{ kgf} = \frac{1 \text{ kg} \times 9.81 \text{ m/s}^2}{g_c} = \text{weight}$$

If, local value of  $g$  is numerically the same as  $g_c$  then the weight of 1 kg becomes equal to 1 kgf.

The gravitational unit of force is 'g' times greater than the absolute unit of force or S.I unit of force, as

$$1 \text{ kgf} = 1 \text{ kg} \times 9.81 \text{ m/s}^2 = 9.81 \text{ m/s}^2 = 9.81 \text{ N}$$

### 1.21 SPECIFIC WEIGHT ( $w_s$ )

It is the weight per unit volume. It is also known as the weight density. It may be expressed in  $\text{kgf/m}^3$ , in MKS system of unit and  $\text{newton/m}^3$  in S.I.

$$\text{Specific weight } (w_s) = \frac{W}{V} = \frac{mg}{V} = \rho \cdot g$$

### 1.22 SPECIFIC VOLUME ( $v_s$ )

It is defined as the volume per unit mass. It may be expressed in  $\text{m}^3/\text{kg}$ .

$$\text{Specific volume } (v_s) = \frac{V}{m} = \frac{1}{\rho}$$

### 1.23 PRESSURE

Pressure is the normal force exerted by a system against unit area of the boundary surface. The unit of pressure depends on the units of force and area. In S.I, the practical units of pressure are  $\text{N/mm}^2$ ,  $\text{N/m}^2$ ,  $\text{kN/m}^2$ ,  $\text{MN/m}^2$  etc.

A bigger unit of pressure known as bar, such that

$$1 \text{ bar} = 1 \times 10^5 \text{ N/m}^2 = 0.1 \times 10^6 \text{ N/m}^2 = 0.1 \text{ MN/m}^2$$

Other practical units of pressure are Pascal (Pa), kilopascal (kPa) & mega Pascal (MPa), such that

$$1 \text{ Pa} = 1 \text{ N/m}^2$$

$$1 \text{ kPa} = 1 \text{ kN/m}^2 = 10^3 \text{ N/m}^2$$

$$1 \text{ MPa} = 1 \times 10^6 \text{ N/m}^2 = 10^3 \text{ kPa} = 1 \text{ N/mm}^2$$

### 1.24 ABSOLUTE, GAUGE AND VACUUM PRESSURE

The pressure is measured in two different systems. In one system, it is measured above the absolute zero or complete vacuum, and is defined as absolute pressure. In other system, pressure is measured above the atmospheric pressure, and is defined as gauge pressure. So

- (a) **Absolute pressure:** It is defined as the pressure which is measured with reference to absolute zero pressure.
- (b) **Gauge pressure:** It is defined as the pressure which is measured with reference to atmospheric pressure. It is measured with the help of a pressure measuring instrument. It is a pressure above the atmospheric pressure.

- (c) **Vacuum pressure:** It is the pressure below the atmospheric pressure. Sometimes it is called as negative gauge pressure. The relationship between the absolute pressure, gauge pressure and vacuum pressure are shown in figure 1.11.

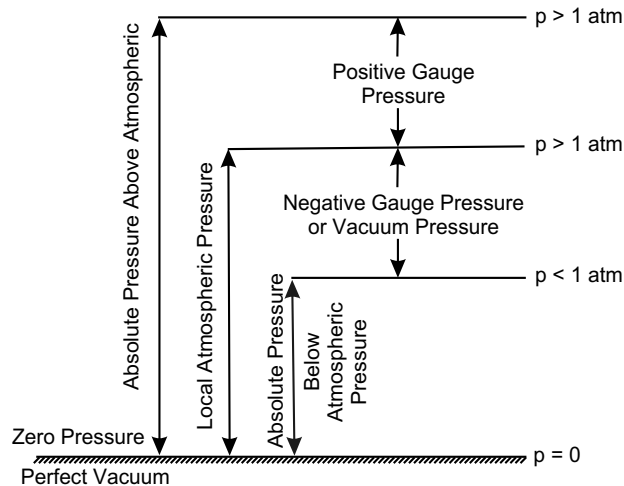

Fig. 1.11

### Mathematically

- (i) Absolute pressure = atmospheric pressure + gauge pressure

$$p_{\text{abs}} = p_{\text{atm}} + p_{\text{gauge}}$$

- (ii) Vacuum pressure = atmospheric pressure – absolute pressure

$$= p_{\text{atm}} - p_{\text{abs}}$$

## 1.25 PRESSURE MEASUREMENT BY MANOMETER

A manometer is normally used to measure pressure. In manometer the pressure is determined according to the hydrostatic formula. The manometric liquid may be mercury, water, alcohol, etc. A U-tube manometer is shown in figure 1.12. Since manometric fluid is in equilibrium, the pressure along a horizontal line AB is the same for either limb of manometer, then

$$p + \frac{\rho_1 g z_1}{g_c} = p_{\text{atm}} + \frac{\rho_2 g z_2}{g_c}$$

Where  $p$  is the absolute pressure in the bulb,  $p_{\text{atm}}$  is the atmospheric pressure exerted on the free surface of liquid and  $\rho_1$  and  $\rho_2$  are the densities of the liquid in the bulb and manometer respectively.

If  $\rho_1$  is small as compared to  $\rho_2$  i.e.,  $\rho_1 \ll \rho_2$ ,  $\frac{\rho_1 \cdot g z_1}{g_c} \approx 0$

then 
$$p - p_{\text{atm}} = \frac{\rho_2 \cdot g z_2}{g_c} = p_{\text{gauge}}$$

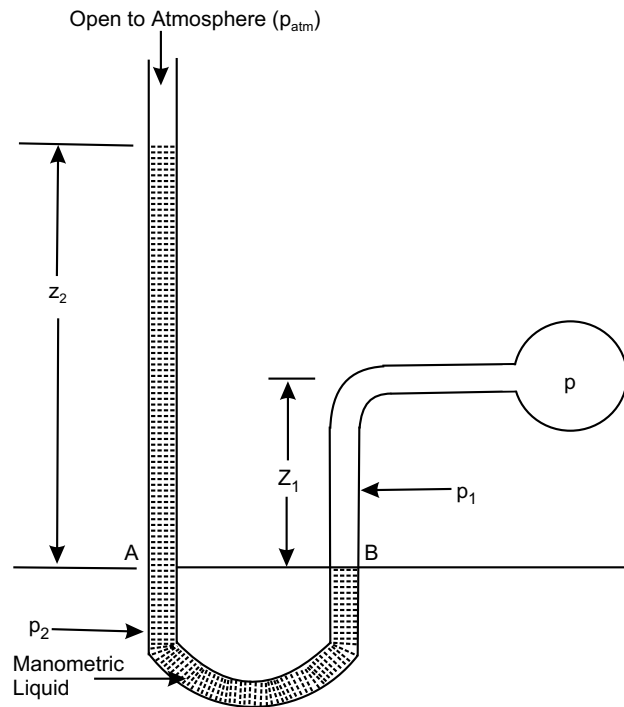

Fig. 1.12

Table: 1.4. Conversion Factor for Pressure

	Bar	dyne/cm <sup>2</sup>	kgf/cm <sup>2</sup> or ata	N/m <sup>2</sup> or Pa	mm Hg at 21°C or torr	mm H <sub>2</sub> O at 21°C	atm
Bar	1	10 <sup>6</sup>	1.01972	10 <sup>5</sup>	750.062	10197.2	0.986923
dyne/cm <sup>2</sup>	10 <sup>-6</sup>	1	1.01972 × 10 <sup>-6</sup>	0.1	750.062 × 10 <sup>-6</sup>	10197.2 × 10 <sup>-6</sup>	0.986923 × 10 <sup>-6</sup>
kgf/cm <sup>2</sup> or ata	0.980665	0.980665 × 10 <sup>6</sup>	1	0.980665	735.559	10000	0.967838
N/m <sup>2</sup> or Pa	10 <sup>-5</sup>	10	10.1972 × 10 <sup>-6</sup>	1	750.062 × 10 <sup>-5</sup>	10197.2 × 10 <sup>-5</sup>	0.986923 × 10 <sup>-5</sup>
mm of Hg at 21°C	1.333233 × 10 <sup>-3</sup>	1.333233 × 10 <sup>3</sup>	1.3595 × 10 <sup>-3</sup>	1.333233	1	13.5951	1.31578 × 10 <sup>-3</sup>
mm of H <sub>2</sub> O at 21°C	98.0665 × 10 <sup>-6</sup>	98.0665	10 <sup>-4</sup>	9.80665	0.073556	1	96.7838 × 10 <sup>-6</sup>
atm	1.01325	1.01325 × 10 <sup>6</sup>	1.03323	1.01325 × 10 <sup>5</sup>	760	103523	1

### 1.26 NORMAL TEMPERATURE AND PRESSURE (N.T.P)

Normal temperature is at 0°C or 273 K temperature and normal pressure is 760 mm of Hg. Normal temperature and pressure are briefly written as N.T.P.

### 1.27 STANDARD TEMPERATURE AND PRESSURE (S.T.P)

The temperature and pressure of any gas, under standard atmospheric condition, is taken as 15°C (288K) and 760 mm of Hg respectively.

### 1.28 ENERGY

The simplest definition of energy is the capacity for doing work. In other words, a system is said to possess energy when it is capable of doing work. The energy can be classified as (i) Stored energy and (ii) Transit energy.

The stored energy is a thermodynamic property as it depends on the point, not upon the path. The stored energy is the energy which is contained within the system boundaries. Examples of stored energy are (i) potential energy (ii) kinetic energy (iii) internal energy etc.

The transit energy is in transition and crosses the system boundaries. Examples of transit energy are (i) heat (ii) work (iii) electrical energy etc. The transit energy is not a thermodynamic property as it depends upon the path.

### 1.29 TYPES OF STORED ENERGY

The potential energy, kinetic energy or an internal energy are the different types of stored energy and are discussed in detail, as follows:

#### 1.29.1 Potential Energy

The energy possessed by a body, or a system for doing work, by virtue of its location or configuration is called potential energy. If a body of mass  $m$  is at an elevation of  $z$  above the datum plane, the potential energy(P.E) possessed by the body is given by

$$PE = mgz = W \cdot z$$

where  $g$  is the acceleration due to gravity.

#### 1.29.2 Kinetic Energy

The energy possessed by a body, or a system for doing work, by virtue of its motion is called kinetic energy. If a body of mass of  $m$  moves with a velocity  $v$  the kinetic energy(KE) possessed by the body is given by

$$KE = \frac{1}{2}mv^2$$

The sum of the potential energy and kinetic energy of a body is called the Mechanical energy of the body.

#### 1.29.3 Internal Energy

This energy is possessed by a body, or a system due to its molecular arrangement and motion of the molecules. It is usually represented by  $U$  and the change in internal energy ( $dU$ ). It depends upon the change in temperature of the system.

$$\therefore \text{change of internal energy } dU = C_v (T_2 - T_1)$$

Where  $C_v$  is specific heat at constant volume &

$T_1$  and  $T_2$  are the temperature at state points

$\therefore$  The total energy of the system ( $E$ ) is equal to the sum of the P.E, K.E and internal energy.

$$\therefore E = P.E + K.E + U$$

[any other form of the energy such as chemical, electrical energy etc. are neglected]

Again 
$$E = mgz + \frac{1}{2}mv^2 + U = ME + U$$

while Mechanical energy ( $M.E$ ) =  $P.E. + K.E = mgz + \frac{1}{2}mv^2$

For unit mass, total energy

$$e = gz + \frac{1}{2}v^2 + u$$

When the system is stationary and the effect of gravity is neglected, then,

$$\therefore E = U \text{ and } e = u$$

### 1.30 LAW OF CONSERVATION OF ENERGY

The law of Conservation of Energy states that *The energy can neither be created nor destroyed, though it can be transformed from one form to any other form, in which the energy can exist.*

### 1.31 POWER

Power may be defined as the rate of doing work or work done per unit time or rate of energy transfer or storage. Mathematically,

$$\begin{aligned} \text{Power} &= \frac{\text{work done}}{\text{time taken}} \\ &= \frac{\text{energy storage or transfer}}{\text{time taken}} \end{aligned}$$

The unit of power in S.I is watt (W)

$$1 \text{ W} = 1 \text{ N}\cdot\text{m/s} = 1 \text{ J/s}$$

A bigger unit of power called kilowatt (kW) or megawatt (MW)

$$1 \text{ kW} = 1000 \text{ W} \text{ and } 1 \text{ MW} = 10^6 \text{ W} = 1000 \text{ kW}$$

If  $T$  is the torque transmitted expressed in N·m or J and the angular speed is  $\omega$  in rad/s, then

$$\begin{aligned} \text{Power (P)} &= T \times \omega \\ &= T \times \frac{2\pi N}{60} \text{ watt, } \omega = 2\pi N/60 \\ &\quad N \text{ is speed in r.p.m} \end{aligned}$$

Hence, 
$$\text{Efficiency } (\eta) = \frac{\text{power output}}{\text{power input}}$$

### Multiple Choice Questions

1. In a closed thermodynamic system there is
  - (a) only mass transfer
  - (b) only energy transfer
  - (c) both mass and energy transfer
  - (d) none of the above
2. In flow system there is
  - (a) no mass transfer across the boundaries
  - (b) neither mass nor energy transfer
  - (c) both mass and energy transfer
  - (d) none of the above
3. In an isolated system there is
  - (a) no mass transfer
  - (b) no energy transfer
  - (c) neither mass nor energy transfer
  - (d) both mass and energy transfer
4. Which of the following are the properties of the system?
  - (a)  $\int p dV$
  - (b)  $\int V dp$
  - (c)  $\int (p dV + V dp)$
  - (d)  $\int dT/T = C_v \cdot dp/T$
5. Which of the following is an intensive property?
  - (a) volume
  - (b) temperature
  - (c) density
  - (d) entropy
6. Which of the following is an extensive property?
  - (a) pressure
  - (b) temperature
  - (c) density
  - (d) volume
7. 1 torr is equivalent to
  - (a) 1 kgf/cm<sup>2</sup>
  - (b) 1 N/m<sup>2</sup>
  - (c) 1 atm
  - (d) 1mm of Hg
8. The expression  $\int p dV$  may be applied for obtaining work of
  - (a) non-flow reversible process
  - (b) steady flow reversible process
  - (c) steady flow non-reversible process
  - (d) steady flow adiabatic reversible process
9. Each of heat and work is
  - (a) point function
  - (b) path function
  - (c) property of a system
  - (d) state description of a system
10. The property which depends only on temperature is
  - (a) internal energy
  - (b) enthalpy
  - (c) entropy
  - (d) none of above
11. A definite area or a space where some thermodynamic process takes place is known as
  - (a) thermodynamic cycle
  - (b) thermodynamic process
  - (c) thermodynamic system
  - (d) thermodynamic law
12. When either of mass or energy is not allowed to cross the boundary of a system; it is then called
  - (a) closed system
  - (b) open system
  - (c) isolated system
  - (d) none of these

13. Which of the following is not a thermodynamic property?  
(a) pressure (b) temperature  
(c) heat (d) specific volume
14. When a process or processes are performed on a system in such a way that the final state is identical with the initial state, it is then known as  
(a) thermodynamic cycle  
(b) thermodynamic property  
(c) thermodynamic process  
(d) zeroth law of thermodynamics
15. Atmospheric pressure is equal to  
(a) 1.013 bar (b) 101.3 kN/m<sup>2</sup>  
(c) 760 mm of Hg (d) all of the above
16. 1 mm of H<sub>2</sub>O is equal to  
(a)  $100 \times 10^{-6}$  bar (b) 0.001 kgf/cm<sup>2</sup>  
(c) 9.80665 Pa (d) 0.077 mm Hg
17.  $-40^{\circ}\text{C}$  is equal to  
(a)  $-40^{\circ}\text{F}$  (b) 230K  
(c)  $400^{\circ}\text{R}$  (d)  $-72^{\circ}\text{F}$
18. A centrifugal fan forms  
(a) closed system (b) open system  
(c) isolated system (d) none of the above
19. Which of the following statement is correct?  
(a) isolated system uninfluenced by surrounding is called universe.  
(b) system and surrounding combine to constitute universe whether there are interaction with each other or not.  
(c) system which only interacts with surrounding is part of the universe.  
(d) system and surrounding put together form universe only if there is interaction between them.
20. Thermodynamic system may be defined as a quantity of matter upon which attention is focussed for study if  
(a) it is only bounded by real surface  
(b) the boundary surfaces are constant in shape and volume.  
(c) it is not bounded by imaginary surface  
(d) it is bounded by either real surfaces or imaginary surfaces irrespective of shape or volume.

**Answers**

1. (b) 2. (c) 3. (c) 4. (c) 5. (b) 6. (d) 7. (d) 8. (a) 9. (b) 10. (a)  
11. (c) 12. (c) 13. (c) 14. (a) 15. (d) 16. (c) 17. (a) 18. (b) 19. (b) 20. (d)

### NUMERICAL EXAMPLES

#### EXAMPLE 1

If  $pv_s = RT$  (where  $v_s = \text{specific volume}$ ,  $p = \text{pressure}$ ,  $R = \text{a constant}$  and  $T = \text{temperature}$ ) determine whether the following quantities (i)  $\int \left( \frac{dT}{T} - \frac{v_s dp}{T} \right)$  and (ii)  $\int \left( \frac{dT}{T} + \frac{pdv_s}{v_s} \right)$  can be used as properties.

#### SOLUTION

Each of the differential is of the form  $(Mdx + Ndy)$ .

Therefore, apply the test  $\left( \frac{\partial M}{\partial y} \right)_x = \left( \frac{\partial N}{\partial x} \right)_y$  [Condition of exact differential equation]

(i) Thus, for  $\left( \frac{dT}{T} - \frac{v_s dp}{T} \right)$  we can write the condition

$$\left[ \frac{\partial \left( \frac{1}{T} \right)}{\partial p} \right]_T = \left[ \frac{\partial \left( \frac{-v_s}{T} \right)}{\partial T} \right]_p$$

or, 
$$\left[ \frac{\partial \left( \frac{1}{T} \right)}{\partial p} \right]_T = \left[ \frac{\partial \left( \frac{-R}{p} \right)}{\partial T} \right]_p \quad \left[ \begin{array}{l} \text{as } pv_s = RT \\ \therefore \frac{v_s}{T} = \frac{R}{p} \end{array} \right]$$

or,  $0 = 0$

Thus,  $\left( \frac{dT}{T} - \frac{v_s dp}{T} \right)$  is an exact differential equation and may be written as  $\frac{dT}{T} - \frac{v_s dp}{T} = dS$  where  $S$  is a point function and hence a property.

(ii) For  $\left( \frac{dT}{T} + \frac{pdv_s}{v_s} \right)$ , we have

$$\left[ \frac{\partial \left( \frac{1}{T} \right)}{\partial v_s} \right]_T = \left[ \frac{\partial \left( \frac{p}{v_s} \right)}{\partial T} \right]_{v_s}$$

or, 
$$\left[ \frac{\partial \left( \frac{1}{T} \right)}{\partial v_s} \right]_T = \left[ \frac{\partial \left( \frac{RT}{v_s^2} \right)}{\partial T} \right]_{v_s}$$

$$\text{or,} \quad 0 = \frac{R}{v_s^2} \left[ \frac{\partial(T)}{\partial T} \right]_{v_s} \quad \left[ A_s p = \frac{RT}{v_s} \right]$$

$$\text{or,} \quad 0 = \frac{R}{v_s^2}$$

But  $\frac{R}{v_s^2} \neq 0$ . So, it is not an exact differential.

Therefore,  $\left( \frac{dT}{T} + \frac{pdv_s}{v_s} \right)$  is not a point function. So, it is not a property.

### EXAMPLE 2

Explain if the following can be used a properties (i)  $\int pd\forall$  (ii)  $\int \forall dp$  (iii)  $\int (pd\forall + \forall dp)$ .

#### SOLUTION

(i)  $\int pd\forall$  is an expression where  $p$  is function of  $\forall$  and they are connected by a line path on  $p$  and  $\forall$  plane. The value  $\int pd\forall$  depends on the area under the line path on  $p$  and  $\forall$  planes. Thus it is not an exact differential, it is a path function, not a point function. So it is not a property.

(ii)  $\int \forall dp$  is such an expression where  $\forall$  is a function of  $p$  and they are connected by a line path on  $p$  and  $\forall$  planes. So it is a path function not a point function. Thus, it is not an exact differential and thus not a property.

$$(iii) \int pd\forall + \int \forall dp = \int d(p \cdot \forall) = p \cdot \forall$$

So, it is an exact differential and hence it is a property.

### EXAMPLE 3

A manometer contains a fluid having a density of  $1200 \text{ kg/m}^3$ . The difference in height of two columns is  $400 \text{ mm}$ . What pressure difference is indicated thus? What would be the height difference, if the same pressure difference is to be measured by a mercury manometer having mass density of mercury  $13600 \text{ kg/m}^3$ .

#### SOLUTION

The pressure difference indicated

$$p_1 = \rho g h = 1200 \times 9.81 \times 400/1000 = 4708.8 \text{ Pa} = 4.7088 \text{ kPa}$$

Again  $p_1 = 4708.8$

$$\Rightarrow 4708.8 = \rho_g g h_g = 13600 \times 9.81 \times h_g$$

$$\Rightarrow h_g = \frac{4708.8}{13600 \times 9.81} = 53.3 \text{ mm}$$

So, length of mercury column  $53.3 \text{ mm}$ .

### EXAMPLE 4

The pressure of steam inside a boiler, measured by pressure gauge is  $1 \text{ N/mm}^2$ . The barometric pressure of the atmosphere is  $765 \text{ mm}$  of mercury. Determine the absolute pressure of steam in  $\text{N/m}^2$ ,  $\text{kPa}$ ,  $\text{bar}$  and  $\text{N/mm}^2$ .

**SOLUTION**

$$\text{Gauge pressure} = 1 \text{ N/mm}^2 = 1 \times 10^6 \text{ N/m}^2$$

$$\text{Atmospheric pressure} = 765 \text{ mm of Hg}$$

We know that atmospheric pressure

$$= 765 \text{ mm of Hg}$$

$$= 765 \times 133.3 = 0.102 \times 10^6 \text{ N/m}^2$$

$$(\because 1 \text{ mm of Hg} = 133.3 \text{ N/m}^2)$$

$\therefore$  Absolute pressure of steam

$$= \text{atmospheric pressure} + \text{gauge pressure}$$

$$= 0.102 \times 10^6 + 1 \times 10^6 = 1.102 \times 10^6 \text{ N/m}^2$$

$$= 1102 \text{ kPa}$$

$$(\because 1 \text{ kPa} = 10^3 \text{ N/m}^2)$$

$$= 11.02 \text{ bar}$$

$$(\because 1 \text{ bar} = 10^5 \text{ N/m}^2)$$

$$= 1.102 \text{ N/mm}^2$$

$$(\because 1 \text{ N/mm}^2 = 10^6 \text{ N/m}^2)$$

**EXAMPLE 5**

In a condenser of a steam power plant, the vacuum pressure is recorded as 700 mm of mercury. If the barometer reading is 760 mm of mercury, determine the absolute pressure in the condenser in  $\text{N/m}^2$ , kPa, bar and  $\text{N/mm}^2$ .

**SOLUTION**

$$\text{Vacuum pressure} = 700 \text{ mm of Hg}$$

$$\text{Barometer reading} = 760 \text{ mm of Hg}$$

We know that absolute pressure

$$= \text{atmospheric pressure} - \text{vacuum pressure}$$

$$= \text{barometer pressure} - \text{vacuum pressure}$$

$$= 760 - 700 = 60 \text{ mm of Hg}$$

$$= 60 \times 133.3 = 7998 \text{ N/m}^2$$

$$= 7.998 \text{ kPa}$$

$$= 0.07998 \text{ bar}$$

$$= 0.007998 \text{ N/mm}^2$$

**EXAMPLE 6**

Compute the quantity of heat required to raise the temperature of a steel forging of mass 180 kg from 300 K to 1265 K. The specific heat of steel = 0.49 kJ/kg K.

**SOLUTION**

$$\text{Given: } m = 180 \text{ kg, } T_1 = 300 \text{ K, } T_2 = 1265 \text{ K, } C = 0.49 \text{ kJ/kg K}$$

We know that quantity of heat required

$$\begin{aligned}
 &= \text{mass} \times \text{specific heat} \times \text{rise in temperature} \\
 &= mC (T_2 - T_1) \\
 &= 180 \times 0.49 (1265 - 300) \\
 &= 85113 \text{ kJ}
 \end{aligned}$$

**EXAMPLE 7**

The forced draught fan supplies air to furnace of the boiler at draught of 30 mm of water. Determine the absolute pressure of air supply if the barometer reads 760 mm mercury, in kgf/cm<sup>2</sup>, bar and kPa.

**SOLUTION**

Since it is a forced draught, the absolute pressure is above atmospheric pressure.

$$\begin{aligned}
 \text{Absolute pressure} &= \text{atmospheric pressure} + \text{gauge pressure} \\
 &= \text{barometer reading} + \text{forced draught reading}
 \end{aligned}$$

$$\text{We know, 1 mm of water } \frac{1}{13.595} = 0.073556 \text{ mm Hg}$$

$$\begin{aligned}
 \therefore \quad 30 \text{ mm of water} &= 30 \times 0.073556 \text{ Hg} \\
 &= 2.20668 \text{ mm Hg}
 \end{aligned}$$

$$\text{Thus, absolute pressure} = 760 + 2.20668 = 762.20668 \text{ mm Hg}$$

$$\begin{aligned}
 &= \frac{762.20668}{735.559} \text{ kgf/cm}^2 \\
 &= 1.03623 \text{ kgf/cm}^2 \\
 &= 1.03623 \times 0.981 = 1.01654 \text{ bar} \\
 &= \frac{1.01654 \times 10^5}{10^3} = 101.654 \text{ kPa}
 \end{aligned}$$

**EXAMPLE 8**

The pressure in a gas pipe is measured by a mercury manometer as shown in the figure. One leg of manometer is open to atmosphere. If the difference in the height of mercury column in the two legs is 450 mm, compute the gas pressure in the pipe in kPa, bar and in atm. The barometric reading is 755 mm Hg. The local acceleration due to gravity is 9.81 m/sec<sup>2</sup> and the mass density of mercury is 13595 kg/m<sup>3</sup>.

**SOLUTION**

Referring figure,

The pressure of gas at plane *a – a* is given by

$$p = p_a + \rho gh \quad [\text{Neglecting the density of gas as compared to that of mercury}]$$

$$\text{And} \quad p_a = \rho gh_0$$

where  $\rho$  is density of mercury

$h_0$  is the barometric height

$h$  is the height of mercury column

$g$  is the local acceleration due to gravity

$$\begin{aligned} \text{So, } p &= \rho g h_0 + \rho g h = \rho g (h_0 + h) \\ &= 13595 \text{ kg/m}^3 \times 9.81 \text{ m/sec}^2 \times (0.755 + 0.450) \text{ m} \\ &= 160.707 \times 10^3 \text{ N/m}^2 \\ &= 160.707 \text{ kPa} \\ &= 1.60707 \text{ bar} \quad [\because 1 \text{ bar} = 100 \text{ kPa}] \end{aligned}$$

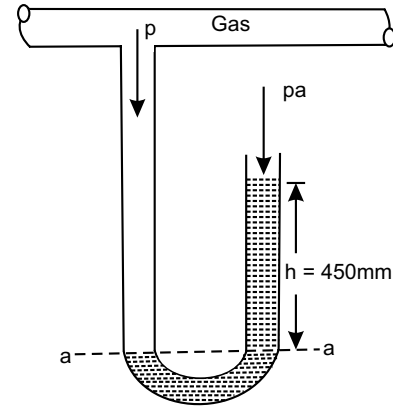

### EXAMPLE 9

Given the vessel shown in the figure fitted with pressure gauges indicating reading of  $A = 300 \text{ kPa}$  and  $B = 100 \text{ kPa}$  gauge. If the barometer reading is  $750 \text{ mm of Hg}$ , determine the reading of gauge  $C$  and convert this value to absolute value.

**SOLUTION**

Let the pressure in one region be  $Y \text{ kPa}$  absolute and the pressure in other region  $X \text{ kPa}$  absolute and barometer

$$\text{pressure} = 750 \text{ mm of Hg} = \frac{750 \times 13.595 \times 9.81}{10^3} \text{ kPa} \approx 100 \text{ kPa}$$

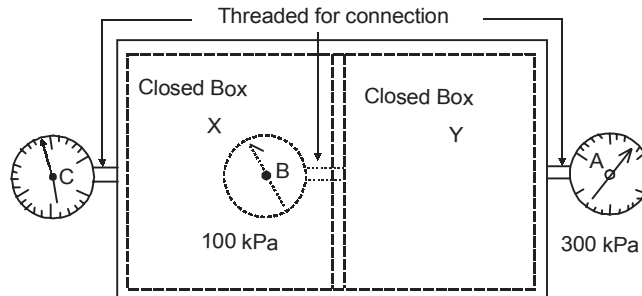

$$\text{Thus} \quad Y - 100 = \text{reading on } A = 300 \text{ kPa} \quad \dots(i)$$

$$\text{and} \quad Y - X = \text{reading on } B = 100 \text{ kPa} \quad \dots(ii)$$

$$\text{and} \quad X - 100 = \text{reading on } C \quad \dots(iii)$$

Solving (i) and (ii),  $Y = 400 \text{ kPa}$ . (abs) and  $X = 300 \text{ kPa}$ . (abs)

Substituting the value of  $X$  in (iii) we get reading on  $C = 200 \text{ kPa}$  gauge.

$\therefore$  Absolute pressure for reading on  $C = 200 + 100 = 300 \text{ kPa}$

### EXAMPLE 10

An inclined manometer with angle of inclination  $\theta = 30^\circ$  is shown in the figure. It is filled to measure the pressure of a gas. The fluid inside the manometer has a density of  $0.75 \text{ g/cm}^3$  and the manometer reading is

labelled on the diagram as  $x = 0.3$  m. If the atmospheric pressure is 101.25 kPa and the acceleration due to gravity is  $g = 9.7$  m/sec<sup>2</sup>, determine the absolute pressure of the gas in kPa.

**SOLUTION**

For inclined manometer, vertical liquid column

$$h = 0.3 \sin 30^\circ = 0.15 \text{ m}$$

The gauge pressure is given by

$$\begin{aligned} p_{\text{gauge}} &= \rho gh \\ &= \frac{0.75 \times 10^{-3}}{(10^{-2})^3} \times 9.81 \times 0.15 \\ &= 1103.625 \text{ Pa} \\ &= 1.103625 \text{ kPa} \end{aligned}$$

Thus absolute pressure is given by

$$\begin{aligned} p_{\text{abs}} &= p_{\text{gauge}} + p_{\text{atm}} \\ &= 1.103625 + 101.25 = 102.353625 \text{ kPa} \end{aligned}$$

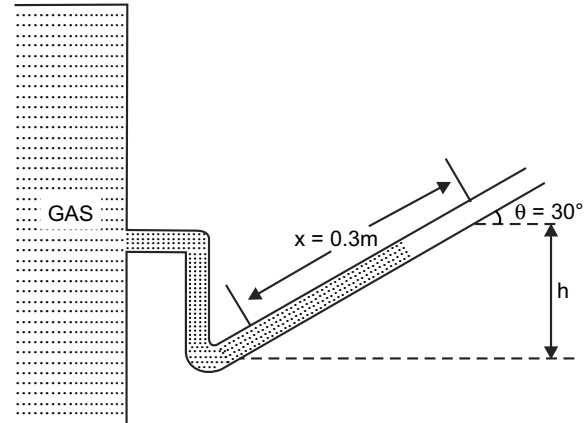
**EXAMPLE 11**

Convert (a) 3 kgf/cm<sup>2</sup> absolute to kgf/cm<sup>2</sup> gauge, (b) 45 cm vacuum to cm of Hg absolute and to kgf/cm<sup>2</sup> absolute (ata). (c) 0.5 kgf/cm<sup>2</sup> absolute i.e., 0.5 ata to cm of Hg vacuum, (d) 25 cm of Hg gauge to cm of Hg absolute and to atmosphere, (e) 1 ata to kPa. Barometer may be assumed to be 760 mm of Hg.

**SOLUTION**

Here,  $1 \text{ kgf/cm}^2 = 735.559 \text{ mm of Hg} = 735.6 \text{ mm of Hg}$

So,  $760 \text{ mm Hg} = 1.03323 \text{ kgf/cm}^2 = 1.033 \text{ kgf/cm}^2$

(a) Absolute pressure – Barometer pressure = Gauge pressure

or,  $3 - 1.033 = \text{Gauge pressure}$

$\therefore$  Gauge pressure = 1.967 kgf/cm<sup>2</sup>

(b) Barometer pressure – Absolute pressure = Vacuum pressure

or,  $76 \text{ cm of Hg} - \text{Absolute pressure} = 45 \text{ cm of Hg}$

$\therefore$  Absolute pressure = (76 – 45) cm Hg

or, = 31 cm of Hg absolute

(c) Barometer pressure – Absolute pressure = Vacuum pressure

or,  $1.033 \text{ kgf/cm}^2 - 0.5 \text{ kgf/cm}^2 = \text{Vacuum pressure}$

or,  $0.533 \text{ kgf/cm}^2 = \text{Vacuum pressure}$

$\therefore$  Vacuum pressure = 0.533 kgf/cm<sup>2</sup>

= 0.533  $\times$  73.56 cm of Hg vacuum

= 39.20748 cm of Hg vacuum.

(d) Abs pressure – Barometer pressure = Gauge pressure

$$\text{Abs pressure} - 76 \text{ cm of Hg} = 25 \text{ cm of Hg}$$

$$\text{Abs pressure} = 101 \text{ cm of Hg absolute}$$

$$= 101/76 \text{ atm} = 1.33 \text{ atm}$$

(e) 1 ata = 1 kgf/cm<sup>2</sup>

$$= 0.981 \times 10^2 \text{ kPa}$$

$$= 98.1 \text{ kPa.}$$

### EXERCISE

1. Explain the terms (a) thermodynamic state (b) thermodynamic process (c) thermodynamic cycle.
2. What do you understand by macroscopic and microscopic view points of thermodynamics?
3. What is thermodynamic system? Explain its different types.
4. What do you understand by property of a system? Distinguish between extensive and intensive properties of a system with the help of an example.
5. What is a thermodynamic process and a cyclic process?
6. Explain the non-equilibrium and quasi-static process. Is the quasi-static process a reversible process?
7. Distinguish between gauge pressure and absolute pressure. How the gauge pressure is converted into absolute pressure?
8. What do you understand by N.T.P and S.T.P? What are their values?
9. Compare the control volume and control mass.
10. Define energy. What is stored energy and transit energy. Discuss the types of stored energy.
11. Distinguish between absolute pressure and gauge pressure. How is one related to the other in case of vacuum.
12. Define the following
  - (a) Point function and Path function
  - (b) Specific weight
  - (c) Specific volume
  - (d) Pressure
  - (e) Temperature
  - (f) Density
  - (g) Flow process & Non-flow process.
13. Mercury of density 13.59508 g/cm<sup>3</sup> is used as monometer fluid. What gauge pressure in bar is exerted by a column of mercury of 760 mm ?

**Ans.** [ 1.01325 bar]

14. Which of the following can be used as properties of the system

$$(a) \int \left( \frac{dT}{T} + \frac{\nabla dp}{T} \right)$$

$$(b) \int \left( \frac{dT}{T} - \frac{\nabla dp}{\nabla} \right).$$

15. A piston has area of 5 cm<sup>2</sup>. What mass must the piston have if it exerts a pressure of 50 kPa above atmospheric pressure on the gas enclosed in the cylinder.
16. A pressure gauge reads 2.4 bar and the barometer reads 75 cm of Hg. Calculate the absolute pressure in bar and in the standard atmosphere.
17. A manometer has a liquid of density 800 kg/cm<sup>3</sup>, the difference in level of the two legs is 300 mm. Determine the pressure difference read by it in kgf/m<sup>2</sup>; bar; kPa.
18. The pressure of steam inside a boiler is recorded by a pressure gauge as 1.2 N/mm<sup>2</sup>. If the barometer reads the atmospheric pressure as 770 mm of Hg, find the absolute pressure of steam inside the boiler in N/m<sup>2</sup>, kPa and bar.

**Ans.** [ 1.3026 × 10<sup>6</sup> N/m<sup>2</sup>, 1302.6 kPa, 13.026 bar]

19. In a condenser, the vacuum is found to be 145 mm of mercury and the barometer reads 735 mm of mercury. Find the absolute pressure in a condenser in N/m<sup>2</sup>, kPa and N/mm<sup>2</sup>.

**Ans.** [ 78647 N/m<sup>2</sup>, 78.647 kPa, 0.078647 N/mm<sup>2</sup>]

**This page  
intentionally left  
blank**

CHAPTER
2

## ZEROth LAW AND TEMPERATURE

---

### 2.1 TEMPERATURE

The temperature is an intensive thermodynamic property of the system, whose value for the entire system is not equal to the sum of the temperature of its individual parts. It determines the degree of hotness or the level of heat intensity of a body or a system. A body is said to be at a high temperature or hot, if it shows high level of heat intensity in it and a body is said to be at a low temperature or cold, if it shows a low level of heat intensity.

### 2.2 ZEROth LAW OF THERMODYNAMICS

This law states, “*When each of two systems are in thermal equilibrium with a third system, then the two systems are also in thermal equilibrium with one another.*”

Let a body  $X$  is in thermal equilibrium with a body  $Y$ , and also separately with a body  $Z$ , then following above law,  $Y$  and  $Z$  will be mutually in thermal equilibrium with each other. A system is said to be in thermal equilibrium, when there is no temperature difference between the parts of the system or between the system and the surroundings. Zeroth law provides the basis of temperature measurement.

### 2.3 MEASUREMENT OF TEMPERATURE

The temperature of a system is a property that determines whether or not a system is in thermal equilibrium with other system. The temperature of a system or body is measured with the help of an instrument known as *Thermometer*. A thermometer may be in the form of a glass tube containing mercury in its stem. Or any physical body with at least one measurable property that changes as its temperature changes can be used as a thermometer, for example, a length of a column of mercury in an evacuated capillary tube. The height of mercury column in a thermometer, therefore, becomes a thermometric property. There are other methods of temperature measurement which utilize various other properties of a materials, which are functions of temperature as thermometric properties. The particular substance that exhibits changes in thermometric properties is called thermodynamic substance. Commonly used properties of materials employed in temperature-sensing devices or thermometers are given below and the names of the corresponding thermometric properties employed.

**Table: 2.1. Types of Thermometer**

Sl.No.	Thermometer	Thermometric Property	Symbol
1.	Mercury alcohol in glass thermometer	Length	L
2.	Constant volume gas thermometer	Pressure	p
3.	Constant pressure gas thermometer	Volume	$\forall$
4.	Electric resistance	Resistance	R
5.	Thermocouple	Electromotive force	E
6.	Radiation (pyrometer)	Intensity of radiation	I or J
7.	Optical pyrometer	Monochromatic radiation	

## 2.4 CONSTANT VOLUME GAS THERMOMETER AND TEMPERATURE SCALE

A schematic diagram of a constant volume gas thermometer is shown in figure 2.1. It is so exceptional in terms of precision and accuracy that it has been adopted internationally as the standard instrument for calibrating other thermometers.

It consists of a constant volume gas bulb which is connected to a mercury column through a flexible tube. The thermometric substance is the gas (normally *hydrogen* or *helium* or some other gas), filled in gas bulb treated as system with system boundaries shown in figure 2.1 and the pressure exerted by it is measured by open tube mercury manometer. When temperature in the system increases, the gas expands and forces the mercury up in the open tube. The constant volume of the gas is maintained by raising or lowering the mercury reservoir. Then the pressure ( $p$ ) of the gas is measured from the height ( $L$ ) of the mercury column in the limb. A similar measure is made by immersing the gas bulb in a bath which is maintained at the triple point of the water.

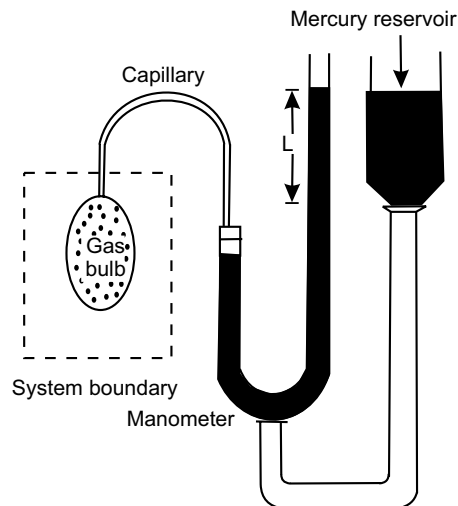
**Fig. 2.1**

Let  $p_p$  denotes the pressure of the gas when bulb is in thermal equilibrium with the bath at the triple point temperature  $T_p$ .

For an ideal gas at constant volume

We have, 
$$\frac{T}{T_{tp}} = \frac{p}{p_{tp}}$$

$\therefore T = \frac{p}{p_{tp}} \times T_{tp}$  (2.1)

The triple point temperature of water has been assigned a value of 273.16 K. Therefore, equation (2.1) can be rewritten as

$$T = 273.16 \frac{p}{p_{tp}} \quad (2.2)$$

The measured pressure ( $p$ ) at the system temperature ( $T$ ) as well as the pressure ( $p_{tp}$ ) at the triple point temperature change depending on the quantity of gas in the gas bulb. A plot of  $T$  calculated from equation (2.2) as a function of  $p_{tp}$  appears as shown in Fig. 2.2. It shows that the value of  $T$  and  $p_{tp} \rightarrow 0$  is identical for different gases. This behaviour can be expected because all gases behave like ideal gases as  $p \rightarrow 0$ . Hence to obtain the correct temperature one should ensure that  $p_{tp}$  is as low as possible. Therefore, to obtain the actual temperature of the system, equation (2.2) is modified as

$$T = 273.16 \text{ Lt}_{p, p_{tp} \rightarrow 0} \left( \frac{p}{p_{tp}} \right)$$

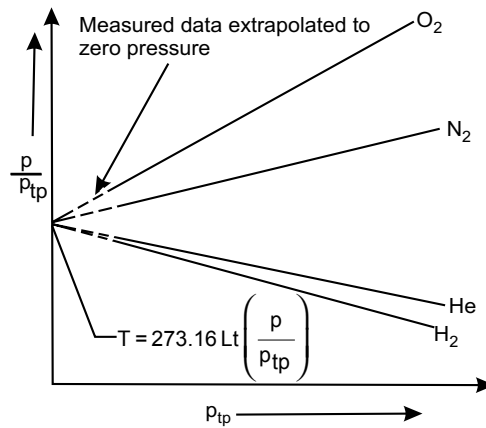

Fig. 2.2

Therefore, in the limit when the pressure tends to zero, the same value is obtained for each gas. Thus, the temperature scale is defined as

$$T = 273.16 \text{ Lt}_{p, p_{tp} \rightarrow 0} \left( \frac{p}{p_{tp}} \right) \quad (2.3)$$

The temperature value which has been measured does not depend on the properties of the substance is called Thermodynamics Temperature Scale.

### 2.4.1 International Practical Temperature Scale (IPTS-68)

In view of the practical difficulties associated with the use of ideal gas thermometer, the International Committee on Weight and Measures has adopted the *International Practical Temperature Scale* in 1968 based on a number of easily reproducible fixed points. The standard fixed point which is easily reproducible by international agreement is triple point of water, the state of equilibrium between steam, ice and liquid water. The temperature at this point is defined as 273.16 Kelvin, abbreviated as 273.16 K, as a matter of convenience. This makes the temperature interval from ice point = 273.16 K to steam point = 373.16 K equal to 100 K, at pressure of 1 atm.

### 2.4.2 Celsius or Centigrade Scale

The ice point of water on this scale is marked as zero, and the boiling point of water, at a pressure of 1 atm is 100. The space between these two points has 100 equal divisions and each division represents one degree Celsius (written as °C); then

$$t = T - 273.16^{\circ}\text{C} \quad (2.4)$$

Thus, the Celsius temperature ( $t_s$ ) at which steam condenses at a pressure of 1 atm

$$\begin{aligned} t_s &= T_s - 273.16^{\circ}\text{C} \\ &= 373.16^{\circ}\text{C} - 273.16^{\circ}\text{C} = 100.0^{\circ}\text{C} \end{aligned}$$

### 2.4.3 Electrical Resistance Thermometer

In the resistance thermometer the change in resistance of a metal wire due to its change in temperature is the thermodynamic property. The wire, frequently, may be incorporated in a Wheatstone Bridge circuit. In a restricted range, the following quadratic equation is often used

$$R_t = R_0 (1 + at + bt^2 + ct^3 + \dots) \quad (2.5)$$

Where  $R_0$  is the resistance of the platinum wire when it is surrounded by melting ice,  $R_t$  is the resistance at temperature  $t$  and  $a$  and  $b$  are constants.

The triple point represents an equilibrium state between solid, liquid and vapour phases of substance. Normal boiling point is the temperature at which the substance boils at standard atmospheric pressure of 760 mm Hg. Normal freezing point is the solidification or melting point temperature of the substance at standard atmospheric pressure.

**Table: 2.2. Fixed Points of the IPTS – 68**

Sl.No.	Equilibrium State	Assigned value of temperature	
		T(K)	t(°C)
1.	Triple point of hydrogen	13.81	-259.34
2.	Boiling point of hydrogen at 33.306 kPa	17.042	-266.108
3.	Normal boiling point of hydrogen	20.28	-252.87
4.	Normal boiling point of neon	27.102	-246.048
5.	Triple point of oxygen	54.361	-218.789

*Contd...*

6.	Normal boiling point of Oxygen	90.188	-182.962
7.	Triple point of Water	273.16	0.01
8.	Normal boiling point of Water	373.15	100.1
9.	Normal freezing point of Antimony (Antimony point)	630.74	357.59
10.	Normal freezing point of Zinc (Zinc point)	692.73	419.58
11.	Normal freezing point of Silver (Silver point)	1235.08	961.93
12.	Normal freezing point of Gold (Gold point)	1337.58	1064.43

The whole temperature scale may be divided into four ranges, based on the available method of measurement. The equation for interpolation for each range are as follows:

- (i) From  $-259.34^{\circ}\text{C}$  (Triple point of Hydrogen) to  $0^{\circ}\text{C}$ : A platinum resistance thermometer of a standard design is used. A polynomial equation of the following form is deployed.

$$R_t = R_0 (1 + at + bt^2 + ct^3) \quad (2.6)$$

Here  $R_0$  is the resistance at the ice point is fitted between resistance of the wire ( $R_t$ ) and the temperature ( $t$ ).

- (ii) From  $0^{\circ}\text{C}$  to  $357.59^{\circ}\text{C}$  (Antimony point): It is also based on platinum resistance thermometer. The diameter of the platinum wire must lie between 0.05 and 0.2 mm and governing equation is

$$R_t = R_0 (1 + at + bt^2) \quad (2.7)$$

- (iii) From  $357.59^{\circ}\text{C}$  to  $1064.43^{\circ}\text{C}$  (Gold point): It is based on standard platinum versus platinum thermocouple. A three term equation, as following, is used.

$$E = a + bt + ct^2 \quad (2.8)$$

Here  $E$  is the EMF of the thermocouple.

- (iv) Above  $1064.43^{\circ}\text{C}$ : The temperature is calculated from Planck's equation for black body radiation.

## 2.5 HEAT AND HEAT TRANSFER

The heat is defined as the form of energy which is transferred, without transfer of mass, across a boundary by virtue of a temperature difference between the system and the surroundings. It is a form of transit energy which can be identified only when it crosses the boundary of a system.

The temperature difference is the 'potential' or 'force' and heat transfer is the 'flux'. The heat can be transferred in three distinct ways, i.e., *conduction*, *convection* and *radiation*. The process of heat transfer between two bodies in direct contact is called conduction. The heat may be transferred between two bodies separated by empty space or gases by electromagnetic waves and the process is known as radiation. A third method of heat transfer is convection through fluid in motion.

The heat always flows from higher temperature to lower temperature without external energy. So, heat is transferred across a boundary from a system at a higher temperature to a system at lower temperature by virtue of the temperature difference. The heat is a form of transit energy, so it is not

a thermodynamic property. It is not a point function, it is a path function. Conventionally when heat flowing into a system, it is considered positive and heat flowing out of a system, it is considered negative, shown in Fig.2.3.

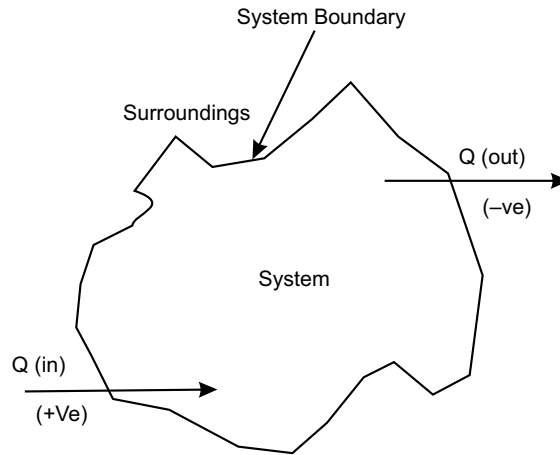

Fig. 2.3

## 2.6 SPECIFIC HEAT

The specific heat of a substance is defined as the amount of heat required to raise the temperature of unit mass of any substance by one degree. It is generally denoted by  $C$  and its unit in S.I is taken as kJ/kg.K. Heat required to raise the temperature of  $m$  kg mass of a substance from an initial temperature of  $T_1$  to a final temperature of  $T_2$ , then

$$\text{Heat required} \quad Q = mC (T_2 - T_1) \text{ kJ} \quad (2.4)$$

where  $T_1$  and  $T_2$  may be either in  $0^\circ\text{C}$  or in K and  $C$  is specific heat in kJ/kg.K.

The solids and liquids do not change or change very negligibly in volume on heating, therefore they have only one specific heat. But gases have the following two specific heats depending upon the process adopted for heating the gas.

- (i) *Specific heat at constant pressure  $C_p$  and*
- (ii) *Specific heat at constant volume  $C_v$*

It is noted that  $C_p$  is always greater than  $C_v$ . Relation between two specific heats is:  $C_p - C_v = R$ , where  $R$  is known as characteristic gas constant and its unit is J/kg K or kJ/kg.K. Value of gas constant ( $R$ ) is different for different gases. For air it is taken as 287J/kg K or 0.278 kJ/kg.K. in S.I.

Ratio of  $C_p$  and  $C_v$  is,  $\frac{C_p}{C_v} = \gamma$  where  $\gamma$  is adiabatic index. For air  $\gamma = 1.4$  [For details see chapter on properties of perfect gas]

## 2.7 THERMAL OR HEAT CAPACITY OF A SUBSTANCE

It is defined as the amount of heat required to raise the temperature of whole mass of a substance through one degree. Mathematically,

Thermal or heat capacity of a substance =  $mC$  kJ

Where  $m$  = mass of the substance in kg, and  $C$  = specific heat of the substance in kJ/kg.K.

## 2.8 WATER EQUIVALENT OF A SUBSTANCE

It may be defined as the quantity of water requires to raise unit temperature by the same quantity of heat which requires the substance to raise its temperature through one degree. Mathematically,

Water equivalent of a substance =  $mC$  kg

Where  $m$  = mass of the substance in kg, and

$C$  = specific heat of the substance in kJ/kg.K.

The thermal capacity and water equivalent of a substance are equal in numerical value, but in different units.

## 2.9 MECHANICAL EQUIVALENT OF HEAT

Heat and work are mutually convertible which was established by *Joule*. He established, experimentally, that certain amount of work is required to produce unit amount of heat. The ratio between work ( $W$ ) and heat ( $H$ ) i.e., is denoted by  $J$  (named after Joule) and is known as *Joule's equivalent or mechanical equivalent of heat*.

## 2.10 WORK

In mechanics, work is the effect of force. The work is said to be done by a force when the force acts upon a body and body moves in the direction of applied force. The magnitude of mechanical work is the product of the force and the distance moved parallel to the direction of applied force. Mathematically

$$W = \int_1^2 dW = FdS$$

where  $F$  is applied force, and  $dS$  is the differential displacement parallel to direction of applied force.

The unit of work depends on the unit of force and unit of distance moved. In S.I, unit of force is newton and unit of distance is meter, so the practical unit work is N-m. It is known also as joule (briefly written as J). So, 1 N-m = 1 J.

In thermodynamics, work may be defined as the energy in transition between the system and surrounding. So, the work may be defined as follows:

- (a) **According to Obert:** *Work is defined as the energy transferred (without the transfer of mass) across the boundary of a system because of an intensive property difference other than temperature that exists between the system and surrounding.*

The pressure difference, i.e., the intensive property difference (between the system and surrounding) at the surface of the system gives rise to a force and the action of this force over a distance is called *mechanical work*.

Electrical work is also the same case. In this case the intensive property difference is the electrical potential difference between the system and surrounding. And the resulting energy transfer across the system and boundary is known as *electrical work*.

- (b) **According to Keenan:** *Work is said to be done by a system during a given operation if the sole effect of the system on things external to the system (surroundings) can be reduced to the raising of a weight.*

The weight may not be raised actually but the net effect external to the system should be the raising of a weight.

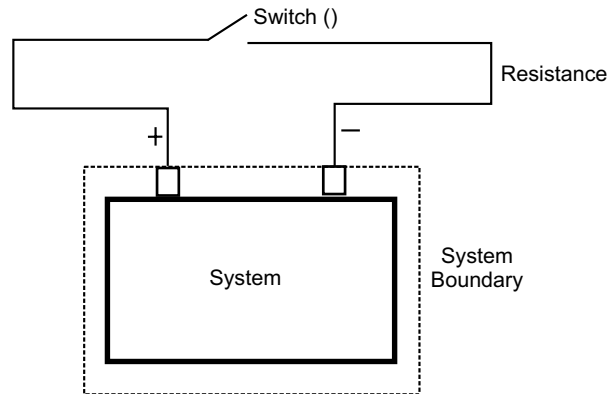

Fig. 2.4 (a)

To give example of this, consider a system consisting of a battery as shown in Fig.2.4(a). The terminals connected to a resistance through a switch is on for a certain period of time, then the current will flow through the battery and resistance. As a result the resistance will be warmer. This clearly shows that the system (battery) has interaction with the surroundings. In other words, energy transfer (electrical energy) has taken place between the system and the surroundings because of potential difference (not the temperature). According to the definition of work, by laws of mechanics, if there is no force which moves through a distance, then no work is done by the system. However, according to the thermodynamic definition, the work is done by system because the resistance can be replaced by an ideal motor (100% efficient) driving a winding drum, thereby raising a weight, as shown in Fig. 2.4(b). Thus, the sole effect external to the system (surrounding) has been reduced to the raising of a weight. Hence, thermodynamic work is done by the system.

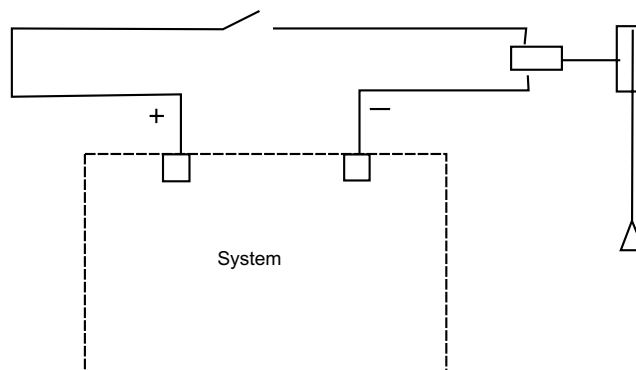

Fig. 2.4 (b)

Also, it is relevant to mention that work is manifested at the system boundary only during any interaction between the system and surroundings. Before interaction no work is present. Only work transfer takes place.

### 2.11 SIGN CONVENTION OF WORK

In thermodynamics, by convention, work done by the system is taken to be positive i.e., when work leaves from the system. The work done on the system is taken to be negative i.e., if work enters into the system from surrounding, as shown in Fig.2.5. In any process when the system does positive work, its surroundings do an equal amount of negative work. Thus, in any process algebraic sum of work done by the system and its surrounding is zero. Mathematically,

$$W_{\text{system}} + (-W_{\text{surrounding}}) = 0 \quad (2.9)$$

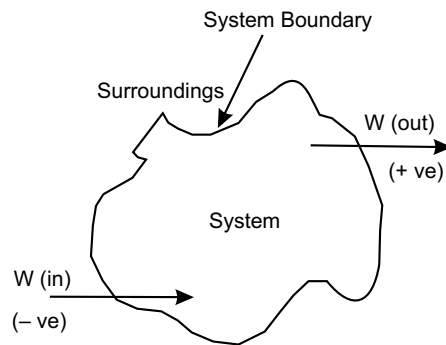

Fig. 2.5

### 2.12 WORK DONE DURING A QUASI-STATIC OR QUASI-EQUILIBRIUM PROCESS

From the concept of mechanics, the differential work done ( $dW$ ) is given by

$$dW = F \cdot dS \quad (2.10)$$

where  $F$  is the applied force and  $dS$  is the differential displacement.

Consider a certain amount of gas contained in a cylinder-piston assembly as shown in the Fig.2.6(a) in a schematic representation of work by a gas. The system, enclosed by the dotted line, constitute the gas contained in the cylinder and Fig. 2.6(b) is representation of work done on a  $p$ - $V$

diagram. The shaded area represents the work done  $\int_1^2 p dV$  by the gas. In a differential time  $dt$ , let the piston of cross-sectional area  $A$  moves a differential distance  $dL$  while the motion of piston is opposed by an external pressure ( $p - dp$ ) where  $dp \rightarrow 0$ . Then, the differential work done by the gas is given by

$$\begin{aligned} dW &= F \cdot dS \\ &= (pA) dL && [\because F = p \times A] \\ &= p \cdot AdL \end{aligned}$$

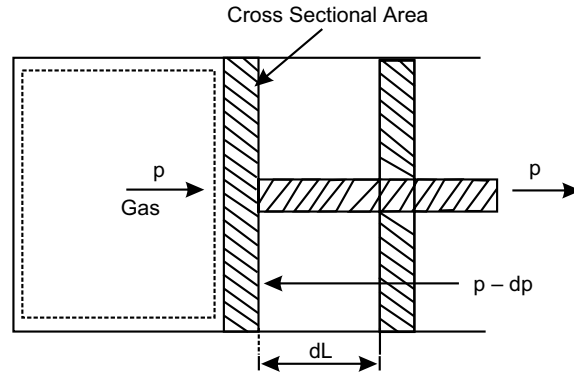

Fig. 2.6 (a)

$$= p \cdot dV \quad [\because dV = A dL]$$

$$\therefore W = \int_1^2 p \cdot dV \quad (2.11)$$

It may be noted that the external pressure ( $p - dp$ ) is always infinitesimally smaller than the gas pressure inside the system. Hence, the expansion process can be reversed at any time by increasing the external pressure infinitesimally more than the gas pressure. That is, if the external pressure is ( $p + dp$ ), the gas undergoes a compression process.

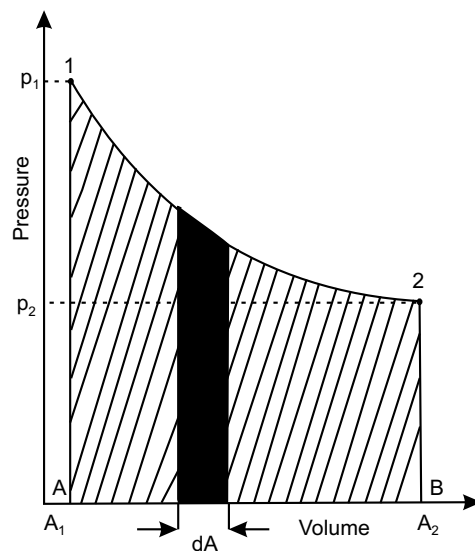

Fig. 2.6 (b)

During the process, the expansion or compression of the gas creating a force on the moving boundary are balanced and hence the process is reversible. Being a reversible one, it must be a

Quasi-Static or Quasi-Equilibrium Process, because ‘a reversible process is a quasi-static process, but a quasi-static process need not be a reversible process’.

### 2.13 WORK AND HEAT TRANSFER — A PATH FUNCTION

Consider that a system, from an initial equilibrium state 1 reaches to a final equilibrium state 2 by two reversible process 1-A-2 and 1-B-2 as shown in Fig.2.7(a). When the system changes from its initial state 1 to final state 2, the quantity of work or heat transfer will depend upon the intermediate stages through which the system passes, i.e., its path.

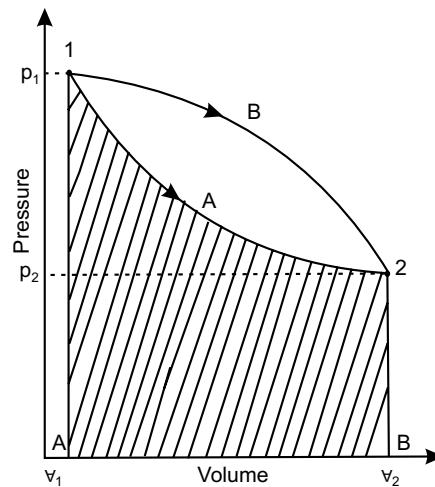

Fig. 2.7 (a)

Figure 2.7(a) shows two different reversible paths 1-A-2 and 1-B-2 connecting the given initial and final states of system. Since  $\int_1^2 p \cdot dV$  represents the area under the curve, the work done during path 1-A-2 is different from the work done during the path 1-B-2. In other words, the work done depends on the path, followed in going from one state to another i.e., by a system.

Hence, it is not possible to evaluate the work done purely from a knowledge of its initial and final states of a system. The work done by a system is a path function and hence it is not a property of a system. Work is an interaction, that is energy transfer, between a system and its surroundings. Hence work is energy in transit. Mathematically work is an inexact differential and written as  $\delta W$ . On integrating for path 1-A-2,

$$\int_{1,A}^2 \delta W = [W]_{1,A}^2 = (W_{1-2})_A \quad (2.12)$$

It should be noted that in the case of inexact differentials such as work,  $\int_1^2 \delta W \neq W_2 - W_1$  because work is not a point function. We never speak of work  $W_1$  in the system in state 1 or work  $W_2$  in state 2. In contrast to this, there is only work, either  $W_{in}$  or  $W_{out}$  in transition, which manifests itself

at the system boundary during a process, and can only be found by integration of  $(pdV)$  along the path followed in the quasi-equilibrium process.

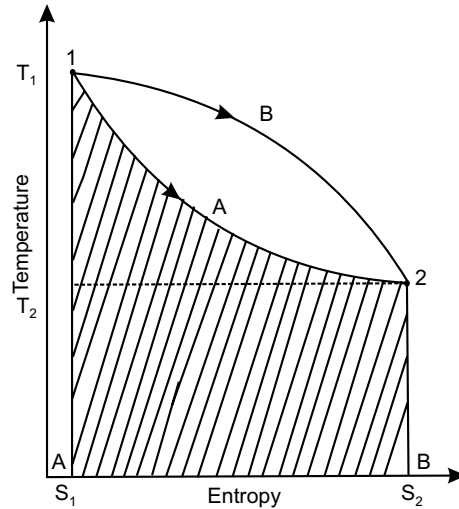

Fig. 2.7 (b)

Like work, heat transfer during from its initial state point 1 to final state point 2 will depend on the intermediate state through which the system passes, i.e., its path. In other words, heat is a path function and is an inexact differential and written as  $\delta Q$ . On integrating for the path 1-A-2 in Fig. 2.7(b)

$$\int_{1,A}^2 \delta Q = [Q]_{1,A}^2 = (Q_{1-2})_A = (Q_2)_A \quad (2.13)$$

It may be noted that in the case of inexact differentials such as heat,  $\int_{1,A}^2 \delta Q \neq Q_2 - Q_1$ , because heat is not a point function and it would be more appropriate to write  $\int_{1,A}^2 \delta Q = (Q_{1-2})_A$ . It can be written as the integral of the product of intensive property ( $T$ ) and differential change of an extensive property, say entropy ( $S$ ), i.e.  $\int_{1,A}^2 T \delta S$ . The  $T$ - $S$  diagram is shown in the figure.

## 2.14 COMPARISON OF HEAT AND WORK

Similarities between heat and work are follows :

- (i) *Heat and Work are neither thermodynamic properties, nor point functions. The system itself does not possess heat and work. When a system undergoes a change, heat transfer or work done may occur. They are both transient phenomena.*
- (ii) *The heat and work are boundary phenomena. They are observed at the boundary of the system.*

- (iii) Heat and work are both transit energy crossing the boundary of the system.
- (iv) The heat and work both are path functions and hence are inexact differentials. They are written as  $\delta Q$  and  $\delta W$ .
- (v) The area under the pressure-volume (i.e.,  $p$ - $\nabla$ ) diagram represents the work done during the process and is given by  $\int p d\nabla$ . Similarly the area under the temperature-entropy i.e., ( $T$ - $S$ ) diagram represents the heat transfer during the process and is given by  $\int T dS$ .
- (vi) Work is written by the integral of the product of the intensive property ( $p$ ) and differential change of the extensive property ( $\nabla$ ).

Heat transfer can also be written as the integral of product of the intensive property ( $T$ ) and the differential change of an extensive property, entropy ( $S$ ).

## 2.15 EXAMPLE OF WORK

### 2.15.1 Paddle Wheel Work

This is also known as Stirring Work where  $\int p d\nabla = 0$ , but work is done.

The paddle wheel work is an illustration of shaft-work. Paddle wheel work process is a process involving friction in which the volume of the system does not change at all, and still work is done on the system.

Representation of the process is provided by a system in which a paddle wheel turns a fixed mass of fluid as shown in Fig.2.8. Consider that in the system weight is lowered, paddle wheel runs. The work is transferred across the system boundary in the fluid system. The volume of the system remains constant and the work,  $\int p d\nabla = 0$ .

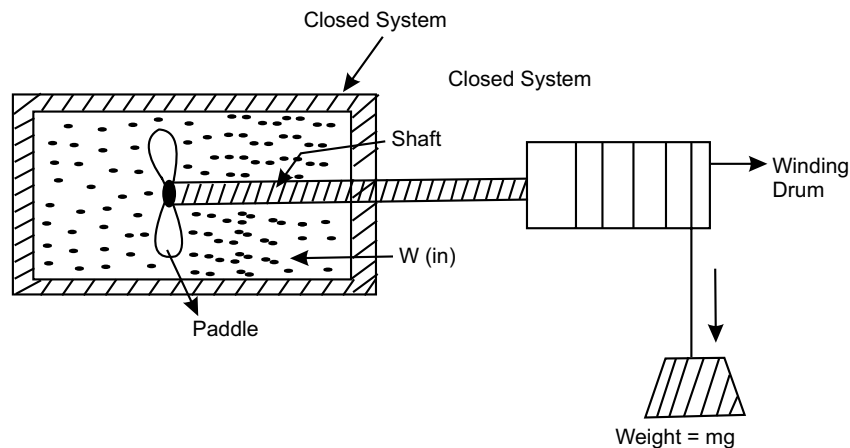

Fig. 2.8

If  $m$  is the mass of the weight lowered through a distance  $dz$  and  $T$  is the torque transmitted by the shaft in rotating through an angle  $d\theta$ , the differential work transfer to the fluid is given by

$$\delta W = mgdz = Td\theta$$

$$\begin{aligned} \text{Work transfer } (W) &= \int_1^2 \delta W \\ &= \int_1^2 mg \, dz = \int_1^2 T \, d\theta \end{aligned} \quad (2.14)$$

Thus,  $\int p dV$  does not represent work for this case, although work has been done on the system. So work may be done on a closed system even though there is no volume change.

### 2.15.2 Extension of Solid Rod

Consider an elastic rod of length  $L$  and cross-sectional area  $A$ , which is fixed at one end as shown in Fig.2.9 as the system. The solid rod is fixed at  $x = 0$ , and a tensile force equal to  $F$  is applied at the other end of the rod.

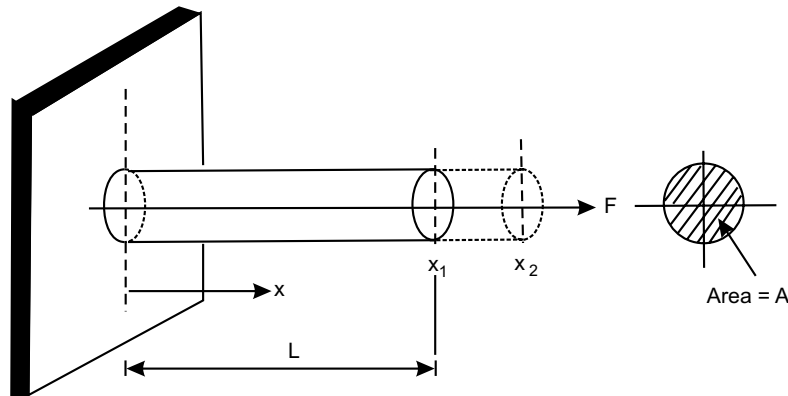

Fig. 2.9

Thus,  $F = \sigma A$

where  $\sigma$  is normal stress acting at the end of the rod. The rod elongates a distance  $dx$  due to elastic property. The work done due to elongation  $dx$  is given by

$$\delta W = -\sigma A dx$$

The negative sign shows that work is done on the rod when  $dx$  is positive. The work done for change of length from  $x_1$  to  $x_2$  is given by,

$$W = - \int_{x_1}^{x_2} (\sigma A dx) \quad (2.15)$$

### 2.15.3 Stretching of a Liquid Film (Surface Tension)

Suppose a liquid film is held between a wire from one side of which can be moved with the help of a sliding wire as shown in Fig.2.10 as a system. The interfacial tension or surface tension which is the force per unit length normal to a line on the surface is given by  $\tau$ . Thus, force is given by,  $F = 2L\tau$ ; when the factor 2 indicates two film surfaces act at the wire length  $L$ .

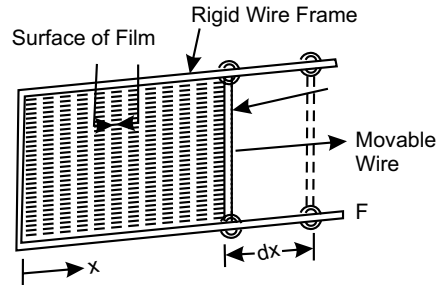

Fig. 2.10

The work for displacement  $dx$  is given by,

$$\delta W = -2L\tau \cdot dx$$

Negative sign shows that work is done on the system when  $dx$  is positive. The surface in contact with wire is  $dA = 2Ldx$

Thus,

$$\delta W = -\tau dA$$

$$\begin{aligned} \therefore W &= - \int_{A_1}^{A_2} \delta W \\ &= - \int_{A_1}^{A_2} \tau dA = -\tau (A_2 - A_1) \end{aligned} \tag{2.16}$$

#### 2.15.4 Free Expansion Process

The free expansion, or unresisted expansion, process is an irreversible non-flow adiabatic process in which the volume of a closed system increases, and still no work at all is done. So, here  $\int pdV$  is finite but work done is zero. Representation of this unresisted expansion process is shown in Fig. 2.11(a) & (b). A free expansion occurs when a fluid is allowed to expand suddenly into a vacuum chamber through an orifice of large dimensions.

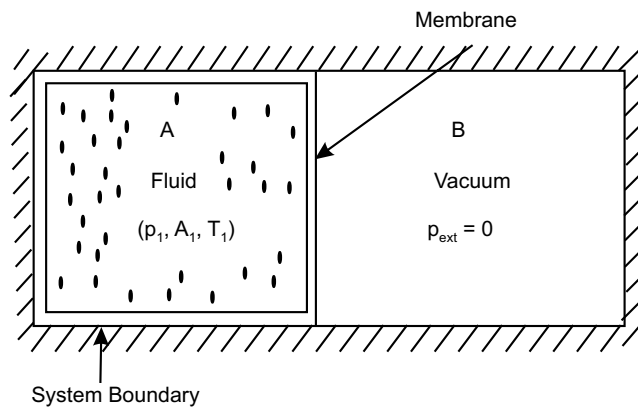

Fig. 2.11(a)

Consider two chambers  $A$  and  $B$  separated by a membrane. The chamber  $A$  contains fluid having volume  $\nabla_1$  pressure  $p_1$  and temperature  $T_1$  and the chamber  $B$  is completely evacuated, pressure i.e.,  $p_{\text{ext}} = 0$ . The fluid is in state 1 in chamber  $A$ . Let the membrane gets ruptured. The fluid then fills both the chambers and reaches state 2. Initial pressure  $p_1$  of the fluid dropped to  $p_2$  in the final state and volume  $\nabla_1$  reaches to volume  $\nabla_2$  in the final state. Both the chambers are completely insulated so that heat transfer is zero.

Let us first consider the fluid and vacuum together as the system shown in Fig.2.11(a), so as no work crosses the system boundary. Next we consider only the fluid as the system as in the figure 2.11(b). We observe that the system boundary moves and volume of the system change from  $\nabla_1$  to  $\nabla_2$ . But it is not quasi-equilibrium process and  $p_{\text{ext}} = 0$ . Hence,  $\int p_{\text{ext}} dV$  is also zero and therefore, no work is done in the process. Free expansion process is thus an example of an expansion process in which  $\int p dV$  is finite, but still  $W_{1-2} = 0$ . Hence, it is adiabatic process where  $Q_{1-2} = 0$  and  $U_{1-2} = 0$

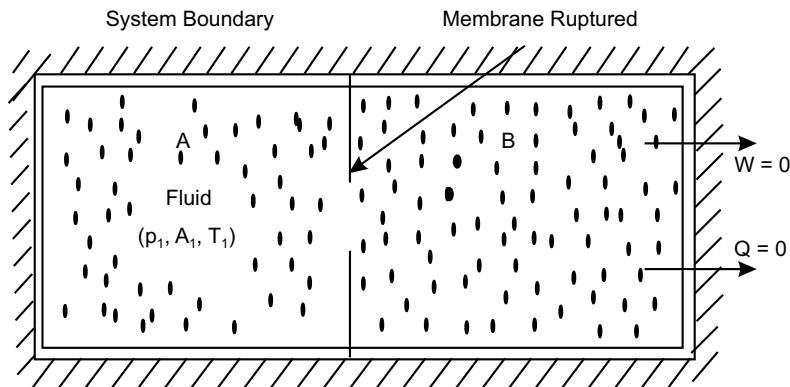

Fig. 2.11 (b)

### 2.15.5 Shaft Work

When a shaft within a system is rotated, by a motor, there is work transfer into the system as shown in the Fig.2.8. This is so since the shaft can rotate a drum which in turn can raise on weight. If  $T$  is the torque applied to shaft running at  $N$  r.p.m, (angular velocity  $\omega$ ) then the rate of work done would be

$$W = T \cdot \omega = \frac{2\pi NT}{60} \quad (2.17)$$

Paddle wheel work is an example of negative shaft-work.

### 2.15.6 Electrical Work

Electrical work done by the flow of a current through electrolytic cell or a conductor or a resistor, etc., is given by

$${}_1W_2 = - \int_1^2 E \cdot I \cdot dt$$

where  $E$  is the potential difference,  $I$  is the current and  $dt$  is the time change.

So, power can be written by

$$P = -\frac{\delta W}{\delta t} = -E \cdot I \quad (2.18)$$

### 2.15.7 Flow Work

The flow work is the work required to move a fluid into or out of a system. To calculate the work required, consider an element of fluid of mass  $dm$  and volume  $d\mathcal{V}$ . It is required to push this fluid into the control volume of an open system through a passage against an existing pressure  $p$  as shown in Fig. 2.12 (a). Cross-sectional area of the passage is  $A$ . The fluid behind this element of fluid acts as a piston, and pushes the fluid into the control volume. Consider the imaginary piston is placed behind this elemental fluid, as shown in figure 2.12 (b). The distance moved by piston is  $dx$ , when the fluid with volume  $d\mathcal{V}$  has been pushed into the control volume.

$$\text{Specific volume of the fluid } v_s = \frac{d\mathcal{V}}{dm},$$

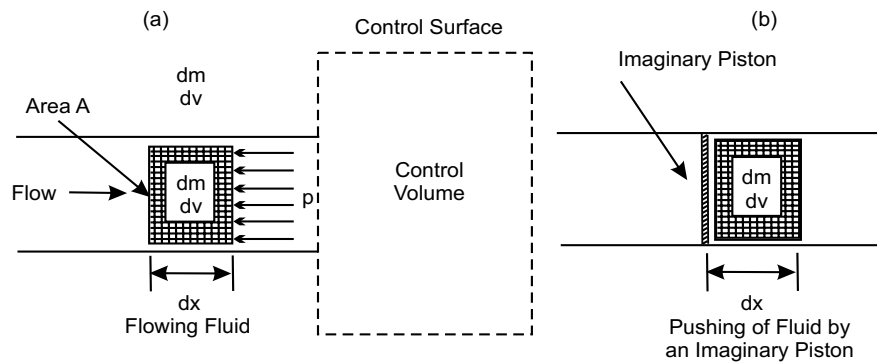

Fig. 2.12 (a & b)

$$\text{Force } F = p \cdot A \text{ and } dx = \frac{d\mathcal{V}}{A}$$

Now the required flow work is

$$\begin{aligned} \delta W &= \text{force} \times \text{distance moved} \\ &= F \times dx \end{aligned}$$

$$= p \cdot A \left( \frac{d\mathcal{V}}{A} \right) = p \cdot d\mathcal{V}$$

Work done per unit mass of the fluid flow is

$$W_{\text{flow}} = \frac{\delta W}{dm}$$

$$\begin{aligned}
 &= \frac{p \cdot d\forall}{dm} \\
 &= p \cdot \left( \frac{d\forall}{dm} \right) = p \cdot v_s \quad (2.19)
 \end{aligned}$$

So the magnitude of the flow work per unit mass of fluid flow is simply the product of the two properties of the fluid, i.e., pressure and specific volume.

### 2.15.8 Non-flow Work

Consider a closed system process, say a cylinder and piston arrangement as shown in the Fig.2.6(b) from 1 to 2. The non-flow work done by the system in the process per unit mass of the substance is

$$W_{\text{nonflow}} = \int_1^2 p dv_s \quad (2.20)$$

and represented by the area 1-2-b-a-1, this is  $p dv_s$  work.

## 2.16 WORK IN NON-FLOW PROCESS VERSUS FLOW PROCESS

A process undergone by a closed system of fixed mass is referred to as a non-flow process. A change of state of a substance taking place while flowing through a control volume in an open system is referred to as a flow process.

The work done in a non-flow process in closed system is called non-flow work. The work done in a flow process in an open system is equal to the non-flow work plus the flow work.

i.e., 
$$w_{\text{flow}} = \int p dv_s + p \cdot v_s$$

### Multiple Choice Questions

- Temperature is a
  - property
  - non property
- Thermometers used in thermodynamic applications are
  - constant volume gas thermometer
  - constant pressure gas thermometer
  - pyrometer
  - all of these
- When heat flows into a system, conventionally it is considered
  - negative
  - positive
- The unit of specific heat of any substance is
  - J/kg
  - Jkg
  - kg/J
  - J/kgK
- The ratio of  $C_p$  and  $C_y$  of any substance is called
  - adiabatic constant
  - isothermal index
  - pressure index
  - isobaric constant

6. Heat and work are
  - (a) exact integrals
  - (b) inexact integrals
7. Temperature is an
  - (a) exact integral
  - (b) inexact integral
8. The amount of work done in free expansion process is
  - (a) non zero
  - (b) zero
  - (c) unity
  - (d) none of these
9. In constant volume gas thermometer temperature is measured in terms of
  - (a) height of mercury column
  - (b) diameter of mercury column
  - (c) volume of mercury column
  - (b) none of these
10. The S.I. unit for water equivalent of a substance is
  - (a) kg
  - (b) J/kgK
  - (c) K
  - (d) none of these
11. The S.I. unit for heat capacity of a substance is
  - (a) kg
  - (b) J/kgK
  - (c) K
  - (d) J
12. The generally accepted values of adiabatic constant for air is
  - (a) 1.04
  - (b) 0.104
  - (c) 10.4
  - (d) 1.4
13. The S.I. unit for adiabatic constant is
  - (a) J/kg
  - (b) kg/J
  - (c) J/kgK
  - (d) unitless, pure number
14. The specific heat for any gaseous substance in constant volume process is generally symbolised by
  - (a)  $C_v$
  - (b)  $C_p$
  - (c)  $C_r$
  - (d) none of these
15. The specific heat for any gaseous substance in constant pressure process is generally symbolised by
  - (a)  $C_v$
  - (b)  $C_p$
  - (c)  $C_r$
  - (d) none of these

### Answers

1. (a) 2. (d) 3. (b) 4. (d) 5. (a) 6. (b) 7. (a) 8. (b) 9. (a) 10. (a)  
 11. (d) 12. (d) 13. (d) 14. (a) 15. (b)

### NUMERICAL EXAMPLES

#### EXAMPLE 1

Over a specified temperature range, the electrical resistance thermometer holds the relationship as:  $R_t = R_0 [1 + \alpha (t - t_0)]$ , where  $R_0$  is resistance in ohm, measured at reference temperature  $t_0$  in  $0^\circ\text{C}$  and  $\alpha$  is material constant with unit of  $(^\circ\text{C})^{-1}$ . The test result are:  $R_t = 51.39$  ohm at  $t = 0^\circ\text{C}$ ,  $R_t = 51.72$  ohm at  $t = 91^\circ\text{C}$ . Determine the reading of the resistance for  $70^\circ\text{C}$ ,  $50^\circ\text{C}$  and  $100^\circ\text{C}$  on this thermometer.

**SOLUTION**

Given  $t_0 = 0^\circ\text{C}, t = 0^\circ\text{C}, R_t = 51.39$

We have  $R_t = R_0 [1 + \alpha(t - t_0)]$

So,  $51.39 = R_0(1 + 0)$

$\therefore R_0 = 51.39$

Again,  $t_0 = 0^\circ\text{C}, t = 91.0^\circ\text{C}, R_t = 51.72$

$\therefore R_t = R_0 [1 + \alpha(t - t_0)]$

$$51.72 = 51.39 [1 + \alpha(91 - 0)]$$

$$= 51.39 + \alpha \times 51.39 \times 91$$

Therefore,  $\alpha = \frac{51.72 - 51.39}{51.39 \times 91} = 7.05657 \times 10^{-5}/^\circ\text{C}$

Thus,  $R_{70^\circ} = R_0 [1 + \alpha(t - t_0)]$

$$= 51.39 [1 + 7.05657 \times 10^{-5} \times 70] = 51.644 \text{ ohm}$$

$$R_{50^\circ} = 51.39 [1 + 7.05657 \times 10^{-5} \times 50] = 51.57 \text{ ohm}$$

$$R_{100^\circ} = 51.39 [1 + 7.05657 \times 10^{-5} \times 100] = 51.75 \text{ ohm}$$

**EXAMPLE 2**

The resistance of a platinum wire is found to be 11 ohms at the ice point, 15.247 ohms at steam point, and 28.887 ohms at the Zinc point. Find the constant  $a$  and  $b$  in the equation.  $R_t = R_0 (1 + at + bt^2)$ .

**SOLUTION**

Here,  $R_0 = 11 \text{ ohm}, R_{\text{steam}} = 15.247 \text{ ohm}, R_z = 28.887 \text{ ohm}$  and Zinc point  $= 419.58^\circ\text{C}$

Following the relation,  $R_t = R_0 (1 + at + bt^2)$

$$15.247 = 11 (1 + a \times 0.01 + b \times 0.01^2)$$

or,  $1.3861 = 1 + 0.01a + 0.0001b$

or,  $0.3861 = 0.01a + 0.0001b$

or,  $38.61 = a + 0.01b$  (i)

And  $28.887 = 11 [1 + a \times 419.58 + b(419.58)^2]$

or,  $2.6261 = 1 + 419.58a + 176047.3764b$

or,  $1.6261 = 419.58a + 176047.3764b$  (ii)

Solving equations (i) and (ii), we obtain the constants as

$$a = 38.6109, b = -0.092$$

**EXAMPLE 3**

The temperature  $t$  on a thermometric scale is defined in terms of a property  $K$  by the relation  $t = a \ln K + b$  where  $a$  and  $b$  are constants. The values of  $K$  are found to be 1.83 and 6.78 at the ice point and the steam point, the temperatures of which are assigned the numbers 0 and 100 respectively. Determine the temperature corresponding to a reading of  $K$  equal to 2.42 on the thermometer.

**SOLUTION**

From the relation  $t = a \ln K + b$ , we have

$$0 = a \ln 1.83 + b \quad (i)$$

and

$$100 = a \ln 6.78 + b \quad (ii)$$

Solving above equations,  $a = 78.68951$ , and  $b = -47.5533282$

Hence, relation is  $t = 78.68951 \ln K - 47.5533282$

For  $K = 42$ , we find  $t = 78.68951 \ln 2.42 - 47.5533282$   
 $= 21.989^\circ\text{C}$

**EXAMPLE 4**

A constant volume gas thermometer containing nitrogen is brought into contact with a system of unknown temperature and then into contact with a system maintained at the triple point of water. The mercury column attached to the device has reading of 59.2 and 2.28 cm respectively for the two systems. If the barometric pressure is 960 m bar (96.0 kPa), what is the unknown temperature in Kelvin, if  $g = 9.806 \text{ m/sec}^2$ . Specific gravity of mercury may be taken as 13.6.

**SOLUTION**

We know 
$$T = 273.16 \frac{P}{P_{tp}}$$

where  $T$  is the unknown temperature,  $p$  is the gauge pressure at unknown temperature,  $p_{tp}$  is the gauge pressure at the triple point of water.

So,  $p_{\text{gauge}}$  at unknown temperature

$$= \left( 13.6 \times 10^3 \times 9.807 \times \frac{59.2}{100} \right) \text{ N/m}^2$$

$$= 78.95 \text{ kPa} = 789.5 \text{ m bar}$$

$\therefore$

$$p_{\text{abs}} = (789.5 + 960) \text{ m bar}$$

$$= 1749.5 \text{ m bar} = 174.95 \text{ kPa} = p$$

Now,  $p_{\text{gauge}}$  at triple point temperature

$$= \left( 13.6 \times 10^3 \times 9.807 \times \frac{2.28}{10^3} \right) \text{ N/m}^2$$

$$= 3.0406 \text{ kPa} = 30.406 \text{ m bar}$$

$\therefore p_{\text{abs}}$

$$= (30.406 + 960) \text{ m bar} = 990.406 \text{ m bar}$$

$$= 99.0406 \text{ kPa} = p_{tp}$$

Hence, the unknown temperature 
$$T = 273.16 \left( \frac{174.95}{99.0406} \right) = 482.52 \text{ K}$$

**EXAMPLE 5**

A constant volume gas thermometer immersed in boiling water of  $t_1 = 100^\circ\text{C}$  reads  $z_1 = 30.0$  cm of Hg. Later the thermometer is immersed in a radiator fluid at temperature of  $150^\circ\text{C}$ . That time, barometric pressure is 76.0 cm Hg. Determine the height  $z_2$  of the mercury column, in cm. Assume the gas in the thermometer as perfect gas.

**SOLUTION**

For perfect gas we can write

$$\frac{p_1 \bar{V}_1}{T_1} = \frac{p_2 \bar{V}_2}{T_2} = \text{constant} \quad (\text{i})$$

At constant volume above relation reduce to

$$\frac{p_1}{T_1} = \frac{p_2}{T_2} \quad (\text{ii})$$

$$\text{So,} \quad \frac{z_0 + z_2}{t_2} = \frac{z_0 + z_1}{t_1} \quad (\text{iii})$$

Here,

$$T_1 = 100 + 273 = 373 \text{ K}, \quad z_1 = 30 \text{ cm}$$

$$T_2 = 150 + 273 = 423 \text{ K}, \quad z_0 = 76 \text{ cm}$$

Applying equation (iii), we get  $z_2 = 44.21$  cm

**EXAMPLE 6**

A soap film is suspended on a  $5 \text{ cm} \times 5 \text{ cm}$  wire frame ABCD as shown in figure. The movable wire BC is displaced by 1 cm to  $B'C'$  by an applied force while the surface tension of soap film remains constant at  $25 \times 10^{-5} \text{ N/cm}^2$ . Estimate the work done in stretching the film in N-m.

**SOLUTION**

The film is a closed system with moving boundary. Work done, on both side of the film.

$$\begin{aligned} W &= \int_{A_1}^{A_2} \tau dA = - \int_{x_1}^{x_2} \tau \cdot 2L dx \\ &= -\tau 2L \int_{x_1}^{x_2} dx = -\tau 2L (x_2 - x_1) \\ &= -25 \times 10^{-5} \times 2 \times 5 \times 1 \\ &= -250 \times 10^{-5} \text{ N}\cdot\text{cm} = -2.5 \times 10^{-5} \text{ N}\cdot\text{m} \end{aligned}$$

The (–) ve sign indicates that work is done on the film.

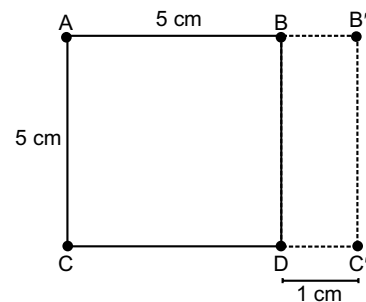
**EXAMPLE 7**

A gas in the cylinder and piston arrangement comprises the system is shown in Fig.2.6(a). It expands from  $1.5 \text{ m}^3$  to  $2 \text{ m}^3$  while receiving 200 kJ of work from a paddle wheel. The pressure on the gas remains constant at 600 kPa. Determine the net work done by the system.

**SOLUTION**

The work done by the piston is given by  $\int p dV$  and this is the work done by the system

$$\begin{aligned} W_{\text{gas}} &= \int_{1.5}^2 p dV \\ &= p \int_{1.5}^2 dV && \text{[pressure is constant]} \\ &= p [V_2 - V_1]_{1.5}^2 \\ &= 6 \times 10^5 (2 - 1.5) \text{ N}\cdot\text{m or J} \\ &= 3 \times 10^5 \text{ J} \end{aligned}$$

The gas also receives 200 kJ from the paddle wheel and this is work done on the system.

Thus, the net work done by the system is,

$$\begin{aligned} W_{\text{net}} &= 3 \times 10^5 - 200 \times 10^3 \\ &= 1 \times 10^5 \text{ N}\cdot\text{m} = 100 \text{ kJ} \end{aligned}$$

**EXAMPLE 8**

A gas is at a pressure of 3 bar in cylinder attached with frictionless movable piston shown in Fig.2.6(a). The spring force exerted through the piston is proportional to the volume of gas. Also additional atmospheric pressure of 1 bar acts on the spring side of piston. Determine the work done by gas in expansion from  $0.1 \text{ m}^3$  to  $0.5 \text{ m}^3$ .

**SOLUTION**

The pressure exerted by the spring

$$\begin{aligned} p_s &= \text{gas pressure} - \text{atmospheric pressure} \\ &= 3 - 1 = 2 \text{ bar} = 2 \times 10^5 \text{ N/m}^2 \end{aligned}$$

Thus, the spring force is given by

$$F_s = p_s \times A = (2 \times 10^5 \times A) \text{ N}$$

where  $A$  is cross-sectional area of piston in  $\text{m}^2$ . This force gives spring displacement of  $x_1 = \frac{\text{volume}}{\text{area}} = \frac{0.1}{A}$

Thus, spring constant is given by  $k_s = \frac{2 \times 10^5 \times A}{\left(\frac{0.1}{A}\right)} = 20 \times 10^5 \text{ A}^2 \text{ N/m}$

Similarly we can write  $x_2 = \frac{0.5}{A}$

The work done against the spring

$$W_s = \int_{x_1}^{x_2} 20 \times 10^5 \times A^2 x dx$$

$$\begin{aligned}
 &= 20 \times 10^5 A^2 \left[ \frac{x^2}{2} \right]_{x_1}^{x_2} \\
 &= 10 \times 10^5 A^2 [x_2^2 - x_1^2] \\
 &= 10 \times 10^5 A^2 \left[ \frac{0.5^2}{A^2} - \frac{0.1}{A^2} \right] \\
 &= 2.4 \times 10^5 \text{ N}\cdot\text{m}.
 \end{aligned}$$

Work done against atmosphere  $W_{\text{atm}} = 1 \times 10^5 (0.5 - 0.1) = 0.4 \times 10^5 \text{ N}\cdot\text{m}$

Thus, total work done by the gas  $W = W_s + W_{\text{atm}}$

$$= 2.4 \times 10^5 + 0.4 \times 10^5 = 2.8 \times 10^5 \text{ N}\cdot\text{m or J}.$$

### EXAMPLE 9

For a system whose mass is 4.5 kg undergoes a process and the temperature changes from 50°C to 100°C. Assume that the specific heat of the system is a function of temperature only. Calculate the heat transfer

during the process for the following relationship  $C_n = \left[ 0.3 + \frac{20}{T + 150} \right] \text{ kJ/kg K}$ .

**SOLUTION**

Here

$$T_1 = 273 + 50 = 323 \text{ K}, T_2 = 273 + 100 = 373 \text{ K}, m = 4.5 \text{ kg}.$$

and  $C_n$

$$= 0.3 + \left( \frac{20}{T + 150} \right)$$

$\therefore$

$$\begin{aligned}
 Q_{1-2} &= \int_{323}^{373} m C_n dT \\
 &= 4.5 \int_{323}^{373} \left[ 0.3 + \frac{20}{T + 150} \right] dT \\
 &= 4.5 \left[ 0.3 \int_{323}^{373} dT + \int_{323}^{373} \frac{dT}{T/20 + 150/20} \right] \\
 &= \left\{ [0.3T]_{323}^{373} + \left[ \frac{1}{0.05} \ln(0.05T + 75) \right]_{323}^{373} \right\} \\
 &= 4.5 \left\{ 0.3 \times 50 + \frac{1}{0.05} [\ln(18.65 + 75) - \ln(16.15 + 75)] \right\} \\
 &= 4.5 \left\{ 15 + \frac{1}{0.05} \ln \frac{93.65}{91.15} \right\} \\
 &= 69.935 \text{ kJ}
 \end{aligned}$$

## EXERCISE

1. Define temperature. Name the different temperature scale in common use. Establish relation between Celsius and Fahrenheit scale?
2. What is absolute temperature ?
3. What do you understand by N.T.P and S.T.P? What are their values?
4. Distinguish between gauge pressure, absolute pressure and atmospheric pressure. What are their relation.
5. Define energy. What is stored energy and transit energy? Discuss the types of stored energy.
6. Define thermodynamic work. Show that both heat and work are a path function not a point function.
7. Work done is given by  $W = \int p dV$ , Is there be any situation where  $dV = 0$  and yet  $dW \neq 0$ ?
8. Which of the following characteristics are true for work? (a) It is a path functions (b) It is not a property of a system. (c) Its differential is not exact. (d) It is not stored in a system (e) It is energy in transit. (f) It can be indentified only during the course of interaction.
9. Which of the characteristics given in question no. 8 are true for heat.
10. State the Zeorth Law of Thermodynamics. How is mercury in thermometer able to find the temperature of a body using the Zeroth Law of Thermodynamics.
11. Power transmission through a rotating shaft is a common engineering practice. Derive a relation to determine the power transmitted through a rotating shaft.

**Ans.** [ $P = T\omega$ ]

12. An aqueous soap solution is maintained in the form of thin film, on a wire frame as shown in Fig 2.10. If the surface tension of the liquid is 72.75 mN/m. Calculate the work done when the movable wire is displaced by 1 cm in the direction indicated.

**Ans.** [ $W = -29.1 \times 10^{-6}$  J]

13. One end of steel rod of 1 cm in diameter and 50 cm in length is fixed and a force is continuously applied at the other end in a direction which is parallel to the length of the rod. Calculate the work done by the force on the steel rod to change its length by 1 cm. Also calculate the stress and force applied on the rod. The Young's modulus of steel is  $2 \times 10^{11}$  N/m<sup>2</sup>.

**Ans.** [ $W = -1.5708$  kJ,  $F = 3.1416 \times 10^5$  N]

14. A piston has area of 5 cm<sup>2</sup>. What mass must the piston have if it exerts a pressure of 50 kPa above atmospheric pressure on the gas enclosed in the cylinder.

**Ans.** [ 7.71 kg ]

15. A pressure guage reads 2.4 bar and the barometer reads 75 cm of Hg. Calculate the absolute pressure in bar and in the standard atmosphere.
16. A manometer has a liquid of density 800 kg/m<sup>3</sup>, the difference in level of the two legs is 300 mm. Determine the presure difference. Read it in kgf/m<sup>2</sup>, bar and kPa.

**This page  
intentionally left  
blank**

CHAPTER
<b>3</b>

## PROPERTIES AND THERMODYNAMIC PROCESSES OF GAS

---

### 3.1 INTRODUCTION

*Vapour* is partially evaporated liquid which are *in contact with liquid surface* and *contains some particles* of liquid in suspension. It does not obey the gas laws. Wet and dry steams are the examples of vapour.

Gas is completely evaporated liquid which are *not in contact with liquid surface* and *does not contain any particles* of liquid in suspension, and it *obeys* the gas laws. Oxygen, hydrogen and superheated steam etc., are the examples of gas.

An *ideal* or perfect gas may be defined as a state of a substance, which *strictly obeys* all the gas laws under all conditions of temperature and pressure. In actual practice, there is no real or actual gas which strictly obeys Boyle's Law, Charle's Law and Gay-Lussac's Law over the entire range of temperature and pressure. But, the real gases which are ordinarily difficult to liquefy (oxygen, hydrogen and air), within certain temperature and pressure limits may be regarded as perfect gases.

### 3.2 GENERAL GAS EQUATION

The gas laws give us the relation between the two variables when the third variable is constant. But in actual practice, all the three variables i.e., pressure, volume and temperature change simultaneously. In order to deal with all practical cases, the Boyle's Law and Charle's Law are combined together to form a general gas equation.

According to Boyle's Law:

$$p \propto \frac{1}{V} \quad \text{or} \quad V \propto \frac{1}{p} \quad [T = \text{constant}]$$

According to Charle's Law:

$$V \propto T \quad [p = \text{constant}]$$

Combining these two relations, we have

$$pV \propto T$$

or

$$pV = KT, \quad \text{or} \quad \frac{pV}{T} = K \quad (3.1)$$

where,  $K$  = constant of proportionality and its value depends on mass and properties of the gas. So, the general equation of gas can be

$$\text{written as, } \frac{p_1 \nabla_1}{T_1} = \frac{p_2 \nabla_2}{T_2} = \text{constant} \quad (3.2)$$

### 3.3 EQUATION OF STATE AND CHARACTERISTIC EQUATION OF GAS

It is modified form of equation of gas. Let us consider  $\nabla$  volume of gas of mass  $m$  kg and  $n$  number of moles having molecular weight  $M$ . The volume of 1 kg mole gas is  $v_m$  and the volume of 1 kg gas is known as *specific volume* ( $v_s$ ).

So,  $v_s = \frac{\nabla}{m}$ ,  $v_m = \frac{\nabla}{n}$  and  $M = \frac{m}{n}$ . Now the equation (3.1) is known as equation of state.

When we consider volume of 1 kg mass, the equation (3.1) will be

$$pv_s = RT \quad (3.3)$$

where  $R$  is known as characteristic gas constant or simply the gas constant. It is different for different gases. In S.I.,  $R = 287$  J/kgK or 0.287 kJ/kgK.

$$\text{Again, } p \frac{\nabla}{m} = RT$$

$$\Rightarrow p \nabla = mRT \quad (3.4)$$

The equation (3.4) is known as characteristic equation of gas. Unit of  $R$  may be obtained as

$$R = \frac{p \nabla}{mT} = \frac{(\text{N/m}^2) \times \text{m}^3}{\text{kg} \cdot \text{K}} = \text{N} \cdot \text{m} / \text{kg} \cdot \text{K} = \text{J} / \text{kg} \cdot \text{K}$$

#### 3.3.1 Physical Significance of $R$

We know characteristic gas constant is  $R = \frac{p \nabla}{mT}$ . So,  $R$  is defined as the amount of work per kg of mass of gas per unit change of absolute temperature.

### 3.4 UNIVERSAL GAS CONSTANT OR MOLAR GAS CONSTANT

We know the equation of state is  $p \nabla = KT$ . When we consider volume of 1 kg mole gas ( $v_m$ ), the equation of state will be

$$pv_m = R_m T \quad (3.5)$$

Here,  $K$  is replaced by  $R_m$ , which is called *universal gas constant* or *molar gas constant*. It is constant for all gases.

$$\text{But, } p \frac{\nabla}{n} = R_m T \quad (3.6)$$

$$\Rightarrow p \nabla = n R_m T = \frac{m}{M} R_m T = m \frac{R_m}{M} T$$

Comparing eqns. (3.4) and (3.6),

$$m \frac{R_m}{M} T = mRT$$

$$\Rightarrow R_m = MR \quad (3.7)$$

This is the relation between universal or *molar gas constant* ( $R_m$ ) and *characteristic gas constant*. So, the universal gas constant of a gas is the product of characteristic gas constant and the molecular mass of the gas. In S.I.,  $R_m = 8314 \text{ J/kg mole}\cdot\text{K} = 8.314 \text{ kJ/kgmole}\cdot\text{K}$

### 3.5 SPECIFIC HEAT OF GAS

The specific heat of a substance may broadly be defined as the *amount of heat required to raise the temperature of its unit mass through one degree*. All the liquids and solids have only one specific heat. But a gas can have any number of specific heat, lying between zero to infinity, depending upon the condition, under which it is heated. Only two types of specific heat of gas, *specific heat at constant volume* ( $C_v$ ) and *specific heat at constant pressure* ( $C_p$ ) are important from the subject point of view.

#### 3.5.1 Specific Heat at Constant Volume ( $C_v$ )

It is the amount of heat required to raise the temperature of unit mass of gas through one degree when it is heated at a constant volume. It is generally denoted by  $C_v$ . Whenever, a gas is heated at constant volume, total heat energy supplied is utilized to increase the temperature, because no work is done by the gas,

$$W_{1-2} = \int_1^2 p dV = p(V_2 - V_1) = 0 \quad (3.8)$$

Hence, total heat ( $Q_{1-2}$ ) supplied to the gas at constant volume equals with change of internal energy of the gas ( $dU$ ).

$$(Q_{1-2})_v = mC_v (T_2 - T_1) = dU = U_2 - U_1 \quad (3.9)$$

So, 
$$C_v = \frac{(Q_{1-2})_v}{m(T_2 - T_1)} \quad (3.10)$$

#### 3.5.2 Specific Heat at Constant Pressure ( $C_p$ )

It is the amount of heat required to raise the temperature of the unit mass of a gas through one degree, when it is heated at constant pressure. It is generally denoted by ( $C_p$ ). Total heat supplied to the gas at constant pressure,

$$(Q_{1-2})_p = mC_p (T_2 - T_1) \quad (3.11)$$

Here, total heat supplied, when gas is heated at constant pressure is utilized

(a) to raise the temperature of gas which increases internal energy of the gas,

$$dU = mC_v (T_2 - T_1) \quad (3.12)$$

(b) to do some external work during expansion  $\delta W = pdV$  which on integration,

$$\int_1^2 \delta W = \int_1^2 pdV$$

$$\Rightarrow W_{1-2} = p(V_2 - V_1) = mR(T_2 - T_1) \quad (3.13)$$

Hence, from above we can write,

$$\delta Q = dU + \delta W \quad (3.14)$$

Integrating within limits, we obtain

$$(Q_{1-2})_p = mC_v(T_2 - T_1) + mR(T_2 - T_1) \quad (3.15)$$

### 3.6 LINEAR RELATION BETWEEN $C_p$ AND $C_v$

Specific heat at constant pressure ( $C_p$ ) is greater than that at constant volume ( $C_v$ ). This can be established as following.

From eqns. (3.15) and (3.11), we can write

$$mC_p(T_2 - T_1) = mC_v(T_2 - T_1) + mR(T_2 - T_1)$$

$$\Rightarrow C_p = C_v + R \quad (3.16)$$

$$\text{Hence, characteristic gas constant } R = C_p - C_v \quad (3.17)$$

### 3.7 RATIO OF $C_p$ AND $C_v$

The ratio of  $C_p$  and  $C_v$  of a gas is an important parameter in the field of thermodynamics. It is known as *adiabatic index* and symbolized by  $\gamma$ . Dividing eqn. (3.16), by  $C_v$  we obtain,

$$\frac{C_p}{C_v} = 1 + \frac{R}{C_v}$$

$$\Rightarrow \gamma = 1 + \frac{R}{C_v} \quad (3.18)$$

The values of  $C_p$  and  $C_v$  of some common gases along with their  $\gamma$  are given in table 3.1.

**Table: 3.1. The values of  $C_p$ ,  $C_v$  and  $\gamma$**

Sl.No.	Name of gases	$C_p$ (kJ/kgK)	$C_v$ (kJ/kgK)	$\gamma$
1	Air	1.000	0.720	1.400
2	Oxygen (O <sub>2</sub> )	0.913	0.653	1.390
3	Hydrogen (H <sub>2</sub> )	14.257	10.133	1.400
4	Nitrogen (N <sub>2</sub> )	1.043	0.745	1.400
5	Carbon-di-oxide (CO <sub>2</sub> )	0.846	0.657	1.290
6	Carbon-mono-oxide (CO)	1.047	0.749	1.400

Contd...

7	Ammonia (NH <sub>3</sub> )	2.177	1.692	1.290
8	Methane (CH <sub>4</sub> )	2.169	1.650	1.310
9	Helium (He)	5.234	3.153	1.660
10	Argon (A)	5.234	3.153	1.660

### 3.8 ENTHALPY OF A GAS

One of the basic qualities most frequently recurring in thermodynamics is *enthalpy*. It is the sum of internal energy ( $U$ ) and the product of pressure and volume ( $p\forall$ ). It is symbolized by  $H$ .

$$\text{So, } H = U + p\forall \quad (3.19)$$

Since,  $(U + p\forall)$  is made up entirely of property, therefore, enthalpy ( $H$ ) is also a property. Specific enthalpy ( $h$ ) is enthalpy per unit mass.

So, by unit mass consideration we have,

$$h = u + pv_s \quad (3.20)$$

Again we know,

$$\begin{aligned} (Q_{1-2})_p &= (U_2 - U_1) + p(\forall_2 - \forall_1) \\ &= (U_2 + p\forall_2) - (U_1 + p\forall_1) = H_2 - H_1 \end{aligned} \quad (3.21)$$

$$\text{For unit mass, } q_{1-2} = h_2 - h_1 \quad (3.22)$$

Thus, for a constant temperature process, total heat supplied to the gas is equal to the change of enthalpy.

### 3.9 THERMODYNAMIC PROCESSES

- (a) When a system changes from one equilibrium state to another equilibrium state, the path of successive states through which the system has passed, is known as a *thermodynamic process*. But in actual practice, no system is in true equilibrium during the process because the properties such as pressure, volume, temperature etc., are changing. However, if the process is assumed to take place sufficiently slowly so that the deviation of the properties at the intermediate states are infinitesimally small, then every state passed through by the system will be in equilibrium and the process is named as *quasi-static* or *reversible* process. It is represented by a *continuous curve* on the pressure-volume diagram in Fig. 3.1 (a) and (b).

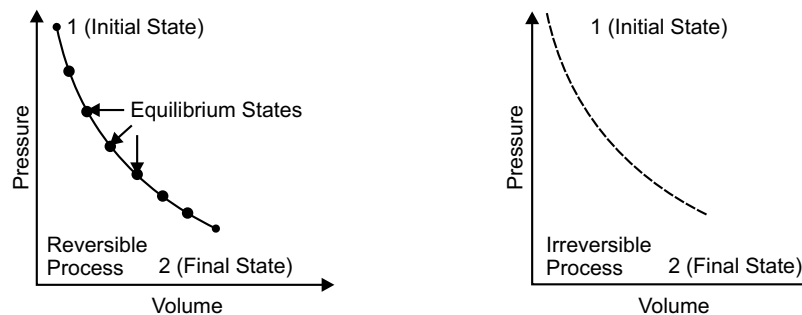

Fig. 3.1 (a) and (b)

- (b) If the process takes place in such a manner that the properties at the intermediate states are not in equilibrium state, except the initial and final states, then the process is said to be *non-equilibrium* or *irreversible* process, represented by broken line on pressure-volume diagram.

### 3.10 CLASSIFICATION OF THERMODYNAMIC PROCESS

All the thermodynamic processes are classified into two groups:

- (i) *Non-flow process*: It is that process which occurs in a closed system and does not permit the transfer of mass across their boundaries. In these processes, mass transfer does not occur but energy crosses the system boundary in the form of heat and work. Work done in this process is,  $W_{1-2} = \int p d\forall$ .
- (ii) *Flow process*: It is that process which does occur in open system and permits the transfer of mass into and from the system. The flow processes may be steady or non-steady flow processes. The common examples of steady flow processes are flow through nozzles, turbine, compressors etc. Work done in flow process is  $W_{\text{flow}} = \int p d\forall + p v_s$ .

### 3.11 HEATING AND EXPANSION OF GASES IN NON-FLOW PROCESS

The heating and expansion of a gas may be performed in many ways. Following are the different non-flow processes as applied to perfect gas. It may be reversible or irreversible.

**(a) Reversible non-flow process:**

- (i) Constant volume (Isochoric) process
- (ii) Constant pressure (Isobaric) process
- (iii) Hyperbolic process
- (iv) Constant temperature (Isothermal) process
- (v) Adiabatic (Isentropic) process
- (vi) Polytropic process

- (b) Irreversible non-flow process:** The free expansion process is an irreversible non-flow process. In case of cooling and compression the above mentioned processes are also applicable. Cooling is negative heating and compression is negative expansion.

### 3.12 CONSTANT VOLUME PROCESS OR ISOCHORIC PROCESS

When gas is heated at constant volume, its pressure and temperature will increase. The process is shown on the pressure-volume ( $p-\forall$ ) and pressure-temperature ( $p-T$ ) diagrams in Fig. 3.2(a) and (b) respectively. Here follows some relationship within this process.

- (a) Pressure, volume-temperature ( $p-\forall-T$ ) relationship:** The general equation of gas

is 
$$\frac{p_1 \forall_1}{T_1} = \frac{p_2 \forall_2}{T_2}$$

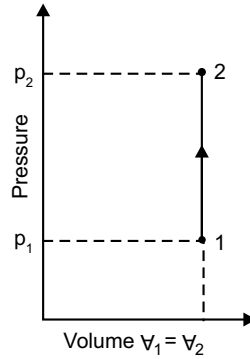

Fig. 3.2 (a)

Since, the gas is heated at constant volume,  $V_1 = V_2$

$$\text{So, } \frac{p_1}{T_1} = \frac{p_2}{T_2} \quad \text{or} \quad \frac{p}{T} = \text{constant} \quad (3.23)$$

Thus, the constant volume process is governed by Gay-Lussac's law.

**(b) Work done by the gas:**

We know that,  $\delta W = p dV$

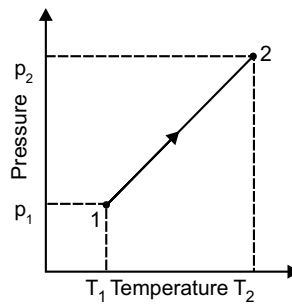

Fig. 3.2 (b)

On integrating from state 1 to state 2, we obtain

$$\int_1^2 \delta W = \int_1^2 p dV = p \int_1^2 dV$$

$$\Rightarrow W_{1-2} = p(V_2 - V_1) = 0 \quad (3.24)$$

**(c) Change in internal energy:** We know that, change in internal energy  $dU = mC_v dT$

On integrating from state 1 to state 2, we obtain

$$\int_1^2 dU = \int_1^2 mC_v dT$$

$$\Rightarrow U_2 - U_1 = mC_v(T_2 - T_1) \quad (3.25)$$

**(d) Supply of heat:** We know heat supplied or heat transfer

$$\delta Q = dU + \delta W$$

On integrating from state 1 to state 2, we have

$$\int_1^2 \delta Q = \int_1^2 dU + \int_1^2 \delta W$$

$$\Rightarrow Q_{1-2} = (U_2 - U_1) + W_{1-2} = mC_v (T_2 - T_1) \quad (3.26)$$

Since, the gas is heating at constant volume,  $W_{1-2} = 0$

**(e) Change in enthalpy**

$$dH = dU + d(p\forall)$$

On integrating from state 1 to state 2, we have

$$\int_1^2 dH = \int_1^2 dU + \int_1^2 d(p\forall)$$

$$\begin{aligned} \Rightarrow H_2 - H_1 &= (U_2 - U_1) + p_1\forall_1 - p_1\forall_2 \\ &= mC_v (T_2 - T_1) + mR (T_2 - T_1) \\ &= m (T_2 - T_1) (C_v + R) \\ &= m(T_2 - T_1) C_p \end{aligned}$$

$$[\because C_p - C_v = R] \quad (3.27)$$

### 3.13 CONSTANT PRESSURE PROCESS OR ISOBARIC PROCESS

When a gas is heated at constant pressure, its temperature and volume both will increase. Since, there is a change in its volume, therefore the heat supplied to the gas is utilized to increase the internal energy of the gas and for some external work.

Consider  $m$  kg of a certain gas being heated at a constant pressure from an initial state 1 to a final state 2 shown in the pressure-volume diagram ( $p - \forall$ ) and pressure-temperature ( $p - T$ ) diagram in Fig. 3.3 (a) and (b). Now let us derive the following relations.

**(a) Pressure, volume-temperature ( $p - \forall - T$ ) relationship**

$$\text{The general equation of gas is } \frac{p_1\forall_1}{T_1} = \frac{p_2\forall_2}{T_2}$$

Since, the gas is heated at constant pressure,  $p_1 = p_2$

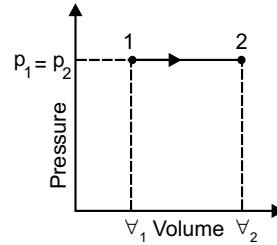

Fig. 3.3 (a)

$$\text{So, } \frac{V_1}{T_1} = \frac{V_2}{T_2} \quad \text{or} \quad \frac{V}{T} = \text{constant} \quad (3.28)$$

Thus, the constant pressure process is governed by Charle's law.

**(b) Work done by the gas**

We know that,  $\delta W = p dV$

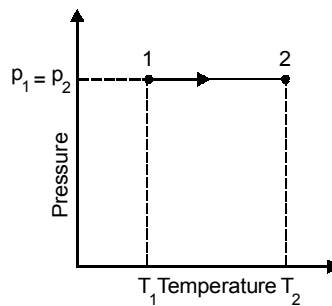

Fig. 3.3. (b)

On integrating from state 1 to state 2, we have

$$\int_1^2 \delta W = \int_1^2 p dV = p \int_1^2 dV$$

$$\Rightarrow \quad W_{1-2} = p(V_2 - V_1) = mR(T_2 - T_1) \quad (3.29)$$

**(c) Change in internal energy**

We know that, change in internal energy  $dU = mC_v dT$

On integrating from state 1 to state 2, we obtain

$$\int_1^2 dU = \int_1^2 mC_v dT$$

$$\Rightarrow \quad U_2 - U_1 = mC_v(T_2 - T_1) \quad (3.30)$$

**(d) Supply of heat**

We know heat supplied or heat transfer  $\delta Q = dU + \delta W$

On integrating from state 1 to state 2, we have

$$\begin{aligned} \int_1^2 \delta Q &= \int_1^2 dU + \int_1^2 \delta W \\ \Rightarrow (Q_{1-2})_p &= (U_2 - U_1) + (W_{1-2})_p \\ &= mC_v(T_2 - T_1) + mR(T_2 - T_1) \\ &= m(T_2 - T_1)(C_v + R) \\ &= m(T_2 - T_1)C_p \quad \left[ \because C_p - C_v = R \right] \end{aligned} \quad (3.31)$$

**(e) Change in enthalpy**

$$dH = dU + d(pV)$$

On integrating from state 1 to state 2, we have

$$\begin{aligned} \int_1^2 dH &= \int_1^2 dU + \int_1^2 d(pV) \\ \Rightarrow H_2 - H_1 &= (U_2 - U_1) + (p_1V_1 - p_1V_1) \\ &= mC_v(T_2 - T_1) + mR(T_2 - T_1) \\ &= m(T_2 - T_1)(C_v + R) \\ &= m(T_2 - T_1)C_p \quad \left[ \because C_p - C_v = R \right] \end{aligned} \quad (3.32)$$

**3.14 HYPERBOLIC PROCESS**

It is a process, in which the gas is heated as expanded in such a way that the product of its pressure and volume remains constant. The hyperbolic process follows law  $pV = \text{constant}$ , so it is governed by Boyle's law. The hyperbolic process is shown in diagram in Fig. 3.4. Its practical application is *isothermal process*, which is discussed below.

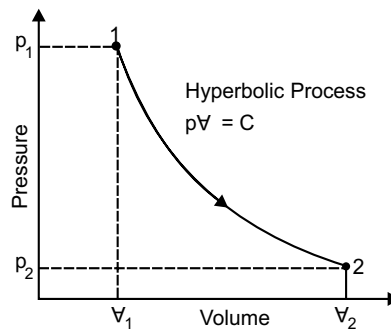

**Fig. 3.4**

**3.15 CONSTANT TEMPERATURE PROCESS OR ISOTHERMAL PROCESS**

During this process, the temperature of the working substance remains constant. This process is a very slow process. Let the Mass of the working substance is  $m$  kg and being heated at constant temperature from initial state 1 to final state 2 which is shown on  $(p - \forall)$  and  $(p - T)$  diagrams in Fig. 3.5 (a) and (b) respectively. The relations for the reversible constant temperature process or isothermal process are discussed below.

**(a) Pressure, volume-temperature  $(p - \forall - T)$  relationship**

The general equation of gas is  $\frac{p_1 \forall_1}{T_1} = \frac{p_2 \forall_2}{T_2}$

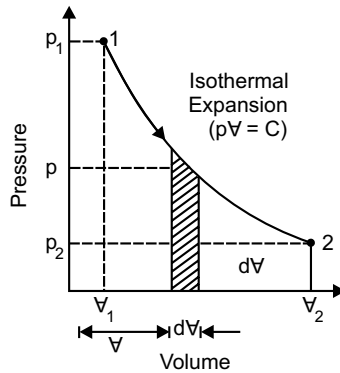

Fig. 3.5 (a)

Since, the gas is heated at constant temperature,  $T_1 = T_2$

So,  $p_1 \forall_1 = p_2 \forall_2$  or  $p \forall = \text{constant}$  (3.33)

Thus, the constant temperature process is governed by Boyle’s law.

**(b) Work done by the gas**

We know that,  $\delta W = p d\forall$

On integrating from state 1 to state 2

$$\int_1^2 \delta W = \int_1^2 p d\forall$$

$\Rightarrow (W_{1-2})_T = \int_1^2 p d\forall$

In isothermal process  $p \forall = \text{constant}$

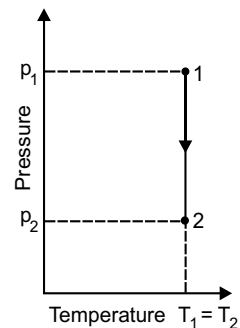

Fig. 3.5 (b)

So,  $pV = p_1V_1$   
 $\Rightarrow p = \frac{p_1V_1}{V}$

Hence,

$$(W_{1-2})_T = \int_{V_1}^{V_2} \frac{p_1V_1}{V} dV = p_1V_1 \int_{V_1}^{V_2} \frac{dV}{V} = p_1V_1 \ln \left( \frac{V_2}{V_1} \right) \quad (3.34)$$

Again we know, expansion ratio ( $r$ ) is the ratio of volume at the end of expansion to volume at the beginning of expansion and compression ratio ( $r$ ) is the ratio of volume at the beginning of compression to volume at the end of compression and  $r = \frac{V_2}{V_1}$

But  $p_1V_1 = p_2V_2 = mRT$

Hence, finally  $(W_{1-2})_T = mRT \ln r \quad (3.35)$

**(c) Change in internal energy**

We know that, change in internal energy  $dU = mC_v dT$

In constant temperature condition,  $T_1 = T_2$  and  $dU = 0$

So, initial internal energy ( $U_1$ ) = final internal energy ( $U_2$ ).

**(d) Supply of heat**

We know heat supplied or heat transfer  $\delta Q = dU + \delta W$

On integrating from state 1 to state 2

$$\int_1^2 \delta Q = \int_1^2 dU + \int_1^2 \delta W$$

$$\Rightarrow Q_{1-2} = (U_2 - U_1) + W_{1-2} = W_{1-2} \int_1^2 \delta Q = p_1V_1 \ln \left( \frac{V_2}{V_1} \right) = mRT \ln \left( \frac{V_2}{V_1} \right) \quad (3.36)$$

**(e) Change in enthalpy**

$$\int_1^2 dH = H_2 - H_1 = mC_p (T_2 - T_1)$$

In constant temperature condition,  $T_1 = T_2$

$$\int_1^2 dH = H_2 - H_1 = 0$$

$\Rightarrow H_2 = H_1 \quad (3.37)$

So, initial enthalpy ( $H_1$ ) = final enthalpy ( $H_2$ ) (3.38)

### 3.16 ADIABATIC PROCESS

During the process, if the working substance neither receives nor gives out heat to its surroundings, is called adiabatic process. It may be *reversible* or *irreversible*. The reversible or *frictionless adiabatic process* is known as *isentropic process*. In isentropic process entropy is constant, i.e.,

$$\int dS = 0.$$

Therefore, an isentropic process need not be adiabatic or reversible. If the isentropic process is reversible, it must be adiabatic. An adiabatic process need not be an isentropic, since entropy can also increase due to friction etc. But if the process is reversible adiabatic it must be isentropic. Now consider  $m$  kg of certain gas being heated adiabatically from an initial state 1 to final state 2 shown in ( $p - \forall$ ) diagram in Fig. 3.6. Relation for a reversible adiabatic process is discussed below.

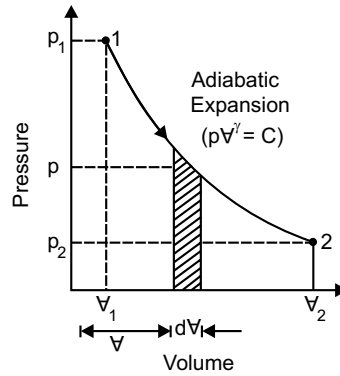

Fig. 3.6

#### (a) Pressure, volume-temperature ( $p - \forall - T$ ) relationship

We know, heat supplied during process,  $\delta Q = dU + \delta W$

In an adiabatic process,  $\delta Q = 0$ ,

So finally,

$$dU + \delta W = 0$$

$$\Rightarrow mC_v dT + pd\forall = 0$$

$$\Rightarrow dT = -\frac{pd\forall}{mC_v dT}$$

Again we know,  $p\forall = mRT$

On differentiation we get,

$$pd\forall + \forall dp = mRdT$$

$$\Rightarrow dT = \frac{pd\forall + \forall dp}{mR} = \frac{pd\forall + \forall dp}{m(C_p - C_v)}$$

$$\text{Hence, } -\frac{pd\forall}{mC_v dT} = \frac{pd\forall + \forall dp}{m(C_p - C_v)}$$

$$\Rightarrow \frac{C_p - C_v}{C_v} = -\frac{pd\forall + \forall dp}{pd\forall}$$

$$\Rightarrow \frac{C_p}{C_v} - 1 = -1 - \frac{\forall dp}{pd\forall}$$

$$\Rightarrow \gamma = -\frac{\forall dp}{pd\forall}$$

$$\Rightarrow \gamma \frac{d\forall}{\forall} = -\frac{dp}{p}$$

Integrating both sides,

$$\gamma \ln \forall + \ln p = \text{constant}$$

$$\Rightarrow \ln(p\forall^\gamma) = \text{constant}$$

$$\Rightarrow p\forall^\gamma = \text{constant}$$

$$\Rightarrow p_1\forall_1^\gamma = p_2\forall_2^\gamma = \text{constant} \quad (3.38)$$

The above equation can also be written in this form as,

$$\frac{p_1}{p_2} = \left(\frac{\forall_2}{\forall_1}\right)^\gamma \quad (3.39)$$

We know from general gas equation,

$$\frac{p_1}{p_2} = \frac{T_1}{T_2} \times \frac{\forall_2}{\forall_1}$$

Hence we get,

$$\left(\frac{\forall_2}{\forall_1}\right)^\gamma = \frac{T_1}{T_2} \times \frac{\forall_2}{\forall_1}$$

$$\Rightarrow \frac{T_1}{T_2} = \left(\frac{\forall_2}{\forall_1}\right)^{\gamma-1} \quad (3.40)$$

Again we can write,

$$\frac{V_2}{V_1} = \left( \frac{p_1}{p_2} \right)^{1/\gamma} \quad (3.41)$$

Substituting the values, in equations (3.40), we obtained

$$\frac{T_1}{T_2} = \left( \frac{p_1}{p_2} \right)^{\frac{\gamma-1}{\gamma}} \quad (3.42)$$

Comparing the values, of equations (3.40) and (3.42) we can write

$$\frac{T_1}{T_2} = \left( \frac{p_1}{p_2} \right)^{\frac{\gamma-1}{\gamma}} = \left( \frac{V_2}{V_1} \right)^{\gamma-1} \quad (3.43)$$

The above equation is known as *Poisson's Equation*.

### (b) Work done

We know that, work done  $\delta W = pdV$

On integrating from state 1 to state 2, we obtain

$$\int_1^2 \delta W = \int_1^2 pdV$$

$$\Rightarrow W_{1-2} = \int_1^2 pdV$$

In adiabatic process of gas

$$pV^\gamma = p_1V_1^\gamma = \text{constant}$$

$$\Rightarrow p = p_1 \left( \frac{V_1}{V} \right)^\gamma$$

Substituting the value of  $p$ , we have

$$\begin{aligned} W_{1-2} &= \int_1^2 \frac{p_1 V_1^\gamma}{V^\gamma} dV \\ &= p_1 V_1^\gamma \left[ \frac{V^{1-\gamma}}{1-\gamma} \right]_1^2 = \frac{p_1 V_1^\gamma V_2^{1-\gamma} - p_1 V_1^\gamma V_1^{1-\gamma}}{1-\gamma} \\ &= \frac{p_2 V_2^\gamma V_2^{1-\gamma} - p_1 V_1^\gamma V_1^{1-\gamma}}{1-\gamma} = \frac{p_2 V_2 - p_1 V_1}{1-\gamma} \end{aligned} \quad (3.44)$$

The equation for work done may also be expressed as follows. We know that  $p_1V_1 = mRT_1$  and  $p_2V_2 = mRT_2$ . Substituting the above values, we have

$$W_{1-2} = \frac{p_2V_2 - p_1V_1}{1-\gamma} = \frac{mRT_2 - mRT_1}{1-\gamma} = mR \frac{T_2 - T_1}{1-\gamma} \quad (3.45)$$

It is also expressed as

$$W_{1-2} = \frac{p_1V_1 - p_2V_2}{\gamma-1} = \frac{p_1V_1}{\gamma-1} \left( 1 - \frac{p_2V_2}{p_1V_1} \right) = \frac{mRT_1}{\gamma-1} \left( 1 - \frac{p_2V_2}{p_1V_1} \right) \quad (3.46)$$

**(c) Change in internal energy:** Change in internal energy

$$\int_1^2 dU = U_2 - U_1 = mC_v (T_2 - T_1) \quad (3.47)$$

**(d) Supply of heat:** Heat supplied during the process

$$Q_{1-2} = 0 \quad (3.48)$$

**(e) Change in enthalpy:**

$$\int_1^2 dH = H_2 - H_1 = mC_p (T_2 - T_1) \quad (3.49)$$

### 3.17 POLYTROPIC PROCESS

The polytropic process is also known as the general law for expansion and compression of gases and it is given by the relation  $pV^n = \text{constant}$ . Here  $n$  is a polytropic index, which may assume any value from zero to infinity, depending upon the manner in which the expansion and compression has taken place. The various equations for polytropic process may be expressed by changing the index ( $n$  for  $\gamma$  in the adiabatic process). Let us consider  $m$  kg of a certain gas being heated polytropically from an initial state 1 to a final state 2, shown in Fig. 3.7 in the ( $p - V$ ) diagram. The following relations for the polytropic process can be derived below.

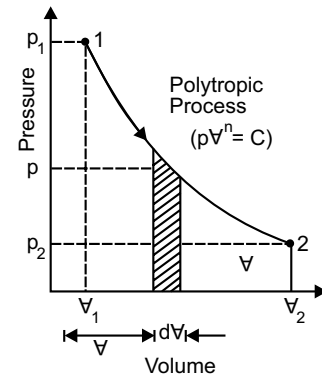

Fig. 3.7

**(a) Pressure, volume-temperature ( $p - V - T$ ) relationship:**

The following relations for the polytropic process are derived in the similar way as discussed for adiabatic process. And we have,

$$(i) \quad p_1V_1^n = p_2V_2^n = \text{constant} \quad (3.50)$$

$$(ii) \quad \frac{T_1}{T_2} = \left( \frac{p_1}{p_2} \right)^{\frac{n-1}{n}} = \left( \frac{V_2}{V_1} \right)^{n-1} \quad (3.51)$$

(b) **Work done:** The equation for the work done during a polytropic process may also be expressed by changing the index  $n$  for  $\gamma$  in the adiabatic process. So we have,

$$W_{1-2} = \frac{p_2 \nabla_2 - p_1 \nabla_1}{1-n} = \frac{mRT_2 - mRT_1}{1-n} = mR \frac{T_2 - T_1}{1-n} \quad (3.52)$$

$$W_{1-2} = \frac{p_1 \nabla_1 - p_2 \nabla_2}{n-1} = \frac{p_1 \nabla_1}{n-1} \left( 1 - \frac{p_2 \nabla_2}{p_1 \nabla_1} \right) = \frac{mRT_1}{n-1} \left( 1 - \frac{p_2 \nabla_2}{p_1 \nabla_1} \right) \quad (3.53)$$

(c) **Change in internal energy:** Change in internal energy

$$\int_1^2 dU = U_2 - U_1 = mC_v (T_2 - T_1) \quad (3.54)$$

(d) **Supply of heat:** Heat supplied during the process

$$\delta Q = dU + \delta W$$

On integration, we have,

$$\begin{aligned} Q_{1-2} = U_{1-2} + W_{1-2} &= mC_v(T_2 - T_1) + \frac{p_1 \nabla_1 - p_2 \nabla_2}{n-1} \\ &= mR \frac{T_2 - T_1}{\gamma - 1} + mR \frac{T_1 - T_2}{n-1} \\ &= mR(T_1 - T_2) \left[ \frac{1}{n-1} - \frac{1}{\gamma-1} \right] \\ &= mR(T_1 - T_2) \left[ \frac{\gamma - n}{(n-1)(\gamma-1)} \right] \end{aligned} \quad (3.55)$$

(e) **Change in enthalpy**

$$\int_1^2 dU = H_2 - H_1 = mC_p (T_2 - T_1) \quad (3.56)$$

### 3.18 GENERAL LAWS FOR EXPANSION AND COMPRESSION

The general laws for expansion and compression of a perfect gas is  $p \nabla^n = \text{constant}$ , when  $n$  is the index of process and it gives the relationship between pressure and volume of a given quantity of gas. The value of  $n$  depends upon the manner of expansion and compression. The following values of  $n$  are important from the subject point of view.

(a) When  $n = 0$  the equation will be  $p \nabla^0 = p = \text{constant}$ . So, expansion and compression will occur under constant pressure and it is *constant pressure process*.

- (b) When  $n = 1$  then equation will be  $p\forall^1 = p\forall = \text{constant}$ . The process is *isothermal* or *hyperbolic process*.
- (c) When  $\gamma > n > 1$ , the expansion or compression is *polytropic*, i.e.,  $p\forall^n = \text{constant}$ .
- (d) When  $n = \gamma$ , the expansion or compression will be *adiabatic*, i.e.,  $p\forall^\gamma = \text{constant}$ .
- (e) When  $n = \alpha$ , the equation will be

$$p\forall^\alpha = C$$

$$\Rightarrow \forall = \left(\frac{C}{p}\right)^{\frac{1}{\alpha}} \alpha \sqrt{\frac{C}{p}} = \text{constant, i.e., constant volume process.}$$

For expansion of a perfect gas for different values of  $n$  is shown in pressure-volume diagram in Fig. 3.8.

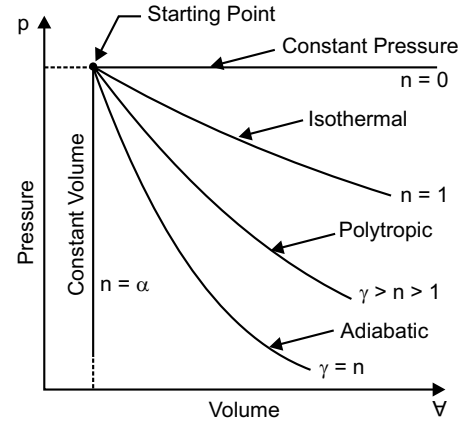

Fig. 3.8

### 3.19 REAL GAS

A hypothetical gas which obeys the law  $p v_s = RT$  at all pressure and temperature is called an *ideal gas*. But in actual practice, there is no actual gas which strictly obeys this gas law over the entire range of temperature and pressure and is called the *real gas*. The real gases are ordinarily difficult to liquefy. The real gas such as oxygen, hydrogen and air within certain temperature and pressure limits may be regarded as ideal or perfect gases. There is small variation of behaviour in real gas from ideal gas.

### 3.20 REAL GAS AND COMPRESSIBILITY FACTOR

We are assuming specific volume of an ideal gas where the equation of gas is  $p(v_s)_{\text{ideal}} = RT$ .

So, 
$$(v_s)_{\text{ideal}} = \frac{RT}{p}$$

If specific volume of a real gas is considered, then,  $p(v_s)_{\text{real}} = RT$  and in that case,

$$(v_s)_{\text{ideal}} = Z \frac{RT}{p}. \text{ Here the term } Z \text{ is being introducing to signify its variation from ideal}$$

gas behaviour and is named as *compressibility factor*, or just *compressibility*.

By definition the value of  $Z$ ,

$$Z = \frac{p(v_s)_{\text{real}}}{RT} = \frac{(v_s)_{\text{real}}}{RT/p} = \frac{(v_s)_{\text{real}}}{(v_s)_{\text{ideal}}} \quad (3.57)$$

So, compressibility factor or compressibility is the ratio between *specific volumes of real gas* and *specific volume of ideal gas*. It is a dimensionless factor. For ideal gas  $Z = 1$  and for real gas  $Z$  is equal to or greater than or less than 1. The *non ideality of gases* is the differences of the real gas volume and volume predicted by ideal gas equation, denoted as  $\alpha$  or  $\forall^R$  where,

$$\alpha = (v_s)_{\text{ideal}} - (v_s)_{\text{real}} = (1 - Z) \frac{RT}{p} \tag{3.58}$$

$\forall^R$  or  $\alpha$  is also termed as the *residual volume of the gas*. In terms of molar quantities,

$$Z = \frac{pv_m}{R_m T} \quad \text{or} \quad v_m = \frac{R_m T}{p} Z$$

An equation of state can be written in terms of  $Z$  as a function of  $p$  and  $T$  instead of  $v_s$  as a function of  $p$  and  $T$ . So,  $Z$  becomes as alternative property. Thus the experimental  $p - v_s - T$  data of pure substance can also be fitted into an equation of state of the form  $Z = f(p, T)$  and can be plotted on a graph of  $Z$  versus  $p$  with  $T$  as parameter. Such a plot is referred to as the compressibility chart. Fig. 3.9 presents a typical compressibility chart for nitrogen.

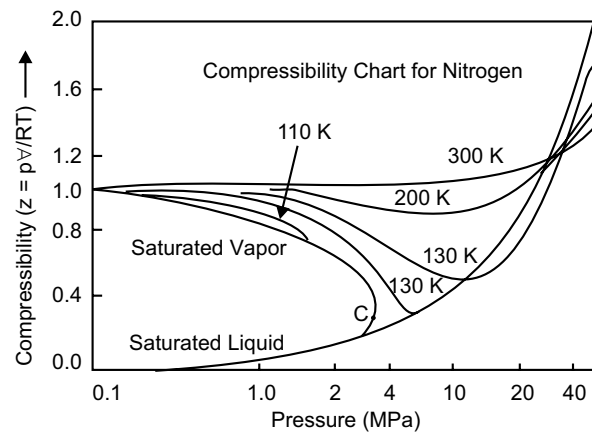

Fig. 3.9

### 3.21 LAW OF CORRESPONDING STATE AND GENERALIZED COMPRESSIBILITY CHART

For a gas, the compressibility factor  $Z$  is a function of  $p$  and  $T$ . Thus, graphs in Fig. 3.10 can be plotted for  $p$  versus  $Z$  at the line of constant temperature and from these graphs, the value of  $Z$  can be found for any value of  $p$  and  $T$  and then volume can be calculated from the equation.

$$v_s = Z \frac{RT}{p} \tag{3.59}$$

For different substance a different compressibility chart is needed. However, one single generalized chart can be developed. The basis for this is the law of corresponding states. For the purpose we consider the dimensionless property called reduced properties  $p_r, T_r, v_{s(r)}$ , known as the reduced pressure, reduced temperature and reduced specific volume respectively. The reduced temperature of a substance is defined as the ratio of the temperature of the substance to its critical temperature, i.e.,  $T_r = \frac{T}{T_c}$ . Similarly reduced pressure

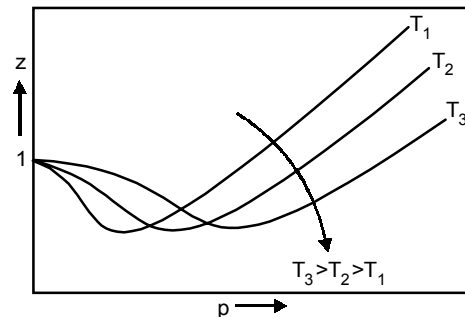

Fig. 3.10

$p_r = \frac{P}{P_c}$  and reduced specific volume  $v_{s(r)} = \frac{v_s}{v_{s(c)}}$ , where  $p_c, T_c, v_{s(c)}$  are the critical properties of the substance.

Now the law of corresponding state may be stated as follows: If two or more substance have the same reduced pressure and reduced temperature then they will have the same reduced volume. Mathematically, it can be expressed in the form  $Z = f(p_r, T_r)$ . This relation is referred to as the generalized equation of state.

This functional relationship can be expressed in terms of van der Waals equation,

$$\text{i.e.,} \quad \left( p + \frac{a}{v_s} \right) (v_s - b) = RT \quad (3.60)$$

$$\text{Here} \quad a = \frac{27R^2T_c^2}{64p_c} \quad \text{and} \quad b = \frac{RT_c}{8p_c}$$

$$\text{Hence} \quad Z^3 - \left( \frac{p_r}{8T_r} + 1 \right) Z^2 + \left( \frac{27p_r}{64T_r^2} \right) Z - \frac{27p_r^2}{512T_r^3} = 0.$$

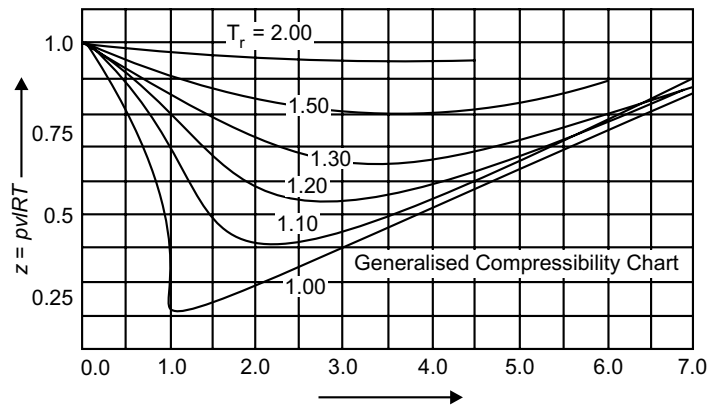

Fig. 3.11

Now, if the actual value of  $Z$  is plotted against the values of  $p_r$  for constant  $T_r$ , one would get the some curve for all substances. Such a plot, as shown in Fig. 3.11 is known as the generalized compressibility chart. The following observations can be made from this chart:

- (i) At all temperatures  $Z \rightarrow 1$  as  $p_r \rightarrow 1$ .
- (ii) At temperature equals to twice the critical temperature  $T_r = 2$  and above,  $Z = 1$  over a wide range of pressures up to five times the critical pressure  $p_r = 5$ .
- (iii) The compressibility factor at the critical point  $Z_c = \frac{P_c v_{s(c)}}{RT} = \frac{P_c v_m}{R_m T_c}$  is called the critical compressibility and is found to be equal to 0.275 for all substances.

	1	2	3	4
Reversible non-flow process $\frac{p_1 \nabla_1}{T_1} = \frac{p_2 \nabla_2}{T_2} = C$	Isobaric (Constant pressure)	Isochoric (Constant volume)	Isothermal (Constant temperature)	Adiabatic or Isentropic
Index n	$n = 0$	$n = \alpha$	$n = 1$	$n = \gamma$
$p - \nabla$ diagram				
$p - \nabla - T$ relation	$\frac{\nabla_1}{T_1} = \frac{\nabla_2}{T_2}$ [Charle's Law]	$\frac{p_1}{T_1} = \frac{p_2}{T_2}$ [Gay-Lussac's Law]	$p_1 \nabla_1 = p_2 \nabla_2$ [Boyle's Law]	$p_1 \nabla_1^\gamma = p_2 \nabla_2^\gamma$ $\frac{T_1}{T_2} = \left(\frac{p_1}{p_2}\right)^{\frac{\gamma-1}{\gamma}} = \left(\frac{\nabla_2}{\nabla_1}\right)^{\frac{\gamma-1}{\gamma}}$

	5	6
Reversible non-flow process $\frac{p_1 \nabla_1}{T_1} = \frac{p_2 \nabla_2}{T_2} = C$	Polytropic	
Index $n$	$n = n$	
$p - \nabla$ diagram		General Gas Equation: $\frac{p_1 \nabla_1}{T_1} = \frac{p_2 \nabla_2}{T_2} = C$
$p - \nabla - T$ relation	$p_1 \nabla_1^n = p_2 \nabla_2^n$ $\frac{T_1}{T_2} = \left(\frac{p_1}{p_2}\right)^{\frac{n-1}{n}} = \left(\frac{\nabla_2}{\nabla_1}\right)^{\frac{n-1}{n}}$	

	<b>1</b>	<b>2</b>	<b>3</b>	<b>4</b>
Work done $W_{1-2} = \int_1^2 p dV$	$p(V_2 - V_1)$ or $mR(T_2 - T_1)$	0	$p_1 V_1 \ln\left(\frac{V_2}{V_1}\right)$ or $mRT \ln\left(\frac{V_2}{V_1}\right)$	$\frac{p_2 V_2 - p_1 V_1}{1 - \gamma}$ or $\frac{mR(T_2 - T_1)}{1 - \gamma}$
Specific heat (C)	$C_p$	$C_v$	$\alpha$	0
Heat added $Q_{1-2} = \int_1^2 dU + W_{1-2}$	$mC_p(T_2 - T_1)$	$mC_v(T_2 - T_1)$	$p_1 V_1 \ln\left(\frac{V_2}{V_1}\right)$	0
Change in internal energy $\int_1^2 dU = U_2 - U_1$	$mC_v(T_2 - T_1)$	$mC_v(T_2 - T_1)$	0	$mC_v(T_2 - T_1)$
Change in enthalpy $\int_1^2 dH = H_2 - H_1$	$mC_p(T_2 - T_1)$	$mC_p(T_2 - T_1)$	0	$mC_p(T_2 - T_1)$

	5	6
Work done $W_{1-2} = \int_1^2 p dV$	$\frac{p_2 V_2 - p_1 V_1}{1 - n}$ or $\frac{mR(T_2 - T_1)}{1 - n}$	
Specific heat (C)		
Heat added $Q_{1-2} = \int_1^2 dU + W_{1-2}$	$\frac{mR(T_2 - T_1)}{1 - n} \left( \frac{\gamma - n}{\gamma - 1} \right)$ or $\frac{p_2 V_2 - p_1 V_1}{1 - n} \left( \frac{\gamma - n}{\gamma - 1} \right)$	
Change in internal energy $\int_1^2 dU = U_2 - U_1$	$mC_v(T_2 - T_1)$	
Change in enthalpy $\int_1^2 dH = H_2 - H_1$	$mC_p(T_2 - T_1)$	

	1	2	3	4
Change in entropy in $T-S$ diagram				
Change in entropy $= S_2 - S_1$	$mC_p \ln\left(\frac{T_2}{T_1}\right)$ or $mC_p \ln\left(\frac{v_2}{v_1}\right)$	$mC_v \ln\left(\frac{T_2}{T_1}\right)$ or $mC_v \ln\left(\frac{p_2}{p_1}\right)$	$m(C_p - C_v) \ln\left(\frac{v_2}{v_1}\right)$ or $m(C_p - C_v) \ln\left(\frac{p_1}{p_2}\right)$	
Steady flow process work done $W_{1-2}$	0	$v(p_1 - p_2)$	$p_1 v_1 \ln\left(\frac{v_2}{v_1}\right)$ or $p_1 v_1 \ln\left(\frac{p_1}{p_2}\right)$	$\frac{\gamma}{\gamma - 1} (p_1 v_1 - p_2 v_2)$

	5	6
Change in entropy in $T-S$ diagram		General Gas Equation:
Change in entropy $= S_2 - S_1$	$m(C_p - nC_v) \ln\left(\frac{V_2}{V_1}\right)$ <p style="text-align: center;">or</p> $mC_v \frac{\gamma - n}{n} \ln\left(\frac{p_1}{p_2}\right)$	$S_2 - S_1 = m \left[ C_v \ln\left(\frac{T_2}{T_1}\right) + (C_p - C_v) \ln\left(\frac{V_2}{V_1}\right) \right] \text{ or}$ $m \left[ C_p \ln\left(\frac{T_2}{T_1}\right) + (C_p - C_v) \ln\left(\frac{p_1}{p_2}\right) \right] \text{ or}$ $m \left[ C_v \ln\left(\frac{p_2}{p_1}\right) + C_p \ln\left(\frac{V_2}{V_1}\right) \right]$
Steady flow process work done $W_{1-2}$	$\frac{n}{n-1} (p_1 V_1 - p_2 V_2)$	

	Boiler	Condenser	Evaporator	Nozzle
<p>Steady flow energy equation to engineering systems</p> $(u_1 + p_1 v_{s1}) + \frac{V_1^2}{2} + gZ_1 + q_{1-2}$ $= (u_2 + p_2 v_{s2}) + \frac{V_2^2}{2} + gZ_2 + w_{1-2}$	$q_{1-2} = h_2 - h_1$	$-q_{1-2} = h_2 - h_1$	$q_{1-2} = h_2 - h_1$	$V_2 = \sqrt{V_1^2 + 2(h_1 - h_2)}$
<p>or</p>	Turbine	Rotary Compressor	Reciprocating Compressor	Heat Exchanger
$m \left( h_1 + \frac{V_1^2}{2} + gZ_1 + q_{1-2} \right)$ $= m \left( h_2 + \frac{V_2^2}{2} + gZ_2 + w_{1-2} \right)$	$w_{1-2} = h_1 - h_2$	$w_{1-2} = h_2 - h_1$	$w_{1-2} = q_{1-2} + (h_2 - h_1)$	$q_{1-2} = h_1 - h_2$

### Multiple Choice Questions

1. If the temperature remains constant, the volume of a given mass of a gas is inversely proportional to the pressure, this is known as
  - (a) Charle's law
  - (b) Boyle's law
  - (c) Joule's law
  - (d) Gay-Lussac's law.
2. The state of a substance whose evaporation from its liquid state is complete is known as
  - (a) steam
  - (b) vapour
  - (c) air
  - (d) perfect gas
3. The characteristic equation of a gas is
  - (a)  $p\forall = \text{constant}$
  - (b)  $p\forall = mR$
  - (c)  $p\forall = mRT$
  - (d)  $p\forall = RT^m$
4. The value of gas constant ( $R$ ) is
  - (a) 287 J/kg
  - (b) 28.7 J/kg
  - (c) 2.87 J/kg
  - (d) 0.287 J/kg
5. The value of universal gas constant ( $R_u$ ) is
  - (a) 8.314 J/kg K
  - (b) 83.14 J/kg K
  - (c) 831.4 J/kg K
  - (d) 8314 J/kg K
6. The gas constant ( $R$ ) is equal to the \_\_\_\_\_ of two specific heats
  - (a) sum
  - (b) difference
  - (c) product
  - (d) ratio
7. The specific heat at constant pressure is \_\_\_\_\_ that of specific heat at constant volume
  - (a) equal to
  - (b) less than
  - (c) more than
8. The ratio of specific heat at constant pressure ( $C_p$ ) and specific heat at constant volume ( $C_v$ ) is
  - (a) equal to one
  - (b) less than one
  - (c) more than one
  - (d) none of these
9. The value of  $C_p/C_v$  for air is
  - (a) 1
  - (b) 1.4
  - (c) 1.8
  - (d) 2.3
10. When the gas is heated at constant pressure then the heat supplied
  - (a) raises the temperature of the gas
  - (b) increases the internal energy of the gas
  - (c) does some external work during expansion
  - (d) both (a) and (b)
  - (e) both (b) and (c)
11. When a gas is heated at constant volume
  - (a) its temperature will increase
  - (b) its pressure will increase
  - (c) both temperature and pressure will increase
  - (d) neither temperature nor pressure will increase

12. The heating of a gas at constant pressure is governed by  
(a) Boyle's law (b) Charle's law  
(c) Gay-Lussac's law (d) Joule's law
13. A process in which the gas is heated or expanded in such a way that the product of its pressure and volume remains constant, is called  
(a) isothermal process (b) isobaric process  
(c) adiabatic process (d) polytropic process
14. The hyperbolic process is governed by  
(a) Boyle's law (b) Charle's law  
(c) Gay-Lussac's law (d) Joule's law
15. The heating of gas at constant \_\_\_\_\_ is governed by Boyle's law  
(a) volume (b) pressure  
(c) temperature (d) none of these
16. In an isothermal process  
(a) internal energy increases (b) internal energy decreases  
(c) there is no change in internal energy  
(d) internal energy first increases and then decreases
17. The expansion ratio ( $r$ ) is the ratio of  
(a)  $\frac{V_1}{V_2}$  (b)  $\frac{V_2}{V_1}$   
(c)  $\frac{V_1 + V_2}{V_2}$  (d)  $\frac{V_1 + V_2}{V_1}$
18. When the expansion or compression of the gas takes places according to the law  $pV^n = \text{constant}$ , then the process is known as  
(a) isothermal process (b) isobaric process  
(c) adiabatic process (d) polytropic process
19. An adiabatic process is one in which  
(a) no heat enters or leaves the gas  
(b) the temperature of the gas changes  
(c) the change in internal energy is equal to the work done  
(d) all of the above
20. The general law of expansion or compression is the process is said to be hyperbolic if  $n$  is equal to  
(a) 0 (b) 1  
(c) 2 (d) none of these
21. If the value of  $n = 0$  in the general law, then the process is called  
(a) isochoric process (b) isobaric process  
(c) isothermal process (d) isentropic process

22. If all the variable of a steam are independent of time it is said to be in
- |                   |                   |
|-------------------|-------------------|
| (a) steady flow   | (b) unsteady flow |
| (c) uniform flow  | (d) closed flow   |
| (e) constant flow |                   |
23. A control volume refers to
- |                             |                             |
|-----------------------------|-----------------------------|
| (a) a fixed region in space | (b) a specified mass        |
| (c) an isolated system      | (d) reversible process only |
| (e) a closed system         |                             |
24. Internal energy of a perfect gas depends on
- |  |
|--|
| (a) temperature, specific heats and pressure |
| (b) temperature, specific heats and enthalpy |
| (c) temperature, specific heats and enthalpy |
| (d) temperature only                         |
25. In reversible polytropic process
- |                                      |  |
|--------------------------------------|--|
| (a) true heat transfer occurs        | (b) the entropy remains constant         |
| (c) the enthalpy remains constant    | (d) the internal energy remains constant |
| (e) the temperature remains constant |  |
26. An isentropic process is always
- |                                   |                               |
|-----------------------------------|-------------------------------|
| (a) irreversible and adiabatic    | (b) reversible and isothermal |
| (c) frictionless and irreversible | (d) reversible and adiabatic  |
| (e) none of these                 |                               |
27. The net work done per kg of gas in a polytropic process is equal to
- |   |                                     |
|---|-------------------------------------|
| (a) $p_1 v_1 \ln \frac{v_2}{v_1}$                 | (b) $p_1 (v_1 - v_2)$               |
| (c) $p_2 \left( v_2 - \frac{v_1}{\gamma} \right)$ | (d) $\frac{p_1 v_1 - p_2 v_2}{n-1}$ |
| (e) $\frac{p_1 n_1 - p_2 n_2}{n-1}$               |                                     |
28. Steady flow occurs when
- |   |
|---|
| (a) conditions do not change with time at any point           |
| (b) conditions are the same at adjacent points at any instant |
| (c) conditions changes steadily with the time                 |
| (d) $dv/dt$ is constant                                       |
29. A reversible process requires that
- |   |
|---|
| (a) there be no heat transfer                             |
| (b) Newton's law of viscosity be satisfied                |
| (c) temperature of system and surrounding be equal        |
| (d) there be no viscous or coulomb friction in the system |
| (e) heat transfer occurs from surroundings to system only |

30. The first law of thermodynamics for steady of law
- (a) accounts for all energy entering and leaving a control volume
  - (b) is an energy balance for a specific mass of fluid
  - (c) is an expansion of the conservation of linear momentum
  - (d) is primarily concerned with heat transfer
  - (e) is restricted in it's application to perfect gases
31. The characteristic equation of gases  $pV = mRT$  holds good for
- (a) monoatomic gases
  - (b) diatomic gases
  - (c) real gases
  - (d) ideal gases
  - (e) mixture of gases
32. A gas which obeys kinetic theory perfectly is known as
- (a) monoatomic gases
  - (b) diatomic gases
  - (c) real gases
  - (d) pure gases
  - (e) perfect gases
33. Work done in a free expansion process is
- (a) zero
  - (b) minimum
  - (c) maximum
  - (d) positive
  - (e) negative
34. Which of the following is not a property of the system
- (a) temperature
  - (b) pressure
  - (c) specific volume
  - (d) heat
  - (e) none of these
35. In a polytropic process equation  $pV^n = \text{constant}$ . If  $n = 0$ , the process is termed as
- (a) constant volume
  - (b) constant pressure
  - (c) constant temperature
  - (d) adiabatic
  - (e) isothermal
36. In a polytropic process equation, if  $n$  is infinitely large, the process is termed as
- (a) constant volume
  - (b) constant pressure
  - (c) constant temperature
  - (d) adiabatic
  - (e) isothermal
37. The process or system that does not involve heat are called
- (a) isothermal process
  - (b) equilibrium process
  - (c) thermal process
  - (d) steady process
  - (e) adiabatic process
38. In a reversible adiabatic process the adiabatic ratio is equal to
- (a)  $\frac{C_p}{C_v}$
  - (b)  $C_p \times C_v$
  - (c)  $\frac{C_v}{C_p}$
  - (d)  $\frac{C_p}{2C_v}$
39. In isothermal process
- (a) temperature increases gradually
  - (b) volume remains constant
  - (c) pressure remains constant
  - (d) enthalpy change is maximum
  - (e) change in internal energy is zero

40. During throttling process  
 (a) internal energy does not change (b) pressure does not change  
 (c) entropy does not change (d) enthalpy does not change  
 (e) volume change is negligible
41. When a gas is to be stored, the type of compression that would be ideal is  
 (a) isothermal (b) adiabatic  
 (c) polytropic (d) constant volume  
 (e) none of above
42. If a process can be stopped at any stage and reversed so that the system and surroundings are exactly restored to their initial states it is known as  
 (a) adiabatic process (b) isothermal process  
 (c) ideal process (d) frictionless process  
 (e) energy less process
43. The state of a substance whose evaporation from its liquid state is complete, is known as  
 (a) vapour (b) perfect gas  
 (c) air (d) steam
44. In S.I. the value of the universal gas constant is  
 (a) 0.8314 J/mole/K (b) 8.314 J/mole/K  
 (c) 83.14 J/mole/K (d) 831.4 J/mole/K  
 (e) 8314 J/mole/K
45. When the gas is heated at constant pressure, the heat supplied  
 (a) increases the internal energy of the gas  
 (b) increases the temperature of the gas  
 (c) does some external work during expansion  
 (d) both (b) and (c)  
 (e) none of the above
46. The gas constant ( $R$ ) is equal to the  
 (a) sum of two specific heats (b) difference of two specific heats  
 (c) product of two specific heats (d) ratio of two specific heats
47. The heat absorbed or rejected during a polytropic process is  
 (a)  $\left(\frac{\gamma - n}{\gamma - 1}\right) \times \text{work done}$  (b)  $\left(\frac{n - \gamma}{\gamma - 1}\right) \times \text{work done}$   
 (c)  $\gamma \times \text{work done}$  (d)  $n\gamma \times \text{work done}$

### Answers

1. (b) 2. (d) 3. (c) 4. (a) 5. (d) 6. (b) 7. (c) 8. (c) 9. (b) 10. (d)  
 11. (c) 12. (b) 13. (a) 14. (a) 15. (c) 16. (c) 17. (b) 18. (d) 19. (d) 20. (b)  
 21. (b) 22. (a) 23. (a) 24. (d) 25. (a) 26. (d) 27. (d) 28. (a) 29. (d) 30. (a)  
 31. (c) 32. (e) 33. (a) 34. (d) 35. (b) 36. (a) 37. (e) 38. (a) 39. (e) 40. (d)  
 41. (a) 42. (c) 43. (b) 44. (e) 45. (d) 46. (b) 47. (a)

## NUMERICAL EXAMPLES

### EXAMPLE 1

Some quantity of air at a temperature of  $20^{\circ}\text{C}$  and at a pressure of 2.15 bar is found to occupy  $0.20\text{m}^3$ . The volume is kept constant when the heat energy equivalent to 20kJ is given to air. Determine the new pressure and temperature. Consider specific heat of air at constant volume  $0.706\text{ kJ/kgK}$ . Any missing data may be assumed.

**SOLUTION**

Here,  $T_1 = 20 + 273 = 293\text{ K}$ ,

$$p_1 = \frac{2.15 \times 10^5}{10^3} \text{ kPa},$$

$$V_1 = 0.20\text{ m}^3, C_v = 0.706\text{ kJ/kgK}, Q_v = 20\text{ kJ}$$

Let us assume  $R = 0.287\text{ kJ/kgK}$

We know,  $p_1 V_1 = mRT_1$

$$\Rightarrow 2.15 \times 100 \times 0.20 = m \times 0.287 \times 293$$

Therefore

$$m = 0.511\text{ kg}$$

Again, heat supplied at constant volume

$$Q_v = mC_v(T_2 - T_1)$$

$$\Rightarrow 20 = 0.511 \times 0.706 (T_2 - 293)$$

$$\Rightarrow T_2 = 348.4\text{ K}$$

As,  $\frac{p_1}{T_1} = \frac{p_2}{T_2}$  being a constant volume process,

$$p_2 = \frac{p_1 T_2}{T_1} = \frac{2.15 \times 348.4}{293} = 2.55\text{ bar} = 255\text{ kPa}$$

### EXAMPLE 2

When 0.1421 kg of a gas is heated from  $27^{\circ}\text{C}$  to  $127^{\circ}\text{C}$ , it is observed that the gas requires 202 kJ of heat if heated at constant pressure and 143 kJ of heat if heated at constant volume. Find the adiabatic index, gas constant and molecular weight of the gas.

**SOLUTION**

Here mass of the gas ( $m$ ) = 0.1421 kg, initial temperature ( $T_1$ ) =  $27 + 273 = 300\text{ K}$ ,

final temperature ( $T_2$ ) =  $127 + 273 = 400\text{ K}$ ,

heat required at constant pressure  $Q_p = 202\text{ kJ}$ ,

heat required at constant volume  $Q_v = 143\text{ kJ}$

Now,  $Q_p = mC_p(T_2 - T_1)$

$$\Rightarrow 202 = 0.1421 (400 - 300)C_p$$

Therefore  $C_p = 14.125 \text{ kJ/kgK}$   
 Again,  $Q_v = mC_v(T_2 - T_1)$   
 $\Rightarrow 143 = 0.1421(400 - 300)C_v$   
 Therefore  $C_v = 10.06 \text{ kJ/kgK}$

So, adiabatic index  $\gamma = \frac{C_p}{C_v} = \frac{14.125}{10.06} = 1.41$

Again,  $R = C_p - C_v = 14.125 - 10.06 = 4.065 \text{ kJ/kgK}$

Assuming,  $R_m = 8.314 \text{ kJ/kgK}$ ,  $M = \frac{R_m}{R} = \frac{8.314}{4.065} \approx 2$ .

**EXAMPLE 3**

If  $0.112 \text{ m}^3$  of gas at  $27^\circ\text{C}$  and  $1.013 \text{ bar}$  is compressed adiabatically to  $1/5^{\text{th}}$  of this volume, determine (i) the mass of the gas (ii) the pressure and temperature at end of compression and (iii) the work done on the gas. Assume  $C_p = 1.005 \text{ kJ/kgK}$ ,  $C_v = 0.718 \text{ kJ/kgK}$ .

**SOLUTION**

Initial volume  $\forall_1 = 0.112 \text{ m}^3$ , initial temperature  $T_1 = (27 + 273) = 300 \text{ K}$ ,  
 initial pressure  $p_1 = 1.013 \text{ bar}$ , final volume  $\forall_2 = \forall_1/5$ .

Adiabatic index  $\gamma = \frac{C_p}{C_v} = \frac{1.005}{0.718} = 1.4$  and

$$R = C_p - C_v = 0.287 \text{ kJ/kgK}$$

Again we know  $m = \frac{p_1 \forall_1}{RT_1} = \frac{1.013 \times 100 \times 0.112}{0.287 \times 300} = 0.1317 \text{ kg}$

But  $p_2 = \left(\frac{\forall_1}{\forall_2}\right)^\gamma p_1 = 1.013 \times 5^{1.4} = 9.642 \text{ bar}$

Again  $T_2 = \left(\frac{\forall_1}{\forall_2}\right)^{\gamma-1} T_1 = 300 \times 5^{0.4} = 571.1 \text{ K}$

Work done on the gas

$$W_{1-2} = \frac{p_2 \forall_2 - p_1 \forall_1}{\gamma - 1} = \frac{mR(T_2 - T_1)}{\gamma - 1} = 25.617 \text{ kJ}$$

**EXAMPLE 4.**

A system contains  $0.15 \text{ m}^3$  of a gas at a pressure of  $3.8 \text{ bar}$  and  $150^\circ\text{C}$ . It is expanded adiabatically till the pressure falls to  $1 \text{ bar}$ . The gas is then heated at a constant pressure till its enthalpy increases by  $70 \text{ kJ}$ . Determine the total work done, Take  $C_p = 1.00 \text{ kJ/kgK}$ ,  $C_v = 0.714 \text{ kJ/kgK}$ .

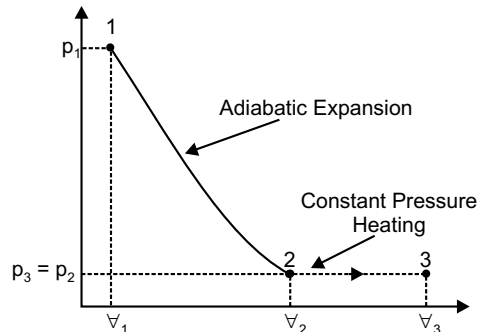
**SOLUTION**

Here,  $v_1 = 0.15 \text{ m}^3$ ,  $p_1 = 3.8 \text{ bar}$ ,  $p_2 = 1.0 \text{ bar}$ ,  $T_1 = 150 + 273 = 423 \text{ K}$ ,  $dH = 70 \text{ kJ}$ .

In Fig., process 1–2 represents adiabatic expansion of the gas and the process 2–3 represents heating at constant pressure. First of all, let us find the temperature  $T_2$  and volume  $v_2$  after the adiabatic expansion.

We know that adiabatic index,  $\gamma = \frac{C_p}{C_v} = \frac{1.000}{0.714} = 1.4$

$$\text{Now,} \quad \frac{423}{T_2} = \left( \frac{p_1}{p_2} \right)^{\frac{\gamma-1}{\gamma}} = \left( \frac{3.8}{1} \right)^{\frac{1.4-1}{1.4}} = 1.465$$

$$\Rightarrow T_2 = 288.7 \text{ K}$$

$$\text{Again,} \quad \frac{0.15}{v_2} = \left( \frac{p_2}{p_1} \right)^{\frac{1}{\gamma}} = \left( \frac{1}{3.8} \right)^{\frac{1}{1.4}} = 0.385$$

$$\Rightarrow v_2 = 0.39 \text{ m}^3$$

Now let us find the temperature  $T_3$  and volume  $v_3$  after constant pressure heating. If  $m$  is the mass of gas contained in the system we know that gas constant

$$R = C_p - C_v = 0.286 \text{ kJ/kgK}$$

$$\text{And} \quad m = \frac{p_1 v_1}{RT_1} = \frac{3.8 \times 10^5 \times 0.15}{286 \times 423} = 0.47 \text{ kg}$$

$$\text{Increase in enthalpy} \quad dH = m C_p (T_3 - T_2)$$

$$\Rightarrow 70 = 0.47 \times 1 (T_3 - 288.7)$$

$$\Rightarrow T_3 = 437.6 \text{ K}$$

Since the heating is at constant pressure,

$$v_3 = \frac{T_3}{T_2} v_2 = \frac{437.6}{288.7} \times 0.39 = 0.59 \text{ m}^3$$

Work done during adiabatic expansion,

$$W_{1-2} = \frac{p_1 \nabla_1 - p_2 \nabla_2}{\gamma - 1} = \frac{(3.8 \times 0.15 - 1.0 \times 0.39) 10^5}{(1.4 - 1) 10^3} = 45 \text{ kJ}$$

And work done during constant pressure heating,

$$W_{2-3} = p_2 (\nabla_3 - \nabla_2) = 1.0 \times 10^2 (0.59 - 0.39) = 20 \text{ kJ}$$

Hence, total work done during constant pressure heating,

$$W = W_{1-2} + W_{2-3} = 45 + 20 = 65 \text{ kJ}$$

### EXAMPLE 5

0.336 m<sup>3</sup> of gas at 10 bar pressure and 150°C temperature expands adiabatically, until its pressure is 4 bar. It is then compressed isothermally, to its original volume. Determine the final temperature and pressure of the gas. Also determine the change in internal energy. Take  $C_p = 0.996 \text{ kJ/kgK}$ ,  $C_v = 0.703 \text{ kJ/kgK}$ .

**SOLUTION**

Here,  $\nabla_1 = \nabla_3 = 0.336 \text{ m}^3$ ,  $p_1 = 10 \text{ bar}$ ,  $p_2 = 4.0 \text{ bar}$ ,  $T_1 = 150 + 273 = 423 \text{ K}$

In figure process 1–2 represents the adiabatic expansion of the gas and the process 2–3 represents the isothermal compression to its original volume.

We know that adiabatic index,

$$\gamma = \frac{C_p}{C_v} = \frac{0.996}{0.703} = 1.417 \text{ and}$$

Gas constant

$$R = C_p - C_v = 0.293 \text{ kJ/kgK}$$

Now,

$$\frac{423}{T_2} = \left( \frac{p_1}{p_2} \right)^{\frac{\gamma-1}{\gamma}} = \left( \frac{10}{4} \right)^{\frac{1.417-1}{1.417}} = 1.31$$

⇒

$$T_2 = 323 \text{ K}$$

Since the compression is isothermal from 2 to 3,

therefore,

$$T_3 = T_2 = 323 \text{ K}$$

If final pressure of the gas is  $p_3$ , for a constant volume process 3–1,

$$p_3 = \frac{T_3}{T_1} p_1 = \frac{323}{423} \times 10 = 7.6 \text{ bar}$$

Let us find the mass of the gas  $m$  and

$$m = \frac{p_1 \nabla_1}{RT_1} = \frac{10 \times 10^5 \times 0.336}{293 \times 423} = 2.7 \text{ kg}$$

Change in internal energy

$$dU = U_3 - U_1 = mC_v(T_3 - T_1) = 2.7 \times 0.703(323 - 423) = -189.8 \text{ kJ}$$

The negative sign indicates that there is a decrease in internal energy.

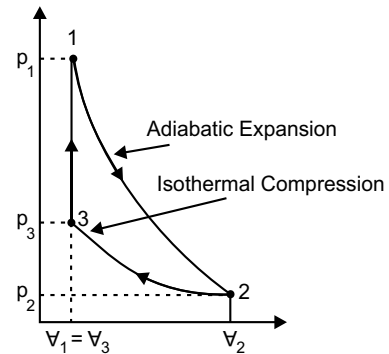

**EXAMPLE 6**

A certain quality of air has a volume of  $0.028 \text{ m}^3$  at a pressure of 1025 bar and  $25^\circ\text{C}$ . It is compressed to a volume of  $0.0042 \text{ m}^3$  according to the law  $pV^{1.3} = \text{constant}$ . Find the constant volume required to bring the air back to its initial temperature.

**SOLUTION**

Here,  $V_1 = 0.028 \text{ m}^3$ ,  $V_2 = 0.0042 \text{ m}^3$ ,  $p_1 = 1.25 \text{ bar}$ ,  $T_1 = 25 + 273 = 298 \text{ K}$ .

Let at the end of compression the final temperature =  $T_2$ , the final pressure =  $p_2$  and pressure at a constant volume required to bring the air back to its initial temperature is  $p_3$ .

$$\text{Now, } \frac{298}{T_2} = \left(\frac{V_2}{V_1}\right)^{n-1} = \left(\frac{0.0042}{0.028}\right)^{1.3-1} = 0.566$$

$$\Rightarrow T_2 = 526.5 \text{ K}$$

$$\text{So, } \frac{1.25}{p_2} = \left(\frac{V_2}{V_1}\right)^n = \left(\frac{0.0042}{0.028}\right)^{1.3} = 0.085$$

$$\Rightarrow p_2 = 14.7 \text{ bar}$$

The work done during compression

$$W_{1-2} = \frac{p_2 V_2 - p_1 V_1}{n-1} = \frac{(0.0042 \times 14.7 - 1.25 \times 0.028) \times 10^5}{(1.3-1)10^3} = 8.913 \text{ kJ}$$

For a constant volume process 2–3, maintaining given condition,  $T_3 = T_1 = 298 \text{ K}$

$$\text{Therefore, } p_3 = \frac{T_3}{T_2} p_2 = \frac{298}{526.5} \times 14.7 = 8.32 \text{ bar}$$

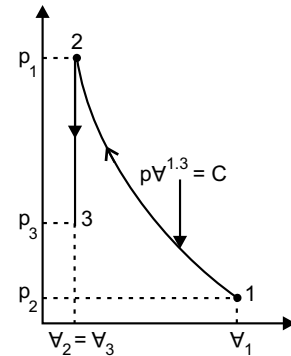
**EXAMPLE 7**

The properties of a closed system change following the relation between pressure and volume as  $pV = 3.0$ , where  $p$  is expressed in bar. Calculate the work done when the pressure increases from 1.5 bar to 7.5 bar.

**SOLUTION**

Here,  $p_1 = 1.5 \text{ bar}$ ,  $p_2 = 7.5 \text{ bar}$

$$\text{So, } V_1 = \frac{3}{1.5} = 2 \text{ m}^3 \quad \text{and} \quad V_2 = \frac{3}{7.5} = 0.4 \text{ m}^3$$

Hence, work done

$$\begin{aligned} W_{1-2} &= \int_{V_1}^{V_2} p dV = 10^5 \int_{V_1}^{V_2} \frac{3}{V} dV = 10^5 [\ln V]_2^{0.4} \times 3 \\ &= -4.83 \times 10^5 \text{ J} = -483 \text{ kJ} \end{aligned}$$

**EXAMPLE 8**

To a closed system 150 kJ of work is supplied. Let the initial volume is  $0.6 \text{ m}^3$  and pressure of the system changes as  $p = (8 - 4v)$ , where  $p$  is in bar. Determine the final volume and pressure of the system.

**SOLUTION**

Here,  $v_1 = 0.6 \text{ m}^3, W_{1-2} = -150 \text{ kJ}$

Hence, work done

$$W_{1-2} = \int_{v_1}^{v_2} p dv = 10^5 \int_{v_1}^{v_2} (8 - 4v) dv$$

$$\begin{aligned} \Rightarrow -150 \times 10^3 &= 10^5 \left[ 8v - 2v^2 \right]_{0.6}^{v_2} \\ &= 10^5 \left[ 8v_2 - 2v_2^2 - 4.08 \right] \end{aligned}$$

$$\Rightarrow 2v_2^2 - 8v_2 + 2.58 = 0$$

$$\Rightarrow v_2 = 0.354$$

So, final pressure  $p_2 = 8 - 4 \times 0.354 = 6.584 \text{ bar}$

**EXAMPLE 9**

A fluid at a pressure of 3 bar and with specific volume of  $0.18 \text{ m}^3/\text{kg}$  contained in a cylinder behind a piston expands reversibly to a pressure of 0.6 bar according to a law  $p = \frac{C}{v^2}$ , where  $C$  is a constant. Calculate the work done by the fluid on the piston.

**SOLUTION**

Here,  $v_1 = 0.18 \text{ m}^3/\text{kg}, p_1 = 3 \text{ bar}, p_2 = 0.6 \text{ bar}$

So,  $C = p_1 v_1^2 = 3(0.18)^2 \text{ bar} \cdot (\text{m}^3/\text{kg})^2 = 0.0972 \text{ bar} \cdot (\text{m}^3/\text{kg})^2$

And  $v_2 = \sqrt{\frac{C}{p_2}} = \sqrt{\frac{0.0972}{0.6}} = 0.402 \text{ m}^3/\text{kg}$

Hence, work done

$$\begin{aligned} W_{1-2} &= \int_{v_1}^{v_2} p dv = \int_{v_1}^{v_2} \frac{C}{v^2} dv = -C \left[ \frac{1}{v} \right]_{v_1}^{v_2} \\ &= -0.0972 \times 10^5 \left[ \frac{1}{0.402} - \frac{1}{0.18} \right] = 29820.9 \text{ N}\cdot\text{m}/\text{kg} \end{aligned}$$

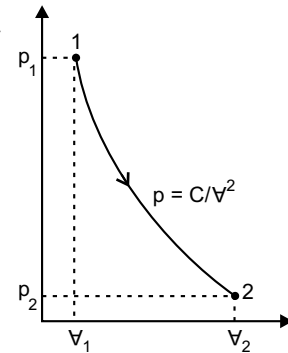

**EXAMPLE 10**

A cylinder contains 1 kg of a certain fluid at an initial pressure of 20 bar. The fluid is allowed to expand reversibly behind a piston according to a law  $p\forall^2 = \text{constant}$ , until the volume is doubled. The fluid is then cooled reversibly at constant pressure until the piston regains its original position. Heat is then supplied reversibly with the piston firmly locked in position until the pressure rises to the original value of 20 bar. Calculate the net work done by the fluid for an initial volume of  $0.05 \text{ m}^3$ .

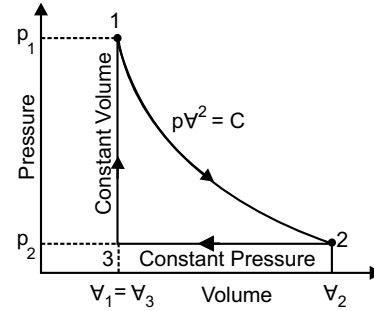

**SOLUTION**

Here,  $m = 1 \text{ kg}, p_1 = 20 \text{ bar}, \forall_1 = 0.05 \text{ m}^3, \forall_2 = 2 \times 0.05 = 0.1 \text{ m}^3$

Now,  $p_2 = \left(\frac{\forall_1}{\forall_2}\right)^2 p_1 = \left(\frac{\forall_1}{2\forall_1}\right)^2 20 = 5 \text{ bar}$

Work done by the fluid from 1 to 2.

$$W_{1-2} = \int_{\forall_1}^{\forall_2} p d\forall = \int_{\forall_1}^{\forall_2} \frac{C}{\forall^2} d\forall = -C \left[ \frac{1}{\forall} \right]_{\forall_1}^{\forall_2} = -p_1 \forall_1^2 \left[ \frac{1}{\forall} \right]_{\forall_1}^{\forall_2}$$

$$= -20 \times 10^5 \times 0.0025 \left[ \frac{1}{0.1} - \frac{1}{0.05} \right] = 50000 \text{ N}\cdot\text{m} = 50 \text{ kNm}$$

And work done during constant pressure process, from 2 to 3

$$W_{2-3} = p_2 (\forall_2 - \forall_3) = 5 \times 10^5 (0.1 - 0.05) = 25000 \text{ N}\cdot\text{m} = 25 \text{ kNm}$$

In constant volume process from 3 to 1,  $W_{2-3} = 0$ .

Net work done by the fluid,

$$W = W_{1-2} - W_{2-3} = 50 - 25 = 25 \text{ kN}\cdot\text{m}$$

**EXAMPLE 11(a)**

A gas is enclosed in a piston cylinder assembly as a system. The gas is initially at a pressure of 500 kPa and occupies a volume of  $0.2 \text{ m}^3$ . The gas is taken to the final state where  $p_2 = 100 \text{ kPa}$  by following two different processes. Calculate the work done by the gas in each case when: (a) the volume of the gas is inversely proportional to the pressure and (b) the process follows the path  $p\forall^\gamma = \text{constant}$ , where  $\gamma = 1.4$ .

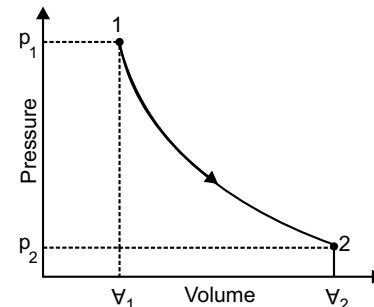

**SOLUTION**

(a) The path followed by the system  $\forall \propto \frac{1}{p}$  i.e.,  $p\forall = \text{constant}$

So,  $\frac{\forall_2}{\forall_1} = \frac{p_1}{p_2}$  and  $p = \frac{p_1 \forall_1}{\forall}$

Hence work done,

$$\begin{aligned}
 W_{1-2} &= \int_{V_1}^{V_2} p dV = p_1 V_1 \int_{V_1}^{V_2} \frac{dV}{V} \\
 &= p_1 V_1 \ln \left( \frac{V_2}{V_1} \right) \\
 &= p_1 V_1 \ln \left( \frac{p_1}{p_2} \right) \\
 &= (500 \times 10^3 \times 0.2 \ln 5) \text{ J} \\
 &= 160.94 \text{ kJ}
 \end{aligned}$$

(b) The path followed by the system,  $p_1 V_1^\gamma = p_2 V_2^\gamma$ .

So, 
$$\left( \frac{V_2}{V_1} \right)^\gamma = \frac{p_1}{p_2}$$

and 
$$V_2 = \left( \frac{p_1}{p_2} \right)^{1/\gamma} V_1 = \left( \frac{500}{100} \right)^{1/1.4} \times 0.2 = 0.6313 \text{ m}^3$$

Hence work done,

$$W_{1-2} = \frac{p_1 V_1 - p_2 V_2}{\gamma - 1} = \frac{(500 \times 0.2 - 100 \times 0.6313) 10^3}{(1.4 - 1) \times 10^3} = 92.175 \text{ kJ}$$

### EXAMPLE 11(b)

Determine the total work done by a gas system following an expansion process as shown in the figure. Initial pressure of the system is  $(50 \text{ E} + 2) \text{ kPa}$

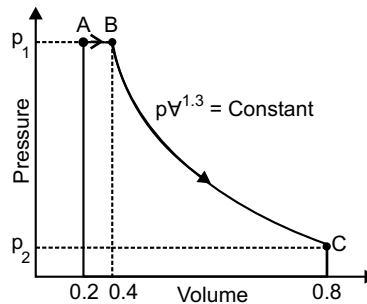

#### SOLUTION

Being a constant pressure process,

$$W_{A-B} = 50 \times 100 (0.4 - 0.2) = 1000 \text{ kJ}$$

Again,

$$p_1 V_1^\gamma = p_2 V_2^\gamma$$

Therefore,

$$p_2 = \left(\frac{V_1}{V_2}\right)^\gamma p_1 = \left(\frac{0.4}{0.8}\right)^{1.3} \times 50 \times 100 = 2030.63 \text{ kPa}$$

Again,

$$W_{B-C} = \frac{p_1 V_1 - p_2 V_2}{\gamma - 1} = \frac{(50 \times 100 \times 0.4 - 2030.63 \times 0.8)}{1.3 - 1} = 1251.65 \text{ kJ}$$

Hence, total workdone

$$W_{A-C} = W_{A-B} + W_{B-C} = 1000 + 1251.65 = 2251.65 \text{ kJ}$$

### EXAMPLE 12

A piston and cylinder arrangement containing a fluid system has a stirring device as shown in the figure. The piston is frictionless and it is held down against the fluid due to atmospheric pressure of 101.3 kPa. The stirring device is turned 9500 revolutions with an average torque against the fluid of 1.25 N-m. Meanwhile the piston of 0.65 m diameter moves out 0.6 m. Determine the net work transfer for the system.

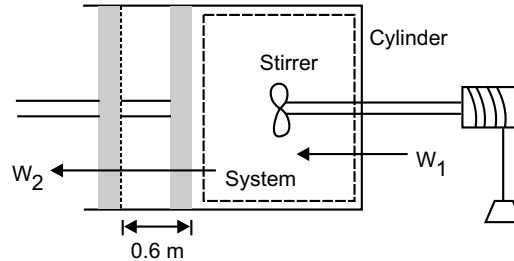

#### SOLUTION

Here, work done by the stirring device upon the system

$$W_1 = 2\pi NT = 2\pi \times 9500 \times 1.25 = 74612.83 \text{ N}\cdot\text{m} = 74.613 \text{ kJ}$$

This is a negative work

Work done by the system upon the surroundings

$$W_2 = pAL = 101.3 \times \left(\frac{\pi}{4} \times 0.65^2\right) \times 0.6 = 20.168 \text{ kJ}$$

Hence, net work transfer for the system.

$$= -74.613 + 20.168 = -54.445 \text{ kJ}$$

### EXAMPLE 13

A piston and cylinder arrangement containing a fluid system has a stirring device in the cylinder. The piston is frictionless and it is held down against the fluid due to the atmospheric pressure of 101.325 kPa. The stirring device is turned 10000 revolutions with an average torque against the fluid of 1.275 Nm. Meanwhile the piston of 0.6 m diameter moves out 0.8 m. Compute the net work transfer for the system.

#### SOLUTION

Here, work done by the stirring device upon the system

$$W_1 = 2\pi NT = 2\pi \times 10000 \times 1.275 = 80110.61 \text{ Nm} = 80.11 \text{ kJ}$$

It is a negative work

Work done by the system upon the surroundings

$$W_2 = pAL = 101.325 \times \left( \frac{\pi}{4} \times 0.6^2 \right) \times 0.8 = 22.92 \text{ kJ}$$

Hence, net work transfer for the system.

$$= -80.11 + 22.92 = -57.19 \text{ kJ}$$

#### EXAMPLE 14

A balloon which is initially collapsed is slowly inflated with helium from a cylinder forming the balloon into a sphere of 5 m in diameter. The atmospheric pressure is 100 kPa. During the filling process the helium inside the cylinder remains constant at 300 K all the time. Determine the work by the cylinder-balloon system.

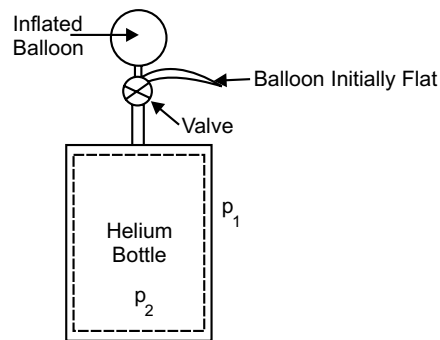

#### SOLUTION

Here displacement work

$$\begin{aligned} W_D &= \left( \int p d\forall \right)_{\text{balloon}} + \left( \int p d\forall \right)_{\text{bottle}} \\ &= p(\forall_2 - \forall_1) + 0 = 100 \times \frac{4}{3} \pi \left( \frac{5}{2} \right)^3 \\ &= 6544.98 \text{ kJ} = 6.545 \text{ MJ} \end{aligned}$$

#### EXAMPLE 15

A spherical balloon of 1 m diameter contains a gas at 150 kPa. The gas inside the balloon is heated until the pressure increases to 450 kPa. During the process of heating, pressure of the gas inside the balloon is proportional to the cube of the diameter of the balloon. Determine the work done by the gas inside the balloon.

#### SOLUTION

Here,  $p \propto D^3 \Rightarrow$

$$p = C \cdot D^3$$

Substituting

$p = 150 \text{ kPa}$  and  $D = 1 \text{ m}$ , we have

$$C = \frac{p}{D^3} = \frac{150}{1^3} = 150 \text{ kPa/m}^3.$$

When  $p = 450 \text{ kPa}$

$$D = \sqrt[3]{\frac{450}{150}} = 1.4422 \text{ m}$$

Now we can consider,  $D_1 = 1 \text{ m}, D_2 = 1.4422 \text{ m}$

Again,  $\forall = \frac{4}{3}\pi\left(\frac{D}{2}\right)^3 = \frac{\pi D^3}{6}$

So,  $d\forall = \frac{\pi}{6} \times 3D^2 \times dD = \frac{\pi D^2}{2} \times dD$

Hence work done

$$\begin{aligned} W &= \int_1^2 p d\forall = \int_{D_1}^{D_2} CD^3 \cdot \frac{\pi D^2}{2} dD = \frac{\pi C}{2} \int_{D_1}^{D_2} D^5 dD \\ &= \frac{\pi C}{2} \left[ \frac{D^6}{6} \right]_1^{1.4417} \\ &= \frac{\pi}{2} \cdot \frac{150}{6} [1.4422^6 - 1^6] \\ &= 314.09 \text{ kJ} \end{aligned}$$

### EXERCISE

1. Write the characteristic equation of a perfect gas, name symbols and state their unit in S.I. Distinguish between specific gas constant and universal gas constant.
2. Derive an expression for heat transfer during polytropic process.
3. Establish a relation between the two specific heat of gas and specific gas constant.
4. Distinguish between gas and vapour.
5. What is perfect gas and what is real gas? Under what condition does a real gas behave as a perfect gas?
6. Establish a relation amongst  $p, \forall, T$  in adiabatic process.
7. What do you understand by enthalpy? Show that for a constant pressure, the heat supplied to the gas is equal to change of enthalpy.
8. What do you understand by a thermodynamic process?
9. Explain the difference between non flow process and a flow process. Derive the equation for work done during a non-flow process.
10. State the law of corresponding states.

11. Define the compressibility factor and explain its significance.
12. A quantity of gas is compressed from 130 kPa and 38°C to 1.25 MPa and 280°C in an engine cylinder. Find the law of the process and determine per kg of the gas the work transfer. Take  $R = 0.287$  kJ/kg for the gas.

**Ans.** [ $p\forall^{1.299} = C$ ,  $W = -238.28$  kJ/kg]

13. A certain gas has  $C_p = 1.9681.507$  kJ/kgK and  $C_v = 1.507$  kJ/kgK. Find its molecular weight and the gas constant.
14. A constant volume chamber of 0.3 m<sup>3</sup> capacity contain 2 kg of this gas at 5°C. Heat is transferred to the gas until the temperature becomes 100°C. Find the work done, the heat transferred, and the changes in internal energy, enthalpy and entropy.
15. 0.2 m<sup>3</sup> of mixture of fuel and air at 1.2 bar and 60°C is compressed until its pressure becomes 12 bar and temperature becomes 270°C, then it is ignited suddenly at constant volume and its pressure becomes twice the pressure at the end of compression. Calculate the maximum temperature reached and change in internal energy. Also compute the heat transfer during the compression process. Consider mixture as a perfect gas and take  $\gamma = 1.072$  kJ/kgK and  $R = 294$  J/kgK.

**Ans.** [813°C, 143.5 kJ, -16 kJ]

16. An ideal gas at 30°C and 1 bar is compressed adiabatically from 5 m<sup>3</sup> to 1 m<sup>3</sup>. Find the temperature, pressure and work done. Take  $\gamma = 1.4$

**Ans.** [304°C, 9.5 bar, 1.125 kJ]

17. A cylinder contains 0.084 m<sup>3</sup> of hydrogen at 7.05 bar and 18°C. It is then compressed adiabatically to 14 bar and then expanded isothermally to the original volume of 0.084 m<sup>3</sup>. Characteristic constant for hydrogen is 4200 J/kgK and its specific heat at constant pressure is 14.28 kJ/kgK. Determine the final pressure of the gas and the amount of heat which must be added to the gas during isothermal expansion. Also calculate the heat which must be subtracted from the gas after expansion in order to reduce it to its initial state of stressor.

**Ans.** [2.25 bar, 34.5 kJ, 24.14 kJ]

# FIRST LAW OF THERMODYNAMICS AND ITS APPLICATION

## 4.1 INTRODUCTION

When a thermodynamic system undergoes a process or a combination of processes, as a result of which the system can be restored to its initial state, then the system is said to have undergone a *cyclic process* or a cyclic change. It is seen from figure 4.1 that a *thermodynamic cycle* may be the combination of any number of processes. But the minimum number of processes required to complete a cycle is two as shown in figure 4.1(c), where process 1 to 2 and 2 to 1 comprising the cycle.

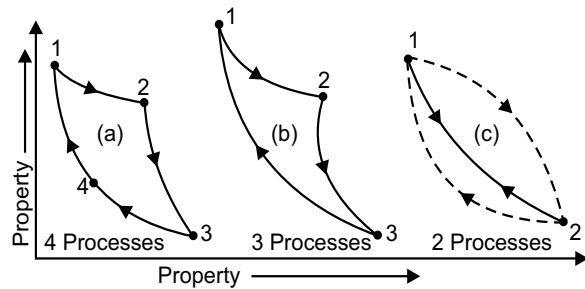

Fig. 4.1

## 4.2 JOULE'S EXPERIMENT

Joule carried out a series of experiment during 1843 and 1848 that subsequently led to the formulation of the *first law of thermodynamics*. Of the several experiments conducted by Joule, the *paddle wheel experiment* described below is considered as a classical one.

This experiment consisted of two-process cycle arrived out on a system comprising of a fluid as shown in figure 4.2., where work  $W$  was done on the system by means of a paddle wheel. The paddle wheel was made to rotate by lowering the mass which is tied to a string and the string was wound on the paddle wheel as shown in Fig. 4.2 (a). While lowering the mass  $m$  through a distance  $Z$ , work was done on liquid (the system) and the amount of work done on the system was measured. This caused a rise in temperature of fluid and the system has reached a different

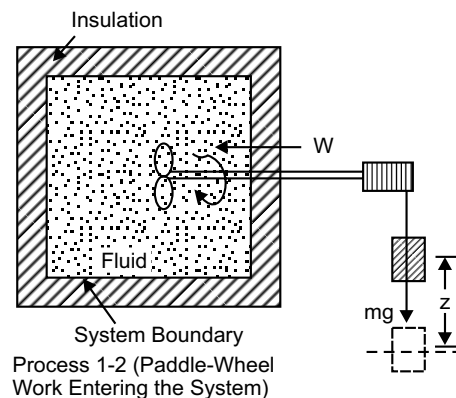
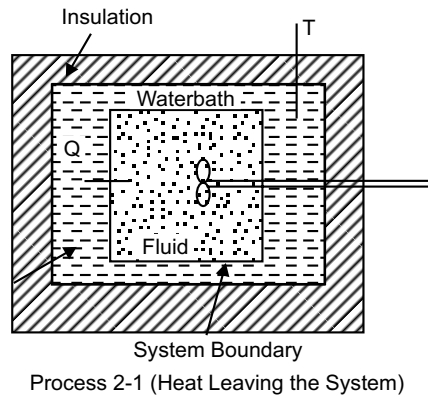

Fig. 4.2 (a)

state. The system was then placed in contact with a water bath as shown in figure 4.2. Heat was thus transferred from the fluid to the water in process 2-1, until the original state of the fluid was restored, as indicated by its temperature. Heat  $Q$  was measured from the increase in energy of water bath.



**Fig. 4.2 (b)**

Joule carried out several experiments involving different types of work interaction. Based on these experimental results Joule found that the *net work done on the system is exactly equal to the net heat interaction*, irrespective of the type of the work interaction, the rate at which work was done and the method employed for transferring the energy in the form of heat from the system. That is

$(\oint \delta Q)_{\text{from the system}} = (\oint \delta W)_{\text{on the system}}$  or  $\oint \delta Q - \oint \delta W = 0$ . Here  $\oint$  denotes integral over a cycle or cyclic integral.

### 4.3 FIRST LAW OF THERMODYNAMICS FOR A SYSTEM UNDERGOING A THERMODYNAMICS CYCLE

The conclusion from the Joule's experiments leads to the statement of the first law of thermodynamics as follows:

*When a closed system undergoes a thermodynamic cycle, during a cycle the cyclic integral of heat transfer is equal to the cyclic integral of work transfers.*

$$\text{Mathematically } \oint \delta Q = \oint \delta W \quad (4.1)$$

Here denotes integral over a cycle or cyclic integral  $\oint$  has been used to indicate the both  $Q$  and  $W$  are inexact differentials.

When heat  $Q$  and work  $W$  are in different units, then a *proportionality factor*, called the *mechanical equivalent of heat*, denoted by a symbol  $J$  is required. So, the first law may be stated as follows, *Whenever a system undergoes a cyclic change, the algebraic sum of work transfers is proportional to the algebraic sum of heat transfers or work and heat are mutually convertible one into other.*

$$\text{Mathematically, } J \oint \delta Q = \oint \delta W \quad (4.2)$$

In M.K.S unit  $J = 427 \text{ kgfm/kcal}$ , If SI is used for heat and work, then  $J = 1$ . So it is not necessary to use any proportionality factor in the first law equation.

#### 4.4 THE IMPORTANT CONSEQUENCES OF THE FIRST LAW OF THERMODYNAMICS

The first law of thermodynamics leads to the following important consequences.

1. *Heat interaction is a path function.*
2. *Energy is a property of a thermodynamic system.*
3. *The energy of an isolated system is conserved.*
4. *A perpetual motion machine of the first kind is impossible.*

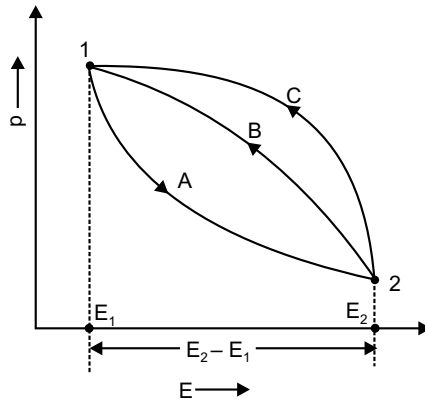

Fig. 4.3

##### 4.4.1 Heat Interaction is a Path Function

Equation (4.1) states the first law for a thermodynamic cycle. But many times we are concerned with heat and work interaction of a system during a single thermodynamic process. We, therefore need the formulation of first law for a process. Referring figure 4.3, suppose a system follows the path 1-A-2 in reaching the final state 2 starting from the initial state 1. Then the system can be restored to the initial state 1 either by the path 2-B-1 or 2-C-1. Then the combination of the processes leads to two different cycles, namely 1-A-2-B-1 and 1-A-2-C-1. Applying the first law thermodynamics to the cycles 1-A-2-B-1 and 1-A-2-C-1 we get:

$$\int_{1-A-2} \delta Q + \int_{2-B-1} \delta Q - \int_{1-A-2} \delta W - \int_{2-B-1} \delta W = 0 \tag{4.3}$$

and

$$\int_{1-A-2} \delta Q + \int_{2-C-1} \delta Q - \int_{1-A-2} \delta W - \int_{2-C-1} \delta W = 0 \tag{4.4}$$

Subtracting equation (4.4) from equation (4.3), we get

$$\int_{2-B-1} \delta Q - \int_{2-C-1} \delta Q - \int_{2-B-1} \delta W + \int_{2-C-1} \delta W = 0$$

$$\text{or, } \int_{2-B-1} \delta Q - \int_{2-C-1} \delta Q = \int_{2-B-1} \delta W - \int_{2-C-1} \delta W = 0 \quad (4.5)$$

We know that work interaction is a path function and  $\int \delta W$  represents the area under the  $p - v$  curve. Hence,

$$\int_{2-B-1} \delta W - \int_{2-C-1} \delta W \neq 0 \quad (4.6)$$

So, from equation (4.5) and (4.6) we get,

$$\int_{2-B-1} \delta Q - \int_{2-C-1} \delta Q \neq 0 \text{ or } \int_{2-B-1} \delta Q \neq \int_{2-C-1} \delta Q \quad (4.7)$$

That is, the heat interaction along the path 2-B-1 is different from the heat interaction along the path 2-C-1. Thus, heat interaction depends on the path followed by a system and *heat interaction is a path function*. It is not a point function or state function and hence its differential is not exact. Heat interaction is not a property of a thermodynamic system.

#### 4.4.2 Energy is a Property of a Thermodynamic System

For the purpose, consider the change of state of a system from 1 to 2, along path *A* and then from 2 to 1 along path *B* and *C*, thus completing two different cycles, namely 1-A-2-B-1 and 1-A-2-C-1, as shown in figure 4.3. According to the first law of thermodynamics for both the cycle 1-A-2-B-1 and 1-A-2-C-1 we get from equation (4.5),

$$\int_{2-B-1} (\delta Q - \delta W) = - \int_{2-C-1} (\delta Q - \delta W) \quad (4.8)$$

We know that  $\int \delta Q$  and  $\int \delta W$  each depends on the path followed by a system. Equation (4.8) shows that the value of  $\int (\delta Q - \delta W)$  connecting the states 1 and 2 is the same for the processes 2-B-1 and 2-C-1. In other words the quantity  $(\delta Q - \delta W)$  does not depend on the path followed by a system, but depends only on the initial and the final states of a system. Hence, the quantity  $(\delta Q - \delta W)$  is an exact differential, thus is a property of a system. Thus, property is called the energy *E*, and then the differential change in the energy of a system is given by

$$dE = \delta Q - \delta W \quad (4.9)$$

Here *dE* is an exact differential. That is, there exists a property called the energy of the system and its differential change is related to the work and heat interactions. We also know that the energy of a system is sum of macroscopic and microscopic modes of energy and is given by

$$E = KE + PE + U \quad (4.10)$$

Where *KE* = Kinetic Energy, *PE* = Potential Energy, and *U* = Internal Energy.

Comparing equations (4.9) and (4.10), we get

$$dE = d(KE) + d(PE) + dU = \delta Q - \delta W$$

So, change in the value of energy is the algebraic sum of the heat supply and the work done during any change in state. This is called the *corollary 1* of the first law of thermodynamics.

#### 4.4.3 The Energy of an Isolated System is Conserved (Law of the Conservation of Energy)

The energy can neither be created nor destroyed though it can be transformed from one form to another. *In an isolated system, the energy of the system remains constant.* According to this law, when a system undergoes a change of state, then both heat transfer and work transfer take place. The net energy transfer is stored within the system and is known as *stored energy* or *total energy* of the system. Mathematically,  $dE = \delta Q - \delta W$ . On integrating this expression for a change of state from 1 to 2, we get,

$$Q_{1-2} - W_{1-2} = E_2 - E_1 \quad (4.11)$$

When  $Q_{1-2}$  = heat transferred to the system during the process from state 1 to 2,  $W_{1-2}$  = work done by the system on the surrounding during the process,

$$E_1 = \text{total energy of the system at state 1} = PE_1 + KE_1 + U_1 = mgZ_1 + \frac{mV_1^2}{2} + U_1,$$

$$E_2 = \text{total energy of the system at state 2} = PE_2 + KE_2 + U_2 = mgZ_2 + \frac{mV_2^2}{2} + U_2.$$

Thus, the above equation (4.11) may be re-written as

$$\begin{aligned} Q_{1-2} - W_{1-2} &= E_2 - E_1 \\ &= (PE_2 + KE_2 + U_2) - (PE_1 + KE_1 + U_1) \\ &= m(gZ_2 - gZ_1) + m\left(\frac{V_2^2}{2} - \frac{V_1^2}{2}\right) + (U_2 - U_1) \end{aligned} \quad (4.12)$$

For *unit mass* this expression gets converted to

$$q_{1-2} - w_{1-2} = g(Z_2 - Z_1) + \left(\frac{V_2^2}{2} - \frac{V_1^2}{2}\right) + (u_2 - u_1) \quad (4.13)$$

*Case (1):* When there is no change in potential energy of the system *i.e.*, when the height of the system from the datum level is same ( $Z_2 = Z_1$ ), then  $PE_2 = PE_1$ . Thus, the equation (4.12) will be

$$Q_{1-2} - W_{1-2} = \left(\frac{V_2^2}{2} - \frac{V_1^2}{2}\right) + (U_2 - U_1) \quad (4.14)$$

*Case (2):* When there is no change in potential energy and also there is no flow of the mass into or out of the system, then  $PE_2 = PE_1$  and  $KE_2 = KE_1$ . Thus, the equation (4.12) takes the form

$$Q_{1-2} - W_{1-2} = (U_2 - U_1) = dU \quad (4.15)$$

In other words, in a closed or no-flow thermodynamic system,  $PE = 0$  and  $KE = 0$ . Thus the equation (4.15) is known as *no-flow energy equation*.

*Case (3):* For an isolated system for which  $Q_{1-2} = 0$  and  $W_{1-2} = 0$ , the above equation (4.11) becomes,  $E_2 - E_1 = 0 \Rightarrow E_2 = E_1$ . So, the total energy of the system at state 2 equals with total energy at state 1, hence the first law of thermodynamics is sometimes designated as *the law of conservation of energy*.

#### 4.4.4 Perpetual Motion Machine of the First Kind is Impossible

A perpetual motion machine is defined as *a machine which produces work energy without consuming an equivalent amount of heat energy from other source* or *a machine which always receives heat from source without producing any work*. It is shown in figure 4.4. So, a machine which violates the first law of thermodynamics *i.e.*, energy can neither be created nor destroyed, but can be transformed from one form to another, is known as *perpetual motion machine of the first kind* (PMM-1). But in actual practice such machine is impossible to obtain, because no machine can produce energy of its own without consuming any other form of energy.

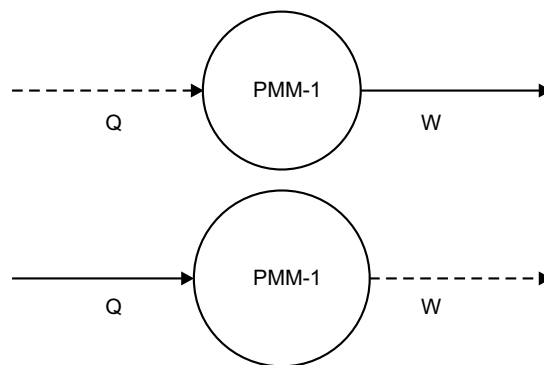

Fig. 4.4

#### 4.5 LIMITATIONS OF FIRST LAW OF THERMODYNAMICS

The following are the limitations of the first law of thermodynamics.

- (a) When a closed system undergoes a thermodynamic cycle, the net heat transfer is equal to the net work transfer.
  - (i) This statement does not specify the direction of flow of heat and work, *i.e.*, whether the heat flows from a hot body to a cold body or from a cold body to a hot body.
  - (ii) It also does not give any condition under which these transfer takes place.
- (b) The heat energy and mechanical work are mutually convertible. Though the mechanical work can be fully converted into heat energy, but only a part of heat energy can be converted into mechanical work. This means that the heat energy and mechanical work are not fully mutually convertible. In other words, there is a limitation on the conversion of one form of energy into another form.

#### 4.6 APPLICATION OF FIRST LAW THERMODYNAMICS TO A NON-FLOW PROCESS

When a system undergoes a change of state or a thermodynamic process then both the heat transfer and work transfer takes place. The net energy transfer is stored within the system and is known as stored energy or total energy of the system and which was discussed in equation (4.11).

$$Q_{1-2} - W_{1-2} = \int_1^2 dE = E_2 - E_1 \quad (4.16)$$

For non-flow process the stored energy is the internal energy only. Thus, equation (4.16) when applied to a non-flow process or a static system may be written as

$$Q_{1-2} - W_{1-2} = \int_1^2 dU = U_2 - U_1 \quad (4.17)$$

It may be noted that heat and work are not properties of the system, but their difference ( $Q_{1-2} - W_{1-2}$ ) during a process is the numerical equivalent of stored energy. Since the stored energy is a property, therefore ( $Q_{1-2} - W_{1-2}$ ) is also a property.

##### 4.6.1 Types of Non-Flow Process

Non-flow processes are of two types

- (a) *Reversible non-flow process*: All the different reversible non-flow processes as applicable for perfect gas are discussed in detail in the previous chapter.
- (b) *Irreversible non-flow process* (free or unresisted expansion process): The free expansion process is an irreversible process. A free expansion occurs when a fluid is allowed to expand suddenly into a vacuum chamber through an orifice of large dimension.

Let us consider the insulated container is divided into two chambers *A* and *B* by a partition as shown in figure 4.5(a). The chamber *A* contains a perfect gas having volume  $\forall_1$ , pressure  $p_1$  and temperature  $T_1$  while the chamber *B* is completely vacuum. As these chambers are insulated, no heat transfer takes place from its surroundings. Now, if the partition is removed, the gas will expand freely and occupy the whole space as shown in figure 4.5(b). By this, the volume of gas increases to  $\forall_2$ , pressure decreases to  $p_2$  and the temperature may also decrease to  $T_2$ . Since there is no expansion of the boundary of the system because it is rigid, therefore no work is done. Thus for a free expansion process of gas following points may be noted:

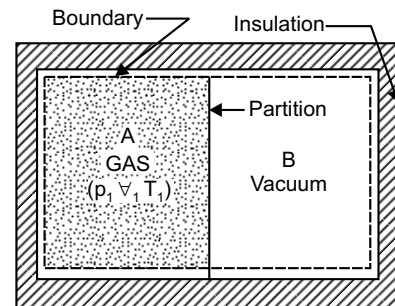

Fig. 4.5 (a)

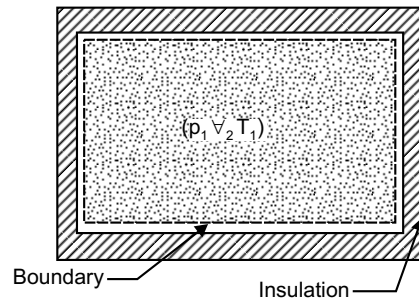

Fig. 4.5 (b)

1. Since the system is perfectly insulated, no heat transfer takes place. So,  $Q_{1-2} = 0$ , therefore, the expansion of the gas may be called as an *adiabatic expansion*.
2. Since the free expansion of the gas from the equilibrium state 1 to the equilibrium of state 2 takes place suddenly, therefore the intermediate states out not be in equilibrium states, as shown on the  $p-\forall$  diagram in figure 4.5(c), thus the process is reversible and expansion is therefore known as is *reversible adiabatic expansion*.
3. Since there is no resistance to overcome during free expansion process, therefore no work is done by the system, *i.e.*,  $W_{1-2} = 0$ , thus the free expansion process is also known as *unresisted expansion process*.

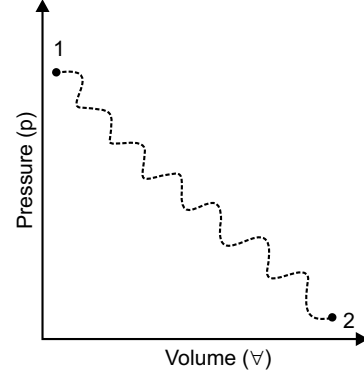

Fig. 4.5 (c)

4. According to the first law of thermodynamics,  $Q_{1-2} = W_{1-2} + \int_1^2 dU$  (4.18)

Since for free expansion,  $Q_{1-2} = 0$  and  $W_{1-2} = 0$ , therefore the change in internal energy,

$$\int_1^2 dU = U_2 - U_1 = 0 \Rightarrow U_2 = U_1 \quad (4.19)$$

In other words, the internal energy of the system in a free expansion process remains constant. Thus, the free expansion process is also known as *constant internal energy process*.

1. We know the change in internal energy  $\int_1^2 dU = mC_v(T_2 - T_1)$  (4.20)

Since  $\int_1^2 dU = 0$ ,  $mC_v(T_2 - T_1) = 0$ , which leads to  $T_2 = T_1$  (4.21)

So, there is no change in temperature of the system. In other words no temperature of the system, in a free expansion process remains constant. But *it cannot be called an isothermal process*, because in an actual isothermal process, work done by the gas is  $W_{1-2} = p_1 \forall_1 \ln\left(\frac{\forall_2}{\forall_1}\right)$  but in free expansion process work done.  $W_{1-2} = 0$ .

2. We know that the change in enthalpy

$$\int_1^2 dT = H_2 - H_1 = mC_p \int_1^2 dT = mC_p (T_2 - T_1) \quad (4.22)$$

$$\text{Since, } \int_1^2 dT = 0, mC_p(T_2 - T_1) = 0, \text{ this leads to } H_2 = H_1 \quad (4.23)$$

In other words, the enthalpy of the system in a free expansion process remains constant. Thus, the free expansion process may also be called *constant enthalpy process*.

#### 4.7 APPLICATION OF FIRST LAW OF THERMODYNAMIC TO A STEADY FLOW PROCESS

The open systems which permit the transfer of mass to and from the system are known as *flow process*. In this process, the mass (working substance) enters into the system and leaves after doing the work. The flow process may be *steady flow* process or *unsteady flow* process.

In steady flow process the rate of mass flow at inlet and outlet is the same, the rate of heat transfer and the rate of work transfer is the same, the state of working substance at any point within the system is the same at all time and there is no change in the chemical composition of the system. Any thermodynamic property will have a fixed value at a particular location and will not alter with time. The property may vary along space co-ordinates ( $x, y, z$ ), but invariant with time, *i.e.*,

$$\left[ \frac{\delta(\text{Property})}{dt} \right]_{(x,y,z)} = 0 . \text{ Therefore if the rate of flow of mass and energy across the control surface}$$

of control volume are constant with time then the flow is called *steady flow*. If the rate of flow of mass and energy across the control surface of control volume are not constant with time then the flow is called *unsteady flow*.

##### 4.7.1 Steady Flow Energy Equation (S.F.E.E)

Consider an open system through which the working substance flows at a steady rate, as shown in figure 4.6. The working substance enters into the system at section 1 and leaves the system at section 2 and, there is no accumulation of mass or energy within the control volume of the system. Let

$A_1, A_2$  = cross sectional area at section 1 and 2 in  $m^2$

$p_1, p_2$  = pressure of fluid at section 1 and 2 in  $N/m^2$

$v_{s1}, v_{s2}$  = specific volume of fluid at section 1 and 2 in  $m^3/kg$

$u_1, u_2$  = specific internal energy at section 1 and 2 in  $J/kg$

$V_1, V_2$  = velocity of fluid at section 1 and 2 in  $m/s$

$Z_1, Z_2$  = height above datum level at section 1 and 2 in  $m$

$q_{1-2}$  = heat supplied to the system in  $J/kg$  of fluid

$w_{1-2}$  = work delivered by the system in  $J/kg$  of fluid.

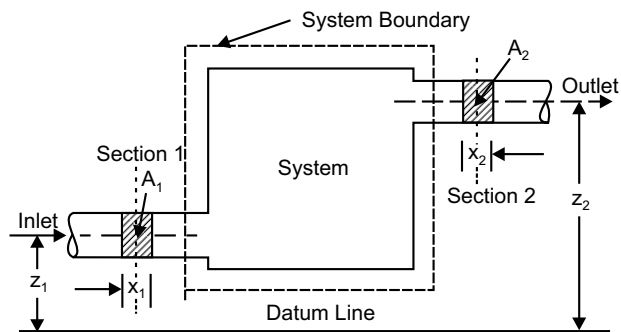

Fig. 4.6

Consider 1 kg of mass of the fluid (working substance). We know that total energy (J/kg) entering the system per kg of working fluid at section 1 is  $e_1$

$$\text{So, } e_1 = u_1 + p_1 v_{s1} + \frac{V_1^2}{2} + gZ_1 + q_{1-2} \quad (4.24)$$

Here flow energy or displacement energy or flow work is the energy required to flow or move the working fluid against its pressure. Flow work or energy

$$FE = (p_1 A_1) x_1 = p_1 (A_1 x_1) = p_1 v_{s1} \quad (4.25)$$

Similarly, total energy (J/kg) leaving the system per kg of working fluid at section 2 is  $e_2$

$$\text{So, } e_2 = u_2 + p_2 v_{s2} + \frac{V_2^2}{2} + gZ_2 + w_{1-2} \quad (4.26)$$

Assuming no loss of energy during flow, then according to law of conservation of energy

$$e_1 = e_2$$

$$\Rightarrow u_1 + p_1 v_{s1} + \frac{V_1^2}{2} + gZ_1 + q_{1-2} = u_2 + p_2 v_{s2} + \frac{V_2^2}{2} + gZ_2 + w_{1-2} \quad (4.27)$$

Again we know that, specific enthalpy of working fluid  $h = u + p v_s$

Thus, equation (4.27) may be re-written as

$$h_1 + \frac{V_1^2}{2} + gZ_1 + q_{1-2} = h_2 + \frac{V_2^2}{2} + gZ_2 + w_{1-2} \quad (4.28)$$

Otherwise,

$$h_1 + k e_1 + p e_1 + q_{1-2} = h_2 + k e_2 + p e_2 + w_{1-2} \quad (4.29)$$

It may be noted that all the terms in equation (4.28) represent the energy flow per unit mass of the working fluid, *i.e.*, in J/kg. If  $m_1, m_2$  be the mass flow rate of working fluid in kg/s then, for a steady flow,  $m_1 = m_2 = m$ , *i.e.*, mass flow rate at section 1 equals with mass flow rate at section 2. When the equation (4.28) is multiplied through by the mass ( $m$ ) in kg/s, then all the term will represent the energy flow per unit time, *i.e.*, in J/s.

Thus the equation (4.28) may be re-written as

$$m \left( h_1 + \frac{V_1^2}{2} + gZ_1 + q_{1-2} \right) = m \left( h_2 + \frac{V_2^2}{2} + gZ_2 + w_{1-2} \right) \quad (4.30)$$

Both the equations (4.28) and (4.30) are known as steady flow energy equation (S.F.E.E.). The steady flow energy equation (4.28) for unit mass flow may be rearranged as

$$\begin{aligned} q_{1-2} - w_{1-2} &= (h_2 - h_1) + \left( \frac{V_2^2}{2} - \frac{V_1^2}{2} \right) + g(Z_2 - Z_1) \\ &= (h_2 - h_1) + (k e_2 - k e_1) + (p e_2 - p e_1) \end{aligned} \quad (4.31)$$

In differential form, S.F.E.E. takes the shape as

$$\delta q - \delta w = dh + d(ke) + d(pe) \quad (4.32)$$

In thermodynamics, the effect of gravity is generally neglected. Therefore equation (4.31) may be re-written as

$$q_{1-2} - w_{1-2} = (h_2 - h_1) + \left( \frac{V_2^2}{2} - \frac{V_1^2}{2} \right) \quad (4.33)$$

Again if  $V_1 = V_2$ , then equation (4.33) will be reduced to

$$q_{1-2} - w_{1-2} = (h_2 - h_1) \quad (4.34)$$

In non-flow process the flow work at inlet and outlet is zero, i.e.,  $p_1 v_{s1} = 0 = p_2 v_{s2}$ . Therefore,  $h_1 = u_1$  and  $h_2 = u_2$ .

Thus, the equation (4.34) will be  $q_{1-2} - w_{1-2} = (u_2 - u_1)$  (4.35)

#### 4.8 MASS BALANCE (CONTINUITY) EQUATION

In steady flow the mass flow rate ( $m$ ) of the working fluid entering and leaving the system at sections 1 and 2 is given by,

$$m = \frac{A_1 V_1}{v_{s1}} = \frac{A_2 V_2}{v_{s2}} \quad (4.36)$$

This equation is known as *equation of continuity*.

#### 4.9 WORK DONE IN A STEADY FLOW PROCESS

Specific enthalpy of working fluid of specific volume  $v$  will be  $h = u + pv$ . Differentiating this expression, we get

$$dh = du + d(pv) = du + pdv + vdp \quad (4.37)$$

According to first law of thermodynamics for closed system, we know that  $\delta q = du + pdv$ .

Now equation (4.37) can be written as,  $dh = \delta q + vdp$ .

Substituting this in equation (4.32), we obtain

$$\delta q - \delta w = (\delta q + vdp) + d(ke) + d(pe)$$

$$\Rightarrow -\delta w = vdp + d(ke) + d(pe) \quad (4.38)$$

If the change in kinetic and potential energies are negligible, i.e.,  $d(ke) = 0$  and  $d(pe) = 0$  then equation (4.38) may be written as

$$-\delta w = vdp \text{ or } \delta w = -vdp$$

On integrating,  $w_{1-2} = \int_1^2 \delta w = - \int_1^2 vdp$  (4.39)

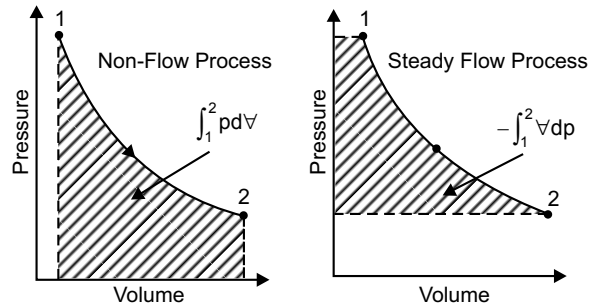

Fig. 4.7

Figures 4.7 (a) & (b) shows the difference between in a non-flow process and steady flow process respectively. In steady flow process, the work done  $w_{1-2} = -\int_1^2 v dp$  instead of  $\int_1^2 p dv$  in a non-flow process. The (–ve) in (4.39) makes the integral positive quantity and represents the work done by the system.

#### 4.10 WORK DONE VARIOUS STEADY FLOW PROCESS

The expression for work done in various steady flow processes are obtained as following:

(a) *Constant volume process:*

$$\text{Work done } W_{1-2} = -\int_1^2 v dp = v(p_1 - p_2) \quad (4.40)$$

(b) *Constant pressure process:*

$$\text{Work done } W_{1-2} = -\int_1^2 v dp = v(p_1 - p_2) = 0 \quad (4.41)$$

(c) *Constant temperature process:*

For perfect gas, when temperature remains constant, we have

$$p v = p_1 v_1 = p_2 v_2 = \text{Constant} = RT$$

Work done

$$\begin{aligned} W_{1-2} &= -\int_1^2 v dp = -\int_1^2 \frac{p_1 v_1}{p} dp = -p_1 v_1 [\ln p_2 - \ln p_1] \\ &= p_1 v_1 \ln \left( \frac{p_1}{p_2} \right) = RT \ln \left( \frac{p_1}{p_2} \right) \\ &= p_1 v_1 \ln \left( \frac{v_2}{v_1} \right) = RT \ln \left( \frac{v_2}{v_1} \right) \end{aligned} \quad (4.42)$$

(d) *Adiabatic process*

For adiabatic process

$$p v^\gamma = p_1 v_1^\gamma = p_2 v_2^\gamma = \text{Constant}$$

$$\Rightarrow v = v_1 \left( \frac{p_1}{p} \right)^{1/\gamma}$$

Work done

$$W_{1-2} = -\int_1^2 v dp = -\int_1^2 v_1 \left( \frac{p_1}{p} \right)^{1/\gamma} dp$$

$$\begin{aligned}
 &= -\nabla_1 p_1^{1/\gamma} \left[ \frac{p_2^{1-1/\gamma}}{1-1/\gamma} - \frac{p_1^{1-1/\gamma}}{1-1/\gamma} \right] \\
 &= \frac{\gamma}{\gamma-1} (p_1 \nabla_1 - p_2 \nabla_2)
 \end{aligned}
 \tag{4.43}$$

(e) *Polytropic process:*

For polytropic process,  $p \nabla^n = p_1 \nabla_1^n = p_2 \nabla_2^n = \text{Constant}$

Proceed identically as done in adiabatic process.

$$\text{Work done } W_{1-2} = \frac{n}{n-1} (p_1 \nabla_1 - p_2 \nabla_2)
 \tag{4.44}$$

### 4.11 THROTTLING PROCESS

The throttling process is an irreversible steady flow expansion process in which a perfect gas is expanded through an orifice of minute dimension such as a narrow throat or a slightly opened valve as shown in figure 4.8. Due to the fall in pressure during expansion, the gas should come out with a large velocity, but due to high frictional resistance between the gas and the walls of the aperture, there is no considerable change in velocity. The K.E of the gas is converted into heat which is utilised in warming the gas to its initial temperature. Here no heat is supplied or rejected during the throttling process and no work is done for free expansion, Therefore  $q_{1-2} = 0$  and  $w_{1-2} = 0$ . Since there is no considerable change in velocity and inlet and outlet are at the same level, therefore,  $V_1 = V_2$  and  $Z_1 = Z_2$ . Now steady flow energy equation (4.28) for unit mass will be reduced to

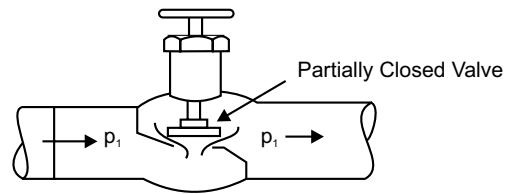

Fig. 4.8

$$h_1 = h_2
 \tag{4.45}$$

It shows that in a throttling process, *total enthalpy before throttling = total enthalpy after throttling*. So, the throttling process is a constant enthalpy process

### 4.12 APPLICATION OF STEADY FLOW ENERGY EQUATION TO ENGINEERING SYSTEM

The application of steady flow energy equation to some of the engineering system such as nozzles, diffusers, boilers, turbine, compressor, condenser, and evaporator are discussed below.

#### 4.12.1 Nozzle and Diffuser

Referring to figure 4.9, a nozzle is a device which increases the velocity as kinetic energy of the working fluid at the expense of its pressure drop. The nozzle is insulated so that no heat enters into or leaves from the system. The flow

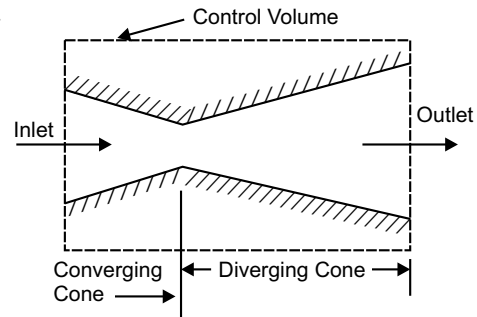

Fig. 4.9

through nozzle is considered as adiabatic process, so  $q_{1-2} = 0$  and the system does not deliver any work, *i.e.*,  $w_{1-2} = 0$ . There is no change in potential energy,  $pe_2 - pe_1 = 0$ . Following equation (4.29) we know that the steady flow energy equation for unit mass flow energy equation is

$$q_{1-2} - w_{1-2} = (h_2 - h_1) + (ke_2 - ke_1) + (pe_2 - pe_1)$$

Thus for nozzle it will be reduced to

$$0 = (h_2 - h_1) + (ke_2 - ke_1)$$

$$\Rightarrow \frac{V_2^2}{2} - \frac{V_1^2}{2} = h_1 - h_2$$

This shows that the increase in K.E. will result in decrease in enthalpy. If the process is reversed, it is obvious that the decrease in K.E. will result in increase of enthalpy. Such a system is known as Diffuser. From the above expression, we have  $V_2 = \sqrt{V_1^2 + 2(h_1 - h_2)}$ . If the initial velocity or velocity of approach  $V_1$  is very small as compared to outlet velocity  $V_2$ , then neglecting  $V_1$ , the expression for  $V_2$  will be  $V_2 = \sqrt{2(h_1 - h_2)}$ . Here, for continuous steady flow,

$$\text{mass flow rate } m = \frac{A_1 V_1}{v_{s1}} = \frac{A_2 V_2}{v_{s2}}$$

#### 4.12.2 Boiler

It is a steam generating device which supplies heat to water and generates steam at certain pressure, as shown in figure 4.10. In this system, there is no change in kinetic energy and potential energy, also there is no work done by the system. So,  $w_{1-2} = 0$ ,  $pe_2 - pe_1 = 0$ ,  $ke_2 - ke_1 = 0$ . Hence the steady flow energy equation for a unit mass flow for a boiler is reduced to  $q_{1-2} = h_2 - h_1$ . This shows that the heat supplied to the system in a boiler increases the enthalpy of the system.

#### 4.12.3 Turbine

A turbine as shown in figure 4.11 is a device which converts energy (K.E) of the working fluid into work in the turbine. The turbine is insulated so that there is no transfer of heat. In other words, the flow through a turbine is considered adiabatic. For turbine  $q_{1-2} = 0$  and the change in kinetic energy and potential energy is negligible, *i.e.*,  $pe_2 - pe_1 = 0$ ,  $ke_2 - ke_1 = 0$ . Then the steady flow energy equation for a unit mass flow for a turbine

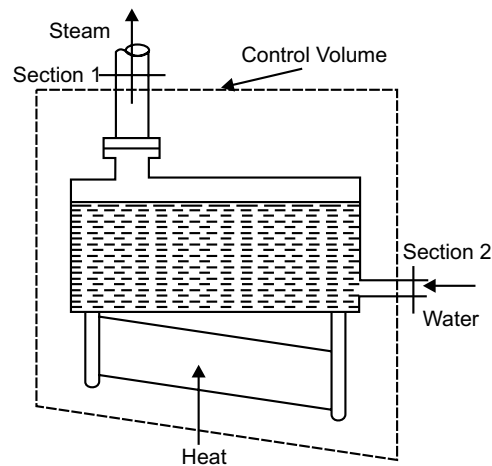

Fig. 4.10

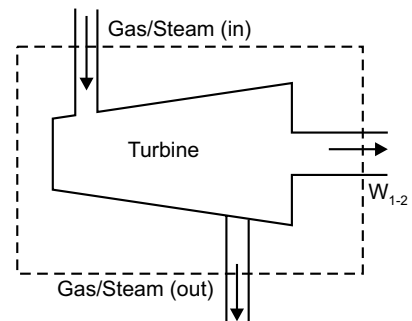

Fig. 4.11

can be written as  $w_{1-2} = h_2 - h_1$ . This shows that the work done by the system is due to decrease in enthalpy of the working fluid.

#### 4.12.4 Compressor

It is a device in which the fluid is compressed by the shaft work. It can be treated as turbine for the purpose of steady flow process. There are two types of compressors:

(a) *Rotary Compressor*: A rotary compressor, as shown in figure 4.12 is a device which compresses air and supplies the same at moderate pressure and in large quantities. In rotary compressor, the process can be treated as adiabatic as it is insulated so that no heat transfer takes place, *i.e.*,  $q_{1-2} = 0$ . In rotary compressor changes in kinetic and potential energies are negligible *i.e.*  $pe_2 - pe_1 = 0$ ,  $ke_2 - ke_1 = 0$ . Then the steady flow energy equation for a unit mass flow for a rotary compressor will be reduced to  $-(w_{1-2}) = h_2 - h_1$  or  $w_{1-2} = h_2 - h_1$ , or. The (-ve) sign is used because work is done on the system. This equation shows that the work is done due to increase in enthalpy.

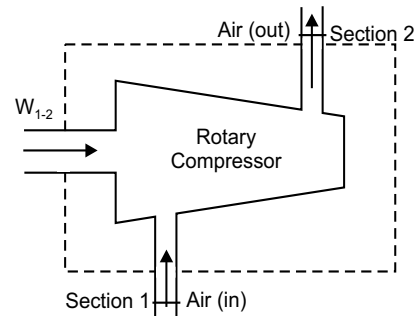

Fig. 4.12

(b) *Reciprocating Compressor*: A reciprocating compressor, as shown in figure 4.13 is device supplying compressed air at a considerable high pressure and in small quantities. The reciprocating compressor is considered as a steady flow system provided it includes the receiver which reduces the fluctuation of flow considerably. Here the change in K.E. and P.E. are negligible, *i.e.*,  $pe_2 - pe_1 = 0$ ,  $ke_2 - ke_1 = 0$ . So, for reciprocating compressor, the steady flow energy equation for a unit mass flow will be reduced to  $[-q_{1-2} - (-w_{1-2})] = h_2 - h_1$  or  $w_{1-2} = q_{1-2} + (h_1 - h_2)$ . The (-ve) sign is used because the heat is rejected and work is done on the system.

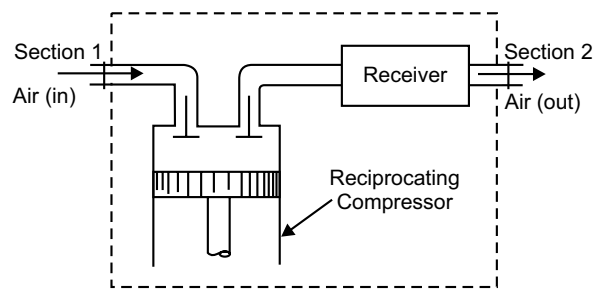

Fig. 4.13

#### 4.12.5 Condenser

A condenser, as shown in figure 4.14 is a device which is used to condense steam in case of steam power plant using water as the cooling medium, whereas in refrigeration system, it is used to condense refrigerant vapour using air as the cooling medium. In this system there is no change in K.E. and P.E., *i.e.*,  $pe_2 - pe_1 = 0$ ,  $ke_2 - ke_1 = 0$ . Also there is no work done by the system, *i.e.*,

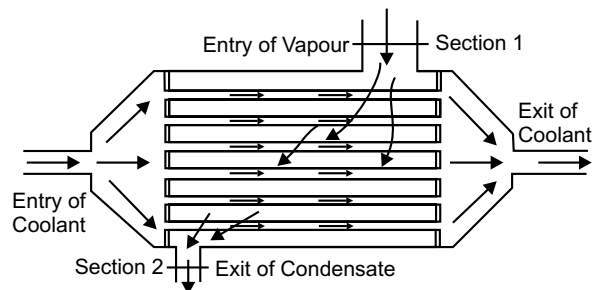

Fig. 4.14

$w_{1-2} = 0$ . So the steady flow energy equation for unit mass will be reduced to  $(-q_{1-2}) = h_2 - h_1$  or  $q_{1-2} = h_1 - h_2$ . The (-ve) sign is taken because the heat is lost by the coolant while passing through the condenser.

#### 4.12.6 Evaporator

The evaporator, as shown in figure 4.15 is a device used in refrigeration systems in which the liquid refrigerant passes, receives heat and leaves as vapour refrigerant. For this system, the change in K.E. and P.E. is negligible. Also there is no work done by the system. So,  $pe_2 - pe_1 = 0$ ,  $ke_2 - ke_1 = 0$  and  $w_{1-2} = 0$ . Hence, the steady flow energy equation for unit mass in a evaporator will be  $q_{1-2} = h_2 - h_1$ . The process occurring in a evaporator is the reverse of that of a condenser.

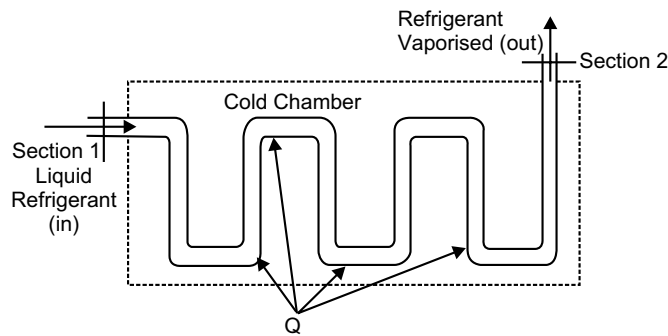

Fig. 4.15

#### 4.12.7 Heat Exchanger

The heat exchanger, as shown in figure 4.16 is a device in which heat is transferred from one fluid to another fluid, where steam is being condensed with the help of cooling water. Here the cooling water flows through the pipes where the steam flows over the tubes. The exchanger is well insulated from its out side. Therefore, heat does not cross the control volume surface; rather it is confined only between the two fluids. The change of K.E. and P.E. are also negligible and there is no central work done. So, for this system  $pe_2 - pe_1 = 0$ ,  $ke_2 - ke_1 = 0$  and  $w_{1-2} = 0$ . Hence, the steady flow energy equation for unit mass in a heat exchanger will be reduced to  $(-q_{1-2}) = h_2 - h_1$  or  $q_{1-2} = h_1 - h_2$ . The(-ve) sign is taken because the heat is lost by the coolant while passing through the heat exchanger.

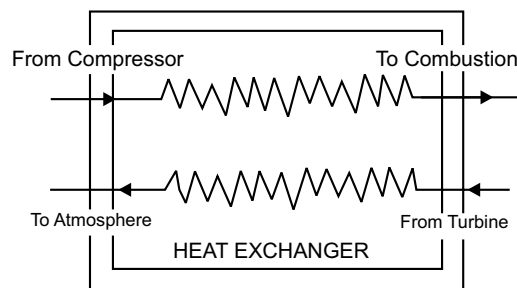

Fig. 4.16

### Multiple Choice Questions

1. Joule's statement establishes that (when expressed in some units) during a cycle
  - (a) heat transfer is equal to work transfer
  - (b) work transfer is only a fraction of the heat transfer
  - (c) heat transfer is only a fraction of work transfer
  - (d) There is no relationship between work transfer and heat transfer
  
2. A system undergoes a process. The energy transfers are tabulated as follows
 

Heat transfer	Work transfer	Change in internal energy
Q	W	U
(a) 52.7 kJ	20.7 kJ	32 kJ
(b) 32 kJ	52.7 kJ	20.7 kJ
(c) 30 kJ	20.4 kJ	52.7 kJ
(d) 20.7 kJ	32 kJ	52.7 kJ
  
3. A system undergoes a cycle of process AB, BC, CD and DA. The internal energy changes for various processes in kJ are
 

AB	BC	CA	DA
(a) 32.5	-18.5	-30	16
(b) 18.5	-32.5	-30	16
(c) 30	-18.5	-32.5	16
(d) 16	-18.5	-32.5	30
  
4. Internal energy of ideal gas is a function of
  - (a) temperature and volume
  - (b) pressure and volume
  - (c) pressure and energy
  - (d) temperature alone
  
5. Internal energy for gas in general can be written as
 

(a) $du = \left(\frac{du}{dt}\right)_v dt + \left(\frac{du}{dv}\right)_T dv$	(b) $du = \left(\frac{du}{dt}\right)_p dt + \left(\frac{du}{dv}\right)_T dv$
(c) $du = \left(\frac{du}{dt}\right)_v dt + \left(\frac{du}{dv}\right)_p dv$	(d) $du = \left(\frac{du}{dt}\right)_p dt + \left(\frac{du}{dv}\right)_p dv$
  
6. Internal energy change of an ideal gas is expressed as
 

(a) $du = C_v dT$	(b) $du = C_p dT$
(c) $du = (C_p - C_v) dT$	(d) $du = C_v dT + \left(\frac{du}{dv}\right)_T dv$
  
7. A closed system undergoes a process 1-2 for which the value of  $W_{1-2}$  and  $Q_{1-2}$  are 50 kJ and +20 kJ respectively. If the system is returned to state 1 and  $Q_{1-2}$  is -10 kJ, the work  $W_{1-2}$  is
  - (a) -80 kJ
  - (b) +40 kJ
  - (c) -20 kJ
  - (d) -40 kJ

8. A closed system goes from state 1 to state 2 in a process for which  $Q = 0$  and  $W = 100$  kJ. Then the system is returned to state 1 in a record process for which  $W = 80$  kJ. The heat transfer for the record process will be

- (a) 20 kJ (b) Zero  
(c) -20 kJ (d) intermediate

9. Figure shows three processes  $P$ ,  $Q$  and  $R$  on  $p - \forall$  plane namely isothermal compression  $p\forall = C$ , isentropic compression  $p\forall^\gamma = C$ , polytropic compression  $p\forall^n = C$  for a perfect gas where  $1 < n < \gamma$ . The correct identification is

- (a)  $P$ (Isothermal),  $Q$ (Isentropic),  $R$ (Polytropic)  
(b)  $P$ (Polytropic),  $Q$ (Isothermal),  $R$ (Isentropic)  
(c)  $P$ (Isentropic),  $Q$ (Polytropic),  $R$ (Isothermal)  
(d)  $P$ (Isothermal),  $Q$ (Polytropic),  $R$ (Isentropic)

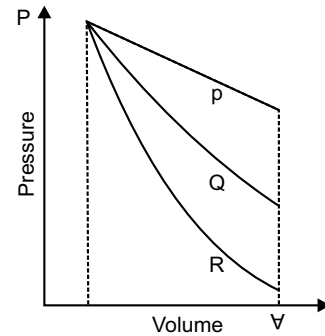

10. The work done in a free expansion process is

- (a) zero (b) minimum  
(c) maximum (d) positive

11. In a steady flow process

- (a) the mass flow rate is constant (b) the heat transfer rate is constant  
(c) the work transfer rate is constant (d) all of the above.

12. The work done in steady flow process is given by

- (a)  $\int_1^2 p d\forall$  (b)  $-\int_1^2 p d\forall$   
(c)  $\int_1^2 \forall dp$  (d)  $-\int_1^2 \forall dp$

13. The throttling process is a

- (a) non-flow process (b) steady flow process  
(c) non-steady flow process (d) unsteady flow process

### Answers

1. (a) 2. (a) 3. (a) 4. (d) 5. (a) 6. (a) 7. (d) 8. (c) 9. (d) 10. (a)  
11. (d) 12. (d) 13. (b)

## NUMERICAL EXAMPLES

### EXAMPLE 1

A closed system receives a heat transfer of 120 kJ and delivers a work transfer of 150 kJ. Compute the change of internal energy.

**SOLUTION**

Here, heat transfer  $Q = 120$  kJ, work transfer  $W = 150$  kJ

We know  $Q = W + U$

$$\Rightarrow U = Q - W = 120 - 150 = -30 \text{ kJ}$$

So, reduction of internal energy = 30 kJ.

### EXAMPLE 2

300 tonne per second of steam is expanded in a turbine from an initial pressure of 90 bar. The specific enthalpies of steam at inlet and exit of the turbine are respectively 3300 kJ/kg and 2200 kJ/kg. Neglecting potential energy and kinetic energy terms and loss due to heat transfer, determine the output of the turbine in MW.

**SOLUTION**

Mass flow rate of steam ( $m$ ) = 300 t/sec, initial pressure  $p_1 = 90$  bar, pressure at exit = 0.1 bar,

specific enthalpy at inlet  $h_1 = 3300$  kJ/kg, specific enthalpy at exit  $h_2 = 2200$  kJ/kg

Work output of the turbine

$$W = m (h_1 - h_2) = 300 \times 10^3 (3300 - 2200) 10^{-3} = 33 \times 10^4 \text{ MW.}$$

### EXAMPLE 3

In an air compressor air flows steadily at the rate of 15 kg per minute. The air enters the compressor at 5 m/s with a pressure of 1 bar and a specific volume of 0.5 m<sup>3</sup>/kg. It leaves the compressor at 7.5 m/s with a pressure of 7 bar and a specific volume of 0.15 m<sup>3</sup>/kg. The internal energy of the air leaving the compressor is 165 kJ/kg greater than that of the air entering. The cooling water in the compressor jackets absorbs heat from the air at the rate of 125 kJ/s. Determine: (i) power required to drive the compressor (ii) ratio of the inlet pipe diameter to outlet pipe diameter.

**SOLUTION**

Here,  $m = 15$  kg/min = 0.25 kg/s;  $V_1 = 5$  m/s;  $p_1 = 1$  bar =  $0.1 \times 10^6$  N/m<sup>2</sup>,

$v_{s1} = 0.5$  m<sup>3</sup>/kg;  $V_2 = 7.5$  m/s;  $p_2 = 7$  bar =  $0.7 \times 10^6$  N/m<sup>2</sup>;

$v_{s2} = 0.15$  m<sup>3</sup>/kg;  $u_2 - u_1 = 165$  kJ/kg =  $165 \times 10^3$  J/kg,

$Q_{1-2} = 125$  kJ/s,  $q_{1-2} = 125/0.25 = 500 \times 10^3$  J/kg

(i) Flow energy at inlet  $p_1 v_{s1} = 0.1 \times 10^6 \times 0.5 = 50 \times 10^3$  J/kg

Flow energy at outlet  $p_2 v_{s2} = 0.7 \times 10^6 \times 0.15 = 105 \times 10^3$  J/kg

Kinetic energy at inlet  $ke_1 = \frac{V_1^2}{2} = \frac{5^2}{2} = 12.5$  J/kg.

$$\text{Kinetic energy at outlet } ke_2 = \frac{V_2^2}{2} = \frac{7.5^2}{2} = 28.1 \text{ J/kg}$$

From the steady flow energy equation for a unit mass flow

$$u_1 + p_1 v_{s1} + ke_1 + pe_1 - q_{1-2} = u_2 + p_2 v_{s2} + ke_2 + pe_2 - w_{1-2}$$

Neglecting the potential energy, the steady flow energy equation for unit mass may be written as

$$u_1 + p_1 v_{s1} + ke_1 - q_{1-2} = u_2 + p_2 v_{s2} + ke_2 - w_{1-2}$$

$$\Rightarrow w_{1-2} - q_{1-2} = (u_2 - u_1) + (p_2 v_{s2} - p_1 v_{s1}) + (ke_2 - ke_1)$$

$$\Rightarrow w_{1-2} - 500 \times 10^3 = 165 - 10^3 + (105 \times 50)10^3 + (28.1 - 12.5)$$

$$\text{So, } w_{1-2} = 720 \times 10^3 \text{ J/kg}$$

$\therefore$  Power required to drive the compressor

$$W_{1-2} = m w_{1-2} = 0.25 \times 720 \times 10^3 \text{ J/s} = 180 \times 10^3 \text{ J/s} = 180 \text{ kW}$$

(ii) Let,  $D_1$  = inlet pipe diameter,  $D_2$  = outlet pipe diameter

$$\text{We know, } \frac{A_1 V_1}{v_{s1}} = \frac{A_2 V_2}{v_{s2}}$$

$$\Rightarrow \frac{A_1}{A_2} = \frac{V_2}{V_1} \cdot \frac{v_{s1}}{v_{s2}}$$

$$\Rightarrow \frac{D_1^2}{D_2^2} = \frac{7.5}{5} \times \frac{0.5}{0.15}$$

$$\text{So, } \frac{D_1}{D_2} = 2.236$$

#### EXAMPLE 4

In a gas turbine, the gases flow at the rate of 5 kg/s. The gases enter the turbine at a pressure 7 bar with a velocity 120 m/s and leaves at a pressure 2 bar with velocity 250 m/s. The turbine is insulated. If the enthalpy of the gas at inlet is 900 kJ/kg and at outlet 600 kJ/kg, determine the capacity of the turbine.

**SOLUTION**

$$\text{Here, } m = 5 \text{ kg/s, } p_1 = 0.7 \times 10^6 \text{ N/m}^2, V_1 = 120 \text{ m/s,}$$

$$p_2 = 0.2 \times 10^6 \text{ N/m}^2, V_2 = 250 \text{ m/s,}$$

$$h_1 = 900 \times 10^3 \text{ J/kg,}$$

$$h_2 = 600 \times 10^3 \text{ J/kg}$$

From the steady flow energy equation for a unit mass flow is

$$h_1 + ke_1 + pe_1 - q_{1-2} = h_2 + ke_2 + pe_2 + w_{1-2}$$

Neglecting the potential energy,

$$w_{1-2} = (h_1 - h_2) + (ke_1 - ke_2) = (h_1 - h_2) + \left( \frac{V_1^2}{2} - \frac{V_2^2}{2} \right)$$

$$= (900 - 600) 10^3 + \frac{1}{2}(120^2 - 250^2) = 275.95 \times 10^3 \text{ J/kg}$$

∴ Capacity of the turbine

$$= mw_{1-2} = 5 \times 275.95 \times 10^3 \text{ J/s} = 1379.75 \times 10^3 \text{ J/s} = 1379.75 \text{ kW}$$

### EXAMPLE 5

A non-flow system has a mass of working fluid of 5 kg. The system undergoes a process in which 140 kJ heat is rejected to the surrounding and the system does 80 kJ of work. Assuming that the initial specific internal energy of the system is 500 kJ/kg, determine the final specific internal energy.

#### SOLUTION

Here,  $Q = -140 \text{ kJ}$ ,  $W = 80 \text{ kJ}$ ,  $u_1 = 500 \text{ kJ/kg}$

As,  $Q - W = U_2 - U_1$ ,

so,  $U_2 - U_1 = -140 - 80 = -220 \text{ kJ}$

Difference in specific internal energy

$$u_2 - u_1 = \frac{U_2 - U_1}{m} = \frac{-220}{5} = -44 \text{ kJ/kg}$$

So,  $u_2 = -44 + 500 = 456 \text{ kJ/kg}$

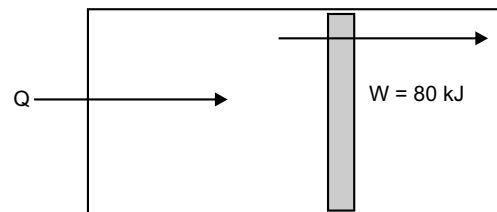

### EXAMPLE 6

A system is taken through a series of processes as a result of which it is restored to the initial state. The work and heat interaction for some of the process are measured and given below. Complete the table and determine the net work done and net heat interaction.

Process	$W(\text{kJ})$	$Q(\text{kJ})$	$\Delta U(\text{kJ})$
1-2	100	200	?
2-3	?	-150	200
3-4	-250	?	?
4-1	300	?	50

#### SOLUTION

From 1<sup>st</sup> law of thermodynamics we know,  $Q - W = U_2 - U_1$ .

For process 1 - 2,

$$\Delta U_{1-2} = Q_{1-2} - W_{1-2} = 200 - 100 = 100 \text{ kJ}$$

For process 2 - 3,

$$W_{2-3} = Q_{2-3} - \Delta U_{2-3} = -150 - 200 = -350 \text{ kJ}$$

For process 4 - 1,

$$Q_{4-1} = W_{4-1} + \Delta U_{4-1} = 300 + 50 = 350 \text{ kJ}$$

For the entire cycle,  $\Delta U = 0$

So,  $\Delta U_{1-2} + \Delta U_{2-3} + \Delta U_{3-4} + \Delta U_{4-1} = 0$

⇒  $100 + 200 + \Delta U_{3-4} + 50 = 0$

⇒  $\Delta U_{3-4} = -350$

For process 3 – 4,

$$Q_{3-4} = W_{3-4} + \Delta U_{3-4} = -250 - 350 = -600 \text{ kJ}$$

Net work done

$$\begin{aligned} W &= W_{1-2} + W_{2-3} + W_{3-4} + W_{4-1} \\ &= 100 - 350 - 250 + 300 = -200 \text{ kJ} \end{aligned}$$

From 1<sup>st</sup> law, it can be said net heat transfer = -200 kJ.

### EXAMPLE 7

A stationary system consisting of 2 kg of fluid whose properties are related as  $u = (196 + 0.718t)$ ,  $p v_s = [0.287(t + 273)]$ , where  $u$  is the specific internal energy (kJ/kg),  $t$  is in °C,  $p$  is pressure (kPa) and  $v_s$  is specific volume ( $\text{m}^3/\text{kg}$ ). This system expands in an adiabatic process following  $p v_s^{1.2} = \text{constant}$ . The initial conditions are  $p_1 = 1 \text{ MPa}$ ,  $t_1 = 200^\circ\text{C}$ , final pressure  $p_2 = 0.1 \text{ MPa}$ . Determine work done and change in energy for the process.

**SOLUTION**

Here,

$$U_1 = m u_1 = 2 (196 + 0.718 \times 200) = 679.2 \text{ kJ}$$

$$v_{s1} = m v_{s1} = 2 \frac{0.287(200 + 273)}{1 \times 10^3} = 0.2715 \text{ m}^3$$

Now,

$$v_{s2} = v_{s1} \left( \frac{p_1}{p_2} \right)^{\frac{1}{1.2}} = 0.2715 \left( \frac{1 \times 10^3}{0.1 \times 10^3} \right)^{\frac{1}{1.2}} = 1.849 \text{ m}^3$$

So,

$$v_{s2} = \left( \frac{v_{s2}}{m} \right) = \frac{1.849}{2} = 0.9245 \text{ m}^3/\text{kg}$$

Hence,

$$t_2 = \frac{p_2 v_{s2}}{0.287} - 273 = \frac{0.1 \times 10^3 \times 0.9245}{0.287} - 273 = 49.12^\circ\text{C}$$

So,

$$U_2 = m u_2 = 2 (196 + 0.718 \times 49.12) = 462.54 \text{ kJ}$$

Here,

$$dE = dU = U_2 - U_1 = 462.54 - 679.2 = -216.66 \text{ kJ}$$

From 1<sup>st</sup> law of thermodynamics

$$\delta W = \delta Q - dE = 0 - (-216.66) = 216.66 \text{ kJ}$$

### EXAMPLE 8

A gas undergoes a thermodynamic cycle consisting of the following processes: (i) *Process 1–2*: constant pressure at  $p = 1.4 \text{ bar}$ ,  $v_{s1} = 0.28 \text{ m}^3$ ,  $W_{1-2} = 10.5 \text{ kJ}$ . (ii) *Process 2–3*: compression with at  $p v_s = \text{constant}$ , and  $U_3 = U_2$ . (iii) *Process 3–1*: constant volume,  $U_1 - U_3 = -26.4 \text{ kJ}$ . There are no significant changes in KE and PE. (a) sketch the cycle on a  $p - v_s$  diagram (b) calculate the net work done for the cycle in kJ (c) calculate the heat transfer.

**SOLUTION**

For process 1-2:

$$p_1 = p_2 = 1.4 \text{ bar} = 140 \text{ kPa}, \quad \forall_1 = 0.28 \text{ m}^3, \quad W_{1-2} = 10.5 \text{ kJ}$$

So,  $W_{1-2} = p_1 (\forall_2 - \forall_1)$

$$\Rightarrow 10.5 = 140(\forall_2 - 0.28)$$

$$\Rightarrow \forall_2 = 0.355 \text{ m}^3$$

For process 2-3:  $\forall_3 = 0.28 \text{ m}^3$

So,  $W_{2-3} = p_2 \forall_2 \ln \left( \frac{\forall_3}{\forall_2} \right) = 140 \times 0.355 \ln \left( \frac{0.28}{0.355} \right) = -11.79 \text{ kJ}$

From 1<sup>st</sup> law of thermodynamics,

$$Q_{2-3} = W_{2-3} + (U_3 - U_2) = W_{2-3}$$

For process 3-1: being a constant volume process,  $W_{3-1} = 0$

$$W_{\text{net}} = W_{1-2} + W_{2-3} + W_{3-1} = 10.5 - 11.79 = -1.29 \text{ kJ}$$

$$Q_{1-2} = W_{1-2} + (U_2 - U_1) = 10.5 + 26.4 = 36.9 \text{ kJ}$$

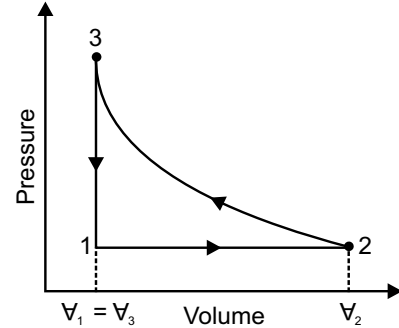

**EXAMPLE 9**

When a system is taken from state *a* to state *b* in the figure shown along path *a-c-b*, 84 kJ of heat flows into the system and the system does 32 kJ of work. (a) how much will the heat flow into the system along path *a-d-b*, if the work done is 10.5 kJ? (b) when the system is returned from *b* to *a* along the curved path, the work done on the system is 21 kJ. Does the system absorb or liberate heat and how much of the heat is absorbed or liberated? Again if  $U_a = 0$  and  $U_d = 42$  kJ, find the heat absorbed in the process *a-d* and *d-b*.

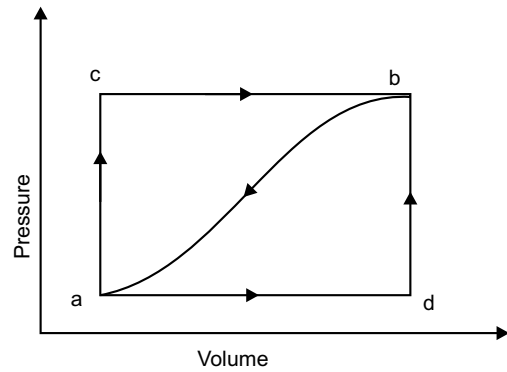

**SOLUTION**

Here,  $Q_{a-c-b} = 84 \text{ kJ}, W_{a-c-b} = 32 \text{ kJ}, W_{a-d-b} = 10.5 \text{ kJ}$

We have,  $Q_{a-c-b} = (U_b - U_a) + W_{a-c-b}$

$$\Rightarrow (U_b - U_a) = 84 - 32 = 52 \text{ kJ}$$

So,  $Q_{a-d-b} = (U_b - U_a) + W_{a-d-b} = 52 + 10.5 = 62.5 \text{ kJ}$

$$Q_{b-a} = (U_a - U_b) + W_{b-a} = -52 - 21 = -73 \text{ kJ}$$

Hence, the system liberates 73 kJ of heat.

$$\text{Now, } W_{a-d-b} = W_{a-d} + W_{d-b} = W_{a-d} = 10.5 \text{ kJ}$$

$$\text{And } Q_{a-d} = (U_d - U_a) + W_{a-d} = 42 - 0 + 10.5 = 52.5 \text{ kJ}$$

$$\text{So, } Q_{d-b} = Q_{a-d-b} - Q_{a-d} = 62.5 - 52.5 = 10 \text{ kJ}$$

### EXAMPLE 10

A fluid system undergoes a non-flow frictionless process following the pressure-volume relation as  $\left(p = \frac{5}{V} + 1.5\right)$  where  $p$  is in bar and  $V$  in  $\text{m}^3$ . During the process the volume changes from  $0.15 \text{ m}^3$  to  $0.05 \text{ m}^3$  and the system rejects 45 kJ of heat. Determine (i) change in internal energy (ii) change in enthalpy.

**SOLUTION**

Here,

$$p_1 = \frac{5}{V_1} + 1.5 = \frac{5}{0.15} + 1.5 = 34.83 \text{ bar and}$$

$$\text{And } p_2 = \frac{5}{V_2} + 1.5 = \frac{5}{0.05} + 1.5 = 101.5 \text{ bar}$$

$$\begin{aligned} \text{Now, } W &= \int_{V_1}^{V_2} p dV = \int_{0.15}^{0.05} \left(\frac{5}{V} + 1.5\right) \times 10^5 dV \\ &= \left[51 \ln \frac{0.05}{0.15} + 1.5(0.05 - 0.15)\right] \times 10^5 \\ &= -5.64 \times 10^5 \text{ J} = -564 \text{ kJ} \end{aligned}$$

From 1<sup>st</sup> law of thermodynamics,

$$\Delta U = Q - W = -45 - (-564) = 519 \text{ kJ}$$

So, internal energy is increased.

Change in enthalpy,

$$\begin{aligned} \Delta H &= \Delta U + (p_2 V_2 - p_1 V_1) \\ &= 519 \times 10^3 + (101.5 \times 0.05 - 34.83 \times 0.15) 10^5 \\ &= 504 \times 10^3 \text{ J} = 504 \text{ kJ} \end{aligned}$$

### EXAMPLE 11

The properties of a system during a reversible constant pressure non-flow process  $p = 1.6 \text{ bar}$  change from  $v_{s1} = 0.3 \text{ m}^3/\text{kg}$ ,  $t_1 = 20^\circ\text{C}$  to  $v_{s2} = 0.55 \text{ m}^3/\text{kg}$ ,  $t_2 = 260^\circ\text{C}$ . The specific heat of the fluid is given by  $C_p = \left(1.5 + \frac{75}{t + 45}\right) \text{ kJ/kg}^\circ\text{C}$ . Determine (i) heat added/kg (ii) work done/kg (iii) change in internal energy/kg (iv) change in enthalpy/kg.

**SOLUTION**

(i) Heat added/kg of the fluid

$$\begin{aligned}
 q &= \int_{t_1}^{t_2} C_p dt = \int_{20}^{260} \left( 1.5 + \frac{75}{t + 45} \right) dt \\
 &= 1.5 [260 - 20] + 75 \ln \frac{260 + 45}{20 + 45} \\
 &= 475.94 \text{ kJ/kg}
 \end{aligned}$$

(ii) Work done/kg of the fluid

$$\begin{aligned}
 w &= \int_{v_1}^{v_2} p dV = p(v_{s2} - v_{s1}) \\
 &= 1.6 \times 10^5 (0.55 - 0.3) \text{ Nm/kg} \\
 &= 40 \times 10^3 \text{ J/kg} = 40 \text{ kJ/kg}
 \end{aligned}$$

(iii) Change in internal energy/kg of the fluid

$$\Delta u = q - w = 475.94 - 40 = 435.94 \text{ kJ/kg}$$

(iv) Change in enthalpy/kg of the fluid

$$h = u + w = q = 475.94 \text{ kJ/kg}$$

**EXAMPLE 12**

Air at 300°C and 1000 kPa (10 bar) expands to 300 kPa (3 bar) respectively following the law  $p v^{1.35} = C$ . Determine the work done per kg of air, and heat transfer if  $C_p = 1 \text{ kJ/kgK}$  and  $C_v = 0.714 \text{ kJ/kgK}$ .

**SOLUTION**

Here,

$$T_1 = 273 + 300 = 573 \text{ K}, R = C_p - C_v = 1 - 0.714 = 0.286 \text{ kJ/kg},$$

Hence, 
$$\gamma = \frac{C_p}{C_v} = \frac{1}{0.714} = 1.4$$

and 
$$T_2 = T_1 \left( \frac{p_2}{p_1} \right)^{\frac{n-1}{n}} = 573 \left( \frac{300}{1000} \right)^{\frac{1.35-1}{1.35}} = 419.37 \text{ K}$$

Work done in reversible polytropic process,

$$\begin{aligned}
 w_{1-2} &= \frac{p_1 v_1 - p_2 v_2}{n-1} = \frac{R(T_1 - T_2)}{n-1} \\
 &= \frac{0.286(573 - 419.37)}{1.35 - 1} = 125.54 \text{ kJ/kg}
 \end{aligned}$$

Heat transferred

$$q = \frac{\gamma - n}{\gamma - 1} \int_1^2 p dv = \frac{1.4 - 1.35}{1.4 - 1} \times 125.54 = 47.08 \text{ kJ/kg}$$

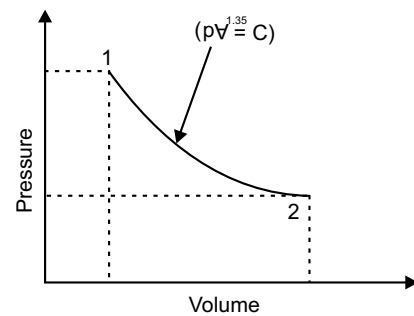

**EXAMPLE 13**

At the inlet to a certain nozzle the specific enthalpy of fluid passing is 2800 kJ/kg and the velocity is 50 m/sec. At the discharge end the specific enthalpy is 2600 kJ/kg. The nozzle is horizontal and there is negligible heat loss from it, (i) find the velocity at exit of the nozzle (ii) if the inlet area is 900 cm<sup>2</sup> and specific volume at inlet is 0.187 m<sup>3</sup>/kg find the mass flow rate (iii) if the specific volume at the nozzle exit is 0.498 m<sup>3</sup>/kg, find the exit area of the nozzle.

**SOLUTION**

Here,  $h_1 = 2800$  kJ/kg,  $h_2 = 2600$  kJ/kg,  $v_{s1} = 0.187$  m<sup>3</sup>/kg,  $v_{s2} = 0.498$  m<sup>3</sup>/kg,  $A_1 = 900$  cm<sup>2</sup>,  $V_1 = 50$  m/s

Applying energy equation at section 1 and 2,

$$h_1 + \frac{V_1^2}{2} + gZ_1 + \frac{\delta Q}{dm} = h_2 + \frac{V_2^2}{2} + gZ_2 + \frac{\delta W}{dm}$$

Depending on the given condition, above equation gets reduced to

$$\begin{aligned} h_1 + \frac{V_1^2}{2} &= h_2 + \frac{V_2^2}{2} \\ \Rightarrow V_2 &= \sqrt{V_1^2 + 2(h_1 - h_2)} \\ &= \sqrt{50^2 + 2(2800 - 2600) \times 10^3} = 634.4 \text{ m/s} \end{aligned}$$

$$\text{Mass flow rate } m = \frac{A_1 V_1}{v_{s1}} = \frac{900 \times 10^{-4} \times 50}{0.187} = 24.06 \text{ kg/s}$$

$$\text{Again, } m = \frac{A_1 V_1}{v_{s1}} = \frac{A_2 V_2}{v_{s2}}$$

$$\begin{aligned} \Rightarrow A_2 &= m \cdot \frac{v_{s2}}{V_2} = 24.06 \times \frac{0.498}{634.4} \\ &= 0.018887 \text{ m}^2 = 188.87 \text{ cm}^2 \end{aligned}$$

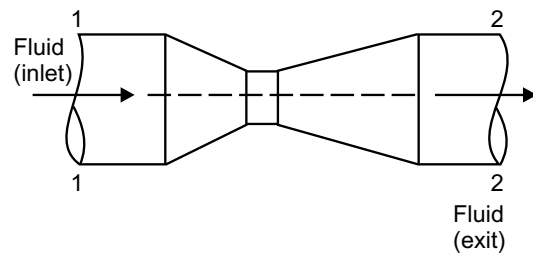
**EXAMPLE 14**

A turbine operates under steady flow condition receiving steam at the following state:

pressure 1.2 MPa, temperature 188°C, enthalpy 2785 kJ/kg, velocity 33.3 m/sec and elevation 3 m. The steam leaves the turbine at the following state:

pressure 20 kPa, enthalpy 2512 kJ/kg, velocity 100 m/sec and elevation 0 m. If heat is lost to the surroundings at the rate of 0.29 kJ/sec and the rate of steam flow through the turbine is 0.42 kg/sec, what is the power output of the turbine in kW?

**SOLUTION**

Here,

$$\begin{aligned} p_1 &= 1.2 \text{ MPa}, p_2 = 20 \text{ kPa}, h_1 = 2785 \text{ kJ/kg}, h_2 = 2512 \text{ kJ/kg}, \\ V_1 &= 33.3 \text{ m/s}, V_2 = 100 \text{ m/s}, Z_1 = 3 \text{ m}, Z_2 = 0 \text{ m} \end{aligned}$$

∴ S.E.F.E. for control volume,

$$h_1 + \frac{V_1^2}{2} + Z_1 g + q_{1-2} = h_2 + \frac{V_2^2}{2} + Z_2 g + w_{1-2}$$

$$\begin{aligned} \Rightarrow w_{1-2} &= (h_1 - h_2) + \frac{1}{2}(V_1^2 - V_2^2) + (Z_1 - Z_2)g + q_{1-2} \\ &= (2785 - 2512) + \frac{1}{2}(33.3^2 - 100^2)10^{-3} + 9.81 \times 3 \times 10^{-3} + \frac{0.29}{0.42} = 269.27 \text{ kJ/kg} \end{aligned}$$

$$\therefore \text{Power output} = mw_{1-2} = 0.42 \times 269.27 = 113.09 \text{ kW}$$

### EXAMPLE 15

At the Intel to a certain nozzle, the specific enthalpy of a fluid passing is 3000kJ/kg and the velocity is 60m/sec. At the discharge end, the specific enthalpy is 2762 kJ/kg. The nozzle is horizontal and there is negligible heat loss from it. (a) find the velocity at exit from the nozzle (b) if the inlet area 0.1m<sup>2</sup> and specific volume at inlet is 0.187 m<sup>3</sup>/kg, find the mass flow rate (c) if the specific volume at the nozzle exit is 0.498m<sup>3</sup>/kg, find exit area of the nozzle.

#### SOLUTION

Here,  $h_1 = 3000 \text{ kJ/kg}$ ,  $h_2 = 2762 \text{ kJ/kg}$ ,  $V_1 = 60 \text{ m/s}$ , negligible  $q_{1-2} = \text{negligible}$ ,  $w_{1-2} = 0$ ,  $A_1 = 0.1 \text{ m}^2$ ,  
 $v_{s1} = 0.187 \text{ m}^3/\text{kg}$ ,  $v_{s2} = 0.498 \text{ m}^3/\text{kg}$

From steady flow energy equation (S.F.E.E.),

$$h_1 + \frac{V_1^2}{2} + Z_1 g + q_{1-2} = h_2 + \frac{V_2^2}{2} + Z_2 g + w_{1-2}$$

$$\Rightarrow (V_2^2 - V_1^2) = 2(h_1 - h_2)$$

$$\Rightarrow V_2 = \sqrt{60^2 + 2(3000 - 2762)10^3} = 692.5 \text{ m/s}$$

$$\text{Mass flow rate} \quad m = \frac{A_1 V_1}{v_{s1}} = \frac{0.1 \times 60}{0.187} = 32.08 \text{ kg/s}$$

$$\text{Exit area of the nozzle} \quad A_2 = \left( \frac{A_1 V_1}{v_{s1}} \right) \cdot \left( \frac{v_{s1}}{V_2} \right) = \frac{32.08 \times 0.498}{692.5} = 0.023 \text{ m}^2$$

### EXAMPLE 16

During a certain flow process the internal energy per kg of the gas decreases by 160 kJ/kg and the flow work increases by 5000 kNm for 10 kg of the gas. Determine the change in total enthalpy, specific enthalpy change in flow work per kg.

#### SOLUTION

$$\text{As,} \quad h_1 = u_1 + p_1 v_{s1} \text{ and } h_2 = u_2 + p_2 v_{s2}$$

$$\begin{aligned} \text{So,} \quad h_2 - h_1 &= (u_2 - u_1) + (p_2 v_{s2} - p_1 v_{s1}) && \left[ \because \text{flow work/mass} = \frac{5000}{10} = 500 \text{ kJ/kg} \right] \\ &= -160 + 500 = 340 \text{ kJ/kg} \end{aligned}$$

- ∴ Specific enthalpy increases = 340 kJ/kg  
 ∴ Total enthalpy increases =  $m(h_2 - h_1) = 10 \times 340 = 3400$  kJ

**EXAMPLE 17**

A boiler is a steady flow system. Assuming that changes in K.E and P.E are negligible, determine the heat transferred per kg of steam if the water enters the boiler with an enthalpy of 160 kJ/kg and the steam leaves the boiler with 3128 kJ/kg.

**SOLUTION**

Now, 
$$h_1 + \frac{V_1^2}{2} + Z_1g + q = h_2 + \frac{V_2^2}{2} + Z_2g + w_s$$

Assuming the changes in K.E and P.E negligible,

$$(q - w_s) = (h_2 - h_1) = 3128 - 160 = 3022 \text{ kJ/kg}$$

For boiler there will be no shaft work, so  $w_s = 0$

Hence, heat transfer 3022 kJ/kg.

**EXERCISE**

1. Explain the first law of thermodynamics for the closed systems undergoing a cyclic change.
2. Define internal energy and prove that it is a property of a steam.
3. State the first law of thermodynamics and prove that for a non-flow process it leads to the energy equation  $Q = \Delta E + Q$ .
4. What is the mechanical equivalent of heat? Write down its value when heat is expressed in kJ and work is expressed in Nm.
5. What do you mean by PMM-I?
6. Why only in constant pressure non-flow process, the enthalpy change is equal to heat transfer?
7. Explain clearly the difference between a non-flow and steady flow process.
8. For isothermal flow and non-flow steady processes, prove that,  $\int_1^2 p dV = - \int_1^2 V dp$ , also state the assumptions made.
9. Write down the general energy equation for steady flow system and simplify when applied for the following systems: (i) centrifugal water pump (ii) reciprocating air compressor (iii) steam nozzle (iv) gas turbine.
10. 1.35 kg of air at 179°C expands adiabatically and reversibly to three times its original volume and during the process, there is fall in temperature to 15.5°C. The mechanical work done during the process is 150 kNm. Determine  $C_p$  and  $C_v$ .
11. The energy of a system increases by 50 kJ while the system is receiving 43 kJ of work. How much heat is transferred and in which direction?

12. 2 kg of a gas at 10 bar expands adiabatically and reversibly till the pressure falls to 5 bar. During the process 0.1224 MNm non-flow work is done by the system and the temperature falls from 378°C to 257°C. Calculate the value of the index of expansion and characteristic gas constant.
13. Determine the characteristic gas constant if specific volume at 27°C and a pressure of 1 bar is 12 m<sup>3</sup>.
14. During a non-flow process, work/°C increase in  $dW/dt = 800 \text{ Nm/}^\circ\text{C}$  and the internal energy is given by  $U = (100 + 5t) \text{ Nm/}^\circ\text{C}$ . Determine the heat transferred from the system if temperature changes from 50°C to 140°C.
15. A gas is contained in a closed rigid tank fitted with paddle wheel. The paddle wheel stirs the gas for 20 minutes with the power varying with time  $W = -10t$  where  $W$  in watts,  $t$  in minutes. Heat transfer from the gas to the surroundings takes place at a constant rate of  $50W$ . Determine (i) rate of change of energy of the gas at  $t = 10$  minutes. (ii) net change in the energy of the gas.
16. A quantity of gas in a closed container has a pressure of 10 bar and volume of 0.925 m<sup>3</sup> and temperature of 27°C. The characteristic gas constant is 287 Nm/kgK. Determine the mass of the gas in the container. If the pressure of the gas is decreased to 5 bar, how will the temperature of the gas be affected?
17. A gas occupies 9 m<sup>3</sup> at a pressure of 2 bar. If it is compressed isothermally to 1.5 m<sup>3</sup> determine the final pressure. 5 kg of gas at 150°C and 1.5 bar is heated at constant pressure until the volume is doubled. Determine the heat added and the final temperature reached.

**This page  
intentionally left  
blank**

## SECOND LAW OF THERMODYNAMICS

---

### 5.1 INTRODUCTION

The first law of thermodynamics gives a quantitative estimate of heat and work interaction between a system and surroundings. If the system undergoes a thermodynamic process or a cycle, the first law cannot indicate whether the process or cycle in a particular direction would occur at all or not. It is the second law of thermodynamics which provides the answer to the questions of limitations in the first law of thermodynamics. Before we state the second law, it is necessary to clearly understand the meaning of the terms like thermal reservoir, source, sink, heat engine, refrigerators and heat pumps.

- (a) **Thermal Reservoir:** A thermal reservoir is a large system to which a finite quantity of energy as heat can be added or from which a finite amount of energy as heat can be extracted without changing its temperature. The ambient atmosphere is an example of a thermal reservoir. The environment constitutes the longest heat reservoir operating without any change in temperature. It is used as a heat sink and sometimes as a heat source.
- (b) **Source:** A source is a thermal reservoir at higher temperature from which energy in the form of heat is received by a heat engine.
- (c) **Sink:** A sink is a thermal reservoir at lower temperature to which energy as heat is rejected by a heat engine.
- (d) **Heat Engine:** A heat engine is a thermodynamic system operating in a cycle to which net positive amount of heat is added, and from which net positive amount of work is obtained. The heat engine operated in a cycle is known a heat engine cycle. A schematic diagram of heat engine is shown in figure 5.1. Thus for the satisfactory operation of a heat engine there should be at least two reservoirs of heat, one at a higher temperature and the other at a lower temperature, as shown in figure 5.1. Heat energy  $Q_H$  is received from the high temperature reservoir (source) at temperature  $T_H$  and is supplied to the engine. A part of this heat energy  $Q_L$  is rejected to the low temperature reservoir(sink) at temperature  $T_L$ . Then, the remaining heat energy *i.e.*,  $(Q_H - Q_L)$  is converted into mechanical work ( $W$ ). The ratio of the maximum mechanical work obtained to the total heat supplied to the engine is known as maximum thermal efficiency ( $\eta_{\max}$ ) of the engine.

Mathematically

$$\begin{aligned}\eta_{\max} &= \frac{\text{maximum work obtained}}{\text{total heat supplied}} \\ &= \frac{W}{Q_H} = \frac{Q_H - Q_L}{Q_H} \\ &= 1 - \frac{Q_L}{Q_H} = 1 - \frac{T_L}{T_H}\end{aligned}$$

For a reversible engine we have,  $\frac{Q_L}{T_L} = \frac{Q_H}{T_H}$ .

**(e) Refrigerator and Heat Pump (Reversible Heat Engine):**

It is a device that removes heat energy from a low temperature body (or reservoir) and rejects it to a high temperature body. It is a thermodynamic system operating in a cycle from which a net negative amount of heat is transferred, and on which a net negative amount of work is done.

Schematic diagram of refrigerator and heat pump are shown in figure 5.2. Though there is no difference between the cycle of operations of refrigerator and a heat pump and achieve the same overall objective, but the basic purpose of each is quite different.

The device is called a refrigerator when the objective is to produce cold. It removes heat from a cool body at low temperature below atmospheric temperature, and rejects it to the surrounding *i.e.*, atmospheric temperature. Thus, a refrigerator  $R$  operates between the temperature of the surrounding, and a temperature below that of the surrounding as shown in figure 5.2(a).

On the other hand, a heat pump is a device which is operating in a cyclic process, when the objective is to maintain the temperature of a hot body at a temperature higher than the temperature of surrounding. Thus, a heat pump  $P$  operates between the temperature of the surrounding, and a temperature above that of the surrounding as shown in figure 5.2(b).

In case of refrigerator, the atmosphere acts as a hot body while in case of a heat pump, the atmosphere acts as a cold body.

The performance of the refrigerator and heat pump is measured in terms of coefficient of performance ( $COP$ ) which is defined as the ratio of the maximum heat transferred *i.e.*, heat taken from the cold body  $Q_L$  (in case of refrigerator) to the amount of work required  $W_R$  to produce the desired effect. From figure 5.2(a) we have,

$$Q_L + W_R = Q_H \quad \text{or, } W_R = Q_H - Q_L$$

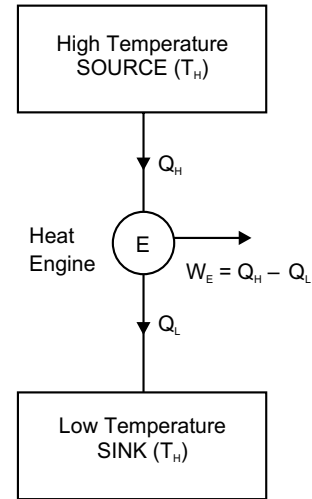

Fig. 5.1

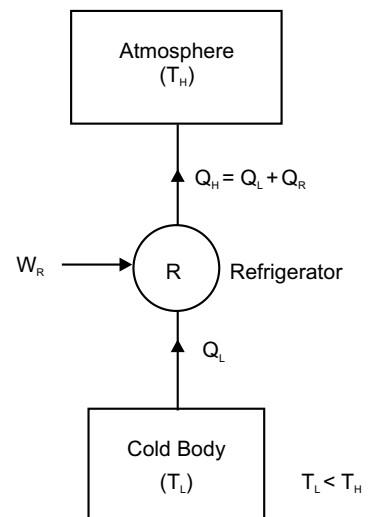

Fig. 5.2 (a)

So, mathematically coefficient of performance for a refrigerator

$$(COP)_R = \frac{Q_L}{W_R} = \frac{Q_L}{Q_H - Q_L} = \frac{T_L}{T_H - T_L}$$

For heat pump coefficient of performance is defined as the ratio of the maximum heat transfer to the hot body  $Q_H$  to the amount of work ( $W_p$ ) required to produce the desired effect. From figure 5.2(b) we have,

$$W_p + Q_L = Q_H \quad \text{or, } W_p = Q_H - Q_L$$

Mathematically, maximum co-efficient of performance for heat pump

$$\begin{aligned} (COP)_P &= \frac{Q_H}{W_p} \\ &= \frac{Q_H}{Q_H - Q_L} = \frac{Q_H - Q_L + Q_L}{Q_H - Q_L} \\ &= 1 + \frac{Q_L}{Q_H - Q_L} = 1 + \frac{T_L}{T_H - T_L} \\ &= 1 + (COP)_R \end{aligned}$$

So, COP of a heat pump is greater than COP of a refrigerator by unity.

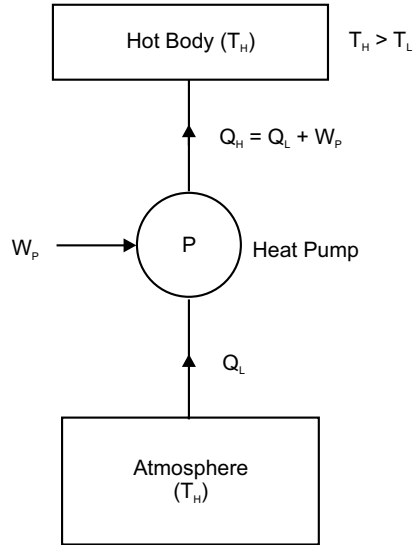

Fig. 5.2 (b)

## 5.2 THE SECOND LAW OF THERMODYNAMICS

There are several statements of the second law of thermodynamics. Out of these, we will discuss two classical statements, known as the *Kelvin-Planck* statement and the *Clausius* statement. The Kelvin-Planck statement refers to a heat engine. The Clausius statement refers to a refrigerator or heat pump (reversible heat engine).

### 5.2.1 Kelvin-Planck Statement of the Second Law of Thermodynamics

According to Kelvin-Planck, *it is impossible to construct an engine working on a cyclic process, whose sole purpose is to convert heat energy from a single thermal reservoir into an equivalent amount of work.* In other words, no actual heat engine, working on a cyclic process, can convert whole of the heat supplied to it, into mechanical work. It means that there is a dissipation egradation of energy in the process of producing mechanical work from the heat supplied. Thus, the Kelvin-Planck statement of the second law of thermodynamics is sometimes known *a law of degradation of energy.*

**(a) Perpetual Motion Machine of the Second Kind (briefly written a PMM-II or PMMSK):** A Perpetual Motion Machine of the Second Kind (PMMSK) is a hypothetical

device (heat engine) which operates in cycle, absorbing energy as heat from a single thermal reservoir and delivering an equivalent amount of work. A schematic diagram of a perpetual motion machine of the second kind is shown in figure 5.3. The Kelvin-Planck statement of the second law of thermodynamics never supports possibility of devising a PMMSK. So, PMMSK violates the second law of thermodynamics. But the PMMSK does not violate the first law of thermodynamics, because, the first law of thermodynamics does not put any restriction as to the fraction of heat drawn from a heat reservoir that can be converted to work. 100% efficient heat engine does not violate the first of thermodynamics.

- (b) **Actual Heat Engine:** The statement implies that a heat engine  $E$  of the type shown in figure 5.3 which will receive heat ( $Q_H$ ) from a high temperature ( $T_H$ ) reservoir, and convert it completely into work, is impossible. The only alternative is that there must be at least one other low temperature ( $T_L$ ) reservoir to which heat  $Q_L$  must be rejected by the engine, because the second law of thermodynamics expresses the fact that the heat engine must reject heat to the low temperature reservoir while drawing heat from the higher temperature reservoir and this also implies that two heat reservoirs are an essential minimum for a heat engine. Accordingly, we obtain a schematic representation of a heat engine as shown in figure 5.1. All heat engines must conform to this representation.

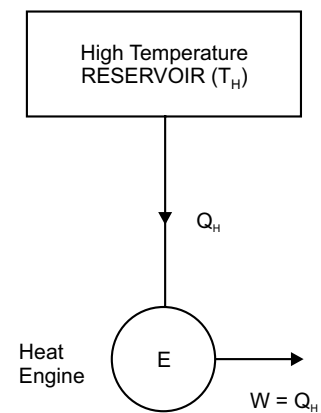

Fig. 5.3

### 5.2.2 Clausius Statement of the Second Law of Thermodynamics

According to Clausius, *it is impossible to construct a device (or self acting machine) working in a cyclic process, to transfer heat from a body at a lower temperature ( $T_L$ ) to a body at a higher temperature ( $T_H$ ) without the aid of an external agency.* In other words, heat cannot flow itself from a cold body to a hot body without the help of an external agency *i.e.*, without the expenditure of Mechanical work.

- (a) **PMM-II:** The device (reversible heat engine *i.e.*, refrigerator or heat pump) which violates the Clausius statement because no input work is supplied to the device to transfer heat from a cold body to a hot body is shown in figure 5.4. Such a device is called perpetual motion machine of the second kind.
- (b) **0 Reversible Heat Engine (Refrigerator/Heat Pump):** The statement implies that refrigerator  $R$  or heat pump  $P$  of the type shown in figure 5.4 which will receive heat  $Q_L$  from a low temperature reservoir and transfer it to a high temperature reservoir is impossible. The only alternative is that there must be some work input ( $W$ ). Accordingly, we obtain a schematic representation of refrigerator and heat

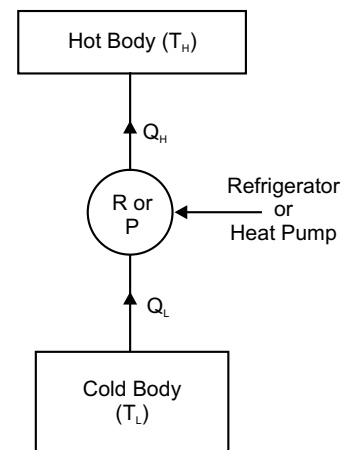

Fig. 5.4

pump as shown in figure 5.2(a) and (b). It is worth pointing out here that the devices in figure 5.2 represents a reversed heat engine since it comprises of all reversible processes.

### 5.3 EQUIVALENCE OF KELVIN-PLANCK AND CLAUSIUS OF SECOND LAW OF THERMODYNAMICS

The Kelvin-Planck and Clausius statement of the second law of thermodynamics are, though appear to be different from each other, but these two statements are virtually equivalent in all respects. The equivalence of Kelvin-Planck and Clausius statements can be proved, if it can be shown that the violation of Kelvin-Planck statement implies the violation of Clausius statement and vice versa.

#### 5.3.1 A Violation of Kelvin-Planck Statement Leads to a Violation of Clausius Statement of the Second Law of Thermodynamics

Consider a system as shown in figure 5.5. In this system, a heat engine having 100% thermal efficiency is violating the Kelvin-Planck statement as it converts the heat energy ( $Q_H$ ) from a single high temperature reservoir  $T_H$ , into a equivalent amount of work *i.e.*,  $W = Q_H$ . This work output of the heat engine can be used to drive a heat pump (reversible heat engine) which  $(W + Q_L) = Q_H + Q_L$  to a high temperature reservoir at  $T_H$ . If the combination of heat engine and a reversible heat engine is considered as a single system, as show in figure 5.5, then the result is a device that operates in a cycle and has no effect on the surroundings other than the transfer of heat  $Q_L$  from a low temperature reservoir to a high temperature reservoir, thus violating the Clausius statement. Hence, a violation of Kelvin-Planck statement leads to a violation of Clausius statement.

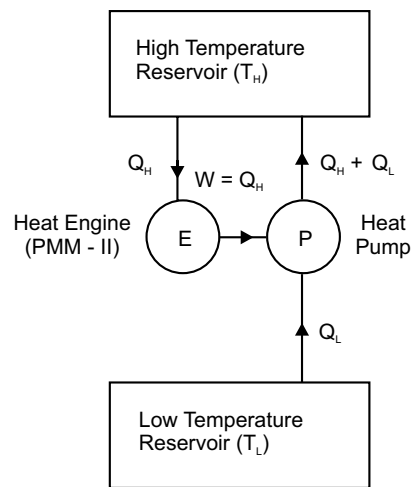

Fig. 5.5

#### 5.3.2 A Violation of Clausius Statement Leads to a Violation of Kelvin-Planck Statement of the Second Law of Thermodynamics

Consider a system as shown in figure 5.6. In this system, a heat pump (PMM-II) is violating the Clausius statement as it transfers heat from a low temperature reservoir at  $T_L$  to a high temperature reservoir at  $T_H$  without any expenditure of work. Now let a heat engine, operating between the same heat reservoirs, receives an amount of heat  $Q_H$  (as discharged by heat pump) from the high temperature reservoir at  $T_H$ , does work  $W_E = Q_H - Q_L$  and rejects an amount of heat  $Q_L$  to the low temperature reservoir at  $T_L$ . If the combination of the heat pump and the

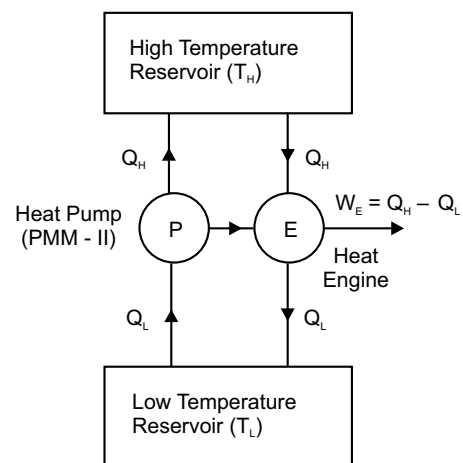

Fig. 5.6

heat engine is considered as a single system, as shown in figure 5.6, then the result is a device that operates in a cycle whose sole effect is to remove heat at the rate of  $(Q_H - Q_L)$  and convert it completely into an equivalent amount of work, thus violating the Kelvin-Planck statement. Hence, a violation of Clausius statement leads to a violation of Kelvin-Planck statement of the second law of thermodynamics.

#### 5.4 REVERSIBLE CYCLE

A thermodynamically reversible cycle consists of reversible processes. The process will be reversible when it is performed in such fashion that the system remains at all time infinitesimally near a state of thermodynamic equilibrium and at the end of process, both the system and the surroundings may be restored to their initial state. Therefore, *reversible processes are purely ideal*. In reversible process there are no dissipative effect, all the work done by the system during the performance of a process in one direction can be returned to the system during the reverse process. For example, consider a process in which the system (gas) is expanded from state 1 to state 2 following the path 1–2 as shown in figure 5.7. If during the thermodynamic process 1–2 the work done on the system by compressing is  $W_{1-2}$  and heat absorbed is  $Q_{1-2}$ , then by extracting heat  $Q_{1-2}$  from the system, we can bring the system and surrounding, back from state 2 to state 1 following the same path 2–1, then the process is said to be reversible process.

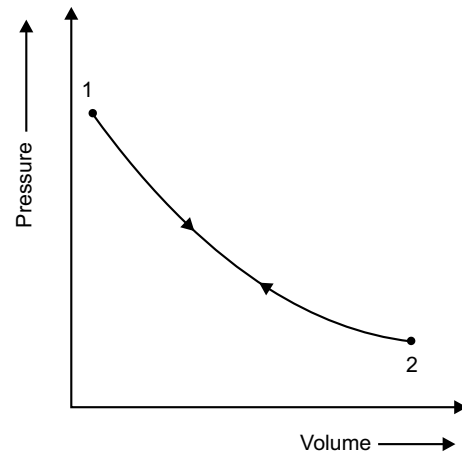

Fig. 5.7

#### 5.5 IRREVERSIBLE CYCLE

A thermodynamic cycle will be irreversible, if any one of the process, constituting the cycle is an irreversible process. When heat and work are not completely restored back by reversing the process, then the process is known as irreversible or natural or real process. In an irreversible process, there is a loss of heat due to friction, radiation or conduction. In actual practice most of the process are irreversible to some degree. In irreversible cycle, the initial condition are not restored at the end of the cycle.

#### 5.6 REVERSIBILITY AND IRREVERSIBILITY OF THERMODYNAMIC PROCESS

##### (a) Reversibility of Thermodynamic Process

Following are the conditions for reversibility of a cycle.

1. The departure from equilibrium is infinitesimal i.e.,  $dT \rightarrow 0$ ,  $dp \rightarrow 0$ . Accordingly, all the processes, taking place in the cycle of operation must be infinitely slowly, i.e., in a quasi-equilibrium manner.
2. The pressure and temperature of the working substance must not differ, appreciably from those of the surroundings at any stage in the process.

3. The working parts of the engine must be friction free, because, there should not be any loss of heat due to friction.
4. There should be no loss of energy during the cycle of operation.

### (b) Irreversibility of Thermodynamic Process

The main causes for the irreversibility are

1. Due to lack of equilibrium during the process.
2. Due to involvement of dissipative effects.
3. Due to mechanical and fluid friction.
4. Due to unrestricted expansion.
5. Due to heat transfer with a finite temperature difference.

It is performed at a finite rate with finite potential differences. If there is some friction involved in the process, it becomes irreversible, because friction converts the mechanical work into heat. This heat cannot supply back the same amount of mechanical work, which was consumed for its production.

### 5.7 CARNOT CYCLE

Carnot cycle is a reversible cycle. This cycle was devised by *Carnot*, in 1828, who was the first scientist to analyse the problem of the efficiency of a heat engine, disregarding its mechanical details. This cycle, operating between two heat reservoirs, consists of an alternate series of two reversible isothermal and two reversible adiabatic or isentropic processes. These cycle can be operated either (i) as a vapour cycle (ii) or as a gas cycle.

- (i) **Vapour Cycle:** A cycle is defined as a vapour cycle when the processes involve change of phase of working substance from liquid to vapour, and from vapour to liquid as shown in figure 5.8 on  $p$ - $V$  diagram .

The Carnot vapour power cycle can be realised by a combination of flow processes as shown in figure 5.9. The cycle of operations is performed in different units having a defined function. The substance, *i.e.*, fluid, flows from one unit to the other unit in a steady flow. In the *boiler* isothermal process occurs, at temperature

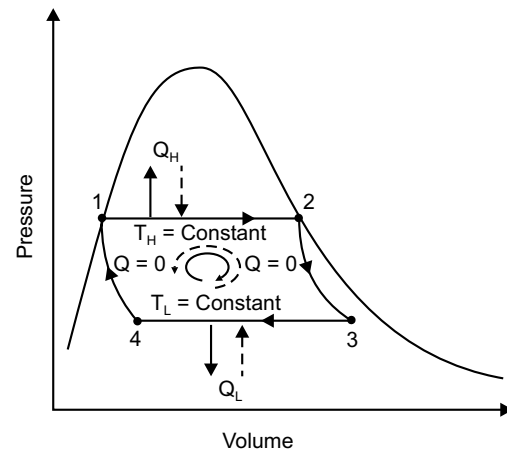

Fig. 5.8

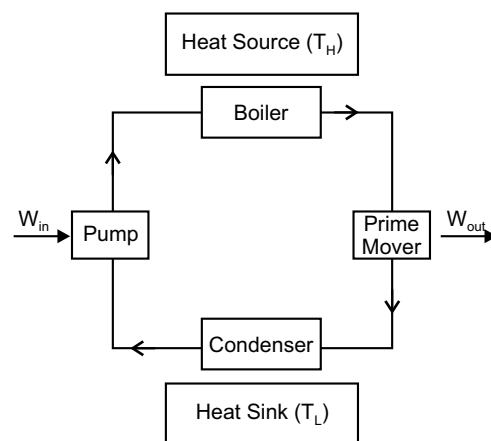

Fig. 5.9

$T_H$  and water is transferred into steam. In the *condenser* steam is transferred into water at temperature  $T_L$ , the reversible adiabatic expansion operation takes place in the *turbine* or *prime mover* and reversible adiabatic compression takes place in the pump.

The Carnot efficiency is given by

$$\begin{aligned}\eta_{\text{Carnot}} &= \frac{T_H - T_L}{T_H} \\ &= 1 - \frac{T_L}{T_H}\end{aligned}$$

(ii) **Gas Cycle:** A cycle, in which the working substance remains a gas throughout, is referred to as a gas cycle, which is shown in figure 5.10.

In the Carnot cycle, the working substance (air supposed to behave like a perfect gas) is subjected to a cyclic operation, consisting of *two isothermal* and *two reversible adiabatic* operations.

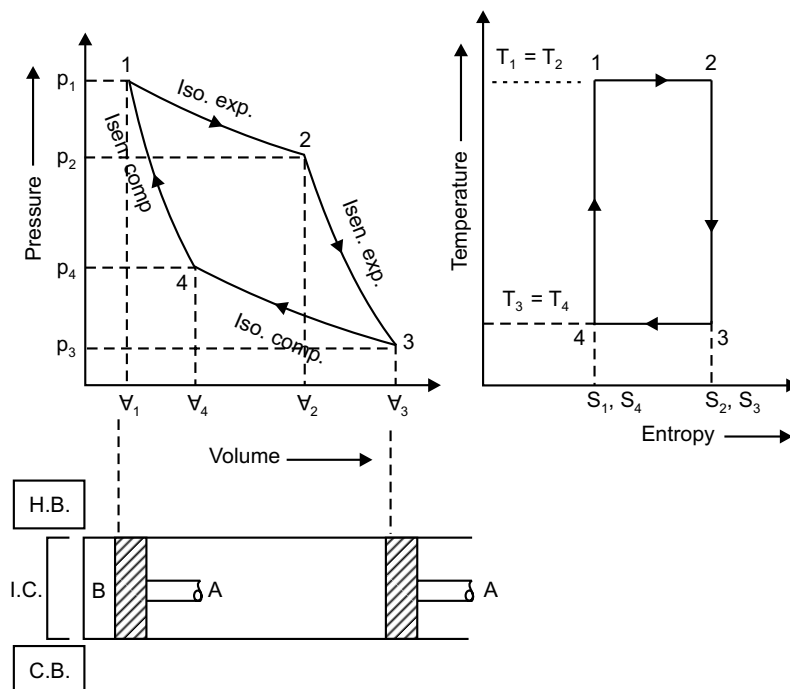

Fig. 5.10

Here, air is enclosed in a cylinder in which frictionless piston  $A$  moves. The walls of the cylinder and piston are perfectly non-conductor of heat. The bottom  $B$  of the cylinder can be covered by an insulating cap *i.e.*, the engine is assumed to work between two sources of infinite heat capacity, one at a higher temperature and other at a lower temperature. Four stages of the Carnot's cycle are

considered. The engine cylinder contains  $m$  kg of air at its original condition represented by point 1 on  $p$ - $\forall$  diagram. At this point  $p_1$ ,  $T_1$  and  $\forall_1$  be the pressure, temperature and volume of the air.

1. *First Stage (Isothermal expansion)*

The source (hot body H.B.) at a higher temperature is brought in contact with the bottom  $B$  of the cylinder. The air expands at constant temperature from  $\forall_1$  to  $\forall_2$  *i.e.*, temperature  $T_2$  at point 2 is equal to  $T_1$ . Isothermal expansion is represented by the curve 1-2 on  $p$ - $\forall$  diagram. Heat supplied by the hot body is totally absorbed by the air and is doing external work.

$\therefore$  Heat supplied = Work done

$$\begin{aligned} \text{So,} \quad Q_{1-2} &= p_1 \forall_1 \ln \left( \frac{\forall_2}{\forall_1} \right) \\ &= mRT_1 \cdot \ln \left( \frac{\forall_2}{\forall_1} \right) \\ &= 2.3 mRT_1 \log \left( \frac{\forall_2}{\forall_1} \right) \\ &= 2.3 mRT_1 \log_r \end{aligned}$$

Let  $\frac{\forall_2}{\forall_1} = r = \text{expansion ratio.}$

2. *Second Stage (Reversible adiabatic expansion)*

The hot body is removed from the bottom of the cylinder and the insulating cap *i.e.*, is brought in contact. The air is now allowed to expand reversibly and adiabatically. Curve is represented by (2-3) on  $p$ - $\forall$  diagram from  $\forall_2$  to  $\forall_3$ . Temperature falls from  $T_2$  to  $T_3$ . No heat is absorbed or rejected by the air.

$\therefore$  Decrease internal energy = Work done by adiabatic exp.

$$= \frac{p_2 \forall_2 - p_3 \forall_3}{\gamma - 1} = \frac{mR(T_2 - T_3)}{\gamma - 1} = \frac{mR(T_1 - T_4)}{\gamma - 1}$$

3. *Third Stage (Isothermal compression)*

Removing the insulating cap from the bottom and is brought the cold body (C.B) in its contact. The air is compressed at constant temperature  $T_3$  from  $\forall_3$  to  $\forall_4$ . Isothermal compression is represented by the curve (3-4) on  $p$ - $\forall$  diagram. Heat is rejected to the cold body and is equal to the work done on the air.

$$\text{Heat rejected } (Q_{3-4}) = p_3 \forall_3 \ln \left( \frac{\forall_3}{\forall_4} \right) = 2.3 mRT_3 \log r$$

$$\left[ \begin{array}{l} \therefore \frac{T_2}{T_3} = \left( \frac{V_3}{V_2} \right)^{\gamma-1} \quad \text{and} \quad \frac{T_1}{T_4} = \left( \frac{V_4}{V_1} \right)^{\gamma-1} \\ \therefore \frac{V_3}{V_2} = \left( \frac{T_2}{T_3} \right)^{\frac{1}{\gamma-1}} \quad \text{and} \quad \frac{V_4}{V_1} = \left( \frac{T_1}{T_4} \right)^{\frac{1}{\gamma-1}} \\ \therefore T_1 = T_2 \text{ and } T_3 = T_4 \quad \therefore \frac{V_3}{V_2} = \frac{V_4}{V_1} \\ \therefore \frac{V_3}{V_4} = \frac{V_2}{V_1} = r \end{array} \right]$$

(4) *Fourth Stage (Reversible adiabatic compression)*

Now the insulated cap is brought in contact with the bottom of the cylinder and the air is allowed to be compressed reversibly and adiabatically represented by the curve (4–1) on  $p$ - $V$  diagram. Temperature increases from  $T_4$  to  $T_1$ . Since no heat is absorbed or rejected,

$\therefore$  Increase in internal energy = Work done

$$= \frac{p_1 V_1 - p_4 V_4}{\gamma - 1} = \frac{mR(T_1 - T_4)}{\gamma - 1}$$

So, decrease in internal energy during reversible adiabatic expansion (2–3) = increase in internal energy during reversible adiabatic compression (4–1)

Work done = Heat supplied – Heat rejected

$$\begin{aligned} \therefore W &= 2.3mRT_1 \log r - 2.3mRT_3 \log r \\ &= 2.3mR \log r (T_1 - T_3) \end{aligned}$$

$$\begin{aligned} \therefore \eta &= \frac{\text{work done}}{\text{heat supplied}} \\ &= \frac{T_1 - T_3}{T_1} = \left( 1 - \frac{T_3}{T_1} \right) \end{aligned}$$

## 5.8 REVERSE CARNOT CYCLE

The Carnot cycle is a reversible cycle. If the processes of the Carnot power cycle are carried out in the reverse order, it will become a refrigerator or heat pump cycle which is discussed before. It is then referred to as reverse Carnot cycle.

## 5.9 CARNOT THEOREM

*It states that, no heat engine working between two temperature can be more efficient than the reversible engine working between the same two temperature or Carnot engine (hypothetical), among all engines operating between two fixed temperature, is the most efficient.*

**Multiple Choice Questions**

- In a power plant, Turbine work = 10,000 kJ, pump work = 10 kJ, heat supplied by boiler = 30,000 kJ. Thermal efficiency of the plant will be
  - 27%
  - 33.333%
  - 33.33%
  - 33.30%
- A refrigerator and heat pump operate between the same temperature limits. If COP of the refrigerator is 4, the COP of the pump would be
  - 3
  - 5
  - 4
  - cannot predict
- Energy requirement to heat an enclosure fully insulated will be less
  - if heat pump is used for heating
  - if electric strip heater is used for heating
  - if steam is used for heating
  - if hot water is used for heating
- It is impossible to construct an engine which while operating in a cycle produces no other effect to extract heat from a single reservoir and do equivalent amount of work.
  - this refers to Clausius statement
  - this refers to Kelvin-Planck statement
  - this refers to Carnot theorem
  - this does not refer to any of the above
- Carnot cycle operates between temperature of 1000 K and 500 K. The Carnot efficiency will be 50% of working substance is
  - air
  - nitrogen
  - ammonia
  - any substance
- Carnot cycle comprises
  - two isothermal processes and two isentropic processes
  - two constant volume processes and two isentropic processes
  - one constant volume, one constant pressure and two isentropic processes
  - two constant pressure and two isentropic processes
- A heat engine is supplied with 800 kJ/sec of heat at 600 K and rejection take place at 300 K. Which of the following results report a reversible cycle.
  - 200 kJ/sec are rejected
  - 400 kJ/sec are rejected
  - 100 kJ/sec are rejected
  - 500 kJ/sec are rejected
- A heat engine is supplied with 800 kJ/sec of heat at 600 K and rejects 100 kJ/sec at 300 K. The data refers to
  - reversible cycle
  - irreversible cycle
  - impossible cycle
  - none of the above
- Equation  $TdS = dU + pdV$  can be applied to processes which are
  - only reversible
  - only irreversible
  - reversible or irreversible
  - none of the above

10. Change in entropy for isothermal process carried on a gas whose specific volume changes from  $V_1$  to  $V_2$  and pressure changes from  $p_1$  to  $p_2$  is given by
- (a)  $\Delta S = -R \ln \frac{V_2}{V_1}$  (b)  $\Delta S = R \ln \frac{p_2}{p_1}$
- (c)  $\Delta S = -R \ln \frac{p_2}{p_1}$  (d)  $\Delta S = -R \ln \frac{V_2}{V_1} + R \ln \frac{p_2}{p_1}$
11. Change in entropy for polytropic process is expressed as
- (a)  $\Delta S = C_v \left( \frac{\gamma - n}{\gamma - 1} \right) \ln \frac{T_2}{T_1}$  (b)  $\Delta S = C_v \left( \frac{\gamma - n}{\gamma - 1} \right) \ln \frac{T_2}{T_1}$
- (c)  $\Delta S = \frac{\gamma - n}{\gamma - 1} \frac{R}{J} \ln \frac{T_2}{T_1}$  (d)  $\Delta S = C_v \left( \frac{\gamma - n}{\gamma - 1} \right) \ln \frac{V_2}{V_1}$
12. The polytropic index of expansion  $n$  in the equation  $p v^n = c$  for constant volume process is
- (a) 1 (b) 1.4
- (c)  $\alpha$  (d) 0 (zero)
13. The change of entropy of a closed system
- (a) is same for every process between two specified states
- (b) is not the same for every process between two specified states
- (c) is same only for isothermal process between two specified states
- (d) is the same only for reversible adiabatic process between two specified states.
14. The entropy of fixed amount of an ideal gas
- (a) decreases in every isothermal compression
- (b) increase in every isothermal compression
- (c) remains same in every isothermal compression
- (d) may increase or decrease in every isothermal compression.
15. The specific internal energy, enthalpy and entropy of an ideal gas are
- (a) each function of temperature alone
- (b) each function of pressure alone
- (c) each function of volume alone
- (d) each of the above statements (a), (b) and (c) are false.
16. One of the  $Tds$  equation has the form
- (a)  $Tds = dh + vdp$  (b)  $Tds = dh - vdp$
- (c)  $Tds = du - pdv$  (d)  $Tds = dh + pdv$
17. The entropy of a fixed amount incompressible substance
- (a) decreases in every process in which temperature increases
- (b) remains same in every process in which temperature increases
- (c) increases in every process in which temperature increases
- (d) is not affected in the process by increase or decrease of temperature.

18. A closed system undergoes a process in which the work done on the system is 5 kJ and heat transfer  $Q$  occurs only at temperature  $T_b$ , the change in entropy for  $Q = 5$  kJ and internally reversible process is:  
(a) positive (b) negative  
(c) zero (d) indeterminate.
19. Same as 18. For  $Q = 0$  and internally reversible process. The change in entropy is  
(a) positive (b) negative  
(c) zero (d) indeterminate
20. Same as 18. For  $Q = -5$  kJ and internally reversible the change in entropy is  
(a) positive (b) negative  
(c) zero (d) indeterminate
21. Same as 18. For  $Q = +5$  kJ and internal irreversibilities present the entropy change is  
(a) positive (b) negative  
(c) zero (d) indeterminate
22. Same as 18. For  $Q = 0$  and internal irreversibilities present the entropy change is  
(a) positive (b) negative  
(c) zero (d) indeterminate
23. Same as 18. For  $Q = -5$  kJ and internal irreversibilities present the entropy change is  
(a) positive (b) negative  
(c) zero (d) indeterminate
24. Which of the following statement is true  
(a) no process is allowed in which the entropies of both the system and surroundings increase  
(b) during a process, the entropy the system might decrease, while the entropy of surroundings increases and conversely.  
(c) no process is allowed in which the entropies of both the system and the surroundings remain unchanged.  
(d) a process can occur in which the entropies of both the system and the surrounding decrease.

**Answers**

1. (d) 2. (b) 3. (a) 4. (b) 5. (d) 6. (a) 7. (b) 8. (c) 9. (c) 10. (c)  
11. (a) 12. (c) 13. (a) 14. (a) 15. (d) 16. (c) 17. (c) 18. (a) 19. (c) 20. (b)  
21. (a) 22. (a) 23. (d) 24. (b)

**NUMERICAL EXAMPLES****EXAMPLE 1**

An engine works between the temperature limits of 1775 K and 375 K. What can be the maximum thermal efficiency of the engine?

**SOLUTION**

Here,

$$T_H = 1775 \text{ K}, T_L = 375 \text{ K}$$

$$\eta_{\max} = \frac{T_H - T_L}{T_H} = \frac{1775 - 375}{1775} = 0.1887$$

**EXAMPLE 2**

A heat engine receives heat @ 1500 kJ/min and gives an output of 8.2 kW. Determine thermal efficiency and the rate of heat rejection.

**SOLUTION**

Here,

$$Q_H = \frac{1500 \times 10^3}{60} = 25 \times 10^3 \text{ J/s}, W = 8.2 \times 10^3 \text{ J/s}$$

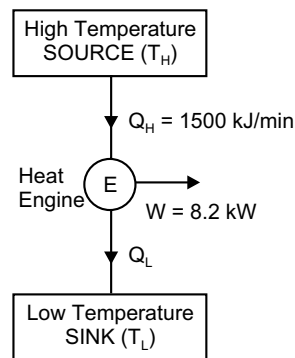

$$\text{Thermal efficiency } \eta_{\text{th}} = \frac{W}{Q_H} = \frac{8.2}{25} = 0.328$$

Rate of heat rejection

$$Q_L = Q_H - W = (25 - 8.2) \times 10^3 = 16.8 \times 10^3 \text{ J/s} = 16.8 \text{ kJ/s}$$

**EXAMPLE 3**

Find the coefficient of performance of heat transfer rate in the condenser of a refrigerator in kJ/hr, which has a refrigeration capacity of 12,000 kJ/hr, when power input is 0.75 kW.

**SOLUTION**

Here,

$$Q_L = 12000 \text{ kJ/hr}$$

$$W_R = 0.75 \times 60 \times 60 \text{ kJ/hr}$$

$$\text{Hence, } (\text{COP})_R = \frac{Q_L}{W_R} = \frac{12000}{0.75 \times 60 \times 60} = 4.44$$

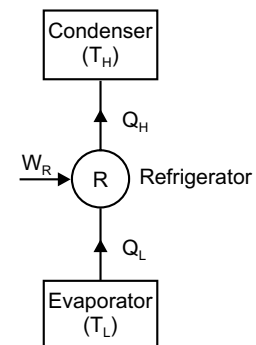

Heat transfer rate

$$Q_H = Q_L + W = 12000 + 0.75 \times 60 \times 60 = 14700 \text{ kJ/hr}$$

**EXAMPLE 4**

A house requires  $2 \times 10^5$  kJ/hr for heating in winter. Heat pump is used to absorb heat from a cold air house. Work required to operate heat pump is  $3 \times 10^4$  kJ/hr. Determine heat abstracted from outside and coefficient of performance.

**SOLUTION**

Heat requirement  $Q_H = 2 \times 10^5$  kJ/hr

Work required operating heat pump  $W = 3 \times 10^4$  kJ/hr

So, heat abstracted from outside

$$Q_L = Q_H - W = 2 \times 10^5 - 3 \times 10^4 = 17 \times 10^4 \text{ kJ/hr}$$

$$(COP)_H = \frac{Q_H}{Q_H - Q_L} = \frac{2 \times 10^5}{2 \times 10^5 - 17 \times 10^4} = 6.66$$

**EXAMPLE 5**

A cyclic heat engine operates between a source temperature of  $1000^\circ\text{C}$  and a sink temperature of  $40^\circ\text{C}$ . Find the least rate of heat rejection per kW net output of the engine.

**SOLUTION**

Here  $T_H = 1000 + 273 = 1273 \text{ K}$ ,  $T_L = 40 + 273 = 313 \text{ K}$

For a reversible heat engine, the rate of heat rejection will be minimum for

$$\eta_{\max} = 1 - \frac{T_L}{T_H} = 1 - \frac{313}{1273} = 0.754$$

Again,  $Q_H = \frac{W_{\text{net}}}{\eta_{\max}} = \frac{1}{0.754} = 1.326 \text{ kW}$

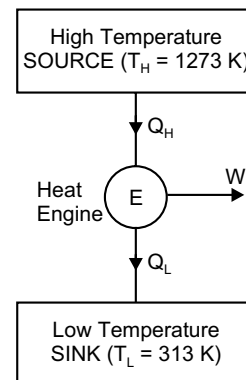

**EXAMPLE 6**

A reversible heat engine operates between two reservoirs at  $600^\circ\text{C}$  and  $40^\circ\text{C}$ . The engine drives a reversible refrigerator, which operates, between reservoirs at  $40^\circ\text{C}$  and  $-20^\circ\text{C}$ . The heat transfer to the engine 2 MJ and the net work output of the combined engine and refrigerator plant is 360 kJ. Find the heat transfer to the refrigerant and the net heat transfer at the reservoir at  $40^\circ\text{C}$ . Also find these values if the efficiency of the heat engine and COP of the refrigerator are each 40% of their maximum possible values.

**SOLUTION**

(i) Here  $T_H = 600 + 273 = 873 \text{ K}$ ,  $T_{H1} = -20 + 273 = 253 \text{ K}$ ,  $T_L = T_{L1} = 40 + 273 = 313 \text{ K}$ .

Let  $Q_H = 2000 \text{ kJ}$  is the heat transfer to the engine and  $Q_{H1}$  is the heat transfer to the refrigerant. So, maximum

efficiency of the heat engine  $\eta_{\max} = 1 - \frac{T_L}{T_H} = 1 - \frac{313}{873} = 0.6415$

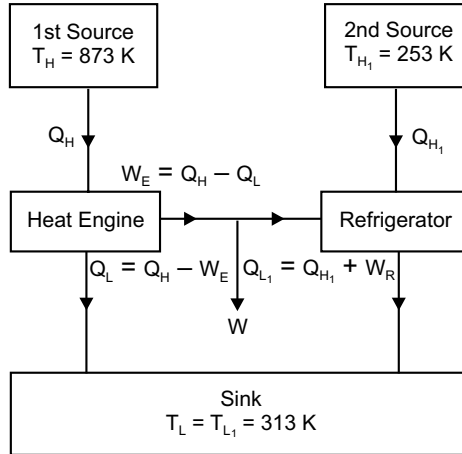

Again, work done  $W_E = Q_H \times \eta_{\max} = 2000 \times 0.6415 = 1283 \text{ kJ}$ .

Since the net work output of the combined heat engine and refrigerator plant is  $W = W_E - W_R = 360 \text{ kJ}$ , work required for the refrigerator  $W_R = W_E - W = 1283 - 360 = 923 \text{ kJ}$ .

We know maximum COP of the refrigerator

$$(\text{COP})_{\max} = \frac{T_{H1}}{T_{H1} - T_{L1}} = \frac{253}{313 - 253} = 4.217$$

Again,

$$(\text{COP})_{\max} = \frac{Q_{H1}}{Q_{H1} - Q_{L1}} = \frac{Q_{H1}}{W_R}$$

$\Rightarrow$

$$Q_{H1} = 4.217 \times 923 = 3892.3 \text{ kJ}$$

Here,

$$Q_{L1} = Q_{H1} + W_R = 3892.3 + 923 = 4815.3 \text{ kJ}$$

And

$$Q_L = Q_H - W_E = 2000 - 1283 = 717 \text{ kJ}$$

Hence, net heat transfer to the reservoir at  $40^\circ\text{C}$  is  $Q_L + Q_{L1} = 717 + 4815.3 = 5532.3 \text{ kJ}$

(ii) When the efficiency of the heat engine and COP of the refrigerator are each 40% of their maximum possible values,

$$\eta_{\text{actual}} = 0.4 \times 0.6415 = 0.2566$$

Work done by the engine

$$W_E = Q_H \times \eta_{\text{actual}} = 2000 \times 0.2566 = 513.2 \text{ kJ}$$

Work required for the refrigerator

$$W_R = W_E - W = 513.2 - 360 = 153.2 \text{ kJ}$$

Now

$$(\text{COP})_{\text{actual}} = 0.4 \times 4.217 = 1.6868$$

So, heat transfer to the refrigerant

$$Q_{H1} = 1.6868 \times 153.2 = 258.4 \text{ kJ}$$

Here,

$$Q_{L1} = Q_{H1} + W_R = 258.4 + 153.2 = 411.6 \text{ kJ and}$$

$$Q_L = Q_H - W_E = 2000 - 411.6 = 1588.4 \text{ kJ}$$

Hence, net heat transfer to the reservoir at 40°C is

$$Q_L + Q_{L1} = 1588.4 + 411.6 = 2000 \text{ kJ}$$

**EXAMPLE 7**

A Carnot engine working between 650 K and 310 K produce 150 kJ of work. Find the thermal efficiency and heat added during the process.

**SOLUTION**

Efficiency  $\eta = 1 - \frac{T_L}{T_H} = 1 - \frac{310}{650} = 0.523$

Heat added  $Q = \frac{W}{\eta} = \frac{150}{0.523} = 286.8 \text{ kJ}$

**EXAMPLE 8**

A Carnot engine is operated between two reservoirs at  $T_H$  and  $T_{H1}$ . The work output of the engine is 0.6 times the heat rejected. The difference in temperature between the source and the sink is 200°C. Calculate the thermal efficiency, source temperature and sink temperature.

**SOLUTION**

Here,  $W = 0.6Q_{H1-L1}$  and  $T_H - T_{H1} = 200^\circ\text{C}$

Thermal efficiency  $\eta = \frac{W}{W + Q_{H1-L1}} = \frac{0.6Q_{H1-L1}}{0.6Q_{H1-L1} + Q_{H1-L1}} = \frac{0.6}{1.6} = 0.375$

Again,  $\eta = \frac{T_H - T_{H1}}{T_H} = \frac{200}{T_H}$

$\Rightarrow T_H = \frac{200}{0.375} = 533.3 \text{ K} = 260.3^\circ\text{C}$

$\Rightarrow T_{H1} = 260.3 - 200 = 60.3^\circ\text{C}$

**EXAMPLE 9**

A Carnot cycle has an efficiency of 32%. Assuming that the lower temperature is kept constant, determine the % increase on the upper temperature of the cycle if the cycle efficiency is raised to 48%.

**SOLUTION**

Here,  $\eta = 1 - \frac{T_L}{T_H} = 0.32$

$\Rightarrow \frac{T_L}{T_H} = 1 - 0.32 = 0.68$

When the efficiency is raised to 48%,  $\frac{T_L}{T} = 1 - 0.48 = 0.52$

So, 
$$\frac{T}{T_H} = \frac{0.68}{0.52} = 1.3077$$

or, 
$$\frac{T_H + x}{T_H} = \frac{1 + 0.3077}{1}$$

$$\Rightarrow x = 0.3077$$

The % increase on the upper temperature of the cycle is 30.77

#### EXAMPLE 10

A vessel of 2.5 m<sup>3</sup> capacity contains 1 kg mole of N<sub>2</sub> at 100°C. If the gas is cooled to 30°C, calculate the change in specific entropy.

#### SOLUTION

The ratio of specific heats is 1.4 and 1 kg-mole of N<sub>2</sub> is 28 kg.

Here  $T_H = 100 + 273 = 373 \text{ K}$ ,  $T_L = 30 + 273 = 303 \text{ K}$

Now, 
$$C_p - C_v = R = \frac{R_u}{M} = \frac{8.314}{28} = 0.297$$

$$\Rightarrow 1.4C_v - C_v = 0.297$$

$$\Rightarrow C_v = 0.74 \text{ kJ/kgK}$$

So, 
$$S_H - S_L = mC_v \ln \frac{T_L}{T_H} = 1.0 \times 0.74 \ln \left( \frac{303}{373} \right) = -0.1536 \text{ kJ/kgK}$$

The negative sign indicates decrease in entropy.

#### EXAMPLE 11

300 kJ/s heat is supplied from a constant fixed source of 290°C to a heat engine. The heat rejection takes place at 8.5°C. The following results were obtained: (i) 215 kJ/s heat rejected (ii) 150 kJ/s heat rejected (iii) 75 kJ/s heat rejected. Determine these cycles are reversible or irreversible.

#### SOLUTION

Applying Clausius inequality to all these processes

(i) 
$$\sum \frac{\delta Q}{T} = \frac{300}{290 + 273} - \frac{215}{8.5 + 273} = -0.2309 < 0$$

Hence, the cycle is irreversible.

(ii) 
$$\sum \frac{\delta Q}{T} = \frac{300}{290 + 273} - \frac{150}{8.5 + 273} = 0$$

Hence, the cycle is reversible.

(iii) 
$$\sum \frac{\delta Q}{T} = \frac{300}{290 + 273} - \frac{75}{8.5 + 273} = 0.2664 > 0$$

Hence, the cycle is impossible.

**EXAMPLE 12**

1 kg of air is heated on constant volume from 100°C to 400°C. If  $C_v = 0.7186$  kJ/kgK, determine the change in entropy in the air.

**SOLUTION**

Change in entropy of air

$$\Delta S = \int_{T_L}^{T_H} \frac{dQ}{T} = \int_{100+273}^{400+273} mC_v \frac{dT}{T} = 1 \times 0.7186 \ln\left(\frac{673}{373}\right) = 0.4241 \text{ kJ/K}$$

**EXAMPLE 13**

A Carnot power cycle operates between 1200 K and 300 K. If 4.8 MJ of heat is supplied to the cycle, determine the heat rejected and the change in entropy for this rejection process.

**SOLUTION**

For Carnot cycle,  $\frac{Q_H}{T_H} = \frac{Q_L}{T_L}$

Hence,  $Q_L = \frac{T_L}{T_H} Q_H = \frac{300}{1200} \times 4.8 = 1.2 \text{ MJ}$

Change in entropy for the process of heat rejection

$$\Delta S = \frac{Q_L}{T_H} = \frac{1.2 \times 10^3}{300} = 0.4 \text{ kJ/K.}$$

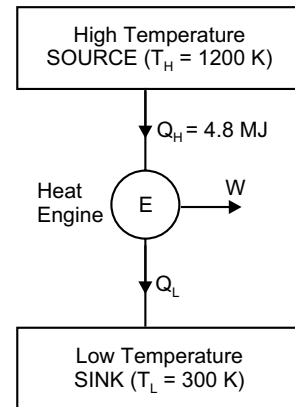

**EXAMPLE 14**

A heat engine receives reversible 420 kJ/cycle heat from a source at 327°C and rejects heat reversible to a sink at 27°C. There are no other heat transfers. For each of the three hypothetical amount heat rejection as (i) 210 kJ/cycle (ii) 105 kJ/cycle (iii) 315 kJ/cycle compute the cyclic integral  $\frac{\delta Q}{T}$  in each case. Show which one is reversible, irreversible or impossible.

**SOLUTION**

Applying Clausius inequality to all these processes

(i)  $\sum \frac{\delta Q}{T} = \frac{420}{327 + 273} - \frac{210}{27 + 273} = 0$

Hence, the cycle is reversible.

(ii)  $\sum \frac{\delta Q}{T} = \frac{420}{327 + 273} - \frac{105}{27 + 273} = 0.35 > 0$

Hence, the cycle is impossible.

(iii)  $\sum \frac{\delta Q}{T} = \frac{420}{327 + 273} - \frac{315}{27 + 273} = -0.35 < 0$

Hence, the cycle is irreversible.

**EXAMPLE 15**

Two bodies each of equal mass  $m$  and equal heat capacity  $C$  are at temperature  $T_1$  and  $T_2$  respectively and  $T_1 > T_2$ . If the first body is used as a source of heat for reversible engine and the second as the sink, show that the maximum work obtainable from such arrangement is  $mC(\sqrt{T_1} - \sqrt{T_2})^2$ .

**SOLUTION**

Let the common temperature of the two bodies be  $T_c$ . Maximum work is obtained when the engine operates along a reversible cycle. In that case, entropy change of the composite system formed by the two bodies is zero. Thus,

$$mC \ln \frac{T_c}{T_1} + mC \ln \frac{T_c}{T_2} = 0$$

$$\Rightarrow mC \ln \frac{T_c^2}{T_1 T_2} = 0$$

$$\Rightarrow \frac{T_c^2}{T_1 T_2} = 1$$

$$\Rightarrow T_c = \sqrt{T_1 T_2}$$

Now the work done

$$\begin{aligned} W_{\text{net}} &= mC(T_1 - T_c) - mC(T_c - T_2) \\ &= mC \left[ (T_1 - \sqrt{T_1 T_2}) - (\sqrt{T_1 T_2} - T_2) \right] \\ &= mC \left[ T_1 + T_2 - 2\sqrt{T_1 T_2} \right] = mC(\sqrt{T_1} - \sqrt{T_2})^2 \end{aligned}$$

**EXAMPLE 16**

A Carnot heat engine draws heat from a reservoir at temperature  $T_A$  and rejects heat to another reservoir at temperature  $T_B$ . The Carnot forward cycle again drives a Carnot reversed cycle engine or Carnot refrigerator, which absorbs heat from reservoir at temperature  $T_C$  and rejects heat to reservoir at temperature  $T_B$ . Derive an expression for the ratio of heat absorbed from reservoir at temperature  $T_C$  to heat drawn from reservoir at temperature  $T_A$ . If  $T_A$  is 500 K and  $T_C$  is 250 K, determine the temperature  $T_B$ , such that heat supplied to engine  $Q_A$  is equal to heat absorbed by refrigerator  $Q_C$ . Determine efficiency and COP of Carnot refrigerator.

**SOLUTION**

$$\eta_{\text{engine}} = \frac{Q_A - Q_B}{Q_A} = \frac{T_A - T_B}{T_A} = \frac{W_{\text{carnot}}}{Q_A}$$

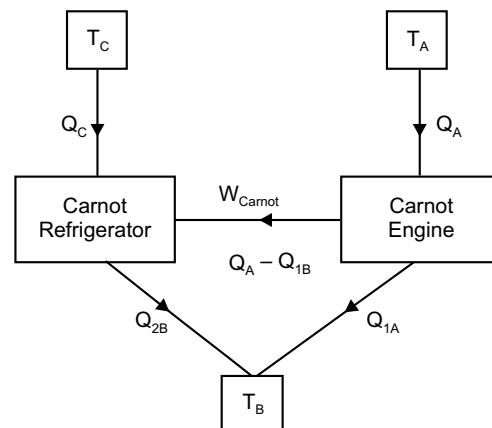

$$\Rightarrow W_{\text{carnot}} = \frac{T_A - T_B}{T_A} \cdot Q_A \quad (\text{a})$$

$$\text{Now, } (COP)_{\text{refrigerator}} = \frac{Q_C}{Q_{2B} - Q_C} = \frac{T_C}{T_B - T_C} = \frac{Q_C}{W_{\text{carnot}}}$$

$$\Rightarrow W_{\text{carnot}} = \frac{T_B - T_C}{T_C} Q_C \quad (\text{b})$$

$$\text{Equating (a) and (b), } \frac{Q_C}{Q_A} = \frac{\frac{T_A - T_B}{T_A}}{\frac{T_B - T_C}{T_C}} = \frac{T_C}{T_A} \left[ \frac{T_A - T_B}{T_B - T_C} \right]$$

$$\Rightarrow 1 = \frac{250 \left( \frac{500 - T_B}{T_B - 250} \right)}{500}$$

$$\Rightarrow T_B = 333.33 \text{ K}$$

$$\text{Hence, } \eta_{\text{engine}} = \frac{T_A - T_B}{T_A} = 0.334$$

$$\text{And } (COP)_{\text{refrigerator}} = \frac{T_C}{T_B - T_C} = 3.$$

**EXAMPLE 17**

A mass  $m$  of a fluid at temperature  $T_1$  is mixed with an equal mass of the same fluid at temperature  $T_2$ . Prove that the resultant change of entropy is  $2mC \ln \frac{0.5(T_1 + T_2)}{\sqrt{T_1 T_2}}$  and also prove that it is always positive.

**SOLUTION**

The thermal equilibrium is obtained at common temperature  $T_c = \frac{T_1 + T_2}{2}$ . Thus, change in entropy is given by

$$\begin{aligned} \Delta S &= mC \int_{T_1}^{T_c} \frac{dT}{T} - mC \int_{T_2}^{T_c} \frac{dT}{T} \\ &= mC \left[ \ln \frac{T_c}{2T_1} - \ln \frac{2T_2}{T_c} \right] \\ &= mC \left[ \ln \frac{T_c}{2T_1} + \ln \frac{T_c}{2T_2} \right] \end{aligned}$$

$$\begin{aligned}
 &= mC \ln \frac{T_c^2}{4T_1T_2} \\
 &= mC \ln \left[ \frac{T_1 + T_2}{2\sqrt{T_1T_2}} \right]^2 = 2mC \ln \left[ \frac{T_1 + T_2}{2\sqrt{T_1T_2}} \right]
 \end{aligned}$$

Now the arithmetic mean  $\frac{T_1 + T_2}{2}$  is always greater than the geometric mean  $\sqrt{T_1T_2}$ . Hence the above result is positive.

### EXAMPLE 18

A hot iron forging of specific heat 0.12 kcal/kgK weighing 30 kg and at a temperature of 500°C is dropped in 200 kg of oil at 20°C and having a specific heat of 0.6 kcal/kgK for quenching. The iron forging has surroundings. Determine entropy change of forging, entropy change of oil and entropy change of universe.

#### SOLUTION

Here,  $T_{\text{forging}} = 500 + 273 = 773 \text{ K}$  and  $T_{\text{oil}} = 20 + 273 = 293 \text{ K}$

By energy balance, a common equilibrium temperature ( $T_c$ ) is obtained after quenching.

So,  $m_{\text{forging}} C_{\text{forging}} (T_{\text{forging}} - T_c) = m_{\text{oil}} C_{\text{oil}} (T_c - T_{\text{oil}})$

$$\Rightarrow 30 \times 0.12 \times (773 - T_c) = 200 \times 0.6 \times (T_c - 293)$$

$$\Rightarrow T_c = 307 \text{ K}$$

Thus,

$$\Delta S_{\text{forging}} = 30 \times 0.12 \ln \left( \frac{307}{773} \right) = -3.32 \text{ kcal/K}$$

and 
$$\Delta S_{\text{oil}} = 200 \times 0.6 \ln \left( \frac{307}{293} \right) = 5.60 \text{ kcal/K}$$

Hence, 
$$\begin{aligned} \Delta S_{\text{universe}} &= \Delta S_{\text{forging}} + \Delta S_{\text{oil}} \\ &= -3.32 + 5.60 = 2.28 \text{ kcal/K} \end{aligned}$$

Thus, the process is irreversible.

### EXERCISE

1. State the limitations of first law of thermodynamics.
2. What is the difference between a heat engine and a reversed heat engine?
3. Enumerate the conditions that must be fulfilled by a reversible process. Give some examples of ideal reversible processes.
4. What is an irreversible process? Give some examples of irreversible processes.

5. Narrate the propositions of Clausius statement and Kelvin-Planck statement.
6. Define heat engine, refrigerator and heat pump.
7. What is the perpetual motion machine of the second kind?
8. What is the efficiency of heat engine?
9. What is COP of the reversible heat engine?
10. Derive the expression for COP of heat pump and refrigerator. Establish the relation between COP of pump and COP of refrigerator.
11. A heat engine is supplied with 278 kJ/s of heat at a constant fixed temperature of 283°C and the heat rejection takes places at 5°C. Then results reported as: (i) 208 kJ/s rejected (ii) 139 kJ/s rejected (iii) 70 kJ/s rejected. Classify which of the results report a reversible cycle or irreversible cycle or impossible cycle.
12. Source *A* can supply energy @11 MJ/min at 320°C. A second source *B* can supply energy @110 MJ/min at 68°C. Which source would you choose to supply energy to an ideal reversible engine that is to produce large amount of power if the temperature of the surroundings is 40°C.
13. A domestic food freezer maintains a temperature of -15°C. The ambient air temperature is 30°C. If heat leaks into the freezer continuously @1.75 kJ/s, what will be the least power necessary to pump this heat out continuously.
14. A heat engine supplied heat @1700 kJ/min and gives an output of 9 kW. Determine the thermal efficiency and rate of heat rejection.
15. A fish freezing plant requires 50 tons of refrigerant. The freezing temperature is -40°C while the ambient temperature is 35°C. If the performance of the plant is 15% of the theoretical reversed Carnot cycle working within the same temperature limits, calculate the power required.

**This page  
intentionally left  
blank**

CHAPTER
6

# ENTROPY

---

## 6.1 INTRODUCTION

When first law of thermodynamics was applied for thermodynamic processes, the existence of a property, internal energy, was found. This is called the *corollary 1 of the First Law of Thermodynamics*. Similarly, when second law of thermodynamics applied to thermodynamic processes, the second law also leads to the definition of a new property, known as *entropy*. So, if the first law is said to be the *law of internal energy*, then second law may be stated to be the *law of entropy*. The term 'entropy' was first introduced by *Clausius*. Entropy means transformation. It is an important thermodynamic property of a working substance, which increases with addition of heat and decreases with its removal. As a matter of fact, it is comparatively more easy to define change of entropy than to define the term entropy. When change of entropy ( $dS$ ) is multiplied by the absolute temperature ( $T$ ), gives the heat ( $\delta Q$ ) absorbed or rejected by the working substance.

Mathematically, heat absorbed by the working substance

$$\delta Q = TdS \quad \therefore dS = \frac{\delta Q}{T} \quad (6.1)$$

So change of entropy is the change of heat per unit absolute temperature.

Entropy may be defined as following:

*Entropy is function of a quantity of heat which shows the possibility of conversion of that heat into work. The increase in entropy is small when heat is added at high temperature and is greater when heat addition is at low temperature. Thus for minimum entropy there is maximum availability for conversion into work, for maximum entropy, there is a minimum availability for conversion into work.*

*It may also be defined as the thermodynamic property of a substance which remains constant when substance is expanded or expressed reversible adiabatically in a cylinder.*

## 6.2 IMPORTANCE OF ENTROPY

In a reversible Carnot cycle, the maximum possible efficiency obtainable is given by

$$\eta_{\max} = \frac{T_H - T_L}{T_H} \quad (a)$$

where  $T_H$  is highest absolute temperature and  $T_L$  is lowest absolute temperature. Again, in general efficiency is given by

$$\begin{aligned}\eta_{\max} &= \frac{\text{maximum work obtained}}{\text{heat applied or absorbed}} \\ &= \frac{\delta W}{\delta Q} \\ \text{or,} \quad \delta W &= \eta_{\max} \times \delta Q \\ &= \left( \frac{T_H - T_L}{T_H} \right) \times \delta Q\end{aligned}\quad (6.2)$$

For one degree temperature drop, the above expression may be written as

$$\begin{aligned}\delta W &= \frac{\delta Q}{T} \quad \text{where } T_H - T_L = 1 \\ &= dS \\ &= \text{change in entropy}\end{aligned}\quad (6.3)$$

It can be understood from above equation that

1. *The maximum amount of work obtained per degree drop in temperature is equal to change of entropy i.e., change of entropy is equal to the maximum work for one degree temperature drop.*
2. *The change in entropy may be regarded as a measure of the rate of availability or unavailability of heat for temperature into work.*
3. *The increase in entropy is obtained from a given quantity of heat at low temperature.*

### 6.3 UNITS OF ENTROPY

We know

$$dS = \frac{\delta Q}{T}$$

So unit of entropy depends upon the unit of heat and the absolute temperature. If  $\delta Q$  is expressed in kJ and  $T$  in K, then unit of entropy kJ/K.

### 6.4 CLAUSIUS THEOREM

Clausius theorem state that “*the cyclic integral  $\left( \frac{\delta Q}{T} \right)$  for a reversible cycle is equal to zero*”

Mathematically

$$\oint_R \frac{\delta Q}{T} = 0$$

The letter  $R$  emphasizes the fact that the equation is valid only for reversible cycle. It can be proved as below.

Consider a system undergoing a reversible process  $1-b-2$  from an equilibrium state 1 to another equilibrium state point 2, by the reversible path is shown in figure 6.1. Let a reversible adiabatic  $1-a$  be drawn through 1 and another reversible adiabatic  $2-c$  be drawn through 2, then reversible isothermal  $a-b-c$  is drawn in such a way that the area enclosed by  $1-a-b$  and  $b-c-2$  are equal on a  $p-v$  diagram.

Then the actual reversible process  $1-b-2$  can be replaced by the combination of the above processes, resulting in the overall process  $1-a-b-c-2$ . The process  $1-b-2$  and  $1-a-b-c-2$  are equivalent if and only if the heat and work interaction are identical for both the processes. Applying the first law of thermodynamics for the two processes,

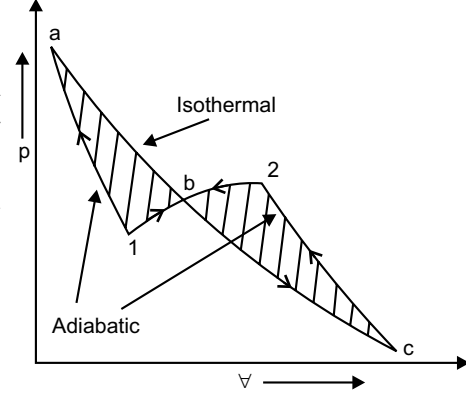

Fig. 6.1

1. For the process  $1-b-2$ ,

$$U_2 - U_1 = Q_{1-b-2} - W_{1-b-2} \quad (a)$$

2. For the process  $1-a-b-c-2$ ,

$$\begin{aligned} U_2 - U_1 &= Q_{1-a-b-c-2} - W_{1-a-b-c-2} \\ &= Q_{1-a} + Q_{a-b-c} + Q_{c-2} - W_{1-a-b-c-2} \\ &= Q_{a-b-c} - W_{1-a-b-c-2} \end{aligned} \quad (b)$$

Since  $1-a$  and  $c-2$  are reversible adiabatic process,  $Q_{1-a} = 0$  and  $Q_{c-2} = 0$

Now consider the cycle  $1-a-b-c-2-b-1$ . The net work done in this cycle is zero since the area enclosed by  $1-a-b$  is equal to the area enclosed by  $b-c-2$  on a  $p-v$  diagram in figure 6.1

$$\text{i.e.,} \quad \oint \delta W = W_{1-a-b-c-2} + W_{2-b-1} = 0$$

$$\text{or,} \quad \begin{aligned} W_{1-a-b-c-2} &= -W_{2-b-1} \\ &= W_{1-b-2} \end{aligned} \quad (c)$$

Comparing the equation (a) and (c), we have

$$\begin{aligned} Q_{1-a-b-c-2} - W_{1-a-b-c-2} &= Q_{a-b-c} - W_{1-b-2} \\ &= Q_{1-b-2} - W_{1-b-2} \end{aligned}$$

$$\therefore Q_{1-a-b-c-2} = Q_{a-b-c} = Q_{1-b-2}$$

That is, heat transferred along in the processes  $1-b-2$  is equal to the heat transferred in the processes  $1-a-b-c-2$ . So, the process  $1-b-2$  can be replaced by the process  $1-a-b-c-2$ .

Any reversible path may be substituted by a reversible zigzag path, between the same end states, consisting of a reversible adiabatic followed by a reversible isothermal and then by a reversible adiabatic, such that the heat transferred during the isothermal processes is same as that transferred during the original process.

Consider a system which undergoes the cyclic change as shown in figure 6.2. Now draw a family of closely spaced adiabatic line similar to  $a-3$  and  $2-f$  covering the entire cycle. Then join the adjacent adiabatic lines  $d-e-f$  as shown in figure 6.2, such that the area of  $1-a-b$  = area of  $b-c-2$  and area of  $3-d-e$  = area of  $e-f-4$ .

Thus the segments  $1-b-2$  and  $3-e-4$  of the reversible cycle are replaced by  $1-a-b-c-2$  and  $3-d-e-f-4$ , respectively. Now the differential cycle  $a-b-c-4-f-e-d-a$  is a Carnot cycle. Thus the original cycle can be transformed into a combination of several differential Carnot cycles. If the adiabatics are close to one another and number of Carnot cycles are large, the saw-toothed zig-zag line will coincide with the original cycle.

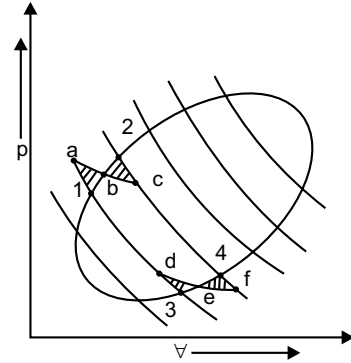

Fig. 6.2

For the elemental cycle  $a-d-f-c$ ,  $dQ_1$  heat is absorbed reversibly at  $T_1$  and  $\delta Q_2$ , heat is rejected reversibly at  $T_2$

$$\therefore \frac{\delta Q_1}{T_1} = \frac{\delta Q_2}{T_2} \quad (6.5)$$

Heat supply is taken as positive and heat rejected as negative

$$\text{So,} \quad \frac{\delta Q_1}{T_1} + \frac{\delta Q_2}{T_2} = 0$$

If similar equations are written from all the elemental Carnot cycles, then for whole original cycle

$$\frac{\delta Q_1}{T_1} + \frac{\delta Q_2}{T_2} + \frac{\delta Q_3}{T_3} + \dots = 0$$

$$\sum \frac{\delta Q}{T} = 0$$

or for a differential Carnot cycles

$$\oint \frac{\delta Q}{T} = 0 \quad [\text{for reversible cycle}]$$

This is known as *Clausius theorem*.

For reversible cycle the thermal efficiency is given by

$$\eta_{\text{th}} = \frac{Q_1 - Q_2}{Q_1} = \frac{T_1 - T_2}{T_1} \quad (6.6)$$

But for an irreversible engine according to Carnot theorem, the thermal efficiency is

$$\frac{Q_1 - Q_2}{Q_1} < \frac{T_1 - T_2}{T_1}$$

or

$$1 - \frac{Q_2}{Q_1} < 1 - \frac{T_2}{T_1}$$

or  $\frac{Q_2}{Q_1} > \frac{T_2}{T_1}$

or  $\frac{Q_2}{T_2} > \frac{Q_1}{T_1}$

or  $\frac{Q_1}{T_1} < \frac{Q_2}{T_2}$

or  $\frac{Q_1}{T_1} - \frac{Q_2}{T_2} < 0$

Therefore, in differential form, for irreversible engine

$$\oint \frac{\delta Q}{T} < 0. \tag{6.7}$$

**6.5 ENTROPY— A POINT FUNCTION OR A PROPERTY OF A SYSTEM**

Let a system shown in Figure 6.3 be taken from an initial equilibrium state 1 to a final equilibrium state 2 by the reversible path *A* and the system is brought back from 2 to 1 by another reversible path *B*. Then the two path *A* and *B* together constitute a reversible cycle. From Clausius theorem, we have

$$\oint_{A,B} \frac{\delta Q}{T} = 0$$

[It can be replaced as the sum of two integrals one for path *A* and other for path *B*]

$$\therefore \int_{1A}^2 \frac{\delta Q}{T} + \int_{2B}^1 \frac{\delta Q}{T} = 0$$

or  $\int_{1A}^2 \frac{\delta Q}{T} = - \int_{2B}^1 \frac{\delta Q}{T}$

Path *B* is a reversible path,

$$\int_{1A}^2 \frac{\delta Q}{T} = \int_{1B}^2 \frac{\delta Q}{T}$$

Since path *A* and *B* represent any two reversible paths,  $\int_1^2 \frac{\delta Q}{T}$  is independent of the path.

So  $\int_1^2 \frac{\delta Q}{T}$  is a property, is a point function, and its values depend on initial and final points only, not on the path

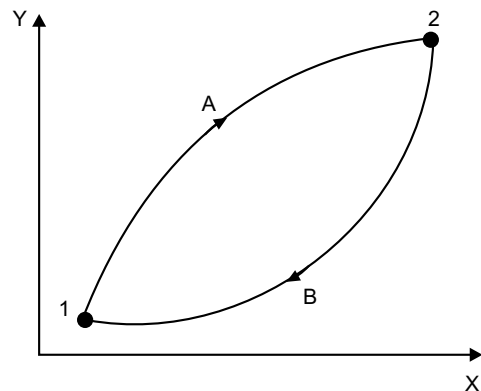

Fig. 6.3

$$\therefore \oint_1^2 \frac{\delta Q}{T} = S_2 - S_1 = dS \text{ (change of entropy)} \quad (6.8)$$

### 6.6 CLAUSIUS INEQUALITY

The Clausius inequality states that *when a closed system undergoes a cyclic process, the cyclic integral of  $\frac{\delta Q}{T}$  is less than zero (negative) for irreversible cyclic process and equal to zero for a reversible cyclic process.*

$$\therefore \oint \frac{\delta Q}{T} < 0 \text{ ( for irreversible process)}$$

$$\oint \frac{\delta Q}{T} = 0 \text{ ( for reversible process)}$$

Combining the above two equation, we have

$$\oint \frac{\delta Q}{T} \leq 0 \quad (6.9)$$

which is called *Clausius inequality*. It is already proved in art.6.4. The Clausius inequality not only gives mechanical expression to the 2nd law of thermodynamics, but it also gives the quantitative measure of irreversibility of the system. For example,

$$\text{For irreversible cyclic process } \oint \frac{\delta Q}{T} < 0$$

$$\text{So, it may be written as } \oint \frac{\delta Q}{T} + m = 0$$

where  $m$  represents the amount by which the given cyclic process is irreversible.

When  $m$  is equal to zero, that is  $\oint \frac{\delta Q}{T} > 0$  is impossible, because it violates the 2nd law of thermodynamics.

### 6.7 PRINCIPLE OF INCREASE OF ENTROPY

The equation for the Clausius inequality is written as

$$\oint \frac{\delta Q}{T} \leq 0 \quad (a)$$

Again we know the change in entropy

$$dS = \frac{\delta Q}{T}$$

Being a thermodynamic property, the cyclic-integral of a entropy is zero, that is  $\oint dS = 0$

Therefore equation (a) may be written as

$$\oint \frac{\delta Q}{T} \leq \oint dS$$

$$\therefore \frac{\delta Q}{T} \leq dS$$

$$\therefore dS \geq \frac{\delta Q}{T} \quad (b)$$

When the process is reversible, then

$$dS = \frac{\delta Q}{T} \quad (6.10)$$

and when the process is irreversible, then

$$dS > \frac{\delta Q}{T} \quad (6.11)$$

In case of isolated system  $\delta Q = 0$ , if we apply the equation (b) in isolated system the equation (b) will be

$$dS \geq 0,$$

when  $dS = 0$ , for reversible cyclic process,  $S = \text{Constant}$

Now for an irreversible cyclic process

$$dS > 0$$

Since, in actual practice, all processes are irreversible, therefore the entropy of such system like universe goes on increasing. This is known as the *principle of increase of entropy*.

## 6.8 ENTROPY AND TEMPERATURE RELATION

Entropy is the thermodynamic property of a working substance that increases with the increase of temperature and decreases with decrease of temperature.

if  $\delta Q$  = heat absorbed,  
 $dS$  = increase in entropy  
 $T$  = absolute temperature

$$\therefore \delta Q = T \cdot dS$$

Consider the heating of a working substance by a reversible process as shown in the figure 6.4 by a curve from 1 to 2 in temperature-entropy diagram.

At a small quantity of heat is supplied  $\delta Q$ ,

$$\delta Q = T \cdot dS$$

= area under curve during change of entropy

$$\therefore \int_1^2 \delta Q = \int_1^2 T \cdot dS$$

$$\int_1^2 dS = \int_1^2 \frac{\delta Q}{T} \quad (6.12)$$

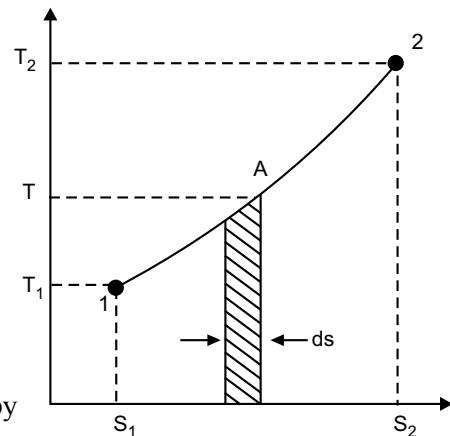

Fig. 6.4

So, total area under the  $T$ - $S$  diagram of any thermodynamic process represents the heat absorbed or heat rejected.

As  $\int \frac{\delta Q}{T}$  is same for all reversible paths between states 1 and 2 it is independent of the path and is a function of end states only.

### 6.9 GENERAL EXPRESSION FOR CHANGE OF ENTROPY OF A PERFECT GAS

Consider a certain quantity of perfect gas heated by any thermodynamic process.

Let,  $m$  = mass of the gas

$p_1$  and  $p_2$  = initial and final pressure

$V_1$  and  $V_2$  = initial and final volume

$T_1$  and  $T_2$  = initial and final absolute temperature

(i) *In terms of volume and absolute temperature*

$$\begin{aligned}\delta Q &= dU + \delta W \\ &= m \cdot C_v \cdot dT + p dV\end{aligned}$$

$$\therefore \frac{\delta Q}{T} = m \cdot C_v \cdot \frac{dT}{T} + p \frac{dV}{T}$$

$$\text{As, } pV = mRT$$

$$\frac{p}{T} = \frac{mR}{V}$$

$$\therefore dS = mC_v \cdot \frac{dT}{T} + \frac{mR}{V} \cdot dV \quad \left[ \because \frac{\delta Q}{T} = dS \right]$$

Integrating within limits,

$$\int_{S_1}^{S_2} dS = mC_v \int_{T_1}^{T_2} \frac{dT}{T} + mR \int_{V_1}^{V_2} \frac{dV}{V}$$

$$\text{or, } (S_2 - S_1) = mC_v (\ln T_2 - \ln T_1) + mR (\ln V_2 - \ln V_1)$$

$$= 2.3 m \left[ C_v \cdot \log \left( \frac{T_2}{T_1} \right) + R \cdot \log \left( \frac{V_2}{V_1} \right) \right]$$

$$= 2.3 m \left[ C_v \cdot \log \left( \frac{T_2}{T_1} \right) + (C_p - C_v) \log \left( \frac{V_2}{V_1} \right) \right]$$

(ii) *In terms of pressure and absolute temperature*

$$\text{We know } \frac{p_1 V_1}{T_1} = \frac{p_2 V_2}{T_2}$$

$$\therefore \frac{V_2}{V_1} = \frac{p_1}{p_2} \cdot \frac{T_2}{T_1}$$

Proceeding in the similar way,

$$\begin{aligned}
 (S_2 - S_1) &= mC_v \cdot \ln \left( \frac{T_2}{T_1} \right) + mR \cdot \ln \left( \frac{p_1}{p_2} \cdot \frac{T_2}{T_1} \right) \\
 &= mC_v \cdot \ln \left( \frac{T_2}{T_1} \right) + mR \cdot \ln \left( \frac{p_1}{p_2} \right) + mR \ln \left( \frac{T_2}{T_1} \right) \\
 &= m \ln \left( \frac{T_2}{T_1} \right) [C_v + R] + mR \ln \left( \frac{p_1}{p_2} \right) \\
 &= 2.3 m \left[ C_p \cdot \log \left( \frac{T_2}{T_1} \right) + R \cdot \log \left( \frac{p_1}{p_2} \right) \right] \\
 &= 2.3 m \left[ C_p \cdot \log \left( \frac{T_2}{T_1} \right) + R \cdot \log \left( \frac{p_1}{p_2} \right) \right]
 \end{aligned}$$

(iii) In terms of pressure and volume

We know,  $\frac{p_1 \forall_1}{T_1} = \frac{p_2 \forall_2}{T_2}$

$$\therefore \frac{T_2}{T_1} = \frac{p_2}{p_1} \cdot \frac{\forall_2}{\forall_1}$$

Proceeding in the similar fashion

$$\begin{aligned}
 (S_2 - S_1) &= mC_v \cdot \ln \left( \frac{p_2}{p_1} \cdot \frac{\forall_2}{\forall_1} \right) + mR \cdot \ln \left( \frac{\forall_2}{\forall_1} \right) \\
 &= mC_v \cdot \ln \left( \frac{p_2}{p_1} \right) + mC_v \cdot \ln \left( \frac{\forall_2}{\forall_1} \right) + mR \ln \left( \frac{\forall_2}{\forall_1} \right) \\
 &= mC_v \cdot \ln \left( \frac{p_2}{p_1} \right) + m \ln \left( \frac{\forall_2}{\forall_1} \right) \cdot (C_v + R) \\
 &= mC_v \cdot \ln \left( \frac{p_2}{p_1} \right) + m \ln \left( \frac{\forall_2}{\forall_1} \right) \cdot C_p \\
 &= 2.3 m \left[ C_v \cdot \log \left( \frac{p_2}{p_1} \right) + C_p \cdot \log \left( \frac{\forall_2}{\forall_1} \right) \right]
 \end{aligned}$$

## 6.10 CHANGE OF ENTROPY OF PERFECT GAS DURING VARIOUS THERMODYNAMIC PROCESS

(a) **Constant volume process (Isochoric process):**

A certain quantity of gas is heated at constant volume, where  
 $p_1$  = Initial pressure,  $T_1$  = Initial temperature

$p_2, T_2$  = Corresponding values of pressure and temperature for the final conditions

$$\begin{aligned} \text{so,} \quad \delta Q &= dU + \delta W \\ &= mC_v \cdot dT + p dV \\ &= mC_v \cdot dT \end{aligned}$$

$$\therefore \frac{\delta Q}{T} = mC_v \cdot \frac{dT}{T}$$

$$\therefore dS = mC_v \cdot \frac{dT}{T}$$

$$\text{Now} \quad \int_{S_1}^{S_2} dS = mC_v \cdot \int_{T_1}^{T_2} \frac{dT}{T}$$

$$\therefore (S_2 - S_1) = mC_v \cdot \ln \left( \frac{T_2}{T_1} \right)$$

$$= mC_v \cdot \ln \left( \frac{p_2}{p_1} \right) \quad \left[ \because \frac{T_2}{T_1} = \frac{p_2}{p_1} \cdot \frac{V_2}{V_1} = \left( \frac{p_2}{p_1} \right) \right]$$

$$= 2.3 mC_v \cdot \ln \left( \frac{p_2}{p_1} \right)$$

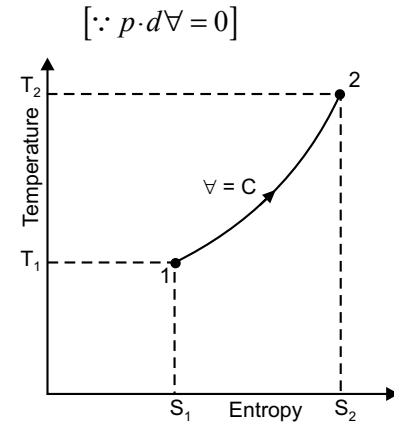

Fig. 6.5

**(b) Constant pressure processes (Isobaric process):**

A certain quantity of a perfect gas heated at constant pressure, where

$m$  = mass of gas,  $V_1$  = initial volume,  $T_1$  = initial temperature

$V_2, T_2$  = Corresponding values of volume and temperature for the final conditions for a small change of temperature

$$\text{Now,} \quad \delta Q = mC_p \cdot dT$$

$$\therefore \frac{\delta Q}{T} = mC_p \cdot \frac{dT}{T}$$

$$\therefore dS = mC_p \cdot \frac{dT}{T}$$

$$\text{Now,} \quad \int_{S_1}^{S_2} dS = mC_p \cdot \int_{T_1}^{T_2} \frac{dT}{T}$$

$$\therefore (S_2 - S_1) = mC_p \cdot [\ln T]_{T_1}^{T_2}$$

$$= mC_p \cdot \ln \frac{T_2}{T_1}$$

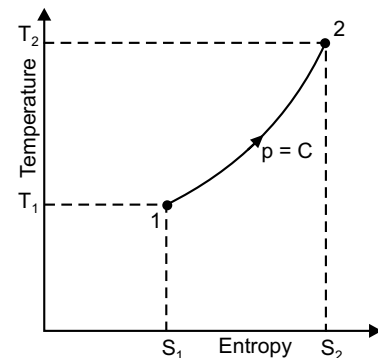

Fig. 6.6

$$\begin{aligned}
 &= 2.3 mC_p \cdot \log \left( \frac{T_2}{T_1} \right) \\
 &= 2.3 mC_p \cdot \log \left( \frac{\forall_2}{\forall_1} \right) \quad \left[ \because \frac{T_2}{T_1} = \frac{\forall_2}{\forall_1} \right]
 \end{aligned}$$

### 6.11 IRREVERSIBILITY

The actual work which a system does is always less than the idealized reversible work, and the difference between the two is called the *irreversibility of the process*.

If,  $I$  = the irreversibility,  
 $W$  = the actual work  
 $W_{\max}$  = the idealized reversible worker maximum work.

Then, Irreversibility,  $I = W_{\max} - W$

This is also sometimes referred to a *degradation* or *dissipation*.

The irreversibility in (i) non-flow process and (ii) steady flow-process is discussed below

#### (i) For a non-flow process

In non-flow process between the equilibrium states, when the system exchanges heat only with environment, irreversibility for unit mass,

$$\begin{aligned}
 i &= w_{\max} - w \\
 i &= [(u_1 - u_2) - T_0 (S_1 - S_2)] - [(u - u_2) + q] \\
 &= T_0 (S_2 - S_1) - q \\
 &= T_0 (\Delta S)_{\text{system}} + T_0 (\Delta S)_{\text{surrounding}}
 \end{aligned}$$

So,  $i \geq 0$

#### (ii) For steady flow-process

$$\begin{aligned}
 i &= w_{\max} - w \\
 &= \left[ \left\{ b_1 + \frac{C_1^2}{2} + gz_1 \right\} - \left\{ b_2 + \frac{C_2^2}{2} + gz_2 \right\} \right] \\
 &\quad - \left[ \left\{ h_1 + \frac{C_1^2}{2} + gz_1 \right\} - \left\{ h_2 + \frac{C_2^2}{2} + gz_2 \right\} + q \right] \\
 &= T_0 (S_2 - S_1) - q \\
 &= T_0 (\Delta S)_{\text{system}} + T_0 (\Delta S)_{\text{surrounding}}
 \end{aligned}$$

The same expression for irreversibility applies to both flow and non-flow process.

**Multiple Choice Questions**

1. Second law of thermodynamics defines
  - (a) heat
  - (b) work
  - (c) enthalpy
  - (d) entropy
  - (e) internal energy
2. For a reversible adiabatic process, the change in entropy is
  - (a) zero
  - (b) minimum
  - (c) maximum
  - (d) infinite
  - (e) unity
3. For any reversible process, the change in entropy of the system and surrounding is
  - (a) zero
  - (b) unity
  - (c) negative
  - (d) positive
  - (e) infinite
4. For any irreversible process the net entropy change is
  - (a) zero
  - (b) positive
  - (c) negative
  - (d) infinite
  - (e) unity
5. The processes of a Carnot cycle are
  - (a) two adiabatics and two constant volume
  - (b) one constant volume and one constant pressure and two isentropics
  - (c) two adiabatics and two isothermals
  - (d) two constant volumes and two isothermals
  - (e) two isothermals and two isentropics
6. Isotropic flow is
  - (a) irreversible adiabatic flow
  - (b) ideal fluid flow
  - (c) perfect gas flow
  - (d) frictionless reversible flow
  - (e) reversible adiabatic flow
7. In a Carnot engine, when the working substance gives heat to the sink
  - (a) the temperature of the sink increases
  - (b) the temperature of the sink remains same
  - (c) the temperature of the source decreases
  - (d) the temperature of both the sink and the source decrease
  - (e) changes depend on the operating conditions
8. If the temperature of the source is increased, the efficiency of a Carnot engine
  - (a) decreases
  - (b) increases
  - (c) does not change
  - (d) will be equal to the efficiency of a practical engine
  - (e) depends on other factors
9. The efficiency of an ideal carnot engine depends on
  - (a) working substance
  - (b) on the temperature of the source only
  - (c) on the temperature of the sink only
  - (d) on the temperature of both the source and the sink
  - (e) on the construction of engine

10. The efficiency of a Carnot engine using an ideal gas as the working substance is
- (a)  $\frac{T_1 - T_2}{T_1}$                       (b)  $\frac{T_1}{T_1 - T_2}$                       (c)  $\frac{T_1 T_2}{T_1 - T_2}$
- (d)  $\frac{T_1 - T_2}{T_1 T_2}$                       (e)  $\frac{T_2(T_1 - T_2)}{T_1(T_1 + T_2)}$
11. In a reversible cycle, the entropy of the system
- (a) increases                      (b) decreases                      (c) does not change
- (d) first increases and then decreases
- (e) depends on the properties of working substance
12. A frictionless heat engine can be 100% efficient only if its exhaust temperature is:
- (a) equal to its input temperature                      (b) less than its input temperature
- (c) 0°C                      (d) 0 K
- (e) -100°C
13. Kelvin-Planck's law deals with
- (a) conservation of energy                      (b) conservation of heat
- (c) conservation of mass                      (d) conservation of heat into work
- (e) conservation of work into heat
14. Which of the following statements is correct according to Clausius statements of second law of thermodynamics?
- (a) it is impossible to transfer heat from a body at a lower temperature to a body at a higher temperature
- (b) it is impossible to transfer heat from a body at a lower temperature to a body at a higher temperature without the aid of an external source
- (c) it is possible to transfer heat from a body at a lower temperature to a body at a higher temperature by using refrigeration cycle
- (d) none of the above
15. According to Kelvin Planck's statement of second law of temperature
- (a) it is impossible to construct an engine working on a cyclic process, whose sole purpose is to convert heat energy into work
- (b) it is possible to construct an engine working on cyclic process, whose sole purpose is to convert the heat energy into work
- (c) it is impossible to construct a device which while working in a cyclic process produces an effect other than the transfer of heat from a colder body to a hotter body
- (d) when two dissimilar metals are heated at one end and cooled at the other, the e.m.f. developed is proportional to the difference of their temperatures at the two ends
- (e) none of the above
16. The property of working substance which increases or decreases as the heat is supplied or removed in a reversible manner is known as
- (a) enthalpy                      (b) internal energy
- (c) entropy                      (d) external energy

17. The entropy may be expressed as a function of
  - (a) pressure and temperature
  - (b) temperature and volume
  - (c) heat and work
  - (d) all of the above
  - (e) none of the above
18. The change of entropy, when heat is absorbed by the gas is
  - (a) positive
  - (b) negative
  - (c) positive or negative
19. Which of the following statements is correct?
  - (a) the increase in entropy is obtained from a given quantity of heat at a low temperature
  - (b) the change of entropy may be regarded as a measure of the rate of the availability of heat for transformation into work.
  - (c) the entropy represents the maximum amount of work obtainable per degree drop in temperature
  - (d) all of the above
20. The condition for the reversibility of cycle is
  - (a) the pressure and temperature of working substance must not differ, appreciably from those of the surroundings at any stage in the process
  - (b) all the processes taking place in the cycle of operation, must be extremely slow
  - (c) the working parts of the engine must be friction-free
  - (d) there should be no loss of energy during the cycle of operation
  - (e) all of the above
21. In an irreversible process there is a
  - (a) loss of heat
  - (b) no loss of work
  - (c) gain of heat
  - (d) no gain of heat
22. The main cause for the irreversibility is
  - (a) mechanical and fluid friction
  - (b) unrestricted expansion
  - (c) heat transfer with a finite temperature difference
  - (d) all of the above
23. The efficiency of the Carnot cycle may be increased by
  - (a) increasing the highest temperature
  - (b) decreasing the highest temperature
  - (c) increasing the lowest temperature
  - (d) decreasing the lowest temperature
  - (e) keeping the lowest temperature constant.
24. Which of the following is the correct statement ?
  - (a) all the reversible engines have the same efficiency
  - (b) all the reversible and irreversible engines have the same efficiency
  - (c) irreversible engines have maximum efficiency
  - (d) all engine are designed as reversible in order to obtain maximum efficiency

### Answers

1. (d) 2. (a) 3. (a) 4. (b) 5. (e) 6. (e) 7. (b) 8. (b) 9. (d) 10. (a)  
 11. (c) 12. (d) 13. (d) 14. (b) 15. (c) 16. (c) 17. (a) 18. (a) 19. (d) 20. (e)  
 21. (a) 22. (d) 23. (d) 24. (a)

### NUMERICAL EXAMPLES

#### EXAMPLE 1

0.05 m<sup>3</sup> of air at a pressure of 8 bar and temperature 280°C expands to eight times its original volume and the final temperature after expansion is 25°C. Calculate the change of entropy of air during the process. Assume  $C_p = 1.005$  kJ/kg K and  $C_v = 0.712$  kJ/kg K.

**SOLUTION**

Given  $\forall_1 = 0.05 \text{ m}^3, p_1 = 8 \text{ bar} = 8 \times 10^5 \text{ N/m}^2$

$$T_1 = 280^\circ\text{C} = (280 + 273) = 553 \text{ K}$$

$$\forall_2 = 8\forall_1 = 8 \times 0.05 = 4 \text{ m}^3$$

$$T_2 = 25^\circ\text{C} = (25 + 273) = 298 \text{ K}$$

$$C_p = 1.005 \text{ kJ/kg K}, C_v = 0.712 \text{ kJ/kg K}$$

Let  $m$  = mass of air in kg

$$\begin{aligned} \text{Here } R &= C_p - C_v = 1.005 - 0.712 = 0.293 \text{ kJ/kg K} \\ &= 293 \text{ J/kg K} \end{aligned}$$

$$\text{As, } p_1 \forall_1 = mRT_1$$

$$m = \frac{p_1 \forall_1}{RT_1} = \frac{8 \times 10^5 \times 0.05}{293 \times 553} = 0.247 \text{ kg}$$

Change of entropy

$$\begin{aligned} (S_2 - S_1) &= 2.3 m \left[ C_v \cdot \log \left( \frac{T_2}{T_1} \right) + R \cdot \log \left( \frac{\forall_2}{\forall_1} \right) \right] \\ &= 2.3 \times 0.247 \left[ 0.712 \log \left( \frac{298}{553} \right) + 0.293 \log \left( \frac{0.4}{0.05} \right) \right] \\ &= 0.568 [-0.19 + 0.26] \\ &= 0.04 \text{ kJ/K} \end{aligned}$$

#### EXAMPLE 2

A vessel of 2.5 m<sup>3</sup> capacity contains 1 kg mole of N<sub>2</sub> at 100°C. If the gas is cooled to 30°C, calculate the change in specific entropy. The ratio of specific heats is 1.4 and one kg-mole nitrogen is 28 kg.

**SOLUTION**

Here,  $\forall = 2.5 \text{ m}^3, M = 1 \text{ kg mole} = 28 \text{ kg}$

$$T_1 = 100^\circ\text{C} = (100 + 273) = 373 \text{ K}$$

$$T_2 = 30^\circ\text{C} = (30 + 273) = 303 \text{ K}$$

$$\gamma = \frac{C_p}{C_v} = 1.4$$

$$R_u = \text{Universal gas constant} = 8.314 \text{ kJ/kg K}$$

$$R = \frac{R_u}{M} = \frac{8.314}{28} = 0.297 \text{ kJ/kg K}$$

$$\therefore C_p - C_v = R \qquad \therefore 1.4C_v - C_v = 0.297$$

$$\text{So, } C_v = \frac{0.297}{0.4} = 0.74 \text{ kJ/kg K}$$

$$\text{Hence, } (S_2 - S_1) = 2.3 m C_v \cdot \log \left( \frac{T_2}{T_1} \right)$$

$$= 2.3 \times 1 \times 0.74 \log \left( \frac{303}{373} \right)$$

$$= -0.1536 \text{ kJ/kg K}$$

(-) indicates decrease in entropy.

### EXAMPLE 3

300 kJ/s of heat is supplied at a constant fixed temperature of  $290^\circ\text{C}$  to a heat engine. The heat rejection takes place at  $8.5^\circ\text{C}$ . The following results were obtained.

- (i) 150 kJ/sec are rejected
- (ii) 215 kJ/sec are rejected
- (iii) 75 kJ/sec are rejected.

Classify which of the result report a reversible, cyclic or irreversible cycle or impossible results. Heat supplied at  $290^\circ\text{C} = 300 \text{ kJ/sec}$  and heat rejected at  $8.5^\circ\text{C}$  (i) 150 kJ/sec (ii) 215 kJ/sec (iii) 75 kJ/sec.

#### SOLUTION

Applying Clausius inequality to the cycle or process

$$\begin{aligned} \text{(i)} \quad \sum_{\text{cyclic}} \frac{\delta Q}{T} &= \frac{300}{290 + 273} - \frac{150}{8.5 + 273} \\ &= 0.5328 - 0.5328 = 0 \end{aligned}$$

$\therefore$  Cycle is reversible

$$\begin{aligned} \text{(ii)} \quad \sum_{\text{cyclic}} \frac{\delta Q}{T} &= \frac{300}{290 + 273} - \frac{215}{8.5 + 273} \\ &= 0.5328 - 0.7638 < 0 \end{aligned}$$

∴ Cycle is irreversible

$$(iii) \quad \sum_{\text{cyclic}} \frac{\delta Q}{T} = \frac{300}{290 + 273} - \frac{75}{8.5 + 273}$$

$$= 0.5328 - 0.2664 = 0.2664 > 0$$

∴ Cycle is impossible by 2nd law of thermodynamics.

#### EXAMPLE 4

One kilogram of air is heated on constant volume from 100°C and 400°C. If  $C_v = 0.7186$  kJ/kg K, determine the change in entropy of the air.

**SOLUTION**

Change of Entropy of air

$$(S_2 - S_1) = \int_{T_1}^{T_2} \frac{\delta Q}{T} = \int_{T_1}^{T_2} m C_v \frac{dT}{T}$$

$$= 2.3 m C_v \cdot \log \left( \frac{T_2}{T_1} \right)$$

$$= 2.3 \times 1 \times 0.7186 \times \log \left( \frac{400 + 273}{100 + 273} \right)$$

$$= 0.4236 \text{ kJ/K}$$

#### EXAMPLE 5

A Carnot power cycle is operated between 1200 K and 300 K. If 4.8 MJ of heat is supplied to the cycle, determine the heat rejected and the change in entropy for the process of heat rejection.

**SOLUTION**

For Carnot Cycle

$$\frac{Q_H}{T_H} = \frac{Q_L}{T_L} \text{ (reversible cycle)}$$

$$\therefore Q_L = \left( \frac{T_L}{T_H} \right) Q_H$$

$$= 4.8 \times \frac{300}{1200} = 1.2 \text{ MJ}$$

Change of entropy for the process heat rejection

$$\Delta S = \frac{Q_L}{T_L} = \frac{1.2 \times 10^3}{300} = 4.0 \text{ kJ/K}$$

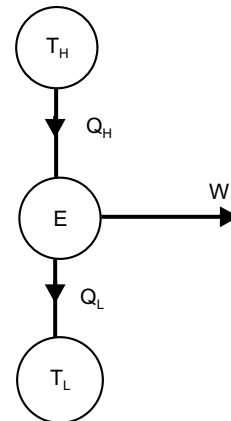

**EXAMPLE 6**

A heat engine receives reversible 420 kJ/cycle of heat from a source at 327°C and rejects heat reversibly to a sink at 27°C. There are no other heat transfers. For each of the three hypothetical amount of heat rejection in (a), (b) and (c) below. Compute the cycle integral of  $\frac{\delta Q}{T}$  from this result. Show which is irreversible which is reversible and which is impossible. (a) 210 kJ/cycle (b) 105 kJ/cycle (c) 315 kJ/cycle.

**SOLUTION**

Here,  $T_1 = 327^\circ\text{C}$ ,  $Q_1 = 420$  kJ/cycle

$$T_2 = 27^\circ\text{C}$$

(a) As  $Q_2 = 210$  kJ/cycle

$$\oint \frac{\delta Q}{T} = \frac{420}{327 + 273} - \frac{210}{27 + 273}$$

$$= \frac{420}{600} - \frac{210}{300} = 0$$

∴ Case is reversible

(b) As  $Q_2 = 105$  kJ/cycle

$$\oint \frac{\delta Q}{T} = \frac{420}{327 + 273} - \frac{105}{27 + 273}$$

$$= 0.35 > 0$$

∴ Case is impossible

(c) As  $Q_3 = 315$  kJ/cycle

$$\oint \frac{\delta Q}{T} = \frac{420}{327 + 273} - \frac{315}{27 + 273}$$

$$= -0.35 < 0$$

∴ Case is irreversible

**EXAMPLE 7**

An iron cube at a temperature of 400°C is dropped into an insulated bath containing 10 kg water at 25°C. The water finally reaches a temperature of 50°C at steady state. Given that the specific heat of water is equal to 4186 J/kg K. Find the entropy changes for the iron cube and the water. Is the process reversible? If so why?

**SOLUTION**

Given temperature of iron cube = 400°C = 400 + 273 = 673 K

Temperature of water = 25°C = 25 + 273 = 298 K

Mass of water = 10 kg

Temperature of water and cube after equilibrium

$$= 50^\circ\text{C} = 50 + 273 = 323 \text{ K}$$

Specific heat of water,  $C_{pw} = 4186 \text{ J/kg K}$

Now, heat lost by iron cube = Heat gained by water

$$\begin{aligned} \text{So, } m_i C_{pi} (673 - 323) &= m_w C_{pw} (323 - 298) \\ &= 10 \times 4186 (323 - 298) \end{aligned}$$

$$\therefore m_i C_{pi} = \frac{10 \times 4186 (323 - 298)}{(673 - 323)} = 2990$$

Where  $m_i$  = Mass of iron in kg, and

$C_{pi}$  = Specific heat of iron in J/kg K.

$$\begin{aligned} \text{Entropy of iron at } 673 \text{ K} &= m_i C_{pi} \ln \left( \frac{673}{273} \right) \\ &= 2990 \ln \left( \frac{673}{273} \right) \\ &= 2697.8 \text{ J/K [ Taking } 0^\circ\text{C as datum]} \end{aligned}$$

$$\begin{aligned} \text{Entropy of water at } 298 \text{ K} &= m_w C_{pw} \ln \left( \frac{298}{273} \right) \\ &= 10 \times 4186 \ln \left( \frac{298}{273} \right) \\ &= 3667.8 \text{ J/K [ Taking } 0^\circ\text{C as datum]} \end{aligned}$$

$$\text{Entropy of iron at } 323 \text{ K} = 2990 \times \ln \left( \frac{323}{273} \right) = 502.8 \text{ J/K}$$

$$\text{Entropy of water at } 323 \text{ K} = 10 \times 4186 \ln \left( \frac{323}{273} \right) = 7040.04 \text{ J/K}$$

$$\text{Changes in entropy of iron} = 502.8 - 2697.8 = -2195 \text{ J/K}$$

$$\text{Change in entropy of water} = 7040.04 - 3667.8 = 3372.24 \text{ J/K}$$

$$\text{Net change in entropy } (\Delta S) = 3372.24 - 2195 = 1177.24 \text{ J/K} > 0$$

Hence, the process is irreversible.

### EXAMPLE 8

An ideal gas is heated from temperature  $T_1$  to  $T_2$  by keeping its volume constant. The gas is expanded back to its initial temperature according to the law  $pV^n = \text{constant}$ . If the entropy change in the two processes are equal, find the value of  $n$  in terms of the adiabatic index  $\gamma$ .

**SOLUTION**

Change in entropy during constant volume process

$$= mC_v \ln \left( \frac{T_2}{T_1} \right) \quad (i)$$

Change in entropy during polytropic process ( $pV^n = \text{constant}$ )

$$= mC_v \left( \frac{\gamma - n}{n - 1} \right) \ln \left( \frac{T_2}{T_1} \right) \quad (ii)$$

For the same entropy, we have

$$\left( \frac{\gamma - n}{n - 1} \right) = 1$$

or,  $(\gamma - n) = (n - 1)$  or,  $2n = \gamma + 1$

$\therefore n = \frac{\gamma + 1}{2}$

**EXAMPLE 9**

Air at 20°C and 1.05 bar occupies 0.025 m<sup>3</sup>. The air is heated at constant volume until the pressure is 4.5 bar, and then cooled at constant pressure back to original temperature. Calculate:

- (i) the net heat flow from the air.  
 (ii) the net entropy change

Sketch the process on  $T$ - $S$  diagram

Assume,  $C_p = 1.005$  kJ/kgK,  $C_v = 0.718$  kJ/kgK

**SOLUTION**

For air

$$T_1 = 20 + 273 = 293 \text{ K}$$

$$V_1 = V_3 = 0.025 \text{ m}^3$$

$$p_1 = 1.05 \text{ bar} = 1.05 \times 10^5 \text{ N/m}^2$$

$$p_2 = 4.5 \text{ bar} = 4.5 \times 10^5 \text{ N/m}^2$$

- (i) Net heat flow:

For a perfect gas (corresponding to point 1 of air)

$$m = \left( \frac{p_1 V_1}{RT_1} \right) = \frac{1.05 \times 10^5 \times 0.025}{0.287 \times 10^3 \times 293} = 0.0312 \text{ kg}$$

For a perfect gas at constant volume

$$\frac{p_1}{T_1} = \frac{p_2}{T_2}$$

or  $\frac{1.05}{293} = \frac{4.5}{T_2}$

$\Rightarrow T_2 = \frac{4.5 \times 293}{1.05} = 1255.7 \text{ K}$

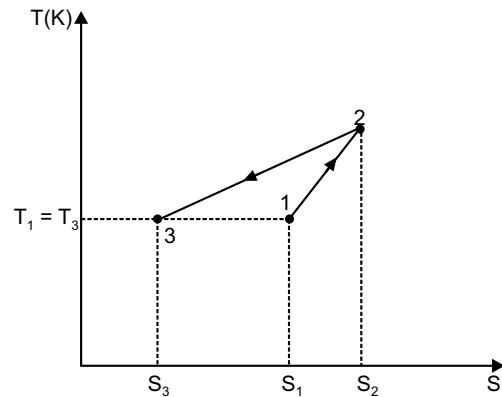

At constant volume,

$$Q_{1-2} = mC_v(T_2 - T_1) = 0.0312 \times 0.718 (1255.7 - 293) \\ = 21.56 \text{ kJ}$$

Also at constant pressure,

$$Q_{2-3} = mC_p(T_1 - T_2) = 0.0312 \times 1.005 (293 - 1255.7) \\ = -30.18 \text{ kJ}$$

Net heat flow =  $Q_{1-2} + Q_{2-3} = 21.56 + (-30.18) = -8.62 \text{ kJ}$

Heat rejected = 8.62 kJ

(ii) Net entropy change:

Referring to figure, net decrease in entropy

$$S_1 - S_3 = (S_2 - S_3) - (S_2 - S_1)$$

At constant pressure  $\delta Q = mC_p dT$ ,

$$\text{So, } S_2 - S_3 = \int_{293}^{1255.7} \frac{mC_p dT}{T} = 0.0312 \times 1.005 \ln \left( \frac{1255.7}{293} \right) \\ = 0.0456 \text{ kJ/K}$$

At constant volume  $\delta Q = mC_v dT$ ,

$$\text{So, } S_2 - S_1 = \int_{293}^{1255.7} \frac{mC_v dT}{T} = 0.0312 \times 0.718 \ln \left( \frac{1255.7}{293} \right) \\ = 0.0326 \text{ kJ/K}$$

$$\text{Hence, } (S_1 - S_3) = (S_2 - S_3) - (S_2 - S_1) \\ = 0.0456 - 0.0326 = 0.013 \text{ kJ/K}$$

Hence, decrease in entropy = 0.013 kJ/K.

### EXAMPLE 10

0.04 kg of carbon dioxide (molecular weight = 44) is compressed from 1 bar, 20°C, until the pressure is 9 bar, and the volume is then 0.003 m<sup>3</sup>. Calculate the change of entropy. Take  $C_p$  for carbon dioxide as 0.88 kJ/kg K, and assume carbon dioxide to be a perfect gas.

#### SOLUTION

Mass of carbon dioxide,  $m = 0.04 \text{ kg}$

Molecular weight,  $M = 44$

Initial pressure,  $p_1 = 1 \text{ bar} = 1 \times 10^5 \text{ N/m}^2$

Initial temperature  $T_1 = 20 + 273 = 293 \text{ K}$

Final pressure  $p_2 = 9 \text{ bar}$

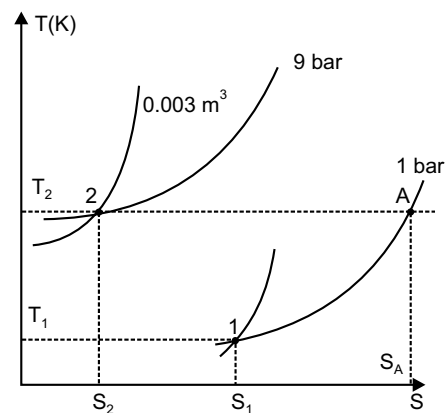

Final volume  $\forall_2 = 0.003 \text{ m}^3$   
 $C_p$  for carbondioxide  $= 0.88 \text{ kJ/kg K}$   
 Characteristics gas constant

$$R = \frac{R_u}{M} = \frac{8314}{44} = 189 \text{ Nm/kgK}$$

To find  $T_2$ , using the relation

$$p_2 \forall_2 = mRT_2$$

$$\therefore T_2 = \frac{p_2 \forall_2}{mR} = \frac{9 \times 10^5 \times 0.003}{0.04 \times 189} = 357 \text{ K}$$

Now  $S_A - S_2 = R \ln \left( \frac{p_2}{p_1} \right) = \left( \frac{189}{10^3} \right) \ln (9/1) = 0.4153 \text{ kJ/kg K}$

Also at constant pressure from 1 to A

$$S_A - S_1 = C_p \ln \frac{T_2}{T_1} = 0.88 \ln \left( \frac{357}{293} \right) = 0.1738 \text{ kJ/kg K}$$

Then  $(S_1 - S_2) = (S_A - S_2) - (S_A - S_1) = 0.4153 - 0.1738$   
 $= 0.2415 \text{ kJ/kg K}$

Hence for 0.04 kg of carbondioxide, decrease in entropy

$$= m(S_1 - S_2) = 0.04 \times 0.2415 = 0.00966 \text{ kJ/k}$$

### EXAMPLE 11

Calculate the change of entropy of 1 kg of air expanding polytropically in a cylinder behind a piston from 7 bar and  $600^\circ\text{C}$  to 1.05 bar. The index of expansion is 1.25.

**SOLUTION**

Here,  $p_1 = 7 \text{ bar} = 7 \times 10^5 \text{ N/m}^2$   
 $T_1 = 600 + 273 = 873 \text{ K}$   
 $p_2 = 1.05 \text{ bar} = 1.05 \times 10^5 \text{ N/m}^2$

Index of expansion,  $n = 1.25$

Mass of air = 1 kg

To find  $T_2$ , using the relation

$$\frac{T_2}{T_1} = \left( \frac{p_2}{p_1} \right)^{\frac{n-1}{n}}$$

$$\Rightarrow \frac{T_2}{873} = \left( \frac{1.05}{7} \right)^{\frac{1.25-1}{1.25}}$$

$$\therefore T_2 = 873 \times \left( \frac{1.05}{7} \right)^{\frac{1.25-1}{1.25}} = 597.3 \text{ K}$$

Now replace the process 1 to 2 by process 1 to A and A to 2.

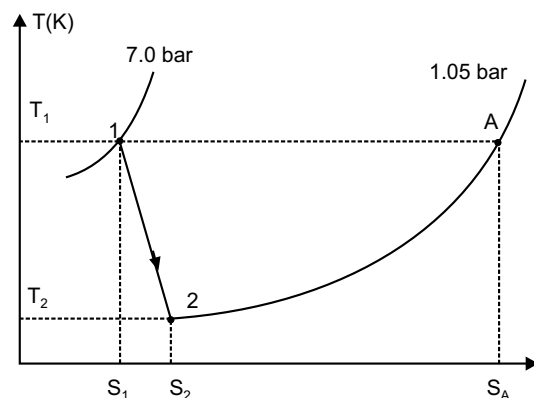

Then at constant temperature from 1 to A

$$S_A - S_1 = R \ln \left( \frac{V_2}{V_1} \right) = R \ln \left( \frac{p_1}{p_2} \right) = 0.544 \text{ kJ/kg K}$$

At constant temperature from A to 2

$$S_A - S_2 = C_p \ln \left( \frac{T_2}{T_1} \right) = 1.005 \ln \left( \frac{873}{597.3} \right) = 0.3814 \text{ kJ/kg K}$$

Then  $S_2 - S_1 = 0.544 - 0.3814 = 0.1626 \text{ kJ/kg K}$

Increase in entropy = 0.1626 kJ/kg K

### EXAMPLE 12

In an air turbine the air expands from 7 bar and 460°C to 1.012 bar and 160°C. The heat loss from the turbine can be assumed to be negligible.

- show that the process is irreversible.
- calculate the change of entropy per kg of air.

#### SOLUTION

Here,

$$p_1 = 7 \text{ bar} = 7 \times 10^5 \text{ N/m}^2$$

$$T_1 = 460 + 273 = 733 \text{ K}$$

$$p_2 = 1.012 \text{ bar} = 1.012 \times 10^5 \text{ N/m}^2$$

$$T_2 = 160 + 273 = 433 \text{ K}$$

- Since heat loss is negligible, the process is adiabatic. For a reversible adiabatic process for a perfect gas,

$$\frac{T_2}{T_1} = \left( \frac{p_2}{p_1} \right)^{\frac{\gamma-1}{\gamma}}$$

$$\therefore \frac{T_2}{733} = \left( \frac{1.012}{7} \right)^{\frac{1.4-1}{1.4}}$$

$$\therefore T_2 = 421.8 \text{ K} = 148.8^\circ\text{C}$$

But the actual temperature 160°C at 1.012 bar. Hence the process is irreversible.

- Change of entropy can be found by considering a reversible constant pressure process between 2 and 2'.

$$\therefore S_2' - S_2 = C_p \ln \left( \frac{T_2}{T_2'} \right) = 1.005 \ln \left( \frac{433}{421.6} \right) = 0.02681 \text{ kJ/kg K}$$

Increase in entropy = 0.02681 kJ/kg K

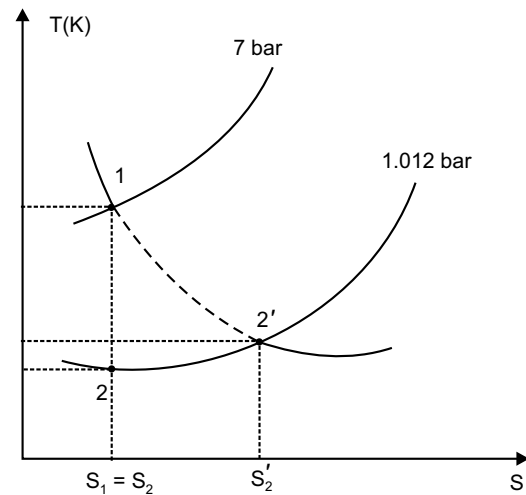

**EXAMPLE 13**

A fluid undergoes a reversible adiabatic compression from 4 bar, 0.3 m<sup>3</sup> to 0.08 m<sup>3</sup> according to  $pV^{1.25} = \text{constant}$ . Determine (i) change in enthalpy (ii) change in internal energy (iii) change in entropy (iv) heat transfer (v) work transfer.

**SOLUTION**

$$p_1 = 4 \text{ bar} = 4 \times 10^5 \text{ N/m}^2$$

$$V_1 = 0.3 \text{ m}^3, V_2 = 0.08 \text{ m}^3$$

For reversible adiabatic process,

$$p_1 V_1^n = p_2 V_2^n \quad \text{(i)}$$

$$\therefore p_2 = p_1 \left( \frac{V_1}{V_2} \right)^n = 4 \left( \frac{0.3}{0.08} \right)^{1.25} = 20.87 \text{ bar}$$

$$\text{(i) We know } \int_{H_1}^{H_2} dH = \int_{p_1}^{p_2} V dp \quad \text{(ii)}$$

$$\text{Also, } p_1 V_1^n = p V^n$$

$$\therefore V = \left( \frac{p_1 V_1^n}{p} \right)^{1/n}$$

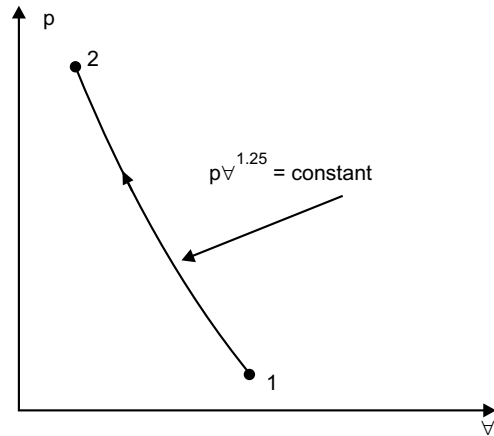

From equation (ii)

$$\int_{H_1}^{H_2} dH = \int_{p_1}^{p_2} \left( \frac{p_1 V_1^n}{p} \right)^{1/n} dp$$

$$\begin{aligned} \text{or, } H_2 - H_1 &= \left( p_1 V_1^n \right)^{1/n} \left[ \frac{p^{1-1/n}}{1-1/n} \right]_{p_1}^{p_2} \\ &= \frac{n(p_2 V_2 - p_1 V_1)}{n-1} \quad \text{[ From equation (i)]} \\ &= \frac{1.25}{(1.25-1) \times 10^3} [20.87 \times 10^5 \times 0.08 - 4 \times 10^5 \times 0.3] \text{ kJ} \\ &= 234.8 \text{ kJ} \end{aligned}$$

∴ Change in enthalpy = 234.8 kJ

$$\begin{aligned} \text{(ii) } H_2 - H_1 &= (U_2 + p_2 V_2) - (U_1 + p_1 V_1) \\ &= (U_2 - U_1) + (p_2 V_2 - p_1 V_1) \end{aligned}$$

$$\begin{aligned} \therefore U_2 - U_1 &= (H_2 - H_1) - (p_2 V_2 - p_1 V_1) \\ &= 234.8 - \left( \frac{20.87 \times 10^5 \times 0.08 - 4 \times 10^5 \times 0.3}{10^3} \right) \\ &= 187.84 \text{ kJ} \end{aligned}$$

- ∴ Change in internal energy = 187.84 kJ  
 (iii) Change in entropy ( $S_2 - S_1$ ) = 0  
 (iv) Heat transfer,  $Q_{1-2} = 0$   
 (v) Work transfer,  $W_{1-2}$   
 ∴  $W_{1-2} = Q_{1-2} - (U_2 - U_1) = 0 - 187.84 = -187.84$  kJ

**EXAMPLE 14**

3 kg of water at 80°C is mixed with 4 kg of water at 15°C in an isolated system. Calculate the change of entropy due to mixing process. Assume specific heat of water at constant pressure in 4.187 kJ/kgK.

**SOLUTION**

Applying first law of thermodynamics to the isolated system:

Total energy before mixing = Total energy after mixing

$$\begin{aligned} \therefore 3C_{pw}(80-0) + 4C_{pw}(15-0) \\ = 7C_{pw}(t_m-0) \end{aligned}$$

[  $C_{pw}$  = Specific heat of water at constant pressure ]

$$\text{or, } 240C_{pw} + 60C_{pw} = 7C_{pw}t_m$$

$$\text{or, } 240 + 60 = 7t_m$$

$$\therefore t_m = \frac{300}{7} = 42.85^\circ\text{C}$$

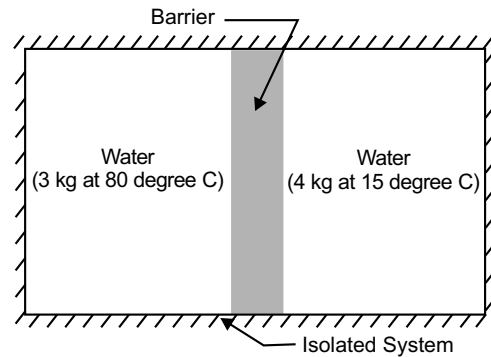

Initial entropy of the system

$$\begin{aligned} &= 3C_{pw} \ln \left( \frac{80 + 273}{273} \right) + 4C_{pw} \ln \left( \frac{15 + 273}{273} \right) \\ &= 0.7709C_{pw} + 0.2139C_{pw} = 0.9848C_{pw} \end{aligned}$$

Final entropy of the system

$$= (3 + 4)C_{pw} \ln \left( \frac{42.85 + 273}{273} \right) = 1.0205C_{pw}$$

Net change in entropy,

$$\begin{aligned} \Delta S &= \text{Final entropy} - \text{Initial entropy} \\ &= 1.0205C_{pw} - 0.9848C_{pw} \\ &= 0.0357C_{pw} \\ &= 0.1495 \text{ kJ/K} \end{aligned} \quad [C_{pw} = 4.187 \text{ kJ/kg K}]$$

∴ Change in entropy = 0.1495 kJ/K.

**EXERCISE**

1. What do you mean by Clausius inequality?
2. What do you mean by the term 'entropy'? What are the characteristics of entropy?

3. Prove that entropy is a property of a system.
4. What is a temperature–entropy diagram?
5. Derive the expressions for entropy changes for a closed system in the following cases: (i) general case for change of entropy of a gas (ii) heating a gas at constant volume (iii) heating a gas at constant pressure (iv) polytropic process.
6. 1 kg of ice at  $-5^{\circ}\text{C}$  is exposed to the atmosphere, which is at  $20^{\circ}\text{C}$ . The ice melts and comes into thermal equilibrium with the atmosphere. Determine the increase of entropy in the universe. What is the minimum amount of work necessary to convert the water back into ice at  $-5^{\circ}\text{C}$ . Take  $C_p$  of the ice  $2.093 \text{ kJ/kg C}$  and the latent heat of fusion of ice  $333.33 \text{ kJ/kg}$ .
7.  $1 \text{ m}^3$  of air is heated reversibly at constant pressure from  $15^{\circ}\text{C}$  to  $300^{\circ}\text{C}$ , and is then cooled reversibly at constant volume back to the initial temperature. If initial pressure is  $1.03 \text{ bar}$ , calculate the net heat flow and overall change of entropy.
8. 1 kg of air is allowed to expand reversibly in a cylinder behind a piston in such a way that the temperature remains constant at  $260^{\circ}\text{C}$  while the volume is doubled. The piston is then moved in, and heat is rejected by the air reversibly at constant pressure until the volume is the same as it was initially. Calculate the net heat flow and the overall change of entropy.
9. In reversible process, the rate of heat transfer to the system per unit temperature rise is given by  $0.5 \text{ kJ/C}$ . Find the change in entropy of the system if its temperature rises from  $500 \text{ K}$  to  $800 \text{ K}$ .
10.  $0.03 \text{ m}^3$  of nitrogen contained in a cylinder behind a piston is initially at  $1.05 \text{ bar}$  and  $15^{\circ}\text{C}$ . The gas is compressed isothermally and reversibly until the pressure is  $4.2 \text{ bar}$ . Calculate the change of entropy, the heat flow, and the work done and sketch the processes on pressure-volume diagram and temperature-entropy diagram. Assume nitrogen to act as a perfect gas and its molecular weight is 28.

## PROPERTIES OF PURE SUBSTANCES

### 7.1 INTRODUCTION

All the thermodynamic devices employ a fluid as a medium of energy transport between the system and the surrounding. This fluid is known as the *working substance*. Substances may exist in various forms. A *phase* is any homogeneous form of a substance, that is, solid, liquid and gas.

A *pure substance is one that is homogeneous and invariable in chemical aggregate*. It may exist in one or more phase, but the chemical composition remains the same in all phases. Thus, solid water (ice), liquid water or water vapour (steam) are pure substance since chemical composition is the same in each phase. In the steam power plant, the working substance is water. It is vaporised to steam in the boiler. The steam flows through and run the turbine. It is condensed to liquid water in the condenser. The water is then returned to the boiler by a pump. The mixtures of water and steam or vapour are pure substance since chemical composition is the same in each phase.

In this chapter, we will consider a system comprising of a single component, that as a system in which only one pure substance is present. Our aim here is to study the phase in which this pure substance may exist, and also the conditions or states as specified by its properties under which it may exist in a particular space. Also in this chapter, we shall consider methods (Table, charts, equations etc.) for the presentation of thermodynamic properties of pure substances.

### 7.2 PHASE EQUILIBRIUM OF A PURE SUBSTANCE ON T-V DIAGRAM

Consider 1 kg of water ice at  $-40^{\circ}\text{C}$  ( $-40^{\circ}\text{F}$ ) contained in piston-cylinder arrangement as shown in figure 7.1. The piston and weights maintain a constant pressure in the cylinder. If we heat the system from outside, change of state of water that take place inside the cylinder as a result of this heating. The change in state of water on heating and cooling at constant pressure on temperature, *i.e.*, specific volume diagram is shown in figure 7.2 in stepwise manner.

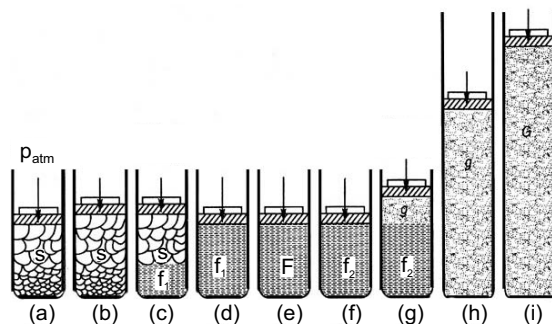
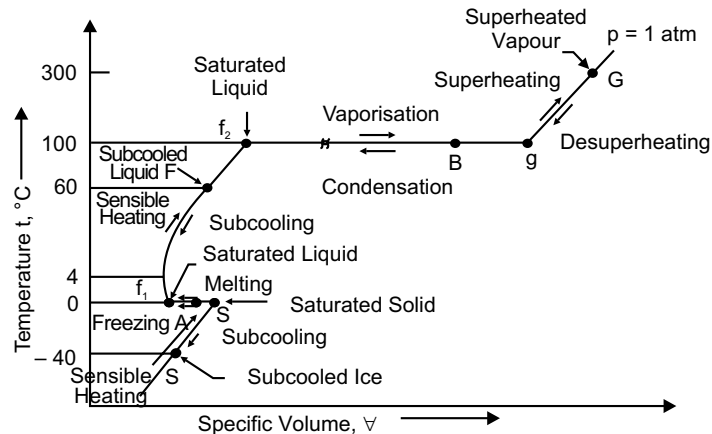

Fig. 7.1

**Step-1**

*Process S–S*: At temperature  $40^{\circ}\text{C}$ , ice is at solid state  $S$ . The volume of ice will increase slightly with the increase in temperature as shown in figure 7.1(b). It will cause the piston to move slightly upwards. At the end of this step, the ice is in state  $S$  as in figure 7.2. It is sensible heating, in which the temperature of the substance change but the phase remain the same, is known as melting of ice into water.

**Fig. 7.2****Step-2**

*Process S– $f_1$* : On further heating, temperature remaining constant at  $0^{\circ}\text{C}$ , ice in state  $S$  melts to water in state  $f_1$ . There is a change of phase from solid to liquid. In this process, there is a nominal decrease in the specific volume, since liquid water at  $0^{\circ}\text{C}$  is heavier than ice. Until all the ice melted to water as shown in figure 7.1(f) in between such as at  $A$  in figure 7.2. There is a mixture of solid and liquid in equilibrium as shown in figure 7.1(c).

It is seen from figure 7.2 that water-ice decrease in volume when changing from solid to liquid phase. It is latent heating, in which the phase changes, with temperature remaining constant.

**Step-3**

*Process  $f_1$ – $f_2$* : On further heating causes the temperature of liquid water at  $f_1$  at  $0^{\circ}\text{C}$  to rise. The temperature continues to rise until point  $f_2$  at  $100^{\circ}\text{C}$  is reached. In this process, the specific volume of water at first decreases as the temperature rises to about  $4^{\circ}\text{C}$ , and then increases. A state of liquid water in between this process of heating, say  $F$  at  $60^{\circ}\text{C}$ , is shown in figure 7.1(e). After reaching  $100^{\circ}\text{C}$  temperature the state is shown in figure 7.1(f). Process  $f_1$ – $f_2$  is *sensible heating*.

**Step-4**

*Process  $f_2$ – $g$* : If heating is continued, water in state  $f_2$  starts evaporating, the temperature remaining constant at  $100^{\circ}\text{C}$ . As a result, there is a large increase in specific volume of water as it changes from liquid phase to vapour phase. Until all the liquid water has evaporated to vapour at  $g$  as in figure 7.1(h). In between such as at  $B$  in figure 7.2. There is a mixture of liquid and vapour in equilibrium as shown in figure 7.1(g). So the process  $f_2$ – $g$  is *latent heating*, called vaporisation of liquid water into water vapour.

**Step-5**

*Process  $g$ – $G$* : On further heating of vapour at  $g$  causes its temperature to rise above  $100^{\circ}\text{C}$ , say to  $350^{\circ}\text{C}$  at  $G$ . The vapour at  $G$ , as shown in figure 7.1(i), occupies a greater volume than the vapour at  $g$ .

We see that there are two kinds of change of state taking place on addition of heat at constant pressure. These are *sensible heating* and *latent heating*. Thus, in figure 7.2, we have melting of ice

in water, (process  $S-f_1$  at  $0^\circ\text{C}$ ) and vaporisation of liquid water into water vapour, (process  $f_2-g$  at  $100^\circ\text{C}$ ).

If the process is carried in the opposite direction by cooling is shown in figure 7.2 starting from  $G$ , process  $G-g$  sensible cooling of water vapour, process  $g-f_2$  condensation of steam, process  $f_2-f_1$  sensible cooling of water, process  $f_1-S$  is fusion of water into ice and finally process  $S-S$  is sensible cooling of ice.

### 7.3 TEMPERATURE AND TOTAL HEAT GRAPH DURING STEAM FORMATION

The process of steam formation, as discussed before, may also be represented on a graph, whose abscissa represents the total heat and the vertical ordinate represents the temperature. The point  $A$  represents the initial condition of water at  $0^\circ\text{C}$  and pressure  $p$ , in bar is shown in figure 7.3. The line  $ABCD$  shows the relation between temperature and heat at a specific pressure of  $p$  (in bar).

For formation of super heated steam from water at freezing point the heat is absorbed in the three stages.

1. Heating of water up to boiling temperature or saturation temperature  $t$  shown by  $AB$ . Heat absorbed by water is known as *sensible heat*.
2. Change of state from liquid to steam is shown by  $BC$ . Heat absorbed during this stage is  $PQ$  known as *latent heat of vaporisation*.
3.  $CD$  is the super heating process. Heat absorbed during this process is given by  $QR$  is known as *heat of superheating*. If pressure increases the boiling point also increases.

The line joining the point  $A, B, E, K$  is known as *saturated liquid line* which forms the boundary between water and steam. Similarly a line passing through any steam points  $L, F, C$  is known as *dry saturated steam line*, which forms boundary lines between wet and superheated steam. When the pressure and saturation temperature increases the latent heat of vaporisation decreases, it becomes zero at  $N$ , where liquid and dry state lines meet. This point is known as *critical point* and the temperature corresponding to the critical point  $N$  is known as *critical temperature* and the pressure as *critical pressure*.

For steam critical temperature =  $374.15^\circ\text{C}$  and critical pressure =  $220.9 \text{ bar} \approx 221 \text{ bar}$ .

### 7.4 PHASE EQUILIBRIUM AT HIGHER PRESSURE

Now increase the weights on the piston in figure 7.1, thus increasing the pressure on ice. We observe

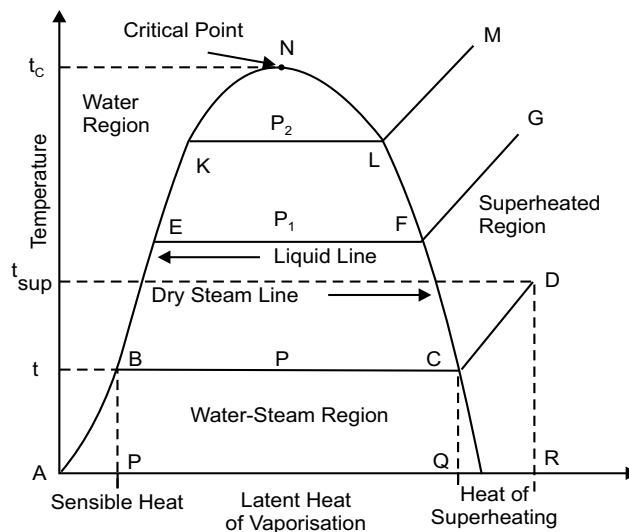

Fig. 7.3

similar changes of state taking place, is shown in figure 7.2, with the following difference shown in figure 7.4.

- As the saturation pressure is increased, the saturation temperature  $t_{\text{sat}}$  for boiling and condensation is also increased.
- As the saturation pressure is increased, the saturation temperature  $t_{\text{sat}}$  for melting and freezing is slightly decreased.
- If the specific volume of saturated liquid water at  $f$  is  $v_f$  and saturated water vapour at  $g$  is  $v_g$  then the increase in specific volume ( $v_g - v_f$ ) becomes smaller and smaller at higher and higher pressures.

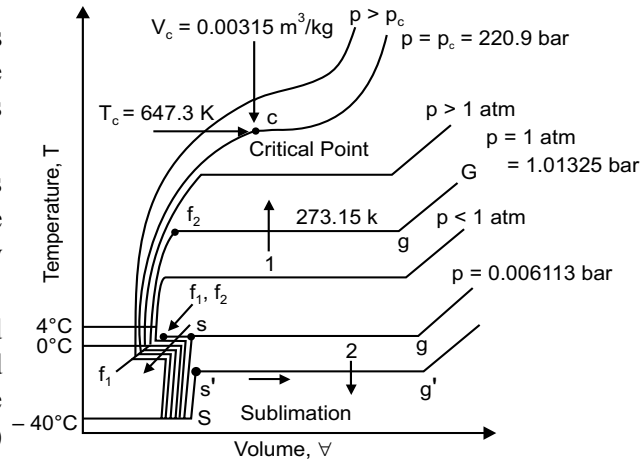

Fig. 7.4

In figure 7.4 at a pressure 220.9 bar shown by line  $p = p_c$ , increase in specific volume ( $v_g - v_f$ ) becomes zero, i.e.,  $v_g = v_f$ . At this pressure  $v_g = v_f = 0.003155 \text{ m}^3/\text{kg}$  and there is no constant temperature vaporisation process. There is a point of inflexion at  $C$  with zero slope at a temperature of  $374.15^\circ\text{C}$  or  $647.15 \text{ K}$  and is called *critical point*. At the critical point the saturated liquid and saturated vapour states are identical. The pressure, temperature and specific volume at this point are named as critical pressure, critical temperature and critical volume. Critical data for some substance are given in table 7.1, with critical temperatures in decreasing order.

Table: 7.1  
Critical Data for Some Substance

Substance	Critical Temperature ( $^\circ\text{C}$ )	Critical Pressure (bar)	Critical Volume ( $\text{m}^3/\text{kg}$ )
Mercury	>1550	>200	–
Water	374.3	220.9	0.003155
Ammonia	132	112.8	–
Carbon-dioxide	31.05	73.9	0.002143
Oxygen	-118.35	50.8	0.002438
Nitrogen	-147	33.99	–
Hydrogen	-239.85	13.0	0.032192
Helium	-267.9	2.29	–

It is seen that there are no separate or distinct liquid and vapour phases at a pressure critical and above. Below the critical temperature and above critical pressure the fluid is considered as *compressed liquid* and as *superheated vapour* if the temperature is higher than critical.

### 7.5 PHASE EQUILIBRIUM AT LOWER PRESSURES

If we decrease the weights in the experiment of the art 7.2, so that pressure on the piston is below atmospheric pressure the saturation temperature for vaporisation decreases. The specific volume during phase change from liquid to vapour is more. The melting point of ice is slightly higher than 0°C. The line of vaporisation and melting processes come closer as shown in figure 7.4. When we go to lower and lower pressure, at a saturation pressure of 0.006113 bar, the line for vaporisation and melting process conjoin at a temperature of 0.01°C. At this temperature and pressure, we see that all the three phases of water solid, liquid and vapour can exist in equilibrium. This known as the *triple point state*. The straight line such as  $s-f_1-f_2-g$  in figure 7.4 is called the *triple point line*.

**Table: 7.2**  
**Triple Point Data for Some Substance**

Substance	Temperature (0°C)	Pressure (bar)
Copper	1083	0.000079
Silver	961	0.01
Zinc	419	5.066
Water	0.01	0.006113
Mercury	-39	0.00000013
Ammonium	-78	6.1
Carbon-dioxide	-52	517
Oxygen	-210	12.53
Nitrogen	-219	0.15
Hydrogen	-259	7.194
Helium	-271	0.5

### 7.6 THERMODYNAMIC SURFACE

Graphical representation of the state of a pure substance which must have two independent properties, and any third as dependent one, can only be provided by a three dimensional plot. Such plots are called *thermodynamic surfaces*. The thermodynamics surfaces of a substance such as water which expands on freezing  $p-v-T$  diagram is shown in figure 7.5. The constant temperature line, one

drawn through the critical point is called *critical isotherm*, and one with a phase transition. Figure 7.6 shows a  $p-v-T$  surface for a normal substance which contracts on freezing.

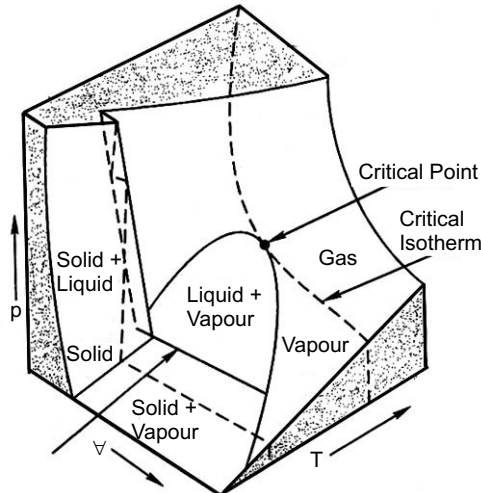

Fig. 7.5

**7.7  $p-v$  DIAGRAM OF A PURE SUBSTANCES**

The  $p-v$  diagram of a pure substance is an another projection of the thermodynamic surface. It is very useful in analysing problem of thermodynamics. Figure 7.6 shows this diagram for a substance like water that expands on freezing.

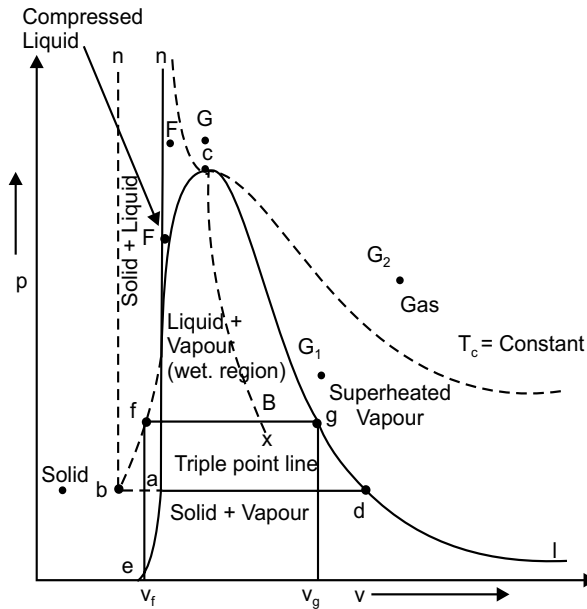

Fig. 7.6

## 7.8 IMPORTANT TERMS OF STEAM

### (a) Wet steam

When the steam contains moisture or particle of water in suspension it is called wet steam. It means evaporation of water not completed and the whole of the latent heat has not been absorbed.

### (b) Dry saturated steam

When the wet steam is further heated and it does not contain any suspended particles of water known as dry saturated steam. The dry saturated steam has absorbed its full latent heat and behaves practically in the same way as a perfect gas.

### (c) Superheated steam

When the dry steam is further heated at a constant pressure, thus rising its temperature it is said to be superheated steam. Since the press is constant the volume of super heated steam increases. The volume of 1 kg of superheated steam is considerably greater than the volume of 1 kg of dry saturated steam at the same pressure.

### (d) Dryness fraction or quality of wet steam

It is the ratio of the mass of actual dry steam to the mass of same quantity of wet steam. It denoted by 'x'

$$x = \frac{m_g}{m_g + m_f} = \frac{m_g}{m}$$

$m_g$  = Mass of actual dry stream

$m_f$  = Mass of water in suspension

$m$  = Mass of wet steam

$$= m_g + m_f$$

### (e) Sensible heat of water

Since specific heat of water at constant pressure = 4.2 kJ/kg K

∴ Heat absorbed by 1 kg of water from 0°C to  $t$ °C (sensible heat)

$$= 1 \times 4.2 \{(t + 273) - (0 + 273)\}$$

$$= 4.2 t \text{ kJ/kg}$$

Note: Sensible heat of water is taken equal to the specific enthalpy =  $h_f$ .

### (f) Latent heat of vaporisation

It is the amount of heat absorbed to evaporate 1 kg of water at its boiling point or saturation temperature without change of temperature. It is denoted by change of temperature  $h_{fg}$  and the value depends on its pressure. Latent heat of steam or heat of vaporisation or water = 2257 kJ/kg at atmospheric pressure. If the steam is wet and dryness fraction is  $x$ , heat absorbed by it during evaporation is  $xh_{fg}$ .

### (g) Enthalpy or total heat of steam

Enthalpy = Sensible heat + Latent heat

It is amount of heat absorbed by water from freezing point to saturation temperature plus the heat absorbed during evaporation denoted by  $h_g$  and the value of dry saturation steam may be read directly from the steam table.

Enthalpy of

(i) *wet steam*

$$h = h_f + xh_{fg}$$

$x$  = dryness fraction

(ii) *dry steam*

in case of dry steam  $x = 1$

$$h = h_g = h_f + h_{fg}$$

(iii) *superheated steam*

If we further add heat to the dry steam its temperature increases while the pressure remains constant. The increase in steam temperature shows the super heat stage of the steam

$$h_{\text{sup}} = h_f + h_{fg} + C_p (t_{\text{sup}} - t)$$

where,  $t_{\text{sup}}$  = temperature other superheated steam

$t$  = saturation temperature at constant pressure

$t_{\text{sup}} - t$  = degree of superheat

$C_p$  of steam lies between 1.67 kJ/kg K to 2.5 kJ/kg K.

### (h) Specific volume of steam

It is the volume occupied by the steam per unit mass at a given temperature and pressure and is expressed in m<sup>3</sup>/kg. It is reciprocal of the density of steam in kg/m<sup>3</sup>. Specific volume decreases as the increases in pressure.

(i) *Wet steam*

Consider 1 kg of wet steam of dryness fraction  $x$ , *i.e.*, this steam will have  $x$  kg of dry steam and  $(1-x)$  kg of water. Let  $v_f$  be the vol of 1 kg of water then, volume of one kg of wet steam

$$= xv_g + (1-x) v_f$$

$\therefore v_f$  is very small as compared to  $v_g$

$\therefore (1-x) v_f$  may be rejected

So, volume of 1 kg of wet steam =  $xv_g$  m<sup>3</sup>

Specific volume of wet steam  $v = xv_g$  m<sup>3</sup>/kg.

(ii) *Dry steam*

We know in case of dry steam mass of water in suspension is zero and dryness fraction = 1

So, specific volume of dry steam =  $v_g$  m<sup>3</sup>/kg

(iii) *Superheated steam*

When the dry saturated steam is further heated under a constant pressure, there is no increase in volume with the rise in temperature. The super heated steam behaves like a perfect gas.

$\therefore$  According to Charle's law

$$\frac{v_{\text{sup}}}{T_{\text{sup}}} = \frac{v_g}{T}$$

$$\text{So, } v_{\text{sup}} = \frac{v_g \cdot T_{\text{sup}}}{T}$$

$v_{\text{sup}}$  = specific volume of super heated steam

$v_g$  = specific volume of dry steam at the pressure of steam formation

$T_{\text{sup}}$  = absolute temperature of super heated steam.

$T$  = absolute temperature at the pressure of steam for motion.

Table: 7.3. Saturated Water and Steam (Temperature) Tables

Temperature in °C  (t)	Absolute pressure in bar  (p)	Specific volume in m <sup>3</sup> /kg		Specific enthalpy in kJ/kg			Specific entropy in kJ/kg			Temperature in °C  (t)
		Water (v <sub>f</sub> )	Steam (v <sub>g</sub> )	Water (h <sub>f</sub> )	Evaporation (h <sub>fg</sub> )	Steam (h <sub>g</sub> )	Water (s <sub>f</sub> )	Evaporation (s <sub>fg</sub> )	Steam (s <sub>g</sub> )	
0	0.00611	0.001000	206.31	0.0	2501.6	2501.6	0.000	9.158	9.158	0
1	0.00657	0.001000	192.61	4.2	2499.2	2503.4	0.015	9.116	9.131	1
2	0.00706	0.001000	176.92	8.4	2496.8	2505.2	0.031	9.074	9.105	2
3	0.00758	0.001000	168.17	12.6	2494.5	2507.1	0.046	9.033	9.079	3
4	0.00813	0.001000	157.27	16.8	2492.1	2508.9	0.061	8.992	9.053	4
5	0.00872	0.001000	147.16	21.0	2489.7	2510.7	0.076	8.951	9.027	5
6	0.00935	0.001000	137.78	25.2	2487.4	2512.6	0.091	8.911	9.002	6
7	0.01001	0.001000	129.06	29.4	2485.0	2514.4	0.106	8.870	8.976	7
8	0.01072	0.001000	120.97	33.6	2482.6	2516.2	0.121	8.830	8.951	8
9	0.01147	0.001000	113.44	37.8	2480.3	2518.1	0.136	8.791	8.927	9
10	0.01227	0.001000	106.43	42.0	2477.9	2519.9	0.151	8.751	8.902	10
11	0.01312	0.001000	99.909	46.2	2475.5	2521.7	0.166	8.712	8.878	11
12	0.01401	0.001000	93.835	50.4	2473.2	2523.6	0.181	8.673	8.854	12
13	0.01497	0.001001	88.176	54.6	2470.8	2525.4	0.195	8.635	8.830	14
14	0.01597	0.001001	82.900	58.7	2468.5	2527.2	0.210	8.597	8.806	14
15	0.01704	0.001001	77.978	62.9	2466.1	2529.1	0.224	8.559	8.783	15
16	0.01817	0.001001	73.384	67.1	2463.8	2530.9	0.239	8.520	8.759	16
17	0.01936	0.001001	69.095	71.3	2461.4	2532.7	0.253	8.483	8.736	17
18	0.02062	0.001001	65.087	75.5	2459.0	2534.5	0.268	8.446	8.714	18
19	0.02196	0.001002	61.341	79.7	2456.7	2536.4	0.282	8.409	8.691	19

(t)	(p)	(v <sub>r</sub> )	(v <sub>g</sub> )	(h <sub>r</sub> )	(h <sub>fg</sub> )	(h <sub>g</sub> )	(s <sub>r</sub> )	(s <sub>fg</sub> )	(s <sub>g</sub> )	(t)
20	0.02337	0.001002	57.838	83.9	2454.3	2538.2	0.296	8.372	8.668	20
21	0.02485	0.001002	54.561	88.0	2452.0	2540.0	0.310	8.336	8.646	21
22	0.02642	0.001002	51.492	92.2	2449.6	2541.8	0.325	8.299	8.624	22
23	0.02808	0.001002	48.619	96.4	2447.2	2543.6	0.339	8.263	8.602	23
24	0.02982	0.001002	45.926	100.6	2444.9	2545.5	0.353	8.228	8.581	24
25	0.03166	0.001003	43.402	104.8	2442.5	2547.3	0.367	8.192	8.559	25
26	0.03360	0.001003	41.034	108.9	2440.2	2549.1	0.381	8.157	8.538	26
27	0.03564	0.001003	38.813	113.1	2437.8	2550.9	0.395	8.122	8.517	27
28	0.03778	0.001004	36.728	117.3	2435.4	2552.7	0.409	8.087	8.496	28
29	0.04004	0.001004	34.769	121.5	2433.1	2554.5	0.423	8.052	8.475	29
30	0.04242	0.001004	32.929	125.7	2430.7	2556.4	0.437	8.018	8.455	30
31	0.04491	0.001005	31.199	129.8	2428.3	2558.2	0.450	7.984	8.434	31
32	0.04753	0.001005	29.572	134.0	2425.9	2560.0	0.464	7.950	8.414	32
33	0.05029	0.001005	28.042	138.2	2423.6	2561.8	0.478	7.916	8.394	33
34	0.05318	0.001006	26.601	142.4	2421.2	2563.6	0.491	7.883	8.374	34
35	0.05622	0.001006	25.245	146.6	2418.8	2565.4	0.505	7.849	8.354	35
36	0.05940	0.001006	23.967	150.7	2416.4	2567.2	0.518	7.817	8.335	36
37	0.06274	0.001007	22.763	154.9	2414.1	2569.0	0.532	7.783	8.315	37
38	0.06624	0.001007	21.627	159.1	2411.7	2570.8	0.545	7.751	8.296	38
39	0.06991	0.001007	20.557	163.3	2409.3	2572.6	0.559	7.718	8.277	39
40	0.07375	0.001008	19.546	167.5	2406.9	2574.4	0.572	7.686	8.258	40
41	0.07777	0.001008	18.592	171.6	2404.5	2576.2	0.585	7.654	8.239	41
42	0.08199	0.001009	17.692	175.8	2402.1	2577.9	0.599	7.622	8.221	42
43	0.08639	0.001009	16.841	180.0	2399.7	2579.7	0.612	7.591	8.203	43
44	0.09100	0.001009	16.036	184.2	2397.3	2581.5	0.625	7.559	8.184	44
45	0.09582	0.001010	15.276	188.4	2394.9	2583.3	0.638	7.528	8.166	45
46	0.10080	0.001010	14.557	192.5	2392.5	2585.1	0.651	7.497	8.148	46
47	0.10612	0.001011	13.877	196.7	2390.1	2586.9	0.664	7.466	8.130	47
48	0.11162	0.001011	13.233	200.9	2387.7	2588.6	0.678	7.435	8.113	48
49	0.11736	0.001012	12.623	205.1	2385.3	2590.4	0.691	7.404	8.095	49

(t)	(p)	(v <sub>r</sub> )	(v <sub>g</sub> )	(h <sub>r</sub> )	(h <sub>fg</sub> )	(h <sub>g</sub> )	(s <sub>r</sub> )	(s <sub>fg</sub> )	(s <sub>g</sub> )	(t)
50	0.12335	0.001012	12.046	209.3	2382.9	2592.2	0.704	7.374	8.078	50
51	0.12961	0.001013	11.499	213.4	2380.5	2593.9	0.716	7.344	8.060	51
52	0.13611	0.001013	10.980	217.6	2378.1	2595.7	0.729	7.314	8.043	52
53	0.14293	0.001014	10.488	221.8	2375.7	2597.5	0.742	7.284	8.026	53
54	0.15002	0.001014	10.022	226.0	2373.2	2599.2	0.755	7.254	8.009	54
55	0.15741	0.001015	9.5789	230.2	2370.8	2601.0	0.768	7.225	7.993	55
56	0.16511	0.001015	9.1587	234.3	2368.4	2602.7	0.780	7.196	7.976	56
57	0.17313	0.001016	8.7598	238.5	2366.0	2604.5	0.793	7.166	7.959	57
58	0.18147	0.001016	8.3808	242.7	2363.5	2606.2	0.806	7.137	7.943	58
59	0.19016	0.001017	8.0208	246.9	2361.1	2608.0	0.818	7.109	7.927	59
60	0.19920	0.001017	7.6785	251.1	2358.6	2609.7	0.831	7.080	7.911	60
61	0.20861	0.001018	7.3532	255.3	2356.1	2611.4	0.844	7.051	7.895	61
62	0.21838	0.001018	7.0437	259.5	2353.7	2613.2	0.856	7.023	7.879	62
63	0.22855	0.001019	6.7493	263.6	2351.3	2614.9	0.868	6.995	7.863	63
64	0.23912	0.001019	6.4690	267.8	2348.8	2616.6	0.881	6.967	7.848	64
65	0.25009	0.001020	6.2023	272.0	2346.4	2618.4	0.893	6.939	7.832	65
66	0.26150	0.001020	5.9482	276.2	2343.9	2620.1	0.906	6.911	7.817	66
67	0.27334	0.001021	5.7062	280.4	2341.4	2621.8	0.918	6.884	7.802	67
68	0.28563	0.001022	5.4756	284.6	2338.9	2623.5	0.930	6.856	7.786	68
69	0.29838	0.001022	5.2558	288.8	2336.4	2625.2	0.943	6.828	7.771	69
70	0.31162	0.001023	5.0463	293.0	2333.9	2626.9	0.955	6.802	7.757	70
71	0.32535	0.001024	4.8464	297.2	2331.4	2628.6	0.967	6.775	7.742	71
72	0.33958	0.001024	4.6557	301.3	2329.0	2630.3	0.979	6.748	7.727	72
73	0.35434	0.001025	4.4737	305.5	2326.5	2632.0	0.991	6.721	7.712	73
74	0.36964	0.001025	4.3000	309.7	2324.0	2633.7	1.003	6.695	7.698	74
75	0.38549	0.001026	4.1341	313.9	2321.5	2635.4	1.015	6.668	7.683	75
76	0.40191	0.001027	3.9757	318.1	2318.9	2637.0	1.027	6.642	7.669	76
77	0.41891	0.001027	3.8243	322.3	2316.4	2638.7	1.039	6.616	7.655	77
78	0.43652	0.001028	3.6796	326.5	2313.9	2640.4	1.051	6.590	7.641	78
79	0.45474	0.001029	3.5413	330.7	2311.4	2642.1	1.063	6.564	7.627	79

(t)	(p)	(v <sub>r</sub> )	(v <sub>g</sub> )	(h <sub>r</sub> )	(h <sub>fg</sub> )	(h <sub>g</sub> )	(s <sub>r</sub> )	(s <sub>fg</sub> )	(s <sub>g</sub> )	(t)
80	0.47360	0.001029	3.4091	334.9	2308.9	2643.8	1.075	6.538	7.613	80
81	0.49311	0.001030	3.2826	339.1	2306.3	2645.4	1.087	6.512	7.599	81
82	0.51329	0.001031	3.1616	343.3	2303.8	2647.1	1.099	6.487	7.586	82
83	0.53416	0.001031	3.0458	347.5	2301.2	2648.7	1.111	6.461	7.572	83
84	0.55573	0.001032	2.9350	351.7	2298.7	2650.4	1.123	6.436	7.559	84
85	0.57803	0.001033	2.8288	355.9	2296.1	2652.0	1.134	6.411	7.545	85
86	0.60108	0.001033	2.7272	360.1	2293.5	2653.6	1.146	6.386	7.532	86
87	0.62489	0.001034	2.6298	364.3	2291.0	2655.3	1.158	6.361	7.519	87
88	0.64948	0.001035	2.5365	368.5	2288.4	2656.9	1.169	6.337	7.506	88
89	0.67487	0.001035	2.4470	372.7	2285.8	2658.5	1.181	6.312	7.493	89
90	0.70109	0.001036	2.3613	376.9	2283.2	2660.1	1.193	6.287	7.480	90
91	0.72815	0.001037	2.2791	381.1	2280.6	2661.7	1.204	6.263	7.467	91
92	0.75606	0.001038	2.2002	385.4	2278.0	2663.4	1.216	6.238	7.454	92
93	0.78489	0.001038	2.1245	389.6	2275.4	2665.0	1.227	6.215	7.442	93
94	0.81461	0.001039	2.0519	393.8	2272.8	2666.6	1.239	6.190	7.429	94
95	0.84526	0.001040	1.9822	398.0	2270.1	2668.1	1.250	6.167	7.417	95
96	0.87686	0.001041	1.9153	402.2	2267.5	2669.7	1.261	6.143	7.404	96
97	0.90944	0.001041	1.8510	406.4	2264.9	2671.3	1.273	6.119	7.392	97
98	0.94301	0.001042	1.7893	410.6	2262.3	2672.9	1.284	6.096	7.380	98
99	0.97761	0.001043	1.7300	414.8	2259.6	2674.4	1.296	6.072	7.368	99
100	1.0133	0.001044	1.6730	419.1	2256.9	2676.0	1.307	6.048	7.355	100
102	1.0876	0.001045	1.5655	427.5	2251.6	2679.1	1.329	6.002	7.331	102
104	1.1668	0.001047	1.4662	435.9	2246.3	2682.2	1.352	5.956	7.308	104
106	1.2504	0.001048	1.3742	444.4	2240.9	2685.3	1.374	5.910	7.284	106
108	1.3390	0.001050	1.2889	452.9	2235.4	2688.3	1.396	5.865	7.261	108
110	1.4327	0.001052	1.2099	461.3	2230.0	2691.3	1.418	5.821	7.239	110
112	1.5316	0.001054	1.1366	469.8	2224.5	2694.3	1.440	5.776	7.216	112
114	1.6362	0.001055	1.0685	478.3	2218.9	2697.2	1.462	5.732	7.194	114
116	1.7465	0.001057	1.0052	486.7	2213.5	2700.2	1.484	5.688	7.172	116
118	1.8628	0.001059	0.94634	495.2	2207.9	2703.1	1.506	5.645	7.151	118

(t)	(p)	(v <sub>f</sub> )	(v <sub>g</sub> )	(h <sub>f</sub> )	(h <sub>fg</sub> )	(h <sub>g</sub> )	(s <sub>f</sub> )	(s <sub>fg</sub> )	(s <sub>g</sub> )	(t)
120	1.9854	0.001061	0.89152	503.7	2202.3	2706.0	1.528	5.601	7.129	120
122	2.1145	0.001063	0.84045	512.2	2196.6	2708.8	1.549	5.559	7.108	122
124	2.2504	0.001064	0.79283	520.7	2190.9	2711.6	1.570	5.517	7.087	124
126	2.3933	0.001066	0.74840	529.2	2185.2	2714.4	1.592	5.475	7.067	126
128	2.5435	0.001068	0.70691	537.8	2179.4	2717.2	1.613	5.433	7.046	128
130	2.7013	0.001070	0.66814	546.3	2173.6	2719.9	1.634	5.392	7.026	130
132	2.8670	0.001072	0.63188	554.8	2167.8	2722.6	1.655	5.351	7.006	132
134	3.0407	0.001074	0.59795	563.4	2161.9	2725.3	1.676	5.310	6.986	134
136	3.2229	0.001076	0.56618	572.0	2155.9	2727.9	1.697	5.270	6.967	136
138	3.4138	0.001078	0.53641	580.5	2150.0	2730.5	1.718	5.229	6.947	138
140	3.6139	0.001080	0.50849	589.1	2144.0	2733.1	1.739	5.189	6.928	140
142	3.8231	0.001082	0.48230	597.7	2137.9	2735.6	1.760	5.150	6.910	142
144	4.0420	0.001084	0.45771	606.3	2131.8	2738.1	1.780	5.111	6.891	144
146	4.2709	0.001086	0.43460	614.9	2125.7	2740.6	1.801	5.071	6.872	146
148	4.5101	0.001089	0.41288	623.5	2119.5	2743.0	1.821	5.033	6.854	148
150	4.7600	0.001091	0.39245	632.2	2113.2	2745.4	1.842	4.994	6.836	150
155	5.4333	0.001096	0.34644	653.8	2097.4	2751.2	1.892	4.899	6.791	155
160	6.1806	0.001102	0.30676	675.5	2081.2	2756.7	1.943	4.805	6.748	160
165	7.0077	0.001108	0.27240	697.2	2064.8	2762.0	1.992	4.713	6.705	165
170	7.9202	0.001114	0.24255	719.1	2048.0	2767.1	2.042	4.621	6.663	170
175	8.9244	0.001121	0.21654	741.1	2030.7	2771.8	2.091	4.531	6.622	175
180	10.027	0.001128	0.19380	763.1	2013.2	2776.3	2.139	4.443	6.582	180
185	11.233	0.001135	0.17386	785.3	1995.1	2780.4	2.187	4.355	6.542	185
190	12.551	0.001142	0.15632	807.5	1976.8	2784.3	2.236	4.268	6.504	190
195	13.987	0.001149	0.14084	829.9	1957.9	2787.8	2.283	4.182	6.465	195
200	15.549	0.001156	0.12716	852.4	1938.5	2790.9	2.331	4.097	6.428	200
205	17.243	0.001164	0.11503	875.0	1918.8	2793.8	2.378	4.013	6.391	205
210	19.077	0.001172	0.10424	897.7	1898.5	2796.2	2.425	3.929	6.354	210
215	21.060	0.001181	0.094625	920.6	1877.7	2798.3	2.471	3.846	6.317	215
220	23.198	0.001190	0.086038	943.7	1856.2	2799.9	2.518	3.764	6.282	220

(t)	(p)	(v <sub>r</sub> )	(v <sub>g</sub> )	(h <sub>r</sub> )	(h <sub>fg</sub> )	(h <sub>g</sub> )	(s <sub>r</sub> )	(s <sub>fg</sub> )	(s <sub>g</sub> )	(t)
225	25.501	0.001199	0.078349	966.9	1834.3	2801.2	2.564	3.682	6.246	225
230	27.976	0.001209	0.071450	990.3	1811.7	2802.0	2.610	3.601	6.211	230
235	30.632	0.001219	0.065245	1013.8	1788.5	2802.3	2.656	3.519	6.175	235
240	33.478	0.001229	0.059654	1037.6	1764.6	2802.2	2.702	3.439	6.141	240
245	36.523	0.001240	0.054606	1061.6	1740.0	2801.6	2.748	3.358	6.106	245
250	39.776	0.001251	0.050037	1085.8	1714.6	2800.4	2.794	3.277	6.071	250
255	43.246	0.001263	0.045896	1110.2	1688.5	2798.7	2.839	3.197	6.036	255
260	46.943	0.001276	0.042134	1134.9	1661.5	2796.4	2.885	3.116	6.001	260
265	50.877	0.001289	0.038710	1159.9	1633.6	2793.5	2.931	3.035	5.966	265
270	55.058	0.001303	0.035588	1185.2	1604.7	2789.9	2.976	2.954	5.930	270
275	59.496	0.001317	0.032736	1210.8	1574.7	2785.5	3.022	2.873	5.895	275
280	64.202	0.001332	0.030126	1236.8	1543.6	2780.4	3.068	2.790	5.858	280
285	69.186	0.001349	0.027733	1263.2	1511.3	2774.5	3.115	2.707	5.822	285
290	74.461	0.001366	0.025535	1290.0	1477.6	2767.6	3.161	2.624	5.785	290
295	80.037	0.001384	0.023513	1317.3	1442.5	2759.8	3.208	2.539	5.747	295
300	85.927	0.001404	0.021649	1345.0	1406.0	2751.0	3.255	2.453	5.708	300
305	92.144	0.001425	0.019927	1373.4	1367.7	2741.1	3.303	2.366	5.669	305
310	98.700	0.001448	0.018334	1402.4	1327.6	2730.0	3.351	2.277	5.628	310
315	105.61	0.001473	0.016856	1432.1	1285.5	2717.6	3.400	2.186	5.586	315
320	112.89	0.001500	0.015480	1462.6	1241.1	2703.7	3.450	2.092	5.542	320
325	120.56	0.001529	0.014195	1494.0	1194.0	2688.0	3.501	1.996	5.497	325
330	128.63	0.001562	0.012989	1526.5	1143.7	2670.2	3.553	1.896	5.449	330
335	137.12	0.001598	0.011854	1560.2	1089.5	2649.7	3.606	1.792	5.398	335
340	146.05	0.001639	0.010780	1595.5	1030.7	2626.2	3.662	1.681	5.343	340
345	155.45	0.001686	0.097631	1632.5	966.4	2598.9	3.719	1.564	5.283	345
350	165.35	0.001741	0.087991	1671.9	895.8	2567.7	3.780	1.438	5.218	350
355	175.77	0.001809	0.078592	1716.6	813.8	2530.4	3.849	1.295	5.144	355
360	186.75	0.001896	0.069398	1764.2	721.2	2485.4	3.921	1.139	5.060	360
365	198.33	0.002016	0.060116	1818.0	610.0	2428.0	4.002	0.956	4.958	365
370	210.54	0.002214	0.049728	1890.2	452.6	2342.8	4.111	0.703	4.814	370
374.15	221.20	0.003170	0.003170	2107.4	0.0	2107.4	4.443	0.000	4.443	374.15

Table: 7.4. Saturated Water and Steam (Pressure) Tables

Absolute pressure in bar (p)	Temperature in °C (t)	Specific volume in m <sup>3</sup> /kg		Specific enthalpy in kJ/kg			Specific entropy in kJ/kg K			Absolute pressure in bar (p)
		Water (v <sub>f</sub> )	Steam (v <sub>g</sub> )	Water (h <sub>f</sub> )	Evaporation (h <sub>fg</sub> )	Steam (h <sub>g</sub> )	Water (s <sub>f</sub> )	Evaporation (s <sub>fg</sub> )	Steam (s <sub>g</sub> )	
0.0061	0.000	0.001000	206.31	0.0	2501.6	2501.6	0.000	9.158	9.158	0.0061
0.010	6.983	0.001000	129.21	29.3	2485.1	2514.4	0.106	8.871	8.977	0.010
0.015	13.04	0.001001	87.982	54.7	2470.8	2525.5	0.196	8.634	8.830	0.015
0.020	17.51	0.001001	67.006	73.5	2460.1	2533.6	0.261	8.464	8.725	0.020
0.025	21.10	0.001002	54.256	88.4	2451.8	2540.2	0.312	8.333	8.645	0.025
0.030	24.10	0.001003	45.667	101.0	2444.6	2545.6	0.354	8.224	8.578	0.030
0.035	26.69	0.001003	39.479	111.8	2438.6	2550.4	0.391	8.132	8.523	0.035
0.040	28.98	0.001004	34.802	121.4	2433.1	2554.5	0.423	8.053	8.476	0.040
0.045	31.03	0.001005	31.141	130.0	2428.2	2558.2	0.451	7.983	8.434	0.045
0.050	32.90	0.001005	28.194	137.8	2423.8	2561.6	0.476	7.920	8.396	0.050
0.060	36.18	0.001006	23.741	151.5	2416.0	2567.5	0.521	7.810	8.331	0.06
0.070	39.03	0.001007	20.531	163.4	2409.2	2572.6	0.559	7.718	8.277	0.07
0.080	41.53	0.001008	18.105	173.9	2403.2	2577.1	0.593	7.637	8.230	0.08
0.090	43.79	0.001009	16.204	183.3	2397.8	2581.1	0.622	7.566	8.188	0.09
0.100	45.83	0.001010	14.675	191.8	2392.9	2584.7	0.649	7.502	8.151	0.10
0.11	47.71	0.001011	13.416	199.7	2388.4	2588.1	0.674	7.444	8.118	0.11
0.12	49.45	0.001012	12.362	206.9	2384.3	2591.2	0.696	7.391	8.087	0.12
0.13	51.06	0.001013	11.466	213.7	2380.3	2594.0	0.717	7.342	8.059	0.13
0.14	52.57	0.001013	10.694	220.0	2376.7	2596.7	0.737	7.296	8.033	0.14
0.15	54.00	0.001014	10.023	226.0	2373.2	2599.2	0.755	7.254	8.009	0.15

(p)	(t)	(v <sub>f</sub> )	(v <sub>g</sub> )	(h <sub>f</sub> )	(h <sub>fg</sub> )	(h <sub>g</sub> )	(s <sub>f</sub> )	(s <sub>fg</sub> )	(s <sub>g</sub> )	(p)
0.16	55.34	0.001015	9.4331	231.6	2370.0	2601.6	0.772	7.215	7.987	0.16
0.17	56.62	0.001015	8.9111	236.9	2366.9	2603.8	0.788	7.178	7.966	0.17
0.18	57.83	0.001016	8.4452	242.0	2363.9	2605.9	0.804	7.142	7.946	0.18
0.19	58.98	0.001017	8.0272	246.8	2361.1	2607.9	0.818	7.109	7.927	0.19
0.20	60.09	0.001017	7.6498	251.5	2358.4	2609.9	0.832	7.077	7.909	0.20
0.21	61.15	0.001018	7.3073	255.9	2355.8	2611.7	0.845	7.047	7.892	0.21
0.22	62.16	0.001018	6.9951	260.1	2353.4	2613.5	0.858	7.018	7.876	0.22
0.23	63.14	0.001019	6.7093	264.2	2351.0	2615.2	0.870	6.991	7.861	0.23
0.24	64.08	0.001019	6.4467	268.2	2348.6	2616.8	0.882	6.964	7.846	0.24
0.25	64.99	0.001020	6.2045	272.0	2346.3	2618.3	0.893	6.939	7.832	0.25
0.26	65.87	0.001020	5.9803	275.7	2344.2	2619.9	0.904	6.915	7.819	0.26
0.27	66.72	0.001021	5.7724	279.2	2342.1	2621.3	0.915	6.891	7.806	0.27
0.28	67.55	0.001021	5.5778	282.7	2340.0	2622.7	0.925	6.868	7.793	0.28
0.29	68.35	0.001022	5.3982	286.0	2338.1	2624.1	0.935	6.847	7.781	0.29
0.30	69.12	0.001022	5.2293	289.3	2336.1	2625.4	0.944	6.825	7.769	0.30
0.32	70.62	0.001023	4.9220	295.6	2332.4	2628.0	0.962	6.785	7.747	0.32
0.34	72.03	0.001024	4.6504	301.5	2328.9	2630.4	0.980	6.747	7.727	0.34
0.36	73.37	0.001025	4.4076	307.1	2325.5	2632.6	0.996	6.711	7.707	0.36
0.38	74.66	0.001026	4.1900	312.5	2322.3	2634.8	1.011	6.677	7.688	0.38
0.40	75.89	0.001027	3.9934	317.7	2319.2	2636.9	1.026	6.645	7.671	0.40
0.42	77.06	0.001027	3.8148	322.6	2316.3	2638.9	1.040	6.614	7.654	0.42
0.44	78.19	0.001028	3.6522	327.3	2313.4	2640.7	1.054	6.584	7.638	0.44
0.46	79.28	0.001029	3.5032	331.9	2310.7	2642.6	1.067	6.556	7.623	0.46
0.48	80.33	0.001029	3.3663	336.3	2308.0	2644.3	1.079	6.530	7.609	0.48
0.50	81.35	0.001030	3.2401	340.6	2305.4	2646.0	1.091	6.504	7.595	0.50
0.52	82.33	0.001031	3.1233	344.7	2302.9	2647.6	1.103	6.478	7.581	0.52
0.54	83.28	0.001031	3.0148	348.7	2300.5	2649.2	1.114	6.455	7.569	0.54
0.56	84.19	0.001032	2.9139	352.5	2298.2	2650.7	1.125	6.431	7.556	0.56
0.58	85.09	0.001033	2.8197	356.3	2295.8	2652.1	1.135	6.409	7.544	0.58
0.60	85.95	0.001033	2.7317	359.9	2293.7	2653.6	1.145	6.388	7.533	0.60

(p)	(t)	(v <sub>f</sub> )	(v <sub>g</sub> )	(h <sub>f</sub> )	(h <sub>fg</sub> )	(h <sub>g</sub> )	(s <sub>f</sub> )	(s <sub>fg</sub> )	(s <sub>g</sub> )	(p)
0.62	86.80	0.001034	2.6491	363.5	2291.4	2654.9	1.155	6.367	7.522	0.62
0.64	87.62	0.001034	2.5715	366.9	2289.4	2656.3	1.165	6.346	7.511	0.64
0.66	88.42	0.001035	2.4985	370.3	2287.3	2657.6	1.174	6.326	7.500	0.66
0.68	89.20	0.001036	2.4297	373.6	2285.2	2658.8	1.183	6.307	7.490	0.68
0.70	89.96	0.001036	2.3647	376.8	2283.3	2660.1	1.192	6.288	7.480	0.70
0.72	90.70	0.001037	2.3031	379.9	2281.4	2661.3	1.201	6.270	7.471	0.72
0.74	91.43	0.001037	2.2448	382.9	2279.5	2662.4	1.209	6.253	7.462	0.74
0.76	92.14	0.001038	2.1895	385.9	2277.7	2663.6	1.217	6.235	7.452	0.76
0.78	92.83	0.001038	2.1369	388.9	2275.8	2664.7	1.225	6.219	7.444	0.78
0.80	93.51	0.001039	2.0869	391.7	2274.1	2665.8	1.233	6.202	7.435	0.80
0.85	95.15	0.001040	1.9721	398.6	2269.8	2668.4	1.252	6.163	7.415	0.85
0.90	96.71	0.001041	1.8691	405.2	2265.7	2670.9	1.270	6.125	7.395	0.90
0.95	98.20	0.001042	1.7771	411.5	2261.7	2673.2	1.287	6.091	7.378	0.95
1.00	99.63	0.001043	1.6938	417.5	2257.9	2675.4	1.303	6.057	7.360	1.00
1.01325	100.00	0.001044	1.6730	419.1	2256.9	2676.0	1.307	6.048	7.355	1.01325
1.05	101.0	0.001045	1.6181	423.3	2254.3	2677.6	1.308	6.025	7.343	1.05
1.10	102.3	0.001046	1.5492	428.8	2250.8	2679.6	1.333	5.995	7.328	1.10
1.15	103.6	0.001047	1.4861	434.2	2247.4	2681.6	1.347	5.966	7.313	1.15
1.20	104.8	0.001048	1.4281	439.3	2244.1	2683.4	1.361	5.937	7.298	1.20
1.25	106.0	0.001049	1.3746	444.4	2240.8	2685.2	1.374	5.911	7.285	1.25
1.30	107.1	0.001050	1.3250	449.2	2237.8	2687.0	1.387	5.885	7.272	1.30
1.35	108.2	0.001050	1.2791	453.4	2234.8	2688.7	1.399	5.860	7.259	1.35
1.40	109.3	0.001051	1.2363	458.4	2231.9	2690.3	1.411	5.836	7.247	1.40
1.45	110.4	0.001052	1.1963	462.8	2229.0	2691.8	1.423	5.812	7.235	1.45
1.50	111.4	0.001053	1.1590	467.1	2226.3	2693.4	1.433	5.790	7.223	1.50
1.60	113.3	0.001055	1.0911	475.4	2220.8	2696.2	1.455	5.747	7.202	1.60
1.70	115.2	0.001056	1.0309	483.2	2215.8	2699.0	1.475	5.706	7.181	1.70
1.80	116.9	0.001058	0.97718	490.7	2210.8	2701.5	1.494	5.668	7.162	1.80
1.90	118.6	0.001059	0.92895	497.9	2206.1	2704.0	1.513	5.631	7.144	1.90
2.00	120.2	0.001061	0.88540	504.7	2201.6	2706.3	1.530	5.597	7.127	2.00

(p)	(t)	(v <sub>r</sub> )	(v <sub>g</sub> )	(h <sub>r</sub> )	(h <sub>fg</sub> )	(h <sub>g</sub> )	(s <sub>r</sub> )	(s <sub>fg</sub> )	(s <sub>g</sub> )	(p)
2.1	121.8	0.001062	0.84586	511.3	2197.2	2708.5	1.547	5.564	7.111	2.1
2.2	123.3	0.001064	0.80980	517.6	2193.0	2710.6	1.563	5.532	7.095	2.2
2.3	124.7	0.001065	0.77677	523.7	2188.9	2712.6	1.578	5.502	7.080	2.3
2.4	126.1	0.001066	0.74641	529.6	2184.9	2714.5	1.593	5.473	7.066	2.4
2.5	127.4	0.001068	0.71840	535.3	2181.1	2716.4	1.607	5.445	7.052	2.5
2.6	128.7	0.001069	0.69247	540.9	2177.3	2718.2	1.621	5.418	7.039	2.6
2.7	130.0	0.001070	0.66840	546.2	2173.7	2719.9	1.634	5.392	7.026	2.7
2.8	131.2	0.001071	0.64600	551.4	2170.1	2721.5	1.647	5.367	7.014	2.8
2.9	132.4	0.001072	0.62509	556.5	2166.6	2723.1	1.660	5.342	7.002	2.9
3.0	133.5	0.001074	0.60553	561.5	2163.2	2724.7	1.672	5.319	6.991	3.0
3.1	134.7	0.001075	0.58718	566.2	2159.9	2726.1	1.683	5.297	6.980	3.1
3.2	135.8	0.001076	0.56995	570.9	2156.7	2727.6	1.695	5.274	6.969	3.2
3.3	136.8	0.001077	0.55373	575.5	2153.5	2729.0	1.706	5.253	6.959	3.3
3.4	137.9	0.001078	0.53843	579.9	2150.4	2730.3	1.717	5.232	6.949	3.4
3.5	138.9	0.001079	0.52397	584.3	2147.3	2731.6	1.727	5.212	6.939	3.5
3.6	139.9	0.001080	0.51029	588.5	2144.4	2732.9	1.738	5.192	6.930	3.6
3.7	140.8	0.001081	0.49733	592.7	2141.4	2734.1	1.748	5.173	6.921	3.7
3.8	141.8	0.001082	0.48502	596.7	2138.6	2735.3	1.758	5.154	6.912	3.8
3.9	142.7	0.001083	0.47333	600.8	2135.7	2736.5	1.767	5.136	6.903	3.9
4.0	143.6	0.001084	0.46220	604.7	2132.9	2737.6	1.776	5.118	6.894	4.0
4.1	144.5	0.001085	0.45159	608.5	2130.2	2738.7	1.786	5.100	6.886	4.1
4.2	145.4	0.001086	0.44147	612.3	2127.5	2739.8	1.795	5.083	6.878	4.2
4.3	146.3	0.001087	0.43181	616.0	2124.9	2740.9	1.803	5.067	6.870	4.3
4.4	147.1	0.001088	0.42257	619.6	2122.3	2741.9	1.812	5.050	6.862	4.4
4.5	147.9	0.001089	0.41373	623.2	2119.7	2742.9	1.820	5.035	6.855	4.5
4.6	148.7	0.001090	0.40526	626.7	2117.2	2743.9	1.829	5.018	6.847	4.6
4.7	149.5	0.001090	0.39714	630.1	2114.7	2744.8	1.837	5.003	6.840	4.7
4.8	150.3	0.001091	0.38934	633.5	2112.2	2745.7	1.845	4.988	6.833	4.8
4.9	151.1	0.001092	0.38186	636.8	2109.8	2746.6	1.853	4.973	6.826	4.9
5.0	151.8	0.001093	0.37466	640.1	2107.4	2747.5	1.860	4.959	6.819	5.0

(p)	(t)	(v <sub>r</sub> )	(v <sub>g</sub> )	(h <sub>r</sub> )	(h <sub>fg</sub> )	(h <sub>g</sub> )	(s <sub>r</sub> )	(s <sub>fg</sub> )	(s <sub>g</sub> )	(p)
5.2	153.3	0.001095	0.36106	646.5	2102.7	2749.2	1.875	4.931	6.806	5.2
5.4	154.8	0.001096	0.34844	652.8	2098.1	2750.9	1.890	4.903	6.793	5.4
5.6	156.2	0.001098	0.33669	658.8	2093.7	2752.5	1.904	4.877	6.781	5.6
5.8	157.5	0.001099	0.32572	664.7	2089.3	2754.0	1.918	4.851	6.769	5.8
6.0	158.8	0.001101	0.31546	670.4	2085.1	2755.5	1.931	4.827	6.758	6.0
6.2	160.1	0.001102	0.30584	676.1	2080.8	2756.9	1.944	4.803	6.747	6.2
6.4	161.4	0.001104	0.29680	681.5	2076.7	2758.2	1.956	4.780	6.736	6.4
6.6	162.6	0.001105	0.28829	686.8	2072.7	2759.5	1.968	4.757	6.725	6.6
6.8	163.8	0.001107	0.28026	692.0	2068.8	2760.8	1.980	4.735	6.715	6.8
7.0	165.0	0.001108	0.27268	697.1	2064.9	2762.0	1.992	4.713	6.705	7.0
7.2	166.1	0.001110	0.26550	702.0	2061.2	2763.2	2.003	4.693	6.696	7.2
7.4	167.2	0.001111	0.25870	706.9	2057.4	2764.3	2.014	4.672	6.686	7.4
7.6	168.3	0.001112	0.25224	711.7	1053.7	2765.4	2.025	4.652	6.677	7.6
7.8	169.4	0.001114	0.24610	716.3	2050.1	2766.4	2.035	4.633	6.668	7.8
8.0	170.4	0.001115	0.24026	720.9	2046.5	2767.4	2.046	4.614	6.660	8.0
8.2	171.4	0.001116	0.23469	725.4	2043.0	2768.4	2.056	4.595	6.651	8.2
8.4	172.4	0.001118	0.22938	729.9	2039.6	2769.4	2.066	4.577	6.643	8.4
8.6	173.4	0.001119	0.22431	734.2	2036.2	2770.4	2.075	4.560	6.635	8.6
8.8	174.4	0.001120	0.21946	738.5	2032.8	2771.3	2.085	4.542	6.627	8.8
9.0	175.4	0.001121	0.21482	742.6	2029.5	2772.1	2.094	4.525	6.619	9.0
9.2	176.3	0.001123	0.21037	746.8	2026.2	2773.0	2.103	4.509	6.612	9.2
9.4	177.2	0.001124	0.20610	750.8	2023.0	2773.8	2.112	4.492	6.604	9.4
9.6	178.1	0.001125	0.20201	754.8	2019.8	2774.6	2.121	4.476	6.597	9.6
9.8	179.0	0.001126	0.19808	758.7	2016.7	2775.4	2.130	4.460	6.590	9.8
10.0	179.9	0.001127	0.19430	762.6	2013.6	2776.2	2.138	4.445	6.583	10.0
10.5	182.0	0.001130	0.18548	772.0	2006.0	2778.0	2.159	4.407	6.566	10.5
11.0	184.1	0.001133	0.17739	781.1	1998.6	2779.7	2.179	4.371	6.550	11.0
11.5	186.0	0.001136	0.17002	789.9	1991.4	2781.3	2.198	4.336	6.534	11.5
12.0	188.0	0.001139	0.16321	798.4	1984.3	2782.7	2.216	4.303	6.519	12.0
12.5	189.8	0.001141	0.15696	806.7	1977.5	2784.2	2.234	4.271	6.505	12.5

(p)	(t)	(v <sub>r</sub> )	(v <sub>g</sub> )	(h <sub>r</sub> )	(h <sub>fg</sub> )	(h <sub>g</sub> )	(s <sub>r</sub> )	(s <sub>fg</sub> )	(s <sub>g</sub> )	(p)
13.0	191.6	0.001144	0.15114	814.7	1970.7	2785.4	2.251	4.240	6.491	13.0
13.5	193.3	0.001146	0.14576	822.5	1964.2	2786.7	2.267	4.211	6.478	13.5
14.0	195.0	0.001149	0.14073	830.1	1957.7	2787.8	2.284	4.181	6.465	14.0
14.5	196.7	0.001151	0.13606	837.5	1951.4	2788.9	2.299	4.154	6.453	14.5
15.0	198.3	0.001154	0.13167	844.6	1945.3	2789.9	2.314	4.127	6.441	15.0
15.5	199.8	0.001156	0.12756	851.6	1939.2	2790.8	2.329	4.100	6.429	15.5
16.0	201.4	0.001159	0.12370	858.5	1933.2	2791.7	2.344	4.074	6.418	16.0
16.5	202.9	0.001161	0.12006	865.3	1927.3	2792.6	2.358	4.049	6.407	16.5
17.0	204.3	0.001163	0.11664	871.8	1921.6	2793.4	2.371	4.025	6.396	17.0
17.5	205.7	0.001166	0.11340	878.2	1915.9	2794.1	2.384	4.001	6.385	17.5
18.0	207.1	0.001168	0.11033	884.5	1910.3	2794.8	2.398	3.977	6.375	18.0
18.5	208.5	0.001170	0.10742	890.7	1904.8	2795.5	2.410	3.955	6.365	18.5
19.0	209.8	0.001172	0.10467	896.8	1899.3	2796.1	2.423	3.933	6.356	19.0
19.5	211.1	0.001174	0.10204	902.7	1894.0	2796.7	2.435	3.911	6.346	19.5
20.0	212.4	0.001177	0.09955	908.5	1888.7	2797.2	2.447	3.890	6.337	20.0
21.0	214.8	0.001181	0.094902	919.9	1878.3	2798.2	2.470	3.849	6.319	21.0
22.0	217.2	0.001185	0.090663	930.9	1868.1	2799.1	2.492	3.809	6.301	22.0
23.0	219.6	0.001189	0.086780	941.6	1858.2	2799.8	2.514	3.771	6.285	23.0
24.0	221.8	0.001193	0.083209	951.9	1848.5	2800.4	2.534	3.735	6.269	24.0
25.0	223.9	0.001197	0.079915	961.9	1839.1	2801.0	2.554	3.699	6.253	25.0
26.0	226.0	0.001201	0.076865	971.7	1829.7	2801.4	2.574	3.665	6.239	26.0
27.0	228.1	0.001205	0.074033	981.2	1820.5	2801.7	2.592	3.632	6.224	27.0
28.0	230.0	0.001209	0.071396	990.5	1811.5	2802.0	2.611	3.600	6.211	28.0
29.0	232.0	0.001213	0.068935	999.5	1802.7	2802.2	2.628	3.569	6.197	29.0
30.0	233.8	0.001216	0.066632	1008.3	1794.0	2802.3	2.646	3.538	6.184	30.0
31.0	235.7	0.001220	0.064473	1017.1	1785.4	2802.3	2.662	3.509	6.171	31.0
32.0	237.4	0.001224	0.062443	1025.4	1776.9	2802.3	2.679	3.480	6.159	32.0
33.0	239.2	0.001227	0.060533	1033.7	1768.6	2802.3	2.694	3.452	6.146	33.0
34.0	240.9	0.001231	0.058731	1041.8	1760.3	2802.1	2.710	3.424	6.134	34.0
35.0	242.5	0.001235	0.057028	1049.7	1752.3	2802.0	2.725	3.398	6.123	35.0

(p)	(t)	(v <sub>r</sub> )	(v <sub>g</sub> )	(h <sub>r</sub> )	(h <sub>fg</sub> )	(h <sub>g</sub> )	(s <sub>r</sub> )	(s <sub>fg</sub> )	(s <sub>g</sub> )	(p)
36.0	244.2	0.001238	0.055417	1057.5	1744.2	2801.7	2.740	3.371	6.111	36.0
37.0	245.8	0.001242	0.053889	1065.2	1736.2	2801.4	2.755	3.345	6.100	37.0
38.0	247.3	0.001245	0.052439	1072.7	1728.4	2801.1	2.769	3.321	6.090	38.0
39.0	248.8	0.001249	0.051061	1080.1	1720.7	2800.8	2.783	3.296	6.079	39.0
40.0	250.3	0.001252	0.049749	1087.4	1712.9	2800.3	2.797	3.272	6.069	40.0
42.0	253.2	0.001259	0.047306	1101.6	1697.8	2799.4	2.823	3.225	6.048	42.0
44.0	256.1	0.001266	0.045078	1115.4	1682.9	2798.3	2.849	3.180	6.029	44.0
46.0	258.8	0.001273	0.043036	1128.8	1668.2	2797.0	2.874	3.136	6.010	46.0
48.0	261.4	0.001279	0.041158	1141.8	1653.9	2795.7	2.897	3.094	5.991	48.0
50.0	263.9	0.001286	0.039425	1154.5	1639.7	2794.2	2.921	3.053	5.974	50.0
52.0	266.4	0.001293	0.037820	1166.9	1625.7	2792.6	2.943	3.013	5.956	52.0
54.0	268.8	0.001299	0.036330	1179.0	1611.8	2790.8	2.965	2.974	5.939	54.0
56.0	271.1	0.001306	0.034942	1190.8	1598.2	2789.0	2.986	2.937	5.923	56.0
58.0	273.4	0.001312	0.033646	1202.4	1584.6	2787.0	3.007	2.899	5.906	58.0
60.0	275.6	0.001319	0.032433	1213.7	1571.3	2785.0	3.027	2.863	5.890	60.0
62.0	277.7	0.001325	0.031295	1224.9	1558.0	2782.9	3.047	2.828	5.875	62.0
64.0	279.8	0.001332	0.030225	1235.8	1544.8	2780.6	3.066	2.794	5.860	64.0
66.0	281.9	0.001338	0.029218	1246.5	1531.8	2778.3	3.085	2.760	5.845	66.0
68.0	283.9	0.001345	0.028267	1257.1	1518.8	2775.9	3.104	2.727	5.831	68.0
70.0	285.8	0.001351	0.027368	1267.4	1506.0	2773.4	3.122	2.694	5.816	70.0
72.0	287.7	0.001358	0.026517	1277.7	1493.2	2770.9	3.140	2.662	5.802	72.0
74.0	289.6	0.001365	0.025711	1287.8	1480.4	2768.2	3.157	2.631	5.788	74.0
76.0	291.4	0.001371	0.024944	1297.7	1467.8	2765.5	3.174	2.600	5.774	76.0
78.0	293.2	0.001378	0.024215	1307.5	1455.4	2762.7	3.191	2.569	5.760	78.0
80.0	295.0	0.001384	0.023521	1317.2	1442.7	2759.9	3.208	2.539	5.747	80.0
82.0	296.7	0.001391	0.022860	1326.7	1430.3	2757.0	3.224	2.510	5.734	82.0
84.0	298.4	0.001398	0.022228	1336.2	1417.8	2754.0	3.240	2.481	5.721	84.0
86.0	300.1	0.001404	0.021624	1345.4	1405.5	2750.9	3.256	2.452	5.708	86.0
88.0	301.7	0.001411	0.021046	1354.7	1393.1	2747.8	3.271	2.424	5.695	88.0
90.0	303.3	0.001418	0.020493	1363.8	1380.8	2744.6	3.287	2.395	5.682	90.0

(p)	(t)	(v <sub>r</sub> )	(v <sub>g</sub> )	(h <sub>r</sub> )	(h <sub>fg</sub> )	(h <sub>g</sub> )	(s <sub>r</sub> )	(s <sub>fg</sub> )	(s <sub>g</sub> )	(p)
92	304.9	0.001425	0.019962	1372.8	1368.5	2741.3	3.302	2.367	5.669	92
94	305.5	0.001432	0.019453	1381.7	1356.3	2738.0	3.317	2.340	5.657	94
96	308.0	0.001439	0.018964	1390.6	1344.1	2734.7	3.332	2.313	5.644	96
98	309.5	0.001446	0.018493	1399.4	1331.9	2731.2	3.346	2.286	5.632	98
100	301.0	0.001453	0.018041	1408.0	1319.7	2727.7	3.361	2.259	5.620	100
105	314.6	0.001470	0.016981	1429.5	1289.2	2718.7	3.396	2.194	5.590	105
110	318.0	0.001489	0.016007	1450.5	1258.8	2709.3	3.430	2.129	5.560	110
115	321.4	0.001508	0.015114	1471.3	1228.2	2699.5	3.464	2.066	5.530	115
120	324.6	0.001527	0.014285	1491.7	1197.5	2698.2	3.497	2.003	5.500	120
125	327.8	0.001547	0.013518	1511.9	1166.5	2678.4	3.530	1.941	5.471	125
130	330.8	0.001567	0.012800	1531.9	1135.1	2667.0	3.561	1.880	5.441	130
135	333.8	0.001588	0.012130	1551.8	1103.3	2655.1	3.593	1.818	5.411	135
140	336.6	0.001611	0.011498	1571.5	1070.9	2642.4	3.624	1.756	5.380	140
145	339.4	0.001634	0.010905	1591.3	1037.9	2629.2	3.655	1.694	5.349	145
150	342.1	0.001658	0.010343	1610.9	1004.2	2615.1	3.686	1.632	5.318	150
155	344.8	1.001683	0.009813	1630.7	969.7	2600.4	3.716	1.570	5.286	155
160	347.3	0.001710	0.009310	1650.4	934.5	2584.9	3.747	1.506	5.253	160
165	349.7	0.001739	0.008833	1670.4	898.5	2568.9	3.778	1.442	5.220	165
170	352.3	0.001770	0.008372	1691.6	860.0	2551.6	3.811	1.375	5.186	170
175	354.6	0.001803	0.007927	1713.3	820.0	2533.3	3.844	1.306	5.150	175
180	357.0	0.001840	0.007497	1734.8	779.1	2513.9	3.877	1.236	5.113	180
185	359.2	0.001881	0.007082	1756.5	736.5	2493.0	3.910	1.164	5.074	185
190	361.4	0.001926	0.006676	1778.7	691.8	2470.5	3.943	1.090	5.033	190
195	363.6	0.001978	0.006276	1801.9	643.9	2445.8	3.978	1.011	4.989	195
200	365.7	0.002037	0.005875	1826.6	591.6	2418.2	4.015	0.926	4.941	200
205	367.8	0.002110	0.005462	1854.2	532.0	2386.2	4.056	0.830	4.886	205
210	369.8	0.002202	0.005023	1886.3	461.2	2347.5	4.105	0.717	4.822	210
215	371.8	0.002342	0.004509	1929.4	365.2	2294.6	4.170	0.566	4.736	215
220	373.7	0.002668	0.003735	2010.3	186.3	2196.6	4.293	0.288	4.581	220
221.2	374.15	0.003170	0.003170	2107.4	000.0	2107.4	4.443	0.000	4.443	221.2

Table: 7.5. Specific Volume of Superheated Steam

Absolute Pressure in bar (p)	Saturation Temperature in °C (t <sub>s</sub> )	Specific volume (v) in m <sup>3</sup> /kg at various temperatures in °C										
		100	150	200	250	300	350	400	500	600	700	800
0.02	17.5	86.08	97.63	109.2	120.7	132.2	143.8	155.3	178.4	201.5	224.6	247.6
0.04	29.0	43.03	48.81	54.58	60.35	66.12	71.89	77.66	89.20	100.7	112.3	123.8
0.06	36.2	28.68	32.53	36.38	40.23	44.08	47.93	51.77	59.47	67.16	74.85	82.54
0.08	41.5	21.50	24.40	27.28	30.17	33.06	35.94	38.83	44.60	50.37	56.14	61.91
0.10	45.8	17.20	19.51	21.83	24.14	26.45	28.75	31.06	35.68	40.30	44.91	49.53
0.15	54.0	11.51	13.06	14.61	16.16	17.71	19.25	20.80	23.89	26.98	30.07	33.16
0.20	60.1	8.585	9.748	10.91	12.07	13.22	14.37	15.53	17.84	20.15	22.45	24.76
0.25	65.0	6.874	7.808	8.737	9.665	10.59	11.52	12.44	14.29	16.14	17.99	19.84
0.30	69.1	5.714	6.493	7.268	8.040	8.811	9.581	10.35	11.89	13.43	14.70	16.51
0.35	72.7	4.898	5.568	6.233	6.896	7.557	8.218	8.879	10.20	11.52	12.84	14.16
0.40	75.9	4.279	4.866	5.448	6.028	6.607	7.185	7.763	8.918	10.07	11.23	12.38
0.45	78.7	3.803	4.325	4.844	5.360	5.875	6.389	6.903	7.930	8.957	9.984	10.99
0.50	81.3	3.418	3.889	4.356	4.821	5.284	5.747	6.209	7.134	8.057	8.981	9.904
0.60	86.0	2.844	3.238	3.628	4.016	4.402	4.788	5.174	5.944	6.714	7.484	8.254
0.70	90.0	2.434	2.773	3.108	3.441	3.772	4.103	4.434	5.095	5.755	6.415	7.074
0.80	93.5	2.126	2.425	2.718	3.010	3.300	3.590	3.879	4.457	5.035	5.613	6.190
0.90	96.7	1.887	2.153	2.415	2.674	2.933	3.190	3.448	3.962	4.475	4.989	5.502
1.00	99.6	1.696	1.936	2.172	2.406	2.639	2.871	3.103	3.565	4.028	4.490	4.952
1.50	111.4	..	1.285	1.444	1.601	1.757	1.912	2.067	2.376	2.685	2.993	3.301
2.00	120.2	..	0.9595	1.080	1.199	1.316	1.433	1.549	1.781	2.013	2.244	2.475

(p)	(t <sub>s</sub> )	100	150	200	250	300	350	400	500	600	700	800
2.5	127.4	..	0.7641	0.8620	0.9574	1.052	1.145	1.239	1.424	1.610	1.795	1.980
3.0	133.5	..	0.6337	0.7164	0.7964	0.8753	0.9535	1.031	1.187	1.341	1.496	1.650
3.5	138.9	..	0.5406	0.6123	0.6814	0.7493	0.8166	0.8835	1.017	1.149	1.282	1.414
4.0	143.6	..	0.4707	0.5343	0.5952	0.6549	0.713 9	0.7725	0.8892	1.005	1.121	1.237
4.5	147.9	..	0.4165	0.4738	0.5284	0.5817	0.6343	0.6865	0.7905	0.8939	0.9971	1.100
5.0	151.8	..	..	0.4250	0.4744	0.5226	0.5701	0.6172	0.7108	0.8040	0.8969	0.9896
6.0	158.8	..	..	0.3520	0.3939	0.4344	0.4742	0.5136	0.5918	0.6696	0.7471	0.8245
7.0	165.0	..	..	0.2999	0.3364	0.3714	0.4057	0.4396	0.5069	0.5737	0.6402	0.7066
8.0	170.4	..	..	0.2608	0.2932	0.3241	0.3543	0.3842	0.4432	0.5017	0.5600	0.6181
9.0	175.4	..	..	0.2303	0.2596	0.2874	0.3144	0.3410	0.3936	0.4458	0.4976	0.5493
10.0	179.9	..	..	0.2059	0.2328	0.2580	0.2824	0.3065	0.3540	0.4010	0.4477	0.4943
11.0	184.1	..	..	0.1859	0.2108	0.2339	0.2563	0.2782	0.3215	0.3644	0.4069	0.4492
12.0	188.0	..	..	0.1692	0.1924	0.2139	0.234 5	0.2547	0.2945	0.3338	0.3729	0.4118
13.0	191.6	..	..	0.1551	0.1769	0.1969	0.2161	0.2348	0.2716	0.3080	0.3441	0.3800
14.0	195.0	..	..	0.1429	0.1636	0.1823	0.2002	0.2177	0.2520	0.2859	0.3194	0.3528
15.0	198.3	..	..	0.1324	0.1520	0.1697	0.1865	0.2029	0.2350	0.2667	0.2980	0.3292
16.0	201.4	..	..	..	0.1419	0.1587	0.1745	0.1900	0.2202	0.2499	0.2793	0.3086
17.0	204.3	..	..	..	0.1329	0.1489	0.1640	0.1786	0.2070	0.2351	0.2628	0.2904
18.0	207.1	..	..	..	0.1250	0.1402	0.1546	0.1684	0.1954	0.2219	0.2481	0.2742
19.0	209.8	..	..	..	0.1179	0.1325	0.1461	0.1593	0.184 9	0.2101	0.2350	0.2597
20.0	212.4	..	..	..	0.1115	0.1255	0.1386	0.1511	0.1756	0.1995	0.2232	0.2467
22.0	217.2	..	..	..	0.1004	0.1134	0.1255	0.1370	0.1593	0.1812	0.2028	0.2242
24.0	221.8	..	..	..	0.09108	0.1034	0.1146	0.1252	0.1458	0.1659	0.1858	0.2054
26.0	226.0	..	..	..	0.08321	0.09483	0.1053	0.1153	0.1344	0.1530	0.1714	0.1895
28.0	230.0	..	..	..	0.07644	0.08751	0.09740	0.1067	0.124 6	0.1419	0.1590	0.1759
30.0	233.8	..	..	..	0.07055	0.08116	0.09053	0.09931	0.1161	0.1323	0.1483	0.1641
32.0	237.4	..	..	..	0.06538	0.07559	0.08451	0.09283	0.1087	0.1239	0.1390	0.1538
34.0	240.9	..	..	..	0.06080	0.07068	0.07920	0.08711	0.1021	0.1165	0.1307	0.1447
36.0	244.2	..	..	..	0.05670	0.06630	0.07448	0.08202	0.09626	0.1100	0.1234	0.1366
38.0	247.3	..	..	..	0.05302	0.06237	0.07025	0.07747	0.09104	0.1041	0.1168	0.1294

(p)	(t <sub>s</sub> )	100	150	200	250	300	350	400	500	600	700	800
40.0	250.3	..	..	..	..	0.05883	0.06645	0.07338	0.08634	0.09876	0.1109	0.1229
42.0	253.2	..	..	..	..	0.05563	0.06300	0.06967	0.08209	0.09397	0.1056	0.1170
44.0	256.0	..	..	..	..	0.05270	0.05986	0.06630	0.07823	0.08961	0.1007	0.1116
46.0	258.8	..	..	..	..	0.05003	0.05699	0.06322	0.07470	0.08562	0.09626	0.1067
48.0	261.4	..	..	..	..	0.04757	0.05436	0.06039	0.07147	0.08197	0.09219	0.1022
50.0	263.9	..	..	..	..	0.04530	0.05194	0.05779	0.06849	0.07862	0.08845	0.09809
55.0	269.9	..	..	..	..	0.04343	0.04666	0.05213	0.06202	0.07131	0.08031	0.08912
60.0	275.6	..	..	..	..	0.03615	0.04222	0.04738	0.05659	0.06518	0.07348	0.08159
65.0	280.8	..	..	..	..	0.03258	0.00848	0.04338	0.05203	0.06003	0.06774	0.07526
70.0	285.8	..	..	..	..	0.02946	0.00523	0.03992	0.04809	0.05559	0.06279	0.06980
75.0	290.5	..	..	..	..	0.02672	0.03243	0.03694	0.04469	0.05176	0.05852	0.06509
80.0	295.0	..	..	..	..	0.02426	0.02995	0.03431	0.04170	0.04839	0.05477	0.06096
85.0	299.2	..	..	..	..	0.02191	0.02776	0.03200	0.03908	0.04544	0.05148	0.05732
90.0	303.3	..	..	..	..	..	0.02579	0.02993	0.03674	0.04280	0.04853	0.05408
95.0	307.2	..	..	..	..	..	0.02403	0.02808	0.03465	0.04045	0.04591	0.05119
100.0	311.0	..	..	..	..	..	0.02242	0.02641	0.03276	0.03832	0.04355	0.04858
110.0	318.0	..	..	..	..	..	0.01961	0.02351	0.02950	0.03466	0.03947	0.04408
120.0	324.6	..	..	..	..	..	0.01721	0.02108	0.02679	0.03160	0.03607	0.04033
130.0	330.8	..	..	..	..	..	0.01510	0.01902	0.02449	0.02902	0.03319	0.03716
140.0	336.6	..	..	..	..	..	0.01321	0.01723	0.02251	0.02680	0.03072	0.03444
150.0	342.1	..	..	..	..	..	0.01146	0.01566	0.02080	0.02488	0.02859	0.03209
160.0	347.3	..	..	..	..	..	0.00976	0.01428	0.01929	0.02320	0.02672	0.03003
170.0	352.3	..	..	..	..	..	..	0.01303	0.01797	0.02172	0.02507	0.02821
180.0	357.0	..	..	..	..	..	..	0.01191	0.01679	0.02040	0.02300	0.02659
190.0	361.4	..	..	..	..	..	..	0.01089	0.01573	0.01922	0.02229	0.02515
200.0	365.7	..	..	..	..	..	..	0.00995	0.01477	0.01816	0.02111	0.02385
210.0	369.8	..	..	..	..	..	..	0.00907	0.01391	0.01720	0.02004	0.02267
220.0	373.7	..	..	..	..	..	..	0.00825	0.01312	0.01633	0.01907	0.02160
221.2	374.15	..	..	..	..	..	..	0.00816	0.01303	0.01622	0.01895	0.02135

**Table: 7.6. Specific Enthalpy of Superheated Steam**

Absolute Pressure in bar (p)	Saturation Temperature in °C (t <sub>s</sub> )	Specific enthalpy (h) in kJ/kg at various temperatures in °C										
		100	150	200	250	300	350	400	500	600	700	800
0.02	17.5	2688.5	2783.7	2880.0	2977.7	3076.8	3177.5	3279.7	3489.2	3705.6	3928.8	4158.7
0.04	29.0	2688.3	2783.5	2879.9	2977.6	3076.8	3177.4	3279.7	3489.2	3705.6	3928.8	4158.7
0.06	36.2	2688.0	2783.4	2879.8	2977.6	3076.7	3177.4	3279.6	3489.2	3705.6	3928.8	4158.7
0.08	41.5	2687.8	2783.2	2879.7	2977.5	3076.7	3177.3	3279.6	3489.1	3705.5	3928.8	4158.7
0.10	45.8	2687.5	2783.1	2879.6	2977.4	3076.6	3177.3	3279.6	3489.1	3705.5	3928.8	4158.7
0.15	54.0	2686.9	2782.4	2879.5	2977.3	3076.5	3177.7	3279.5	3489.1	3705.5	3928.7	4158.7
0.20	60.1	2686.3	2782.3	2879.2	2977.1	3076.4	3177.1	3279.4	3489.0	3705.4	3928.7	4158.7
0.25	65.0	2685.7	2782.0	2879.0	2977.0	3076.3	3177.0	3279.3	3489.0	3705.4	3928.7	4158.6
0.30	69.1	2685.1	2781.6	2878.7	2976.8	3076.1	3176.9	3279.3	3488.9	3705.4	3928.7	4158.6
0.35	72.7	2684.5	2781.2	2878.5	2976.7	3076.0	3176.8	3279.2	3488.9	3705.3	3928.7	4158.6
0.40	75.9	2683.8	2780.9	2878.2	2976.5	3075.9	3176.8	3279.1	3488.8	3705.3	3928.6	4158.6
0.45	78.7	2683.2	2780.5	2878.0	2976.3	3075.8	3176.7	3279.1	3488.8	3705.2	3928.6	4158.5
0.50	81.3	2682.6	2780.1	2877.7	2976.1	3075.7	3176.6	3279.0	3488.7	3705.2	3928.6	4158.5
0.60	86.0	2681.3	2779.4	2877.3	2975.8	3075.4	3176.4	3278.8	3488.6	3705.1	3928.5	4158.5
0.70	90.0	2680.0	2778.6	2876.8	2975.5	3075.2	3176.2	3278.7	3488.5	3705.0	3928.4	4158.4
0.80	93.5	2678.8	2777.8	2876.3	2975.2	3075.0	3176.0	3278.5	3488.4	3705.0	3928.4	4158.4
0.90	96.7	2677.5	2777.1	2875.8	2974.8	3074.7	3175.8	3278.4	3488.3	3704.9	3928.3	4158.3
1.00	99.6	2676.2	2176.3	2875.4	2974.5	3074.5	3175.6	3278.2	3488.1	3704.8	3928.2	4158.3
1.50	111.4	..	2772.5	2872.9	2972.9	3073.3	3174.7	3277.5	3487.6	3704.4	3927.9	4158.0
2.00	120.2	..	2768.5	2870.5	2971.2	3072.1	3173.8	3276.7	3487.0	3704.0	3927.6	4157.8

(p)	(t <sub>s</sub> )	100	150	200	250	300	350	400	500	600	700	800
2.5	127.4	..	2764.5	2868.0	2969.6	3070.9	3172.8	3275.9	3486.5	3703.6	3927.3	4157.6
3.0	133.5	..	2760.4	2865.5	2967.9	3069.7	3171.9	3275.2	3486.0	3703.2	3927.0	4157.3
3.5	138.9	..	2756.3	2863.0	2966.2	3068.4	3170.9	3274.4	3485.4	3702.7	3926.7	4157.1
4.0	143.6	..	2752.0	2860.4	2964.5	3067.2	3170.0	3273.6	3484.9	3702.3	3926.4	4156.9
4.5	147.9	..	2746.7	2857.8	2962.8	3066.0	3169.1	3272.9	3484.3	3701.9	3926.1	4156.7
5.0	151.8	..	..	2855.1	2961.1	3064.8	3168.1	3272.1	3483.8	3701.5	3925.8	4156.4
6.0	158.8	..	..	2849.7	2957.6	3062.3	3166.2	3270.6	3482.7	3700.7	3925.1	4155.9
7.0	165.0	..	..	2844.2	2954.0	3059.8	3164.3	3269.0	3481.6	3699.9	3924.5	4155.5
8.0	170.4	..	..	2838.6	2950.4	3057.3	3162.4	3267.5	3480.5	3699.1	3923.9	4155.0
9.0	175.4	..	..	2832.7	2946.8	3054.7	3160.5	3266.0	3479.4	3698.2	3923.3	4154.5
10.0	179.9	..	..	2826.8	2943.0	3052.1	3158.5	3264.4	3478.3	3697.4	3922.7	4154.1
11.0	184.1	..	..	2820.7	2939.3	3049.6	3156.6	3262.9	3477.2	3696.6	3922.0	4153.6
12.0	188.0	..	..	2814.4	2935.4	3046.9	3154.6	3261.3	3476.1	3695.8	3921.4	4153.1
13.0	191.6	..	..	2808.0	2931.5	3044.3	3152.7	3259.7	3475.0	3695.0	3920.8	4152.7
14.0	195.0	..	..	2801.4	2927.6	3041.6	3150.7	3258.2	3473.9	3694.1	3920.2	4152.2
15.0	198.3	..	..	2794.7	2923.5	3038.9	3148.7	3256.6	3472.8	3693.3	3919.6	4151.7
16.0	201.4	..	..	..	2919.4	3036.2	3146.7	3255.0	3471.7	3692.5	3918.9	4151.3
17.0	204.3	..	..	..	2915.3	3033.5	3144.7	3253.5	3470.6	3691.7	3918.3	4150.8
18.0	207.1	..	..	..	2911.0	3030.7	3142.7	3251.9	3469.5	3690.9	3917.7	4150.3
19.0	209.8	..	..	..	2906.7	3027.9	3140.7	3250.3	3468.4	3690.0	3917.1	4149.8
20.0	212.4	..	..	..	2902.4	3025.0	3138.6	3248.7	3467.3	3689.2	3916.5	4149.4
22.0	217.2	..	..	..	2893.4	3019.3	3134.5	3245.5	3465.1	3687.6	3915.2	4148.4
24.0	221.8	..	..	..	2884.2	3013.4	3130.4	3242.3	3462.9	3685.9	3914.0	4147.5
26.0	226.0	..	..	..	2874.7	3007.4	3126.1	3239.0	3460.6	3684.3	3912.7	4146.6
28.0	230.0	..	..	..	2864.9	3001.3	3121.9	3235.8	3458.4	3682.6	3911.5	4145.6
30.0	233.8	..	..	..	2854.8	2995.1	3117.5	3232.5	3456.2	3681.0	3910.3	4144.7
32.0	237.4	..	..	..	2844.4	2988.7	3113.2	3229.2	3454.0	3679.3	3909.0	4143.8
34.0	240.9	..	..	..	2833.6	2982.2	3108.7	3225.9	3451.7	3677.7	3907.8	4142.8
36.0	244.2	..	..	..	2822.5	2975.6	3104.2	3222.5	3449.5	3676.1	3906.5	4141.9
38.0	247.3	..	..	..	2811.0	2968.9	3099.7	3219.1	3447.2	3674.4	3905.3	4141.0

(p)	(t <sub>s</sub> )	100	150	200	250	300	350	400	500	600	700	800
40.0	250.3	..	..	..	..	2962.0	3095.1	3215.7	3445.0	3672.8	3904.1	4140.0
42.0	253.2	..	..	..	..	2955.0	3090.4	3212.3	3442.7	3671.1	3902.8	4139.1
44.0	256.0	..	..	..	..	2947.8	3085.7	3208.8	3440.5	3669.5	3901.6	4138.2
46.0	258.8	..	..	..	..	2940.5	3080.9	3205.3	3438.2	3667.8	3900.3	4137.2
48.0	261.4	..	..	..	..	2933.1	3076.1	3201.8	3435.9	3666.2	3899.1	4136.3
50.0	263.9	..	..	..	..	2925.5	3071.2	3198.3	3433.7	3664.5	3897.9	4135.3
55.0	269.9	..	..	..	..	2905.8	3058.7	3189.3	3427.9	3660.4	3894.8	4133.0
60.0	275.6	..	..	..	..	2835.0	3045.8	3180.1	3422.2	3656.2	3891.7	4130.7
65.0	280.8	..	..	..	..	2863.0	3032.4	3170.8	3416.4	3652.1	3888.6	4128.8
70.0	285.8	..	..	..	..	2839.0	3018.7	3161.2	3410.6	3647.9	3885.4	4126.0
75.0	290.5	..	..	..	..	2814.1	3004.5	3151.6	3404.7	3643.7	3882.4	4123.7
80.0	295.0	..	..	..	..	2786.6	2989.9	3141.6	3398.8	3639.5	3879.2	4121.3
85.0	299.2	..	..	..	..	2757.1	2974.7	3131.5	3392.8	3635.4	3876.1	4119.0
90.0	303.3	..	..	..	..	..	2959.0	3121.2	3386.8	3631.1	3873.0	4116.7
95.0	307.2	..	..	..	..	..	2942.7	3110.7	3380.7	3627.0	3869.9	4114.4
100.0	311.0	..	..	..	..	..	2925.8	3099.9	3374.6	3622.7	3866.8	4112.0
110.0	318.0	..	..	..	..	..	2889.6	3077.8	3362.2	3614.2	3860.5	4107.3
120.0	324.6	..	..	..	..	..	2849.7	3054.8	3349.6	3605.7	3854.3	4102.7
130.0	330.8	..	..	..	..	..	2805.0	3030.7	3336.8	3597.1	3848.0	4098.0
140.0	336.6	..	..	..	..	..	2754.2	3005.6	3323.8	3588.5	3841.7	4093.3
150.0	342.1	..	..	..	..	..	2694.8	2979.1	3310.6	3579.8	3835.4	4088.6
160.0	347.3	..	..	..	..	..	2620.8	2951.3	3297.1	3571.0	3829.1	4084.0
170.0	352.3	..	..	..	..	..	..	2921.7	3283.5	3562.2	3822.8	4079.3
180.0	357.0	..	..	..	..	..	..	2890.3	2269.6	3553.4	3816.5	4074.6
190.0	361.4	..	..	..	..	..	..	2856.7	3255.4	3544.5	3810.2	4070.0
200.0	365.7	..	..	..	..	..	..	2820.5	3241.1	3535.5	3803.8	4065.3
210.0	369.8	..	..	..	..	..	..	2781.3	3226.5	3526.5	3797.5	4060.6
220.0	373.7	..	..	..	..	..	..	2738.8	3211.7	3517.4	3791.1	4055.9
221.2	374.15	..	..	..	..	..	..	2734.5	3210.7	3516.4	3789.1	4054.7

Table: 7.7. Specific Entropy of Superheated Steam

Absolute Pressure in bar (p)	Saturation Temperature in °C (t <sub>s</sub> )	Specific entropy (s) in kJ/kg K at various temperatures in °C										
		100	150	200	250	300	350	400	500	600	700	800
0.02	17.5	9.193	9.433	9.648	9.844	10.025	10.193	10.351	10.641	10.904	11.146	11.371
0.04	29.0	8.873	9.113	9.328	9.524	9.705	9.874	10.031	10.321	10.585	10.827	11.051
0.06	36.2	8.685	8.925	9.141	9.337	9.518	9.686	9.844	10.134	10.397	10.639	10.864
0.08	41.5	8.552	8.792	9.008	9.204	9.385	9.554	9.711	10.001	10.265	10.507	10.731
0.10	45.8	8.449	8.689	8.905	9.101	9.282	9.450	9.608	9.898	10.162	10.404	10.628
0.15	54.0	8.261	8.502	8.718	8.915	9.096	9.264	9.422	9.712	9.975	10.217	10.442
0.20	60.1	8.126	8.368	8.584	8.781	8.962	9.130	9.288	9.578	9.842	10.084	10.309
0.25	65.0	8.022	8.264	8.481	8.678	8.859	9.028	9.186	9.476	9.739	9.981	10.206
0.30	69.1	7.936	8.179	8.396	8.593	8.774	8.943	9.101	9.391	9.654	9.897	10.121
0.35	72.7	7.864	8.107	8.325	8.522	8.703	8.872	9.030	9.320	9.583	9.826	10.050
0.40	75.9	7.801	8.045	8.263	8.460	8.641	8.810	8.968	9.258	9.522	9.764	9.989
0.45	78.7	7.745	7.990	8.208	8.405	8.587	8.755	8.914	9.204	9.467	9.709	9.934
0.50	81.3	7.695	7.941	8.159	8.356	8.538	8.707	8.865	9.155	9.419	9.661	9.886
0.60	86.0	7.609	7.855	8.074	8.272	8.454	8.622	8.781	9.071	9.334	9.576	9.801
0.70	90.0	7.535	7.783	8.002	8.200	8.382	8.551	8.709	9.000	9.263	9.505	9.730
0.80	93.5	7.470	7.720	7.940	8.138	8.320	8.489	8.648	8.938	9.214	9.444	9.669
0.90	96.7	7.413	7.664	7.884	8.083	8.266	8.435	8.593	8.884	9.147	9.389	9.614
1.00	99.6	7.362	7.614	7.835	8.034	8.217	8.386	8.544	8.835	9.098	9.341	9.565
1.50	111.4	..	7.419	7.644	7.845	8.028	8.198	8.356	8.647	8.911	9.153	9.378
2.00	120.2	..	7.279	7.507	7.710	7.894	8.064	8.223	8.514	8.778	9.020	9.245

(p)	(t <sub>s</sub> )	100	150	200	250	300	350	400	500	600	700	800
2.5	127.4	..	7.169	7.400	7.604	7.789	7.960	8.119	8.410	8.674	8.917	9.142
3.0	133.5	..	7.077	7.312	7.518	7.703	7.874	8.034	8.326	8.590	8.833	9.058
3.5	138.5	..	6.998	7.237	7.444	7.631	7.802	7.962	8.254	8.518	8.761	8.986
4.0	143.6	..	6.929	7.171	7.380	7.568	7.740	7.899	8.192	8.456	8.699	8.925
4.5	147.9	..	6.866	7.112	7.323	7.512	7.684	7.844	8.137	8.402	8.645	8.870
5.0	151.8	..	..	7.059	7.272	7.461	7.634	7.795	8.088	8.353	8.596	8.821
6.0	158.8	..	..	6.966	7.183	7.374	7.548	7.709	8.003	8.268	8.511	8.737
7.0	165.0	..	..	6.886	7.107	7.300	7.475	7.636	7.931	8.196	8.440	8.665
8.0	170.4	..	..	6.815	7.040	7.235	7.411	7.573	7.868	8.134	8.377	8.603
9.0	175.4	..	..	6.751	6.980	7.177	7.354	7.517	7.812	8.079	8.323	8.549
10.0	179.9	..	..	6.692	6.926	7.125	7.303	7.467	7.763	8.029	8.273	8.500
11.0	184.1	..	..	6.638	6.876	7.078	7.257	7.421	7.718	7.985	8.229	8.455
12.0	188.0	..	..	6.587	6.831	7.034	7.214	7.379	7.677	7.944	8.188	8.415
13.0	191.6	..	..	6.539	6.788	6.994	7.175	7.340	7.639	7.906	8.151	8.378
14.0	195.0	..	..	6.494	6.748	6.956	7.139	7.305	7.603	7.871	8.116	8.343
15.0	198.3	..	..	6.451	6.710	6.921	7.104	7.271	7.570	7.839	8.084	8.311
16.0	201.4	..	..	..	6.674	6.887	7.072	7.239	7.540	7.808	8.054	8.281
17.0	204.3	..	..	..	6.640	6.856	7.042	7.210	7.511	7.779	8.025	8.252
18.0	207.1	..	..	..	6.607	6.826	7.013	7.182	7.483	7.752	7.998	8.226
19.0	209.8	..	..	..	6.576	6.797	7.986	7.155	7.457	7.727	7.973	8.200
20.0	212.4	..	..	..	6.545	6.770	6.960	7.130	7.432	7.702	7.949	8.176
22.0	217.2	..	..	..	6.488	6.718	6.911	7.082	7.386	7.657	7.904	8.132
24.0	221.8	..	..	..	6.434	6.670	6.866	7.038	7.344	7.615	7.862	8.091
26.0	226.0	..	..	..	6.382	6.625	6.824	6.998	7.305	7.577	7.825	8.053
28.0	230.0	..	..	..	6.333	6.582	6.784	6.960	7.269	7.541	7.789	8.018
30.0	233.8	..	..	..	6.286	6.542	6.747	6.925	7.235	7.508	7.756	7.986
32.0	237.4	..	..	..	6.240	6.504	6.712	6.891	7.203	7.477	7.726	7.955
34.0	240.9	..	..	..	6.195	6.467	6.679	6.860	7.172	7.447	7.697	7.927
36.0	244.2	..	..	..	6.151	6.432	6.647	6.829	7.144	7.420	7.669	7.900
38.0	247.3	..	..	..	6.109	6.397	6.616	6.801	7.117	7.393	7.643	7.874

### 7.8.1 Steam Tables and Their Uses

The properties of dry saturated steam like its temperature of formation *i.e.*, saturation temperature, sensible heat, latent heat of vaporisation, enthalpy or total heat, specific volume of water, specific volume of vapour, enthalpy of liquid and enthalpy of vapour, vary with pressure and can be found by experiments only. Then properties have been carefully determined and made available in a tabular form known as steam tables.

There are two important steam tables, one in terms of absolute pressure and other in terms of temperature. The properties of dry saturated steam is shown in the five tables (from 7.3 to 7.7).

### 7.9 ENTROPY OF STEAM

The entropy of steam consist of

- Increase in entropy of water during heating from freezing point to boiling point, corresponding to the pressure at which the water is being heated.
- Increase in entropy during evaporation.
- Increase in entropy during super heating.

### 7.10 ENTROPY OF WATER

Consider 1 kg of water being heated at a constant pressure from freezing point ( $0^\circ\text{C}$  or  $273\text{ K}$ ) to the boiling temperature. Now consider an instant when the absolute temperature of water is  $T\text{ K}$ .

Let for small rises in temperature of  $dT$ , the heat absorbed by 1 kg of water is  $\delta q$  then

$$\begin{aligned}\delta q &= \text{mass} \times \text{specific heat of water} \times \text{rise in temperature} \\ &= 1 \times C_w \times dT \\ &= C_w \cdot dT\end{aligned}\quad \left[ \begin{array}{l} C_w = \text{specific heat of water} \\ = 4.2 \text{ kJ/kg K} \end{array} \right]$$

we know that increase in entropy for rise in temperature  $dT$

$$ds = \frac{\delta q}{T} = C_w \cdot \frac{dT}{T}$$

total increase in entropy of water from freezing point to boiling point

$$\int_0^s ds = \int_{273}^T \frac{C_w dT}{T}$$

$$\therefore S_f = C_w \cdot \ln \left( \frac{T}{273} \right) = 2.3 C_w \log \left( \frac{T}{273} \right)$$

$S_f$  can be directly steen from the steam tables.

### 7.11 ENTROPY INCREASES DURING EVAPORATION

When the water is completely evaporated into steam it absorbs full latent heat  $h_{fg}$  at constant temperature  $T$ , corresponding to the given pressure. We know that

$$\text{Entropy} = \frac{\text{heat absorbed}}{\text{absolute temperature}}$$

Increase of entropy during evaporation

$$S_{fg} = \frac{h_{fg}}{T}$$

If the steam is wet with dryness fraction  $x$ , the evaporation will be partial. In such a case heat absorbed =  $xh_{fg}$

$$\therefore \text{Increase in entropy} \quad S_{fg} = \frac{xh_{fg}}{T}$$

### 7.12 ENTROPY OF WET AND DRY STEAM

The entropy of wet and dry steam above the freezing point of water is the entropy of water plus the entropy during evaporation.

$\therefore$  Increase in entropy

$$= S_f + \frac{xh_{fg}}{T}$$

$$= S_f + xs_{fg} \quad (\text{for wet steam})$$

$$= S_f + s_{fg}$$

$$= S_g \quad (\text{for dry steam})$$

$S_g$  can directly be read from steam tables.

### 7.13 ENTROPY FOR SUPERHEATED STEAM

During super heating heat is supplied at constant pressure and the temperature of dry steam ( $T$ ) increases to the temperature of superheated steam ( $T_{\text{sup}}$ ) For a small rise in temp  $dT$  the heat absorbed.

$$\delta q = 1 \times C_p \cdot dT$$

$$\therefore \quad \frac{\delta q}{T} = \frac{C_p \cdot dT}{T}$$

$$\therefore \quad dS = C_p \cdot \frac{dT}{T}$$

$C_p$  = specific heat of super heated steam may be taken between 1.67 to 2.5 kJ/kg K.

$\therefore$  Total increase in entropy from  $T$  K to  $T_{\text{sup}}$  K.

$$\int_{S_g}^{S_{\text{sup}}} ds = C_p \int_T^{T_{\text{sup}}} \frac{dT}{T}$$

$$\therefore \quad S_{\text{sup}} - S_g = C_p \cdot \ln \left( \frac{T_{\text{sup}}}{T} \right)$$

$$\therefore (S_{\text{sup}} - S_g) = 2.3 C_p \cdot \log \left( \frac{T_{\text{sup}}}{T} \right)$$

$(S_{\text{sup}} - S_g)$  = increase in entropy of superheated steam.

$\therefore$  For 1 kg of super heated steam

$$\begin{aligned} S_{\text{sup}} &= S_g + 2.3 C_p \log \left( \frac{T_{\text{sup}}}{T} \right) \\ &= \left( S_f + \frac{h_{fg}}{T} \right) + 2.3 C_p \log \left( \frac{T_{\text{sup}}}{T} \right) \end{aligned}$$

#### 7.14 EXTERNAL WORK OF EVAPORATION

Latent heat of vaporisation supplied during the evaporation not only changes the phase of the substance but also does an external work in moving the piston at constant pressure due to increase in volume from  $v_f$  to  $v_g$ .

$\therefore$  External work of evaporation per kg of dry saturated steam

$$= p (v_g - v_f) \text{ kJ}$$

$$= p v_g \text{ kJ}$$

[ $\because v_f$  is very small at low pressure]

$\therefore$  External work of evaporation per kg of wet steam

$$= p x v_g \text{ kJ}$$

And external work of evaporation per kg of superheated steam

$$= p v_{\text{sup}} \text{ kJ}$$

#### 7.15 INTERNAL LATENT HEAT

It is obtained by subtracting the external work of evaporation from the *latent heat of evaporation*.

$\therefore$  Internal latent heat of dry saturated steam

$$= (h_{fg} - p v_g) \text{ kJ/kg}$$

#### 7.16 INTERNAL ENERGY OF STEAM

The internal energy of steam is defined as the difference between the enthalpy of the steam and the external work of evaporation.

$\therefore$  Internal energy of dry saturated steam

$$u_g = h_g - p v_g \text{ kJ/kg}$$

Internal energy of wet steam

$$u = (h_f + x h_{fg} - p x v_g) \text{ kJ/kg}$$

Internal energy of superheated steam

$$u_{\text{sup}} = h_{\text{sup}} - p v_{\text{sup}} \text{ kJ/kg}$$

**7.17 TEMPERATURE-ENTROPY DIAGRAM OF WATER AND STEAM**

It is useful in solving the problem on adiabatic expansion and compression of steam. The abscissa of the diagram represents the entropy of the vertical ordinate showing the values of temperature as shown in figure 7.7. Consider 1 kg of water and steam above the freezing point of water at constant pressure. When heat is added to the water entropy will increase where the logarithmic curve increase in entropy =  $S_f = AB$ .

On further heating water starts evaporating and receives heat at constant temperature  $T$ . Entropy goes on increasing till the entire latent heat required to evaporate 1 kg of water has been supplied, increase in entropy  $S_{fg} = BC$ .

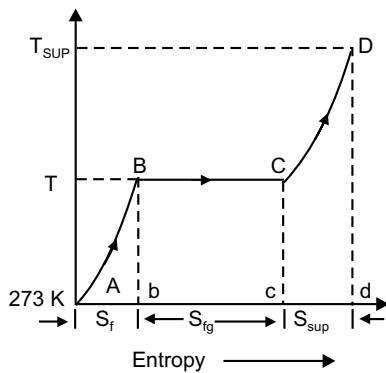

Fig. 7.7

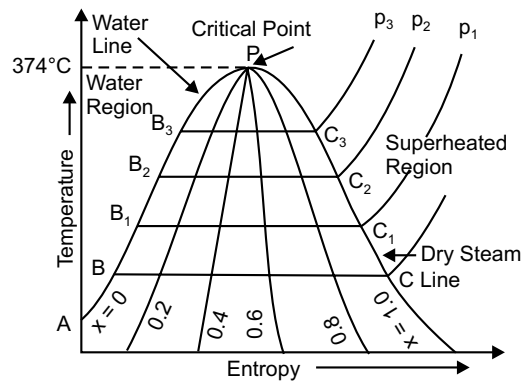

Fig. 7.8

If we draw a family of similar curves at different pressure and plot the points  $B_1, B_2$  and  $C_1, C_2$  etc., then the line joining the points  $A, B_1, B_2, B_3$  etc. is called water line. Similarly, the line joining the points  $C, C_1, C_2, C_3$  etc. is called dry steam line. The point where the water and dry steam line meets ( $P$ ) is called *critical point*, it is represented by  $374.15^\circ\text{C}$ .

**7.18 ISOTHERMAL LINES ON T-S DIAGRAM**

We know that there is no change of temperature during isothermal process.

1 kg of wet steam at  $250^\circ\text{C}$ ,  $x = 0.2$  at  $A$  expanded isothermally up to  $x = 0.8$  at  $B$

$\therefore$  increase in entropy

$$\begin{aligned} &= S_b - S_a \\ &= 5.42 - 3.45 \\ &= 1.97 \text{ kJ/kg. K.} \end{aligned}$$

Isothermal line  $AB$  is shown in figure 7.9.

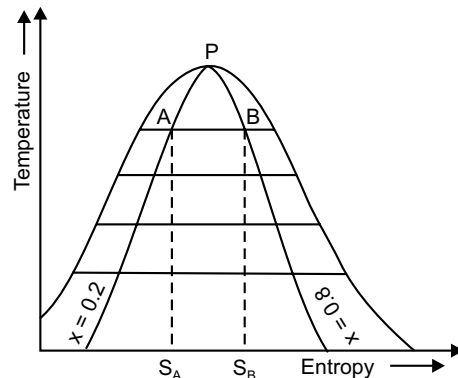

Fig. 7.9

**7.19 ISENTROPIC LINES**

There is no increase or decrease in enthalpy or total heat during an isentropic process. There is no change in entropy during the process.

Consider a sample of 1 kg of wet steam at temperature of 310°C and dryness fraction of 0.8 at *A*. Let the sample expanded isentropically till its dryness fraction 0.6 marks *B*.

$$T_A = 310^\circ\text{C}, T_B = 40^\circ\text{C}$$

$$\begin{aligned} \text{Fall in temperature} &= 310 - 40 \\ &= 270^\circ\text{C} \end{aligned}$$

It is shown in figure 7.10 on *t-s* diagram.

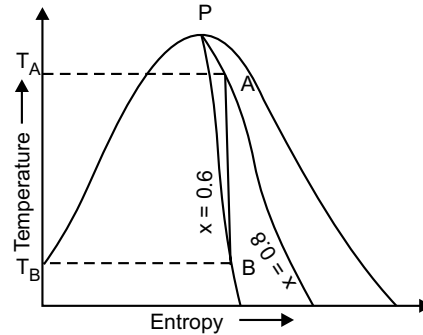

Fig. 7.10

### 7.20 ENTHALPY-ENTROPY (h-s) DIAGRAM FOR WATER AND STEAM OR MOLLIER CHART

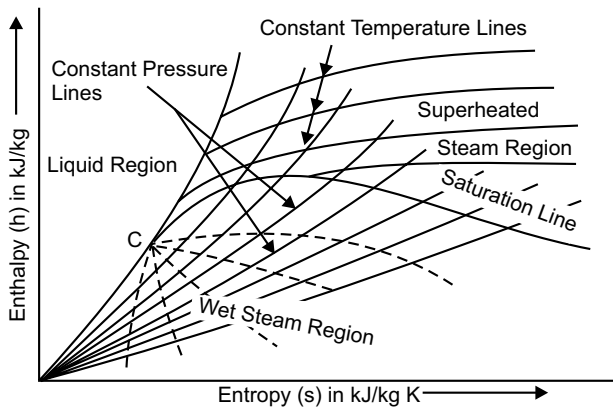

Fig. 7.11

Mollier chart is a graphical representation of the steam tables, in which the enthalpy (*h*) is plotted along the ordinate and entropy (*s*) along abscissa. First of all, enthalpy and entropy of water and dry saturated steam, for any particular pressure, are obtained from the steam tables. These values of enthalpies and entropies are plotted and then liquid line and dry saturated line is obtained. Both these line meet at *C*, *i.e.*, the critical point as shown in figure 7.11. The critical point corresponds to the enthalpy of liquid and dry saturated steam at 221.2 bar. The enthalpy-entropy chart like temperature-

entropy chart, is also very useful in solving the problems in adiabatic or isentropic expansion and compression of steam. In actual diagram, abscissa of the diagram represents the entropy of 1 kg of water and steam, *i.e.*, specific entropy above the freezing point of water and the vertical ordinate shows the values of specific enthalpy *i.e.*, total heat, as shown in figure 7.12.

The diagram is divided into two parts by a line termed as saturation line. Upper region of the saturation line is called superheated region where temperature of steam increases at given pressure and lower region of saturation line is called wet region where temperature of steam remains constant at a given pressure.

The Mollier diagram has the following lines

1. Dryness fraction lines
2. Constant volume (*i.e.*, specific volume) line
3. Constant pressure lines
4. Isothermal lines
5. Isentropic lines and
6. Throttling line

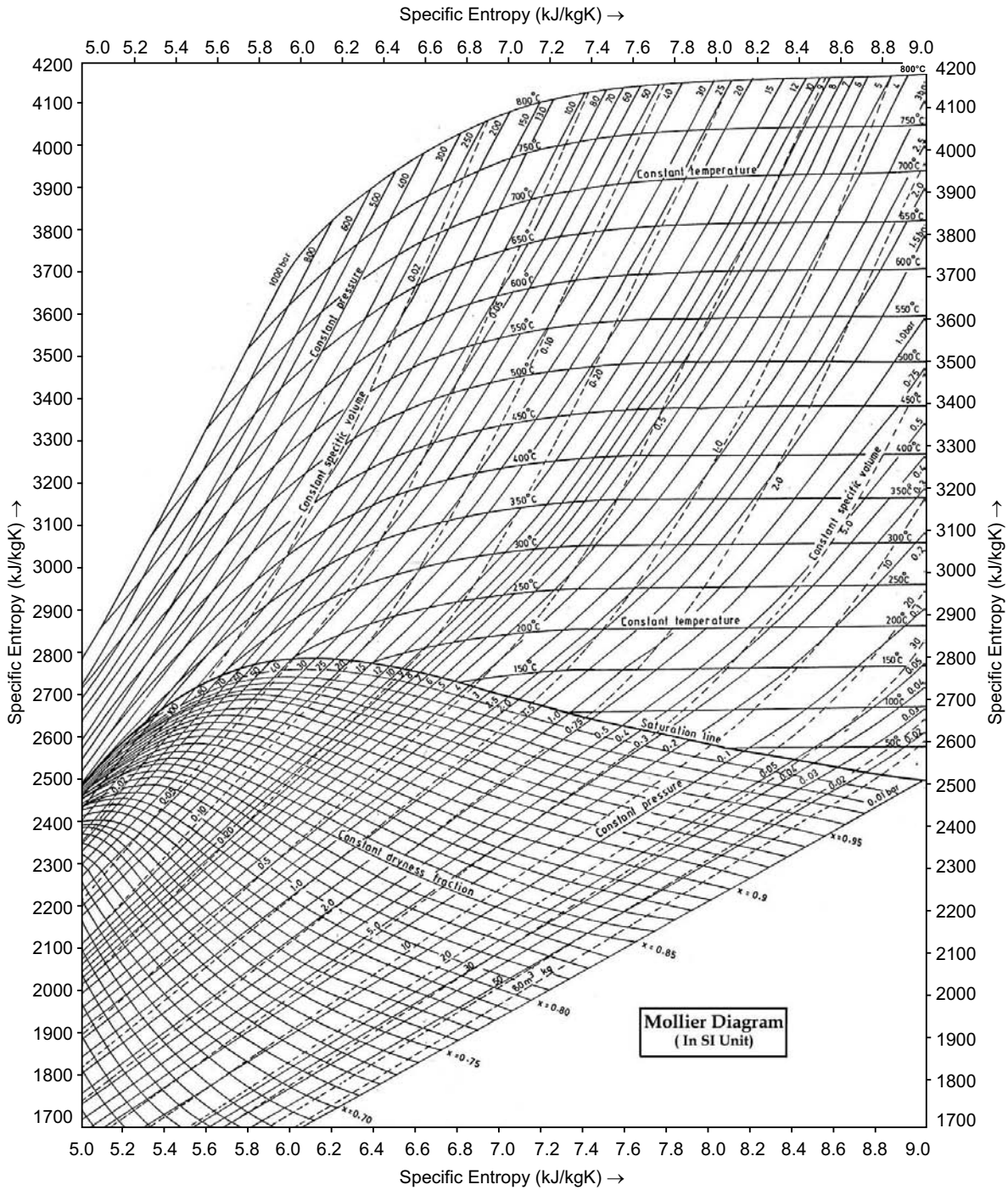

Fig. 7.12

**7.21 DRYNESS FRACTION LINES ON H-S DIAGRAM**

Below the saturation line is known as wet region, so the dryness fraction lines are drawn only below the saturation (which represents dryness fraction equal to 1.0). These lines represent the condition of wet steam between various values of enthalpy and entropy as shown in figure 7.13. For example, a sample of 1 kg of wet steam of dryness of 0.9 is represented by the line *AB* which is shown in figure 7.13. If *A* and *B* be the initial and final stage, then enthalpy at point *A* is  $h_A = 2500$  kJ/kg and enthalpy at point *B* is  $h_B = 2400$  kJ/kg is shown in figure 7.13.

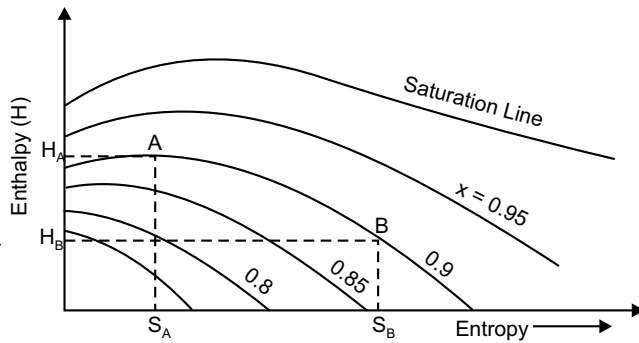

Fig. 7.13

**7.22 CONSTANT VOLUME LINE**

The constant volume lines are drawn in both the wet region and superheated steam region. These lines are straight in the wet steam region, but curved upwards above the saturation curve, i.e., superheated region as shown in figure 7.14 by parts *AB* and *CD* of line of constant volume 1.0.

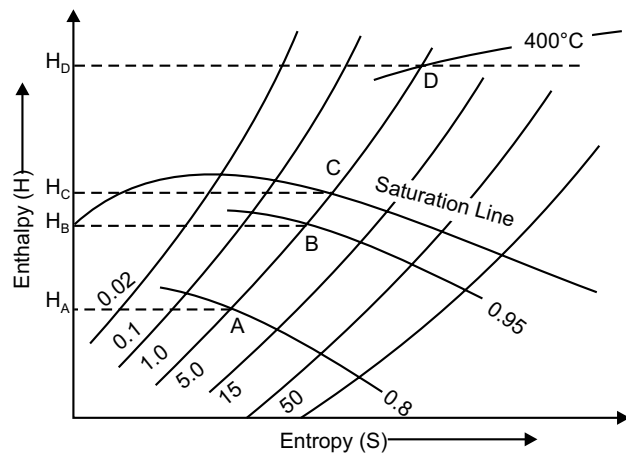

Fig. 7.14

**7.23 CONSTANT PRESSURE LINE**

Constant pressure lines are drawn in both upper and lower region of saturated steam line. These lines are straight in the wet region because during vaporisation the increase of enthalpy is directly proportional to the increase in quality, and hence to the increase in entropy. It is curve and it is closer to wet region than superheated region is shown in figure 7.15.

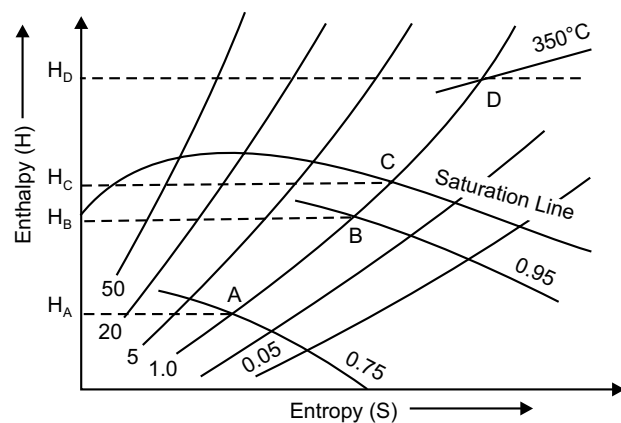

Fig. 7.15

**7.24 ISOTHERMAL LINE**

The isothermal lines or constant pressure lines are drawn only above the saturation line. These lines represent the condition of superheated steam between various values of enthalpy and entropy, as shown in figure 7.16 by the line *AB*.

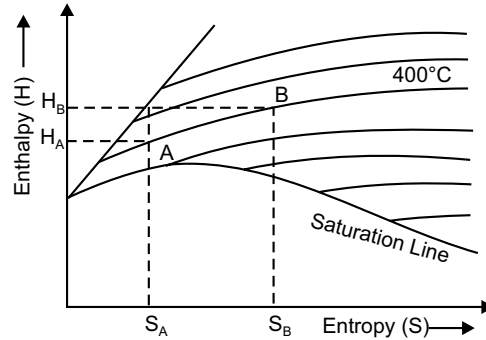

Fig. 7.16

### 7.25 ISENTROPIC LINE ON (H-S) DIAGRAM

Isentropic process is a reversible adiabatic process. In this process entropy is constant. So isentropic line is parallel to vertical axis by the line  $AB$  which is shown in figure 7.17.

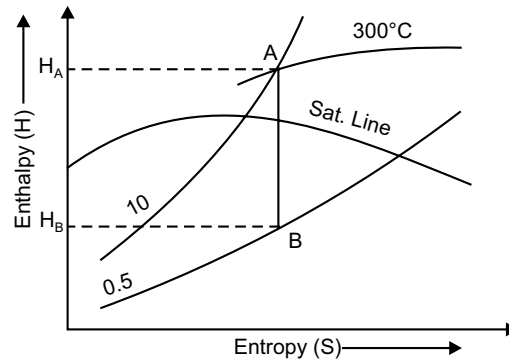

Fig. 7.17

### 7.26 THROTTLING LINES ON H-S DIAGRAM

In throttling process enthalpy before throttling is equal to enthalpy after throttling *i.e.*, there is no change of enthalpy. So enthalpy line  $AB$  will be parallel to horizontal axis as shown in figure 7.18.

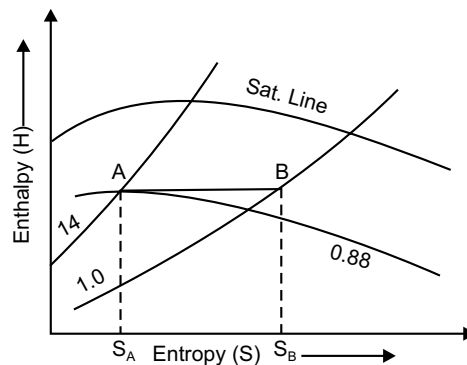

Fig. 7.18

### Multiple Choice Questions

Choose the correct answer

1. (a) Specific volume of water decreases on freezing; (b) Boiling point of water decreases with increasing pressure; (c) Specific volume of CO<sub>2</sub> increases on freezing; (d) Freezing temperature of water decreases with increasing pressure.
2. (a) The slope of vaporisation curve is always negative; (b) The slope of vaporisation curve is always positive; (c) The slope of sublimation curve is negative for all pure substances; (d) The slope of fusion curve is positive for all pure substances; (e) The slope of fusion curve is positive for all pure substances.
3. (a) The process of passing from liquid to vapour is condensation; (b) An isothermal line is also a constant pressure line during wet region; (c) Pressure and temperature are independent during phase change; (d) The term dryness fraction is used to describe the fraction by mass of liquid in the mixture of liquid water and water vapour.
4. The latent heat of vaporisation at critical point is  
(a) less than zero; (b) greater than zero; (c) equal to zero; (d) none of above.
5. (a) Critical point involves equilibrium of solid and vapour phases; (b) Critical point involves equilibrium of solid and liquid phases; (c) Critical point involves equilibrium of solid, liquid and vapour phases; (d) Triple point involves equilibrium of solid, liquid and vapour phases.
6. With the increase in pressure  
(a) boiling point of water increases and enthalpy of evaporation increases.
7. With increase in pressure  
(a) enthalpy of dry saturated steam increases; (b) enthalpy of dry saturated steam decreases.  
(c) enthalpy of dry saturated steam remains same; (d) enthalpy of dry saturated steam first increases and then decreases.
8. Dryness fraction of steam is defined as  
(a) mass of water vapour in suspension/(mass of water vapour in suspension + mass of dry steam);  
(b) mass of dry steam/mass of water vapour in suspension; (c) mass of dry steam/(mass of dry steam + mass of water vapour in suspension); (d) mass of water vapour in suspension/mass of dry steam.
9. The specific volume of water when heated at 0°C  
(a) first increases and then decreases; (b) first decreases and then increases; (c) increases steadily  
(d) decreases steadily
10. Only throttling calorimeter is used for measuring:  
(a) Very low dryness fraction up to 0.7; (b) Very high dryness fraction up to 0.98; (c) dryness fraction of only low pressure steam; (d) dryness fraction of only high pressure steam
11. Heat of superheated steam is given by

$$(a) h_{sup} = h_f + h_{fg} + C_{ps} \log_e \frac{T_{sup}}{T_s}; (b) h_{sup} = h_f + xh_{fg}; (c) h_{sup} = h_f + h_{fg}; (d) h_{sup} = h_f + xh_{fg} + C_{ps} \log_e \frac{T_s}{273}$$

12. Volume of wet steam (per kg) with dryness fraction  $x$  is given by  
 (a)  $x^3 v_g$ ; (b)  $x v_f$ ; (c)  $x^2 (v_g - v_f)$ ; (d)  $x^2 v_g$ ; (e) none of these
13. Internal latent heat is given by  
 (a)  $h_{fg} - \frac{P v_g}{J}$ ; (b)  $h_g - \frac{P v_g}{J}$ ; (c)  $h_{sup} - \frac{P v_f}{J}$ ; (d)  $h_{fg} + \frac{P v_g}{J}$ ; (e) none of the above
14. Entropy of 1 kg of water at  $TK$  is given by  
 (a)  $C_{pw} \log_e \frac{T}{273}$ ; (b)  $C_{pw} \log_e \frac{T_2}{T_1}$ ; (c)  $C_{pw} \log_e \frac{T}{273}$ ; (d)  $C_{pw} \log_e \frac{T_2}{273}$ ; (e) none of the above
15. Entropy of wet steam (1 kg) is given by  
 (a)  $s_f + \frac{x h_{fg}}{T_s}$ ; (b)  $s_g + \frac{x h_{fg}}{T_s}$ ; (c)  $s_f + \frac{h_{fg}}{T_s}$ ; (d)  $s_f + C_{ps} \log_e \frac{T_{sup}}{T_s}$ ; (e) none of the above
16. In throttling process  
 (a)  $h_1^2 = h_2$ ; (b)  $h_1 = h_2$ ; (c)  $h_1 = h_2 + \frac{h_{fg}}{T_s}$ ; (d)  $h_2 = h_1 + \frac{h_{fg}}{T_s}$ ; (e) none of the above
17. In isentropic process  
 (a)  $w = 2(u_2 - u_1)$ ; (b)  $w = (u_2 - u_1)^2$ ; (c)  $w = u_2 - u_1$ ; (d)  $w = (u_2 - u_1)^{1/2}$ ; (e) none of the above

### Answers

1. (d) 2. (a) 3. (b) 4. (c) 5. (d) 6. (b) 7. (b) 8. (c) 9. (b) 10. (b)  
 11. (a) 12. (e) 13. (a) 14. (a) 15. (a) 16. (b) 17. (c)

### NUMERICAL EXAMPLES

#### EXAMPLE 1

Determine the quantity of heat required to produce 1 kg of steam at a pressure of 6 bar at a temperature of  $25^\circ\text{C}$  under the following conditions.

(a) When the steam is wet having a dryness fraction 0.9, (b) When the steam is dry saturated, (c) When it is super heated at a constant pressure at  $250^\circ\text{C}$ . Assume the mean specific heat of superheated steam to be  $2.3 \text{ kJ/kg}$ .

#### SOLUTION

Here,  $p = 6 \text{ bar}$ ,  $t_w = 25^\circ\text{C}$ ,  $x = 0.9$

$$t_{sup} = 250^\circ\text{C}$$

Following values are obtained from steam table for  $p = 6 \text{ bar}$

$$h_f = 670.4 \text{ kJ/kg}, h_{fg} = 2085 \text{ kJ/kg}$$

$$t = 158.8^\circ\text{C}$$

(a) When the steam is wet, entropy of total heat of 1 kg of wet steam

$$\begin{aligned} h &= h_f + x h_{fg} \\ &= 670.4 + 0.9 \times 2085 \\ &= 2546.9 \text{ kJ} \end{aligned}$$

Since the water is at a temperature of 25°C therefore heat already in water

$$= 4.2 \times 25 = 105 \text{ kJ}$$

Heat actually required

$$= 2546.9 - 105 = 2441.9 \text{ kJ}$$

(b) When the steam is dry, saturated entropy or total heat of 1 kg of dry saturated steam

$$\begin{aligned} h_g &= h_f + h_{fg} \\ &= 670.4 + 2085 = 2755.4 \text{ kJ} \end{aligned}$$

Heat actually required

$$= 2755.4 - 105 = 2650.4 \text{ kJ}$$

(c) When the steam is superheated, enthalpy or total heat of 1 kg of superheated steam

$$\begin{aligned} h_{\text{sup}} &= h_g + C_p (t_{\text{sup}} - t) \\ &= 2755.4 + 2.3 [(250 + 273) - (158.8 + 273)] \\ &= 2965.16 \text{ kJ} \end{aligned}$$

Heat actually required

$$= 2965.16 - 105 = 2860.16 \text{ kJ}$$

### EXAMPLE 2

Steam enters an engine at a pressure of 12 bar with a 67°C of superheat. It is exhausted at a pressure of 0.15 bar and 0.95 dryness fraction. Find the drop in entropy of the steam.  $C_p = 2.04 \text{ kJ/kg}$

**SOLUTION**

Here,  $p_1 = 12 \text{ bar}$ ,  $(t_{\text{sup}} - t) = 67^\circ\text{C}$

$$p_2 = 0.15 \text{ bar}, x = 0.95$$

From steam table corresponding to a pressure of 12 bar, we have

$$h_f = 798.4 \text{ kJ/kg}, h_{fg} = 1984.3 \text{ kJ/kg}$$

We know that enthalpy or total heat of 1 kg of superheated steam

$$h_{\text{sup}} = h_f + h_{fg} + C_p (t_{\text{sup}} - t) = 798.4 + 1984.3 + 2.04 \times 67 = 2919.38 \text{ kJ/kg}$$

Similarly for pressure 0.15 bar from steam tables

$$h_f = 226 \text{ kJ/kg}, h_{fg} = 2373.2 \text{ kJ/kg}$$

We know enthalpy or total heat of 1 kg of wet steam

$$h = h_f + xh_{fg} = 226 + 0.95 \times 2373.2 = 2480.54 \text{ kJ/kg}$$

Drop in enthalpy of the steam

$$= h_{\text{sup}} - h = (2919.38 - 2480.54) = 438.84 \text{ kJ/kg}$$

### EXAMPLE 3

A steam engine obtains steam from a boiler at a pressure of 15 bar and 0.98 dry. It was observed that the steam loses 21 kJ of heat per kg as it flows through the pipeline, pressure remaining constant. Calculate dryness fraction of steam at the engine end of the pipeline.

**SOLUTION**

Given  $p = 15 \text{ bar}$ , heat loss = 21 kJ/kg.

From steam tables corresponding to the pressure of 15 bar, we have

$$h_f = 844.6 \text{ kJ/kg} \quad \text{and} \quad h_{fg} = 1945.3 \text{ kJ/kg}$$

∴ Enthalpy of wet steam at the boiler end

$$\begin{aligned} h_1 &= h_f + x \cdot h_{fg} \\ &= 844.6 + 0.98 \times 1945.3 \\ &= 2751 \text{ kJ/kg} \end{aligned}$$

As steam loses 21 kJ/kg of steam, enthalpy of wet steam at the engine end

$$h_2 = h_f + x_2 h_{fg} \quad \text{and} \quad h_2 = 2751 - 21 = 2730 \text{ kJ}$$

$$\therefore 2730 = 844.6 + x_2 \times 1945.3$$

$$\therefore x_2 = 0.97$$

Therefore, at the end of pipeline dryness fraction is 0.97.

#### EXAMPLE 4

Calculate the enthalpy of 1 kg of steam at a pressure of 8 bar and dryness fraction of 0.8. How much heat would be rejected to raise 2 kg of its steam from water at 20°C?

**SOLUTION**

Here,  $p = 8 \text{ bar}$  and  $x = 0.8$

Enthalpy of 1 kg of steam, from steam table

$$h_f = 720.9 \text{ kJ/kg} \quad \text{and} \quad h_{fg} = 2046.5 \text{ kJ/kg}$$

$$\begin{aligned} \therefore h &= h_f + x h_{fg} \\ &= 720.9 + 0.8 \times 2046.5 \\ &= 2358.1 \text{ kJ} \end{aligned}$$

Heat required to rise 2 kg of this steam from water at 20°C.

$$\text{Heat already in water} = 4.2 \times 20 = 84 \text{ kJ}$$

$$\begin{aligned} \therefore \text{Heat required per kg of steam} \\ &= 2358.1 - 84 \\ &= 2274.1 \text{ kJ} \end{aligned}$$

$$\begin{aligned} \therefore \text{Heat required for 2 kg of steam} \\ &= 2 \times 2274.1 = 4548.2 \text{ kJ} \end{aligned}$$

#### EXAMPLE 5

Find the entropy of 1 kg of dry saturated steam at a pressure of 5.2 bar. The boiling point of water at this pressure is given by 152.6°C and the total heat at this temperature is utilised.

**SOLUTION**

Here,  $p = 5.2 \text{ bar}$  and  $T = 152.6^\circ\text{C} = 152.6 + 273 = 425.6 \text{ K}$

From steam table,  $h_{fg} = 2102.7 \text{ kJ/kg}$

We know entropy of 1 kg of dry saturated steam

$$S_g = S_f + \frac{h_{fg}}{T}$$

$$\begin{aligned}
 &= 2.3 C_w \log \left( \frac{T}{273} \right) + \frac{h_{fg}}{T} \\
 &= 2.3 \times 4.2 \log \left( \frac{425.6}{273} \right) + \frac{2102.7}{425.6} \\
 &= 1.863 + 4.94 \\
 &= 6.803 \text{ kJ/kg K}
 \end{aligned}$$

**EXAMPLE 6**

Calculate the entropy of 1 kg of wet steam with dryness fraction of 0.9 at a pressure of 8.4 bar.

**SOLUTION**

Here,  $x = 0.9$  and  $p = 8.4$  bar

From steam table for pressure 8.4 bar, boiling point is 172.4°C

$$\therefore T = 172.4 + 273 = 445.4 \text{ K}$$

$$h_{fg} = 2039.6 \text{ kJ/kg} \quad S_f = 2.066 \text{ kJ/kgK}$$

For 1 kg of wet steam, entropy

$$\begin{aligned}
 S &= S_f + \frac{x h_{fg}}{T} \\
 &= 2.066 + \frac{0.9 \times 2039.6}{445.4} \\
 &= 2.066 + 4.12 = 6.186 \text{ kJ/kg K}
 \end{aligned}$$

Also  $S = S_f + x S_{fg}$  directly can be read from steam table.

**EXAMPLE 7**

In a Carnot cycle, heat is supplied at 350°C and is rejected at 25°C. The working fluid is water, which while receiving heat, evaporates from liquid at 350°C to steam at 350°C. From the steam tables the entropy change for this process 1.438 kJ/kg. If the cycle operates on a stationary mass of 1 kg of water, find the heat supplied, work done and heat rejected per cycle, what is the pressure of water during heat reception?

**SOLUTION**

Here,  $T_1 = 350^\circ\text{C} = 350 + 273 = 623 \text{ K}$ ,  $T_2 = 25^\circ\text{C} = 25 + 273 = 298 \text{ K}$

$$(S_2 - S_1) = 1.438 \text{ kJ/kg K}$$

Heat supplied per cycle

$$= (S_2 - S_1) T_1 = 1.438 \times 623 = 895.87 \text{ kJ/kg}$$

Work done per cycle

$$= (S_2 - S_1) (T_1 - T_2) = 1.438 (623 - 298) = 467.35 \text{ kJ/kg}$$

Heat rejected per cycle

$$= (S_2 - S_1) T_{200} = 1.438 \times 298 = 428.52 \text{ kJ/kg}$$

From the steam tables corresponding to 350°C the pressure is 165.35 bar.

**EXERCISE**

1. What is pure substance?
2. Draw and explain a  $p$ - $T$  (pressure-temperature) diagram for a pure substance.
3. What is a triple point?
4. Explain with a neat diagram  $p$ - $v$ - $T$  surface.
5. Does wet steam obey laws of perfect gases?
6. Describe the process of formation of steam and give its graphical representation also.
7. Explain the following terms relating to steam formation:  
(i) Sensible heat of water (ii) Latent heat of steam (iii) Dryness fraction of steam (iv) Enthalpy of wet steam (v) Superheated steam.
8. What advantages are obtained if superheated steam is used in steam prime movers?
9. What do you mean by following:  
(i) Internal latent heat (ii) Internal energy of steam (iii) External work of evaporation (iv) Entropy of evaporation (v) Entropy of wet steam (vi) Entropy of superheated steam.
10. Write a short note on Mollier Chart.
11. 300 tonnes per second of steam is expanded in a turbine from an initial pressure of 90 bar to 0.1 bar. The specific enthalpy of steam at inlet and exit of the turbine are 3300 kJ/kg and 2200 kJ/kg, respectively. Neglecting potential energy and kinetic energy terms and heat transfer loss, find the output of the turbine in MW.
12. A 0.025 m<sup>3</sup> vessel contains 0.3 kg of steam at 2 MPa. Determine the quality and enthalpy of the steam.
13. In a throttling calorimeter, the steam produced by a boiler is admitted at a pressure of 17 bar absolute. After throttling, the steam is discharged into the atmosphere at 120°C. Find the quality of boiler steam if the barometer reads 760 mm of Hg. Take for superheated steam,  $C_p$  as 2.1 kJ/kgK. Show the process diagrammatically.
14. Steam at 6 bar absolute from a fire-tube boiler is passed through a throttling calorimeter. After throttling, the steam is let out into the atmosphere at 120°C. If the barometer reading is 750 mm of Hg, find the change of entropy per kg of steam while  $C_p$  is 2.1 kJ/kgK for superheated steam.
15. 0.5 kg of steam at 00 kPa and 0.98 dry is superheated at constant pressure to 300°C. Using steam table find the amount of heat added to the steam in the superheater. Take  $C_p$  as 2.1 kJ/kgK for superheated steam.
16. Determine the quantity of heat required to produce 1 kg of steam at a pressure of 6 bar at 25°C when steam is (i) wet with 0.90 dry (ii) dry saturated (iii) superheated at constant 250°C. Assume mean specific heat for superheated steam 2.3 kJ/kgK.
17. A steam engine obtains steam from a boiler at 15 bar and 0.98 dry. While flowing through pipeline at constant pressure, rate of heat loss is 2.1 kJ/kg. What is dryness fraction at the end of pipeline?
18. At 300°C and 20 bar pressure, what is the volume of 1 kg superheated steam?
19. Feed water is supplied to the boiler at 45°C and is converted into steam at 5.5 bar pressure at 188°C. Assuming relevant data, compute rate of heat supply.

- 
20. At constant 18 bar pressure 0.9 dry steam is heated until dry and saturated. What is increase in volume, heat supplied, and work done per kg of steam? Now volume remaining constant, what amount of heat is to be extracted for reducing pressure to 14 bar?
  21. What is the mass of 0.8 dry steam of 0.50 m<sup>3</sup> at 4 bar? What is enthalpy of 1 m<sup>3</sup> of steam?
  22. 0.8 dry steam is produced at 8 bar. Calculate (i) external work done during evaporation (ii) internal latent heat of steam.
  23. Determine internal energy per kg of superheated steam at 14 bar and 573 K. If the steam is expanded to 1.4 bar and 0.8 dry, what is the change in internal energy?

**This page  
intentionally left  
blank**

## THERMODYNAMIC AIR STANDARD CYCLES

---

### 8.1 INTRODUCTION

Thermodynamic cyclic process consists of a series of thermodynamic processes, which takes place in a certain order, and the initial conditions are restored at the end of the processes. The study of various thermodynamic cycles is very much essential for the power developing system.

A cycle, which requires four piston strokes and two complete revolutions of the crank, is known as *four stroke cycle*.

When a cycle requires only two piston strokes and one revolution of the crank, is known as *two stroke cycle*. When air is assumed to be the working fluid (substance) inside the engine cylinder, the cycle is called as an *air cycle*.

### 8.2 ASSUMPTIONS IN THERMODYNAMIC CYCLES

The analysis of all thermodynamic cycles or air cycles is based on the following assumptions:

1. The gas in the engine cylinder is a perfect gas, *i.e.*, it obeys the gas laws and constant specific heats.
2. All the expansion and compression are isentropic or reversible adiabatic and takes place without any internal friction.
3. The properties of the working substance can be calculated by the application of the characteristic equation for a perfect gas *i.e.*,  $p\forall = mRT$

or

$$R = \frac{p\forall}{mT}$$
$$= \frac{R_m}{M} = \frac{\text{universal gas constant}}{\text{molecular weight of gas}}$$
$$= \frac{8314}{29} \approx 287 \text{ J/kg K}$$
$$= 0.287 \text{ kJ/kg K for air}$$

This value of  $R$  are same at moderate temperatures.

4. The working substance is a fixed mass of air either contained in a closed system or flowing at constant rate round a closed circuit.
5. The kinetic and potential energies of working substances are neglected.
6. The gas does not undergo any chemical changes, the addition of heat from outside source and removal of heat to outside sink is by simple heat transfer.

### 8.3 CLASSIFICATION OF THERMODYNAMIC CYCLES

The thermodynamic cycles, in general, may be classified into the following two types;

(1) Reversible or ideal and (2) Irreversible or natural or real cycle. These have already been discussed, in detail, in chapter 5.

### 8.4 IMPORTANT PARAMETERS IN AIR STANDARD CYCLE ANALYSIS

#### (a) Air Standard Efficiency (Thermal Efficiency)

It is defined as the ratio of net work transfer during cycle to the net heat transfer to the cycle. It is denoted by  $\eta$ .

#### (b) Specific Work Transfer

It is work transfer per unit mass of the working substance ( $w$ )

#### (c) Specific Air Consumption

It is the quantity of working substance required for doing unit work transfer or the flow rate of working substance for unit power. It is inverse of specific work transfer.

#### (d) Work Ratio

It is the ratio of net work transfer in a cycle to the positive work transfer during the cycle. It is denoted by  $r_w$  and is given by

$$r_w = \frac{\text{positive work transfer} - \text{negative work transfer}}{\text{positive work transfer}}$$

$$= \frac{\text{net work transfer in a cycle}}{\text{positive work transfer in a cycle}}$$

### 8.5 IMPORTANT TERMS USED IN THERMODYNAMIC CYCLES

- (a) **Cylinder bore:** The inner diameter of the cylinder, in which the piston moves, is known as cylinder bore.
- (b) **Stroke length:** The piston moves through the cylinder due to rotation of the crank. Its extreme positions are known as top dead centre (TDC) and bottom dead centre (BDC) respectively as shown in figure 8.1. The distance between these two extreme positions is known as stroke length or simply stroke.
- (c) **Clearance volume:** The volume occupied by the working fluid, when piston reaches the top dead centre, is known as clearance volume. It is generally denoted by  $\nabla_c$ .

- (d) **Swept volume:** The volume swept by the piston, when it moves between the two extreme positions is known as swept volume or displacement volume or stroke volume. It is generally denoted by  $\nabla_s$ .

$$\therefore \nabla_s = \text{piston area} \times \text{stroke length} = \frac{\pi d^2}{4} \times l$$

- (e) **Total cylinder volume:** The volume occupied by the working fluid, when the piston is at the bottom dead centre, is known as total cylinder volume. Total cylinder volume ( $\nabla$ ) is equal to the sum of clearance volume  $\nabla_c$  and swept volume ( $\nabla_s$ ).

$$\therefore \nabla = \nabla_c + \nabla_s \quad (8.1)$$

- (f) **Compression ratio:** The ratio of total cylinder volume to clearance volume is known as compression ratio. It is denoted generally by ( $r$ )

$$\therefore r = \frac{\nabla_c + \nabla_s}{\nabla_s} = 1 + \frac{\nabla_s}{\nabla_c}$$

- (g) **Expansion ratio:** It is the ratio of cylinder to the volume of cylinder when gas starts to expand. Sometimes it is equal to compression ratio.

- (h) **Cut-off ratio:** It is the ratio of the volume at the point of cut off of fuel to the clearance volume. It is generally denoted by  $\rho$

$$\rho = \frac{\text{cut-off volume}}{\text{clearance volume}} \quad (8.2)$$

- (i) **Mean effective pressure:** As a matter of fact, pressure in the cylinder keeps on changing with the position of the piston. For all sorts of calculations, we need the mean effective pressure, which may be defined as the constant pressure acting on the piston during the working stroke. It will be able to do the same amount of work, as done by the actual varying pressure, produced during the cycle. Mean effective pressure is the ratio of work done to the stroke volume or piston displacement volume. It is denoted by  $p_m$

$$p_m = \frac{\text{work done}}{\text{stroke volume}} \quad (8.3)$$

- (j) **Efficiency of cycle:** It may be defined as the ratio of work done to the heat supplied during a cycle. Mathematically

$$\text{Efficiency of cycle } (\eta) = \frac{\text{work done}}{\text{heat supplied}}$$

Again work done is equal to heat supplied minus the heat rejected, the efficiency of cycle therefore may also be expressed

$$\eta = \frac{\text{heat supplied} - \text{heat rejected}}{\text{heat supplied}} \quad (8.4)$$

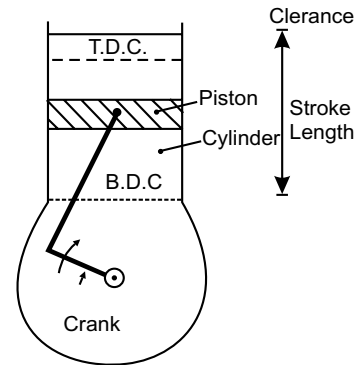

Fig. 8.1

This efficiency is the theoretical efficiency of the cycle. Therefore it is known as *theoretical thermal efficiency*. This efficiency does not take into account the practical losses, which occur in running of the engine. When air is assumed to be the working substance inside the engine cylinder, the efficiency obtained is known as *air standard efficiency*. It is also called *ideal efficiency*.

**(k) Indicated thermal efficiency:** It is the ratio of the heat equivalent to one kW hour to the heat in fuel per I.P. hour. Mathematically it is

$$\begin{aligned}\eta_i &= \frac{\text{heat equivalent to 1 kWh}}{\text{heat in fuel per I.P. hour}} \\ &= \frac{3600}{(m_f \cdot C)} = \frac{3600 \text{ I.P.}}{m_f \cdot C} \quad (8.5)\end{aligned}$$

Here  $m_f$  is mass of fuel in kg/h,  $C$  is calorific value of fuel in kJ/kg and I.P. is the indicated power.

**(l) Relative efficiency:** It is also known as efficiency ratio. The relative efficiency of an I.C. engine is the ratio of indicated thermal efficiency to air standard efficiency. Mathematically

$$\eta_R = \frac{\text{indicated thermal efficiency}}{\text{air standard efficiency}} \quad (8.6)$$

## 8.6 TYPES OF THERMODYNAMIC CYCLES

Though there are many types of thermodynamic cycles, yet the following are important from the subject point of view:

(1) Carnot cycle (2) Stirling cycle (3) Ericsson cycle (4) Joule cycle (5) Otto cycle (6) Diesel cycle and (7) Dual combustion cycle.

## 8.7 CARNOT CYCLE

We have already discussed the Carnot cycle in chapter 5.

## 8.8 OTTO CYCLE

The first successful engine working on this cycle was built by A. Otto. These days many gas, petrol and many of the oil engines run on this cycle. It is also known as *constant volume cycle*. Here heat is received and rejected at constant volume. In comparison to the other cycles the air is assumed to be the working substance.

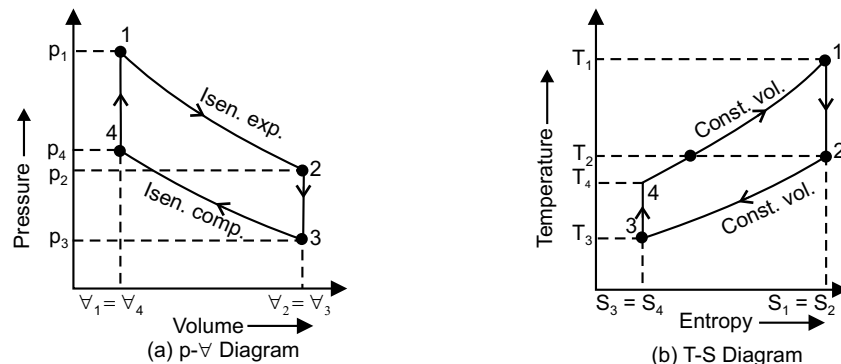

Fig. 8.2

The ideal otto cycle consists of two constant volume and two reversible adiabatic or isentropic processes as shown in  $p$ - $\forall$  and  $T$ - $S$  diagram in figure 8.2. Let engine cylinder contains  $m$  kg of air at point 1 and at this point pressure =  $p_1$ , volume =  $\forall_1$ , temperature =  $T_1$ .

1. *First stage (reversible adiabatic or isentropic expansion)*

The air is expanded reversibly and adiabatically from temperature  $T_1$  to  $T_2$ . In this process no heat is absorbed or rejected by the air as shown by (1–2).

2. *Second stage (constant volume cooling)*

The air is cooled at constant volume from temp  $T_2$  to  $T_3$ , shown by (2–3). Heat rejected by air during this process  $Q_{2-3} = mC_v (T_2 - T_3)$

3. *Third stage (reversible adiabatic or isentropic compression)*

The air is compressed reversibly and adiabatically from temperature  $T_3$  to  $T_4$  as shown by the curve (3–4). Here no heat is absorbed or rejected by the air.

4. *Fourth stage (constant volume heating)*

The air is now heated at constant volume from temp  $T_4$  to  $T_1$ , given by curve (4–1). Heat absorbed by the air during this process  $Q_{4-1} = mC_v (T_1 - T_4)$

We see that the air has been brought back to its original condition of pressure volume and temperature, thus completing the cycle.

$$\begin{aligned}
 \therefore \quad \text{Work done} &= \text{heat absorbed} - \text{heat rejected} \\
 &= mC_v (T_1 - T_4) - mC_v (T_2 - T_3) \\
 \therefore \quad \eta_{\text{otto}} &= \frac{\text{work done}}{\text{heat absorbed}} \\
 &= \frac{mC_v (T_1 - T_4) - mC_v (T_2 - T_3)}{mC_v (T_1 - T_4)} \\
 &= 1 - \frac{T_2 - T_3}{T_1 - T_4} \\
 &= 1 - \frac{T_3 (T_2 / T_3 - 1)}{T_4 (T_1 / T_4 - 1)} \tag{8.7}
 \end{aligned}$$

Also for reversible adiabatic compression process (3–4), we know

$$\begin{aligned}
 \left( \frac{T_3}{T_4} \right) &= \left( \frac{\forall_4}{\forall_3} \right)^{\gamma-1} = \left( \frac{1}{r} \right)^{\gamma-1} & \left[ \because r = \frac{\forall_3}{\forall_4} = \frac{\forall_2}{\forall_1} \right] \\
 \therefore \quad \frac{T_2}{T_1} &= \frac{T_3}{T_4} = \left( \frac{1}{r} \right)^{\gamma-1} \\
 \therefore \quad \frac{T_1}{T_4} &= \frac{T_2}{T_3} \\
 \therefore \quad \eta_{\text{otto}} &= 1 - \frac{T_3}{T_4} = 1 - \frac{T_2}{T_1} = 1 - \frac{1}{(r)^{\gamma-1}} \tag{8.8}
 \end{aligned}$$

### 8.9 JOULE'S CYCLE

It consists of two constant pressure and two reversible adiabatic or isentropic processes. It is shown in  $p$ - $\forall$  and  $T$ - $S$  diagram in figure 8.3. Let the engine cylinder contains  $m$  kg air and its pressure =  $p_1$ , volume =  $\forall_1$ , temperature =  $T_1$

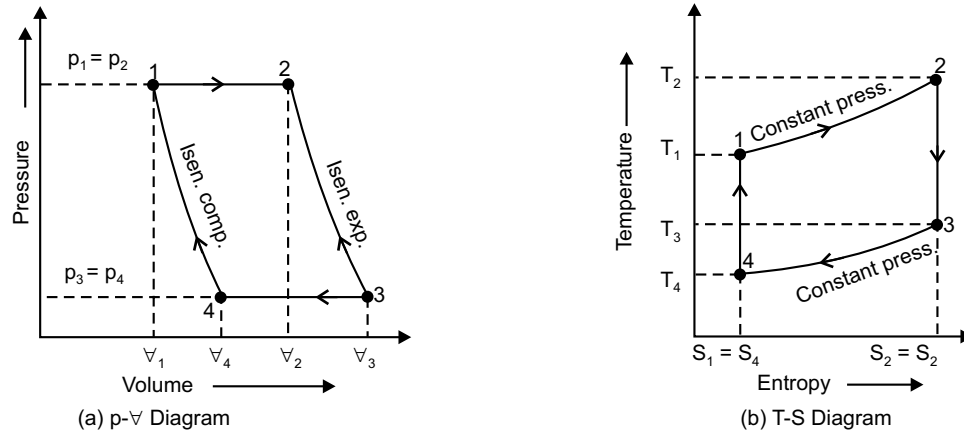

Fig. 8.3

1. *First stage (constant pressure heating)*

Air is heated at constant pressure from initial temperature  $T_1$  to final temperature  $T_2$ . So heat supplied to the air

$$Q_{1-2} = mC_p (T_2 - T_1)$$

2. *Second stage (isentropic expansion)*

Air is allowed to expand reversibly and adiabatically from  $\forall_2$  to  $\forall_3$ . Temperature falls from  $T_2$  to  $T_3$  and no heat is absorbed or rejected.

3. *Third stage (constant pressure cooling)*

The air is now cooled at constant pressure from temperature  $T_3$  to temperature  $T_4$ . Heat rejected by the air

$$Q_{3-4} = mC_p (T_3 - T_4)$$

4. *Fourth stage (isentropic compression)*

Temperature increases from  $T_4$  to  $T_1$ . No heat is absorbed or rejected by the air. No interchange of heat takes place during two adiabatic processes. So work done by constant pressure process

$$\begin{aligned} &= \text{Heat supplied} - \text{Heat rejected} \\ &= mC_p (T_2 - T_1) - mC_p (T_3 - T_4) \\ &= mC_p [(T_2 - T_1) - (T_3 - T_4)] \end{aligned}$$

$$\begin{aligned} \therefore \eta_{\text{joule}} &= \frac{\text{Work done}}{\text{Heat supplied}} \\ &= \frac{mC_p \{(T_2 - T_1) - (T_3 - T_4)\}}{mC_p (T_2 - T_1)} \\ &= 1 - \frac{T_3 - T_4}{T_2 - T_1} \end{aligned}$$

$$= 1 - \frac{T_3 (1 - T_4 / T_3)}{T_2 (1 - T_1 / T_2)} \tag{8.9}$$

Again for isentropic expansion process

$$\frac{T_3}{T_2} = \left( \frac{V_2}{V_3} \right)^{\gamma-1} = \left( \frac{p_3}{p_2} \right)^{\frac{\gamma-1}{\gamma}}$$

For isentropic compression process

$$\frac{T_4}{T_1} = \left( \frac{V_1}{V_4} \right)^{\gamma-1} = \left( \frac{p_4}{p_1} \right)^{\frac{\gamma-1}{\gamma}}$$

As  $\frac{T_3}{T_2} = \frac{T_4}{T_1}$

$\therefore \frac{T_3}{T_2} = \frac{T_4}{T_1} \quad [\because p_1 = p_2 \text{ and } p_3 = p_4]$

$\therefore \eta_{\text{joule}} = 1 - \frac{T_3}{T_2} = 1 - \frac{T_4}{T_1} = 1 - \frac{1}{r^{\gamma-1}} \tag{8.10}$

**8.10 DIESEL CYCLE**

This cycle is devised by Dr Rudolph Diesel with an idea to attain a higher thermal efficiency with a high compression ratio. It is also known as *constant pressure cycle* as heat is received at constant pressure.

An ideal diesel cycle consists of two reversible adiabatic or isentropic, a constant pressure and a constant volume processes as shown in  $p$ - $V$  and  $T$ - $S$  diagram in figure 8.4. Let the engine contains  $m$  kg of air at point where, pressure =  $p_1$ , volume =  $V_1$ , temperature =  $T_1$

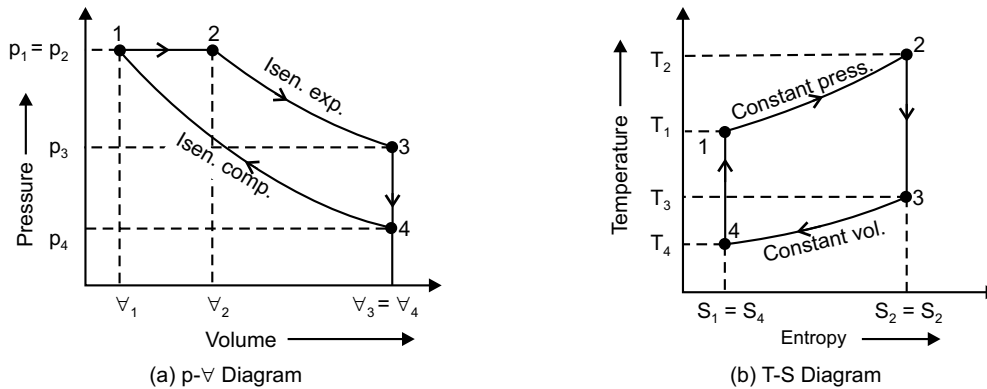

Fig. 8.4

1. *First stage (constant pressure heating)*

Air is heated at constant pressure from initial temperature  $T_1$  to final temperature  $T_2$ . So heat supplied to the air  $Q_{1-2} = mC_p (T_2 - T_1)$ . Since supply of heat is cut off at point 2 therefore it is known as *cut off point*.

2. *Second stage (reversible adiabatic or isentropic expansion)*

The air is expanded reversibly and adiabatically from temperature  $T_2$  to  $T_3$ . No heat is absorbed or rejected by the air.

3. *Third stage (constant volume cooling)*

Air is now cooled at constant volume from temperature  $T_3$  to  $T_4$ . So heat rejected by the air  $Q_{3-4} = mC_v (T_3 - T_4)$

4. *Fourth stage (reversible adiabatic or isentropic compression)*

The air compressed reversibly and adiabatically from temperature  $T_4$  to  $T_1$  and in this process, no heat is absorbed or rejected thus the air has been brought to its original conditions completing the cycle.

Therefore, 
$$\begin{aligned} \text{Work done} &= \text{heat absorbed} - \text{heat rejected} \\ &= mC_p (T_2 - T_1) - mC_v (T_3 - T_4) \end{aligned}$$

$$\begin{aligned} \eta_{\text{diesel}} &= \frac{\text{Work done}}{\text{Heat supplied}} \\ &= \frac{mC_p (T_2 - T_1) - mC_v (T_3 - T_4)}{mC_p (T_2 - T_1)} \\ &= 1 - \frac{C_v}{C_p} \left( \frac{T_3 - T_4}{T_2 - T_1} \right) = 1 - \frac{1}{\gamma} \frac{(T_3 - T_4)}{(T_2 - T_1)} \end{aligned} \quad (8.11)$$

$$\text{Compression ratio} = r = \left( \frac{V_4}{V_1} \right)$$

$$\text{Cut off ratio } \rho = \frac{V_2}{V_1}$$

$$\begin{aligned} \text{Expansion ratio } r_1 &= \left( \frac{V_3}{V_2} \right) = \left( \frac{V_4}{V_2} \right) \quad [ \because V_3 = V_4 ] \\ &= \frac{V_4}{V_1} \times \frac{V_1}{V_2} = r \times \frac{1}{\rho} = \frac{r}{\rho} \end{aligned}$$

At constant pressure heating process 1 – 2

$$\frac{V_1}{T_1} = \frac{V_2}{T_2}$$

$$\therefore T_2 = T_1 \frac{V_2}{V_1} = T_1 \times \rho$$

Similarly for isentropic expansion process (2–3)

$$\left( \frac{T_3}{T_2} \right) = \left( \frac{V_2}{V_3} \right)^{\gamma-1} = \left( \frac{1}{r_1} \right)^{\gamma-1} = \left( \frac{\rho}{r} \right)^{\gamma-1}$$

$$\therefore T_3 = T_2 \left( \frac{\rho}{r} \right)^{\gamma-1} = T_1 \rho \left( \frac{\rho}{r} \right)^{\gamma-1}$$

For isentropic compression process (4-1)

$$\frac{T_1}{T_4} = \left( \frac{V_4}{V_1} \right)^{\gamma-1} = (r)^{\gamma-1}$$

$$\therefore T_1 = T_4 \cdot (r)^{\gamma-1}$$

$$\therefore T_2 = T_1 \rho = T_4 \cdot (r)^{\gamma-1} \rho$$

$$\therefore T_3 = T_4 (r)^{\gamma-1} \rho \left( \frac{\rho}{r} \right)^{\gamma-1} = T_4 \cdot \rho^\gamma$$

$$\begin{aligned} \therefore \eta_{\text{diesel}} &= 1 - \frac{1}{\gamma} \left[ \frac{T_3 - T_4}{T_2 - T_1} \right] \\ &= 1 - \frac{1}{\gamma} \left[ \frac{T_4 \cdot \rho^\gamma - T_4}{T_4 \cdot r^{\gamma-1} \cdot \rho - T_4 \cdot r^{\gamma-1}} \right] \\ &= 1 - \frac{1}{(r)^{\gamma-1}} \left[ \frac{(\rho^\gamma - 1)}{\gamma(\rho - 1)} \right] \end{aligned} \quad (8.12)$$

### 8.11 COMPARISON BETWEEN THE EFFICIENCY OF OTTO AND DIESEL CYCLE FOR SAME COMPRESSION RATIO

Efficiency of Otto cycles

$$\eta_{\text{otto}} = 1 - \frac{1}{r^{\gamma-1}}$$

And efficiency of diesel cycle

$$\eta_{\text{diesel}} = 1 - \frac{1}{r^{\gamma-1}} \left[ \frac{(\rho^\gamma - 1)}{\gamma(\rho - 1)} \right]$$

The efficiency of the ideal Diesel cycle is lower than that of Otto cycle, for the same compression ratio. This is due to the fact that the cut-off ratio  $\rho$  is always greater than unity and hence the term within the large bracket of  $\eta_{\text{diesel}}$  increases with increase of cut-off ratio. Thus the negative term increases and the efficiency is reduced.

The Diesel cycle efficiency increases with decrease in cut-off ratio and approaches maximum (equal to Otto cycle efficiency) when the term within the large bracket is unity.

### Multiple Choice Questions

- The air standard otto cycle comprises:
  - two constant pressure processes and two constant volume processes
  - two constant pressure processes and two constant entropy processes
  - two constant volume processes and two constant entropy processes
  - none of the above
- The air standard efficiency of otto cycle is given by:
 

(a) $\eta = 1 + \frac{1}{r^{\gamma+1}}$	(b) $\eta = 1 - \frac{1}{r^{\gamma-1}}$
(c) $\eta = 1 + \frac{1}{r^{\gamma-1}}$	(d) $\eta = 2 - \frac{1}{r^{\gamma-1}}$
- The thermal efficiency of theoretical otto cycle:
  - increase with increase in compression ratio
  - increases with increase in isentropic index  $\gamma$
  - does not depend upon the pressure ratio
  - follows all the above
- The work output of theoretical otto cycle:
  - increases with increase in compression ratio
  - increases with increase in pressure ratio
  - increases with increase in adiabatic index  $\gamma$
  - follows all the above
- For same compression ratio:
  - thermal efficiency of otto cycle is greater than that of diesel cycle
  - thermal efficiency of otto cycle is less than that of diesel cycle
  - thermal efficiency of otto cycle is same as that for diesel cycle
  - thermal efficiency of otto cycle cannot be predicted
- In air standard diesel cycle, at fixed compression ratio and fixed value of adiabatic index ( $\gamma$ ):
  - thermal efficiency increases with increase in heat addition cut-off ratio
  - thermal efficiency decreases with increase in heat addition cut-off ratio
  - thermal efficiency remains same with increase in heat addition cut-off ratio
  - none of the above

### Answers

1. (b)      2. (b)      3. (d)      4. (d)      5. (a)      6. (b)

## NUMERICAL EXAMPLES

### EXAMPLE 1

In an Otto cycle the temperature at the beginning and end of the isentropic compression are 316 K and 596 K respectively. Determine the air standard efficiency and the compression ratio, take  $\gamma = 1.4$

**SOLUTION**

Here  $T_3 = 316 \text{ K}$ ,  $T_4 = 596 \text{ K}$ ,  $\gamma = 1.4$ ,  $r = \frac{V_3}{V_4}$

We know for isentropic compression

$$\frac{T_3}{T_4} = \left(\frac{V_4}{V_3}\right)^{\gamma-1} = \frac{1}{(r)^{\gamma-1}} = \frac{1}{(r)^{1.4-1}} = \frac{1}{r^{0.4}}$$

$$\therefore (r)^{0.4} = \left(\frac{T_4}{T_3}\right) = \left(\frac{596}{316}\right)$$

$$\therefore r = \left(\frac{596}{316}\right)^{1/0.4} = 4.885$$

Air standard efficiency

$$\eta = 1 - \frac{1}{(r)^{\gamma-1}}$$

$$\begin{aligned} \therefore \eta &= 1 - \frac{T_3}{T_4} = 1 - \frac{316}{596} = \frac{596 - 316}{596} = \frac{280}{596} \\ &= 0.47 \end{aligned}$$

### EXAMPLE 2

An air motor works on Joule's cycle between 5 bar and 1 bar. The temperature at the beginning of isentropic expansion is 773 K and at the beginning of isentropic compression is 293 K. Determine the work done per kg of air and ideal efficiency. Assume  $C_p = 1 \text{ kJ/kgK}$  and  $\gamma = 1.4$ .

**SOLUTION**

Given  $p_1 = p_2 = 5 \text{ bar}$        $p_3 = p_4 = 1 \text{ bar}$   
 $T_2 = 773 \text{ K}$ ,  $T_4 = 293 \text{ K}$ ,  $C_p = 1 \text{ kJ/kg K}$ ,  $\gamma = 1.4$ .

We know that for isentropic expansion process

$$\frac{T_3}{T_2} = \left(\frac{p_3}{p_2}\right)^{\frac{\gamma-1}{\gamma}} = \left(\frac{1}{5}\right)^{\frac{1.4-1}{1.4}} = (0.2)^{0.286} = 0.6311$$

$$\therefore T_3 = T_2 \times 0.6311 = 773 \times 0.6311 = 488 \text{ K}$$

Similarly for isentropic compression process

$$\frac{T_4}{T_1} = \left(\frac{p_4}{p_1}\right)^{\frac{\gamma-1}{\gamma}} = \left(\frac{1}{5}\right)^{\frac{1.4-1}{1.4}} = (0.2)^{0.286} = 0.6311$$

$$\therefore T_1 = \frac{T_4}{0.6311} = \frac{293}{0.6311} = 464 \text{ K}$$

$\therefore$  Heat supplied

$$\begin{aligned} &= mC_p (T_2 - T_1) \\ &= 1 \times 1 (773 - 464) = 309 \text{ kJ} \end{aligned}$$

$\therefore$  Heat rejected

$$\begin{aligned} &= mC_p (T_3 - T_4) \\ &= 1 \times 1 (488 - 293) = 195 \text{ kJ} \end{aligned}$$

$\therefore$  Work done

$$\begin{aligned} &= \text{Heat supplied} - \text{Heat rejected} \\ &= (309 - 195) = 114 \text{ kJ} \end{aligned}$$

$$\text{Ideal efficiency} = \frac{\text{Work done}}{\text{Heat supplied}} = \frac{114}{309} = 0.369$$

### EXAMPLE 3

In a diesel engine the compression ratio is 13:1 and the fuel is cut off at 8% of the stroke. Find the air standard efficiency of the engine, take  $\gamma$  for air = 1.4.

**SOLUTION**

$$\text{Given, } r = \text{compression ratio} = \frac{V_4}{V_1} = 13$$

Since the cut off takes place at 8% of the stroke, therefore volume at cut off,

$$\begin{aligned} V_2 &= V_1 + 8\% \text{ of the stroke volume} \\ &= V_1 + 0.08 (V_4 - V_1) \end{aligned}$$

Let us assume the clearance volume  $V_1 = 1 \text{ m}^3$ , So  $V_4 = 13 \text{ m}^3$

$$\therefore V_2 = V_1 + 0.08 (13 - 1) = 1 + 0.08 \times 12 = 1.96 \text{ m}^3$$

$$\text{Cut off ratio} = \frac{V_2}{V_1} = \frac{1.96}{1} = 1.96$$

$$\begin{aligned} \text{Efficiency } \eta &= 1 - \frac{1}{(r)^{\gamma-1}} \left[ \frac{\rho^\gamma - 1}{\gamma(\rho - 1)} \right] \\ &= 1 - \frac{1}{(13)^{1.4-1}} \left[ \frac{1.96^{1.4} - 1}{1.4(1.96 - 1)} \right] \\ &= 1 - 0.417 = 0.583 \end{aligned}$$

**EXAMPLE 4**

In an ideal diesel cycle, the temperature at the beginning and end of compression are  $57^\circ\text{C}$  and  $603^\circ\text{C}$  respectively. The temperatures at the beginning and end of expansion are  $1950^\circ\text{C}$  and  $870^\circ\text{C}$  respectively. Determine the ideal efficiency of the cycle. Take  $\gamma = 1.4$ , if the compression ratio is 14 and the pressure at the beginning of the compression is 1 bar, calculate the maximum pressure in the cycle.

**SOLUTION**

Here,

$$T_4 = 57 + 273 = 330 \text{ K}, T_1 = 603 + 273 = 876 \text{ K}$$

$$T_2 = 1950 + 273 = 2223 \text{ K}, T_3 = 870 + 273 = 1143 \text{ K}.$$

$$r = \frac{V_4}{V_1} = 14, p_4 = 1 \text{ bar}$$

Therefore,

$$\begin{aligned} \eta &= 1 - \frac{1}{\gamma} \left[ \frac{T_3 - T_4}{T_2 - T_1} \right] \\ &= 1 - \frac{1}{\gamma} \left[ \frac{1143 - 330}{2223 - 876} \right] \\ &= 1 - 0.431 = 0.569 \end{aligned}$$

Maximum pressure in the cycle =  $p_1$

For reversible adiabatic compression

$$p_1 V_1^\gamma = p_4 V_4^\gamma$$

So,

$$p_1 = \left( \frac{V_4}{V_1} \right)^\gamma \cdot p_4 = (14)^{1.4} \times 1 = 40.23 \text{ bar}$$

**EXAMPLE 5**

An air standard diesel cycle has a compression ratio of 18 and the heat transfer to the working fluid per cycle is  $1800 \text{ kJ/kg}$ . At the beginning of the compression process the pressure is  $0.1 \text{ MPa}$  and the temperature is  $15^\circ\text{C}$ . Determine (a) the pressure and temperature at each point in the cycle (b) thermal efficiency (c) effective pressure.

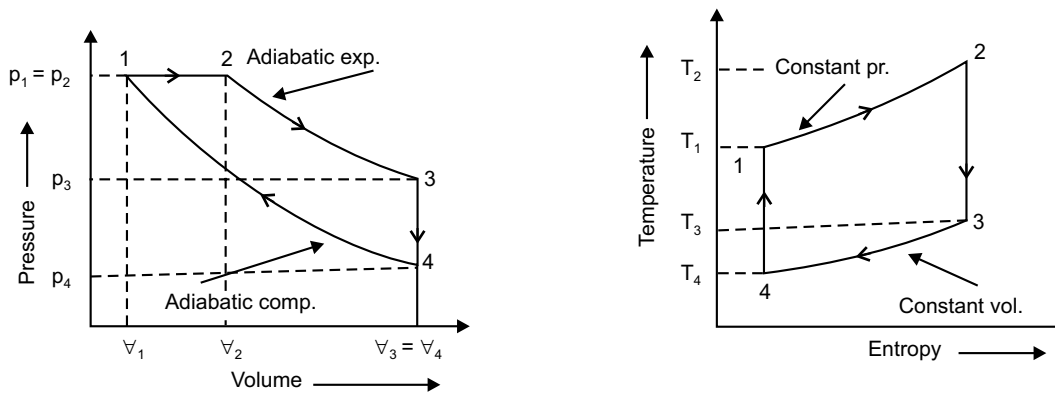

**SOLUTION**

Here,

$$p_4 = 0.1 \text{ MPa} = 100 \text{ kPa}, T_4 = 15^\circ\text{C} = 15 + 273 = 288 \text{ K}$$

$$r = \text{compression ratio} = \left( \frac{v_4}{v_1} \right) = 18$$

Now,

$$v_4 = \frac{RT_4}{p_4} = \frac{0.287 \times 288}{100} = 0.827 \text{ m}^3/\text{kg}$$

 $\therefore$ 

$$v_1 = \frac{v_4}{r} = \frac{0.827}{18} = 0.046 \text{ m}^3/\text{kg}$$

 $\therefore$ 

$$\frac{T_1}{T_4} = \left( \frac{v_4}{v_1} \right)^{\gamma-1} = (18)^{1.4-1} = 3.1777$$

 $\therefore$ 

$$T_1 = 288 \times 3.1777 = 915.17 \text{ K}$$

Again,

$$\frac{p_1}{p_4} = \left( \frac{v_4}{v_1} \right)^\gamma = (18)^{1.4} = 57.2$$

 $\therefore$ 

$$p_1 = p_4 \times 57.2 = \frac{100 \times 57.2}{1000} = 5.72 \text{ MPa}$$

**EXAMPLE 6**

Gas is entering a turbine @ 15 kg/s, while 1 kg gas occupies 0.45 m<sup>3</sup>. Power developed by the pump is 12,000 kW. Velocities and enthalpies at inlet and outlet section of the turbine are 50 m/s, 110 m/s, 1260 kJ/kg and 400 kJ/kg respectively. Find out the amount of heat rejected and also the cross-section at the inlet.

**SOLUTION**Rate of flow of gases  $m = 15 \text{ kg/s}$ ,

Volume of gases at the inlet

$$v_s = 0.45 \text{ m}^3/\text{kg}$$

Power developed by the turbine  $P = 12000 \text{ kW}$ 

$$\therefore \text{ Work done } w = \frac{12000}{15} = 800 \text{ kW/kg}$$

Enthalpy of the gases at the inlet  $h_1 = 1260 \text{ kJ/kg}$ Enthalpy of the gases at the outlet  $h_2 = 400 \text{ kJ/kg}$ Velocity of the inlet  $V_1 = 50 \text{ m/sec}$ Velocity at the outlet  $V_2 = 110 \text{ m/sec}$ 

(i) Heat rejected

$$h_1 + \frac{V_1^2}{2} + q = h_2 + \frac{V_2^2}{2} + w$$

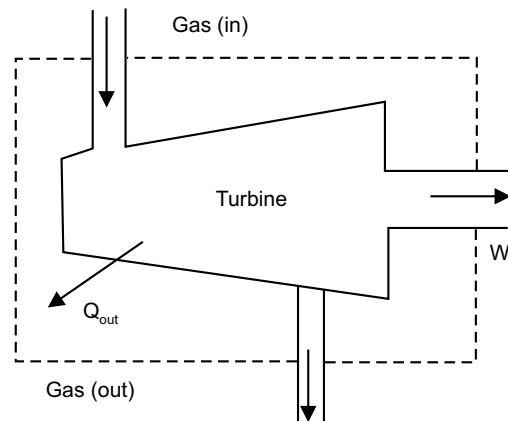

$$\text{or, } 1260 + \frac{50^2}{2 \times 10^3} + q = 400 + \frac{110^2}{2 \times 10^3} + 800$$

$$\text{or, } 1260 + \frac{2500}{2 \times 1000} + q = 400 + \frac{110 \times 110}{2 \times 1000} + 800$$

$$\text{or, } 1260 + 1.25 + q = 400 + 6.05 + 800$$

$$\therefore q = -55.2 \text{ kJ/kg}$$

$$\text{So, heat rejected @ } 55.2 \text{ kJ/kg} = 55.2 \times 15 \text{ kJ/s} = 828 \text{ kW}$$

$$\text{Therefore, Inlet area} = \frac{\text{volume flow rate}}{\text{velocity}} = \frac{0.45 \times 15}{50} = 0.135 \text{ m}^2$$

**EXAMPLE 7**

Some amount of fluid is heated from  $50^\circ\text{C}$  to  $450^\circ\text{C}$  at constant 2 bar pressure. Initial and final specific volumes of the fluid are  $1 \text{ m}^3/\text{kg}$  and  $1.8 \text{ m}^3/\text{kg}$ . Determine (i) heat added to the fluid (ii) work done of the fluid (iii) change in internal energy (iv) change in enthalpy for a steady flow process. Assume  $C_p = 2.5 + \frac{40}{T + 20}$

**SOLUTION**

$$v_{s1} = 1 \text{ m}^3/\text{kg}, T_1 = 50^\circ\text{C}, v_{s2} = 1.8 \text{ m}^3/\text{kg}, T_2 = 450^\circ\text{C}$$

Specific heat at constant 2 bar pressure

$$C_p = 2.5 + \frac{40}{T + 20}$$

(i) Heat added per kg of the fluid is given by

$$\begin{aligned} q &= \int_{T_1}^{T_2} C_p \cdot dT = \int_{50}^{450} \left( 2.5 + \frac{40}{T + 20} \right) dT \\ &= \left[ 2.5T + 40 \ln(T + 20) \right]_{50}^{450} \\ &= 2.5(450 - 50) + 40 \ln \left( \frac{450 + 20}{50 + 20} \right) \\ &= 2.5 \times 400 + 40 \ln \left( \frac{470}{70} \right) \\ &= 1076 \text{ kJ/kg} \end{aligned}$$

(ii) Work done/kg of the fluid

$$\begin{aligned} w &= \int_{v_{s1}}^{v_{s2}} p dv_s \\ &= p(v_{s2} - v_{s1}) \\ &= 2 \times 10^5 (1.8 - 1) = 2 \times 10^5 \times 0.8 \text{ N.m/kg} \\ &= 160 \times 10^3 = 160 \text{ kJ/kg} \end{aligned}$$

(iii) Change in internal energy

$$\Delta u = q - w = 1076 - 160 = 996 \text{ kJ/kg}$$

(iv) Change in enthalpy (for steady flow process)

$$\Delta h = q = 1076 \text{ kJ/kg}$$

### EXAMPLE 8

Calculate the entropy change of 10 gm of water at 20°C when it is converted to ice at -10°C. Assume the specific heat of water to remain constant at 4.2 J/gm K and that of ice to be half of the value and taking the latent heat of fusion of ice at 0°C to be 335 J/gm

**SOLUTION**

Entropy change of water from 20°C to 0°C

$$\Delta S_1 = \int_{273+20}^{273+0} \frac{mC_p \cdot dT}{T} = 10 \times 4.2 [\ln T]_{293}^{273} = -2.97 \text{ J/K}$$

Entropy change of water from 0°C to ice at 0°C

$$\Delta S_2 = \frac{mL}{T} = \frac{10 \times 335}{273+0} = -12.27 \text{ J/K}$$

Entropy change of ice at 0°C to ice at -10°C

$$\Delta S_3 = \int_{273+0}^{273-10} \frac{mC_p \cdot dT}{T} = 10 \times \frac{4.2}{2} [\ln T]_{273}^{263} = -0.783 \text{ J/K}$$

∴ Net entropy change

$$\begin{aligned} \Delta S &= \Delta S_1 + \Delta S_2 + \Delta S_3 \\ &= -2.97 - 12.27 - 0.783 = -16.023 \text{ J/K} \end{aligned}$$

### EXAMPLE 9

A lump of steel of mass 10 kg at 627°C is dropped in 100 kg oil at 30°C. The specific heats of steel and oil are 0.5 kJ/kg K and 3.5 kJ/kg K respectively. Calculate the entropy change of the steel the oil and universe.

**SOLUTION**

Let the final temperature at equilibrium = TK

Here for thermal equilibrium heat lost by steel = Heat gained by oil

$$\begin{aligned} \therefore [mC_p \cdot (\Delta T)]_{\text{steel}} &= [mC_p \cdot (\Delta T)]_{\text{oil}} \\ \therefore 10 \times 0.5 (627 + 273 - T) &= 100 \times 3.5 \times [T - (273 + 30)] \\ \therefore T &= 311.41 \text{ K} \end{aligned}$$

∴ Change of entropy of steel

$$(\Delta S)_{\text{steel}} = \int_{627+273}^{311.41} \frac{mC_p \cdot dT}{T}$$

$$= 10 \times 0.5 \ln \left( \frac{311.41}{900} \right) = -5.306 \text{ J/K}$$

∴ Change of entropy of oil

$$(\Delta S)_{\text{oil}} = \int_{30+273}^{311.41} \frac{mC_p \cdot dT}{T}$$

$$= 100 \times 3.5 \ln \left( \frac{311.41}{303} \right) = 9.582 \text{ J/K}$$

∴ Change of entropy of the universe

$$(\Delta S)_{\text{universe}} = (\Delta S)_{\text{steel}} + (\Delta S)_{\text{oil}}$$

$$= -5.306 + 9.582 = 4.276 \text{ kJ/K}$$

### EXAMPLE 10

The compression ratio in an air standard Otto cycle is 8. At the beginning of the compression stroke the pressure is 0.1 MPa and the temperature is 15°C. The heat transfer to the air per cycle is 1800 kJ/kg. Determine (a) the pressure and temperature at the end of each process of the cycle (b) thermal efficiency (c) mean effective pressure

**SOLUTION**

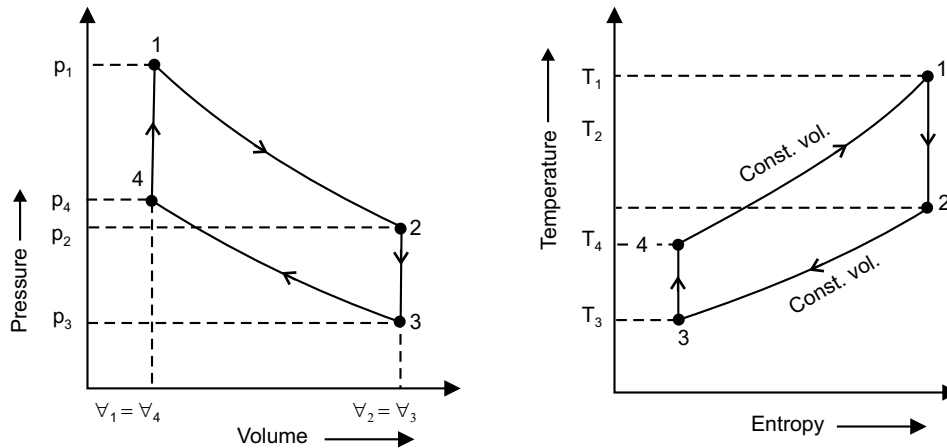

Heat rejected in constant volume process (2-3)

$$Q_{2-3} = mC_v(T_2 - T_3)$$

Heat absorbed in constant volume process (4-1)

$$Q_{4-1} = mC_v(T_1 - T_4)$$

Given

$$p_3 = 0.1 \text{ MPa} = 100 \text{ kPa}, T_3 = (273 + 15) = 288 \text{ K}$$

$$r = \frac{V_3}{V_4} = \frac{V_2}{V_1} = 8, \text{ heat transfer} = 1800 \text{ kJ/kg}$$

Now, 
$$\frac{T_4}{T_3} = \frac{T_1}{T_2} = (r)^{\gamma-1} = (8)^{0.4} = 2.297$$

$\therefore$  
$$T_4 = T_3 \times 2.297 = 661.54 \text{ K}$$

$$T_1 = 2.297 T_2 \quad \text{(i)}$$

Again,  $mC_v[(T_1 - T_4) - (T_2 - T_3)] = 1800$

or  $C_v(2.297 T_2 - 661.54 - T_2 + 288) = 1800$  [For unit mass, is,  $m = 1 \text{ kg}$ ]

or  $C_v(1.197 T_2 - 373.54) = 1800$

$\therefore$  
$$T_2 = \left( \frac{1800}{C_v} + 373.54 \right) \times \frac{1}{1.197} \quad \text{(ii)}$$

Assuming,  $C_p = 1 \text{ kJ/kgK}$ ,  $C_v = \frac{C_p}{\gamma} = \frac{1}{1.4} = 0.714$

From equation (ii),  $T_2 = 2418.17 \text{ K}$

From equation (i),  $T_1 = 5554.54 \text{ K}$

Again, 
$$\frac{p_4}{p_3} = (r)^\gamma = (8)^{1.4} = 18.379 = \frac{p_1}{p_2} \quad \text{(iii)}$$

$\therefore$  
$$p_4 = 100 \times 18.379 = 1837.9 \text{ kPa}$$

For constant volume process, 
$$\frac{p_2}{T_2} = \frac{p_3}{T_3}$$

$\therefore$  
$$p_2 = 100 \times \frac{2418.17}{288} = 839.64 \text{ kPa}$$

From equation (iii),  $p_1 = 839.64 \times 18.379 = 15431.74 \text{ kPa}$

Thermal efficiency  $\eta = 1 - \frac{1}{(r)^{\gamma-1}} = 1 - \frac{1}{(8)^{0.4}} = 0.5647$

Again we can write  $\nabla_3 = 8\nabla_4 = 8\nabla_1 = \nabla_2$

$\therefore$  
$$\text{Work done} = \frac{1}{\gamma-1} [(p_1\nabla_1 - p_2\nabla_2) - (p_4\nabla_4 - p_3\nabla_3)]$$

$\therefore$  
$$1800 = \frac{1}{0.4} [15431.74\nabla_1 - 839.64 \times 8\nabla_1 - 1837.9\nabla_1 + 100 \times 8\nabla_1]$$

$\therefore$  
$$\nabla_1 = 0.0938 \text{ m}^3/\text{kg}$$

$\therefore$  
$$\text{Stroke volume} = 0.0938 \times 8 = 0.7504 \text{ m}^3/\text{kg}$$

$\therefore$  
$$\text{Mean effective pressure} = \frac{\text{Work done}}{\text{Stroke volume}}$$

$$= \frac{1800}{0.7504} = 2398.72 \text{ kPa}$$

**EXAMPLE 11**

An air standard otto cycle operates with the compression and expansion strokes being polytropic with  $n = 1.35$  for each stroke. Calculate the thermal efficiency of the cycle for a compression ratio of 9.

**SOLUTION**

Compression ratio ( $r$ ) = 9, Polytropic constant ( $n$ ) = 1.35

Efficiency of the otto cycle is

$$\begin{aligned}\eta_{\text{otto}} &= 1 - \frac{1}{(r)^{\gamma-1}} \\ &= 1 - \frac{1}{9^{1.35-1}} = 0.5365\end{aligned}$$

**EXAMPLE 12**

An air standard diesel cycle has a compression ratio of 22 and cut off ratio of 2.2. Determine the thermal efficiency of the cycle.

**SOLUTION**

Compression ratio ( $r$ ) = 22, Cut-off ratio ( $\rho$ ) = 2.2

$$\begin{aligned}\text{So, } \eta_{\text{diesel}} &= 1 - \frac{1}{(r)^{\gamma-1}} \left[ \frac{\rho^{\gamma} - 1}{\gamma(\rho - 1)} \right] \\ &= 1 - \frac{1}{(22)^{1.4-1}} \left[ \frac{(2.2)^{1.4} - 1}{1.4(2.2 - 1)} \right] \\ &= 0.6515\end{aligned}$$

**EXERCISE**

1. What is a cycle? what is the difference between an ideal and actual cycle?
2. What is an air-standard efficiency?
3. What is relative efficiency?
4. Derive expressions of efficiency in the following cases:  
(i) Carnot cycle; (ii) Diesel cycle; (iii) Dual combustion cycle.
5. Explain "Air standard analysis" which cycle has been adopted for I.C. engine cycle. State the assumption made for air standard cycle.
6. Efficiency of Otto cycle and Diesel cycle—which one is more?
7. A 6-cylinder petrol engine has volume compression ratio 5:1 and clearance volume in each cylinder is 110 cc. Engine consumes fuel 10 kg/hr. having calorific value 10,000 k cal/kg. Engine runs at 2400 rpm and efficiency ratio 0.66. Estimate mean effective pressure developed.

**Ans.** [7.038 kgf/cm<sup>2</sup>]

8. Carnot engine produces 150 kJ work between 650 K and 37°C. what is the thermal efficiency and heat added during the process?
9. Being operated between two reservoirs at  $T_1$  and  $T_3$ , output of Carnot engine is 0.6 times the heat rejected. Determine thermal efficiency, temperatures of source and sink, if source is 200°C higher than sink.

**Ans.** [37.5%, 260.3°C, 60.3°C]

10. Initial and final temperatures of isentropic compression in an Otto cycle are 316 K and 323°C, respectively. What is the compression ratio and air-standard efficiency? Take  $\gamma = 1.4$ .

**Ans.** [4.885, 47%]

11. Engine, working on Otto cycle has stroke 22.5 cm and 0.15 m diameter. Calculate air-standard efficiency of the engine, while  $\gamma = 1.4$  and clearance volume =  $1.25 \times 10^{-3} \text{ m}^3$ .

**Ans.** [43.6%]

12. In a diesel engine, fuel cut-off is at 8% of the stroke. What is its air-standard efficiency, being compression ratio 13:1 and  $\gamma$  (air) = 1.4 ?

**Ans.** [58.3%]

13. In a ideal diesel engine clearance volume is 10% of swept volume while stroke is 0.2 m and diameter 150 mm. If cut-off occurs at 6% of the stroke, calculate its air-standard efficiency and compression ratio.

**Ans.** [57.53%, 11]

14. A 4-cylinder 4-stroke petrol engine has bore 6.5 cm, stroke 95 mm, speed 3000 rpm, clearance volume 65 cc, relative efficiency 50%, calorific value of fuel used 46 MJ/kg. When tested it develops 70 Nm torque. Determine, specific fuel consumption, brake mean effective pressure of the engine.

**Ans.** [0.308925 kg/kWh, 6.976 bar]

15. A 4-stroke petrol engine having 6 cylinders is to operate with a compression ratio of 8, and delivers power of 300 kW at 2400 rpm. Find out engine bore and stroke length and fuel consumption rate while stroke is 1.6 times the bore, mechanical efficiency 88% indicated mean effective pressure 9.5 kgf/cm<sup>2</sup>, relative efficiency 50% and calorific value of fuel 11000 kcal/kg.

**Ans.** [134.36 mm, 214.98 mm, 83.067 kg/hr.]

16. Following are the particulars of a 2-stroke diesel engine; bore = 10 cm stroke = 150 mm, piston speed = 300 m/min, torque developed = 58 Nm, mechanical efficiency = 0.80, indicated thermal efficiency = 0.40, calorific value of fuel = 44 MJ/kg. Determine (i) indicated power (ii) indicated mean effective pressure (iii) fuel consumption rate on brake power basis.

17. A 4-cylinder 2-stroke petrol engine develops 30 kW at 2500 rpm. Mean effective pressure of each is 800 kN/m<sup>2</sup> and mechanical efficiency 80%. Calculate diameter and stroke of each cylinder, of stroke to bore ratio is 1.5. Also calculate the brake specific fuel consumption of the engine, if brake thermal efficiency is 28% and calorific value of petrol is  $44 \times 10^6 \text{ J/kg}$ .

**Ans.** [5.75 cm, 8.625 cm, 0.2922 kg/kwh]

# STEAM POWER CYCLE

## 9.1 INTRODUCTION

We have already discussed the air standard cycle in the previous chapter. In this chapter, we shall discuss the steam power cycle, *i.e.*, thermodynamic cycle of vapour. In a vapour cycle, all the theory remains the same, except the working substance, which is steam. Though there are many vapour cycles, from the subject point of view, important vapour power cycles are (i) *Carnot vapour power cycle* which is already discussed in chapter 5 (ii) *Rankine vapour cycle*.

## 9.2 RANKINE CYCLE

Rankine cycle is a thermodynamic cycle. It is *modified form of Carnot cycle*. It has practical application on thermal power plant (steam power plant). It consists of four units, *i.e.*, boiler, turbine, condenser and fuel pump. Schematic diagram of steam power plant or turbine plant is shown in figure 9.1.

Consider 1 kg of saturated water at pressure  $p_1$  and absolute temperature  $T_1$  as represented by point 1 in figure 9.2 (a), (b) and (c). The cycle is completed by the following four processes: *isothermal expansion, isentropic expansion, isothermal compression and isentropic compression*.

*Process: (1–2)*

Reversible adiabatic expansion in the turbine.

*Process: (2–3)*

Constant pressure transfer of heat in the condenser.

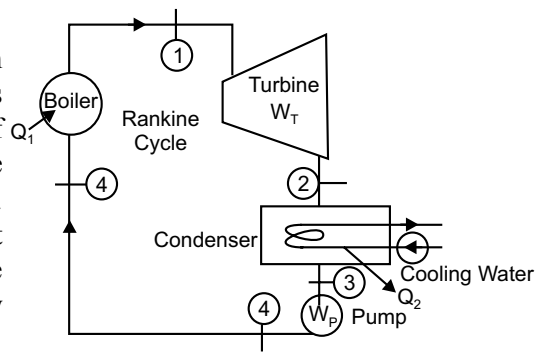

Fig. 9.1

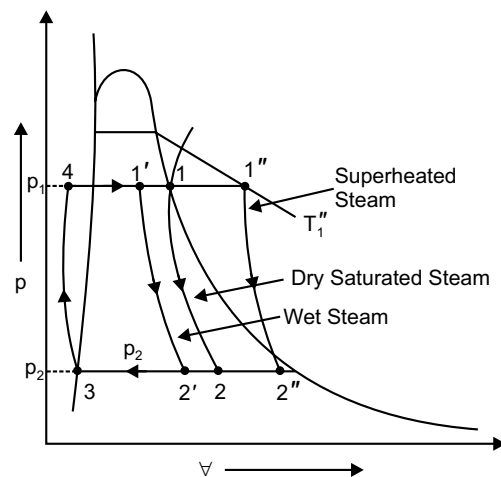

Fig. 9.2 (a)

Process: (3–4)

Reversible adiabatic pumping process in the fuel pump.

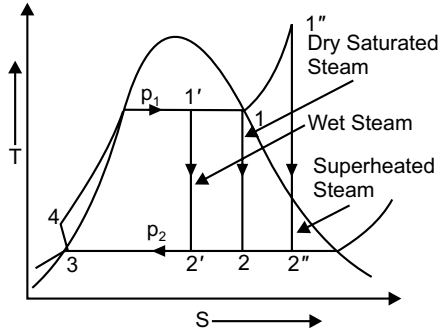

Fig. 9.2(b)

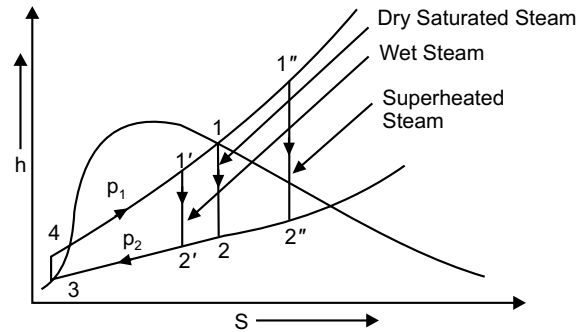

Fig. 9.2(c)

Process: (4–1)

Constant pressure transfer of heat in the boiler.

Figure 9.1 shows the Rankine cycle and figure 9.2,  $p-v$ ,  $T-S$  and  $h-s$  diagram (when the saturated steam enters the turbine, the steam can be wet or superheated also). Consider 1 kg of fluid, applying steady flow energy equation (S.F.E.E) to boiler, turbine, condenser and pump.

(i) For boiler (as control volume), we get

$$h_{f4} + q_1 = h_1 \quad \Rightarrow \quad q_1 = h_1 - h_{f4} \quad (9.1)$$

(ii) For turbine (as control volume), we get

$$h_1 = w_T + h_2 \quad \Rightarrow \quad w_T = h_1 - h_2 \quad (9.2)$$

[ $w_T$  = Turbine work]

(iii) For condenser, we get

$$h_2 = q_2 + h_{f3} \quad \Rightarrow \quad q_2 = h_2 - h_{f3} \quad (9.3)$$

(iv) For the feed pump, we get

$$h_{f3} + w_p = h_{f4} \quad \Rightarrow \quad w_p = h_{f4} - h_{f3} \quad (9.4)$$

[ $w_p$  = Pump work]

$\therefore$  Efficiency of the Rankine cycle

$$\begin{aligned} \eta &= \frac{w_{net}}{q_1} = \frac{w_T - w_p}{q_1} \\ &= \frac{(h_1 - h_2) - (h_{f4} - h_{f3})}{q_1} \end{aligned} \quad (9.5)$$

Using general property relation for reversible adiabatic compression,

$$T \cdot ds = dh - v dp \quad \text{and} \quad ds = 0$$

$$\therefore \quad dh = v dp$$

$$\Rightarrow \quad \Delta h = v_3 \cdot \Delta p$$

$$\Rightarrow \quad h_{f4} - h_{f3} = v_3(p_1 - p_2)$$

As  $(h_{f4} - h_{f3})$  is very small in comparison to  $w_T$  and can be neglected, especially when the boiler pressure is low.

$$\eta_{\text{Rankine}} = \frac{h_1 - h_2}{h_1 - h_{f4}}$$

### 9.3 VAPOUR COMPRESSION REFRIGERATION CYCLE

The refrigeration cycles are classified as *vapour compression refrigeration cycle* and *gas refrigeration cycle* based on the working medium employed in the refrigerator. The basic components involved in a vapour compression refrigeration plant are shown in schematic diagram of vapour compression refrigeration plant in figure 9.3. There are four basic units, compressor, condenser, throttle valve and evaporator. The  $p-v$ ,  $T-S$ ,  $h-s$  and schematic diagram is shown in figures 9.4 and 9.5.

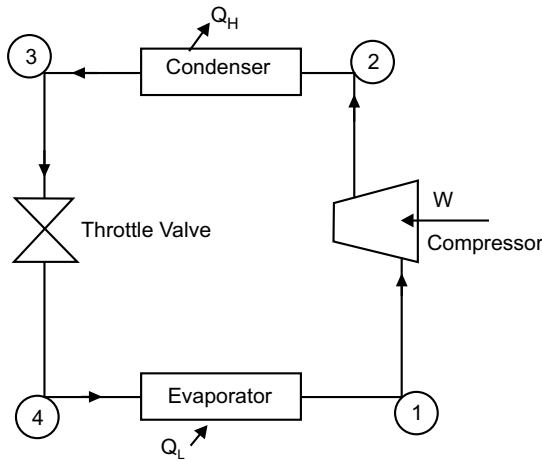

Fig. 9.3

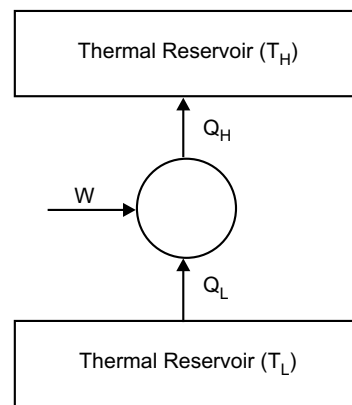

Fig. 9.4

The vapor compression refrigeration cycle consists of following processes.

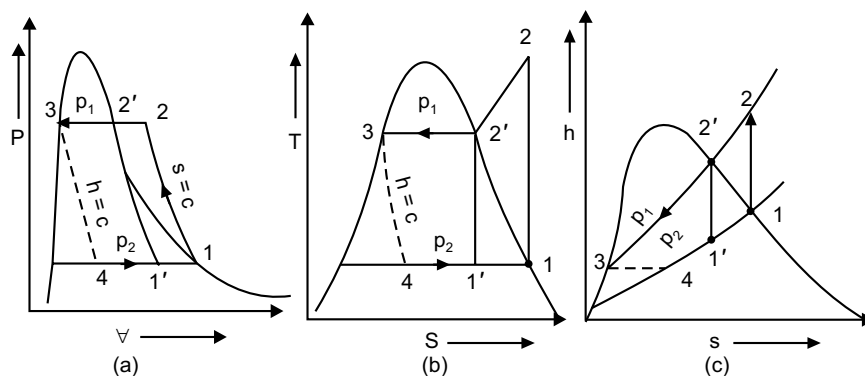

Fig. 9.5

*Process 1–2:* The working fluid at state 1 (a mixture of liquid and vapour) is isentropically compressed to state 2 (saturated vapour) inside the compressor.

*Process 2–3:* Isothermal energy rejection as heat ( $Q_H$ ) to the surroundings at  $T_H$  in a condenser. At the end of the process, the working fluid is available at state 3 (saturated liquid).

*Process 3–4:* In throttle valve, the working fluid is expanded isentropically to a low pressure. The temperature of the working fluid is  $T_L$  at the end of the expansion process.

*Process 4–1:* Isothermal energy transfer as heat ( $Q_L$ ) from the low temperature body at  $T_L$  to the working fluid. If the flow rate of the refrigerant or working through the device is  $m$  then, energy extracted from the cold body

$$Q_L = m (h_1 - h_4) \quad (9.6)$$

Work done on the compressor

$$W = m (h_2 - h_1) \quad (9.7)$$

$$\therefore \text{COP} = \frac{Q_L}{W} = \frac{m (h_1 - h_4)}{m (h_2 - h_1)} = \frac{h_1 - h_4}{h_2 - h_1} \quad (9.8)$$

Since process 3–4 is a throttling process, we have  $h_4 = h_3$

### Multiple Choice Questions

- The Rankine Cycle, as compared to Carnot Cycle, has work ratio
  - high
  - low
- The ideal cycle on which a steam engine works is
  - Carnot Cycle
  - Rankine Cycle
  - Otto Cycle
  - Joule Cycle
- In a Rankine Cycle with superheated steam
  - the work done increases
  - the specific steam consumption decreases
  - the dryness fraction of steam after isentropic expansion increases
  - all of the above
- Rankine Cycle comprises
  - two isothermal and two isentropics
  - two isobarics and two isothermals
  - two isobarics and two isentropics
  - two isothermals and two isochorics
- Which one is a thermodynamic cycle?
  - Diesel Cycle
  - Rankine Cycle
  - Otto Cycle
  - Joule Cycle
- The highest temperature during the cycle, in a vapour compression system, occurs after
  - compression
  - condensation
  - expansion
  - evaporation

7. In a vapour compression system, the lowest temperature during the cycle occurs after  
 (a) compression (b) condensation  
 (c) expansion (d) evaporation
8. Sub-cooling in a refrigerator cycle  
 (a) does not alter COP (b) increases COP (c) decreases COP

### Answers

1. (a)    2. (b)    3. (d)    4. (c)    5. (b)    6. (a)    7. (d)    8. (c)

### NUMERICAL EXAMPLES

#### EXAMPLE 1

In a steam power cycle, the steam supply is at 15 bar and dry and saturated. The condenser pressure is 0.4 bar. Calculate the Carnot and Rankine efficiency of the cycle. Neglect pump work.

#### SOLUTION

Steam supply pressure ( $p_1$ ) = 15 bar,  $x_1 = 1$ , and condenser pressure ( $p_2$ ) = 0.4 bar

From steam tables, at 15 bar

$$t_s = 198.3^\circ\text{C}, h_g = 2789.9 \text{ kJ/kg}, s_g = 6.4406 \text{ kJ/kg K}$$

So,  $T_1 = 198.3 + 273 = 471.3 \text{ K}$

From steam tables, at 0.4 bar

$$t_s = 75.9^\circ\text{C}, h_f = 317.7 \text{ kJ/kg}, h_{fg} = 2319.2 \text{ kJ/kg}$$

$$s_f = 1.0261 \text{ kJ/kg K}, s_{fg} = 6.6448 \text{ kJ/kg K}$$

So,  $T_2 = 75.9 + 273 = 348.9 \text{ K}$

$$\eta_{\text{Carnot}} = \frac{T_1 - T_2}{T_1} = \frac{471.3 - 348.9}{471.3} = 0.259$$

$$\eta_{\text{Rankine}} = \frac{\text{Adiabatic or isentropic heat drop}}{\text{Heat supplied}} = \frac{h_1 - h_2}{h_1 - h_f}$$

But,  $h_2 = h_{f2} + x_2 h_{fg2} = 317.7 + x_2 \times 2319.2$

As steam expands isentropically,  $s_1 = s_2$

$$\therefore 6.6448 = 1.0261 + x_2 \times 6.6448$$

$$\therefore x_2 = 0.845$$

$$\therefore h_2 = 317.7 + 0.845 \times 2319.2 = 2277.4 \text{ kJ/kg}$$

$$\therefore \eta_{\text{Rankine}} = \frac{2789.9 - 2277.4}{2789.9 - 317.7} = 0.2073.$$

**EXAMPLE 2**

In a Rankine cycle, the steam at inlet to turbine is saturated at a pressure of 35 bar and the exhaust pressure is 0.2 bar. Determine (i) pump work (ii) turbine work (iii) Rankine efficiency (iv) condenser heat flow (v) dryness at the end of expansion. Assume flow rate of 9.5 kg/s.

**SOLUTION**

Pressure and condition of steam at inlet to the turbine  $p_1 = 35$  bar,  $x = 1$ ,

exhaust pressure  $p_2 = 0.2$  bar, flow rate  $m = 9.5$  kg/sec

From the steam tables, at 35 bar

$$h_1 = 2802 \text{ kJ/kg}, s_{g1} = 6.1228 \text{ kJ/kg K}$$

at 0.20 bar,

$$h_{f3} = h_f = 251.5 \text{ kJ/kg}, h_{g3} = 2358.4 \text{ kJ/kg}$$

$$v_f = 0.001017 \text{ m}^3/\text{kg}, s_f = 0.8321 \text{ kJ/kg K}$$

$$s_{fg3} = 7.0773 \text{ kJ/kg K}$$

(i) The pump work

$$\begin{aligned} &= (p_5 - p_3) v_f \\ &= [(35 - 0.2) \times 10^5 \times 0.001017] \times 10^{-3} \text{ kJ/kg} \\ &= 3.54 \text{ kJ/kg} \end{aligned}$$

$$\text{also } h_{f4} - h_{f3} = 3.54 \text{ kJ/kg}$$

$$\therefore h_{f4} = 3.54 + 251.5 = 255.04 \text{ kJ/kg}$$

Power required to drive the pump  $= 9.5 \times 3.54 = 33.63$  kW

(ii) Turbine work

$$s_1 = s_2 = s_{f2} + x_2 s_{fg2}$$

$$\therefore 6.1228 = 0.8321 + x_2 \times 7.0773$$

$$\therefore x_2 = \frac{6.1228 - 0.8321}{7.0773} = 0.747$$

$$\begin{aligned} \therefore h_2 &= h_{f2} + x_2 h_{fg2} \\ &= 251.5 + 0.747 \times 2358.4 = 2013 \text{ kJ/kg.} \end{aligned}$$

Turbine work  $= m(h_1 - h_2) = 9.5(2802 - 2013) = 7495.5$  kW

[Pump work is very small in comparison to turbine work]

(iii) Rankine efficiency

$$\eta_{\text{Rank}} = \frac{h_1 - h_2}{h_1 - h_{f2}} = \frac{2802 - 2013}{2802 - 251.5} = 0.3093$$

(iv) Condenser heat flow

$$\begin{aligned} &= m(h_2 - h_{f2}) \\ &= 9.5(2013 - 251.5) = 16734.25 \text{ kW} \end{aligned}$$

(v) The dryness at the end of expansion

$$x_2 = 0.747$$

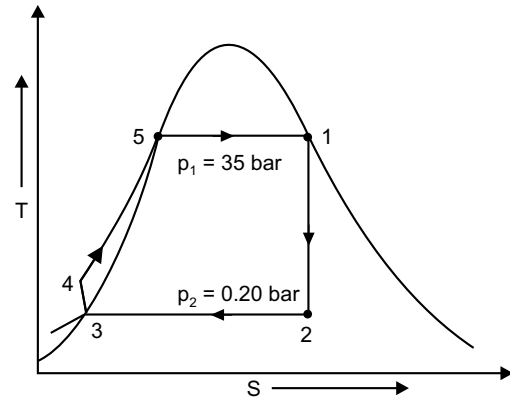

**EXAMPLE 3**

Determine the amount of heat which should be supplied to 2 kg of water at 25°C to convert it into steam at 5 bar and 0.9 dry. Consider specific heat of water = 4.18 kJ/kgK.

**SOLUTION**

Mass of water to be converted into steam  $m_w = 2$  kg, temperature of water  $t_w = 25^\circ\text{C}$ , pressure of steam 5 bar, dryness fraction = 0.9

From steam table, at 5 bar,

$$h_f = 640.1 \text{ kJ/kg}, h_{fg} = 2107.4 \text{ kJ/kg}$$

∴ Enthalpy of 1 kg of steam (above 0°C)

$$\begin{aligned} h &= h_f + xh_{fg} \\ &= 640.1 + 0.9 \times 2107.4 \\ &= 2536.76 \text{ kJ/kg} \end{aligned}$$

∴ Sensible heat associated with 1 kg of water

$$\begin{aligned} &= m_w \times C_{pw} (t_w - 0) \\ &= 1 \times 4.18 (25 - 0) = 104.5 \text{ kJ} \end{aligned}$$

∴ Net quantity of heat to be supplied per kg of water

$$= 2536.76 - 104.5 = 2432.26 \text{ kJ}$$

∴ Total heat to be supplied  $= 2 \times 2432.26 = 4864.52 \text{ kJ}$

**EXAMPLE 4**

What amount of heat would be required to produce 4.4 kg of steam at pressure of 6 bar and temperature of 250°C from water at 30°C. Take specific heat for superheated steam as 2.2 kJ/kgK.

**SOLUTION**

Here,  $m = 4.4$  kg,  $p = 6$  bar,  $t_{sup} = 250^\circ\text{C}$   
temperature of water  $= 30^\circ\text{C}$ ,  $C_{ps} = 2.2$  kJ/kgK.

From steam table at 6 bar,

$$t_s = 158.8^\circ\text{C}, h_f = 670.4 \text{ kJ/kg}, h_{fg} = 2085 \text{ kJ/kg}$$

Enthalpy of 1 kg superheated steam recorded from 0°C

$$\begin{aligned} h_{sup} &= h_f + h_{fg} + C_{ps} [t_{sup} - t_s] \\ &= 670.4 + 2085 + 2.2 (250 - 158.8) \\ &= 2956 \text{ kJ} \end{aligned}$$

Heat already with 1 kg of water

$$= 1 \times 4.18 (30 - 0) = 125.4 \text{ kJ}$$

Net amount of heat required to be supplied/kg

$$= 2956 - 125.4 = 2830.6 \text{ kJ/kg}$$

Total Heat required

$$= 4.4 \times 2830.6 = 12454.6 \text{ kJ}$$

**EXAMPLE 5**

If a certain amount of steam is produced at a pressure of 8 bar and dry = 0.8. Calculate (i) external work done during evaporation (ii) internal latent heat of steam.

**SOLUTION**

Here,  $p = 8$  bar and  $x = 0.8$

From steam tables at 8 bar

$$v_g = 0.240 \text{ m}^3/\text{kg} \quad h_{fg} = 2046.5 \text{ kJ/kg}$$

(i) External work during evaporation

$$\begin{aligned} &= p \cdot x \cdot v_g = 8 \times 10^5 \times 0.8 \times 0.24 \text{ N-m} \\ &= \frac{8 \times 10^5 \times 0.8 \times 0.24}{1000} \text{ kJ} = 153.6 \text{ kJ} \end{aligned}$$

(ii) Internal latent heat

$$\begin{aligned} &= x h_{fg} - \text{external work} \\ &= 0.8 \times 2046.5 - 153.6 = 1483.6 \text{ kJ} \end{aligned}$$

**EXAMPLE 6**

Find the specific volume enthalpy and internal energy of wet steam at 18 bar. Dryness fraction = 0.85

**SOLUTION**

Here,  $p = 18$  bar and  $x = 0.85$

From steam tables at  $p = 18$  bar

$$\begin{aligned} h_f &= 884.6 \text{ kJ/kg} & h_{fg} &= 1910.3 \text{ kJ/kg} \\ v_g &= 0.110 \text{ m}^3/\text{kg} & h_f &= 884.5 \text{ kJ/kg} \\ h_g &= 2794.8 \text{ kJ/kg} \end{aligned}$$

(i) Specific volume of wet steam

$$v = x v_g = 0.85 \times 0.110 = 0.0935 \text{ m}^3/\text{kg}$$

(ii) Specific enthalpy of wet steam

$$\begin{aligned} h &= h_f + x h_{fg} \\ &= 884.5 + 0.85 \times 1910.3 = 2508.25 \text{ kJ/kg} \end{aligned}$$

(iii) Specific internal energy of wet steam

$$\begin{aligned} w &= (1-x) h_f + x h_g = (1-0.85)884.5 + 0.85 \times 2794.8 \\ &= 2508.25 \text{ kJ/kg} \end{aligned}$$

**EXAMPLE 7**

10 kg of water at 45°C is heated at constant pressure of 10 bar until it becomes superheated vapour at 300°C. Find the change in volume, enthalpy, internal energy and entropy. Consider specific heats for superheated steam and water are 2.25 kJ/kgK and 4.187 kJ/kgK respectively.

**SOLUTION**

At  $p = 10 \text{ bar} = 1000 \text{ kPa}$   
 $t_s = 273 + 179.9 = 452.9 \text{ K}, t_{\text{sup}} = 300 + 273 = 573 \text{ K}$   
 $v_g = 0.194, C_{pw} = 4.187, C_{ps} = 2.25, h_{fg} = 2013.6 \text{ kJ/kg}, h_g = 2776.1 \text{ kJ/kg}$

Now, 
$$v_{\text{sup}} = \frac{v_g \times t_{\text{sup}}}{t_s} = \frac{0.194 \times 573}{452.9}$$

$$= 0.245 \text{ m}^3/\text{kg}$$

At  $45^\circ\text{C}$ ,  $v_f = 0.00101 \text{ m}^3/\text{kg}$

Change in volume

$$= m(v_{\text{sup}} - v_f)$$

$$= 10(0.245 - 0.00101) = 2.4399 \text{ m}^3 = 2.44 \text{ m}^3$$

Change in enthalpy

$$\therefore \Delta H = m[C_{pw}(t_s - t_1) + h_{fg} + C_{ps}(t_{\text{sup}} - t_s)]$$

$$= 10[4.187(179.9 - 45) + 2013.6 + 2.25(300 - 179.9)]$$

$$= 28486.5 \text{ kJ}$$

$$h_{\text{sup}} = h_g + C_{ps}(300 - t_s)$$

$$= 2776.1 + 2.25(300 - 179.9) = 3046.3 \text{ kJ/kg}$$

So, 
$$h_1 = h_{\text{sup}} - \frac{\Delta H}{m}$$

$$= 3046.3 - \frac{28486.5}{10} = 3046.3 - 2848.65$$

$$= 197.65 \text{ kJ/kg}$$

Change in internal energy

$$u_1 = h_1 - p_1 v_1 = 197.65 - 1000(0.00101) = 196.64 \text{ kJ/kg}$$

$$u_{\text{sup}} = h_{\text{sup}} - p_{\text{sup}} \times v_{\text{sup}}$$

$$= 3046.3 - 1000 \times 0.245 = 2801.3 \text{ kJ/kg}$$

$$\therefore \Delta U = m(u_{\text{sup}} - u_1) = 10(2801.3 - 196.64) = 26046.6 \text{ kJ}$$

Change in entropy

$$\Delta S = m \left[ C_{pw} \int_{273+45}^{273+176.9} \frac{dT}{T} + S_{fg} + C_{ps} \int_{273+179.9}^{273+300} \frac{dT}{T} \right]$$

$$= 10 \left[ 4.187 \ln \left( \frac{452.9}{318} \right) + 4.45 + 2.25 \ln \left( \frac{573}{452.9} \right) \right]$$

$$= 64.59 \text{ kJ/K}$$

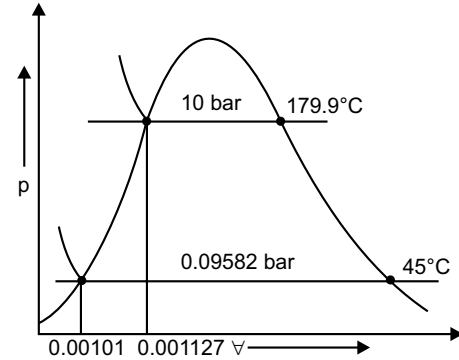

**EXERCISE**

1. Draw the Carnot vapour power cycle on  $p$ - $v$ ,  $T$ - $S$  and  $h$ - $S$  diagrams. Establish that its efficiency depends on temperature limits only.
2. Explain the working of a steam power plant with the help of Rankine cycle.
3. What are the limitations for which the Carnot cycle is not used in steam power plants?
4. Show Rankine cycle on  $p$ - $v$  and  $T$ - $S$  diagrams and explain the processes involved.
5. Draw the Rankine cycle on  $T$ - $S$  diagram using dry saturated steam and obtain an expression for the Rankine cycle efficiency.
6. Draw the schematic diagram of steam power plant.
7. Draw layout of a vapour compression refrigerating system and also show corresponding  $p$ - $v$  and  $h$ - $s$  diagrams. State functions of each components.

# BIBLIOGRAPHY

---

## THERMODYNAMICS

1. Arora, C.P., *Thermodynamics*, Tata Mc Graw-Hill Publishing Company Limited, New Delhi, 2001.
2. Ballaney, P.L., *Thermal Engineering*, Khanna Publishers, Delhi, 2003.
3. Khurmi, R.S. and Gupta, J.K., *A Text book of Thermal Engineering*, S. Chand & Company Ltd., 1996.
4. Rao, Y.V.C., *Engineering Thermodynamics*, University Press (India) Private Limited, Hyderabad, 2003.
5. Rajput, R.K., *Thermal Engineering* (6th ed.), Laxmi Publications Pvt. Ltd., New Delhi, 2006.

**This page  
intentionally left  
blank**

**Group-B**  
*Fluid Mechanics*

**This page  
intentionally left  
blank**

CHAPTER  
1

# INTRODUCTION AND FUNDAMENTAL CONCEPTS

## 1.1 DEFINITION OF FLUID

To speak very loosely, fluid is a state of matter which flows. From the view point of Fluid Mechanics, all matters are segregated into two states, one is solid and the other is fluid. Hence, both liquid and gas are termed as fluid. Fluid is so defined as *one which under continuously applied tangential stress, starts deforming continuously as long as shear stress is applied*. By nature, any fluid may be Real or Ideal, Newtonian or Non-Newtonian, Compressible or Incompressible. It is of special mention that no fluid is truly ideal, but is nearly ideal.

## 1.2 FLUID MECHANICS AND ITS PERVIEW

Fluid mechanics is that branch of mechanics, which studies behavioural aspects of fluids, either in motion or at rest, with subsequent effects of boundaries, which may be either solid or fluid. Fluid statics deals with fluid at rest. But fluid dynamics concerns about the fluid at motion.

From our day-to-day activities to highly specialised phenomenon may be included within the perview of fluid mechanics. From breathing to blood flow, floating of ships to swimming against current, motion of submarines to flight of Concord aircrafts, water distribution network to turbine action in hydel plant, design of missile to rotation of windmill are a few glimpses where fluid mechanics has direct involvement.

## 1.3 FLUID AS A CONTINUUM

Continuum is an idealisation of continuous description of matter and properties of matter considered as continuous function of space variables. In molecular concept there exists intermolecular space, but in continuum approach, actual conglomeration of separate molecules occur, leaving no empty space within the matter or system. Schematically it is shown in figure 1.1.

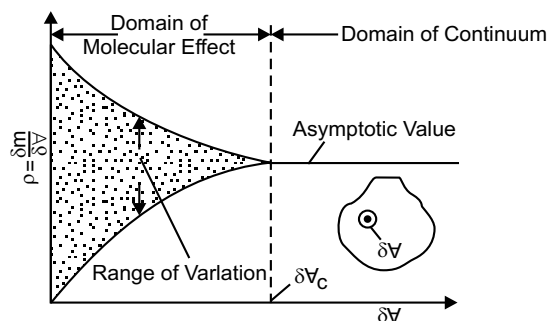

Fig 1.1

In liquids, the cohesive force amongst all molecules are strong enough, so that the entire mass of liquid can behave as a continuous mass of substance. So, liquids can be analysed through continuum approach. This is true for solid also.

But in case of gases, the story is somewhat different. Mean free path of a gas is an average distance of molecules between two successive collisions. If this mean free path of a gas is less than 1/100 th part of a characteristic length, that gas can be considered continuous and can be analysed through continuum approach. Deviation of any gas from this minimum value will cease it to form continuum.

## 1.4 PROPERTIES OF FLUID

There exist a few characteristics of a fluid in continuum, independent of motion of fluid. These characteristics are termed as basic properties of a fluid. Such a few properties are discussed hereinafter.

### 1.4.1 Density

The density of fluid is defined as mass per unit volume. It is symbolised by ‘ $\rho$ ’ (*rho*). The density at a point within fluid is expressed as

$$\rho = \lim_{\delta V \rightarrow 0} \frac{\delta m}{\delta V} = \frac{dm}{dV} \quad (1.1)$$

where  $\delta m$  and  $\delta V$  represent elemental mass and elemental volume, respectively. Otherwise it can be said as specific mass. Sometimes the term ‘mass density’ is also used. The dimensional expression of density is  $ML^{-3}$ .

### 1.4.2 Specific Weight

The specific weight is the weight of fluid per unit volume, and is symbolised by ‘ $\gamma$ ’ (*gamma*). It can be expressed as,

$$\gamma = \frac{dw}{dV} = \frac{dm \times g}{dV} = \left( \frac{dm}{dV} \right) \times g = \rho \times g \quad (1.2)$$

where ‘ $g$ ’ is the acceleration due to gravity. Dimensionally, specific weight is  $ML^{-2}T^{-2}$ . Weight density is another name of specific weight.

### 1.4.3 Specific Volume

The specific volume is the volume of the fluid per unit mass. It is the reciprocal of mass density. So,

$$v_s = \frac{dV}{dm} = \frac{1}{\rho} \quad (1.3)$$

Dimensionally specific volume is  $M^{-1}L^3$ .

### 1.4.4 Specific Gravity

The specific gravity of a liquid ( $S$ ) is the ratio of its density or specific weight to that of water under standard temperature and pressure, (standard pressure = 1atm. and standard temperature = 4°C). So,

$$S = \frac{\gamma_{\text{liq}}}{\gamma_{\text{water}/4^\circ\text{C}}} = \frac{\rho_{\text{liq}}}{\rho_{\text{water}/4^\circ\text{C}}} \quad (1.4)$$

Being a ratio, specific gravity has no unit and is a pure number.

### 1.4.5 Viscosity and Newton's Law of Viscosity

It is a property of the fluid, the effect of which is better understood when the fluid is in motion. In a fluid flow, while different fluid elements move with different velocities, each element will feel some resistance due to friction. Now it begins to move at a strain rate proportional to shearing stress. Referring to figure 1.2(a), showing shearing effect of two adjacent layers, displacement occurred in elemental time ' $\delta t$ ' is ' $\delta u \cdot \delta t$ ', subtending shearing strain ' $\delta\theta$ '. So,

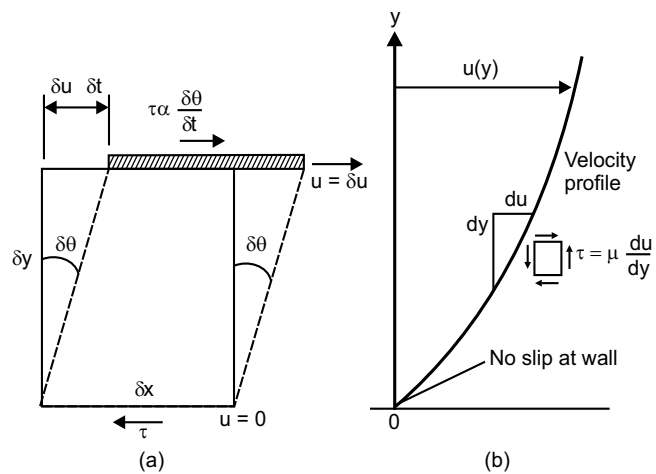

Fig. 1.2

$$\tau \propto \frac{\delta\theta}{\delta t} \quad (1.5a)$$

From geometry, we can say,  $\tan \delta\theta = \frac{\delta u \cdot \delta t}{\delta y}$

Considering ' $\delta\theta$ ' be very small and within limits,  $\tan d\theta \approx d\theta$

and 
$$d\theta = \frac{du \cdot dt}{dy}$$

Therefore 
$$\frac{d\theta}{dt} = \frac{du}{dy} \quad (1.5b)$$

Following equation (1.5a), within limits and introducing constant of proportionality, we obtain

$$\tau = \mu \frac{d\theta}{dt} = \mu \frac{du}{dy} \quad (1.5c)$$

In fluid mechanics our concentration focuses on velocity distribution [figure 1.2 (b)] and hence,

$$\tau = \mu \frac{du}{dy} \quad (1.5d)$$

This relationship is famous as *Newton's law of viscosity*, after *Sir Isaac Newton*, who proposed this law in 1687. This constant of proportionality ' $\mu$ ' (*mu*) is termed as *coefficient of viscosity* or *coefficient of dynamic* or *kinetic viscosity*. Dimensionally, it is expressed as  $ML^{-1}T^{-1}$ .

Another type of viscosity exists which is kinematic viscosity. Coefficient of kinematic viscosity is the ratio of kinetic viscosity and mass density. It is expressed as ' $\nu$ ' (*nu*).

$$\nu = \frac{\mu}{\rho} \quad (1.5e)$$

Dimensionally, kinematic viscosity is  $L^2T^{-1}$ .

Two factors are generally responsible for generation of viscosity:

1. *Intermolecular force of cohesion.*
2. *Exchange of molecular momentum.*

#### 1.4.5.1 Newtonian and Non-Newtonian Fluid

In this article, a term has an obvious appearance that is *Rheology*.

As per the strict definition, rheology is concerned with the description of the flow behaviour of all types of matter. By convention, however, the main interests of rheology are restricted to industrially relevant materials with properties intermediate between those of ideal solids and liquids. So, an useful engineering definition of rheology is the description of materials using '*constitutive equation*' between the stress history and strain history.

The fluid which obeys Newton's law of viscosity is called Newtonian Fluid, *e.g.*, air and water.

There are certain fluids, where the linear relationship between shear stress ( $\gamma$ ) and deformation rate  $\left(\frac{d\theta}{dt}\right)$  or velocity gradient  $\left(\frac{du}{dy}\right)$  does not exist. And these are specified as Non-Newtonian Fluid. It is also of various types, which is shown in this tree diagram.

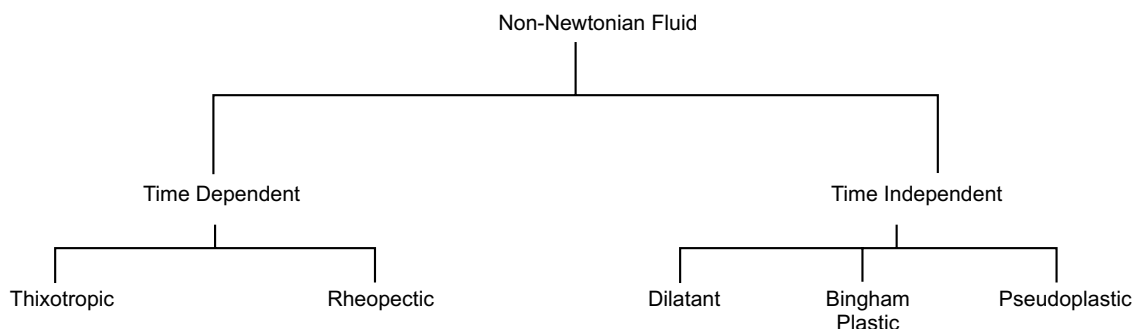

A generalised Power-law model can describe both Newtonian and Non-Newtonian fluid as following:

$$\tau = A \left( \frac{du}{dy} \right)^n + B \quad (1.6)$$

- (i) When  $n = 1$ ,  $B = 0$ , it is Newtonian fluid.
- (ii) When  $n > 1$ , the fluid is dilatant, i.e., quicksand, butter, printing ink.
- (iii) When  $n < 1$ , the fluid is pseudoplastic, i.e., gelatine, blood, milk, paper pulp, etc.
- (iv) When  $n = 1$ ,  $B \neq 0$ , the fluid is Bingham plastic, i.e., sewage sludge, drilling muds, etc.

Thixotropic fluid is a special type of Non-Newtonian fluid, which shows an increase in apparent viscosity with time. Lipstick and certain paints show thixotropic behaviour.

In reverse, the Non-Newtonian fluids showing decrease in apparent viscosity with time are Rheopectic fluid, e.g, bentonite solution, gypsum suspensions in water etc. Illustration of various type of fluids is shown in figure 1.3.

#### 1.4.5.2 Real Fluid and Ideal Fluid

All the fluid which we encounter in our day to day activities may have some viscosity. Some of them have the property of compressibility, i.e., under pressure the volume gets reduced. These are the real fluids.

In order to achieve simplifications

in various theories of fluid, sometimes it is assumed to be inviscid or non-viscous and incompressible. And any inviscid, incompressible fluid is an ideal fluid. But in reality, there exists no ideal fluid.

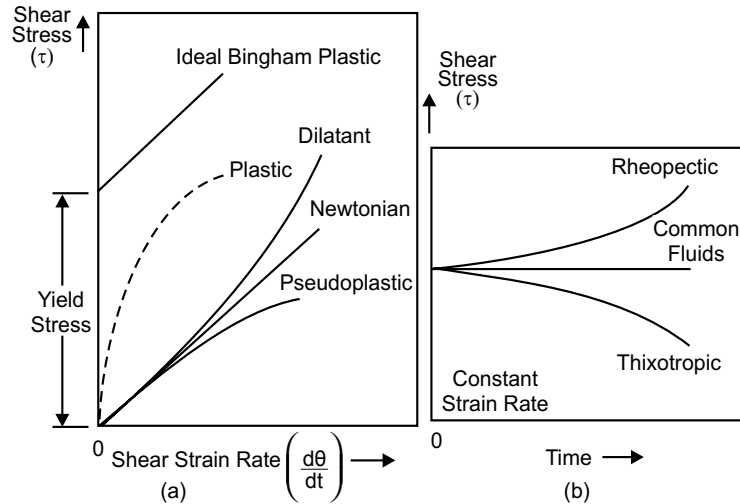

Fig. 1.3

#### 1.4.6 Bulk Modulus of Elasticity and Compressibility

Bulk modulus of elasticity ( $E$ ) is defined as the ratio of volumetric stress to volumetric strain. So,

$$E = \frac{Lt}{\delta V \rightarrow 0} \frac{-\delta p}{\left( \frac{\delta V}{V} \right)}$$

$$= - \frac{dp}{\left( \frac{dV}{V} \right)}$$

We can express mass of substance as

$$m = \rho \nabla$$

Taking differential of above equation, we obtain

$$dm = \rho d\nabla + \nabla d\rho$$

Mass being an invariant parameter,  $dm = 0$

$$\text{So, } \rho d\nabla + \nabla d\rho = 0$$

$$\text{Therefore, } -\frac{d\nabla}{\nabla} = \frac{d\rho}{\rho}$$

Substituting in the expression of bulk modulus of elasticity, we obtain

$$E = \frac{dp}{d\rho/\rho} = \rho \frac{dp}{d\rho} \quad (1.7)$$

The bulk modulus of elasticity is dimensionally expressed as  $ML^{-1}T^{-2}$  and that values for water and air at atmospheric pressure are approximately 2000 MPa and 0.101 MPa.

Compressibility ( $K$ ) or coefficient of compressibility is defined as reciprocal of bulk modulus of elasticity. So,

$$K = \frac{1}{E} = \frac{1}{\rho} \frac{d\rho}{dp} \quad (1.8)$$

The property of compressibility is usually referred in the context of gas. Dimensionally, it is  $M^{-1}LT^{-2}$ .

$$\text{For an isothermal process, } \frac{p}{\rho} = \text{Constant}$$

$$\therefore \frac{dp}{d\rho} = \text{Constant} = \frac{p}{\rho}$$

$$\therefore \text{Bulk modulus}(E) = \rho \cdot \frac{dp}{d\rho} = p \quad (1.8a)$$

$$\text{For an isentropic process, } \frac{p}{\rho^\gamma} = \text{Constant} = C$$

$$\therefore dp = C \cdot \gamma \cdot \rho^{\gamma-1} \cdot d\rho$$

$$\Rightarrow \frac{dp}{d\rho} = C \cdot \gamma \cdot \rho^{\gamma-1}$$

$$= \left( \frac{p}{\rho^\gamma} \right) \cdot \gamma \cdot \rho^{\gamma-1} = \gamma \left( \frac{p}{\rho} \right)$$

$$\therefore \text{Bulk modulus}(E) = \rho \cdot \frac{dp}{d\rho} = \gamma \cdot p \quad (1.8b)$$

*Mach Number* ( $Ma$ ) is a very useful dimensionless parameter for the analysis of flow, especially compressible. It is the ratio of velocity of fluid flow to the velocity of sound in the flowing medium at that condition. So,

$$Ma = \frac{V}{a} \tag{1.9}$$

The Mach Number is named after Ernst Mach (1838–1916), an Austrian physicist. The value of Mach number 0.30 is a very significant one, below which a flow normally is considered to be incompressible. Variety of fluid flow according to Mach Number are:

- 0.3 <  $Ma$  < 0.8 : Subsonic Flow
- 0.8 <  $Ma$  < 1.0 : Subsonic-Transonic Flow
- 1.0 <  $Ma$  < 1.2 : Supersonic-Transonic Flow
- 1.2 <  $Ma$  < 3.0 : Supersonic Flow
- 3.0 <  $Ma$  : Hypersonic Flow

### 1.4.7 Surface Tension of Liquid

Referring to figure 1.4 (a), the molecule ‘ $p$ ’ with diameter ‘ $2a$ ’ experiences equal attraction from surrounding molecules at all direction. But the molecule ‘ $q$ ’ on the surface experiences a resultant inward pull due to unbalanced cohesive force of the molecules. The horizontal components of cohesive force of the molecules keep a fluid particle on the surface under tension and this tensile force acting normal to a unit length on the surface is called surface tension  $\sigma$  (*sigma*).

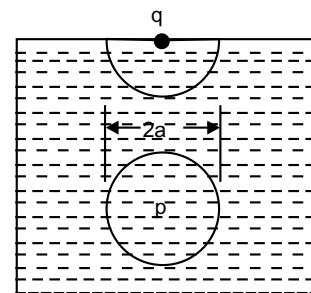

Fig. 1.4(a)

Figures 1.4 (b) and (c) show a small differential membrane area of the interface with radii of curvature of  $R_1$  and  $R_2$ , If the pressure difference be  $\Delta p$ , then from equilibrium in vertical direction gives,

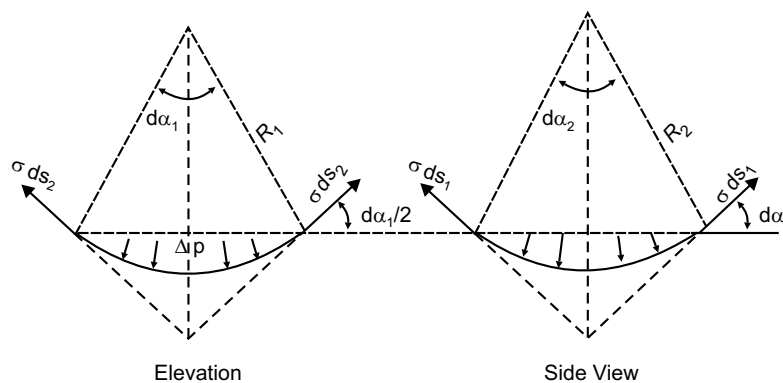

Fig. 1.4(b)

$$\Delta p \cdot ds_1 \cdot ds_2 = 2(\sigma \cdot ds_2) \sin \frac{d\alpha_1}{2} + 2(\sigma \cdot ds_1) \sin \frac{d\alpha_2}{2}$$

$$\begin{aligned}
 &= \sigma \cdot (ds_2 \cdot d\alpha_1 + ds_1 \cdot d\alpha_2) \\
 &= \sigma \cdot \left( ds_2 \cdot \frac{ds_1}{R_1} + ds_1 \cdot \frac{ds_2}{R_2} \right) \\
 &= (ds_1 \cdot ds_2) \cdot \sigma \cdot \left( \frac{1}{R_1} + \frac{1}{R_2} \right) \\
 \Rightarrow \quad &\Delta p = \sigma \cdot \left( \frac{1}{R_1} + \frac{1}{R_2} \right) \\
 \Rightarrow \quad &\sigma = \frac{\Delta p}{\left( \frac{1}{R_1} + \frac{1}{R_2} \right)} \quad (1.10)
 \end{aligned}$$

The dimensional formula for surface tension is  $MT^{-2}$ , as ' $\sigma$ ' is considered as force per unit length.

#### 1.4.8 Capillarity

It is a phenomenon by virtue of which it is understood that if a liquid either rises or falls in a tube dipped into the liquid. This rise or fall depends upon whether force of adhesion is more than that of cohesion or not. In the adjoining figure, considering vertical equilibrium, we have capillary rise or depression ' $h$ ' as

$$\begin{aligned}
 \frac{\pi d^2}{4} h \rho g &= \sigma \pi D \cos \theta \\
 \Rightarrow \quad h &= \frac{4\sigma \cos \theta}{\rho g D} \quad (1.11)
 \end{aligned}$$

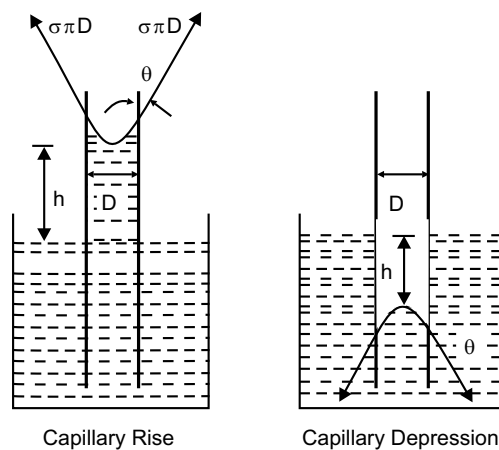

Fig. 1.5

For pure water in air in clean glass tube,  $\theta = 0^\circ$  and in case of mercury it is capillary depression and  $\theta =$  nearly  $130^\circ$  (Fig. 1.5).

### Parameters Dimensions and Unit

Parameter	Dimension	Units		
		C.G.S	S.I.	Commonly Used
Density	$ML^{-3}$	gm/cc	$kg/m^3$	$kg/m^3$
Specific Weight	$ML^{-2}T^{-2}$	dyne/cc	$N/m^3$	$N/m^3$
Specific Volume	$M^{-1}L^3$	cc/gm	$m^3/kg$	$m^3/kg$
Specific Gravity	PURE NUMBER			
Dynamic Viscosity or Kinetic Viscosity	$ML^{-1}T^{-1}$	dyne.s /cm <sup>2</sup> = poise	$Ns/m^2$ = Pas	poise or centipoise
Kinematic Viscosity	$L^2T^{-1}$	cm <sup>2</sup> /s = stoke	$m^2/s$	stoke or centistoke
Bulk Modulus	$ML^{-1}T^{-2}$	dyne/cm <sup>2</sup>	$N/m^2$ = Pascal (Pa)	1MPa = $10^6 N/m^2$ = $1 N/mm^2$
Compressibility	$M^{-1}LT^2$	cm <sup>2</sup> /dyne	$m^2/N$	
Surface Tension	$MT^{-2}$	dyne/cm	$N/m$	$N/m$

### Multiple Choice Questions

- An ideal fluid is
  - very viscous
  - one which obeys Newton's law of viscosity
  - frictionless and incompressible
  - none of these.
- A fluid is a substance that
  - always expands until it fills any containers
  - is practically incompressible
  - cannot withstand any shear force
  - cannot remain at rest under the action of any shear force
  - obeys Newton's law of viscosity
  - none of the above.
- Shear stress in a fluid flowing between two parallel plates
  - is constant over the c/s
  - is zero at the plate and increase linearly to the midpoint
  - varies parabolically across the section
  - is zero at the midpoint and varies linearly with the distance from the midpoint.

4. The property of fluid by virtue of which it offers resistance to shear is called
  - (a) surface tension
  - (b) adhesion
  - (c) cohesion
  - (d) viscosity
  - (e) all of the above.
5. Newton's law of viscosity states that shear stress is directly proportional to
  - (a) velocity
  - (b) velocity gradient
  - (c) shear strain
  - (d) viscosity
6. Newton's law of viscosity relates
  - (a) pressure, velocity and viscosity
  - (b) shear stress and rate of angular deformation in a fluid
  - (c) shear stress, temperature, viscosity and velocity
  - (d) pressure, viscosity and rate of angular deformation
  - (e) none of the above.
7. Stoke is the unit of
  - (a) surface tension
  - (b) viscosity
  - (c) kinematic viscosity
  - (d) none of the above
8. Poise is the unit of
  - (a) mass density
  - (b) kinematic viscosity
  - (c) velocity gradient
  - (d) dynamic viscosity
9. Specific volume has the dimension of
  - (a)  $M^{-1}L^3$
  - (b)  $ML^{-3}$
  - (c)  $MLT^{-1}$
  - (d)  $M^{-1}L^{-1}T$ .
10. The S.I. unit of specific gravity is
  - (a)  $N/m^3$
  - (b) Pascal
  - (c) dyne
  - (d) none of the above.
11. The ratio of velocity of fluid and that of air is defined by
  - (a) Froude's Number
  - (b) Nusselt's Number
  - (c) Mach Number
  - (d) Chezy's coefficient.
12. Compressibility of a fluid is the reciprocal of
  - (a) acceleration due to gravity
  - (b) modulus of rigidity
  - (c) bulk modulus of elasticity
  - (d) Poisson's Ratio.
13. A liquid has a viscosity of 0.005 Pas and a density of  $850 \text{ kg/m}^3$ . The kinematic viscosity may be obtained correctly as
  - (a)  $5.882 \mu\text{m}^2/\text{s}$
  - (b)  $0.0652 \times 10^{-4} \text{ m}^2/\text{s}$
  - (c) 5.895 stoke
  - (d)  $0.00582 \text{ kg/m}^3$

14. The atmospheric pressure measured as 760 mm of mercury column is equal to  
 (a) 1.033 m of water column  
 (b) 0.1033 N/mm<sup>2</sup>  
 (c) 10.33 N/mm<sup>2</sup>  
 (d) 10.33 m of water column  
 (e) none of the above
15. Surface tension has the dimension  
 (a)  $F$   
 (b)  $FL^{-1}$   
 (c)  $FL^{-2}$   
 (d)  $FL^{-3}$
16. Capillarity is due to  
 (a) adhesion  
 (b) cohesion  
 (c) adhesion and cohesion  
 (d) neither adhesion nor cohesion.
17. A perfect gas  
 (a) has zero viscosity  
 (b) has constant viscosity  
 (c) is incompressible  
 (d) satisfies  $p = \rho RT$
18. The bulk modulus of elasticity  
 (a) is independent of pressure and viscosity  
 (b) increases with the pressure  
 (c) has the dimensions of  $\left(\frac{1}{\rho}\right)$   
 (d) is larger when the fluid is more compressible.
19. An ideal fluid is the one which is  
 (a) non-viscous and incompressible  
 (b) compressible and has low density  
 (c) elastic and viscous  
 (d) steady and incompressible
20. Which fluid does not experience shear stress during flow?  
 (a) pseudoplastic  
 (b) dilatant  
 (c) inviscid  
 (d) Newtonian

### Answers

1. (c) 2. (d) 3. (b) 4. (d) 5. (b) 6. (b) 7. (c) 8. (d) 9. (a) 10. (d)  
 11. (c) 12. (c) 13. (a) 14. (d) 15. (b) 16. (c) 17. (d) 18. (b) 19. (a) 20. (c)

### Fill in the blanks

- The rise of sap in a tree is a phenomenon of \_\_\_\_\_.
- The spherical shape of rainwater drop is a phenomenon of \_\_\_\_\_.
- Cavitation is a phenomenon due to \_\_\_\_\_.

4. The flow of an oil jet without break up is due to \_\_\_\_\_.
5. Cohesion acts between molecules of \_\_\_\_\_.
6. If Mach Number is less than 0.3, the fluid is \_\_\_\_\_.
7. Mass \_\_\_\_\_ and density are the same parameter.
8. Pascal is the S.I. unit of \_\_\_\_\_.
9. An ideal fluid is \_\_\_\_\_ and \_\_\_\_\_.
10. Printers ink is a \_\_\_\_\_ Newtonian fluid.
11. In Newton's law of viscosity the flow must be \_\_\_\_\_.
12. The velocity distribution of fluid following Newton's law of viscosity may be linear or \_\_\_\_\_.
13. Capillary angle in pure water in air in a clear glass tube is \_\_\_\_\_.
14. Capillary rise of mercury in glass tube is \_\_\_\_\_ upward.

### Answers

1. capillarity 2. surface tension 3. vapour pressure 4. viscosity 5. same fluid 6. incompressible 7. density  
8. stress 9. inviscid incompressible 10. non 11. laminar 12. non-linear 13. zero degree 14. convex

### NUMERICAL EXAMPLES

#### EXAMPLE 1

A circular disc of diameter ' $d$ ' is slowly rotated in a liquid of large viscosity ' $\mu$ ' at a small distance ' $h$ ' from a fixed surface. Derive an expression for torque ' $T$ ' necessary to maintain an angular velocity ' $\omega$ '.

#### SOLUTION

Let us consider an annular element of width ' $dr$ ' at a distance ' $r$ ' from centre line.

$$\text{From Newton's law, shear stress } \tau = \mu \frac{du}{dy} \quad (a)$$

$$\therefore \text{Shear force } dF_s = \tau \times \text{Area} = \mu \frac{du}{dy} (2\pi r \cdot dr) \quad (b)$$

$$\therefore \text{Torque produced } dT = dF_s \times r = \mu \frac{du}{dy} \cdot (2\pi r^2 \cdot dr) \quad (c)$$

As ' $h$ ' is very small, velocity distribution may be considered linear.

$$\therefore \frac{du}{dy} = \frac{r\omega}{h}$$

$$\text{So, } dT = \mu \left( \frac{r\omega}{h} \right) \cdot 2\pi r^2 dr$$

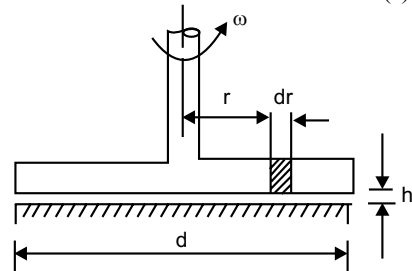

$$= \frac{2\pi\mu\omega}{h} \cdot r^3 dr$$

$$\therefore \text{Total torque } T = \int_0^{d/2} dT = \frac{2\pi\mu\omega}{h} \int_0^{d/2} r^3 dr = \frac{\pi\mu\omega d^4}{32h} \quad (d)$$

**EXAMPLE 2**

A fluid has an absolute viscosity of 0.048 Pas and a specific gravity of 0.913. Such fluid flow over flat solid surface, the velocity at a point 75 mm away from the surface is 1.125 m/s. Calculate shear stresses at solid boundary, at points 25 mm, 50 mm and 75 mm away from boundary surface. Assume (i) linear and (ii) parabolic velocity distribution with the vertex at the point 75 mm away from the surface where the velocity is 1.125 m/s.

**SOLUTION**

(i) For linear distribution,  $v = 1.125$  m/s at  $y = 75$  mm = 0.075 m

$$\text{So, } \frac{dv}{dy} = \frac{1.125}{0.075} = 15$$

$$\therefore \text{Shear stress } \tau = \mu \frac{dv}{dy} = 0.048 \times 15 = 0.75 \text{ N/m}^2$$

As, the velocity distribution is linear,  $\frac{dv}{dy} = \text{constant}$  and so shear stress has the uniform value.

(ii) Let the equation of parabolic distribution:  $v = A + By + Cy^2$

$$\text{at } y = 0, v = 0 \quad \Rightarrow A = 0$$

$$\text{at } y = 0.075 \text{ m, } v = 1.125 \text{ m/s} \quad \Rightarrow 0.075B + (0.075)^2C = 1.125 \quad (a)$$

$$\text{and } \frac{dv}{dy} = 0 \quad \Rightarrow B + 0.15C = 0 \quad (b)$$

$$\text{Solving (a) and (b), } B = 30, C = -200$$

$$\text{Therefore, } v = 30y - 200y^2$$

$$\therefore \frac{dv}{dy} = 30 - 400y$$

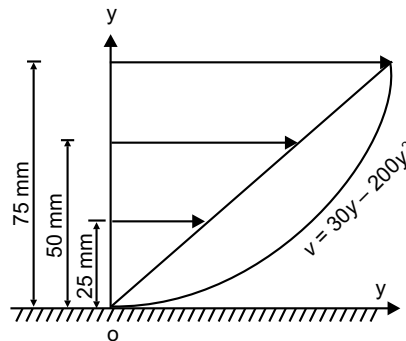

Hence at	$y=0,$	$\frac{dv}{dy} = 30,$	$v=0$	$\Rightarrow \tau = 1.44 \text{ N/m}^2$
	$y=0.025,$	$\frac{dv}{dy} = 20,$	$v=0.625$	$\Rightarrow \tau = 0.96 \text{ N/m}^2$
	$y=0.050,$	$\frac{dv}{dy} = 10,$	$v=0.880$	$\Rightarrow \tau = 0.48 \text{ N/m}^2$
	$y=0.050,$	$\frac{dv}{dy} = 0,$	$v=1.125$	$\Rightarrow \tau = 0.$

**EXAMPLE 3**

A cylinder of 0.12 radius rotates concentrically inside a fixed cylinder of 0.13 m radius. Both the cylinders are 0.3 m long. Determine the viscosity of the liquid which fills the space between the cylinders if a torque of 0.88 Nm is required to maintain angular velocity of  $2\pi$  rad/s.

**SOLUTION**

Torque = Shear stress  $\times$  Surface area  $\times$  Lever arm

$$\Rightarrow 0.88 = \tau \times (2\pi r \times 0.3) \times r \quad (\text{a})$$

$$\Rightarrow \tau = \frac{0.467}{r^2}$$

Now 
$$\frac{dv}{dr} = \frac{\tau}{\mu} = \frac{0.467}{\mu r^2}$$

$$\Rightarrow dv = \frac{0.467 dr}{\mu r^2} \quad (\text{b})$$

Integrating (b), 
$$\int_{v_{\text{out}}}^{v_{\text{in}}} dv = \frac{0.467}{\mu} \int_{0.13}^{0.12} \frac{dr}{r^2}$$

$$\Rightarrow V_{\text{in}} - V_{\text{out}} = \frac{0.467}{\mu} \left( \frac{1}{0.12} - \frac{1}{0.13} \right)$$

$$\Rightarrow \omega \times 0.12 - 0 = \frac{0.2993}{\mu}$$

$$\Rightarrow 2\pi \times 0.12 = \frac{0.2993}{\mu}$$

$$\Rightarrow \mu = 0.3970 \text{ Pas}$$

Hence, absolute value is 0.3970 Pas

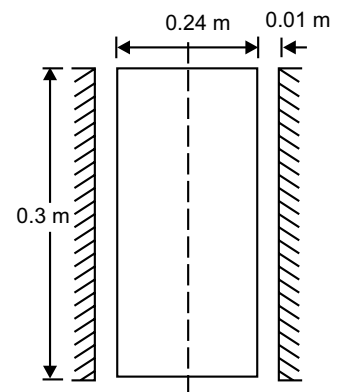

**EXAMPLE 4**

The velocity profile is a laminar flow through a round pipe is expressed as  $u = 2U \left(1 - \frac{r^2}{r_0^2}\right)$ , where

$U$  = average velocity,  $r_0$  = radius of pipe. Draw dimensionless shear stress profile  $\left(\frac{\tau}{\tau_0}\right)$  against  $\left(\frac{r}{r_0}\right)$  where  $\tau_0$  is wall shear stress. Find  $\tau_0$ , when oil flows with absolute viscosity  $4 \times 10^{-2}$  Ns/m<sup>2</sup> and velocity of 4 m/s in a pipe of diameter 150 mm.

**SOLUTION**

Given:  $u = 2U \left(1 - \frac{r^2}{r_0^2}\right)$

$$\therefore \frac{du}{dr} = -\frac{4Ur}{r_0^2}$$

$$\therefore \tau = \mu \frac{du}{dr} = -\frac{4\mu Ur}{r_0^2}$$

and  $\tau_0 = \mu \left. \frac{du}{dr} \right|_{r=0} = -\frac{4\mu U}{r_0}$

So,  $\frac{\tau}{\tau_0} = \frac{r}{r_0}$  and the plot is shown.

From (c),  $\tau_0 = -\frac{4 \times 4 \times 10^{-2} \times 4}{0.075} = 8.534 \text{ N/m}^2$  (in absolute value)

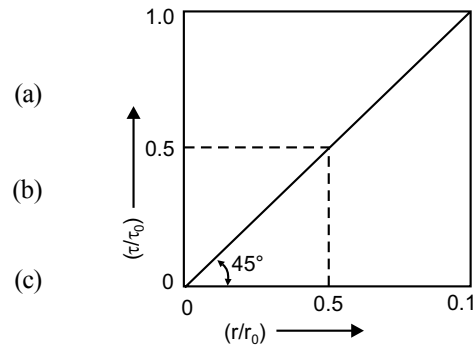
**EXAMPLE 5**

Neglecting temperature effect, the empirical pressure-density relation for water is

$\left(\frac{p}{p_a}\right) = 3001 \times \left(\frac{\rho}{\rho_a}\right)^7 - 3000$ . Determine isothermal bulk modulus of elasticity and compressibility of water at 1, 10 and 100 atmospheric pressure.

**SOLUTION**

The relation given,  $\left(\frac{p}{p_a}\right) = 3001 \times \left(\frac{\rho}{\rho_a}\right)^7 - 3000$ . (a)

Differentiating with respect to  $\rho$ ,

$$\frac{1}{p_a} \cdot \frac{dp}{d\rho} = 7 \times 3001 \times \frac{\rho^6}{\rho_a^7}$$

$$\Rightarrow \frac{dp}{d\rho} = 7 \times 3001 \times p_a \times \frac{\rho^6}{\rho_a^7}$$

$$\Rightarrow \quad \rho \frac{dp}{d\rho} = 7 \times 3001 \times p_a \times \left( \frac{\rho}{\rho_a} \right)^7 \quad (b)$$

From equation (1.7),

$$\begin{aligned} E &= \rho \frac{dp}{d\rho} \\ &= 7 \times 3001 \times p_a \times \left( \frac{\rho}{\rho_a} \right)^7 \\ &= 7 \times 3001 \times p_a \times \left( \frac{p}{p_a} + 3000 \right) \times \frac{1}{3001} \end{aligned}$$

[Substituting from(a)]

$$= 7 \times p_a \times \left( \frac{p}{p_a} + 3000 \right) \quad (c)$$

From equation (c)

$$\begin{aligned} \text{So, at } p &= 1p_a, & E_1 &= 21007 p_a \\ p &= 10p_a, & E_{10} &= 21070 p_a \\ p &= 100p_a, & E_{100} &= 21700 p_a \end{aligned}$$

If  $p_a = 1.0132 \times 10^5 \text{ N/m}^2$ ,

$$\begin{aligned} E_1 &= 2.1284 \times 10^9 \text{ N/m}^2, K_1 = 0.4698 \times 10^{-9} \text{ m}^2/\text{N} \\ E_{10} &= 2.1348 \times 10^9 \text{ N/m}^2, K_{10} = 0.4684 \times 10^{-9} \text{ m}^2/\text{N} \\ E_{100} &= 2.1986 \times 10^9 \text{ N/m}^2, K_{100} = 0.4548 \times 10^{-9} \text{ m}^2/\text{N} \end{aligned}$$

### EXAMPLE 6

A cylinder  $0.35 \text{ m}^3$  of air at  $50^\circ\text{C}$  and  $276 \text{ kN/m}^2$  absolute. The air is compressed to  $0.071 \text{ m}^3$ .

(i) Assuming isothermal condition, what is the pressure at new volume and bulk modulus of elasticity at new state? (ii) Assuming isentropic condition, what is the pressure and bulk modulus of elasticity for  $\gamma = 1.4$ .

**SOLUTION**

(i) For isothermal condition

$$\begin{aligned} p_1 \nabla_1 &= p_2 \nabla_2 \\ \Rightarrow 0.35 \times (276 \times 10^3) &= 0.071 \times p_2 \\ \Rightarrow p_2 &= 1360 \times 10^3 \text{ N/m}^2 = 1.36 \text{ MPa} \end{aligned}$$

$\therefore$  Isothermal bulk modulus  $= p_2 = 1.36 \text{ MPa}$

(ii) For isentropic condition,

$$\begin{aligned} p_1 \nabla_1^{1.4} &= p_2 \nabla_2^{1.4} \\ \Rightarrow (0.35)^{1.4} \times (276 \times 10^3) &= (0.071)^{1.4} \times p_2 \\ \Rightarrow p_2 &= 2.575 \text{ MPa} \end{aligned}$$

$\therefore$  Isentropic bulk modulus  $= \gamma p_2 = 1.4 \times 2.575 = 3.605 \text{ MPa}$

**EXAMPLE 7**

The mean free path of a gas is  $\lambda = 1.26 \frac{\mu}{\rho} (RT)^{-1/2}$ . Find out air density when mean free path is

10 mm, temperature 20°C,  $\mu = 1.8 \times 10^{-5}$  kg/ms,  $R = 287$  J/kg K.

**SOLUTION**

Here,  $\lambda = 10 \text{ mm} = 0.01 \text{ m}$ ,  $\mu = 1.8 \times 10^{-5} \text{ kg/ms}$   
 $T = 20^\circ\text{C} = 293 \text{ K}$ ,  $R = 287 \text{ J/kg K}$

From the given relation:  $\lambda = 1.26 \frac{\mu}{\rho} (RT)^{-1/2}$

$$\begin{aligned} \Rightarrow \rho &= 1.26 \frac{\mu}{\lambda} (RT)^{-1/2} \\ &= 1.26 \times \frac{1.8 \times 10^{-5}}{0.01} (287 \times 293)^{-1/2} \\ &= 7.82 \times 10^{-6} \text{ kg/m}^3. \end{aligned}$$

**EXAMPLE 8**

A shaft 80 mm in diameter is being pushed through a bearing sleeve of 80.2 mm diameter and 0.3 m long. Assumed uniform clearance is flooded with lubricating oil of viscosity 0.1 kg/ms and specific gravity 0.9. (i) If the shaft moves axially at 0.8 m/s, calculate resistance force exerted by oil on the shaft. (ii) If shaft is axially fixed and rotated at 1800 r.p.m., estimate resisting torque exerted by oil and power required.

**SOLUTION**

(i) Given,

$$\mu = 0.1 \text{ kg/ms}, l = 0.3 \text{ m}, y = \frac{0.2 \text{ mm}}{2} = 0.0001 \text{ m},$$

$$v = 0.8 \text{ m/s}, d = 80 \text{ mm} = 0.08 \text{ m}$$

$\therefore$  Resisting force =  $\tau \times \pi dl$

$$= \left( \mu \times \frac{v}{y} \times \pi dl \right)$$

$$= \left( 0.1 \times \frac{0.8}{0.0001} \times \pi \times 0.08 \times 0.3 \right) \text{ N}$$

$$= 60.32 \text{ N}$$

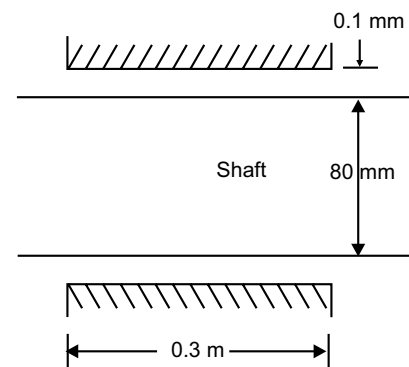

(ii) Given,

$$\mu = 0.1 \text{ kg/ms}, l = 0.3 \text{ m}, y = 0.0001 \text{ m}, d = 0.08 \text{ m}, N = 1800 \text{ rpm}$$

$$v = \frac{\pi d N}{60} = 7.539 \text{ m/s}$$

$$\begin{aligned}
 \therefore \text{Resisting force} &= \left( \mu \times \frac{v}{y} \right) \times \pi dl \\
 &= \left( 0.1 \times \frac{7.539}{0.0001} \times \pi \times 0.08 \times 0.3 \right) \text{N} \\
 &= 568.4272 \text{ N} \\
 \therefore \text{Resisting torque} &= (568.4272 \times 0.04) \text{ Nm} \\
 &= 22.737 \text{ Nm} \\
 \therefore \text{Power transmitted} &= \left( 22.737 \times \frac{2\pi \times 1800}{60} \times \frac{1}{1000} \right) \text{ kW} \\
 &= 4.285 \text{ kW}
 \end{aligned}$$

**EXAMPLE 9**

A body weighing 1000 N slides down at a uniform speed of 1 m/s along a lubricated inclined plane making  $30^\circ$  with the horizontal. The viscosity of lubricant is 0.1 kg/ms and contact area of the body is  $0.25 \text{ m}^2$ . Determine the lubricant thickness assuming linear velocity distribution.

**SOLUTION**

Let the thickness of oil =  $h$  m

$$\therefore \text{Velocity gradient } \left( \frac{du}{dy} \right) = \frac{1}{h} \text{ per sec}$$

$$\therefore \text{Shearing viscous force acting } (F)$$

$$= \mu \cdot \frac{du}{dy} \cdot A$$

$$= 0.1 \times \frac{1}{h} \times 0.25 = \frac{0.025}{h} \text{ kgm/s}^2 = \frac{0.025}{h} \text{ N}$$

Horizontal component of the body =  $1000 \sin 30^\circ = 500 \text{ N}$

$$\therefore \text{From condition of equilibrium, } \frac{0.025}{h} = 500 \text{ mm}$$

$$\Rightarrow h = 5 \times 10^{-5} \text{ m} = 0.05 \text{ mm}$$

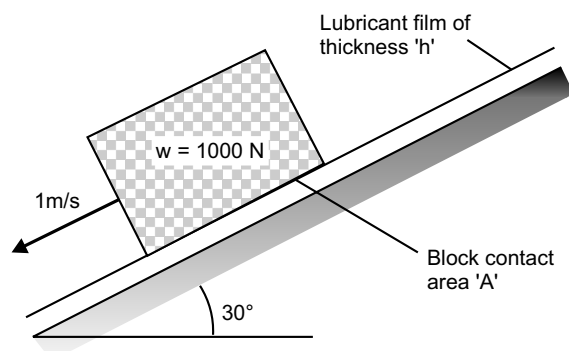
**EXAMPLE 10**

A uniform film of oil 0.13 mm thick separates two discs, each of 200 mm diameter, mounted co-axially. Ignoring the edge effects, calculate the torque necessary to rotate one disc relative to other at a speed of 7 r.p.m., if the oil has a viscosity of 0.14 Pas.

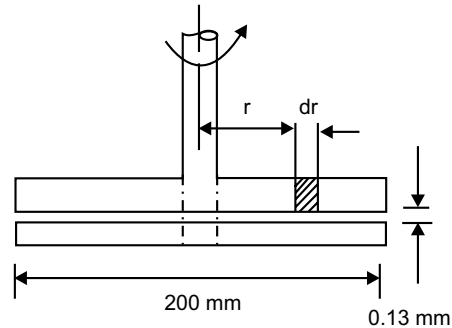
**SOLUTION**

Let us consider an annular element of width ' $dr$ ', at a distance  $r$  from centreline.

Here, 
$$\mu \frac{du}{dy} = \frac{2\pi r N}{dy} \mu = \frac{2\pi r \times 7}{0.13 \times 10^{-3}} \times 0.14 = 47365.55 r$$

$\therefore$  Force acting on this element  $(dF) = 47365.55 \times 2\pi r dr$

$\therefore$  Torque acting on this element  $(dT) = dF \times r = 297606.53 r^3 dr$

$\therefore$  Total torque  $(T) = \int dT = \int_0^{0.1} 297606.53 r^3 dr = 7.44 \text{ Nm.}$

**EXAMPLE 11**

A piston 79.6 mm diameter and 210 mm long works in a cylinder of 80 mm diameter. If the annular space is filled with a lubricating oil of viscosity 0.065 kg/ms, calculate the speed at which the piston will move through the cylinder, when an axial load of 85.6 N is applied. Neglect inertia of the piston.

**SOLUTION**

Effective area subjected to shear  $(A) = (\pi \times 0.0796 \times 0.21) \text{ m}^2$

Let the speed of rotation =  $v$  m/s

$\therefore$  Viscous force acting on the piston  $(F)$

$$= 0.065 \times \frac{v}{\left(\frac{80 - 79.6}{2}\right) \times 10^{-3}} \times (\pi \times 0.0796 \times 0.21) \text{ N}$$

$$= (17.0673 \times v) \text{ N}$$

As per given condition:

$$17.0673 \times v = 85.6$$

$$\Rightarrow v = 5.01 \text{ m/s.}$$

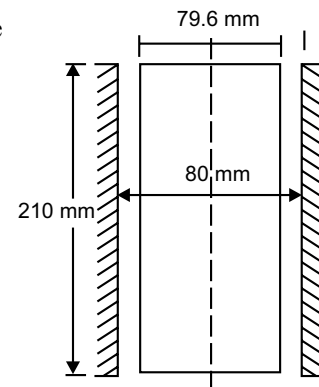

**EXAMPLE 12**

Two large plane surfaces are 3 cm apart. A very thin plate of negligible thickness with surface area  $0.5 \text{ m}^2$  is placed between the surfaces while above the plate is filled up with glycerine and below the plate is filled up with lubricating oil. Find out the force required to drag the plate at a velocity of  $0.45 \text{ m/s}$  when (i) it lies exactly at middle of two surfaces (ii) it is 2 cm away from bottom surface,  $\mu_g = 0.81 \text{ Pas}$ ,  $\mu_o = 0.245 \text{ Pas}$ .

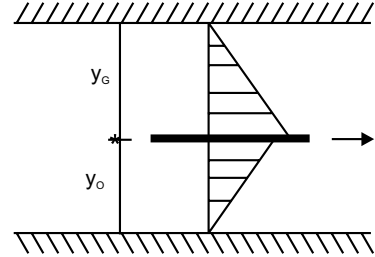
**SOLUTION**

Effective area subjected to shear ( $A$ ) =  $0.5 \text{ m}^2$

Velocity of drag ( $V$ ) =  $0.45 \text{ m/s}$

Total Drag force = Drag force due to glycerine + Drag force due to oil

$$\Rightarrow F = F_G + F_o$$

$$(i) \quad \text{Here } y_G = y_o = 3 \text{ cm}/2 = 1.5 \text{ cm}$$

$$\therefore F_G = \mu_G \times \frac{V}{y_G} \times A = \left( 0.81 \times \frac{0.45}{1.5 \times 10^{-2}} \times 0.5 \right) \text{ N}$$

$$= 12.15 \text{ N}$$

$$\text{and } F_o = \mu_o \times \frac{V}{y_o} \times A = \left( 0.245 \times \frac{0.45}{1.5 \times 10^{-2}} \times 0.5 \right) \text{ N}$$

$$= 3.675 \text{ N}$$

$$\therefore \text{Total Force (F)} = (12.15 + 3.675) \text{ N} = 15.825 \text{ N}$$

$$(i) \quad \text{Here } y_o = 2 \text{ cm}, y_G = 3 - 2 = 1 \text{ cm}$$

$$\therefore F_G = \mu_G \times \frac{V}{y_G} \times A = \left( 0.81 \times \frac{0.45}{1 \times 10^{-2}} \times 0.5 \right) \text{ N} = 18.225 \text{ N}$$

$$F_o = \mu_o \times \frac{V}{y_o} \times A = \left( 0.245 \times \frac{0.45}{2 \times 10^{-2}} \times 0.5 \right) \text{ N} = 2.756 \text{ N}$$

$$\therefore \text{Total Force (F)} = (18.225 + 2.756) \text{ N} = 20.981 \text{ N}.$$

**EXAMPLE 13**

A vertical gap  $2.25 \text{ cm}$  wide of infinite extent contains a fluid of viscosity  $1.98 \text{ Pas}$  and specific gravity  $0.92$ . A metal plate of  $1.25 \text{ m} \times 1.25 \text{ m} \times 0.25 \text{ cm}$  needs to be lifted with a constant velocity of  $0.18 \text{ m/s}$ , through the gap. Assuming the plate lying exactly at the middle of the gap, find the required force of lift. Mass density of plate is  $1415 \text{ kg/m}^3$ .

**SOLUTION**

$$\text{Volume of the plate} = (1.25 \times 1.25 \times 0.25 \times 10^{-2}) \text{ m}^3$$

$$= 3.90625 \times 10^{-3} \text{ m}^3$$

$$\begin{aligned} \therefore \text{ Self weight of plate} &= (3.90625 \times 10^{-3} \times 1415 \times 9.807) \text{ N} \\ &= 54.207 \text{ N} \\ \text{Specific weight of fluid} &= (0.92 \times 1000 \times 9.807) \text{ N/m}^3 \\ &= 9022.44 \text{ N/m}^3 \\ \therefore \text{ Buoyant force acting upward} &= (9022.44 \times 3.90625 \times 10^{-3}) \text{ N} \\ &= 35.244 \text{ N} \end{aligned}$$

Therefore effective downward force ( $F_1$ ) = (54.207 – 35.244) N = 18.963 N

When the plate is within fluid, wall-to-plate clearance on each side

$$\begin{aligned} &= \frac{2.25 - 0.25}{2} \text{ cm} \\ &= 1 \times 10^{-2} \text{ m} \end{aligned}$$

Area of plate subjected to shear

$$= (1.25 \times 1.25) \text{ m}^2 = 1.5625 \text{ m}^2$$

$\therefore$  Shear force acting on each side of plate

$$= \left( 1.98 \times \frac{0.18}{1 \times 10^{-2}} \times 1.5625 \right) \text{ N} = 55.687 \text{ N}$$

$\therefore$  Total shear force on both side of plate ( $F_2$ )

$$= (2 \times 55.687) \text{ N} = 111.374 \text{ N}$$

To lift up the plate, the total shear force ( $F_2$ ) and effective downward force ( $F_1$ ) of the plate will have to overcome.

So the net drag force  $F = F_1 + F_2$

$$\begin{aligned} &= (18.963 + 111.374) \text{ N} \\ &= 130.337 \text{ N.} \end{aligned}$$

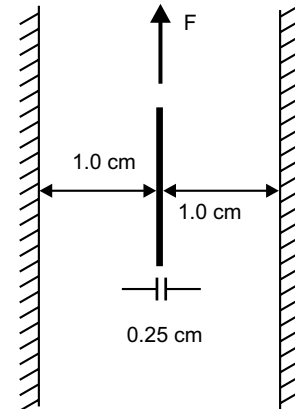

#### EXAMPLE 14

The surface tension of water in contact with air at 20°C is 0.0705 N/m. The pressure inside a water droplet is 0.018 N/cm<sup>2</sup> higher than outside pressure. What is the diameter of the water droplet?

**SOLUTION**

From equation (1.10),  $\Delta p = 0.018 \text{ N/cm}^2 = 180 \text{ N/m}^2$

$$\sigma = 0.0705 \text{ N/m}$$

$$\text{and } R_1 = R_2 = R$$

$$\therefore \sigma = \frac{\Delta p}{\left(\frac{2}{R}\right)}$$

$$\Rightarrow R = \frac{2\sigma}{\Delta p} = \frac{2 \times 0.0705}{180} = 7.834 \times 10^{-4} \text{ m}$$

So, diameter of the droplet =  $(2 \times 7.834 \times 10^{-4})$  m  
 $= 1.5668 \times 10^{-3}$  m = 1.57 mm.

**EXAMPLE 15**

Find surface tension of a soap bubble of 48 mm diameter while pressure inside is 3.12 Pa higher than atmospheric one.

**SOLUTION**

As it is a hollow bubble it will have two sets of interface surface, one is inner surface and inside air, other is outer surface and outside air. And surface tension will act both outside surface and inside surface of bubble. Hence

$$R = \frac{4\sigma}{\Delta p}$$

$$\Rightarrow \sigma = \frac{\Delta p \cdot R}{4} = \frac{3.12 \times 48 \times 10^{-3}}{4 \times 2} \text{ N/m} = 0.01872 \text{ Nm.}$$

**EXAMPLE 16**

Calculate capillary rise in a glass tube of 2.35 mm diameter, when vertically immersed in (i) mercury (ii) water. Surface tension in contact with air is 0.518 N/m for mercury and 0.07238 N/m for water. Specific gravity and angle of contact for mercury is 13.596 and  $130^\circ$  respectively.

**SOLUTION**

Here,  $\rho_w = 1000 \text{ kg/m}^3$ ,  $\sigma_w = 0.07238 \text{ N/m}$

$\rho_m = (13.596 \times 1000) \text{ kg/m}^3$ ,  $\sigma_m = 0.518 \text{ N/m}$

$\theta_w = 0^\circ$ ,  $\theta_m = 130^\circ$

$\therefore$  Capillary rise for water

$$h_w = \frac{4\sigma_w \cos\theta_w}{\rho_w \times g \times d} = \frac{4 \times 0.07238 \times \cos 0^\circ}{1000 \times 9.807 \times 2.35 \times 10^{-3}} \text{ m}$$

$$= 0.01256 \text{ m} = 12.56 \text{ mm}$$

Capillary depression for mercury

$$h_m = \frac{4\sigma_m \cos\theta_m}{\rho_m \times g \times d} = \frac{4 \times 0.518 \times \cos 130^\circ}{(13.596 \times 1000) \times 9.807 \times 2.35 \times 10^{-3}} \text{ m}$$

$$= -4.2505 \times 10^{-3} \text{ m} = -4.25 \text{ mm}$$

Here, (–) ve sign indicates capillary fall instead of capillary rise.

**EXAMPLE 17**

The space between a shaft and a concentric sleeve is filled up with Newtonian fluid. If a force of 550 N is applied parallel to the shaft, the sleeve attains a speed of 1.3 m/s. How much speed will attain the sleeve, if above force is increased to 1550 N, the temperature being the same?

**SOLUTION**

Let the clearance between shaft and sleeve be ' $dy$ ', radius of the shaft ' $r$ ' and length of sleeve ' $l$ '.

Viscosity remaining same, we obtain two sets of equations

$$550 = \mu \times \frac{1.3}{dy} \times (2\pi r l) \quad (a)$$

$$1550 = \mu \times \frac{V}{dy} \times (2\pi r l) \quad (b)$$

$$\text{Doing (b) } \div \text{ (a), } \frac{1550}{550} = \frac{V}{1.3}$$

$$\Rightarrow V = 3.66 \text{ m/s.}$$

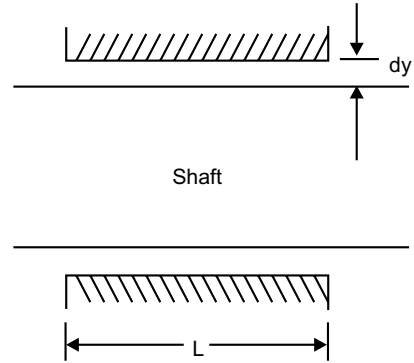
**EXAMPLE 18**

A hydraulic ram 200 mm diameter and 1.2 m long moves within a concentric cylinder 200.2 mm diameter. The annular clearance is filled with oil of relative density 0.85 and kinematic viscosity  $400 \text{ mm}^2/\text{s}$ . What is the viscous force resisting the motion when the ram moves at a speed of  $120 \text{ mm/s}$ .

**SOLUTION**

$$\begin{aligned} \text{Dynamic viscosity } (\mu) &= \nu \rho \\ &= (400 \times 10^{-6} \times 0.85 \times 10^3) \text{ Ns/m}^2 \\ &= 0.34 \text{ Ns/m}^2 \end{aligned}$$

$$\begin{aligned} \text{So, Shear stress } \tau &= \mu \times \frac{du}{dy} \\ &= 0.34 \times \frac{120}{\left(\frac{200.2 - 200}{2}\right)} \end{aligned}$$

$$\begin{aligned} &= 408 \text{ N/m}^2 \\ \therefore \text{ Shear force } (F) &= \tau \times (\pi dl) \\ &= 408 \times (\pi \times 200 \times 10^{-3} \times 1.2) \text{ N} \\ &= 307.62 \text{ N.} \end{aligned}$$

**EXAMPLE 19**

The space between two large flat and parallel walls 25 mm apart is filled with liquid of viscosity  $0.7 \text{ Ns/m}^2$ . Within this space a thin flat plate  $250 \times 250$  is towed at a velocity of  $150 \text{ mm/s}$  at a distance of 19 mm from one wall, the plate and its movement being parallel to the walls. Assuming linear variations of velocity between the plate and the walls, determine the force exerted by the liquid on the plate.

**SOLUTION**Effective area of plate on shear ( $A$ )

$$= 250 \times 250 \times 10^{-6} \text{ m}^2$$

$$= 0.0625 \text{ m}^2$$

Velocity of drag ( $V$ ) = 150 mm/s = 0.15 m/s

$$\text{Total drag force } (F) = \left( \mu \times \frac{V}{t_1} + \mu \times \frac{V}{t_2} \right) A$$

$$= 0.7 \times 0.15 \left( \frac{1}{6} + \frac{1}{19} \right) \times \frac{1}{10^{-3}} \times 0.0625 \text{ N}$$

$$= 1.439 \text{ N.}$$

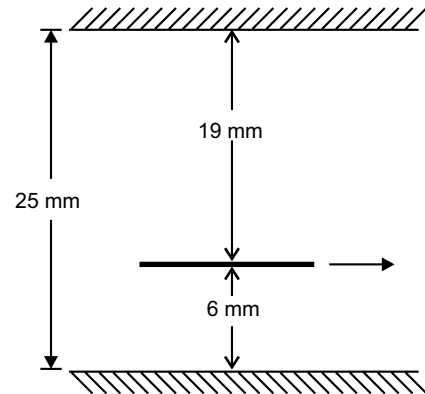
**EXAMPLE 20**

A large plate moves with speed  $v_0$  over a stationary plate on a layer of oil. If the velocity profile is that of a parabola, with the oil at the plates having the same velocity as the plates, what is the shear stress on the moving plate from the oil? If a linear profile is assumed, what is the shear stress on the upper plate?

**SOLUTION**

Let us assume equation of parabolic velocity profile

$$v^2 = k_1 y$$

(a)

Applying boundary condition at  $y = d, v = v_0$ 

$$\text{From (a), } v_0^2 = k_1 d$$

$$\Rightarrow k_1 = \frac{v_0^2}{d}$$

$$\therefore v^2 = \frac{v_0^2}{d} \cdot y$$

$$\Rightarrow v = v_0 \sqrt{\frac{y}{d}}$$

$$\text{So, } \frac{dv}{dy} = \frac{v_0}{\sqrt{d}} \cdot \frac{1}{2} \cdot y^{-1/2}$$

$$= (1/2) \frac{v_0}{\sqrt{dy}}$$

$$\text{At } y = d, \tau = \mu \frac{dv}{dy} \Big|_{y=d} = \frac{\mu}{2} \cdot \frac{v_0}{\sqrt{d}} \cdot \frac{1}{\sqrt{d}} = \frac{\mu v_0}{2d}$$

Considering linear profile,  $v = k_2 y$ 

$$\text{at } y = d, v = v_0 \quad \Rightarrow k_2 = \frac{v_0}{d}$$

$$\therefore v = \frac{v_0}{d} \cdot y$$

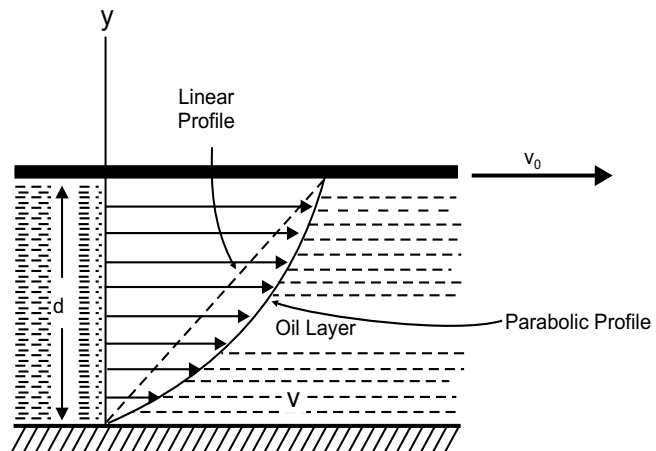

$$\Rightarrow \frac{dv}{dy} = \frac{v_0}{d}$$

$$\therefore \tau = \mu \frac{dv}{dy} = \mu \frac{v_0}{d}$$

$$\text{At } y = d, \tau = \mu \frac{v_0}{d}.$$

### EXERCISE

1. (a) State and explain Newton's law of viscosity.  
(b) Define Newtonian and Non-Newtonian fluids with examples.
2. Define the following terms
  - (a) Surface Tension
  - (b) Rheology
  - (c) Ideal fluid
  - (d) Bulk modulus of elasticity of a compressible fluid
3. Explain dynamic viscosity and kinematic viscosity. Give their dimensions.
4. Explain the phenomenon of capillarity. Obtain an expression for capillary rise of a fluid.
5. A plunger is moving through a cylinder at a speed of 6.1 m/s. The diameter and length of the plunger are 126.7 mm and 25 mm respectively. The diameter of the cylinder is 127 mm. The film of oil separating plunger from the cylinder has a viscosity of 0.95765 N-s/m<sup>2</sup>. What is the force required to maintain this motion?

**Ans.** [12.275 N]

6. Calculate the density, specific weight and volume of chloride gas at 25°C and pressure of 6,00,000 N/m<sup>2</sup> absolute.

**Ans.** [ 17.1 kg/m<sup>3</sup>, 168 N/m<sup>3</sup>, 0.0585 m<sup>3</sup>/kg]

7. A high pressure steel container is partially full of a liquid at a pressure of 10 atm. The volume of the liquid is 1.232 L. At a pressure of 25 atm, the volume of the liquid equals 1.231 L. What is the average bulk modulus of elasticity of the liquid over the given range of pressure of the temperature after compression is allowed to return to the original temperature. What is the coefficient of compressibility?

**Ans.** [1.872 × 10<sup>6</sup> k Pa, 0.000534 m<sup>2</sup>/MN]

8. Water is moving through a pipe. The velocity profile is given by  $v = \frac{\beta}{4\mu} \left( \frac{d^2}{4} - r^2 \right)$  What is the shear stress at the wall of the pipe and at  $r = d/4$ . If the given profile persists a distance  $L$  along the pipe, what drag is induced by the water on the pipe in the direction of flow over this distance?

**Ans.**  $\left[ -\frac{2\beta r}{4}, -\frac{\beta d}{8}, \frac{\beta \pi d^2 L}{4} \right]$

9. A cylinder of weight 9.1 kg, diameter 152 mm and height 127 mm slides through a lubricated pipe. The clearance between cylinder and pipe is 0.025 mm. If the cylinder is observed to decelerate @  $0.61 \text{ m/s}^2$  when the speed is 6.1 m/s, what is the viscosity of the oil?

**Ans.** [ $6.411 \times 10^{-3} \text{ Pas}$ ]

10. In a stream of glycerine in motion, at a certain point, the velocity gradient is 0.25 m/s/m. Mass density of fluid is  $1268.4 \text{ kg/m}^3$  and kinematic viscosity is  $6.30 \times 10^{-4} \text{ m}^2/\text{s}$ . Calculate shear stress at that point.

**Ans.** [ $0.2 \text{ N/m}^2$ ]

11. Surface tension of water in contact with air at  $20^\circ\text{C}$  is given as 0.0716 N/m. Pressure inside a droplet of water is to be  $0.0147 \text{ N/cm}^2$  greater than the outside pressure, calculate diameter of droplet of water.

**Ans.** [1.94 mm]

12. Find surface tension in a soap bubble of 30 mm diameter when the inside pressure is  $1.962 \text{ N/m}^2$  above atmosphere.

**Ans.** [0.00735 N/mm]

13. Capillary rise in the glass tube used for measuring water level is not to exceed 0.5 mm. Determine its minimum size, given that surface tension for water in contact with air = 0.07112 N/m.

**Ans.** [5.8 cm]

14. A very large thin plate is centered in a gap of width 6 cm with different oil of unknown viscosities above and below, the viscosity of one being twice that of the other. When pulled at a velocity of 30 cm/s, the resulting force on  $1 \text{ m}^2$  of plate due to viscous shear on both sides is 29.4 N. Assuming viscous flow and neglecting all end effects, calculate viscosities of the oil.

**Ans.** [0.98 Pas, 1.96 Pas]

# FLUID STATICS

---

## 2.1 FORCES ON FLUID ELEMENT

If an infinitesimally small region in the continuum of fluid can be separated out, then that particular region is defined as a *fluid element*. A fluid element, on isolation from all its surroundings is subjected to variety of forces, whether it is in rest or in motion. All the forces acting on any fluid element can be classified broadly into two groups:

- (a) **Body Forces:** are forces acting throughout the body of the fluid element and distributed over entire volume of the element. Forces due to gravitational acceleration, electromagnetic field are such body forces. These are expressed as force per unit mass.
- (b) **Surface Forces:** are forces acting directly on the surface of fluid element in contact. Viscous force is such a surface force. All surface forces are normally resolved along normal direction and perpendicular to the normal (tangential) direction. Hence surface forces have two components, one is *normal force* and the other is *tangential force*.

### 2.1.1 Pascal's Law of Hydrostatics

Let us consider a small tetrahedral fluid element OABC as shown in Figure 2.1. Triangular face ABC has an infinitesimally small area  $dA$ , which makes angle  $\alpha$  with  $x$ -plane (bounded by  $y$ -axis and  $z$ -axis), angle  $\beta$  with  $y$ -plane (bounded by  $x$ -axis and  $z$ -axis) and angle  $\gamma$  with  $z$ -plane (bounded by  $x$ -axis and  $y$ -axis). Now projection of ' $dA$ ' on  $x$ -plane,  $y$ -plane and  $z$ -plane are

$$\left. \begin{aligned} dA \cdot \cos \alpha &= \frac{1}{2} dy \cdot dz \\ dA \cdot \cos \beta &= \frac{1}{2} dx \cdot dz \\ dA \cdot \cos \gamma &= \frac{1}{2} dx \cdot dy \end{aligned} \right\} \quad (2.1)$$

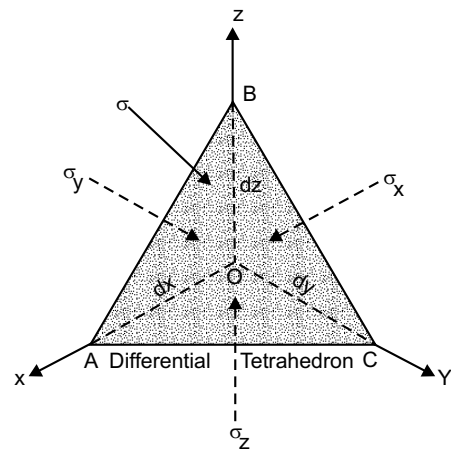

Fig. 2.1

Now,  $\sigma$  is pressure of fluid in any arbitrary direction and  $\sigma_x$ ,  $\sigma_y$ ,  $\sigma_z$  indicate pressure along  $x$ -axis,  $y$ -axis and  $z$ -axis respectively.

To attain conditions of equilibrium of the tetrahedral element, the normal surface forces due to fluid pressure along the co-ordinate axes will have to be resolved. Therefore

$$\left. \begin{aligned} \sigma_x \frac{dy dz}{2} - \sigma \cdot dA \cdot \cos \alpha &= 0 \\ \sigma_y \frac{dx dz}{2} - \sigma \cdot dA \cdot \cos \beta &= 0 \\ \sigma_z \frac{dx dy}{2} - \sigma \cdot dA \cdot \cos \gamma &= 0 \end{aligned} \right\} \quad (2.2)$$

Clubbing (2.1) & (2.2), we obtain,

$$\left. \begin{aligned} \sigma_x &= 0 \\ \sigma_y &= 0 \\ \sigma_z &= 0 \end{aligned} \right\} \quad (2.3)$$

$$\text{or} \quad \sigma = \sigma_x = \sigma_y = \sigma_z \quad (2.4)$$

As the direction of  $\sigma$  acting normal to the surface  $dA$  is arbitrary, *pressure at a point in a static fluid is the same in all direction*. This is known as *Pascal's Law* of hydrostatics, as established by a French Mathematician, *B.Pascal* in 1653. Very commonly the stress  $\sigma$  in equation (2.4) is denoted as  $p$ , a scalar quantity.

## 2.2 EQUILIBRIUM OF STATIC FLUID ELEMENT

Let us consider a differential fluid element in the shape of a parallelepiped, shown in figure 2.2. It is subjected to both body force and surface force. Body force arises due to earth's field of gravitation and surface force due to normal pressure acting on element.

The component of body force along co-ordinate axes are  $X$ ,  $Y$  and  $Z$ , per unit mass. Mass density of the element is  $\rho$ . Normal pressure  $p$  is acting on rear surface of the element in  $x$ -plane, as shown.

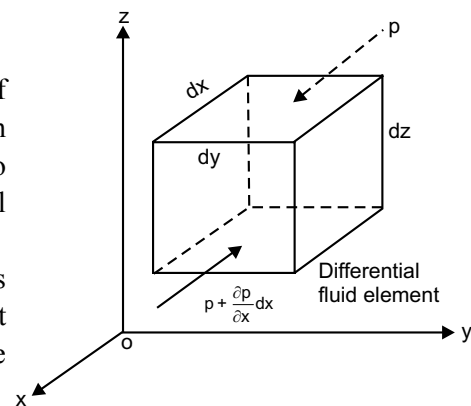

Fig. 2.2

$$\text{Rate of change of } p \text{ along } dx \text{ length} = \frac{\partial p}{\partial x}$$

$$\text{So, the normal pressure on front surface of the element in } x\text{-plane} = \left( p + \frac{\partial p}{\partial x} dx \right)$$

Considering equilibrium of forces along  $x$ -axis

$$p \, dy \, dz - \left( p + \frac{\partial p}{\partial x} \, dx \right) dy \, dz + X \, \rho \, dx \, dy \, dz = 0$$

$$\Rightarrow p - p - \frac{\partial p}{\partial x} \, dx + X \, \rho \, dx = 0$$

$$\Rightarrow \frac{1}{\rho} \frac{\partial p}{\partial x} = X \tag{2.5}$$

In the similar fashion, we can consider the equilibrium along  $y$ -axis and  $z$ -axis, finally yielding *Euler's Equations of Equilibrium* as

$$\frac{1}{\rho} \frac{\partial p}{\partial x} = X \tag{2.6a}$$

$$\frac{1}{\rho} \frac{\partial p}{\partial y} = Y \tag{2.6b}$$

$$\frac{1}{\rho} \frac{\partial p}{\partial z} = Z \tag{2.6c}$$

### 2.3 SOLUTION OF EULER'S EQUATIONS

Let us consider a specific case, where the fluid is static and  $z$ -axis coincides with the direction of gravitational acceleration. Here component of body forces along  $x$ -axis and  $y$ -axis are zero, *i.e.*,  $X = 0 = Y$ .

Due to special choice of coordinate axes, the partial differential form in equation (2.6c) can be changed to total differential form. Replacing  $Z$  by  $-g$  [ $(-)$ ve sign due to downward direction of  $g$ ], above equation can be re-written as

$$\frac{1}{\rho} \frac{dp}{dz} = -g \tag{2.7}$$

Solution of this equation may be found for the following cases.

#### 2.3.1 Incompressible Fluid (uniform density)

Adjoining figure 2.3 illustrates this specific condition. To find expression of pressure  $p$  at any  $z$  height, we are to integrate equation (2.7).

$$\int \frac{1}{\rho} \, dp = \int -g \, dz$$

$$\Rightarrow \frac{p}{\rho} = -gz + C_0$$

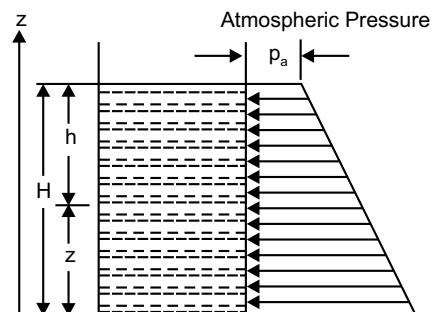

Fig. 2.3

$$\Rightarrow p = -\rho gz + C, \text{ where } C = \rho \cdot C_0 \quad (2.8)$$

Applying boundary condition as, at  $z = H, p = p_a$

$$p_a = -\rho gH + C$$

$$\Rightarrow C = p_a + \rho gH \quad (2.9)$$

Substituting in equation (2.8),  $p = -\rho gz + p_a + \rho gH$

$$\Rightarrow p = p_a + \rho g(H - z) = p_a + \rho gh \quad (2.10)$$

Here this expression is formed in terms of absolute pressure. In terms of gauge pressure,  $p_a = 0$  and it will be,  $p = \rho gh$  (2.11)

### 2.3.2 Isothermal State

At initial reference level, say, on earth's surface, the pressure and mass density of compressible fluid are  $p_0$  and  $\rho_0$  respectively. Applying Boyle's Law,

$$\frac{p}{\rho} = \frac{p_0}{\rho_0} \quad (2.12)$$

Substituting in equation(2.7),  $\frac{1}{\rho} dp = -g dz$

$$\Rightarrow \frac{dp}{p} \cdot \frac{p_0}{\rho_0} = -g dz \quad [\text{substituting from eq. 2.12}] \quad (2.13)$$

Integrating  $\frac{p_0}{\rho_0} \int_{p_0}^p \frac{dp}{p} = -g \int_{z_0}^z dz$

$$\Rightarrow \frac{p_0}{\rho_0} \ln \left( \frac{p}{p_0} \right) = -g(z - z_0) \quad (2.14)$$

$$\Rightarrow \ln \left( \frac{p}{p_0} \right) = -\frac{\rho_0 g}{p_0} (z - z_0)$$

$$\Rightarrow \frac{p}{p_0} = \exp \left[ -\frac{\rho_0 g}{p_0} (z - z_0) \right] \quad (2.15)$$

For a perfect gas,

$$\frac{p_0}{\rho_0} = R T_0 \quad (2.16)$$

Substituting in equation (2.15),

$$\frac{p}{p_0} = \exp \left[ -\frac{g}{RT_0} (z - z_0) \right]$$

$$\Rightarrow p = p_0 \cdot \exp \left[ \frac{-g(z - z_0)}{RT_0} \right] \quad (2.17)$$

### 2.3.3 Adiabatic State

For an adiabatic process,

$$\frac{p}{\rho^k} = \frac{p_0}{\rho_0^k} \quad (2.18)$$

$$\Rightarrow \rho = \rho_0 \left( \frac{p}{p_0} \right)^{1/k} \quad (2.19)$$

Substituting in equation (2.7),

$$\frac{1}{\rho_0} \left( \frac{p_0}{p} \right)^{1/k} \cdot dp = -g dz \quad (2.20)$$

$$\text{Integrating} \quad \frac{1}{\rho_0} \cdot p_0^{1/k} \int_{p_0}^p p^{-1/k} \cdot dp = -g \int_{z_0}^z dz \quad (2.21)$$

$$\Rightarrow p_0^{1/k} \cdot \left[ \frac{p^{1-1/k}}{1-1/k} \right]_{p_0}^p = -g \rho_0 (z - z_0)$$

$$\Rightarrow p_0^{1/k} \cdot \left( \frac{k}{k-1} \right) \cdot [p^{1-1/k} - p_0^{1-1/k}] = -g \rho_0 (z - z_0) \quad (2.22)$$

$$\Rightarrow g \rho_0 (z - z_0) = p_0 \cdot p_0^{1/k-1} \cdot \left( \frac{k}{k-1} \right) \cdot [p_0^{1-1/k} - p^{1-1/k}] \quad (2.23)$$

So, from equation (2.23),

$$(z - z_0) = \left( \frac{k}{k-1} \right) \frac{p_0}{\rho_0 g} \left[ 1 - \left( \frac{p}{p_0} \right)^{\frac{k-1}{k}} \right]$$

$$\begin{aligned} \Rightarrow \frac{p}{p_0} &= \left[ 1 - (z - z_0) \frac{\rho_0 g}{p_0} \left( \frac{k-1}{k} \right) \right]^{\frac{k}{k-1}} \\ &= \left[ 1 - (z - z_0) \frac{g}{RT_0} \left( \frac{k-1}{k} \right) \right]^{\frac{k}{k-1}} \end{aligned} \quad (2.24)$$

### 2.3.4 Polytropic State

In a polytropic process,

$$\frac{p}{\rho^n} = \frac{p_0}{\rho_0^n} \quad (2.25)$$

Following equation (2.24) and (2.25), we can write,

$$\frac{p}{p_0} = \left[ 1 - (z - z_0) \frac{g}{RT_0} \left( \frac{n-1}{n} \right) \right]^{\frac{n}{n-1}} \quad (2.26)$$

### 2.3.5 Temperature Lapse Rate

The variation of temperature in atmosphere with altitude from M.S.L. is shown in figure 2.4. Troposphere is in contact with the surface of the earth up to an altitude of 7 km in polar and 14 km in equatorial region, averaging 11 km in general. And lapse rate ( $\alpha$ ) of temperature is constant, 6.5 K/km, and  $T_0 = 288$  K, while

$$T = T_0 - \alpha z \quad (2.27)$$

As we know,  $p = \rho RT$  and from equation (2.7)

$$\frac{dp}{p} = -\frac{g}{R} \frac{dz}{(T_0 - \alpha z)} \quad (2.28)$$

Integrating within limits,

$$\begin{aligned} \ln \left( \frac{p}{p_0} \right) &= \frac{g}{R\alpha} \ln \left( \frac{T_0 - \alpha z}{T_0 - \alpha z_0} \right) \\ \Rightarrow \frac{p}{p_0} &= \exp. \left[ \frac{g}{R\alpha} \ln \left( \frac{T_0 - \alpha z}{T_0 - \alpha z_0} \right) \right] \end{aligned} \quad (2.29)$$

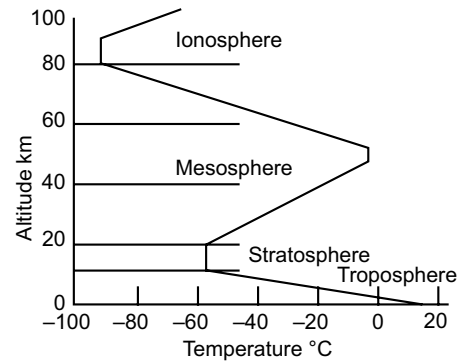

Fig. 2.4

## 2.4 GAUGE PRESSURE AND ABSOLUTE PRESSURE

The air in the atmosphere exerts a natural pressure on all the surfaces in contact, which is known as *Atmospheric Pressure*. It varies with change of altitude and can be measured with the help of a barometer. Hence atmospheric pressure is sometimes denoted as *Barometric Pressure*. In normal condition this pressure at mean sea level is

$$\begin{aligned} &76 \text{ cm of mercury column} \\ &= 10.33 \text{ m of water column} \\ &= 10,330 \text{ kgf/m}^2 = 101.32 \text{ kN/m}^2 = 1.013 \text{ bar} \end{aligned}$$

The pressure exerted by any fluid can be measured either (i) absolute zero as datum, or (ii) atmospheric pressure as datum. When pressure is measured considering vacuum or absolute

zero as datum, it is called an *Absolute Pressure*. If the datum be atmospheric pressure, the measured pressure is termed as *Gauge Pressure*. So,

$$\text{Gauge pressure} = \text{Absolute pressure} - \text{Atmospheric pressure.}$$

If gauge pressure is below atmospheric pressure, then it is called *Negative gauge pressure* or *Vacuum pressure* or *Suction pressure*.

**2.4.1 Barometer**

The instrument which measures atmospheric pressure is known as barometer and is shown in figure 2.5. The column of mercury rises in the inverted tube by capillarity and the space above this column apparently empty but actually is filled up with mercury vapour, is known as *Torricellian Vacuum*. Hence the atmospheric pressure can be expressed as,

$$p_{\text{atm}} = p_{\text{vap}} + \rho gh \tag{2.30}$$

Generally, the effect of vapour pressure is neglected in computation of atmospheric pressure but an error of 0.14% to 0.16% is invoked.

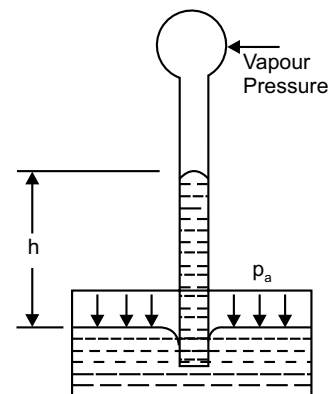
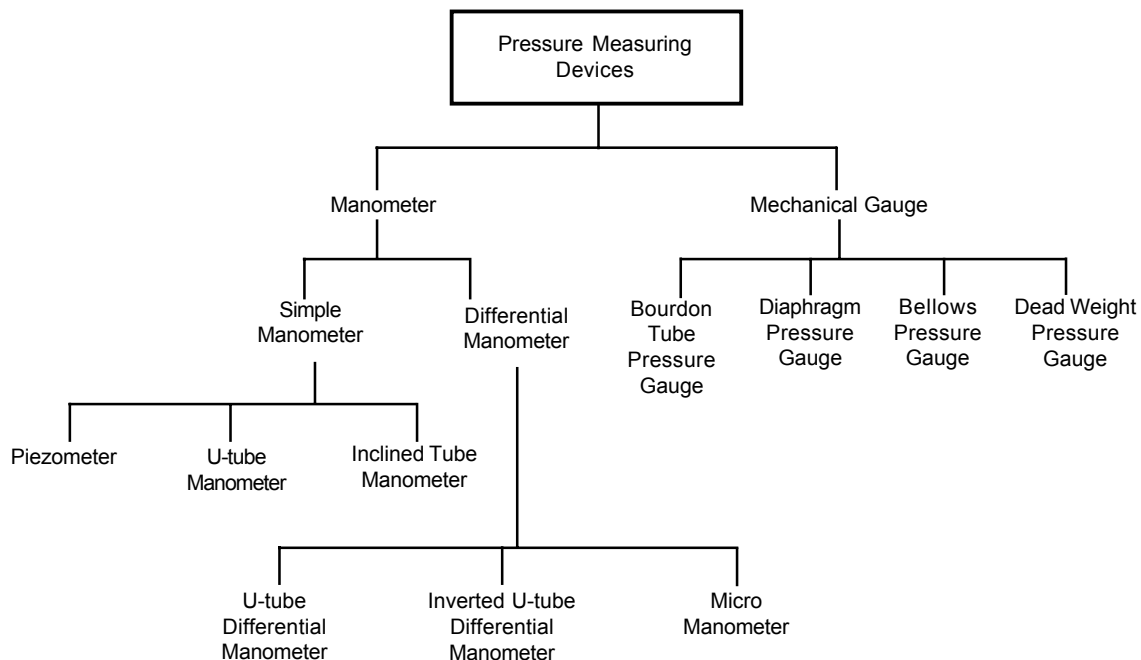

Fig. 2.5

**2.5 MEASUREMENT OF PRESSURE**

There happens to exist number of devices, applying which the fluid pressure can be measured.



## 2.6 MANOMETER

A manometer is a device for measuring the difference between two pressures by balancing a column of liquid.

### 2.6.1 Simple Manometer

It measures pressure at point in a fluid contained in a conduit or vessel.

- (a) **Piezometer:** It is an ordinary vertical tube, connected to a conduit carrying liquid is used to measure gauge pressure, and is called a piezometer tube or simply a piezometer, as 'piezo' means 'pressure'.

The liquid in piezometer rises freely until equilibrium. In figure 2.6, 'h' is the pressure head at A. Piezometer cannot measure pressure too high due to large length of tube and vacuum pressure due to air entrance inside conduit.

- (b) **U-tube manometer:** A U-tube, as shown in figure 2.7, may be used to measure pressure in a conduit or container having a fluid of mass density  $\rho_A$ . The manometric tube should contain a liquid having mass density  $\rho_B$ , such that  $\rho_B > \rho_A$ . For water and alcohol, common manometric fluid is mercury, while for gas it may be water.

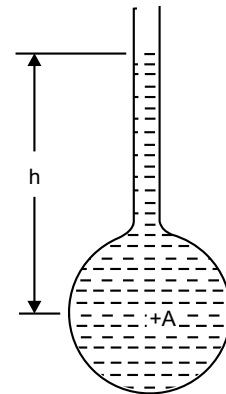

Fig. 2.6

Now in order to write an equation for pressure equilibrium, following mnemonic, first suggested by Professor John Foss of Michigan State University, can be used.

$$p_{\downarrow} = p^{\uparrow} + \gamma |\Delta z| \quad (2.31)$$

Following this, pressure at P

$$p_p = p_1 + \rho_A \cdot g (y + x) \quad (2.32)$$

Then jump across along the same line at Q. As level is not changing, then

$$p_Q = p_p = p_1 + \rho_A \cdot g (y + x) \quad (2.33)$$

Now, pressure at open end of the tube

$$\begin{aligned} p_{\text{atm}} &= p_Q - \rho_B \cdot g \cdot x \\ &= p_1 + \rho_A \cdot g (y + x) - \rho_B \cdot g \cdot x \end{aligned} \quad (2.34a)$$

$$\Rightarrow p_1 = p_{\text{atm}} + (\rho_B - \rho_A) g x - \rho_A \cdot g \cdot y \quad (2.34b)$$

- (c) **Inclined tube manometer:** It is just a modification of an ordinary U-tube manometer, for improvement of sensitivity, shown in figure 2.8.

The c/s area of the reservoir is made much higher than that of the inclined tube. This arrangement enables the manometric liquid remain practically constant in the reservoir due to a small change in pressure. The inclined tube facilitates the movement 'l' of the meniscus to be recorded with greater sensitivity, and satisfies the relation

$$h = l \sin\theta \quad (2.35)$$

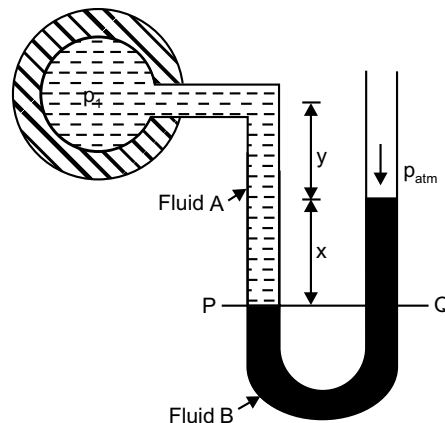

Fig. 2.7

Here smaller the inclination, higher is the sensitivity. But an inclination less than  $5^\circ$  makes the reading of the exact position of meniscus troublesome and hence should not be used.

**2.6.2 Differential Manometer**

It is used to determine a small or moderately high pressure difference between any two points in two conduits or two reservoirs.

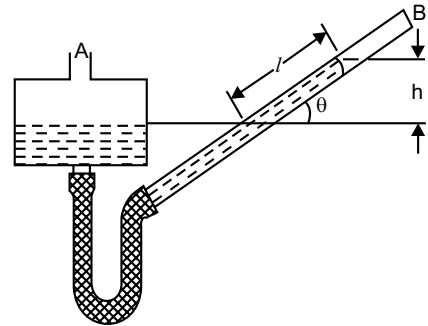

Fig. 2.8

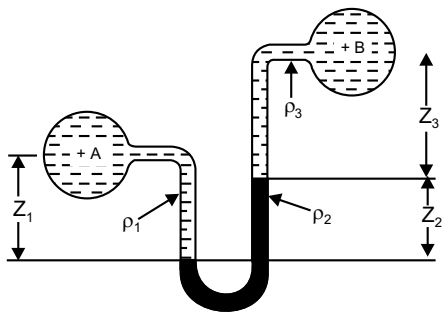

Fig. 2.9

A light oil even air may be the manometric fluid.

Normally *U*-tube differential manometer is employed to ascertain high pressure difference (Fig. 2.9). Inverted *U*-tube manometer, shown in figure 2.10, generally measures low or moderate pressure difference. The procedure for obtaining equilibrium equation for pressure difference is same as before. Referring figure 2.9.

$$\begin{aligned}
 p_A + \rho_1 g z_1 - \rho_2 g z_2 - \rho_3 g z_3 &= p_B \\
 \Rightarrow p_A - p_B &= \rho_2 g z_2 + \rho_3 g z_3 - \rho_1 g z_1
 \end{aligned} \tag{2.36}$$

Again for inverted *U*-tube manometer in figure 2.10,

$$\begin{aligned}
 p_A - \rho_1 g z_1 + \rho_2 g z_2 + \rho_3 g z_3 &= p_B \\
 \Rightarrow p_A - p_B &= \rho_1 g z_1 - \rho_2 g z_2 - \rho_3 g z_3
 \end{aligned} \tag{2.37}$$

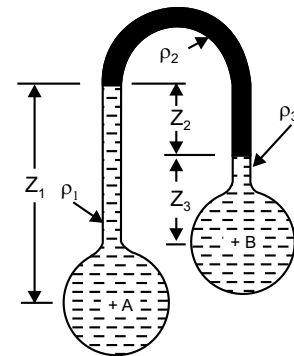

Fig. 2.10

**2.6.2.1 Micromanometer**

Sometimes it is necessary to measure small pressure difference accurately and micromanometer is employed. As shown in figure 2.11, it is seen that other than manometric fluid and working fluid, another gauge fluid is used. The equation of hydrostatic equilibrium will be

$$\begin{aligned}
 p_1 + \rho_w \cdot g (h + \Delta z) + \rho_G \cdot g (z + \frac{y}{2} - \Delta z) \\
 - \rho_m \cdot g \cdot y - \rho_G \cdot g (z - \frac{y}{2} + \Delta z) - \rho_w \cdot g (h - \Delta z) &= p_2
 \end{aligned} \tag{2.38}$$

Here  $\rho_m > \rho_G > \rho_w$

From continuity of gauge liquid

$$A \cdot \Delta z = a \cdot y/2 \tag{2.39}$$

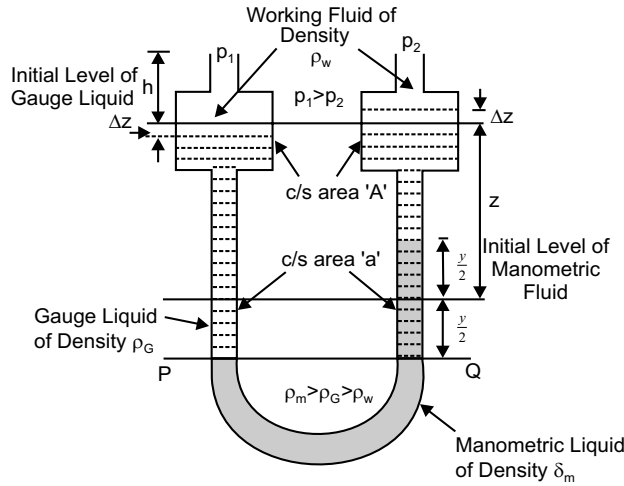

Fig. 2.11

Clubbing (2.38) and (2.39), we find

$$\begin{aligned}
 & p_1 + \rho_w \cdot g \left( h + \frac{a}{A} \cdot \frac{y}{2} \right) + \rho_G \cdot g \left( z + \frac{y}{2} - \frac{a}{A} \cdot \frac{y}{2} \right) - \rho_m \cdot g \cdot y \\
 & - \rho_G \cdot g \left( z - \frac{y}{2} + \frac{a}{A} \cdot \frac{y}{2} \right) - \rho_w \cdot g \left( h - \frac{a}{A} \cdot \frac{y}{2} \right) = p_2 \\
 \Rightarrow & p_1 + \rho_w \cdot g \cdot \frac{a}{A} \cdot y + \rho_G \cdot g \cdot y - \rho_G \cdot g \cdot \frac{a}{A} \cdot y - \rho_m \cdot g \cdot y = p_2 \\
 \Rightarrow & p_1 - p_2 = gy \left[ \rho_m - \rho_G \left( 1 - \frac{a}{A} \right) - \rho_w \cdot \frac{a}{A} \right] \tag{2.40}
 \end{aligned}$$

If  $A \gg a, \frac{a}{A} \approx 0$

$$\text{Therefore, } p_1 - p_2 \approx gy (\rho_m - \rho_G) \tag{2.41}$$

### 2.7 HYDROSTATIC FORCE ON SUBMERGED PLANE SURFACE

Let us consider a plane surface of arbitrary shape and of area  $A$ , completely submerged below the free surface of liquid  $MN$ . The plane makes an angle  $\theta$  with the horizontal. The reference system of axes is shown in figure 2.12. The force acting on the elemental area  $dA$  at a vertical depth  $h$  can be written

$$dF = \rho gh \, dA \tag{2.42}$$

On integration over the entire area  $A$ , total force acts as

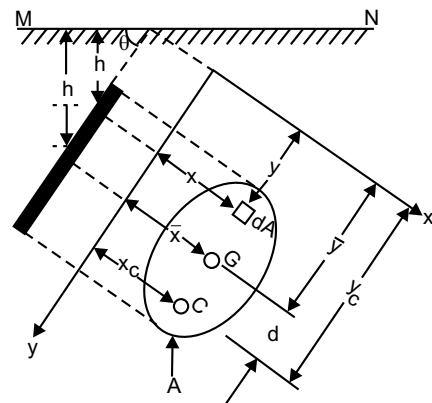

Fig. 2.12

$$\begin{aligned}
 F &= \int_A dF = \int_A \rho g h dA = \int_A \rho g y \sin \theta dA & [\because h = y \sin \theta] \\
 &= \rho g \sin \theta \int_A y dA & (2.43)
 \end{aligned}$$

As we know, centroidal coordinate of the plane is  $G(\bar{x}, \bar{y})$

$$\bar{y} = \frac{\int_A y dA}{\int_A dA} \quad \text{So, } \int_A y dA = A\bar{y}$$

Substituting in equation (2.43),

$$\begin{aligned}
 F &= \rho g \sin \theta (A\bar{y}) \\
 &= \rho g A\bar{h} & [\because \bar{h} = \bar{y} \sin \theta] & (2.44)
 \end{aligned}$$

This is the resultant hydrostatic force acting on the plane. Let us consider the point  $C(x_C, y_C)$  as centre of pressure, where the above force acts. Considering moment equilibrium about  $x$ -axis, we can write,

$$\begin{aligned}
 y_C \cdot F &= \int_A y dF \\
 \Rightarrow y_C &= \frac{1}{F} \int_A y \cdot (\rho g y \sin \theta dA) \\
 &= \frac{\int_A (\rho g y^2 \sin \theta dA)}{\int_A (\rho g y \sin \theta dA)} = \frac{\int_A y^2 dA}{\int_A y dA} & (2.45)
 \end{aligned}$$

Similarly, from moment equilibrium about  $y$ -axis,

$$\begin{aligned}
 x_C &= \frac{1}{F} \int_A x dF \\
 &= \frac{\int_A (\rho g xy \sin \theta dA)}{\int_A \rho g y \sin \theta dA} = \frac{\int_A xy dA}{\int_A y dA} & (2.46)
 \end{aligned}$$

Again, second moment of area about  $x$ -axis, applying parallel axis theorem,

$$\int_A y^2 dA = I_x = I_{\bar{x}} + A\bar{y}^2 \quad (2.47 \text{ a})$$

and product moment of area, applying parallel axis theorem

$$\int_A xy dA = I_{xy} = I_{\bar{x}\bar{y}} + A\bar{x}\bar{y} \quad (2.47 \text{ b})$$

Substituting in equation (2.45) and (2.46),

$$y_C = \frac{I_{\bar{x}} + A\bar{y}^2}{A\bar{y}} = \frac{I_{\bar{x}}}{A\bar{y}} + \bar{y} \quad (2.48 \text{ a})$$

$$x_C = \frac{I_{\bar{x}\bar{y}} + A\bar{x}\bar{y}}{A\bar{y}} = \frac{I_{\bar{x}\bar{y}}}{A\bar{y}} + \bar{x} \quad (2.48 \text{ b})$$

It is of special mention that, while the plane area becomes symmetrical about any of the centroidal axes  $x = \bar{x}$  or  $y = \bar{y}$ , then  $I_{\bar{x}\bar{y}}$  becomes zero and

$$d = y_C - \bar{y} = \frac{I_{\bar{x}}}{A\bar{y}} \quad (2.49)$$

## 2.8 HYDROSTATIC FORCE ON SUBMERGED CURVED SURFACE

A curved surface of total area  $A$  in 3-D Cartesian coordinate system is shown in figure 2.13. Its outer surface is subjected to atmospheric pressure, while the inner surface under liquid pressure. Free surface of the liquid coincides with  $x - y$  plane. An elemental area  $dA$  is considered, while an elemental force  $dF$  acts along the outer normal to this area. If  $l$ ,  $m$ , and  $n$  be the direction cosines of the outer normal to  $dA$ , then

$$\begin{aligned} dA_x &= dA \cdot l = dA \cos\alpha \\ dA_y &= dA \cdot m = dA \cos\beta \\ dA_z &= dA \cdot n = dA \cos\gamma \end{aligned} \quad (2.50)$$

Here  $dA_x$ ,  $dA_y$ ,  $dA_z$  are the projections of  $dA$  on  $x$ -plane,  $y$ -plane and  $z$ -plane, respectively. So, along  $x$ ,  $y$  and  $z$  direction, components of forces are

$$dF_x = \rho g z dA_x$$

$$dF_y = \rho g z dA_y$$

$$dF_z = \rho g z dA_z$$

On integration total forces on those three planes are

$$F_x = \int \rho g z dA_x = \rho g \bar{z}_x A_x \quad (2.51 \text{ a})$$

$$F_y = \int \rho g z dA_y = \rho g \bar{z}_y A_y \quad (2.51 \text{ b})$$

$$F_z = \int \rho g z dA_z = \rho g A_z = \rho g \nabla \quad (2.51 \text{ c})$$

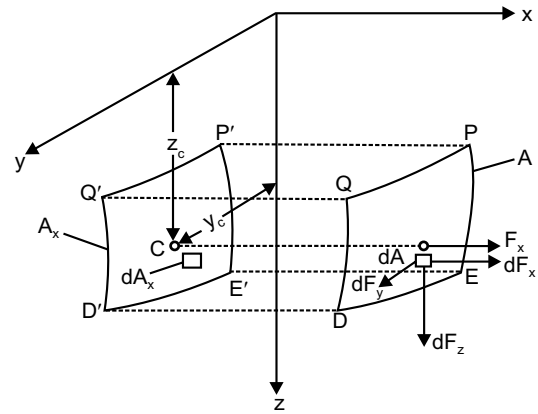

Fig. 2.13

Here  $\bar{z}_x$  and  $\bar{z}_y$  are centroid of the projected area  $A_x$  and  $A_y$  respectively and  $\nabla$  is the volume of liquid supported vertically by the surface  $A$ . To find the coordinate of centre of pressure  $C$  of the horizontal force  $F_x$ ,

$$\begin{aligned}
 z_C &= \frac{\int z \cdot dF_x}{F_x} & \text{and} & & y_C &= \frac{\int y \cdot dF_x}{F_x} \\
 &= \frac{\int z^2 \cdot dA_x}{A_x \cdot \bar{z}_x} & & & &= \frac{\int yz \cdot dA_x}{A_x \cdot \bar{z}_x} \\
 &= \frac{I_y}{A_x \cdot \bar{z}_x} & & & &= \frac{I_{yz}}{A_x \cdot \bar{z}_x} \tag{2.52}
 \end{aligned}$$

### 2.9 BUOYANCY & ARCHIMEDES LAW

While a body is submerged *entirely* or *partially* in a *non-reacting, insoluble, static* fluid, it experiences an upward vertical lift. This phenomenon is called ‘buoyancy’ and the upward thrust generated is ‘buoyant force’.

Referring to figure 2.14, the resultant horizontal force in any direction for such a closed surface is zero. To evaluate the vertical resolution of resultant hydrostatic force, an elemental vertical prism of c/s are  $dA_z$  is assumed, the top surface which is at  $z_1$  height and bottom surface at  $z_2$  height. Considering the condition of vertical equilibrium,

$$\begin{aligned}
 dF_B &= dF_2 - dF_1 \\
 &= p_2 \cdot dA_z - p_1 \cdot dA_z \\
 &= \rho g (z_2 - z_1) dA_z \\
 &= \rho g d\forall \tag{2.53}
 \end{aligned}$$

Where  $d\forall$  is the volume of the elemental prism. Integrating the equation we obtain,

$$F_B = \int_{\forall} \rho g d\forall = \rho g \forall \tag{2.54}$$

Here  $\forall$  is total volume of the body. To obtain the point of action of buoyant force,

$$\begin{aligned}
 x_B \cdot F_B &= \int x \cdot dF_B \\
 \Rightarrow x_B &= \frac{\int x \cdot \rho g d\forall}{\rho g \forall} = \frac{\int x d\forall}{\forall} \tag{2.55}
 \end{aligned}$$

And  $x_B$  is the centroid of the displaced volume of liquid. Explaining this, *Archimedes* (285–212 B.C.) propounded his famous law, which states,

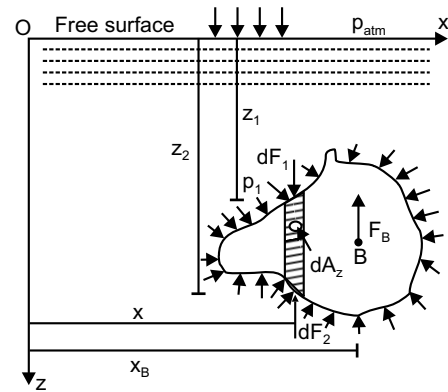

Fig. 2.14

If a body is immersed partially or entirely in a non-reacting, insoluble, static fluid, it experiences a reduction of its actual weight and this reduction equals with weight of the displaced volume of fluid.

### 2.10 EQUILIBRIUM AND METACENTRE

A body, submerged or floating in a fluid may experiences three types of hydrostatic equilibrium, depending on the relative position of centre of gravity ( $G$ ) and centre of buoyancy ( $B$ ) of the fluid. They are (i) stable equilibrium (ii) unstable equilibrium and (iii) neutral equilibrium.

A body is said to be in stable equilibrium, if being tilted by a small angle and then released, returns back to its initial position of equilibrium, by keeping the original vertical axis as vertical.

A body is said to be in unstable equilibrium, if on being tilted and released, not returns back to its original position but moves further away from it.

A body is said to be in neutral equilibrium, which when tilted by a small angle, neither returns back to its original position nor moves away from it, and simply adapts equilibrium in its new position.

A pictorial illustration is provided in figure 2.15 to show that in (i) stable equilibrium,  $G$  is below  $B$  (ii) unstable equilibrium,  $G$  is above ' $B$ ' and (iii) neutral equilibrium,  $G$  coincides with  $B$ .

In vertically stable condition  $G$  and  $B$  lies on the same vertical line. On tilt,  $G$  lies on the same old line while  $B$  shifts away. A vertical line passing through new position of  $B$  intersects the old line holding  $G$  at  $M$ . This point is defined as metacentre, and  $GM$  as metacentric height. From the adjacent figure 2.16, it can be said that,

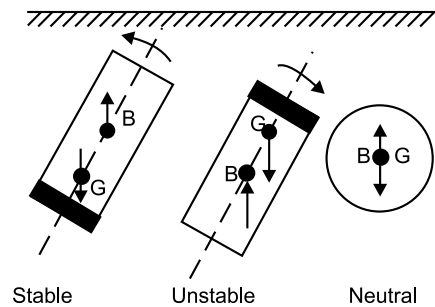

Fig. 2.15

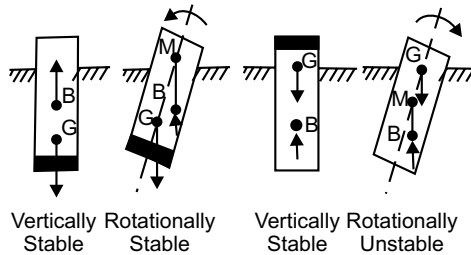

Fig. 2.16

$$\begin{aligned}
 \overline{GM} &= \overline{BM} - \overline{BG} \\
 &= 0 \quad \text{for neutral equilibrium} \\
 &> 0 \quad \text{for stable equilibrium} \\
 &< 0 \quad \text{for unstable equilibrium.}
 \end{aligned}
 \tag{2.56}$$

#### 2.10.1 Determination of Metacentric Height

Figure 2.17 shows c/s of a floating boat in equilibrium condition, with respective position of  $G$  and  $B$ . In tilted position, elemental prism (dotted line)  $mn$  of c/s  $dA$  changes to  $m'n'$ . The coordinates of  $B$  and  $B'$  are  $(x, y, z)$  and  $(x', y', z')$

Initial volume  $\nabla = \int_A z dA$  (2.57 a)

New immersed volume  $\nabla' = \int_A (z + x\alpha) dA$  (2.57 b)

If the rotation  $\alpha$  is so provided that both the above volumes remaining the same,

$$\int_A z dA = \int_A (z + x\alpha) dA$$

$$\Rightarrow \int_A x \cdot dA = 0$$

(2.58)

This implies that  $y$ -axis must pass through centroid of area  $A$ . Now,

$$\nabla \cdot x = \int_A x \cdot z dA, \quad \nabla \cdot y = \int_A y \cdot z dA, \quad \nabla \cdot z = \frac{1}{2} \int_A z^2 dA$$

(2.59)

$$\nabla' \cdot x' = \int_A x(z + x\alpha) dA, \quad \nabla' \cdot y' = \int_A y(z + x\alpha) dA, \quad \nabla' \cdot z' = \frac{1}{2} \int_A (z^2 - x^2\alpha^2) dA$$

So, considering,  $\nabla = \nabla'$

$$BB' = x' - x = \frac{\alpha}{\nabla} \int_A x^2 dA = \frac{\alpha}{\nabla} \cdot I_y$$

$$\Rightarrow BM \cdot \alpha = \frac{\alpha}{\nabla} \cdot I_y$$

$$\Rightarrow BM = \frac{I_y}{\nabla}$$

(2.60)

Hence,  $\overline{GM} = \overline{BM} - \overline{BG} = \frac{I_y}{\nabla} - \overline{BG}$  (2.61)

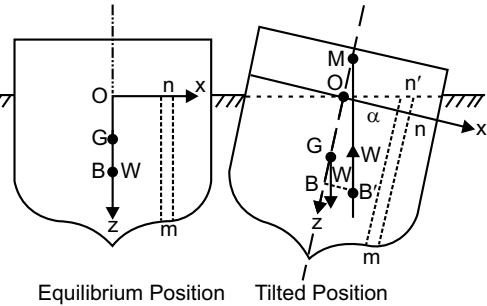

**Multiple Choice Questions**

1. Pressure at a point in a static mass of liquid depends upon
  - (a) shape and size of container
  - (b) depth below free liquid surface
  - (c) specific weight of liquid and depth below free liquid surface
  - (d) all the above
  
2. Differential form of pressure variation in static fluid is ( $z$  measured vertically upward)
 

(a) $dp = -\gamma dz$	(b) $dp = -\rho dz$
(c) $dp = -\gamma dz$	(d) $dp = -z dp$
  
3. Atmospheric pressure is
 

(a) gauge pr. – Abs. pr.	(b) abs. pr. – Gauge pr.
(c) abs. pr. – Vacuum pr.	(d) gauge pr. + Vacuum pr.

4. Pressure in metre of oil (sp. gr. = 0.78), equivalent to 80 m of water is
  - (a) 64.32
  - (b) 80.64
  - (c) 102.56
  - (d) 88.18
5. In isothermal atmosphere, the pressure
  - (a) varies in same way as in density
  - (b) linearly decrease with elevation
  - (c) exponentially increase with elevation
  - (d) remains constant
6. To avoid capillary correction in manometer, diameter of tube should be
  - (a) = 5 mm
  - (b) < 3 mm
  - (c) < 5 mm, > 3 mm
  - (d) ≥ 6 mm
7. Centre of pressure for a plane, vertically immersed in static mass of fluid is
  - (a) always above centroid of area
  - (b) always coinciding with centroid of area
  - (c) sometimes above, sometimes below centroid of area
  - (d) always below centroid of area
8. Horizontal force component on a submerged curved surface is
  - (a) weight of liquid vertically above the surface
  - (b) weight of liquid retained in the surface
  - (c) product of area and pr. at centroid
  - (d) force on a vertical projection of curved surface
9. Vertical force component on a submerged curved surface is
  - (a) force on horizontal projection of curved surface
  - (b) product of area and pr. at centroid
  - (c) weight of liquid vertically above curved surface
  - (d) its horizontal component
10. A small boat carrying 5 passengers in a pond. If all passengers jump out of boat to pond, the water level in pond will
  - (a) rise
  - (b) fall
  - (c) not change
11. Buoyant force is
  - (a) resultant force on floating body from fluid surrounding
  - (b) resultant force on any body
  - (c) volume of displaced liquid
  - (d) force necessary to maintain equilibrium of a submerged body
12. Line of action of buoyant force acts through
  - (a) C.G. of any submerged body
  - (b) centroid of volume of any floating body
  - (c) centroid of displaced volume of fluid
  - (d) centroid of horizontal projection of body

13. A body will float in stable equilibrium, if
  - (a) metacentric height zero
  - (b) C.G. is below centre of buoyancy
  - (c) metacentric height positive and C.G. above centre of buoyancy
  - (d) metacentre above C.G.
14. Normal stress is same in all direction at a point in a fluid
  - (a) when the fluid is at rest
  - (b) when fluid is inviscid
  - (c) when fluid is inviscid and incompressible
15. Hydrostatic force on one side of a circular surface of unit area, with centroid 10 m below free water level (density  $\rho$ ) is
  - (a)  $< 10 \rho g$
  - (b)  $= 10 \rho g$
  - (c)  $\rho g \times$  vert.dist. from free surface to centre of pressure
  - (d) none of the above.
16. Differential manometer is used to measure
  - (a) velocity at a point in fluid
  - (b) pressure at a point in fluid
  - (c) difference of pressure between two points in fluid
  - (d) none of the above
17. Water column equivalent to 760 mm of mercury is
  - (a) 1.033 m
  - (b) 10.33 m
  - (c) 0.033 N/mm
  - (d) 10.33 N/mm<sup>2</sup>
18. Hydrostatic law states that rate of increase of pressure in a vertical direction is equal to
  - (a) density of fluid
  - (b) specific gravity of fluid
  - (c) specific weight of fluid
  - (d) none of the above
19. Sensitiveness of an ordinary *U*-tube manometer can be increased without changing manometer fluid by
  - (a) setting it horizontal
  - (b) keeping it vertical
  - (c) setting it inclined
  - (d) none of the above
20. A manometer may be
  - (a) single limbed
  - (b) double limbed
  - (c) multilimbed
  - (d) all of the above
21. Mercury is used in barometer on account of
  - (a) negligible capillary effect
  - (b) high density
  - (c) very low vapour pressure
  - (d) low compressibility

- 
22. The problems of hydrostatics are influenced by following forces
- (a) gravity and viscous force
  - (b) gravity and pressure force
  - (c) viscous and surface tension force
  - (d) gravity and surface tension force
23. Indicate the variation of hydrostatic pressure with depth below free surface
- (a) it decreases with increase in depth
  - (b) there is no change with depth
  - (c) it increases with increase in depth
  - (d) after a certain depth, there is no change in pressure
24. Absolute pressure in flow system
- (a) always above local atm. pr.
  - (b) is a vacuum pressure
  - (c) may be above, below or equal to the local atm. pr.
  - (d) is also called negative pr.
25. Local atmospheric pressure is measured by
- (a) barometer
  - (b) bourdon gauge
  - (c) vacuum gauge
  - (d) manometer
26. Gauge pressure in flow system are measured by
- (a) manometer
  - (b) aneroid barometer
  - (c) vacuum gauge
  - (d) bourdon gauge
27. Absolute pressure is measured by
- (a) Bourdon gauge
  - (b) aneroid barometer
  - (c) differential manometer
  - (d) hook gauge
28. Point through which resultant hydrostatic force acts is called
- (a) metacentre
  - (b) centre of pressure
  - (c) centre of buoyancy
  - (d) centre of gravity
29. Mercury is used in manometer for measuring
- (a) low pressure accurately
  - (b) large pressure only
  - (c) all pressure except smaller ones
  - (d) very low pressure
30. A floating body displaces a volume of liquid equal to
- (a) its own volume
  - (b) its own weight
  - (c) its submerged weight
  - (d) none of the above
31. Centre of buoyancy is
- (a) the point through submerged weight of body acts
  - (b) the point through which buoyancy force acts
  - (c) the point through which resultant hydrostatic force acts
  - (d) centre of gravity of liquid displaced by the body

32. Metacentric height is the distance between  
 (a) C.G. and metacentre (b) C.G. and centre of buoyancy  
 (c) metacentre and centre of buoyancy (d) none of the above
33. Metacentric height of a floating body depends on  
 (a) the shape of its water-line area (b) volume of liquid displaced by the body  
 (c) distance between metacentre and C.G. (d) none of the above
34. A floating body will remain in stable equilibrium so long as  
 (a) metacentre lies below C.G. (b) metacentre above C.G.  
 (c) metacentre and C.G. at the same position (d) none of the above
35. A differential manometer is used for measurement of  
 (a) pressure at a point (b) velocity at a point  
 (c) difference of pressure at two points (d) discharge

### Answers

1. (c) 2. (a) 3. (b) 4. (c) 5. (c) 6. (d) 7. (d) 8. (d) 9. (c) 10. (b)  
 11. (d) 12. (c) 13. (d) 14. (a) 15. (c) 16. (c) 17. (b) 18. (c) 19. (c) 20. (d)  
 21. (c) 22. (b) 23. (c) 24. (c) 25. (a) 26. (a) 27. (b) 28. (b) 29. (c) 30. (b)  
 31. (b) 32. (a,b) 33. (a) 34. (b) 35. (c)

### True or False

1. Law of Archimedes is valid for a vessel in free fall.
2. A submarine can cruise smoothly under water only when C.G. is above centre of buoyancy.
3. To decrease frequency of rolling, the metacentric height of a passenger ship is kept lower than that of naval or cargo ship.
4. Centre of pressure is independent of orientation of the area.
5. A piezometer is used to measure gauge pressure of liquid.
6. Pascal's Law is not valid for incompressible fluid.
7. Different diameters in two limbs of a *U*-tube manometer will not affect operation of manometer.
8. Pressure decreases as depth of liquid increases.
9. Fluid pressure on a surface rarely acts normal to the surface.
10. Study of pressure exerted by fluid in motion is known as hydrostatics.

### Answers

1. True            2. False            3. True            4. False            5. True  
 6. False            7. False            8. False            9. False            10. False

### Fill in the Blanks

1. Body and Surface force acting on a fluid element in static equilibrium are \_\_\_\_\_ and \_\_\_\_\_.
2. Pressure at all points on a horizontal plane in a continuous fluid at rest is \_\_\_\_\_.
3. Pressure in a fluid at rest remains \_\_\_\_\_ on a plane normal to the body force.
4. Buoyant force in case of a satellite moving in a circular orbit is \_\_\_\_\_.
5. Once it starts to rise, an inflated balloon attains a definite height, when the buoyant force \_\_\_\_\_ the weight.
6. Centre of gravity of the displaced fluid is the centre of \_\_\_\_\_.
7. The resultant force exerted on a body by a surrounding static fluid is \_\_\_\_\_ force.
8. Centre of pressure is the \_\_\_\_\_ on the submerged area at which resultant \_\_\_\_\_ force is supposed to act.
9. Atmospheric pressure is also known as \_\_\_\_\_ pressure.
10. In measuring gauge pressure with an instrument \_\_\_\_\_ pressure is taken as datum.
11. Pressure \_\_\_\_\_ atmospheric pressure is known as vacuum pressure.
12. Any pressure measured taking datum as zero is termed as \_\_\_\_\_ pressure.
13. Name of S.I. unit of pressure is \_\_\_\_\_.
14. A pressure of absolute zero can exist only in complete \_\_\_\_\_.
15. \_\_\_\_\_ is a simplest form of single-limb manometer.
16. An inclined single limbed manometer is useful for measurement of \_\_\_\_\_ pressure.
17. \_\_\_\_\_ manometer is used to measure pressure difference between two points in closed conduit.
18. Inverted U-tube differential manometer is used for measuring difference of \_\_\_\_\_ pressure.
19. Generally for measurement of high pressure \_\_\_\_\_ gauges are used.
20. The most common type of mechanical pressure gauge is \_\_\_\_\_ pressure gauge.

### Answers

- |                     |                  |                       |                |                  |
|---------------------|------------------|-----------------------|----------------|------------------|
| 1. weight, pressure | 2. same          | 3. constant           | 4. zero        | 5. equals        |
| 6. buoyancy         | 7. buoyant       | 8. point, hydrostatic | 9. barometric  | 10. atmospheric  |
| 11. below           | 12. absolute     | 13. Pascal            | 14. vacuum     | 15. Piezometer   |
| 16. small           | 17. Differential | 18. low               | 19. mechanical | 20. Bourdon tube |

### NUMERICAL EXAMPLES

#### EXAMPLE 1

A barometer is made by dipping a graduated inverted tube into the measuring liquid open in atmosphere. Estimate the height of liquid column in the barometer where atmospheric pressure is  $100 \text{ kN/m}^2$ . (a) when the liquid is mercury and (b) when the liquid is water. The measuring temperature is  $50^\circ\text{C}$  where vapour

pressure of mercury and water  $0.015 \times 10^4 \text{ N/m}^2$  and  $1.23 \times 10^4 \text{ N/m}^2$  and densities are  $13500 \text{ kg/m}^3$  and  $980 \text{ kg/m}^3$  respectively. What would be % error if effect of vapour is neglected?

**SOLUTION**

(a) Equation of pressure equilibrium including effect of vapour pressure is

$$100 \times 10^3 = 0.015 \times 10^4 + 13500 \times 9.807 \times h_m$$

$$\Rightarrow h_m = 0.754 \text{ m}$$

without considering effect of vapour pressure,

$$100 \times 10^3 = 13500 \times 9.807 \times h'_m$$

$$\Rightarrow h'_m = 0.755 \text{ m}$$

$$\therefore \text{Percentage error} = \frac{0.755 - 0.754}{0.754} \times 100 = 0.1326$$

(b) Equation of pressure equilibrium including effect of vapour pressure is

$$100 \times 10^3 = 1.23 \times 10^4 + 980 \times 9.807 \times h_w$$

$$\Rightarrow h_w = 9.125 \text{ m}$$

without considering effect of vapour pressure,

$$100 \times 10^3 = 980 \times 9.807 \times h'_w$$

$$\Rightarrow h'_w = 10.405 \text{ m}$$

$$\therefore \text{Percentage error} = \frac{10.405 - 9.125}{9.125} \times 100 = 14.027.$$

**EXAMPLE 2**

Density ( $\text{kg/m}^3$ ) of a fluid mixture varies with  $z$  as  $\rho = 10.1 \left[ 1 - \frac{z}{500} + \left( \frac{z}{1000} \right)^2 \right]$ . Assuming the

mixture to be stationary, determine the pressure difference between bottom and top of a 60 m tall reactor.

**SOLUTION**

$$\text{As we know } \frac{dp}{dz} = -\rho g$$

$$\therefore dp = -\rho g dz = 10.1g \left[ 1 - \frac{z}{500} + \left( \frac{z}{1000} \right)^2 \right] dz$$

Integrating,

$$\int_{p_0}^p dp = -10.1g \int_0^{60} \left[ 1 - \frac{z}{500} + \left( \frac{z}{1000} \right)^2 \right] dz$$

$$\begin{aligned} \Rightarrow p - p_0 &= -10.1g \left[ z - \frac{z^2}{2 \times 500} + \frac{z^3}{3 \times 10^6} \right]_0^{60} \\ &= -10.1 \times 9.807 \left( 60 - \frac{60^2}{1000} + \frac{60^3}{3 \times 10^6} \right) \end{aligned}$$

$$= -5.593 \times 10^3 \text{ N/m}^2$$

So, the difference of pressure is 5.593 kN/m<sup>2</sup>

### EXAMPLE 3

Find the atmospheric pressure just at the end of troposphere which extends upto a height of 11.02 km from sea level. Consider a temperature variation in the troposphere as  $T = 288.16 - 6.49 \times 10^{-3}z$ , where  $z$  in metre and  $T$  in Kelvin. Atmospheric pressure at sea level is 101.32 kN/m<sup>2</sup>.

**SOLUTION**

As we know  $\frac{dp}{dz} = -\rho g$  and  $p = \rho RT$

$$\therefore dp = -\rho g dz = \frac{-p}{RT} g dz$$

$$\Rightarrow \frac{dp}{p} = -\frac{g dz}{RT} = -\frac{g}{R} \cdot \frac{dz}{(288.16 - 6.49 \times 10^{-3}z)} \quad (a)$$

Integrating equation (a)

$$\ln\left(\frac{p}{p_0}\right) = \frac{g}{R} \cdot \ln\left[\frac{(288.16 - 6.49 \times 10^{-3}z)}{(288.16 - 6.49 \times 10^{-3}z_0)}\right] \times \frac{1}{6.49 \times 10^{-3}} \quad (b)$$

Now,  $p_0 = 101.32 \times 10^3 \text{ N/m}^2$ ,  $z_0 = 0$ ,  $z = 11.02 \times 10^3 \text{ m}$ ,  $R = 287 \text{ J/kg K}$

Substituting in equation (b)

$$\begin{aligned} \ln p - \ln(101.32 \times 10^3) \\ = \frac{9.807}{287} \ln\left[\frac{(288.16 - 6.49 \times 10^{-3} \times 11.02 \times 10^3)}{288.16}\right] \times \frac{1}{6.49 \times 10^{-3}} \end{aligned}$$

$$\Rightarrow \ln p = 10.024$$

$$\Rightarrow p = (e)^{10.024} = 22561.76 \text{ N/m}^2 = 22.562 \text{ kN/m}^2.$$

### EXAMPLE 4

Find the pressure at an elevation of 300 m above the sea level by assuming (a) an isothermal condition of air and (b) an isentropic condition of air. Pressure and temperature at sea level are 101.32 kN/m<sup>2</sup> and 293.15 K. Consider air to be an ideal gas with  $R = 287 \text{ J/kgK}$  and  $\gamma = 1.4$

**SOLUTION**

(a) As we know  $\frac{dp}{\rho} = -g \cdot dz$  and  $\frac{p}{\rho} = \frac{p_0}{\rho_0}$

$$\therefore \frac{dp}{p} \cdot \frac{p_0}{\rho_0} = -g \cdot dz \quad (a)$$

Integrating (a),

$$\frac{p_0}{\rho_0} \int_{p_0}^p \frac{dp}{p} = -g \int_{z_0}^z dz \tag{b}$$

Finally from equation (2.17), we obtain,

$$p = p_0 \cdot \exp \left[ \frac{-g(z - z_0)}{RT_0} \right] \tag{c}$$

[Students will have to complete the integration obtained from (b) to (c). Otherwise marks will be deducted in University Exam.]

Here,

$$p_0 = 101.32 \text{ kN/m}^2, T_0 = 293.15 \text{ K}, R = 287 \text{ J/kgK.}$$

$$z_0 = 0, z = 3000 \text{ m.}$$

Substituting in equation (c)

$$p = 71.42 \text{ kN/m}^2$$

(b) Go through article 2.3.3 and deduce the final equation as,

$$\frac{p}{p_0} = \left[ 1 - (z - z_0) \frac{g}{RT_0} \left( \frac{\gamma - 1}{\gamma} \right) \right]^{\frac{\gamma}{\gamma - 1}} \tag{d}$$

Substituting the values and  $\gamma = 1.4$

$$p = 70.07 \text{ kN/m}^2.$$

**EXAMPLE 5**

What is the pressure intensity in the ocean at a depth of 1500 m, assuming (a) salt water incompressible with specific weight of 10050 N/m<sup>3</sup> and (b) salt water compressible and weight 10050 N/m<sup>3</sup> at the free surface and  $E = 2070 \text{ MN/m}^2$  (constant).

**SOLUTION**

(a) Here pressure

$$p = \rho gh = 10050 \times 1500 \text{ N/m}^2 = 15.075 \text{ MPa}$$

(b) As we know

$$\frac{1}{\rho} \frac{dp}{dz} = g \text{ and } E = \rho \frac{dp}{d\rho},$$

Clubbing both equations we obtain,

$$\frac{E \cdot d\rho}{\rho} = g\rho dz \tag{a}$$

Integrating,

$$E \int_{\rho_0}^{\rho} \frac{d\rho}{\rho^2} = g \int_{z_0}^z dz$$

$$\Rightarrow \frac{E}{g} \left[ -\frac{1}{\rho} \right]_{\rho_0}^{\rho} = (z - z_0)$$

$$\Rightarrow \frac{E}{g} \left( \frac{1}{\rho_0} - \frac{1}{\rho} \right) = (z - z_0)$$

$$\Rightarrow \frac{\rho}{\rho_0} = \frac{E}{E - \rho_0 g (z - z_0)} \quad (b)$$

Again, 
$$dp = E \frac{d\rho}{\rho} \quad (c)$$

Integrating, 
$$\int_{p_0}^p dp = E \int_{\rho_0}^{\rho} \frac{d\rho}{\rho} \quad (d)$$

$$\Rightarrow p - p_0 = E \cdot \ln \left( \frac{\rho}{\rho_0} \right) \quad (e)$$

From equations (b) and (e)

$$p - p_0 = E \cdot \ln \left( \frac{E}{E - \rho_0 g (z - z_0)} \right) \quad (f)$$

Substituting the values,

$$p = 15.13 \text{ MPa.}$$

#### EXAMPLE 6

A hydraulic press has a ram of 28 cm diameter and plunger of 5 cm diameter. How much weight can be lifted by the press when 438 N force is applied on the piston?

**SOLUTION**

$$\text{c/s area of ram} = \frac{\pi}{4} \times (0.28)^2 \text{ m}^2 = 0.06157 \text{ m}^2$$

$$\text{c/s area of plunger} = \frac{\pi}{4} \times (0.05)^2 \text{ m}^2 = 1.9634 \times 10^{-3} \text{ m}^2$$

Stress or pressure intensity on plunger

$$= \frac{438}{1.9634 \times 10^{-3}} \text{ N/m}^2 = 223082.408 \text{ N/m}^2$$

Same pressure intensity will act under ram, by virtue of Pascal's law

$$\therefore \text{Force generated over ram} = (223082.408 \times 0.06157) \text{ N} \\ = 13.735 \text{ kN.}$$

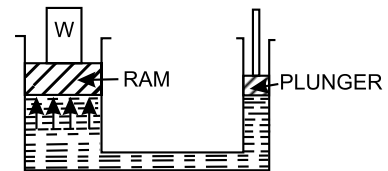

#### EXAMPLE 7

In the adjacent figure, left tube is filled with water, right tube with  $\text{CCl}_4$  (sp.gr. = 1.59) and middle bent part with compressed air at  $300 \text{ kN/m}^2$ . Barometer reads 76 cm of mercury. Determine

- pressure difference in  $\text{kN/m}^2$  between  $A$  and  $B$ , if  $z = 0.45 \text{ m}$
- absolute pressure in  $B$  in mm of mercury.

**SOLUTION**

Following the mnemonic in (2.31),

Absolute pressure at  $A$

$$p_A = (300 \times 10^3 + 1.8 \times 10^3 \times 9.807) \text{ N/m}^2 \\ = (317.6526 \times 10^3) \text{ N/m}^2$$

Absolute pressure at B

$$p_B = [300 \times 10^3 + (1.8 - 0.45) \times 10^3 \times 9.807 \times 1.59] \text{ N/m}^2$$

$$= (321.0507 \times 10^3) \text{ N/m}^2$$

∴ Pressure difference between A and B

$$p_B - p_A = (3.3981 \times 10^3) \text{ N/m}^2$$

$$= 3.391 \text{ kN/m}^2$$

Equivalent height of mercury column for absolute pressure at B

$$= \frac{321.0507 \times 10^3}{10^3 \times 9.807 \times 13.569} \text{ m} = 2.4078 \text{ m.}$$

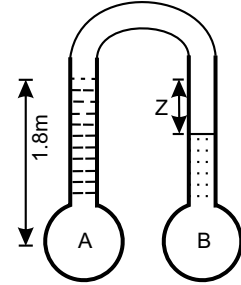

**EXAMPLE 8**

A multi-tube using water and mercury is used to measure pressure of air in a vessel, as shown in the figure. For the given values of height, calculate gauge pressure in the vessel.  $h_1 = 0.5 \text{ m}$ ,  $h_2 = 0.5 \text{ m}$ ,  $h_3 = 0.3 \text{ m}$ ,  $h_4 = 0.7 \text{ m}$ ,  $h_5 = 0.1 \text{ m}$ ,  $h_6 = 0.5 \text{ m}$

**SOLUTION**

Specific weight of air ( $\gamma_a$ ) = 12 N/m<sup>3</sup>

water ( $\gamma_w$ ) =  $10^3 \times 9.807 = 9807 \text{ N/m}^3$

mercury ( $\gamma_m$ ) =  $13.596 \times 9.807 = 133335.97 \text{ N/m}^3$

As the pressure is to be expressed in gauge pressure,  $p_{atm} = 0$  at open end of tube. Following the principle in (2.31), equation of pressure equilibrium is

$$p_{atm} + h_6 \cdot \gamma_m + h_5 \cdot \gamma_m - h_5 \cdot \gamma_w - h_4 \cdot \gamma_w + h_4 \cdot \gamma_m$$

$$- h_3 \cdot \gamma_m - (h_2 - h_3) \gamma_w + h_2 \cdot \gamma_m - h_1 \cdot \gamma_a = p$$

$$\Rightarrow p = 0 + 0.5 \gamma_m + 0.1 \gamma_m - 0.1 \gamma_w - 0.7 \gamma_w + 0.7 \gamma_m - 0.3 \gamma_m - (0.5 - 0.3) \gamma_w + 0.5 \gamma_m - 0.4 \gamma_a$$

$$= (0.5 + 0.1 + 0.7 - 0.3 + 0.5) \gamma_m - (0.1 + 0.7 - 0.2) \gamma_w - 0.4 \gamma_a = 1.5 \gamma_m - 0.6 \gamma_w - 0.4 \gamma_a$$

$$= 1.5 \times 133335.97 - 0.6 \times 9807 - 0.4 \times 12$$

$$= 194114.955 \text{ N/m}^2$$

$$= 194.11 \text{ kN/m}^2.$$

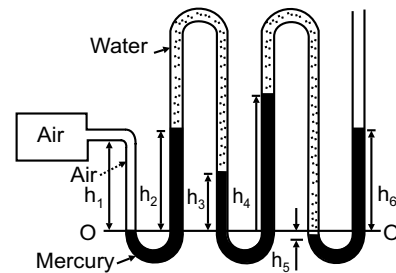

**EXAMPLE 9**

A typical differential manometer is attached to two sections at A and B, as in the figure. Calculate pressure difference between sections A and B. Densities of water and mercury 1000 kg/m<sup>3</sup> and 13570 kg/m<sup>3</sup>, respectively.

**SOLUTION**

Here,  $p_G = p_C = p_D$  and  $p_E = p_F$

So, following the principle in (2.31),

$$p_A - \rho_w \cdot g \cdot z - \rho_w \cdot g \cdot 0.6 + \rho_w \cdot g \cdot (0.6 + z) = p_B$$

$$\Rightarrow p_A - p_B = 0.6 \cdot \rho_m \cdot g - 0.6 \cdot \rho_w \cdot g$$

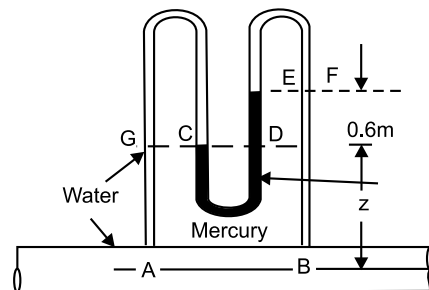

$$= 0.6 (13570 - 1000) \times 9.807 \text{ N/m}^2$$

$$= 73964.39 \text{ N/m}^2 = 73.96 \text{ kN/m}^2$$

**EXAMPLE 10**

Diameters of reservoir and tube in an inclined tube manometer are 50 mm and 5 mm respectively. What will be % error in measuring  $p_s$ , if reservoir deflection is neglected?

**SOLUTION**

Let the level of gauge fluid deflects from  $b - b$  to  $c - c$ , by a height ' $h$ '.

From continuity of fluid,

$$\frac{\pi}{4} \times (50)^2 \times h = \frac{\pi}{4} \times (5)^2 \times R$$

$$\Rightarrow h = 0.01 R$$

Now  $p_{C-C} = p_D$

$$\Rightarrow p_s = \rho_g \cdot g (h + R \sin \theta)$$

$$= \rho_g \cdot g (0.01R + R/2)$$

$$= \rho_g \times g \times 0.51R$$

Again without considering deflection of gauge fluid

$$p'_s = p_{b-b} = \rho_g \times g \times R \sin \theta = \rho_g \times g \times 0.5 R$$

From (c) and (d) error in per cent

$$= \frac{p_s \times p'_s}{p_s} \times 100 = \frac{0.01}{0.51} \times 100 = 1.96$$

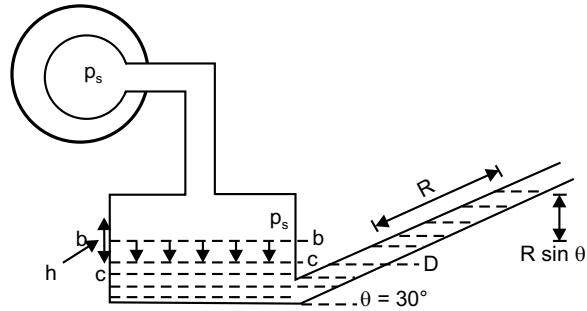

(a)

(b)

(c)

(d)

**EXAMPLE 11**

Calculate the pressure difference between pipes  $A$  and  $B$  for the inverted  $U$ -tube manometers.

**SOLUTION**

From equilibrium of pressure,

$$p_A - 0.165 \rho_w \cdot g + 0.05 \rho_{oil} \cdot g + (0.165 - 0.05 - 0.05) \rho_w \cdot g = p_B$$

$$\Rightarrow p_A - p_B = 0.165 \cdot \rho_w \cdot g - 0.065 \cdot \rho_w \cdot g - 0.05 \cdot \rho_{oil} \cdot g$$

$$= 0.1 \times 10^3 \times 9.807 - 0.05 \times 0.9 \times 10^3 \times 9.807$$

$$= 539.385 \text{ N/m}^2$$

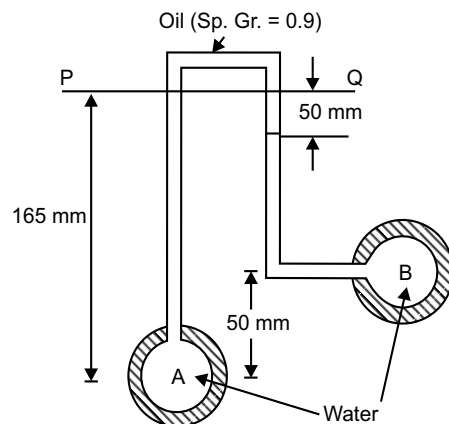

**EXAMPLE 12**

A manometer attached to a tank containing three different fluids is shown in the figure. What will be the difference in the elevation of the mercury column in the manometer?

**SOLUTION**

The equation of pressure equilibrium will be,

$$\begin{aligned}
 p_{\text{air}} + p_{\text{oil}} + p_{\text{water}} + \rho_w \times g \times 1.0 - \rho_m \times g \times y &= 0 \\
 \Rightarrow 30 \times 10^3 + 0.82 \times 10^3 \times 9.807 \times (5 - 2) + 10^3 \times 9.807 \times (2 - 0) \\
 &+ 10^3 \times 9.807 \times 1.0 = 13.596 \times 10^3 \times 9.807 \times y \\
 \Rightarrow (13.596 \times 9.807)y &= 30 + 0.82 \times 9.807 \times 3 + 9.807 \times 3 \\
 \Rightarrow y &= 0.6265 \text{ m.}
 \end{aligned}$$

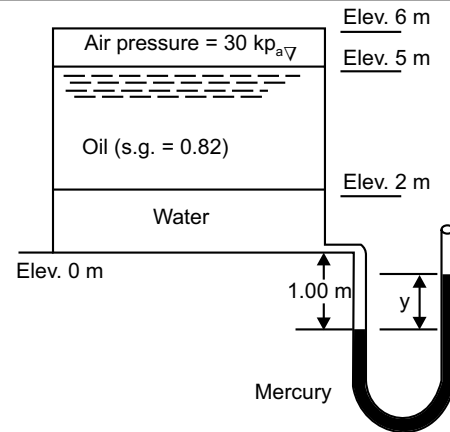

**EXAMPLE 13**

A differential manometer is attached to two tanks, as in the figure. Calculate pressure difference between chambers A and B. Specific gravities of oil, carbon tetrachloride and mercury are 0.89, 1.59 and 13.596 respectively.

**SOLUTION**

From the equilibrium of pressure,

$$\begin{aligned}
 p_A + 0.89 \times 10^3 \times 9.807 \times 1.1 + 13.596 \times 10^3 \times 9.807 \times 0.3 \\
 - 1.59 \times 10^3 \times 9.807 \times 0.8 - p_B &= 0 \\
 p_A - p_B &= 12474.504 - 9601.053 - 40000.792 \\
 &= -37127.341 \text{ N/m}^2 = -37.127 \text{ kPa}
 \end{aligned}$$

The result shows that  $p_B$  is higher than  $p_A$  and the difference of pressure is 37.127 kPa.

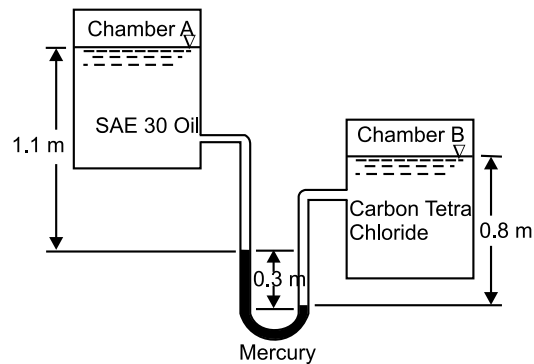

**EXAMPLE 14**

Determine the pressure difference between points A and B. Specific gravities of benzene, kerosene and air are 0.88, 0.82 and  $1.2 \times 10^{-3}$  respectively.

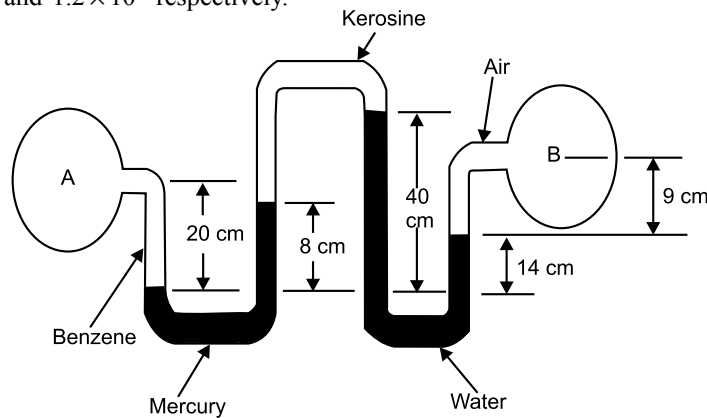

**SOLUTION**

Considering pressure equilibrium

$$\begin{aligned}
 p_A + \gamma_b \times 0.2 - \gamma_m \times 0.08 - \gamma_k \times (0.4 - 0.08) + \gamma_w \times (0.4 - 0.14) - \gamma_a \times 0.09 &= p_B \\
 \Rightarrow p_A - p_B &= \gamma_m \times 0.08 + \gamma_k \times 0.32 + \gamma_a \times 0.09 - \gamma_b \times 0.2 - \gamma_w \times 0.26 \\
 &= 13.596 \times 10^3 \times 9.807 \times 0.08 + 0.82 \times 10^3 \times 9.807 \times 0.32 \\
 &\quad + 1.2 \times 10^{-3} \times 10^3 \times 9.807 \times 0.09 - 0.88 \times 10^3 \times 9.807 \times 0.20 - 10^3 \times 9.807 \times 0.26 \\
 &= 10^3 \times 9.807 (1.08768 + 0.2624 + 1.08 \times 10^{-4} - 0.176 - 0.26) \\
 &= 8965.44 \text{ N/m}^2 = 8.965 \text{ kPa}
 \end{aligned}$$

**EXAMPLE 15**

Referring to the figure, if  $p_B - p_A = 99.0 \text{ kPa}$ , what must the height  $H$  be? Sp. gravity of Meriam red oil = 0.827.

**SOLUTION**

From equilibrium of pressure,

$$\begin{aligned}
 p_A - \gamma_w \times H - \gamma_0 \times 0.18 + \gamma_m \times (0.18 + H + 0.35) &= p_B \\
 \Rightarrow p_B - p_A &= -\gamma_w \times H - \gamma_0 \times 0.18 + \gamma_m \times (H + 0.53) \\
 &= (\gamma_m - \gamma_w) H - \gamma_0 \times 0.18 + \gamma_m \times 0.53 \\
 &= (13.596 - 1) \times 10^3 \times 9.807 \times H - 0.827 \times 10^3 \times 9.807 \\
 &\quad \times 0.18 + 13.596 \times 10^3 \times 9.807 \times 0.53 \\
 \Rightarrow 99 \times 10^3 &= 7.057 \times 10^3 \times 9.807 + 12.596 \times 10^3 \times 9.807 \times H \\
 \Rightarrow -12.596 \times 9.807 \times H &= 7.057 \times 9.807 - 99 \\
 \Rightarrow H &= 0.241 \text{ m}
 \end{aligned}$$

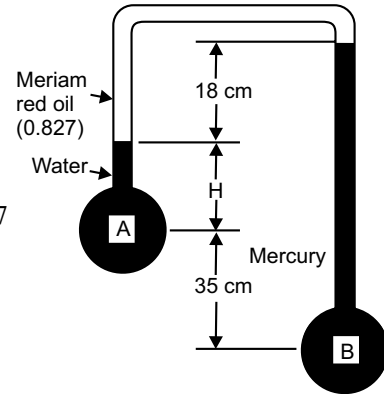
**EXAMPLE 16**

Neglecting air pressure, compute the difference in pressure in tanks  $A$  and  $B$ , while  $d_1 = 300 \text{ mm}$ ,  $d_2 = 150 \text{ mm}$ ,  $d_3 = 460 \text{ mm}$ ,  $d_4 = 200 \text{ mm}$ .

**SOLUTION**

Equation of pressure equilibrium will be

$$\begin{aligned}
 p_A + \gamma_w \times d_1 - \gamma_m \times d_3 - \gamma_m \times d_4 \sin 45^\circ &= p_B \\
 \Rightarrow p_A - p_B &= \gamma_m \times 0.46 + \gamma_m \times 0.2 \times 1/\sqrt{2} - \gamma_w \times 0.3 \\
 &= 10^3 \times 9.807 (13.596 \times 0.46 + 13.596 \times 0.2 \times 1/\sqrt{2} - 0.3) \\
 &= 77249 \text{ N/m}^2 \\
 &= 77.249 \text{ kN/m}^2
 \end{aligned}$$

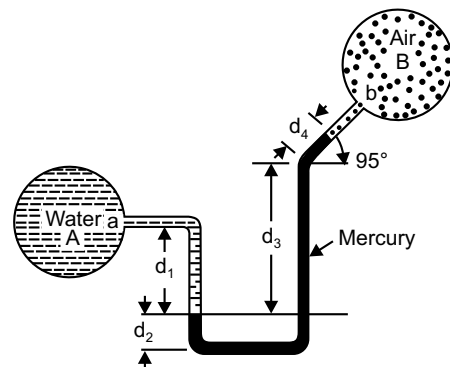
**EXAMPLE 17**

For the setup shown in the figure, what is the absolute pressure in drum  $A$  at position  $a$ ? Assume an atmospheric pressure of  $101.3 \text{ kPa}$ .

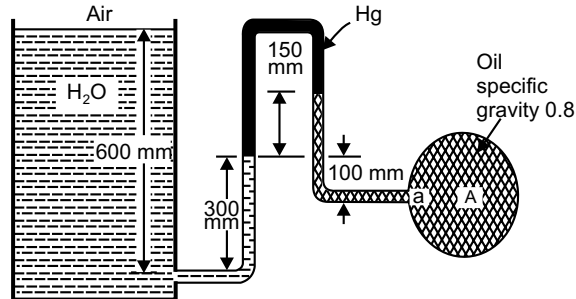

**SOLUTION**

From the equation of pressure equilibrium,

$$\begin{aligned}
 p_{\text{atm}} + \gamma_w \times (0.6 - 0.3) - \gamma_m \times 0.15 + \gamma_o \times (0.15 + 0.1) &= p_A \\
 \Rightarrow p_A &= 101.3 \times 10^3 + 10^3 \times 9.807 \times 0.3 - 13.596 \times 10^3 \times 9.807 \times 0.15 \\
 &\quad + 0.8 \times 10^3 \times 9.807 \times 0.25 \\
 &= 86.203 \text{ kPa}
 \end{aligned}$$

**EXAMPLE 18**

The pressure and temperature of air at MSL are 101.3 kN/m<sup>2</sup> and 15°C respectively. Calculate the pressure and density at an altitude of 3 km, if the lapse rate is 7°C per km, and  $R = 287 \text{ J/kg K}$ .

**SOLUTION**

For any polytropic state,

$$\begin{aligned}
 \frac{p}{\rho^n} &= \frac{p_0}{\rho_0^n} \\
 \Rightarrow \frac{\rho RT}{\rho^n} &= \frac{\rho_0 RT_0}{\rho_0^n} && [\because p = \rho RT \text{ and } p_0 = \rho_0 RT_0] \\
 \Rightarrow \frac{T}{\rho^{n-1}} &= \frac{T_0}{\rho_0^{n-1}} \\
 \Rightarrow \frac{T}{T_0} &= \left( \frac{\rho}{\rho_0} \right)^{n-1} && \text{(a)}
 \end{aligned}$$

Again,

$$\begin{aligned}
 \frac{p}{p_0} &= \frac{\rho RT}{\rho_0 RT_0} = \left( \frac{\rho}{\rho_0} \right) \left( \frac{T}{T_0} \right) \\
 &= \left( \frac{T}{T_0} \right)^{\frac{1}{n-1}} \cdot \left( \frac{T}{T_0} \right) \\
 &= \left( \frac{T}{T_0} \right)^{\frac{n}{n-1}} && \text{(b)}
 \end{aligned}$$

Change of pressure in a polytropic state, as given in equation (2.26)

$$\frac{p}{p_0} = \left[ 1 - (z - z_0) \frac{g}{RT_0} \left( \frac{n-1}{n} \right) \right]^{\frac{n}{n-1}} \quad (c)$$

$$\Rightarrow \left( \frac{T}{T_0} \right)^{\frac{n}{n-1}} = \left[ 1 - (z - z_0) \frac{g}{RT_0} \frac{n-1}{n} \right]^{\frac{n}{n-1}}$$

$$\Rightarrow \frac{T}{T_0} = \left[ 1 - \left( \frac{n-1}{n} \right) \frac{gz}{RT_0} \right] \quad (d)$$

differentiating (d) with respect to 'z'

$$\frac{dT}{dz} = - \frac{g}{R} \left( \frac{n-1}{n} \right)$$

$$\Rightarrow n = \left[ 1 - \frac{R}{g} \left( \frac{dT}{dz} \right) \right]^{-1} \quad (e)$$

So, the polytropic power index  $n$  for the present case will be

$$\begin{aligned} n &= \left[ 1 - \frac{287}{9.807} \times \left( \frac{7}{1000} \right) \right]^{-1} \\ &= 1.2576 \end{aligned}$$

Applying equation (c),

$$\begin{aligned} \frac{p}{p_0} &= \left[ 1 - (3000 - 0) \frac{9.807}{287 \times (273 + 15)} \left( \frac{1.2576 - 1}{1.2576} \right) \right]^{\frac{1.2576}{1.2576 - 1}} \\ &= 0.6910 \end{aligned}$$

$$\begin{aligned} \Rightarrow p &= 101.3 \times 0.6910 \\ &= 70.00 \text{ kN/m}^2 \end{aligned}$$

Applying equation (2.27), temperature at 3000 m will be

$$\begin{aligned} T &= T_0 - \alpha z \\ &= \left[ \left( 15 - \frac{7}{1000} \times 3000 \right) + 273 \right] \\ &= 267 \text{ K} \end{aligned}$$

From the equation of state, the density at 3000 m

$$\rho = \frac{p}{RT} = \frac{70 \times 10^3}{287 \times 267} = 0.913 \text{ kg/m}^3$$

**EXAMPLE 19**

The diameters of a small piston and a large piston of a hydraulic jack are 4 cm and 11 cm respectively. A force of 85 N is applied on small piston. Find the load lifted by large piston while the small one is 40 cm above the large one. Density of liquid 1000 kg/m<sup>3</sup>.

**SOLUTION**

$$\text{c/s area of small piston } (a) = \frac{\pi}{4} \times (0.04)^2 \text{ m}^2$$

$$\text{large piston } (A) = \frac{\pi}{4} \times (0.11)^2 \text{ m}^2$$

$$\text{Force on small piston } (F_a) = 85 \text{ N}$$

So, pressure intensity at X-X

$$\begin{aligned} &= \frac{F_a}{a} + \rho \times g \times 0.4 \\ &= \frac{85}{\frac{\pi}{4} \times (0.04)^2} + 1000 \times 9.807 \times 0.4 \text{ N/m}^2 \\ &= 71563.65 \text{ N/m}^2 \end{aligned}$$

∴ Force generated on large piston

$$\begin{aligned} &= 71563.65 \times \frac{\pi}{4} \times (0.11)^2 \text{ N} \\ &= 680.09 \text{ N} \end{aligned}$$

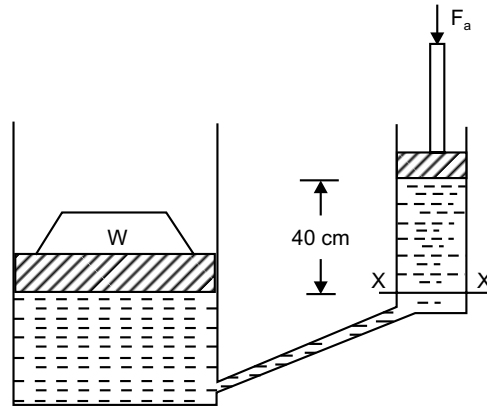

**EXAMPLE 20**

Find out the value of *h* of an inverted U-tube manometer, as shown.

**SOLUTION**

Equation of pressure equilibrium

$$p_A - \gamma_A \times 0.3 - \gamma_m \times h + \gamma_B \times (h + 0.3) - p_B = 0 \quad (a)$$

As both the pipe are in same datum,  $p_A = p_B$

$$\text{From (a), } \gamma_B \times (h + 0.3) - \gamma_m \times h - \gamma_A \times 0.3 = 0$$

$$\Rightarrow (\gamma_B - \gamma_m) h = (\gamma_A - \gamma_B) \times 0.3$$

$$\Rightarrow (1.0 - 0.7) h = (1.2 - 1.0) \times 0.3$$

$$\Rightarrow h = 0.2 \text{ m}$$

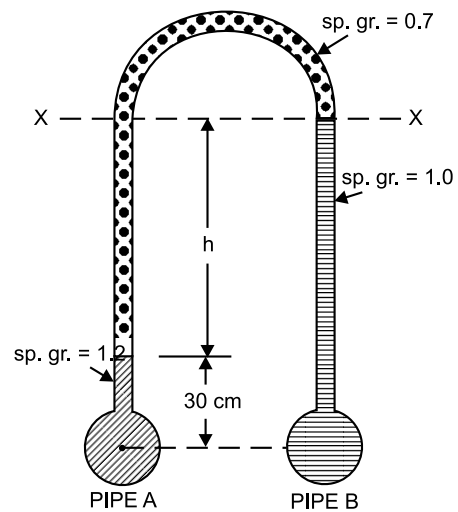

**EXAMPLE 21**

A circular plate 3 m diameter is submerged in water as shown in the figure. Its greatest and least depths are below the surface being 2 m and 1 m respectively. Find total pressure on front face of the plate and position of centre of pressure.

**SOLUTION**

$$\text{Area of the plate } (A) = \frac{\pi}{4} \times 3^2 = 7.0685 \text{ m}^2$$

$$\sin \theta = \frac{2-1}{3} = \frac{1}{3}$$

Distance of centre of gravity from the free surface of water

$$\bar{h} = 1 + 1.5 \sin \theta = 1.5 \text{ m}$$

$\therefore$  Total pressure force on the front of the plate.

$$\begin{aligned} F &= \gamma \bar{h} \cdot A \\ &= (10^3 \times 9.807 \times 1.5 \times 7.0685) \text{ N} \\ &= 103981.17 \text{ N} \end{aligned}$$

If the distance of centre of pressure from free surface of water is  $h^*$ ,

$$\begin{aligned} h^* &= \frac{I \sin^2 \theta}{A \bar{h}} + \bar{h} = \frac{\frac{\pi}{64} \times 3^4 \times \left(\frac{1}{3}\right)^2}{\frac{\pi}{4} \times 3^2 \times 1.5} + 1.5 \\ &= 1.5416 \text{ m} \end{aligned}$$

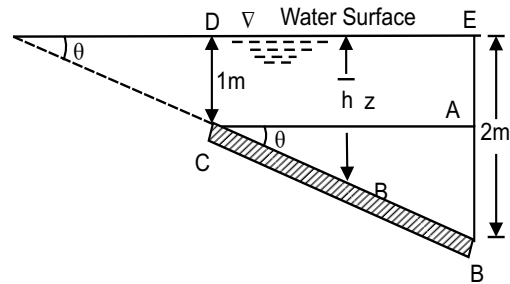
**EXAMPLE 22**

An inclined rectangular sluice gate  $AB$ ,  $1.2 \text{ m} \times 5 \text{ m}$ , shown in the figure is installed to control the discharge of water.  $A$  is hinged. Determine the force normal to the gate applied at  $B$  to open it.

**SOLUTION**

$$\text{Area of gate } (A) = (1.2 \times 5) \text{ m}^2 = 6 \text{ m}^2$$

Depth of C.G. of the gate from free surface of water

$$\begin{aligned} \bar{h} &= 5 - BG \sin 45^\circ \\ &= \left(5 - \frac{0.6}{\sqrt{2}}\right) \text{ m} = 4.576 \text{ m} \end{aligned}$$

$\therefore$  Total pressure force acting on the plate

$$\begin{aligned} F &= \gamma A \bar{h} \\ &= (10^3 \times 9.807 \times 6 \times 4.576) \text{ N} = 269260.99 \text{ N} \end{aligned}$$

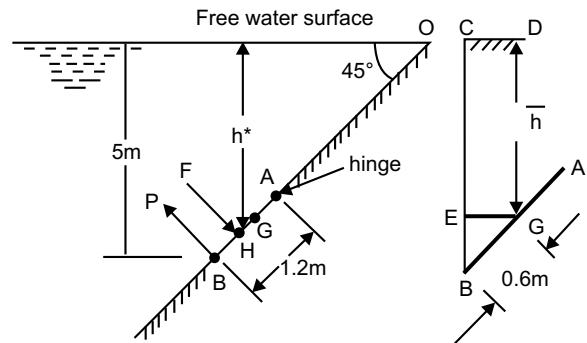

Depth of centre of pressure

$$h^* = \left( \frac{5.0 \times 1.2^3}{12} \times \frac{\sin^2 45^\circ}{6 \times 4.576} \right) + 4.576 = 4.589 \text{ m}$$

Here,  $OH = \frac{h^*}{\sin 45^\circ} = 6.489 \text{ m}$ , and  $OB = \frac{5}{\sin 45^\circ} = 7.071 \text{ m}$

$\therefore BH = OB - OH = (7.071 - 6.489) \text{ m} = 0.582 \text{ m}$   
 $AH = AB - BH = (1.2 - 0.582) \text{ m} = 0.618 \text{ m}$

Take moment of force about  $A$ ,

$$P \times AB = F \times AH$$

$$\Rightarrow P = F \times \frac{AH}{AB}$$

$$= \left( 269260.99 \times \frac{0.618}{1.2} \right) \text{ N} = 138669.41 \text{ N}$$

**EXAMPLE 23**

A cubical tank has sides of 1.5 m. It contains water for the lower 0.6 m depth. Upper remaining part is filled with oil of sp. gr. 0.9. Calculate total pressure and position of centre of pressure for one vertical side of the tank.

**SOLUTION**

The pressure intensity variation diagram is shown in the figure

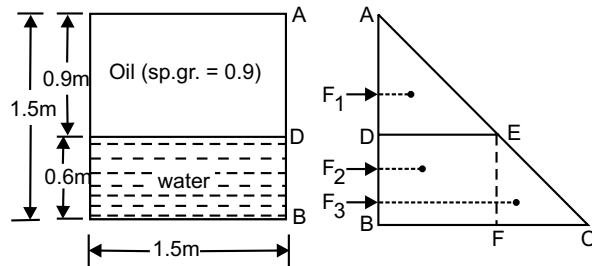

Pressure intensity

$$\begin{aligned} \text{at } D (p_D) &= \rho_{oil} \times g \times h_{oil} \\ &= (0.9 \times 10^3 \times 9.807 \times 0.9) \text{ N/m}^2 \\ &= 7943.67 \text{ N/m}^2 \end{aligned}$$

$$\begin{aligned} \text{at } B (p_B) &= 7943.67 + \rho_w \times g \times h_w \\ &= (7943.67 + 10^3 \times 9.807 \times 0.6) \text{ N/m}^2 \\ &= 13827.87 \text{ N/m}^2 \end{aligned}$$

$\therefore DE = 7943.67 \text{ N/m}^2$  and  $BC = 13,827.87 \text{ N/m}^2$

Now,

$$\begin{aligned} F_1 &= (1/2 \times 0.9 \times 7943.67) \times 1.5 = 5361.98 \text{ N} \\ h_1 &= (2/3 \times 0.9) \text{ m} = 0.6 \text{ m below } A \\ F_2 &= (0.6 \times 7943.67) \times 1.5 = 7149.303 \text{ N} \\ h_2 &= (0.9 + 0.6/2) \text{ m} = 1.2 \text{ m below } A \\ F_3 &= 1/2 \times 0.6 \times (13827.87 - 7943.67) \times 1.5 = 2647.89 \text{ N} \end{aligned}$$

$$h_3 = (0.9 + 2/3 \times 0.6) \text{ m} = 1.3 \text{ m below } A$$

$$\text{Total Force } (F) = F_1 + F_2 + F_3 = 15,159.17 \text{ N}$$

If  $F$  acts at a depth  $h^*$  from free surface of liquid, taking moment of all forces about  $A$ ,

$$F \times h^* = F_1 \times h_1 + F_2 \times h_2 + F_3 \times h_3$$

$$\begin{aligned} \Rightarrow h^* &= \frac{(5361.98 \times 0.6) + (7149.303 \times 1.2) + (2647.89 \times 1.3)}{15,159.17} \text{ m} \\ &= 1.0052 \text{ m} \end{aligned}$$

### EXAMPLE 24

The figure shows the  $c/s$  of a tank full of water under pressure. Length of the tank is 2 m. An empty cylinder lies along the length of the tank on one of its corner as shown. Find horizontal and vertical components of the force acting on the curved surface  $ABC$  of the cylinder.

**SOLUTION**

Gauge pressure indicated on the gauge

$$\begin{aligned} &= 0.2 \text{ kgf/cm}^2 = (0.2 \times 9.807) \text{ N/cm}^2 \\ &= (0.2 \times 9.807) \times 10^4 \text{ N/m}^2 \end{aligned}$$

$\therefore$  Equivalent pressure head

$$= \frac{0.2 \times 9.807 \times 10^4}{10^3 \times 9.807} \text{ m} = 2 \text{ m}$$

$\therefore$  Equivalent free surface of water will be 2 m above tank top.

$\therefore$  Horizontal component of force

$$\begin{aligned} &= \gamma \bar{h} \times (\text{area projected on vertical plane}) \\ &= 10^3 \times 9.807 \times (2 + 1.5/2) \times (1.5 \times 2) \\ &= 80907.75 \text{ N} \end{aligned}$$

Vertical component of force

$$\begin{aligned} &= \text{Weight of water supported by curved surface } ABC \\ &= \text{Weight of water in } CODEABC \\ &= \text{Weight of water in } (CODFBC - AEFB) \end{aligned} \tag{a}$$

Weight of water in  $CODFBC$  ( $W_1$ )

$$= \text{Weight of water in } (COB + ODFBO)$$

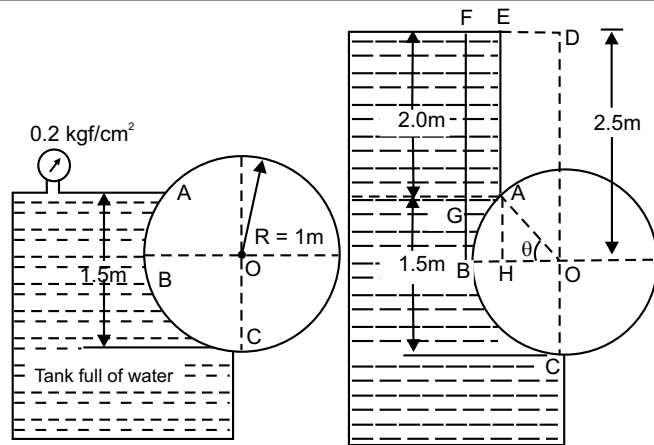

$$= \left( \frac{\pi}{4} \times 1^2 \times \gamma \right) \times 2 + (\gamma \times 1 \times 2.5) \times N$$

$$= 64439.799 \text{ N} \tag{b}$$

Weight  $AEFB$  ( $W_2$ ) =  $[\gamma \times \text{area of } (AEFG + AGBH - ABH)] \times 2 \text{ N}$  (c)  
 But area  $ABH$  = Area  $AOB - \Delta AOH$

$$= \pi R^2 \times \frac{\theta}{360^\circ} - \frac{1}{2} \times 1 \sin \theta \times 1 \cos \theta$$

$$= \pi R^2 \times \frac{30}{360^\circ} - \frac{1}{2} \times \sin 30^\circ \times \cos 30^\circ \quad \left[ \because \theta = \sin^{-1} \left( \frac{0.5}{1.0} \right) = 0.5 \right]$$

$$= 0.04529 \text{ m}^2$$

From (c),

$$W_2 = 10^3 \times 9.807 [2.0 \times (1 - 1 \cos 30^\circ) + 0.5 \times (1 - 1 \cos 30^\circ) - 0.04529] \times 2 \text{ N}$$

$$= 5681.126 \text{ N}$$

Substituting (b) and (c) in (a)

Vertical component of force

$$= (64439.799 - 5681.126) \text{ N} = 58758.673 \text{ N.}$$

**EXAMPLE 25**

A dam has a parabolic shape  $y = y_0 \left( \frac{x}{x_0} \right)^2$  as shown in figure, having  $x_0 = 6 \text{ m}$  and  $y_0 = 9 \text{ m}$ . The

fluid is water with density  $1000 \text{ kg/m}^3$ . Compute horizontal, vertical and resultant thrust exerted by water per metre length of the dam.

**SOLUTION**

Substituting values,  $y = y_0 \left( \frac{x}{x_0} \right)^2$

$$= 9 \left( \frac{x}{6} \right)^2 = \frac{x^2}{4}$$

$$\text{or, } x^2 = 4y$$

Horizontal thrust by water ( $\gamma A \bar{h}$ )

$$F_x = \text{force on vertical surface } OB$$

$$= [10^3 \times 9.807 \times (9 \times 1) \times 9/2]$$

$$= 397183.5 \text{ N}$$

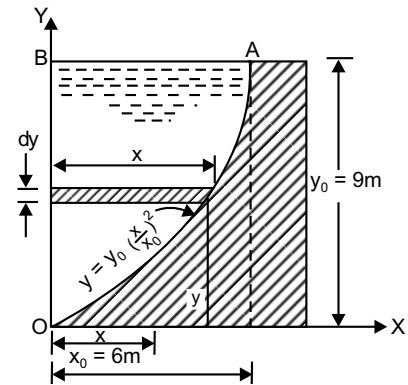

Vertical thrust by water

$$\begin{aligned}
 F_y &= \left[ 10^3 \times 9.807 \times \int_0^9 x dy \times 1 \right] \text{N} \\
 &= \left[ 9807 \times \int_0^9 2\sqrt{y} dy \right] \text{N} \\
 &= 19614 \left[ \frac{2}{3} y^{\frac{3}{2}} \right]_0^9 \text{N} \\
 &= 353052 \text{ N}
 \end{aligned}$$

Resultant thrust exerted by water

$$\begin{aligned}
 F &= \sqrt{F_x^2 + F_y^2} \\
 &= \sqrt{397183.5^2 + 353052^2} \text{ N} = 531413.63 \text{ N}
 \end{aligned}$$

and

$$\theta = \tan^{-1} \left( \frac{F_y}{F_x} \right) = 41.63^\circ$$

### EXAMPLE 26

A float valve regulates the flow of oil of sp. gr. 0.8 into a cistern. The spherical float is 15 cm in diameter.  $AOB$  is a weightless link carrying the float at one end, and a valve at the other end which closes the pipe through which oil flows into cistern. The link is mounted in a frictionless hinge at  $O$  and  $\angle AOB = 135^\circ$ .  $OA = 20$  cm and the distance between centre of the float and the hinge is 50 cm. When the flow is stopped,  $AO$  will be vertical. The valve is to be pressed on to the seat with a force of 9.81 N to completely stop the flow of oil into the cistern. It was observed that the flow of oil is stopped when the free surface of oil in the cistern is 35 cm below hinge. Determine weight of the float.

**SOLUTION**

Let weight of the float =  $W$

When the oil flow stopped, position of float is shown in the figure. Let the centre of float is  $h$  below level of oil.

$$\text{Now, } \sin 45^\circ = \frac{0.35 + h}{0.50}$$

$$\Rightarrow h = 0.00355 \text{ m}$$

$$\begin{aligned}
 \text{Volume of oil displaced} &= \frac{2}{3}\pi r^3 + \pi r^2 \times h \\
 &= \frac{2}{3}\pi(0.075)^3 + \pi(0.075)^2 \times 0.00355 \text{ m}^3 \\
 &= 9.463 \times 10^{-4} \text{ m}^3
 \end{aligned}$$

$$\begin{aligned}
 \therefore \text{Buoyant force} &= (0.8 \times 10^3 \times 9.807 \times 9.463 \times 10^{-4}) \text{ N} \\
 &= 7.424 \text{ N}
 \end{aligned}$$

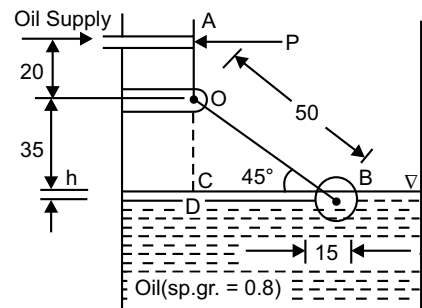

∴ Net vertical force on float =  $(7.424 - W)$  N

Take moment about hinge  $O$

$$P \times 0.2 = (7.424 - W) \times 0.5 \cos 45^\circ$$

$$\Rightarrow 9.81 \times 0.2 = (7.424 - W) \times 0.5 \times \frac{1}{\sqrt{2}}$$

$$\Rightarrow W = 1.875 \text{ N}$$

**EXAMPLE 27**

A rectangular pontoon is 5 m long, 3 m wide and 1.20 m high. The depth of immersion of the pontoon is 0.8 m in sea-water. If C.G. is 0.6 m above bottom of pontoon, determine metacentric height. The density of sea water =  $1025 \text{ kg/m}^3$ .

**SOLUTION**

Here,  $AG = 0.6 \text{ m}$ ,  $AB = 1/2 \times 0.8 = 0.4 \text{ m}$

∴  $BG = AG - AB = (0.6 - 0.4) \text{ m} = 0.2 \text{ m}$

Volume of the submerged part

$$\nabla = 3 \times 0.8 \times 5 \text{ m}^3 = 12 \text{ m}^3$$

Moment of inertia of plan of the pontoon

$$I = \frac{5 \times 3^3}{12} \text{ m}^4 = 11.25 \text{ m}^4$$

∴ Metacentric height

$$\begin{aligned} GM &= \frac{I}{\nabla} - BG \\ &= \left( \frac{11.25}{12} \right) - 0.2 \text{ m} \\ &= 0.7375 \text{ m} \end{aligned}$$

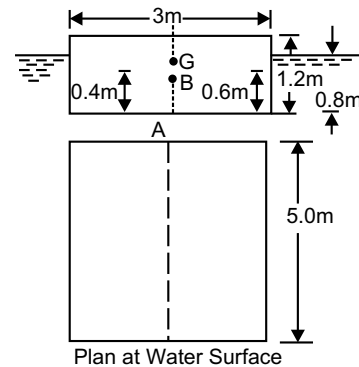

**EXERCISE**

1. State and prove Pascal's Law of pressure at a point.
2. Prove that pressure varies exponentially with elevation for isothermal condition.
3. Derive Euler's equation of motion along a streamline for an ideal fluid.
4. Differentiate between (i) absolute and gauge pressure (ii) simple manometer and differential manometer (iii) manometer and mechanical gauge.
5. Explain the working principle of a micromanometer.
6. What is temperature lapse rate? Derive its expression.

7. Find out expression for the force acting and its point of action on submerged plane surface due to hydrostatic effect.
8. Explain how will you find the resultant pressure on a curved surface immersed in a liquid.
9. Define the term buoyancy and centre of buoyancy. Obtain the expression for buoyant force and its centre of action.
10. What is metacentre? Derive an expression for metacentric height in terms of centre of gravity and centre of buoyancy.
11. An open tank contains water up to a depth of 1.5 m and above it an oil of sp.gr. = 0.8 for a depth of 2 m. Find the pressure intensity at the interface of the two liquids and at bottom of the tank.  
**Ans.** [15.7 kPa, 30.4 kPa]
12. Diameters of a small piston and a large piston of a hydraulic jack are 2 cm and 10 cm respectively. A force of 60 N is applied on the small piston. Find the load lifted by large piston when (i) pistons are at same level (ii) small piston is 20 cm above large piston. Liquid inside the jack is water.  
**Ans.** [ 1500 N, 1520.5 N]
13. Determine gauge and absolute pressure at 2 m below free surface of water, while atmospheric pressure is 101.043 kPa.  
**Ans.** [0.01962 MPa, 0.12066 MPa]
14. A simple manometer used to measure pressure of oil (sp. gr. = 0.8) flowing in a pipeline. Its right limb is open to atmosphere and left limb is connected to the pipe. Centre of the pipe is 9 cm below the level of mercury (sp. gr. =13.6) in the right limb. If difference of mercury level in the two limbs is 15 cm, determine absolute pressure of oil in the pipe in N/cm<sup>2</sup>.  
**Ans.** [12.058 N/cm<sup>2</sup>]
15. A U-tube differential manometer connects two pressure pipe *A* and *B*. Pipe *A* contains carbon tetrachloride having a specific gravity 1.594 under a pressure of 11.772 N/cm<sup>2</sup> and pipe *B* contains oil (sp. gr. = 0.8) under a pressure of 11.772 N/cm<sup>2</sup>. The pipe *A* lies 2.5m above pipe *B*. Find the difference of pressure measured by mercury as fluid filling U-tube.  
**Ans.** [31.36 cm of mercury]
16. An inverted differential manometer containing an oil of sp. gr. 0.9 is connected to find difference of pressures at two points of a pipe containing water. If manometer reading is 40 cm, find the difference of pressures.  
**Ans.** [392.4 N/m<sup>2</sup>]
17. Calculate the pressure at a height of 8000 m above MSL if atmosphere pressure is 101.3 kN/m<sup>2</sup> and temperature 15°C at MSL assuming (a) air is incompressible (b) pressure variation follows isothermal law (c) pressure variation follows adiabatic law.  
**Ans.** [607.5 Pa, 31.5 Pa, 37.45 Pa]

[Note: Take density of air at MSL = 1.285 kg/m<sup>3</sup> and neglect variation of gravitational acceleration with altitude.]

18. A micromanometer consist of two cylindrical bulbs  $A$  and  $B$  each  $10 \text{ cm}^2$  c/s area, which are connected by a  $U$ -tube, with vertical limbs each of  $0.25 \text{ cm}^2$  c/s area. A liquid of sp. gr. 1.2 is filled in  $A$  and another liquid of sp.gr. 0.9 is filled in  $B$ , the surface of separation being in the limb attached to  $B$ . Find the displacement of the surface of separation, when the pressure on the surface in  $B$  is greater than that in  $A$  by an amount equal to 1.5 cm head of water.

**Ans.** [4.26 cm]

19. What is the position of the centre of pressure for a vertical semi-circular plane submerged in homogeneous liquid with its diameter  $d$  at the free surface?

**Ans.** [on centreline at depth]

20. How thick is the layer of liquid mud of sp.gr. 1.6 at the bottom of the tank with water 7.5 m deep above it, if there is a pressure of  $5 \text{ kg/cm}^2$  against the bottom of the tank?

**Ans.** [26.56 m]

21. A solid cylinder of diameter 5 m has a height of 5 m. Find the metacentric height of the cylinder, if sp.gr. of the material is 0.7 and floating in water with its axis vertical. State, whether the equilibrium is stable or unstable.

**Ans.** [– 0.304 m, unstable]

22. A rectangular pontoon 8 m long, 7 m wide and 3 m deep weighs 588.6 kN. It carries on its upper deck an empty boiler of 4 m diameter weighing 392.4 kN. The C.G. of the boiler and the pontoon are at their respective centres along a vertical line. Find the metacentric height. Weight density of sea-water is  $10104 \text{ N/m}^3$ .

**Ans.** [0.325 m]

**This page  
intentionally left  
blank**

CHAPTER
<b>3</b>

# KINEMATICS OF FLUID FLOW

---

## 3.1 INTRODUCTION

The kinematics of fluid flow deals with only the space-time behaviour and associated velocity and acceleration, but without taking the effect of different forces associated in it. This chapter provides some definitions and types of fluid flow and the ways to characterise them in space-time frame and also the equation of continuity. Understanding of fluid kinematics is a pre-requisite to achieve a better understanding of dynamics of flow governed by the force criterion.

## 3.2 SCALAR AND VECTOR FIELD

From the name itself scalar is a parameter, which can be *scaled* or measured. Scalar quantity has only magnitude, no direction or sense. Mass, density, temperature, etc., are scalar quantities. If at every point in a region, scalar quantities, a scalar function has a defined value, the region is defined as a *scalar field*.

Vector means a *carrier*, which carries, in the present context, some physical quantity from one place to another. So a vector quantity is specified by its magnitude, direction and sense. Force, velocity and displacement are such vector quantities. If a vector function at every point in a region has a definite value, the region is called a *vector field*.

## 3.3 DESCRIPTION OF FLUID FLOW

A flow field is region, where at every instant of time, flow is defined at each and every point. Usually a flow field is described by velocity, a vector quantity, defined at each point, bearing same or different magnitude, direction and sense. Normally, the entire picture of fluid motion in any flow field are described by two approaches, one after *Lagrange* and another after *Leonhard Euler*.

### 3.3.1 Lagrangian Approach

Here motion of a fluid is described by the kinematic behaviour of individual fluid particle. A fluid particle can be described, at any instant of time, by their spatial coordinates. So in a 3-D rectangular Cartesian frame, it can be expressed as,

$$\left. \begin{aligned} x &= x(x_0, y_0, z_0, t) \\ y &= y(x_0, y_0, z_0, t) \\ z &= z(x_0, y_0, z_0, t) \end{aligned} \right\} \quad (3.1)$$

Here  $x_0, y_0, z_0$  are initial coordinates and  $x, y, z$  are coordinates at  $t$ -th instant of time. Hence a position vector of particle can be defined as,

$$\vec{S} = \vec{i} x + \vec{j} y + \vec{k} z \quad (3.2)$$

Here  $\vec{S}$  is the position vector and  $\vec{i}, \vec{j}, \vec{k}$  are unit vectors along  $x$ -axis,  $y$ -axis and  $z$ -axis respectively. The velocity and acceleration of the particle along three axes, at any instant of time will be:

$$\left. \begin{aligned} u &= \left( \frac{dx}{dt} \right)_{x_0, y_0, z_0} \\ v &= \left( \frac{dy}{dt} \right)_{x_0, y_0, z_0} \\ w &= \left( \frac{dz}{dt} \right)_{x_0, y_0, z_0} \end{aligned} \right\} \quad (3.3a)$$

$$\left. \begin{aligned} a_x &= \left( \frac{d^2x}{dt^2} \right)_{x_0, y_0, z_0} \\ a_y &= \left( \frac{d^2y}{dt^2} \right)_{x_0, y_0, z_0} \\ a_z &= \left( \frac{d^2z}{dt^2} \right)_{x_0, y_0, z_0} \end{aligned} \right\} \quad (3.3b)$$

### 3.3.2 Eulerian Approach

This approach considers velocity vector  $\vec{V}$  and its variation at every location ( $\vec{S}$ ) of fluid flow, instead of considering movement of individual fluid particle. The flow field in this approach is expressed as,

$$\vec{V} = V(\vec{S}, t) \quad (3.4)$$

where,  $\vec{V} = \vec{i} u + \vec{j} v + \vec{k} w$  and  $\vec{S} = \vec{i} x + \vec{j} y + \vec{k} z$

$$\text{So, } \left. \begin{aligned} u &= u(x, y, z, t) \\ v &= v(x, y, z, t) \\ w &= w(x, y, z, t) \end{aligned} \right\} \quad (3.5)$$

### 3.4 CLASSIFICATION OF FLOW

The velocity of flow and other hydrodynamic parameters like pressure, density, etc., are variable from one point to other point or from one instant of time to other instant of time. Depending on these variations, fluid flow can broadly be classified as:

- (i) *Laminar and Turbulent flow*
- (ii) *Steady and Unsteady flow*
- (iii) *Uniform and Non-uniform flow*
- (iv) *Rotational and Irrotational flow*
- (v) *One, Two and Three dimensional flow*

### 3.4.1 Laminar and Turbulent Flow

*Laminar flow* is one where fluid particles move along a smooth path in layers, with one layer (lamina) sliding smoothly over an adjacent layer. Laminar flow generally occurs when velocity of flow is small or viscosity is high. The velocity distribution in closed conduit is parabolic.

To interpret physically, a *turbulent flow* is a laminar flow on which small but random fluctuating motion is superimposed, as shown in figure 3.1. These random fluctuations, called turbulence, may vary from point to point and from time to time. Time average velocity of turbulent flow is called *temporal mean velocity*. Here shear stress depends on both viscosity and distribution of turbulence.

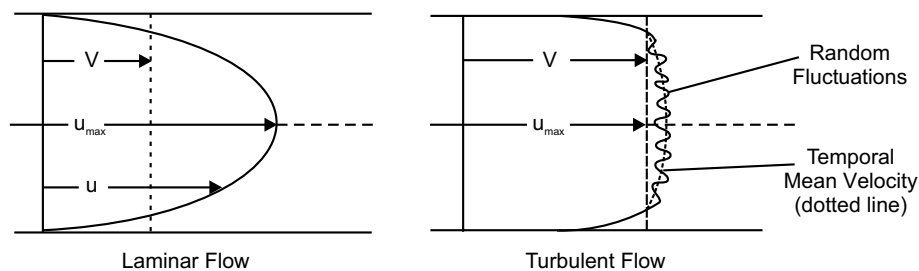

Fig. 3.1

Experimentations on Reynold's apparatus show (Fig. 3.2) that the path of dye in laminar flow is almost a straight line, while in turbulent flow, wavy, broken, discontinuous lines are found. A dimensionless number, *Reynold's Number* characterises whether a flow is laminar or turbulent.

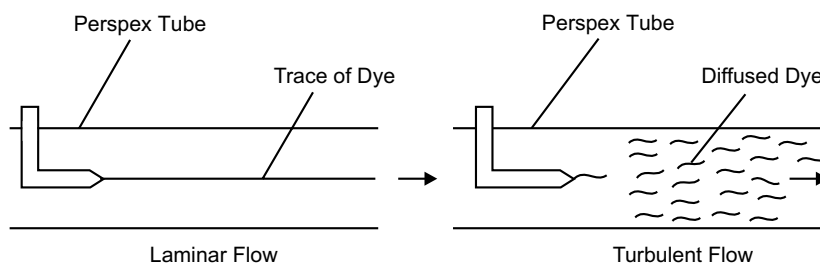

Fig. 3.2

### 3.4.2 Steady and Unsteady Flow

A flow is said to be *steady*, if physical properties, such as velocity, pressure or density do not change with time, at any point. That is,

$$\frac{\partial V}{\partial t} = 0, \frac{\partial p}{\partial t} = 0, \frac{\partial \rho}{\partial t} = 0 \quad (3.6)$$

If at any point, above characteristics, either one or some or all, change with time, then the flow will be defined as an *unsteady flow*. So,

$$\frac{\partial V}{\partial t} \neq 0, \frac{\partial p}{\partial t} \neq 0, \frac{\partial \rho}{\partial t} \neq 0 \quad (3.7)$$

Tidal bore in a river is an example of natural unsteady flow.

To determine whether a flow is steady or unsteady, influence of random fluctuations associated with turbulence is generally neglected and only general fluid motion is taken into consideration. The steady and unsteady flow at a point for laminar and turbulent flow is shown in figure 3.3.

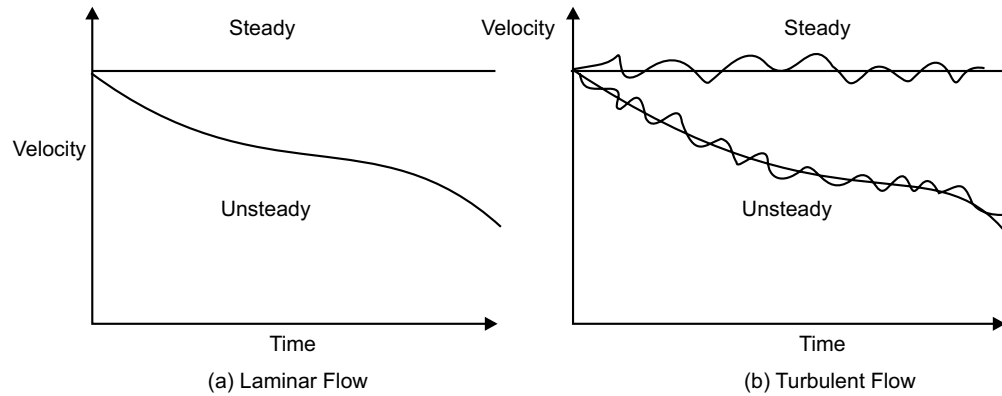

Fig. 3.3

### 3.4.3 Uniform and Non-uniform Flow

*Uniform flow* is one, where at every point of the flow field, velocity is identical in magnitude and direction, *i.e.*, spatially invariant. So,

$$\frac{\partial V}{\partial S} = 0 \quad (3.8)$$

However uniform flow is not possible in a real fluid, in the strictness of definitions.

If the velocity of flow of the fluid changes from point to point at any instant, it is *non-uniform flow*. Mathematically,

$$\frac{\partial V}{\partial S} \neq 0 \quad (3.9)$$

All these four types of flow discussed till now can also combine to each other to generate (i) *steady uniform flow* (ii) *steady non-uniform flow* (iii) *unsteady uniform flow* (iv) *unsteady non-uniform flow*.

### 3.4.4 Rotational and Irrotational Flow

If the fluid particles, while moving in the direction of flow, rotate about their mass centre, the flow is defined as a *rotational flow*.

A flow will be considered *irrotational*, if fluid particles, during moving in the direction of flow, do not rotate about their mass centre. No irrotational flow can exist for a real fluid. For the irrotational flow,

$$\frac{\partial v}{\partial x} = \frac{\partial u}{\partial y} \quad (3.10)$$

### 3.4.5 Compressible and Incompressible Flow

A *compressible flow* is one, where density of the fluid is not constant and varies from point to point.

A flow will be considered *incompressible*, if the density of fluid is spatially invariant, *i.e.*, does not change from point to point.

### 3.4.6 One, Two and Three Dimensional Flow

*One dimensional* flow is defined as the flow, where flow properties like velocity, pressure and density vary in one direction only, *i.e.*, in longitudinal directions. So,

$$V = f(x, t) \text{ or } V = f(y, t) \text{ or } V = f(z, t) \quad (3.11a)$$

In *two dimensional* flow, above flow parameters vary in two mutually perpendicular directions, *i.e.*,

$$V = f(x, y, t) \text{ or } V = f(y, z, t) \text{ or } V = f(x, z, t) \quad (3.11b)$$

In *three dimensional* flow, variation of flow properties occur in all the three directions, generating a most complex type of motion to analyse.

## 3.5 DESCRIPTION OF FLOW PATTERNS

Fluid mechanics is a highly visual subject. The flow patterns can be visualised in many a different way, and sketches or photographs of these facilitates a lot to understand the flow, qualitatively and often quantitatively also. Some of the basic line patterns are described here.

### 3.5.1 Streamline, Stream Function and Stream Tube

A *streamline* is an imaginary line through the flow field, such that at every point of it, the tangent indicates the direction of the velocity vector at the point, as shown in figure 3.4. If  $u$  and  $v$  are the components of  $V$  along  $x$  and  $y$ -direction respectively, then,

$$\frac{v}{u} = \tan \theta = \frac{dy}{dx}$$

Here  $dy$  and  $dx$  are  $y$  and  $x$ -component of the differential displacement  $dS$  long a streamline, in the immediate vicinity of  $P$ . Therefore, the differential equation of the streamline will be

$$\frac{u}{dx} = \frac{v}{dy} \quad (3.12)$$

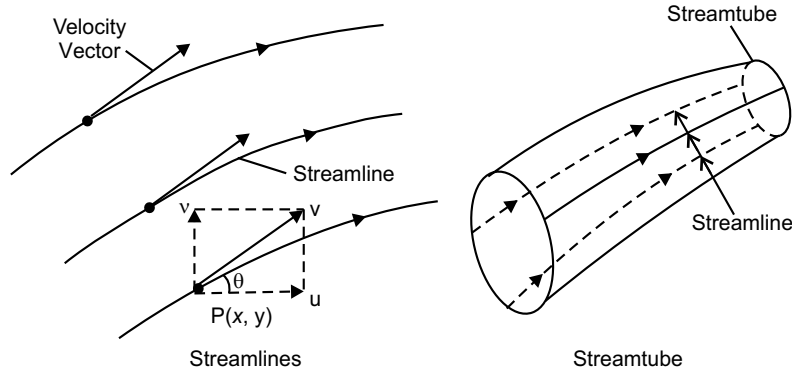

Fig. 3.4

In three dimensional flow system, it will be,

$$\frac{u}{dx} = \frac{v}{dy} = \frac{w}{dz} \quad (3.13)$$

The *stream function*  $\psi$  (psi) is defined as a scalar function of space and time, such that its partial derivative with respect to any direction gives the velocity component at right angles to this direction. So,  $\psi = (x, y, t)$  can be defined such that,

$$u = \frac{\partial \psi}{\partial y} \text{ and } v = -\frac{\partial \psi}{\partial x} \quad (3.14)$$

Since  $\psi$  is a point function, at every point of the flow field,

$$d\psi = \frac{\partial \psi}{\partial x} \cdot dx + \frac{\partial \psi}{\partial y} \cdot dy = -v \cdot dx = 0$$

$$\Rightarrow \psi = \text{Constant}$$

So on a streamline, the value of stream function is constant.

The *streamtube* is an imaginary tube formed by a group of streamlines passing through a small closed curve, may or may not be circular. The cross-section of stream tube is finite and its surface across which there cannot be any flow is called a *stream surface*.

### 3.5.2 Pathline

A *pathline* is the trajectory of an individual fluid particle over a period of time. In a steady laminar flow, a pathline coincides with a streamline. In an unsteady flow, as a particle falls on a new streamline at every instant of time, pathline and streamline are not the same. Two pathlines can intersect each other or can form a loop. In capillary surface waves, pathlines are circular but streamlines are sinusoidal. The equation of pathline is:

$$x = \int u dt, \quad y = \int v dt, \quad z = \int w dt \quad (3.15)$$

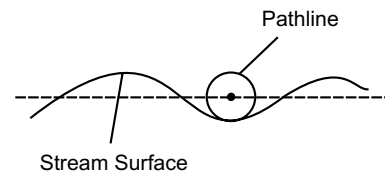

Fig 3.5

### 3.5.3 Streakline

In flow visualisation, it is common practice to inject smoke into gas and dye into liquids. A *streakline* is a locus line at a given instant, connecting temporary locations of all fluid particles passing through a given point of injection. It is also called a *filament line*. In a steady laminar flow, the streamline, pathline and streakline are identical.

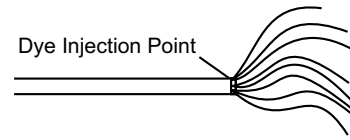

Fig. 3.6

### 3.5.4 Timeline

A *timeline* is a set of fluid particles that form a line at a given instant.

### 3.5.5 Equipotential Lines and Flow Net

A velocity potential  $\phi$  (phi) is defined as scalar function of space and time, so that its negative partial derivative with respect to any direction gives fluid velocity in that direction.

So, velocity potential  $\phi = f(x, y, t)$  is such that,

$$u = -\frac{\partial\phi}{\partial x}, \quad v = -\frac{\partial\phi}{\partial y}, \quad w = -\frac{\partial\phi}{\partial z} \quad (3.16)$$

*Equipotential line* is a line for which velocity potential is constant at every point.

A *grid* obtained by drawing a series of streamlines and equipotential lines is defined a orthogonal flow net or simply the *flow net* (Fig. 3.7).

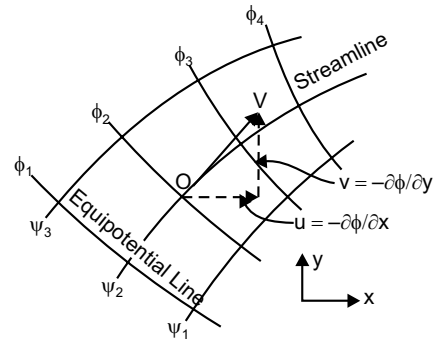

Fig. 3.7

## 3.6 CONSERVATION OF MASS

The law of conservation of mass states that, *mass can neither be created nor destroyed*. Mathematically, for a closed system of mass  $m$ ,

this law can be expressed as,  $\frac{dm}{dt} = 0$ . Hence

for a control volume, the law of conservation of mass can be re-instated as (Fig. 3.8),

$$\text{Rate of influx} - \text{Rate of efflux} = \text{Rate of accumulation}$$

This statement can be expressed analytically in terms of velocity and density field of a flow and resulting expression is known as *equation of continuity*.

### 3.6.1 Continuity Equation in Three Dimension

Let us consider a parallelepiped defining a differential control volume of mass  $\rho dx dy dz$ . Components of velocity along  $x$ -axis,  $y$ -axis and  $z$ -axis are  $u$ ,  $v$  and  $w$  respectively. Referring to figure 3.9,

$$\text{Rate of mass influx through ABCD face} = \rho u \cdot dy \cdot dz$$

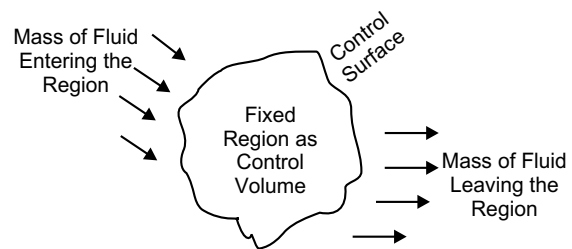

Fig. 3.8

Rate of mass efflux through EFGH face

$$= \rho \cdot u \cdot dy \cdot dz + \frac{\partial}{\partial x} (\rho \cdot u \cdot dy \cdot dz) dx$$

Rate of mass accumulation along x-direction

$$= \rho \cdot u \cdot dy \cdot dz - \left[ \rho \cdot u \cdot dy \cdot dz + \frac{\partial}{\partial x} (\rho \cdot u \cdot dy \cdot dz) dx \right]$$

$$= - \frac{\partial}{\partial x} (\rho u dx dy dz)$$

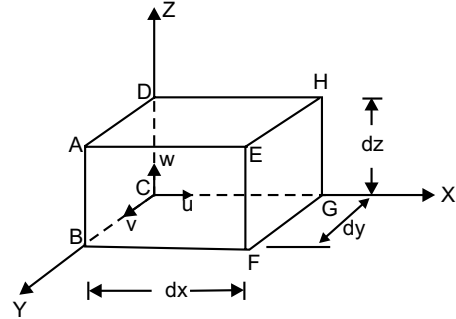

Fig. 3.9

(3.17a)

Similarly rate of mass accumulation along y-direction

$$= - \frac{\partial}{\partial y} (\rho v dx dy dz)$$

(3.17b)

and along z-direction = - \frac{\partial}{\partial z} (\rho w dx dy dz)

(3.17c)

So, total mass accumulation rate

$$= - \left[ \frac{\partial}{\partial x} (\rho u) + \frac{\partial}{\partial y} (\rho v) + \frac{\partial}{\partial z} (\rho w) \right] dx dy dz$$

(3.18)

Again rate of mass increase in control volume

$$= \frac{\partial}{\partial t} (\rho dx dy dz) = \frac{\partial \rho}{\partial t} (dx dy dz)$$

(3.19)

Equating (3.18) and (3.19) we have,

$$- \left[ \frac{\partial}{\partial x} (\rho u) + \frac{\partial}{\partial y} (\rho v) + \frac{\partial}{\partial z} (\rho w) \right] dx dy dz = \frac{\partial \rho}{\partial t} (dx dy dz)$$

$$\Rightarrow \frac{\partial \rho}{\partial t} + \frac{\partial}{\partial x} (\rho u) + \frac{\partial}{\partial y} (\rho v) + \frac{\partial}{\partial z} (\rho w) = 0$$

(3.20)

This is the most general form of equation of continuity in three dimensional Cartesian coordinate system. It is applicable for steady and unsteady flow, uniform and non-uniform flow, compressible and incompressible flow.

(i) For steady flow:  $\frac{\partial \rho}{\partial t} = 0$

$$\text{Continuity equation: } \frac{\partial}{\partial x} (\rho u) + \frac{\partial}{\partial y} (\rho v) + \frac{\partial}{\partial z} (\rho w) = 0$$

(3.21)

(ii) For incompressible flow:  $\rho = \text{constant}$

$$\text{Continuity equation: } \frac{\partial u}{\partial x} + \frac{\partial u}{\partial x} + \frac{\partial u}{\partial x} = 0 \quad (3.22)$$

### 3.6.2 Continuity Equation in Two Dimension

In this case, velocity component along  $z$ -direction,  $w = 0$ . So generalised expression will be

$$\frac{\partial \rho}{\partial t} + \frac{\partial}{\partial x}(\rho u) + \frac{\partial}{\partial y}(\rho v) = 0 \quad (3.23)$$

$$(i) \text{ For steady flow: } \frac{\partial}{\partial x}(\rho u) + \frac{\partial}{\partial y}(\rho v) = 0 \quad (3.24)$$

$$(ii) \text{ For incompressible flow: } \frac{\partial u}{\partial x} + \frac{\partial v}{\partial y} = 0 \quad (3.25)$$

### 3.6.3 Continuity Equation in One Dimension

Here the velocity components both along  $y$ -direction and  $z$ -direction are zero, *i.e.*,  $v = 0 = w$ . So generalised expression is

$$\frac{\partial \rho}{\partial t} + \frac{\partial}{\partial x}(\rho u) = 0 \quad (3.26)$$

$$(i) \text{ For steady flow: } \frac{\partial}{\partial x}(\rho u) = 0 \quad (3.27)$$

$$(ii) \text{ For incompressible flow: } \frac{\partial u}{\partial x} = 0$$

$$\Rightarrow u = \text{constant}$$

$$\Rightarrow A \times u = \text{constant}$$

$$\Rightarrow Q = Au = \text{constant} \quad (3.28)$$

Here,  $A$  is  $c/s$  area of a conduit. So, through a closed conduit of uniform  $c/s$ , rate of flow is constant for a steady incompressible flow of fluid. This is equally true for conduit of variable  $c/s$ .

A streamtube as shown in Fig. 3.10 is considered with  $c/s$  area of influx end is  $dA_1$  and of efflux end is  $dA_2$ . The principle of conservation of fluid mass can be expressed mathematically as,  $\rho_1 dA_1 V_1 = \rho_2 dA_2 V_2$ .

For incompressible fluid,  $\rho_1 = \rho_2$ .

So,  $dA_1 = dA_2 = \text{volume rate of flow} = dQ$ .

Hence, total volume rate of flow

$$Q = \int dQ = \int dA_1 V_1 = \int dA_2 V_2 = A_1 V_1 = A_2 V_2 \quad (3.29)$$

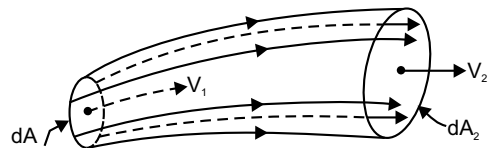

Fig. 3.10

### 3.6.4 Continuity Equation in Cylindrical Polar Coordinate

In this system of coordinate, a point in space is described by  $(r, \theta, z)$ . Generalised continuity equation in space takes the shape as,

$$\frac{\partial \rho}{\partial t} + \frac{1}{r} \frac{\partial}{\partial r} (\rho \cdot V_r \cdot r) + \frac{1}{r} \frac{\partial}{\partial \theta} (\rho \cdot V_\theta) + \frac{\partial}{\partial z} (\rho \cdot V_z) = 0 \quad (3.30)$$

$$(i) \quad \text{For steady flow:} \quad \frac{1}{r} \frac{\partial}{\partial r} (\rho \cdot V_r \cdot r) + \frac{1}{r} \frac{\partial}{\partial \theta} (\rho \cdot V_\theta) + \frac{\partial}{\partial z} (\rho \cdot V_z) = 0 \quad (3.31)$$

$$(ii) \quad \text{For incompressible flow:} \quad \frac{1}{r} \frac{\partial}{\partial r} (V_r \cdot r) + \frac{1}{r} \frac{\partial}{\partial \theta} (V_\theta) + \frac{\partial}{\partial z} (V_z) = 0 \quad (3.32)$$

### 3.6.5 Continuity Equation in Spherical Polar Coordinate

In this system, any point in space is described by  $(R, \theta, \phi)$ . Continuity equation in its generalised form can be expressed as,

$$\frac{\partial \rho}{\partial t} + \frac{1}{R^2} \frac{\partial}{\partial R} (R^2 \cdot \rho \cdot V_R) + \frac{1}{R \sin \phi} \frac{\partial}{\partial \theta} (\rho \cdot V_\theta) + \frac{1}{R \sin \phi} \frac{\partial}{\partial \phi} (\rho \cdot V_\phi \cdot \sin \phi) = 0 \quad (3.33)$$

For a steady incompressible flow, it reduces to,

$$\frac{1}{R} \frac{\partial}{\partial R} (R^2 \cdot V_R) + \frac{1}{\sin \phi} \frac{\partial}{\partial \theta} (V_\theta) + \frac{1}{\sin \phi} \frac{\partial}{\partial \phi} (V_\phi \cdot \sin \phi) = 0 \quad (3.34)$$

### 3.6.6 Velocity and Acceleration

Let us consider  $V$  as the resultant velocity at any point in a Eulerian flow field and  $u, v, w$  are its components along  $x$ -axis,  $y$ -axis and  $z$ -axis respectively. So,

$$\left. \begin{aligned} u &= f_1(x, y, z, t) \\ v &= f_2(x, y, z, t) \\ w &= f_3(x, y, z, t) \end{aligned} \right\} \quad (3.35)$$

$$\text{So,} \quad V = \sqrt{u^2 + v^2 + w^2} = \sqrt{\left(\frac{dx}{dt}\right)^2 + \left(\frac{dy}{dt}\right)^2 + \left(\frac{dz}{dt}\right)^2}$$

Total or substantial acceleration  $a$  has components along  $x$ -axis,  $y$ -axis and  $z$ -axis as  $a_x, a_y, a_z$  respectively. Applying chain rule of differentiation, we find,

$$a_x = \frac{du}{dt} = \frac{\partial u}{\partial x} \frac{dx}{dt} + \frac{\partial u}{\partial y} \frac{dy}{dt} + \frac{\partial u}{\partial z} \frac{dz}{dt} + \frac{\partial u}{\partial t}$$

$$\begin{aligned}
&= u \frac{\partial u}{\partial x} + v \frac{\partial u}{\partial y} + w \frac{\partial u}{\partial z} + \frac{\partial u}{\partial t} \\
&= \frac{\partial u}{\partial t} + \left[ u \frac{\partial u}{\partial x} + v \frac{\partial u}{\partial y} + w \frac{\partial u}{\partial z} \right] \\
&= \text{Local Acceleration} + \text{Convective Acceleration} \quad (3.36)
\end{aligned}$$

Local acceleration is the rate of increase of velocity with respect to time at a given point in the flow field. It is also termed as *temporal acceleration*. For the  $x$ -axis,  $\frac{\partial u}{\partial t}$  is local acceleration.

Convective acceleration is the rate of change of velocity due to change of position of fluid particles in a fluid flow. For the  $x$ -axis,  $\left( u \frac{\partial u}{\partial x} + v \frac{\partial u}{\partial y} + w \frac{\partial u}{\partial z} \right)$  is the convective acceleration.

Following the same principle,

$$\left. \begin{aligned}
a_y &= \frac{\partial v}{\partial t} + \left[ u \frac{\partial v}{\partial x} + v \frac{\partial v}{\partial y} + w \frac{\partial v}{\partial z} \right] \\
a_z &= \frac{\partial w}{\partial t} + \left[ u \frac{\partial w}{\partial x} + v \frac{\partial w}{\partial y} + w \frac{\partial w}{\partial z} \right]
\end{aligned} \right\}$$

For steady flow, there exists no local acceleration, i.e.,

$$\frac{\partial u}{\partial t} = \frac{\partial v}{\partial t} = \frac{\partial w}{\partial t} = 0 \quad (3.37)$$

In two dimensional flow, 
$$\left. \begin{aligned}
a_x &= \frac{\partial u}{\partial t} + \left[ u \frac{\partial u}{\partial x} + v \frac{\partial u}{\partial y} \right] \\
a_y &= \frac{\partial v}{\partial t} + \left[ u \frac{\partial v}{\partial x} + v \frac{\partial v}{\partial y} \right]
\end{aligned} \right\} \quad (3.38)$$

In one dimensional flow,

$$\begin{aligned}
a_x &= \frac{\partial u}{\partial t} + u \frac{\partial u}{\partial x} \\
\Rightarrow a_s &= \frac{\partial u}{\partial t} + u \frac{\partial u}{\partial S} \quad (3.39)
\end{aligned}$$

This is tangential total acceleration. The expression for normal acceleration,

$$a_n = \frac{\partial u_n}{\partial t} + \frac{u^2}{r} \quad \text{where, } u_n = u \cdot \frac{dS}{r}$$

Features of acceleration of different types of flow are summarised as following:

- (i) *Steady uniform flow:* *No acceleration*
- (ii) *Steady non-uniform flow:* *Convective acceleration*
- (iii) *Unsteady uniform flow:* *Local or temporal acceleration*
- (iv) *Unsteady non-uniform flow:* *Both acceleration*

In polar coordinate system,

$$\left. \begin{aligned} a_r &= V_r \cdot \frac{\partial V_r}{\partial r} + \frac{V_\theta}{r} \frac{\partial V_r}{\partial \theta} - \frac{V_\theta^2}{r} \\ a_\theta &= V_r \cdot \frac{\partial V_\theta}{\partial r} + \frac{V_\theta}{r} \frac{\partial V_\theta}{\partial \theta} - \frac{V_r \cdot V_\theta}{r} \end{aligned} \right\}$$

where,  $V_r$  and  $V_\theta$  are components of velocity along radial direction and azimuthal direction respectively.

### Multiple Choice Questions

1. Steady flow is one in which
  - (a) velocity does not change from place to place
  - (b) velocity may change in direction but magnitude remains unchanged
  - (c) velocity at given point does not change with time
  - (d) mass flow rate remains constant
2. A flow is said to be uniform when
  - (a) at any given instant, velocity vector remains unchanged in magnitude and direction
  - (b) at any instant, velocity vector has the same directions at all points in the flow field
  - (c) at any instant, velocity vector may change its direction, but magnitude remains unchanged
  - (d) none of the above
3. The flow of river during the heavy rainfall is
  - (a) steady, uniform, 2-D flow
  - (b) unsteady, uniform, 3-D flow
  - (c) unsteady, non-uniform, 3-D flow
  - (d) none of the above
4. Continuity equation is based on the principle of
  - (a) conservation of energy
  - (b) conservation of mass
  - (c) conservation of momentum
  - (d) Newton's law of viscosity
5. Laminar flow is characterised by
  - (a) irregular motion of fluid particle
  - (b) fluid particles moving in layers parallel to the boundary
  - (c) high Reynold's number of flow
  - (d) none of the above

6. A turbulent flow is considered steady, when
  - (a) discharge remains constant
  - (b) velocities at a point are time invariant
  - (c) temporal mean velocity at a point remains time invariant
  - (d) none of the above
7. One obtains a steady, uniform flow
  - (a) when ideal fluid passes through a long pipe at constant rate
  - (b) when real fluid passes through a long pipe at constant rate
  - (c) when ideal fluid passes through a converging duct at constant rate
  - (d) when real fluid passes through a converging duct at constant rate
8. Flow of water passing through a pipe is laminar, when
  - (a) fluid is ideal
  - (b) fluid is real
  - (c) velocity of flow is more than critical velocity
  - (d) Reynold's number is less than 2000
9. An ideal fluid flowing through a tapering pipe is an example of
  - (a) steady and uniform flow
  - (b) steady and non-uniform flow
  - (c) unsteady and uniform flow
  - (d) unsteady and non-uniform flow
10. A streamline is a line
  - (a) drawn normal to velocity vector at any point
  - (b) such that, streamline divides the passage into equal number of parts
  - (c) which is along the path of a particle
  - (d) tangent to which is in the direction of velocity vector at every point
11. Streamline, pathline and streakline are identical, when
  - (a) flow is uniform
  - (b) flow is steady
  - (c) flow velocities do not change steadily with time
  - (d) flow is neither steady nor uniform
12. The material acceleration zero for a
  - (a) steady flow
  - (b) steady and uniform flow
  - (c) unsteady and uniform flow
  - (d) unsteady and non-uniform flow
13. Continuity equation in generalised form is
  - (a)  $A_1 V_1 = A_2 V_2$
  - (b)  $\rho_1 A_1 = \rho_2 A_2$
  - (c)  $\rho_1 A_1 V_1 = \rho_2 A_2 V_2$
  - (d)  $p_1 A_1 V_1 = p_2 A_2 V_2$
14. Irrotational flow means
  - (a) fluid does not rotate while moving
  - (b) fluid moves in a straight line
  - (c) net rotation of fluid particles about their mass center is zero
  - (d) none of the above

15. If the fluid particles move in a zigzag way, the flow is called  
 (a) unsteady flow (b) turbulent flow  
 (c) non-uniform flow (d) incompressible flow
16. If the density of fluid changes from point to point in a flow region, it is called  
 (a) steady flow (b) unsteady flow  
 (c) non-uniform flow (d) compressible flow
17. If velocity in a fluid flow changes with respect to length of direction of flow, it is called  
 (a) unsteady flow (b) compressible flow  
 (c) irrotational flow (d) none of the above
18. The acceleration of a fluid particle in the direction of  $x$  is given by  
 (a)  $u \frac{\partial u}{\partial x} + v \frac{\partial v}{\partial y} + w \frac{\partial w}{\partial z} + \frac{\partial u}{\partial t}$  (b)  $u \frac{\partial u}{\partial x} + u \frac{\partial v}{\partial y} + u \frac{\partial w}{\partial z} + \frac{\partial u}{\partial t}$   
 (c)  $u \frac{\partial u}{\partial x} + v \frac{\partial u}{\partial y} + w \frac{\partial u}{\partial z} + \frac{\partial u}{\partial t}$  (d) none of the above
19. The local acceleration of a fluid particle in the direction of  $y$  is given by  
 (a)  $\frac{\partial v}{\partial t}$  (b)  $u \frac{\partial u}{\partial x} + v \frac{\partial v}{\partial y}$   
 (c)  $v \frac{\partial v}{\partial x}$  (d) none of the above
20. The convective acceleration of a fluid particle in the direction of  $z$  is given by  
 (a)  $u \frac{\partial w}{\partial x} + v \frac{\partial w}{\partial y} + w \frac{\partial w}{\partial z}$  (b)  $w \frac{\partial u}{\partial x} + w \frac{\partial v}{\partial y} + w \frac{\partial w}{\partial z}$   
 (c)  $u \frac{\partial w}{\partial z} + v \frac{\partial w}{\partial y} + w \frac{\partial w}{\partial x}$  (d)  $w \frac{\partial w}{\partial x} + w \frac{\partial w}{\partial y} + w \frac{\partial w}{\partial z}$
21. A control volume refers to  
 (a) a fixed region in space (b) a specified mass  
 (c) a closed system (d) a reversible process only
22. One dimensional flow is  
 (a) steady uniform flow (b) uniform flow  
 (c) flow which neglect changes in a transverse direction  
 (d) restricted to flow in a straight line
23. A practical example of steady non-uniform flow is given by  
 (a) motion of river around bridge piers  
 (b) steadily increasing flow through a pipe  
 (c) constant discharge through a long, straight tapering pipe  
 (d) none of the above



5. Flow of water through a river bed may be uniform or may be non-uniform.
6. In turbulent flow, shear stress depends on viscosity and turbulence distribution.
7. For a steady flow, tangential velocities do not vary in magnitude with the variation of gap between streamline.
8. In a turbulent flow, a pathline coincide with a streamline.
9. The equation of continuity is valid both for incompressible and compressible flow.
10. A flow net can be obtained associating a set of streamlines and a set of streaklines.

### Answers

- |          |          |          |         |           |
|----------|----------|----------|---------|-----------|
| 1. False | 2. True  | 3. True  | 4. True | 5. False  |
| 6. True  | 7. False | 8. False | 9. True | 10. False |

### NUMERICAL EXAMPLES

#### EXAMPLE 1

In a 1-D flow field, the velocity at a point may be given in the Eulerian system as  $u = x + t$ . Determine the displacement of fluid particle whose initial position is  $x_0$  at initial time  $t_0$  in Lagrangian system.

**SOLUTION**

Here,

$$u = x + t$$

$$\Rightarrow \frac{dx}{dt} = x + t$$

$$\Rightarrow \frac{dx}{dt} - x = t$$

The solution of this 1<sup>st</sup> degree differential equation  $x = Ae^t - t - 1$

The value of constant  $A$  can be found out by applying boundary condition.

$$x_0 = Ae^{t_0} - t_0 - 1$$

$$\Rightarrow A = \frac{x_0 + t_0 + 1}{e^{t_0}}$$

$$\text{So, } x = \left( \frac{x_0 + t_0 + 1}{e^{t_0}} \right) e^t - t - 1 = (x_0 + t_0 + 1)e^{(t-t_0)} - t - 1.$$

#### EXAMPLE 2

A 2-D flow is described in Lagrangian system as  $x = x_0 e^{-kt} + y_0 (1 - e^{-2kt})$ ,  $y = y_0 e^{kt}$ . Find (a) equation of pathline of the particle (b) velocity components in Eulerian system.

**SOLUTION**

(a) Pathline will be found out by eliminating  $t$  from these two equations. Substituting the value of  $y$  we have,

$$x = x_0 e^{-kt} + y_0 (1 - e^{-2kt}) = x_0 \left( \frac{y_0}{y} \right) + y_0 \left[ 1 - \left( \frac{y_0}{y} \right)^2 \right]$$

$$\Rightarrow y^2 x - x_0 y_0 y - y_0 y^2 + y_0^3 = 0$$

$$\Rightarrow y^2 (x - y_0) - x_0 y_0 y + y_0^3 = 0$$

This is the equation of pathline.

(b)  $x$ -component of velocity

$$\begin{aligned} u &= \frac{dx}{dt} = \frac{d}{dt} \left[ x_0 e^{-kt} + y_0 (1 - e^{-2kt}) \right] \\ &= -kx_0 e^{-kt} + 2ky_0 e^{-2kt} \\ &= -k \left[ x - y_0 (1 - e^{-2kt}) \right] + 2ky_0 e^{-2kt} \\ &= -kx + ky_0 - ky_0 e^{-2kt} + 2ky_0 e^{-2kt} \\ &= -kx + ky_0 + ky_0 e^{-2kt} \\ &= -kx + ky_0 (1 + e^{-2kt}) \\ &= -kx + ky e^{-kt} (1 + e^{-2kt}) \\ &= -kx + ky (e^{-kt} + e^{-3kt}) \end{aligned}$$

$$y\text{-component of velocity, } v = \frac{dy}{dt} = \frac{d}{dt} (y_0 e^{kt}) = y_0 k e^{kt} = ky.$$

**EXAMPLE 3**

Given a velocity field  $\vec{V} = (4 + xy + 2t)\vec{i} + 6x^3\vec{j} + (3xt^2 + z)\vec{k}$ . Find the acceleration of a fluid particle  $(2, 4, -4)$  and time  $t = 3$ .

**SOLUTION**

For the given velocity field, components along  $x$ ,  $y$  and  $z$  axes are:

$$\left. \begin{aligned} u &= 4 + xy + 2t \\ v &= 6x^3 \\ w &= 3xt^2 + z \end{aligned} \right\}$$

So,

$$a_x = \frac{\partial u}{\partial t} + u \frac{\partial u}{\partial x} + v \frac{\partial u}{\partial y} + w \frac{\partial u}{\partial z}$$

$$= 2 + 4y + xy^2 + 2ty + 6x^4$$

$$a_y = \frac{\partial v}{\partial t} + u \frac{\partial v}{\partial x} + v \frac{\partial v}{\partial y} + w \frac{\partial v}{\partial z}$$

$$= 72x^2 + 18x^3y + 36x^2t$$

$$a_z = \frac{\partial w}{\partial t} + u \frac{\partial w}{\partial x} + v \frac{\partial w}{\partial y} + w \frac{\partial w}{\partial z}$$

$$= 6xt + 12t^2 + 3xyt^2 + 6t^3 + 3xt^2 + z$$

Substituting

$$x=2, y=4, z=-4, t=3 \text{ we have}$$

$$a_x = 170 \text{ units}, a_y = 572 \text{ units}, a_z = 1296 \text{ units}$$

and

$$a = \sqrt{a_x^2 + a_y^2 + a_z^2} = 1426.78 \text{ units}$$

#### EXAMPLE 4

Find the acceleration component at a point (1,1,1) for the following flow field  $u = 2x^2 + 3y$ ,

$$v = -2xy + 3y^2 + 3zy \text{ and } w = \frac{3}{2}z^2 + 2xz - 9y^2z.$$

**SOLUTION**

Components of acceleration

$$a_x|_{(1,1,1)} = \left( \frac{\partial u}{\partial t} + u \frac{\partial u}{\partial x} + v \frac{\partial u}{\partial y} + w \frac{\partial u}{\partial z} \right)_{(1,1,1)} = 32 \text{ units}$$

$$a_y|_{(1,1,1)} = \left( \frac{\partial v}{\partial t} + u \frac{\partial v}{\partial x} + v \frac{\partial v}{\partial y} + w \frac{\partial v}{\partial z} \right)_{(1,1,1)} = -7.5 \text{ units}$$

$$a_z|_{(1,1,1)} = \left( \frac{\partial w}{\partial t} + u \frac{\partial w}{\partial x} + v \frac{\partial w}{\partial y} + w \frac{\partial w}{\partial z} \right)_{(1,1,1)} = 23 \text{ units}$$

#### EXAMPLE 5

Find the acceleration components along radial and azimuthal direction at a point  $r = 2a$ ,  $\theta = \pi/2$

$$\text{for a 2-D flow field } V_r = -u \left( 1 - \frac{a^2}{r^2} \right) \cos \theta \text{ and } V_\theta = u \left( 1 + \frac{a^2}{r^2} \right) \sin \theta.$$

**SOLUTION**

$$\frac{\partial V_r}{\partial \theta} = u \sin \theta \left(1 - \frac{a^2}{r^2}\right), \quad \frac{\partial V_\theta}{\partial \theta} = u \cos \theta \left(1 + \frac{a^2}{r^2}\right)$$

$$\frac{\partial V_r}{\partial r} = -\frac{2ua^2}{r^3} \cos \theta, \quad \frac{\partial V_\theta}{\partial r} = -\frac{2ua^2}{r^3} \sin \theta$$

Hence, acceleration in radial direction

$$a_r|_{(2a, \pi/2)} = \left( V_r \cdot \frac{\partial V_r}{\partial r} + \frac{V_\theta}{r} \frac{\partial V_r}{\partial \theta} - \frac{V_\theta^2}{r} \right)_{(2a, \pi/2)} = -\frac{5u^2}{16} \text{ units}$$

and that along azimuthal direction

$$a_\theta|_{(2a, \pi/2)} = \left( V_r \cdot \frac{\partial V_\theta}{\partial r} + \frac{V_\theta}{r} \frac{\partial V_\theta}{\partial \theta} - \frac{V_r \cdot V_\theta}{r} \right)_{(2a, \pi/2)} = 0 \text{ unit}$$

### EXAMPLE 6

Given the velocity field  $\vec{V} = 6x \vec{i} + (16y + 10) \vec{j} + (20t^2) \vec{k}$  m/s. What is the pathline of a particle which is at (2,4,6) at time  $t = 2s$ ?

**SOLUTION**

Component of velocity in  $x$ -direction  $u = \frac{dx}{dt} = 6x$

Integrating 
$$\int_2^x \frac{dx}{x} = 6 \int_2^t dt$$

$\Rightarrow \ln x = 6t - 11.307$

Similarly for  $y$ -direction and  $z$ -direction, we can have

$$\int_4^y \frac{dy}{16y + 10} = \int_2^t dt$$

$\Rightarrow \ln(16y + 10) = 16t - 27.695$

and 
$$\int_6^z dz = 20 \int_2^t t^2 dt$$

$\Rightarrow z = \frac{20}{3} t^3 - 47.33$

Solving for  $t$ , we have 
$$t = \left[ \frac{3}{20} (z + 47.33) \right]^{1/3}$$

So, finally the equation of the pathline will be

$$\ln x + \ln(16y + 10) = 22t - 39 = 11.689(z + 47.33)^{1/3} - 39.$$

### EXAMPLE 7

A velocity field is given by  $u = 3y^2$ ,  $v = 2x$ ,  $w = 0$  in arbitrary units. Is this flow steady or unsteady? Is it 2-D or 3-D? At (2,1,0) compute (a) velocity (b) local acceleration (c) convective acceleration.

#### SOLUTION

This flow is steady, all equations here are time invariant. The flow is 2-D as everywhere.

(a) The velocity field is  $\vec{V} = 3y^2 \vec{i} + 2x \vec{j}$

At (2,1,0),  $\vec{V} = 3 \vec{i} + 4 \vec{j}$  and magnitude  $= \sqrt{3^2 + 4^2} = 5$  units

(b) Local acceleration in two directions

$$\frac{\partial u}{\partial t} = 0, \quad \frac{\partial v}{\partial t} = 0$$

(c) Convective acceleration in two directions

$$\left( u \frac{\partial u}{\partial x} + v \frac{\partial u}{\partial y} \right)_{2,1,0} = 12xy|_{2,1,0} = 24 \text{ units}$$

$$\left( u \frac{\partial v}{\partial x} + v \frac{\partial v}{\partial y} \right)_{2,1,0} = 6y^2|_{2,1,0} = 6 \text{ units}$$

### EXAMPLE 8

The velocity vector for a field  $\vec{V} = -x \vec{i} + 2y \vec{j} + (3-z) \vec{k}$ . Find equation of the streamline passing (1,1,2).

#### SOLUTION

Here,

$$u = -x, v = 2y, w = 3 - z$$

From the equation of streamline,

$$\frac{u}{dx} = \frac{v}{dy} = \frac{w}{dz}$$

$$\Rightarrow \frac{dx}{-x} = \frac{dy}{2y} = \frac{dz}{3-z}$$

Integrating within limits, 
$$\int_1^x \frac{dx}{-x} = \int_1^y \frac{dy}{2y}$$

$$\Rightarrow x = \frac{1}{\sqrt{y}}$$

$$\Rightarrow \int_1^y \frac{dy}{2y} = \int_2^z \frac{dz}{3-z}$$

$$\Rightarrow \frac{1}{\sqrt{y}} = 3 - z$$

Combining these two results,  $x = \frac{1}{\sqrt{y}} = 3 - z$

### EXAMPLE 9

Two velocity components are given as  $u = \frac{-2xyz}{(x^2 + y^2)^2}$  and  $w = \frac{y}{(x^2 + y^2)}$ . Find the third

component such that they satisfy the continuity equation.

#### SOLUTION

For an incompressible flow, the equation of continuity is

$$\frac{\partial u}{\partial x} + \frac{\partial v}{\partial y} + \frac{\partial w}{\partial z} = 0$$

Now, 
$$\frac{\partial u}{\partial x} = \frac{6x^2yz - 2y^3z}{(x^2 + y^2)^3} \text{ and } \frac{\partial w}{\partial z} = 0$$

Substituting in the governing equation, we have

$$\frac{6x^2yz - 2y^3z}{(x^2 + y^2)^3} + \frac{\partial v}{\partial y} + 0 = 0$$

$$\Rightarrow \partial v = \frac{-6x^2yz + 2y^3z}{(x^2 + y^2)^3} \partial y$$

On integration we have, 
$$v = \frac{z(x^2 - y^2)}{(x^2 + y^2)^2} + C$$

### EXAMPLE 10

The velocity components in a 2-D flow field for an incompressible fluid are expressed as

$u = \frac{y^3}{3} + 2x - x^2y$  and  $v = xy^2 - 2y - \frac{x^3}{3}$ . Show that these functions represent a possible case of an irrotational flow.

**SOLUTION**

Here,  $\frac{\partial u}{\partial x} = 2 - 2xy$  and  $\frac{\partial v}{\partial y} = 2xy - 2$

Now,  $\frac{\partial u}{\partial x} + \frac{\partial v}{\partial y} = 2 - 2xy + 2xy - 2 = 0$

**EXAMPLE 11**

A gas, following  $p = \rho RT$ , flows steadily in a horizontal pipe of constant diameter. Considering the flow isothermal and  $p_1 : p_2 = 8 : 9$ , find the ratio of  $V_1$  and  $V_2$ .

**SOLUTION**

From the given condition, we can write  $A_1 = A_2$  and  $T_1 = T_2$

From the principle of conservation of mass,

$$\rho_1 A_1 V_1 = \rho_2 A_2 V_2$$

$$\Rightarrow \rho_1 V_1 = \rho_2 V_2 \quad [\because A_1 = A_2]$$

$$\Rightarrow \frac{p_1}{RT_1} V_1 = \frac{p_2}{RT_2} V_2$$

$$\Rightarrow p_1 V_1 = p_2 V_2 \quad [\because \text{flow isothermal}]$$

$$\begin{aligned} \Rightarrow \frac{V_1}{V_2} &= \frac{p_2}{p_1} \\ &= \frac{9}{8} \end{aligned}$$

**EXAMPLE 12**

Referring to adjoining figure, find the discharge in pipe 1 and velocity of flow in pipe 3.

**SOLUTION**

Cross-sections of

$$\text{pipe 1 } (A_1) = \frac{\pi}{4} \times 0.3^2 = 0.07068 \text{ m}^2$$

$$\text{pipe 2 } (A_2) = \frac{\pi}{4} \times 0.2^2 = 0.03141 \text{ m}^2$$

$$\text{pipe 3 } (A_3) = \frac{\pi}{4} \times 0.15^2 = 0.01767 \text{ m}^2$$

$$\text{Discharge of pipe 1 } (Q_1) = A_1 V_1 = 0.07068 \times 2.5 = 0.1767 \text{ m}^3/\text{s}$$

From the concept of continuity,

$$Q_1 = Q_2 + Q_3$$

$$\Rightarrow 0.1767 = 0.03141 \times 2 + 0.01767 V_3 = 0.1767$$

$$\Rightarrow V_3 = 6.44 \text{ m/s}$$

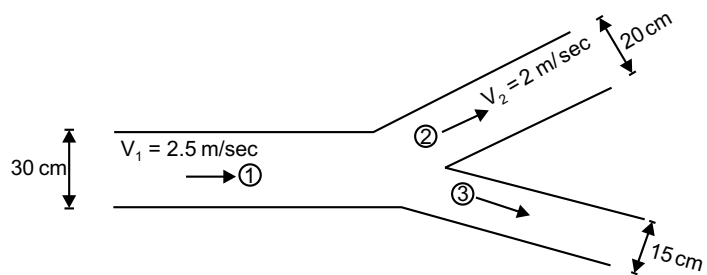

**EXAMPLE 13**

In the adjoining figure,  $CD$  carries  $1/3^{\text{rd}}$  of flow in  $AB$ . Find volume rate of flow in  $AB$ , velocity in  $BC$ , velocity in  $CD$  and diameter of  $CE$ .

**SOLUTION**

Volume rate of flow in  $AB$

$$Q_{AB} = \frac{\pi}{4} \times 1.2^2 \times 3 = 3.393 \text{ m}^3/\text{s}$$

Again,  $Q_{BC} = Q_{AB}$

$$\Rightarrow \frac{\pi}{4} \times 1.5^2 V_{BC} = 3.393$$

$$\Rightarrow V_{BC} = 1.92 \text{ m/s}$$

But,  $Q_{CD} = \frac{1}{3} Q_{AB}$

$$\Rightarrow \frac{\pi}{4} \times 0.8^2 V_{CD} = \frac{3.393}{3}$$

$$\Rightarrow V_{CD} = 2.25 \text{ m/s}$$

Now,  $Q_{BC} = Q_{CD} + Q_{CE}$

$$\Rightarrow 3.393 = \frac{3.393}{3} + \frac{\pi}{4} Q_{CE}^2 \times 2.5$$

$$\Rightarrow Q_{CE} = 1.0733 \text{ m}$$

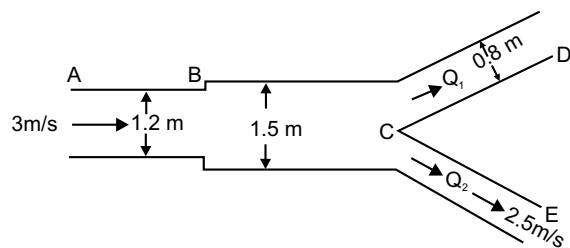
**EXAMPLE 14**

A jet of water from a 25 mm diameter nozzle is directed vertically upwards. Assuming that jet remains and neglecting any loss of energy what will be the diameter at a point 4.5 m above nozzle, if velocity with which jet leaves the nozzle is 12 m/s.

**SOLUTION**

If velocity at 4.5 m above the nozzle be  $V$ , using equation of motion,

$$V^2 = 12^2 - 2 \times 9.807 \times 4.5$$

$$\Rightarrow V = 7.465 \text{ m/s}$$

From equation of continuity,

$$\frac{\pi}{4} \times 0.025^2 \times 12 = \frac{\pi}{4} \times D^2 \times 7.465$$

$$\Rightarrow D = 0.031696 \text{ m} = 31.696 \text{ mm}$$

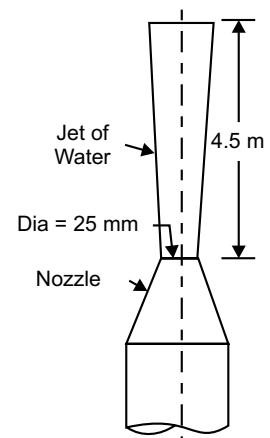

**EXAMPLE 15**

The velocity vector for a 2-D incompressible flow field is given by  $\vec{V} = \left( \frac{x}{x^2 + y^2} \right) \vec{i} + \left( \frac{y}{x^2 + y^2} \right) \vec{j}$ . State whether the flow is continuous or discontinuous.

**SOLUTION**

Here,  $u = \frac{x}{x^2 + y^2}, v = \frac{y}{x^2 + y^2}$

So,  $\frac{\partial u}{\partial x} = \frac{1}{(x^2 + y^2)} - \frac{2x^2}{(x^2 + y^2)^2}$

$$\frac{\partial v}{\partial y} = \frac{1}{(x^2 + y^2)} - \frac{2y^2}{(x^2 + y^2)^2}$$

Hence,  $\frac{\partial u}{\partial x} + \frac{\partial v}{\partial y} = 0$

So, the flow field satisfies continuity. Hence the flow is continuous.

**EXAMPLE 16**

A nurse is withdrawing blood from a patient, as shown in the figure. The piston is being withdrawn at speed of 6.35 mm/s. The piston allows air to move through its peripheral region of clearance with the glass at the cylinder @ 0.02 cm<sup>3</sup>/s. What is the average speed of blood flow in the needle? Choose the region just to the right of the piston to the tip of the needle as a control volume. Inside diameter of needle and tube is 0.5 mm and 5 mm respectively.

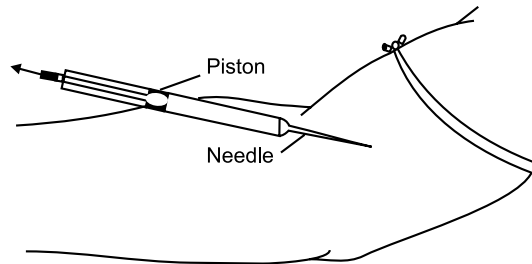

**SOLUTION**

Let the average speed of blood flow in the needle is  $V$  m/s.

From conservation of mass, it can be said

*Total blood collected = blood sucked through needle + blood collected through peripheral clearance.*

$$\rho_b \times \frac{\pi}{4} \times 5^2 \times 6.35 = \rho_b \times \frac{\pi}{4} \times 0.5^2 V + \rho_b \times 0.0 \times 10^3$$

$$\Rightarrow V = 555 \text{ mm/s} = 55.5 \text{ cm/s}$$

**EXAMPLE 17**

Meriam red oil (sp. gr. = 0.827) flows through 750 mm diameter pipeline @40 kL/min. Compute volume flux, average velocity and mass flux.

**SOLUTION**

Volume flux  $Q = \frac{40,000 \times 10^3}{60 \times 10^6} = 0.667 \text{ m}^3/\text{s}$

Again,  $0.667 = AV = \frac{\pi}{4} \times 0.75^2 \times V$

$\Rightarrow V = 1.509 \text{ m/s}$

Mass flux  $= \rho Q = 0.827 \times 10^3 \times 0.667 = 551.609 \text{ kg/s}$

**EXAMPLE 18**

Water flows steadily at three sections, as shown in the figure, through a box. Diameters at sections 1, 2, 3 are 7.5 cm, 5.0 cm, 2.5 cm respectively. Flow rate in section 1 is  $0.03 \text{ m}^3/\text{s}$  in and velocity in section 2 is  $10 \text{ m/s}$ . Compute average velocity and volume flux at section 3.

**SOLUTION**

Let us assume flow through section 3 is inward.

So,  $Q_1 + Q_3 = Q_2$

$\Rightarrow Q_3 = \frac{\pi}{4} \times 0.05^2 \times 10 - 0.03 = -0.0103 \text{ m}^3/\text{s}$

Negative sign indicates that the assumed direction of flow through section 3 is outward and its magnitude  $0.0103 \text{ m}^3/\text{s}$ . Now, average velocity at section 3.

$$= \frac{0.0103}{\frac{\pi}{4} \times 0.025^2} = 20.98 \text{ m/s}$$

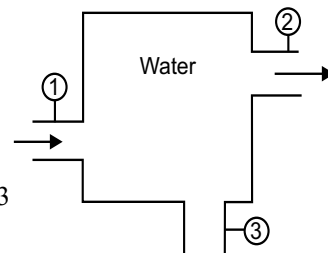
**EXAMPLE 19**

A diffuser consists of two parallel circular plates of 20 cm diameter 0.5 cm apart and connected to a 3 cm pipe as shown in the figure. If the streamline are assumed to be radial in the diffuser, what mean velocity in the pipe will correspond to an exit velocity of  $0.5 \text{ m/s}$ ?

**SOLUTION**

From continuity equation,

$$Q_{\text{pipe}} = Q_{\text{plates}}$$

$\Rightarrow \frac{\pi}{4} \times 0.03^2 V = \pi \times 0.2 \times 0.005 \times 0.5$

$\Rightarrow V = 2.2 \text{ m/s}$

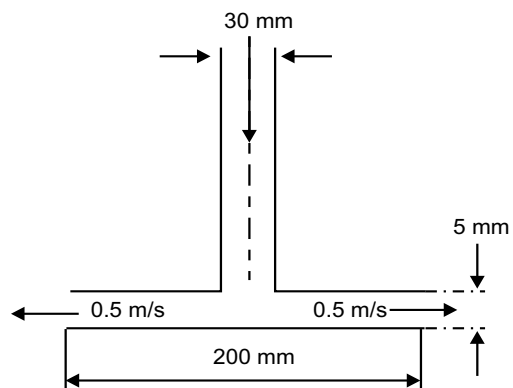

**EXAMPLE 20**

A liquid is flowing at constant  $Q$  through a divergent pipe, as shown in the figure. Assume velocity axial and uniform at any section, find out the acceleration at the inlet and outlet of the pipe.

**SOLUTION**

Let the diameter is  $D_x$  at a distance  $x$  from  $D_1$ .

Now, 
$$D_x = D_1 + \frac{x}{l}(D_2 - D_1)$$

The velocity at this section, 
$$u = \frac{4Q}{\pi \left[ D_1 + \frac{x}{l}(D_2 - D_1) \right]^2}$$

And 
$$\frac{\partial u}{\partial x} = \frac{-8Q}{\pi \left[ D_1 + \frac{x}{l}(D_2 - D_1) \right]^3} \times \frac{D_2 - D_1}{l}$$

So, convective acceleration 
$$= u \frac{\partial u}{\partial x} = \frac{-32Q^2 (D_2 - D_1)}{\pi^2 l \left[ D_1 + \frac{x}{l}(D_2 - D_1) \right]^5}$$

Convective acceleration at the inlet (for  $x = 0$ ) 
$$= \frac{-32Q^2 (D_2 - D_1)}{\pi^2 l D_1^5}$$

Convective acceleration at outlet (for  $x = l$ ) 
$$= \frac{-32Q^2 (D_2 - D_1)}{\pi^2 l D_2^5}$$

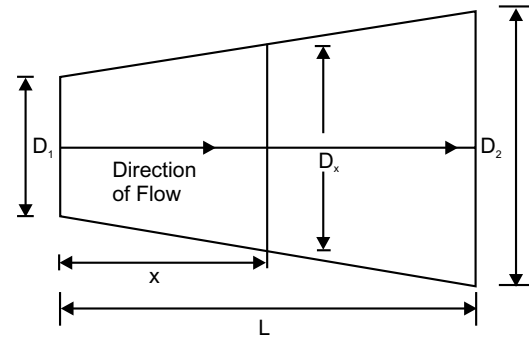
**EXERCISE**

1. Define (a) streamline (b) pathline (c) timeline (d) streakline.
2. Write the differences between (a) steady and unsteady flow (b) uniform and non-uniform flow (c) laminar and turbulent flow (d) rotational and irrotational flow.
3. Define velocity potential function and stream function. What are the conditions for the flow to be irrotational?
4. Obtain an expression for continuity equation for a two dimensional flow.
5. Explain local acceleration and convective acceleration.
6. The velocity vector in a fluid flow is given by  $\vec{V} = 2x^3 \vec{i} - 5x^2 y \vec{j} + 4t \vec{k}$ . Find velocity and acceleration of a fluid particle at (1, 2, 3) at time  $t = 1$ .

**Ans.** [10.95 units, 16.12 units]

7. Calculate the unknown velocity components of the following so that they satisfy continuity equations:  
(a) (b)

(a)  $u = 4x^2$ ,  $v = 4xyz$  (b)  $u = 4x^2 + 3xy$ ,  $w = z^3 - 4xy - 2yz$

**Ans.** [(a)  $w = -8xz - 2xz^2 + f(x, y)$

(b)  $v = -8xy - \frac{y^2}{2} + 3yz^2 + f(x, z)$ ]

8. If for a 2-D potential flow, the velocity potential is given by  $\phi = 4x(3y - 4)$ , determine the velocity at point (2, 3). Determine also the value of stream function  $\Psi$  at this point.

**Ans.** [40 units,  $\psi = 6x^2 - 4\left(\frac{3}{2}\right)y^2 - 4y$ , -18]

9. For the steady incompressible flow, are the following values of  $u$  and  $v$  are possible? (a)  $u = 4xy + y^2$ ,  $v = 6xy + 3x$  (b)  $u = 2x^2 + y^2$ ,  $v = -4xy$ .

**Ans.** [(a) No. (b) Yes]

10. Show that,  $u = -\frac{2xyz}{(x^2 + y^2)^2}$ ,  $v = \frac{(x^2 - y^2)z}{(x^2 + y^2)^2}$ ,  $w = \frac{y}{x^2 + y^2}$  are the velocity components of a possible fluid motion. Is this motion irrotational?

**Ans.** [Yes]

11. A pipeline 60 cm diameter bifurcates at a Y junction into two branches 40 cm and 30 cm in diameter. If the rate of flow in the main pipe is 1.5 m<sup>3</sup>/s and the mean velocity of flow in the 30 cm pipe is 7.5 m/s, determine the rate of flow in 40 cm pipe.

**Ans.** [0.97 m<sup>3</sup>/s]

**This page  
intentionally left  
blank**

CHAPTER
4

## DYNAMICS OF FLUID FLOW

---

### 4.1 INTRODUCTION

In the previous chapter, the aspects related to displacement, acceleration and velocity of a fluid flow have been elaborated. It did not take into account of force effect. Here aspect of forces in case of a fluid flow is taken into consideration in dealing flow of a fluid. So this discussion is sometimes designated as *kinetics of fluid flow*. The dynamic behaviour of fluid flow is analysed using *Newton's 2<sup>nd</sup> law of motion*.

Here various types of forces coming into play are forces due to gravity ( $F_G$ ), pressure ( $F_P$ ), viscosity ( $F_V$ ), turbulence effect ( $F_T$ ), elasticity ( $F_E$ ) etc. Hence net force ( $F$ ) can be written as,

$$F = F_G + F_P + F_V + F_T + F_E \quad (4.1)$$

Considering only  $x$ -direction, the equation of motion is

$$F_x = ma_x = (F_G + F_P + F_V + F_T + F_E)_x \quad (4.2)$$

For  $y$  and  $z$ -direction also, similar expressions can be found.

Here as change of volume being small, the effects of elasticity are neglected, and hence *Reynold's equation* is obtained as

$$F_x = ma_x = (F_G + F_P + F_V + F_T)_x \quad (4.3)$$

At low Reynold's number, effect of turbulence becomes negligible. Considering this in view, following equations in three mutually perpendicular directions are obtained as *Navier-Stokes equation*.

$$\left. \begin{aligned} F_x &= ma_x = (F_G + F_P + F_V)_x \\ F_y &= ma_y = (F_G + F_P + F_V)_y \\ F_z &= ma_z = (F_G + F_P + F_V)_z \end{aligned} \right\} \quad (4.4)$$

For an ideal fluid flow, the effect of viscosity can be neglected. Hence

$$F_x = ma_x = (F_G + F_P)_x \quad (4.5)$$

This equation is known as *Euler's equation of motion*.

## 4.2 EQUATION OF STEADY MOTION ALONG STREAMLINE

Let us consider a frictionless steady flow along a streamline. A cylindrical differential element as shown in figure 4.1 of length  $dS$  and cross sectional area  $dA$  is assumed along streamline. Intensity of pressures on the faces of the element are  $p$  and  $(p + dp)$ . So the pressure force acting on the element tending to accelerate fluid mass will be

$$p \cdot dA - (p + dp)dA = -dp \cdot dA \quad (4.6)$$

If  $\gamma$  be the unit weight of fluid mass, gravity force acting vertically downward will be  $(\lambda \cdot dA \cdot dS)$ . Component of gravity force along direction of motion will be

$$= -(\lambda \cdot dA \cdot dS) \cos \theta = -(\lambda \cdot dA \cdot dS) \frac{dz}{dS} = -(\lambda \cdot dA \cdot dz) \quad (4.7)$$

Therefore, the net force acting on the element

$$F = -dp \cdot dA - \lambda \cdot da \cdot dZ \quad (4.8)$$

The velocity being  $V$  along the direction of motion, acceleration for the steady flow will be  $\left( V \cdot \frac{dV}{dS} \right)$ . Applying Newton's law of motion, we have,

$$\begin{aligned} -dp \cdot dA - \lambda \cdot dA \cdot dZ &= \frac{\lambda}{g} \cdot dA \cdot dS \cdot V \frac{dV}{dS} \\ \Rightarrow \frac{dp}{\rho} + VdV + gdZ &= 0 \end{aligned} \quad (4.9)$$

This equation is commonly referred as one-dimensional *Euler's equation for an ideal fluid*, as it was first derived by *Leonhard Euler* in about 1750. And it is applicable irrespective of any fluid flow, whether compressible or incompressible.

For a real fluid, referring to figure 4.2, an additional term, force due to fluid friction will be effective. If  $\tau$  be the shear stress and  $r$  be the radius of the fluid element, the frictional force along the direction of motion will be  $(-\tau \cdot 2 \cdot \pi r dS)$ . Modifying equation (4.9), we arrive at

$$\begin{aligned} -dp \cdot dA - \lambda \cdot dA \cdot dZ - 2\pi r \cdot \tau \cdot dS &= \frac{\gamma}{g} dA \cdot dS \cdot V \frac{dV}{dS} \\ \Rightarrow \frac{dp}{\rho} + VdV + gdZ &= -\frac{2\tau \cdot dS}{\rho r} \end{aligned} \quad (4.10)$$

This is *Euler's equation for one-dimensional real fluid flow*.

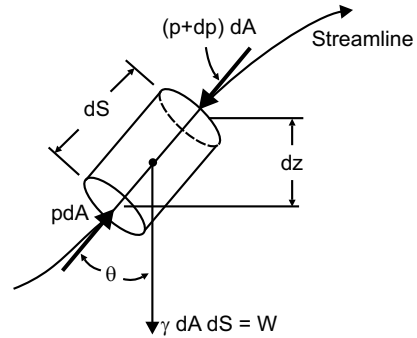

Fig. 4.1

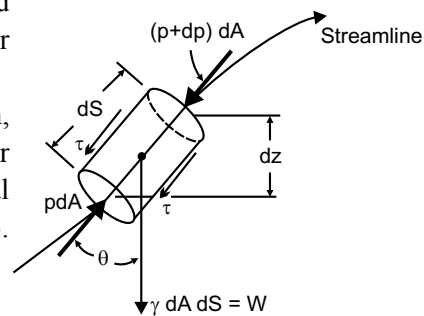

Fig. 4.2

### 4.3 BERNOULLI'S EQUATION

For the case of an incompressible *ideal* fluid where  $\rho = \text{constant}$ , equation (4.9) can be integrated as,

$$\int \frac{dp}{\rho} + \int VdV + \int gdZ = \text{Constant}$$

$$\Rightarrow \frac{p}{\rho} + \frac{V^2}{2} + gZ = \text{Constant} \quad (4.11)$$

$$\Rightarrow \frac{p}{\gamma} + \frac{V^2}{2g} + Z = \text{Constant}$$

If the fluid becomes *real and incompressible*, integration over two section 1 and 2 of total fluid element length  $l$  yields,

$$\int_1^2 \frac{dp}{\rho} + \int_1^2 VdV + \int_1^2 gdZ = - \int_1^2 \frac{2\tau \cdot dS}{\rho r}$$

$$\Rightarrow \frac{p_2 - p_1}{\rho} + \frac{V_2^2 - V_1^2}{2} + g(Z_2 - Z_1) = - \frac{2\tau}{\rho r} (l_2 - l_1)$$

$$\Rightarrow \frac{p_2 - p_1}{\gamma} + \frac{V_2^2 - V_1^2}{2g} + (Z_2 - Z_1) = - \frac{2\tau}{\gamma r} l \quad (4.12)$$

$$\Rightarrow \left( \frac{p_1}{\gamma} + \frac{V_1^2}{2g} + z_1 \right) - \left( \frac{p_2}{\gamma} + \frac{V_2^2}{2g} + Z_2 \right) = \frac{2\tau}{\gamma r} l$$

Applying equation (4.11) over two section 1 and 2, we have,

$$\left( \frac{p_1}{\gamma} + \frac{V_1^2}{2g} + Z_1 \right) - \left( \frac{p_2}{\gamma} + \frac{V_2^2}{2g} + Z_2 \right) = 0 \quad (4.13)$$

Hence right-hand side of equation (4.12), is designated as

$$h_f = \frac{2\tau \cdot l}{\gamma \cdot r} \quad (4.14)$$

This is the *head-loss* between two pre-selected sections in a conduit carrying *real fluid*. Equations (4.12) and (4.13) are popularly known as *Bernoulli's equation* for real and ideal fluid respectively, as an honour to *Daniel Bernoulli*, who first propounded it, in the year 1738. Now the *assumptions* for Bernoulli's equation for ideal fluid can be listed as:

- (i) *Flow is steady*
- (ii) *Flow is incompressible for Mach number less than 0.3.*
- (iii) *Flow is frictionless or inviscid.*

- (iv) Flow is along a streamline.  
 (v) No shaft work or transfer of heat between two pre-selected sections.

#### 4.4 DIFFERENT HEADS

In the equation (4.11), each term on the left-hand side has the dimension of length. Thus it can be termed

$\frac{p}{\gamma}$  = Pressure Head,  $\frac{V^2}{2g}$  = Velocity Head,  $Z$  = Datum Head and sum of these three heads is

denoted by *total head* ( $H$ ). So for an incompressible ideal fluid,  $H_1 = H_2$  and for incompressible real fluid,  $H_1 - H_2 = h_f$ . Again,

$$\text{Pressure head} = \frac{p}{\gamma} = \frac{p \cdot A \cdot l}{\gamma \cdot A \cdot l} = \text{pressure energy per unit weight}$$

$$\text{Velocity head} = \frac{V^2}{2g} = \frac{V^2 \cdot m}{2g \cdot m} = \frac{1/2mV^2}{mg} = \text{kinetic energy per unit weight}$$

$$\text{Datum head} = Z = \frac{mgZ}{mg} = \text{potential energy per unit weight}$$

So, total head at any section of a conduit carrying incompressible fluid is  
 $H = [\text{pressure energy} + \text{K.E.} + \text{P.E.}]$  per unit weight.

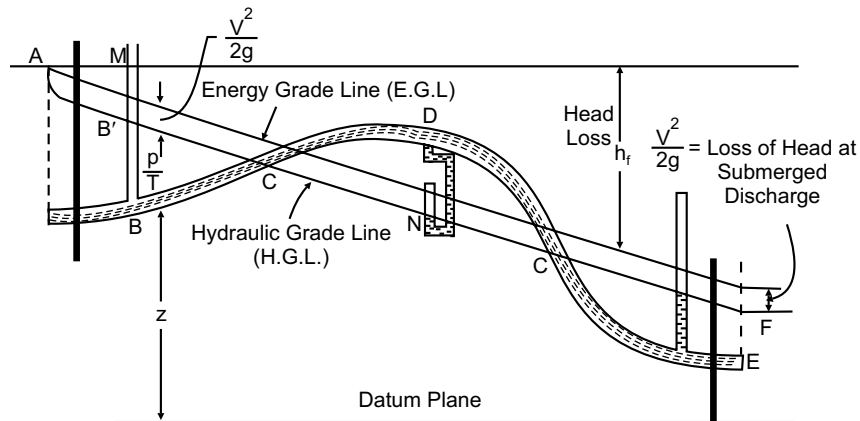

Fig. 4.3

#### 4.5 HYDRAULIC GRADE LINE (HGL) AND ENERGY GRADE LINE (EGL)

Summation of pressure head and datum head at each section for a conduit of incompressible flow, if joined by an imaginary line is called *hydraulic grade line* (HGL) or *piezometric head line* (PHL) or *static head* (SH).

The locus of the total head along the length of the conduit is *energy grade line* (EGL). Sometimes it is also called *total head line* (THL). Illustration is given in Fig. 4.3.

#### 4.6 MAJOR AND MINOR HEAD LOSS

The head loss in a conduit carrying incompressible fluid, as shown in equation (4.14) is termed as *major head loss*. This is the frictional head loss resulting from wall shear stress within the conduit. For a circular pipe flowing full, the expression for major head loss is

$$h_f = f \cdot \frac{L}{D} \cdot \frac{V^2}{2g} \quad (4.15)$$

Here  $L$  is the length and  $D$  is the diameter of the conduit and  $V$  is the velocity of flow. The factor  $f$  is known as *friction factor*. This equation is popularly known as *Darcy-Weisbach equation*. In a slightly different form, if  $D$  is replaced by hydraulic radius  $R_h$ , equation (4.15) becomes

$$h_f = f \cdot \frac{L}{R_h} \cdot \frac{V^2}{2g} \quad (4.16)$$

For a circular conduit flowing full, hydraulic radius  $R_h = D/4$  and hence,

$$h_f = f \cdot \frac{4L}{D} \cdot \frac{V^2}{2g} = 4f \cdot \frac{L}{D} \cdot \frac{V^2}{2g} = C_f \cdot \frac{L}{D} \cdot \frac{V^2}{2g} \quad (4.17)$$

This is *Fanning's equation* and  $C_f$  is known as *coefficient of friction*.

Some gas and water pipelines include pipe bends, valves,  $T$ -joints and regions where cross sectional area of the pipe changes abruptly. Local frictional loss at these points, including entrance and exit arise out of the effect of separation and are known as *minor losses*. It is expressed as

$$h_f = K \cdot \frac{V^2}{2g} \quad (4.18)$$

Here  $K$  is a constant bearing different value for commercial fittings, entrance and exit.

#### 4.7 ABSOLUTE AND RELATIVE ROUGHNESS

The internal wall of the conduit or open channel cannot be perfectly smooth. Some protrusions evenly or unevenly spaced and of variable heights are noticed inside the wall. Average height of these protrusions is defined as *absolute roughness*. It is symbolised by  $\epsilon$  (epsilon) and expressed in the unit of length.

When absolute roughness is divided by the diameter of the pipe, the obtained quantity is called *relative roughness* ( $\epsilon_r$ ). Relative roughness  $\epsilon_r = \epsilon/D$  is a *pure number*.

#### 4.8 REYNOLD'S NUMBER

In a fluid flow through a completely filled conduit, gravity force and capillarity have very negligible effect on flow pattern. Only the significant forces acting are *inertia force* and *fluid friction* due to viscosity. The ratio of inertia force to viscous force is called *Reynold's number* ( $R_e$ ), in the honour of *Osborne Reynold*, who presented this through his experimental work in 1882. So,

$$R_e = \frac{\rho VD}{\mu} = \frac{VD}{\nu} \quad (4.19)$$

Reynold's number is a quantity which determines whether the flow is laminar or turbulent. If it is less than 2000, the flow is laminar. Turbulent flow starts at 4000. In between laminar and turbulent flow, transition flow exists where  $2000 < Re < 4000$ .

Both the friction factor and coefficient of friction are dependent on Reynold's number ( $R_e$ ) and relative roughness ( $\epsilon_r$ ) as  $f = \phi_1(R_e, \epsilon_r)$  and  $C_f = \phi_2(R_e, \epsilon_r)$ . For a hydraulically smooth pipe, the effect of relative roughness become negligible and friction factor depends only on Reynold's number.

#### 4.9 APPLICATION OF BERNOULLI'S EQUATION

Bernoulli's equation has wide variety of applications in the solution of a number of fluid flow problems. This equation along with the equation of continuity serves very effectively for measurement of flow through pipes. Some flow measuring devices, otherwise known as flow-meters are discussed here.

##### 4.9.1 Orificemeter

An *orifice* is an opening (usually circular) in the wall of a tank or in a plate normal to the axis of the pipe, the plate being either at the end or at any intermediate location of the pipe. A standard sharp-edged orifice is shown in figure 4.4. Thickness of the orifice will be small enough, so that cannot affect the flow of fluid through it. While the streamlines converge towards approaching an orifice, they continue to converge beyond upstream of the orifice, until reaching at section  $x-y$  where they become parallel. This section  $x-y$  bears a minimum area or diameter of flow and the section is defined as *vena contracta*. Beyond vena contracta, streamlines diverge.

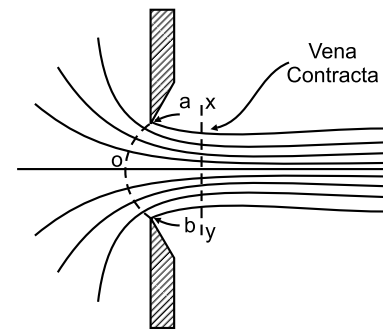

Fig. 4.4

The performance of an orifice is related with three constants, namely, *coefficient of contraction* ( $C_c$ ), *coefficient of velocity* ( $C_v$ ), *coefficient of discharge* ( $C_d$ ).

*Coefficient of contraction* is the ratio of the area of a jet at vena contracta ( $A_c$ ) to the area of orifice ( $A_o$ ).

$$\text{So, } C_c = \frac{\text{Area at vena contracta}}{\text{Area of orifice}} = \frac{A_c}{A_o} \quad (4.20a)$$

Ideal velocity is one that would be attained in the jet at frictionless condition. *Coefficient of velocity* is the ratio of actual average velocity at vena contracta ( $V_c$ ) to ideal velocity ( $V_i$ ).

$$\text{So, } C_v = \frac{\text{Actual average velocity}}{\text{Ideal velocity}} = \frac{V_c}{V_i} \quad (4.20b)$$

*Coefficient of discharge* is the ratio of actual rate of discharge ( $Q$ ) to ideal rate of discharge ( $Q_i$ ) at no-friction and no-contraction condition.

$$\text{So, } C_d = \frac{\text{Actual rate of discharge}}{\text{Ideal discharge}} = \frac{Q}{Q_i} \quad (4.20c)$$

The mutual relationship amongst these three coefficients can easily be established as

$$C_d = \frac{Q}{Q_i} = \frac{A_c \times V_c}{A_o \times V_i} = \frac{A_c}{A_o} \times \frac{V_c}{V_i} = C_c \times C_v \quad (4.21)$$

An orifice or an orifice-plate, when used in a pipeline, is called an orificemeter, which provides a simple and cheap arrangement for measurement of flow through a pipe. An orificemeter fitted along a horizontal pipe line is shown in Fig. 4.5, where section 1 is assumed at upstream side and section 2 at vena contracta. Applying Bernoulli's equation at these two section yields,

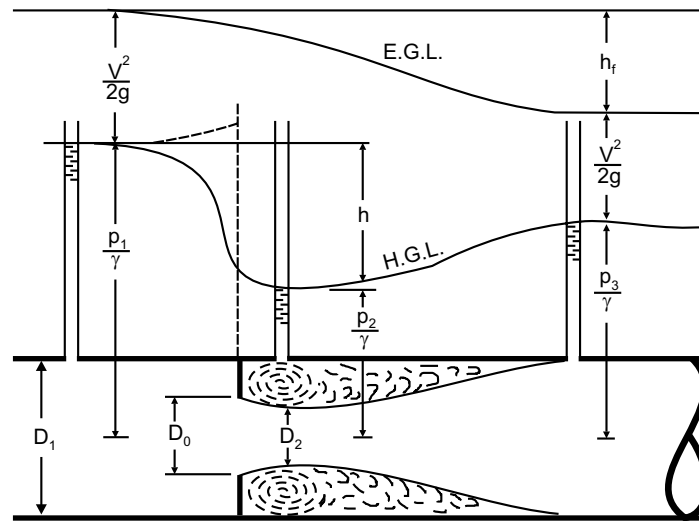

Fig. 4.5

$$\begin{aligned} \frac{p_1}{\gamma} + \frac{V_1^2}{2g} &= \frac{p_2}{\gamma} + \frac{V_2^2}{2g} \\ \Rightarrow \frac{p_1}{\gamma} - \frac{p_2}{\gamma} &= \frac{V_2^2}{2g} - \frac{V_1^2}{2g} \end{aligned} \quad (4.22)$$

If  $h$  be the piezometric head difference at these two sections, above equation can be written as,

$$\begin{aligned} h &= \frac{V_2^2}{2g} - \frac{V_1^2}{2g} \\ \Rightarrow V_2 &= \sqrt{2gh + V_1^2} \end{aligned} \quad (4.23)$$

This is the ideal velocity at section 2. Now the actual velocity at this section will be

$$V_2 = C_v \sqrt{2gh + V_1^2} .$$

Again,

$$A_1 V_1 = A_2 V_2 = C_c \cdot A_o \cdot V_2$$

$$\Rightarrow V_1 = C_c \cdot \frac{A_o}{A_1} \cdot V_2 \quad (4.24)$$

$$\text{Hence, } V_2^2 = C_v^2 \left[ 2gh + \left( C_c \cdot \frac{A_0}{A_1} \cdot V_2 \right)^2 \right] \quad (4.25)$$

$$\Rightarrow V_2^2 \left[ 1 - C_v^2 C_c^2 \left( \frac{A_0}{A_1} \right)^2 \right] = C_v^2 \cdot 2gh$$

$$\Rightarrow V_2^2 \left[ 1 - C_d^2 \left( \frac{A_0}{A_1} \right)^2 \right] = C_v^2 \cdot 2gh \quad [\because C_d = C_v \times C_c]$$

$$\Rightarrow V_2 = C_v \sqrt{\frac{2gh}{1 - C_d^2 \left( \frac{A_0}{A_1} \right)^2}}$$

So, actual discharge

$$\begin{aligned} Q &= A_2 V_2 = C_c \cdot A_0 \cdot V_2 = C_c \cdot A_0 \cdot C_v \sqrt{\frac{2gh}{1 - C_d^2 \left( \frac{A_0}{A_1} \right)^2}} \\ &= C_d \cdot A_0 \cdot \sqrt{\frac{2gh}{1 - C_d^2 \left( \frac{A_0}{A_1} \right)^2}} \end{aligned} \quad (4.26)$$

#### 4.9.2 Venturimeter

A venturimeter is a device which is used to measure both compressible as well as incompressible flow rate through a conduit. *G.B. Venturi*, the famous Italian physicist investigated its principle in about 1791 and it was applied to measurement by *Clemens Herschel* in 1886. As shown in figure 4.6, a venturimeter attached along a horizontal pipe consists of a tube having constricted *throat* producing increased velocity and reduced pressure, followed by a diverging part. Applying Bernoulli's equation in section 1 and 2,

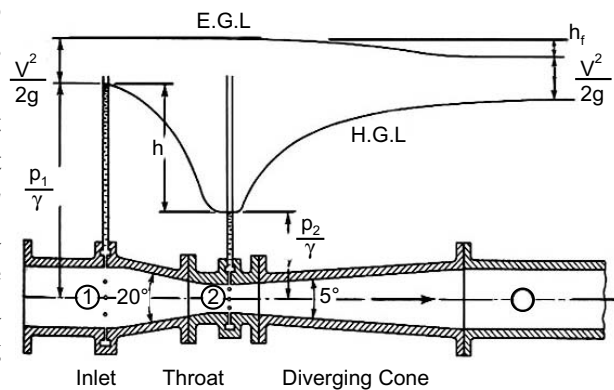

Fig. 4.6

$$\frac{p_1}{\gamma} + \frac{V_1^2}{2g} = \frac{p_2}{\gamma} + \frac{V_2^2}{2g}$$

$$\Rightarrow \frac{V_2^2}{2g} - \frac{V_1^2}{2g} = \frac{p_1}{\gamma} - \frac{p_2}{\gamma} = h \quad (4.27)$$

Here  $h$  is the piezometric head difference. Now ideal discharge

$$Q_i = A_1 V_1 = A_2 V_2$$

$$\Rightarrow V_1 = \frac{Q_i}{A_1}, V_2 = \frac{Q_i}{A_2} \quad (4.28)$$

Hence,

$$h = \frac{V_2^2}{2g} - \frac{V_1^2}{2g} = \frac{Q_i^2}{2g} \left( \frac{1}{A_2^2} - \frac{1}{A_1^2} \right)$$

$$\Rightarrow Q_i = A_1 A_2 \sqrt{\frac{2gh}{A_1^2 - A_2^2}} \quad (4.29)$$

So, actual discharge  $Q = C_d \cdot Q_i$

$$= C_d A_1 A_2 \sqrt{\frac{2gh}{A_1^2 - A_2^2}} \quad (4.30)$$

If a *U-tube manometer* is employed to measure the difference in pressure head at section 1 and 2, then for a definite level difference (say  $x$ ) of manometric fluid in the two limbs, it is

$$\frac{p_1}{\gamma} - \frac{p_2}{\gamma} = x \left( \frac{\gamma_m}{\gamma} - 1 \right)$$

$$\Rightarrow h = x \left( \frac{\gamma_m}{\gamma} - 1 \right) \quad (4.31)$$

$$\text{If an inverted } U\text{-tube manometer is used, then } h = x \left( 1 - \frac{\gamma_m}{\gamma} \right) \quad (4.32)$$

#### 4.10 STATIC PRESSURE AND STAGNATION PRESSURE

The static pressure is a parameter necessary for description of the state of a flowing fluid. The hydrostatic pressure created by collision of molecules is known as *static pressure* in a fluid flow. When the fluid is at rest, this pressure is the same in all the directions.

While a fluid is flowing past an immersed body, there exists a particular streamline which strikes a points on the body, almost vertically. As a result, resultant velocity at that point reduces to zero, converting the entire kinetic energy of fluid to the increased pressure. This point on the body

is defined as *stagnation point* or point of stagnation (Fig. 4.7). The values of pressure, density and temperature at stagnation point are defined as *stagnation pressure* ( $p_s$ ), *stagnation density* ( $\rho_s$ ) and *stagnation temperature* ( $T_s$ ). Stagnation pressure is possible to occur only in the case of *reversible adiabatic process* or *isentropic process*.

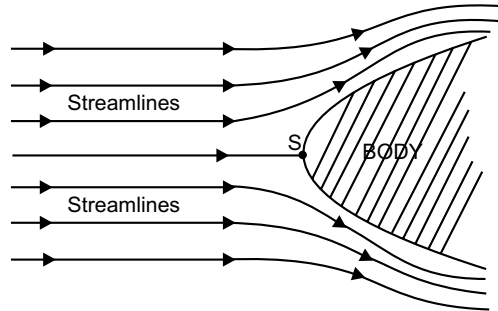

Fig. 4.7

From the definition itself, it is evident that stagnation pressure is the algebraic summation of static pressure ( $p_o$ ) and dynamic pressure, i.e.,

$$\frac{p_s}{\gamma} = \frac{p_o}{\gamma} + \frac{V^2}{2g} \tag{4.33}$$

**4.11 PITOT TUBE**

It is a device used for measuring the velocity of flow at any point in a pipe or an open channel. The principle of measurement of flow using *pitot-tube* was first adopted by *Henri Pitot*, a French scientist in 1732, during velocity measurement in River Seine.

In its simplest form, a pitot-tube is a right-angled glass tube, long enough to neglect the effect of capillarity, shown in Fig. 4.8. One end of the tube is directed to face the flow while its other end is open to atmosphere. If the rise along fluid be  $h$ , then employing the concept of stagnation pressure,

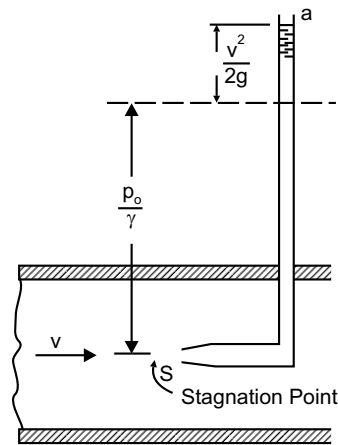

Fig. 4.8

$$\frac{p_s}{\gamma} - \frac{p_o}{\gamma} = \frac{V^2}{2g} = h$$

$$\Rightarrow V = \sqrt{2gh} \tag{4.34}$$

This is the theoretical velocity through the pitot-tube. Actual velocity of flow can be obtained by introducing the coefficient of pitot-tube, as

$$V_{ac} = C_p \sqrt{2gh} \tag{4.35}$$

The value of  $C_p$  lies between 0.97 and 1.00, depending on the degree of turbulence.

Another arrangement of pitot-tube is shown in Fig. 4.9, where piezometer at section  $a$  measures static pressure and pitot-tube at section  $b$  measures total pressure or stagnation pressure.

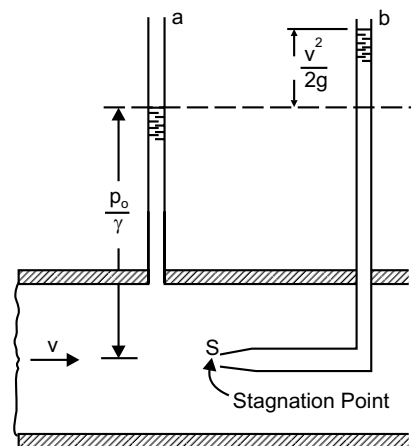

Fig 4.9

The arrangement of measurement of static pressure and total pressure when are combined into one instrument, it is called *pitot-static tube*. A particular type of pitot-tube is *Prandtl's tube* or *Prandtl's static tube*. Schematic views of normal pitot-static tube and Prandtl's tube are given in Fig. 4.10 and 4.11.

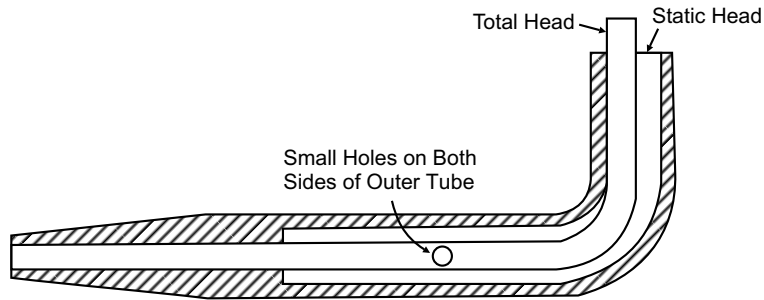

Fig. 4.10

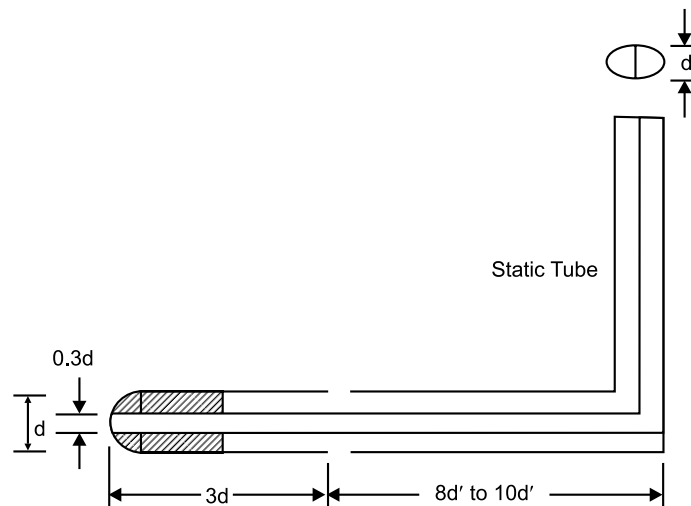

Fig. 4.11

### Multiple Choice Questions

- Bernoulli's equation is obtained by the integration of
  - Navier-Stokes equation
  - Reynold's equation
  - Euler's equation
  - none of these
- Bernoulli's equation written in the form  $\frac{p}{\gamma} + \frac{V^2}{2g} + z = \text{constant}$ , represents total energy per unit
  - volume
  - mass
  - weight
  - none of these

3. Piezometric head is the summation of
  - (a) velocity head and datum head
  - (b) pressure head and velocity head
  - (c) velocity head in the direction of flow
  - (d) none of these
4. HGL indicates the variation of
  - (a) total energy in direction of flow
  - (b) piezometric head in direction of flow
  - (c) velocity head in direction of flow
  - (d) pressure head in direction of flow
5. EGL always lies
  - (a) above
  - (b) below
  - (c) parallel to
  - (d) along HGL
6. EGL in pipe flow is a graphical representation of Bernoulli's equation and measured above
  - (a) centerline of pipe
  - (b) top of the pipe
  - (c) arbitrary horizontal datum
  - (d) top of piezometer tube
7. Total energy represented by Bernoulli's equation has the unit
  - (a) kgm/m
  - (b) Nm/N
  - (c) kgm<sup>2</sup>/s
  - (d) kgm/s
8. Stagnation point is a point where
  - (a) pressure is zero
  - (b) total energy is zero
  - (c) velocity of flow reduces to zero
  - (d) total energy is maximum
9. Pitot-tube is an instrument for measuring
  - (a) pressure of flow
  - (b) velocity of flow
  - (c) discharge of fluid
  - (d) total energy
10. Stagnation pressure is the sum of
  - (a) vacuum pressure and static pressure
  - (b) static pressure and dynamic pressure
  - (c) dynamic pressure and vacuum pressure
  - (d) none of these
11. Venturimeter is used to measure
  - (a) piezometric head
  - (b) velocity head
  - (c) discharge through a pipe
  - (d) none of these
12. A venturimeter is preferable to orificemeter, because
  - (a) it is cheaper
  - (b) it is more convenient to use
  - (c) energy loss is less
  - (d) it requires smaller length
13.  $C_d$  of an orificemeter is always
  - (a) greater than  $C_c$
  - (b) equal to  $C_c$
  - (c) equal to  $C_v$
  - (d) less than  $C_c$
14. Which of the following devices is used for measuring pipe flow?
  - (a) mouthpiece
  - (b) notch
  - (c) weir
  - (d) orificemeter

15. In orifice flow, vena contracta represents
- (a) jet has maximum flow area
  - (b) pressure is above atmosphere
  - (c) jet area is minimum and streamline are parallel
  - (d) pressure is below atmosphere
16. Reynold's number is the ratio of
- (a) inertia force and gravity force
  - (b) inertia force and viscous force
  - (c) pressure force and inertia force
  - (d) none of these
17. Value of Reynold's number below which flow through closed conduit will be laminar is
- (a) 5,000
  - (b) 20,000
  - (c) 2,000
  - (d) 3,000
18. Reynold's number is expressed as
- (a)  $\frac{\rho VD}{\mu}$
  - (b)  $\frac{V^2 D}{\rho}$
  - (c)  $\frac{V \rho^2 D}{\nu}$
  - (d)  $\frac{V^2 D^2}{\nu}$
19. Energy loss in pipeline is due to
- (a) viscous action only
  - (b) surface roughness only
  - (c) pipe wall friction and viscous action
  - (d) turbulent shear stress alone
20. Minor loss in pipe flow are those
- (a) which have small magnitude
  - (b) which are caused by local disturbances caused by valves, bends etc.
  - (c) caused by friction
  - (d) none of these.
21. The unit of relative roughness is
- (a) m
  - (b) N
  - (c) kg
  - (d) dimensionless, pure number
22. The parameters on which the friction factor is dependent are
- (a) relative roughness and Reynold's number
  - (b) absolute roughness and viscosity
  - (c) Reynold's number and specific gravity
  - (d) none of these
23. Coefficient of discharge ( $C_d$ ) in terms of  $C_c$  and  $C_v$  are
- (a)  $C_d = C_c \times C_v$
  - (b)  $C_d = C_c / C_v$
  - (c)  $C_d = C_v / C_c$
  - (d) none of these
24. Bernoulli's equation can be applied to
- (a) venturimeter
  - (b) pitot-tube
  - (c) orificemeter
  - (d) all of these

25. For hydrodynamicly smooth boundaries, friction factor for turbulent flow is
  - (a) dependent on Reynold's number
  - (b) constant
  - (c) function of Reynold's number and relative roughness
  - (d) dependent on roughness only
26. The losses in fluid flow is more in
  - (a) laminar flow
  - (b) turbulent flow
  - (c) transition flow
  - (d) critical flow
27. HGL is
  - (a) always above centerline of pipe
  - (b) always sloping downward in sloping direction
  - (c) never above EGL
  - (d) none of these
28. Bernoulli's equation is based on
  - (a) principle of conservation of energy
  - (b) principle of conservation of mass
  - (c) principle of conservation of momentum
  - (d) none of these
29. Euler's equation of motion can be integrated when it is assumed that
  - (a) continuity equation is satisfied
  - (b) fluid is incompressible
  - (c) velocity potential exists and density is constant
  - (d) flow is irrotational and incompressible
30. Specify, which of the following must be fulfilled by the flow of any fluid, real or ideal, laminar or turbulent
  - (a) Newton's law of viscosity
  - (b) continuity equation
  - (c) velocity at boundary must be zero
  - (d) velocity normal to solid boundary is zero
31. Head loss in turbulent flow of pipe
  - (a) varies directly as the velocity
  - (b) varies directly as the square of the velocity
  - (c) varies inversely as the square of the velocity
  - (d) varies approximately as the square of the velocity
32. In laminar flow through a closed conduit, discharge varies
  - (a) linearly as the viscosity
  - (b) as the square of the radius
  - (c) inversely as the pressure drop
  - (d) inversely as the viscosity
33. For laminar flow in a pipe of circular cross section Darcy friction factor is
  - (a) independent of Reynold's number and independent of pipe wall friction
  - (b) inversely proportional to Reynold's number and independent of pipe wall roughness
  - (c) directly proportional to Reynold's number and independent of pipe wall roughness
  - (d) inversely proportional to Reynold's number and directly proportional to pipe wall roughness

34. From the following statement, choose the correct one related to Bernoulli's equation
- equation is valid for steady flow of an incompressible ideal or real fluid along a streamline
  - energy equation for the flow of a frictionless fluid of constant density along a streamline with gravity as the only body force
  - equation is derived from dynamic consideration involving gravity, viscous and inertia forces
  - constant in the equation varies across streamlines if flow is irrotational
35. Euler's equation of motion is a
- statement of energy balance
  - preliminary step to derive Bernoulli's equation
  - statement of conservation of momentum for a real, incompressible fluid
  - statement of conservation of momentum for an inviscid fluid flow
36. Study of fluid motion with forces causing flow is known as
- kinematics of fluid flow
  - kinetics of fluid flow
  - statics of fluid flow
  - none of the above
37. The term  $V^2/2g$  in Bernoulli's equation is known as
- kinetic energy
  - pressure energy
  - kinetic energy per unit weight
  - none of these
38. Difference of pressure head ( $h$ ) measured by mercury-oil differential manometer is given by
- $h = x \left( 1 - \frac{S_g}{S_o} \right)$
  - $h = x (S_g - S_o)$
  - $h = x (S_o - S_g)$
  - $h = x \left( \frac{S_g}{S_o} - 1 \right)$
39. Ratio of area of jet at vena-contracta to area of orifice is known as
- coefficient of discharge
  - coefficient of velocity
  - coefficient of contraction
  - coefficient of viscosity
40. Ratio of actual velocity at vena-contracta to ideal velocity
- coefficient of discharge
  - coefficient of velocity
  - coefficient of contraction
  - coefficient of viscosity

### Answers

1. (c) 2. (c) 3. (c) 4. (b) 5. (a) 6. (c) 7. (b) 8. (c) 9. (b) 10. (b)  
 11. (c) 12. (c) 13. (d) 14. (d) 15. (c) 16. (b) 17. (c) 18. (a) 19. (c) 20. (b)  
 21. (d) 22. (a) 23. (a) 24. (d) 25. (a) 26. (b) 27. (c) 28. (a) 29. (c) 30. (b)  
 31. (d) 32. (d) 33. (b) 34. (a) 35. (a) 36. (b) 37. (c) 38. (d) 39. (c) 40. (b)

### True or False

1. Friction factor in the Darcy-Weisbach equation is given by  $f = \tau_0 / 0.5\rho V^2$
2. Minor losses can be expressed either as fraction of kinetic energy or equivalent length.
3. HGL cannot have positive slope.
4. Concept of hydraulic radius is relevant to both laminar and turbulent flow.
5. In ageing of pipes, friction factor increases linearly with tie.
6. The term  $V^2 / 2g$  in Bernoulli's equation is known as kinetic energy per unit weight.
7. Orificemeter can also be used for measuring flow of an open channel.
8. In orificemeter, coefficient of discharge is always less than unity.
9. At stagnation point, velocity of flow is maximum.
10. In a hydraulically smooth pipe, Reynold's number is not dependent on relative roughness.

### Answers

- |          |          |          |          |          |
|----------|----------|----------|----------|----------|
| 1. False | 2. True  | 3. False | 4. False | 5. False |
| 6. True  | 7. False | 8. True  | 9. False | 10. True |

### NUMERICAL EXAMPLES

#### EXAMPLE 1

A vertical venturimeter shown in figure, has an area ratio 5, with throat diameter 1 cm. When oil of specific gravity 0.8 flows through it, mercury in the differential gauge indicates a difference in height of 12 cm. Find discharge through venturimeter.

#### SOLUTION

Difference in piezometric head

$$\left( \frac{p_1}{\gamma} + Z_1 \right) - \left( \frac{p_2}{\gamma} + Z_2 \right) = x \left( \frac{\gamma_m}{\gamma_{oil}} - 1 \right)$$

$$\Rightarrow h = 0.12 \left( \frac{13.596}{0.8} - 1 \right) = 1.919 \text{ m}$$

But,  $A_1 = 5A_2$  and

$$A_2 = \frac{\pi}{4} \times 0.01^2 = 7.8539 \times 10^{-5} \text{ m}^2$$

So, actual discharge through venturimeter, from equation (4.30)

$$\begin{aligned} Q &= C_d A_1 A_2 \sqrt{\frac{2gh}{A_1^2 - A_2^2}} \\ &= 0.98 \times 5 \times (7.8539 \times 10^{-5})^2 \sqrt{\frac{2 \times 9.807 \times 1.919}{(5 \times 7.8539 \times 10^{-5})^2 - (7.8539 \times 10^{-5})^2}} \\ &= 4.819 \times 10^{-4} \text{ m}^3/\text{s} \end{aligned}$$

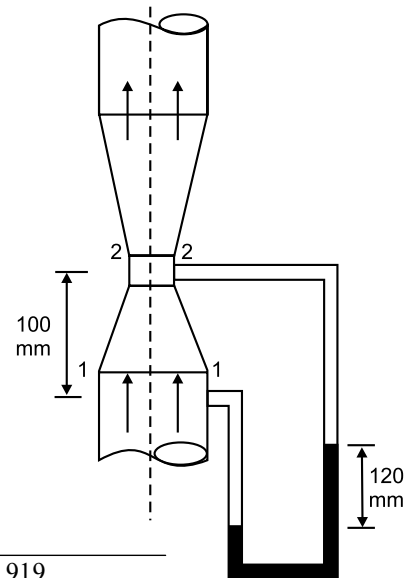

**EXAMPLE 2**

A pitot-static tube is used to measure velocity of water in a pipe. The stagnation pressure head is 8 m and static pressure head is 6 m. Calculate the velocity of flow, assuming coefficient of tube 0.98.

**SOLUTION**

Referring to equation (4.33)

$$\frac{V^2}{2g} = \frac{p_s}{\gamma} - \frac{p_o}{\gamma} = 8 - 6 = 2$$

$$\Rightarrow V = 6.263$$

Introducing discharge coefficient, actual velocity of flow =  $0.98 \times 6.263 = 6.137$  m/s

**EXAMPLE 3**

A vertical pipe of 1 m diameter and 20 m length has a pressure head of 5.5 m of water at the upper end. When water flows through the pipe at an average velocity of 4.5 m/s, the head loss due to friction is 1.2 m. Find the pressure at the lower end of the pipe, when the flow is (a) upward (b) downward.

**SOLUTION**

(a) For upward flow; upper section is considered section 2–2 and lower section is 1–1

Here,  $\frac{p_2}{\gamma} = 5.5$  m,  $V_1 = V_2 = 4.5$  m/s,  $h_f = 1.2$  m,  $(Z_2 - Z_1) = 20$  m

Applying Bernoulli's equation

$$\frac{p_1}{\gamma} + \frac{V_1^2}{2g} + Z_1 = \frac{p_2}{\gamma} + \frac{V_2^2}{2g} + Z_2 + h_f$$

$$\Rightarrow \frac{p_1}{\gamma} = \frac{p_2}{\gamma} + (Z_2 - Z_1) + h_f = 5.5 + 20 + 1.2 = 26.7$$
 m

(a) For downward flow; upper section is 1–1 and lower section is 2–2.

Here,  $\frac{p_1}{\gamma} = 5.5$  m,  $V_1 = V_2 = 4.5$  m/s,  $h_f = 1.2$  m,  $(Z_1 - Z_2) = 20$  m

Applying Bernoulli's equation

$$\frac{p_1}{\gamma} + \frac{V_1^2}{2g} + Z_1 = \frac{p_2}{\gamma} + \frac{V_2^2}{2g} + Z_2 + h_f$$

$$\Rightarrow \frac{p_2}{\gamma} = \frac{p_1}{\gamma} + (Z_1 - Z_2) - h_f = 5.5 + 20 - 1.2 = 24.3$$
 m

**EXAMPLE 4**

A siphon is shown in the figure. *A* is 1 m above water level, indicates point 1. Bottom of siphon is below *A*. Assuming friction to be negligible, determine velocity of flow at outlet and the pressure at *A*.

**SOLUTION**

Applying Bernoulli's equation at 1 and 2

$$\frac{p_1}{\gamma} + \frac{V_1^2}{2g} + Z_1 = \frac{p_2}{\gamma} + \frac{V_2^2}{2g} + Z_2$$

Here,  $Z_1 = -1$  m,  $Z_2 = -8$  m, atmospheric pressure  $= \frac{p_1}{\gamma} = \frac{p_2}{\gamma} = 0$  and cross-sectional area of the tank is much larger than of the tube, so,  $V_1 \ll V_2$ .

$$\text{Hence, } Z_1 = \frac{V_2^2}{2g} + Z_2$$

$$\Rightarrow V_2 = 11.717 \text{ m/s} \approx V_A$$

Again, applying Bernoulli's equation at 1 and A

$$\frac{p_1}{\gamma} + \frac{V_1^2}{2g} + Z_1 = \frac{p_A}{\gamma} + \frac{V_A^2}{2g} + Z_A$$

$$\text{But, } Z_1 = -1 \text{ m, } Z_A = 0, \frac{p_1}{\gamma} = 0$$

$$\text{Hence, } Z_1 = \frac{p_A}{\gamma} + \frac{V_A^2}{2g}$$

$$\Rightarrow \frac{p_A}{\gamma} = -7.999 \text{ m}$$

So, at A, the pressure is negative, *i.e.*, suction pressure.

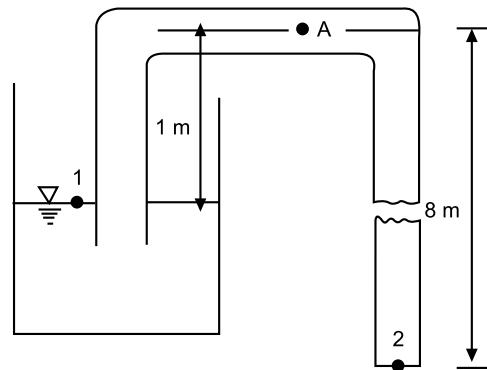
**EXAMPLE 5**

Referring to the figure of siphon carrying oil (0.8), calculate (a) velocity of oil through siphon (b) pressure at A, B and C. (c) maximum height of C can be accommodated above the level in the vessel (d) maximum vertical depth of right limb of siphon. Take vapour pressure at working temperature 29.5 kPa and atmospheric pressure 101 kPa.

**SOLUTION**

(a) Applying Bernoulli's equation at 1 and D, where  $Z_1 = 1.5 + 4 = 5.5$  m,  $Z_D = 0$ ,

$$\text{atmospheric pressure} = \frac{p_1}{\gamma} = \frac{p_D}{\gamma} = 0, \text{ and } V_1 \ll V_D,$$

$$\text{we have } Z_1 = \frac{V_D^2}{2g}$$

$$\Rightarrow V_D = 10.386 \text{ m/s}$$

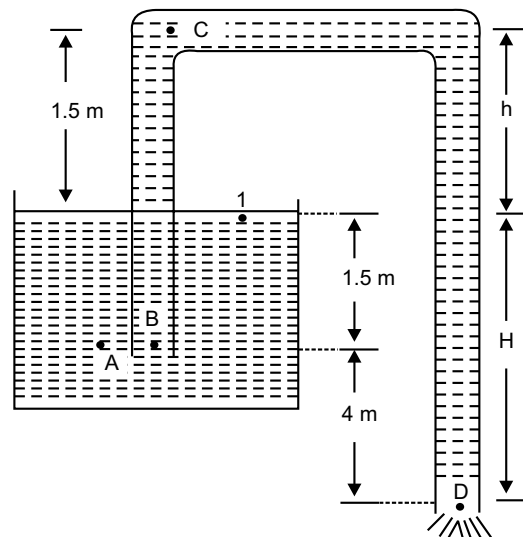

(b) As cross-section of siphon tube does not change, velocity of oil through siphon will be  $V_B = V_D = 10.386 \text{ m/s}$ .

Here  $\frac{p_A}{\gamma} = \frac{p_1}{\gamma} + 1.5 = 1.5 \text{ m of oil (gauge)}$  and  $Z_A = 4 \text{ m} = Z_B$  and  $V_A = 0$ .

Applying Bernoulli's equation at  $A$  and  $B$

$$\frac{p_A}{\gamma} = \frac{p_B}{\gamma} + \frac{V_B^2}{2g}$$

$$\Rightarrow \frac{p_B}{\gamma} = 1.5 - \frac{10.386^2}{2 \times 9.807} = -4.0 \text{ m of oil (gauge)}$$

So, absolute pressure at  $B = 101 - 4 \times 0.8 \times 9.807 = 69.62 \text{ kPa}$

Absolute pressure at  $A = 101 + 1.5 \times 0.8 \times 9.807 = 112.768 \text{ kPa}$

Applying Bernoulli's equation between 1 and  $C$

$$\frac{p_1}{\gamma} + \frac{V_1^2}{2g} + Z_1 = \frac{p_C}{\gamma} + \frac{V_C^2}{2g} + Z_C$$

$$\Rightarrow \frac{p_C}{\gamma} = (5.5 - 7) - \frac{10.386^2}{2 \times 9.807} = -7 \text{ m of oil (gauge)}$$

Absolute pressure at  $C = 101 - 7 \times 0.8 \times 9.807 = 46.08 \text{ kPa}$

(c) At maximum height of  $C$ , the pressure will be equal with vapour pressure. Considering absolute pressure, Bernoulli's equation yields

$$\frac{p_1}{\gamma} + \frac{V_1^2}{2g} + Z_1 = \frac{p_{vap}}{\gamma} + \frac{V_C^2}{2g} + Z'_C$$

$$\Rightarrow \frac{101 \times 10^3}{0.8 \times 9.807 \times 10^3} + 5.5 = \frac{29.5 \times 10^3}{0.8 \times 9.807 \times 10^3} + \frac{10.386^2}{2 \times 9.807} + (5.5 + h)$$

$$\Rightarrow h = 3.614 \text{ m}$$

(d) Let  $H$  be the value of maximum depth at which pressure at  $C$  equals to vapour pressure. Now applying Bernoulli's equation at 1 and  $D$ ,  $V_D = \sqrt{2gH}$

Again, Bernoulli's equation at 1 and  $C$ , considering absolute pressure,

$$\frac{p_1}{\gamma} + H = \frac{29.5 \times 10^3}{0.8 \times 9.807 \times 10^3} + \frac{V_D^2}{2g} + H + 1.5$$

$$\Rightarrow H = \frac{101 \times 10^3}{0.8 \times 9.807 \times 10^3} - \frac{29.5 \times 10^3}{0.8 \times 9.807 \times 10^3} - 1.5 = 7.613 \text{ m}$$

**EXAMPLE 6**

Water flows through a  $300 \times 150$  venturimeter @  $0.037 \text{ m}^3/\text{s}$  and differential gauge is deflected 1 m. Specific gravity of the gauge liquid is 1.25. Determine coefficient of discharge of the meter.

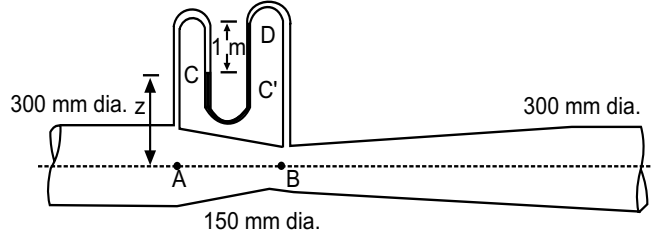
**SOLUTION**

Applying Bernoulli's equation between  $A$  and  $B$ , where  $Z_A = 0 = Z_B$  yields

$$\frac{p_A}{\gamma} + \frac{V_A^2}{2g} = \frac{p_B}{\gamma} + \frac{V_B^2}{2g} \quad (a)$$

Applying equation of continuity between  $A$  and  $B$ ,

$$V_A = \left( \frac{A_B}{A_A} \right) V_B$$

$$\Rightarrow V_A^2 = \left( \frac{A_B}{A_A} \right)^2 V_B^2 \quad (b)$$

Substitution (b) into (a), we obtain  $V_B = \sqrt{\frac{2g(p_A - p_B)}{\gamma \left( 1 - \frac{A_B^2}{A_A^2} \right)}}$

So, actual discharge  $Q = C_d A_B V_B = C_d A_B \sqrt{\frac{2g(p_A - p_B)}{\gamma \left( 1 - \frac{A_B^2}{A_A^2} \right)}}$  (c)

Again from differential gauge,

$$\frac{p_A}{\gamma} - Z - (1.25 \times 1) + (Z + 1) = \frac{p_B}{\gamma}$$

$$\Rightarrow \frac{p_A}{\gamma} - \frac{p_B}{\gamma} = 0.25$$

Substituting in (c) we obtain,

$$0.037 = C_d A_B V_B = C_d \cdot \frac{\pi}{4} \cdot 0.15^2 \sqrt{\frac{2 \times 9.807 \times 0.25}{\left( 1 - \frac{0.15^4}{0.3^4} \right)}}$$

$$\Rightarrow C_d = 0.9155$$

**EXAMPLE 7**

A venture section of a pipe flow is shown in the figure. Derive an expression for  $V_2$ , just sufficient to cause the reservoir liquid to rise in tube upto section 1.

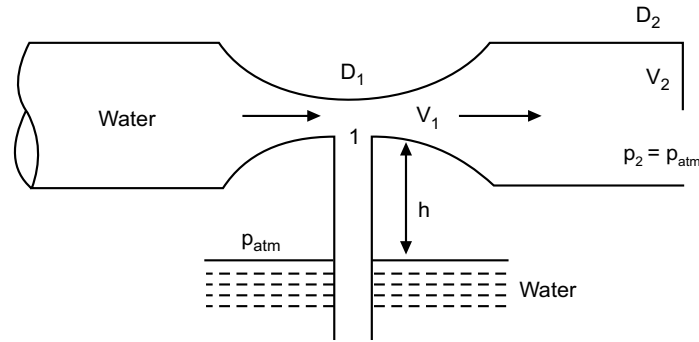
**SOLUTION**

For the liquid to rise through the tube,  $p_{\text{atm}} - p_1 \geq \gamma h$  (a)

Using continuity equation,  $V_1 = \left(\frac{A_2}{A_1}\right)V_2 = \left(\frac{D_2}{D_1}\right)^2 V_2$

Applying Bernoulli's equation at 1 and 2, while  $Z_1 = Z_2$

$$\frac{p_1}{\gamma} + \frac{V_1^2}{2g} = \frac{p_2}{\gamma} + \frac{V_2^2}{2g} = \frac{p_{\text{atm}}}{\gamma} + \frac{V_2^2}{2g}$$

$$\Rightarrow p_{\text{atm}} - p_1 = \gamma \frac{(V_1^2 - V_2^2)}{2g} = \gamma \frac{V_2^2}{2g} \left[ \left(\frac{D_2}{D_1}\right)^4 - 1 \right] \quad \text{(b)}$$

Comparing the two values, given in equations (a) and (b)

$$\gamma \frac{V_2^2}{2g} \left[ \left(\frac{D_2}{D_1}\right)^4 - 1 \right] \geq \gamma h$$

$$\Rightarrow V_2 = \sqrt{\frac{2gh}{\left[\left(\frac{D_2}{D_1}\right)^4 - 1\right]}}$$

**EXAMPLE 8**

Air flows through a duct and Pitot-static tube measuring the velocity is attached to a differential manometer containing water. If deflection of the manometer is 100 mm, calculate air velocity, assuming  $\rho_{\text{air}} = 1.22 \text{ kg/m}^3$  and coefficient of tube be 0.98.

**SOLUTION**

Now, 
$$\frac{p_s}{\gamma} - \frac{p_o}{\gamma} = h_{\text{water}} = \frac{0.1 \times 9.807 \times 10^3}{1.22 \times 9.807} = 81.967 \text{ m of air}$$

Applying equation (4.35)

$$V_{ac} = C_p \sqrt{2gh} = 0.98 \sqrt{2 \times 9.807 \times 81.967} = 39.294 \text{ m/s}$$

**EXAMPLE 9**

Water flows at a velocity of 1.417 m/s. A differential gauge which contains a liquid of specific gravity 1.25 is attached to a Pitot-static tube. What is the deflection of the gauge fluid? Coefficient of the tube is 1.

**SOLUTION**

Following equation (4.35)

$$V = C_p \sqrt{2gh_w}$$

$$\Rightarrow 1.417 = 1 \sqrt{2 \times 9.807 \times h_w}$$

$$\Rightarrow h_w = 0.1023 \text{ m of water}$$

From manometric equation of differential gauge,

$$h_w = \left( \frac{\gamma_m}{\gamma_w} - 1 \right) h_m$$

$$\Rightarrow 0.1023 = \left( \frac{1.25}{1} - 1 \right) h_m$$

$$\Rightarrow h_m = 0.4092 \text{ m}$$

**EXAMPLE 10**

A vertical venturimeter carries a liquid of sp.gr. 0.8. Inlet and outlet diameters are 150 mm and 75 mm respectively. Pressure connection at throat is 150 mm above inlet. If actual flow rate is 40 lit/s and  $C_d = 0.96$ , calculate (a) pressure difference between inlet and throat (b) difference in mercury level in a U-tube manometer connected between inlet and throat.

**SOLUTION**

(a) Let inlet is section 1 and throat is section 2. Here,

$$A_1 = \frac{\pi}{4} 0.15^2 = 0.01767 \text{ m}^2, \quad A_2 = \frac{\pi}{4} 0.075^2 = 4.4178 \times 10^{-3} \text{ m}^2,$$

$$Q = 40 \times 10^3 \times 10^{-6} \text{ m}^3/\text{s}, \quad C_d = 0.96.$$

Substituting in  $Q = C_d A_1 A_2 \sqrt{\frac{2gh}{A_1^2 - A_2^2}}$  we can obtain,  $h = 4.25 \text{ m}$

So, piezometric head difference

$$h = \left( \frac{p_1}{\gamma} + Z_1 \right) - \left( \frac{p_2}{\gamma} + Z_2 \right)$$

$$\begin{aligned} \Rightarrow 4.25 &= \left( \frac{p_1}{\gamma} - \frac{p_2}{\gamma} \right) + (0 - 0.15) \\ \Rightarrow \frac{p_1}{\gamma} - \frac{p_2}{\gamma} &= 4.4 \\ \Rightarrow p_1 - p_2 &= 4.4 \times 0.8 \times 9.807 = 34.52 \text{ kPa} \end{aligned}$$

(b) Again using equation (4.31)

$$\begin{aligned} h + 0.15 &= \left( \frac{\gamma_m}{\gamma} - 1 \right) h_m \\ \Rightarrow 4.4 &= \left( \frac{13.596}{0.8} - 1 \right) h_m \\ \Rightarrow h_m &= 0.275 \text{ m} \end{aligned}$$

### EXAMPLE 11

The head loss from the entrance to the throat of a  $254 \times 127$  venturimeter is  $1/6^{\text{th}}$  times the throat velocity head. If mercury in the differential gauge attached to the meter deflects 101.6 mm, what is the flow of water through the venturimeter?

**SOLUTION**

Difference in piezometric head

$$h = \left( \frac{\gamma_m}{\gamma} - 1 \right) h_m = \left( \frac{13.596}{1} - 1 \right) 0.1016 = 1.2797 \text{ m}$$

Being horizontal, Bernoulli's equation applied at entrance and throat yields

$$\begin{aligned} \frac{p_1}{\gamma} + \frac{V_1^2}{2g} &= \frac{p_2}{\gamma} + \frac{V_2^2}{2g} + h_f = \frac{p_2}{\gamma} + \frac{V_2^2}{2g} + \frac{1}{6} \frac{V_2^2}{2g} \\ \Rightarrow \frac{p_1}{\gamma} - \frac{p_2}{\gamma} &= 1.167 \frac{V_2^2}{2g} - \frac{V_1^2}{2g} \\ \Rightarrow 1.2797 &= 1.167 \frac{Q^2}{2g} \left( \frac{1}{A_2^2} - \frac{1}{A_1^2} \right) \\ &= \frac{Q^2}{2 \times 9.807} \frac{1}{(\pi/4)^2} \left( \frac{1.167}{0.127^4} - \frac{1}{0.254^4} \right) = 0.06 \text{ m}^3/\text{s} \end{aligned}$$

[Here  $C_d$  is not introduced in the computation, because its effect has already been considered in terms of headloss]

### EXAMPLE 12

The air supply to an oil-engine is measured by inducting air directly from the atmosphere into a large reservoir through a sharp edged orifice of 50 mm diameter. Pressure difference across the orifice is measured

by an alcohol manometer set at a slope of  $\theta = \sin^{-1}(0.1)$  to the horizontal. Calculate the volume flow rate of air if manometer reading is 271 mm. Consider sp.gr. of alcohol is 0.8,  $C_d = 0.62$ ,  $C_c = 0.6$ , atm.pr. = 775 mm of Hg, atm. temp. = 15.8°C.

**SOLUTION**

Vertical height of manometric fluid

$$h_{al} = h \cdot \sin \theta = 0.271 \times 0.1 = 0.0271 \text{ m}$$

Equivalent height of air column

$$h_{air} = \left( \frac{\gamma_m}{\gamma} - 1 \right) h_{al} = \left( \frac{0.8 \times 10^3}{1.217} - 1 \right) 0.0271 = 17.787 \text{ m}$$

Here,  $V_1 = 0$ , as section 1 is open to atmosphere, and

$$\begin{aligned} V_2 &= C_v \sqrt{2gh_{air} + V_1^2} = \frac{C_d}{C_c} \sqrt{2gh_{air}} \\ &= \frac{0.62}{0.6} \sqrt{2 \times 9.807 \times 17.787} \\ &= 19.3 \text{ m/s} \end{aligned}$$

Applying equation of continuity, flow rate

$$Q = A_2 V_2 = C_c A_0 V_2 = 0.6 \times \frac{\pi}{4} \times 0.05^2 \times 19.3 = 0.02273 \text{ m}^3/\text{s}$$

**EXAMPLE 13**

What is the size of an orifice required to discharge 0.016 m<sup>3</sup>/s of water under a head of 8.69 m, while  $C_d = 1.0$ .

**SOLUTION**

Velocity of flow

$$V = \sqrt{2gh} = \sqrt{2 \times 9.807 \times 8.69} = 13.055 \text{ m/s}$$

Applying equation of continuity, c/s area

$$A = \frac{Q}{V} = \frac{0.016}{13.055} \times 10^6 = 1225.58 \text{ mm}^2$$

**EXAMPLE 14**

Flow of air at 49°C is measured by a Pitot-static tube. If the velocity of air is 18.29 m/s and the coefficient of tube is 0.95, what differential reading will be shown in a water manometer? Assume density of air to be constant at 1.2 kg/m<sup>3</sup>.

**SOLUTION**

Applying equation (4.35)

$$\begin{aligned} V &= C_p \sqrt{2gh_{air}} \\ \Rightarrow 18.29 &= 0.95 \sqrt{2 \times 9.807 \times h_{air}} \\ \Rightarrow h_{air} &= 18.89792 \text{ m} \end{aligned}$$

Again from equation of differential manometer

$$h_{\text{air}} = \left( \frac{\gamma_w}{\gamma_{\text{air}}} - 1 \right) h_w$$

$$\Rightarrow 18.89792 = \left( \frac{10^3}{1.2} - 1 \right) h_w$$

$$\Rightarrow h_w = 0.022704 \text{ m} = 22.704 \text{ mm}$$

### EXAMPLE 15

A pump is installed in a pipeline, 5 cm dia., carrying oil of *sp. gr.* 0.83. It returns the oil to a 5 cm dia. pipe at the same elevation with a pressure increase of 1.4 kg/cm<sup>2</sup>. Quantity of oil flowing in the pipeline is 10 lit/s. The motor driving the pump delivers 3.8 metric H.P. to the pump shaft. Calculate loss of energy in the pump in kg-m/kg and kg-m/s.

#### SOLUTION

Applying Bernoulli's equation at sections 1 and 2,

$$\begin{aligned} \frac{p_1}{\gamma} + \frac{V_1^2}{2g} + Z_1 + \text{energy from pump} \\ = \frac{p_2}{\gamma} + \frac{V_2^2}{2g} + Z_2 + \text{losses in pump} \end{aligned}$$

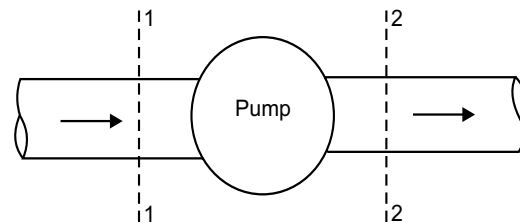

Here,  $Z_1 = Z_2$ ,  $V_1 = V_2$  and  $p_2 > p_1$

$$\frac{p_1}{\gamma} + \text{energy from pump} = \frac{p_2}{\gamma} + \text{losses in pump}$$

$$\Rightarrow \text{losses in pump} = \left( \frac{p_1}{\gamma} - \frac{p_2}{\gamma} \right) + \text{energy from pump}$$

$$\begin{aligned} \text{So,} \quad &= -\frac{1.4 \times 100^2}{10^3 \times 0.83} + \text{energy from pump} \\ &= -16.87 \text{ m} + \text{energy from pump} \end{aligned}$$

Now, energy from pump =  $3.8 \times 75 = 285 \text{ kg} \times \text{m/s}$

Energy from pump per kg of oil

$$= \frac{285}{10 \times 10^3 \times 10^{-6} \times 0.83 \times 10^3} = 34.3 \text{ kgm/kg}$$

So, losses in pump

$$= (-16.87 + 34.3) = 17.43 \text{ kgm/kg of oil}$$

$$\text{or, } 17.43 \times (10 \times 10^3 \times 10^{-6} \times 0.83 \times 10^3) = 144.7 \text{ kgm/s}$$

**EXAMPLE 16**

Water moves steadily through turbine @ 0.23 m<sup>3</sup>/s. Pressure at (1) and (2) are 186.4 kN/m<sup>2</sup> and 19.6 kN/m<sup>2</sup> respectively. Neglecting transfer of heat, determine the H.P. delivered to the turbine from water.

**SOLUTION**

Here,

$$A_1 = \frac{\pi}{4} 0.2^2 = 0.03141 \text{ m}^2, A_2 = \frac{\pi}{4} 0.4^2 = 0.12566 \text{ m}^2$$

So,

$$V_1 = \frac{0.23}{0.03141} = 7.322 \text{ m/s}, V_2 = \frac{0.23}{0.12566} = 1.83 \text{ m/s}$$

Applying Bernoulli's equation at sections 1 and 2

$$\frac{p_1}{\gamma} + \frac{V_1^2}{2g} + Z_1 = \frac{p_2}{\gamma} + \frac{V_2^2}{2g} + Z_2 + H$$

Head delivered to the turbine

$$\begin{aligned} H &= \frac{p_1 - p_2}{\gamma} + (Z_1 - Z_2) + \frac{V_1^2 - V_2^2}{2g} \\ &= \frac{(186.4 - 19.6)10^3}{9.807 \times 10^3} + (1.3 - 0) + \frac{7.322^2 - 1.83^2}{2 \times 9.807} = 24.8675 \text{ m} \end{aligned}$$

H.P. delivered to turbine

$$= \frac{\gamma Q H}{75} = \frac{10^3 \times 0.23 \times 24.8675}{75} = 76.26 \text{ metric H.P.}$$

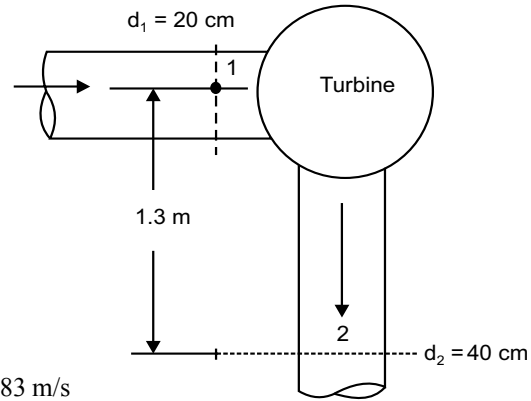
**EXAMPLE 17**

A venturimeter with 30 cm diameter inlet and 15 cm throat is used for measuring flow of oil of sp.gr. 0.9. The oil-mercury differential gauge shows a reading of 33 cm. Assuming the coefficient of meter 0.98, calculate the discharge.

**SOLUTION**

Here,  $A_1 = \frac{\pi}{4} 0.3^2 = 0.07068 \text{ m}^2, A_2 = \frac{\pi}{4} 0.15^2 = 0.01767 \text{ m}^2$

Again,  $h_{\text{oil}} = \left( \frac{\gamma_m}{\gamma_{\text{oil}}} - 1 \right) h_m = \left( \frac{13.596}{0.9} - 1 \right) 0.33 = 4.655 \text{ m}$

To obtain the discharge through venturimeter, substitute values in  $Q = C_d A_1 A_2 \sqrt{\frac{2gh}{A_1^2 - A_2^2}}$

which is 0.17089 m<sup>3</sup>/s.

**EXAMPLE 18**

A 20 cm waterpipe has in it a venturimeter of throat diameter 12.5 cm as shown in the figure, which is connected to a mercury manometer showing a difference of 86.5 cm. Find the velocity in the throat and the discharge.

**SOLUTION**

Applying Bernoulli's equation in sections 1 and 2,

$$\frac{p_1}{\gamma} + \frac{V_1^2}{2g} = \frac{p_2}{\gamma} + \frac{V_2^2}{2g} + y_1$$

From the principle of manometer

$$\frac{p_1}{\gamma} + y_2 + 0.865 - (0.865 \times 13.596) - y_2 - y_1 = \frac{p_2}{\gamma}$$

$$\Rightarrow \frac{p_1}{\gamma} = 10.8955 + y_1 + \frac{p_2}{\gamma}$$

Substituting (b) in (a)

$$10.8955 + y_1 + \frac{p_2}{\gamma} + \frac{V_1^2}{2g} = \frac{p_2}{\gamma} + \frac{V_2^2}{2g} + y_1$$

$$\begin{aligned} \Rightarrow \frac{V_2^2}{2g} &= 10.8955 + \frac{V_1^2}{2g} = 10.8955 + \frac{V_2^2}{2g} \left( \frac{A_2}{A_1} \right)^2 \\ &= 10.8955 + \frac{V_2^2}{2g} \left( \frac{0.125}{0.2} \right)^4 \end{aligned}$$

$$\Rightarrow 0.8474 \frac{V_2^2}{2g} = 10.8955$$

$$\Rightarrow V_2 = 15.88 \text{ m/s}$$

$$\text{Discharge } Q = A_2 V_2 = \frac{\pi}{4} \times 0.125^2 \times 15.88 = 0.1948 \text{ m}^3/\text{s}$$

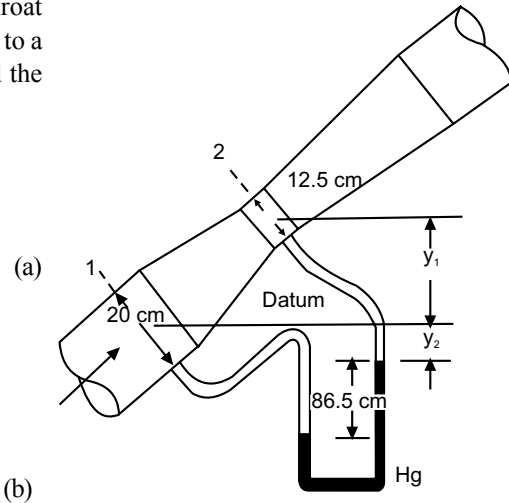
**EXAMPLE 19**

A venturimeter is installed in a pipeline of 30 cm diameter. The throat-pipe diameter ratio is 1:3. The pressure in the pipeline is 137.7 kN/m<sup>2</sup> and the vacuum in the throat 37.5 cm of mercury. If 4% of the differential head is lost between gauges, find the flow in the pipeline.

**SOLUTION**

Let us consider pipeline as section 1 and throat section 2.

$$\text{So, } \frac{A_2}{A_1} = \left( \frac{1}{3} \right)^2 = \frac{1}{9} = \frac{V_1}{V_2}$$

$$\Rightarrow A_1 = 9A_2 \text{ and } V_2 = 9V_1$$

Again, 
$$p_2 = -0.375 \times 13.596 \times 9.807 = -50 \text{ kN/m}^2$$

Now, 
$$\frac{p_1}{\gamma} + \frac{V_1^2}{2g} = \frac{p_2}{\gamma} + \frac{V_2^2}{2g} + h_f$$

$$= \frac{p_2}{\gamma} + \frac{V_2^2}{2g} + 0.04 \left( \frac{p_1}{\gamma} - \frac{p_2}{\gamma} \right) \quad \left[ \because h_f = 4\% \text{ of } \left( \frac{p_1}{\gamma} - \frac{p_2}{\gamma} \right) \right]$$

$$\Rightarrow 0.96 \left( \frac{p_1}{\gamma} - \frac{p_2}{\gamma} \right) = \frac{V_2^2}{2g} - \frac{V_1^2}{2g}$$

$$\Rightarrow 0.96 \left( \frac{137.7 + 50}{9.807} \right) = \frac{(9V_1)^2}{2 \times 9.807} - \frac{V_1^2}{2 \times 9.807}$$

$$\Rightarrow V_1 = 2.122 \text{ m/s}$$

So, discharge 
$$Q = A_1 V_1 = \frac{\pi}{4} \times 0.3^2 \times 2.122 = 0.1499 \text{ m}^3/\text{s}$$

### EXAMPLE 20

At a point in the pipeline where diameter is 20 cm, velocity of water is 4 m/s and pressure 3.5 kg/cm<sup>2</sup>. At a point 15 m downstream, diameter reduces to 10 cm. Calculate pressure at this point if pipe is vertical with (a) downward flow and (b) upward flow.

#### SOLUTION

Considering no head loss between 1 and 2, velocity at 2 is

$$V_2 = \frac{A_1}{A_2} V_1 = \left( \frac{0.2}{0.1} \right)^2 \times 4 = 16 \text{ m/s}$$

(a) Here, 
$$\frac{p_1}{\gamma} + \frac{V_1^2}{2g} + Z_1 = \frac{p_2}{\gamma} + \frac{V_2^2}{2g} + Z_2$$

$$\Rightarrow \frac{3.5 \times 10^4}{1000} + \frac{4^2}{2 \times 9.807} + 15 = \frac{p_2}{\gamma} + \frac{16^2}{2 \times 9.807} + 0$$

$$\Rightarrow \frac{p_2}{\gamma} = 37.7638 \text{ m of water} = 3.77638 \text{ kg/cm}^2$$

(b) Here, 
$$\frac{p_1}{\gamma} + \frac{V_1^2}{2g} + Z_1 = \frac{p_2}{\gamma} + \frac{V_2^2}{2g} + Z_2$$

$$\Rightarrow \frac{3.5 \times 10^4}{1000} + \frac{4^2}{2 \times 9.807} + 0 = \frac{p_2}{\gamma} + \frac{16^2}{2 \times 9.807} + 15$$

$$\Rightarrow \frac{p_2}{\gamma} = 7.7638 \text{ m of water} = 0.77638 \text{ kg/cm}^2$$

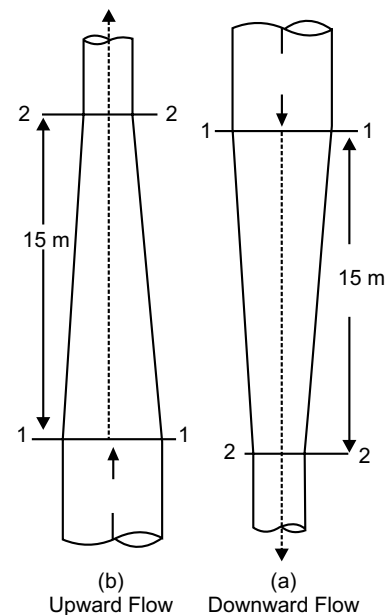

**EXAMPLE 21**

The velocity of water in pipeline was measured with Pitot-static tube. The difference of head at the centre of the pipe was 89 mm of water. If mean velocity of water is *three-fourth* the velocity at the centre, determine rate of flow. Diameter of the pipe is 280 mm. Take  $C_p = 0.99$ .

**SOLUTION**

Velocity at the centre of the pipe

$$V = C_p \sqrt{2gh} = 0.99 \sqrt{2 \times 9.807 \times 0.089} = 1.308 \text{ m/s}$$

Mean velocity  $= \frac{3}{4} \times 1.308 = 0.981 \text{ m/s}$

Rate of flow  $Q = AV = \frac{\pi}{4} 0.28^2 \times 0.981 = 0.0604 \text{ m}^3/\text{s}$

**EXAMPLE 22**

Adjacent figure shows a siphon discharging oil (sp.gr. = 0.84) from a reservoir into open air. If the velocity of flow in the pipe is  $V$ , the head loss from point 1 to 2 is  $2V^2/2g$ , and that from point 2 to 3 is  $3V^2/2g$ , determine the volume flow rate in the siphon pipe and absolute pressure at point 2. Assume an atmosphere pressure 101.358 kPa.

**SOLUTION**

Different head losses between sections are as following:

$$h_{1-2} = \frac{2V^2}{2g}, \text{ and } h_{2-3} = \frac{3V^2}{2g}$$

$$\therefore h_{1-3} = h_{1-2} + h_{2-3} = \frac{5V^2}{2g}$$

Applying Bernoulli's equation between sections 1 and 3

$$\frac{p_1}{\gamma} + \frac{V_1^2}{2g} + Z_1 = \frac{p_3}{\gamma} + \frac{V_3^2}{2g} + Z_3 + h_{1-3}$$

Here,  $V_1 = 0$ ,  $V_2 = V_3 = V$  and being open to atmosphere,  $p_1 = p_3 = 0$

So,  $(4.6 - 1.5) = \frac{V^2}{2g} + 0 + \frac{5V^2}{2g}$

$$\Rightarrow V = 3.183 \text{ m/s} = V_2 = V_3$$

Volume flow rate  $Q = A_3 V_3 = \frac{\pi}{4} \times 0.075^2 \times 3.183 = 0.014 \text{ m}^3/\text{s}$

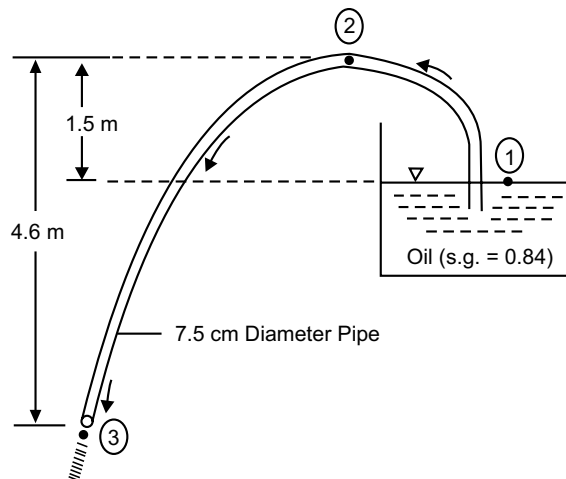

Applying Bernoulli's equation between sections 1 and 2

$$\frac{p_1}{\gamma} + \frac{V_1^2}{2g} + Z_1 = \frac{p_2}{\gamma} + \frac{V_2^2}{2g} + Z_2 + h_{1-2}$$

$$\Rightarrow (4.6 - 1.5) = \frac{p_2}{\gamma} + \frac{3.183^2}{2 \times 9.807} + 4.6 + 2 \frac{3.183^2}{2 \times 9.807}$$

$$\Rightarrow \frac{p_2}{\gamma} = -3.049 \text{ m of oil}$$

$$\Rightarrow p_2|_{\text{gauge}} = (-3.409 \times 0.84 \times 9.807) = -25.117 \text{ kPa}$$

$$\Rightarrow p_2|_{\text{absolute}} = (101.358 - 25.117) = 76.241 \text{ kPa}$$

### EXAMPLE 23

Compute the ideal flow rate through the pipe system shown in the figure.

#### SOLUTION

Applying Bernoulli's equation between 1 and 2 and assuming no head loss,

$$\frac{p_1}{\gamma} + \frac{V_1^2}{2g} + Z_1 = \frac{p_2}{\gamma} + \frac{V_2^2}{2g} + Z_2$$

$$\Rightarrow \frac{p_1}{\gamma} + \frac{V_1^2}{2g} + 0.6 \sin 30^\circ = \frac{p_2}{\gamma} + 0 + 0$$

$$\Rightarrow \frac{V_1^2}{2g} = \left( \frac{p_2}{\gamma} - \frac{p_1}{\gamma} \right) - 0.3$$

Again from the equation of manometer,

$$\frac{p_1}{\gamma} - 1.2 \sin 60^\circ = \frac{p_2}{\gamma}$$

$$\Rightarrow \left( \frac{p_1}{\gamma} - \frac{p_2}{\gamma} \right) = 1.0392$$

Combining these two results, we obtain

$$\frac{V_1^2}{2g} = 1.0392 - 0.3 = 0.7392$$

$$\Rightarrow V_1 = 3.807 \text{ m/s}$$

Ideal flow rate  $Q = A_1 V_1 = \frac{\pi}{4} 0.2^2 \times 3.807 = 0.1196 \text{ m}^3/\text{s}$

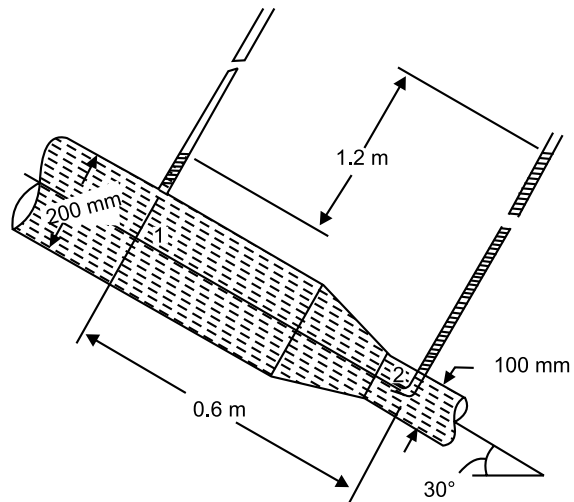

**EXAMPLE 24**

The flow from two reservoirs mixes together and flows through a common pipe. Both reservoir contain same liquid and open to atmosphere. Neglecting frictional loss, find flow rate through common pipe.

**SOLUTION**

Applying Bernoulli's equation between 1 and 2

$$\frac{p_1}{\gamma} + \frac{V_1^2}{2g} + Z_1 = \frac{p_2}{\gamma} + \frac{V_2^2}{2g} + Z_2$$

$$\Rightarrow \frac{p_{atm}}{\gamma} + 0 + h_1 = \frac{p_2}{\gamma} + \frac{V_2^2}{2g} + 0$$

$$\Rightarrow \frac{p_{atm}}{\gamma} + h_1 = \frac{p_2}{\gamma} + \frac{V_2^2}{2g}$$

(a)

Applying Bernoulli's equation between 3 and 4, in the similar way,

$$\Rightarrow \frac{p_{atm}}{\gamma} + h_2 = \frac{p_4}{\gamma} + \frac{V_4^2}{2g} \tag{b}$$

Applying Bernoulli's equation between 5 and 6, in the similar way

$$\frac{p_5}{\gamma} + \frac{V_5^2}{2g} + Z_5 = \frac{p_6}{\gamma} + \frac{V_6^2}{2g} + Z_6$$

$$\Rightarrow \frac{p_5}{\gamma} + \frac{V_5^2}{2g} + 0 = \frac{p_{atm}}{\gamma} + \frac{V_6^2}{2g} + (-h_3)$$

$$\Rightarrow \frac{p_5}{\gamma} = \frac{p_{atm}}{\gamma} - h_3 \tag{c}$$

As points 2,4 and 5 lie on the boundary of control volume, as shown in the figure,

$$p_2 = p_4 = p_5 \tag{d}$$

Substituting (c) and (d) into (a),

$$\frac{p_{atm}}{\gamma} + h_1 = \frac{p_{atm}}{\gamma} - h_3 + \frac{V_2^2}{2g}$$

$$\Rightarrow V_2 = \sqrt{2g(h_1 + h_3)} \tag{e}$$

Substituting (c) and (d) into (b),

$$\frac{p_{atm}}{\gamma} + h_2 = \frac{p_{atm}}{\gamma} - h_3 + \frac{V_4^2}{2g}$$

$$\Rightarrow V_4 = \sqrt{2g(h_2 + h_3)} \tag{f}$$

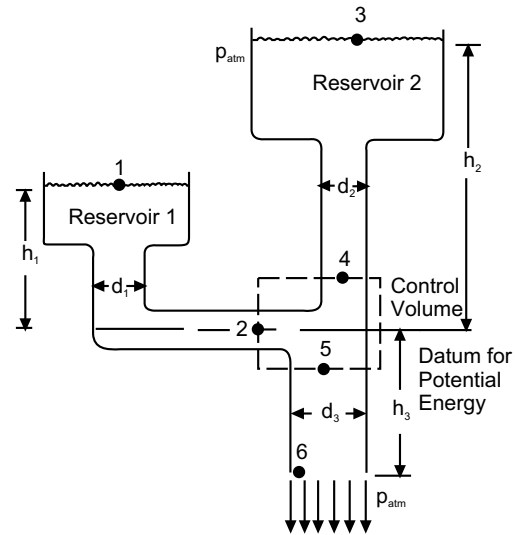

So, flow through common pipe

$$\begin{aligned} Q &= Q_1 + Q_2 = A_1V_2 + A_2V_4 \\ &= \frac{\pi}{4} \left[ d_1^2 \sqrt{2g(h_1 + h_3)} + d_2^2 \sqrt{2g(h_2 + h_3)} \right] \\ &= \frac{\pi}{4} \sqrt{2g} \left[ d_1^2 \sqrt{h_1 + h_3} + d_2^2 \sqrt{h_2 + h_3} \right] \end{aligned}$$

### EXAMPLE 25

In the figure, the fluid flowing is air ( $\gamma_a = 12 \text{ N/m}^3$ ) and the manometric fluid is Meriam Red Oil (sp. gr. = 0.827). Assuming no loss, compute the flow rate.

#### SOLUTION

Applying Bernoulli's equation between sections 1 and 2,

$$\frac{p_1}{\gamma_a} + \frac{V_1^2}{2g} + Z_1 = \frac{p_2}{\gamma_a} + \frac{V_2^2}{2g} + Z_2$$

$$\Rightarrow \frac{p_1}{\gamma_a} + 0 + 0 = \frac{p_2}{\gamma_a} + \frac{V_2^2}{2g} + 0$$

$$\Rightarrow \frac{p_1}{\gamma_a} - \frac{p_2}{\gamma_a} = \frac{V_2^2}{2g} \quad \text{(a)}$$

From the equation of manometer,

$$\frac{p_1}{\gamma_a} + \left( \frac{y+8}{100} \right) - 0.827 \times 10^3 \times 9.807 \times 0.08 \times \frac{1}{12} - \frac{y}{100} = \frac{p_2}{\gamma_a}$$

$$\Rightarrow \frac{p_1}{\gamma_a} - \frac{p_2}{\gamma_a} = 53.989 \quad \text{(b)}$$

Solving (a) and (b),  $\frac{V_2^2}{2g} = 53.989$

$$\Rightarrow V_2 = 32.541 \text{ m/s}$$

$$\text{Flow rate } Q = A_2V_2 = \frac{\pi}{4} 0.06^2 \times 32.541 = 0.092 \text{ m}^3/\text{s}$$

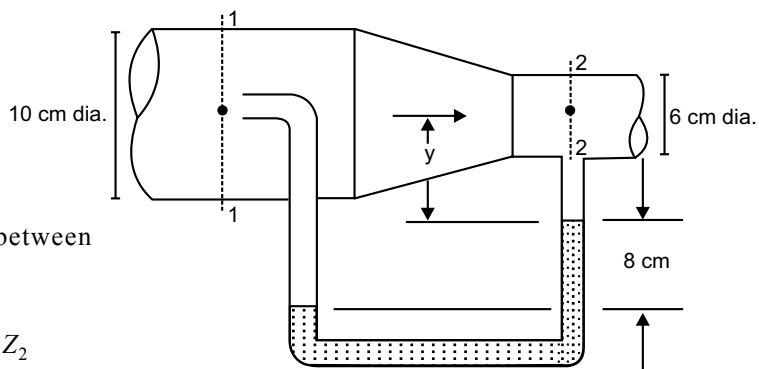

[Assuming  $V_1 \ll V_2$ ]

### EXAMPLE 26

Inlet and throat diameters of a horizontal venturimeter are 30 cm and 10 cm respectively. The liquid flowing through the venturimeter is water. Pressure intensity at inlet is  $13.734 \text{ N/cm}^2$ , while vacuum pressure at

throat is 37 cm of mercury. Find flow rate, assuming 4% of the differential head is lost between inlet and throat. Find also value of  $C_d$ .

**SOLUTION**

$$\text{Now, } A_1 = \frac{\pi}{4} 0.3^2 = 0.07068 \text{ m}^2, A_2 = \frac{\pi}{4} 0.1^2 = 7.854 \times 10^{-3} \text{ m}^2$$

$$p_1 = 13.734 \text{ N/cm}^2 = 137.34 \text{ kPa}$$

$$p_2 = -37 \text{ cm of Hg} = -(0.37 \times 13.596 \times 9.807) = -49.33 \text{ kPa}$$

Therefore, differential head

$$h = \frac{p_1}{\gamma} - \frac{p_2}{\gamma} = \frac{(137.34 + 49.33) \times 10^3}{9.807 \times 10^3} = 19.034 \text{ m of water}$$

$$\text{Head loss } h_f = 0.04h = 0.76137 \text{ m of water}$$

$$\text{Coefficient of discharge } C_d = \sqrt{\frac{h - h_f}{h}} = 0.979$$

$$\text{Flow rate } Q = C_d A_1 A_2 \sqrt{\frac{2gh}{A_1^2 - A_2^2}} \text{ and substitute the values to find as } 0.14949 \text{ m}^3/\text{s}.$$

### EXAMPLE 27

In a vertical pipe conveying oil (sp.gr. = 0.8), two pressure gauges have been installed at  $A$  and  $B$ , where the diameters are 16 cm and 8 cm respectively.  $A$  is 2 m above  $B$ . The pressure gauge readings show that pressure at  $B$  is greater than pressure at  $A$  by  $0.981 \text{ N/cm}^2$ . Neglecting all losses, calculate the flow rate. If gauges at  $A$  and  $B$  are replaced by tubes filled with same liquid and connected to a  $U$ -tube containing mercury, calculate difference in mercury level in two limbs of the  $U$ -tube.

**SOLUTION**

$$\text{Here, } A_1 = \frac{\pi}{4} 0.16^2 = 0.0201 \text{ m}^2,$$

$$A_2 = \frac{\pi}{4} 0.08^2 = 5.0265 \times 10^{-3} \text{ m}^2$$

Applying Bernoulli's theorem,

$$\frac{p_1}{\gamma} + \frac{V_1^2}{2g} + Z_1 = \frac{p_2}{\gamma} + \frac{V_2^2}{2g} + Z_2$$

$$\Rightarrow \frac{p_1 - p_2}{\gamma} + (Z_1 - Z_2) = \frac{V_2^2 - V_1^2}{2g}$$

$$\Rightarrow -\frac{0.981 \times 10^4}{9.807 \times 10^3 \times 0.8} + 2 = \frac{Q_2^2}{2g} \left[ \frac{1}{A_2^2} - \frac{1}{A_1^2} \right]$$

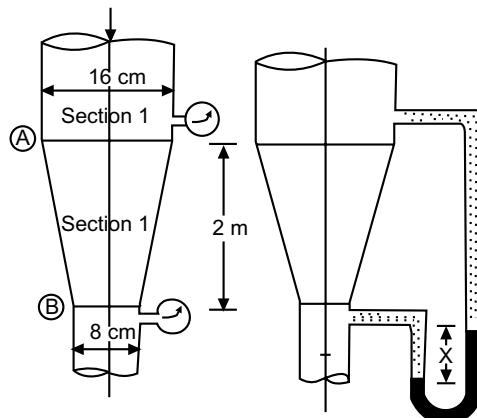

$$\Rightarrow 0.7496 = \frac{Q_2^2}{2 \times 9.807} \left[ \frac{1}{(5.0265 \times 10^3)^2} - \frac{1}{(0.0201)^2} \right]$$

$$\Rightarrow Q = 0.019906 \text{ m}^3/\text{s}$$

Piezometric head difference

$$h_{\text{oil}} = \frac{p_1 - p_2}{\gamma} + (Z_1 - Z_2)$$

$$\Rightarrow = 0.7496 \text{ m} = h_m \left( \frac{\gamma_m}{\gamma_{\text{oil}}} - 1 \right) = h_m \left( \frac{13.596}{0.8} - 1 \right)$$

$$\Rightarrow h_m = 0.04686 \text{ m}$$

#### EXAMPLE 28

A submarine moves horizontally in sea and has its axis 15 m below the surface of water. A Pitot-tube properly placed just in front of the submarine and along its axis is connected to the two limbs of U-tube containing mercury. Difference of mercury level is found to be 170 mm. Find speed of the submarine knowing that sp.gr. of mercury is 13.6 and that of sea water is 1.026 with respect to fresh water.

**SOLUTION**

$$\text{Now, } h_{\text{sea}} = h_m \left( \frac{\gamma_m}{\gamma_{\text{sea}}} - 1 \right) - 0.17 \left( \frac{13.6}{1.026} - 1 \right) = 2.0834 \text{ m}$$

Speed of the submarine

$$V = C_p \sqrt{2gh_{\text{sea}}} = 1.0 \sqrt{2 \times 9.807 \times 2.0834} = 6.3924 \text{ m/s}$$

#### EXAMPLE 29

A Pitot tube is inserted in a pipe of 300 mm diameter. Static pressure in a pipe is 100 mm of mercury (vacuum). The stagnation pressure at the centre of the pipe, recorded by a Pitot-tube is 0.981 N/cm<sup>2</sup>. Calculate rate of flow of water through pipe, if mean velocity of flow is 0.85 times the central velocity. Take  $C_v = 0.98$ .

**SOLUTION**

$$\text{Area of pipe } A = \frac{\pi}{4} 0.3^2 = 0.07068 \text{ m}^2,$$

$$\text{Static pressure } p_o = -100 \text{ mm or Hg} = -13.3335 \times 10^3 \text{ N/m}^2$$

$$\text{Stagnation pressure } p_s = 0.981 \times 10^4 \text{ N/m}^2$$

$$\text{Rise in fluid } h = \frac{p_s}{\gamma} - \frac{p_o}{\gamma} = \frac{9.81 + 13.3335}{9.807} = 2.359 \text{ m}$$

$$\text{Velocity at centre } V = 0.98 \sqrt{2 \times 9.807 \times 2.359} = 6.666 \text{ m/s}$$

Mean velocity  $V_m = 0.85 \times 6.666 = 5.6661 \text{ m/s}$

Rate of flow  $Q = V_m \times A = 5.6661 \times 0.07068 = 0.400479 \text{ m}^3/\text{s}$

### EXAMPLE 30

Find the discharge of water flowing through a pipe 30 cm diameter placed in an inclined position where a venturimeter is inserted, having throat diameter of 15 cm. Level difference of manometric fluid (sp.gr. = 0.6) is 30 cm. Head loss between inlet and throat is 0.2 times the kinetic head of pipe.

**SOLUTION**

Here,  $A_1 = \frac{\pi}{4} 0.3^2 = 0.07068 \text{ m}^2$ ,  $A_2 = \frac{\pi}{4} 0.15^2 = 0.01767 \text{ m}^2$

Now,  $h_w = h_m \left( 1 - \frac{\gamma_m}{\gamma_w} \right) = 0.3 \left( 1 - \frac{0.6}{1.0} \right) = 0.12 \text{ m}$

$$= \left( \frac{p_1}{\gamma} + Z_1 \right) - \left( \frac{p_2}{\gamma} + Z_2 \right)$$

Again,  $\frac{p_1}{\gamma} + \frac{V_1^2}{2g} + Z_1 = \frac{p_2}{\gamma} + \frac{V_2^2}{2g} + Z_2 + h_f$

$\Rightarrow \left( \frac{p_1}{\gamma} + Z_1 \right) - \left( \frac{p_2}{\gamma} + Z_2 \right) = \frac{V_2^2}{2g} - \frac{V_1^2}{2g} + 0.2 \frac{V_1^2}{2g}$

$\Rightarrow 0.12 = \frac{Q_2}{2g} \left[ \frac{1}{A_2^2} - 0.8 \frac{1}{A_1^2} \right]$

$$= \frac{Q_2}{2 \times 9.807} \left[ \frac{1}{0.01767^2} - \frac{1}{0.07068^2} \right]$$

$\Rightarrow = 0.0279 \text{ m}^3/\text{s}$

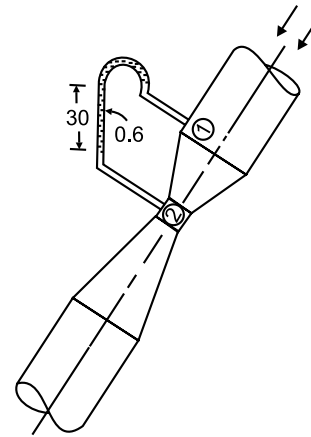

### EXERCISE

- (a) State Bernoulli's theorem for steady flow of an incompressible fluid.  
(b) Derive an expression for Bernoulli's equation from the first principle.
- Write down Euler's equation of motion along a streamline and show how Bernoulli's equation can be derived from it for a compressible fluid.
- With the aid of a diagram, mention a device for measuring the velocity of flow at any point in a pipe.
- Define (i) total pressure (ii) static pressure (iii) stagnation pressure (iv) HGL (v) EGL.
- What is venturimeter? Derive an expression for the discharge through a venturimeter.
- What is the difference between Pitot tube and Pitot-static tube?
- Compare relative merits and demerits of an orificemeter and a venturimeter.
- Define an orificemeter. Obtain an expression for flow rate through an orificemeter.

9. Water is pumped at the rate of 300 lit/s through a 30 cm pipe up to a hill top. On the hill top, which has an elevation of 50 m, the diameter of pipeline reduces to 20 cm. If the pump maintains a pressure of 1 kg/cm<sup>2</sup> at the hill top, what is the pressure at the foot-hill having zero elevation?

**Ans.** [6.373 kg/cm<sup>2</sup>, 258.6 H.P.]

10. Water flows @75 lit/s in a pipe whose diameter at sections 1-1 and 2-2 are 300 mm and 150 mm respectively, which are at heights of 5 m and 3 m above datum. If pressure at 1-1 be 450 kPa, neglecting loss of energy, calculate pressure at 2-2.

**Ans.** [461.177 kPa]

11. Oil of specific gravity 0.90 flows in a pipe of 30 cm diameter @120 lit/s and pressure at point A is 0.25 kg/cm<sup>2</sup> gauge. If the point A is 5.2 m above datum, compute total energy at A in terms of metre of oil.

**Ans.** [8.152 m]

12. A vertical venturimeter of  $d/D = 0.6$  is fitted in a 10 cm dia. pipe. Throat is 20 cm above inlet and  $C_d = 0.92$ . Determine (i) pressure difference at inlet and throat (ii) difference on a vertical differential manometer, when liquid of sp.gr. = 0.8 flows through the venturimeter @50 lit/s.

**Ans.** [1.33 kg/cm<sup>2</sup>, 1.024 m]

13. A venturimeter is used for measuring petrol (sp.gr. = 0.81) in a pipe line inclined 35° to horizontal. If throat area ratio is 4 and difference in mercury level in the gauge is 5 cm, calculate flow rate in lit/hr. if pipe diameter is 30 cm.

**Ans.** [ $2.52 \times 10^5$  lit/hr.]

14. A pipe carrying oil (sp.gr. = 0.877) changes in size from 15 cm at section A to 45 cm at section B. Section A is 3.6 m lower than B and the pressures are 0.92 kg/cm<sup>2</sup> and 0.61 kg/cm<sup>2</sup> respectively. If discharge is 0.145 m<sup>3</sup>/s, determine head loss and direction of flow.

**Ans.** [3.32 m of oil, A to B]

15. Find the velocity of flow of CCl<sub>4</sub> (sp.gr. = 1.59) through a pipe, when a differential gauge attached to Pitot tube shows a reading of 10 cm. Take the coefficient of Pitot tube as 0.98.

**Ans.** [3.77 m/s]

16. A Pitot-tube was used to measure the quantity of water flowing in a pipe of 30 cm diameter. The water was raised to a height of 25 cm above centerline of the pipe in a vertical limb of the tube. If mean velocity is 0.78 times the velocity at center and  $C_p = 0.98$ , find quantity of water in lit/s. Static pressure head at the center of the pipe is 20 cm.

**Ans.** [53.52 lit/s]

17. Water flows @0.147 m<sup>3</sup>/s through a 15 cm diameter orifice inserted in a 30 cm diameter pipe. If pressure gauges fitted  $u/s$  and  $d/s$  of the orifice plate have shown readings of 1.8 kg/cm<sup>2</sup> and 0.9 kg/cm<sup>2</sup> respectively, find the coefficient of discharge of the orificemeter.

**Ans.** [0.61]

18. An orificemeter with orifice diameter 15 cm is inserted in a pipe of 30 cm diameter. The pressure gauges fitted  $u/s$  and  $d/s$  of the orificemeter gives readings of 4.715 N/cm<sup>2</sup> and 9.81 N/cm<sup>2</sup> respectively. Find the flow rate while  $C_d = 0.6$ . If instead of water, oil of sp.gr. = 0.8 is flowing through the orificemeter in which pressure difference is measured by a mercury-oil differential manometer on two sides of the orificemeter, find rate of flow of oil when reading of manometer is 40 cm.

**Ans.** [108.434 lit/s, 122.68 lit/s]

# BIBLIOGRAPHY

---

## FLUID MECHANICS

1. Daugherty, R.L., Franzini, J.B., Finnemore, E.J., Fluid Mechanics with Engineering Applications (SI Metric Ed.) McGraw-Hill Book Co., Singapore, 1989.
2. White, F.M., Fluid Mechanics (4th. Ed.), McGraw-Hill Companies Inc., Singapore, 1999.
3. Evett, J.B. and Liu, C., Schaum's 2500 Solved Problems in Fluid Mechanics and Hydraulics, McGraw-Hill Book Co., Singapore, 1989.
4. Ray, D.N., Applied Fluid Mechanics, Affiliated East West Press Pvt. Ltd., New Delhi, 2002.
5. Modi, P.N. and Seth, S.M., Hydraulics and Fluid Mechanics, Standard Book House, Delhi, 1987.
6. Som, S.K. and Biswas, G., Introduction to Fluid Mechanics and Fluid Machines, Tata McGraw-Hill Publishing Company Limited, New Delhi, 2004.
7. Bansal, R.K., A Text Book of Fluid Mechanics and Hydraulic Mechanics, Laxmi Publications Pvt. Ltd., New Delhi.
8. Jain, A.K., Fluid Mechanics.

**This page  
intentionally left  
blank**

**ENGINEERING & TECHNOLOGY EXAMINATIONS, JUNE-2005**  
**MECHANICAL SCIENCE**  
**SEMESTER-2**

**Time: 3 Hours**

**Full Marks: 70**

**Note:** Answer Question No. 1 and any *three* from **Group–A** and any *two* from **Group–B**.

---

1. Choose the correct answer for any ten of the following: 10 × 1 = 10
- (a) Work done in a free expansion process is
    - (i) Positive
    - (ii) Negative
    - (iii) Zero
    - (iv) Maximum
  - (b) The internal energy of system is a function of only
    - (i) Pressure
    - (ii) Absolute temperature
    - (iii) Volume
    - (iv) Pressure and temperature
  - (c) Entropy change depends on
    - (i) Heat transfer
    - (ii) Mass transfer
    - (iii) Change of temperature
    - (iv) Thermodynamic state
  - (d) The cycle with constant volume heat addition and heat rejection is called
    - (i) Carnot cycle
    - (ii) Joule cycle
    - (iii) Rankine cycle
    - (iv) Otto cycle
  - (e) ‘Tripple point’ of a pure substance is a point at which
    - (i) Liquid and vapour exist together
    - (ii) Solid and vapour exist together
    - (iii) Solid and liquid exist together
    - (iv) Solid, liquid and vapour phases exist together
  - (f) The more effective way of increasing the efficiency of a Carnot engine is to
    - (i) Increase the upper temperature
    - (ii) Decrease the upper temperature
    - (iii) Increase the lower temperature
    - (iv) Decrease the lower temperature
  - (g) An ideal fluid is the one which is
    - (i) Non-viscous and incompressible
    - (ii) Compressible and has low density
    - (iii) Elastic and viscous
    - (iv) Steady and incompressible
  - (h) Mercury is used in barometers on account of its
    - (i) Negligible capillary effect
    - (ii) High density
    - (iii) Very low vapour pressure
    - (iv) Low compressibility

- (i) A stagnation point is a point in fluid flow where
- (i) Pressure is zero                      (ii) Velocity of flow reduces to zero
- (iii) Total energy is zero                (iv) Total energy is maximum
- (j) Which fluid does not experience shear stress during flow?
- (i) Pseudo plastic                        (ii) Dilatant
- (iii) Inviscid                                (iv) Newtonian

### Group-A

(Answer any *three* questions)

2. (a) What do you mean by control volume? 2
- (b) What is Quasi-static process? 4
- (c) A certain gas has  $C_p = 1.968$  and  $C_v = 1.507$  kJ/kg. Find its molecular weight and the gas constant. 6
- A constant volume chamber of  $0.3 \text{ m}^3$  capacity contains 2 kg of this gas at  $5^\circ\text{C}$ . Heat is transferred to the gas until the temperature becomes  $100^\circ\text{C}$ . Find the work done, the heat transferred, and the changes in internal energy, enthalpy and entropy.
3. (a) What is a steady flow process? Write the steady flow energy equation for a control volume and explain the various terms in it. 3
- (b) At the inlet to a certain nozzle, the enthalpy of the fluid passing is 3000 kJ/kg and the velocity is 60 m/s. At the discharge end; the enthalpy is 2762 kJ/kg. The nozzle is horizontal and there is negligible heat loss from it. (a) Find the velocity at exit from the nozzle. (b) If the inlet area is  $0.1 \text{ m}^2$  and the specific volume at inlet is  $0.187 \text{ m}^3/\text{kg}$ , find the mass flow rate. (c) If the specific volume at the nozzle exit is  $0.498 \text{ m}^3/\text{kg}$ , find the exit area of the nozzle. 9
4. (a) State Clausius inequality and explain its significance. 4
- (b) Define COP of a refrigerator and a heat pump. Establish the relation  $\text{COP}_{\text{hp}} = \text{COP}_{\text{ref}} + 1$ . 8
5. (a) What is a pure substance? 2
- (b) What is the 'critical point'? State the values of critical pressure and critical temperature of water. 3
- (c) What are the four basic components of a steam power plant? Show by a block diagram. 3
- (d) Draw the nature of  $p$ - $v$  and  $T$ - $S$  plots of a Rankine cycle (with superheated steam at turbine inlet). 4
6. (a) Draw a block diagram of a vapour compression refrigeration cycle and also show the corresponding  $p$ - $v$  and  $T$ - $S$  plots. 5

- (b) An engine working on the Otto cycle is supplied with air at 0.1 MPa, 35°C. The compression ratio is 8. Heat supplied is 2100 kJ/kg. Calculate the maximum pressure and temperature of the cycle, the cycle efficiency, and the mean effective pressure (For air,  $C_p = 1.005$ ,  $C_v = 0.718$  and  $R = 0.287$  kJ/kg K). 7

### Group-B

(Answer any *two* questions)

7. (a) State and explain Newton's law of viscosity. 3  
 (b) Define non-Newtonian fluid with two examples. 3  
 (c) The space between two large flat and parallel walls 25 mm apart is filled with liquid of viscosity 0.7 N.S/m<sup>2</sup>. Within this space a thin flat plate, 250 mm × 250 mm is towed at a velocity of 150 mm/s at a distance of 19 mm from one wall, the plate and its movement being parallel to the walls. Assuming linear variation in velocity between the plates and the walls. Determine the force exerted by the liquid on the plate. 6
8. (a) Define the term "bulk" modulus of elasticity" of a compressible fluid. 2  
 (b) State Pascals law of hydrostatics. 2  
 (c) Calculate the atmospheric pressure at the end of troposphere which extends up to a height of 11 km from sea level. Consider a temperature variation in the troposphere as  $T = 288 - 0.00649z$  where  $z$  is the elevation in metres and  $T$  is temperature in kelvin. The atmospheric pressure at sea level is 101 kN/m, for air  $R = 287$  J/kg K. Derive the equation you see for your calculation. 8
9. (a) Write the difference between steady flow and uniform flow. 2  
 (b) Define (i) Streamline and (ii) Streakline 2  
 (c) Obtain an expression for continuity equation for a two dimensional flow. 5  
 (d) A two dimensional flow is described in the Lagrangian as  

$$X = X_0 e^{kt} + Y_0 (1 - e^{-2kt})$$

$$Y = Y_0 e^{kt}$$
 Find the equation of path line of the particle and the velocity components in Eulerian system. 3
10. (a) Write Bernoulli's equation and describe the various terms in it. 2  
 (b) What are the assumptions involved in the derivation of Bernoulli's equation? 3  
 (c) Water flows through a 300 mm × 150 mm venturimeter at the rate of 0.037 m<sup>3</sup>/s and differential gauge is deflected 1 m as shown in the figure. Specific gravity of the gauge liquid is 1.25. Determine the coefficient of discharge of the meter. 7

**ENGINEERING & TECHNOLOGY EXAMINATIONS, JUNE - 2006**  
**MECHANICAL SCIENCE**  
**SEMESTER- 2**

**Time Allotted: 3 Hours**

**Full Marks: 70**

The figures in the margin indicate full marks.

Candidates are required to give their answers in their own words as far as practicable.

Any missing data may be assumed suitably with Justification.

**Note:** Answer Question No. 1 and any *three* from **Group–A** and any *two* from **Group–B**.

---

1. Choose the correct answers for any *ten* of the following: 10 × 1 = 10
- (i) An open system is one in which
- (a) heat and work cross the boundary of the system, but the mass of the working substance does not
  - (b) mass of working substance crosses the boundary of the system but the heat and work do not
  - (c) both the heat and work as well as mass of the working substances cross the boundary of the system
  - (d) neither the heat and work nor the mass of the working substances crosses the boundary of the system.
- (ii) Which of the following is an intensive property of a thermodynamic system ?
- (a) Volume
  - (b) Temperature
  - (c) Mass
  - (d) Energy.
- (iii) During throttling process
- (a) internal energy does not change
  - (b) pressure does not change
  - (c) entropy does not change
  - (d) enthalpy does not change
  - (e) volume change is negligible.
- (iv) Kelvin-Planck's law deals with
- (a) conservation of energy
  - (b) conservation of heat
  - (c) conservation of mass
  - (d) conversion of heat into work
  - (e) conversion of work into heat.
- (v) If a heat engine attains 100% thermal efficiency, it violates
- (a) zeroth law of thermodynamics
  - (b) first law of thermodynamics
  - (c) second law of thermodynamics
  - (d) law of conservation of energy.

- (vi) For an irreversible process entropy change is
- (a) greater than  $\delta Q / T$  (b) equal to  $\delta Q / T$   
 (c) less than  $\delta Q / T$  (d) equal to zero.
- (vii) The continuity equation ( at two sections 1 and 2 ) for an incompressible fluid is given as
- (a)  $\rho_1 A_1 V_1^2 = \rho_2 A_2 V_2^2$  (b)  $\rho_1 A_1 V_1 = \rho_2 A_2 V_2$   
 (c)  $A_1 V_1 = A_2 V_2$  (d)  $\rho_1^2 A_1 V_1 = \rho_2^2 A_2 V_2$ .
- (viii) Euler's equation is written as
- (a)  $\frac{dp}{\rho} + v^2 \cdot dv + g \cdot dz = 0$  (b)  $\frac{dp}{\rho} + v \cdot dv + g \cdot dz = 0$   
 (c)  $\frac{dp}{\rho} + v^2 \cdot dv + g^2 \cdot dz = 0$  (d)  $\frac{dp}{\rho^2} + v^2 \cdot dv + g \cdot dz = 0$ .
- (ix) Kinematics viscosity is defined as equal to
- (a) dynamic viscosity  $\times$  density (b) dynamic viscosity / density  
 (c) dynamic viscosity / pressure (d) pressure  $\times$  density.
- (x) For pipes, turbulent flow occurs when Reynolds number is
- (a) less than 2000 (b) between 2000 and 4000  
 (c) more than 4000 (d) less than 4000.
- (xi) The change of entropy when heat is absorbed by the gas is
- (a) positive (b) negative  
 (c) positive or negative (d) none of these.
- (xii) Spherical shape of droplets of mercury is due to
- (a) high density (b) high surface tension  
 (c) high adhesion (d) low vapour pressure.

### Group–A

(Answer any three)

2. (a) Explain intensive property. 2
- (b) Prove that for polytropic process  $W_{1-2} = \frac{P_2 V_2 - P_1 V_1}{1 - n}$  4
- (c) A gas is enclosed in a piston-cylinder assembly as a system. The gas is initially at a pressure of 500 kPa and occupies a volume of  $0.2 \text{ m}^3$ . The gas is taken to the final state where  $P_2 = 100 \text{ kPa}$  by following two different processes. Calculate the work done by the gas in each case.

- (i) The volume of the gas is inversely proportional to the pressure.
- (ii) The process follows the path.  $PV^\gamma = \text{constant}$  where  $\gamma = 1.4$ . 6
3. (a) Explain first law of thermodynamics for a closed system undergoing a change of state. 3
- (b) A turbine operates under steady flow conditions, receiving steam at the following state:  
Pressure 1.2 MPa, Temperature 188°C, Enthalpy 2785 kJ/kg, Velocity 33.3 m/sec and elevation 3 m. The steam leaves the turbine at the following state:  
Pressure 20 kPa, Enthalpy 2512 kJ/kg, Velocity 100 m/sec and elevation 0 m. Heat is lost to the surroundings at the rate of 0.29 kJ/kg. If the rate of steam flow through the turbine is 0.42 kg/sec. what is the power output of the turbine in kW? 9
4. (a) What is cyclic heat engine? 4
- (b) A Carnot cycle has an efficiency of 32%. Assuming that the lower temperature is kept constant, determine the percentage increase of the upper temperature of the cycle if the cycle efficiency is raised to 48%. 8
5. (a) Write the principle of entropy. 3
- (b) Calculate the entropy change of 10 gm of water at 20°C, when it is converted to ice at -10°C. Assume the specific heat of water to remain constant at 4.2 J/gmK and that of ice to be half of the value and taking the latent heat of fusion of ice at 0°C to be 335 J/gm. 9
6. (a) Prove that entropy change for an ideal gas
- $$s_2 - s_1 = c_p \ln \frac{T_2}{T_1} - R \ln \frac{p_2}{p_1} \quad 5$$
- (b) A vessel of volume 0.04 m<sup>3</sup> contains a mixture of saturated water and saturated steam at a temperature of 250°C. The mass of the liquid present is 9 kg. Find the pressure, the mass, the specific volume, the enthalpy, the entropy and the internal energy. 7

### Group-B

( Answer any two questions)

7. (a) State Newton's law of viscosity. 2
- (b) What is Bulk Modulus of Elasticity ? 2
- (c) The space between two large flat and parallel walls 25 mm apart is filled with a liquid of absolute viscosity 0.7 Ns/m<sup>2</sup>. Within this space a thin flat plate, 250 mm × 250 mm is towed at a velocity of 150 mm/s at a distance of 6 mm from one wall, the plate and its movement being parallel to the walls. Assuming linear variations of velocity between the plate and the walls, determine the force exerted by the liquid on the plate. 8
8. (a) The velocity distribution for a two-dimensional incompressible flow is given by
- $$u = -\frac{x}{x^2 + y^2}, \quad v = -\frac{y}{x^2 + y^2}$$
- Show that it satisfies continuity. 4

- (b) Water is flowing through two different pipes A and B to which an inverted differential manometer having an oil of sp.gr. 0.9 is connected. The pressure in the pipe A is 2.5 m of water. Find the pressure in the pipe B for the manometer readings as shown in Fig. 1. 8

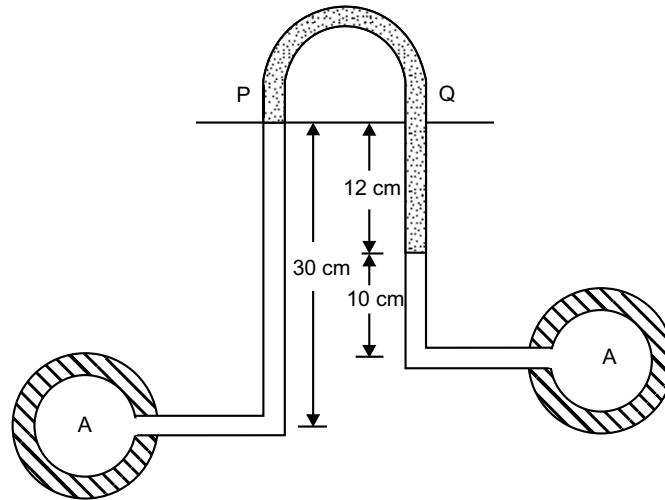

Fig. 1

9. (a) Derive Euler's equation of motion along a streamline. 5  
 (b) A vertical venturimeter shown in Fig. 2 has an area ratio of 5. It has a throat diameter of 1 cm. When oil of sp. gr. 0.8 flows through it the mercury in the differential gauge indicates a difference in height of 12 cm. Find the discharge through the venturimeter. 7

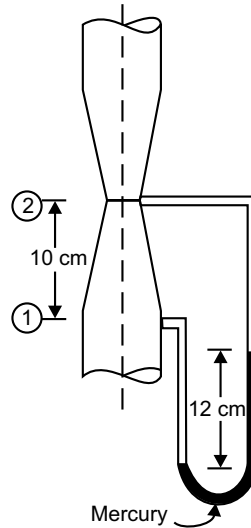

Fig. 2

**ENGINEERING & MANAGEMENT EXAMINATIONS,  
JUNE - 2007  
MECHANICAL SCIENCE  
SEMESTER- 2**

**Time: 3 Hours**

**Full Marks: 70**

**Group-A  
(Multiple Choice Type Questions)**

- 
1. Choose the correct alternatives for the following: 10 × 1 = 10
- (i) Which of the following quantities is not a property of a system?  
(a) Pressure (b) Temperature  
(c) Heat (d) Specific volume.
- (ii) During throttling process  
(a) internal energy does not change  
(b) pressure does not change  
(c) entropy does not change  
(d) enthalpy does not change  
(e) volume does not change.
- (iii) Thermal power plant works on  
(a) Carnot cycle (b) Joule cycle  
(c) Rankine cycle (d) Otto cycle.
- (iv) Work done in a free expansion process is  
(a) positive (b) negative  
(c) zero (d) maximum.
- (v) The more effective way of increasing efficiency of Carnot engine is to  
(a) increase higher temperature  
(b) decrease higher temperature  
(c) increase lower temperature  
(d) decrease lower temperature.
- (vi) A refrigerator and a heat pump operate between the same temperature limits. If C.O.P. of the refrigerator is 4, the C.O.P. of the pump would be  
(a) 3 (b) 4  
(c) 5 (d) cannot be predicted  
(e) None of these.

- (vii) A pitot tube is used for measuring
- (a) state of flow (b) density of fluid  
(c) velocity of fluid (d) none of these.
- (viii) Stream line, path line and streak line are identical when
- (a) the flow is uniform  
(b) the flow is steady  
(c) the flow velocities do not change steadily with time  
(d) the flow is neither steady nor uniform.
- (ix) Bernoulli's equation deals with the law of conservation of
- (a) mass (b) momentum  
(c) energy (d) work.
- (x) Which fluid does not experience shear stress during flow?
- (a) Pseudoplastic (b) Dilatant  
(c) Inviscid (d) Newtonian.

**Group-B****(Short Answer Type Questions)**Answer any *three* questions

3 × 5 = 15

2. (a) What is the basic difference between a process and a cycle? 2  
(b) Show that work done in isothermal process from state 1 to state 2 is given by:  
 $W_{1-2} = p_1 V_1 (\ln p_1 - \ln p_2)$ . 3
3. What is steady flow process? Write the steady flow energy equation for a single stream entering and a single stream leaving a control volume and explain the various terms in it. 2 + 3
4. (a) State second law of thermodynamics. 3  
(b) What is a perpetual motion machine of 2nd kind? 2
5. (a) Explain the no-slip condition of viscous fluids. 2  
(b) State and prove Pascal's law of hydrostatics. 3
6. A hot plate of area  $0.125 \text{ m}^2$  is pulled at  $0.25 \text{ m/s}$  with respect to another parallel plate  $1 \text{ mm}$  distant from it the space between the plates containing water of viscosity  $0.001 \text{ N-s/m}^2$ . Find the force necessary to maintain this velocity and also the power required. 5

**Group-C****(Long Answer Type Questions)**Answer any *three* questions.

3 × 5 = 45

7. (a) A mass of 8 kg gas expands within a flexible container so that p-v relationship is of the form  $pv^{1.2} = \text{constant}$ . The initial pressure is 1000 kPa and the initial volume is  $1 \text{ m}^3$ . The final pressure is 5 kPa. If specific internal energy of the gas decreases by 40 kJ/kg. find the heat transfer in magnitude and direction. 7
- (b) A heat pump working on the Carnot cycle takes in heat from a reservoir at  $5^\circ\text{C}$  and delivers heat to a reservoir at  $60^\circ\text{C}$ . The heat pump is driven by a reversible heat engine which takes in heat from a reservoir at  $840^\circ\text{C}$  and rejects heat to a reservoir at  $60^\circ\text{C}$ . The reversible heat engine also drives a machine that absorbs 30 kW. If the heat pump extracts 17 kJ/s from the  $5^\circ\text{C}$  reservoir, determine (a) the rate of heat supply from the  $840^\circ\text{C}$  source and (b) the rate of heat rejection to the  $60^\circ\text{C}$  sink. 8
8. (a) A lump of steel of mass 10 kg at  $627^\circ\text{C}$  is dropped in 100 kg of oil at  $30^\circ\text{C}$ . The specific heats of steel and oil are 0.5 kJ/kg-K and 3.5 kJ/kg-K respectively. Calculate the entropy change of the steel, the oil and the universe. 7
- (b) At the inlet to a certain nozzle, the enthalpy of the flowing fluid is 3000 kJ/kg and the velocity is 60 m/s. At the discharge end the enthalpy is 2762 kJ/kg. The nozzle is horizontal and there is negligible heat loss from it.
- (i) Find the velocity at exit from the nozzle,
- (ii) If the inlet area is  $0.1 \text{ m}^2$  and the specific volume at inlet is  $0.187 \text{ m}^3/\text{kg}$ , find the mass flow rate,
- (iii) If the specific volume at the nozzle exit is  $0.498 \text{ m}^3/\text{kg}$ , find the exit area of the nozzle. 8
9. (a) What is a pure substance? 2
- (b) What is the “critical point”? State the values of critical pressure and critical temperature of water. 3
- (c) Why is Carnot cycle not practicable for a steam power plant? 3
- (d) In an ideal air-standard diesel cycle, the pressure and temperature at intake are 1.03 bar and  $27^\circ\text{C}$  respectively. The maximum pressure in the cycle is 47 bar and heat supplied during the cycle is 545 kJ/kg. Determine
- (i) The compression ratio
- (ii) The temperature at the end of compression
- (iii) The temperature at the end of combustion
- (iv) The air standard efficiency. 7
- Assume  $\gamma = 1.4$  and  $C_p = 1.004 \text{ kJ/kg-K}$  for air.
10. (a) How does a heat pump differ from a refrigerator? 3
- (b) A household refrigerator is maintained at a temperature of  $2^\circ\text{C}$ . Every time the door is opened, warm material is phased inside, introducing an average of 420 kJ but making

only a small change in the temperature of the refrigerator. The door is opened 20 times a day and the refrigerator operates at 15% of the ideal COP. The cost of work is Rs. 5.00 per kWh. What is the monthly bill for this refrigerator? The atmosphere is at 30°C. 6

- (c) A blower handles 1 kg/s of air at 20°C and consumes a power of 15 kW. The inlet and outlet velocities of air are 100 m/s and 150 m/s respectively. Find the exit air temperature, assuming adiabatic conditions. Take  $C_p$  of air as 1.005 kJ/kg-K. 6
11. (a) Draw the rheological curve for a class of Newtonian and non-Newtonian fluids. 3
- (b) Distinguish between incompressible and compressible flow. 3
- (c) What is the stagnation pressure at a point in a fluid flow? 2
- (d) Two pipes A and B are in the same elevation. Water is contained in A and rises to a level of 1.8 m above it. Carbon tetrachloride (Sp. Gr. 1.6) is contained in B. The inverted U-tube is filled with compressed air at 350 kN/m<sup>2</sup> and 27°C. Barometer reads 760 mm of mercury.
- Determine:
- (i) The Pressure difference between A and B if  $z = 0.4$  m, and
- (ii) The absolute pressure in B. 7

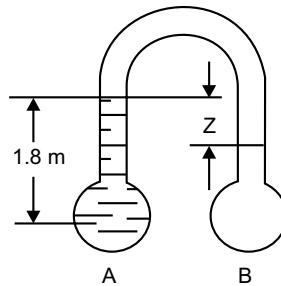

12. (a) A diffuser consists of two circular parallel plates 200 mm in diameter and 5 mm apart and connected to a 30 mm diameter pipe as shown in fig. below. If the stream lines are assumed to be radial in the diffuser, what mean velocity in the pipe will correspond to an exit velocity of 0.5 m/s. 5

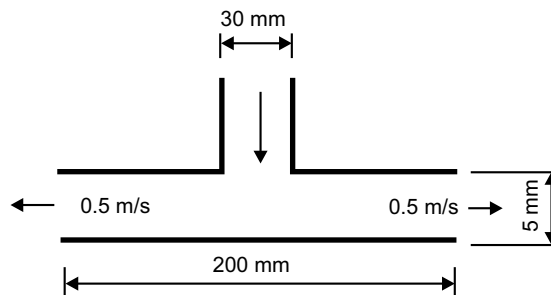

- (b) A venturimeter with inlet and throat diameters are 150 mm and 75 mm respectively is mounted in a vertical pipe carrying water, the flow being upwards. The throat section is 250 mm above the inlet of the venturimeter. The discharge of the venturimeter is 40 lit/sec. Find the static pressure difference between the inlet and throat section if the coefficient of discharge for venturimeter is 0.96. 10

**ENGINEERING & MANAGEMENT EXAMINATIONS, JUNE - 2008**  
**MECHANICAL SCIENCE**  
**SEMESTER - 2**

**Time: 3 Hours**

**Full Marks: 70**

**Group-A**  
**( Multiple Choice Type Questions )**

- 
1. Choose the correct alternatives for the following: 10 × 1 = 10
- (i) Which of the following is an intensive thermodynamic property?  
(a) Volume (b) Temperature  
(c) Mass (d) Energy.
- (ii) For an irreversible process, change in entropy is  
(a) greater than  $dQ/T$  (b) less than  $dQ/T$   
(c) zero (d) equal to  $dg/T$ .
- (iii) During throttling which of the following quantity does not change?  
(a) Internal energy (b) Entropy  
(c) Pressure (d) Enthalpy.
- (iv) Work done in a free expansion is  
(a) Positive (b) Negative  
(c) Zero (d) Maximum.
- (v) A cycle with constant volume heat addition and constant volume heat rejection is  
(a) Otto cycle (b) Diesel cycle  
(c) Joule cycle (d) Rankine cycle.
- (vi) Triple point of a pure substance is a point at which ,  
(a) liquid and vapour coexist (b) solid and vapour coexist  
(c) solid and liquid coexist (d) all three phases coexist.
- (vii) Bernoulli's equation deals with the conservation of  
(a) Mass (b) Momentum  
(c) Energy (d) Work.
- (viii) Continuity equation is based on the principle of conservation of  
(a) Mass (b) Momentum  
(c) Energy (d) Entropy.

- (ix) A Pitot tube is used for measuring
- |                      |                         |                      |
|----------------------|-------------------------|----------------------|
| (a) State of fluid   | (b) Velocity of fluid   |                      |
| (c) Density of fluid | (d) Viscosity of fluid. | <input type="text"/> |
- (x) Dynamic viscosity has dimensions of
- |                      |                            |                      |
|----------------------|----------------------------|----------------------|
| (a) $MLT^{-2}$       | (b) $ML^{-1} T^{-1}$       |                      |
| (c) $ML^{-1} T^{-2}$ | (d) $M^{-1} L^{-1} T^{-1}$ | <input type="text"/> |

**Group-B****(Short Answer Type Questions)**Answer any *three* of the following.

3 × 5 = 15

- State the first law of thermodynamics for a closed system undergoing a cycle and a process.
- Explain thermodynamic equilibrium.
- The fluid flow is given by  $\vec{V} = x^2 Y_i + Y^2 z - (2xyz + yz^2)_k$ . Show that this is a case of possible steady incompressible flow. Calculate the velocity and acceleration at (2, 1, 3).
- Draw a block diagram of vapour compression refrigeration cycle and also show the corresponding P-V and T-S plots.
- Derive Bernoulli's equation from first principles, stating the assumptions.
- Explain PMM-1 and PMM-2.

**Group-C****(Long Answer Type Questions)**Answer any *three* of the following.

3 × 15 = 45

- Which is a more effective way of increasing the efficiency of a Carnot engine to increase source temperature ( $T_1$ ), keeping sink temperature ( $T_2$ ) constant or to decrease  $T_2$  keeping  $T_1$  constant.
  - State Clausius inequality.
  - A mass of  $m$  kg of liquid (specific heat =  $C_p$ ) at a temperature  $T_1$  is mixed with an equal mass of the same liquid at a temperature  $T_2$  ( $T_1 > T_2$ ) and the system is thermally insulated. Show that the entropy change of the universe is given by  $2 m C_p l \left( \frac{T_1 + T_2}{\sqrt{T_1 T_2}} \right)$  and prove that this is necessarily positive. 3 + 2 + 10
- Derive the expression for efficiency of an Otto cycle and show the process on p-V and T-s planes.
  - For the same compression ratio, explain why the efficiency of Otto cycle is greater than that of Diesel cycle.

- (c) In a diesel engine the compression ratio is 13 : 1 and fuel is cut off at 8% of the stroke. Find the air standard efficiency of the engine. Take  $\gamma$  for air = 1.4. 5 + 3 + 2 + 5
10. (a) A gas occupies  $0.024 \text{ m}^3$  at 700 kPa and  $95^\circ\text{C}$ . It is expanded in the non-flow process according to the law  $pV^{1.2} = \text{constant}$  to a pressure of 70 kPa after which it is heated at a constant pressure back to its original temperature.  
Sketch the process on, the  $p$ - $V$  and  $T$ - $s$  diagrams and calculate for the whole process the work done and the heat transferred. Take  $C_p = 1.047$  and  $C_v = 0.775 \text{ kJ/kg K}$  for the gas.
- (b) A rigid closed tank of volume  $3 \text{ m}^3$  contains 5 kg of wet steam at a pressure of 200 kPa. The tank is heated until the steam becomes dry saturated. Determine the pressure and the heat transfer to the tank. 8 + 7
11. (a) Write the steady flow energy equation for a single steam entering and single steam leaving a control volume and explain the various terms.
- (b) At the inlet to a nozzle, the enthalpy of the fluid passing is 3000 kJ/kg and velocity is 60 m/s. At the exit, the enthalpy is 2762 kJ/kg. The nozzle is horizontal and there is negligible heat loss.
- (i) Find the velocity at the nozzle exit?
- (ii) The inlet area is  $0.1 \text{ m}^2$  and the specific volume at inlet is  $0.187 \text{ m}^3/\text{kg}$ . Find the mass flow rate.
- (iii) If the specific volume at the nozzle exit is  $0.498 \text{ m}^3/\text{kg}$ , find the exit area of the nozzle. 6 + 9
12. (a) Derive Euler's equation of motion along a streamline.
- (b) A venturimeter has inlet and throat diameters of 300 mm and 150 mm. Water flows through it at the rate of  $0.065 \text{ m}^3/\text{s}$  and the differential gauge is deflected by 1.2 m. The specific gravity of the manometric liquid is 1.6. Determine the coefficient of discharge of the venturimeter.
- (c) A jet of water from a 25 mm diameter nozzle is directed vertically upwards. Assuming that the jet remains circular and neglecting any loss of energy, what will be the diameter of the jet at a point 4.5 m above the nozzle, if the jet leaves the nozzle with a velocity of 12 m/s? 5 + 5 + 5
13. (a) A circular disk of diameter  $d$  is slowly rotated in a liquid of viscosity  $\mu$  at a small distance  $h$  from a fixed surface. Derive an expression for the torque  $T$  necessary to maintain an angular velocity  $\omega$ .
- (b) Distinguish between the follow:
- (i) laminar and turbulent flow
- (ii) compressible and incompressible fluid
- (iii) static pressure and stagnation pressure
- (iv) viscous and inviscid fluid. 7 + 8
14. Write short notes on any *three* of the following: 3 × 5
- (a) Pitot tube (b) Orifice meter
- (c) Point function and path function (d) Streamline streakline and pathline.

# INDEX

---

## Group-A

### *Thermodynamics*

#### **A**

Absolute pressure 17  
Adiabatic expansion 110  
Adiabatic index 38, 62  
Adiabatic process 47, 71, 114  
Air cycle 229  
Air standard efficiency 230, 232

#### **B**

Boiler 116  
Boundary 4  
Boyle's Law, Charle's Law and Gay-Lussac's Law 59

#### **C**

Carnot cycle 139, 249  
Carnot efficiency 140  
Carnot theorem 142  
Centigrade scale 36  
Characteristic equation of gas 60  
Characteristic gas constant 38, 61  
Chemical equilibrium 9  
Classification of properties of a system 7  
Clausius inequality 162  
Clausius statement 136

Clausius Theorem 158  
Clearance volume 230  
Closed system 4, 6  
Co-efficient of performance 134  
Compressibility 76  
Compressibility factor 76  
Compression ratio 231  
Compressor 117  
Condenser 117  
Conduction 37  
Convection 37  
Constant enthalpy process 111  
Constant internal energy process 110  
Constant pressure cycle 235  
Constant pressure line 219  
Constant pressure process 9, 66, 114, 166  
Constant temperature process 69, 114  
Constant volume cycle 232  
Constant volume gas thermometer 34  
Constant volume line 219  
Constant volume process 9, 64, 114, 165  
Continuum 3  
Control mass 6, 7  
Control surface 6, 7  
Control volume 4, 5, 6, 7, 111

Convection 37  
Critical compressibility 78  
Critical isotherm 188  
Critical point 78, 185, 216  
Critical pressure 185  
Critical temperature 78, 185  
Cut-off ratio 231  
Cyclic process 103  
Cylinder bore 230

## D

Derived Units 14  
Diesel cycle 235  
Diffuser 116  
Displacement energy 112  
Dry saturated steam 189  
Dryness fraction 189  
Dryness fraction lines 219

## E

Efficiency 22  
Efficiency of cycle 231  
Electrical resistance thermometer 36  
Electrical work 39, 48  
Enthalpy 63, 157, 189  
Entropy 3, 157  
Equation 113  
Equation of continuity 113  
Equation of state 60  
Evaporator 118  
Exact differentials 7  
Expansion ratio 231  
Extensive properties 7  
External combustion engines 3

## F

First law of thermodynamics 103, 105, 133  
First law thermodynamics 105  
Flow energy 112  
Flow process 50, 64, 111  
Flow work 49, 112, 113  
Four stroke cycle 229

Free expansion process 48  
Freezing point 36  
Frictionless adiabatic process 71  
Fundamental units 13

## G

Gas cycle 140  
Gas refrigeration cycle 251  
Gauge pressure 17

## H

Heat capacity 39  
Heat engine 3, 133  
Heat exchanger 118  
Heat pump (Reversible heat engine) 134  
Heat pumps 133  
Heterogeneous system 8  
High temperature 33  
Homogeneous system 8  
Hyperbolic process 68

## I

Ideal efficiency 232  
Ideal gas 35, 76  
Indicated thermal efficiency 232  
Inexact differentials 43, 44, 45, 104  
Intensive properties 7  
Intensive property 44  
Internal combustion engine 3  
Internal energy 20  
International practical temperature scale 36  
Irreversibility 139, 167  
Irreversible 64  
Irreversible non-flow process 64, 109  
Isentropic lines 216  
Isentropic process 71  
Isobaric process 66, 166  
Isochoric process 64, 165  
Isolated system 5, 105  
Isothermal lines 216  
Isothermal process 68, 110

**J**

Joule's cycle 234

**K**

Kelvin-Planck statement 135

Kinetic energy 20

**L**

Latent heat of vaporisation 185

Latent heating 184

Law of conservation of energy 21, 108, 112

Law of internal energy 157

Law of the conservation of energy 107

Low temperature 33

**M**

Macroscopic approach 3

Manometer 18

Mass balance equation 113

Mean effective pressure 231

Mechanical equilibrium 9

Mechanical equivalent of heat 39

Mechanical work 39

Melting point 36

Microscopic approach 3

Molar gas constant 60

Molar volume 8

Mollier chart 217

Momentum 16

**N**

No-flow energy equation 108

Non-ideality of gases 77

Non-flow process 50, 64, 109, 113, 114, 167

Non-flow work 50

Nozzle 115

**O**

Open system 5, 6

Otto cycle 232

**P**

Paddle wheel work 45

Path function 13, 44, 105, 106

Path 9

Perfect gas 59

Perpetual motion machine of the first kind (PMM-1) 108

Perpetual motion machine of the second kind 135

Phase 8, 183

Phase equilibrium 183

PMM-II 136

Point function 13, 44, 106

Poisson's equation 73

Polytropic index 74

Polytropic process 74, 115

Potential energy 20

Principle of increase of entropy 163

Process 9

Properties of a system 7

Property 7

Pump work 250

Pure substance 183

**Q**

Quasi-equilibrium 41

Quasi-equilibrium process 48

Quasi-static 41, 63

Quasi-static process 43

**R**

Radiation 37

Rankine cycle 249

Real gas 76

Reciprocating compressor 117

Reduced pressure 77

Reduced specific volume 77

Reduced temperature 77

Refrigerators 133, 134

Relative efficiency 232

Residual volume 77  
Reversibility 138  
Reversible adiabatic expansion 110  
Reversible non-flow process 64, 109  
Reversible process 43, 63  
Rotary compressor 117

**S**

Saturated liquid line 185  
Saturated steam line 185  
Second law of thermodynamics 133  
Sensible heating 184  
Shaft-work 45, 48  
Sink 133  
Source 133  
Specific air consumption 230  
Specific enthalpy 63, 112, 113, 189  
Specific heat 38, 61  
Specific heat at constant pressure 38, 61  
Specific heat at constant volume 38, 61  
Specific volume 8, 17  
Specific volume of ideal gas 77  
Specific volumes of real gas 77  
Specific weight 17  
Specific work transfer 230  
Standard atmospheric pressure 36  
State function 106  
State of a system 7  
State point 7  
Steady flow 111  
Steady flow energy equation 116, 118  
Steady flow energy equation (S.F.E.E) 111, 112, 116, 117, 118  
Steady flow process 111, 113, 167  
Steam tables 213  
Stored energy 20, 107  
Stroke length 230  
Superheated steam 189  
Superheated vapour 187  
Supplementary units 13

Surrounding 4  
Swept volume 231  
system boundary 4, 6

## T

Temperature scale 35  
Theoretical thermal efficiency 232  
Thermal equilibrium 33  
Thermal efficiency ( $\eta_{\max}$ ) 133  
Thermal engineering 3  
Thermal equilibrium 9, 34  
Thermal reservoir 133  
Thermodynamic co-ordinates 7  
Thermodynamic cycle 103  
Thermodynamic equilibrium 8  
Thermodynamic property 33, 38, 111  
Thermodynamic substance 33  
Thermodynamic surface 187  
Thermodynamic system 105  
Thermodynamic system 4  
Thermodynamics 3  
Thermometric property 33  
Thermometric substance 34  
Throttling lines 220  
Throttling process 115  
Total cylinder volume 231  
Total energy 107  
Transit energy 20  
Transit energy 37  
Triple point 34, 187  
Triple point line 187  
Triple point of water 36  
Triple point temperature 34  
Turbine 116  
Turbine work 250  
Two stroke cycle 229

## U

Universal gas constant 60  
Universe 4  
Unresisted expansion process 110

Unsteady flow 111

Unsteady flow process 111

## **V**

Vacuum pressure 18

van der Walls equation 78

Vapour 59

Vapour compression refrigeration cycle 251

Vapour cycle 139

## **W**

Water equivalent 39

Wet steam 189

Wheatstone bridge 36

Work ratio 230

Working substance 183

## **Z**

Zeroth law of thermodynamics 33

**Group-B****Fluid Mechanics****A**

Absolute pressure 294  
Absolute roughness 361  
Archimedes law 301  
Atmospheric pressure 294

**B**

Barometer 295  
Barometric pressure 294  
Bernoulli's equation 359  
Bingham plastic 267  
Body forces 289, 290  
Bulk modulus of elasticity 267  
Buoyancy 301

**C**

Capillarity 270  
Centre of buoyancy 302  
Centre of gravity 302  
Characteristic length 264  
Co-efficient of compressibility 268  
Coefficient of contraction 362  
Coefficient of discharge 362  
Coefficient of dynamic 266  
Coefficient of friction 361  
Coefficient of velocity 266, 362  
Coefficient of viscosity 266  
Compressibility 267  
Compressible flow 333  
Continuity equation 335  
Continuum 263  
Convective acceleration 339

**D**

Darcy-Weisbach equation 361  
Datum head 360  
Density 264

Differential manometer 297  
Dilatant 267

**E**

Equipotential line 335  
Euler's equations 291, 357

**F**

Fanning's equation 361  
Filament line 335  
Flow 331  
Flow net 335  
Flow-meters 362  
Fluid dynamics 263  
Fluid element 289  
Fluid mechanics 263  
Fluid statics 263, 289  
Friction factor 361

**G**

Gauge pressure 294, 295

**H**

Head-loss 359  
Hydraulic grade line 360  
Hydrostatic force 298

**I**

Ideal fluid 267  
Inclined tube manometer 296  
Incompressible flow 333  
Irrotational flow 333  
Isentropic process 268, 366  
Isothermal process 268

**K**

Kinetic viscosity 266  
Kinetics of fluid flow 357

**L**

Laminar flow 331  
Local acceleration 339

**M**

Mach number 269  
Major head loss 361  
Mass density 264, 290  
Mean free path 264  
Metacentric height 302  
Micromanometer 297  
Minor losses 361

**N**

Navier-stokes equation 357  
Neutral equilibrium 302  
Newton's law of viscosity 265, 266  
Newtonian fluid 266, 267  
Non-newtonian fluid 266  
Non-uniform flow 332  
Normal force 289

**O**

Orifice 362  
Orificemeter 363  
Orifice-plate 363

**P**

Pascal's law 289, 290  
Pathline 334  
Piezometer 296  
Piezometric head line 360  
Pitot-static 367  
Pitot-tube 366  
Prandtl's tube 367  
Pseudoplastic 267

**R**

Real Fluid 267

Relative roughness 361  
Reynold's equation 357  
Reynold's number 331, 361  
Rheology 266  
Rotational flow 333

**S**

Scalar field 329  
Simple manometer 296  
Specific gravity 265  
Specific mass 264  
Specific volume 264  
Specific weight 264  
Stable equilibrium 302  
Stagnation density 366  
Stagnation point 366  
Stagnation pressure 366  
Stagnation temperature 366  
Static head 360  
Static pressure 365  
Steady 331  
Streakline 335  
Stream function 334  
Stream surface 334  
Streamline 333  
Streamtube 334  
Suction pressure 295  
Surface forces 289, 290  
Surface tension 269

**T**

Tangential force 289  
Temperature lapse rate 294  
Temporal acceleration 339  
Temporal mean velocity 331  
Timeline 335  
Total head 360  
Total head line 360  
Turbulent flow 331

**U**

Uniform flow 332

Unstable equilibrium 302

Unsteady flow 332

U-tube manometer 296

**V**

Vacuum pressure 295

Vector field 329

Velocity head 360

Velocity potential 335

Vena contracta 362

Venturimeter 364

Viscosity 265

**W**

Weight density 264