



AC Circuits

1st Edition

Table of Contents

Preface	4
Module 1 – AC Signal Overview	5
Section 1.1 – AC Introduction.....	5
Section 1.2 – Sinusoids	6
Section 1.3– Defining AC Voltage Types for Common AC Waveforms	12
Section 1.3.1 – Peak and Peak to Peak Voltage.....	15
Section 1.3.2 – Average Voltage.....	16
Section 1.3.3 – Root Mean Square (RMS) Voltage	16
Section 1.4– Sine Wave, Square Wave, and Triangle Wave Example Problems.....	18
Section 1.4.1 – Example Calculations of Vpp, Vpk, Vavg, and Vrms for Sine Waves	18
Section 1.4.2 – Example Calculations of Vpp, Vpk, Vavg, and Vrms for Square Waves.....	20
Section 1.4.3 – Example Calculations of Vpp, Vpk, Vavg, and Vrms for Triangle Waves	23
Module 2 – AC Circuits Math Background	26
Module 3 – RLC Circuit Analysis with AC Sources	32
Section 3.1 – Introduction of Impedance and Admittance and the Laplace Transform	32
Section 3.2 – Series RLC Circuits.....	33
Section 3.3 – Parallel RLC Circuits.....	41
Section 3.4 – AC Power Calculations	44
Section 3.5 –AC Maximum Power Transfer.....	50
Module 4 – Passive Filters	53
Section 4.1 – Low Pass Filters (LPF)	54
Section 4.2 – High Pass Filters (HPF)	57
Section 4.3 –Band Pass Filters (BPF).....	59
Section 4.4 –Band Stop Filters (BSF).....	66
Module 5 – Transformers	68
Module 6 – Diodes and AC to DC Conversion	72
Section 6.1 – Diode Constant Drop Model.....	73
Section 6.2 – Diode Logic Circuits.....	78
Section 6.3 – Protection Diodes	79
Section 6.4 – Rectifiers	80
Module 7 –Operational Amplifiers (OpAmps)	84
Section 7.1 – OpAmps Used as Comparators.....	86
Section 7.2 – OpAmps used as Amplifiers	89
Section 7.2.1 – Inverting OpAmp Configuration.....	92
Section 7.2.2 – Non-Inverting OpAmp Configuration.....	94
Section 7.3 – Superposition with OpAmps	95
References and Links	96
Appendix	98

Preface

This eBook was written as the sequel to the eBook titled *DC Circuits*, which was written in 2016 by Chad Davis. The DC Circuits eBook (<https://shareok.org/handle/11244/52245>) should be reviewed prior to reading this book. While the first book covered only DC circuits, this book covers Alternating Current (AC) circuits as well as a brief introduction of electronics. It is broken up into seven modules. Module 1 covers the theory of AC signals. Since only DC sources are used in the first eBook, details of AC signals such as sinusoidal waveforms (or sine waves), square waves, and triangle waves are provided. Module 2, titled *AC Circuits Math Background*, covers the mathematics needed for solving AC circuit problems. The background material in Modules 1 and 2 are combined in Module 3 to solve circuits with AC sources with resistors, inductors, and capacitors (RLC circuits).

Note: The term **RLC circuit** will apply to circuits that contain resistors and capacitor and/or inductors in this eBook. Therefore, the RLC term will also apply to RL and RC circuits.

Module 4 focuses on using RLC circuits as passive filters. Content that is traditionally associated with AC Circuits material ends in Module 4, but additional content is included in Modules 5 to 7 to provide more practical knowledge that builds upon the theory learned in AC circuits. Topics in these final three modules include transformers, diodes, and operational amplifiers. These topics in Modules 5 to 7 are the foundation of the field of electronics. Only an overview is provided in this eBook, but if it peaks your interest <http://www.allaboutcircuits.com/textbook/semiconductors/> has a detailed open source eBook on electronics.

An important thing to realize is that most of the information covered in DC circuit theory also applies to AC circuit theory. In fact, it is a good idea to think of a DC signal as one that can be obtained by freezing time in an AC signal and looking at the “instantaneous” voltage or current values at that moment in time. With this in mind, it should be apparent that KVL, KCL, Ohm’s law, and all of the other primary equations used in DC circuits also apply to AC circuits, since the AC circuit is simply a DC circuit that continually changes values. While DC voltage or current signals are typically given capital letter variables (V or I), AC waveforms are given lower case variables and often written as a function of time, $v(t)$ or $i(t)$. In this eBook scalar values that define the different types of AC voltages and currents are given capital letters (V_{pk} , I_{pk} , V_{pp} , I_{pp} , V_{avg} , I_{avg} , V_{rms} , I_{rms} , and A) as defined in [Module 1](#).

One goal of this book is to provide practical information to better equip the reader to put circuit theory into practice. The picture on the cover of this book shows an example of a RLC circuit built on a breadboard. After the completion of this book you will understand how RLC circuits work and many of the applications they are used for, as well as obtain a foundation in electronics. While providing practical information, this eBook tries to avoid going into too many tangents that result in numerous pages being skipped over by the reader. Links are provided throughout the eBook where more background information is available when I felt the temptation to depart from the main point. Many of the links come from allaboutcircuits.com, which is a very good open educational resource. If a link doesn’t open copy it into your browser or search for the document title online.

The circuits in this eBook are created with a user friendly circuit drawing and simulation tool called [Multisim](#). Creating new circuits and simulating them to verify that your calculations are correct is a good way to hone your circuit analysis skills. By providing an explanation of how to verify calculations in Multisim, this eBook enables the reader to create more complicated problems, while having a method to check the results. This is vitally important with AC circuits because the complex algebra involved in solving them is very tedious and mistakes are frequently made by students that are learning the problem solving techniques. The DC probes and Multimeters were used extensively in the [DC Circuits eBook](#), but in this eBook AC probes and the MultiSim oscilloscope will also be used to make more complicated AC measurements.

Module 1 – AC Signal Overview

Module 1 is broken up into the following 4 sections.

- [Section 1.1](#) – AC Introduction
- [Section 1.2](#) – Sinusoids
- [Section 1.3](#) – Common AC Waveforms and Voltage Types
- [Section 1.4](#) – Sine Wave, Square Wave, and Triangle Wave Example Problems

Section 1.1 – AC Introduction

When analyzing Direct Current (DC) circuits, calculations and measurements were simplified because the currents and voltages remained at a constant value when the circuit was at steady state. For Alternating Current (AC) circuits, the steady state voltage and current fluctuates in such a manner that the current periodically changes directions in the circuit. With the signals in the circuit being much more complicated, the analysis of AC circuits is also at a higher complexity level. An important thing to realize is that most of the information covered in DC circuit theory also applies to AC circuit theory. In fact, it is a good idea to think of a DC signal as one that can be obtained by freezing time in an AC signal and looking at the instantaneous voltage or current values at that specified time. With this in mind, it should be apparent that KVL, KCL, Ohm’s law, and all of the other primary equations used in DC circuits also apply to AC circuits since the AC circuit is only a DC circuit that continually changes values. While DC voltage or current signals are given capital letter variables (V or I), AC signals are given lower case variables and written as a function of time, $v(t)$ or $i(t)$. In this eBook scalar values that define the different types of AC voltages and currents are given capital letters (Vpk, Ipk, Vpp, Ipp, Vavg, Iavg, Vrms, Irms, and A). These AC parameters are defined in sections 1.2 to 1.4.

Note: In the DC Circuits eBook [Figure 1.7a](#) showed how to change the probe settings in MultiSim and described each of the “periodic” probe measurements. For convenience, the explanation and Figure (see [Figure 1.0](#)) is repeated here. When the current and voltage probes are normally placed in Multisim the “Instantaneous and periodic” probe setting is the default so you will see 5 voltage measurements (as shown in [Figure 1.0](#)). From top to bottom these measurements are: 1-Instantaneous, 2-peak to peak (Vpp or Ipp), 3-Root-Mean-Square (Vrms or Irms), 4-average (Vavg or Iavg), and 5-frequency of the signal. The average voltage is labeled V(dc) in the Multisim probe because the average voltage is equivalent to the DC value. The instantaneous voltage is the value at a specific time and will continuously change as the AC current flows through the circuit. These four **additional parameters** for voltage or current are only used for AC circuits. When dealing with DC circuits there is only one type of voltage and current so only the instantaneous measurements are needed. To get only the DC current or voltage click on the probe settings and change the default to “Instantaneous Only” as shown in [Figure 1.0](#).

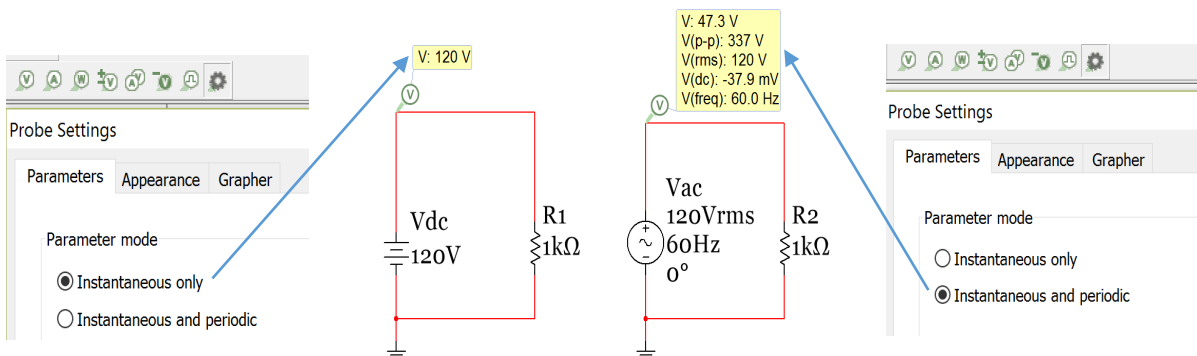
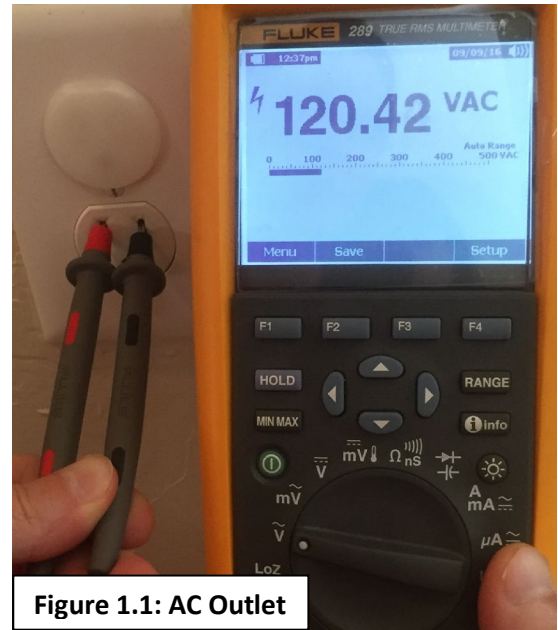

Figure 1.0: Preferred probe settings for DC circuits (Left) and AC circuits (Right).

Before analyzing AC circuits it is good to have a brief history of DC and AC circuits. This link (<http://www.allaboutcircuits.com/news/why-is-the-us-standard-60-hz/>) provides some DC and AC background and discusses how the United States (US) power system standardized on 60 Hertz (Hz) sinusoidal signals and Europe, and most of the rest of the world, standardized on 50 Hz sinusoidal signals (Sinusoids are discussed in detail in [Section 1.2](#)). This eBook will focus primarily on 60 Hz signals. The voltage levels used in AC circuits is also an important factor. US most commonly uses a Root Mean Square (RMS – discussed in detail in [Section 1.3](#)) voltage level between 110 and 120 Volts. 110 Vrms and 120 Vrms are often used interchangeably to describe the same signal. In the previous link 110 Vrms is used, but 120 Vrms is a more commonly referred to value and therefore 120 Vrms will be used for the amplitude of a standard AC outlet voltage signal in this eBook. According to this [link](#) the average RMS voltage is really around 117 Vrms.

[Figure 1.1](#) shows a Multimeter in AC mode measuring the RMS voltage of a standard US electrical outlet. In this case, the measurement is slightly higher than 120 Vrms. [Figure 1.2](#) shows how a 120 VRMS, 60 Hz voltage source would appear if plotted on an oscilloscope. Notice, that the top AC outlet in [Figure 1.1](#) is concealed with a safety cover to avoid an accidental shock. One important note about AC is that it is usually considered much more dangerous than DC for many reasons. The following link discussed electrical safety in great detail and provides data that shows that a 60 Hz AC signals can result in heart fibrillation at much lower currents than DC.



<http://www.allaboutcircuits.com/textbook/direct-current/chpt-3/ohms-law-again/>

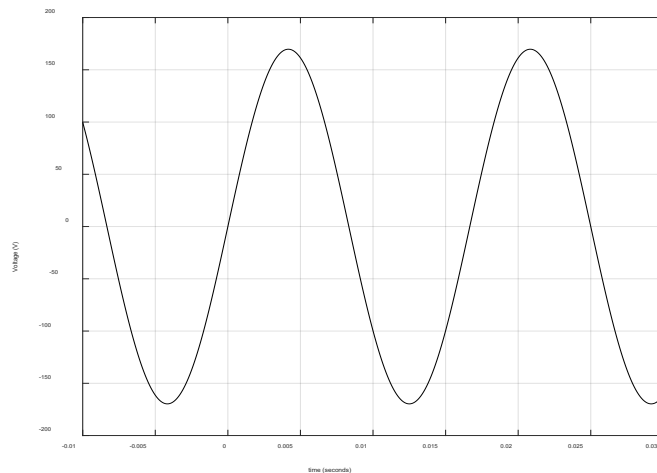

There are many applications based on sinusoids. The AC power outlet voltage signal shown in [Figure 1.1](#) is sinusoidal and can be characterized by [Equation 1.1](#). If the amplitude is 120 Vrms, the frequency is 60 Hz, and the phase shift is zero then the voltage equation would be:

$$\rightarrow v(t) = 120\sqrt{2} \cdot \sin(120 \cdot \pi \cdot t)$$

Note: The Amplitude (or peak voltage of a symmetrical sine wave) is equal to the RMS voltage multiplied by $\sqrt{2}$ (e.g. 120 Vrms = 169.7 Vpk). This will be discussed in more detail in [Section 1.2](#). This AC outlet signal is plotted in [Figure 1.2](#) and is what you would see if you connected the wall outlet of [Figure 1.1](#) signal to an oscilloscope.

Figure 1.2: Standard AC outlet signal in U.S. homes (120 Vrms, 60 Hz sinusoid)

Section 1.2 – Sinusoids

A sinusoid is described in this eBook as a signal that is governed by [Equation 1.1](#). A sine wave or a cosine wave are both considered sinusoids and they can be converted to each other through a 90° (or a $\pi/2$ radians) phase shift.

- $\sin(\omega t) = \cos(\omega t - \pi/2)$ or $\cos(\omega t) = \sin(\omega t + \pi/2)$

[Equation 1.1](#) will be referred to as “**sinusoidal form**” throughout this eBook. Since it is desirable to have zero initial values for voltage and current sine waves are preferred for circuits (instead of cosine waves that have max amplitude at t=0). The terms sinusoid and sine wave will often be used interchangeably in this eBook.

$$[1.1] \quad \boxed{v(t) = A \cdot \sin(\omega \cdot t + \theta)} \text{ or } \boxed{i(t) = A \cdot \sin(\omega \cdot t + \theta)}$$

- **A = Amplitude** (or peak value of the sinusoid assuming the signal is symmetric about the x axis)
- **θ = Phase shift** (units = radians)
- **t = time** (units = seconds)
- **ω = angular frequency** (units = rad/sec)
- v(t) or i(t) = The equation for the AC voltage or current. (The Amplitude sets the units of v(t) or i(t))

$$[1.2] \quad \boxed{\omega = 2 \cdot \pi \cdot f = \frac{2 \cdot \pi}{T}} \quad \mathbf{f = Frequency} \text{ (units = Hertz) and } \mathbf{T = Period} \text{ (units = seconds)}$$

In order to plot a sinusoid that is symmetrical about the x-axis (i.e. no DC offset) from the sinusoidal form ([Equation 1.1](#)) or to conversely write the sinusoidal form equation from the plot you need to know **3 things**:

- 1) **Amplitude (A)**: This can be measured from the difference of the maximum and minimum voltage divided by 2 → **A = (max – min)/2**. If the sinusoid is symmetric then $A = \max = |\min|$, but if it is NOT symmetric then a DC offset is added to [Equation 1.1](#) as follows: $v(t) = V_{DC} + A \cdot \sin(\omega \cdot t + \theta)$
- 2) **Period (T)**: The period can be measured as the time between sinusoidal peaks on the plot. Once the period is measured, ω can be calculated as $\omega = 2 \cdot \pi / T$ as shown in [Equation 1.2](#).
- 3) **Time Shift (t_s)**: The time shift is determined by measuring the **distance between the y axis and the nearest starting cycle of the sine wave**. If the sine wave begins its positive cycle before x = 0 (left of the y axis) then t_s has a negative value and the sinusoid is said to be “advanced”. If the sine wave begins its positive cycle after x = 0 (right of the y axis) then t_s has a positive value and the sinusoid is said to be “delayed”. Once the angular frequency (ω) and time shift (t_s) are known, then the phase shift (θ) can be determined from $(-\omega \cdot t_s)$ as shown in equations 1.3.

$$[1.3] \quad \boxed{\theta = -\omega \cdot t_s} \quad \mathbf{Note:} \text{ time shift (t}_s\text{) and phase shift (}\theta\text{) always have opposite signs.}$$

Example 1.1) Determine the sinusoidal form equation for the signal in [Figure 1.2](#).

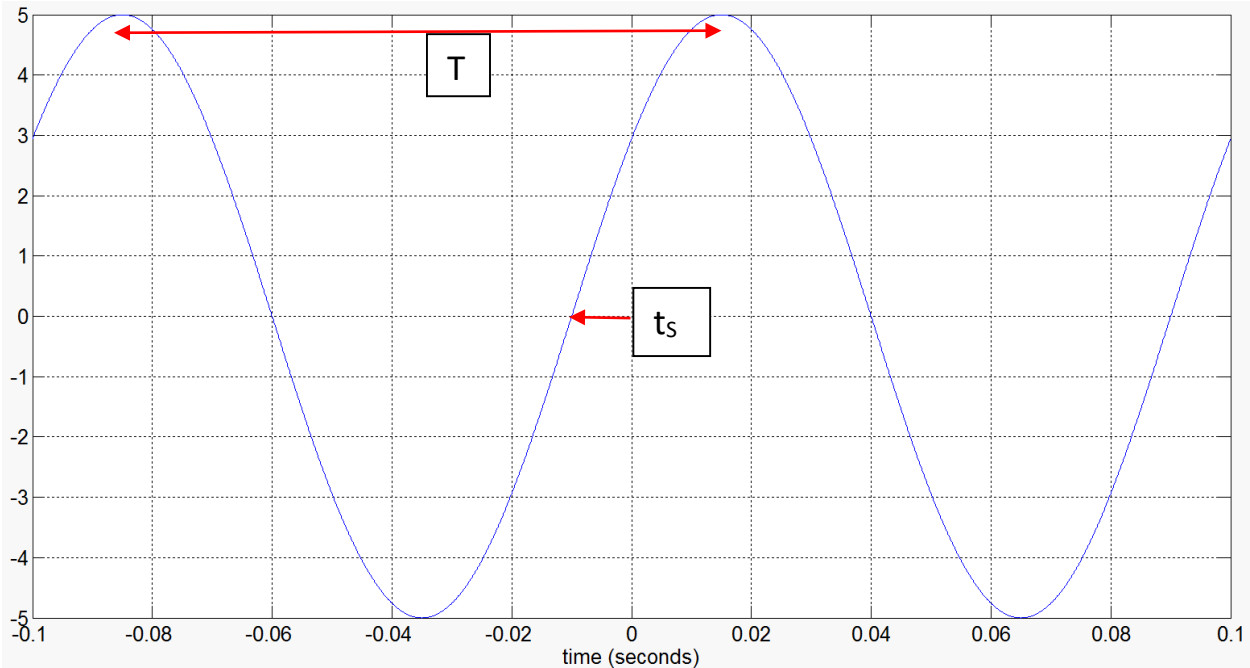

Figure 1.3: Plot of a symmetric sine wave used in Example 1.1.

Find the 3 items need to write the sinusoidal equation (**A**, **T**, **t_s**) and convert **T** to **ω** and **t_s** to **θ** .

- 1) Amplitude = **A = 5** (no units for the y axis are given, but we would normally assume it is volts).
- 2) Period = **T = ~ (0.015 seconds) – (-0.085) = 0.1 sec** or 100 msec. Once the period is measured, ω is calculated as $\omega = 2 \cdot \pi / T = 2 \cdot \pi / 0.1 = \mathbf{20 \pi \text{ rad/sec}}$
- 3) t_s = the time shift is **~ -0.01 seconds** as shown by the red arrow on [Figure 1.1](#). Now that t_s and θ are known the phase shift can be calculated by [Equation 1.3](#) $\rightarrow \theta = -\omega \cdot t_s = -20\pi (-0.01) = \mathbf{0.2 \pi}$

Using results from 1) through 3) yields $\rightarrow v(t) = \mathbf{5 \sin (20 \pi \cdot t + 0.2\pi)}$

Since the time shift was negative the sine wave in [Figure 1.2](#) is considered to be “advanced” when compared to a sine wave with no phase shift.

Example 1.1 showed how to determine the sinusoidal form equation when a plot of the sine wave is available. Example 1.2 shows how to plot the sine wave if the equation is available.

Note: If you want to find the phase difference between two signals it is often easier to measure the time difference between the **peaks** and then use [Equation 1.3](#) to convert to phase (see [Figure 2.2](#) in [Module 2](#)).

Example 1.2) Plot the sine wave that is represented by the equation: $i(t) = 20 \cdot \sin (200 \cdot t - 30^\circ) \text{ mA}$

Note: In the equation for Example 1.2 the units are given at the end of the equation as mA. Whenever you write the sinusoidal form of a voltage or current you should include the units at the end like this. If no units are given assume $v(t)$ is Volts and $i(t)$ is Amps. Additionally, the phase shift is listed with a degree sign, but the phase shift must be in radians for the units to agree. Since most people can comprehend degrees better than radians listing the phase shift in degrees is a common practice. If you do this make sure you label it with the degrees symbol.

CAUTION: If you are analyzing an equation that lists phase shift in degrees make sure you convert it to radians before adding it to the $\omega \cdot t$ term in the sinusoidal form equation.

First, convert the phase shift to radians. $\theta = -30^\circ * (\pi \text{ radians}/180^\circ) = -\pi/6 \text{ radians}$
 To plot the sine wave from the sinusoidal form equation you need A, T, and t_s .

- 1) **A = 20 mA** (Make sure the y axis is labeled with mA)
- 2) **T = $2\pi/\omega = 2\pi/200 = 0.01\pi = 31.4159 \text{ msec}$**
- 3) **$t_s = -\theta/\omega = -(-\pi/6 \text{ rad}) / (200 \text{ rad/sec}) = +2.618 \text{ msec}$**

Now that these three parameters are known the sine wave can easily be plotted by hand. Use t_s to determine where to start the sine wave. Use **A** to know how far above and below the X axis it goes and use **T** to determine how much time elapses in one cycle of the sine wave. The final plot should look like the following figure. The Matlab code is shown to the right of [Figure 1.4](#).

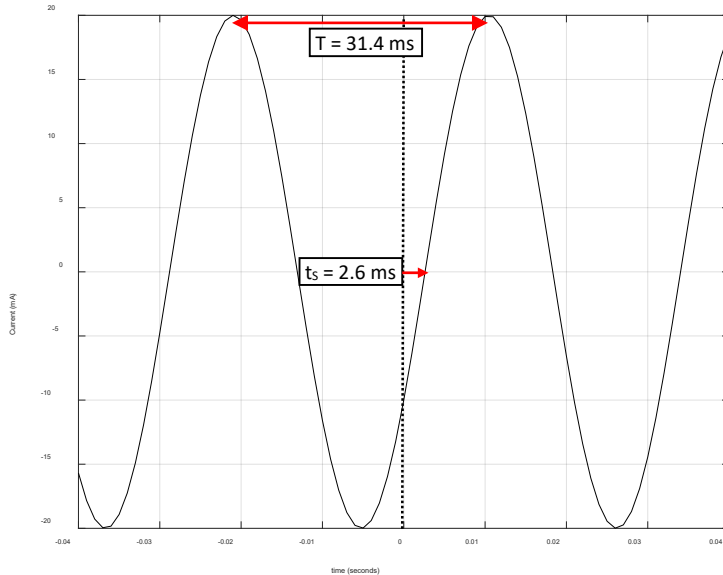

```

% Step 1 - Determine the Amplitude, A
A = 20; % Make sure mA is on y axis label
% Step 2 - Determine the Period, T
w = 200; % This is given in Example 1.2
T = 2*pi/w; % This is used to draw i(t) by hand
% Step 3 - Determine the Time Shift, ts
Theta = -30; % Degrees (This is Given in Example 1.2)
Theta = -30*pi/180; % Radians
ts = -Theta/w % This is used to draw i(t) by hand
% Plotting in Matlab
t = -0.04:0.001:0.04;
i = A*sin(w*t + Theta);
plot(t,i,'k')
grid on
xlabel('time (seconds)')
ylabel('Current (mA)')
    
```

Figure 1.4: Plot for Example 1.2

Note: In Module 3 we will use the term “lead” to describe a signal that is an advanced version of another signal and “lag” to describe a signal that is a delayed version of another signal.

For example, in [Figure 1.5](#) the left plot shows that the solid black sine wave is advanced (or leading the dashed blue sine wave) because the time shift of the solid black sine wave (referenced to the blue sine wave) is a negative value. The following is the best way to think of this:

- **The leading sine wave is the sine wave that completes its sinusoidal cycle first.**

The right plot of [Figure 1.5](#) shows the opposite case where the solid black sine wave has a time shift that is positive resulting in a delay. In the right plot the black sine wave can be said to be lagging the blue dashed sine wave. Keep in mind you can also say it in the reverse order and change lagging to leading (i.e. the blue sine wave in the right plot of [Figure 1.5](#) is leading the black sine wave because its sinusoidal cycle is completed first).

Some of the Matlab code for plots in this eBook are included at the end of the [Appendix](#).

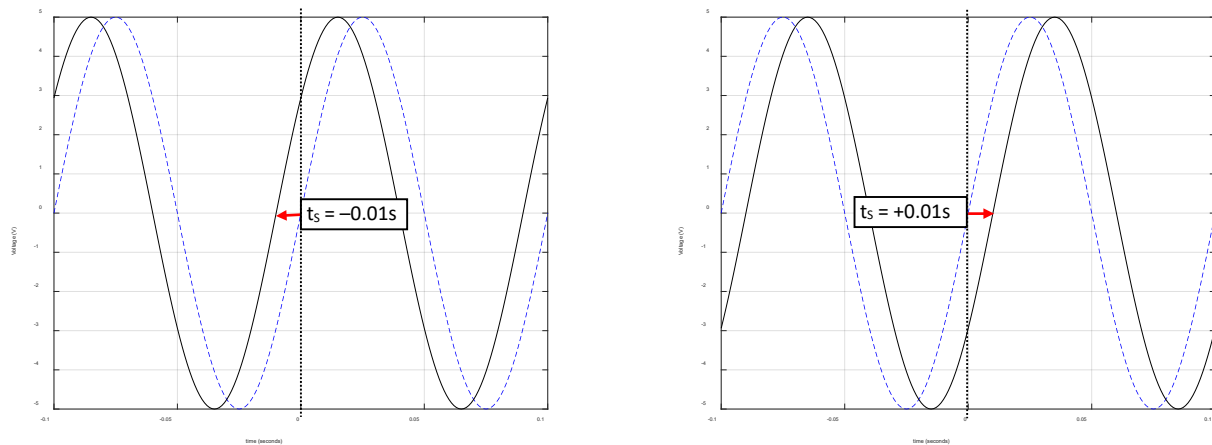

Figure 1.5: Dashed Blue Line (Zero time shift), Solid Black Line (Left, $t_s = -0.01s$, Right, $t_s = +0.01s$)

Music is another area where sinusoids are present. Each musical note is a sinusoid at a different frequency. If you are new to the idea of frequency a good way to understand it is download a tone generator app that will play different frequencies through your mobile device. You will find that as you increase the frequency that you will stop being able to hear the sound as the frequency approaches or slightly exceeds 20 kHz. This is due to the limitation of the human ear. Other animals, such as dogs, can hear much higher frequencies. The following link describes the frequencies of the different notes of the musical scale in detail:

<http://www.allaboutcircuits.com/textbook/alternating-current/chpt-1/ac-waveforms/>

When musical notes (or any sound for that matter) are played and different frequencies are present at different times a frequency versus time plot can be used to characterize the “spectrum” of the sound over time. Two popular frequency versus time plots are the spectrogram and the power spectrum density (psd) plot.

[Figure 1.6](#) shows the spectrogram and the psd for a train whistle sound that is sampled at a frequency of 8 kHz. See this [link](#) for more information about sampling.

The Spectrogram (top plot of [Figure 1.6](#)) shows the frequency versus time and uses a color code to show the amplitude at different frequencies. The psd plot (bottom plot of [Figure 1.6](#)) shows the amplitude versus normalized frequency (Actual_Frequency/0.5·Sampling_Frequency) for a block of time, which in this case is the complete 1.6 seconds of the train whistle sound. The 6 red lines of the spectrogram can be correlated to the 6 spikes in the psd plot. These plots help characterize sound so operations can be performed to enhance/amplify certain frequencies (e.g. an audio equalizer) or remove/attenuate certain frequencies (i.e. filtering – See [Module 4](#)). Another reason characterizing the frequency spectrum of a signal is important is that the sounds can be replaced by computer generated sounds. For example, vocoders (like Siri on an iPhone) digitally speaks like a human by pre-analyzing the spectrum of speech for the language setting that is selected. In [Module 4](#) another type of frequency response plot called the Bode plot will be used to characterize RLC filters.

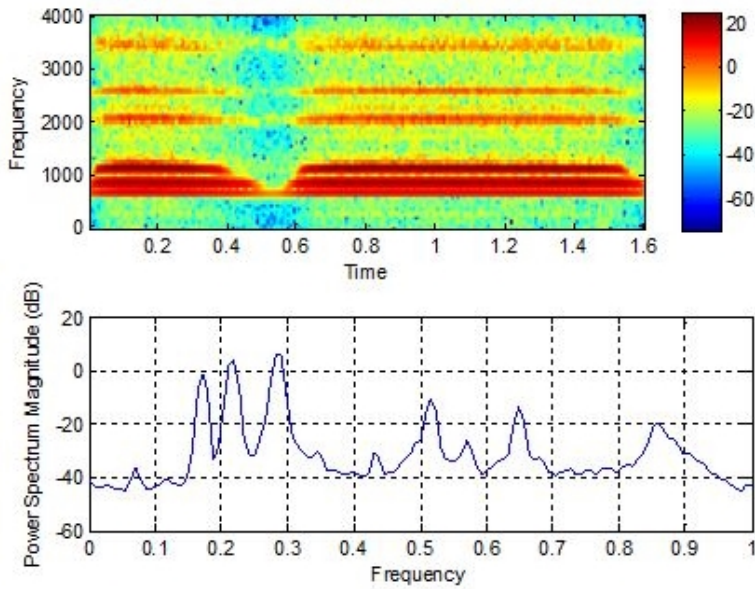

Figure 1.6: Spectrogram (top) and psd plot (bottom) of a train whistle sound

The following statement is perhaps the most important thing about sinusoids.

Any periodic waveform (one that repeats every T seconds) can be created by a sum of sinusoids.

For example, a square wave with amplitude (A) and a fundamental frequency (f_0) is created by taking an infinite sum of odd harmonic sine waves as follows (The **red bolded numbers** are called the harmonics):

$$v(t) = \frac{4 \cdot A}{\pi} \left[\frac{\sin(1 \cdot 2\pi f_0 \cdot t)}{1} + \frac{\sin(\mathbf{3} \cdot 2\pi f_0 \cdot t)}{\mathbf{3}} + \frac{\sin(\mathbf{5} \cdot 2\pi f_0 \cdot t)}{\mathbf{5}} + \frac{\sin(\mathbf{7} \cdot 2\pi f_0 \cdot t)}{\mathbf{7}} + \dots + \frac{\sin(N \cdot 2\pi f_0 \cdot t)}{N} \right]$$

<http://www.allaboutcircuits.com/textbook/alternating-current/chpt-7/square-wave-signals/>

A triangle wave with amplitude (A) and fundamental frequency (f_0) is also created by taking an infinite sum of odd harmonic sine waves, but with slightly different constants and alternating signs of each term:

$$v(t) = \frac{8 \cdot A}{\pi^2} \left[\frac{\sin(1 \cdot 2\pi f_0 \cdot t)}{1} - \frac{\sin(\mathbf{3} \cdot 2\pi f_0 \cdot t)}{\mathbf{9}} + \frac{\sin(\mathbf{5} \cdot 2\pi f_0 \cdot t)}{\mathbf{25}} - \frac{\sin(\mathbf{7} \cdot 2\pi f_0 \cdot t)}{\mathbf{49}} + \dots - \frac{\sin(N \cdot 2\pi f_0 \cdot t)}{N^2} \right]$$

These links from Wikipedia show the equations and also have an option for you to play the sound of the waveforms.

https://en.wikipedia.org/wiki/Square_wave https://en.wikipedia.org/wiki/Triangle_wave

The square and triangle waves will be closer to exact as more terms (or harmonics) are included. [Figure 1.7](#) (see Matlab code in the Appendix) shows a square and triangle wave created with different numbers of terms with $A = 1$ and $f_0 = 60$ Hz.

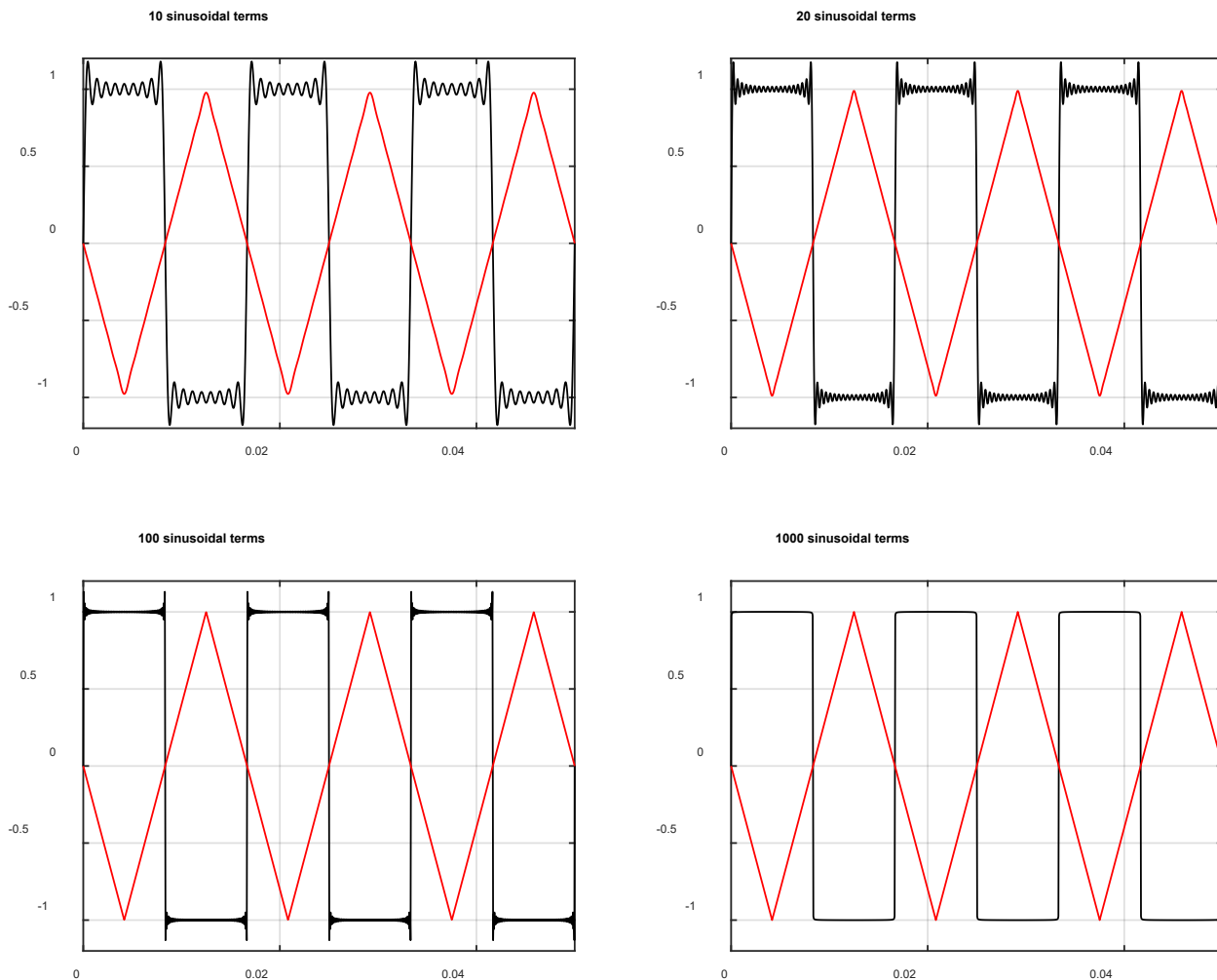

Figure 1.7: Square wave (black) and Triangle wave (red) created with different numbers of sinusoidal terms.

Section 1.3– Defining AC Voltage Types for Common AC Waveforms

In this section the three common waveforms that have been previously discussed (sine wave, square wave, and triangle wave) will be described in more detail. These three are the most common waveforms and are the three that are available in practically all function generators as shown in [Figure 1.8](#) and [Figure 1.9](#).

ONLY periodic waveforms (signals that repeat their pattern every T seconds) are discussed in this eBook.

[Figure 1.8](#) shows the Multisim tool that is a replica of the Agilent 33120A function generator. The knobs and buttons work in the same way as the actual Agilent device works. **A red box is drawn around the sine wave, square wave, and triangle wave buttons.** The Multisim symbol for the function generator has the title XFG1 and the output and ground connectors are wired into channel A of the generic Multisim 2-channel scope that is titled XSC1. In [Figure 1.8](#) a 1 kHz square wave is selected.



Figure 1.8: Agilent Function Generator and Multisim 2-Channel Oscilloscope.

Figure 1.9 shows the generic Multisim function generator tool and the scope tool that is a replica of the Tektronix TDS 2024 Oscilloscope. The knobs and buttons work in the same way as the actual Tektronix device works. The Multisim symbol for the function generator has the title XFG2 and the + output and ground connectors are wired into channel 2 of the Tektronix scope that is titled XSC1. In this example a 60 Hz sine wave with a peak voltage of 10 V is selected. The right side of the Oscilloscope shows 5 measurements. Figure 1.10 shows a zoomed in view of these 5 measurements.

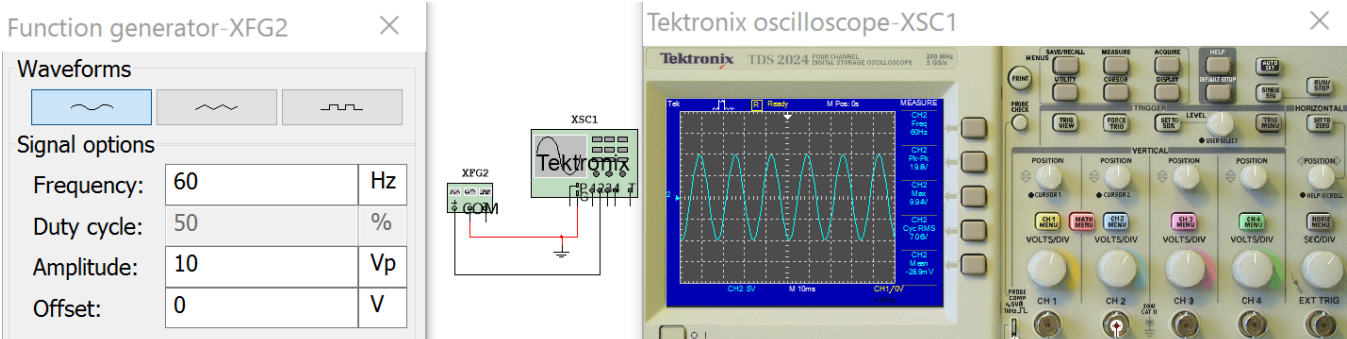

Figure 1.9: Multisim Function Generator and Tektronix Oscilloscope.

The primary goal of this section is to show how to solve the peak to peak (V_{pp}), peak (V_{pk}), average (V_{avg}), and root mean square voltage (V_{rms}) for the sine wave, square wave, and triangle wave. Figure 1.8 and Figure 1.9 shows two ways that you can simulate these three signals and two ways that you can make these four measurements in Multisim. Figure 1.10 shows that V_{pk} is called V_{max} and the V_{avg} is called V_{mean} on the Tektronix oscilloscope. Another terminology note is that V_{rms} is frequently referred to as V_{AC} .

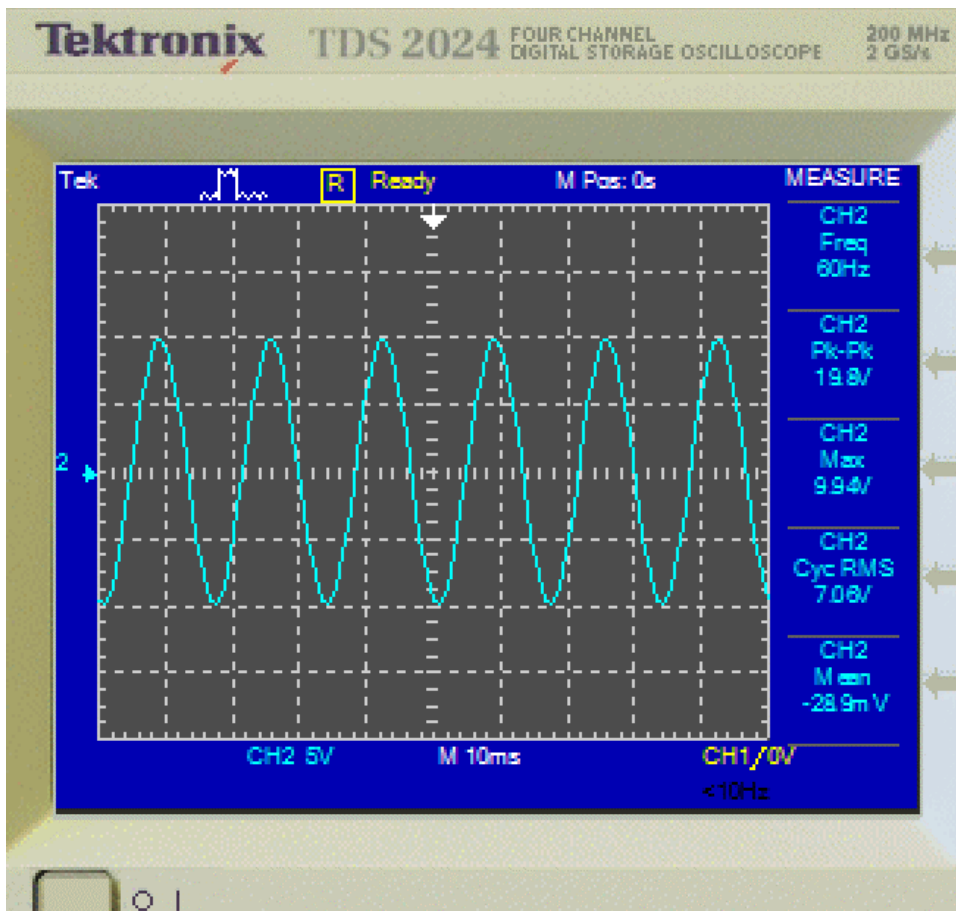

Figure 1.10: From top to bottom (F, Vp-p, Vpk, Vrms, and Vavg) Measurements from Figure 1.9

You can also use a Multimeter to measure AC waveforms, but you only get the RMS current or voltage. The meter in [Figure 1.11](#) is put in AC mode (the wavy line) and is measuring the RMS current in the AC circuit. The voltage could also be measured if the meter was placed across a component and the V button selected.

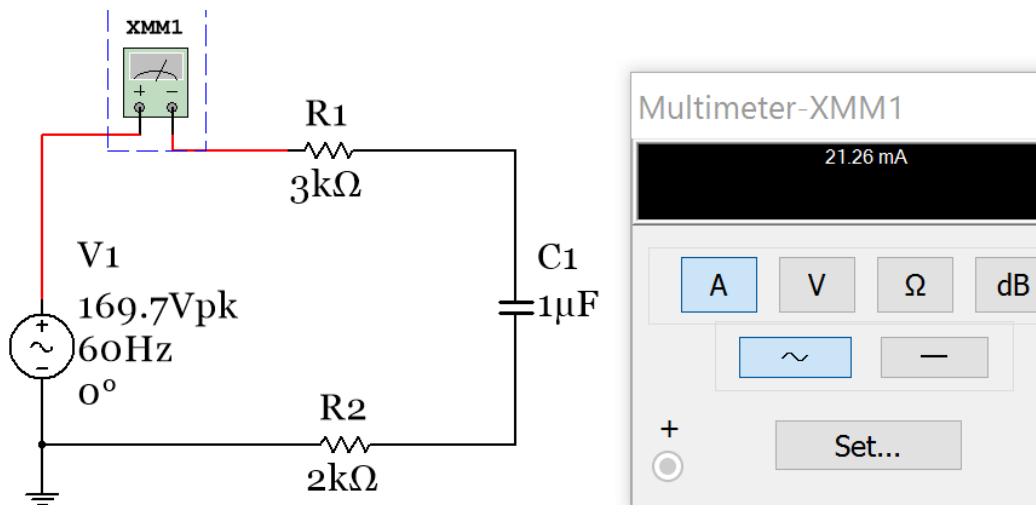

Figure 1.11: Using the Multisim Multimeter to measure the RMS current (also called IAC)

Section 1.3.1 – Peak and Peak to Peak Voltage

Determining the peak (Vpk) and peak to peak (Vpp) voltage (or current) for the sine wave, square wave, and triangle wave is a simple process, as described in the two bullets below. The voltage variable will primarily be used in this eBook, but the following AC currents can also be determined: Ipp, Ipk, Irms, and Iavg

- **Vpk** is the maximum value of any periodic waveform. This includes sine, square, and triangle waves.
- **Vpp** is the difference between the maximum and minimum values of a periodic waveform.
- **A**, which is the amplitude of a sinusoid that was defined in [section 1.2](#), is equal to Vpp/2. It is also equal to Vpk if the sinusoid is symmetric about the x-axis (i.e. There is no DC offset and max = |min|).

[1.4]
$$A = \frac{v_{pp}}{2}$$
 Where: v_{pp} is the maximum – minimum of a sinusoid

[Figure 1.12](#) shows both scenarios: with and without a DC offset. Keep in mind that when measuring an AC signal on an oscilloscope you must put it in DC coupling mode if you want to see the DC offset. When the oscilloscope is in AC coupling mode the DC offset is automatically filtered out. The DC coupling setting is changed by clicking on the Blue shaded button that corresponds to the channel on the bottom of the oscilloscope ([Figure 1.12](#) shows both channels are in DC coupling mode). This figure shows that XFG1 has a symmetric (DC offset = 0) triangle wave with a Vpp of 16 V (amplitude = 8) and sine wave with a 5 V DC offset and a Vpp of 20 V (Amplitude =10).

Note: To change the color of the plot in the Multisim oscilloscope you have to change the wire color going into the + terminal on channel A or B. To change the color you right click on the wire and click on “segment color”. Also, if the – pin of the oscilloscope is desired to be referenced to ground you can leave it unwired.

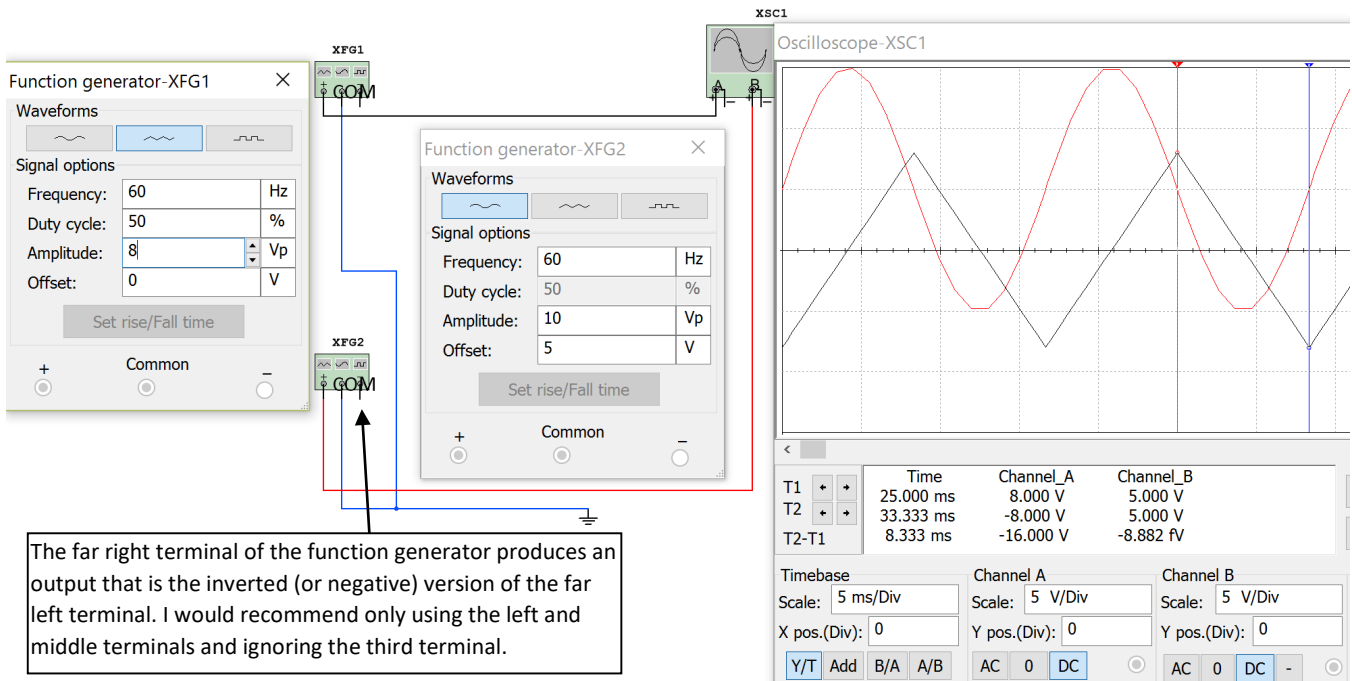

Figure 1.12: Using the Multisim function generator to plot two waveforms on the Multisim oscilloscope

Section 1.3.2 – Average Voltage

The average voltage (Vavg) is the voltage measured by a Multimeter in DC mode. Periodic signals (i.e. they repeat their pattern every T seconds) that are **symmetrical** about the x-axis have an **average voltage of zero**. The average value for a waveform that is not symmetric can either be calculated by using integration ([Equation 1.5](#)) or using the area method. The area method is preferred for most waveforms because it is usually much easier to calculate. This is especially true for square waves and triangle waves.

$$[1.5] \quad v_{avg} = \frac{1}{T} \int_0^T v(t) dt \quad \text{Where: } v(t) \text{ is the periodic signal, } T \text{ is the period}$$

The average value of any periodic signal can also be solved numerically using the **area method**.

Step 1) Break up the periodic square wave into rectangles over 1 period and label the areas A_I, A_{II}, A_{III}, A_{IV}, etc.

*Step 2) Find the sum of the areas over 1 period (A_{Total}). **Note:** Negative voltage peaks produce negative areas.*

Step 3) Divide the sum of the area (A_{Total}) by the period (T) → v_{avg} = A_{Total}/T

Section 1.3.3 – Root Mean Square (RMS) Voltage

Vpk, Vpp, and Vavg are key AC voltage quantities, but the most important AC voltage type is the RMS voltage (Vrms). The **R**oot **M**ean **S**quare (RMS) voltage is found by:

- 1) **S**quaring all (or as many points as possible) along one period of a periodic waveform.
- 2) Finding the **M**ean (or the average) of all of the square values found in step 1).
- 3) Taking the square **R**oot of the mean found in step 2).

The RMS value for any periodic waveform can be calculated mathematically by using [Equation 1.6](#).

$$[1.6] \quad v_{rms} = \sqrt{\frac{1}{T} \int_0^T v(t)^2 dt} \quad \text{Where: } v(t) \text{ is the periodic signal, } T \text{ is the period}$$

The RMS voltage is an important quantity in AC circuits because it allows the AC power delivered to a load to be equated to the DC power. Vrms can be defined as the magnitude of AC voltage that produces the same amount of average power on a load as an equivalent DC voltage, as shown in [Figure 1.13](#).

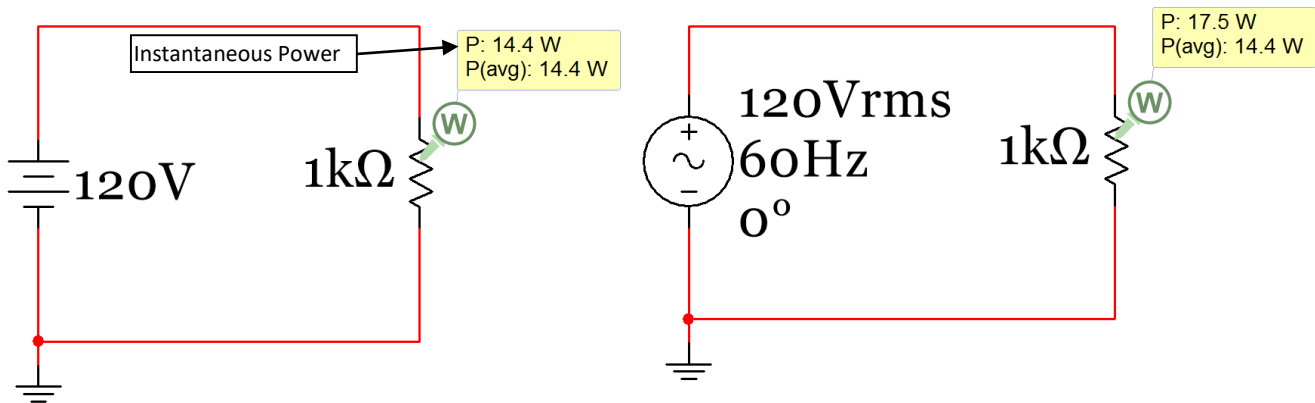

Figure 1.13: Instantaneous and Average Power of a circuit with a DC source (left) and an AC source (right).

The top power measurement in the power probe box in [Figure 1.13](#) is the “instantaneous power” (P_{inst}) and the bottom power value is called the “average power” (P_{AVG}). Since voltage and current doesn’t change in a DC circuit at steady state P_{inst} and P_{avg} are the same. For AC circuits P_{inst} is determined in the same way as it is in a DC circuit, but P_{avg} is determined using RMS current and voltage. The P_{inst} value continually changes in an AC circuit as the voltage and current change. At the moment in time the MultiSim circuit in [Figure 1.13](#) was paused, P_{inst} just happened to be equal to 17.5 W, but the voltage could theoretically have been anywhere from $-V_{pk}$ to $+V_{pk}$ depending on when the circuit was paused. Since P_{inst} depends on the instantaneous voltage (or the exact voltage at the moment it was paused) it changes from 0 to V_{pk}^2/R . Recall in [section 1.1](#) it was stated “it is a good idea to think of a DC signal as one that can be obtained by freezing time in an AC signal and looking at the instantaneous voltage or current values at that specified time.”

Note: In the DC Circuits book instantaneous power (P_{inst}) is given a positive value when it is dissipated (or absorbed) by a resistor, but a **negative** value when power is supplied (or delivered) by a **source**.

- For DC power these equations were used in the DC Circuits eBook: $P_{DC} = P_{inst} = V \cdot I = V^2/R = I^2 \cdot R$
- For AC power the RMS values (V_{rms} and I_{rms}) are used: $P_{AC} = P_{avg} = V_{rms} \cdot I_{rms} = V_{rms}^2/R = I_{rms}^2 \cdot R$

Caution: Make sure the RMS voltage (V_{rms}) and current (I_{rms}) are used when AC power is calculated.

There are **simplified methods** for determining the RMS voltage or current for symmetrical waveforms (i.e. DC offset = 0) as shown in equations 1.7 to 1.9 below. Notice only the peak voltage is needed to determine V_{rms} . The phase and frequency have no effect.

[1.7] $v_{rms} = \frac{v_{pk}}{\sqrt{2}} = 0.7071 v_{pk}$ *Where: V_{pk} is the peak of a symmetrical sinusoid*

[1.8] $v_{rms} = 1 v_{pk}$ *Where: V_{pk} is the peak of a symmetrical square wave*

[1.9] $v_{rms} = 0.577 v_{pk}$ *Where: V_{pk} is the peak of a symmetrical triangle wave*

For any periodic square waves (symmetrical or not symmetrical) the RMS value can be calculated using the following steps. This method will be referred to as the “**modified area method**” because it is a slight modification of the area method that was used to find the average voltage. If you get confused on the order of the steps, double checking the units can help catch mistakes.

- Step 1) Break up the periodic square wave into rectangular sections over 1 period and square the peak voltage of each. If the section is above the x-axis square the maximum voltage and if it is below the x-axis square the minimum voltage. Call these values α_1, α_2 , etc. The units are V^2 (or A^2 if it is a current waveform).
- Step 2) Multiply each α value (found in Step 1) by the base of the rectangle (Δt) so that you get $\alpha_1 \cdot \Delta t_1, \alpha_2 \cdot \Delta t_2$, etc. The units for each of these terms will be $V^2 \cdot \text{sec}$ (or $A^2 \cdot \text{sec}$ if it is a current waveform).
- Step 3) Sum the values from Step 2 to get α_{Total} . The units will be $V^2 \cdot \text{sec}$.
- Step 4) Divide the value of α_{Total} (determined in Step 3) by the period (T). The units will now be V^2 .
- Step 5) Take the square root of the result of Step 4. The units will now be V and this result is V_{rms} .

Make sure you only use the modified area method for periodic square waves.

- Triangle waves and all other periodic waveforms (except only symmetrical sinusoids and periodic square waves) must use the integration method ([Equation 1.6](#)) to determine the RMS value.

Section 1.4– Sine Wave, Square Wave, and Triangle Wave Example Problems

This section provides example calculations of V_{pk} , V_{pp} , V_{avg} , and V_{rms} for sine waves, square waves, and triangle waves. To save time and reduce calculation errors the integration formulas (Equations 1.5 and 1.6) should be avoided for situations where there is a simplified method. [Table 1.1](#) shows the simplified methods available for different types of AC waveforms.

Table 1.1) Table Showing V_{pk} and V_{pp} values and Simplified Methods for Determining V_{avg} and V_{rms}

	Waveforms that are symmetrical about x-axis			Waveforms that are NOT symmetrical		
	Sine Wave	Square Wave	Triangle Wave	Sine Wave	Square Wave	Triangle Wave
V_{pp}	Vpp is always the maximum voltage - the minimum voltage (i.e. $V_{max}-V_{min}$)					
V_{pk}	Vpk is always the maximum voltage (i.e. V_{max})					
V_{avg}	0			The DC offset	Area Method	
V_{rms}	$0.7071 \cdot V_{pk}$ Equation [1.7]	$1.0 \cdot V_{pk}$ Equation [1.8]	$0.577 \cdot V_{pk}$ Equation [1.9]	Use Integration Equation [1.6]	Modified Area Method	Use Integration Equation [1.6]

Section 1.4.1 – Example Calculations of V_{pp} , V_{pk} , V_{avg} , and V_{rms} for Sine Waves

Example 1.3) Using [Table 1.1](#) as guidance determine V_{pp} , V_{pk} , V_{avg} , V_{rms} , and Amplitude of a symmetrical sine wave with the sinusoidal form equation $v(t) = 6 \sin(200t)$

- $V_{pp} = \max - (\min) = 6 - (-6) = \mathbf{12\ V}$ (measured to be 11.91 V with the Multisim oscilloscope and 11.9 V with the Multisim voltage probe). The true value is 12 V (which is twice the amplitude entered in XFG1).
- $V_{pk} = \max = \mathbf{6\ V}$ (measured as 5.958 V with the scope)
- $\text{Amplitude} = A = V_{pp}/2 = \mathbf{6\ V}$
- $V_{avg} = \mathbf{0\ V}$ (as stated in [Table 1.1](#) for any symmetrical sine wave). The probe measures it as 2.24 mV.
- $V_{rms} = V_{pk}/\sqrt{2} = 6/\sqrt{2} = \mathbf{4.24\ V}$ ([Table 1.1](#) says to use [Equation 1.5](#) for symmetrical sine waves)

These values are verified below using the Multisim function generator, Multimeters, probes, and the scope.

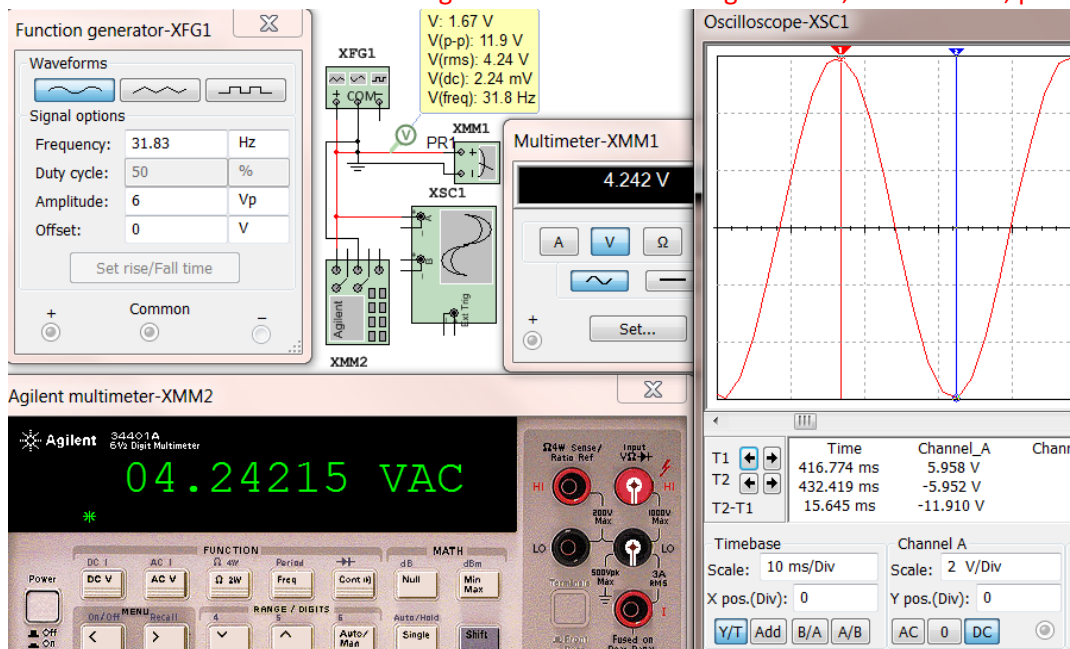

Figure 1.14: Function generator (XFG1), Multimeters (XMM1 and XMM2), Scope (XSC1), and Probe (box)

V: 1.67 V
 V(p-p): 11.9 V
 V(rms): 4.24 V
 V(dc): 2.24 mV
 V(freq): 31.8 Hz

Figure 1.15: Close up view of the AC Voltage Probe from Example 1.3

In the Multisim probe box from Example 1.3 (Figure 1.15) the Vpp, Vrms, Vavg, and the frequency are shown as V(p-p) = 11.9V, V(rms) = 4.24 V, V(dc) = 2.24 mV, and V(freq)=31.8 Hz respectively. The actual peak to peak voltage (Vpp) should have been 12V, but the Multisim probes will often have a slight error as it does in this case. The Vavg (or V(dc)) should have been 0, but it reads 2.24 mV in the probe box. Again, this level of inaccuracy can be expected. The top value that reads 1.67 V is called the “instantaneous voltage”. For an AC signal this value constantly changes. If you freeze the time in an AC circuit the problem can be treated as a DC problem and the instantaneous voltage measured would be the DC voltage that would be used for that problem.

For example 1.3 the rms voltage probe and the two Multimeters all had the same result, but for the next example that has a sine wave with a DC offset it will show the two Multimeters do not produce the correct result. The DC offset cannot be accounted for with either of the Multisim Multimeter or the Agilent Multimeter because they have “AC Coupling” on the input, which removes DC before the measurement is made. Therefore, **if you have a signal that is not symmetric only the voltage probe to can be used measure Vrms or Irms.**

Example 1.4) Using Table 1.1 as guidance determine Ipp, Ipk, Iavg, Irms, and Amplitude of a non-symmetrical sine wave with the sinusoidal form equation $i(t) = 3 + 8 \sin(120\pi t)$

This sinusoidal current has a DC offset of 3V and is plotted in Figure 1.16.

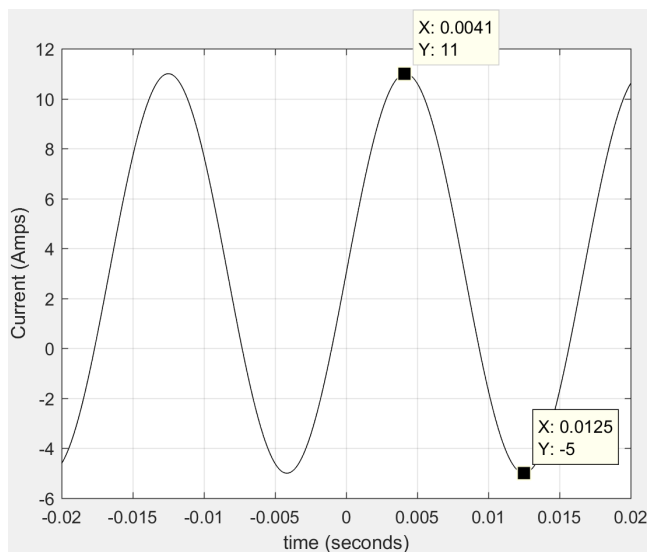

Figure 1.16: Non-symmetrical sine wave in Example 1.4

- $I_{pp} = \max - (\min) = 11 - (-5) = \mathbf{16A}$
- $I_{pk} = \max = \mathbf{11A}$
- $\text{Amplitude} = A = I_{pp}/2 = \mathbf{8A}$
- $I_{avg} = (\max + \min)/2 = \mathbf{3A}$ (This is the “DC offset” that Table 1.1 refers to for any non-symmetrical sine wave).
- $T = 2\pi/\omega = 2\pi/120\pi = \mathbf{0.01667 \text{ sec}}$

Table 1.1 states that the integration method (Equation 1.6) must be used for non-symmetrical sine waves. This method is shown below.

$$i_{rms} = \sqrt{\frac{1}{T} \int_0^T i(t)^2 dt} = \sqrt{\frac{1}{T} \int_0^T (3 + 8 \sin(120\pi t))^2 dt}$$

$$i_{rms} = \sqrt{\frac{1}{0.01667} \int_0^{0.01667} [9 + 48 \sin(120\pi t) + 64 \sin(120\pi t)^2] dt} = \mathbf{6.4 A}$$

The integration in Example 1.4 was solved using the online [Wolfram Alpha Integration Widget](#). Multisim verifies the results of Example 1.4 in [Figure 1.17](#). Since the waveform was not symmetric only the probe box was used for the verification. Also, since the function generator can only output voltage signals the voltage probe was used. Anytime you want to know the Vpp, Vrms, and Vavg (or Ipp, Irms, and Iavg) values you can use this method even if it is a current waveform. If it is a current waveform just replace the Volts units with Amps.

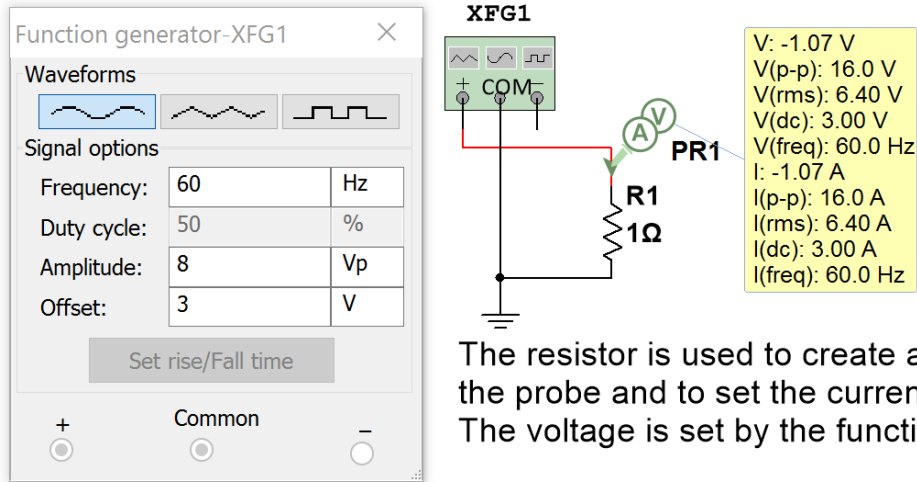

The resistor is used to create a node for the probe and to set the current level. The voltage is set by the function generator.

Figure 1.17: Multisim Verification of Values Calculated in Example 1.4. Note: $I_{rms} = 6.4V_{rms}/1\Omega = 6.4A$

Section 1.4.2 – Example Calculations of Vpp, Vpk, Vavg, and Vrms for Square Waves

The term “square wave” in this eBook will be used to define any signal that has a periodic series of rectangular pulses. The most common square wave is one that has a period with one rectangular pulse above the x-axis (high pulse) and one below the x-axis (low pulse) as shown in Example 1.5. An important parameter for square waves with only one high and one low pulse per period is the duty cycle (DC), which is defined in [Equation 1.10](#).

$$[1.10] \quad DC = \frac{t_{high}}{t_{high} + t_{low}} \quad \text{Where: } t_{high} \text{ is the time of the high pulse \& } t_{low} \text{ is the time of the low pulse.}$$

Example 1.5) Using [Table 1.1](#) as guidance, determine Vpp, Vpk, Vavg, and Vrms for the following symmetric 50% duty cycle square wave.

The cursors on the scope show the high time 50 ms and since the duty cycle is 50% the low time is also 50 ms. The period is equal to $t_{high} + t_{low}$

- $T = 50 \text{ ms} + 50 \text{ ms} = 100 \text{ ms} = 0.1 \text{ sec.}$
- $V_{pk} = 3V$ (Max voltage on the plot)
- $V_{pp} = \text{max} - \text{min} = 3 - (-3) = 6V$
- $V_{avg} = 0$ (symmetrical square wave in [Table 1.1](#))

Solve for Vrms using the **modified area method**

- 1) Square peaks of each area: $\alpha_1 = (3)^2 = 9V^2$ $\alpha_2 = (-3)^2 = 9V^2$
- 2) $\alpha_1 \cdot t_1 = 9V^2 \cdot 0.05s = 0.45 V^2s$ $\alpha_2 \cdot t_2 = 9V^2 \cdot 0.05s = 0.45 V^2s$
- 3) Total modified area = $\alpha_1 \cdot t_1 + \alpha_2 \cdot t_2 = 0.45 V^2s + 0.45 V^2s = 0.9 V^2s$
- 4) $0.9 V^2s / T = 0.9 V^2s / 0.1s = 9V^2$
- 5) $V_{rms} = \sqrt{9 V^2} = 3V$

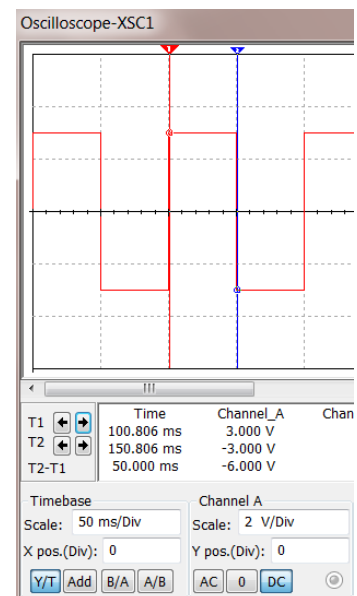

The calculations in Example 1.5 are verified in [Figure 1.18](#). The Duty Cycle in the XFG only affects square waves.

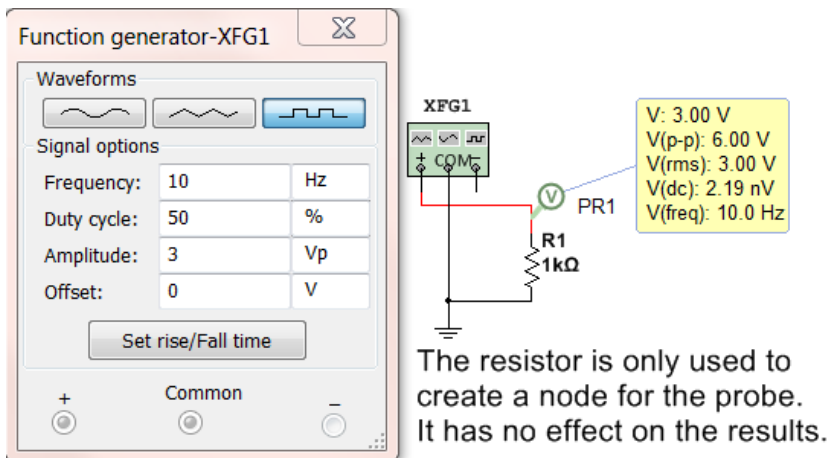

Figure 1.18: Multisim Verification of Values Calculated in Example 1.5

Example 1.6) Using Table 1.1 as guidance, determine V_{pp} , V_{pk} , V_{avg} , and V_{rms} for the following non-symmetric 50% duty cycle square wave that has a DC offset of 2V.

- $T = 50 \text{ ms} + 50 \text{ ms} = 100 \text{ ms} = 0.1 \text{ sec.}$
- $V_{pk} = 5\text{V}$ (Max voltage on the plot)
- $V_{pp} = \text{max} - \text{min} = 5 - (-1) = 6\text{V}$ (Verified in Figure 1.19)

Solve for V_{avg} using the **area method**

- 1) $A_I = 5\text{V} \cdot 0.05\text{s} = 0.25 \text{ Vs}$ $A_{II} = -1\text{V} \cdot 0.05\text{s} = -0.05 \text{ Vs}$
- 2) $A_{\text{Total}} = A_I + A_{II} = 0.25 \text{ Vs} + -0.05 \text{ Vs} = 0.2 \text{ Vs}$
- 3) $V_{avg} = A_{\text{Total}} / T = 0.2 \text{ Vs} / 0.1\text{s} = 2\text{V}$ (Verified in Figure 1.19)

Solve for V_{rms} using the **modified area method**

- 1) Square peaks: $\alpha_1 = (5)^2 = 25\text{V}^2$ $\alpha_2 = (-1)^2 = 1\text{V}^2$
- 2) $\alpha_1 \cdot t_1 = 25\text{V}^2 \cdot 0.05\text{s} = 1.25 \text{ V}^2\text{s}$ $\alpha_2 \cdot t_2 = 1\text{V}^2 \cdot 0.05\text{s} = 0.05 \text{ V}^2\text{s}$
- 3) Total Modified Area = $\alpha_1 \cdot t_1 + \alpha_2 \cdot t_2 = 1.25 \text{ V}^2\text{s} + 0.05 \text{ V}^2\text{s} = 1.3 \text{ V}^2\text{s}$
- 4) $1.3 \text{ V}^2\text{s} / T = 1.3 \text{ V}^2\text{s} / 0.1\text{s} = 13\text{V}^2$
- 5) $V_{rms} = \sqrt{13\text{V}^2} = 3.61\text{V}$ (Verified in Figure 1.19)

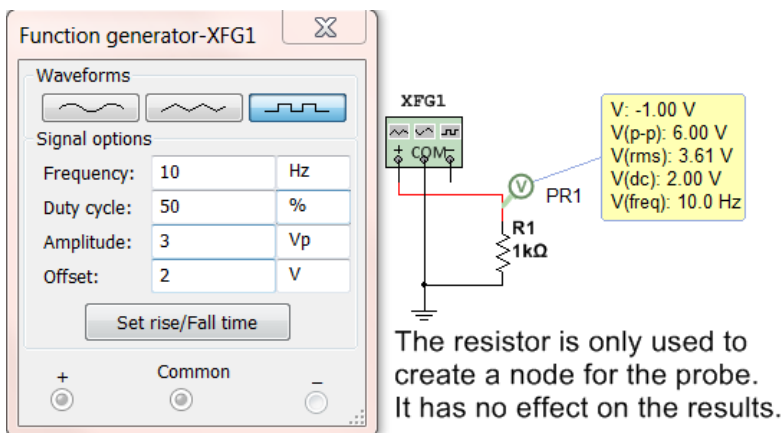
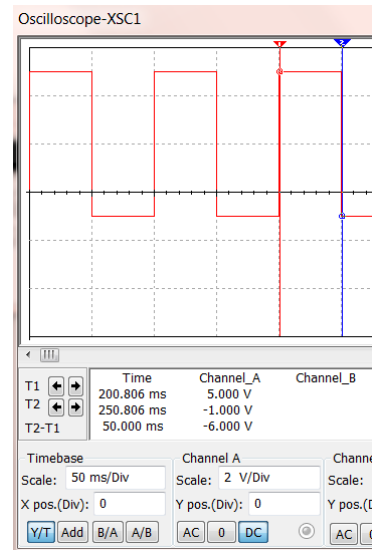

Figure 1.19: Multisim Verification of Values Calculated in Example 1.6

Example 1.7) Using [Table 1.1](#) as guidance, determine V_{pp} , V_{pk} , V_{avg} , and V_{rms} for the following non-symmetric 80% duty cycle square wave that has a DC offset of -2 V.

- t_{high} is shown to be $\sim 80\text{ms}$ on the scope plot.
- Solving for t_{low} using [Equation 1.10](#) gives $t_{low} = 20\text{ ms}$
- $T = 80\text{ ms} + 20\text{ ms} = 100\text{ ms} = 0.1\text{ sec.}$
- $V_{pk} = 3\text{V}$ (Max voltage on the plot)
- $V_{pp} = \text{max} - \text{min} = 3 - (-7) = 10\text{V}$ (Verified in [Figure 1.20](#))

Solve for V_{avg} using the **area method**

- 1) $A_I = 3\text{V} \cdot 0.08\text{s} = 0.24\text{ Vs}$ $A_{II} = -7\text{V} \cdot 0.02\text{s} = -0.14\text{ Vs}$
- 2) $A_{Total} = A_I + A_{II} = 0.24\text{ Vs} + -0.14\text{ Vs} = 0.1\text{ Vs}$
- 3) $V_{avg} = A_{Total} / T = 0.1\text{ Vs} / 0.1\text{s} = 1\text{V}$ (Verified in [Figure 1.20](#))

Solve for V_{rms} using the **modified area method**

- 1) Square peaks: $\alpha_1 = (3)^2 = 9\text{V}^2$ $\alpha_2 = (-7)^2 = 49\text{V}^2$
- 2) $\alpha_1 \cdot t_1 = 9\text{V}^2 \cdot 0.08\text{s} = 0.72\text{ V}^2\text{s}$ $\alpha_2 \cdot t_2 = 49\text{V}^2 \cdot 0.02\text{s} = 0.98\text{ V}^2\text{s}$
- 3) Total Modified Area = $\alpha_1 \cdot t_1 + \alpha_2 \cdot t_2 = 0.72\text{ V}^2\text{s} + 0.98\text{ V}^2\text{s} = 1.7\text{ V}^2\text{s}$
- 4) $1.7\text{ V}^2\text{s} / T = 1.7\text{ V}^2\text{s} / 0.1\text{s} = 17\text{V}^2$
- 5) $V_{rms} = \text{sqrt}(17\text{V}^2) = 4.12\text{V}$ (Verified in [Figure 1.20](#))

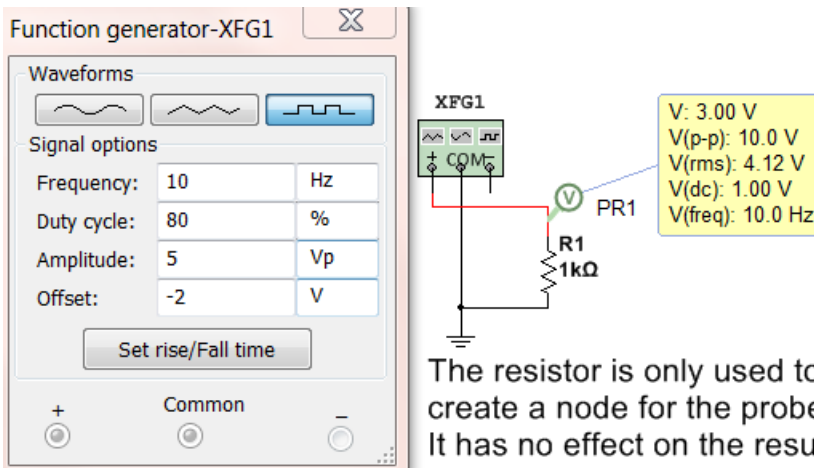
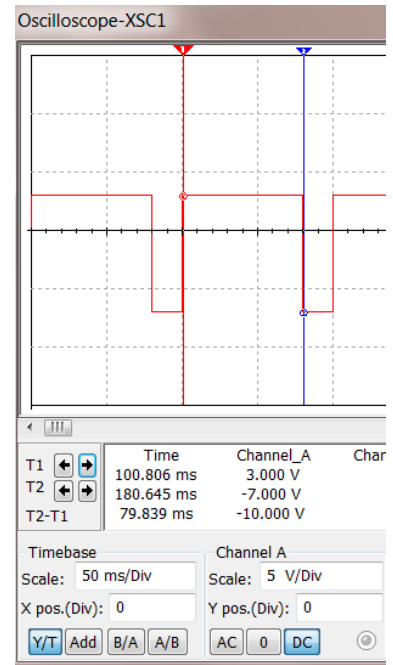

Figure 1.20: Multisim Verification of Values Calculated in Example 1.6

Examples 1.5, 1.6, and 1.7 show realistic square waves that have one high pulse and one low pulse per period, but you can also use these methods to determine the V_{pp} , V_{pk} , V_{avg} , and V_{rms} for a square wave that has multiple high and low pulses (see Example 1.8). Unfortunately, Multisim cannot be used to verify answers when there is more than one high and one low pulse.

Example 1.8) One cycle of a periodic square wave is shown in the figure below. Using Table 1.1 as guidance, determine the V_{pp} , V_{pk} , V_{avg} , and V_{rms} values for this square wave.

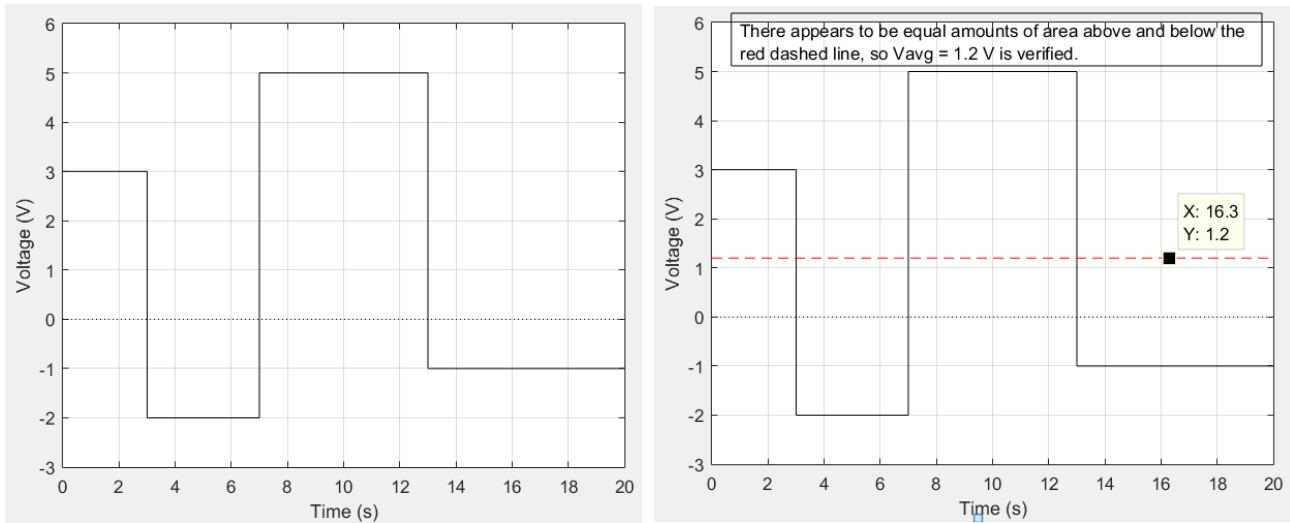

Figure 1.21: One cycle of a periodic square wave in Example 1.8 (Left), Average Value shown in right plot.

- $T = 20$ sec. (From plot)
- $V_{pk} = 5V$ (Max voltage on the plot)
- $V_{pp} = \max - \min = 5 - (-2) = 7V$

Solve for V_{avg} using the **area method** (labeling the areas from left to right in ascending order)

- 1) $A_I = 3V \cdot 3s = 9Vs$ $A_{II} = -2V \cdot 4s = -8Vs$ $A_{III} = 5V \cdot 6s = 30Vs$ $A_{IV} = -1V \cdot 7s = -7Vs$
- 2) $A_{Total} = A_I + A_{II} + A_{III} + A_{IV} = 9Vs - 8Vs + 30Vs - 7Vs = 24 Vs$
- 3) $V_{avg} = A_{Total} / T = 24 Vs / 20 s = 1.2V$ (See the plot above-right with the red dashed line)

Solve for V_{rms} using the **modified area method**

- 1) Square peaks: $\alpha_1 = (3)^2 = 9V^2$ $\alpha_2 = (-2)^2 = 4V^2$ $\alpha_3 = (5)^2 = 25V^2$ $\alpha_4 = (-1)^2 = 1V^2$
- 2) $\alpha_1 \cdot t_1 = 9V^2 \cdot 3s = 27V^2s$ $\alpha_2 \cdot t_2 = 4V^2 \cdot 4s = 16V^2s$ $\alpha_3 \cdot t_3 = 25V^2 \cdot 6s = 150V^2s$ $\alpha_4 \cdot t_4 = 1V^2 \cdot 7s = 7V^2s$
- 3) Total Modified Area = $\alpha_1 \cdot t_1 + \alpha_2 \cdot t_2 + \alpha_3 \cdot t_3 + \alpha_4 \cdot t_4 = 27 V^2s + 16 V^2s + 150 V^2s + 7 V^2s = 200 V^2s$
- 4) $200 V^2s / T = 200 V^2s / 20s = 10 V^2$
- 5) $V_{rms} = \sqrt{10V^2} = 3.16V$

Section 1.4.3 – Example Calculations of V_{pp} , V_{pk} , V_{avg} , and V_{rms} for Triangle Waves

Triangle waves aren't nearly as common as sine waves and square waves, but they are present from time to time in AC circuits. One example is when high frequency square wave pulses are transmitted in a circuit that have such narrow pulses that the components can't handle the speed due to slew rate ($\Delta v / \Delta t$) limitations and the square wave is converted to a waveform that looks more like a triangle. A saw tooth is another popular triangular waveform that ramps upwards until it reaches its positive peak (just like a standard triangle wave) and then drops instantaneously to its negative peak (like a standard square wave). The term "triangle wave" in this eBook will be used to define any signal that has a periodic series of triangular pulses. The most common triangle wave is one where each period has one triangular section above the x-axis and one below the x-axis with a slope that has a constant magnitude, but alternates signs as shown in Example 1.9.

Example 1.9) Using [Table 1.1](#) as guidance, determine V_{pp} , V_{pk} , V_{avg} , and V_{rms} for the following symmetric triangle wave. **Note:** The Duty Cycle in the function generator settings below also has an effect on triangle waves. If the Duty cycle is set to a minimum value of 1 then the triangle wave will look like a “saw tooth” wave that will ramp up to its peak nearly instantaneously and drop down to its negative peak more slowly. The reverse will happen if a Duty Cycle is set to the maximum value of 99. Stop and restart the simulation when making changes.

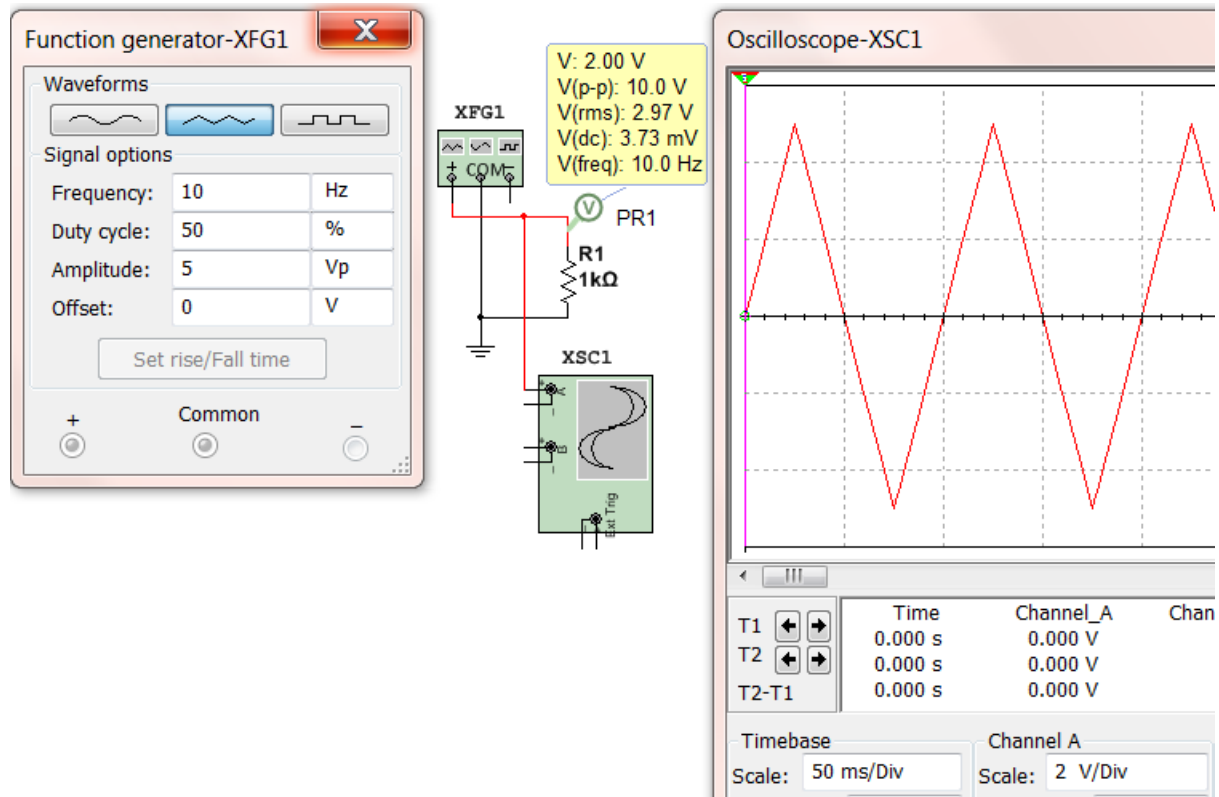

Figure 1.22: Multisim function generator settings and scope print for triangle wave in Example 1.9.

- $T = 1/F = 1/10 = 0.1 \text{ sec.}$
- $V_{pk} = 5\text{V}$ (Max voltage on the oscilloscope plot)
- $V_{pp} = \text{max} - \text{min} = 5 - (-5) = 10\text{V}$ (Verified with Multisim voltage probe)
- $V_{avg} = 0$ (symmetrical square wave in [Table 1.1](#)) (Verified as $\sim 0 \text{ V}$ with Multisim voltage probe)

For triangle waves the integration method ([Equation 1.6](#)) must be used for V_{rms} . There is no simplification.

- Each line needs to be broken up in separate functions over one period. The easiest way to do this is determine the slope ($5/0.025 = 200$) and break the waveform up into 2 sections.
- From $t = 0$ to $T/2$, $v_1(t) = 200 \cdot t$ and From $t = T/2$ to T , $v_2(t) = -200 \cdot t$

$$v_{rms} = \sqrt{\frac{1}{T} \int_0^T v(t)^2 dt} = \sqrt{\frac{1}{T} \left[\int_{-T/4}^{T/4} (200 \cdot t)^2 dt + \int_{T/4}^{3T/4} (10 - 200 \cdot t)^2 dt \right]}$$

$$v_{rms} = \sqrt{\frac{1}{0.1} \left\{ [13333.333 \cdot t^3]_{-0.025}^{0.025} + [100 \cdot t - 2000 \cdot t^2 + 13333.33 \cdot t^3]_{0.025}^{0.075} \right\}}$$

$v_{rms} = \sqrt{8.3333} = 2.89 \text{ V}$ * The Multisim probe value was very close to this value (2.97 V).

Example 1.10) Using Table 1.1 as guidance, determine V_{pp} , V_{pk} , and V_{avg} for the following figure that shows one cycle of a non-symmetric periodic triangle wave. Note: The Multisim function generator can't be used to create a complicated waveform like this. Since calculating V_{rms} for triangle waves is arduous and not frequently necessary this example will leave it out and only solve V_{pk} , V_{pp} , and V_{avg} .

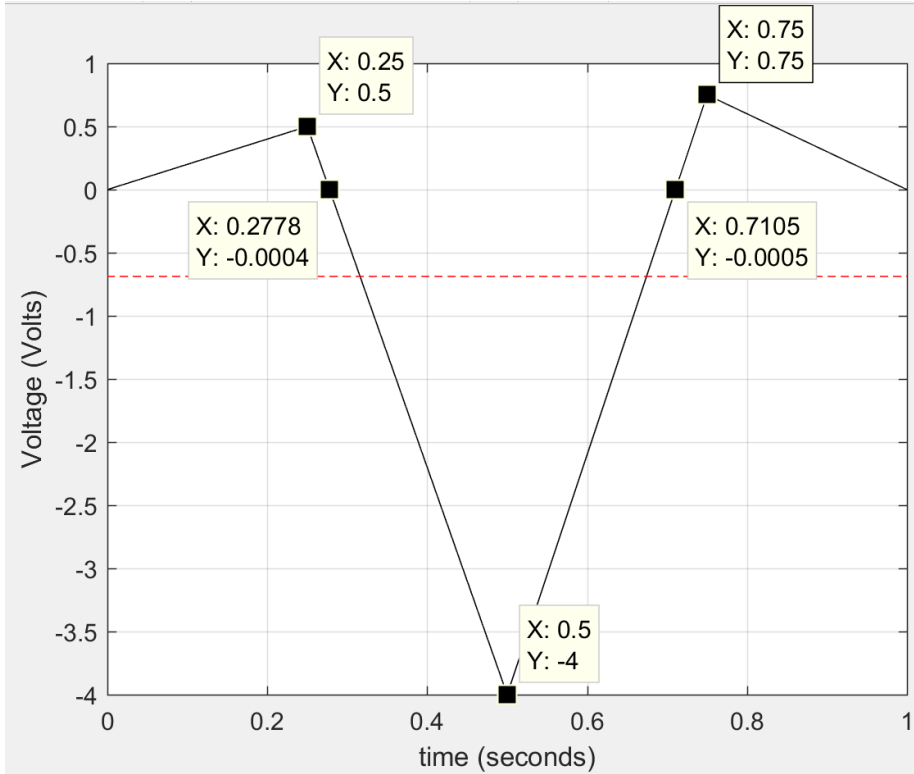

Figure 1.23: Triangle wave for Example 1.10.

- $T = 1 \text{ sec.}$
- $V_{pk} = 0.75\text{V}$ (Max voltage)
- $V_{pp} = \text{max} - \text{min} = 0.75 - (-4) = 4.75\text{V}$

Solve for V_{avg} using the **area method** (labeling the areas from left to right of each right angle triangle in ascending order). Assume the Y values shown in Figure 1.23 that are -.0004 and -.0005 are equal to zero.

- 1) $A_I = \frac{1}{2} b \cdot h = \frac{1}{2} (0.25 - 0) \text{ sec} \cdot 0.5\text{V} = 0.0625\text{Vs}$
 $A_{II} = \frac{1}{2} b \cdot h = \frac{1}{2} (0.2778 - 0.25) \text{ sec} \cdot 0.5\text{V} = \frac{1}{2} 0.0278 \text{ sec} \cdot 0.5\text{V} = 0.00695 \text{ Vs}$
 $A_{III} = \frac{1}{2} b \cdot h = \frac{1}{2} (0.5 - 0.2778) \text{ sec} \cdot (-4\text{V}) = \frac{1}{2} 0.222 \text{ sec} \cdot (-4\text{V}) = -0.4444 \text{ Vs}$
 $A_{IV} = \frac{1}{2} b \cdot h = \frac{1}{2} (0.7105 - 0.5) \text{ sec} \cdot (-4\text{V}) = \frac{1}{2} 0.2105 \text{ sec} \cdot (-4\text{V}) = -0.421 \text{ Vs}$
 $A_V = \frac{1}{2} b \cdot h = \frac{1}{2} (0.75 - 0.7105) \text{ sec} \cdot 0.75\text{V} = \frac{1}{2} 0.0395 \text{ sec} \cdot 0.75\text{V} = 0.014813 \text{ Vs}$
 $A_{VI} = \frac{1}{2} b \cdot h = \frac{1}{2} (1 - 0.75) \text{ sec} \cdot 0.75\text{V} = \frac{1}{2} 0.25 \text{ sec} \cdot 0.75\text{V} = 0.09375 \text{ Vs}$
- 2) $A_{\text{Total}} = A_I + A_{II} + A_{III} + A_{IV} + A_V + A_{VI} = 0.0625 + 0.00695 - 0.4444 - 0.421 + 0.014813 + 0.09375 = -0.6874\text{Vs}$
- 3) $V_{avg} = A_{\text{Total}} / T = -0.6874 \text{ Vs} / 1 \text{ s} = -0.6874 \text{ V}$ (See the plot above with the red dashed line shows this value looks like the midpoint between the positive and negative parts of the waveform.)

Module 2 – AC Circuits Math Background

Module 1 described common types of AC sources. From this point on the focus will be solely on sinusoidal inputs that were represented in Equation 1.1 in Section 1.2 as the following:

- **Sinusoidal Form** $\rightarrow v(t) = A \cdot \sin(\omega \cdot t + \theta)$

Module 2 will provide the math background needed to be able to solve RLC circuits with AC sources. The first mathematical simplification is to represent the sinusoidal signal as a “phasor” that has a set amplitude and phase. The “phasor form” of a sinusoid is the amplitude and phase represented in polar form.

- **Phasor Form** $\rightarrow V = A \angle \theta$

Capital letters are used for Phasor variables and lower case letters are used for sinusoidal form variables. Phasor form is convenient because all signals in any RLC circuit will have the same frequency as the source (or input) frequency. For example, the following figure shows an RC circuit and the input and output voltage signals. Notice that the **frequencies of v_{in} and v_{out} are the same**, but both the amplitude and phase change.

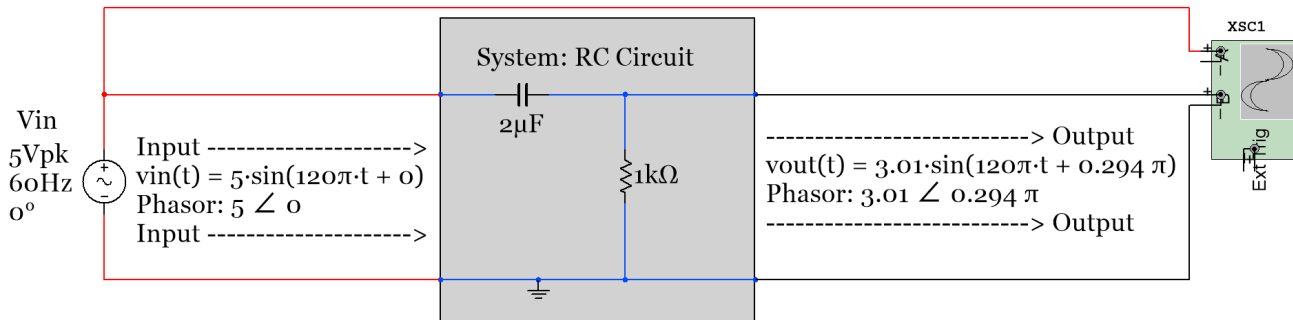
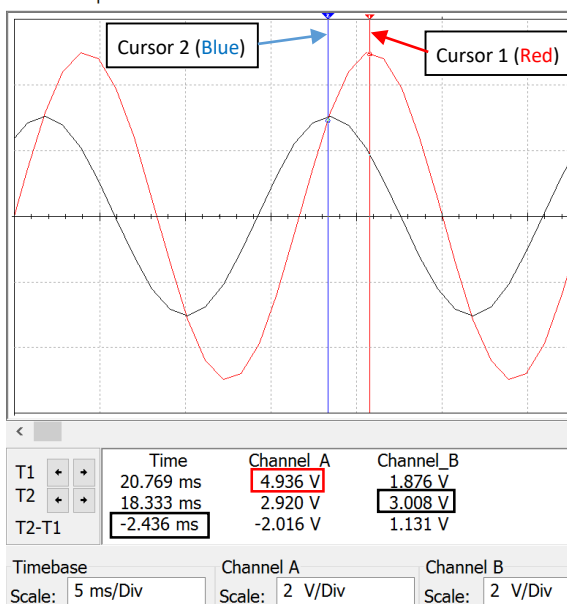

Figure 2.1: Example showing how an RC circuit affects the amplitude and phase of a sinusoidal input.

Oscilloscope-XSC1



- * The **Red** waveform is the input waveform with a peak voltage of $\sim 5V$ and a phase of 0 . Phasor = $5 \angle 0$
 - * The **Black** waveform is the output that has an amplitude of $\sim 3V$ and a 0.294π phase $\rightarrow 3 \angle 0.294\pi$
 - * The phase can be verified using the time cursors of the oscilloscope plot. The time difference between the two peaks is equal to ~ 2.436 ms. The value is negative because the peak of the output is to the left of the input. The time shift is measured to be: $t_s = -2.436$ ms
 - * Eq. 1.3) $\theta = -\omega \cdot t_s = -(120\pi \cdot -2.436 \text{ ms}) = +0.292 \pi$
- This is very close to the actual phase shift of $+0.294\pi$. This slight difference comes from the inability to precisely measure the time shift on the scope.

Figure 2.2: Oscilloscope plot of Figure 2.1

Figure 2.2 shows how the phase shift and amplitude can be determined using Multisim, but there is some measurement error due to the limited resolution of the scope plots. The frequency could also be found in the scope plot by measuring the period and using the equation $f = 1/T$. It can be seen that the frequency stays the same in Figure 2.2 since the output and input always have the same time shift between them. Therefore, the phasor can be used to describe the signal, and the math required to determine the output phasor can be accomplished using simple vector operations of the phasors instead of trigonometry. The frequency can be removed from the calculations. Example 3.1 in Module 3 shows how to calculate the output phasor ($3 \angle 0.294\pi$) for the circuit in Figure 2.1, but before getting to that it will be beneficial for many students at this point to review vector addition, subtraction, multiplication, and division for vectors in polar and rectangular form. If your skills in this area are not solid then you will have a very difficult time solving the circuits in Module 3.

The vectors in this section will be used to represent currents, voltages, admittances, and impedances in Module 3. The impedance for capacitors and inductors are -90° and $+90^\circ$ out of phase respectively with resistors which leads to the xy plot in Figure 2.3 where the y-axis represents the imaginary plane and the x-axis represents the real plane. The two types of vector forms are rectangular and polar (Recall: Phasors are in polar form). An example of a vector in quadrant 1 is shown in Figure 2.3 with the variables labeled that are used in rectangular form ($X + jY$) and polar form ($A \angle \theta$).

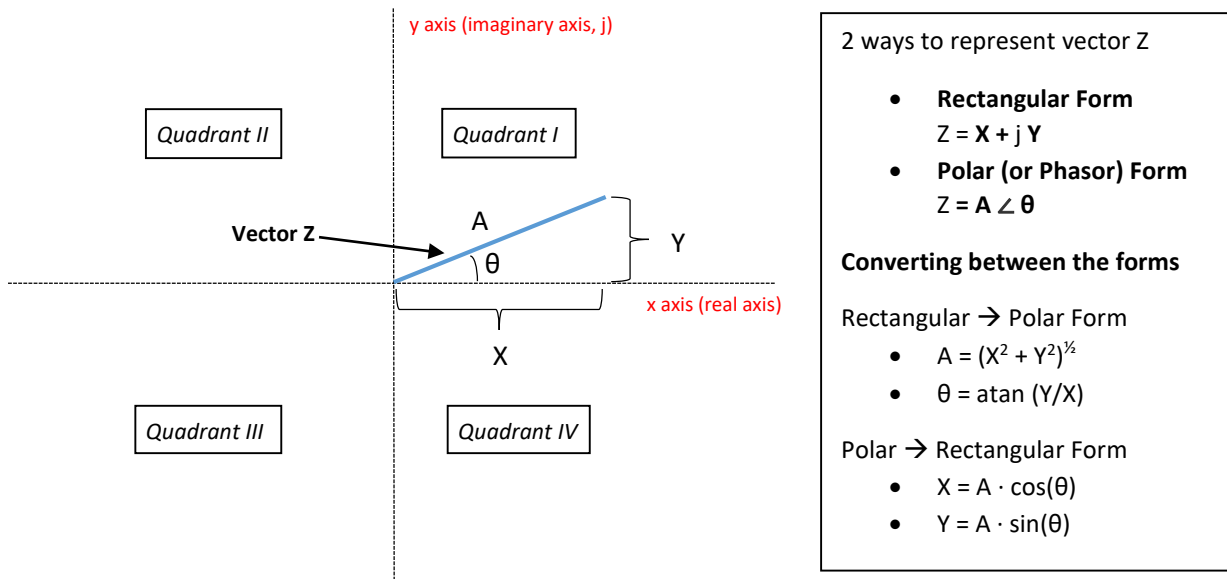

Figure 2.3: XY plot of vector Z (Note: Z is just the variable used for the vector. Any variable can be used).

In polar (or Phasor) form the angle, θ , is always taken with respect to the positive real x-axis such that a unit length vectors lying on the positive or negative x or y axes can be represented as follows:

- $Z_1 = 1 \angle 0^\circ$ lies on the positive (+) side of the x-axis and has a rectangular form as $Z_1 = 1 + j \cdot 0$ or just $Z_1 = 1$
- $Z_2 = 1 \angle 90^\circ = 1 \angle \pi/2$ lies on the (+) side of the y-axis and has a rectangular form as $Z_2 = 0 + j \cdot 1$ or $Z_2 = j$
- $Z_3 = 1 \angle 180^\circ = 1 \angle \pi$ lies on the (-) side of the x-axis and has a rectangular form as $Z_3 = -1 + j \cdot 0$ or $Z_3 = -1$
- $Z_4 = 1 \angle 270^\circ = 1 \angle -\pi/2$ lies on the (-) side of the y-axis and has a rectangular form as $Z_4 = 0 - j \cdot 1$ or $Z_4 = -j$

Note: The angles for Z_1 to Z_4 were given in degrees and signified by a degree symbol, but when converting it to radians no symbol is needed. It is always assumed the angle is in radians if there is no degree symbol. When radians are used to list the angle it is preferred to put the radians value as a fraction of π . Always represent a phasor such that the angle is between -180° and $+180^\circ$ (or $-\pi$ and $+\pi$). If the angle, θ , is greater than π then

subtract 2π until θ is between $-\pi$ and $+\pi$. Conversely, if θ is **less than $-\pi$** then add 2π until θ is between $-\pi$ and $+\pi$.

Converting between rectangular and polar form is something that needs to be done frequently when solving AC circuits because:

- When **adding or subtracting** vectors rectangular form is much easier.
- When **multiplying or dividing** vectors polar form is much easier.

When **combining impedances or admittances** or when using a **KVL** or **KCL**, vectors are added or subtracted so all vectors should be converted to rectangular form. When using **Ohm's law** vectors are multiplied or divided so all vectors are converted to polar form.

Converting from polar to rectangular form (as shown in Example 2.1) is straightforward, but converting from rectangular to polar form (as shown in Example 2.2) is trickier due to the ambiguity of the angle. For example, when Y and X have the same value the arc tangent (atan) of 1 is equal to 45° , but this situation can occur in two different situations: **Quadrant I** where X and Y are positive or **Quadrant III** where X and Y are negative. If the vector was in quadrant I then $\theta = +45^\circ$, but if the vector was in quadrant III then $\theta = -180^\circ + 45^\circ = -135^\circ$. In order to avoid mistakes when calculating θ the "reference angle" (θ_{REF}) should be found and then the quadrant should be determined based on the signs of X and Y as shown below.

- $\theta_{REF} = \text{atan}(|Y|/|X|)$ Note: Take the absolute value of Y and X so θ_{REF} is always between 0° and 90° .

Next, the reference angle can be used to find the actual angle by knowing what quadrant the vector is in.

- I. Quadrant I ($X > 0, Y > 0$): $\theta = \theta_{REF}$
- II. Quadrant II ($X < 0, Y > 0$): $\theta = 180^\circ - \theta_{REF}$ OR $\pi - \theta_{REF}$
- III. Quadrant III ($X < 0, Y < 0$): $\theta = -180^\circ + \theta_{REF}$ OR $-\pi + \theta_{REF}$
- IV. Quadrant IV ($X > 0, Y < 0$): $\theta = -\theta_{REF}$

Example 2.1) Convert the following vectors from polar to rectangular form.

$$Z_1 = 1.414 \angle 3\pi/4 \quad Z_2 = 1.6 \angle \pi/6 \quad Z_3 = 3 \angle -\pi/2 \quad Z_4 = 7 \angle 7\pi$$

- $Z_1 = 1.414 \angle 3\pi/4 \rightarrow Z_1 = X + jY = 1.414 \cos(3\pi/4) + j 1.414 \sin(3\pi/4) = \underline{-1 + j1}$
- $Z_2 = 1.6 \angle \pi/6 \rightarrow Z_2 = X + jY = 1.6 \cos(\pi/6) + j 1.6 \sin(\pi/6) = \underline{1.386 + j0.8}$
- $Z_3 = 3 \angle -\pi/2 \rightarrow Z_3 = X + jY = 3 \cos(-\pi/2) + j 3 \sin(-\pi/2) = \underline{-j3}$
- $Z_4 = 7 \angle 7\pi \rightarrow Z_4 = X + jY = 7 \cos(7\pi) + j 7 \sin(7\pi) = \underline{-7}$

Example 2.2) Convert the following vectors from rectangular to polar form.

$$Z_1 = j2 \quad Z_2 = -1 + j \quad Z_3 = -3 - j4 \quad Z_4 = (0, -1)$$

- $Z_1 = j2 = 0 + j2 = X + jY$
 - $A = [0^2 + 2^2]^{1/2} = \underline{2}$
 - θ lies on the positive y-axis so it is equal to 90° or $\underline{\pi/2}$
 - $Z_1 = 0 + j2 \rightarrow Z_1 = A \angle \theta = \underline{2 \angle \pi/2}$
- $Z_2 = -1 + j = X + jY$
 - $A = [(-1)^2 + 1^2]^{1/2} = \underline{1.414}$
 - $\theta_{REF} = \text{atan}(|1|/|-1|) = \underline{\pi/4}$
 - $\theta = \pi - \theta_{REF}$ (Quadrant II) = $\underline{3\pi/4}$
 - $Z_2 = -1 + j \rightarrow Z_2 = A \angle \theta = \underline{1.414 \angle 3\pi/4}$

- $Z_3 = -3 - j4 = X + j Y$
 - $A = [(-3)^2 + (-4)^2]^{1/2} = \underline{5}$
 - $\theta_{REF} = \text{atan}(|-4|/|-3|) = 53.13^\circ (\pi / 180) = \underline{.295\pi}$
 - $\theta = -\pi + \theta_{REF}$ (Quadrant III) = $\underline{-0.705\pi}$
 - $Z_3 = \underline{5\angle -0.705\pi}$
- $Z_4 = (0, -1) \rightarrow$ This (X,Y) notation simply means $X = 0, Y = -1$ so $Z_4 = 0 - 1 j$
 - $A = [0^2 + (-1)^2]^{1/2} = \underline{1}$
 - θ is on the negative y-axis so it is equal to $\underline{-\pi/2}$
 - $Z_4 = \underline{1\angle -\pi/2}$

After mastering the ability to convert vectors between rectangular and polar form it is time to add, subtract, multiply, and divide vectors. When adding or subtracting vectors they should be put in rectangular form and the real parts are added or subtracted and the imaginary parts are added or subtracted separately as shown in the following example. Multiplying and dividing vectors is shown in Example 2.4.

Example 2.3) Practice adding and subtracting different combinations of vectors from Examples 2.1 and 2.2.

$$Z_1 = j 2 \quad Z_2 = 1.6 \angle \pi/6 \quad Z_3 = -3 - j 4$$

- We will need to first convert Z_2 to rectangular form: $Z_2 = 1.6 \angle \pi/6 \rightarrow Z_2 = 1.386 + j 0.8$

Addition Method $\rightarrow (X_1 + j Y_1) + (X_2 + j Y_2) = (X_1 + X_2) + j (Y_1 + Y_2)$

- $Z_1 + Z_2 = (0 + j 2) + (1.386 + j 0.8) = (0 + 1.386) + j (2 + 0.8) = \underline{1.386 + j 2.8}$
- $Z_1 + Z_3 = (0 + j 2) + (-3 - j 4) = (0 + -3) + j (2 - 4) = \underline{-3 - j 2}$
- $Z_2 + Z_3 = (1.386 + j 0.8) + (-3 - j 4) = (1.386 + -3) + j (0.8 - 4) = \underline{-1.614 - j 3.2}$

Subtraction Method $\rightarrow (X_1 + j Y_1) - (X_2 + j Y_2) = (X_1 - X_2) + j (Y_1 - Y_2)$

- $Z_1 - Z_2 = (0 + j 2) - (1.386 + j 0.8) = (0 - 1.386) + j (2 - 0.8) = \underline{-1.386 + j 1.2}$
- $Z_1 - Z_3 = (0 + j 2) - (-3 - j 4) = (0 - -3) + j (2 - -4) = \underline{3 + j 6}$
- $Z_2 - Z_3 = (1.386 + j 0.8) - (-3 - j 4) = (1.386 - -3) + j (0.8 - -4) = \underline{4.1386 + j 4.8}$

For addition problems, plotting the vectors can be very helpful in determining if the answer is correct. If you put the second (Z_2) vector on the tail of the first vector (Z_1) the resultant vector ($Z_1 + Z_2$) is the vector from the origin (point 0,0) to the tail of Z_2 . This is demonstrated in [Figure 2.4](#).

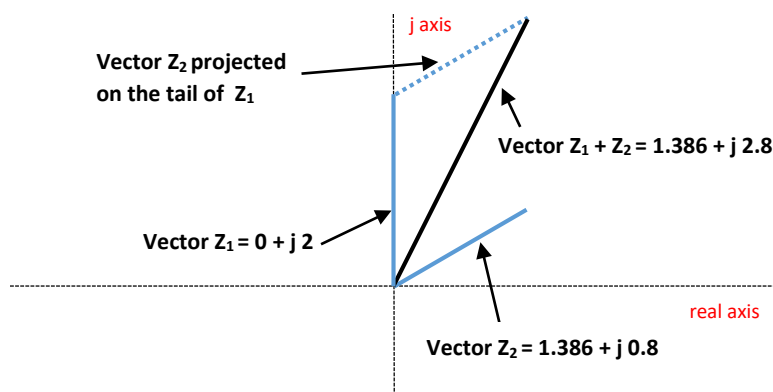

Figure 2.4: Visualization of the addition of two vectors.

The subtraction of vectors is also shown in Example 2.3, but addition of vectors is something that is far more commonly done in AC circuit problems. Since the visualization method shown in [Figure 2.4](#) makes catching math mistakes very easy, it is highly recommended any time vector addition is performed. In fact, a common practice

in [Module 3](#) will be to determine the total impedance by adding individual impedances and making an **impedance plot**, which is a plot of all of the impedance vectors in a series circuit.

Example 2.4) Practice multiplying and dividing different combinations of vectors from Example 2.1 and 2.2.

$$Z_1 = j 2 \quad Z_2 = 1.6 \angle \pi/6 \quad Z_3 = -3 -j4$$

- We will need to first convert Z_1 and Z_3 to polar form: $Z_1 = j 2 \rightarrow Z_1 = 2 \angle \pi/2$, $Z_3 = -3 -j 4 \rightarrow Z_3 = 5 \angle -0.705\pi$

Multiplication Method $\rightarrow [A_1 \angle \theta_1] \cdot [A_2 \angle \theta_2] = (A_1 \cdot A_2) \angle (\theta_1 + \theta_2)$

- $Z_1 \cdot Z_2 = [2 \angle \pi/2] \cdot [1.6 \angle \pi/6] = (2 \cdot 1.6) \angle (\pi/2 + \pi/6) = 3.2 \angle (2\pi/3)$
- $Z_1 \cdot Z_3 = [2 \angle \pi/2] \cdot [5 \angle -0.705\pi] = (2 \cdot 5) \angle (\pi/2 + -0.705\pi) = 10 \angle -0.205\pi$
- $Z_2 \cdot Z_3 = [1.6 \angle \pi/6] \cdot [5 \angle -0.705\pi] = (1.6 \cdot 5) \angle (\pi/6 + -0.705\pi) = 8 \angle -0.538\pi$

Division Method $\rightarrow [A_1 \angle \theta_1] \div [A_2 \angle \theta_2] = (A_1/A_2) \angle (\theta_1 - \theta_2)$

- $Z_1 \div Z_2 = [2 \angle \pi/2] \div [1.6 \angle \pi/6] = (2 / 1.6) \angle (\pi/2 - \pi/6) = 1.25 \angle (\pi/3)$
- $Z_1 \div Z_3 = [2 \angle \pi/2] \div [5 \angle -0.705\pi] = (2 / 5) \angle (\pi/2 - -0.705\pi) = 0.4 \angle 1.205\pi = 0.4 \angle -0.795\pi$
 - **Note:** 1.205π is $> \pi$ so to get the final angle between $-\pi$ and π we had to subtract 2π .
- $Z_2 \div Z_3 = [1.6 \angle \pi/6] \div [5 \angle -0.705\pi] = (1.6 / 5) \angle (\pi/6 - -0.705\pi) = 0.32 \angle 0.8717\pi$

Multiplication and division of vectors will be done when Ohm's Law is used in AC circuits. Addition, multiplication, and division will all be used when you combine two impedances in parallel $\rightarrow Z_{Total} = (Z_1 \cdot Z_2)/(Z_1 + Z_2)$

Before ending the discussion on sinusoidal form and how it is represented by a phasor, the concept of the "rotating phasor" is shown in [Figure 2.5](#). This is a good way to see the connection between the phasor ($A \angle \theta$) and the sinusoid it represents, $A \sin(\omega \cdot t + \theta)$. When time equals zero, $\sin \omega \cdot t$ is also equal to zero and the phasor is located at $A \angle \theta$ as shown in [Figure 2.5](#).

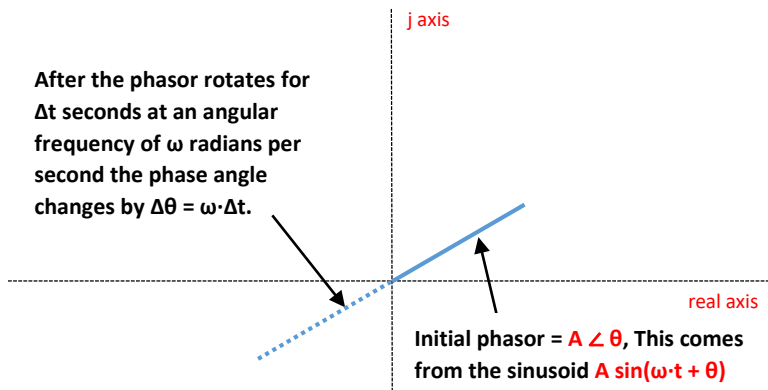

Figure 2.5: Rotating Phasor Visualization.

The phasor (or the vector $A \angle \theta$) can be thought of as being rotated by an angular velocity of ω radians per second. The time variable t in the term $\sin \omega \cdot t$ can be represented by the variable Δt because the initial time is zero for the rotating phasor concept. The amplitude (A) of the phasor will not change as it rotates, but the phase (θ) will change so that the new phase angle is equal to the initial phase and the product of ω and Δt .

Example 2.5) If $v(t) = 5 \sin(90 \cdot t - 0.2\pi)$, where is the phasor located at after 21.32 ms?

- Initially the phasor is located at $5 \angle -0.2\pi$
- The amount of phase change is $\rightarrow \Delta\theta = \omega \cdot \Delta t = 90 \text{ rad/sec} (0.02132 \text{ sec}) = 1.9188 \text{ radians} = 0.61\pi$
- The final phase angle is equal to $\rightarrow \theta = -0.2\pi + 0.61\pi = 0.41\pi$
- The new location of the phasor is equal to $\rightarrow 5 \angle 0.41\pi$

The connection between the phasor and the original sinusoidal function $v(t)$ is as follows:

- If you put in 21.32 ms into the $v(t)$ equation you get $\rightarrow 5 \sin(90 \cdot 0.02132 - 0.2\pi) = 4.8$
- $5 \angle 0.41\pi$ was the value of the final phasor and $5 \sin(0.41\pi) = 4.8$

Example 2.6) If $v(t) = 12 \sin(1200t + 0.8\pi)$, where is the phasor located at after 3.892 seconds? Make sure the final phasor location is listed as a value between $-\pi$ and $+\pi$ so it can be easily visualized on the real, imaginary (x,y) axis. **ALWAYS put phase values between $-\pi$ and $+\pi$ (or -180° and $+180^\circ$).**

- Initially the phasor is located at $12\angle+0.8\pi$
- The amount of phase change is $\rightarrow \Delta\theta = \omega \cdot \Delta t = 1200 \text{ rad/sec} (3.892 \text{ sec}) = 4670.4 \text{ radians} = 1486.6345\pi$
- The final phase angle is equal to $\rightarrow \theta = +0.8\pi + 1486.6345\pi = 1487.4345\pi$ \leftarrow This is $> \pi$ so subtract multiples of 2π
- If 2π is continually subtracted from 1487.4345π until θ is between $-\pi$ and π the value is equal to is at the same location as 0.19π . This can be found by subtracting 2π until θ is between $-\pi$ and π you get -0.5655π
- The new location of the phasor is equal to \rightarrow $12\angle-0.5655\pi$

The following is only done to verify the result:

- If you put in 3.892 s into the $v(t)$ equation you get $\rightarrow 12 \sin(1200 \cdot 3.892 + 0.8\pi) = -11.74678$
- $5\angle 0.41\pi$ was the value of the final phasor and $12 \sin(-0.5655\pi) = -11.74678$

ALWAYS put phase values between $-\pi$ and $+\pi$ (or -180° and $+180^\circ$)

Module 3 – RLC Circuit Analysis with AC Sources

Module 3 is broken up into the following 5 sections.

- [Section 3.1](#) – Introduction of Impedance and Admittance and the Laplace Transform
- [Section 3.2](#) – Series RLC Circuits
- [Section 3.3](#) – Parallel RLC Circuits
- [Section 3.4](#) – AC Power Calculations
- [Section 3.5](#) – AC Maximum Power Transfer

Section 3.1 – Introduction of Impedance and Admittance and the Laplace Transform

Before solving RLC circuits with AC sources there is some terminology that needs to be discussed. First of all this eBook focuses only on RLC circuits with AC sources. For brevity, these types of circuits will be referred to as “AC Circuits”. For **DC circuits at steady state**, resistors were the only components used in calculations because all **capacitors** in the circuit were replaced with **open circuits** and all **inductors** in the circuit were replaced with **short circuits**. For **AC circuits at steady state** the **capacitors/inductors** no longer can be replaced with **open/short** circuits, but instead are included in the calculations. The remainder of this module will look only at AC circuits at steady state. Transient analysis of AC circuits is accomplished by using Laplace Transform solving techniques. Some Laplace Transform examples are shown in the [Appendix](#).

The impedance, Z , is shown for resistors, capacitors, and inductors in the left side of [Table 3.1](#) in both rectangular and polar (Phasor) form. The magnitude of the impedance is called the reactance, X . For AC circuits in series the impedance of the components can be added together to get the total impedance, just like the resistors were added together to get the total resistance in DC circuits. For networks of components in parallel and series the math for combining them because very time consuming since for each combination a complex algebra problem must be performed. For this reason only series (section 3.2) and parallel (section 3.3) AC circuits will be discussed in this eBook. However, the same rules for combining resistors are used for combining impedances as shown in the DC and AC equation comparison below:

<u>Equations Used in DC Circuits</u>	<u>Equations Used in AC Circuits</u>
- N Resistors in series: $R_{tot} = R_1 + R_2 + \dots R_N$	- R , L , and C s in series: $Z_{tot} = Z_1 + Z_2 + \dots Z_N$
- 2 Resistors in parallel: $R_{tot} = \frac{R_1 \cdot R_2}{R_1 + R_2}$	- 2 Impedances in parallel: $Z_{tot} = \frac{Z_1 \cdot Z_2}{Z_1 + Z_2}$
- N Resistors in parallel: $R_{tot} = \frac{1}{\frac{1}{R_1} + \frac{1}{R_2} + \dots \frac{1}{R_N}}$	- R , L , and C s in parallel: $Z_{tot} = \frac{1}{\frac{1}{Z_1} + \frac{1}{Z_2} + \dots \frac{1}{Z_N}}$
- Conductance: $G = \frac{1}{R}$	- Admittance: $Y = \frac{1}{Z}$
- N Resistors in parallel: $G_{tot} = G_1 + G_2 + \dots G_N$	- R , L , and C s in parallel: $Y_{tot} = Y_1 + Y_2 + \dots Y_N$
- Ohm's Law: $V = I \cdot R$ or $I = \frac{V}{R} = V \cdot G$	- Ohm's Law: $V = I \cdot Z$ or $I = \frac{V}{Z} = V \cdot Y$

Table 3.1) Impedance, Reactance, Admittance, and Susceptance for Resistors, Capacitors, and Inductors

Component	Impedance = $Z = R + j X$ (Units = Ω)			Reactance Variable: X Units = Ω	Admittance = $Y = G + j B$ (Units = Siemens)			Susceptance Variable: B Units (Siemens)
	Laplace Form	Vector Form			Laplace Form	Vector Form		
		X + j Y	A \angle θ			X + j Y	A \angle θ	
Resistor	R	$Z_R = R$	$R \angle 0$	0	G	$Y_R = G = 1/R$	$G \angle 0$	0
Inductor	Ls	$Z_L = j L \omega$	$L \omega \angle 90^\circ$	$X_L = L \omega$	$1/(Ls)$	$Y_L = -j/(L \omega)$	$1/(L \omega) \angle -90^\circ$	$B_L = 1/(L \omega)$
Capacitor	$1/(Cs)$	$Z_C = -j/C \omega$	$1/(C \omega) \angle -90^\circ$	$X_C = 1/(C \omega)$	Cs	$Y_C = j C \omega$	$C \omega \angle 90^\circ$	$B_C = C \omega$

Section 3.2 – Series RLC Circuits

For DC circuits with series resistors all of the resistors are added to determine the total resistance. Then the current in the loop is calculated from Ohm’s Law ($I = V_s/R_{tot}$). For AC circuits the same process is followed except resistance is changed to impedance and each of the variables is a phasor instead of a scalar. The next three examples show the process.

Example 3.1) Verify the output (V_{out}) for the circuit in [Figure 3.1](#) by finding the total impedance and using Ohm’s Law. Go to [Figure 3.2](#) to see the oscilloscope plot of the waveforms

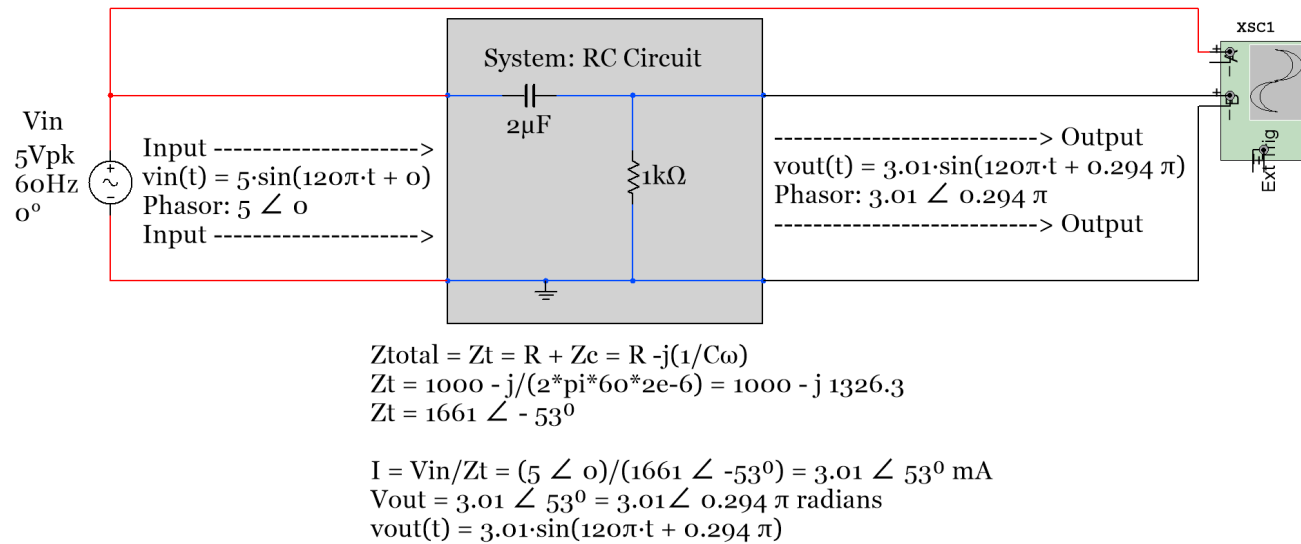

Figure 3.1: Solving for the output in phasor and sinusoidal form for Example 3.1.

For this example the voltage across the capacitor could also be solved for by using Ohm’s Law.

- $V_C = I \cdot Z_C = I \cdot X_C \angle -90^\circ = I \cdot (C \cdot \omega)^{-1} \angle -90^\circ = (3.01 \angle 53^\circ) \cdot [(2e-6) \cdot (2 \cdot \pi \cdot 60)]^{-1} \angle -90^\circ = 4 \angle -37^\circ = \underline{4 \angle -0.20556\pi}$
- $v_C(t) = 4 \sin(120 \pi t - 0.20556\pi)$

Example 3.1 shows the process of solving series AC circuits, but one thing that isn’t addressed is the leading and lagging aspects that were discussed in [Section 1.2](#).

Recall: A waveform is leading another waveform if it completes its sinusoidal cycle first. Mathematically, a waveform leads another waveform if it has a larger phase. Since the phase of V_{out} ($\theta = 53^\circ$) is greater than V_{in} ($\theta = 0^\circ$) in Example 3.1 V_{out} is leading.

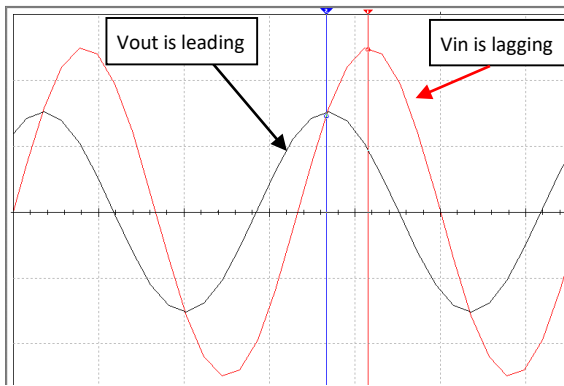

Figure 3.2: Scope plot of the circuit in Example 3.1

The **leading waveform** will be the one with the **largest phase**, but there is a mnemonic called “ELI the ICE man” that can be used to determine which waveform is leading or lagging without calculating the phase.

ELI the ICE man

The **L** and the **C** stand for **inductor** and **capacitor**, respectively (I will frequently use **Blue font for inductors** and **red font for capacitors**). If the circuit is a series RL circuit it is an **ELI** circuit and if it is a series RC circuit it is an **ICE** circuit. If the circuit is a series RLC circuit, then the quadrant of the total impedance will determine whether it is an ELI or ICE circuit. If Z_{total} is in **quadrant I** it is an **ELI** circuit and if it is in **quadrant IV** it is an **ICE** circuit. The “**E**” stands for the potential, which is the **input voltage**. The “**I**” stands for the **current** in the single loop AC circuit. Since the current and voltage across a resistor are always in phase with each other in a series AC circuit then the current (I) can also be used to represent the voltage across a resistor for lead/lag determination. If “**E**” is written to the left of “**I**” (i.e. ELI) then “**E**” (or V_{in}) is “first” and leads “**I**” (the current or voltage across the resistor). The opposite is true for ICE circuits. In summary:

- **ELI** – Any RL circuit or an RLC series AC circuit with a total impedance in quadrant I.
- The input voltage (V_{in}) **leads** the current (I) or the voltage across any resistor (V_R) in an **ELI** circuit.
- **ICE** – Any RC circuit or an RLC series AC circuit with a total impedance in quadrant IV.
- The input voltage (V_{in}) **lags** the current (I) or the voltage across any resistor (V_R) in an **ICE** circuit.

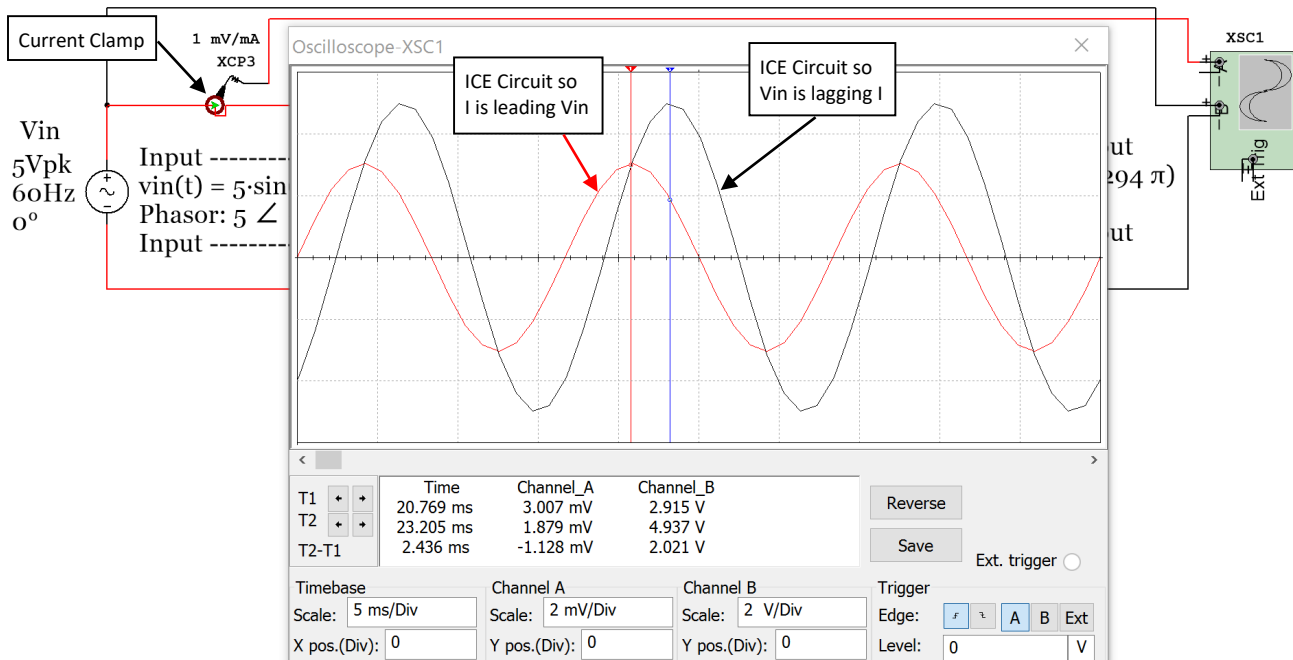

Figure 3.3: Input Voltage and Current scope plot of circuit in Example 3.1.

For the circuit in example 3.1 the input voltage and current are plotted in Figure 3.3. The current can be plotted on a scope using the current clamp as shown in Figure 3.3. The current clamp conversion is shown in this example to be 1 mV/mA so the peak current reading of the red current waveform is 3.007 mV, which equates to 3.007 mA. The next example is an RLC circuit. Notice how in the calculations in Figure 3.4 that the current and V_R both have a phase angle of -18.5° . This means they are “in phase” with each other.

Example 3.2) Solve the circuit in Figure 3.4 for V_R and verify it with the Multisim oscilloscope.

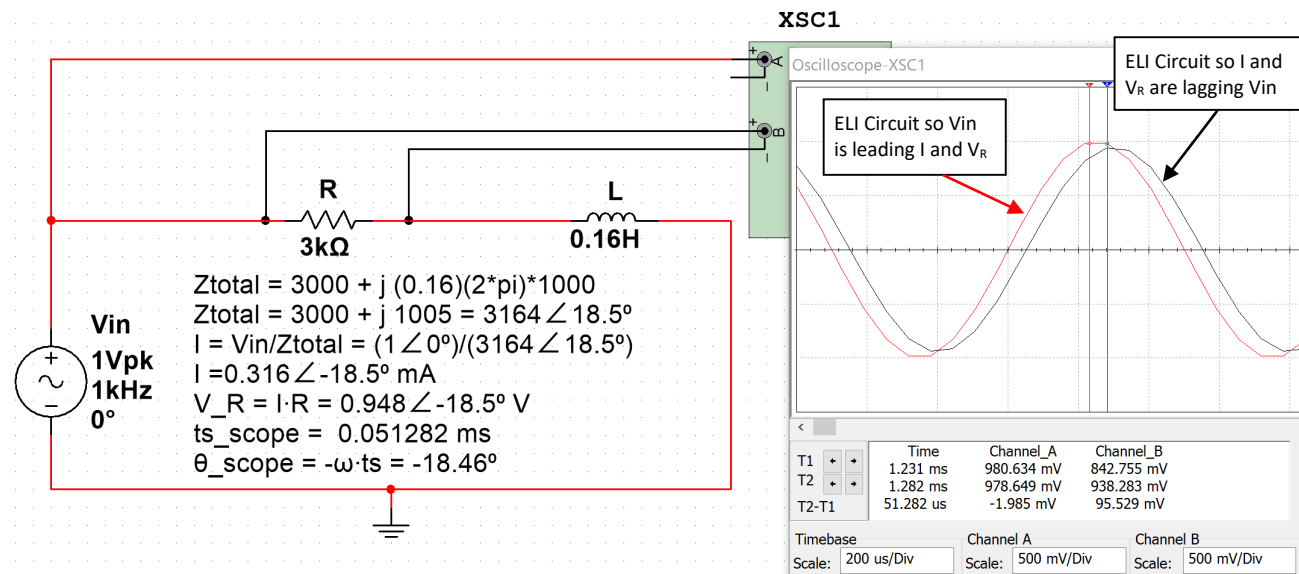

Figure 3.4: Circuit and Scope plot for Example 3.2. V_{in} is the Red sinusoid and V_R is the black sinusoid.

The calculations for Example 3.2 are shown in [Figure 3.4](#). The following link can be used to verify the total impedance calculation in a RLC circuit: <http://hyperphysics.phy-astr.gsu.edu/hbase/electric/powerac.html>

The phase of V_{R1} that was calculated using the time shift measurement from the scope is equal to -18.46° and the value was calculated as -18.5° . V_{in_pk} should be equal to 1 V, but is measured as 980.634 mV and V_{R1_pk} should be equal to 948 mV, but it is measured as 938.284 mV in Multisim. The small errors of the time shift and peak voltage measurements are expected due to limited resolution of the Multisim oscilloscope.

Note: If the minus sign of the Multisim oscilloscope is left disconnected then it is automatically assumed to be ground. Therefore, only the + side of channel A is connected in [Figure 3.4](#). If you want to take a scope measurement across a component that is not connected to ground (i.e. v_R in [Figure 3.4](#)) then you connect the two sides of the component to the + and – side of the scope channel. Most oscilloscopes in the real world require that the minus sign (or black clip) be connected to ground. For example, [Figure 3.6](#) shows a sinusoid that is connected to channel 1 of a Rigol DS1074 oscilloscope. This scope has 4 channels. Each channel has a probe that has a black clip that can only be connected to ground as shown in [Figure 3.5](#). If you want to take a measurement across a component that is NOT connected to ground (i.e. differential measurement) then you have to connect 2 different probes to the two sides of the component and use the Math subtraction function to determine the voltage across the component.



Figure 3.5: Rigol Oscilloscope Probe: <http://www.prc68.com/l/RigolDS1052E.shtml>

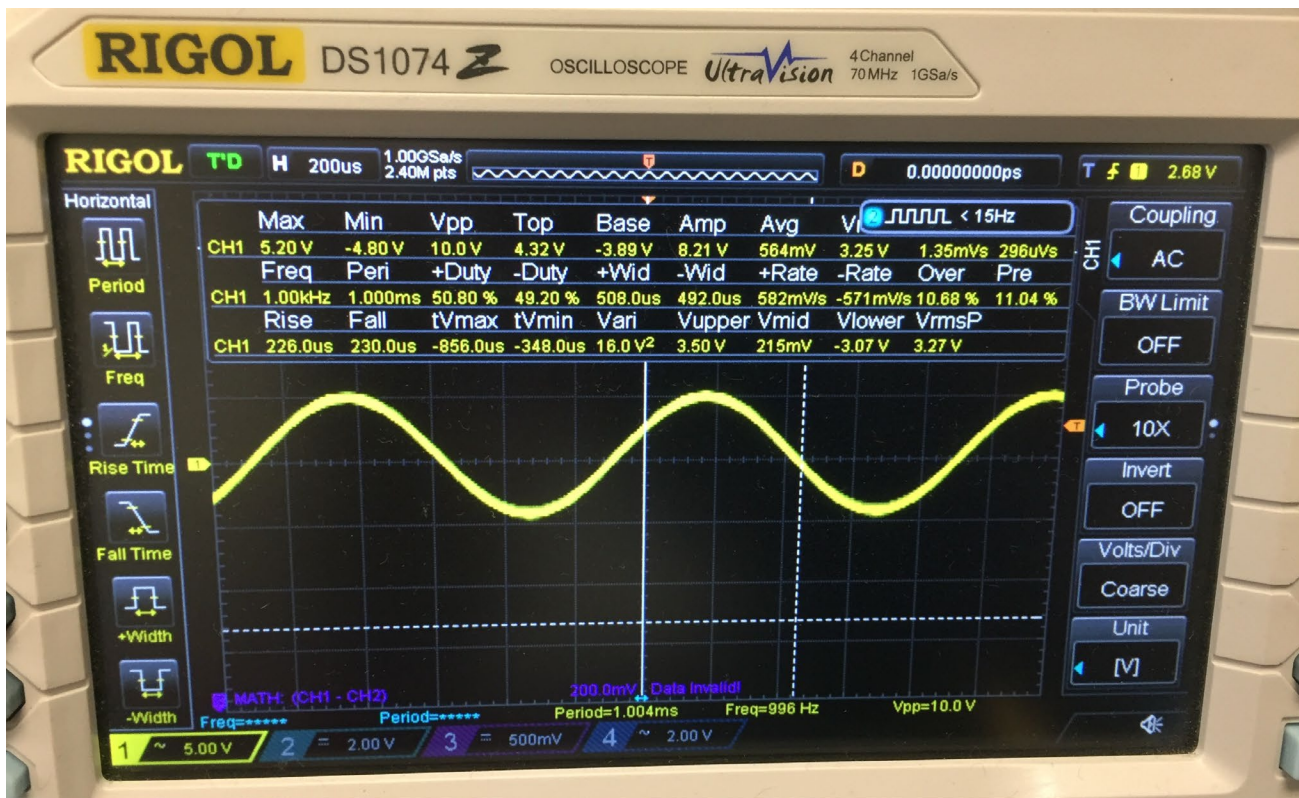

Figure 3.6: Photo of Rigol DS1074 Oscilloscope with a 10Vp-p sine wave at 1 kHz.

Example 3.3) Solve the circuit in Example 3.2 for the voltage across the inductor and verify it in Multisim.

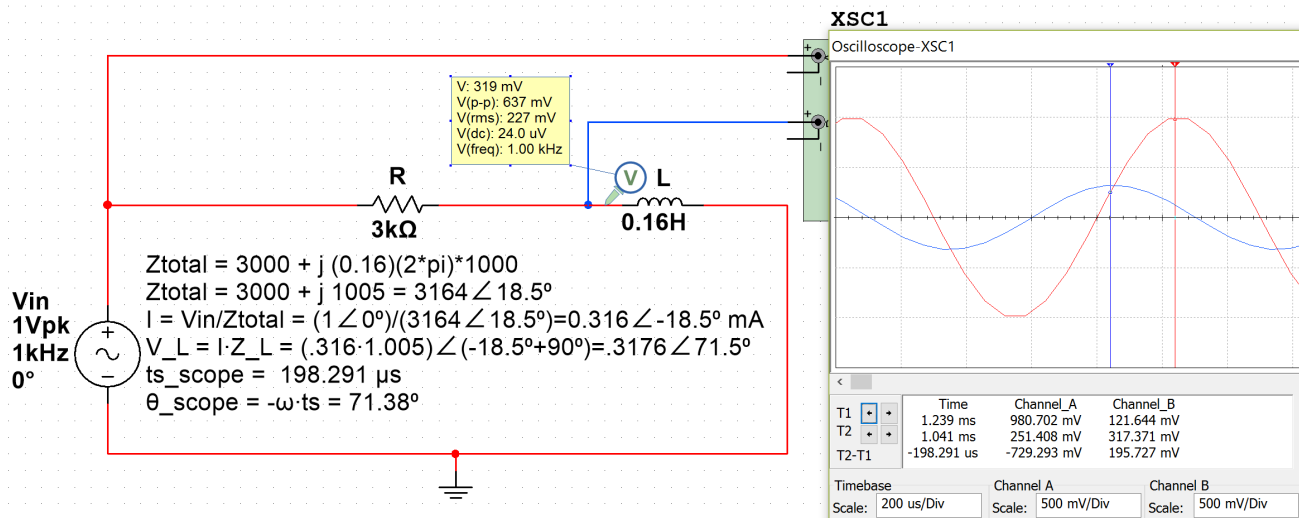

Figure 3.7: Circuit and Scope plot for Example 3.3. V_{in} is the Red sinusoid and V_L is the blue sinusoid.

Calculation and simulation results comparison for Example 3.3

- $V_L = 0.3176 \angle 71.5^\circ$ (Calculated), V_L Phase Measurement from scope = 71.38°
- V_L Amplitude Measurement: $V_L = V_{pp}/2 = 637\text{mV}/2 = 0.3185 \text{ V}$ (Probe) or 0.317371 V (Scope)
- Notice that V_L leads V_{in} in the scope plot, but this cannot be determined from the ELI the ICE man mnemonic that only relates V_{in} and I (or V_R). V_L has **larger phase** than V_{in} so it **leads** V_{in} .

The last series AC circuit example will be a RLC circuit. For this example the impedance plot will be drawn to help determine the phasor of the total impedance that will result when all impedances are added. Even though only one resistor, one capacitor, and one inductor are in this circuit there could be multiple components in series and the same process of summing all impedances would still be performed in the same way it is done in Example 3.4.

Example 3.4) Solve for the total impedance phasor (Z_T) in the circuit in [Figure 3.8](#) when $L = 0.2 \text{ H}$ and when $L = 1.8 \text{ H}$.

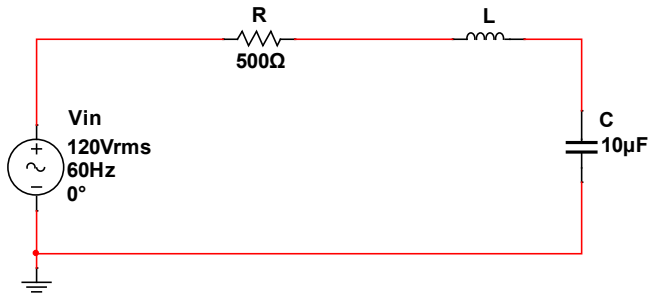

$$V_{in_pk} = 120 V_{in_rms} \cdot \sqrt{2} = 169.7 \text{ V}$$

$$V_{in} = 169.7 \angle 0^\circ$$

$$Z_{tot} = R + jL\omega - j/(C\omega)$$

$$Z_{tot} = 500 + j(L \cdot 120\pi) - j/(10e-6 \cdot 120\pi)$$

$$Z_{tot} = 500 - j 189.86 = 534.8 \angle -20.8^\circ \quad (L = 0.2 \text{ H})$$

$$Z_{tot} = 500 + j 413.33 = 648.7 \angle 39.6^\circ \quad (L = 1.8 \text{ H})$$

Figure 3.8: Circuit for Example 3.4

The phasors for the total impedance (Z_{tot}) for each of the two cases ($L = 0.2 \text{ H}$ and $L = 1.8 \text{ H}$) are calculated in [Figure 3.8](#). An impedance plot is performed in [Figure 3.9](#) to help verify the total impedance was calculated correctly.

- Case 1 where $L = 0.2 \text{ H}$ results in Z_{tot} in **quadrant IV**, which means it is an **ICE** circuit and V_{in} **lags** the current and the voltage across the resistor.
- Case 2 where $L = 1.8 \text{ H}$ results in Z_{tot} in **quadrant I**, which means it is an **ELI** circuit and V_{in} **leads** the current and the voltage across the resistor.

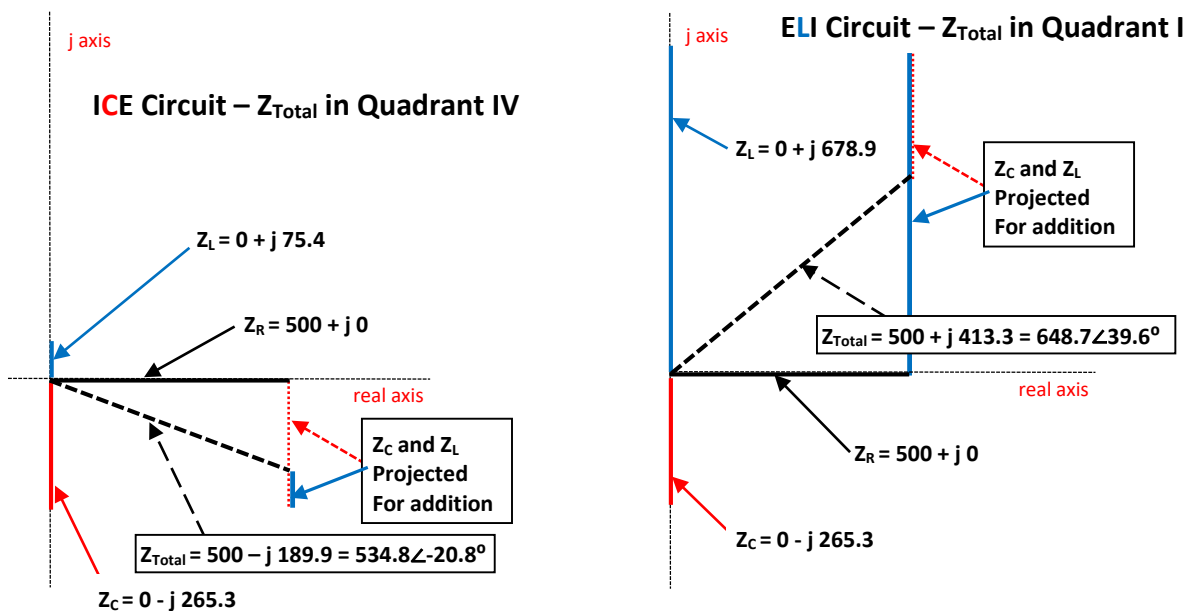

Figure 3.9: Impedance Plots for Example 3.4. Case 1: $L = 0.2 \text{ H}$ (Left Plot), Case 2: $L = 1.8 \text{ H}$ (Right Plot)

Example 3.5) Solve for the loop current and V_R for each of the two cases in Example 3.4 ($L = 0.2 \text{ H}$ and $L = 1.8 \text{ H}$) and represent them in phasor form and sinusoidal form. Verify the loop current results with Multisim.

First, the current will be calculated using Ohm's Law and the Multisim values will be measured on the scope.

* Case 1: $L = 0.2 \text{ H}$, $Z_{\text{Total}} = 534.8 \angle -20.8^\circ$ (see Fig. 3.9)	* Case 2: $L = 1.8 \text{ H}$, $Z_{\text{Total}} = 648.7 \angle 39.6^\circ$ (see Fig. 3.9)
* $I = \frac{169.7 \angle 0^\circ}{534.8 \angle -20.8^\circ} = 0.3173 \angle 20.8^\circ = 0.3173 \angle 0.116\pi$	* $I = \frac{169.7 \angle 0^\circ}{648.7 \angle 39.6^\circ} = 0.2616 \angle -39.6^\circ = 0.2616 \angle -0.22\pi$
* $V_R = I \cdot R = (0.3173 \angle 0.116\pi) \cdot 500\Omega = 158.7 \angle 0.116\pi$	* $V_R = I \cdot R = (0.2616 \angle -0.22\pi) \cdot 500\Omega = 130.8 \angle -0.22\pi$
* V_R (Multisim Probe) = $113 \text{ Vrms} \cdot \sqrt{2} = 159.8 \text{ V}$	* V_R (Multisim Probe) = $91.4 \text{ Vrms} \cdot \sqrt{2} = 129.6 \text{ V}$
* $i(t) = 0.3173 \sin(120 \pi t + 0.116 \pi)$	* $i(t) = 0.2616 \sin(120 \pi t - 0.22 \pi)$
* $v_R(t) = 158.7 \sin(120 \pi t + 0.116 \pi)$	* $v_R(t) = 130.8 \sin(120 \pi t - 0.22 \pi)$
* Multisim <u>Current</u> Verification for Case 1 and Case 2 current calculations (See Figure 3.10 below).	
* Multisim Amplitude, $A = 312 \text{ mV}$	* Multisim Amplitude, $A = 257 \text{ mV}$
* Multisim Time Shift, $t_s = -0.94 \text{ ms}$	* Multisim Time Shift, $t_s = 1.833 \text{ ms}$
* Phase Shift, $\theta = -t_s \cdot \omega = xyz \cdot 120 \cdot \pi = 20.3^\circ$	* Multisim Phase Shift, $\theta = -t_s \cdot \omega = -39.7^\circ$

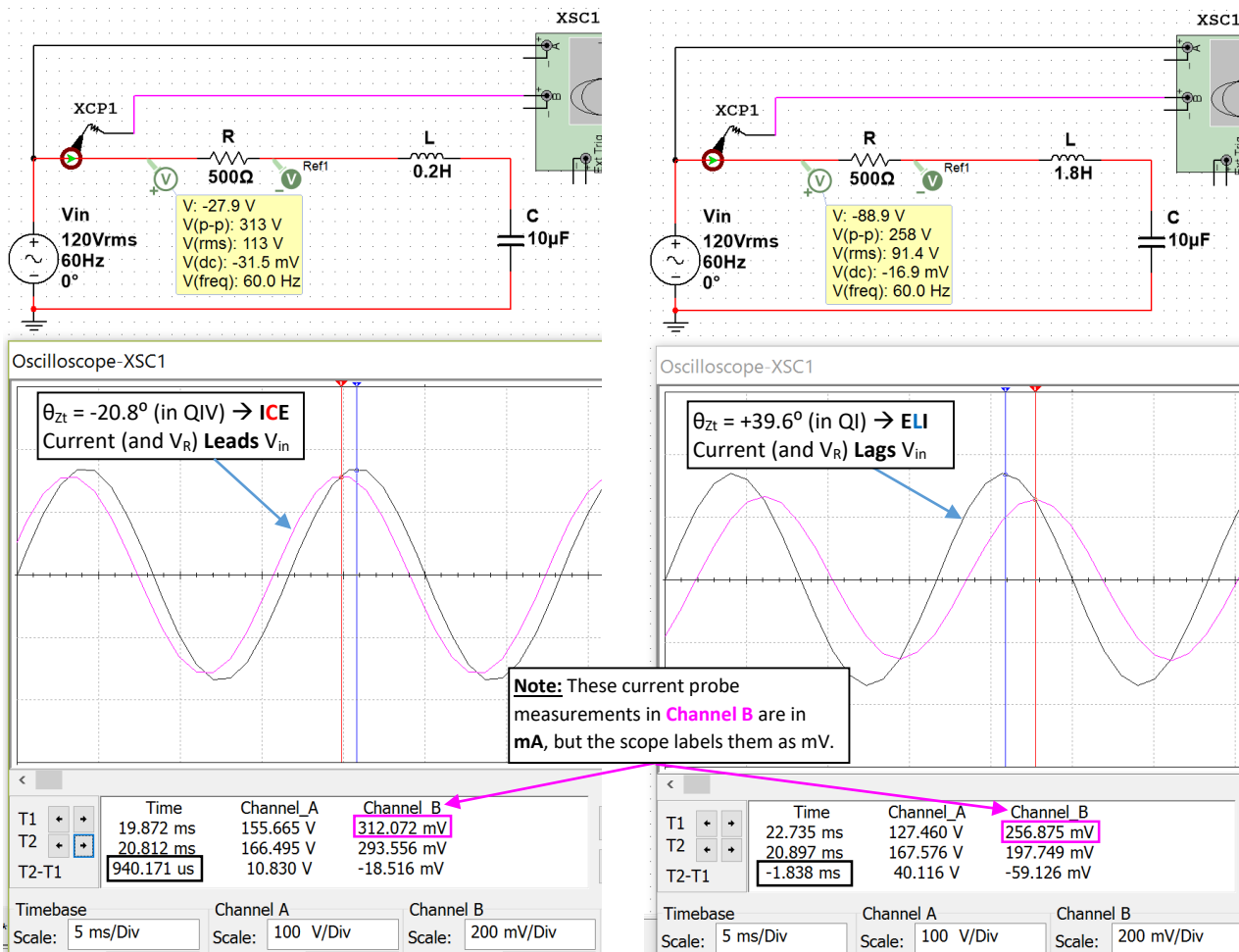

Figure 3.10: Current (Pink) and V_{in} (Black) Plots for Case 1: $L = 0.2 \text{ H}$ (Left) and Case 2: $L = 1.8 \text{ H}$ (Right)

Example 3.6) Solve for the **inductor** and **capacitor** voltage for the two cases in Example 3.4. Case 1: $L = 0.2 \text{ H}$ and Case 2: $L = 1.8 \text{ H}$. Represent voltages in phasor form and sinusoidal form. Verify the **Case 1** values in Multisim.

V_L (peak voltage) will be solved two different ways: 1) Ohm's Law and 2) Voltage Divider Rule (VDR).

* Case 1: $Z_{\text{Total}} = 534.8 \angle -20.8^\circ$ and $I = 0.3173 \angle 20.8^\circ$ * Case 2: $Z_{\text{Total}} = 648.7 \angle 39.6^\circ$ and $I = 0.2616 \angle -39.6^\circ$

* $V_L = I \cdot Z_L = (0.3173 \angle 20.8^\circ) \cdot 0.2 \cdot \omega \angle 90^\circ = 23.9 \angle 110.8^\circ$ * $V_L = I \cdot Z_L = (0.2616 \angle -39.6^\circ) \cdot 1.8 \cdot \omega \angle 90^\circ = 177.5 \angle 50.4^\circ$

* (VDR) $V_L = V_{in} \cdot \frac{Z_L}{Z_{\text{Total}}} = 120 \cdot \sqrt{2} \cdot \frac{0.2\omega \angle 90^\circ}{534.8 \angle -20.8^\circ} = 23.9 \angle 110.8^\circ$ * (VDR) $V_L = V_{in} \cdot \frac{Z_L}{Z_{\text{Total}}} = 120 \cdot \sqrt{2} \cdot \frac{1.8\omega \angle 90^\circ}{648.7 \angle 39.6^\circ} = 177.5 \angle 50.4^\circ$

* $v_L(t) = 23.9 \sin(120 \pi t + 0.616 \pi)$ Note: $0.616 \pi = 110.8^\circ$ * $v_L(t) = 177.5 \sin(120 \pi t + 0.28 \pi)$ Note: $0.28 \pi = 50.4^\circ$

* Multisim Case 1: $V_L = 23.8 \text{ V}$ (scope), $V_L = 17.2 \text{ Vrms} \cdot \sqrt{2} = 24.3 \text{ V}$ (probe), $t_s = -5.128 \text{ms}$, $\theta = -t_s \cdot \omega = 110.8^\circ$

* $V_C = I \cdot Z_C = (0.3173 \angle 20.8^\circ) \cdot \frac{1}{(10^{-6}) \cdot \omega} \angle -90^\circ = 84.2 \angle -69.2^\circ$ * $V_C = I \cdot Z_C = (0.2616 \angle -39.6^\circ) \cdot \frac{1}{10^{-6} \omega} \angle -90^\circ = 69.4 \angle 129.6^\circ$

* $v_C(t) = 84.2 \sin(120 \pi t - 0.384 \pi)$ Note: $-0.384 \pi = -69.2^\circ$ * $v_C(t) = 69.4 \sin(120 \pi t + 0.72 \pi)$ Note: $0.72 \pi = 129.6^\circ$

* Multisim Case 1: $V_C = 81.7 \text{ V}$ (scope), $V_C = 58.9 \text{ Vrms} \cdot \sqrt{2} = 83.3 \text{ V}$ (probe), $t_s = 3.205 \text{ms}$, $\theta = -t_s \cdot \omega = -69.2^\circ$

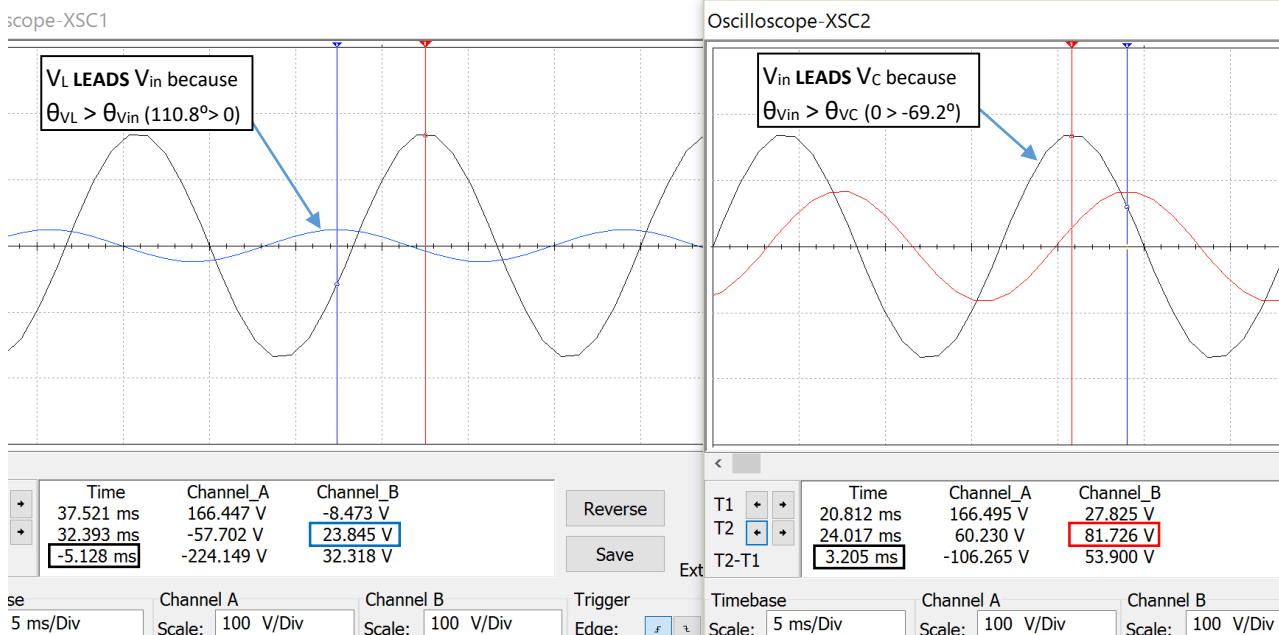
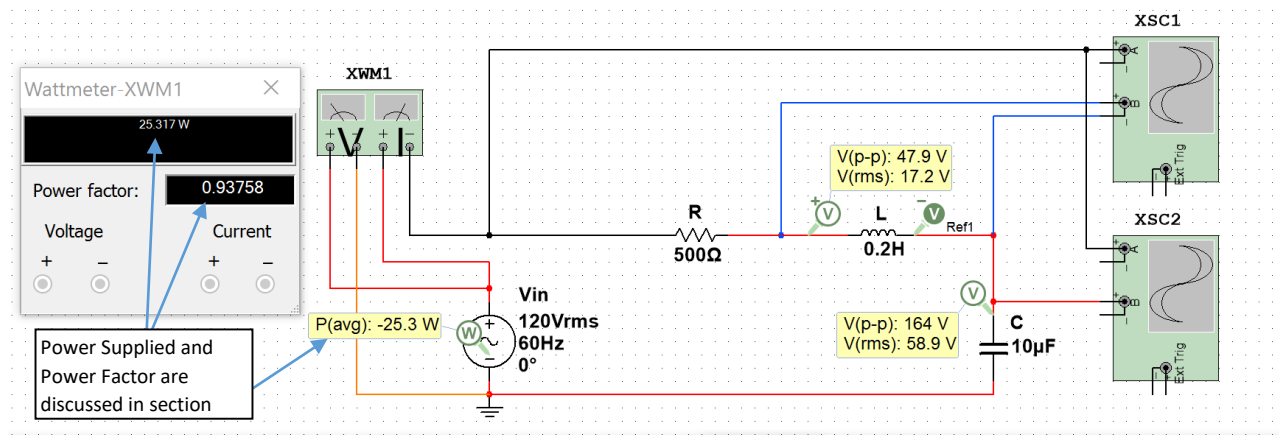

Figure 3.11: Case 1 in Example 3.6, V_{in} (Black) & V_L (Blue) (Left Plot), V_{in} (Black) & V_C (Red) (Right Plot)

The process involved in solving RLC series circuits is summarized in [Table 3.2](#).

Table 3.2) Summary of the process used to solve for all parameters in a series RLC circuit.

Process for solving RLC Series Circuits
1) Add all impedances to get the total impedance (Z_{total}) * The magnitude of the inductor's impedance is the Inductive Reactance (X_L) * The magnitude of the capacitor's impedance is the Capacitive Reactance (X_C)
2) Convert to Phasor form: Input voltage = $V_{in_pk} \angle \theta$ and Total Impedance = $A_{Zt} \angle \theta_{Zt}$ * If $\theta_{Zt} > 0$ it is an ELI circuit and V_{in} LEADS I and V_R * If $\theta_{Zt} < 0$ it is an ICE circuit and V_{in} LAGS I and V_R
3) Calculate the Current using $I = V_{in}/Z_{total}$
4) Find voltage phasors using Ohm's Law: $V_R = I \cdot R$, $V_L = I \cdot Z_L$, $V_C = I \cdot Z_C$ * When comparing 2 signals, the one with the largest phase LEADS.
5) Write the series circuit's loop current and all voltages in sinusoidal form: $A \cdot \sin(\omega \cdot t + \theta)$

Section 3.3 – Parallel RLC Circuits

In this section a slight modification of the process in [Table 3.2](#) is used to solve parallel RLC circuits.

Table 3.3) Summary of the process used to solve for all parameters in a parallel RLC circuit.

Process for solving RLC Parallel Circuits
1) Add all admittances to get the total admittance (Y_{total}) * The magnitude of the inductor's admittance is the Inductive Susceptance (B_L) * The magnitude of the capacitor's admittance is the Capacitive Susceptance (B_C)
2) Convert to Phasor form: Input voltage = $V_{in_pk} \angle \theta$ and Total Admittance = $A_{Yt} \angle \theta_{Yt}$
3) Convert Y_{total} to Z_{total} using the following equation: $Y = 1/Z$ * ELI the ICE man is only used for series circuits, but if $\theta_{Zt} > 0$ then V_{in} LEADS the source current
4) Calculate the source current using $I_s = V_{in}/Z_{total}$ or skip step 3) and use $I_s = V_{in} \cdot Y_{total}$
5) Find currents through each component using Ohm's Law: $I_R = V_{in}/R$, $I_L = V_{in} \cdot Y_L$, $I_C = V_{in} \cdot Y_C$ * Note: From KVL you know that $V_{in} = V_R = V_L = V_C$
6) Write the currents and voltages in sinusoidal form: $A \cdot \sin(\omega \cdot t + \theta)$

Before doing an example of solving an AC parallel RLC circuit the following figure shows a comparison from series and parallel resistor circuits. Notice how the current is the same through all components in the series circuit and the voltage is the same across all components in the parallel circuit.

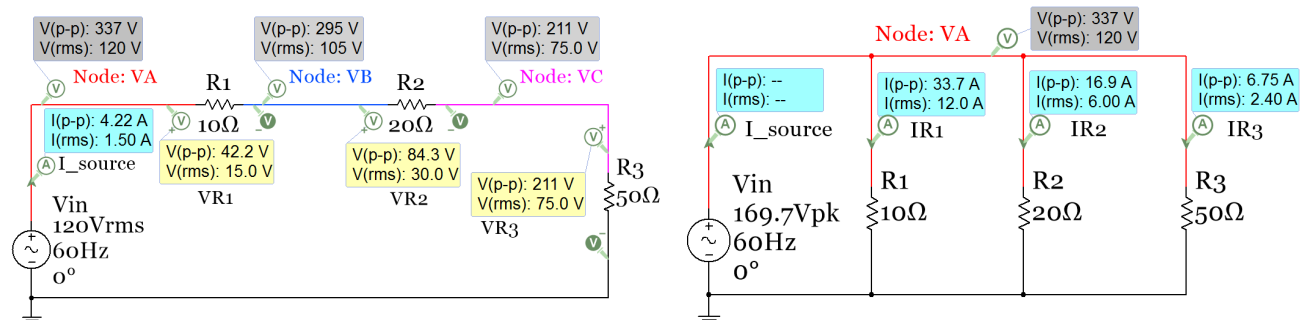
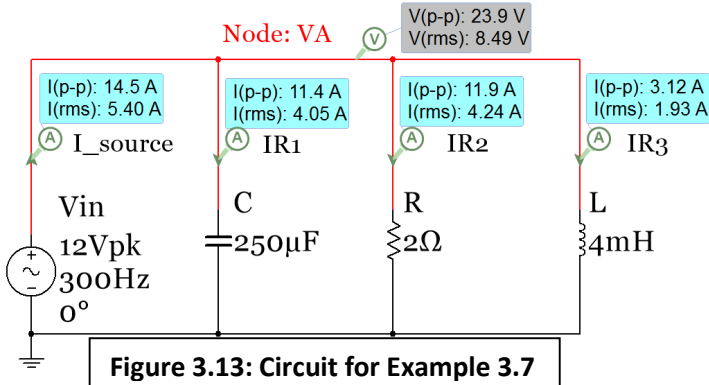

Figure 3.12: Series (Left) and Parallel (Right) circuit comparison with AC input voltage and only resistors.

Figure 3.12 shows two different types of Multisim AC sources. The series circuit has a Multisim source called "AC_Power" and the voltage is in RMS. The parallel circuit has the Multisim source called "AC_Voltage" and the voltage is in peak voltage. The phasor voltage for the parallel circuit is $V_{in} = 169.7\angle 0^\circ$. Since V_{in} is in peak voltage it is in the form required for phasor form. Since the units are Volts no units are listed after the phasor (Volts assumed if not units). The source in the series circuit is in RMS so it must be converted to peak before writing in phasor form: $V_{in_pk} = 120 V_{in_rms} \cdot \sqrt{2} = 169.7 V \rightarrow V_{in} = 169.7\angle 0^\circ$. However, it is acceptable nomenclature to write the phasor amplitude in RMS if the units are included (i.e. $V_{in} = 120\angle 0^\circ V_{rms}$).

Example 3.7) Solve for the following parallel RLC circuit and verify values in Multisim.



Steps 1 to 3 of Table 3.3

$Y_R = G = 1/R = 1/2 = 0.5 \Omega$
 $B_C = C \cdot \omega = 250e-6 \cdot 600 \cdot \pi = 0.471239 \Omega$
 $Y_C = j B_C = j 0.471239 \Omega = \mathbf{0.471239\angle 90^\circ}$
 $B_L = 1/L \cdot \omega = 1/(0.004 \cdot 600 \cdot \pi) = 0.132629 \Omega$
 $Y_L = -j B_L = -j 0.132629 \Omega = \mathbf{0.132629\angle -90^\circ}$
 $Y_{Tot} = Y_R + Y_C + Y_L = 0.5 + j 0.33861 \Omega$
 $Y_{Tot} = 0.603868 \angle 34.10663^\circ$
 $Z_{Tot} = 1/Y_{Tot} = (1\angle 0^\circ)/(0.603868\angle 34.10663^\circ)$
 $Z_{Tot} = \mathbf{1.655991\angle -34.1066^\circ}$

Steps 4 to 6 of Table 3.3 (Multisim Peak Values listed in Red Font and RMS values listed in Blue Font)

- Since the total impedance has an angle less than 0° the source current, I_s , will lead the input voltage.
- $V_{in} = V_R = V_L = V_C = 12\angle 0^\circ$ (Phasor Form) $\mathbf{v_{in}(t) = v_R(t) = v_L(t) = v_C(t) = 12 \cdot \sin(600 \cdot \pi + 0^\circ)}$ (Sinusoidal Form)

$I_{source} = I_s = V_{in}/Z_{Total} = (12\angle 0^\circ)/(1.655991\angle -34.1066^\circ) = \mathbf{7.2464\angle 34.1066^\circ}$ Multisim: $I_s = 14.5/2 = \mathbf{7.25A}$
 $i_s(t) = \mathbf{7.2464 \cdot \sin(600 \cdot \pi + 34.1066^\circ)}$ $I_{s,RMS} = 7.2464/\sqrt{2} = \mathbf{5.1 A_{RMS}}$ Multisim: $\mathbf{5.4 A_{RMS}}$ (Off due to DC offset)

- $I_R = V_{in}/R = (12\angle 0^\circ)/(2\angle 0^\circ) = \mathbf{6\angle 0^\circ}$ Multisim: $I_R = 11.9 A_{p-p}/2 = \mathbf{5.95 A}$ (Close to calculated)
- $i_R(t) = \mathbf{6 \cdot \sin(600 \cdot \pi + 0^\circ)}$ $I_{R,RMS} = 6/\sqrt{2} = \mathbf{4.24 A_{RMS}}$ Multisim: $\mathbf{4.24 A_{RMS}}$ (Correct since no DC offset is added)

$I_L = V_{in} \cdot Y_L = (12\angle 0^\circ) \cdot (0.132629\angle -90^\circ) = \mathbf{1.59\angle -90^\circ}$ Multisim: $I_L = 3.12 A_{p-p}/2 = \mathbf{1.56 A}$ (Close to calculated)
 $i_L(t) = \mathbf{1.59 \cdot \sin(600 \cdot \pi - 90^\circ)}$ $I_{L,RMS} = 1.59/\sqrt{2} = \mathbf{1.13 A_{RMS}}$ Multisim: $\mathbf{1.93 A_{RMS}}$ (WAY Off due to DC offset)

- $I_C = V_{in} \cdot Y_C = (12\angle 0^\circ) \cdot (0.471239\angle 90^\circ) = \mathbf{5.65\angle 90^\circ}$ Multisim: $I_C = 11.4 A_{p-p}/2 = \mathbf{5.7 A}$ (Close to calculated)
- $i_C(t) = \mathbf{5.65 \cdot \sin(600 \cdot \pi + 90^\circ)}$ $I_{C,RMS} = 5.65/\sqrt{2} = \mathbf{4 A_{RMS}}$ Multisim: $\mathbf{4.05 A_{RMS}}$ (Close: no DC offset is added)

The reason the RMS I_s and I_L don't match the calculations is due to the DC offset that is wrongly included in the simulation as shown in Figure 3.14 (this link gives more info). Here are some options to avoid this error.

- 1) Measure only the peak to peak probe current in Multisim and convert it to RMS $\rightarrow I_{RMS} = I_{p-p}/(2\sqrt{2})$
- 2) Calculate I_s and use a current source instead of a voltage source. There is no DC offset in Figure 3.14.
- 3) Double click on the inductor and enter a DC initial condition value to negate what Multisim adds in.

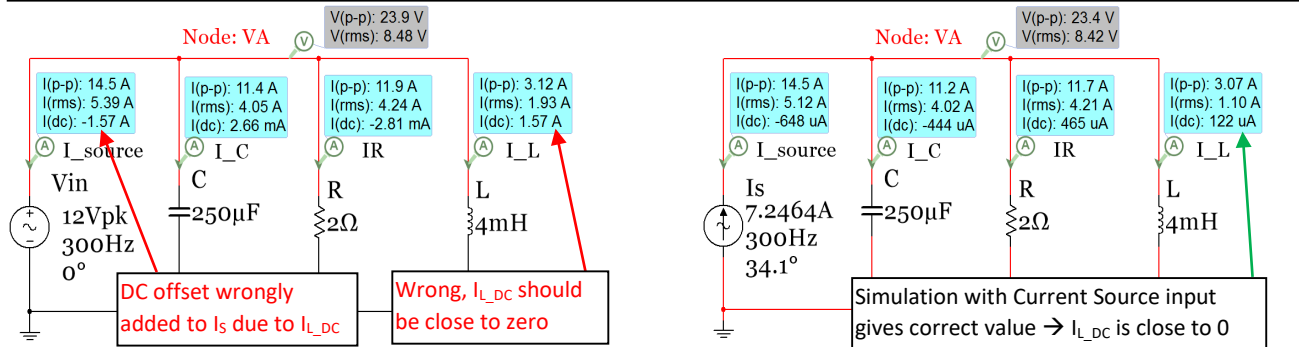

Figure 3.14: Parallel circuit in Example 3.7 with AC Voltage source (Left) and AC Current Source (Right).

All of the voltages and currents have been calculated above and the magnitudes were verified in Multisim. To verify the phase the oscilloscope is needed. To remove the DC offset of the inductor, method 3 described in [Figure 3.14](#) will be used. [Figure 3.15](#) shows the dialog that comes up when you double click on the inductor. Since the DC offset was measured to be 1.57A, a value of -1.57A is entered into the initial condition box to correct for the DC offset. [Figure 3.16](#) (Left) shows the plot of V_{in} and I_S for the initial circuit without modifying the initial condition of the inductor. Due the DC offset the peak value of I_S is measured to be 8.738 A which is about 1.5 A higher than the calculated value of I_{S_pk} (7.2464 A). In the right plot of [Figure 3.16](#) the initial condition of the inductor is included and the DC offset is removed from both I_L and I_S .

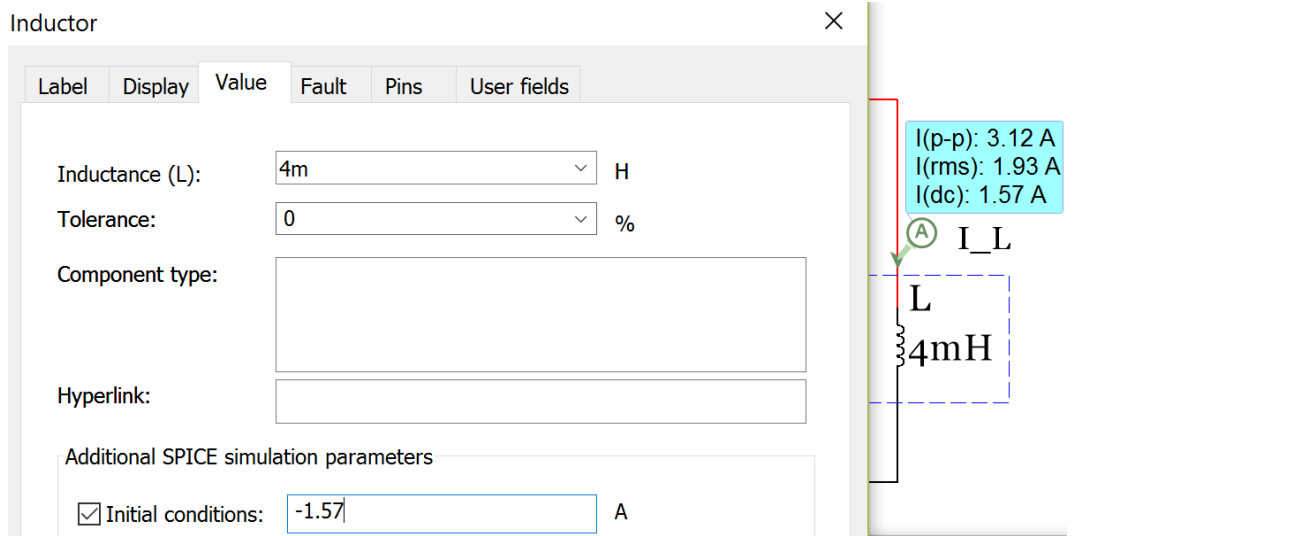

Figure 3.15: Inductor dialogue box to enter the DC offset as the initial condition.

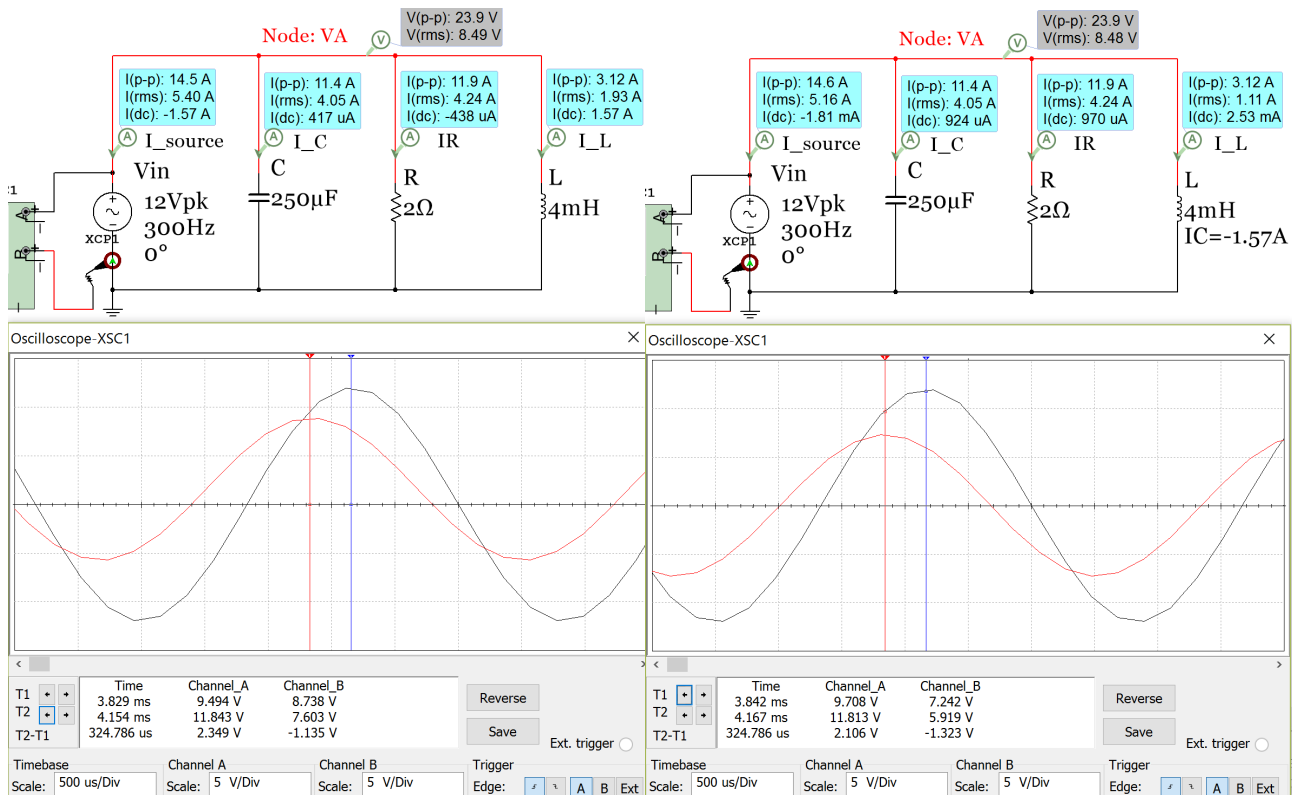

Figure 3.16: Parallel RLC circuit from Example 3.7 – Phase Verification in Multisim.

The time shift, t_s , in [Figure 3.16](#) is measured to be -0.324786 ms (t_s is negative because its sinusoidal cycle starts before V_{in}). The phase of I_s is calculated below and matches the calculated value (34.1°) fairly closely.

- $\theta = -t_s \cdot \omega = -(-0.000324786 \text{ sec}) \cdot (300 \cdot 2\pi \text{ radians/sec}) = 0.6122 \text{ radians} \rightarrow 35^\circ$
- Even though the ELI the ICE man mnemonic doesn't apply to parallel circuits it DOES apply once the total impedance is determined and you want to compare the source current to the input voltage. In this example I_s LEADS V_{in} (ICE) because the total impedance phase angle is in quadrant IV (-34.1°). This is verified in [Figure 3.16](#).

[Figure 3.17](#) shows the capacitor current and V_{in} (Left) and the inductor current and V_{in} (Right). Recall that the phase shift is positive if the time shift is negative (or shifted left) and vice versa.

- Both plots below show the time difference between peaks is 0.8333 ms. Multiplying the magnitude of the time shift by the angular frequency of V_{in} (600π) results in $\pi/2$ (or 90°).
- It can be clearly seen that I_C has a $+90^\circ$ phase shift since it is shifted $1/4$ period to the left of V_{in} .
- The peak current of I_C is measured to be 5.649 A. This is very close to the calculated value of 5.65 A.
- It can be clearly seen that I_L has a -90° phase shift since it is shifted $1/4$ period to the right of V_{in} .
- The peak current of I_L is measured to be 1.549 A. This is very close to the calculated value of 1.59 A.

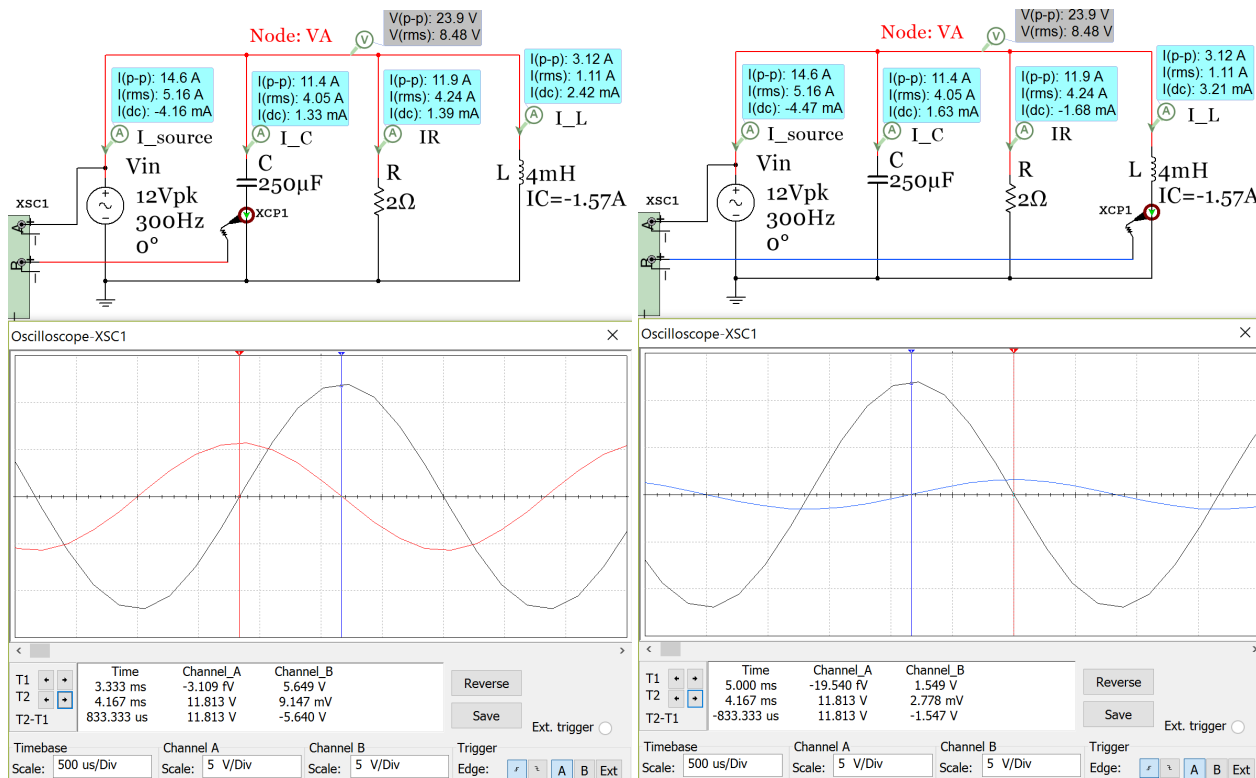

Figure 3.17: Example 3.7 verification: Left: I_C (Red) and V_{in} (Black) plots, Right: I_L (Blue) and V_{in} (Black) plots

Section 3.4 – AC Power Calculations

In section 1.3.3 the RMS voltage was found to be an important quantity in AC circuits because it allows the AC power delivered to a load to be equated to the DC power. V_{rms} can be defined as the magnitude of AC voltage that produces the same amount of average power on a load as an equivalent DC voltage, as shown in [Figure 1.13](#). As previously discussed, if an AC circuit is frozen at a specific time the current and voltage at that time is simply a DC value that is referred to as “instantaneous”. Example 3.8 below shows the series circuit used in [Figure 3.12](#) with power probes included. The instantaneous voltage (V_{inst}) and current (I_{inst}) can be multiplied

together to get the instantaneous power (P_{inst}) as shown in [Equation 3.1](#). Since P_{inst} constantly changes and only applies to a specific instant of time it is not frequently used for AC power. Instead, the average power (shown in [Equation 3.2](#)) is the primary type of power used for circuits with AC sources. The average power is can be determined by [Equation 3.2](#) or it can be determined by finding the average instantaneous power over 1 period (see [Table 3.4](#) and [Figure 3.20](#) for an example).

$$[3.1] \quad P_{inst} = I_{inst} \cdot V_{inst} \quad (\text{This is the same as freezing the circuit and treating values as DC})$$

$$[3.2] \quad P_{avg} = P = I_{RMS} \cdot V_{RMS} \cdot PF \quad (P \text{ or } P_{avg} \text{ is called } \underline{\text{Real Power}}. \text{ The units are } \underline{\text{Watts}})$$

$$[3.3] \quad PF = \text{Power Factor} = \cos \theta_{Zt} \quad (\theta_{Zt} \text{ is the total impedance phase angle})$$

Note: If $\theta_{Zt} > 0$ (ELI) the power factor (PF) is said to be “Lagging.” If $\theta_{Zt} < 0$ (ICE) the PF is “Leading.”

$$[3.4] \quad S = I_{RMS} \cdot V_{RMS} \quad (S \text{ is called } \underline{\text{Apparent Power}}. \text{ The units are } \underline{\text{V}\cdot\text{A}})$$

$$[3.5] \quad Q = I_{RMS} \cdot V_{RMS} \cdot \sin \theta_{Zt} \quad (Q \text{ is also called } \underline{\text{Reactive Power}}. \text{ The units are } \underline{\text{VAR}})$$

P, S, and Q make up what is referred to as the **Power Triangle**. This “triangle” (or vector in phasor form) has the same angle as the total impedance, but the amplitude is equal to S (or $V_{RMS} \cdot I_{RMS}$).

Resistors only have real power (P). Capacitors and inductors only have reactive power (Q). The apparent power (S) is thought of as the total power that is possible for the ideal case where Q = 0.

Example 3.8) Calculate the instantaneous and average power magnitudes for each component and source in the circuit below and show that the magnitude of the power supplied is equal to the power dissipated.

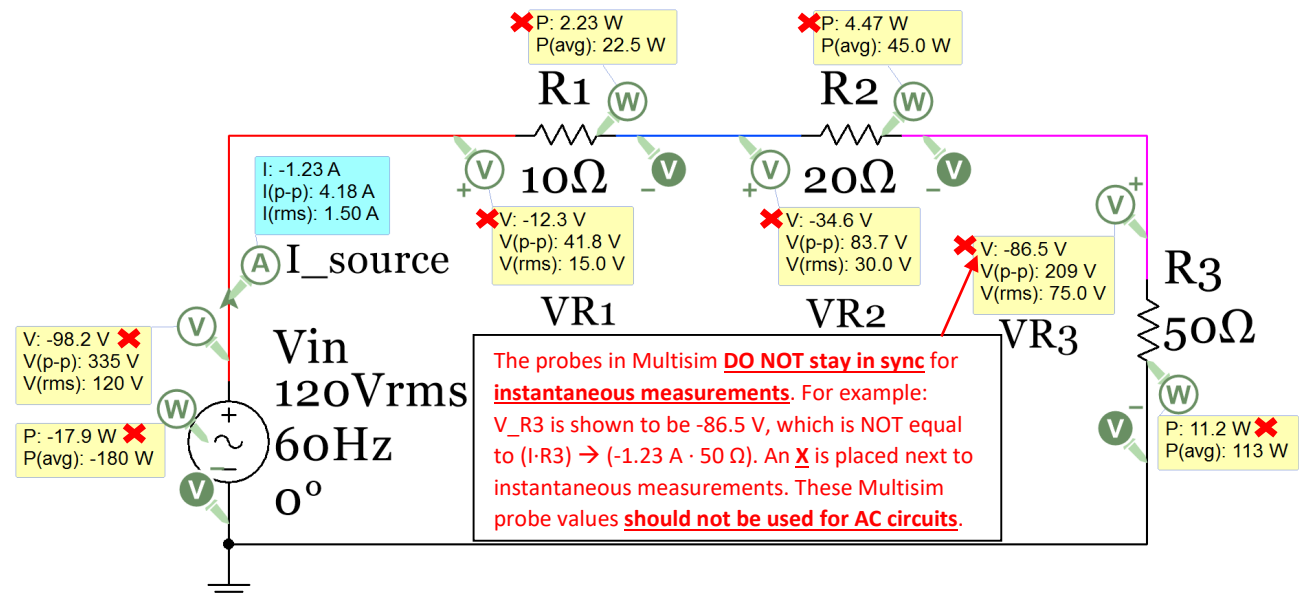

Figure 3.18: Circuit for Example 3.8

Since there are only resistors in this circuit $\theta_{Zt} = 0$ and the power factor = 1 so $Q = 0$ and $S = P = V_{RMS} \cdot I_{RMS}$. The Multisim power probes show instantaneous power (P) and average power (P(avg)). The magnitude of the

instantaneous power supplied will constantly change between 0 and $V_{in_pk} \cdot I_{in_pk}$, but the average (or real) power supplied will remain constant at a value of $V_{RMS} \cdot I_{RMS}$. The magnitude of the supply power is equal to the dissipated power for both P_{inst} and P_{avg} as shown below. Recall, the sign of supplied power is always set as a negative. For instantaneous power there are infinite solutions depending on when the circuit is paused (or frozen in time). Since the instantaneous measurements in Multisim aren't in sync (i.e. not associated with the same moment in time) they will not be displayed in future circuits. They were only displayed in this example to point out this limitation in Multisim and to make sure you don't use them in any calculations.

Instantaneous power calculations: (This is the same process used in DC circuits): At the moment the Multisim simulation is paused the voltage source has a voltage of **-98.2 V**. The following calculations show that the magnitude of the power supplied is equal to the power dissipated at this moment in time. The calculated values won't match the Multisim values because the instantaneous probe values are not in sync.

- $R_{Total} = 10 \Omega + 20 \Omega + 50 \Omega = 80 \Omega$, Current: $I_{inst} = V_{inst}/R_{Total} = -98.2 \text{ V} / 80 \Omega = 1.2275 \text{ A}$
- $P_{supplied} = V_{inst} \cdot I_{inst} = (-98.2 \text{ V}) \cdot (1.2275 \text{ A}) = \underline{120.5 \text{ W}}$ (power is always listed as positive in this eBook)
- $P_{10\Omega} = (1.2275 \text{ A})^2 \cdot (10 \Omega) = \underline{15.07 \text{ W}}$, $P_{20\Omega} = (1.2275 \text{ A})^2 \cdot (20 \Omega) = \underline{30.14 \text{ W}}$, $P_{50\Omega} = (1.2275 \text{ A})^2 \cdot (50 \Omega) = \underline{75.33 \text{ W}}$
- $\sum P_{dissipate} = P_{10\Omega} + P_{20\Omega} + P_{50\Omega} = 15.07 \text{ W} + 30.14 \text{ W} + 75.33 \text{ W} = \underline{120.5 \text{ W}} = \sum P_{supplied}$

Average power calculations: This is the same process as before, but the current and voltage instantaneous values are replaced with RMS values. Each value is calculated below and the Multisim measurement is included in blue font and shown next to the calculated value to be used as verification. For the voltage across the resistors $I^2 \cdot R$ was used previously and $I \cdot V$ is used below. Another option that can be used is V^2/R .

- $R_{Total} = 10 \Omega + 20 \Omega + 50 \Omega = 80 \Omega$, Current: $I_{RMS} = V_{in_RMS}/R_{Total} = 120 \text{ V} / 80 \Omega = \underline{1.5 \text{ A}}$ Multisim \rightarrow (1.5A)
- $P_{supplied} = V_{in_RMS} \cdot I_{RMS} = (120 \text{ V}) \cdot (1.5 \text{ A}) = \underline{180 \text{ W}}$ (180 W) \rightarrow Always use the **$P=V \cdot I$** equation for sources.
- $V_{10\Omega} = (1.5 \text{ A}) \cdot (10 \Omega) = \underline{15 \text{ V}}$ (15V), $V_{20\Omega} = (1.5 \text{ A}) \cdot (20 \Omega) = \underline{30 \text{ V}}$ (30V), $V_{50\Omega} = (1.5 \text{ A}) \cdot (50 \Omega) = \underline{75 \text{ V}}$ (75V)
- $P_{10\Omega} = (1.5 \text{ A}) \cdot (15 \text{ V}) = \underline{22.5 \text{ W}}$ (22.5W), $P_{20\Omega} = (1.5 \text{ A}) \cdot (30 \text{ V}) = \underline{45 \text{ W}}$ (45W), $P_{50\Omega} = (1.5 \text{ A}) \cdot (75 \text{ V}) = \underline{112.5 \text{ W}}$ (113W)
- $\sum P_{dissipate} = P_{10\Omega} + P_{20\Omega} + P_{50\Omega} = 22.5 \text{ W} + 45 \text{ W} + 112.5 \text{ W} = \underline{180 \text{ W}} = \sum P_{supplied}$

Example 3.8 showed that the average power in AC circuits uses the RMS voltage and currents in the power formula of [Equation 3.2](#). For AC circuits with only resistors the current and voltages are always "in phase" with each other which maximizes the average power. For RLC circuits the capacitors and/or inductors in the circuit causes the current and voltage to be out of phase (as explained previously with the ELI the ICE man mnemonic), which results in a reduced average (or real) power. [Figure 3.19](#) shows an AC circuit with only a resistor and a circuit with a capacitor added that results in the voltage and current being out of phase. In [Table 3.4](#) and [Figure 3.20](#) provide a detailed analysis showing the effects of adding a capacitor (resulting in the current and voltage going out of phase) on the instantaneous and average power.

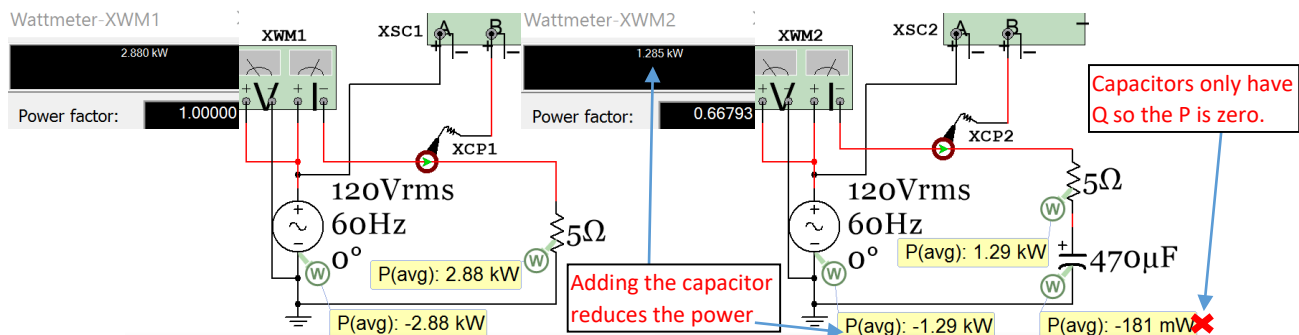

Figure 3.19: Circuit showing that adding a capacitor (or inductor) reduces the average power.

Table 3.4) Instantaneous Values for 2 RC circuits. Case 1: (No Capacitor), Case 2: 470 μF Capacitor added.

1 Period with 40 pts	Case 1: No Cap.			Case 2, 470μF	
t(ms)	V_inst	I_inst	P_inst	I_inst	P_inst
0	0	0	0	0.557	0
0.25	0.939	0.188	0.176	0.679	0.637
0.5	1.854	0.371	0.688	0.784	1.454
0.75	2.724	0.545	1.484	0.87	2.37
1	3.527	0.705	2.488	0.934	3.295
1.25	4.243	0.849	3.6	0.976	4.139
1.5	4.854	0.971	4.712	0.993	4.82
1.75	5.346	1.069	5.716	0.986	5.271
2	5.706	1.141	6.512	0.955	5.447
2.25	5.926	1.185	7.024	0.9	5.332
2.5	6	1.2	7.2	0.823	4.936
2.75	5.926	1.185	7.024	0.725	4.299
3	5.706	1.141	6.512	0.61	3.482
3.25	5.346	1.069	5.716	0.48	2.566
3.5	4.854	0.971	4.712	0.338	1.641
3.75	4.243	0.849	3.6	0.188	0.797
4	3.527	0.705	2.488	0.033	0.116
4.25	2.724	0.545	1.484	-0.123	-0.335
4.5	1.854	0.371	0.688	-0.276	-0.511
4.75	0.939	0.188	0.176	-0.422	-0.396
5	0	0	0	-0.557	0
5.25	-0.939	-0.188	0.176	-0.679	0.637
5.5	-1.854	-0.371	0.688	-0.784	1.454
5.75	-2.724	-0.545	1.484	-0.87	2.37
6	-3.527	-0.705	2.488	-0.934	3.295
6.25	-4.243	-0.849	3.6	-0.976	4.139
6.5	-4.854	-0.971	4.712	-0.993	4.82
6.75	-5.346	-1.069	5.716	-0.986	5.271
7	-5.706	-1.141	6.512	-0.955	5.447
7.25	-5.926	-1.185	7.024	-0.9	5.332
7.5	-6	-1.2	7.2	-0.823	4.936
7.75	-5.926	-1.185	7.024	-0.725	4.299
8	-5.706	-1.141	6.512	-0.61	3.482
8.25	-5.346	-1.069	5.716	-0.48	2.566
8.5	-4.854	-0.971	4.712	-0.338	1.641
8.75	-4.243	-0.849	3.6	-0.188	0.797
9	-3.527	-0.705	2.488	-0.033	0.116
9.25	-2.724	-0.545	1.484	0.123	-0.335
9.5	-1.854	-0.371	0.688	0.276	-0.511
9.75	-0.939	-0.188	0.176	0.422	-0.396
10	0	0	0	0.557	0

Table 3.4 shows 40 instantaneous data points over 1 period of V, I, and P of the circuits shown in Figure 3.19. The instantaneous values are plotted over 1 period for both cases. To determine the average (or real) power (Pavg) take an average of the instantaneous power values over 1 period or use Equation 3.2. $\rightarrow P_{avg} = V_{RMS} \cdot I_{RMS} \cdot \cos(\theta_{zt})$

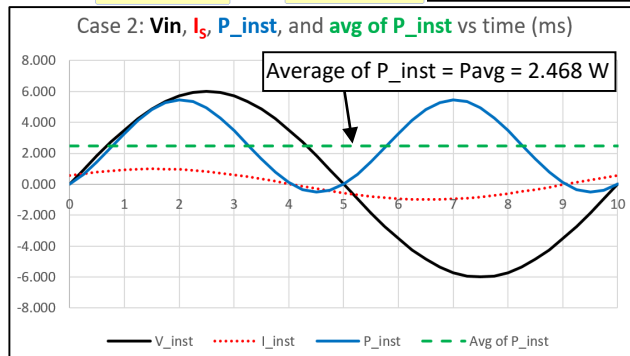
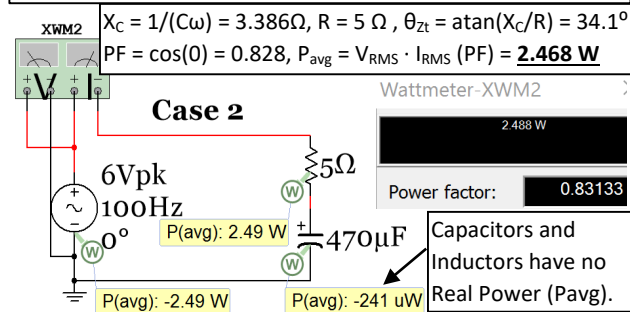
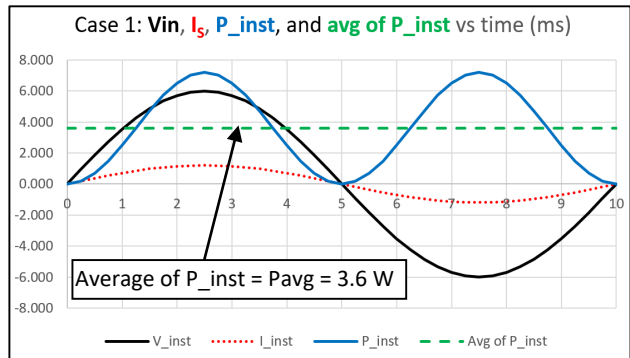
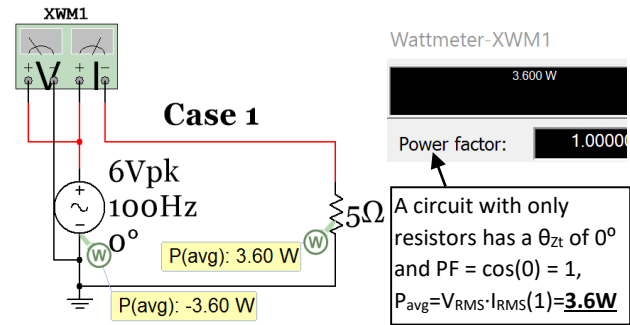

Figure 3.20: Data in Table 3.4 plotted

Example 3.9) For the following RLC series circuit calculate the values of $v_{R1}(t)$, $v_{L2}(t)$, S , P , and Q and draw the power triangle. Determine what component needs to be added to the circuit to eliminate the apparent power and produce a power factor of 1.

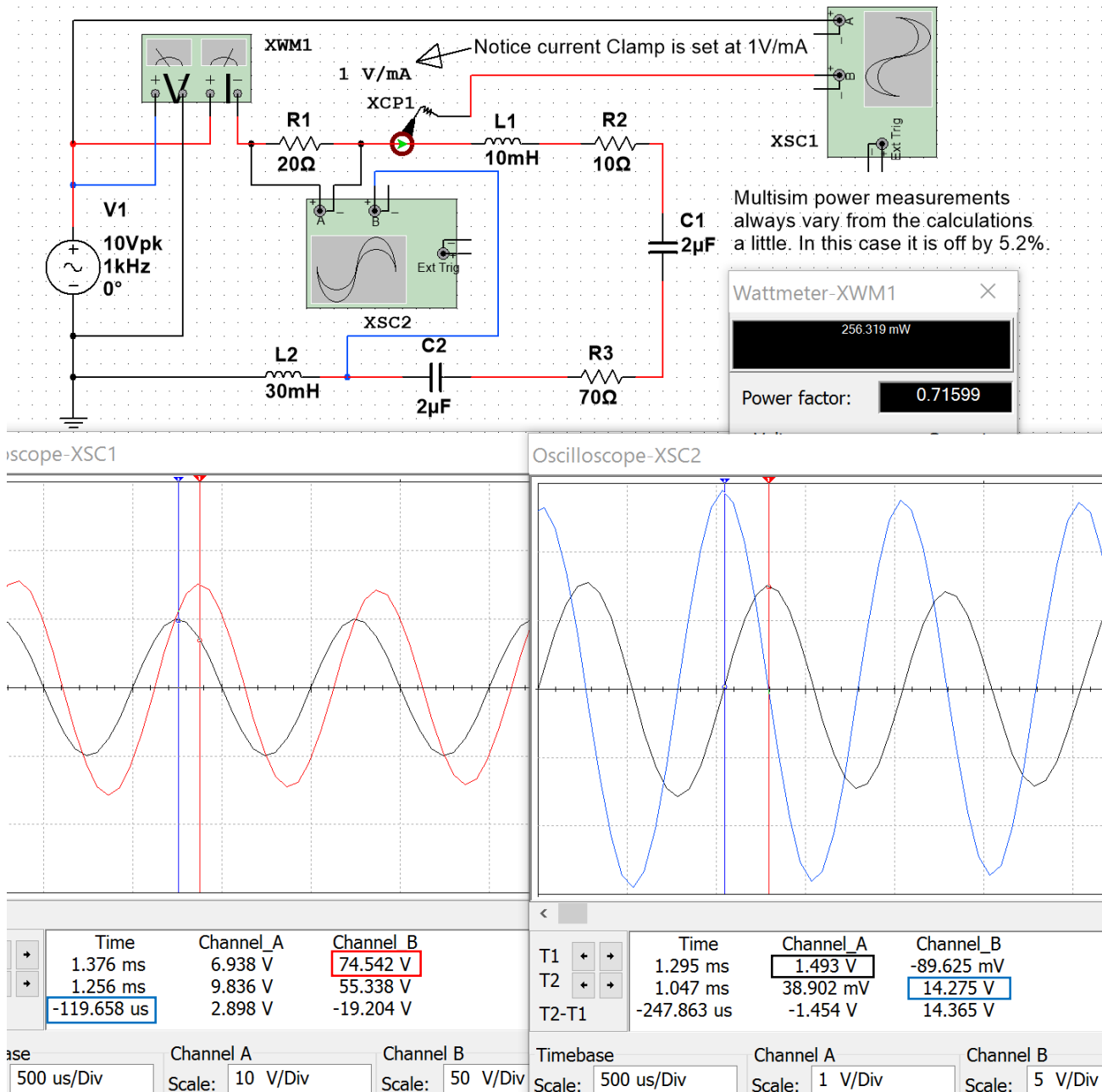

Figure 3.21: Circuit for Example 3.9

- $\omega = 2\pi \cdot f = 2\pi \cdot 1000 = 6283.2 \text{ rad/sec}$. $X_{L1} = L_1 \cdot \omega = 62.8\Omega$, $X_{L2} = L_2 \cdot \omega = 188.5\Omega$, $X_{C1} = X_{C2} = 1/(2\mu\text{F} \cdot \omega) = 79.6\Omega$
- $Z_{\text{Total}} = R1 + jX_{L1} + R2 + R3 - jX_{C1} + jX_{L2} - jX_{C2} = 20 + j62.8 + 10 + 70 - j79.6 + j188.5 - j79.6$
- $Z_{\text{Total}} = 100 + j92.17 = 136\angle 42.67^\circ \Omega \text{ (EII)}$ $I = V_{\text{in}}/Z_{\text{Total}} = 10\angle 0^\circ/136\angle 42.67^\circ = 73.53\angle -42.67^\circ \text{ mA}$
- Time shift, t_s , of current = $-\theta/\omega = -42.67^\circ \cdot (\pi/180^\circ)/6283.2 \text{ rad/sec} = 0.119 \text{ ms}$ (0.1197 ms in Multisim)
- $V_{R1} = I \cdot R1 = (73.53\angle -42.67^\circ \text{ mA}) \cdot (20\angle 0^\circ) = 1.47\angle -42.67^\circ$ (1.493) $\rightarrow v_{R1}(t) = 1.471 \cdot \sin(2000\pi \cdot t - 0.237\pi)$
- $V_{L2} = I \cdot R1 = (73.53\angle -42.67^\circ \text{ mA}) \cdot (188.5\angle 90^\circ) = 13.9\angle 47.33^\circ$ (14.275) $\rightarrow v_{L2}(t) = 13.9 \cdot \sin(2000\pi \cdot t + 0.263\pi)$
- Figure 3.21 shows V_{R1} and V_{L2} are 90° out of phase. Calculations agree $\rightarrow \theta_{VL2} - \theta_{VR1} = 47.33^\circ - -42.67^\circ = 90^\circ$

The power calculations are shown below. $PF = \cos(\theta_{Z_t}) = \cos(42.67^\circ) = \mathbf{0.7353}$ ([0.71599 in Multisim](#))

- $S = I_{RMS} \cdot V_{RMS} = (0.07353/\sqrt{2}) \cdot (10/\sqrt{2}) = \mathbf{0.368\ V \cdot A}$
- $Q = I_{RMS} \cdot V_{RMS} \cdot \sin(\theta_{Z_t}) = (0.07353/\sqrt{2}) \cdot (10/\sqrt{2}) \sin(42.67^\circ) = \mathbf{0.249\ VAR}$
- $P = I_{RMS} \cdot V_{RMS} \cdot \cos(\theta_{Z_t}) = (0.07353/\sqrt{2}) \cdot (10/\sqrt{2}) \cos(42.67^\circ) = \mathbf{0.27\ W}$ ([0.256319 W in Multisim](#))

To get the power factor equal to 1 a capacitor must be added to move Z_t from quadrant I to on the x axis.

- $Z_{Total} = 100 + j 92.17$, Need X_C of added capacitor equal to $92.17\Omega \rightarrow C = 1/(X_C \cdot \omega) = \mathbf{1.7267\ \mu F}$
- This capacitor is added into the circuit below. The current is now in phase with V_{in} and $PF = \sim 1$.

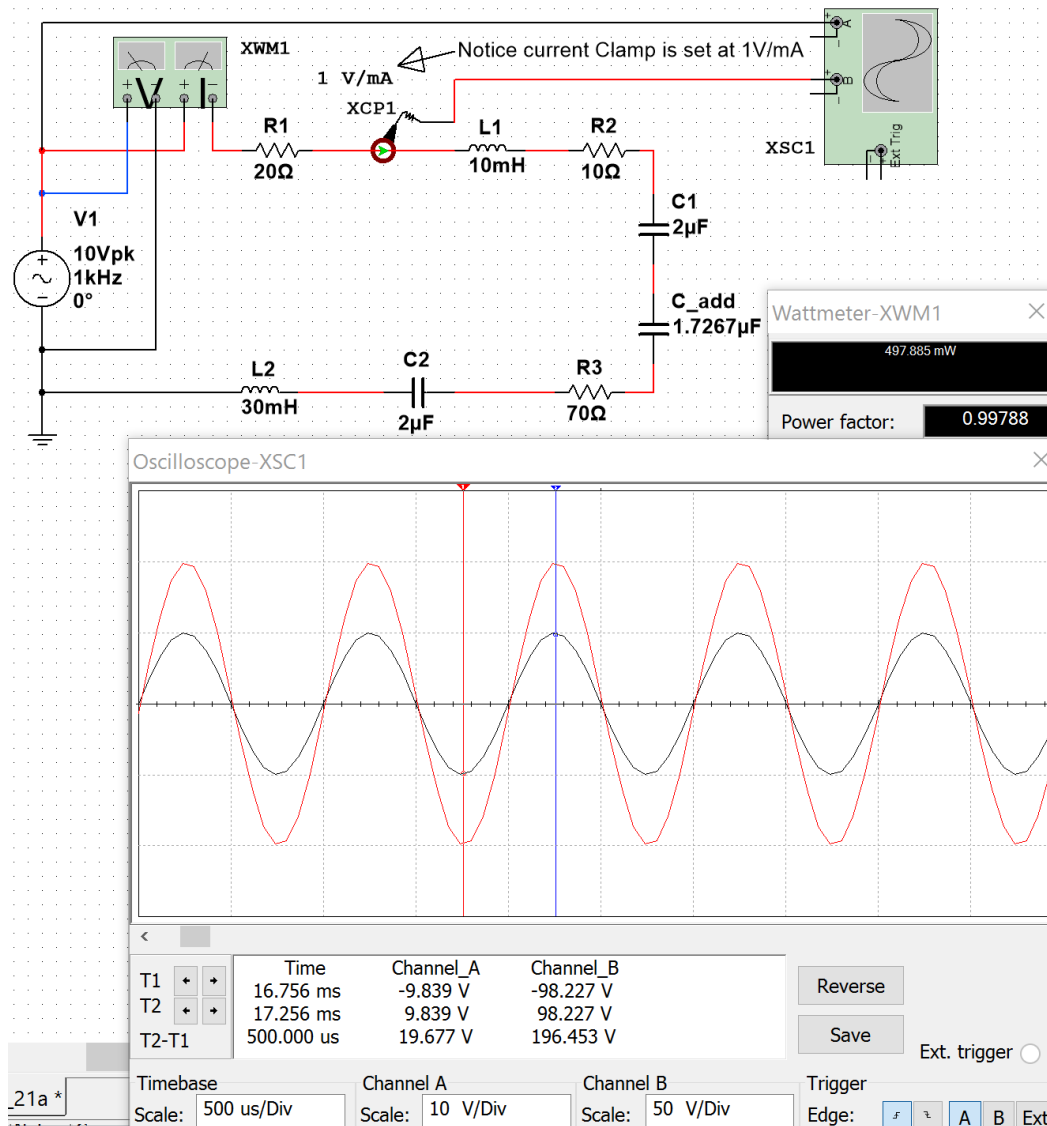

Figure 3.22: Verification that added capacitor makes power factor go to approximately 1.

The power triangle for the circuit before the capacitor is added is shown in [Figure 3.23](#).

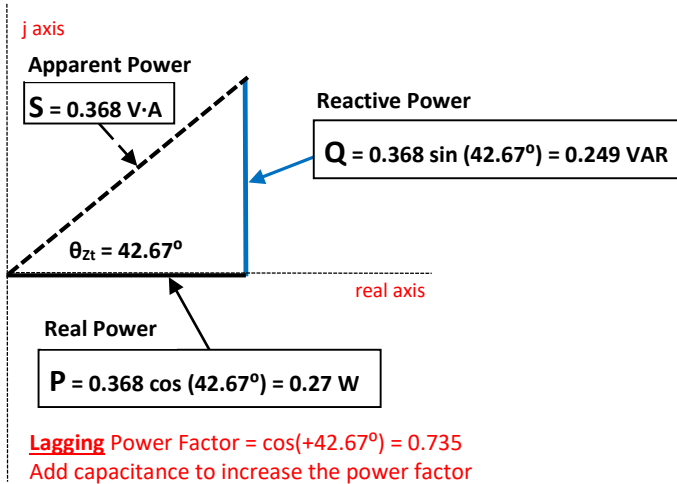

Figure 3.23: Power Triangle for the circuit in Example 3.9.

Example 3.9 is a very practical problem because power companies are constantly trying to make the power factor closer to 1 in their transmission lines. The load of the customers they supply electricity to is primarily inductive (due to motors) so the transmission line circuit is initially in quadrant I (ELI). The power companies purposely add large capacitors into the line to remove the VARs and increase the power factor closer to 1. When the peak load ends when businesses shut down for the day the capacitors added to negate inductance might add too much reactance and move the total impedance into quadrant IV (ICE). When this happens the some of the capacitance added to the line is removed. This is a continual process that the power companies monitor to increase the power factor and save money by making the transmission line more efficient.

Section 3.5 –AC Maximum Power Transfer

Example 3.9 showed how to modify a circuit to increase the power factor so that more of the power that is generated is delivered to the load and less VAR waste occurs. This section contains a similar concept, but also factors in the resistance balancing that is needed to maximize power transfer. For DC circuits the Maximum Power Transfer Theorem stated that the maximum power transfer occurs when the load resistance is equal to the Thevenin resistance of the circuit where the load is connected. In [Figure 3.24](#) it can be seen that as the value of R_L is close to zero on the x-axis the power dissipated by R_L is also close to zero, but when R_L reaches 1000 Ω , which is the value of R_{th} , the power dissipated in R_L is at its maximum.

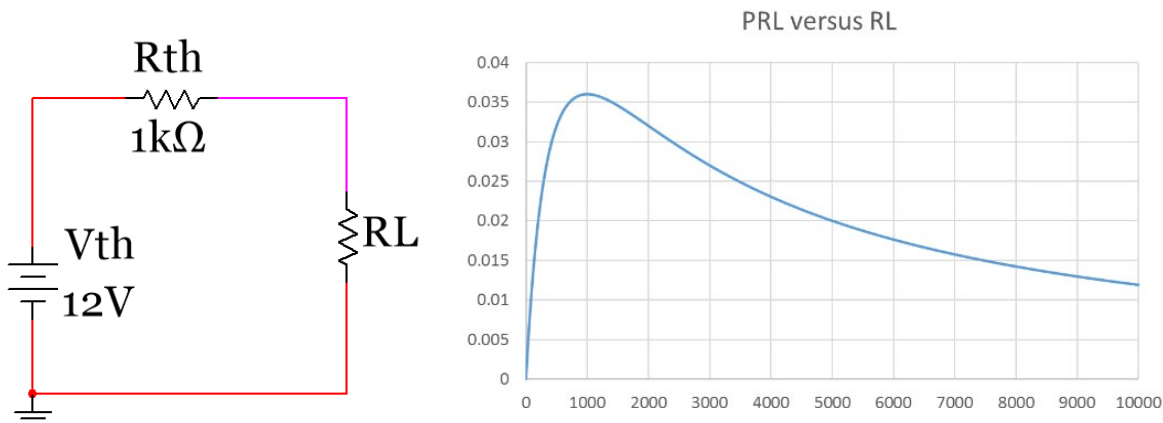

Figure 3.24: Graphical representation of the Maximum Transfer Theorem ($R_L = R_{th}$) for DC circuits

For AC circuits the theorem is modified to account for the resistance and the reactance.

[3.6] $Z_{Load} = Z_{Source}^*$ (Maximum Power Transfer Theorem for AC circuits)

The * in Equation 3.6 denotes the conjugate. The following two scenarios could occur:

1. You know the source impedance (Z_{Source}) and need to select a load impedance (Z_{Load}) for maximum power transfer so you try to set it equal to the conjugate of the source.
2. You have a set load and need to modify the source for maximum power transfer so you try to make the source impedance equal to the conjugate. This is the scenario of Example 3.9.

Example 3.10) Determine the load impedance for maximum power transfer if the source impedance is equal to $3 + j 4$. Use the A+jB Block and A-jB Block parts in Multisim that are located in the following directory: Group → Basic, Family → Z_Load. Solve the problem to determine the apparent, reactive, and real power.

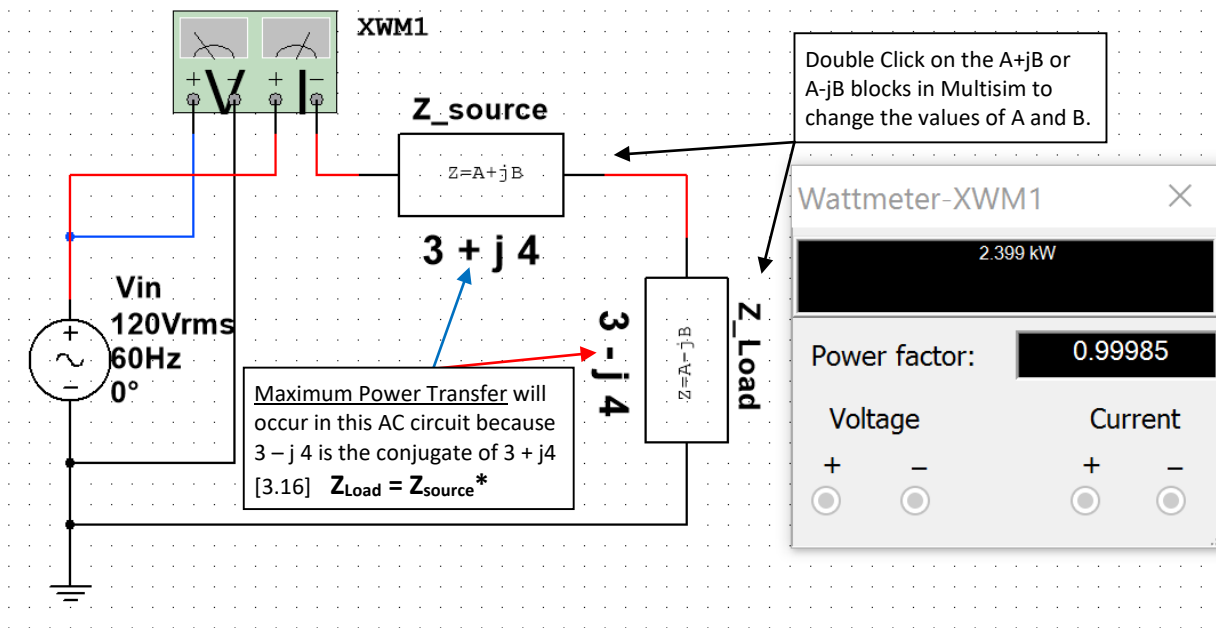

Figure 3.25: Circuit including Multisim Z_loads for Example 3.10.

- The Load impedance must be $3 - j 4$ for maximum power transfer (as shown in Figure 3.25).
- $Z_{total} = (3 + j 4) + (3 - j 4) = 6 \Omega$
- $I_{RMS} = V_{RMS}/Z_{total} = (120 \angle 0^\circ)/(6 \angle 0^\circ) = 20 A_{RMS}$
- $\theta_{Zt} = 0^\circ \rightarrow PF = \cos(0^\circ) = 1$
- $S = I_{RMS} \cdot V_{RMS} = (20 A_{RMS}) \cdot (120 V_{RMS}) = \mathbf{2400 V \cdot A}$
- $P = S \cdot \cos(0^\circ) = \mathbf{2400 W} \rightarrow$ Multisim has value equal to $\mathbf{2399 W}$
- $Q = S \cdot \sin(0^\circ) = \mathbf{0 VAR}$

The Z_load blocks made Example 3.10 easier. If given only the reactance of a capacitor or inductor instead of the actual value of them, Z_load blocks allow you to skip the step of calculating inductance or capacitance. For AC circuits with multiple impedances in series and parallel Z_loads simplify the problem in Multisim.

Power transmission and distribution systems (as seen in [Figure 3.26](#)) is the most important application of RLC circuits. Examples that showed how impedance matching is performed to increase the amount of power delivered to the load was shown in examples 3.9 and 3.10. The following link contains a convenient interactive interface that solves for some of the AC parameters in a series RLC circuit. <http://hyperphysics.phy-astr.gsu.edu/hbase/electric/powerac.html>

For deeper reading on transmission lines Chapter 14 of the AllAboutCircuits.com - *Alternating Current* eBook is recommended. <http://www.allaboutcircuits.com/textbook/alternating-current/chpt-14/50-ohm-cable/>

The following link also provides a brief overview of the electrical effects of the physical size of the transmission line. <http://www.allaboutcircuits.com/technical-articles/introduction-to-the-transmission-line/>

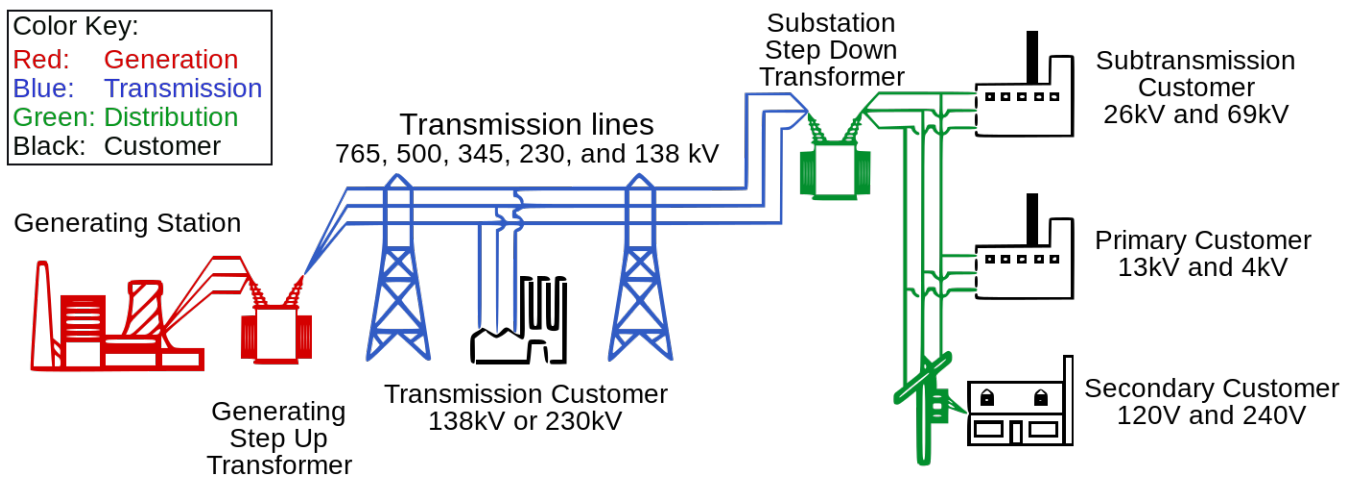

Figure 3.26: Electrical Transmission System Overview. Source: [Public domain image](#)

The following link shows a figure with more information about the electrical grid and includes different sources of electrical generation such as: wind, solar, hydro-electric, nuclear, and coal.

https://commons.wikimedia.org/wiki/File:Electricity_Grid_Schematic_English.svg

Module 4 – Passive Filters

While power transmission is probably the most important application of RLC circuits, filtering is a close second. Chapter 8 of the AllAboutCircuits.com - *Alternating Current* eBook provides details about filters and is recommended reading to gain a deeper understanding about the subject.

<http://www.allaboutcircuits.com/textbook/alternating-current/chpt-8/what-is-a-filter/>

There are two main categories of filters: **passive** and **active**. **Active filters** require a power source for operation, but **passive filters** do not. Active filters include **Operational Amplifiers** (discussed in [Module 7](#)), while passive filters use **inductors and/or capacitors** to filter signals. In this eBook only passive filters are covered, but references for active filters are provided in [Module 7](#) and a active filter example is shown in [Figure A.4](#) in the appendix.

In this section some of the common RL, RC, and RLC passive filters are discussed and example circuits with calculations are provided to provide an overview of the topic. The frequency response tool called the Bode plot will be used to provide a graphical understanding of how filter work. Many applications have Bode plot function. In Matlab the function **bode** (or **bodeplot**) can be used to determine the **magnitude response** (how much the output magnitude changes from the input) and **phase response** (how much the output phase changes from the input) for a range of input frequencies. The Matlab function **bodemag** can also be used if only the magnitude response is needed. The value obtained from the Bode magnitude response will be referred to as the **gain** (V_{out}/V_{in}) for the remainder of this document. Performing frequency analysis of circuits in Matlab with the Bode plot requires the circuit to be solved in the Laplace domain. An example of the Laplace solving method is shown for a Band Pass Filter in [Figure 4.15](#) and also for Low Pass and High Pass filters in the [Appendix](#) in [Figure A.1](#), [Figure A.2](#), and [Figure A.3](#).

Multisim also has a Bode plot tool that is very useful when simulating AC circuits. The tool is located 4 spots below the Multimeter on the right side of the Multisim window. To understand how to use the Multisim Bode plot [Figure 4.1](#) shows a circuit with two resistors that form a voltage divider and reduces the output voltage by 50% (i.e. Gain = 0.5 V/V). The gain can also be represented in decibels (or dB). [Equation 4.1](#) shows how to convert from the “absolute” gain (which is in units of either V/V or A/A) to dB.

$$[4.1] \quad \boxed{Gain_{dB} = 20 \cdot \log_{10}(Gain_{V/V})}$$

For example, the magnitude of the gain in Volt/Volt (or V/V) for the circuit in [Figure 4.1](#) is calculated as:

- Voltage Divider Rule: $V_{out} = V_{in} [1k\Omega / (1k\Omega + 1k\Omega)] \rightarrow G_{V/V} = \frac{V_{out}}{V_{in}} = 0.5 \frac{V}{V}$
- $G_{dB} = 20 \cdot \log_{10}(0.5 \frac{V}{V}) = \mathbf{-6.021 \text{ dB}}$
- Notice the Multisim Bode Plot cursor shows the magnitude is a constant value of **-6.021 dB**.
- Since it is known that resistors don't change the phase, the phase is verified in [Figure 4.2](#) where the **phase is shown to be 0° for this circuit**. This means that **0° is added to the input phase to get the output phase**. This process might seem pointless for this circuit because the phase doesn't affect the output, but it will be important for circuits that have a Bode plot with a non-zero phase change.

[Equation 4.2](#) shows the output from the Bode plot given a specific input voltage, $v_{in}(t) = A \cdot \sin(\omega \cdot t + \theta)$.

$$[4.2] \quad \boxed{v_{out}(t) = A \cdot G_{V/V} \cdot \sin(\omega \cdot t + \theta + \Delta\theta)}$$
 Get $G_{V/V}$ and $\Delta\theta$ from the Bode plot at the input frequency.

Example 4.1 shows how to apply [Equation 4.2](#) to determine the output of a LPF circuit.

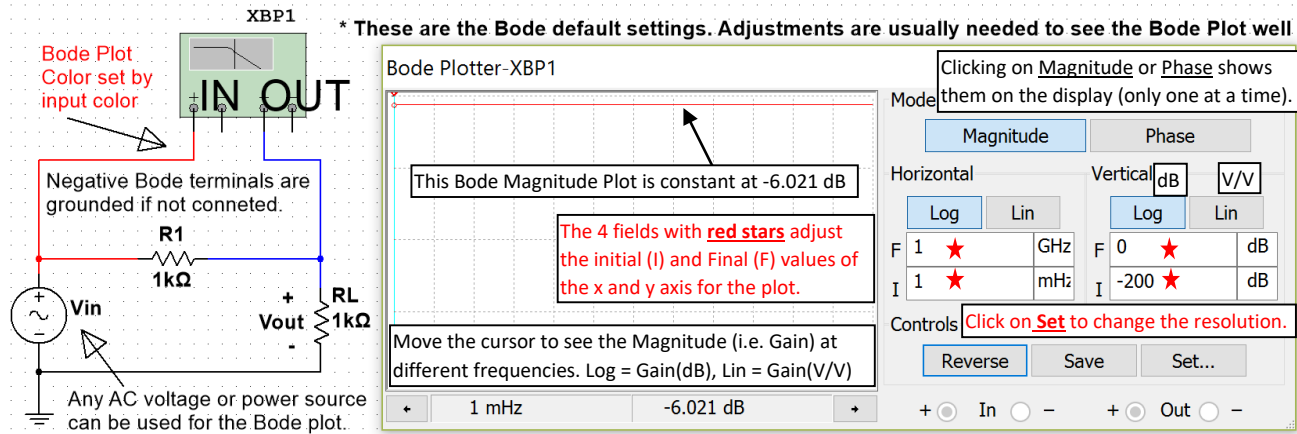

Figure 4.1: Multisim Bode Plot with the default settings.

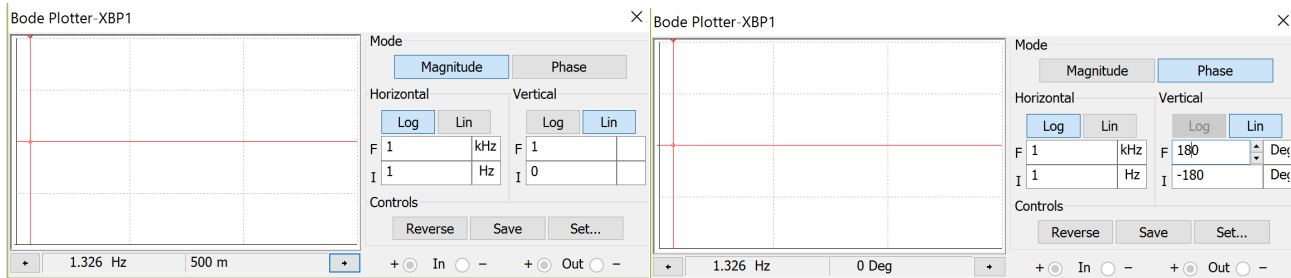

Figure 4.2: Bode Plot from [Figure 4.1](#) with adjustments: Magnitude Response (Left), Phase Response (Right).

The cursors are set in [Figure 4.2](#) at 1.326 Hz for both the magnitude (left) and phase (right) modes. At 1.326 Hz the gain is listed as “500 m” (or 0.5 V/V) and the phase is 0°. It is apparent from the bode plot that both the gain and phase are constant so the cursors for this circuit will result in 500 m and 0° no matter what the frequency value of the input signal. However, for circuits with inductors or capacitors both the gain and phase will change as the frequency changes so changing the frequency limits, resolution, and cursor position are needed to determine the gain and phase at the desired frequency. Applying the values in the Bode plot in [Figure 4.2](#) to the following input signal at a frequency of 1.326 Hz $\rightarrow v_{in}(t) = 3 \cdot \sin(2\pi \cdot 1.326 \cdot t)$

Using [Equation 4.2](#), the following result is obtained for the output signal from the circuit in [Figure 4.1](#).

- $v_{out}(t) = A \cdot G_V \cdot \sin(\omega \cdot t + \theta + \Delta\theta) = 3 \cdot 0.5 \cdot \sin(2\pi \cdot 1.326 \cdot t + 0^\circ) = 1.5 \cdot \sin(2\pi \cdot 1.326 \cdot t)$

Section 4.1 – Low Pass Filters (LPF)

In general terms, a low pass filter (LPF) allows input signals with lower frequencies to pass through to the output while attenuating (i.e. reducing the amplitude) input signals with higher frequencies. The circuits in Figures 4.3 through 4.5 are called **1st order LPF circuits** because they only have one reactive component (i.e. capacitor or inductor). Only 1st order LPF circuits will be discussed in this section. [Figure A.2](#) in the appendix shows how to solve higher order filter circuits using the Laplace solving method. The capacitor or inductor in the 1st order LPF causes a 3dB frequency (f_{3dB}), which is the point at which the slope of the Bode magnitude plot changes by 20 **dB/decade**. A decade is a **factor of 10 in frequency** and 20 dB is 10 V/V (i.e. a **factor of 10 in gain**). For 1st order LPF circuits, the reactive component causes the slope of the Bode magnitude plot to gradually change from flat (0 dB/dec) to -20 dB/dec at f_{3dB} . The 3dB frequency can either be denoted as angular frequency (ω_{3dB}) or cyclic frequency (f_{3dB}). ω_{3dB} is equal to the inverse of the time constant (τ) for a 1st order LPF or HPF. The reason the

3dB subscript is used is due to the gain in the Bode magnitude plot being 3dB below the “passband” at f_{3dB} as shown in Figures 4.3 through 4.7. The **pass band** is the flat region of the Bode magnitude plot that corresponds to the frequency range where the gain is at its highest value. Over the pass band frequency range the Bode phase plot approaches 0° for RLC circuits and non-inverting OpAmp circuits and approaches 180° for inverting OpAmp circuits. Operational Amplifiers (OpAmps) are discussed in [Module 7](#). For RLC circuits each inductor or capacitor causes a $\pm 90^\circ$ phase change in the Bode phase plot. The part of the frequency response that is not in the pass band is called the **stop band**.

[4.3]
$$3dB \text{ Angular Frequency} = \omega_{3dB} = \frac{1}{\tau} \quad * \text{ For a 1}^{st} \text{ order RL or RC circuit}$$

[4.4]
$$3dB \text{ Cyclic Frequency} = f_{3dB} = \frac{1}{2\pi \cdot \tau} \quad * \text{ For a 1}^{st} \text{ order RL or RC circuit}$$

[4.5]
$$\text{Capacitor Time Constant } (\tau) = \tau_C = R_{eq}C$$

[4.6]
$$\text{Inductor Time Constant } (\tau) = \tau_L = \frac{L}{R_{eq}}$$

- R_{eq} is the equivalent resistance “seen” by the capacitor or inductor.

In DC circuits the time constant (τ) for capacitors and inductors was used for transient analysis of DC circuits in the decaying term $\rightarrow e^{-t/\tau}$. The larger the time constant the longer it took to charge the voltage of a capacitor or to charge the current in an inductor. For filtering, a larger the time constant results in a smaller 3dB frequency.

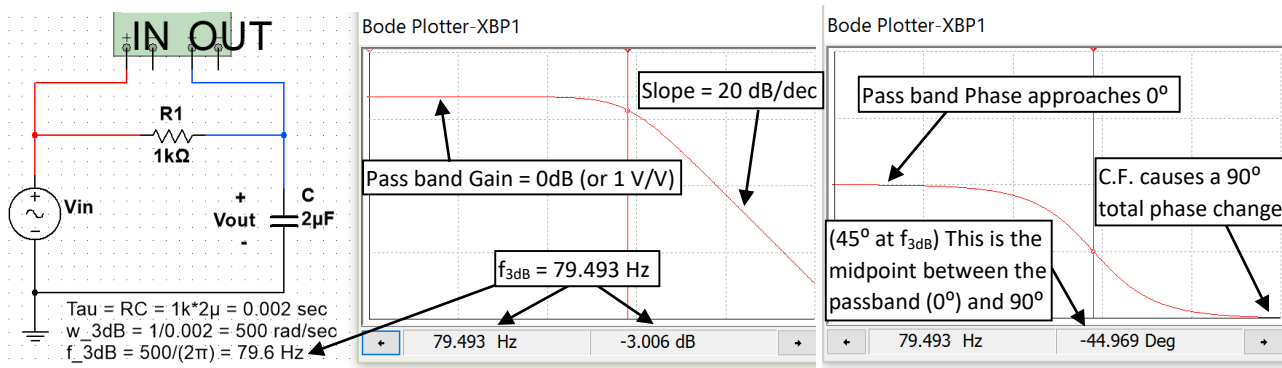

Figure 4.3: 1st Order RC Low Pass Filter Circuit with a 3dB frequency (f_{3dB}) calculated to equal 79.6 Hz.

Figure 4.3 shows the 3dB frequency is calculated at 79.6 Hz and the gain is 3 dB below the pass band gain at that frequency. Since the output is usually desired to be a resistive load, a common variant of the RC filter in [Figure 4.3](#) is shown in [Figure 4.4](#). **Recall that a capacitor acts as an open circuit at DC**, so the steady state DC output for the circuit in [Figure 4.4](#) is equal to $0.5 \cdot V_{in}$ using the same voltage divider calculation that was used for the circuit in [Figure 4.1](#). With the pass band gain at 0.5 V/V (or -6 dB) the gain at f_{3dB} is equal to -9 dB (3dB below -6dB) as shown below.

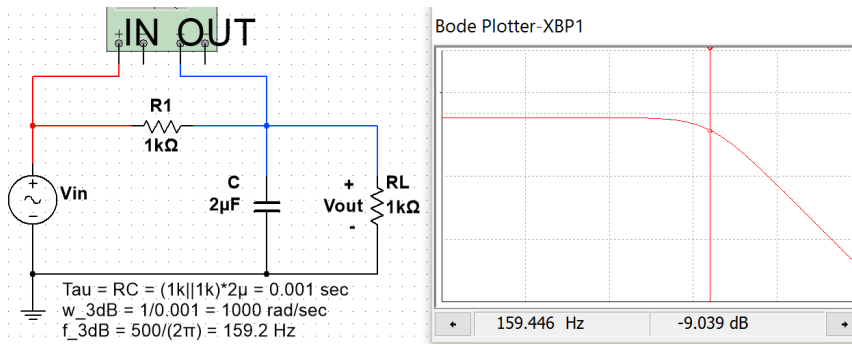

Figure 4.4: 1st Order RC Low Pass Filter Circuit with the output across a resistor.

Next, an RL LPF is shown in [Figure 4.5](#). Recall that an inductor acts as a short circuit at DC steady state, so the DC voltage will not be reduced due to an inductor being in series between the output and the input. In other words, the inductor will act like a short circuit at DC and V_{out} will equal V_{in} . So at DC (or 0 Hz), which is the far left of the x-axis of the Bode plot, the gain will be equal to 1 V/V (or 0 dB) just like it was in the 1st order RC filter with one resistor (see [Figure 4.3](#)). Since it is a 1st order filter and therefore only has one reactive component (the inductor) the slope of the Bode magnitude plot will be equal to (20 dB/dec) as it was for the circuit in [Figure 4.3](#). The Bode phase response plot is also the same as the RC LPF circuit in [Figure 4.3](#).

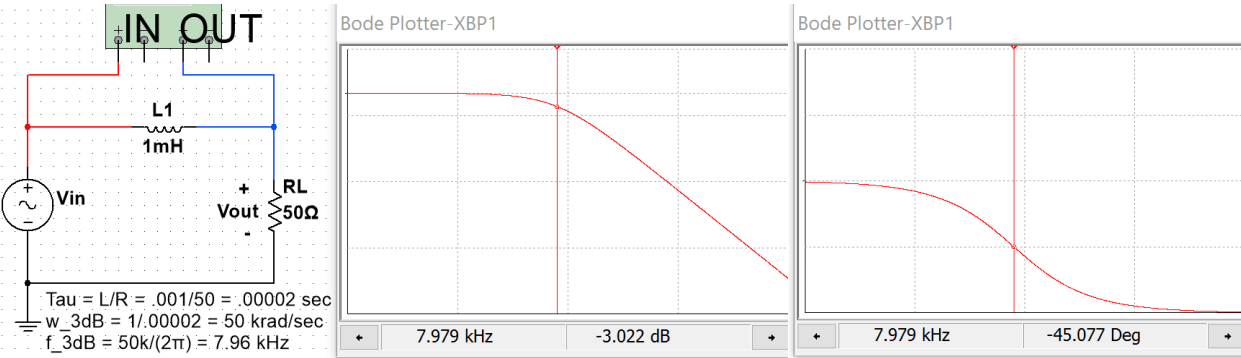

Figure 4.5: 1st Order RL Low Pass Filter Circuit with a 3dB frequency (f_{3dB}) equal to 7.96 kHz.

Example 4.1) Determine the output, $v_{out}(t)$, from the circuit in [Figure 4.5](#) for each of the following inputs:

- $v_{in1}(t) = 5 \sin(2\pi \cdot 7.96 \cdot t)$
- $v_{in2}(t) = 120 \sin(2\pi \cdot 0.796 \cdot t + 20^\circ)$
- $v_{in3}(t) = 0.32 \sin(2\pi \cdot 79.6 \cdot t - 150^\circ)$

For each of the inputs the frequency is used to determine the magnitude and phase change from the Bode plot.

- $v_{in1}(t)$ is at $f_{in} = 7.96$ Hz. The Bode plot shows at $f_{in} \rightarrow \Delta\theta = -45^\circ$ and $G_{dB} = -3dB \rightarrow G_{V/V} = \mathbf{0.7071}$
- $v_{out1}(t) = A \cdot G_{V/V} \cdot \sin(\omega \cdot t + \theta + \Delta\theta) = 5 \cdot \mathbf{0.7071} \cdot \sin(2\pi(7.96) \cdot t + 0^\circ - 45^\circ)$
- $v_{out1}(t) = \mathbf{3.54 \sin(15.92\pi \cdot t - 45^\circ)}$
- $v_{in2}(t)$ is at $f_{in} = 0.796$ Hz. The Bode magnitude plot shows that 1 decade less than f_{3dB} the gain is safely in the passband. With only 1 resistor, the gain should be ~ 0 dB (or 1 V/V) and $\Delta\theta$ should be $\sim 0^\circ$.
- $v_{out2}(t) = A \cdot G_{V/V} \cdot \sin(\omega \cdot t + \theta + \Delta\theta) = 120 \cdot \mathbf{1} \cdot \sin(2\pi(0.796) \cdot t + 20^\circ + 0^\circ)$
- $v_{out2}(t) = \mathbf{120 \sin(1.592\pi \cdot t + 20^\circ) = v_{in2}(t)}$
- $v_{in3}(t)$ is at $f_{in} = 79.6$ Hz which is 1 decade greater than f_{3dB} . For a 1st order LPF the gain drops by 20 dB in 1 decade due to the reactive component so the gain is ~ -23 dB (or 0.07071 V/V) and $\Delta\theta$ is $\sim -90^\circ$.
- $v_{out3}(t) = A \cdot G_{V/V} \cdot \sin(\omega \cdot t + \theta + \Delta\theta) = 0.32 \cdot \mathbf{0.07071} \cdot \sin(2\pi(79.6) \cdot t - 150^\circ - 90^\circ)$
- $v_{out3}(t) = \mathbf{0.02265 \sin(159.2\pi \cdot t - 240^\circ) = 0.02265 \sin(159.2\pi \cdot t + 120^\circ)}$
- Recall the phase in sinusoidal form should be between -180° and 180° so -240° is converted to $\mathbf{+120^\circ}$.

Note: A 2nd order LPF is solved with Matlab using the Laplace Transform method in [Figure A.2](#) in the Appendix.

Section 4.2 – High Pass Filters (HPF)

In general terms, a high pass filter (HPF) acts in opposite fashion as a LPF where it allows input signals with higher frequencies to pass through to the output while attenuating (i.e. reducing the amplitude) input signals with lower frequencies. The circuit in [Figure 4.6](#) is the most common type of High Pass Filter (HPF). Anytime a capacitor is placed in series in between the input and output a HPF is produced. When a capacitor is placed in this fashion it is often called a coupling capacitor or a DC blocking capacitor because the capacitor blocks the DC signal and prevents it from getting to the output. The gain at 0 Hz is 0 V/V so the far left side of the Bode magnitude plot starts low and ramps up at 20 dB/dec until it reaches the 3dB frequency. Then (at f_{3dB}) the slope is gradually reduced by 20 dB/dec resulting in a flat response (0 dB/dec).

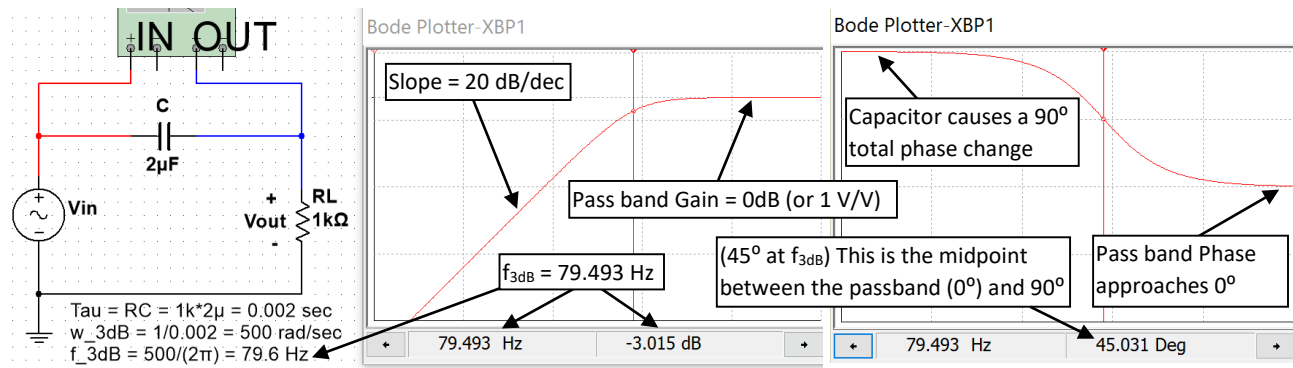

Figure 4.6: RC High Pass Filter Circuit with a 3dB frequency (f_{3dB}) equal to 79.6 Hz.

The other 1st order filter with only one resistor is an RL circuit with the output taken across the inductor as shown in [Figure 4.7](#).

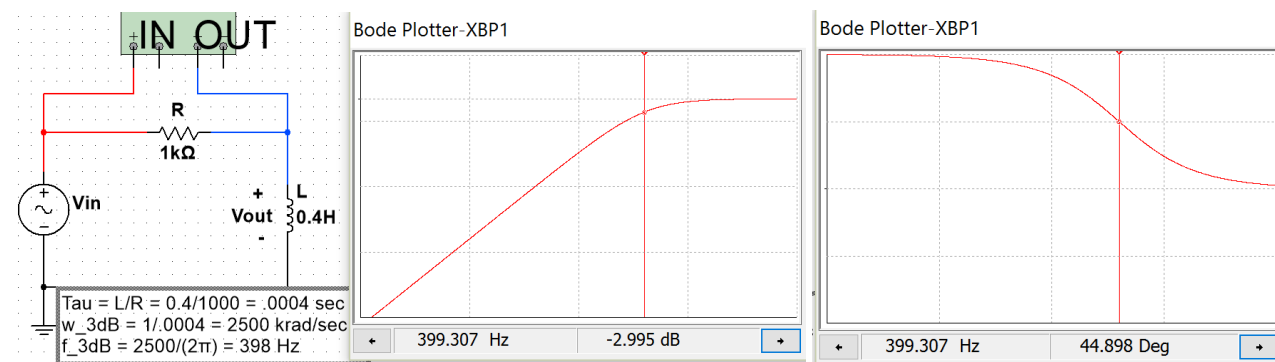

Figure 4.7: RL High Pass Filter Circuit with a 3dB frequency (f_{3dB}) equal to 398 Hz.

Example 4.2) Design a RC HPF circuit that has a 3dB frequency of 1 kHz and determine the output if the standard AC wall outlet signal (equation shown below) is the input and the output is connected to a 10Ω load resistance.

- $v_{in1}(t) = 120\sqrt{2} \sin(2\pi \cdot 60 \cdot t)$

To achieve a f_{3dB} frequency of 1 kHz [Equation 4.4](#) shows the time constant is equal to $1 / (2\pi \cdot 1000) = 0.159$ msec.

[Equation 4.5](#) shows that the time constant for a RC circuit is $\tau = R_{eq}C$, where R_{eq} is equal to the resistor in the circuit. To avoid reducing the gain only one resistor will be used in the circuit. **C can be solved for using the**

equation $C = \tau/R_{eq} = 0.000159/100 = 1.59 \mu\text{F}$. This HPF circuit is shown below and the Bode magnitude plot in Multisim verifies that the gain is approximately -3 dB at 1 kHz.

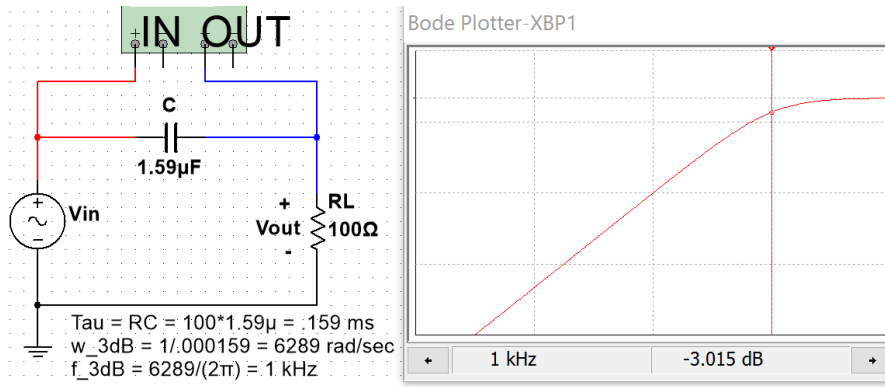

Figure 4.8: RC HPF design for Example 4.2 with Multisim verification of the 1 kHz f_{3dB} .

To determine the output from the AC wall outlet signal the gain and phase at 60 Hz are shown in Figure 4.9.

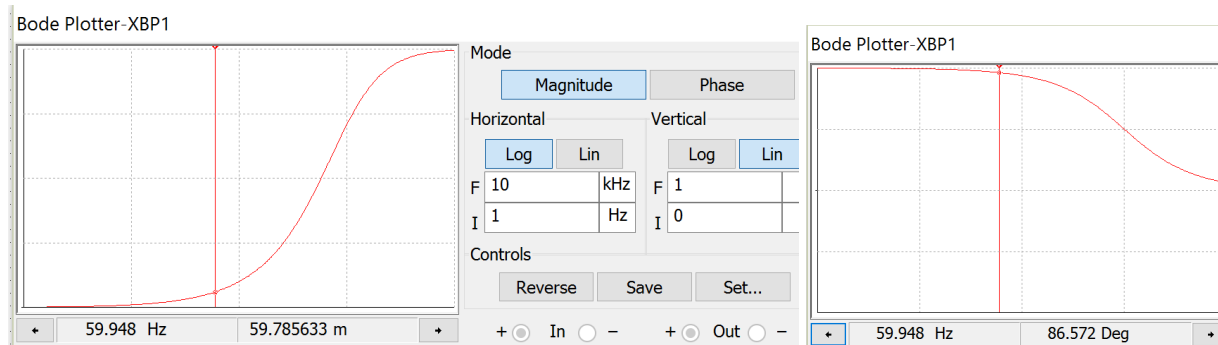

Figure 4.9: RC HPF design for Example 4.2 with Multisim gain and phase change at 60 Hz.

The “Lin” option for the Bode magnitude plot is used in Figure 4.9 to avoid having to manually do the dB to V/V conversion. The value shown in the left plot of Figure 4.9 is 59.785633 m (or $G_{V/V} = 0.059785633 \text{ V/V}$). Since 60 Hz is less than 1 decade away from the 1 kHz f_{3dB} the phase change should be approximately 90° different from the passband. To be more exact, we will use the cursor value at a frequency as close to 60 Hz as possible on the Bode phase plot (recall the resolution of the Bode plot is limited so exactly 60 Hz can’t be selected). The value of the phase change ($\Delta\theta$) in the right plot of Figure 4.9 is equal to 86.572° .

- $v_{out}(t) = A \cdot G_{V/V} \cdot \sin(\omega \cdot t + \theta + \Delta\theta) = 169.7 \cdot 0.0597856 \cdot \sin(2\pi(60) \cdot t + 0^\circ + 86.572^\circ)$
- $v_{out1}(t) = 10.15 \sin(120\pi \cdot t + 86.572^\circ)$

Using the Bode plot to determine the output signal is much easier than solving the problem algebraically. The following steps show how to solve this problem and the values are verified in the Multisim scope plot in Figure 4.10. The problem solving technique shown below is the same process that was performed in Section 3.2 - Series RLC Circuits. The Blue Font shows the Multisim measurements. Notice that they closely match the calculations.

- $\omega = 2\pi \cdot f = 2\pi \cdot 60 = 377 \text{ rad/sec.}$
- $X_C = 1/(1.59\mu\text{F} \cdot \omega) = 1668.3 \Omega$
- $Z_{Total} = R_L - j X_C = 100 - j 1668.3$ $Z_{Total} = 1671.3 \angle -86.57^\circ \Omega$ (ICE) (Notice: V_{RL} leads V_{in} in Figure 4.10)
- $I = V_{in}/Z_{Total} = 169.7 \angle 0^\circ / 1671.3 \angle -86.57^\circ = 101.5 \angle +86.57^\circ \text{ mA}$
- Time shift, t_s , of current = $-\theta/\omega = -86.57^\circ \cdot (\pi/180^\circ) / 377 \text{ rad/sec} = -0.401 \text{ ms}$ (**-4.017 ms in Multisim**)
- $V_{RL} = I \cdot R_L = (101.5 \angle +86.57^\circ \text{ mA}) \cdot (100 \angle 0^\circ) = 10.15 \angle 86.57^\circ$ (**10.154**) $\rightarrow v_{RL}(t) = 10.15 \cdot \sin(120\pi \cdot t + 86.57^\circ)$

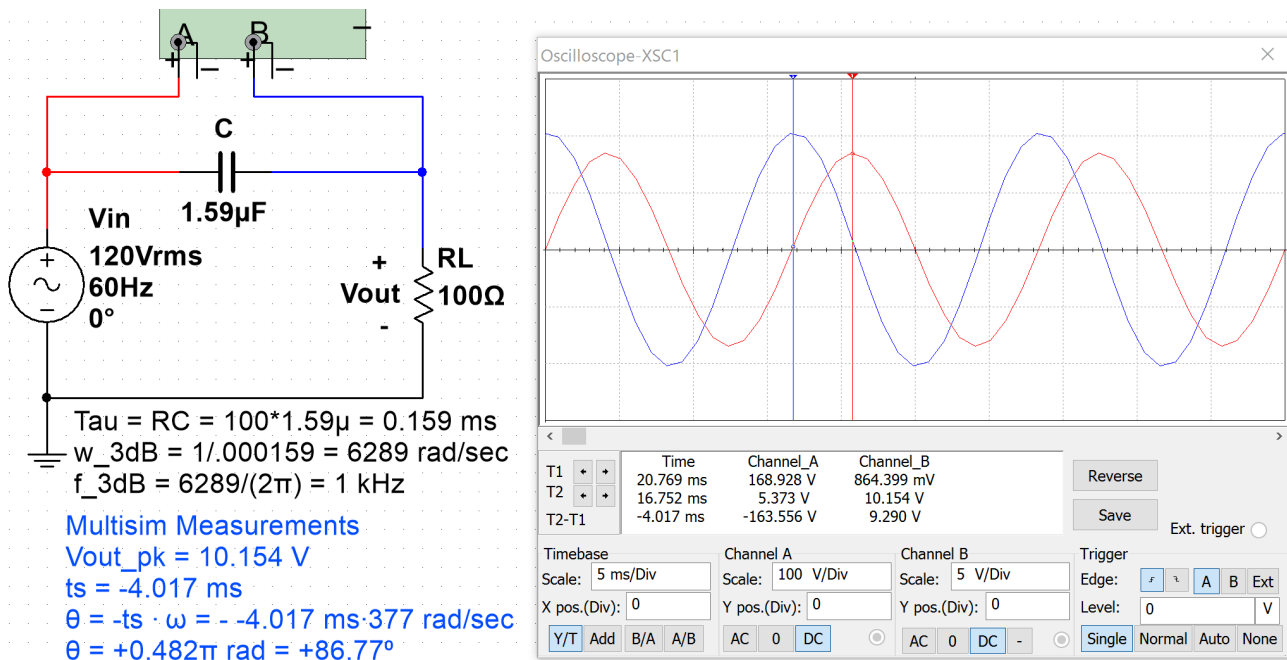

Figure 4.10: Multisim oscilloscope verification of Bode plot and calculated results of Example 4.2.

A 2nd order HPF is solved with Matlab using the Laplace Transform method in [Figure A.3](#) in the Appendix.

Section 4.3 –Band Pass Filters (BPF)

In general terms, High Pass Filters “partially reject” signals with frequencies below $f_{3\text{dB}}$ and Low Pass Filters “partially reject” signals with frequencies above $f_{3\text{dB}}$. The word “partially” is used because complete rejection would mean that an input signal at a specific sinusoidal frequency is multiplied by zero to completely remove it (and that doesn’t occur). However, the further away the input signal’s frequency is from $f_{3\text{dB}}$ the more rejection (or attenuation) occurs (i.e. the amplitude is multiplied by a value that approaches zero). At this point, before discussing Band Pass and Band Stop filters the terms “Pass Band” and “Stop Band” need to be reviewed.

- Pass Band – Section of the frequency response (or Bode magnitude plot) that is “passed”.
- Stop Band – Section of the frequency response (or Bode magnitude plot) that is “rejected”.

[Figure 4.11](#) and [Figure 4.12](#) show the Bode magnitude plots for the 4 categories of filters that are commonly used. [Figure 4.11](#) shows the pass band and stop band for 1st order Low Pass and High Pass filters. [Figure 4.12](#) shows the pass band and stop band for the 2nd order Band Pass Filter circuit in [Figure 4.13](#) and the pass band and stop band for 2nd order Band Stop Filter for the circuit in [Figure 4.16](#). Only the most basic LPF, HPF, BPF, and BSF will be discussed in this eBook. Multiple capacitors and inductors can be arranged to produce higher order passive filters that have steeper Bode magnitude plots and therefore attenuate the signals at frequencies in the stop band to a greater extent (i.e. make the gain closer to 0 V/V).

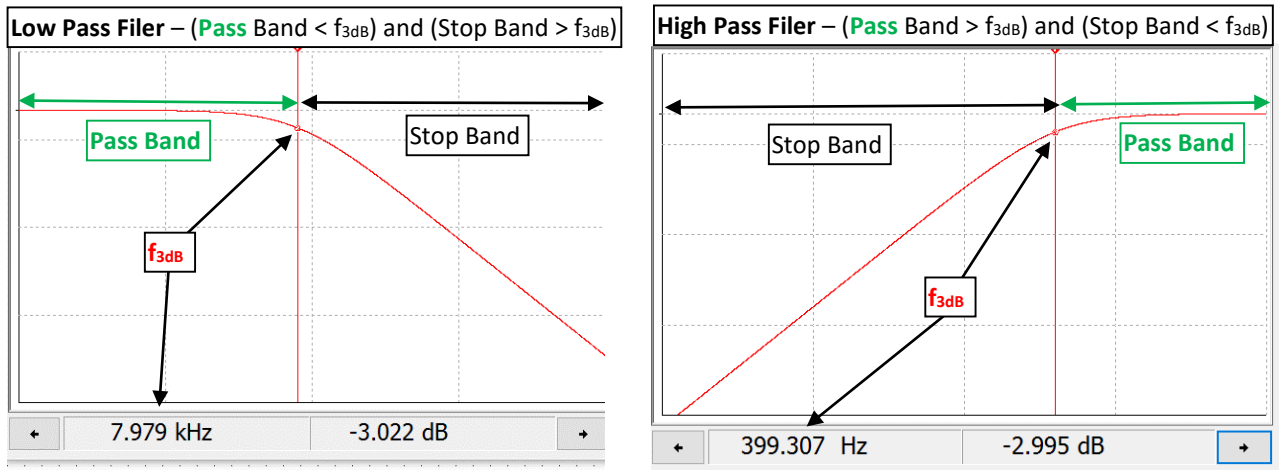

Figure 4.11: 1st order LPF from circuit in Figure 4.5 (Left). 1st order HPF from circuit in Figure 4.7 (Right)

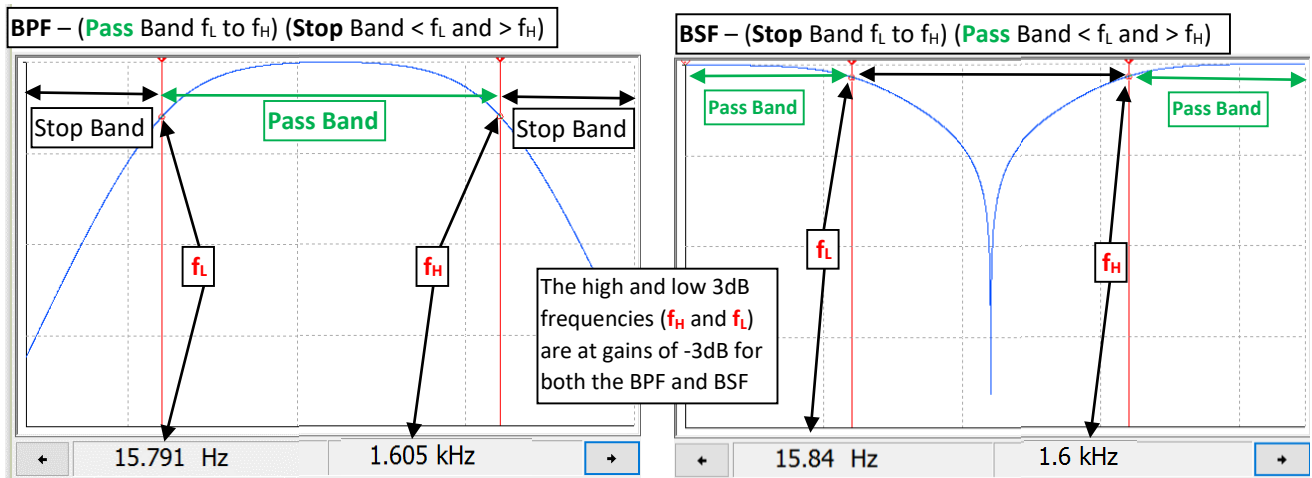

Figure 4.12: 2nd order BPF from circuit in Figure 4.13 (Left). 2nd order BSF from circuit in Figure 4.16 (Right)

By combining the RL LPF in Figure 4.5 and the RC HPF in Figure 4.6 a RLC BPF can be created as shown in Figure 4.13. The values of the components in the circuit give it a wide pass band which makes it a “Low-Q” BPF.

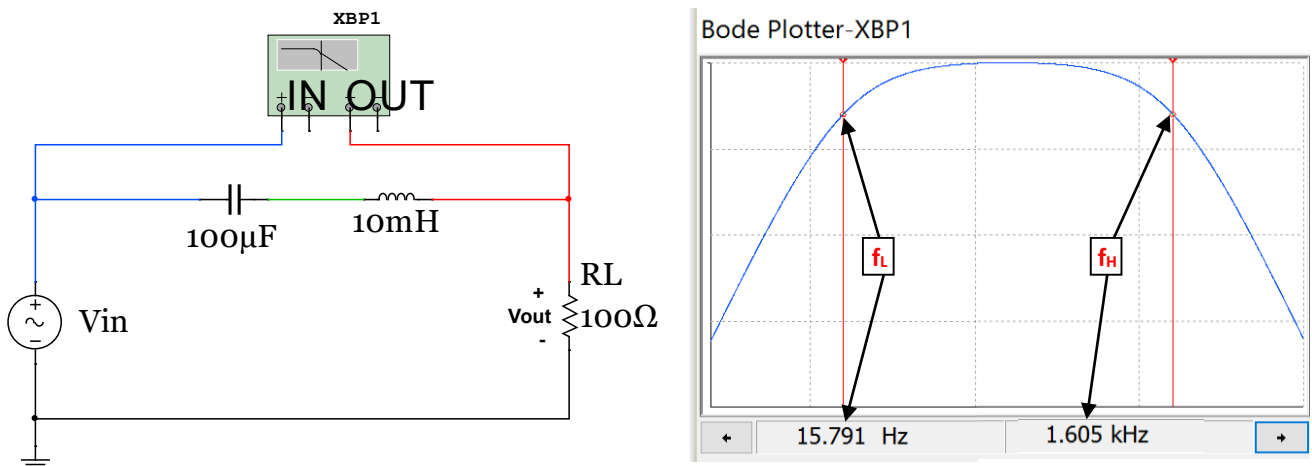

Figure 4.13: 2nd Order Low-Q RLC Band Pass Filter.

The Bode plot in [Figure 4.13](#) has 5 dB per division scale on the y-axis and a logarithmic scale on the x-axis that increases 1 decade (a factor of 10 in Hertz) every division. The y-axis values for f_L and f_H are at gain values as close to -3 dB as possible with the best resolution of the Bode plot that was possible. The Bode plot shows two cursors on the Bode plot, but in Multisim only one cursor is available. The Bode plots in sections 4.3 and 4.4 with two 3dB frequencies shown were created by splicing two different Multisim Bode magnitude plots together.

When the pass band of a BPF is wide it is called a broad band or Low-Q filter and when the pass band is narrow they it is called a narrow band or High-Q filter. The Q in Low-Q and High-Q comes from the “**Quality Factor**” parameter. **Q** is used for RLC Band Pass filters as a measure of **frequency selectivity**. If **Q** is low then the filter is not designed to select a specific frequency, but pass a range of frequencies instead. To determine the Quality Factor the resonant frequency needs to first be calculated using [Equation 4.7](#). RLC circuits like those shown in [Figures 4.13](#) and [4.14](#) tend to resonate (or cause oscillations) at a specific frequency as shown in [Figure 4.15](#). This frequency is also called the “center frequency” because it is the geometric mean of the pass band as shown in [Equation 4.8](#). The pass band region is quantified by a term called bandwidth (BW) that is the frequency range between the low 3 dB frequency (f_L) and the high 3 dB frequency (f_H) as shown in [Equation 4.9](#).

$$[4.7] \quad \boxed{\text{Resonant Frequency} = f_0 = \text{Center Frequency} = f_c = \frac{1}{2\pi\sqrt{L \cdot C}}}$$

$$[4.8] \quad \boxed{f_c = \sqrt{f_L \cdot f_H}}$$

$$[4.9] \quad \boxed{BW = f_H - f_L}$$

$$[4.10] \quad \boxed{\text{Quality Factor} = Q = \frac{f_c}{BW}}$$

Equations 4.7 through 4.10 are true for the series RLC BPF shown in this section regardless of the values of the components. For the circuit in [Figure 4.13](#) the [Equation 4.7](#) produces the following results:

- $f_0 = f_c = \frac{1}{2\pi\sqrt{L \cdot C}} = \frac{1}{2\pi\sqrt{10^{-3}H \cdot 100^{-6}F}} = 159.155 \text{ Hz}$

For a **Low-Q** Band Pass Filters with a large bandwidth (at least 2 decades of frequency difference between f_L and f_H like the BPF example shown in [Figure 4.12](#)) the low and high 3 dB frequencies can be approximated fairly closely with equations 4.11 and 4.12, which are the same equations used for 1st order LPF and HPF circuits.

$$[4.11] \quad \boxed{f_L \cong \frac{1}{2\pi \cdot R \cdot C}} \quad \text{*This is accurate for series RLC BPF when } f_H \text{ and } f_L \text{ are separated by 2 decades.}$$

$$[4.12] \quad \boxed{f_H \cong \frac{R}{2\pi \cdot L}} \quad \text{*This is accurate for series RLC BPF when } f_H \text{ and } f_L \text{ are separated by 2 decades.}$$

When f_L and f_H become closer together, [Equation 4.11](#) and [Equation 4.12](#) become less accurate. For example, in the circuit in [Figure 4.13](#), [Equation 4.11](#) and [Equation 4.12](#) calculate the values as follows (The Multisim values are in Blue Font):

- $f_L \cong \frac{1}{2\pi \cdot R \cdot C} = \frac{1}{2\pi \cdot 100\Omega \cdot 100^{-6}F} = 15.9 \text{ Hz}$ **Multisim: 15.791 Hz**
- $f_H \cong \frac{R}{2\pi \cdot L} = \frac{100\Omega}{2\pi \cdot 10^{-3}H} = 1.59 \text{ kHz}$ **Multisim: 1.605 kHz**

In this example f_L and f_H obey the rule of thumb that states the 3 dB frequencies (f_L and f_H) need to be two decades or more apart for the approximations of equations 4.11 and 4.12 to be accurate. Using the approximate calculations in equations 4.11 and 4.12 the bandwidth and quality factor can be calculated as:

- $BW = f_H - f_L = 1.59 \text{ kHz} - 15.9 \text{ Hz} = 1575.6 \text{ Hz}$
- $Q = \frac{f_c}{BW} = \frac{159.155 \text{ Hz}}{1575.6 \text{ Hz}} = 0.1$

A series RLC BPF circuit with a Q value of 0.1 can be safely called Low-Q. Furthermore, if the capacitor in the circuit in [Figure 4.13](#) is changed to a value of 10 μF then f_L becomes **159 Hz** which is only one decade from f_H . When this circuit (with a 10 μF capacitor) is simulated in Multisim the f_L and f_H values are **147 Hz** and **1.734 kHz** respectively, which shows equations 4.11 and 4.12 have significant error when the 3 dB frequencies are only one decade apart. Using the approximate calculations in equations 4.11 and 4.12, the bandwidth and quality factor can be calculated as follows:

Note: The number in Blue Font is the BW determined from Multisim which will be much more accurate than equations 4.11 and 4.12 when f_L and f_H are only one decade apart.

- $f_c = \frac{1}{2\pi\sqrt{L \cdot C}} = \frac{1}{2\pi\sqrt{10^{-3}H \cdot 10^{-6}F}} = 503.3 \text{ Hz}$
- $BW = f_H - f_L = 1.59 \text{ kHz} - 159 \text{ Hz} = 1432.4 \text{ Hz}$ **Multisim: BW = 1587 Hz**
- $Q = \frac{f_c}{BW} = \frac{503.3 \text{ Hz}}{1432.4 \text{ Hz}} = 0.35$

A Q value of 0.35 would still probably be considered a Low-Q filter, but there is no simple method or equation to use to easily calculate f_L and f_H for that circuit. Unfortunately, there is no perfect Q cut-off point that separates a High-Q from a Low-Q filter, but there are approximate equations that can be accurately used for series RLC circuits that are extremely Low-Q or extremely High-Q. Equations 4.11 and 4.12 can be accurately used for extremely Low-Q series RLC circuits like shown in [Figure 4.13](#) where f_H and f_L separated by 2 decades (Note: The Q value was 0.1 for the circuit in [Figure 4.13](#)).

Example 4.3) Design a circuit that filters out frequencies that are NOT in the audio range (20 Hz to 20 kHz). Use the Bode plot to determine the output due to the following two signals.

- $v_{in1}(t) = 5 \sin(2\pi \cdot 1000 \cdot t)$ This signal should pass through the filter with little to no attenuation.
- $v_{in2}(t) = 2.3 \sin(2\pi \cdot 50,000 \cdot t + 0.2\pi)$ This signal is beyond 20 kHz so it should be significantly attenuated.

A low-Q BPF can be used since the upper and lower frequency limits are at least 2 decades apart. If we set the 3dB frequencies at 20 Hz (f_L) and 20 kHz (f_H) only the edges of the audio range will be slightly attenuated. The resistor needed in the series RLC BPF circuit can be selected as many different values and still achieve the desired 3dB frequencies. To keep the current in the circuit fairly low **a resistor value of 1 k Ω will be selected**. Equations 4.11 and 4.12 are used to determine the values of the capacitor and inductor that is needed.

- Set $f_L = \frac{1}{2\pi \cdot R \cdot C} = 20 \rightarrow C = \frac{1}{2\pi \cdot R \cdot f_L} = \frac{1}{2\pi \cdot 1000 \cdot 20} = 7.96 \mu\text{F}$

- Set $f_H = \frac{R}{2\pi \cdot L} = 20,000 \rightarrow L = \frac{R}{2\pi \cdot f_H} = \frac{1000}{2\pi \cdot 20,000} = 7.96 \text{ mH}$

The following shows the final circuit design along with the Bode magnitude plot showing f_L is at 20 Hz and f_H is at 20 kHz. Two separate Bode Magnitude plots are shown so the exact gain can be seen.

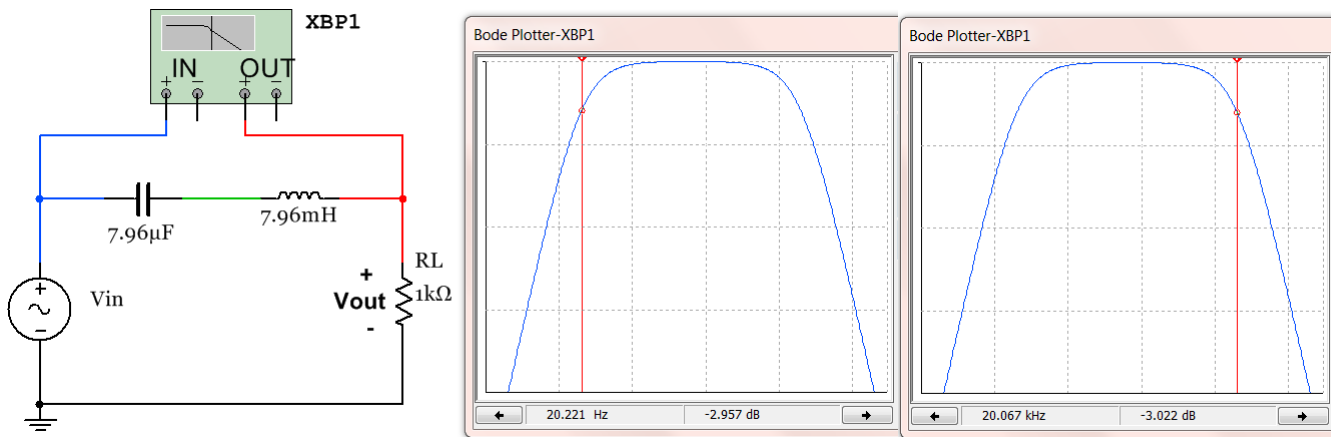

Next, the Bode Plot is shown at the frequency of V_{in1} (1 kHz) and V_{in2} (50 kHz).

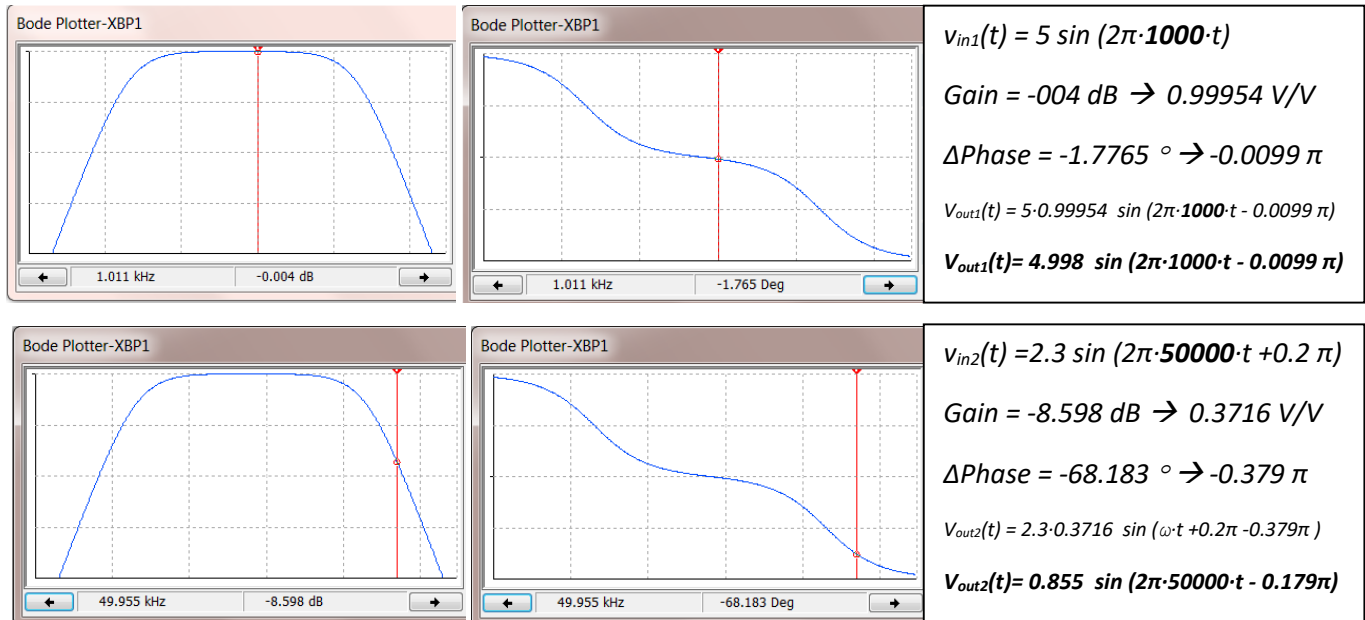

Next, equations 4.13 and 4.16 are introduced that can be accurately used for extremely **High-Q series RLC circuits**. If the Q value is calculated to be 10 or greater, like the one shown in [Figure 4.14](#), great accuracy is achieved, but when Q drops lower than 10 equations 4.13 to 4.16 become less accurate as shown in the following example for a series RLC BPF circuit with $Q = 3.16$.

For **High-Q filters** Q and BW can be calculated using equations [4.13](#) and [4.14](#) and then f_L and f_H can be calculated using equations [4.15](#) and [4.16](#). These equations produce very close approximations when Q is 10 or greater as shown in the next example. [Equation 4.13](#) shows that X_C equals X_L at the center frequency, f_C , for High-Q BPFs.

[4.13]
$$Q = \frac{X_L}{R} = \frac{2\pi \cdot f_c \cdot L}{R} = \frac{X_C}{R} = \frac{1}{2\pi \cdot f_c \cdot R \cdot C}$$
 Only use [Equation 4.13](#) if $Q \geq 10$.

$$[4.14] \quad BW = \frac{f_c}{Q}$$

$$[4.15] \quad f_L \cong f_c - \frac{BW}{2}$$

$$[4.16] \quad f_H \cong f_c + \frac{BW}{2}$$

When the capacitor in the series RLC circuit in [Figure 4.13](#) is changed to a much smaller value, f_L moves to the right (as shown in [Figure 4.14](#)), which results in the bandwidth narrowing and Q increasing. Now the **High-Q filter equations (4.13 to 4.16)** can be used to produce accurate results (see the Multisim comparison below).

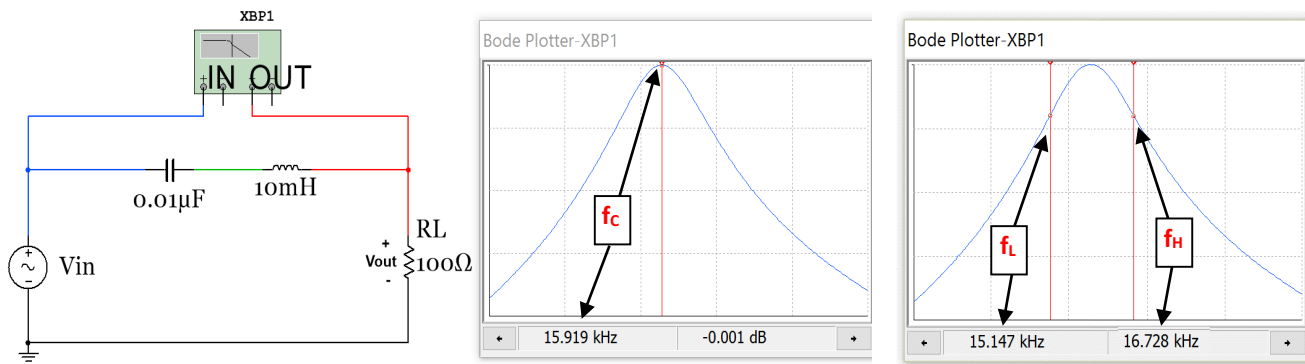

Figure 4.14: 2nd order High-Q RLC Bandpass Filter with 2 screen shots of the Bode Magnitude plot.

- $f_c = \frac{1}{2\pi\sqrt{L\cdot C}} = \frac{1}{2\pi\sqrt{0.01H\cdot 0.01^{-6}F}} = 15.9155 \text{ kHz}$ **Multisim: $f_c = 15.919 \text{ kHz}$**
- $Q = \frac{X_C}{R} = \frac{X_L}{R} = \frac{2\pi\cdot f_c\cdot L}{R} = \frac{2\pi\cdot 15915.5\text{Hz}\cdot 0.01H}{100\Omega} = \underline{10}$
- $BW = \frac{f_c}{Q} = \frac{15.919 \text{ kHz}}{10} = 1.59155 \text{ kHz}$
- $f_L \cong 15.9155 \text{ kHz} - \frac{1591.55 \text{ kHz}}{2} = 15.12 \text{ kHz}$ **Multisim: $f_L = 15.147 \text{ kHz}$**
- $f_H \cong 15.9155 \text{ kHz} + \frac{1591.55 \text{ kHz}}{2} = 16.71 \text{ kHz}$ **Multisim: $f_H = 16.728 \text{ kHz}$**

This shows when Q equal to 10 equations 4.15 and 4.16 give very close approximations, but if the **capacitor is increased to a value of 0.1 μF** and Q is reduced the approximation is not as accurate (as shown below).

- $f_c = \frac{1}{2\pi\sqrt{L\cdot C}} = \frac{1}{2\pi\sqrt{0.01H\cdot 0.1^{-6}F}} = 5.033 \text{ kHz}$ **Multisim: $f_c = 5.038 \text{ kHz}$**
- $Q = \frac{X_C}{R} = \frac{X_L}{R} = \frac{2\pi\cdot f_c\cdot L}{R} = \frac{2\pi\cdot 5.033 \text{ kHz}\cdot 0.01H}{100\Omega} = \underline{3.16}$
- $BW = \frac{f_c}{Q} = \frac{50.33 \text{ kHz}}{3.16} = 1591.55 \text{ kHz}$
- $f_L \cong 50.33 \text{ kHz} - \frac{1591.55 \text{ kHz}}{2} = 4.237 \text{ kHz}$ **Multisim: $f_L = 4.301 \text{ kHz}$**
- $f_H \cong 50.33 \text{ kHz} + \frac{1591.55 \text{ kHz}}{2} = 5.829 \text{ kHz}$ **Multisim: $f_H = 5.894 \text{ kHz}$**

These values show that when C was increased to 0.1 μ F and **Q = 3.16** the approximations of equations 4.15 and 4.16 are still **fairly accurate**, but not nearly as accurate as when Q was equal to 10 for the circuit in [Figure 4.14](#).

In summary, there is not a perfect cut-off for the Quality Factor, Q, which classifies a series RLC BPF as High-Q or Low-Q. The following Rules of Thumb help determine which equations to use to calculate f_L and f_H .

- You should only expect “very close” results (i.e. that the calculated f_L and f_H frequencies are at -3 dB gain points) with [Equations 4.15 and 4.16](#) when **Q \geq 10**. Q values of 10 or greater should definitely classify the series BPF as **High-Q**.
- You should only expect “very close” results with [Equations 4.11 and 4.12](#) for f_L and f_H when **f_L and f_H are 2 decades in frequency apart**. If this occurs the BPF or BSF should definitely be classified as **Low-Q**.
- If f_L and f_H are closer to each other than 2 decades in frequency **and** the Q value is less than 10 then there is no easy way to accurately determine the values of f_L and f_H . This would be a problem that would need to be solved using the Laplace Transform method (as shown in the [Appendix](#)). In this situation, the determination of whether to classify the filter as High-Q or Low-Q is also not clear.

Before moving on to Band Stop Filters the idea of resonance in RLC circuits and the “resonant frequency” defined in [Equation 4.7](#) should be explained in more detail. For the circuit in [Figure 4.14](#) the resonant frequency, f_0 , (or center frequency, f_c) is calculated as 15.92 kHz. The figure below shows the transient response of the circuit in [Figure 4.14](#) when the input voltage is a 1 V DC signal that is suddenly applied (i.e. a step input, $u(t)$). Since the capacitor acts as an open circuit at DC the voltage across the resistor will approach zero at steady state. However, in the transient region the voltage across the resistor will oscillate (or resonate) at the resonant frequency until the oscillations die out as steady state is reached as shown in [Figure 4.15](#). The cursors in [Figure 4.15](#) are placed at locations where the difference between them is the half-period of the oscillations. $T/2$ can be determined from these cursors as (0.000518 – 0.000487 = 0.000031 seconds) which equates to a frequency of $(1/(2 \cdot 0.000031)) = \sim 15.92$ kHz) which is equal to the calculated resonant frequency from [Equation 4.7](#). The Matlab bode magnitude plot in [Figure 4.15](#) is also shown to match the Multisim Bode plot in [Figure 4.14](#) closely.

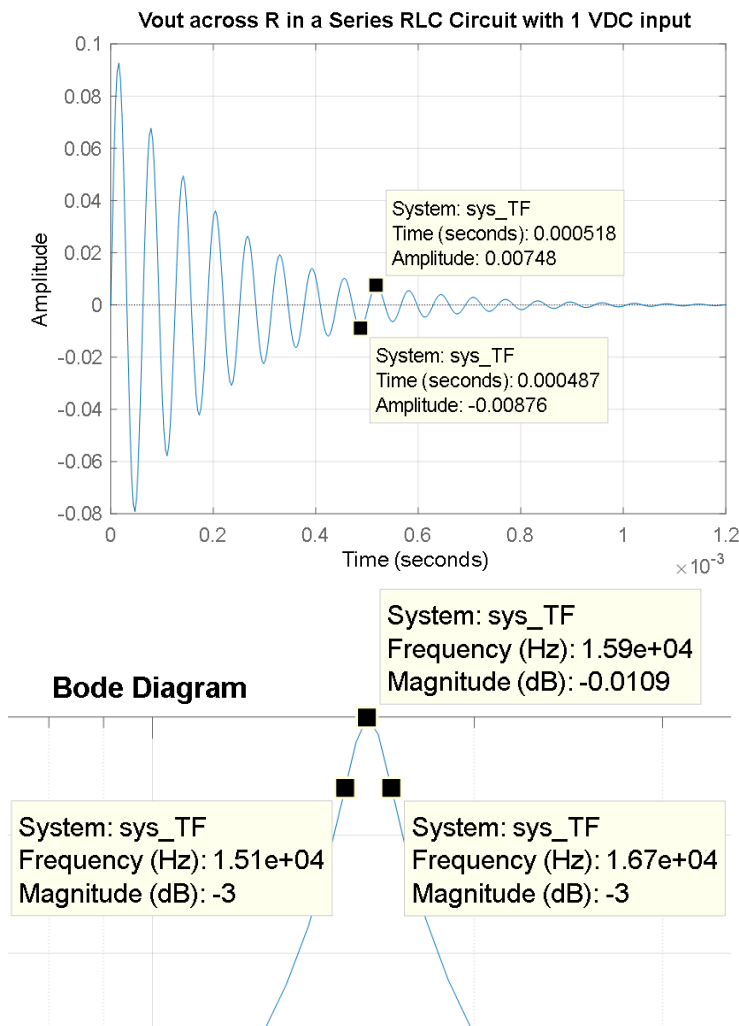

```

% Step response and Bode Magnitude Plot of
an RLC series circuit
C = 0.01e-6;
L = 10e-3;
R = 100;
syms s
Zt = R + 1/(C*s) + L*s;
Vin_s = 1; %Laplace Transform of delta function
Vout_s = Vin_s*R/Zt; %VDR
% Since Vin_s is equal to 1 Vout_s is actually
equal to (Vout(s)/Vin(s))
TF_sym = Vout_s;
% Find the numerator & denominator of
TF_sym
[num_TF_sym,den_TF_sym]=numden(TF_sym)
% Convert num & den to polynomial form
num_TF = sym2poly(num_TF_sym);
den_TF = sym2poly(den_TF_sym);
% Find the transfer function (Vo/Vin)
sys_TF = tf(num_TF,den_TF);
figure(1)
step(sys_TF)%This is the step response
title ('Vout across R in a Series RLC Circuit with
1 VDC input')
figure(2)
h = bodeplot(sys_TF)
setoptions(h,'FreqUnits','Hz','PhaseVisible','off')

```

Figure 4.15: Matlab step response and Bode plot simulation of the 2nd order High-Q filter circuit in Figure 4.14.

Section 4.4 –Band Stop Filters (BSF)

Band Stop Filter (BSF) will not be covered in as much detail as the other filters since its applications are not as numerous as the others. A Band Stop Filter (also called Band Reject Filter or Notch Filter) is essentially the opposite of a BPF because it partially rejects a range of frequencies in its stop band, but passes low and high frequencies that are outside the stop band. The term notch filter is used in the previous sentence because it is a much more descriptive term than BSF. The notch in the filter can be used to eliminate specific noise that is present in a circuit. A common application of a notch filter is to remove 60 Hz noise from AC devices that are plugged into AC wall outlets. Wires or cables that travel in close proximity to 60 Hz noise sources tend to pick up noise, which can sometimes negatively affect the performance of the circuit. By adding in a 60 Hz notch filter the noise can be eliminated to improve the performance of the circuit.

A common 2nd order (2 reactive elements: 1 inductor and 1 capacitor) BSF circuit is shown in Figures 4.16. The Bode magnitude plot and calculations of the center frequency (f_c) and the bandwidth (BW) are also included. These two parameters characterize the notch in the BSF and the equations that apply to them are shown in

equations 4.7 and 4.9. The steeper the notch the more “selective” the filter is at rejecting frequencies. The term quality factor (Q) shown in [Equation 4.10](#) is used to quantify how selective the notch is. As described in [Section 4.3](#), the quality factor was also used to determine how selective a BPF is at “passing” the center frequency. The 2nd order Low-Q BPF in [Figure 4.13](#) is in many ways the opposite of the BSF shown in [Figure 4.16](#). The parallel capacitor and inductor result in something frequently referred to as a “Tank Circuit”, which oscillates at its resonant frequency and stores energy (like a storage tank). Notice that the inductor causes f_L and the capacitor causes f_H , but it was the opposite for the series RLC BPF. The center frequency of the tank-style RLC BSF circuit also uses [Equation 4.7](#) like the series RLC BPF.

Note: The quality factor (and High-Q and Low-Q classifications) will not be applied to the Band Stop Filter and only the following two equations will be given for the situation when f_H and f_L are separated by 2 decades.

[4.17] $f_L \cong \frac{R}{2\pi \cdot L}$ *This is accurate for tank-style RLC BSF when f_H and f_L are separated by 2 decades.

[4.18] $f_H \cong \frac{1}{2\pi \cdot R \cdot C}$ *This is accurate for tank-style RLC BSF when f_H and f_L are separated by 2 decades.

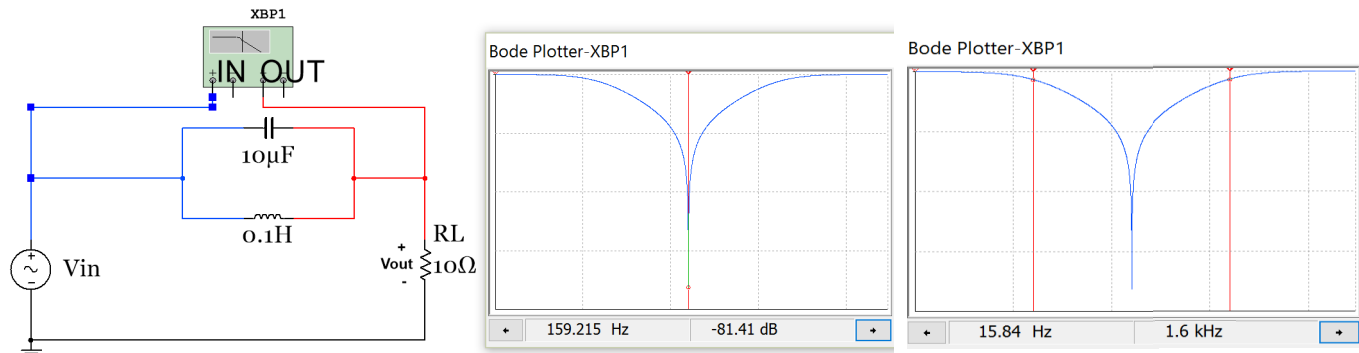

Figure 4.16: 2nd order RLC Band Stop Filter.

This BSF circuit in [Figure 4.16](#) (with **L=100 mH**) has the same f_C , f_L , and f_H as the BPF circuit in [Figure 4.13](#) (as shown in the bulleted calculations below). The only difference (other than it is the opposite type of filter with the pass band and stop bands reversed) is that f_H comes from the capacitor and f_L comes from the inductor.

- $f_C = \frac{1}{2\pi\sqrt{L \cdot C}} = \frac{1}{2\pi\sqrt{0.1H \cdot 10^{-6}F}} = 159.155 \text{ Hz}$ **Multisim: 159.215 Hz**
- $f_H \cong \frac{1}{2\pi \cdot R \cdot C} = \frac{1}{2\pi \cdot 10\Omega \cdot 10^{-6}F} = 1.59 \text{ kHz}$ **Multisim: 1.6 kHz**
- $f_L \cong \frac{R}{2\pi \cdot L} = \frac{10\Omega}{2\pi \cdot 0.1H} = 15.9 \text{ Hz}$ **Multisim: 15.84 Hz**
- $BW = f_H - f_L = 1.59 \text{ kHz} - 15.9 \text{ Hz} = 1575.6 \text{ Hz}$ **Multisim: BW = 1584 Hz**

If the inductor in [Figure 4.16](#) is changed to a value of **L= 10 mH** then f_L becomes **159 Hz** which is only one decade from f_H . When this circuit (with a 10 mH inductor) is simulated in **Multisim the f_L and f_H values are 146.3 Hz and 1.732 kHz** respectively and the bandwidth is $(1732 - 146.3 = 1585.7 \text{ Hz})$. The Multisim simulated values are shown below to be much different than the calculated values from equations 4.17 and 4.18. The error results by using equations 4.17 and 4.18 when f_L and f_H are only being one decade apart.

- $f_C = \frac{1}{2\pi\sqrt{L \cdot C}} = \frac{1}{2\pi\sqrt{10^{-3}H \cdot 10^{-6}F}} = 503.3 \text{ Hz}$ **Multisim: $f_C = 503.4 \text{ Hz}$**
- $BW = f_H - f_L = 1.59 \text{ kHz} - 159 \text{ Hz} = 1432.4 \text{ Hz}$ **Multisim: BW = 1585.7 Hz**

Module 5 – Transformers

A brief overview of transformers is needed in this eBook for two reasons. First of all, the invention of the transformer led to AC voltages being used as the primary electric power source worldwide (Read: https://en.wikipedia.org/wiki/War_of_Currents for more information on this topic). Additionally, transformers are included in this eBook because without them rectifier circuits (Section 6.3) that convert an AC voltage to a DC voltage could not be adequately covered. If this module is not in depth enough, the following two links from allaboutcircuits.com are recommended as additional resources.

<http://www.allaboutcircuits.com/textbook/alternating-current/chpt-9/mutual-inductance-and-basic-operation/>

<http://www.allaboutcircuits.com/video-lectures/transformers-part-1/>

Figure 5.1 shows a transformer with the following quantities labeled: primary voltage (V_p), primary current (I_p), secondary voltage (V_s), secondary current (I_s), and the turns ratio ($N_p:N_s$ or N_p/N_s). The primary side of the transformer connects to the input and the secondary side of the transformer connects to the output (or load).

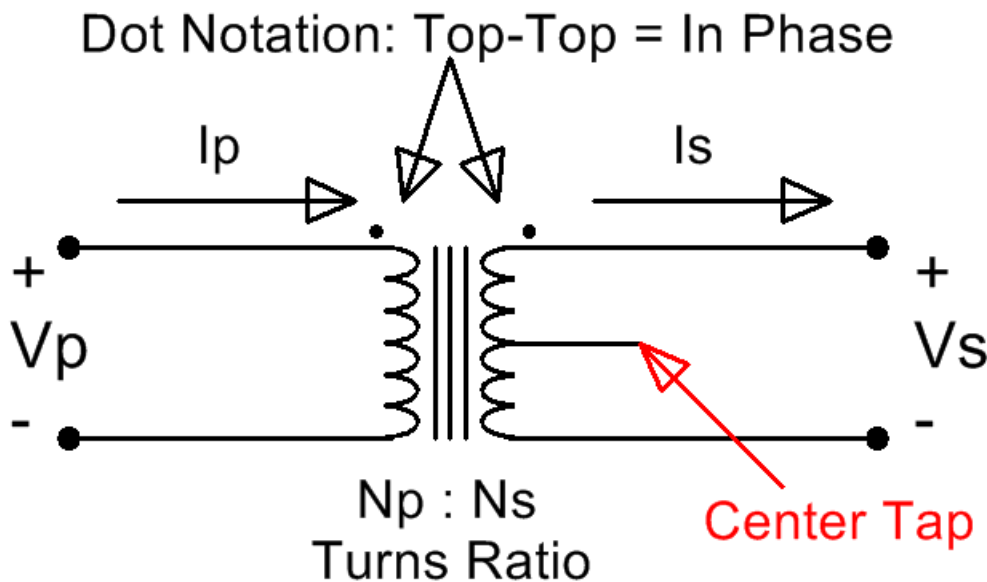

Figure 5.1: Iron Core Transformer Symbol

The vertical lines in the center of the transformer signify that it has an iron core. An iron core transformer is usually used for low frequency applications, including power transmission, which is the primary application addressed in this eBook. The curves on either side of the core represent the magnetic coil of wire that is wrapped around the primary and secondary sides of the transformer. The turns-ratio is the ratio of the number of primary coil turns of wire to the number of secondary coil turns of wire. The turns ratio is usually listed as $N_p:N_s$ or N_p/N_s . The middle line extending horizontally from the center of the secondary is called the center tap. Some transformers have this physical connection (or tap) that separates two sections of the secondary coil. If the tap is left unwired as shown in Figure 5.1 then the transformer will act as a standard transformer and can be used for half wave or full wave bridge rectifier circuits as shown in Section 6.3. However, if the middle wire is used then both sides of the tap will have its own turns-ratio value that must be factored into the problem. There are three possible wiring methods for standard transformer applications that use only two wires: top and middle legs, bottom and middle legs, and top and bottom legs. All three wires can be used in certain applications such as parallel (or center tap) full wave rectifier circuits (Shown in the third figure from the top in this [link](#)). The two

dots above the primary and secondary coil symbols are used to label the type of phase change the transformer will have. The dot notation states that if both dots are on top (or if there is only a single dot on top) then the primary and secondary voltages will be in phase (0° phase shift) and if one is on top and the other is on bottom then there will be a 180° phase shift.

Governed by [Faraday's law \(Equation 5.1\)](#), current from the input voltage source (V_p) is forced through the primary coil of wire, which results in a magnetic flux being generated in the iron core. The flux travels through the iron core and induces a voltage difference on the secondary coil of wire (V_s) as shown in [Figure 5.2](#).

[5.1]
$$e = N \frac{d\Phi}{dt}$$
 *Where e is the induced voltage, N is the # of turns, and Φ is the flux.

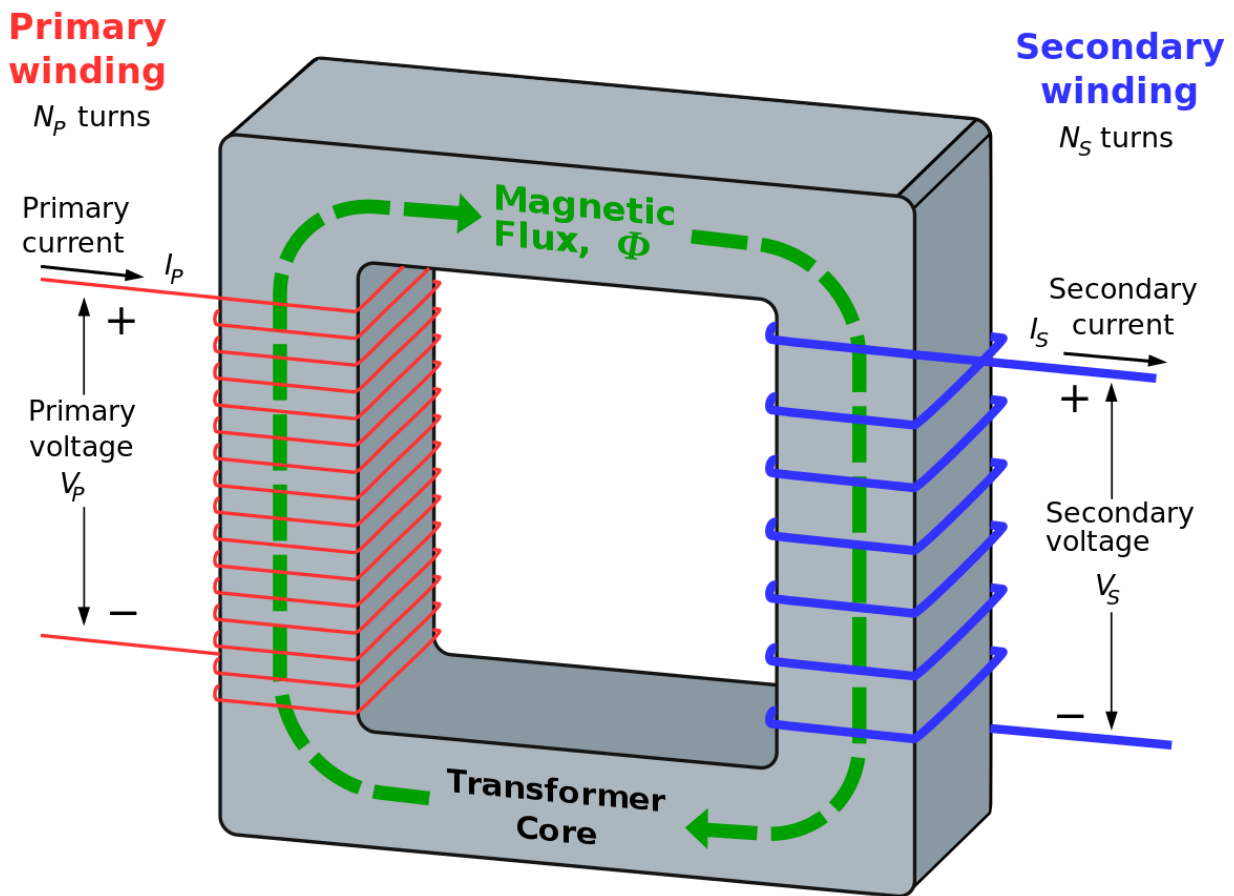

Figure 5.2: Internal Diagram of a Transformer. “[Ideal transformer and induction law](#)” image © BillC. Used under a CC BY-SA 3.0 license.

In this eBook the transformer will be assumed to be ideal (100% efficient), but there is magnetizing and leakage inductance as well as resistance in the primary and secondary coils that reduce the efficiency. If the standard (non-center tapped) transformer Multisim part called 1P1S (which stands for 1 primary and 1 secondary) is used the turns ratio as well as the inductances and resistances that reduce the efficiency can be entered. The default values for the 1P1S transformer are shown in [Figure 5.3](#). The first tab allows the turns-ratio to be set. The next three tabs allow the imperfections that cause efficiency reduction to be set. For this part it allows each of these imperfections to be removed making the transformer truly idea. These settings will be set this way for the circuits in this eBook so that the calculations will match Multisim closely.

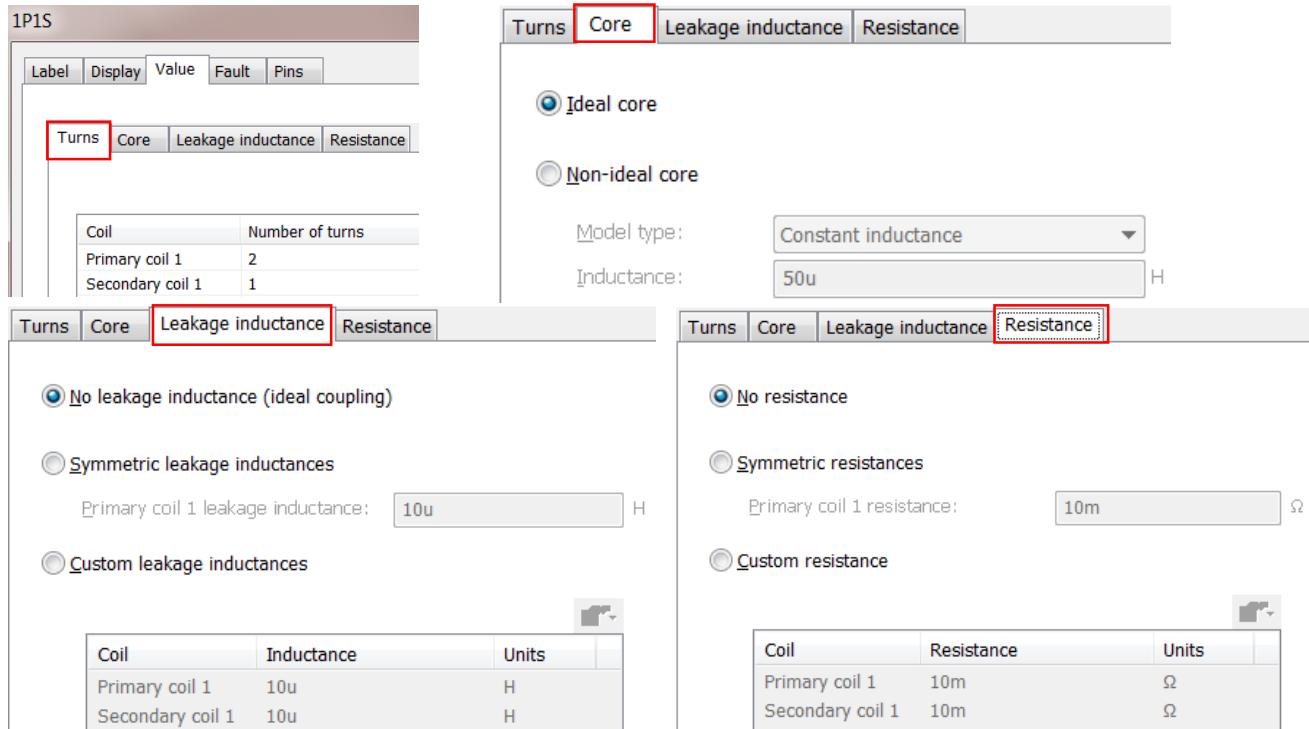

Figure 5.3: 1P1S Multisim Transformer User Interface with resistance and inductance values set to ideal.

The ideal transformer equations that determine the ratios of the primary and secondary voltage and currents are shown in equations 5.2 and 5.3.

$$[5.2] \quad \frac{V_P}{V_S} = \frac{N_P}{N_S}$$

$$[5.3] \quad \frac{I_S}{I_P} = \frac{N_P}{N_S}$$

Example 5.1) Calculate V_s , I_s , and I_p for a 1S1P 2:1 ideal **Step-Down** transformer with a standard 120 Vrms wall outlet power signal connected to the primary and a 1 k Ω resistor connected to the secondary as shown in [Figure 5.4](#). Also, calculate the primary and secondary power.

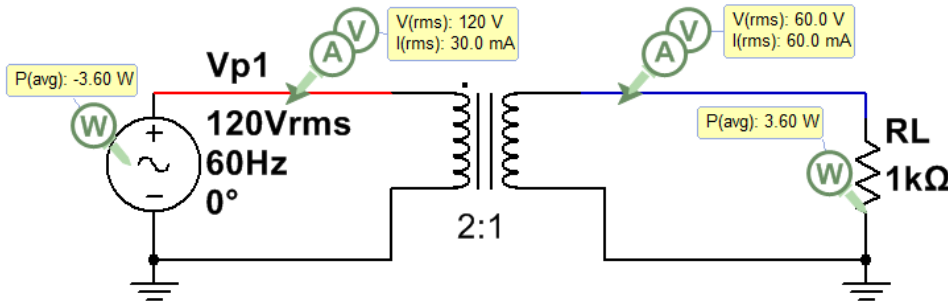

Figure 5.4: 2:1 Step Down Transformer for Example 5.1.

This problem must be solved in the correct sequence (as follows):

- 1) The secondary voltage can be calculated from [Equation 5.2](#) $\rightarrow V_s = V_p / (N_p / N_s) = 120 / 2 = \mathbf{60 \text{ Vrms}}$
- 2) The secondary current can be calculated using Ohm's Law $\rightarrow I_s = V_s / R_L = 60 \text{ Vrms} / 1 \text{ k}\Omega = \mathbf{60 \text{ mArms}}$
- 3) The primary current can be calculated using [Equation 5.3](#) $\rightarrow I_p = I_s / (N_p / N_s) = 60 \text{ mArms} / 2 = \mathbf{30 \text{ mArms}}$
- 4) 100% efficient so $P_p = P_s = V_p \cdot I_p = V_s \cdot I_s = \mathbf{3.6 \text{ W}}$

Keep in mind that a real transformer will NOT be 100% efficient. The voltage ratios in [Equation 5.2](#) will remain close to true for non-ideal transformers, but the current ratio ([Equation 5.3](#)) will become inaccurate because additional primary current will be required by the source due to the power loss in the transformer.

The transformer in Example 5.1 is called a Step Down transformer because the voltage is reduced at the primary. A Step Down transformer has a turns-ratio > 1 . Example 5.2 shows a **Step Up transformer (turns-ratio < 1)**.

Example 5.2) Calculate V_s , I_s , and I_p for a 1S1P 2:1 ideal **Step-Down** transformer with a standard 120 Vrms wall outlet power signal connected to the primary and a 1 k Ω resistor connected to the secondary. Also, calculate the primary and secondary power.

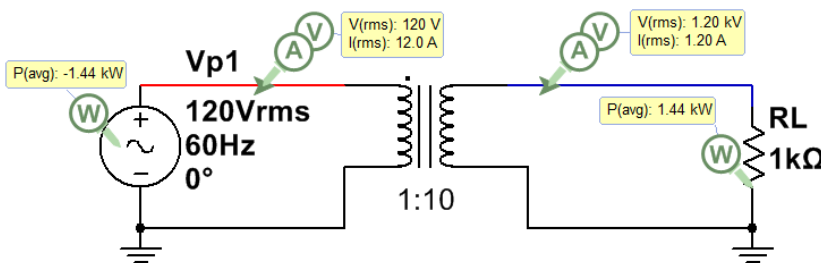

Transformer Calculations

- 1) $V_s = V_p / (N_p / N_s) = 120 / (0.1) = 1.2 \text{ kVrms}$
- 2) $I_s = V_s / R_L = 1.2 \text{ kVrms} / 1 \text{ k}\Omega = 1.2 \text{ Arms}$
- 3) $I_p = I_s / (N_p / N_s) = 1.2 \text{ Arms} / (0.1) = 12 \text{ Arms}$
- 4) $P_p = P_s = V_p \cdot I_p = V_s \cdot I_s = 1.44 \text{ kW}$

Figure 5.5: 1:10 Step Up Transformer for Example 5.2.

Module 6 – Diodes and AC to DC Conversion

Note: There some additional [Diode example problems](#) at the end of the Appendix. A diode is a device that acts like a current valve, where current is allowed to flow from anode to cathode, but not allowed to flow from cathode to anode (base of triangle). When current is allowed to flow the diode is said to be **forward biased** and when current is blocked it is **reverse biased**. There are many different types of diodes. The two main types discussed in this eBook are shown in Figures 6.1 (switching diodes) and 6.2 (rectifier diodes).

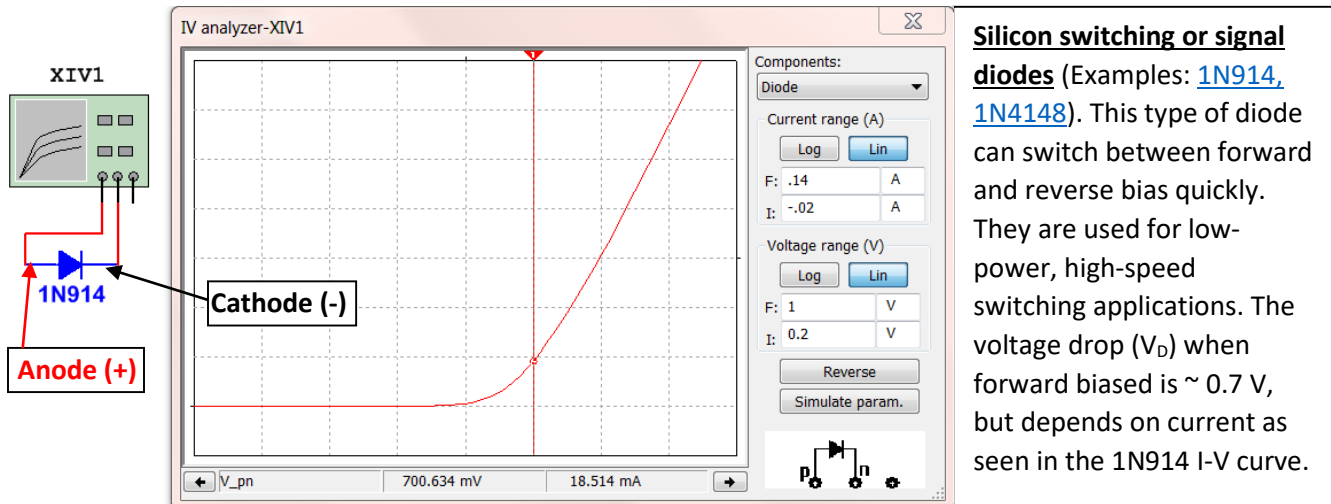

Figure 6.1: Characteristic Curve (I_D vs V_D) of a 1N914 silicone switching diode (also called signal diode).

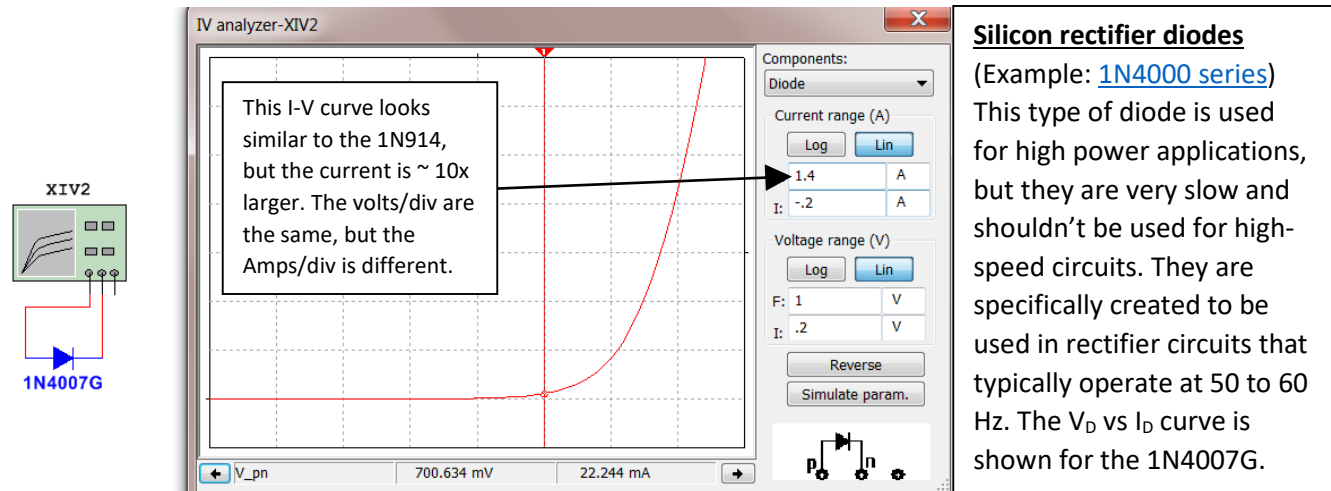

Figure 6.2: Characteristic Curve (I_D vs V_D) of a 1N4007 silicone rectifier diode.

A few other types of diodes are discussed below. An I_D vs. V_D curve can be done for any diode using the Multisim I-V Analysis tool (as shown in Figures 6.1 and 6.2) if the voltage at a specific current is needed to be known.

- A **Schottky diode** can be used for rectifiers or switching circuits. They have a forward voltage drop much smaller than silicon diodes ($V_D = \sim 0.3$ V).
- A **Zener diode** works differently than the other diodes discussed thus far. They are designed to work in the reverse voltage region (where the other diodes prevent current from flowing). They are often used for reference voltage or low-power voltage regulator applications.
- A **Light emitting diode (LED)** is a type of diode that emits light as current flows through it. The smaller LEDs that are often used in a breadboard typically have a current limit (or rating) of around 20 mA. This

[Sparkfun tutorial](#) is a good source for more information. [Figure 6.3](#) shows the I_D vs. V_D curve for a typical low power [Red LEDs](#) (Left) and [Green LEDs](#) (Right). When too much current flows through a green LED the light color will change from green to yellow. This typically happens shortly before it is destroyed so if you see a green LED turn yellow cut off the power ASAP!

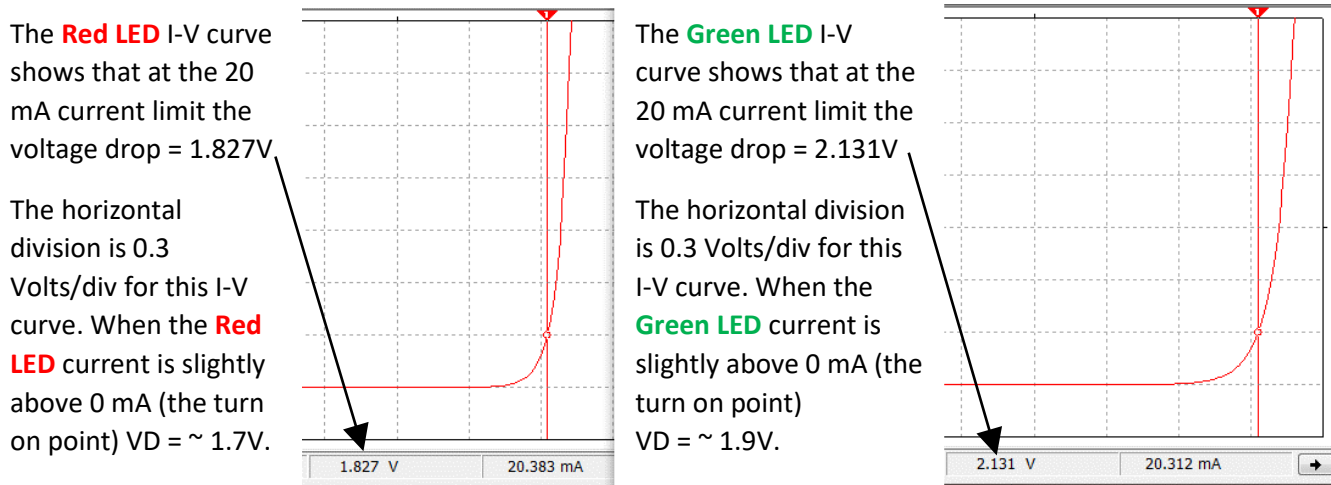

Figure 6.3: Characteristic Curve (I_D vs V_D) of a low power 5mm Red LED (Left) and Green LED (Right).

The following are some good links to learn more about diodes if the next three sections leave some questions unanswered: <http://www.futureelectronics.com/en/diodes/diodes.aspx>

<http://www.allaboutcircuits.com/textbook/semiconductors/chpt-3/introduction-to-diodes-and-rectifiers/>

Section 6.1 – Diode Constant Drop Model

In order to solve circuits that include diodes, a model for the diode is needed. There are many different types of models that can be used, but the one that offers the best combination of accurate results and ease of use is the Constant Drop Model. Before showing how to implement the Constant Drop Model, the process to solve problems with diodes in them is listed below. All of the circuits in this section will only include DC sources. By understanding how diodes affect circuits with DC sources, it is not a difficult jump to apply it to AC circuits also.

Process for Solving DC Circuits with Diodes using the Constant Drop Model

- 1) Assume Forward or Reverse Bias for each diode in the circuit.
- 2) Replace each diode with their model and **solve** for the forward bias current or reverse bias voltage.
 - a. Reverse Bias – Diode replaced open circuit. Solve for voltage drop from anode to cathode.
 - b. Forward Bias – Diode replaced with battery. Solve for current flowing from anode to cathode.
 - The battery is placed with the + side where the anode of the diode was in the circuit. The value of the voltage is approximated based on the type of diode. Assume the following: Schottky Diode = 0.3 V, Silicone switching or rectifier diodes = 0.7 V, Red LED = 1.8 V, Green LED = 2.1 V.
- 3) **Check the conditions** for forward or reverse bias to make sure assumption in part 1 was correct:
 - a. Forward Bias Condition: $I_D > 0$ (i.e. The current calculated in part 2 is flowing from anode to cathode)
 - b. Reverse Bias Condition: $V_D < \text{Diode Turn On Voltage}$ (i.e. The voltage calculated in part 2 is less than the values shown above \rightarrow Schottky = 0.3V, Silicone = 0.7V, Red LED = 1.8V, Green LED = 2.1 V.
- 4) If the assumptions from part 1 are verified in part 3 the problem is done. If any of the diodes don't meet the conditions in part 3, start the problem over by going back to step 1 and make different assumptions.

Example 6.1) Follow the DC Diode Analysis process to solve the following circuit if D1 is a silicone diode.

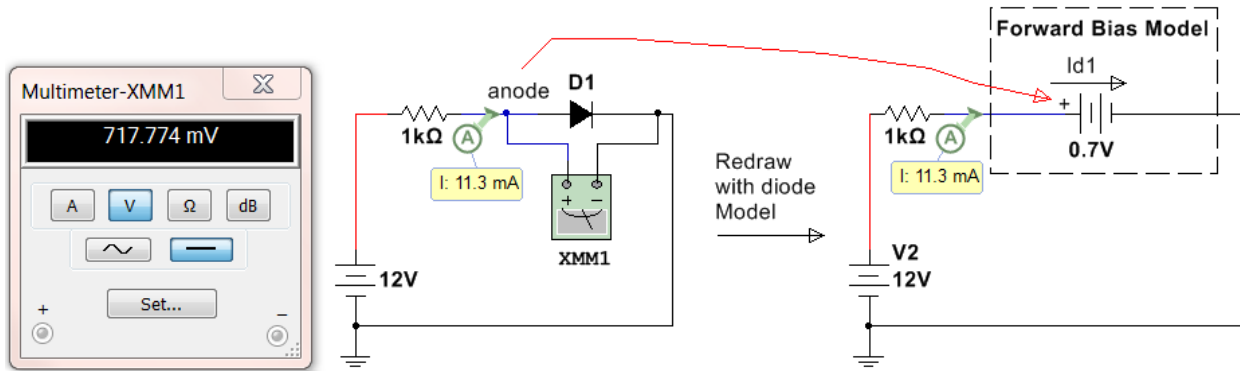

Figure 6.4: Circuit for Example 6.1

Step 1) D1 will be **assumed to be forward biased** because the 12V source will force current clockwise in this circuit, which is the direction from the anode to cathode of the diode.

Step 2) The circuit on the right side of Figure 6.4 shows the forward bias model replacing the diode. **The node where the anode was connected is connected to the + side of the battery.** 0.7 V is used for the battery voltage because the problem stated it is a silicone diode. Next, calculate the current, I_{D1} .

- $I_{D1} = I_R = \Delta V/R = (12 - 0.7)/1k\Omega = \mathbf{11.3\ mA}$ (This is verified in Multisim in Figure 6.4)
- **Note:** The actual diode voltage is shown in Multimeter XMM1 to be 717.774 mV, but there is no way to know the exact voltage across the diode unless a simulation tool is available. The approximate Constant Drop Model voltage used for silicone diodes is 0.7 V is very close to 0.717774 V so the calculations were identical to the Multisim calculation (within the accuracy of the current probe).

Step 3) Verify the diode is forward biased by making sure that $I_{D1} > 0$ and **flowing from anode to cathode**. The current is 11.3 mA and the direction is clockwise in the circuit (which is from the anode to cathode).

Step 4) The **forward bias** condition assumed in Step 1) **is verified** in Step 3) so the **problem is done**.

Example 6.2) Follow the DC Diode Analysis process to solve the following circuit if D2 is a silicone diode.

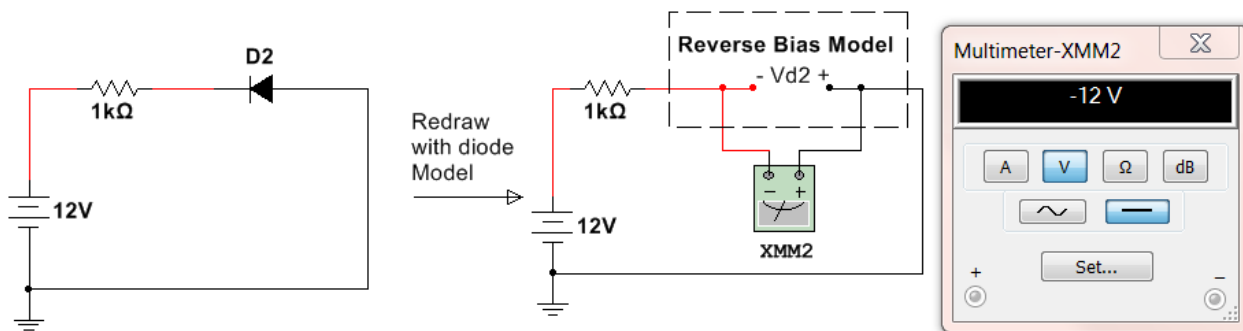

Figure 6.5: Circuit for Example 6.2

Step 1) D2 will be **assumed to be reverse biased**.

Step 2) The circuit on the right side of [Figure 6.4](#) shows the reverse bias model. **Notice the + side of the Multimeter that is measuring V_{D2} is on the same node as the anode was connected.** To solve for V_{D2} there are two possible methods.

- Find the node voltage on the + and – sides of the open circuit and subtract them. $V_{D2+} = 0$ (grounded) and $V_{D2-} = 12 - I \cdot R = 12 - 0 \cdot R = 12 \text{ V}$ (current = 0 A due to open circuit). $V_{D2} = V_{D2+} - V_{D2-} = \underline{-12 \text{ V}}$
- Do a KVL around the loop including $V_{D2} \rightarrow -12\text{V} + I \cdot R - V_{D2} = 0 \rightarrow V_{D2} = \underline{-12 \text{ V}}$
- $V_{D2} = -12 \text{ V}$ is verified in Multisim in [Figure 6.5](#).

Step 3) $V_{D2} < 0.7$ so the reverse bias condition is verified (0.7 V is used here because it is a silicon diode)

Step 4) The reverse bias condition assumed in Step 1) **is verified** in Step 3) so the **problem is done**.

Example 6.3) Follow the DC Diode Analysis process to solve the following circuit if $D1$ is a silicone diode.

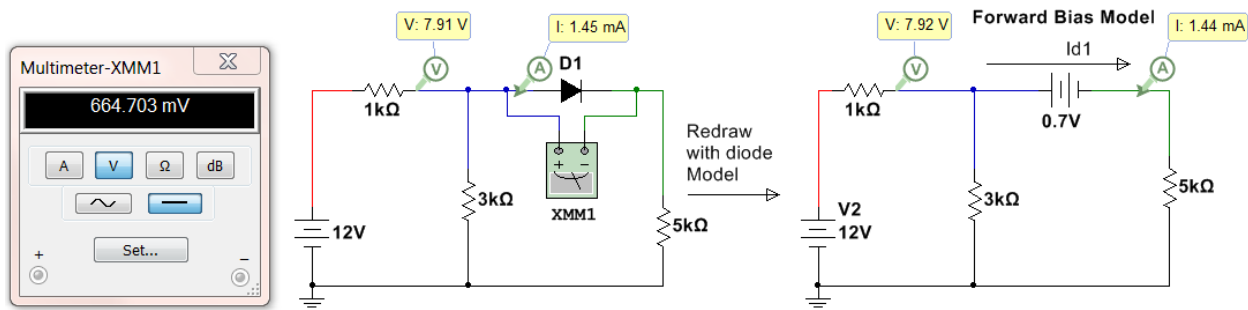

Figure 6.6: Circuit for Example 6.3

Step 1) $D1$ will be **assumed to be forward biased** because the 12V source will force current clockwise in this circuit, which is the direction from the anode to cathode of the diode.

Step 2) The circuit on the right side of [Figure 6.6](#) shows the forward bias model replacing the diode. **The node where the anode was connected is connected to the + side of the battery.** 0.7 V is used for the battery voltage because the problem stated it is a silicone diode. Next, calculate the current, I_{D1} . The mesh matrix method used in the DC Circuits eBook will be used.

$$\begin{bmatrix} 1000 + 3000 & -3000 \\ -3000 & 3000 + 5000 \end{bmatrix} \begin{bmatrix} I1 \\ I2 \end{bmatrix} = \begin{bmatrix} 12 \\ -0.7 \end{bmatrix}$$

- Solving this matrix yields $I2 = I_{D1} = \underline{1.44 \text{ mA}}$ (This is verified in Multisim in the right circuit of [Figure 6.6](#))
- **Note:** The actual diode voltage is shown in Multimeter XMM1 to be 664.703 mV. The 0.7 V diode drop assumption yielded a slightly different result than the actual values (shown in the left circuit in [Figure 6.6](#)).

Step 3) Verify the diode is forward biased by making sure that $I_{D1} > 0$ and flowing from anode to cathode. The current is 1.44 mA and the direction is clockwise in the 2nd loop (which is from the anode to cathode).

Step 4) The forward bias condition assumed in Step 1) **is verified** in Step 3) so the **problem is done**.

Example 6.4) Follow the DC Diode Analysis process to solve the following circuit with a green LED.

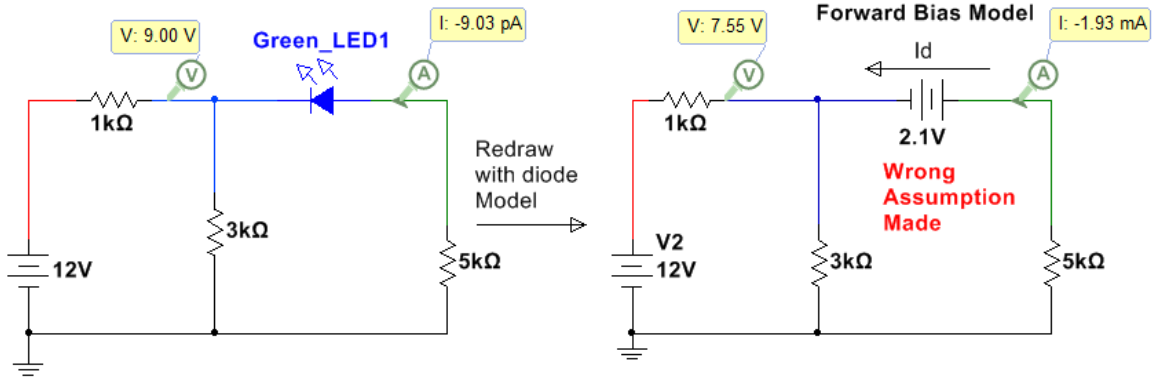

Figure 6.7: Circuit for Example 6.4 with the **wrong assumption made**.

Step 1) The LED will be **assumed to be forward biased**. It is fairly obvious that this is the wrong assumption, but it will be done anyway to show how to restart the problem in step 4 if the assumption is wrong.

Step 2) Solving for I_D (which is the counterclockwise current in the 2nd loop)

$$\begin{bmatrix} 1000 + 3000 & -3000 \\ -3000 & 3000 + 5000 \end{bmatrix} \begin{bmatrix} I_1 \\ I_2 \end{bmatrix} = \begin{bmatrix} 12 \\ 2.1 \end{bmatrix}$$

- Solving this matrix yields $I_2 = 1.93 \text{ mA}$ (clockwise). $I_D = -I_2 = -1.93 \text{ mA}$ (This is verified in Multisim in [Figure 6.7](#))
- **Note:** The probe values in the left circuit of [Figure 6.7](#) with the green LED are way different because the wrong assumption was made.

Step 3) I_D is flowing from cathode to anode so the forward biased assumption cannot be verified.

Step 4) The **forward bias** condition assumed in Step 1) **is WRONG** in Step 3) so start over at step 1.

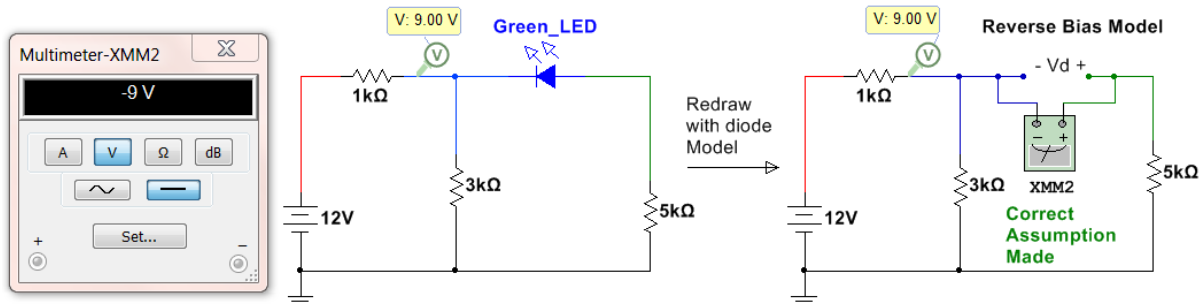

Figure 6.8: Circuit for Example 6.4 with the **correct assumption made**.

Redo Step 1) The LED will be **assumed to be reverse biased**. Since forward was wrong this must be correct.

Redo Step 2) Doing a KVL around the outer loop. $-12 + I_1 \cdot 1k\Omega - V_D + I_2 \cdot 5k\Omega = 0$, All current flows through the first loop so $I_1 = 12/(4k\Omega) = 3 \text{ mA}$ and $I_2 = 0 \text{ A} \rightarrow V_D = -12 + 3\text{mA} \cdot 1k\Omega + 0 \cdot 5k\Omega = -9 \text{ V}$ (Verified in Multisim)

Redo Step 3) $V_D = -9 \text{ V} < 2.1 \text{ V}$ so reverse bias is verified.

Redo Step 4) The **reverse bias** condition assumed in Step 1) **is verified** in Step 3) so the **problem is done**.

Example 6.5) Follow the DC Diode Analysis process to solve the following left circuit in [Figure 6.9](#).

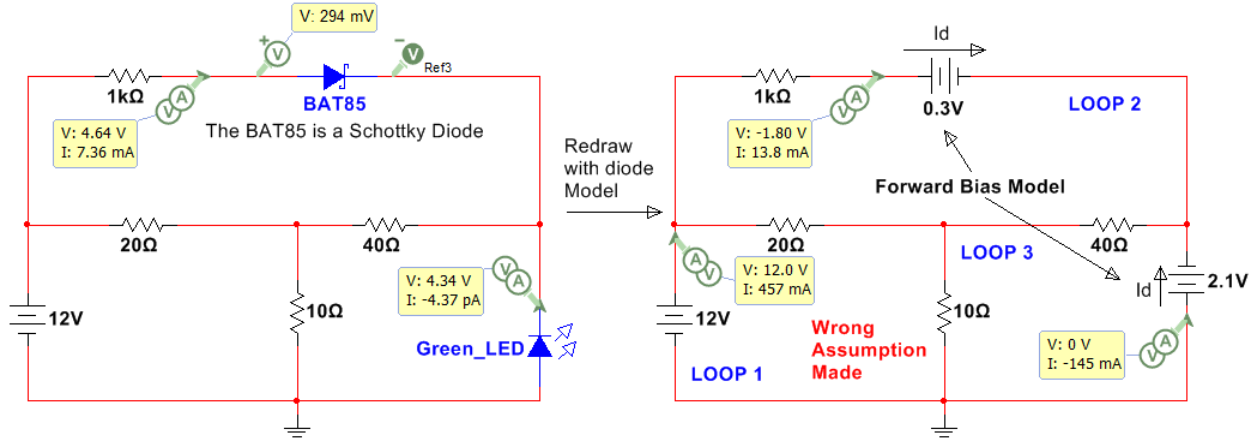

Figure 6.9: Circuit for Example 6.5 with the **wrong assumptions made**.

Step 1) Assume **Both diodes are forward biased** (1 of 4 possibilities). Model is shown in [Figure 6.9](#) (Right).

Step 2) Solving for the loop currents. Assuming currents are clockwise $\rightarrow I_{Bat85} = I_2$ and $I_{LED} = -I_3$

$$\begin{bmatrix} 20 + 10 & -20 & -10 \\ -20 & 20 + 1000 + 40 & -40 \\ -10 & -40 & 10 + 40 \end{bmatrix} \begin{bmatrix} I_1 \\ I_2 \\ I_3 \end{bmatrix} = \begin{bmatrix} 12 \\ -0.3 \\ 2.1 \end{bmatrix}$$

Assuming currents are clockwise, solving this matrix yields $\rightarrow I_1 = 457.4 \text{ mA}$, $I_2 = 13.8 \text{ mA}$, $I_3 = 144.5 \text{ mA}$. (These values are verified in Multisim in the right circuit of [Figure 6.9](#))
 $I_{BAT85} = I_1 = \underline{13.8 \text{ mA}}$ and $I_{LED} = -I_3 = \underline{-144.5 \text{ mA}}$

Step 3) I_{BAT85} is flowing from anode to cathode so the forward biased assumption is verified, but the I_{LED} is flowing from the cathode to anode so forward bias **cannot be verified**.

Step 4) If either diode is assumed wrong, one of the other 4 possibilities must be tried. There is a good chance the BAT85 is forward biased, but you can't be sure until you verify both are correct. **Go back to step 1**.

Redo Step 1) The **LED** will be assumed to be **reverse biased** and the **BAT85** assumed to be **forward biased**.

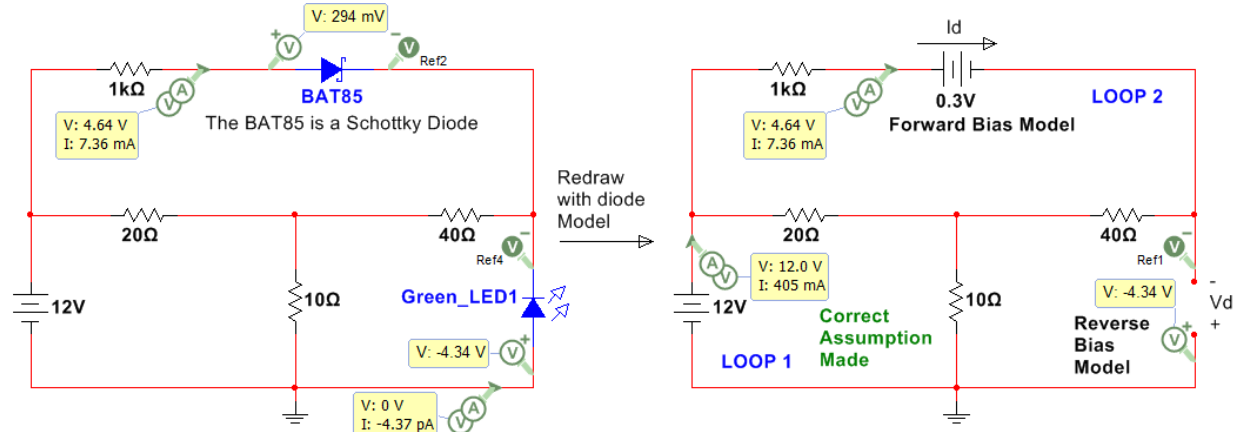

Figure 6.10: Circuit for Example 6.5 with the **correct assumption made**.

Redo Step 2) Loop 3 has an open circuit so this becomes a 2-loop circuit.

$$\begin{bmatrix} 20 + 10 & -20 \\ -20 & 20 + 1000 + 40 \end{bmatrix} \begin{bmatrix} I_1 \\ I_2 \end{bmatrix} = \begin{bmatrix} 12 \\ -0.3 \end{bmatrix}$$

Solving yields $\rightarrow I_1 = 404.9 \text{ mA}$, $I_2 = I_{BAT85} = \underline{7.36 \text{ mA}}$
 KVL around outer loop $\rightarrow -12 + I_2 \cdot 1k + 0.3 - V_D = 0$
 $V_D = -12 + 7.36 \text{ mA} \cdot 1k + 0.3 = \underline{-4.34V}$ (verified in Multisim)

Redo Step 3) $V_D = -4.34V < 2.1V$ (reverse verified), $I_{BAT85} = \underline{7.36 \text{ mA}}$ from anode to cathode (forward verified)

Redo Step 4) The assumptions in redo Step 1) **is verified** in Step 3) so the **problem is done**.

Section 6.2 – Diode Logic Circuits

There are many applications where the basic diode calculations shown in Section 6.1 can be used to give circuitry more control. One way is by using diodes to create logic gates. The circuit in [Figure 6.11](#) shows diodes acting as an OR gate. To make this section easier to understand Multisim virtual parts are used that show actual images of the part. When either of the two switches is flipped to the ON position (up) then the LED will turn on. When the switch is in the down position there is an open circuit connected to the diode so a pull down resistor is used to make sure the voltage at the diode is 0V when the switch is in the OFF position and 5V when the switch is in the ON position. The left circuit has both switches OFF and the right circuit has Switch 2 ON. Switch 1 could have been turned on instead of Switch 2 (or both could be turned on) and the same output would occur.

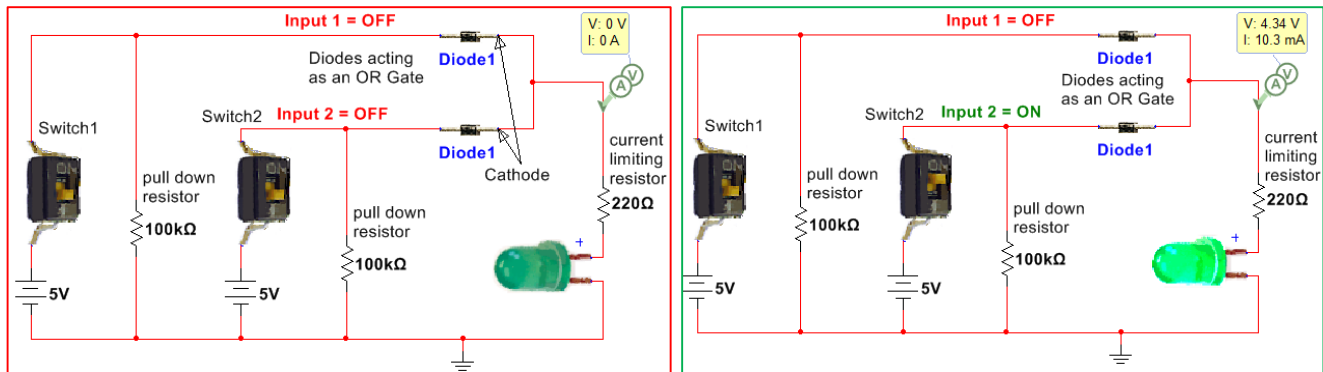

Figure 6.11: Diodes acting as an OR GATE.

The circuit in [Figure 6.12](#) shows diodes acting as an AND gate. The output voltage (Vout) will only go to 5V when both switches are flipped to the ON position (up) as shown in [Figure 6.12](#). When either switch is turned off the voltage will drop across the resistor that sets the voltage levels (200 kΩ in [Figure 6.12](#)). The higher this resistor value is the lower the current will be and the lower the voltage will be when both switches aren't pressed. In this case with a 200 kΩ resistor used when either switch is ON Vout drops below 2V which is the minimum voltage required by the gate of the MOSFET to turn it on and cause current to flow from the 5V rail through the drain.

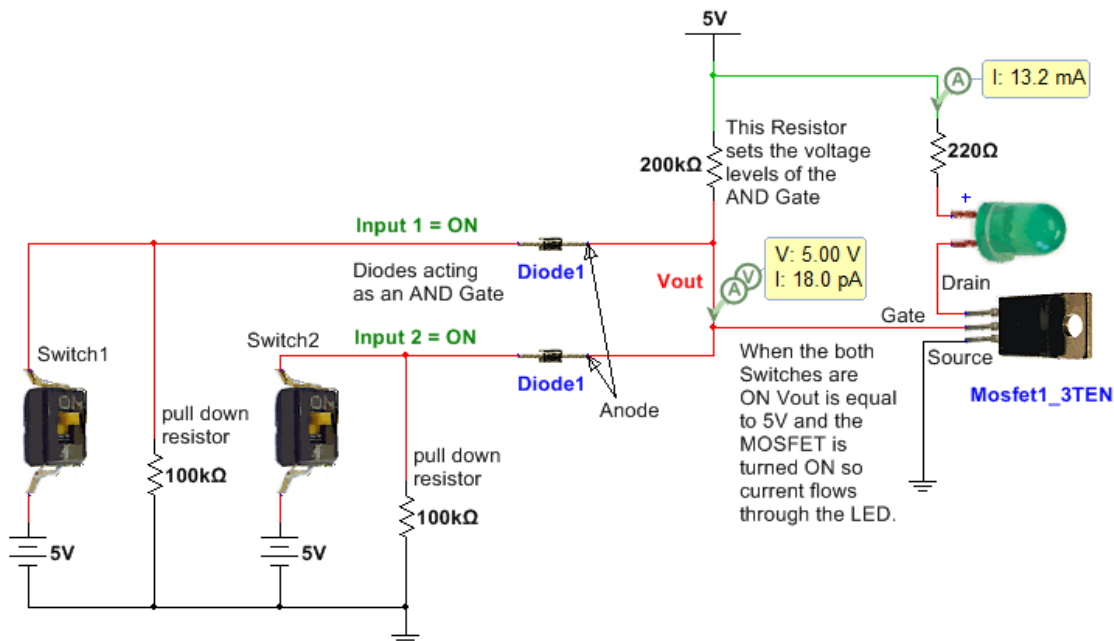

Figure 6.12: Diodes acting as an AND GATE.

Section 6.3 – Protection Diodes

One of the most important uses of diodes is to protect circuitry from voltage spikes that occur when inductive elements such as motors start or stop. “Protection diodes” that serve this function are referred to by many different names. Some of these names are: flyback, flywheel, freewheeling, snubber, and catch diodes. The magnitude of the voltage across an inductor is $V_L = L \frac{di}{dt}$ so when the inductive load is turned on or off the current changes from 0 to non-zero producing a large slope and in return a large voltage spike. Because MOSFET transistors (as shown in [Figure 6.12](#)) are activated with only voltage signals (**Note:** current is required to activate BJT transistors) they are especially susceptible to damage when turning on or off an inductive load. A diode can be positioned across the inductive load so that the voltage spike doesn’t reach the circuitry as shown in [Figure 6.13](#). The protection diode could also be placed across the MOSFET instead of the motor to provide protection for the MOSFET. For this situation, the anode of the diode would connect to the source and the cathode would connect to the drain. The protection diode needs to be a fast switching style diode like a 1N914.

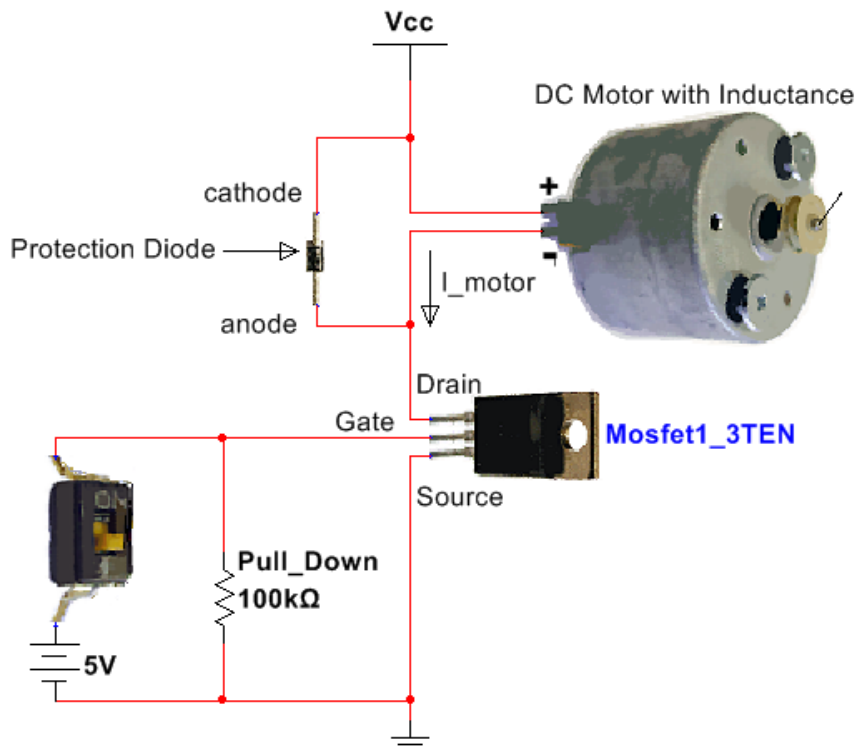

Figure 6.13: Using a protection diode to prevent damaged circuitry due to $V_L = L \frac{di}{dt}$

Protection from $V_L = L \frac{di}{dt}$ is such a problem for MOSFETs that some have internal protection as shown in the following figure taken from the [BS170 datasheet](#). Even if a diode has internal protection it is usually not enough to keep the MOSFET from being damaged so adding an external protection diode as shown in [Figure 6.13](#) is recommended.

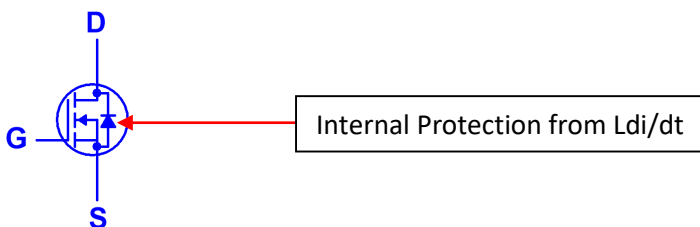

Figure 6.14: Internal protection in a [BS170 MOSFET](#).

Section 6.4 – Rectifiers

One of the most important uses of diodes is to rectify an AC signal so it can be converted to a DC signal. When the diode is connected in series between an AC signal and a resistor only one side of the AC waveform can pass through. If the diode is oriented as shown in [Figure 6.15](#) only the positive cycles are passed through, but if the diode is flipped only the negative cycles pass through. The circuit in [Figure 6.15](#) shows a half-wave rectifier circuit. It is called half-wave because only half of the cycles pass through and the other half are rejected (or zeroed out). For this circuit the input voltage is 2 V_{rms} or 2.8 V_{pk}. The peak input voltage to rectifier circuit is typically called V_s because it is usually connected to the secondary of a transformer. The peak voltage across the resistor is called V_{o,pk} and is one diode drop less than V_s for a half-wave rectifier with only one diode. The reason the “with only one diode” disclaimer was used in the previous sentence is due to the fact that sometimes multiple diodes will be included in series to get V_{o,pk} to the desired level. In the circuit in [Figure 6.15](#) V_s is measured by Multisim as 2.807 and V_{o,pk} was measured as 2.234 V which makes the diode drop around 0.6 V instead of the 0.7 V that we will assume in all rectifier calculations that use silicone rectifier diodes. Keep this in mind as one of the sources of error when Multisim doesn’t match up as closely to rectifier hand calculations as desired. If the peak output voltage (V_{o,pk}) needed to be lower than 2.234 V then another diode could be placed in series with the 1N4007G diode to reduce it by another 0.6 or 0.7 volts.

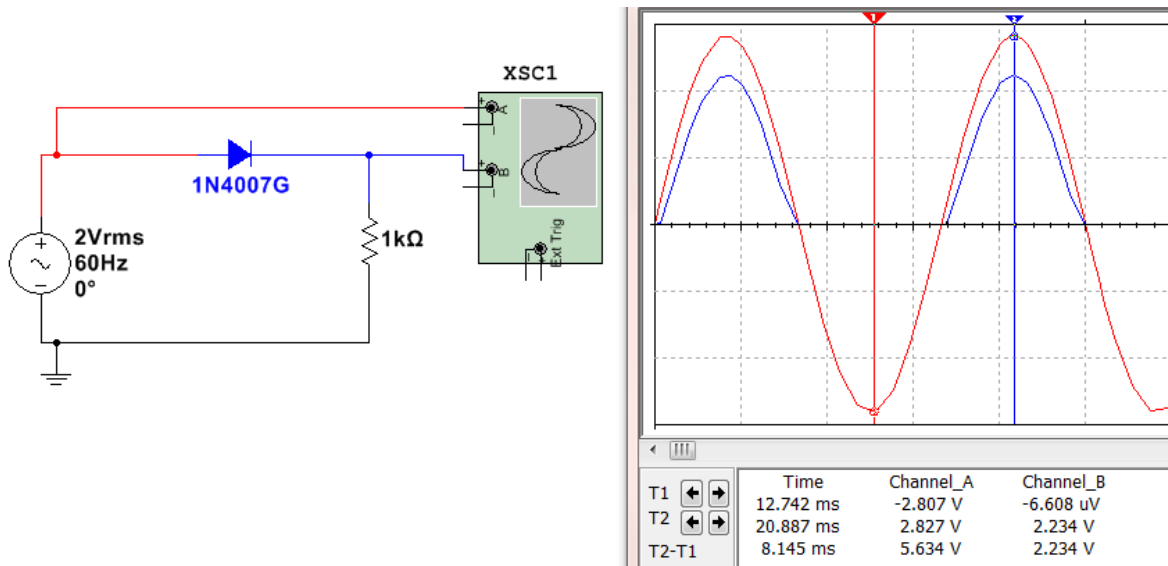

Figure 6.15: Half-Wave Rectifier with one of the [1N4000 series](#) silicone rectifier diodes.

Rectification is the first step in converting an AC signal to a DC signal. The next step would be to add a capacitor in parallel with the load resistor where V_{o,pk} is measured so that the voltage will not be allowed to drop very fast due to the time constant of the capacitor. Once the “smoothing capacitor” is added the rectifier is called a “Peak Rectifier”. An example of a half-wave peak rectifier is shown in [Figure 6.16](#). The calculations and Multisim measurements of a **half-wave peak rectifier** are shown below (See equation summary in [Table 6.1](#)).

- **V_s** = peak input voltage = $120 \cdot \sqrt{2} = \mathbf{169.7 \text{ V}}$ (169.634 V in Multisim - [Figure 6.16](#)).
- **V_{o,pk}** = peak output voltage = $V_s - 0.7 \text{ V} = \mathbf{169 \text{ V}}$ (169.026 V in Multisim - [Figure 6.16](#)).
- **V_r** = ripple voltage (V_{o,pk} – minimum V_{out}) = $\frac{V_{o,pk}}{fRC} = \frac{169}{60 \cdot 50k \cdot 1\mu} = \mathbf{56.3 \text{ V}}$ (~ 41.3V in [Figure 6.16](#)).
- **% V_r** = percent ripple = the ripple voltage divided by V_{o,pk} = $(56.3/169) = \mathbf{33.3\%}$
- **V_{o,DC}** = the approximate DC voltage (centerline of the ripple). In [Figure 6.16](#) V_{o,DC} is equal $169 - 0.5 \cdot V_r = 169 - 0.5 \cdot 41.3 = \mathbf{148.4 \text{ V}}$. The DC voltage probe in [Figure 6.16](#) measures the DC voltage as 149 V.

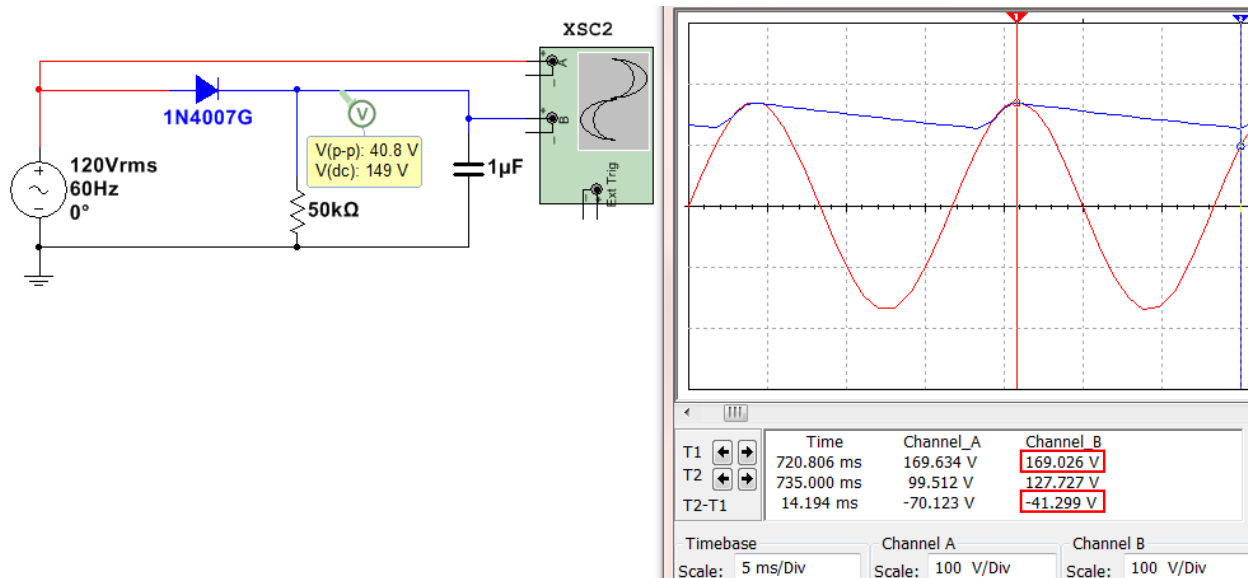

Figure 6.16: Half-Wave Peak Rectifier.

The other type of rectifier is called a full-wave rectifier. It allows the negative peaks to be flipped to positive instead of zeroing them out. There are two common types of full-wave peak rectifiers:

- Full-Wave Peak Bridge Rectifier (See [Figure 6.17](#))
- Full-Wave Peak Parallel Rectifier or Full-Wave Peak Center Tapped Rectifier (This type will not be discussed in this eBook, but the equations are in [Table 6.1](#) and the circuit can be seen in the third figure from the top in this [link](#)).

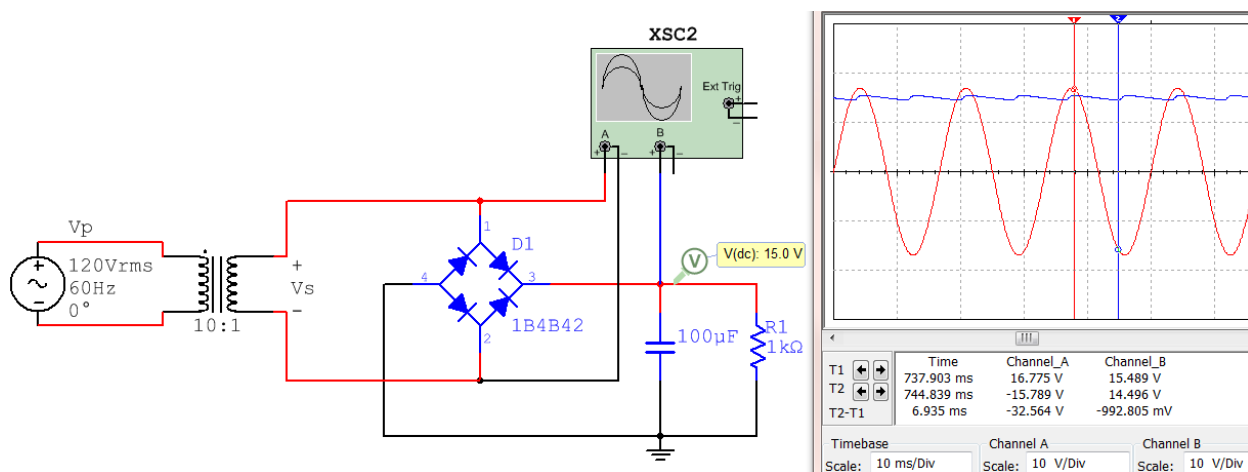

Figure 6.17: Full-Wave Peak Bridge Rectifier.

- $V_s =$ peak input voltage = $120 \cdot \sqrt{2} / 10 = 16.97 \text{ V}$ (16.775 V in [Figure 6.17](#)).
- $V_{o,pk} =$ peak output voltage = $V_s - 2 \cdot 0.7 \text{ V} = 15.57 \text{ V}$ (15.49 V in Multisim - [Figure 6.17](#)).
- $V_r =$ ripple voltage ($V_{o,pk} - \text{minimum } V_{out}$) = $\frac{V_{o,pk}}{2fRC} = \frac{15.57}{2 \cdot 60 \cdot 1k \cdot 100\mu} = 1.3 \text{ V}$ ($\sim 1 \text{ V}$ in [Figure 6.17](#)).
- $\% V_r =$ percent ripple = the ripple voltage divided by $V_{o,pk} = (1.3/15.57) = 8.3\%$
- $V_{o,DC} =$ the approximate DC voltage of the output (centerline of the ripple). In [Figure 6.17](#) $v_{o,DC}$ is equal to $15.57 - 0.5 \cdot V_r = 14.92 \text{ V}$. The DC voltage probe in [Figure 6.17](#) measures the DC voltage as 15 V.

The equations for half-wave and full-wave peak rectifiers that were shown in Figures 6.16 and 6.17 are summarized in [Table 6.1](#). **Note:** The **Full Wave Center Tapped** equations are shown, but this type of rectifier circuit is not covered in detail in this eBook.

Table 6.1: Peak Rectifier Summary, Note: $V_{\mu} = V_{o,pk}$

Type	#	PRV	$V_{o,pk}$	V_r	$V_{o,DC}$	$i_{D,avg}$	$i_{D,max}$
½ Wave	1	V_S	$V_S - V_D$	$V_{\mu}/(f_iRC)$	$V_{\mu} - \frac{1}{2} V_r$	$I_L[1+\pi(2V_{\mu}/V_r)^{\frac{1}{2}}]$	$I_L[1+2\pi(2V_{\mu}/V_r)^{\frac{1}{2}}]$
Full-Wave, Bridge	4	$V_S - V_D$	$V_S - 2V_D$	$V_{\mu}/(\underline{2}f_iRC)$	$V_{\mu} - \frac{1}{2} V_r$	$I_L[1+\pi(V_{\mu}/2V_r)^{\frac{1}{2}}]$	$I_L[1+2\pi(V_{\mu}/2V_r)^{\frac{1}{2}}]$
Full Wave, C.T.	2	$2V_S - V_D$	$V_S - V_D$	$V_{\mu}/(\underline{2}f_iRC)$	$V_{\mu} - \frac{1}{2} V_r$	$I_L[1+\pi(V_{\mu}/2V_r)^{\frac{1}{2}}]$	$I_L[1+2\pi(V_{\mu}/2V_r)^{\frac{1}{2}}]$

Nomenclature / Notes for [Table 6.1](#)

- ½ Wave = ½ Wave Peak Rectifier (1 diode, 1 resistor, 1 capacitor)
- Full Wave, C.T. = Full Wave Center Tapped Peak Rectifier (2 diodes, 1 resistor, 1 capacitor)
- Full Wave, Bridge = Full Wave Bridge Peak Rectifier (4 diodes, 1 resistor, 1 capacitor)
- # = Number of Diodes in the circuit.
- V_S = Peak input voltage (if there is a transformer, this is the secondary voltage) **NEVER use V_{rms} for V_S .**
- $V_{\mu} = V_{o,pk}$ = Peak output voltage across the load resistor
- V_D = Diode drop (Depends on the current, but we will assume 0.7 V for calculations) (See [Figure 6.2](#))
- V_r = Ripple Voltage. The difference between $V_{o,pk}$ and the minimum of the rectified/filtered V_{out} signal.
 - Note: $V_r = V_{\mu}$ if it is NOT a peak rectifier (i.e. no capacitor).
- f_i = The frequency of the input signal (usually 60 Hz in U.S.)
- R = Load Resistor
- C = Capacitor that is in parallel with the load resistor
- $V_{o,DC}$ = The DC (or average) voltage across the load resistor. (This is typically what you design for). The **approximate equation for $V_{o,DC}$ in [Table 6.1](#) is more accurate the smaller the value of V_r .**
- PRV = Peak Reverse Voltage for each of the diodes (also called PIV, Peak Inverse Voltage).
 - For a sinusoid input this calculated value must be < the peak repetitive reverse voltage limit found on the spec. sheet. For the 4000 series rectifier diodes the PRV limit increases from 1N4001 to 4007.
 - The continuous reverse voltage limit on the spec. sheet is referring to a situation where you have a large DC value being blocked by the diode.
- $i_{D,avg}$ = Average current of the diode. This value should be less than the average forward rectified current limit on the spec. sheet.
- $i_{D,max}$ = Peak current of the diode. This value should be less than the maximum forward rectified current limit on the spec. sheet.
- $I_L = V_{o,DC} / R$ = This is approximately the average current through the load resistor.

Example 6.6) Calculate the ripple voltage, % V_r , and approximate DC voltage for the Full Wave bridge peak rectifier in [Figure 6.18](#). Assume all diodes have voltage drops of 0.7 Volts.

The circuit in [Figure 6.18](#) shows the Full Wave bridge peak rectifier drawn in two different ways. The left circuit requires a diode bridge to be used (4 diodes in one package configured as a bridge). The right circuit is much more convenient and useful because it allows for specific individual diodes (such as the 1N4007) to be used.

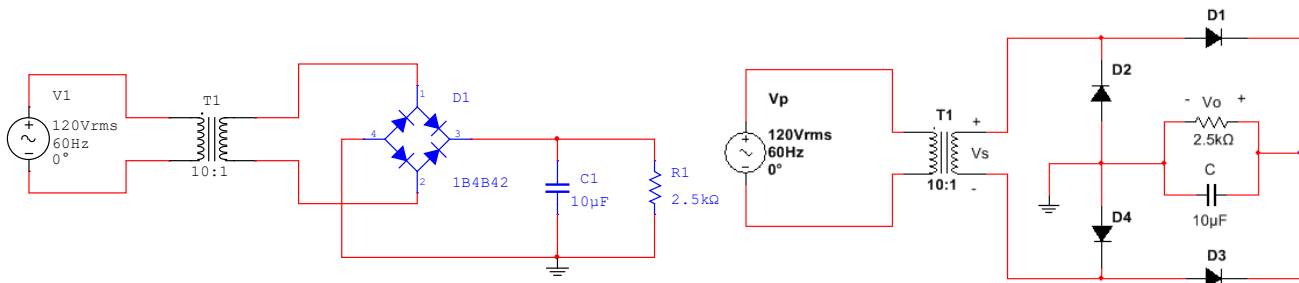
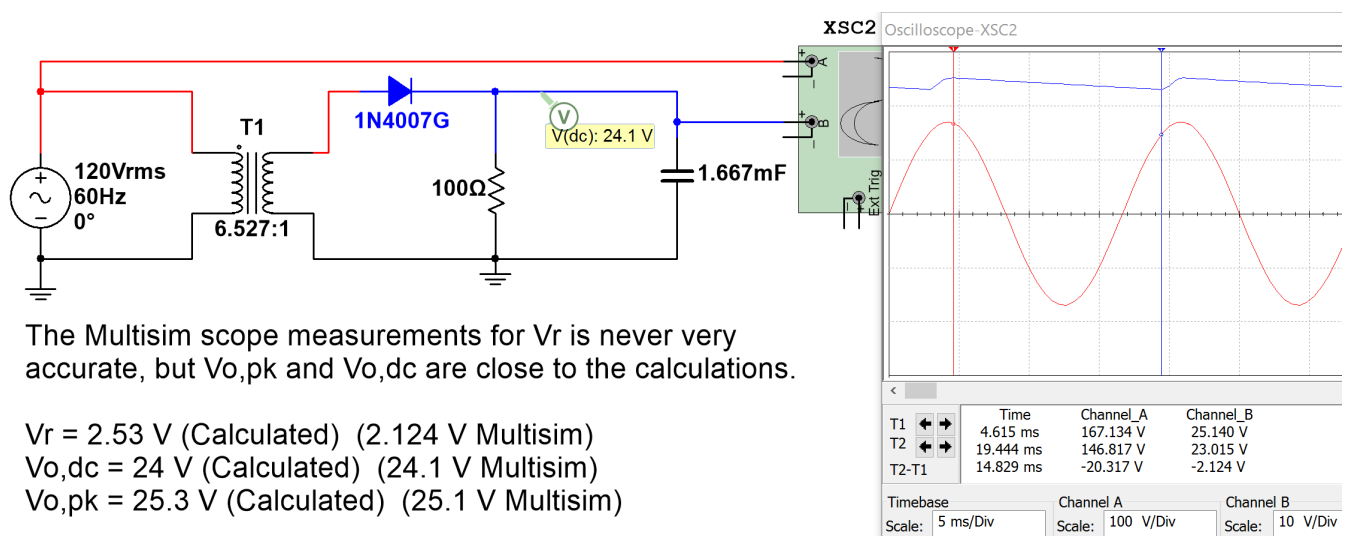

Figure 6.18: Full-Wave Peak Bridge Rectifier for Example 6.6.

- $V_{in,rms} = V_{p,rms} = 120V_{rms}$
- $V_{in,pk} = V_{p,pk} = 120 \cdot \sqrt{2} = 169.7 \text{ V}$
- $V_{s,pk} = 169.7 / (\text{Turns ratio}) = 169.7 / (N_p/N_s) = 169.7 / 10 = 16.97 \text{ V}$
- $V_{o,pk} = V_{s,pk} - 2 \cdot 0.7 \text{ V} = 15.6 \text{ V}$
- $V_r = V_{o,pk} / (2 \cdot f_i \cdot R \cdot C) = 15.6 / (2 \cdot 60 \cdot 2500 \cdot 10e-6) = 5.2 \text{ V}$ (**Note:** The 2 is used for a full wave rectifier)
- $\% V_r = V_r / V_{o,pk} = 5.2 / 15.6 = \mathbf{33.3\%}$
- $V_{O,DC} = V_{o,pk} - \frac{1}{2} (V_r) = 15.6 - \frac{1}{2} (5.2) = \mathbf{13 \text{ V}}$

Example 6.7) Determine the turns ratio of the transformer and the capacitor value needed if you wanted to use a half-wave peak rectifier with a 1N4007 diode to produce a DC voltage of 24 V with 10% ripple from a standard 120 Vrms 60 Hz AC power outlet. You are required to use a load resistor of 100 Ω.

- Given $\rightarrow \%V_r = 10\%$ Equation 1) $\%V_r = 0.1 = V_r / V_{o,pk}$
- Given $\rightarrow V_{O,DC} = 24$ Equation 2) $V_{O,DC} = 24 = V_{o,pk} - \frac{1}{2} (V_r)$
- Solve equations 1 and 2 for $V_{o,pk}$ and $V_r \rightarrow 24 = V_{o,pk} - \frac{1}{2} (0.1 \cdot V_{o,pk}) = 0.95 V_{o,pk} \rightarrow \mathbf{V_{o,pk} = 25.3 \text{ V}}$
- $V_r = 0.1 \cdot V_{o,pk} \rightarrow \mathbf{V_r = 2.53 \text{ V}}$
- We need to select a transformer turns ratio that puts $V_{o,pk} = 25.3$.
- $V_s = V_{o,pk} + 0.7 \rightarrow V_s = 26 \text{ V}$
- Turns Ratio = $169.7 / 26 \rightarrow \mathbf{N_p/N_s = 6.527}$ (At this point it would be best to select a common transformer you can purchase like a 6:1 and recalculate the V_r needed, but we will leave it as 6.527 in this example.)
- $V_r = 2.53 \text{ V} = V_{o,pk} / (f_i \cdot R \cdot C) \rightarrow 2.53 \text{ V} = 25.3 \text{ V} / (60 \cdot 100 \cdot C) \rightarrow \mathbf{C = 1.667 \text{ mF}}$



The Multisim scope measurements for V_r is never very accurate, but $V_{o,pk}$ and $V_{o,dc}$ are close to the calculations.

- $V_r = 2.53 \text{ V}$ (Calculated) (2.124 V Multisim)
- $V_{o,dc} = 24 \text{ V}$ (Calculated) (24.1 V Multisim)
- $V_{o,pk} = 25.3 \text{ V}$ (Calculated) (25.1 V Multisim)

Figure 6.19: Full-Wave Peak Rectifier design for Example 6.7.

Module 7 –Operational Amplifiers (OpAmps)

Operational Amplifiers (OpAmps) are integrated circuits (ICs) with a minimum of 5 pins. Sometimes multiple OpAmps are packaged together in a single IC. One example of this style of packaging is the LM324 Quad OpAmp. The two types of LM324 IC packages available are the 14 pin Dual Inline Package (DIP) and the 14 pin Small Outline Package (SOP). The pinout mapping and a photo of the DIP package are shown in [Figure 7.1](#). The LM324 is an inexpensive general purpose (i.e. low power) OpAmp (see Figures 7.8 and 7.9 for more info). For details about this OpAmp read the datasheet at this link: <https://www.fairchildsemi.com/datasheets/LM/LM324.pdf>

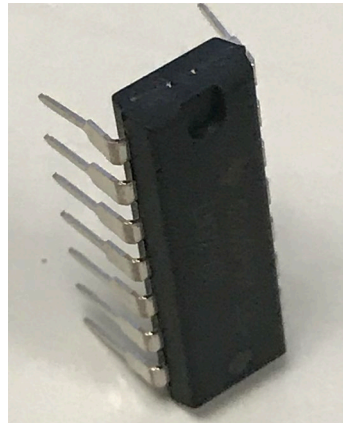
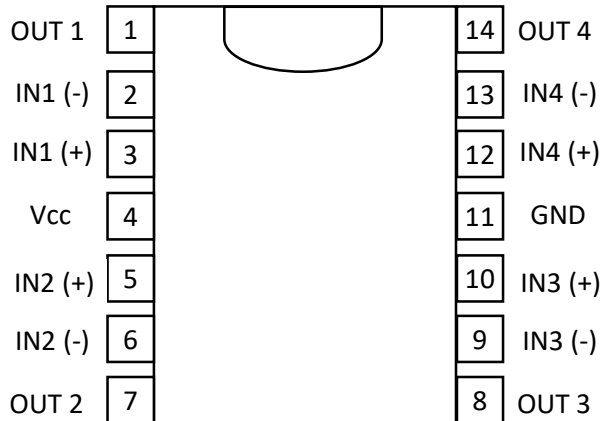

Figure 7.1: LM324 Quad OpAmp IC Pinout (Left), LM324 14-DIP package photo (Right)

The 14-DIP (Dual Inline Package) is called a “through-hole” part. Its pins can be plugged into a breadboard or into holes on a printed circuit board (PCB) or soldering proto board. The 14-SOP (Small Outline Package) is a “surface mount” part. It is one of the most popular surface mount IC packages and its 14 pins can only be connected by soldering them to pads on a PCB. The names for each of the 14 pins are shown in [Figure 7.1](#). To minimize the number of pins required all 4 of the OpAmps use the same power pins. Pin 4 (Vcc) is called the positive rail and pin 11 (GND) can either be grounded for circuits only needing a single supply (where the output can go from 0V to Vcc) or connected to a negative voltage for circuits requiring a dual supply (where the output can go from $-V_{cc}$ to $+V_{cc}$). The LM324 datasheet states that the limits for supplies for this OpAmp are: (min = $\pm 1.5V$, max = $\pm 16V$ for a Dual Supply) or (min = 3V, max = 32V for single supply). [Figure 7.2](#) shows the standard method of connecting power to an OpAmp in both dual and single supply options (**Note that the rails must be reversed for Multisim simulations**). OpAmps have 2 inputs (inverting or $-$ input) and (non-inverting or $+$ input) and one output (Vout). **Note:** *There some additional [OpAmp example problems](#) at the end of the Appendix.*

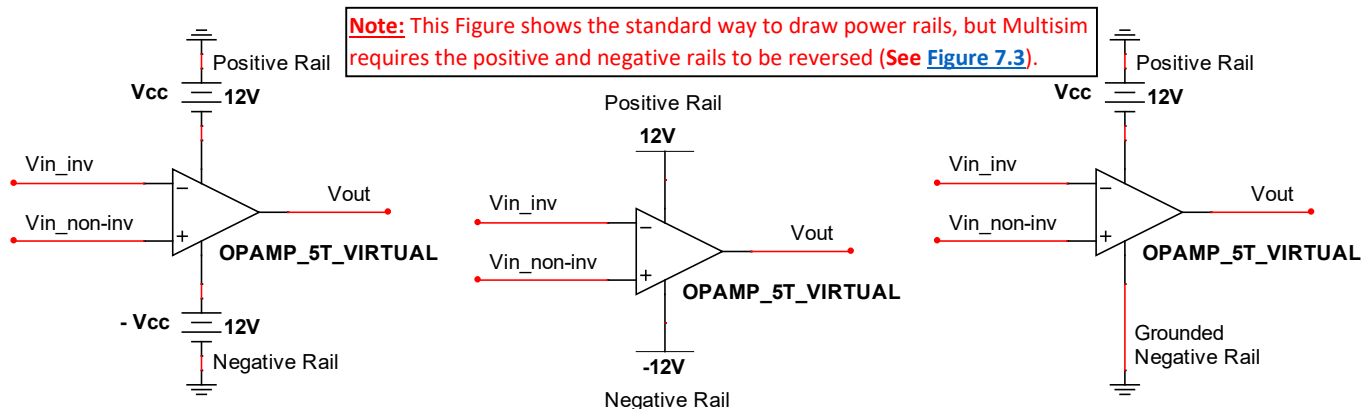

Figure 7.2: Dual Supply (Left), Dual Supply Alternate Form (Middle), Single Supply (Right).

As noted in [Figure 7.2](#) Multisim requires the positive and negative rails to be reversed from the standard way of drawing them. If you connect power rails as they are shown in [Figure 7.2](#) Multisim gives the following error when running a simulation: “A simulation error has occurred. Would you like to run the Convergence Assistant to attempt to resolve this problem automatically?” If Yes is selected it takes a long time to try to fix the problem, but isn’t able to fix it. The way Multisim requires the power rails to be drawn is shown on the top right of [Figure 7.3](#).

The **OPAMP_5T_VIRTUAL** in Multisim is a good part to use (and will be used for all circuits in this eBook) because the default internal parameters allow it to closely match hand calculations with the **Ideal OpAmp Model** (Explained in [Section 7.2](#)) and also allow easy adjustments of these parameters if needed. Double clicking on the OpAmp in Multisim brings up the interface in [Figure 7.3](#) that can be used to set the OpAmp internal parameters. The 5 parameters that factor into whether or not an OpAmp can be assumed to be “ideal” are shown in the bottom right section of [Figure 7.3](#). The parameters (A, FU, CMRR, RI) that are labeled 1) through 4) in [Figure 7.3](#) are assumed to be infinity for the Ideal Model and the values for those parameters in the OPAMP_5T_VIRTUAL are large enough to be approximated as infinity. The 5th parameter is R0 which is 10 Ω for the OPAMP_5T_VIRTUAL and assumed to be 0 for the Ideal Model. A 10 Ω value is close enough to zero for the Ideal Model to give accurate results as long as the output of the OpAmp is not connected to a load resistance that is too small. If the load resistance is smaller than around 1 kΩ then it is best to set the R0 value to a lower value (or even to 0) to closely match the Ideal Model calculations with Multisim. The “output short circuit current” parameter is the maximum allowable current that can be sourced or sunk by this OpAmp. In [Figure 7.3](#) it is labeled with an * next to. Since it only has a 25 mA value it might need to be increased. If it is changed to a very large value (like 1000 Amps) then you won’t have to worry about the current being limited internally by the OpAmp model in Multisim and the calculations will match the simulations more closely.

Learning about the details of the parameters in [Figure 7.3](#) are important to gain a full understanding of OpAmps, but it will be left out in this eBook. A Texas Instrument (TI) white paper SLOA011 titled “[Understanding Operational Amplifier Specifications](#)” provides more information about the internal parameters of OpAmps. TI has an abundance of high quality technical literature that will be frequently referenced in this module.

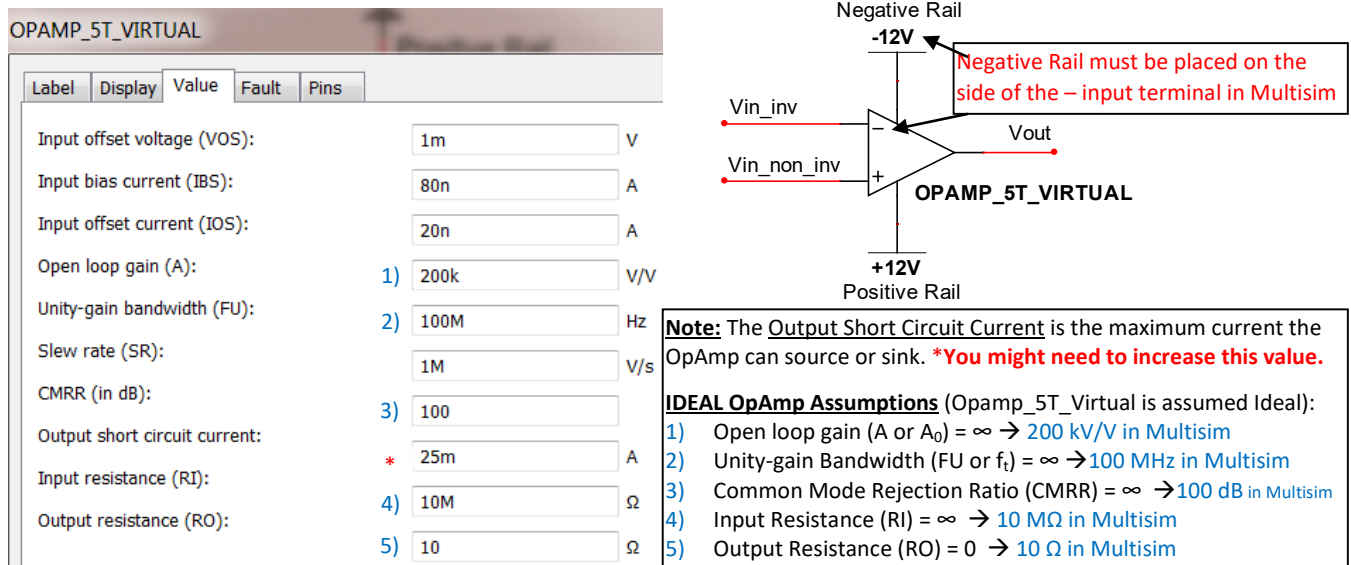

Figure 7.3: 5-Terminal Virtual OpAmp Internal Parameters and method to connect power rails in Multisim.

The following link is a 94 page document that provides a good overview of OpAmps and includes many applications and useful OpAmp-based circuits. This document titled “HANDBOOK OF OPERATIONAL AMPLIFIER APPLICATIONS” had its latest revision in September 2016. <http://www.ti.com/lit/an/sboa092b/sboa092b.pdf>

One thing that is not addressed in that TI Handbook is active filtering. [Module 4](#) described passive filtering with RLC circuits, but for many applications active filtering with OpAmps is preferred. The following two links to TI documents provide good information about active filtering.

- SLOA093: “Filter Design in 30 Seconds” <http://www.ti.com/lit/an/sloa093/sloa093.pdf>
- SLOA096: “More Filter Design on a Budget” <http://www.ti.com/lit/an/sloa096/sloa096.pdf>

I would be remiss if I didn’t also mention “[The Art of Electronics](#)” by Horowitz and Hill because many consider it the ultimate source for anything involving analog electronics. Unfortunately, there is no eBook on this one, but having this document on your shelf will make you feel like a real Electrical or Computer Engineer and give you a nice reference to have on hand in case you need an additional resource.

Section 7.1 – OpAmps Used as Comparators

A comparator is a device that compares two input pins and sends the output to one of the rails depending on which output is higher. Ideally, an IC specially designed to operate as a comparator (like the [LM293](#)) would be used for this type of application, but people often will simply use an OpAmp in “open loop” mode (i.e. without feedback). The following TI document explains the reasons for not using OpAmps as comparators and also elaborates on the differences between them: SLOA067 – [Op Amp and Comparators – Don’t Confuse Them!](#)

With that said, if an OpAmp is used as a comparator no feedback is included to limit the gain of the OpAmp (as will be done when designing amplifiers in [Section 7.2](#)). Since the gain (V_{out}/V_{in}) is not limited it will be equal to the “Open Loop Gain, A_o ” (or internal gain of the OpAmp), which is nearly infinite. Since the V_{out} is limited by the rail voltages the output of a comparator is always equal to one of the rail voltages (+Vcc, -Vcc, or ground). [Figure 7.4](#) shows a dual supply comparator circuit (Left) and a single supply comparator circuit (Right) drawn with the positive and negative supplies connected to the locations that will allow the circuit to be correctly simulated in Multisim. These “reversed positive and negative rail connections” will be done in all circuits in the remainder of this module, but remember that it is the opposite of how it will normally be shown in technical documents.

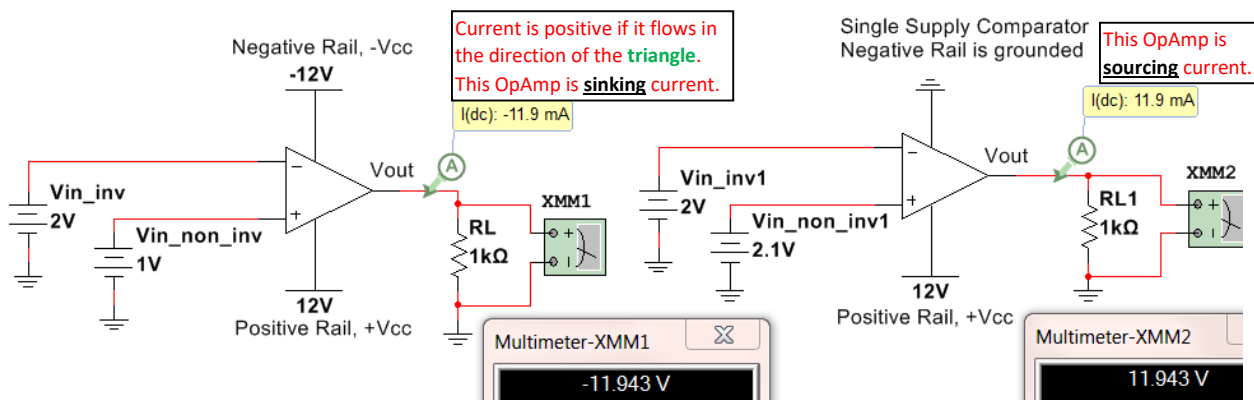

Figure 7.4: Dual Supply Comparator (Left), Single Supply Comparator (Right)

- If $V_{in_non_inv} > V_{in_inv}$ then $V_{out} \approx +V_{cc}$. or $V(+)>V(-)$ then $V_{out} \approx +V_{cc}$
- If $V_{in_inv} > V_{in_non_inv}$ then $V_{out} \approx -V_{cc}$ for the dual supply circuit or **0V for the single supply** circuit.

V_{out} is assumed to go all the way to the rail voltage in open loop configurations, but there is often a signal swing limit that will prevent the OpAmp from going all the way to the rail. In [Figure 7.4](#) V_{out} only goes to 11.943V instead of 12V. Special OpAmps designed to go “rail to rail” are often needed if V_{out} needs to go to V_{cc} . Once V_{out} is determined from the two bullets above the current through the load (R_L) can be calculated as $I_{RL} = V_{out}/R_L$.

- If V_{out} is > 0 then current is **sourced** OUT OF the OpAmp and **down** through the load.
- If V_{out} is < 0 then current is **sunked** INTO the OpAmp and **up** through the load.

Example 7.1) Determine V_{out} and the magnitude and direction of the current across the load resistor in the following circuit before (Left circuit) and after the switch is closed (right circuit) if $V_{in} = 5V$. Does the OpAmp source or sink current for each case? The simulated results are shown in the Figure below.

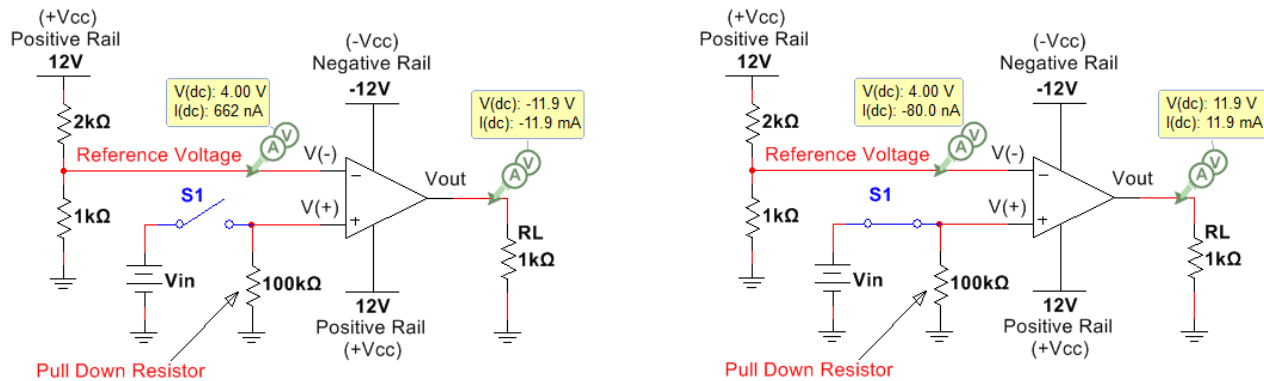

Figure 7.5: Circuit before (Left) and after (Right) Switch, S1 is closed if $V_{in} = 5 V$.

Before solving this problem some explanations are needed. When designing a comparator circuit (either with an OpAmp or with a comparator IC) one of the input pins (either $V(+)$ or $V(-)$) is often set to a fixed reference voltage. Since almost no current flows into either of the input pins of an OpAmp or a comparator IC due to the near-infinite input resistance a voltage divider can be used to set the reference voltage. In [Figure 7.5](#), for both the left and right circuits, the reference voltage (V_{ref}) is set using the following voltage divider rule (VDR) equation:

- $V_{ref} = 12 \cdot 1k\Omega / (1k\Omega + 2k\Omega) = 4 V$

V_{ref} is tied to $V(-)$ in this circuit, but it could just have easily been connected to $V(+)$ if the situation called for it. This is a very practical circuit that is used extensively when integrating sensors in circuitry. The “ V_{in} ” voltage in [Figure 7.5](#) could be the voltage from a sensor and the design calls for V_{out} to go to 12 V when V_{in} is greater than V_{ref} and to $-12 V$ when V_{in} is less than V_{ref} (or if the switch isn’t closed). With that said it is time to solve the problem.

Before the Switch is closed

- The pulldown resistor is necessary so that before the switch is closed **$V(+)$ is tied to ground (0V)**. Without the pulldown resistor $V(+)$ would be connected to an open circuit and would be “floating” at an unknown voltage. A **large value is usually used for a pullup or pulldown resistor** so there is not very much current wasted.
- As previously stated $V(-) = V_{ref} = 4 V$ from the VDR calculation.
- Since $4V > 0V \rightarrow V(-) > V(+)$ → **$V_{out} = -12 V$**
- The current flows up through the load → $I_{RL} = (0 - -12) / 1000 = 12 \text{ mA (Up)}$
- The **OpAmp is sinking current** since the current flows into it. The negative supply is supplying all of the power to this circuit before the switch is closed.

After the Switch is closed

- V_{in} (5V) is connected to the 100 kΩ pulldown resistor making **$V(+)$ = 5V**.

- As previously stated $V(-) = V_{ref} = 4\text{ V}$ from the VDR calculation.
- Since $5\text{ V} > 4\text{ V} \rightarrow V(+) < V(-) \rightarrow \mathbf{V_{out} = +12\text{ V}}$
- The current flows down through the load $\rightarrow I_{RL} = (12 - 0)/1000 = \mathbf{12\text{ mA (Down)}}$
- The **OpAmp is sourcing current** since the current flows out of it. The positive supply is supplying all of the power to this circuit after the switch is closed.

If using an actual comparator IC (like the previously mentioned [LM293](#)) was used the first step to simulating it in Multisim would be to search for the part. [Figure 7.6](#) shows how to search for it. Select “All Groups: and type in LM293 in the component field. In this case, 4 options including LM293 at the beginning of the name appear and all are surface mount ICs, but they will have close to the same properties as the [through-hole DIP version](#). The LM293 is an 8-pin Dual comparator which means there are two comparators in the IC.

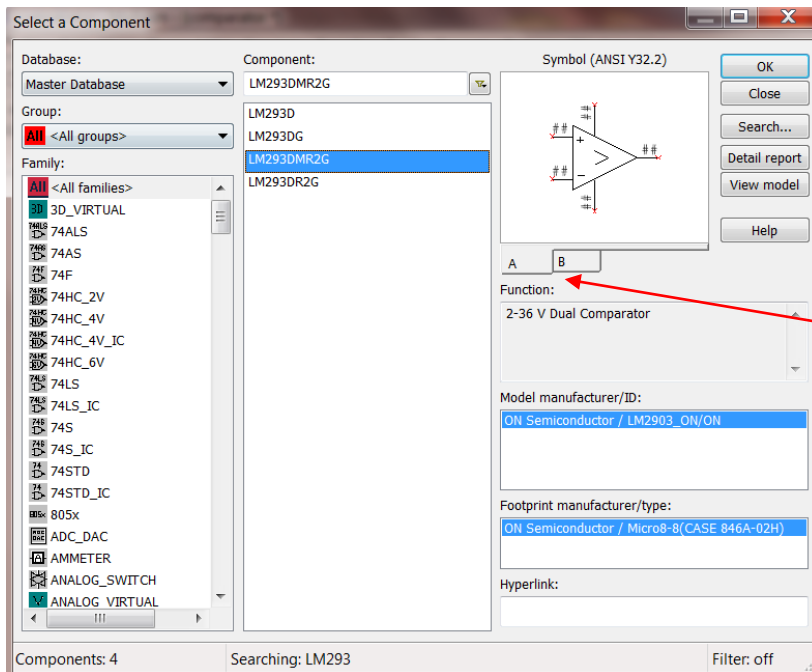

Two Comparators can be selected (A, B). The pin numbers will be different depending on which one is selected. In [Figure 7.7](#) both A and B are selected and all pin numbers are shown in Multisim. Since the 2 comparators on the Dual IC have a common ground and Vcc only one has to be connected to Vcc and ground and the other two show a red x.

Figure 7.6: Searching for parts in Multisim – LM293, 8-pin Dual Comparator selected

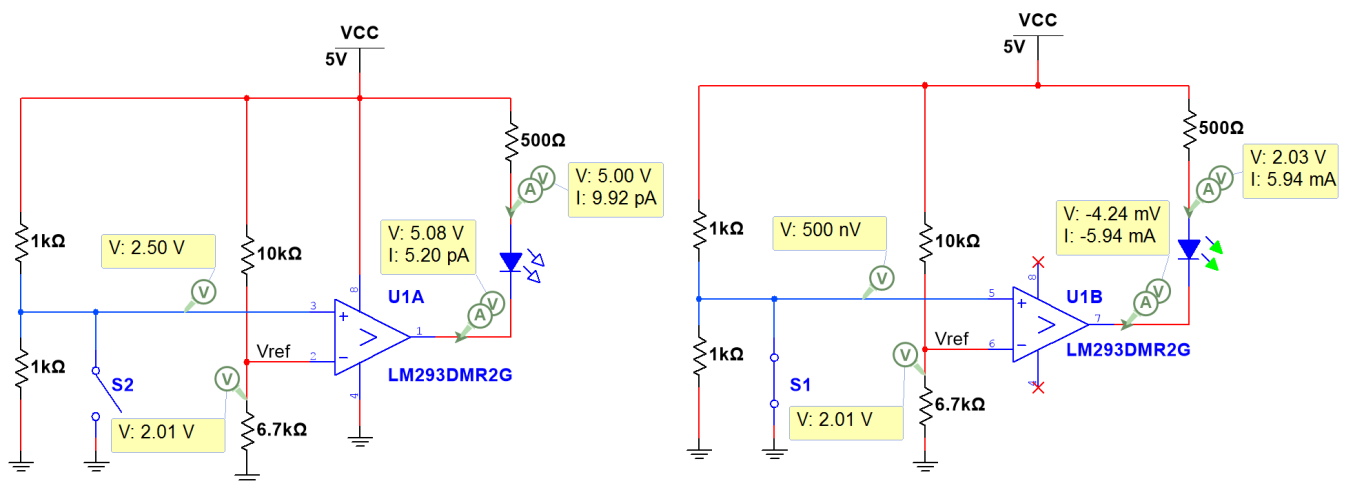
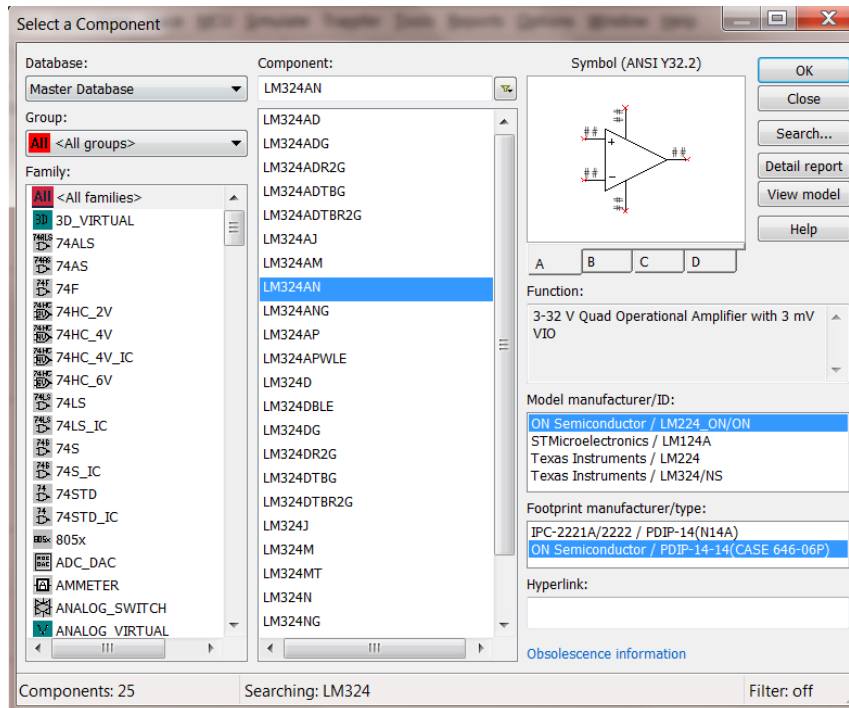

Figure 7.7: Circuit using the LM293 showing that the output goes low and sinks current when $IN- > IN+$

The circuit in [Figure 7.7](#) shows that the LM293 operates in an **active low configuration**, where it turns an LED on by **sinking** current through it when $IN^- > IN^+$ (**Note:** IN^- is labeled V_{ref} on the schematic). The LM293 has a **high impedance (or Open Collector) output** so a pullup resistor has to be used for it to work the way it is was intended. In [Figure 7.7](#) the pullup resistor is put in series with an LED so it will turn on an LED when the output goes low. When $IN^+ > IN^-$ it doesn't source current like a normal OpAmp operates (as shown in [Figure 7.5](#)). Instead, it sends the output to V_{cc} so that no current flows between V_{cc} and the pullup resistor because there is no voltage difference \rightarrow Recall from the [Davis DC Circuits book](#): $I_R = \Delta V/R = (V_{cc} - V_{cc})/R = 0$

Section 7.2 – OpAmps used as Amplifiers

For this section the **OPAMP_5T_VIRTUAL** part in Multisim will also be used for all circuits except the one in [Figure 7.9](#) and [Figure 7.11](#). Those circuits are built using the LM324 that was described in [Figure 7.1](#).



Of the 25 [LM324](#) options, a DIP version from **Fairchild Semiconductor** (referred to in [Figure 7.1](#)) will be selected (LM324AN). **Note:** An **ON Semiconductor** part is selected instead because they acquired Fairchild semiconductor in 2015. PDIP stands for “Plastic Dual Inline Package” and is one of the most popular IC types for through-hole applications. **Note:** DIP packages will have higher power ratings than surface mount parts. The LM224 is selected in the “Model manufacturer/ID”, because this is in the same family as the LM324. Notice, there are 4 OpAmps (A, B, C, D) that can be selected. In [Figure 7.9](#) an example is shown that uses all 4 OpAmps in a circuit.

Figure 7.8: Searching for parts in Multisim – LM324 14-pin Quad DIP OpAmp selected

The circuits in [Figures 7.9 to 7.12](#) include four OpAmps and is used to amplify a signal at four different gains and turn on LEDs. [Figure 7.9](#) shows has a DC input voltage and shows how all 14 of the LM324 quad OpAmp would be implemented for this circuit and [Figure 7.10](#) shows the results if the LM 324 is replaced with four virtual OpAmps (OpAmp_5T_Virtual). The green LED has an adjustable current threshold. By double clicking on the LED in Multisim the threshold can be changed. The 5 mA default is used in all of the figures in this eBook. For the circuits in [Figure 7.9](#) and [Figure 7.10](#) with a DC input of 120 mV all OpAmps source enough current to turn on the LEDs except the OpAmp connected to LED4. The 470 Ω resistor is used to limit the current through the LEDs to around 20 mA, which is a common current rating for many types of LEDs. When the input is a DC voltage the results are nearly identical for the LM324 ([Figure 7.9](#)) and the virtual OpAmp ([Figure 7.10](#)). The only significant difference can be seen in the output of the top left OpAmp that is connected to LED1. It has a gain large enough to **saturate** the OpAmp. **Saturating** the OpAmp (also commonly referred to as **clipping**) occurs when your output is limited by the rail voltage. The Virtual OpAmp allows V_{out} to go very close to the positive 12 V rail, but the LM324 limits the voltage to 10.3 Volts in this example.

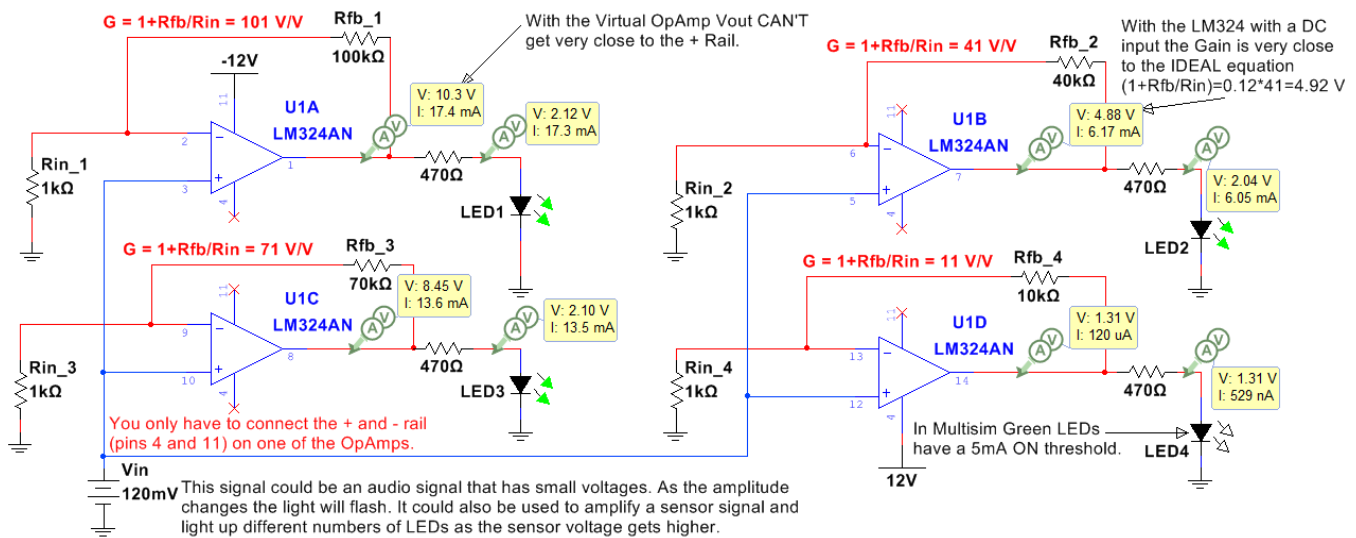

Figure 7.9: Non-Inverting Configuration Example that uses all 4 of the LM324 OpAmps with a DC input.

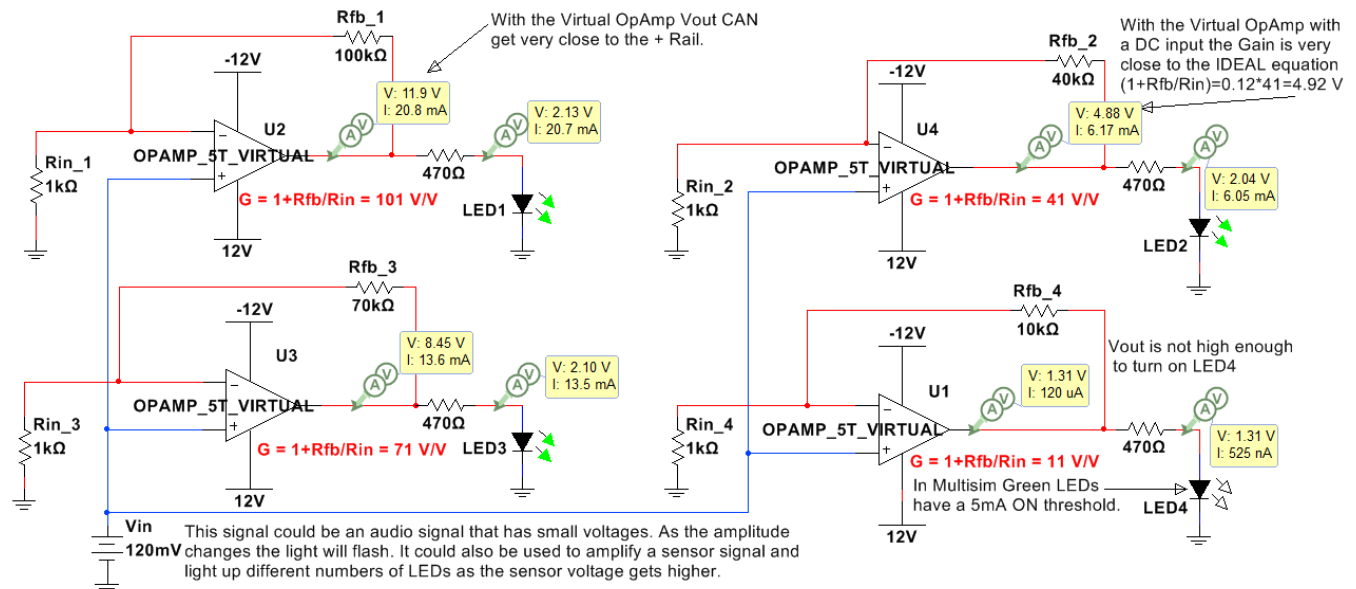

Figure 7.10: The circuit in Figure 7.9 with the OpAmps replaced with the Virtual 5 Terminal OpAmp.

For DC input signals, the **closed loop gain ($G = V_{out}/V_{in}$)** is usually very close to the **Ideal OpAmp gain** (Equations 7.2 and 7.3 for the inverting and non-inverting OpAmp configurations respectively) for all types of OpAmps because the **open loop gain (A_0)** is always an extremely large value (e.g. 200,000 V/V for the Virtual OpAmp in Figure 7.3), but in reality A_0 and G are reduced as the frequency increases once the frequency reaches the OpAmps internal 3dB frequency (which usually occurs at low frequencies). For example, the 3dB internal frequency for the LM324 is approximately 30 Hz when $V_{cc} = 15$ V and ~ 80 Hz when $V_{cc} = 30$ V as shown in Figure 5 of the LM324 datasheet. The ideal closed loop gain equations are modified for the situation where A_0 is NOT assumed to be infinity and are shown in Equation 7.4. When the signal is a high frequency sinusoid then the V_{out} is greatly reduced in the LM324 (Figure 7.11), but not in the Virtual OpAmp (Figure 7.12) because the Virtual OpAmp assumes A_0 remains at 200,000 V/V for all frequencies.

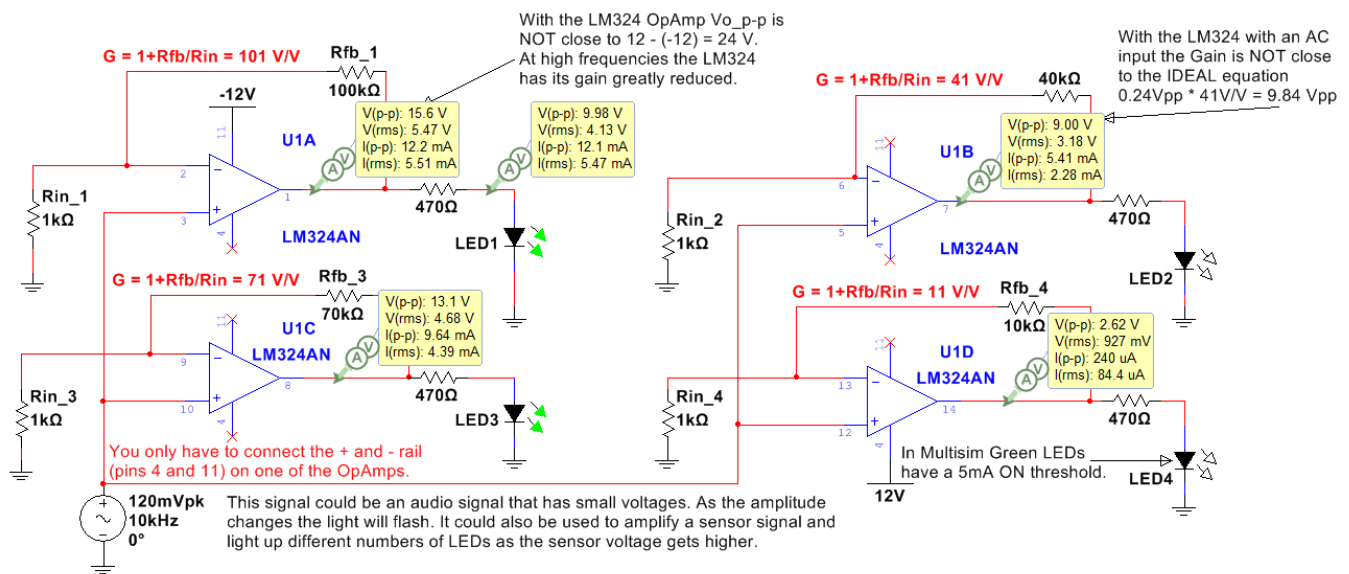

Figure 7.11: Example circuit that uses all 4 of the LM324 OpAmps with an 10 kHz AC input.

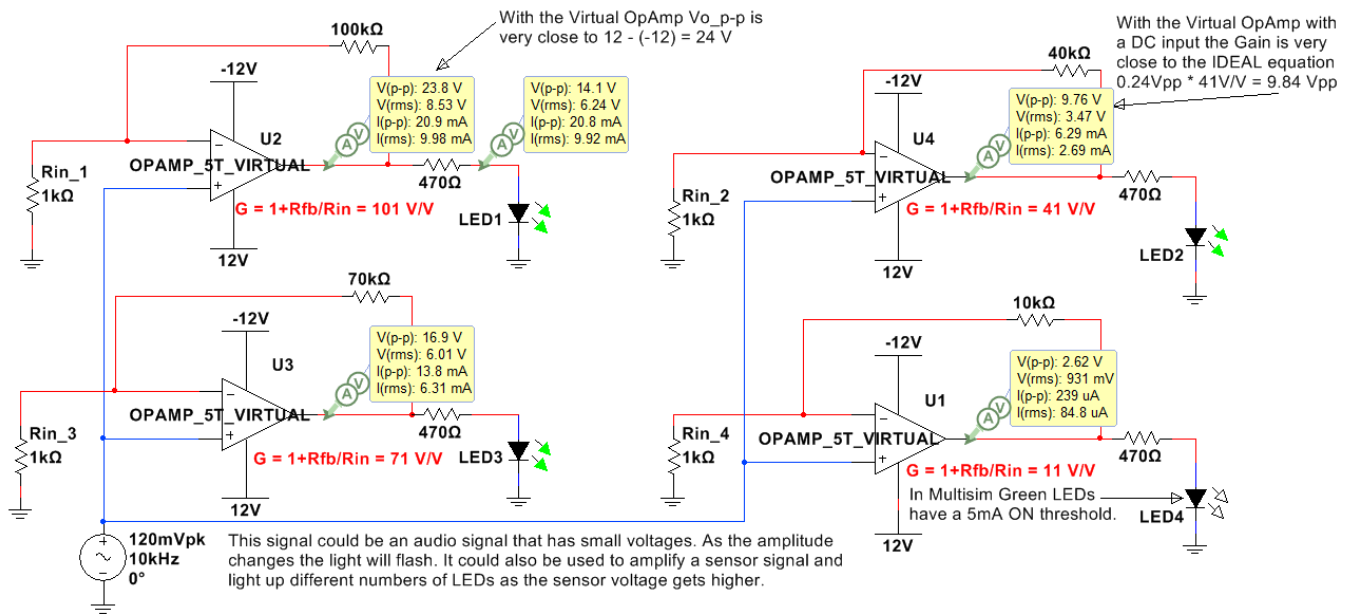

Figure 7.12: The circuit in Figure 7.11 with the OpAmps replaced with the Virtual 5 Terminal OpAmp.

Important OpAmp terms that have been previously mentioned are described in more detail in the bullets below along with the inverting and non-inverting gain equations. Sections 7.2.1 and 7.2.2 show example circuits.

- **Closed loop voltage gain (G)** is equal to V_{out}/V_{in} when a feedback resistor (R_{fb}) is connected from the output pin of the OpAmp to the inverting (-) terminal of the OpAmp as shown in the circuits in Figure 7.9 to 7.12. If R_{fb} is replaced with a wire (or $R_{fb} = 0\ \Omega$) the gain is equal to 1 V/V for the non-inverting configuration and 0 V/V for the inverting configuration.
- **Open loop voltage gain (A_0)** is the internal gain of the OpAmp. A_0 is assumed to be equal to infinity at low frequencies and decrease by approximately 20 dB/dec as frequency increases. A_0 would be the gain of the OpAmp if no feedback resistor is used and the OpAmp operates in the open loop mode as a

comparator as shown in Figures 7.4 and 7.5. A_0 will always be large enough to send the output to one of the rail voltages if no feedback (R_{fb}) is included in the OpAmp.

- **Ideal Gain equations** are simplified equations for closed loop gain and have the following assumptions:
 - 1) Open loop gain (A_0) = ∞
 - 2) Unity-gain Bandwidth (FU or f_t) = ∞
 - 3) Common Mode Rejection Ratio (CMRR) = ∞
 - 4) Input Resistance (RI) = ∞
 - 5) Output Resistance (RO) = 0
- As frequency increases the assumptions 1) and 2) of the ideal model are not valid and cause the open loop gain (A_0) to become small enough that the ideal gain equations become increasingly inaccurate. This results in the need for a new set of gain equations where A_0 is assumed to be finite. If the input frequency is beyond the internal 3 dB frequency of the OpAmp (f_{3db}) a good approximation of A_0 can be found from [Equation 7.1](#), where f_{in} is the input frequency and f_t is the OpAmps Unity Gain Bandwidth.

$$[7.1] \quad \boxed{A_0 \cong \frac{f_t}{f_{in}}} \quad * \text{ This is a good approximation when } f_{in} > f_{3dB}$$

- **Inverting Configuration:** If the input voltage is connected the in input resistance (R_{in}) that is connected to the inverting (-) terminal of the OpAmp it is called the “inverting configuration”. An example with a DC input is shown in [Figure 7.13](#) and an example with an AC signal is shown in [Figure 7.14](#). The closed loop gain equations for an inverting OpAmp are shown in 7.2 and 7.3.

$$[7.2] \quad \boxed{G_{ideal} = \frac{v_{out}}{v_{in}} \cong \frac{-R_{fb}}{R_{in}}}$$

- **Non-Inverting Configuration:** If the input voltage is connected to the in non-inverting input terminal (+) of the OpAmp it is called the “non-inverting configuration”. An example with a DC input is shown in [Figure 7.15](#) and an example with an AC signal is shown in [Figure 7.16](#).

$$[7.3] \quad \boxed{G_{ideal} = \frac{v_{out}}{v_{in}} \cong 1 + \frac{R_{fb}}{R_{in}}}$$

- **Finite A_0 gain OpAmp equation:** If A_0 cannot be assumed to be infinity (usually because the input frequency it too high) then equations 7.2 and 7.3 can be corrected using [Equation 7.4](#).

$$[7.4] \quad \boxed{G = \frac{v_{out}}{v_{in}} \cong \frac{G_{ideal}}{1 + \frac{R_{fb}}{R_{in}} + \frac{1}{A_0}}} \quad * \text{ **Note:** When } A_0 \text{ is infinity then } G = G_{ideal}.$$

Section 7.2.1 – Inverting OpAmp Configuration

The inverting OpAmp configuration is shown in [Figure 7.13](#) (DC input) and [Figure 7.14](#) (AC input).

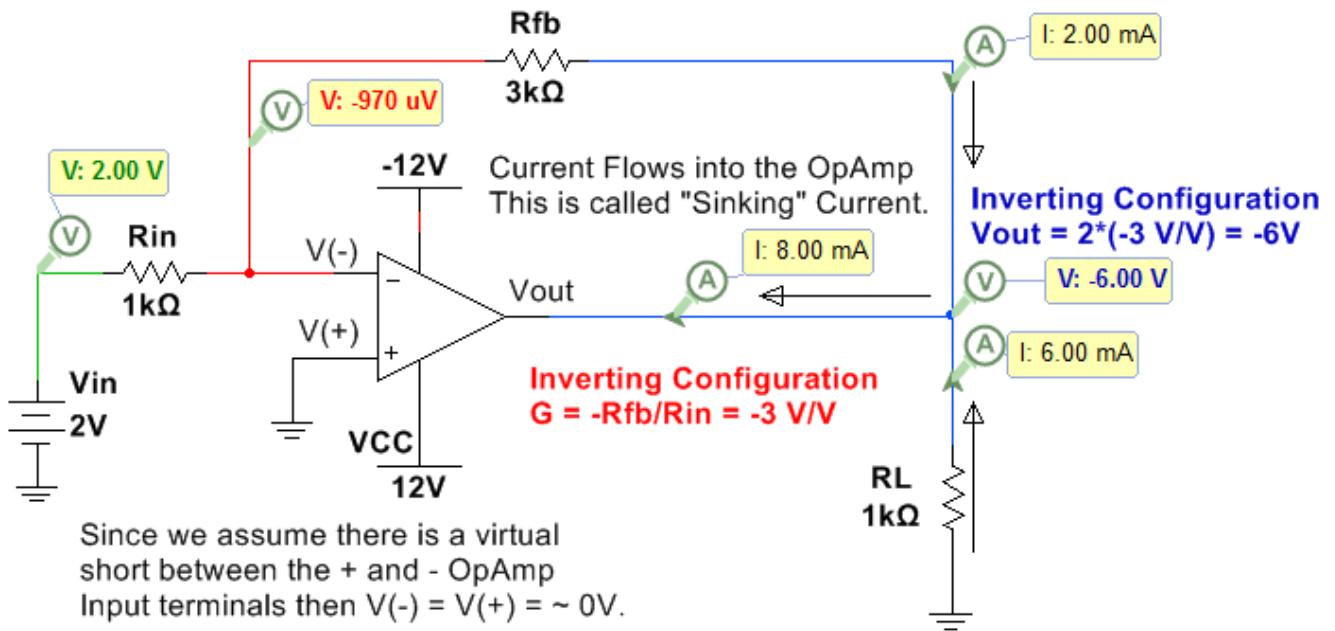

Figure 7.13: Inverting Configuration with a DC input.

In the circuit below the instantaneous voltage values (top numbers) are also shown so you can see that at that moment in time the circuit behaves exactly like the DC circuit in [Figure 7.13](#) ($V_{out} = -.994V \cdot (-3 V/V) = 2.98 V$).

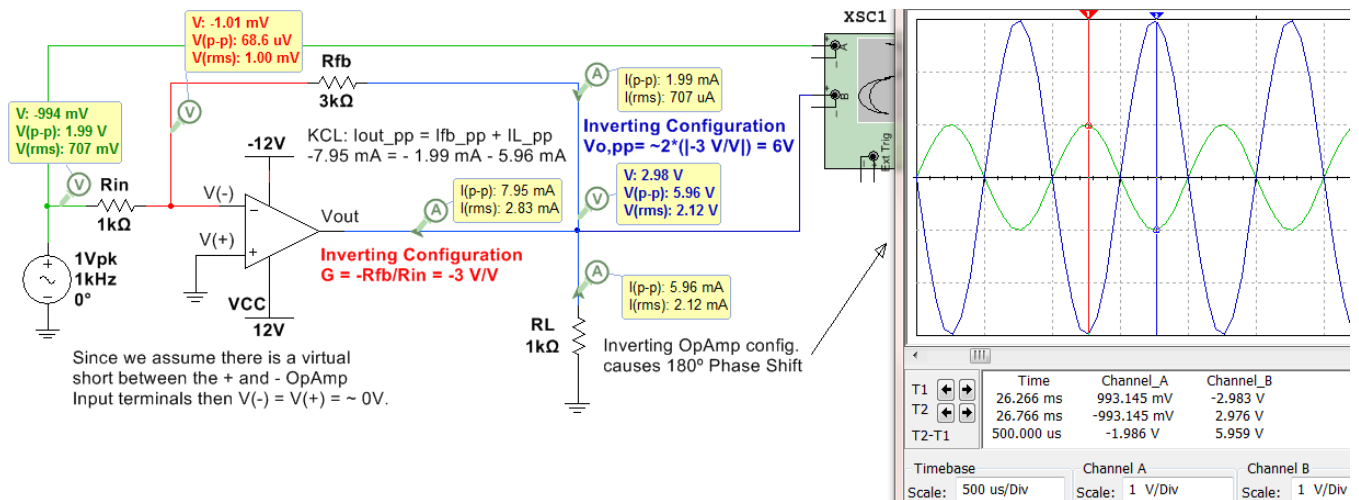

Figure 7.14: Inverting Configuration with an AC input.

Since the virtual OpAmp in [Figure 7.14](#) has a fixed A_0 of 200,000 V/V regardless of the input frequency the ideal gain in [Equation 7.2](#) matched closely with the Multisim measurements. If an actual OpAmp were used (like the LM324) the gain would be reduced due to the increase in frequency that results in a finite A_0 . For this same reason, Multisim also matches the Non-inverting OpAmp configuration circuit with an AC input in [Figure 7.16](#).

Section 7.2.2 – Non-Inverting OpAmp Configuration

The non-inverting OpAmp configuration is shown in [Figure 7.15](#) (DC input) and [Figure 7.16](#) (AC input).

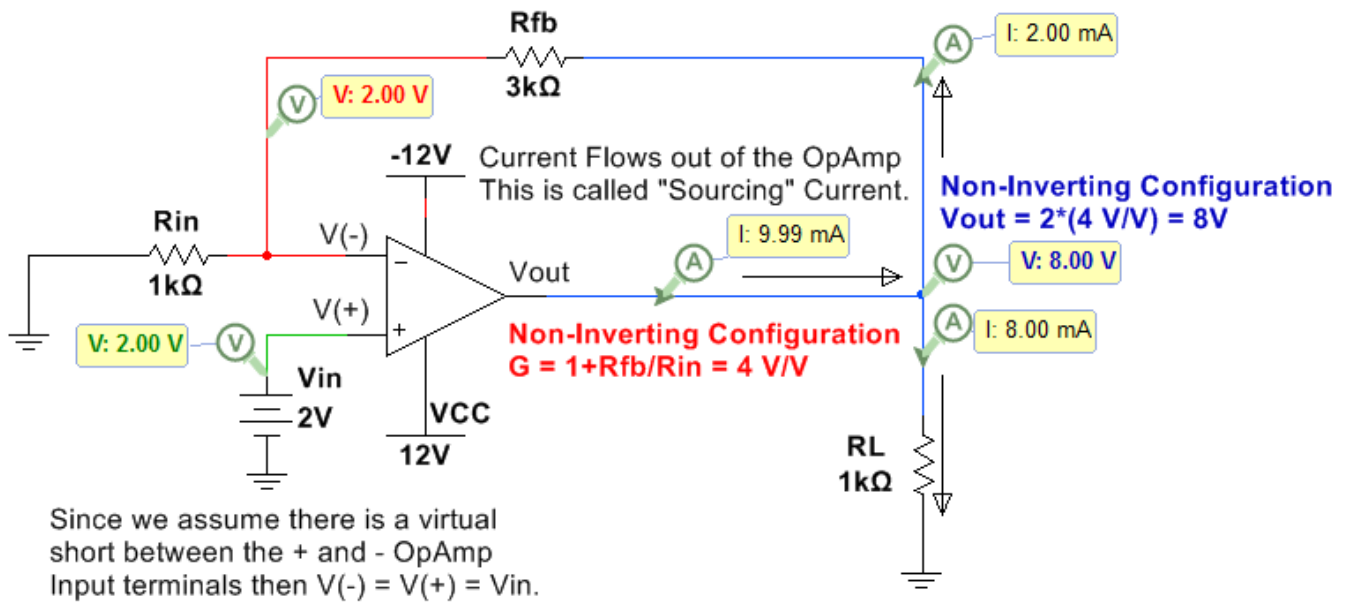

Figure 7.15: Non-Inverting Configuration with a DC input.

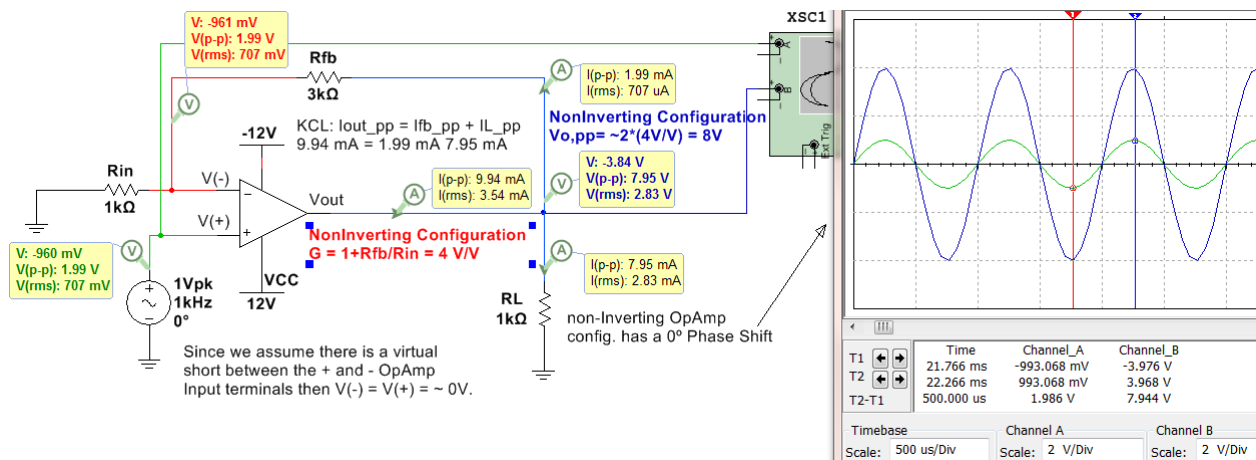

Figure 7.16: Non-Inverting Configuration with an AC input.

Section 7.3 – Superposition with OpAmps

With DC circuits the superposition principle was a good method for solving circuits with multiple inputs and can also be applied to OpAmp circuits. Superposition is accomplished by breaking the overall problem with multiple inputs up into sub-problems where the circuit was solved “Due to Only” one input at a time and then the values are added together to get the result due to all inputs. The inputs not involved in the sub-problem are “zeroed out” as follows.

- Independent Voltage Sources are replaced with short circuits.
- Independent Current Sources are replaced with open circuits.

Using the equations in [section 7.2](#) and the superposition method more complicated OpAmp circuits can be solved. The example in [Figure 7.17](#) shows a “Differential Amplifier” configuration where R_{in} and R_{fb} from [section 7.2](#) is replaced with $R1$ and $R2$. **Note:** In OpAmp technical documents R_{fb} is commonly referred to as $R2$ and R_{in} is commonly referred to as $R1$. A voltage divider with $R3$ and $R4$ is used on the + OpAmp input such that $V(+)=Vin2 \cdot R4 / (R3+R4)$. Recall that this voltage divider is possible because we assume that **NO Current flows into either input terminal of the OpAmp** due to the infinite impedance assumption.

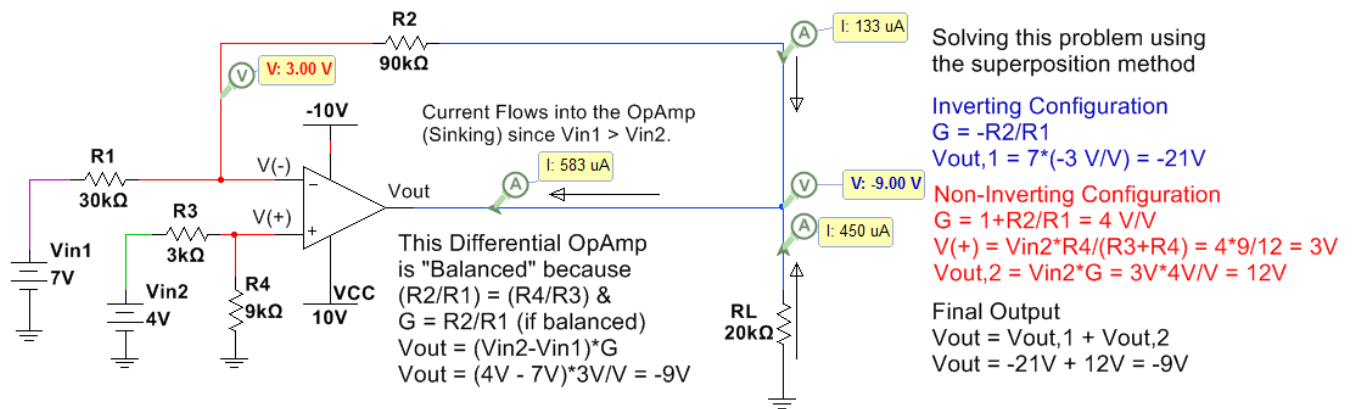

Figure 7.17: Differential OpAmp Configuration.

In [Figure 7.18](#), a summing amplifier is simulated and solved using the superposition method. Two additional OpAmp circuits are shown in the Appendix: 4th order Butterworth Low Pass Filter in [Figure A.4](#) and an instrumentation amplifier in [Figure A.5](#).

The equation for a summing OpAmp is:

$$V_{out} = -R_{fb}/R_{in1} \cdot Vin1 - R_{fb}/R_{in2} \cdot Vin2 - R_{fb}/R_{in3} \cdot Vin3 = 3(-1) + 4(-1) + 5(-1) = -12\text{V}$$

Note: A weighted summer can be created by modifying the resistor values.

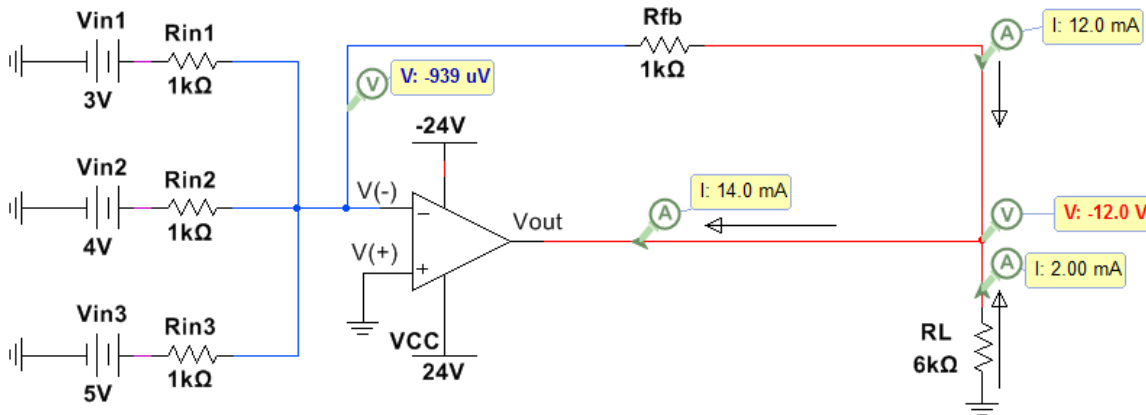

Figure 7.18: Summing OpAmp Configuration.

References and Links

The following references and links provide supporting information for this module. All references in this module are either cited within the module within brackets or URL links are either embedded in hyperlinks or fully listed.

References and Links not listed in other Modules

- [1] DC Circuits, Chad Davis: <https://shareok.org/handle/11244/52245>
- [2] <http://www.allaboutcircuits.com/textbook/semiconductors/>
- [3] Electronics Overview: <http://www.allaboutcircuits.com/textbook/semiconductors/>
- [4] Multisim: <http://www.ni.com/multisim/>

Module 1 – References and Links

- [5] AC and DC Background: <http://www.allaboutcircuits.com/news/why-is-the-us-standard-60-hz/>
- [6] Electrical Safety: <http://www.allaboutcircuits.com/textbook/direct-current/chpt-3/ohms-law-again/>
- [7] Frequencies of different musical notes: <http://www.allaboutcircuits.com/textbook/alternating-current/chpt-1/ac-waveforms/>
- [8] Sampling Information: <http://www.dspguide.com/ch3/2.htm>
- [9] Square wave information: <http://www.allaboutcircuits.com/textbook/alternating-current/chpt-7/square-wave-signals/>
- [10] Square wave information: https://en.wikipedia.org/wiki/Square_wave
- [11] Triangle wave information: https://en.wikipedia.org/wiki/Triangle_wave

Module 3 – References and Links

- [12] RLC Calculations: <http://hyperphysics.phy-astr.gsu.edu/hbase/electric/powerac.html>
- [13] Rigol Oscilloscope Information: <http://www.prc68.com/l/RigolDS1052E.shtml>
- [14] Error simulating inductors in MultiSim: <https://forums.ni.com/t5/Multisim-and-Ultiboard/Offset-problem-in-simulating-current-and-voltage-phase-relation/td-p/1194627>
- [15] Alternating Current eBook: <http://www.allaboutcircuits.com/textbook/alternating-current/chpt-14/50-ohm-cable/>
- [16] Electrical effects of the physical size of the transmission lines: <http://www.allaboutcircuits.com/technical-articles/introduction-to-the-transmission-line/>
- [17] The following link shows a figure with more information about the electrical grid and includes different sources of electrical generation such as: wind, solar, hydro-electric, nuclear, and coal: https://commons.wikimedia.org/wiki/File:Electricity_Grid_Schematic_English.svg

Module 4 – References and Links

- [18] Filter Overview: <http://www.allaboutcircuits.com/textbook/alternating-current/chpt-8/what-is-a-filter/>

Module 5 – References and Links

- [19] History of the transformer: https://en.wikipedia.org/wiki/War_of_Currents
- [20] Transformer Basics: <http://www.allaboutcircuits.com/textbook/alternating-current/chpt-9/mutual-inductance-and-basic-operation/>
- [21] Transformer Video Lectures; <http://www.allaboutcircuits.com/textbook/alternating-current/chpt-9/mutual-inductance-and-basic-operation/>
- [22] Rectifiers: <http://www.allaboutcircuits.com/textbook/semiconductors/chpt-3/rectifier-circuits/>

[23] Faraday's Law: <http://www.allaboutcircuits.com/textbook/alternating-current/chpt-9/mutual-inductance-and-basic-operation/>

[24] Internal Diagram of a Transformer:
https://en.wikipedia.org/wiki/Transformer#/media/File:Transformer3d_col3.svg

Module 6 – References and Links

[25] 1N914 switching diode datasheet: <https://www.fairchildsemi.com/datasheets/1N/1N914.pdf>

[26] 1N4000 series rectifier diode datasheet: <https://www.fairchildsemi.com/datasheets/1N/1N4007.pdf>

[27] Diodes Sparkfun tutorial: https://learn.sparkfun.com/tutorials/light-emitting-diodes-leds?_ga=1.259343308.774591033.1477860341

[28] Red LED ordering info: <https://www.sparkfun.com/products/9590>

[29] Green LED ordering info: <https://www.sparkfun.com/products/9592>

[30] Diode Overview: <http://www.futureelectronics.com/en/diodes/diodes.aspx>

[31] Diode Overview: <http://www.allaboutcircuits.com/textbook/semiconductors/chpt-3/introduction-to-diodes-and-rectifiers/>

[32] BS170 MOSFET datasheet: http://www.onsemi.com/pub_link/Collateral/BS170-D.PDF

Module 7 – References and Links

[33] LM324 OpAmp datasheet: <https://www.fairchildsemi.com/datasheets/LM/LM324.pdf>

[34] A Texas Instrument (TI) white paper SLOA011 titled *Understanding Operational Amplifier Specifications*:
<http://www.ti.com/lit/an/sloa011/sloa011.pdf>

[35] Texas Instrument (TI) Handbook of Operational Amplifier Applications:
<http://www.ti.com/lit/an/sboa092b/sboa092b.pdf>

[36] SLOA093: "Filter Design in 30 Seconds" <http://www.ti.com/lit/an/sloa093/sloa093.pdf>

[37] SLOA096: "More Filter Design on a Budget" <http://www.ti.com/lit/an/sloa096/sloa096.pdf>

[38] Art of Electronics: https://www.amazon.com/Art-Electronics-Paul-Horowitz/dp/0521809266/ref=dp_ob_title_bk

[39] SLOA067 – *Op Amp and Comparators – Don't Confuse Them!*:
<http://forums.parallax.com/discussion/download/96248&d=1350228174>

Appendix

[Figure A.1](#) shows the step response and the Bode magnitude plots for a series RL LPF with the same topology as shown in [Figure 4.5](#) and a series RC HPF with the same topology as shown in [Figure 4.6](#). The step response is the output voltage across the resistor if the input voltage is a 1 V DC source that is suddenly applied with a switch. The LPF (RL Circuit with black curves in [Figure A.1](#)) shows that the input voltage is passed to the output since V_{out} at steady state is 1 V. When studying DC transients in the DC circuits eBook the equation for $v_C(t)$ and $v_R(t)$ was found to be: $v_R(t) = Vin_{DC} \cdot (1 - e^{-t/\tau})$ and $v_L(t) = Vin_{DC} \cdot (e^{-t/\tau})$ [Click Here to Go Back to Module 4](#).

The HPF (RC Circuit with red curves in [Figure A.1](#)) shows that the input voltage is blocked and doesn't pass to the output since V_{out} at steady state is 1 V. When studying DC transients in the DC circuits eBook the equation for $v_C(t)$ and $v_R(t)$ was found to be: $v_C(t) = Vin_{DC} \cdot (1 - e^{-t/\tau})$ and $v_R(t) = Vin_{DC} \cdot (e^{-t/\tau})$

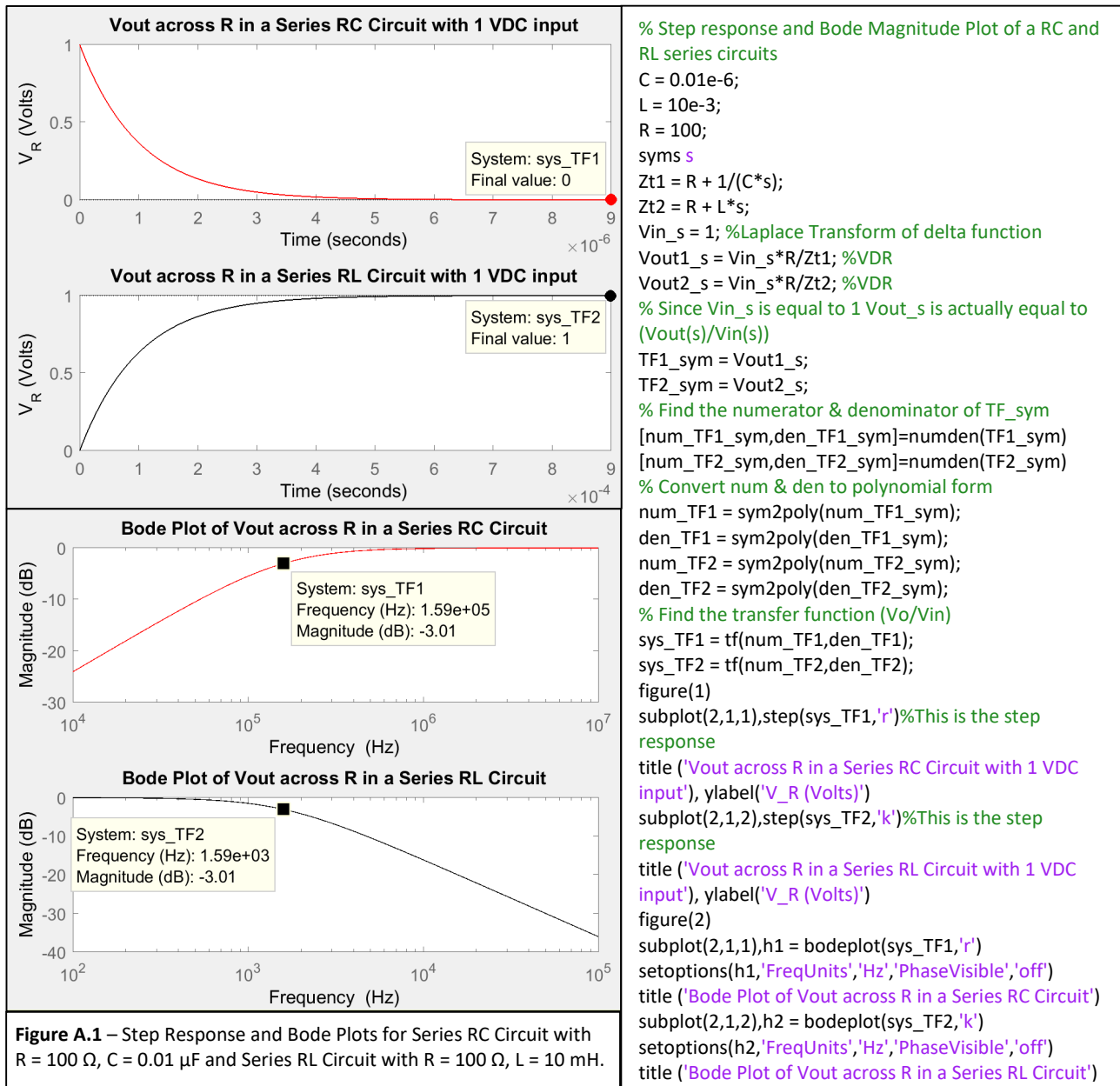

The following is an example of a 2nd order LPF that is solved for in Matlab in [Figure A.2](#). The problem is solved using the Laplace method in Matlab and the step response and Bode plot are shown below. The problem is also solved for by hand to get $v_{out}(t)$ (Shown in bold – called vo_calc) and the step response of $v_{out}(t)$ is plotted below the Matlab solution step response to show the same results are achieved. [Click Here to Go Back to Module 4](#).

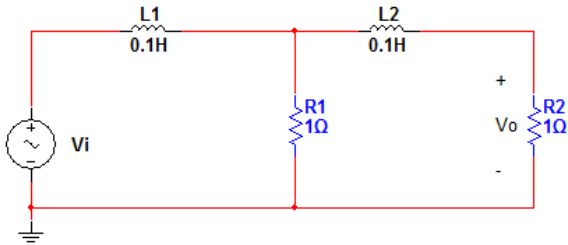

Code	
<pre> syms s t; A = [0.1*s+1 -1; -1 1+0.1*s+1]; B = [1;0]; Vout = inv(A)*B [num_sym,den_sym] = numden(Vout(2)) hs = tf(sym2poly(num_sym),sym2poly(den_sym)) %The following was calculated using partial fractions expansion and taking the inverse Laplace transform of Vout(s). vo_calc = 1 - 1.171*exp(-3.819*t) + 0.170*exp(-26.180*t) ; time = 0:0.05:3; %first 3 seconds f2 = symfun(vo_calc,t); vo_t_calc = double(f2(time')); figure(1); subplot(2,1,1); step(hs); axis([0 3 0 1]) subplot(2,1,2); plot(time,vo_t_calc); title('Calculated Step Response'); axis([0 3 0 1]) xlabel('Time(seconds)'); ylabel('Amplitude'); bode(hs) </pre>	
Figures	
Figure A.2 – 2nd Order LPF Matlab Solution	

The following is an example of a 2nd order HPF that is solved for in Matlab in [Figure A.3](#). The problem is solved using the Laplace method in Matlab and the step response and Bode plot are shown below. The problem is also solved for by hand to get $v_{out}(t)$ (Shown in bold – called vo_calc) and the step response of $v_{out}(t)$ is plotted below the Matlab solution step response to show the same results are achieved. [Click Here to Go Back to Module 4](#).

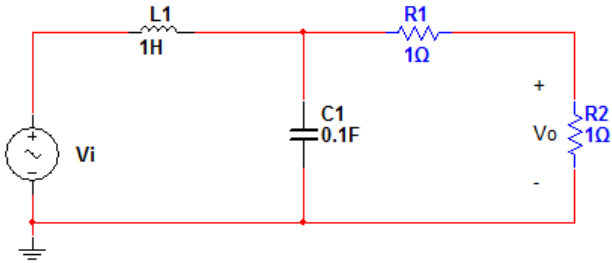

Code	
	<pre> syms s t; A = [1*s+1/(0.1*s) -1/(0.1*s); -1/(0.1*s) 1/(0.1*s)+1+1]; B = [1;0]; Vout = inv(A)*B [num_sym,den_sym] = numden(Vout(2)) hs = tf(sym2poly(num_sym),sym2poly(den_sym)) %The following was calculated using partial fractions expansion and taking the inverse Laplace transform of Vout(s). vo_calc = 1/2-1/2*exp(-3*t)*cos(1.118*t)-1/1.118*exp(-3*t)*sin(1.118*t); time = 0:0.05:3; %first 3 seconds f2 = symfun(vo_calc,t); vo_t_calc = double(f2(time')); figure(1); subplot(2,1,1); step(hs); subplot(2,1,2); plot(time,vo_t_calc); title('Calculated Step Response'); xlabel('Time(seconds)'); ylabel('Amplitude'); bode(hs); </pre>

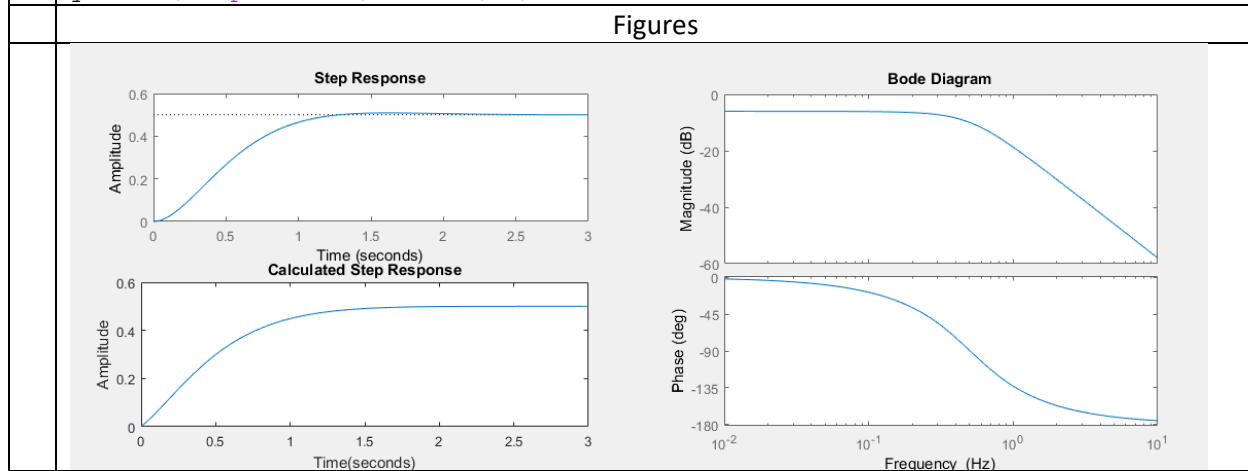

Figure A.3 – 2nd Order HPF Matlab Solution

Figure A.4 shows an example of an active filter. This filter is a 4th order Butterworth LPF filter with a 3dB frequency at approximately 1 kHz. The Bode magnitude plot is shown. Since it is a 4th order filter (4 capacitors are present) the slope of the stop band increases from -20 dB/dec for a 1st order LPF (as described in Module 4) to -80 dB/dec. This means that at 10 kHz (on decade beyond the - 3 dB point) the gain will drop to approximately -83 dB. Each of the OpAmps is a 2nd order LPF and when two are cascaded in series it produces a 4th order filter. A third OpAmp could be included after the 2nd OpAmp to add gain so that the pass band is not limited to 0 dB (or 1 V/V) like it is for passive RLC filters. Another important application for test and measurement equipment where multiple OpAmps are used is the instrumentation amplifier shown in Figure A.5.

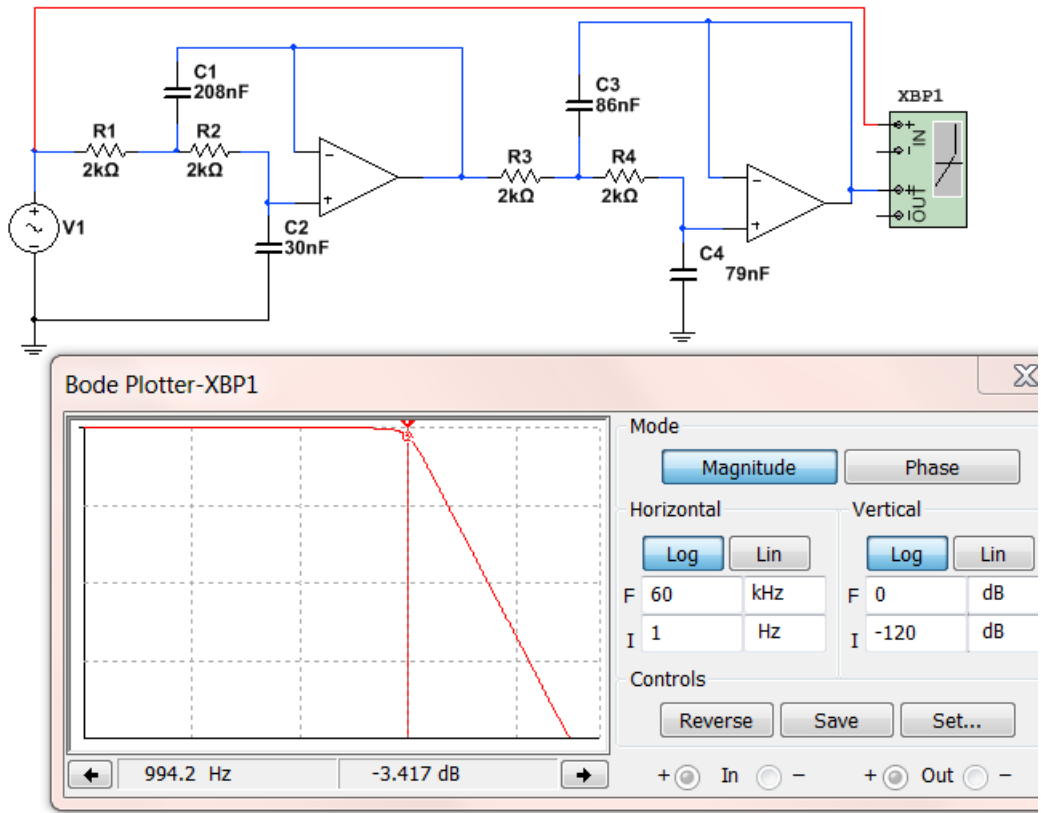

Figure A.4: 4th Butterworth LPF with a 3dB frequency at approximately 1 kHz.

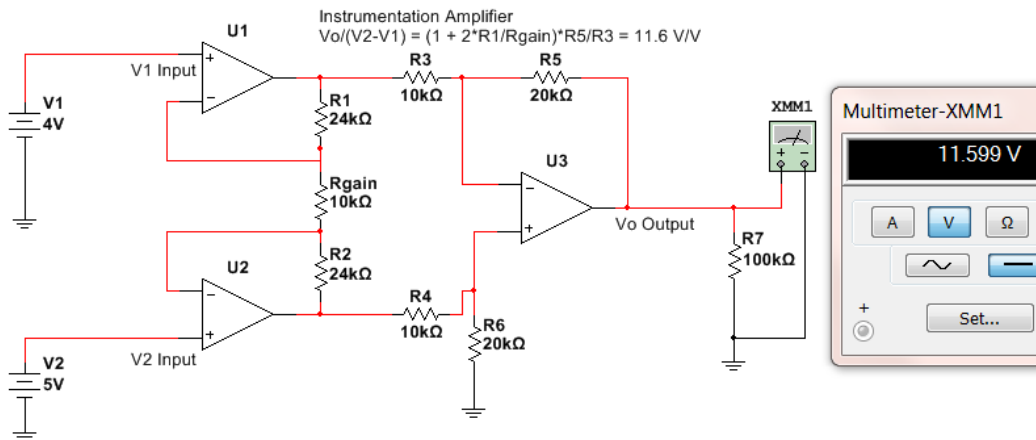

Figure A.5: Instrumentation Amplifier – useful for test and measurement equipment.

Matlab Code for [Figure 1.7](#)

```
% Plotting a square wave and triangle wave from sinusoids

N = 10; % Number of sinusoidal terms
fo = 60; %Fundamental Frequency
T = 1/fo; %Period
A = 1; % Amplitude
Num_T = 3; %Number of periods to plot
Num_pts_per_period = 500; % # of points per period
tfinal = Num_T*T;
dt = T/Num_pts_per_period;
t = 0:dt:tfinal;
sq = 0*t;
tr=sq;
for j=1:N-1
    k = 2*j-1; %This is the harmonic for the square wave
    k_t = 2*(j-1)+1; %This is the harmonic for the triangle wave
    sq = sq+(A*4/pi)*sin(2*pi*fo*t*k)/k;
    tr = tr+(-1)^j*(A*8/pi^2)*sin(2*pi*fo*t*k_t)/(k_t^2);
end
% The plot is set up to manually change the last digit on the subplot...
% command to override the figure with a different number of terms.
subplot(2,2,1),
plot(t,sq,'k')
hold
plot(t,tr,'r')
hold off
grid on
title ('10 sinusoidal terms') % Change this to match N
axis([0,0.05,-1.2,1.2])
```

Diode Example Problems

- 1) What is the current limit of the red and green LEDs that we use in the lab and the ones that are used in the example circuits in the [Davis DC Circuits book](#)? **Put answer in mA. 20mA**
- 2) The assumed constant drop model forward bias voltage drops for different types of diodes are given in the diodes lab template. Which of the following is NOT CORRECT?
 - a. 1N914 = 0.7V
 - b. Red LED = 1.8V
 - c. Green LED = 2.1V
 - d. BAT85 = 0.7V
 - e. 1N4007 = 0.7V
- 3) If you use the assumed forward bias voltage drops for the constant drop model, what is the current flowing through a 1N914 switching diode if the anode is connected to a 9V battery and the cathode is connected to one leg of a 1 k Ω resistor and the other leg of the resistor is connected to ground? **Put answer in mA. $(9-0.7)/1k = 8.3 \text{ mA}$**
- 4) If you put a square wave through a diode what type of current limit are you concerned with?
 - a. Continuous
 - b. DC
 - c. Periodic
 - d. Repetitive
- 5) The following figure shows a sketch of what you might see on the scope if a square wave input (V_i) is connected to the anode of a diode and the output (V_o) is connected to the cathode of the diode. What is the section called that is labeled with a line with arrows on its tail and head? Hint: Your answer should include 3 words that are spelled correctly. **Reverse Recovery Time**

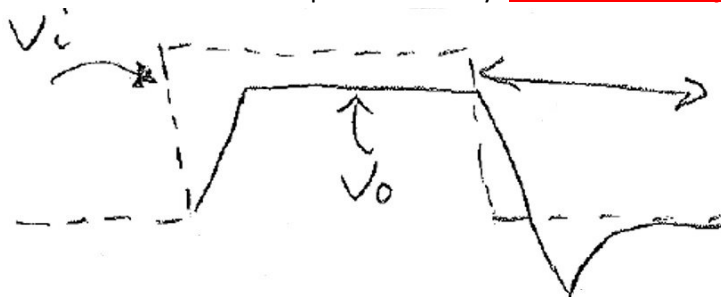

- 6) How many diodes would you need if you were going to build an AND gate using diode logic? **2**
- 7) When using switches as inputs and the switch is open it is called floating. To avoid this you should always force the signal to either ground using a **Pull-Down** resistor or force the signal to the positive rail voltage using a **Pull-Up** resistor.

- 8) **This is a Zener regulator problem that is not covered in this book, but it is a very useful circuit.** If R_d in the Zener regulator is $100\ \Omega$, what is the minimum value of R_L where the circuit continues to regulate at approximately $9V$? You can assume for this problem that the voltage across the Zener diode stays at $9V$ as long as current flows through it in the correct direction.

If R_L is infinity (or not present) you get the maximum possible current flowing through the Zener. $I_{max} = (12 - 9)/100 = 30\text{ mA}$. Notice the $100\ \Omega$ resistor sets how much maximum current you have in the circuit. If the maximum current flowing in the circuit is 30 mA then the current through R_L can't be greater than 30 mA . The worst case (min. resistor) when $I_{RL} = 30\text{ mA}$ is when $R_L = 9/30\text{mA} = \underline{300\ \Omega}$

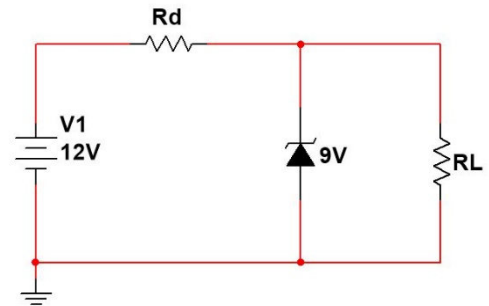

- 9) If the ripple voltage in the following circuit is $2V$, what is the average (or DC) voltage? Assume the transformer is ideal. **14.57 V** (see solution below)
- 10) In the following circuit what resistance value would you need to get a ripple voltage of $2V$? Assume the transformer is ideal. **648.8 Ω** (see solution below)

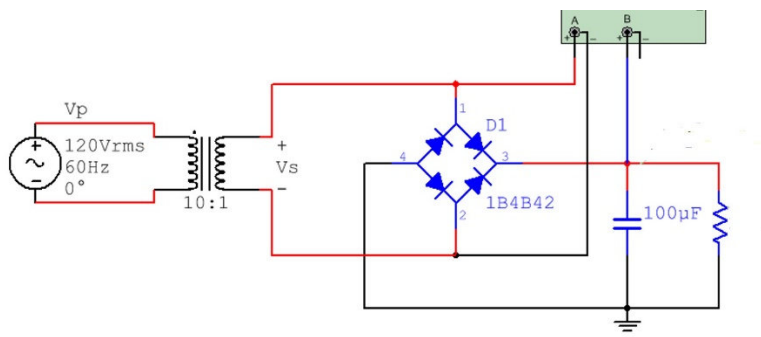

Answers to problems 9 and 10

- $V_s =$ peak input voltage $= 120 \cdot \sqrt{2}/10 = \underline{16.97\text{ V}}$
 - $V_{o,pk} =$ peak output voltage $= V_s - 2 \cdot 0.7V = \underline{15.57\text{ V}}$
 - $V_r =$ ripple voltage ($V_{o,pk} - \text{minimum } V_{out}$) $= \frac{V_{o,pk}}{2fRC} = \frac{15.57}{2 \cdot 60 \cdot 648.8 \cdot 100\mu} = \underline{2V}$ ← Given
 - $V_{o,DC} =$ the approximate DC voltage of the output (centerline of the ripple). is equal to $15.57 - 0.5 \cdot V_r = \underline{14.57\text{ V}}$.
- 11) If you connect a battery, resistor, and LED in series it is good idea to connect the anode of the LED to ground if you want it to light up. **FALSE – It should be cathode (that is the negative side). Current flows through the diode from anode to cathode. Note: Zener diodes allow current to flow in both directions.**
- 12) The term “test impedance” in a zener diode datasheet can be used to help you figure out the slope in the zener region of the zener diode characteristic curve. **True – See page 2 of the Zener diode notes. Test impedance = Z_z and the slope of the Zener region is $= 1/Z_z$ We often treat the Zener region like we treat the forward bias region in the constant drop model and just assume the Zener voltage is equal to a constant voltage (For a Zener this is the test voltage, V_T) and accept that it will be slightly wrong because the voltage changes slightly as the current changes (according to the slope, $1/Z_z$).**

- 13) **True or False:** In a half wave rectifier circuit (like the one shown in the figure below) the negative peaks can be passed through instead of the positive peaks by simple reversing the diode direction. **TRUE**

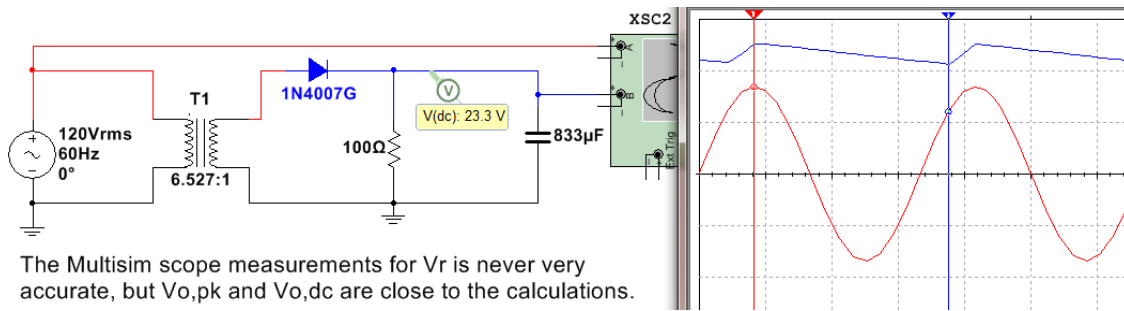

- 14) To measure the voltage across the resistor in a Full wave bridge rectifier with a oscilloscope that doesn't have differential probes you need to put two probes on the two sides of the resistor, connect the ground clips to ground, and use the Math Function A + B. **FALSE – You should use the A-B function.**
- 15) DC Diode Biasing Problem. I am giving you some information to make this problem faster to solve. If it is known that the following circuit has a XMM3 reading of 190.9 mA and a XMM4 reading of 181.8 mA. Show the diode current and voltage for each of the diodes and verify forward or reverse bias.

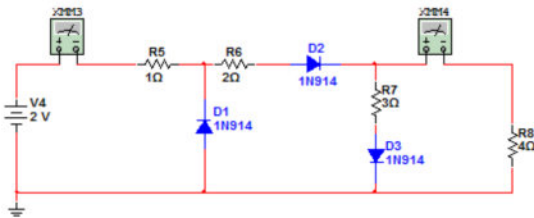

Assume D1 is reverse biased & D2 and D3 are forward biased.

Use the Mesh matrix method to solve for I_1 and I_2 (see Module 2 of [DC Circuits](#) for help on this).

$$\begin{vmatrix} 1+2+3 & -3 \\ -3 & 3+4 \end{vmatrix} \begin{vmatrix} I_1 \\ I_2 \end{vmatrix} = \begin{vmatrix} -0.7 \\ +0.7 \end{vmatrix}$$

$$I_1 = I_{D2} = 0.1909 \text{ A and } I_2 = 0.1818 \text{ A} \rightarrow I_{D3} = I_1 - I_2 = 0.0091 \text{ A}$$

Both I_{D2} and I_{D3} have currents flowing from anode to cathode, so forward bias checks out.

D1 – Check for Reverse Bias

$$\text{KVL around 1}^{\text{st}} \text{ loop: } -2 + 1 * 0.1909 = -1.81 \text{ V}$$

Since V_{D1} is less than 0.7V, reverse bias checks out.

- 16) If you built a Full-Wave Bridge rectifier (without using a transformer) with a 1 k Ω resistor and a 4.7 μ F capacitor to convert an AC input voltage of 30 Volts peak to peak at 1kHz to a DC voltage what approximate DC voltage (using the DC voltage equation in the notes) would you get across the load resistor? Also, determine the Peak Revers Voltage (or Peak Inverse Voltage) across each of the 4 diodes in this circuit.

$$R_L = 1 \text{ k}\Omega \quad C = 4.7 \cdot 10^{-6} \text{ F} \quad F = 1 \text{ kHz}$$

$$V_{s,pk} = 15 \text{ Vpk}$$

$$V_{o,pk} = 15 - 2 \cdot 0.7 = \underline{\mathbf{13.6 \text{ V}}}$$

$$V_r = V_{o,pk} / (2FRC) = 13.6 / (2 \cdot 1000 \cdot 1000 \cdot 4.7 \cdot 10^{-6}) = \underline{\mathbf{1.45 \text{ V}}}$$

$$V_{o,DC} = V_{o,pk} - \frac{1}{2} \cdot V_r = 13.6 - 1.45/2 = \underline{\mathbf{12.88 \text{ V}}}$$

OpAmp Example Problems

- 1) Design an OpAmp circuit with an adjustable gain using only a 10kΩ potentiometer, a 1 kΩ fixed resistor, and one other fixed resistor. The input voltage is a 1V peak sinusoid ($V_i(t) = 1\sin(\omega \cdot t)$) and the output ranges from 5V peak to 15V peak ($V_o(t) = 5\sin(\omega \cdot t)$ to $15\sin(\omega \cdot t)$). Draw the circuit in the space below and list the value of the “one other fixed resistor”.

It must be a **non-inverting** configuration OpAmp circuit with the resistor equal to **4 kΩ**

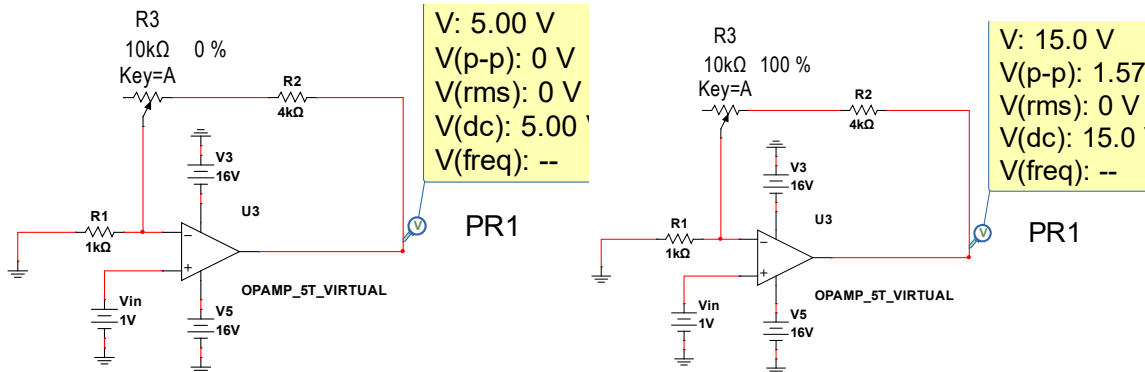

- 2) If you wanted to achieve a gain of 8 V/V gain and the OpAmp has a unity gain bandwidth of 1MHz and your input voltage to the OpAmp is $V_i(t) = 2\sin(2\pi \cdot 10,000 \cdot t)$ what resistor ratio R_2/R_1 would you use. You also want the output in phase with the input. **$R_2/R_1 = 7.7$**

Find A_o first. $A_o = f_t/f_{op} = 1M/10k = 100$ V/V (If you get this you get 1 point.)

$$8 = [1 + R_2/R_1] / [(1 + (1 + R_2/R_1)/A_o)]$$

$$8(1 + (1 + R_2/R_1)/100) = 1 + R_2/R_1 \rightarrow 8 + .08 + .08(R_2/R_1) = 1 + R_2/R_1 \rightarrow 7.08 = 0.92 R_2/R_1$$

$$R_2/R_1 = 7.7$$

- 3) If the unity gain bandwidth of the OpAmp in the following circuit is 1 MHz and $V_i = 0.5\sin(2\pi \cdot 50,000 t)$, what is the **peak to peak** output voltage? Be careful on peak voltage versus peak to peak voltage! Since the input frequency is high you CANNOT assume it is ideal.

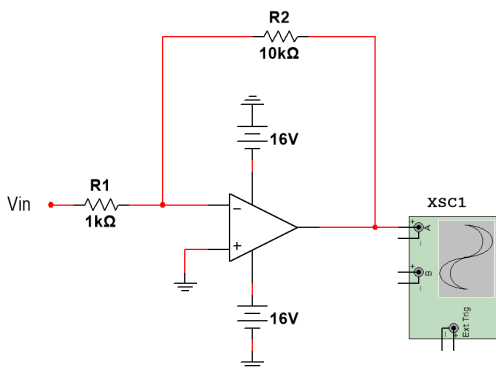

$$V_{i,pk} = 0.5. V_{i,p-p} = 1V$$

$$A_o = f_t/f_{op} = 1M/50k = 20$$
 V/V

$$V_{o,p-p} = V_{i,p-p} * |(-R_2/R_1) / [1 + (1 + R_2/R_1)/A_o]|$$

$$V_{o,p-p} = 1 * |(-10) / [1 + (1 + 10)/20]| = \mathbf{6.45 V_{p-p}}$$

Note: if the ideal assumption would have been made the output would have been way off $\rightarrow 1 * 10 = 10V_{p-p}$

- 4) If the potentiometer in the circuit below is turned to ZERO % so that no potentiometer resistance is in the circuit, what will the voltage across RL be equal to?

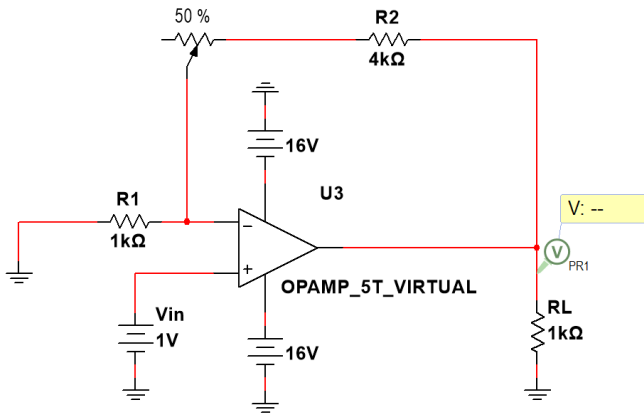

Non-inverting OpAmp
 $V_o = 1 * (1 + R2/R1) = 1 * (1 + 4) = \underline{5V}$

- 5) Assuming the following OpAmp can be treated as ideal, what size of potentiometer would be needed for the value of PR1 in the circuit below to read 5.5V. **Note:** 50% means that one half of the total potentiometer resistance is in the circuit.

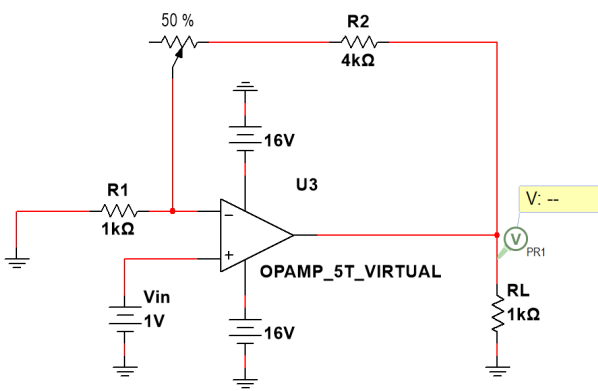

Non-inverting OpAmp
 $V_o = 5.5 = 1 * (1 + R2/R1) = 1 * (1 + (4k + 0.5R_x)/1k)$
 Solving for $R_x \rightarrow R_x = \underline{1k\Omega}$

- 6) If a Butterworth low pass Active OpAmp filter had a passband gain of 200 V/V what is that gain in dB?
 $20 * \log_{10}(200) = \underline{46 \text{ dB}}$