



**CONSTRUCTION
SAFETY**



HOISTING AND RIGGING

SAFETY MANUAL

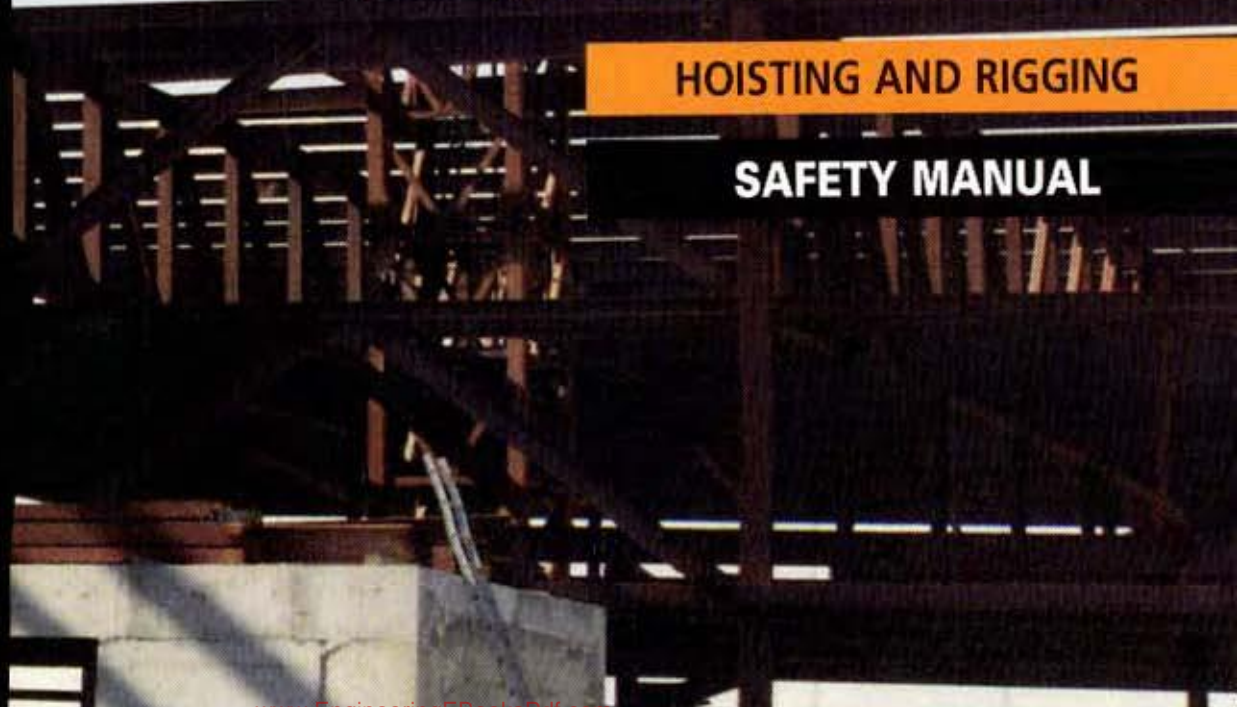

HOISTING and RIGGING

Safety Manual

Construction Safety Association of Ontario
21 Voyager Court South
Etobicoke, Ontario M9W 5M7
(416) 674-2726
1-800-781-2726
Fax (416) 674-8866

In the past, members of the public have used printed information that was outdated by subsequent improvements in knowledge and technology. We therefore make the following statement for their protection in future.

The information presented here was, to the best of our knowledge, current at time of printing and is intended for general application. This publication is not a definitive guide to government regulations or to practices and procedures wholly applicable under every circumstance. The appropriate regulations and statutes should be consulted. Although the Construction Safety Association of Ontario cannot guarantee the accuracy of, nor assume liability for, the information presented here, we are pleased to answer individual requests for counselling and advice.

© Construction Safety Association of Ontario, 1995

ISBN 0-919465-70-6

UPDATED May 1997

Second printing, August 1998

Third printing, May 1999

Fourth printing, April 2000

TABLE of CONTENTS

Introduction	1
Section 1: Hoisting and Rigging Hazards	3
Procedures and Precautions	5
Determining Load Weights	15
Weights of Common Materials	18
Section 2: Fibre Ropes, Knots, Hitches	20
Fibre Rope Characteristics	21
Inspection of Fibre Rope	22
Safe Working Load (SWL)	23
Care, Storage, Use	26
Knots and Hitches	30
Section 3: Hardware, Wire Rope, Slings	34
Wire Rope	36
Sling Configurations	47
Sling Angles	53
Centre of Gravity	55
Sling SWLs	57
Sling Types	64
Rigging Hardware	78
Hoisting Tips	89
Section 4: Rigging Tools and Devices	90
Jacks	92
Blocking and Cribbing	95
Rollers	96
Inclined Planes	97
Lever-Operated Hoists	98
Chain Hoists	98
Grip-Action Hoists or Tirlfors	100
Electric Hoists and Pendant Cranes	102
Winches	104
Anchorage Points	105
Section 5: Introduction to Crane Operations	110
Responsibilities	112
Basic Types and Configurations	114
Hazards in Crane Operating Areas	129
Working near Powerlines	133
Factors Affecting Crane Capacity	139
Setup Summary	162
Machine Selection	163
Signalling	165
Appendix: Excerpts from <i>Occupational Health and Safety Act</i> and <i>Regulations for Construction Projects</i>	167

INTRODUCTION

Purpose of this Manual

This manual is intended as a working guide for training workers and supervisors in the fundamentals of safe rigging and hoisting.

The information covers not only ropes and knots but hoisting equipment from cranes to chainfalls and rigging hardware from rope clips to spreader beams. Equally important is the attention paid at every point to correct procedures for inspection, maintenance, and operation.

Knowledge of the equipment and materials with which we work is one of the most important factors in occupational health and safety. Each item has been designed and developed to serve a specific purpose. Recognizing its capabilities and limitations not only improves efficiency but minimizes hazards and helps prevent accidents.

This manual identifies the basic hazards in rigging and hoisting, explains the safeguards necessary to control or eliminate these hazards, and spells out other essential safety requirements.

The information should be used in conjunction with the applicable regulations by contractors, supervisors, operators, riggers, and others delivering or receiving instruction in the basics of safe rigging and hoisting.

Health and Safety Law

Occupational Health and Safety Act

Safety legislation for Ontario construction in general consists of the *Occupational Health and Safety Act*, which came into force on 1 October 1979. Its purpose is to protect workers against health and safety hazards on the job.

The *Occupational Health and Safety Act* is based on the "internal responsibility" concept for management and workers. This encourages both groups to work out solutions to health and safety problems with the guidance of the Ministry of Labour.

The *Act* provides us with the framework and the tools to achieve a safe and healthy workplace. It sets out the rights and duties of all parties in the workplace. It establishes procedures for dealing with jobsite hazards and provides for enforcement of the law where compliance has not been achieved voluntarily.

Over the years the *Act* has been revised to meet the changing requirements of Ontario's workplaces.

Regulations

There are various regulations under the *Act* for construction in particular.

The most extensive are the *Regulations for Construction Projects* (Ontario Regulation 213/91). There are also special regulations for controlled products under the Workplace Hazardous Materials Information System (WHMIS) and for designated substances such as asbestos.

Construction regulations are generally based on health and safety problems that have recurred over the years. In many cases, the regulations have been proposed jointly by management and labour groups as a means of controlling or eliminating problems that have historically resulted in fatalities, lost-time injuries, and occupational diseases.

The *Regulations for Construction Projects* have been periodically revised over the years.

The Appendix to this manual includes excerpts from the *Occupational Health and Safety Act* and *Regulations for Construction Projects* (Ontario Regulation 213/91). These selected sections are intended for reference only. Neither the Appendix nor the manual should be considered a substitute for study of the appropriate legislation.

Review Ontario's *Occupational Health and Safety Act*, *Regulations for Construction Projects*, and other applicable health and safety regulations to make sure that you know what to expect from others on the job—and what others expect from you.

Section 1

Hoisting and Rigging Hazards

- Procedures and Precautions**
- Determining Load Weights**
- Weights of Common Materials**

Section 1

Hoisting and Rigging Hazards

All too often we read of crane and rigging accidents that cause death and extensive property damage.

Most crane and rigging accidents can be prevented by field personnel following basic safe hoisting and rigging practices.

The single most important precaution in rigging and hoisting is to determine load weight before attempting any lift.

Labour and management both have a responsibility to ensure the safety of all parties involved in hoisting and rigging. Major rigging operations must be planned and supervised by competent personnel to guarantee that the best methods and most suitable equipment are employed.

It is imperative that all workers who prepare, use, and work with or around hoisting and rigging equipment are well trained in both safety and operating procedures. All hoisting equipment should be operated only by trained personnel.

This section

- identifies common hazards and causes of hoisting and rigging accidents
- specifies the procedures and precautions necessary for the safe rigging, lifting, and landing of loads
- explains methods of determining load weight
- provides weight tables for common construction materials.

Procedures and Precautions

Remember: The single most important precaution in hoisting and rigging is to determine the weight of the load before attempting to lift it.

At the same time, riggers must also

- determine the available capacity of the equipment being used
- rig the load so that it is stable (unless the centre of gravity of the load is below the hook, the load will shift)
- make allowances for any unknown factors.

In addition, riggers must be aware of common hazards, factors that reduce capacity, the inspection and use of slings, and safe practices in rigging, lifting, and landing loads.

Common Hazards

- **SWL not known.** Know the safe working loads of the equipment and tackle being used. Never exceed these limits.
- **Defective components.** Examine all hardware, equipment, tackle, and slings before use. **Destroy** any defective components. Equipment merely discarded may be picked up and used by someone unaware of its defects.
- **Unsafe equipment.** No one with reasonable cause to believe that equipment is unsafe or unsuitable should use it until the defect has been reported to a supervisor, the safety of the equipment has been confirmed, and orders to proceed have been issued by a person in authority who is then responsible for the safety of everyone involved in the operation.
- **Hazardous wind conditions.** Never carry out any hoisting or rigging operation when winds create hazards for workers, the general public, or property such as material and equipment. Assess load size and shape to determine whether high winds may cause problems. In particular, avoid handling loads that present large wind-catching surfaces. Even though the weight of the load is within the normal capacity of the equipment, high or gusting winds may prevent proper control during the lift. Wind-loading can be critical to how the load is rigged, lifted, and landed, with consequences for the safety of everyone involved. When winds reach 25-30 mph, consider limiting hoisting operations.
- **Hazardous weather conditions.** When the visibility of riggers or hoist crew is impaired by snow, fog, rain, darkness, or dust, strict supervision must be exercised and, if necessary, the lift should be suspended. At sub-freezing temperatures, supervision must ensure that no part of the hoisting device or tackle is shock-loaded or impacted, since brittle fracture of the steel may result.

- **Electrical contact.** One of the most frequent killer of riggers is electrocution caused by the contact of hoisting device, load line, or load with powerlines. When working with or around cranes that are within a boom's length of any powerline, ensure that a competent signaller is stationed at all times within view of the operator to warn when any part of the machine or its load approaches the minimum distances specified in the *Regulations for Construction Projects*.

Voltage Rating of Powerline	Minimum Distance
750 to 150,000 volts	3 metres (10')
150,001 to 250,000 volts	4.5 metres (15')
over 250,000 volts	6 metres (20')

Be especially careful when working near overhead lines that have long spans. These lines tend to swing laterally in the wind and can cause unexpected contact. For a summary of requirements, see the illustration on the next page.

Factors that Reduce Capacity

The safe working loads of all hoisting and rigging equipment are based on almost ideal conditions seldom achieved in the field. Riggers must therefore recognize the factors that can reduce the capacity of equipment.

- **Hoist line not plumb.** The safe working loads of hoisting equipment apply only to freely-suspended loads on plumb hoist lines. If the hoist line is not plumb during load handling, side loads are created which can destabilize the equipment and cause structural failure with no warning.
- **Swing.** The rapid swinging of suspended loads subjects equipment to additional stresses that can cause collapse. The force of the swinging action makes the load drift away from the machine, increasing the radius and side-loading the equipment. The load must always be kept directly below the boom point or upper load block.

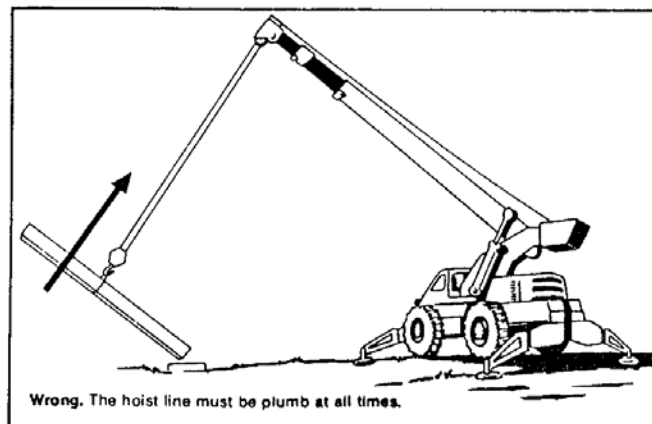

Requirements near Powerlines

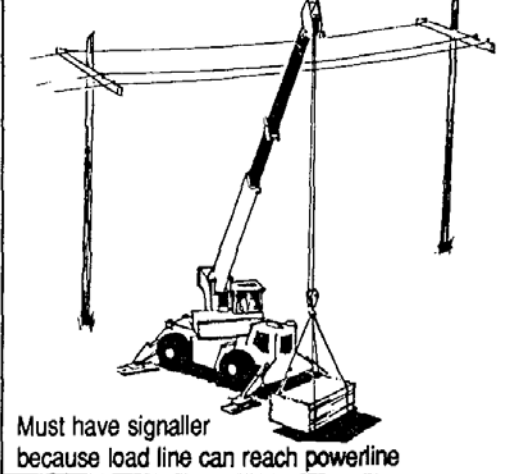
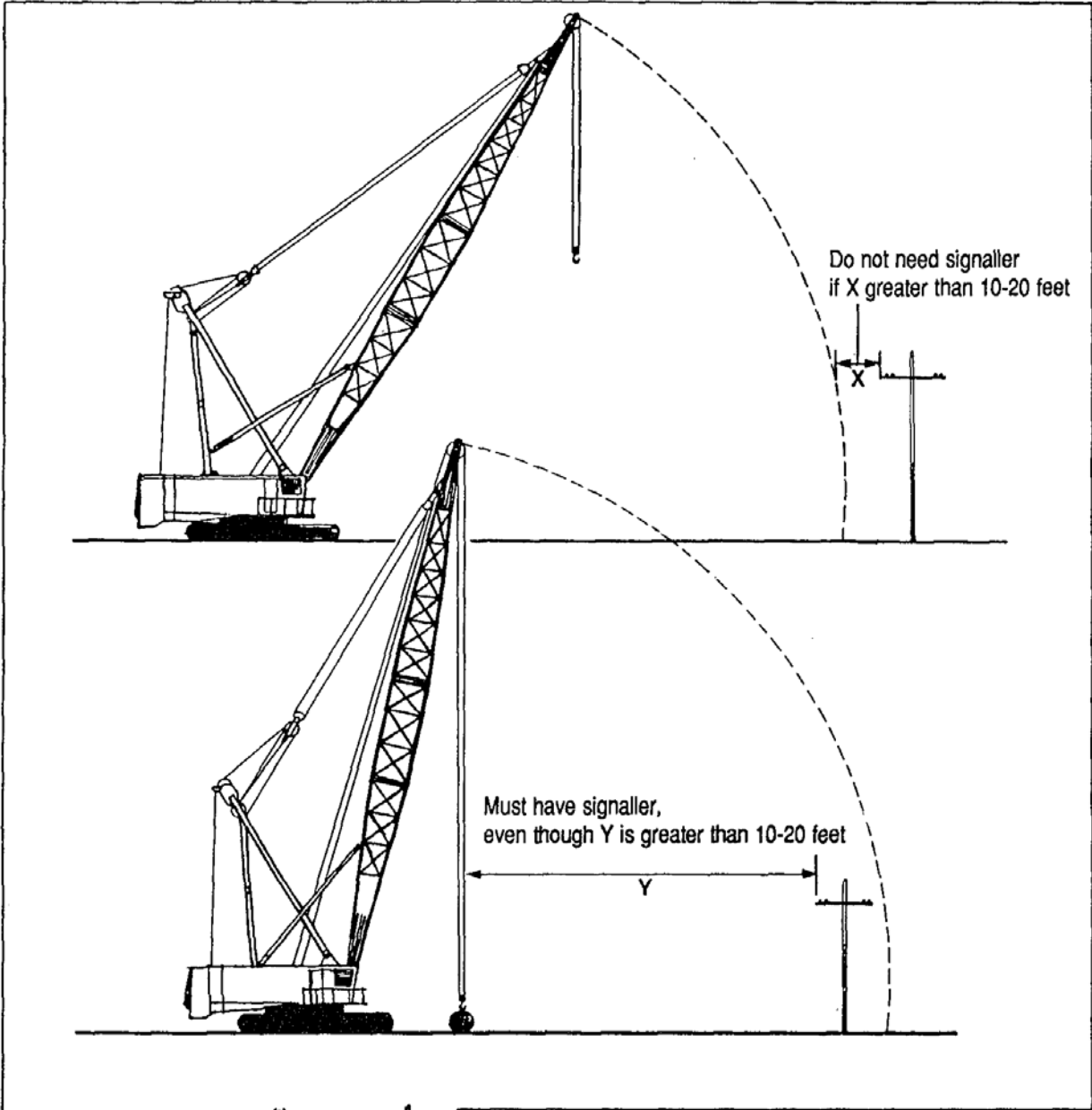

- **Condition of equipment.** The rated safe working loads apply only to equipment and hardware in good condition. Any equipment damaged in service should be taken out of service and repaired or destroyed.
- **Dynamic forces.** The safe working loads of most rigging and hoisting equipment are determined from static loads and the appropriate safety factor is applied to account for dynamic motions of the load and equipment. To ensure that the safe working load is not exceeded during operation, allow for wind loading and other dynamic forces created by the normal operational movements of the machine and its load. Always avoid the sudden snatching, swinging, and stopping of suspended loads. Rapid acceleration and deceleration can only increase the stresses on both the machine and the tackle.
- **Weight of tackle.** The rated loads of most hoisting equipment do not generally account for the weight of hook blocks, hooks, slings, equalizer beams, and other part of the lifting tackle. Their combined weight must be subtracted from the load capacity of the equipment to determine the maximum allowable load to be lifted.

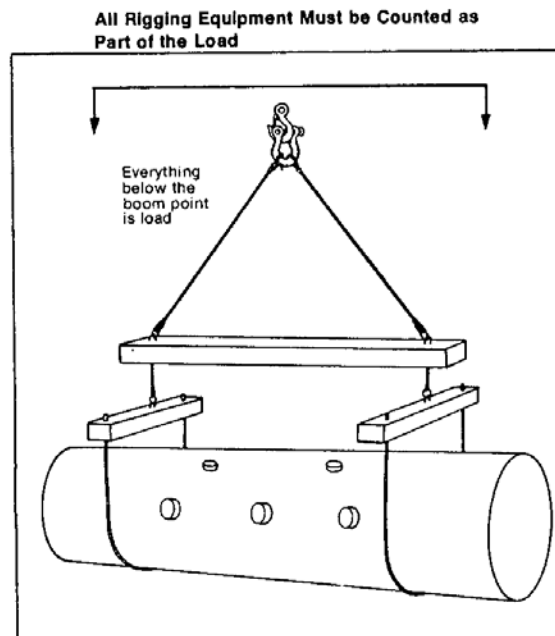

Slings

After the hoist rope, the sling is the most commonly used piece of rigging equipment. Observe the following precautions with slings.

- Never use damaged slings. Inspect slings regularly to ensure their safety. Check wire rope slings for kinking, wear, abrasion, broken wires, worn or cracked fittings, loose seizings and splices, crushing, flattening, and rust or corrosion. Pay special attention to the areas around thimbles and other fittings.

- Slings should be marked with an identification number and their maximum capacity on a flat ferrule or permanently attached ring. Mark the capacity of the sling for a vertical load or at an angle of 45°. Ensure that everyone is aware of how the rating system works.

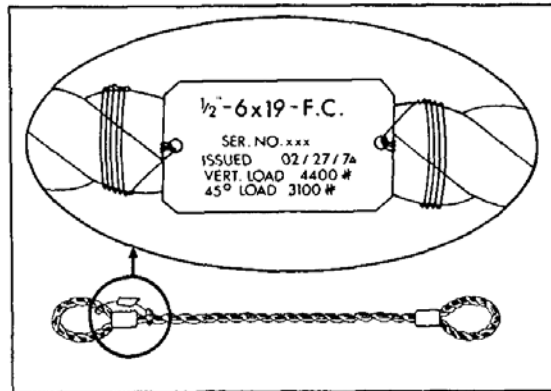

- Avoid sharp bends, pinching, and crushing. Use loops and thimbles at all times. Corner pads that prevent the sling from being sharply bent or cut can be made from split section of large-diameter pipe, corner saddles, padding, or blocking.

Ensure that Slings are Protected at All Sharp Corners on Heavy Items

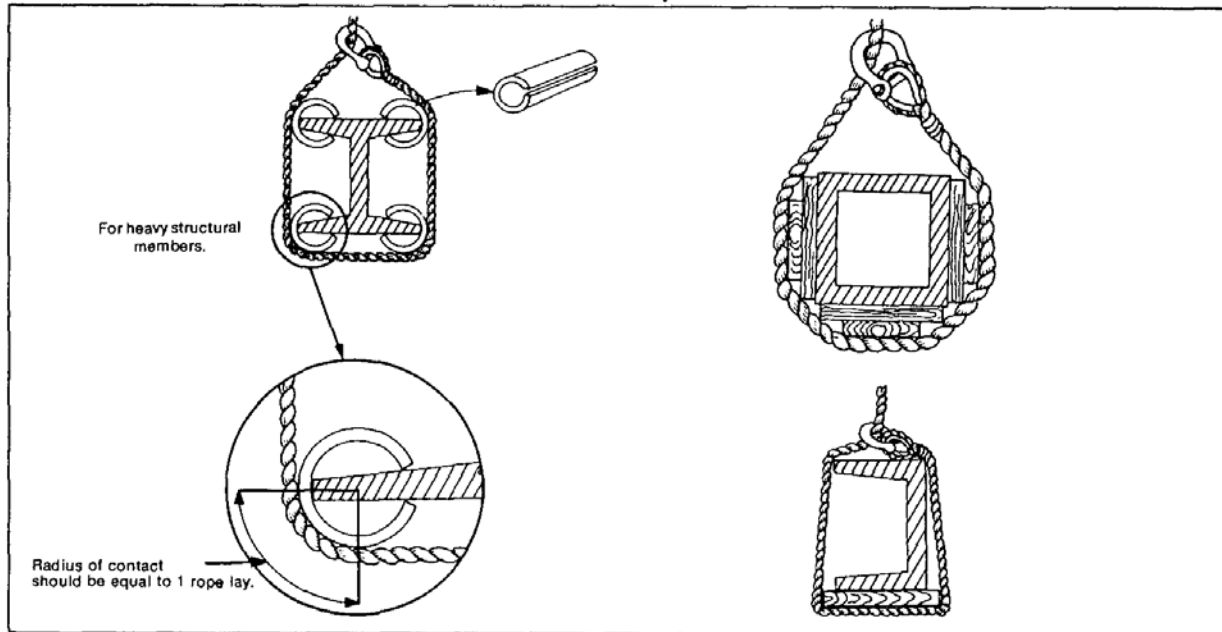

- Never allow wire rope slings, or any wire rope, to lie on the ground for long periods of time or on damp or wet surfaces, rusty steel, or near corrosive substances.
- Avoid dragging slings out from underneath loads.

- Keep wire rope slings away from flame cutting and electric welding.
- Never make slings from discarded hoist rope.
- Avoid using single-leg wire rope slings with hand-spliced eyes. The load can spin, causing the rope to unlay and the splice to pull out. Use slings with Flemish Spliced Eyes.
- Never wrap a wire rope completely around a hook. The sharp radius will damage the sling.
- Avoid bending the eye section of wire rope slings around corners. The bend will weaken the splice or swaging. There must be no bending near any attached fitting.
- Ensure that the sling angle is always greater than 45° . When the horizontal distance between the attachment points on the load is less than the length of the shortest sling leg, then the angle is greater than 60° and generally safe.

Never Wrap a Rope Around a Hook

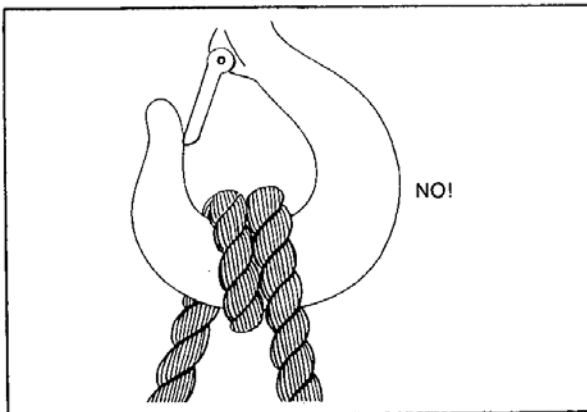

Check on Sling Angle

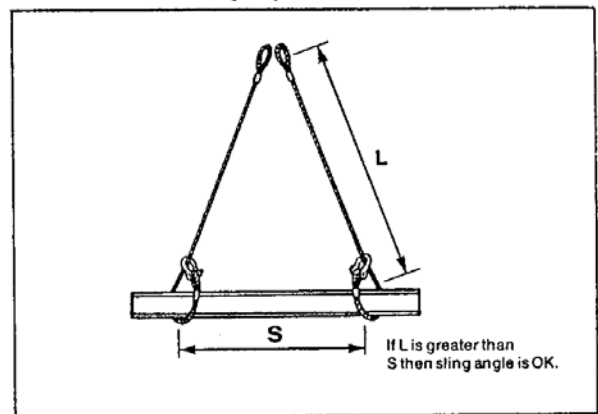

Do Not Permit Bending Near Any Splice or Attached Fitting

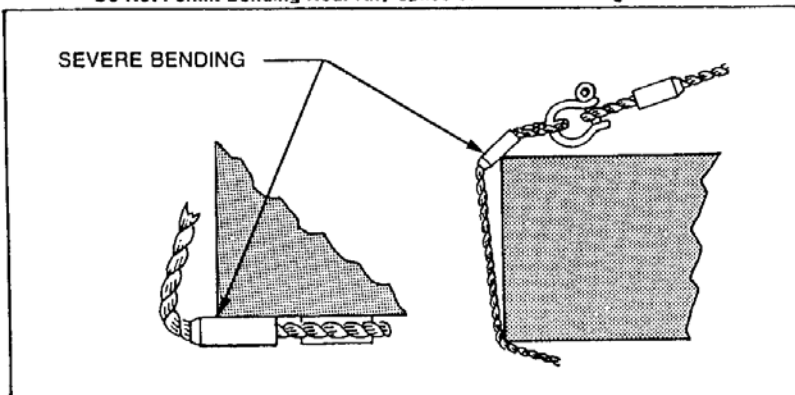

- **Multi-leg slings.** Do not assume that a multi-leg bridle sling will safely lift a load equal to the safe load on one leg multiplied by the number of legs. There is no way of knowing that each leg is carrying its fair share of the load. With slings having more than two legs and a rigid load, it is possible for some of the legs to take practically the full load while the others merely balance it.

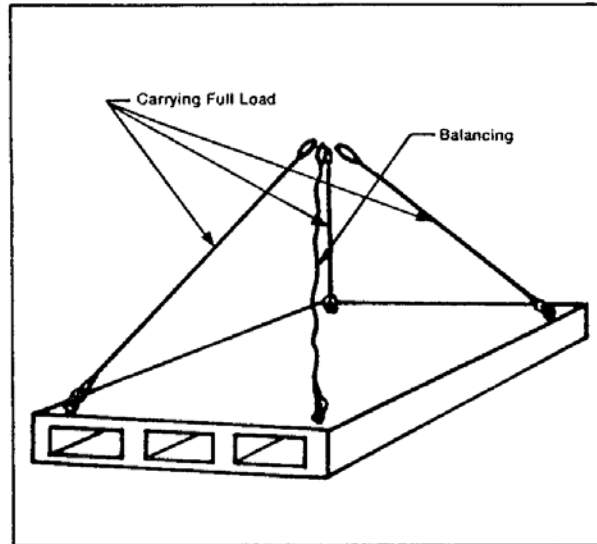

As a result, when lifting rigid objects with three- or four-leg bridle slings, make sure that at least three of the legs alone can support the total load. In other words, consider multi-leg slings used on a rigid load as having only three legs. Where the load is flexible and can adjust itself to the sling legs, assume that each leg can take its own share of the load.

When using multi-leg slings to lift loads in which one end is much heavier than the other, the tension on the most heavily loaded leg is much more important than the total weight. The sling must be selected to suit the most heavily loaded leg rather than the total weight.

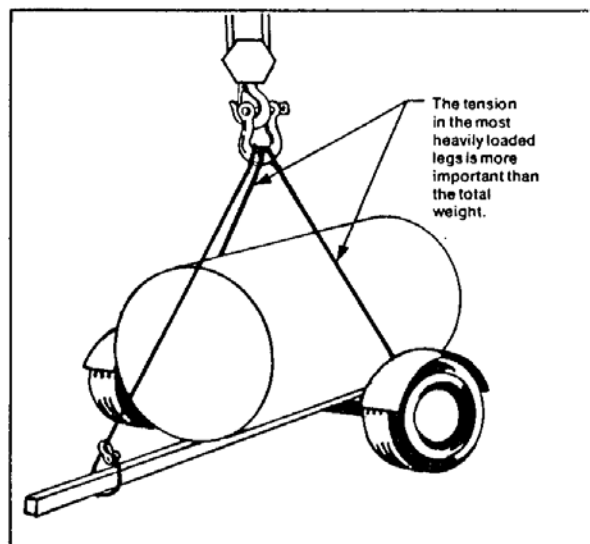

- When using choker hitches, do not force the eye down towards the load once tension is applied. Rope damage is the invariable result.
- Whenever two or more rope eyes must be placed over a hook, install a shackle on the hook with the shackle pin resting in the hook and attach the rope eyes to the shackle. This will prevent the spread of the sling legs from opening up the hook and prevent the eyes from damaging each other under load.

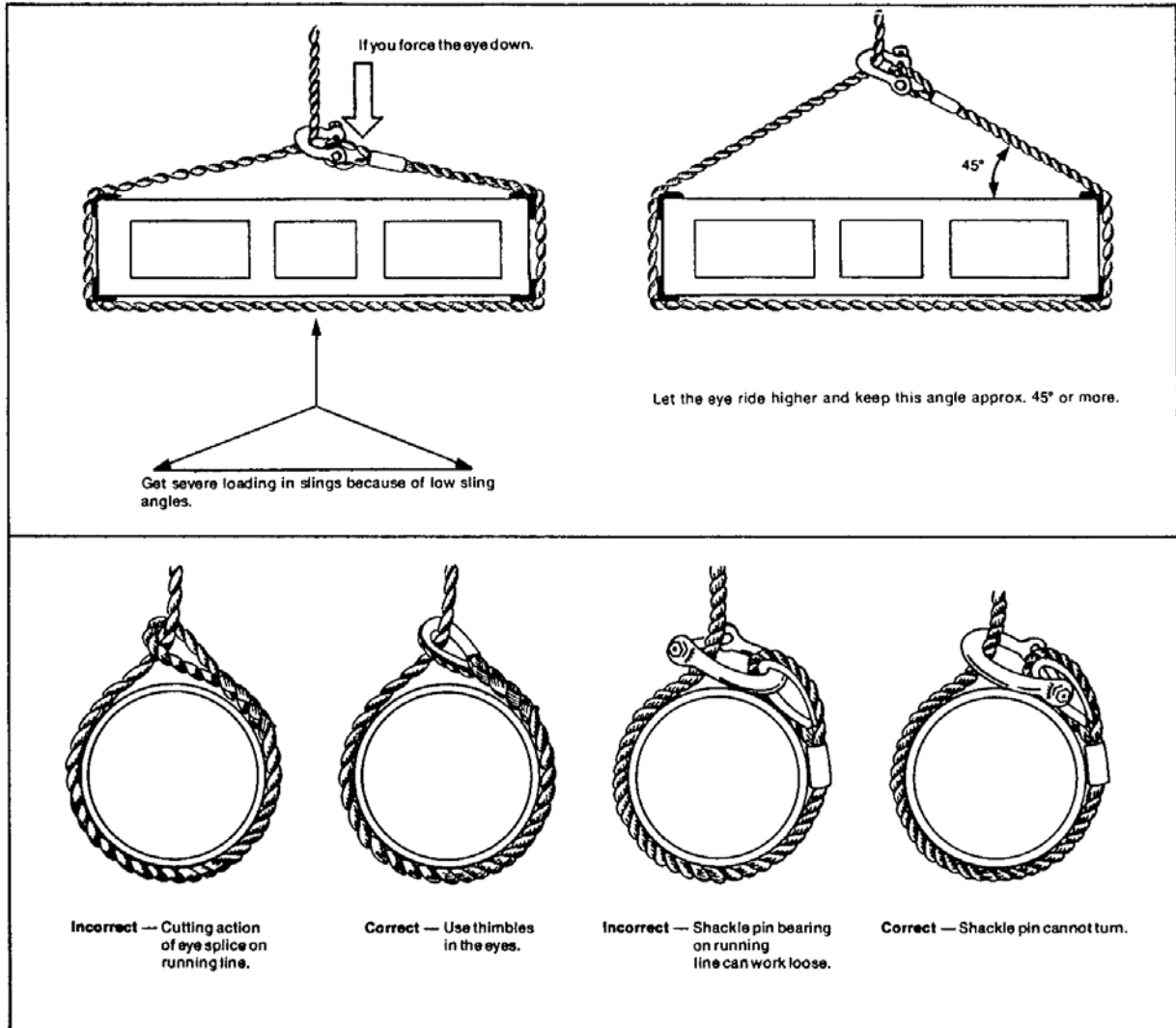

Rigging, Lifting, and Landing Loads

- Rig loads to prevent any parts from shifting or dislodging during the lift. Suspended loads should be securely slung and properly balanced before they are set in motion.
- Keep the load under control at all times. Where personnel may be endangered by a rotating or swaying load, use one or more taglines to prevent uncontrolled motion.

Whenever 2 or more ropes are to be Placed Over a Hook — Use a Shackle

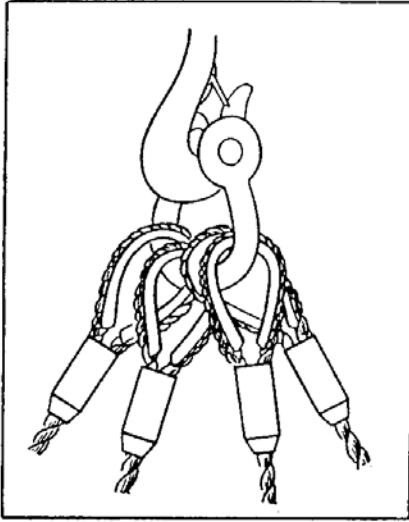

Use Tag Lines to Control All Loads

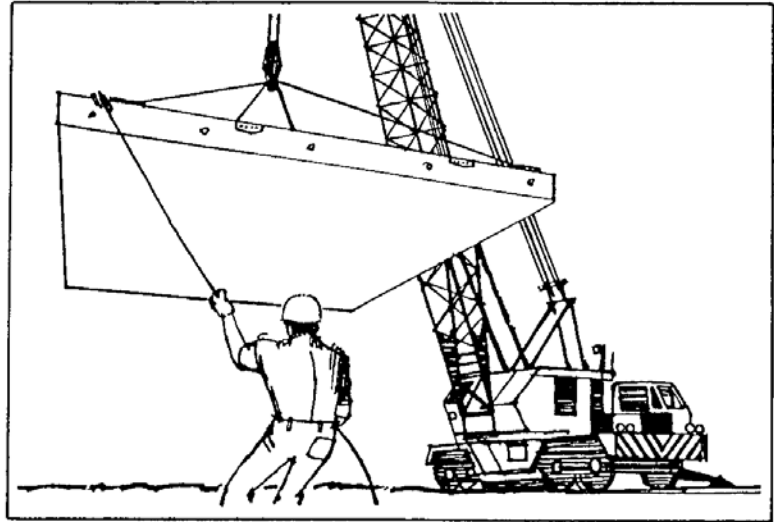

- Loads must be safely landed and properly blocked before being unhooked and unslung.
- Lifting beams should be plainly marked with their weight and designed working loads and should only be used for their intended purpose.
- Never wrap the hoist rope around the load. Attach the load to the hook by slings or other rigging devices adequate and suitable to the load being lifted.
- The load line should be brought over the load's centre of gravity before the lift is started.
- Keep hands away from pinch points as slack is being taken up.
- Wear gloves when handling wire rope.
- Make sure that everyone stands clear when loads are being lifted, lowered, and freed of slings. As slings are being withdrawn, their hooks may catch under the load and suddenly fly loose.

- Before making a lift, check to see that the sling is properly attached to the load.
- Never work under a suspended load unless it has been adequately supported from below and all conditions have been approved by the supervisor in charge of the operation.
- Never make temporary repairs to a sling. Procedures for proper repair should be established and followed.
- Secure the unused legs of a multi-leg sling before it is lifted.

Secure All Unused Sling Legs

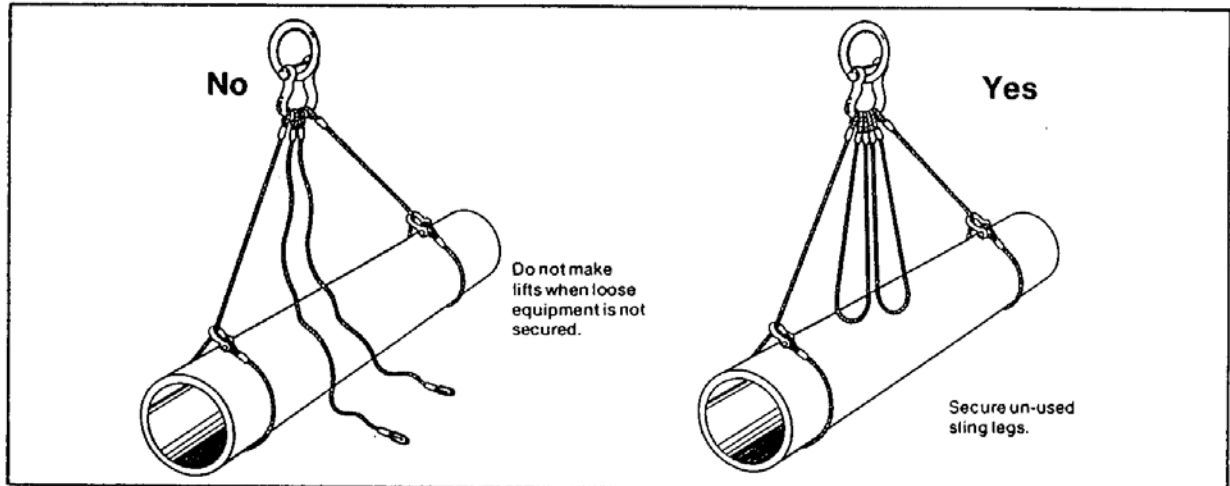

- Never point-load a hook unless it is designed and rated for such use.
- Make sure that the load is free before lifting and that all sling legs are taking the load.
- When using two or more slings on a load, ensure that they are all made from the same material.
- Prepare adequate blocking before loads are lowered. Blocking can help prevent damage to slings.
- **Operators:** Avoid impact loading caused by sudden jerking during lifting and lowering. Take up slack on the sling gradually. Avoid lifting or swinging the load over workers below.

Determining Load Weights

The most important step in any rigging operation is determining the weight of the load to be hoisted.

This information can be obtained from shipping papers, design plans, catalogue data, manufacturer's specifications, and other dependable sources. When such information is not available, it is necessary to calculate the load weight.

Let's take **steel** as our example.

On erection plans, the size of steel beams is usually supplied together with their weight per length of foot and the length of the member. Consequently it's easy to compute the weight of any member to be lifted.

Where angle, plate, or built-up members are involved, however, the weights must be calculated. Memorizing one basic weight and two formulas will give the rigger a reasonably accurate estimate of weight.

The basic weight is that of 1 square foot of steel an inch thick—about 40 pounds. So two plates of steel each measuring 1 1/2" by 3' by 6' would weigh a total of

$$2 \times 1.5 \times 3 \times 6 \times 40 = 2,160 \text{ pounds}$$

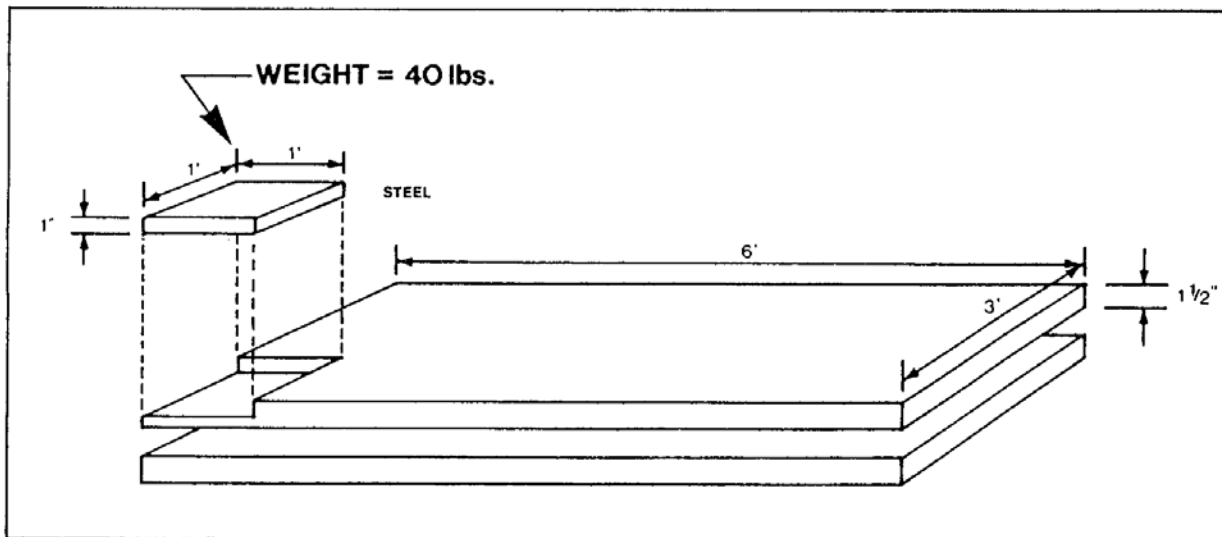

The weights of angles can also be figured with results close enough for safe job use. An angle is a structural shape which can be considered a bent plate with some additional metal at the centre for strength and a lesser amount of metal at the tips for ease of rolling. If the angle is flattened out, the result is a plate.

For example, a 5 by 3 by 1/4 inch angle would flatten out to approximately an 8 by 1/4 inch plate. This should weigh 40 pounds x 8/12 x 1/4 or 6.65 pounds per foot.

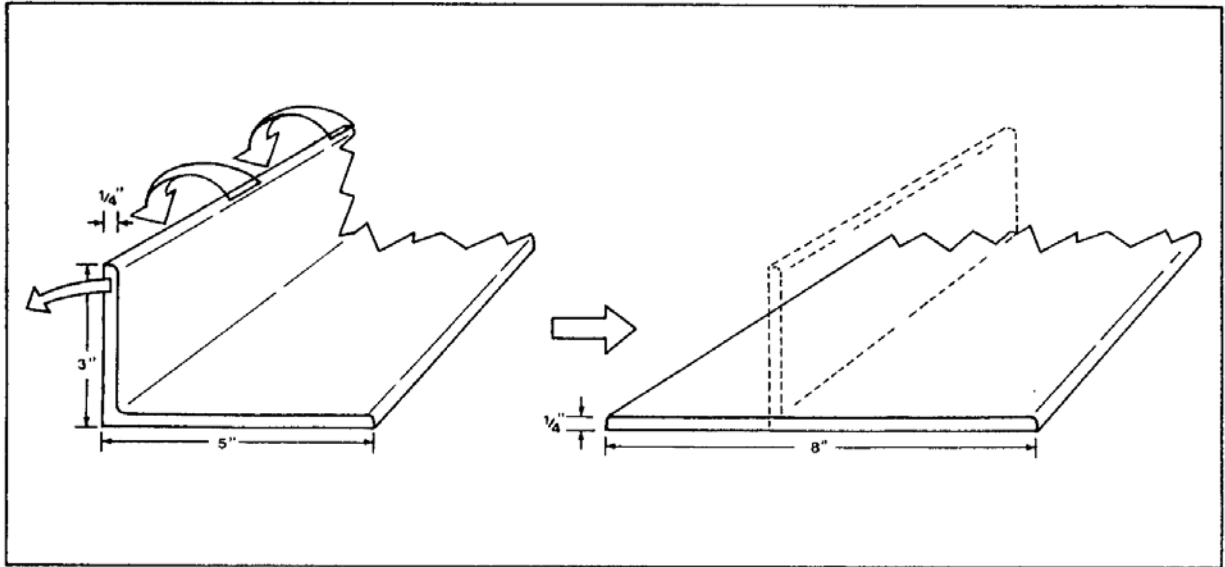

Weights of any structural shape can be computed in this manner by separating the parts or flattening them into rectangles which, in turn, become parts of multiples of a square foot of steel an inch thick.

Plates, however, are often rolled into tanks or other shapes. You must determine the square foot area of such parts **before** you calculate their weight.

This requires learning the two simple formulas for computing the circumference and the area of a circle. The circumference (or distance around the edge of a circle) is found by multiplying the diameter by 3.14.

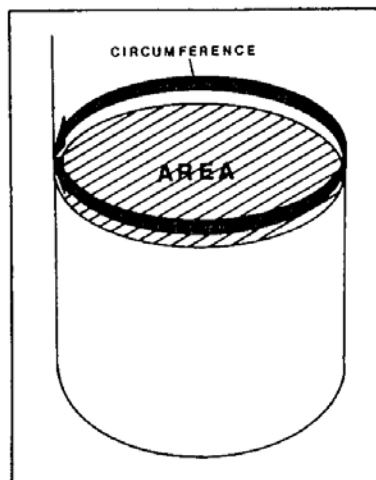

A stack 6 ft. in diameter would have a circumference of 6 ft. x 3.14, or 18.84 ft. To compute the weight of this stack, if it were 30 ft. high and made of $\frac{3}{8}$ in. plate, mentally unroll it and flatten it out (Fig. 1.1). This gives a plate 18.84 ft. wide by 30 ft. long by $\frac{3}{8}$ " thick. The weight is:

$$18.84 \times 30 \times \frac{3}{8} \times 40 = 8,478 \text{ lbs.}$$

The second formula gives the area of circular objects.

$$\text{AREA} = 3.14 \times \frac{\text{diameter}}{2} \times \frac{\text{diameter}}{2}$$

Thus, if the stack had an end cap $\frac{3}{8}$ " thick and 6 ft. in diameter it would have a surface area:

$$\text{AREA} = 3.14 \times \frac{6}{2} \times \frac{6}{2} = 28.3 \text{ sq. ft.}$$

and would weigh

$$28.3 \times 3 \times \frac{40}{8} = 425 \text{ lbs. (Figure 1.2)}$$

Figure 1.1 Load Weight Determination

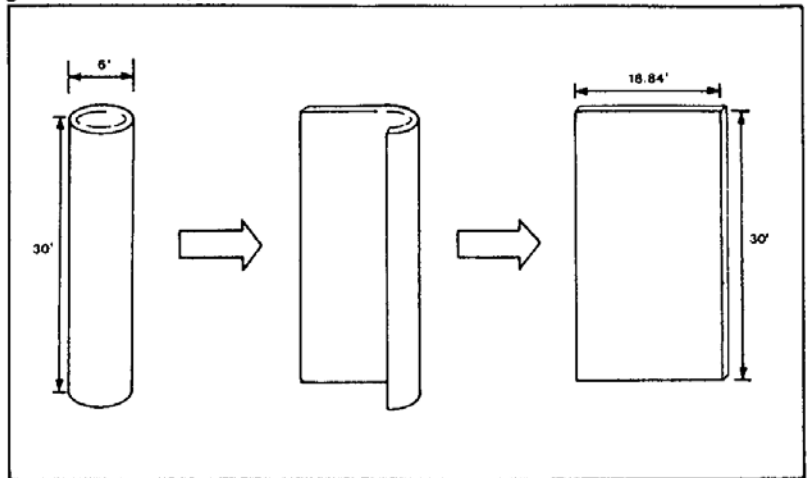

radius (r) = diameter divided by 2

$$\text{area} = \pi (3.14) \times r^2$$

For other materials the weights are normally based on their weight per cubic foot, so you have to determine how many cubic feet of material (the volume) you are hoisting in order to estimate the weight.

For example, suppose you have a bundle of spruce lumber to hoist and the bundle is 12 ft. long, 3' high and 4' wide. (Fig. 1.3) The weight per cubic foot from Table 1.2 is 28 lbs. so the weight of this bundle is $12 \times 3 \times 4 \times 28 = 4,032$ lbs.

The time taken to calculate the approximate weight of any object, whether steel, plates, columns, girders, castings, bedplates, etc. is time well spent and may save a serious accident through failure of lifting gear. The following tables of weights of various materials (Tables 1.1, 1.2, 1.3) should enable any rigger to compute the approximate weight of a given load. When in doubt, do not hesitate to seek advice from an engineer or foreman on the job.

Fig. 1.2 Load Weight Determination

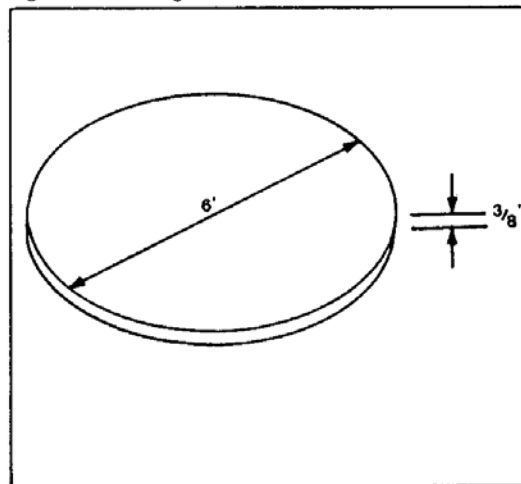

Fig. 1.3 Load Weight Determination

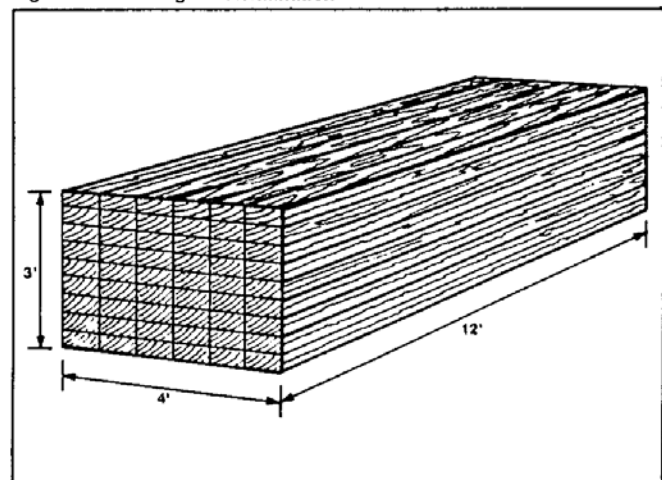

Table 1.1

APPROXIMATE WEIGHT PER FOOT OF LENGTH OF ROUND STEEL BARS AND RODS			
Diameter (Inches)	Weight (Lbs.) Per Ft. of Length	Diameter (Inches)	Weight (Lbs.) Per Ft. of Length
3/16	.094	1 3/8	5.05
1/4	.167	1 1/2	6.01
5/16	.261	1 5/8	7.05
3/8	.376	1 3/4	8.18
7/16	.511	1 7/8	9.39
1/2	.668	2	10.68
9/16	.845	2 1/8	12.06
5/8	1.04	2 1/4	13.52
3/4	1.50	2 3/8	15.06
7/8	2.04	2 1/2	16.69
1	2.67	2 5/8	18.40
1 1/8	3.38	2 3/4	20.20
1 3/16	3.77	2 7/8	22.07
1 1/4	4.17	3	24.03

TABLE 1.2

WEIGHTS OF MATERIALS (Based On Volume)			
Material	Approximate Weight Lbs. Per Cubic Foot	Material	Approximate Weight Lbs. Per Cubic Foot
METALS		TIMBER, AIR-DRY	
Aluminum	165	Cedar	22
Brass	535	Fir, Douglas, seasoned	34
Bronze	500	Fir, Douglas, unseasoned	40
Copper	560	Fir, Douglas, wet	50
Iron	480	Fir, Douglas, glue laminated	34
Lead	710	Hemlock	30
Steel	490	Pine	30
Tin	460	Poplar	30
MASONRY		Spruce	28
Ashlar masonry	140-160	LIQUIDS	
Brick masonry, soft	110	Alcohol, pure	49
Brick masonry, common (about 3 tons per thousand)	125	Gasoline	42
Brick masonry, pressed	140	Oils	58
Clay tile masonry, average	60	Water	62
Rubble masonry	130-155	EARTH	
Concrete, cinder, haydite	100-110	Earth, wet	100
Concrete, slag	130	Earth, dry (about 2050 lbs. per cu. yd.)	75
Concrete, stone	144	Sand and gravel, wet	120
Concrete, stone, reinforced (4050 lbs. per cu. yd.)	150	Sand and gravel, dry	105
ICE AND SNOW		River sand (about 3240 lbs. per cu. yd.)	120
Ice	56	VARIOUS BUILDING MATERIALS	
Snow, dry, fresh fallen	8	Cement, portland, loose	94
Snow, dry, packed	12-25	Cement, portland, set	183
Snow, wet	27-40	Lime, gypsum, loose	53-64
MISCELLANEOUS		Mortar, cement-lime, set	103
Asphalt	80	Crushed rock (about 2565 lbs. per cu. yd.)	90-110
Tar	75		
Glass	160		
Paper	60		

Table 1.3

WEIGHTS OF MATERIALS (Based on Surface Area)			
Material	Approximate Weight Lbs. Per Square Foot	Material	Approximate Weight Lbs. Per Square Foot
CEILINGS (Per Inch of Thickness)		FLOORING (Per Inch of Thickness)	
Plaster board	5	Hardwood	5
Acoustic and fire resistive tile	2	Sheathing	2.5
Plaster, gypsum-sand	8	Plywood, fir	3
Plaster, light aggregate	4	Wood block, treated	4
Plaster, cement sand	12	Concrete, finish or fill	12
ROOFING		Mastic base	12
Three-ply felt and gravel	5.5	Mortar base	10
Five-ply felt and gravel	6.5	Terrazzo	12.5
Three-ply felt, no gravel	3	Tile, vinyl 1/8 inch	1.5
Five-ply felt, no gravel	4	Tile, linoleum 3/16 inch	1
Shingles, wood	2	Tile, cork, per 1/16 inch	0.5
Shingles, asbestos	3	Tile, rubber or asphalt 3/16 inch	2
Shingles, asphalt	2.5	Tile, ceramic or quarry 3/4 inch	11
Shingles, 1/4 inch slate	10	Carpeting	2
Shingles, tile	14	DECKS AND SLABS	
PARTITIONS		Steel roof deck 1 1/2" — 14 ga.	5
Steel partitions	4	— 16 ga.	4
Solid 2" gypsum-sand plaster	20	— 18 ga.	3
Solid 2" gypsum-light agg. plaster	12	— 20 ga.	2.5
Metal studs, metal lath, 3/4" plaster both sides	18	— 22 ga.	2
Metal or wood studs, plaster board and 1/2" plaster both sides	18	Steel cellular deck 1 1/2" — 12/12 ga.	11
Plaster 1/2"	4	— 14/14 ga.	8
Hollow clay tile 2 inch	13	— 16/16 ga.	6.5
3 inch	16	— 18/18 ga.	5
4 inch	18	— 20/20 ga.	3.5
5 inch	20	Steel cellular deck 3" — 12/12 ga.	12.5
6 inch	25	— 14/14 ga.	9.5
Hollow slag concrete block 4 inch	24	— 16/16 ga.	7.5
6 inch	35	— 18/18 ga.	6
Hollow gypsum block 3 inch	10	— 20/20 ga.	4.5
4 inch	13	Concrete, reinforced, per inch	12.5
5 inch	15.5	Concrete, gypsum, per inch	5
6 inch	16.5	Concrete, lightweight, per inch	5-10
Solid gypsum block 2 inch	9.5	MISCELLANEOUS	
3 inch	13	Windows, glass, frame	8
MASONRY WALLS (Per 4 Inch of Thickness)		Skylight, glass, frame	12
Brick	40	Corrugated asbestos 1/4 inch	3.5
Glass brick	20	Glass, plate 1/4 inch	3.5
Hollow concrete block	30	Glass, common	1.5
Hollow slag concrete block	24	Plastic sheet 1/4 inch	1.5
Hollow cinder concrete block	20	Corrugated steel sheet, galv.	
Hollow haydite block	22	— 12 ga.	5.5
Stone, average	55	— 14 ga.	4
Bearing hollow clay tile	23	— 16 ga.	3
		— 18 ga.	2.5
		— 20 ga.	2
		— 22 ga.	1.5
		Wood Joists — 16" ctrs. 2 x 12	3.5
		2 x 10	3
		2 x 8	2.5
		Steel plate (per inch of thickness)	40

Section 2

Fibre Ropes, Knots, Hitches

- Fibre Rope Characteristics**
- Inspection of Fibre Rope**
- Safe Working Load (SWL)**
- Care, Storage, Use**
- Knots**
- Hitches**

Section 2

Fibre Ropes, Knots, Hitches

Fibre rope is a commonly used tool which has many applications in daily hoisting and rigging operations.

Readily available in a wide variety of synthetic and natural fibre materials, these ropes may be used as

- slings for hoisting materials
- handlines for lifting light loads
- taglines for helping to guide and control loads.

There are countless situations where the rigger will be required to tie a safe and reliable knot or hitch in a fibre rope as part of the rigging operation.

Fastening a hook, making eyes for slings, and tying on a tagline are a few of these situations.

This section addresses the correct selection, inspection, and use of fibre rope for hoisting and rigging operations. It also explains how to tie several knots and hitches.

Characteristics

The fibres in these ropes are either natural or synthetic. Natural fibre ropes should be used cautiously for rigging since their strength is more variable than that of synthetic fibre ropes and they are much more subject to deterioration from rot, mildew, and chemicals.

Polypropylene is the most common fibre rope used in rigging. It floats but does not absorb water. It stretches less than other synthetic fibres such as nylon. It is affected, however, by the ultraviolet rays in sunlight and should not be left outside for long periods. It also softens with heat and is not recommended for work involving exposure to high heat.

Nylon fibre is remarkable for its strength. A nylon rope is considerably stronger than the same size and construction of polypropylene rope. But nylon stretches and hence is not used much for rigging. It is also more expensive, loses strength when wet, and has low resistance to acids.

Polyester ropes are stronger than polypropylene but not so strong as nylon. They have good resistance to acids, alkalis, and abrasion; do not stretch as much as nylon; resist degradation from ultraviolet rays; and don't soften in heat.

All fibre ropes conduct electricity when wet. When dry, however, polypropylene and polyester have much better insulating properties than nylon.

Inspection

Inspect fibre rope regularly and before each use. Any estimate of its capacity should be based on the portion of rope showing the **most** deterioration.

Check first for external wear and cuts, variations in the size and shape of strands, discolouration, and the elasticity or "life" remaining in the rope.

Untwist the strands without kinking or distorting them. The inside of the rope should be as bright and clean as when it was new. Check for broken yarns, excessively loose strands and yarns, or an accumulation of powdery dust, which indicates excessive internal wear between strands as the rope is flexed back and forth in use.

If the inside of the rope is dirty, if strands have started to unlay, or if the rope has lost life and elasticity, do not use it for hoisting.

Check for distortion in hardware. If thimbles are loose in the eyes, seize the eye to tighten the thimble (Figure 2.1). Ensure that all splices are in good condition and all tucks are done up (Figure 2.2) .

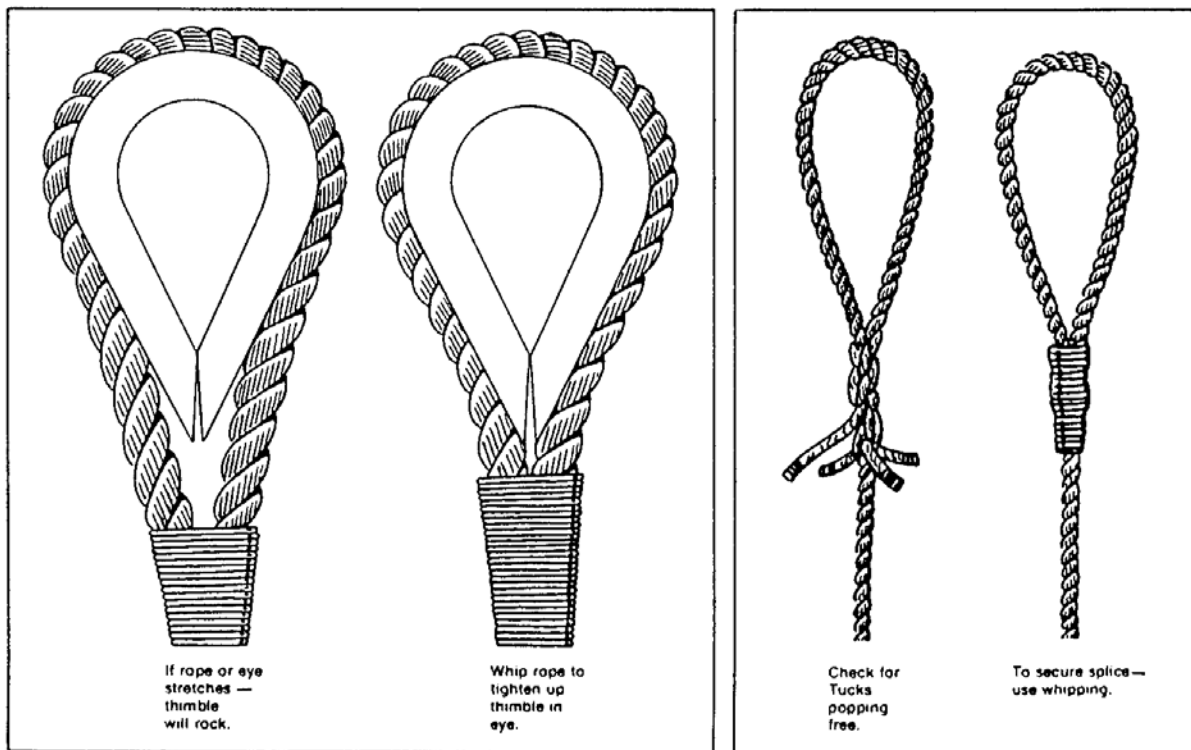

Figure 2.1

Figure 2.2

Defective or damaged fibre rope should be destroyed or cut up so that it cannot be used for hoisting.

Safety Factors

Fibre rope must have a factor of safety to account for loads over and above the weight being hoisted and for reduced capacity due to

- wear, broken fibres, broken yarns, age, variations in size and quality
- loads imposed by starting, stopping, swinging, and jerking
- increases in line pull caused by friction over sheaves
- decreases in strength caused by bending over sheaves
- inaccuracies in load weight
- getting wet and drying out, mildew and rot
- strength reductions caused by knots
- yarns weakened by ground-in dirt and abrasives.

The safety factor for all fibre rope is 5. For hoisting or supporting personnel, the safety factor is 10.

The safety factor does **not** provide extra usable capacity. Safe working loads must **never** be exceeded.

Safe Working Loads

Safe working loads (SWL) can be calculated as shown in Figure 2.3.

$$\begin{aligned} \text{SWL} &= \frac{\text{Breaking Strength}}{\text{Factor of Safety}} \\ &= \frac{\text{Breaking Strength}}{5} \end{aligned}$$

For example, a rope rated at 1500 lbs. breaking strength has a safe working load of 300 lbs.

$$\frac{1500 \text{ lbs.}}{5} = 300 \text{ lbs.}$$

Figure 2.3

The tables in Figure 2.4 are for purposes of illustration only. Check manufacturer's ratings for the SWL of the rope you are using, which may well differ from what is shown in these tables.

SWLs are for the common three-strand fibre ropes generally used for rigging. Figures are based on ropes with no knots or hitches.

Sample Safe Working Loads of Fibre Ropes

APPROXIMATE SAFE WORKING LOADS OF NEW FIBRE ROPES — POUNDS					
3-Strand Ropes					
Safety Factor = 5					
Nominal Rope Diameter (Inches)	Manila	Nylon	Polypropylene	Polyester	Polyethylene
3/16	100	200	150	200	150
1/4	120	300	250	300	250
5/16	200	500	400	500	350
3/8	270	700	500	700	500
1/2	530	1,250	830	1,200	800
5/8	880	2,000	1,300	1,900	1,050
3/4	1,080	2,800	1,700	2,400	1,500
7/8	1,540	3,800	2,200	3,400	2,100
1	1,800	4,800	2,900	4,200	2,500
1 1/8	2,400	6,300	3,750	5,600	3,300
1 1/4	2,700	7,200	4,200	6,300	3,700
1 1/2	3,700	10,200	6,000	8,900	5,300
1 5/8	4,500	12,400	7,300	10,800	6,500
1 3/4	5,300	15,000	8,700	12,900	7,900
2	6,200	17,900	10,400	15,200	9,500

APPROXIMATE SAFE WORKING LOADS OF NEW BRAIDED SYNTHETIC FIBRE ROPES (LBS.)			
SAFETY FACTOR = 5			
Nominal Rope Diameter (Inches)	Nylon Cover Nylon Core	Nylon Cover Polypropylene Core	Polyester Cover Polypropylene Core
1/4	420	—	380
5/16	640	—	540
3/8	880	680	740
7/16	1,200	1,000	1,060
1/2	1,500	1,480	1,380
9/16	2,100	1,720	—
5/8	2,400	2,100	2,400
3/4	3,500	3,200	2,860
7/8	4,800	4,150	3,800
1	5,700	4,800	5,600
1 1/8	8,000	7,000	—
1 1/4	8,800	8,000	—
1 1/2	12,800	12,400	—
1 5/8	16,000	14,000	—
1 3/4	19,400	18,000	—
2	23,600	20,000	—

Figure 2.4

Caution: These tables are for purposes of illustration and comparison only. Check manufacturer's ratings for the SWL of the specific fibre rope you are using.

When load tables are not available, the following procedures work well for **new** nylon, polypropylene, polyester, and polyethylene ropes.

Since rope on the job is rarely new, you will have to judge what figures to use.

If you have any doubt about the type of rope or its condition, don't use it. There is no substitute for safety.

MANILA ROPE

- Change the rope diameter into eighths of an inch.
- Square the numerator and multiply by 20.

Example:

- (a) $\frac{1}{2}$ inch manila rope = $\frac{4}{8}$ inch diameter.
SWL = $4 \times 4 \times 20 = 320$ lb.
- (b) $\frac{5}{8}$ inch manila rope
SWL = $5 \times 5 \times 20 = 500$ lb.
- (c) 1 inch manila rope = $\frac{8}{8}$ inch diameter.
SWL = $8 \times 8 \times 20 = 1280$ lb.

NYLON ROPE

- Change the rope diameter into eighths of an inch.
- Square the numerator and multiply by 60.

Example:

- $\frac{1}{2}$ inch nylon rope = $\frac{4}{8}$ inch diameter.
SWL = $4 \times 4 \times 60 = 960$ lb.

POLYPROPYLENE ROPE

- Change the rope diameter into eighths of an inch.
- Square the numerator and multiply by 40.

Example:

- $\frac{1}{2}$ inch polypropylene rope = $\frac{4}{8}$ inch diameter.
SWL = $4 \times 4 \times 40 = 640$ lb.

POLYESTER ROPE

- Change the rope diameter into eighths of an inch.
- Square the numerator and multiply by 60.

Example:

- $\frac{1}{2}$ inch polyester rope = $\frac{4}{8}$ inch diameter.
SWL = $4 \times 4 \times 60 = 960$ lb.

POLYETHYLENE ROPE

- Change the rope diameter into eighths of an inch.
- Square the numerator and multiply by 35.

Example:

- 1 inch polyethylene rope = $\frac{8}{8}$ inch diameter.
SWL = $8 \times 8 \times 35 = 2240$ lb.

Care

- To unwind a new coil of fibre rope, lay it flat with the inside end closest to the floor. Pull the inside end up through the coil and unwind counterclockwise.
- After use, recoil the rope clockwise. Keep looping the rope over your left arm until only about 15 feet remain. Start about a foot from the top of the coil and wrap the rope about six times around the loops. Then use your left hand to pull the bight back through the loops and tie with a couple of half-hitches to keep the loops from uncoiling (Figure 2.5).

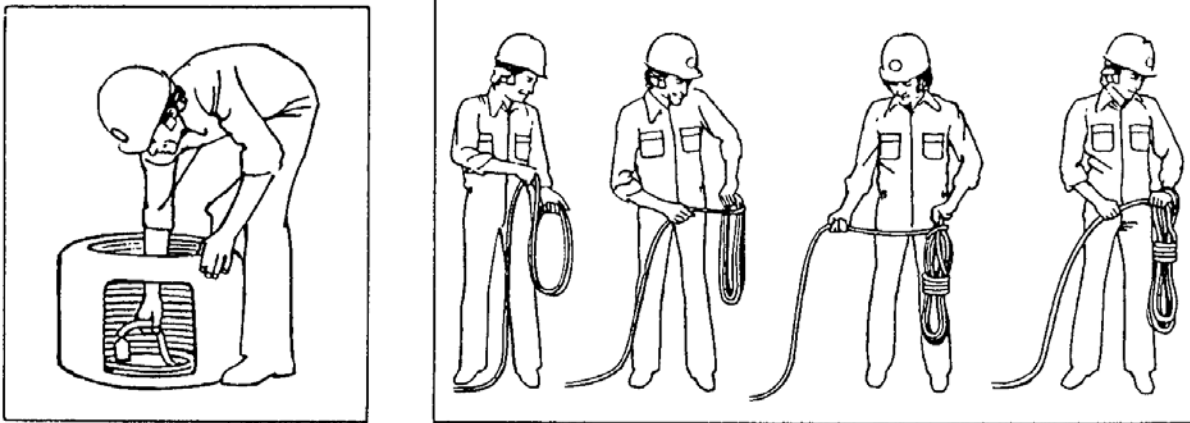

Figure 2.5

- Remove kinks carefully. Never try to pull them straight. This will severely damage the rope and reduce its strength.
- When a fibre rope is cut, the ends must be bound or whipped to keep the strands from untwisting. Figure 2.6 shows the right way to do this.

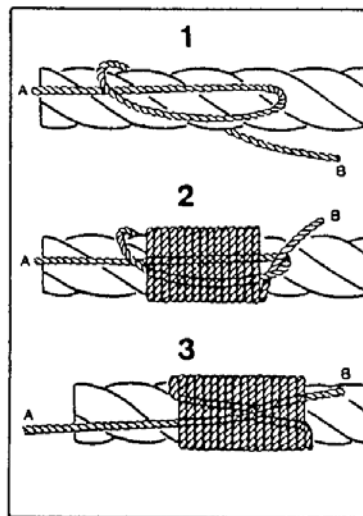

Figure 2.6

Storage

- Store fibre ropes in a dry cool room with good air circulation—temperature 10-21°C (50-70°F), humidity 40-60%.
- Hang fibre ropes in loose coils on large diameter wooden pegs well above the floor (Figure 2.7).

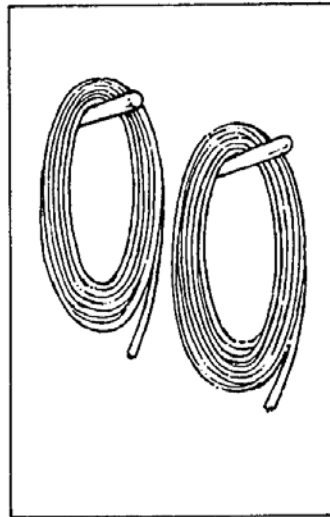

Figure 2.7

- Protect fibre ropes from weather, dampness, and sunlight. Keep them away from exhaust gases, chemical fumes, boilers, radiators, steam pipes, and other heat sources.
- Let fibre ropes dry before storing them. Moisture hastens rot and causes rope to kink easily. Let a frozen rope thaw completely before you handle it. Otherwise fibres can break. Let wet or frozen rope dry naturally.
- Wash dirty ropes in clean cool water and hang to dry.

Use

- Never overload a rope. Apply the safety factor of 5 (10 for ropes used to support or hoist personnel). Then make further allowances for the rope's age and condition.
- Never drag a rope along the ground. Abrasive action will wear, cut, and fill the outside surfaces with grit.
- Never drag a rope over rough or sharp edges or across itself. Use softeners to protect rope at the sharp corners and edges of a load.
- Avoid all but straight line pulls with fibre rope. Bends interfere with stress distribution in fibres.

- Always use thimbles in rope eyes. Thimbles cut down on wear and stress.
- Keep sling angles at more than 45°. Lower angles can dramatically increase the load on each leg (Figure 2.8). The same is true with wire rope slings.
- Never use fibre rope near welding or flame cutting. Sparks and molten metal can cut through the rope or set it on fire.
- Keep fibre rope away from high heat. Don't leave it unnecessarily exposed to strong sunlight, which weakens and degrades the rope.
- Never couple left-lay rope to right-lay.
- When coupling wire and fibre ropes, always use metal thimbles in both eyes to keep the wire rope from cutting the fibre rope.
- Make sure that fibre rope used with tackle is the right size for the sheaves. Sheaves should have diameters at least six—preferably ten—times greater than the rope diameter.

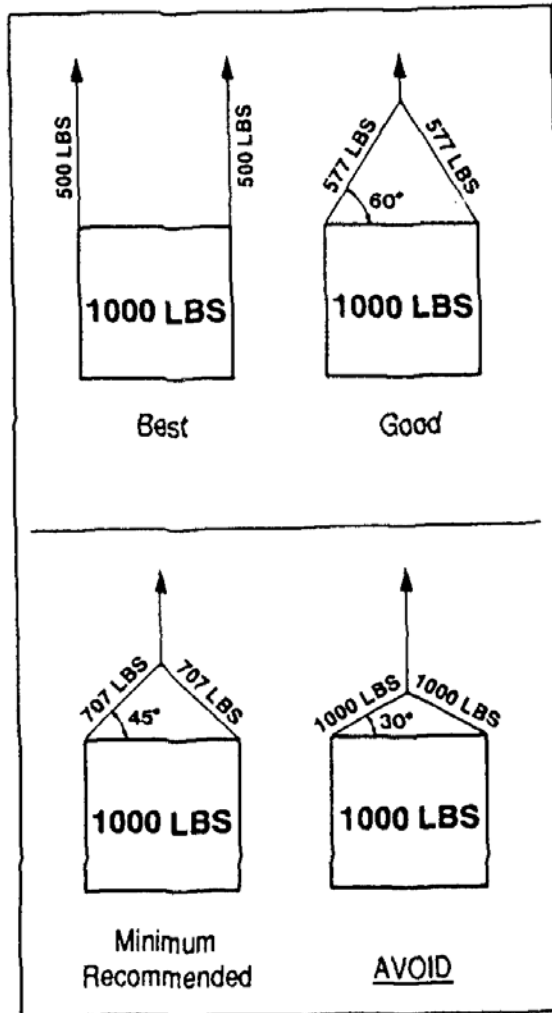

Figure 2.8

Insulating Characteristics

It is occasionally necessary to use ropes for work close to electrical powerlines. A knowledge of the insulating characteristics of fibre ropes is therefore important.

All ropes will conduct electricity when they are wet. However, polyester, polyethylene, and polypropylene ropes each have good and consistent insulating properties under conditions of low or high humidity.

Nylon is **not** recommended where insulation against high voltage is required. It absorbs moisture from the atmosphere and, unless dried and varnished, its insulating properties vary widely.

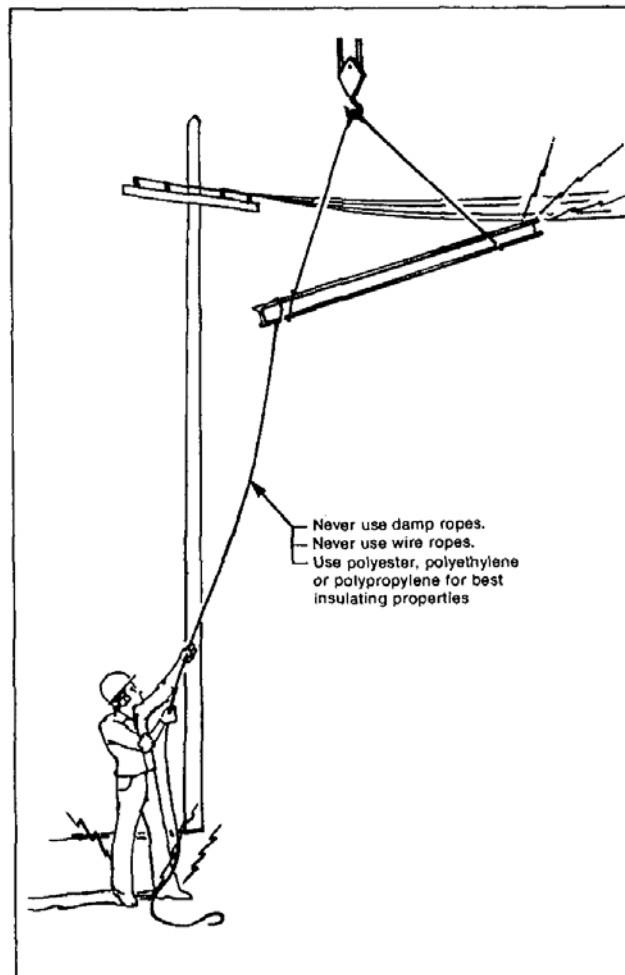

Knots

Whenever practical, avoid tying knots in rope. Knots, bends, and hitches reduce rope strength considerably. Just how much depends on the knot and how it is applied. Use a spliced end with a hook or other standard rigging hardware such as slings and shackles to attach ropes to loads.

In some cases, however, knots are more practical and efficient than other rigging methods, as for lifting and lowering tools or light material.

For knot tying, a rope is considered to have three parts (Figure 2.9).

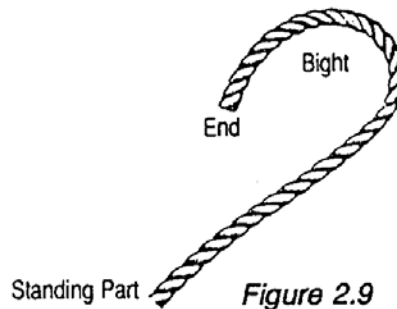

The **end** is where you tie the knot. The **standing part** is inactive. The **bight** is in between.

Following the right sequence is essential in tying knots. Equally important is the the direction the end is to take and whether it goes over, under, or around other parts of the rope.

There are overhand loops, underhand loops, and turns (Figure 2.10).



Figure 2.10

WARNING - When tying knots, always follow the directions *over* and *under* precisely. If one part of the rope must go under another, do it that way. Otherwise an entirely different knot—or no knot at all—will result.

Once knots are tied, they should be drawn up slowly and carefully to make sure that sections tighten evenly and stay in proper position.

Bowline

Never jams or slips when properly tied. A universal knot if properly tied and untied. Two interlocking bowlines can be used to join two ropes together. Single bowlines can be used for hoisting or hitching directly around a ring.

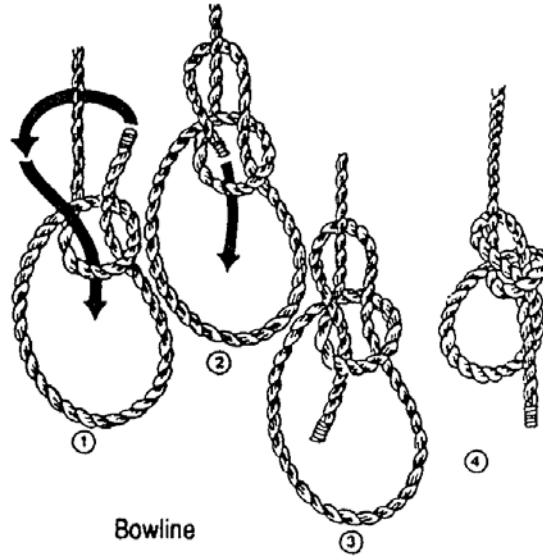

Bowline

Bowline on the Bight

Used to tie a bowline in the middle of a line or to make a set of double-leg spreaders for lifting pipe. Can also be used as a sling—sit in one loop and put the other around the back and under the arms.

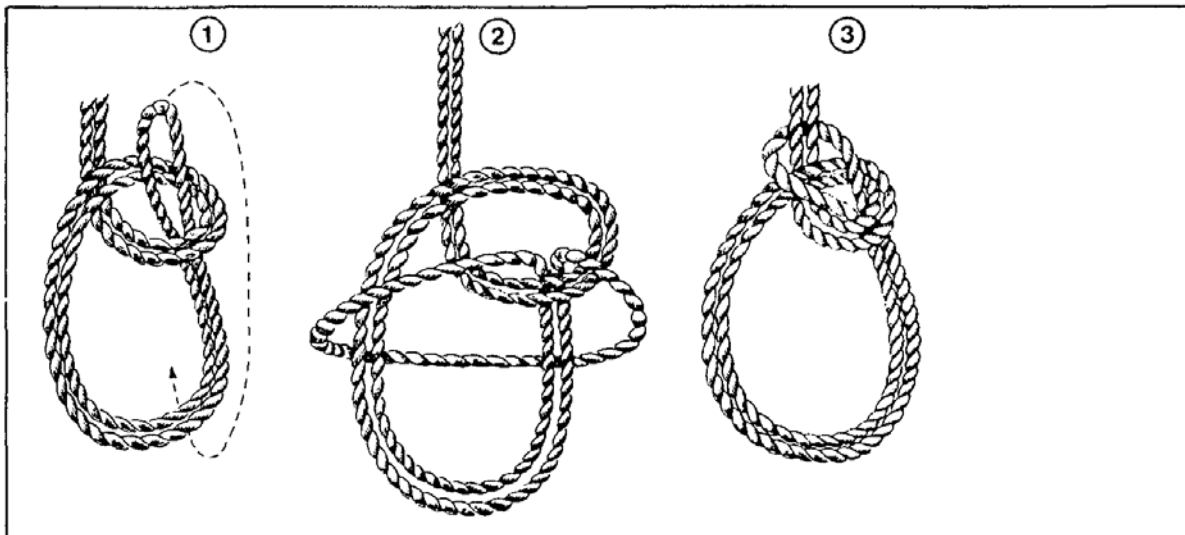

Triple Sliding Hitch

Generally used to tie a lanyard to a lifeline. Use 16 mm nylon rope for lanyards, not manila. **Caution:** Make sure that both ends come out the same side, as shown.

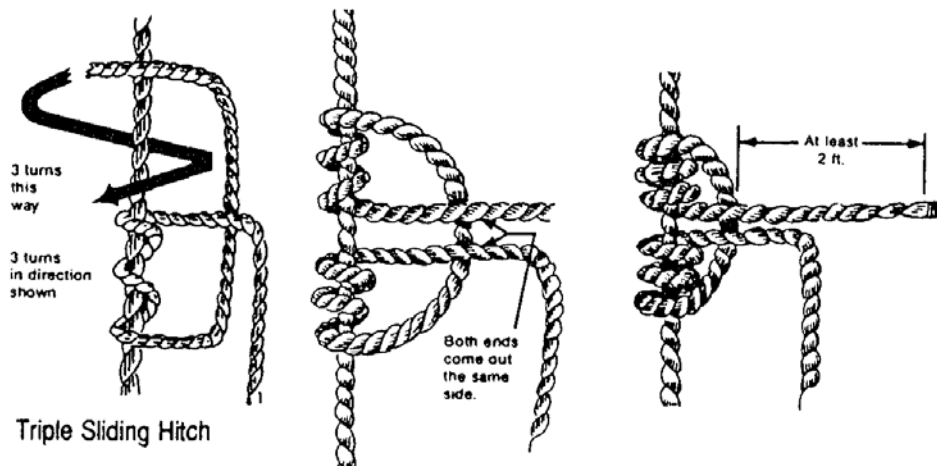

Triple Sliding Hitch

Pipe Hitch

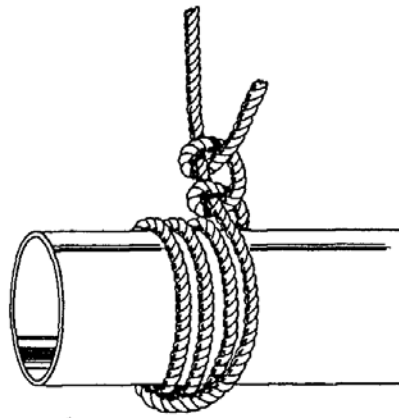

Reef or Square Knot

Can be used for tying two ropes of the same diameter together. It is unsuitable for wet or slippery ropes and should be used with caution since it unties easily when either free end is jerked. Both live and dead ends of the rope must come out of the loops at the same side.

Reef or Square Knot

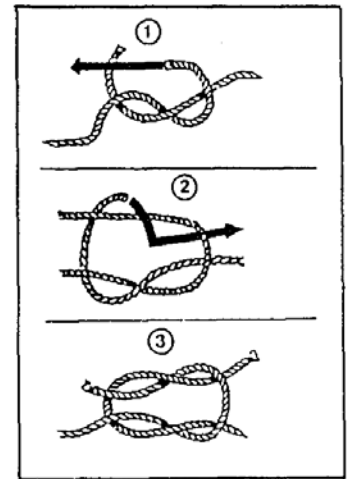

Two Half Hitches

Two half hitches, which can be quickly tied, are reliable and can be put to almost any general use.

Two Half Hitches

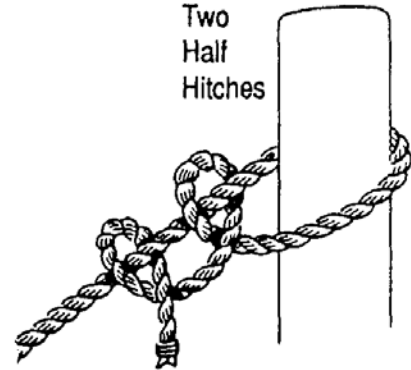

Running Bowline

The running bowline is mainly used for hanging objects with ropes of different diameters. The weight of the object determines the tension necessary for the knot to grip.

Make an overhand loop with the end of the rope held toward you (1). Hold the loop with your thumb and fingers and bring the standing part of the rope back so that it lies behind the loop (2). Take the end of the rope in behind the standing part, bring it up, and feed it through the loop (3). Pass it behind the standing part at the top of the loop and bring it back down through the loop (4).

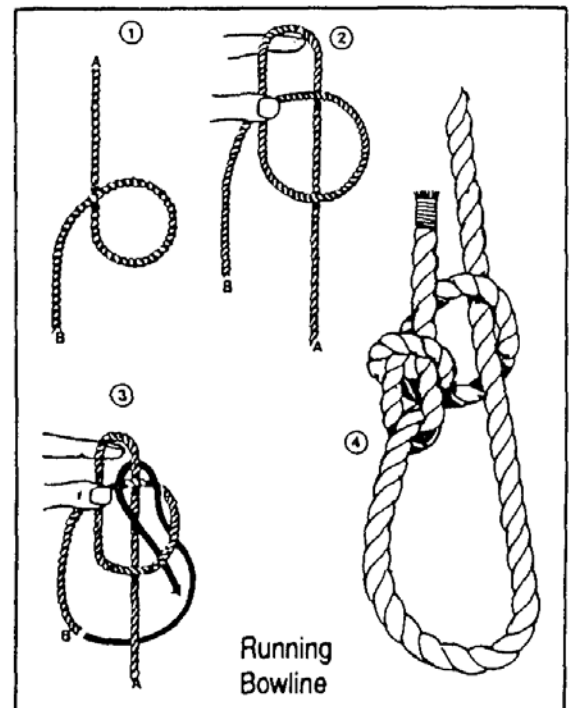
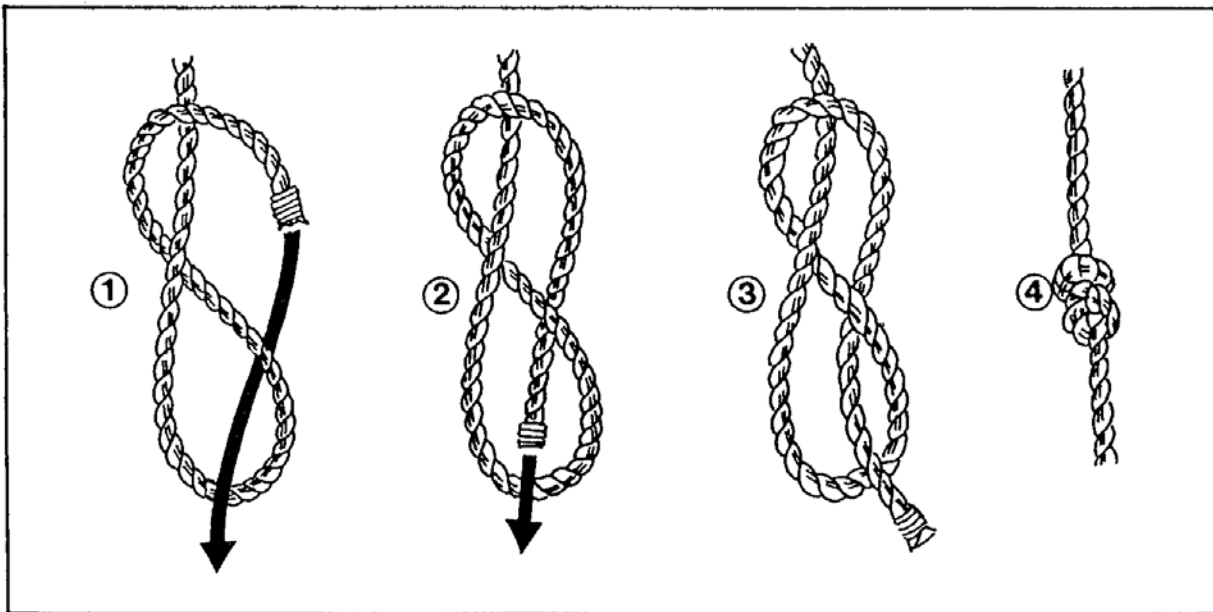

Figure-Eight Knot

This knot is generally tied at the end of a rope to temporarily prevent the strands from unlaying. The figure-eight knot can be tied simply and quickly and will not jam as easily as the overhand knot. It is also larger, stronger, and does not injure the rope fibres. The figure-eight knot is useful in preventing the end of a rope from slipping through a block or an eye.

To tie the figure-eight knot, make an underhand loop (1). Bring the end around and over the standing part (2). Pass the end under and then through the loop (3). Draw up tight (4).

Figure Eight Knot



Section 3

Hardware, Wire Rope, Slings

- Wire Rope**
- Sling Configurations**
- Sling Angles**
- Centre of Gravity**
- Sling SWLs**
- Sling Types**
- Rigging Hardware**
- Hoisting Tips**

Hardware, Wire Rope, Slings

The rigger must be able to rig the load to ensure its stability when lifted. This requires a knowledge of safe sling configurations and the use of related hardware such as shackles, eyebolts, and wire rope clips.

Determining the safe working load of the rigging equipment as well as the weight of the load is a fundamental requirement of safe rigging practice.

If the rigger has reasonable cause to believe that any equipment or tackle assigned for the job is unsafe or unsuitable, the rigger should not use or operate the equipment or tackle until it has been reported to the supervisor and orders to proceed have been issued by someone in authority who is then responsible for the safety of all personnel involved in the lift.

The safe working loads of all hoisting equipment and rigging hardware are based on almost ideal conditions seldom achieved in the field. It is therefore important to recognize the factors such as wear, improper sling angles, point loading, and centre of gravity that can affect the rated safe working loads of equipment and hardware.

This section describes the selection and safe use of various types of slings and different kinds of rigging hardware. Subjects include factors that can reduce capacity, inspection for signs of wear, calculating safe sling angles, and requirements for slings and hardware under the *Regulations for Construction Projects*.

Wire Rope

Selection

In selecting equipment, we must consider not only how to get the job done as economically as possible but also how to eliminate hazards to personnel, public, and property for as long as the rope will be used and under all anticipated conditions of exposure and operation.

Although nothing can take the place of experience in making these decisions, it is possible to summarize some of the main points to consider.

Many factors influence the selection of wire rope. Rope strength, although of major importance, is only one factor. Pay attention to the other factors such as size, grade, type, and construction that are specified by equipment or rope manufacturers who base their recommendations on actual working conditions.

Always consider six basic requirements when selecting wire rope:

- 1) The rope must possess enough strength to take the maximum load that may be applied, with a factor of safety of at least 5 to 1—and 10 to 1 when the rope will be used to carry personnel.

Wire ropes that are supplied as rigging on cranes must possess factors of safety as follows:

- live or running ropes that wind on drums or pass over sheaves
 - = 3.5 to 1 under operating conditions
 - = 3.0 to 1 when erecting the boom
- pendants or standing ropes
 - = 3.0 to 1 under operating conditions
 - = 2.5 to 1 when erecting the boom.

- 2) The rope must withstand repeated bending without failure of the wires from fatigue.
- 3) The rope must resist abrasion.
- 4) The rope must withstand distortion and crushing.
- 5) The rope must resist rotation.
- 6) The rope must resist corrosion.

Types of Construction

The number of wires in a rope is an important factor in determining a rope's characteristics. But the arrangement of the wires in the strand is also important.

Basic Types

The four basic constructions are illustrated in Figure 1:

- (1) **Ordinary** – all wires are the same size.
- (2) **Warrington** – outer wires are alternately larger and smaller.
- (3) **Filler** – small wires fill spaces between larger wires.
- (4) **Seale** – wires of outer layer are larger diameter than wires of inner layer.

On ropes of **Ordinary** construction the strands are built in layers. The basic seven-wire strand consists of six wires laid around a central wire. A nineteen-wire strand is constructed by adding a layer of twelve wires over a seven-wire strand. Adding a third layer of eighteen wires results in a 37-wire strand.

In this type of construction the wires in each layer have different lay lengths. This means that the wires in adjacent layers contact each other at an angle. When the rope is loaded the wires rub against each other with a sawing action. This causes eventual failure of the wires at these points.

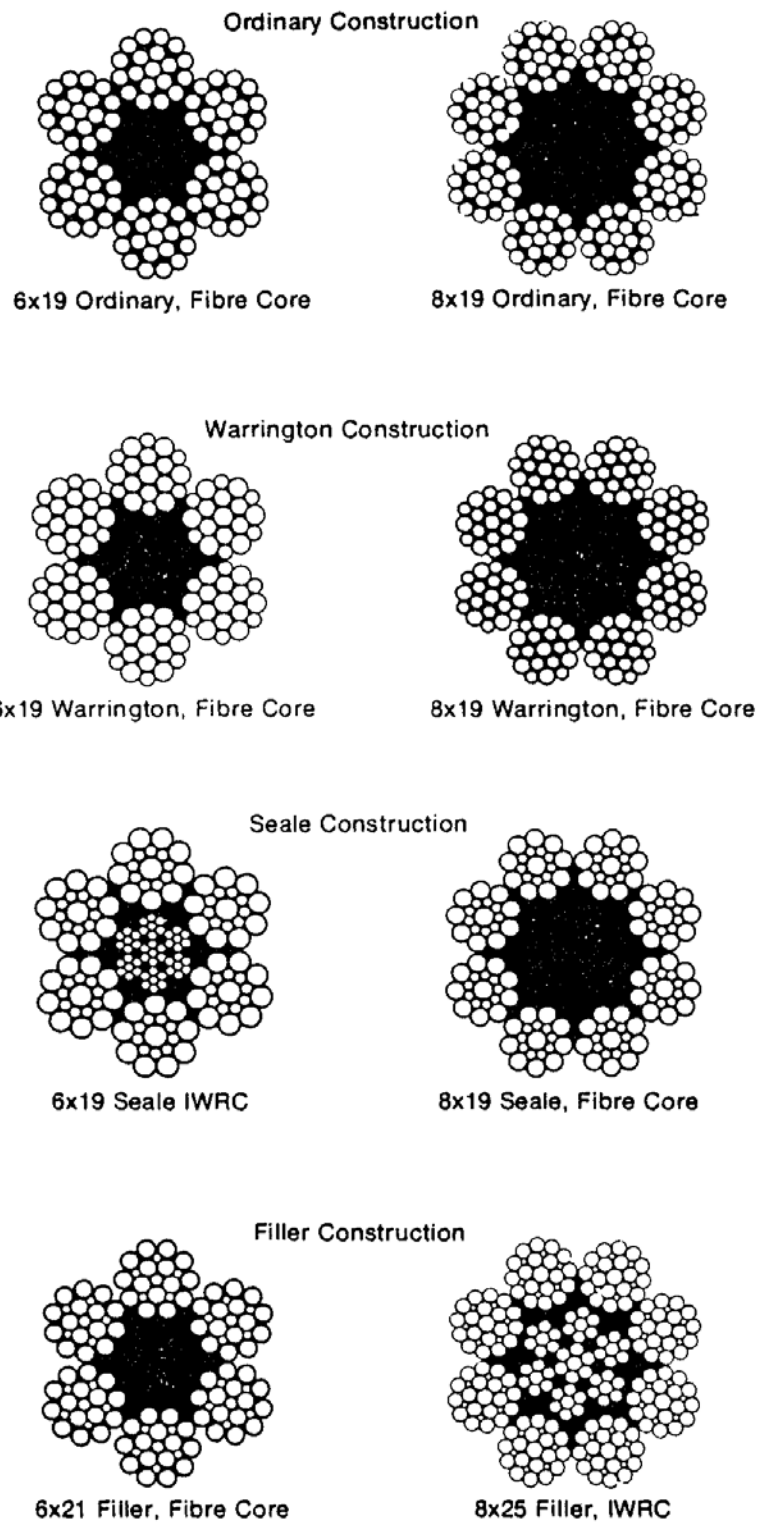

BASIC WIRE ROPE CONSTRUCTIONS

Figure 1

Wire Rope Inspection

It is essential to have a well-planned program of regular inspection carried out by an experienced inspector.

All wire rope in continuous service should be checked daily during normal operation and inspected on a weekly basis. A complete and thorough inspection of all ropes in use must be made at least once a month. Rope idle for a month or more should be given a thorough inspection before it is returned to service.

A record of each rope should include date of installation, size, construction, length, extent of service and any defects found.

The inspector will decide whether the rope must be removed from service. His decision will be based on

- (1) details of the equipment on which the rope has been used,
- (2) maintenance history of the equipment,
- (3) consequences of failure, and
- (4) experience with similar equipment.

Conditions such as the following should be looked for during inspection.

Broken Wires

Occasional wire breaks are normal for most ropes and are not critical provided they are at well spaced intervals. Note the area and watch carefully for any further wire breaks. Broken wire ends should be removed as soon as possible by bending the broken ends back and forth with a pair of pliers. This way broken ends will be left tucked between the strands.

Construction regulations under The Occupational Health and Safety Act establish criteria for retiring a rope based on the number of wire breaks

Worn and Abraded Wires

Abrasive wear causes the outer wires to become "D" shaped. These worn areas are often shiny in appearance (Figure 2). The rope must be replaced if wear exceeds $\frac{1}{3}$ of the diameter of the wires.

Reduction in Rope Diameter

Reduction in rope diameter can be caused by abrasion of outside wires, crushing of the core, inner wire failure, or a loosening of the rope lay. All new ropes stretch slightly and decrease in diameter after being used.

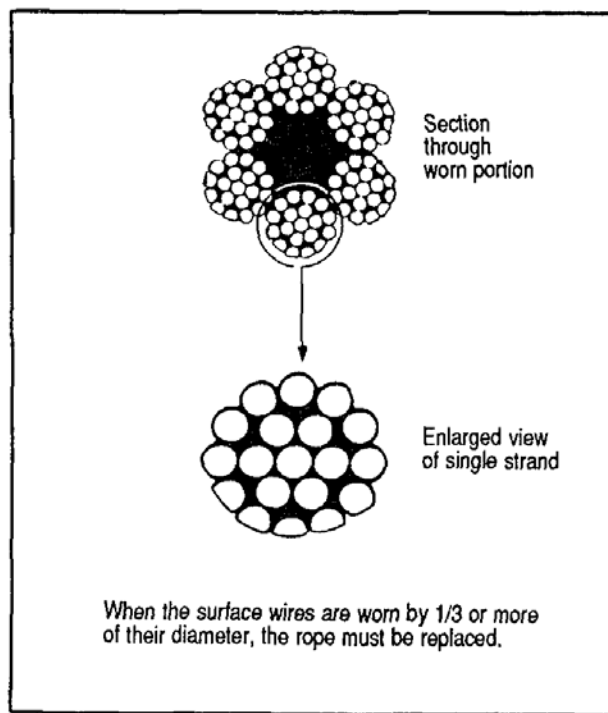

Figure 2



Snagged wires resulting from drum crushing



Rope that has been jammed after jumping off sheave



Rope subjected to drum crushing. Note the distortion of the individual wires and displacement from their original position. This is usually caused by the rope scrubbing on itself.



Localized crushing of rope



Drum crushing

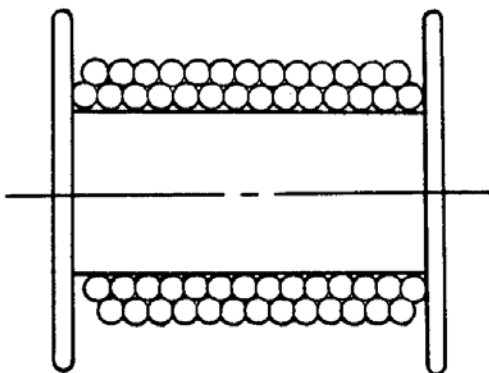

With no more than 2 layers on drum, use any kind of rope.

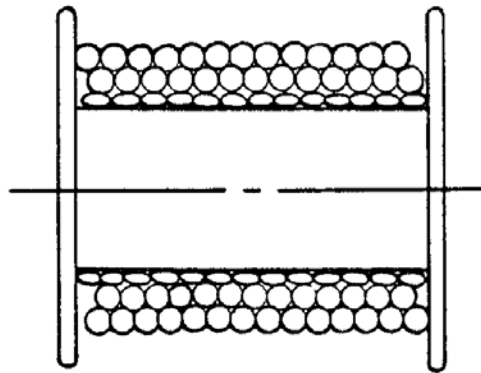

With more than 2 layers on drum, there is danger of crushing. Use larger rope or IWRC rope.

CRUSHED, JAMMED AND FLATTENED STRANDS

Figure 3

Rope Stretch

All steel ropes will stretch during initial periods of use. Called "constructional stretch", this condition is permanent. It results when wires in the strands and strands in the rope seat themselves under load. Rope stretch can be recognized by increased lay length. Six-strand ropes will stretch about six inches per 100 feet of rope while eight-strand ropes stretch approximately 10 inches per 100 feet. Rope stretched by more than this amount must be replaced.

Corrosion

Corrosion is a very dangerous condition because it can develop inside the rope without being seen. Internal rusting will accelerate wear due to increased abrasion as wires rub against one another. When pitting is observed, consider replacing the rope. Noticeable rusting and broken wires near attachments are also causes for replacement. Corrosion can be minimized by keeping the rope well lubricated.

Crushed, Flattened or Jammed Strands

These dangerous conditions require that the rope be replaced (Figure 3). They are often the result of crushing on the drum.

High Stranding and Unlaying

These conditions will cause the other strands to become overloaded. Replace the rope or renew the end connection to reset the rope lay (Figure 4).

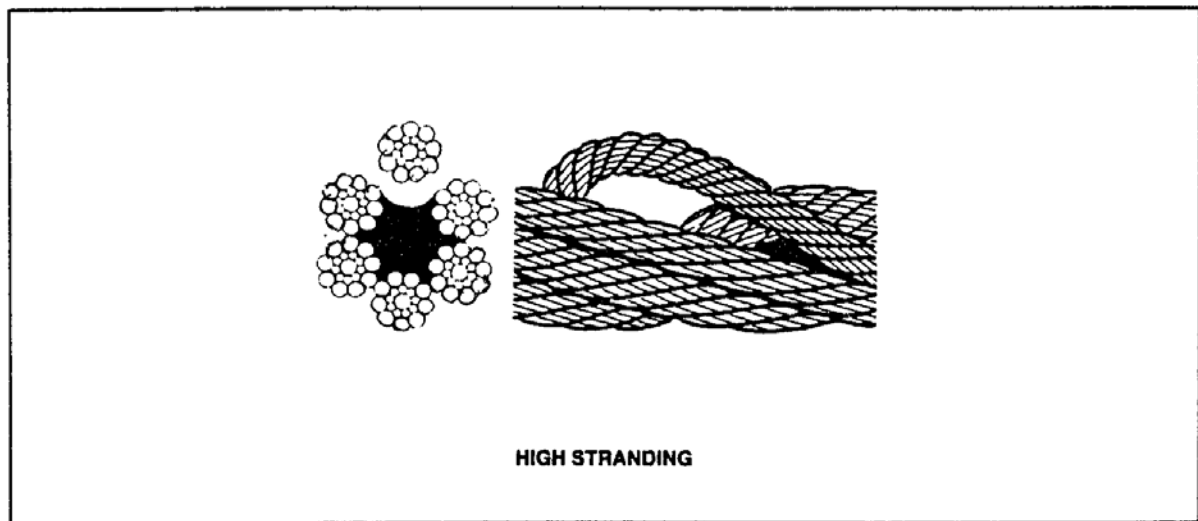

Figure 4

Bird Caging

Bird caging is caused by the rope being twisted or by a sudden release of an overload (Figure 5). The rope, or the affected section, must be replaced.



Multi-strand rope "birdcages" because of torsional unbalance. Typical of buildup seen at anchorage end of multi-fall crane application.



A birdcage caused by sudden release of tension and resulting rebound of rope from overloaded condition. These strands and wires will not return to their original positions.

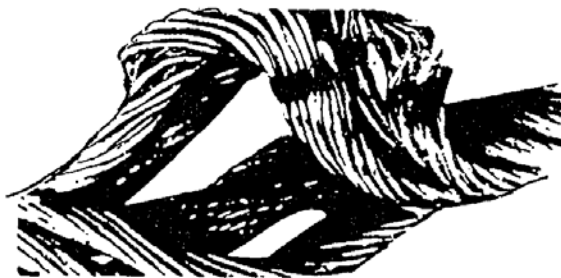

A birdcage which has been forced through a tight sheave

BIRD CAGING

Figure 5

Kinks

Kinking is caused by loops that have been drawn too tightly as a result of improper handling (Figure 6). Kinks are permanent and will require that the rope, or damaged section, be taken out of service.

Core Protrusion

Core protrusion can be caused by shock loads and/or torsional imbalance (Figure 7). This condition requires that the rope be taken out of service.

Electrical Contact

Rope subjected to electrical contact will have wires that are fused, discoloured or annealed and must be removed from service.

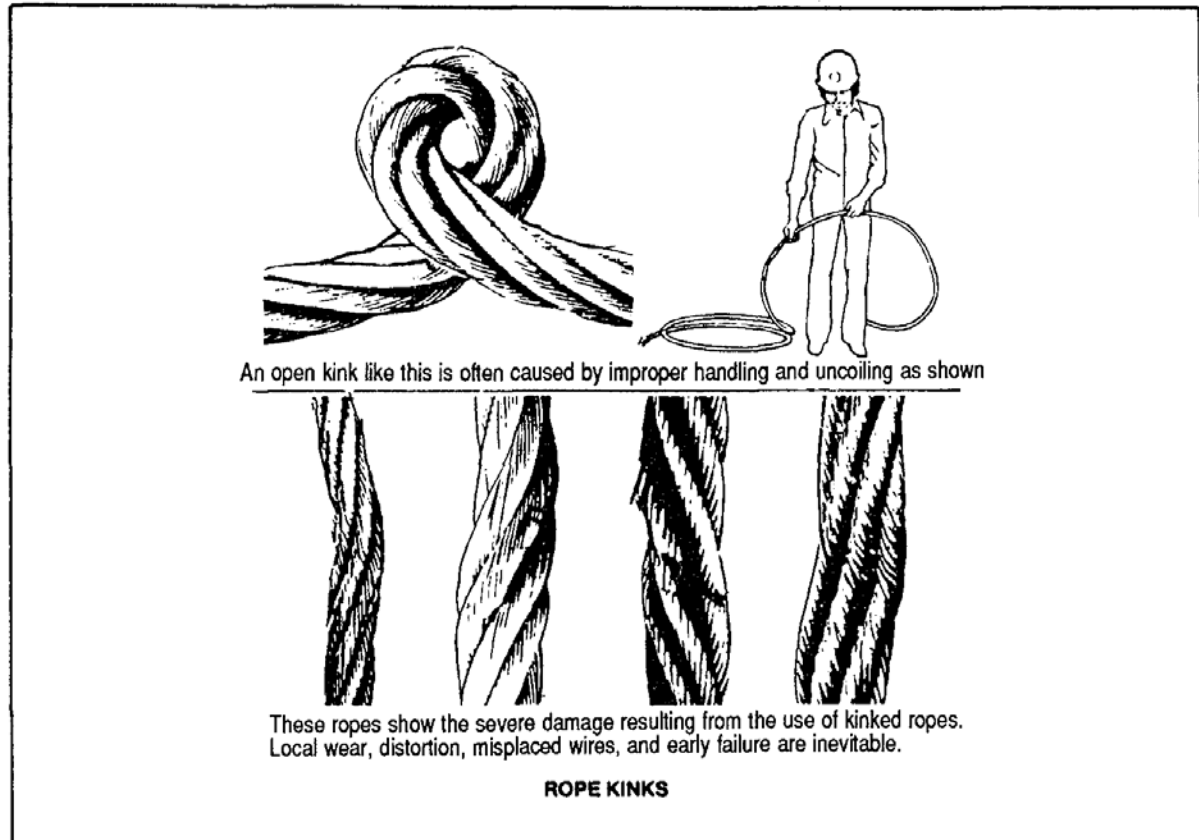

Figure 6

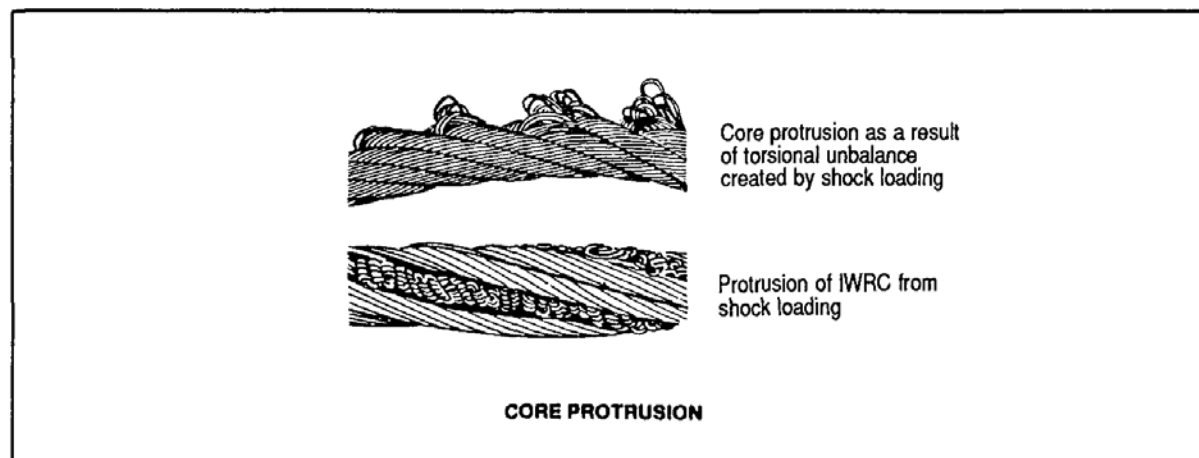
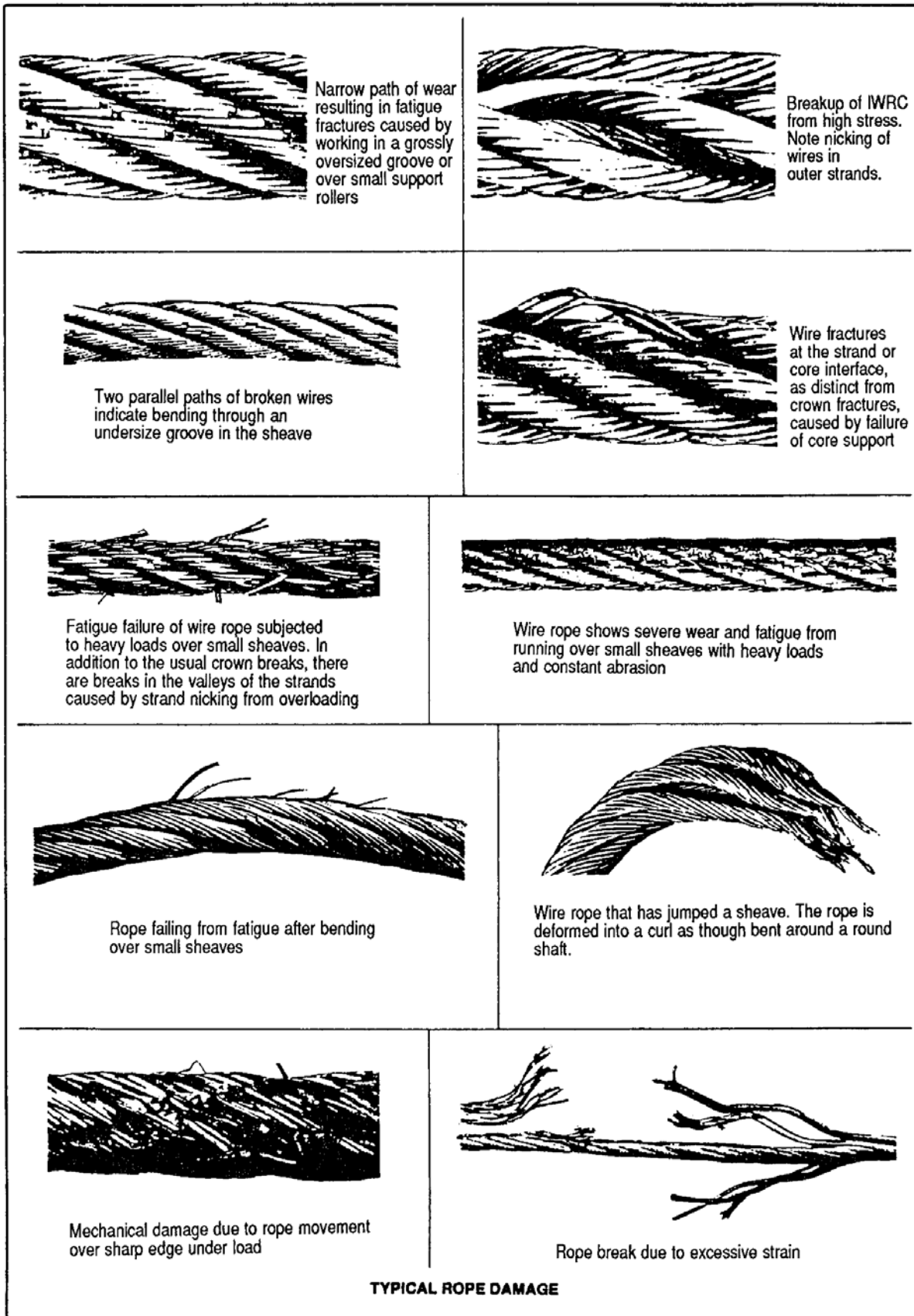

Figure 7

Figure 8 illustrates examples of rope damage while Table 6 identifies likely causes of typical faults.



TYPICAL ROPE DAMAGE

Figure 8

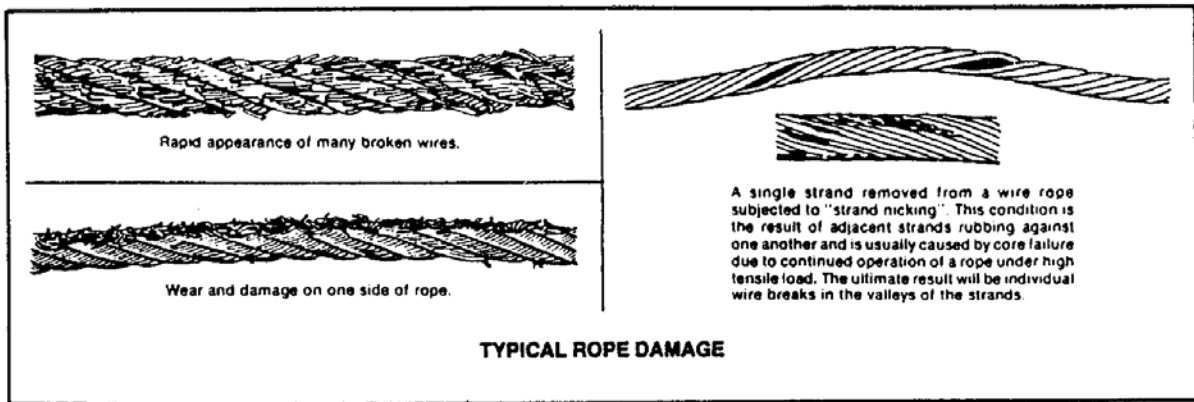

TYPICAL ROPE DAMAGE

Figure 8 (Continued)

TABLE 6

FAULT	POSSIBLE CAUSE	FAULT	POSSIBLE CAUSE
Accelerated Wear	Severe abrasion from being dragged over the ground or obstructions. Rope wires too small for application or wrong construction or grade. Poorly aligned sheaves. Large fleet angle. Worn sheaves with improper groove size or shape. Sheaves, rollers and fairleads having rough wear surfaces. Stiff or seized sheave bearings. High bearing and contact pressures.	Broken Wires or Undue Wear on One Side of Rope	Improper alignment. Damaged sheaves and drums.
		Broken Wires Near Fittings	Rope vibration.
		Burns	Sheave groove too small. Sheaves too heavy. Sheave bearings seized. Rope dragged over obstacle.
Rapid Appearance of Broken Wires	Rope is not flexible enough. Sheaves, rollers, drums too small in diameter. Overload and shock load. Excessive rope vibration. Rope speed too high. Kinks that have formed and been straightened out. Crushing and flattening of the rope. Reverse bends. Sheave wobble.	Rope Core Charred	Excessive heat.
		Corrugation and Excessive Wear	Rollers too soft. Sheave and drum material too soft.
		Distortion of Lay	Rope improperly cut. Core failure. Sheave grooves too big.
		Pinching and Crushing	Sheave grooves too small.
Rope Broken Off Square	Overload, shock load. Kink. Broken or cracked sheave flange.	Rope Chatters	Rollers too small.
Strand Break	Overload, shock load. Local wear. Slack in 1 or more strands.	Rope Unlays	Swivel fittings on Lang Lay ropes. Rope dragging against stationary object.
		Crushing and Nicking	Rope struck or hit during handling.
Corrosion	Inadequate lubricant. Improper type of lubricant. Improper storage. Exposure to acids or alkalis.	High Stranding	Fittings improperly attached. Broken strand. Kinks, dog legs. Improper seizing.
Kinks, Dog Legs, Distortions	Improper installation. Improper handling.	Reduction in Diameter	Broken core. Overload. Corrosion. Severe wear.
Excessive Wear in Spots	Kinks or bends in rope due to improper handling in service or during installation. Vibration of rope on drums or sheaves.	Bird Cage	Sudden release of load.
		Strand Nicking	Core failure due to continued operation under high load.
Crushing and Flattening	Overload, shock load. Uneven spooling. Cross winding. Too much rope on drum. Loose bearing on drum. Faulty clutches. Rope dragged over obstacle.	Core Protrusion	Shock loading. Disturbed rope lay. Rope unlays. Load spins.
		Stretch	Overload. Untwist of Lang Lay ropes.

Procedures and Precautions with Wire Rope

- Ensure that the right size and construction of rope is used for the job.
- Inspect and lubricate rope regularly according to manufacturer's guidelines.
- Never overload the rope. Minimize shock loading. To ensure there is no slack in the rope, start the load carefully, applying power smoothly and steadily.
- Never use frozen ropes.
- Take special precautions and/or use a larger size rope whenever
 - the exact weight of the load is unknown
 - there is a possibility of shock loading
 - conditions are abnormal or severe
 - there are hazards to personnel.
- Use softeners to protect rope from corners and sharp edges.
- Avoid dragging rope out from under loads or over obstacles.
- Do not drop rope from heights.
- Store all unused rope in a clean, dry place.
- Never use wire rope that has been cut, kinked, or crushed.
- Ensure that rope ends are properly seized.
- Use thimbles in eye fittings at all times.
- Prevent loops in slack lines from being pulled tight and kinking. If a loop forms, don't pull it out—unfold it. Once a wire rope is kinked, damage is permanent. A weak spot will remain no matter how well the kink is straightened out.
- Check for abnormal line whip and vibration.
- Avoid reverse bends.
- Ensure that drums and sheaves are the right diameter for the rope being used.
- Ensure that sheaves are aligned and that fleet angle is correct.
- Sheaves with deeply worn or scored grooves, cracked or broken rims, and worn or damaged bearings must be replaced.
- Ensure that rope spools properly on the drum. Never wind more than the correct amount of rope on any drum. Never let the rope cross-wind.

Slings

General

Slings are often severely worn and abused in construction. Damage is caused by

- failure to provide blocking or softeners between slings and load, thereby allowing sharp edges or corners of the load to cut or abrade the slings
- pulling slings out from under loads, leading to abrasion and kinking
- shock loading that increases the stress on slings that may already be overloaded
- traffic running over slings, especially tracked equipment.

Because of these and other conditions, as well as errors in calculating loads and estimating sling angles, it is strongly recommended that safe working loads be based on a safety factor of at least 5:1.

For the same reasons, slings must be carefully inspected before each use.

Sling Angles

The rated capacity of any sling depends on its size, its configuration, and the angles formed by its legs with the horizontal.

For instance, a two-leg sling used to lift 1000 pounds will have a 500-pound load on each leg at a sling angle of 90° . The load on each leg will go up as the angle goes down. At 30° the load will be 1000 pounds on each leg! See Figure 9.

Keep sling angles greater than 45° whenever possible. The use of any sling at an angle lower than 30° is extremely hazardous. This is especially true when an error of only 5° in estimating the sling angle can be so dangerous.

Sling Configurations

Slings are not only made of various material such as wire rope and nylon web. They also come in various configurations for different purposes. Common configurations are explained on the following pages.

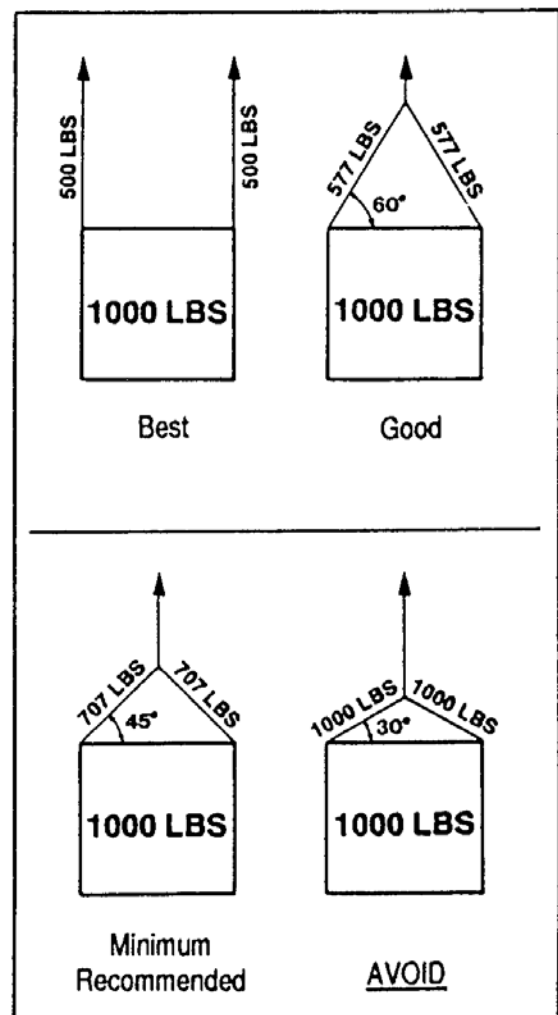

Figure 9

Sling Configurations

The term "sling" covers a wide variety of configurations for fibre ropes, wire ropes, chains and webs. Correct application of slings commonly used in construction will be explained here because improper application can be dangerous.

The **Single Vertical Hitch** (Figure 10) supports a load by a single vertical part or leg of the sling. The total weight of the load is carried by a single leg, the sling angle is 90° (sling angle is measured from the horizontal) and the weight of the load can equal the maximum safe working load of the sling and fittings. End fittings can vary but thimbles should be used in the eyes. The eye splices on wire ropes should be **Mechanical-Flemish Splices** for best security.

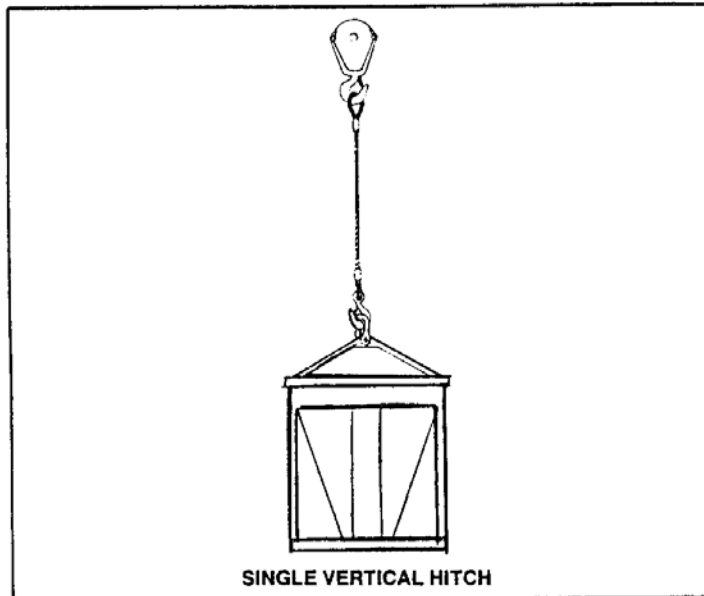

Figure 10

The single vertical hitch must not be used for lifting loose material, lengthy material or anything difficult to balance. This hitch provides absolutely no control over the load because it permits rotation. Use single vertical hitches only on items equipped with lifting eyebolts or shackles.

Bridle Hitch (Figs 11, 12, 13). Two, three or four single hitches can be used together to form a bridle hitch for hoisting an object with the necessary lifting lugs or attachments. Used with a wide assortment of end fittings, bridle hitches provide excellent load stability when the load is distributed equally among the legs, the hook is directly over the load's centre of gravity and the load is raised level. To distribute the load equally it may be necessary to adjust the leg lengths with turnbuckles. Proper use of a bridle hitch requires that sling angles be carefully measured to ensure that individual legs are not overloaded.

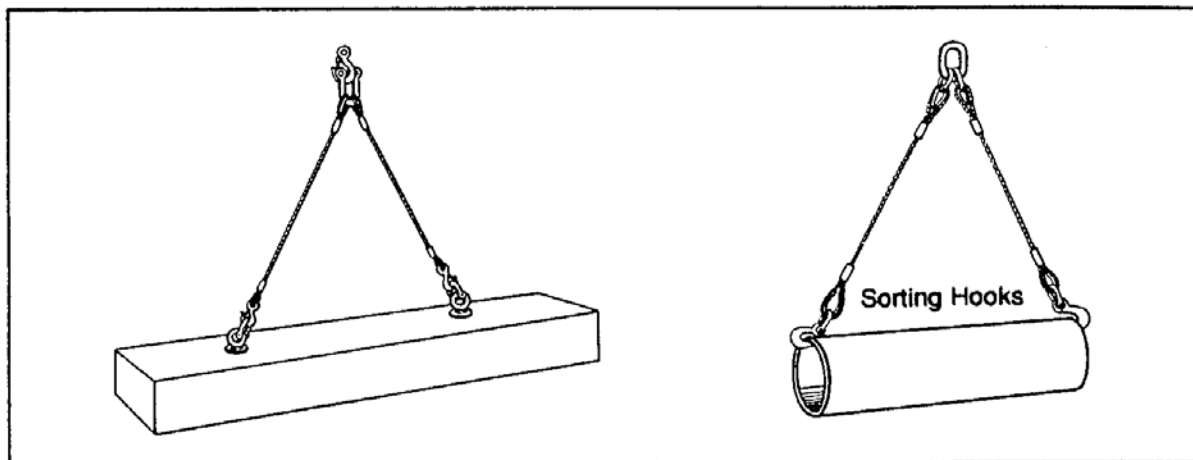

Figure 11

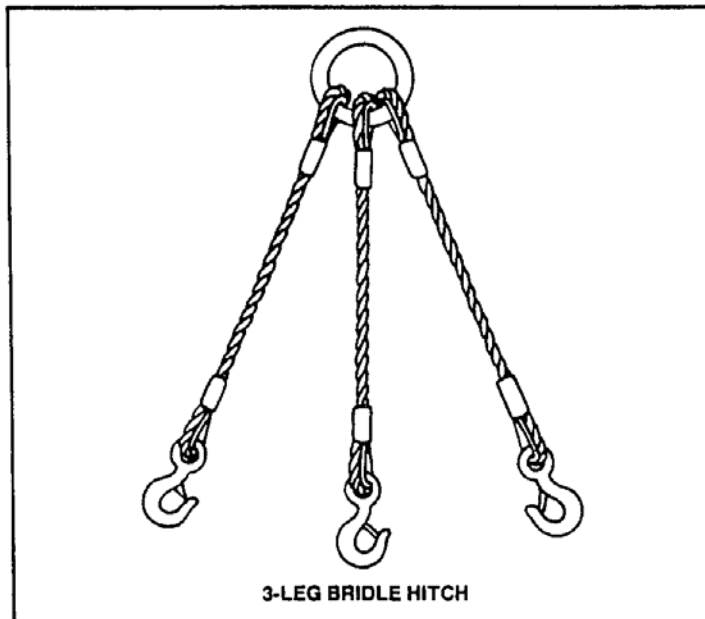

Figure 12

Because the load may not be distributed evenly when a four-leg sling lifts a rigid load, assume that the load is carried by three of the legs only and "rate" the four-leg sling as a three-leg sling.

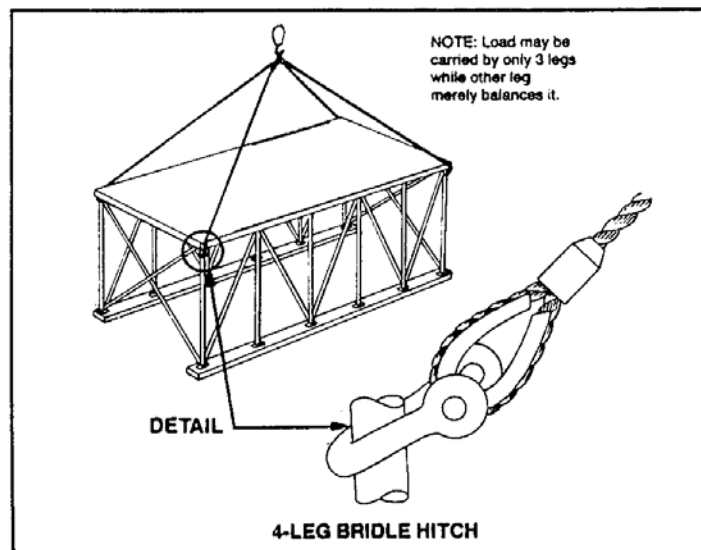

Figure 13

The **Single Basket Hitch** (Figure 14) is used to support a load by attaching one end of the sling to the hook, then passing the other end under the load and attaching it to the hook. Ensure that the load does not turn or slide along the rope during a lift because both load and rope can be damaged.

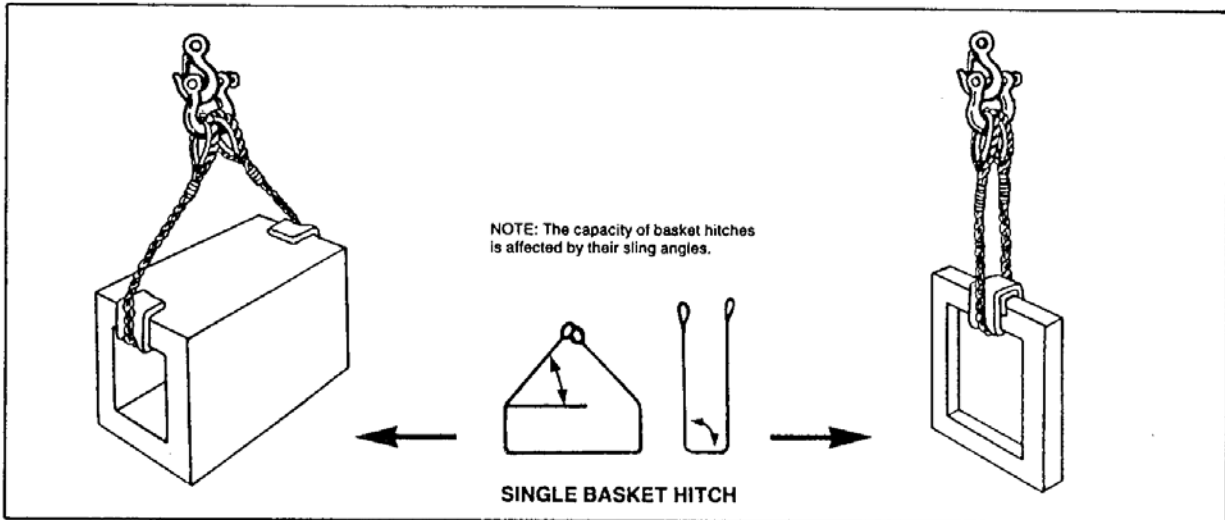

Figure 14

The **Double Basket Hitch** (Figure 15) consists of two single basket hitches passed under the load. They must be placed under the load so that it is balanced. The legs of the hitches must be kept far enough apart to provide balance but not so far apart that low angles are created and the legs pull in toward the centre. The angle between the load and the sling should be approximately 60° or greater to avoid slippage. On smooth surfaces, both sides of the hitch should be snubbed against a change of contour to prevent the rope from slipping as load is applied. Otherwise use a double wrap basket hitch.

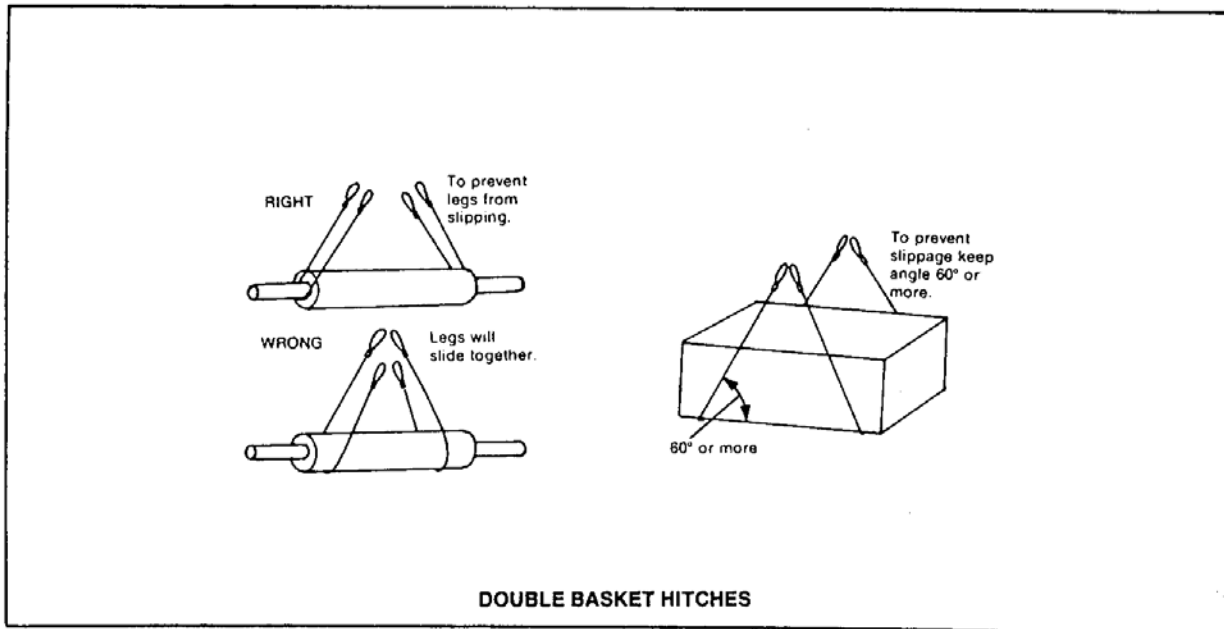

Figure 15

The **Double Wrap Basket Hitch** (Figure 16) is a basket hitch wrapped completely around the load and compressing it rather than merely supporting it, as does the ordinary basket hitch. The double wrap basket hitch can be used in pairs like the double basket hitch. This method is excellent for handling loose material, pipe, rod or smooth cylindrical loads because the sling is in full 360° contact with the load and tends to draw it together.

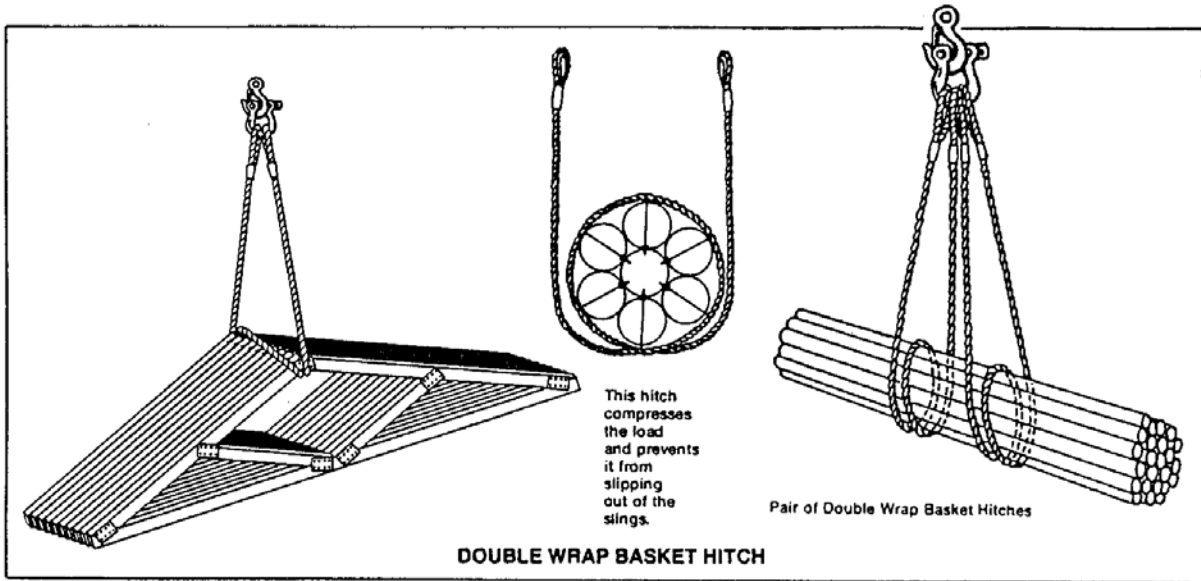

Figure 16

The **Single Choker Hitch** (Figure 17) forms a noose in the rope. It does not provide full 360° contact with the load, however, and therefore should not be used to lift loads difficult to balance or loosely bundled. The single choker can also be doubled up to provide twice the capacity or to turn a load. (Doubling a single choker hitch is not the same as using a double choker hitch.)

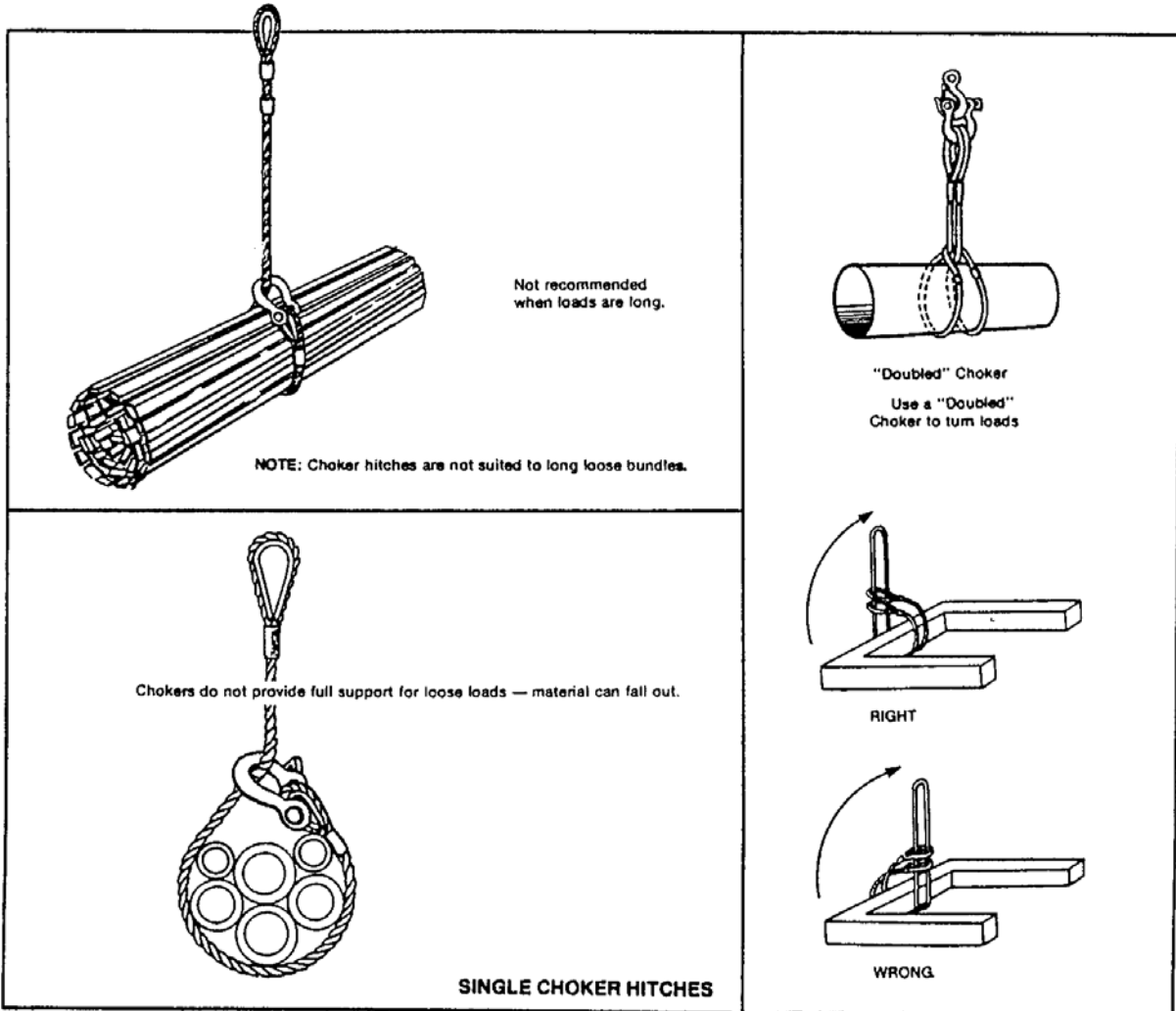

Figure 17

When it is necessary to turn a load, the choker is made by placing both eyes of the sling on top of the load with the eyes pointing opposite to the direction of the turn. The centre of the sling is passed around the load, through both eyes and up to the hook. This hitch provides complete control over the load during the entire turning operation, and the load automatically equalizes between the two supporting legs of the sling.

The **Double Choker Hitch** (Figure 18) consists of two single chokers attached to the load and spread to provide load stability. Like the single choker, the double choker does not completely grip the load. But because the load is less likely to tip, the double choker is better suited for handling loosely bundled items.

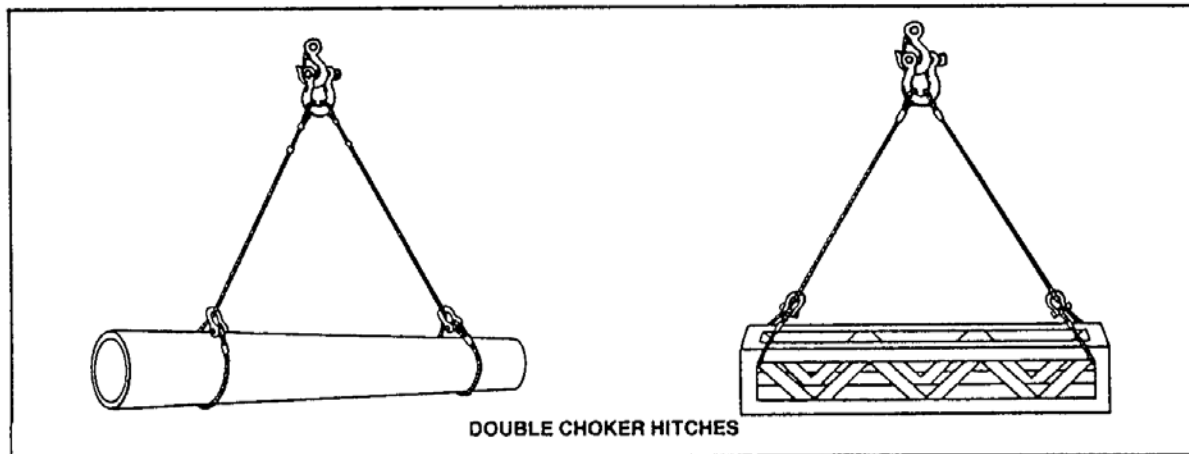

Figure 18

A **Double Wrap Choker Hitch** (Figure 19) is formed by wrapping the sling completely around the load and hooking it into the vertical part of the sling. This hitch is in full 360° contact with the load and tends to draw it tightly together. It can be used either singly on short, easily balanced loads or in pairs on longer loads.

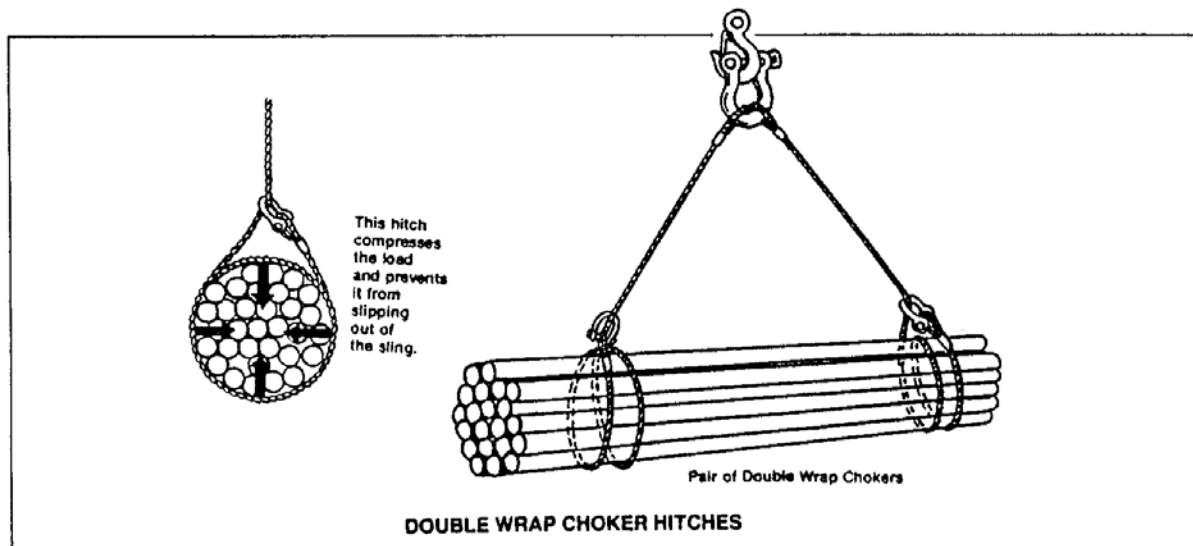
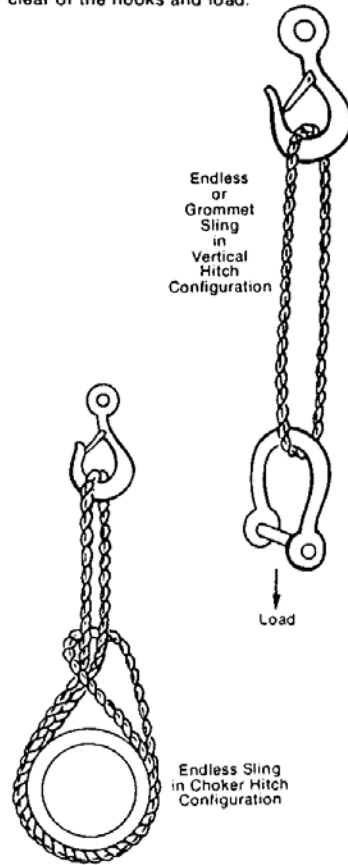

Figure 19

Endless Slings or Grommet Slings (Figure 20) are useful for a variety of applications. Endless chain slings are manufactured by attaching the ends of a length of chain with a welded or mechanical link. Endless web slings are sewn. An endless wire rope sling is made from one continuous strand wrapped onto itself to form a six-strand rope with a strand core. The end is tucked into the body at the point where the strand was first laid onto itself. These slings can be used in a number of configurations, as vertical hitches, basket hitches, choker hitches and combinations of these basic arrangements. They are very flexible but tend to wear more rapidly than other slings because they are not normally equipped with fittings and thus are deformed when bent over hooks or choked.

NOTE: Ensure that the splice is always clear of the hooks and load.



Endless or Grommet Sling in Vertical Hitch Configuration

Endless Sling in Choker Hitch Configuration

ENDLESS OR GROMMET SLINGS

Figure 20

Braided Slings (Figure 21) are usually fabricated from six to eight small-diameter ropes braided together to form a single rope that provides a large bearing surface, tremendous strength, and flexibility in every direction. They are easy to handle and almost impossible to kink. The braided sling can be used in all the standard configurations and combinations but is especially useful for basket hitches where low bearing pressure is desirable or where the bend is extremely sharp.

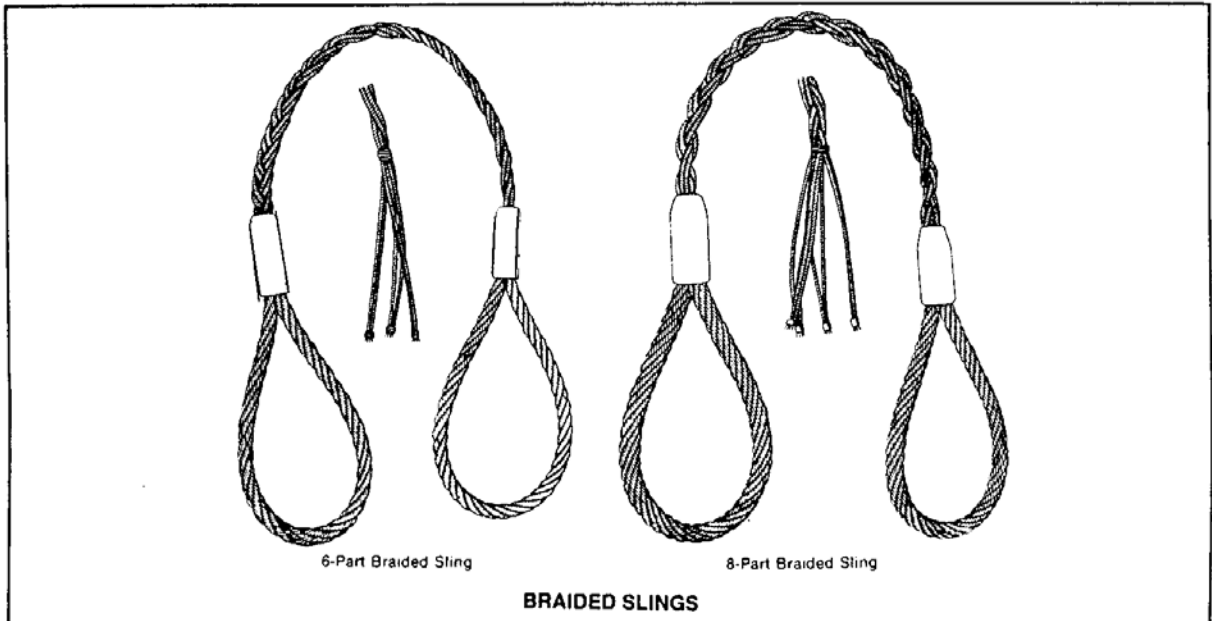

6-Part Braided Sling

8-Part Braided Sling

BRAIDED SLINGS

Figure 21

Sling Angles

The loading in any type of sling is affected by the angle of the legs. If possible, keep leg angles greater than 45° from the horizontal. Sling angles approaching 30° are extremely hazardous and must be avoided at all costs. The sharp increase in loading at low angles is clearly shown in Figure 22.

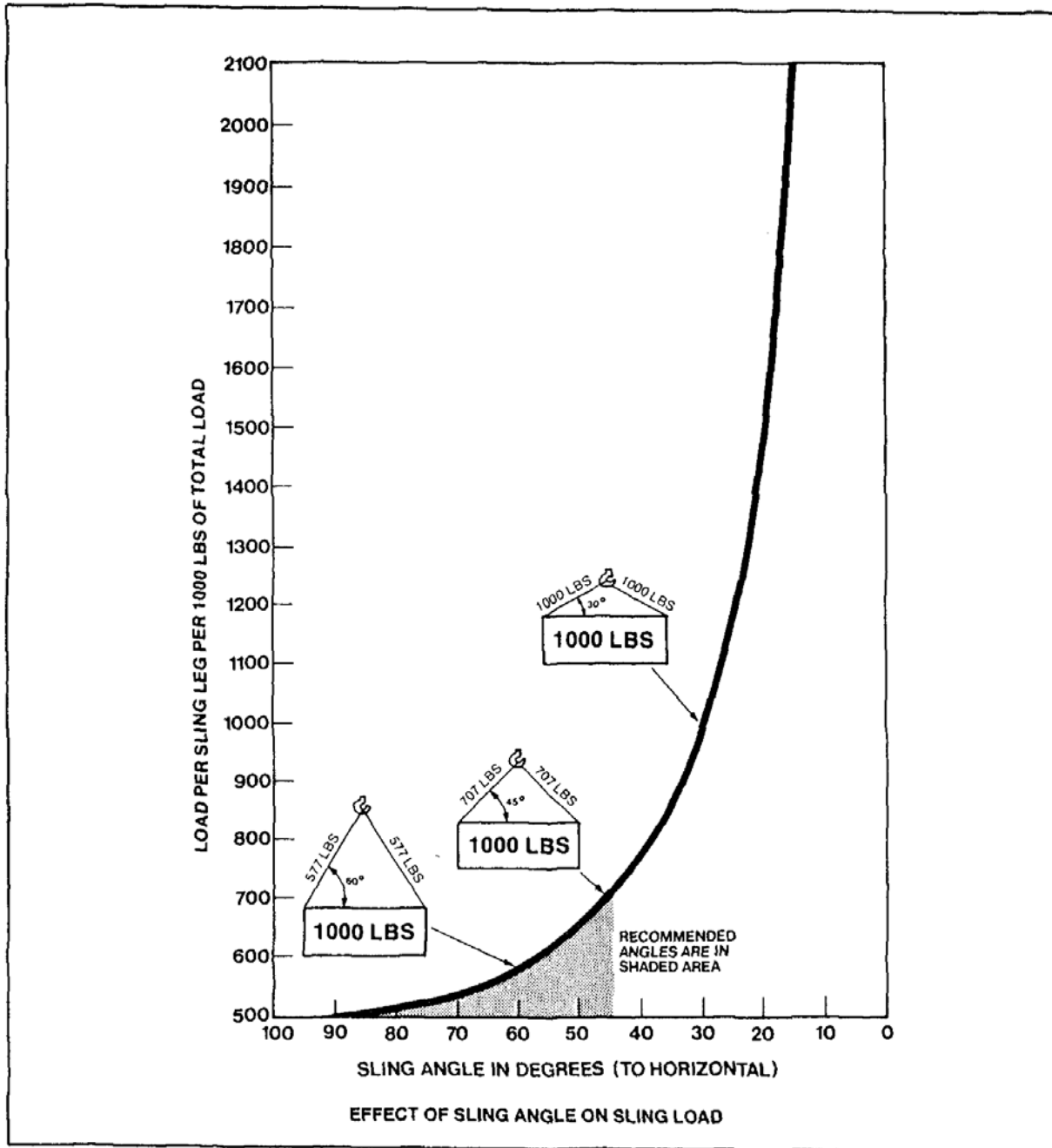

Figure 22

Low sling angles also create large, horizontal compressive forces in the load which may be sufficient to cause buckling, especially in long, flexible loads.

Some load tables list sling angles as low as 15° but the use of any sling at an angle less than 30° is extremely dangerous. Not only are the loads in each leg high at these low angles but an error in measurement as little as 5° can affect the load in the sling drastically. Data in Figure 23 illustrates the effect of a 5° error in angle measurement on the sling load. Notice that there is a 50% error in the assumed load at the 15° sling angle.

Figure 23

EFFECT OF SLING ANGLE MEASUREMENT ERROR ON LOADS				
Assumed Sling Angle	Assumed Load (Pounds Per Leg)	Actual Angle (is 5° Less Than Assumed Angle)	Actual Load (Pounds Per Leg)	Error %
90°	500	85°	502	0.4
75°	518	70°	532	2.8
60°	577	55°	610	5.7
45°	707	40°	778	9.1
30°	1,000	25°	1,183	18.3
15°	1,932	10°	2,880	49.0

Centre of Gravity

It is always important to rig the load so that it is stable. The load's centre of gravity must be directly under the main hook and below the lowest sling attachment point before the load is lifted (Figure 24).

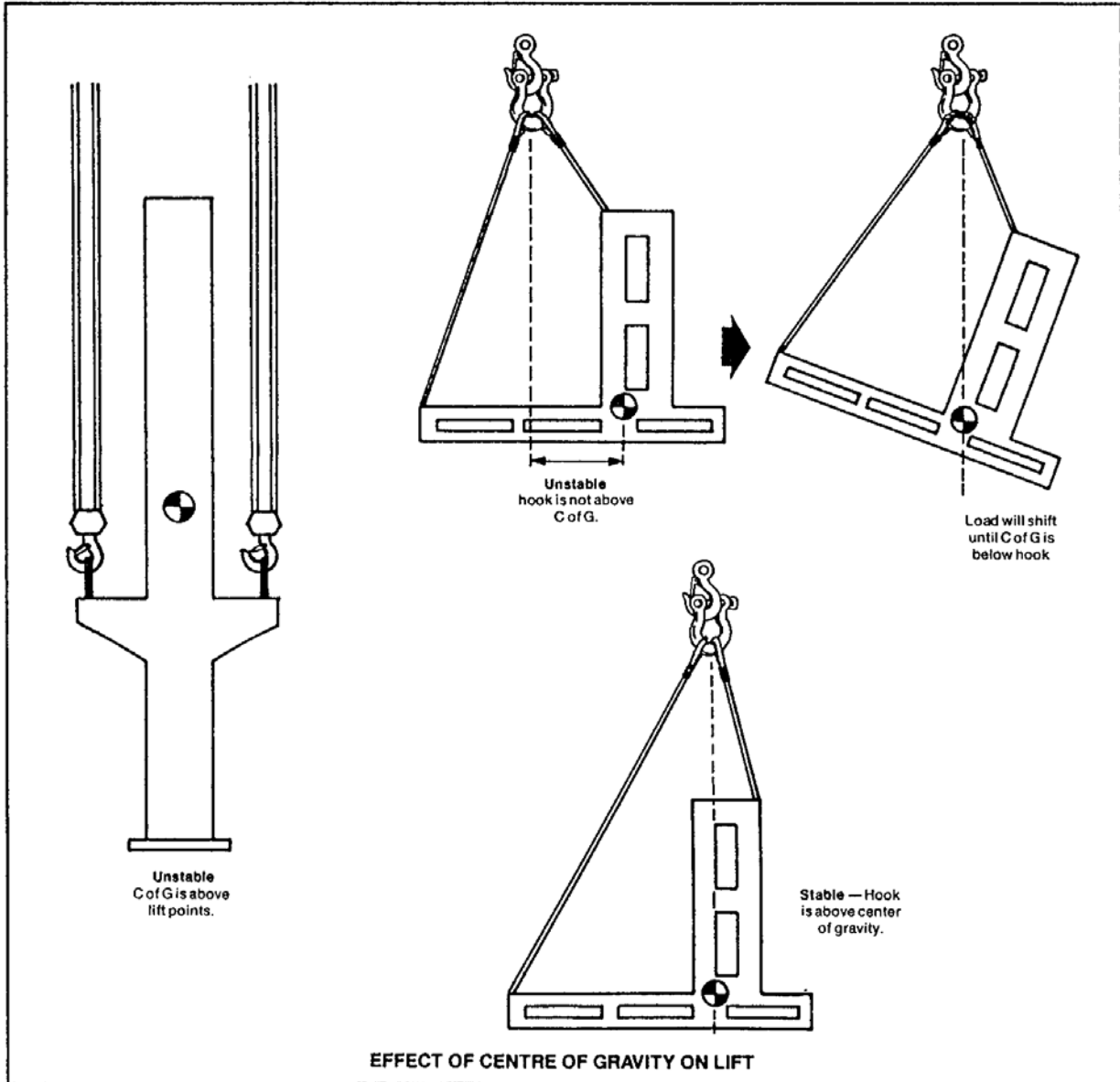

Figure 24

Centre of gravity is the point around which an object's weight is evenly balanced. The entire weight may be considered concentrated at this point. A suspended object will always move until its centre of gravity is directly below its suspension point. To make a level or stable lift, the crane or hook block must be directly above this point **before the load is lifted**. Thus a load which is slung above and through the centre of gravity will not topple or slide out of the slings (Figure 25).

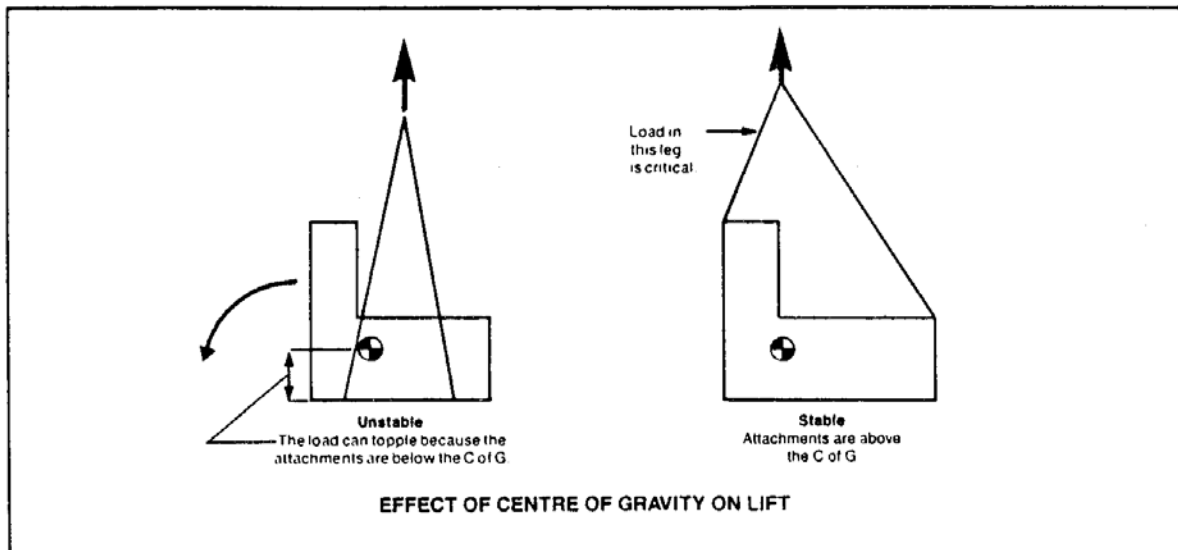

Figure 25

An object symmetrical in shape and uniform in composition will have its centre of gravity at its geometric centre. With odd-shaped objects, the centre of gravity can be more difficult to locate. Often the rigger must guess where it lies, rig accordingly, signal for a trial lift and then, by watching the suspended load, determine the centre of gravity more exactly, adjusting hook, load and sling suspension for the best balance and stability. The centre of gravity will lie somewhere along a line drawn vertically from the hook down through the load.

Remember that when the centre of gravity is closer to one sling attachment point than the other, the sling legs must be of unequal length, which means that their angles and loads will also be unequal.

When a lifted load tilts and rigging is not corrected, the tension will sharply increase on one sling leg and decrease on the other. If any load tilts more than 5° after it is lifted clear of the ground it should be landed and rigged over again.

It is equally important to ensure that the support points of a load (i.e. where the slings are attached to the load) lie above its centre of gravity. Under suspension, an object's centre of gravity will always seek the lowest level below the point of support. This knowledge is especially important for lifting pallets, skids or the base of any object since they all have a tendency to topple. But this type of load will be inherently stable if the attachments are above the centre of gravity.

Safe Working Loads

Knowledge of safe working loads (SWL) is essential to the use of ropes, slings, and rigging hardware. As indicated in previous sections, the safe working load should be stamped, pressed, printed, tagged, or otherwise indicated on all rigging equipment.

Field Calculation Formula

The **field calculation formula** can be used to compute the safe working load of a wire rope in tons of 2,000 pounds. The formula applies to new wire rope of Improved Plow steel and a factor of safety of 5.

$$\text{S.W.L.} = \text{DIAMETER} \times \text{DIAMETER} \times 8$$

(where DIAMETER = nominal rope diameter in inches)

OR

$$\text{S.W.L.} = D^2 \times 8$$

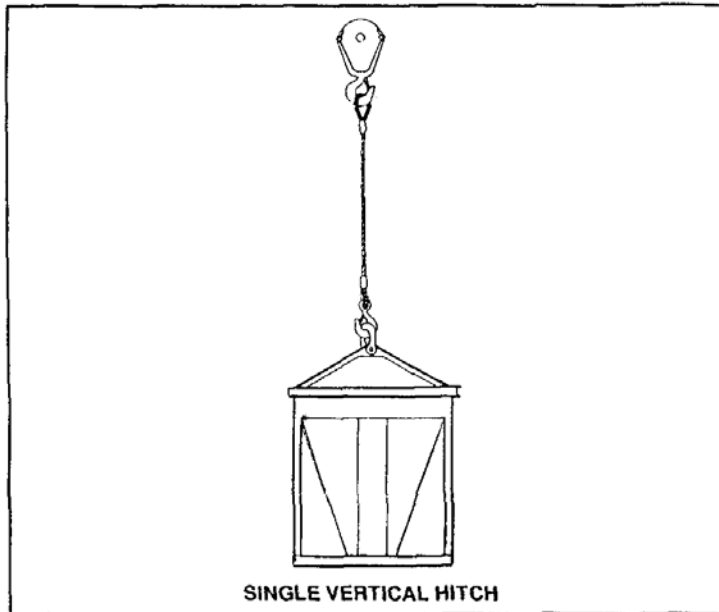

Examples:

- (a) $\frac{1}{2}$ inch diameter rope
S.W.L. = $\frac{1}{2} \times \frac{1}{2} \times 8 = 2$ tons
- (b) $\frac{5}{8}$ inch diameter rope
S.W.L. = $\frac{5}{8} \times \frac{5}{8} \times 8 = 3.125$ tons
- (c) 1 inch diameter rope
S.W.L. = $1 \times 1 \times 8 = 8$ tons

Sling Angle and SWL

Sling angles are crucial in determining safe working loads (SWLs) for many sling configurations. In tables of SWLs, capacities are given for bridle and basket hitches at angles of 60° , 45° , and 30° . Measuring these angles can be difficult on a construction site since the measuring tools required are generally not available.

There are, however, two angles you can easily determine before consulting tables. The first is a 90° angle formed by two legs of a bridle or basket hitch at the crane hook or master link (Figure 26). This corresponds to a 45° angle.

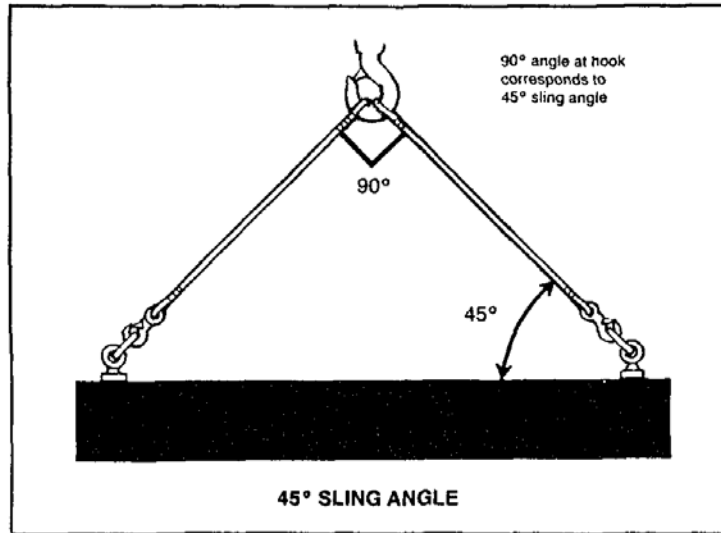

Figure 26

The second angle easy to identify is a 60° sling angle (Figure 27). For a bridle hitch, a 60° sling angle can be recognized when the distance between the attachment points is equal to the length of a sling leg; for a basket hitch, when the distance between the points where the sling first contacts the load is equal to the length of one inclined leg of the sling.

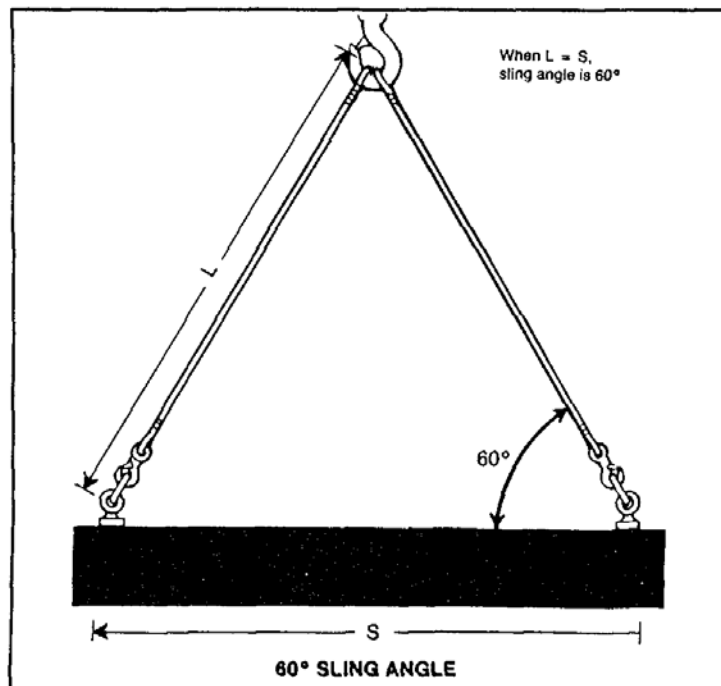

Figure 27

Estimating Sling SWLs

Because it is difficult to remember all load, size, and sling angle combinations provided in tables, some general rules can be used to estimate safe working loads for common sling configurations.

Each rule is based on the safe working load of a single vertical hitch of a given size and material and on the ratio H/L .

H is the vertical distance from the saddle of the hook to the top of the load. L is the distance, measured along the sling, from the saddle of the hook to the top of the load (Figure 28).

If you cannot measure the entire length of the sling, measure along the sling from the top of the load to a convenient point and call this distance l . From this point measure down to the load and call this distance h . The ratio h/l will be the same as the ratio H/L (Figure 28).

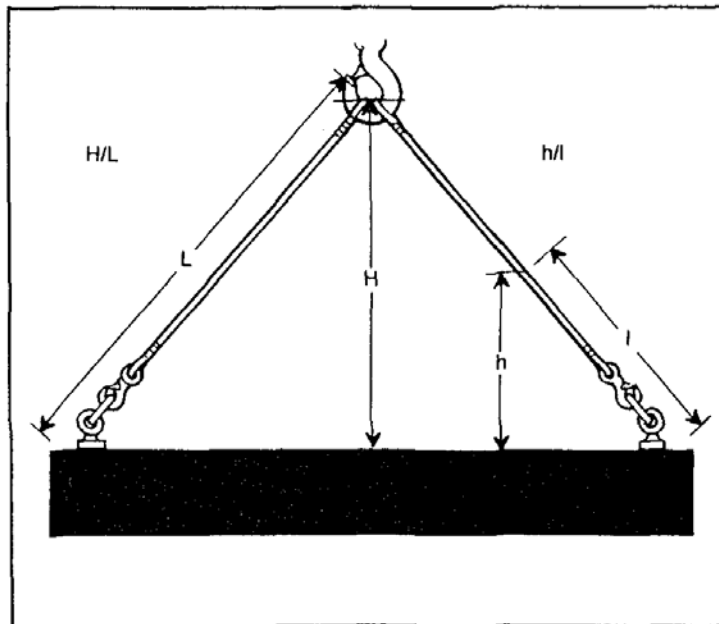

Figure 28

H/L or h/l will apply equally to the following rules for different sling configurations. The efficiencies of end fittings must also be considered to determine the capacity of the sling assembly.

REMEMBER: the smaller the sling angle, the lower the safe working load.

Bridle Hitches (2-Leg) (Figure 29)

$$\text{S.W.L.} = \text{S.W.L. (of Single Vertical Hitch)} \times \frac{H}{L} \times 2$$

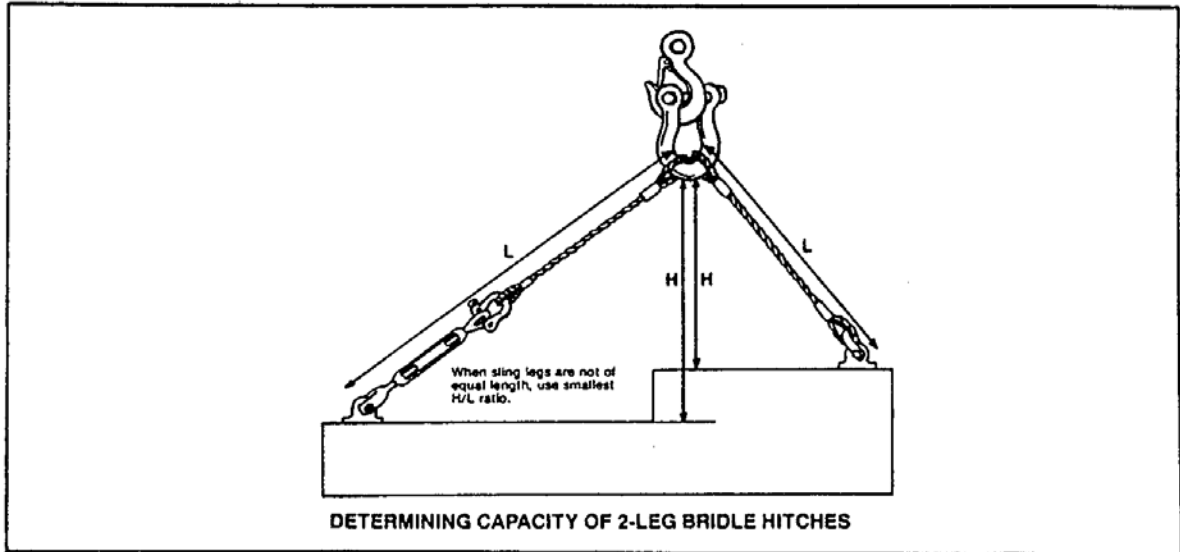

Figure 29

Bridle Hitches (3- and 4-Leg) Figures 30 and 31

Three- and four-leg hitches are rated equally to account for the possibility of unequal load distribution in a four-leg hitch.

$$\text{S.W.L.} = \text{S.W.L. (of Single Vertical Hitch)} \times \frac{H}{L} \times 3$$

Three-leg hitches are less susceptible to unequal distribution since the load can tilt and equalize the loads in each leg. However, lifting an irregularly shaped, rigid load with a three-leg hitch may develop unequal loads in the sling legs. To be safe, use the formula for a two-leg bridle hitch under such circumstances.

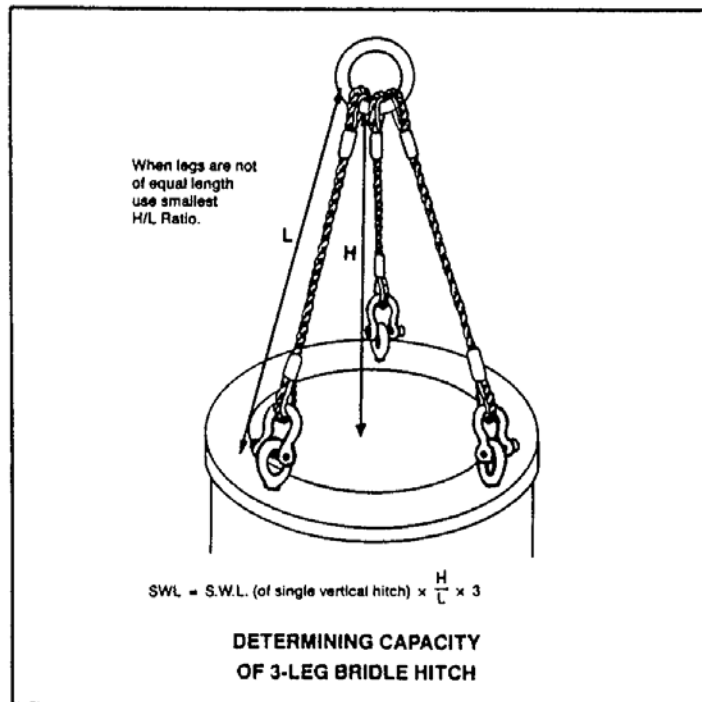

Figure 30

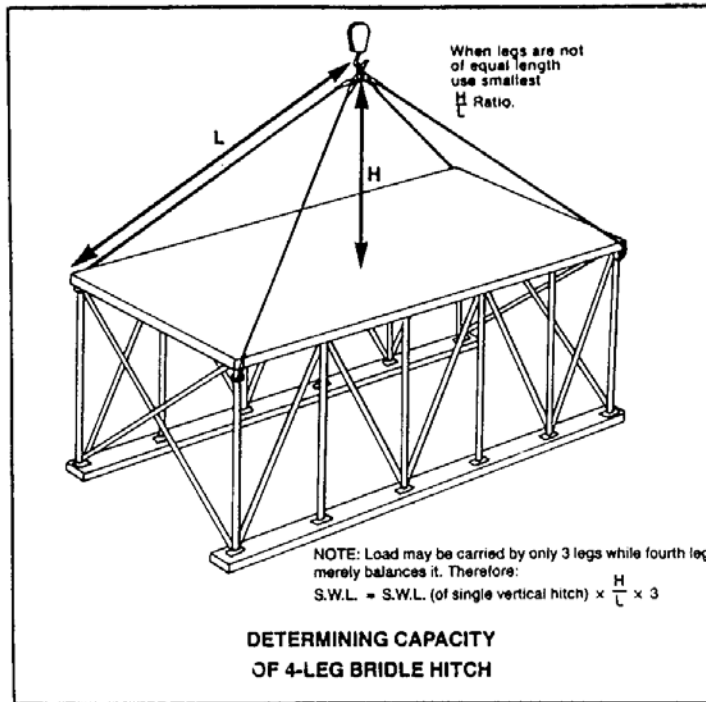

Figure 31

Remember that the rated capacity of a multi-leg sling is based on the assumption that all legs are used. If this is not the case, de-rate the sling assembly accordingly and hook all unused legs to the crane hook so they will not become snagged during the lift.

Single Basket Hitch Figure 32

For vertical legs — $S.W.L. = S.W.L. \text{ (of Single Vertical Hitch)} \times 2$.

For inclined legs — $S.W.L. = S.W.L. \text{ (of Single Vertical Hitch)} \times \frac{H}{L} \times 2$

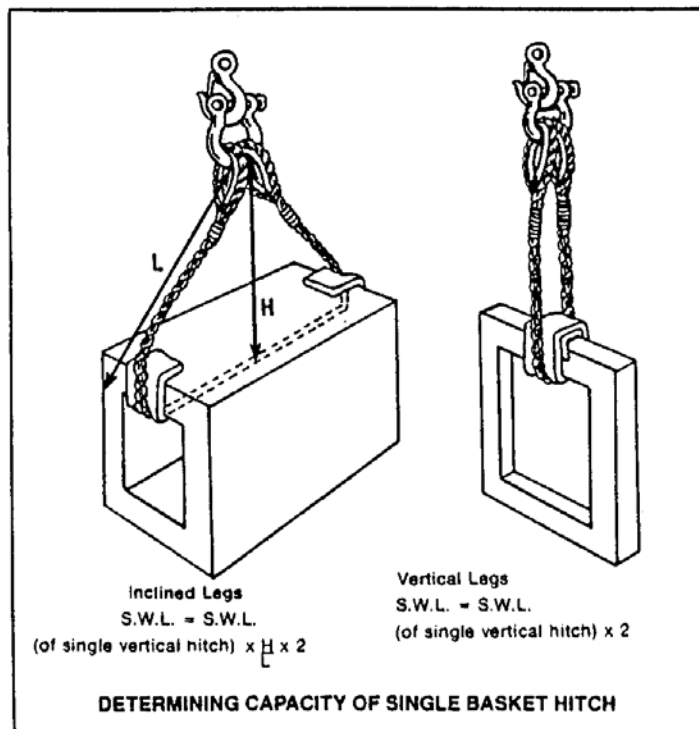

Figure 32

Double Basket Hitch

For vertical legs:

$$SWL = SWL \text{ (of single vertical hitch) } \times 3$$

For inclined legs:

$$SWL = SWL \text{ (of single vertical hitch) } \times H/L \times 3$$

Double Wrap Basket Hitch

Depending on configuration, SWLs are the same as for the single basket or double basket hitch.

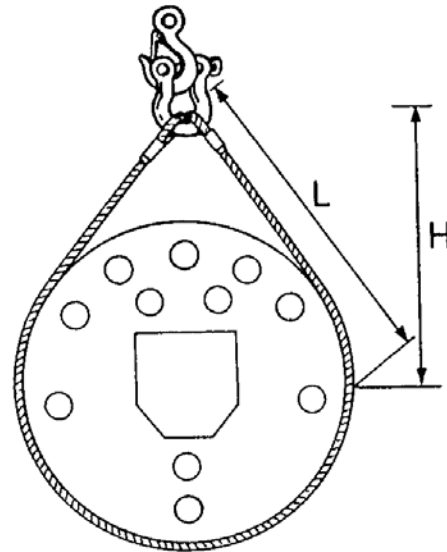

DETERMINING CAPACITY OF DOUBLE BASKET HITCH WITH INCLINED LEGS

Single Choker Hitch

For sling angles of 45° or more —

$$S.W.L. = S.W.L. \text{ (of Single Vertical Hitch) } \times \frac{3}{4}$$

Sling angles of less than 45° are not recommended.

If they must be used the formula is:

$$S.W.L. = S.W.L. \text{ (of Single Vertical Hitch) } \times \frac{A}{B}$$

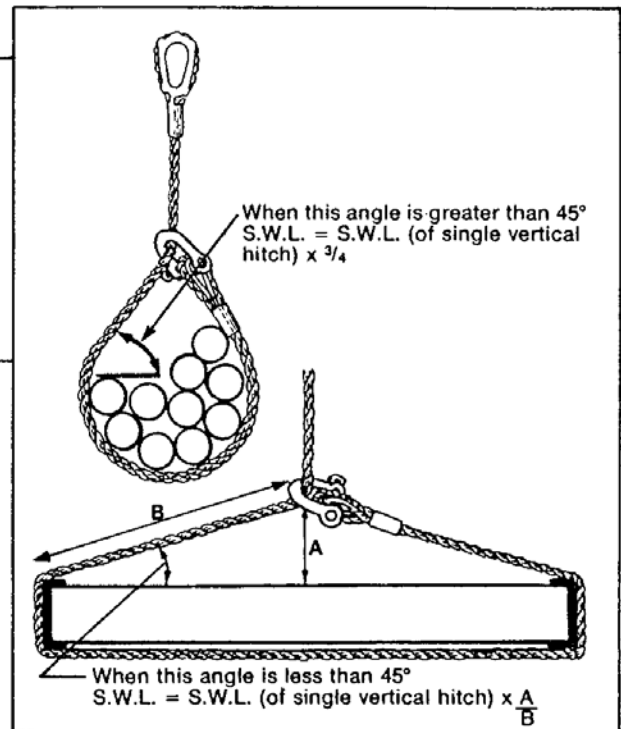

DETERMINING CAPACITY OF SINGLE CHOKER HITCH

Endless and Grommet Slings

Although grommet slings support a load with two legs, their safe working load is usually taken as 1.5 times the safe working load of a single vertical hitch. This reduction allows for capacity lost because of sharp bends at the hook or shackle.

Double Choker Hitch

For sling angles of 45° or more (formed by the choker) —

$$\text{S.W.L.} = \text{S.W.L. (of Single Vertical Hitch)} \times \frac{H}{L} \times \frac{3}{4}$$

Sling angles of less than 45° (formed by the choker) are not recommended. If they must be used the formula is:

$$\text{S.W.L.} = \text{S.W.L. (of Single Vertical Hitch)} \times \frac{A}{B} \times \frac{H}{L} \times 2$$

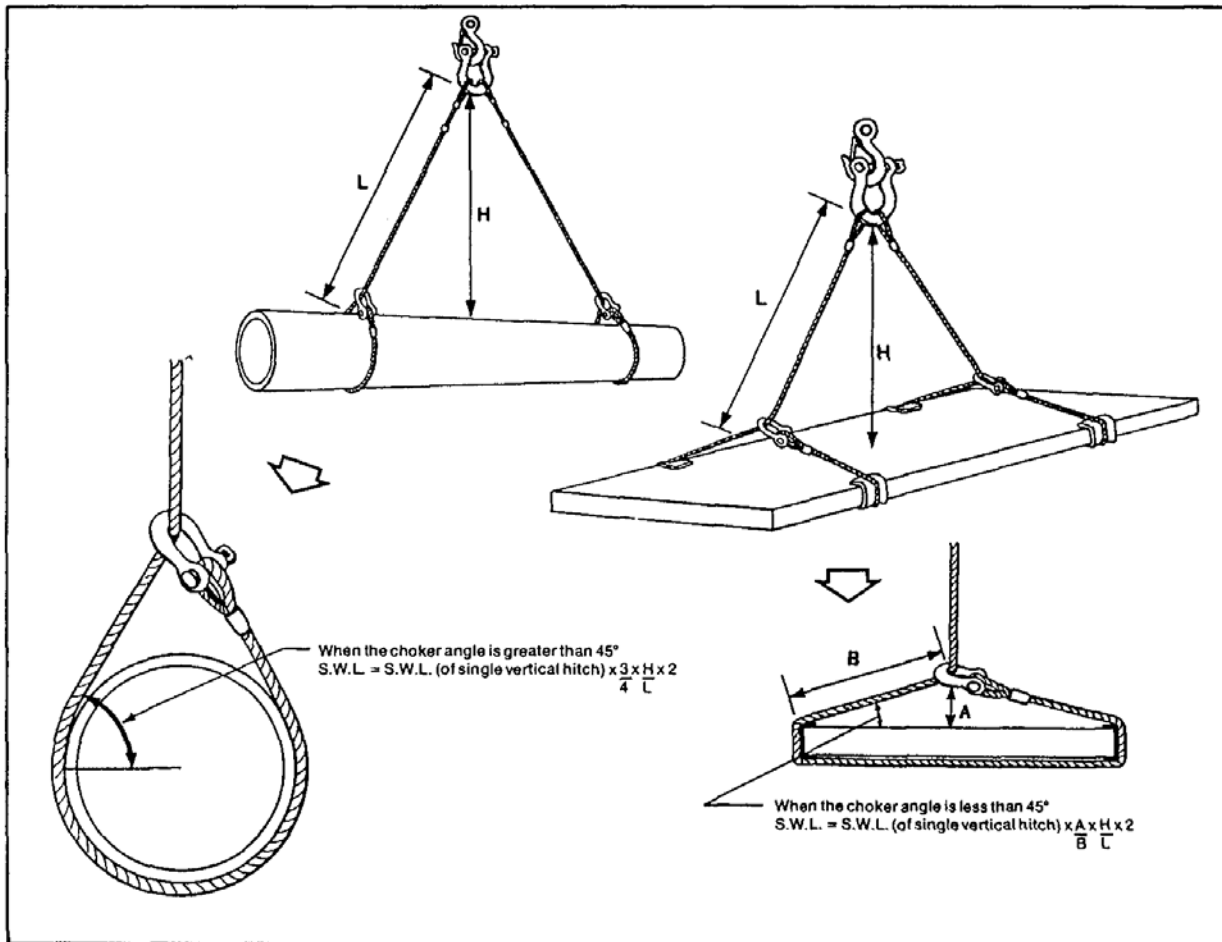

DETERMINING CAPACITY OF DOUBLE CHOKER HITCH

Double Wrap Choker Hitch

Depending on configuration, safe working loads are the same as for the Single Choker Hitch or the Double Choker Hitch.

Types of Slings

Wire rope slings should be inspected frequently for broken wires, kinks, abrasion and corrosion. Inspection procedures and replacement criteria outlined in the session on wire rope apply and must be followed regardless of sling type or application.

All wire rope slings should be made of improved plow steel with independent wire rope cores to reduce the risk of crushing. Manufacturers will assist in selecting the rope construction for a given application.

It is recommended that all eyes in wire rope slings be equipped with thimbles, be formed with the Flemish Splice and be secured by swaged or pressed mechanical sleeves or fittings. With the exception of socketed connections, this is the only method that produces an eye as strong as the rope itself, with reserve strength should the mechanical sleeve or fitting fail or loosen.

The capacity of a wire rope sling can be greatly affected by being bent sharply around pins, hooks or parts of a load. The wire rope industry uses the term "D/d ratio" to express the severity of bend. "D" is the diameter of curvature that the rope or sling is subjected to and "d" is the diameter of the rope.

Wire Rope Slings





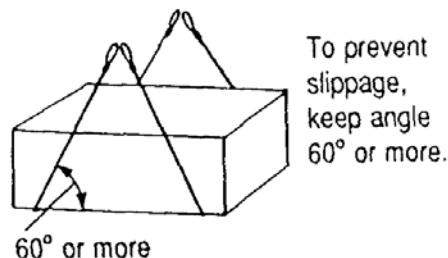
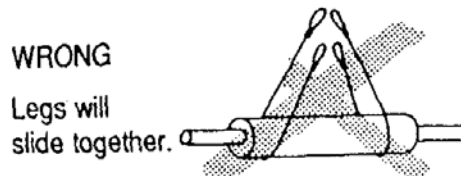
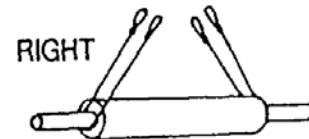
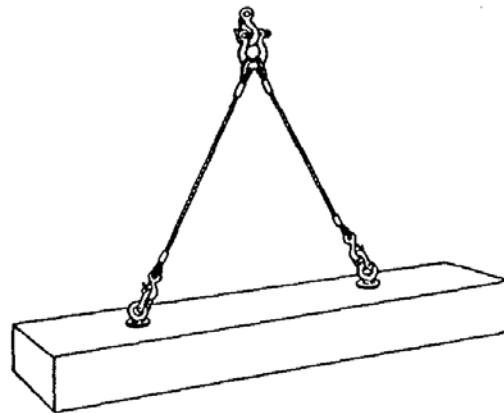

The use of wire rope slings for lifting materials provides several advantages over other types of sling. While not as strong as chain, it has good flexibility with minimum weight. Breaking outer wires warn of failure and allow time to react. Properly fabricated wire rope slings are very safe for general construction use.

On smooth surfaces, the basket hitch should be snubbed against a step or change of contour to prevent the rope from slipping as load is applied. The angle between the load and the sling should be approximately 60 degrees or greater to avoid slippage.





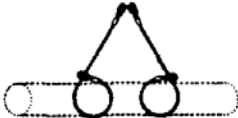

On wooden boxes or crates, the rope will dig into the wood sufficiently to prevent slippage. On other rectangular loads, the rope should be protected by guards or load protectors at the edges to prevent kinking.

Loads should not be allowed to turn or slide along the rope during a lift. The sling or the load may become scuffed or damaged.

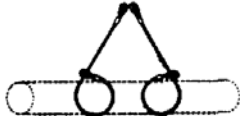

WIRE ROPE SLINGS 6 x 19 Classification Group, Improved Plow Steel, Fibre Core						
Rope Diameter (Inches)	MAXIMUM SAFE WORKING LOADS — POUNDS (Safety Factor = 5)					
	Single Vertical Hitch 	Single Choker Hitch 	Single Basket Hitch (Vertical Legs) 	2-Leg Bridle Hitch & Single Basket Hitch With Legs Inclined  		
				60°	45°	30°
3/16	600	450	1,200	1,050	850	600
1/4	1,100	825	2,200	1,900	1,550	1,100
5/16	1,650	1,250	3,300	2,850	2,350	1,650
3/8	2,400	1,800	4,800	4,150	3,400	2,400
7/16	3,200	2,400	6,400	5,550	4,500	3,200
1/2	4,400	3,300	8,800	7,600	6,200	4,400
9/16	5,300	4,000	10,600	9,200	7,500	5,300
5/8	6,600	4,950	13,200	11,400	9,350	6,600
3/4	9,500	7,100	19,000	16,500	13,400	9,500
7/8	12,800	9,600	25,600	22,200	18,100	12,800
1	16,700	12,500	33,400	28,900	23,600	16,700
1 1/8	21,200	15,900	42,400	36,700	30,000	21,200
1 1/4	26,200	19,700	52,400	45,400	37,000	26,200
1 3/8	32,400	24,300	64,800	56,100	45,800	32,400
1 1/2	38,400	28,800	76,800	66,500	54,300	38,400
1 5/8	45,200	33,900	90,400	78,300	63,900	45,200
1 3/4	52,000	39,000	104,000	90,000	73,500	52,000
1 7/8	60,800	45,600	121,600	105,300	86,000	60,800
2	67,600	50,700	135,200	117,100	95,600	67,600
2 1/4	84,000	63,000	168,000	145,500	118,800	84,000
2 1/2	104,000	78,000	208,000	180,100	147,000	104,000
2 3/4	122,000	91,500	244,000	211,300	172,500	122,000
				If used with Choker Hitch multiply above values by 3/4. 		
				For Double Basket Hitch multiply above values by 2. 		

Note: Table values are for slings with eyes and thimbles in both ends, Flemish Spliced Eyes and mechanical sleeves.

WIRE ROPE SLINGS						
6 x 19 Classification Group, Improved Plow Steel, IWRC						
Rope Diameter (Inches)	MAXIMUM SAFE WORKING LOADS — POUNDS (Safety Factor = 5)					
	Single Vertical Hitch	Single Choker Hitch	Single Basket Hitch (Vertical Legs)	2-Leg Bridle Hitch & Single Basket Hitch With Legs Inclined		
						
			60°	45°	30°	
3/16	650	480	1,300	1,100	900	650
1/4	1,150	860	2,300	2,000	1,600	1,150
5/16	1,750	1,300	3,500	3,000	2,500	1,750
3/8	2,550	1,900	5,100	4,400	3,600	2,550
7/16	3,450	2,600	6,900	6,000	4,900	3,450
1/2	4,700	3,500	9,400	8,150	6,650	4,700
9/16	5,700	4,200	11,400	9,900	8,050	5,700
5/8	7,100	5,300	14,200	12,300	10,000	7,100
3/4	10,200	7,650	20,400	17,700	14,400	10,200
7/8	13,750	10,300	27,500	23,800	19,400	13,750
1	17,950	13,450	35,900	31,100	25,400	17,950
1 1/8	22,750	17,000	45,500	39,400	32,200	22,750
1 1/4	28,200	21,200	56,400	48,800	39,900	28,200
1 3/8	34,800	26,100	69,600	60,300	49,200	34,800
1 1/2	41,300	31,000	82,600	71,500	58,400	41,300
1 5/8	48,600	36,400	97,200	84,200	68,700	48,600
1 3/4	55,900	41,900	111,800	96,800	79,000	55,900
1 7/8	65,400	49,000	130,800	113,300	92,500	65,400
2	72,600	54,500	145,200	125,700	102,700	72,600
2 1/4	90,300	67,600	180,600	156,400	127,700	90,300
2 1/2	111,800	83,700	223,600	193,600	158,100	111,800
2 3/4	131,100	98,200	262,200	227,000	185,400	131,100
				If used with Choker Hitch multiply above values by 3/4.		
						
				For Double Basket Hitch multiply above values by 2.		
						

Note: Table values are for slings with eyes and thimbles in both ends, Flemish Spliced Eyes and mechanical sleeves.

Chain Slings

Chain slings are suited to applications requiring flexibility and resistance to abrasion, cutting and high temperatures.

Chain slings must be made from alloy steel and marked with the letter "T", the number "8" or some combination of the two. Alloy chain is the only type which can be used for overhead lifting.

As with all slings and associated hardware, chain slings must have a factor of safety of 5. In North America, chain manufacturers usually give safe working loads, or working load limits as they are known in the chain industry, based on a factor of safety of 3.5 or 4. Always check with manufacturers to determine the factor of safety on which their safe working loads are based.

If the factor of safety is less than 5, calculate the safe working load of the chain by multiplying the catalogue safe working load by the manufacturer's factor of safety and dividing by 5.

$$\frac{\text{CATALOGUE S.W.L.} \times \text{MANUFACTURER'S F.S.}}{5} = \text{S.W.L. (based on factor of safety of 5)}$$

Example — 1/2" Alloy Steel Chain

$$\begin{aligned} \text{Catalogue S.W.L.} &= 13,000 \text{ lbs.} \\ \text{Factor of Safety} &= 3.5 \\ \frac{13,000 \text{ lbs.} \times 3.5}{5} &= 9,100 \text{ lbs.} \end{aligned}$$

This chain sling must be de-rated to 9,100 lbs. for construction applications.

Wherever they bear on sharp edges, chain slings should be padded to prevent links from being bent and to protect the load. Never tie a knot in a chain sling to shorten the reach. Slings can be supplied with grab hooks or shortening clutches for such applications.

Inspect chain slings for inner link wear and wear on the outside of the link barrels (Figure 33). Manufacturers publish tables of allowable wear for various link sizes. Many companies will also supply wear gauges to indicate when a sling must be retired or links replaced. Gauges or tables from a particular manufacturer should only be used on that brand of chain since exact dimensions of a given nominal size can vary from one manufacturer to another.

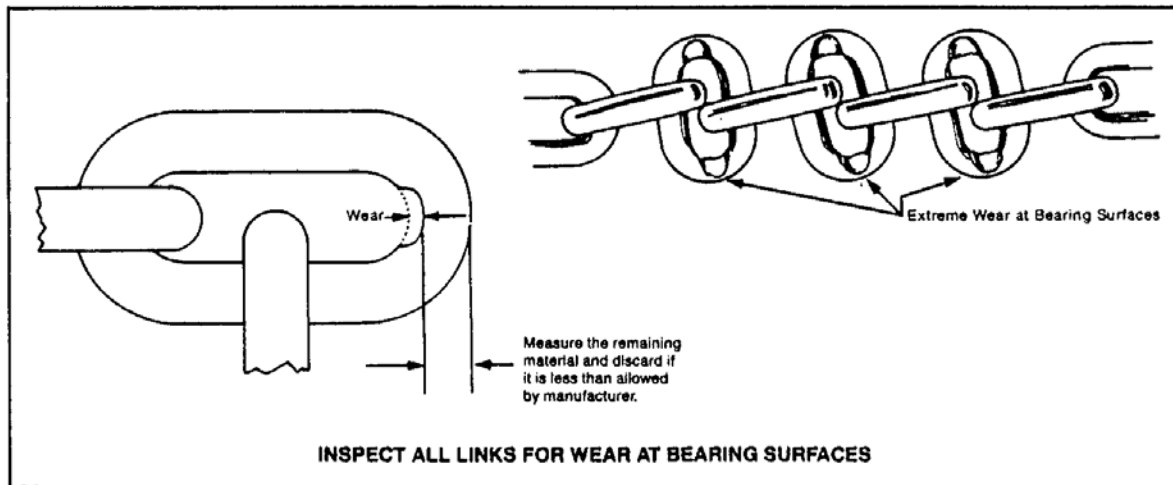

Figure 33

Chain slings should also be inspected for nicks and gouges which cause stress concentrations and weaken the link (Figure 34). Nicks and gouges should be ground out and the new diameter checked with gauges or tables.

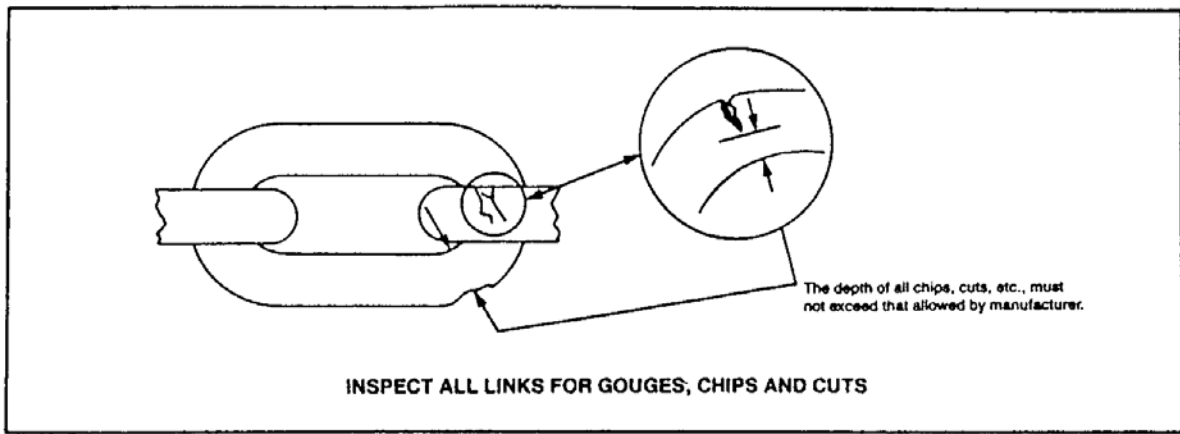

Figure 34

Never use repair links or mechanical coupling links to splice broken lengths of alloy steel chain. They are much weaker than the chain links. Never use a chain if the links are stretched or do not move freely.

Table 5.2 gives safe working loads for grade 8 ("T") alloy steel chain.

Table 5.2

GRADE T (8) ALLOY STEEL						
MAXIMUM SAFE WORKING LOADS - POUNDS						
Safety Factor = 5 per OH&S Regulations						
Chain Size (Inches)	Single Vertical Hitch	Single Choker Hitch	Single Basket Hitch (Vertical Legs)	2-Leg Bridle Hitch & Single Basket Hitch With Legs Inclined		
				60°	45°	30°
1/4	2,800	2,100	5,600	4,850	3,959	2,800
3/8	5,680	4,260	11,360	9,838	8,032	5,680
1/2	9,600	7,200	19,200	16,627	13,574	9,600
5/8	14,480	10,860	28,960	25,079	20,475	14,480
3/4	22,640	16,980	45,280	39,212	32,013	22,640
7/8	27,360	20,520	54,720	47,388	38,687	27,360
1	38,160	28,620	76,320	66,093	53,958	38,160
1 1/4	57,840	43,380	115,680	100,179	81,786	57,840

	<p>If used with Choker Hitch multiply above values by 3/4.</p>
<p>Use only alloy steel chain. Links will be stamped with 8 or T.</p>	<p>For Double Basket Hitch multiply above values by 2.</p>

Strength based on ISO Standards and adjusted to reflect a safety factor of 5.

--

Synthetic Web Slings

Web slings are available in two materials — nylon and polyester (Dacron). Nylon is resistant to many alkalis whereas polyester is resistant to many acids. Consult the manufacturer before using web slings in a chemical environment. Nylon slings are more common but polyester slings are often recommended where headroom is limited since they stretch only half as much as nylon slings.

Synthetic web slings offer a number of advantages for rigging purposes.

- Their relative softness and width create much less tendency to mar or scratch finely machined, highly polished or painted surfaces and less tendency to crush fragile objects than fibre rope, wire rope or chain slings (Figure 35).

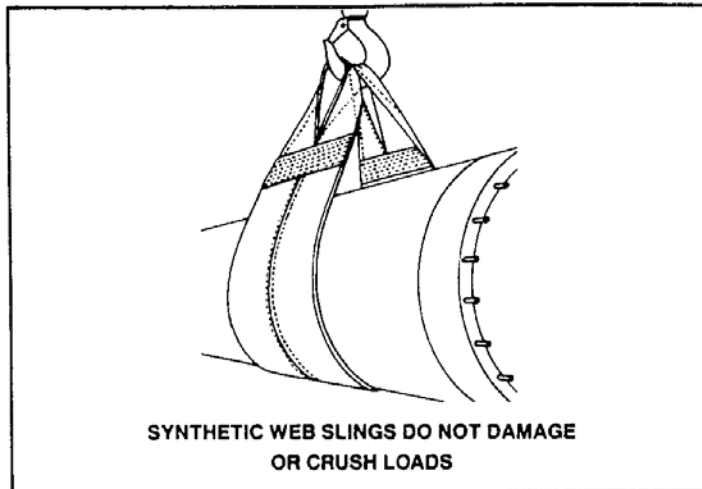

Figure 35

- Because of their flexibility, they tend to mold themselves to the shape of the load (Figure 36).

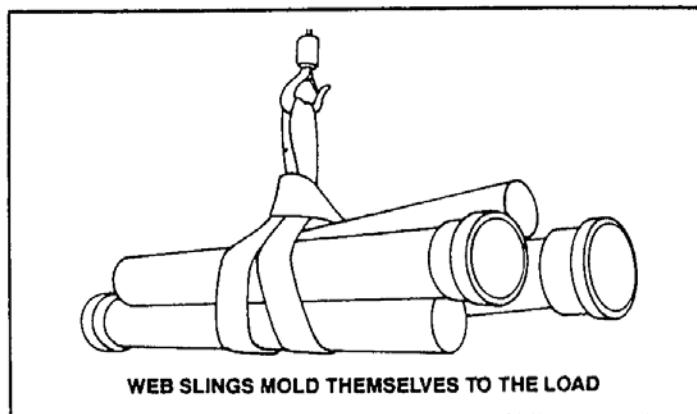

Figure 36

- Synthetic web slings are not affected by moisture and certain chemicals.
- They do not rust and thus will not stain ornamental precast concrete or stone.
- They are non-sparking and can be used safely in explosive atmospheres.
- They minimize twisting and spinning during lifting.
- Their light weight permits ease of rigging, their softness precludes hand cuts, and the danger of harm from a free-swinging sling is minimal.
- They are elastic and stretch under load more than either wire rope or chain and can thus absorb heavy shocks and cushion loads. In cases where sling stretching must be minimized, a sling of larger load capacity or a polyester sling should be used.

Synthetic web slings are available in a number of configurations useful in construction.

Endless or Grommet Slings — both ends of one piece of webbing lapped and sewn to form a continuous piece. They can be used as vertical hitches, bridle hitches, in choker arrangements or as basket hitches. Because load contact points can be shifted with every lift, wear is evenly distributed and sling life extended (Figure 37).

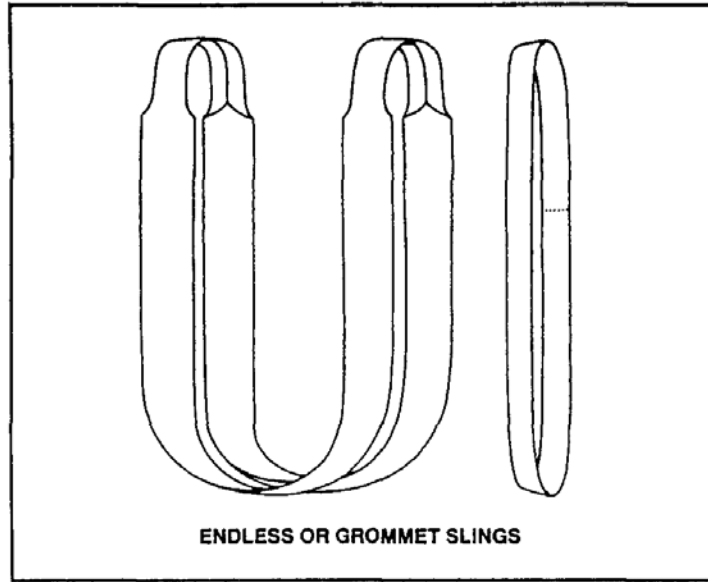

Figure 37

Standard Eye-and-Eye — webbing assembled and sewn to form a flat body sling with an eye at each end and eye openings in the same plane as the sling body. The eyes may be either full web width or tapered by being folded and sewn narrower than the webbing width (Figure 38).

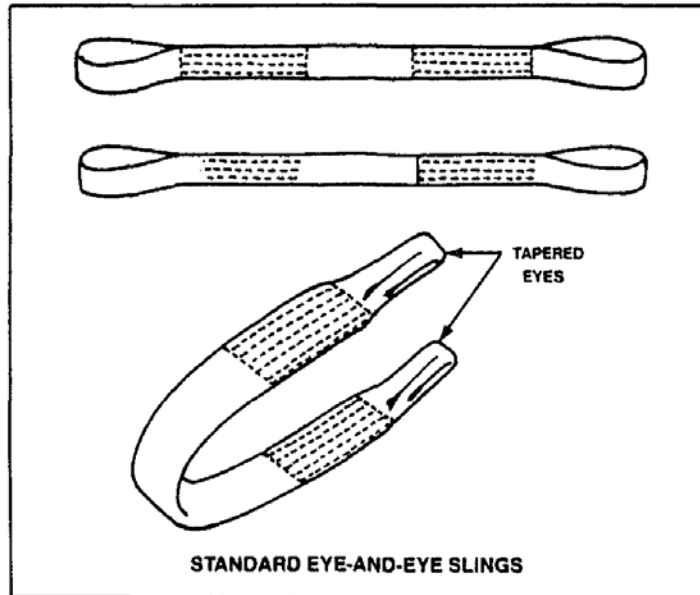

Figure 38

Twisted Eye — an eye-and-eye with twisted terminations at both ends. The eye openings are at 90° to the plane of the sling body. This configuration is available with either full-width or tapered eyes (Figure 39).

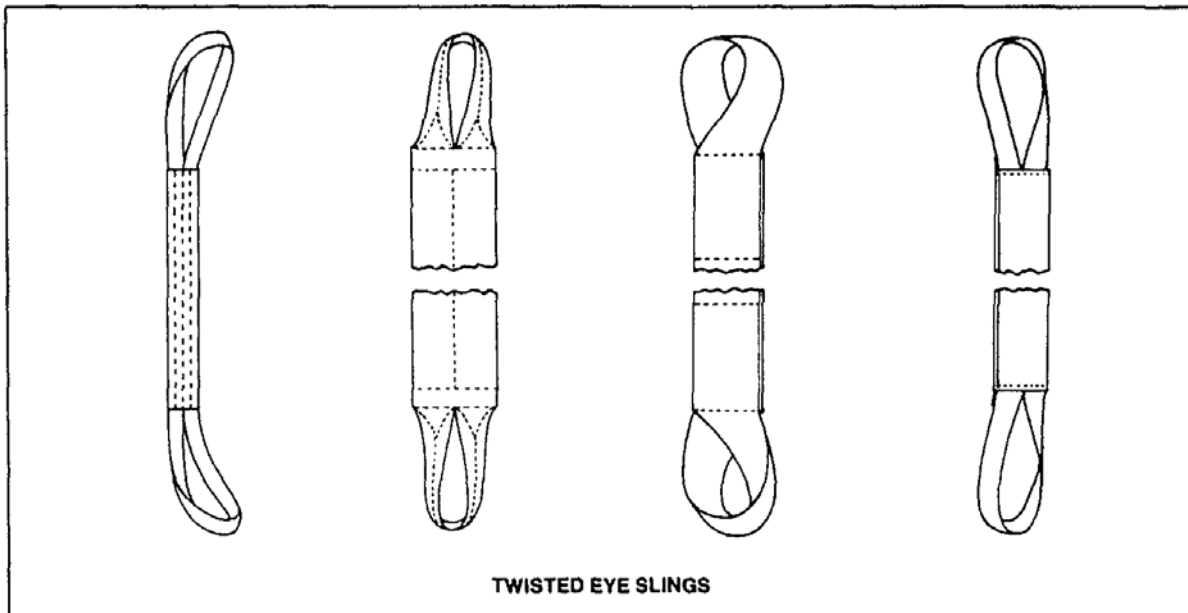

Figure 39

In place of sewn eyes, web slings are available with metal end fittings. The most common are triangle and choker hardware. Combination hardware consists of a triangle for one end of the sling and a triangle/rectangle (choker attachment) for the other end. With this arrangement, choker and basket as well as straight hitches may be rigged. Such attachments help reduce wear in the sling eyes and thus lengthen sling life (Figure 40).

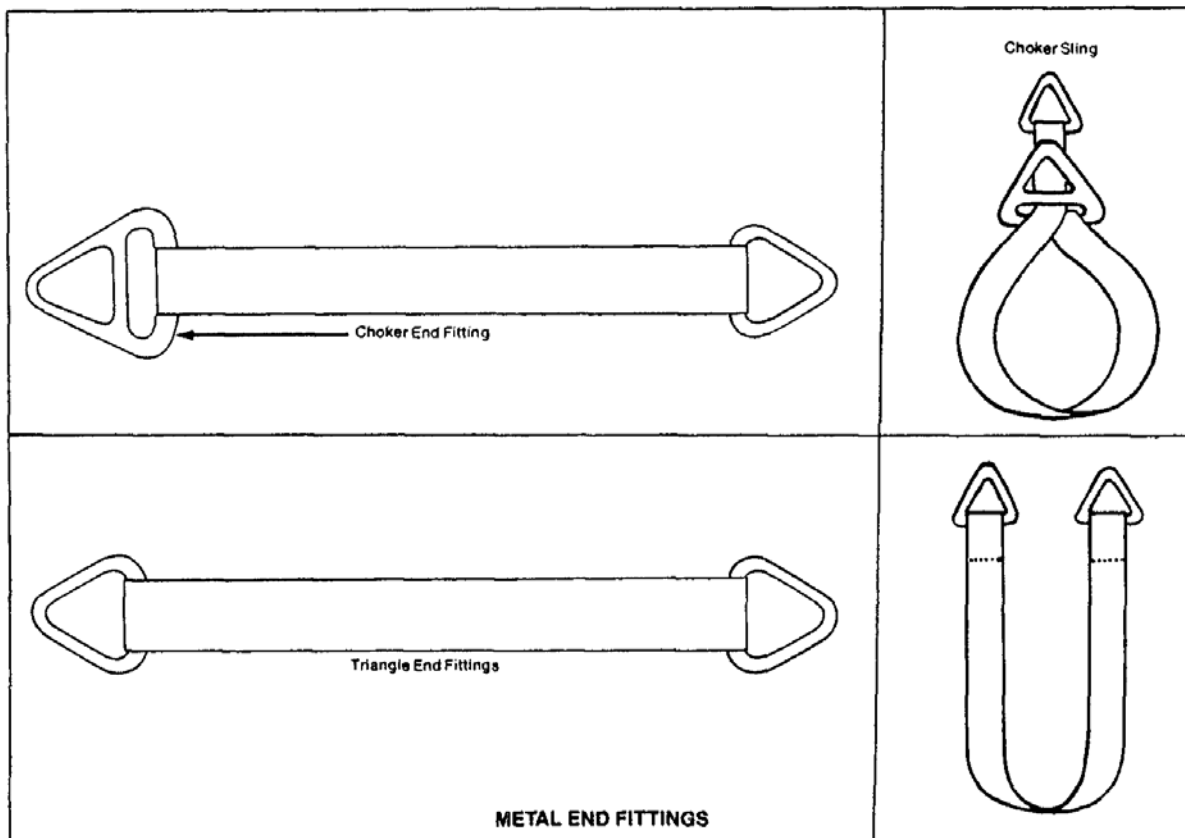

Figure 40

Despite their inherent toughness, synthetic web slings can be cut by repeated use around sharp-cornered objects and abraded by continually hoisting rough-surfaced loads.

Protective devices offered by most sling manufacturers can minimize these effects.

- **Buffer strips** of leather, nylon, or other materials sewn on the body of the sling protect against wear (Figure 41A). Leather pads are most resistant to wear and cutting, but are subject to weathering and deterioration. They are not recommended in lengths over six feet because their stretch characteristics differ from those of webbing. On the other hand, nylon web wear pads are more resistant to weathering, oils, grease and most alkalis. Moreover they stretch in the same ratio as the sling body.
- **Edge guards** consist of strips of webbing or leather sewn around each edge of the sling (Figure 41B). This is necessary whenever sling edges are subject to damage.
- **Sleeve or sliding tube wear pads** are available for slings used to handle material with sharp edges. The pads are positioned on the sling where required, will not move when the sling stretches, adjust to the load and cover both sides of the sling (Figure 41C).

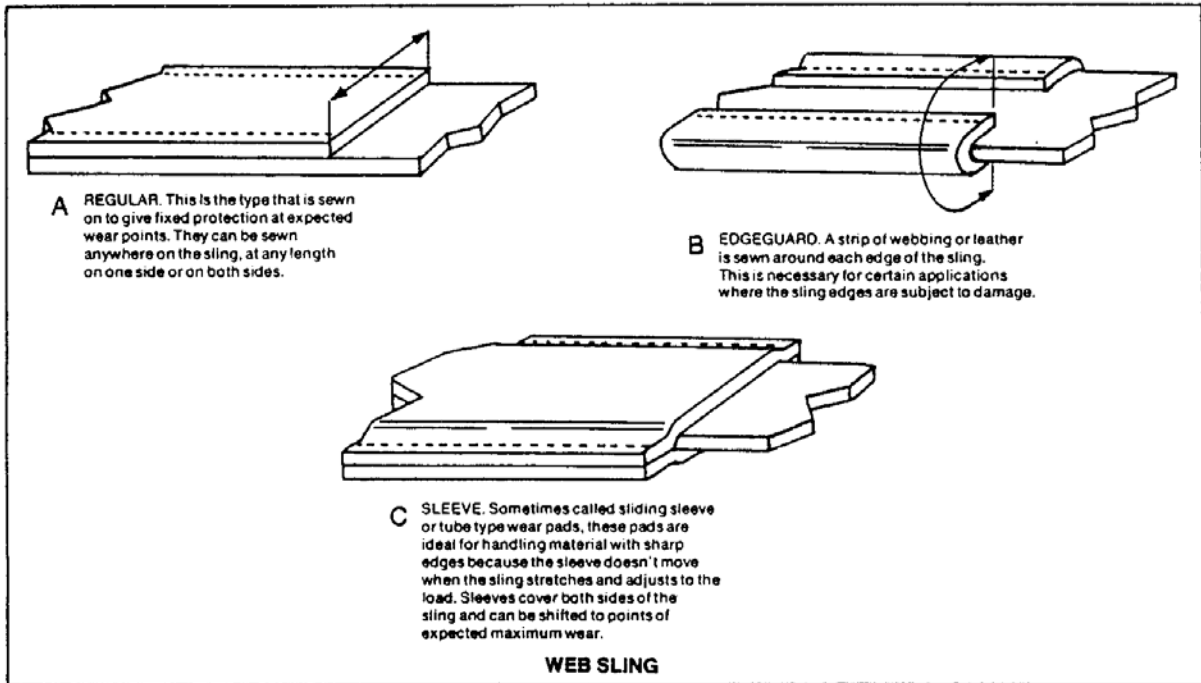

Figure 41

- **Reinforcing strips** sewn into the sling eyes double or triple the eye thickness and greatly increase sling life and safety.
- **Coatings** provide added resistance to abrasion and chemicals as well as a better grip on slippery loads. Coatings can be brightly coloured for safety or load rating.
- **Cotton-faced nylon webbing** affords protection for hoisting granite and other rough-surfaced material.

The rated capacity of synthetic web slings is based on the tensile strength of the webbing, a factor of safety of 5 and the fabrication efficiency. Fabrication efficiency accounts for loss of strength in the webbing after it is stitched and otherwise modified during manufacture. Fabrication efficiency is typically 80 to 85% for single-ply slings but will be lower for multi-ply slings and very wide slings.

Although manufacturers provide tables for bridle and basket configurations, these should be used with extreme caution. At low sling angles one edge of the web will be overloaded and the sling will tend to tear (Figure 42).

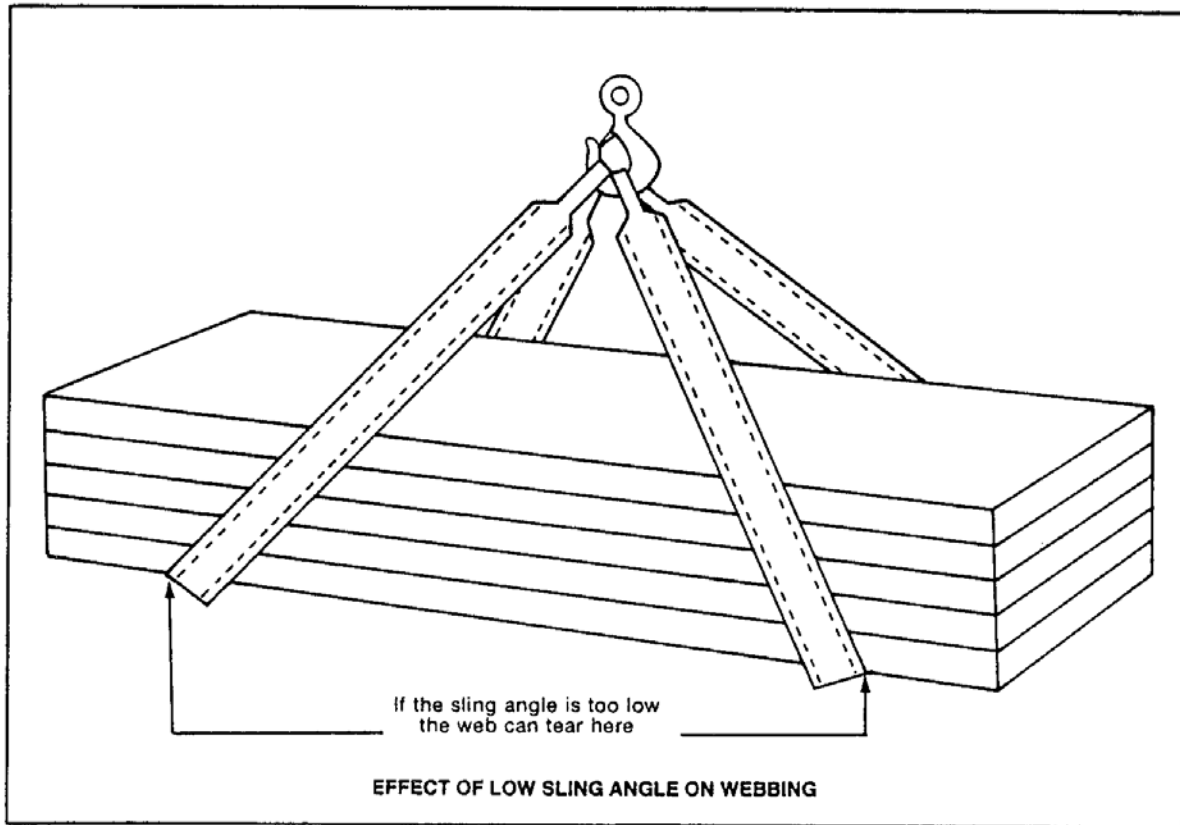

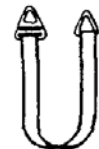
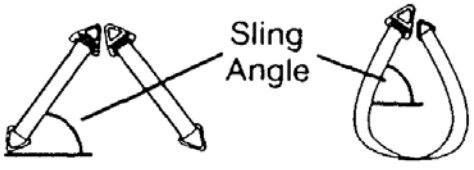
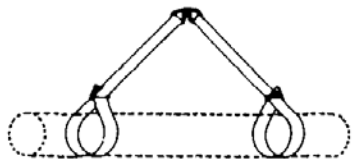

Figure 42

Slings with aluminum fittings should never be used in acid or alkali environments. Nylon and polyester slings must not be used at temperatures above 194°F (90°C).

Inspect synthetic web slings regularly. Damage is usually easy to detect. Cuts, holes, tears, frays, broken stitching, worn eyes and worn or distorted fittings, and burns from acid, caustics or heat are immediately evident and signal the need for replacement. Do not attempt repairs yourself.

NYLON WEB SLINGS

6800 lb/in Material						
Web Width (Inches)	Maximum Safe Working Loads—Pounds (Safety Factor = 5) (Eye & Eye, Twisted Eye, Triangle Fittings, Choker Fittings)					
	Single Vertical Hitch	Single Choker Hitch	Single Basket Hitch (Vertical Legs)	2-Leg Bridle Hitch & Single Basket Hitch With Legs Inclined		
						
			60°	45°	30°	
1	1,100	825	2,200	1,905	1,555	1,100
2	2,200	1,650	4,400	3,810	3,110	2,200
3	3,300	2,475	6,600	5,715	4,665	3,300
4	4,400	3,300	8,800	7,620	6,220	4,400
5	5,500	4,125	11,000	9,525	7,775	5,500
6	6,600	4,950	13,200	11,430	9,330	6,600
				<p>If used with Choker Hitch multiply above values by $\frac{3}{4}$.</p> 		

1. For safe working loads of endless or grommet slings, multiply above values by 2.
2. Values have been adjusted to reflect fabrication efficiency (FE) using formulas and tables developed by the Web Sling Association. This accounts for strength loss due to stitching and manufacture.
3. All web slings must carry a load rating tag as specified in OH&S Regulations.

Metal Mesh Slings

Metal mesh slings, also known as wire or chain mesh slings, are well adapted for use where loads are abrasive, hot or tend to cut fabric slings and wire ropes. They resist abrasion and cutting, grip the load firmly without stretching and can withstand temperatures up to 550°F (288°C). They have smooth, flat bearing surfaces, conform to irregular shapes, do not kink or tangle and resist corrosion (Figure 43).

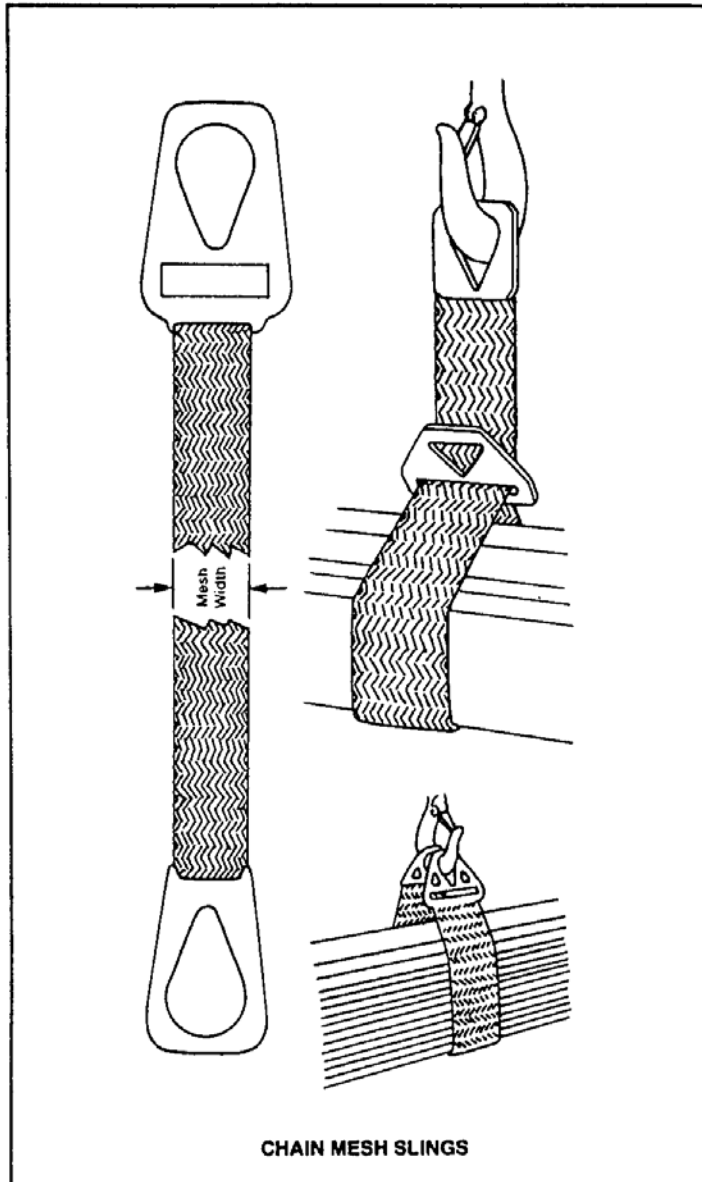



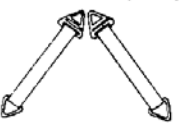

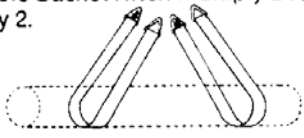

Figure 43

For handling loads that would damage the mesh, or for handling loads that the mesh would damage, the slings can be coated with rubber or plastic. See Table 7 for safe working loads.

Note that there is no reduction in safe working load for the choker hitch. This is because the hinge action of the mesh prevents any bending of individual wire spirals.

TABLE 7

METAL (WIRE OR CHAIN) MESH SLINGS						
Sling Width (Inches)	MAXIMUM SAFE WORKING LOADS — POUNDS (Safety Factor = 5)					
	Single Vertical Hitch	Single Choker Hitch	Single Basket Hitch (Vertical Legs)	2-Leg Bridle Hitch & Single Basket Hitch Non-Vertical Legs		
						
			60°	45°	30°	
HEAVY DUTY CLASSIFICATION (10 GAUGE MESH)						
2	1,500	1,500	3,000	2,600	2,100	1,500
3	2,700	2,700	5,400	4,700	3,800	2,700
4	4,000	4,000	8,000	6,900	5,600	4,000
6	6,000	6,000	12,000	10,400	8,500	6,000
8	8,000	8,000	16,000	13,800	11,300	8,000
10	10,000	10,000	20,000	17,300	14,100	10,000
12	12,000	12,000	24,000	20,800	17,000	12,000
MEDIUM DUTY CLASSIFICATION (12 GAUGE MESH)						
2	1,350	1,350	2,700	2,300	1,900	1,350
3	2,000	2,000	4,000	3,500	2,800	2,000
4	2,700	2,700	5,400	4,700	3,800	2,700
6	4,500	4,500	9,000	7,800	6,400	4,500
8	6,000	6,000	12,000	10,400	8,500	6,000
10	7,500	7,500	15,000	13,000	10,600	7,500
12	9,000	9,000	18,000	15,600	12,700	9,000
LIGHT DUTY CLASSIFICATION (14 GAUGE MESH)						
2	900	900	1,800	1,600	1,300	900
3	1,400	1,400	2,800	2,400	2,000	1,400
4	2,000	2,000	4,000	3,500	2,800	2,000
6	3,000	3,000	6,000	5,200	4,200	3,000
8	4,000	4,000	8,000	6,900	5,700	4,000
10	5,000	5,000	10,000	8,600	7,100	5,000
12	6,000	6,000	12,000	10,400	8,500	6,000
				For Double Basket Hitch multiply above values by 2.		
						

Note: Values for a single choker hitch are the same as values for a single vertical hitch.

Fibre Rope Slings

Fibre rope slings are preferred for some applications because they are pliant, grip the load well and do not mar its surface. They should be used only on light loads, however, and must never be used on objects that have sharp edges capable of cutting the rope or in applications where the sling will be exposed to high temperatures, severe abrasion or acids.

The choice of rope type and size will depend on the application, the weight to be lifted and the sling angle. Before lifting any load with a fibre rope sling, be sure to inspect the sling carefully. Fibre slings, especially manila, deteriorate far more rapidly than wire rope slings and their actual strength is very difficult to estimate.

Like other slings, fibre rope slings should be inspected regularly. Look for external wear and cutting, internal wear between strands, and deterioration of fibres.

Open up the rope by untwisting the strands but take care not to kink them. The inside of the rope should be as bright and clean as when it was new. Check for broken or loose yarns and strands. An accumulation of powder-like dust indicates excessive internal wear between strands as the rope is flexed back and forth during use.

Proper Method of Opening Up the Rope

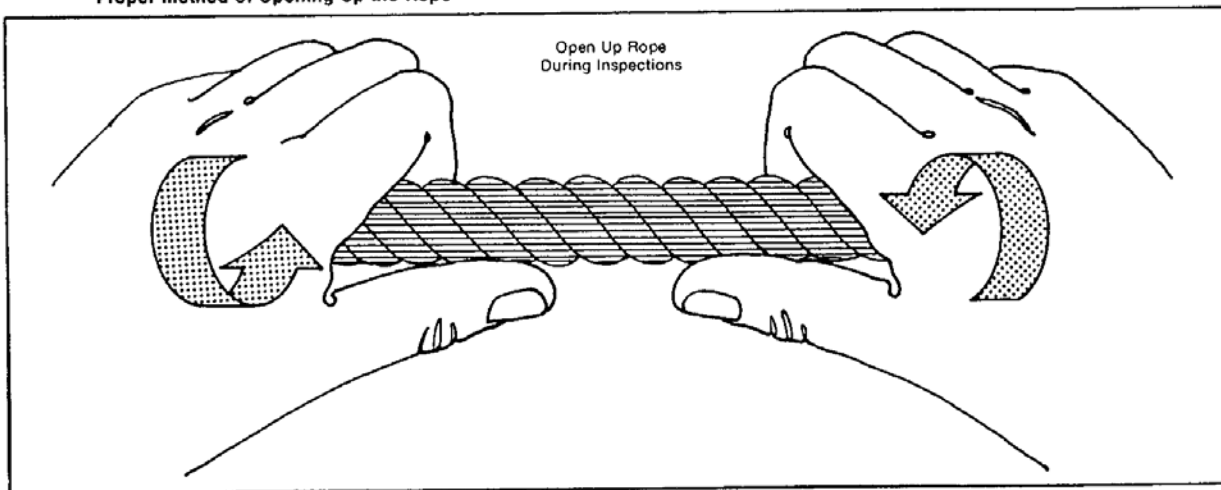

Rigging Hardware

Know what hardware to use, how to use it, and how its safe working loads (SWL) compare with the rope or chain used with it.

All fittings must be of adequate strength for the application. Only forged alloy steel load-rated hardware should be used for overhead lifting. Load-rated hardware is stamped with its SWL (Figure 44).

Inspect hardware regularly and before each lift. Telltale signs include

- wear
- cracks
- severe corrosion
- deformation/bends
- mismatched parts
- obvious damage.



Figure 44

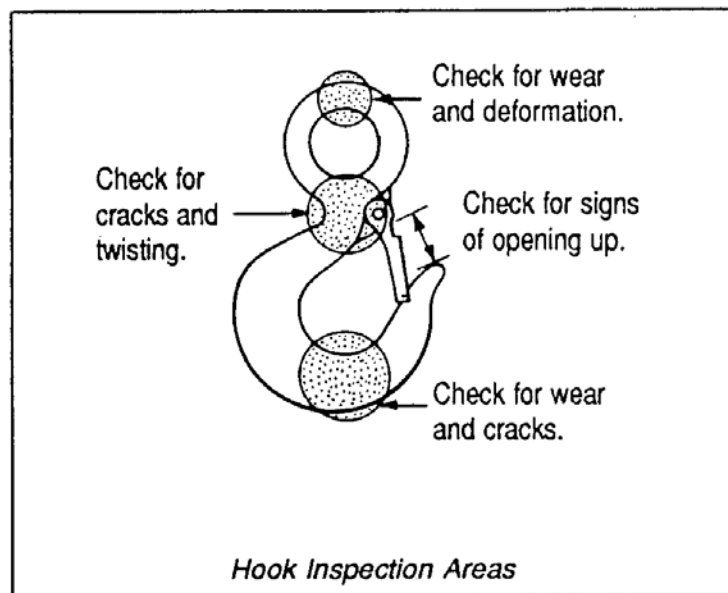

Figure 45

Hoisting Hooks

- Should be equipped with safety catches (except for sorting or grab hooks).
- Should be forged alloy steel with SWL stamped or marked on the saddle.
- Should be loaded at the middle of the hook. Applying the load to the tip will load the hook eccentrically and reduce the safe working load considerably.
- Should be inspected regularly and often. Look for wear, cracks, corrosion, and twisting—especially at the tip—and check throat for signs of opening up (Figure 45).

Safety Tip

Whenever two or more ropes are to be placed over a hook, use a shackle to reduce wear and tear on thimble eyes.

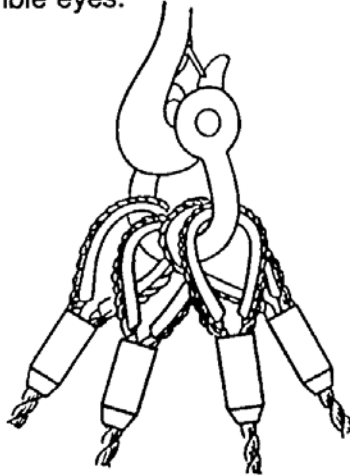

Wire Rope Clips

Wire rope clips are widely used for making end terminations. Clips are available in two basic designs: U-bolt and fist grip.

When using U-bolt clips, make sure you have the right type of clip. Forged alloy clips are recommended. Always make certain that U-bolt clips are attached correctly. The U-section must be in contact with the dead end of the rope. Tighten and retighten nuts as required by the manufacturer.

To determine the number of clips and the torque required for specific diameters of rope, refer to Figure 46. For step-by-step instructions on attaching clips, refer to Figure 47.

INSTALLATION OF WIRE ROPE CLIPS			
Rope Diameter (inches)	Minimum Number of Clips	Amount of Rope Turn Back From Thimble (inches)	Torque in Foot-Pounds Unlubricated Bolts
5/16	2	5 1/2	30
3/8	2	6 1/2	45
7/16	2	7	65
1/2	3	11 1/2	65
9/16	3	12	95
5/8	3	12	95
3/4	4	18	130
7/8	4	19	225

Figure 46

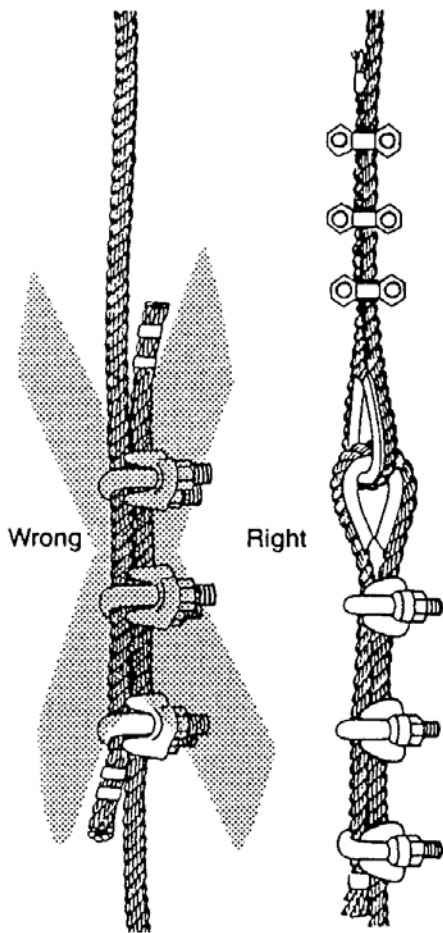

STEP 1



APPLY FIRST CLIP one base width from dead end of wire rope. U-Bolt over dead end. Live end rests in clip saddle. Tighten nuts evenly to recommended torque.

STEP 2

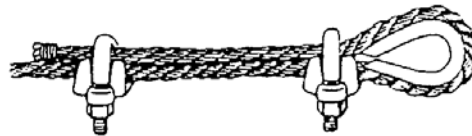

APPLY SECOND CLIP as close to loop as possible. U-Bolt over dead end. Turn nuts firmly but DO NOT TIGHTEN.

STEP 3

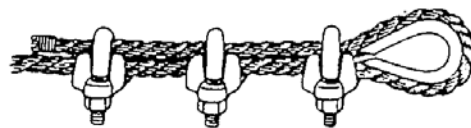

APPLY ALL OTHER CLIPS. Space evenly between first two and 6-7 rope diameters apart.

STEP 4

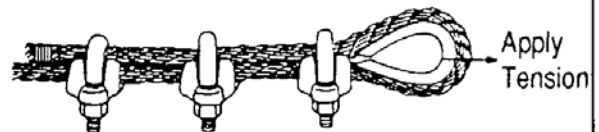

APPLY TENSION and tighten all nuts to recommended torque.

STEP 5

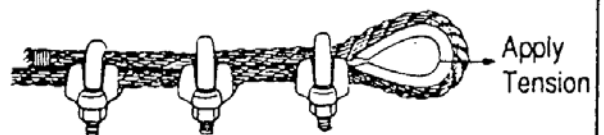

CHECK NUT TORQUE after rope has been in operation.

Figure 47

Swivels

- Reduce bending loads on rigging attachments by allowing the load to orient itself freely.
- Should be used instead of shackles in situations where the shackle may twist and become eccentrically loaded.
- Can provide approximate capacities shown in Figure 48. See manufacturer's table for the exact SWL of the swivel you are using.

SWIVELS (ALL TYPES)	
— Weldless Construction	
— Forged Alloy Steel	
Stock Diameter (Inches)	Max. Safe Working Load (Pounds)
1/4	850
5/16	1,250
3/8	2,250
1/2	3,600
5/8	5,200
3/4	7,200
7/8	10,000
1	12,500
1 1/8	15,200
1 1/4	18,000
1 1/2	45,200

Figure 48

Shackles

- Available in various types (Figure 49).
- For hoisting, should be manufactured of forged alloy steel.
- Do not replace shackle pins with bolts (Figure 50). Pins are designed and manufactured to match shackle capacity.
- Check for wear, distortion, and opening up (Figure 51). Check crown regularly for wear. Discard shackles noticeably worn at the crown.
- Do not use a shackle where it will be pulled or loaded at an angle. This severely reduces its capacity and opens up the legs (Figure 52).
- Do not use screw pin shackles if the pin can roll under load and unscrew (Figure 53).

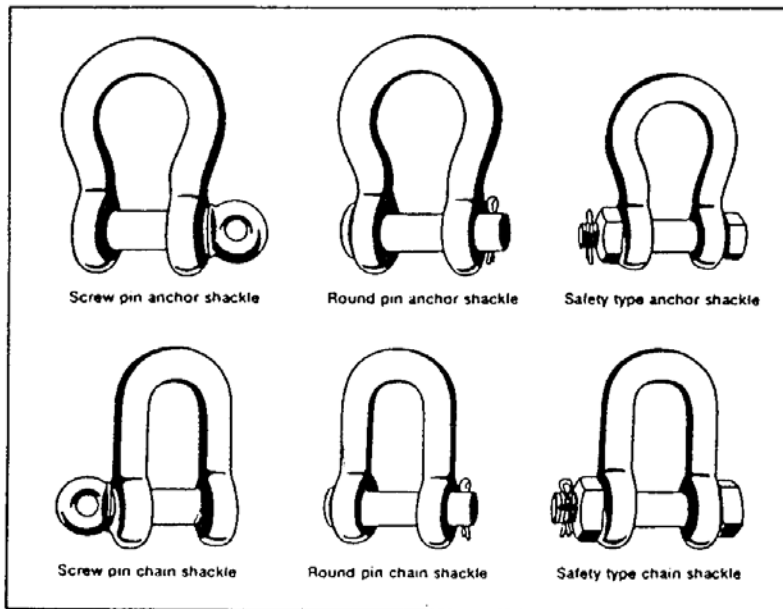

Figure 49

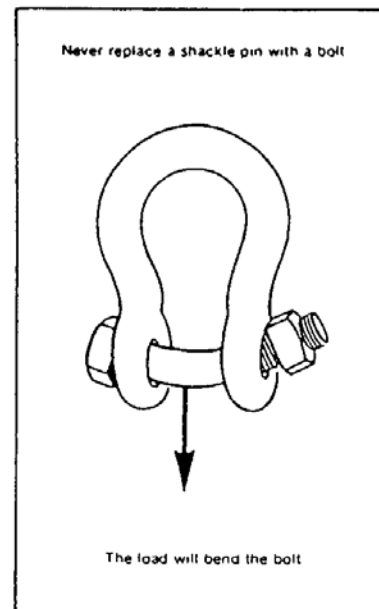

Figure 50

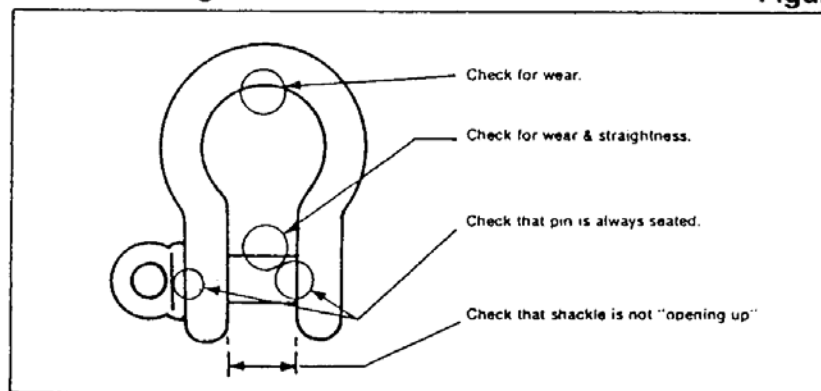

Figure 51

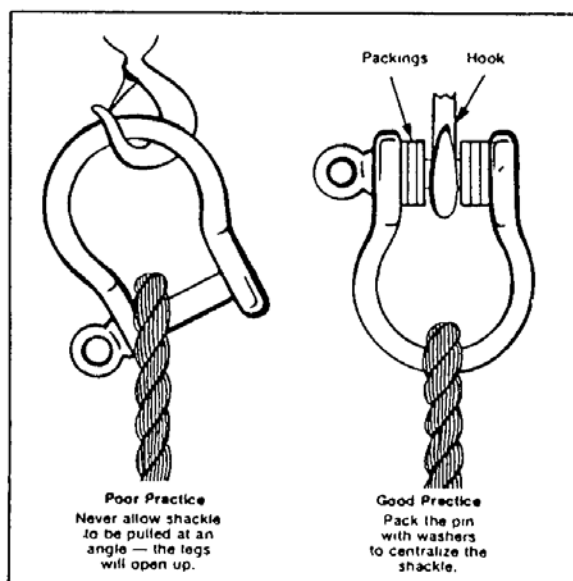

Figure 52

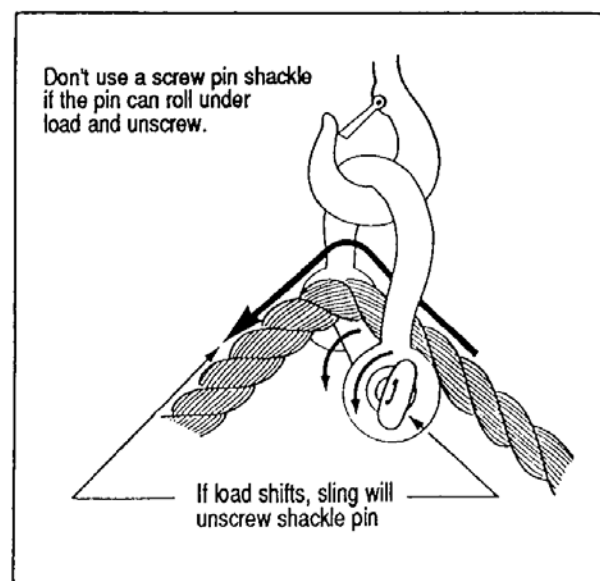
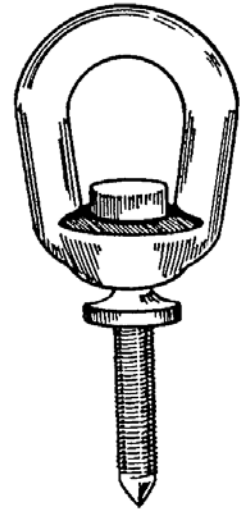

Figure 53

Eye Bolts

- For hoisting, use eye or ring bolts of forged alloy steel.
- Use bolts with shoulders or collars. Shoulderless bolts are fine for vertical loading but can bend and lose considerable capacity under angle loading (Figure 54). Even with shoulders, eye and ring bolts lose some capacity when loaded on an angle.
- Make sure that bolts are at right angles to hole, make contact with working surface, and have nuts properly torqued (Figure 55).
- Pack bolts with washers when necessary to ensure firm, uniform contact with working surface (Figure 55).
- Make sure that tapped holes for screw bolts are deep enough for uniform grip (Figure 55).
- Apply loads to the plane of the eye, never in the other direction (Figure 55). This is particularly important with bridle slings, which always develop an angular pull in eye bolts unless a spreader bar is used.
- Never insert the point of a hook in an eye bolt. Use a shackle instead (Figure 55).
- Do not reeve a sling through a pair of bolts. Attach a separate sling to each bolt.



Swivel
Eye Bolt

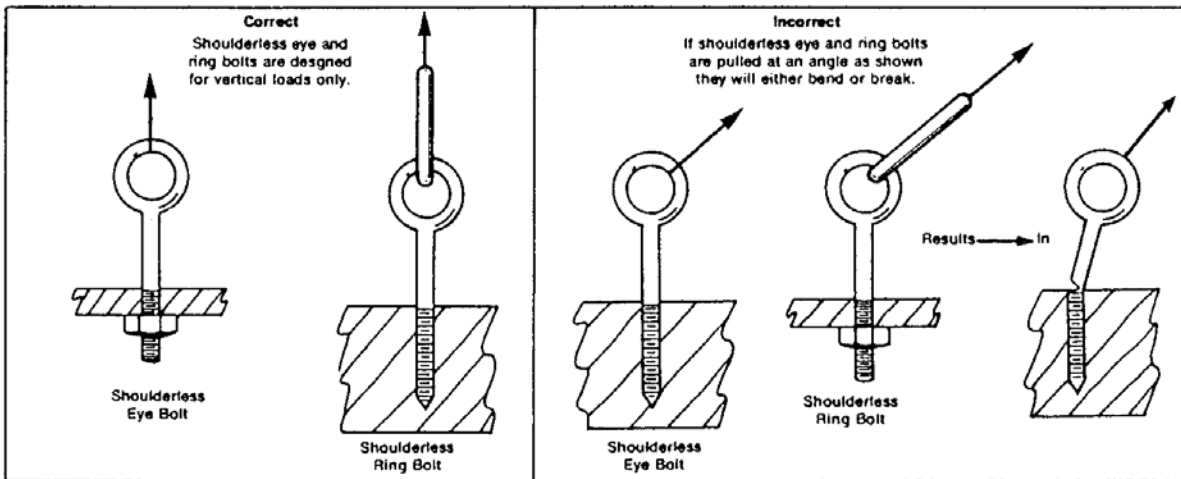

Figure 54

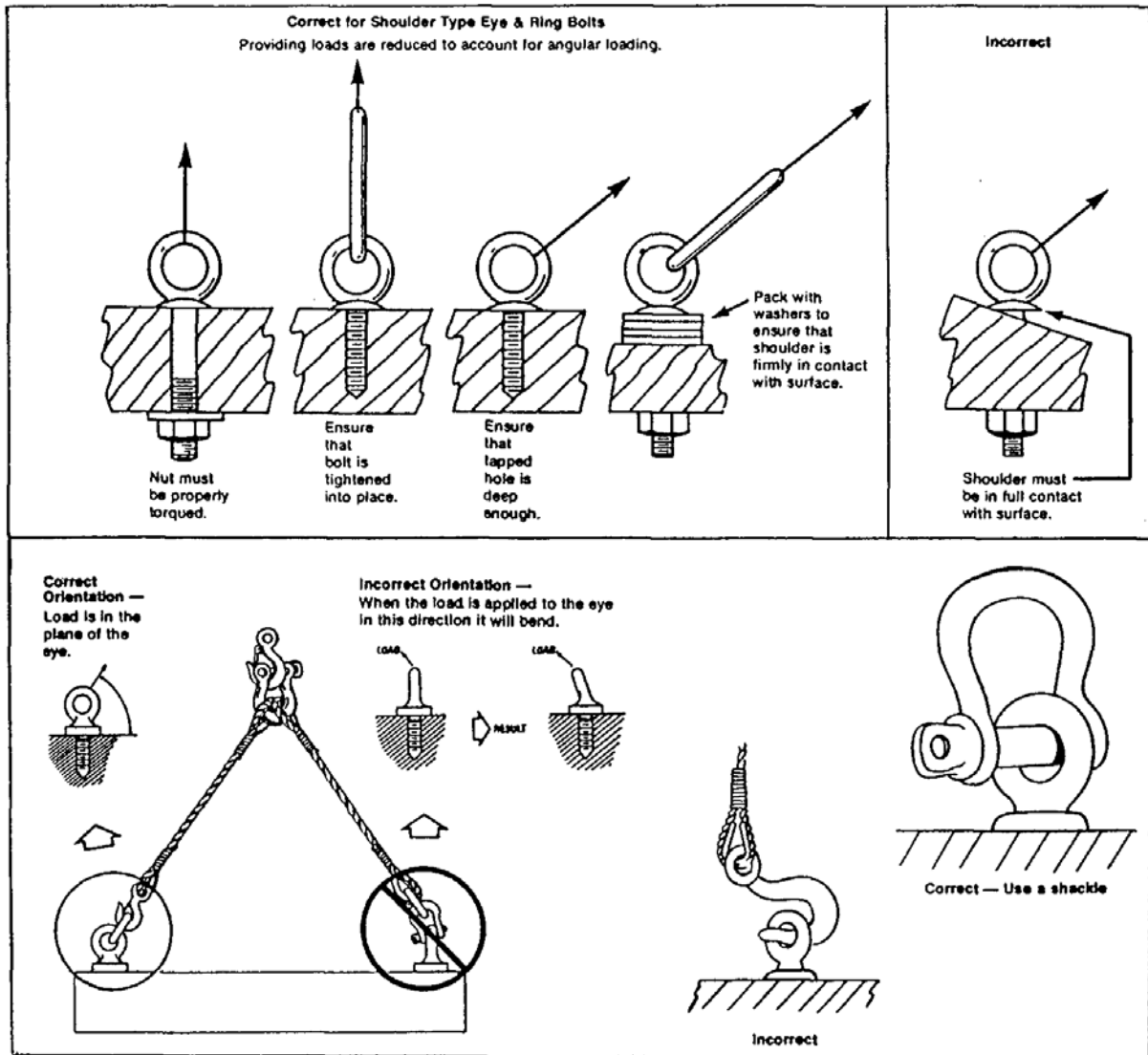

Figure 55

Snatch Blocks

- A single or multi-sheave block that opens on one side so a rope can be slipped over the sheave rather than threaded through the block (Figure 56).
- Available with hook, shackle, eye, and swivel end fittings.
- Normally used when it's necessary to change the direction of pull on a line. Stress on the snatch block varies tremendously with the angle between the lead and load lines. With both lines parallel, 1000 pounds on the lead line results in 2000 pounds on the block, hook, and anchorage. As the angle between the lines increases, the stress is reduced (Figure 57).
- To determine the load on block, hook, and anchorage, multiply the pull on the lead line or the weight of the load being lifted by a suitable factor from the table in Figure 19.33 and add 10% for sheave friction.



Figure 56

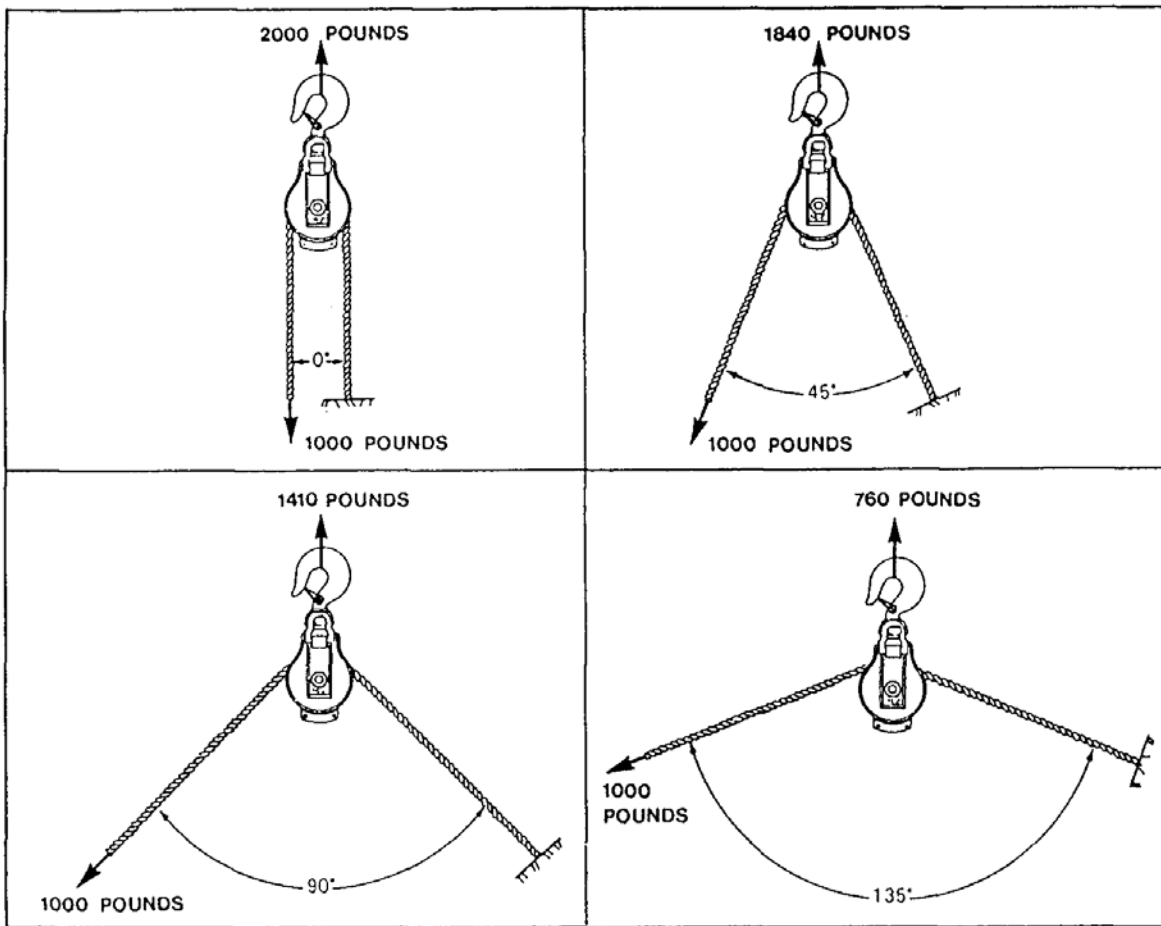

Figure 57

MULTIPLICATION FACTORS FOR SNATCH BLOCK LOADS	
Angle Between Lead and Load Lines	Multiplication Factor
10°	1.99
20°	1.97
30°	1.93
40°	1.87
45°	1.84
50°	1.81
60°	1.73
70°	1.64
80°	1.53
90°	1.41
100°	1.29
110°	1.15
120°	1.00
130°	.84
135°	.76
140°	.68
150°	.52
160°	.35
170°	.17
180°	.00

Turnbuckles

- Can be supplied with eye end fittings, hook end fittings, jaw end fittings, stub end fittings, and any combination of these (Figure 58).
- Rated loads are based on the outside diameter of the threaded portion of the end fitting and on the type of end fitting. Jaw, eye, and stub types are rated equally; hook types are rated lower.
- Should be weldless alloy steel.
- When turnbuckles are exposed to vibration, lock frames to end fittings. This will prevent turning and loosening. Use wire or manufacturer-supplied lock nuts to prevent turning (Figure 59).
- When tightening a turnbuckle, do not apply more torque than you would to a bolt of equal size.
- Inspect turnbuckles frequently for cracks in end fittings (especially at the neck of the shank), deformed end fittings, deformed and bent rods and bodies, cracks and bends around the internally threaded portion, and signs of thread damage.

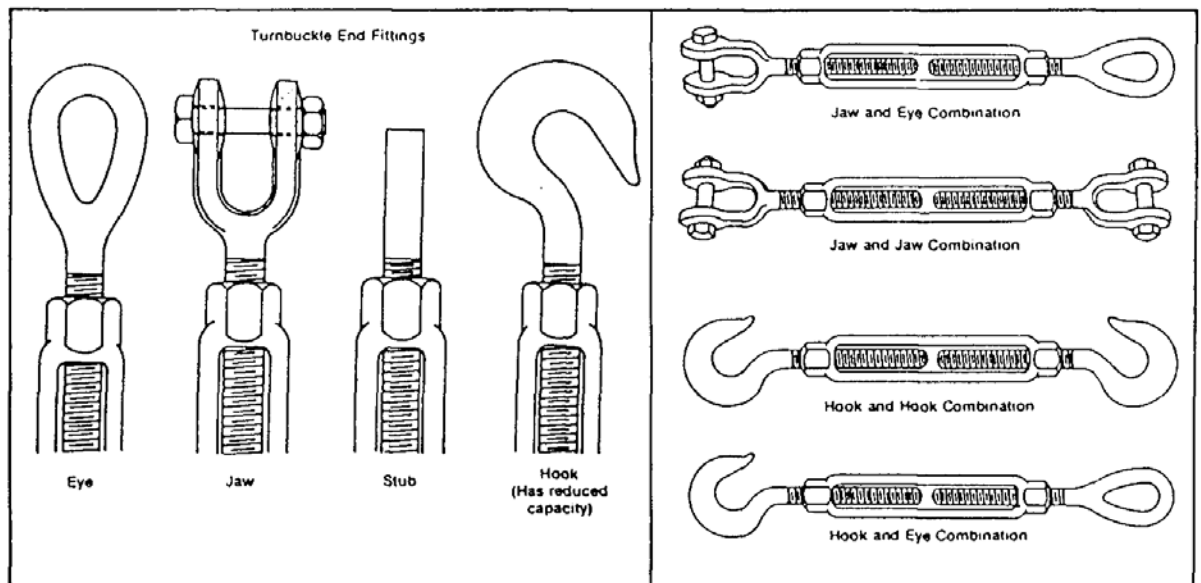

Figure 58

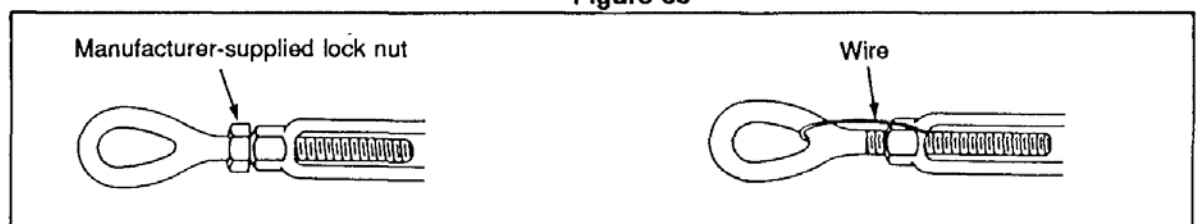

Figure 59

Table 8 gives the safe working loads for turnbuckles based on the diameter of the shank. Note how the use of hook end fittings reduces capacity.

TABLE 8

TURNBUCKLES — Weldless Construction — Forged Alloy Steel		
End Fitting, Stock Diameter (Inches)	SWL of Any Combination of Jaw End Fittings, Eye End Fittings and Stub End Fittings (Lbs)	SWL of Any Turnbuckle Having a Hook End Fitting (Lbs)
1/4	500	400
5/16	800	700
3/8	1,200	1,000
1/2	2,200	1,500
5/8	3,500	2,250
3/4	5,200	3,000
7/8	7,200	4,000
1	10,000	5,000
1 1/4	15,200	5,000
1 1/2	21,400	7,500
1 3/4	28,000	—
2	37,000	—
2 1/2	60,000	—
2 3/4	75,000	—

Figure 60 shows the areas of a turnbuckle that require special attention during inspection.

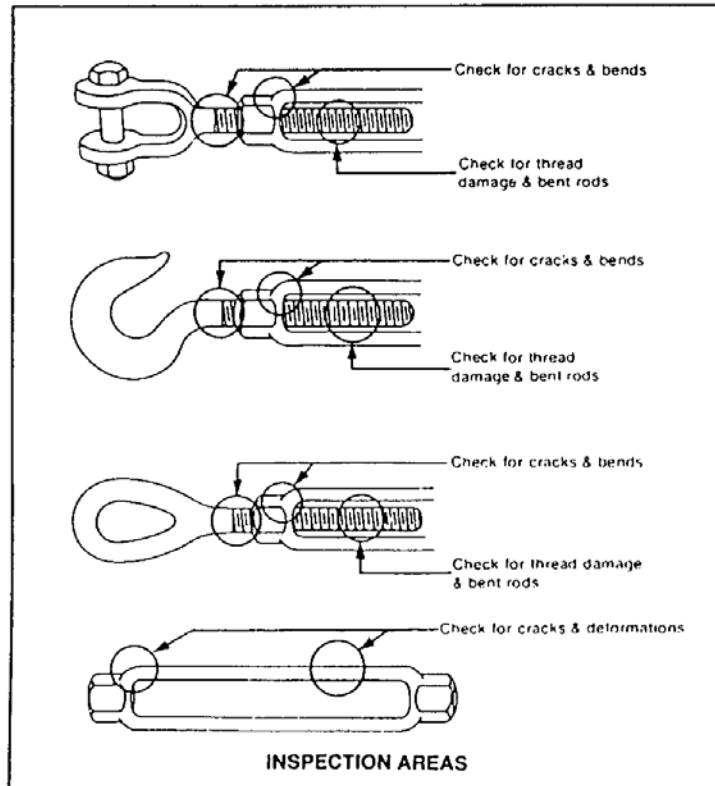

Figure 60

Spreader and Equalizer Beams

Spreader beams are usually used to support long loads during lifts. They eliminate the hazard of the load tipping, sliding, or bending as well as the possibility of low sling angles and the tendency of the slings to crush the load.

Equalizer beams are used to equalize the load in sling legs and to keep equal loads on dual hoist lines when making tandem lifts.

Spreader and equalizer beams are both normally fabricated to suit a specific application. If a beam is to be used which has not been designed for the application, make sure that it has adequate width, depth, length, and material.

The capacity of beams with multiple attachment points depends on the distance between the points. For example, if the distance between attachment points is doubled, the capacity of the beam is cut in half.

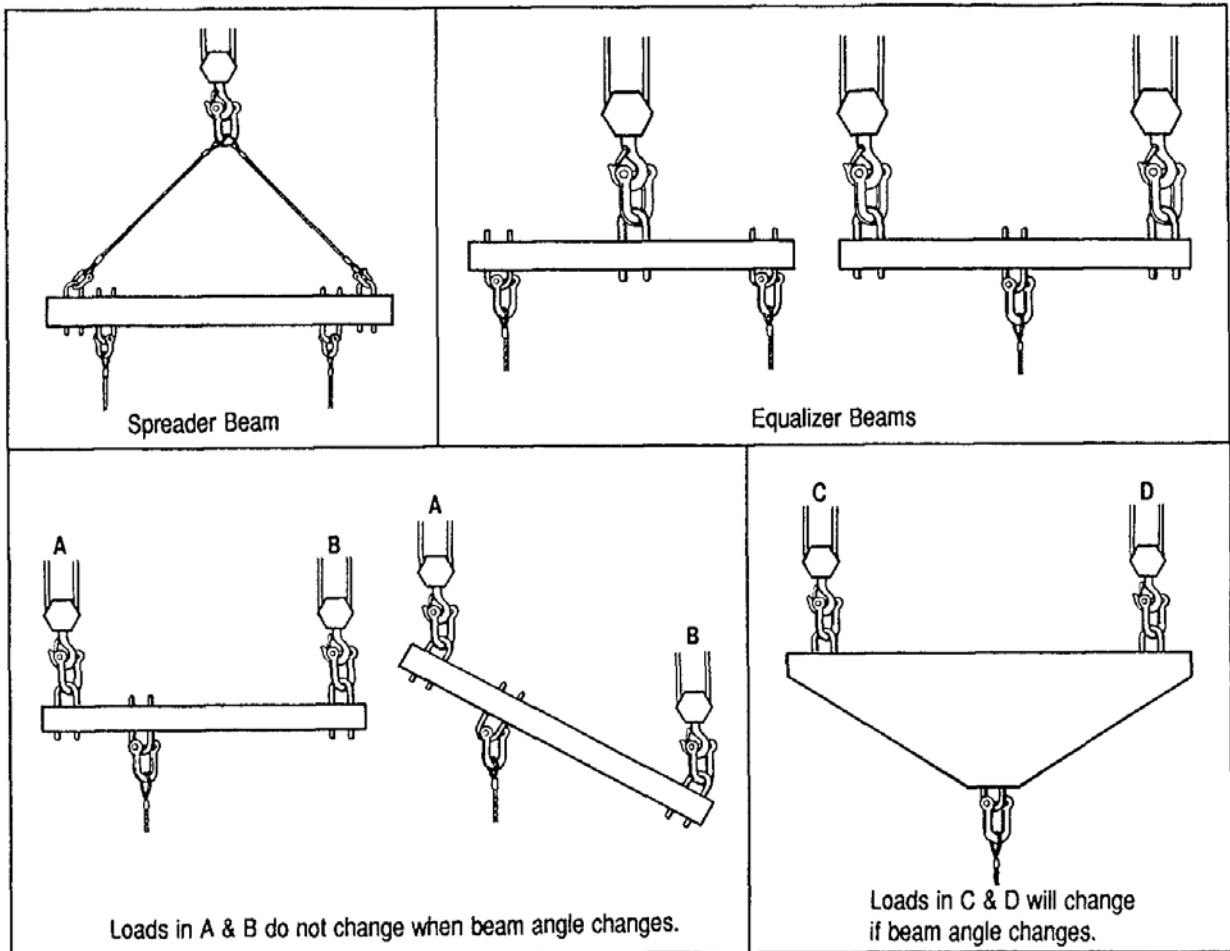

Hoisting Tips

- Never wrap a wire rope sling completely around a hook. The tight radius will damage the sling.
- Make sure the load is balanced in the hook. Eccentric loading can reduce capacity dangerously (Figure 61).

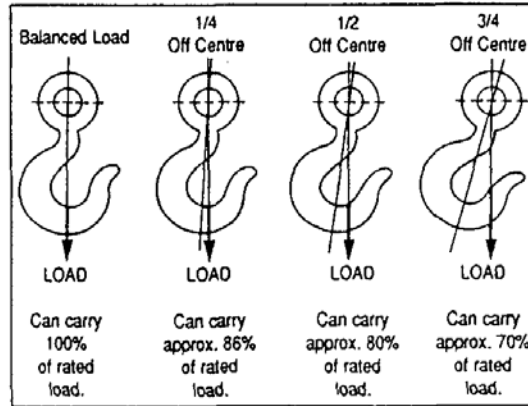

Figure 61

- Never point-load a hook unless it is designed and rated for such use. Point-loading can cut capacity by more than half (Figure 62).
- Never wrap the crane hoist rope around the load. Attach the load to the crane hook by slings or other rigging devices.
- Avoid bending wire rope slings near attached fittings or at eye sections.
- Understand the effect of pull angle on beam load (Figure 63).

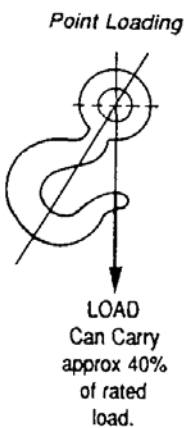

Figure 62

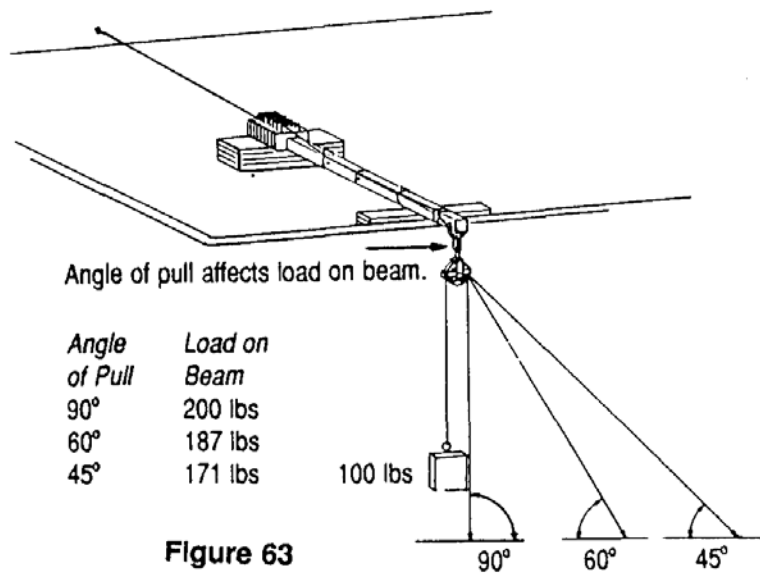

Figure 63

Section 4

Rigging Tools and Devices

- Jacks (ratchet, hydraulic)**
- Blocking and Cribbing**
- Rollers**
- Inclined Planes**
- Lever-Operated Hoists**
- Chain Hoists**
- Grip-Action Hoists (Tirfors)**
- Electric Hoists and Pendant Cranes**
- Winches**
- Anchorage Points**

Rigging Tools and Devices

The *Regulations for Construction Projects* require that an inspection and maintenance program be implemented to ensure that rigging equipment is kept in safe condition. Procedures must ensure that inspection and maintenance have not only been carried out but have been duly recorded.

Rigging operations often involve the use of various tools and devices such as jacks, rollers, hoists, and winches. Each has its own unique features, uses, and requirements for safe operation and maintenance.

The construction regulations also require that the manufacturer's operating instructions for such tools and devices be available on site. The rigger must read and follow all of these instructions to operate and maintain the equipment properly. The rigger must also read any warning information which may be stamped, printed, tagged, or attached to the rigging device.

This section identifies some of the commonly used rigging tools and devices and explains procedures for their safe operation and maintenance.

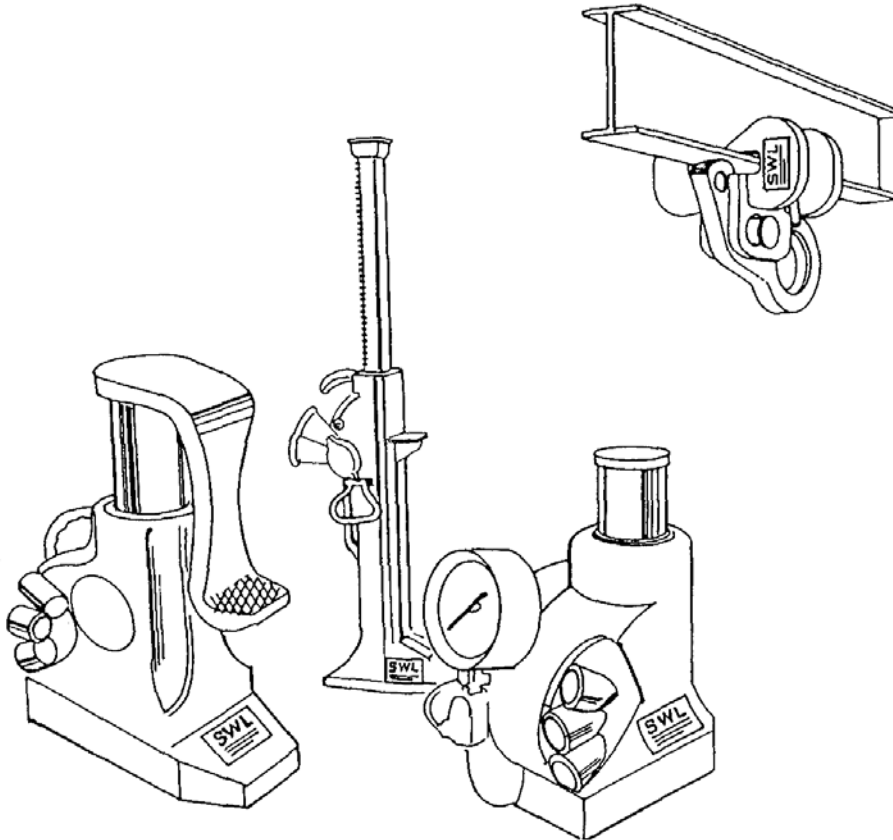

Jacks

While there are a great many types of jacks, the ratchet jack and heavy duty hydraulic jack are the two types most commonly used in construction.

Ratchet jacks are usually limited to capacities under 20 tons because of the physical effort required to raise such a load. They do, however, have a much longer travel than hydraulic jacks and can therefore lift loads higher without having to re-block. Most ratchet jacks have a foot lift or "toe" near the base to lift loads which are close to the ground. Lifts can be made from the "head" or the "toe" of the jack. These jacks are often called toe jacks or track jacks (Figure 1).

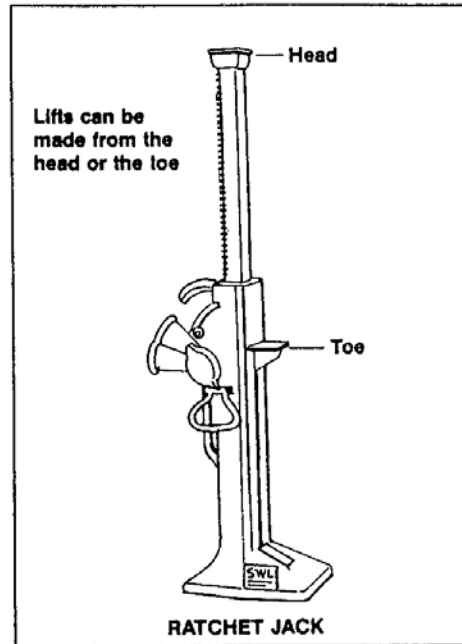

Figure 1

Do not use extensions or "cheaters" on the handles supplied with ratchet jacks. If cheaters are necessary the jack is overloaded.

Hydraulic jacks are very popular in construction because they are quite compact and can lift very heavy loads. They are readily available in capacities ranging from a few tons to 100 tons. Some specialty units have capacities up to 1,000 tons. Lift heights are usually limited to approximately 8 inches or less but some can go as high as 36 inches (Figure 2).

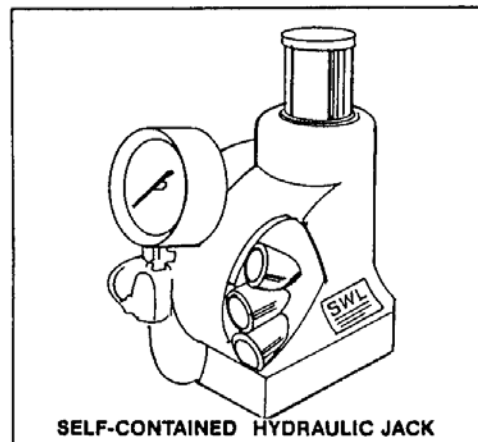

Figure 2

Hydraulic jacks are also available in low profile models that can be positioned under a load close to the ground (Figure 3). Also known as "button jacks", these are useful for lifting a load high enough to get a regular jack in place.

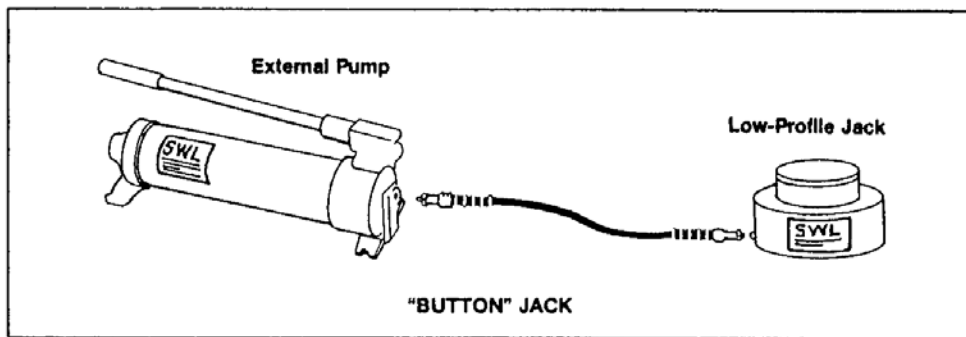

Figure 3

Like ratchet jacks, hydraulic jacks are available with toe lifts (Figure 4).

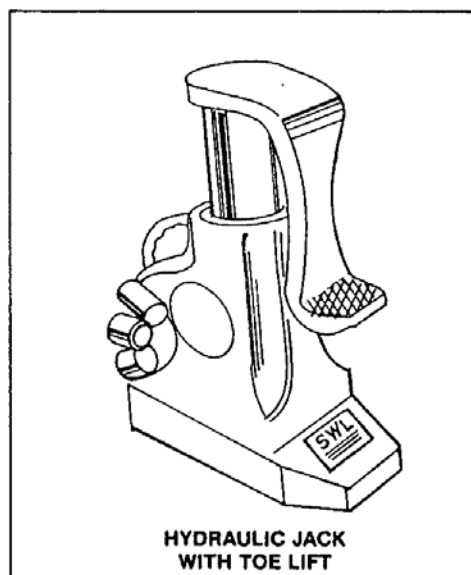

Figure 4

The pumps powering hydraulic jacks may be contained in the jacks or be separate external power units. Separate units may be hand-operated or electrically powered, but the self-contained pumps are always hand-operated.

With all types of hydraulic jacks it is critical that no further force be applied after the ram has run its full travel. The resultant high pressure in the hydraulic fluid can damage the seals and, in the case of external power units, burst the hoses.

Most external power units are equipped, however, with pressure relief valves. At the factory one valve will be set at the absolute maximum pressure while another will be adjustable to lower settings by the user. Make sure you are familiar with the operation of this safety feature.

Most hydraulic jacks can be fitted with a gauge on the housing or at the pump to monitor hydraulic pressure. When used with a given jack, the gauges can be calibrated to measure the approximate load on the unit.

Hoses connecting pumps to jacks require careful attention. Make sure they are free of kinks and cracks. Check the couplings, especially at the crimp. This area is prone to cracking and is often the weak link in the hose assembly. Threads should also be checked for damage, wear, cross-threading and tightness. Remember that these hoses have to withstand pressures up to 10,000 psi.

Don't use hoses that are unnecessarily long. Shorter hoses will leave the area less congested and reduce the chance of accidental damage.

The handles on jacks or hand-operated pump units are designed so that the rated capacity and pressure can be obtained with little physical effort. Don't use extensions or "cheaters" on the handles. Again, if the load can't be raised with the handle supplied the jack is overloaded.

Jacks should only be used in a true vertical position for lifting. Otherwise side-loading can cause the piston to rub against the housing. If this happens, the piston will be scored and allow fluid to leak at the seal which may cause the jack to slip.

Be extremely careful when using hydraulic jacks in welding areas or around corrosive chemicals. Sparks or acids can cause pitting on the ram or damage hoses.

Hydraulic jacks are generally not equipped with check valves. But check valves can be installed in the hoses of an external pump and are recommended. Alternatively, some hydraulic jacks have retaining nuts that can be screwed against the housing to hold the load for a short time.

Jacks should never be used for long-term support of a load. Blocking is much more stable and safe. Whenever possible, the load should be progressively blocked as jacking proceeds. This will allow for the unexpected.

Always jack loads one end at a time. Never jack loads one side at a time as this will be far less stable than jacking the ends.

If it is necessary to work or even reach under a load on jacks, place safety blocking under the load as a precaution.

Make sure timbers used for blocking or cribbing are long enough to distribute the load over a large enough area and provide sufficient stability. Crib height should not exceed the length of timbers used.

All jacks should be thoroughly inspected periodically, depending on how they are used. For regular use at one location they should be inspected every six months or more frequently if the lifts approach capacity. Jacks sent out for special jobs should be inspected when received and when returned. Jacks subjected to high loads or shock should be inspected immediately.

Because jack bases are relatively small, care must be taken to ensure that the floor or ground can withstand the high pressures often associated with jacking operations. Blocking or matting under the jacks will distribute the load over a greater area and reduce bearing pressure.

Jacks - Inspection

Whether ratchet or hydraulic, all jacks should be inspected before each shift or use. Check for:

- improper engagement or extreme wear of pawl and rack
- cracked or broken rack teeth
- cracked or damaged plunger
- leaking hydraulic fluid
- scored or damaged plunger
- swivel heads and caps that don't function properly
- damaged or improperly assembled accessory equipment

Remember: When using jacks, always try to block as you go. Never use jacks for long-term support. Block properly instead.

Blocking and Cribbing

Blocking or cribbing must

- be sufficient to support load
- be set on firm, level ground or floor
- be close together
- be dry and free of grease
- be stacked no higher than the length of the timbers used
- follow the jacking process
- distribute load over enough area to provide stability.

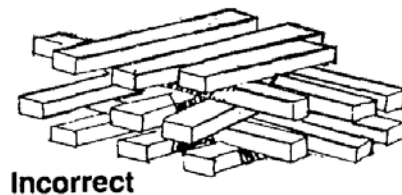
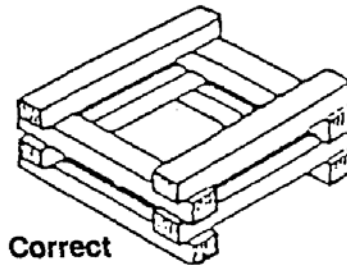

Note: In some cases, solid blocking may be required.

Rollers

Rollers can be used for moving loads horizontally or on slight inclines, provided the surface is firm and even. Rollers may be aluminum or steel round stock, heavy steel pipe, or a manufactured caster unit (Figure 5).

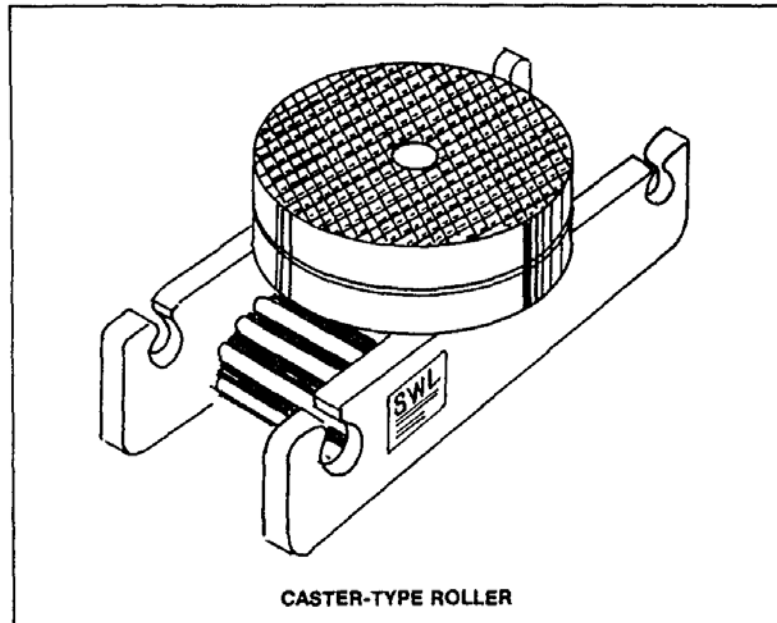

Figure 5

Cylinder rollers are useful for short distances or where the load will have to negotiate corners. The rollers can be placed on angles to swing the ends of the load, allowing turns in tight areas (Figure 6).

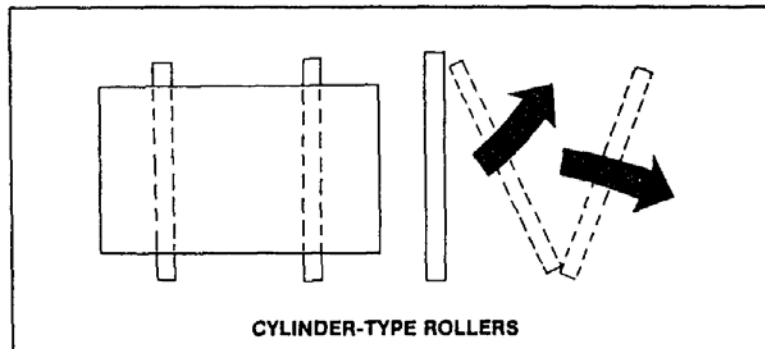

Figure 6

Cylinder rollers should be round, true and smooth to minimize the force required to move the load.

Caster rollers can be supplied in a number of configurations for flat surfaces, tracks, I-beams or channels. They create very little friction and allow heavy loads to be moved with little force. In fact, the rigger may sometimes require more friction to provide an extra measure of control. In this case cylinder rollers may be favored to ensure that the load will not get away.

The most important aspect in rolling is control of the load. Make sure that all equipment including slings and hardware is sufficient to handle the loads that will be developed at each stage of the operation. Always attach a second means of restraint such as a tirtor or winch to the load to allow for the unexpected. The possibility of shock loads should be considered when sizing winches or tirtors for back-up protection.

Check the condition of floors or ground before using rollers. Bearing pressure can be reduced by using more rollers and large steel or aluminum mats to distribute the load. Make sure the joints in the mats or skids are staggered. It is often necessary to assess the structure supporting floors. Temporary shoring may be necessary.

Inclined Planes

The method used to calculate the required pull up an incline, as shown in the videotape, is only approximate. Though widely used because of its simplicity, the method yields values higher than the actual force required. The formula is more accurate for slight inclines (1:5) than steep inclines (1:1). Table 1 shows the difference between the actual pull required and the pull calculated with friction of 5%.

TABLE 1

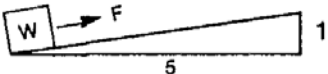
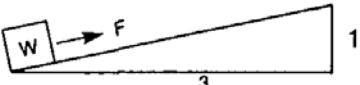
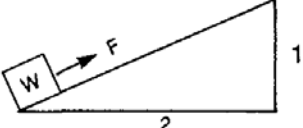
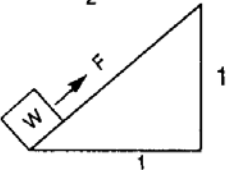
Actual Force versus Force Calculated by Simplified Method with 5% Friction	
	Simplified Method $F = .250W$ Actual Force $F = .245W$ Error: 2%
	Simplified Method $F = .383W$ Actual Force $F = .364W$ Error: 5%
	Simplified Method $F = .550W$ Actual Force $F = .492W$ Error: 12%
	Simplified Method $F = 1.05W$ Actual Force $F = .742W$ Error: 42%

For most applications the simplified method is adequate because the value used for friction is itself only approximate.

Formula (5% Friction)

$$F = W \times H/L \times .05W$$

where

F = Required Force
 H = Height
 L = Length
 W = Weight of Load

Table 2 lists some examples of coefficients of friction. Note that some of the combinations of materials have a considerable range of values.

TABLE 2

Examples of Friction Coefficients	
Steel on Steel	40 - 60%
Leather on Metal	60%
Wood on Stone	40%
Iron on Stone	30 - 70%
Grease Plates	15%
Load on Wheels or Rollers	2 - 5%

Lever-Operated Hoists or Come-Alongs

Come-alongs are a very portable means of lifting or pulling loads short distances. They can be used vertically, horizontally or on an angle. Otherwise all points covered in the section on chain hoists apply equally to come-alongs.

A come-along that requires the use of a cheater or the help of another worker to move a load is inadequate for the job. Use a come-along with a larger capacity.

Lever-Operated Hoist - Safety Precautions

- Inspect for defects.
- Do not use cheater on hoist handle.
- Do not overload. Safe working load (SWL) should be marked on device.
- Do not apply the load to the tip of the hook.
- Do not use the hoist chain as a sling or choker.
- Make sure of your footing before operating the hoist.
- Do not leave the suspended load unattended.
- Keep hoist chain straight.
- Stand clear of load and pulling path of hoist chain.
- Keep upper and lower hooks in a straight line so that the frame is free to swivel.
- Do not use a hoist with a twisted, kinked, damaged, or worn chain.
- Ensure that anchorage and structure will support the load.

CHAIN HOISTS

Chain hoists are useful because the load can be stopped and kept stationary at any point. Because of their slow rate of travel, chain hoists also allow precise vertical placement.

Chain hoists should be rigged so that there is a straight line between the upper and lower hooks. They are intended for use in a vertical or near vertical position only. If rigged at an angle, the upper hook can be damaged at the shank and the throat may open up. If the gear housing is resting against an object while under load it can be damaged or broken (Figure 10).

Always make sure that the hoist is hanging freely.

Before using the hoist, inspect the chain for nicks, gouges, twists, and wear. Check the chain guide for wear. Hooks should be measured for signs of opening up. Ensure that the hooks swivel freely and are equipped with safety catches. If the hoist has been subjected to shock loads or dropped, it should be inspected thoroughly before being put back in service. Check the load brake by raising the load a couple of inches off the ground and watching for creep.

If the hoist chain requires replacement, follow the manufacturer's recommendations. Different manufacturers use different pitches for their load chain. Chain intended for one brand of hoist will not mesh properly with the lift wheel of another brand and the hoist will not operate properly, if at all.

The load chain on chain hoists is case-hardened to reduce surface wear and is unsuitable for any other use. Load chain will stretch 3% before failing, whereas Grade 8 alloy chain will stretch at least 15%. Load chains are too brittle for any other application. Any load chain removed from a hoist should be destroyed by cutting it into short pieces. Never try to repair a load chain yourself. Welding will destroy the heat treatment of the chain entirely.

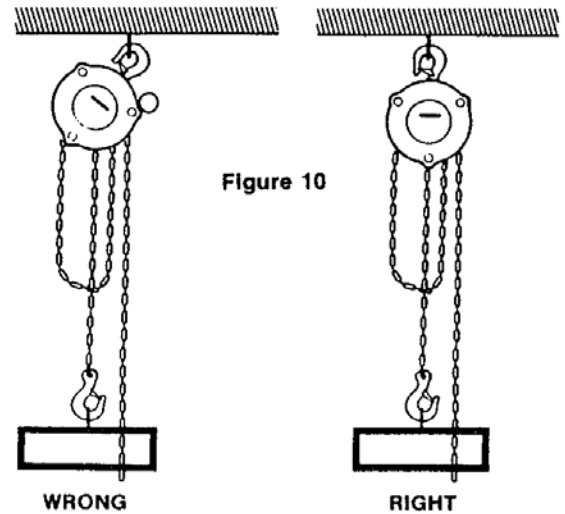

Chain Hoist - Safety Precautions

- Inspect for wear and damage regularly.
- Do not overload.
- Do not leave a suspended load unattended.
- Do not stand under the load.
- Do not use the hoist chain as a sling or choker.
- Do not apply the load to the tip of the hook.
- Avoid hoisting on angles.
- Chain hoists must be used in the vertical position.
- Only one operator should pull on a single hand chain at one time.
- Ensure that load chain is properly seated in wheels or sprockets before lifting.
- Ensure that anchorage and structure will support the load.
- Maintain the chain hoist according to manufacturer's specifications.

Grip-Action Hoists or Tirfors

Grip-action hoists, commonly known by the tradename Tirfor, are useful for long lifts or pulls since they act on a continuous length of wire rope. Like the come-along, they can be used in any orientation. The tirfor can draw rope through the unit, as a come-along draws chain, or pull itself along a fixed rope, as on a swingstage (Figure 11).

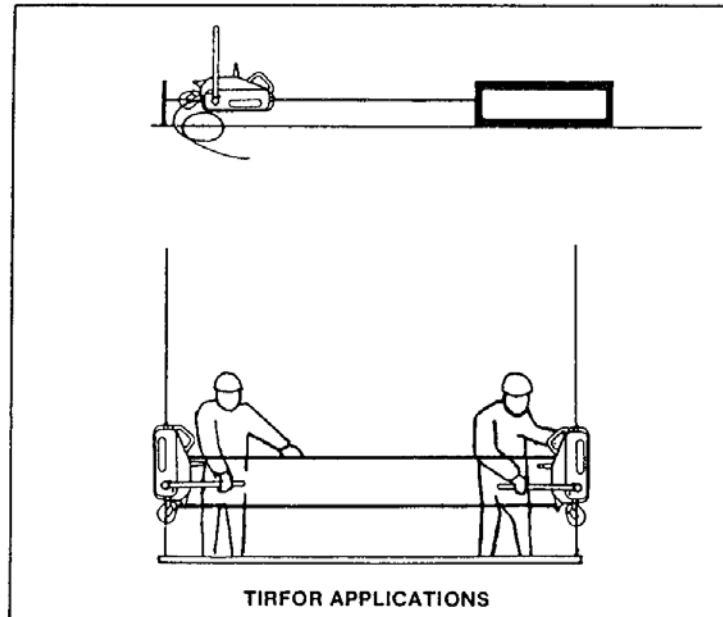

Figure 11

Tirfors are available with capacities ranging from 3/4 to 3 1/2 tons. The rope can be reeved through a block system to gain mechanical advantage and increase the capacity of the unit.

Tirfors are operated by two levers — one for forward motion, the other for reverse. The levers operate two jaws which alternately grip and draw the rope through the unit. Figure 12 illustrates the action of the jaws on the rope. A third lever releases both jaws to allow rope to be installed, tensioned, or disengaged.

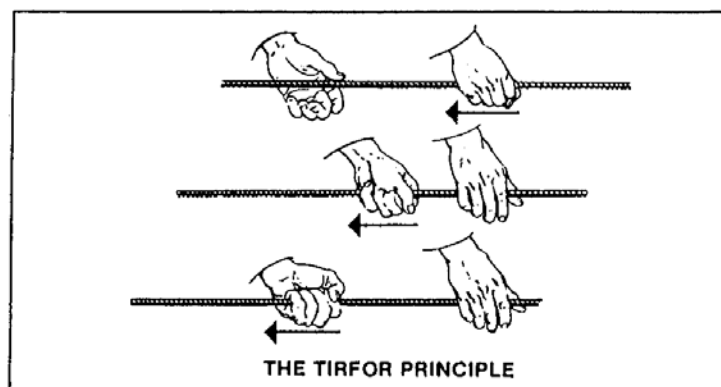

Figure 12

Tirfors can be fitted with hydraulic rams to operate the levers. Up to four units can be operated simultaneously from a single hydraulic power supply (Figure 13).

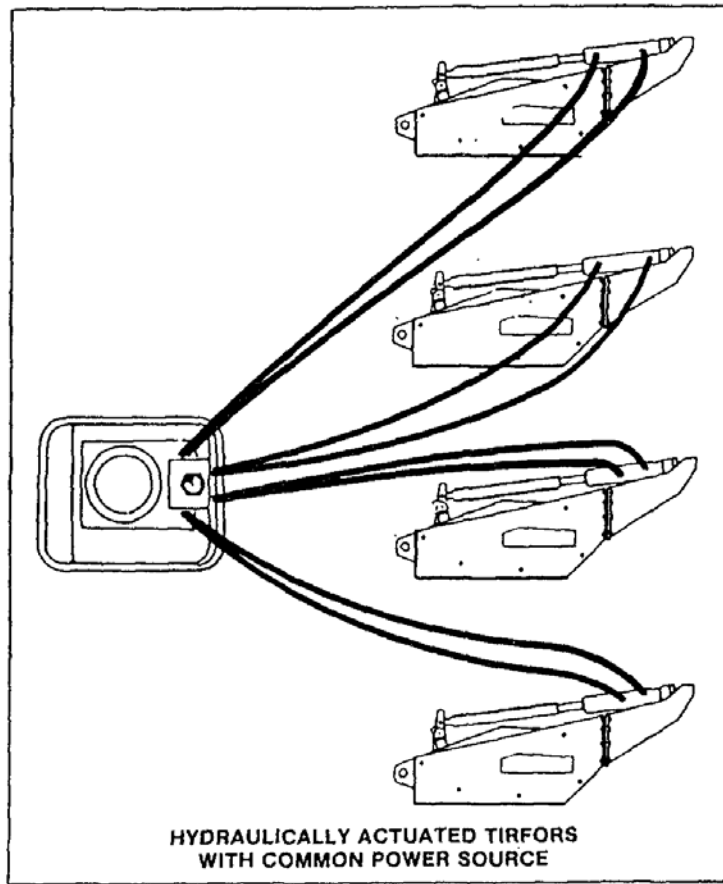

Figure 13

Another type of grip-action hoist uses discs to clamp and drive the rope in a continuous motion (Figure 14). These are available with electric, air, or hydraulic motors. Disc type hoists provide greater rope speed but less capacity than the jaw type.

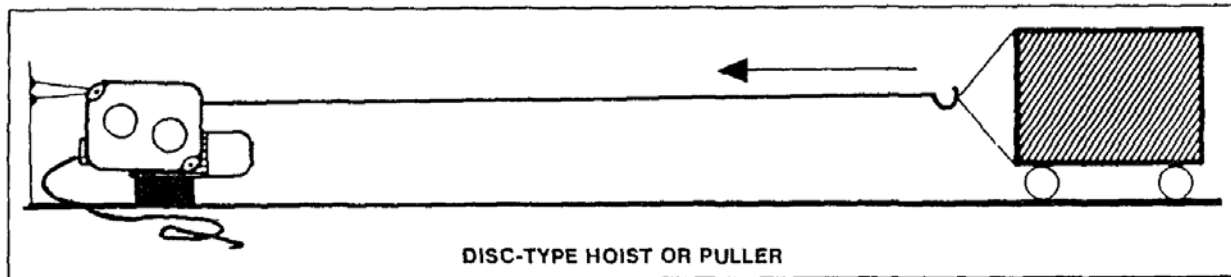

Figure 14

Tirfor ropes are specifically designed for the clamping and pulling forces applied to them. The ropes are galvanized and unlubricated and have very tight diameter tolerance. No other rope should ever be used on tirfors.

Handle tirfor rope carefully to ensure that it does not kink. Kinked rope will jam in the mechanism and prevent the rope from passing through the hoist. Ropes must be kept free from dirt and oil to ensure smooth, safe operation.

Like chain falls and come-alongs, tirfors should be tested under load to ensure that the unit functions properly in both directions and that there is no slippage.

Electric Wire Rope Hoists, Electric Chain Hoists, Pendant Cranes

Electric wire rope and electric chain hoists may be suspended from a fixed point or a trolley. The trolley may be motorized but very often the hoist is moved by tugging gently on the pendant. These units can only move along a fixed straight line (beam).

Pendant cranes, on the other hand, trolley along a bridge (east-west) which travels on rails (north-south). Pendant cranes have greater capacity than the other hoists and usually have two or more parts of line.

Apart from these differences, the devices are quite similar in operating procedures and precautions. Hoist operators must adhere to the following points.

- Know and never exceed the safe load limit of the hoisting equipment.
- Ensure that controls work properly without excessive play, delay or effort.
- Check pendant control cable for cuts, kinking, or signs of wear.
- Check hoist cables for fraying, kinking, crushing, and twisting between the cable and the drum.
- Look at the hoist drum for proper alignment and stacking of the cable.
- Inspect the hook for cracks, bending, or distortion, and the safety latch for proper operation.
- Don't try to lengthen or repair the load chain or rope.
- Read and follow manufacturer's instructions and all instructions and warnings on the hoist.
- Position the hoist directly over the load.
- After the hook is placed in the lifting ring, apply slight pressure to the hoist to ensure that the lifting ring is seated in the bottom of the hook and that the hook is properly aligned.
- Between lifts, check whether the rope is properly seated on the drum.
- Ensure that the intended path of travel is clear of people and obstructions and that the intended destination is ready to receive the load.
- Check brakes for excessive drift.
- Ensure proper clearance for movement.
- Position yourself on the pendant side of the hoist to get maximum clearance from the load and to prevent entanglement of cables.
- Avoid sudden starts, stops, or reverses.
- Raise the load only high enough to avoid obstructions.
- Do not hoist loads over workers; wait until the area is vacated.
- Be alert for any variation in hoist operation and any possible malfunction.
- Do not leave a load suspended in the air. If a short delay is unavoidable, lock the controls.
- Do not allow unqualified personnel to operate hoists.
- Never operate hoist to extreme limits of chain or rope.
- Avoid sharp contact between two hoists, between hoist and end post, and between hooks and hoist body.
- Never use the hoist rope or chain as a sling.
- Never use chain or rope as a ground for welding or touch a live welding electrode to the chain or rope.
- Avoid swinging the load or hook when travelling the hoist.
- Pull in a straight line so that neither hoist body, load chain nor rope is angled around anything.

Some hoists are equipped with limit switches. Generally these devices stop the wind automatically at its maximum allowable up position, down position and travel limits (if rail-mounted). Check limit switches daily for correct operation.

Whenever the operator does not have a clear view of the load and its intended path of travel, a signalman must direct operations. Signals for pendant cranes differ from those for mobile and tower cranes since machine movements are different (Figure 15). Make sure that everyone involved knows the signals required for pendant cranes.

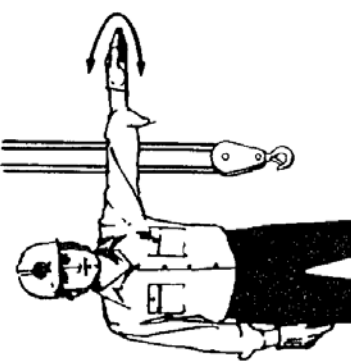
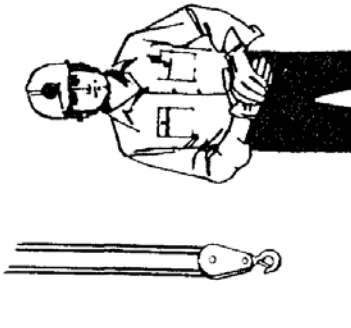
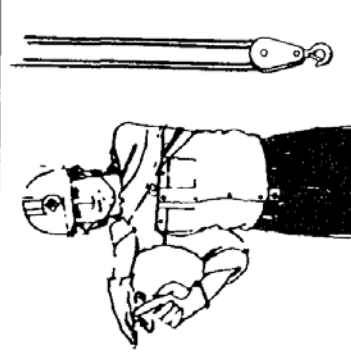
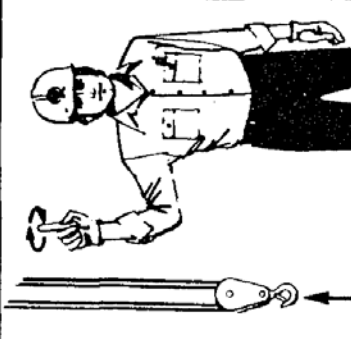
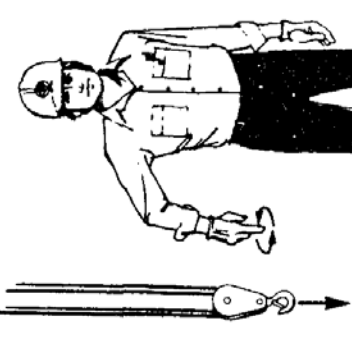
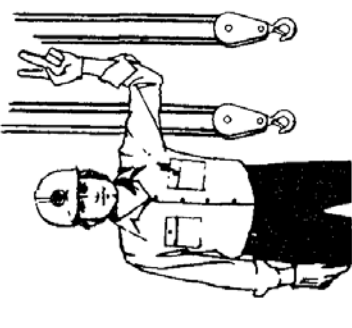
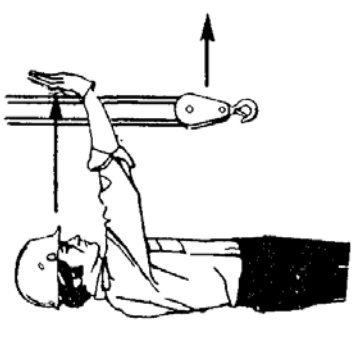
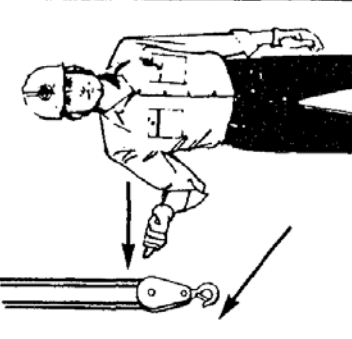
	<p>STOP. Arm extended, palm down, move hand right and left.</p>		<p>DOG EVERYTHING. Clasp hands in front of body.</p>		<p>MOVE SLOWLY. Use one hand to give any motion signal and place other hand motionless in front of hand giving the motion signal. (HOIST SLOWLY SHOWN AS EXAMPLE.)</p>		<p>HOIST. With forearm vertical, forefinger pointing up, move hand in small horizontal circles.</p>
	<p>LOWER. With arm extended downward, forefinger pointing down, move hand in small horizontal circles.</p>		<p>MULTIPLE TROLLEYS. Hold up one finger for block marked "1" and two fingers for block marked "2". Regular signals follow.</p>		<p>TRAVEL. Arm extended forward, hand open and slightly raised, making pushing motion in direction of travel.</p>		<p>TROLLEY TRAVEL. Palm up, fingers closed, thumb pointing in direction of motion, jerk hand horizontally.</p>

SIGNALS FOR PENDANT CRANES

Figure 15

Winches

Base-mounted winches, or tuggers, are a compact, versatile tool for many hoisting and pulling operations. They are particularly useful in areas not accessible to mobile cranes or where there is not enough headroom for a crane to operate. Figure 16 shows a tugger and snatch block arrangement for hoisting. Make sure that the rope leaves the drum at a downward angle and that the loose end is securely anchored.

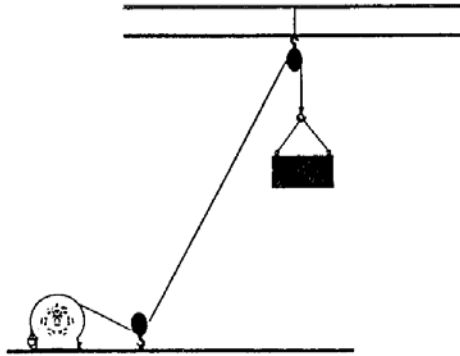
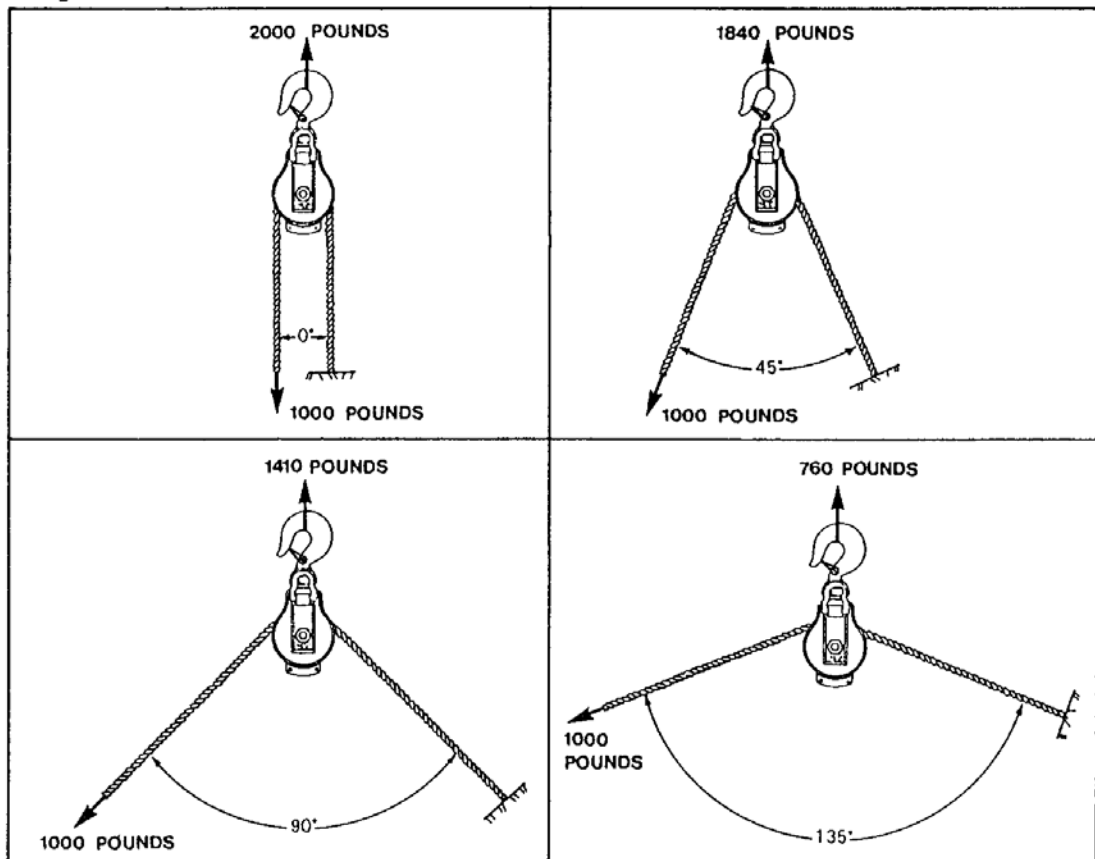

Figure 16

The forces on snatch blocks and their anchorage points depend on the angle by which the direction of pull is changed. The diagrams below indicate how snatch block loads vary with rope angle.



Wire rope used on tuggers should have an independent wire rope core to resist crushing as it is compressed by successive layers of rope on the drum.

Anchorage Points

Hoists, winches, tilters, and other rigging devices require secure anchorage points. Anchors may be overhead, in the floor, or at lateral points in walls or other structures. The arrangement may involve columns, beams, beam clamps, welded lugs, slings, or block and tackle. Whatever the method, riggers must be certain of the loads involved and the anchorage required.

Load on Structure

The following examples illustrate how to calculate the load on the structure in two typical applications.

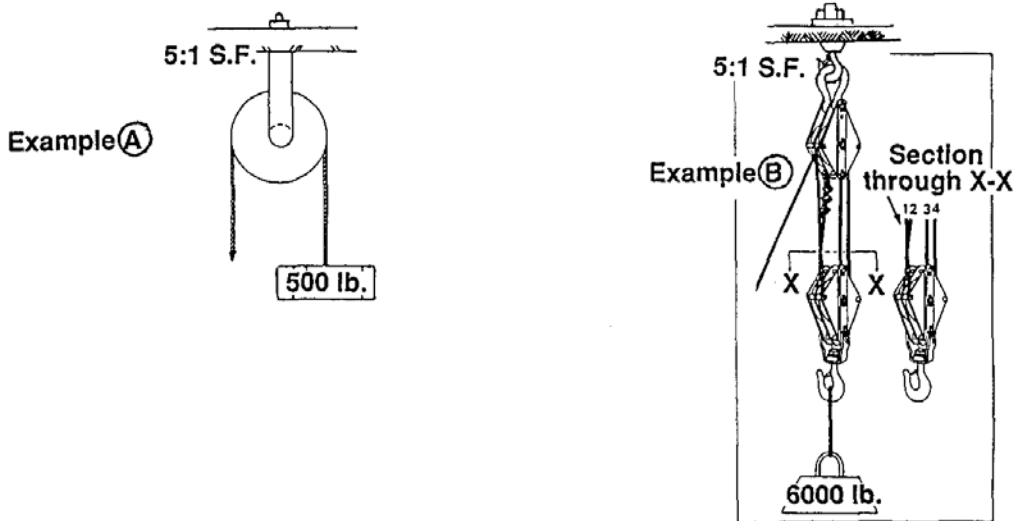

$$\text{Lead Line Load} = \text{Load} + \text{Parts of Line at Load}$$

$$\begin{aligned} \text{Lead Line Load A} &= 500 + 1 \\ &= 500 \text{ lb} \end{aligned}$$

$$\begin{aligned} \text{Lead Line Load B} &= 6000 + 4 \\ &= 1500 \text{ lb} \end{aligned}$$

$$\text{Load on Structure} = \text{Load} + \text{Lead Line Load}$$

$$\begin{aligned} \text{Load on Structure A} &= 500 + 500 \\ &= 1000 \text{ lb} \end{aligned}$$

$$\begin{aligned} \text{Load on Structure B} &= 6000 + 1500 \\ &= 7500 \text{ lb} \end{aligned}$$

Columns

Columns are generally not designed to withstand significant lateral forces. Anchorage points should be placed at the base, near a connection to a beam or other lateral support (Figure 1). Because the member is already in compression, the effect of a small deflection is amplified and the column could buckle.

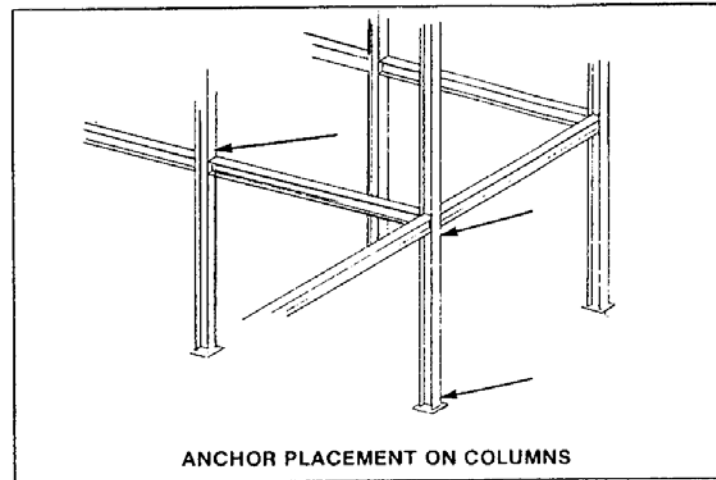

Figure 1

Beams

Load beams near column or other vertical support points to minimize bending (Figure 2). If the beam is an I section, it may be necessary to weld stiffeners to the web to withstand the additional shear force applied (Figure 3).

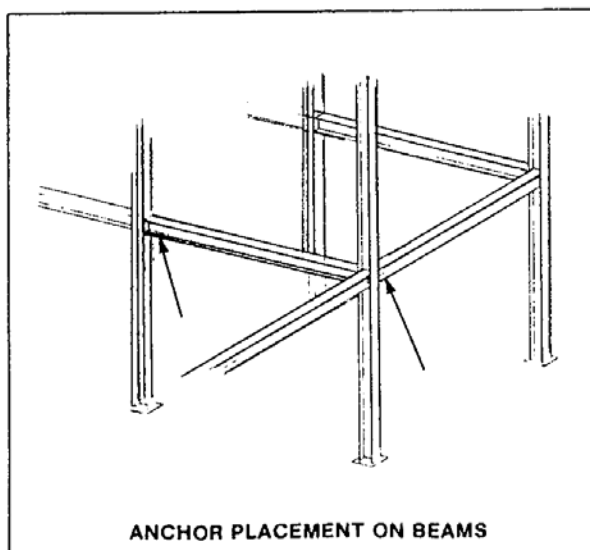

Figure 2

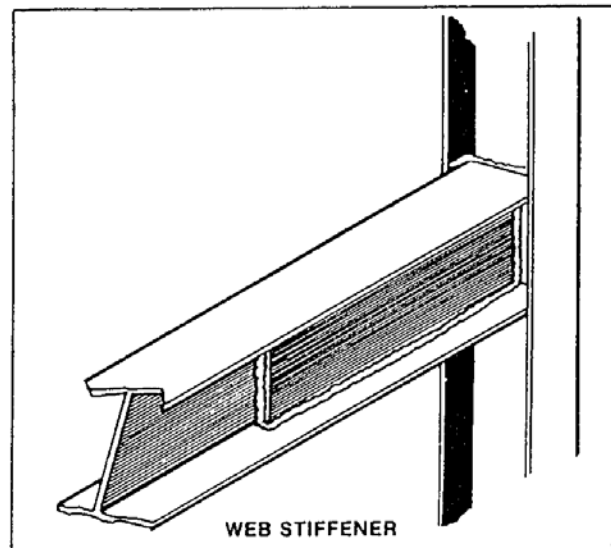

Figure 3

Beam Clamps

Beam clamps provide a very secure anchorage point if used correctly. They are commonly available with capacities up to 12 tons and have various jaw widths. Figure 5 shows different types.

The jaws are usually designed for a range of flange widths. For example, one clamp might fit flanges 4½" to 9" wide. Clamps should never be used on flanges outside the range specified as they will not afford sufficient grip on the member.

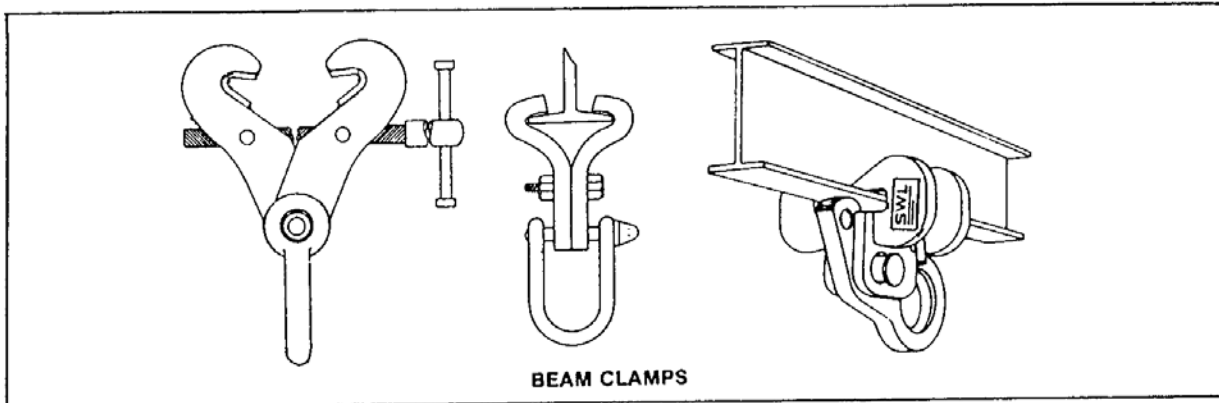

Figure 5

Most beam clamps are designed for use at 90° to the flange. For applications requiring an angle loading, make sure that the clamp is designed for it and that the beam can withstand it (Figure 6).

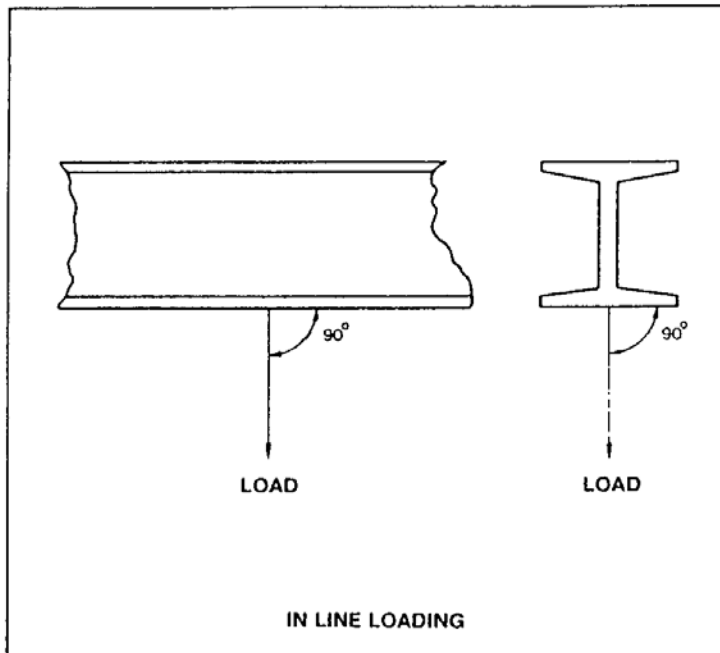

Figure 6

Be particularly careful that the load does not deform the flange. This is most likely to occur with light sections where the flange is wide and thin.

Beam clamps should be centred on the flange and properly seated.

Manufacturers are required to mark beam clamps with safe working loads. But the ratings apply only to the clamps. The capacity of the beam must be evaluated separately.

Slings

Slings are a common method of anchoring equipment to a structure. The double wrap basket hitch is the preferred method since the load in the sling is shared on two legs and the double wrap distributes the load on the member. It is also less prone to slippage than a single choker or single basket hitch. Make sure that the sling is long enough to avoid sharp angles in the legs (Figure 7).

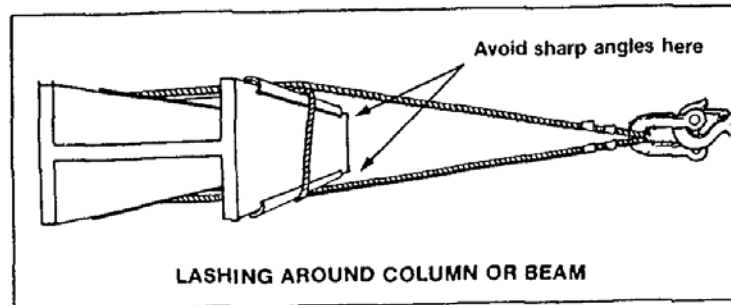

Figure 7

The use of softeners will protect the member and the sling from damage and increase the radius of bending in the sling. Figure 8 shows how strength diminishes as wire rope is bent around smaller and smaller diameters.

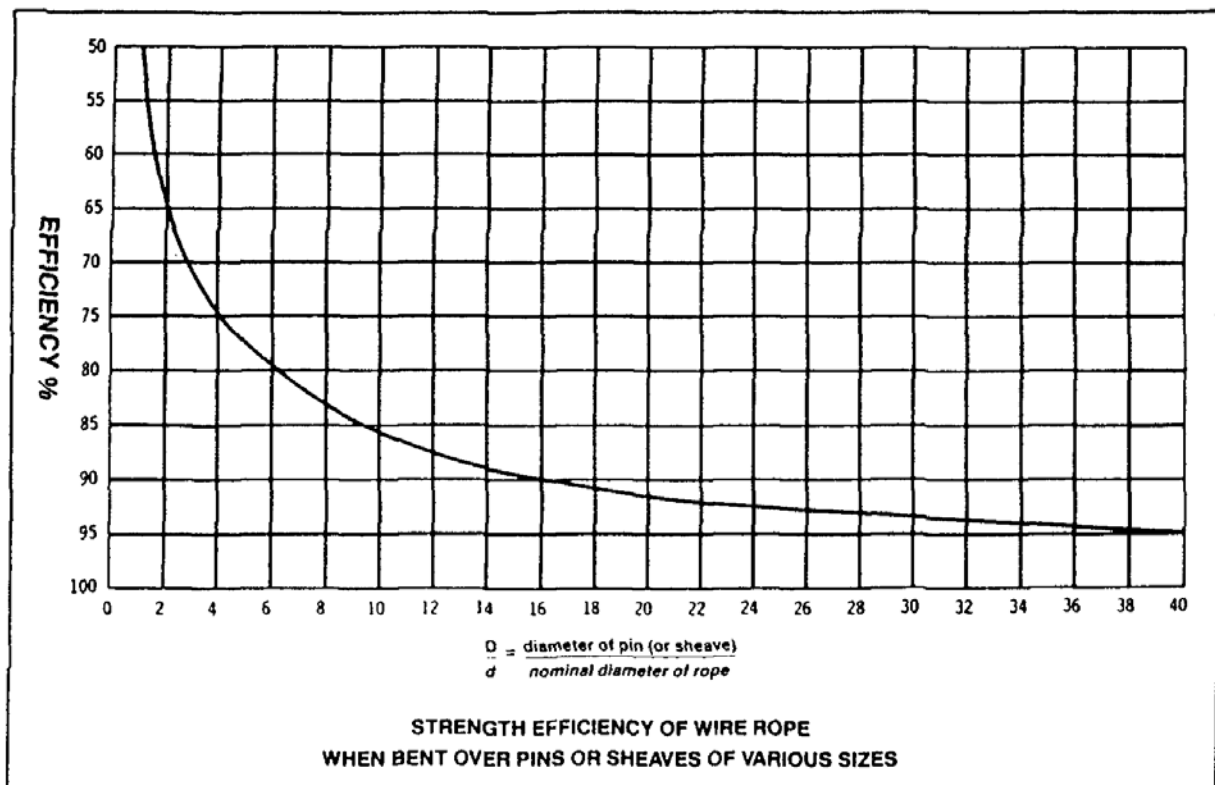

Figure 8

Welded Lugs

Lugs welded to a beam or column must be compatible with the member in metallic composition. The appropriate welding rod must also be used. The lug should be welded on the centreline of the flange, in line with the web (Figure 9). Keep loading in line with the lug. Avoid side loading.

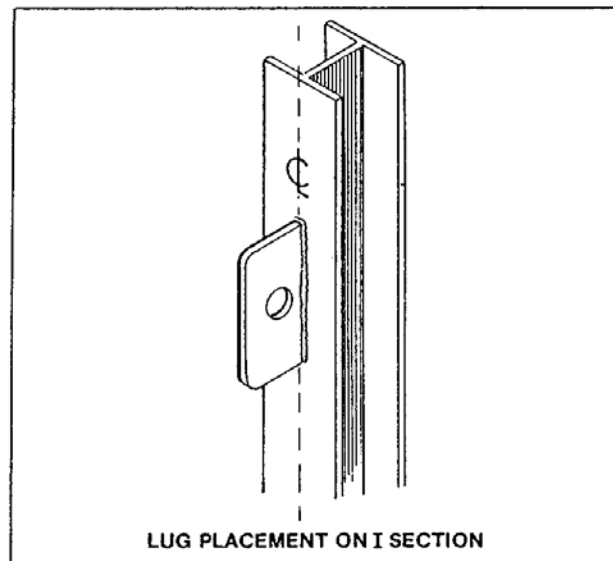

Figure 9

Whatever the method of attachment, it is important to realize that the structure is usually not designed for the additional loads applied. The only way to be sure is through evaluation by a structural engineer.

Section 5

Introduction to Crane Operations

- Responsibilities**
- Basic Types and Configurations**
- Hazards in Crane Operating Areas**
- Working near Powerlines**
- Factors Affecting Crane Capacity**
- Setup Summary**
- Machine Selection**
- Signalling**

Introduction to Crane Operations

Crane operation carries with it a greater potential for disaster than nearly any other activity on a construction project. Crane accidents are often the most costly construction accidents when measured either in lives or in dollars. All personnel involved in crane operations must understand their jobs, their responsibilities, and their part in the overall safety of each lift.

Preparation begins with a clear definition of responsibilities. No single set of guidelines can cover every detail of the many different types of crane operations. But this section spells out primary responsibilities for the major parties involved—owners, operators, site supervision, and workers.

Responsibilities entail knowledge. Riggers must be trained and experienced. They must know how to

- establish weights
- judge distances, heights, and clearances
- select tackle and hardware suitable to the load
- rig the load safely.

Signallers must be competent and capable of directing the crane and load to ensure safe, efficient operation. Knowledge of the handsignals for hoisting is a must, as it is for operators.

The crane operator is generally responsible for the safety of the operation as soon as the load is lifted clear of the ground. Whenever there is reasonable cause to believe that the lift may be dangerous or unsafe, the operator must refuse to proceed until the concern has been reported to the supervisor, any hazard has been corrected, and safe conditions have been confirmed.

This section includes information of use to riggers, operators, and others involved either directly or indirectly in crane operations. The information covers major responsibilities, hazards and safeguards in crane operating areas, factors that affect crane capacity, pinch points and other hazards around equipment, considerations for safe setup, requirements for providing signallers, and the international handsignals for hoisting.

Responsibilities

Crane Owner

The crane owner must ensure that

- safe, suitable equipment is provided to meet the requirements of the job
- operators are capable and aware of their responsibilities
- maintenance, repair, transport, assembly, and other personnel are trained and experienced to handle their specific jobs
- training and upgrading are provided for all personnel
- responsibilities and authority are clearly designated for each crew
- a thorough equipment maintenance and inspection program is in operation, including logbooks and other required documentation
- client and site supervision are capable and aware of their responsibilities
- equipment is maintained and inspected in accordance with manufacturer's requirements and applicable regulations.

Operator

The operator is generally responsible for the safety of the crane operation as soon as the load is lifted. Operators must know

- the particular model of crane they operate, its characteristics, functions, and limitations
- the information in the crane's operating manual
- the crane's load chart, including all notes and warnings, and how to calculate or determine the crane's actual net capacity in every possible configuration
- proper inspection and maintenance procedures to be followed in accordance with the guidelines of manufacturer and owner
- any site conditions that may affect crane operation, including the presence of overhead powerlines
- basic load rigging procedures.

In addition, the Operator must

- inform the owner, in writing, of any problems with the machine, preferably in the machine's logbook
- record in the logbook all inspection, maintenance, and work done on the crane in the field
- check that the site is properly prepared for crane operation
- review plans and requirements with site supervision
- find out the load and rigging weight and where the load is to be placed

[Although operators are NOT responsible for determining load weights, they become responsible if they do so or if they lift the load without checking the weight with site supervision.]

- determine the number of parts of hoist line required
- check the load chart to ensure that the crane has enough net capacity for each planned lift
- select the best boom, jib, and crane configuration to suit load, site, and lift conditions
- assume responsibility for assembling, setting up, and rigging the crane properly
- follow the manufacturer's operating instructions in accordance with the load chart
- consider all factors that may reduce crane capacity and adjust the load weight accordingly
- maintain communication with signallers
- ensure that the oiler is in a safe place during operation
- operate in a smooth, controlled, and safe manner
- shut down and secure the machine properly when leaving it unattended.

Site Supervision

Site supervision (foreman, rigger foreman, lead hand of the trade involved, etc.) has overall responsibility for the lift and must therefore plan all phases of the operation. Specifically, site supervisors must

- supervise all work involving the crane
- determine the correct load weight and radius and inform the operator
- ensure that the rigging crew is experienced and capable of establishing weights; judging distances, heights, and clearances; selecting tackle and lifting gear suitable to the loads; rigging the load safely and securely
- supervise the rigging crew
- ensure that the load is properly rigged
- ensure that signallers are capable of directing the crane and load, including use of the international hand signals where other forms of communication are not possible
- designate signallers and identify them to the operator
- ensure the safety of the rigging crew and other personnel affected by crane operations
- keep the public and all non-essential personnel clear of the crane during operation
- control the movements of all personnel in the area affected by the lift
- ensure all required precautions when the lift is near powerlines
- ensure that all personnel involved in the operation understand their jobs, responsibilities, and their role in the overall safety of each lift.

Basic Types and Configurations

The evolution of the mobile crane has led to many types and designs to satisfy both the general as well as the specific needs of construction and industrial operations. This manual is concerned with mobile cranes used for construction purposes as well as industrial applications.

The basic operational characteristics of all mobile cranes are essentially the same. They include:

- Adjustable boom lengths
- Adjustable boom angles
- Ability to lift and lower loads
- Ability to swing loads
- Ability to travel about the jobsite under their own power.

Within the broad category of mobile cranes there have evolved the following basic types and configurations:

- Boom Trucks
- Industrial Cranes
- Carrier-Mounted Lattice Boom Cranes
- Crawler-Mounted Lattice Boom Cranes
- Carrier-Mounted Telescopic Boom Cranes
- Crawler-Mounted Telescopic Boom Cranes
- Rough Terrain Cranes
- Mobile Tower Cranes
- Heavy Lift Mobile Cranes.



Boom Trucks

Unlike all other mobiles, these cranes are mounted on carriers not designed solely for crane service. They are mounted on a commercial truck chassis that has been specially strengthened to accept the crane. They are, however, a type of mobile crane with respectable capacity and boom length.

Included in this basic type of machine are two common configurations.

TELESCOPING BOOM
 Boom sections are usually telescoped either manually or hydraulically.

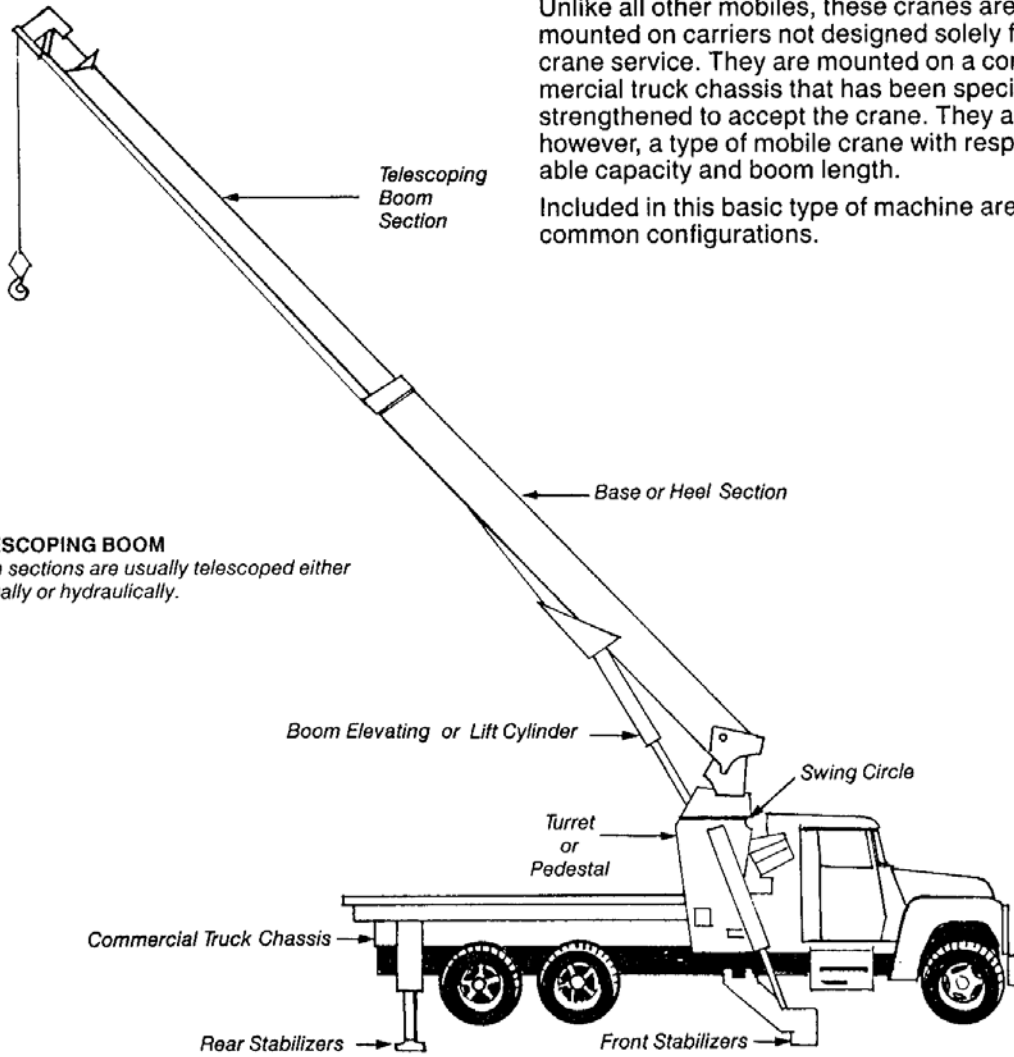

KNUCKLE BOOM
 The boom articulates (folds) under hydraulic pressure and may or may not be equipped with a powered drum and wire rope.

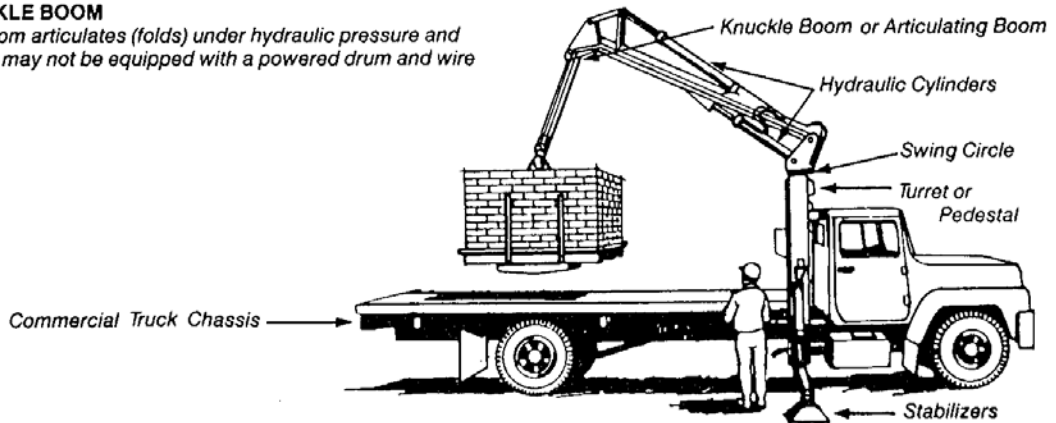

Industrial Cranes

These cranes are primarily intended for operation in industrial locations where working surfaces are significantly better than those found on most construction sites.

Although these cranes will not be analyzed specifically, their characteristics are basically identical to those of telescopic boom mobiles, which are covered in detail.

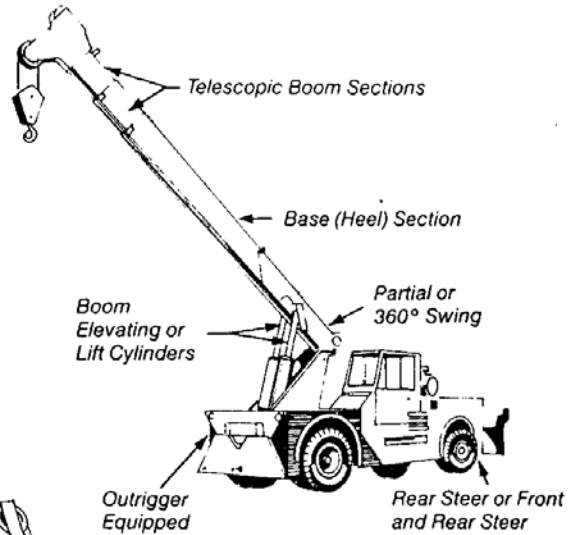

PICK AND CARRY

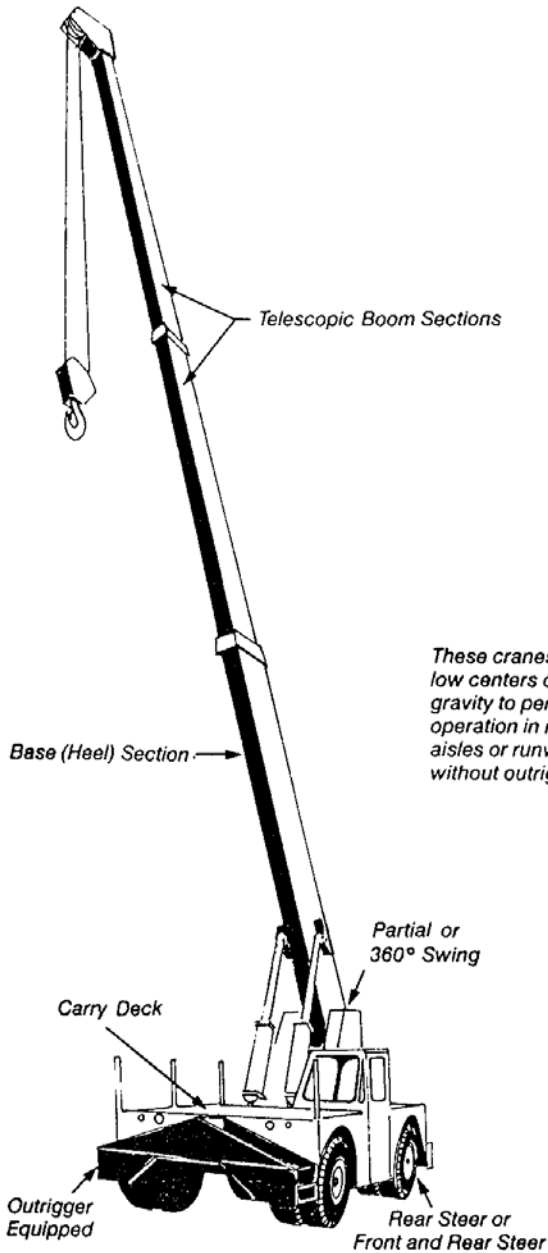

CARRY DECK — ROTATING BOOM

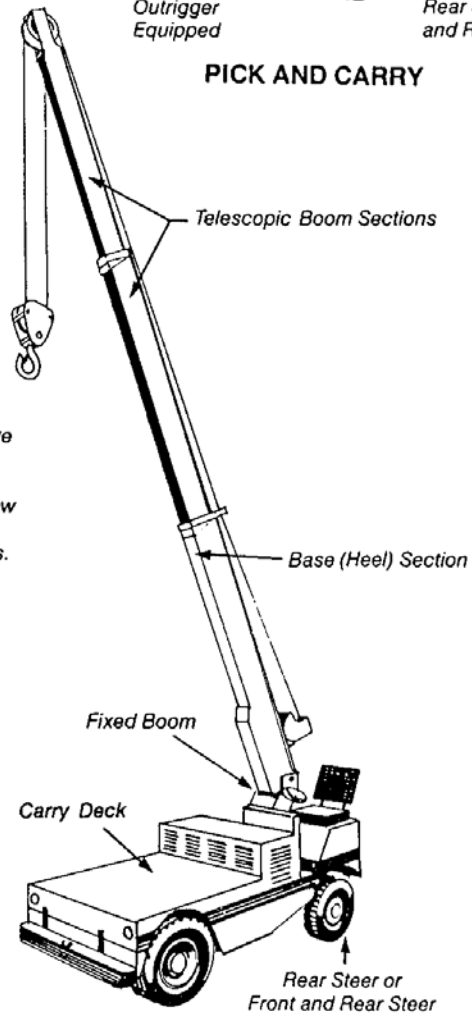

CARRY DECK — FIXED BOOM

These cranes have low centers of gravity to permit operation in narrow aisles or runways without outriggers.

Carrier-Mounted Lattice Boom Cranes

This "truck type" carrier must not be confused with the ordinary commercial truck chassis. It is specially designed for crane service and the heavy loads these cranes are required to withstand.

Carrier-mounted cranes are also commonly referred to as "Truck Cranes", "Conventional Cranes", "Friction Cranes", "Mobile Cranes", etc.

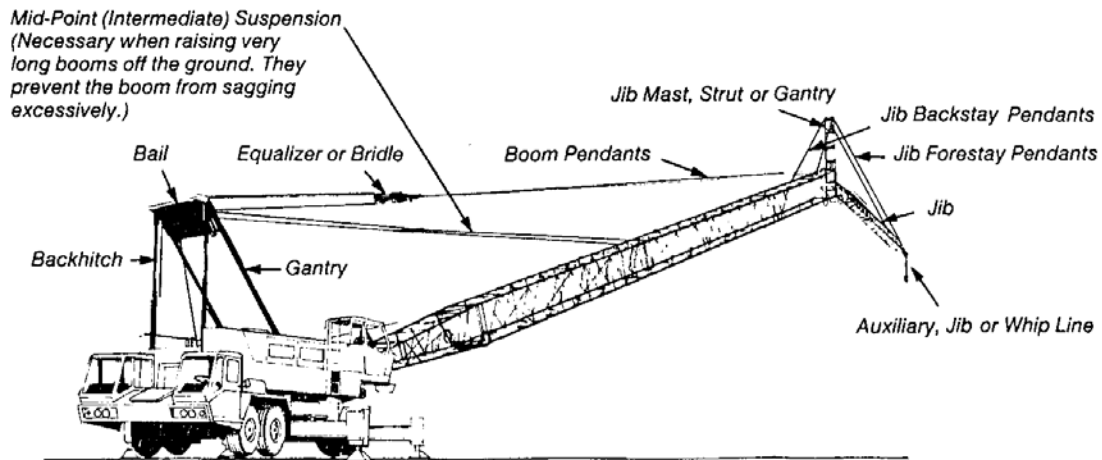
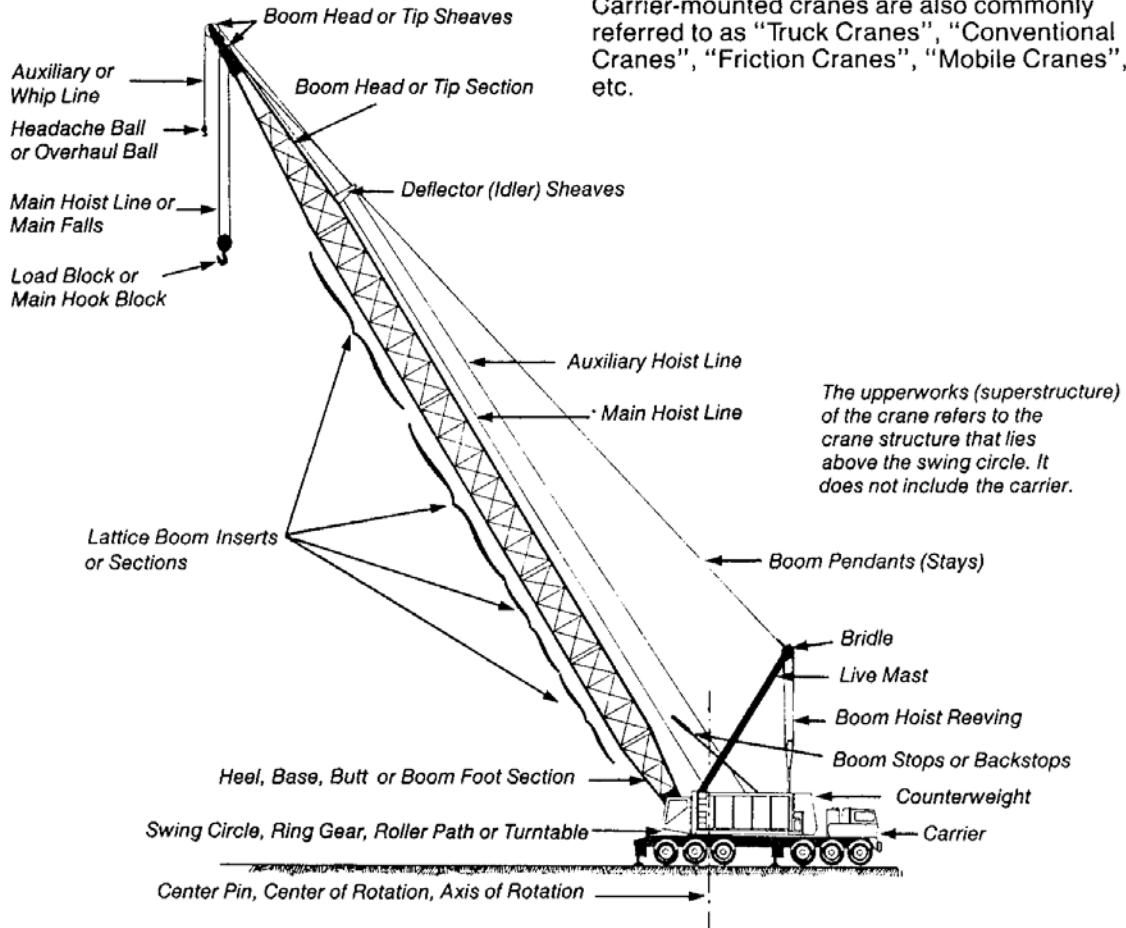

Carrier-Mounted Lattice Boom Cranes continued

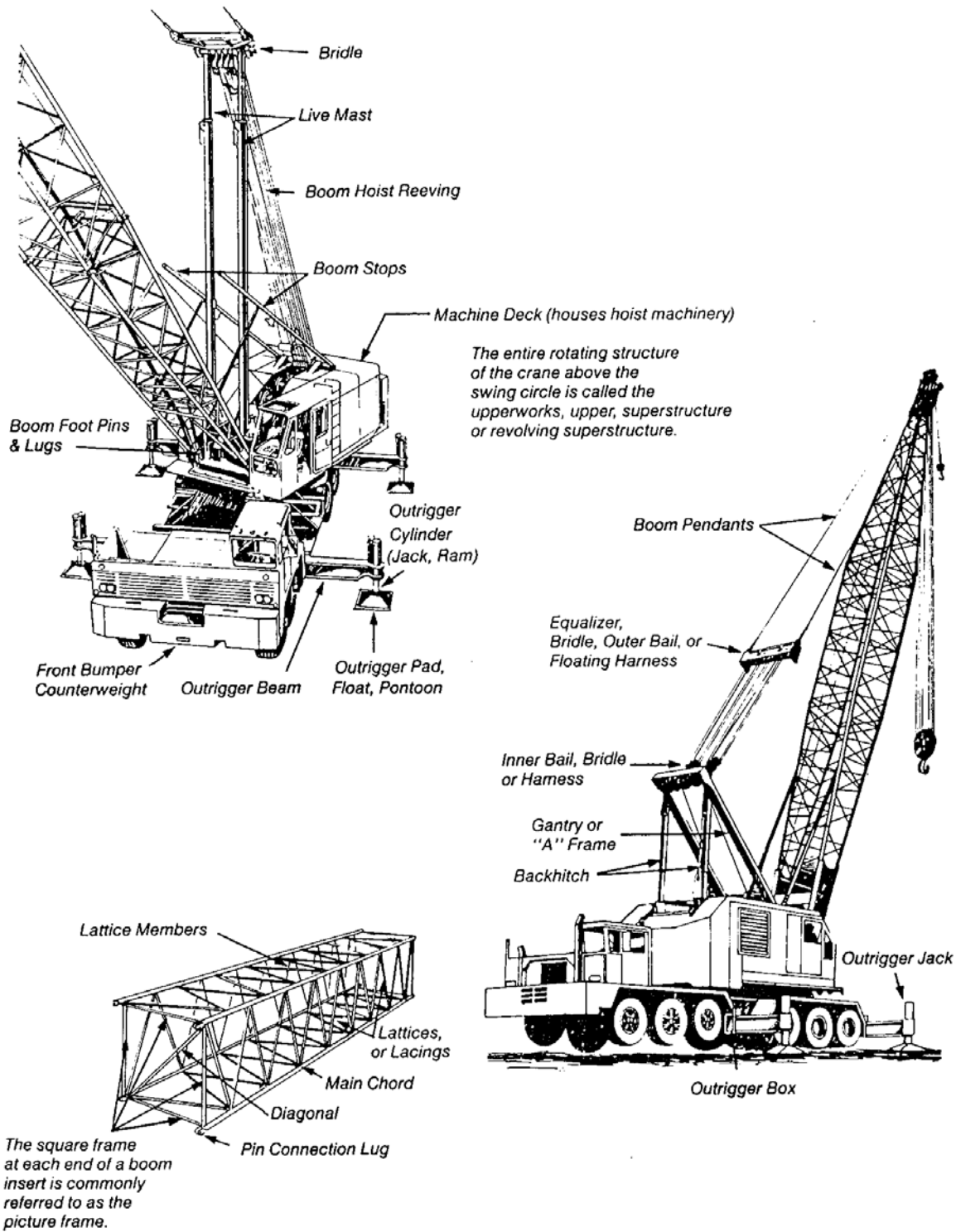

Crawler-Mounted Lattice Boom Cranes

Except for their base and method of load rating, the upperworks of these machines are identical to the carrier-mounted units

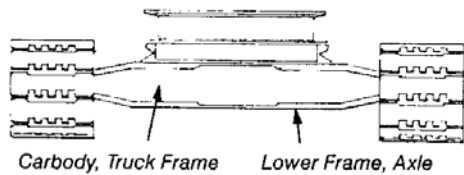
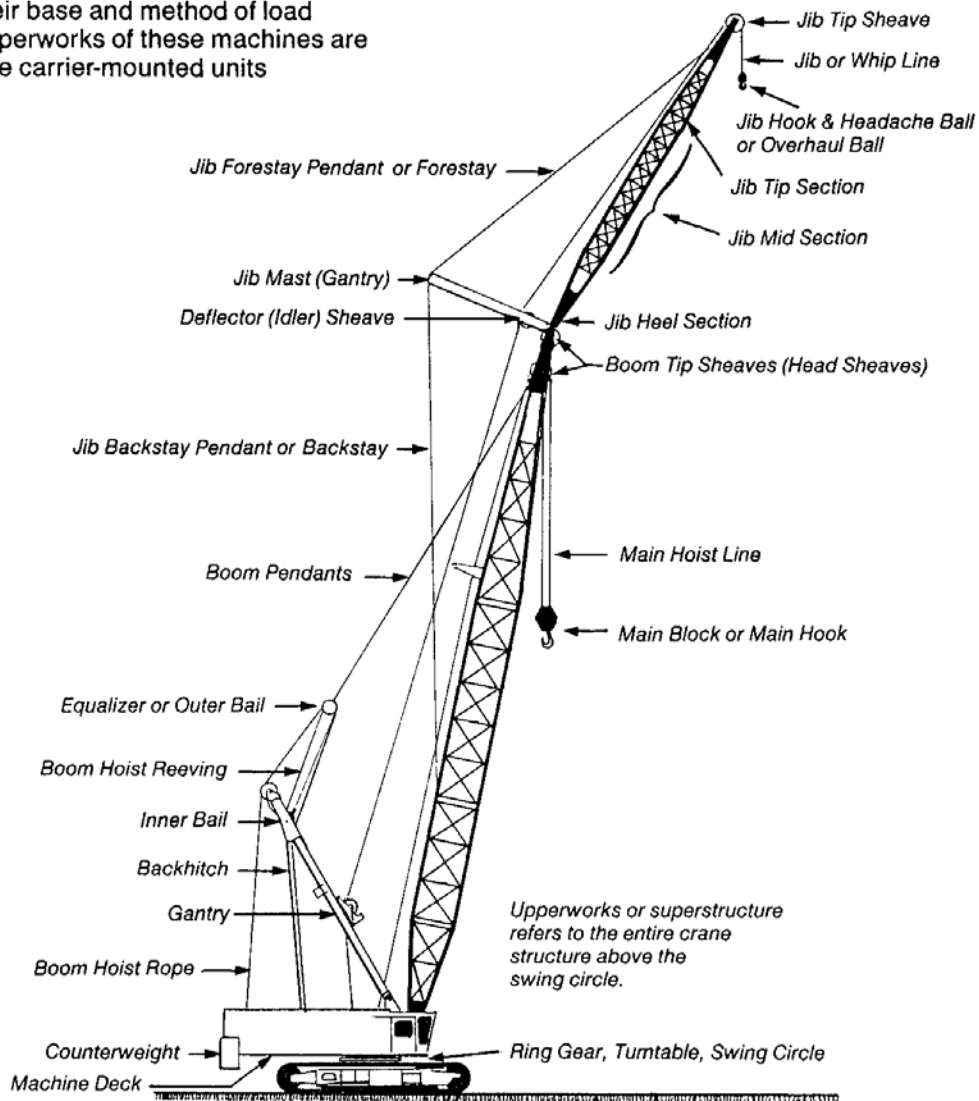
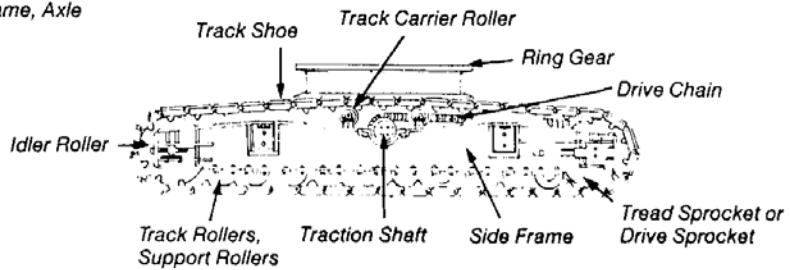
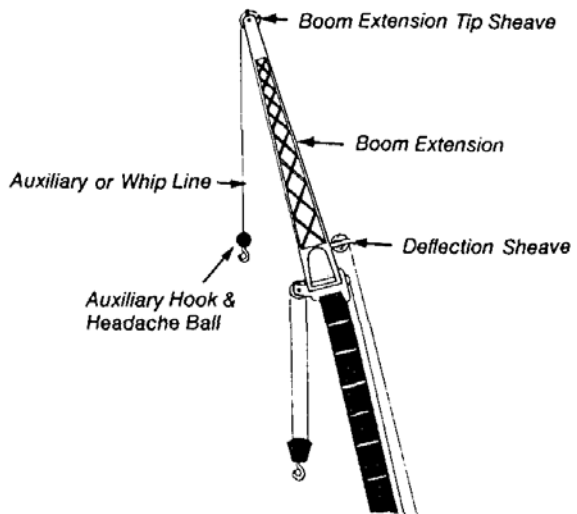
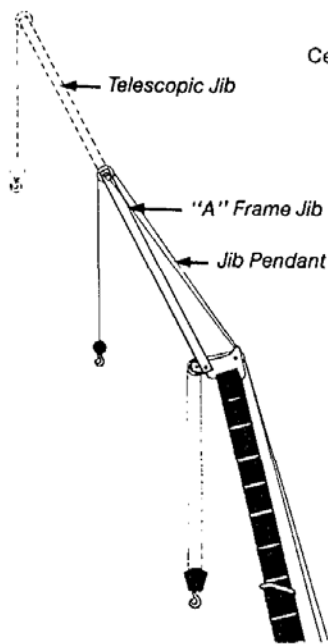
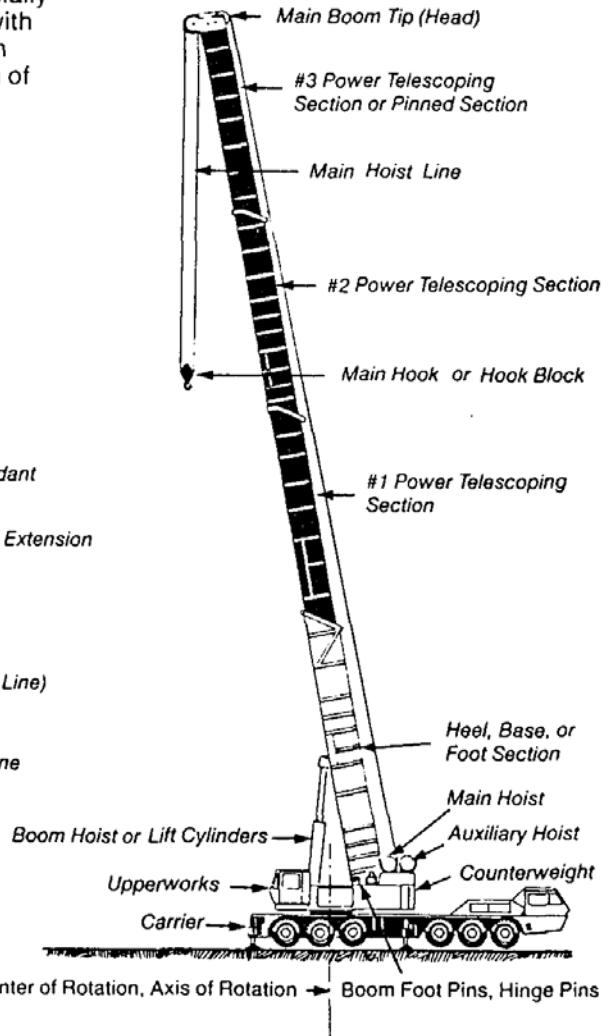
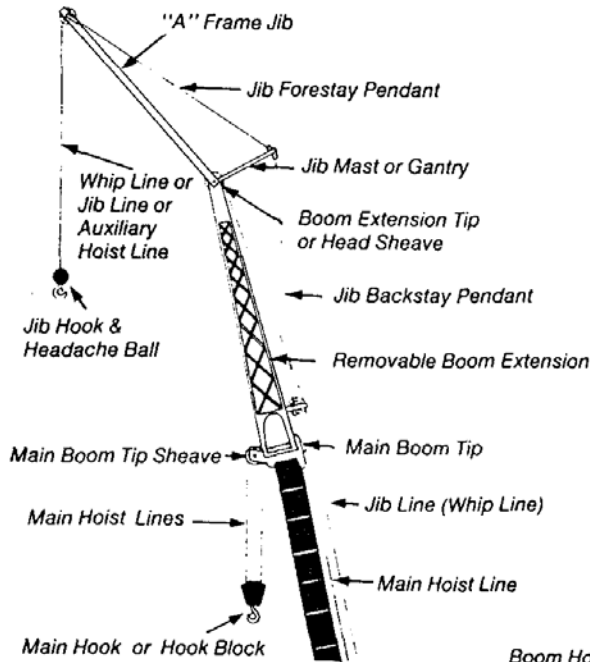

Illustration shows a unit with traction shaft and chain drive but hydrostatic track drive systems are also available.



Carrier-Mounted Telescopic Boom Cranes

These machines are also mounted on specially designed carriers. They can be equipped with a variety of jibs and boom extensions which can be stowed on or under the heel section of the main boom.



Carrier-Mounted Telescopic Boom Cranes continued

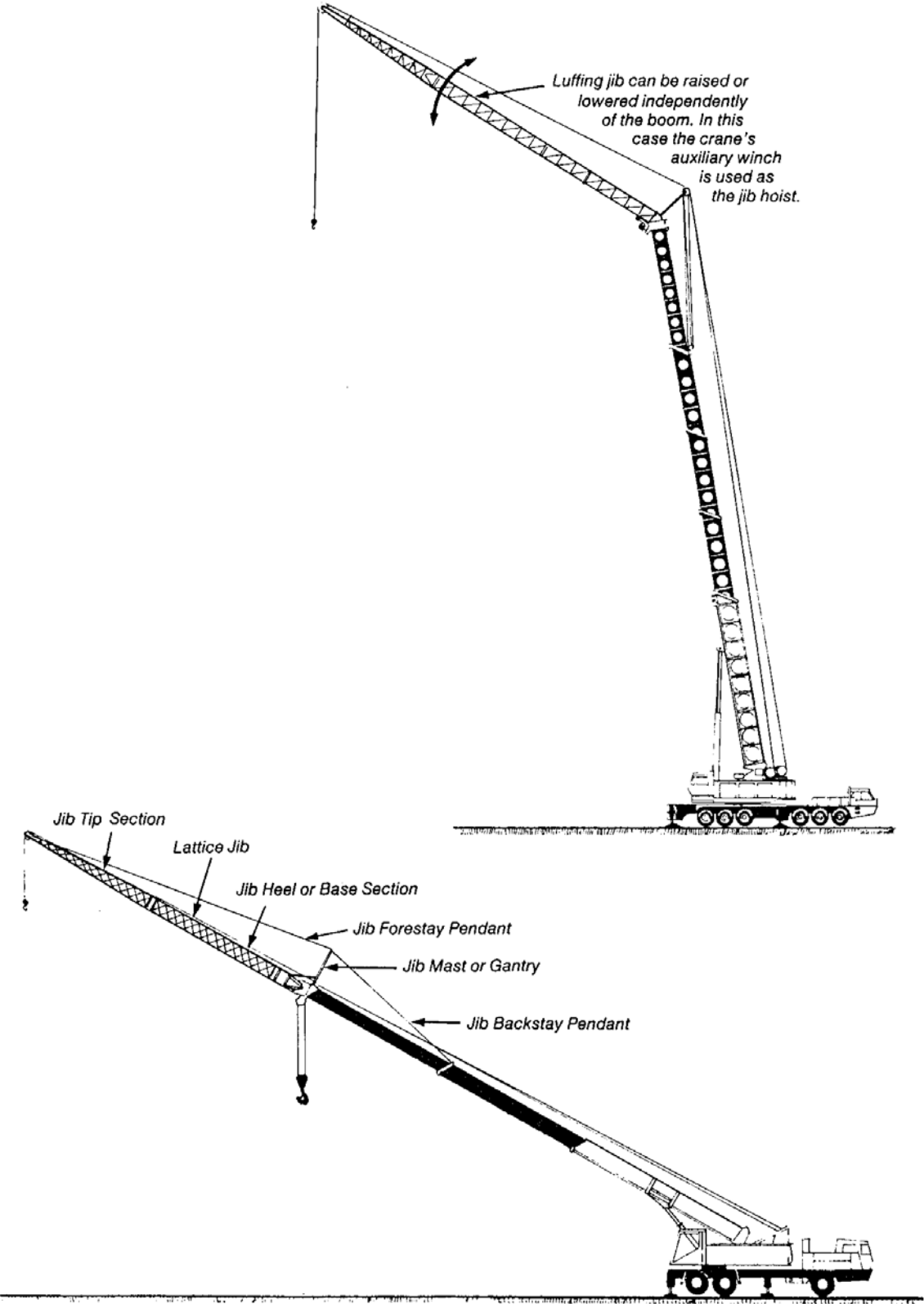

Carrier-Mounted Telescopic Boom Cranes continued

Carrier-mounted telescopic boom cranes are subdivided by the type of head section (boom tip section) they are equipped with.

FULL POWER BOOMS

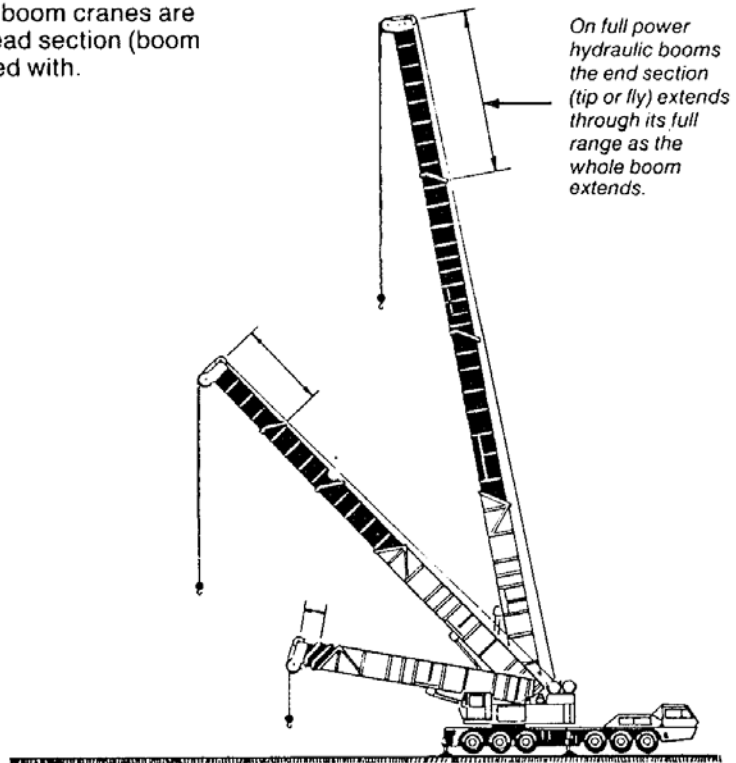

PINNED BOOMS

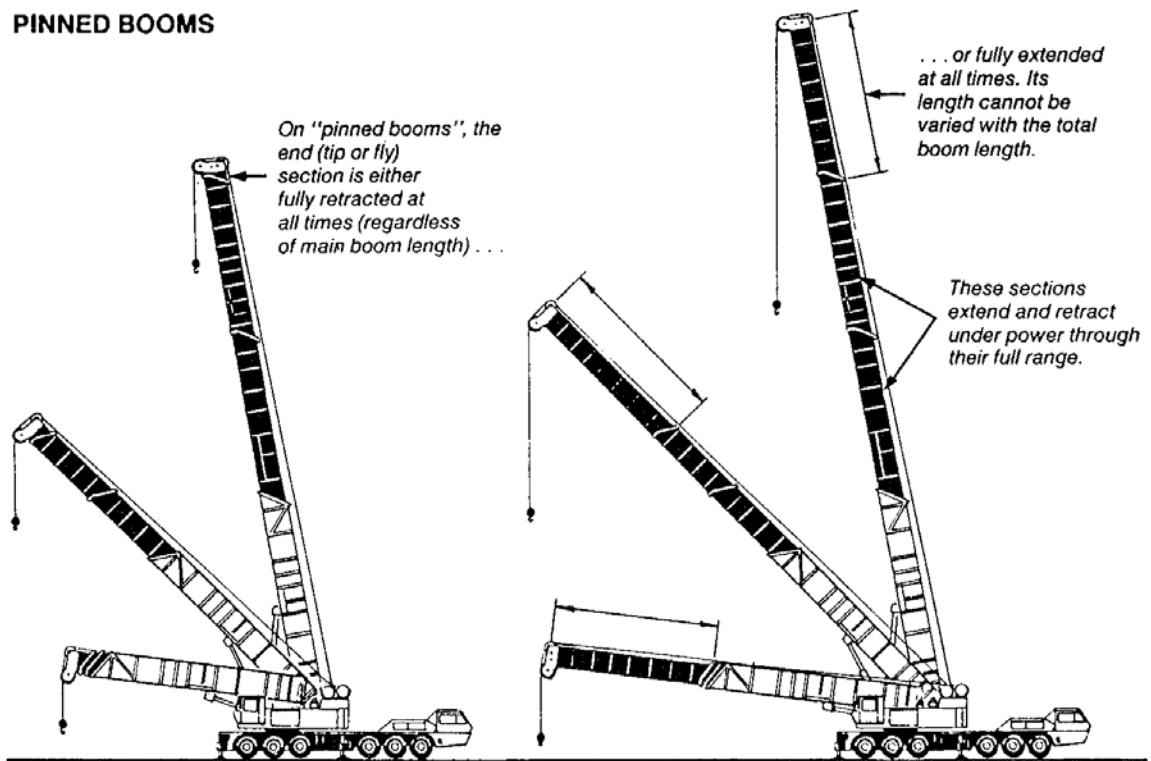

Crawler-Mounted Telescopic Boom Cranes

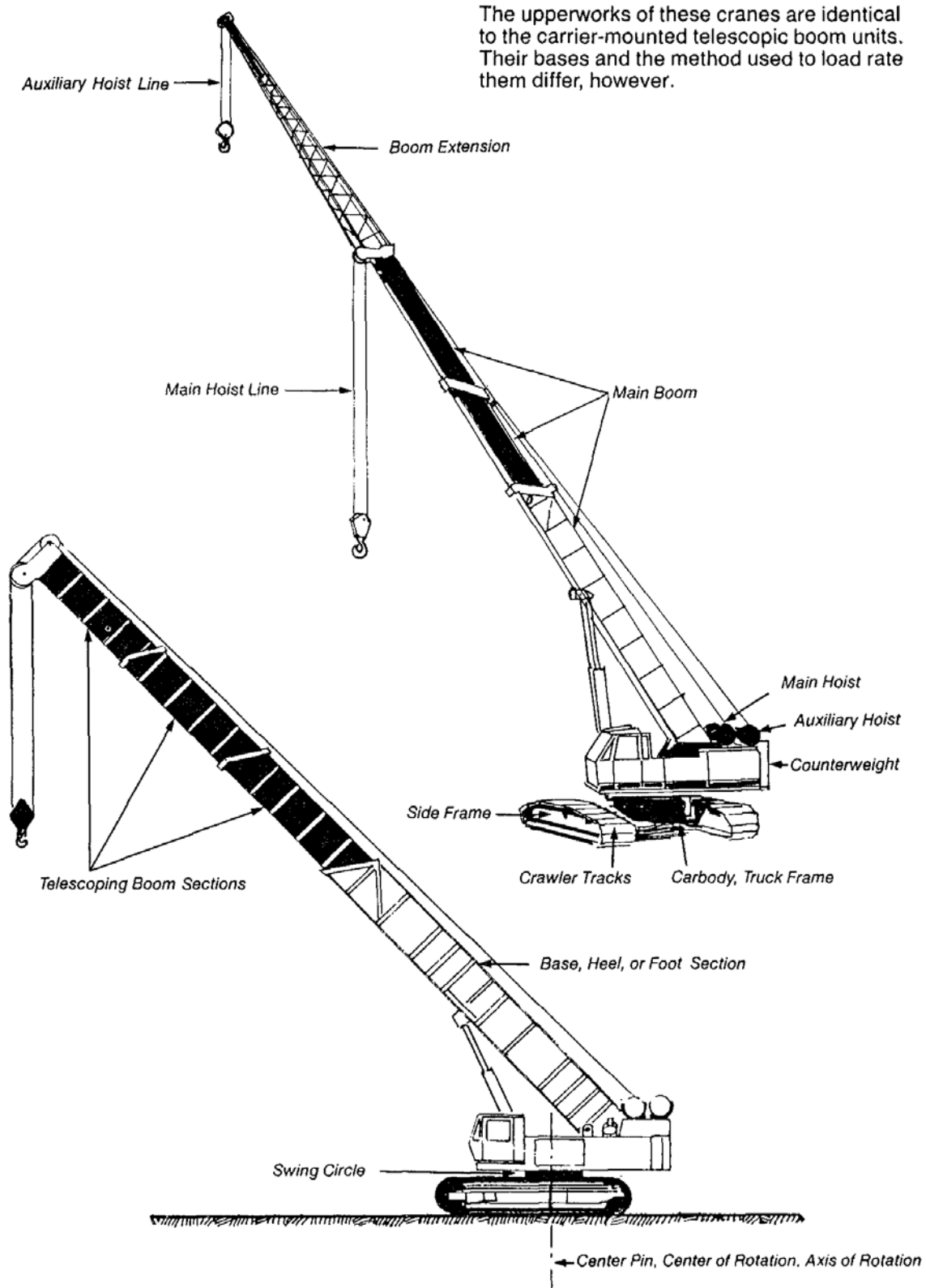

Rough Terrain Cranes

The rough terrain crane's oversized tires facilitate movement across the rough terrain of construction sites and other broken ground. Their short wheel base and crab-steering improve maneuverability. In "pick and carry" operations on rough terrain, however, they are still subject to the same operating restrictions that apply to other cranes.

Like carrier-mounted telescopic boom cranes, rough terrain units are available with either full power booms or pinned booms and the same types of jibs and boom extensions. There are two basic configurations.

FIXED CAB

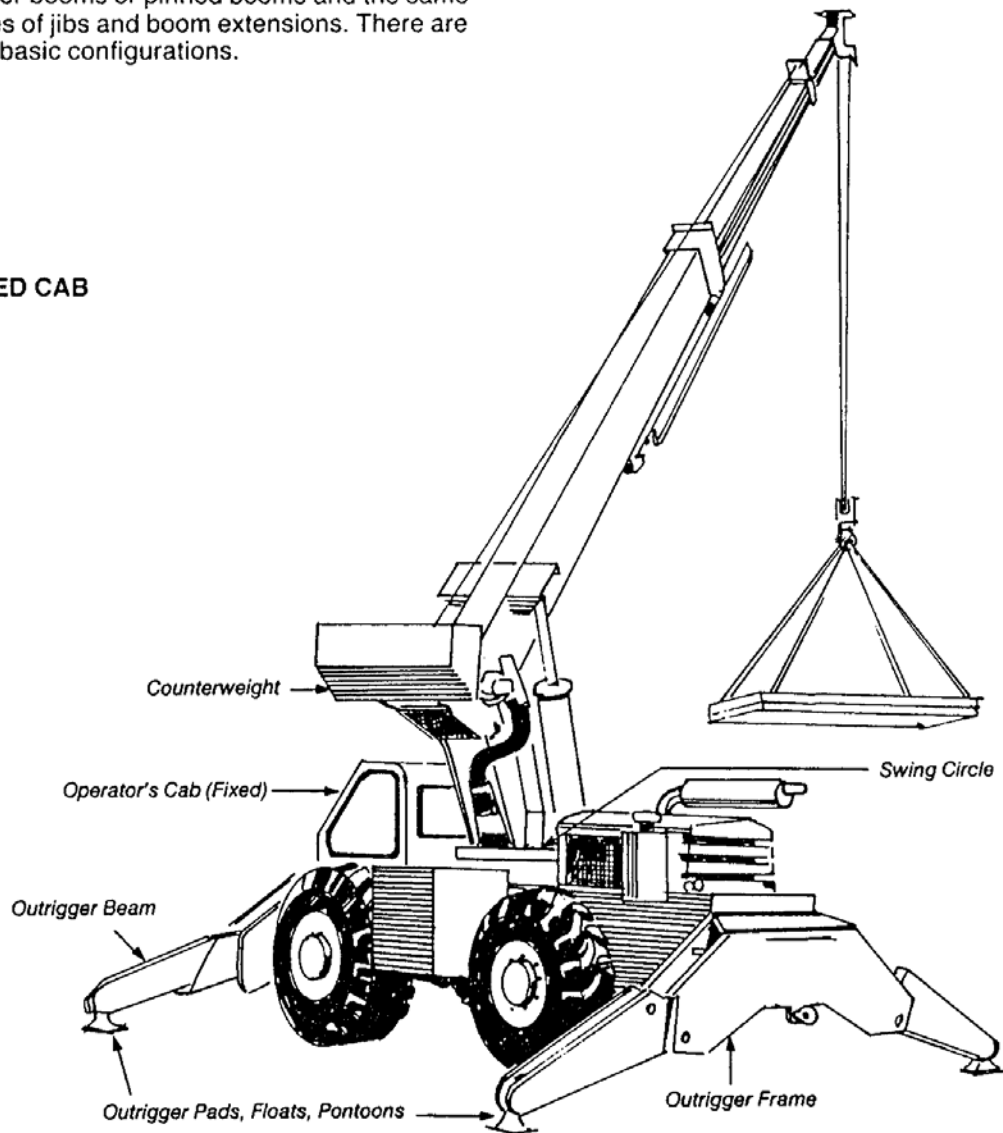

Rough Terrain Cranes continued

ROTATING CAB

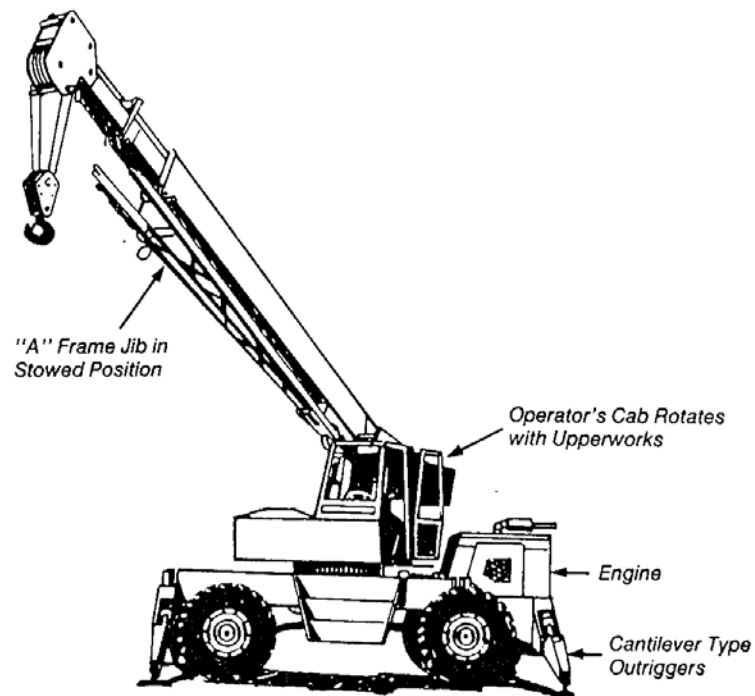
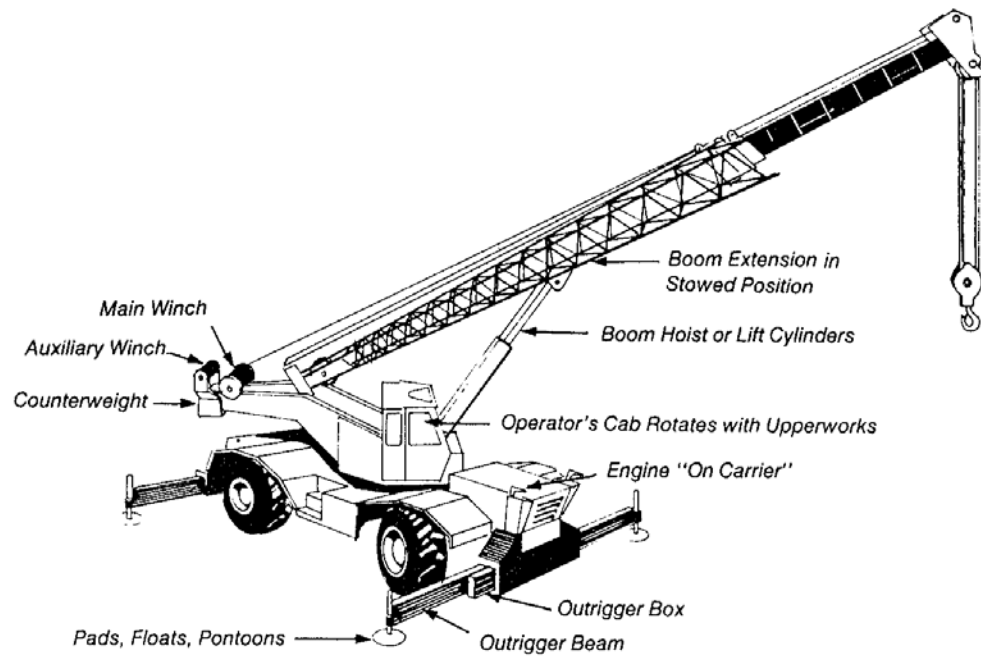

Rough Terrain Cranes continued

Like the carrier-mounted telescopic boom cranes, rough terrain cranes can be equipped with either full power booms or pinned booms as well as with a variety of jibs and boom extensions which can also be stowed on or under the heel section of the main boom.

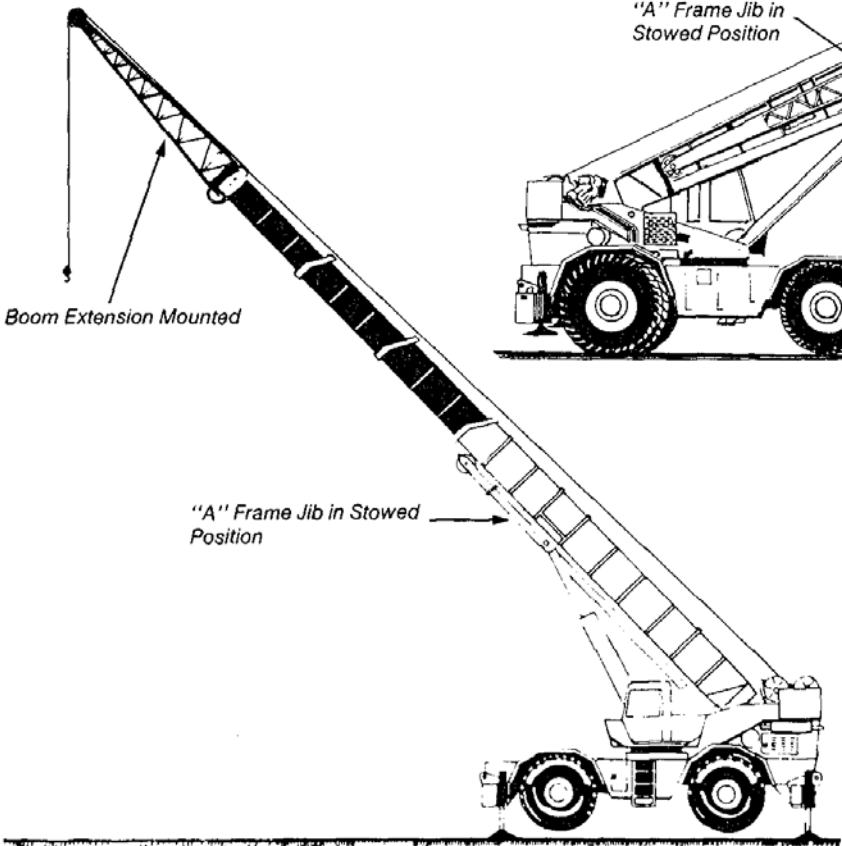
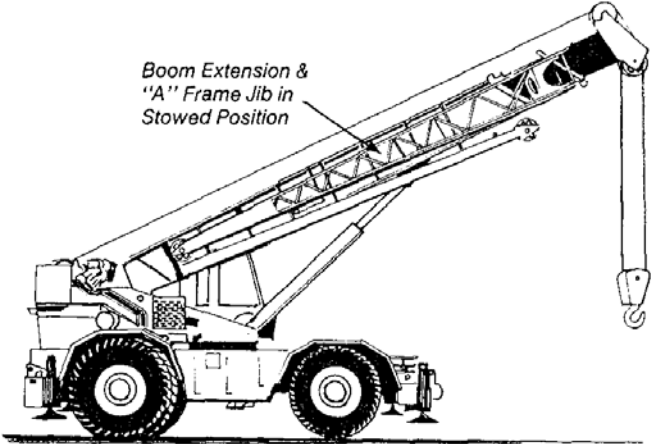
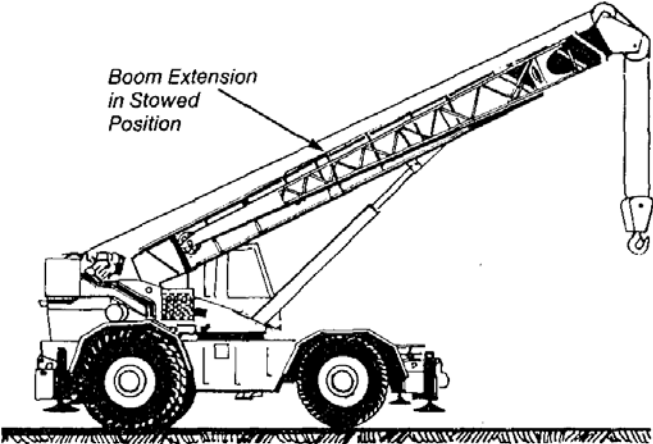

Heavy Lift Mobile Cranes

These cranes combine the best features of derricks and lattice boom mobile cranes. Typically they use very large extended counterweights, masts and often roller rings that move the boom's fulcrum and the crane's tipping axis further away from the center of gravity.

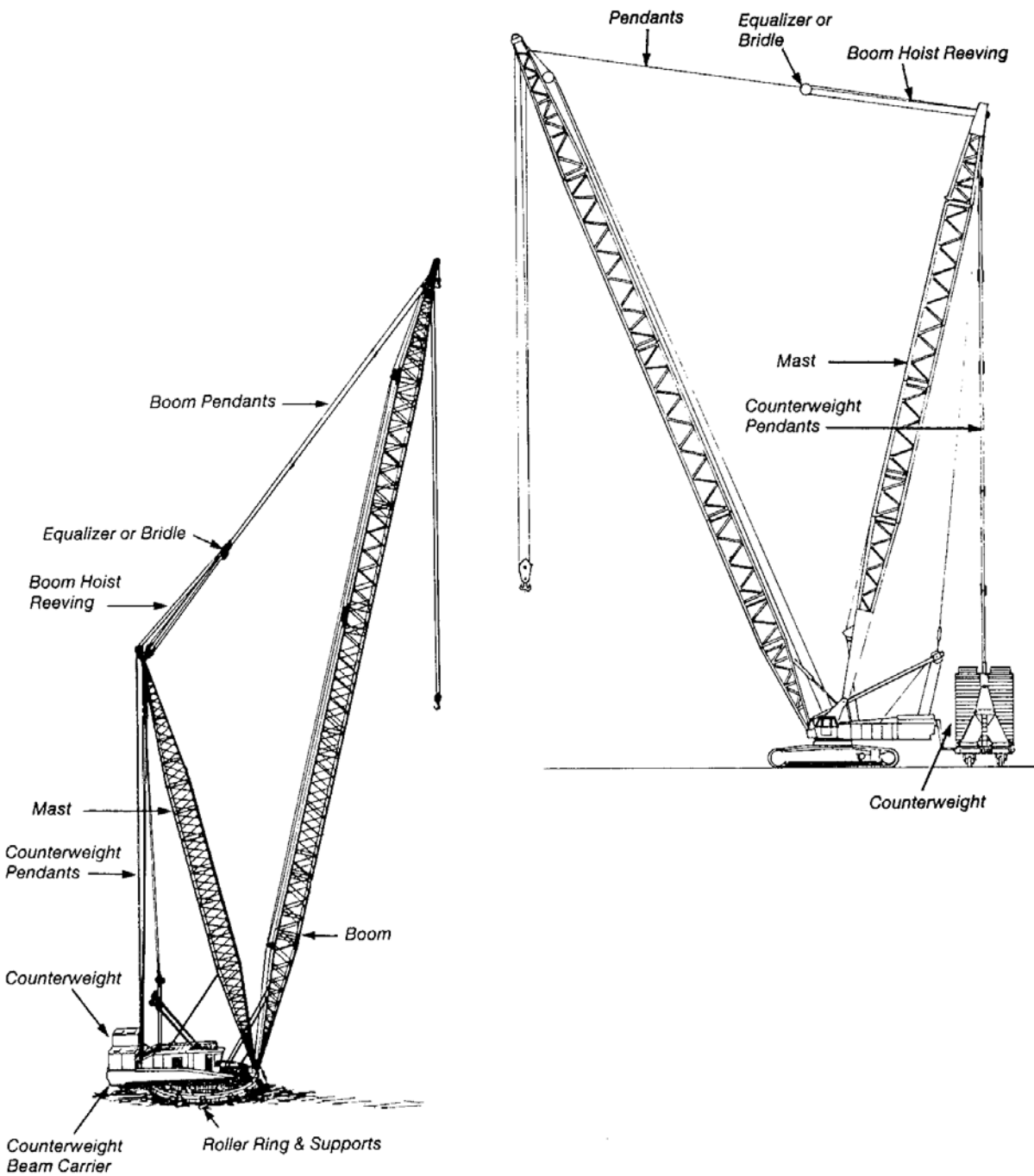

Tower Cranes

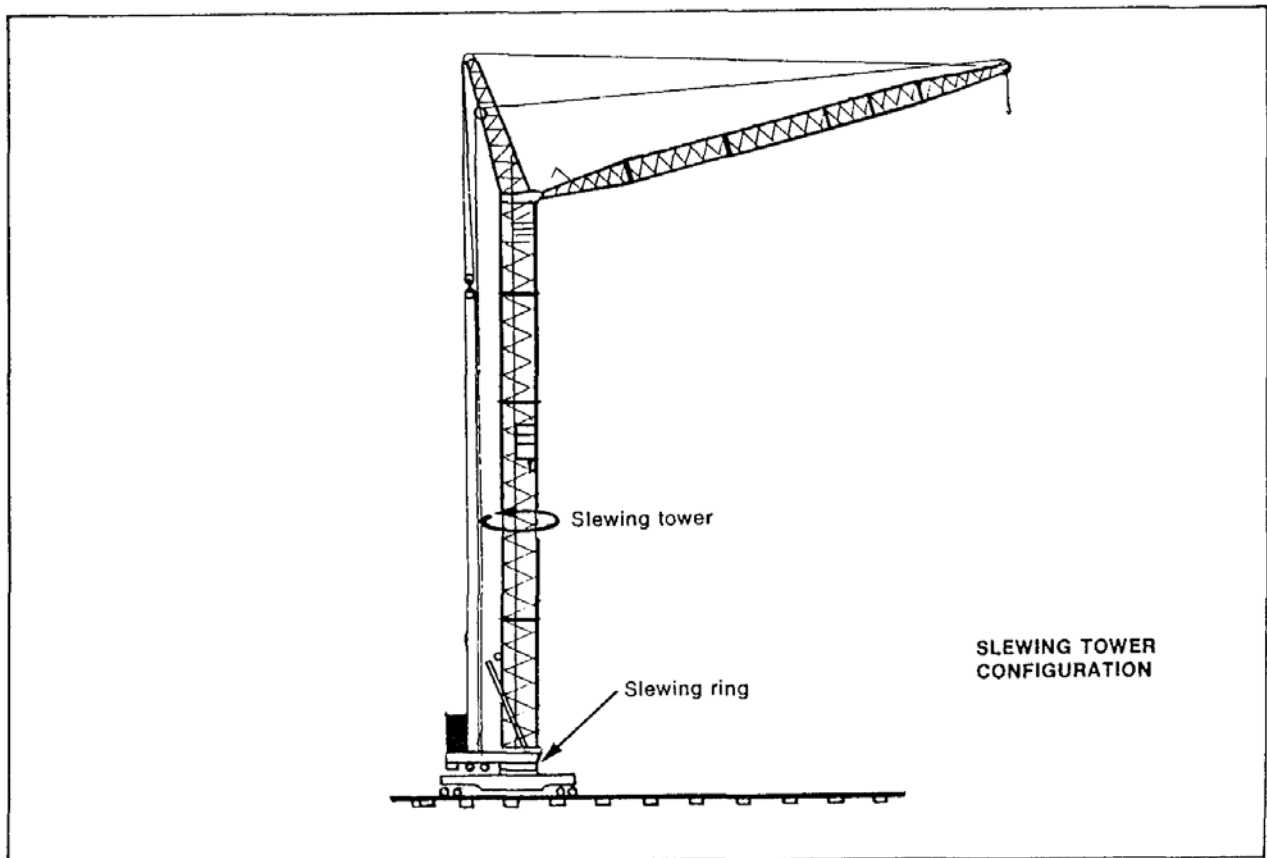
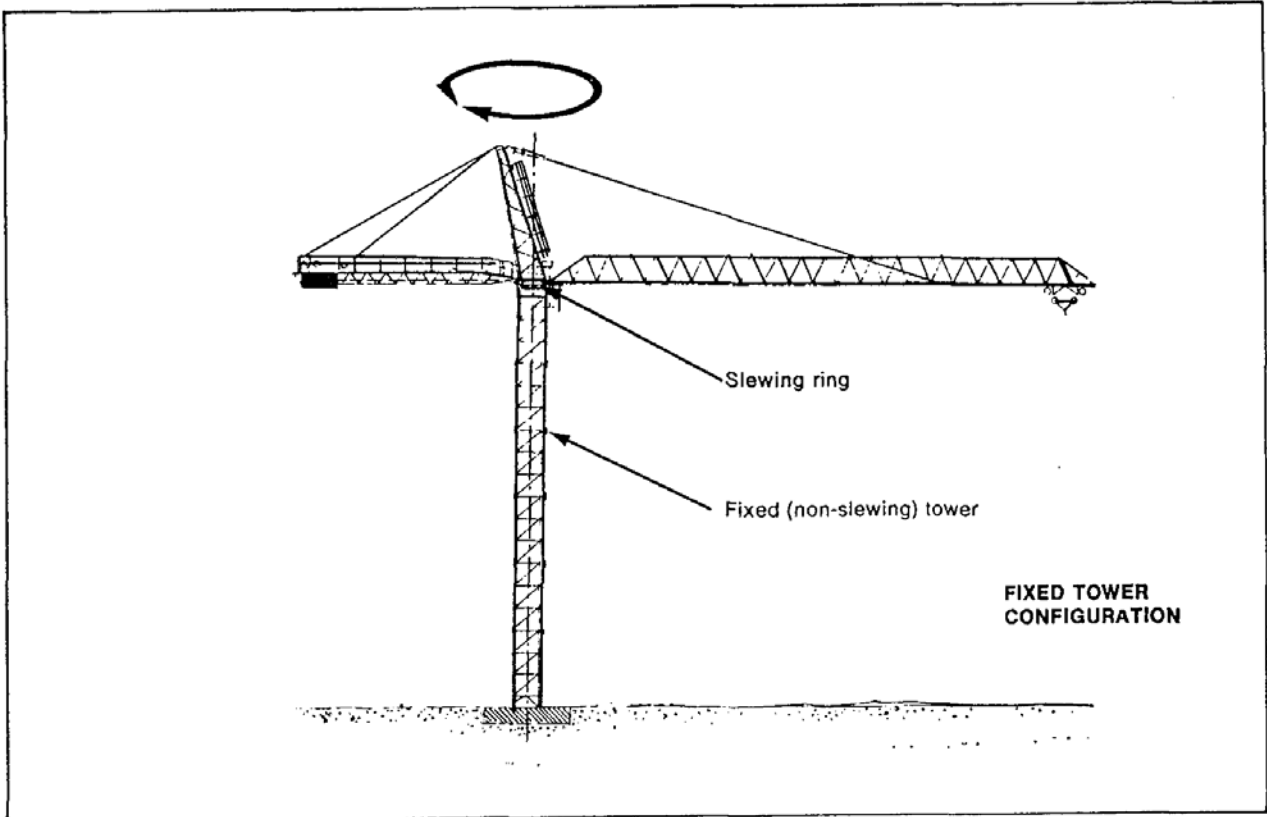

Hazards in Crane Operating Areas

Over 50% of all mobile crane accidents are the result of mistakes made when the crane was being set up.

All of these accidents can be prevented by following the manufacturer's recommendations for assembly and dismantling, by using the correct components, and by observing the precautions outlined in this section.

Remember: Improvising or taking shortcuts in assembly and setup can be fatal.

Use the checklist on the next page for reviewing the factors to consider in planning for crane and hoisting operations.

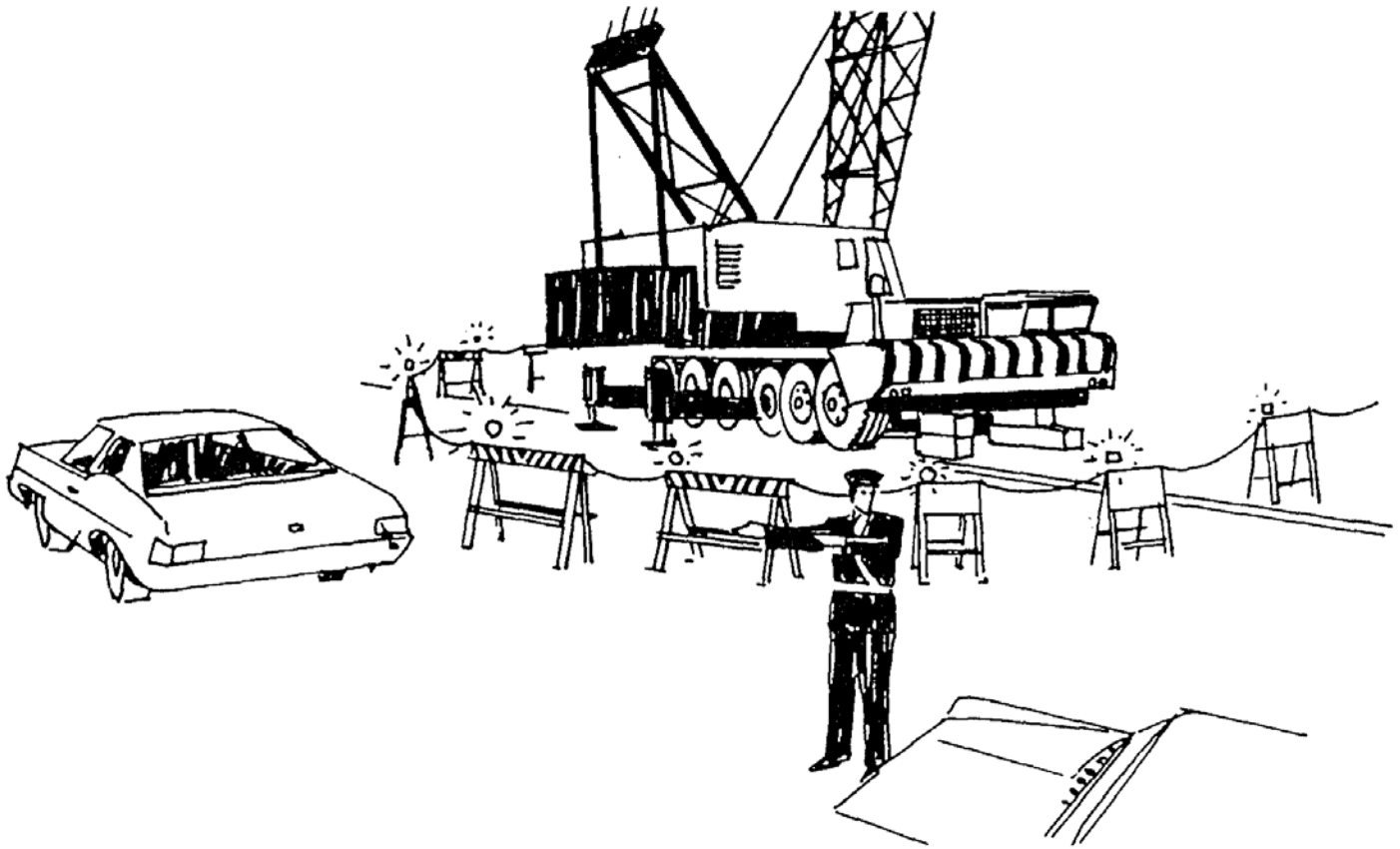

PRE-JOB CHECKLIST

Whoever requires that a crane be used—project engineer, site superintendent, foreperson, building owner, contractor, architect, or consultant—is as responsible for its safe operation as the operator.

If a working area has not been adequately prepared for the crane, the operation will be unsafe, regardless of machine capacity or operator skill. Consider the following factors.

- Can the machine get onto the site? Is the access road adequately graded and compacted? Is the access ramp too steep?
- Will the machine have to travel over buried pipes, sewers, mains, etc. that might be crushed?
- Is there room for the crane to maneuver in its designated position on site? Is there room to erect or extend the boom? Can trucks hauling boom sections get into position and be unloaded safely? Is there enough room and timber blocking to store boom sections properly?
- Will an area be designated and roped off for use by the erection crew? Will it be large enough for components to be stacked, handled, and assembled without endangering other site personnel?
- Has the crane's position been identified for every lift? What will the maximum operating radius be? Will there be at least two feet of clearance between the counterweight and nearest object? What obstacles or other hazards might be posed by existing buildings or structures?
- Are operating areas graded, compacted, and levelled? Are they away from shoring locations, excavations, slopes, trenches, embankments, etc. which could subside under machine weight and vibration? Are operating areas over cellars, buried pipes, mains, etc. that may collapse?
- Will clearance and visibility be problems where other cranes, hoists, or equipment will be operating? Will operators have a clear view of other equipment to avoid collisions and keep hoisting ropes and loads from fouling? Will operators be provided with direct communication to warn one another of impending danger? Will the overall lifting program be laid out, controlled, and prioritized by one person in contact with all operators and each rigging crew?
- Will crane operating areas be away from public traffic and access? Will signallers and warning signs be provided when crane operations may overlap with public areas? Has police cooperation been arranged to provide traffic and pedestrian control?
- Have operators been warned and have provisions been made to keep cranes from working within a boom's length of powerlines without
 - a) shutting off power
 - b) having the powerlines insulated, or
 - c) providing signallers to warn the operator when any part of the crane or load nears the limits of approach specified by the *Regulations for Construction Projects*?

Voltage Rating of Powerline	Minimum Distance
750 to 150,000 volts	3 metres (10')
150,001 to 250,000 volts	4.5 metres (15')
over 250,000 volts	6 metres (20')

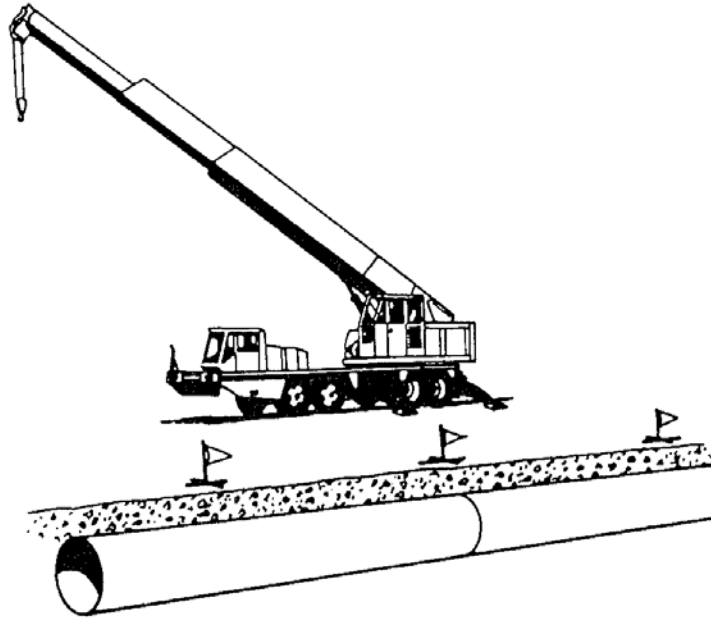

MARK THE LOCATION OF ALL UNDERGROUND SERVICES THAT COULD BE CRUSHED BY THE WEIGHT OF THE CRANE.

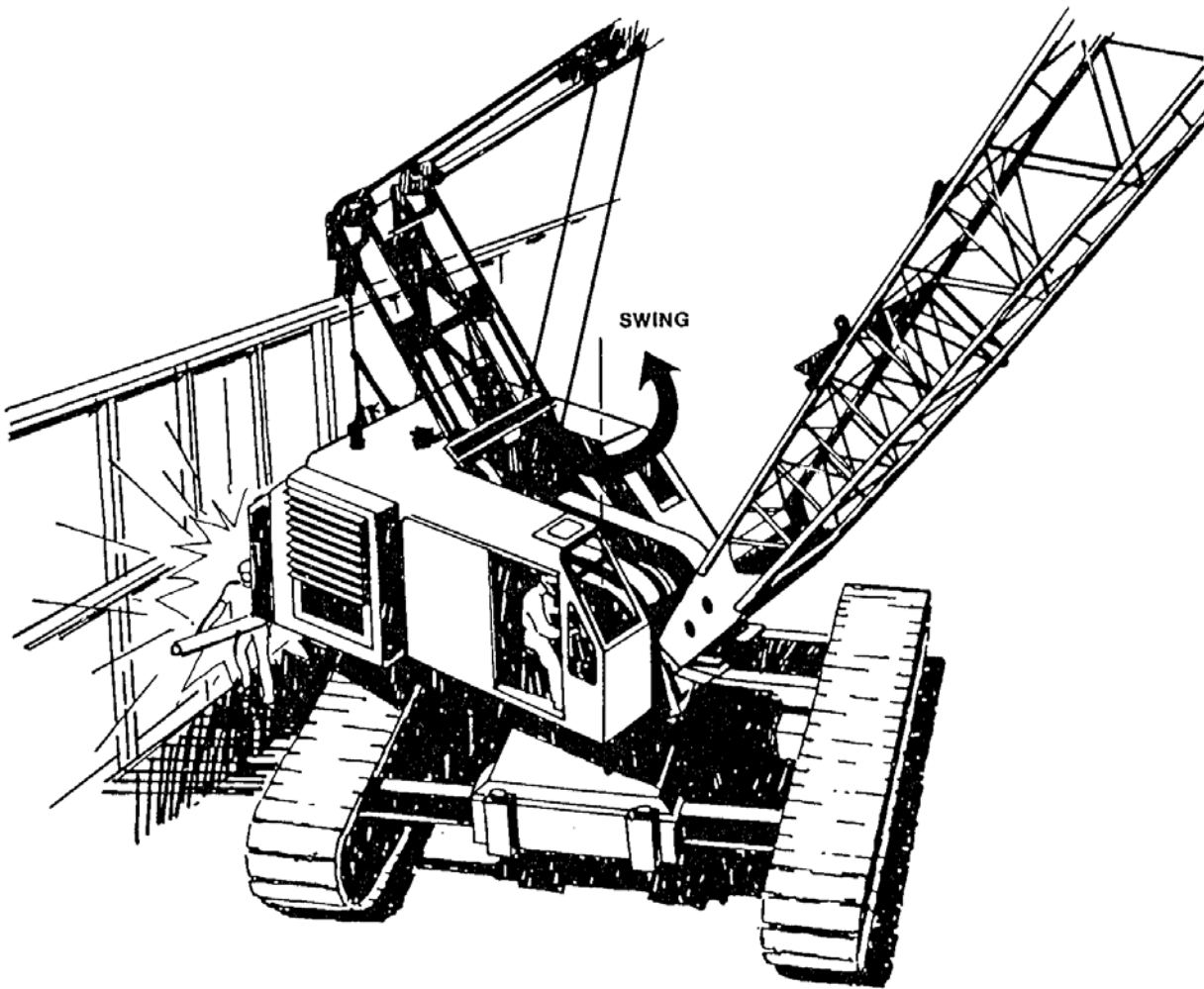

FENCE OR BARRICADE AREAS IN WHICH PERSONNEL COULD BE TRAPPED AND CRUSHED.

Danger Areas

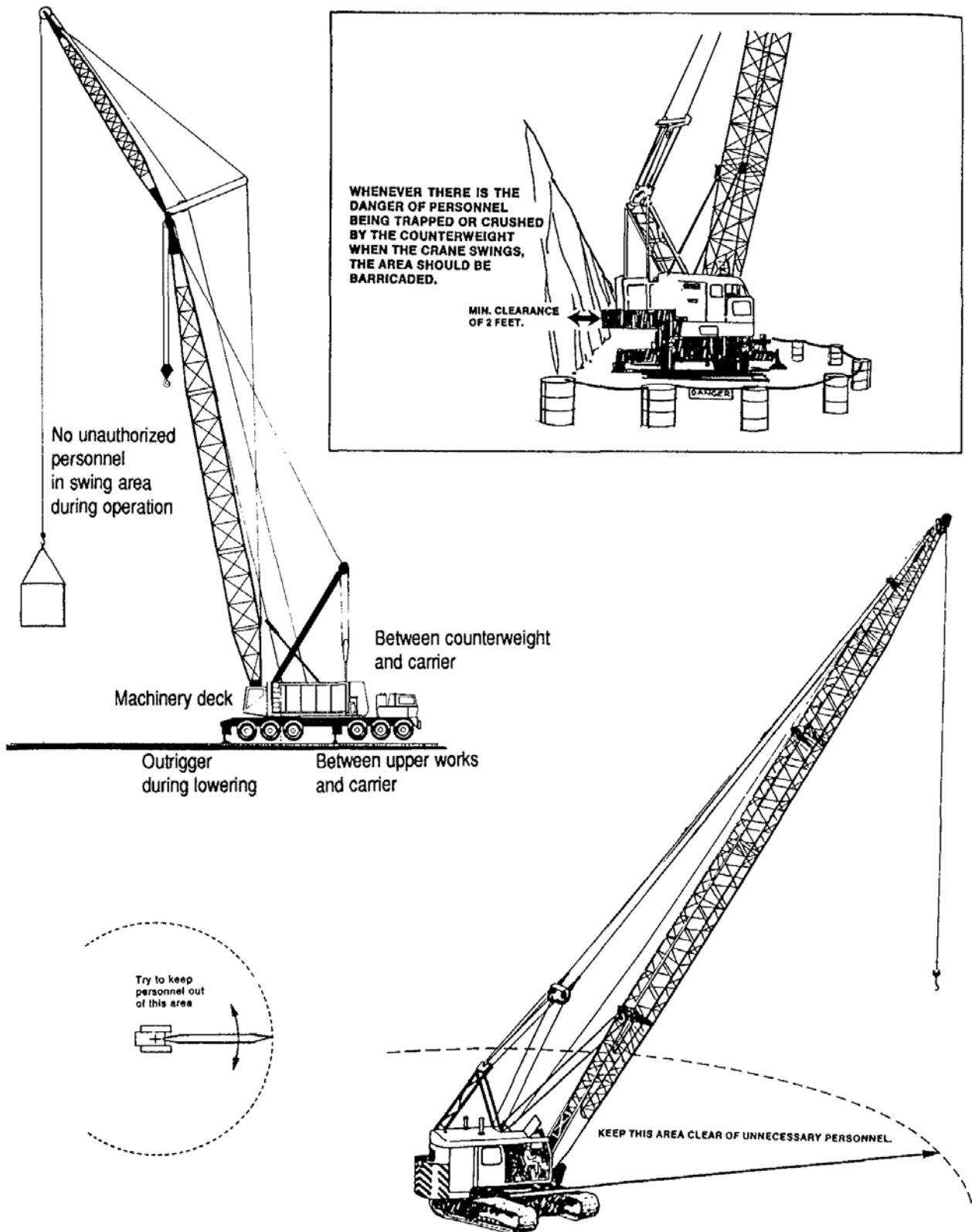

Working near Powerlines

High voltage contact is the largest single cause of fatalities associated with cranes. All can be prevented. The power company or utility may consider (if given advance notification) shutting down the line temporarily or moving the line. If it

is not possible to have the line moved or the power shut off the following procedures should be enforced by the project supervisor and strictly followed by all operators.

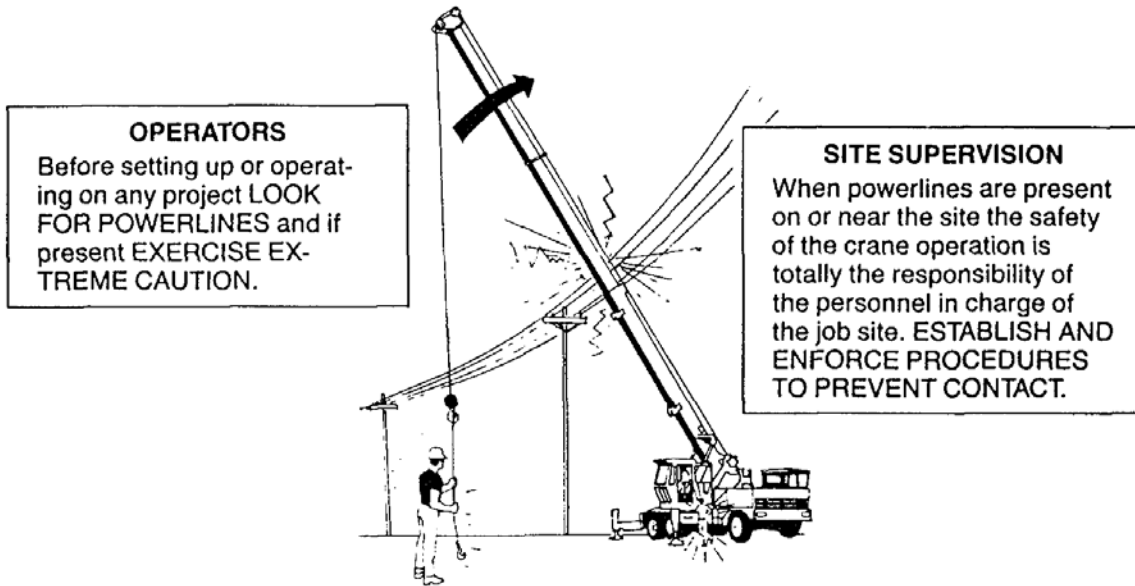

- (1) **KEEP YOUR DISTANCE.** Surrounding every live powerline is an area referred to as the absolute limit of approach. It is strictly forbidden to move any crane boom, load line or load into this area unless the powerline has been de-energized. There are no exceptions.

This absolute limit of approach varies according to local, provincial, state and federal laws or crane manufacturer's recommendations, but is generally as shown:

PRE-JOB PLANNING
The time to take care of powerline problems is during pre-job planning after the first site survey is made by a contractor. Take care of the problem prior to the crane's arrival to avoid job delays and prevent accidents.

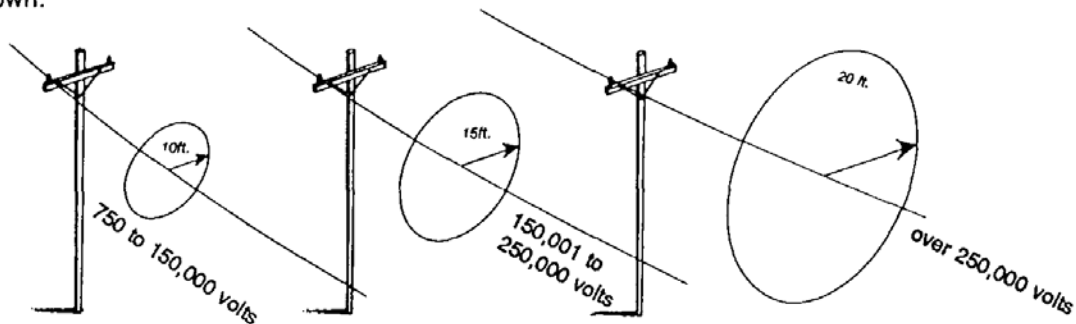

- (2) Treat all wires and electrical equipment as "hot" until you have reliable information to the contrary.
- (3) Notify the utility company when and where any crane is to be working near powerlines.

Working near Powerlines continued

- (4) Use a qualified signaller whenever the crane is within a boom's length of the lines. The signaller must warn the operator when the machine is approaching the lines

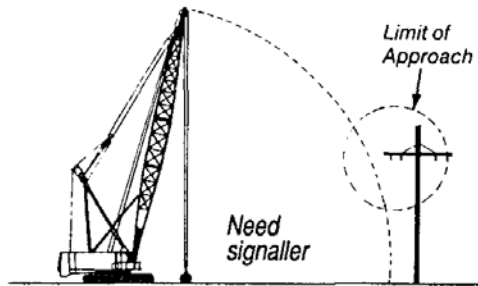

because the operator may not be able to accurately judge the distance. The signaller should have no other duties while the machine is working near the powerline.

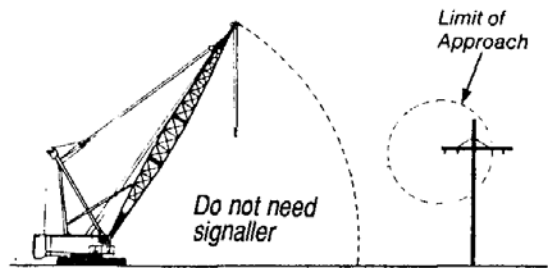

- (5) Do not rely on ground rods for safety. They provide little or no protection; people touching the crane or load will still draw enough current to kill even with the best ground rods in place.
- (6) Don't rely on proximity warning devices, hook insulators, insulating boom guards, swing limit stops, or any other similar devices as each type has serious limitations.
- (7) Except for the operator, keep *all* personnel well away from the crane whenever it is working close to powerlines. Don't allow anyone standing on the ground to touch the crane.
- (8) Don't allow anyone to touch the load, the crane, or the crane hook until the signalman indicates that it is safe to do so.
- (9) Avoid using taglines except when it is possible for the load to spin into the powerline. (Note: Although all ropes will conduct electricity, dry polypropylene provides better insulating properties than most commercially available rope.)
- (10) Slow down the operating cycle of the machine by reducing hoisting, booming, swinging and travel speeds.

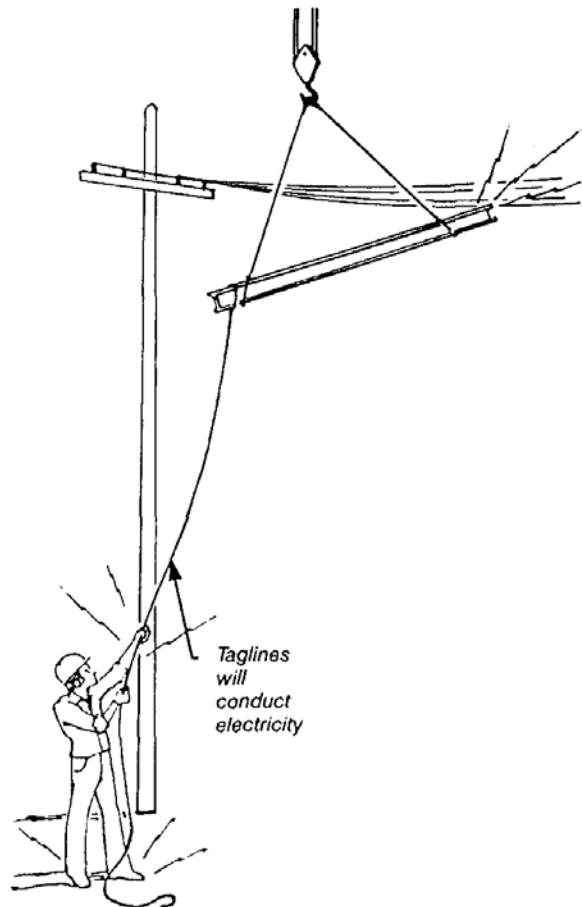

Working near Powerlines continued

(11) Exercise caution when working near overhead lines having long spans as they tend to swing laterally in the wind and accidental contact could occur.

(12) Exercise caution when travelling the crane as uneven ground can cause the boom to weave or bob into the lines.

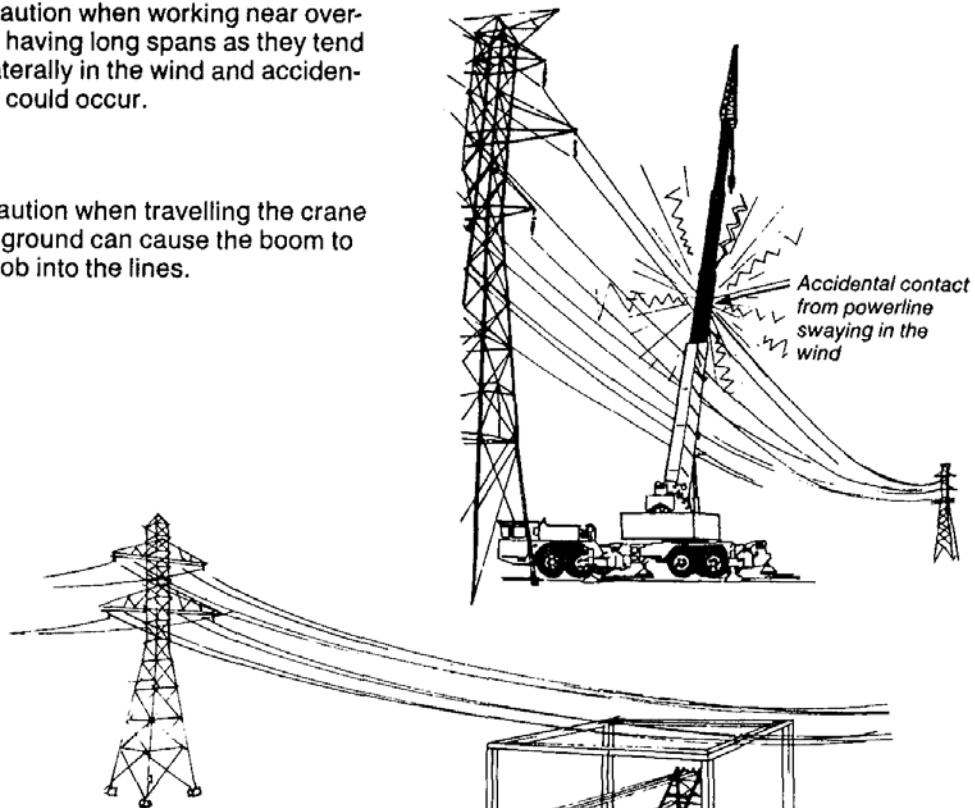

(13) Ensure that whenever cranes must repeatedly travel beneath powerlines a route is plainly marked and "rider poles" are erected on each side of the crossing approach to ensure that the crane structure is lowered to a safe height.

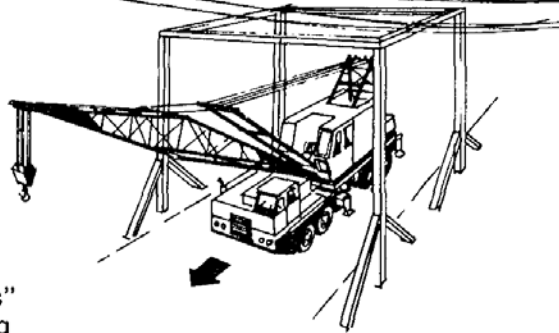

(14) The operator must not leave the crane if the boom, when lowered, can enter the limit of approach.

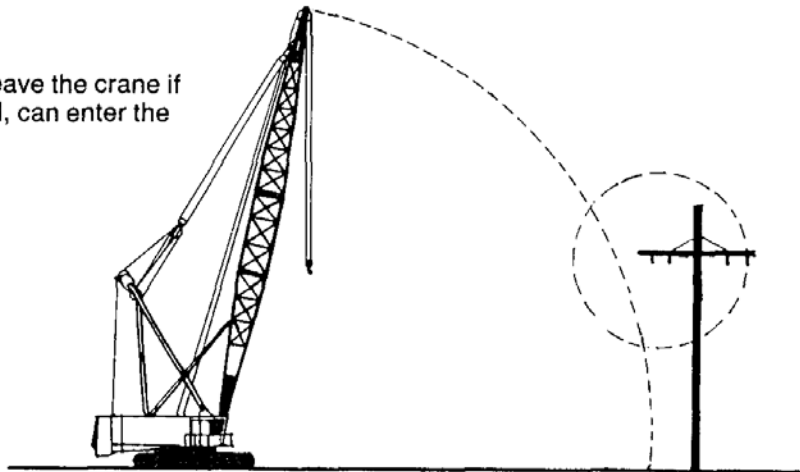

Working near Powerlines continued

IN THE EVENT OF CONTACT

- (1) Remain inside the cab. **DO NOT PANIC.** If you are able to realize what happened then you are safe where you are.
- (2) Instruct all other personnel to keep away from the machine, ropes and load. The complete machine, load, and the ground around it will be "hot".
- (3) Unaided, and without anyone approaching the machine, try to remove the contact. Move away from the line in the reverse direction to that which caused the contact (for example, if you swung left into the wire, swing right to break the contact). Remember—once an arc has been struck, it can draw out a considerable distance before it breaks so keep moving away from the line until the arc breaks and then continue moving until you are at least 10 or 15 feet away from the line. *Caution:* If the crane's ropes appear to be welded to the powerline do not move away from the line as it may snap and whip. Stay where you are until help arrives.
- (4) If the machine cannot be moved away or disengaged from the contact, remain inside the machine until the electrical authorities de-energize the circuit and confirm that conditions are safe.

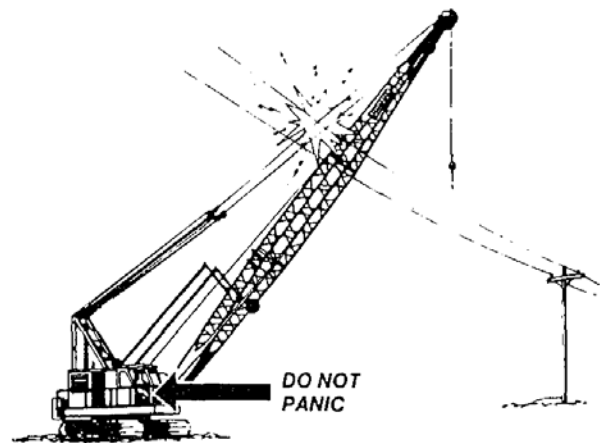

- (5) Completely inspect the machine for possible damage caused by the electrical contact. Wire rope should be replaced if it touches a line since the arc is usually of sufficient power to either weld, melt or badly pit the rope. The damaged section of rope will look like it was burned with a torch.
- (6) Report every incident involving contact with a live line to the electrical authority and safety inspector so that inspections and repairs can be made to prevent damaged powerlines from falling at a later date.

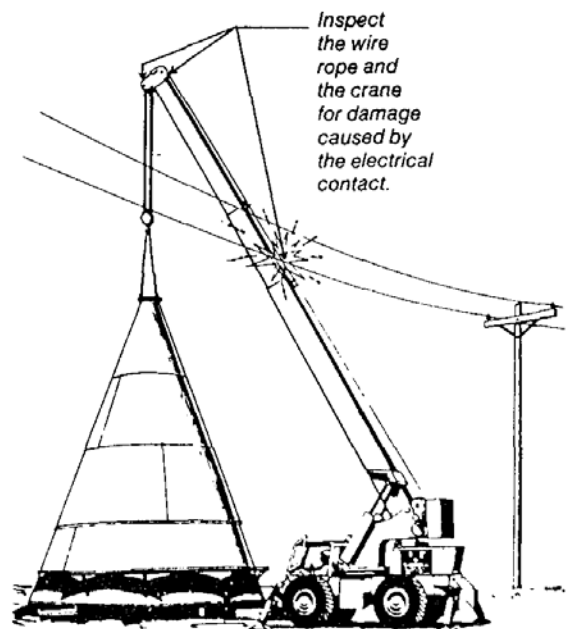

Working near Powerlines continued

BAILOUT PROCEDURE

If the operator decides to leave the machine, he must *jump* clear. He must never step down allowing part of his body to be in contact with the ground while any other part is touching the machine.



WRONG



RIGHT (BUT STILL DANGEROUS)
The operator should never leave the machine unless absolutely necessary.

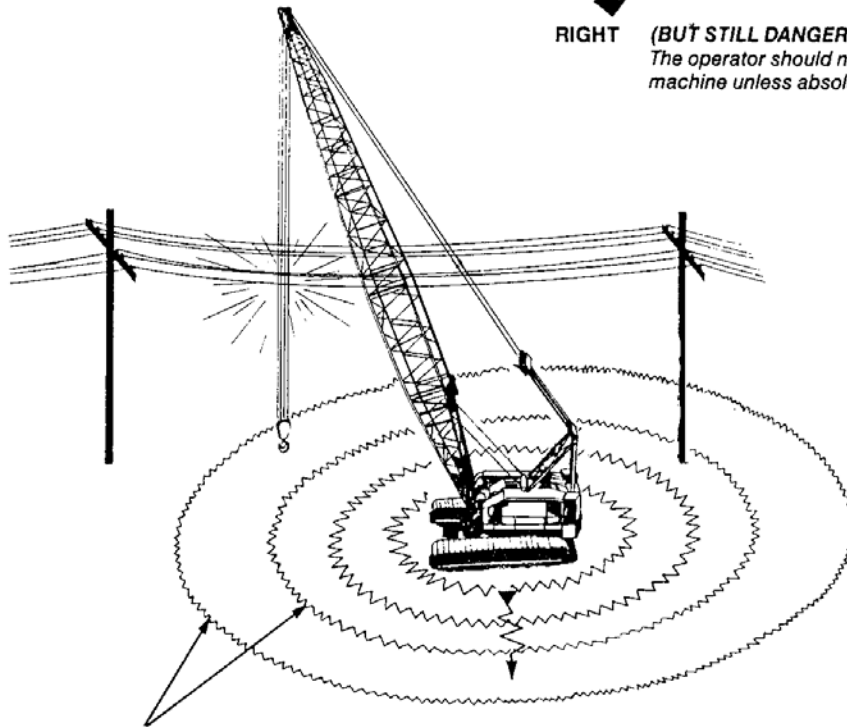

HIGH VOLTAGE CONTACT will result in electrical current flowing down the boom and through the crane to ground. The ground will then be energized with a high voltage near the crane and lower voltage farther away.

Because of the hazardous voltage differential in the ground the operator should jump with his feet together, maintain balance and shuffle or hop slowly across the affected area. Do not take large steps because it is possible for one foot to be in a high voltage area and the other to be in a lower voltage area. The difference between the two can kill.

Working near Transmitters

When operating near radio, TV or microwave transmitters the crane boom and load can become electrically charged. The boom acts like an antenna and becomes "hot". The charge is not electrically dangerous when compared with the effect of contacting electricity but it can cause burns to personnel handling loads. The greatest danger to personnel exists when they "jump" from the effect of this shock and fall or trip.

Grounding the crane will not likely have any effect. The only real solution is to insert a synthetic web sling between the crane's load block and the load. This will isolate the riggers from the crane and protect them from burns. The crane operator will not be affected when in the machine but should wear rubber gloves when getting on and off the crane.

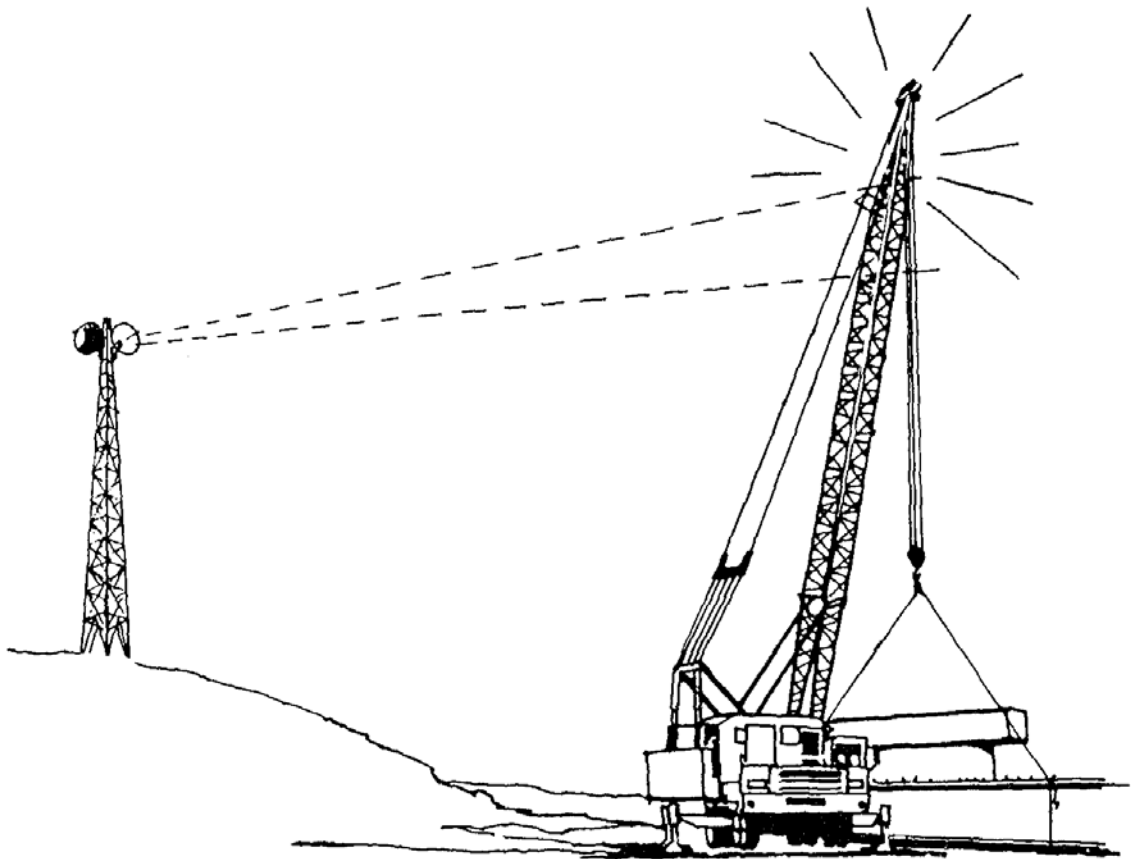

Factors Affecting Crane Capacity

Capacities and other information included in the load charts for cranes are based on almost perfect conditions seldom achieved under actual operation.

It is vital to know not only how to determine capacity correctly from the chart but also to recognize the factors that can reduce a crane's capacity below the chart ratings.

These factors, described on the following pages, include

- poor machine condition
- variations in boom angle
- variations in load radius
- errors in boom angle indicators during critical lifts
- quadrants of operation
- sweep area
- tires not clear of the ground
- division of sweep area into quadrants
- improper use of outriggers
- soft footing
- crane not level
- sideloading
- increase in load radius
- rapid swing rate
- impact loading
- rapid acceleration or deceleration of load
- duty cycle operations
- high wind speeds.

The information concludes with an illustration of proper setup.

Poor Machine Condition

Load chart ratings apply only to cranes maintained in condition as good as new and as stipulated by the manufacturer. The boom is one of the more critical elements of the crane and *must* be in perfect condition at all times.

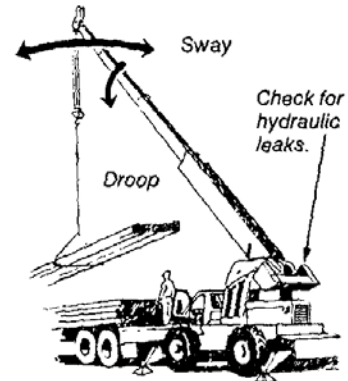
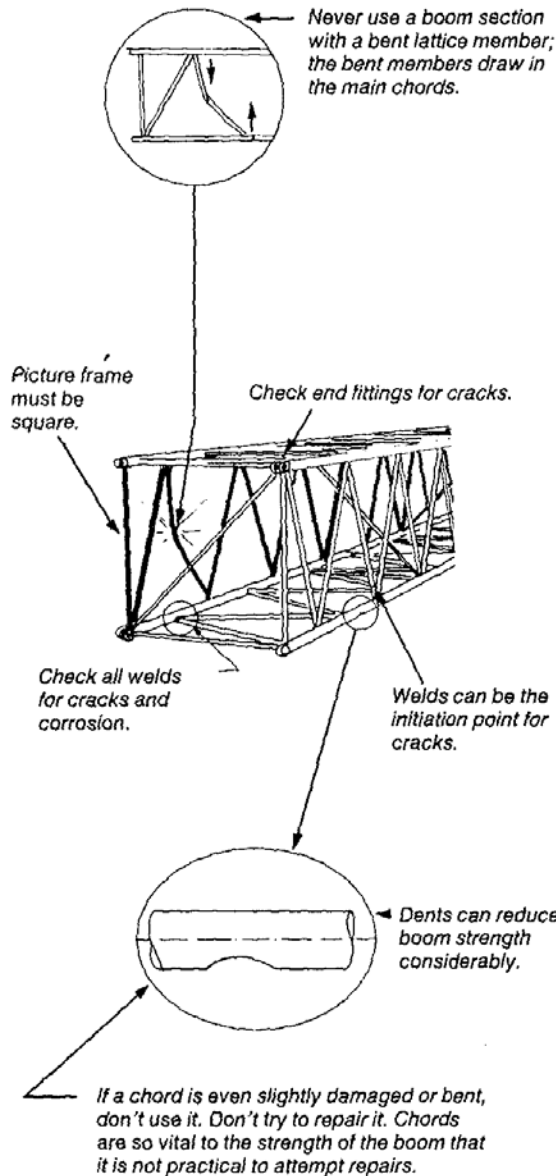

Check telescopic booms for conditions such as:

- Sway
- Droop
- Cracks around the hinge pin
- Rust (could be sign of crack)
- Flaking or cracked paint (could be sign of overload)
- Bulges, creases or waviness of the plates in the boom (could be signs of overload)
- Worn pads.

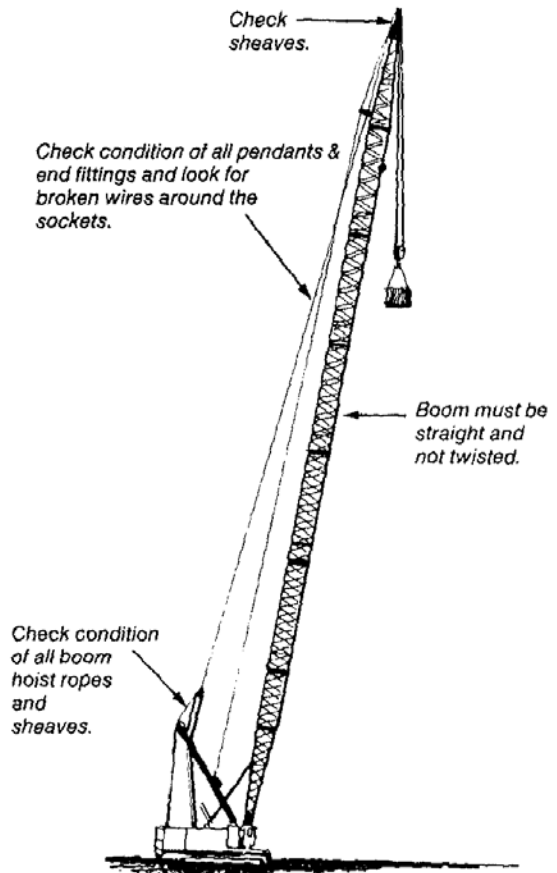

Boom Angle

The capacities listed in the load chart are also based on and vary with the boom angle of the machine.

On telescopic boom cranes the boom angle is the angle between the base (bottom) of the heel section of the main boom and the horizontal while the boom is under load.

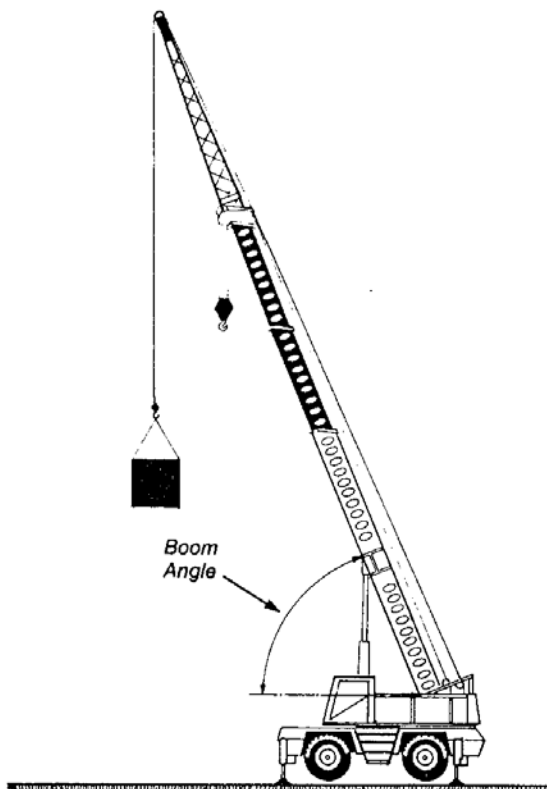
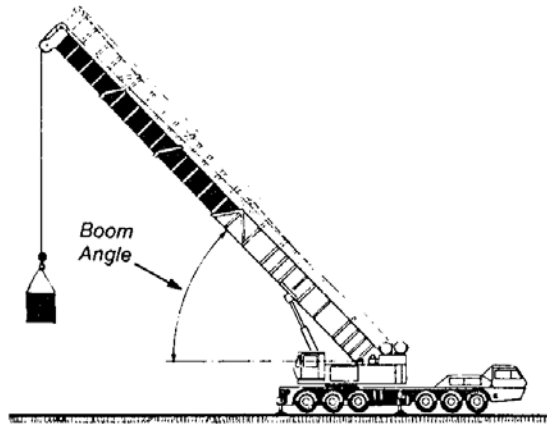

Because of boom and machine deflection (and pendant stretch on lattice booms) expect the boom angle to lower somewhat from its unloaded condition once a load is applied. Expect even larger boom angle reductions when the crane is "on rubber" because of tire deflection.

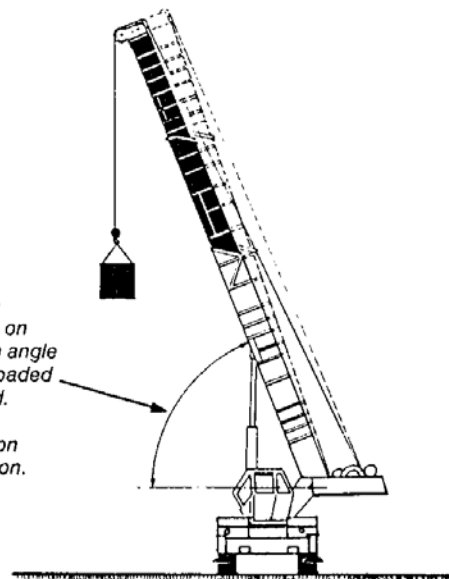

Load Radius

The capacities listed in the load chart also depend on and vary with the crane's load radius.

The load radius is the horizontal distance measured from the center of rotation of the crane (center pin) to the load hook (center of gravity of the load) *while the boom is loaded*.

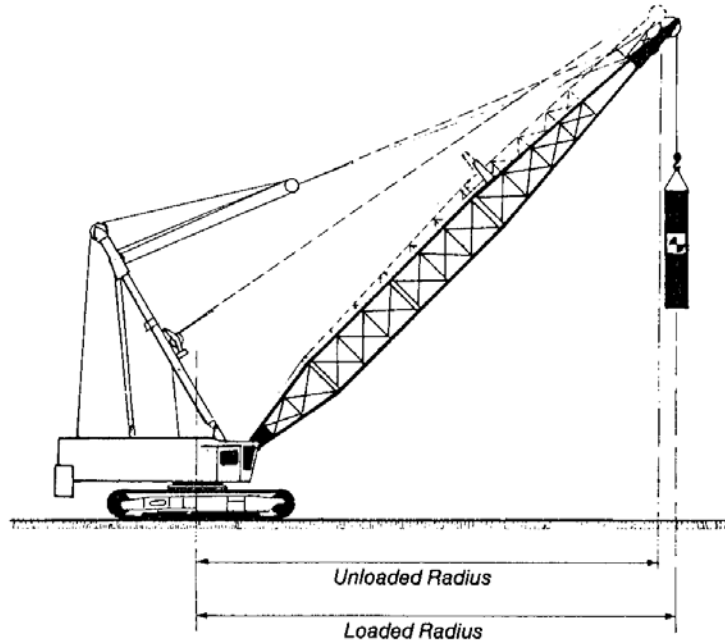

Because of boom and machine deflection and pendant stretch, expect the load radius to increase when the load is lifted off the ground. Expect even larger increases in radius when the crane is "on rubber" because of tire deflection.

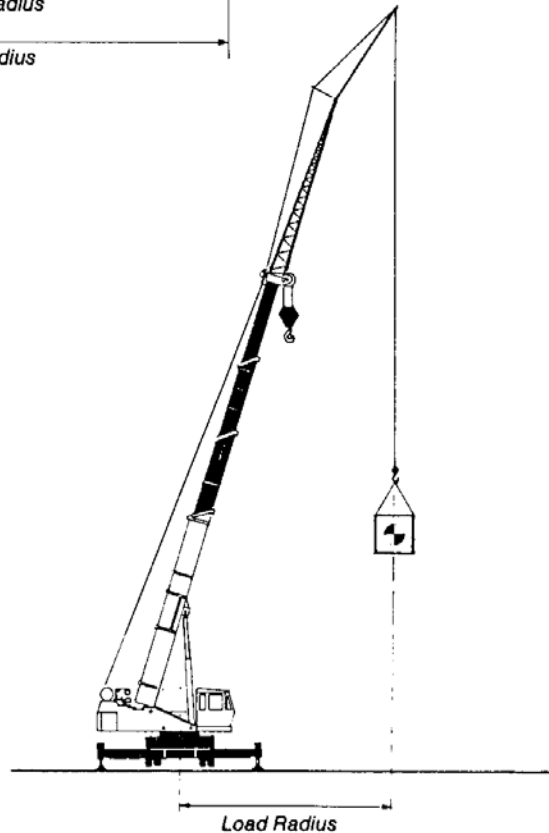
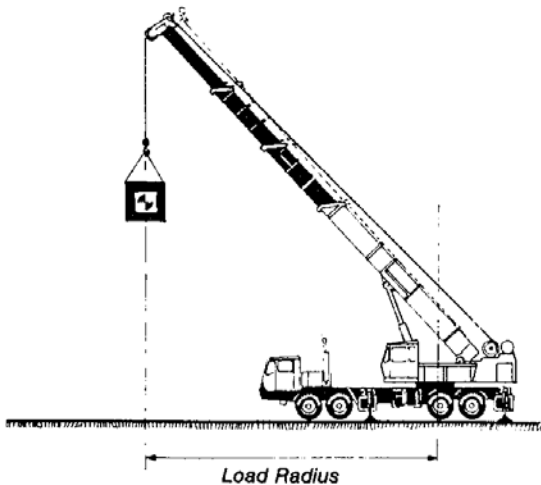

Boom Angle Indicators and Critical Lifts

Boom angle indicators are required on all mobile cranes but they must not be relied on for accuracy during critical lifts because:

- They can give as much as a 2° reading error in boom angle which can substantially affect the gross capacity reading on the load chart.
- The indicators are mounted on the base section of the boom and may not register the deflection of the extended sections under heavy load particularly if the wear pads are worn excessively. Consequently the boom angle may actually be lower than the indicator reads.

For these reasons, using boom angle indicator readings during critical lifts can be misleading. Rely on load radius (where possible) or if the boom angle must be used (for example when lifting from a jib) assume the correct reading to be *lower* than what the indicator actually says.

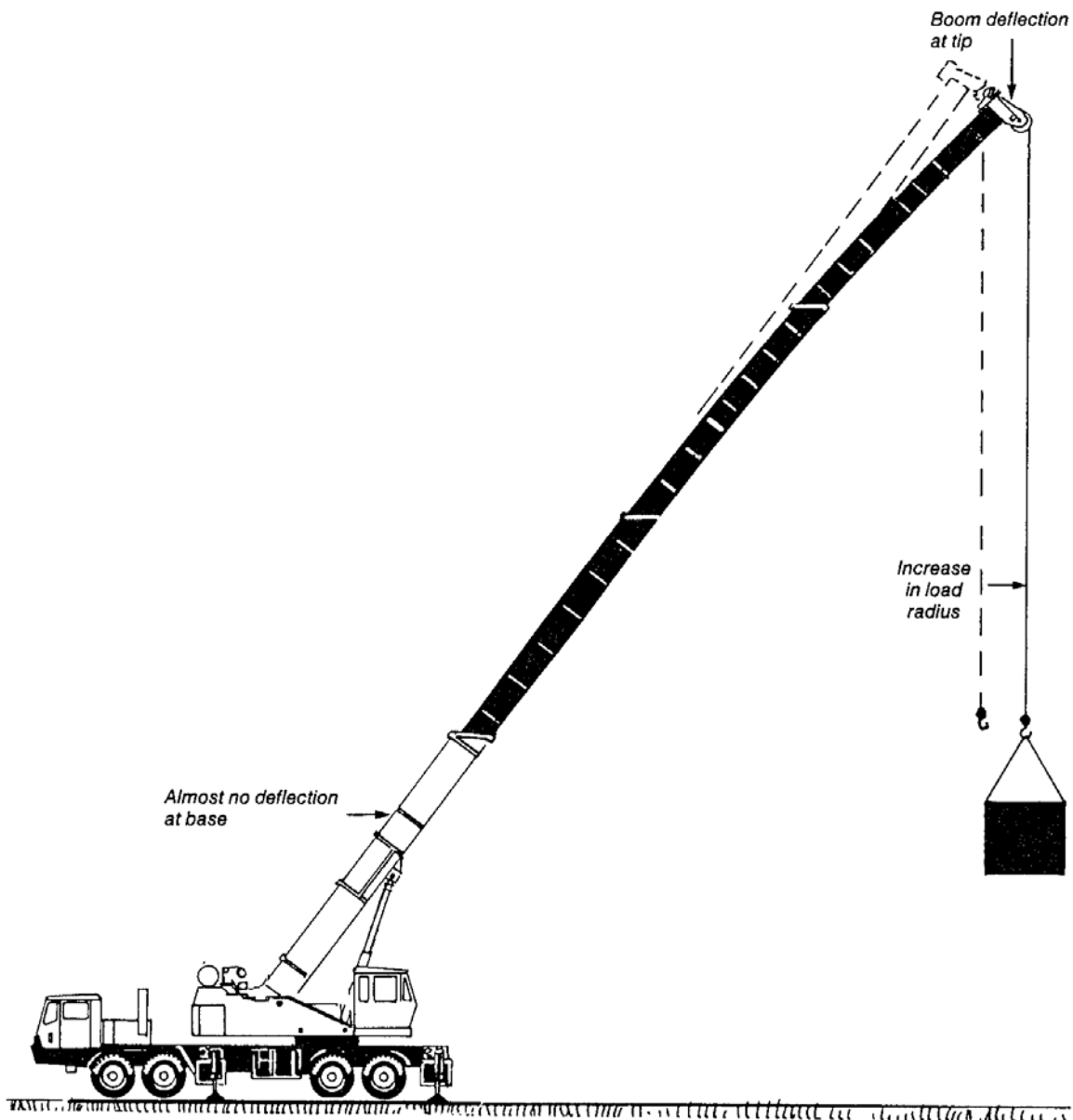

Importance of Quadrants

The leverage and capacity of a crane change during rotation of the upperworks. Leverage and capacity are also affected by the location of the tipping axis. For these reasons the crane's stability can change during operation.

To provide uniform stability, regardless of the position of the upperworks relative to the carrier, the crane's capacity is adjusted by the manufacturer according to the quadrant of operation.

These capacity changes are identified in the load chart by the quadrant of operation.

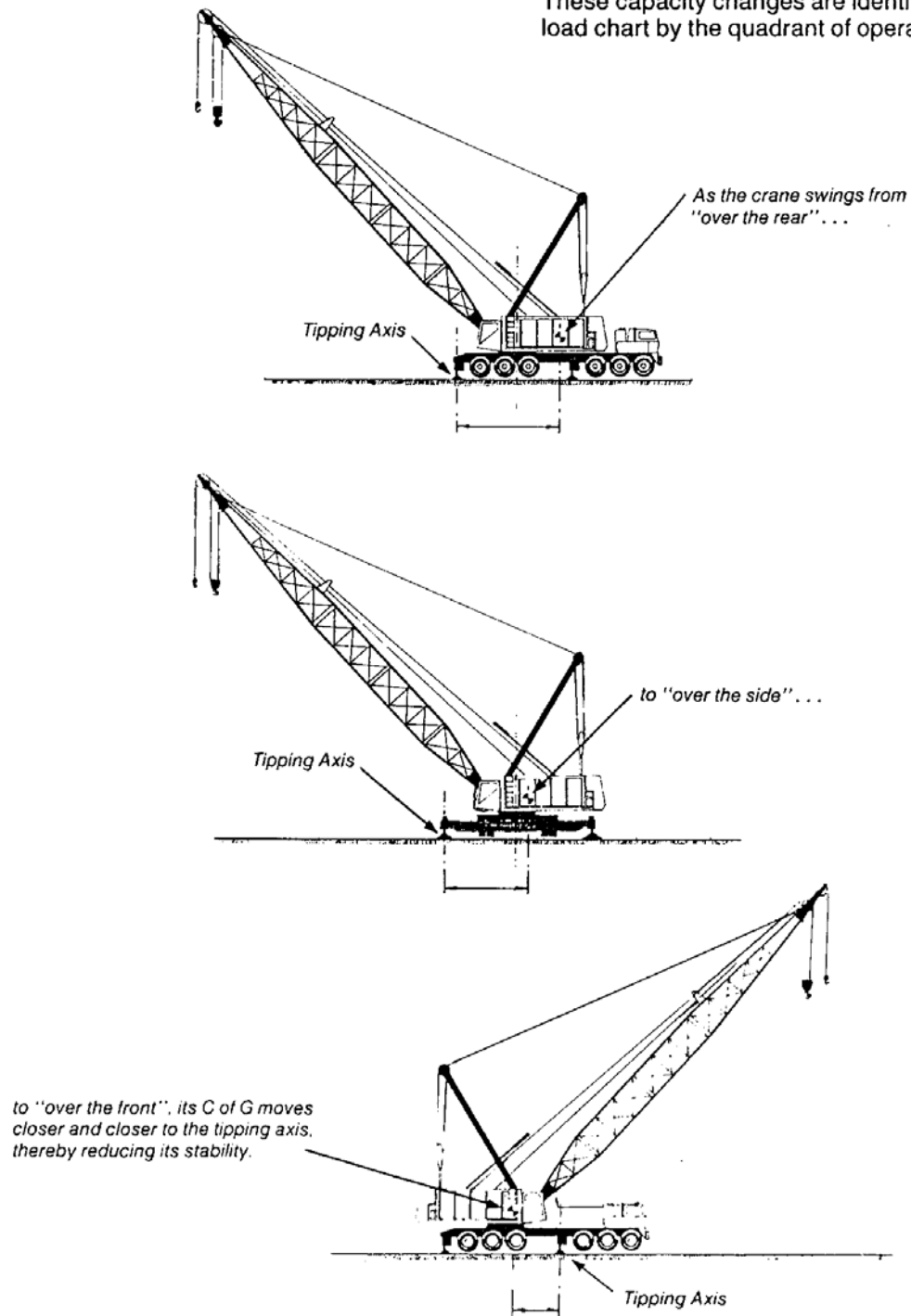

Sweep Area

The sweep area is the total area that the crane boom can swing over.

The sweep area is divided into operating areas called quadrants of operation. The crane's capacity is then based on the quadrants.

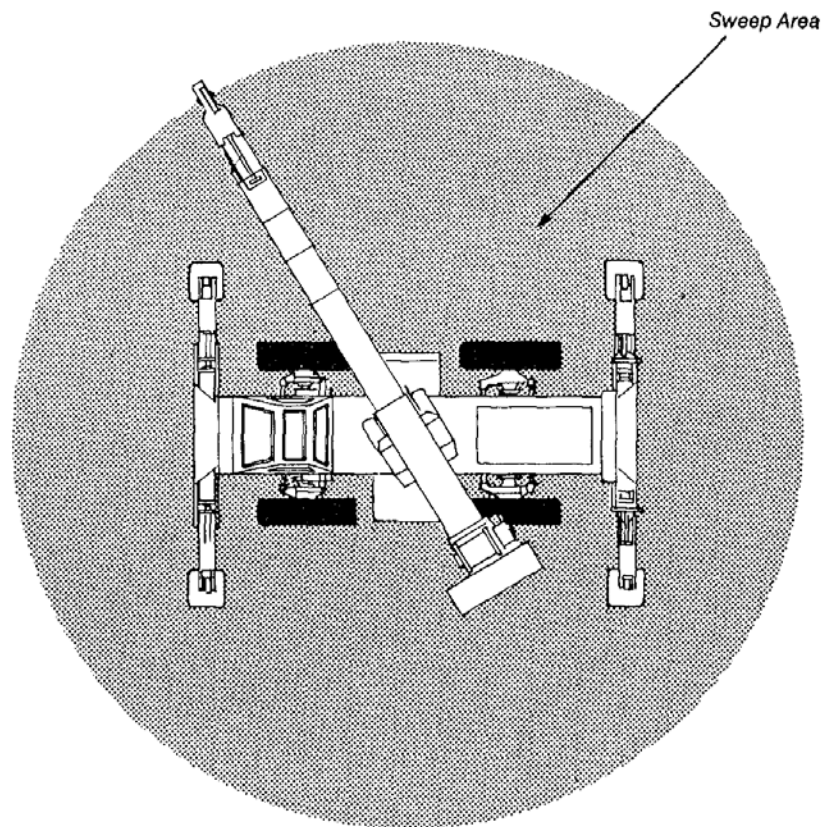

Division of Sweep Area into Quadrants

The crane is said to be in a particular quadrant of operation when the load hook is located over that portion of the sweep area.

Caution: Not every make and model of crane can be operated in all of these quadrants. The diagrams are for reference only. Consult load charts to determine quadrants of operation for particular makes and models.

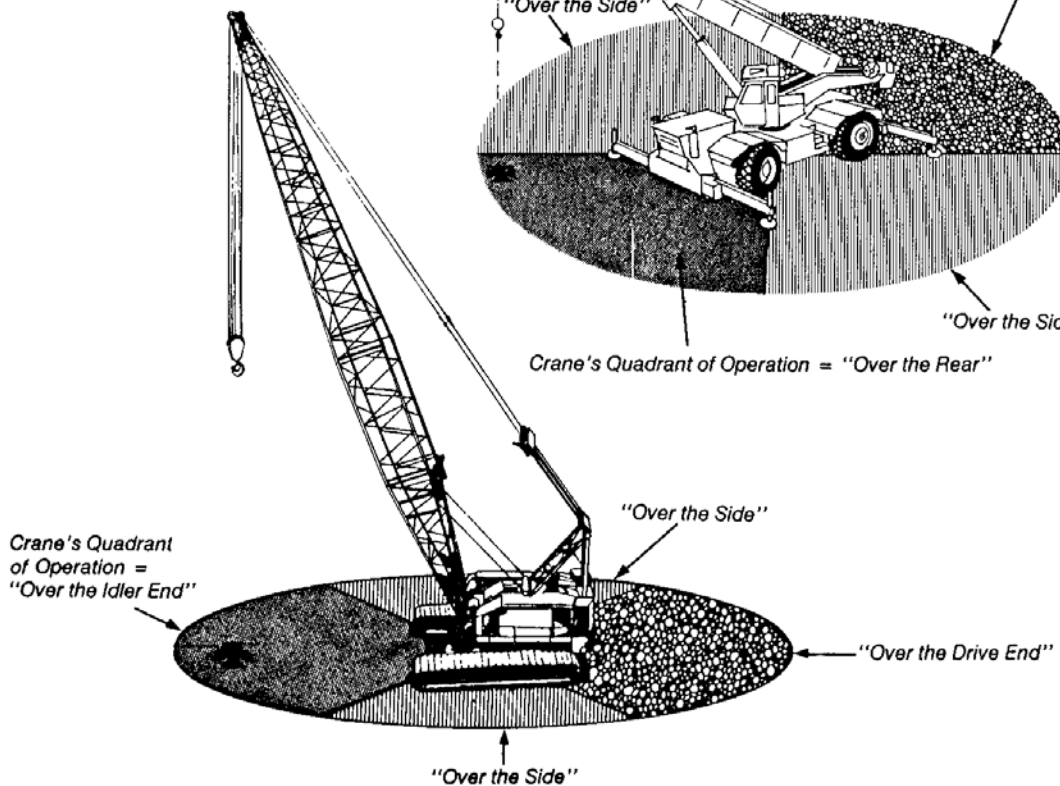
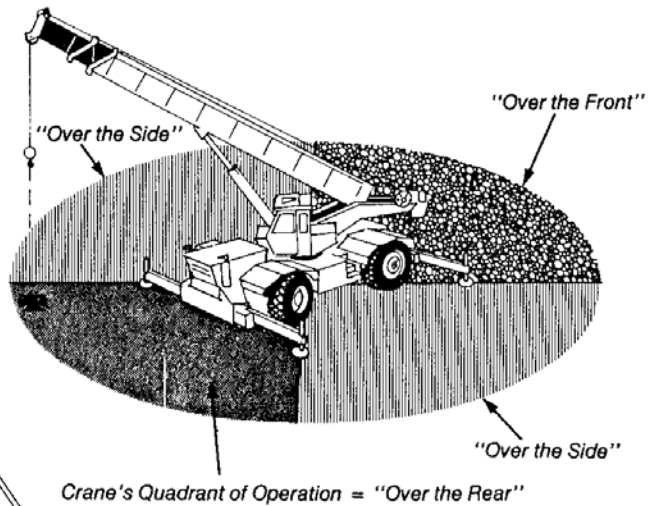
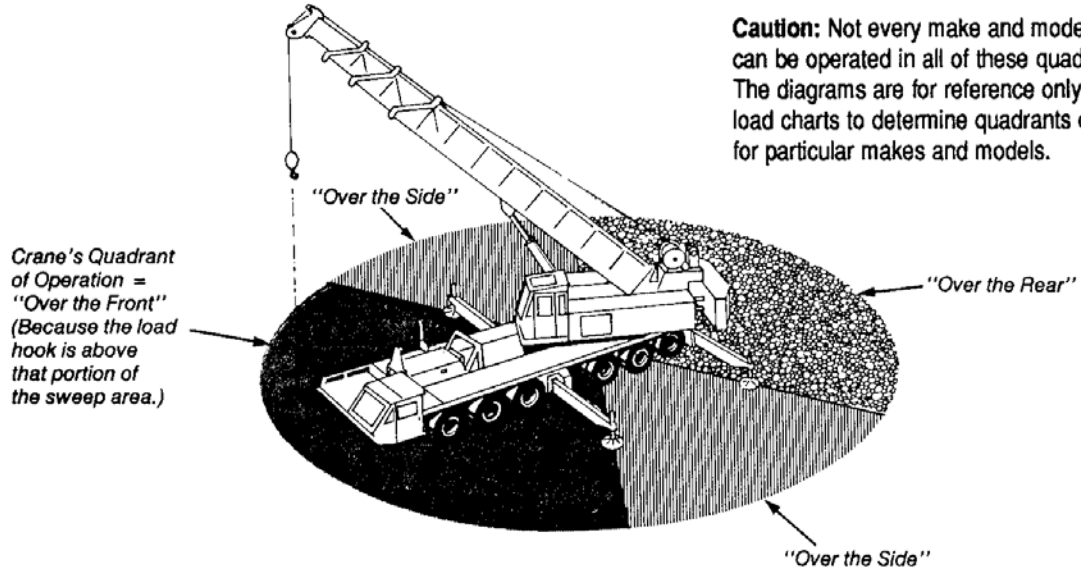

Improper Use of Outriggers

The load chart ratings of carrier-mounted and rough terrain mobile cranes apply to only two base configurations:

- "On Outriggers"
- "On Tires"

"On Outriggers"

Full chart ratings apply only when

- all outrigger beams are fully extended, and
- all tires are clear of the ground.

Unless these two conditions are met, machine capacity drops to the "on tires" rating. There is no in-between.

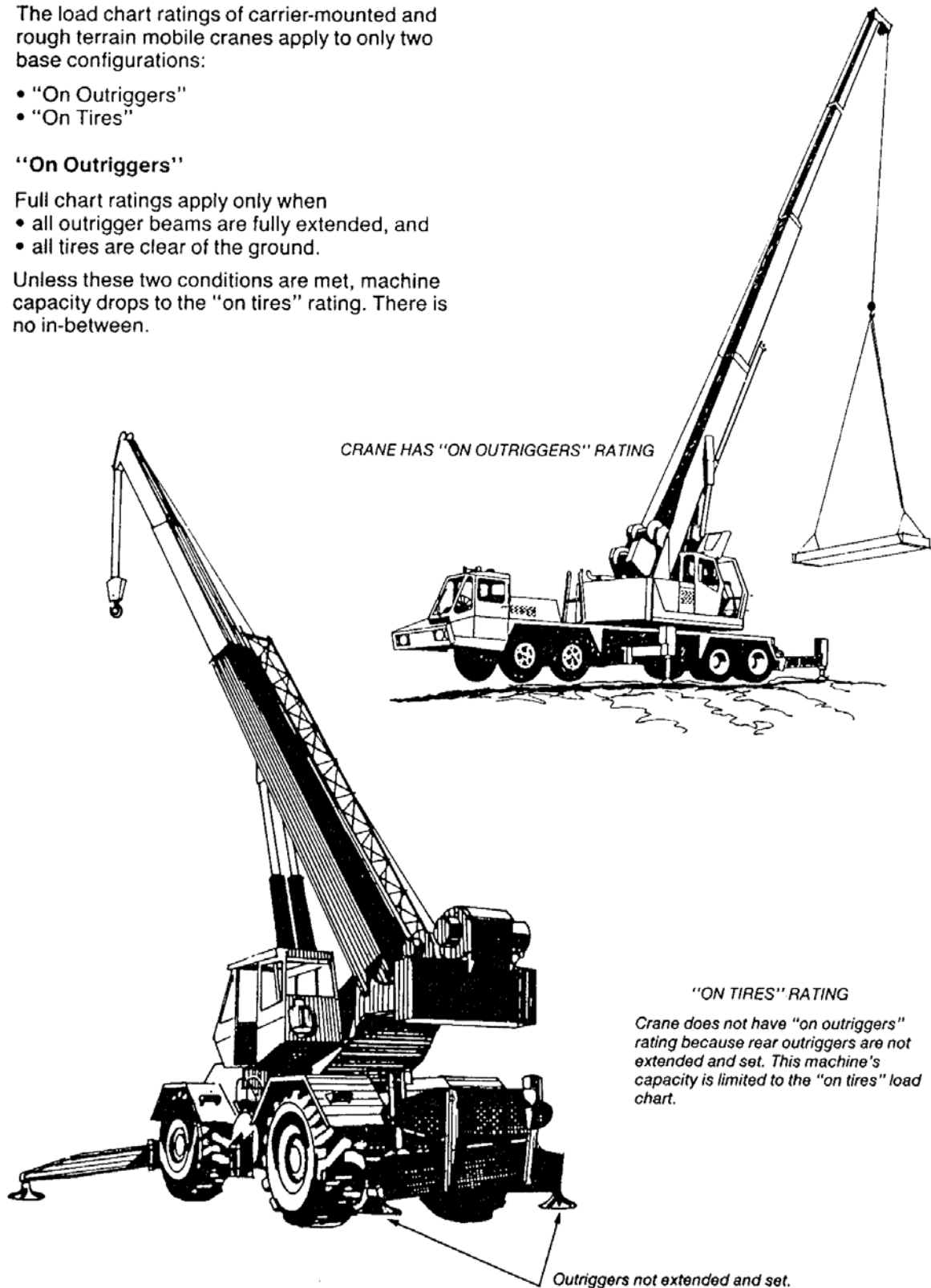

Improper Use of Outriggers continued

"ON TIRES" RATING

Full "on outrigger" ratings do not apply because the carrier wheels are touching the ground.

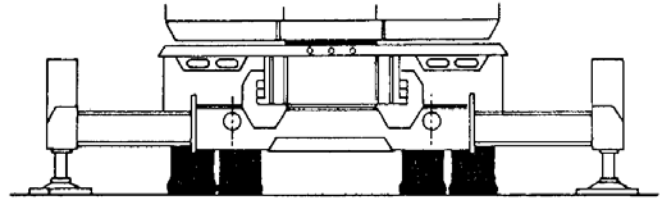

"ON TIRES" RATING

Full "on outrigger" ratings do not apply because ALL outrigger beams are not fully extended.

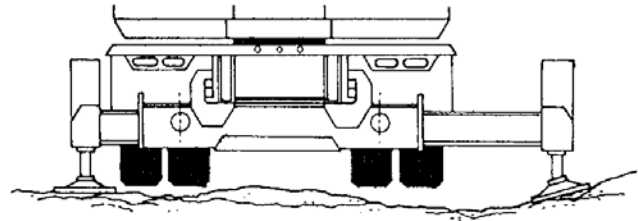

"ON OUTRIGGER" RATING

Full "on outrigger" ratings apply because

- all beams are fully extended
- all tires are clear of the ground.

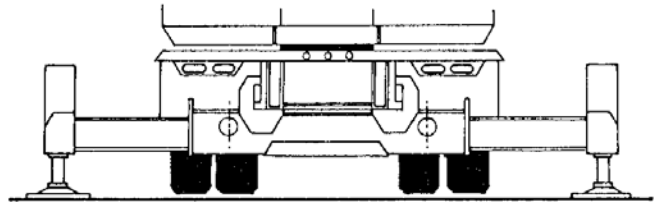

Tires should be just clear of the ground to keep ram length as short as possible and thus minimize rocking action.

"On Tires"

Full chart ratings apply only when

- tires are per manufacturer's specifications
- tires are in good condition
- specified tire pressure is maintained, and
- crane speed does not exceed manufacturer's specifications.

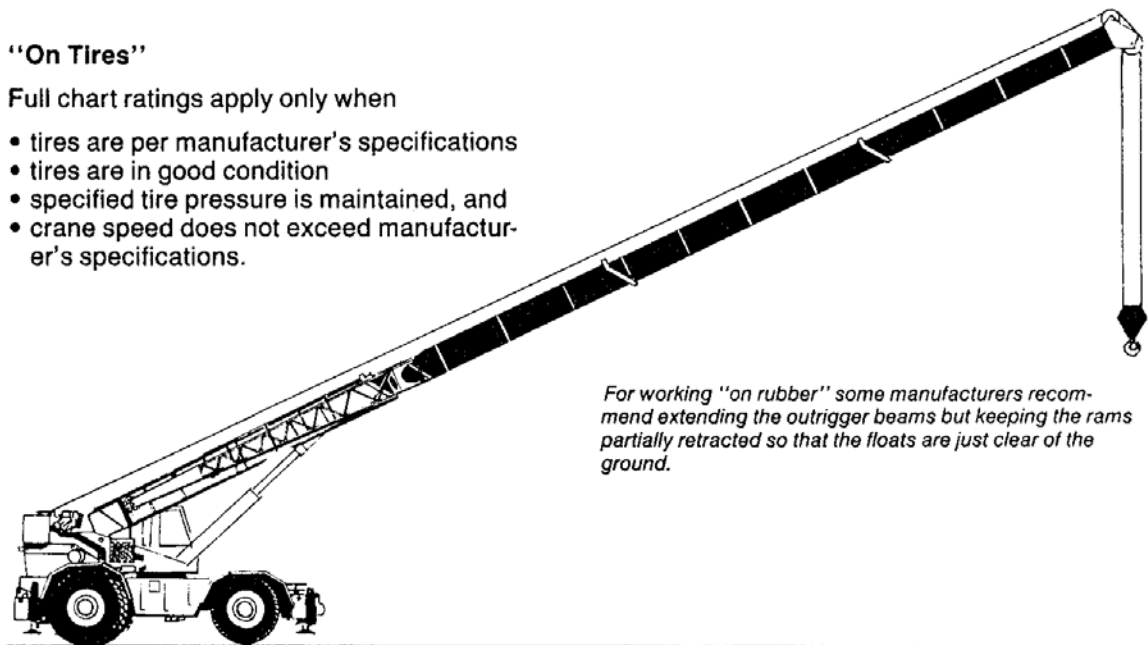

For working "on rubber" some manufacturers recommend extending the outrigger beams but keeping the rams partially retracted so that the floats are just clear of the ground.

Soft Footing

Load chart ratings apply only when the ground conditions are firm enough to support the crane and *keep it level during the lift*. If the ground is soft or unstable, the tires, crawlers or outriggers will sink or subside causing loss of capacity. In almost all cases, heavy duty blocking having large bearing areas will be necessary to prevent sinking and provide a solid base for the crane.

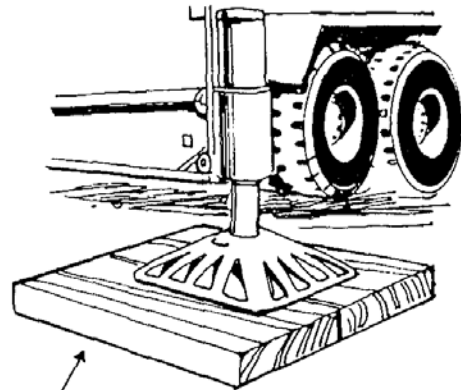

Use solid blocking under all floats.

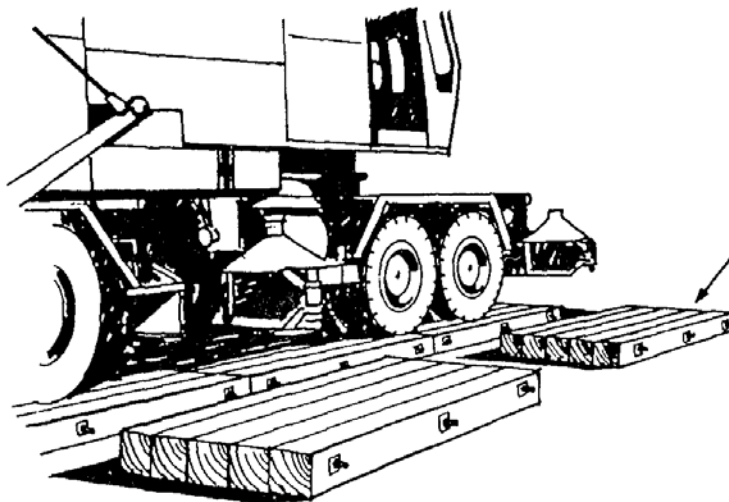
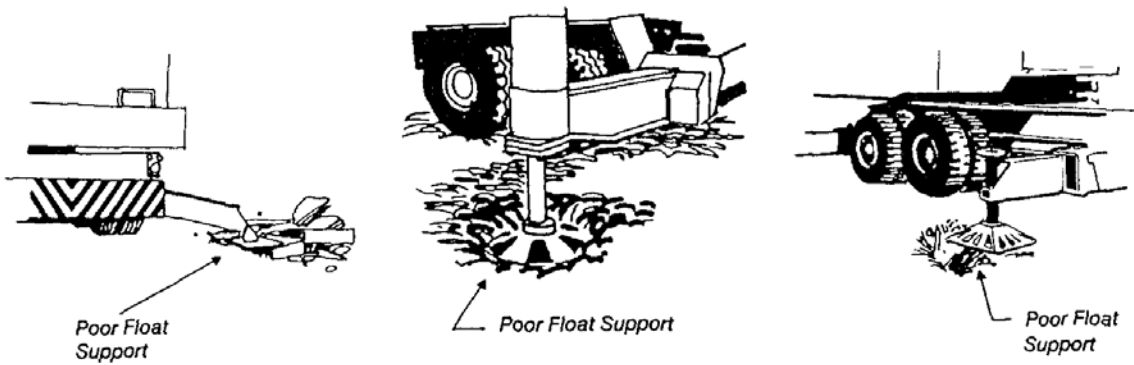

On soft ground or on backfilled material, timber or steel mats must be used to prevent the crane from sinking or settling.

Crane Not Level

All load chart ratings are based on the machine being perfectly level in all directions. This applies to cranes "on crawlers", "on tires", "on outriggers" and when travelling with load.

One of the most severe effects of being out-of-level is that side loads develop in the boom. Because of side loads all mobile cranes lose capacity *rapidly* as the degree of out-of-level increases.

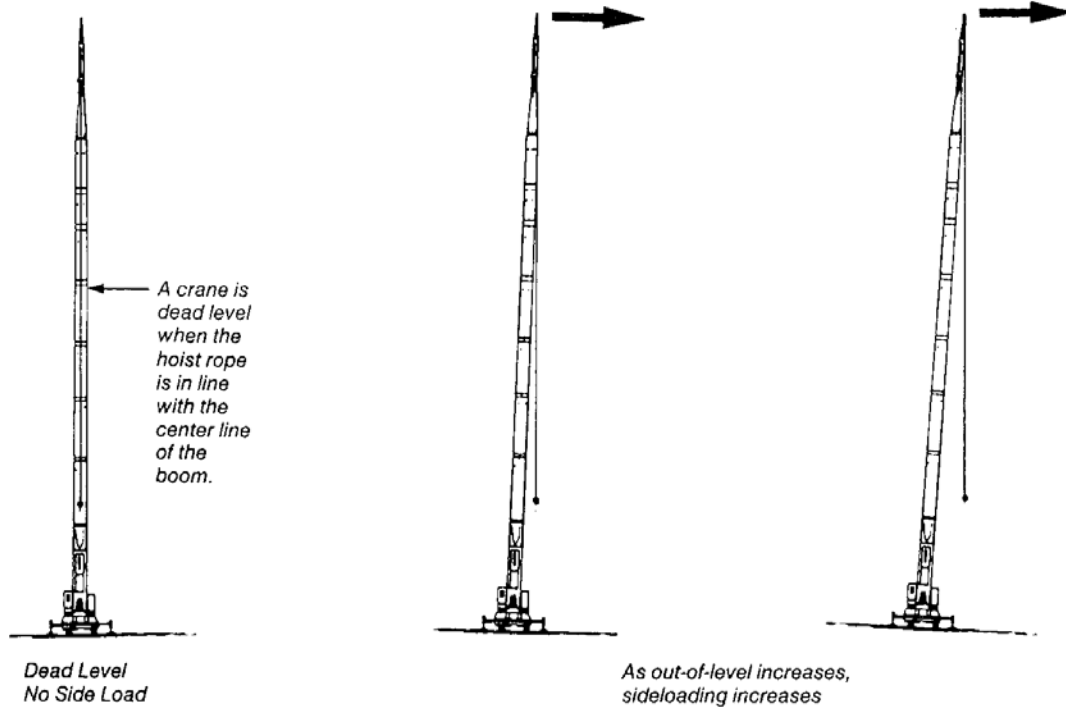
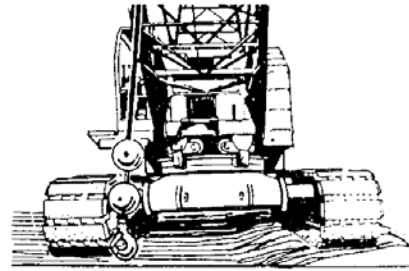

The following table for a particular lattice boom crane indicates the possible capacity loss due to being out of level.

Boom Length and Lift Radius	Chart Capacity Lost When Crane Out of Level By		
	1°	2°	3°
Short Boom, Minimum Radius	10%	20%	30%
Short Boom, Maximum Radius	8%	15%	20%
Long Boom, Minimum Radius	30%	41%	50%
Long Boom, Maximum Radius	5%	10%	15%

Similar information can be obtained from the manufacturers for all cranes. Machines that are used on barges are provided with "list charts" that identify crane capacity with barge list (expressed as degrees). Capacity loss due to barge list is the same as capacity loss due to an out-of-level condition on ground.

Crane Not Level continued

Caution: If the crane is not level the load chart does not apply. You must either level the crane by using its outriggers or level the ground the machine is resting on.

Even though the crane might have been properly levelled during set-up, ground subsidence during operation can cause an out-of-level condition. Check level frequently.

It is also important to note that when a crane is set up off level, swinging from the high side to the low side increases the operating radius. It also increases the load on the turntable, on the outriggers and on the supporting frame structure.

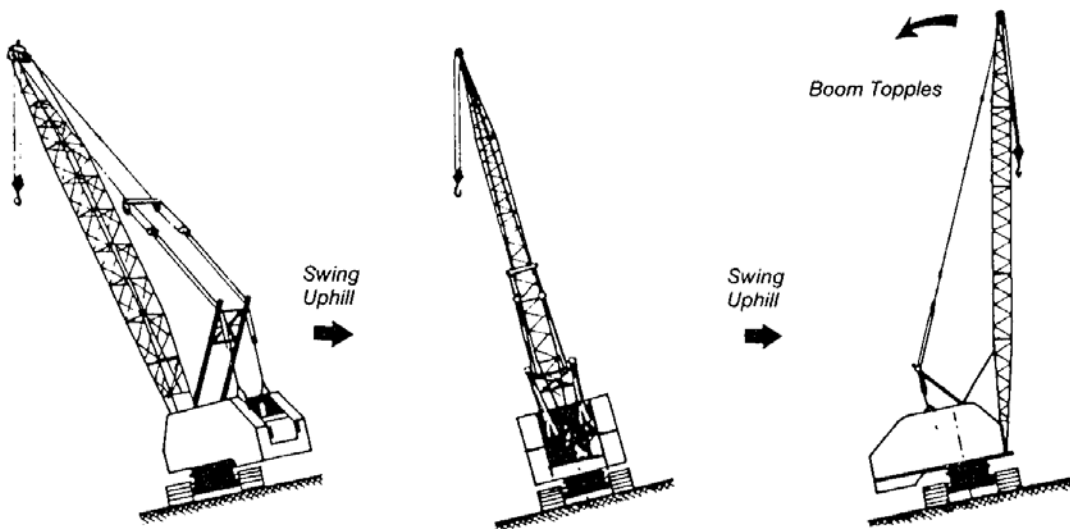
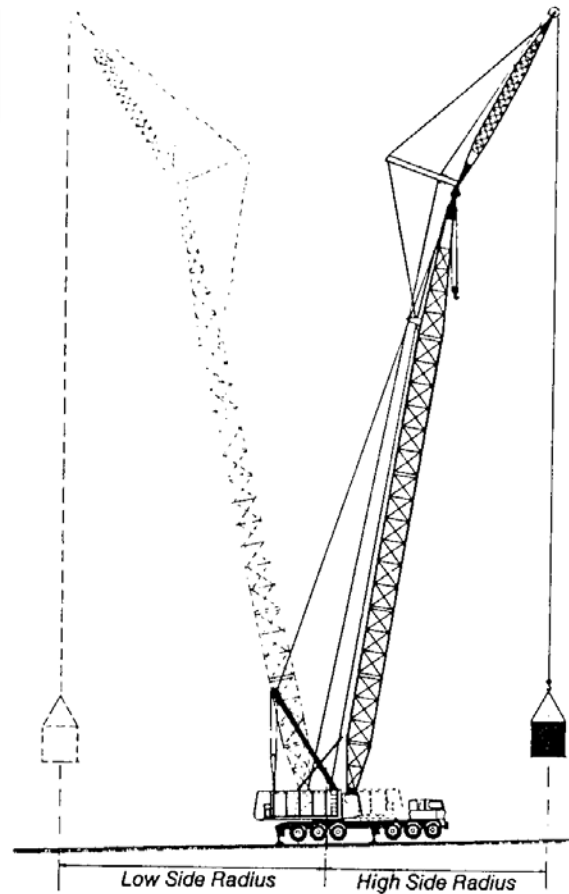

Caution: A boom at maximum elevation (minimum radius) on the low side cannot be swung over to the high side without risking collapse of the boom over the cab.

Sideloading

Load chart ratings apply only when the load is picked up directly under the boom tip. If the load is to either side of the boom tip, side-loading occurs and decreases capacity. This applies to both lattice and telescopic booms and is one of the most common causes of boom failure. It usually causes structural failure and always occurs without warning.

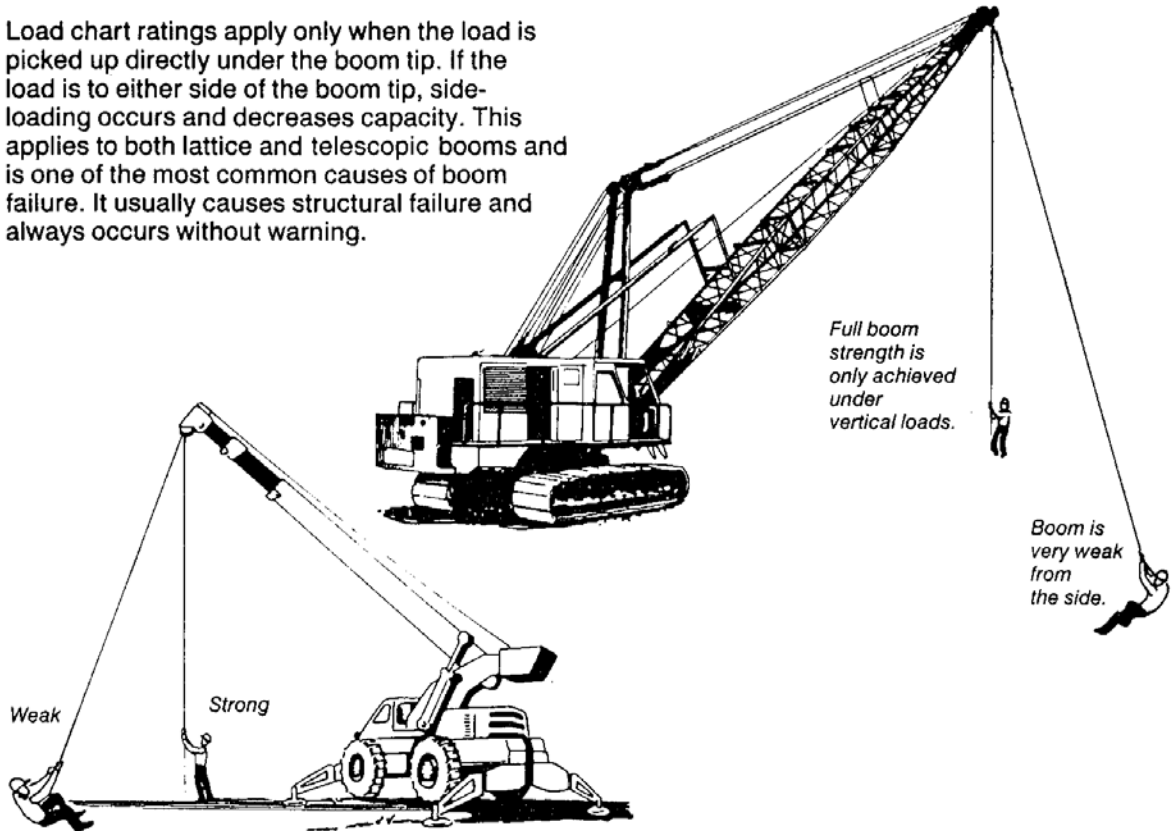

- Sideloading occurs when the crane is not level.

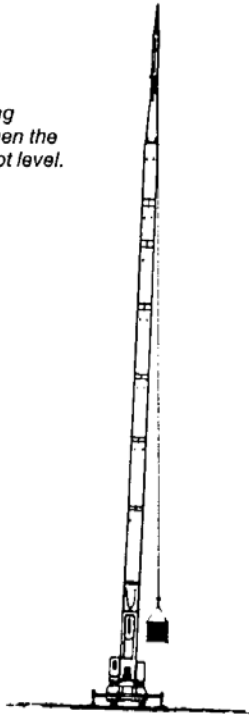

- Sideloading occurs when a load is dragged or pulled sideways.

This can buckle the boom, damage the swing mechanism or overturn the crane if the boom is at a high angle.

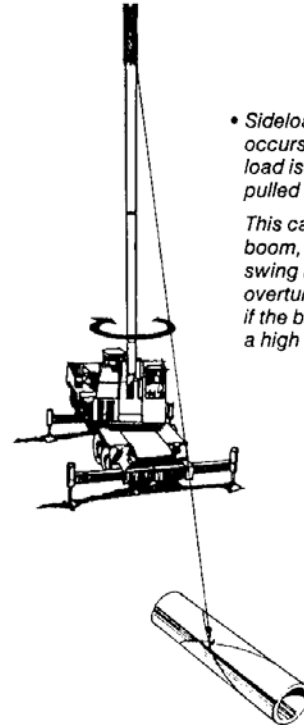

Sideloadng continued

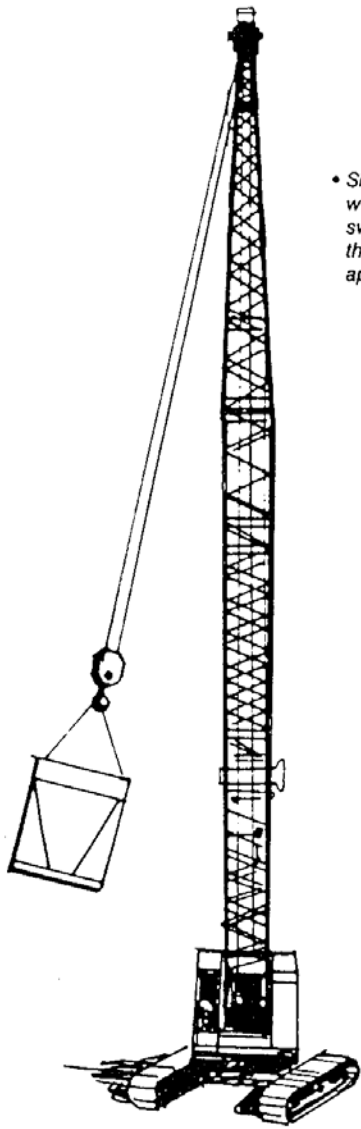

- Sideloadng occurs whenever a load is swung rapidly or when the swing brake is applied suddenly.

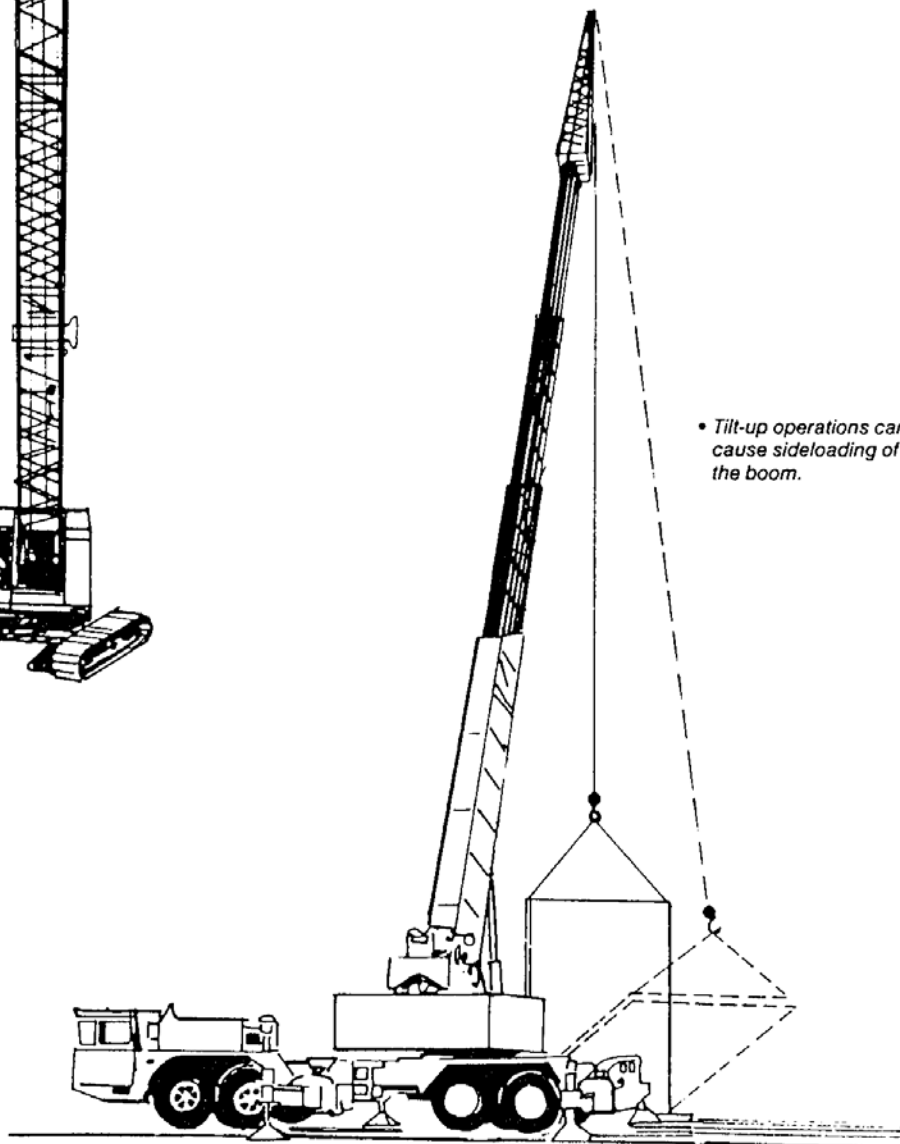

- Tilt-up operations can cause sideloading of the boom.

Increase of Load Radius

Load chart ratings apply only when the hoist line is vertical at all times and the load is freely suspended during the lift. If the line is not vertical, regardless of the reasons, capacity is lost. In addition to the examples relating to side loading

(see previous pages), the following conditions produce non-vertical hoist lines which result in increased load radius and reduced capacity.

- Reaching beyond the vertical extends the load radius and tends to draw the boom forward and decreases the crane's capacity. It will tip or fail more easily and with a lower hook load than listed in the load chart for the boom tip radius.

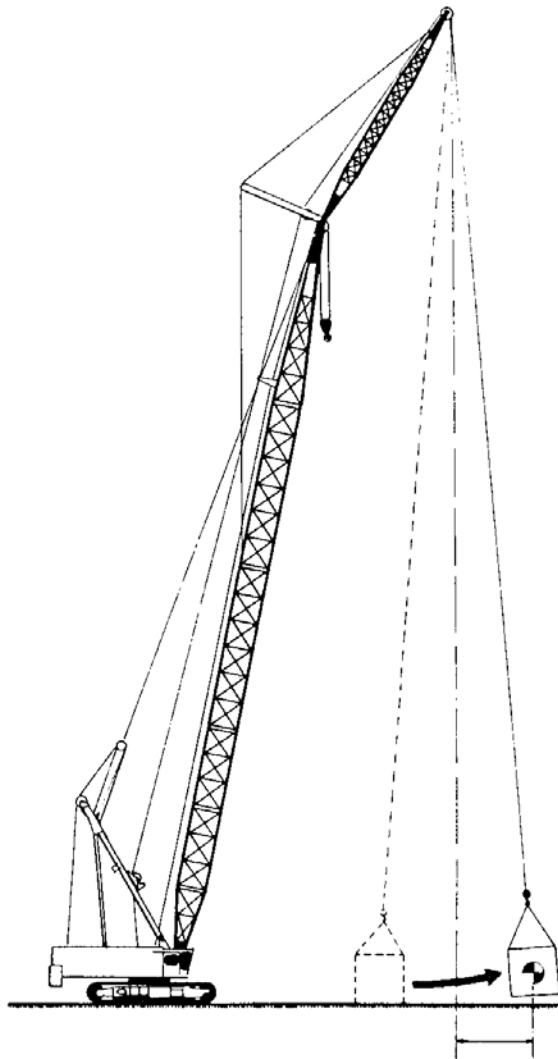
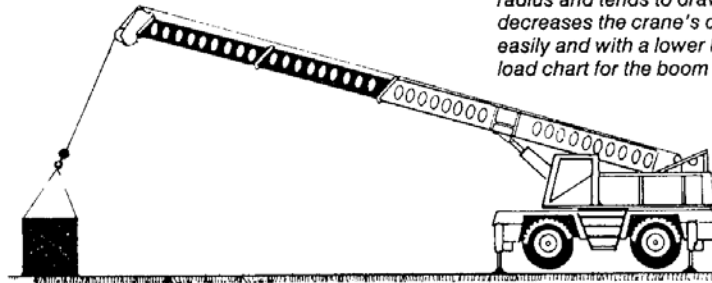

- Rapid swing causes increased load radius which decreases stability and reduces capacity.

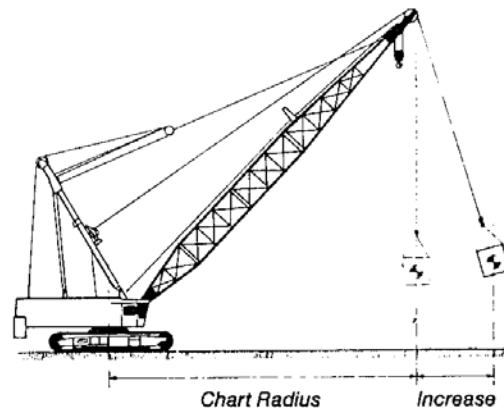

- Lifting inside the boom tip radius puts a load component on the boom that acts to tip it backward. After the load is clear of the ground it will swing out increasing the radius and tend to tip the crane forward.

Increase of Load Radius continued

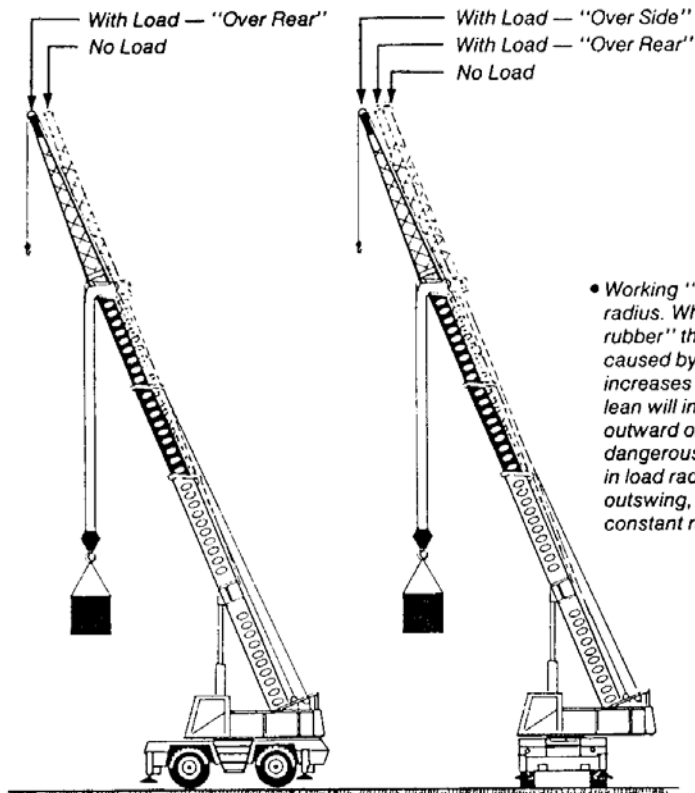

- Working "on rubber" can also produce an increase of load radius. When lifting a heavy load "over the rear" "on rubber" the crane will lean slightly toward the load. This is caused by boom, tire and carrier deflection. This lean increases when picking "over the side" "on rubber". The lean will increase operating radius so the load will swing outward once it clears the ground. This outswing is dangerous to anything in the path of the load. The increase in load radius may also overload the machine. To overcome outswing, boom up as the load is lifted to maintain a constant radius.

- Swinging a load from "over the end" to "over the side" will increase lean. This is especially noticeable when operating "on tires". Since tilt acts to increase load radius, it must be compensated for when swinging the load. Swing slowly. Change boom angle (raise or lower boom) while swinging to maintain a constant radius and prevent inswing or outswing of load.

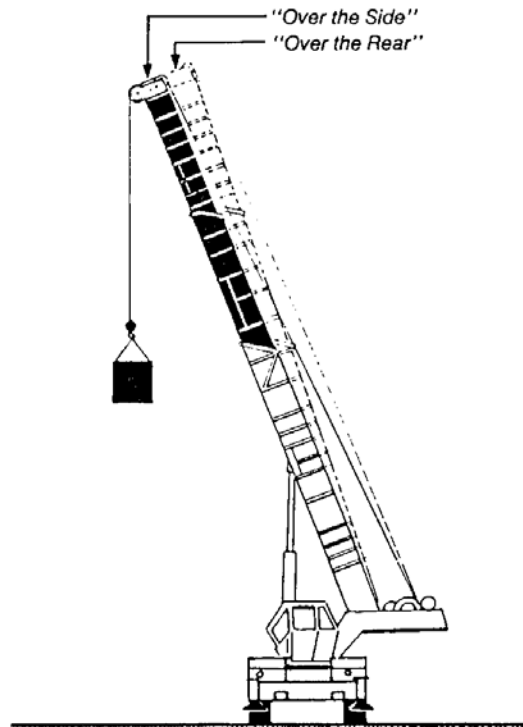

Rapid Swing Rate

Load chart ratings apply only when the load is vertically in line with the boom tip at all times. Rapid swing rates make this an impossible condition to meet.

Therefore, load chart capacities do not allow for fast swings.

The swing rate must be adjusted to keep the load directly below the boom tip at all times.

(1) START SWING



(2) DURING SWING



(3) STOP SWING

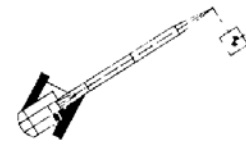

(1) When the swing is started the load will lag behind the boom tip causing sideloading and reducing capacity.

(2) Rapid swinging of a load causes it to drift away from the machine increasing the load radius and reducing capacity; the load will also lag behind the boom tip causing sideloading.

(3) When the crane's swing is stopped the load will keep going causing sideloading and reducing capacity.

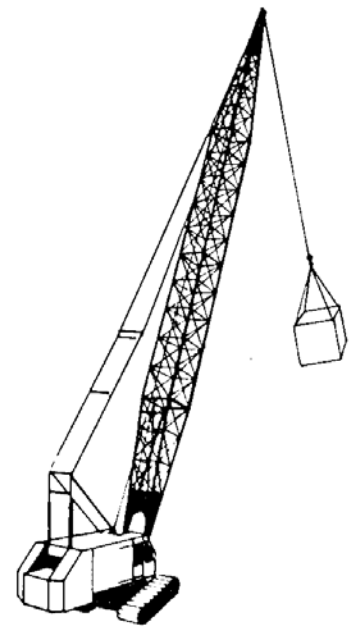
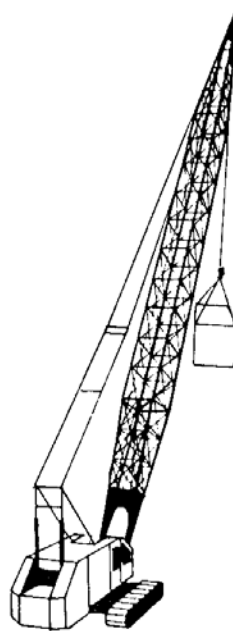
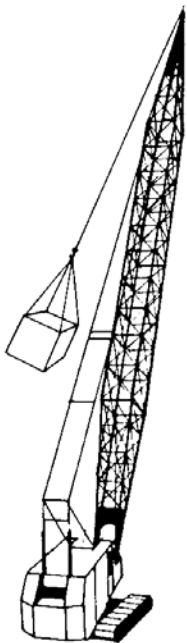

Rapid Swing Rate continued

Caution: On long boom mobile cranes, rapid swing rates, rapid swing acceleration, or rapid application of the swing brake can overturn the crane or collapse the boom *with or without load on the hook.*

- Moving the dead weight of the boom at the start of a swing or trying to stop it at the end of a swing causes the boom to sideload itself.
- The centrifugal force of the boom during a high speed swing creates a high forward tipping load.
- At high boom angles, the boom can collapse over the back of the machine if the boom is accelerated or decelerated rapidly.

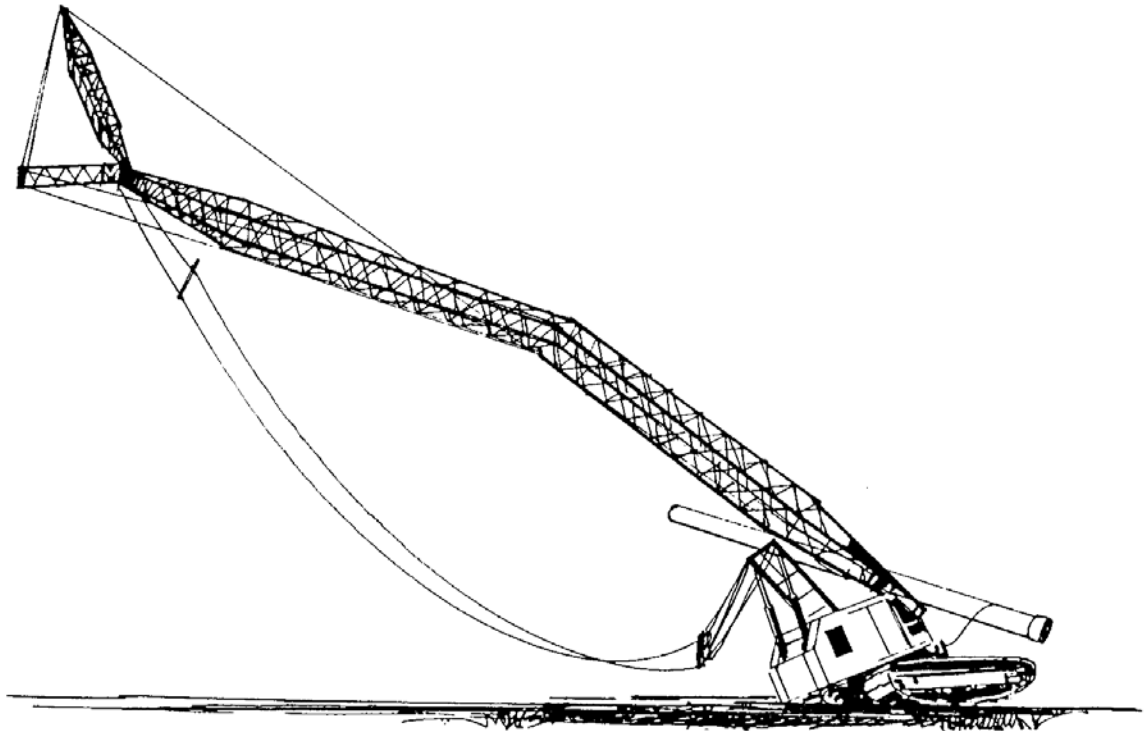

Impact Loading and Rapid Acceleration or Deceleration of Load

Load chart capacities do not allow for sudden starting or stopping of the load, impact loading or sudden machine movements.

The following situations create such conditions and reduce crane capacity below the chart ratings.

- Sudden release of a load causes a rapid change in load and impact loading. Crane will recoil initially, then full weight of load will suddenly be applied to the hook. The result can be overturning or structural failure. The same thing can happen when a frozen, caught or stuck load is pulled and suddenly breaks free.

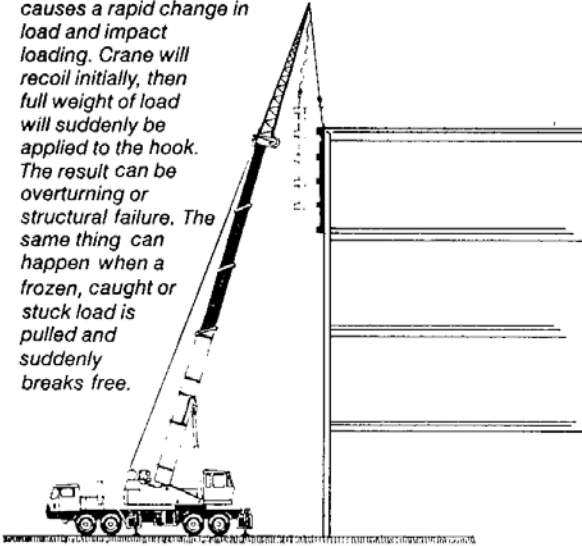

- Sudden snatching of a load causes impact loading and the hoist rope or boom can fail.

Ease into all loads to avoid impact loading.

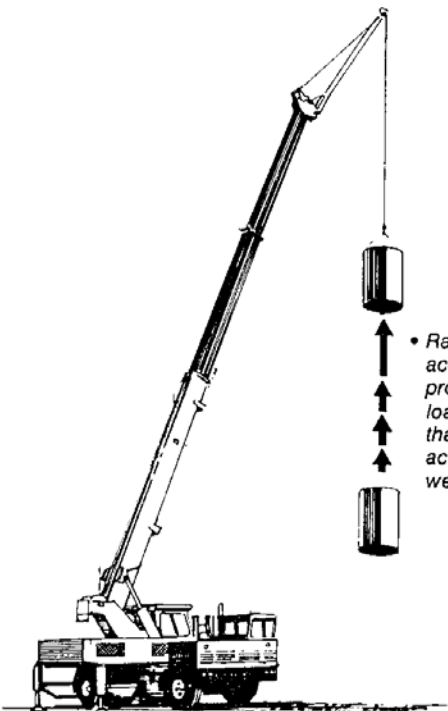
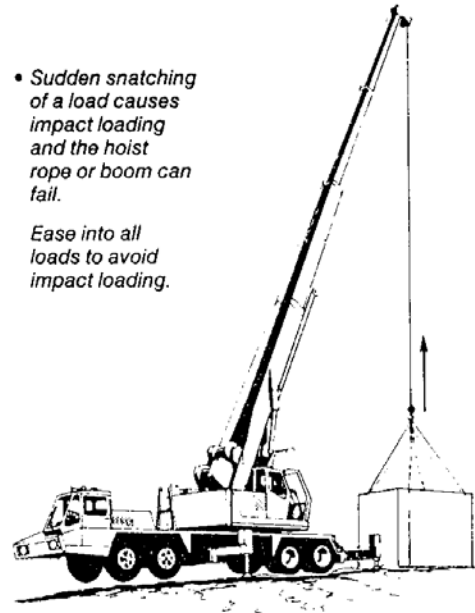

- Rapid hoist acceleration produces hook loads higher than the actual load weight.

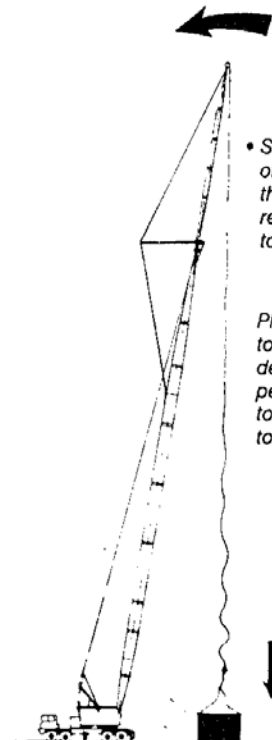

- Sudden release of a load causes the boom to recoil and perhaps topple.

Place all loads gently to allow boom deflection and pendant stretch to gradually return to normal.

Impact Loading and Rapid Acceleration or Deceleration of Load continued

- Rapid stopping of the load produces hook loads higher than the actual load weight (see table).

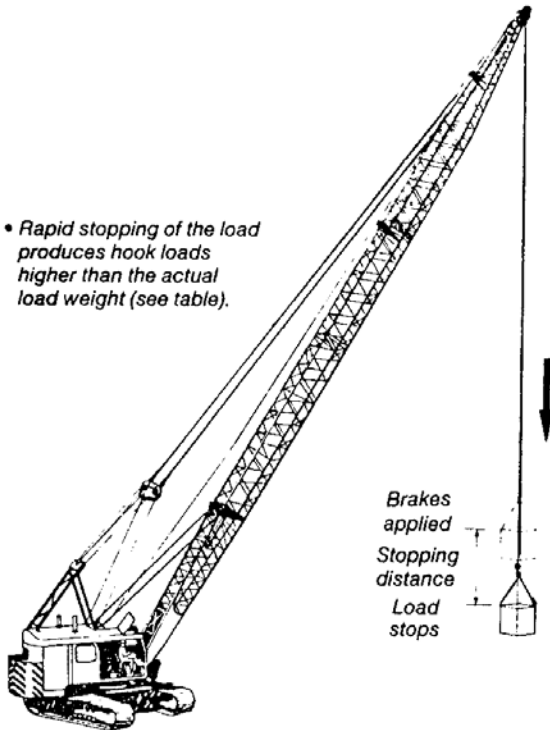

- "Pick and carry" operations subject the carrier and boom to shock loads. In order to ensure that the chart capacities are not exceeded, move the crane and load as smoothly as possible.

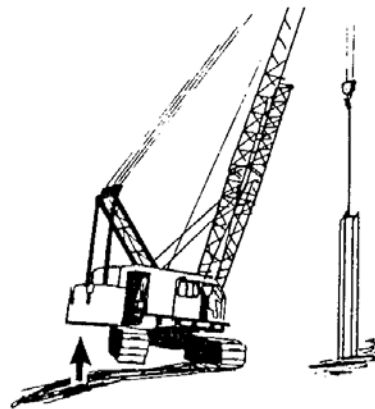

Sudden brake application during lowering will increase the hook load by the percentage shown according to the lowering speed and stopping distance. Note how rapidly the loads increase as the stopping distance decreases.

INCREASE IN HOOK LOADS

LINE SPEED FT/MIN.	STOPPING DISTANCE (FT)		
	10	6	2
100	0.4%	0.7%	2.2%
150	1.0%	1.6%	4.9%
200	1.7%	2.9%	8.6%
250	2.7%	4.5%	13.5%
300	3.9%	6.5%	19.4%
350	5.3%	8.8%	26.4%
400	6.9%	11.5%	34.5%

- Don't extract pilings, casings or similar loads by yanking or jerking on them. The practice of pulling on the load until the machine has tipped, then releasing the hoist line, allowing the machine to drop back and catching the hoist line on a clutch or brake may break the boom. If the piling or casing won't dislodge with a smooth, steady pull, use an extractor, pulling frame or similar device.

- Demolition work can be particularly hazardous. Shock loadings and sideloadings during work with demolition balls and clamshell buckets can be severe. The repetitive nature of such work imposes heavy demands on all parts of the machine. Restrict demolition ball weights to not more than 50% of capacity ("on rubber" capacities for truck cranes) at the maximum radius at which you handle the ball, with the boom length you are using. In addition to this requirement, ensure that the ball weight never exceeds 50% of the available line pull.

Duty Cycle Operations

Full load chart ratings may not apply when cranes are used in high speed production operations (duty cycle operations) such as concrete placing, steel erection, draglining, clam, magnet or grapple work.

The manufacturer will either specify in the load chart that lift crane ratings be reduced by a percentage (usually 20%) for duty cycle operations or will supply a separate load chart for such operations.

The capacity reduction is recommended because the speed of these operations produces increases in crane loads from sload, swing-out and impact as well as higher temperatures in critical components such as brakes, clutches, pumps and motors.

The following are duty cycle operations:

- *Draglining, Clam, Grapple and Magnet Operations*

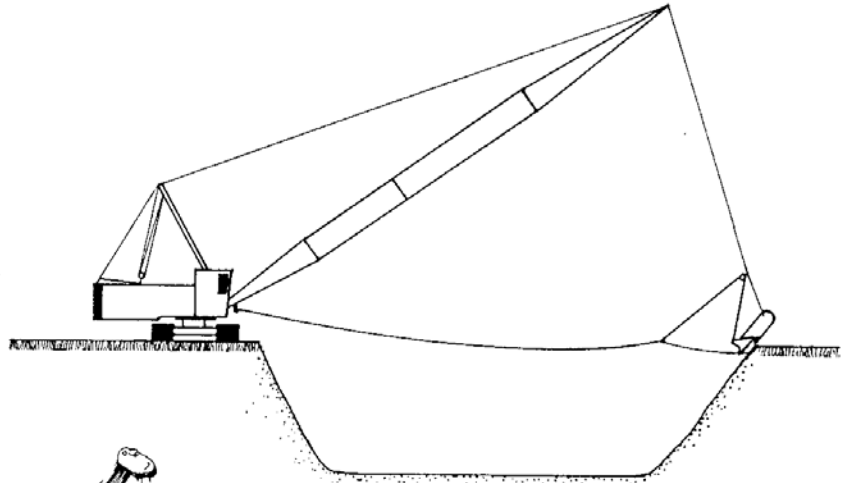

- *High Speed, High Volume Concrete Placement*

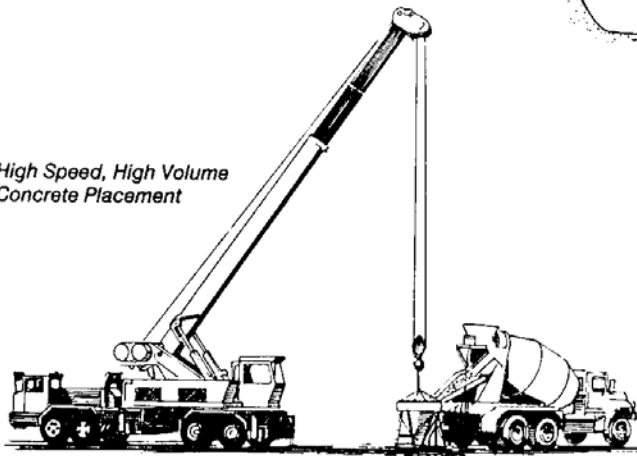

- *High Speed, High Volume Steel Erection*

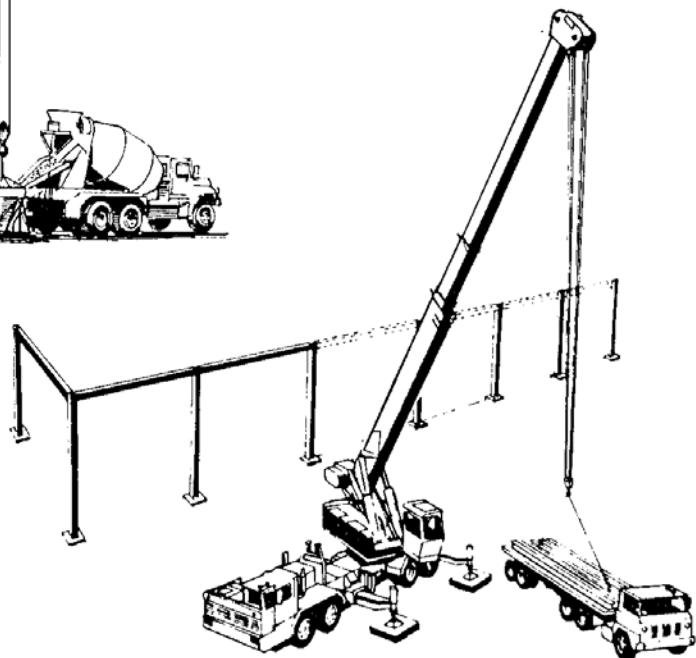

High Wind Speeds

Almost all crane manufacturers specify in the load chart that chart ratings must be reduced under windy conditions, and they may also recommend a shut-down wind velocity. In almost all cases, when the wind speed exceeds *30 mph*, it is advisable to *stop* operations.

Wind affects both the crane and the load, reducing the rated capacity of the crane. Never make a full capacity lift if it is windy. Use a great deal of discretion even when lifting under moderate wind conditions of *20 mph*.

It is advisable to avoid handling loads that present large wind-catching surfaces. The result could be loss of control of the load and crane even though the weight of the load is within the normal capacity of the crane.

A *20 mph* wind exerts a force of only $1\frac{1}{8}$ lb/ft² on a flat-surfaced load (the force on a 4 ft. by 8 ft. sheet of plywood = 36 lbs.) so only loads having very large sail areas would require crane capacity derating. At *30 mph*, however, the wind exerts a force of 2.53 lb/ft² of flat surface area (equals 80 lbs. on a sheet of 4 ft. by 8 ft. plywood). This wind force on the load at *30 mph* is enough to cause non-vertical hoist lines and loads that are very difficult to control.

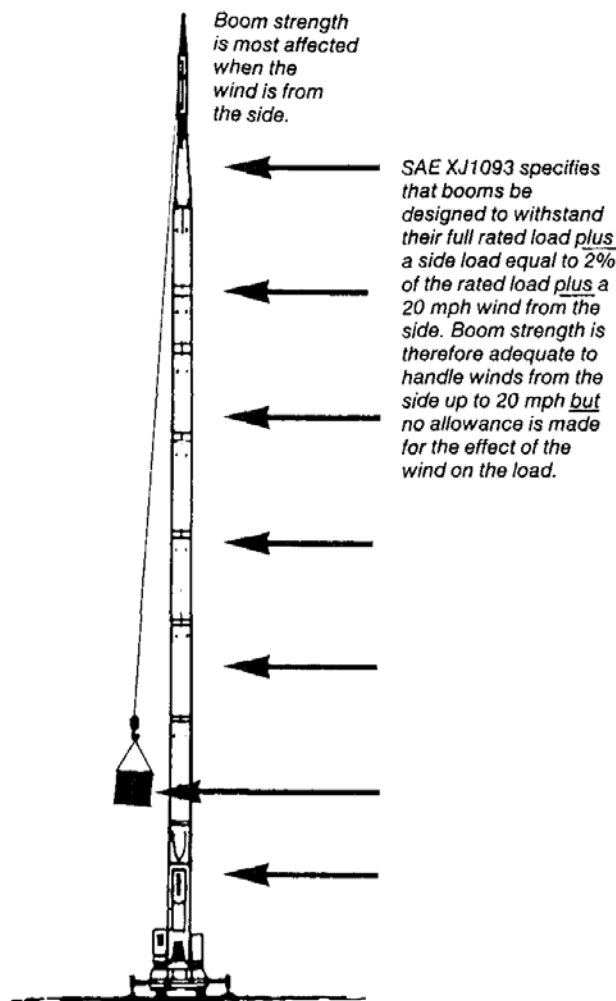

Setup Summary

A crane is properly set up for lifting when the following conditions are met.

For Cranes Operating "On Outriggers"

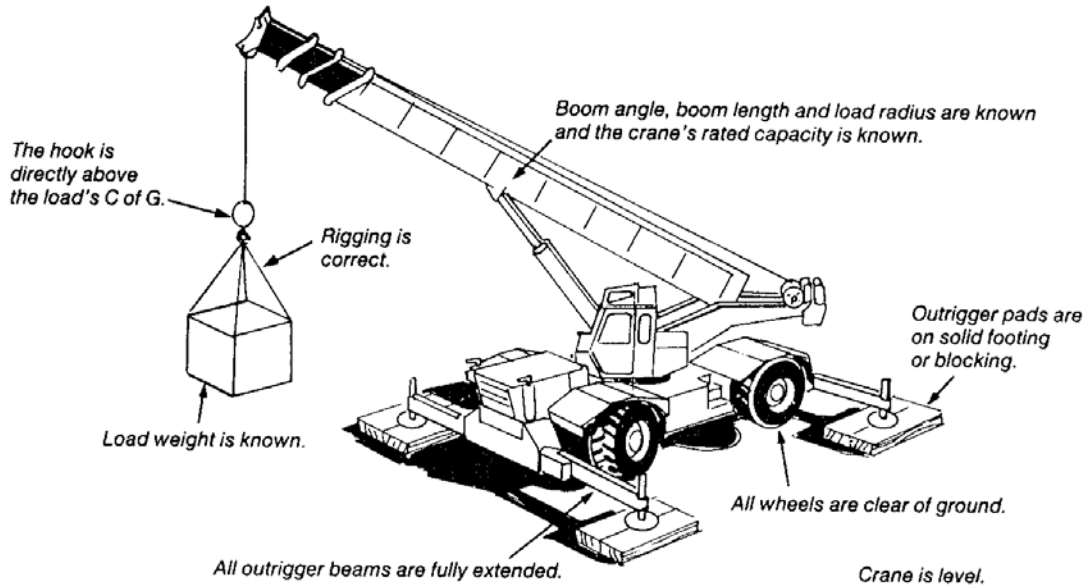

For Crawler-Mounted Cranes or When Lifting "On Rubber"

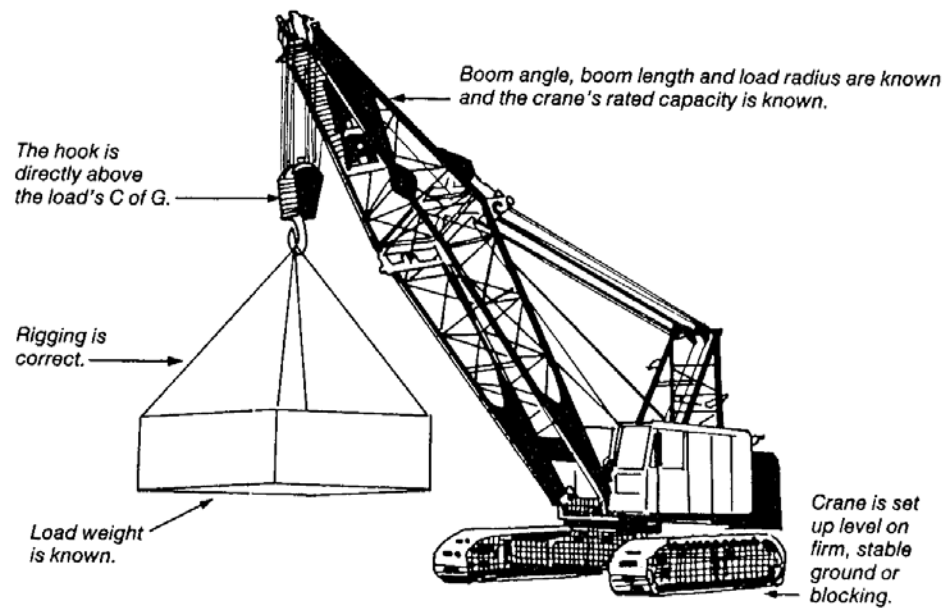

Machine Selection

One basic requirement for any crane safety program is making sure that the right machine is selected for the job. If crane characteristics do not match job requirements, unsafe conditions are created before any work is done. Jobsite personnel are forced to "make do" and improvise in a rush—a surefire recipe for accidents.

CHECKPOINTS

No machine should be selected to do any lifting on a specific job until its size and characteristics are considered against:

- the weights, dimensions, and lift radii of the heaviest and largest loads
- the maximum lift height, the maximum lift radius, and the weight of the loads that must be handled at each
- the number and frequency of lifts to be made
- how long the crane will be required on site
- the type of lifting to be done (for example, is precision placement of loads important?)
- the type of carrier required (this depends on ground conditions and machine capacity in its various operating quadrants: capacity is normally greatest over the rear, less over the side, and non-existent over the front)
- whether loads will have to be walked or carried
- whether loads will have to be suspended for lengthy periods
- the site conditions, including the ground where the machine will be set up, access roads and ramps it must travel, space for erection, and any obstacles that might impede access or operation
- service availability and unit cost
- the cost of operations such as erection, dismantling, on- and off-site transport, and altering boom length.

RESULTS

The selected machine should

- be able to make all of its lifts in its standard configuration (that means having the capacity and boom length to do all known tasks, with jib, extra counterweight, and special reeving held in reserve for any unexpected problems)
- have at least a 5% working margin with respect to the load capacity of every lift
- be highly mobile and capable of being routed with a minimum amount of tearing down
- have enough clearance between load and boom and adequate head room between the load and whatever rigging is required to make the lift.

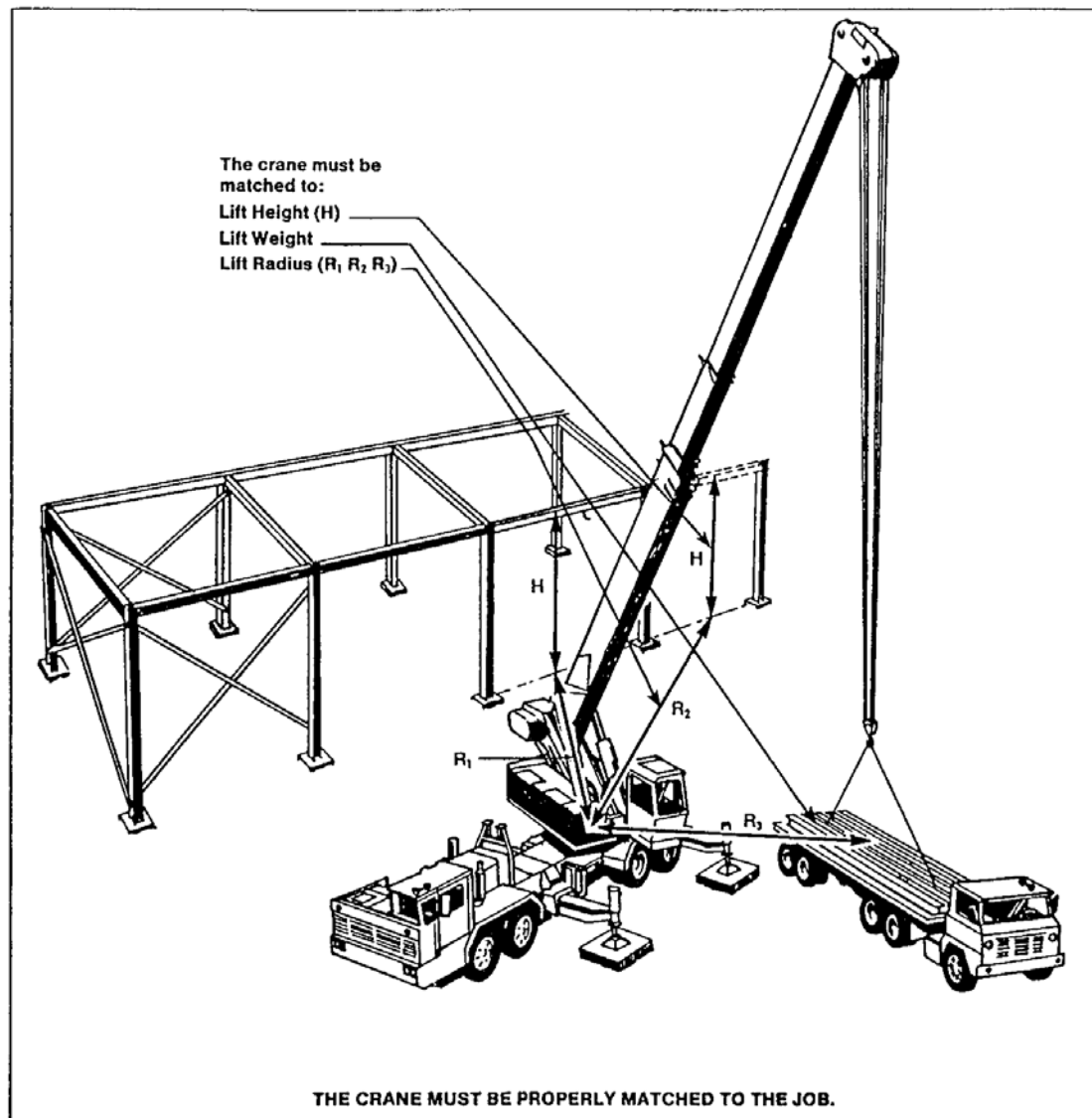

Those responsible for equipment selection must ensure that the crane is going to be safe and reliable for as long as it will be used, and under all anticipated conditions to which it will be exposed during operation.

Certain equipment considerations and requirements apply to all cranes. These requirements can be specified in purchase orders and rental agreements. Machines should be rented only from reputable suppliers. Note that all cranes of the same model number may not have the same capacity rating. The correct rating should be determined from the manufacturer through the serial number.

Any changes in counterweight and boom inserts made by the owner should be checked. After such changes, capacities and other data in the load chart may no longer apply.

A machine designed, manufactured, inspected, tested, and maintained in accordance with Canadian Standards Association *Standard Z150-1974 Mobile Cranes* should meet the requirements of all major codes and regulations.

Signalling

Signalling is an important part of crane operation, but is often not treated with the respect it deserves. Signallers must be used whenever

- the operator cannot see the load
- the operator cannot see the load's landing area
- the operator cannot see the path of travel of the load or of the crane
- the operator is far enough away from the load to make the judgment of distance difficult
- the crane is working within a boom's length of the approach limits to powerlines or electrical equipment.

Where loads are picked up at one point and lowered at another, two signallers may be required—one to direct the lift and one to direct the descent.

Hand signals should be used only when the distance between the operator and the signaller is not great and conditions allow for clear visibility. The international handsignals for hoisting appear on the following page.

Telephone or radio communications between operator and signaller can be extremely effective.

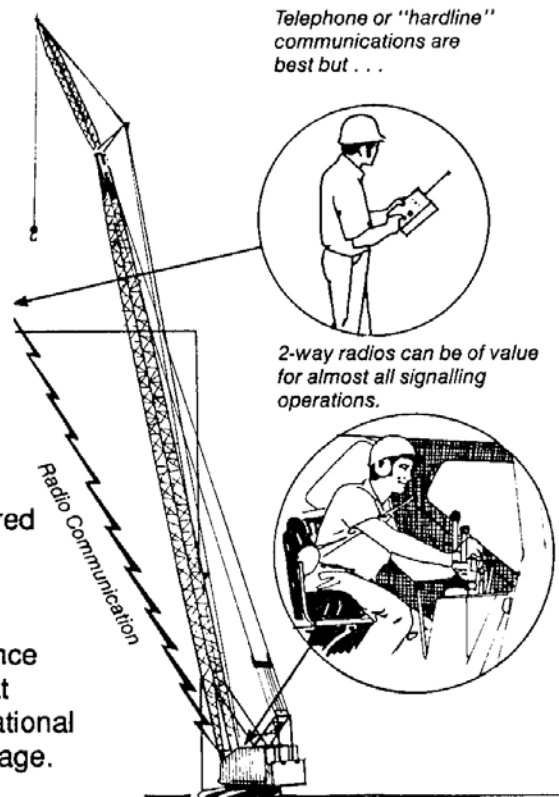

HAND SIGNALS FOR HOISTING OPERATIONS

Load Up  1	Load Down  2	Load Up Slowly  3	Load Down Slowly  4	Boom Up  5	Boom Down  6
Boom Up Slowly  7	Boom Down Slowly  8	Boom Up Load Down  9	Boom Down Load Up  10	Everything Slowly  11	Use Whip Line  12
Use Main Line  13	Travel Forward  14	Turn Right  15	Turn Left  16	Shorten Hydraulic Boom  17	Extend Hydraulic Boom  18
Swing Load  19	Stop  20	Close Clam  21	Open Clam  22	Dog Everything  23	<p>No response should be made to unclear signals.</p>

APPENDIX

Excerpts from
Occupational Health and Safety Act

and

Regulations for Construction Projects [Ontario Regulation 213/91]

Excerpts from Occupational Health and Safety Act

PART III DUTIES OF EMPLOYERS AND OTHER PERSONS

	<p>23.—(1) A constructor shall ensure, on a project undertaken by the constructor that,</p> <p>(a) the measures and procedures prescribed by this Act and the regulations are carried out on the project;</p> <p>(b) every employer and every worker performing work on the project complies with this Act and the regulations; and</p> <p>(c) the health and safety of workers on the project is protected.</p> <p>(2) Where so prescribed, a constructor shall, before commencing any work on a project, give to a Director notice in writing of the project containing such information as may be prescribed. R.S.O. 1990, c. O.1, s. 23.</p>	Duties of constructor	
Notice of project			
Duties of licensee	<p>24.—(1) A licensee shall ensure that,</p> <p>(a) the measures and procedures prescribed by this Act and the regulations are carried out with respect to logging in the licensed area;</p> <p>(b) every employer performing logging in the licensed area for the licensee complies with this Act and the regulations; and</p> <p>(c) the health and safety of workers employed by employers referred to in clause (b) is protected.</p> <p>(2) In this section, "licensed area" means the lands on which the licensee is authorized to cut Crown timber. R.S.O. 1990, c. O.1, s. 24.</p>		
Definition			
Duties of employers	<p>25.—(1) An employer shall ensure that,</p> <p>(a) the equipment, materials and protective devices as prescribed are provided;</p> <p>(b) the equipment, materials and protective devices provided by the employer are maintained in good condition;</p> <p>(c) the measures and procedures prescribed are carried out in the workplace;</p> <p>(d) the equipment, materials and protective devices provided by the employer are used as prescribed; and</p> <p>(e) a floor, roof, wall, pillar, support or other part of a workplace is capable of supporting all loads to which it may be subjected without causing the materials therein to be stressed beyond the allowable unit stresses established under the <i>Building Code Act</i>.</p> <p>(2) Without limiting the strict duty imposed by subsection (1), an employer shall,</p> <p>(a) provide information, instruction and supervision to a worker to protect the health or safety of the worker;</p> <p>(b) in a medical emergency for the purpose of diagnosis or treatment, provide, upon request, information in the possession of the employer, including confidential business information, to a legally qualified medical practitioner and to such other persons as may be prescribed;</p> <p>(c) when appointing a supervisor, appoint a competent person;</p>		
Idem		Idem	
		Idem	
		Additional duties of employers	
			<p>(d) acquaint a worker or a person in authority over a worker with any hazard in the work and in the handling, storage, use, disposal and transport of any article, device, equipment or a biological, chemical or physical agent;</p> <p>(e) afford assistance and co-operation to a committee and a health and safety representative in the carrying out by the committee and the health and safety representative of any of their functions;</p> <p>(f) only employ in or about a workplace a person over such age as may be prescribed;</p> <p>(g) not knowingly permit a person who is under such age as may be prescribed to be in or about a workplace;</p> <p>(h) take every precaution reasonable in the circumstances for the protection of a worker;</p> <p>(i) post, in the workplace, a copy of this Act and any explanatory material prepared by the Ministry, both in English and the majority language of the workplace, outlining the rights, responsibilities and duties of workers;</p> <p>(j) prepare and review at least annually a written occupational health and safety policy and develop and maintain a program to implement that policy;</p> <p>(k) post at a conspicuous location in the workplace a copy of the occupational health and safety policy;</p> <p>(l) provide to the committee or to a health and safety representative the results of a report respecting occupational health and safety that is in the employer's possession and, if that report is in writing, a copy of the portions of the report that concern occupational health and safety; and</p> <p>(m) advise workers of the results of a report referred to in clause (l) and, if the report is in writing, make available to them on request copies of the portions of the report that concern occupational health and safety.</p> <p>(3) For the purposes of clause (2) (c), an employer may appoint himself or herself as a supervisor where the employer is a competent person.</p> <p>(4) Clause (2) (j) does not apply with respect to a workplace at which five or fewer employees are regularly employed. R.S.O. 1990, c. O.1, s. 25.</p> <p>26.—(1) In addition to the duties imposed by section 25, an employer shall,</p> <p>(a) establish an occupational health service for workers as prescribed;</p> <p>(b) where an occupational health service is established as prescribed, maintain the same according to the standards prescribed;</p> <p>(c) keep and maintain accurate records of the handling, storage, use and disposal of biological, chemical or physical agents as prescribed;</p> <p>(d) accurately keep and maintain and make available to the worker affected such records of the exposure of a worker to biological, chemical or physical agents as may be prescribed;</p>

- (e) notify a Director of the use or introduction into a workplace of such biological, chemical or physical agents as may be prescribed;
- (f) monitor at such time or times or at such interval or intervals the levels of biological, chemical or physical agents in a workplace and keep and post accurate records thereof as prescribed;
- (g) comply with a standard limiting the exposure of a worker to biological, chemical or physical agents as prescribed;
- (h) establish a medical surveillance program for the benefit of workers as prescribed;
- (i) provide for safety-related medical examinations and tests for workers as prescribed;
- (j) where so prescribed, only permit a worker to work or be in a workplace who has undergone such medical examinations, tests or x-rays as prescribed and who is found to be physically fit to do the work in the workplace;
- (k) where so prescribed, provide a worker with written instructions as to the measures and procedures to be taken for the protection of a worker; and
- (l) carry out such training programs for workers, supervisors and committee members as may be prescribed.

(2) For the purposes of clause (1) (a), a group of employers, with the approval of a Director, may act as an employer.

(3) If a worker participates in a prescribed medical surveillance program or undergoes prescribed medical examinations or tests, his or her employer shall pay,

- (a) the worker's costs for medical examinations or tests required by the medical surveillance program or required by regulation;
- (b) the worker's reasonable travel costs respecting the examinations or tests; and
- (c) the time the worker spends to undergo the examinations or tests, including travel time, which shall be deemed to be work time for which the worker shall be paid at his or her premium rate as may be proper. R.S.O. 1990, c. O.1, s. 26.

Duties of supervisor

27.—(1) A supervisor shall ensure that a worker,

- (a) works in the manner and with the protective devices, measures and procedures required by this Act and the regulations; and
- (b) uses or wears the equipment, protective devices or clothing that the worker's employer requires to be used or worn.

Additional duties of supervisor

(2) Without limiting the duty imposed by subsection (1), a supervisor shall,

- (a) advise a worker of the existence of any potential or actual danger to the health or safety of the worker of which the supervisor is aware;
- (b) where so prescribed, provide a worker with written instructions as to the measures and procedures to be taken for protection of the worker; and
- (c) take every precaution reasonable in the circumstances for the protection of a worker. R.S.O. 1990, c. O.1, s. 27.

Duties of workers

28.—(1) A worker shall,

- (a) work in compliance with the provisions of this Act and the regulations;
- (b) use or wear the equipment, protective devices or clothing that the worker's employer requires to be used or worn;
- (c) report to his or her employer or supervisor the absence of or defect in any equipment or protective device of which the worker is aware and which may endanger himself, herself or another worker; and
- (d) report to his or her employer or supervisor any contravention of this Act or the regulations or the existence of any hazard of which he or she knows.

Idem

(2) No worker shall,

- (a) remove or make ineffective any protective device required by the regulations or by his or her employer, without providing an adequate temporary for removing or making ineffective the protective device has ceased, the protective device shall be replaced immediately;
- (b) use or operate any equipment, machine, device or thing or work in a manner that may endanger himself, herself or any other worker; or
- (c) engage in any prank, contest, feat of strength, unnecessary running or rough and boisterous conduct.

(3) A worker is not required to participate in a prescribed medical surveillance program unless the worker consents to do so. R.S.O. 1990, c. O.1, s. 28.

Consent to medical surveillance

29.—(1) The owner of a workplace that is not a project shall,

Duties of owners

(a) ensure that,

- (i) such facilities as are prescribed are provided,
- (ii) any facilities prescribed to be provided are maintained as prescribed,
- (iii) the workplace complies with the regulations, and
- (iv) no workplace is constructed, developed, reconstructed, altered or added to except in compliance with this Act and the regulations; and

(b) where so prescribed, furnish to a Director any drawings, plans or specifications of any workplace as prescribed.

(2) The owner of a mine shall cause drawings, plans or specifications to be maintained and kept up to date not more than six months last past on such scale and showing such matters or things as may be prescribed.

Mine plans

(3) Where so prescribed, an owner or employer shall,

Plans of workplaces

(a) not begin any construction, development, reconstruction, alteration, addition or installation to or in a workplace until the drawings, layout and specifications thereof and any alterations thereto have been filed with the Ministry for review by an engineer of the Ministry for compliance with this Act and the regulations; and

(b) keep a copy of the drawings as reviewed in a convenient location at or near the workplace and such drawings shall be produced by the owner or employer upon the request of an inspector for his or her examination and inspection.

Additional information

(4) An engineer of the Ministry may require the drawings, layout and specifications to be supplemented by the owner or employer with additional information.

Fees

(5) Fees as prescribed for the filing and review of drawings, layout or specifications shall become due and payable by the owner or employer upon filing. R.S.O. 1990, c. O.1, s. 29.

Duty of project owners

30.—(1) Before beginning a project, the owner shall determine whether any designated substances are present at the project site and shall prepare a list of all designated substances that are present at the site.

Tenders

(2) If any work on a project is tendered, the person issuing the tenders shall include, as part of the tendering information, a copy of the list referred to in subsection (1).

Idem

(3) An owner shall ensure that a prospective constructor of a project on the owner's property has received a copy of the list referred to in subsection (1) before entering into a binding contract with the constructor.

Duty of constructors

(4) The constructor for a project shall ensure that each prospective contractor and subcontractor for the project has received a copy of the list referred to in subsection (1) before the prospective contractor or subcontractor enters into a binding contract for the supply of work on the project.

Liability

(5) An owner who fails to comply with this section is liable to the constructor and every contractor and subcontractor who suffers any loss or damages as the result of the subsequent discovery on the project of a designated substance that the owner ought reasonably to have known of but that was not on the list prepared under subsection (1).

(6) A constructor who fails to comply with this section is liable to every contractor and subcontractor who suffers any loss or damages as the result of the subsequent discovery on the project of a designated substance that was on the list prepared under subsection (1). R.S.O. 1990, c. O.1, s. 30.

Idem

31.—(1) Every person who supplies any machine, device, tool or equipment under any rental, leasing or similar arrangement for use in or about a workplace shall ensure,

Duties of suppliers

- (a) that the machine, device, tool or equipment is in good condition;
- (b) that the machine, device, tool or equipment complies with this Act and the regulations; and
- (c) if it is the person's responsibility under the rental, leasing or similar arrangement to do so, that the machine, device, tool or equipment is maintained in good condition.

(2) An architect as defined in the *Architects Act*, and a professional engineer as defined in the *Professional Engineers Act*, contravenes this Act if, as a result of his or her advice that is given or his or her certification required under this Act that is made negligently or incompetently, a worker is endangered. R.S.O. 1990, c. O.1, s. 31.

Architects and engineers

32. Every director and every officer of a corporation shall take all reasonable care to ensure that the corporation complies with,

Duties of directors and officers of a corporation

- (a) this Act and the regulations;
- (b) orders and requirements of inspectors and Directors; and
- (c) orders of the Minister. R.S.O. 1990, c. O.1, s. 32.

Application

PART V RIGHT TO REFUSE OR TO STOP WORK WHERE HEALTH OR SAFETY IN DANGER

43.—(1) This section does not apply to a worker described in subsection (2).

- (a) when a circumstance described in clause (3) (a), (b) or (c) is inherent in the worker's work or is a normal condition of the worker's employment; or
- (b) when the worker's refusal to work would directly endanger the life, health or safety of another person.

Idem

(2) The worker referred to in subsection (1) is,

- (a) a person employed in, or a member of, a police force to which the *Police Services Act* applies;
- (b) a full-time, or a volunteer, firefighter as defined in the *Fire Departments Act*;
- (c) a person employed in the operation of a correctional institution or facility, a training school or centre, a place of secure custody designated under section 24.1 of the *Young Offenders Act* (Canada) or a place of temporary detention designated under subsection 7 (1) of that Act or a similar institution, facility, school or home;

- (d) a person employed in the operation of,
 - (i) a hospital, sanatorium, nursing home, home for the aged, psychiatric institution, mental health or mental retardation centre or a rehabilitation facility,
 - (ii) a residential group home or other facility for persons with behavioural or emotional problems or a physical, mental or developmental handicap,
 - (iii) an ambulance service or a first aid clinic or station,
 - (iv) a laboratory operated by the Crown or licensed under the *Laboratory and Specimen Collection Centre Licensing Act*, or
 - (v) a laundry, food service, power plant or technical service or facility used in conjunction with an institution, facility or service described in subclause (i) to (iv).

(3) A worker may refuse to work or do particular work where he or she has reason to believe that,

Refusal to work

- (a) any equipment, machine, device or thing the worker is to use or operate is likely to endanger himself, herself or another worker;
- (b) the physical condition of the workplace or the part thereof in which he or she works or is to work is likely to endanger himself or herself; or
- (c) any equipment, machine, device or thing he or she is to use or operate or the physical condition of the workplace or the part thereof in which he or she works or is to work is in contravention of this Act or the regulations and such contravention is likely to endanger himself, herself or another worker.

Report of refusal to work

(4) Upon refusing to work or do particular work, the worker shall promptly report the circumstances of the refusal to the worker's employer or supervisor who shall forthwith investigate the report in the presence of the worker and, if there is such, in the presence of one of,

	<p>(a) a committee member who represents workers, if any;</p> <p>(b) a health and safety representative, if any; or</p> <p>(c) a worker who because of knowledge, experience and training is selected by a trade union that represents the worker, or if there is no trade union, is selected by the workers to represent them,</p>				
	who shall be made available and who shall attend without delay.				
Worker to remain near work station	(5) Until the investigation is completed, the worker shall remain in a safe place near his or her work station.				
Refusal to work following investigation	(6) Where, following the investigation or any steps taken to deal with the circumstances that caused the worker to refuse to work or do particular work, the worker has reasonable grounds to believe that,				
	(a) the equipment, machine, device or thing that was the cause of the refusal to work or do particular work continues to be likely to endanger himself, herself or another worker;				
	(b) the physical condition of the workplace or the part thereof in which he or she works continues to be likely to endanger himself or herself; or				
	(c) any equipment, machine, device or thing he or she is to use or operate or the physical condition of the workplace or the part thereof in which he or she works or is to work is in contravention of this Act or the regulations and such contravention continues to be likely to endanger himself, herself or another worker,				
	the worker may refuse to work or do the particular work and the employer or the worker or a person on behalf of the employer or worker shall cause an inspector to be notified thereof.				
	(7) An inspector shall investigate the refusal to work in the presence of the employer or a person representing the employer, the worker, and if there is such, the person mentioned in clause (4) (a), (b) or (c).	Investigation by inspector			
	(8) The inspector shall, following the investigation referred to in subsection (7), decide whether the machine, device, thing or the workplace or part thereof is likely to endanger the worker or another person.	Decision of inspector			
	(9) The inspector shall give his or her decision, in writing, as soon as is practicable, to the employer, the worker, and, if there is such, the person mentioned in clause (4) (a), (b) or (c).	Idem			
	(10) Pending the investigation and decision of the inspector, the worker shall remain at a safe place near his or her work station during the worker's normal working hours unless the employer, subject to the provisions of a collective agreement, if any,	Worker to remain at a safe place pending decision			
	(a) assigns the worker reasonable alternative work during such hours; or				
	(b) subject to section 50, where an assignment of reasonable alternative work is not practicable, gives other directions to the worker.				
	(11) Pending the investigation and decision of the inspector, no worker shall be assigned to use or operate the equipment, machine, device or thing or to work in the	Duty to advise other workers			
	workplace or in the part of the workplace being investigated unless, in the presence of a person described in subsection (12), the worker has been advised of the other worker's refusal and of his or her reasons for the refusal.				
		Idem	(12) The person referred to in subsection (11) must be,		
			(a) a committee member who represents workers and, if possible, who is a certified member;		
			(b) a health and safety representative; or		
			(c) a worker who because of his or her knowledge, experience and training is selected by the trade union that represents the worker or, if there is no trade union, by the workers to represent them.		
		Entitlement to be paid	(13) A person shall be deemed to be at work and the person's employer shall pay him or her at the regular or premium rate, as may be proper,		
			(a) for the time spent by the person carrying out the duties under subsections (4) and (7) of a person mentioned in clause (4) (a), (b) or (c); and		
			(b) for time spent by the person carrying out the duties under subsection (11) of a person described in subsection (12). R.S.O. 1990, c. O.1, s. 43.		
		Definition	44.—(1) In sections 45 to 48, "dangerous circumstances" means a situation in which,		
			(a) a provision of this Act or the regulations is being contravened;		
			(b) the contravention poses a danger or a hazard to a worker; and		
			(c) the danger or hazard is such that any delay in controlling it may seriously endanger a worker.		
		Non-application	(2) Sections 45 to 49 do not apply to,		
			(a) a workplace at which workers described in clause 43 (2) (a), (b) or (c) are employed; or		
			(b) a workplace at which workers described in clause 43 (2) (d) are employed if a work stoppage would directly endanger the life, health or safety of another person. R.S.O. 1990, c. O.1, s. 44.		
			45.—(1) A certified member who has reason to believe that dangerous circumstances exist at a workplace may request that a supervisor investigate the matter and the supervisor shall promptly do so in the presence of the certified member.	Bilateral work stoppage	
			(2) The certified member may request that a second certified member representing the other workplace party investigate the matter if the first certified member has reason to believe that dangerous circumstances continue after the supervisor's investigation and remedial actions, if any.	Investigation by second certified member	
			(3) The second certified member shall promptly investigate the matter in the presence of the first certified member.	Idem	
			(4) If both certified members find that the dangerous circumstances exist, the certified members may direct the constructor or employer to stop the work or to stop the use of any part of a workplace or of any equipment, machine, device, article or thing.	Direction following investigation	
			(5) The constructor or employer shall immediately comply with the direction and shall ensure that compliance is effected in a way that does not endanger a person.	Constructor or employer's duties	

	(6) If the certified members do not agree whether dangerous circumstances exist, either certified member may request that an inspector investigate the matter and the inspector shall do so and provide the certified members with a written decision.	Investigation by inspector	47.—(1) This section applies, and section 45 does not apply, to a constructor or an employer.	Unilateral work stoppage
	(7) After taking steps to remedy the dangerous circumstances, the constructor or employer may request the certified members or an inspector to cancel the direction.	Cancellation of direction	(a) against whom the adjudicator has issued a declaration under section 46; or	
	(8) The certified members who issued a direction may jointly cancel it or an inspector may cancel it.	Idem	(b) who advises the committee at a workplace in writing that the constructor or employer adopts the procedures set out in this section respecting work stoppages.	
Delegation by certified member	(9) In such circumstances as may be prescribed, a certified member who represents the constructor or employer shall designate a person to act under this section in his or her stead when the certified member is not available at the workplace. R.S.O. 1990, c. O.1, s. 45.		(2) A certified member may direct the constructor or employer to stop specified work or to stop the use of any part of a workplace or of any equipment, machine, device, article or thing if the certified member finds that dangerous circumstances exist.	Direction re work stoppage
Declaration against constructor, etc.	46.—(1) A certified member at a workplace or an inspector who has reason to believe that the procedure for stopping work set out in section 45 will not be sufficient to protect a constructor's or employer's workers at the workplace from serious risk to their health or safety may apply to the adjudicator for a declaration or recommendation described in subsection (5), or both.		(3) The constructor or employer shall immediately comply with the direction and shall ensure that compliance is effected in a way that does not endanger a person.	Constructor's or employer's duties
Notice	(2) An applicant shall give written notice of an application to the constructor or employer and to a Director.		(4) After complying with the direction, the constructor or employer shall promptly investigate the matter in the presence of the certified member.	Investigation by constructor, etc.
Minister a party	(3) The Minister is entitled to be a party to a proceeding before the adjudicator.		(5) If the certified member and the constructor or employer do not agree whether dangerous circumstances exist, the constructor or employer or the certified member may request that an inspector investigate the matter and the inspector shall do so and provide them with a written decision.	Investigation by inspector
Mediation	(4) The Minister may appoint an inspector to attempt to mediate a settlement of the issues between the applicant and the constructor or employer at any time after an application is made.		(6) After taking steps to remedy the dangerous circumstances, the constructor or employer may request the certified member or an inspector to cancel the direction.	Cancellation of direction
Declaration and recommendation	(5) If the adjudicator finds that the procedure for stopping work set out in section 45 will not be sufficient to protect the constructor's or employer's workers at the workplace from serious risk to their health or safety, the adjudicator,	Idem	(7) The certified member who made the direction or an inspector may cancel it. R.S.O. 1990, c. O.1, s. 47.	
	(a) may issue a declaration that the constructor or employer is subject to the procedure for stopping work set out in section 47 for the period specified; and	Entitlement to investigate	48.—(1) A certified member who receives a complaint that dangerous circumstances exist is entitled to investigate the complaint.	
	(b) may recommend to the Minister that an inspector be assigned to oversee the health and safety practices of the constructor or employer at the workplace on a full-time or part-time basis for a specified period.	Entitlement to be paid	(2) The time spent by a certified member in exercising powers and carrying out duties under this section and sections 45 and 47 shall be deemed to be work time for which the member's employer shall pay the member at the regular or premium rate as may be proper. R.S.O. 1990, c. O.1, s. 48.	
Criteria	(6) In making a finding under subsection (5), the adjudicator shall determine, using the prescribed criteria, whether the constructor or employer has demonstrated a failure to protect the health and safety of workers and shall consider such other matters as may be prescribed.	Complaint re direction to stop work	49.—(1) A constructor, an employer, a worker at the workplace or a representative of a trade union that represents workers at the workplace may file a complaint with the adjudicator if he, she or it has reasonable grounds to believe that a certified member at the workplace recklessly or in bad faith exercised or failed to exercise a power under section 45 or 47.	
	(7) The decision of the adjudicator on an application is final.	Limitation	(2) A complaint must be filed not later than fourteen days after the event to which the complaint relates.	
	(8) The employer shall reimburse the Treasurer of Ontario for the wages, benefits and expenses of an inspector assigned to the employer as recommended by the adjudicator. R.S.O. 1990, c. O.1, s. 46.	Decision final	(3) The Minister is entitled to be a party to a proceeding before the adjudicator.	
		Costs of inspector	(4) The adjudicator shall make a decision respecting the complaint and may make such order as he or she considers appropriate in the circumstances including an order decertifying a certified member.	
			(5) The decision of the adjudicator is final. R.S.O. 1990, c. O.1, s. 49.	

**PART VI
REPRISALS BY EMPLOYER PROHIBITED**

No discipline, dismissal, etc., by employer

50.—(1) No employer or person acting on behalf of an employer shall,

- (a) dismiss or threaten to dismiss a worker;
- (b) discipline or suspend or threaten to discipline or suspend a worker;
- (c) impose any penalty upon a worker; or
- (d) intimidate or coerce a worker,

because the worker has acted in compliance with this Act or the regulations or an order made thereunder, has sought the enforcement of this Act or the regulations or has given evidence in a proceeding in respect of the enforcement of this Act or the regulations or in an inquest under the *Coroners Act*.

(2) Where a worker complains that an employer or person acting on behalf of an employer has contravened subsection (1), the worker may either have the matter dealt with by final and binding settlement by arbitration under a collective agreement, if any, or file a complaint with the Ontario Labour Relations Board in which case any regulations governing the practice and procedure of the Board apply with all necessary modifications to the complaint.

Arbitration

(3) The Ontario Labour Relations Board may inquire into any complaint filed under subsection (2), and section 91 of the *Labour Relations Act*, except subsection (5), applies with all necessary modifications as if such section, except subsection (5), is enacted in and forms part of this Act.

Inquiry by Ontario Labour Relations Board

(4) On an inquiry by the Ontario Labour Relations Board into a complaint filed under subsection (2), sections 104, 105, 108, 110 and 111 of the *Labour Relations Act* apply with all necessary modifications.

idem

(5) On an inquiry by the Ontario Labour Relations Board into a complaint filed under subsection (2), the burden of proof that an employer or person acting on behalf of an employer did not act contrary to subsection (1) lies upon the employer or the person acting on behalf of the employer.

Omnis of proof

(6) The Ontario Labour Relations Board shall exercise jurisdiction under this section on a complaint by a Crown employee that the Crown has contravened subsection (1).

Jurisdiction when complaint by Crown employee

R.S.O. 1990, c. O.1, s.50 (1-6).

Board may substitute penalty

(7) If the Ontario Labour Relations Board determines, on a complaint filed under subsection (2), that an employer has imposed a penalty on an employee for cause, the Board may substitute such lesser penalty as it considers just and reasonable in all the circumstances.

Exception

(8) Despite subsection (2), a person who is subject to a rule or code of discipline under the *Police Services Act* shall have his or her complaint in relation to an alleged contravention of subsection (1) dealt with under that Act. R.S.O. 1990, c. O.1, s. 50

**PART VIII
ENFORCEMENT**

Powers of inspector

54.—(1) An inspector may, for the purposes of carrying out his or her duties and powers under this Act and the regulations,

- (a) subject to subsection (2), enter in or upon any workplace at any time without warrant or notice;
- (b) take up or use any machine, device, article, thing, material or biological, chemical or physical agent or part thereof;
- (c) require the production of any drawings, specifications, licence, document, record or report, and inspect, examine and copy the same;
- (d) upon giving a receipt therefor, remove any drawings, specifications, licence, document, record or report inspected or examined for the purpose of making copies thereof or extracts therefrom, and upon making copies thereof or extracts therefrom, shall promptly return the same to the person who produced or furnished them;
- (e) conduct or take tests of any equipment, machine, device, article, thing, material or biological, chemical or physical agent in or about a workplace and for such purposes, take and carry away such samples as may be necessary;
- (f) require in writing an employer to cause any tests described in clause (e) to be conducted or taken, at the expense of the employer, by a person possessing such special expert or professional knowledge or qualifications as are specified by the inspector and to provide, at the expense of the employer, a report or assessment by that person;
- (g) in any inspection, examination, inquiry or test, be accompanied and assisted by or take with him or her any person or persons having special, expert or professional knowledge of any matter, take photographs, and take with him or her and use any equipment or materials required for such purpose;
- (h) make inquiries of any person who is or was in a workplace either separate and apart from another person or in the presence of any other person that are or may be relevant to an inspection, examination, inquiry or test;
- (i) require that a workplace or part thereof not be disturbed for a reasonable period of time for the purposes of carrying out an examination, investigation or test;
- (j) require that any equipment, machine, device, article, thing or process be operated or set in motion or that a system or procedure be carried out that may be relevant to an examination, inquiry or test;
- (k) require in writing an employer to have equipment, machinery or devices tested, at the expense of the employer, by a professional engineer and to provide, at the expense of the employer, a report bearing the seal and signature of the professional engineer stating that the equipment, machine or device is not likely to endanger a worker;

(l) require in writing that any equipment, machinery or device not be used pending testing described in clause (k);			
(m) require in writing an owner, constructor or employer to provide, at the expense of the owner, constructor or employer, a report bearing the seal and signature of a professional engineer stating,			Entry in dwellings
(i) the load limits of a floor, roof or temporary work or part of a building, structure or temporary work,			Representative to accompany inspector
(ii) that a floor, roof or temporary work is capable of supporting or withstanding the loads being applied to it or likely to be applied to it, or			
(iii) that a floor, roof or temporary work, or part of a building, structure or temporary work is capable of supporting or withstanding all loads to which it may be subjected without causing the materials therein to be stressed beyond the allowable unit stresses established under the <i>Building Code Act</i> or established by regulation;			Consultation with workers
(n) require in writing an owner of a mine or part thereof to provide, at the owner's expense, a report in writing bearing the seal and signature of a professional engineer stating that the ground stability of, the mining methods and the support or rock reinforcement used in the mine or part thereof is such that a worker is not likely to be endangered;			Entitlement in time from work
(o) require in writing, within such time as is specified, a person who is an employer, manufacturer, producer, importer, distributor or supplier to produce records or information, or to provide, at the expense of the person, a report or evaluation made or to be made by a person or organization having special, expert or professional knowledge or qualifications as are specified by the inspector of any process or biological, chemical or physical agents or combination of such agents present, used or intended for use in a workplace and the manner of use, including,	Order for inspections		
(i) the ingredients thereof and their common or generic name or names,	Seizure of documents or things		
(ii) the composition and the properties thereof,	Possession		
(iii) the toxicological effect thereof,	Notice and receipt		
(iv) the effect of exposure thereto whether by contact, inhalation or ingestion,	Report to justice		
(v) the protective measures used or to be used in respect thereof,			
(vi) the emergency measures used or to be used to deal with exposure in respect thereof, and	Procedure		
(vii) the effect of the use, transport and disposal thereof; and			
(p) require the production of any materials concerning the content, frequency and manner of instruction of any training program and inspect, examine and copy the materials and attend any such program.	Orders by inspectors where non-compliance		
		(2) An inspector shall only enter a dwelling or that part of a dwelling actually being used as a workplace with the consent of the occupier or under the authority of a search warrant issued under section 158 of the <i>Provincial Offences Act</i> .	
		(3) Where an inspector makes an inspection of a workplace under the powers conferred upon him or her under subsection (1), the constructor, employer or group of employers shall afford a committee member representing workers or a health and safety representative, if any, or a worker selected by a trade union or trade unions, if any, because of knowledge, experience and training, to represent it or them and, where there is no trade union, a worker selected by the workers because of knowledge, training and experience to represent them, the opportunity to accompany the inspector during his or her physical inspection of a workplace, or any part or parts thereof.	
		(4) Where there is no committee member representing workers, no health and safety representative or worker selected under subsection (3), the inspector shall endeavour to consult during his or her physical inspection with a reasonable number of the workers concerning matters of health and safety at their work.	
		(5) The time spent by a committee member representing workers, a health and safety representative or a worker selected in accordance with subsection (3) in accompanying an inspector during his or her physical inspection, shall be deemed to be work time for which he or she shall be paid by his or her employer at his or her regular or premium rate as may be proper. R.S.O. 1990, c. O.1, s. 54.	
		55. Subject to subsection 9 (26), an inspector may in writing direct a health and safety representative or a member designated under subsection 9 (23) to inspect the physical condition of all or part of a workplace at specified intervals. R.S.O. 1990, c. O.1, s. 55.	
		56.—(1) While acting under the authority of this Act, an inspector may, without a warrant or court order, seize any thing that is produced to him or her or that is in plain view if the inspector reasonably believes that this Act or a regulation has been contravened and that the thing will afford evidence of the contravention.	
		(2) The inspector may remove the thing seized or may detain it in the place in which it is seized.	
		(3) The inspector shall inform the person from whom the thing is seized as to the reason for the seizure and shall give the person a receipt for it.	
		(4) The inspector shall bring a thing seized under the authority of this section before a provincial judge or justice of the peace or, if that is not reasonably possible, shall report the seizure to a provincial judge or justice of the peace.	
		(5) Sections 159 and 160 of the <i>Provincial Offences Act</i> apply with necessary modifications in respect of a thing seized under the authority of this section. R.S.O. 1990, c. O.1, s. 56.	
		57.—(1) Where an inspector finds that a provision of this Act or the regulations is being contravened, the inspector may order, orally or in writing, the owner, constructor, licensee, employer, or person whom he or she believes to be in charge of a workplace or the person whom the inspector believes to	

	be the contravener to comply with the provision and may require the order to be carried out forthwith or within such period of time as the inspector specifies.				
	(2) Where an inspector makes an oral order under subsection (1), the inspector shall confirm the order in writing before leaving the workplace.	Idem			
	(3) An order made under subsection (1) shall indicate generally the nature of the contravention and where appropriate the location of the contravention.	Contents of order			
	(4) An order made under subsection (1) may require a constructor, a licensee or an employer to submit to the Ministry a compliance plan prepared in the manner and including such items as required by the order.	Compliance plan			
	(5) The compliance plan shall specify what the constructor, licensee or employer plans to do to comply with the order and when the constructor, licensee or employer intends to achieve compliance.	Idem	No hearing required prior to making order		
	(6) Where an inspector makes an order under subsection (1) and finds that the contravention of this Act or the regulations is a danger or hazard to the health or safety of a worker, the inspector may,	Orders by inspector where worker endangered	Entry into barricaded area		
	(a) order that any place, equipment, machine, device, article or thing or any process or material shall not be used until the order is complied with;				
	(b) order that the work at the workplace as indicated in the order shall stop until the order to stop work is withdrawn or cancelled by an inspector after an inspection;				
	(c) order that the workplace where the contravention exists be cleared of workers and isolated by barricades, fencing or any other means suitable to prevent access thereto by a worker until the danger or hazard to the health or safety of a worker is removed.				
	(7) Despite clause (6) (b), a constructor, a licensee or an employer who gives notice to an inspector of compliance with an order made under subsection (6) may resume work pending an inspection and decision by an inspector respecting compliance with the order if, before the resumption of work, a committee member representing workers or a health and safety representative, as the case may be, advises an inspector that in his or her opinion the order has been complied with.	Resumption of work pending inspection			
Additional orders	(8) In addition to the orders that may be made under subsection (6), where an inspector makes an order under subsection (1) for a contravention of section 37 or 41 or a Director has been advised of an employer's inability to obtain an unexpired material safety data sheet, the inspector may order that the hazardous material shall not be used or that the thing that causes, emits or produces the hazardous physical agent not be used or operated until the order is withdrawn or cancelled.				
Posting of notice	(9) Where an inspector makes an order under this section, he or she may affix to the workplace, or to any equipment, machine, device, article or thing, a copy thereof or a notice in the prescribed form and no person, except an inspector, shall remove such copy or notice unless authorized to do so by an inspector.				
					(10) Where an inspector makes an order in writing or issues a report of his or her inspection to an owner, constructor, licensee, employer or person in charge of the workplace, the owner, constructor, licensee, employer or person in charge of the workplace shall forthwith cause a copy or copies thereof to be posted in a conspicuous place or places at the workplace where it is most likely to come to the attention of the workers and shall furnish a copy of such order or report to the health and safety representative and the committee, if any, and the inspector shall cause a copy thereof to be furnished to a person who has complained of a contravention of this Act or the regulations.
					(11) An inspector is not required to hold or afford to an owner, constructor, licensee, employer or any other person an opportunity for a hearing before making an order. R.S.O. 1990, c. O.1, s. 57.
					58. Where an order is made under clause 57 (6) (c), no owner, constructor, employer or supervisor shall require or permit a worker to enter the workplace except for the purpose of doing work that is necessary or required to remove the danger or hazard and only where the worker is protected from the danger or hazard. R.S.O. 1990, c. O.1, s. 58.
					59.—(1) Within three days after a constructor or employer who has received an order under section 57 believes that compliance with the order has been achieved, the constructor or employer shall submit to the Ministry a notice of compliance.
					(2) The notice shall be signed by the constructor or employer and shall be accompanied by,
					(a) a statement of agreement or disagreement with the contents of the notice, signed by a member of the committee representing workers or by a health and safety representative, as the case may be; or
					(b) a statement that the member or representative has declined to sign the statement referred to in clause (a).
					(3) The constructor or employer shall post the notice and the order issued under section 57 for a period of fourteen days following its submission to the Ministry in a place or places in the workplace where it is most likely to come to the attention of workers.
					(4) Despite the submission of a notice of compliance, a constructor or employer achieves compliance with an order under section 57 when an inspector determines that compliance has been achieved. R.S.O. 1990, c. O.1, s. 59.
					60. In addition to any other remedy or penalty therefor, where an order made under subsection 57 (6) is contravened, such contravention may be restrained upon an application made without notice to a judge of the Ontario Court (General Division) made at the instance of a Director. R.S.O. 1990, c. O.1, s. 60.
					61.—(1) Any employer, constructor, licensee, owner, worker or trade union which considers himself, herself or itself aggrieved by any order made by an inspector under this Act or the regulations may, within fourteen days of the making thereof, appeal to the adjudicator who shall hear and dispose of the appeal as promptly as is practicable.

Method	(2) An appeal to the adjudicator may be made in writing or orally or by telephone, but the adjudicator may require the grounds for appeal to be specified in writing before the appeal is heard.		statement, report or result of any examination, test or inquiry acquired, furnished, obtained, made or received under the powers conferred under this Act or the regulations;
Parties	(3) The appellant, the inspector from whom the appeal is taken and such other persons as the adjudicator may specify are parties to an appeal under this section.		(c) no person shall publish, disclose or communicate to any person any secret manufacturing process or trade secret acquired, furnished, obtained, made or received under the provisions of this Act or the regulations;
Powers of the adjudicator	(4) On an appeal under this section, the adjudicator may substitute his or her findings for those of the inspector who made the order appealed from and may rescind or affirm the order or make a new order in substitution therefor, and for such purpose has all the powers of an inspector and the order of the adjudicator shall stand in the place of and have the like effect under this Act and the regulations as the order of the inspector.		(e) no person to whom information is communicated under this Act and the regulations shall divulge the name of the informant to any person; and
Order, extended meaning	(5) In this section, an order of an inspector under this Act or the regulations includes any order or decision made or given or the imposition of any terms or conditions therein by an inspector under the authority of this Act or the regulations or the refusal to make an order or decision by an inspector.		(f) no person shall disclose any information obtained in any medical examination, test or x-ray of a worker made or taken under this Act except in a form calculated to prevent the information from being identified with a particular person or case. R.S.O. 1990, c. O.1, s. 63 (1); 1992, c. 14, s. 2 (2, 3).
Decision of adjudicator final	(6) A decision of the adjudicator under this section is final.	Employer access to health records	(2) No employer shall seek to gain access, except by an order of the court or other tribunal or in order to comply with another statute, to a health record concerning a worker without the worker's written consent.
Suspension of order by adjudicator pending disposition of appeal	(7) On an appeal under subsection (1), the adjudicator may suspend the operation of the order appealed from pending the disposition of the appeal. R.S.O. 1990, c. O.1, s. 61.	Compellability, civil suit	(3) An inspector or a person who, at the request of an inspector, accompanies an inspector, or a person who makes an examination, test, inquiry or takes samples at the request of an inspector, is not a compellable witness in a civil suit or any proceeding, except an inquest under the <i>Coroners Act</i> , respecting any information, material, statement or test acquired, furnished, obtained, made or received under this Act or the regulations.
Obstruction of inspector	62.—(1) No person shall hinder, obstruct, molest or interfere with or attempt to hinder, obstruct, molest or interfere with an inspector in the exercise of a power or the performance of a duty under this Act or the regulations.	Power of Director to disclose	(4) A Director may communicate or allow to be communicated or disclosed information, material, statements or the result of a test acquired, furnished, obtained, made or received under this Act or the regulations.
Assistance to inspector	(2) Every person shall furnish all necessary means in the person's power to facilitate any entry, inspection, examination, testing or inquiry by an inspector in the exercise of his or her powers or performance of his or her duties under this Act or the regulations.	Medical emergencies	(5) Subsection (1) does not apply so as to prevent any person from providing any information in the possession of the person, including confidential business information, in a medical emergency for the purpose of diagnosis or treatment. R.S.O. 1990, c. O.1, s. 63 (2-5).
	(3) No person shall knowingly furnish an inspector with false information or neglect or refuse to furnish information required by an inspector in the exercise of his or her duties under this Act or the regulations.	False information, etc.	64. A Director may, upon receipt of a request in writing from the owner of a workplace who has entered into an agreement to sell the same and upon payment of the fee or fees prescribed, furnish to the owner or a person designated by the owner copies of reports or orders of an inspector made under this Act in respect of the workplace as to its compliance with subsection 29 (1). R.S.O. 1990, c. O.1, s. 64.
	(4) No person shall interfere with any monitoring equipment or device in a workplace.	Monitoring devices	65.—(1) No action or other proceeding for damages, prohibition or mandamus shall be instituted respecting any act done in good faith in the execution or intended execution of a person's duties under this Act or in the exercise or intended exercise of a person's powers under this Act or for any alleged neglect or default in the execution or performance in good faith of the person's duties or powers if the person is,
	(5) No person shall knowingly,	Obstruction of committee, etc.	(a) an employee of the Ministry or a person who acts as an advisor for the Ministry;
	(a) hinder or interfere with a committee, a committee member or a health and safety representative in the exercise of a power or performance of a duty under this Act;		(b) a director or employee of the Agency or a person who acts as an advisor for the Agency;
	(b) furnish a committee, a committee member or a health and safety representative with false information in the exercise of a power or performance of a duty under this Act; or		
	(c) hinder or interfere with a worker selected by a trade union or trade unions or a worker selected by the workers to represent them in the exercise of a power or performance of a duty under this Act. R.S.O. 1990, c. O.1, s. 62.		
	63.—(1) Except for the purposes of this Act and the regulations or as required by law,	Information confidential	
	(a) an inspector, a person accompanying an inspector or a person who, at the request of an inspector, makes an examination, test or inquiry, shall not publish, disclose or communicate to any person any information, material,		
			Copies of reports
			Immunity

- (c) the adjudicator or a person to whom the adjudicator has delegated powers or duties;
- (d) a health and safety representative or a committee member;
- (e)² a worker selected by a trade union or trade unions or by workers to represent them; or
- (f) an employee of a medical clinic, an association or a training centre referred to in clause 16 (1) (n) or an association referred to in subsection 18 (1).

(2) Subsection (1) does not, by reason of subsections 5 (2) and (4) of the *Proceedings Against the Crown Act*, relieve the Crown of liability in respect of a tort committed by a Director, an inspector or an engineer of the Ministry to which it would otherwise be subject and the Crown is liable under that Act for any such tort in a like manner as if subsection (1) had not been enacted. R.S.O. 1990, c. O.1, s. 65.

Liability of Crown

PART IX OFFENCES AND PENALTIES

Penalties

66.—(1) Every person who contravenes or fails to comply with,

- (a) a provision of this Act or the regulations;
- (b) an order or requirement of an inspector or a Director; or
- (c) an order of the Minister.

is guilty of an offence and on conviction is liable to a fine of not more than \$25,000 or to imprisonment for a term of not more than twelve months, or to both.

Idem

(2) If a corporation is convicted of an offence under subsection (1), the maximum fine that may be imposed upon the corporation is \$500,000 and not as provided therein.

Defence

(3) On a prosecution for a failure to comply with,

- (a) subsection 23 (1);
- (b) clause 25 (1) (b), (c) or (d); or
- (c) subsection 27 (1).

it shall be a defence for the accused to prove that every precaution reasonable in the circumstances was taken.

Accused liable for acts or neglect of managers, agents, etc.

(4) In a prosecution of an offence under any provision of this Act, any act or neglect on the part of any manager, agent, representative, officer, director or supervisor of the accused, whether a corporation or not, shall be the act or neglect of the accused. R.S.O. 1990, c. O.1, s. 66.

Certified copies of documents, etc., as evidence

67.—(1) In any proceeding or prosecution under this Act,

- (a) a copy of an order or decision purporting to have been made under this Act or the regulations and purporting to have been signed by the Minister or an inspector;

- (b) a document purporting to be a copy of a notice, drawing, record or other document, or any extract therefrom given or made under this Act or the regulations and purporting to be certified by an inspector;
- (c) a document purporting to certify the result of a test or an analysis of a sample of air and setting forth the concentration or amount of a biological, chemical or physical agent in a workplace or part thereof and purporting to be certified by an inspector; or
- (d) a document purporting to certify the result of a test or an analysis of any equipment, machine, device, article, thing or substance and purporting to be certified by an inspector,

is evidence of the order, decision, writing or document, and the facts appearing in the order, decision, writing or document without proof of the signature or official character of the person appearing to have signed the order or the certificate and without further proof.

(2) In any proceeding or prosecution under this Act, a copy of an order or decision purporting to have been made under this Act or the regulations and purporting to have been signed by the Minister, a Director or an inspector may be served,

Service of orders and decisions

- (a) personally in the case of an individual or in case of a partnership upon a partner, and in the case of a corporation, upon the president, vice-president, secretary, treasurer or a director, or upon the manager or person in charge of the workplace; or
- (b) by registered letter addressed to a person or corporation mentioned in clause (a) at the last known place of business of the person or corporation,

and the same shall be deemed to be good and sufficient service thereof. R.S.O. 1990, c. O.1, s. 67.

Place of trial

68.—(1) An information in respect of an offence under this Act may, at the election of the informant, be heard, tried and determined by the Ontario Court (Provincial Division) sitting in the county or district in which the accused is resident or carries on business although the subject-matter of the information did not arise in that county or district.

Provincial judge required

(2) The Attorney General or an agent for the Attorney General may by notice to the clerk of the court having jurisdiction in respect of an offence under this Act require that a provincial judge preside over the proceeding. R.S.O. 1990, c. O.1, s. 68.

Limitation on prosecutions

69. No prosecution under this Act shall be instituted more than one year after the last act or default upon which the prosecution is based occurred. R.S.O. 1990, c. O.1, s. 69.

Excerpts from Regulations for Construction Projects [Ontario Regulation 213/91]

"competent worker", in relation to specific work, means a worker who,

- (a) is qualified because of knowledge, training and experience to perform the work,
- (b) is familiar with the *Occupational Health and Safety Act* and with the provisions of the regulations that apply to the work, and
- (c) has knowledge of all potential or actual danger to health or safety in the work;

PROTECTIVE CLOTHING, EQUIPMENT AND DEVICES

21.— (1) A worker shall wear such protective clothing and use such personal protective equipment or devices as are necessary to protect the worker against the hazards to which the worker may be exposed.

(2) A worker's employer shall require the worker to comply with subsection (1).

*Instruction,
Training*

(3) A worker required to wear protective clothing or use personal protective equipment or devices shall be adequately instructed and trained in the care and use of the clothing, equipment or device before wearing or using it.

Headwear

22.— (1) Every worker shall wear protective headwear at all times when on a project.

(2) Protective headwear shall be a safety hat that,

(a) consists of a shell and suspension that is adequate to protect a person's head against impact and against flying or falling small objects; and

(b) has a shell which can withstand a dielectric strength test at 20,000 volts phase to ground.

NOTE: *Adherence to Class B requirements of Canadian Standards Association Standard Z94.1-M1977 Industrial Protective Headwear complies with the intent of this section.*

23.— (1) Every worker shall wear protective footwear at all times when on a project.

Footwear

(2) Protective footwear shall be a safety shoe or safety boot,

(a) with a box toe that is adequate to protect the wearer's toes against injury due to impact and is capable of resisting at least 125 joules impact; and

(b) with a sole or insole that is adequate to protect the wearer's feet against injury due to puncture and is capable of resisting a penetration load of 1.2 kilonewtons when tested with a DIN standard pin.

NOTE: *Grade 1 toe protection with sole protection in accordance with Canadian Standards Association Standard Z195-M1984 Protective Footwear complies with the intent of subsection 23(2).*

24. A worker shall use protection appropriate in the circumstances when there is a risk of eye injury to the worker.

*Eye
Protection*

NOTE: *Appropriate protection according to Canadian Standards Association Standard CAN/CSA-Z94.3-M88 Industrial Eye and Face Protectors complies with the intent of this section.*

25. A worker shall use protection appropriate in the circumstances when there is a risk of injury on a project from contact between the worker's skin and,

*Skin
Protection*

(a) a noxious gas, liquid, fume or dust;

(b) an object that may puncture, cut or abrade the skin;

(c) a hot object, hot liquid or molten metal; or

(d) radiant heat.

*Fall
Protection*

26.— (1) Unless a safety net or travel restraint system is being used, a worker shall wear a fall arrest system if the worker may fall,

(a) a distance of more than three metres;

(b) into operating machinery;

(c) into water or another liquid; or

(d) into or onto a hazardous substance or object.

(2) In subsection (1), "travel restraint system" means a mechanism which restricts the movement of a worker on a work surface.

(3) A fall arrest system,

(a) shall be adequately secured to a fixed support or to a lifeline that is securely fastened to the project;

(b) shall be so arranged that if the wearer falls, the wearer will be suspended not more than 1.5 metres below his or her location before the fall; and

(c) shall apply a peak fall arrest force not greater than eight kilonewtons to the wearer.

(4) A fixed support shall be capable of resisting the arrest forces in case of a fall and be free of sharp edges that might cut or chafe the connection between the fall arrest system and the fixed support.

Lanyard

(5) A lanyard used in a fall arrest system shall have a nominal diameter of at least sixteen millimetres and be made of nylon rope or other durable material of equivalent impact strength and elasticity.

(6) A lifeline in a fall arrest system,

Lifeline

- (a) shall have a nominal diameter of at least sixteen millimetres and be made of polypropylene or other durable material that provides at least equal protection to the user;
- (b) shall extend to the ground or be provided with a positive stop that prevents the connection from the fall arrest system to the lifeline from running off the end of the lifeline;
- (c) shall be connected to an object that is capable of resisting the arrest forces in case of a fall;
- (d) shall be free of knots, splices and imperfections;
- (e) shall be used in such a way that it is not likely to be cut or chafed; and
- (f) shall be used by only one person at a time.

NOTE: Adherence to Canadian Standards Association Standard Z259.1-1976 Fall-Arresting Safety Belts and Lanyards for the Construction and Mining Industries and Canadian Standards Association Standard Z259.2-M1979, Fall-Arresting Devices, Personnel Lowering Devices and Life Lines, complies with the intent of this section.

27.— (1) A worker who may drown shall wear a lifejacket.

Drowning Protection

- (2) If a worker may drown at a project,
- (a) at least two workers trained to perform rescue operations shall be available to perform rescue operations;
 - (b) rescue equipment shall be provided in a suitable location on or near the project; and
 - (c) all workers on the project shall be advised of the rescue procedures to be followed and their role, if any, in carrying out a rescue.

(3) The rescue equipment shall include,

- (a) a seaworthy boat equipped with a ring buoy attached to fifteen metres of polypropylene rope that is 9.5 millimetres in diameter, a boat hook and, for every person required for a rescue operation using the boat, a lifejacket;
- (b) if there is a current in the water, a line extending across the water with floating objects attached to it that are capable of providing support for a person in the water; and
- (c) an alarm system capable of warning a worker of the necessity of carrying out a rescue operation.

(4) The boat shall be power-driven if the water is likely to be rough or swift.

(5) The alarm system shall be activated when a rescue operation is necessary.

(6) In this section, "lifejacket" means a personal flotation device that provides buoyancy adequate to keep a worker's head above water, face up, without effort by the worker.

Material Storage, Movement

37.— (1) Material or equipment at a project shall be stored and moved in a manner that does not endanger a worker.

(2) No material or equipment to be moved by a crane or similar hoisting device shall be stored under or in close proximity to an energized outdoor overhead electrical conductor.

Blocking

38. Blocking, support chains, metal bands, wire rope and rigging components shall be removed from material or equipment in a manner that does not endanger a worker.

Material Equipment Piling, Stacking, Storing

39. Material and equipment at a project shall be piled or stacked in a manner that prevents it from tipping, collapsing or rolling.

93.— (1) All vehicles, machinery, tools and equipment shall be maintained in a condition that does not endanger a worker.

(2) No vehicle, machine, tool or equipment shall be used,

- (a) while it is defective or hazardous;
- (b) when the weather or other conditions are such that its use is likely to endanger a worker; or
- (c) while it is being repaired or serviced.

(3) A copy of the manufacturer's operating manual for a vehicle, machine, tool or for equipment used at a project shall be kept readily available at the project.

103.— (1) No worker shall operate a shovel, backhoe or similar excavating machine in such a way that it or part of its load passes over a worker.

(2) No worker shall operate a crane or similar hoisting device in such a way that part of its load passes over another worker unless the other worker is receiving the load or is engaged in sinking a shaft.

(3) If practicable, a worker who is receiving a load or is engaged in sinking a shaft shall be positioned so that no load or part of a load carried by a crane or similar hoisting device passes over the worker.

CRANES, HOISTING AND RIGGING

Signaller 104. No vehicle, machine or equipment, or crane or similar hoisting device, or shovel, backhoe or similar excavating machine shall be operated unless the operator is assisted by a signaller,

- (a) where the operator's view of the intended path of travel of any part of it or its load is obstructed; or
- (b) where it is in a location in which a person may be endangered by any part of it or its load.

105. An operator of a vehicle, machine or equipment, or crane or similar hoisting device, or shovel, backhoe or similar excavating machine who is required to be assisted by a signaller shall operate it as directed by the signaller.

106.— (1) A signaller shall be a competent worker and shall not perform other work while acting as a signaller.

- (2) A signaller,
 - (a) shall be clear of the intended path of travel of the vehicle, machine or equipment, crane or similar hoisting device, shovel, backhoe or similar excavating machine or its load;
 - (b) shall be in full view of the operator of the vehicle, machine or equipment, crane or similar hoisting device, shovel, backhoe or similar excavating machine;
 - (c) shall have a clear view of the intended path of travel of the vehicle, machine or equipment, crane or similar hoisting device, shovel, backhoe or similar excavating machine or its load; and
 - (d) shall watch the part of the vehicle, machine or equipment or crane or similar hoisting device, shovel, backhoe or similar excavating machine or its load whose path of travel the operator cannot see.

(3) The signaller shall communicate with the operator by means of a telecommunication system or, where visual signals are clearly visible to the operator, by means of prearranged visual signals.

NOTE: *Charts and decals of Crane and Hoist Hand Signals are available from the Construction Safety Association of Ontario, Toronto, Ontario.*

108. Blocking shall be installed to prevent the collapse or movement of part or all of a piece of equipment that is being dismantled, altered or repaired if its collapse or movement may endanger a worker.

Blocking

Lifting Jack 111.— (1) A lifting jack shall have its rated capacity legibly cast or stamped on it in a place where it can be readily seen.

(2) A lifting jack shall be equipped with a positive stop to prevent overtravel or, if a positive stop is not practicable, with an overtravel indicator.

Miscellaneous Object Hazard 113. No object or material shall be placed, left or stored in a location or manner that may endanger a worker.

Certificate 150.— (1) No worker shall operate a crane or similar hoisting device capable of raising, lowering or moving material that weighs more than 7,260 kilograms unless the worker holds a certificate as required for the crane or similar hoisting device under the *Apprenticeship and Tradesmen's Qualification Act*.

(2) No worker shall operate a crane or similar hoisting device, other than one described in subsection (1), unless,

- (a) the worker has written proof of training indicating that he or she is trained in the safe operation of the crane or similar hoisting device; or
- (b) the worker is being instructed in the operation of the crane or similar hoisting device and is accompanied by a person who meets the requirements of clause (a).

(3) A worker shall carry his or her proof of training while operating a crane or similar hoisting device.

NOTE: *A worker being trained, under the direct supervision of a qualified operator, who has proof of registration in a recognized training program shall be deemed to meet the intent of subsection (2). A worker who has training creditation issued by the Ministry of Skills Development shall be deemed to meet the intent of subsection (2). Only a training program prepared by the industry in conjunction with the Ministry of Skills Development, approved by the latter, and endorsed by the Ministry of Labour or an equivalent training program approved by the Ministry of Skills Development and endorsed by the Ministry of Labour shall be deemed as meeting the intent of subsection (2).*

151.— (1) No crane or similar hoisting device shall be subjected to a load greater than its rated load-carrying capacity.

Capacity

(2) The manufacturer of a crane or similar hoisting device or a professional engineer shall determine its rated load-carrying capacity in accordance with,

- (a) for a mobile crane, Canadian Standards Association Standard Z150-1974 Safety Code for Mobile Cranes; and
- (b) for a tower crane, Canadian Standards Association Standard Z248-1976 Code for Tower Cranes.

(3) Every crane or similar hoisting device shall have affixed to it a load rating plate,

Load Rating Plate

- (a) that the operator can read while at the controls; and
- (b) that contains enough information for the operator to determine the load that can be lifted for each configuration of the crane.

(4) A luffing boom crane, other than a tower crane, shall have affixed to it a boom angle indicator that the operator can read while at the controls.

Boom Angle Indicator

152.— (1) The owner of a crane or similar hoisting device shall keep a permanent record of all inspections of, tests of, repairs

Inspection Records

- to, modifications to and maintenance of the crane or similar hoisting device.
- Log Book* (2) The owner of a crane or similar hoisting device shall prepare a log book for it for use at a project that shall include the record referred to in subsection (1) covering the period that is the greater of,
- (a) the immediately preceding twelve months; and
 - (b) the period the crane or similar hoisting device is on the project.
- (3) The log book shall be kept with the crane or similar hoisting device.
- (4) The owner of a crane or similar hoisting device shall retain and make available to the constructor on request copies of all log books and records for the crane or similar hoisting device.
- Platform, etc. at Work Place* 153. No worker shall use as a work place a platform, bucket, basket, load, hook, sling or similar device that is capable of moving and is supported by a cable attached to the boom of a crane or similar hoisting device.
- Set Up, Assembly, etc.* 154.— (1) A crane or similar hoisting device shall be set up, assembled, extended and dismantled only by a competent worker acting in accordance with the written instructions of the manufacturer and in such a manner as to not endanger any person or property.
- Sections* (2) No crane or similar hoisting device shall include sections that are not designed for it or that are damaged.
- Nuts, Bolts, etc.* (3) No crane or similar hoisting device shall include nuts, bolts, pins or fastenings that are not the size and quality specified by the manufacturer.
155. Unless otherwise specified by its manufacturer, a crane or similar hoisting device,
- (a) shall be equipped with a device to indicate whether its turntable is level; and
 - (b) shall be operated with its turntable level.
156. An outrigger or stabilizing device used on a crane or similar hoisting device,
- (a) shall be extended to meet load capacity chart requirements; and
 - (b) shall rest on blocking able to support the crane or similar hoisting device and its maximum load without failure or without deformation or settlement which affects its stability.
- 167.— (1) The pilot of a helicopter that is hoisting materials shall be competent to fly an externally-loaded helicopter. *Helicopters*
- (2) The pilot shall be in charge of the hoisting operation and shall determine the size and weight of loads to be hoisted and the method by which they are attached to the helicopter.
- (3) Ground personnel including signallers for a helicopter being used to hoist materials shall be competent workers.
- (4) The constructor shall take precautions against hazards caused by helicopter rotor downwash.

CABLES, SLINGS, RIGGING

- Construction* 168.— (1) A cable used by a crane or similar hoisting device,
- (a) shall be steel wire rope of the type, size, grade and construction recommended by the manufacturer of the crane or similar hoisting device;
 - (b) shall be compatible with the sheaves and the drum of the crane or similar hoisting device;
 - (c) shall be lubricated to prevent corrosion and wear;
 - (d) shall not be spliced; and
 - (e) shall have its end connections securely fastened and shall be kept with at least three full turns on the drum.
- (2) No cable used by a crane or similar hoisting device,
- (a) subject to subsection (3), shall contain six randomly-distributed wires that are broken in one rope lay or three or more wires that are broken in one strand in a rope lay;
 - (b) shall be smaller than its nominal rope diameter by more than,
 - (i) one millimetre for a diameter up to and including nineteen millimetres,
 - (ii) two millimetres for a diameter greater than nineteen millimetres up to and including twenty-nine millimetres, and
 - (iii) three millimetres for a diameter greater than twenty-nine millimetres;
 - (c) shall be worn by more than one-third of the original diameter of its outside individual wires;
 - (d) shall show evidence of kinking, bird-caging, corrosion or other damage resulting in distortion of the rope structure; or
 - (e) shall show evidence of possible rope failure including rope damage caused by contact with electricity.
- (3) No cable that is static or is used for pendants,
- (a) shall contain three or more broken wires in one lay or in a section between end connectors; or
 - (b) shall have more than one broken wire at an end connector.
- (4) Rotation-resistant wire rope shall not be used for a cable for boom hoist reeving and pendants. *Ro*
- (5) Rotation-resistant wire rope shall not be used where an inner wire or strand for a cable is damaged or broken. *Re*
169. A cable used by a crane or similar hoisting device shall be capable of supporting at least, *So*
- (a) three-and-one-half times the maximum load to which it is likely to be subjected if it is used on a device other than a tower crane and it winds on a drum or passes over a sheave;

- (b) five times the maximum load to which it is likely to be subjected if it is used on a tower crane and it winds on a drum or passes over a sheave;
- (c) three times the maximum load to which it is likely to be subjected if it is a pendant or is not subject to winding or bending; and
- (d) ten times the maximum load to which it is likely to be subjected if the crane or similar hoisting device is used for supporting persons.

NOTE: *The load rating capacity of individual rigging components determined in accordance with applicable International Standards Organization standards meets the intent of this section.*

Inspection 170.— (1) All cable used by a crane or similar hoisting device shall be visually inspected by a competent worker at least once a week when the crane or similar hoisting device is being used.

(2) The worker performing an inspection shall record the condition of the rope or cable inspected in the log book for the crane or similar hoisting device.

Fastening 171.— (1) A cable used by a crane or similar hoisting device shall be securely attached.

- (a) by binding and fastening the cable around an oval thimble in a way that is strong enough to prevent the cable thimble from separating; or
- (b) by fastening the cable within either a tapered socket by means of virgin zinc or a wedge-type socket fitted with a wire rope clip at the dead end to prevent the accidental release or loosening of the wedge.

(2) The dead end cable of a wedge socket assembly on a hoisting line shall extend between 100 millimetres and 300 millimetres out of the socket.

172.— (1) A container, sling or similar device for rigging or hoisting an object, including its fittings and attachments, *Sling, etc.*

- (a) shall be suitable for its intended use;
- (b) shall be suitable for and capable of supporting the object being rigged or hoisted;
- (c) shall be so arranged as to prevent the object or any part of the object from slipping or falling;
- (d) shall be capable of supporting at least five times the maximum load to which it may be subjected; and
- (e) shall be capable of supporting at least ten times the load to which it may be subjected if it is to be used to support a person.

(2) A sling or similar device made of web-type fabric or nylon shall be labelled to indicate its load rating capacity.

(3) No sling or similar device for rigging or hoisting made of web-type fabric or nylon shall be used if it may be cut.

173.— (1) Every hoisting hook shall be equipped with a safety catch. *Safety Catch*

(2) No safety catch is required on a hoisting hook used in placing structural members if the method of placing protects workers to the same standard as a safety catch does.

(3) A hoisting hook shall have its load rating legibly cast or stamped on it in a location where the person using the hook can readily see it.

(4) A hoisting hook shall not be used if it is cracked, has a throat opening that is greater than as manufactured or is twisted from the plane of the unbent hook.

174. A hook block shall have its load rating and weight legibly cast or stamped on it in a conspicuous location. *Hook Block*

Over-hauling Weight **175.—** (1) An overhauling weight used on the cable of a crane or similar hoisting device,

- (a) shall be prevented from sliding up or down the cable; and
- (b) shall be securely attached to the load hook and the cable.

(2) No overhauling weight used on the cable of a crane or similar hoisting device shall be split.

Chain **176.** Only an alloy steel chain or a chain manufactured for the purpose shall be used for hoisting.

177.— (1) No alloy chain shall be annealed or welded.

(2) A chain used for hoisting shall be selected, annealed, normalized and repaired in accordance with the specifications of its manufacturer.

Clamp **178.** A friction-type clamp used in hoisting materials shall be constructed so that an accidental slackening of the hoisting cable does not release the clamp.

Guide Ropes **179.—** (1) If a worker may be endangered by the rotation or uncontrolled motion of a load being hoisted by a crane or similar hoisting device, one or more guide ropes or tag lines shall be used to prevent the rotation or uncontrolled motion.

(2) No guide rope or tag line shall be removed from a load referred to in subsection (1) until the load is landed and there is no danger of it tipping, collapsing or rolling.

Piles **180.—** (1) Piles and sheet-piling shall be adequately supported to prevent their uncontrolled movement while they are being hoisted, placed, removed or withdrawn.

(2) No worker shall be in an area where piles or sheet-piling are being hoisted, placed, removed or withdrawn unless the worker is directly engaged in the operation.

Notes

Notes

Notes

Notes

Notes