

# ELECTRIC MOTORS & VARIABLE FREQUENCY DRIVES

Energy Efficiency  
Reference Guide



# TABLE OF CONTENTS

---

Section	Page	
1	Introduction	1
2	Motor Classification	3
3	Operating Principles	7
a.	Major Parts	7
b.	Operation	7
c.	Motor Power and Torque	9
d.	Torque-Speed Characteristics of Motors	11
4	AC Motors	13
a.	3-Phase Induction Motors	15
b.	Squirrel Cage Motors	16
c.	Wound Rotor Induction Motor	19
d.	Single Phase Induction Motors	21
e.	Split Phase Motors	23
f.	Capacitor Motors	25
g.	Shaded Pole Motors	29
h.	Synchronous Motors	30
i.	Hysteresis Motor	34
j.	Universal Motors	36

<b>5</b>	<b>DC Motors</b>	<b>39</b>
a.	Separately Excited DC Motor	40
b.	Series Field DC Motor	41
c.	Compound DC Motor	43
d.	Permanent Magnet DC Motors	44
<b>6</b>	<b>Advanced Motors</b>	<b>45</b>
a.	Electronically Commutated Motor (ECM)	45
b.	Switched Reluctance Motor (SRM)	46
c.	Permanent Magnet Motors	47
d.	Other Advanced Motors	47
<b>7</b>	<b>Motor Selection</b>	<b>51</b>
a.	Electrical Supply Considerations	51
b.	Motor Considerations	60
c.	Driven Load Considerations	65
d.	Speed	68
e.	Starting and Stopping	69
f.	Custom Motors	69
g.	Environmental Factors	70
h.	Physical Factors	71
i.	Efficiency and Economics	76
<b>8</b>	<b>Motor Controls</b>	<b>93</b>
a.	Motor Protection	93

b.	Motor Starting	96
c.	Motor Stopping	109
d.	Motor Speed Control	111
e.	Eddy Current Clutches	114
<b>9</b>	<b>Maintenance</b>	<b>119</b>
a.	Common Failure Modes	119
b.	Maintenance Frequency	119
c.	Bearings	120
d.	Vibration	124
e.	Insulation	125
f.	VFD Bearing Failure	128
g.	Grounding	129
<b>10</b>	<b>Repair or Replace?</b>	<b>131</b>
<b>11</b>	<b>Energy Efficiency Opportunities</b>	<b>135</b>
a.	Motor Resizing	135
b.	Speed Adjustments	135
c.	Load Adjustments	136
d.	Power Factor	136
<b>12</b>	<b>Variable Frequency Drives</b>	<b>137</b>
a.	VFD Technology Overview	138
b.	VFD Operation	140

<b>13</b>	<b>VFD Selection considerations</b>	<b>143</b>
a.	Electrical Considerations	143
b.	Harmonic Considerations	145
c.	Motor Considerations	150
d.	Physical & Environmental Issues	155
e.	Vibration and Resonance	158
<b>14</b>	<b>VFD Application Considerations and Savings Estimation</b>	<b>161</b>
a.	Driven Load Characteristics and Power Requirements	161
b.	Comparison with Conventional Control Methods	168
c.	Economics	176
d.	Cost Considerations	177
e.	Calculation of Energy Savings	179
f.	Operating Savings	185
g.	Simple Payback Evaluation	188
h.	Net Present Value Evaluation	189
i.	Monitoring and Verification	190
j.	System Efficiency	192
k.	Electrical Efficiency	193
l.	Cost per Unit Product	193
m.	Reliability and Maintenance	193

<b>15</b>	<b>Case Studies</b>	<b>195</b>
a.	Case Study: Replacement of Eddy-Current Drive with a VFD	195
b.	Case Study: Replacement of Damper Controls with VFDs in an HVAC System	198
c.	Case Study: Replacement of Vacuum Pump Controls with a VFD in a Dairy Facility	201
<b>16</b>	<b>Bibliography</b>	<b>205</b>
	<b>Appendix A Recommended Web Links</b>	<b>211</b>
	<b>Appendix B Industry Acronyms and Glossary</b>	<b>217</b>
	<b>Appendix C Useful Formulas</b>	<b>229</b>
	<b>Appendix D Conversion Factors</b>	<b>235</b>
	<b>INDEX</b>	<b>237</b>



# LIST OF TABLES

---

	Page
Table 4-1: Squirrel Cage NEMA Design Characteristics	17
Table 4-2: AC Single Phase Induction Motors (Ref. 22)	22
Table 7-1: Nominal System vs. Motor Nameplate Voltage	52
Table 7-2: Motor Characteristic vs. Voltage	53
Table 7-3: Induction Motor Selection	62
Table 7-4: Single Phase Motor Selection	64
Table 7-5: Repetitive Duty Cycle Example	67
Table 7-6: Standard Motor Enclosures	71
Table 7-7: Maximum Operation Temperature Allowed	73
Table 7-8: CSA Minimum Nominal Efficiencies for Energy Efficient Motors	83
Table 7-9: What Is an Extra Percentage Point of Motor Efficiency Improvement Worth?	85
Table 9-1: Frequency of Maintenance,	120
Table 9-2: Bearing Vibration Limits	125
Table 9-3: Motor Insulation Resistance at Specified Voltages	126
Table 9-4: Recommended Steps to Prevent VFD Bearing Problems	130
Table 10-1: Economics of Repair or Replacing a Motor	131
Table 12-1: Potential VFD Energy Saving	139
Table 13-1: NEMA's Standard Enclosure Types	155
Table 14-1: PWM VFD Efficiency as a Function of VFD Power Rating	165
Table 14-2: Power Required by a Fan or Pump	168

Table 14-3: Energy Savings by Removing Dampers	176
Table 14-4: Load Profile	180
Table 14-5: Weighted Power Calculations for Outlet Damper Method	180
Table 14-6: Weighted Power Calculations for the Variable Inlet Vane	181
Table 14-7: Weighted Power Calculations for the VFD	181
Table 14-8: Savings from these Control Methods	182
Table 14-8: VFD Costs and Savings Checklist	188

# LIST OF ILLUSTRATIONS

---

	Page
Figure 2-1: AC Motor Family Tree	3
Figure 2-2: DC Motor Family Tree	4
Figure 3-1: Force on a Conductor in a Magnetic Field	8
Figure 3-2: Torque Example	9
Figure 3-3: Typical Torque-Speed Graph	11
Figure 4-1: Development of a Rotating Magnetic Field	13
Figure 4-2: Resulting Fields	14
Figure 4-3: Squirrel Cage	16
Figure 4-4: Torque-Speed Graphs of Design A, B, C, D Motors	17
Figure 4-5: Wound Rotor Induction Motor	19
Figure 4-6: Wound Rotor Torque-Speed Graph for Various External Resistances	20
Figure 4-7: Split Phase Motor	24
Figure 4-8: Capacitor Start Motor	26
Figure 4-9: Capacitor Start – Capacitor Run Motor	27
Figure 4-10: Capacitor Run Motor	28
Figure 4-11: Shaded Pole Motor	29
Figure 4-12: Exciter for Brushless Synchronous Motor	31
Figure 4-13: Non-Excited Synchronous Motor Rotor	32
Figure 4-14: Single Phase Reluctance Motor	34
Figure 4-15: Hysteresis Motor	35
Figure 4-16: Universal Motor	37
Figure 5-1: Torque Production in a DC Motor	40
Figure 5-2: Separately Excited DC Motor	41
Figure 5-3: Series Field Motor	42
Figure 5-4: Compound DC Motor	43
Figure 5-5: Permanent Magnet DC Motor	44
Figure 6-1: Electronically Commutated Motor (ECM)	45

Figure 6-2: Written Pole Motor	49
Figure 6-3: Hybrid Motor	50
Figure 7-1: 3-phase Squirrel Cage Induction Motors Derating Factor Due to Unbalanced Voltage	54
Figure 7-2: Power Factor Triangle	56
Figure 7-3: Voltage Flicker Curve	57
Figure 7-4: Voltage Flicker Curve - Example	59
Figure 7-5: Repeating Duty Cycle Curve	67
Figure 7-6: Insulation Life vs. Temperature	74
Figure 7-7: Annual Operating Costs of a 20 HP Motor	76
Figure 7-8: Motor Losses	78
Figure 7-9: Typical Motor Efficiency vs. Load	79
Figure 7-10: Typical Efficiencies of Standard and Energy Efficient Motors	82
Figure 7-11: Typical Power Factor vs. Load	91
Figure 8-1: Manual Starter	98
Figure 8-2: Magnetic Starter	99
Figure 8-3: Primary Resistance Starter	101
Figure 8-4: Autotransformer Starter	102
Figure 8-5: Solid State Starter (Simplified)	103
Figure 8-6: Wye-Delta Starter	104
Figure 8-7: Example of a DC Motor Starter	108
Figure 9-1: Antifriction Bearing	122
Figure 9-2: Plain Bearing	123
Figure 12-1: Block diagram of a typical PWM VFD	141
Figure 13-1: Harmonic Amplitudes	146
Figure 13-2: Voltage and Current Waveforms	150
Figure 13-3: Half Cycle Voltage Waveform for a Typical PWM Inverter	151
Figure 13-4: The Effect of Reduced Cooling on Torque Capability	154
Figure 14-1: Constant Torque Load	162
Figure 14-2: Constant Horsepower Load	163
Figure 14-3: Variable Torque Load	164

Figure 14-4: Plot of Outlet Pressure Versus the Flow of Air	169
Figure 14-5: Variations in Flow	170
Figure 14-6: System Curves Function of Throttle Positions	171
Figure 14-7: Pressure Versus Flow Curve	172
Figure 14-8: Fan Curves Function of Inlet Vane Setting	172
Figure 14-9: Fan and Inlet Vane Settings Curve	173
Figure 14-10: Fan Curves at Various Speeds	174
Figure 14-11: Power Law Approximation	175
Figure 14-12: Demand (kW) and Apparent Power (kVA)	183
Figure 14-13: Electrical Energy (kWh) and Hourly Ontario Energy Price (HOEP) (\$/kWh) Price	184
Figure 14-14: Resulting Electric Energy Cost for 24 hours	184



# 1 INTRODUCTION

---

A world without electric motors is difficult to imagine. From the tiniest motor found in a quartz watch to the largest, motors are used in many diverse applications.

There are a multitude of motor types to choose from. Each has its own unique characteristics, making one motor type a better choice for an application than another.

This guide provides an overview of both electric motors and variable speed drives (VFD). It is not intended to turn the reader into an expert, but rather to serve as a concise stand-alone reference with an emphasis on energy efficiency.

This guide is intended for both the novice and the experienced user. Some relevant theory is provided along with equations, such as calculations of torque and horsepower. The specific topics covered in this guide include: basic motor and VFD theory, motor types, appropriate applications, and economics.

“Rules of thumb,” examples and other anecdotal commentary are scattered throughout the text.

These commentaries are formatted in an italic font, as are the equations. Finally, links to websites for the latest in motor and/or VFD programs and knowledge bases are included at the end of this guide.

The guide commences with a discussion on motors, followed by the VFD information.



## 2 MOTOR CLASSIFICATION

An electric motor is a device that converts electrical energy into kinetic energy (i.e. motion).

Most motors described in this guide spin on an axis, but there are also specialty motors that move linearly. All motors are either alternating current (AC) or direct current (DC), while a few can operate on both (See Figure 2-1 and Figure 2-2).

The following lists the most common motors in use today. Each motor type has unique characteristics that make it suitable to particular applications.

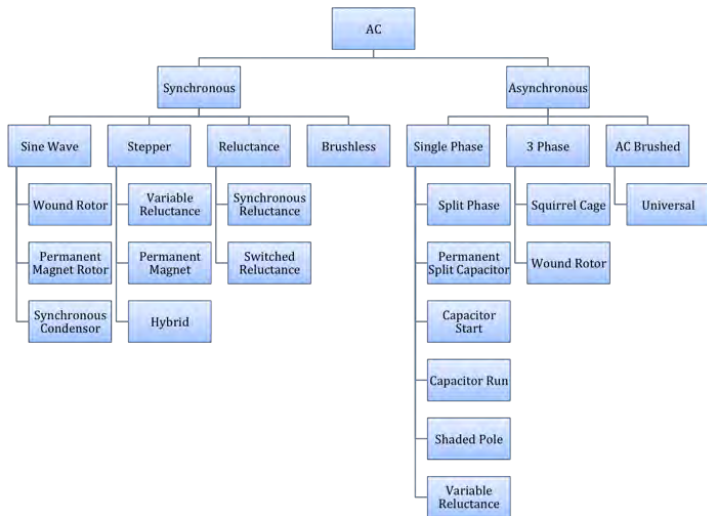
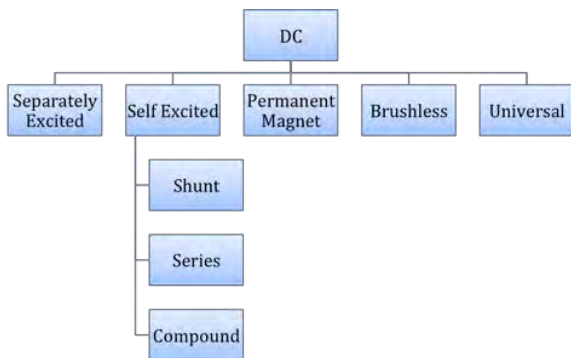

Figure 2-1: AC Motor Family Tree

## 2 Motor Classification



**Figure 2-2: DC Motor Family Tree**

### Alternating Current (AC) Motors

AC motors include 3-phase and single-phase types.

4

**3-phase AC induction motors** are the most widely used motors in industrial and commercial applications.

They are divided into two sub-categories:

- Squirrel cage motors
- Wound rotor motors

**3-phase Synchronous motors** are most commonly used in very large industrial applications or where exact speed is required.

**Single-phase induction motors** are used where three-phase power is not available; typically in residential, commercial and agricultural applications. They are also used in applications with power requirements below 1 horsepower (HP).

The main sub-categories include:

- Split phase
- Capacitor run
- Capacitor start
- Capacitor start – capacitor run
- Shaded pole
- Universal motors

**Universal motors** are mostly operated on AC power, but they can operate on either AC or DC. Tools and appliances are among the most frequent applications.

**DC motors** are often used in applications where precise speed control is required. They are divided into three sub-categories:

- Series
- Shunt
- Compound

**Advanced motors** have been developed in recent years, a number of which do not neatly fall within traditional motor classifications. They are typically used in OEM applications.

Examples include:

- Electronically commutated motors
- Switched reluctance
- Permanent magnet motors

## 2 Motor Classification

## 3 OPERATING PRINCIPLES

---

### a. Major Parts

All motors have two basic parts:

- The STATOR (stationary part)
- The ROTOR (rotating part)

The design and fabrication of these two components determines the classification and characteristics of the motor. Additional components (e.g. brushes, slip rings, bearings, fans, capacitors, centrifugal switches, etc.) may also be unique to a particular type of motor.

### b. Operation

The motors described in this guide all operate on the principle of electromagnetism. Other motors do exist that operate on electrostatic and Piezoelectric principles, but they are less common.

In electric motors, the magnitude of the force varies directly with the strength of the magnetic field and the amount of current flowing in the conductor (Figure 3-1).

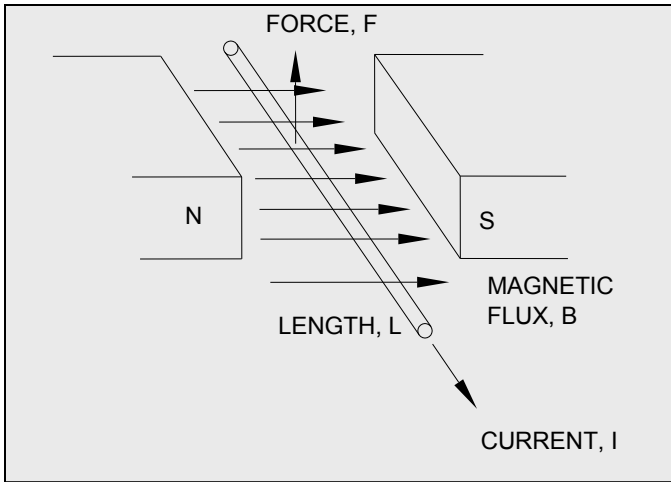

**Figure 3-1: Force on a Conductor in a Magnetic Field**

8

$F = ILB$ , where:

$F$  – Force (newtons)

$I$  – Current (Amperes)

$L$  – Length (metres)

$B$  – Magnetic Flux Density (webers/m<sup>2</sup>)

In general, the rotor of an electric motor lies within a magnetic field created by the stator. The magnetic field induces a current within the rotor, and the resultant force caused by the magnetic fields in the stator and rotor (and thus torque) causes it to turn.

### c. Motor Power and Torque

The nameplate on electric motors expresses the mechanical power rating in either horsepower or kilowatts.

$$\text{Horsepower Rating} = \frac{\text{Kilowatt Rating}}{0.746}$$

Two important factors that determine mechanical power output are torque and speed.

Torque is a measure of force that tends to produce a rotation. It is often stated in pound-feet or Newton-metres.

To better understand the concept of torque, consider a large one foot long wrench being used to remove a nut (See Figure 3-2). If one applies 2 pounds of force at the end of this wrench, the torque would be 2 pound-feet. Until the nut starts to turn, no work is actually being performed. When the nut actually starts to turn, work is being performed. Assuming the same force continues to be applied to the wrench handle, the power is essentially the rotational speed times the torque applied.

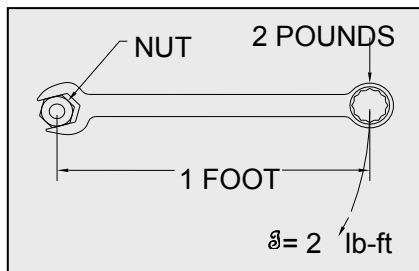

**Figure 3-2: Torque Example**

### 3 Operating Principles

Motor speed is commonly stated in revolutions per minute (RPM).

Motor horsepower is defined as the rotational speed of the motor multiplied by the torque.

$$\text{Kilowatts} = \frac{\text{Speed(RPM)} \times \text{Torque(N} \cdot \text{m)}}{9.5488}$$

$$\text{Horsepower} = \frac{\text{Speed(RPM)} \times \text{Torque(pound} - \text{feet)}}{5252}$$

The slower the motor operates the more torque it must produce to deliver the same power output. To withstand the greater torque, lower speed motors need stronger components and are generally larger, heavier and more expensive than those of higher speed motors of the same power rating.

10

There is sometimes confusion with the concept of torque and speed with horsepower. To illustrate the difference, consider the starting motor of the automobile engine. This specialty motor is designed for high torque but relatively low horsepower. Its sole purpose is to slowly turn the car engine to get it started. Conversely, the motor in a small fan rotates at high speed, but is easily stopped. The latter motor produces low torque. A final example is a 3 HP table saw motor. Shoving a piece of wood into the spinning blade will barely slow the motor down as the motor combines both speed and torque for the application.

## d. Torque-Speed Characteristics of Motors

Torque produced by a motor typically varies with speed.

Each motor type has its own torque speed relationship which, when plotted as torque vs. speed, helps in the selection process (Figure 3-3).

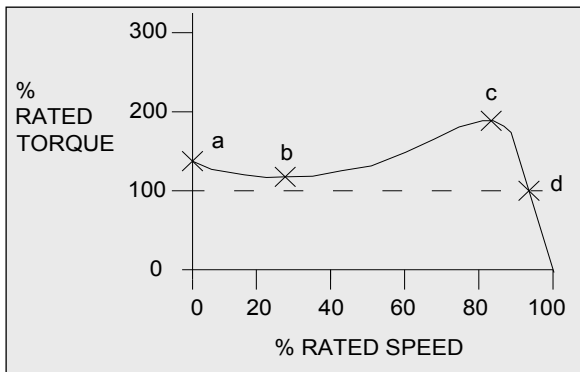

**Figure 3-3: Typical Torque-Speed Graph**

Some important points found on a torque-speed graph include:

1. **Starting torque** – the torque produced at zero speed. If the motor needs to turn a load that is difficult to start (a high inertia load) one would choose a motor with high starting torque.
2. **Pull-up torque** – the minimum torque produced during acceleration from standstill to operating speed. This may be critical for an application that needs

### 3 Operating Principles

power to go through some temporary barriers before achieving the working level output.

3. **Breakdown torque** – the maximum torque that the motor can produce before stalling.
4. **Full load torque** (also braking torque) – the torque produced at full load speed that gives the rated output of the motor. *At this point the torque times the speed divided by 5252 equals the nameplate horsepower rating, or divided by 9.5488 for the kilowatt rating.*

Another important aspect of the torque-speed relationship that is not indicated in Figure 3-3 is **pull-out torque**. As the load on the motor is increased, the motor torque and the [torque angle](#) will also increase. However if the torque angle exceeds 90 degrees the torque will begin to fall and the motor will lose synchronization and eventually stop. The pull out torque is typically 1.5 times the continuously rated torque.

## 4 AC MOTORS

A common feature of all AC motors is a rotating magnetic field produced by the stator windings.

This concept can be illustrated for three phase motors by considering three coils placed equally around the rotor. Each coil is connected to one phase of a three-phase power supply (Figure 4-1).

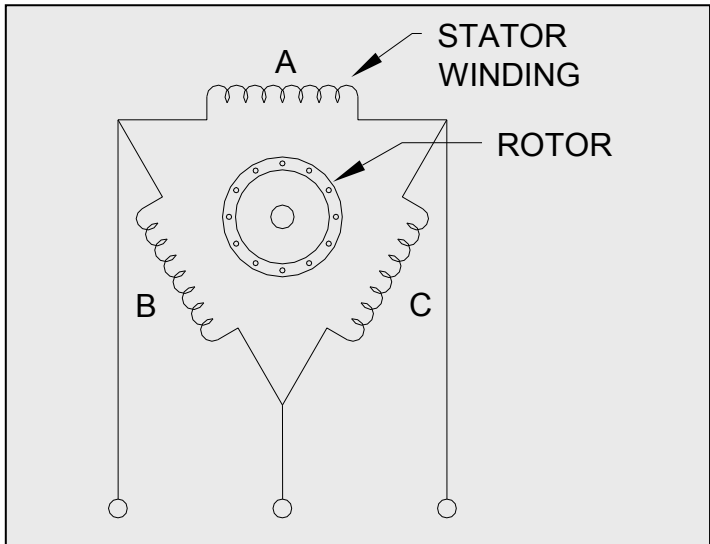

**Figure 4-1: Development of a Rotating Magnetic Field**

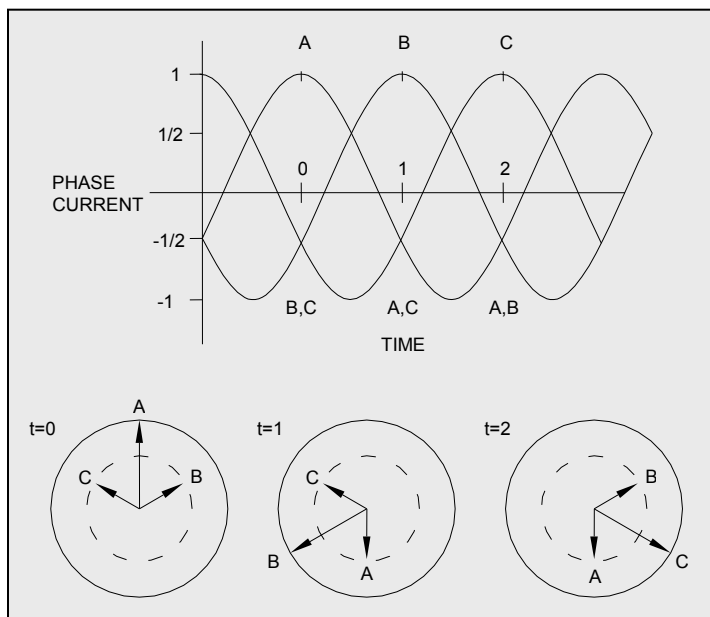

**Figure 4-2: Resulting Fields**

The current through each coil varies sinusoidal with time,  $120^\circ$  out of phase with the other coils. This means that the current in coil B is delayed by  $1/3$  of a period from that in A, and the current in coil C is delayed by  $1/3$  of a period from that in B (Figure 4-2).

The rotor sees the net rotating magnetic field created by the three coils and rotates, creating the torque on the motor drive shaft. This field rotates either clockwise or counter clockwise, depending on the order of the phases connected to the motor.

Reversing a 3-phase motor's direction is simply achieved by changing the connection order of two of the three conductors.

The rotating field speed depends on the number of magnetic poles in the stator and is referred to as the synchronous speed.

$$\text{Synchronous Speed} = \frac{120 \times \text{Frequency}}{\text{Number of Poles}}$$

Frequency refers to the power supply frequency (e.g. 60 Hz).

The number of magnetic poles (or simply poles) is the principal design factor affecting speed in AC motors.

### a. 3-Phase Induction Motors

The rotor of an induction motor does not rotate at synchronous speed or the speed of the magnetic field of the stator, but lags slightly. This lag is usually expressed as a percentage of the synchronous speed called "slip." Motor slip is the result of the interaction between the magnetic field of the stator and the magnetic field resultant from the induced currents flowing in the rotor.

The rotor bars cut through the magnetic lines of force resulting in induced current. This induced current produces the required torque. As the motor slows down (i.e. slip increases) when load is added, more torque is created.

$$\text{Slip} = \frac{\text{Synchronous Speed} - \text{Running Speed}}{\text{Synchronous Speed}} \times 100$$

3-phase induction motors are very robust and reliable and are the most common type of motor in use.

Unfortunately, power factor<sup>1</sup> tends to be poor for reduced loads. This is due to the current that is supplied to simply maintain the magnetic field.

### b. Squirrel Cage Motors

The rotor of a squirrel cage motor is made of conductive bars that are parallel to the shaft and short circuited by the end rings in which they are physically supported (Figure 4-3).

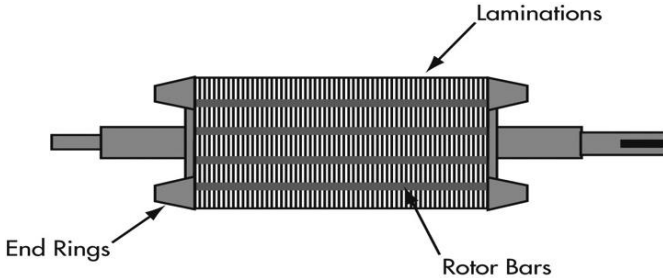

**Figure 4-3: Squirrel Cage**

Bar size, shape and resistance significantly influence torque-speed characteristics. A break in a rotor bar or end ring connection can lead to a more serious condition including high frequency vibrations and even motor failure.

In order to facilitate the selection of motors, NEMA (National Electrical Manufacturers Association) has assigned letter designations A, B, C, D and E to describe standard torque-

---

<sup>1</sup> For more on power factor, see also pages 63 and 100.

speed design characteristics of squirrel cage motors up to 200 HP (Table 4-1 and Figure 4-4).

**Table 4-1: Squirrel Cage NEMA Design Characteristics**

Design Type	Starting Torque	Starting Current	Breakdown Torque	Full Load Slip	Typical Applications	Relative Efficiency
A Seldom used	normal	high	high	<5%	machine tools, fans, pumps	medium or high
B	normal	normal	normal	<5%	same as A	same as A
C	high	normal	low	<5%	compressors, crushers, conveyors	medium
D	very high	low	n/a	>5%	punch presses, high inertial loads elevators	low
E	normal	high	high	<3%	same as A	high

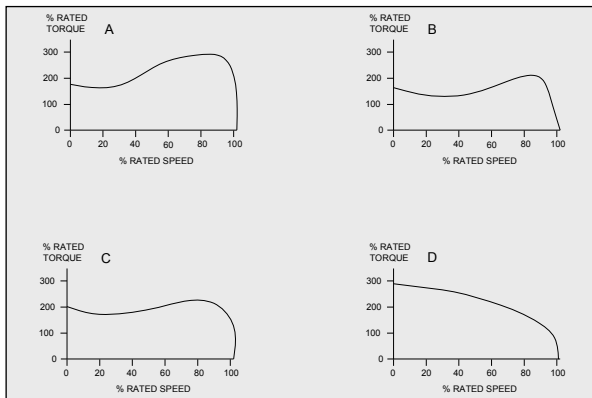

**Figure 4-4: Torque-Speed Graphs of Design A, B, C, D Motors**

## 4 AC Motors

Design type B is the most common and suits the majority of motor applications.

Design A motors are not generally specified today due to the high starting current. Design B motors should be specified instead.

Motors are also referred to as being general, definite or special purpose.

A general purpose motor is any motor which is designed in standard ratings, such as those specified in the National Electrical Manufacturers Association (NEMA) Standards Publication MG-1 (2011).

18 A definite purpose motor is any motor designed in standard ratings with standard operating characteristics or standard mechanical construction for use under service conditions other than usual, such as those specified in NEMA Standards Publication MG 1-2011.

A special purpose motor is any motor (other than a general purpose motor or definite purpose motor) which has special operating characteristics or special mechanical construction (or both) designed for a particular application. Motors over 500 HP are usually considered special purpose rather than general purpose, and are designed for the specific application.

### c. Wound Rotor Induction Motor

The wound rotor induction motor operates on the same principles as the squirrel cage motor, but differs in the construction of the rotor. Instead of shorted bars, the rotor is made up of windings that terminate at slip rings on the shaft.

This type of motor is used in special applications where a high starting torque is required.

Connection of external resistance to the rotor circuit via the slip rings permits variation of motor torque-speed characteristics (Figure 4-5 & Figure 4-6). After starting, the slip rings are shorted together.

*Shorting the external connection results in operation similar to squirrel cage motors.*

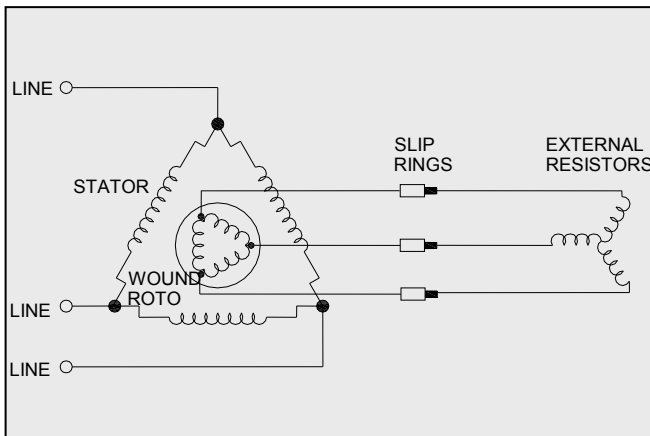

**Figure 4-5: Wound Rotor Induction Motor**

Speed range variation of about 5:1 can be achieved by adding external resistance to the rotor circuit; however, this is at the expense of electrical efficiency unless a slip energy recovery circuit is used.

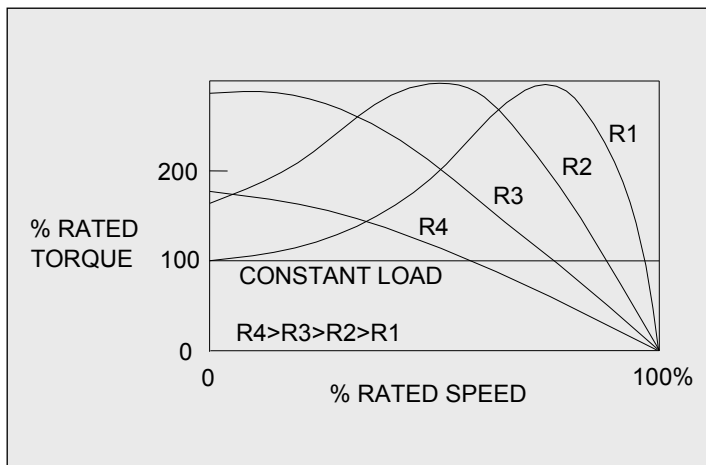

**Figure 4-6: Wound Rotor Torque-Speed Graph for Various External Resistances**

The maximum torque that a wound rotor motor can produce is determined by the design of its rotor, whereas the speed at which this torque is developed depends on external rotor resistance.

Each wound rotor design has a family of torque-speed curves that correspond to various values of external rotor resistance.

## d. Single Phase Induction Motors

When a single-phase induction motor is running it develops a rotating magnetic field, however, before the rotor begins to turn the stator produces only a pulsating stationary field.

To produce a rotating field, and thus a starting torque, an auxiliary starting winding is placed at right angles to the main stator winding so that the currents through them are out of phase by  $90^\circ$  (1/4 of a period in time). This places the magnetic fields  $90^\circ$  out of alignment. As a result, the rotor wants to align the magnetic poles, which creates a starting torque. The physical placement of the start winding and its relative polarity to the main winding results in the motor consistently turning in one direction when started. Once the motor has started, the auxiliary winding is often removed from the circuit by a centrifugal switch. Table 4-2 shows the single-phase induction motor type, range of starting torque, efficiency range, and associated applications.

**Table 4-2: AC Single Phase Induction Motors (Ref. 22)**

<b>Motor Type</b>	<b>Starting Torque</b>	<b>Efficiency</b>	<b>Application</b>
Split Phase	Low	Medium	Direct Drive Fans, Centrifugal Pumps, Air and Refrigeration Compressors
	Medium	Medium	Belted Fans, Air and Refrigeration Compressors, Major Appliances
Capacitor Start	Medium	Medium	Belted Fans, Compressors, Centrifugal Pumps, Industrial, Farm, Major Appliances, Commercial Appliances, Business Equipment
	High	Medium	Positive Displacement Pumps, Air and Refrigeration Compressors.
Capacitor Start / Run	Medium	High	Belted Fans, Centrifugal Pumps
	High	High	Positive Displacement Pumps, Air and Refrigeration Compressors, Industrial, Farm, Major Appliances, Commercial Appliances, Business Equipment
Permanent Split Capacitor	Low	High	Direct Drive Fans, Refrigeration Compressor, Business Equipment
Shaded Pole	Low	Low	Direct Drive Fans

A failed start winding circuit will result in a motor that makes a low humming sound and will start in either direction by carefully providing a slight spin by hand.

Single phase induction motors are used in applications where three phase power is not available, and are generally in the fractional horsepower to 10 HP range. Larger than 10 HP single-phase motors are possible and are usually matched with power electronics to limit starting currents that would otherwise be very high.

### e. Split Phase Motors

Split phase motors use a starting winding with a different resistance/reactance ratio than that of the main stator winding to produce the phase difference required for starting.

The phase difference is not the desired  $90^\circ$ , and the magnetic fields are not equal. This results in a lower starting torque than other motor designs.

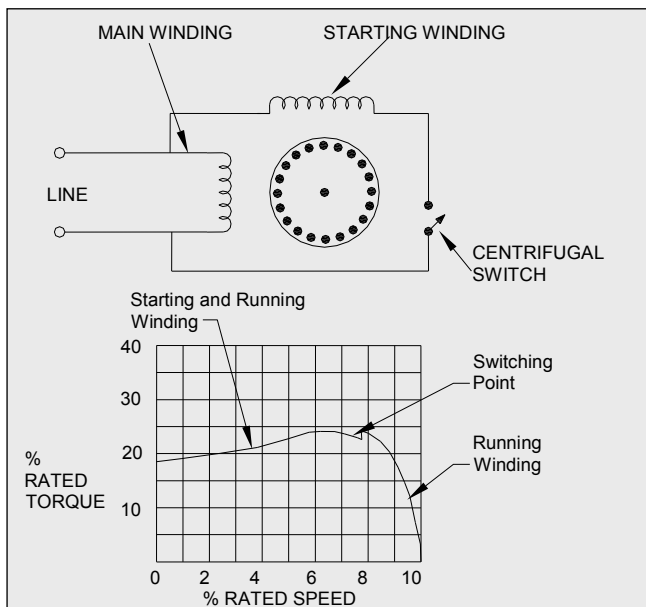

**Figure 4-7: Split Phase Motor**

Split phase motor starting torque, however, is sufficient for many applications such as refrigerated display case circulation fans and some types of power tools (e.g. drill press). This type of motor is cheap to produce and is therefore a favourite in OEM products. Typical sizes range up to about 1/2 HP.

## f. Capacitor Motors

Many single-phase motors use a capacitor in series with one of the stator windings to optimize the field phase difference for starting. Capacitive current leads voltage by  $90^\circ$ . Adding capacitance causes a phase shift in one winding relative to the other. The result is a higher starting torque than a split phase motor can produce.

Capacitor motors are used in high starting torque applications such as compressors and air conditioners. Typical sizes range up to about 10 HP.

### Capacitor Start Motor

In a capacitor start motor, a capacitor connected in series with the starting winding is sized to maximize starting torque (Figure 4-8).

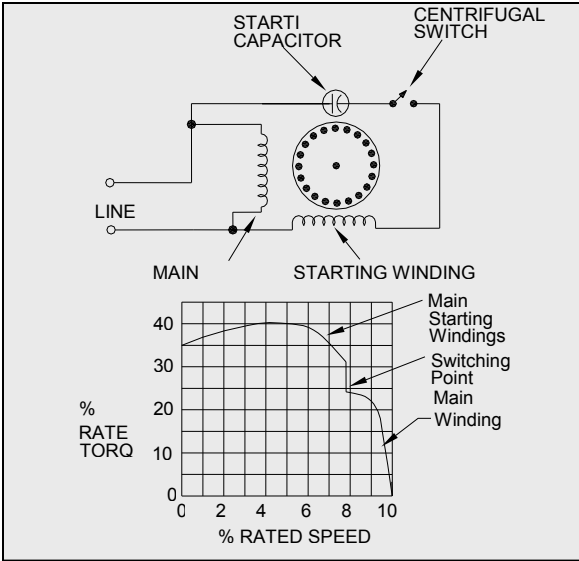

**Figure 4-8: Capacitor Start Motor**

The starting winding is removed from the circuit by a centrifugal switch or electronic relay when the motor reaches running speed. Starting torque is higher than for capacitor run motors, with running performance similar to a split phase motor.

### Capacitor Start – Capacitor Run Motors

This design uses a capacitor optimized for running characteristics in series with the main stator winding (Figure 4-9). A second capacitor in series with the starting winding optimizes starting torque. The starting capacitor is switched out of the circuit at running speed.

Occasionally the capacitor will fail and the motor will not start. A simple test is to remove the capacitor and check with an ohmmeter (Ref.1). If possible, set to the highest ohms scale. Upon contact with the terminals, the ohm value should drop rapidly and then slow down and rise again. This means the capacitor should be operational. However, if the ohms go immediately to a low value near zero, the capacitor is shorted. If the value stays very high, the capacitor is open circuited. Installing a new capacitor of equal rating should remedy the problem.

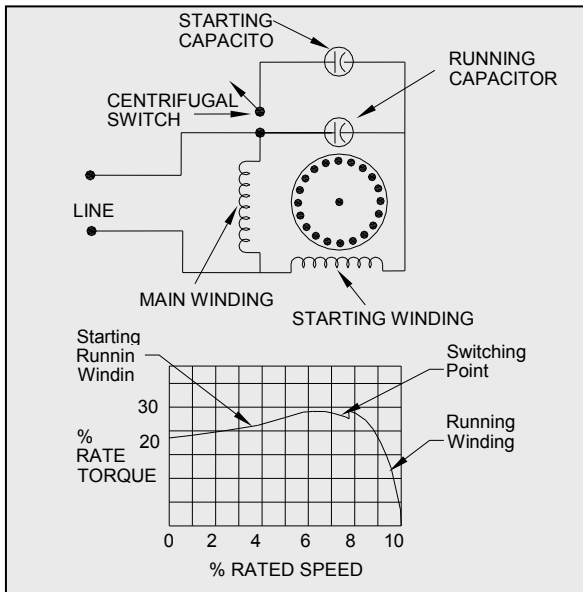

**Figure 4-9: Capacitor Start - Capacitor Run Motor**

Both starting torque and running characteristics are optimized.

## 4 AC Motors

### Capacitor Run Motor (or Permanent Split Capacitor Motor)

Capacitor run motors use a capacitor permanently connected in series with one of the start windings to achieve a compromise between good starting torque and good running characteristics.

This design is lower in cost than other capacitor motors that incorporate capacitor-switching systems.

These motors achieve better starting torque and running characteristics than a split phase motor and are sometimes called permanent split capacitor (PSC) motors.

*New furnace fan motors sometimes use capacitor run motors.*

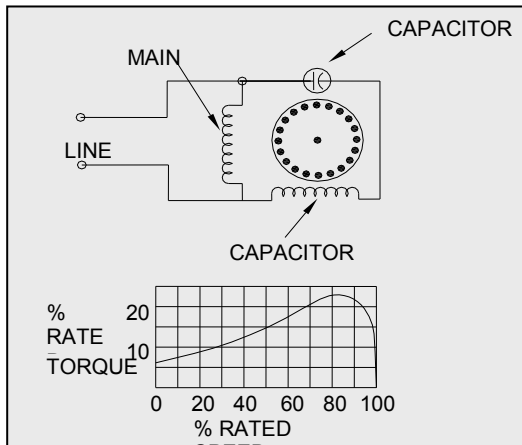
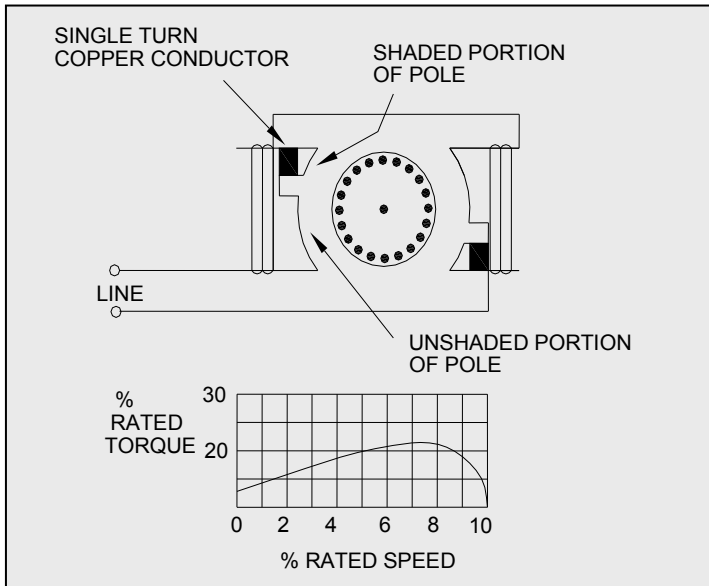

**Figure 4-10: Capacitor Run Motor**

## g. Shaded Pole Motors

A shaded pole motor is the simplest form of a single-phase motor and is very low in cost (Figure 4-11).

It develops a rotating field by delaying the build-up of magnetic flux through part of the pole structure.



**Figure 4-11: Shaded Pole Motor**

The shaded portion of the pole has a single turn of copper conductor around it. The currents induced in this coil create a second electrical phase, resulting in a 2-phase rotating magnetic field.

## 4 AC Motors

The magnetic flux in the unshaded portion increases with the current through its winding. Magnetic flux increases in the shaded portion; however, it is delayed by the current induced in the copper field.

The magnetic field sweeps across the pole face from the unshaded portion to the shaded portion, developing a torque in the squirrel cage.

To maximize torque, the rotor is made with relatively high resistance.

Shaded pole motors are used where low torque is acceptable (such as fans) and are usually less than 1/4 HP.

*Due to their very low efficiency, shaded pole motors should only be used in applications where the motor is either very small or operates for very short periods of time (e.g. shower fan motor).*

### h. Synchronous Motors

A synchronous motor produces magnetic poles at fixed positions on the rotor.

These poles lock onto the rotating field of the stator and turn the rotor at synchronous speed based on the 60Hz supply frequency.

A simple way to determine the speed of a synchronous motor is to divide 3600 by half the number of poles. For example, a 2 pole machine will turn at 3600 rpm, a 4 pole 1800 rpm, 6 pole 1200 rpm, etc.

There are several different types of single and 3-phase synchronous motors.

Low horsepower synchronous motors are significantly more expensive than induction motors. However, motors greater than 1000 HP have comparable costs. Their use is typically limited to applications where uniform speed is absolutely required and motor slip cannot be tolerated (See Section 4 a).

### Excited Rotor Synchronous Motor

The magnetic poles on the rotor are electromagnets supplied with direct current, either by slip rings from a stationary external DC power supply or internally by an alternator mounted on the rotor shaft (brushless type) (Figure 4-12). This process of generating a magnetic field by means on an electric current is called excitation.

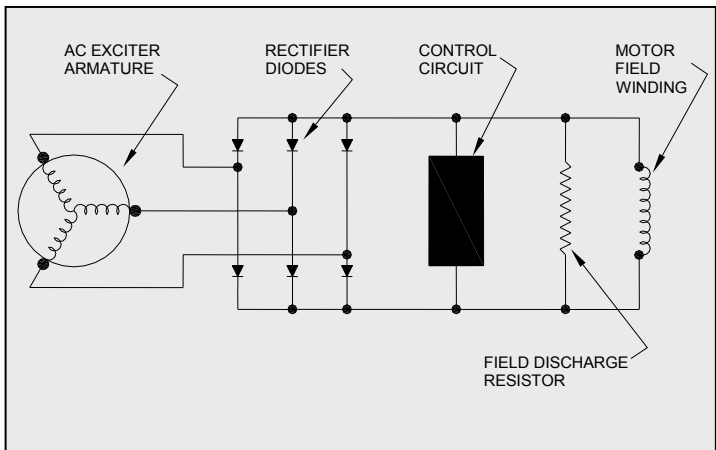

**Figure 4-12: Exciter for Brushless Synchronous Motor**

## 4 AC Motors

The amount of excitation can be adjusted by varying the rotor current on the brush-type motor or the alternator field excitation on the brushless type.

Altering the level of rotor excitation changes the power factor of the motor.

The motor can run with a lagging power factor (underexcited) or a leading power factor (overexcited).

An overexcited synchronous motor can be used to correct poor power factor in a plant and can be adjusted as needed. Such a setup is sometimes referred to as having a “synchronous condenser.”

### Non Excited or Reluctance Rotor Synchronous Motor

32

This design uses an iron rotor shaped to favour fixed paths for magnetic flux (Figure 4-13). They typically range from fractional horsepower to about 30 HP.

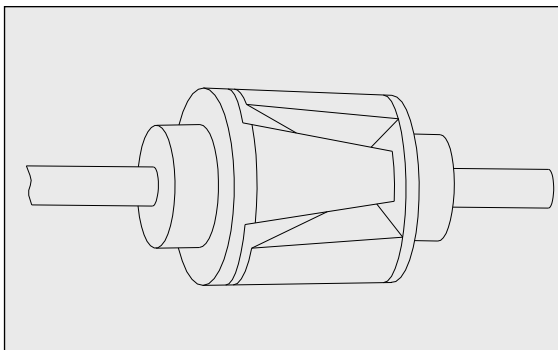

**Figure 4-13: Non-Excited Synchronous Motor Rotor**

Permanent magnets are sometimes used on the rotors of smaller motors.

Reluctance rotor motors have low power factors during operation. They are also physically larger than the excited type motors of a similar power rating.

### Single Phase Synchronous Motors

Any single-phase stator configuration can be used to make a reluctance type synchronous motor (Figure 4-14).

The rotor is essentially a squirrel cage with some of its bars removed in positions that favour specific magnetic flux paths.

During start-up, the rotor lags the rotating magnetic field, similar to an induction motor.

When the motor approaches synchronous speed, reluctance torque causes the rotor to synchronize with the stator field.

This design is used in low power applications where synchronous speed is required.

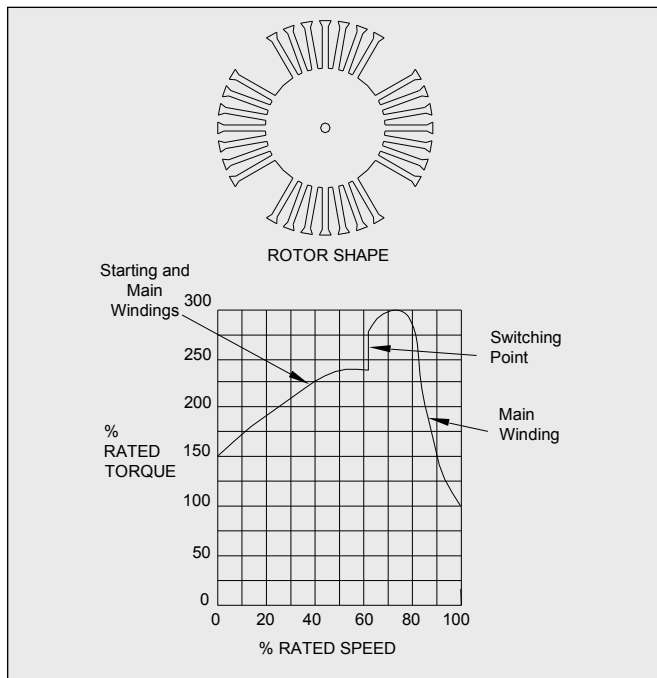
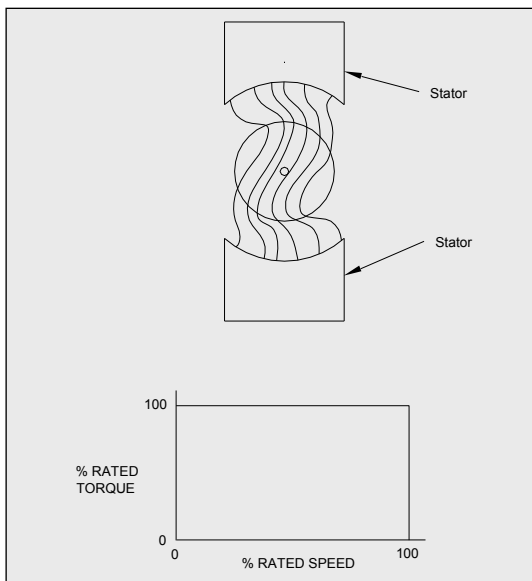

**Figure 4-14: Single Phase Reluctance Motor**

### i. Hysteresis Motor

For a hysteresis motor, the rotor is typically a cylinder of magnetically hard steel without any windings or teeth (Figure 4-15).

Stator windings are usually a split capacitor type, with the capacitor chosen to approximate two phase operation as closely as possible.



**Figure 4-15: Hysteresis Motor**

The high retentivity of the rotor material causes its magnetic orientation to lag behind the rotating magnetic field by a fraction of a rotation.

Interaction between the rotating field and the rotor's magnetic polarity subjects the rotor to a torque that is consistent from standstill to synchronous speed.

- This design allows synchronization of high inertia loads.
- Operation is generally smooth and quiet because of the smooth rotor periphery.
- Hysteresis motors are generally used in low power applications, such as clocks.

### j. Universal Motors

Universal motors are series wound, with rotor circuitry similar to DC motors (Figure 4-16).

The term universal results from their ability to operate on either **DC** or **AC** power.

The operation and construction of these motors closely resemble DC motors, with components designed for efficiency on AC up to the line frequency (See Section 5 b).

Operating speeds typically range from 3,000 to 15,000 RPM. The speed will drop with increasing load.

A high horsepower to size ratio is characteristic of this design.

36

Maintenance requirements per hour of operation are higher than other designs due to the brush/commutator setup.

On motors with accessible brushes (typically coin-slot screw plugs on either side of the motor), brush condition should be checked occasionally to ensure adequate brush material remains. When the brush is getting close to the holder or braided end lead, it should be replaced with the same size and type of brush. If the brush runs out and the holder touches the commutator, there will be a lot of sparking when the motor is operated. Should this occur, stop the motor immediately. Permanent damage may have been caused, but new brushes may remedy the situation.

*Common uses of these motors include low duty cycle applications such as power saws, drills, vacuum cleaners and lawn mowers. Sizes up to about 2 HP are common.*

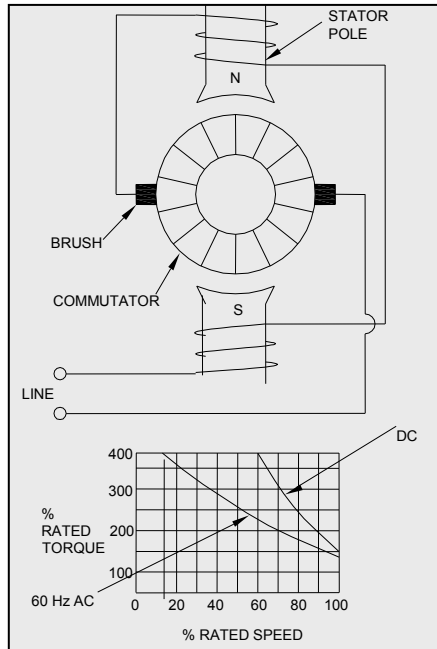

**Figure 4-16: Universal Motor**



## 5 DC MOTORS

---

DC motors possess characteristics that make them attractive for certain applications. For example, very high torque at low speeds makes the series DC motor attractive for traction and engine starting applications.

Varying the supply voltage to a DC motor can control the rotational speed.

The following is a general description typical of the DC motors:

The rotating part (rotor) of a DC motor is called the armature, and consists of windings similar to those in a wound rotor induction motor (Figure 5-1).

The stationary part (stator) introduces a magnetic field by either permanent magnets or field windings that act on the armature.

Current flows through the armature windings via carbon brushes and a commutator assembly. The commutator assembly is easily recognizable as a ring of parallel diametrically opposite pairs of rectangular shaped copper contacts at one end of the armature. Each pair of contacts is connected to a coil wound on the armature. The carbon brushes maintain contact with the commutator assembly via springs. When the motor is turned on, current flows in through one brush via a commutator contact connected to a coil winding on the armature, which is represented as “A” in Figure 5-1. The current then flows out through the other carbon brush via a diametrically opposite commutator contact, which is seen as

“B” in Figure 5-1. This causes the armature to appear as a magnet with which the stator field interacts. The armature field will attempt to align itself with the stator field. When this occurs, torque is produced and the armature will move slightly. At this time, connection with the first pair of commutator contacts is broken and the next pair lines up with the carbon brushes. This process repeats and the motor continues to turn.

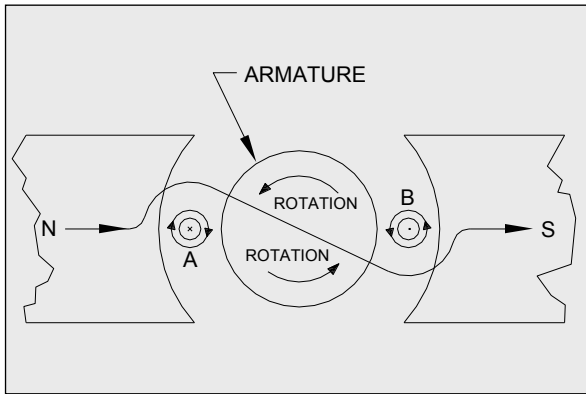

**Figure 5-1: Torque Production in a DC Motor**

### a. Separately Excited DC Motor

The field (or stator) coil contains a relatively large number of turns that minimizes the current required to produce a strong stator field (Figure 5-2). It is connected to a separate DC power supply, thus making field current independent of load or armature current.

Excellent speed regulation is characteristic of this design that lends itself well to speed control by variation of the field current.

*Separately excited DC motors can race to dangerously high speeds (theoretically infinity) if current to the field coil is lost. Because of this, applications should include some form of field current protection as an unprotected motor could literally fly apart.*

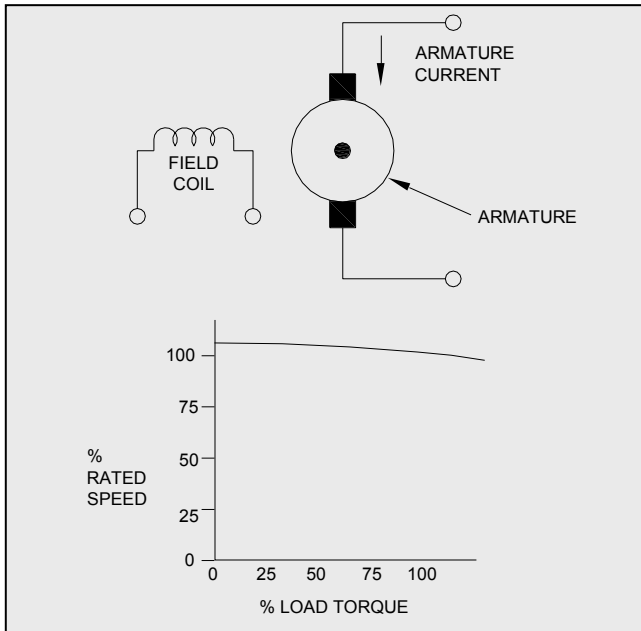

**Figure 5-2: Separately Excited DC Motor**

## b. Series Field DC Motor

The field coil has a relatively small number of turns, and is connected in series with the armature (Figure 5-3). Because it carries full armature current, the magnetic field strength increases with load and armature current.

## 5 DC Motors

Very high starting torque is the characteristic of this design.

Speed regulation is poor with a very high no load speed.

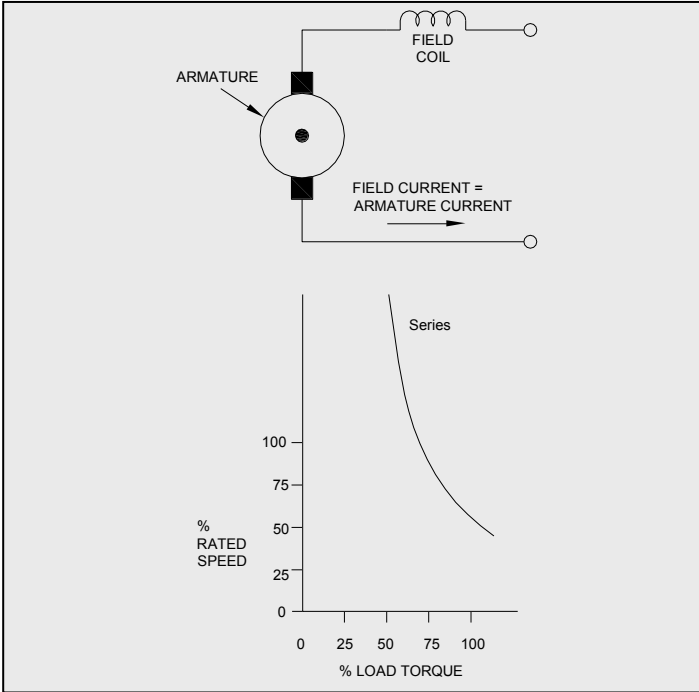

**Figure 5-3: Series Field Motor**

### c. Compound DC Motor

The compound DC motor uses both series and shunt field windings, which are usually connected so that their fields add cumulatively (Figure 5-4).

This two winding connection produces characteristics intermediate to the shunt field and series field motors.

Speed regulation is better than that of the series field motor.

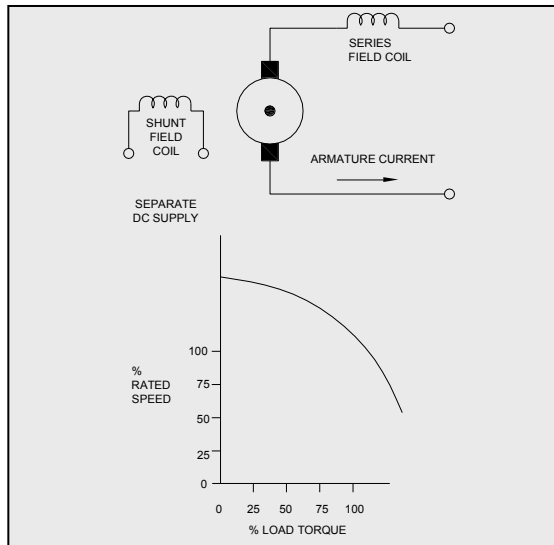

**Figure 5-4: Compound DC Motor**

## d. Permanent Magnet DC Motors

These motors use permanent magnets in place of field windings to establish the stator magnetic field (Figure 5-5).

Permanent magnets provide constant field strength, with motor characteristics similar to that of the shunt field DC motor.

*Permanent magnet motors are often used in low horsepower applications, particularly those that are battery operated (e.g. windshield wiper motor). However, with recent developments in magnet technology, permanent magnet motors can be greater than 200 HP.*

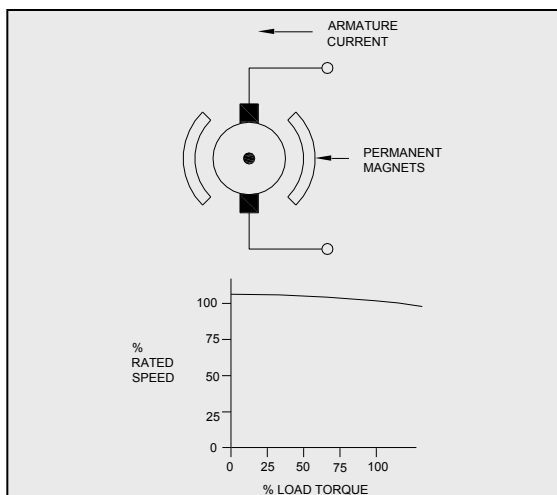

**Figure 5-5: Permanent Magnet DC Motor**

## 6 ADVANCED MOTORS

### a. Electronically Commutated Motor (ECM)

An ECM is an electronically commutated permanent magnet DC motor (Figure 6-1).

Electronics provide precisely timed voltages to the coils and use rotation position sensors for timing.

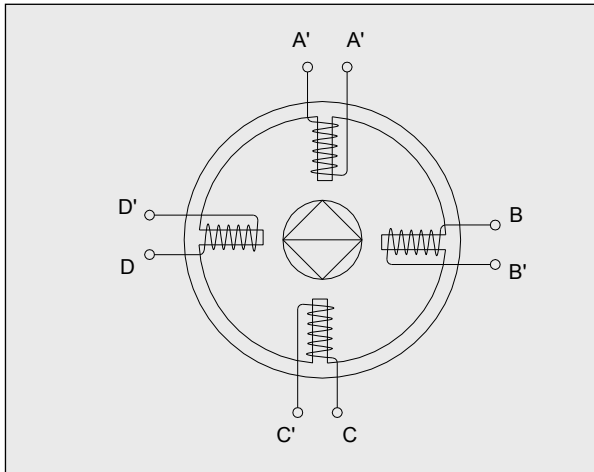

**Figure 6-1: Electronically Commutated Motor (ECM)**

The electronic controller can be programmed to vary the torque speed characteristics of the motor for a wide variety of OEM applications such as fans and drives.

## 6 Advanced Motors

Although presently more costly than alternative motor technologies, the higher efficiency and flexible operating characteristics of these motors make them attractive.

An ECM is essentially a brushless DC motor with all speed and torque controls built in (Ref. 2). Typical applications include variable torque drives for fans and pumps, commercial refrigeration, and appliances.

*For furnace fans, efficiency can be 20 to 30 percentage points higher than a standard induction motor at full load. For constant air circulation, ECM's have a definite advantage over standard direct drive blower motors. At half speed, the ECM might consume as little as 10% of the energy of a multi speed blower motor.*

*For appliances such as washing machines, the ECM can replace the mechanical transmission due to the wide range of torque speed characteristics it can produce.*

46

### Switched Reluctance Motor (SRM)

The advantage of a switched reluctance motor is high torque at low speed, plus a very high-speed range.

As with the ECM, electronics provide precisely timed voltages to the coils and use rotation position sensors for timing. Switched Reluctance motors are used in several hundred thousand premium washing machines per year. No transmission is required (Ref.19).

## b. Permanent Magnet Motors

The combination of new high strength magnetic materials in the rotor and new power electronics produce high efficiency variable speed motors ranging from sub fractional to multiple horse power units. Generally, these motors/controls are purpose built and are therefore incorporated into OEM products.

Permanent magnet applications can be divided into 4 categories:

1. Applications that require the attractive and/or repelling force of the magnet (i.e. magnetic torque drives);
2. Applications that require the magnet's magnetic field to convert mechanical energy to electrical energy (i.e. generators);
3. Applications that require the magnet's magnetic field to convert electrical energy to mechanical energy (i.e. actuators); and
4. Applications that require the magnet's magnetic field to control electron or ion beams (i.e. ion pumps).

## c. Other Advanced Motors

### Written Pole Motor

Written-Pole motors are special single-phase AC motors that can change the position of magnetic poles while the motor operates (Figure 6-2) (Ref.3).

## 6 Advanced Motors

In written-pole motors, “permanent” magnet poles are continuously and instantaneously written on a magnetic layer in the rotor by an exciter pole in the stator. The magnetic poles are written to a different spot on the rotor during each revolution when rotor speed changes. This keeps the pole pattern at a constant poles/sec speed.

Most written-pole motors feature an external rotor that spins around an internal stator, opposite that of conventional motors. This inverted structure creates a flywheel effect that allows the machine to ride through brief power disturbances. A 3-phase generator built into the motor provides power to external loads for up to 15 seconds at full load.

The rotor’s construction with permanent magnets reduces starting current. Written-pole motors need only one-third the amount of starting current as conventional induction motors.

48

*The written pole motor has found a market in areas with a large number of external power line disturbances brought on by lightning, as they are more immune to such disturbances than power electronics.*

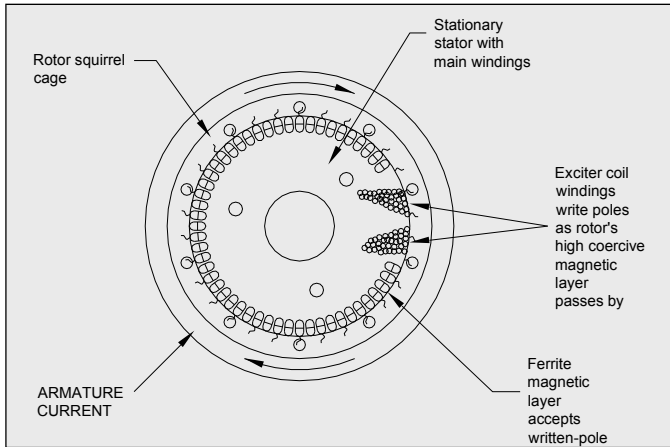

**Figure 6-2: Written Pole Motor**

## Linear DC Motors

A linear DC motor, like a rotating DC motor, generates mechanical force by the interaction of current in conductors and magnetic flux provided by permanent rare-earth magnets (Ref.4).

These motors are constructed of a stator assembly and a slider. The stator assembly contains a laminated steel structure with conductors wound in transverse slots. The slider houses magnets, commutation components and a bearing surface.

Some linear DC motors use a brushless slider that contains an additional set of magnets that activate hall-effect sensors and solid-state switches to commutate the motor windings. This type of motor is capable of precision accuracy to 0.1 micron and does not deteriorate with wear. It can drive loads directly with a wide range of thrust and travel.

## 6 Advanced Motors

### Linear AC Motors

Linear AC motors (LIMs) are often used in rail propulsion systems. Stator coils are embedded along the track. Examples of linear AC Motors include the Vancouver Sky Train and the Tomorrowland Transit Authority at Walt Disney World. Speeds of up to 400 km/h are achievable.

### Hybrid Motor

The hybrid motor combines the qualities of variable reluctance (VR) and permanent magnet (PM) motors to achieve desirable features of each (Figure 6-3). They have high detent torque and excellent holding and dynamic torque, and they can operate at high stepping speeds. Normally, they exhibit step angles of 0.9 to 5 degrees. If the phases are energized one at a time in the order indicated, the rotor would rotate in increments of 1.8 degrees. This motor can be driven two phases at a time to yield more torque. It can also be driven to alternate between one and two phase to produce half steps or 0.9 degree increments.

50

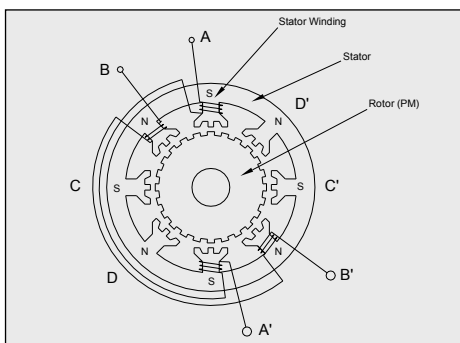

**Figure 6-3: Hybrid Motor**

## 7 MOTOR SELECTION

---

There are several considerations that should be evaluated when selecting a motor for a particular application, such as the mechanical requirements of the driven load, the electrical distribution system, motor classification, energy efficiency, and the physical and environmental considerations. The ultimate selection will be a motor available from a manufacturer that meets or exceeds the required specifications.

### a. Electrical Supply Considerations

The electrical supply distribution system must supply the correct voltage and have sufficient capacity to start and operate the motor load. Table 7-1 provides a cross comparison of nominal system voltage to show what one might find on a typical motor nameplate.

The limit to the supply voltage is dependent on the current required to operate the motor. For example, a 50 HP motor will require 150 Amps to operate at 208/120 volts, but requires only 50 Amps at 600/347 volts.

Therefore, it would not be economically practical to provide motors beyond a certain HP rating for a given voltage when the conductor size becomes too large, both in the supply to and within the motor.

#### Single Phase

Single-phase motors are rated for 120/240 volts at 60 Hz.

## 7 Motor Selection

### 3-Phase

3-phase motors up to 100 HP are available for 200, 240/460, 460 or 600 volts at 60 Hz. For 125 HP and up, they are available for 460, 600, 2400 or 4160 volts at 60 Hz.

### Voltage and Frequency

Motors can be specified to operate on voltages and frequencies other than standard. An example of this is low voltage 400 Hz motors that are used in the aircraft industry, as well as some mine tool applications.

The nominal supply voltage of the power system and the utilization or nameplate voltage on the motor often differ. The following table (Table 7-1) shows the relation between motor nameplate voltage and the correct supply voltage for that motor.

**Table 7-1: Nominal System vs. Motor Nameplate Voltage**

<b>Nominal System Voltage</b>	<b>Motor Nameplate Voltage</b>
120 – 1 phase	115
208/120 – 3 phase	200
240 – 1 phase or 3 phase	230
480/277 – 3 phase	460
600/347 – 3 phase	575
2400 – 3 phase	2300
4160/2400 – 3 phase	4000

3-phase induction motors are designed to operate successfully with voltage variations of  $\pm 10\%$ . Table 7-2 shows the effects

of a 10% variation on a typical Design B induction motor at full load.

**Table 7-2: Motor Characteristic vs. Voltage**

Characteristic	Voltage	
	110%	90%
Slip	-17%	+23%
Efficiency	+1%	-2%
Power Factor	-3%	+1%
Current	-7%	+11%
Temperature °C	-4%	+7%
Starting Torque	+21%	-19%
Starting Current	+10%	-10%

*The use of a motor with a non-standard or incorrect utilization voltage from the supply system should be avoided.*

*For example, a motor with a nameplate voltage of 440 V is sometimes connected to a 480 V system. While the maximum allowable voltage for the motor is 484 V (110% x 440) there is no allowance for an upward supply voltage variation (for example, the utility can supply 500 volts and be within accepted tolerances) as the motor is already operating at its upward supply voltage limit. A motor of the proper voltage rating should be used, or a transformer should be installed to supply the correct voltage.*

Phase voltage unbalance must be less than 1% for proper motor operation. A phase unbalance of 3.5% results in a temperature rise of 25% and a current increase of 6-10 times the voltage unbalance. These effects occur due to

## 7 Motor Selection

negative sequence currents flowing in the motor. Voltage unbalance is calculated as follows.

$$V \text{ Unbalance} = \frac{\text{Maximum Deviation from Average}}{V \text{ Average}} \times 100$$

*As an example, if line voltages were measured as 600, 585, and 609 volts, the average is 598 volts. The maximum deviation from average is 13 volts (598-585), and thus the voltage unbalance is  $(13/598) \times 100 = 2.2\%$ .*

If a motor must be operated with a phase unbalance of greater than 1%, then the motor should be derated according to the following graph shown in Figure 7-1.

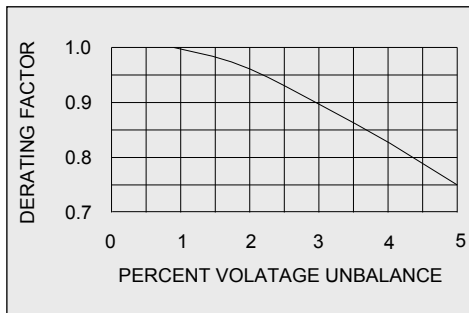

**Figure 7-1: 3-phase Squirrel Cage Induction Motors Derating Factor Due to Unbalanced Voltage**

A motor should not be operated if the phase unbalance is greater than 5%.

Frequency variation of up to 5% is permitted for normal motor operation. However, this should never be a problem if the system is supplied from a utility. Motor speed varies directly with the frequency of the power supply.

## Power Factor

Most AC motors require reactive power from the supply system to develop magnetic fields. Measured in kVARs, reactive power does not provide any mechanical work.

Useful mechanical work is developed from real power supplied by the supply system and is measured in kilowatts (kW).

The supply distribution system provides both real and reactive power to operate the motor. The vector sum of real and reactive power is called the apparent power and is expressed in kVA.

*The reactive component stays essentially constant whether a motor is lightly or heavily loaded. Therefore, lightly loaded motors are said to have a lower power factor than a fully loaded motor. A facility with a very low uncorrected power factor is indicative of a significantly high number of under loaded motors.*

If you are billed for kVA, then you are paying for the reactive power component and you are not getting any useful work. The measure of real power (kW) divided by total power (kVA) is defined as the “power factor.” The highest power factor achievable is 1 or “unity” power factor and is often expressed as a percentage with 1 equal to 100%.

## 7 Motor Selection

Industrial customers install capacitors to cancel the inductive component of motor loads to improve their power factor. In Figure 7-2, the vertical vector above the real power line represents the inductive component and the horizontal vector represents the real power. The hypotenuse vector equals the square root of the sum of the squared real and reactive vectors (See the equation following Figure 7-2).

The vertical vector pointing below the horizontal line represents the capacitive reactance. When the capacitive reactance equals the inductive reactance, the two vertical vectors cancel each other out, leaving only the real power component (i.e. unity power factor). However, if capacitance exceeds inductance, a leading power factor will result which could result in over voltage and harmonic problems. To avoid this, capacitors should be switched on and off to match at the service entrance or, better still, installed at the motor load.

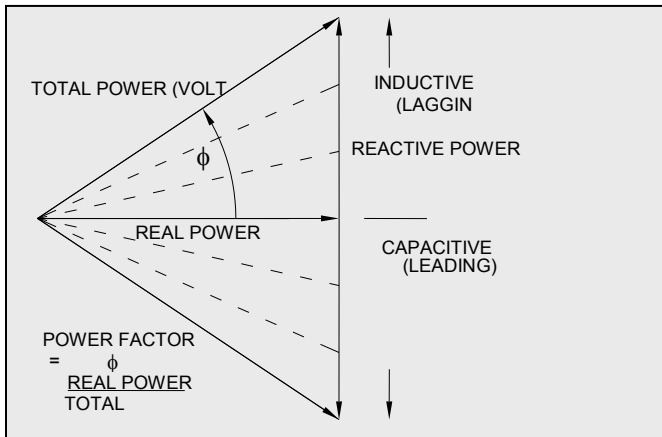

**Figure 7-2: Power Factor Triangle**

$$\text{Apparent Power} = \sqrt{\text{Real Power}^2 + \text{Reactive Power}^2}$$

## Voltage Flicker

Starting motors or other large loads causes a voltage drop on the supply system due to the effect of their high inrush currents on the circuit impedance. This may be perceived as a flicker in lighting circuits. As the motor comes up to speed, the current falls to normal operating levels and system voltage rises. This flicker becomes objectionable when the magnitude of the voltage drop and the frequency of occurrence exceed certain thresholds.

This threshold of objection is shown on a voltage flicker curve (Figure 7-3).

57

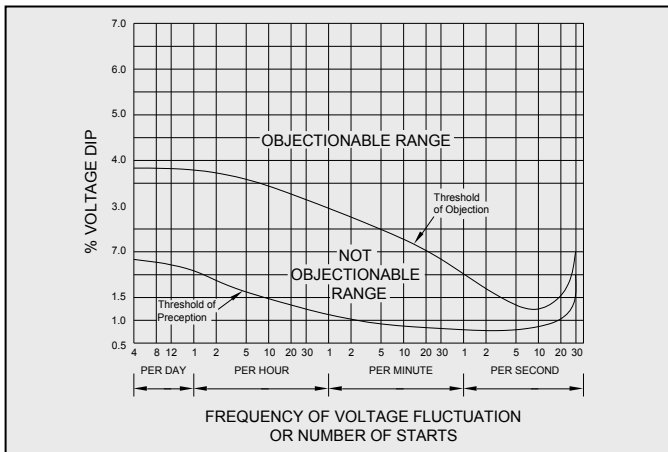

**Figure 7-3: Voltage Flicker Curve**

## 7 Motor Selection

If the magnitude of voltage drop and the frequency of occurrence lie below the threshold of objection, but above the threshold of perception, people notice the light flicker, but generally do not find it irritating.

If the magnitude of the voltage drop and the frequency of occurrence lie below the threshold of perception, people do not generally notice any flicker.

Some electronic devices such as PCs, televisions and PLCs may not be able to tolerate voltage flicker as well as others. While some devices can ride through minor flicker incidents, others may lock up or suffer component failure.

*As an example, consider a 5 HP motor supplied by a 208 V feeder that also supplies 120 V lighting circuits (Figure 7-4).*

Assume:

- 5 HP motor
- Full Load Amps = 16 A
- Starting current = 96 A
- Feeder impedance = 0.06  $\Omega$

Calculate Feeder Voltage Drop:

$$\begin{aligned} \text{Voltage Drop Along Feeder} &= \text{Starting current (A)} \\ &\times \text{Feeder Impedance } (\Omega) \\ &= 96\text{A} \times 0.06 \Omega \\ &= 6 \text{ V} \end{aligned}$$

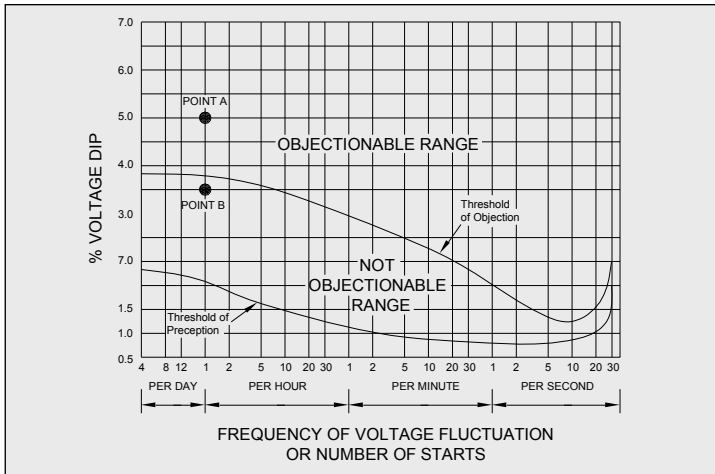

**Figure 7-4: Voltage Flicker Curve - Example**

The 6 V drop along the feeder is equal to 5% of the voltage on the 120 V lighting circuit and causes a noticeable flicker.

59

If the motor is started once every hour then the point on the flicker curve is in the objectionable range (point A).

To correct this problem, the lighting circuits can be supplied from a separate feeder, or the voltage drop along the feeder can be reduced. In this case, a drop of 3.6% or less is not objectionable.

Supplying the lighting from a different feeder or upgrading the feeder is one approach that is often used.

A reduced voltage starter for the motor is another alternative and is often a very cost effective solution.

## 7 Motor Selection

If the starting current is limited to 70% of its normal value by use of a reduced voltage starter, the voltage dip is 3.5% ( $70\% \times 5\%$ ) and the motor starting once per hour is not objectionable (Point B).

### b. Motor Considerations

#### 3-Phase Motor

##### **Induction Motor Selection**

Wound rotor induction motors operate on the same principles as the squirrel cage motor, but differ in rotor construction. They are considered the workhorse of the industry because of their relatively low cost, high availability, and minimal maintenance requirements.

60

3-phase squirrel cage induction motors, in the 1 to 200 HP range, are specified by their design type: A, B, C, D, and E.

These standard designs are suited to particular classes of applications based on the load requirements typical of each class.

Wound rotor induction motors are useful in some applications because their rotor circuits can be altered to give the desired starting or running characteristics; however, they require brush servicing maintenance.

Table 7-3 can be used to help determine which design type should be selected.

Design B motors are by far the most common and satisfy virtually all applications, except where high starting torque or high peak loads are encountered.

Design A is rarely used in new applications, as the starting current is higher than design B for virtually the same starting torque. Design A is included here for completeness only.

**Table 7-3: Induction Motor Selection**

Classification	Starting Torque (Percent Rated Load Torque)	Breakdown Torque (Percent Rated Load Torque)	Starting Current	Slip	Typical Applications
Design A and B Normal starting current	100-200%	200-250%	Normal	<5%	Fans, blowers, centrifugal pumps and compressor, etc., where starting torque requirements are relatively low.
Design C High starting torque and normal starting current.	200 – 250%	200-250%	Normal	<5%	Conveyors, crushers, string machines, agitators, reciprocating pumps and compressors, etc., where starting under load is required.
Design D High starting torque and slip.	275%	275%	Low	>5%	High peak loads with flywheels such as punch presses, shears, elevators, extractors, winches and hoists, oil-well pumping and wiredrawing machines.
Wound rotor	Any torque up to the breakdown value	225-275%	Depends on starting torque.	Depends on Rotor resistance	Where high starting, or limited (2:1) speed are required and where high inertia loading must be accelerated.

## Synchronous Motor Selection

A synchronous motor is sometimes selected instead of an induction motor because of its operating characteristics. It is significantly more expensive and only used if it can be justified by the following considerations:

### Speed

Synchronous motors operate at synchronous speed with no speed drop over the load range. They should be selected if exact speed is required.

### Power Factor Correction

Synchronous motors can generate reactive power to correct poor supply system power factor while delivering mechanical power. When supplying reactive power they are said to be operating at a leading power factor.

### Lower Operating Costs

Synchronous motors are often more energy efficient than induction motors, especially in the larger horsepower ranges.

*General rule of thumb: If the horsepower requirement exceeds the motor speed (in RPM), then a synchronous motor should be selected.*

## Direct Current Motor Selection

DC motors are often selected where precise speed control is required, as DC speed control is simpler, less costly and spans a greater range than AC speed control systems.

## 7 Motor Selection

Where very high starting torque and/or high over-torque capability is required, DC motors are often selected.

They are also appropriate where equipment is battery powered.

### Single Phase Motor

Single-phase motors are selected according to the type of load or application for which they are intended. Table 7-4 lists motor types, characteristics and typical uses for single-phase motors.

**Table 7-4: Single Phase Motor Selection**

Type	Typical RPM	Starting Torque as Percent of Full-Load Torque	Comparative Efficiency	Typical Applications
Shaded Pole	1050, 1550, 3000	Very Low 50-100%	Low	Small directdrive fans and blowers.
Permanent Split Capacitor (PSC)	825, 1075, 1625	Low 75-150%	Moderate	Directdrive fans and blowers
SplitPhase	1140, 1725, 3450	Low to Moderate 130-170%	Moderate	Belt-drive and directdrive fans and blowers, small tools, centrifugal pumps, and appliances
Capacitor-Start	1140, 1725, 3450	Moderate to High 200-400%	Moderate to High	Pumps, compressors, tools, conveyors, farm equipment, and industrial ventilators

### c. Driven Load Considerations

For a motor to drive a load properly, it must produce enough torque to accelerate from standstill to operating speed, and it must supply enough power for all possible demands without exceeding its design limits.

For example, a motor with inadequate starting torque for the connected load will either not turn or will act sluggishly during acceleration. The starting current may persist for too long and consequently trip overload protection. While running, an undersized motor may stall if the load suddenly increases (e.g. too many sheets fed into a paper shredder).

To specify the motor properly, certain characteristics of the load should be considered.

*If replacing an existing motor is considered, monitoring the power input to the motor over a period of time will determine an optimum size. Inexpensive battery powered data loggers work well for load trending.*

Motors must be sized to accommodate the running load's speed and torque requirements. Load types can be classified into different duty cycles describing operating time and load variations.

Higher efficiency motors have less slip and spin faster than older motors of the same power rating. Consideration should be placed on the effect of a speed change to the process, especially with centrifugal equipment, as the increased speed would create unintended issues.

## 7 Motor Selection

There are three general classifications of duty cycle that describe most motor loads: continuous, repetitive and intermittent duty.

### Continuous Duty – Torque Constant

The majority of motor applications are continuous duty.

This cycle has essentially a constant motor load for an indefinitely long period of time.

*Size motors for the horsepower requirement of the continuous load.*

### Repetitive Duty Cycle – Variable Torque

This motor application has various loads that are well defined and repeating. *For example, a plastic injection-moulding machine.*

For repetitive duty cycle loads, the motor rating is determined from the root-mean-square or RMS horsepower.

The RMS horsepower is calculated by the following equation:

$$HP_{RMS} = \sqrt{\frac{\sum HP^2 t}{\sum t}}$$

The RMS horsepower is the square root of the sums of the horsepower squared, times the time interval; divided by the sums of the time intervals.

For example, consider the following horsepower-time curve (Figure 7-5).

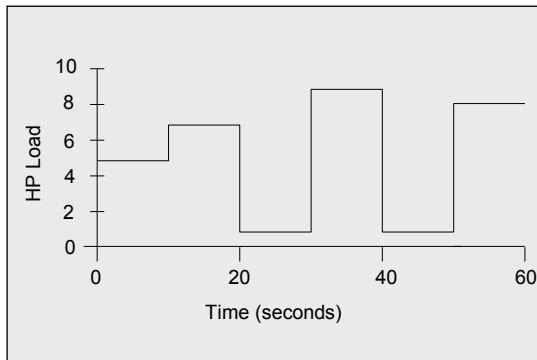

**Figure 7-5: Repeating Duty Cycle Curve**

For this load, the time interval and load are detailed in the following table.

**Table 7-5: Repetitive Duty Cycle Example**

Time (sec)	0 - 10	10-20	20-30	30-40	40-50	50-60
Load (HP)	5	7	1	9	1	8
HP <sup>2</sup> t	250	490	10	810	10	640

The RMS horsepower is calculated as:

$$HP_{RMS} = \sqrt{\frac{\sum 250 + 490 + 10 + 810 + 10 + 640}{\sum 10 + 10 + 10 + 10 + 10 + 10}} = 6.07$$

## 7 Motor Selection

*The next higher standard rating, a 7.5 HP motor, would be the appropriate choice since 6.07 HP motors aren't available.*

### Intermittent Duty

This cycle alternates between indefinite intervals of load and no-load; load and rest; or load, no-load and rest. An example of intermittent duty would be a *garage door opener*.

Select the motor so the horsepower rating of the motor matches the loaded power requirement.

### d. Speed

Motor selection is also dependent upon the speed requirements. The application must be evaluated to determine if it is constant speed, multi-speed, or adjustable speed.

Examples of each are listed below.

Constant speed Example – vent fan.

Multi-speed Example – furnace fan.

Adjustable speed Example – transmission free washing machine.

## e. Starting and Stopping

Motor selection should be dependent upon the following as well:

1. Frequency of starting and stopping. For frequent starts, ensure winding and core temperature do not exceed motor rating.
2. Starting torque requirement. Pay special attention to high inertia loads to ensure motor starting torque is adequate.
3. Acceleration restrictions. Ensure the motor driving the load reaches full speed quickly enough to avoid tripping the overload protection. Conversely, some loads require time to accelerate to full speed (e.g. a conveyor belt) – a variable speed drive may be justified to achieve this and keep current lower when starting up.

## f. Custom Motors

Manufacturers' lines of "standard" motors offer models that suit most applications. Standard motors are less expensive, have proven engineering and are available on shorter lead times. However, motors can be ordered with a myriad of variations to fit special applications where a standard motor is not suitable. Each motor supplier can provide specific information on availability lead-time and price.

### g. Environmental Factors

#### Usual Service Conditions

Motor ratings apply to motors operating under usual service conditions.

NEMA Standard MG-1 2011 specifies usual environmental conditions as:

1. Exposure to an ambient temperature in the range of 0°C to 40°C; when water-cooling is used, in the range of 10°C to 40°C.
2. Exposure to an altitude that does not exceed 3300 feet (1000 metres).
3. Installation on a rigid mounting surface.
4. Installation in areas or supplementary enclosures that do not seriously interfere with the ventilation of the machine.

#### Unusual Service Conditions

NEMA Standard MG1-2011 advocates consulting the manufacturer or section 14.3 if the motor is to be operated in unusual service conditions.

## h. Physical Factors

### Enclosure

The enclosure for the motor should be chosen to protect it from the expected operating environment.

Table 7-6 lists standard enclosures as specified by NEMA.

**Table 7-6: Standard Motor Enclosures**

<b>Types</b>	<b>Characteristics</b>
Open:	
Drip-proof (ODP)	Operate with dripping liquids up to 15' from vertical
Splash-proof	Operate with splashing liquids up to 100' from vertical
Guarded	Guarded by limited size openings (less than $\frac{3}{4}$ in.)
Semi-guarded	Only top half of motor guarded.
Drip-proof fully guarded	Drip proof motor with limited size openings.
Externally ventilated	Ventilated with separate motor driven blower, can have other types of protection.
Pipe ventilated	Openings accept inlet ducts or pipe for air-cooling.
Weather protected type 1	Ventilating passages minimize entrance of rain, snow, and airborne particles. Passages are less than $\frac{3}{4}$ in. in diameter.
Weather protected type 2	Motors have in addition to type 1, passages to discharge high-velocity particles blown into the motor.

Types	Characteristics
<b>Totally enclosed:</b>	
Non-ventilated (TENV)	Not equipped for external cooling.
Fan-cooled (TEFC)	Cooled by external integral fan.
Explosion-proof (TEXP)	Withstands internal gas explosion. Prevents ignition of external gas.
Dust-ignition-proof	Excludes ignitable amounts of dust and amounts of dust that would degrade performance.
Waterproof	Excludes leakage except around shaft.
Pipe-ventilated	Openings accept inlet ducts or pipe for air-cooling.
Water-cooled	Cooled by circulating water.
Water to air-cooled	Cooled by water-cooled air.
Air-to-air cooled	Cooled by air-cooled air.
Guarded TEFC	Fan cooled and guarded by limited size openings.
Encapsulated	Has resin-filled windings for severe operating conditions.

## Mounting and Base Considerations

Motors are generally mounted horizontally with feet attached to the floor, but other arrangements are common:

- Wall mounted
- Ceiling mounted
- Pedestal mounted
- Face mounted
- Flange mounted

The size and length of the shaft can be specified if the standard shaft types or materials are not suitable for the required mounting arrangement or machine configuration.

## Insulation

Insulation systems are rated by standard NEMA (National Electrical Manufacturers Association) classifications according to maximum allowable operating temperatures as seen in Table 7-7.

**Table 7-7: Maximum Operation Temperature Allowed**

Temperature Tolerance Class	Max. Operation Temperature Allowed		Allowable Temp. Rise @ Full Load (SF=1.0)	Allowable Temp. Rise (SF=1.15)
	°C	°F		
A	105	221	60	70
B	130	266	80	90
F	155	311	105	115
H	180	356	125	-

Class A is an older obsolete classification. Class B is the current standard.

Class F and H are used for higher temperature applications and are often available as “standard” from many motor manufacturers.

## 7 Motor Selection

As a general rule of thumb, motors should not operate at temperatures above their rated maximum. For each 10 °C rise above the rated maximum temperature, the life span of the motor could be reduced by half.

Figure 7-6 shows the relationship between insulation life and winding temperature for each insulation class.

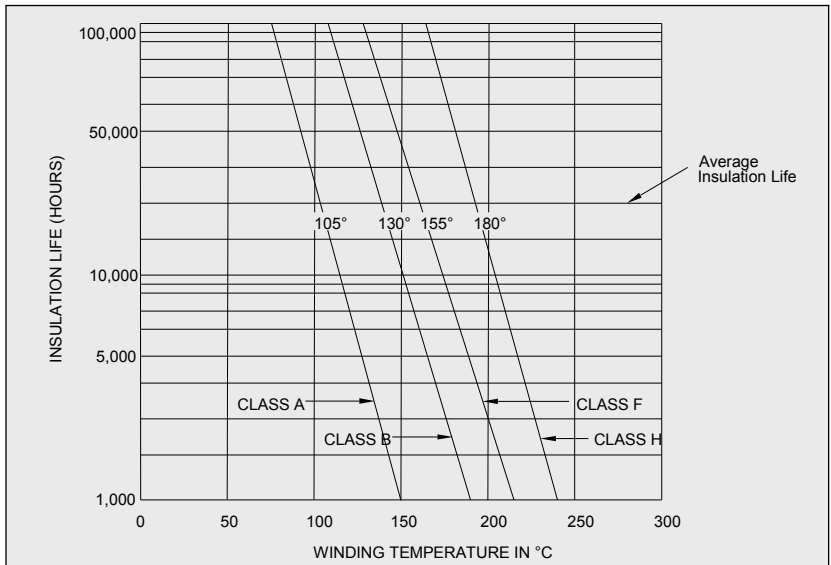

**Figure 7-6: Insulation Life vs. Temperature**

### Service Factors

Motor service factor is an indication of the ability to exceed the mechanical power output rating on a sustained basis. A service factor of greater than 1.0 allows for a period of peak horsepower demand. This service factor eliminates the need to

select the next larger motor size. At an ambient temperature of 40 °C, the standard service factor for integral HP motors up to 200 HP is 1.15.

Motor efficiency is usually reduced during operation at the service factor rating.

Service factors for higher temperatures or high altitude (>3,300 feet) can often be specified where required.

## Noise

If a motor is applied in an area where noise levels are of concern, motors equipped with plain bearings and specially designed ventilation systems are available. Plain bearings are quieter than roller or ball bearings.

*If noise is a real issue, there are many active and passive technologies available to substantially reduce audible noise. Motors inherently have repetitive noise emissions and therefore lend themselves to noise cancelling techniques.*

*Producing an equal and opposite phase waveform of the noise effectively cancels or substantially reduces motor noise. Noise cancelling headphones for air passengers use these techniques to effectively block out engine noise.*

## i. Efficiency and Economics

When selecting a motor for a particular application, both its capital cost and the cost of energy for operation should be considered.

### Energy Costs

The cost of electricity to run a motor for one year can easily exceed the purchase price of the motor.

Figure 7-7 shows the operating cost for a typical standard efficiency 20 HP motor operating for one year at 88% efficiency.

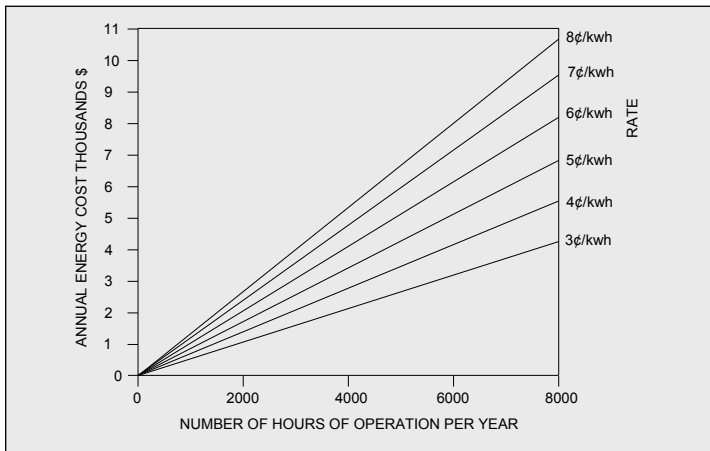

**Figure 7-7: Annual Operating Costs of a 20 HP Motor**

*Since the operating cost over the life of a motor is often many times its purchase price, small differences in motor efficiency can yield significant savings.*

## Motor Efficiency

The efficiency of a motor is the ratio of mechanical power output to the electrical power input and is usually expressed as a percentage.

$$\text{Efficiency} = \frac{\text{Output}}{\text{Input}} \times 100 = \frac{\text{Input} - \text{Losses}}{\text{Input}} \times 100$$

Electric motors are generally efficient devices, but with enhanced materials and improved design they can operate with fewer losses. These are referred to as energy efficient motors because they produce the same mechanical output power using less electrical input power than a standard motor.

Motors can experience losses, whereby they consume electrical energy but do not contribute useful mechanical energy output.

Losses occur in five areas:

- Core losses
- Stator losses
- Rotor losses
- Friction and windage
- Stray load losses

The breakdown of these losses, and their associated percentages, can be seen in Figure 7-8: Motor Losses.

## 7 Motor Selection

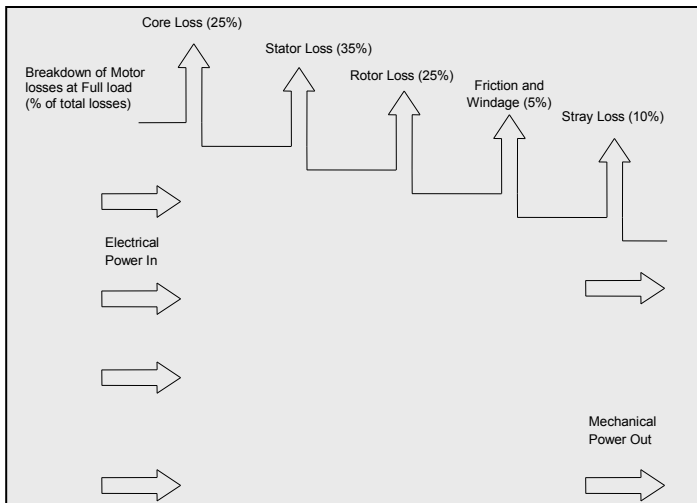

**Figure 7-8: Motor Losses**

78

Core losses are comprised of hysteresis losses (the energy required to magnetize the core) and eddy current losses in the stator core (magnetically induced circulating currents). Core losses make up about 25% of the total losses.

Stator losses are due to the  $I^2R$  heating effect of current flowing through the resistance of the stator windings. They account of approximately 35% of the total.

Rotor losses are caused by the  $I^2R$  heating effect in the rotor. Rotor losses are responsible for about 25% of the total.

Friction and windage losses include bearing friction, wind friction on the rotor assembly, and the motor's cooling fan load. They make up about 5% of the total.

## Efficiency and Motor Sizing

The efficiency of induction motors varies with load.

Peak efficiency occurs between about 60% and 100% of full load depending on design, and drops significantly below about 30% of full load (Figure 7-9).

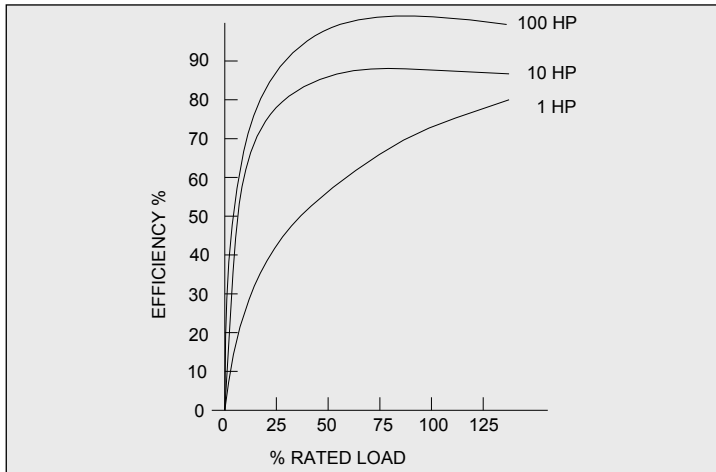

**Figure 7-9: Typical Motor Efficiency vs. Load**

Good engineering practice dictates slightly over-sizing a motor for the following reasons:

- To allow for an increase in production
- To accommodate load fluctuations and overloads
- To accommodate the increase in load as the driven load wears
- To increase motor operating life due to lower winding temperatures

## 7 Motor Selection

Sizing a motor for operation at about 75% of full load provides what is generally considered to be a reasonable margin. A service factor of 1.15 allows an additional 15% margin over full load to accommodate short-term peak load conditions.

Induction motors should not be grossly oversized (<50% load) as the initial cost and energy costs are greater and the power factor and efficiency are lower.

### Life Cycle Cost

An electric motor can consume up to ten times its purchase cost annually over its lifetime, which can range from 15 to 25 years or more.

Improvements in efficiency can result in substantial savings in life cycle cost which includes the capital and operating costs.

80

$$\text{Life Cycle Cost} = C + E_T + M$$

Where:

C = initial capital cost plus installation

$E_T$  = total energy cost = Hr/yr x \$/kWh x avg. kW x years

M = total maintenance cost = annual \$ x years

More complex calculations include discount factors, inflation, energy price increases etc., all brought back to a present value. However, since energy is the most significant factor in lifecycle cost, simple comparisons can be quickly made using this formula.

*For example, a 10 HP motor operates 50% of the time at an average output of 7.5 HP. Its efficiency is 88%. Purchase price is \$700 and installation is \$100. The motor is expected to last 10 years and cost \$30/year to maintain. Electricity price is \$0.05/kWh.*

*Energy consumption would be as follows:*

$$C = 700 + 100$$

$$E_T = 8,760 \times 0.5 \left( \frac{7.5 \times 0.746}{0.88} \right) \times 0.05 \times 10$$

$$M = 30 \times 10$$

$$\text{Life Cycle Cost} = 800 + 13,924 + 300 = \$15,024$$

*Performing the same calculation for an energy efficient motor (93%) that costs \$150 more to buy, but has the same installation and maintenance costs, would yield a lifecycle cost of \$14,425, a saving of \$599.*

## Motor Loss Reduction

Reducing the resistance of the windings minimizes stator and rotor  $I^2R$  heating losses. This is achieved by increasing cross sectional area, using higher conductivity materials or both.

Core losses are reduced by employing high-grade steel in the core laminations. This is generally achieved by increasing the silicon content of the steel.

Thinner core laminations result in lower eddy core losses.

## 7 Motor Selection

Increasing the cross sectional area of the stator and rotor lead to lower magnetic flux levels and thus lower hysteresis losses.

Frictional losses are reduced with the use of smaller or better bearings.

Windage losses are minimized by using smaller fans. Even so, energy efficient motors usually run cooler than standard motors.

### Energy Efficient vs. Standard Motors

Typical energy efficient motors are generally 1.5% to 8% more efficient than their standard motor counterparts with efficiency gains as high as 12% in the 1 HP range (Figure 7-10).

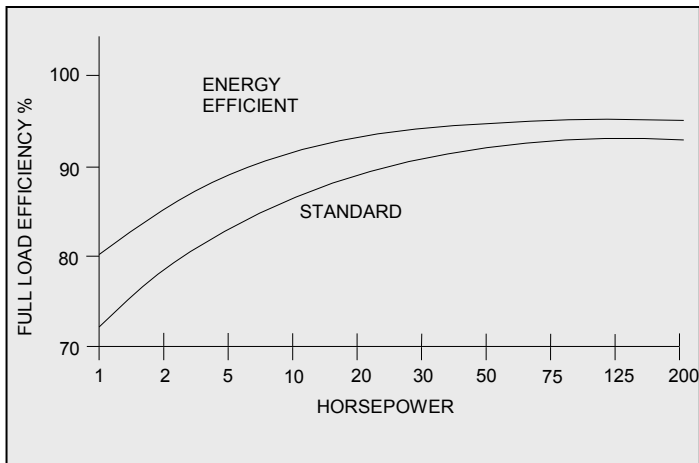

**Figure 7-10: Typical Efficiencies of Standard and Energy Efficient Motors**

There is quite a variation among different manufacturers as to how the qualitative terms “High Efficiency,” “Premium Efficiency,” and “Energy Efficient” are applied to 3-phase induction motors. CSA Standard C390 (2010) states that an energy-efficient 3-phase induction motor is a motor rated from 1 to 200 HP, for which the nominal efficiency rating, at 75% or 100% of the rated load, is equal to or greater than the efficiency values shown in

Table 7-8. CSA C390 is the recognized standard in Canada.

Other efficiency rating standards are described in the following paragraphs, including NEMA’s voluntary premium efficiency program.

**Table 7-8: CSA Minimum Nominal Efficiencies  
for Energy Efficient Motors**

<b>Horsepower</b>	<b>5</b>	<b>7.5</b>	<b>10</b>	<b>15</b>	<b>20</b>	<b>25</b>	<b>30</b>
<b>ODP 1200rpm</b>	87.5	88.5	90.2	90.2	91.0	91.7	92.4
<b>TEFC 1800rpm</b>	87.5	89.5	89.5	91.0	91.0	92.4	92.4
<b>Horsepower</b>	<b>40</b>	<b>50</b>	<b>75</b>	<b>100</b>	<b>125</b>	<b>150</b>	<b>200</b>
<b>ODP 1200rpm</b>	93.0	93.0	93.6	94.1	94.1	94.5	94.5
<b>TEFC 1800rpm</b>	93.0	93.0	94.1	94.5	94.5	95.0	95.0

## Efficiency Ratings

Standardized tests are used to establish motor efficiency and performance.

Manufacturers use a dynamometer that loads the motor and measures the input and output power to test for efficiency.

## 7 Motor Selection

There are three distinct standards commonly used to measure motor efficiency:

- CSA C390 (IEEE 112 method B)
- IEC 34-2 (British BS-269)
- JEC-37

There are some differences among these three methodologies, but the main difference is in the determination of stray load losses (Ref.18).

IEEE 112 Method B determines the stray load losses through an indirect process. The IEC standard assumes stray load losses to be fixed at 0.5% of input while the JEC standard assumes there are no stray load losses. Therefore, motor efficiencies determined by different standards are not comparable. Differences can be 5 percentage points or more.

84

Generally, CSA C390 (IEEE 112 Method B) is considered to be the most accurate method. Future harmonization among standards is likely, but will take time to implement.

NEMA has implemented a voluntary program that permits manufacturers to label their motors as “Premium Efficiency” if they meet or exceed minimum levels set by NEMA (NEMA Premium™, MG-1 2011 voluntary standard is applicable to motors of 1 to 500 HP). Table 7-9 illustrates the advantage of premium efficiency over an energy efficient motor, in terms of energy savings, for a selection of motors.

**Table 7-9: What Is an Extra Percentage Point of Motor Efficiency Improvement Worth?**

Horsepower	Motor Efficiency at 75% Load		Annual Savings	
	Energy Efficient Motor	Premium Efficiency Motor	Annual Energy Savings, kWh	Dollar Savings, \$/year
10	92.2	93.2	520	40
25	93.8	94.8	1260	100
50	95.0	96.0	2455	195
100	95.3	96.3	4875	390
200	96.2	97.2	9575	765

*Based on operation of an 1800 RPM TEFC motor with an efficiency 1.0% higher than that of a typical premium efficiency motor with 8000 hr/year operation at 75% load at \$0.08/kWh. Source - Motor Systems Tip Sheet #2, November 2012, US DOE Publication (Ref.21).*

In Canada, induction motors between 1 and 200 HP sold after 1998 must meet the minimum efficiency standards set in the CSA Standard CAN/CSA-C390-2010. Such motors are called EPAct motors.

## 7 Motor Selection

The requirements for small motor energy efficiencies can be found in the following documents:

- IEC60034-30-1 (March 2014)
- DOE Small Motor Rule (March 2015)
- Amendment 14 to Canada's Energy Efficiency Regulations

In recognition that motors are often part of an OEM piece of equipment, minimum efficiency requirements are being set (e.g. EER for air conditioners). This assures that the manufacturer will optimize overall efficiency in their design.

When comparing motor efficiencies, the comparison should be based on the “Nominal Efficiency” of the motor using one of the above test methods.

86

*Free software is available on-line to help in selecting energy efficient motors.*

In Canada, “**CanMOST**” (Ref.7) is a reliable program to use. CanMost was derived from “**IMSSA**” (International Motor Selection and Savings Analysis) software, an international version of the successful **MotorMaster+**, developed by the U.S. motor energy-management software Washington State University Extension Energy Program (see recommended weblinks at the end of the guide). The software is easy to use, comprehensive and up to date with present motors.

CanMOST's database is comprised of:

- Data on 25,000 North American motors
- The European Database of Efficient Electric Motor Systems (EuroDEEM), with 18,000 European motors
- Data on some 575 volt motors that are available only in Canada

## Selecting Energy Efficient Motors

Because energy efficient and premium efficiency motors use more and stronger materials, they are also more expensive.

Premium efficiency motors should be selected when the cost premium over an energy efficient motor is recovered through reduced operating costs over a reasonable period of time.

Applications with high annual running hours and average to high loading are good candidates for energy efficient motors.

The operating cost of an electric motor can be calculated by knowing the horsepower rating of the motor, the motor loading, annual hours of operation and the blended electricity rate. The “blended” rate is an average electrical rate that takes into account both the demand and energy charge. The simplest method of obtaining a blended rate is to divide the total electric bill by the kWh consumed during the billing period. The resultant \$/kWh provides a ballpark number for comparative purposes.

*Utility billings can vary significantly and the number of line items can include kW demand, power factor, time of use, debt*

## 7 Motor Selection

*retirement charges, etc. An infrequently used motor operated coincidentally with the customer's peak could have a significant impact on the operating cost in terms of \$/hour of operation due to the resultant peak demand charges which would overshadow the \$/kWh charge.*

$$\text{Operating Cost} = \frac{0.746 \times \text{HP} \times \text{Loading} \times \text{Operating Hours} \times \text{Rate}}{\text{Motor Efficiency}}$$

If the actual motor loading is not known, an estimate of 65% can be used.

Motors with different efficiencies can be compared on an economic basis by calculating the annual operating costs and comparing these savings to the price differential between the motors.

The most common economic analysis used for electric motors is a simple payback analysis.

$$\text{Simple Payback} = \frac{\text{Price Premium}}{\text{Annual Electrical Savings}}$$

*For example, if a premium efficiency motor cost \$400 more than a standard motor and is expected to save \$300 per year in electricity, the simple payback would be  $400/300 = 1.33$  years.*

*Companies generally accept a payback in the range of 1 to 2 years or less. Longer paybacks may still be acceptable for other users including homeowners.*

Another way to estimate savings is as follows:

$$\text{\$Saving Per Year} = A \times 0.746 \times B \times C \times \left( \frac{1}{D} - \frac{1}{E} \right) \times F \times 100$$

Where:

- A=Motor Nameplate Horsepower
- B=Total Dollar Cost Per Kilowatt
- C=Hours Run Per Year
- D="Standard" Motor Efficiency-%
- E="Premium" Motor Efficiency-%
- F=Load Factor (avg. load HP/nameplate HP)

Therefore, if a 40 HP, 94.5% premium efficiency motor operating at 75% of rating for 6000 hours per year, the annual savings compared to a standard 89% efficient motor will be:

$$\begin{aligned} 40 \times 0.746 \times 0.05 \times 6,000 \times \left( \frac{1}{89} - \frac{1}{94.5} \right) \times 0.75 \times 100 \\ = \$439 \text{ savings per year} \end{aligned}$$

Annual savings will increase in proportion with electricity price, running hours per year, and load factor.

### Assessing Existing Motor Inventory

Taking an inventory of existing motors can form the basis for an efficiency improvement plan. Sizes, type, duty cycle, and loading are all important factors to record. The motor's history including previous rewinds (if known) should be recorded. Monitoring motors with high running hours helps establish optimum sizing.

## 7 Motor Selection

The largest motors with high duty cycles should be scrutinized for energy efficient replacements. Substantially oversized motors would also be likely candidates if the run time justifies the change. Previously repaired motors with high run times should be tested for efficiency using a dynamometer or equivalent means.

Such testing would be limited to very large motors for economic reasons. Armed with this information, sound business cases can be developed to compete for capital improvement funding.

Having a motor inventory helps in deciding whether to buy new or to repair a failed motor. Older small motors are typically not worth repairing given the higher efficiency products available for their replacement.

### Power Factor Issues

Motor power factor also drops significantly below 75% load (Figure 7-11). A lightly loaded motor will typically have a poorer power factor, resulting in a higher kVAR input than a motor more closely matched to the load.

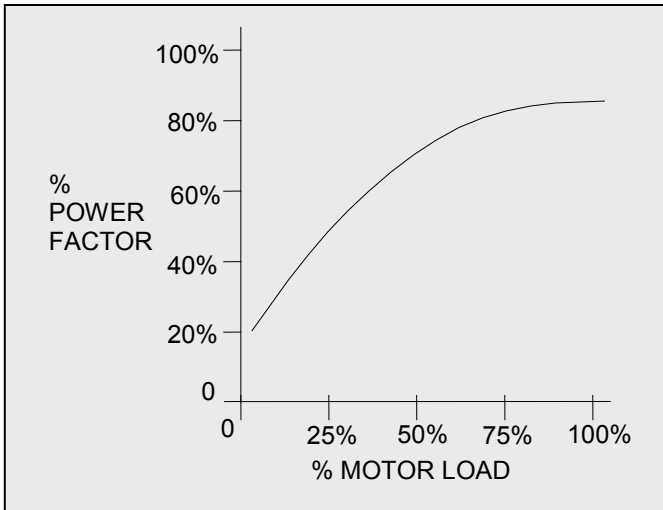

**Figure 7-11: Typical Power Factor vs. Load<sup>2</sup>**

Therefore, if you are being billed in kVA, your cost of running the motor will be more than the work (kW) it is doing at 50%.

---

<sup>2</sup> Note: Power Factor can vary with motor size and design as well as load.



## 8 MOTOR CONTROLS

---

There are four major motor control topics:

- Motor Protection
- Starting
- Stopping
- Speed Control

### a. Motor Protection

Motor protection safeguards the motor, the supply system and personnel from various upset conditions of the driven load, the supply system or the motor itself. Motor protection can be provided by the following common mechanisms: a disconnect device, an overcurrent protection, and an overload protection. The other forms of protection include low voltage protection, phase reversal protection, and ground fault protection.

93

#### Disconnect Device

A suitable disconnect device of sufficient capacity is required usually within sight of the motor, in accordance with Canadian Electric Code requirements. The purpose is to open the supply conductors to the motor, allowing personnel to work safely on the installation.

#### Overcurrent Protection

Overcurrent protection interrupts the electrical supply in the event that there is excessive current demand on the supply system. Usually in the form of fuses or circuit breakers, these

## 8 Motor Controls

devices operate when a short circuit or a very heavy overload occurs.

*Usually there is a reason for the activation (trip) of the motor overcurrent protection. Investigate repeated tripping thoroughly and avoid increasing the trip setting level until it can be confirmed the motor can safely tolerate a higher setting. Operating currents should be measured on all 3 phases to ensure the phases are balanced and the motor is not running constantly in an overloaded condition.*

### Overload Protection

Overload protection safeguards the motor from mechanical overload conditions.

Four common overload protection devices are:

- Overload relay
- Thermal overload relay
- Electronic overload relay
- Fuses

An **overload relay** operates on the magnetic action of the load current flowing through a coil. When the load current becomes too high, a plunger is pulled up into the coil, interrupting the circuit. The tripping current is adjusted by altering the initial position of the plunger with respect to the coil.

A **thermal overload relay** uses a heater connected in series with the motor supply. The amount of heat produced increases with supply current. If an overload occurs, the heat produced causes a set of contacts to open, interrupting the circuit. Installing a

different heater for the required trip point changes the tripping current. This type of protection is very effective because the heater closely approximates the actual heating within the windings of the motor, and has a “memory” to prevent immediate reset and restarting.

With **electronic overloads**, the load current is sensed and the heating effect on the motor is computed. If an overload condition exists, the sensing circuit interrupts the power circuit. The tripping current can be adjusted to suit the particular application. Electronic overloads often perform additional protective functions, such as ground fault and phase loss protection.

**Fuses** can also be used to protect a motor, provided some that form of single phasing protection is also used to prevent motor operation if only one fuse blows.

### Other Protection

Low voltage protection operates when the supply voltage drops below a set value. The motor must be restarted upon resumption of normal supply voltage.

Low voltage release interrupts the circuit when the supply voltage drops below a set value, and re-establishes the circuit when the supply voltage returns to normal. Phase failure protection interrupts the power in all phases of a 3-phase circuit upon failure of any one phase. Normal fusing and overload protection may not adequately protect a 3-phase motor from damaging single-phase operation. This is a particularly critical issue for motors supplied by a delta configuration voltage. Without this protection, the motor will

## 8 Motor Controls

continue to operate if one phase is lost. Large negative sequence currents are developed in the rotor circuit, causing excessive current and heating in the stator windings that will eventually burn out. Phase failure protection is the only effective way to protect a motor properly from single phasing.

Phase reversal protection operates upon detection of a phase reversal in a 3-phase circuit. This type of protection is used in applications such as elevators where it would be damaging or dangerous to have the motor run in reverse.

Ground fault protection operates when one phase of a motor shorts to ground, thus preventing high currents from damaging the stator windings and the iron core.

Other motor protection devices include bearing and winding temperature monitors, current differential relays, and vibration monitoring.

*Generally, the level of protection used will rise in proportion with the value of the motor. Therefore, motors less than 20 HP will not normally have anything more than overload and overcurrent protection, unless the motor is driving a critical process.*

### b. Motor Starting

Induction motor starters must supply the motor with sufficient current to provide adequate starting torque under worst-case line voltage and load conditions.

## 3-Phase Motor Starters

Many types of 3-phase starters are available, such as:

- Manual (or across-the-line)
- Magnetic
- Reduced voltage
- Primary resistance
- Autotransformer
- Solid state
- Wye-delta
- Variable speed drive
- Part winding
- Power factor controller

Each of these starters will be discussed in detail in the following sections.

### **Manual or Across-the-Line Starters**

An across the line starter is the least expensive option and is usually used for induction motors (Figure 8-1). All NEMA design induction motors up to 200 HP, and many larger ones, can withstand full induction starts.

Manual starters are often used for smaller motors – up to about 10 HP. They consist of a switch with one set of contacts for each phase and a thermal overload device. The starter contacts remain closed if the power is removed from the circuit and the motor restarts when power is reapplied.

*If there is a chance of injury from a motor restarting unexpectedly, a magnetic starter should be used instead.*

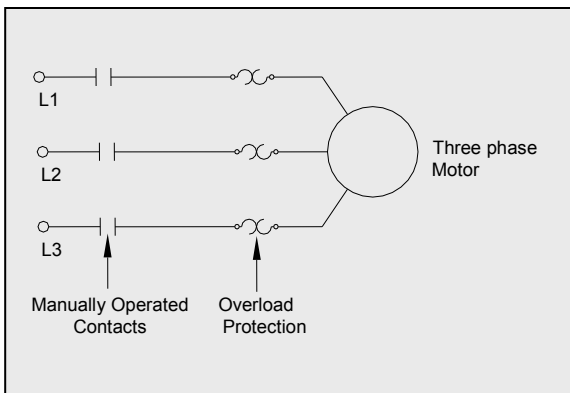

**Figure 8-1: Manual Starter**

### Magnetic Starters

98

Magnetic starters are used with larger motors or where remote control is desired (Figure 8-2). The main element of the starter is the contactor, which is a set of contacts operated by an electromagnetic coil. Energizing the coil causes the contacts to close, allowing large currents to be initiated and interrupted by a control signal. The control voltage does not need to be the same as the motor supply voltage, and is often low voltage, allowing the start and stop controls to be located away from the power circuit.

*A fuse protected step-down transformer is often used for higher voltage motors. In addition to start and stop functions, the low voltage supply can also power remote status lights, etc.*

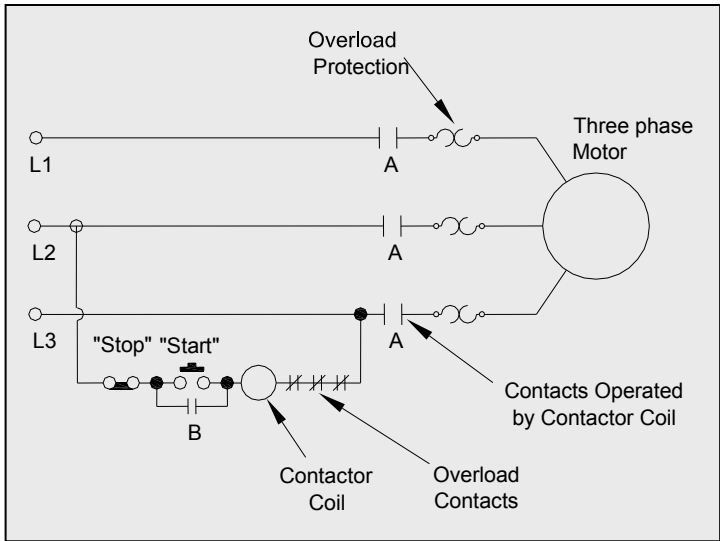

**Figure 8-2: Magnetic Starter**

Closing the starter button contacts energizes the contactor coil. An auxiliary contact B on the contactor is wired to seal in the coil circuit.

The contactor de-energizes if: 1) the control circuit is interrupted by pressing the stop button, 2) the thermal overload relay trips, or 3) if power is lost.

The overload contacts are arranged so an overload trip on any phase will cause all phases to open.

Contactors are rated for various operating voltages and are sized according to motor HP and type of duty expected.

## 8 Motor Controls

*Installing an extra Emergency RED STOP button next to a motor (or remotely) makes good sense when choosing a magnetic starter. The normally closed stop buttons are wired in series in the stop circuit such that depressing any one of them de-energizes the magnetic contactor.*

### Reduced Voltage Starters

If the driven load or the power distribution system cannot accept a full voltage start, some type of reduced voltage or “soft” starting scheme must be used. Reduced voltage starters do not save energy. They are simply intended to address starting issues such as voltage sag and mechanical protection, and can only be used where low starting torque is acceptable. (Also see Power Factor Controller).

### Primary Resistance Starters

Closing the contacts at A connects the motor to the supply via resistors that provide a voltage drop, thus reducing the starting voltage available to the motor (Figure 8-3). The resistors' value is chosen to provide adequate starting torque while minimizing starting current. Motor inrush current declines during acceleration, reducing the voltage drop across the resistors and providing more motor torque. This results in smooth acceleration.

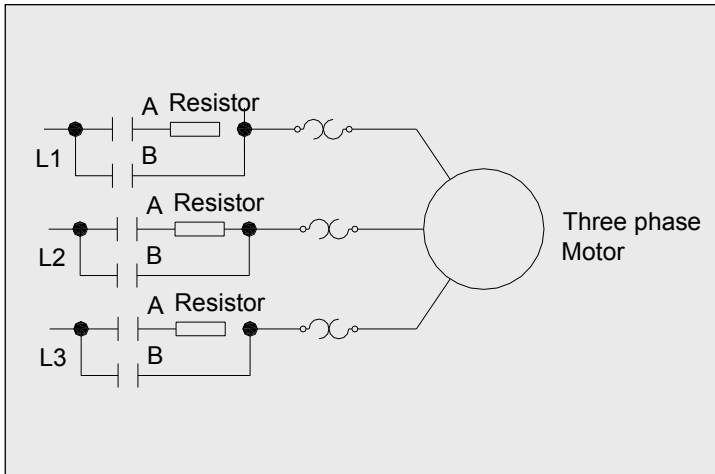

**Figure 8-3: Primary Resistance Starter**

### Autotransformer Starters

101

An autotransformer is a single winding transformer on a laminated core, with taps at various points on the winding (Figure 8-4). The taps are usually expressed as a percentage of the total number of turns and, thus, percentage of applied voltage output.

Three autotransformers are connected in a wye configuration, or two in an open delta configuration, with taps selected to provide adequate starting current.

The motor is first energized at a reduced voltage by closing contacts A.

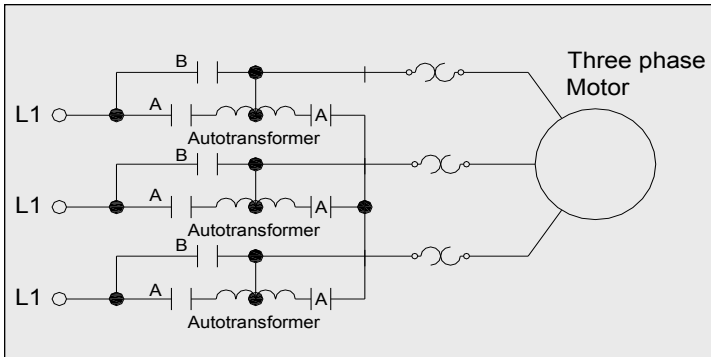

**Figure 8-4: Autotransformer Starter**

After a short time, the autotransformers are switched out of the circuit by opening contacts A and closing contacts B, thus applying full voltage to the motor. The autotransformers do not need to have high capacity as they are only used for a very short period of time.

### Solid State Starters

Solid state starters use thyristors or other solid state devices (e.g. silicon controlled rectifier, triacs, transistors, etc.) to control the voltage applied to the motor. A thyristor is essentially an electronic switch that can replace a mechanical contactor. However, unlike a mechanical contactor, a thyristor can be turned on and off at a point on the AC waveform during each cycle.

For a 60-cycle AC, this can be 120 times per second per phase (i.e. on-off cycle per half cycle). Reducing the ON time during each cycle has the effect of reducing the average voltage output to the motor. By gradually increasing the ON time, the voltage

increases gradually to full voltage. By reducing the voltage on start, current is also reduced. Start-up time tends to be longer as a result compared to a line voltage start. The starting function does not save energy, but rather addresses starting issues including voltage sag and mechanical protection.

Since the thyristors can be precisely controlled, it is possible (depending on the features of the individual starter) to limit starting current and also provide soft stopping (very useful for loads such as parts conveyors to prevent relative shifting on the belt).

Starting current and torque are easily adjusted and solid state starters often include other functions such as overload protection. A simplified solid state starter pictorial can be seen in **Figure 8-5**.

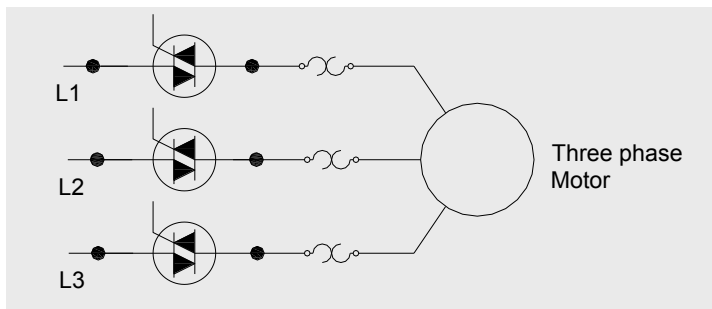
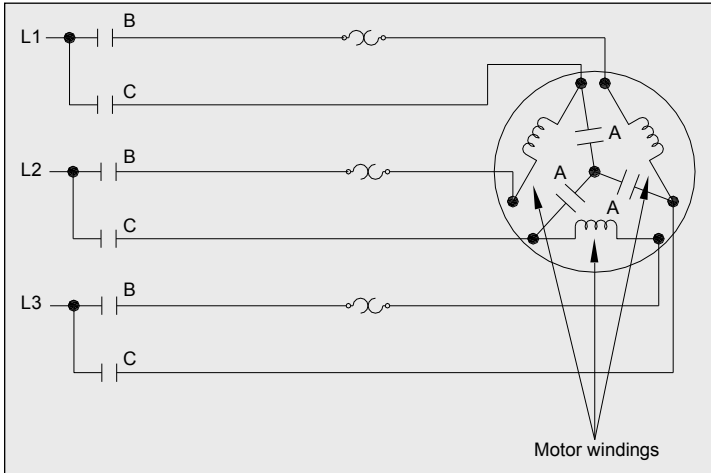

**Figure 8-5: Solid State Starter (Simplified)**

*Light dimmers use thyristors to dim lights. Turning the knob or moving the slider changes the portion of time the thyristor is turned on during each  $\frac{1}{2}$  cycle. Full brightness is achieved when the thyristor is turned on at the start of each  $\frac{1}{2}$  cycle.*

## Wye-Delta Starting

Wye-delta starting (Figure 8-6) can be used with motors where all six leads of the stator windings are available (on some motors only three leads are accessible).



**Figure 8-6: Wye-Delta Starter**

By first closing contacts A and B, the windings are connected in a wye configuration that presents only 57% of rated voltage to the motor. Full voltage is then applied by reconnecting the motor in a delta configuration by closing contacts C and opening those at A.

The starting current and torque are 33% of their full voltage ratings, limiting applications to loads requiring very low starting torque.

*This type of starter is physically large and costly, as many contactors are required to perform this task. Loads such as large chillers may employ a wye-delta starter. Solid state starters are becoming less costly and are competing with this special motor/starter arrangement.*

### **Variable Frequency Drive Starting**

Variable frequency drives (VFDs) are also an effective means of starting a motor. By accelerating the motor up to speed by ramping the frequency of the voltage applied to the motor, inrush current can be minimized while maintaining sufficient torque to drive the load. This application of VFDs does not save energy; however, variable torque applications do. More details on VFDs are discussed later in this guide.

### **Power Factor Controller**

A power factor controller (PFC) is a solid-state device which reduces voltage to the motor when the motor is lightly loaded. The magnetizing current and resistive losses are reduced in proportion to this reduction in voltage.

When the load increases, the voltage rises to normal. The reduction in voltage results in improved power factor during these low load periods.

PFCs have been produced for single and 3-phase induction motors. To save energy, the average motor load needs to be minimal for extended periods of operating

## 8 Motor Controls

time. Constant load devices such as compressors are not good candidates for PFCs if the motor has been optimally sized for the load. A table saw motor would be a potential application if the motor is operated for extended periods and the material throughput is not constant. PFCs can also provide soft starting and stopping functions.

*Originally developed by NASA in 1984, variations of PFC's have been marketed for several years. Many have been promoted to the consumer market as energy saving receptacles. While the basic concept is sound, the plugs will do little to save energy in modern appliances that have been mandated to be energy efficient. Older appliances such as refrigerators may provide modest energy savings using these devices.*

### Part Winding Starters

106

Part winding starters are sometimes used on motors wound for dual voltage operation, such as a 230/460 V motor. These motors have two sets of windings that are connected in parallel for low voltage and in series for high voltage operation.

When used on the lower voltage, energizing only one winding can start the motor. This limits the starting current and torque to approximately one half of the full voltage values. The second winding is then connected normally once the motor nears operating speed.

### Single Phase Motor Starters

Single-phase motors are typically under 10 HP. Starters range from a simple dry contact switch for small single-phase motors to magnetic contactors for larger sizes.

Solid-state starters can be used for soft start motors to limit inrush current as well as provide variable speed capability. This type of starter is particularly suited to farm applications as it permits the use of larger motors on constrained single-phase lines.

*As noted previously, magnetic starters are always recommended if safety is a concern. A simple switch may cost only a few dollars, whereas a magnetic starter may cost \$100 or more. However, this minimal cost difference may prevent a serious injury from occurring.*

## DC Motor Starters

Because the DC resistance of most motor armatures is low (0.05 to 0.5 ohms), and because the counter electric magnetic field (EMF) does not exist until the armature begins to turn, it is necessary to use an external starting resistance in series with the armature of a DC motor to keep the initial armature current at a safe value. As the armature begins to turn, counter EMF increases. Because the counter EMF opposes the applied voltage, the armature current is reduced.

As the motor comes up to normal speed and full voltage is applied across the armature, the external resistance in series with the armature is decreased or eliminated. Controlling the starting resistance in a DC motor is accomplished manually by an operator, or by any of several automatic devices. The automatic devices are usually just switches controlled by motor speed sensors (Figure 8-7).



## c. Motor Stopping

The most common method of stopping a motor is to remove the supply voltage and allow the motor and load to come to a stop. In some applications however, the motor must be stopped more quickly or held in position by some sort of braking device. The types of braking devices are: electrical, regenerative, and mechanical.

### Electrical Braking

Electrical braking uses the windings of the motor to produce a retarding torque. The kinetic energy of the rotor and the load is dissipated as heat in the rotor bars of the motor. Two means of electrical braking are plugging and dynamic braking.

Plugging brings an induction motor to a very quick stop by connecting the motor for reverse rotation while it is running. To prevent the motor from reversing after it has come to a stop, the power is removed by means of a zero speed switch.

Dynamic braking is achieved by removing the AC power supply from the motor and applying direct current to one of the stator phases.

Neither plugging nor dynamic braking can hold the motor stationary after it has stopped.

*Hand held circular and portable miter saws often employ electric braking. When the switch is released, the motor stops the spinning blade faster than if it were allowed to coast. If this feature stops working on a universal motor, check the brushes for wear and replace if necessary.*

## 8 Motor Controls

### Regenerative Braking

Regenerative braking is a means of slowing a motor to a standstill by temporarily converting it to a generator when a stop command is issued. The motor (now generator) output is dissipated through power resistors or applied to charge a battery.

*Regenerative braking is used in hybrid electric vehicles. Some of the energy is dissipated by conventional brakes, while a portion is returned to the vehicle battery. For vehicles, this arrangement is needed to give the driver better control over braking. Charge acceptance of the battery depends on its state of charge.*

### Mechanical Braking

110

Mechanical braking refers to devices external to the motor that provide retarding torque.

Most rely on friction in a drum or disc brake arrangement and are set with a spring and released by a solenoid or motor.

These devices have the ability to hold a motor stationary.

An eddy current brake is an electromechanical device that provides a retarding torque by inducing eddy currents in a drum via an electromagnetic rotor attached to the motor shaft. Altering the rotor current can control the amount of braking force.

Eddy current brakes cannot hold the motor stationary.

## d. Motor Speed Control

Motor speed control can be classified into five general types:

1. Multi-speed motors
2. Variable voltage speed control
3. Wound rotor motor control
4. DC motor control
5. Eddy current clutches
6. Variable frequency drives for induction and synchronous motors
7. Mechanical speed control
8. Advanced motors

The following section describes each of these motor speed controls.

### Multi-speed Motors

Multi-speed motors are induction motors with specially wound stators that allow the number of magnetic poles to be changed by reconnecting the windings of the motor.

Single winding multi-speed motors allow a speed ratio of 2:1. Pole changing is accomplished by reconnecting the windings, which doubles the number of poles by reversing the current in each alternate coil group. This is known as consequent pole changing.

Two winding motors can be configured for any number of poles, so other speed ratios are possible. Three speeds are possible by configuring one of the two windings for consequent pole changing. Four speeds are possible by

## 8 Motor Controls

configuring each of the two windings for consequent pole changing.

Because two winding multi-speed motors have to accommodate a second set of windings, they are often larger for a given horsepower than their single speed counterparts.

Multi-speed motors are a relatively inexpensive option where fixed and limited discrete operating speeds are acceptable. These motors are often found in applications such as ventilating fans and pumps.

Typically, multi-speed motors are not particularly efficient at reduced speed. This type of motor is therefore a poor choice for driving fans at low speed for constant air-flow applications.

An ECM would be a better choice for variable speed fans.

112

### Variable Voltage Speed Controllers

These controllers typically use Silicon Controlled Rectifiers (SCRs) to control the voltage to the motor.

Under reduced voltage, a motor will “slip” more and thus its speed will be reduced.

This control scheme is generally limited to fan applications and requires a motor with high slip rotors.

The control is imprecise and has limited application to single phase Permanent Split Capacitor (PSC) motors. These are typically found in agricultural applications up to several HP.

Variable voltage speed controllers are no longer used in industrial and commercial applications.

## Wound Rotor Motor Control

Wound rotor motors are a special type of induction motor with copper windings on the rotor, rather than typical aluminum, squirrel cage rotor bars.

Connections to these windings are available through a slip ring assembly on the shaft.

If the windings are connected as a short circuit, the motor operates like a fixed speed squirrel cage motor, but if resistance is added to the circuit the slip of the motor increases thus allowing the speed of the motor to be adjusted.

As an alternative, an electronic circuit can be used instead of resistors to reduce wasted energy. This circuit recovers the energy and feeds it back to the AC supply system, increasing the overall efficiency of the motor operation.

This motor control technique was once a popular method of speed control, but has largely been replaced by electronic VFDs.

*Higher maintenance is required for wound rotor motors. Periodic cleaning and brush replacement is needed.*

## DC Motor Control

Direct current (DC) motors are inherently variable speed machines. Speed and torque control is achieved by varying the armature voltage, the field excitation, or both.

## 8 Motor Controls

Traditionally, speed control for a DC motor came from a motor-generator, or M-G set. In an M-G set, an AC motor drives a DC generator to provide variable voltage DC for motor operation. M-G sets are large, inefficient and require a lot of maintenance.

M-G sets have now been replaced with microprocessor controlled rectifier sets, which permit simple and accurate speed control, high efficiency and reliability.

However, due to the complexity, cost and maintenance associated with a DC motor, they are seldom used in new applications. Many existing DC drive applications are being replaced with AC motors and VFDs.

New applications using DC motors and drives are usually engineered applications where AC motors and drives cannot fulfill a load requirement. An example is for traction drives where the starting torque requirements exceed that available from AC motors.

*Exercise treadmills typically use 90V DC motors whose speed is varied by a variable voltage DC controller.*

### e. Eddy Current Clutches

Eddy current clutches can be used to control standard AC squirrel-cage induction motors. However, they are low efficiency compared to VFDs and have limited applications.

An eddy current clutch has essentially three major components:

- A steel drum directly driven by an AC motor;
- A rotor with poles; and
- Windings on the poles that provide the variable flux required for speed control.

A voltage is applied to the pole windings to establish a flux and thus relative motion occurs between the drum and its output rotor.

By varying the applied voltage, the amount of torque transmitted is varied and therefore the speed can be varied.

## Variable Frequency Drives (VFDs) for Induction and Synchronous Motors

VFDs are applied when there is a need to control speed (induction and synchronous) and eliminate slip (induction).

The speed of induction motors can be adjusted by electrical and mechanical means. Variable frequency drives control motor speed electrically.

Using a VFD can improve overall energy efficiency in spite of the fact that the drive itself consumes energy. Applications where the load requirement varies over a wide range with significant part load operation make VFDs an attractive option. Overall energy savings are realized using VFDs compared to the alternative methods of varying output (e.g. fan dampers and pump throttling valves).

## 8 Motor Controls

A more comprehensive guide to VFD applications and selection can be found later in this document.

### Mechanical Speed Control

Variable speed operation of machines can be achieved by using a fixed speed motor with a mechanical speed control device. Examples include fluid couplings, adjustable pulley systems, magnetic speed control, and mechanical transmissions such as belt drives, chain drives, gearboxes, etc. An advantage of mechanical speed control devices is their lack of harmonic issues. These devices cause neither input nor output harmonics, and is thus certainly one of the reasons why they are selected over electrical speed control.

116 Mechanical methods of speed control require the motor to operate at a constant speed, where the choice of coupling alters the speed for the applied load. The efficiency of the systems is dependent on a number of factors including belt tension, type and number of belts/chains, etc. Typical mechanical methods have constant and preset speeds that cannot be dynamically adjusted to variable loads. Mechanical speed control devices typically have low efficiencies at low loads.

Mechanical speed control devices have internal losses, but these losses are usually fewer than when other means of control, such as pump throttling or fan baffling, are used. Energy savings for part load centrifugal loads can be 30% or more compared with mechanical throttling methods (Ref.14). The latter statement also applies to VFDs.

## Advanced Motors

All advanced motors allow for variable speed operation. They are now starting to be used in original equipment manufacturer applications, for instance as blower motors in high-end heat pumps and air compressors. Some advanced motors have become available as general purpose motors with ratings up to approximately 600 HP.



## 9 MAINTENANCE

---

In general, motors are very reliable machines that require little maintenance. However, it is important that preventive maintenance be performed to extend motor life and reduce the possibility of unplanned outages and lost production.

### a. Common Failure Modes

Insulation failure and bearing failure are the two most common types of motor failures and are often preventable with simple maintenance.

### b. Maintenance Frequency

The frequency or time interval between maintenance overhauls depends on a number of factors, including:

- Running hours
- Frequency of starts, plugging, or reversals
- Load
- Operating environment, temperature, or dirt
- Importance to production

Motors operating continuously under normal service conditions should, on average, be overhauled every five or six years. Motors operating under more severe conditions should be overhauled more frequently. For motors operating fewer hours, the calendar time interval can be extended accordingly.

Routine maintenance inspection and lubrication should be performed according to the manufacturer's recommendations.

## 9 Maintenance

Where no recommendations exist, Table 9-1 could be used as a suggested guide for lubrication and inspection intervals.

**Table 9-1: Frequency of Maintenance<sup>3,4</sup>**

<b>Speed</b>	<b>HP Size</b>	<b>8 Hours/Day Operation</b>	<b>24 Hours/Day Operation</b>
3600 RPM	1 - 25	5 Years	2 Years
	30 - 40	6 Months	2 Months
	>40	4 Months	2 Months
1800 RPM	1 - 20	5 Years	2 Years
	25 - 50	4 Years	1 ½ Years
	60 - 70	1 Year	4 Months
	>75	9 Months	3 Months
1200 RPM and Below	1 - 10	5 Years	2 Years
	15-30	4 Years	1 ½ Years
	>40	1 Year	4 Months

120

### c. Bearings

Two types of bearings are commonly used in motors: 1) antifriction and 2) plain.

#### Antifriction Bearings

Antifriction bearings use rolling elements between the bearing and the rotating shaft (Figure 9-1). Ball bearings and roller bearings are examples of this type.

<sup>3</sup> Source: Electrical Apparatus Service Association.

<sup>4</sup> Smaller motors in the table are usually fitted with sealed bearings. These bearings should be replaced at the indicated intervals.

These bearings generally use grease as a lubricant. Some ball and roller bearings used in motors are sealed and need no maintenance, but many are unsealed and require periodic repacking with grease.

The manufacturer's recommendations should be followed with respect to the frequency and grade of grease with which bearings should be packed. However, grease volume control continues to be a problem for industry and simply following OEM recommendations may not be enough to solve this problem. The "Machinery Lubrication" publication provided the following simple equation to determine the volume of grease to be added.

The formula is:

$$G = 0.114 \times D \times B$$

Where:

G = the amount of grease in ounces;

D = the bearing outside diameter in inches; and

B = the bearing width in inches.

Once the volume is found, it must be converted into shots, or pumps of the grease gun. To obtain the value used to convert the number, the user will need the grease gun and a small weighting scale to determine the output per full stroke of the handle. The average value is approximately 18 shots per ounce for most manual guns, but grease gun output can vary by a factor of 10.

## 9 Maintenance

Avoid mixing different types of grease, as some types are incompatible with others.

Greasing bearings is often regarded in many industries as a low skill job to be relegated to the plant “handy person.” Without proper training, the wrong grease can end up being used and/or the bearings can get under (but mostly over) greased which leads to higher failure rates.

Many motor manufacturers have resorted to sealed bearings and permanently lubricated sintered bearings on smaller motors to avoid mistreatment.

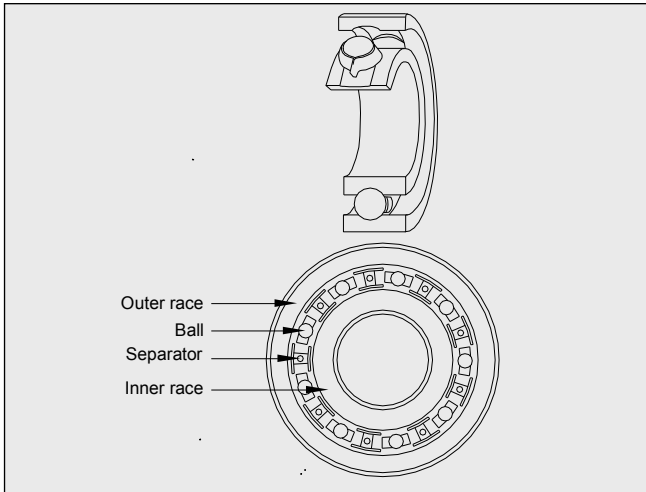

**Figure 9-1: Antifriction Bearing**

## Plain Bearings

Plain bearings are made of a soft material such as bronze or Babbitt (Figure 9-2).

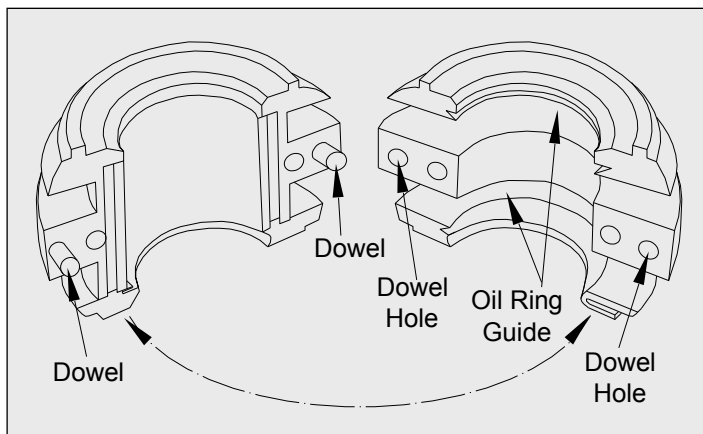

**Figure 9-2: Plain Bearing**

They cannot support thrust loads, as some antifriction bearings can, and are designed to operate only with horizontal shafts.

Plain bearings are quieter than antifriction bearing types.

Oil is used to lubricate this type of bearing, and supports the moving surfaces with a thin film while they are turning. Operation without sufficient lubrication will cause immediate damage.

An oil ring is often used to transport oil from a reservoir to the top of the shaft. It is a large loose fitting ring with its top half resting on the shaft and its bottom half in the oil reservoir.

## 9 Maintenance

The action of the oil ring can sometimes be confirmed via a sight plug in the top of the bearing.

The reservoir should be kept filled to the proper level with the correct grade and type of oil. As with grease, avoid mixing different types of oil as some are incompatible with others.

### d. Vibration

Excessive vibration can shorten bearing life and reduce motor efficiency.

In order to minimize vibration, the driven load should be well balanced and aligned with the motor. A portable accelerometer can be used to measure the vibration of a motor to determine if the balance is acceptable. This balancing and alignment can have a measurable impact on energy efficiency and should be monitored to identify performance changes.

*Couplings are available to provide better isolation between the motor and load shafts, and are more tolerant of slight misalignment.*

Vibration can also be a result of worn bearings. Clearance and end play of the bearings and shaft should be measured to determine if bearing replacement is required.

NEMA limits on the amplitude of vibration are shown in Table 9-2.

**Table 9-2: Bearing Vibration Limits**

<b>Motor Synchronous Speed (rpm)</b>	<b>Amplitude of Vibration (in)</b>	<b>Amplitude of Vibration (mm)</b>	<b>Peak Velocity, (mm/s)</b>
3000 and above	0.0010	0.0254	3.8
1500 – 2999	0.0015	0.0381	3.8
1000 – 1599	0.0020	0.0508	3.0-3.8
999 and below	0.0025	0.0635	2.0-3.0

Ultrasonic compressed air leak detectors with a solid probe can be used to record a “vibration signature”. Trending of vibration measurements over time is useful for identifying bearing degradation and the need for replacement.

### e. Insulation

Motor winding insulation provides electrical separation of both the conductors and mechanical components, and the conductors themselves. Insulation is subject to mechanical and electrical stresses, which over time reduce its ability to provide this separation.

High operating temperatures severely affect insulation life.

To maximize insulation life:

- Ventilation screens and shrouds should be kept clean and unobstructed.
- Dirt and grease should be kept off the motor to prevent restriction of heat dissipation.
- Dust and dirt should be vacuumed (preferred) or blown out of open motors.

## 9 Maintenance

- Only low pressure (<5 psi), dry, oil-free air should be used to blow out dirt.

Contamination of the windings with oil, grease or chemicals can adversely affect insulation. Totally enclosed motors should be used in areas where contamination can occur.

Moisture can cause insulation systems to fail. If the windings are suspected of being wet or are in areas of high humidity, the insulation resistance should be measured before the motor is energized. Readings of less than 1 megohm per kV rating plus 1 megohm indicate that the windings should be dried or that the insulation has failed (see Table 9-3).

**Table 9-3: Motor Insulation Resistance at Specified Voltages**

Voltages	Insulation Resistance
600 volts and below	1.5 megohm
2300 volts	3.5 megohm
4000 volts	5.0 megohm

Space heaters can be installed in some motors to prevent moisture build-up when the motor is not operating. The same heating effect can be achieved by applying an AC or DC voltage to one phase of the motor while it is not operating. The voltage level must be determined so that stator temperature is maintained above the dew point of the air.

Polarization index testing is used to determine the condition of the insulation of large (>500 HP) motors.

The polarization index, or P.I., is the ratio of the insulation resistance values taken at two time intervals. The typical P.I.

test uses the insulation resistance value at ten minutes compared with the value obtained at one minute.

$$P.I. = R_{10}/R_1$$

Where  $R_{10}$  = 10 minute resistance value

$R_1$  = 1 minute resistance value

A polarization index of 2 or more indicates the windings are in acceptable condition.

The Hi-potential or Hipot test is an overvoltage test that determines if a winding has a certain level of insulation strength. Good insulation can withstand voltage levels much higher than the voltages used in Hipot testing.

DC Hipot testing is a good non-destructive, routine test to ensure insulation strength. The voltage level applied for one minute of DC Hipot testing of motors operating at 600 volts or less can be determined as follows:

$$V_{test} = 1.7 \times (2E + 1,000) \text{ for new motors}$$

$$V_{test} = 2E + 2000 \text{ for motors which have been in service}$$

Where  $V_{test}$  = DC Hipot test voltage

$E$  = Rated voltage of the motor

AC Hipot testing is used by motor manufacturers and motor repair centres as a pass/fail type of test to determine if there is any weakness in the insulation system.

Due to the currents involved in AC Hipot testing, a breakdown of insulation causes permanent damage, so it is considered a destructive test and should not be used as part of a maintenance program.

*The latest maintenance and refurbishment techniques for asynchronous and synchronous motors are described in CSA C391-11 and CSA C392-11.*

*Periodic maintenance of larger motors includes disassembly, cleaning, hipotting and bearing replacement to ensure longer reliable life. Motors with slip rings or commutators are inspected to ensure wear is not excessive. Additional cleaning and dressing of the commutator or rings may be needed, particularly if excessive sparking or discoloration is observed.*

### f. VFD Bearing Failure

128

Occasionally, bearings fail in VFD driven motors due to common mode currents flowing through the motor shaft. This can lead to pitting and eventual failure of the motor bearings. Solutions to the problem include insulating the bearings with ceramic or other non-conductive materials to stop the current from traversing the bearing and the installation of shaft grounding brushes (Table 9-4)(Ref.8).

Installing the insulated bearings on the non-driven end may be helpful.

*Not all motors exhibit this elusive problem. Just knowing that the problem can exist is helpful, should this relatively rare condition occur.*

Additional information on VFD maintenance items can be found later in this document.

## g. Grounding

One of the largest potential causes of motor bearing damage due to bearing currents is inadequate grounding, especially at high operating frequencies (Ref. 8).

*Audible bearing noise is a symptom, however, the damage has been done by the time it is noticeable.*

**Table 9-4: Recommended Steps to Prevent VFD Bearing Problems**

Every VFD Application	Set carrier frequency <6kHz
	Specify VFD model with carrier
	Frequency adjustability increments no larger than 1 kHz
	Shortest possible conductor lengths
	Shielded cable with continuous low-impedance ground path from the VFD to the motor
< 25 HP motor	Shaft grounding device
25 HP & larger motor	Insulated motor bearings or ESIM <sup>1</sup>
Long lead conductor	Inductive or RCL filter
Difficult access to motor	Insulated motor bearings or ESIM <sup>1</sup>
Motor bearing failure despite protection	Voltage analysis to locate damaging current loops
Noisy motor bearing operation	Vibration analysis to look for signs of EDM <sup>2</sup> in motor bearings
Failed motor bearing removed from motor	Inspect motor bearing races for signs of pitting or "fluting"

<sup>1</sup>ESIM – Electrostatically Shielded Induction Motor

<sup>2</sup>EDM – Electric Discharge Machining

## 10 REPAIR OR REPLACE?

---

The cost of repairing an existing motor is often much less than replacing. However, the number of running hours the motor sees per year will play heavily in the decision to repair or replace. The following example, seen in Table 10-1, illustrates a simple economic analysis.

**Table 10-1: Economics of Repair or Replacing a Motor**

Motor Size HP	40
Existing Motor Efficiency	87%
Premium Motor Efficiency	94.5%
Annual Energy Cost Savings (\$0.05/kWh)	\$1073
Repair Price – Rewind Only	\$1000
New Premium Eff. Motor	\$1700
Price Differential	\$700
Load Factor	0.75
Hours/Year	8000
Simple Payback Months on Differential	~8.3
Simple Payback Months on Replacement Cost	~25

The motor in this example has a both a high load factor and high annual running hours, which contribute significantly to the case for replacement with an energy efficient motor. Even replacement of a healthy standard efficiency motor is somewhat attractive; however, the decision to repair is less clear for motors that have few running hours per year.

If the motor is a critical piece of equipment, replacement may be a good option in terms of reliability.

## 10 Repair or Replace?

A winding analyzer is a tool that can be used to test the windings in an electric motor, both for diagnosing existing conditions and verifying repairs. Standard test protocols are in place to ensure safe and accurate testing is performed. Different testing modes can evaluate the condition of the insulation, indicate the presence of shorts or identify an incorrect number of turns in a coil. Qualified technicians should perform these tests, as improper testing can damage the motor.

If the decision is to repair, caution should be exercised in selecting a repair facility. For larger motors, it is prudent to request core loss testing of the motor before and after the rewind is performed to ensure that the core has not been damaged. A damaged core will not only have higher losses, but if the damage is localized it may lead to hot spots in the stator core, resulting in a potentially shortened life expectancy. Disassembly and repair of the core would be needed to correct the problem (Ref.13).

For the most current standards describing the latest refurbishment methods for asynchronous and synchronous motors refer to CSA C391-11 and CSA C392-11.

Quality motor repair requires care to be taken at each step. Since modern insulation systems may include epoxies, stripping insulation from the stator core is often a difficult task to perform. Many repair shops bake the core to effectively burn out the old winding so it can be stripped. If the oven temperature is too high, the varnishes used to insulate the laminations could break down. Laminations accidentally peened over could short together, resulting in hot spots and increased losses. If using either the wrong wire gauge or not

enough wire, the coils will turn in the slots. For these reasons, it is important to get to know your repair facility and to insist on loss tests being performed. A low cost poor quality rewind may cost more in the long run due to higher run losses and a possible shorter life; however, done properly, even a high efficiency motor can be rewound without incurring any loss in efficiency.

## 10 Repair or Replace?

## 11 ENERGY EFFICIENCY OPPORTUNITIES

---

If the decision has been made to replace an existing standard efficiency motor with a high efficiency or premium version, care must be taken to ensure that the result will in fact yield actual savings. Done incorrectly, the new motor could, in some instances, consume more energy than the old motor. That is not to say the new motor is less efficient, but rather the new motor-load combination performs differently than the old combination. This can result in more work being done when the increase is not needed. Therefore, when changing a motor, ensure that the load is adjusted to match the new motor.<sup>9</sup>

### a. Motor Resizing

A common practice is to oversize a motor to be sure that it is capable of driving the load. An oversized motor is less efficient and contributes to a lower power factor. For variable loads, ensure the motor never exceeds its full load or service factor rating.

### b. Speed Adjustments

Energy efficient motors typically operate at lower slip than standard efficiency motors. This means for a variable torque load, an energy efficient motor will operate at a higher RPM at the balance point and will consume more energy. To correct this problem, the pulley ratio between the motor and load needs to be adjusted for belt drives.

### c. Load Adjustments

For direct coupled variable torque loads, an energy efficient motor will tend to run faster, as noted in the previous subsection. For these situations, the load will need to be adjusted. Examples include changing fan pitch or trimming pump impellers. This requires special skills to accomplish.

### d. Power Factor

Energy efficient motors typically have higher power factors than standard efficiency motors. Existing power factor correction capacitors will need to be re-evaluated to ensure overcorrection is not occurring.

## 12 VARIABLE FREQUENCY DRIVES

---

The following sections will provide an overview of VFD technology and their operation.

The primary focus will be on ‘off-the-shelf’, low voltage VFDs used in conjunction with AC, poly-phase, induction motors from fractional to 500 HP range that are:

- 600V or less
- IGBT PWM (pulse width modulated using insulated gate bipolar transistors)
- Commercially available

Selecting the proper VFD for your application is best achieved by understanding the technology, your specific load requirements and asking the right question up front. This question might be:

***“Does my load profile vary sufficiently to justify a VFD as an energy saving measure?”***

NOTE: It is strongly recommended that individuals or companies installing VFDs secure the services of a professional specialist qualified in VFDs in order to understand and maximize the available benefits.

Project managers who are not familiar with VFD technology often undervalue the importance of obtaining the correct data, analysis and up-front engineering that is necessary to thoroughly understand the system.

## 12 Variable Frequency Drives

VFDs may be referred to by a variety of other names, such as variable speed drives, adjustable speed drives, or inverters.

Engineered products for special and large motor applications are not included in this guide.

### a. VFD Technology Overview

A **Variable-Frequency Drive (VFD)** is a device that controls the voltage and frequency that is being supplied to a motor and therefore controls the speed of the motor and the system it is driving. By meeting the required process demands, the system efficiency is improved.

A VFD is capable of adjusting both the speed and torque of an induction motor. Therefore, it provides continuous range process speed control (as compared to the discrete speed control that gearboxes or multi-speed motors provide).

Fixed speed motors (or AC induction motors) serve the majority of applications. In these applications or systems, control elements such as dampers and valves are used to regulate flow and pressure. These devices usually result in inefficient operation and energy loss because of their throttling action.

It is often desirable to have a motor operate at two or more discrete speeds, or to have fully variable speed operation. The conventional control elements can often be replaced by incorporating variable speed operation using a VFD.

Substantial energy savings can be achieved in many of these applications by varying the speed of the motors and the driven

load using a commercially available VFD. Savings include capital costs and maintenance costs associated with these control elements.

Table 12-1 shows some typical loads and their energy savings potential.

**Table 12-1: Potential VFD Energy Saving**

<b>Type Of Load</b>	<b>Applications</b>	<b>Energy Consideration</b>
Variable Torque Load - HP varies as the cube of the speed - Torque varies as the square speed	<ul style="list-style-type: none"> <li>- Centrifugal Fans</li> <li>- Centrifugal Pumps</li> <li>- Blowers</li> <li>- HVAC Systems</li> </ul>	Lower speed operation results in significant energy savings as power to the motor drops with the cube of the speed.
Constant Torque Load - Torque remains the same at all speeds - HP varies directly with the speed.	<ul style="list-style-type: none"> <li>- Mixers</li> <li>- Conveyors</li> <li>- Compressors</li> <li>- Printing Presses</li> </ul>	Lower speed operation saves energy in direct proportion to the speed reduction.
Constant Horsepower Load - Develops the same horsepower at all speeds. - Torque varies inversely with the speed.	<ul style="list-style-type: none"> <li>- Machine tools</li> <li>- Lathes</li> <li>- Milling machines</li> <li>- Punch presses</li> </ul>	No energy savings at reduced speeds; however, energy savings can be realized by attaining the optimized cutting and machining speeds for the part being produced.

### b. VFD Operation

Electronic VFDs can vary the voltage and frequency to an induction motor using a technique called Pulse Width Modulation (PWM). VFDs have become the preferred way to achieve variable speed operation, as they are relatively inexpensive and very reliable.

VFDs use power semiconductor devices called insulated-gate bipolar transistors (IGBT). Using PWM, the speed of the motor and torque characteristics can be adjusted to match the load requirements.

The first step in the PWM process is to convert the AC supply voltage into DC by the use of a rectifier. DC power contains voltage ripples that are smoothed using filter capacitors. This section of the VFD is often referred to as the DC link.

This DC voltage is then converted back into AC. The conversion is typically achieved through the use of power electronic devices such as IGBT power transistors using a technique called Pulse Width Modulation (PWM). The output voltage is turned on and off at a high frequency, with the duration of on-time, or width of the pulse, controlled to approximate a sinusoidal waveform.

The entire process is controlled by a microprocessor which monitors the:

- Incoming voltage supply;
- Speed set-point;
- DC link voltage; and

- Output voltage and current to ensure operation of the motor within established parameters.

Figure 12-1 shows a typical PWM VFD.

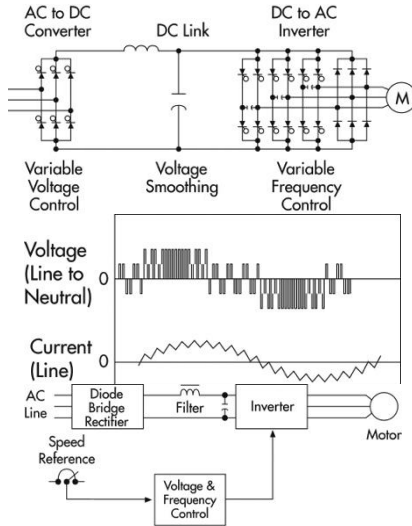

**Figure 12-1: Block diagram of a typical PWM VFD**

In the simplest drives or applications, the speed reference is simply a set-point; however, in more complex applications, the speed reference comes from a process controller such as a Programmable Logic Controller (PLC) or a tachometer.

Older drive technologies, such as Current Source Inverters and Variable Voltage Controllers, used SCRs or Thyristors as control devices. These technologies have now been replaced by the PWM VFD, which can regulate the speed of an induction

## 12 Variable Frequency Drives

motor between 10% to 200%. Wider speed ranges are possible depending on the model and options selected.

The speed accuracy is affected by the slip of the motor, resulting in slightly slower operation than the synchronous speed for a given frequency. The accuracy can be increased greatly by using tachometer feedback. Extremely precise speed and position control of the motor shaft can be achieved by using a VFD with Vector Control.

The VFD can provide many solutions depending on the required application. For example, a VFD can provide the following:

1. Energy savings on fan and pump applications
2. Better process control and regulation
3. Speeding up or slowing down a machine or process
4. Inherent power-factor correction
5. Bypass capability in the event of an emergency
6. Protection from overload currents
7. Safe acceleration

# 13 VFD SELECTION CONSIDERATIONS

---

When investigating VFD technology, the following implications should be considered:

- Electrical;
- Harmonic;
- Motor;
- Physical and environmental issues; and
- Vibration and resonance.

## a. Electrical Considerations

Successful application and maintenance of VFD drives requires an understanding of their impact on the motor and electrical distribution system.

143

The application of VFDs to induction motors can cause effects that must be considered for successful operation.

Examples include:

- The ability of a motor to cool itself effectively is reduced as the motor is slowed down. Over-sizing the motor or providing external forced air ventilation may be required with extended operation at low speeds and high loads.

## 13 VFD Selection Considerations

- Operation at different speeds can cause mechanical resonances in driven equipment. These speeds should be identified and programmed out of the motor's operating range.
- VFDs generate harmonic voltages and currents that can, in some cases, cause undesirable effects on the electrical distribution system and affect equipment operation. If a power quality problem is suspected, the electrical system should be examined by a qualified person. Sometimes isolation transformers, line reactors or filtering devices will be required to minimize these effects. Contact your local electrical utility representative for more information. Installation of filtering devices should be considered at the time of purchase of VFDs to minimize power quality issues in the electrical system. A practitioner trained in this area should be used to evaluate and determine this requirement.

AC drives require an acceptable electrical supply for safe, successful and reliable operation.

Single-phase drives have standardized voltages of 120 and 240 volts. Three phase motors have standardized voltages of 200, 230, 460 and 575 volts.

The nominal supply voltage of the distribution system is normally higher than the drive nameplate voltage to allow for voltage drops from the distribution transformer to the point of utilization.

Rated frequency is usually 60 Hz (hertz or cycles per second) in North America. However, the typical three-phase high

voltage value differs from Canada to the USA. In Canada, the most common is 575V, whereas the standard in the USA is 480V.

## b. Harmonic Considerations

Harmonic distortion of voltage and current is produced in electrical systems by non-linear loads such as VFDs, welders, rectifiers, Uninterruptible Power Supplies (UPS), arc furnaces, etc. Harmonics cause electrical waveform distortion that can propagate through the entire power system and even outside of the plant.

The source of harmonic distortion in VFDs is the solid-state power switching devices used to generate the varying supply frequencies.

These effects, known as “line harmonic currents”, are multiples of the fundamental 60 Hz supply current. For example, a frequency of 180 Hz is called the third harmonic. These currents generate harmonic voltage distortions that often exceed acceptable levels.

For more information, refer to the CEATI Power Quality Energy Efficiency Reference Guide.

### Harmonic Components

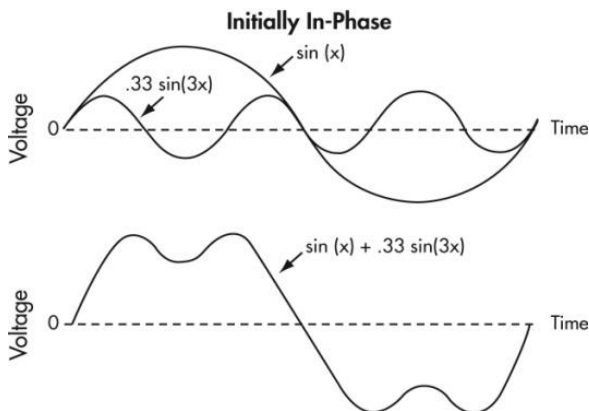

**Figure 13-1: Harmonic Amplitudes**

The odd harmonic amplitudes usually decrease with increasing frequency, so the lowest order harmonics are the most significant. Even numbered harmonics are not normally generated by VFD drive systems.

Harmonics occur as long as the harmonic generating equipment is in operation and tend to be of a steady magnitude.

Harmonics may be greatly magnified by power factor correction capacitors. The supply system inductance can resonate with capacitors at certain harmonic frequencies developing large currents and voltages, which can damage equipment.

## Effects of Harmonics

Microprocessors, numerically controlled machines, and process controllers all rely on accurate control signals. The presence of harmonics can cause these devices to malfunction. Harmonics can also cause interference with computers and the improper operation of electronic equipment. They can also cause capacitor and fuse failure.

Motors run at higher temperatures in the presence of harmonic currents. Motors consume more energy as they have to overcome 'counter rotating' torques created by odd harmonics.

This may cause premature breakdown of insulating materials and a reduction in life. The motor will also drop in overall efficiency, experience voltage stresses on its windings and experience torque pulsations.

## Dealing with Harmonics

If a harmonic problem is suspected, it should be confirmed before any attempt at corrective action is taken. A fairly simple test consists of viewing the power system waveforms on an oscilloscope or using a portable power meter with harmonic analysis functions. Significant waveform distortion is an indication of harmonic presence. Power harmonic analyzers can be used to measure the magnitude of the individual harmonics. This work is often best left to an expert in power quality services.

There are a variety of ways in which users can resolve these problems, after ensuring the installation meets the applicable electrical code including adequate grounding:

### **Separate Supply**

Ideally, loads producing harmonics and sensitive loads should be supplied from entirely separate feeders and independent transformers.

### **Isolation Transformers and Line Reactors**

Isolation transformers and line reactors are frequently used to protect the drive as well as the AC line from distortion.

### **Filters**

Harmonic filters can be used to reduce the amplitude of one or more fixed frequency currents to prevent them from entering the rest of the system. Filters can be custom designed to suit the electrical environment.

### **Cable Length**

Cable length should be kept as short as possible (i.e. less than 15 meters or 50 feet wherever possible).

As a general rule of thumb, it is considered good practice to buy a complete drive system that includes line reactors rather than just purchasing the drive on its own. Generally, a 3% to 5% impedance line reactor will prevent harmonics generated by a VFD from interfering with sensitive equipment on the distribution system.

If non-linear loads exceed 20% of the total plant load, special consideration should be given to performing a harmonic study and minimizing potential harmonic impact through the use of isolation transformers in addition to line reactors.

## Specifying Drives for Harmonics

Drive specifications often cite that *“The power conditioning equipment shall not produce voltage distortion or notches in excess of the limits suggested in IEEE Std 519-2014”*, but it may be unclear what this means for a particular installation. What does meeting IEEE 519 mean when installing a drive on a power system?

IEEE’s Recommended Practices and Requirements for Harmonic Control in Electric Power Systems, IEEE Std 519-2014, is often referenced but may not be well understood.

IEEE 519 contains sections on problems caused by harmonic currents and voltages, calculation examples, application examples, and the harmonic currents caused by different types of power converters and non-linear loads.

From a practical drive application point of view, meeting harmonic requirements for drives means having less than 5% total harmonic distortion of the current at the terminals of the drive at rated load. At low power demand with variable torque loads, the current’s total harmonic distortion (THD) may be higher than 5% as measured by a harmonic analyzer, but the magnitude of the harmonic current will be less than those produced at full load.

## c. Motor Considerations

### Electrical Issues

Application of a PWM VFD can cause voltage transients well above the rated voltage of the motor that can lead to failure of the insulation system in a very short period of time.

To understand this, consider the way in which a PWM inverter approximates a sinusoidal current waveform. The following figures show typical voltage and current waveforms for Pulse Width Modulation inverters.

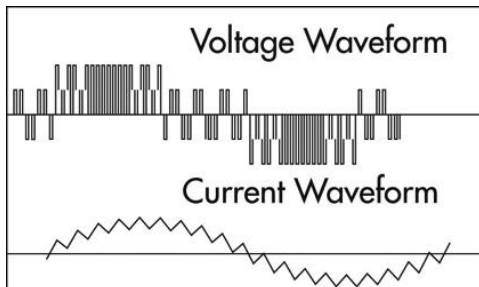

**Figure 13-2: Voltage and Current Waveforms**

The voltage waveform is made up of a series of pulses controlled by the inverter's output devices. The width or duration of these pulses is controlled to approximate a sinusoidal current waveform. Figure 13-3 is a half cycle voltage waveform for a typical PWM inverter operating on a 600-volt system.

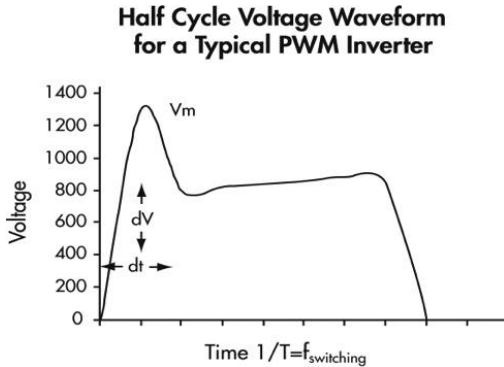

**Figure 13-3: Half Cycle Voltage Waveform for a Typical PWM Inverter**

The maximum voltage stress on the insulation system ( $V_m$ ) can be significantly higher than the motor's rated voltage and have extremely fast voltage rise times (shown in Figure 13-3).

Due to multiple reflections or resonance effects, the frequency can increase due to the interactions of the PWM switching frequency and waveshape, the cable length supplying the motor, and the inductance of the motor.

A voltage reflection of up to two times the applied voltage can occur due to standing waves or a “ringing effect”, and becomes more problematic with longer cable runs (typically greater than 15 m or 50 feet).

A “ringing effect” creates very high voltage stresses across the first few turns of the motor windings, and can result in interim short-circuits and ground wall insulation failure.

## 13 VFD Selection Considerations

This problem can be minimized by using appropriate filtering, using motors with improved insulation systems (inverter duty motors) and ensuring that repaired motors have upgraded insulation systems.

Many VFDs provide for user adjustment of the switching frequency. This frequency can be adjusted over a range as broad as 500 Hz to 20 kHz. The choice of switching frequency can be significant because it defines the number of voltage overshoots occurring at the motor in a certain amount of time. Higher switching frequencies will result in higher numbers of overshoots and higher magnitudes, which will stress the motor's insulation system. If the motor's peak voltage rating is higher than the level of the overshoot, high switching frequency should not be a problem. If, however, the overshoot levels are higher than the peak voltage rating of the motor, the use of a lower switching frequency may reduce the overshoot levels below the peak voltage rating of the motor. However, too low a frequency may cause an audible noise from the motor that may be undesirable in some applications, such as HVAC systems.

152

Factors to consider include:

- Reducing cable runs where possible;
- Using inverter output filter reactors (1%-3% impedance is typical);
- Using a lower switching frequency;
- For new and repaired motors, using additional lacing on end turns, phase paper, VPI resin and pulse resistant magnet wire enamel (triple, quad or new heavy build); and

- Maintaining the original winding design when rewinding motors, since reducing turns increases inter-turn voltage levels.

### Motor Selection Issues

Thermal considerations of motor operation with a VFD should be one of the first areas of attention for successful application.

As the motor speed is reduced, the amount of cooling available from the motor's ventilation system is reduced, so motor torque must be limited at reduced speed to avoid overheating.

In addition to the reduced cooling capability, motors have additional internal heating due to the non-sinusoidal voltages and currents from the inverter operation.

The application of a VFD to a variable torque load, such as a fan or centrifugal pump, does not usually present problems, but constant torque or constant horsepower loads can cause motor overheating at reduced speeds because there is less air flow over the motor.

It should be noted that many applications where a DC motor has been replaced by an AC induction motor with an inverter are of the constant torque or constant horsepower class.

Figure 13-4 shows the allowable torque of NEMA design A&B motors due to reduced cooling from operating at reduced speeds. It can be used as a guide for de-rating motors or selecting an appropriately oversized motor.

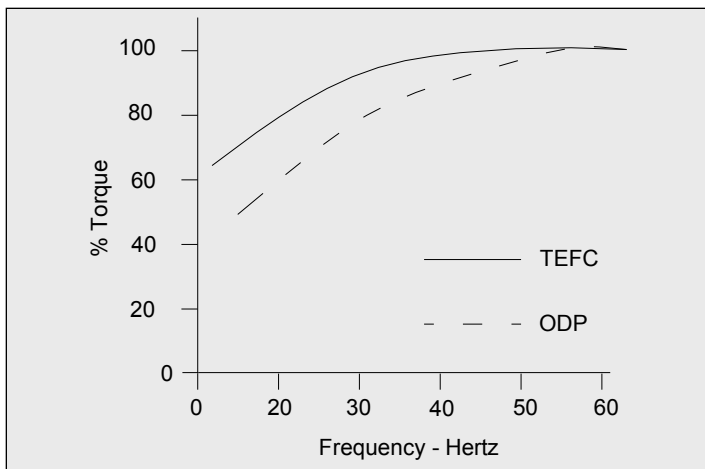

**Figure 13-4: The Effect of Reduced Cooling on Torque Capability**

154

The use of a motor with a 1.15 service factor and class F insulation is generally recommended to allow for additional heating due to harmonics.

The ability of a motor to cool itself effectively is reduced as the motor is slowed down. Oversizing the motor or providing external forced air ventilation may be required with extended operation at low speeds and high loads.

“Inverter duty” motors are designed for optimized performance when operated with VFDs. These motors typically have better insulation systems and can also be force ventilated with auxiliary blowers available as an option. This allows them to run cooler, rather than having to oversize them when running high torque loads.

When applying a PWM inverter it is important to check for shaft currents on motors with frequent or unusual bearing failures. Shaft currents are not normally a problem with motors less than 20" in core diameter, but can become a problem with high frequency harmonics associated with inverter use. Shaft voltages exceeding 0.3-0.5 volts may indicate potential trouble and may require shaft grounding or insulating the non-drive bearing.

#### d. Physical & Environmental Issues

VFDs must be selected to ensure that they have adequate protection from their environmental conditions.

VFDs are usually mounted into an electrical enclosure with other electrical devices, or as a standalone unit in its own enclosure.

NEMA has determined standard enclosure types to protect electrical equipment and to protect people from exposure to that equipment for standard environmental conditions. They are designated as in Table 13-1.

**Table 13-1: NEMA's Standard Enclosure Types**

Type	NEMA Enclosure
1	General Purpose-indoor
2	Drip proof-indoor
3	Dust tight, Rain tight, Sleet tight-Outdoor
3R	Rain proof, Sleet Resistant-Outdoor
3S	Dust tight, Rain tight, Sleet proof-Outdoor
4	Watertight, Dust tight, Sleet Resistant
4X	Watertight, Dust tight, Corrosion Resistant
5	Dust tight-indoor

## 13 VFD Selection Considerations

Type	NEMA Enclosure
6	Submersible, Water tight, Dust tight
6P	Watertight+Prolonged Submersion
7	Class I, Group A, B, C or D Hazardous Locations, Air-Break-Indoor
8	Class I, Group A, B, C or D Hazardous Locations, Oil-immersed-Indoor
9	Class II, Group E, F, or G Hazardous Locations Air-Break-Indoor
10	Bureau of Mines
11	Corrosion-Resistant and Drip proof Oil-Immersed
12	Industrial Use, Dust tight and Drip tight-Indoor
12K	Industrial Use, Dust tight and Drip tight with knockouts
13	Oil tight and Dust tight-Indoor

The following is a more detailed description for commonly used enclosure types:

156

- **Type 1**—Enclosures constructed for indoor use to provide a degree of protection to personnel against access to hazardous parts and to provide a degree of protection for the equipment inside the enclosure against the ingress of solid foreign objects (falling dirt).
- **Type 2**—Enclosures constructed for indoor use to provide a degree of protection to personnel against access to hazardous parts, to provide a degree of protection for the equipment inside the enclosure against the ingress of solid foreign objects (falling dirt) and to provide a degree of protection with respect to harmful effects on the equipment due to the ingress of water (dripping and light splashing).

- **Type 3**—Enclosures constructed for either indoor or outdoor use to provide a degree of protection to personnel against access to hazardous parts, to provide a degree of protection of the equipment inside the enclosure against the ingress of solid foreign objects (falling dirt and windblown dust), to provide a degree of protection with respect to harmful effects on the equipment due to the ingress of water (rain, sleet, snow) and that will be undamaged by the external formation of ice on the enclosure.
- **Type 4X**—Enclosures constructed for either indoor or outdoor use to provide a degree of protection to personnel against access to hazardous parts, to provide a degree of protection for the equipment inside the enclosure against the ingress of solid foreign objects (windblown dust), to provide a degree of protection with respect to harmful effects on the equipment due to the ingress of water (rain, sleet, snow, splashing water, and hose directed water), to provide an additional level of protection against corrosion and that will be undamaged by the external formation of ice on the enclosure.

In addition to protection from contamination and the ingress of dirt, dust, water, etc., operation within the following limits would be considered usual operating conditions:

1. Exposure to an ambient temperature in the range of  $-15^{\circ}\text{C}$  to  $40^{\circ}\text{C}$ .
2. Exposure to an altitude that does not exceed 3300 feet (1000 meters).
3. Installation on a rigid mounting surface.

4. Installation in areas or supplementary enclosures that do not seriously interfere with the ventilation of the drive.

Contact the VFD manufacturer for unusual service conditions.

### e. Vibration and Resonance

There is a general assumption that slowing down rotating equipment leads to less wear and tear and hence promotes more favorable maintenance conditions. Frequently, equipment life can be extended through the benefits of variable speed. However, there are a number of detrimental mechanical conditions that can arise when equipment is slowed down.

Most machines are designed to operate at a speed that is selected at a calculated safe margin below the first critical speed or natural frequency of the shaft.

In certain cases, to facilitate shaft design, some high speed machines are designed to operate between the first and second critical speeds. A speed reduction for a machine of this type could result in operation at the first critical speed.

For larger installations, contact should be made with the machine manufacturer to ensure that the critical speeds are known and dealt with appropriately.

Resolving vibration and resonance usually involves programming the VFD so that it will not operate equipment in the critical speed range.

If the design data cannot be located, field tests should be performed or the complete apparatus should be measured and the critical speeds recalculated.



# 14 VFD APPLICATION CONSIDERATIONS AND SAVINGS ESTIMATION

---

The following section will discuss:

- Driven load characteristics and power requirements;
- Cost considerations;
- Energy and operational savings;
- Simple payback and Net Present Value;
- Monitoring and Verification;
- System and electrical efficiencies; and
- Reliability and maintenance.

## a. Driven Load Characteristics and Power Requirements

161

The characteristics of the driven load are important in motor selection and were discussed in Section 0. The behavior of torque and horsepower with respect to speed partially determines the requirements of the motor-drive system.

We can categorize drive applications by their operational torque requirements:

- Constant Torque Loads
- Constant Horsepower Loads
- Variable Torque Loads
- Efficiency of Electric Motors and Drives

### Constant Torque Loads

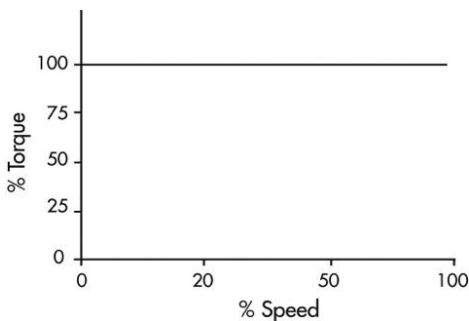

**Figure 14-1: Constant Torque Load**

A constant torque load is characterized as one in which the torque is constant, regardless of speed. As a result, the horsepower requirement is directly proportional to the operating speed of the application and varies directly with speed. Since torque is not a function of speed, it remains constant while the horsepower and speed vary proportionately.

Typical examples of constant torque applications include:

- Conveyors
- Extruders
- Mixers
- Positive displacement pumps and compressors

Some of the advantages VFDs offer in constant torque applications include precise speed control and starting and stopping with controlled acceleration/deceleration.

For constant torque loads the speed range is typically 10:1. These applications usually result in moderate energy savings at

## 14 VFD Application Considerations and Savings Estimation

lower speeds. However, specific energy remains constant since a slower speed results in less production or work performed.

### Constant Horsepower Loads

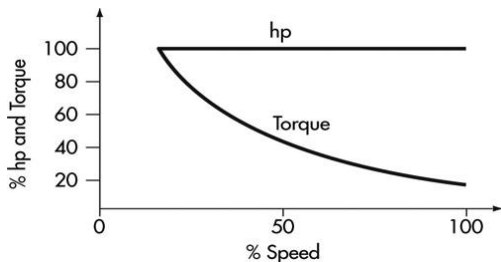

**Figure 14-2: Constant Horsepower Load**

The second type of load characteristic is constant power. In these applications the torque requirement varies inversely with speed. As the torque increases the speed must decrease to have a constant horsepower load. The relationship can be written as:

$$\text{Power} = \text{speed} \times \text{torque} \times \text{constant}$$

Examples of this type of load would be a lathe, or drilling and milling machines where heavy cuts are made at low speed and light cuts are made at high speed.

These applications do not offer energy savings at reduced speeds.

### Variable Torque Loads

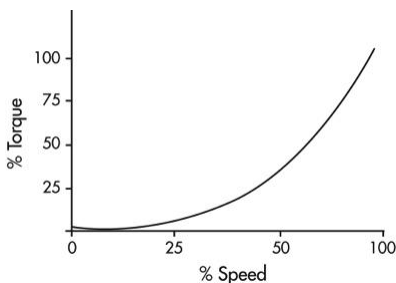

**Figure 14-3: Variable Torque Load**

The third type of load characteristic is a variable torque load. Examples include centrifugal fans, blowers and pumps. The use of a VFD with a variable torque load may return significant energy savings.

164

In these applications:

- Torque varies directly with speed squared
- Power varies directly with speed cubed

This means that at *half speed*, the horsepower required is approximately *one eighth of rated maximum*.

Throttling a system by using a valve or damper is an inefficient method of control because the throttling device dissipates energy that has been imparted to the fluid. A variable frequency drive simply reduces the total energy into the system when it is not needed.

- In addition to the major energy saving potential, a drive also offers the benefits of increased process

## 14 VFD Application Considerations and Savings Estimation

control which often impacts product quality and reduces scrap.

- For variable torque loads a 3:1 speed range is typical.

### Efficiencies of Motors and Drives

In Section 7 i, motor efficiency and sizing considerations were discussed.

A VFD is very efficient. Typical efficiencies of 97% or more are available at full load. At reduced loads the efficiency drops. Typically, VFDs over 10 HP have over 90% efficiency for loads greater than 25% of full load. This is the operating range of interest for practical applications.

The following table shows the efficiency of typical VFDs at various loads.

**Table 14-1: PWM VFD Efficiency as a Function of VFD Power Rating**

VFD HP rating	Efficiency (%)				
	Load, % of Drive Rated Power Output				
	12.5	25	50	75	100
1	48	74	84	87	89
5	80	88	92	94	95
10	83	90	94	95	96
20	86	93	95	96	97
30	88	93	95	96	97
50	86	92	95	96	97
60	87	92	95	96	97
75	86	93	96	97	97
100	89	94	96	97	97
200	81	95	96	97	97

Table from the U.S. Department of Energy's Advanced Manufacturing Office - Motor Tip Sheet No. 11: *Adjustable Speed Drive Part-Load Efficiency*.

## 14 VFD Application Considerations and Savings Estimation

The system efficiency is lower than the product of motor efficiency and VFD efficiency because the motor efficiency varies with load and because of the effects of harmonics on the motor.

Unfortunately, it is nearly impossible to know what the motor/drive system efficiency will be, but because the power input to a variable torque system drops so remarkably with speed, an estimate of the system efficiencies is really all that is needed.

When calculating the energy consumption of a motor drive system, estimated system efficiency in the range of 80-90% can be used with motors ranging from 10 HP and larger and loads of 25% and greater.

In general, lower efficiency ranges correspond to small motor sizes and loads and higher efficiency ranges correspond to larger motors and loads.

Research is currently underway to develop a standard protocol for determining the efficiency of a VFD. Below is the abstract from an article entitled “Benchmark Study to Establish a Test Protocol for Determining the Efficiency of Variable Frequency Drives (VFDs)”:

“Many industrial processes require precise and accurate control over system parameters such as flow, pressure, temperature, process speed, etc. The use of a variable frequency drive (VFD) to match the motor driven equipment’s speed and torque to the requirements of the process load can result in large energy savings, particularly in variable torque or centrifugal loads. It is estimated that 30% of industrial motor systems may benefit

from the application of a VFD to control motor speed and torque.”

A VFD can be set up in many ways, each differently affecting operating efficiency, due to the infinite number of operating points between torque and speed. To date, there is no widely accepted test protocol that allows for an efficiency comparison between VFD manufacturers and applications. Very little data on VFD system efficiencies exist and there has been no consensus for a standard to characterize VFD system efficiency at any given operating point.

Recently acquired VFD system testing results indicate a significant variation of 2% to 8% in VFD system efficiency between manufacturers and applications, particularly at low loads and low speeds. The potential energy savings in Canada alone for a 2% efficiency improvement in VFD applications is estimated at over 1,000 GWh per year or 200 MW. The aim of this work is to report a benchmark study of 3 VFD sizes from 5 different manufacturers and to establish a common test protocol for determining the efficiency of the VFDs.

This proposed test protocol would form the basis of a new standard, CSA C838-13: *Energy Efficiency Test Methods for Three-Phase Variable Frequency Drive Systems*.

## b. Comparison with Conventional Control Methods

### Estimating Energy Savings

Fans and pumps are designed to be capable of meeting the maximum demand of the system in which they are installed.

However, quite often the actual demand could vary and be much less than the designed capacity. These conditions are accommodated by adding outlet dampers to fans or throttling valves to pumps.

These are effective and simple controls, but severely affect the efficiency of the system.

168

Using a VFD to control the fan or pump is a more efficient means of flow control than simple valves or inlet or outlet dampers. The power input to fans and pumps varies with the cube of the speed, so even seemingly small changes in speed can greatly impact the power required by the load. The table below shows the power required by a fan or pump as the speed of the machine is reduced.

**Table 14-2: Power Required by a Fan or Pump**

<b>Speed of Fan/Pump</b>	<b>Mechanical Power Required</b>
100%	100%
90%	73%
75%	42%
50%	13%

Power Required by Fan/pump as a Function of Speed

## 14 VFD Application Considerations and Savings Estimation

In addition to major energy savings potential, a drive also offers built-in power factor correction, better process control and motor protection.

The most common application is the centrifugal fan or pump that imparts energy in to the working fluid by centrifugal force. This results in an increase in pressure and produces air flow at the outlet of the fan or liquid flow from a pump.

Figure 14-4 is an example of what a typical centrifugal fan can produce at its outlet at a given speed.

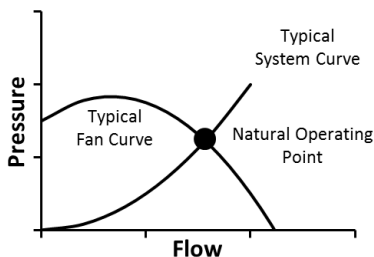

**Figure 14-4: Plot of Outlet Pressure Versus the Flow of Air**

Standard fan and pump curves will usually show a number of curves for different speeds, efficiencies and power requirements. These are all useful for selecting the optimum fan or pump for any application. They are also needed to predict operation and other parameters when the operation is changed.

Figure 14-4 also shows a system curve added to the fan curve. The system curve is not a product of the fan, but a curve showing the requirements of the system that the fan is used on.

## 14 VFD Application Considerations and Savings Estimation

It shows how much pressure is required from the fan to overcome system losses and produce an air flow.

The fan curve is a plot of fan capability independent of a system. The system curve is a plot of “load” requirement independent of the fan. The intersection of these two curves is the natural operating point. It is the actual pressure and flow that will occur at the fan outlet when this system is operated. Without external influences, the fan will operate only at this point.

Many systems, however, require operation at a wide variety of points. Figure 14-5 illustrates a profile of the typical variations in flow experienced in a typical system. How these variations are produced and controlled will have a direct effect on the energy saved.

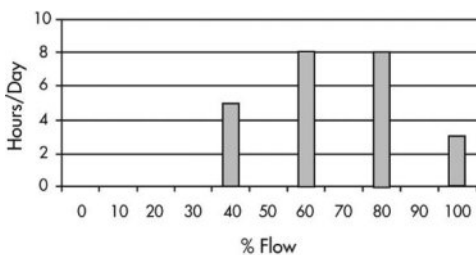

**Figure 14-5: Variations in Flow**

There are several methods used to modulate or vary the flow of a system to achieve the optimum points. Some of these include:

- Outlet dampers on fans and valves on pumps
- Inlet dampers or guide vanes on fans
- VFD control

## 14 VFD Application Considerations and Savings Estimation

Each of these methods affects either the system curve or the fan curve to produce a different natural operating point. In so doing, they may also change the fan's efficiency and the power requirements.

### Outlet Dampers and Valve Throttle Positions

The outlet dampers on a fan system and valves on a pump system affect the system curve by increasing the resistance to flow through their throttling action.

The system curve is a simple function that can be stated as  $P = K \times (\text{Flow})^2$ . P is the pressure required to produce a given flow in the system. K is a function of the system and represents the friction to air flow. The outlet vanes affect the K portion of the formula.

Figure 14-6 shows several different system curves indicating different throttle positions.

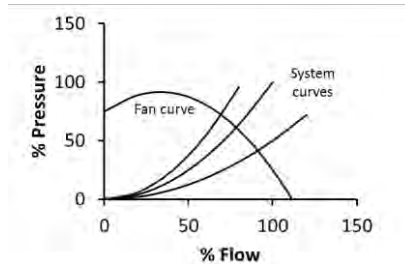
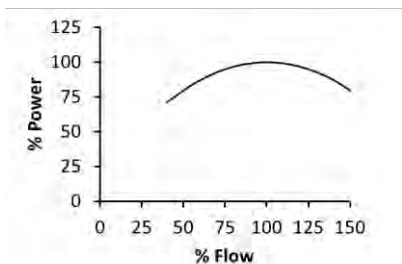

**Figure 14-6: System Curves Function of Throttle Positions**

Figure 14-7 presents a curve of the power requirement for this type of operation. From this curve, it can be seen that the

## 14 VFD Application Considerations and Savings Estimation

power decreases gradually as the flow is decreased. At 50% flow 80% power is required.



**Figure 14-7: Pressure Versus Flow Curve**

### Variable Inlet Vanes

This method modifies the fan curve so that it intersects the system curve at a different point.

There is no equivalent on a pumping system as throttling valves are never placed on the suction side of a pump.

Figure 14-8 illustrates several different system curves indicating different guide vane positions.

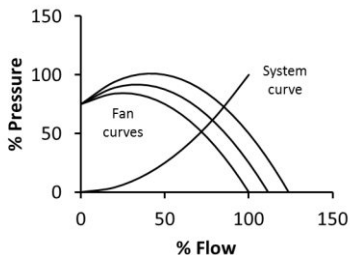

**Figure 14-8: Fan Curves Function of Inlet Vane Setting**

## 14 VFD Application Considerations and Savings Estimation

Figure 14-9 shows that the power required by this method drops, and to a greater extent than it did in the outlet throttle method. At 50% flow 60% power is required.

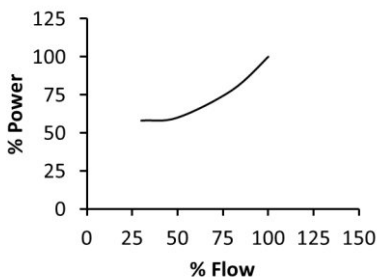

**Figure 14-9: Fan and Inlet Vane Settings Curve**

### Variable Frequency Drives

This method takes advantage of the change in the fan or pump curve that occurs when the speed of the machine is changed.

These changes are quantified in a set of formulas called the Affinity Laws.

These laws are as follows:

$$\frac{Q_1}{Q_2} = \frac{N_1}{N_2} \quad \frac{P_1}{P_2} = \frac{(N_1)^2}{(N_2)^2} \quad \frac{HP_1}{HP_2} = \frac{(N_1)^3}{(N_2)^3}$$

Where: N = Speed

Q = Flow

P = Pressure

HP = Mechanical Power (electrical input power is calculated by applying the motor efficiency)

## 14 VFD Application Considerations and Savings Estimation

Note: when the flow and pressure laws are combined, the result is a formula that matches the system curve formula:

$$\text{SYSTEM Pressure CURVE } P = K \times (N)^2$$

Thus, the machine will follow the system curve when its speed is changed.

Figure 14-10 is a representation of the adjustable-speed method.

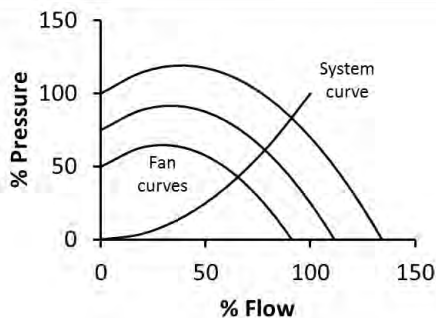

**Figure 14-10: Fan Curves at Various Speeds**

The theoretical power formula from the affinity laws shows the effect of the cube functions.

The preceding examples are used in pure friction systems where there is no static back pressure requirement for fans or static head requirement for pumps. For applications with a static component, a system curve must be developed to assess the performance of the variable speed fan or pump through its entire expected range of operation.

## 14 VFD Application Considerations and Savings Estimation

For most applications that a user will consider, the square law approximation should be used. Only fans with little or no static pressure, such as cooling tower fans and roof vent fans with domes, or pumps with no static head such as discharge pumps, will approximate a cube function.

Figure 14-11 illustrates the significant reduction in power achieved by this method.

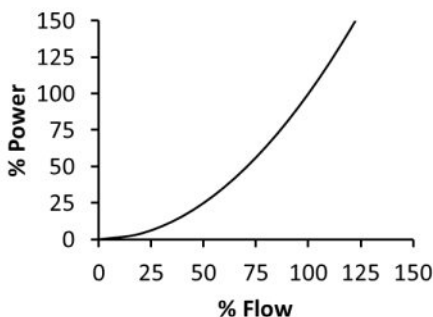

**Figure 14-11: Power Law Approximation**

The adjustable-speed method achieves flow control in a way that closely matches system or load curve. At 50% flow only 25% of the power is required.

This allows the fan or pump to produce the desired results with the minimum of input power.

The other two methods modify system parameters that generally results in a reduction of the machine's efficiency. This is why the power demand is greater than the adjustable-speed method.

### c. Economics

Economics is typically one of the most important factors involved in selecting industrial equipment, but the method of evaluation is not straightforward. Many important economic considerations are often ignored in VFD evaluations.

Table 14-3 represents the potential energy savings derived from the replacement inlet or outlet dampers with a VFD. This information should be used as a guideline only, as savings will vary depending on actual conditions.

**Table 14-3: Energy Savings by Removing Dampers**

<b>Potential Energy Savings from Replacing an Inlet or Outlet Damper with a VFD</b>				
<b>Airflow Volume (percent of maximum)</b>	<b>Daily Operating Time (hours)</b>	<b>Energy Consumed with Damper (kWh/year)</b>	<b>Energy Consumed Using a VFD (kWh/year)</b>	<b>Difference in Energy Consumption (kWh/year)</b>
50%	2	18 500	4 800	13 700
60%	3	29 300	9 800	19 500
70%	6	61 700	26 800	34 900
80%	6	63 300	35 900	27 400
90%	4	44 200	32 600	11 600
100%	3	34 200	35 200	-1 000
Total	24	251 200	145 100	106 100

Reference: Office of Energy Efficiency, Natural Resources Canada, "How Much Will I Save"

### d. Cost Considerations

The cost of VFDs can vary greatly, depending on the options required.

The cost should include:

- New motor purchase;
- Power conditioning equipment;
- Installation;
- Electrical system upgrade;
- Torsional analysis;
- Space; and
- Cooling.

#### Motor

The cost of an inverter duty motor should be considered for a new system; however, if the system is being considered for an upgrade to a VFD then the existing motor should be reviewed for size, capacity and efficiency. Usually only high efficiency motors should be considered.

#### Power Conditioning Equipment

The cost of any power conditioning equipment, such as harmonic filters, should be included. This includes filters for incoming power to the motor as well as power conditioners for harmonic voltages and currents sent back to the power supply from the drive.

## 14 VFD Application Considerations and Savings Estimation

### Installation

Installation, labour and commissioning charges for the drive, motor and power conditioning apparatus should be determined.

### Electrical System Upgrade

Upgrading the electrical system may be necessary if reliability greater than what the present system can offer is required. Potential upgrades include relay protective systems, supply transformer redundancy, transfer switching/alternate feeders, maintenance, and emergency staff training and preventive maintenance programs.

### Torsional Analysis

178

Torsional vibration is an angular vibration transmitted along the driveshaft, typically along its axis of rotation. If the torsional vibration is uncontrolled it can lead to premature component failures. Therefore, a torsional analysis should be conducted for large drive applications to determine if the VFDs are having an impact on the driveshaft due to the continuous speed adjustments. This is not a problem in smaller applications, as the loads are not significant enough to cause issues.

### Space Requirements

This includes the cost of any indoor space requirements for the drive and filters, as well as any outdoor space costs, such as those associated with transformers, filters or reactors.

### Cooling

Additional cooling may be required for drive installation. Water-cooling may be a much more economical alternative for large applications, although HVAC equipment is often used.

### e. Calculation of Energy Savings

It is now appropriate to estimate the power consumption and compare the power consumption for each of the various methods to determine potential savings.

The fan selected for this example is a unit operating at 300 RPM producing a 100 percent flow rating of 2,500 m<sup>3</sup>/min, with a motor shaft power (or electrical input) requirement of 25 kW. Pumps would be dealt with in a similar manner using the appropriate pump curve.

The fan will operate 8,000 hours per year. With no control available and at an energy cost of \$0.10/kWh, the annual electricity cost will be:

$$(25 \text{ kW}) (8,000 \text{ hrs}) (\$0.10/\text{kWhr}) = \\ \$20,000/\text{year}$$

It should be noted that the motor efficiency was not taken into account in these calculations.

To determine the potential savings from a control method, a load profile must be developed. For this example, the following load profile is determined.

**Table 14-4: Load Profile**

<b>% Flow</b>	<b>% Duty Cycle</b>
100	20
75	40
50	40

### Required Power

For each operating point, a required power from the fan curve can be obtained (from the preceding curves for each control scheme).

This power is multiplied by the percent of time that the fan operates at this point. These calculations are then summed to produce a “weighted power” that represents the average energy consumption of the fan.

From the outlet damper curve (Table 14-5), the weighted power calculations for the outlet damper method are as follows.

**Table 14-5: Weighted Power Calculations for Outlet Damper Method**

<b>% Flow</b>	<b>% Duty Cycle</b>	<b>Power Required (kW)</b>	<b>Weighted Power (kW)</b>
100	20	25 (1.00) = 25.0	25.0 (0.2) = 5.0
75	40	25 (0.96) = 24.0	24.0 (0.4) = 9.6
50	40	25 (0.88) = 22.0	22.0 (0.4) = 8.8
Average Annual Power			23.4 kW

## 14 VFD Application Considerations and Savings Estimation

The weighted power calculations for the variable inlet vane (Table 14-6) method are as follows.

**Table 14-6: Weighted Power Calculations for the Variable Inlet Vane**

<b>% Flow</b>	<b>% Duty Cycle</b>	<b>Power Required (kW)</b>	<b>Weighted Power (kW)</b>
100	20	25 (1.00) = 25.0	25.0 (0.2) = 5.0
75	40	25 (0.73) = 18.3	18.3 (0.4) = 9.6
50	40	25 (0.60) = 15.0	15.0 (0.4) = 6.0
Average Annual Power			20.6 kW

The weighted power calculations for the VFD (Table 14-7) method are as follows.

**Table 14-7: Weighted Power Calculations for the VFD**

<b>% Flow</b>	<b>% Duty Cycle</b>	<b>Power Required (kW)</b>	<b>Weighted Power (kW)</b>
100	20	25 (1.00) = 25.0	25.0 (0.2) = 5.0
75	40	25 (0.55) = 13.8	18.3 (0.4) = 5.5
50	40	25 (0.25) = 6.3	15.0 (0.4) = 2.5
Average Annual Power			13.0 kW

The annual cost of operation for the three control methods are as follows:

Outlet Dampers: 23.4 kW x \$0.10/kWhr x 8000 hours x \$18,720

Inlet Dampers: 20.6 kW x \$0.10/kWhr x 8000 hours x \$16,480

## 14 VFD Application Considerations and Savings Estimation

VFD Control:  $13.0 \text{ kW} \times \$0.10/\text{kWhr} \times 8000 \text{ hours} \times \$10,400$

The savings from these control methods are as follows.

**Table 14-8: Savings from these Control Methods**

<b>Control Type</b>	<b>Annual Operating Cost</b>	<b>Annual Savings</b>
None	\$20,000	0
Outlet Dampers	\$18,720	\$1,280
Inlet Dampers	\$16,480	\$3,520
VFD Control	\$10,400	\$9,600

The above calculations use a simple “blended” cost for electricity. How your utility charges for electricity usually depends on a number of factors including demand, energy, time of use and other factors. Your local utility representative should be contacted for more detail on how to calculate your electricity cost.

182

The other element of electrical power cost is the apparent power charge, measured in kVA, which compensates the utility for the peak current that must be delivered during the month. Each utility rate structure is different and contacting your utility can ensure that the correct rates are being used. The figure below illustrates the daily demand (kW) and the apparent power (kVA). The ratio between kW and kVA is the power factor. Most utilities now charge a power factor penalty (i.e. charging for apparent power (kVA)) rather than kW.

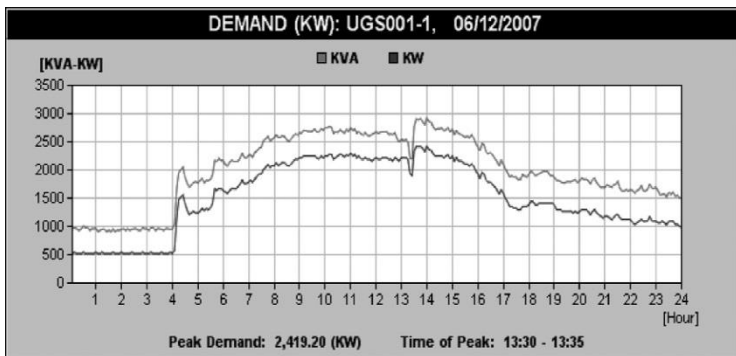

**Figure 14-12: Demand (kW) and Apparent Power (kVA)**

Courtesy of UGS Profiler, Real time monitoring

The most significant factor affecting demand is the power required by the load. Variable frequency drives provide significant savings if the demand can be reduced.

It is also important to keep in mind the actual cost of the kilowatt-hours (kWh) of energy being saved. In the case of fixed price contracts or increasing rate blocks, the kWh saved are the last ones that would have otherwise been purchased and would usually have been charged at the highest price. However, some utilities continue to use inverted and/or fixed cost rate structures so the actual cost per kWh is dependent on the utility's rate structure.

In deregulated markets where the price per kWh varies depending on the supply and demand, each application's energy savings will be dependent on the electric energy price for that period.

## 14 VFD Application Considerations and Savings Estimation

For example, the fluctuating volatile price in Ontario, Canada is illustrated below:

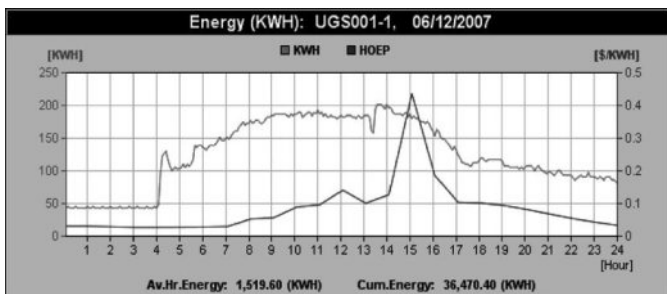

**Figure 14-13: Electrical Energy (kWh) and Hourly Ontario Energy Price (HOEP) (\$/kWh) Price**

Courtesy of UGS Profiler, Real time monitoring

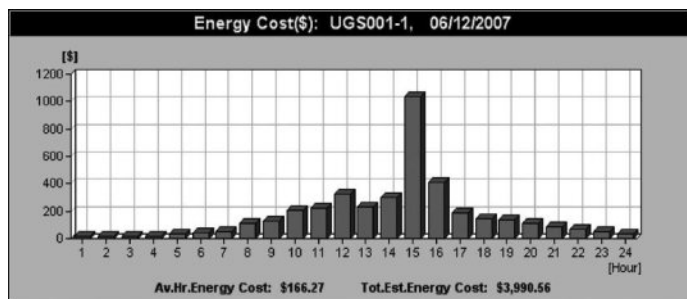

**Figure 14-14: Resulting Electric Energy Cost for 24 hours**

Courtesy of UGS Profiler, Real time monitoring.

Thus, it is important to properly evaluate the true benefit of energy savings since using an “average energy cost” can be misleading.

Although electrical savings are important, there are also other factors that should be included as part of an evaluation of the

life-cycle costs of the equipment. For example, when pumps or fans are operated at reduced speeds there are often significant maintenance savings due to reduced wear on seals, bearings, shafts, etc. The purchase price is typically less than 10% of the life cycle costs when operating and maintenance costs are considered. Productivity increases from reduced downtimes and reduced waste from optimized process control should also be quantified for significant life cycle cost economics.

### f. Operating Savings

#### Capital Savings

Use of a VFD may avoid certain capital investments. Examples are gearboxes, control valves, fluid coupling/mechanical speed changing equipment and reduced voltage starters.

#### Process Flow and Operational Improvements

Often the installation of the VFD will result in operational improvements and these efficiencies should be factored into the savings.

#### Elimination of other Mechanical Control Devices

The installation of the VFD may eliminate some mechanical control devices including valves and dampers. The costs associated with the removal, purchase, and maintenance of these devices also needs to be included in the VFD savings evaluation.

## 14 VFD Application Considerations and Savings Estimation

### Maintenance / Useful Life Savings

The reduction of maintenance and downtime may be quite substantial if an AC variable frequency drive is employed. Contributing factors are the elimination of control valves, current-limit feature (prevents motor burnouts caused by multiple restarts) and the protection of the motor insulation (it will be shielded from external voltage problems).

Useful equipment life, such as for bearings, can be extended by operating at reduced speeds. Stresses and metal fatigue in the drive train shafts will be lowered.

Improvements to VFD technology and 'off the shelf' spares have reduced repair time significantly and have generally not resulted in operational issues.

186

### Over-Speed Capability Savings

The over-speed capability of variable frequency drives can save considerable operating costs, as well as investment, if increases in production levels occur. For example, the airflow through an existing fan may be increased by retrofitting a VFD to the fan motor, which will allow operation at a frequency higher than an existing 60 Hz rating.

### Precautions

A variable frequency drive is typically the most cost effective choice if the duty cycle is more evenly distributed over the entire range of flow rates. Relative energy savings improve if the performance and system resistance curves are steep.

## 14 VFD Application Considerations and Savings Estimation

Many potentially good VFD applications are passed up because benefits other than energy savings are overlooked. Frequently, process control and reliability far outweigh efficiency related benefits to the user. By using the average cost of energy in savings analyses, the savings can be understated for variable frequency applications. Instead, both the energy and demand charges of the local utility's rate schedule should be used.

For variable torque loads, the variable frequency drive savings can be significantly greater since the horsepower varies proportionally to the cube of the speed.

For horsepower applications above 25 HP, installation costs are usually comparable to the total capital cost for the drive. Below 25 HP, installation costs may be more than the cost of the drive.

### VFD Savings Software

Software is available from several VFD manufacturers, suppliers and, in some cases, local utilities and government organizations.

These resources are very useful for estimating energy savings and exploring control options. Several will allow performance data to be input when it is available to make the analysis even more accurate.

Each source of software assumes a basic understanding of VFD technology and a thorough understanding of the application.

## g. Simple Payback Evaluation

The *simple payback method* is frequently used to determine how long it would take for a piece of equipment to “pay for itself” through saved costs. The payback time is calculated as follows:

$$\text{Number of Years} = \frac{\text{Total Initial Capital Cost}}{\text{Total Annual Savings}}$$

This method should only be used as a risk indicator. Simple payback neglects the impact of a number of important variables, such as tax incentives, inflation, etc.

Table 14-9 provides a ‘VFD checklist’ of costs and savings and can help avoid overlooking economic considerations.

**Table 14-9: VFD Costs and Savings Checklist**

<b>Capital Costs</b>	<b>Capital Savings</b>	<b>Operational Costs and Saving</b>	<b>Other</b>
Drive Motor Power Conditioning Equipment Installation Electrical System Upgrade Torsional Analysis Space Requirements Cooling	Control valves Gear box Fluid coupling/ mechanical speed changing equipment Reduced voltage starters	Energy (total energy consumed, peak demand change) Maintenance/ useful life/ downtime Overspeed capability	Salvage Value Tax Implications

## h. Net Present Value Evaluation

Calculating the net present value (NPV) is a better technique for appraising the profitability of an investment. By using the discounted cash flow technique, the NPV takes into account the time value of money.

A summary of this approach appears in the following steps:

1. Evaluate the cost/savings of the factors in the above table for each option that is being considered (e.g. purchasing a VFD or purchasing a mechanical drive system instead). Capital costs will be expressed in total dollars; operating expenses will be expressed in terms of time.
2. Determine the real discount rate that should be used for each time dependent and future-valued factor. For example, for energy savings calculations:
  - $x\%$  per annum = nominal discount rate
  - $y\%$  per annum = rate at which electricity rates will rise
  - $i\% = \{x/y - 1\}\%$

As another example, salvage value in years from the present should be discounted using the rate at which the interest rate is expected to rise between now and 'n' years.

3. The factors for each option should be discounted to their present values, using the appropriate discount rate. The number of years used for time dependent factors should be chosen as a reasonable payback period. Present value tables and annuity tables are useful for the discounting process.

## 14 VFD Application Considerations and Savings Estimation

4. The net present value (NPV) of each option is found by summing the costs and savings that have been calculated in present value terms for each factor.
5. For any option, if:
  - NPV > 0, there is a net gain
  - NPV < 0, there is a net loss
  - NPV = 0, breakeven occurs at the time under consideration.
6. The option with the greatest positive value of NPV is the most profitable.
7. The procedure could be repeated assuming different total time periods.
8. A comparison between two options could also be made by using the relative difference between the options for each factor and finding one NPV.

### i. Monitoring and Verification

It is important to establish a Measurement and Verification plan (M&V) before the project execution for several reasons, including:

1. Verifying that the estimated savings are achieved.
2. Meeting demand side management incentive application requirements.
3. Obtaining support for future projects through demonstrating validated success.

Guidelines for developing Measurement and Verification plans are provided in the following documents:

- IPMVP
- CEATI M&V Guide

## 14 VFD Application Considerations and Savings Estimation

Energy savings are determined by comparing the energy use before the project starts (base case) and then again after the installation of the energy conservation measures (post project).

Proper determination of savings includes adjusting for changes that affect energy use that are not caused by the conservation measures. Adjustments will vary based on the application and will include considerations such as weather, product or occupancy conditions between the baseline and post project periods.

M&V activities generally take place in the following steps:

1. Define the pre-project baseline, including:
  - a) Equipment and systems
  - b) Baseline energy use (and cost)
  - c) Factors that influence baseline energy useThe baseline can be defined through site surveys; spot, short-term, or long term metering; and/or analysis of billing data.
2. Define the post-project installation situation, including:
  - a) Equipment and systems
  - b) Post-project energy use (and cost)
  - c) Factors that influence post project energy use
3. Site surveys; spot, short-term, or long-term metering; and/or analysis of billing data can be used for the post-project assessment.
4. Conduct ongoing M&V activities to verify the operation of the installed equipment/systems, determine current year savings, and estimate savings for subsequent years.

NOTE: Adding a VFD is often part of an equipment upgrade.

This can affect process flow or related operations. It is important that the post project energy use is equally adjusted to match the pre-installation operating conditions.

Measurement and verification can be a fairly complex process and the success of the current VFD project or future energy efficiency projects may depend upon an accurate and detailed measurement and verification process. It must be included as part of the project costs. It is recommended that a professional practitioner be used to ensure that the measurements are done correctly. Usually the costs associated with the M&V can be recovered from available incentives.

The CEATI Energy Savings Measurement Guide provides details on the process for undertaking measurement and verification of the project.

### j. System Efficiency

The system efficiency is defined as the ratio of output units versus input units. For example, a motor nameplate may indicate 2 kW (output unit), however, the electrical energy to produce this output is actually 2.5 kW (input unit). Therefore, the system efficiency is 0.80, or 80%. The difference in system efficiencies is calculated by subtracting the old system efficiency from the new system efficiency.

If the system efficiency value is negative, this indicates a decline in efficiency since the system optimization. The outcome should always be positive.

### k. Electrical Efficiency

The electrical efficiency improvement is determined by comparing the base case measured electrical consumption with the electrical use determined during the project evaluation metering.

$$\text{Efficiency Improvement} = \text{Post Project Efficiency} - \text{Base Case Efficiency}$$

### l. Cost per Unit Product

This calculation incorporates billing data to give a dollar value to the optimization. Using the formula presented in the base case, apply the post-project metering data.

$$\frac{\text{Demand Charge for Motor} + (\text{OP kWh} \times \text{OP Rate} + \text{FP kWh} \times \text{FP Rate})}{\# \text{ of Units Produced per Day}}$$

OP Rate = the rate per kWh of on-peak energy consumption

FP Rate = the rate per kWh of off-peak energy consumption

To compare against the base case, subtract the base case number from the post-optimization number. If the resulting number is negative, then the cost per unit product has increased. The number should always be positive.

### m. Reliability and Maintenance

Solid-state electronics in VFDs are relatively maintenance free.

Most drive manufacturers supply built-in diagnostics as well as protection relays and fuses.

## 14 VFD Application Considerations and Savings Estimation

When service is required, trained personnel are needed to troubleshoot and repair the drive.

Routine maintenance may include cleaning/replacing filters, where fitted, in addition to standard electrical maintenance activities such as cleaning and inspection on a regular basis.

When repairing electric motors being operated by VFDs, the repair shop should utilize “inverter duty” magnet wire in any rewinds. In addition, they should not reduce the number of turns in coil groups as this increases the electrical stress per turn in the winding.

If the motor failed due to overheating, consideration should be given as to whether sufficient cooling is available to the motor. Fitting an external cooling fan or over-sizing the motor are two options that may be considered.

Your drive supplier or motor repair shop will be able to provide assistance for any service problems.

## 15 CASE STUDIES

---

### a. Case Study: Replacement of Eddy-Current Drive with a VFD

#### Company Background

The company is a 100,000 square foot plant that produces approximately 1 million linear feet of stainless steel tubing per month for its customers in the automotive, food, pharmaceutical and petrochemical industries.

#### Project Overview

The production process consists of drawing stainless steel tubing through dies to reduce their diameter and/or wall thickness. This drawing process is carried out on a drawbench.

Each tube typically goes through several breaking draws that rapidly form the tube close to its final dimensions. Next, the tube undergoes a few final “finishing” draws to achieve the exact tube size. The drawbench used for breaking draws operates 24 hours 5 days per week, performing approximately 1,200 draws per day.

The breaking drawbench is powered by a 150 HP motor running at 1,800 rpm. This motor is coupled to a speed reducer through an eddy current clutch that is known to be an inefficient, although reliable, technology.

## 15 Case Studies

### Approach

The implementation team used data collected by the plant engineering department to analyze the existing system. This included observing the operation of other equipment similar to the breaking drawbench and noting where similar operating parameters could be applied to the breaking drawbench.

Due to the wide variety of tube diameters, wall thickness, material used and orders received each week, a single representative product does not exist. To obtain data representative of actual operation, the project team randomly selected orders and then performed a detailed analysis of the intermediate steps to which the tubing undergoes. The team compared the power requirement that plant engineering measured in the base case study against the measured system power requirements.

196

### Project Implementation

A VFD using vector drive options was selected as it can continuously monitor the current, voltage and angular position of the AC induction motors. Prior to the development of vector drive controls, only DC motors, which are less reliable and require more maintenance than their AC counterparts, could be used in applications requiring accurate torque and speed control. Today, vector drive options are a regular feature of VFDs.

In order to accomplish the project goals, the team replaced the magnetic starter and eddy current clutch with a VFD vector drive and line reactor. A line reactor was included as a system specification to avoid and harmonic issues on the distribution

system. The plant engineer also wanted to increase the torque output to the drawbench, improve overall drive efficiency, and reduce energy consumption. Thus, the standard efficiency 150 HP, 1,800 rpm motor was replaced with a high efficiency 200 HP, 1,200 rpm motor. The lower speed motor was chosen as it produces greater torque than the higher speed motor.

## Results

As a result of the changes implemented by the team, the breaking drawbench now requires less energy to draw a tube, even though the motor size was increased from 150 HP to 200 HP. For a typical draw, the eddy current coupling system required 190 HP to draw a tube, while the more efficient VFD drive requires less than 90 HP. The projected total annual operating time was also reduced by 623 hours as a result of the modifications, since the greater horsepower available enabled many of the tubes to be reduced to the desired size with a smaller number of draws.

The modifications reduced the breaking drawing bench's total annual energy consumption from 439,065 kWh to 290,218 kWh and reduced the total annual electricity costs by 34 percent from the base case cost of \$20,812.

An estimated 2,762 hours of labor per year will be saved as a result of these changes. Personnel estimate that one draw was eliminated from 1/2 of the orders processed. Time is not only saved through the reduced number of draws required to “break” a tube, but is also saved by minimizing other operations required by the drawing process, such as degreasing, cut-off, swaging, and annealing.

## 15 Case Studies

Assuming a labour rate of \$8.50 per hour, the labour reduction amounts to labour cost savings of \$23,473 per year.

The reduced number of draws necessary also saved an estimated \$41,322 of stainless steel, as fewer draws equate to fewer swaged ends cut off (waste) after each draw. Including other direct savings of \$5,415, the total cost savings is \$77,266. When measured against the project's \$34,000 cost, the simple payback came in at about 6 months.

### Energy and Cost Savings

Project Implementation Costs	\$34,000
Annual Energy Cost Savings	\$7,056
Annual non-energy cost savings (labour & scrap)	\$70,210
Simple Payback (years)	1/2
Demand Savings (kW)	189
Annual Energy Savings (kWh)	148,847

## b. Case Study: Replacement of Damper Controls with VFDs in an HVAC System

### Company Background

A small textile processing plant processing raw fiber wanted to improve the HVAC system performance in its plant. The company worked with a VFD specialist to retrofit 15 of the system's fan motors with variable frequency drives (VFDs). As the plant operated 24/7, savings on the HVAC system could be cost efficient and provide better space conditioning and air quality for its workers.

## Project Overview

The ventilation system uses nine supply fans and nine return fans to control and maintain proper ambient conditions, cool process machinery and provide proper air quality to its workers. Initially, a mixture of return air and fresh air is cleaned, cooled and humidity adjusted by four air washers. This air is then supplied to the facility by the nine supply fans and distributed to the plant through ceiling mounted ducts and diffusers. Nine return fans pull air through the processing area into a network of ducts. Any suspended particulate is filtered out at the inlet of each return fan.

Factors that influence the pressure, volume or resistance of the system directly impact the fan power requirements. Therefore, air density, changes to damper positions, system pressure and air filter pressure drops, supply and return air system interaction and parallel fan operation all affect how much power the fans require and must be monitored to ensure the efficient functioning of the system. Variable inlet guide vanes and outlet dampers initially controlled the system's air flow, but were highly inefficient. Setting these devices was imprecise and resetting them could only be done manually.

## Approach

To determine how to improve ventilation system performance, the company and a VFD specialist collected base case system data over two weeks to measure the performance of the existing system. Motor power was electronically logged, damper positions were manually recorded based on visual inspection of the damper linkages and power was measured on each fan at ten-minute intervals. These data were analyzed and

## 15 Case Studies

the team then developed a load duty cycle to calculate energy demand, operating hours (peak, and off-peak periods) and annual energy consumption during this period for both the return fans and supply fans. This data was later compared to the new system data, collected from after installation.

### Project Implementation

After determining that the ventilation system's fans were significantly oversized, the team retrofitted 15 of the 18 fans with VFDs. The remaining fans always ran at full flow and did not need VFDs. A power and energy measurement was connected to each of the VFDs to gather load data for the new system. The system logged each fan's speed and power consumption in 15-minute intervals and savings analysis reports were generated. With the VFDs installed, damper control was no longer necessary so the fan control dampers were left fully opened.

200

### Results

Installation of the VFDs reduced the ventilation system's total electricity demand from approximately 322 kW to 133 kW, a 59% reduction. The total annual energy consumption for the fans similarly fell 59% from approximately 2,700,000 kWh to 1,100,000 kWh. The energy efficiency gains were possible because the VFDs enabled plant personnel to fully open the fan control dampers and reduced fan speed. This resulted in a large drop in power consumption and allowed the system to operate more efficiently. These electricity savings translated to annual energy cost savings of about \$101,000.

The cost of the project was \$130,000 and included:

- Cost of the feasibility study
- Capital cost
- Installation cost
- Engineering
- M&V activities

The simple payback for the project's cost was 1.3 years.

### Energy and Cost Savings

Project Implementation Costs	\$130,000
Annual Energy Cost Savings	\$101,000
Simple Payback (years)	1.3
Demand Savings (kW)	189
Annual Energy Savings (kWh)	1,579,400

## c. Case Study: Replacement of Vacuum Pump Controls with a VFD in a Dairy Facility

201

### Company Background

A dairy farm uses a vacuum system to operate automatic milking equipment that milks cows and sends the milk to a holding tank. Prior to undertaking the project, the dairy vacuum system was utilizing a vacuum pump with a 30 HP motor that controlled vacuum levels by bleeding in air from the atmosphere, which is standard practice in the industry.

## 15 Case Studies

### Project Overview

Modern dairy milking systems used in dairy farms utilize a vacuum for automatically milking the animals. In typical dairy vacuum milking systems, several milking units are attached to the animals with teat cups and a vacuum is introduced into the milking lines by a vacuum pump which draws milk from the teats into a storage tank.

The vacuum pump is driven by a constant speed AC motor. To maintain the stable vacuum needed for milking cows, air must be removed from the system at the same rate at which it leaks into the system. Air typically enters the system through pulsators, leaks and units becoming detached from animals.

Conventional vacuum control is accomplished by running a constant speed vacuum pump sized to the largest possible airflow and allowing air to bleed into the system through a pressure regulating system.

202

With some technical assistance from their utility, the farm examined their vacuum pumping system to determine whether it was operating efficiently. The evaluation determined that the system's motor was oversized for the required vacuum and the farm could lower its energy costs with a smaller, more efficient system.

### Project Implementation

Using the recommendations provided, the farm decided to implement a system that reduced the motor size and operated with a VFD. The motor was replaced with a new, energy efficient 20 HP motor.

In addition, the farm installed a VFD on the new motor to adjust the pumping system speed based on the system load.

The dairy could have installed a larger VFD on the existing 30 HP motor, but that would have increased the capital cost and missed the opportunity for a more efficient motor.

## Project Results

The implementation of the new vacuum pump system resulted in energy savings and more efficient production for the farm. While the original system drew 16 kW, the new system never uses more than 4.5 kW, even during peak needs. The farm was able to decrease the horsepower required by the vacuum system by 30% of the system's total capacity without any decrease in vacuum pressure or system capacity. In addition, the VFD was able to change the pump's speed to more precisely match the process vacuum requirements.

The project's implementation has allowed the farm to achieve annual energy savings of \$5,520 and 55,000 kWh, representing over 70% of the electricity used by that system. With a total cost of \$8,200 the simple payback was only 1.5 years.

The project also reduced maintenance costs and will lead to increased equipment life.

## 15 Case Studies

### **Energy and Cost Savings**

Project Implementation Costs	\$8,200
Annual Energy Cost Savings	\$5,520
Simple Payback (years)	1.5
Demand Savings (kW)	11.5
Annual Energy Savings (kWh)	55,000

## 16 BIBLIOGRAPHY

---

1. Lawrie, Robert J., “Electric Motor Manual”, McGraw Hill, 1987.
2. “Electronically Commutated Motor,” NuAire.  
<http://www.nuaire.com/pdf/ecm-20101123.pdf>
3. “Written Pole Single Phase Motors,” Precise Power.  
<http://www.written-pole.com>
4. “The DC Linear Motor,” Cleveland State University.  
[http://www.csuohio.edu/academic/success\\_in\\_math/posters/CSU/CSU\\_2011/poster\\_13.pdf](http://www.csuohio.edu/academic/success_in_math/posters/CSU/CSU_2011/poster_13.pdf)
5. “Hybrid Step Motor,” National Instruments.  
<http://zone.ni.com/devzone/cda/ph/p/id/287#toc3>
6. Smeaton, Robert W. “Motor Application & Maintenance Handbook,” 2<sup>nd</sup> Edition, 1987.
7. “CanMOST - The Canadian Motor Selection Tool,” Natural Resources Canada.  
<http://oee.nrcan.gc.ca/industrial/equipment/software/intro.cfm?attr=24>
8. “*Are Bearing Currents Causing Your Motor Failures?*” Engineering Update, Greenheck Fan Corporation, Volume 6, Issue 1, Spring 2004.

## 16 Bibliography

9. Spear, Mike, "Get A Fix on ASD Problems, - Adjustable Speed Drives Sometimes May Harm Bearings and Lubricants," Chemical Processing, December 2005.
10. "Motor Decisions Matter," Consortium for Energy Efficiency. <http://www.motorsmatter.org/>
11. "NEMA Premium Motors," National Electrical Manufacturers Association.  
<http://www.nema.org/gov/energy/efficiency/premiu/>
12. "Best Practices on Motors, Pumps and Fans" U.S. Department of Energy.  
<http://www1.eere.energy.gov/industry/bestpractices/motors.html>
13. "The Effect of Repair / Rewinding on Motor Efficiency EASA/AEMT Rewind Study and Good Practice Guide to Maintain Motor Efficiency," EASA 2003.  
[http://www.easa.com/resources/booklets/EASA\\_AEMT\\_RewindStudy](http://www.easa.com/resources/booklets/EASA_AEMT_RewindStudy)
14. "Laboratory Testing Of The Magnadrive Adjustable-Speed Coupling Systems (ASCS)," Motor Systems Resource Facility (MSRF), Oregon State University, January 2000.

15. “Appliance & Equipment Standards,” U.S. Department of Energy.  
[http://www.eere.energy.gov/buildings/appliance\\_standards/notices\\_rules.html](http://www.eere.energy.gov/buildings/appliance_standards/notices_rules.html)
16. “Energy-Efficient Motor Systems Assessment Guide,” Natural Resources Canada, 2004.
17. “Motor Terms,” Rockwell Automation, 2005.  
<http://www.ab.com/support/abdrives/documentation/fb/1022.pdf>
18. Brunner, Conrad U, “Motor Efficiency Standards SEEEM Harmonization Initiative”, IEA Electric Motor Systems Workshop, Paris, 15-16 May 2006.
19. Little, Arthur, “Opportunities for Energy Savings in the Residential and Commercial Sectors with High-Efficiency Electric Motors,” U.S. Department of Energy, December 1999.
20. “Analysis of Energy Conservation Standards for Small Electric Motors,” Building Technologies Office of Energy Efficiency and Renewable Energy, U.S. Department of Energy, June 2003.
21. “When to Purchase NEMA Premium™ Efficiency Motors - Motor Systems Tip Sheet #2,” U.S. Department Of Energy Publication, November 2012.

22. “Energy Management Guide for Selection and Use of Single-Phase Motors,” National Electrical Manufacturers Association Standards Publication MG11-2012.
23. “Testing of Synchronous Machines during Refurbishment” - CSA C391-11.
24. “Testing of Asynchronous Motors during Refurbishment” - CSA C392-11F.
25. *Canadian Electrical Code 2012*, Canadian Standards Association
26. CSA C390 (2010) Energy Efficient Test Methods for Three Phase Induction Motors, Canadian Standards Association
27. *EASA Technical Manual (2012)*, Electrical Apparatus Service Association, St. Louis
28. *IEEE 519-2014 Recommended Practices and Requirements for Harmonic Control in Electrical Power Systems*, Institute of Electrical and Electronic Engineers, New York
29. *IEEE Standard 112-2004 Test Procedure for Polyphase Induction Motors and Generators*, Institute of Electrical and Electronic Engineers, New York
30. *NEMA Standard MG1 (2011), Motors and Generators*, National Electrical Manufacturers Association, Washington DC

31. NEMA Standard MG10 (2013), Energy Management Guide for Selection and Use of Polyphase Motors, National Electrical Manufacturers Association, Washington DC
32. *Variable Frequency Drives Application Guide (1993)*, Electric Power Research Institute, Palo Alto California
33. Robert S Carrow: Electrician's Technical Reference: Variable Frequency Drives (2006), Delmar Thomson Learning ISBN076681923X
34. Pierre Angers: Benchmark Study to Establish a Test Protocol for Determination of Efficiency for Variable Frequency Drives, Hydro-Québec, 2008



## APPENDIX A RECOMMENDED WEB LINKS

---

Tools and resources listing organizations & programs, software and literature:

<http://www.ceati.com>

Energy Efficiency Guides, such as this one, are available free to download from the CEATI website.

1. **Natural Resources Canada** - Introduction page for “CanMOST” The Canadian Motor Selection Tool  
<http://oee.nrcan.gc.ca/industrial/equipment/software/intro.cfm?attr=24>
2. **NEMA Premium Motors**  
<http://www.nema.org/gov/energy/efficiency/premium/>
3. **US Department of Energy** – Appliance & Equipment Standards  
[http://www.eere.energy.gov/buildings/appliance\\_standards/notices\\_rules.html](http://www.eere.energy.gov/buildings/appliance_standards/notices_rules.html)
4. **Copper Motor Rotor Project** -Using copper as a rotor material to improve efficiency  
<http://www.copper-motor-rotor.org/>

## Appendix A Recommended Web Links

5. **US Department of Energy** - Best Practices on Motors, Pumps and Fans  
<http://www1.eere.energy.gov/industry/bestpractices/motors.html>
6. **BC Hydro Power Smart** - Electric Motors  
<http://www.bchydro.com/powersmart/business/resources/reference-guides.html>
7. **US Department of Energy** - Software Downloads, including Motor Master  
<http://www1.eere.energy.gov/industry/bestpractices/software.html#mm>
8. **Electrical Apparatus Service Association, Inc.** - The Effect of Repair / Rewinding on Motor Efficiency EASA/AEMT Rewind Study and Good Practice Guide to Maintain Motor Efficiency - EASA 2003  
[http://www.easa.com/resources/booklets/EASA\\_AEMT\\_RewindStudy](http://www.easa.com/resources/booklets/EASA_AEMT_RewindStudy)
9. **CEE Motor Guidebook 2013.** – A Guidebook for Industrial Efficiency Programs - EASA 2013  
<http://www.motorsmatter.org/CEEMotorGuidebook.pdf>
10. **CEE Premium Efficiency Motors List 2012.**  
<http://library.cee1.org/content/cee-premium-efficiency-motors-list>

11. **Continuous Energy Improvement in Motor Driven Systems.**  
[http://energy.gov/sites/prod/files/2014/04/f15/amo\\_motors\\_guidebook\\_web.pdf](http://energy.gov/sites/prod/files/2014/04/f15/amo_motors_guidebook_web.pdf)
12. **MotSize selection tool for DOL Motors.** – ABB motor selection software.  
<http://www.abb.com/product/ap/seitp322/ca19386a4d958412c1256dcf003d74ff.aspx>
13. **MotorMaster+.** – NEMA Premium® efficiency motor selection and management tool.  
<http://www.energy.gov/eere/amo/articles/motormaster>

[www.energyefficiency.org](http://www.energyefficiency.org)

The Canadian Energy Efficiency Centre was created by the Canadian Energy Efficiency Alliance to help facilitate and ease access to energy efficiency information and resources. The Alliance promotes and advances energy efficiency and its related benefits to the economy and the environment.

[www.eere.energy.gov/industry/](http://www.eere.energy.gov/industry/)

The Industrial Technologies Program works with U.S. industry to improve industrial energy efficiency and environmental performance.

[www.ieee.org](http://www.ieee.org)

A non-profit organization, IEEE is the world's leading professional association for the advancement of technology.

## Appendix A Recommended Web Links

[www.nema.org](http://www.nema.org)

NEMA is the trade association of choice for the electrical manufacturing industry, and is the largest trade association for manufacturers of electrical products in the United States.

[www.electrofed.com/councils/EEMAC/](http://www.electrofed.com/councils/EEMAC/)

The Electrical Equipment Manufacturers Association of Canada (EEMAC) is the meeting place for over 80 companies involved in the manufacturing and sale of electrical products, systems, and components in Canada. EEMAC focuses on the economic well-being of the industry.

[http://www.motorsmatter.org/case\\_studies/MidAmerican\\_VF\\_D.pdf](http://www.motorsmatter.org/case_studies/MidAmerican_VF_D.pdf)

214

Utility Case Studies, such as this one, offers further examples of VFDs installed in a rubber manufacturing plant.

<http://www.Energy-Efficiency.com>

Presentations and useful references are available that support the triple bottom line that energy efficiency provides, i.e.:

- Economic Prosperity
- Environmental Performance
- Social Responsibility

<http://www.nrcan.gc.ca/energy/offices-labs/office-energy-efficiency>

Natural Resources Canada's Office of Energy Efficiency offers online help such as:

- Description
- Estimated Savings
- Purchasing Tips
- Other useful links including manufacturing.

<http://publications.gc.ca/collections/Collection/M92-242-2002-11E.pdf>

Fact sheets such as the above provide additional support.

[http://www.pumps.org/content\\_detail.aspx?id=2436](http://www.pumps.org/content_detail.aspx?id=2436)

There are many more resources, such as the Hydraulic Institute which is a market transformation initiative created to assist North American pump system users gain a more competitive business advantage through strategic, broad-based energy management and pump system performance optimization. A primary objective of the initiative is to change the decision-making process for the purchase of pumping systems and additional resources, such as the VFD.

<http://new.abb.com/drives/software-tools>

ABB VSD calculator

<https://ecenter.ee.doe.gov/em/tools/Pages/VSDCalcFans.aspx>

US Department of Energy VSD fan calculator.

## Appendix A Recommended Web Links

<https://ecenter.ee.doe.gov/em/tools/Pages/VSDCalcPumps.aspx>

US Department of Energy VSD pump calculator.

## APPENDIX B INDUSTRY ACRONYMS AND GLOSSARY

---

### Industry Acronyms

AC = alternating current  
ASD = adjustable speed drive  
BHP = brake horsepower  
CDM = conservation and demand management  
CFM = cubic feet per minute  
CSI = current source inverter  
DC = direct current  
DSM = demand side management  
DSP = digital signal processor  
ECC = eddy current coupling  
FPM = feet per minute  
GPM = gallon per minute  
GTO = gate turnoff (thyristor)  
HDF = harmonic distortion factor  
IGBT = insulated gate bi-thermal thyristor  
LCI = load-commutated inverter  
NPV = net present value  
PAM = pulse amplitude modulation  
PLC = programmable logic controller  
PWM = pulse width modulated (inverter)  
SCR = silicon-controlled rectifier  
SR = switched reluctance  
THD = total harmonic distortion  
V = voltage  
VSI = variable source inverter  
VVI = variable voltage inverter

## Appendix B Industry Acronyms and Glossary

Air Gap	The space between the rotating (rotor) and stationary (stator) member in an electric motor.
Altitude	The atmospheric altitude (height above sea level) at which the motor will be operating; NEMA standards call for an altitude not exceeding 3,300 ft. (1,000 meters). As the altitude increases above 3,300 ft. and the air density decreases, the air's ability to cool the motor decreases - for higher altitudes higher grades of insulation or a motor derating are required. DC motors require special brushes for high altitudes (Ref. 17).
Ambient Temperature	The temperature of the surrounding cooling medium, such as gas or liquid, which comes into contact with the heated parts of the motor. The cooling medium is usually the air surrounding the motor. The standard NEMA rating for ambient temperature is not to exceed 40°C.
Ampere	A unit of current that is a measure of the rate of electron flow. It is often abbreviated as Amp. The unit of current flow is the amp.
Antifriction Bearing	An antifriction bearing is a bearing utilizing rolling elements between the stationary and rotating assemblies.
Armature	The portion of the magnetic structure of a DC or universal motor that rotates.
Breakdown Torque	The maximum torque a motor will develop at rated voltage without a relatively abrupt drop or loss in speed.

## Appendix B Industry Acronyms and Glossary

Brush	A piece of current conducting material (usually carbon or graphite) which rides directly on the commutator of a commutated motor and conducts current from the power supply to the armature windings.
Capacitance	Capacitance is that property of a system of dielectrics and conductors that allows for the storage of electrically separated charges when a potential difference exists between the conductors. A capacitor does not dissipate real energy (watts).
Capacitor	A device that can store electrical charge. In an AC circuit, a capacitor causes the voltage to lead the current. The unit of capacitance is the Farad.
Commutator	A cylindrical device mounted on the armature shaft and consisting of a number of wedge-shaped copper segments arranged around the shaft (insulated from it and each other). The motor brushes ride on the periphery of the commutator and electrically connect and switch the armature coils to the power source.
Conductor	Any material that offers little resistance to the flow of electricity such as copper.
Constant Horsepower	Describes a load that decreases with increasing speed. Common applications are variable speed processes that are changing diameters such as lathes, winders, unwinders, and metal-cutting tools. With an initial large diameter work piece, maximum torque and slow speeds are required.

## Appendix B Industry Acronyms and Glossary

Constant Torque	Describes a load where the torque required is constant throughout the speed range e.g. a friction load. Friction loads require the same amount of torque at low speeds as at high speeds. The horsepower requirement, however, increases with speed. Common applications include general machinery, hoists, conveyors, etc.
CSA	Canadian Standards Association
Drip-Proof Motor	An open motor in which the ventilating openings are so constructed that drops of liquid or solid particles falling on it, at any angle not greater than 15 degrees from the vertical, cannot enter either directly or by striking and running along a horizontal or inwardly inclined surface.
Duty Cycle	The relationship between the operating and rest times or repeatable operation at different loads. A motor that can continue to operate within the temperature limits of its insulation system, after it has reached normal operating (equilibrium) temperature is considered to have a continuous duty (CONT.) rating. One that never reaches equilibrium temperature, but is permitted to cool down between operations is operating under intermittent duty (INT.) conditions such as a crane and hoist motor that are often rated 15 or 30 min. duty.
Eddy Currents	Localized currents induced in an iron core by alternating magnetic flux. These currents translate into losses (heat) and their minimization is an important factor in lamination design.

## Appendix B Industry Acronyms and Glossary

Efficiency	The efficiency of a motor is the ratio of mechanical energy output to electrical energy input. It represents the effectiveness with which the motor converts electrical energy into mechanical energy.
Electromotive Force (EMF)	A synonym for voltage usually used to describe induced or generated voltages in an electric circuit.
Field	The term used to describe the stationary part of a DC machine. The field provides the magnetic flux that interacts with the armature.
Flux	The magnetic field that is established around a current carrying conductor or a permanent magnet.
Fractional-Horsepower Motor	A motor usually built in a frame smaller than that having a continuous rating of one horsepower, open construction, at 1700 -1800 rpm.
Frequency	The rate at which alternating current reverses its direction of flow. The unit of frequency is either Hertz or cycles per second.
Full-Load Current	The current flowing through the line when the motor is operating at full-load torque and full-load speed with rated frequency and voltage applied to the motor terminals.
Full-Load Speed	The speed of the motor at rated voltage, frequency and load.
Full-Load Torque	That torque of a motor necessary to produce its rated horsepower at full-load speed, sometimes referred to as running torque.
Hertz (Hz)	One cycle per second (as in 60 Hz. which is 60 cycles per second).

## Appendix B Industry Acronyms and Glossary

Horsepower	<p>The measure of rate of work. One horsepower is equivalent to lifting 33,000 pounds to a height of one foot in one minute. The horsepower of a motor is expressed as a function of torque and rpm.</p> <p>where:            HP = horsepower,            T = torque (lb.ft.), and            RPM = revolutions per minute.</p> <p>The SI equivalent of horsepower is kilowatts.  <math>kW = HP \times 0.746</math></p>
Hysterisis	A lagging of the resulting magnetization in a ferromagnetic material caused by a changing magnetic field.
Hysterisis Loss	The resistance to becoming magnetized (magnetic orientation of molecular structure) offered by materials results in energy being expended and corresponding loss. Hysterisis loss in a magnetic circuit is the energy expended to magnetize and demagnetize the core.
IEC	International Electrotechnical Commission
IEEE	Institute of Electrical and Electronic Engineers
Impedance	<p>Propensity of a circuit or device to impede the flow of AC current.</p> <p>The real part of impedance is the resistance, and the imaginary part is the reactance.</p>
Inductance	<p>Represents the propensity of a conductor to store energy in an associated magnetic field.</p> <p>Opposes the change of alternating current, but does not oppose the flow of steady current, such as direct current.</p> <p>Can be thought of as electrical inertia.</p>

Induction Motor	An induction motor is an alternating current motor in which the primary winding on one member (usually the stator) is connected to the power source and a secondary winding or a squirrel-cage secondary winding on the other member (usually the rotor) carries the induced current. There is no physical electrical connection to the secondary winding, its current is induced.
Inertial Load	A load (flywheel, fan, etc.) that tends to cause the motor shaft to continue to rotate after the power has been removed (stored kinetic energy). If this continued rotation cannot be tolerated, some mechanical or electrical braking is needed. This application may require a special motor due to the energy required to accelerate the inertia.
Insulation Class	Since there are various ambient temperature conditions a motor might see and different temperature ranges within which motors run and insulation is sensitive to temperature; motor insulation is classified by the temperature ranges at which it can operate for a sustained period of time.
Inverter	An electronic device that converts fixed frequency and voltage to variable frequency and voltage.
JEC	Japanese Electrotechnical Committee
Laminations	The steel portion of the rotor and stator cores made up of a series of thin laminations (sheets) that are stacked and fastened together by cleats, rivets or welds. Laminations are used instead of a solid piece in order to reduce eddy-current losses.

## Appendix B Industry Acronyms and Glossary

Line Voltage	The voltage supplied to the input terminals of an electric device.
Magnetic Field	The magnetic influence of electric currents and magnetic materials and can be specified by both a direction and magnitude.
Magnetic Flux	The integral over a specified surface of the component of magnetic induction perpendicular to the surface.
Magnetic Pole	The portions of a magnet that appear to generate or absorb the flow of the external magnetic induction.
NEMA	National Electrical Manufacturers Association is a non-profit organization organized and supported by manufacturers of electric equipment and supplies. NEMA has set standards on: HP ratings, Speeds, frame sizes and dimensions, standard voltages and frequencies with allowable variations, service factors, torques, starting current & kVA, enclosures.
Phase	A term used to describe the spatial relationship of windings in an electric motor or voltages and currents in an electric circuit.
Power Factor	The ratio of total watts to the total root mean square (RMS) volt-Amperes.
PWM	Pulse Width Modulation – when applied to a variable speed drive, the inverter adjusts both the width of the output voltage pulses as well as the frequency to improve the sinusoidal shape of the output voltage waveform.

## Appendix B Industry Acronyms and Glossary

Reactance	<p>The opposition to the flow of alternating current by the inductance or capacitance of a component or circuit.</p> <p>Reactance is inductive if the imaginary part of the impedance is positive.</p> <p>Reactance is capacitive if the imaginary part of impedance is negative.</p>
Rectifier	<p>A rectifier is a device which may be used to convert alternating current to direct current (by conducting current easily in one direction and negligibly in the opposite direction).</p>
Resistance	<p>A physical property of a circuit that impedes the flow of current. For AC circuits, resistance limits the current that is in phase with the voltage. When current flows through a resistance, a voltage drop develops across the resistance (Ohm's Law).</p> <p>It is the real part of impedance and usually represents the conversion of electrical energy into heat.</p>
Retentivity	<p>The capacity to retain magnetism after the magnetizing action has ceased.</p>
Rotor	<p>The rotating member of an electric motor.</p>
Service Factor	<p>When used on a motor nameplate, a number which indicates how much above the nameplate rating a motor can be loaded without causing serious degradation, (i.e., a 1.15 S-F can produce 15% greater torque than the 1.0 S-F rating of the same motor).</p>
Slip	<p>The ration of the difference between the synchronous speed and the actual speed of the rotor to the synchronous speed of the rotor.</p>

## Appendix B Industry Acronyms and Glossary

Slip Ring	Continuous conducting rings on the rotor from which brushes conduct current into or out of the motor.
Standards Organizations	ANSI - American National Standards Institute BASEEFA - British Approval Service for Electrical Equipment in Flammable Atmospheres CE - Compliance to European Standards CSA - Canadian Standards Association EPACT - 1997 U.S. Energy Policy Act IEC - International Electrotechnical Commission IEEE - Institute of Electrical and Electronics Engineers ISO - International Standards organization MIL - Military Specifications MSHA - U.S. Mining, Safety, Health Administration NAFTA - North American Free Trade Agreement NEC - National Electric Code NEMA - National Electrical Manufacturers Association UL - Underwriter's Laboratories
Stator	The stationary part of an AC motor housing the steel laminations and the windings.
Synchronous Speed	The speed of the rotation of the magnetic flux produced by the stator windings. The lines of force that represent magnetic induction.
Temperature Rise	Each NEMA temperature code has an associated temperature rise which when added to the ambient and hot spot should not exceed the temperature handling of the insulation system.

## Appendix B Industry Acronyms and Glossary

UL	Underwriter's Laboratories (the UL approval mark with a subscripted letter "C" indicates the device has been tested by UL to Canadian Standards).
Torque	The turning force applied to a shaft, usually expressed as pound-feet (English) or Newton-meters (metric).
Variable Torque	Variable torque loads increase torque with speed and are usually associated with centrifugal fan and pump loads, where, in theory, the horsepower requirement varies as the cube of the speed change. Variable torque loads provide the greatest savings potential for VFD's.
Voltage	The standard unit of electromotive force that produces a flow of current in a conductor. The unit of electromotive force is the volt.
Watt	A measurement of power in an electrical circuit that is equal to one joule of energy being expended in one second.



## APPENDIX C USEFUL FORMULAS

---

### Calculating the Horsepower Requirement of a Load

The mechanical load required by the driven equipment is known as the Brake Horsepower (BHP). The BHP value can be calculated by the following:

$$BHP = \frac{T \times N}{5,250} \text{ (required HP)}$$

Where:

BHP = horsepower required to drive the load

T = Torque (lb-ft) force x radius

N = base speed of motor (rpm)

Once the machine BHP (speed times torque) requirement is determined, the motor horsepower (HP) can be calculated:

$$\text{Rated Motor HP} = \frac{\text{BHP}}{\text{Motor Efficiency (\%)} / 100}$$

If the calculated horsepower falls between standard available motor ratings, select the higher available horsepower rating. It is good practice to allow some margin when selecting the motor horsepower.

For many applications, it is possible to calculate the horsepower required without actually measuring the torque required.

## Appendix C Useful Formulas

Several typical examples:

### For Conveyors:

$$HP(\text{vertical}) = \frac{\text{weight}(lb) \times \text{velocity}(FPM)}{33,000 \times \text{efficiency}}$$

$$HP(\text{horizontal}) = \frac{\text{weight}(lb) \times \text{velocity}(FPM) \times \text{coefficient of friction}}{33,000 \times \text{efficiency}}$$

### For Fans and Blowers:<sup>5</sup>

Effect of speed on horsepower:

HP = k1 x speed(RPM)<sup>3</sup> – horsepower varies as the 3rd power of speed

T = k2 x speed(RPM)<sup>2</sup> – torque varies as the 2nd power speed

Flow = k3 x speed(RPM) – flow varies directly as the speed

$$HP = \frac{CFM \times \text{pressure}(\frac{lb}{in^2})}{229 \times (\text{efficiency of fan})}$$

$$HP = \frac{CFM \times (\text{inches of water gauge total pressure})}{6,362 \times (\text{efficiency of fan})}$$

Total pressure = static pressure + velocity pressure

$$\text{Velocity pressure} = V^2 \times \left(\frac{1}{1,096.7}\right)^2 \times \text{density}$$

---

<sup>5</sup> All references to horsepower are mechanical shaft power and not electrical input power, unless otherwise noted by accounting for the motor efficiency.

## For Pumps:

$$hp = \frac{GPM \times head(ft) \times specificgravity}{3,960 \times \% \text{ eff. of pump}}$$

Specific gravity of water = 1.0

1 ft<sup>3</sup> per sec = 448 GPM

1 PSI = A head of 2.309 ft for water weighing 62.36 lb/ft<sup>3</sup> at 62°F

### *Constant Displacement Pumps*

Effect of speed on horsepower (hp) = k x speed(RPM).

Horsepower and capacity vary directly with the speed.

Displacement pumps under constant head require approximately constant torque at all speeds.

### *Centrifugal Pumps*

Effect of speed on input brake horsepower:

$hp = k_1 \times \text{speed(RPM)}^3$  - horsepower varies as the 3rd power of speed

$T = k_2 \times \text{speed(RPM)}^2$  - torque varies as the 2nd power of speed

$\text{Flow} = k_3 \times \text{speed(RPM)}$  - flow varies directly as the speed

### *Centrifugal Pump Efficiency (Typical)*

500 to 1,000 gal./min. = 70% to 75%

1,000 to 1,500 gal./min. = 75% to 80%

## Appendix C Useful Formulas

Larger than 1,500 gal./min. = 80% to 85%

Displacement pumps may vary between 50% to 80% efficiency, depending on size of the pumps.

*Horsepower Required*

$$HP = \frac{\text{torque}(lb - ft) \times \text{speed}(RPM)}{5,250}$$

$$HP = \text{torque}(lb - ft) \times \text{speed}(RPM) \times 63,000$$

$$\text{Torque}(lb - ft) = \frac{HP \times 5,250}{\text{speed}(RPM)}$$

Ohm's Law

$$\text{Amperes} = \frac{\text{volts}}{\text{ohms}}$$

$$\text{Ohms} = \frac{\text{volts}}{\text{amperes}}$$

$$\text{Volts} = \text{amperes} \times \text{ohms}$$

Power in DC Circuits

$$\text{Horsepower} = \frac{\text{volts} \times \text{amperes}}{746}$$

$$\text{Watts} = \text{volts} \times \text{amperes}$$

$$\text{Kilowatthours} = \frac{\text{volts} \times \text{amperes} \times \text{hours}}{1,000}$$

## Power in AC Circuits

## Kilovolt-Amperes (kVA)

$$kVA(\text{single} - \text{phase}) = \frac{\text{volts}(\text{line to line}) \times \text{amperes}(\text{on line})}{1,000}$$

$$kVA(\text{three} - \text{phase}) = \frac{\text{volts}(\text{line to line}) \times \text{amperes}(\text{on line}) \times 1.73}{1,000}$$

## Kilowatts (kW)

$$kW(\text{single} - \text{phase}) = \frac{\text{volts}(\text{line to line}) \times \text{amperes}(\text{on line}) \times \text{power factor}}{1,000}$$

$$kW(\text{three} - \text{phase}) = \frac{\text{volts}(\text{line to line}) \times \text{amperes}(\text{on line}) \times \text{power factor} \times 1.73}{1,000}$$

$$\text{Power factor (PF)} = \frac{kW}{kVA}$$

## Three-Phase AC Circuits

$$HP = \frac{\text{volts}(\text{line to line}) \times \text{amperes}(\text{on line}) \times 1.73 \times \text{EFF} \times \text{PF}}{746}$$

$$\text{Motor amps} = \frac{HP \times 746}{\text{volts}(\text{line to line}) \times 1.73 \times \text{EFF} \times \text{PF}}$$

$$\text{Motor amps} = \frac{kVA \times 1,000}{1.73 \times \text{volts}(\text{line to line})}$$

$$\text{Motor amps} = \frac{kW \times 1,000}{1.73 \times \text{volts}(\text{line to line}) \times \text{PF}}$$

$$\text{Power factor} = \frac{kW \times 1000}{\text{volts}(\text{line to line}) \times \text{amperes}(\text{on line}) \times 1.73}$$

$$\text{Kilowatt} - \text{hours} = \frac{\text{volts}(\text{line to line}) \times \text{amperes}(\text{on line}) \times \text{hours} \times 1.73 \times \text{PF}}{1000}$$

$$\text{Power(watts)} = \text{volts}(\text{line to line}) \times \text{amperes}(\text{on line}) \times \text{hours} \times 1.73 \times \text{PF}$$

## Appendix C Useful Formulas

$$PF = \text{displacement power factor} = \cosine\ angle = \frac{kW}{kVA}$$

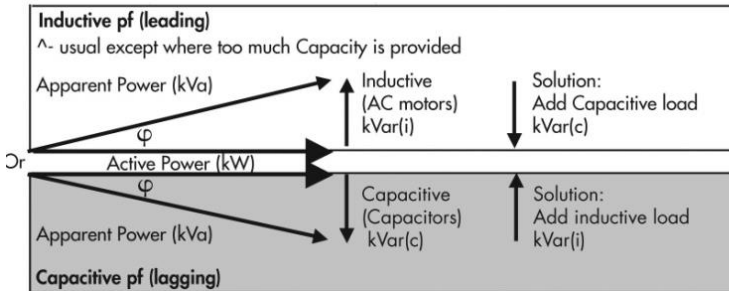

Ideal: pf should be at unity (1.0) i.e.:

$\phi$  is zero  
and kVa is equal to kW  
(Apparent Power) (Active or 'Real' Power)

**Figure 23: Power Triangle - Illustrating Relationships Between**

1. Active (kW) and Apparent Power (kVa)
2. Ration of Active Vs Apparent Power is the Power Factor (kW/kVa)
3. Inductive Vs Capacitive load (kVar)
4. Inductive (leading) Vs Capacitive (lagging)

# APPENDIX D CONVERSION FACTORS

	<b>Multiply</b>	<b>By</b>	<b>To Obtain</b>
<b>Length</b>	Meters Meters Inches Feet	3.281 39.37 0.0254 0.3048	Feet Inches Meters Meters
<b>Torque</b>	Newton- Meters lb-ft lb-in lb-ft	0.7376 1.3558 0.0833 12.00	lb-ft Newton- Meters lb-ft lb-in
<b>Rotation</b>	RPM RPM Degrees/sec Rad/sec	6.0 0.1047 0.16667 9.549	Degrees/sec Rad/sec RPM RPM
<b>Moment of Inertia</b>	Newton- Meters <sup>2</sup> oz-in <sup>2</sup> lb-in <sup>2</sup> Slug-ft <sup>2</sup> oz-in-sec <sup>2</sup> lb-in-sec <sup>2</sup>	2.42 0.000434 0.00694 32.17 0.1675 2.68	lb-ft <sup>2</sup> lb-ft <sup>2</sup> lb-ft <sup>2</sup> lb-ft <sup>2</sup> lb-ft <sup>2</sup> lb-ft <sup>2</sup>
<b>Power</b>	Watts lb-ft/min HP HP	0.00134 0.0000303 746 30300	HP HP Watts lb-ft/min
<b>Temperature</b>	Degree C = (Degree F-32) x 5/9 Degree F = (Degree C x 9/5) + 32		

## Appendix D Conversion Factors

# INDEX

---

- 3-Phase AC Induction
  - Motors, 11
- AC Motors, 20
- Adjustable Speed Drives (ASDs), 146
- Advanced Motors, 60, 64
- AFD Bearing Problem
  - Prevention, 162
- Air Gap, 261
- Altitude, 261
- Ambient Temperature, 261
- ASD Bearing Failure, 160
- Assessing Existing Motor
  - Inventory, 116
- BC Hydro Power Smart
  - on Electric Motors, 255
- Bearing, 261
- Bearings, 151
- Bearings, Antifriction, 151
- Bearings, Ball, 151
- Bearings, Greasing, 152
- Bearings, Plain, 153
- Bearings, Roller, 151
- Bearings, Vibration, 156
- Braking, Electrical, 139
- Braking, Mechanical, 140
- Breakdown Torque, 261
- Brush, 261
- Brushes, 49
- CanMOST, 112, 249, 254
- Capacitance, 262
- Capacitor, Starting, 36
- Common Failure Modes, 149
- Commutator, 262
- Considerations, Mounting and Base, 95
- Controller, Power Factor, 133
- Cost, Life Cycle, 104
- Cost, Operating, 113
- CSA, 262
- CSA C390, 110
- CSA Minimum Nominal Efficiencies, 109
- Custom, 91
- DC Motor, 51
- DC Motor Control, 144
- DC, Compound, 56
- DC, Electronically Commutated (ECM), 60
- DC, Linear, 65
- DC, Permanent Magnet, 58, 63
- DC, Separately Excited, 53
- DC, Series Field, 55
- Drip-Proof Motor, 263

## Index

- Duty Cycle, 263
- Duty Cycle, Continuous, 87
- Duty Cycle, Intermittent, 90
- Duty Cycle, Repetitive, 87
- Economics, 163
- Eddy Currents, 263
- Efficiency, 109, 263
- Efficiency and Economics, 99
- Efficiency and Motor Sizing, 103
- Efficiency, EE vs. Standard Motors, 107
- Efficiency, NEMA Premium, 110
- Efficiency, Selecting Energy Efficient Motors, 113
- Electrical Supply Distribution System, 68
- Enclosure, 93
- Energy Costs, 99
- Environmental Factors, 92
- EPAAct, 111
- Factors, Physical, 93
- Fractional-Horsepower Motor, 264
- Friction and windage losses, 103
- Full-Load Current, 264
- Glossary, 260
- Grounding, 161
- Hertz (Hz), 264
- Horsepower, 15, 264
- Hybrid, 66
- Hysteresis, 46, 265
- Hysteresis Loss, 265
- IEC, 265
- IEEE, 265
- IEEE 122 Method B, 110
- Impedance, 265
- Inductance, 265
- Induction Motor, 265
- Induction Motor Selection, 82
- Induction, 3-Phase AC, 79
- Induction, 3-Phase AC, 22
- Induction, Capacitor, 34
- Induction, Capacitor Run, 37
- Induction, Capacitor Start, 34
- Induction, Capacitor Start – Capacitor Run, 36
- Induction, Shaded Pole, 39
- Induction, Split Phase, 32
- Induction, Squirrel Cage, 23
- Induction, Squirrel Cage NEMA Design Characteristics, 25

- Inertial Load, 265
- Insulation, 95, 156
- Inverter, 266
- JEC, 109, 110, 266
- Laminations, 266
- Load Adjustments, 167
- Load, Driven, 86
- Loss Reduction, 106
- Losses, Core, 102
- Magnetic Field, 266
- Magnetic Field, Rotating, 20
- Magnetic Flux, 14, 266
- Magnetic Starter, 126
- Maintenance, 149
- Maintenance Frequency, 149
- Manual Starter, 125
- Minimum Motor
  - Insulation Resistance, 158
- Motor Classifications, 79
- Motor Controls, 119
- Motor Losses, 102
- Motor Protection, 119
- Motor Resizing, 166
- Motor Selection, 68
- Motor Starting, 123
- Motor Stopping, 138
- Motor, Advanced, 12
- Motor, DC, 12
- Motor, Direct Current,
  - Selection, 84
- Motor, Induction, Single
  - Phase, Selection, 85
- Motor, Induction,
  - Selection,, 79
- Motor, Induction, Single
  - Phase, 84
- Motor, Induction, Wound
  - Rotor, 27
- Motor, Starter, 3-Phase, 124
- Motor, Universal, 12
- MotorMaster+, 112
- Multi-speed, 141
- Natural Resources Canada, 249, 254
- NEMA, 92, 93, 254, 266
- Noise, 98
- Operation, 13
- Part Winding Starters, 135
- Parts, Major, 13
- Payback, Simple, 114
- Phase Unbalance, 71
- Pole, 266
- Power and Torque, 15
- Power Factor, 72, 118, 167, 267
- Power Factor Correction, 83
- Power, Apparent, 73
- Primary Resistance Starter, 128
- Protection, Disconnect, 119

## Index

- Protection, Other, 122
- Protection, Overload, 120
- Protection, Overcurrent, 120
- Reactance, 267
- Recommended Web Links, 254
- Rectifier, 267
- Repair or Replace, 163
- Reversing, 3-Phase Motor, 22
- RMS Horsepower, 88
- Service Conditions, Usual, 92
- Service Factor, 97, 268
- Service Factors, 97
- Single Phase, 69
- Single Phase AC
  - Induction Motors, 11
- Slip, 22, 268
- Slip Ring, 268
- Solid State Starters, 130
- Speed, 83, 90
- Speed Adjust, 167
- Standard Motor
  - Enclosures, 94
- Standards Organizations, 268
- Starter Autotransformer, 129
- Starter, DC, 136
- Starter, Primary
  - Resistance, 128
- Starter, Reduced Voltage, 127
- Starter, Single Phase, 135
- Starting and Stopping, 91
- Switched Reluctance (SRM), 62
- Synchronous, 41
- Synchronous, 11
- Synchronous Motor
  - Selection, 83
- Synchronous Speed, 22
- Synchronous, Excited Rotor, 42
- Synchronous, Non Excited or Reluctance Rotor, 44
- Synchronous, Single Phase, 45
- Temperature Rise, 269
- Torque, 15
- Torque Variable, Repetitive Duty Cycle – , 87
- Torque, Breakdown, 18
- Torque, Constant, Continuous Duty, 87
- Torque, Full load, 19
- Torque, Pull-up, 18
- Torque, Starting, 18
- Torque-Speed, 17
- Torque-Speed Graphs, 26
- Universal, 48
- Unusual Service
  - Conditions, 92

- US DOE, 254
- US DOE Best Practices
  - on Motors , Pumps and Fans, 250, 255
- US DOE Software
  - Downloads, 255
- Variable Torque, 269
- Vibration, 155
- Voltage and Frequency, 69
- Voltage Flicker, 75
- Voltage Unbalance, 71
- Wound Rotor Motor
  - Control, 143
- Written Pole, 64
- Wye-Delta Starter, 132
- Wye-Delta Starting, 132



Your feedback and comments are appreciated.

Please provide suggestions to:

[info@ceati.com](mailto:info@ceati.com)

## Energy Efficiency is Good Business

- Economic Prosperity
- Environmental Performance
- Social Responsibility
- Security