

A Practical Guide to  
**Noise and  
Vibration  
Control for  
HVAC Systems**

SECOND EDITION (SI)

**Mark E. Schaffer**



# **A Practical Guide to Noise and Vibration Control for HVAC Systems**

---

---

*The first edition of this book was prepared under ASHRAE Research Project RP-526, sponsored by TC 2.6, Sound and Vibration.*

---

---

## **ABOUT THE AUTHOR**

**Mark E. Schaffer, PE, Member ASHRAE**, is president of Schaffer Acoustics Inc., a southern California acoustical consulting and testing firm. He has been an acoustical consultant for 34 years and an HVAC subcontractor for 5 years. He is an active member of ASHRAE Technical Committee 2.6, Sound and Vibration, and a co-presenter of the ASHRAE Professional Development Seminar on HVAC noise and vibration control. He has participated in the development of *ASHRAE Handbook* chapters in that area.

**Updates/errata for this publication will be posted on the  
ASHRAE Web site at [www.ashrae.org/publicationupdates](http://www.ashrae.org/publicationupdates).**

# **A Practical Guide to Noise and Vibration Control for HVAC Systems**

**SECOND EDITION**

**Mark E. Schaffer**



**American Society of Heating, Refrigerating  
and Air-Conditioning Engineers, Inc.**

ISBN 978-1-936504-02-2

© 2011 American Society of Heating, Refrigerating and Air-Conditioning Engineers, Inc.

1791 Tullie Circle, N.E., Atlanta, GA 30329

www.ashrae.org

All rights reserved.

First edition 1991; Second edition 2011

Printed in the United States of America

Cover design by Tracy Becker.

ASHRAE has compiled this publication with care, but ASHRAE has not investigated, and ASHRAE expressly disclaims any duty to investigate, any product, service, process, procedure, design, or the like that may be described herein. The appearance of any technical data or editorial material in this publication does not constitute endorsement, warranty, or guaranty by ASHRAE of any product, service, process, procedure, design, or the like. ASHRAE does not warrant that the information in the publication is free of errors, and ASHRAE does not necessarily agree with any statement or opinion in this publication. The entire risk of the use of any information in this publication is assumed by the user.

No part of this publication may be reproduced without permission in writing from ASHRAE, except by a reviewer who may quote brief passages or reproduce illustrations in a review with appropriate credit, nor may any part of this publication be reproduced, stored in a retrieval system, or transmitted in any way or by any means—electronic, photocopying, recording, or other—without permission in writing from ASHRAE. Requests for permission should be submitted at [www.ashrae.org/permissions](http://www.ashrae.org/permissions).

---

Library of Congress Cataloging-in-Publication Data

Schaffer, Mark E., 1949-

A practical guide to noise and vibration control for HVAC systems / Mark E. Schaffer. -- 2nd ed.  
p. cm.

Includes bibliographical references.

Summary: "A guide that presents rules for controlling the noise and vibration of HVAC Systems"--

Provided by publisher.

ISBN 978-1-936504-02-2 (softcover)

1. Heating--Equipment and supplies--Noise. 2. Ventilation--Equipment and supplies--Noise. 3. Air conditioning--Equipment and supplies--Noise. 4. Noise control. I. American Society of Heating, Refrigerating and Air-Conditioning Engineers. II. Title.

TH7015.S33 2011

697--dc22

2011002509

---

## ASHRAE STAFF

### SPECIAL PUBLICATIONS

**Mark Owen**

*Editor/Group Manager of  
Handbook and Special Publications*

**Cindy Sheffield Michaels**

*Managing Editor*

**Matt Walker**

*Associate Editor*

**Elisabeth Parrish**

*Assistant Editor*

**Heather Medlock**

*Assistant Editor*

**Michshell Phillips**

*Editorial Coordinator*

### PUBLISHING SERVICES

**David Soltis**

*Group Manager of Publishing Services  
and Electronic Communications*

**Tracy Becker**

*Graphics Specialist*

**Jayne Jackson**

*Publication Traffic Administrator*

### PUBLISHER

**W. Stephen Comstock**

# Contents

---

Preface	xv
Acknowledgments	xvii
Introduction	xix
Chapter 1—General Design Guidelines	1
Chapter 2—Airside Equipment	25
Chapter 3—Water-Side Equipment	73
Chapter 4—Packaged and Unitary Equipment	89
Chapter 5—Vibration Isolation	101
Chapter 6—Specifications	117
Chapter 7—Construction Phase Tasks	125
Chapter 8—Troubleshooting Noise and Vibration Complaints	143
Appendix A—Some Basics of HVAC Acoustics	167
Appendix B—Acoustical Rating Systems and Criteria	177
Appendix C—Measuring HVAC System Noise	191
Appendix D—Using Manufacturers' Sound Data	197
Appendix E—Definitions and Abbreviations	201
Appendix F—Addresses of Agencies and Associations	207
Appendix G—Bibliography and Selected References	209



# Illustrations

---

## FIGURES

### Introduction

- A Example of an air-handling unit room with several acoustical problems. **xx**
- B Example of an air-handling unit room with optimal acoustical features. **xxii**

### Chapter I

- 1-1 Guideline for duct chase, shaft, and enclosure sizing. **4**
- 1-2 Acoustical comparison of various building core area layouts. **5**
- 1-3 Guidelines for the preliminary selection of mechanical room walls. **6**
- 1-4 Sample mechanical penthouse equipment layout. **7**
- 1-5 Labyrinth air path used for sound attenuation at an equipment room ventilation opening. **10**
- 1-6 Upward noise control for mechanical rooms. **10**
- 1-7 Downward noise control using an auxiliary ceiling. **11**
- 1-8 Section views through two types of floating floor assemblies. **12**
- 1-9 Sound transmission at perimeter mechanical rooms. **12**
- 1-10 Electrical conduit routing into a mechanical room. **13**
- 1-11 Pipe lagging for noise control. **14**
- 1-12 Examples of rumbly and quieter parallel fan installations. **15**
- 1-13 Guidelines for a basement built-up fan system. **16**
- 1-14 Typical duct silencer arrangement at vane-axial fan. **17**

## Illustrations

- 1-15 Reflected and refracted equipment sound at a building perimeter. **18**
- 1-16 Structural support of rooftop equipment for vibration control. **19**
- 1-17 Guidelines for mechanical room wall selection. **20**
- 1-18 Duct and pipe penetrations through walls. **21**
- 1-19 Plan view of return air shaft with supply duct takeoffs obstructing return airflow. **22**
- 1-20 Acoustical comparison of several duct chase, shaft, and enclosure constructions. **23**
- 1-21 Two typical duct laggings. **24**
- 1-22 Noise control duct enclosure. **24**

## Chapter 2

- 2-1 Inlet and discharge octave band  $L_W$  values for a 925 mm plenum fan. **27**
- 2-2 Sound power level comparison for three types of centrifugal fans. **28**
- 2-3 Guidelines for centrifugal fan installations. **29**
- 2-4 Inline fan airflow patterns. **30**
- 2-5 Cutaway view into a mixed flow fan. **31**
- 2-6 Inline fan sound power level comparison. **31**
- 2-7 Guidelines for ducted axial flow fan installations. **32**
- 2-8 Guidelines for unducted axial flow fan installations. **33**
- 2-9 Inlet side of a direct-drive plenum fan. **34**
- 2-10 Discharge side of a belt-drive plenum fan. **34**
- 2-11 Power roof ventilators (mushroom fans) mounted on intake duct silencers and roof curbs. **35**
- 2-12 Mushroom type exhaust fan on vibration-isolated roof curb. **36**
- 2-13 Inlet octave band  $L_W$  comparison for three propeller fans. **37**
- 2-14 Propeller fan with a 12-socket aluminum hub and plastic blades. **37**
- 2-15 Ultra-low-noise propeller fan with backswept airfoil blades. **38**
- 2-16 Lined hood for propeller fan noise control. **38**
- 2-17 Vibration isolation suspension for propeller fans. **39**
- 2-18 Noisy and quiet installations of ceiling-mounted exhaust fans. **39**
- 2-19 Minimum clearance at AHU and cabinet fan inlet. **41**
- 2-20 Plenum AHU with supply ducts attached to the top of discharge plenum. **42**
- 2-21 Cutaway sketch of a plenum fan air-handling unit. **42**

**A Practical Guide to Noise and Vibration Control for HVAC Systems**

- 2-22 Guidelines for VAV unit installation. **43**
- 2-23 Laboratory air valve and its “noise flow” directions. **45**
- 2-24 Good inlet duct connection to a supply air ceiling diffuser. **47**
- 2-25 Poor inlet duct connection to a supply air ceiling diffuser. **47**
- 2-26 The effect of installing a damper behind a grille. **48**
- 2-27 Attenuation for lined and unlined sheet metal ductwork. **49**
- 2-28 Breakout transmission loss for three types of sheet metal ductwork. **50**
- 2-29 Guidelines for minimizing regenerated noise in elbows. **52**
- 2-30 Guidelines for minimizing regenerated noise in takeoffs. **52**
- 2-31 Guidelines for minimizing regenerated noise in transitions and offsets. **53**
- 2-32 Guidelines for minimizing regenerated noise in duct tees. **53**
- 2-33 In-duct attenuation for various duct liner thicknesses. **54**
- 2-34 The speaking tube (cross-talk) problem. **55**
- 2-35 Attenuation of rectangular elbows with and without turning vanes (lined and unlined). **57**
- 2-36 Attenuation of rectangular and radius elbows (lined and unlined). **57**
- 2-37 Flexible duct with spunbond nylon inner liner. **58**
- 2-38 Cutaway view into a dissipative duct silencer. **59**
- 2-39 Cutaway view of a duct silencer with film-lined baffles. **59**
- 2-40 Cutaway view of a reactive (“packless,” “no-fill,” or “no-media”) duct silencer. **61**
- 2-41 Cutaway view of an elbow duct silencer. **61**
- 2-42 In-duct attenuation of duct silencers and lined ductwork. **62**
- 2-43 Comparative insertion loss of dissipative, film-lined, and reactive duct silencers. **62**
- 2-44 Guidelines for duct silencer placement near fans and duct fittings. **63**
- 2-45 Duct silencer placement near a mechanical room wall. **64**
- 2-46 General guidelines for sound-attenuating plenum design. **66**
- 2-47 Acoustical louver cutaway. **66**
- 2-48 Sound transmission loss of acoustical and weatherproof louvers. **67**
- 2-49 Acoustical louver in a parking garage ventilation shaft. **67**
- 2-50 Basis for fan selection in a VAV system. **68**
- 2-51 Nested inlet vanes obstruct airflow. **70**
- 2-52 Variable-frequency drive. **70**

## Illustrations

### Chapter 3

- 3-1 Water-cooled screw chiller with several noise and vibration control treatments. **74**
- 3-2 ARI-370  $L_W$  values for a 875 kW air-cooled chiller with and without factory noise reduction options. **75**
- 3-3 ATC-128 octave band  $L_P$  values at 15 m from the air inlet side of three types of 2800 kW cooling towers. **76**
- 3-4 ATC-128 octave band  $L_P$  values for cooling towers of the same fabrication series but with fans of different diameters. **77**
- 3-5 View of “standard” cooling tower induced-draft fan. **78**
- 3-6 View of an induced-draft fan with wide-chord blades. This fan type can be as much as 12 dBA quieter than a “standard” fan of the same diameter. **78**
- 3-7 ATC-128 octave band  $L_P$  values for cooling towers with “standard” and wide-chord fan blades. **79**
- 3-8 Cooling tower basin with free-falling condenser water. **80**
- 3-9 Honeycomb water basin silencers installed several centimeters above the water surface. **80**
- 3-10 Outdoor noise control barrier installation. **81**
- 3-11 Close-up view of a sample of a sound-absorbing, outdoor noise barrier panel. **81**
- 3-12 Low-noise control sequence for a two-cell cooling tower. **82**
- 3-13 Pump impeller sizing guideline for minimizing the strength of the blade passage frequency tone. **83**
- 3-14 Proper installation of an end-suction pump. **84**
- 3-15 Proper installation of an inline pump. **85**
- 3-16 Vibration isolation for piping riser. **87**
- 3-17 Duct and pipe penetrations through walls. **87**
- 3-18 Sealing pipe penetrations for sound isolation. **88**

### Chapter 4

- 4-1 Very noisy rooftop unit installation. **90**
- 4-2 Moderately noisy rooftop unit installation. **90**
- 4-3 Moderately quiet rooftop unit installation. **91**
- 4-4 Quietest rooftop unit installation. **91**
- 4-5 Guidelines for suspended heat pump units. **94**
- 4-6 Guidelines for floor-mounted heat pumps. **94**

## **A Practical Guide to Noise and Vibration Control for HVAC Systems**

- 4-7 Small condensing unit noise control. **96**
- 4-8 Guidelines for fan coil unit installations. **97**
- 4-9 Guidelines for vibration isolation of split systems. **98**
- 4-10 Indoor fan coil section of a ductless split system. **98**
- 4-11 Outdoor condensing unit typically used with ductless split systems; it can also be used with ducted fan coil units. **99**
- 4-12 Remote radiator for engine-generator sets can be quiet with an oversized, variable-speed cooling fan. **100**

### **Chapter 5**

- 5-1 Elastomeric pads. **106**
- 5-2 Elastomeric or compressed fiberglass isolation mounts. **107**
- 5-3 Seismically rated elastomeric mounts. **108**
- 5-4 Two types of spring floor mounts. **108**
- 5-5 Spring hanger installation. **109**
- 5-6 Two types of spring floor mounts with seismic/wind-loading standby restraints. **110**
- 5-7 Pneumatic isolators ("air bags") supporting a rooftop air-cooled chiller. **111**
- 5-8 Cast-metal floor mount. **111**
- 5-9 Thrust restraint at mid-height of fan inlet panel. **112**
- 5-10 Flanged and threaded flexible pipe (pump) connectors. **113**
- 5-11 Braided metal pump connector is not an effective vibration isolator. **113**
- 5-12 Floor mount spring isolator under a height-saving bracket with a separate seismic restraint. **114**
- 5-13 Pump mounted on combination isolator/restraint. **115**

### **Chapter 7**

- 7-1 Overhead plan views of AHU rooms showing the effects of a duct offset. **132**
- 7-2 Properly installed dual-duct variable air volume unit. **135**
- 7-3 Check of large duct elbow verifying screw attachment of turning vanes. **136**
- 7-4 Conduit debris short-circuiting isolator effectiveness. **137**
- 7-5 Overloaded spring hanger. **138**
- 7-6 Overloaded free-standing floor mount. **138**
- 7-7 Short-circuited floor mount isolator whose shipping shims have not been removed. **139**

## Illustrations

- 7-8 Faulty spring hanger installation with hanger rod touching the hanger box. **139**
- 7-9 Taut outdoor “flexible” conduit forms a vibration “short-circuit” at cooling tower. **141**
- 7-10 Pipe risers without vibration isolation. **141**

## Chapter 8

- 8-1 Frequency ranges of the most likely sources of common acoustical complaints. **144**
- 8-2 Example of poor fan discharge duct design. **150**
- 8-3 Fan installation with poor discharge duct system aerodynamics. **151**
- 8-4 Restrained spring isolator with a “short circuit” between its baseplate and equipment mounting plate. **155**
- 8-5 View into the fan section of a rooftop unit. **156**
- 8-6 Excellent rooftop package unit installation. **156**
- 8-7 Improperly installed fan-powered variable-air-volume unit. **157**
- 8-8 Proper installation of an indoor self-contained packaged HVAC unit. **157**
- 8-9 Closely spaced circular duct fittings produce turbulence and noise. **158**
- 8-10 Closely spaced rectangular duct fittings produce turbulence and noise. **158**
- 8-11 Improper duct transition at fan inlet. **159**
- 8-12 Vane-axial fan intakes too close to wall. **159**
- 8-13 Duct split using radius elbows. **160**
- 8-14 Faulty installation of a large equipment isolator with stanchion restraints. **160**
- 8-15 Proper installation of a large equipment isolator with stanchion restraints. **161**
- 8-16 Braided metal pump connectors do not provide significant vibration isolation. **161**
- 8-17 Neoprene pump connectors provide better isolation of pump vibration from attached piping. **162**
- 8-18 Incomplete vibration isolation at cooling tower. **162**
- 8-19 Taut “flexible” conduit forms a vibration short-circuit at vane-axial fan. **163**
- 8-20 Correctly installed flexible conduit between electrical disconnect and motor. **163**
- 8-21 View of pipe penetration from below roof. **164**
- 8-22 Non-isolated pipe penetration. **164**
- 8-23 Improperly placed neoprene hanger. **165**

## **A Practical Guide to Noise and Vibration Control for HVAC Systems**

### **Appendix A**

- A-1 Airborne and structure-borne sound transmission. **168**
- A-2 Airborne and structure-borne sound transmission from equipment. **169**
- A-3 Chart for adding decibel values. **170**
- A-4 Everyday sound sources—their frequencies and wavelengths. **171**
- A-5 Frequencies at which various types of HVAC equipment generally control their sound spectra. **172**
- A-6 Sound pressure levels of some everyday activities. **173**

### **Appendix B**

- B-1 Frequency weighting curves. **178**
- B-2 Blank RC chart. **180**
- B-3 Blank RC mark II chart. **181**
- B-4 Blank NC chart. **183**
- B-5 Octave band spectrum rated at NC-45. **184**
- B-6 Blank NCB chart. **185**
- B-7 Quality of speech communication in background noise. **189**

### **Appendix C**

- C-1 Sound level meter. **192**
- C-2 Sound measurement plan. **193**
- C-3 Blank sound measurement data sheet. **194**
- C-4 Completed sound measurement data sheet. **195**

## **TABLES**

### **Chapter 1**

- 1-1 Maximum Mid-Span Deflections for Above-Grade Structures that Support Vibration-Isolated HVAC Equipment **7**
- 1-2 Selection Guidelines for Slabs Separating Mechanical Equipment Rooms from Noise-Sensitive Occupied Spaces **9**

### **Chapter 2**

- 2-1 Suggested Maximum Airflow Velocities for Various Ductwork Installations **51**
- 2-2 Suggested Maximum Airflow Velocities in Elbows for Rectangular

## **Illustrations**

Ductwork **51**

2-3 Acoustical Characteristics of the Various Types of Ductwork **58**

## **Chapter 3**

3-1 Maximum Recommended Waterflow Rates **86**

## **Chapter 5**

5-1 Vibration Isolation Selection Guide **102**

## **Chapter 7**

7-1 Common Value Engineering Proposals and Their Potential Acoustical  
Impacts **126**

7-2 Procedure for Converting from A-Weighted  $L_W$  Values to Unweighted  $L_W$   
Values **127**

## **Appendix A**

A-1 Octave Band Center Frequencies and Their Frequency Ranges **172**

A-2 Subjective Impressions of Sound Level Differences **174**

## **Appendix B**

B-1 Recommended Indoor Sound Criteria **187**

B-2 Industrial Noise Levels Requiring Employer Action **188**

B-3 Sample Municipal Code Limits **189**

## **Appendix C**

C-1 Adjustment Values for Determining Equipment Sound Levels in the Presence  
of Constant Background Noise **196**

# Preface

---

Since the publication of the 1991 edition of this guide, building owners and managers have been paying more attention to occupant comfort, and municipal codes have become more attentive to property-to-property noise emissions. As a result, the HVAC community has become much more sensitive to the acoustical design of its products and systems. Many equipment manufacturers are producing quieter products and sometimes use the acoustical benefit as the primary marketing feature. Increased attention to product acoustical performance is evidenced by the fact that the number of HVAC acoustical testing laboratories has almost doubled since 1991. Also, increased internationalization has permitted access to low-noise HVAC products from Europe and Asia.

System designers are paying closer attention to the acoustical performance of the products and systems that they specify, and many building owners now require acoustical consultants on project design teams.

Unfortunately, not all industry changes have been for the quieter. Energy-efficient screw (rotary) compressors have been the source of many noise and vibration complaints, and the momentum to remove internal acoustical liner from ductwork, or to cover it with solid sheet metal in air-handling units and terminal boxes, has reduced the palette of noise reduction strategies that can be used in system designs. These and other factors increase the importance of *system* design in the form of more careful attention to vibration isolation and the airflow aerodynamics in air distribution systems. Therefore, the main theme of this guide has not changed over the past 20 years—that is, most HVAC system noise and vibration problems are *system* problems that are due to the improper selection, design, or installation of the components into a complete *system*. More careful attention to these factors will greatly reduce the number and severity of noise and vibration complaints.



# Acknowledgments

---

The information in this guide was taken from hundreds of publications and was produced with the help of dozens of people. The author wishes to particularly thank the following people:

The authors of the many articles, manuals, bulletins, and books from which many of the guidelines and figures were taken;

The members of ASHRAE Technical Committee 2.6, Sound and Vibration, for their direct contributions, review comments, encouragement, and patience;

The staff of Gary Davis & Associates, Santa Monica, CA, for much of the artwork;

The staffs of the acoustical consulting firms of McKay Conant Brook, Westlake Village, CA, and Paul S. Veneklasen & Associates, Santa Monica, CA, for their assistance;

Ms. Barbara A.J. Schaffer for her unending patience and support;

Mr. Eli Schaffer of Schaffer Mechanical, Inc., for his help in understanding HVAC systems;

Mr. David Peters of Southland Industries, Long Beach, CA, for his review comments of the original publication;

Messrs. Jerry Lilly, Karl Peterman, Rob Lilkendey, John Paulauskis and Mark Fly for their very helpful and thorough reviews of the second edition;

Dr. David T. Blackstock of the Applied Research Laboratories, Austin, TX, for his  
insistence on the correct usage of the English language; and

The entire membership of ASHRAE for its support of technical research in all areas  
of HVAC system design.

# Introduction

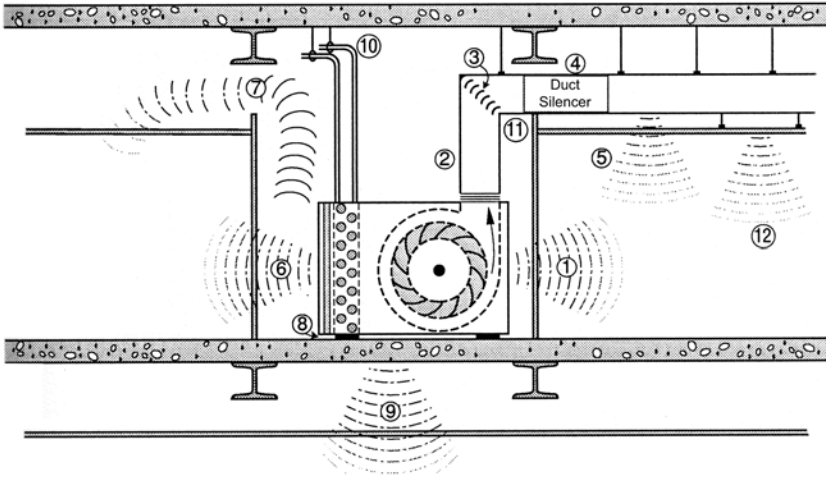
---

Over the past few decades, building design teams have become more aware of the potential noise and vibration problems from HVAC systems. Mechanical engineers are specifying sound traps (duct silencers), acoustical louvers, sound-absorbing duct liners, and vibration isolators, while architects are designing mechanical room walls and slabs with high sound transmission class (STC) ratings. Despite the addition of these noise and vibration control features in more and more building designs, complaints of excessive HVAC system noise and vibration are still common. Investigations into these complaints by acoustical professionals have found that, in many cases, the correct equipment and materials were used, but they were not properly integrated into a *quiet system*, or some seemingly insignificant detail was omitted that negated the expected acoustical benefit.

## A TYPICAL APPROACH

Figure A shows a typical air-handling unit (AHU) mechanical room in which some of the most common system-related acoustical faults are noted. Of the 12 faults noted, very few have to do with the specific equipment or materials used. Most of the faults are *system* related; that is, the individual components are not designed and installed as if they were part of a whole system. Airflow through the AHU/ductwork layout shown in the figure would generate excessive turbulence, noise, and rumble. The small mechanical room would have restricted airflow in places, resulting in locally turbulent airflow and unexpected noise and rumble in the tenant space. The vibration isolators would not perform as expected because they are resting on a flexible floor structure. The designers of this hypothetical system did not consider all of the *system (interactive)* effects of the various components and how they would control the amount of noise and vibration that enters the building's occupied spaces.

## Introduction



1. AHU panel vibration “couples” to the lightweight, flexible gypsum wall just a few centimeters away. This coupling lets low frequency noise pass easily through the wall.
2. The counterclockwise rotation of the fan’s discharge airstream is forced to change its spin direction at the downstream elbow. The turbulence generated at the change can produce unstable flow with a very high, fluctuating pressure drop, thereby resulting in fan instability that is heard as rumble.
3. Problem 2 is aggravated if the elbow’s turning vanes do not have long trailing edges to straighten the airflow and control the turbulence.
4. The duct silencer is too close to the elbow. This compounds the turbulence problem.
5. Rectangular ductwork and duct silencers do not control the rumble produced by turbulent airflow.
6. The AHU’s air inlet is too close to the wall. This causes two acoustical problems: unstable fan operation leading to surge and rumble, and direct exposure of the inlet noise to the mechanical room wall.
7. The lack of a duct silencer in a mechanical room return air opening allows fan noise to travel into the ceiling cavity, then through the lightweight acoustical ceiling into the occupied space.
8. The unit is resting on thin cork/neoprene isolation pads that are too stiff to adequately isolate the fan vibration.
9. The poorly isolated unit is resting on a relatively flexible floor slab without sufficient structural support. This arrangement allows unit vibration to enter the slab.
10. The chilled water piping is rigidly attached to the slab above, thereby letting unit vibration enter the slab.
11. Ductwall vibration in the duct silencer (or any other part of the trunk duct system) touching the drywall partition can cause the partition to act as a sounding board and radiate low frequency noise into the occupied space.
12. Suspending ceiling from supply duct causes ceiling to be a sound radiator.

**Figure A** Example of an air-handling unit room with several acoustical problems.

## A Practical Guide to Noise and Vibration Control for HVAC Systems

### A BETTER APPROACH

Correcting a noise or vibration problem usually costs much more than preventing one. The real costs include not only the direct payments to the retrofitting contractor but also the time required to coordinate the investigation and retrofit and the loss of goodwill from the complaining tenants. Therefore, in most cases the slight extra cost for prevention (usually about 1% to 2% of the total HVAC system cost) is money well spent.

Specifying quiet equipment and adding noise control materials to an HVAC system design are necessary initial steps of the design process. Calculations during the initial steps can be used to estimate the sound levels in a room or to select noise control materials to achieve a design goal. Comparing equipment sound data for competing products can help in the selection of quiet equipment. However, design decisions based on such work lose their value if the equipment and materials are not integrated into a properly designed *system* or if certain system detailing is ignored.

Figure B shows one version of a typical AHU room in which basic construction materials are integrated into a quiet system. The AHU and ductwork are selected and laid out for the best aerodynamics possible (this also reduces pressure drop and, therefore, fan horsepower). The AHU room is large enough for good aerodynamics in the room and for adequate clearance between the unit and the walls. The supporting structure has been stiffened with a housekeeping pad and beam to permit better vibration isolation.

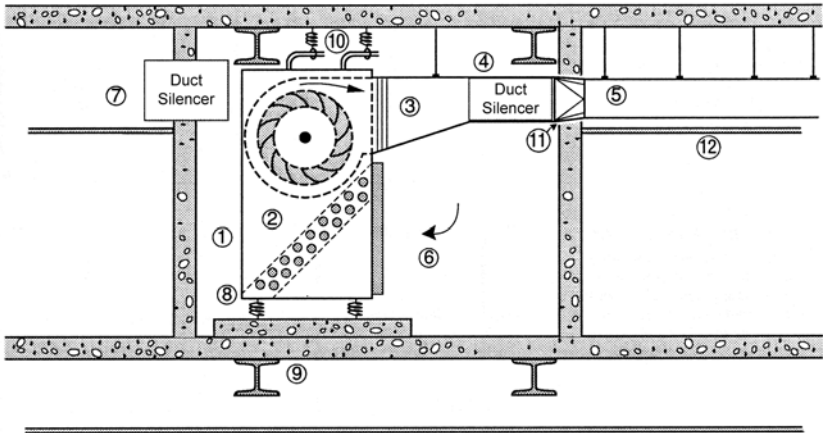
### SUMMARY OF THIS GUIDE

This guide presents information that will help engineers, architects, contractors, and others with little acoustical experience to develop project designs that avoid the kinds of problems shown in Figure A. Chapter 1 includes general noise control design guidelines to be addressed during the various design phases and includes some information on the architectural and structural aspects of HVAC system design. Chapter 2 addresses the selection and use of airside system components. Chapter 3 looks at the selection and use of waterside and central plant equipment.

Packaged and unitary equipment are addressed in Chapter 4. Guidelines for selecting and using vibration isolation systems are included in Chapter 5. Sample specifications for acoustical materials and the acoustical performance of HVAC equipment are given in Chapter 6, along with some examples of poorly written specifications. Reviewing submittals and making site inspections are addressed in Chapter 7. Chapter 8 gives suggestions for troubleshooting HVAC noise and vibration complaints.

## Introduction

The appendices present background information, including some basics of HVAC system acoustics, the use of criteria and manufacturer's published sound data, and how to make sound level measurements. Appendices with definitions of acoustical terminology, abbreviations, and addresses of relevant agencies and associations are also included.



1. Keeping a minimum 600 mm clearance reduces coupling between AHU and wall. Masonry wall provides excellent low frequency sound isolation.
2. Use of a horizontal discharge AHU eliminates the need for a turbulence-producing airflow.
3. Gradual transition at AHU outlet minimizes turbulence.
4. Duct silencer is far enough away from AHU outlet to avoid excessive regenerated noise and turbulence.
5. Circular ductwork controls the transmission of low frequency noise and rumble into the occupied space.
6. The large clearance at the AHU inlet keeps the unit away from the wall and avoids excessive inlet turbulence.
7. The return air duct silencer controls AHU noise via the return air path.
8. The unit is resting on high-deflection, steel spring vibration isolators.
9. The floor assembly supporting the unit has a housekeeping pad and at least one major beam under the unit. Additional stiffness and mass help to control the transmission of unit vibration into the slab.
10. The chilled water pipes are suspended by vibration isolation hangers.
11. The supply trunk duct does not touch the wall. A 13 mm gap surrounding the duct is filled with a non-hardening sealant.
12. Ceiling not suspended from supply duct.

**Figure B** Example of an air-handling unit room with optimal acoustical features.

# I

## General Design Guidelines

---

Virtually every survey on office comfort finds that, after temperature problems, excessive HVAC system noise levels are responsible for more complaints than any other aspect of the office environment. Some of the many causes of the excessive noise can be traced to one or more of the following:

- Incorrect design of the HVAC systems and their equipment area walls and slabs
- Cost-cutting without regard for the noise and vibration implications
- Improper installation
- Improper start-up or commissioning
- Ignoring the selection and/or installation guidelines published by HVAC equipment and noise/vibration control product manufacturers

To minimize the possibility that design decisions could cause noise or vibration problems, a project's design team must consider the acoustical impacts of all design decisions, whether they are part of the schematic, design development, construction documents, value engineering, or construction administration phases of a project. The team members should also follow the selection and installation guidelines that are published by most equipment and noise/vibration control product manufacturers.

All too often the area of HVAC acoustical design is limited to the addition of duct silencers, duct lining, plenum lining, and vibration isolators at the end of the Construction Documents (Working Drawings) phase, after the mechanical engineer has virtually completed the HVAC system design and long after the structural system has been designed. These "add-on" acoustical treatments may control the

## General Design Guidelines

noise and vibration, but if they are not properly integrated into the system, they can reduce the system's performance and energy efficiency. If selected or installed improperly, they can even *cause* noise or vibration problems. Therefore, noise and vibration control design should begin during the project's Schematic Design phase and continue throughout the entire design process. This is even more critical if the use of fibrous materials, such as fiberglass and mineral wool, is not permitted.

Some "add-on" acoustical treatments may be required no matter how well a system is designed, but the use of some, such as duct liner and duct silencers, can sometimes be minimized if the HVAC system is designed with noise and vibration control in mind from the start.

**The more noise and vibration control you *DESIGN IN*, the less you have to *ADD ON*.**

The design phase of a new facility occurs in sub-phases with titles such as Pre-schematic Design, Schematic Design (SD), Design Development (DD), and Construction Documents (CD). The placement and sizing of mechanical equipment rooms and duct shafts are typically set during the Schematic Design phase. Therefore, many critical decisions for HVAC system noise and vibration control are needed in this early design phase. More detailed noise and vibration control decisions can wait until the DD and CD phases.

One crucial SD phase milestone is the completion of the structural system design. Delaying the acoustical design until after the structural system design is essentially complete sometimes leaves the design team with little flexibility in selecting and locating cost-effective noise and vibration control treatments. Troubleshooting investigations into HVAC system acoustical problems often find that the locations of shear walls, beams, columns, and cross-bracing make effective retrofit solutions either very expensive or, in some cases, impossible. Good acoustical design decisions made in cooperation with the structural engineer can avoid this kind of problem and minimize the cost of noise and vibration control treatments.

Proper acoustical design requires broad cooperation in the areas of architecture, structural engineering, mechanical engineering, electrical engineering, and acoustics. To that end, the design team should begin by working together in the areas of (1) system type determination, (2) preliminary equipment selection, (3) mechanical room and duct shaft sizing, and (4) space planning.

## **A Practical Guide to Noise and Vibration Control for HVAC Systems**

### **SYSTEM TYPE DETERMINATION**

Each type of HVAC system has its own set of layout and operating features that determine which noise and vibration control measures are most cost-effective. Therefore, the choice of one system type over another should not be made without considering the cost of controlling noise and vibration. For example, a built-up rooftop penthouse HVAC system would generate almost all of its noise and vibration in the penthouse and would, therefore, require most attention there to prevent complaints from the occupants below the equipment rooms and near the duct shafts. On the other hand, a system using water-source heat pump units distributed throughout the building's ceiling plenums would require much less concern for noise and vibration control at the central plant but much more care in the selection, placement, and installation of the dozens of noise and vibration sources (the heat pump units) that are scattered throughout the building. It is, therefore, essential that the acoustical properties of all potential system types be considered before finalizing the selection.

### **PRELIMINARY EQUIPMENT SELECTION**

After determining the type of system, the mechanical engineer should make preliminary equipment selections as soon as possible to allow for a preliminary noise analysis and to determine the probable sizes of the mechanical equipment rooms and duct shafts. The primary acoustical guideline is to select the quietest equipment possible, which usually means selecting the most efficient equipment (i.e., the lowest kilowatt rating at the maximum operating duty point). Since the original publication of this guide, virtually all of the major equipment manufacturers have updated their equipment selection procedures to include acoustical data that have been determined in accordance with internationally recognized testing procedures. Therefore, obtaining the acoustical information necessary for comparing equipment alternatives is much easier than it was in the past.

### **MECHANICAL ROOM SIZING**

Economic pressure to maximize a building's usable/rentable space has resulted in less space being available for the HVAC systems and other building services. This reduction in equipment room size often forces the mechanical engineer to either select small, inefficient equipment or to shoehorn properly sized equipment into a restricted space. A similar problem occurs at duct shafts, which often contain either undersized ducts with excessive air velocities or properly sized ducts that are too close to the shaft walls. All such cases can lead to excessive noise. To minimize the possibility of this problem, mechanical rooms and duct shafts should be sized as follows:

## General Design Guidelines

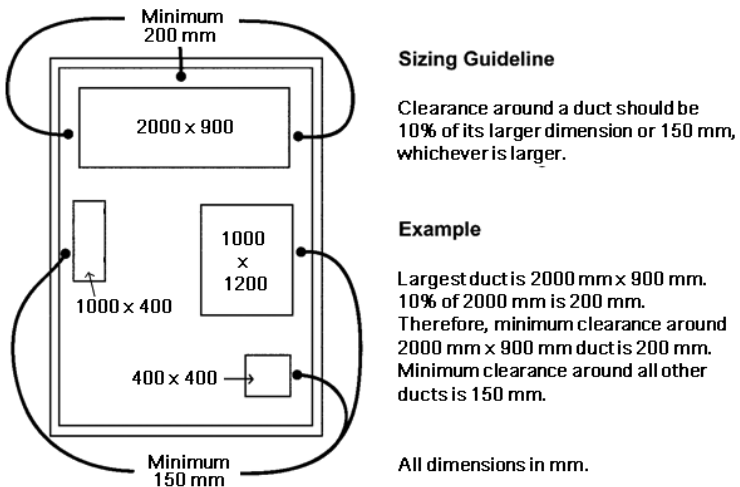
1. All HVAC equipment rooms should have a floor area large enough to allow a clearance of at least 610 mm around all equipment. Building codes and equipment maintenance requirements may necessitate larger clearances in some cases.
2. Ductwork should be sized for the proper air velocity (see the section titled "Duct System Components" in Chapter 2) and shafts should be sized to provide sufficient clearances around the ducts (see Figure 1-1 for guidelines).

## SPACE PLANNING

The primary acoustical goal of space planning is to locate the noisy equipment as far as possible from the building's noise and vibration-sensitive areas. For HVAC system design, this is most important in the location of chiller rooms, fan/AHU rooms, cooling towers, and rooftop package units.

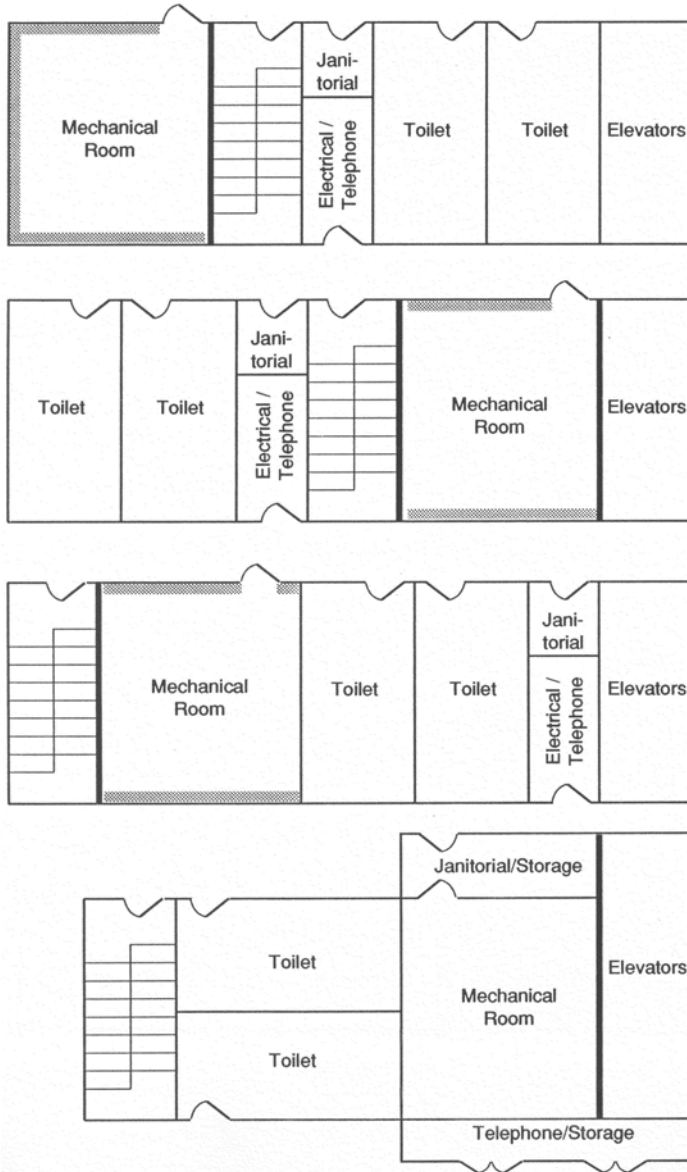
A common space-planning problem involves the placement of an AHU room in the core area on a typical floor of a multistory office building. The best core area plans surround the AHU room with buffer zones such as toilet and storage rooms, as well as elevator, stair, and duct shafts as shown in Figure 1-2.

Effective space planning can also help minimize the construction costs of mechanical room walls and slabs. For instance, if a mechanical equipment room is adjacent to a non-sensitive room, then the construction of the common wall is not



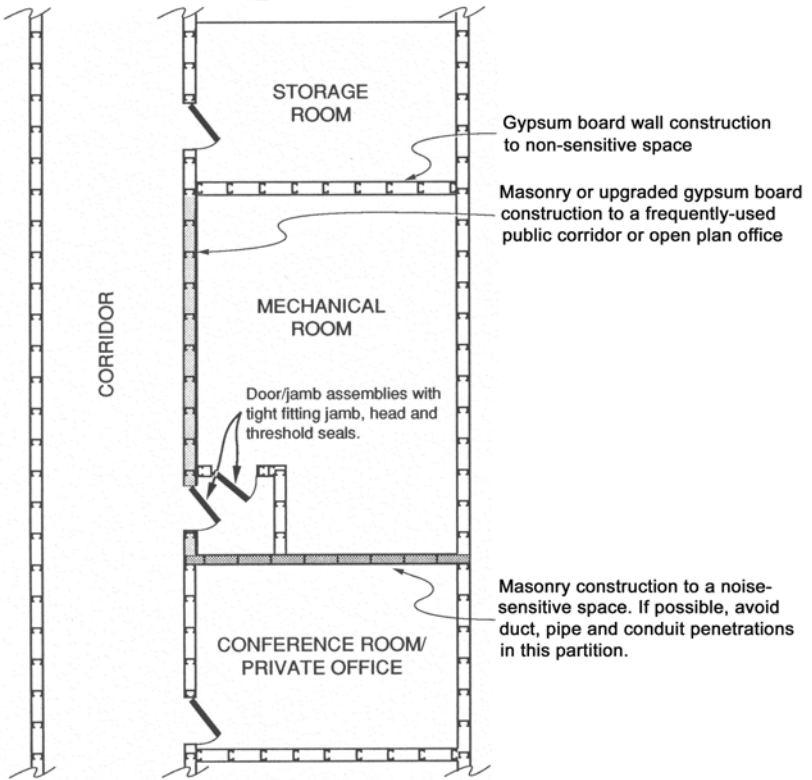
**Figure 1-1** Guideline for duct chase, shaft, and enclosure sizing.

**A Practical Guide to Noise and Vibration Control for HVAC Systems**



**Figure I-2** Acoustical comparison of various building core area layouts.

### General Design Guidelines

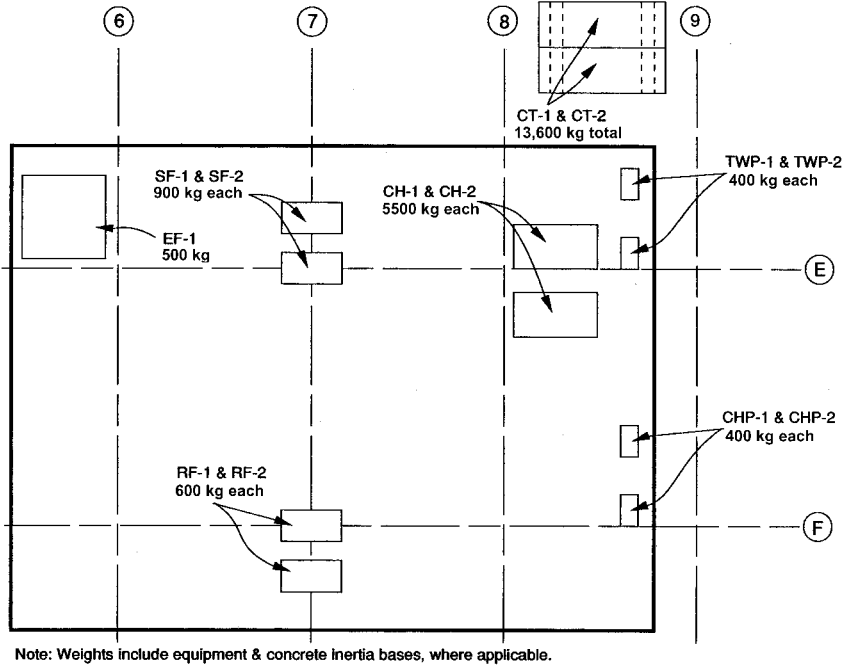


**Figure 1-3** Guidelines for the preliminary selection of mechanical room walls.

critical, so lightweight gypsum board walls are typically acceptable. However, if the adjacent room is a conference room or private office, then a double-studded partition, or perhaps even a fully grouted masonry wall, may be needed. Figure 1-3 shows the concept.

After the preliminary space plans for the HVAC equipment areas has been determined, the mechanical engineer should distribute equipment layouts to the rest of the design team showing approximate weights and sizes of all equipment. A sample layout is shown in Figure 1-4. The structural engineer should use this information to select beams with maximum loaded deflections as listed in Table 1-1. The recommended deflection limits may be somewhat smaller than structural engineers would

**A Practical Guide to Noise and Vibration Control for HVAC Systems**



**Figure I-4** Sample mechanical penthouse equipment layout.

**Table I-1. Maximum Mid-Span Deflections for Above-Grade Structures that Support Vibration-Isolated HVAC Equipment**

Equipment to be Mounted on Vibration Isolators	Maximum Structural Deflection due to Equipment Load (Composite Action for Concrete/ Metal Deck Floor Systems)
Cooling towers	8 mm
All other HVAC equipment	6 mm

## **General Design Guidelines**

typically select for floor and roof beams. The equipment sizes and manufacturer-recommended maintenance clearances should be given to the architect, who can allocate equipment rooms of the proper size.

## **Slab Selection**

The schematic design phase is also the proper time to determine the thicknesses (and, therefore, the weights) of the slabs that provide sound isolation between equipment rooms and any occupied spaces that are either above or below the equipment room. Table 1-2 gives preliminary slab thickness suggestions for various types of equipment.

## **MECHANICAL EQUIPMENT ROOMS AND OUTDOOR EQUIPMENT AREAS**

### **Central Plants**

Some of the noisiest equipment in a commercial HVAC system is located in the central plant. The most frequently used chillers—centrifugal, rotary, and screw—produce enough noise in some rooms to require hearing protection per OSHA requirements. Air compressors and vacuum pumps can also generate high noise levels. The ventilation openings that serve these rooms are acoustical “holes” that let equipment noise transfer to nearby areas that may be noise-sensitive.

### *Noise and Vibration Control Guidelines for Central Plants*

1. For a large enough building site, locate the central plant away from any building with perimeter noise-sensitive areas.
2. Treat ventilation passages with acoustical louvers, duct silencers, or acoustically lined plenums to control the noise that escapes to the community (see Figure 1-5 and the section titled “Duct Silencers, Plenums, and Acoustical Louvers” in Chapter 2 for more information).
3. If the central plant is in an occupied building, install all equipment and piping with vibration isolators in accordance with the “Vibration Isolation Selection Guide” table in Chapter 5.
4. Make electrical connections to all central plant equipment with slack, flexible conduits.
5. For noise control to noise-sensitive areas, either above or below, consider the following options:
  - a. For upward noise control, use a building standard slab and a noise control enclosure around the chillers and air compressors (see Figure 1-6).

**A Practical Guide to Noise and Vibration Control for HVAC Systems**

**Table I-2. Selection Guidelines for Slabs Separating Mechanical Equipment Rooms from Noise-Sensitive Occupied Spaces**

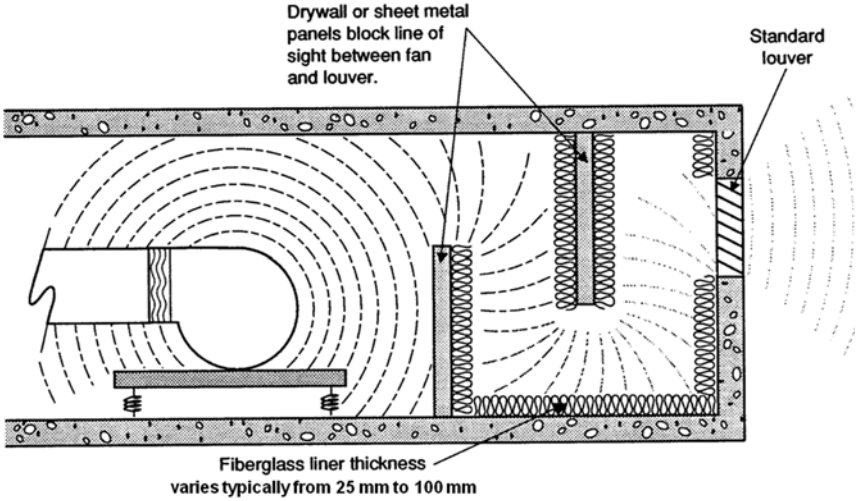
Equipment Type	Total Size or Total Motor Kilowatt (kW) Rating in Equipment Room	Slab Thickness in Millimeters (2300 kg/m <sup>3</sup> concrete)*	
		Over a Noise-Sensitive Occupancy (e.g., NC-35)	Over a Somewhat Sensitive Occupancy (e.g., NC-40)
Reciprocating chiller	All sizes	200**	200
Centrifugal chiller	Up to 1000 kW	200	150
	1000 kW and larger	200**	200
Screw chiller	All sizes	200**	200
Unducted fan or AHU (either side unducted)	Up to 7.5 kW	100	75
	7.5 to 22.5 kW	160	100
	Over 22.5 kW	200**	150
Ducted fan or AHU (both sides ducted)	Up to 22.5 kW	100	75
	22.5 kW and larger	150**	100
Pump	Up to 18.5 kW	100	75
	18.5 kW to 75 kW	150	100
	Over 75 kW	200	160
Cooling Tower, Evaporative Cooler, Air-cooled Condenser, Air-cooled Chiller	Up to 22.5 kW	150	100
	22.5 kW to 75 kW	200**	150
	Over 75 kW	200**	200

\* For mechanical equipment rooms housing multiple pieces of equipment and different types of equipment, determine the slab thickness for each equipment type and use the largest value for the entire equipment room. Increases slab thickness by 33% if 110 pcf concrete is used.

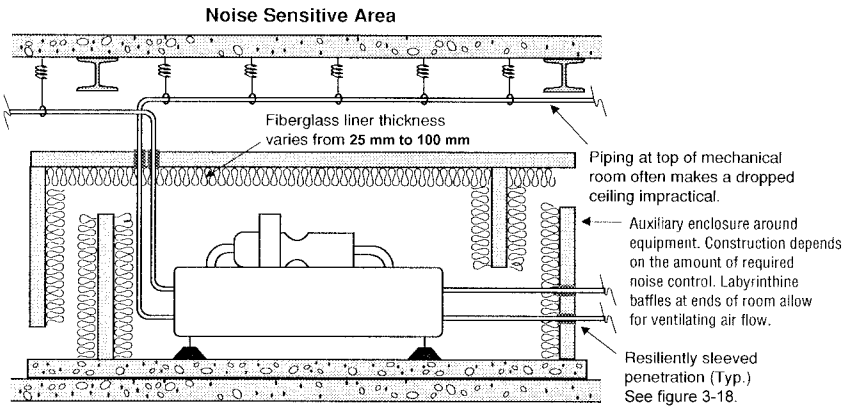
\*\* Some installations of this type, and equipment rooms with several types of equipment, each requiring a 200 mm thick slab, will require a "floating floor" assembly per Figure I-10.

Note: Do not locate mechanical equipment adjacent to room with a criteria rating of NC-30 or less.

**General Design Guidelines**



**Figure 1-5** Labyrinth air path used for sound attenuation at an equipment room ventilation opening.



**Figure 1-6** Upward noise control for mechanical rooms.

## A Practical Guide to Noise and Vibration Control for HVAC Systems

- b. For downward noise control, use a building standard slab with a gypsum board ceiling suspended below using spring hangers (see Figure 1-7). The suspended ceiling is also an alternative to an equipment enclosure for upward noise control, but it can be difficult to implement where the room has a lot of suspended piping and conduits.
  - c. For both upward and downward noise control, consider a monolithic slab weighing at least  $500 \text{ kg/m}^2$ .
  - d. In the most critical cases, including screw chiller and vane axial installations, use a  $500 \text{ kg/m}^2$  floating floor assembly. Figure 1-8 shows section views of two types of floating floors.
6. For rooftop or mid-level central plants, consider the following additional guidelines:
- a. Do not extend the central plant to the edge of the slab. This lets equipment noise leak through the small gap between the slab edge and the building skin. See Figure 1-9 for a suggested noise control method.

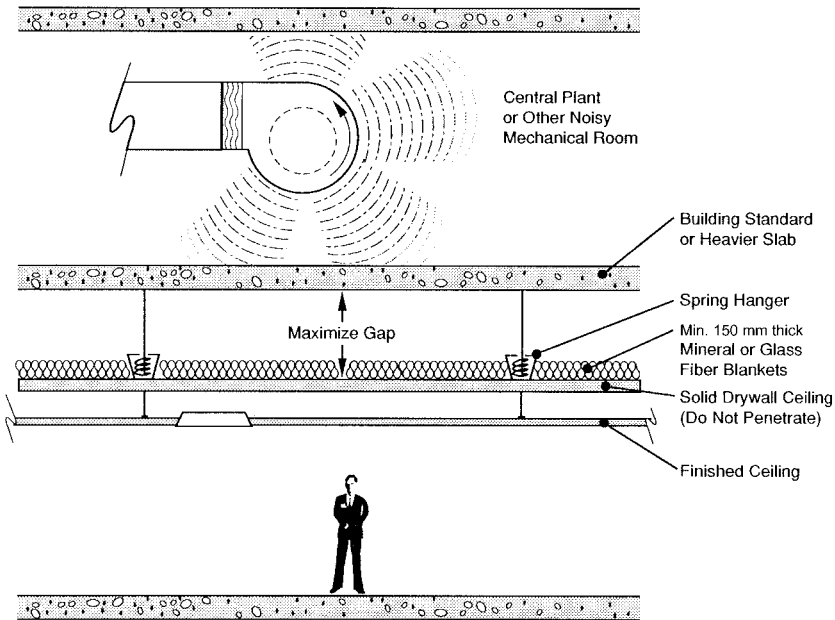
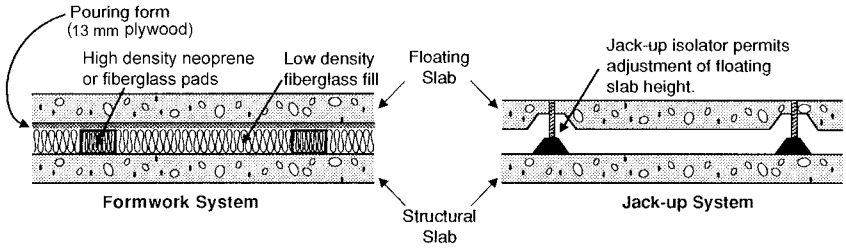
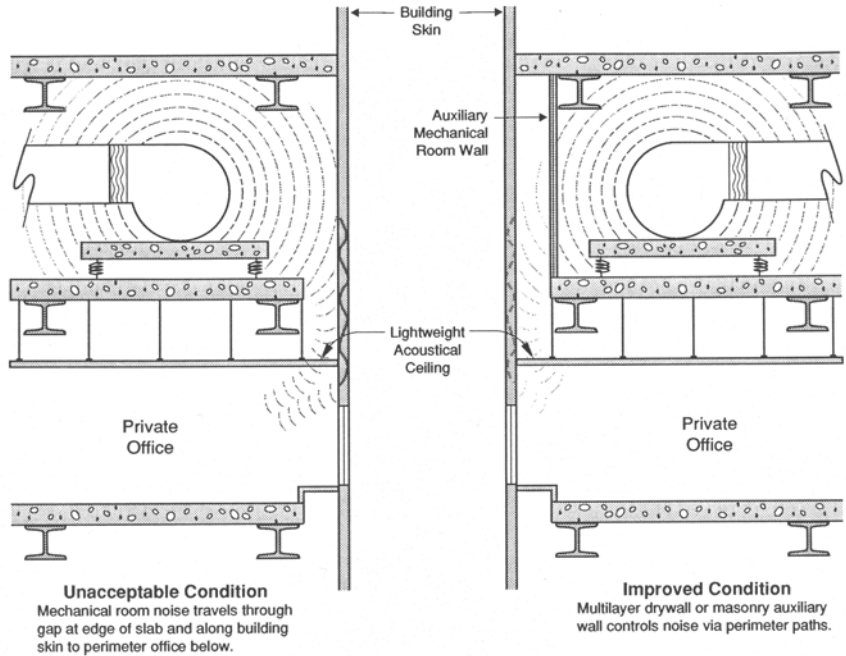


Figure 1-7 Downward noise control using an auxiliary ceiling.

**General Design Guidelines**



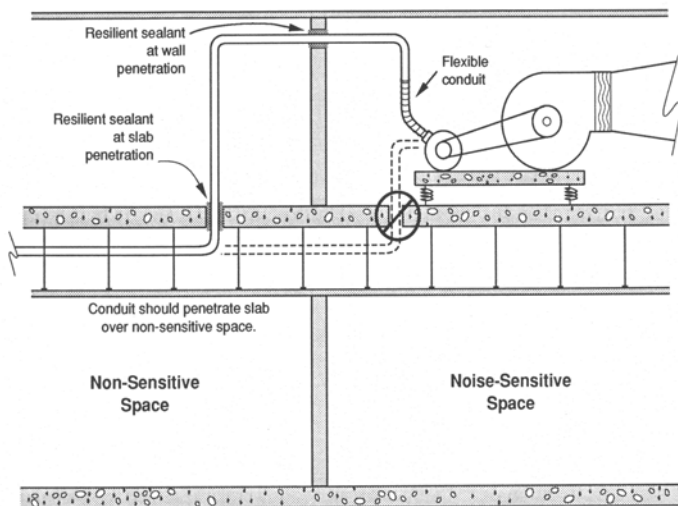
**Figure I-8** Section views through two types of floating floor assemblies.



**Figure I-9** Sound transmission at perimeter mechanical rooms.

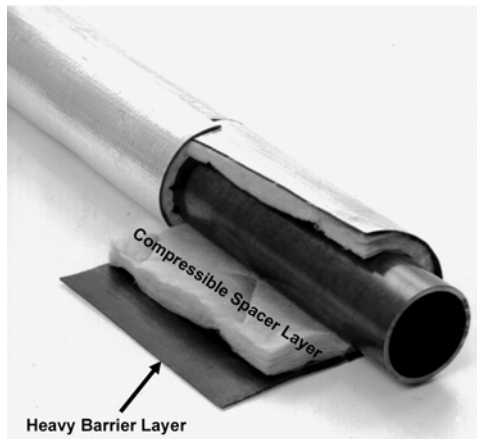
### A Practical Guide to Noise and Vibration Control for HVAC Systems

- b. Electrical conduits serving central plant equipment should not penetrate a floor or ceiling slab that is common to a noise-sensitive area. These conduits should penetrate the slab in non-sensitive areas and enter the plant through wall penetrations (see Figure 1-10).
- c. If the central plant is located next to a stair, duct, or elevator shaft, the common wall should be either masonry or a multi-layer gypsum board construction, depending on the noise levels of the central plant equipment.
- d. In critical installations, the extensions of floor drains beneath the central plant floor (above an occupied space ceiling) may require either a gypsum board enclosure or pipe lagging. Figure 1-11 shows a photo of a pipe lagging product. The effectiveness of pipe lagging depends on the thickness of the compressible spacer layer, available from 13 to 50 mm thick (thicker is better), and the surface density of the outer barrier material, usually barium-loaded vinyl that is available in surface-densities that range from 2.5 to 10 kg/m<sup>2</sup> (denser is better).



**Figure 1-10** Electrical conduit routing into a mechanical room.

## General Design Guidelines



**Figure I-11** Pipe lagging for noise control includes a compressible spacer layer and a heavy barrier layer.

## Air-Handling Unit Rooms

The system aspect of HVAC noise and vibration control is most important in the design of air-handling unit (AHU) rooms. Figures A and B in this guide's introduction compare noisy and quieter AHU room installations. Consider the following guidelines for AHU equipment rooms.

### *Noise and Vibration Control Guidelines for AHU Rooms*

1. The room's floor area should be at least  $1 \text{ m}^2$  per  $340 \text{ L/s}$  of total maximum fan airflow. For example, an AHU with a pair of  $9400 \text{ L/s}$  fans would need an equipment room floor area of at least  $55 \text{ m}^2$ . A larger floor area would be needed for a unit with an oversized cabinet that houses special filters or a humidifier.
2. The placement of the unit and ductwork in the room should allow smooth airflow from the return air openings to the AHU inlet.
3. The type of unit and the location of its discharge opening(s) should allow the use of a supply duct system that meets the requirements of SMACNA for smooth airflow from the AHU discharge and through the supply ducts.
4. In VAV systems, fan capacity should be controlled with a variable frequency drive (VFD) motor speed controller.
5. Where possible, allow for a vestibule between the AHU room and the occupied space. The doors serving the vestibule should each weigh at least  $34 \text{ kg/m}^2$  and

## A Practical Guide to Noise and Vibration Control for HVAC Systems

have airtight, full-perimeter seals and automatic door bottoms. The doors should hinge outward so that the negative room pressure will help pull the door tight to the jamb seals.

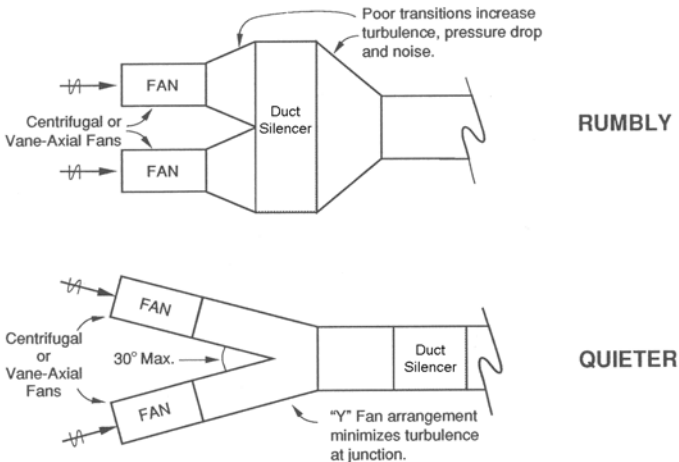
6. If a vestibule is not possible, then specify a sound-rated door assembly (including door, frame, and seals) whose Sound Transmission Class (STC) rating is equal to that of the wall, typically STC-50 or higher.
7. Specify a duct silencer at all AHU room wall openings above the ceiling used to collect common plenum return air.

### Built-Up Air-Handling Systems

Because built-up air-handling systems typically use large, noisy equipment and handle very large air quantities, attention to noise and vibration control is required in all of the design phases, especially the early phases.

#### *General Guidelines for Built-Up Basement and Rooftop AHU Installations*

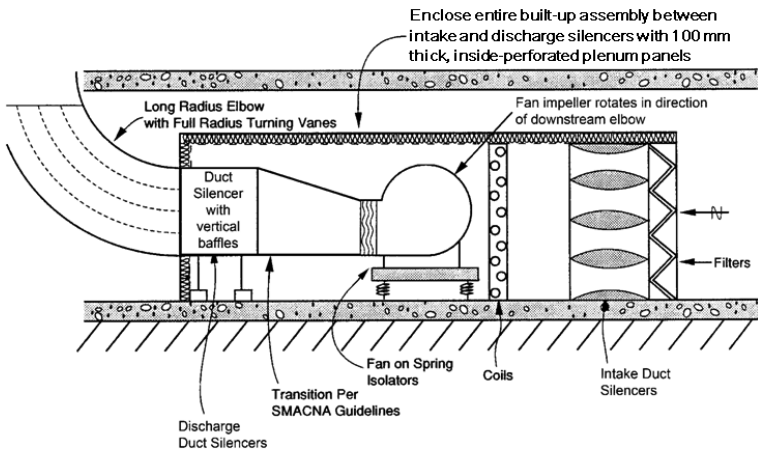
1. Arrange the equipment and duct shaft locations for smooth airflow at the recommended velocity and pressure drop.
2. When two supply fans (centrifugal or vane-axial) are to operate in parallel, arrange them in a "Y" discharge arrangement as shown in Figure 1-12.



**Figure 1-12** Examples of rumbly and quieter parallel fan installations.

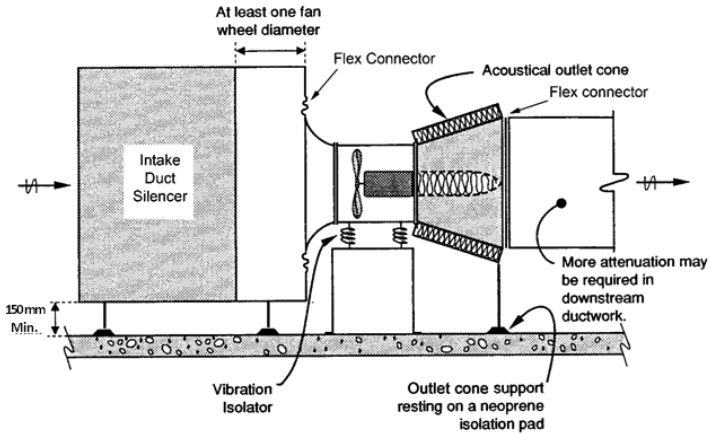
### General Design Guidelines

3. Equipment and piping should be suspended or supported with vibration isolators according to the "Vibration Isolation Selection Guide" table in Chapter 5.
4. Electrical connections to equipment should be made using slack, flexible conduits.
5. Acoustical louvers, or duct silencers behind standard louvers, may be required at fresh air intakes and exhaust air outlets to control noise transmission to the outside.
6. If the equipment room is directly above a noise-sensitive space, consider using either an auxiliary equipment enclosure or a floating floor (refer to Figures 1-8 and 1-9).
7. If the equipment room is directly below a noise-sensitive space, consider using an upgraded cabinet construction or an auxiliary enclosure around the entire built-up assembly, as shown in Figure 1-13.
8. In general, when vane-axial fans are used, duct silencers are required on both the inlet and discharge sides of the fans (see Figure 1-14). Extreme cases will require an auxiliary sheet metal housing around the fan to control its case-radiated noise.



**Figure 1-13** Guidelines for a basement built-up fan system.

## A Practical Guide to Noise and Vibration Control for HVAC Systems



**Figure I-14** Typical duct silencer arrangement at vane-axial fan.

### *Additional Guidelines for All Above-Grade Equipment Rooms:*

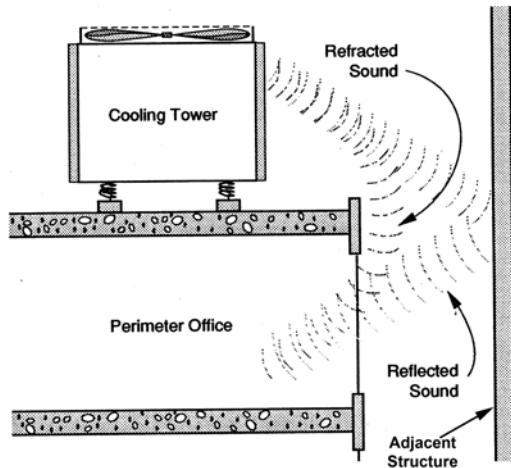
1. Do not locate the equipment adjacent to a noise-sensitive area. For example, don't place the equipment at the roof perimeter where sound can refract around the edge of the building and enter through the perimeter glass (see Figure 1-16).
2. If the equipment must be over a noise-sensitive area, then the equipment room floor construction and the interior ceiling assembly, if any, must provide adequate sound isolation. See Table 1-2 for general slab selection guidelines.
3. The floor structure supporting the equipment must be very stiff. Figure 1-16 shows various support methods. For all methods, the supporting structure should deflect less than 6 mm due to the combination of the dead and operating equipment loads.
4. Select vibration isolators for the equipment and its attached piping in accordance with the "Vibration Isolation Selection Guide" table in Chapter 5.

## EQUIPMENT ROOM WALLS AND SLABS

### Wall Selection

Mechanical room walls should not be selected solely on the basis of their STC ratings. The STC rating system was developed to rate the ability of walls, doors, and

## General Design Guidelines



**Figure 1-15** Reflected and refracted equipment sound at a building perimeter. Do not locate noisy equipment near a roof perimeter where this can happen.

windows to control the transmission of speech and other noises that have very little low-frequency sound energy. It does not rate the acoustical performance in the low-frequency range that is prevalent in HVAC system noise spectra. Low-frequency performance is determined by a wall's mass *and* stiffness, and masonry walls are much more massive and stiff than gypsum board walls. Therefore, where low-frequency noise is a potential problem, use masonry construction. Figure 1-17 includes guidelines for mechanical room wall selections.

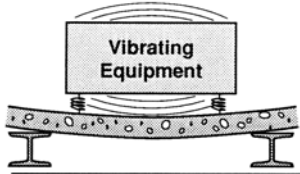
## Wall Penetrations

Where ductwork or piping penetrates a wall, the penetration should be made with the duct or pipe floating inside a sleeve, and with a resilient sealant filling the gap (see Figure 1-18).

## DUCT CHASES · SHAFTS · ENCLOSURES · LAGGINGS

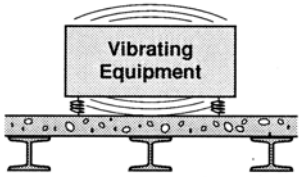
Duct chases and shafts are required for a variety of architectural purposes. Enclosures and laggings are add-on elements that are used strictly for noise control. Keep these distinctions in mind when reviewing the guidelines given below.

## A Practical Guide to Noise and Vibration Control for HVAC Systems



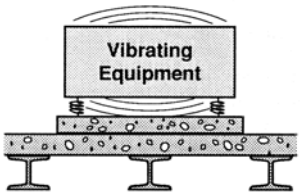
### Poor

Concentration of equipment weight between beams causes excessive roof deflection and vibration transmission, even for isolated equipment.



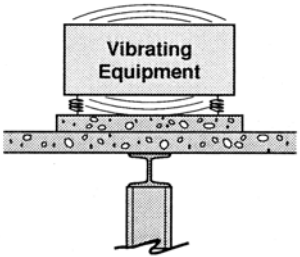
### Fair

Additional beam under equipment stiffens roof.



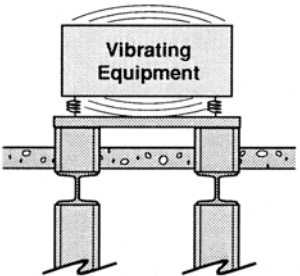
### Good

Further addition of housekeeping pad adds mass and stiffness to roof.



### Very Good

A column directly under the equipment gives the roof a very high local stiffness, but some equipment vibration still enters the roof slab.

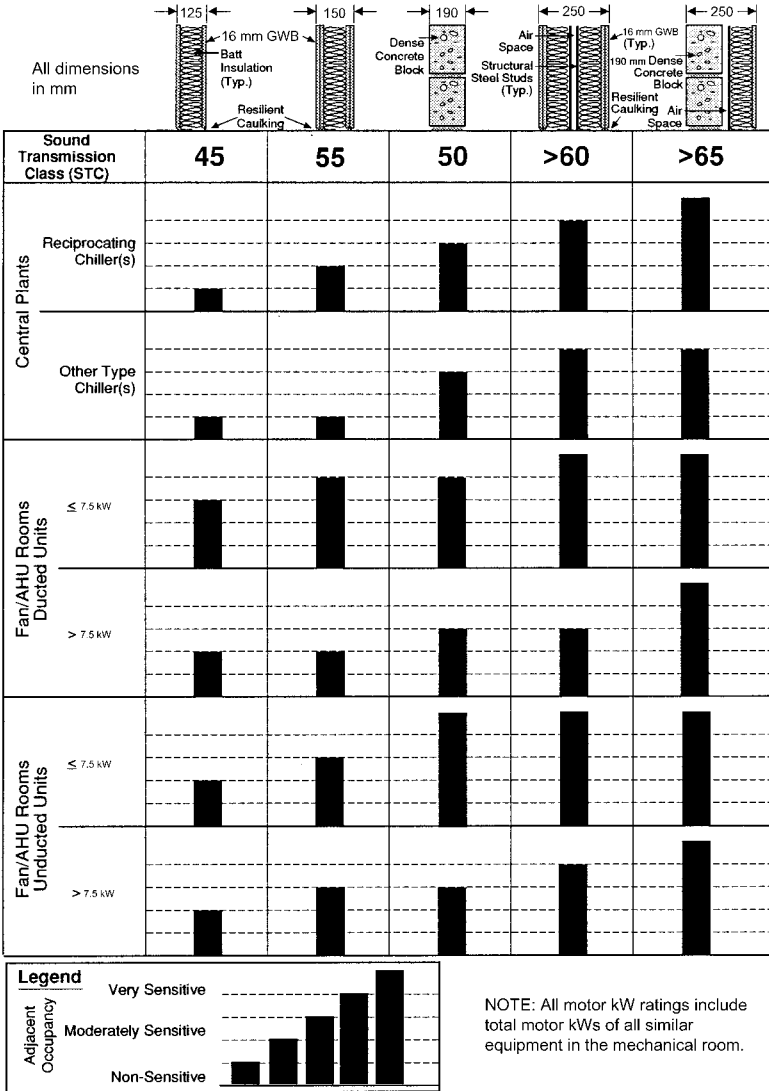


### Best

Mounting equipment on a steel frame supported by column extensions keeps virtually all vibration out of the roof slab.

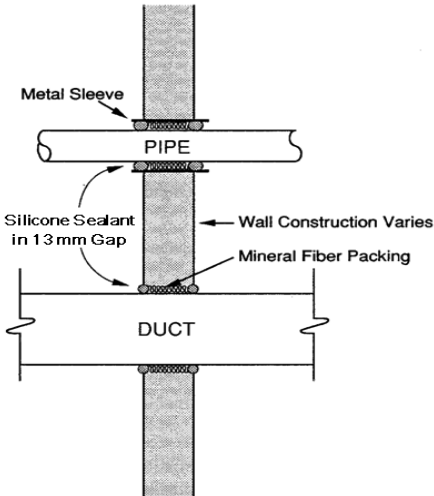
**Figure I-16** Structural support of rooftop equipment directly under for vibration control.

**General Design Guidelines**



**Figure I-17** Guidelines for mechanical room wall selection.

## A Practical Guide to Noise and Vibration Control for HVAC Systems



Note: Support pipes & ducts on both sides of the wall without permitting contact with the wall or its framing

**Figure 1-18** Duct and pipe penetrations through walls.

### Location

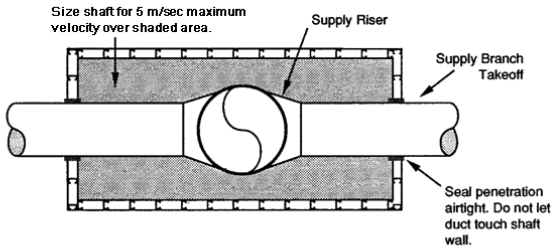
Locate shafts and chases, especially those whose ducts are large and carry high-velocity airflow, as far as possible from noise-sensitive areas.

### Sizing

To be effective at the low frequencies where noise control is usually needed, chases, shafts, and enclosures should be sized so that there is a minimum clearance around each enclosed duct of at least 10% of its larger dimension or 150 mm, whichever is larger. Figure 1-1 shows an example.

Return air shafts that also contain supply air ducts and their branch takeoffs should be sized for no more than 2.5 to 5 m/s return air velocity. The 5 m/s upper limit applies where the supply duct riser and its takeoffs are localized restrictions to the return airflow, as shown in Figure 1-19.

## General Design Guidelines



**Figure 1-19** Plan view of return air shaft with supply duct takeoffs obstructing return airflow.

## Construction

Figure 1-20 generically compares the sound isolation performance of several shaft, chase, and enclosure constructions. In general, higher wall mass and larger clearances around ducts provide better sound isolation. The higher stiffness of a masonry shaft provides excellent low-frequency sound isolation.




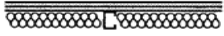

In installations where shaft walls are used for architectural masking, but not for fire protection, the shaft construction sometimes extends only a few centimeters above the ceiling, leaving the ductwork exposed to the ceiling plenum. Verify that in such a situation, the shaft wall is not needed for noise control purposes. If it is, make sure that the shaft wall construction extends from slab to slab.

Figure 1-21 shows typical duct lagging assemblies. Laggings provide good mid and high frequency noise reduction but provide only small amounts of low-frequency noise reduction. Instead of lagging, use an airtight gypsum board enclosure where significant low-frequency noise reduction is needed.

Figure 1-22 shows a section through a gypsum board duct enclosure. Note that the figure caption shows that the enclosure framing does not touch the duct. This is very important because contact between a duct and any part of its enclosure can allow duct wall vibration to be amplified by the enclosure, which then uses the “sounding board effect” to convert the vibration into noise that is then radiated into the adjacent area.

An enclosure for low-frequency noise control may not be necessary if circular, instead of rectangular, ductwork is used.

**A Practical Guide to Noise and Vibration Control for HVAC Systems**

Construction	Description	Comment
	Grouted and Sealed Masonry Block 90 mm - 290 mm Thick	Best for Chases and Shafts Housing Large, High Velocity Ducts
	Double layer 16 mm Type "X" Drywall, 100 mm CH Stud, Mineral Fiber Blankets, 25 mm Gypsum Core Board	Very Good. Acceptable in Most Applications
	Single layer 16 mm Type "X" Drywall, 65 mm CH Stud, 25 mm Gypsum Core Board	Acceptable Where Ducts are Not Large and Air Velocities are Moderate
	Double layer 16 mm Type "X" Drywall, Friction-Fit Mineral Fiber Batts	Acceptable Where Ducts are Not Large and Air Velocities are Moderate. Increasing Stud Thickness (To 20 or 16 G) And Width (To 100 or 150 mm) Improves Performance
	Single layer 16 mm Type "X" Drywall, 65 mm Stud	Acceptable Where Ducts are Small and Air Velocities are Low

**Figure I-20** Acoustical comparison of several duct chase, shaft, and enclosure constructions.

### General Design Guidelines

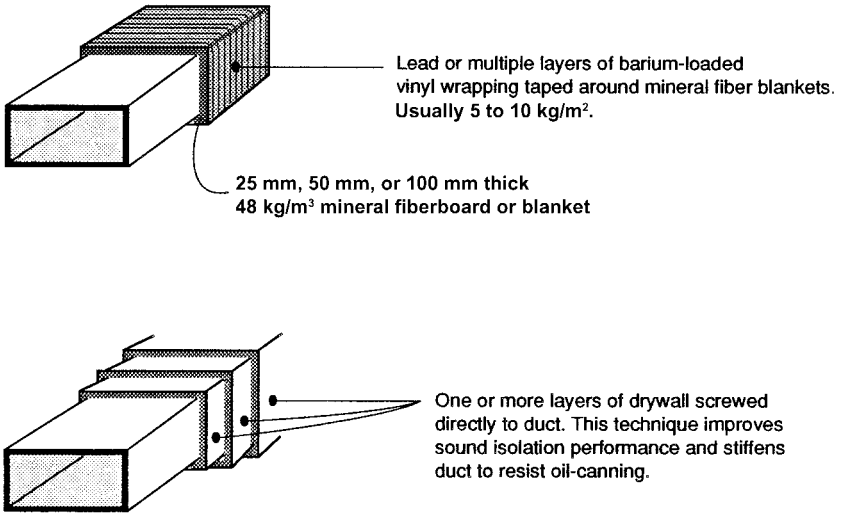


Figure I-21 Two typical duct laggings.

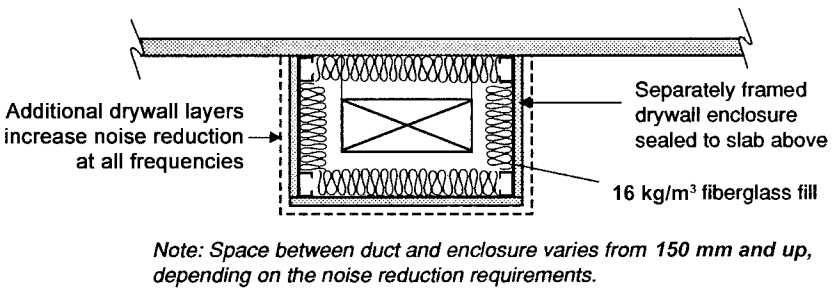


Figure I-22 Noise control duct enclosure.

## 2

# Airside Equipment

---

## FANS

Because most HVAC noise complaints are associated with fans, selecting and integrating them properly with the air distribution system will preclude a large percentage of possible noise problems. A fan can be used as the central element in a ventilation system or as a component in a piece of packaged equipment, such as an air-handling unit (AHU), cooling tower, air-cooled chiller, generator radiator, etc. This section of the guide deals specifically with the selection of fans in all of their likely applications. The acoustical performance of AHUs is addressed later in this chapter.

The first step in selecting a fan for a noise-sensitive application is to select the quietest equipment available for the most likely operating condition. In a constant volume system, this is simply the set of design operating conditions, e.g., airflow and system static pressure. In variable air volume (VAV) systems, the selection should be made for the most likely range of part-load operating conditions (typically in the range from 60% to 85% of full capacity).

All of the major fan manufacturers offer fan selection computer programs that include octave band sound power level ( $L_W$ ) values based on laboratory measurements conducted in accordance with *AMCA Standard 300, Reverberant Room Method for Sound Testing of Fans*. The  $L_W$  values are typically given for the octave bands with center frequencies from 63 to 8000 hertz, inclusive. (Refer to Appendix D for more information on the use of manufacturers' published and submitted acoustical data.) There is no longer a need to use the  $L_W$  estimating procedures that were included in early editions of the *ASHRAE Handbook*. Those early estimating procedures have been proven to be inaccurate, with errors as large as 30 dB in some

## Airside Equipment

cases. Only  $L_W$  values measured in accordance with AMCA 300 should be used in calculations and specifications.

In general, fan noise at a particular operating condition correlates loosely with energy usage at that condition, so when comparing fans of the same type, the selection that operates at the lowest motor kW rating will usually be the one that produces the least noise.

All fans produce both broadband noise as well as tonal noise at the fan's fundamental blade passage frequency (BPF) and its first few integer multiples, which are referred to as "overtones" or "harmonics." The fundamental BPF is easily calculated from the following equation:

$$BPF = RPM \cdot N / 60$$

where RPM is the fan rotation rate and  $N$  = the number of fan blades.

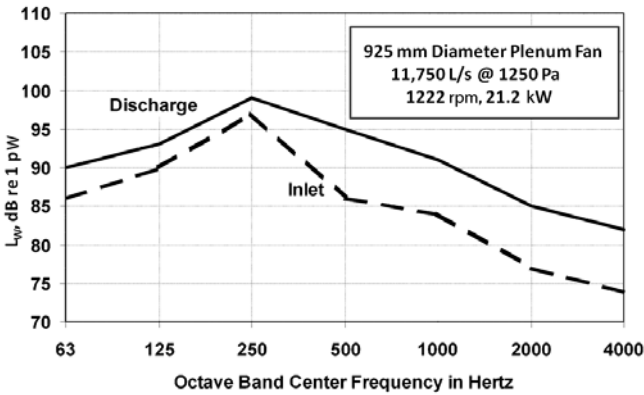
For instance, a 1000 rpm fan with nine blades would have a fundamental BPF of 150 hertz, which is in the 125 hertz octave band. This fan would also produce BPF overtones at 300 hertz, 450 hertz, 600 hertz, etc., but the overtones'  $L_W$  values are generally lower than those of the fundamental BPF. In general, the strength of a fan's BPF tone is proportional to its total pressure performance, so a fan that operates at a high pressure will usually have a louder BPF tone than if it were operating at a lower pressure.

Most fan manufacturers measure only inlet  $L_W$  values, but a few also measure the discharge  $L_W$  values for some of their product lines. The difference between the inlet and discharge  $L_W$  values can be as large as 10 dB in some octave bands, depending on the fan's operating conditions; discharge values are typically higher, as shown in Figure 2-1, which compares the inlet and discharge  $L_W$  values for a 925 mm diameter plenum fan operating at 11,750 L/s at 1250 Pa total pressure. Each fan type and operating condition will have its own unique pair of inlet and discharge acoustical spectra. Therefore, always request both the inlet and discharge  $L_W$  values for a fan and assume that, unless otherwise noted, any submitted values are valid for only the inlet side of the fan.

## Centrifugal Fans

Centrifugal fans discharge their air at an angle of 90 degrees relative to its inlet flow direction. These fans are either single or dual inlet, with several possible blade shapes, each with its own set of acoustical characteristics. Of the three blade shapes used in fans in most commercial systems, the forward-curved (FC) blades are the most cost-effective in systems with low airflow and low static pressure, whereas fans with backward-inclined (BI) and airfoil (AF) blades are more efficient and quieter where higher airflow and static pressure performance are needed. Industrial fans and material transfer fans are very noisy because their blade shapes are designed for very high pressure performance that is not needed in commercial and residential systems.

## A Practical Guide to Noise and Vibration Control for HVAC Systems



**Figure 2-1** Inlet and discharge octave band  $L_w$  values for a 925 mm plenum fan.

Figure 2-2 compares the inlet  $L_w$  values of three commercial 925 mm diameter fans operating at 9400 L/s and 750 Pa total pressure of similar motor kW rating, each of which has a different blade shape. The 125 hertz octave band “spikes” in the BI and AF spectra are due mainly to the strengths of their BPF tones. The FC fan’s  $L_w$  spectrum does not show a strong BPF tone, but its higher 63 hertz band  $L_w$  value can be a problem because of the expense required to control noise in that frequency band.

Centrifugal fans of all types will produce unexpectedly high noise levels if duct fittings or other airflow obstructions are too close to the fan inlet or discharge. The amount of excessive noise cannot be quantified; ongoing ASHRAE-sponsored research is attempting to quantify the effect for all types of fans. Figure 2-3 shows the current “best practice” guidelines for inlet clearance and discharge ductwork configurations for centrifugal fans.

### Inline Fans

Inline fans do not change the direction of airflow and are typically used in ducted applications and include the vane-axial, tube-axial, propeller, and inline centrifugal types, as well as others. Each type of inline fan is best for a specific range of operating conditions. They all produce significant BPF tones, with vane-axial and tube axial fans producing the strongest, while the tones from inline centrifugal fans are not as prominent.

## Airside Equipment

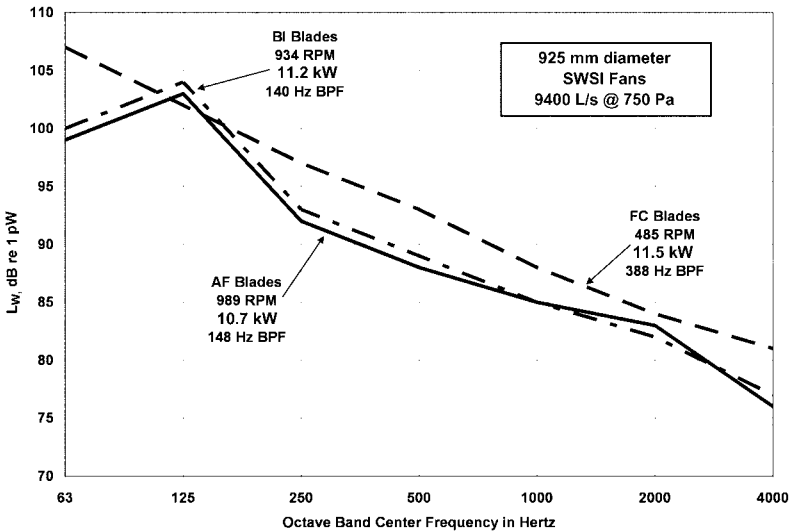
### Mixed Flow Fans

Mixed flow fans are inline fans, but the airflow direction through them is midway between axial and centrifugal flow. Figure 2-4 compares the airflow paths through typical inline fans and a mixed flow fan. Figure 2-5 shows a cutaway rendering of a mixed flow fan, whose main acoustical benefit is the relatively low strength of its BPF tones. Figure 2-6 compares the inlet  $L_W$  spectra of vane-axial, inline centrifugal, and mixed flow fans of equal physical size and motor kW operating at 23,500 L/s and 1000 Pa total pressure.

Figures 2-7 and 2-8 show recommendations for ducted and unducted inline fans of all types, keeping in mind that these fans are very sensitive to distorted inlet airflows.

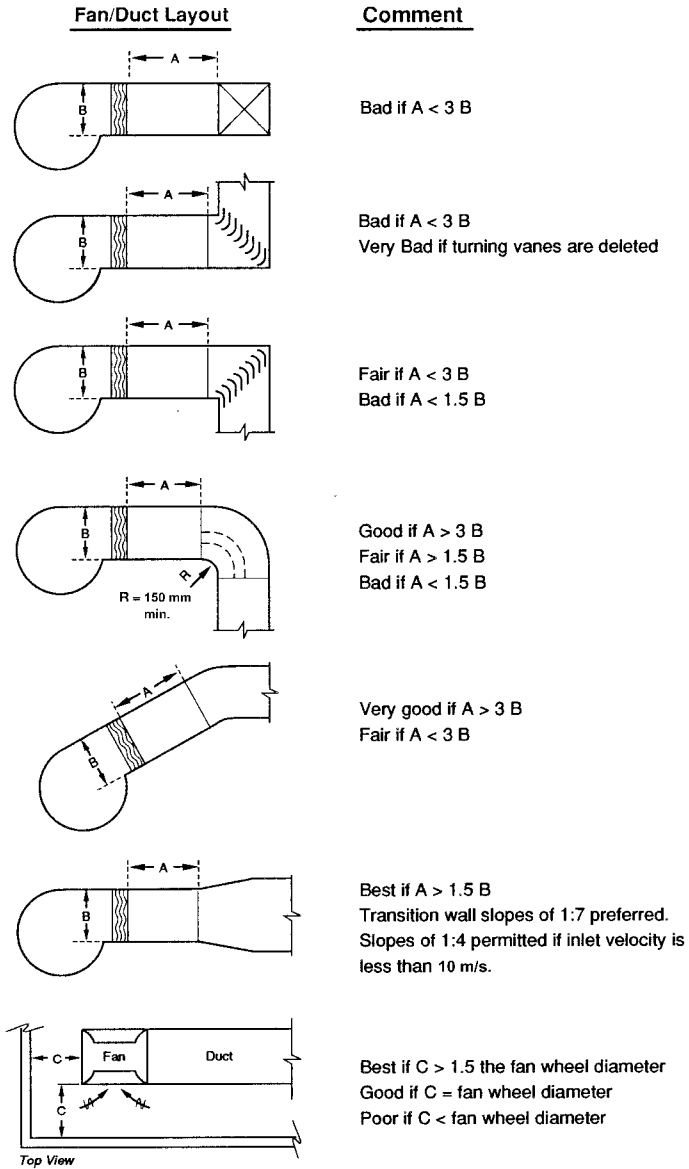
### Plenum Fans

Plenum fans are single-inlet centrifugal fans whose impeller designs have been optimized for maximum efficiency in a discharge plenum. Their discharge air leaves the impeller in a 360 degree radial pattern. They are typically used in custom



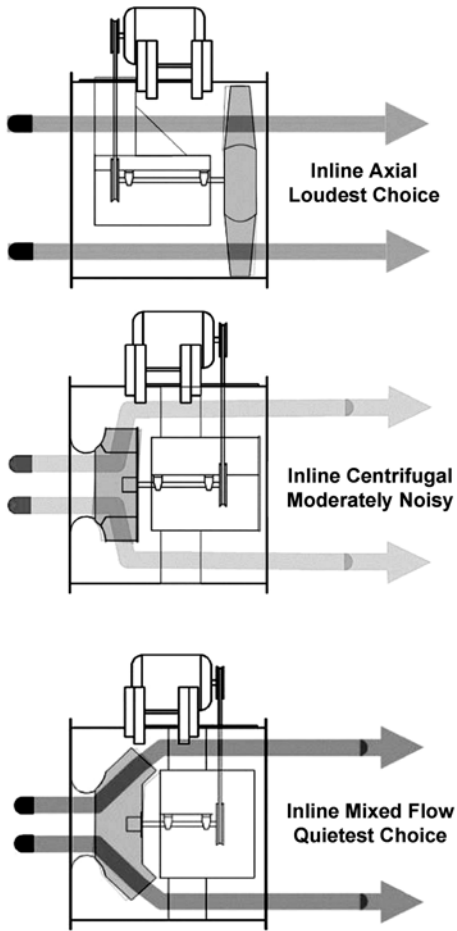
**Figure 2-2** Sound power level comparison for three types of centrifugal fans.

**A Practical Guide to Noise and Vibration Control for HVAC Systems**



**Figure 2-3** Guidelines for centrifugal fan installations.

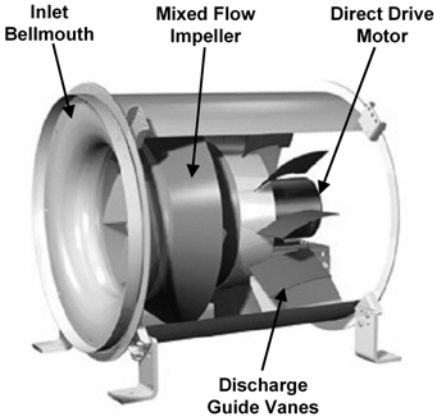
### Airside Equipment



Sketches courtesy of the Greenheck Fan Corporation.

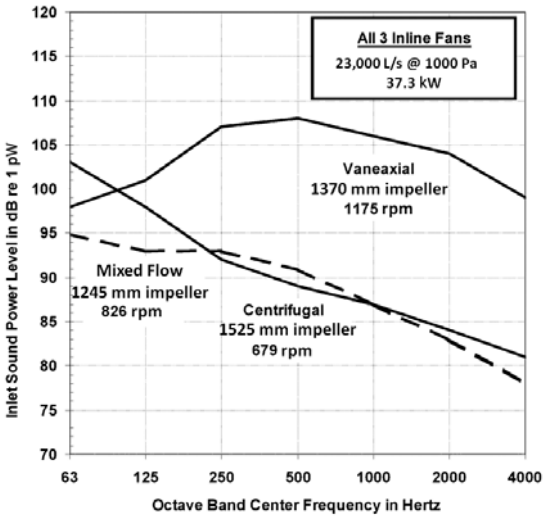
**Figure 2-4** Inline fan airflow patterns.

**A Practical Guide to Noise and Vibration Control for HVAC Systems**



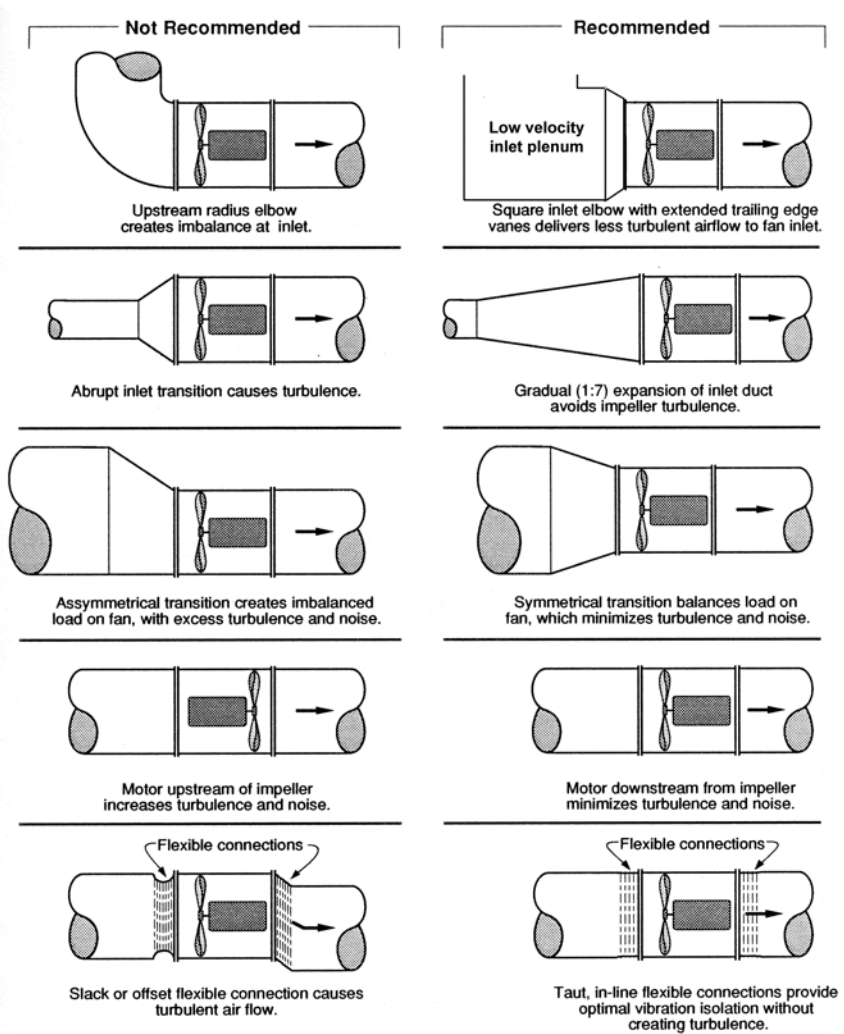
Rendering courtesy of the Greenheck Fan Corporation.

**Figure 2-5** Cutaway view into a mixed flow fan.



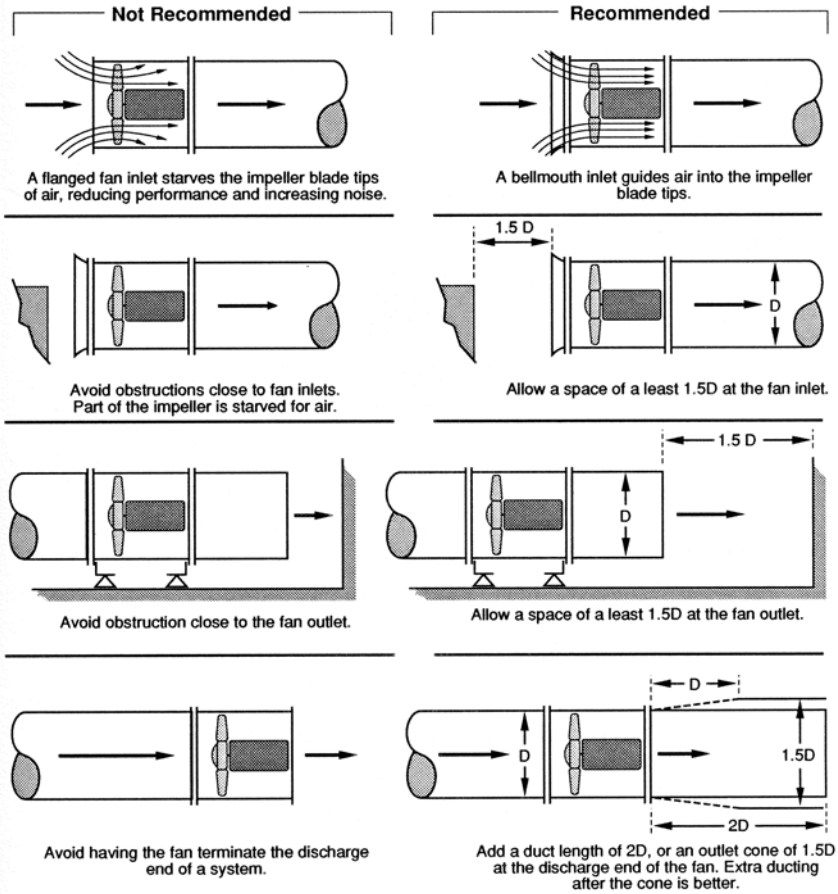
**Figure 2-6** Inline fan sound power level comparison.

**Airside Equipment**



**Figure 2-7** Guidelines for ducted axial flow fan installations.

**A Practical Guide to Noise and Vibration Control for HVAC Systems**



**Figure 2-8** Guidelines for unducted axial flow fan installations.

## Airside Equipment

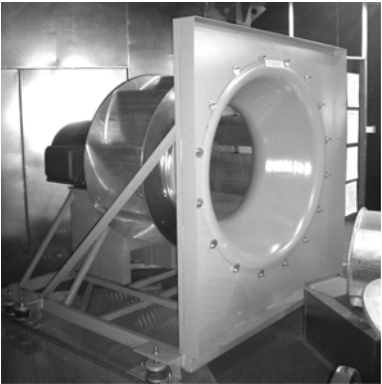
and semi-custom (modular) air-handling units (see Chapter 4 titled “Packaged and Unitary Equipment”). Figures 2-9 and 2-10 show inlet and discharge views, respectively, of direct-drive and belt-drive plenum fans. These fans are typically available with either 9, 10, or 12 blades.

## Power Roof Ventilators

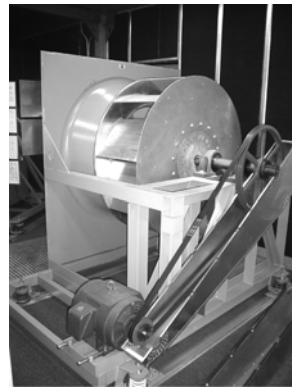
Power roof ventilators (mushroom fans) are usually used for exhaust applications but are sometimes used for supply or makeup air. Because they use centrifugal impellers, they can tolerate moderate amounts of static pressure, so duct silencers can be used with these fans where no other noise control mitigation is feasible and care is taken to have two to three equivalent diameters of straight duct between the fan and the silencer. Figure 2-11 shows a fan installation with a duct silencer inserted between the fans and their curbs. Large mushroom fans installed near noise-sensitive or vibration-sensitive areas may be mounted on roof curbs with internal isolation. A sketch of such a curb is shown in Figure 2-12.

## Panel Fans

Panel fans, which use propeller fan wheels, are typically selected for unducted, low static pressure applications. There are several propeller blade shapes (e.g., stamped steel, cast aluminum, backswept airfoil, etc.), so be sure to consider them all when selecting a propeller fan for a noise-sensitive application.



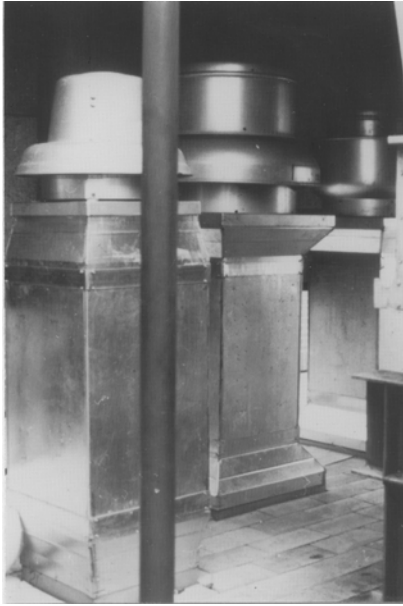
**Figure 2-9** Inlet side of a direct-drive plenum fan.



Photos courtesy of Energy Labs Inc.

**Figure 2-10** Discharge side of a belt-drive plenum fan.

**A Practical Guide to Noise and Vibration Control for HVAC Systems**



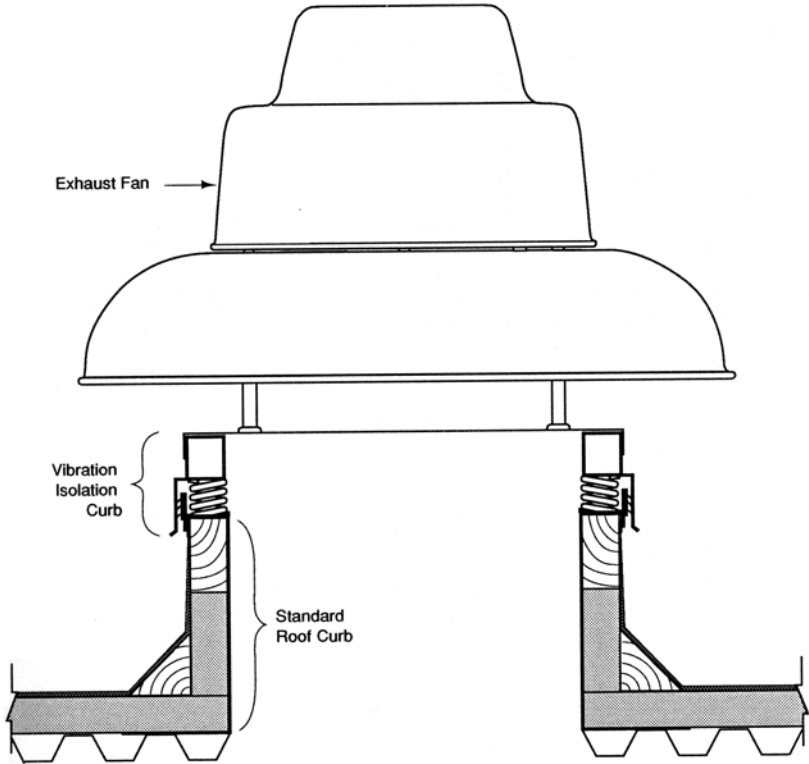
**Figure 2-11** Power roof ventilators (mushroom fans) mounted on intake duct silencers and roof curbs.

Since “add-on” noise control products, such as duct silencers or even duct-work, are often not feasible because of the static pressure losses that they create, selection of the quietest propeller fan available is often needed for a noise-sensitive application. Figure 2-13 compares the inlet  $L_W$  values of three 1200 mm propeller fans operating at 9400 L/s and 125 Pa static pressure. The noisiest of these fans uses cast aluminum blades, while the quietest uses backswept, airfoil-shaped, fiberglass blades that are either form-cast or handmade. Figures 2-14 and 2-15 show two types of propeller fans that can be optimized for high performance and low noise in a panel fan arrangement.

If the quietest panel fan selection still creates excessive outdoor noise levels, for instance, at a nearby residential property line, a sound-attenuating hood similar to that shown in Figure 2-16 can be used to provide attenuation in the range of 3–5 dBA.

Few panel fans are fabricated with sufficient vibration isolation for noise-sensitive applications. For those cases, the panel fan may be suspended from four isolation hangers in arrangement similar to that shown in Figure 2-17.

## Airside Equipment



**Figure 2-12** Mushroom type exhaust fan on vibration-isolated roof curb.

## Ceiling Exhaust and Cabinet Fans

Ceiling exhaust and cabinet fans used to be standard in conference rooms to remove cigarette and cigar smoke; however, with many fewer buildings permitting smoking, the dominant use for these fans is now in residential bathrooms, kitchens, and utility rooms. These fans are typically rated in terms of sones, where 1 sone is roughly equivalent to a sound level in the 35 to 40 dBA range. Doubling the number of sones is roughly equivalent to adding 10 dBA to the sound level, so 2 sones is typically in the 45 to 50 dBA range, 4 sones is in the 55 to 60 dBA range, etc. Most of these fans have ratings of several sones, but some manufacturers have recently developed low-capacity fans that are as quiet as 1 sone. For rooms with cabinet fans, Figure 2-18 shows noisy and quieter installations of this fan type.

### A Practical Guide to Noise and Vibration Control for HVAC Systems

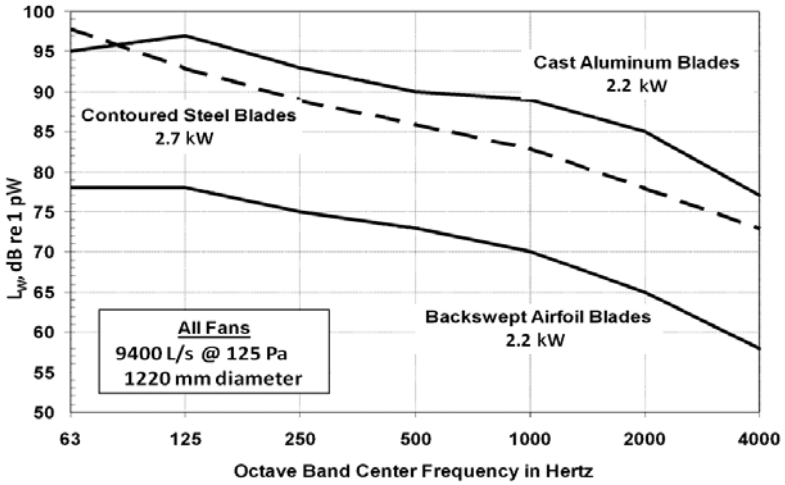


Figure 2-13 Inlet octave band  $L_w$  comparison for three propeller fans.

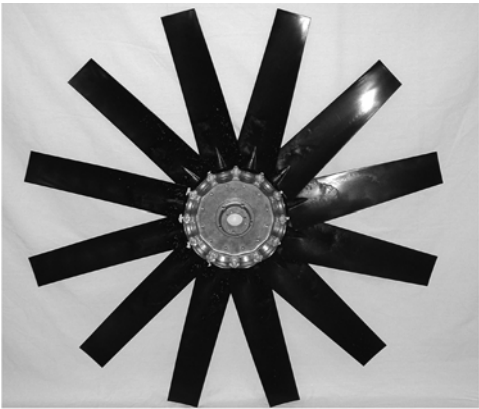
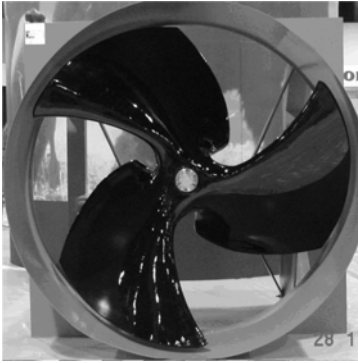


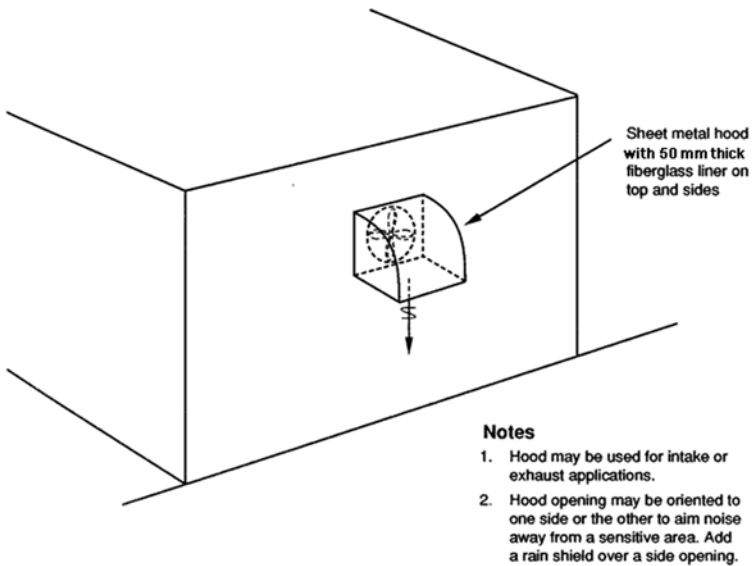
Photo courtesy of Multi-Wing America.

Figure 2-14 Propeller fan with a 12-socket aluminum hub and plastic blades. This fan can be selected for use with 2, 3, 4, 6, 8, 9, or 12 blades of any custom length or blade twist to optimize airflow and acoustical performance.

### Airside Equipment



**Figure 2-15** Ultra-low-noise propeller fan with backsweppt airfoil blades. Versions of this fan are available with 2, 3, or 4 blades of adjustable blade twist and diameters up to 12.3 m for very large capacities.

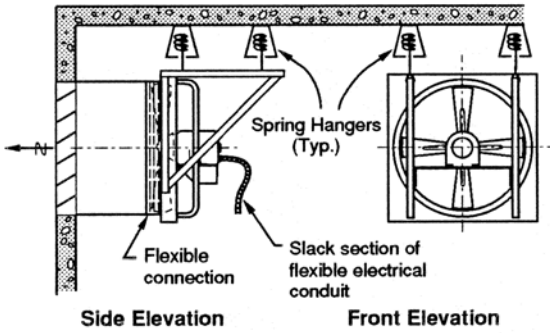


#### Notes

1. Hood may be used for intake or exhaust applications.
2. Hood opening may be oriented to one side or the other to aim noise away from a sensitive area. Add a rain shield over a side opening.

**Figure 2-16** Lined hood for propeller fan noise control.

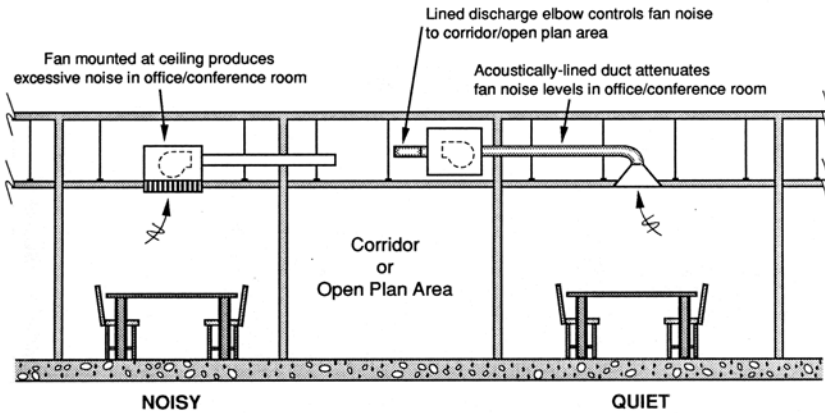
### A Practical Guide to Noise and Vibration Control for HVAC Systems



**NOTE:**

Position hangers on line of center of gravity of fan unit. Supplemental sections of steel angle or channel may be secured to fan mounting frame, as required, for support.

**Figure 2-17** Vibration isolation suspension for propeller fans.



**Figure 2-18** Noisy and quiet installations of ceiling-mounted exhaust fans.

## Airside Equipment

### *General Guidelines for Controlling Fan Noise and Vibration*

1. Select the most efficient type and size of fan for the application. This will also, in most cases, be the least noisy. Low discharge velocity is also preferred. For fans in VAV applications, see the fan selection guidelines given in the section titled “Special Variable-Air-Volume (VAV) System Concerns” later in this chapter.
2. Select the fan to operate on the right side of the fan curve, safely away from the stall region and near the peak of the kilowatt curve.
3. Allow a clearance of at least 1 fan wheel diameter at all unducted fan inlets and 1.5 wheel diameters at all unducted fan outlets.
4. Use vibration isolation mounts or hangers, with auxiliary bases, if required, for all fans over 0.75 kW located near noise-sensitive areas.
5. Attach ductwork to fans with canvas or elastomeric flexible connectors.
6. Inlet and discharge duct transitions should be gradual to minimize pressure drop and maximize static regain. The total included angle within the transition should be no more than 15 degrees (1:4 slope) for discharge transitions and 45 degrees (1:1 slope) for inlet transitions.
7. In ducted discharge installations, the nearest downstream damper, duct silencer, elbow, offset, transition, or takeoff should be at least three equivalent duct diameters from the fan outlet. The equivalent duct diameter,  $D_e$ , for a rectangular duct is found from the equation

$$D_e = \sqrt{\frac{4 \cdot A \cdot B}{\pi}}$$

where  $A$  and  $B$  are the rectangular duct's cross-section dimensions.

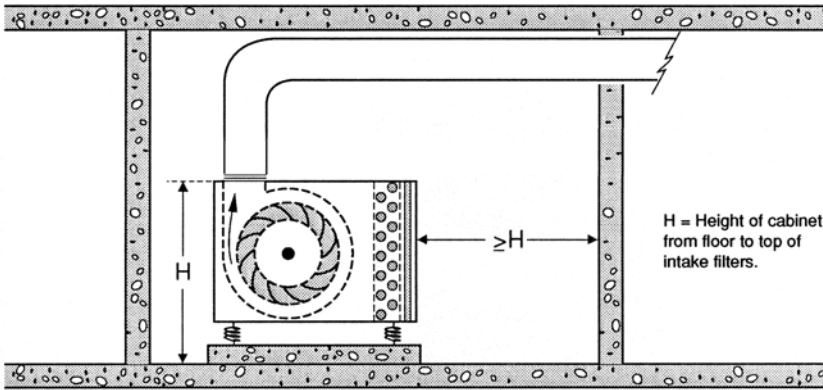
8. All duct system fittings, especially near a fan inlet or discharge, should be designed for the lowest practical pressure drop.
9. Because noise travels upstream and downstream from a fan, duct silencers and/or acoustical duct liner are sometimes required in both the inlet and discharge air paths.
10. Refer to the section titled “Duct System Components” later in this chapter for additional guidelines.

## **AIR-HANDLING UNITS (AHU) AND FAN-COIL UNITS (FCU)**

### **Air-Handling Units (Draw-Through and Blow-Through)**

All of the general guidelines and special guidelines for centrifugal fans apply to air-handling units with one variation: the distance between the unit intake and the nearest wall should be at least the height of the unit (see Figure 2-19). Also note that factory acoustical data for AHUs should be determined in accordance with the most

## A Practical Guide to Noise and Vibration Control for HVAC Systems



**Figure 2-19** Minimum clearance at AHU and cabinet fan inlet.

recent revision of AHRI 260—not an obsolete revision and not per AMCA 300, which is for fans only.

### Air-Handling Units Using Plenum Fans

Systems with this type of AHU can sometimes be designed with short supply air path duct silencers, or sometimes without any silencers. Originally, plenum fans were simply single-inlet, single-width centrifugal fans without a fan scroll. Their designs are now optimized for use in open plenums, such that these fans are now quieter and more efficient than before. The quietest variation of a plenum fan AHU uses a fan that is selected for the lowest possible  $L_w$  values, and has 100 mm thick sound-absorbing insulation behind perforated cabinet liner in all cabinet sections. This unit's discharge plenum can be outfitted with several discharge duct openings to help minimize the number of duct fittings in and near the mechanical room. Figure 2-20 shows an external view of a plenum AHU with two top outlets with radius elbows that direct the supply air in opposite directions. This arrangement precludes the need for a T-split discharge fitting. Figure 2-21 shows a cutaway sketch of a blow-through plenum AHU.

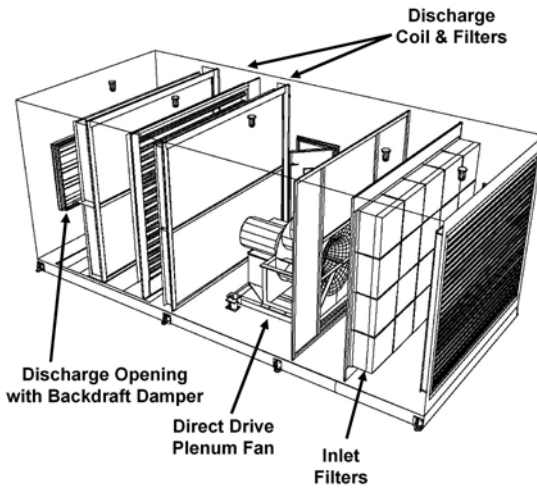
### Fan-coil Units

Motor hum from single-phase motors is a common noise problem in fan-coil units because this kind of motor is prone to high internal vibration, and because this type of motor is typically attached directly to the unit housing, which acts a sounding board for the motor's vibration. Therefore, a fan-coil unit in a noise-sensitive application should be specified with a three-phase motor and a fan-motor sub-assembly that is

## Airside Equipment



**Figure 2-20** Plenum AHU with supply ducts attached to the top of discharge plenum.



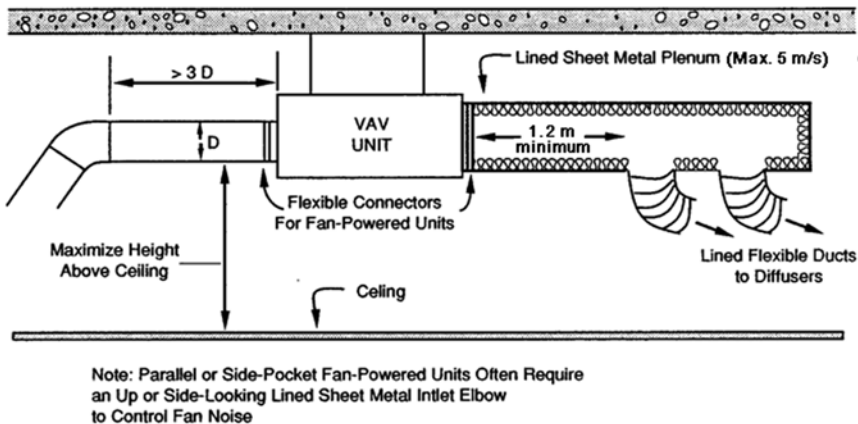
**Figure 2-21** Cutaway sketch of a plenum fan air-handling unit.

## A Practical Guide to Noise and Vibration Control for HVAC Systems

mounted on spring isolators within the unit housing. An electronically commutated motor (ECM) will provide additional noise and vibration reduction because these motors produce less vibration than other low-kW motors.

### TERMINAL UNITS (CAV, VAV, AND FAN-POWERED VAV BOXES)

Experience has shown that the problems with this type of equipment typically occurs because of excessive inlet static pressure, excessive inlet air velocity, incorrect installation, or a misunderstanding of the acoustical performance data given in manufacturers' catalogs. Past ASHRAE research has shown that the acoustical testing and rating procedures used for this equipment has resulted in published Noise Criteria (NC) rating estimates that are almost impossible to achieve in a real-world installation. Therefore, the specifying engineer should understand how to use the cataloged ratings for a specific application. Refer to Appendix D, "Using Manufacturer's Sound Data." The guidelines shown in Figure 2-22 and in the checklist below will help minimize the chances of excessive terminal unit noise. The guidelines apply to single-duct, dual-duct, and induction units, as well as parallel and series fan-powered units.



**Figure 2-22** Guidelines for VAV unit installation.

## Airside Equipment

### *Terminal Unit Selection and Application Checklist*

1. Establish the Room Criteria (RC), Noise Criteria (NC), or Balanced Noise Criteria (NCB) rating for each room with the help of the table in Table B-1 (see Appendix B).
2. Use the manufacturers' published octave band discharge and radiated  $L_W$  data for a static pressure difference of 250 Pa to select the quietest unit that will meet the design objectives; this will typically occur for a maximum inlet velocity of about 9 m/s for single-duct and dual-duct boxes and 6 m/s for fan-powered boxes.
3. For a terminal unit in a return air ceiling plenum with distributed return air grilles in a mineral tile or fiberglass ceiling:
  - a. Verify that the unit's 125 hertz radiated octave band  $L_W$  value is no more than 32 points above the NC, RC, or NCB rating that was selected for the room below the terminal unit. For instance, the 125 hertz radiated octave band  $L_W$  value for a terminal unit above a room with an NC/RC/NCB rating of 40 should not exceed 72 dB.
  - b. Locate the unit as high in the plenum space as possible and at least 1.5 m from any return air grille.
  - c. If a unit must be located less than 1.5 m from a return air grille, it may be necessary to install a fiberglass-lined sheet metal elbow on top of the grille with its discharge opening aimed away from the terminal unit.
4. If the terminal unit is installed above a room with a gypsum board ceiling having no openings, its 125 hertz radiated octave band  $L_W$  value can be as much as 40 points higher than the room's NC/RC/NCB rating. For instance, a terminal unit above a room with a solid gypsum board ceiling may produce a 125 hertz radiated sound power level of 80 dB if it is installed above a room with an NC-40 design criteria rating.
5. Do not locate a terminal unit over a space with an NC, RC, or NCB rating less than 35 (e.g., private offices, conference rooms, classrooms, etc.).
6. Do not locate a fan-powered terminal unit over a space with an NC, RC, or NCB rating less than 40. Instead, locate it over a nearby nonsensitive space, such as a corridor, toilet, or storage room.
7. The high- or medium-pressure ductwork entering the terminal unit should be straight, with no fittings or dampers, for at least three equivalent duct diameters upstream of the unit.
8. Connect high- or medium-pressure ductwork to the unit's inlet with a short, flexible, canvas duct connector, not a length of flexible ductwork.

## A Practical Guide to Noise and Vibration Control for HVAC Systems

9. The low-pressure discharge duct should be fiberglass-lined sheet metal, not unlined sheet metal or fiberglass ductboard.
10. Duct taps into the unit's discharge plenum should be at least 1200 mm downstream from the unit outlet.

Terminal units that are exposed in occupied areas without ceilings are common sources of noise complaints. Ceilings are almost always needed to control terminal unit radiated noise.

### LABORATORY AIR VALVES

Cylindrical venturi air valves with plunger valve assemblies are often used in laboratory makeup and exhaust air duct systems. A photo of such an air valve is shown in Figure 2-23. These valves have no particular acoustical advantage over traditional terminal units, and their selection and installation guidelines are similar to those for terminal units with the additional warning that any acoustical analysis should consider the valve's discharge, radiated, and exhaust  $L_W$  performance ratings. Discharge noise travels in the direction of airflow, while exhaust noise travels in the direction opposite to the airflow.

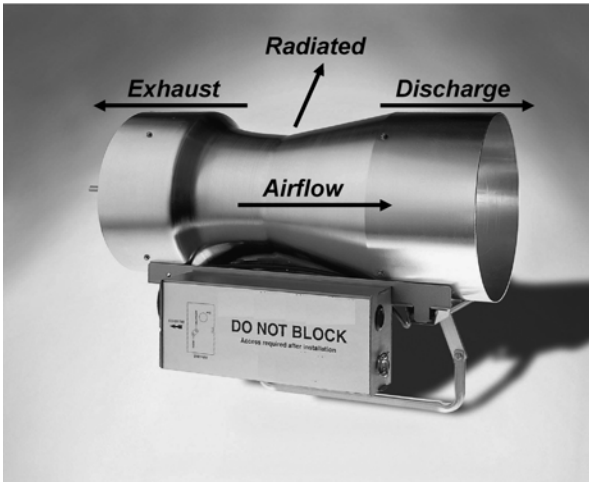


Photo courtesy of Phoenix Controls Corporation.

**Figure 2-23** Laboratory air valve and its “noise flow” directions.

## **Airside Equipment**

### **GRILLES, REGISTERS, AND DIFFUSERS (AIR DEVICES)**

Because air devices are directly exposed to the occupied space, noise reduction treatments cannot be added between them and the space occupants. Therefore, they must be selected with the appropriate acoustical ratings.

#### ***Air Device Selection and Application Checklist***

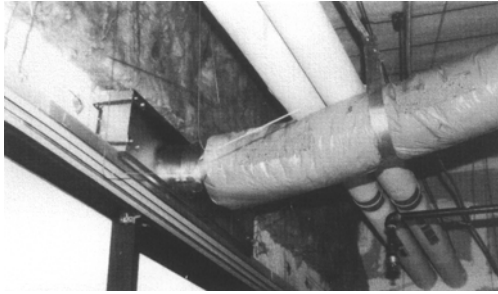
1. Establish the NC, RC, or NCB ratings for all noise-sensitive areas in the building with the help of Table B-1 (see Appendix B).
2. Select each supply and return air device to have a manufacturer's NC rating at least five points below the room's established NC, RC, or NCB rating. Lower NC ratings will be needed if the room is served by several devices.
3. The ductwork serving a supply air device should be straight for at least three equivalent duct diameters upstream of the device's duct collar. Wavy ductwork will cause uneven airflow into the device, creating extra pressure drop and noise. See Figures 2-24 and 2-25 for a comparison of good and bad airflow entry conditions.
4. The ductwork serving a supply air diffuser or return air grille should be at least the same size as the device's inlet collar. Using a short collar transition to adapt the device's collar to either a larger or smaller duct can result in unexpectedly high noise due to turbulence at the transition adapter. If a transition is needed to match a duct to its air device, the transition should conform to the guidelines given in the section below titled "Duct System Components."
5. Do not attach a balancing damper to a device's duct collar. It should be at least three equivalent duct diameters away from the device. Figure 2-26 shows the effect of adding a balancing damper close to a supply outlet's duct collar.

Pay close attention to the catalog data when selecting a linear diffuser. If the diffusers will be installed with close-fitting inlet plenums, verify that the catalog data used to make the selection are based on the same inlet plenum configuration.

### **DUCT SYSTEM COMPONENTS**

While duct systems must be designed to deliver air within a given space and at a reasonable cost, they must not be allowed to generate or transmit excessive noise in the process. The excessive turbulence that often results from an inefficient duct layout causes excess pressure drop and can lead to roar and rumble that can be difficult and expensive to control. Also, the use of improper duct materials for a given application can allow excessive levels of other system noises (usually from fans or variable-volume terminal units) to be transmitted into occupied spaces.

## A Practical Guide to Noise and Vibration Control for HVAC Systems



**Figure 2-24** Good inlet duct connection to a supply air ceiling diffuser. With a straight flex duct path, the diffuser will produce the manufacturer's cataloged noise levels.



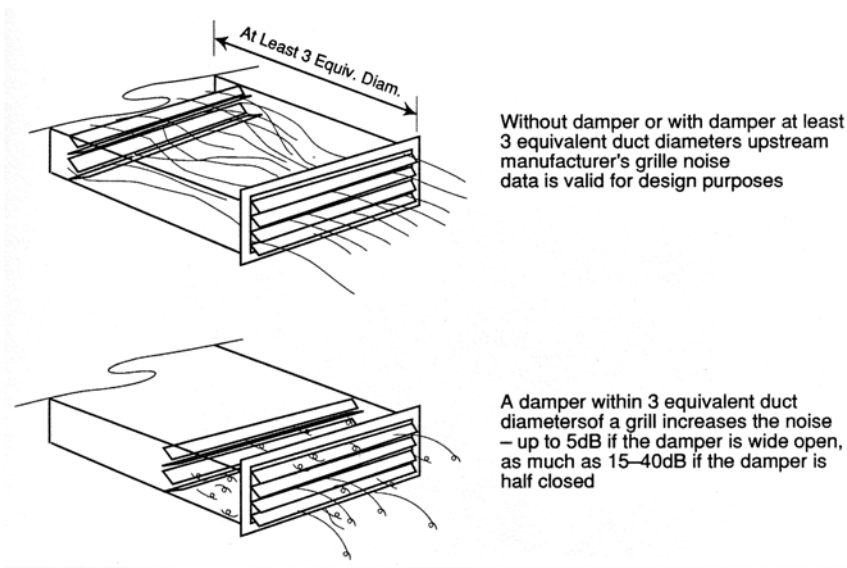
**Figure 2-25** Poor inlet duct connection to a supply air ceiling diffuser. The winding flex duct path causes excessive air turbulence and noise at the diffuser's inlet collar. This diffuser could produce noise levels as much as 15 dB higher than the manufacturer's catalog data.

The main acoustical characteristics of duct system components are in-duct attenuation, breakout attenuation, and self-noise generation. All of these characteristics should be considered when selecting, sizing, and routing ductwork.

### In-Duct Attenuation

*In-duct attenuation* refers to the reduction of sound as it travels in the airstream inside of a duct. Unlined metal ducts provide limited amounts of low-frequency in-duct

## Airside Equipment



**Figure 2-26** The effect of installing a damper behind a grille.

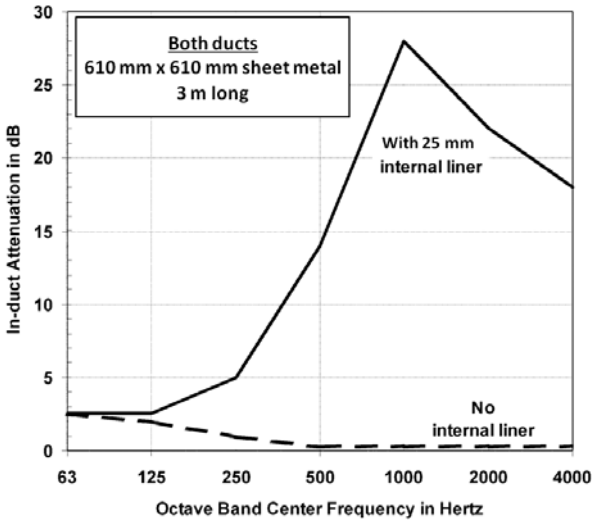
attenuation and almost no in-duct attenuation at high frequencies. Adding an internal fibrous or foam liner that conforms with all of the NFPA Standard 90A limits for smoke and combustibility will have little effect on low-frequency attenuation but will greatly improve the attenuation at mid and high frequencies. Figure 2-27 shows a sample comparison of the in-duct attenuation in lined and unlined sheet metal ductwork. Fiberglass ductboard and flexible ducts exhibit very high in-duct attenuation performance at all frequencies because of their breakout transmission loss characteristics. See the section on breakout transmission loss below.

Some publications, including early versions of the *ASHRAE Handbook*, stated that external thermal insulation increases the low-frequency in-duct attenuation of metal ductwork. That statement was never corroborated, and recent testing has shown that external wrapping has no significant effect on the in-duct attenuation of metal ductwork.

### Breakout Transmission Loss (BTL)

*Breakout transmission loss* (BTL) refers to the reduction of noise that is transmitted through a duct wall. The BTL at all frequencies increases with ductwall mass,

## A Practical Guide to Noise and Vibration Control for HVAC Systems



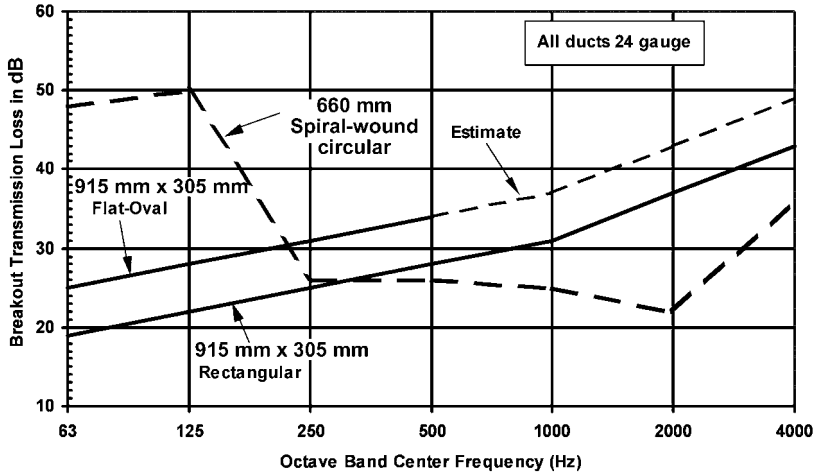
**Figure 2-27** Attenuation for lined and unlined sheet metal ductwork.

i.e., lower gauge number means that less noise will break out of the ductwork. However, such improvements quickly reach a point of diminishing returns. The best way to improve low-frequency breakout performance is to increase the duct's stiffness. Spiral-wound circular ductwork is very stiff, so it is the preferred duct type where low-frequency breakout noise control is needed. Longitudinal-seam circular ductwork is slightly less stiff, so it provides somewhat less breakout transmission loss. Flat-oval ducts are significantly less stiff than either spiral-wound or long-seam circular and, therefore, provide much less low-frequency breakout noise control. The relative flexibility of rectangular duct walls makes them even more prone to poor duct breakout noise control. Figure 2-28 shows a sample comparison of breakout transmission loss through rectangular, spiral-wound circular, and flat-oval ductwork. Higher values of BTL will result in lower sound levels outside of the ductwork.

### Self-Noise

*Self-noise* (also called self-generated or regenerated noise) refers to the turbulence-induced noise that is produced in duct fittings and other duct system components that

## Airside Equipment



**Figure 2-28** Breakout transmission loss for three types of sheet metal ductwork.

obstruct or divert airflow, e.g., elbows, takeoffs, transitions, dampers, duct silencers, etc. The amount of noise generated at each duct system component depends on the duct type, localized airflow velocity, and type of fitting. Self-noise is not usually a problem where the trunk duct velocity is below 7.5 m/s and if diffuser branch ducts are sized to match the diffuser's duct collar. Following the guidelines given in the SMACNA "HVAC Duct Construction Standards—Metal and Flexible" (1995) and designing the duct system for the lowest possible airflow velocities and pressure drop will avoid most self-generated noise and rumble problems. Tables 2-1 and 2-2 give recommended maximum airflow velocities for various types of ductwork. Figures 2-29 through 2-32 compare the scale of self-generated noise produced by various types of elbows, takeoffs, transitions, tees, and offsets.

## Duct and Plenum Linings






Duct and plenum linings are semi-rigid fibrous or foam boards that are attached to the inner walls of ducts and plenums to attenuate sound. They also provide thermal insulation. The typical 25 mm thick liner provides good high-frequency sound attenuation but has almost no effect on low-frequency sound. Better low-frequency attenuation occurs with an increase in the lining thickness to 50 or 100 mm because the lining occupies a larger percentage of the cross section

**A Practical Guide to Noise and Vibration Control for HVAC Systems**

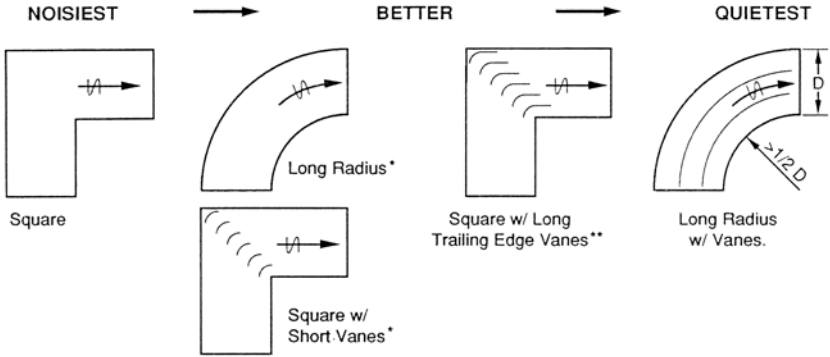
**Table 2-1. Suggested Maximum Airflow Velocities  
 for Various Ductwork Installations**

Duct Location	RC or NC Rating in Adjacent Occupancy	Max. Airflow Velocity in m/s	
		Rectangular	Circular
In shaft or above solid drywall ceiling	45	17.5	25
	35	12.5	22.5
	25 or less	7.5	12.5
Above suspended acoustical ceiling	45	12.5	22.5
	35	8.5	17.5
	25 or less	5	10

**Table 2-2. Suggested Maximum Airflow Velocities  
 in Elbows for Rectangular Ductwork**

Lowest NC or RC Rating Served by Duct System					
	Square	Radius	Square, Short Vanes	Square, Long Vanes	Radius With Vanes
Maximum Velocity in m/sec					
50+	10	12.5	12.5	14	15
45	8	10	10	12	13
40	6.5	8.5	8.5	11.5	12.5
35	5	6.5	6.5	8.5	9
30	4	5	5	6	7.5
25	3	4	4	5	6
20 or less	Do not use	2.5	2.5	3	3

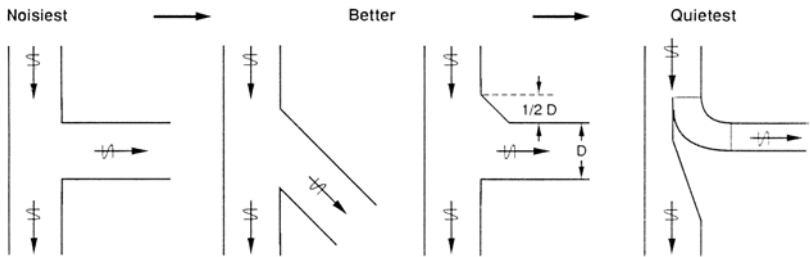
**Airside Equipment**



\* Airflow velocity and proximity of upstream and downstream fittings and fans determine which type is preferable.

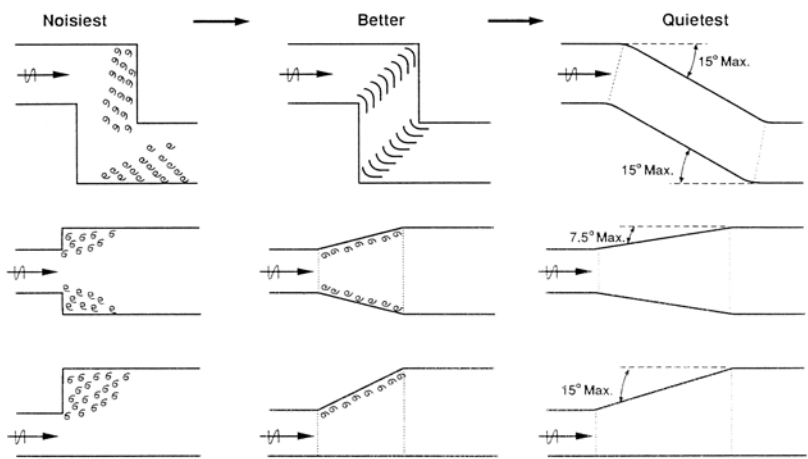
\*\* Trailing edge length should be at least 3 times the vane spacing.

**Figure 2-29** Guidelines for minimizing regenerated noise in elbows.

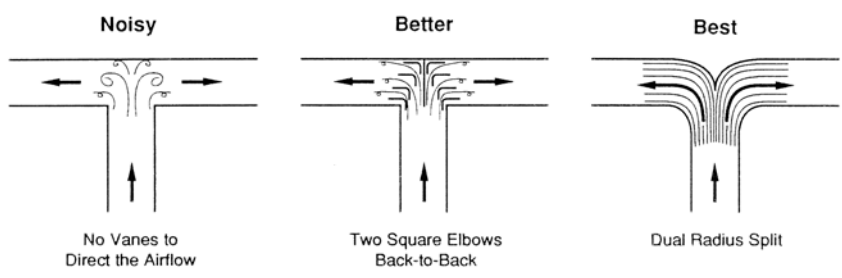


**Figure 2-30** Guidelines for minimizing regenerated noise in takeoffs.

**A Practical Guide to Noise and Vibration Control for HVAC Systems**



**Figure 2-31** Guidelines for minimizing regenerated noise in transitions and offsets.



**Figure 2-32** Guidelines for minimizing regenerated noise in duct tees.

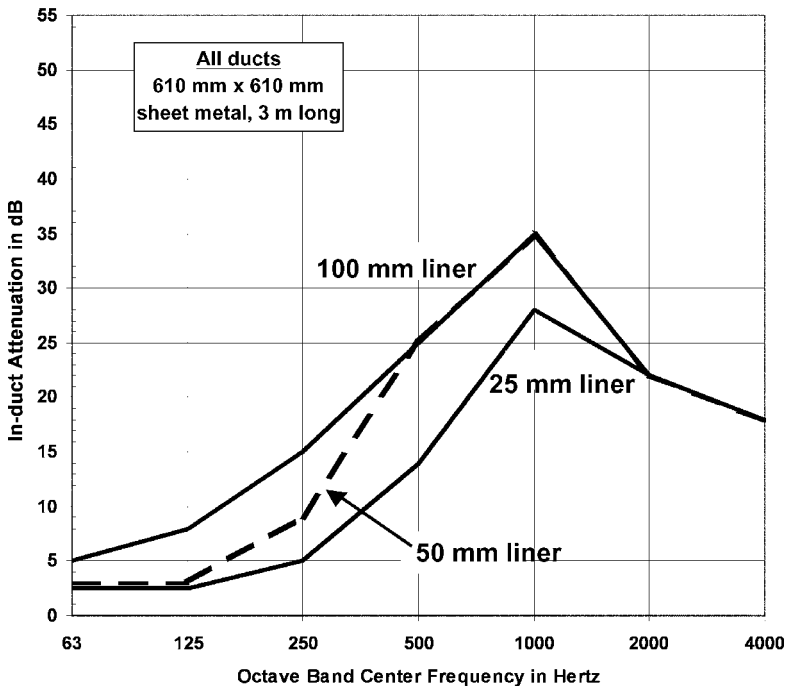
## Airside Equipment

of the duct's sheet metal face area. Figure 2-33 compares the sound attenuation in a 610 by 610 mm duct for various lining thicknesses.

Duct lining is very effective in controlling the “cross-talk” or “speaking tube” effect between rooms that share a common duct. For this use, a lined elbow can have the same acoustical effect as 600 to 2400 mm of straight, lined ductwork or up to 30 m of straight, unlined duct. Figure 2-34 shows how the “speaking tube” problem can occur and how to mitigate it.

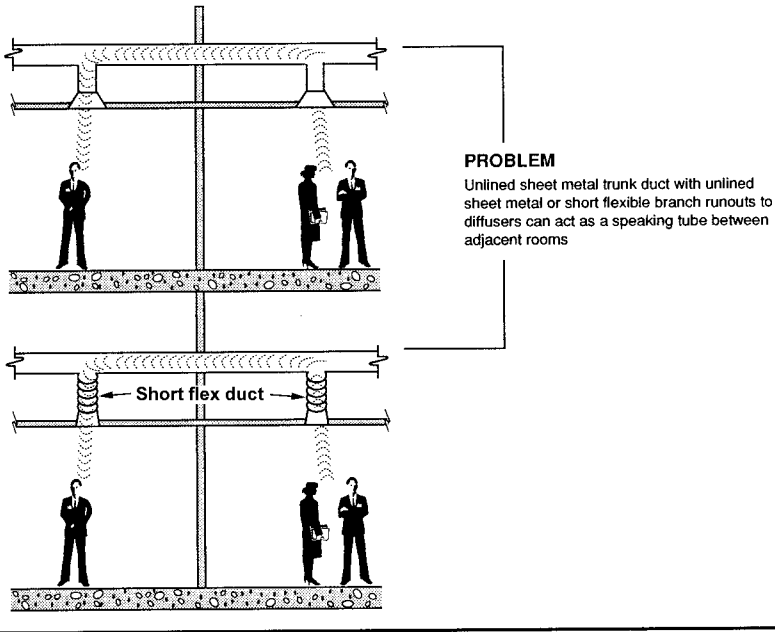
## Fiberglass Ductboard

Fiberglass ductboard is rigid fiberglass board with a thin external aluminum vapor barrier. It is typically used in residential construction because it is relatively inexpensive and is easy to modify in the field with a knife. Due to its very low density it can permit breakout noise transmission problems, a feature that also results in high in-duct attenuation.

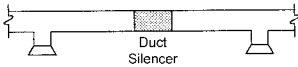


**Figure 2-33** In-duct attenuation for various duct liner thicknesses.

## A Practical Guide to Noise and Vibration Control for HVAC Systems



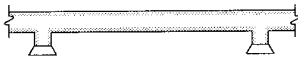
### SOLUTIONS



Insert a duct silencer in the trunk duct



Use fiberglass lined flex duct, 2 m long with at least one elbow, 600 mm closest to air device to be straight



Add 25 mm thick duct liner in trunk and branch ducts

**Figure 2-34** The speaking tube (cross-talk) problem.

## Airside Equipment

### Elbows and Takeoffs

Elbows and takeoffs provide in-duct attenuation, especially at mid and high frequencies, due to reflection from the duct walls and other mechanisms. Figure 2-35 compares the in-duct attenuation of square elbows with and without internal duct liner. Radius elbows provide less attenuation because they guide the air (and the noise) more smoothly through the turn. Figure 2-36 compares the attenuation of square and radius elbows.

### Flexible Ducts

Flexible ducts are typically used for duct connections to ceiling diffusers. They provide significant amounts of in-duct attenuation, mainly because their lightweight construction provides substantial breakout (i.e., they are very poor for controlling breakout sound transmission). Flexible ducts with a spunbond nylon inner liner provide higher in-duct attenuation than flex ducts with polyethylene liner. Figure 2-37 shows a flex duct with spunbond nylon liner.

Table 2-3 can help you select the best type of ductwork as a function of its required acoustical properties. For example, if low-frequency breakout noise control is important, the table would suggest using either lined or unlined circular ductwork; however, note that the lined version would be needed if mid-frequency in-duct attenuation is also important.

## DUCT SILENCERS, PLENUMS, AND ACOUSTICAL LOUVERS

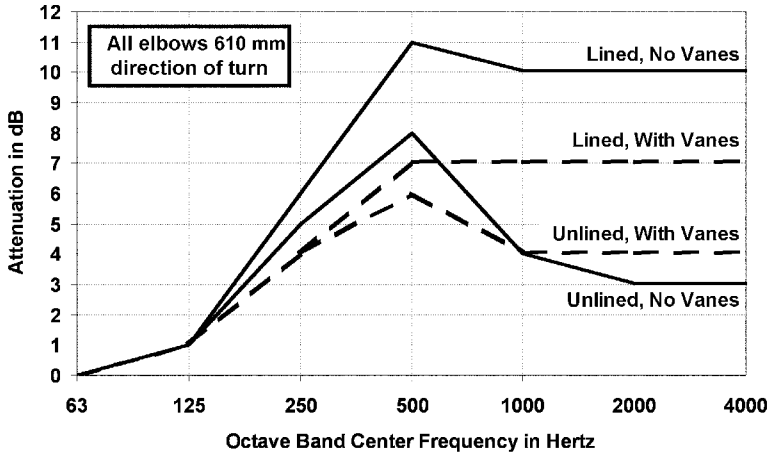
### Duct Silencers

#### (Also Called Sound Traps, Duct Attenuators, Mufflers)

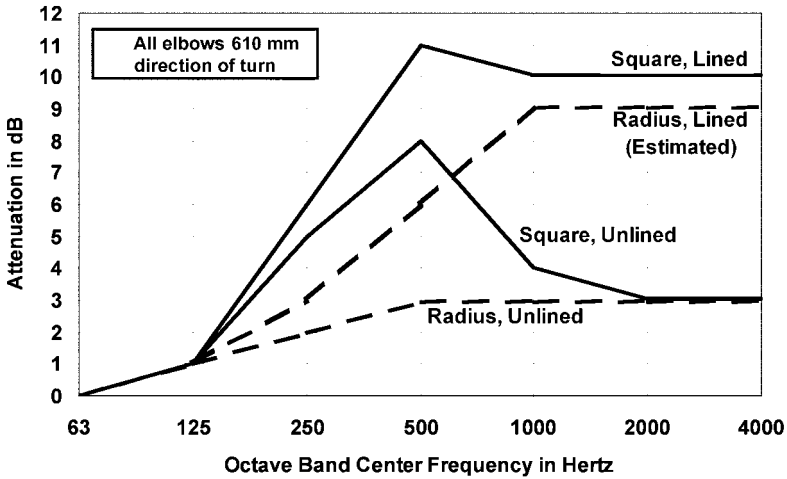
Duct silencers are prefabricated sections of ductwork with internal baffles made of light gauge, perforated sheet metal. Their acoustical performance depends mainly on their baffle design. Each type of duct silencer has a unique material filling its baffles, as follows:

- **Dissipative:** The baffles are filled with a sound-absorptive medium, such as fiberglass, mineral wool, or treated cotton. Specially designed open-cell foams that conform with all of the NFPA 90A requirements have a very large cost premium but can be used in duct silencers where fibrous materials are not permitted. Figure 2-38 shows a view into a dissipative silencer before its final fabrication step.
- **Film-Lined:** Similar to dissipative, except that the acoustic fill in the baffles is encapsulated in thin film bags to control moisture absorption and prevent erosion of the fibers into the airstream (see Figure 2-39). The film lining

**A Practical Guide to Noise and Vibration Control for HVAC Systems**



**Figure 2-35** Attenuation of rectangular elbows with and without turning vanes (lined and unlined).



**Figure 2-36** Attenuation of rectangular and radius elbows (lined and unlined).

**Airside Equipment**



**Figure 2-37** Flexible duct with spunbond nylon inner liner.

**Table 2-3. Acoustical Characteristics of the Various Types of Ductwork**

Ductwork Type	In-Duct Attenuation		Breakout Attenuation	
	Low Frequency	Mid and High Frequencies	Low Frequency	Mid and High Frequencies
Rectangular, unlined	Fair	Poor	Fair	Excellent
Rectangular, lined	Fair	Excellent	Fair	Excellent
Circular, unlined	Poor	Poor	Excellent	Good
Circular, lined	Poor	Excellent	Excellent	Good
Fiberglass ductboard	Excellent	Excellent	Poor	Fair
Flexible acoustical duct	Excellent	Excellent	Poor	Fair
Unlined elbow, all duct types	Poor	Fair	—	—
Lined elbow, all duct types	Poor	Excellent	—	—

**A Practical Guide to Noise and Vibration Control for HVAC Systems**

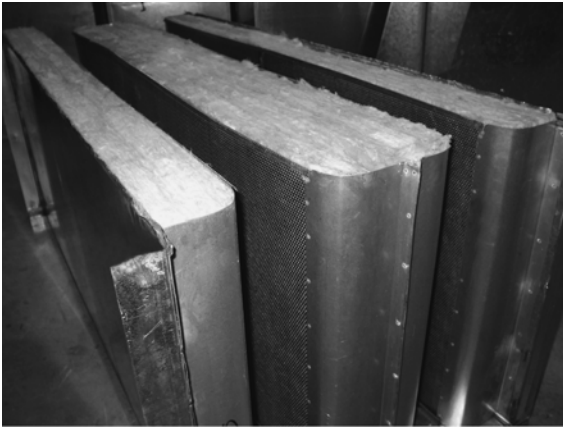


Photo courtesy of Dynasonics, a division of PCI Industries Inc.

**Figure 2-38** Cutaway view into a dissipative duct silencer.



Photo courtesy of Vibro-Acoustics, a division of BVA Systems Ltd.

**Figure 2-39** Cutaway view of a duct silencer with film-lined baffles.

## Airside Equipment

reduces the silencer's acoustical performance at mid and high frequencies and may also affect low-frequency performance, depending on the type of film and how it is installed in the baffles. Care must be taken when specifying the film material, as many films do not conform with the flame spread and smoke rating limits given in NFPA Standard 90A.

- **Reactive:** Also called “no fill,” “packless,” or “no media;” the baffles are empty but are formed from sheet metal with special perforation patterns that provide moderate amounts of insertion loss over a narrow frequency range using the Helmholtz resonator effect (see Figure 2-40).

Duct silencers can be built in any shape that can be fabricated using sheet metal. Figure 2-41 shows an “elbow silencer,” a combination duct silencer/duct elbow. Double-elbow, T-shaped, and transition silencers are also available.

Because its internal baffles obstruct airflow, a duct silencer also generates airflow turbulence that can lead to significant self-noise and static pressure loss if it is not incorporated properly into the air distribution system. Silencers are available in many different configurations whose acoustical and aerodynamic performance depend on the size, shape, and length of the baffles. Long, wide baffles provide more attenuation than short, narrow ones. High sound insertion loss performance usually requires either a silencer that is very long or a shorter one that has a high static pressure drop and self-noise. Since silencers should generally be selected for a static pressure loss of no more than about 70 Pa, proper silencer selection is an iterative process in which silencers of various lengths and baffle widths are compared to find the one(s) that will provide the required sound insertion loss at an acceptable static pressure loss. Typically, higher velocity systems will require longer silencers with narrower baffles to provide acceptable performance. Ultimately, silencer selection is an optimization process that considers (1) the insertion loss required to meet the specified acoustical criteria, (2) the space available, and (3) the maximum permissible pressure drop (including aerodynamic system effects).

Figure 2-42 compares the insertion loss performance of two types of dissipative duct silencers with that for 3 m of lined ductwork. The duct silencers' insertion losses shown as the upper and lower curves in the figure bracket the wide range of insertion loss values that are typically available. Note the correlation of insertion loss and pressure drop (PD). Figure 2-43 compares the insertion loss performance of 1.5 m long duct silencers of the dissipative, film-lined, and packless types.

To perform at or near the ratings given in manufacturers' catalogs, duct silencers should be installed in accordance with the guidelines given in Figures 2-44 and 2-45. Closer proximity to a fan, AHU, or duct fitting can cause excess turbulence that can lead to higher self-noise and higher pressure drop and could force the fan to operate in rotating stall, thereby creating a low-frequency rumble that the

**A Practical Guide to Noise and Vibration Control for HVAC Systems**



Photo courtesy of Vibro-Acoustics, a division of BVA Systems Ltd.

**Figure 2-40** Cutaway view of a reactive (“packless,” “no-fill,” or “no-media”) duct silencer.

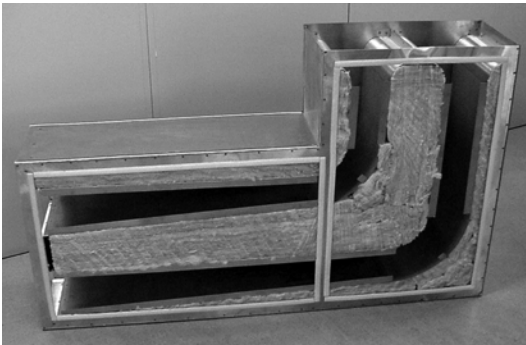
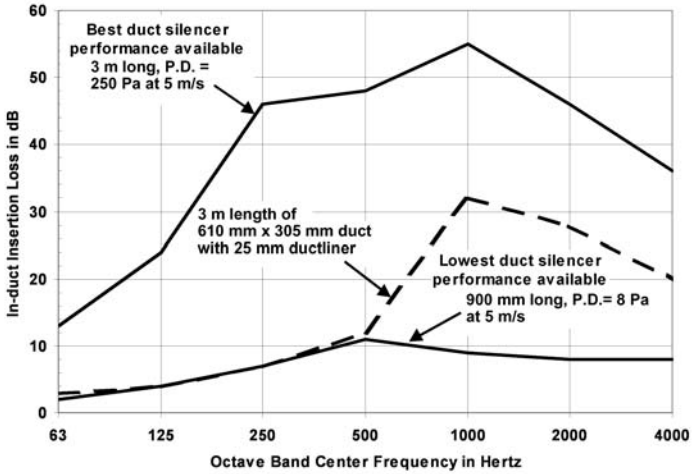


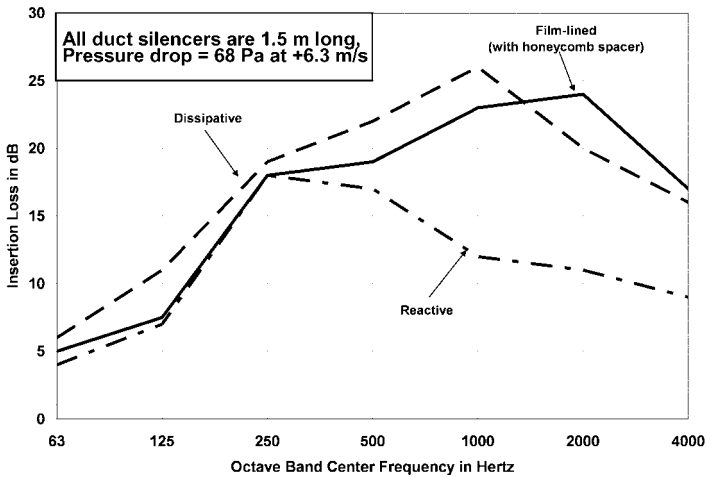
Photo courtesy of Vibro-Acoustics, a division of BVA Systems Ltd.

**Figure 2-41** Cutaway view of an elbow duct silencer.

### Airside Equipment

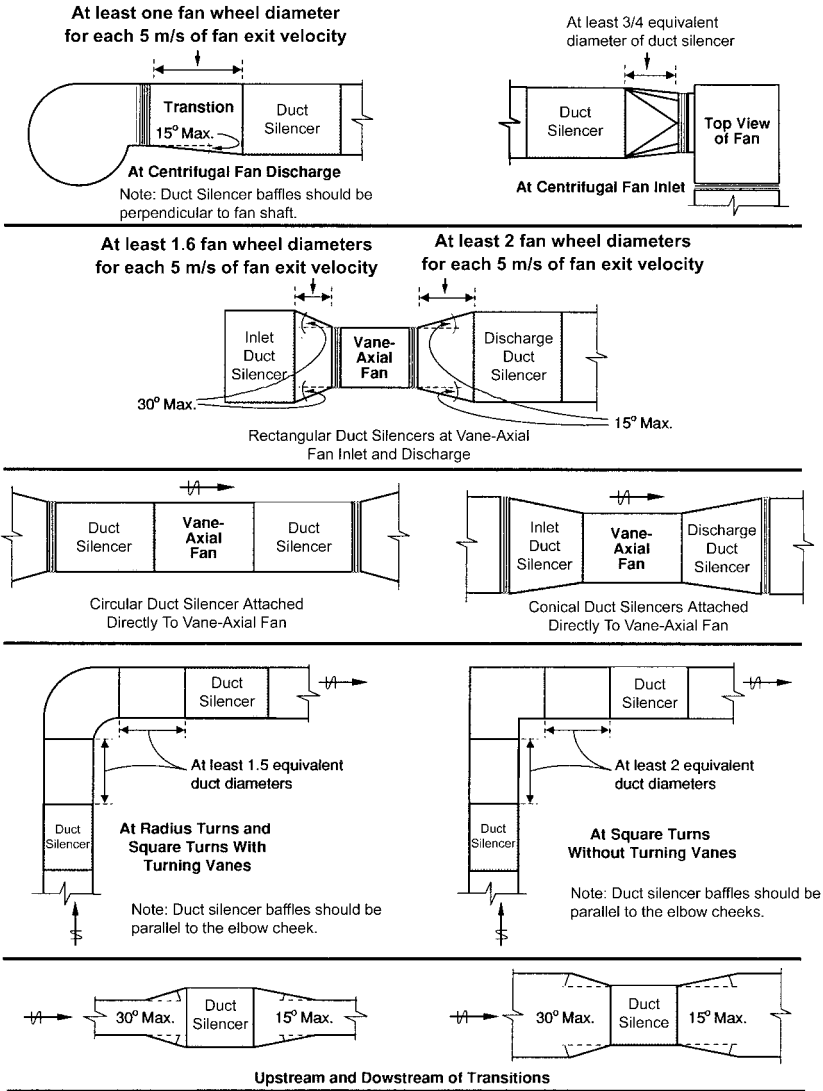


**Figure 2-42** In-duct attenuation of duct silencers and lined ductwork.



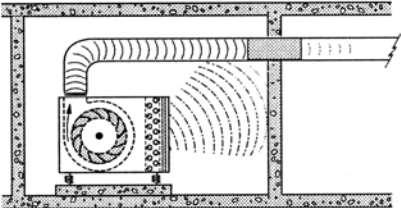
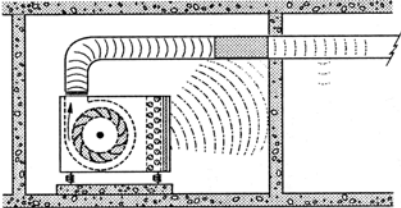
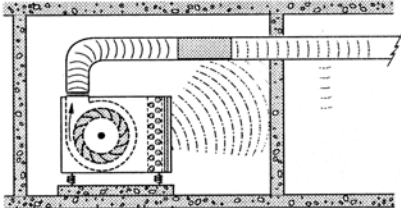
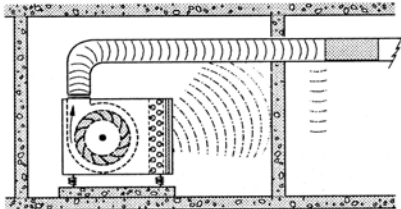
**Figure 2-43** Comparative insertion loss of dissipative, film-lined, and reactive duct silencers.

**A Practical Guide to Noise and Vibration Control for HVAC Systems**



**Figure 2-44** Guidelines for duct silencer placement near fans and duct fittings.

**Airside Equipment**

Duct Silencer Placement	Comment
 <p data-bbox="383 454 517 475">Centered in Wall</p>	<p data-bbox="741 253 781 270">Best</p> <p data-bbox="741 298 982 361">Controls ductborne noise and mechanical room noise that "breaks into" duct</p>
 <p data-bbox="394 732 506 753">Outlet at Wall</p>	<p data-bbox="741 531 827 548">Very Good</p> <p data-bbox="741 576 982 618">Practical alternate where fire damper is required at wall</p>
 <p data-bbox="348 1010 552 1031">Inside Mechanical Room</p>	<p data-bbox="741 808 781 826">Fair</p> <p data-bbox="741 854 1003 916">Mechanical room noise "breaks into" duct without reduction through duct silencer</p>
 <p data-bbox="337 1288 563 1308">Outside of Mechanical Room</p>	<p data-bbox="741 1086 781 1104">Poor</p> <p data-bbox="741 1131 1003 1194">All noise in duct "breaks out" over occupied space before being reduced by duct silencer</p>

**Figure 2-45** Duct silencer placement near a mechanical room wall.

## A Practical Guide to Noise and Vibration Control for HVAC Systems

silencer will not attenuate. The author was recently called to resolve a complaint of excessive rumble in a college library where a silencer with a catalogued PD of 70 Pa generated an actual PD of more than 250 Pa because it was “shoehorned” between an AHU outlet and a duct elbow. The silencer’s extra PD threw the AHU’s fan into rotating stall, thereby causing rumble complaints in the library. A complete reconfiguration of the duct system was needed to eliminate the rotating stall condition and resolve the complaint.

### Acoustical Plenums

If space is available, a plenum with an interior sound-absorbing lining (50- to 400-mm-thick) can provide significant fan noise reduction at all frequencies. Recently completed ASHRAE-sponsored research shows that the plenum attenuation equation in the *2003 ASHRAE Handbook—Applications* is conservative at low frequencies. Later editions of the Handbook will include a more accurate method for estimating the insertion loss as a function of plenum dimensions and interior wall surface finish. Figure 2-46 gives some general guidelines for maximizing plenum insertion loss.

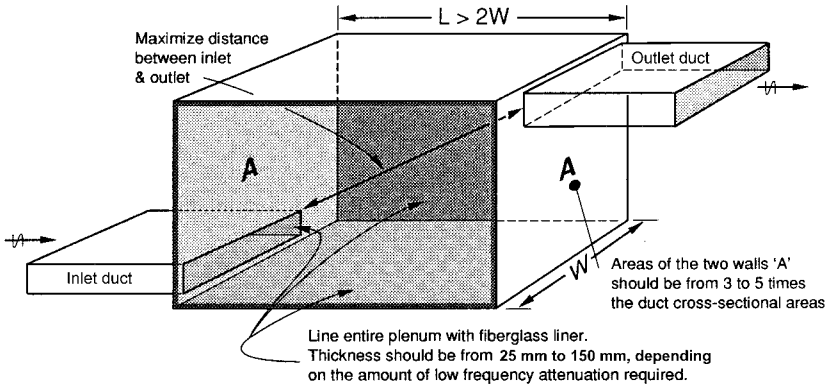
### Acoustical Louvers

Acoustical louvers are used primarily in equipment rooms and air shafts where noise control is needed at a ventilation opening. These louvers use fiberglass-filled baffles and are available in thicknesses from 100 to 600 mm. The upper surface of each baffle is solid, while the lower surface is perforated. Figure 2-47 shows a cutaway view of an acoustical louver with airfoil-shaped baffles. Parallelogram-shaped baffles with flat upper and lower surfaces and herringbone “sightproof” blades are also available. Figure 2-48 compares the octave band sound transmission loss performance of a typical 300 mm thick acoustical louver with that of a standard weatherproof louver with a 50% net open area. Figure 2-49 shows a photo of an acoustical louver in a garage ventilation system.

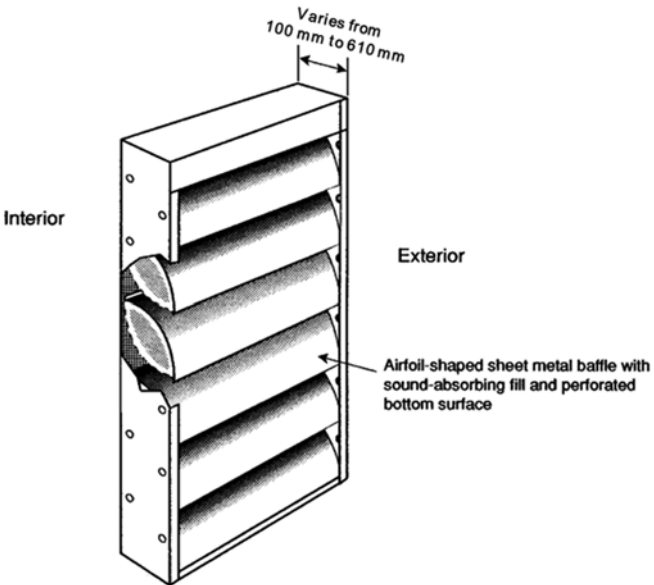
Because the free area of an acoustical louver can be as small as 15% of its face area, care must be taken when sizing these louvers since a face area velocity of 2.5 m/s could create a free area velocity of as much as 15 m/s, which would generate a high static pressure loss and high levels of self-generated noise and would entrain rain at an intake louver. Controlling water entrainment and excessive air pressure drop often requires selecting acoustical louvers for face velocities in the 1 to 1.5 m/s range.

Don’t confuse a louver’s Transmission Loss (TL) ratings with its Noise Reduction (NR) ratings, which are always 6 dB higher than the TL values. The TL values indicate the attenuation of the louver if it is installed in an opening between two adjacent rooms that are both very reverberant. The NR values are calculated from the TL values and assume that the “quiet” side of the louver opens to the outdoors. Conservative acoustical calculations typically use TL values since the exterior

### Airside Equipment

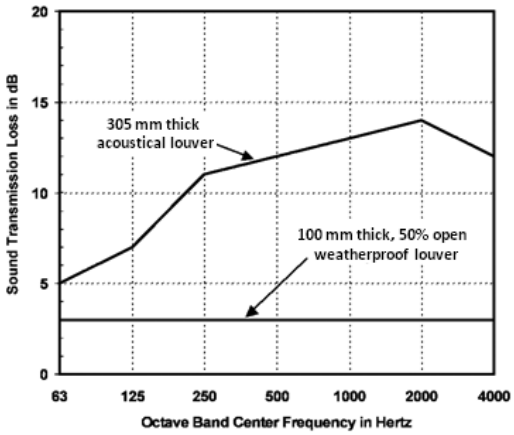


**Figure 2-46** General guidelines for sound-attenuating plenum design.



**Figure 2-47** Acoustical louver cutaway.

**A Practical Guide to Noise and Vibration Control for HVAC Systems**



**Figure 2-48** Sound transmission loss of acoustical and weatherproof louvers.



**Figure 2-49** Acoustical louver in a parking garage ventilation shaft.

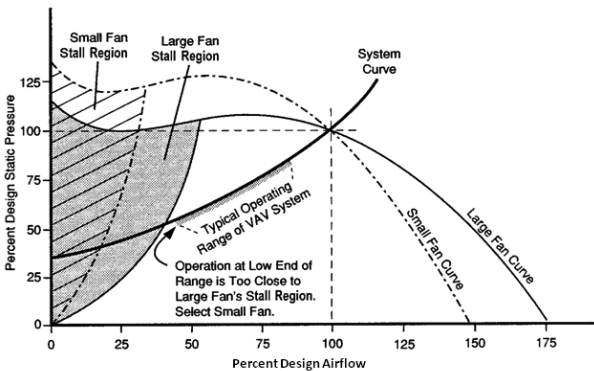
## Airside Equipment

landscape often has nearby reflective surfaces of some kind (e.g., the ground, other buildings).

## SPECIAL VARIABLE-AIR-VOLUME (VAV) SYSTEM CONCERNS

### Fans and AHUs

In an earlier section, this guide recommended that fans should be selected to operate at maximum efficiency at the design airflow rate. That guideline holds true for constant-volume systems. But for VAV systems, following this guideline can result in low-frequency noise problems due to fan stall when operating at partial load. Figure 2-50 compares the operation of two fans: a large one selected for optimum efficiency at 100% design airflow and a smaller fan that is optimized at about 80% of design airflow. The figure shows how operation of the system at about 40% of design airflow (not unusual in VAV systems) can bring the system close to the large fan's stall region. Since the small fan would not operate near its stall region at 40% of design airflow, it is a better selection even though its  $L_W$  values may be slightly higher at the full-capacity design operating point.



**Figure 2-50** Basis for fan selection in a VAV system.

## A Practical Guide to Noise and Vibration Control for HVAC Systems

The method chosen for controlling a fan's capacity can affect its noise. Each type of capacity control device has its unique effect on fan noise. Inlet vanes, scroll dampers, scroll curtains, and other similar devices result in higher fan noise because they add turbulence to the airstream by obstructing the airflow. This is shown in Figure 2-51, where a set of adjustable guide vanes are nested inside the bellmouth inlet of an airfoil centrifugal fan. The airflow obstruction caused by the vanes can raise a fan's  $L_W$  values by as much as 15 dB, depending on the octave band of concern and the fan's operating conditions. On the other hand, variable-frequency drive (VFD) motor speed controllers reduce a fan's capacity by slowing it down, which gives the dual benefits of lower noise and lower energy consumption. Figure 2-52 shows a VFD mounted on the side of a large air-handling unit. The concept of *system* must be remembered, because it is the combined effect of the fan and its control method that determines how much noise is generated.

VFD motor controllers are the most desirable method of capacity control. However, even their use requires following certain system-related guidelines:

1. The fan's vibration isolators should be selected on the basis of the fan's lowest practical rpm rate; for a 1000 rpm fan in a typical commercial system, the lowest practical rate might be as low as 500 rpm.
2. The VFD controller should have a feature called "critical frequency band jump." This feature allows a user to program the controller to "jump" over certain fan/motor rpm settings that might excite sympathetic vibrations in the building structure. The more advanced VFDs permit "jumping" over several frequencies.

### Control System

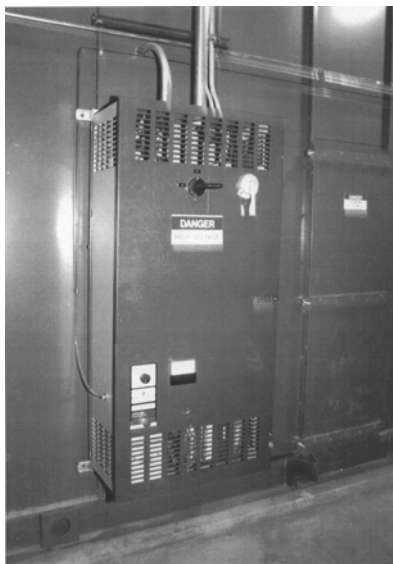
Some VAV system noise problems have been traced to control system problems. While most of the problems are due to poor installation, some are caused by design team neglect. The mechanical engineer must be sure to specify high-quality equipment that will operate in its optimal range and not near the edge of its specification range where tolerances can lead to inaccurate fan control. Also, the in-duct static pressure sensor must be placed in a section of duct having the lowest possible turbulence, i.e., at least three equivalent duct diameters from any elbow, takeoff, transition, offset, damper, etc., to ensure that it transmits accurate static pressure readings to the control system.

VAV system noise problems have often been traced to improper air balancing. For example, downstream dampers are often set up to require higher-than-design static pressure delivery from a fan. This causes the fan to operate at an inefficient (and, therefore, noisy) point on its curve, perhaps even in its stall region. The air balance specification should require that the contractor perform the air balance with the specific requirement that the final system static pressure should be as low as possible.

### Airside Equipment



**Figure 2-51** Nested inlet vanes obstruct airflow.



**Figure 2-52** Variable-frequency drive.

## **RAISED FLOOR AIR DISTRIBUTION**

All of the guidelines presented above also apply to the design of raised floor air distribution systems, with the addition of three very important additional concerns:

1. If the supply air reaches the underfloor plenum via a shaft that is served by a rooftop air-handling unit or packaged unit, verify that the velocity of air that exits the discharge openings at the bottom of the shaft does not exceed 7.5 m/s. This may be difficult in installations where the underfloor plenum height is small, and it may require multiple openings at the bottom of the shaft.
2. Office partitions in areas that use raised floor air distribution typically rest on top of the raised floor and do not extend to the structural floor below. In such cases the continuous underfloor plenum can be a sound leakage path between adjacent rooms. One way to provide moderate speech privacy between adjacent rooms is to install a short duct elbow with 50-mm-thick acoustical liner in the floor plenum space under each floor diffuser, making sure that the elbow openings in adjacent rooms are not facing each other.
3. Because the air velocities in an underfloor plenum and through floor diffusers are very low, the system is often *too quiet*. Increasing the discharge air velocity of the floor diffuser could raise the room sound level, but such velocities would create undesirable drafts near the floor. Therefore, an electronic background noise masking system may be needed to provide speech privacy in open plan and private offices where a raised floor air distribution system is used.



## 3

# Water-Side Equipment

---

## CHILLERS

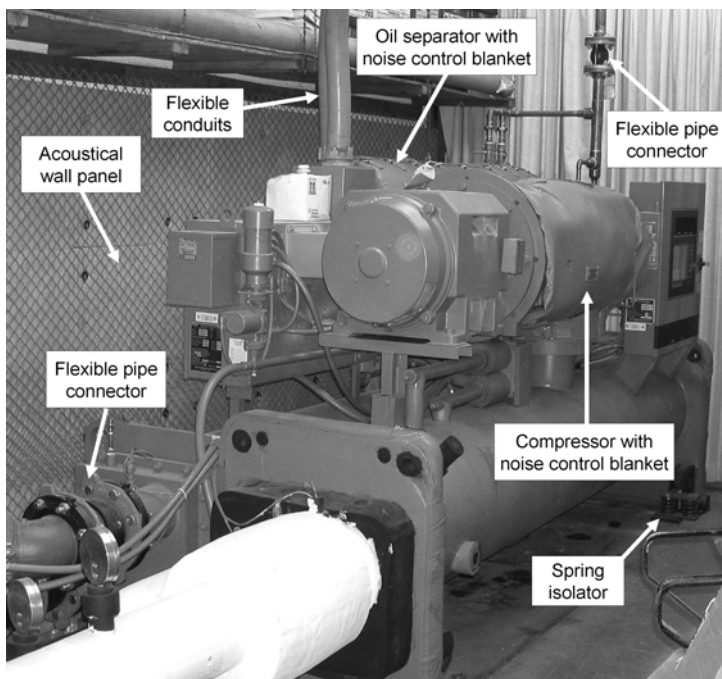
After fans and air-handling units, chillers are the most significant sources of noise and vibration in HVAC systems. Their noise signatures include high levels of broadband sound, but complaints of chiller noise and vibration are usually associated with the tones generated by their compressors, so treating these tones will go a long way toward reducing the number of complaints.

Each compressor type—centrifugal, reciprocating, scroll, screw (rotary), and magnetic bearing—has its own characteristic tonal structure that is related to the speeds of its rotating components. Chilled-water systems that use absorption chillers also generate tones, but they are typically caused by the chiller's associated pumps. Like the blade passage frequency (BPF) tones in fans, chiller tones include a fundamental tone and one or more harmonics, which are integer multiples of the fundamental. The relative strengths of the fundamental and harmonic tones vary with operating point.

Screw compressors have become very popular because of their low cost and energy efficiency, but the mid-frequency tones (in the 250 to 1000 hertz octave bands) produced by dual-screw compressors can be particularly troublesome because the tones are very strong. Single-screw compressors generate tones that are somewhat quieter than dual-screw compressor tones.

Factory noise-reduction options for chillers typically include heavy insulated blankets that can be wrapped around the compressors and other noise-radiating components. Figure 3-1 shows a photo of a water-cooled screw chiller with blankets wrapped around its compressor (foreground) and oil separator (background). The blankets do not provide any significant low-frequency noise reduction, but they reduce the strength of the compressor tones by about 3 dB. Some manufacturers

### Water-Side Equipment



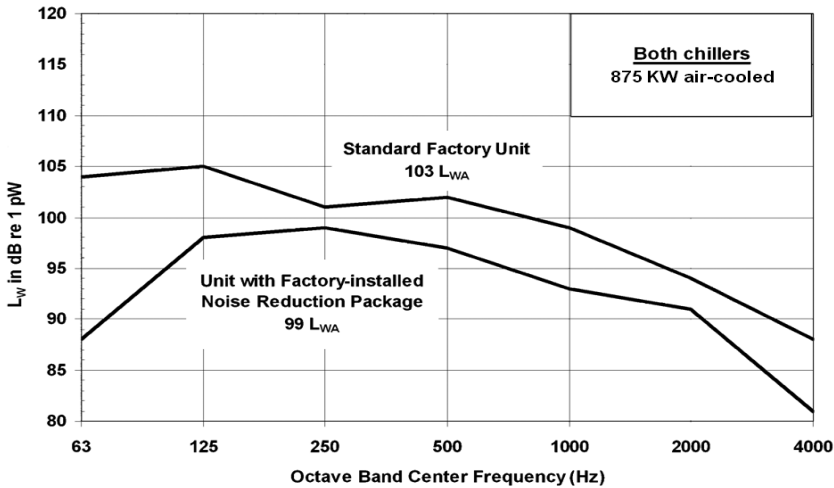
**Figure 3-1** Water-cooled screw chiller with several noise and vibration control treatments.

offer sheet metal compressor enclosures, which reduce the compressor tones by about 5 to 7 dB. Additional noise reduction requires a complete chiller enclosure like that shown in Figure 1-7.

Several factory noise control options are available for air-cooled chillers, including compressor blankets, sheet metal compressor enclosures, and low-noise, low-rpm condenser fans. The chart in Figure 3-2 shows the effectiveness of a factory-option noise reduction package for an 875 kW air-cooled screw chiller. The package includes acoustically-lined sheet metal compressor enclosures and low-noise condenser fans.

Compressor vibration is often as troublesome as compressor noise, so proper vibration isolation of the chiller and its associated pumps and piping is typically necessary. Figure 3-1 shows spring floor mounts (background near bottom right corner) and flexible pipe connectors at the condenser water connection (left foreground) and

**A Practical Guide to Noise and Vibration Control for HVAC Systems**



**Figure 3-2** ARI-370  $L_{w}$  values for a 875 kW air-cooled chiller with and without factory noise reduction options.

rupture disk discharge piping (top background). Flexible pipe connectors should also be used at the chilled water piping connections (under the insulation in the photo).

See the section entitled “Mechanical Equipment Rooms and Outdoor Equipment Areas” in Chapter 1 for guidelines related to the design of chiller rooms.

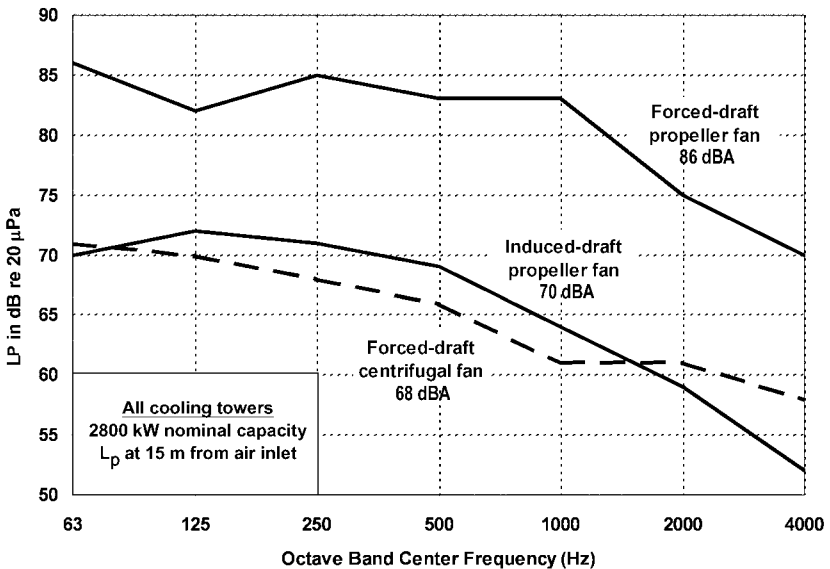
**COOLING TOWERS · EVAPORATIVE COOLERS · AIR-COOLED CONDENSING UNITS**

The dominant noise source for this type of equipment is the fan, which can be either a centrifugal fan in a forced-draft arrangement or a propeller fan in either a forced-draft or induced-draft arrangement. Both fan types produce high levels of low-frequency noise that can be difficult and costly to control. Since “add-on” noise control treatments usually interfere with equipment efficiency, it is best to select the quietest unit that conforms with the application’s space and cost parameters and consider adding such acoustical treatments as barriers or close-coupled duct silencers only if absolutely necessary. The noise ratings of cooling towers, evaporative coolers, and air-cooled condensers are obtained in accordance with the Cooling Technology Institute’s Acceptance Test Code ATC-128. Consider the following equipment selection and placement guidelines.

## Water-Side Equipment

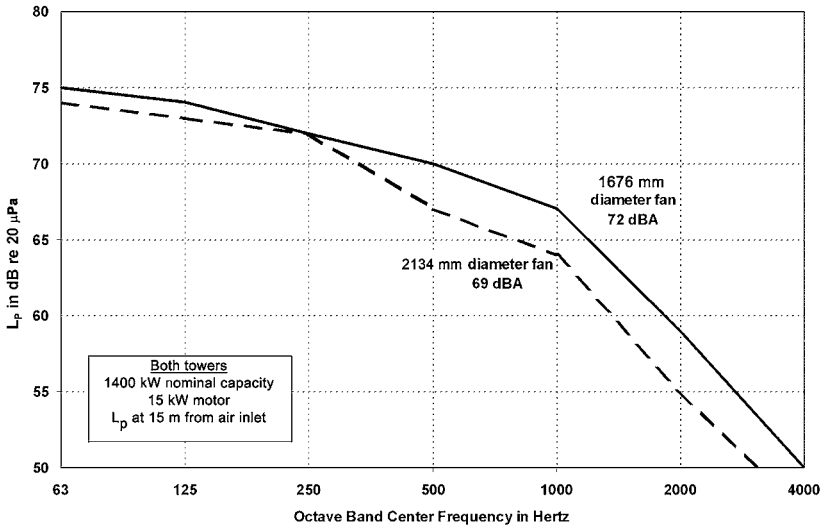
### *Guidelines for Cooling Towers, Evaporative Coolers, and Air-Cooled Condensing Units*

1. Compare the ATC-128 acoustical data for various types of equipment that will serve the required function. For example, Figure 3-3 compares the ATC-128 octave band sound levels at a distance of 15 m from the air inlet for three types of 2800 kW cooling towers. Note that the tower with the forced-draft propeller fan is much noisier than the other types.
2. Compare the ATC-128 acoustical data for equipment with standard-sized fans and oversized fans (larger diameter). Increasing a fan diameter by one size typically yields a lower fan rpm and provides a reduction of about 3 dB at all frequencies. Figure 3-4 compares the octave band sound levels for fans of two different diameters.
3. Compare the ATC-128 acoustical data for equipment with narrow blades and wide-chord blades. The wide-chord blades usually result in lower fan RPM rates and lower noise levels. Figures 3-5 and 3-6 show views of standard blades and



**Figure 3-3** ATC-128 octave band  $L_p$  values at 15 m from the air inlet side of three types of 2800 kW cooling towers.

**A Practical Guide to Noise and Vibration Control for HVAC Systems**



**Figure 3-4** ATC-128 octave band  $L_p$  values for cooling towers of the same fabrication series but with fans of different diameters.

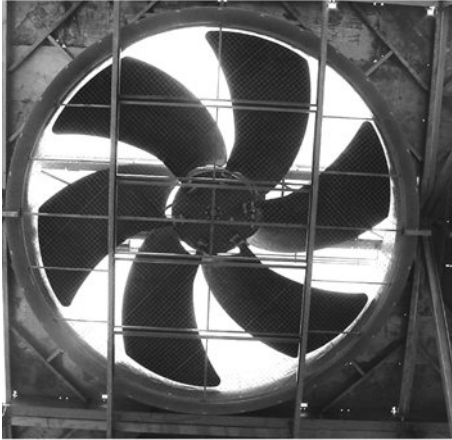
wide-chord blades from within the cooling tower basins. Figure 3-7 compares the octave band sound levels of two of these fans.

4. Open towers and evaporative coolers also produce water noise (see Figure 3-8). Some equipment manufacturers offer water basin silencers that interrupt the waterfall a few centimeters above the basin. The remaining drop of only a few centimeters can reduce the water noise by as much as 4 to 8 dBA. Figure 3-9 shows a view of water basin silencers installed in a tower.
5. Locate the equipment where a building or the natural topography (hillsides, berms, etc.) will act as a noise barrier between the equipment and any noise-sensitive areas. Tall, solid barriers are often used for visual and acoustical screening of outdoor equipment. For the greatest effect, such a barrier used for noise control purposes should be installed as close as possible to the noise source, blocking line-of-sight to the noise-sensitive area. However, with air-cooled equipment, be sure that the barrier is not so close to the equipment that it reduces airflow or causes air recirculation, either of which will reduce the equipment's capacity. Also, be sure that the side of the barrier facing the noise source has a sound-absorbing surface with weather protection; these barrier-absorber combinations

### Water-Side Equipment

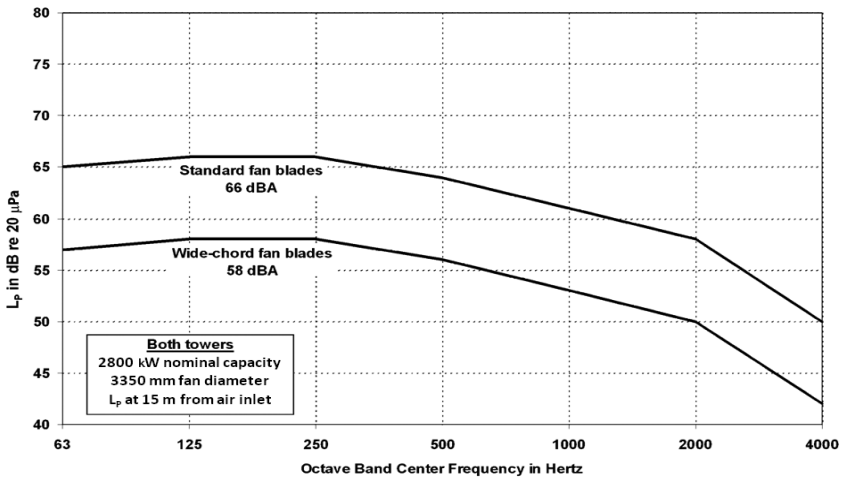


**Figure 3-5** View of “standard” cooling tower induced-draft fan.



**Figure 3-6** View of an induced-draft fan with wide-chord blades. This fan type can be as much as 12 dBA quieter than a “standard” fan of the same diameter.

**A Practical Guide to Noise and Vibration Control for HVAC Systems**

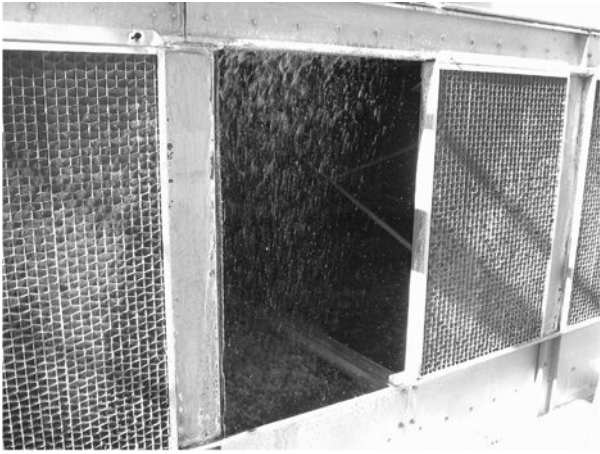


**Figure 3-7** ATC-128 octave band  $L_p$  values for cooling towers with “standard” and wide-chord fan blades.

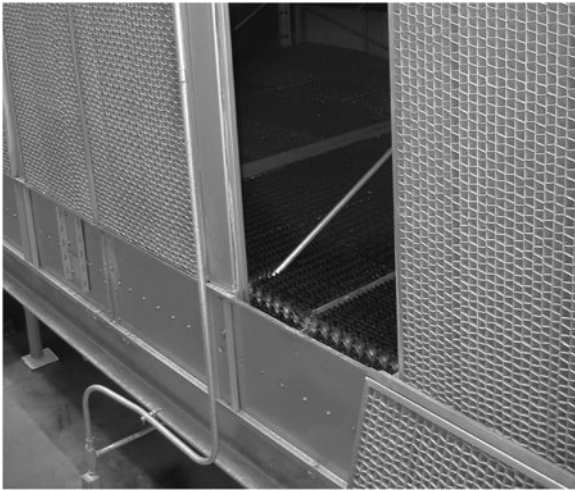
are also used for highway noise barriers. Figure 3-10 shows a sound-absorptive barrier at a cooling tower installation. The photo in Figure 3-11 shows a close-up of a sample barrier; note that the fibrous, sound-absorbing material is sandwiched between a solid back-wall and a fluted, perforated front face. The flutes provide rain protection for the fibrous material by keeping the perforations out of direct contact with it.

6. If the equipment has a “quiet” side (e.g., opposite the air inlet side of a forced-draft cooling tower), orient it toward any noise-sensitive areas. A piece of equipment’s “quiet” side can be determined by a review of its ATC-128 sound level data sheet.
7. As the load on the equipment varies throughout the day, the intermittent starting and stopping of the fans can cause additional noise complaints. This is especially true of belt-drive equipment where “belt squeal” occurs when full motor torque is applied instantly at start-up. Variable-speed drives or “soft-start” starters eliminate this problem (see discussion below).

### Water-Side Equipment



**Figure 3-8** Cooling tower basin with free-falling condenser water.



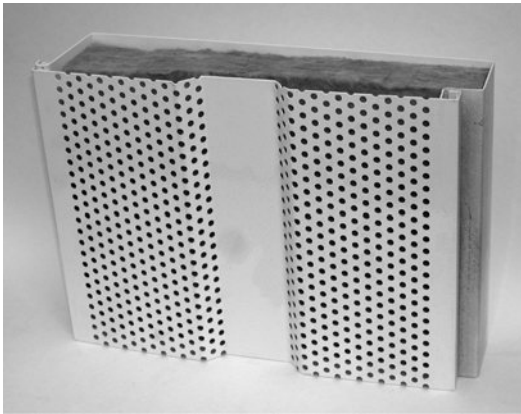
**Figure 3-9** Honeycomb water basin silencers installed several centimeters above the water surface to reduce the velocity of the falling water before it hits the basin.

**A Practical Guide to Noise and Vibration Control for HVAC Systems**



Photo courtesy of Empire Acoustical Systems.

**Figure 3-10** Outdoor noise control barrier installation.



**Figure 3-11** Close-up view of a sample of a sound-absorbing, outdoor noise barrier panel. The perforated front layer faces the noise source. Noise penetrates through the perforations and is absorbed by the fibrous fill material. The solid back layer controls sound transmission to the noise-sensitive region behind it.

## Water-Side Equipment

- For a multi-cell tower installation, the control sequence can be set up to minimize equipment noise emissions to surrounding areas. The “typical” control sequence for a two-cell cooling tower with a pair of single-speed fan motors would leave Fan #1 on virtually full-time and bring Fan #2 on when required by the load. Under this scenario the tower noise levels would remain constant over the entire 51% to 100% operating range and would decrease by only 3 dB at loads below 50% of full capacity.

Alternatively, if the two fans are controlled by VFD motor controllers, and if the control sequence is set up correctly, the sound levels can be greatly reduced at lower operating capacities. Figure 3-12 shows how the sound level would vary for a proportional control sequence that does not let either fan speed up beyond 50% of its maximum rpm until the second fan is also at the same operating point. Note that the sound level at 50% of full capacity under this control sequence is about 10 dBA lower than the “full load” sound level. Similar noise reduction can be achieved with a VFD controlling one fan, while the second fan uses a two-speed motor.

## BOILERS

Boiler manufacturers rarely measure their equipment’s noise, so calculations for predicting boiler noise exposure at noise-sensitive locations are rarely done. The combustion process in some boilers produces strong low-frequency noise that

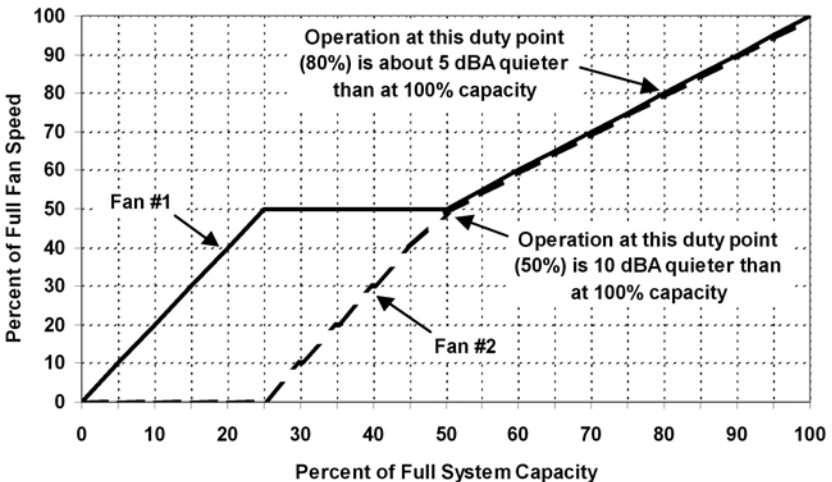


Figure 3-12 Low-noise control sequence for a two-cell cooling tower.

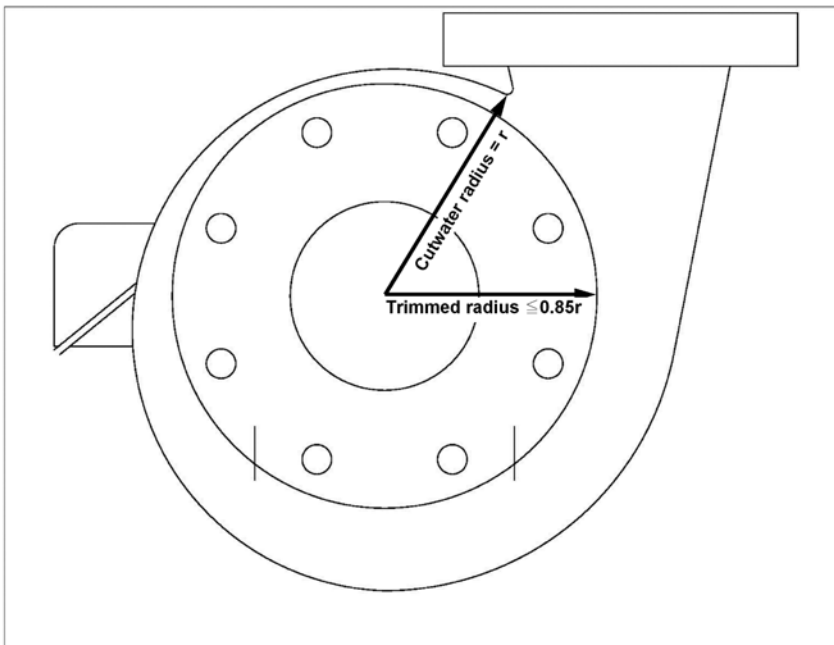
## A Practical Guide to Noise and Vibration Control for HVAC Systems

is carried through the flue system and eventually radiates into the atmosphere. The flue outlet should be placed away from any noise-sensitive areas so that the low frequency rumble is not excessive near a building's perimeter windows or ventilation openings.

Forced-draft boilers use high-pressure induced-draft fans for combustion air, and octave band  $L_w$  values are available for these fans, so an acoustical analysis is possible for this part of the system. Care should be taken to locate the combustion air fan remote from noise-sensitive areas. Also, isolate flue pipes from the building structure where they pass near vibration-sensitive areas.

### PUMPS

Pumps are rarely responsible for airborne noise problems. However, structure-borne vibration transmission due to inadequate vibration isolation of the pump or its attached piping or conduit can cause severe noise problems. Problems of this type are usually heard as a strong tone at the pump's impeller blade passage frequency, which is generated at the clearance between the impeller tips and the

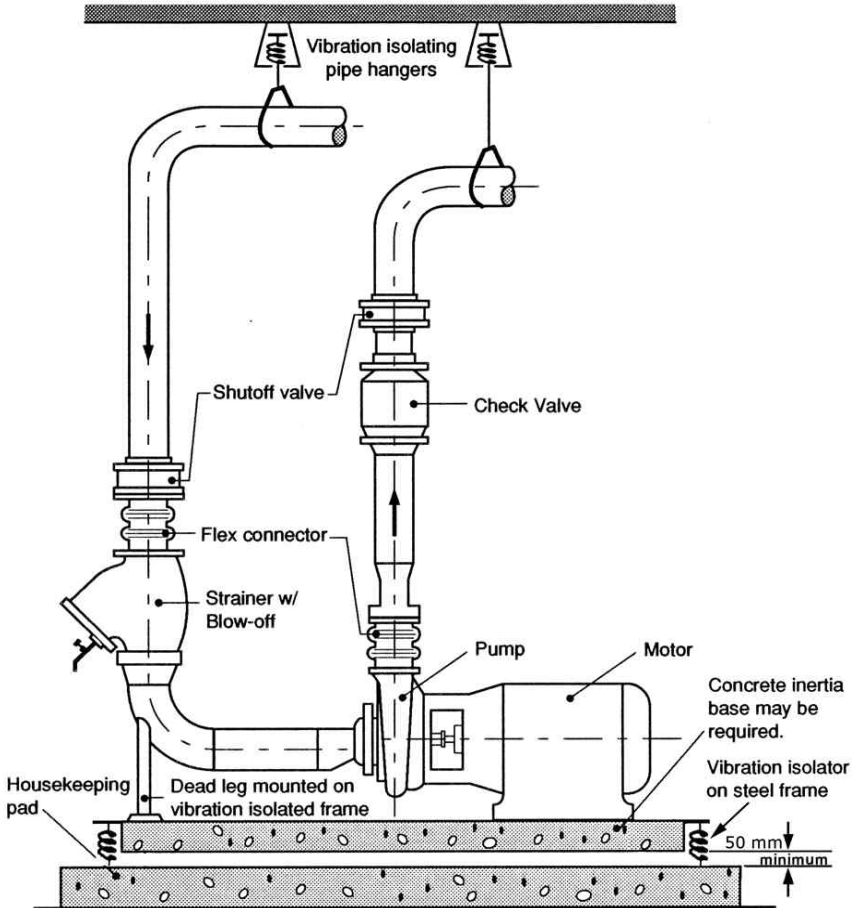


**Figure 3-13** Pump impeller sizing guideline for minimizing the strength of the blade passage frequency tone.

### Water-Side Equipment

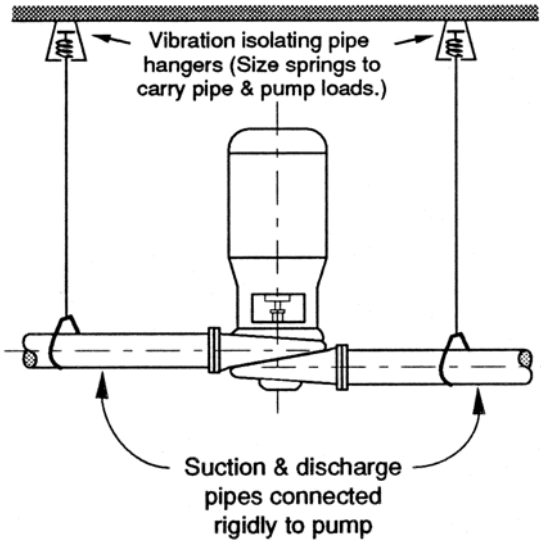
cutwater (see Figure 3-13). Specifying the impeller radius to be no more than about 85% of the cutwater radius (or about 90% of its untrimmed radius) will help minimize the problem.

Figures 3-14 and 3-15 show the proper installations for base-mounted and in-line pumps. Note, in particular, that the base-mounted assembly shows the suction elbow mounted on the isolated frame.



**Figure 3-14** Proper installation of an end-suction pump.

## A Practical Guide to Noise and Vibration Control for HVAC Systems



**Figure 3-15** Proper installation of an inline pump.

### PIPING SYSTEMS

There are five primary acoustical concerns with piping systems:

1. Excessive fluid velocity flow across valves, strainers, and backflow preventers (check valves) can cause high levels of broadband noise due to the strong turbulence.
2. Inadequate vibration isolation allows the pipes to serve as transmission paths for noise and vibration generated by the attached rotating equipment.
3. Unsealed pipe penetrations through sound-rated walls and slabs can allow sound leakage through the penetrations.
4. Penetrations with piping that is allowed to touch the penetrated wall or floor can result in structure-borne transmission of piping system vibration into the wall or floor, which, in turn, can transmit the vibration into nearby walls or floors.
5. Undersized valves or valve actuators are occasionally responsible for cavitation noise, valve chatter, or whistle.

### Water-Side Equipment

Unfortunately, acoustical testing that would help optimize the selection of valves and strainers has not been done, so the general rule of thumb is to select these items one size larger than the attached piping if they include a component that is in the fluid stream. For example, a butterfly valve (disc in the waterflow) should be upsized, whereas a gate valve permits unobstructed flow and does not need to be oversized. An exception to the “one size larger” rule of thumb applies to throttling control valves, which must be sized to provide proper control. Table 3-1 gives the recommended maximum water velocities for pipes that are above lightweight acoustical ceilings in typical office areas. If the piping system is enclosed in a gypsum board shaft or horizontal enclosure, somewhat higher velocities may be acceptable.

In general, all pumped pipe risers, mechanical room piping, and all piping mains require vibration isolation in the form of either floor mounts or hangers. See the chapter titled “Vibration Isolation” for more information.

Figure 3-16 shows how to isolate a pipe riser with neoprene pads under steel load-distributing plates where minimal vibration isolation is needed. Greater vibration control would need spring isolators. Details for preserving sound isolation at wall and slab penetrations while maintaining the necessary isolation between the pipe and the structure are shown in Figures 3-17 and 3-18.

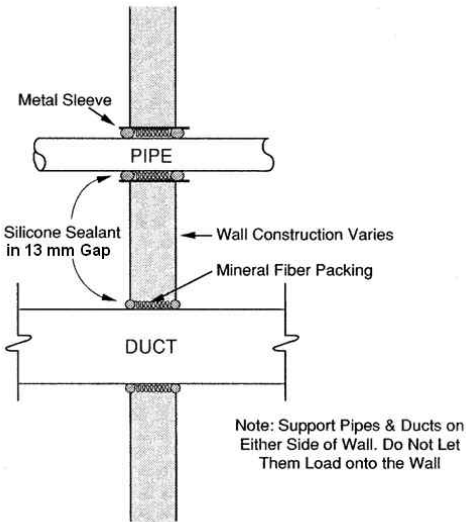
**Table 3-1. Maximum Recommended Waterflow Rates**

<b>Nominal Pipe Size, mm</b>	<b>Maximum Velocity in m/s</b>	<b>Approximate Max. L/s for Schedule 40 Pipe</b>
25	1	0.5
50	1.2	2.5
75	1.5	7
100	2	15
125	2.2	27
150	2.4	45
200	2.7	88
250	2.9	145
300 or more	3	215

**A Practical Guide to Noise and Vibration Control for HVAC Systems**

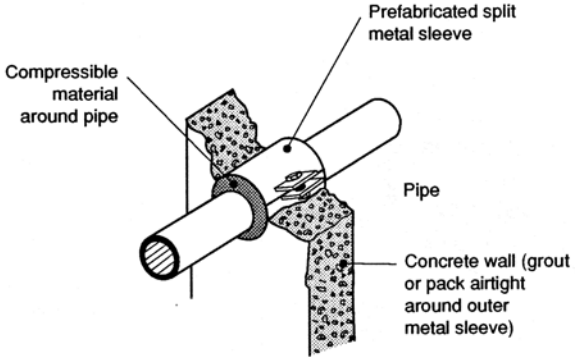


**Figure 3-16** Vibration isolation for piping riser. The use of neoprene pads under the steel load-distributing plates indicates that the nearby occupancy was not very noise-sensitive. For more critical cases, steel spring isolators would be used.

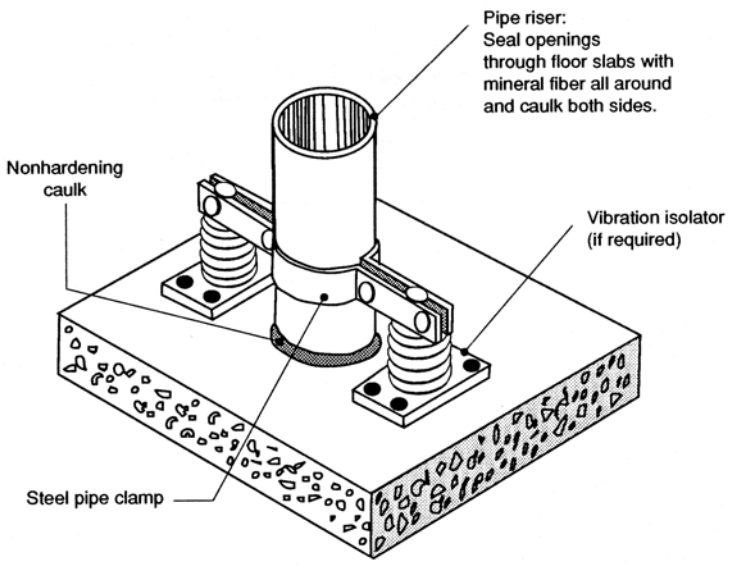


**Figure 3-17** Duct and pipe penetrations through walls.

### Water-Side Equipment



### Horizontal Penetration



### Vertical Penetration

Sketches courtesy of McGraw-Hill Book Company.

**Figure 3-18** Sealing pipe penetrations for sound isolation.

## 4

# Packaged and Unitary Equipment

---

*Note:* For information on air-handling units, see the section titled “Air-Handling Units and Fancoil Units” in Chapter 2.

### **ROOFTOP PACKAGE UNITS (AIR-CONDITIONING AND AIR-HANDLING VERSIONS)**

Rooftop units (RTUs) are responsible for some of the most frustrating and expensive noise and vibration problems; frustrating because after building occupancy it is often very difficult to track down the specific cause(s) of the problem(s), and expensive because the solution can require lifting the unit off the roof while extensive changes are being made to the building's roof and roof structure. For example, a successful 1989 retrofit for a 210 kW unit cost \$40,000.

The major noise sources in RTU systems are the fan(s) and compressors(s). In package units larger than 70 kW, it is very important to design the duct system in strict accordance with SMACNA guidelines for low static pressure losses because many units of this type use forward-curved (FC) fans, which cannot accommodate high duct system static pressures without generating high levels of low-frequency noise. Most large RTU noise complaints occur where excessive duct system static pressure causes an FC supply fan to operate in rotating stall.

Proper matching of the roof's structural design, the placement of the RTU, and the use of vibration isolators are critical in controlling vibration from the RTU's fan(s) and compressor(s). The design guidelines given below and in Figures 4-1 through 4-4 address all of these potential problems.

### Packaged and Unitary Equipment

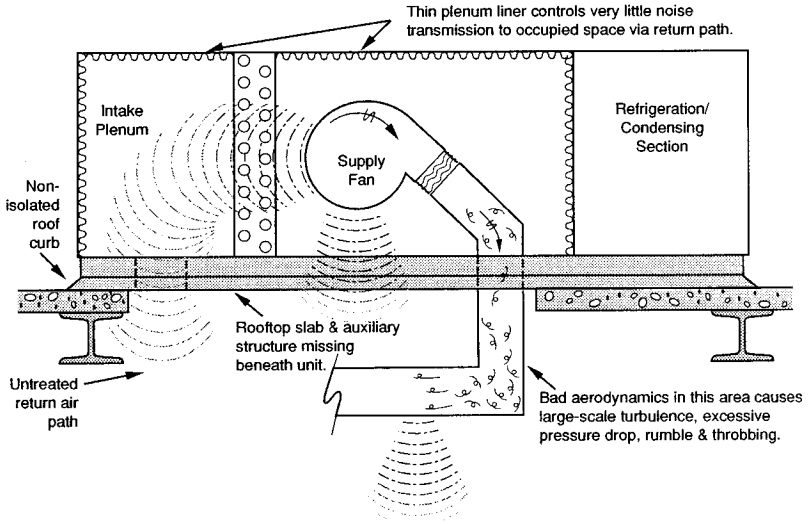


Figure 4-1 Very noisy rooftop unit installation.

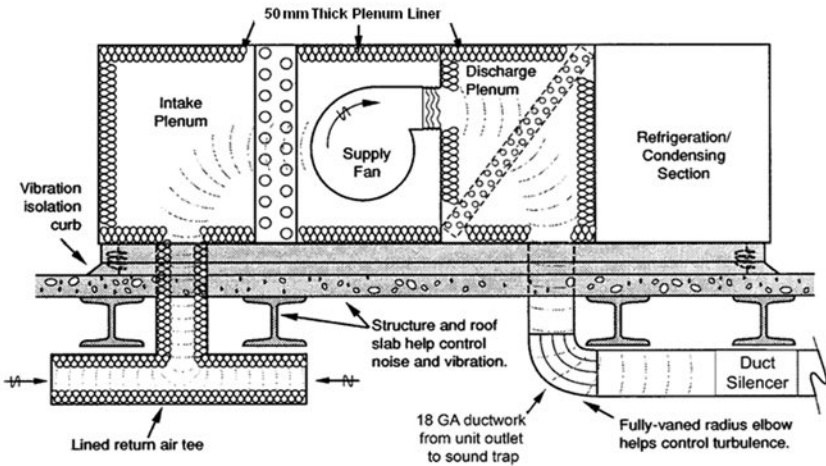
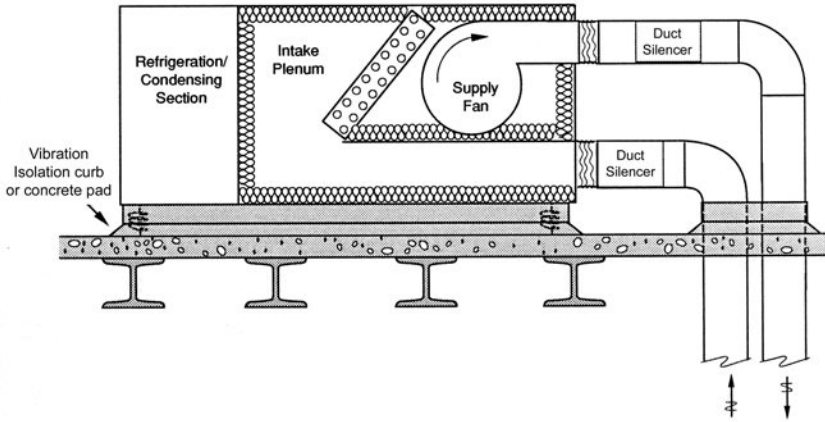
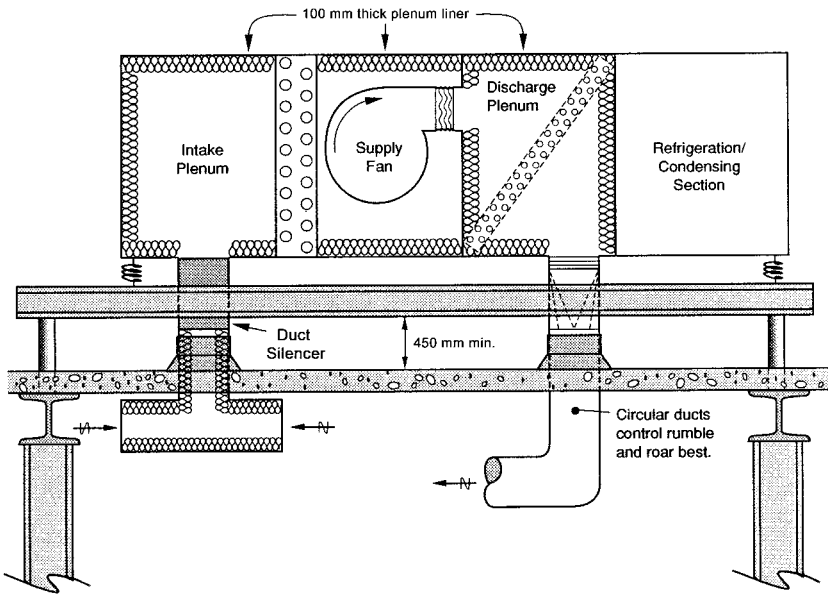


Figure 4-2 Moderately noisy rooftop unit installation.

### A Practical Guide to Noise and Vibration Control for HVAC Systems



**Figure 4-3** Moderately quiet rooftop unit installation.



**Figure 4-4** Quietest rooftop unit installation.

## Packaged and Unitary Equipment

### *Rooftop Unit Design Guidelines (All Sizes)*

1. The roof structure should be stiff enough so that the marginal deflection of the structure due to the equipment load is no more than 6 mm. This may require either reduced column spacing or auxiliary steel framing in the vicinity of the unit.
2. The unit should be at least 8 m from any private office or other noise-sensitive area. When locating a unit, keep in mind that an unducted return air opening can be as noisy as the ducted opening at the supply air end of the unit.
3. Mount the unit on a prefabricated vibration isolation roof curb. Factory-installed internal vibration isolation is often ineffective. (See Chapter 5 for more information on vibration isolation.)
4. Make all ductwork, piping, and electrical connections to the unit with flexible connectors.

*For units at 70 kW and larger, consider the following **additional** steps:*

1. Avoid downblast units. Instead, select either a side-discharge unit or a down-discharge unit with a discharge plenum. Some manufacturers use a discharge plenum as the heating section in a heating/cooling unit. Even if the heating capability is not required, specify this type of unit to take advantage of the acoustical and aerodynamic benefits provided by the discharge plenum.
2. For installations over noise-sensitive areas, mount the unit on high-deflection (50 to 100 mm) spring isolators resting on an elevated steel frame that is supported 600 to 900 mm above the roof by extensions of the building columns.
3. Also, for installations over noise-sensitive areas, use a parallel arrangement of circular supply ducts to distribute the conditioned air to the occupied space. Circular ductwork radiates far less low-frequency noise and rumble than rectangular ductwork. The transition from the unit's rectangular opening to the circular ductwork should be heavy (1.6 or 2.0 mm thick steel) to help control breakout noise through the flat portions of the transition.
4. Because the ducts attached to these units are often very wide, the ceiling and wall subcontractors are often tempted to attach their framing to the ductwork or its hangers. This must be avoided because contact with an oil-canning duct can cause audible creaking of the attached wall or ceiling.
5. The roof construction under and around the unit should be dense concrete for controlling downward noise transmission. Within the curb boundaries, do not cut out more of the roof than is necessary for the duct penetrations. All roof penetrations for conduit and piping should be outside the curb.
6. Any noise control steps considered for the supply airside (duct silencers, duct lining, etc.) should also be considered for the return airside. Return air plenums

## **A Practical Guide to Noise and Vibration Control for HVAC Systems**

on larger units can often accommodate duct silencers inside the plenum directly on top of the return air inlet. Another common noise control design for the return air path splits the return air inlet into a lined “T” arrangement just below the unit. This distributes the noise over a wider area at a somewhat lower level.

7. Refer to the section titled “Duct System Components” in Chapter 2 for duct system design guidelines.

### **WATER-SOURCE HEAT PUMPS**

The noise and vibration generated by water-source heat pump units vary widely among manufacturers, depending mainly on the size of the fan and the type of compressor used. The extent of vibration isolation used to mount the compressor and fan in the unit’s cabinet is also critical, e.g., spring isolation is much more effective than elastomeric pads, grommets or bushings, especially for horizontal heat pumps that are suspended in ceiling plenums where the ceiling tile is a lightweight mineral fiber or fiberglass. Guidelines for suspended horizontal and floor-mounted vertical heat pumps are given below.

#### ***Guidelines for Suspended Water-Source Heat Pumps (See Figure 4-5)***

1. Suspend the unit as high as possible in the ceiling plenum using spring isolation hangers.
2. Make condenser water connections to the unit with slack, flexible rubber or neoprene hose connectors—many heat pump manufacturers offer these as standard accessories.
3. Condensate drain hookups may also require short flexible connectors.
4. Make electrical connections with slack, flexible conduit.
5. The discharge duct should be fiberglass-lined sheet metal, at least 1.5 m long, and sized for a velocity of 5 m/s or less. An alternate is a 900 mm long duct silencer that is selected for a static pressure drop of no more than 35 Pa.
6. Diffuser branch takeoffs from the unit’s discharge duct should be at least 1.2 m downstream from the unit outlet.
7. A fiberglass-lined sheet metal elbow should be attached to the unit’s return air inlet.

#### ***Guidelines for Floor-Mounted Water-Source Heat Pumps (See Figure 4-6)***

1. Locate the unit in a closet next to a corridor or other nonsensitive area. None of the closet’s walls should be common with a bedroom or other noise-sensitive area.
2. The closet should be large enough to allow adequate return airflow into the unit; allow at least a 150 mm clearance all around the unit. In some cases, fiberglass

### Packaged and Unitary Equipment

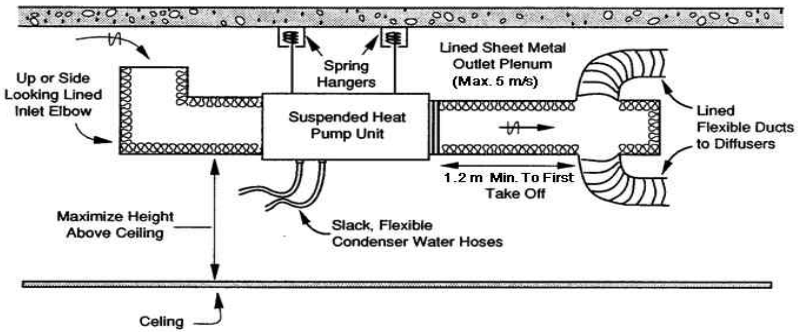


Figure 4-5 Guidelines for suspended heat pump units.

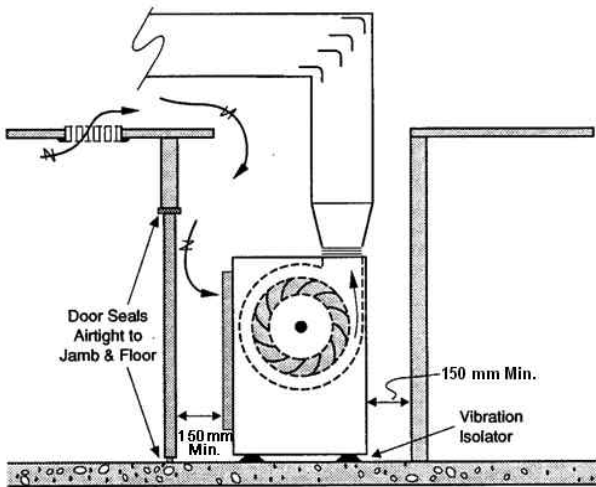


Figure 4-6 Guidelines for floor-mounted heat pumps.

## **A Practical Guide to Noise and Vibration Control for HVAC Systems**

plenum liner from 25 to 100 mm thick should be surface-applied to the closet walls. Be sure to account for this when determining the required closet size.

3. The closet door should be metal or solid core wood and have airtight, full perimeter jamb and head seals, and either a solid threshold sweep seal or an automatic door bottom. Double doors need astragal closures to seal the gap between the door panels. Provide a return air silencer at the return air opening into the closet.
4. Using a louvered closet door for return airflow is not recommended. However, if one is used, install a sheet metal shield with 50 mm thick fiberglass plenum liner behind the louver to reduce direct sound transmission from the unit to the occupied space.
5. Mount the heat pump on vibration isolators. The type selected will depend on the unit's size and the noise-sensitivity of the occupancies near the unit.
6. Make condenser water connections to the unit with slack, flexible rubber or neoprene hose connectors—many heat pump manufacturers offer these as standard accessories.
7. Condensate drain hookups may also require short flexible connectors.
8. Make electrical connections with slack, flexible conduit.
9. Size the discharge duct for a velocity of 5 m/s or less.

A wall-mounted, water-source heat pump should never be used in a room with a criteria rating below NC/RC/NCB-50. This type of unit has very little internal noise or vibration control, so the lack of a closet around it exposes the noise from its fan and compressor to the occupied space at levels that are generally unacceptable in residences and offices. Also, because this type of unit is typically attached directly to wall studs, its fan and compressor vibration are transmitted to the surrounding walls, which radiate the vibration energy as audible hum.

### **WALL-MOUNTED PACKAGE UNITS**

Units of this type in the capacity range of 7 to 18 kW are frequently used in construction trailers and school classrooms. These units were originally designed for use in telecommunications shacks, where equipment noise levels are not important. Their use is not recommended in rooms where speech communication is important because they typically generate sound levels in the range of 50 to 65 dBA, which is excessive for a classroom or any room where good speech intelligibility is needed. Teachers, for example, turn these units off when they begin lecturing to students.

A horizontal version of this type of unit in the 2.5 to 5 kW range is commonly used in hotel guest rooms and produces sound levels that range from about 50 to 60 dBA, depending on the quality of the unit, its fan speed, and its compressor mode setting. Sound ratings for these units are obtained in accordance with AHRI Standard 350, which gives the A-weighted  $L_{w}$  value at each operating point in terms of

## Packaged and Unitary Equipment

bels (1 bel = 10 decibels). Specifying a maximum AHRI 350 rating of 5.0 bels will result in a sound level of about 43 dBA in the middle of the room.

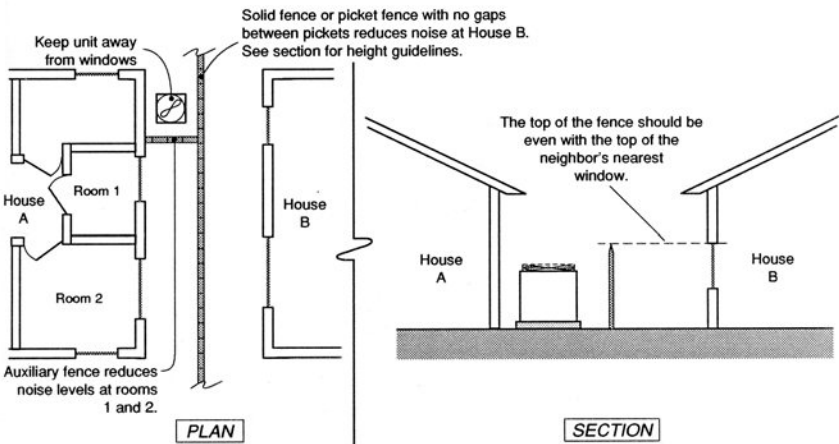
### SMALL COMMERCIAL AND RESIDENTIAL SPLIT SYSTEMS (UNDER 35 KW)

Two kinds of noise problems are common with split systems. The first is condensing unit noise disturbing either a neighbor or the system's user. Figure 4-7 shows how the problem can occur and how to avoid it with a solid fence of the proper height. Be sure to follow the condensing unit manufacturer's guidelines for placement of the fence so that it does not restrict condenser air circulation.

The second kind of problem involves the indoor fan/coil unit or furnace and the location of its ductwork and grilles. Figure 4-8 shows guidelines for two kinds of fan/coil unit installations.

Vibration problems most frequently associated with split systems are caused by rigid contact between the building and either the outdoor condensing unit, the indoor fan/coil unit, or the refrigerant piping. Figure 4-9 gives guidelines for avoiding this kind of problem.

Ductless split systems have been used successfully in Asia for many years and are now common throughout the rest of the world. These systems' indoor fancoil units and outdoor condensing and heat pump units are quieter than the more traditional split system components. Figures 4-10 and 4-11 show photos of an indoor evaporator section and an outdoor condensing section of this system type, respectively. Some versions of this unit use a variable-speed evaporator fan, so the indoor



**Figure 4-7** Small condensing unit noise control.

### A Practical Guide to Noise and Vibration Control for HVAC Systems

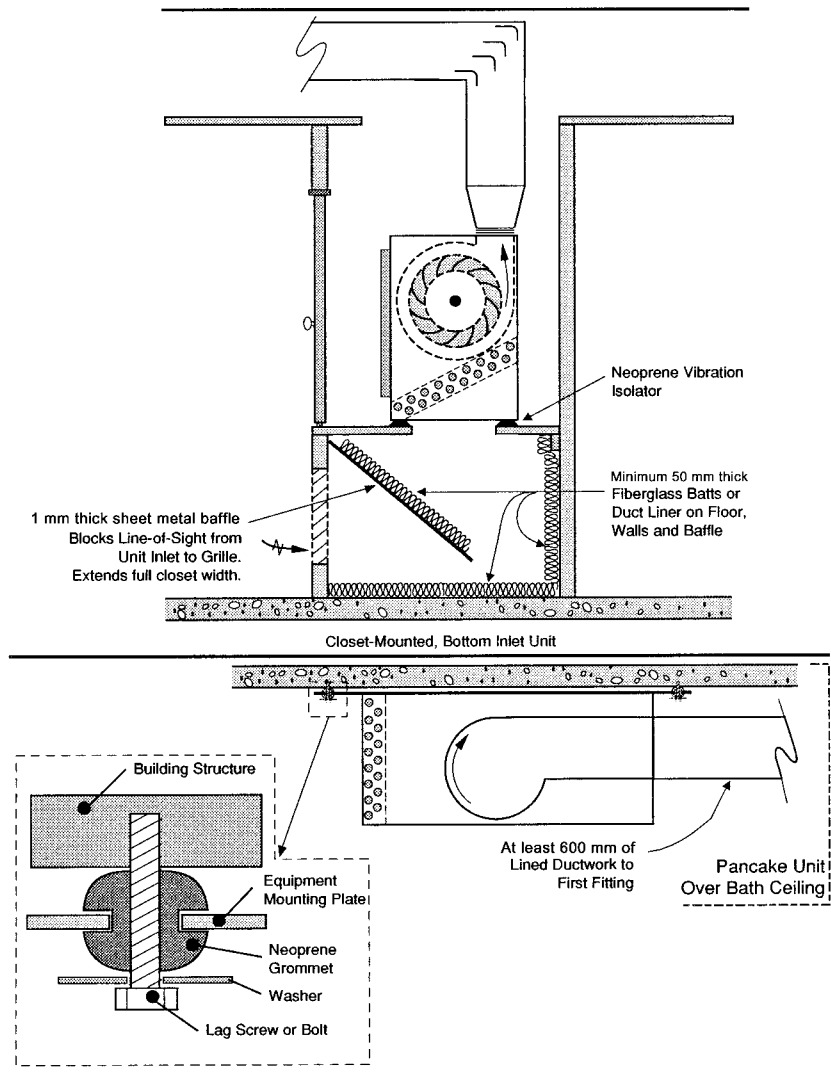
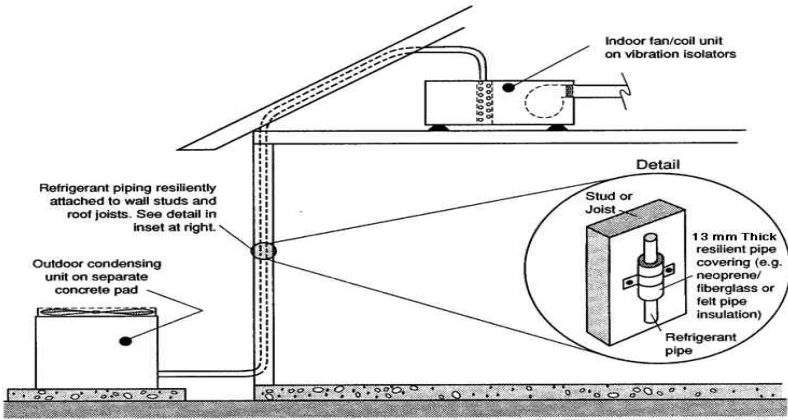


Figure 4-8 Guidelines for fan coil unit installations.

## Packaged and Unitary Equipment



**Figure 4-9** Guidelines for vibration isolation of split systems.



**Figure 4-10** Indoor fan coil section of a ductless split system. This type of equipment with a variable-speed tangential fan can be very quiet.

## A Practical Guide to Noise and Vibration Control for HVAC Systems



**Figure 4-11** Outdoor condensing unit typically used with ductless split systems; it can also be used with ducted fan coil units.

sound level for small capacities of this unit can be as low as the 35 to 45 dBA range, depending on the thermostatically controlled fan speed. The condensing/heat pump unit is also quieter than its traditional system counterpart.

### **STANDBY, EMERGENCY, AND DISTRIBUTED ENERGY GENERATOR SETS**

The skid-mounted radiators in engine-generator sets are often as loud as the engines, and in indoor installations they are often installed directly behind a discharge louver that directs both the radiator noise and the engine noise to the outside, where a noise-sensitive area may be present. This potential problem can be addressed by using a remote radiator (see Figure 4-12). The benefits of a remote radiator are as follows:

1. Since the hot radiator is outside the generator room, less ventilation air is needed in the room, so the ventilation inlet and discharge louvers can be smaller. The reduced louver size helps control the amount of engine-generator noise that is transmitted to the outdoors.
2. The remote radiator can be located as needed to control the impact of its noise to any surrounding noise-sensitive areas.
3. Remote radiators are available with low-noise, variable-speed fans that are as much as 20 dBA quieter than skid-mounted fans.

## Packaged and Unitary Equipment

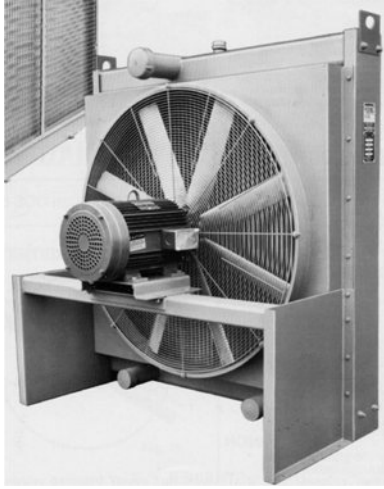


Photo courtesy of Young Touchstone, a Wabtec Company.

**Figure 4-12** Remote radiator for engine-generator sets can be quiet with an oversized, variable-speed cooling fan.

Where a remote radiator is not feasible, duct silencers can be used at the generator room's air intake and discharge openings to reduce noise emissions. However, the "silenced" openings must be oversized so that the static pressure losses through the silencers are compatible with the radiator fan performance.

## 5

# Vibration Isolation

---

HVAC equipment that is rigidly attached to a slab, wall, or ceiling can transmit the equipment vibration into the mounting surface and cause unacceptable levels of structure-borne noise that can be heard in remote locations throughout the building. Likewise, piping, conduits, and ductwork can act as transmission paths of structure-borne sound if they form rigid connection paths between the building and the vibrating equipment. Isolating equipment vibration from building slabs, walls, and ceilings is essential for controlling structure-borne sound transmission. There are many types of vibration isolation systems for HVAC equipment, and the most cost-effective selection for each piece of equipment depends on the following factors:

1. The equipment type, drive-type (direct, gear or belt), rpm, and motor kW rating.
2. The mass and location of the vibrating component(s) within the equipment enclosure or on the equipment skid.
3. The nature of the equipment's vibration—vertical or horizontal, rotating or reciprocating.
4. The location of the equipment relative to nearby noise and vibration-sensitive areas.
5. The stiffness of the building structure supporting the isolated equipment (usually related to the column spacing and beam depth).
6. The spacing between isolator mounting points.

These factors were all considered in the development of Table 5-1, “Vibration Isolation Selection Guide,” which is based on Table 42 in Chapter 47, “Sound and Vibration Control,” in the *2003 ASHRAE Handbook—Applications*. Brief descriptions of the isolator and base types are given below.

**Table 5-1. Vibration Isolation Selection Guide**

Equipment Type	kW or Other Rating	RPM	Equipment Location											
			Slab on Grade			Floor Span								
						Up to 7 m			7 to 9 m			9 to 12 m		
			Base Type	Isolator Type	Min. Defl., mm	Base Type	Isolator Type	Min Defl., mm	Base Type	Isolator Type	Min Defl., mm	Base Type	Isolator Type	Min Defl., mm
<b>Refrigerator Machines and Chillers</b>														
Reciprocating	All	All	A	2	6	A	4	19	A	4	38	A	4	63
Centrifugal, screw	All	All	A	1	6	A	4	19	A	4	38	A	4	38
Open Centrifugal	All	All	C	1	6	C	4	19	C	4	38	C	4	38
Absorption	All	All	A	1	6	A	4	19	A	4	38	A	4	38
<b>Air Compressors and Vacuum Pumps</b>														
Tank-mounted horiz.	Up to 7.5	All	A	3	19	A	3	19	A	3	38	A	3	38
	7.5 and up	All	C	3	19	C	3	19	C	3	38	C	3	38
Tank-mounted vert.	All	All	C	3	19	C	3	19	C	3	38	C	3	38
Base-mounted	All	All	C	3	19	C	3	19	C	3	38	C	3	38
Large Reciprocating	All	All	C	3	19	C	3	19	C	3	38	C	3	38
<b>Pumps</b>														
Close-coupled	Up to 5.5	All	B	2	6	C	3	19	C	3	19	C	3	19
	5.5 and up	All	C	3	19	C	3	19	C	3	38	C	3	38
Large inline	3 to 18.5	All	A	3	19	A	3	38	A	3	38	A	3	38
	18.5 and up	All	A	3	38	A	3	38	A	3	38	A	3	63

**Table 5-1. Vibration Isolation Selection Guide (continued)**

Equipment Type	kW or Other Rating	RPM	Equipment Location											
			Slab on Grade			Floor Span								
						Up to 7 m			7 to 9 m			9 to 12 m		
			Base Type	Isolator Type	Min. Defl., mm	Base Type	Isolator Type	Min Defl., mm	Base Type	Isolator Type	Min Defl., mm	Base Type	Isolator Type	Min Defl., mm
End suction and split case	Up to 18.5	All	C	3	19	C	3	19	C	3	19	C	3	19
	18.5 to 90	All	C	3	19	C	3	19	C	3	19	C	3	63
	90 and up	All	C	3	19	C	3	38	C	3	63	C	3	88
Cooling Towers	All	Up to 300	A	1	6	A	4	88	A	4	88	A	4	88
		301 to 500	A	1	6	A	4	63	A	4	63	A	4	63
		501 and up	A	1	6	A	4	19	A	4	19	A	4	38
Boilers (Fire-tube)	All	All	A	1	6	B	4	19	B	4	38	B	4	63
<b>Axial Fans, Fan Heads, Cabinet Fans, Fan Sections</b>														
Up to 600 mm diameter	All	All	A	2	6	A	3	19	A	3	19	C	3	19
600 mm diameter and up	Up to 500 Pa s.p.	Up to 300	B	3	63	C	3	88	C	3	88	C	3	88
		300 to 500	B	3	19	B	3	38	C	3	63	C	3	63
		501 and up	B	3	19	B	3	38	B	3	38	B	3	38
	500 Pa s.p. and up	Up to 300	C	3	63	C	3	88	C	3	88	C	3	88
		300 to 500	C	3	38	C	3	38	C	3	63	C	3	63
		501 and up	C	3	19	C	3	38	C	3	38	C	3	63

**Table 5-1. Vibration Isolation Selection Guide (continued)**

Equipment Type	kW or Other Rating	RPM	Equipment Location											
			Slab on Grade			Floor Span								
						Up to 7 m			7 to 9 m			9 to 12 m		
			Base Type	Isolator Type	Min. Defl., mm	Base Type	Isolator Type	Min Defl., mm	Base Type	Isolator Type	Min Defl., mm	Base Type	Isolator Type	Min Defl., mm
<b>Centrifugal Fans</b>														
Up to 600 mm diameter	All	All	B	2	6	B	3	19	B	3	19	C	3	38
600 mm diameter and up	Up to 30	Up to 300	B	3	63	B	3	88	B	3	88	B	3	88
		300 to 500	B	3	38	B	3	38	B	3	63	B	3	63
		501 and up	B	3	19	B	3	19	B	3	19	B	3	38
	30 and up	Up to 300	C	3	63	C	3	88	C	3	88	C	3	88
		300 to 500	C	3	38	C	3	38	C	3	63	C	3	63
		501 and up	C	3	25	C	3	38	C	3	38	C	3	63
<b>Propeller Fans</b>														
Wall-mounted	All	All	A	1	6	A	1	6	A	1	6	A	1	6
Roof-mounted	All	All	A	1	6	A	1	6	B	4	38	D	4	38
Heat Pumps	All	All	A	3	19	A	3	19	A	3	19	A/D	3	38
Condensing Units	All	All	A	1	6	A	4	19	A	4	38	A/D	4	38

**Table 5-1. Vibration Isolation Selection Guide (continued)**

Equipment Type	kW or Other Rating	RPM	Equipment Location											
			Slab on Grade			Floor Span								
						Up to 7 m			7 to 9 m			9 to 12 m		
			Base Type	Isolator Type	Min. Defl., mm	Base Type	Isolator Type	Min Defl., mm	Base Type	Isolator Type	Min Defl., mm	Base Type	Isolator Type	Min Defl., mm
<b>Packaged AH, AC, H and V Units</b>														
All	Up to 7.5	All	A	3	19	A	3	19	A	3	19	A	3	19
	7.5 and up, up to 1 kPa s.p.	Up to 300	A	3	19	A	3	88	A	3	88	C	3	88
		300 to 500	A	3	19	A	3	63	A	3	63	A	3	63
		501 and up	A	3	19	A	3	38	A	3	38	A	3	38
	7.5 and up, 1 kPa s.p. and up	Up to 300	B	3	19	C	3	88	C	3	88	C	3	88
		300 to 500	B	3	19	C	3	38	C	3	63	C	3	63
501 and up		B	3	19	C	3	38	C	3	38	C	3	63	
Packaged Rooftop Eqmt.	All	All	A/D	1	6	D	3	19	See Reference Note No: 17					
<b>Ducted Rotating Equipment</b>														
Small fans, fan-powered boxes	Up to 300 L/s	All	A	3	13	A	3	13	A	3	13	A	3	13
	300 L/s & up	All	A	3	19	A	3	19	A	3	19	A	3	19
Engine-Generators	All	All	A	3	19	C	3	38	C	3	63	C	3	88

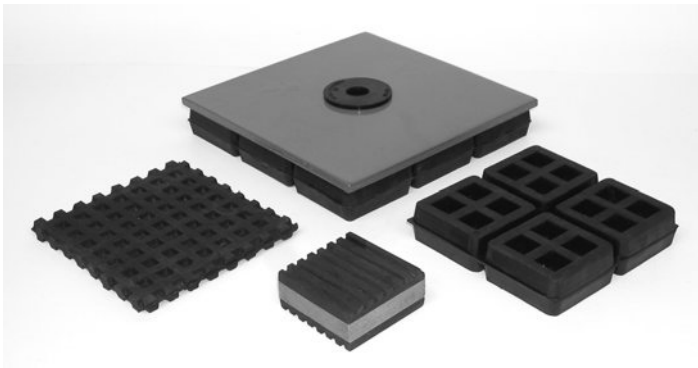
## Vibration Isolation

### ISOLATOR TYPES

Each of the isolators described below is available in different sizes to accommodate a wide range of load ratings. For example, Type 3 floor mounts are available with load capacities that range from about 9 to 18,000 kg. The references to “static deflection” in the descriptions below refer to the compression of the isolator’s spring or neoprene element under the equipment load. It does not refer to the motion of the isolator while the equipment is operating.

#### **Type I—Ribbed or Waffled Neoprene Pad or Compressed Fiberglass Pad**

These isolators are usually used where the vibration frequency of concern is at least 100 hertz; and they are typically selected for a load of about  $0.04 \text{ kg/mm}^2$  and a static deflection of less than 1.2 mm. They are available in durometer ratings from 30 to 70, with the higher ratings able to support heavier loads. Pads with lower durometer ratings are more resilient, but carry less weight, than those with higher durometer ratings. These pads can be stacked in sandwiches with metal load-distributing plates between the pads for higher static deflections (but not higher load capacities). Figure 5-1 shows four types of neoprene pads, including a metal/neoprene assembly with a neoprene bushing that prevents metal-to-metal contact where the isolator is bolted to a floor structure.



Products courtesy of Mason Industries.

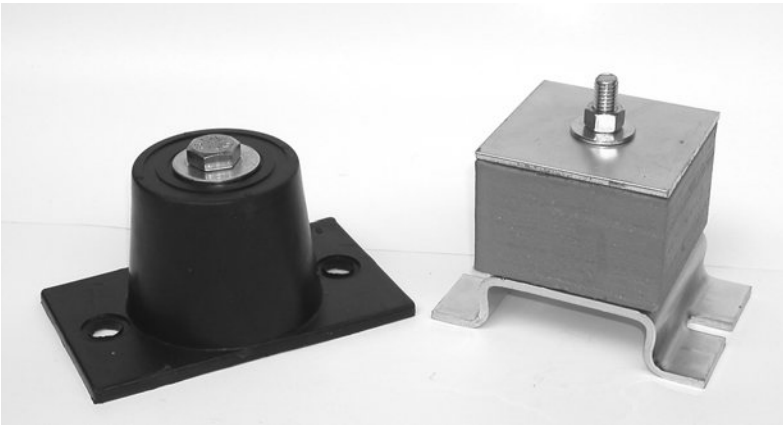
**Figure 5-1** Elastomeric pads. The elastomeric bushing inserted in the metal load-distributing plate prevents metal-to-metal contact between the plate and its thru-bolt.

## **Type 2—Neoprene-in-Shear or Compressed Fiberglass Floor Mount**

These isolators have equipment mounting bolts and base plates for direct attachment to a building structure without the use of neoprene bushings. They are usually used where the vibration frequency of concern is at least 50 hertz and are usually selected for a static deflection up to 10 mm (see Figure 5-2). A seismic version (neoprene element captive in a steel housing) of this isolator type is shown in Figure 5-3. Hanger versions of this type are also available.

## **Type 3—Steel Spring Floor Mounts and Hangers**

These isolators are used with a wide range of static deflections, from about 12 to 100 mm. The isolation elements in these units are coiled compression springs that typically rest on neoprene cups or pads. The spring elements should be selected to accommodate a load that is 50% higher than the design load before “bottoming out.” For proper horizontal stability, the spring’s loaded (compressed) height should be approximately equal to its coil diameter. Figure 5-4 shows two sizes of floor-mount spring isolators. The neoprene pad under the spring baseplate is an essential part of the isolator because it reduces the strength of the high-frequency vibration energy that “leaks” through the spring coils.



Products courtesy of Mason Industries and Kinetics Noise Control.

**Figure 5-2** Elastomeric or compressed fiberglass isolation mounts are used where a static deflection less than 10 mm is needed.

## Vibration Isolation



Products courtesy of Mason Industries.

**Figure 5-3** Seismically rated elastomeric mounts. The mount on the left (75 mm tall) has a nominal load rating of about 40 kg. The mount on the right (165 mm tall) has a nominal load rating of as much as 700 kg.



Products courtesy of Mason Industries.

**Figure 5-4** Two types of spring floor mounts. The mount on the left is for low loads and static deflections of less than 25 mm. The mount on the right is for larger loads and static deflections greater than 25 mm.

## A Practical Guide to Noise and Vibration Control for HVAC Systems

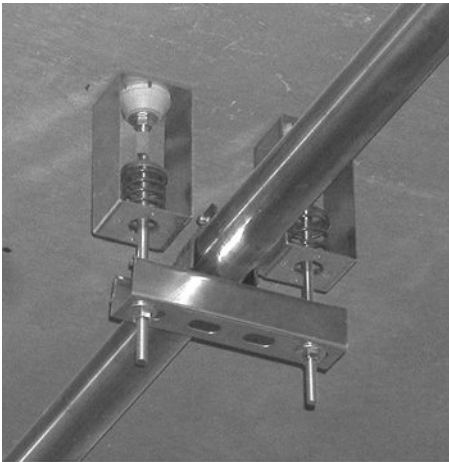
Isolation hangers contain a spring element within a hanger box. As in the floor mount, a hanger's spring should rest in a neoprene cup to control high-frequency vibration. The load of the suspended equipment or pipe is transferred to the top of the spring via a length of all-thread rod. To minimize the potential for "short-circuiting" due to misalignments in the field, specify hangers that allow the all-thread rods to be misaligned as much as 15 degrees from vertical without touching the hanger box. Figure 5-5 shows properly installed spring hangers in a trapeze arrangement.

### Type 4—Restrained Spring Isolator

Type 4 is similar to Type 3, with the addition of a restraining assembly that limits equipment movement during start-up, earthquakes, or high winds. This isolator is also often used with waterside equipment (e.g., cooling towers, chillers, piping, etc.) to limit uplift when the equipment is drained for service or maintenance. The photo in Figure 5-6 shows two versions of this isolator type.

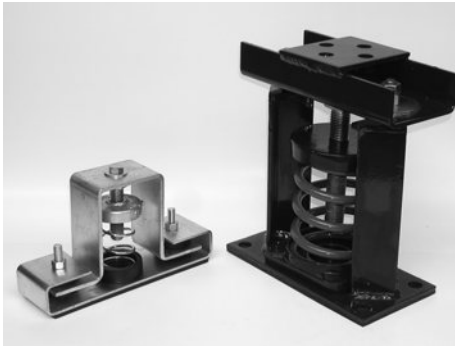
### Base Types

- *Type A:* No base; isolator attached directly to the equipment frame or mounting leg.



**Figure 5-5** Spring hanger installation with proper spring compression and hanger rod centered through hole at bottom of hanger box.

## Vibration Isolation



Products courtesy of Mason Industries.

**Figure 5-6** Two types of spring floor mounts with seismic/wind-loading standby restraints. The mount on the left is for low loads and static deflections under 25 mm. The mount on the right is for larger loads and static deflections greater than 25 mm.

- *Type B*: Structural steel rails or frame (channel or wide flange, depending on the load and the frame size) with height-saving brackets, as required.
- *Type C*: Concrete inertia base whose weight is equal to that of the isolated equipment.

## Other Isolator Types

Pneumatic isolators (air springs) generally provide the highest degree of vibration isolation and are typically used where very large fans, chillers, or electrical transformers are installed near noise-sensitive or vibration-sensitive areas. The isolator is usually a neoprene bellows with equipment and floor-base mounting plates. Pneumatic isolators can be used as free-standing units or in restraint housings. Figure 5-7 shows pneumatic isolators in restraint housings supporting an air-cooled chiller. As with automobile tires, the pneumatic bellows in these isolators need occasional refilling; this usually requires the presence of a permanent 700 kPa pneumatic system that includes an air compressor and load-leveling valves that maintain the isolated equipment at the proper operating height.

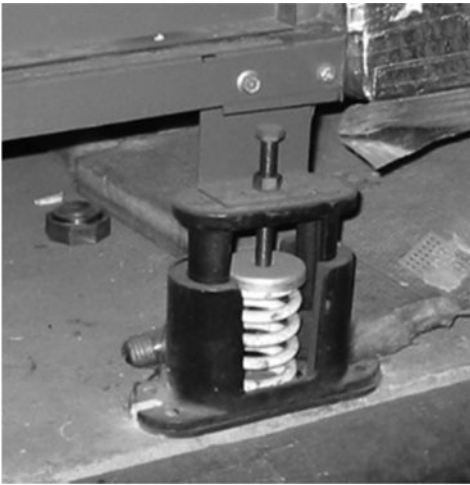
Cast metal floor mounts are still available but are not recommended because of their potential for “short-circuiting.” See Figure 5-8.

**Thrust restraints** are required where a medium- or high-pressure fan (e.g., inline, plenum, etc.) is installed with vibration isolators. Their purpose is to prevent metal-to-metal contact between the fan and any part of the air distribution system by counteracting the fan’s thrust force. Figure 5-9 shows a thrust restraint inserted between a plenum fan and its inlet bulkhead wall. A similar restraint is installed on

**A Practical Guide to Noise and Vibration Control for HVAC Systems**



**Figure 5-7** Pneumatic isolators (“air bags”) supporting a rooftop air-cooled chiller. Thin metal tubing connects 700 kPa compressed air to each isolator.



**Figure 5-8** Cast-metal floor mount is prone to “short-circuiting” and should never be used. Instead, use a floor mount like that shown in Figure 5-6.

## Vibration Isolation



Photo courtesy of Governair Inc.

**Figure 5-9** Thrust restraint at mid-height of fan inlet panel prevents contact between the panel and the equipment housing framework. An identical restraint is installed on the opposite side of the fan.

the opposite side of the fan. The restraints' springs work in compression to resist the fan's thrust toward the bulkhead wall during fan operation.

**Flexible pipe (pump) connectors** are used to reduce the transmission of water-side equipment vibration to a building structure. A flexible, watertight material (usually neoprene, rubber, or a more advanced elastomer) with either flanged or threaded ends is installed in a pipe as close as possible to the vibrating equipment. Best performance occurs when the connector is installed in a pipe that is parallel to the equipment shaft. Flexible connectors should never be used to accommodate equipment/piping misalignment because the static offset stresses the elastomer and shortens its service life. The pipes should be properly aligned before installing the flexible connector. The photo in Figure 5-10 shows flanged and threaded flexible connectors.

“Flexible” metal hoses, whether braided or unbraided, are not as effective as elastomeric pipe connectors, but they may be the only option available for refrigerant relief piping and piping that carries natural gas or corrosive or very hot fluids. In these cases, select the metal hose for a length to be at least ten times the nominal pipe diameter. Figure 5-11 shows short connectors of this type on an end suction pump.

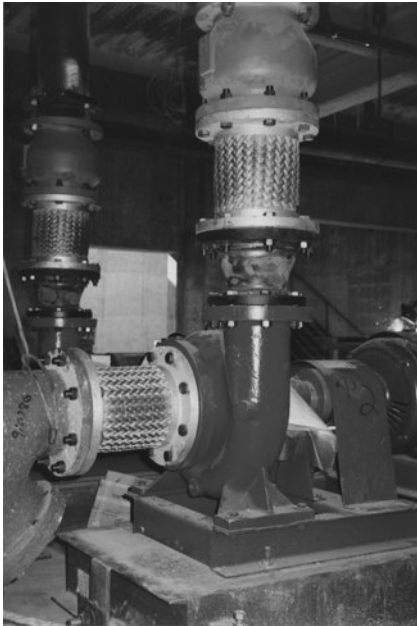
**Frames and Bases:** Lightweight, flexible equipment frames can result in excessive equipment vibration being transmitted into a supporting building structure. A stiff,

**A Practical Guide to Noise and Vibration Control for HVAC Systems**



Products courtesy of Mason Industries.

**Figure 5-10** Flanged and threaded flexible pipe (pump) connectors.



**Figure 5-11** Braided metal pump connector is not an effective vibration isolator.

## Vibration Isolation



**Figure 5-12** Floor mount spring isolator under a height-saving bracket with a separate seismic restraint.

auxiliary steel frame or concrete-filled inertia base is sometimes required to mitigate the vibration transmission. The auxiliary frame or base stabilizes the equipment, lowers its center of gravity, and stiffens its isolator attachment points. Figure 5-12 shows a frame with height-saving brackets that lowers the center of gravity that is seen by the isolator. Base-mounted pumps frequently require inertia bases that serve as stiff platforms to help keep the motor and pump shafts aligned.

Equipment vibration can “leak” past an inertia base due to the entrapped air between the bottom of the base and its housekeeping pad or floor slab. Also, construction debris can be unknowingly trapped beneath a base and cause a “short-circuit.” Minimize the possibility of these problems by specifying that the inertia base float as least 50 mm above the housekeeping pad or slab. If the inertia base’s smaller footprint dimension is more than 1 m, leave one or more air relief openings near the center of the inertia base.

Frames and bases should be designed to minimize the number of isolators required to carry the load. Proper isolator loading is more difficult to achieve as the number of isolators increases. Three isolators is the optimal number, although four are most frequently used.

### Special Concerns with Seismic and Wind-Loading Restraints

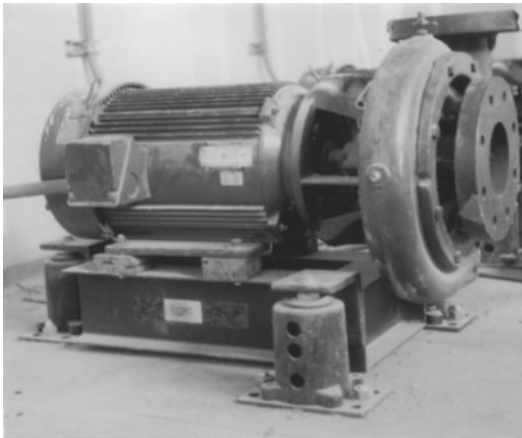
Vibration-isolated HVAC system components that are installed in seismic areas or outdoors above occupied spaces may need standby restraints (sometimes called “snubbers”) to prevent the components from being shaken or blown loose

## A Practical Guide to Noise and Vibration Control for HVAC Systems

from their building attachments. Individual snubbers can be installed around an equipment frame after the equipment has been set in place on its isolators. Alternatively, the snubbers can be integrated into the isolators themselves. Figure 5-12 shows a vibration-isolated equipment frame with a snubber installed just to the right of the isolator. Figure 5-13 shows a pump mounted on spring isolators with integral snubber restraints.

Isolated equipment is prone to horizontal offset if pulled or pushed by the attachment of a misaligned pipe. If separate isolators and seismic snubbers are used, small offsets may not cause a “short-circuiting” problem. However, when a combination isolator/snubber is used, the offset can easily cause a “short-circuit” that will let equipment vibration bypass the isolator. The ASHRAE publication, *A Practical Guide to Seismic Restraint*, and the new FEMA Manual 412, *Installing Seismic Restraints for Mechanical Equipment*, show how restraints should be installed to prevent “short-circuiting” of the vibration isolators.

There are literally dozens of other variations of isolators, frames, and bases for both general and specific uses. A qualified isolation equipment vendor will have an engineering staff that can design and deliver an isolator or complete isolation system for a specific purpose.



**Figure 5-13** Pump mounted on combination isolator/restraint under height-saving bracket. This type of isolator is not recommended because it is prone to short-circuiting.

## **Vibration Isolation**

### **The Importance of the Supporting Structure**

Vibration isolation systems work as expected only if the supporting structure is much stiffer than the isolator. As a worst case, a supporting structure with approximately the same static deflection as an isolator resting on it can amplify the equipment vibration that is transmitted into the structure. This problem can be avoided by working with the structural engineer to ensure that all structures that accommodate either supported or suspended equipment on isolators have a static deflection of no more than 20% of the isolator's static deflection. For example, the structure that supports a piece of equipment on 25 mm deflection isolators should have a static deflection of no more than 5 mm. The sketches in Figure 1-16 in Chapter 1 show the effect qualitatively.

## 6

# Specifications

---

Construction drawings are the primary tools for presenting design requirements to a contractor. However, they do not do the whole job because they cannot fully define the quality of an HVAC system's materials and workmanship. Drawings also cannot always define special installation procedures. Those tasks are often done with specifications.

The Construction Specification Institute (CSI) has reserved section 23.04.48 for vibration control products in its new six-digit numbering format. The more familiar section 15074 is the reserved section in the old five-digit format. Neither the old nor the new CSI format reserves a section specifically for noise control products. Some specifiers prefer to include the acoustical performance specifications for all system components in a single section titled "Noise Control." For example, the acoustical specifications for fans, air-handling units, terminal units, diffusers, chillers, cooling towers, duct silencers, duct liners, etc., would all be in the same specification section. Unfortunately, an acoustical specification in this location could be overlooked by an equipment vendor who is focusing only on the overall specification section for his/her product. The acoustical specification is less likely to be overlooked if it is included in that component's project specification section. The section below gives some example acoustical specifications that can be included in the various products' specification sections.

## **SAMPLE SPECIFICATIONS**

### **Fans**

Acoustical specifications for fans should specify the maximum sound power level ( $L_w$ ) values according to the latest revision of AMCA Standard 300. A sample specification is shown below.

## Specifications

*When tested in complete accordance with the latest revision of AMCA 300, "Reverberant Room Method for Sound Testing of Fans," in a laboratory registered by AMCA to perform the test, the tested  $L_W$  values shall not exceed the values scheduled in the following table when operating at the scheduled operating conditions.*

Mark	Air-flow in L/s	TSP in Pa	Inlet/Outlet	Maximum $L_W$ values in dB re 1 pW Octave Band Center Frequency in Hz							
				63	125	250	500	1000	2000	4000	8000
SF-1	1000	1125	Outlet	98	98	95	90	86	82	77	71
SF-2	8400	525	Outlet	95	92	88	85	82	77	71	65
SF-2	8400	475	Inlet	93	90	86	83	80	75	69	63

## Air-Handling Units and Fancoil Units

Acoustical specifications for AHUs should specify the maximum  $L_W$  values according to the latest revision of AHRI Standard 260. A sample specification is shown below.

*All AHUs listed in the schedule below shall be tested in complete accordance with the latest revision of AHRI Standard 260, "Sound Rating of Ducted Air Moving and Conditioning Equipment." When operating at the maximum design capacities, the tested  $L_W$  values shall not exceed the values scheduled in the following table.*

Mark	Location	Maximum $L_W$ values in dB re 1 pW Octave Band Center Frequency in Hz							
		63	125	250	500	1000	2000	4000	8000
AH-1	SA discharge	86	90	94	92	88	83	80	75
AH-1	RA inlet	77	85	75	73	71	68	66	62
AH-1	ExA discharge	86	89	86	85	80	75	72	67
AH-1	OA inlet	85	89	87	84	83	76	71	66
AH-1	Case-radiated	78	81	76	64	58	53	50	45

**A Practical Guide to Noise and Vibration Control for HVAC Systems**

**Chillers**

Some chillers produce more noise at partial load than at full load. Therefore, specify the maximum  $L_p$  values under all operating conditions, as follows.

*Chiller  $L_p$  values shall be obtained in complete accordance with the latest revision of AHRI Standard 575, "Method of Measuring Machinery Sound Within an Equipment Space." The representative octave band  $L_p$  values, as defined in the standard, shall not exceed the values scheduled below for chillers operating at any operating condition between 25% and 100% of the maximum design capacity.*

Mark	Maximum $L_p$ at 1 m in dB re 20 $\mu$ Pa Octave Band Center Frequency in Hz							
	63	125	250	500	1000	2000	4000	8000
CH-1	85	89	92	89	84	84	82	80
CH-2	83	86	87	89	88	86	85	82

**Duct Silencers**

Duct silencers attenuate the noise that travels through them, but they also create "self-noise" due to the turbulent airflow that they generate. Silencers, therefore, must be specified with two sets of acoustical performance limits: a set of minimum insertion loss values and a set of maximum "self-noise" values. Also, because the acoustical and aerodynamic performances of duct silencers are so closely linked, it is customary to specify a maximum pressure drop in the acoustical specification. A sample specification is shown below.

*When tested in complete accordance with the latest revision of ASTM E477, "Standard Method of Testing Duct Liner Materials and Prefabricated Silencers for Acoustical and Airflow Performance" in a laboratory that is NVLAP-accredited to conduct the test, the acoustical and aerodynamic performance of all duct silencers shall conform to the values given in the following schedules.*

Mark	Type	Airflow in L/s	Velocity in m/s	Max. P.D. in Pa	Minimum Dynamic Insertion Loss in dB Octave Band Center Frequency in Hz						
					63	125	250	500	1000	2000	4000
ST-1	R	+9400	+5.8	20	4	7	14	17	12	11	9
ST-2	F	+8400	+4.9	68	6	10	18	33	38	30	18
ST-3	D	8400	7.5	38	7	15	22	32	30	20	14

Type Legend: D = Dissipative, F = Film-lined, R = Reactive

## Specifications

Mark	Type	Airflow in L/s	Velocity in m/s	Max. P.D. in Pa	Maximum Self-Noise Sound Power Level in dB re 1 pW (0.37 m <sup>2</sup> face area)						
					Octave Band Center Frequency in Hz						
					63	125	250	500	1000	2000	4000
ST-1	R	+9400	+5.8	20	56	49	44	45	53	56	50
ST-2	F	+8400	+4.9	68	63	54	52	50	47	48	47
ST-3	D	8400	7.5	38	56	56	55	54	55	56	49

Type Legend: D = Dissipative, F = Film-lined, R = Reactive

Positive (+) values for airflow and velocity indicate the airflow and noise travel in the same direction, whereas negative (–) values indicate that airflow and noise travel in opposite directions. Good design practice recommends selecting silencers with static pressure drop of no more than 63 Pa.

## Vibration Isolators

Specifications for vibration isolators should include detailed descriptions of their fabrication materials and methods. The sample specification below is a very abbreviated example that includes a vibration isolator/frame selection schedule.

*All vibration isolators shall be selected to have a minimum static deflection as scheduled below and a reserve load capacity of at least 50% of the design load. All spring isolators shall have a loaded height/diameter ratio in the range of 0.8 to 1.2. To provide adequate frame stiffness all frame and base members shall have a height that is at least 10% of the spacing between adjacent isolators. All spring hangers shall function properly with a hanger rod misalignment of no more than 15 degrees from vertical in any direction. Seismic/wind-loading restraints and cables shall not affect the isolation system effectiveness during normal operating conditions. All vibration isolators shall be selected in complete conformance with the schedule below.*

Mark	RPM	Motor kW	Min. Static Deflection in mm	Isolator Type	Frame Type
CH-1	3600	125	25	Spring mount	WF
SF-1-12	1150	18.5	50	Spring mount	channel
P-1,2	1750	22	50	Spring mount	WF
EF-1	750	1	3	Hanger	channel
B-1	—	—	3	Pad mount	—
CHW piping	—	---	25	Spring mount	—
CW piping	—	—	25	Spring mount	—

**A Practical Guide to Noise and Vibration Control for HVAC Systems**

**Duct and Plenum Liners**

The acoustical specification for duct and plenum liners should include their locations and acoustical performance. Because the relevant ASTM testing standard permits mounting the tested samples in one of several mounting arrangements per ASTM E795, it is important to specify the mounting type. A sample is shown below.

*Duct and plenum liners are rigid or semi-rigid foam or mineral fiber boards with coatings to prevent fiber erosion under all expected airflow conditions. Duct liner of the specified thickness shall be located as shown on the drawings and as listed below.*

- a. All supply air ducts up to 8 m from fan discharge—50 mm thick.
- b. All other supply air ductwork—25 mm thick.

*Plenum liner of the specified thickness shall be located as shown in the drawings and as listed below.*

- a. Supply fan discharge plenum—100 mm thick.
- b. Supply fan intake plenum—50 mm thick.

*The sound absorption coefficients of all duct and plenum liners shall be determined in complete accordance with the latest revision of ASTM C423, “Standard Test Method for Sound Absorption and Sound Absorption Coefficients by the Reverberation Room Method,” in a laboratory that is NVLAP-accredited to conduct the test. The sound absorption coefficient values of all duct and plenum liners shall conform to the schedule below. Samples shall be tested with a Type A mounting in complete accordance with the latest revision of ASTM E795, “Standard Practices for Mounting Test Specimens during Sound Absorption Tests.”*

		<b>Minimum Sound Absorption Coefficient Octave Band Center Frequency in Hz</b>					
<b>Service</b>	<b>Thickness, mm</b>	<b>125</b>	<b>250</b>	<b>500</b>	<b>1000</b>	<b>2000</b>	<b>4000</b>
Duct	25	0.13	0.50	0.70	0.95	0.98	0.99
Duct	50	0.25	0.70	0.96	0.99	0.99	0.99
Plenum	50	0.25	0.70	0.96	0.99	0.99	0.99
Plenum	100	0.72	0.95	0.99	0.99	0.99	0.99

**Specifications**

**TERMINAL UNITS**

While terminal units are sometimes specified in terms of their cataloged NC ratings, a complete acoustical specification should include more detailed information. A sample specification is shown below. Note the distinction between *discharge* and *radiated* noise.

*All terminal units shall be tested in complete accordance with the latest revision of AHRI 880, “Standard for Air Terminals,” in a laboratory that is AHRI-certified to conduct the test. When operating at the design capacities scheduled below, the tested  $L_W$  values shall not exceed the scheduled values. Units used in a pressure-independent system shall be tested with their inlet velocity sensors installed.*

			Maximum Discharge $L_W$ in dB re 1 pW Octave Band Center Frequency in Hz					
Mark	Design Aiflow in L/s	Static Pressure in Pa	125	250	500	1000	2000	4000
VAV-1	700	250	66	63	60	58	55	52
VAV-2	470	250	63	60	56	55	53	51
VAV-3	280	250	60	58	54	52	50	48

			Maximum Radiated $L_W$ in dB re 1 picowatt Octave Band Center frequency in Hz					
Mark	Design Aiflow in L/s	Static Pressure in Pa	125	250	500	1000	2000	4000
VAV-1	700	250	62	53	48	45	43	41
VAV-2	470	250	58	48	42	40	37	35
VAV-3	280	250	55	48	40	36	34	31

**EXAMPLES OF HOW “NOT” TO SPECIFY**

Because specifications offer the opportunity to precisely define acoustical requirements, do not waste the opportunity and detail them with *imprecise* statements, such as:

## **A Practical Guide to Noise and Vibration Control for HVAC Systems**

***“The HVAC equipment shall not produce objectionable noise or vibration.”***

This statement misses the mark on two counts. First, it refers to only the HVAC *equipment*, not the entire system. One of the main points of this guide is that most HVAC noise problems are caused by how the *system* is put together. Secondly, the statement does not define the phrase objectionable noise or vibration. Subjective statements such as this do not belong in contract documents.

***“All HVAC system noise and vibration shall be completely eliminated.”***

This statement recognizes that the *system* performance is important, but it mistakenly requires that all “noise and vibration shall be completely eliminated.” In fact, some system noise is desirable for masking other annoying building sounds, such as conversations in nearby work areas or transformer and lighting ballast hum.

***“HVAC system noise shall not exceed NC-40.”***

By requiring the contractor to meet a certain NC (Noise Criteria) design goal, this statement assumes that the contractor will perform an acoustical analysis. Unless the project is design/build, the contractor probably will not have the capability and should not have that responsibility. The statement also specifies only one NC rating, presumably for the entire building. A review of Table B-1 in Appendix B shows that an NC, RC, or NCB rating should be selected for each type of building occupancy.

***“Duct silencers shall attenuate fan noise by 25 dB.” or “Fan noise shall not exceed 85 dB.”***

These statements specify only one acoustical characteristic of a duct silencer and a fan with no frequency qualification. The sample specifications at the beginning of this chapter give recommended specification characteristics at specific octave bands for various HVAC system components.

***“All vibration isolators shall be 90% efficient.”***

This statement gives an unreasonable, incomplete requirement that is difficult and expensive to field-verify. First of all, it is hard to justify the same isolation efficiency at a roof-mounted, 700 kW reciprocating chiller and a smooth-running, 4 kW, 3600 rpm pump mounted on grade. Secondly, the concept of isolation efficiency only applies to a perfect isolator with an infinitely stiff base attachment. A proper vibration isolation specification details certain fabrication requirements for the isolators and their bases and refers to a schedule on the drawings where the isolators and base construction for each piece of equipment are listed.

***“All equipment shall be mounted on the manufacturer's standard isolation base, subject to approval.”***

The requirement for a manufacturer's “standard isolation base” can come back to

## **Specifications**

haunt you if you aren't completely familiar with all of the isolation packages offered by each manufacturer. Manufacturers are continually re-engineering their products so that yesterday's "standard isolation package" may not resemble today's. More importantly, a "standard isolation package" cannot be matched to the structural conditions in every building. Every isolator should be selected on the basis of the equipment's vibration characteristics, the noise/vibration sensitivity of the surrounding areas, and the mounting location's structural stiffness.

*“When field conditions result in an interference between ductwork and another building service, the contractor shall install ductwork offsets and transitions as necessary to avoid the interference.”*

This sentence is supposed to save time when an interference is discovered on a job by instructing the contractor to take care of the problem without bothering the design team. Unfortunately, when an offset or transition occurs in a medium- or high-velocity duct, especially near a fan or takeoff, an unexpected result can be excessive airflow noise, fan noise, or duct rumble. The contractor should never be allowed to change the duct system design near a fan or takeoff without a review by the mechanical engineer. A more proper statement would be:

*“When field conditions result in an interference at any medium- or high-velocity duct, the contractor shall submit a revised duct layout for review by the mechanical engineer.”*

# 7

## Construction Phase Tasks

---

### VALUE ENGINEERING (COST-CUTTING)

Many projects have a “value engineering” phase in which the contractor presents cost-saving alternatives to the HVAC system design. The contractor and other project team members can bring valuable experience to a project and propose changes that could allow the deletion or reduction of some acoustical treatments. However, since most contractors are unaware of the acoustical impacts of their cost-saving proposals, it is important that the design team review them for their noise and vibration impacts. This is especially important because most cost-saving proposals involve either reducing the size of equipment, ductwork, and mechanical rooms or substituting cheaper equipment in place of what was specified. Table 7-1 lists some common value engineering proposals and their potential acoustical impacts.

### SUBMITTALS AND SHOP DRAWING REVIEWS

Great care must be taken in reviewing submittals, especially those that include manufacturer's sound data. To be reliable, the submitted sound data must be collected and reported exactly as required in the appropriate test standard. Incorrect factory data can easily lead to unexpected noise problems on the job site. A more thorough discussion of manufacturers' sound data is included in the ASHRAE publication, *Application of Manufacturers' Sound Data*.

### Fans, Air-Handling Units (AHU), and Fancoil Units (FCU)

Pay particular attention when reviewing sound power level ( $L_W$ ) submittals. Some manufacturers submit octave band sound power levels that are calculated by the obsolete ASHRAE calculation method, while others submit A-weighted octave

**Construction Phase Tasks**

**Table 7-1. Common Value Engineering Proposals  
 and Their Potential Acoustical Impacts**

<b>Value Engineering Proposal</b>	<b>Possible Acoustical Impact</b>
Reduce fan size and speed up the fan	Higher noise level due to fan inefficiency and higher outlet velocity
Reduce duct sizes	Higher noise level and increasing chance of rumble due to higher airflow velocities
Reduce duct wall thickness (increase gauge number)	Greater chance of rumble due to flexible duct walls; lighter weight allows more breakout sound transmission through duct walls
Reduce equipment room size	Higher noise level in adjacent spaces due to proximity of equipment to wall(s)
Delete masonry walls, use drywall partitions at mechanical rooms	Higher levels of low-frequency noise and rumble in adjacent spaces
Replace VFD motor controllers with inlet vanes for fan capacity control	Higher noise levels at all operating capacities due to addition of inlet vanes at fan inlet
Reduce sizes of terminal units or grilles	Increased noise due to higher airflow velocities
Fiberglass ductboard instead of sheet metal ductwork	More breakout sound transmission through duct walls
Use neoprene mounts instead of steel spring isolators	The lower static deflection of neoprene will reduce vibration isolation effectiveness
Delete duct silencers	Higher noise levels throughout the duct system
Reduce the number of VAV zones	Higher noise levels near the larger VAV terminal units
Change from “chilled water” system to large rooftop package units	Higher noise levels on the top floor directly beneath the rooftop unit and unacceptable shaft-wall vibration—both impacts due to excessive air turbulence in the ductwork near the unit and poor vibration isolation inside the unit

**A Practical Guide to Noise and Vibration Control for HVAC Systems**

band  $L_W$  values that at first glance make a unit appear to be very quiet at low frequencies. Since virtually all fan and AHU acoustical specifications specify unweighted octave band  $L_W$  values, it is important that any submitted A-weighted  $L_W$  values be converted to unweighted values using the simple procedure given in Table 7-2. The example represented in the table shows how correction factors are added to the submitted A-weighted  $L_W$  values to obtain the unweighted values for a typical forward-curved centrifugal fan. The A-weighting adjustments can be used for any octave band  $L_p$  or  $L_W$  spectrum.

Fans, AHUs, and FCUs produce different sound power levels at their intakes and discharges, yet most fan manufacturers mistakenly submit the same  $L_W$  data for both locations. Verify that the submittal is for the correct side of the equipment. This kind of equipment also produces case-radiated noise, which can be significant in some applications.

For equipment used in variable air volume systems, verify that the submitted  $L_W$  data include the effects of whatever capacity control device is used. Ensure that the specified fan type, diameter, speed, and performance curve are submitted. All of these parameters will affect the noise level.

An acoustical performance submittal for a fan, AHU, or FCU should include at least the following:

1. The name and location of the laboratory conducting the test.
2. The date of the test.
3. A complete identification of the equipment, e.g., series name, model number, etc.

**Table 7-2. Procedure for Converting from A-Weighted  $L_W$  Values to Unweighted  $L_W$  Values**

	Octave Band Center Frequency in Hertz							
	63	125	250	500	1000	2000	4000	8000
Submitted A-weighted $L_W$ values in dB re 1 pW	71	77	80	80	77	76	74	69
Adjustment factor to remove A-weighting	+26	+16	+9	+3	+1	-1	-1	+1
Resulting unweighted $L_W$ values in dB re 1 pW	97	93	89	83	78	75	73	70

### **Construction Phase Tasks**

4. The equipment operating conditions, e.g., airflow, total static pressure, rpm, and motor kW rating.
5. A statement confirming that the measurements were obtained in complete conformance with the applicable test standard (AMCA 300 for fans, AHRI 260 for AHUs and FCUs).
6. The unweighted octave band sound power levels and a note as to whether the values are for discharge, inlet, or case-radiated noise.

### **Terminal Units and Lab Air Valves**

Terminal unit and lab air valve submittals sometimes include only the unit's single-number NC rating at various combinations of airflow and differential pressure operating conditions. These NC ratings can be used to compare the relative loudness of different terminal units, but there is no way to ensure that the published NC rating will occur in a field installation because the published values are based on atypical system designs and room conditions. The only way to be sure of a terminal unit's field performance is to use the published discharge and radiated octave band  $L_W$  values in a set of calculations that are based on the actual design conditions, e.g., unit location and operating point, room dimensions and surface finishes, ceiling type and height, etc.

An acoustical performance submittal for any kind of air terminal unit or lab air valve should include at least the following:

1. The name and location of the laboratory conducting the test.
2. The complete equipment model number.
3. The equipment operating conditions airflow and static pressure drop.
4. A statement that the measurements were obtained in complete conformance with the latest revision of test standard AHRI 880.
5. For terminal units, the octave band  $L_W$  values for discharge and case-radiated noise.
6. For lab air valves, the octave band  $L_W$  values for discharge, exhaust, and case-radiated noise.

### **Air Devices**

Test standard AHRI 890 is used to determine the octave band  $L_W$  values for air devices at various airflows. A standard adjustment is applied to the measured data at each airflow to determine estimates of the device's flow-dependent NC ratings in a large room. An acoustical performance submittal for any kind of air device should include at least the following:

## **A Practical Guide to Noise and Vibration Control for HVAC Systems**

1. The name and location of the laboratory conducting the test.
2. The device's complete model number and dimensions.
3. The airflow quantities used during the test.
4. The presence of any appurtenances, e.g., dampers, plenums, etc.
5. A statement that the measurements were obtained in complete conformance with the latest revision of test standard AHRI 890.
6. The octave band  $L_W$  values and standardized NC rating at each airflow.

Be very careful to note the following in the submittal:

1. If there will be a damper attached to the device's inlet (thereby converting it to a register) verify that the submitted NC rating was determined with the damper in place. The presence of a damper can add from 5 to 15 points to a device's NC rating.
2. Any device with adjustable deflectors or vanes will produce different sound levels depending on the deflector or vane settings. Therefore, verify that the submitted NC rating is based on the vane or deflector positions that will be used in the field installation.
3. Slot diffusers are typically tested for airflow and sound under two conditions:
  - a. Installed in a very large plenum, and
  - b. Installed in a small, close-fitting sheet metal boot with a round or oval duct connection.

Verify that the submitted acoustical data are for the appropriate plenum configuration for the project application.

### **Water-Source Heat Pumps**

There are no acoustical test codes specifically for water-source heat pumps. However, since these units typically have ducted discharges, their discharge  $L_W$  values should be determined in accordance with AHRI 260, "Sound Rating of Ducted Air Moving and Conditioning Equipment." And since the inlet of this equipment is typically unducted, the proper test procedure for determining inlet  $L_W$  values is AHRI 350, "Sound Rating of Non-Ducted Indoor Air-Conditioning Equipment," which is usually used to determine the combination of inlet and case-radiated sound power level in each octave band from 63 to 4000 hertz.

Since this equipment can operate in "fan only," "cooling," and "heating" modes, the submittal should include octave band  $L_W$  values for all three modes of operation.

An acoustical performance submittal for a water-source heat pump should include at least the following:

### **Construction Phase Tasks**

1. The name and location of the laboratory conducting the test.
2. The test date.
3. A complete identification of the equipment, e.g., series name, model number, etc.
4. The equipment operation conditions, e.g., operating mode, airflow, TSP, rpm, and motor kW rating.
5. A statement confirming that the measurements were made in complete conformance with the applicable test standard (AHRI 260, AHRI 350, etc.). Any variations from strict compliance with the test standards should be fully explained. The inclusion of any noise reduction products or packages should be noted in the submittal.
6. The unweighted  $L_W$  values in the octave bands from at least 63 to 4000 hertz for each operating mode (fan only, cooling, and heating) and a note as to whether the values are for discharge, inlet, or case-radiated noise. All three should typically be reported.

### **Cooling Towers and Evaporative Coolers**

Factory noise data for cooling tower, evaporative coolers, and similar equipment are measured in accordance with Cooling Technology Institute's Acceptance Test Code ATC-128. An acoustical performance submittal for this type of equipment should include at least the following:

1. The name and location of the laboratory conducting the test.
2. A complete identification of the equipment, e.g., type, series name, model number, etc.
3. The equipment's operating conditions; for equipment with variable-speed fans, the test should be run at 50%, 75%, and 100% of full fan speed.
4. A statement confirming that the measurements were obtained in complete conformance with the latest revision of test standard ATC-128 and that the measured data include fan and water noise (if applicable).
5. The octave band  $L_p$  values for each operating condition at distances of 1.5 and 15 m from all four sides of the equipment, as well as above the fan discharge.

### **Water-Cooled Chillers**

The noise of indoor water-cooled chillers is measured in accordance with AHRI 575. An acoustical performance submittal for an indoor water-cooled chiller should include at least the following:

## **A Practical Guide to Noise and Vibration Control for HVAC Systems**

1. The name and location of the laboratory conducting the test.
2. A complete identification of the equipment, e.g., series name, model number, etc.
3. The equipment's operating conditions; for variable capacity equipment, the test should be run at 50%, 75%, and 100% of full capacity.
4. A statement confirming that the measurements were obtained in complete conformance with the latest revision of test standard AHRI 575.
5. The octave band  $L_P$  values for each operating condition at a distance of 1 m from all four sides of the equipment.

### **Air-Cooled Chillers**

The noise of air-cooled chillers is measured in accordance with AHRI 370. An acoustical performance submittal for an air-cooled chiller should include at least the following:

1. The name and location of the laboratory conducting the test.
2. A complete identification of the equipment, e.g., series name, model number, etc.
3. The equipment's operating conditions; for variable capacity equipment, the test should be run at 50%, 75%, and 100% of full capacity.
4. A statement confirming that the measurements were obtained in complete conformance with the latest revision of test standard AHRI 370.
5. The octave band  $L_W$  values for each operating condition.

### **SHOP DRAWINGS**

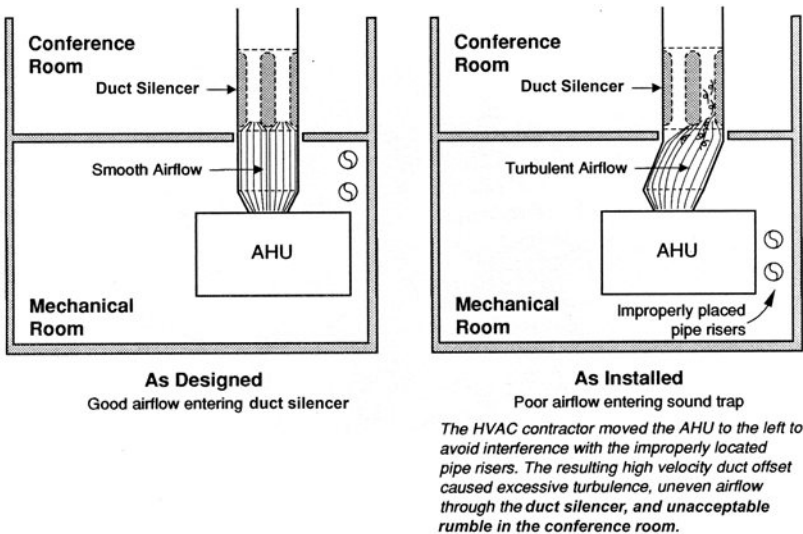
In the early construction phase coordination that often precedes the start of construction in a large project, the ductwork subcontractor will prepare a set of shop drawings that will help identify field interferences with other trades (e.g., plumbing, electrical, and structural). These shop drawings inevitably include ductwork layouts that differ from those in the design drawings. The shop drawing reviewer must, therefore, be careful to verify that any proposed revised duct routings do not result in noise problems.

For ductwork shop drawings:

1. Verify that the proposed duct runs, especially the trunk ducts, have not been moved near noise-sensitive areas.
2. Verify that the proposed duct sizes conform to the specified maximum air velocities.

### Construction Phase Tasks

3. Verify that there are no dampers or duct silencers shown within three equivalent duct diameters of duct fittings or fan discharge openings.
4. Pay particular attention to offsets and transitions that may have been added in medium- and high-pressure duct systems, especially near equipment rooms. An improperly located offset or transition can cause excessive regenerated noise due to the extra turbulence. It can also cause the creation of excessive static pressure drop that can force the fan to operate in rotating stall or surge. Figure 7-1 shows an example where an unexpected offset caused a very troublesome noise problem at the discharge of an air-handling unit.
5. Verify that all duct penetrations through sound-rated slabs and partitions (usually those with insulation batts in their stud cavities) are sleeved and caulked airtight.
6. Verify that all of the specified duct and plenum liners, duct silencers, and acoustical louvers are shown on the shop drawings.
7. Verify that all duct silencers are in the right locations and that their attenuating baffles are oriented properly. For duct silencers near elbows, the baffles should be oriented in the plane of the turn.
8. If a special duct gauge is specified, verify that it is shown on the drawings.



**Figure 7-1** Overhead plan views of AHU rooms showing the effects of a duct offset.

## **A Practical Guide to Noise and Vibration Control for HVAC Systems**

For piping system shop drawings:

1. Verify that pipe runs have not been located above ceilings or in shafts that are adjacent to noise-sensitive areas.
2. Verify that no pipe runs will interfere with the design drawing duct locations; any interference should be resolved by moving the pipe, not by adding an offset in the ductwork.
3. Be sure that the pipe sizes agree with the specified maximum waterflow velocities.
4. Verify that all of the specified flexible pipe connectors are shown at pumps, chillers, boilers, cooling towers, and other waterside equipment.
5. Verify that all pipe penetrations through sound-rated partitions and slabs are sleeved and sealed airtight without making contact with the wall or slab.

For air balance reports:

1. Verify that the total fan pressure, fan speed, operating kW rating, and airflow are consistent with the performance curve for each fan.
2. Excessive duct leakage will force the balancing technician to increase the fan rpm (and noise) to achieve the design airflows. Compare traverse readings with air device totals to determine if duct leakage is occurring.
3. Compare the measured airflow for each grille and register with the design values in the contract documents.
4. Verify that the in-duct static pressure just upstream of the terminal unit that is farthest from the fan does not significantly exceed the minimum required to operate the terminal unit.

## **SITE INSPECTIONS**

A building's design team takes great care in developing guidelines and details that are intended to minimize the possibility of noise and vibration problems. If the guidelines and details are not followed, not only is the design time wasted, but also the problems that the details were intended to avoid can occur.

The items in the checklists below can be applied to site inspections of buildings under construction or to troubleshoot situations where visual observation is the first step in solving the problem. If the answer to any question is "No," the possibility of a noise or vibration problem exists.

### ***Site Inspection Checklist for Fan and Air-Handling Unit Installations***

1. Is the installed equipment exactly as submitted and approved?
2. For unducted inlets, is the inlet at least 1 full fan wheel diameter from the nearest obstruction?

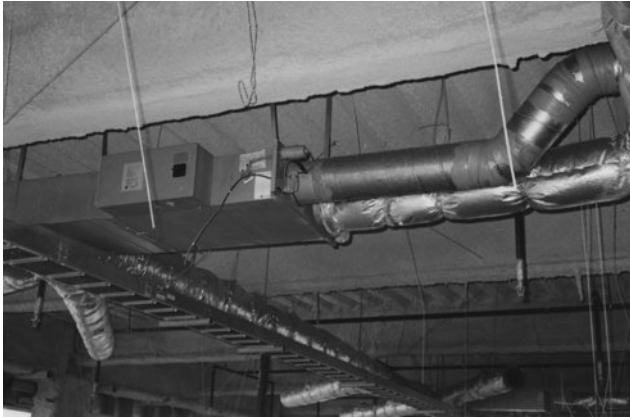
### **Construction Phase Tasks**

3. For ducted inlets, is the nearest elbow, offset, or transition at least 3 equivalent duct diameters from the unit inlet?
4. For unducted outlets, is the nearest airflow obstruction at least 1.5 fan wheel diameters from the unit discharge?
5. For ducted outlets, does the outlet transition have an expansion angle of 15 degrees or less?
6. For ducted outlets, is the first elbow, offset, damper, backflow preventer, or duct silencer at least 3 equivalent duct diameters downstream of the unit discharge opening?
7. Does the electrical conduit serving the unit have a flexible loop to prevent vibration transmission via the conduit? Can the conduit be easily moved?
8. Is the duct system attached to the equipment with a flexible canvas connector?
9. Does the equipment float freely on its vibration isolators? It should rock freely when pushed or jumped on.
10. Is the ductwork installed in accordance with the approved shop drawings and SMACNA guidelines?
11. Are there any unexpected elbows, offsets, transitions, etc.?
12. In systems with airflow of 900 L/s and higher, is all medium- and high-pressure ductwork made of sheet metal (instead of fiberglass ductboard)?
13. Is the fan rotation correct?

### ***Site Inspection Checklist for Terminal Units***

1. Is every unit exactly as submitted and approved?
2. Is every unit installed in accordance with the approved shop drawings and located away from noise-sensitive areas?
3. Is every unit free of contact with nearby pipes, walls, ceilings, etc.?
4. Is the nearest upstream duct elbow or offset at least 3 equivalent duct diameters from the unit inlet? See Figure 7-2 for a proper unit installation.
5. Is the duct leading to the box inlet made of metal, either aluminum or steel? Flexible inlet ducts permit inlet noise breakout into the ceiling plenum.
6. Is the low-pressure discharge duct made of sheet metal with a minimum 25 mm thick internal acoustical liner?
7. In a system using the ceiling plenum for return air, is the nearest return air grille at least 1.5 m from the nearest terminal unit?
8. In troubleshooting situations, is the complete ceiling in place and is the air system balanced?

**A Practical Guide to Noise and Vibration Control for HVAC Systems**



**Figure 7-2** Properly installed dual-duct variable air volume unit. The unit is installed high in the plenum cavity and the two inlet ducts are straight for several duct diameters upstream of the unit. Airflow is from right to left.

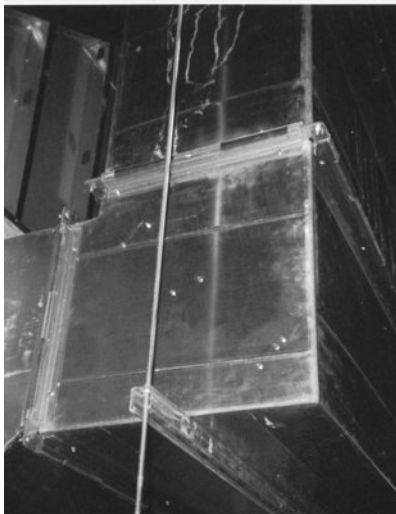
***Site Inspection Checklist for Ductwork***

1. Is all ductwork free of visible oil-canning or other movement?
2. Is all ductwork free of contact with other trades' work?
3. Do ducts that penetrate walls avoid contact with the wall? Are the gaps around the ducts sealed with a silicone-based sealant?
4. Is the high/medium-pressure duct system free of steep-angle transitions or offsets that may have been installed to avoid field interferences?
5. Do all high- or medium-velocity rectangular elbows have turning vanes? Check for turning vanes by looking for the weld spots or sheet metal screws at the appropriate places on the elbow cheeks. The photo in Figure 7-3 shows the screws that were used to install turning vanes inside a large elbow.
6. Check duct gauge labels and reinforcements against SMACNA requirements.

***Site Inspection Checklist for Vibration Isolators***

1. Is all rotating equipment and its attached piping either mounted on or suspended from vibration isolators?
2. Are the installed isolation systems exactly as submitted and approved? Check isolator labels against the approved shop drawings.

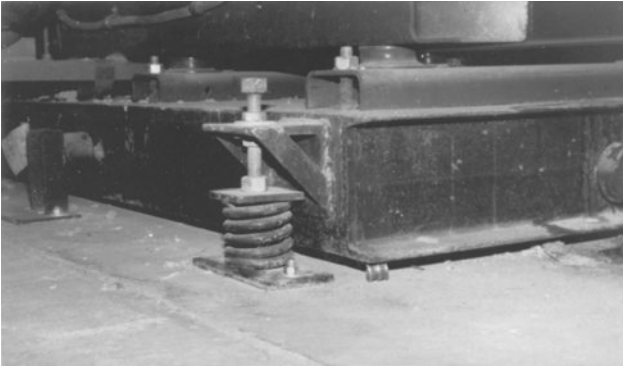
### Construction Phase Tasks



**Figure 7-3** Check of large duct elbow verifying screw attachment of turning vanes.

3. Are all vibration isolation hangers attached directly to the stiffest parts of the structure above (i.e., beams)? They should not be installed in the middle of a floor diaphragm or at the bottom or in the midspan of the hanger rod.
4. Are all floor-mounted vibration isolators installed directly over or very near stiff structural elements, e.g., beams or beam intersections?
5. Are the frames of all vibration-isolated equipment free from distortion or sagging?
6. Are all inertia bases fully filled with the specified amount of concrete?
7. Can all isolated equipment move freely on its isolators? Check this by rocking or jumping on the equipment while it is operating. A reasonably healthy person can rock a properly isolated 1750 kW chiller or cooling tower.
8. Is the area under an isolated frame/base free from tools or construction debris that might “short-circuit” the isolation? See Figure 7-4 for an example where a small piece of electrical conduit is “short-circuiting” an isolated equipment frame.
9. Are the isolators properly loaded to give the specified deflection? This can be checked by comparing each isolator's loaded height with its free height (given on

**A Practical Guide to Noise and Vibration Control for HVAC Systems**



**Figure 7-4** Conduit debris short-circuiting isolator effectiveness. The small piece of flexible conduit forms a rigid contact path between the equipment frame and the slab, allowing equipment vibration to bypass the spring. Also note that the spring is overloaded and should be replaced with one that can accommodate a heavier load.

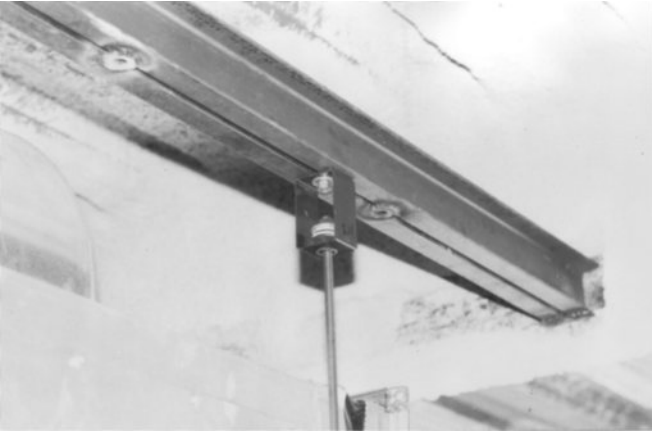
its submittal sheet). Figure 7-5 shows an overloaded spring hanger. Figure 7-6 shows an overloaded spring floor mount.

10. Have the shipping shims been removed from the isolators and seismic/wind-loading restraints? Figure 7-7 shows a “short-circuited” isolation floor mount whose shipping shims have not been removed.
11. Does every hanger rod freely penetrate the hole in the bottom of the hanger box? Figure 7-8 shows an installation where the hanger rod is touching the hanger box, thereby “short-circuiting” the spring isolator.
12. Are thrust restraints keeping the fans centered on their isolators while they are operating?
13. Is the floor/roof free of feelable vibration? Check this in areas surrounding the equipment.
14. Do the seismic or wind-loading restraints remain “out-of-contact” during normal equipment operation?

***Site Inspection Checklist for Central Plants Near Occupied Spaces***

1. Is all of the installed equipment exactly as submitted and approved?
2. Is all floor or roof-mounted equipment and piping supported on vibration isolators?

### Construction Phase Tasks

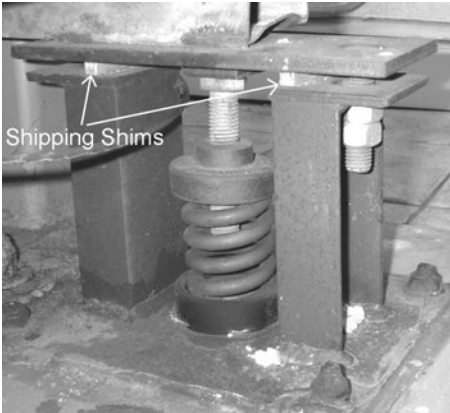


**Figure 7-5** Overloaded spring hanger.



**Figure 7-6** Overloaded free-standing floor mount. The overloading allowed the gussets welded to the side of the equipment frame to rest on top of the isolator baseplate. The lower right corner of the gusset was burned off to eliminate the gusset/baseplate contact. The proper action would have been to replace the overloaded spring with a stiffer one able to carry the heavy load.

**A Practical Guide to Noise and Vibration Control for HVAC Systems**



**Figure 7-7** Short-circuited floor mount isolator whose shipping shims have not been removed.



**Figure 7-8** Faulty spring hanger installation with hanger rod touching the hanger box. This allows pipe vibration to bypass the spring and enter the building structure above.

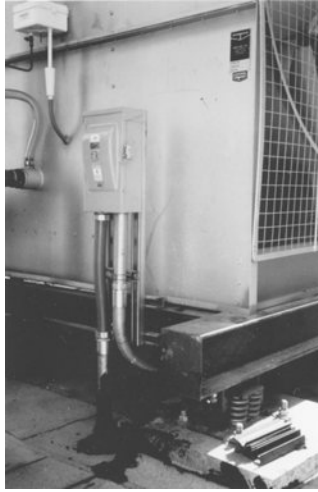
### **Construction Phase Tasks**

3. Is all suspended equipment and piping hung from the slab above with vibration isolation hangers that are attached directly to stiff portions of the structure above?
4. Is there any debris lodged beneath vibration isolation frames or concrete inertia bases that might short-circuit the isolators? Check this by visual inspection and by rocking or jumping on the equipment. Figure 7-4 shows a small piece of conduit debris that is “short-circuiting” a floor-mounted spring isolator.
5. Does the electrical conduit serving the equipment have a flexible loop to prevent vibration transmission via the conduit?
6. Are all pipe penetrations sleeved through walls and slabs to avoid contact with the wall or slab?
7. Are the walls constructed according to the specifications?

### ***Site Inspection Checklist for Cooling Towers, Air-Cooled Chillers, and Air-Cooled Condensers***

1. Is all of the equipment installed exactly as submitted and approved?
2. Is the “noisy” side of the equipment aimed away from the most noise-sensitive area?
3. For rooftop installations, is the unit mounted on high-deflection spring isolators mounted on piers or grillage beams that are directly supported by column extensions or major roof beams? Mounting arrangements that transfer the equipment load to the roof might encounter problems due to slab flexibility.
4. Does the equipment float freely on its isolators? Figure 7-9 shows an isolated cooling tower whose taut electrical conduit forms a vibration transmission path between the tower and the roof structure.
5. Is the equipment free from visible vibration?
6. Is all attached piping isolated from the building? Rigidly attached piping or riser clamps resting directly on a slab can carry vibration from the equipment into the building structure. Figure 7-10 shows three pipe risers whose clamp ears are resting directly on the floor slab. The noise and vibration sensitivity of the nearby occupancies will determine whether the clamps should rest on neoprene pads or spring floor mounts.

**A Practical Guide to Noise and Vibration Control for HVAC Systems**



**Figure 7-9** Taut outdoor “flexible” conduit forms a vibration “short-circuit” at cooling tower. The grillage under the cooling tower is resting on spring isolators, but the short conduit between the disconnect and the roof penetration transmits tower vibration into the roof.



**Figure 7-10** Pipe risers without vibration isolation. The pipe clamps transmit pipe vibration to the slab.



## 8

# Troubleshooting Noise and Vibration Complaints

---

It has been the author's experience that the airside noise and vibration complaints that are the most difficult to mitigate are those associated with excessive duct system static pressure drops and airflow turbulence that cause the fan to operate in either stall or surge. The large majority of these problems can be avoided by following the various guidelines given in this book, the chapter titled "Sound and Vibration Control" in the most recent *ASHRAE Handbook—Applications*, and in the most recent editions of the SMACNA publications titled *HVAC Systems—Duct Design* and *HVAC Duct Construction Standards—Metal and Flexible*.

The most troublesome waterside noise and vibration problems are usually associated with inadequate vibration isolation at equipment and piping and untreated equipment room openings, e.g., either ventilation openings or pipe penetrations. Keep these potential problems in mind when investigating a noise or vibration complaint.

### GENERAL APPROACH

#### A. Describe the complaint as completely as possible.

1. Is the complaint one of noise, vibration, or both?
2. Is the problem heard, felt, or seen?
3. What word(s) best describes the complaint—rumble, roar, hiss, ripples in a cup of coffee, etc.?
4. Is the problem continuous or repetitive on a certain schedule?
5. Is the problem at its worst at any particular time of day or time of year?
6. Can the problem be associated with the operation of a specific piece of equipment?

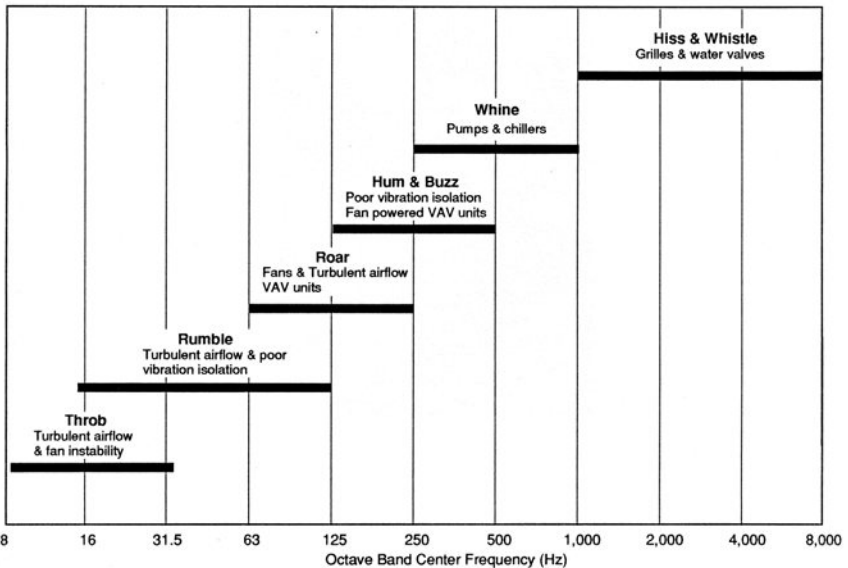
## Troubleshooting Noise and Vibration Complaints

The search for the answers to the above questions may lead not only to the specific source of the problem but also to its solution without the assistance of an acoustical professional. Whether or not an acoustical professional is retained, all of the questions should be answered before beginning an investigation. Some of the most frequent noise complaints are noted later in this chapter. Figure 8-1 gives some of the complaint names and the frequency ranges usually associated with the complaint.

### B. Determine the source of the complaint.

This is usually the most difficult step because there are often many possible sources, including some that are not even part of the HVAC system. An example is rumble at the top floor of a building that could be caused by the HVAC system but could also be due to ineffective vibration isolation at the elevators' motor-generator sets or at least a half-dozen other reasons.

Determining the source is often done by turning off individual pieces of equipment and asking the complainant if the problem has gone away. This procedure works well as long as each piece of equipment can be turned off individually.



**Figure 8-1** Frequency ranges of the most likely sources of common acoustical complaints.

## **A Practical Guide to Noise and Vibration Control for HVAC Systems**

Unfortunately, this procedure sometimes cannot be used to find a problem associated with a chilled water pump, for example, because its associated chiller, which could be source of the complaint, should also be turned off to prevent chiller damage. If the noise/vibration problem disappears when both machines are turned off, then a more detailed analysis by an acoustical professional may be required to isolate the exact cause(s) and transmission path(s).

### **C. Investigate the source and the transmission path.**

Find out what it is about the source, its appurtenances, its operation, or any attached system components that might be responsible for the complaints. First, look at as much of the system as possible. For an airside system, are the fans and ductwork all installed according to the contract documents, the guidelines given in this book, and the SMACNA publication titled “HVAC Systems—Duct Design”? For a waterside system, are the required vibration isolators installed on all equipment and piping? If the source can operate at variable capacities, operate it at various setpoints to determine if the problem occurs in a particular operating range. An example of this is where the part-load rotation rate of a variable-speed fan resonates with one of a building's structural resonances. The solution depends on the frequency and strength of the resonance.

If there are no obvious visible causes for the complaint, a test and balance technician should be called in to verify that the equipment is operating properly. Field investigations of airside noise complaints often find that the fan is operating in a stall condition (i.e., toward the left side of the fan curve), which can cause very high levels of low-frequency rumble. The problem is often caused by excessive static pressure in the fan's associated ductwork due to an installation that does not comply with the ASHRAE and SMACNA guidelines.

Remember that a single source may be causing more than one problem; that is, excessive noise or vibration may be transmitted from a source to a complaint area by more than one path. The air-handling unit room described in the introduction of this guide is a good example. Turbulent discharge airflow conditions, a noisy fan, an undersized mechanical room, and ineffective vibration isolation could all be causes of complaints. Solving only one of the problems may not be satisfactory.

Conversely, a problem may only occur when two different system components are operating a particular way. For example, a built-up system using parallel supply fans with slightly different rpm rates will often exhibit a surge or throb. The surge/throb is caused by either turbulent airflow conditions through the fan system or the unequal operation of the fans themselves. The throb/surge rate is proportional to the rpm difference between the two fans.

### **D. Select the best retrofit.**

After analyzing the problem, review the possible solutions for their probable acoustical effectiveness and their impact on system operation. The effectiveness of

## Troubleshooting Noise and Vibration Complaints

a retrofit depends on many factors and is frequently limited by the space available and the system's flexibility to accept a change. For example, adding a duct silencer to solve a fan noise problem could worsen the problem if space constraints require locating the silencer too close to the fan discharge. The turbulence caused by this close placement could result in excessive silencer self-noise and excessive pressure drop that could put the fan into a stall condition, causing an increase in the noise level.

## SPECIFIC COMPLAINTS

Characterizations of noise complaints are listed in **bold**; possible causes are then listed with mitigation strategies noted below it in *italics*.

### **Buzz**

Misaligned fan—rotating wheel hitting against its housing.

—*Check bearings, realign and balance fan.*

Ineffective or missing vibration isolation at a high-speed machine, e.g., a chiller.

—*Make sure the equipment floats freely on its isolators.*

—*Install isolation where necessary to permit equipment to float freely without contacting the building or other building services.*

Ineffective or missing vibration isolation at a variable-frequency motor speed controller.

—*Make sure that the controller and all attached conduits are isolated from the building using neoprene or spring isolators and flexible conduits.*

### **Click—Intermittent**

Loose accessory or debris in ductwork.

—*Visually inspect ductwork. Tighten loose connections or remove debris.*

Ceiling wires vibrating against ductwork, metal grid, or light fixtures.

—*Inspect ceiling hanger wires in the vicinity of the complaint and move them as necessary to avoid contact with other metal objects.*

### **Drumming: “It sounds like a drum roll or a machine gun”**

Airborne reciprocating compressor noise transmitting through a lightweight wall.

—*Make an airtight seal at all wall penetrations into the equipment room, and*

—*Build an airtight noise enclosure around the equipment, or*

—*Furr out an additional gypsum board assembly to “double-up” the existing wall, or*

## **A Practical Guide to Noise and Vibration Control for HVAC Systems**

—*Replace the existing gypsum board assembly with masonry.*  
(*The acoustical performance of the floor slab and the effectiveness of the vibration isolators sometimes limit the improvements.*)

Airborne reciprocating compressor noise transmitting through a lightweight slab.

- Make an airtight seal at all slab penetrations into the equipment room, and*
- Build an airtight enclosure around the equipment if the complaint is from the floor above, or*
- Install a vibration-isolated gypsum board ceiling assembly between the equipment and the complaint area to create a “double-barrier” assembly.*

Structure-borne vibration from a reciprocating compressor transmitted via ineffective or short-circuited isolators or via contact between piping/conduit and a mechanical room wall/slab.

- Verify that the equipment floats freely on its vibration isolators, and*
- Verify that all attached piping is isolated from the building via spring hangers, floor mounts, and sealed penetrations, and*
- Verify that all attached electrical conduits are slack and flexible.*

### **Hiss**

Air leak in duct or AHU cabinet.

- Visually inspect duct and seal all leaks. If done safely, a lit candle can be used to find an air leak.*

Excessive airflow in VAV box or grille.

- Reduce airflow through the air distribution device, or*
- Move grille damper upstream of flexible duct, or*
- Replace with quieter equipment selection (e.g., usually a larger size to reduce air velocity).*

Sound leak through door undercut or return air grille.

- Verify proper door alignment in its frame, and*
- Install frame-mounted door seals and automatic door bottom to ensure airtight door closure.*
- Attach lined boot over return air grille.*

Air leak in pneumatic control system.

- Trace piping to leak and repair or replace faulty component.*

## **Troubleshooting Noise and Vibration Complaints**

Airflow turbulence noise transmitted through thin, circular ductwork or pipe.

- Rarely a problem; an airtight enclosure or lagging spaced from 50 to 100 mm away from the pipe or duct usually helps. Install fiberglass batting in the gap between the enclosure and the pipe/duct.*
- Leak in steam piping system.*

### **Hum**

Structure-borne vibration due to ineffective or missing vibration isolation at equipment or piping.

- Verify that the equipment floats freely on isolators during operation.*
- Verify that isolators are sufficiently deflected when loaded.*

Structure-borne vibration due to rigid contact between pipe or conduit and the building.

- Detach pipe or conduit from building and reattach with isolator or resilient clamp.*

Common non-HVAC source; structure-borne vibration due to ineffective or missing transformer vibration isolation.

- Insert neoprene or spring/neoprene isolators under transformer.*
- Make all conduit connections with flexible conduits.*

Structure-borne vibration from internally isolated equipment whose shipping bolts, blocks, or shims have not yet been released.

- Release shipping bolts, blocks, or shims to allow the equipment to float freely on its internal isolators.*

### **Roar: “It's as noisy as when I'm driving on the freeway”**

Excessive duct velocity and airflow turbulence.

- Reduce airflow velocity by increasing duct size or adding another duct to share the airflow.*
- Replace high-pressure-drop fitting with one having better aerodynamic performance and lower pressure drop.*

Excessive fan noise due to poor fan selection.

- Replace fan with a more efficient selection.*

Excessive fan roar due to lack of duct silencer or duct liner.

- Replace a duct section with a duct silencer, or*
- Replace an unlined duct section with lined ductwork.*

## **A Practical Guide to Noise and Vibration Control for HVAC Systems**

Lightweight ceiling near a mechanical room with a plenum return air opening.

- *Install a duct silencer or thickly lined duct elbow (a lined boot) at the equipment room return air opening.*

Lightweight ceiling under a high velocity duct.

- *Replace duct with one of thicker duct gauge, or*
- *Laminate and strap gypsum board directly to duct walls, or*
- *Enclose duct in a gypsum board enclosure, or*
- *Replace ceiling with solid gypsum board, or*
- *Lay gypsum board panels on top of ceiling.*

Medium- or high-velocity duct with closely spaced fittings.

- *Reconfigure ductwork to allow 3 equivalent duct diameters between adjacent fittings.*

### **Rumble: “I can see the walls shaking and can almost hear/feel the air vibrating around me”**

Fan operating in rotating stall because of excessive duct system static pressure.

- *This usually happens when a duct system presents an unexpectedly high pressure drop and the fan rpm rate is increased to deliver the necessary airflow without regard to fan pressure. The first step is to inspect **all** control system components to be sure that no damper is improperly restricting airflow. Then check to be sure that there is no debris in the ductwork that seriously obstructs airflow. Then check to be sure that no system component was field-modified in a manner that would increase its pressure drop. The solution for any of these problems is to reconfigure the duct and control systems for the lowest possible pressure drop. A variable volume fan will then automatically reduce its speed for the lower pressure drop. A constant volume fan will need to be manually adjusted for the lower system static pressure.*

Excessively turbulent inlet airflow conditions at fan.

- *Move fan or obstruction to provide adequate inlet clearance.*

Excessively turbulent discharge airflow condition at fan.

- *Reconfigure discharge duct according to SMACNA recommendations. Figures 8-2 and 8-3 show examples of extremely turbulent fan/duct discharge airflow conditions that caused noise complaints.*

## Troubleshooting Noise and Vibration Complaints



**Figure 8-2** Example of poor fan discharge duct design. The mitered elbow with turning vanes and steep transition downstream of the fan outlet cause fan instability and accompanying noise and rumble. A better installation would have used a horizontal discharge fan with fewer downstream fittings.

Excessive static pressure in duct system due to an improper air balance.

- Rebalance system by opening dampers to reduce system pressure, and*
- Reduce fan rpm to match fan performance to the new system curve.*

Ceiling grid suspended from ductwork.

- Remove ceiling hangers from ductwork and reattach to building structure using a different suspension method that does not touch the ductwork.*

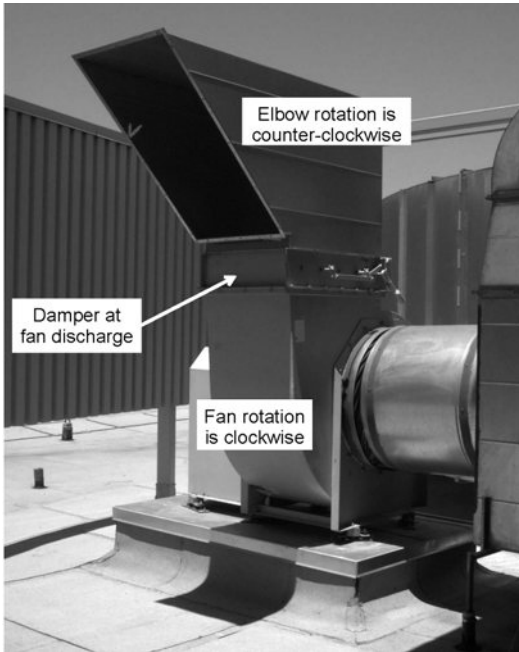
Oil-canning of fan housing.

- Check belt and sheave alignments,*
- Add reinforcing stiffeners to housing panels.*

Oil-canning ductwork caused by turbulent airflow.

- Reduce airflow velocity and/or reconfigure ductwork according to SMACNA requirements for smoother airflow and lower pressure drop.*

**A Practical Guide to Noise and Vibration Control for HVAC Systems**



**Figure 8-3** Fan installation with poor discharge duct system aerodynamics. The close-coupled discharge damper and reverse-direction elbow create extremely high turbulence that creates rotating fan stall, performance reduction, and rumble.

- Add duct reinforcing in accord with SMACNA guidelines—helps only if the original installation was not installed or reinforced according to SMACNA guidelines.*
- Replace ductwork with that of thicker duct gauge or with spiral-wound circular ductwork.*
- Lag ductwork with additional reinforcements and gypsum board between the reinforcements.*

Excessive fan vibration due to imbalance.

- Balance fan.*

Excessive fan vibration because of loose adjustable sheave.

- Replace the adjustable sheave with a fixed one of the proper pitch.*

## **Troubleshooting Noise and Vibration Complaints**

Excessive fan vibration because of worn shaft or bearings or misaligned shaft.

— *Realign or replace shaft and bearings as needed.*

Fan surging because of loose belts.

— *Tighten or replace belts.*

Duct or pipe touching wall or ceiling assembly.

— *Break contact between the pipe/duct and the wall/ceiling assembly.*

Fan, cooling tower, pump, or piping not properly vibration-isolated from the building.

— *Install vibration isolation mounts or hangers at all equipment attachments to the building. Install vibration isolators at all connected piping, electrical conduits.*

— *Verify that ducts are attached with flexible duct connectors.*

Common non-HVAC source, unisolated elevator motor-generator sets.

— *Install vibration isolation mounts under the motor-generator sets.*

— *Verify that the attached electrical conduit is flexible and not rigidly attached to the building.*

## **Squeal**

Belt slippage during fan start-up.

— *This is normal for high kW, constant-speed fans.*

— *Convert to a variable-speed drive or a “soft start” motor starter.*

Belt slippage during normal operation.

— *Tighten belts, check sheave alignment.*

## **Surge: “The roar or hum comes and goes about once every second or so”**

Fan drive instability due to fan belt mismatch.

— *Replace with a matched set of new belts and realign the sheaves.*

Fan instability due to poor airflow conditions at inlet

— *Improve airflow conditions by either increasing clearance to the fan inlet or by installing a velocity-smoothing grid at the fan inlet.*

Fan instability due to poor airflow conditions at discharge

— *Improve discharge airflow conditions by reconfiguring the discharge ductwork to move all duct fittings and appurtenances at least 3 equivalent duct diameters downstream of the fan discharge opening.*

## **A Practical Guide to Noise and Vibration Control for HVAC Systems**

Fan instability due to operation at the left side of the fan curve.

- *Reconfigure ductwork and/or dampers to reduce system static pressure drop, and*
- *Reduce fan rpm to move operation to the right side of the curve, or*
- *Replace fan with one that can accommodate the higher static pressure.*

Pump instability because of worn rotor bearings.

- *Replace rotor bearings.*

Parallel fans operating at slightly different rpm rates.

- *Usually occurs with paired belt-drive fans.*
- *Convert to direct-drive fans on a single or master-slave VFD arrangement.*

Chiller control system misadjusted.

- *Readjust control system to load the compressor properly.*

### **Tap**

See *Click*

### **Throb**

See *Surge* or *Rumble*.

### **Whine**

Blade passage tone of vane-axial fan, inadequate noise control at or near fan.

- *Verify proper fan selection for the operating setpoint.*
- *Verify smooth airflow conditions at fan inlet and outlet.*
- *Verify the presence of close-coupled duct silencers on one or both sides of the fan.*

Blade passage tone of vane-axial fan, inadequate vibration isolation at fan.

- *Verify that the fan floats freely on its vibration isolators.*
- *Verify the presence of neoprene pads at the base of the spring isolators.*
- *Verify that the duct(s) is (are) connected to the fan via flexible connectors.*
- *Verify the presence of flexible conduit connections to the motor.*

Pump impeller blade tone, inadequate vibration isolation at pump or piping.

- *Make sure the pump floats freely on its vibration isolators and the piping is not rigidly connected to any part of the building.*

## Troubleshooting Noise and Vibration Complaints

Airborne “pumping tone” from an indoor, water-cooled screw (rotary) chiller

- *Verify that the problem is not due to structure-borne vibration caused by rigid attachment of chiller, its piping, or its conduits to building.*
- *If the problem is verified as airborne, enclose the entire chiller in an airtight enclosure (enclosing only the compressor is usually ineffective because there is typically significant radiation from the oil separator and heat exchangers), or*
- *Install a vibration-isolated gypsum board ceiling assembly between the equipment and the complaint area to create a “double-barrier” assembly.*
- *Adding 50 mm thick sound-absorbing panels to the equipment room ceiling and walls will be effective if only a small amount of noise reduction (about 3 to 5 dBA) is needed.*

Structure-borne “pumping tone” from a water-cooled, indoor screw (rotary) chiller.

- *Verify that the chiller is mounted on high-deflection spring isolators that have neoprene inserts under the springs; in extreme cases, pneumatic isolators are needed.*
- *Verify that all piping and conduits are resiliently attached to the chiller.*
- *Verify that all piping is attached to the building using spring hangers that have neoprene inserts.*
- *Verify that all isolators are properly adjusted to preclude “short-circuiting.” Figure 8-4 shows a “short-circuited” restrained spring mount.*

Airborne “pumping tone” from an outdoor, air-cooled screw (rotary) chiller.

- *Install an airtight enclosure around the compressors and oil separator (and the heat exchangers, if feasible).*
- *Install a barrier to block the line-of-sight between the chiller and the complaint area (verify that the barrier does not restrict airflow to the chiller's condenser airflow).*

## Whistle

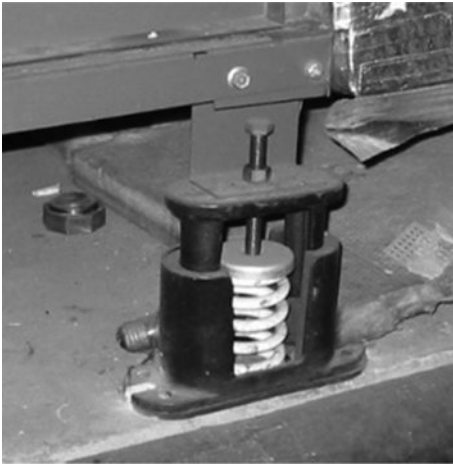
Water valve instability.

- *Inspect valve to be sure the control mechanism is functioning properly.*

Excessive airflow through an air outlet or inlet.

- *Reduce airflow through the device.*

## A Practical Guide to Noise and Vibration Control for HVAC Systems



**Figure 8-4** Restrained spring isolator with a “short circuit” between its baseplate and equipment mounting plate. This type of isolator has become obsolete and is not recommended for any type of HVAC equipment.

Uneven airflow through a grille or diffuser.

—*Adjust the upstream ductwork to straighten the airflow into the device’s inlet collar.*

Damper or extractor too close to grille or diffuser inlet.

—*Remove damper or extractor or move it upstream at least 3 duct widths from the device’s inlet collar.*

Raw sheet metal edge exposed to airflow.

—*Trim edge to be as short as possible or turn edge to be blunt.*

### SITE INSPECTION PHOTOGRAPHS

Figures 8-5 through 8-23 show proper and improper installations of various HVAC system components. In many cases, direct comparisons are made to highlight the most common problems in the areas of vibration isolation, ductwork, and equipment installation.

### Troubleshooting Noise and Vibration Complaints



**Figure 8-5** View into the fan section of a rooftop unit; the tight cabinet clearance and airflow obstructions at the fan inlet cause excessive turbulence, pressure drop, and noise.

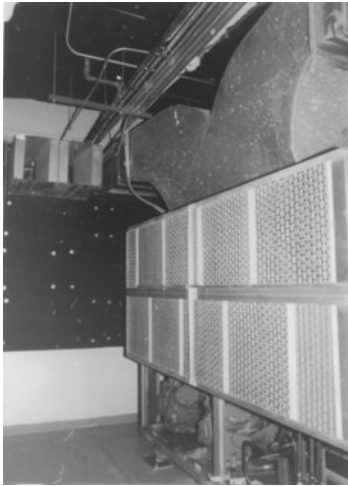


**Figure 8-6** Excellent rooftop package unit installation; the unit is resting on spring isolators and an elevated frame, thereby avoiding contact with the roof.

**A Practical Guide to Noise and Vibration Control for HVAC Systems**

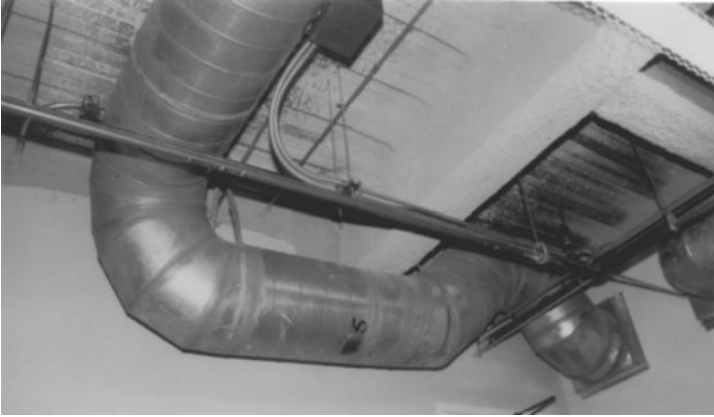


**Figure 8-7** Improperly installed fan-powered variable-air-volume unit. The unit is resting on the ceiling grid. This allows unit vibration to transmit directly into the partition below. The partition then acts as a sounding board, radiating noise into the occupied space.



**Figure 8-8** Proper installation of an indoor self-contained packaged HVAC unit. Note the dual radius supply duct split on top of the unit; the return air sound traps to the left of the supply duct, the black plenum liner on the mechanical room wall, and the spring isolator under the unit.

### Troubleshooting Noise and Vibration Complaints

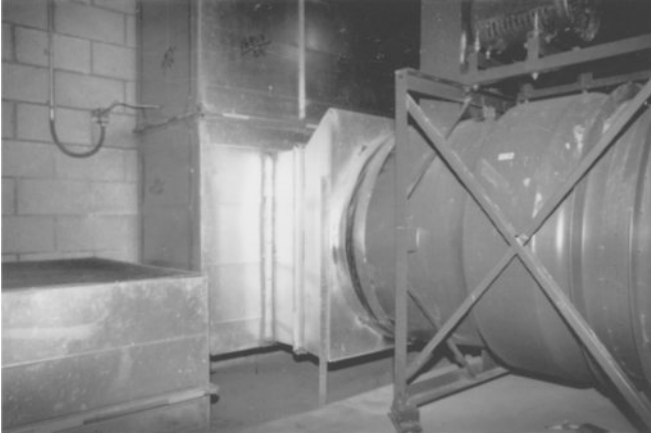


**Figure 8-9** Closely spaced circular duct fittings produce turbulence and noise. This duct run does not follow the guideline recommending 3 duct diameters between adjacent fittings. It has five fittings within 8 m.



**Figure 8-10** Closely spaced rectangular duct fittings produce turbulence and noise. A better offset around the pipes could have been made with a duct section on a 45° slope between the vertical and horizontal sections.

**A Practical Guide to Noise and Vibration Control for HVAC Systems**

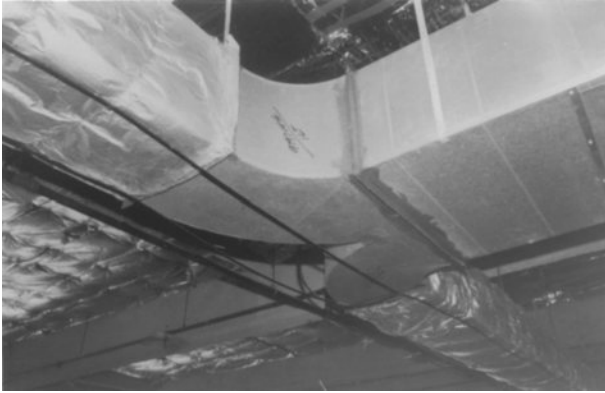


**Figure 8-11** Improper duct transition at fan inlet. The high-velocity airflow in the short, abrupt transition between the fan outlet and the vertical duct causes turbulence and rumble.

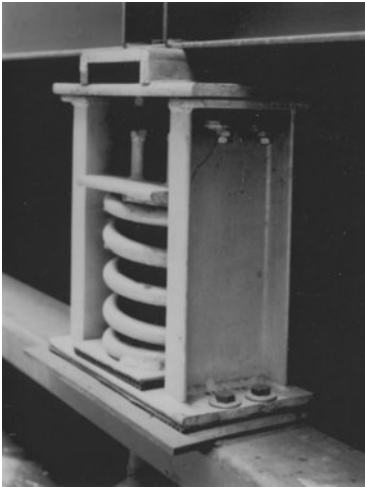


**Figure 8-12** Vane-axial fan intakes too close to wall. Airflow through the restricted area between the fans and the wall causes turbulence, surging, and rumble.

### Troubleshooting Noise and Vibration Complaints



**Figure 8-13** Duct split using radius elbows. This design is preferred because it produces less pressure drop and noise than a bullhead tee.

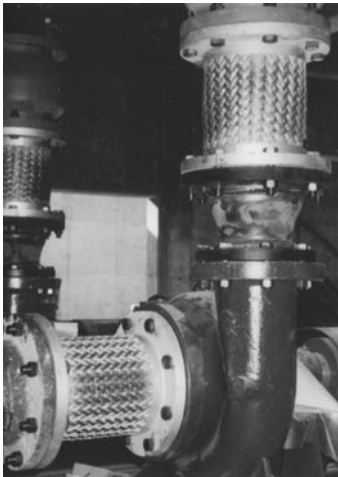


**Figure 8-14** Faulty installation of a large equipment isolator with stanchion restraints. The spring top plate is touching the near stanchion and the equipment mounting plate is resting on the stanchions. Both conditions allow equipment vibrations to bypass the spring and enter the building structure through the isolator baseplate.

**A Practical Guide to Noise and Vibration Control for HVAC Systems**

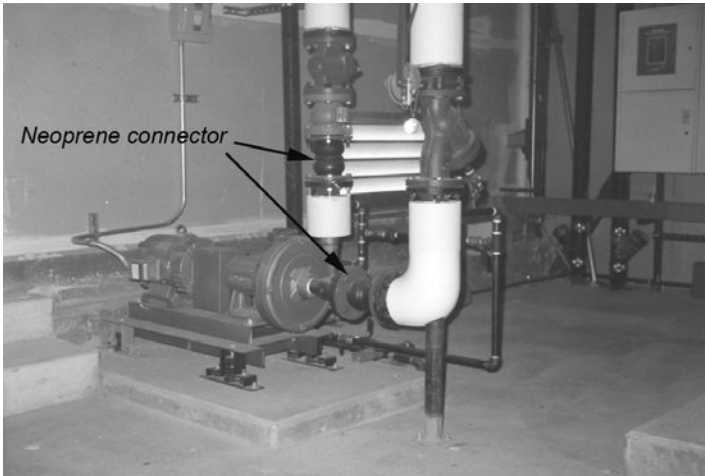


**Figure 8-15** Proper installation of a large equipment isolator with stanchion restraints. Note that the springs are centered between the stanchions and are properly compressed and that the equipment mounting plate is floating about 6 mm above the stanchion top plates.



**Figure 8-16** Braided metal pump connectors do not provide significant vibration isolation.

### Troubleshooting Noise and Vibration Complaints

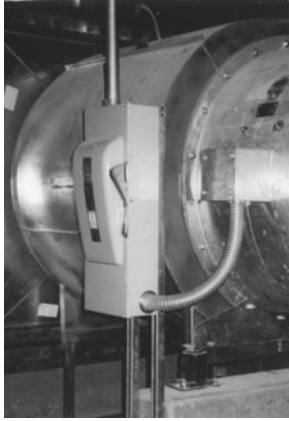


**Figure 8-17** Neoprene pump connectors provide better isolation of pump vibration from attached piping.



**Figure 8-18** Incomplete vibration isolation at cooling tower. Even though the tower is isolated, the condenser water pipe supports are mounted rigidly to the roof. This allows some tower vibration to enter the roof structure.

**A Practical Guide to Noise and Vibration Control for HVAC Systems**



**Figure 8-19** Taut “flexible” conduit forms a vibration short-circuit at vane-axial fan. Spring isolators under the vane-axial fan perform as expected, but the tight conduit arc transmits fan vibration into the disconnect, which is rigidly supported on the floor. A longer, more slack conduit would provide better isolation.



**Figure 8-20** Correctly installed flexible conduit between electrical disconnect and motor. The flexible installation reduces fan and motor vibration in the floor slab.

## Troubleshooting Noise and Vibration Complaints



**Figure 8-21** View of pipe penetration from below roof. The pipe on the right is contacting the left edge of its penetration. This installation allowed pipe vibration to excite the roof slab, which radiated the energy as noise.



**Figure 8-22** Non-isolated pipe penetration. Rigid contact allows pipe vibration to enter the wall, which radiates the energy as noise.

**A Practical Guide to Noise and Vibration Control for HVAC Systems**



**Figure 8-23** Improperly placed neoprene hanger. The drywall assembly forms a vibration transmission bridge across the isolator. This type of interference can be identified and corrected in pre-construction coordination meetings.



## Appendix A

# Some Basics of HVAC Acoustics

---

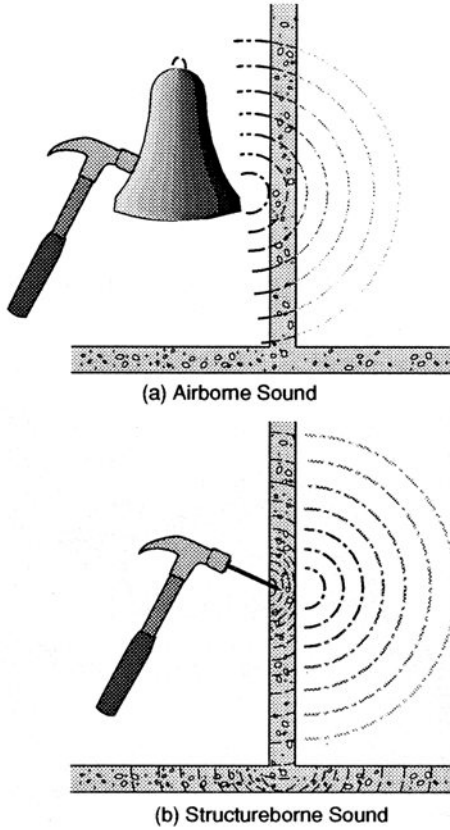
Sound and vibration are unavoidable features of all HVAC systems. Turbulent airflow in fans, ductwork, and plenums generates sound that can intrude into occupied spaces. Waterflow through pumps, central plant equipment, and piping systems also generate noise that may require control. Additionally, the operation of rotating and reciprocating equipment, such as fans, pumps, and chillers, creates noise and vibration that can be transmitted throughout building structures and annoy building occupants or be emitted into the environment and cause noise complaints at nearby properties.

### **AIRBORNE AND STRUCTUREBORNE SOUND**

HVAC system noise reaches building occupants by airborne and structureborne sound transmission paths. The principles of the two types of sound transmission are shown in Figure A-1. When the hammer in the figure hits the bell, *airborne* sound transmission carries the ringing sound throughout the room and through the walls to adjacent rooms. The transmission is considered to be *airborne* because the source does not touch the building. Conversely, the impact of the hammer on a nail that is embedded in a wall causes *structureborne* transmission that carries the impulse throughout the entire building structure, so that even occupants in rooms on other floors can hear it. The contact of the source to the building makes this a *structureborne* sound transmission path.

Figure A-2 shows how airborne and structureborne transmission carry sound and vibration from a piece of equipment throughout a building. Airborne transmission carries sound directly from the equipment to the surrounding rooms. Even though the equipment in the figure is shown to be on vibration isolators, it still transmits vibration energy to the building structure. The energy enters the walls

### Some Basics of HVAC Acoustics

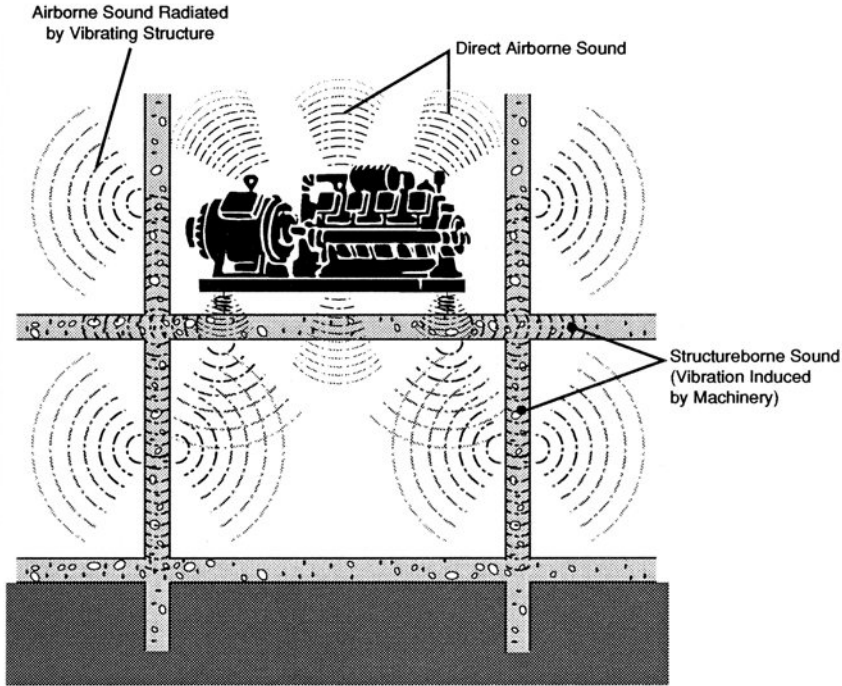


**Figure A-1** Airborne and structure-borne sound transmission.

and ceilings, which radiate it as sound throughout the building. The isolators reduce the structureborne energy to acceptable levels, but they do not eliminate it completely.

Good acoustical design addresses the potential for both airborne and structureborne transmission through the effective use of space planning, structural design, equipment selection, duct system design, and “add-on” noise and vibration control products and systems, where necessary.

## A Practical Guide to Noise and Vibration Control for HVAC Systems



**Figure A-2** Airborne and structure-borne sound transmission from equipment.

### BASIC TERMINOLOGY

The acoustical terms most frequently encountered in HVAC system design are *decibels*, *frequency*, *octave bands*, *sound pressure level*, and *sound power level*. These terms are explained below. Definitions of other acoustical terms are given in the glossary in Appendix E.

#### Decibel

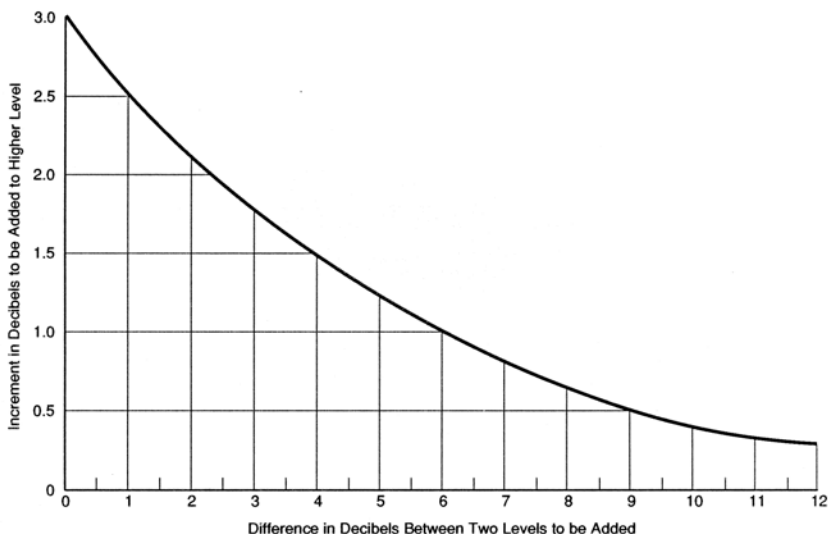
The decibel (dB) is the basic unit for acoustical calculations and measurements. It applies to sound pressure levels ( $L_p$ ), sound power levels ( $L_w$ ), insertion loss (IL), transmission loss (TL), and other acoustical properties of HVAC equipment and construction materials.

## Some Basics of HVAC Acoustics

Because the decibel scale is logarithmic, the combined sound level of two or more sound sources is not found by arithmetically adding their individual sound levels. For example, two identical sources producing 50 dB each generate a total of 53 dB, not 100 dB. Conversely, if two identical sources produce a combined sound level of 80 dB, shutting one off drops the level to 77 dB, not 40 dB. The chart in Figure A-3 can be used for adding decibels. For the addition of more than two noise sources, first perform the calculation for the two highest  $L_P$  values, then perform the calculation again using the previous sum plus the next highest  $L_P$  value, etc. This calculation procedure applies to either  $L_P$  values or  $L_W$  values.

## Frequency

What we hear as sound is the back-and-forth oscillatory motion of the air molecules next to our eardrums. This oscillatory disturbance of the air around us is caused by a corresponding oscillatory motion of the air molecules near one or more sound sources. Each back-and-forth motion is called a cycle. The frequency of the sound is the number of times the air molecules vibrate back and forth each second and is expressed in terms of cycles per second (cps) or hertz (Hz).



**Figure A-3** Chart for adding decibel values.

**A Practical Guide to Noise and Vibration Control for HVAC Systems**

Audible sound occurs in the frequency spectrum that spans from about 20 to 20,000 Hz. Figure A-4 shows the approximate frequency ranges of some everyday sounds.

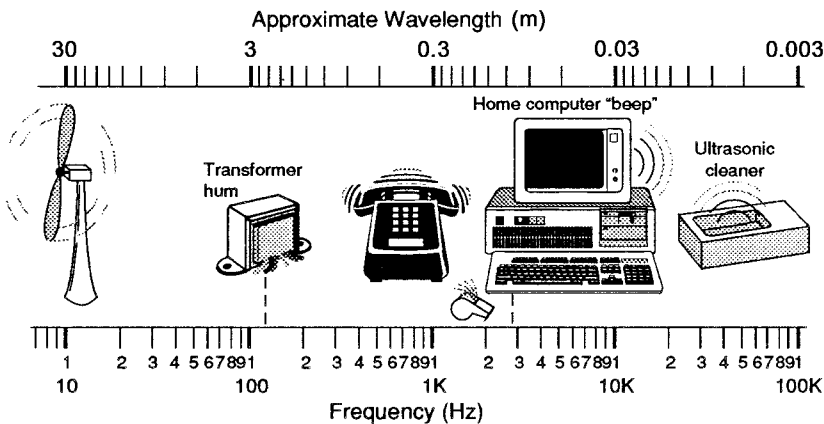
**Octave Bands**

For convenience, the frequency spectrum is divided into octave bands, each of which is a continuous range of frequencies identified by its logarithmic center frequency. The highest frequency of each octave band is twice its lowest frequency. Figure A-5 shows the center frequencies of the octave bands that are most important in HVAC acoustics, as well as the octave band distribution of noise from various kinds of HVAC equipment. Acoustical analyses at narrower frequency ranges (1/3 octave wide or even narrower) are frequently used for troubleshooting noise complaints and product development research.

Table A-1 shows the lower and upper frequency limits for each of the eight octave bands that are typically encountered in HVAC noise analyses.

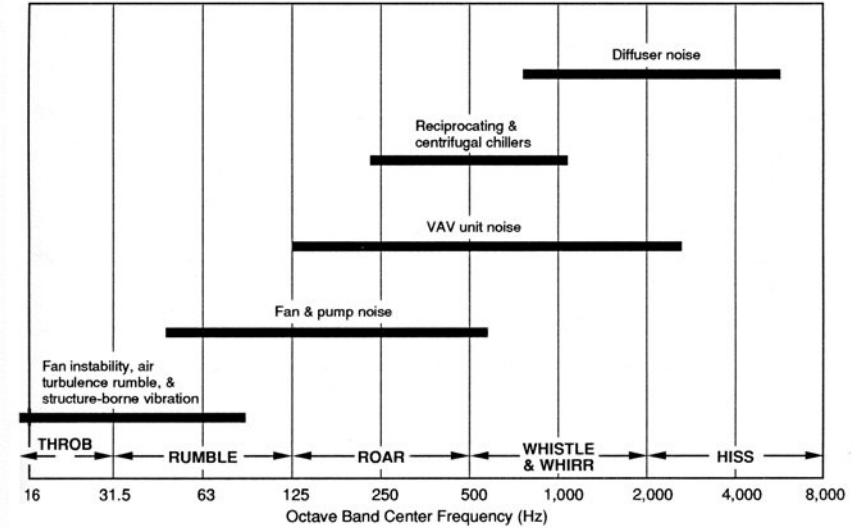
**Sound Pressure Level**

Sound pressure level, abbreviated  $L_p$  or SPL, is expressed in dB and is the most widely used acoustical descriptor. It indicates the level of sound at a specific location at a specific time for a specific set of conditions. Each octave band (or



**Figure A-4** Everyday sound sources—their frequencies and wavelengths.

**Some Basics of HVAC Acoustics**



**Figure A-5** Frequencies at which various types of HVAC equipment generally control their sound spectra.

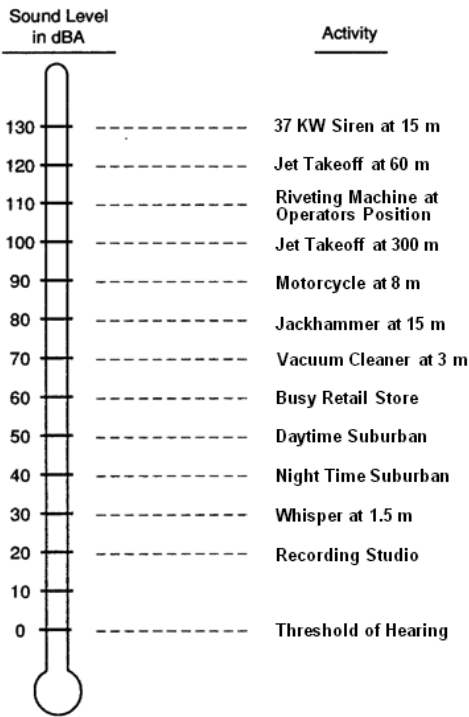
**Table A-1. Octave Band Center Frequencies and Their Frequency Ranges**

Octave Band Center Frequency In Hertz	Lower Frequency Limit in Hertz	Upper Frequency Limit in Hertz
63	44	88
125	88	177
250	177	354
500	354	707
1000	707	1414
2000	1414	2828
4000	2828	5656
8000	5656	11,312

**A Practical Guide to Noise and Vibration Control for HVAC Systems**

1/3-octave band) of a sound spectrum can have its own  $L_p$  value. For most HVAC installations, the  $L_p$  can range from less than 10 dB in a very quiet recording studio or concert hall to as much as 125 dB in a very noisy fan or chiller room. Figure A-6 shows the approximate sound pressure levels for common everyday activities.

Each person hears changes in sound level differently, but the average perceptions of sound level changes are fairly well understood and are summarized in Table A-2. Note that the 3 dB drop that results from shutting down one of two iden-



**Figure A-6** Sound pressure levels of some everyday activities.

**Some Basics of HVAC Acoustics**

**Table A-2. Subjective Impressions of Sound Level Differences**

<b>Subjective Impression</b>	<b>63 Hz Octave Band</b>	<b>125 Hz Octave Band</b>	<b>250+ Hz Octave Bands</b>
Half as Loud	-6 dB	-8 dB	-10 dB
Significantly Quieter	-3 dB	-4 dB	-5 dB
Just Barely Quieter	-1 dB	-1.5 dB	-2 dB
Just Barely Louder	+1 dB	+1.5 dB	+2 dB
Significantly Louder	+3 dB	+4 dB	+5 dB
Twice as Loud	+6 dB	+8 dB	+10 dB

tical sound sources yields a “just perceptible” reduction in loudness. Try this using two radios tuned to the same station at the same volume level. Notice that the loudness after turning off one of the radios is only a little quieter than before, not half as loud.

**Sound Power Level**

Sound power level, abbreviated  $L_W$ , PWL, or SWL, also expressed in dB, is used to indicate the amount of sound that a source produces. The sound power levels that are generated by an HVAC system component depend on its operating conditions; in general, operation at higher motor kW rating for a given piece of equipment will usually be louder than at a lower kW rating. Sound power levels are used as the starting points for most acoustical calculations. The effects of the equipment’s location and the attenuation due to any nearby architectural elements and HVAC system components are accounted for in the calculation process.

The  $L_W$  values for each type of HVAC component are determined in specially designed acoustical laboratories through the use of nationally recognized test standards.  $L_W$  values cannot be measured directly but are calculated from  $L_P$  or sound intensity measurements. Each octave band or 1/3-octave band of a sound spectrum can have its own  $L_W$  value.

Because  $L_P$  and  $L_W$  are both expressed in dB and describe levels of sound, they are often confused with each other. In fact,  $L_P$  and  $L_W$  are easy to understand when compared with joules (J) and the temperature in degrees. Just as the number of

## **A Practical Guide to Noise and Vibration Control for HVAC Systems**

joules can be used to indicate the amount of heat released by a piece of equipment, the  $L_W$  value indicates the amount of sound it radiates. The temperature in degrees at some location away from a heat source depends on the distance from the source and the environment's thermal characteristics. Similarly, the  $L_P$  value at a given listener's location away from a sound source depends on the distance from the source and the acoustical characteristics of the environment between the source and the listener.

Acoustical professionals and other trained engineers use equipment  $L_W$  values to calculate the expected  $L_P$  values in a finished installation. The calculations are typically done in octave bands, although A-weighted calculations (see Appendix B, "Acoustical Rating Systems and Criteria") are sufficient in some instances. The chapter titled "Sound and Vibration Control" in the quadrennial *ASHRAE Handbook—Applications* (2007, 2011, etc.) is one of many references that explain the calculation process.

### **CHARACTERISTICS OF HVAC NOISE**

The noise of HVAC system components can be characterized as either broadband or tonal. Broadband noise contains sound energy of similar strength over a wide range of contiguous frequencies. Rain and wind create broadband noise. HVAC system examples are airflow through ductwork and diffusers and waterflow through pipes.

Tonal noise contains sound energy at discrete frequencies and is usually more annoying than broadband noise of equal sound level.

Many kinds of HVAC equipment produce both broadband and tonal noise. For instance, fans with fewer than 20 blades typically generate strong tones at the blade passage frequency along with broadband noise caused by the turbulent airflow through the fan. Likewise, a screw chiller's compressor creates very strong "pumping tones" at frequencies that depend on the rotation rate of its screws, while the turbulent flow of water and refrigerant through the chiller package piping create broadband noise. In many cases, equipment that produces strong tones also produces significant vibration at the tonal frequencies, so careful attention to both noise and vibration control are needed.



## Appendix B

# Acoustical Rating Systems and Criteria

---

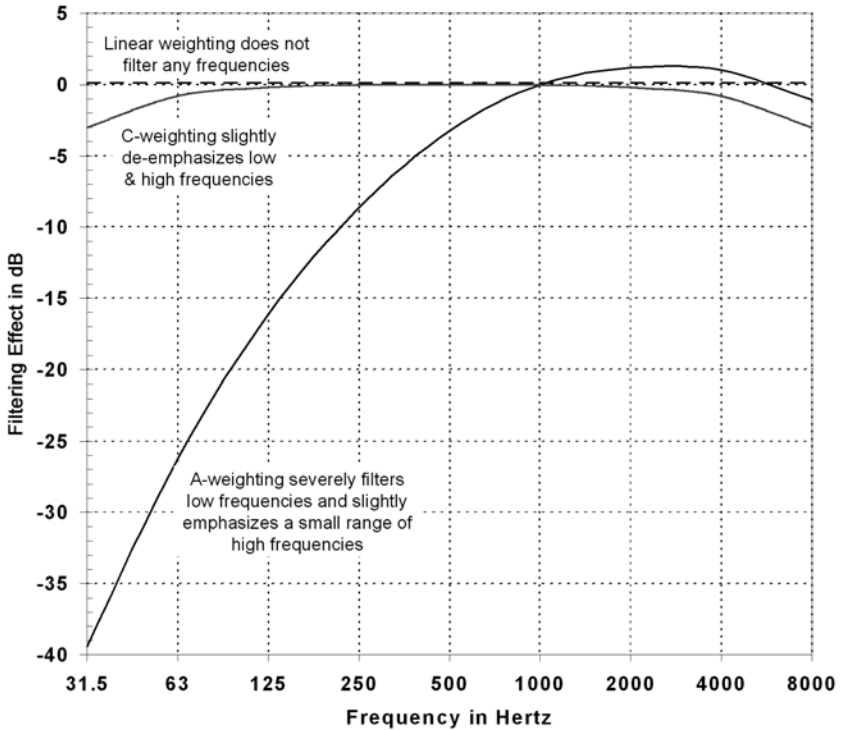
Because the human response to noise depends on so many factors (e.g., level, frequency content, modulation rates, etc.), it is difficult to describe an acceptable noise environment. Several single-number rating methods, each with its own set of assumptions and limiting conditions, have been developed to help establish acceptable sound exposure criteria in and around buildings, but no single method has been universally accepted. The methods that are most frequently used to rate HVAC system noise are the A-weighted sound level (dBA), C-weighted sound level (dBC), loudness level (sones), Room Criteria Mark II (RC Mk II), Noise Criteria (NC), and Balanced Noise Criteria (NCB) rating systems. A brief description of each rating system is given below.

### **A-WEIGHTED SOUND LEVEL (dBA)**

The A-weighted sound level ( $L_{pA}$ ), expressed in dBA, is often used to rate HVAC noise where either hearing conservation or outdoor noise exposure is of concern. The dBA method has gained popularity because an acoustical environment's A-weighted sound level can be used to roughly assess its subjective loudness and because it can be easily measured with an inexpensive, handheld sound level meter. (More information on sound level meters is given in Appendix C.) A sound level meter's A-weighting electrical circuit filters the measured noise in accordance with the lowest curve shown in Figure B-1. The effect of the curve is to filter out most of the sound's low-frequency content in a manner that is similar to the filtering that occurs in the human ear.

Measuring the A-weighted sound level is rarely valuable when investigating a noise complaint because it provides no information on the frequency content of the noise. The A-weighted sound level is most useful when comparing the relative loudness of one acoustical environment with another *similar* environment. For

### Acoustical Rating Systems and Criteria



**Figure B-1** Frequency weighting curves. Effects of linear, A-weighting, and C-weighting filters.

example, in the case of diffuser noise, measuring the A-weighted sound level at various airflow quantities could help determine if lowering the air quantity to the diffuser would be an effective noise reduction treatment.

### C-WEIGHTED SOUND LEVEL (dBC)

The turbulence caused by wind blowing over a sound level meter's microphone can create very high levels of self-generated noise at low frequencies. If the meter is set to its "linear" (unfiltered) mode, then the unfiltered sound energy at all frequencies, including the turbulence-generated self-noise, will be included in the  $L_p$  value that is displayed by the meter. The dashed line in Figure B-1 shows the

## A Practical Guide to Noise and Vibration Control for HVAC Systems

“linear” filter response. The C-weighting filter was designed to filter out most of the turbulence-generated self-noise with little or no filtering effect at the frequencies of sound that are typically produced by HVAC equipment.

The C-weighted sound level ( $L_{PC}$ ), expressed in dBC, is often used in conjunction with a microphone windscreen to measure unweighted sound levels outdoors in the presence of low-to-moderate winds. In the absence of octave band data, comparing an acoustical environment's  $L_{PA}$  and  $L_{PC}$  values can provide a rough estimate of frequency balance but usually will not provide enough information to develop noise reduction treatments when troubleshooting a noise complaint.

### LOUDNESS LEVEL (SONES)

The sone rating method was developed to give system designers a linear scale for rating the approximate loudness of non-ducted fans, such as the small cabinet fans used in residential bathrooms, kitchens, and utility rooms, and for propeller panel fans used in general ventilation applications. Unlike the various decibel-based ratings, for which a doubling of the loudness requires an approximate 10 dB increase in the sound level, the sone method is linear, such that a doubling of the sone rating is approximately a doubling of the loudness. For example, a rating of 1 sone is the approximate loudness of sound environment with an A-weighted sound level in the range of 35 to 40 dBA; a 2 sone rating would apply to an environment where the sound level is in the 45 to 50 dBA range, and a 4 sone rating would correlate with a sound level in the 55 to 60 dBA range.

Unfortunately, there are two different methods for calculating a sone rating, and they always result in different values. Therefore, since a sone rating is a single number that does not provide any information on the frequency content of the sound spectrum, and since there is no universally accepted method for calculating a sone rating, its usefulness should be limited to comparing the approximate loudness of fans of the same type from the same manufacturer.

### ROOM CRITERIA (RC) AND RC MARK II

The Room Criteria (RC) rating method and its successor method, RC Mark II, were intended to help rate the acoustical acceptability of *measured* octave band  $L_p$  spectra in finished buildings. They were never intended for rating *calculated*  $L_p$  values obtained during the system design phase; nonetheless, they are sometimes used erroneously for this purpose. Both of the RC methods compare a set of field-measured, octave band  $L_p$  values with a set of reference curves. Figure B-2 shows the original RC reference curves, and Figure B-3 shows the RC Mark II reference curves.

Both of the RC rating methods have two factors: (1) a numerical value that rates the ease of voice communication in the measured acoustical environment and

### Acoustical Rating Systems and Criteria

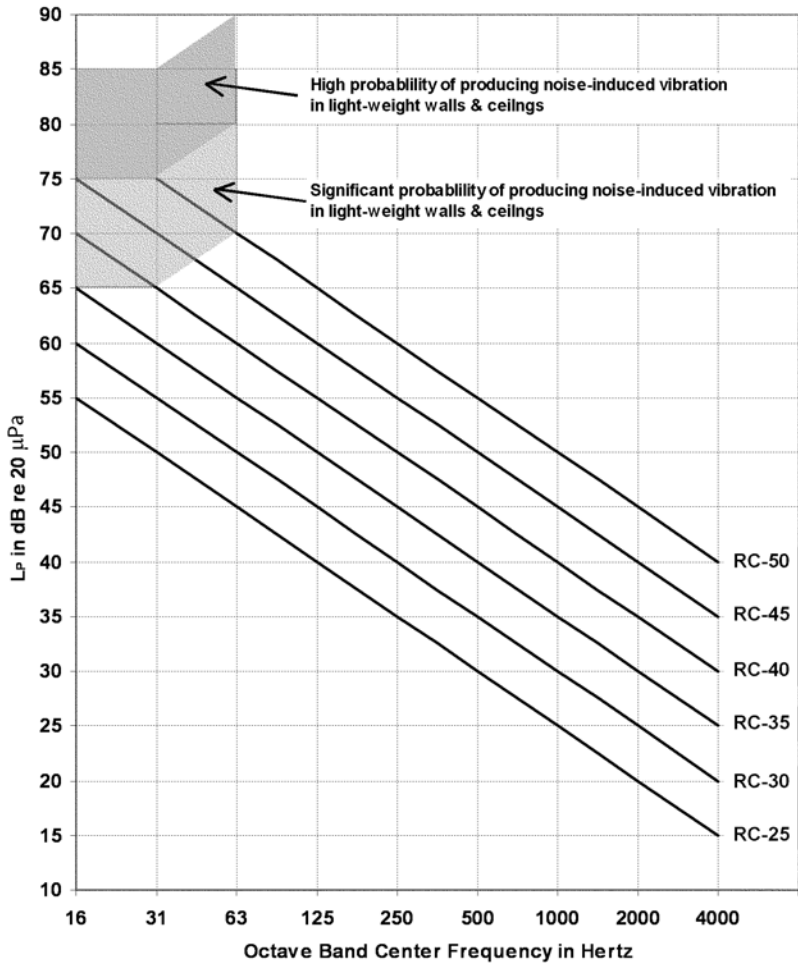
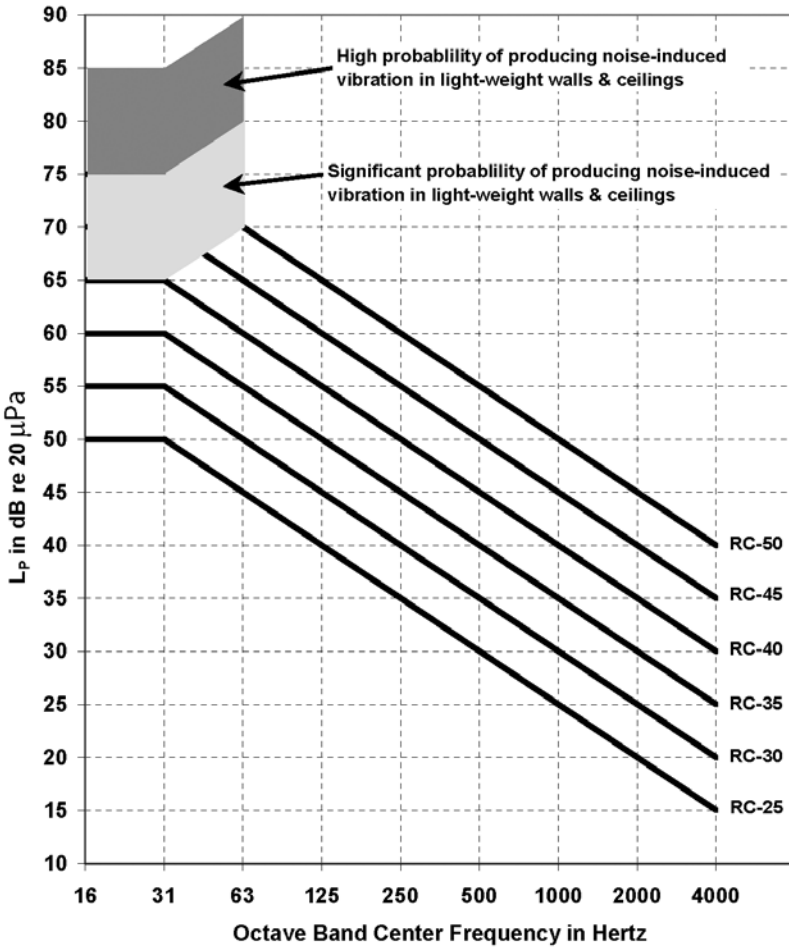


Figure B-2 Blank RC chart.

**A Practical Guide to Noise and Vibration Control for HVAC Systems**



**Figure B-3** Blank RC mark II chart.

## Acoustical Rating Systems and Criteria

(2) an alphabetical suffix that indicates the subjective quality of the noise. The RC Mark II method also includes a quality assessment index (QAI) value that indicates the relative balance between the measured spectrum's low, middle, and high frequency octave band sound levels. Details on the use of both methods are given in Chapter 47 of the *2003 ASHRAE Handbook—Applications*. Proponents of the RC-based methods recommended using only the RC Mark II method as a diagnostic tool when investigating noise complaints.

## NOISE CRITERIA (NC) AND BALANCED NOISE CRITERIA (NCB)

The NC rating method was the first widely used method for rating octave band  $L_p$  spectra. Like the RC method, it can be used to compare field-measured octave band  $L_p$  values with a set of reference curves (see Figure B-4). However, since it is also a design tool, the NC method can also be used to assess the results of design phase acoustical calculations, for example, to determine whether or not a system needs a quieter fan or an “add-on” noise reduction treatment, such as a duct silencer or acoustical louver.

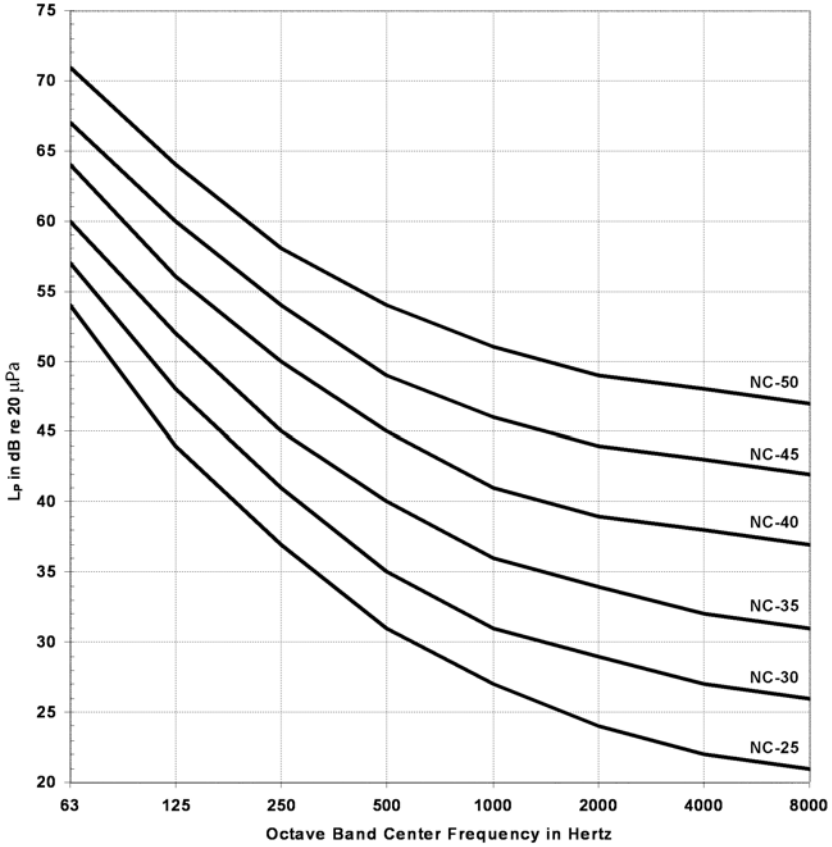
The NC rating of an octave band  $L_p$  spectrum is determined by finding the highest reference curve that is tangent to the octave band spectrum. Figure B-5 shows an example of a spectrum that is rated at NC-45 because its 125 Hz sound level is tangent to the NC-45 curve and no other octave band level is tangent to a higher NC reference curve. Because NC ratings are defined only on five-point increments, there is no precisely defined rating such as NC-42. Spectra that fall between NC reference curves are described by their proximity to the nearest curve.

The NC rating method is still the most popular rating method; however, it should be used with caution when rating field-measured  $L_p$  values because the NC reference curves do not extend to the 16 and 31 Hz octave bands, regions where some of the most troublesome HVAC noise and vibration control problems occur. The NCB method, a successor to the NC method, attempts to resolve this shortcoming by defining reference values in the 16 and 31 Hz octave bands while also adjusting the slopes of the reference curves at the higher frequency bands (see Figure B-6). Like RC Mark II, the complete NCB method rates spectral balance. A complete description of the use of both methods can be found in *ANSI Standard S12.2-1995, Standard Criteria for Evaluating Room Noise*.

## WHICH RATING METHOD IS BEST?

None of the octave band rating methods has received unequivocal acceptance by the entire acoustical consulting community because none of the methods has all of the attributes necessary for properly rating the wide range of HVAC noise environments; a very complicated method based on 1/3-octave  $L_p$  values would be

**A Practical Guide to Noise and Vibration Control for HVAC Systems**



**Figure B-4** Blank NC chart.

### Acoustical Rating Systems and Criteria

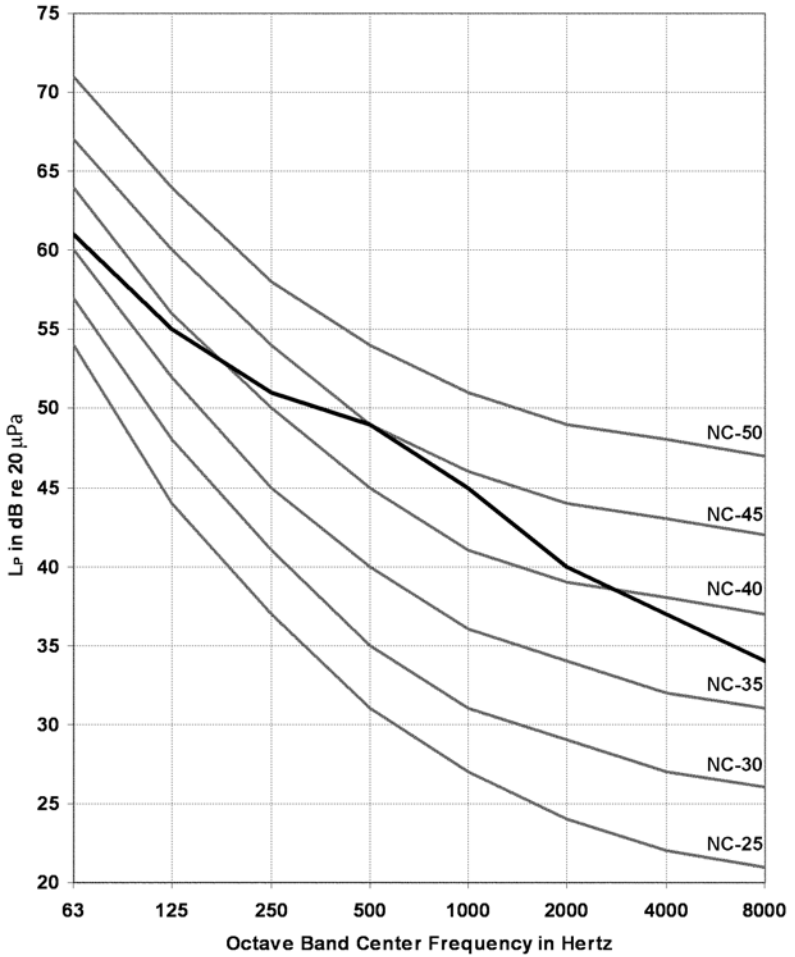
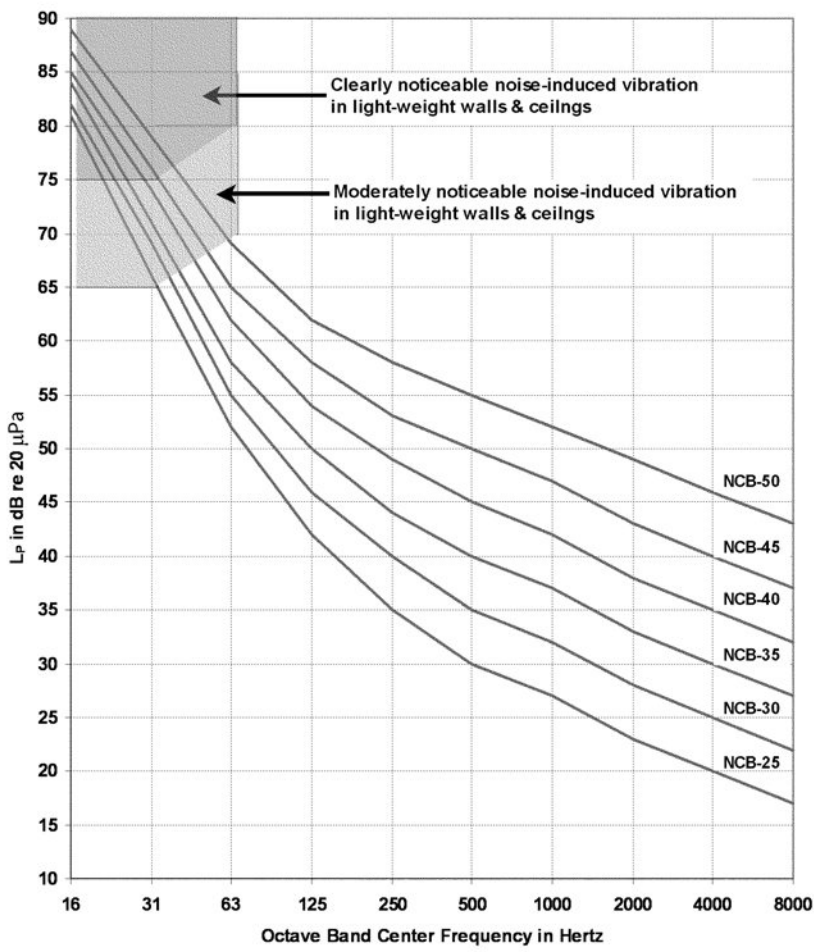


Figure B-5 Octave band spectrum rated at NC-45.

**A Practical Guide to Noise and Vibration Control for HVAC Systems**



**Figure B-6** Blank NCB chart.

## **Acoustical Rating Systems and Criteria**

required. Since virtually all HVAC equipment noise data are published in octave bands, ASHRAE Technical Committee TC 2.6 is currently attempting to combine the best attributes of all four octave band methods to develop a single rating method that is optimal for the majority of design and commissioning uses. Updated criteria recommendations will appear in either the “Sound and Vibration Fundamentals” chapter of the latest quadrennial ASHRAE Handbook—Fundamentals (2005, 2009, etc.) or the “Sound and Vibration Control” chapter of the latest quadrennial *ASHRAE Handbook—Applications* (2007, 2011, etc.).

Since the RC and RC Mark II methods were developed specifically for diagnosing noise complaints, they should not be used to establish design phase criteria or for commissioning purposes. The NC and NCB methods were intended to assess system designs, and it is the author's opinion that the NCB system is more relevant if the 16 and 31 hertz octave band levels are ignored; acoustical performance data for HVAC system components are not available in these two octave bands, so calculations in these bands are irrelevant. The author, therefore, recommends using the NCB reference curves in Figure B-6 (ignoring the 16 and 31 hertz octave bands) as maximum limit curves for assessing system designs. In other words, if NCB-35 is the chosen criterion for a given room, none of the octave band  $L_p$  values from 63 to 8000 hertz may exceed the NCB-35 curve.

## **ACCEPTABILITY CRITERIA**

### **Indoor Sound Criteria**

In general, acceptable HVAC system noise has the following five qualities:

- It is not too loud.
- Its level does not fluctuate significantly over short time periods.
- It does not have audible tones.
- It is spectrally balanced (i.e., not too much rumble, roar, or hiss).
- It is not too quiet.

The first three qualities apply to HVAC system noise in virtually all spaces. The last two qualities apply in rooms where sound quality is important and where the HVAC system noise provides masking to reduce the distracting effects of intruding sounds generated outside of the room.

Table B-1 gives ranges of recommended numerical design goals for various building occupancies. The design goals given in the table are the result of a consensus and, in some instances, may be considered conservative. Depending on economic considerations, they may be increased slightly (up to five points) where all five of the qualities listed above exist.

**A Practical Guide to Noise and Vibration Control for HVAC Systems**

**Table B-I. Recommended Indoor Sound Criteria**

Type of Area	Recommended Design Goal NC, RC or NCB (See Notes a & b below)
Single & multi-family residences	25 to 35
Hotels/Motels	
Guest rooms & suites	25 to 35
Meeting/banquet rooms	25 to 35
Hallways, corridors, lobbies, service & support areas	35 to 45
Offices	
Private offices & conference rooms	25 to 35
Rooms with frequent teleconferencing	20 to 25
Open-plan office areas	35 to 40
Corridors, hallways & other public areas	35 to 45
Hospitals & clinics	
Private rooms, Exam rooms	25 to 35
Semi-private rooms, wards & waiting rooms	35 to 40
Operating rooms	25 to 35
Corridors, hallways & waiting rooms	35 to 45
Performing Arts Spaces	
Recording studios & sound stages	(See Note c)
Concert & recital halls	(See Note c)
Drama theaters	20 to 25
Music teaching rooms	25 to 30
Solo & ensemble practice rooms	30 to 35
Sanctuaries, Temples & Mosques (See Note c)	25 to 35
Movie theaters	30 to 35
Schools	
Classrooms (See Note d)	25 to 30
Lecture halls with speech amplification	30 to 35
Lecture halls without speech amplification	25
Libraries	35 to 40
Courtrooms	
Unamplified speech	25 to 35
Amplified speech	30 to 35
Recording studios, sound stages and associated control rooms	(See Note c)
Arenas & Gymnasiums	
Gyms & natatoriums	40 to 50
Large arenas with amplified speech	45 to 55

<sup>a</sup>Values and ranges are based on judgment and experience, not on qualitative evaluation of human reactions. They represent general limits of acceptability for typical building occupancies. Higher or lower values may be appropriate and should be based on a careful analysis of economics, space usage and user needs.

<sup>b</sup>When spectral balance is important specify criteria in terms of RC-XX(N). If spectral balance is not as important as sound level specify criteria in terms of NC or NCB.

<sup>c</sup>Retain an experienced acoustical consultant for guidance with spaces that have critical acoustical needs.

<sup>d</sup>The recommended design goal conforms with the 35 dBA & 55 dBC limits specified in ANSI Standard S12.60-2002.

## Acoustical Rating Systems and Criteria

At industrial sites or buildings where hearing conservation is more important than acoustical quality, the A-weighted sound level rating is usually adequate. Table B-2 gives the Occupational Safety and Health Administration (OSHA) limits that require action by employers (such as periodic hearing tests and/or other hearing protection strategies) for a range of daily noise exposures.

## Outdoor Sound Criteria

Outdoor  $L_P$  limits are usually established by municipal codes in terms of maximum acceptable  $L_{PA}$  values, although several municipalities now also mandate octave band limits. Some municipal codes specify the limits in terms of “ambient plus 5 dBA,” whereas specific  $L_{PA}$  limits are specified in other codes. Table B-3 gives examples of municipal code  $L_{PA}$  limits for various land uses.

## Speech Communication in a Noisy Environment

In some situations the quality of speech communication in an indoor or outdoor environment may be critical, for example, where an emergency notification system must be audible or where reliable speech communication between two people is necessary. The audibility of such speech can be estimated using the chart in Figure B-7, where the distance between speakers, the voice level, and the background sound level in dBA are known.

**Table B-2. Industrial Noise Levels Requiring Employer Action**

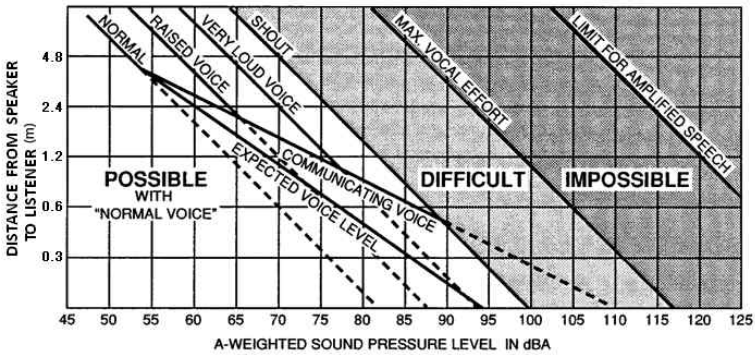
<b>Average Daily Exposure Time</b>	<b>Average Sound Level above Which Employer Action Is Required</b>
8 hours	85 dBA
4 hours	90 dBA
2 hours	95 dBA
1 hour	100 dBA
30 minutes	105 dBA
15 minutes	110 dBA

**A Practical Guide to Noise and Vibration Control for HVAC Systems**

**Table B-3. Sample Municipal Code Limits\***

Property Zoning	Maximum Sound Level in dBA	
	Day (7 a.m.-10 p.m.)	Night (10 p.m.-7 a.m.)
Single Family Residential	50	45
Multi-Family Residential	55	50
Commercial	60	55
Industrial	70	70

\* Note: Some municipal codes mandate the limits at property lines, while others place the limit at any habitable location on the property. Some municipalities use different time periods for day and night.



**Figure B-7** Quality of speech communication in background noise.



## Appendix C

# Measuring HVAC System Noise

---

Interested readers with access to sound-measuring equipment may want to make their own sound level measurements to either rate an HVAC noise environment using one of the rating systems described in Appendix B or to investigate an HVAC system noise complaint. In either case, meaningful results require selecting the proper instrumentation and following the proper measurement procedure.

### **INSTRUMENTATION**

The great majority of HVAC sound level measurements are made in the field using a battery-operated, handheld sound level meter such as that shown in Figure C-1. The meter uses a microphone, preamplifier, internal weighting filters, and a visual readout to measure and display the  $L_p$  values. The black ball on top of the meter is a low-density foam windscreen that is specifically designed for use with the meter. Sound level meters with octave band or 1/3-octave band filters are called spectrum analyzers, and those that are able to measure all of the frequency bands simultaneously are called realtime spectrum analyzers. The meter in Figure C-1 is a real-time spectrum analyzer; the vertical bars in the display window represent the  $L_p$  values for the various octave bands.

The most useful spectrum analyzers have high (Type 1) or moderate (Type 2) precision microphone; linear, A-weighting, and C-weighting filter networks; octave band filters with center frequencies from 31 to 8000 Hz; and an LCD display. Sound level meters without octave band filters are much less useful because they cannot be used to determine the NC, NCB, or RC rating in a room, and, in a troubleshooting situation, they provide very little information on the frequency content of the offending noise; knowing the frequency of an offending noise is required to determine the most cost-effective noise mitigation.

## Measuring HVAC System Noise



**Figure C-1** Sound level meter with a foam windscreen protecting its microphone.

## MEASUREMENT PLAN

Meaningful sound level measurements require a comprehensive measurement plan, such as the one shown in Figure C-2. Troubleshooting a noise complaint almost always requires measuring the  $L_P$  values in the octave bands from 31 to 4000 Hz. Frequently, the  $L_P$  values for the 1/3-octave bands from 16 to 4000 Hz are needed when the complaint is related to a strong tone.

A spectrum analyzer's readout will often show a fluctuating value, especially in the lower octave bands. This is normal because low-frequency sound levels are rarely constant. If the displayed value fluctuates over a range of less than 4 dB, record its "eyeball" average. If the fluctuation is 5 dB or more, record the highest and lowest displayed values. Modern spectrum analyzers are able to store the maximum, minimum, and average  $L_P$  values in each frequency band over a selected measurement period.

Figure C-3 shows a sound measurement data sheet that can be used to record the results of an octave band sound measurement. An example of a completed sheet is shown in Figure C-4.

## A Practical Guide to Noise and Vibration Control for HVAC Systems

1. Before arriving at the measurement site, verify the battery life and calibration of the sound level meter.
2. Before making any measurements at the site, walk slowly through the measurement area and listen for sound level or sound quality variations. This will help to choose the best measurement location(s). Fill out a Sound Measurement Data Sheet (Figure C-4) with the details of the measurement.
3. If the measurement is made in a windy area or in a room with airflow, a specially-designed open-cell foam windscreen should be fitted over the microphone. Even with a windscreen,  $L_p$  measurements in the presence of a 9+ m/s breeze may be disrupted by excessive airflow. The windscreen should be supplied by the sound level meter manufacturer specifically for use with the meter. Even in areas with low wind it's a good idea to always use a windscreen to protect the delicate microphone from possible damage; the small amount of high frequency attenuation inherent in the windscreen is usually insignificant for HVAC noise measurements.
4. Check the meter's instruction manual to determine which way to point the microphone. If the manual is not available orient the microphone at a  $45^\circ$  angle from the predominant sound source.
5. In almost all cases the sound level meter's "Fast/Slow" or "Fast/Slow/Impulse" switch should be set to the "Slow" position. This makes it easier to determine the readout value.
6. Hold the sound level meter at arm's length or attach it to a tripod.
7. If possible, make all measurements with the microphone at least 1 m from any surface. This applies to sound sources, room boundaries, people and room furnishings.
8. When measuring sound in a specific area - for example, to troubleshoot a noise complaint - move the sound level meter very slowly so the microphone scans throughout a 600 to 900 mm region near the complaint area.
9. For outdoor measurements at a property line, for instance, move the meter slowly so that the microphone samples sound over that part of the property line that has the greatest exposure from the noise source(s) being tested.
10. Record the measurement results on the Sound Measurement Data Sheet (Figure C-4) and the blank worksheet for the desired rating method (See Figures B-2, B-3, B-4, or B-6).
11. If measuring the sound levels of a specific source, make a separate "ambient" measurement with the source turned off and adjust the "source-on" results per the procedure shown in Figure C-5 per the procedure described in Table C-1.
12. Compare the measured results with the selected criteria determined using Table B-4.

**Figure C-2** Sound measurement plan.

**Measuring HVAC System Noise**

**Sound Measurement Data Sheet**

Project: \_\_\_\_\_ Address: \_\_\_\_\_

Measured by: \_\_\_\_\_

Date & Time: \_\_\_\_\_ Location in Bldg/Onsite: \_\_\_\_\_

Equipment                      Mfr. & Model No.                      Serial No.                      Operating Condition

\_\_\_\_\_  
 \_\_\_\_\_  
 \_\_\_\_\_

				Octave Band Center Frequency in Hertz								
#	Measurement Condition	dBA	Lin	31	63	125	250	500	1000	2000	4000	8000
1												
2												
3												
4												

Sketch or Comments

**Figure C-3** Blank sound measurement data sheet.

**A Practical Guide to Noise and Vibration Control for HVAC Systems**

**Sound Measurement Data Sheet**

Project: Hillside Estates Address: 12345 Canyon Drive

Measured by: MES Slidevale, UT

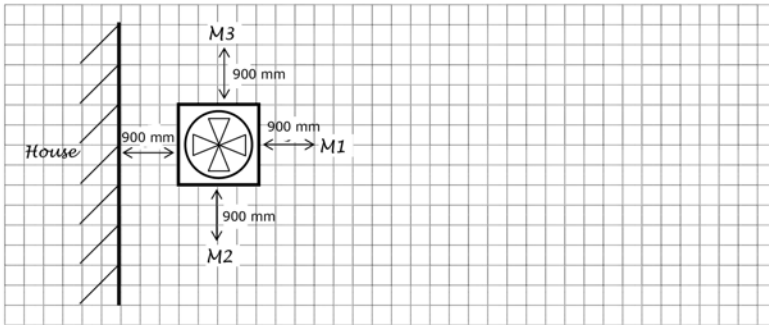
Date & Time: 5-2-05, 11:12 AM Location in Bldg/Onsite: Backyard

Equipment Mfr. & Model No. Serial No. Operating Condition

Heat Pump Unit CoolDude 3.5 HP123489 Cooling Mode

#	Measurement Condition	dBA	Lin	Octave Band Center Frequency in Hertz								
				31	63	125	250	500	1000	2000	4000	8000
1	<i>Ambient</i>	54	72	70	64	62	58	52	45	45	33	24
2	<i>M1</i>	69	78	70	66	73	73	69	62	55	45	35
3	<i>M2</i>	71	79	70	66	74	73	70	65	57	45	33
4	<i>M3</i>	72	79	71	67	73	74	71	66	57	46	32

Sketch or Comments



**Figure C-4** Completed sound measurement data sheet.

## Measuring HVAC System Noise

It may sometimes be necessary to measure the noise due to a particular piece of HVAC equipment in the presence of background noise from other sources that cannot be turned off, such as automobile traffic or certain types of office machines. Determining the  $L_P$  value due to the selected equipment alone requires making two measurements, one with the equipment operating with the background noise and another with only the background noise (with the equipment turned off). This situation might occur, for example, when determining if the property line noise exposure from a cooling tower meets a local noise ordinance. The adjustment values given in Table C-1 will help to determine the  $L_P$  value of a particular machine in a sound field with background noise.

When reporting an HVAC system  $L_P$  measurement, always also report the microphone location, the time, equipment operating conditions, and ambient noise conditions.

## VIBRATION MEASUREMENTS

While the control of HVAC system noise and vibration are of equal importance, measuring vibration is not usually necessary for determining the sources or transmission paths of disturbing noise. Also, the techniques and instrumentation used for vibration measurement and analysis are specialized and are beyond the scope of this guide. Therefore, the reader should consult other sources, such as The Vibration Institute, for descriptions of methods of vibration measurement and analysis.

**Table C-1. Adjustment Values for Determining Equipment Sound Levels in the Presence of Constant Background Noise**

Difference between Measurement Result #1 and Measurement Result #2	Adjustment* to Measurement Result #1 to Obtain Equipment Sound Level
10 dB or more	0 dB
6-9 dB	-1 dB
4 or 5 dB	-2 dB
3 dB	-3 dB
2 dB	-4 dB
0 or 1 dB	Equipment sound level cannot be accurately determined, but is at least 6 dB below Measurement Result #1

Measurement #1 = Equipment Being Tested Plus Background Noise  
 Measurement #2 = Background Noise Only

\* Adjustment applies to all types of frequency weightings and filters.

## Appendix D

# Using Manufacturers' Sound Data

---

In response to demands by engineers and architects for accurate sound data, industry standards have been developed for measuring and rating the acoustical performance of various types of HVAC equipment. The published ratings based on the standards have proven to be very helpful. However, misunderstanding and/or misapplication of the published data often lead to installations that are noisier than expected. For this reason, ASHRAE has published a companion publication to this guide titled *Application of Manufacturers' Sound Data* to help system designers use and interpret factory-supplied acoustical data. The publication also includes application guidelines similar to those found in this guide.

Although most of the test standards mentioned below require performance data in octave bands, many laboratories acquire the data in 1/3-octave bands, so such data might be available when trying to assess the likelihood of a strong tone in the noise spectrum of a piece of equipment.

When reviewing manufacturers' submitted acoustical data, be sure to verify the following:

- **Fans**—All acoustical data should be expressed in terms of unweighted octave band  $L_W$  values that are measured in complete accordance with the latest revision of AMCA Standard 300. Data should be supplied for the fan's discharge opening, inlet opening, as well as its case-radiated noise.
- **Air-Handling Units and Fan Coil Units**—All acoustical data should be expressed in terms of unweighted octave band  $L_W$  values that are measured in complete accordance with the latest revision of AHRI Standard 260. The data should be supplied for all openings, whether ducted or unducted, and case-radiated noise. Verify that the "end reflection loss" has been applied properly

## Using Manufacturers' Sound Data

for the submitted data, as this could create an error of as much as 10 dB or more in the 63 hertz octave band.

- **Terminal Units**—Ignore published NC ratings. Accept only octave band  $L_W$  values that are measured in complete accordance with the latest revision of AHRI Standard 880. The data should be supplied for both the discharge and case-radiated noise.
- **Laboratory Air Valves**—All acoustical data should be expressed in terms of octave band  $L_W$  values that are measured in complete accordance with the latest revision of AHRI Standard 880. The data should be supplied for the discharge (in the direction of the airflow), exhaust (in the direction opposite to the airflow), and radiated noise.
- **Duct Silencers**—All acoustical performance data should be expressed in terms of the octave band dynamic insertion loss and self-noise  $L_W$  values that are measured in complete accordance with the latest revision of ASTM E477. Static pressure drop values should also be included for various positive and negative airflow velocities.
- **Grilles and Diffusers**—All acoustical data should be expressed in terms of octave band  $L_W$  values that are measured in complete accordance with the latest revision of AHRI Standard 890. Lacking such data, assume that the field NC rating of each device will be at least five points higher than the cataloged rating.
- **Linear (Slot) Diffusers**—These diffusers are factory-tested with two types of plenums. The first is a very large plenum in which the airflow approaching the diffuser is at a very low velocity. The second test is done with a very small, close-fitting plenum that delivers relatively high-velocity, turbulent airflow to the diffuser inlet. The close-fitting plenum arrangement can add as much as 20 NC rating points to diffuser's "low-velocity plenum" NC rating. Verify which plenum for any submitted acoustical data.
- **Registers**—Registers are rarely tested for noise generation, but informal factory tests have shown that a wide-open damper attached directly to a grille or diffuser inlet collar can add as much as 5 NC rating points to a device's "no damper" NC rating. Closing the damper can add as much as 20 NC rating points, depending on the damper setting and the upstream airflow conditions.
- **Chillers**—All acoustical data should be expressed in terms of the unweighted octave band  $L_p$  values measured in complete accordance with the latest revision of AHRI Standard 575. Note that field-measured  $L_p$  values will usually be higher than the AHRI-575 values because of sound energy buildup in the equipment room. The increase can be as much as 15 dB in a small room.

## **A Practical Guide to Noise and Vibration Control for HVAC Systems**

- **Cooling Towers**—All acoustical data should be expressed in terms of the unweighted octave band  $L_P$  values measured at the ten locations specified in CTI Test Code ATC-128. Verify that the submitted data include fan and water noise.
- **Unducted Package Units** (e.g., PTACs, ductless split-system fan-coil units, etc.)—The indoor noise of these units should be expressed in terms of the unweighted octave band  $L_W$  values determined in complete accordance with the latest revision of AHRI Standard 350. The outdoor noise should be expressed in terms of the unweighted octave band  $L_W$  values determined in complete accordance with the latest revision of AHRI Standard 270.
- **Small Outdoor Equipment** (e.g., residential condensing units)—All acoustical data should be expressed in terms of the unweighted octave band  $L_W$  values determined in complete accordance with the latest revision of AHRI Standard 270.
- **Large Outdoor Packaged Equipment** (all types)—All acoustical data should be expressed in terms of the unweighted octave band  $L_W$  values determined in complete accordance with the latest revision of ARI Standard 370.



## Appendix E

# Definitions and Abbreviations

---

### DEFINITIONS

***absorption coefficient:*** The fraction of incident sound that is absorbed by a given material, usually given in octave bands.

***acoustical louver:*** A specially built louver using sound-attenuating baffles instead of single-thickness bent steel or extruded aluminum blades.

***aerodynamic noise:*** Noise due to turbulent airflow. See *self-noise* and *self-generated noise*.

***ambient sound:*** The combination of all near and far sounds, none of which is particularly dominant.

***attenuation:*** A general term that describes the reduction of sound energy by any of several mechanisms, including divergence, diffusion, absorption, scattering, transmission loss, insertion loss, etc.

***A-weighted sound level:*** The sound level measured using the A-weighting network of a sound level meter. For broadband sounds, the A-weighted sound level is loosely correlated with the perception of loudness. It is expressed in dBA.

***background sound:*** All sounds, except sound from a particular source of interest.

***balanced noise criteria (NCB):*** A single-number criteria rating system developed to rate steady-state HVAC system noise.

## Definitions and Abbreviations

***bel***: One bel = 10 decibels (dB)

***blade passage frequency (BPF)***: The frequency of a tone produced by the rotation of the blades on a fan wheel or pump impeller (equal to RPM times number of blades/60).

***breakout***: The transmission of sound through a duct wall (from inside to outside).

***broadband noise***: Noise of random character with no discernable tones (e.g., rain or wind.)

***decibel (dB)***: The primary unit of sound measurement; used to quantify sound pressure level, sound power level, as well as several types of attenuation mechanisms.

***duct silencer***: A specially built section of ductwork incorporating internal sound-attenuating baffles; especially effective in the middle frequency range. Also called *sound traps*, *duct attenuators*, or *mufflers*.

***dynamic insertion loss***: The sound insertion loss of a duct silencer while handling airflow. It is expressed in dB.

***equivalent duct diameter***: For circular ducts, this is the actual diameter. For rectangular and flat-oval ducts, this is approximately the square root of the product of the height times the width.

***flanking path***: An indirect sound transmission path, such as the structure-borne path between two adjacent rooms.

***floating floor***: A floor assembly in which an array of fiberglass, neoprene, or spring isolators supports a topping slab that floats above a structural slab; useful for noise control, but not vibration control.

***frequency***: The number of oscillations per second, generally expressed in hertz (Hz) or cycles per second (cps).

***fundamental frequency***: The lowest resonance frequency of a vibrating object.

***insertion loss***: The sound level reduction at a given location due to the insertion of a noise control device, such as a duct silencer or acoustical louver. It is expressed in dB. See also *dynamic insertion loss*.

## **A Practical Guide to Noise and Vibration Control for HVAC Systems**

**masking:** The process through which the audibility of one sound is reduced because of the presence of another.

**noise:** Undesirable sound that interferes with rest, sleep, mental concentration, or speech communication.

**noise criteria (NC):** A single-number noise rating system developed to rate steady-state continuous noise in a room from all types of equipment, including fans, mixing boxes, diffusers, etc.

**noise reduction coefficient (NRC):** A single-number rating system used to compare the approximate sound-absorbing characteristics of building materials.

**octave:** A continuous range of frequencies whose upper frequency limit is twice that of its lower frequency limit. Typical center frequencies for HVAC analyses are 62.5, 125, 250, 500, 1000, 2000, 4000, and 8000 hertz, although the 8000 hertz band is often ignored and the 31.25 hertz band is sometimes considered when investigating noise and vibration complaints. The lower frequency limit for each octave band is 70.7% of the center frequency, while the upper frequency limit is 141.4% of the center frequency. For example, the 1000-hertz octave band contains noise energy at all frequencies from 707 to 1414 hertz.

**octave band level (OBL):** The sound pressure level of the sound energy within a single octave band. It is expressed in dB.

**random noise:** See *broadband noise*.

**regenerated noise:** The noise caused by turbulent flow in air and water systems, usually expressed as  $L_W$  values in octave bands.

**resonance:** The natural oscillation of a construction assembly, resilient element, or air column that persists after the shutoff of an outside excitation. The ringing sounds that you hear after hitting a bell or plucking a guitar string are examples of resonance.

**resonance frequency:** A frequency at which resonance occurs.

**room criteria (RC):** A single-number noise rating system developed to diagnose and rate the HVAC noise exposure in a room. This rating system should not be used for design analysis or building commissioning.

## Definitions and Abbreviations

**seismic restraints:** Auxiliary restraints that hold a piece of vibration-isolated equipment in place in the event of an earthquake. They must be designed and installed very carefully to avoid “short-circuiting” the vibration isolators. These same restraints are often used to resist wind-loading on outdoor equipment.

**self-noise:** The regenerated noise occurring in duct silencers or duct fittings.

**self-generated noise:** See *self-noise*.

**short-circuiting:** The process by which the improper adjustment of a seismic or wind-loading restraint lets equipment vibration bypass an isolator.

**sones:** A linear scale that is used to rate the approximate loudness of an unducted fan.

**sound level meter:** A meter, usually handheld, that is used to measure sound pressure levels.

**sound power level ( $L_W$  or  $PWL$ ):** The total acoustic energy radiated per unit time. It is usually given in octave bands (dB re 1 pW) and, in general, is not affected by the acoustic environment.

**sound pressure level ( $L_P$  or  $SPL$ ):** The calculated or measured level of sound pressure, expressed in dB (re 20  $\mu$ Pa), at a specific location under a specific set of equipment operating conditions. The frequency range of the measurement or calculation must be indicated along with the  $L_P$  value in dB. The  $L_P$  value of any source varies with the distance from the source and depends upon the acoustic environment between the source and the listener.

**sound transmission class ( $STC$ ):** A single-number rating system used to compare the sound-isolating characteristics of partitions, doors, or windows used to separate occupied spaces. It should not be used to select mechanical equipment room partitions or slabs.

**sound trap:** See *duct silencer*.

**structure-borne sound:** Sound that radiates from a construction assembly after traveling through a building's structure in the form of vibration.

**vibration isolation:** The control of equipment vibration by the insertion of resilient elements (usually a steel spring or elastomeric element) between the equipment and a supporting structure. Also applies to the resilient attachment of service connections (conduits, pipes, ducts, etc.) to the equipment.

## **A Practical Guide to Noise and Vibration Control for HVAC Systems**

### **ABBREVIATIONS**

ADC	Air Diffusion Council
AHU	air-handling unit
AMCA	Air Movement and Control Association
ANSI	American National Standards Institute
AHRI	Air Conditioning and Refrigeration Institute
ASHRAE	American Society of Heating, Refrigerating and Air-Conditioning Engineers
ASTM	American Society for Testing and Materials
CAV	constant air volume (a type of air terminal)
CTI	Cooling Technology Institute
dB	decibel
dBA	A-weighted decibel
dBC	C-weighted decibel
HVI	Heating and Ventilating Institute
Hz	hertz (cycles per second)
kg/m <sup>2</sup>	kilograms per square metre (surface density)
kg/m <sup>3</sup>	kilograms per cubic metre (volume density)
kW	motor power rating in kilowatts
L <sub>p</sub>	sound pressure level
L <sub>PA</sub>	A-weighted sound pressure level
L <sub>PC</sub>	C-weighted sound pressure level
L <sub>W</sub>	sound power level
L <sub>WA</sub>	A-weighted sound power level
L <sub>WC</sub>	C-weighted sound power level
L/s	liters per second
m/s	metres per second
NC	noise criteria
NCB	balanced noise criteria
NFPA	National Fire Prevention Association
NR	noise reduction
NRC	noise reduction coefficient
NVLAP	National Voluntary Laboratory Accreditation Program
OBL	octave band sound pressure level
Pa	Pascals (pressure)

### **Definitions and Abbreviations**

PTAC	packaged terminal air conditioner
PWL	sound power level
RC	room criteria
rpm	revolutions per minute
SMACNA	Sheet Metal and Air Conditioning Contractor's National Association
SP	static pressure
SPL	sound pressure level
STC	sound transmission class
TP	total pressure
TSP	total static pressure
TL	transmission loss
VAV	variable air volume
VFD	variable-frequency drive (motor speed controller)

## Appendix F

# Addresses of Agencies and Associations

---

Air Diffusion Council (ADC)  
1901 N. Roselle Road, Suite 800  
Schaumburg, Illinois 60195  
<http://www.flexibleduct.org>

Air Conditioning, Heating, and Refrigeration Institute (AHRI)  
2111 Wilson Blvd., Suite 500  
Arlington, VA 22201  
<http://www.ahrinet.org>

Air Movement and Control Association (AMCA)  
30 West University Drive  
Arlington Heights, IL 60004-1893  
<http://www.amca.org>

American Society of Heating, Refrigerating, and Air-Conditioning Engineers  
(ASHRAE)  
1791 Tullie Circle N.E.  
Atlanta, GA 30329  
<http://www.ashrae.org>

ASTM International (ASTM)  
100 Barr Harbor Drive  
West Conshohocken, PA 19428-2959  
<http://www.astm.org>

**Addresses of Agencies and Associations**

American National Standards Institute (ANSI)  
25 West 43<sup>rd</sup> Street, 4<sup>th</sup> Floor  
New York, NY 10036  
<http://www.ansi.org>

Cooling Technology Institute (CTI)  
PO Box 73383  
Houston, TX 77273-3383  
<http://www.cti.org>

Sheet Metal and Air Conditioning Contractor's National Association  
(SMACNA)  
4201 Lafayette Center Drive  
Chantilly, VA 20151-1219  
<http://www.smacna.org>

The Vibration Institute  
6262 S. Kingery Highway  
Suite 212  
Willowbrook, IL 60527  
<http://www.vibinst.org>

## Appendix G

# Bibliography and Selected References

---

### BOOKS

- Beranek, L.L. (ed.) 1988. *Noise and Vibration Control—Revised edition*. New York: McGraw-Hill.
- Egan, M.D. 1972. *Concepts in Architectural Acoustics*. New York: McGraw-Hill.
- Egan, M.D. 1988. *Architectural Acoustics*. New York: McGraw-Hill.
- Harris, C.M. (ed.) 1991. *Handbook of Acoustical Measurements and Noise Control*, 3rd ed. New York: McGraw-Hill.
- Jones, R.S. 1984. *Noise and Vibration Control in Buildings*. New York: McGraw-Hill.
- Miller, L.N. 1971. *Lecture Notes on Noise and Vibration Control for Mechanical and Electrical Equipment in Buildings*. Cambridge, MA: Bolt, Beranek, & Newman, Inc.
- Nevins, R.G. 1976. *Air Diffusion Dynamics*. Chicago, IL: Air Diffusion Council.
- Sharland, I. 1972. *Woods Practical Guide to Noise Control*. Colchester, UK: Woods of Colchester, Ltd.
- Woods, R.I. (ed.) 1972. *Noise Control in Mechanical Services*. Colchester, UK: Sound Research Laboratories.
- Fry, A.T. (ed.) 1988. *Noise Control in Building Services*. Colchester, UK: Sound Research Laboratories.
- FEMA. 2002. *FEMA 412-Installing Seismic Restraints for Mechanical Equipment*. Washington, DC: Federal Emergency Management Administration.
- ASHRAE. 2000. *A Practical Guide to Seismic Restraint*. Atlanta, GA: American Society of Heating, Refrigerating and Air-Conditioning Engineers, Inc.

## Bibliography and Selected References

### INDUSTRY MANUALS, HANDBOOKS, AND BULLETINS

- AMCA. 2002. *Publication 201-02, Fans and systems*. Arlington Heights, IL: Air Movement and Control Association, Inc.
- AMCA. 1998. *Publication 202-98—Troubleshooting*. Arlington Heights, IL: Air Movement and Control Association, Inc.
- ASHRAE. 2003. *ASHRAE Handbook—HVAC Applications*, Chapter 47. Atlanta, GA: American Society of Heating, Refrigerating and Air-Conditioning Engineers, Inc. (Revised every four years.)
- ASHRAE. 2005. *ASHRAE Handbook—Fundamentals*, Chapter 7. Atlanta, GA: American Society of Heating, Refrigerating, and Air-Conditioning Engineers, Inc. (Revised every four years.)
- SMACNA. 1990. *HVAC system—Duct design*. Vienna, VA: Sheet Metal and Air-Conditioning Contractor's Association.
- SMACNA. 1995. *HVAC duct construction standards—Metal and flexible*. Vienna, VA: Sheet Metal and Air-Conditioning Contractor's Association.
- SMACNA. 1998. *Seismic restraint manual: Guidelines for mechanical systems*. Vienna, VA: Sheet Metal and Air-Conditioning Contractor's Association.
- Graham, J.B. 1959. *Fan noise*. Bulletin F-105. Buffalo, NY: Buffalo Forge Company.
- Hassal, J.R., and K. Zaveri. 1979. *Acoustic noise measurements*, 4th ed. Naerum, Denmark: Bruel & Kjaer.
- Hirschorn, M. 1989. *Noise Control Reference Handbook*. Bronx, NY: Industrial Acoustics Company.
- Peterson, A.P.G., and E.E. Gross. 1972. *Handbook of Noise Measurement*, 7th ed. Concord, MA: General Radio Company.
- Schultz, T.J. 1986. *Acoustical uses of perforated metal*. Milwaukee, WI: Industrial Perforators Association.
- Baltimore Aircoil Co. 2005. *Product and Application Handbook*, pp. J20-J54. Baltimore, MD: Baltimore Aircoil Company.
- Owens-Corning Fiberglas Company. 1987. *Noise Control Design Guide*. Publ. No. 5-BL-11691-E. Toledo, OH: Owens-Corning Fiberglas Company.
- Trane Company. 1982. *Fans and their application in air conditioning*. La Crosse, WI: The Trane Company.
- Trane Company. 1986. *Acoustics in air conditioning*. Application Manual FNDAM-5. La Crosse, WI: The Trane Company.
- Trane Company. 2002. *Indoor sound—Sound advice from Trane for sound sensitive large rooftop installations*. Bulletin RT-EB-80. La Crosse, WI: The Trane Company.

**A Practical Guide to Noise and Vibration Control for HVAC Systems**

**INDUSTRY PERIODICALS**

*Heating/Piping/Air Conditioning  
Sound and Vibration  
Specifying Engineer*

**JOURNALS**

*ASHRAE Journal  
Journal of the Acoustical Society of America  
Journal of Sound and Vibration  
Noise Control Engineering Journal*



*A Practical Guide to Noise and Vibration Control for HVAC Systems* will be useful for engineers, architects, contractors, and other building industry professionals who have little or no experience with acoustical terms or concepts. The book presents practical design guidelines that are supplemental to the information found in the sound and vibration chapters in the ASHRAE Handbook. The information in the guide can be used to develop system designs that minimize the possibility of excessive HVAC system noise and vibration in and around buildings or to conduct troubleshooting investigations for resolving noise and vibration problems.

This second edition of the guide has been revised to highlight the acoustical features of a wide range of HVAC system components while also bringing the reader up to date on new noise and vibration control products. It also addresses new strategies for selecting equipment and designing systems.

Based on comments from readers of the first edition, the guide has been reorganized for easier use and includes more charts, tables, and photographs.

The original publication was made possible by funds from ASHRAE research.



American Society of Heating, Refrigerating  
and Air-Conditioning Engineers, Inc.  
1791 Tullie Circle, NE  
Atlanta, GA 30329

[www.ashrae.org](http://www.ashrae.org)

ISBN 978-1-936504-02-2



Product code: 90339 1/11