

The McGraw-Hill Companies

**SIGMA  
SERIES**

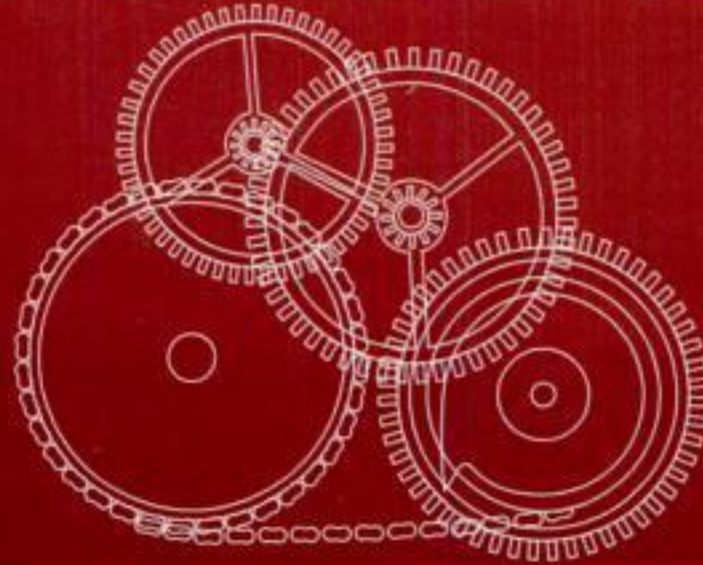

# Machine Design

S. G. Kulkarni



Copyrighted material



**Tata McGraw-Hill**

Published by the Tata McGraw-Hill Publishing Company Limited,  
7 West Patel Nagar, New Delhi 110 008.

Copyright © 2008, by Tata McGraw-Hill Publishing Company Limited.

No part of this publication may be reproduced or distributed in any form or by any means, electronic, mechanical, photocopying, recording, or otherwise or stored in a database or retrieval system without the prior written permission of the publishers. The program listings (if any) may be entered, stored and executed in a computer system, but they may not be reproduced for publication.

This edition can be exported from India only by the publishers,  
Tata McGraw-Hill Publishing Company Limited

ISBN (13): 978-0-07-064788-6

ISBN (10): 0-07-064788-7

Managing Director: *Ajay Shukla*

General Manager: Publishing—SEM & Tech Ed: *Vibha Mahajan*

Asst. Sponsoring Editor: *Shukti Mukherjee*

Jr. Editorial Executive: *Surabhi Shukla*

Executive—Editorial Services: *Sohini Mukherjee*

Senior Production Executive: *Anjali Razdan*

General Manager: Marketing—Higher Education & School: *Michael J Cruz*

Product Manager: SEM & Tech Ed: *Biju Ganesan*

Controller—Production: *Rajender P Ghanesla*

Asst. General Manager—Production: *B L Dogra*

Information contained in this work has been obtained by Tata McGraw-Hill, from sources believed to be reliable. However, neither Tata McGraw-Hill nor its authors guarantee the accuracy or completeness of any information published herein, and neither Tata McGraw-Hill nor its authors shall be responsible for any errors, omissions, or damages arising out of use of this information. This work is published with the understanding that Tata McGraw-Hill and its authors are supplying information but are not attempting to render engineering or other professional services. If such services are required, the assistance of an appropriate professional should be sought.

Typeset at The Composers, 260, C.A. Apt., Paschim Vihar, New Delhi 110 063 and printed at  
Avon Printers, 271, FIE, Patparganj, Delhi 110 092

Cover Printer: Rashtriya Printer

RCLQCRXXRBXLY

The **McGraw-Hill** Companies

---

# Contents

*Preface*

*xiii*

---

## **1 FUNDAMENTAL CONCEPTS**

**1**

- 1.1 Force, Torque 1
- 1.2 Work, Power and Energy 2
- 1.3 Machine and Machine Elements 3
- Worked Examples 3
- Objective Questions 4
- Review Questions 5
- Practice Problems 5
- Answers 5

---

## **2 DESIGN PROCEDURE, SIMPLE STRESSES**

**6**

- 2.1 Induced Stress 6
- 2.2 Strength 6
- 2.3 Load—Capacity 6
- 2.4 Design of Machine Member 6
- 2.5 Factor of Safety 7
- 2.6 Design Procedure 7
- 2.7 Simple Stress: Different Situations 7
- 2.8 Manufacturing Tolerances 11
- Worked Examples 12
- Objective Questions 25
- Review Questions 27
- Practice Problems 28
- Answers 31

---

## **3 COMBINED STRESSES: THEORIES OF FAILURE**

**32**

- 3.1 Definition 32
- 3.2 Combined Bending Moment and Axial Load 32
- 3.3 Design Equation 32
- 3.4 Combined Normal and Shear Stress 33
- 3.5 Theories of Failure 34
- 3.6 Forms of Design Equations to be Used in Practice 35
- 3.7 Mohr's Circle Diagram 35
- 3.8 Practical Design Aspects 35
- Worked Examples 36

Objective Questions 41  
Review Questions 42  
Practice Problems 43  
Answers 45

---

**4 VARIABLE LOADING**

**46**

4.1 Types 46  
4.2 Endurance Limit 46  
4.3 Design Equation for Machine Element Subjected to Variable Loading 47  
4.4 Stress Concentration 49  
4.5 Notch Sensitivity 49  
4.6 Miner's Equation 50  
4.7 Loading in the Finite Life Range 50  
4.8 Another form of Goodman Diagram 50  
4.9 Designing for Variable Loading with Combined Stresses 50  
4.10 Practical Design Aspects 51  
Worked Examples 52  
Objective Questions 60  
Review Questions 61  
Practice Problems 62  
Answers 65

---

**5 COTTER AND KNUCKLE JOINT**

**66**

5.1 Introduction 66  
5.2 Cotter Joint 66  
5.3 Design Procedure 66  
5.4 Knuckle Joint or Pin Joint 66  
Worked Examples 66  
Objective Questions 73  
Review Questions 74  
Practice Problems 74  
Answers 75

---

**6 DESIGN OF LEVERS**

**76**

6.1 Introduction 76  
6.2 Design Materials and Procedures 76  
Worked Examples 76  
Objective Questions 82  
Review Questions 82  
Practice Problems 82  
Answers 84

---

**7 SHAFTS AND COUPLINGS**

**85**

7.1 Introduction 85  
7.2 Design Equation 85  
7.3 Weakening Effect 86  
7.4 Different Types of Couplings 86

<u>Worked Examples</u>	86
<u>Objective Questions</u>	99
<u>Review Questions</u>	100
<u>Practice Problems</u>	101
<u>Answers</u>	104

**8 SPRINGS****105**

<u>8.1 Definition</u>	105
<u>8.2 Functions of Springs</u>	105
<u>8.3 Classification of Springs</u>	105
<u>8.4 Material</u>	105
<u>8.5 Design Equations for Close Coiled Helical Spring</u>	105
<u>8.6 Active Number of Turns N</u>	107
<u>8.7 Design of Carriage Spring</u>	107
<u>8.8 Spring with Extra Full Length Leaves</u>	108
<u>8.9 Design of Spring Subjected to Variable Load</u>	109
<u>8.10 Springs with Non-Circular Cross Section</u>	110
<u>8.11 Surging of Helical Compression Spring</u>	110
<u>Worked Examples</u>	110
<u>Objective Questions</u>	119
<u>Review Questions</u>	120
<u>Practice Problems</u>	121
<u>Answers</u>	124

**9 BOLT LOADING****125**

<u>9.1 Introduction</u>	125
<u>9.2 Design of Bolts for Easy Situation</u>	125
<u>9.3 Preloading of Bolts</u>	126
<u>9.4 Advantages of Preloading</u>	127
<u>9.5 Use of Spring Washers and Gaskets</u>	127
<u>9.6 Eccentric Loading of Bolts</u>	127
<u>Worked Examples</u>	129
<u>Objective Questions</u>	135
<u>Review Questions</u>	136
<u>Practice Problems</u>	137
<u>Answers</u>	140

**10 POWER SCREW****141**

<u>10.1 Introduction</u>	141
<u>10.2 Thread Profiles</u>	141
<u>10.3 Efficiency and Power Loss Due to Friction</u>	141
<u>10.4 Column Effect</u>	143
<u>10.5 Design Procedure</u>	143
<u>10.6 Other Varieties of Screws</u>	144
<u>Worked Examples</u>	145
<u>Objective Questions</u>	158
<u>Review Questions</u>	159

*Practice Problems* 160

*Answers* 161

---

**11 BELT, ROPE AND CHAIN DRIVE**

**162**

11.1 Introduction 162

11.2 Types 162

11.3 Length of the Belt 163

11.4 Ratio of Tensions and Power Transmission 163

11.5 Centrifugal Tension 165

11.6 Flat and V Belt Comparison 165

11.7 Strength of Belt 166

11.8 Creep 166

11.9 Design Procedure 167

11.10 Design of Chain Drive 167

*Worked Examples* 168

*Objective Questions* 177

*Review Questions* 178

*Practice Problems* 179

*Answers* 182

---

**12 BRAKES**

**183**

12.1 Types of Brakes 183

12.2 Material 183

12.3 Design of Brakes 183

12.4 Block Brakes or Short Shoe Brake 183

12.5 Band Brake 184

12.6 Long Shoe Brakes 185

12.7 Pivoted Type Shoe Brake 187

12.8 Heat Dissipation in Brakes 188

*Worked Examples* 188

*Objective Questions* 199

*Review Questions* 200

*Practice Problems* 201

*Answers* 206

---

**13 CLUTCHES**

**207**

13.1 Introduction 207

13.2 Principle of Friction Clutches 207

13.3 Practical Design Aspects 209

13.4 Theory of Centrifugal Clutch 209

*Worked Examples* 210

*Objective Questions* 215

*Review Questions* 217

*Practice Problems* 218

*Answers* 220

---

**14 SPUR GEAR**

**221**

14.1 Definitions 221

14.2 Design Equations 223

- 14.3 Wear Strength 224
- 14.4 Dynamic Tooth Load 224
- 14.5 Practical Design Aspects 226
- Worked Examples* 226
- Objective Questions* 240
- Review Questions* 241
- Practice Problems* 242
- Answers* 246

**15 HELICAL GEARS****247**

- 15.1 Introduction 247
- 15.2 Force Analysis 247
- 15.3 Equivalent Spur Gear: Formative Number of Teeth 248
- 15.4 Design Equations 248
- 15.5 Practical Design Aspects 249
- Worked Examples* 249
- Objective Questions* 258
- Review Questions* 260
- Practice Problems* 260
- Answers* 262

**16 BEVEL GEARS****263**

- 16.1 Introduction 263
- 16.2 Equivalent Relationships 264
- 16.3 Lewis Equation for Bevel Gear 264
- 16.4 Force Analysis 265
- 16.5 Practical Design Aspects 266
- Worked Examples* 266
- Objective Questions* 274
- Review Questions* 275
- Practice Problems* 276
- Answers* 277

**17 WORM GEAR****278**

- 17.1 Introduction 278
- 17.2 Nomenclature 278
- 17.3 Design Equations 278
- 17.4 Practical Design Aspects 279
- 17.5 Force Analysis 279
- Worked Examples* 280
- Objective Questions* 285
- Review Questions* 286
- Practice Problems* 287
- Answers* 288

**18 SLIDING CONTACT BEARINGS****289**

- 18.1 Introduction 289
- 18.2 Viscosity 290

18.3 Petroff's Equation 291  
18.4 Bearing Characteristic Number 291  
[18.5 Nomenclature 292](#)  
[18.6 Heat Generated and Dissipated 293](#)  
[18.7 Parameters Affecting the Bearing Performance 293](#)  
[18.8 Sommerfield and Other Dimensionless Numbers 293](#)  
*Worked Examples* 294  
*Objective Questions* 303  
*Review Questions* 304  
*Practice Problems* 305  
*Answers* 307

---

**19 ROLLING CONTACT BEARINGS 308**

[19.1 Introduction 308](#)  
[19.2 Construction and Types 308](#)  
[19.3 Definitions 309](#)  
19.4 Selection of Rolling Contact Bearing 311  
19.5 Selection for Variable Loading 311  
19.6 Preloading or Duplexing 312  
19.7 Comparison between the Sliding and Rolling Contact Bearings 312  
*Worked Examples* 313  
*Objective Questions* 317  
*Review Questions* 317  
*Practice Problems* 318  
[Answers 320](#)

---

**20 MISCELLANEOUS ELEMENTS 321**

[20.1 Welded Joints 321](#)  
[20.2 Design of Welded Joint 321](#)  
[20.3 Design of Flywheel 323](#)  
*Worked Examples* 325  
[Objective Questions 331](#)  
*Review Questions* 332  
*Practice Problems* 332  
[Answers 337](#)

---

**21 STATISTICAL CONSIDERATIONS AND OPTIMUM DESIGN 338**

[21.1 Statistical Considerations 338](#)  
[21.2 Optimum Design 339](#)  
[21.3 Statistical Consideration in Deciding Factor of Safety 339](#)  
*Worked Examples* 341  
[Objective Questions 345](#)  
[Review Questions 345](#)  
[Practice Problems 345](#)  
*Answers* 347

---

[Appendix 1 348](#)  
[Appendix 2 377](#)  
[Index 390](#)

---

# Preface

This book was first published as part of TMH Outline Series and was well received by the students and teachers alike. The new edition, is now being published as Sigma Series. I have expanded the material by adding numerous problems at the end of each chapter. This will give students an opportunity to try and reinforce the concepts learned. I hope that the new format of the book is more convenient and will be appreciated by the students.

The seeds of this book were planted over thirty-five years ago when as a teacher in the Government Engineering College, Aurangabad, I tried to use different methods to make the subject easy to understand for the students and by giving a large number of problems as exercises.

The book has been written mainly for the prefinal- and final-year students studying for the Mechanical Engineering degree course and comprehensively covers a major portion of the syllabi prescribed by various Indian universities. The students preparing for B section of A.M.I.E.(Mechanical) will also find it useful. The final-year students of diploma courses in Mechanical Engineering will find the first ten chapters of the book in line with their syllabus. Practicing engineers will also find it useful as a great number of challenging problems are included in the text.

The theoretical part has been given a brief but precise coverage which makes it an indispensable supplement to any standard book on the subject.

The subject matter is divided into two parts of which the part of basic theory to be applied for design of any machine component is covered in the first four chapters. The second chapter includes the concept of manufacturing tolerances required to be used in designing of a machine component. Chapters 5 through 20 are devoted to explaining the procedures of designing different machine elements such as bolts, power screw, springs, shafts, belt and rope drives, gears of different types, sliding contact and rolling contact bearings as the titles of the chapters suggest. The last chapter is a new concept of machine design termed Optimum Design, giving a basic concept of optimization used in Machine Design as suggested by J.B. Johnson.

Machine Design is not an exact science as there are a variety of methods to arrive at the solution in the form of specifications of any machine element satisfying the necessary functional requirements and no solution is a unique solution to the problem. There may be more than one solution and all may be reasonably correct. This aspect becomes clear as the readers go through the solved problems where many assumptions have to be made for solving them. This may cause confusion in the minds of the students. In order to avoid this possibility, most of the problems have been formulated by stating all the assumptions required to solve them. But such an approach should not deter them from using their own thinking and reasoning abilities. Hence, some problems which require the students to make their own assumptions are also included. This will familiarize them with the process of making proper assumptions and will therefore, make them better equipped to tackle the practical problems, they may require to handle in their field of study or work.

I am grateful to all those who aided in the development of the text and to the Editors in charge of the McGraw-Hill Publishing company for the constant encouragement in writing this book. I would like to convey a special thanks to Mr. M G Navare (then Area Manager, TMH Publishing Co.) who introduced me to the company and persuaded me to write the book.

Last but not the least, I would like to thank my wonderful wife, Mrs. Veena Kulkarni, who was very supportive and encouraging while I was writing this book.

S G KULKARNI

# Fundamental Concepts

## CONCEPT REVIEW

### 1.1 FORCE, TORQUE

According to Newton's second law of motion, force may be defined as

$$F = m \times a$$

In SI units one newton is the force required to accelerate a mass of one kg with an acceleration of one metre per second squared.

If a body is in rotational motion at an angular speed of  $\omega$  r/s, with radius of rotation  $r$ , the force which keeps the body in rotation is *centripetal force* given by

$$\text{Centripetal force} = mr\omega^2 = mv^2/r$$

where  $v$  is tangential velocity in m/s.

Force that exists away from the centre due to mass of the body and is equal and opposite to the centripetal force is termed as *centrifugal force*.

For a rotating body of mass  $m$  with its mass assumed to be concentrated in a ring of radius  $k$ , the product  $mk^2$  is known as *mass moment of inertia* of the body and is denoted by letter  $I$ .

$\therefore$

$$I = mk^2$$

Two equal and opposite parallel forces at a distance  $x$  form a couple given by

$$C = F \cdot x \text{ N.m}$$

A couple due to force  $F$  as shown in Fig. 1.1 causes twisting of the shaft and is termed as torque  $T$  acting on the shaft. It is given by

$$T = F \times r \text{ N.m}$$

This torque causes the rotational motion of shaft or disc mounted on it and may be written as

$$T = I\alpha \text{ N.m}$$

where  $I$  is the moment of inertia of disc and shaft and  $\alpha$  is the angular acceleration in rad/sec<sup>2</sup>.

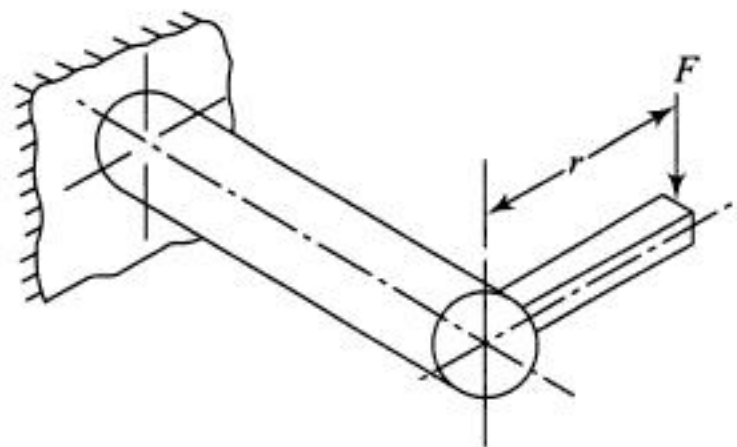

Fig. 1.1

### 1.2 WORK, POWER AND ENERGY

Work done in displacing a force  $F$  Newtons by a distance  $d$  metres is given as

$$\text{Work} = F \times d \text{ N.m}$$

Work done in causing the angular motion  $\theta$  radians of a body subjected to torque  $T$  is given by

$$\text{Work} = T\theta \text{ N.m}$$

The rate of doing work is defined as *power*. Thus

$$P = F(d/t) = F \times v \text{ N.m/s}$$

$$P = T(\theta/t) = T \times \omega \text{ N.m/s}$$

The capacity to do the work is termed as *energy*.

**Table 1.1** Mass Moments of Inertia of Common Solids

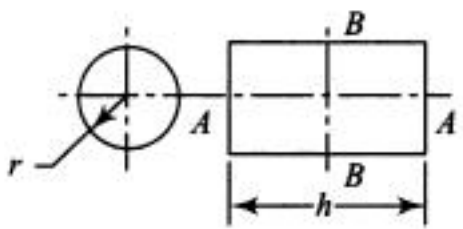
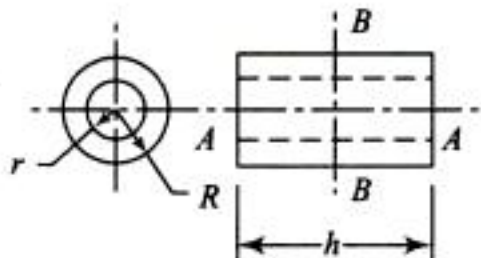
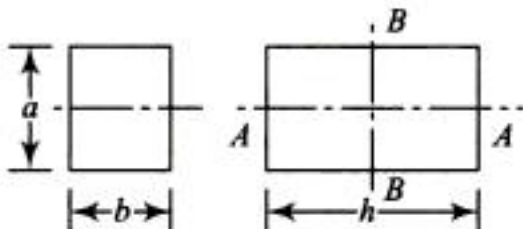
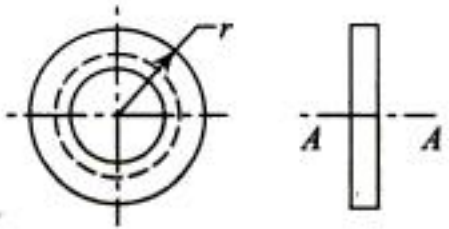
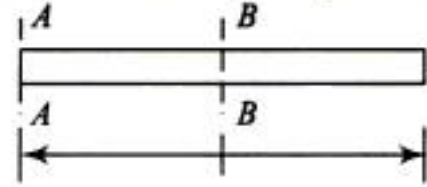
Solid	Mass $M$ - $I$ $I_m$	Radius of gyration $K$
1. Sphere 	about $AA = \frac{2}{5} Mr^2$	$0.6325 r$
2. Cylinder 	about $AA = \frac{1}{2} Mr^2$ about $BB = M \left( \frac{h^2}{12} + \frac{r^2}{4} \right)$	$0.0707 r$ $0.289 \sqrt{h^2 + 3r^2}$
3. Hollow Cylinder 	about $AA = \frac{1}{2} M(R^2 + r^2)$ about $BB = M \left( \frac{h^2}{12} + \frac{R^2 + r^2}{4} \right)$	$0.707 \sqrt{R^2 + r^2}$ $0.289 \sqrt{h^2 + 3(R^2 + r^2)}$
4. Prism 	about $AA = \frac{M}{12} (a^2 + b^2)$ about $BB = \frac{M}{12} (h^2 + b^2)$	$0.2887 \sqrt{a^2 + b^2}$ $0.2887 \sqrt{h^2 + b^2}$
5. Thin Ring 	about $AA = Mr^2$	$r$
6. Thin Uniform Rod 	about $BB = \frac{MI^2}{12}$ about $AA = \frac{MI^2}{3}$	$l/\sqrt{12}$ $l/\sqrt{3}$

### 1.3 MACHINE AND MACHINE ELEMENTS

*Machine* is a device to perform useful work when some form of energy is supplied to it. Lever, power screw, inclined plane are examples of simple machines while lathe, i.c. engines, washing machine etc., are examples of complex machines.

The smallest component of machine such as a bolt, spring, pin etc. is termed as a *machine element* for the purpose of machine design.

### WORKED EXAMPLES

- 1.1 It is required to lift water at the top of a 20 m high building at the rate of 50 litres/min. Assuming the losses due to friction equivalent to 5 m and those due to leakage equal to 5 m head of water; efficiency of pump 90% and efficiency of motor 90%, decide the kilowatt capacity of motor required to drive the pump.

*Solution:*

$$\text{Work to be done} = wQHg$$

$$w = 1 \text{ kg/litre}$$

$$Q = 50 \text{ litres per min.}$$

$$H = 20 + 5 + 5 = 30 \text{ m}$$

$w$  = density of water

$Q$  = discharge

$H$  = head of water

$g$  = gravitational constant

$$\therefore \text{Work output/min} = 1 \times 50 \times 30 \times 9.81 \text{ N.m/min}$$

$$\therefore \text{Input power} = \frac{1 \times 50 \times 30 \times 9.81}{0.9 \times 0.9 \times 1000 \times 60} = 0.302 \text{ kW.}$$

- 1.2 A power screw is rotated at constant angular speed of 1.5 revolutions/s by applying a steady torque of 15 N.m. How much work is done per revolution? What is the power required?

*Solution:*

$$\text{Work per revolution} = T\theta$$

$$= 15 \times 2\pi$$

$$= 94.24 \text{ Nm per revolution}$$

$$P = \text{Work/s} = (\text{Work/rev}) \times (\text{No. of revolutions/s})$$

$$= 94.24 \times 1.5 = 141.36 \text{ W.}$$

$$T = 15 \text{ N.m}$$

$$\theta = 1 \text{ revolution} = 2\pi \text{ rad.}$$

- 1.3 Power is transmitted by an electric motor to a machine by using a belt drive. The tensions on the tight and slack side of the belt are 2200 N and 1000 N respectively and diameter of the pulley is 600 mm. If speed of the motor is 1500 r.p.m, find the power transmitted.

*Solution:*

$$D = \text{Diameter of pulley in mm}$$

$$N = \text{Speed r.p.m}$$

$$P = T\omega$$

$$= Fr\omega = Fv$$

$$F = T_1 - T_2 = 2200 - 1000 = 1200 \text{ N}$$

$$v = \frac{\pi DN}{60} = \frac{\pi \times 600 \times 1500}{1000 \times 60} = 47.12 \text{ m/s}$$

$$P = \frac{1200 \times 47.12}{1000} = 56.548 \text{ kW}$$

$$F = \text{Tangential force, N}$$

$$v = \text{Peripheral velocity, m/s}$$

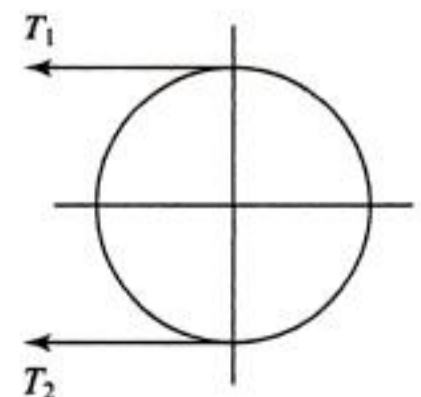

**Fig. E-1.3**

- 1.4 The flywheel of an engine has a mass of 200 kg and radius of gyration equal to 1 m. The average torque on the flywheel is 1200 N.m. Find the angular acceleration of flywheel and the angular speed after 10 seconds starting from rest.

*Solution:*

$$I = mk^2 = 2000 \times (1)^2 = 2000 \text{ kgm}^2$$

$$T = I\alpha, \quad \therefore \alpha = \frac{T}{I} = \frac{1200}{2000} = 0.6 \text{ rad/s}^2$$

$$\omega = \omega_0 + \alpha t = 0 + 0.6 \times 10 = 6 \text{ rad/s.}$$

- 1.5 Calculate the moment of inertia and radius of gyration of a solid sphere of mass 10 kg and diameter 6.5 m about its centroidal axis.

*Solution:*

$$I = \frac{2}{5} mr^2 = \frac{2}{5} \times 10 \times \left(\frac{6.5}{2}\right)^2 = 49 \text{ kg.m}^2$$

$$k = 0.6325 \times 3.25 = 2.055 \text{ m (Refer Table 1.1)}$$

- 1.6. Calculate the work done per minute by a punch tool making 20 working strokes per min when a 30 mm diameter hole is punched in 5 mm thick plate with ultimate shear strength of 450 MPa in each stroke.

*Solution:* Force required to punch one hole = area sheared  $\times$  ultimate shear strength =  $\pi dt \times S_s$

where  $d$  = diameter of hole in mm

$t$  = thickness of plate in mm

$S_s$  = ultimate shear strength in MPa.

$$= \frac{\pi \times 30 \times 5 \times 450}{1000} = 212.0575 \text{ kN}$$

Work done/min = Average force  $\times$  Thickness of plate  $\times$  No. of holes/min

$$= \frac{212.0575}{2} \times \frac{5}{1000} \times 20 = 10.692875 \text{ kN.m}$$

## OBJECTIVE QUESTIONS



- 1.1 A force of 50 N acts on a roller of mass 10 kg initially at rest on a frictionless surface. The roller travels 10 m while the force acts. The work done on the roller is  
 (a) zero (b) 125 J (c) 250 J (d) 500 J
- 1.2 A cricket ball of mass 150 gm is moving with a velocity of 12 m/s and is hit by a bat such that it is turned back with a velocity of 20 m/s. The force of blow acts on the ball for 0.01 s. Average force exerted on ball by the bat is  
 (a) 120 N (b) 240 N (c) 480 N (d) 960 N
- 1.3 A flywheel with moment of inertia of 10 kgm<sup>2</sup> rotating with 120 r.p.m. will stop in 5 revolutions at a braking torque of  
 (a)  $2.5 \times 10^2$  N.m (b) 50.265 N.m (c) 62.5 N.m (d) 103.3 N.m
- 1.4 Force required to punch a hole of 20 mm diameter in a 5 mm thick plate with ultimate shear strength of 250 MPa is  
 (a) 100 kN (b) 78.54 kN (c) 314.16 kN (d) 5 kN

- 1.5 In a machine a force of 120 N is required to lift a load of 3000 N and a force of 200 N is required to lift a load of 7000 N. Hence a force of 250 N will be required to lift a load of  
 (a) 87500 N                      (b) 9500 N                      (c) 6250 N                      (d) 8000 N
- 1.6 A table has a heavy circular top of radius 1 m and mass 20 kg. It has four legs of negligible mass fixed symmetrically on its circumference. Maximum mass that may be placed anywhere on the table without toppling is  
 (a) 20 kg                      (b) 24 kg                      (c) 48 kg                      (d) 10 kg
- 1.7 Bar is the unit of  
 (a) area                      (b) time                      (c) pressure                      (d) mass

## REVIEW QUESTIONS

- 1.1 Define a machine. How does it differ from a component? How is the component of a machine different from its element?
- 1.2 Compare force and torque, mass and mass moment of inertia.
- 1.3 Define work. Differentiate between power and energy.
- 1.4 Derive the relationship between power and torque.

## PRACTICE PROBLEMS

- 1.1 Find the moment of inertia of a flywheel of mass 100 kg and diameter 1 m if the mass is distributed uniformly over the area. If this flywheel is subjected to a uniform torque of 100 N.m, find the time required to attain a speed of 2000 r.p.m. starting from rest.
- 1.2 If above flywheel has its mass concentrated in a rim of radius 600 mm, how much time will it take to stop from a speed of 1800 r.p.m. when a braking torque of 120 N.m is applied.
- 1.3 A rope is passing over a free rotating pulley. One end of the rope is attached to a mass of 100 kg and the other end to a mass of 25 kg. Neglecting the friction and mass of the pulley find tension in the rope.
- 1.4 35 kW power is transmitted from one shaft to the other at 1500 r.p.m. of a driver pulley having 600 mm diameter. Find the tensions in the belt if the ratio of tensions is 2.

## ANSWERS

### Objective Questions

- (1) d      (2) c      (3) b      (4) b      (5) b      (6) c      (7) c

### Practice Problems

- (1) 12.5 kgm<sup>2</sup>, 26.18 sec      (2) 56.54 sec      (3) 392 N      (4) 148.6 N, 74.3 N

---

# Design Procedure, Simple Stresses

---

## CONCEPT REVIEW

---

### 2.1 INDUCED STRESS

A machine element offers resistance to failure when an external force acts on it. This resistance per unit area is termed as *induced stress*. The induced stress normal to the cross section is designated by letter  $\sigma$  and that tangential to cross section is designated as  $\tau$ .

### 2.2 STRENGTH

Any material can resist the effect of external force acting on it up to a limited value of induced stress. This limiting value is termed as the *strength* of material.  $S$  is used to represent strength. Thus  $S_y$ ,  $S_{ut}$ ,  $S_{uc}$ ,  $S_s$ ,  $S_{ys}$  represent yield point strength, ultimate tensile strength, ultimate compressive strength, ultimate shear strength and yield point shear strength respectively. The unit of strength is same as that of induced stress, i.e. MPa which is  $10^6 \text{ N/m}^2$  or  $\text{N/mm}^2$ .

### 2.3 LOAD—CAPACITY

Different forces acting on a machine element due to useful work to be done or due to the situation of working constitute the load on the machine member. This load may deform the member, cause wear and tear, or in extreme case may cause fracture of the member.

The material used for manufacture and the dimensions of cross section of machine element decide *capacity* of the member to resist the above-mentioned effects of load.

### 2.4 DESIGN OF MACHINE MEMBER

The procedure of machine design basically involves selection of material and dimensions of cross

section of the machine member in such a manner that load does not cause failure of the member by deformation, wear or fracture. This may be achieved by writing in equation form as

Capacity of the member to resist failure > the effect of load  
 or in the form of known quantities, as,  
 Strength per unit area of cross-section > induced stress  
 or according to the type of failure  
 $S > \sigma$  or  $\tau$ , where  $S$  is the tensile, compressive or shear strength.

## 2.5 FACTOR OF SAFETY

The above equation may be conveniently written by using sign of equality as

$$S = \sigma \text{ (or } \tau) \times \text{Constant}$$

or 
$$\sigma \text{ (or } \tau) = \frac{S}{\text{Constant}} \quad (2.1a)$$

This constant decides how much more the strength should be as compared to the induced stress. It assures the safety of machine member from failure and hence is termed as *factor of safety* and may be designated as F.S. Right hand side of Eq. (2.1) is termed as permissible or safe or allowable stress, while left hand side is induced stress.

F.S. may be arbitrarily selected as 3 to 5 based on yielding or 5 to 7 based on fracture failure. Exact knowledge of situation helps the designer to select F · S. more precisely.

## 2.6 DESIGN PROCEDURE

Designing of machine elements involves following steps:

- Specifying the problem
- Selection of proper mechanism
- Analysis of forces
- Selection of material
- Selection of factor of safety
- Calculation of cross-sectional dimensions using basic design equation
- Modifying and finalising dimensions with proper tolerances and preparing drawings with proper instruction for manufacturing.

Class-room problems usually involve only last four steps, while practical problems may involve some more steps.

## 2.7 SIMPLE STRESS: DIFFERENT SITUATIONS

- (a) *Direct tensile stress*: The load causes uniformly distributed tensile induced stress on any cross section of the member (Fig. 2.1). Hence design equation may be written for ductile material when yielding is the criteria of failure as.

Induced stress 
$$\sigma_t = \frac{P}{A} = \frac{S_y}{F \cdot S} \quad (2.1b)$$

For brittle material or ductile material with fracture as criteria of failure,

Induced stress 
$$\sigma_t = \frac{P}{A} = \frac{S_{ut}}{F \cdot S} \quad (2.2)$$

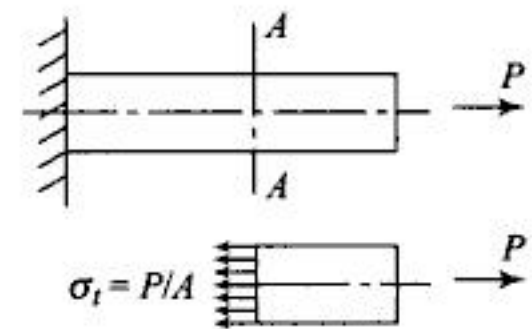

**Fig. 2.1**

- (b) *Direct compressive stress:* For any section  $AA$  (Fig. 2.2) design equation may be written as

$$\sigma_c = \frac{P}{A} = \frac{S_{uc}}{F \cdot S} \quad (2.3)$$

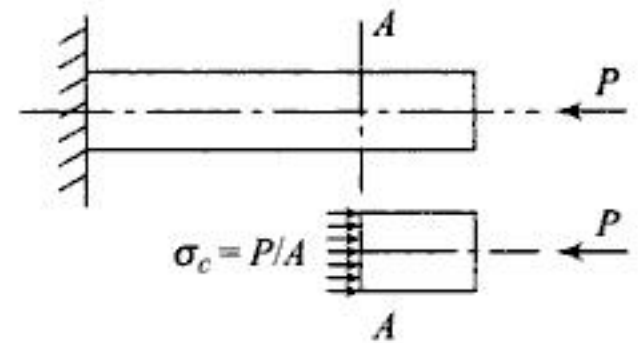

Fig. 2.2

- (c) *Direct shear stress:* (Fig. 2.3)

In above case load  $P$  causes the induced stress tangential to the specific cross section for which design equation is

Induced shear stress  $\tau_i = \frac{P}{A} = \frac{S_{ys}}{F \cdot S}$  for ductile material =  $\frac{S_s}{F \cdot S}$  for brittle material

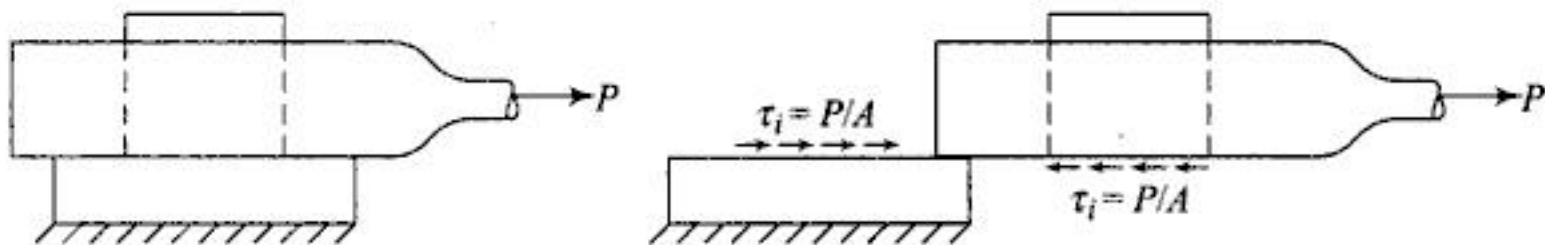

Fig. 2.3

- (d) *Double shear:* If the possibility of failure due to shear is at the two sections  $AA$  and  $BB$  (Fig. 2.4), resistance is offered by these sections to the applied shear force. The design equation then becomes

$$\begin{aligned} \tau &= \frac{P}{2A} = \frac{S_{ys}}{F \cdot S} \quad \text{for ductile material} \\ &= \frac{S_s}{F \cdot S} \quad \text{for brittle material} \end{aligned} \quad (2.4)$$

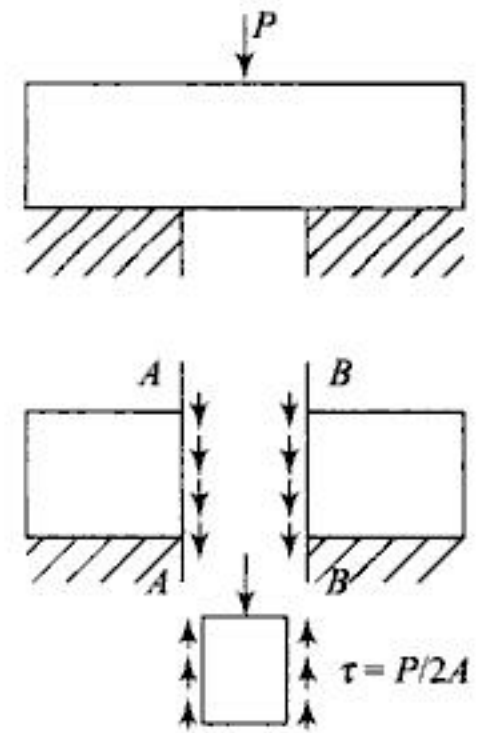

Fig. 2.4

- (e) *Bearing:* The two components such as shaft and bearing (Fig. 2.5) rub against each other causing wear. Wear can be kept minimum by limiting the bearing pressure between the components. The limiting value of bearing pressure  $P_b$  is based on compressive strength of softer material and the rubbing velocity. This bearing pressure is assumed to act uniformly on projected area  $d \times l$ . Hence the design equation is

$$P_b = \frac{P}{\text{Projected area}} = \frac{P}{dl} \quad (2.5)$$

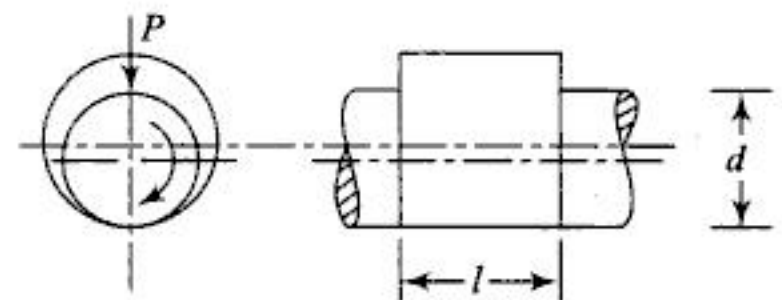

Fig. 2.5

- (f) *Bending:* The machine element when loaded as in Fig. 2.6 bends under given load. As a result, the nature of induced stress is tensile at outer fibre and compressive at the inner. All materials are weak under tension than under compression, hence design equation by using basic strength of material formula

$$\frac{M}{I} = \frac{\sigma_t}{y} = \frac{E}{R}$$

Becomes  $\left. \begin{aligned} \sigma_t &= \frac{My}{I} = \frac{S_y}{F \cdot S} && \text{for ductile material} \\ &= \frac{S_{ut}}{F \cdot S} && \text{for brittle material} \end{aligned} \right\} (2.6)$

Again  $\left. \begin{aligned} \sigma_t &= \frac{E}{R} y = \frac{S_y}{F \cdot S} && \text{for ductile material} \\ &= \frac{S_{ut}}{F \cdot S} && \text{for brittle material} \end{aligned} \right\} (2.7)$

Equation (2.6) is useful for determination of cross-sectional dimensions. The ratio  $\frac{I}{y}$  is termed as *section modulus* where

$I$  is moment of inertia of cross section about the axis of bending and  $y$  is distance of the fibre from the neutral axis. Equation (2.7) is useful for finding permissible radius of curvature.

A transverse shear stress is also induced in the cross-section but it does not occur at the top and bottom fibre and hence may be neglected. For pure bending there is no transverse shear stress:

- (g) **Twisting:** A pure twisting moment acting on the machine member (Fig. 2.7) of circular cross section induces torsional shear stress. The shear stress is zero at centre and increases with the increase in radius. Therefore, the design equation for torque  $T$  is

$$\text{and } \left. \begin{aligned} \tau &= \frac{T}{Z_p} = \frac{S_{ys}}{F \cdot S} && \text{for ductile material} \\ \tau &= \frac{T}{Z_p} = \frac{S_s}{F \cdot S} && \text{for brittle material} \end{aligned} \right\} (2.8)$$

- (h) **Permissible elastic deformation:** In some machine components elastic deformation is not allowed to exceed a particular limit. Equations to be used in such case are as under:

For direct tension or compression

$$\delta = \frac{Pl}{AE} \tag{2.9}$$

where  $\delta$  is deformation and  $l$  the original length of member.

For bending, various deflection equations from strength of material may be used. For twisting moment  $T$ , if  $\theta$  is the permissible angle of twist then

$$\theta = \frac{Tl}{JG} \tag{2.10}$$

where  $l$  = length of shaft, mm

$J$  = Polar moment of inertia of cross section, mm<sup>4</sup>

$G$  = Modulus of rigidity, MPa

$Z_p$  = Polar section modulus =  $\frac{J}{r}$  mm<sup>3</sup>

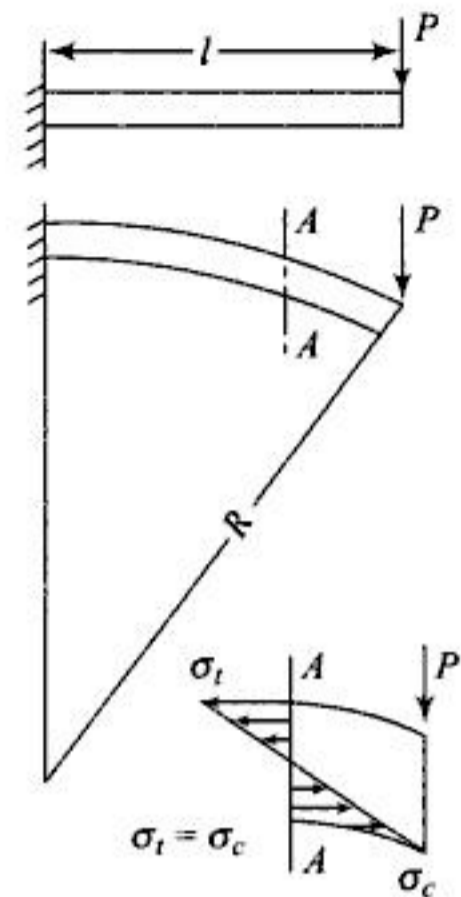

Fig. 2.6

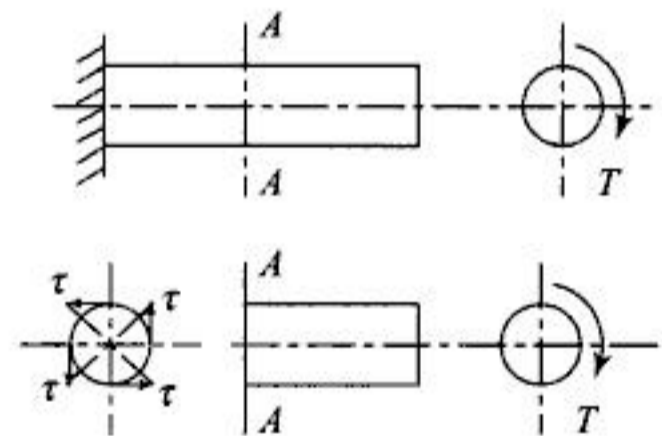
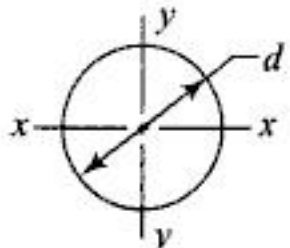
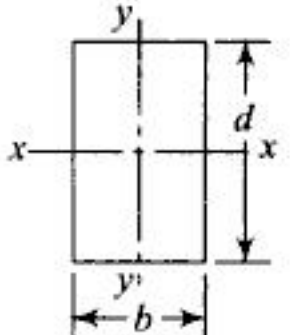
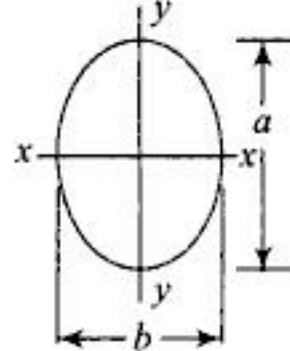
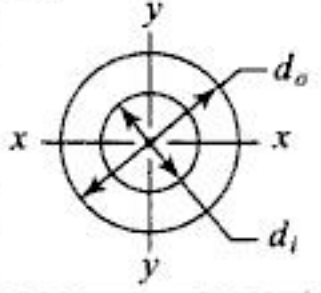
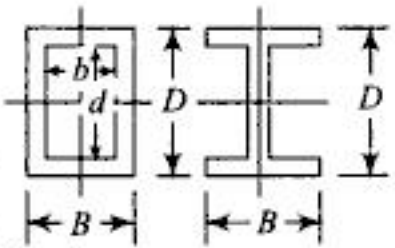

Fig. 2.7

**Table 2.1** Moments of Inertia of Some Standard Cross Section

Section Figure	$I_{xx}$	$I_{yy}$	$Z_{xx}$	$Z_{yy}$
(1) Circle 	$\frac{\pi}{64} d^4$	$\frac{\pi}{64} d^4$	$\frac{\pi}{32} d^4$	$\frac{\pi}{32} d^4$
(2) Rectangle 	$\frac{1}{12} b d^3$	$\frac{\pi}{64} d b^3$	$\frac{1}{6} b d^2$	$\frac{1}{6} d b^2$
(3) Ellipse 	$\frac{\pi}{65} b a^3$	$\frac{\pi}{64} a b^3$	$\frac{\pi}{32} b a^2$	$\frac{\pi}{32} a b^2$
(4) Hollow Circular 	$\frac{\pi}{64} (d_o^4 - d_i^4)$	$\frac{\pi}{64} (d_o^4 - d_i^4)$	$\frac{\pi}{32} \left( \frac{d_o^4 - d_i^4}{d_o} \right)$	$\frac{\pi}{32} \left( \frac{d_o^4 - d_i^4}{d_o} \right)$
(5) Box or I Section 	$\frac{1}{12} B D^3 - \frac{1}{2} b d^3$	$\frac{1}{2} D B^2 - \frac{1}{2} d b^3$	$\frac{1}{6} \left[ \frac{B D^2 - b d^2}{D} \right]$	$\frac{1}{6} \left[ \frac{D B^2 - d b^2}{B} \right]$
Section $b = B - 1t$ $d = D - 2t$ } for I section	Polar moment of inertia and,		$J = I_{xx} + I_{yy}$ Polar Section modulus = $\frac{I_{xx} + I_{yy}}{\text{depth}/2}$	

### 2.8 MANUFACTURING TOLERANCES

Tolerance is defined as the permissible deviation from the basic dimension. It is impracticable to get a machine part of an accurate basic size as it increases the cost without increasing the utility of part. A large tolerance decreases the cost (Fig. 2.8).

Size of the part when specified by providing tolerance on either side of basic size is termed as the *unilateral method*. Specifying the size by providing tolerance on both sides of basic size is *bilateral method of tolerances*. A bar diagram shows the maximum and minimum sizes of hole and shaft. The diagram 2.9 indicates the shaft and hole tolerances for clearance fit. Similar diagram results for interference fit except that, the hole and shaft tolerance positions are interchanged and in place of clearance there is interference. Figure 2.10 shows the results of bilateral and unilateral tolerances respectively. From this figure it can be concluded that in bilateral method of tolerances the type of fit may change by changing tolerance range. Bilateral method is used for dimensioning holes.

H.T: Hole tolerance                      LMC: Least Metal Condition  
 S.T: Shaft tolerance                    MMC: Maximum Metal Condition  
 B.S: Basic size

As tolerance is deviation from the basic size, the two sizes obtained are termed as lower (or fundamental) deviation and upper deviation and are designated as

$ei$  – lower deviation on shaft       $EI$  – lower deviation on hole  
 $es$  – upper deviation on shaft       $ES$  – upper deviation on hole  
 $IT$  – Tolerance

Thus

$$es = ei + IT \text{ and } ES = EI + IT$$

The method of tolerance where basic size is used for shaft is known as *basic shaft system*. The method which uses basic size for hole is termed as *basic hole system*. Former method is used when standard shafts are available and the latter when standard reamers are available.

The method of *selective assembly* is used when parts are to be produced on a very large scale. In this method, a large tolerance range is used and the assembly is made by selecting holes and shafts with small clearance or interference. This reduces the cost but gives a close fit. This method requires sorting of shafts and holes in different groups. This requires additional labour and also more number of gauges and increases the cost of production. It also results in non-interchangeable assembly which needs complete replacement of assembly, e.g. ball bearings.

**Preferred numbers:** Preferred numbers are used for standardisation. They are obtained by using the series having numbers in G.P with common ratio as  $\sqrt[n]{10}$ . Captain Renard put forth this concept and hence, the series are termed as R 5, R 10, R 20, where 5, 10, 20 etc. are values of  $n$ . Thus the series can be written for numbers between 10 and 100 as

R5 10, 16, 25, 40, 63 with common ratio =  $\sqrt[5]{10} = 1.6$

R10 10, 12.5, 16, 20, 25, 31.5, 40, 50, 63, 80 with common ratio =  $\sqrt[10]{10} = 1.25$

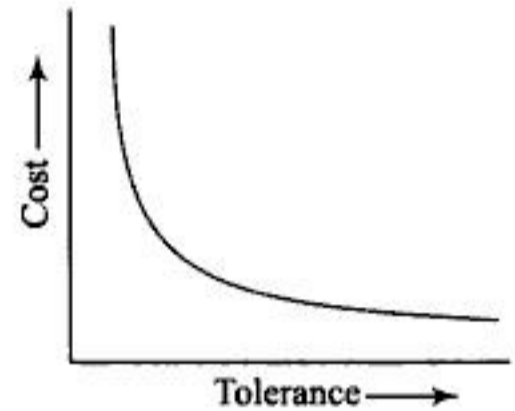

Fig. 2.8

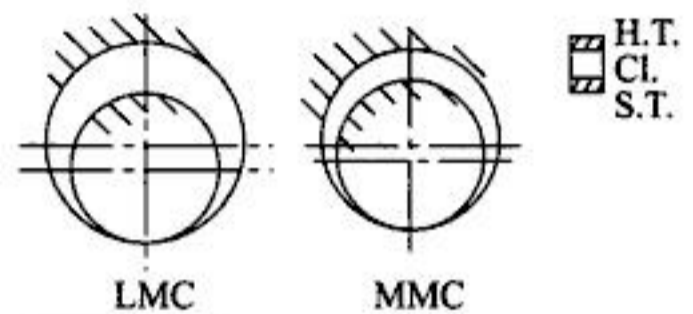

Fig. 2.9

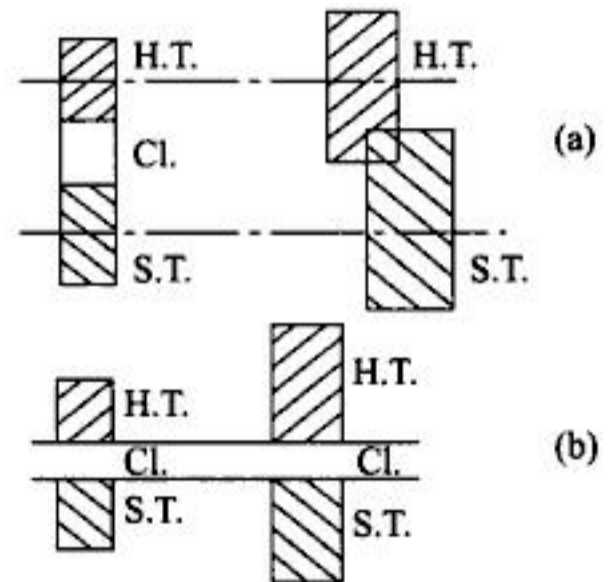

Fig. 2.10

## WORKED EXAMPLES

- 2.1 An m.s bar of 12 mm diameter is subjected to an axial load of 50 kN in tension. Find the magnitude of induced stress.

*Solution:* 
$$\sigma_t = \frac{P}{A} = \frac{50 \times 10^3}{\frac{\pi}{4} \times (12)^2} = 442.09 \text{ MPa}$$

- 2.2 If the length of bar in above example is 1 m and the modulus of elasticity of the material of the bar is  $2 \times 10^5$  MPa, find the elongation of bar.

*Solution:* 
$$\delta l = \frac{Pl}{AE} = \frac{50 \times 10^3 \times 1000 \times 4}{\pi \times (12)^2 \times 2 \times 10^5} = 2.21 \text{ mm}$$

- 2.3 If Poisson's ratio for the material of bar in above example is 0.3, find the change in diameter of the bar.

*Solution:* Poisson's ratio  $\mu = \frac{\text{lateral strain}}{\text{longitudinal strain}}$

$$\text{Longitudinal strain} = \frac{\delta l}{l} = 2.21 \times 10^{-3}$$

$$\therefore \text{Lateral strain} = 0.3 \times 2.21 \times 10^{-3} = \frac{\text{decrease in diameter}}{\text{original diameter}}$$

$$\therefore \text{Decrease in diameter} = 0.663 \times 10^{-3} \times 12 = 7.956 \times 10^{-3} \text{ mm.}$$

- 2.4 If ultimate tensile strength for the material of bar in the above example is 650 MPa, find the factor of safety.

*Solution:* 
$$F \cdot S = \frac{S_{ut}}{\sigma_t} = \frac{650}{442.09} = 1.47$$

- 2.5 A steel wire of 6 mm diameter is used for hoisting. 100 m length of wire is hanging vertically with a load of 1.5 kN being lifted at the lower end of wire. The density of wire material is  $7.7 \times 10^4$  N/m<sup>3</sup> and  $E = 2 \times 10^5$  MPa. Determine the total elongation of wire.

*Solution:* Total elongation = elongation due to weight  $W$  (1.5 kN) + elongation due to self weight  $W_1$  acting from C.G. of wire at  $L/2$

Now 
$$W_1 = \frac{\pi}{4} \left( \frac{6}{1000} \right)^2 \times 1 \times 7.7 \times 10^4 \times 100 \text{ N}$$

$$= 217.71 \text{ N}$$

$$\therefore \text{Total elongation} = \frac{WL}{AE} + \frac{W_1 L}{2AE}$$

$$= \frac{1.5 \times 1000 \times 1 \times 10^5}{\frac{\pi}{4} (6)^2 \times 2 \times 10^5} + \frac{217.71 \times 1 \times 10^5}{2 \times \frac{\pi}{4} (6)^2 \times 2 \times 10^5}$$

$$= 28.44 \text{ mm}$$

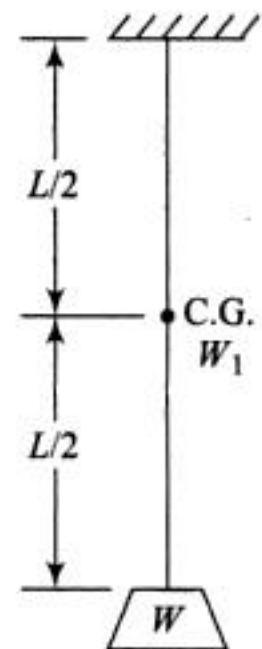

**Fig. E-2.5**

- 2.6 A steel flat 10 mm wide and 12 mm thick bar is bent into a circular arc of radius 12 m. Find the maximum intensity of stress induced in the cross section.

$$E = 2 \times 10^5 \text{ MPa}$$

*Solution:*

$$\sigma_t = \frac{E}{R} y = \frac{2 \times 10^5}{12 \times 1000} \times \frac{t}{2} = \frac{2 \times 10^5 \times 6}{12 \times 1000} = 100 \text{ MPa}$$

- 2.7 The thickness of flanges and web of a 200 mm × 75 mm standard channel is 12 mm and 6 mm respectively. Find moment of inertia of section about *XX* and *YY* axes.

*Solution:*

$$I_{xx} = \frac{1}{12} \times 75 \times 200^3 - \frac{1}{12} \times 69 \times 176^3$$

$$= 18652288 \text{ mm}^4$$

To find  $I_{yy}$ , let us find  $\bar{x}$

$$\bar{x} = \frac{a_f x_1 + a_w x_2 + a_f x_3}{2a_f + a_w}$$

$a_f, a_w$  — areas of flange and web respectively

$x_1, x_2, x_3$  — distances of C.G. of areas from reference line *AB*

$$\bar{x} = \frac{(75 \times 12 \times 37.5) \times 2 + 176 \times 6 \times 3}{75 \times 12 \times 2 + 176 \times 6}$$

$$= 24.74 \text{ mm}$$

using parallel axis theorem

$$I_{yy} = \left( \frac{1}{12} \times 12 \times 75^3 \right) \times 2 + [75 \times 12 (37.5 - 24.74)^2] \times 2$$

$$+ \frac{1}{12} \times 176 \times 6^3 + 176 \times 6 \times (24.74 - 3)^2 = 1638166.4 \text{ m}^4$$

- 2.8 Two identical steel bars are pin connected and a load of 500 kN is attached to point *B*. Find the required area of cross section of bars so that the normal stress in bars is limited to 200 MPa. Also find the vertical displacement of point *B*.  $E = 200 \text{ GPa}$ ,  $BC = AB = 3 \text{ m}$ .

*Solution:* From the equilibrium of forces

$$2(1/\sqrt{2}) F_1 - 500 = 0$$

$$F_1 = 354 \text{ kN}$$

Required area  $A = \frac{F_1}{\text{permissible stress}}$

$$= \frac{354 \times 1000}{200} = 1770 \text{ mm}^2$$

By approximation

$$BB' = \frac{DB'}{\cos 45^\circ}$$

where  $DB$  is the extension of either link.

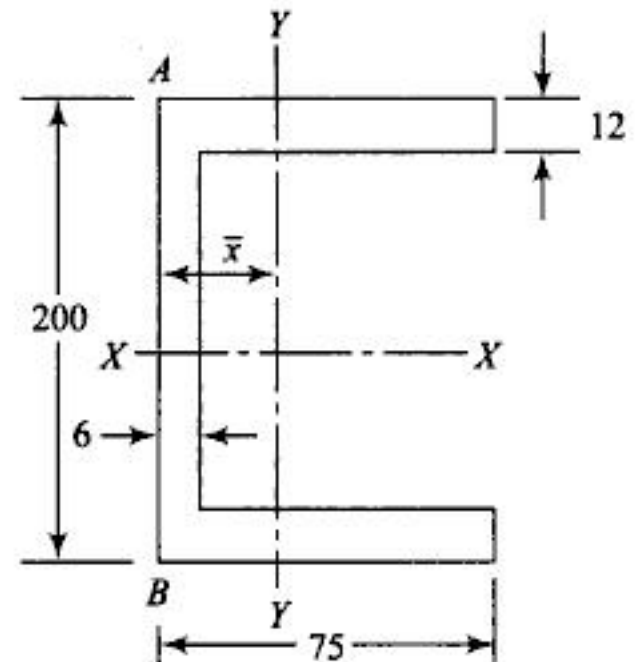

Fig. E-2.7

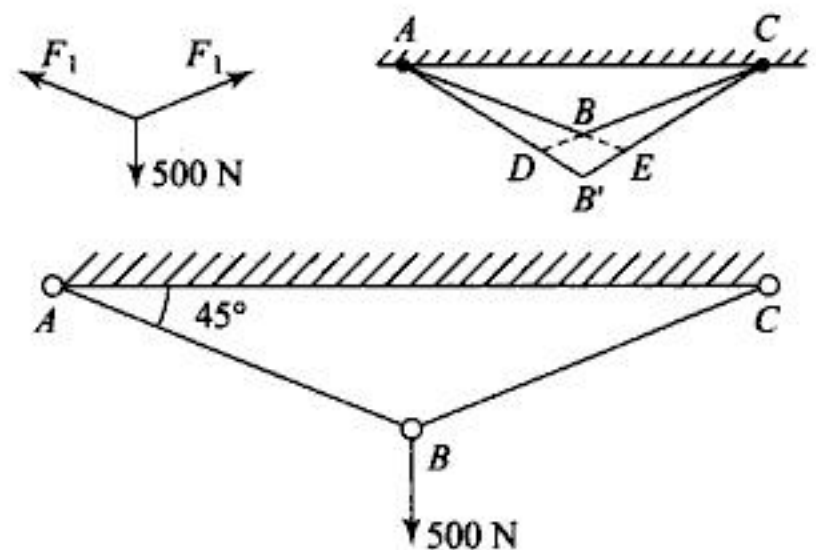

Fig. E-2.8

$$DB' = \frac{Pl}{AE} = \frac{354 \times 3000 \times 10^3}{1770 \times 2 \times 10^5} = 3 \text{ mm}$$

$$BB' = \frac{3}{1/\sqrt{2}} = 4.25 \text{ mm}$$

2.9 A machine element is subjected to an axial load of 200 kN. Design the member.

*Solution:* First three steps of design procedure are eliminated and we start from the 4th step, i.e. selection of material. The materials available are m.s., C.I, A, I, copper and its alloys. The last two may not be used due to high cost and with no specific reason for using them. As the load is tensile and C.I is weak under tension, m.s is the appropriate choice.

Referring to the Table 2 hot rolled 14C6 or 20C8 steel may be used for which  $S_y = 300 \text{ MPa}$ ,  $S_{at} = 400 - 500 \text{ MPa}$ .

In absence of any specific condition the factor of safety of 3 to 5 based on  $S_y$  may be used. Let  $F \cdot S = 3$ ,  $S_y = 300 \text{ MPa}$  and  $P = 200 \text{ kN}$

$$\sigma_t = \frac{P}{A} = \frac{S_y}{F \cdot S}, \quad \therefore \frac{200 \times 10^3}{\frac{\pi}{4} d^2} = \frac{300}{3}$$

$$d = 50.46 \text{ mm}$$

For standardisation let  $d = 50 \text{ mm}$  even though it may reduce  $F \cdot S$  slightly. If we round it off to the next standard diameter of 55 mm cost may increase which is undesirable.

2.10 If length of the element in above example is 1000 mm, what maximum axial load should act on the rod such that deformation in axial direction is not more than 0.5 mm ?

$$E = 2 \times 10^5 \text{ MPa}$$

*Solution:*

$$\delta l = \frac{Pl}{AE}, \quad \therefore P = 0.5 \times \frac{\pi (50)^2 \times 2 \times 10^5}{1000 \times 1000} = 196.35 \text{ kN}$$

Thus, if maximum permissible elongation is the criteria of design, the rod cannot take a load of 200 kN even though induced stress is within the permissible limit.

2.11 A compression member of FG 200 C.I has to support a load of 750 kN. Using a ratio of 2 for the outer to inner diameter and  $F \cdot S$  as 6, based on the ultimate strength, find the diameters of the rod using  $S_{uc} = 630 \text{ MPa}$  for FG 200 C.I.

*Solution:*

From Fig. E-2.11, the area of cross section of machine member is

$$A = \frac{\pi}{4} [(2d)^2 - d^2] = 0.75\pi d^2$$

where  $d$  is the inner diameter.

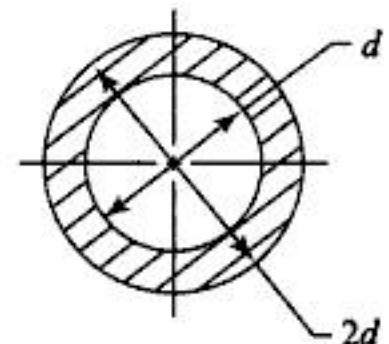

**Fig. E-2.11**

$$\therefore \sigma_c = \frac{P}{A} = \frac{S_{uc}}{F \cdot S}, \quad \therefore 0.75 \pi d^2 = \frac{750 \times 10^3 \times 6}{630}$$

$$\therefore d = 55.05 \text{ mm rounded to } 55 \text{ mm}$$

$$\therefore \text{outer diameter} = 2d = 110 \text{ mm}$$

- 2.12 If the compression member in Example 2.11 has square cross section with the side of outer square, double the side of inner square, find the cross-sectional dimension.

*Solution:*

$$A = 4b^2 - b^2 = 3b^2$$

$$\therefore \sigma_c = \frac{P}{A} = \frac{S_{uc}}{F \cdot S}$$

$$\therefore A = \frac{P}{S_{uc}} (F \cdot S)$$

$$\therefore 3b^2 = \frac{750 \times 10^3 \times 6}{630}$$

$$\therefore b = 48.79 \text{ mm rounded to } 50 \text{ mm}$$

$$\therefore \text{outer side} = 2b = 100 \text{ mm.}$$

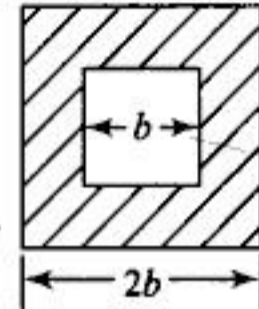

**Fig. E-2.12**

- 2.13 If the material for compression member in Examples 2.11 and 2.12 is 30 C8 steel what will be the changes in design ?

*Solution:*

As the compressive strengths of 200 FG C.I. and 30 C8 steel are approximately same, the dimensions of cross section will also remain the same. Use of 200 FG C.I may reduce the cost. As C.I or steel pipes are readily available, use of circular cross section is preferable.

- 2.14 A hollow compression member is subjected to an axial load of 50 kN. The material used is 200 FG C.I with  $S_{uc} = 600$  MPa. Find the cross-sectional dimensions if
- the section is hollow circular with outer diameter 1.5 times the inner diameter
  - the section is square box with side of outer square 1.5 times the side of inner square
  - the section is square the outer side of which is 1.5 times diameter  $D$  of circular bore. Based on ultimate strength  $F \cdot S = 6$ .

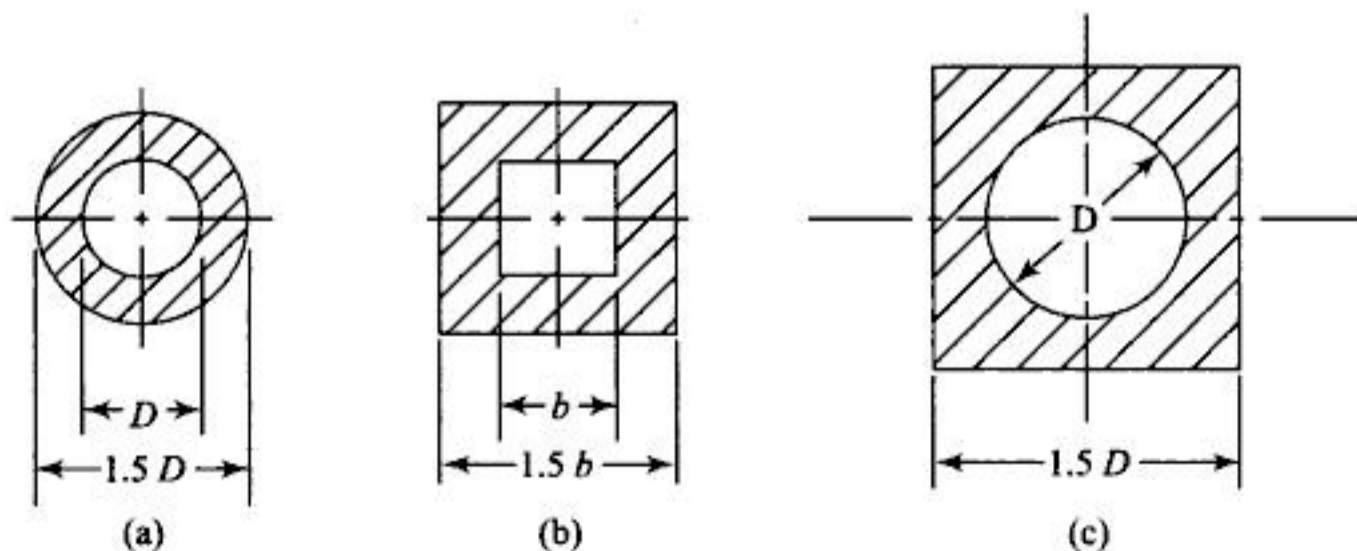

**Fig. E-2.14**

Solution:

For compressive load

$$A = \frac{P}{\sigma_c} \text{ where } A \text{ is the area of cross section}$$

$$\therefore A = \frac{50,000}{100} = 500 \text{ mm}^2$$

For case (a)

$$A = \frac{\pi}{4} (1.5^2 - 1) D^2$$

$$= 0.9817 D^2 \text{ for section at } a$$

$$A = 0.9817 D^2 = 500 \text{ mm}^2$$

$\therefore$

$$D = 22.568 \text{ mm}$$

For case (b)

$$A = 1.25 b^2$$

$\therefore$

$$1.25 b^2 = 500, \quad \therefore b = 20 \text{ mm}$$

For case (c)

$$A = \left(2.25 - \frac{\pi}{4}\right) D^2$$

$$= 1.46 D^2 = 500 \text{ mm}^2, \quad \therefore D = 18.5 \text{ mm modified to } 20 \text{ mm.}$$

$$\sigma_c = \frac{S_{uc}}{F \cdot S} = \frac{600}{6} = 100 \text{ MPa}$$

$$P = 50,000 \text{ N}$$

- 2.15 A link shown in Fig. E-2.15 is subjected to a tensile load of 40 kN with  $h = 2t$ ,  $L = 475$  mm. Maximum permissible elongation is 0.125 mm. The material used is 30 C8 steel with  $S_y = 330$  MPa,  $S_{ut} = 500$  MPa. Find 'h' and 't'.

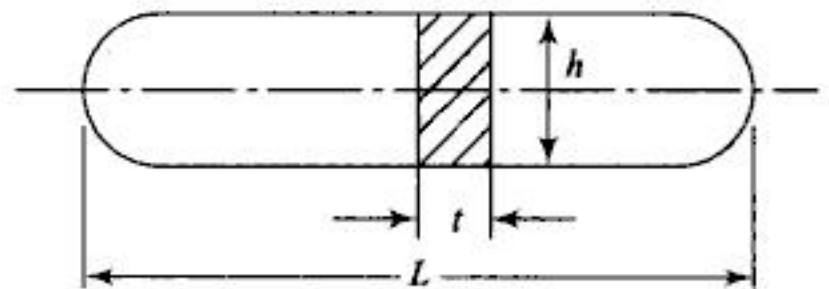

Fig. E-2.15

Solution:

Failure of the link may take place under two conditions

Condition 1: Induced stress  $\leq$  permissible stress  
let  $F \cdot S = 4$

$$\therefore \sigma_t = \frac{P}{A} = \frac{S_y}{F \cdot S}$$

$$\therefore A = h \times t = \frac{40 \times 10^3 \times 4}{330} = 484.848 \text{ mm}^2$$

Putting

$$h = 2t, t = 15.56 \text{ rounded to } 16 \text{ mm}$$

$$h = 32 \text{ mm}$$

Condition 2: Permissible elongation  $\leq 0.125$  mm. Now  $\delta l = \frac{Pl}{AE}$

$$\therefore 0.125 = \frac{40 \times 10^3 \times 475}{h \times t \times 2 \times 10^5}$$

$$t = 19.49 \text{ rounded to } 20 \text{ mm} \quad h = 40 \text{ mm.}$$

Thus, with  $t = 20$  mm and  $h = 40$  mm both induced stress and deformation will be within limit.

- 2.16 If a slot of 15 mm width has to be cut in the link of Example 2.15 what modification in  $h$  and  $t$  is required?

Solution:

There is no need of separate calculation if thickness is to be kept the same. The designer should see that the area of cross section remains same for the link with slot. This is achieved by increasing the dimension  $h$  by 15 mm which is the width of the slot. Thus the modified dimensions will be  $t = 20$  mm and  $h = 55$  mm.

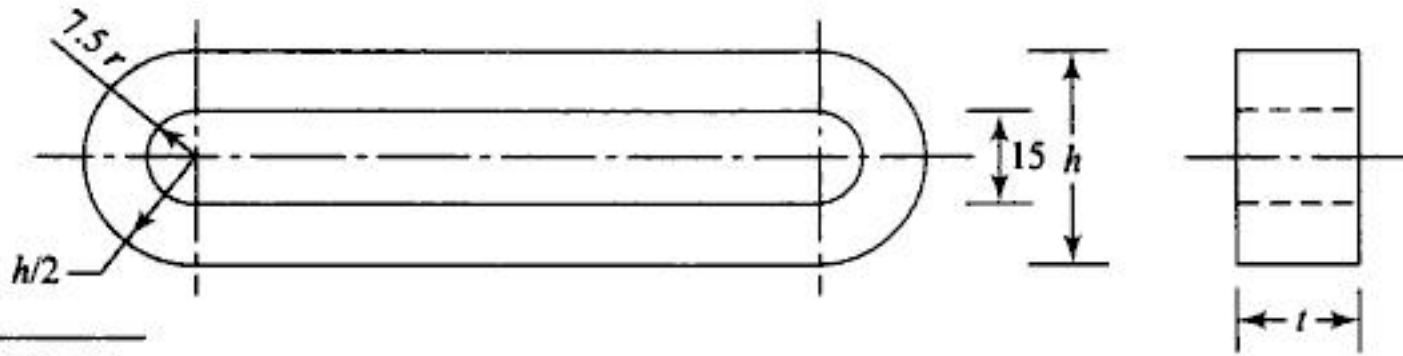

**Fig. E-2.16**

2.17 A shaft is supported with two bearings and is subjected to a radial load of 70 kN. Permissible bearing pressure is 1.5 MPa. Diameter of shaft is 100 mm. Find the length of bearings.

*Solution:*

$$\text{Permissible bearing pressure} = \frac{\text{load on each bearing}}{\text{projected area of each bearing}}$$

Load on each bearing = 35 kN

Projected area of each bearing = diameter of shaft × length of bearing

Substituting

$$1.5 = \frac{35,000}{100l}, \quad \therefore l = 233.33 \text{ mm modified to } 235 \text{ mm.}$$

2.18 Solve Example 2.14 for the section shown in Fig. E-2.18.

*Solution:*

$$\begin{aligned} \text{Area of section} &= \left( \frac{\pi}{4} - 0.25 \right) D^2 \\ &= 0.5354 D^2 = 500 \text{ mm}^2 \\ D &= 30.56 \text{ mm, modified to } 30 \text{ mm.} \end{aligned}$$

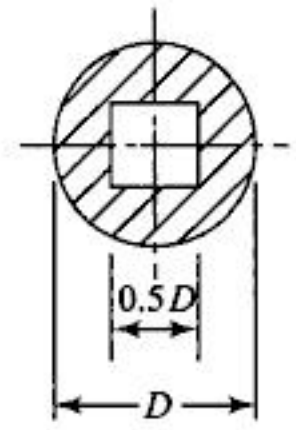

**Fig. E-2.18**

2.19 Two links of 30 C8 steel are connected by a pin of the same material. The links are subjected to an axial tensile load of 5 kN and have a rectangular cross section with width to thickness ratio of 2 : 1. Design the links and the pin.

*Solution:*

First, let us decide the dimensions of pin. The pin is subjected to single shear and bearing as shown in Fig. E-2.19 (a) and (b) respectively. Let  $P_b = 30 \text{ MPa}$ .

Again as  $S_y = 330 \text{ MPa}$  for 30 C8 steel,  $S_{ys} = 0.5 S_y = 166 \text{ MPa}$ . Let  $F \cdot S = 3$

(a) Bearing failure of pin,

$$\therefore P = P_b \times d \times l, \quad \therefore d \times l = \frac{5 \times 10^3}{30} = 165.67 \text{ mm}^2$$

length  $l$  of the pin depends on the thickness of links. Let us calculate it.

(b) 
$$\sigma_t = \frac{P}{A} = \frac{S_y}{F \cdot S}$$

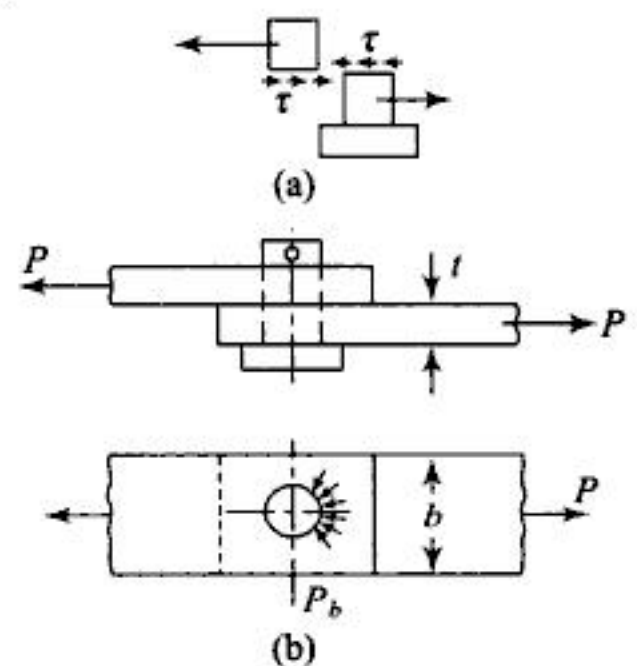

**Fig. E-2.19**

Area of cross section of link

$$= \frac{5000 \times 3}{330} = b \times t = 2t^2$$

$\therefore t = 6.74 \cong 10 \text{ mm}$  and  $b = 20 \text{ mm}$

$\therefore$  Length of pin  $l = 20 \text{ mm}$ ,  $\therefore d = 8.285 \cong 10 \text{ mm}$ . Let us check diameter of the pin for shear

$$\tau = \frac{P}{A} = \frac{5000 \times 4}{\pi \times 10^2} = 63.66 \text{ MPa}$$

$\therefore$  F.S =  $\frac{165}{63.66} = 2.59$

F.S is less than 3 and by increasing the diameter of the pin, hole for the pin in the link will have to be increased. Hence there is no harm in keeping the pin weaker.

Portion of the link to receive the pin will be modified in shape as shown in Fig. E-2.19(c). Let us check margin  $l_1$  of the link at the end.

This margin is decided by considering failure at the end of the link by shearing as shown in Fig. E-2.19(d).

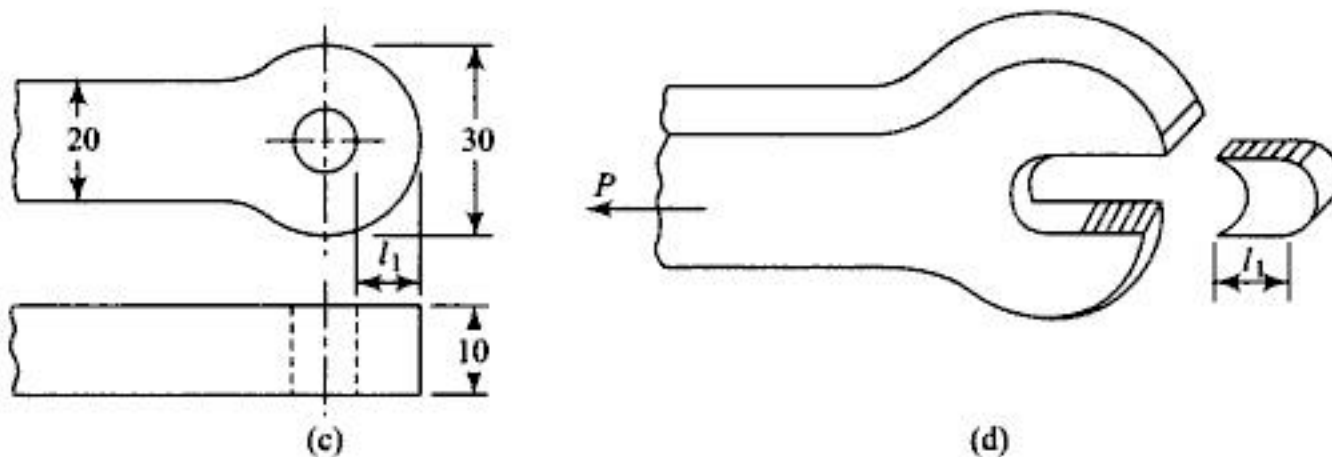

Fig. E-2.19

$$\tau = \frac{P}{2A} = \frac{S_{ys}}{F \cdot S}, \text{ Let } F \cdot S = 4$$

$\therefore 2 \times l_1 \times 10 = \frac{5000 \times 4}{165}$

$\therefore l_1 = 24.24$  rounded to 25 mm

2.20 A hypothetical machine element is subjected to bending moment as shown in Fig. E-2.20(a).  $P = 6 \text{ kN}$ ,  $l = 350 \text{ mm}$ . Material is 30 C8 steel with  $S_y = 350 \text{ MPa}$ ,  $F \cdot S = 3$ . Find the dimensions of the most economical cross section.

Solution:

The conventional cross sections used are (a) solid circular, (b) rectangular and (c) I section as shown in Fig. E-2.20 (b)

Maximum bending moment acting on fixed end =  $P \times l$   
 $= 6 \times 1000 \times 350 = 21 \times 10^5 \text{ N.mm}$

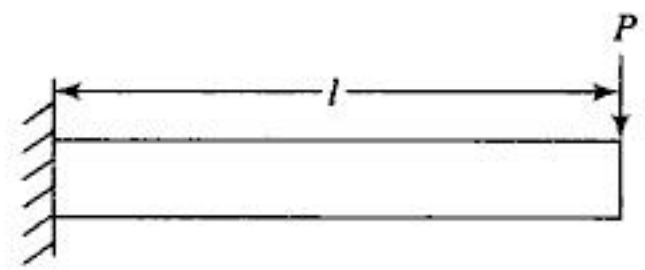
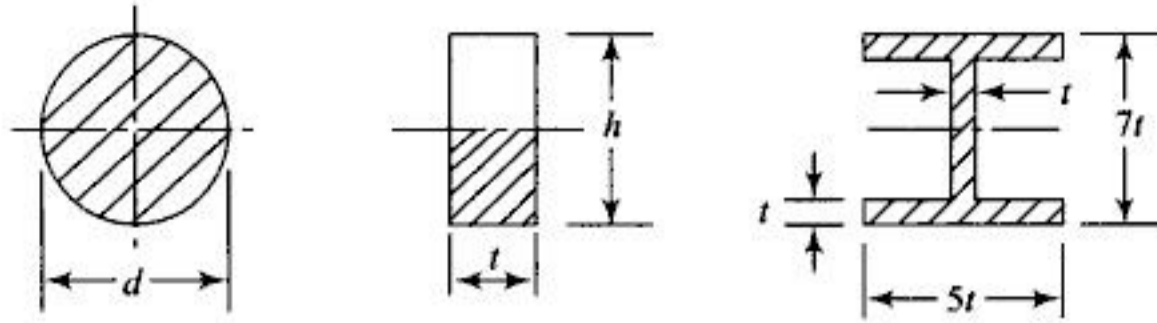

Fig. E-2.20(a)

**Fig. E-2.20(b)**

$$\therefore \sigma_t = \frac{M}{Z} = \frac{S_r}{F \cdot S}, \text{ Let } F \cdot S = 3$$

$$Z = \frac{21 \times 10^5 \times 3}{350} = 18000 \text{ mm}^3$$

(a) for circular section  $I_{xx} = I_{yy} = \frac{\pi}{64} d^4 \text{ mm}^4$

$$\therefore Z_{xx} = \frac{\pi}{32} d^3 = 18000 \text{ mm}^3, \therefore d = 56.8 \text{ mm} \cong 60 \text{ mm}$$

(b) for rectangular section  $I_{xx} = \frac{1}{12} th^3$

$$\therefore Z_{xx} = \frac{1}{6} th^2 = \frac{1}{6} t \times (2t)^2 = 18,000 \text{ mm}^3$$

$$\therefore t = 30 \text{ mm}, h = 90 \text{ mm}$$

(c) for I section

$$I_{xx} = \frac{1}{12} 4t(7t)^3 - \frac{1}{12} 3t \times (5t)^3$$

$$= 83.08 t^4$$

$$Z_{xx} = \frac{I_{xx}}{3.5t} = 2373t^3 = 18,000 \text{ mm}^3$$

$$\therefore t = 9.11 \text{ mm} \times 10 \text{ mm}$$

Thus, most economical section is the one with minimum cross-sectional area.

(a) for circular section cross-sectional area =  $\frac{\pi}{4} \times 60^2 = 2827.43 \text{ mm}^2$

(d) for rectangular section cross-sectional area =  $90 \times 30 = 2700 \text{ mm}^2$

(c) for I section cross-sectional area =  $(170 \times 40 - 50 \times 30) = 1300 \text{ mm}^2$

Hence, I section is preferable.

- 2.21 A C.I pulley of 600 mm diameter transmits 30 kW at 300 r.p.m. The pulley is secured to the shaft by means of key. The material for shaft and key is 30C8 steel. Find the diameter  $d$  of shaft and dimensions of key, assuming width of key =  $d/4$ . For 30C8 Steel  $S_y = 330 \text{ MPa}$ .

**Solution:**

$v$  = peripheral speed of pulley in m/s

$D$  = diameter of pulley in m

$F_t$  = Tangential force on pulley

$$v = \frac{\pi DN}{60} = \frac{\pi \times 600 \times 300}{60 \times 1000} = 9.424 \text{ m/s}$$

$$\text{Power} = F_t \times v$$

$$\therefore F_t = \frac{30 \times 1000}{9.424} = 3183.36 \text{ N}$$

$$\begin{aligned} \therefore \text{Torque} &= F_t \times \text{radius of pulley} \\ &= \frac{3183.36 \times 300}{1000} = 955 \text{ N.m} = 955 \times 10^3 \text{ N.mm} \end{aligned}$$

$$\text{Safe} \quad \tau = \frac{S_{ys}}{F \cdot S} = \frac{165}{5} = 33 \text{ MPa, as } S_{ys} = 0.5 S_y$$

Again

$$T = \tau \cdot Z_p$$

$$\therefore Z_p = \frac{955 \times 10^3 \times 5}{165} = 28.94 \times 10^3 \text{ mm}^3 = \frac{\pi}{16} d^3$$

$$d = 52.8 \text{ mm} \approx 55 \text{ mm}$$

F·S of 5 is selected because the strength of shaft is reduced due to keyway. The key fails due to shearing and crushing (Fig. E-2.21).

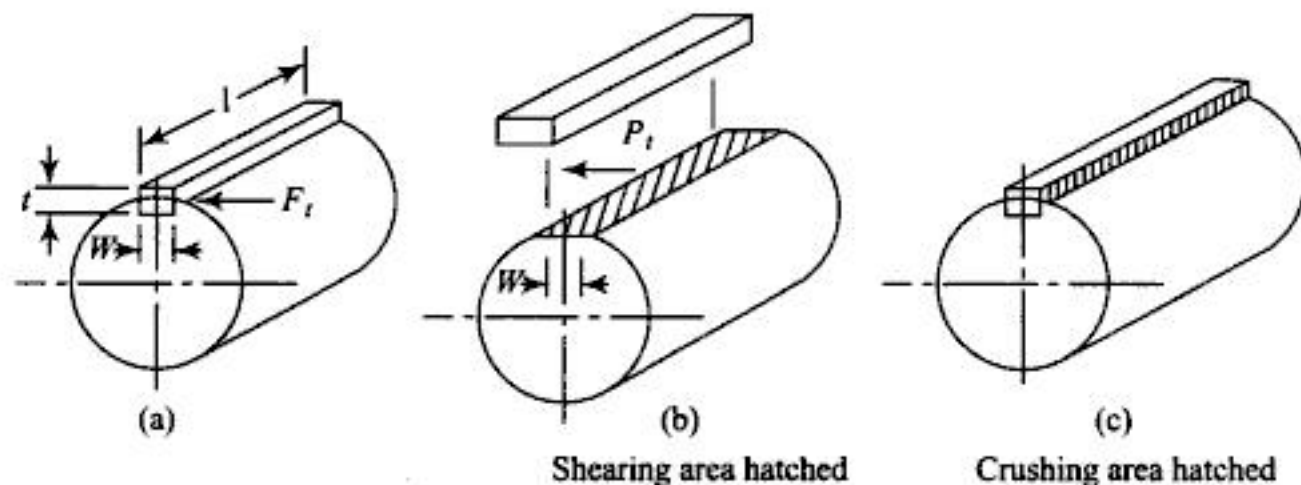

**Fig. E-2.21**

The key is subjected to a tangential force

$$P_t = \frac{T}{d/2} = \frac{955 \times 10^3}{55/2} = 34727.3 \text{ N}$$

$$w = \frac{d}{4} = 14 \text{ mm}$$

From Fig. E-2.21 (b), shearing area is  $w \times l$

$$\therefore \tau = \frac{34727.3}{w \times l} = \frac{165}{F \cdot S}, \text{ Let } F \cdot S = 4$$

$$\therefore l = 60.133 \text{ mm} \approx 60 \text{ mm}$$

F·S for key is chosen less than the F.S for shaft as replacement of key is easier and economical.

Crushing of key is used to find thickness 't'. Crushing area is  $\frac{t}{2} \times l$

$$S_{uc} = 630 \text{ MPa, F.S} = 4 \text{ based on } S_{uc}$$

$$\sigma_c = \frac{34727.3}{\frac{t}{2} \times 60} = \frac{S_{uc}}{\text{F.S}} = \frac{630}{4}, \quad \therefore t = 7.349 \cong 8 \text{ mm}$$

$\therefore$  The key should be rectangular with dimensions as,  $t = 8 \text{ mm}$   
 $w = 14 \text{ mm}$   
 $l = 60 \text{ mm}.$

2.22 The pulley in Example 2.21 has 4 straight arms of elliptic section with the major axis of ellipse being double the minor axis. Determine the cross section of arms using  $S_{ut} = 140 \text{ MPa}$  for C.I.

*Solution:*

The torque on pulley causes b.m on arms as shown in Fig. E-2.22. Take the maximum length of arms equal to difference between radius of pulley and radius of shaft, i.e.  $= 300 - 27.5 = 272.5 \text{ mm}.$

$$\therefore \text{Maximum b.m on each arm} = \frac{3183.36 \times 272.5}{4} = 216866.4 \text{ N.mm}$$

Taking F.S = 7

$$\sigma_t = \frac{216866.4}{Z} = \frac{140}{7}$$

$$Z = 10843.32 \text{ mm}^3 = \frac{\pi}{32} b a^2 = \frac{\pi}{32} b (2b)^2 = \frac{\pi}{8} b^3$$

$$\therefore b = 30.22 \text{ mm} \cong 32 \text{ mm, } a = 64 \text{ mm}.$$

2.23 A hollow steel shaft 3 m long transmits 25 kN.m torque. The total angle of twist not exceeding  $2^\circ$  and permissible shear stress is equal to 60 MPa, find the inner and outer diameter of shaft.  $G = 0.8 \times 10^5 \text{ MPa}.$

*Solution:*

$$\theta = \frac{Tl}{JG}, \quad \therefore \frac{2 \times \pi}{180} = \frac{25 \times 10^6 \times 3000}{\frac{\pi}{32} (d_o^4 - d_i^4) \times 0.8 \times 10^5}$$

$$d_o^4 - d_i^4 = 2.7356 \times 10^8 \text{ mm}^4$$

Again induced  $\tau = \frac{16Td_o}{\pi(d_o^4 - d_i^4)} = 60 \text{ MPa}$

$$\therefore 60 = \frac{16 \times 25 \times 10^6 d_o}{\pi \times 2.7356 \times 10^8}$$

$$\therefore d_o = 128.91 \text{ mm} \cong 130 \text{ mm}$$

$$d_i = 58.91 \text{ mm} \cong 58 \text{ mm}$$

Inner diameter is modified on the lower side as it increases the section modulus.

2.24 Calculate the value of maximum clearance, hole tolerance and shaft tolerance according to the basic hole system for following combinations. Basic size is 50 mm. (1)  $H_7 p_6$ , (2)  $H_6 g_5$

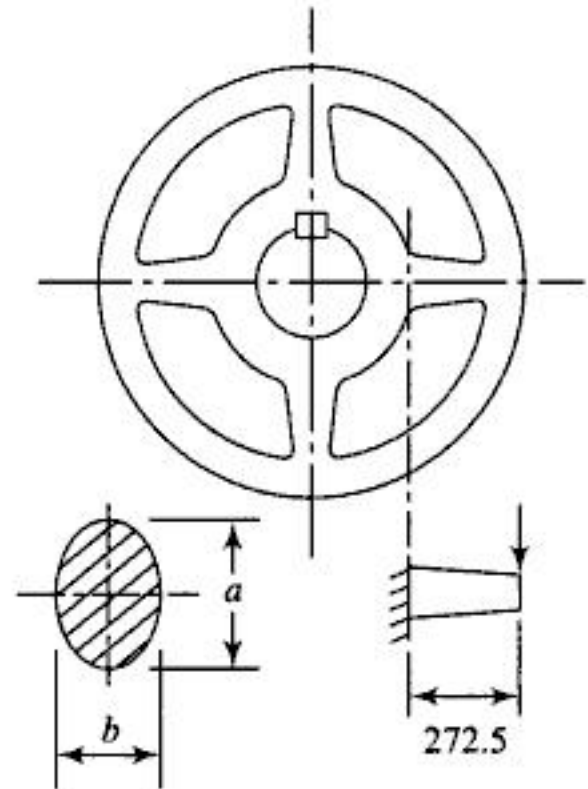

**Fig. E-2.22**

Tolerance grade	Tolerance in microns
7	$7.5 \times \sqrt[3]{d}$
6	$4.7 \times \sqrt[3]{d}$
5	$3.2 \times \sqrt[3]{d}$

Fundamental deviation in microns  
for hole  $H \dots 0$

for shaft  $g \dots 8 \sqrt[3]{d^2}$

for shaft  $p \dots 2.1 \sqrt[3]{d^2}$

*Solution:*

1. For  $H_7p_6$  combination,  $IT$  for shaft =  $4.7 \sqrt[3]{50} = 17.315$  microns

$IT$  for hole =  $7.3 \sqrt[3]{50} = 26.89$  microns

Fundamental deviation for hole  $H = 0$  microns

Fundamental deviation for shaft  $p = 2.1 \sqrt[3]{50^2} = 28.5$  microns

$\therefore$  Hole size = 50.00 mm to 50.02689 mm

Shaft size = 50.0285 mm to 50.04581 mm

These sizes are obtained as

Min. size of hole = Basic size + Fundamental deviation  
=  $50 + 0.00 = 50.00$  mm

Max. size of hole = Minimum size + Tolerance  
=  $50.00 + 0.02689 = 50.02689$  mm

Min. size of shaft =  $50 + 0.0285 = 50.0285$  mm

Max. size of shaft =  $50.0285 + 0.01731 = 50.04581$  mm

2. For  $H_6g_5$  combination

$IT$  for shaft =  $3.2 \times \sqrt[3]{50} = 11.79$  microns

$IT$  for hole =  $4.7 \times \sqrt[3]{50} = 17.31$  microns

Fundamental deviation for hole  $H = 0.00$  microns

Fundamental deviation for shaft  $p = -8 \sqrt[3]{2500} = -108.57$  microns

Hole size = 50.00 mm to 50.01731 mm

Shaft size = 49.90322 mm to 49.89143 mm

2.25 Using the table for tolerances find the type of fit, maximum and minimum clearance or interference for 150 G7 - e8 combination.

*Solution:*

For G7 hole of basic size = 150 mm

$EI = 14$  microns,  $IT = 40$  microns

For e8 shaft  $ei = -85$  micron,  $IT = 63$  microns

Hole size = 150.014 to 150.054 mm

Shaft size =  $(150 - 0.085 - 0.063) = 149.852$  mm to 149.915 mm

Max. clearance = Max. hole size - Min. shaft size =  $150.054 - 149.852 = 0.202$  mm

Min. clearance = Min. hole size - Max. shaft size =  $150.014 - 149.915 = 0.099$  mm.

- 2.26 What are the values of maximum interference, hole tolerance and shaft tolerance in following cases?
- (a) Hole size Max. 50.025 mm. Min. 50.000 mm  
 Shaft size Max. 50.042 mm. Min. 50.026 mm
- (b) Hole size Max. 200.046 mm. Min. 200.000 mm  
 Shaft size Max. 200.079 mm. Min. 200.050 mm

*Solution:*

- (a) Maximum interference = Max. shaft size – Min. hole size = 50.042 – 50.00 = 0.042 mm  
 Hole tolerance = 50.025 – 50.00 = 0.025 mm  
 Shaft tolerance = 50.042 – 50.026 = 0.016 mm
- (b) Max. interference = 200.079 – 200.00 = 0.079 mm  
 Hole tolerance = 0.046 mm  
 Shaft tolerance = 0.029 mm

- 2.27 Draw the bar diagram and state the type of fit for 80 H<sub>6</sub>J<sub>5</sub> and 90 H<sub>6</sub>P<sub>5</sub> combination of shaft and hole.

*Solution:*

From the Table 7 for grade 6 and 5, tolerances are 22 and 15 microns respectively. While lower deviation for H<sub>6</sub> hole, J<sub>5</sub> shaft and P<sub>5</sub> shaft is +9, –9 and +37 microns respectively.

∴ For H<sub>6</sub>J<sub>5</sub> combination

Hole size = 80.031 mm to 80.009 mm

Shaft size = 80.006 mm to 79.991 mm

For H<sub>6</sub>P<sub>5</sub> combination

Hole size = 80.031 mm to 80.009 mm

Shaft size = 80.052 mm to 80.37 mm

H<sub>6</sub>J<sub>5</sub> bar diagram

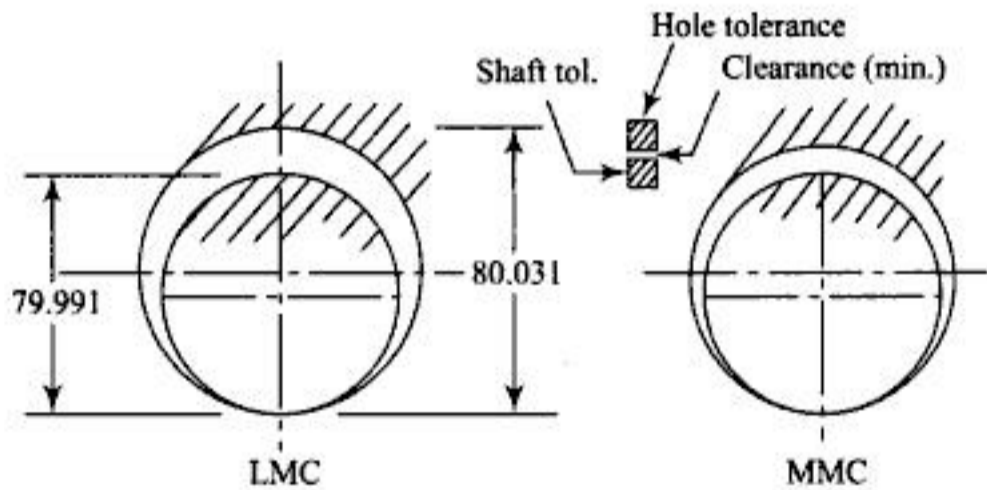

**Fig. E-2.27a**

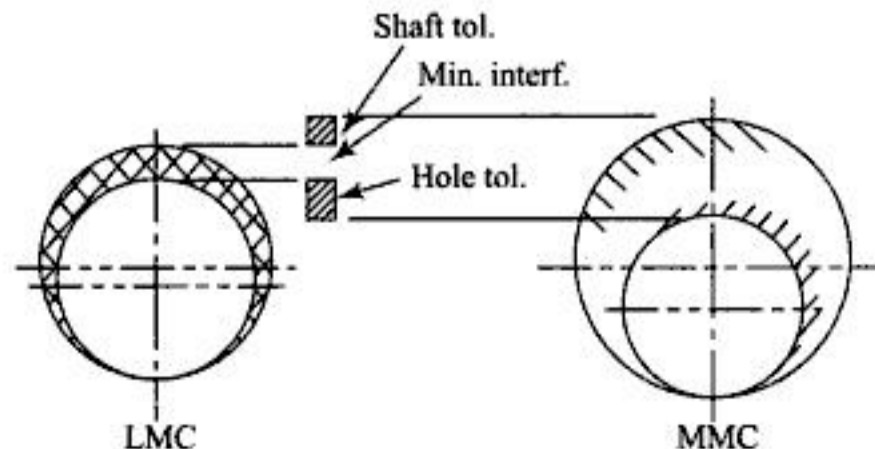

**Fig. E-2.27b**

2.28 Determine the limiting dimensions of a gudgeon pin and piston of 20 H<sub>6</sub>g<sub>5</sub> combination.

*Solution:*

For a (g<sub>5</sub>) type shaft fundamental deviation is (-16) microns and tolerance is 9 microns and for an H<sub>6</sub> hole of 20 mm diameter, fundamental deviation and tolerance are 0.00 and +13 microns respectively.

$$\begin{aligned} \text{Min. shaft size} &= 20 - (0.016) = 19.984 \text{ mm} \\ \text{Max. shaft size} &= 19.984 + (0.009) = 19.993 \text{ mm} \\ \text{Min. hole size} &= 20.00 \text{ mm} \\ \text{Max. hole size} &= 20.00 + 0.013 = 20.013 \text{ mm} \\ \text{Min. clearance} &= \text{Min. hole} - \text{Max. shaft} = 0.007 \text{ mm} \\ \text{Max. clearance} &= \text{Max. hole} - \text{Min. shaft} = 0.029 \text{ mm.} \end{aligned}$$

2.29 Design a shaft and hole combination for selective assembly with a maximum and minimum interference of 0.030 mm and 0.018 mm respectively. A batch of holes of varying sizes from 60 mm to 60.024 mm and shafts of varying sizes from 60.024 to 60.048 mm are produced.

*Solution:*

Four groups of holes of min. and max. sizes

Min. size	60.00 mm	60.006 mm	60.012 mm	60.018 mm
Max. size	60.006 mm	60.012 mm	60.042 mm	60.024 mm

Four corresponding groups of shafts of sizes

Min. size	60.024 mm	60.030 mm	60.036 mm	60.042 mm
Max. size	60.030 mm	60.036 mm	60.042 mm	60.048 mm

2.30 If the maximum and minimum interference in above example have been changed to 0.032 mm and 0.016 mm respectively suggest the groups.

Three groups of holes of following sizes are suggested:

60.00 mm	60.008 mm	60.016 mm
60.008 mm	60.016 mm	60.048 mm

Corresponding 3 groups for sizes of shafts are:

60.024 mm	60.032 mm	60.040 mm
60.032 mm	60.040 mm	60.048 mm

2.31 Suggest the types of fits for the shaft and hole in Example 2.26.

*Solution:*

From the Table 7, 50 H<sub>7</sub>P<sub>6</sub> and 200 H<sub>7</sub>P<sub>6</sub> are the type of fits.

2.32 Considering, maximum interference between a hole and shaft of 100 mm nominal diameter as 47 microns and minimum interference 3 microns, find the dimensions of parts with basic shaft system and basic hole system.

Assuming equal tolerance on hole and shaft; from the bar diagram tolerance on shaft and

$$\text{hole is} = \frac{1}{2} (47 - 3) = 22 \text{ Microns}$$

∴ With basic hole system, the dimensions are

$$\begin{aligned} \text{hole size} &= 100.00 \text{ and } 100.022 \text{ mm} \\ \text{shaft size} &= 100.025 \text{ and } 100.47 \text{ mm} \end{aligned}$$

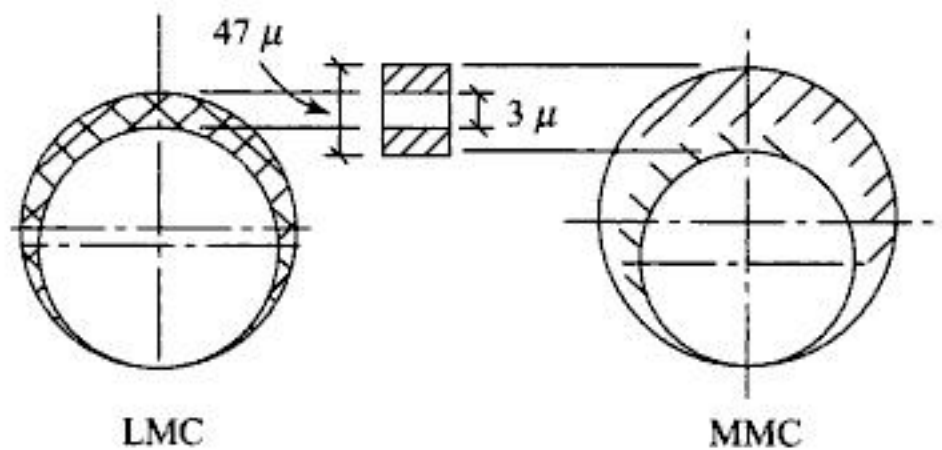

Fig. E-2.32

and with basic shaft system the dimensions are

shaft size = 100.00 and 100.022 mm.

hole size = 99.097 and 99.075 mm.

2.33 Write *R* 10/3 series, *R* 20/3 series for numbers between 10 and 100.

*Solution:*

For *R* 10 series, ratio is  $\sqrt[10]{10} = 1.26$

∴ Numbers in *R* 10 series are 10, 12.5, 16, 20, 25, 31.5, 40, 50, 63, 80, 100.

∴ *R* 10/3 series is obtained by taking every third number, i.e.

10, 20, 40, 80 or 12.5, 25, 50, 100 or 16, 31.5, 63

Similarly *R* 20 series is obtained by taking step ratio  $\sqrt[20]{10}$  and then to obtain *R* 20/3 we take every third number.

∴ *R* 20 series 10, 11.2, 12.5, 14, 16, 18, ..., 80, 90, 100

∴ *R* 20/3 series 10, 14, 20, 28, 40, 56, 80, or  
11.2, 16, 22.4, 31.5, 45, 63, 90 or  
14, 20, 28, 40, 56, 80.

## OBJECTIVE QUESTIONS

- 2.1 Opening and closing of wheel valve requires application of  
 (a) coplanar forces (b) spatial forces (c) moment (d) couple
- 2.2 Polar section modulus of a hollow shaft with inner diameter as half the outer diameter *D* is approximately  
 (a)  $0.472 D^3$  (b)  $0.587 D^3$  (c)  $0.184 D^3$  (d)  $0.5 D^3$
- 2.3 A cantilever is likely to fail due to excessive stress in  
 (a) single shear (b) torsional shear (c) tension (d) compression
- 2.4 Increase in factor of safety causes decrease in  
 (a) cost (b) size  
 (c) induced stress (d) strength of machine member.
- 2.5 Bending moment at *A* on the cantilever shown in Fig. O-2.5  
 (a) 120 kN.m (b) 60 kN.m  
 (c) zero (d) 40 kN.m
- 2.6 A bar of length *L* metres hanging vertically weighing *W* N/m carries a load of *P* Newton at the free end. The tensile force at a distance *d* metres from support of the bar in Newton is  
 (a) *P* (b)  $\{P + W(L - d)\}$  (c)  $\{P + W(L + d)\}$  (d)  $(P + Wd)$
- 2.7 The area under stress-strain curve represents  
 (a) material hardness (b) breaking strength  
 (c) energy required to cause the failure (d) none of the above
- 2.8 Which of the following is dimensionless?  
 (a) Young's modulus (b) stress (c) strain (d) deformation

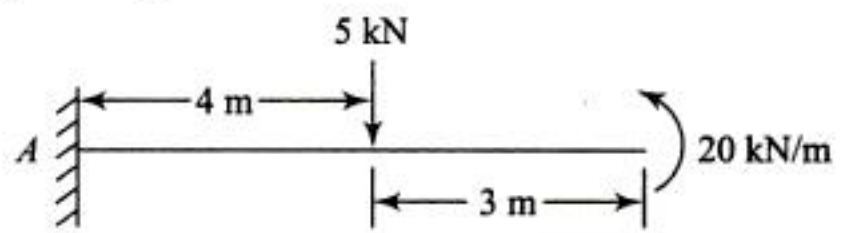

Fig. O-2.5



You have either reached a page that is unavailable for viewing or reached your viewing limit for this book.

- 2.21 Bilateral method of tolerancing is used  
 (a) in producing parts on large scale (b) for dimensioning of holes  
 (c) for dimensioning of shafts (d) in selective assembly
- 2.22 Interference fit is produced  
 (a) under minimum metal condition (b) in the assembly of parts with minimum tolerances  
 (c) under maximum metal condition (d) in basic shaft system
- 2.23 The cost of production can be reduced by  
 (a) using a large factor of safety (b) using large tolerances  
 (c) using low quality material for production (d) using unskilled labour

## REVIEW QUESTIONS

- ■ ■ ■ ■ ■ ■ ■
- 2.1 What are the different possibilities of failure of any machine element?  
 2.2 What is the role of force analysis in design procedure?  
 2.3 Define "Machine Design".  
 2.4 Differentiate between induced stress and safe or design stress.  
 2.5 What is factor of safety? Why is it necessary? Why a very small or a very large factor of safety should not be used?  
 2.6 What is moment of inertia of section? How does it differ from mass moment of inertia?  
 2.7 What is section modulus and polar section modulus? Find the section modulus for rectangular area in terms of width and thickness.  
 2.8 Compare the section modulus of rectangular section about the two axes. Explain how is it beneficial to use rectangular section in a direction in which depth is larger when subjected to bending moment.  
 2.9 Find the polar section modulus of hollow shaft.  
 2.10 Define simple stress and give few examples of machine components subjected to simple stress.  
 2.11 Differentiate between single and double shear.  
 2.12 In what respect does bending stress differ from direct tensile or compressive stress?  
 2.13 Differentiate between direct shear stress and torsional shear stress.  
 2.14 Compare rectangular box section, hollow circular section, elliptic section subjected to bending moment in terms of economy.  
 2.15 Why is transverse shear stress neglected while designing a part subjected to bending moment due to transverse load?  
 2.16 Design of a part subjected to bending moment is done on the basis of safe tensile stress. Why?  
 2.17 Equation (2.8) is applicable to only circular cross sections. Why?  
 2.18 Why is the value of permissible bearing pressure for most components smaller than the permissible crushing stress even though bearing stress is developed due to crushing of the two components against each other?  
 2.19 What should be the method of design if a component has more than one possibilities of failure?  
 2.20 Discuss the factors affecting selection of material for machine element.  
 2.21 Define failure. What are the possible modes of failure?  
 2.22 Why is designing essential before manufacture?  
 2.23 Why are the tolerances used in manufacture?  
 2.24 Which type of components should be given bilateral tolerances? Why?



You have either reached a page that is unavailable for viewing or reached your viewing limit for this book.

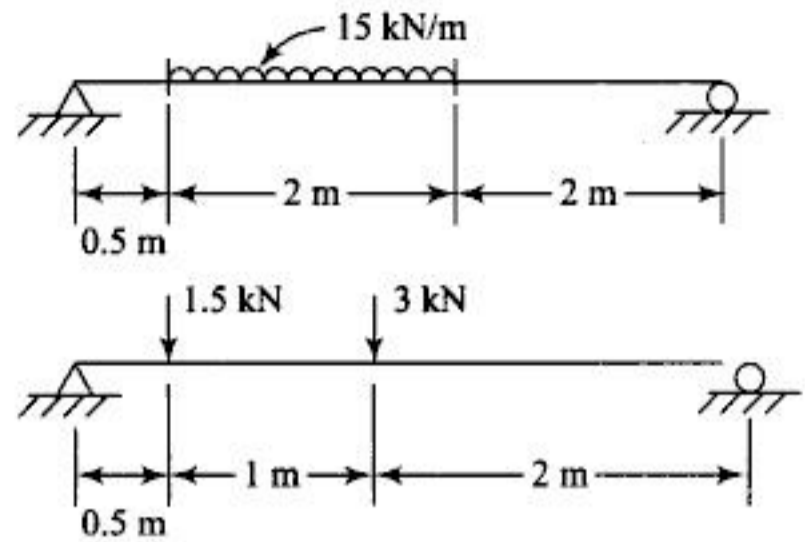
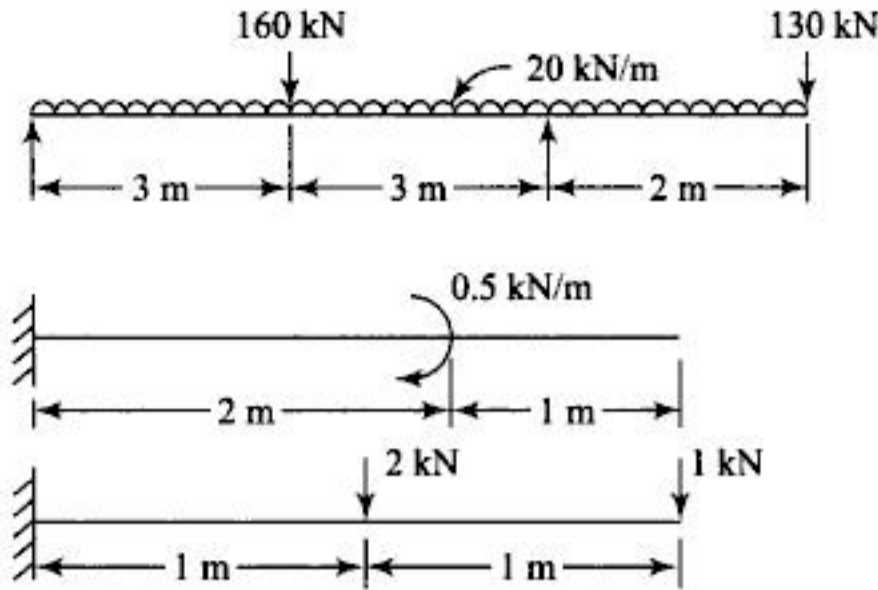

Fig. P-2.5

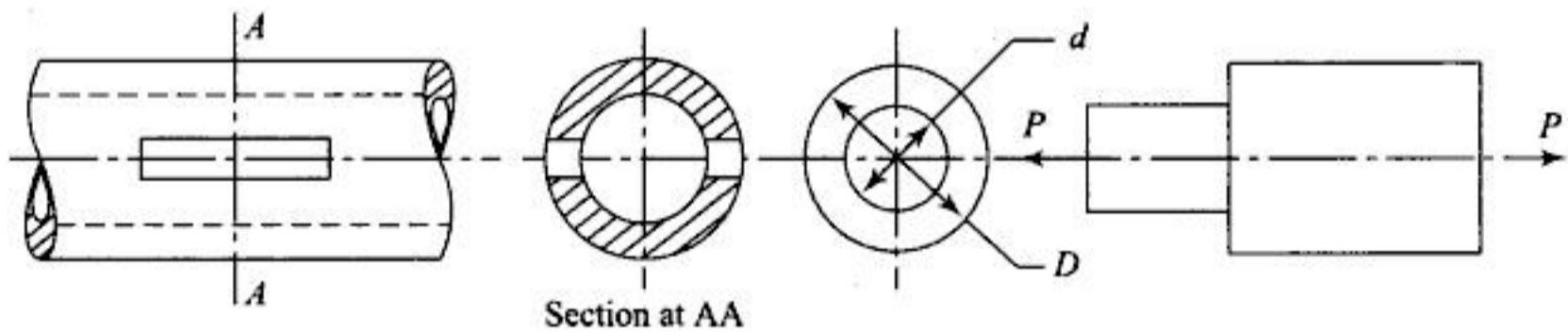

Fig. P-2.8 and P-2.9

2.9 A machine component shown in Fig. P-2.9 is made of 30C8 steel.

$D = 1.5 d$ ,  $F \cdot S = 4$  based on  $S_y$ . Neglecting the effect of stress concentration, find  $D$  and  $d$  if  $P = 40$  kN.

- 2.10 A circular bar shown in Fig. P-2.10 is subjected to a tensile axial load of 20 kN. End of the rod has a slot of 7.5 mm thickness. The material of the rod is 35C8 steel with  $S_y = 350$  MPa,  $S_{uc} = 500$  MPa and a factor of safety of 4 based on  $S_y$ . Find  $d$  and  $d_1$ .
- 2.11 A circular rod is used as handle for rotating the screw of a screw jack. The frictional torque between the screw and nut is 11 kN mm. Find the diameter of rod of 30C8 steel.  $F \cdot S$  is 3.5 based on  $S_y$ .

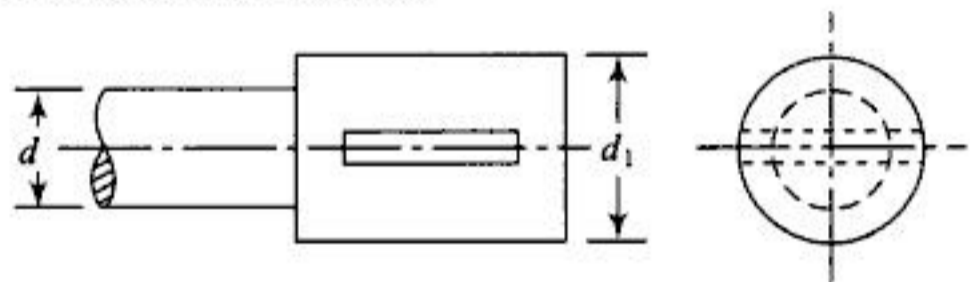

Fig. P-2.10

- 2.12 The lever keyed to the shaft in Fig. P-2.12 has a rectangular section with  $h = 3t$ . A load of 10 kN is gradually applied at the end of the lever. Find the section of lever at  $AA$ . Also find the dimensions of key. Material for lever and key is 20C4 steel with  $S_y = 300$  MPa,  $S_{uc} = 500$  MPa,  $F \cdot S$  is 3 based on  $S_y$  and 5 based on  $S_{uc}$ .

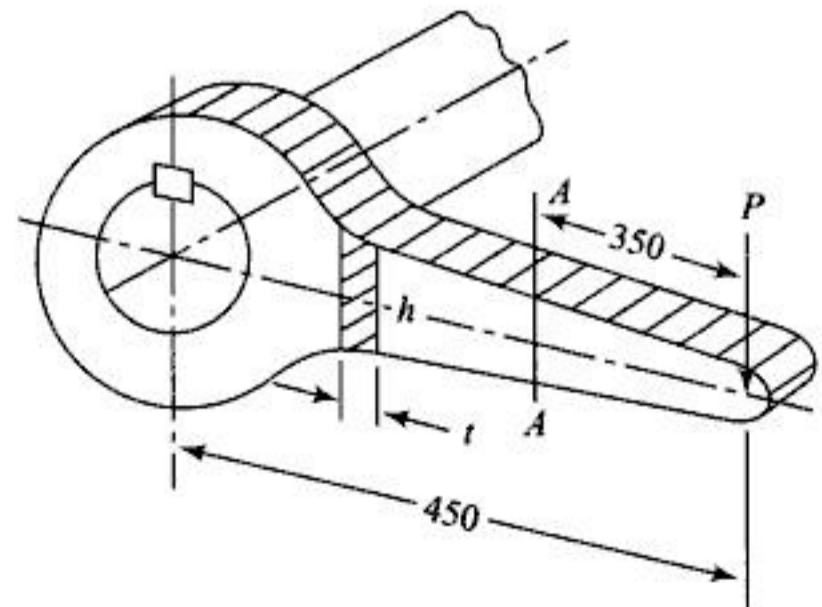

Fig. P-2.12



You have either reached a page that is unavailable for viewing or reached your viewing limit for this book.



You have either reached a page that is unavailable for viewing or reached your viewing limit for this book.

# Combined Stresses: Theories of Failure

## CONCEPT REVIEW

### 3.1 DEFINITION

A part subjected to two types of loading simultaneously gets a combination of stresses induced at a point in the cross section. The design equations are based on the failure of the component at that point where these combined stresses exceed the limit.

### 3.2 COMBINED BENDING MOMENT AND AXIAL LOAD

A hypothetical member subjected to two loads simultaneously may be treated as a member subjected to  $P_1$  and  $P_2$  separately. The stresses under  $P_1$  and  $P_2$  are calculated separately and superimposed on each (Fig. 3.1 and Fig. 3.2).

$$\sigma_{t_1} = \frac{M}{Z} = \frac{P_1 l}{Z}$$

$$\sigma_{t_2} = \frac{P_2}{A}$$

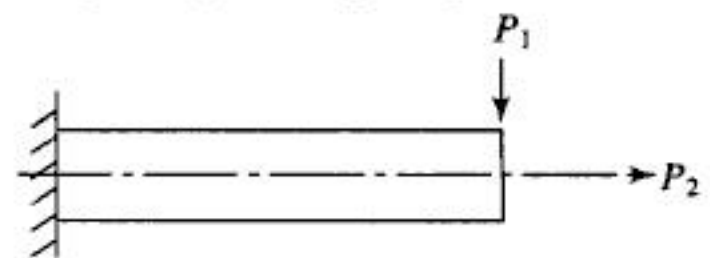

**Fig. 3.1**

$$\therefore \text{Total induced stress at the top fibre} = \sigma_{t_1} + \sigma_{t_2} = \frac{P_1 l}{Z} + \frac{P_2}{A}$$

$$\text{and total induced stress at the bottom fibre} = -\sigma_{t_1} + \sigma_{t_2} = -\frac{P_1 l}{Z} + \frac{P_2}{A}$$

### 3.3 DESIGN EQUATION

Design equation for the component may be written as

$$\frac{P_1 l}{Z} + \frac{P_2}{A} = \frac{S_y}{N}$$



You have either reached a page that is unavailable for viewing or reached your viewing limit for this book.



You have either reached a page that is unavailable for viewing or reached your viewing limit for this book.



You have either reached a page that is unavailable for viewing or reached your viewing limit for this book.

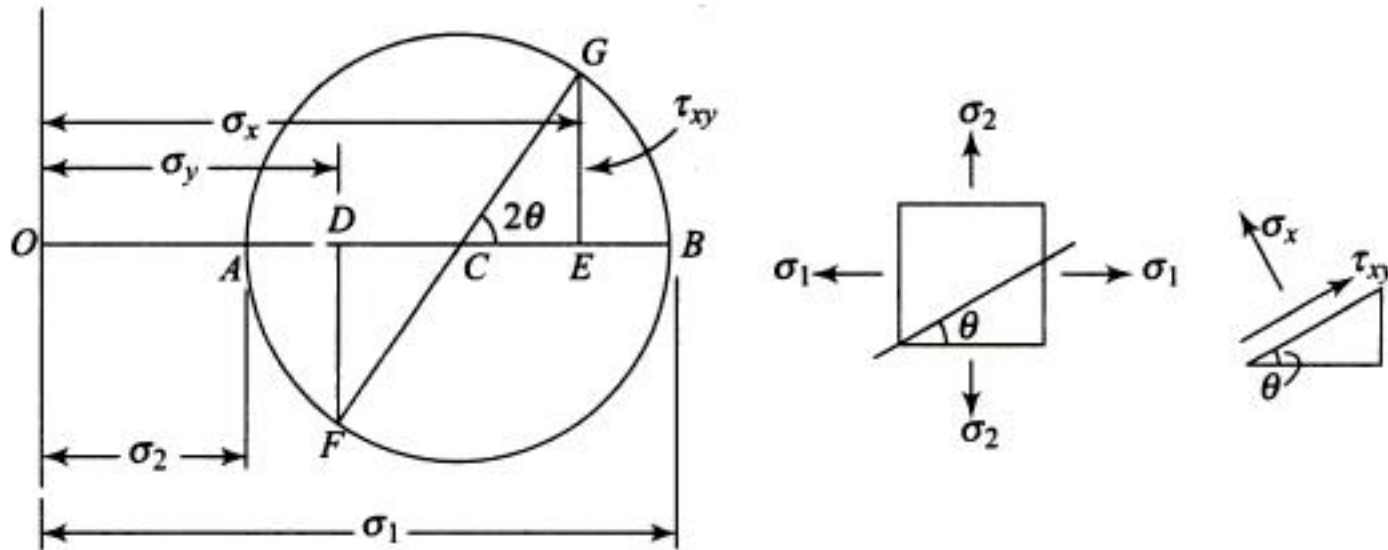

**Fig. 3.5**

Maximum strain theory allows higher values of  $\sigma_1$  under biaxial stress condition if both  $\sigma_1$  and  $\sigma_2$  are positive.

Total strain energy theory does not hold good for the condition  $\sigma_1 = \sigma_2 = \sigma_3$ .

The energy of distortion theory has same limitation as that of maximum shear stress theory.

In practice, the maximum principal stress and maximum strain theories are not applicable if failure occurs by yielding, and cannot be used for ductile materials. Maximum principal stress theory is used for brittle materials while maximum strain theory is used for pressure vessels. Maximum shear stress and maximum energy of distortion theories are applicable to ductile materials.

## WORKED EXAMPLES

- 3.1 A frame of C clamp as shown in Fig. E-3.1 is subjected to a load of 5 kN. The material is 200 FG C.I. Eccentricity  $e = 50$  mm. If the section is rectangular with  $h = 3b$ , find the dimensions  $b$  and  $h$ .  $F \cdot S = 5$ .

*Solution:*

Total stress at inner fibre, 
$$\sigma_t = \frac{5000}{b \times h} + \frac{5000 \times 50 \times 6}{bh^2}$$

$\therefore$  Design equation is

$$\frac{5000}{3b^2} + \frac{5000 \times 50 \times 6}{9b^3} = \frac{200}{5}$$

Thus, by trial and error  $b = 17$  mm  
 $h = 51$  mm.

- 3.2 Solve the above example assuming the cross section of I section as shown in Fig. E-3.2.

*Solution:*

Area of section =  $15 t^2$

$$\begin{aligned} \text{M.I. of section} &= \frac{1}{12} \times 5t(7t)^3 - \frac{1}{12} \times 4t(5t)^3 \\ &= 101.25 t^4 \end{aligned}$$

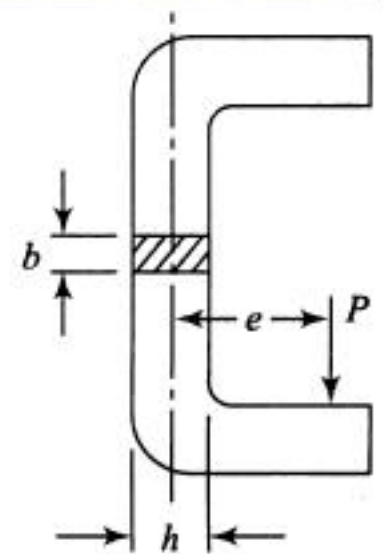

**Fig. E-3.1**

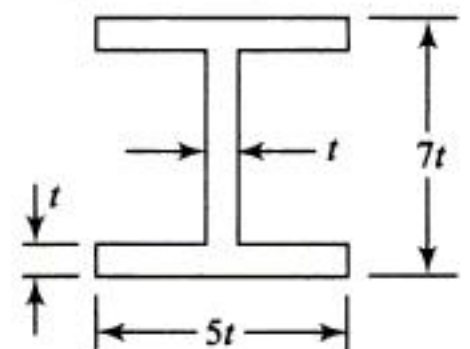

**Fig. E-3.2**



You have either reached a page that is unavailable for viewing or reached your viewing limit for this book.



You have either reached a page that is unavailable for viewing or reached your viewing limit for this book.



You have either reached a page that is unavailable for viewing or reached your viewing limit for this book.

- 3.9 A load  $P = 44 \text{ kN}$  is applied to a crankshaft at a distance of 200 mm from the bearing (Fig. E-3.9). Material for the shaft is 30C4 steel with  $S_y = 276 \text{ MPa}$ . Using factor of safety of 2 and maximum shear stress theory find the diameter of the shaft.

*Solution:*

$$\text{Bending moment} = 44000 \times 200 \text{ N.mm}$$

$$\sigma = \frac{M}{Z} = \frac{44000 \times 200 \times 32}{\pi d^3} = \frac{89636}{d^3} \times 10^3 \text{ MPa}$$

$$\tau = \frac{T}{Z_p} = \frac{44000 \times 150 \times 16}{\pi d^3} = \frac{33.61 \times 10^6}{d^3} \text{ MPa}$$

Using maximum shear stress criteria

$$\frac{S_y}{N} = \sqrt{(\sigma^2 + 4\tau^2)}, \quad \therefore \frac{10^6}{d^3} \sqrt{(89.63)^3 + 4(33.61)^2} = \frac{276}{2}$$

$$d = 87.06 \text{ mm rounded to } 90 \text{ mm.}$$

- 3.10 A cylindrical shaft of outer diameter double the inner diameter is subjected to a bending moment of 15000 N.m and torque of 25000 N.m. Find the dimensions of shaft with F · S of 2.

*Solution:*

$$\sigma = \frac{M}{Z} = \frac{32 \times 15000 \times 10^3}{\pi(d_0^4 - d_i^4)/d_0} = \frac{32 \times 15000 \times 2 \times 10^3}{\pi \times 15 d_i^3} = 20371.83/d_i^3$$

$$\tau = \frac{T}{Z_p} = \frac{25000 \times 16 \times 10^3}{\pi(d_0^4 - d_i^4)/d_0} = 2 \times \frac{25000 \times 16 \times 10^3}{15\pi d_i^3} = 2 \times \frac{8488.2636}{d_i^3} \times 10^3$$

Let the material be 30C8 with  $S_y = 350 \text{ MPa}$

$$\therefore \frac{350}{2} = \frac{10^3}{d_i^2} \sqrt{(20371.83)^2 + 4(2 \times 8488.2636)^2}$$

$$\therefore d_i = 60.9, \quad \therefore d_i = 60 \text{ mm}$$

$$d_0 = 120 \text{ mm}$$

- 3.11 A hub is press fitted on a shaft. An element in the hub is subjected to a radial compressive stress (pressure) of 50 MPa and hoop stress of 75 MPa. Find the factor of safety if (a) hub is made of 30C8 steel with  $S_y = 350 \text{ MPa}$ . Using maximum shear stress theory (b) if the hub is made of C.I with  $S_{ut} = 200 \text{ MPa}$ ,  $S_{uc} = 700 \text{ MPa}$ .

*Solution:*

(a) Using maximum shear stress theory

$$\tau_{\max} = \frac{\sigma_1 - \sigma_2}{2} = \frac{75 - (-50)}{2} = 62.5 \text{ MPa}$$

$$F \cdot S = \frac{S_{ys}}{\tau_{\max}} = \frac{350/2}{62.5} = 2.8 \text{ as } S_{ys} = 0.5 S_y$$

(b) For brittle materials, using coulomb—Mohr's theory

$$\frac{\sigma_1}{S_{ut}} + \frac{\sigma_2}{S_{uc}} = \frac{1}{F \cdot S}$$

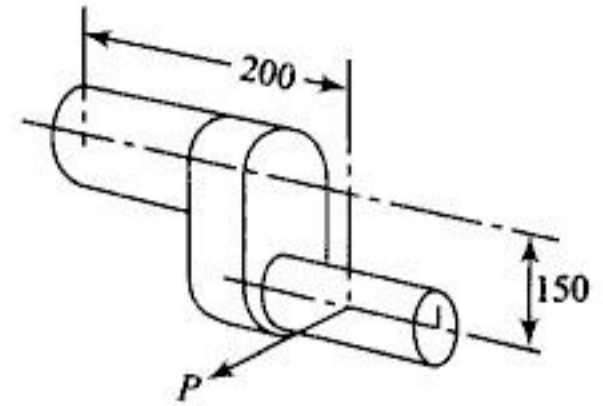

Fig. E-3.9



You have either reached a page that is unavailable for viewing or reached your viewing limit for this book.



You have either reached a page that is unavailable for viewing or reached your viewing limit for this book.



You have either reached a page that is unavailable for viewing or reached your viewing limit for this book.

- 3.7 Find the factor of safety for the following condition of stresses. The material used is 30 C4 steel with  $S_y = 310$  MPa. Use three theories of failure of Problem 3.6.
- (a)  $\sigma_x = 70$  MPa,  $\sigma_y = 30$  MPa.
  - (b)  $\sigma_x = 70$  MPa,  $\tau_{xy} = 30$  MPa clockwise.
  - (c)  $\sigma_x = -10$  MPa,  $\sigma_y = -60$  MPa,  $\tau_{xy} = 30$  MPa anti-clockwise.
  - (d)  $\sigma_x = 50$  MPa,  $\sigma_y = 20$  MPa,  $\tau_{xy} = 40$  MPa.
- 3.8 A  $400 \times 400$  mm plate of 45C8 steel has normal stress acting on all edges.  $\sigma_x = 40$  MPa,  $\sigma_y$  is compressive in nature. Using maximum shear stress theory factor of safety is 3. Find the change in length in  $x$  direction.  $S_y = 400$  MPa,  $E = 2.1 \times 10^5$  MPa and  $\mu = 0.25$ .

- 3.9 The frame of a portable hydraulic rivetter is shown in Fig. P-3.9. Load  $P$  is 45 kN. The material used for the frame is 40 C8 steel with yield strength of 400 MPa. Find the dimensions of I section for the frame using factor of safety of 2.5.
- 3.10 The frame of a press is shown in Fig. P-3.10.  $P = 60$  kN,  $e = 200$  mm and  $d = 150$  mm. The material used is 50C4 steel with yield point strength of 450 MPa. Using factor of safety of 3, find the dimension  $t$ .

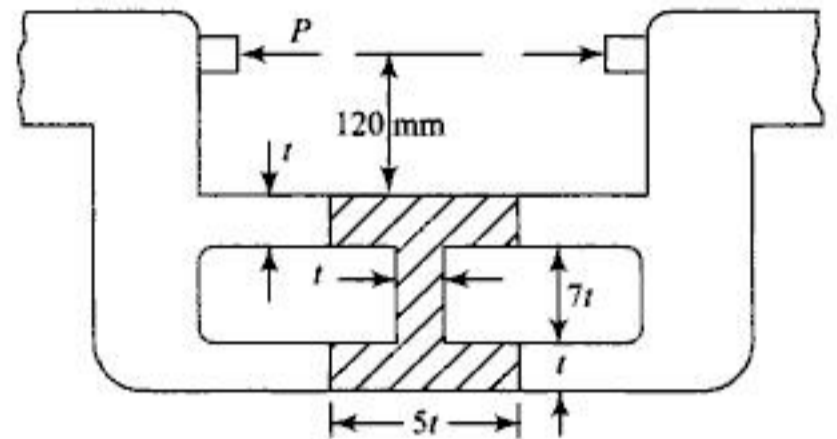

Fig. P-3.9

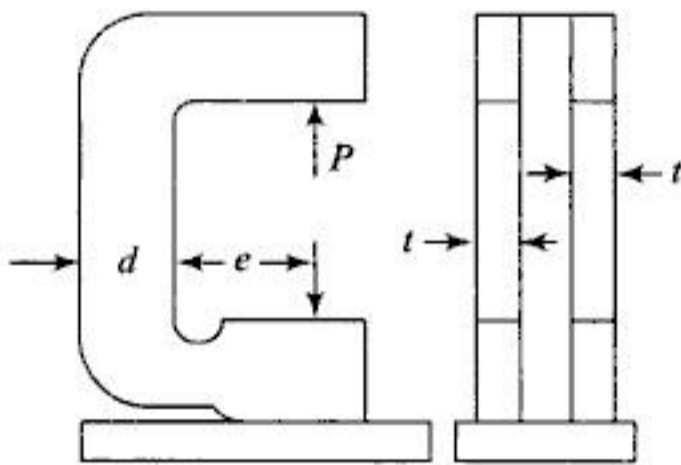

Fig. P-3.10

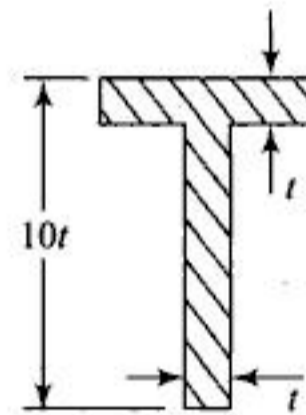

Fig. P-3.11

- 3.11 Solve Problem 3.9 using a  $T$  section as shown in Fig. P-3.11. How is it economical? Why is it not practicable?
- 3.12 A 50 mm diameter non-rotating shaft of steel with  $S_y = 400$  MPa is subjected to a steady torque of 1500 Nm. Find the permissible steady bending moment that can be superposed on it if the factor of safety by Mises Hencky theory is 13.
- 3.13 A 30 mm diameter steel shaft is subjected to maximum bending moment of 100 Nm; an axial tensile force of 5000 N and a torque of 200 Nm.  $S_y = 240$  MPa. Determine factor of safety by all theories of failure.
- 3.14 Determine the diameter of a ductile steel bar subjected to an axial tensile load of 40000 N and a torsional moment of  $16 \times 10^5$  Nmm. Use factor of safety of 5,  $E = 2.1 \times 10^5$  MPa,  $S_y = 210$  MPa. Use (i) Maximum shear stress theory, (ii) Max. E.D. theory.
- 3.15 A machine part is designed by using maximum E.D. theory and a factor of safety of 3. The material has  $S_{yp} = 400$  MPa,  $\sigma_x = 150$  MPa,  $\tau_{xy} = 0$ , Find  $\sigma_y$ .



You have either reached a page that is unavailable for viewing or reached your viewing limit for this book.



You have either reached a page that is unavailable for viewing or reached your viewing limit for this book.



You have either reached a page that is unavailable for viewing or reached your viewing limit for this book.

For a definite period of life Eq. (4.1) is used.

A machine part subjected to a load other than the completely reversible type is designed by splitting the stress in two components as shown in Fig. 4.3. The mean or static stress is designated by  $\sigma_m$  and the variable stress is  $\sigma_v$ . The maximum and minimum values of stresses are given by  $\sigma_{max}$  and  $\sigma_{min}$  respectively.

$$\sigma_m = \frac{\sigma_{max} + \sigma_{min}}{2}, \sigma_v = \frac{\sigma_{max} - \sigma_{min}}{2}$$

When  $\sigma_v = 0$ , the load induces a static stress only and failure occurs at  $S_y$  or  $S_u$ . At  $\sigma_m = 0$ , the load is completely reversible and failure occurs at  $S_e$ . These two conditions are shown in the diagram suggested by Soderberg (Fig. 4.4) by points *A* and *B* respectively.

Thus .

$$OA = S_e$$

$$OB = S_y$$

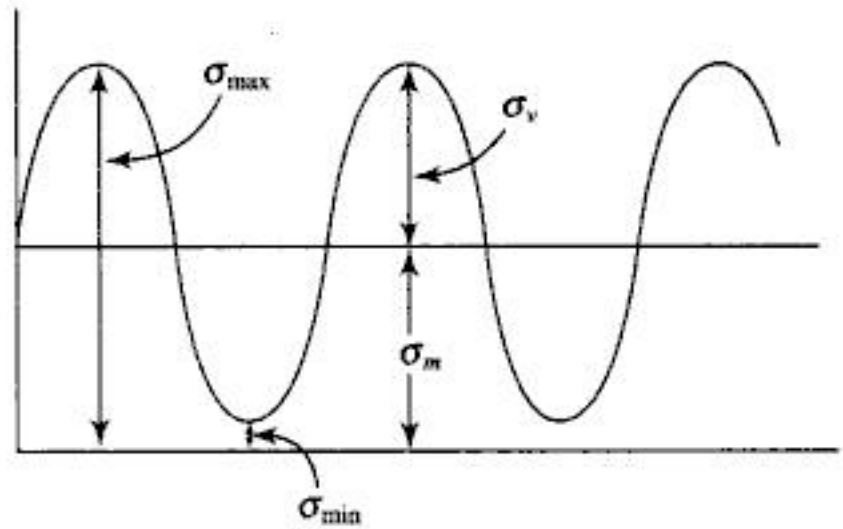

Fig. 4.3

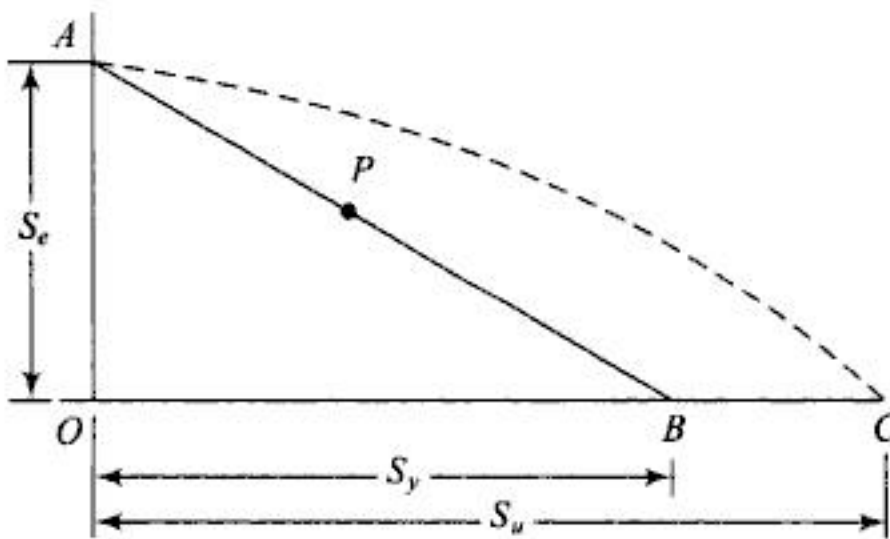

Fig. 4.4

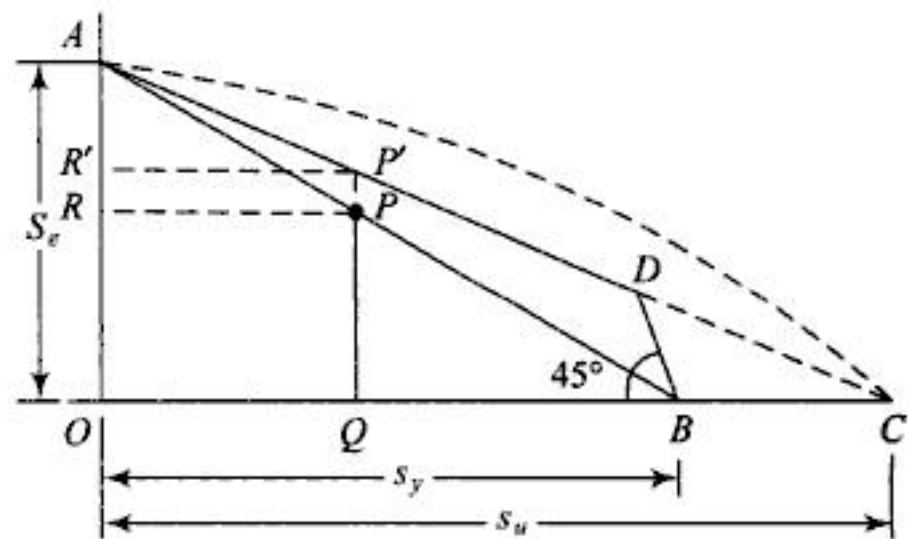

Fig. 4.5

According to Soderberg any combination of  $\sigma_m$  and  $\sigma_v$  may be represented by a point on the straight line joining points *A* and *B*. The actual combination of  $\sigma_m$  and  $\sigma_v$  causing failure of the machine element is represented by a point on the parabola (shown dotted) joining points *A* and *C* where  $OC = S_u$ . The parabola is suggested by Gerber.

Goodman's line lies between these two lines such that the first part of Goodman's line is obtained by joining the points *A* and *C* till the line *BD* making an angle of  $45^\circ$  with abscissa intersects at *D* (Fig. 4.5).

Using Soderberg's diagram  $PR = \sigma_m (F \cdot S)$

$$PQ = \sigma_v (F \cdot S)$$

$$\frac{BQ}{OB} = \frac{PQ}{AO}$$

or

$$\frac{S_y - \sigma_m (F \cdot S)}{S_y} = \frac{\sigma_v (F \cdot S)}{S_e}$$

or

$$\frac{\sigma_m}{S_y} + \frac{\sigma_v}{S_e} = \frac{1}{F \cdot S}$$

(4.3)



You have either reached a page that is unavailable for viewing or reached your viewing limit for this book.



You have either reached a page that is unavailable for viewing or reached your viewing limit for this book.



You have either reached a page that is unavailable for viewing or reached your viewing limit for this book.



You have either reached a page that is unavailable for viewing or reached your viewing limit for this book.



You have either reached a page that is unavailable for viewing or reached your viewing limit for this book.



You have either reached a page that is unavailable for viewing or reached your viewing limit for this book.



You have either reached a page that is unavailable for viewing or reached your viewing limit for this book.



You have either reached a page that is unavailable for viewing or reached your viewing limit for this book.



You have either reached a page that is unavailable for viewing or reached your viewing limit for this book.



You have either reached a page that is unavailable for viewing or reached your viewing limit for this book.



You have either reached a page that is unavailable for viewing or reached your viewing limit for this book.



You have either reached a page that is unavailable for viewing or reached your viewing limit for this book.



You have either reached a page that is unavailable for viewing or reached your viewing limit for this book.



You have either reached a page that is unavailable for viewing or reached your viewing limit for this book.



You have either reached a page that is unavailable for viewing or reached your viewing limit for this book.

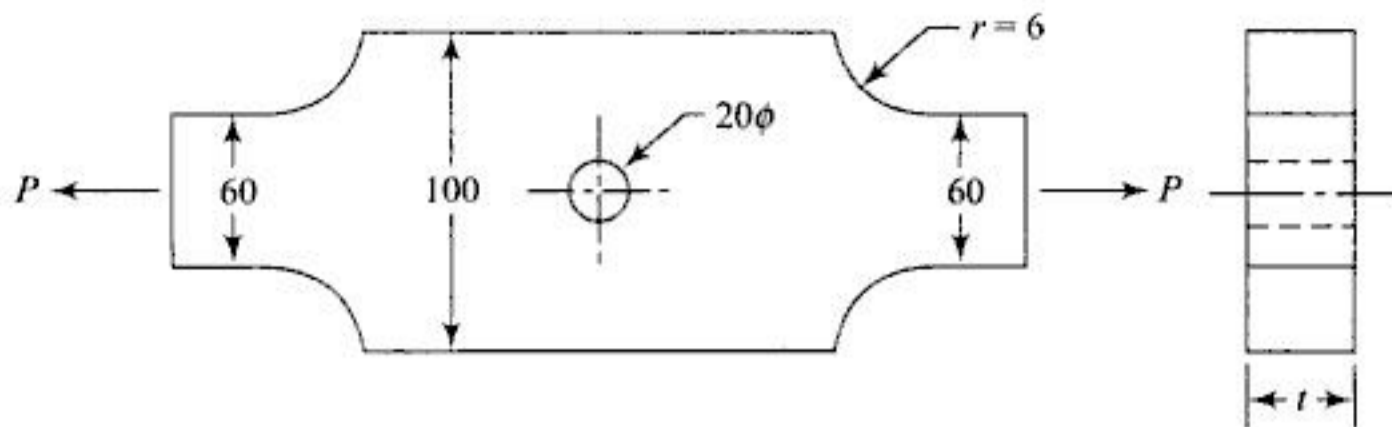

Fig. P-4.9

- 4.10 A bar of 50C8 steel is subjected to a tensile load  $P$  varying from 0 to maximum. The properties of material are  $S_u = 1.2$  GPa,  $S_y = 600$  MPa,  $K_t = 1.8$ ,  $q = 0.95$ , size factor = 0.85 and reliability factor = 0.868. Find the maximum  $P$  value for  $2.5 \times 10^5$  number of cycles. Diameter of bar is 20 mm.
- 4.11 The work cycle of mechanical component subjected to completely reversible loading consists of the following:
- (a)  $\pm 350$  MPa for 85% of time
  - (b)  $\pm 400$  MPa for 12% of time
  - (c)  $\pm 500$  MPa for 3% of time

The material for the component is 50 C4 steel with  $S_u = 660$  MPa,  $S_e = 280$  MPa. Determine the life of the component.

- 4.12 A transmission shaft carries a pulley mid-way between two bearings. The b.m on the shaft varies from 200 to 600 N.m and the torque on the pulley varies from 100 to 300 Nm. For the shaft material  $S_u = 550$  MPa. The endurance strength correction factor for torque = 0.6,  $K_a = 0.85$ ,  $K_b = 0.88$  for both b.m as well as torque. S.C.F for b.m is 1.6 and for torque 1.3. Find the diameter of shaft using Von Mises Hencky theory. Use  $F \cdot S = 2$  and  $S_y = 300$  MPa.
- 4.13 Calculate the life of the component subjected to  $\sigma_m = 210$  MPa,  $\sigma_v = 116$  MPa and S.C.F = 1.4. The material tests  $S_{ut} = 630$  MPa and  $S_e = 0.36 S_{ut}$ .
- 4.14 A shaft of 30 mm diameter made of 30C8 steel has a 7.5 mm transverse hole. It is subjected to (a) fluctuating torque between 0 and 90 N.m, (b) completely reversed torque of 40 N.m, (c) a torque varying between 15 to 85 N.m. Find the factor of safety in each case.  $K_a = 0.85$ ,  $K_b = 0.84$ ,  $K_c = 0.6$ ,  $S_{ys} = 0.577 S_y$ ,  $S_y = 300$  MPa,  $K_t = 2.5$ ,  $q = 0.95$ ,  $S_e = 200$  MPa.
- 4.15 A circular rod of 30C8 steel with all the characteristic as Problem 4.14 is subjected to a b.m varying between 50 and 1000 N.m and an axial load varying between 5 and 15 kN tensile. The maximum of two loads occur simultaneously. Find the diameter of the rod using  $F \cdot S$  equal to 3.

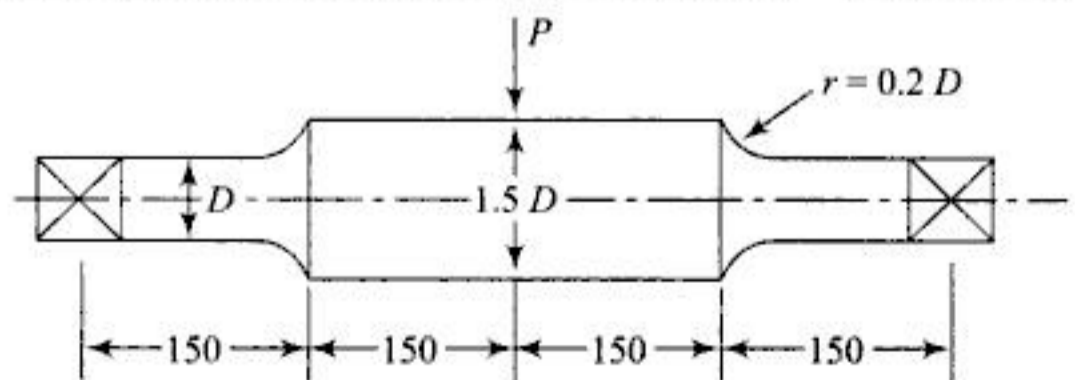

Fig. P-4.16

- 4.16 A beam of a circular section is subjected to a load  $P$  varying between 5 to 15 kN. It is machined from 20 C4 steel. Determine the diameter  $D$  using  $F \cdot S = 2$ ,  $q = 0.95$ ,  $S_{ut} = 560$  MPa,  $S_y = 300$  MPa,  $S_v = 280$  MPa.
- 4.17 Find the dimension  $D$  for the beam in Problem 4.16 when it is subjected to a steady load of magnitude 15 kN.

- 4.18 A rectangular plate of Problem 4.3 with  $D = 60$  mm,  $d = 40$  mm is subjected to an axial load of 25 kN. Find the radius ' $r$ ' of the fillet for the plate of 30C8 steel with  $S_y = 300$  MPa.



You have either reached a page that is unavailable for viewing or reached your viewing limit for this book.



You have either reached a page that is unavailable for viewing or reached your viewing limit for this book.



You have either reached a page that is unavailable for viewing or reached your viewing limit for this book.

Failure of portion of the rod receiving the cotter:

Consider section *BB* of rod where the slot for the cotter is made Fig. E-5.1(d) for which

$$\sigma_t = \frac{P}{A} = 90 \quad \text{or} \quad \frac{10000}{\left(\frac{\pi}{4} d_1^2 - d_1 t\right)} = 90 \quad (5.4)$$

Substituting  $d_1 t = 100$  from Eq. (5.2)

$$d_1 = 16.7 \text{ mm modified to } 20 \text{ mm.}$$

If the cotter is stronger than the rod, application of an external force will cause double shearing of the rod as shown in Fig. E-5.1(e)

$$\therefore \tau = \frac{P}{2A} = \frac{10000}{2ld_1} = 50 \text{ MPa} \quad (5.5)$$

$$\therefore l = \frac{10000}{2 \times 50 \times 20} = 5 \text{ mm modified to } 10 \text{ mm.}$$

The sleeve may be made out of C.I or 30 C8 steel. Let us design using both the materials and see which is economical.

Considering the tearing failure at section *CC*, Fig. E-5.1(f) and (g)

Using C.I 
$$\sigma_1 = \frac{P}{A} = \frac{10000}{\left\{ \frac{\pi}{4} (d_2^2 - d_1^2) - (d_2 - d_1) t \right\}} = 20 \quad (5.6)$$

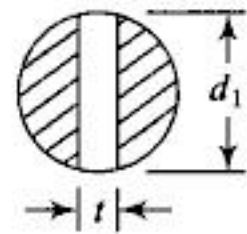

Fig. E-5.1d

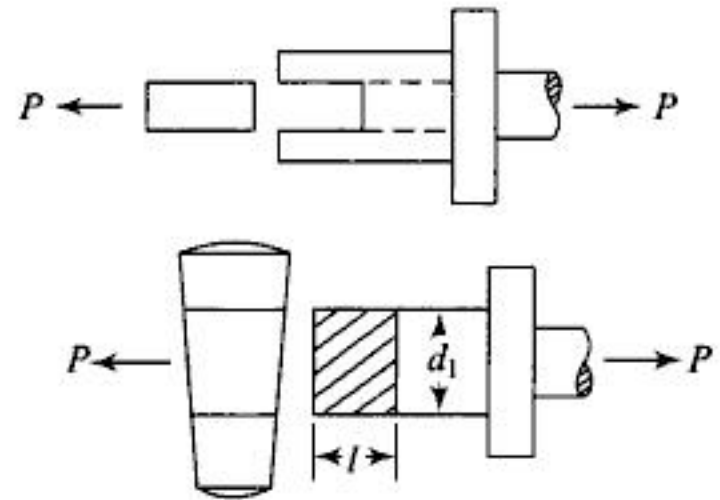

Fig. E-5.1e

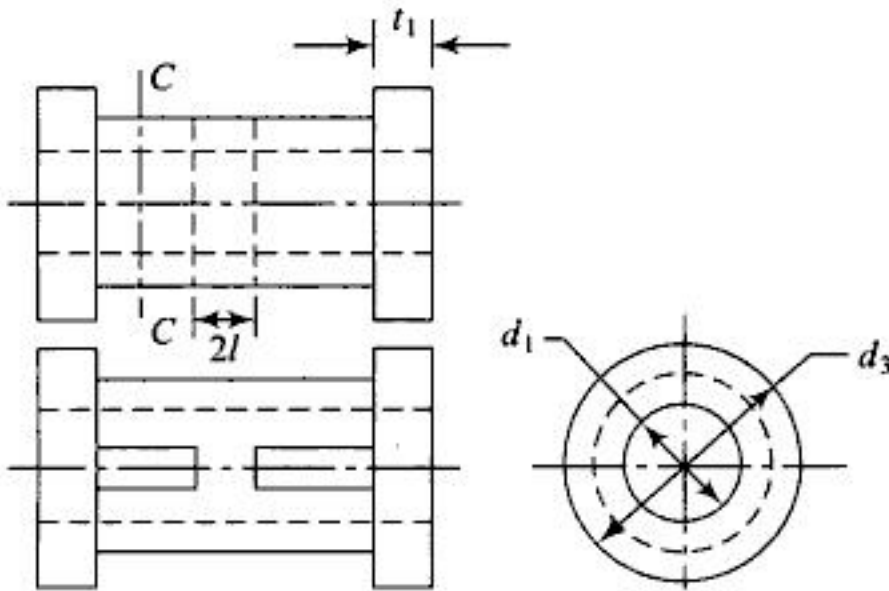

Fig. E-5.1f

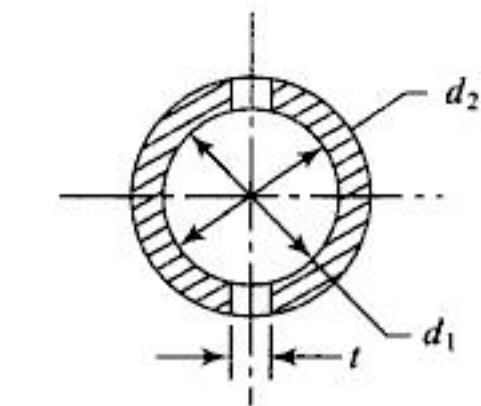
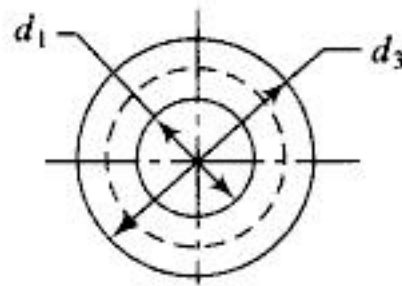

Fig. E-5.1g

Substituting  $d_1 = 20 \text{ mm}$  and  $t = 6 \text{ mm}$  we get  $d_2 = 34 \text{ mm}$  modified to  $35 \text{ mm}$ . Crushing of cotter against the sleeve:

$$\sigma_c = \frac{P}{A} = \frac{10000}{(d_3 - d_1)t} = 100, \quad \therefore d_3 = 36.67 \text{ mm modified to } 40 \text{ mm}$$



You have either reached a page that is unavailable for viewing or reached your viewing limit for this book.



You have either reached a page that is unavailable for viewing or reached your viewing limit for this book.



You have either reached a page that is unavailable for viewing or reached your viewing limit for this book.

(b) Bearing of pin: Using Eq. 2.6 from Chapter 2 and taking  $P_b = 20$  MPa we get,

$$20 = \frac{15000}{20 \times t}, \quad \therefore t = 37.5 \text{ mm modified to 40 mm.}$$

(c) Bending check: Here the induced bending stress using shearing and bearing is calculated and checked if it is within the limit. The pin may be considered as a simply supported beam with the load and reactions, both uniformly distributed. Hence, the maximum b.m at the centre is taken as the mean of the b.m due to (a) concentrated load and (b) uniformly distributed load,

i.e.  $M = \frac{Pl}{6}$  where  $l$  is the length of the pin between the points  $A$  and  $B$  which may be taken as  $1.5 t = 60$  mm.

$$\therefore \frac{15000 \times 60}{6} = \sigma_t Z = \sigma_t \frac{\pi}{32} d_p^3 = \frac{\pi}{32} \cdot (20)^3 \sigma_t$$

$\therefore \sigma_t = 190.98$  MPa. This value being high, let us increase the value of  $d_p$  to 30 mm so that the induced stress becomes

$$\sigma_t = \frac{15000}{6 \times \pi (30)^2} = 56.58 \text{ MPa}$$

which is well within the limit. Hence,  $d_p = 30$  mm. Also, an increase in  $d_p$  reduces the value of  $t$  as the projected area is  $d_p \cdot t$ . This in turn reduces the bending moment and the height of the single eye as well as the double eye thereby reducing the cost of material.

*Design of rod with single eye:*

At the section  $AA$

$$\sigma_t = \frac{P}{\frac{\pi}{4} d^2} = \frac{S_y}{F.S}$$

$$\therefore \frac{15000 \times 4}{\pi d^2} = \frac{330}{3}$$

$$\therefore d = 13.17 \text{ mm modified to 20 mm.}$$

The thickness  $t$  of the eye is the same as that found for a pin under bearing. As the diameter of the pin is modified from 20 mm to 30 mm, the thickness may be changed from 40 mm to

$$40 \times \frac{20}{30} = 26.67 \text{ mm modified to 30 mm.}$$

$\therefore$  For tearing failure of the rod at section  $BB$

$$\sigma_t = \frac{P}{(d_o - d_p) t} = \frac{330}{3}$$

$$\therefore \frac{15000}{(d_o - 30) 30} = 110 \text{ MPa}$$

$$\therefore d_o = 34.54 \text{ modified to 40 mm.}$$

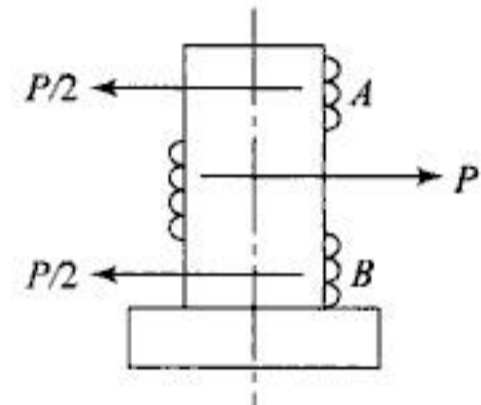

Fig. E-5.4c

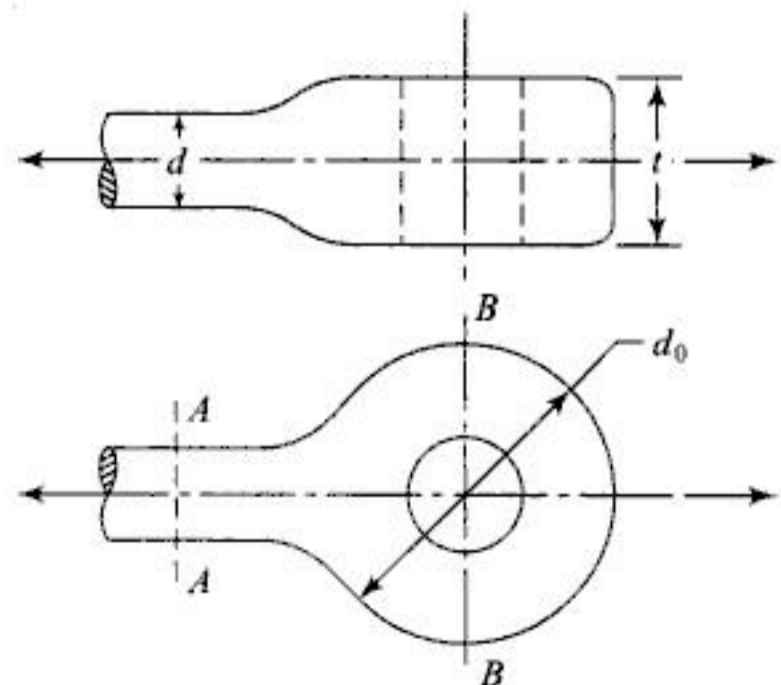

Fig. E-5.4d



You have either reached a page that is unavailable for viewing or reached your viewing limit for this book.



You have either reached a page that is unavailable for viewing or reached your viewing limit for this book.



You have either reached a page that is unavailable for viewing or reached your viewing limit for this book.

# Design of Levers

## CONCEPT REVIEW

### 6.1 INTRODUCTION

A rigid rod capable of turning about a fixed point and doing some useful work after the application of an effort is termed as a lever. The fixed point about which a lever turns is the *fulcrum*. Levers may be straight or bent. A straight tommy bar used to operate a screw jack, the lever of a lever loaded safety valve, a bell crank lever and a rocker arm are the different types of levers.

### 6.2 DESIGN MATERIALS AND PROCEDURES

A lever may be forged or cast and accordingly forged steel or cast steel or C.I may be used. It is always subjected to a bending moment and hence is designed for the bending failure while the fulcrum pin and the support are designed as the pin for a knuckle joint.

## WORKED EXAMPLES

- 6.1 A tommy bar is used to operate upon a screw jack for which, the frictional torque to be overcome is 50 N.m. Find the length and the diameter of the rod made of 30C8 steel.

*Solution:*

A frictional torque of  $50 \times 1000$  N.mm may be overcome by applying a manual force of 250 N at the end of a lever of length  $l$ .

$$\therefore l = \frac{50000}{250} = 200 \text{ mm.}$$

For 30C8 steel,  $S_y = 330$  MPa. Therefore, when the factor of safety is 4,  $\sigma_t = 80$  MPa.

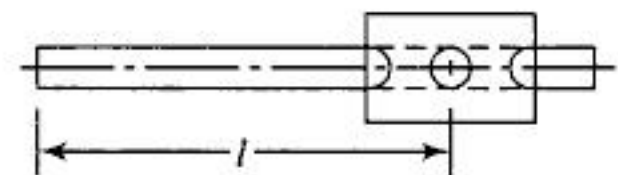

**Fig. E-6.1**



You have either reached a page that is unavailable for viewing or reached your viewing limit for this book.



You have either reached a page that is unavailable for viewing or reached your viewing limit for this book.



You have either reached a page that is unavailable for viewing or reached your viewing limit for this book.

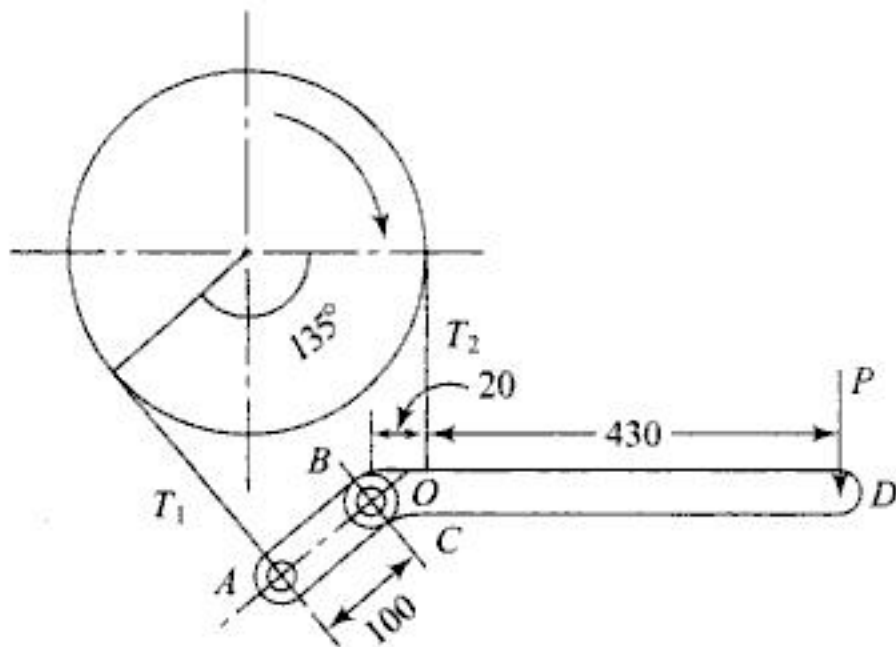

**Fig. E-6.5a**

Reaction at the fulcrum =  $\sqrt{(1000 + 622.22 + 3000 \cos 45^\circ)^2 + (3000 \sin 45^\circ)^2} = 4302 \text{ N.}$

Bearing of pin: Assuming  $l = d$   $4302 = 20 d_p^2$ ,  $\therefore d_p = 14.66 \cong 15 \text{ mm}$

Maximum b.m at AA =  $3000 \times (100 - 7.5) = 277500 \text{ N.mm}$

Taking the rectangular section with the ratio  $h : t = 3 : 1$

we get,  $277500 = \sigma_t t h^2 / 6 = \sigma_t \times 1.5 t^3$

$$\therefore t = \sqrt[3]{\frac{277500}{80 \times 1.5}} = 13.22 \text{ mm modified to } 15 \text{ mm}$$

$$\therefore h = 45 \text{ mm.}$$

Using a bush of thickness 1 mm, the hole for the pin has a diameter of 17 mm.

$$\therefore \text{The section at the hole has } Z = \frac{\frac{1}{12} \times 15 \times (45)^3 - \frac{1}{12} \times 15 \times (17)^3}{22.5} = 4789.56 \text{ mm}^3$$

$$\therefore \text{The induced value of } \sigma_t = \frac{3000 \times 100}{4789.56} = 62.63 \text{ MPa}$$

which is within the limit.

The actual value of  $Z$  is slightly greater than the calculated value since the thickness at the base is increased and hence, the section is more safe.

The dimensions of the pin at  $A$  may be kept the same as the dimensions of the fulcrum pin. Due to shear, the failure of the pin at  $B$  induces.

$$\tau = \frac{4300}{2 \times \frac{\pi}{4} (15)^2} = 12.16 \text{ MPa which is a safe value.}$$

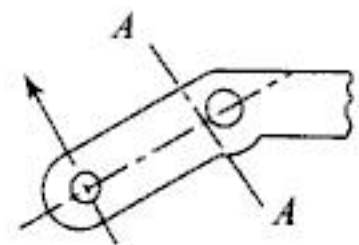
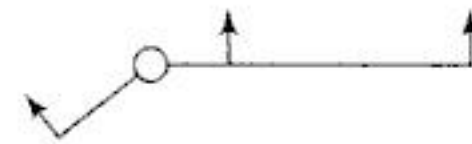

**Fig. E-6.5b**

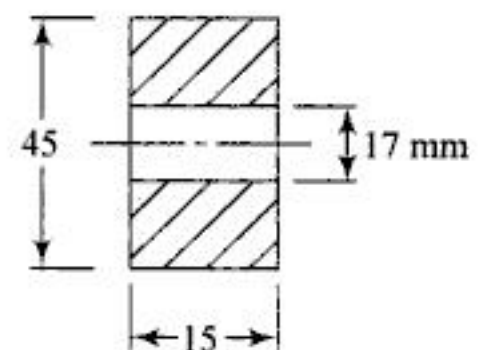

**Fig. E-6.5c**

6.6 Design a foot lever shown in Fig. E-6.6. For the lever, a key and a shaft permissible value of  $\sigma_t = 80 \text{ MPa}$ ,  $\tau = 40 \text{ MPa}$ .

*Solution:*

Twisting moment acting on the shaft =  $1000 \times 800 \text{ N.mm} = \frac{\pi}{16} d^3 \times 40$



You have either reached a page that is unavailable for viewing or reached your viewing limit for this book.



You have either reached a page that is unavailable for viewing or reached your viewing limit for this book.



You have either reached a page that is unavailable for viewing or reached your viewing limit for this book.

- 6.9 A cranked lever (Fig. E-6.7) is subjected to a force of 500 N ( $l = 400$  mm) applied at the radius of 500 mm, design the lever for  $\sigma_t = 90$  MPa,  $\tau = 40$  MPa,  $\sigma_c = 100$  MPa.
- 6.10 Design a rocker arm as shown in Fig. P-6.2. The force due to gas pressure is 3000 N. The length of each arm is 100 mm from the fulcrum. Use I section with forged steel for rocker arm with  $S_y = 330$  MPa and  $N = 4$ . For the pin  $P_b = 20$  MPa,  $S_y = 300$  MPa.

## ANSWERS



### Objective Questions

- (1) b      (2) c      (3) a      (4) b      (5) d

### Practice Problems

- (1)  $t = 15$  mm,  $b = 45$  mm,  $d_p = l = 16$  mm
- (2)  $d_p = 25$  mm,  $l = 50$  mm,  $t = 12$  mm for I section of width  $4t$  and height  $7t$ .
- (3)  $d_p = 40$  mm, length of the pin  $l = 80$  mm section of lever near the fulcrum  $= 30 \times 90$  mm<sup>2</sup> and at the load end  $= 20 \times 40$  mm<sup>2</sup>
- (7)  $\tau = 25$  mm,  $B = 75$  mm,  $d_p = 15$  mm
- (8) Rectangular section of lever  $b = 50$  mm,  $t = 17$  mm  $\rightarrow$  20 mm,  $d_p = 20$  mm,  $l = 20$  mm, section of the lever at fulcrum  $d_o = 55$  mm
- (9)  $d = 31.69 \rightarrow 35$  mm,  $D = 43.26 \rightarrow 45$  mm,  $D_1 = 50$  mm,  $t = 12$  mm,  $B = 40$  mm
- (10)  $d_p = 15$  mm,  $L_p = 45$  mm, I section  $t = 6$  mm, depth  $= 6t = 36$  mm, width  $= 4t = 24$  mm.



You have either reached a page that is unavailable for viewing or reached your viewing limit for this book.



You have either reached a page that is unavailable for viewing or reached your viewing limit for this book.



You have either reached a page that is unavailable for viewing or reached your viewing limit for this book.

= Torque transmitted by B

$$(T_{1B} - T_{2B}) \times 250 = 200,000$$

and  $T_{1B} = 3 T_{2B}$

$$2T_{2B} \times 250 = 200,000$$

$$T_{2B} = 400 \text{ N and } T_{1B} = 1200 \text{ N}$$

Resultant force at A = 4000 N vertically downwards.

Resultant force at B = 1600 N acting horizontally towards right.

Neglecting the mass of the pulley, the vertical s.f and b.m diagrams are as shown in Fig. E-7.4(b).

Vertical reactions  $R_{CV} = R_{DV} = 2000 \text{ N}$   
 Maximum vertical b.m =  $2000 \times 450 = 900,000 \text{ N.mm}$

From the horizontal S.F diagram

$$R_{CH} = 533.33 \text{ N, } R_{DH} = 2133.33 \text{ N}$$

Maximum b.m at D =  $1600 \times 300 = 480,000 \text{ N.mm}$

From the torque diagram shown in Fig. E-7.4 (b) torque at A = 200000 N.mm

From the b.m diagram the resultant b.m at A

$$= \sqrt{(900,000)^2 + \frac{(480,000)^2}{2}}$$

$$= 93.145 \times 10^4 \text{ N.mm}$$

∴ A is the critical point

$$T_e \text{ at } A = 10^4 \sqrt{(1.5 \times 93.145)^2 + (1.2 \times 20)^2} = 141.76 \times 10^4 \text{ N.mm}$$

$S_y = 400 \text{ MPa}$ . Hence  $S_{ys} = 200 \text{ MPa}$  using a factor of safety of 2.5 and weakening effect due to the keyway equal to 0.75.

$$(1) \tau = \frac{200 \times 0.75}{2.5} = 60 \text{ MPa}$$

$$(2) d = \sqrt[3]{\frac{16 T_e}{\pi \tau}} = \sqrt[3]{\frac{16 \times 141 \times 76 \times 10^4}{\pi \times 60}} = 49.36 \text{ mm rounded to } 50 \text{ mm}$$

$$(3) \text{ Also } \theta = \frac{Tl}{JG} = \frac{200,000 \times 750 \times 32}{\pi (50)^4 \times 0.8 \times 10^5} = 0.003 \text{ rad}$$

The length  $l$  is to be taken between the points between which the torque acts (i.e. between A and B).

7.5 A 600 mm diameter pulley driven by a horizontal belt transmits power to a 200 mm diameter pinion. The pulley has a mass of 90 kg,  $K_m = 2$ ,  $K_f = 1.5$  and  $\tau = 40 \text{ MPa}$ . Find the diameter of the shaft.

**Solution:**

Taking moments of vertical forces @ A with weight of pulley =  $90 \times 9.81 = 882.9 \text{ N}$

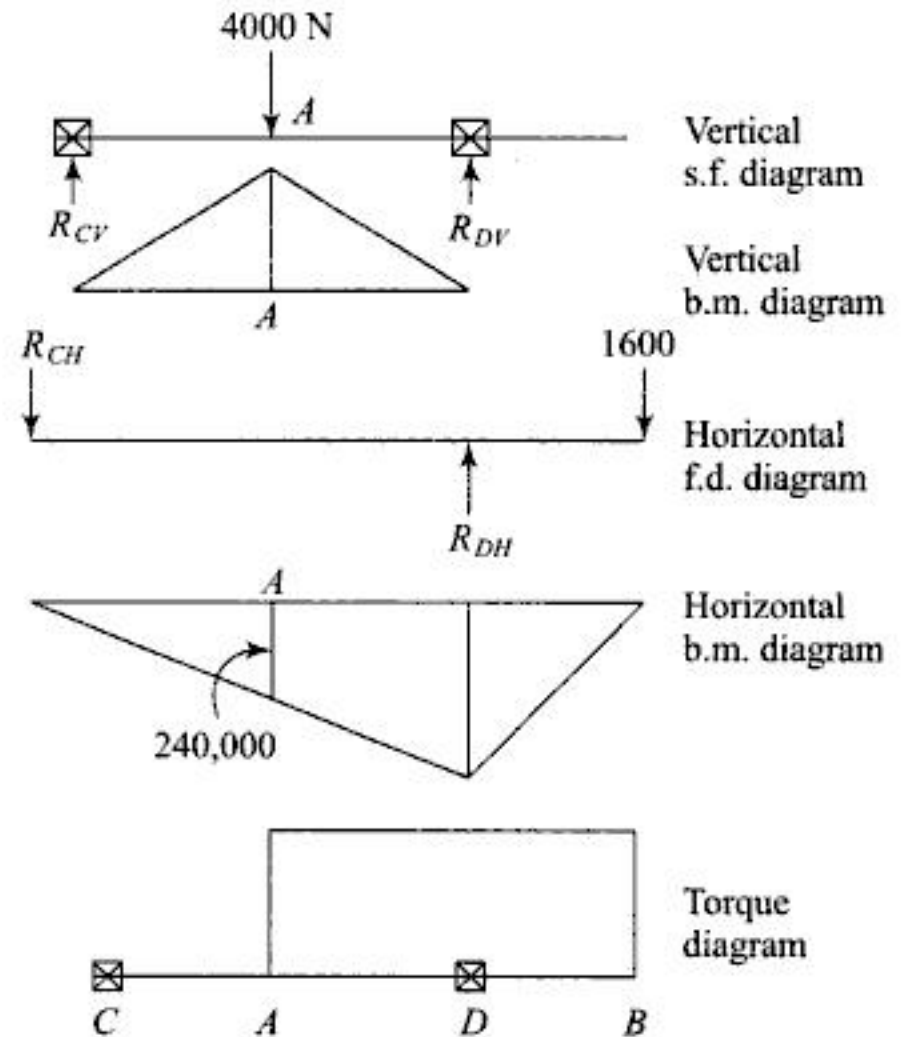

Fig. E-7.4b



You have either reached a page that is unavailable for viewing or reached your viewing limit for this book.



You have either reached a page that is unavailable for viewing or reached your viewing limit for this book.



You have either reached a page that is unavailable for viewing or reached your viewing limit for this book.





You have either reached a page that is unavailable for viewing or reached your viewing limit for this book.



You have either reached a page that is unavailable for viewing or reached your viewing limit for this book.



You have either reached a page that is unavailable for viewing or reached your viewing limit for this book.



You have either reached a page that is unavailable for viewing or reached your viewing limit for this book.



You have either reached a page that is unavailable for viewing or reached your viewing limit for this book.



You have either reached a page that is unavailable for viewing or reached your viewing limit for this book.



You have either reached a page that is unavailable for viewing or reached your viewing limit for this book.



You have either reached a page that is unavailable for viewing or reached your viewing limit for this book.



You have either reached a page that is unavailable for viewing or reached your viewing limit for this book.



You have either reached a page that is unavailable for viewing or reached your viewing limit for this book.



You have either reached a page that is unavailable for viewing or reached your viewing limit for this book.



You have either reached a page that is unavailable for viewing or reached your viewing limit for this book.



You have either reached a page that is unavailable for viewing or reached your viewing limit for this book.



You have either reached a page that is unavailable for viewing or reached your viewing limit for this book.



You have either reached a page that is unavailable for viewing or reached your viewing limit for this book.

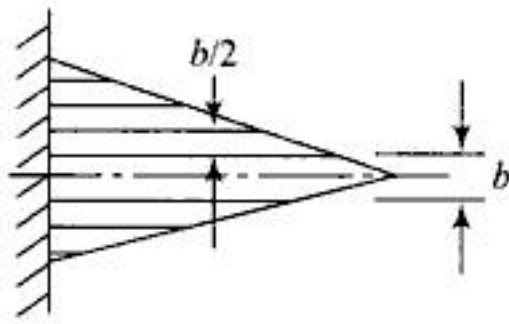

Fig. 8.5

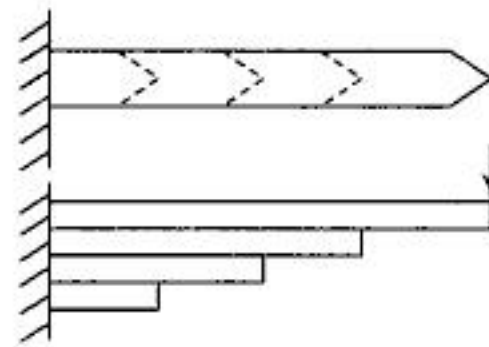

Fig. 8.6

Integrating the above equation

$$\therefore \frac{dy}{dx} = \frac{12Plx}{EBt^3} + c_1$$

and  $y = \frac{12Plx^2}{2EBt^3} + c_1x + c_2$  on further integration.

Substituting  $\frac{dy}{dx} = 0$  at  $x = l$  and  $y = 0$  at  $x = l$

We have  $c_1 = \frac{-12Pl^2}{EBt^3}$ ,  $c_2 = \frac{6Pl^3}{EBt^3}$

$\therefore$  Maximum deflection  $y$  at  $x = 0$  is given by

$$y = \frac{6Pl^3}{EBt^3} \tag{8.4}$$

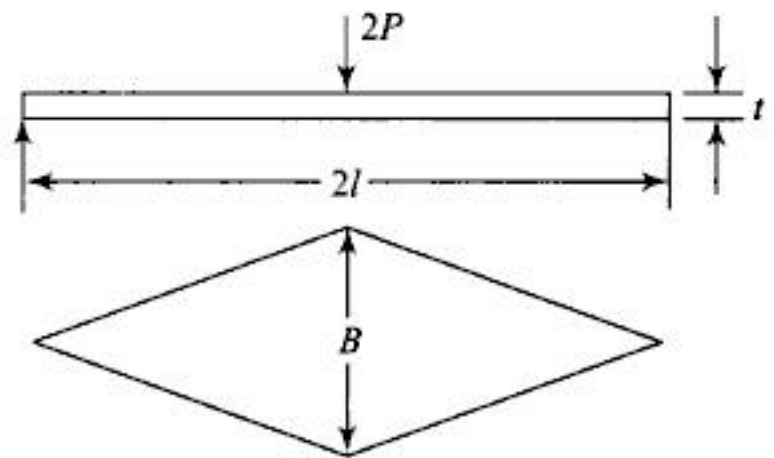

Fig. 8.7

A leaf spring of simply supported type as shown in Fig. 8.7 will give the same equations of stress and deflection as Eqs (8.3) and (8.4) when the load is  $2P$  and the unsupported length is  $2l$ .

### 8.8 SPRING WITH EXTRA FULL LENGTH LEAVES

The leaves which are cut from the original triangular leaf, are termed as graduated leaves. In actual practice some extra leaves with the same length as that of the top leaf are added to increase the stiffness of the spring.

The extra full length leaves behave as ordinary cantilever beam for which the deflection is

$$y = \frac{4Pl^3}{Ebt^3}$$

Let  $n_e$  and  $n_g$  represent the number of extra full length and graduated leaves respectively.

As the leaves are stacked over each other the total load is shared by them such that deflection of the two is the same.

Let

$$P = P_g + P_e$$

$$\delta_g = \frac{6P_g l^3}{En_g b t^3} = \delta_e = \frac{4P_e l^3}{En_e b t^3}$$

$$\therefore \frac{P_g}{2n_g} = \frac{P_e}{3n_e} = \frac{P_g + P_e}{(2n_g + 3n_e)} = \frac{P}{(2n_g + 3n_e)}$$

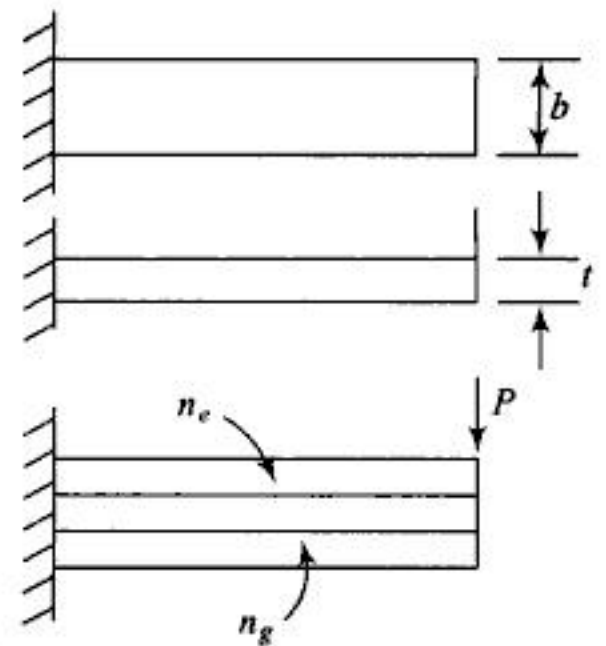

Fig. 8.8



You have either reached a page that is unavailable for viewing or reached your viewing limit for this book.



You have either reached a page that is unavailable for viewing or reached your viewing limit for this book.



You have either reached a page that is unavailable for viewing or reached your viewing limit for this book.

$$\text{Stiffness of inner spring, } K_2 = \frac{77000 \times 25}{8 \times 5^3 \times 9} = 213.88 \text{ N/mm as } C = 5$$

Total load = Load shared by outer spring for 19 mm deflection + Load shared by outer spring for further deflection + Load shared by inner spring for further deflection.

$$\text{Load causing 19 mm deflection of outer spring} \\ = 311.012 \times 19 = 5909.22 \text{ N}$$

$$\text{Remaining load} = 849090.78 \text{ N}$$

It is shared by two springs in proportion to the stiffnesses

$$\therefore \text{Load shared by outer spring} = \frac{311.012 \times 849090.78}{(311.012 + 213.88)} \\ = 50311.191 \text{ N}$$

$$\therefore \text{Total load on outer spring} = \\ 50311.191 + 5909.22 = 56220.411 \text{ N}$$

- 8.4 A spring loaded safety valve is held against its seat by a close coiled helical compression spring. The diameter of the valve is 75 mm and blow off pressure is 1.1 MPa. Mean diameter of the coil is 100 mm and compression is 25 mm. Find the diameter of spring bar and the number of active coils if permissible shearing stress is 500 MPa and  $G = 0.8 \times 10^5$  MPa.

*Solution:*

$$\text{Maximum load on the spring} = 1.1 \times \frac{\pi}{4} \times 75^2 = 4859.6511 \text{ N}$$

$$\text{Now, } 500 = \frac{8K \times 4859.65 \times C}{\pi \times (100/C)^2}$$

$$\therefore KC^3 = 404.04 \text{ putting } K = \frac{4C-1}{4C-4} + \frac{0.615}{C}$$

$$\text{by trial and error } C = 7$$

$$\therefore d = 150/7 = 21.43 \text{ mm} \cong 21.50 \text{ mm}$$

$$n = \frac{0.8 \times 10^5 \times 21.5 \times 25}{8 \times 7^3 \times 4859.65} = 3.224 \text{ modified to } 4 + 2 = 6.$$

- 8.5 In the above example let the normal pressure on the valve be 1.00 MPa, blow off pressure remaining the same. The deflection of spring causing the opening of valve is 3.5 mm. What will be the change in the design procedure and calculations?

*Solution:*

The maximum load and hence the dimensions  $d$  remains unchanged. For calculating the number of active turns the force causing the deflection  $\delta = 3.5$  mm is given by

$$P = \frac{\pi}{4} (1.1^2 - 1^2) \times 75^2 = 485.965 \text{ N}$$

$$\therefore n = \frac{0.8 \times 10^5 \times 21.5 \times 3.5}{8 \times 7^3 \times 485.965} = 4.51 \text{ modified to } 5 + 2 = 7$$



You have either reached a page that is unavailable for viewing or reached your viewing limit for this book.



You have either reached a page that is unavailable for viewing or reached your viewing limit for this book.



You have either reached a page that is unavailable for viewing or reached your viewing limit for this book.



You have either reached a page that is unavailable for viewing or reached your viewing limit for this book.



You have either reached a page that is unavailable for viewing or reached your viewing limit for this book.

- 8.17 A helical compression spring is subjected to a load varying between 800 and 1500 N. The material used is oil tempered cold drawn wire having  $S_{ys} = 700$  MPa and  $S_{es} = 356$  MPa. Find the diameter of the wire and the number of coils if  $C = 5$  and  $N = 2.5$ .

*Solution:*

$$K_m = 1 + \frac{0.615}{5} = 1.123 \quad K_v = \frac{4C - 1}{4C - 4} = 1.1875$$

$$P_m = \frac{800 + 1500}{2}, \quad \therefore \tau_m = \frac{8 \times 1.123 \times 1150 \times 5}{\pi d^2} = \frac{16443.252}{d^2} \text{ MPa}$$

$$P_v = 750 \text{ N}$$

$$\therefore \tau_v = \frac{8 \times 1.1875 \times 750 \times 5}{\pi d^2} = \frac{11339.789}{d^2} \text{ MPa}$$

Using Soderberg's modified equation we have,

$$\frac{1}{N} = \frac{\tau_m - \tau_v}{S_{ys}} + \frac{2\tau_v}{S_{es}}$$

$$\therefore \frac{1}{2.5} = \frac{5103.463}{700 d^2} + \frac{2 \times 11339.789}{356 d^2}$$

$$\therefore d = 13.322 \text{ mm and } D_m = 66.61 \text{ mm.}$$

If the deflection of the spring during load variation is assumed as 7 mm

$$n = \frac{0.8 \times 10^5 \times 13.322 \times 7}{8 \times 5^3 \times 700} = 10.6576 \cong 11$$

$\therefore$  Total number of turns = 13.

- 8.18 A close coiled helical compression spring has a mean coil diameter of 60 mm and the diameter of the wire is 10 mm. Number of active and inactive coil turns is 11 and 2 respectively. Free length of the spring is 210 mm. Decide the maximum load that can be applied on the spring if the minimum load is one third of the maximum load. Use  $F \cdot S = 1.5$ ,  $S_{ys} = 700$  MPa and  $S_{es} = 1360$  MPa.

*Solution:*

$$K_m = 1.1025, \quad K_v = 1.15$$

$$P_m = \frac{3P_{\min} + P_{\min}}{2} = 2P_{\min}, \quad P_v = \frac{3P_{\min} - P_{\min}}{2} = P_{\min}$$

$$\tau_m = \frac{8 \times 1.1025 \times 2P_{\min} \times 6}{\pi (10)^2} = 0.337 P_{\min} \text{ MPa}$$

$$\tau_v = \frac{8 \times 1.15 \times P_{\min} \times 6}{\pi (10)^2} = 0.1758 P_{\min} \text{ MPa}$$

$$\therefore \frac{1}{1.5} = \frac{(0.337 - 0.1758) P_{\min}}{700} + \frac{2 \times 0.1758 P_{\min}}{360}$$

$$\therefore P_{\min} = 552.36 \text{ N, } P_{\max} = 1657 \text{ N.}$$



You have either reached a page that is unavailable for viewing or reached your viewing limit for this book.



You have either reached a page that is unavailable for viewing or reached your viewing limit for this book.



You have either reached a page that is unavailable for viewing or reached your viewing limit for this book.

- 8.10 Design a compression spring made of square steel wire subjected to a maximum load of 3000 N. Spring index = 7, deflection under load = 150 mm, permissible shear stress = 40 MPa and  $G = 0.8 \times 10^5$  MPa.
- 8.11 A close coiled helical compression spring is subjected to a continuously varying load. The maximum load = 600 N, minimum load = 200 N, spring index = 6,  $S_{ys} = 650$  MPa,  $S_{es} = 350$  MPa. Find the factor of safety if the diameter of the wire is 6.44 mm.
- 8.12 A railway wagon is resting on six helical springs. The mass of the wagon causes a load of  $15 \times 10^4$  N. The dynamic load due to irregularities is 50 kN. Corresponding to an amplitude of oscillation of 20 mm, design the spring with the NiCr steel having  $S_{ys} = 750$  MPa,  $S_{es} = 400$  MPa,  $C = 6$ ,  $G = 0.84 \times 10^5$  MPa and factor of safety = 2.25.
- 8.13 Design a cantilever leaf spring to absorb 800 N.m energy. The deflection is 150 mm, length of the spring = 600 mm, permissible stress = 875 MPa and  $E = 2 \times 10^5$  MPa.
- 8.14 A semi-elliptic laminated spring 1 m long carries a central load of 5 kN. It is made of spring steel with a safe bending stress of 450 MPa. Maximum deflection of the spring is 130 mm. Calculate the thickness, width and number of leaves of the spring.
- 8.15 In Fig. P-8.15 a cantilever spring of maximum width 600 mm and length 1 m rests on a close coiled helical spring of 10 mm wire diameter. The spring index is 10 and number of active coils is 8. Calculate the thickness of the cantilever spring if a load of 2.1 kN causes a deflection of 40 mm at the end of the cantilever. Also calculate the stresses induced in the leaf and helical springs.
- 8.16–8.18 Design a close coiled helical spring for.  
 Maximum load = 4.5 kN, Deflection = 40 mm,  $\tau = 500$  MPa and  $C = 6$ .  
 $P = 500$  N,  $C = 8$ , Deflection 8 mm and  $\tau = 400$  MPa.  
 $P = 200$  N – 800 N,  $C = 5$ , Deflection = 10 mm,  $S_y = 800$  MPa,  $S_e = 350$  MPa and F·S = 2.
- 8.19 A close coiled helical compression spring used for front suspension of an automobile has spring stiffness of 80 N/mm. The ends of the spring are squared and ground and the design load is 7.5 kN. Find the diameter of the wire and free length of the spring if the material used has a safe shear stress of 580 MPa. Assume  $C = 6$ .
- 8.20 A machine is supported on four springs for vibration isolation. The load on the foundation is 70 kN and the deflection due to this load is 12 mm. Design the spring for a safe shear stress of 450 MPa, considering a solid deflection of 25 mm and the outside diameter of the spring not exceeding 150 mm.
- 8.21 A P-Bronze helical spring is required to absorb 9000 N.mm of energy without exceeding the maximum permissible shear stress of 50 MPa. Calculate the dimensions of spring if the maximum deflection is 20 mm. Assume spring index = 6.
- 8.22 Two concentric helical springs having the maximum diameters 50 mm and 30 mm respectively are subjected to a maximum total load of 1.5 kN. Maximum deflection under this load is 18 mm and the deflection when compressed solid is 25 mm. The material for both the springs is same and  $\tau_{safe} = 550$  MPa. Design the springs with suitable assumptions.
- 8.23 The spring rates for two concentric springs are 50 N/mm and 30 N/mm for the outer and inner spring respectively. The outer spring is 15 mm longer than the inner spring. If the total load is 3.5 kN, find the load carried by each spring.
- 8.24 A helical spring of spring rate 25 N/mm is arranged in series with another spring of stiffness 35 N/mm. Find the force required to give a total deflection of 50 mm.

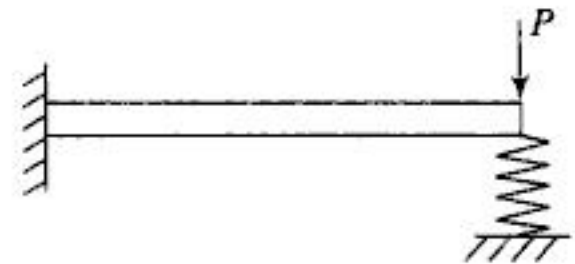

Fig. P-8.5



You have either reached a page that is unavailable for viewing or reached your viewing limit for this book.



You have either reached a page that is unavailable for viewing or reached your viewing limit for this book.



You have either reached a page that is unavailable for viewing or reached your viewing limit for this book.

or 
$$A = \left( \frac{60 \times \sigma_t}{S_y} \right)^{2/3} \quad \text{for } d < 45 \text{ mm} \quad (9.1)$$

$$= \left( \frac{40 \times \sigma_t}{S_y} \right)^{2/3} \quad \text{for } d > 45 \text{ mm}$$

The initial tightening produces a tensile load given by

$$F_i = 2860 d \text{ N, where } d = \text{diameter of the bolt in mm} \quad (9.2)$$

The tightening torque is given by

$$T = CdF_i \text{ where } C \text{ is a constant} = 0.2. \quad (9.3)$$

### 9.3 PRELOADING OF BOLTS

In the applications like pressure vessels and cylinder covers, it is essential to apply the initial tightening torque to make a joint leakproof. The initial tightening elongates the bolt and compresses the connected members. This situation is represented by point *A* in Fig. 9.1

$\delta_b$  = elongation of bolt

$\delta_p$  = compression of the part

*BC* = external force  $F_e$

*AF* = initial tightening load  $F_i$

*BJ* = increase in bolt load due to external load =  $\Delta F$

*JG* = decrease in part load due to  $F_e = F_e - \Delta F$

*CE* = limiting value of external load when the joint opens, =  $F_o$

By similar triangles *AFD* and *CED*

$$\frac{F_o}{F_i} = \frac{\delta_b + \delta_p}{\delta_b} \quad (9.4)$$

As  $\delta_b$  and  $\delta_p$  are inversely proportional to stiffnesses  $K_b$  and  $K_p$ ,  $\delta_b/\delta_p = K_p/K_b$

$$\frac{F_o}{F_i} = \frac{K_p + K_b}{K_p} \quad (9.5)$$

#### Effect of External Load $F_e$ on Bolt Load and Part Load

The load on the bolt increases by  $\Delta F$  (*BJ*) which increases the deflection of the bolt by  $\Delta\delta_b = AJ$ . There is a decrease in load on the part by  $(F_e - \Delta F)$ , i.e. *JG* which reduces the compression of the part by the same amount, i.e.  $JG = \Delta\delta_p$ . Using the relationship between deflection and stiffness we can write

$$\Delta\delta_b = \frac{\Delta F}{K_b} = \frac{F_e - \Delta F}{K_p} = \Delta\delta_p$$

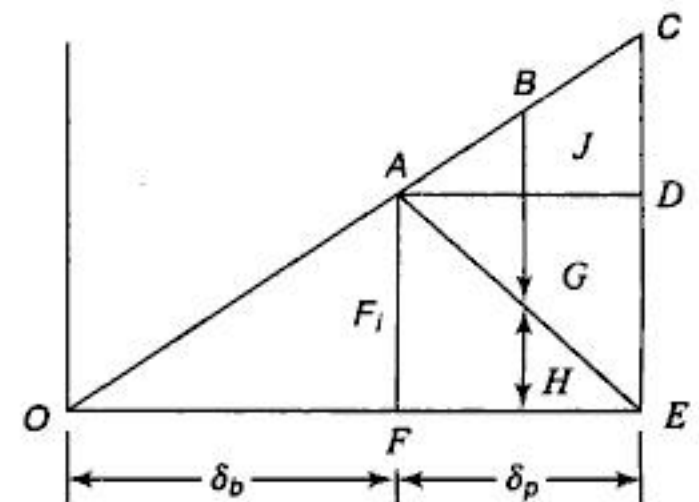

Fig. 9.1



You have either reached a page that is unavailable for viewing or reached your viewing limit for this book.



You have either reached a page that is unavailable for viewing or reached your viewing limit for this book.



You have either reached a page that is unavailable for viewing or reached your viewing limit for this book.

Referring to Table 6 and using the coarse series, M 16 × 2 ISO metric threads with a root area of 157 mm<sup>2</sup> may be used.

$$\text{Initial tightening} = 2860 d = 2860 \times 16 = 45760 \text{ N}$$

$$\therefore \text{Tightening stress} = \frac{45760}{157} = 291.46 \text{ MPa}$$

$$\text{Tightening torque} = CdF_i = 0.2 \times 16 \times 45760 = 146432 \text{ N.mm.}$$

9.2 A steel bolt of M 16 × 2 is 300 mm long and carries an impact load of 5000 N.mm. If the threads stop adjacent to the nut and  $E = 2.1 \times 10^5 \text{ MPa}$

(a) find the stress in the root area.

(b) find the stress if the shank area is reduced to root area.

*Solution:*

(a) From Fig. E-9.2, energy stored =  $\frac{1}{2} F \cdot \delta$

$$\delta = F/k \quad \text{where } k \text{ is the stiffness}$$

$$U = \frac{F^2}{2k} \quad \text{for tensile load } \delta = \frac{P}{AE}$$

$$\therefore \text{Stiffness of bolt } k = \frac{AE}{l}$$

$$\text{For } 16 \times 2 \text{ threads, shank area } A = \frac{\pi}{4} \times 16^2 = 201.06 \text{ mm}^2$$

$$\therefore k = \frac{201.06 \times 2.1 \times 10^5}{300} = 140742 \text{ N/mm}$$

$$\begin{aligned} \text{Again, } U &= \frac{F^2}{2k}, \quad \therefore F = \sqrt{2Uk} \\ &= \sqrt{2 \times 5000 \times 140742} = 37515.6 \text{ N} \end{aligned}$$

From Table 6 root area for M16 × 2 bolt is 157 mm<sup>2</sup>

$$\therefore \sigma = \frac{37515.6}{157} = 238.94 \text{ MPa}$$

(b) Now,  $A_c = 157 \text{ mm}^2 = \text{Area of reduced shank}$

$$\therefore k = \frac{157 \times 2.1 \times 10^5}{300} = 109900.00 \text{ N/mm}$$

$$F = \sqrt{2 \times 5000 \times 109900.00} = 33151.168 \text{ N}$$

$$\therefore \sigma = \frac{33151.168}{157} = 211.153 \text{ MPa.}$$

9.3 A cast iron cylinder head is fastened to a cylinder of bore 500 mm with 8 stud bolts. The maximum pressure inside the cylinder is 2 MPa. The stiffness of part  $k_p = 3k_b$ . What should be the initial lightening load so that the joint is leakproof at maximum pressure.

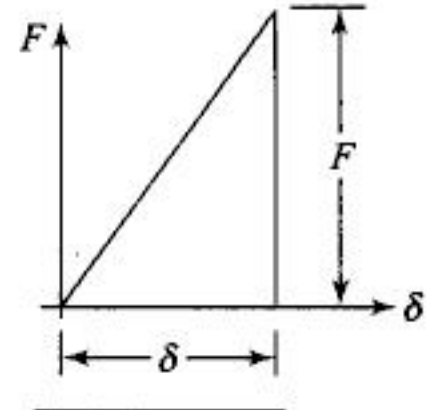

**Fig. E-9.2**



You have either reached a page that is unavailable for viewing or reached your viewing limit for this book.



You have either reached a page that is unavailable for viewing or reached your viewing limit for this book.



You have either reached a page that is unavailable for viewing or reached your viewing limit for this book.



You have either reached a page that is unavailable for viewing or reached your viewing limit for this book.



You have either reached a page that is unavailable for viewing or reached your viewing limit for this book.



You have either reached a page that is unavailable for viewing or reached your viewing limit for this book.



You have either reached a page that is unavailable for viewing or reached your viewing limit for this book.



You have either reached a page that is unavailable for viewing or reached your viewing limit for this book.



You have either reached a page that is unavailable for viewing or reached your viewing limit for this book.

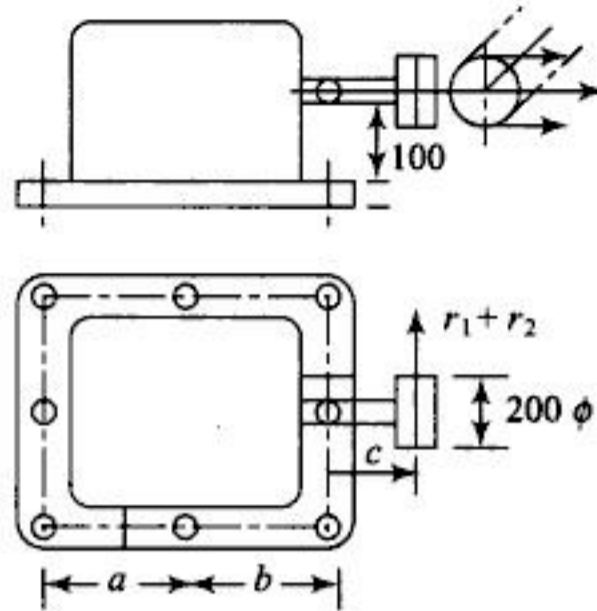

**Fig. P-9.17**

- 9.18 What will be the size of the bolts in the above problem if the belt center line is inclined at  $30^\circ$  with the horizontal as shown by dotted lines.
- 9.19 The material for the bolts shown in Fig. P-9.19 10C4 steel with  $S_y = 210$  MPa,  $N = 3$ ,  $a = 100$  mm,  $b = 200$  mm,  $c = 250$  mm,  $d = 115$  mm. The diameter of the bolts is 16 mm. Find  $P_1$  and  $P_2$ .

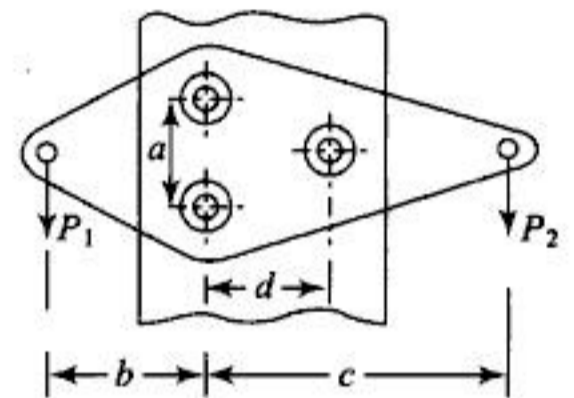

**Fig. P-9.19**

## ANSWERS

### Objective Questions

- (1) c    (2) a    (3) a    (4) a    (5) c    (6) a    (7) b    (8) b    (9) c  
 (10) b    (11) c    (12) b    (13) b

### Practice Problems

- (1) M 20 × 1.5, 57200 N, 22.8 N.m    (2) M 30 × 3.5    (3) M 80 × 6  
 (4) 61 kN    (5) (a) 234 MPa, (b) 206.88 MPa  
 (6)  $F_e = 45,000$  N, Joint does not open, M 30 × 3.5    (7) 7378.24 N,  
 (8) 1.377, 7490 N    (9) M 20 × 2.5    (10) M 12 × 1.75
- (11)  $\frac{Pl(a+b)}{6a^2 + 4b^2 - 4ab} - \frac{P}{8}$
- (12) With F.S = 6,  $S_y = 333$  MPa, M 16 × 2 bolts can be used in both cases.  
 (13) M 24 × 3, 68640 N, 329.472 Nm  
 (14) (a) M27 × 3, (b) M33 × 3.5  
 (15)  $d = 6.32 \rightarrow 10$  mm    (16) M8 × 1.25    (17) M10 × 1.5  
 (18) M10 × 1.5    (19)  $P_1 = 19860$  N,  $P_2 = 22362.7$  N



You have either reached a page that is unavailable for viewing or reached your viewing limit for this book.



You have either reached a page that is unavailable for viewing or reached your viewing limit for this book.



You have either reached a page that is unavailable for viewing or reached your viewing limit for this book.

10. Find the height  $H$  of the nut using

$$H = n \times p \quad (10.11)$$

11. Check the threads of the nut for shearing by using the equation

$$\tau = \frac{W}{\pi d_n t \cdot n} \quad (10.12)$$

where  $t$  = thickening of threads at the root

12. Find  $L/k$  by using the equation

$$L/k = \sqrt{\frac{2C\pi^2 E}{S_y}} \quad (10.13)$$

If the calculated value of  $L/k$  exceeds the actual  $L/k$  ratio, use J.B. Johnson's formula (Eq. (10.9)) to check for buckling. Else, use Euler's formula (Eq. (10.8)) to check for the same. The buckling or crippling load obtained from Eqs (10.8) or (10.9) must be 2–3 times the actual compressive load. If the actual load is tensile, then this calculation need not be done.

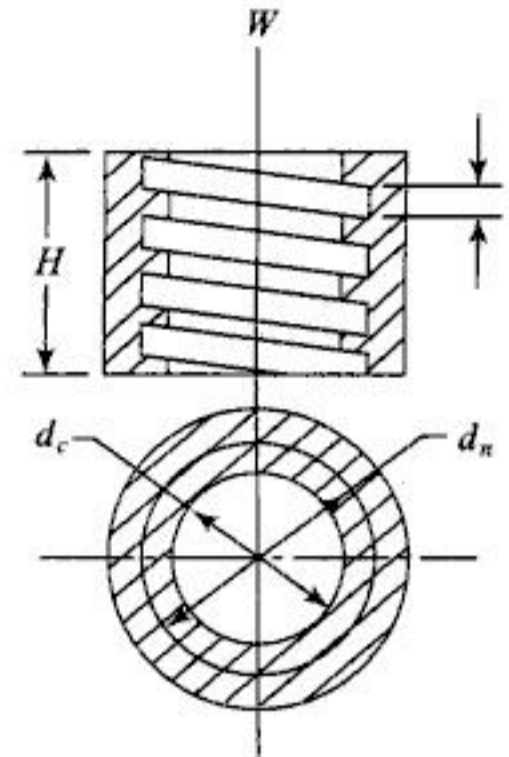
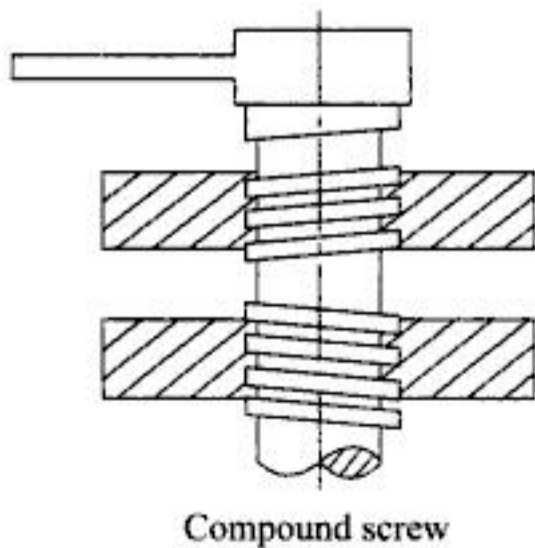

Fig. 10.4

### 10.6 OTHER VARIETIES OF SCREWS

Multistart threads may be used to increase the linear displacement of a screw in one revolution. But this increases the angle  $\alpha$  and if  $\alpha > \phi$ , the screw may overhaul. For this purpose a compound screw (Fig. 10.5) may be used for increasing the linear displacement per revolution. Total displacement in one revolution =  $p_1 + p_2$  as the threads are of opposite hands. In differential screws (Fig. 10.6) the threads of the same hand with a small difference in the pitch are used so that the total displacement per revolution is equal to the difference of the two pitches. This is used in precision equipments.



Compound screw

Fig. 10.5

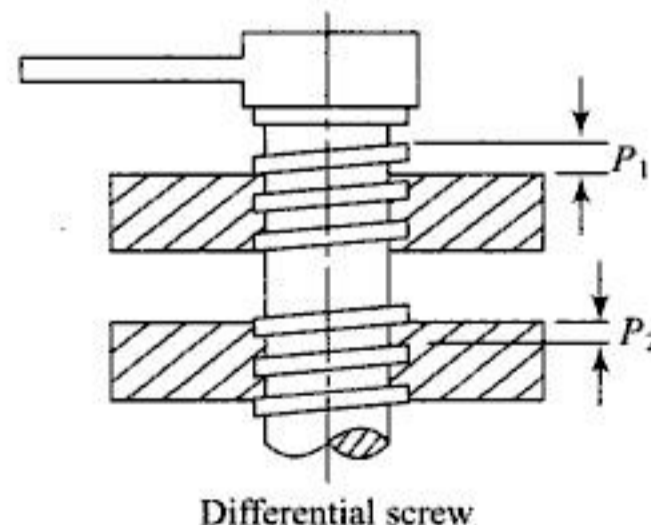

Differential screw

Fig. 10.6

A ball bearing screw is used for reducing the friction between the screw and the nut. The use of this screw increases the cost of manufacturing (Fig. 10.7). They are used in precision machine tools.



You have either reached a page that is unavailable for viewing or reached your viewing limit for this book.



You have either reached a page that is unavailable for viewing or reached your viewing limit for this book.



You have either reached a page that is unavailable for viewing or reached your viewing limit for this book.

10.4 The lead screw of a lathe has trapezoidal threads. To drive the tool carriage the screw has to exert an axial force of 20 kN. The thrust is carried by the collar. The length of the lead screw is 1.5 m. Coefficients of friction at the collar and nut are 0.1 and 0.15 respectively. Suggest suitable size of the screw and height of the nut if the permissible bearing pressure is 4 MPa.

*Solution:*

Since the speed of the screw is high permissible,  $P_b$  is very small. Hence, it is advisable to base the preliminary calculation on wear of the screw. Using Eq. 10.10 we get

$$W = P_b \times \frac{\pi}{4} (d_n + d_c) (d_n - d_c) \cdot n$$

putting  $(d_n + d_c) = 2 d_m$ ,  $(d_n - d_c) = p$ ,  $n = \frac{H}{p}$  and  $\frac{H}{d_m} = \psi$

we get

$$d_m = \sqrt{\frac{2W}{\pi\psi P_b}} = \sqrt{\frac{2 \times 20000}{\pi \times 1.5 \times 4}} = 46.06 \text{ mm}$$

Here the adapted value of  $\psi$  is 1.5.

The nearest standard size is 55 mm  $\times$  9 mm. From Table 10

$$\begin{aligned} \therefore d_n &= 55 \text{ mm}, p = 9 \text{ mm}, d_c = 45.5 \text{ mm} \\ d_m &= 50.5 \text{ mm}, \beta = 15^\circ \text{ for trapezoidal thread} \\ H &= 1.5 \times 50.5 = 75.75 \end{aligned}$$

$$\therefore \text{Number of threads of nut} = \frac{75.75}{9} = 8.41 \text{ modified to } 9$$

Now, we check for the maximum shear stress

$$\alpha = \tan^{-1} \frac{9}{\pi \times 50.5} = 3.25^\circ$$

modified coefficient of friction =  $0.15 \sec 15^\circ = 0.15529$

$$\therefore \varphi = 8.82^\circ$$

$$\therefore T_f = 20000 \times \frac{50.5}{2} \times \tan(3.25^\circ + 8.82^\circ) = 107986.07 \text{ N.mm}$$

$$\therefore \tau_{\text{ind}} = \frac{16 \times 107986}{\pi \times (45.5)^3} = 5.838 \text{ MPa}$$

$$\sigma_c = \frac{50000 \times 4}{\pi \times (45.5)^2} = 30.75 \text{ MPa}$$

$$\therefore \tau_{\text{max}} = \frac{1}{2} \sqrt{(30.75)^2 + 4(5.838)^2} = 16.44 \text{ MPa}$$

$$\text{Actual } L/k = \frac{1500}{0.25 \times 50.5} = 118.81$$



You have either reached a page that is unavailable for viewing or reached your viewing limit for this book.



You have either reached a page that is unavailable for viewing or reached your viewing limit for this book.



You have either reached a page that is unavailable for viewing or reached your viewing limit for this book.

*Solution:*

For the screw let  $\sigma_c = 80 \text{ MPa}$  considering crushing failure

of screw, 
$$d_c = \sqrt{\frac{100000 \times 4}{\pi \times 80}} = 39.89 \text{ mm.}$$

Therefore, we use screw of 48 mm nominal diameter and a pitch of 8 mm.

$$\therefore \alpha = \tan^{-1} \frac{8}{\pi \times 44} = 3.31^\circ. \text{ Let } \mu = 0.12$$

$$\therefore \phi = \tan^{-1} 0.12 = 6.84^\circ$$

$$\therefore T_f = 100000 \times \frac{44}{2} \tan (6.84 + 3.31) = 393860.76 \text{ N.mm}$$

$$\therefore \tau_m = \frac{393860.76 \times 16}{\pi (40)^3} = 31.34 \text{ MPa}$$

$$\text{Induced } \sigma_c = \frac{100000 \times 4}{\pi (40)^3} = 79.57 \text{ MPa}$$

$\therefore$  As per the energy of distortion theory maximum induced stress

$$= \sqrt{(79.57)^2 + 3(31.34)^2} = 96.32 \text{ MPa}$$

$$\therefore \text{F.S} = 300/96.32 = 3.11$$

Considering buckling  $L/k = \frac{500}{0.25 \times 40} = 50$

Using J.B. Johnson's formula

$$P_c = 300 \times \frac{\pi}{4} \times 40^2 \left[ 1 - \frac{300 (50)^2}{4 \times 0.25 \times \pi^2 \times 2.1 \times 10^5} \right]$$

$= 240572.59 \text{ N}$  which is 2.4 times the actual load and hence safe value.

*Nut:* For the P-bronze nut  $P_b = 15 \text{ MPa}$

$$\therefore \text{Number of threads in the nut} = \frac{100000 \times 4}{\pi (48^2 - 40^2) \times 15} = 12.057$$

Use 13 threads so that height of the nut is 104 mm.

To calculate the thickness of the nut let  $\sigma_t = 60 \text{ MPa}$ . Considering tearing of nut

$$\sigma_t = \frac{100000 \times 4}{\pi (d_0^2 - 48^2)}, \quad \therefore d_0 = 66.52 \text{ mm modified to } 70 \text{ mm.}$$

Thickness of the nut collar may be calculated by considering shearing.

Let  $\tau = 30 \text{ MPa}$



You have either reached a page that is unavailable for viewing or reached your viewing limit for this book.



You have either reached a page that is unavailable for viewing or reached your viewing limit for this book.



You have either reached a page that is unavailable for viewing or reached your viewing limit for this book.

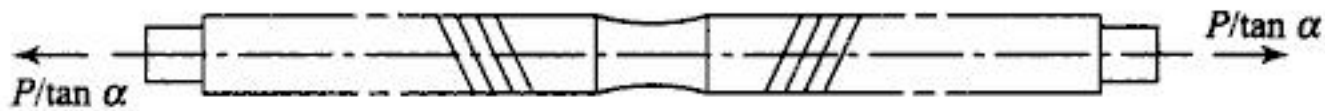

**Fig. E-10.9c**

$$\therefore 3t \times t = \frac{3046.37}{50}, \therefore t = 3.69 \text{ mm}$$

Let us adapt  $t = 4 \text{ mm}$  and  $b = 12 \text{ mm}$

Moment of inertia of the cross section in the plane of link =  $\frac{1}{12} \times 4(12)^3$

$$\therefore \text{Value of } k \text{ for the cross section in the plane of the link} = \frac{4 \times 12 \times 12}{12 \times 4} = 12 \text{ mm.}$$

$$\therefore L/k = \frac{120}{12} = 10 \text{ which is a very small value.}$$

Similarly m-I of the c/s in the plane perpendicular to the plane of the link =  $1/2 \times 12(4)^3$ ,

$$\therefore k \text{ in this plane} = \frac{64}{48} = 1.33$$

$$\therefore L/k = \frac{120}{1.33} = 90.22 < 117. \text{ Hence, use J. B.}$$

Johnson's formula.

The link in the plane is considered to be fixed at both the ends. Hence,  $C = 4$

$$\begin{aligned} \therefore P_{cr} &= S_y A \left( 1 - \frac{S_y (L/k)^2}{4C\pi^2 E} \right) \\ &= 300 \times 48 \left( 1 - \frac{300(90.22)^2}{4 \times 4 \times \pi^2 \times 2.1 \times 10^6} \right) = 13339.647 \text{ N} \end{aligned}$$

which is very large as compared to the actual load of 2046.37 N. Hence, there is no possibility of buckling.

Pins at the joints are designed with bearing, shearing and bending consideration just like a pin in the knuckle joint. Load on each pin is 4092.74 N. Use  $P_b = 20 \text{ MPa}$  and  $l : d = 1 : 1$ .

$$4092.74 = 20 \times d^2, \therefore d = l = 14.305 \text{ mm} \cong 15 \text{ mm.}$$

The attachment of the link to the nut may be done as shown in Fig. E-10.9(e) such that the length of the pin is  $15 + (2 \times \text{thickness of link}) = 23 \text{ mm}$ . With a small clearance it may be 24 mm.

$$\therefore \text{Bending moment on the pin} = 4092.74 \times 24/6$$

$$\therefore \sigma_t = \frac{M}{Z} = \frac{4092.74 \times 32 \times 24}{\pi \times (15)^3 \times 6} = 49.4 \text{ MPa}$$

There is no harm caused to the pin due to bending as the stress induced due to bending is small.

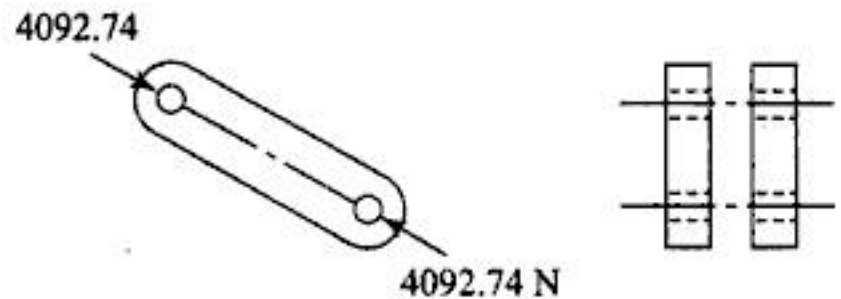

**Fig. E-10.9d**

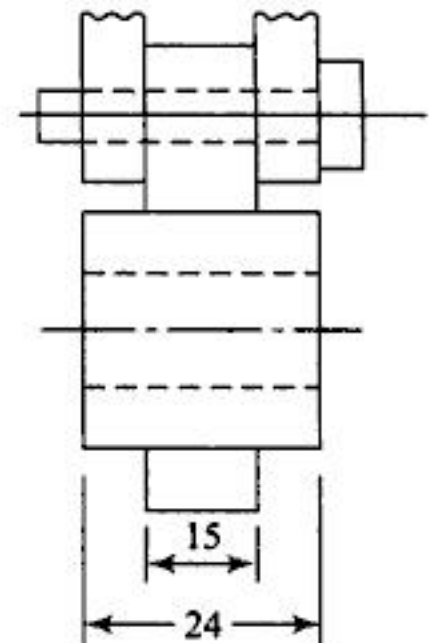

**Fig. E-10.9e**



You have either reached a page that is unavailable for viewing or reached your viewing limit for this book.



You have either reached a page that is unavailable for viewing or reached your viewing limit for this book.



You have either reached a page that is unavailable for viewing or reached your viewing limit for this book.



You have either reached a page that is unavailable for viewing or reached your viewing limit for this book.



You have either reached a page that is unavailable for viewing or reached your viewing limit for this book.



You have either reached a page that is unavailable for viewing or reached your viewing limit for this book.



You have either reached a page that is unavailable for viewing or reached your viewing limit for this book.

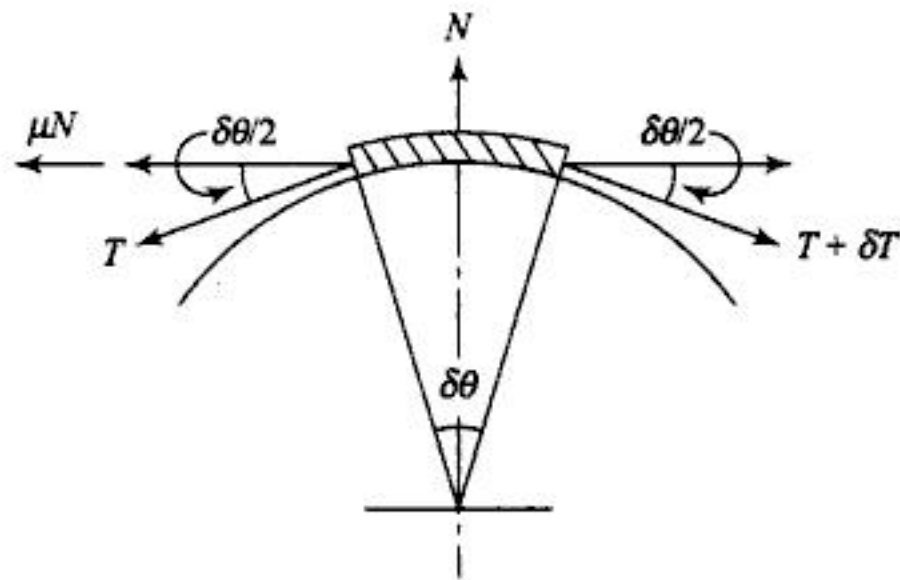

**Fig. 11.4**

Equations (i) and (ii) become

$$\mu N - \delta T = 0 \tag{iii}$$

$$N - T \delta \theta = 0 \tag{iv}$$

Substituting the value of  $N$  from (iv) in (iii)

$$\delta T = \mu T \delta \theta \tag{v}$$

or 
$$\frac{\delta T}{T} = \mu \delta \theta \tag{vi}$$

or 
$$\int_{T_2}^{T_1} \frac{dT}{T} = \mu \int_0^\theta d\theta$$

or 
$$\frac{T_1}{T_2} = e^{\mu\theta} \tag{11.1}$$

Power transmitted  $P = \text{Tangential force} \times v$   

$$= (T_1 - T_2)v \tag{11.2}$$

where  $v = \text{peripheral velocity in m/s} = \frac{\pi DN_1}{60} = \frac{\pi dN_2}{60}$  where  $N_1$  and  $N_2$  are the speeds of the bigger and smaller pulleys respectively.

For the  $V$  belt the same expressions are used by modifying  $\mu$  to  $\mu'$ .

From Fig. 11.5  $N$  is the resultant of  $N_1$  and  $N_2$ . Since both the forces are equal hence,

$$N = N_1 \sin \alpha/2 + N_2 \sin \alpha/2$$

$$= 2 N_1 \sin \alpha/2$$

$\therefore N_1 = \frac{N}{2 \sin \alpha/2} = \frac{N}{2} \operatorname{cosec} \frac{\alpha}{2}$

$\therefore$  Equation (iv) is written as  $2 \cdot \frac{N}{2} \operatorname{cosec} \frac{\alpha}{2} - T \delta \theta = 0$

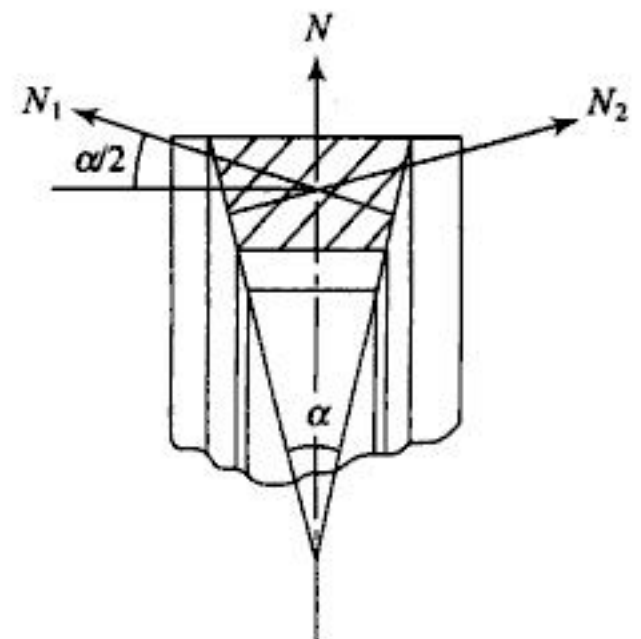

**Fig. 11.5**



You have either reached a page that is unavailable for viewing or reached your viewing limit for this book.



You have either reached a page that is unavailable for viewing or reached your viewing limit for this book.



You have either reached a page that is unavailable for viewing or reached your viewing limit for this book.



You have either reached a page that is unavailable for viewing or reached your viewing limit for this book.



You have either reached a page that is unavailable for viewing or reached your viewing limit for this book.



You have either reached a page that is unavailable for viewing or reached your viewing limit for this book.



You have either reached a page that is unavailable for viewing or reached your viewing limit for this book.

= Bending moment on four arms with section modulus  $Z = \frac{\pi}{32}tb^2$

Using  $\sigma_t = 10 \text{ MPa}$

$$\text{b.m} = 4 \sigma_t \times z = 4 \times 10 \times \frac{\pi}{32} t (37.04)^2$$

$\therefore t = 7.32 \text{ mm}$ . Let us adapt  $t = 10 \text{ mm}$ .

For the bigger pulley, torque =  $(751.54 - 356.18) \times 300 = 6 (\sigma_t \cdot Z)$

$$= 10 \times 6 \times \frac{\pi}{32} t (54.3)^2$$

$\therefore t = 6.82 \text{ mm}$ . We take the thickness  $t = 10 \text{ mm}$ .

$$\text{thickness of rim} = \frac{d}{300} + 2 = 3 \text{ mm for the smaller pulley}$$

$$= \frac{600}{300} + 2 = 4 \text{ mm for the bigger pulley}$$

11.4 It is required to design a leather cross belt drive to connect 7.5 kW, 1440 r.p.m electric motor to a compressor running at 480 r.p.m. The distance between the centres of the pulleys is twice the diameter of the bigger pulley. The belt should operate at 20 m/s approximately and its thickness is 5 mm. Density of leather =  $950 \text{ kg/m}^3$  and  $S_{ut} = 25 \text{ MPa}$ .

*Solution:*

$$v = \frac{\pi dn}{60}, \therefore d = \frac{20 \times 60}{\pi \times 1440} = 0.265 \text{ m}$$

The nearest standard diameter is 250 mm.

$$\therefore D = \frac{1440}{480} \times 250 = 750 \text{ mm}, \therefore v = 18.86 \text{ m/s}$$

Centre distance = 1.5 m

$$\therefore L = 2C + \frac{\pi}{2} (0.75 + 0.25) + \frac{(0.75 - 0.25)^2}{4 \times 3} = 4.654 \text{ m}$$

$$\phi = \sin^{-1} \frac{D + d}{2C} = \sin^{-1} \frac{1}{3} = 19.47^\circ$$

$$\therefore \theta = 180 + 38.94 = 218.94^\circ$$

$$\frac{T_1}{T_2} = e^{0.25 \times \frac{218.94}{180} \pi} = 2.6$$

$$T_1 - T_2 = \frac{P}{v} = \frac{7.5 \times 1000}{18.86} = 397.65 \text{ N}$$

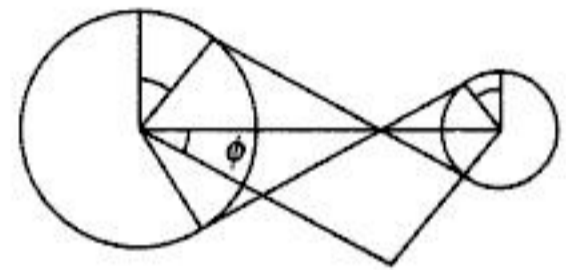

**Fig. E-11.4**



You have either reached a page that is unavailable for viewing or reached your viewing limit for this book.



You have either reached a page that is unavailable for viewing or reached your viewing limit for this book.



You have either reached a page that is unavailable for viewing or reached your viewing limit for this book.



You have either reached a page that is unavailable for viewing or reached your viewing limit for this book.

$$P_b = 0.89 \times 19.96 \times 1 = 17.76 \text{ N/mm}^2$$

This is smaller than the actual bearing pressure. Hence it is advisable to use the duplex 10 B chain for which  $A = 2 \times 67$ ,  $q = 2 \times 0.95$

$$P_c = 60.1 \text{ N}$$

$$\begin{aligned} \therefore \text{Actual bearing pressure} &= \frac{2133.33 - 33 + 60.1}{2 \times 67} \\ &= 16.36 \text{ N/mm}^2 \text{ which is less than } 17.76 \text{ Nmm}^2. \end{aligned}$$

Hence the chain is safe.

$\therefore$  We use the duplex 10 B chain.

Other details may be worked out by referring to manufacturer's catalogue.

## OBJECTIVE QUESTIONS

- 11.1 Ratio of tensions  $\frac{T_1}{T_2}$  in a V belt drive is given by  
 (a)  $e^{\mu\theta}$  (b)  $e^{\mu\theta \operatorname{cosec} \alpha}$  (c)  $e^{\mu\theta \operatorname{cose} \alpha/2}$  (d)  $e^{\mu\theta \cos \alpha/2}$   
 where  $\theta$  = angle of lap,  $\alpha$  = groove angle.
- 11.2 In case of a belt drive the maximum power is transmitted if the value of centrifugal tension is  
 (a)  $\frac{1}{3}$  tension  $T_1$  on tight side (b)  $\frac{1}{3}$  total tension  $T_t$  on tight side  
 (c)  $\frac{1}{3}$  tension  $T_s$  on slack side (d)  $\frac{1}{3}$  the sum of  $(T_1 + T_2)$
- 11.3 Magnitude of initial tension in the belt should be  
 (a) zero (b)  $T_1 + \frac{T_2}{2}$  (c)  $\frac{T_1 + T_2 + 2T_c}{2}$  (d)  $T_1 - T_2$
- 11.4 The magnitude of velocity of the belt for maximum power transmission should be  
 (a)  $\sqrt{\frac{T_t}{3m}}$  (b)  $\sqrt{2gh}$  (c)  $(T_1 - T_2) \cdot r$  (d)  $\frac{\text{Power}}{(T_1 - T_2)}$
- 11.5 Maximum induced stress in the belt is  
 (a)  $\frac{T_1}{bt}$  (b)  $\frac{T_t}{bt}$  (c)  $\frac{T_t}{bt} + \frac{Et}{d}$  (d)  $\frac{T_1}{bt} + \frac{Et}{D}$
- 11.6 Slip is the result of  
 (a) insufficient friction between the belt and the pulley  
 (b) unequal elongation of belt due to  $T_1$  and  $T_2$   
 (c) elongation of belt due to  $T_t$   
 (d) none of the above
- 11.7 The angle of contact in a belt drive should be  
 (a) more than  $150^\circ$  in the smaller pulley (b) more than  $150^\circ$  in the larger pulley  
 (c)  $180^\circ$  (d) between  $150^\circ$  and  $200^\circ$  on either pulley



You have either reached a page that is unavailable for viewing or reached your viewing limit for this book.



You have either reached a page that is unavailable for viewing or reached your viewing limit for this book.



You have either reached a page that is unavailable for viewing or reached your viewing limit for this book.

- 11.15 Solve Problem 11.14 using a cross belt drive.
- 11.16 In an open belt drive the smaller pulley is of 300 mm diameter and rotates at 300 r.p.m. The bigger pulley has a diameter of 500 mm and is situated at a distance of 576 mm centre to centre from the smaller pulley. The coefficient of friction is 0.25, when 4 kW is being transmitted. Which of the following alternatives is more effective to increase power to be transmitted:
- increasing initial tension by 10%
  - increasing  $\mu$  by 10%
  - increasing angle of lap to  $190^\circ$  by using idler pulley
- 11.17 A compressor is driven by an electric motor by a flat leather belt. The details of the belt drive are
- | Item              | Diameter | $\theta$    | $\mu$ | $N$       | Power |
|-------------------|----------|-------------|-------|-----------|-------|
| Motor pulley      | 300 mm   | $144^\circ$ | 0.3   | 900 r.p.m | 22 kW |
| Compressor pulley | 1200 mm  | $216^\circ$ | 0.25  | 225 r.p.m | 22 kW |
- Thickness of belt = 8 mm, maximum permissible stress in the belt = 2.8 MPa, the density of the belt =  $1000 \text{ kg/m}^3$ . Calculate the width of the belt.
- 11.18 In an electric motor and a compressor V belt drive, diameters of the motor and the compressor pulley are 250 mm and 1250 mm respectively. Groove angle for the motor pulley is  $35^\circ$  whereas compressor pulley is flat. The centre distance is 2 m. The power to be transmitted is 20 kW at 1750 r.p.m of the motor pulley. Each belt has a mass of 0.3 kg/m and area of c/s of the belt =  $200 \text{ mm}^2$ . The maximum permissible stress is 2.5 MPa. Determine the number of belts required if the coefficient of friction for both the pulleys is 0.3.
- 11.19 In the flat belt drive of Problem 11.18, V belts are used with a groove angle of  $60^\circ$  then, with other parameters remaining the same calculate the increase in power. Area of flat and V belts is the same.
- 11.20 In the Problem 11.18 find the number of belts required if the same amount of power is transmitted by using V belt drive of groove angle  $45^\circ$  and the area of c/s of belts is  $140 \text{ mm}^2$ .
- 11.21 Two parallel shafts connected by a crossed belt have pulleys of diameters 400 mm and 600 mm. The centre distance is 5 m. The direction of rotation of the driven shaft is to be reversed by using an open belt drive. State whether we can use the same belt. If not what is the remedy? If a belt of thickness 8 mm and width 100 mm is used and initially 63 kW power is transmitted at 600 r.p.m. calculate the change in the transmitted power when an open belt drive is used. In case the same amount of power is to be transmitted what modification is required?
- 11.22 Find the width of the leather belt 6 mm thick transmitting 20 kW at 500 r.p.m of 750 mm diameter pulley,  $\theta = 150^\circ$ ,  $\mu = 0.3$ ,  $m = 1000 \text{ kg/m}^3$ , permissible maximum tensile stress 2.75 MPa.
- 11.23 V belt with cross-sectional area of  $250 \text{ mm}^2$  and angle of groove  $45^\circ$  has density  $1.5 \text{ mg/m}^3$ . The angle of lap is  $180^\circ$ . The coefficient of friction between pulley and belt is 0.25 and maximum stress is limited to 4.75 MPa. Find the maximum H.P that can be transmitted.
- 11.24 A roller chain is used to connect two shafts spaced 25 pitches apart to transmit 75 kW at 300 r.p.m of a 17 tooth driver sprocket to 34 tooth driven sprocket. The working period is 18 hrs. per day with abnormal service conditions. Specify the length and size of chain.
- 11.25 A double strand No. 8 type roller chain is used to transmit power between a 15 tooth driving sprocket relating at 500 r.p.m. Driving source is an electric motor and a moderate shock is expected. Driven sprocket has 60 teeth. Determine the rated power and approximate centre distance, if the chain length is 90 pitches. From Table power rating of chain is 16.99 kW, tooth correction factor is 0.85, multiple strand factor is 1.7, service correction factor is 1.3, pitch = 25.4 mm.



You have either reached a page that is unavailable for viewing or reached your viewing limit for this book.



You have either reached a page that is unavailable for viewing or reached your viewing limit for this book.



You have either reached a page that is unavailable for viewing or reached your viewing limit for this book.

$$T_1 \cdot b - T_2 \cdot c + P \cdot a = 0 \quad \text{for clockwise rotation} \quad (12.8)$$

$$T_2 \cdot b - T_1 \cdot c + P \cdot a = 0 \quad \text{for anticlockwise rotation} \quad (12.9)$$

The brake becomes self-locking if  $T_1 \cdot b = T_2 \cdot c$  or  $T_2 \cdot b = T_1 \cdot c$  for Eqs (12.8) and (12.9) respectively. For an additive brake (Fig. 12.4), Eqs. (12.8) and (12.9) change to

$$T_1 \cdot b + T_2 \cdot c - P \cdot a = 0 \quad \text{and} \quad (12.10)$$

$$T_2 \cdot b + T_1 \cdot c - P \cdot a = 0 \quad (12.11)$$

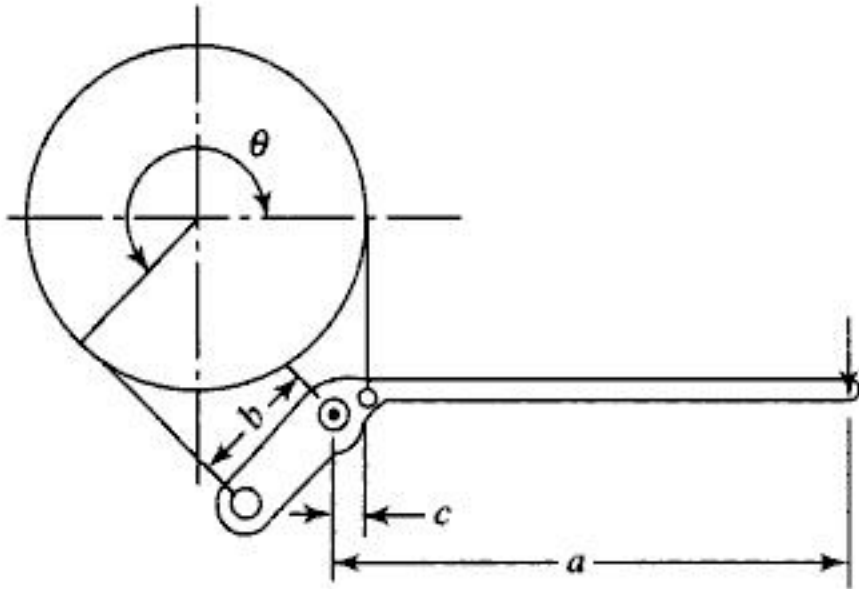

Fig. 12.3

Fig. 12.4

Here moments of  $T_1$  and  $T_2$  are added together hence it is called as, additive brakes whereas in a differential band brake, the moments are subtracted from each other. The additive brake does not become self-locking in any case but requires a larger braking force.

### 12.6 LONG SHOE BRAKES

When the angle of contact of the shoe and the brake drum is larger than  $60^\circ$ , the pressure distribution is non-uniform and hence, the normal reaction  $N$  cannot be assumed to act at a point. This type of shoe brake is termed as the *long shoe brake*.

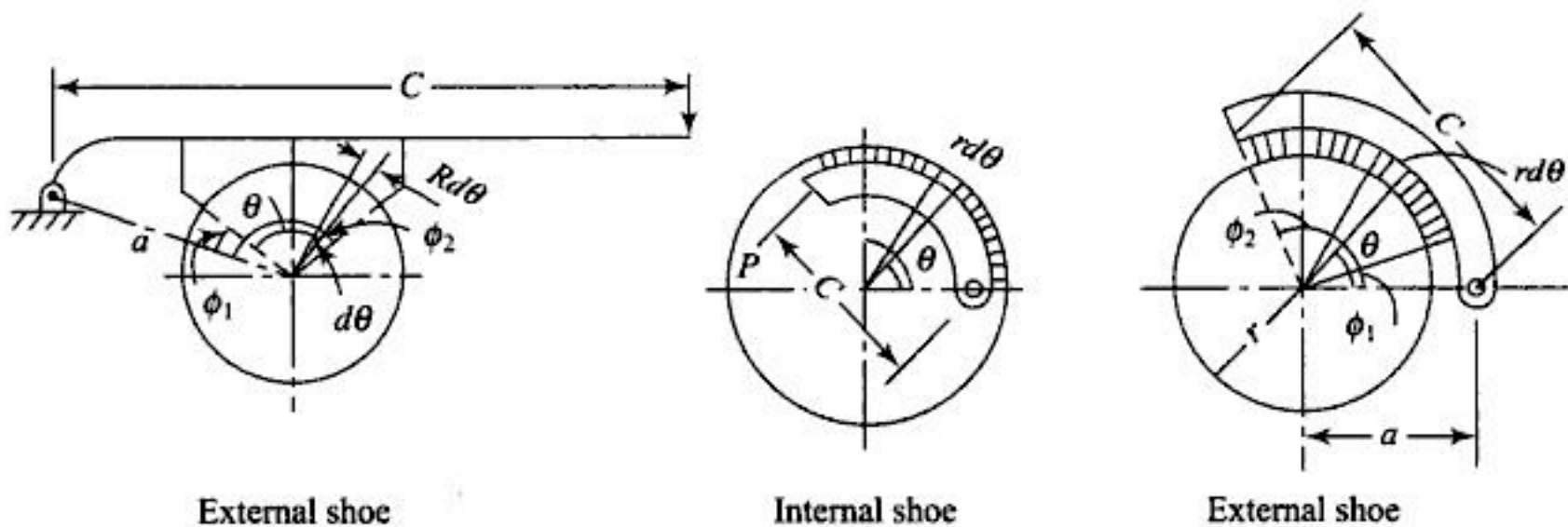

Fig. 12.5



You have either reached a page that is unavailable for viewing or reached your viewing limit for this book.



You have either reached a page that is unavailable for viewing or reached your viewing limit for this book.



You have either reached a page that is unavailable for viewing or reached your viewing limit for this book.

Further calculation of dimension may be made by using Eq. 12.22 for heat dissipation

$$V = \frac{\pi \times 0.75 \times 600}{60} = 23.56 \text{ m/s}$$

$$pV = 1.93 \times 10^6, \quad \therefore p = 0.0819 \times 10^6 \text{ Pa}$$

$$N = p \times \text{Area of contact}, \quad \therefore \text{Area of contact} = \frac{2000}{0.0819} = 24420 \text{ mm}^2$$

Let the angle of contact be  $60^\circ$

$$\therefore 375 \times \frac{\pi}{3} \times b = 24420$$

$$\therefore b = 62.18 \text{ mm. Let us adapt } b = 100 \text{ mm.}$$

$$\therefore \text{Angle of contact will be } 37.5^\circ$$

$$\text{Maximum b.m on the lever} = P(a - b)$$

$$= 830 \times 664 \text{ N.mm}$$

$$= \sigma_z = 70 \times \frac{1}{6} bt^2$$

$$\therefore t = \sqrt{\frac{830 \times 600 \times 6}{70 \times 100}} = 20.66 \text{ mm} \cong 21 \text{ mm.}$$

The dimension of the fulcrum pin may be calculated by first finding the reaction at the fulcrum.  
Reaction at fulcrum in vertical direction =  $2000 - 830 = 1170 \text{ N}$

$$\text{Horizontal reaction} = 0.3 \times 2000 = 600 \text{ N}$$

$$\therefore \text{Resultant reaction} = \sqrt{1170^2 + 600^2} = 1314.87 \text{ N}$$

Dimensions of the fulcrum pin may be calculated by using the method described in chapter two using Eqs. 2.2.4 to 2.2.7.

12.2 In the brake shown in Fig. E-12.2 diameter of the drum rotating at a speed of 100 r.p.m is 600 mm. Find the breaking torque and the amount of heat generated per unit time.  $\mu = 0.3$ .

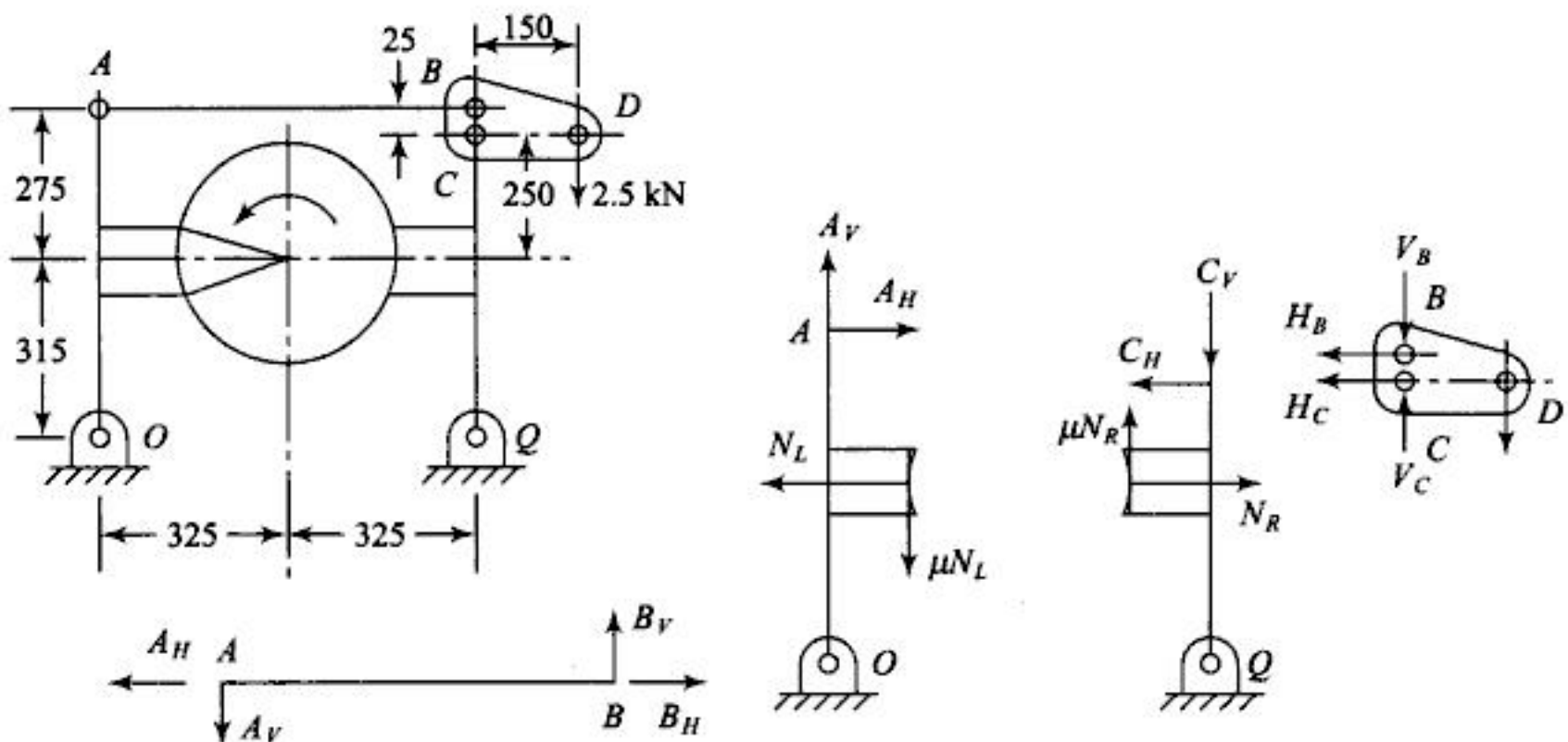

Fig. E-12.2



You have either reached a page that is unavailable for viewing or reached your viewing limit for this book.



You have either reached a page that is unavailable for viewing or reached your viewing limit for this book.



You have either reached a page that is unavailable for viewing or reached your viewing limit for this book.

Similarly for the second block  $\frac{T_2}{T_1} = \frac{(1 + \mu \tan \theta)}{(1 - \mu \tan \theta)}$

and for the third block  $\frac{T_3}{T_2} = \frac{(1 + \mu \tan \theta)}{(1 - \mu \tan \theta)}$  and so on.

$$\therefore \frac{T_n}{T_0} = \frac{T_n}{T_{n-1}} \times \dots \times \frac{T_2}{T_1} \times \frac{T_1}{T_0} = \left( \frac{1 + \mu \tan \theta}{1 - \mu \tan \theta} \right)^n$$

Now, power to be absorbed = 450 kW =  $\frac{2\pi NT}{60000}$

Substituting  $T = 7162 = (T_n - T_0) \times 0.4 \text{ N.m}$   
 $T_n - T_0 = 17905 \text{ N}$  (iii)

Again from the equilibrium equation for the lever

$$200 \times 1.2 - T_n \times \frac{25}{1000} + T_0 \times \frac{100}{1000} = 0$$

$\therefore T_n - 4 T_0 = 9600$  (iv)

From Eqs. (iii) and (iv)

$$T_0 = 2768.33 \text{ N and } T_n = 20673.33 \text{ N}$$

$$\frac{T_n}{T_0} = \frac{20673.33}{2768.33} = 7.468 = \left( \frac{1 + \mu \tan \theta}{1 - \mu \tan \theta} \right)^n$$

Again  $\frac{1 + \mu \tan \theta}{1 - \mu \tan \theta} = \frac{1 + 0.35 \tan 15^\circ}{1 - 0.35 \tan 15^\circ} = 1.2$

$\therefore n = 11.2$ , say 12.

Therefore 12 blocks should be used.

- 12.5 Calculate the value of torque that the back-stop in Fig. E-12.5 can resist if the maximum pressure between the lining and the drum is 1.4 MPa. Also find the coefficient of friction required to hold the load.  $b = 30 \text{ mm}$ .

*Solution:*

Backstop should operate when the direction of rotation reverses.

$$T_1 = p_{\max} br = 1.4 \times 30 \times 320 = 13440 \text{ N}$$

For the backstop to operate when the rotation is reversed

$$13440 \times 50 = T_2 \times 200$$

$\therefore T_2 = 3360 \text{ N}$

$\therefore \text{Torque} = (13440 - 3360) \times \frac{320}{1000} = 3225.6 \text{ N.m}$

Again  $\frac{T_1}{T_2} = 4 = e^{\mu\theta}$

As  $\theta = 210^\circ$ ,  $\mu = 0.378$ .

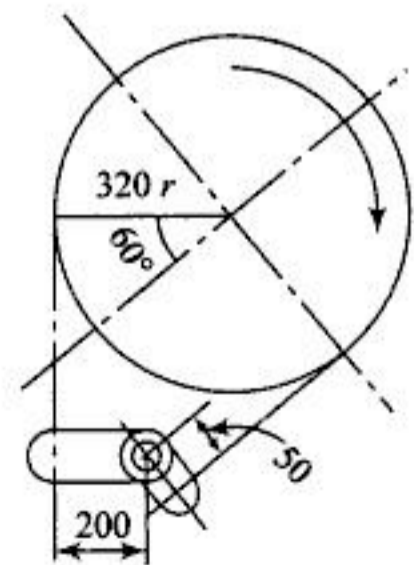

Fig. E-12.5



You have either reached a page that is unavailable for viewing or reached your viewing limit for this book.



You have either reached a page that is unavailable for viewing or reached your viewing limit for this book.



You have either reached a page that is unavailable for viewing or reached your viewing limit for this book.

$$\therefore \text{Resultant reaction} = \sqrt{(2.08307)^2 + (0.5367)^2} = 2.151 \text{ kN}$$

Similarly for the left hand shoe

$$R_x = \frac{0.2636 \times 28 \times 125}{1000} \left[ \frac{1}{2} \sin^2 120^\circ + 0.32 \left( \frac{\pi}{3} - \frac{\sin 240^\circ}{4} \right) \right] - 0.95 \times 0.5$$

$$= 0.2604 \text{ kN}$$

$$R_y = \frac{0.2696 \times 28 \times 125}{1000} \left[ \left( \frac{\pi}{3} - \frac{\sin 240^\circ}{4} \right) - \frac{0.32}{2} \sin^2 120^\circ \right] - 0.95 \times 0.866$$

$$= 0.2565 \text{ kN}$$

$$\therefore R = \sqrt{(0.2604)^2 + (0.2565)^2} = 0.3655 \text{ kN.}$$

- 12.10 Find the value of  $p_{\max}$  for each shoe and the value of torque exerted by the brake. Also find the power, absorbed for the pivoted type of shoe brake shown in Fig. E-12.10 (a) and (b).

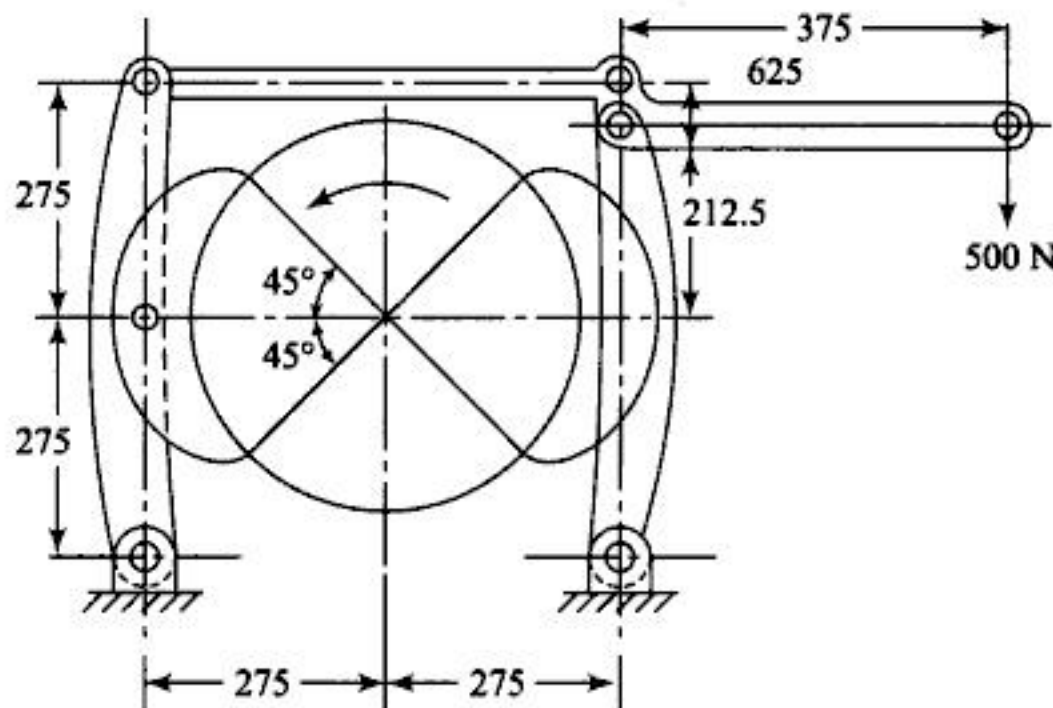

**Fig. E-12.10a**

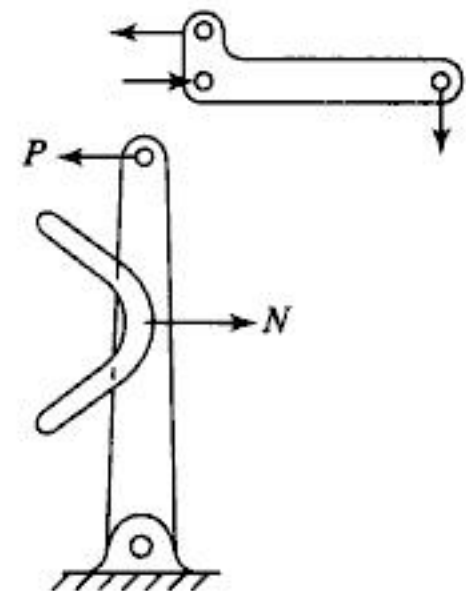

**Fig. E-12.10b**

*Solution:*

For the right hand shoe

$$P = \frac{500 \times 375}{62.5} = 3000 \text{ N}$$

$$\therefore 3000 \times 487.5 - \frac{p_m b r_m}{2} (\theta + \sin \theta) \times 275 = 0$$

$$\therefore 3000 \times 487.5 - \frac{p_m \times 100 \times 250}{2} \left( \frac{\pi}{2} + \sin \frac{\pi}{2} \right) \times 275 = 0$$

$$\therefore p_m = 0.166 \text{ MPa}$$



You have either reached a page that is unavailable for viewing or reached your viewing limit for this book.



You have either reached a page that is unavailable for viewing or reached your viewing limit for this book.



You have either reached a page that is unavailable for viewing or reached your viewing limit for this book.

12.5 Draw the free body diagram of each link of the brake shown in Fig. P-12.5. Calculate the force  $P$  if the power to be absorbed is 15 kW at 200 r.p.m. Check the design for heating.  $\mu = 0.3$ .

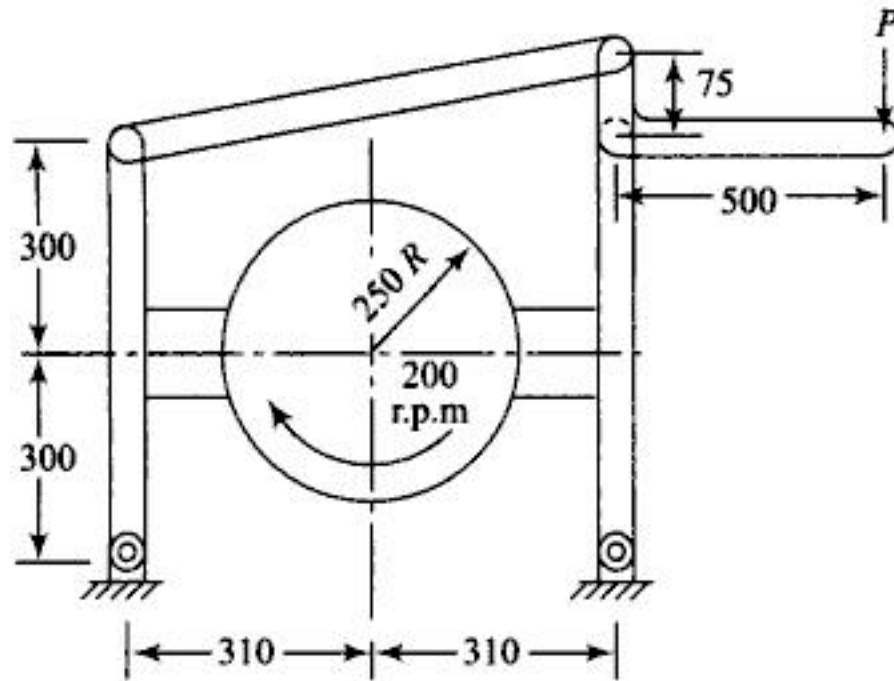

Fig. P-12.5

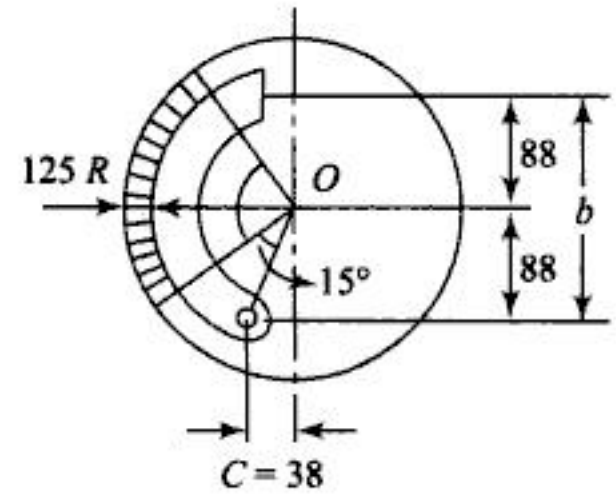

Fig. P-12.6

12.6 In an internal expanding shoe brake shown in Fig. P-12.6,  $\phi_1 = 15^\circ$  and  $\phi_2 = 105^\circ$ . The value of maximum shoe pressure is 0.7 MPa,  $\mu = 0.25$ , width of the lining = 50 mm. Find the torque capacity if the inner radius of the drum is 125 mm.

12.7 Find the width of the shoe in an internal expanding shoe brake with  $\phi_1 = 15^\circ$  and  $\phi_2 = 150^\circ$ ,  $\mu = 0.35$ ,  $p_m = 0.85$  MPa,  $R = 150$  mm,  $b = 250$  mm, distance of pivot from the centre of drum = 125 mm. The power to be absorbed is 10.38 kW at 120 r.p.m.

12.8 For the brake shown in Fig. P-12.8,  $\mu = 0.3$ . The permissible maximum pressure is 1 MPa and the force at the end of the lever is 622 N. Find the width of the band and the torque capacity.

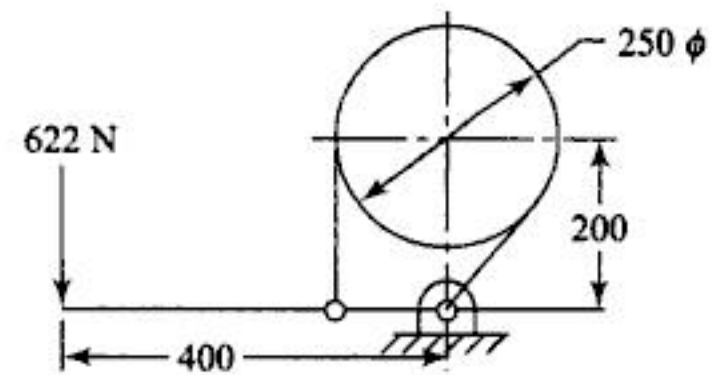

Fig. P-12.8

12.9 Design a brake shown in Fig. P-12.9 of torque capacity of 900 N.m,  $\mu = 0.3$ ,  $p_m = 0.525$  MPa,  $b =$  width of the shoe =  $\frac{D}{3}$  where  $D$  is the diameter of drum. Find the values of  $P$ ,  $D$  and  $b$ .

12.10 A double block brake brings the brake drum rotating at a speed of 300 r.p.m to rest within 5 seconds. The brake drum diameter is 600 mm and a torque capacity of 10000 N.m. The permissible bearing pressure is 0.5 MPa. Determine the actuating force at the end of the lever of length 1 m. The distance between the two fulcrums is 500 mm and the axis of the drum shaft is at a distance of 350 mm from the line joining the two fulcrums. Design the shoe, pivot pin and find the cross section of the lever at the critical section  $\mu = 0.3$ .

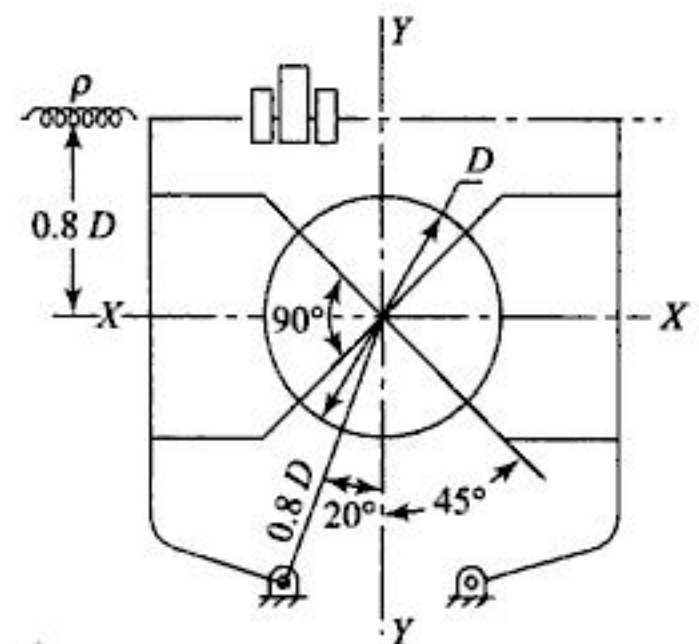

Fig. P-12.9



You have either reached a page that is unavailable for viewing or reached your viewing limit for this book.



You have either reached a page that is unavailable for viewing or reached your viewing limit for this book.



You have either reached a page that is unavailable for viewing or reached your viewing limit for this book.

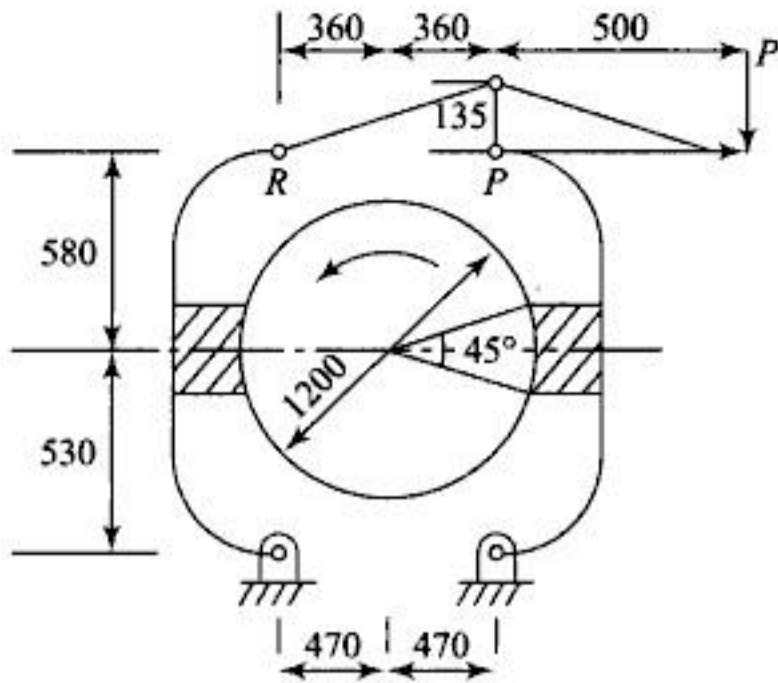

Fig. P-12.24

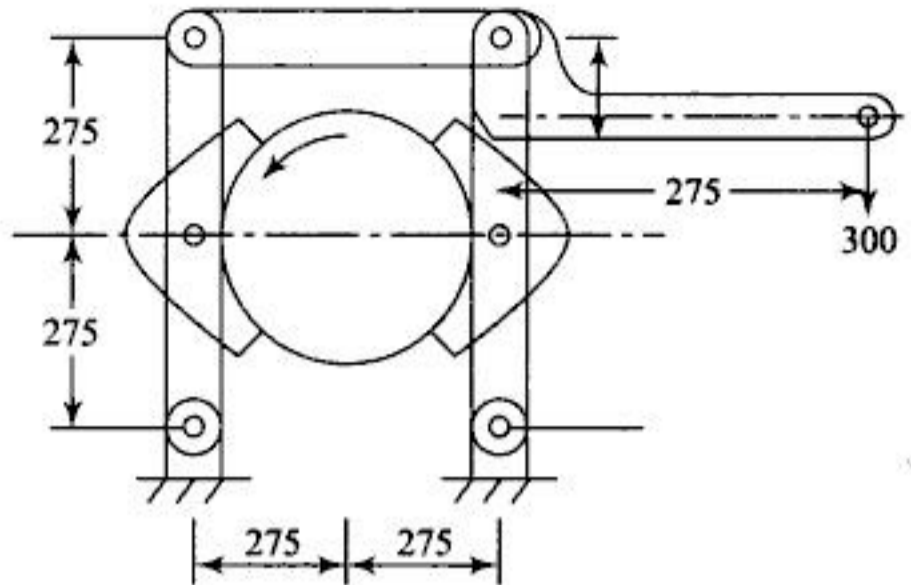

Fig. P-12.25

12.28 In a band and block brake  $\theta = 15^\circ$ , number of blocks is 12. The thickness of the block 75 mm; diameter of drum 850 mm. The least force applied at 500 mm from the fulcrum on the lever is 610.8 N,  $a = 150$  mm,  $b = 30$  mm. Find the power absorbed at 240 r.p.m if  $\mu = 0.4$ .

## ANSWERS

### Objective Questions

- (1) b (2) c (3) b (4) b (5) d (6) b (7) c (8) c (9) b  
 (10) c (11) c (12) c

### Practice Problems

- (1) 1811 N, 167.67 N.m (2) 1365 N for anticlockwise rotation (3) 174 mm  
 (4)  $134^\circ$  (5) 713.26 N,  $b = 105$  mm, for angle of contact of  $60^\circ$   
 (6) 258.00 N.m (7) 50 mm (8) 50 mm, 532 N.m  
 (9)  $D = 308.3$  modified to 310 mm,  $P = 9087.216$  N,  $b = 103.33$  mm  
 (10)  $P = 1940.87$  N,  $b = 73.8 \rightarrow 75$  mm for angle of contact  $30^\circ$ , lever of 30C8 steel section  $63 \times 21$  mm, pivot pin dia. 20 mm  
 (11) 467.5 N, 515 N, 571.4 N (12)  $b = 216.66 \rightarrow 220$  mm  
 (13) 85.86 N.m, 321.59 rev, 8.575 sec (14) 16588.6 N  
 (15) distance of pivot from A 62.5 mm, 416.67 N for both  
 (16)  $b = 80$  mm; shaft diameter 30 mm, band is safe  
 (17) anticlockwise, dia. of cylinder = 45.66  $\rightarrow$  50 mm, self-locking not possible  
 (18) clockwise, 0.261, 1156.3 N.m (19)  $D = 380$  mm, 4811.4 N, 2.45 MPa  
 (20)  $\frac{T_1 b - P(b+c)}{P(b+c) - T_2 b}$  (21) 1067.99 N.m (22) 457.92 kW  
 (23)  $T = 1082.75$  N.m,  $P = 3735.2$  N,  $P = 7264.18$  N  
 (25) max. pr. intensity = 0.166 for RHS, 0.187 for LHS; 593.88 N.m; 37.31 kW, yes  
 (26) 28 mm, 182.616 N.m, 2.151 kN for RHS, 5.5 kN for LHS, pr. intensity for RHS is 0.36 MPa  
 (27) anticlockwise 180 N.m, clockwise 221.54 N.m (28) 225 kW.



You have either reached a page that is unavailable for viewing or reached your viewing limit for this book.



You have either reached a page that is unavailable for viewing or reached your viewing limit for this book.



You have either reached a page that is unavailable for viewing or reached your viewing limit for this book.

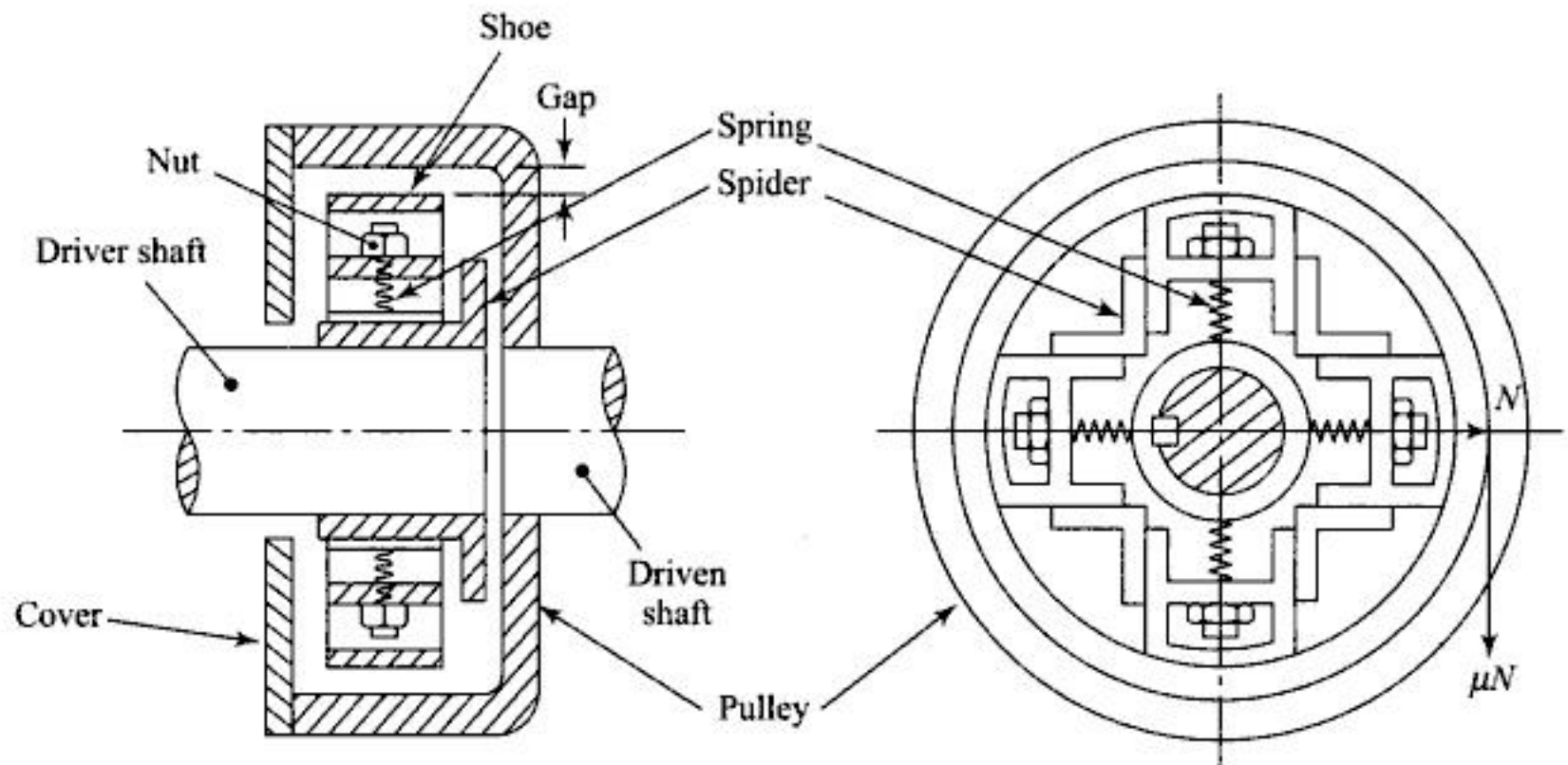

**Fig. 13.3**

keeps them away from the inner radius of pulley rim. When driver shaft starts rotating the c.f force acts on shoes. When this force overcomes the spring force it comes in contact with the inner radius of rim. This speed is designated as engagement speed. Further increase in speed increases the force  $N$  on the inner radius of rim. The frictional force on the rim is  $\mu N$ . If the engagement speed is  $\omega_1$  and the maximum speed of rotation of driver shaft is  $\omega_2$  then

$N = mr(\omega_2^2 - \omega_1^2)$  where  $m$  is the mass of the shoe in kg,  $r$  the radius of C.G of shoe. If  $R$  is the inner radius of rim, ' $n$ ' is the number of shoes and  $\mu$  the coefficient of friction then frictional torque

$$T_f = n \times \mu \times mr(\omega_2^2 - \omega_1^2) \times R \quad \text{(vii)}$$

Usually three, four or six shoes are used. In some clutches the thin plates are used as spring, while in others, springs are not used.

## WORKED EXAMPLES



- 13.1 A clutch plate with maximum diameter 60 mm has maximum lining pressure of 0.35 MPa. The power to be transmitted at 400 r.p.m is 135 kW and  $\mu = 0.3$ . Find inside diameter and spring force required to engage the clutch. If the springs with spring index 6 and material spring steel with safe shear stress 600 MPa is used find the wire diameter if 6 springs are used.

*Solution:*

$$T_f = \frac{60 \times 1000 \times 135}{2\pi \times 400} = 3222.88 \text{ N.m}$$

Using Eq. (v) and (i),

$$T_f = \mu W r_m = \mu \pi p_m (r_2^2 - r_1^2) r_m$$



You have either reached a page that is unavailable for viewing or reached your viewing limit for this book.



You have either reached a page that is unavailable for viewing or reached your viewing limit for this book.



You have either reached a page that is unavailable for viewing or reached your viewing limit for this book.

- 13.16 Friction affects the engagement force as well as disengagement force in case of  
 (a) c.f clutch (b) cone clutch  
 (c) single plate clutch (d) multiple plate clutch
- 13.17 The number of effective surfaces with 5 steel and 4 brass plates in multiple plate clutch is  
 (a) 5 (b) 9 (c) 8 (d) 4
- 13.18 Mass of shoe of centrifugal clutch of maximum speed 1000 r.p.m is 2.25 kg hence with maximum speed of 1500 r.p.m for the same power transmission the mass of the shoe should be  
 (a) 1.5 kg (b) 1 kg (c) 4.5 kg (d) 1.12 kg

## REVIEW QUESTIONS

- 13.1 What is the difference between a clutch and coupling? How clutch differs from brake?
- 13.2 Explain the working of single plate clutch by drawing a neat sketch. What is the function of toggle lever?
- 13.3 Why are more springs used in single plate clutch?
- 13.4 What are the desirable properties of friction material to be used for clutches?
- 13.5 Compare the cone clutch and single plate clutch explaining why cone clutch is rarely being used nowadays.
- 13.6 Derive the relationship of friction torque in clutches using uniform intensity of pressure theory.
- 13.7 Derive the relationship for friction torque in clutches using uniform rate of wear assumption. Explain why this assumption is usually used in designing clutch.
- 13.8 Derive the expression for friction torque in centrifugal clutch.
- 13.9 What are the fields of application of different types of clutches? Explain the reasons for the same.
- 13.10 Explain the working of a centrifugal clutch by drawing a neat sketch.
- 13.11 What is the engagement factor? Why does it occur?
- 13.12 How the speed of engagement affects the capacity of centrifugal clutch? Why too small or too large engagement speed should be avoided?
- 13.13 What will be the effect of stiffness of spring and the mass of the shoe on the engagement speed and the capacity of centrifugal clutch?
- 13.14 Why the driven shaft should be a splined shaft in case of cone and plate clutch?
- 13.15 Why too small (less than  $8^\circ$ ) or too large (more than  $36^\circ$ ) cone angle should be avoided in case of cone clutch?
- 13.16 What is the role of heat dissipation in the design of clutch?
- 13.17 Cone angle in cone clutch should be between  $10^\circ$  to  $15^\circ$ , why?
- 13.18 What should be the range of the ratio of inner to outer diameter of plate clutch friction surfaces? Why?
- 13.19 Why the springs are fitted with initial tension in centrifugal clutch? How is the initial tension adjusted?
- 13.20 The centrifugal clutches are used for the engines which cannot be started under load. Explain.
- 13.21 Why are the slots provided on the clutch plate?
- 13.22 Which assumption is used in designing the clutch out of (a) uniform rate of wear, (b) uniform intensity of pressure? Why?
- 13.23 Multiple plate clutches are used on two-wheelers while single plate clutches are used on four-wheelers. Why?

## Spur Gear

### CONCEPT REVIEW

#### 14.1 DEFINITIONS

1. A pair of spur gears is equivalent to a pair of cylindrical discs keyed to parallel shafts and having line contact used to transmit torque.
2. Pitch circle diameter is the diameter of the circle which by pure rolling would transmit the same motion as the actual gear wheel.
3. The pitch point is the point of contact of two pitch circles.
4. The circular pitch  $p$  is the distance measured along the pitch circle circumference from the point on one tooth to the corresponding point on the next tooth. It is calculated as,

$$p = \frac{\text{pitch circle circumference}}{\text{No. of teeth}}$$

$$= \frac{\pi d_p}{t_p} = \frac{\pi d_g}{t_g}$$

5. Module is the pitch circle diameter divided by number of teeth

i.e.  $m = \frac{d_p}{t_p} = \frac{d_g}{t_g}$  mm for spur gears

6. Circular pitch  $p = \frac{\pi d_p}{t_p} = \pi m$  mm

7. The addendum is the radial distance from the pitch circle to the top of the tooth.

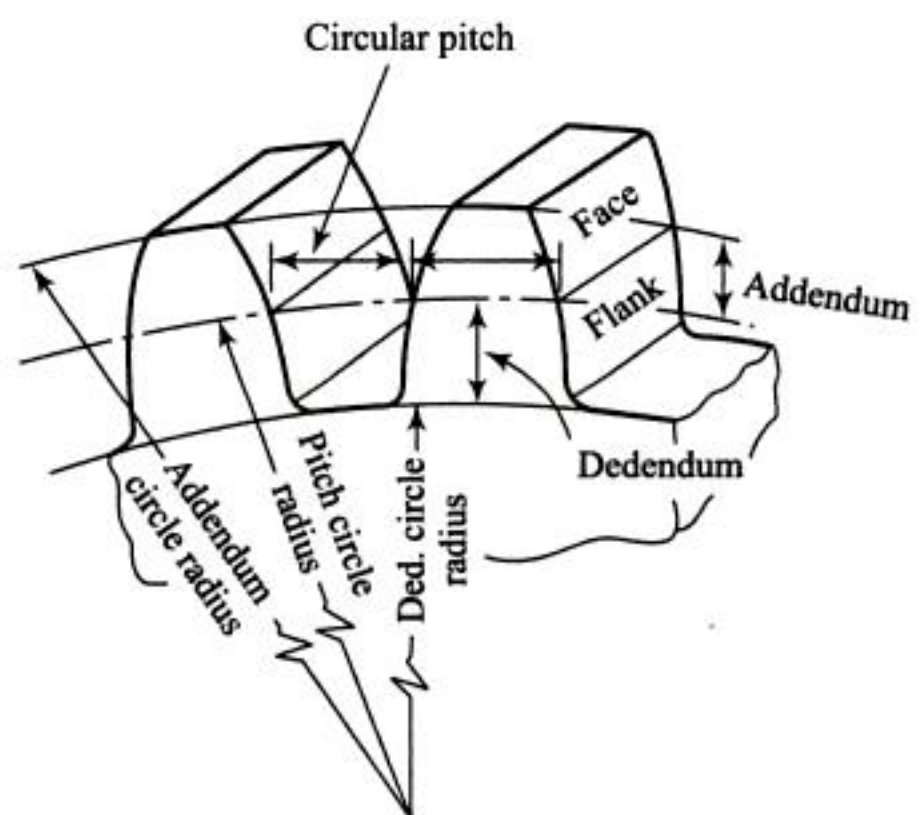

Fig. 14.1

8. The dedendum is the radial distance from the pitch circle to the bottom of the tooth space.
9. A pinion is the smaller of the two mating gears.
10. A rack is a gear wheel with infinitely large number of teeth hence pitch circle circumference is a straight line, or it is a gear with infinite radius.
11. Pressure angle  $\phi$  or angle of obliquity is the angle which the common normal to the profiles of the two teeth at the point of contact makes with the common tangent to the two pitch circles at the pitch point.
12. Condition of correct gearing: For velocity ratio to remain constant the contact surfaces should have a profile such that the common normal to the two contacting surfaces intersects the line joining the centres at a fixed point.
13. The profiles satisfying this condition are known as conjugate profiles.
14. Involute, epi and hypo cycloid are the standard curves satisfying this condition.
15. It is common practice to use involute profile for gear teeth due to ease of manufacture and possibility of more precision in cutting involute profile.
16. Interference takes place in the involute gears which can be avoided if the addendum circles of two mating gears cut the common tangent between the points of tangency.
17. This places the limitation on the minimum number of teeth on the pinion which is given by the expression,

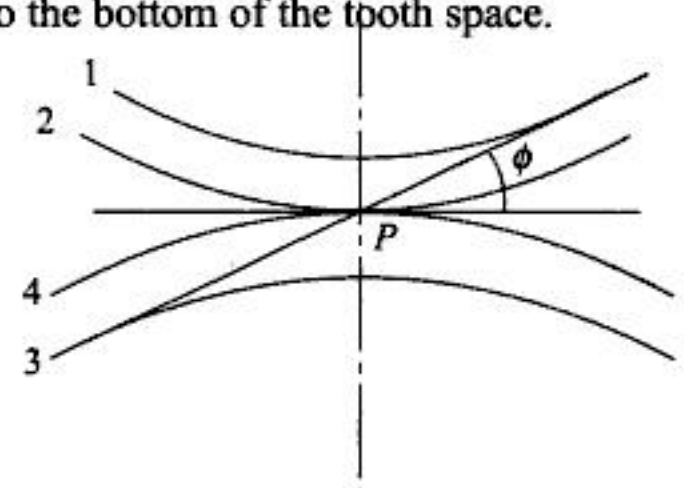

Fig. 14.2

$$t_p = \frac{2a_w t_p / t_g}{\left(\sqrt{1 + A \sin^2 \phi}\right) - 1} = \frac{2a_w / G}{\left(\sqrt{1 + A \sin^2 \phi}\right) - 1}$$

where addendum =  $a_w m$

and

$$A = \frac{t_p}{t_g} \times \left(\frac{t_p}{t_g} + 2\right) = \frac{1}{G} \left(\frac{1}{G} + 2\right)$$

For contact between the rack and pinion,

$$t_p = \frac{2a_r}{\sin^2 \phi} \text{ where addendum} = a_r m$$

For  $20^\circ$  pressure angle  $t_p = 17.1$  say 18 for  $a_r = 1$ ; for  $14\frac{1}{2}^\circ$  pressure angle  $t_p = 31.9$  say 32. Hence for calculation of pinion, the starting value of number of teeth to be assumed should be 18 to 20 for  $20^\circ$  pressure angle and 32 for  $14\frac{1}{2}^\circ$ . Force acting on the tooth of spur gear  $F_n$  is normal to the tooth profile which is resolved in two components namely,

$$\begin{aligned} F_r &= F_n \sin \phi \\ F_t &= F_n \cos \phi \\ F_r &= F_t \tan \phi \end{aligned}$$

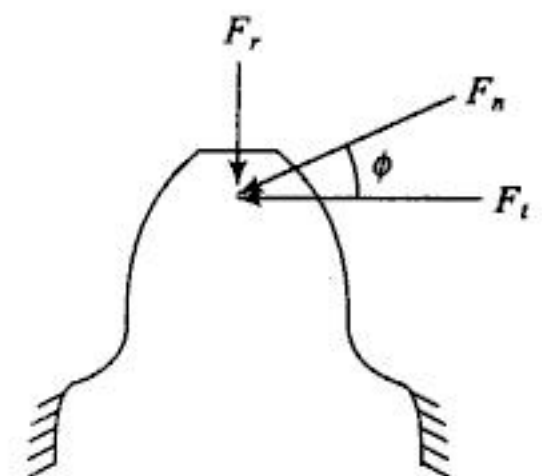

Fig. 14.3

## 14.2 DESIGN EQUATIONS

### (a) Beam strength or Lewis Equation

The tooth subjected to  $F_t$  and  $F_r$  may be treated as cantilever and the actual stress distribution is as shown in Fig. 14.4(c) but the design is based only on bending as in 14.4(b). Let  $b$  and  $t$  be the width and thickness of the tooth at the root

$$\therefore z = \text{section modulus} = \frac{1}{6} bt^2$$

$$\therefore \sigma_t = \frac{M}{z} = \frac{F_t h}{\frac{1}{6} bt^2} = \frac{6F_t h}{6t^2}$$

$$\therefore F_t = \sigma_t \times b \frac{t^2}{6h} \text{ multiplying both numerator and denominator by } p$$

$$= \sigma_t \cdot b \cdot p \left( \frac{t^2}{6hp} \right)$$

The bracketed quantity depends on the form of the tooth and is termed as Lewis form stress factor 'y'

$$\therefore F_t = \sigma_t \cdot b \cdot p \cdot y$$

$\sigma_t$  is permissible static bending stress which is modified to  $K_v \sigma_t$  where  $K_v$  is the velocity factor used for taking into account the fatigue loading

$$\therefore F_t = K_v \sigma_t \cdot b \cdot p \cdot y \quad (14.2.1)$$

$$K_v = \frac{3}{3+V} \text{ for peripheral velocity } V < 10 \text{ m/s}$$

$$= \frac{6}{6+V} \text{ for } 10 \text{ m/s} < V < 20 \text{ m/s}$$

$$= \frac{5.6}{5.6 + \sqrt{V}} \text{ for } v > 10 \text{ m/s}$$

$$y = 0.154 - \frac{0.912}{\text{No. of teeth}} \text{ for } 20^\circ \text{ full depth teeth}$$

$$= 0.175 - \frac{0.841}{\text{No. of teeth}} \text{ for } 20^\circ \text{ stub teeth}$$

$$= 0.124 - \frac{0.684}{\text{No. of teeth}} \text{ for } 14\frac{1}{2}^\circ \text{ pressure angle}$$

usually  $b = 10m$  to  $15m$  where  $m = \text{module}$

Lewis form factors can also be obtained directly from Table 28. The values given in the table are modified for stress concentration and load sharing ratio.

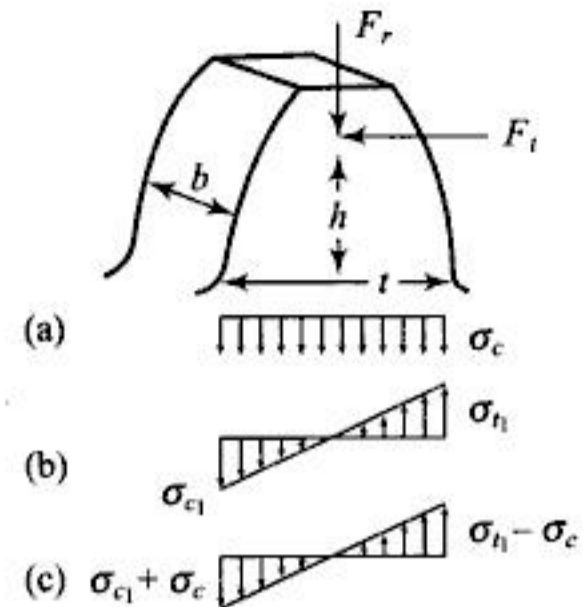

Fig. 14.4

## 14.5 PRACTICAL DESIGN ASPECTS

The involute profile is normally used for gears as the involute rack has a straight line profile as shown in Fig. 14.6. Involute profile poses the difficulty of interference when number of teeth is reduced below the minimum number of teeth. This difficulty is overcome by (a) using stub teeth of which height is less than the full depth teeth, (b) by using composite profile with cycloidal curve at the root of the tooth and (c) by increasing centre distance.



Fig. 14.6

In epicyclic gear train internal gears are used. The teeth of these internal gears are stronger than those of the corresponding spur gears. Operation is smooth and quiet because a greater number of teeth are in contact.

Gears are made from gray and alloy C.I, C.S., forged steel, brass, bronze and impregnated fabric. Heat treatments such as through hardening, case hardening, nitriding, induction or flame hardening may be used for improvement of surface strength.

Lubrication of gears is important and may be achieved by (a) applying lubricant by an oil can, drip oiler or brush, (b) dipping larger gear into bath of oil in case of gears in enclosed casing, (c) using *EP* lubricant if contact pressure is high.

While mounting the gears, care should be taken to see that the shafts are parallel.

Spur gears are highly efficient, the loss of power in friction being only 1 to 2%.

## WORKED EXAMPLES

- 14.1 In a spur gear drive the diameter of pinion is 80 mm and the centre distance 160 mm. The power to be transmitted is 4.5 kW at 800 r.p.m of pinion. Using  $20^\circ$  full depth teeth and material for pinion a steel with permissible static bending stress of 200 MPa and for gear a steel with a permissible static bending stress of 150 MPa, determine the necessary module and width of the teeth using Lewis Equation only.

*Solution:*

$$V = \frac{\pi d_p N_p}{60} = \frac{\pi \times 80 \times 800}{1000 \times 60} = 3.35 \text{ m/s}$$

$$\therefore F_t = \frac{P}{V} = \frac{4.5 \times 1000}{3.35} = 1342.87 \text{ N}$$

$$K_v = \frac{3}{3 + 3.35} = 0.472$$

As the material for the gear is weak, let us test the gear for beam strength

$$t_g = \frac{d_g}{m} = \frac{240}{m} \left( \text{as centre distance} = \frac{d_p + d_g}{2}, \therefore d_g = 240 \text{ mm} \right)$$

$$\therefore y_g = 0.154 - \frac{0.912 \times m}{240}$$

$\therefore$  Lewis Equation for gear

$$F_t = K_v \sigma_g y_g b \cdot p$$

Let  $b = 12 \text{ m}$

$$\therefore 1342.87 = 0.472 \times 150 \times \left( 0.154 - \frac{0.912 \text{ m}}{240} \right) \times 12 \pi m^2$$

By trial and error  $m = 2 \text{ b} = 24 \text{ mm}$

$$t_g = 120, t_p = 40$$

$$\therefore \text{For gear } y_g = 0.154 - \frac{0.912}{120} = 0.1464$$

$$\text{for pinion } y_p = 0.154 - \frac{0.912}{40} = 0.1312$$

$$\sigma_g y_g = 21.96 \text{ and } \sigma_p y_p = 26.24 \quad (\because \sigma_p y_p > \sigma_g y_g)$$

Thus the pinion is stronger than gear hence  $m$  and  $b$  based on the strength of the gear are satisfactory for the pinion.

- 14.2 A pair of gears is to be designed for compact size. Power to be transmitted 20 kW at 1450 r.p.m of pinion and gear ratio 4 : 1. Tooth profile  $20^\circ$  stub. Material for pinion C.S and for gear C.I. Determine the module and necessary face width by using Lewis Equation.

*Solution:*

For compact size use minimum number of teeth. Let addendum = module

$$t_p = \frac{2a_w / G}{\left( \sqrt{1 + A \sin^2 \phi} \right) - 1} = \frac{0.5}{\sqrt{1 + \frac{1}{4} \left( \frac{1}{4} + 2 \right) \sin^2 20^\circ} - 1}$$

$$= 15.44 \text{ say } 16$$

$$t_g = 64, \sigma_p = 100 \text{ MPa}, \sigma_g = 70 \text{ MPa}$$

$$y_p = 0.175 - \frac{0.841}{16} = 0.1224, \therefore y_p \sigma_p = 12.24 \text{ MPa}$$

$$y_g = 0.175 - \frac{0.841}{64} = 0.1618, \therefore y_g \sigma_g = 11.33$$

$\therefore$  Let us design gear

$$V = \frac{\pi \times 16 \text{ m} \times 1450}{60 \times 1000} = 1.214 \text{ m/s}$$

$$\therefore K_v = \frac{3}{3 + 1.214 \text{ m}}$$

$$F_t = \frac{P}{V} = \frac{20,000}{1.214 \text{ N}} = \frac{16474.464}{\text{m}}$$

∴ Lewis Equation for gear with  $b = 12 \text{ m}$

$$F_t = K_v \sigma_g y_g b \times p$$

$$\frac{16474.464}{m} = \left( \frac{3}{3 + 1.214 m} \right) \times 11.33 \times 12\pi \text{ m}^2$$

by trial and error  $m = 5 \text{ mm}$ ,  $b = 60 \text{ mm}$ .

- 14.3 A train of gears transmitting 5.6 kW at 1440 r.p.m is shown in Fig. E-14.3(a),  $t_a = 20$ ,  $t_b = 100$ ,  $t_c = 25$ ,  $t_d = 150$ ,  $m_a = m_b = 5 \text{ mm}$ ,  $m_c = m_d = 6 \text{ mm}$ ,  $\phi = 20^\circ$ . Calculate tangential and radial forces between A and B and between C and D; and resultant reactions at bearings  $E_1$  and  $E_2$ .

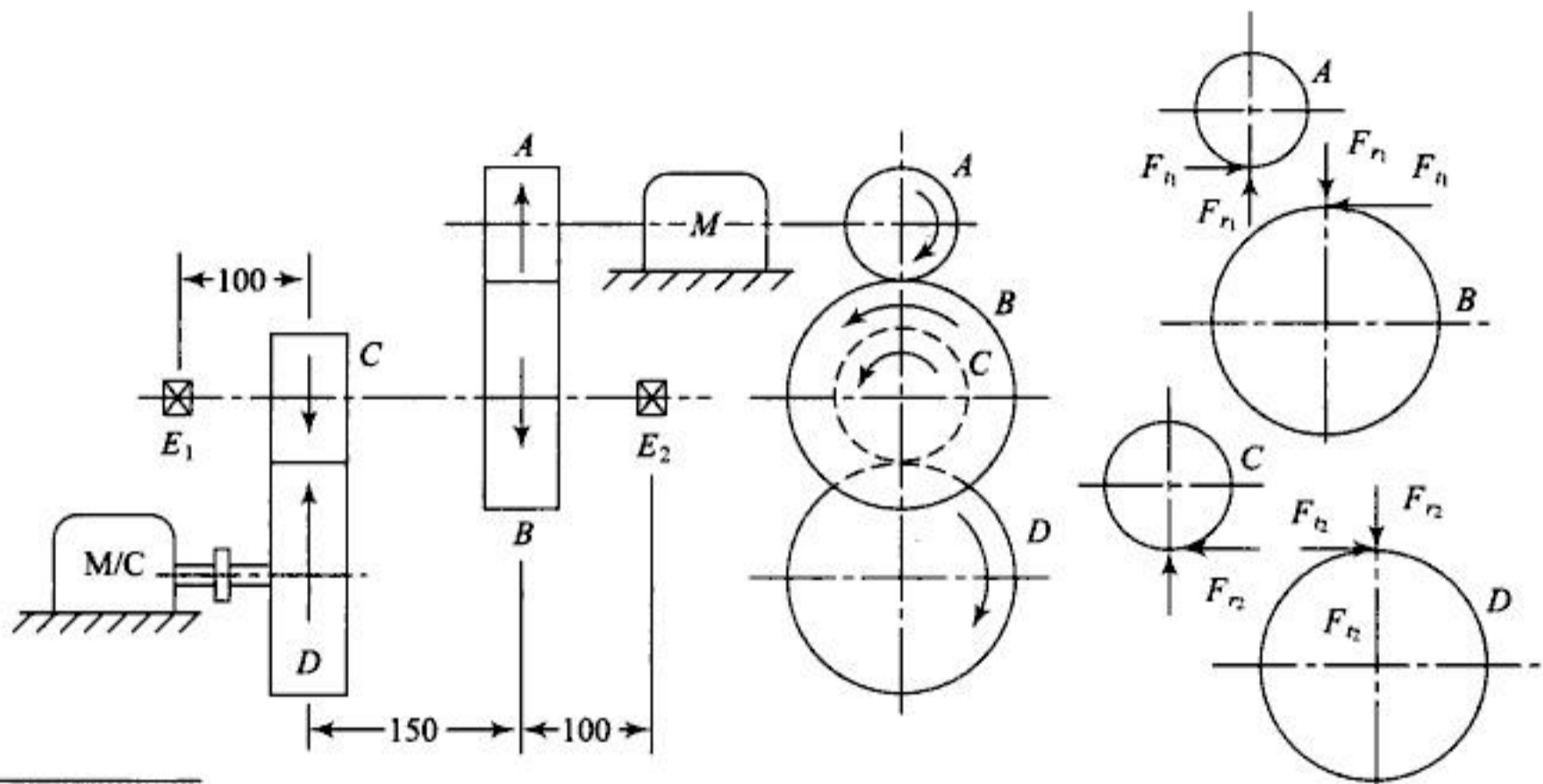

Fig. E-14.3a

Solution:

$$F_{t_1} = \frac{P}{V_1} \text{ where } V_1 = \frac{\pi d_a N_a}{60} \quad d_a = t_a m_a = 100 \text{ mm}$$

$$d_b = t_b m_b = 500 \text{ mm}, \quad d_c = t_c m_c = 150 \text{ mm}$$

$$d_d = t_d m_d = 900 \text{ mm}$$

$$\therefore V_1 = \frac{\pi \times 100 \times 1440}{60 \times 1000}$$

$$= 7.54 \text{ m/s}$$

$$\therefore F_{t_1} = \frac{5.6 \times 1000}{7.54} = 742.7 \text{ N}; \quad F_{r_1} = F_{t_1} \tan \phi = 270.32 \text{ N}$$

*Solution:*

$$y_p = 0.124 - \frac{0.684}{20} = 0.0898, \quad d_p = 20 \times 5 = 100 \text{ mm}$$

$$V = \frac{\pi \times 100 \times 1000}{60 \times 1000} = 5.236 \text{ m/s}$$

$$K_v = \frac{3}{3 + 5.236} = 0.3642$$

$$\therefore F_t = \frac{10 \times 1000}{5.236} = 1909.5548 \text{ N}$$

As the pinion and gear are of the same material let us check pinion for induced bending stress

$$F_t = K_v \sigma_y b p, \therefore \sigma = \frac{1909.5548}{0.3642 \times 0.0898 \times 60 \times \pi \times 5} \\ = 61.96 \text{ MPa which is safe}$$

$$F_w = d_p b k_w Q, F k_w = \frac{S_{es}^2}{1.4} \times \sin 14 \frac{1^\circ}{2} \times \left( \frac{1}{E_p} + \frac{1}{E_g} \right) = \frac{600^2}{1.4} \times 0.25 \times \frac{2}{10^5} \\ = 1.2876 \text{ N/mm}^2$$

$$\therefore F_w = 100 \times 60 \times 1.2876 \left( \frac{2 \times 2.5}{2.5 + 1} \right) = 11036.571 \text{ N}$$

$$F_0 = \sigma_y b p = 100 \times 0.0898 \times 60 \times \pi \times 5 = 8463.45 \text{ N}$$

$\therefore F_d$  should not exceed 8463.45 N

$$8463.45 = 1909.8548 + \frac{21 \times 5.236 (60 C + 1909.5548)}{21 \times 5.236 + \sqrt{60 C + 1909.5548}}$$

By trial and error the equation is satisfied for  $C = 330 \text{ N/mm}$  for which the error is 0.06 mm

$\therefore$  0.06 mm error is permissible

- 14.7 A  $20^\circ$  full depth steel pinion meshes with a C.I gear with 220 B.H.N. Centre distance is 200 mm and the speed ratio 3 : 1. The speed of the pinion is 600 r.p.m. The module and the face width of the pair are 5 mm and 50 mm respectively. The dynamic tooth factor is 8 N/mm/micron. Wear load factor  $0.95 \text{ N/mm}^2$ . The tooth pitch error  $e = 8 + 1.25 (m + 0.25 \sqrt{d})$  microns where  $m =$  module in mm and  $d =$  p.c.d of gear in mm. Assume permissible static stress for pinion 110 MPa and for gear 55 MPa. Find the maximum safe power transmitted by the spur gear pair.

*Solution:*

$$\text{Centre distance } C = \frac{d_p + d_g}{2}, \quad \frac{d_g}{d_p} = 3$$

$$\therefore 200 = \frac{d_p + 3d_p}{2}, \quad \therefore d_p = 100 \text{ mm}, d_g = 300 \text{ mm}$$

$$k = 11500, N_p = 1800 \text{ r.p.m.}, t_p = 20, \text{ Total error} = 0.106 \text{ mm}$$

$$\therefore F_i = \frac{0.106 \times 1800 \times 20}{30} \sqrt{11500 \times 60 \times 1.66 \times 10^{-3}} = 4304.9 \text{ N}$$

$$\therefore F_t + F_i = 3183 + 4304.9 = 7487.9 \text{ N}$$

$$F_0 = 140 \times 0.1084 \times 12 \times \pi \times 25 = 14303.042 \text{ N}$$

$$\therefore F_w = F_t + F_i = 7487.9 \text{ N} = d_p b k Q$$

$$Q = \frac{2 \times 3}{3 + 1} = 1.5$$

$$\therefore k_w = \frac{5429.88}{100 \times 60 \times 1.5} = 0.8274 \text{ N/mm}^2$$

$$k_w = \frac{S_{es}^2}{1.4} \sin \phi \left( \frac{1}{E_p} + \frac{1}{E_g} \right), E_p = E_g = 2 \times 10^5, \phi = 20^\circ$$

$$\therefore 0.8274 = \frac{S_{es}^2}{1.4} \times \frac{0.342 \times 2}{2 \times 10^5}, \therefore S_{es} = 581.98 \text{ MPa}$$

$$\text{Again } S_{es} = 2.75 \text{ B.H.N} - 70$$

$$\therefore \text{B.H.N} = \frac{581.98 + 70}{2.75} = 237$$

- 14.10 Two  $20^\circ$  full depth spur gears carry 35 kW at 860 r.p.m, speed ratio is 2 : 1 with centre distance 225 mm. Module = 5 mm. The error on both gears taken together is 0.122 mm. Calculate necessary face width material steel,  $k_w = 1.2$ .

*Solution:*

$$\frac{d_p + d_g}{2} = 225 \text{ and } \frac{d_g}{d_p} = 2, \therefore d_p = 150 \text{ mm}$$

$$V = \frac{\pi \times 150 \times 860}{60 \times 1000} = 6.7544 \text{ mm}$$

$$F_t = \frac{35 \times 1000}{6.75} = 5185.185 \text{ N}$$

$$\therefore F_d = \frac{0.122 \times 860 \times 30}{30} \sqrt{11500 b^2 \times 5.535 \times 10^{-5}} + 5185.185$$

$$m_e = \frac{G^2}{1 + G^2} \frac{\pi b \rho r_p^2}{2g} = 5.535 b \times 10^{-5} \frac{\text{N sec}^2}{\text{mm}}$$

$$F_w = d_p b k_w Q = 150 \times 1.2 \times b \times \frac{4}{3} = 240 b$$

Using

$$F_w = F_d, b = 33.176 \text{ mm say } 35 \text{ mm.}$$

- 14.11 A pair of spur gears with  $20^\circ$  involute full depth teeth has a module of 8 mm. The p.c.d of gear is 360 mm. The gear ratio is 2.5 : 1. Calculate number of teeth on each wheel, addendum, total depth, clearance, outside diameter, root diameters, dedendum, base circle diameter. State whether the interference will occur?

*Solution:*

$$d_g = 360 \text{ mm and } d_p = 360/2.5 = 144 \text{ mm}$$

$$N_g = 360/8 = 45 \text{ and } N_p = 18$$

$$\text{Addendum} = m = 8 \text{ mm}$$

$$\text{Dedendum} = 1.157 m = 9.256 \text{ mm}$$

$$\therefore \text{Total depth} = 17.256 \text{ mm} \quad (\text{add.} + \text{ded.})$$

$$\therefore \text{Clearance} = 1.256 \text{ mm} \quad (\text{ded.} - \text{add.})$$

$$\text{Outside diameter} = \text{p.c.d} + 2 \text{ addendum}$$

$$\therefore \text{For pinion outside diameter} = 144 + 2 \times 8 = 160 \text{ mm}$$

$$\text{For gear outside diameter} = 360 + 2 \times 8 = 376 \text{ mm}$$

$$\text{Root diameter of pinion} = \text{Outside diameter} - 2 \times \text{Total depth}$$

$$= 160 - 2 \times 17.256 = 125.488 \text{ mm}$$

$$\text{Root diameter of gear} = 376 - 2 \times 17.256 = 341.488 \text{ mm}$$

$$\text{Radius of base circle of pinion} = \frac{\text{p.c.d (pinion)}}{2} \times \cos 20^\circ = 169.14467 \text{ mm}$$

Interference occurs if the

$$N_g < \frac{2 a_w}{\left(\sqrt{1 + A \sin^2 20^\circ}\right) - 1} \text{ where } A = \frac{1}{2.5} \left(\frac{1}{2.5} + 2\right) = 0.96$$

$$\text{R.H.S} = 36.59. \text{ As } N_g = 45, \text{ i.e. } N_g > 36.59$$

$\therefore$  Interference does not occur.

14.12 Design a pair of spur pinion and gear made of cast steel and C.I respectively. The diameter of pinion is 140 mm and it transmits 30 kW at 1250 r.p.m. The gear ratio is 3 : 1 and teeth are  $20^\circ$  full depth involute.

*Solution:*

The problem may be solved by first assuming minimum number of teeth necessary to avoid interference and then checking it at the end from the module obtained. Let us assume  $t_p = 16$  and  $t_g = 48$ .

$$\therefore y_p = 0.154 - \frac{0.912}{16} = 0.097, \quad \therefore \sigma_p y_p = 110 \times 0.097 = 10.67$$

$$y_g = 0.154 - \frac{0.912}{48} = 0.135$$

$$\therefore \sigma_g y_g = 55 \times 0.135 = 7.425$$

$\therefore$  gear has to be designed.

$$V = \frac{\pi \times 140 \times 1250}{60 \times 1000} = 9.163 \text{ m/s}, \quad \therefore K_v = \frac{6}{6 + 9.163} = 0.3957$$

$$F_t = \frac{30 \times 1000}{9.163} = 3274 \text{ N}$$

Let  $b = 12 \text{ m}$ , Lewis Equation may be written as

$$3274 = 0.3957 \times 7.425 \times 12 \text{ m} \times \pi m.$$

$$\therefore m = 5.436 \text{ mm say } 6 \text{ mm}, \quad b = 60 \text{ mm}$$

With this module the number of teeth on pinion may be changed to 24 so that the p.c diameter of pinion is 144 mm and that of gear 432 mm.

- 14.13 Check the design of Problem 14.12 for wear strength and dynamic tooth load assuming B.H.N 250 for pinion material. Assume an error of 0.04 mm for which  $C = 228$  kN/m.

*Solution:*

$$y_g = 0.141 \text{ for a number of teeth } 72$$

$$F_0 = 55 \times 0.141 \times 60 \times 6\pi = 8777.0 \text{ N}$$

For B.H.N 250,

$$S_{es} = 2.75 \times 250 - 70 = 617.5 \text{ MPa}$$

$$\therefore k_w = \frac{(617.5)^2}{1.4} \sin 20^\circ \left( \frac{1}{2 \times 10^5} + \frac{1}{1 \times 10^5} \right)$$

$$= 1.397 \text{ N/mm}^2, \quad Q = \frac{2 \times 3}{3 + 1} = 1.5$$

$$\therefore F_w = dpbk_w = 144 \times 60 \times 1.397 \times 1.5 = 18105.12 \text{ N}$$

This is satisfactory as  $F_w > F_t$

$$F_d = \frac{21V(bC + F_t)}{21V + \sqrt{bC + F_t}} + F_t$$

$$= \frac{21 \times 9.163 [60 \times 228 + 3274]}{21 \times 9.163 + \sqrt{60 \times 228 + 3274}} = 3274 = 13275.335 \text{ N}$$

$F_d$  with reduced error to 0.02 mm comes

$$F_d = 9896.5 \text{ N but still } F_d > F_0$$

$\therefore$  Thus modification in design by increasing  $m = 8$  mm, reducing number of teeth to 18,  $b = 80$  mm gives

$$F_0 = \sigma_y b p \quad y_g = 0.1371 \text{ for a number of teeth } 54$$

$$= 55 \times 0.1371 \times 80 \times \pi \times 8 = 15161 \text{ N}$$

$$F_w = 144 \times 80 \times 1.397 \times 1.5 = 24140.16 \text{ N}$$

$$F_d = 15482 \text{ N with } e = 0.04 \text{ mm}$$

which can be reduced further by reducing error slightly. Hence the design is satisfactory.

- 14.14 A pair of spur gears has pinion made of material with 80 MPa safe static bending stress, gear made of material with safe static bending stress of 55 MPa. The module and face width of the teeth are 5 mm and 60 mm respectively. The pinion rotates at 600 r.p.m. The number of teeth on pinions and gear are 20 and 80 respectively. Find the capacity in kW of the gear drive. The error

is limited to  $e = 16 + 1.25 (m + 0.25 \sqrt{d})$  microns. B.H.N of the pinion material is 250.

*Solution:*

For finding capacity the condition to be satisfied is  $F_d < F_0$  and  $F_d < F_w$ .

$$e_p = 16 + 1.25 (5 + 0.25 \sqrt{100}) = 25.375 \text{ microns for pinion}$$

$$e_g = 16 + 1.25 (5 + 0.25 \sqrt{400}) = 28.5 \text{ microns for gear}$$

$$\therefore \text{total error} = 53.875 \text{ microns} = 0.053875 \text{ mm}$$

$$C = k_e \left( \frac{E_g E_p}{E_g + E_p} \right)$$

$$= 0.114 \times 0.053875 \left( \frac{2 \times 1 \times 10^{10}}{3 \times 10^5} \right) = 409.45 \text{ N/mm}$$

$$V = \frac{\pi \times 100 \times 600}{60,000} = 3.14 \text{ m/s}$$

$$\therefore F_d = \frac{21 \times 3.14 (60 \times 409.45 + F_t)}{21 \times 3.14 + \sqrt{60 \times 409.45 + F_t}} + F_t$$

$$y_p = 0.154 - \frac{0.912}{20} = 0.1084, \therefore \sigma_p y_p = 8.672$$

$$y_g = 0.1426, \therefore \sigma_g y_g = 9.843$$

$$\therefore F_0 = \sigma_g y_g b p_e = 7.843 \times 60 \times \pi \times 5 = 7391.85 \text{ N}$$

From previous problem  $k_w = 1.397 \text{ N/m}^2$

$$\begin{aligned} \therefore F_w &= d p b k_w Q \quad \text{where} \quad Q = \frac{2 \times 4}{4 + 1} = 1.6 \\ &= 100 \times 60 \times 1.397 \times 1.6 = 13411.2 \text{ N} \end{aligned}$$

$\therefore$  If  $F_d < F_0$  then both conditions are satisfied.

$\therefore$  Let  $F_d = F_0$  from which  $F_t < 500 \text{ N}$ , this is too small.

Hence using the same material for gear as that of pinion and increasing module to 6 mm.

$$F_0 = 80 \times 0.1426 \times 60 \times \pi \times 6 = 12902.144 \text{ N}$$

for which

$$F_t = 5000 \text{ N}, \therefore P = \frac{5000 \pi}{1000} = 15.7 \text{ kW.}$$

- 14.15 Find the incremental dynamic load occurring on a pair of spur gears of the Problem 14.14 using equivalent mass. Assume pinion to be solid disc and gear of C.I and spokes with inside diameter 380 mm.

*Solution:*

$$e_p = 25.375 \text{ microns}, e_g = 28.5 \text{ microns}$$

$\therefore$  Combined error = 0.053875 mm from previous problem.

$$t = \frac{60}{20 \times 600} = \frac{1}{200} \text{ sec}, E_p = 1 \times 10^{11} \text{ N/m}^2, E_g = 2 \times 10^{11} \text{ N/m}^2$$

$$k = \frac{b \left( \frac{E_p E_g}{E_p + E_g} \right)}{9} = 7.4 \times 10^9 b \text{ N/m}$$

$$m'_g = \frac{\pi b \rho}{2 r_0^2} (r_0^4 - r_i^4)$$

*Note:* In this solution unit of mass used is kg instead of  $\text{N sec}^2/\text{m}$  used in Examples 14.8 and 14.9, but answer does not differ.

$$b = 60 \text{ mm} = \frac{60}{1000} \text{ m}, \rho = 7200 \text{ kg/m}^3, r_0 = \frac{240}{1000} \text{ m} \quad \text{and} \quad r_i = \frac{190}{1000} \text{ m}$$

using  $m = 6 \text{ mm}$

$$\therefore m'_g = \frac{\pi \times 0.06 \times 7200 \times (0.24^4 - 0.19^4)}{2(0.24)^2} = 23.73 \text{ kg}$$

$$\therefore m'_p = \pi \times 0.06 \times 7800 \times \left( \frac{60}{1000} \right)^2 = 5.292 \text{ kg}$$

- 14.12 Velocity factor is used to take care of  
 (a) effect of high velocity (b) possibility of fatigue failure  
 (c) possibility of high wear (d) pitting
- 14.13 Material combination factor is used for finding  
 (a) beam strength (b) dynamical load  
 (c) wear strength (d) heat capacity
- 14.14 Out of the pinion and gear, design should be made of the gear for which  
 (a) Lewis factor  $y$  is smaller (b) bending stress  $\sigma_g$  is smaller  
 (c)  $\sigma_b y$  is smaller (d)  $\sigma_b y$  is bigger
- 14.15 Dynamic tooth load depends on  
 (a) pitch line velocity (b) misalignment of shafts  
 (c) inaccuracy in tooth profile (d) pressure angle
- 14.16 The expression used for the wear strength of the gear is  
 (a)  $F_w = d_p b k_w Q$  (b)  $F_w = d_g b k_w Q$   
 (c)  $F_w = F_o$  (d)  $F_w = F_t + \frac{21V(bc + F_t)}{21V + \sqrt{bc + F_t}}$
- 14.17 The spur gears are used for gear ratios up to  
 (a) 6 (b) 2 (c) 10 (d) 20
- 14.18 For 50 mm diameter gear of involute  $20^\circ$  teeth the interference will occur if module is  
 (a) 1.5 mm (b) 2.01 mm (c) 3.0 mm (d) 4.0 mm
- 14.19 If the dynamic tooth load is not within the limit it is advisable for making design safer to  
 (a) reduce the module (b) reduce the face width  
 (c) reduce the error (d) reduce the hardness
- 14.20 If two pairs of spur gears are used for speed reductions from 1800 r.p.m to 200 r.p.m the speed of the 2nd pinion for compact gear box should be  
 (a) 900 r.p.m (b) 600 r.p.m (c) 450 r.p.m (d) 800 r.p.m
- 14.21 With the point of view of wear strength,  $20^\circ$  pressure angle is  
 (a) superior to  $14\frac{1}{2}^\circ$  (b) inferior to  $14\frac{1}{2}^\circ$   
 (c) as good as  $14\frac{1}{2}^\circ$  (d) none of the above

## REVIEW QUESTIONS

- 14.1 Explain the action of forces on the spur gear tooth when power is to be transmitted from one shaft to the other.
- 14.2 Define (a) module, (b) circular pitch, (c) face width of gear, (d) addendum, (e) pressure angle.
- 14.3 Explain the importance of Lewis form factor in designing the spur gear. Derive the equation of beam strength of spur gear.
- 14.4 What are the causes of failure of gear tooth?
- 14.5 How number of teeth affects the design of gears?
- 14.6 Explain the concept of wear strength and further state the method of checking the design of gear for wear strength.

- 14.7 What are different materials used for gears? What type of heat treatment is recommended?
- 14.8 Why is it preferred to use involute type teeth for gears? What is stub teeth? Why are they used?
- 14.9 Why dynamic load is induced in the gear teeth? Explain the procedure of designing for dynamic load using Buckingham Equation.
- 14.10 Describe method used to calculate the dynamic load on gears using M.F. Spotts' equation of mechanics.
- 14.11 Write a short note on "Lubrication of gears".
- 14.12 What are the applications of spur gears? Explain in brief.
- 14.13 After studying the topic of helical gears, explain why spur gears are preferred in certain applications.
- 14.14 Define beam strength of the tooth and derive the relationship for the same.
- 14.15 Write a short note on 'Velocity Factor' explaining its significance in gear tooth design.
- 14.16 What are the conditions to be satisfied for the safe design of spur gear tooth?
- 14.17 Explain why a less number of teeth is desirable but not practicable below a particular number. How is that number decided?
- 14.18 Write short notes on (i) Pitting and (ii) Seizure of gear teeth.

## PRACTICE PROBLEMS

- 14.1 The gear train shown in Fig. P-14.1 is required to transmit 40 kW at 1500 r.p.m of pinion *A*. The speed ratio between *A* and *B* is 5 : 2 and between *C* and *D* is 3 : 1. Find the speeds of gears *B*, *C* and *D* and number of teeth on each wheel if module is 5 mm, Also find the reactions on bearings  $R_1$  and  $R_2$  if pressure angle is  $20^\circ$ .

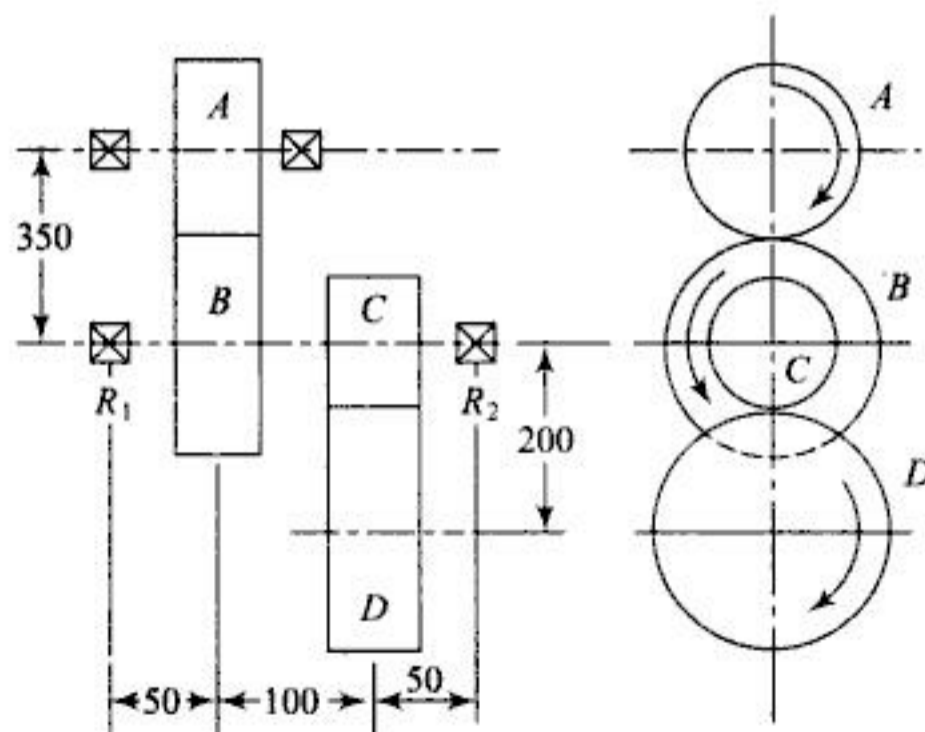

**Fig. P-14.1**

- 14.9 A 35 kW is to be transmitted at 450 r.p.m to a shaft with gear ratio 4 : 1 using  $20^\circ$  full depth involute spur gear drive. Pinion is made of heat treated C.S with  $\sigma_t = 200$  MPa and gear with high grade C.I with  $\sigma_t = 90$  MPa, module is 10 mm. Design the pair and check it for wear and dynamic tooth load  $k_w = 4.25$  N/mm<sup>2</sup>,  $C = 632$  N/mm.
- 14.10 Two-stage spur gear reducer is used to transmit 7.5 kW. Input shaft rotates 720 r.p.m and output shaft at 80 r.p.m. Pressure angle  $20^\circ$  number of teeth on pinion 18,  $\sigma_t$  for all gears = 100 MPa,  $k_w = 0.142$  (B.H.N/100)<sup>2</sup>. Design the gear drive by Lewis Equation and specify surface hardness.
- 14.11 Two meshing spur gears with  $20^\circ$  full depth teeth have module of 6 mm. Pinion has 20 teeth and gear ratio 80. Pinion and gears are solid discs with  $b = 50$  mm. Speed of the pinion is 900 r.p.m. Find the dynamic load for an error of  $e = 32 + 2.5(m + 0.25\sqrt{d})$  where  $m$  and  $d$  are in mm and error is in microns.
- 14.12 Two meshing spur gears have  $20^\circ$  full depth teeth. Gears are solid discs;  $t_p = 25$ ,  $t_g = 75$ ,  $b = 60$  mm, speed of the pinion 1,760 r.p.m. The power to be transmitted 60 kW,  $m = 5$  mm. Find the required value of B.H.N and check the teeth for bending  $e = 16 + 2.5(m + 0.25\sqrt{d})$ .
- 14.13 Two gears with  $m = 6$  mm,  $20^\circ$  full depth teeth mesh with each other with gear ratio 2. The number of teeth on pinion = 24,  $b = 75$  mm. Speed of pinion is 860 r.p.m,  $e = 32 + 2.5(m + 0.25\sqrt{d})$  microns. B.H.N of pinion and gear 320. Find the kW capacity of the pair.
- 14.14 A spur gear drive is required to transmit 25 kW at 200 r.p.m of pinion. The velocity ratio is 2 : 1. The centre distance is 450 mm. The safe static stress for the material is 55 MPa. Design the gears. Assume involute teeth of  $20^\circ$  pressure angle. Use beam strength equation.
- 14.15 Check the gears in Problem 14.14 for wear strength and dynamic load. Hardness of the material may be 300 B.H.N. Let the error in cutting the teeth be 0.04 mm.

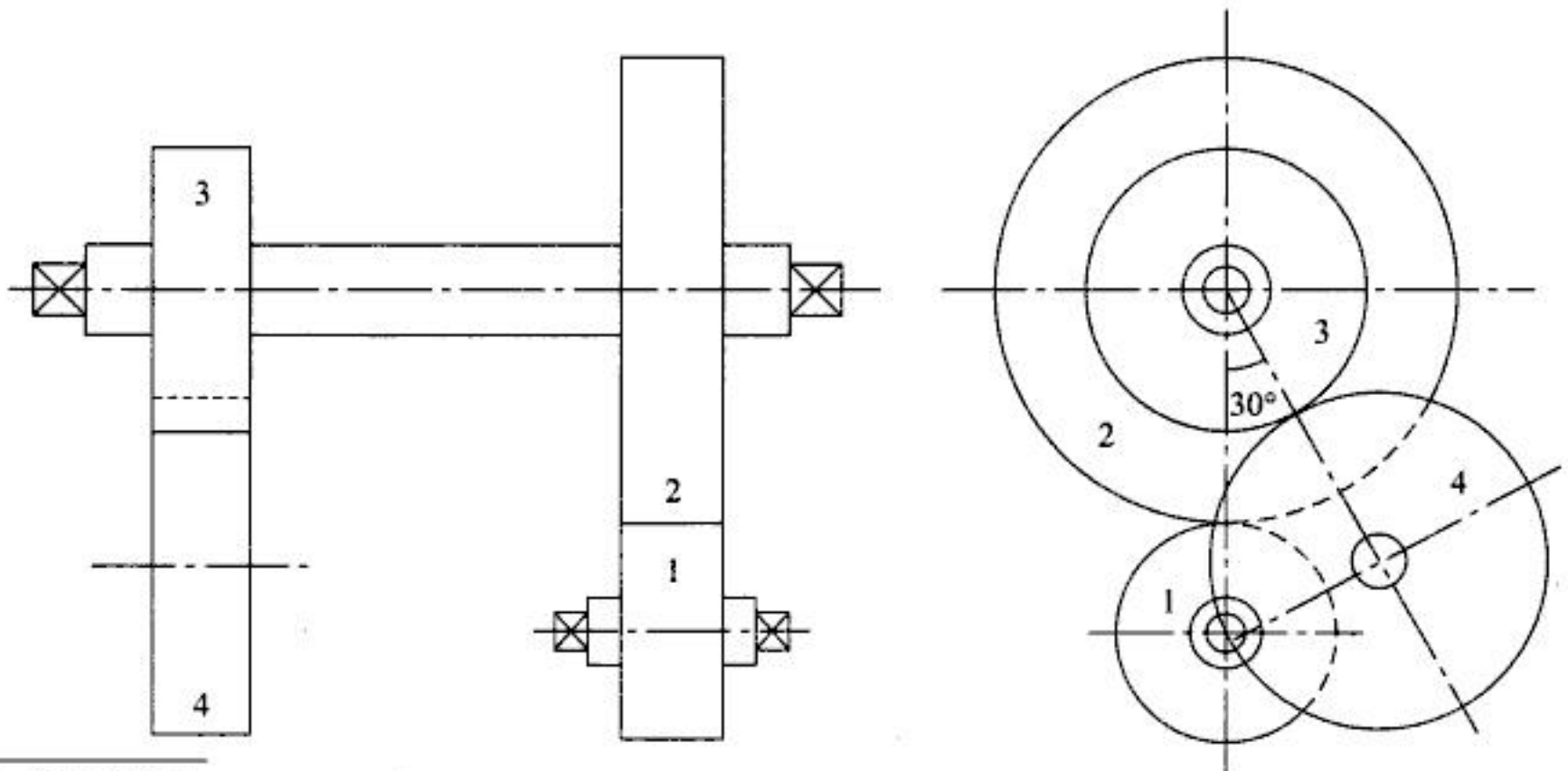

**Fig. P-14.15**

- 14.16 The number of teeth on gears 1, 2, 3 and 4 are 24, 36, 18 and 36 respectively. The pressure angle is  $20^\circ$  module = 4 mm. Gear 1 is driver and rotates at 1500 r.p.m transmitting 16 kW. Determine the tooth forces on the gears.



You have either reached a page that is unavailable for viewing or reached your viewing limit for this book.

- 14.30 A pair of spur gears with  $20^\circ$  full depth teeth is used to transmit 20 kW at 900 r.p.m of pinion. The gear ratio is 6 : 1. The material for pinion is C.S with permissible static stress 55 MPa. Determine the module and face width of the gear from the standpoint of beam strength; wear strength and dynamic tooth load. Assume minimum number of teeth on pinion.  $K_v = 3/(3 + V)$ , wear factor =  $1.3 \text{ N/mm}^2$ ,  $C$  for 0.07 mm, error = 590 kN.m. Use Buckingham equation for dynamic tooth load.
- 14.31 A pair of gears with  $20^\circ$  full depth teeth of involute profile have  $m = 6 \text{ mm}$ ,  $b = 75 \text{ mm}$ ,  $d_p = 144 \text{ mm}$ ,  $d_g = 288 \text{ mm}$ . The pinion rotates at 1200 r.p.m and transmits 60 kW. Find the required B.H.N of gear material.  $e = 32 + 2.5 (m + 0.25 \sqrt{d})$  microns. Use Spott's approach.
- 14.32 Solve above problem using Buckingham equation for dynamic tooth load.
- 14.33 What conclusion can be drawn by comparing the two results in the above problem.

## ANSWERS

### Objective Questions

- (1) c (2) c (3) d (4) c (5) a (6) c (7) d (8) d (9) c (10) d (11) a  
 (12) b (13) c (14) c (15) c (16) a (17) a (18) d (19) c (20) b (21) a

### Practice Problems

- (1) Vertical reactions 755 N, 1991 N, Speed of B 600 r.p.m, of D = 200 r.p.m, Horizontal reactions 2075 N, 527041 N,  $t_A = 40$ ,  $t_B = 100$ ,  $t_C = 20$ ,  $t_D = 60$ .
- (2) 3 mm.
- (3)  $V_R$  454.62 N ↓, 5936.57 N ↓, H.R. 6565.77 N ← and 3227.6285 N ←
- (4)  $V_B = 14875.378 \text{ N} \downarrow$   $V_B = 4369.4 \text{ N} \downarrow$   $H_B = 4989.41 \text{ N}$ ,  $H_A = 807.52 \text{ N} \rightarrow$
- (5) 2728.4 N, 4547.33 N,  $N_4/N_0 = 1 + \frac{N_2 N_3}{N_1 N_4}$
- (6)  $m = 4 \text{ mm}$ ,  $b = 35 \text{ mm}$
- (7)  $m = 8 \text{ mm}$ ,  $b = 96 \text{ mm}$ ,  $d_p = 128 \text{ mm}$ ,  $d_g = 448 \text{ mm}$ .
- (8)  $b = 120 \text{ mm}$ , assuming mass of gear 50 kg, diameter of gear shaft = 90 mm,  $d_p = 180 \text{ mm}$ ,  $d_g = 1080 \text{ mm}$
- (9)  $b = 58.42$ , modified to 100 mm.
- (10)  $m = 5 \text{ mm}$ , B.H.N = 240. (11) 2373 N (12) B.H.N = 300
- (13) 50 kW (14)  $m = 6 \text{ mm}$ ,  $b = 90 \text{ mm}$ . (16) 2122 N, 4244 N.
- (25)  $m = 6 \text{ mm}$ ,  $d_p = 96 \text{ mm}$ ,  $d_g = 384 \text{ mm}$  (26) 23.236 kW using M.F. Spott's approach
- (27) 1953.158 N (28) 78.87 kW (29) 27.09 → 30 mm
- (30) Design is modified to use C.S for both the pinion and gear with  $m = 6 \text{ mm}$ ,  $b = 72 \text{ mm}$ .
- (31) 250.6 B.H.N (32) 427.35 B.H.N
- (33) Buckingham approach is more conservative.



You have either reached a page that is unavailable for viewing or reached your viewing limit for this book.



You have either reached a page that is unavailable for viewing or reached your viewing limit for this book.



You have either reached a page that is unavailable for viewing or reached your viewing limit for this book.



You have either reached a page that is unavailable for viewing or reached your viewing limit for this book.



You have either reached a page that is unavailable for viewing or reached your viewing limit for this book.



You have either reached a page that is unavailable for viewing or reached your viewing limit for this book.



You have either reached a page that is unavailable for viewing or reached your viewing limit for this book.



You have either reached a page that is unavailable for viewing or reached your viewing limit for this book.



You have either reached a page that is unavailable for viewing or reached your viewing limit for this book.



You have either reached a page that is unavailable for viewing or reached your viewing limit for this book.



You have either reached a page that is unavailable for viewing or reached your viewing limit for this book.



You have either reached a page that is unavailable for viewing or reached your viewing limit for this book.



You have either reached a page that is unavailable for viewing or reached your viewing limit for this book.



You have either reached a page that is unavailable for viewing or reached your viewing limit for this book.



You have either reached a page that is unavailable for viewing or reached your viewing limit for this book.



You have either reached a page that is unavailable for viewing or reached your viewing limit for this book.



You have either reached a page that is unavailable for viewing or reached your viewing limit for this book.



You have either reached a page that is unavailable for viewing or reached your viewing limit for this book.



You have either reached a page that is unavailable for viewing or reached your viewing limit for this book.



You have either reached a page that is unavailable for viewing or reached your viewing limit for this book.



You have either reached a page that is unavailable for viewing or reached your viewing limit for this book.



You have either reached a page that is unavailable for viewing or reached your viewing limit for this book.



You have either reached a page that is unavailable for viewing or reached your viewing limit for this book.



You have either reached a page that is unavailable for viewing or reached your viewing limit for this book.



You have either reached a page that is unavailable for viewing or reached your viewing limit for this book.



You have either reached a page that is unavailable for viewing or reached your viewing limit for this book.



You have either reached a page that is unavailable for viewing or reached your viewing limit for this book.



You have either reached a page that is unavailable for viewing or reached your viewing limit for this book.



You have either reached a page that is unavailable for viewing or reached your viewing limit for this book.



You have either reached a page that is unavailable for viewing or reached your viewing limit for this book.

- 17.12 Find the power that can be transmitted to a phosphor-bronze gear from a hardened steel worm rotating at 1500 r.p.m with a transmission ratio of 25. The centre distance is 300 mm. The teeth are  $14\frac{1}{2}^\circ$  involute.
- 17.13 Find the diameter of worm for worm gear drive with  $\alpha = 20^\circ$  and pitch 35 mm double start threads.
- 17.14 A worm gear reducer unit is used for centre distance of 275 mm. Find the worm diameter and axial module.
- 17.15 If for the above unit gear ratio is 20 what is approximate power input rating in order to prevent overheating?
- 17.16 For a pair of worm and worm gear with transmission ratio 20 and centre distance 400 mm. Find the axial module and the lead angle.
- 17.17 A hardened steel worm rotating at 1250 r.p.m transmits power to a phosphor bronze gear with transmission ratio 15 : 1, centre distance is 225 mm. Recommend the power for which the pair should be used.
- 17.18 Find the power transmitted by considering failures in bending, wear and heat dissipation for a work and worm gear drive and decide the safe power to be transmitted if the worm rotates at 2500 r.p.m and *p*-bronze gear rotates at 100 r.p.m. Centre distance is 300 mm for *p*-bronze safe  $\sigma = 55$  MPa.
- 17.19 Compute the efficiency of drive in the above problem.
- 17.20 In the above problem assuming power to be transmitted 15 kW, find the diameter of worm and gear shafts.
- 17.21 A hardened steel worm rotating at 2500 r.p.m transmits power to a *p*-bronze gear with transmission ratio 20 : 1. The centre distance is 240 mm. The teeth are  $14\frac{1}{2}^\circ$  involute. Complete the design.

## ANSWERS

### Objective Questions

- (1) c      (2) d      (3) c      (4) a      (5) b      (6) c      (7) d      (8) d      (9) c  
 (10) d      (11) d      (12) b      (13) c      (14) c

### Practice Problems

- (1) Triple start, 60      (2) 320.52 mm, 17.57 kW, 26.37 kW      (3) 12.94 kW  
 (4) 11.35 kW      (5) Lewis Equation 14.7 kW, Heat Cap. 8.57 kW, Wear Cap. 11.57 kW  
 (6)  $d_w = 90$  mm,  $d_g = 360$  mm, triple start,  $t_g = 45$       (7) 136 mm, 45.33 mm      (8) 15.71 kW  
 (9)  $9^\circ - 27' - 7''$       (10) Double start, 40      (11) Single start  $d_w = 40$ ,  $d_g = 140$ ,  $m = 4$  mm  
 (12) Double start,  $t_g = 50$ ,  $m = 10$  mm      (13) 61.21 mm  
 (14) 92.86 mm,  $ma = 9.85$  mm      (15) 16.263 kW      (16) 14 mm,  $14.57^\circ$       (17) 12.748 kW  
 (18) 15.71 kW with heat dissipation criteria. Calculated value of  $P_c = 34$  mm should be reduced to 32 mm to get centre distance 305 mm with double start threads.  
 (19) 40%.  
 (20) Worm shaft 60 mm, gear shaft 60 mm assuming length of shaft between the bearing  $2b$ .



You have either reached a page that is unavailable for viewing or reached your viewing limit for this book.



You have either reached a page that is unavailable for viewing or reached your viewing limit for this book.



You have either reached a page that is unavailable for viewing or reached your viewing limit for this book.

### 18.6 HEAT GENERATED AND DISSIPATED

Heat generated is due to friction torque  $T_f$

$$T_f = \mu W \cdot d/2$$

$$\therefore H_g = \frac{2\pi N}{60} T_f = \mu W \cdot \frac{D}{2} \cdot \frac{2\pi N}{60} = \mu W V \text{ watts} \quad (\text{iv})$$

Heat dissipated is given by Lasche's equation

$$H_d = \frac{(\Delta t + 18)^2}{K} LD \text{ watts} \quad (\text{v})$$

$$\Delta t = T_B - T_A$$

Difference between bearing temp.  $T_B$  and surrounding temp.  $T_A$

$$K = 0.273 \text{ for bearing of heavy construction in } ^\circ\text{C m}^2/\text{W}$$

$$= 0.484^\circ\text{C m}^2/\text{W with light or medium construction}$$

If operating temperature  $t_0$  is given, then  $\Delta t = \frac{1}{2} (t_0 - t_A)$ .

### 18.7 PARAMETERS AFFECTING THE BEARING PERFORMANCE

Small clearance causes more heat generation but has greater load capacity. Large clearance reduces the heat generation but is mechanically undesirable. The value of clearance ratio  $c/D$  should be between 0.001 to 0.002.

Value of  $h_o$ , for satisfactory operation of bearing should be 0.00015 mm diameter.

Larger  $L/D$  ratio is desirable to minimize end leakage but with the point of view of space limitation, manufacturing tolerances and shaft deflection, smaller  $L/D$  ratio is desirable.  $L/D$  should be within 1 to 2 and  $L/D < 1$  used for highly loaded engine bearings.

The pressure at which oil film breaks and metal to metal contact begins is known as critical pressure. It depends on the material and degree of smoothness of surfaces in contact.

### 18.8 SOMMERFIELD AND OTHER DIMENSIONLESS NUMBERS

The theory of hydrodynamic lubrication is based on Reynold's equation. Comprehensive computer solutions to this equations were obtained by Raimondi and Boyde and have been tabulated in the tables giving correlation between many dimensionless numbers. They are also available in the form of charts. These charts or tables are entered using a number which is introduced in Article 18.4 and is known as Sommerfield number given by

$$S = \frac{ZN'}{p} \left(\frac{D}{c}\right)^2 \text{ or } \frac{ZN}{p} \left(\frac{r}{c_r}\right)^2 \text{ where } \frac{D}{c} \text{ or } \frac{r}{c_r} \text{ is the reciprocal of clearance ratio. } N' \text{ is } N/60, \text{ i.e.}$$

revolutions per sec.



You have either reached a page that is unavailable for viewing or reached your viewing limit for this book.



You have either reached a page that is unavailable for viewing or reached your viewing limit for this book.



You have either reached a page that is unavailable for viewing or reached your viewing limit for this book.



You have either reached a page that is unavailable for viewing or reached your viewing limit for this book.



You have either reached a page that is unavailable for viewing or reached your viewing limit for this book.



You have either reached a page that is unavailable for viewing or reached your viewing limit for this book.



You have either reached a page that is unavailable for viewing or reached your viewing limit for this book.



You have either reached a page that is unavailable for viewing or reached your viewing limit for this book.



You have either reached a page that is unavailable for viewing or reached your viewing limit for this book.



You have either reached a page that is unavailable for viewing or reached your viewing limit for this book.



You have either reached a page that is unavailable for viewing or reached your viewing limit for this book.



You have either reached a page that is unavailable for viewing or reached your viewing limit for this book.



You have either reached a page that is unavailable for viewing or reached your viewing limit for this book.



You have either reached a page that is unavailable for viewing or reached your viewing limit for this book.



You have either reached a page that is unavailable for viewing or reached your viewing limit for this book.



You have either reached a page that is unavailable for viewing or reached your viewing limit for this book.



You have either reached a page that is unavailable for viewing or reached your viewing limit for this book.



You have either reached a page that is unavailable for viewing or reached your viewing limit for this book.



You have either reached a page that is unavailable for viewing or reached your viewing limit for this book.



You have either reached a page that is unavailable for viewing or reached your viewing limit for this book.



You have either reached a page that is unavailable for viewing or reached your viewing limit for this book.



You have either reached a page that is unavailable for viewing or reached your viewing limit for this book.



You have either reached a page that is unavailable for viewing or reached your viewing limit for this book.



You have either reached a page that is unavailable for viewing or reached your viewing limit for this book.



You have either reached a page that is unavailable for viewing or reached your viewing limit for this book.



You have either reached a page that is unavailable for viewing or reached your viewing limit for this book.



You have either reached a page that is unavailable for viewing or reached your viewing limit for this book.



You have either reached a page that is unavailable for viewing or reached your viewing limit for this book.



You have either reached a page that is unavailable for viewing or reached your viewing limit for this book.



You have either reached a page that is unavailable for viewing or reached your viewing limit for this book.



You have either reached a page that is unavailable for viewing or reached your viewing limit for this book.



You have either reached a page that is unavailable for viewing or reached your viewing limit for this book.



You have either reached a page that is unavailable for viewing or reached your viewing limit for this book.



You have either reached a page that is unavailable for viewing or reached your viewing limit for this book.



You have either reached a page that is unavailable for viewing or reached your viewing limit for this book.



You have either reached a page that is unavailable for viewing or reached your viewing limit for this book.



You have either reached a page that is unavailable for viewing or reached your viewing limit for this book.



You have either reached a page that is unavailable for viewing or reached your viewing limit for this book.



You have either reached a page that is unavailable for viewing or reached your viewing limit for this book.



You have either reached a page that is unavailable for viewing or reached your viewing limit for this book.



You have either reached a page that is unavailable for viewing or reached your viewing limit for this book.



You have either reached a page that is unavailable for viewing or reached your viewing limit for this book.



You have either reached a page that is unavailable for viewing or reached your viewing limit for this book.



You have either reached a page that is unavailable for viewing or reached your viewing limit for this book.



You have either reached a page that is unavailable for viewing or reached your viewing limit for this book.



You have either reached a page that is unavailable for viewing or reached your viewing limit for this book.



You have either reached a page that is unavailable for viewing or reached your viewing limit for this book.



You have either reached a page that is unavailable for viewing or reached your viewing limit for this book.



You have either reached a page that is unavailable for viewing or reached your viewing limit for this book.



You have either reached a page that is unavailable for viewing or reached your viewing limit for this book.



You have either reached a page that is unavailable for viewing or reached your viewing limit for this book.



You have either reached a page that is unavailable for viewing or reached your viewing limit for this book.



You have either reached a page that is unavailable for viewing or reached your viewing limit for this book.



You have either reached a page that is unavailable for viewing or reached your viewing limit for this book.



You have either reached a page that is unavailable for viewing or reached your viewing limit for this book.



You have either reached a page that is unavailable for viewing or reached your viewing limit for this book.



You have either reached a page that is unavailable for viewing or reached your viewing limit for this book.



You have either reached a page that is unavailable for viewing or reached your viewing limit for this book.



You have either reached a page that is unavailable for viewing or reached your viewing limit for this book.



You have either reached a page that is unavailable for viewing or reached your viewing limit for this book.



You have either reached a page that is unavailable for viewing or reached your viewing limit for this book.



You have either reached a page that is unavailable for viewing or reached your viewing limit for this book.



You have either reached a page that is unavailable for viewing or reached your viewing limit for this book.



You have either reached a page that is unavailable for viewing or reached your viewing limit for this book.



# Machine Design

This book on *Machine Design* discusses the various theories and components of machine design. It highlights the procedural aspects of designing machine elements to meet functional requirements under different conditions.

## SALIENT FEATURES:

- ② Crisp recap of the principles and concepts at the beginning of every chapter
- ② Graded solved problems with assumptions formulated to help students gain conceptual clarity
- ② Pedagogy includes
  - 250 Solved examples
  - 474 Practice problems
  - 341 Theory questions
  - 305 Objective type questions

Visit us at : [www.tatamcgrawhill.com](http://www.tatamcgrawhill.com)

ISBN-13: 978-0-07-064788-6

ISBN-10: 0-07-064788-7



9 780070 647886



Tata McGraw-Hill

Copyrighted material