

Industrial Boilers and Heat Recovery Steam Generators

Design, Applications, and Calculations

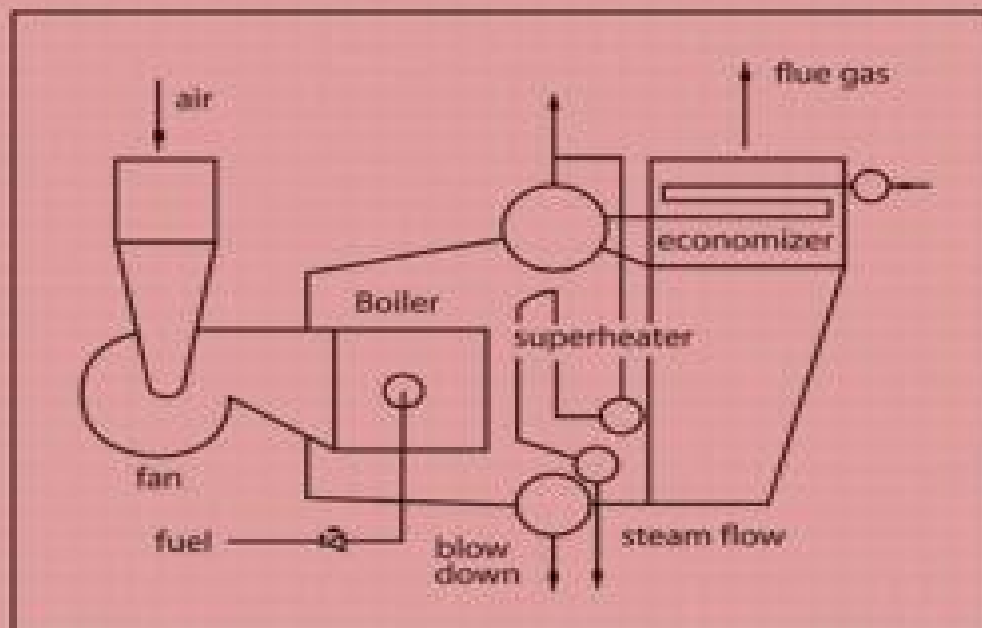

V. Ganapathy

Industrial Boilers and Heat Recovery Steam Generators

Design, Applications, and Calculations

V. Ganapathy

*ABCO Industries
Abilene, Texas, U.S.A.*



MARCEL DEKKER, INC.

NEW YORK • BASEL

ISBN: 0-8247-0814-8

This book is printed on acid-free paper.

Headquarters

Marcel Dekker, Inc.
270 Madison Avenue, New York, NY 10016
tel: 212-696-9000; fax: 212-685-4540

Eastern Hemisphere Distribution

Marcel Dekker, AG
Hutgasse 4, Postfach 812, CH-4001 Basel, Switzerland
tel: 41-61-260-6300; fax: 41-61-260-6333

World Wide Web

<http://www.dekker.com>

The publisher offers discounts on this book when ordered in bulk quantities. For more information, write to Special Sales/Professional Marketing at the headquarters address above.

Copyright © 2003 by Marcel Dekker, Inc. All Rights Reserved.

Neither this book nor any part may be reproduced or transmitted in any form or by any means, electronic or mechanical, including photocopying, microfilming, and recording, or by any information storage and retrieval system, without permission in writing from the publisher.

Current printing (last digit):

10 9 8 7 6 5 4 3 2 1

PRINTED IN THE UNITED STATES OF AMERICA

To all professionals involved in steam generation
and energy conservation.

Preface

The role of boilers and heat recovery steam generators (HRSGs) in the industrial economy has been profound. Boilers form the backbone of power plants, cogeneration systems, and combined cycle plants. There are few process plants, refineries, chemical plants, or electric utilities that do not have a steam plant. Steam is the most convenient working fluid for industrial processing, heating, chilling, and power generation applications. Fossil fuels will continue to be the dominant energy providers for years to come.

This book is about steam generators, HRSGs, and related systems. There are several excellent books on steam generation and boilers, and each has been successful in emphasizing certain aspects of boilers and related topics such as mechanical design details, metallurgy, corrosion, constructional aspects, maintenance, or operational issues. This book is aimed at providing a different perspective on steam generators and is biased toward thermal and process design aspects of package boilers and HRSGs. (The terms “waste heat boiler” and “HRSG” are used in the same context.) My emphasis on thermal engineering aspects of steam generators reinforced by hundreds of worked-out real-life examples pertaining to boilers, HRSGs, and related systems will be of interest to engineers involved in a broad field of steam generator–related activities such as consulting, design, performance evaluation, and operation.

During the last three decades I have had the opportunity to design hundreds of package boilers and several hundred waste heat boilers that are in operation in the U.S. and abroad. Based on my experience in reviewing numerous specifications of boilers and HRSGs, I feel that consultants, plant engineers, contractors, and decision makers involved in planning and developing steam plants often do not appreciate some of the important and subtle aspects of design and performance of steam generators.

- Many engineers still feel that by raising the exit gas temperature in boilers with economizers, one can avoid acid dew point concerns. It is the feed water temperature—not the gas temperature—that determines the tube wall temperature (and hence the corrosion potential).
- Softened water is sometimes suggested for attemperation for steam temperature control, even though it will add solids to steam that can cause problems such as deposition of solids in superheaters and steam turbines.
- To operate steam plants more efficiently, plant engineers should be able to understand and appreciate the part load characteristics of boilers and HRSGs. However while specifying boilers and HRSGs, often only the performance at 100% load is stressed.
- HRSG steam generation and temperature profiles cannot be arbitrarily arrived at, as pinch and approach points determine this. For example, I have seen several specifications call for a 300°F exit gas temperature from a single pressure unfired gas turbine HRSG generating saturated steam at 600 psig using feedwater at about 230°F. A simple analysis reveals that only about 340–350°F is thermodynamically feasible.
- Supplementary firing in gas turbine HRSGs is an efficient way to generate steam compared with steam generation in a packaged boiler. The book explains why this is so, with examples in [Chapters 1](#) and [8](#). Cogeneration engineers can make use of this information to minimize fuel costs in their plants.
- A few waste heat boiler specifications provide the flue gas flow in volumetric units instead of mass units, leading to confusion. Lack of information on molecular weight or gas pressure can lead to incorrect evaluation of density and hence the mass flow. Also, volume of flue gas is often given in cfm (cubic feet per minute) and one is not sure whether it is acfm (actual cubic feet per minute) or scfm (standard cubic feet per minute). The difference in mass flow can be significant depending on the basis.
- Although flue gas analysis affects gas specific heat, heat transfer, boiler duty, and temperature profiles, these data are often not given in specifications for waste heat boilers. For example, the ratio of specific heats of flue gases from combustion of natural gas and fuel oil is about 3.5%, which is not insignificant. This is due to the 18% volume of water vapor in natural gas products of combustion versus 12% in fuel oil combustion products.

- A few consultants select boilers and HRSGs based on surface area, although it can vary significantly based on tube geometry or fin configuration. With finned tubes, as can be seen from several examples in this book, the variation in surface areas could be in the range of 200–300% for the same duty.
- Operating cost due to fuel consumption or gas pressure drop across heating surfaces is often ignored by many consultants in their evaluation and only initial costs are compared while purchasing steam generators or HRSGs, resulting in a poor selection for the end user. A few plants are now realizing that the items of steam plant equipment they purchased years ago based on low initial costs are draining their cash reserves through costly fuel and electricity bills and hence are scrambling to improve their design and performance.
- Many engineers are not aware of recent developments in oil- and gas-fired packaged boilers and are still specifying boilers using refractory lined furnace walls and floors!
- Plant engineers often assume that a boiler designed for 600 psig, for example, can be operated at 200 psig and at the same capacity. The potential problems associated with significant changes in steam pressure and specific volume in boiler operation are discussed in [Chapters 1 and 3](#).
- Condensing exchangers are being considered in boilers and HRSGs not only for improvement in efficiency but also to recover and recycle the water in the flue gases, which is a precious commodity in some places.
- Emission control methods such as flue gas recirculation increase the mass flow of flue gases through the boiler; yet standard boilers are being selected that can be expensive to operate in terms of fan power consumption. Many are not aware of the advantages of custom-designed boilers, which can cost less to own and operate.
- A few steam plant professionals do not appreciate the relation between boiler efficiencies and higher and lower heating values, and thus specify values that are either impossible to accomplish or too inefficient.

As a result of this “knowledge/information gap” in process engineering aspects of boilers or HRSG, the end user may need to settle for a product with substandard performance and high costs. This book elaborates on various design and performance aspects of steam generators and heat recovery boilers so that anyone involved with them will become more informed and ask the right questions during the early stages of development of any steam plant project. This will give the best chance of selecting the steam generator with the right design and parameters. Even a tiny improvement in design, efficiency, operating costs, or performance goes a long way in easing the “energy crunch.”

The first four chapters describe some of the recent trends in power generation systems, a few aspects of steam generator and HRSG design and performance, and the impact of emissions on boilers in general. The remaining

chapters deal with calculations that should be of interest to steam plant engineers. I authored the *Steam Plant Calculations Manual* (Marcel Dekker, Inc.) several years ago and had been thinking of adding more examples to this work for quite some time. This book builds on that foundation.

Chapter 1 is an introductory discussion of power plants and describes some of the recent developments in power systems such as the supercritical Rankine cycle, the Kalina cycle, the Cheng cycle, and the integrated coal gasification and combined cycle (IGCC) plant that is fast becoming a reality.

The second chapter describes heat recovery systems in various industries. The role of the HRSG in sulfur recovery plants, sulfuric acid plants, gas turbine plants, hydrogen plants, and incineration systems is elaborated.

Chapter 3, on steam generators, describes the latest trends in custom-designed package boilers and the limitations of standard boilers developed decades ago. Emission regulations have resulted in changes in boiler operating parameters such as higher excess air and FGR rates that impact boiler performance significantly. It should be noted that there can be several designs for a boiler simply because the emission levels are different, although the steam parameters may be identical. If an SCR system is required, it necessitates the addition of a gas bypass system, adding to the cost and complexity of boiler design. These are explained through quantitative and practical examples.

Chapter 4, on emissions, describes the various methods used in boilers and HRSGs to limit NO_x and CO and how their designs are impacted. For example, the HRSG evaporator may have to be split up to accommodate the selective catalytic reduction (SCR) system; gas bypass dampers may have to be used in packaged steam generators to achieve the optimal gas temperature at the catalyst for NO_x conversion at various loads. Flue gas recirculation (FGR) adds to the fan power consumption if the standard boiler is not redesigned. It may also affect the boiler efficiency through higher exit gas temperature due to the larger mass flow of flue gases. Other methods for emission control, such as steam injection and burner modifications, are also addressed.

Chapters 4–8, which present calculations pertaining to various aspects of boilers and HRSGs and their auxiliaries, elaborate on the second edition of the *Steam Plant Calculations* book. Several examples have also been added. **Chapter 5** deals with calculations such as conversion of mass to volumetric flowrates, energy utilization from boiler blowdown, general ASME code calculations, and life cycle costing methods. (ASME has been updating the allowable stress values for several boiler materials and one should use the latest data.) Also provided are ABMA and ASME guidelines on boiler water, for evaluating the blowdown or estimating the steam for deaeration. Life cycle costing is explained through a few examples.

Chapter 6 deals with combustion calculations, boiler efficiency, and emission conversion calculations. Simplified combustion calculation procedures

such as the MM Btu method are explained. Often boiler efficiency is cited on a Higher Heating Value basis, while a few engineers use the Lower Heating Value basis. The relation between the two is illustrated. The ASME PTC 4.1 method of calculating heat losses for estimating boiler efficiency is elaborated, and simplified equations for boiler efficiency are presented. Examples illustrate the relation between oxygen in turbine exhaust gases and fuel input. Correlations for dew point of various acid vapors are given with examples.

Chapter 7 explains boiler circulation calculations in both fire tube and water tube boilers. Fluid flow in blowoff and blowdown lines, which involve two-phase flow calculations, can be estimated by using the procedures shown. The problem of flow instability in boiling circuits is explained, along with measures to minimize this concern, such as use of orifices at the inlet to the tubes. Calculations involving orifices and safety valves should also be of interest to plant engineers.

Chapter 8 on heat transfer has over 65 examples of sizing, off-design performance calculations pertaining to boilers, superheaters, economizers, HRSGs, and air heaters. Tube wall temperature calculations and calculations with finned tubes for insulation performance will help engineers understand the design concepts better and even question the boiler supplier. HRSG temperature profiles are also explained, with methods described for evaluating off-design HRSG performance.

The last chapter deals with pumps, fans, and turbines and examples show the effect of a few important variables on their performance. The impact of air density on boiler fan operation is illustrated, and the effect of elevation and temperature on flow and head are explained. With flue gas recirculation being used in almost all boilers, the effect of density on the volume is important to understand. The effect of inlet air temperature on Brayton cycle efficiency is also explained and plant engineers will appreciate the need for inlet air-cooling in summer months in large gas turbine plants. The efficiency of cogeneration is explained, as are also power output calculations using steam turbines.

A simple quiz is given at the end of the book. Its purpose is to recapitulate important aspects of boiler and HRSG performance discussed in the book.

In sum, the book will be a valuable addition to anyone involved in steam plants, cogeneration systems, or combined cycle plants. Many examples are based on my personal experience and hence, the conclusions drawn do not reflect the views of any organization. It is possible, due to lack of information on my part or to the rapid developments in steam plant engineering and technology, that I have expressed some views that may not be current or may be against the grain; if so, I express my regrets. I would appreciate readers bringing these to my attention. The calculations have been checked to the best of my ability; however if there are errors, I apologize and would appreciate your feedback. It is my fervent hope that

this book will be the constant companion of professionals involved in the steam generation industry.

I would like to thank ABCO Industries for allowing me to reproduce several of the drawings and photographs of boilers and HRSGs. I also thank other sources that have provided me with information on recent developments on various technologies.

V. Ganapathy

Contents

Preface

- 1 Steam and Power Systems
- 2 Heat Recovery Boilers
- 3 Steam Generators
- 4 Emission Control in Boilers and HRSGs
- 5 Basic Steam Plant Calculations
- 6 Fuels, Combustion, and Efficiency of Boilers and Heaters
- 7 Fluid Flow, Valve Sizing, and Pressure Drop Calculations
- 8 Heat Transfer Equipment Design and Performance
- 9 Fans, Pumps, and Steam Turbines

Appendix 1: A Quiz on Boilers and HRSGs

Appendix 2: Conversion Factors

Appendix 3: Tables

Glossary

Bibliography

1

Steam and Power Systems

INTRODUCTION

Basic human needs can be met only through industrial growth, which depends to a great extent on energy supply. The large increase in population during the last few decades and the spurt in industrial growth have placed tremendous burden on the electrical utility industry and process plants producing chemicals, fertilizers, petrochemicals, and other essential commodities, resulting in the need for additional capacity in the areas of power and steam generation throughout the world. Steam is used in nearly every industry, and it is well known that steam generators and heat recovery boilers are vital to power and process plants. It is no wonder that with rising fuel and energy costs engineers in these fields are working on innovative methods to generate electricity, improve energy utilization in these plants, recover energy efficiently from various waste gas sources, and simultaneously minimize the impact these processes have on environmental pollution and the emission of harmful gases to the atmosphere. This chapter briefly addresses the status of various power generation systems and the role played by steam generators and heat recovery equipment.

Several technologies are available for power generation such as gas turbine based combined cycles, nuclear power, wind energy, tidal waves, and fuel cells, to mention a few. [Figure 1.1](#) shows the efficiency of a few types of power systems.

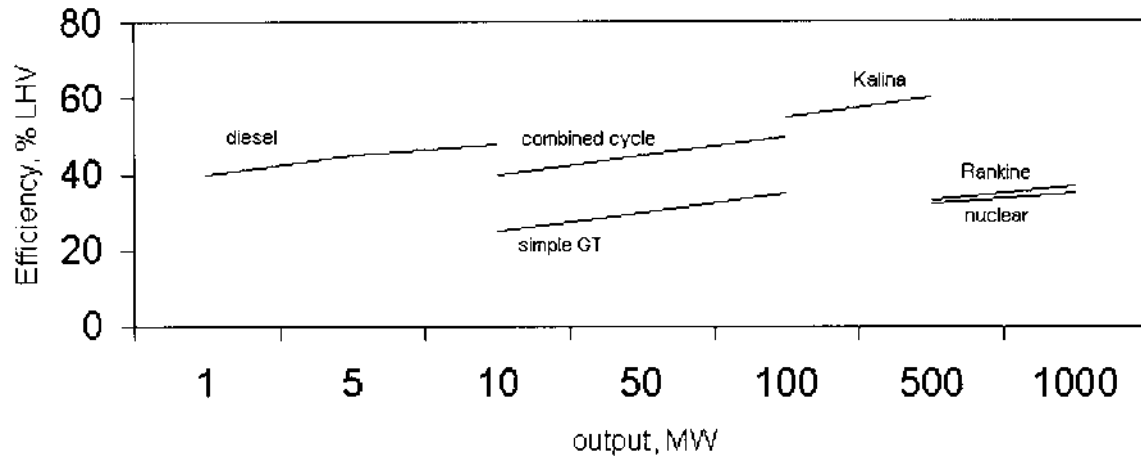

FIGURE 1.1 Efficiency of typical power systems.

About 40% of the world's power is, however, generated by using boilers fired with pulverized coal and steam turbines operating on the Rankine cycle. Large pulverized coal fired and circulating fluidized bed supercritical pressure units are being considered as candidates for power plant capacity addition, though several issues such as solid particle erosion, metallurgy of pressure parts, maintenance costs, and start-up concerns remain. It may be noted that in Europe and Japan supercritical units are more widespread than in the United States.

In spite of escalation in natural gas prices, gas turbine capacity has increased by leaps and bounds during the last decade. Today's combined cycle plants are rated in thousands of megawatts, unlike similar plants decades ago when 100 MW was considered a very high rating. Steam pressure and temperature ratings for heat recovery steam generators (HRSGs) in combined cycle plants have also increased, from 1000 psig a decade or so ago to about 2400 psig. Reheaters, which improve the Rankine cycle efficiency and are generally used in utility boilers, are also finding a place in HRSGs. Complex multipressure, multimodule HRSGs are being engineered and built to maximize energy recovery.

Repowering existing steam power plants typically 30 years or older with modern gas turbines brings new useful life in addition to offering a few advantages such as improved efficiency and lower emissions. A few variations of this concept are shown in Fig. 1.2. In boiler repowering, the gas turbine exhaust is used as combustion air for the boiler. Owing to the size of such plants, solid fuel firing may be feasible and perhaps economical. Another option is to increase the power output of the steam turbine by not using the extraction steam for feedwater heating, which is performed by the turbine exhaust gases in the HRSG. The exhaust gases can also generate steam with parameters in the HRSG similar to these of the original coal-fired boiler plant, which can be taken out of service. Because gas turbines typically use premium fuels, the emissions of NO_x, CO₂, and SO_x are also reduced in these repowering projects. It may be noted that the various HRSG options discussed above are challenging to design and build, because numerous parameters are site-specific and cost factors vary from case to case.

Significant advances have been made in research and development of alternative methods of coal utilization such as fluidized bed combustion and gasification; integrated coal gasification and combined cycle (IGCC) plants are not research projects any longer. A few commercial plants are in operation throughout the world. Figure 1.3 shows a typical plant layout.

Research into working fluids for power generation have also led to new concepts and efficient power generation systems such as the Kalina cycle (Fig. 1.4), which uses a mixture of ammonia and water as the working fluid in Rankine cycle mode. The use of organic vapor cycles in low temperature energy recovery

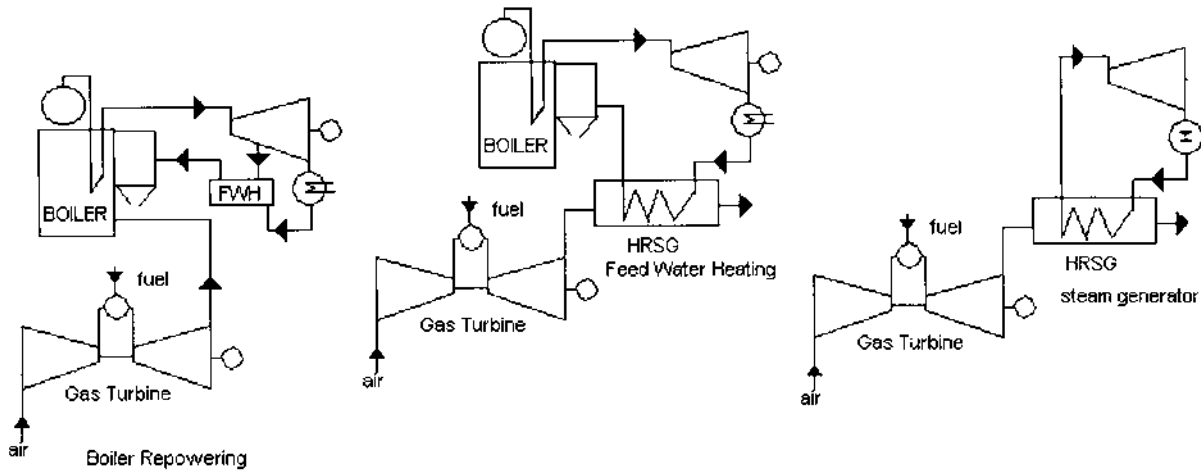

FIGURE 1.2 Repowering concepts to salvage aging power plants.

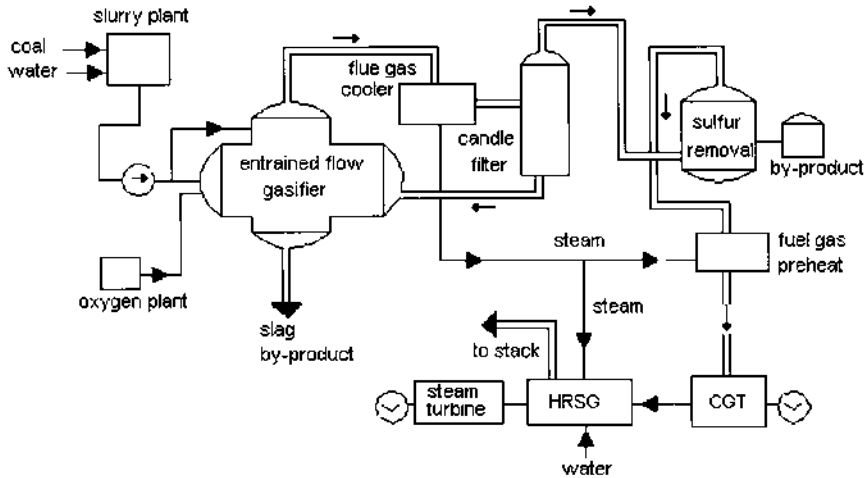

FIGURE 1.3 Wabash integrated coal gasification and combined cycle plant.

applications is also widespread. Gas turbine technology is being continuously improved to develop advanced cycles such as the intercooled aero derivative (ICAD), humid air turbine (HAT), and Cheng cycle. We have come a long way from the 35% efficiency level of the Rankine cycle to the 60% level in combined cycle plants.

Heat sources in industrial processes can be at very high temperatures, 1000–2500°F, or very low, on the order of 250–500°F, and applications have been developed to recover as much energy from these effluents as possible in order to improve the overall energy utilization. Heat recovery steam generators form an important part of these systems. (Note: The terms waste heat boiler, heat recovery boiler, and heat recovery steam generator are used synonymously). Waste gas streams sometimes heat industrial heat transfer fluids, but in nearly 90% of the applications steam is generated, that is used for either process or power generation via steam turbines.

Condensing heat exchangers are used in boilers and in HRSGs when economically viable to recover a significant amount of energy from flue gases that are often below the acid and water dew points. The condensing water removes acid vapors present in the gas stream along with particulates if any. In certain process plants, energy recovery and pollution control go hand in hand for economic and environmental reasons. Though expensive, condensing economizers, in addition to improving the efficiency of the plant, help conserve water, a precious commodity in some areas. See [Chapter 3](#) for a discussion on condensing exchangers.

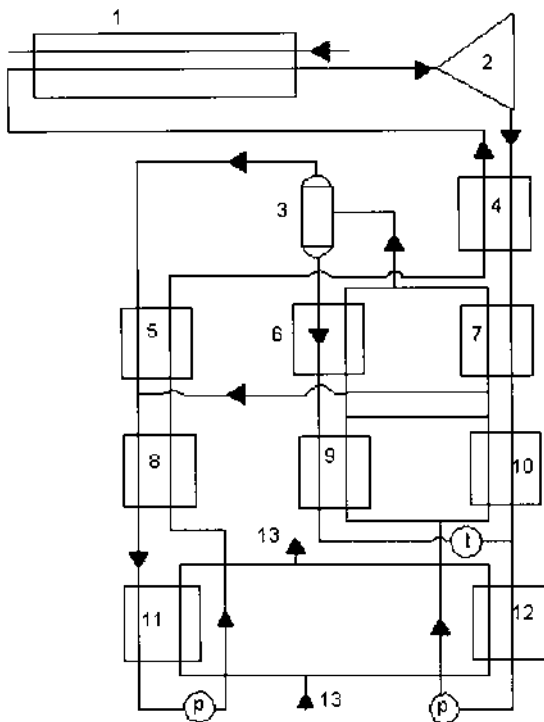

FIGURE 1.4 Kalina cycle scheme at Canoga Park, CA. 1, HRVG; 2, turbine; 3, flash tank; 4, final preheater; 5, HP preheater; 6, second recuperator; 7, vaporizer; 8, HP preheater; 9, first recuperator; 10, LP preheater; 11, HP condenser; 12, LP condenser; 13, cooling water; t, throttling device; p, pump.

Today if we walk into any chemical plant, refinery, cogeneration plant, combined cycle plant, or conventional power plant, we can see the ubiquitous steam generators and heat recovery boilers, because steam is needed virtually everywhere for process and power generation. Boiler and HRSG designs are being continuously improved to meet the challenges of higher efficiency and lower emissions and to handle special requirements if any. For example, one of the requirements for auxiliary boilers in large combined cycle plants is quick start-up; packaged boilers generating saturated or superheated steam are required to come up from hot standby condition to 100% capacity in a few minutes if the gas turbine trips. Packaged boilers with completely water-cooled furnaces (Fig. 1.5) are better suited for this application than refractory-lined boilers. In addition to generating power or steam efficiently, today's plants must also meet strict



FIGURE 1.5 Packaged steam generator with completely water-cooled furnace. (Courtesy of ABCO Industries, Abilene, TX.)

environmental regulations relating to emissions of NO_x, SO_x, CO, and CO₂, which adds to the complexity of their designs.

RANKINE CYCLE

A discussion on boilers would be incomplete without mentioning the Rankine cycle. The steam-based Rankine cycle has been synonymous with power generation for more than a century. In the United States, utility boilers typically use subcritical parameters (2400 psi, 1050/1050°F), whereas in Europe and Japan, supercritical plants are in vogue (4300 psi, 1120/1120°F). The net efficiency of power plants has increased steadily from 36% in the 1960s for subcritical coal-fired plants to 45% for supercritical units commissioned in the 1990s. Several technological improvements in areas such as metallurgy of boiler tubing, reduction in auxiliary power consumption, improvements in steam turbine blade design and metallurgy, pump design, burner design, variable pressure condenser design, and multistage feedwater heating coupled with low boiler exit gas temperatures have all contributed to improvements in efficiency. An immediate advantage of higher efficiency is lower emissions of CO₂ and other pollutants. Current state-of-the-art coal-fired supercritical steam power systems operate at up to 300 bar and 600°C with net efficiencies of 45%. These plants have good

efficiencies even at partial load compared to subcritical units, and plant costs are comparable to those of subcritical units. At 75% load, for example, the efficiency reduction in a supercritical unit is about 2% compared to 4% for subcritical units. At 50% load, the reduction is 5.5–8% for supercritical versus 10–11% for subcritical. These units are of once-through design. Cycle efficiencies of 36% in the 1960s (160 bar, 540/540°C) rose to about 40% in 1985 and to 43–45% in 1990. These gains have been made through [1–3]

- Increases in the main and reheat steam temperatures and main steam pressure, including transitions to supercritical conditions
- Changes in cycle configuration, including increases in the number of reheat stages and the number of feedwater heaters
- Changes in condenser pressure and lowering of the exit gas temperature from the boiler (105–115°C)
- Reductions in auxiliary power consumption through design and development
- Improvements in the performance of various types of equipment such as turbines and pumps, as mentioned above

One of the concerns with the steam-based Rankine cycle is that a higher steam temperature is required with higher steam pressure to minimize the moisture in the steam after expansion. Moisture impacts the turbine performance negatively through wear, deposit formation, and possible blockage of the steam path. As can be seen in Fig. 1.6, a higher steam pressure for the same temperature

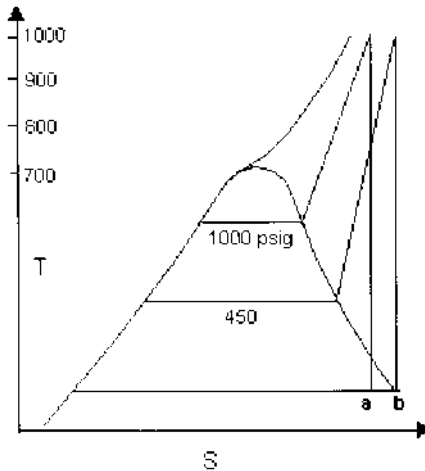

FIGURE 1.6 T–S diagram showing expansion of steam.

results in higher moisture after expansion. Hence steam temperatures have been increasing along with pressures, adding to metallurgical concerns. This implies a need for higher boiler tube wall thickness and materials with higher stress values at high temperatures. Multistage reheating minimizes the moisture concern after expansion; however, this adds to the complexity of the boiler and HRSG design. Also with HRSGs, the steam-based Rankine cycle limits the effectiveness of heat recovery, because steam boils at constant temperature and significant energy is lost, which brings us to the Kalina cycle.

KALINA CYCLE

A recent development in power generation technology is the Kalina cycle, which basically follows the Rankine cycle concept except that the working fluid is 70% ammonia–water mixture. It has the potential to be 10–15% more efficient than the Rankine cycle and uses conventional materials of construction, making the technology viable. Figure 1.4 shows the scheme of the demonstration plant at Canoga Park, CA, which has been in operation since 1995 [4–6]. In the typical steam–water-based Rankine cycle, the loss associated with the working fluid in the condensing system is large; also, the heat is added for the most part at constant temperature; hence there are large energy losses, resulting in low cycle efficiency.

In the Kalina cycle, heat is added and rejected at varying temperatures (Fig. 1.7a), which reduces these losses. The steam–water mixture boils or condenses at constant temperature, whereas the ammonia–water mixture has varying boiling and condensing temperatures and thus closely matches the temperature profiles of the heat sources. The distillation condensation subsystem (DCSS) changes the concentration of the working fluid, enabling condensation of the vapor from the turbine to occur at a lower pressure. The DCSS brings the mixture concentration back to the 70% level at the desired high inlet pressure before entering the heat recovery vapor generator (HRVG). The HRVG is similar in design to an HRSG.

The ammonia–water mixtures have many basic features unlike those of either ammonia or water, which can be used to advantage:

1. The ammonia–water mixture has a varying boiling and condensing temperature, which enables the fluid to extract more energy from the hot stream by matching the hot source better than a system with a constant boiling and condensing temperature. This results in significant energy recovery from hot gas streams, particularly those at low temperatures, such as the geothermal heat source of Fig. 1.7b. By changing the working fluid concentration from 70% to about 45%, condensation of the vapor is enabled at a lower pressure, thus

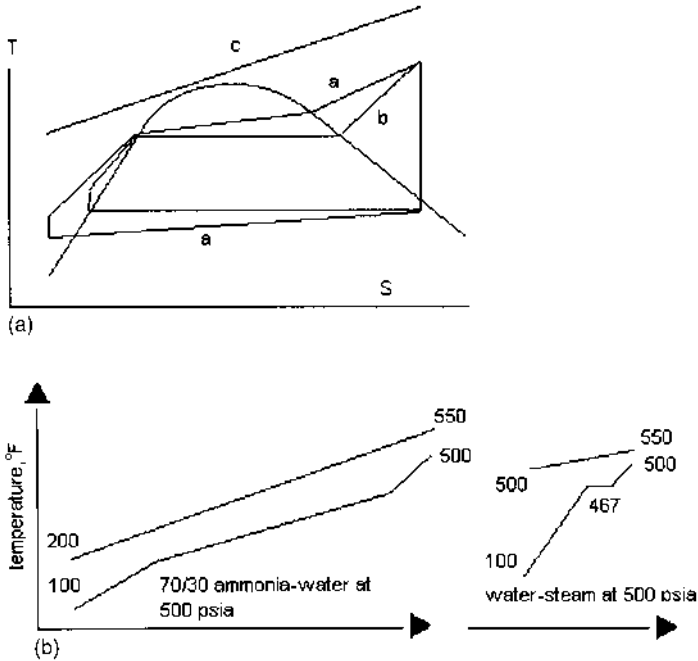

FIGURE 1.7 (a) Cycle diagram: Kalina vs. steam Rankine systems. (b) Temperature profiles of (left) Kalina and (right) steam heat recovery systems.

recovering additional energy from the vapor in the turbine with lower energy losses at the condenser system. As can be seen in Fig. 1.7b, the energy recovered with a steam system is very low, whereas the ammonia-water mixture is able to recover a large fraction of the available energy from the hot exhaust gases. A steam plant would have to use a multiple-pressure system to recover the same fraction of energy, but this increases the complexity and cost of the steam plant. The lower the temperature of the gas entering the boiler, the better is the Kalina system compared to the steam system.

2. The thermophysical properties of an ammonia-water mixture can be altered by changing the ammonia concentration. Thus, even at high ambient temperatures, the cooling system can be effective, unlike in a steam Rankine system, where the condenser efficiency drops off as the cooling water temperature or ambient temperature increases. The Kalina cycle can also generate more power at lower cooling water temperatures than a steam Rankine cycle.

3. The ammonia–water mixture has thermophysical properties that cause mixed fluid temperatures to change without a change in heat content. The temperature of water or ammonia does not change without a change in energy.
4. Water freezes at 32°F, whereas pure ammonia freezes at –108°F. Ammonia–water solutions have very low freezing temperatures. Hence at low ambient temperatures, the Kalina plant can generate more power without raising concerns about freezing.
5. The condensing pressure of an ammonia–water mixture is high, on the order of 2 bar compared to 0.1 bar in a steam Rankine system, resulting in lower specific volumes of the mixture at the turbine exhaust and consequently smaller turbine blades. The expansion ratio in the turbine is about 10 times smaller. This reduces the cost of the turbine condenser system. With steam systems, the condenser pressure is already at a low value, on the order of 1 psia; hence further lowering would be expensive and not worth the cost.
6. The losses associated with the cooling system are smaller due to the lower condensing duty, and hence the cooling system components can be smaller and the environmental impact less.

Example of a Kalina System

A 3 MW plant has been in operation in California for more than a decade. In this plant, 31,450 lb/h of ammonia vapor enters the turbine at 1600 psia, 960°F and exhausts at 21 psia. The ammonia concentration varies throughout the system. The main working fluid in the HRVG is at 70% concentration, whereas at the condenser it is at 42%. The leaner fluid has a lower vapor pressure, which allows for additional turbine expansion and greater work output. The ability to vary this concentration enables the performance to be varied and improved irrespective of the cooling water temperature.

Following the expansion in the turbine, the vapor is at too low a pressure to be completely condensed at the available coolant temperature. Increasing the pressure would increase the temperature and hence reduce the power output. Here is where the DCSS comes in. The DCSS enables condensing to be achieved in two stages, first forming an intermediate mixture leaner than 70% and condensing it, then pumping the intermediate mixture to higher pressure, reforming the working mixture, and condensing it as shown in Fig. 1.4. In the process of reforming the mixture (back to 70%), additional energy is recovered from the exhaust stream, which increases the power output. Calculations show that the power output can be increased by 10–15% in the DCSS compared to the Rankine system based on a steam–water mixture.

The HRVG for the Kalina cycle is a simple once-through steam generator with an inlet for the 70% ammonia liquid mixture, which is converted into vapor at the other end. The vapor-side pressure drop is large, on the order of hundreds of pounds per square inch due to the two-phase boiling process. Conventional materials such as carbon and alloy steels are adequate for the HRVG components.

Studies have been made on large combined cycle plants using the Kalina cycle concept. Using an ABB 13 E gas turbine, 227 MW can be generated at a heat rate of 6460 Btu/kWh (52.8%). This system produces an additional 12.1 MW compared to a two-pressure steam bottoming cycle. Though the cost details are not made available, it is felt that they are comparable on the basis of dollars per kilowatt.

Several variations of the Kalina cycle have been studied. One of the options for power generation cycles is shown in Fig. 1.8. It employs a reheat turbine. A cooling stage is included between the high pressure and intermediate turbines. First the vapor is superheated in the HRVG and expanded in the high pressure stage. Then it is reheated in the HRVG and expanded in the intermediate stage to generate more power. At this point the superheat remaining in the vapor is removed to vaporize a portion of the working fluid, which has been preheated in the economizer section. This additional vapor is then combined with the vapor generated in the HRVG and then superheated. The cooled vapor is then expanded in the low pressure stage. These heat exchanges enable the working fluid to recover more energy from the exhaust gas stream. A 4.5 MW Kalina system is in operation in Japan that uses energy recovered from a municipal incineration heat recovery system, and a 2 MW plant using geothermal energy is in operation in

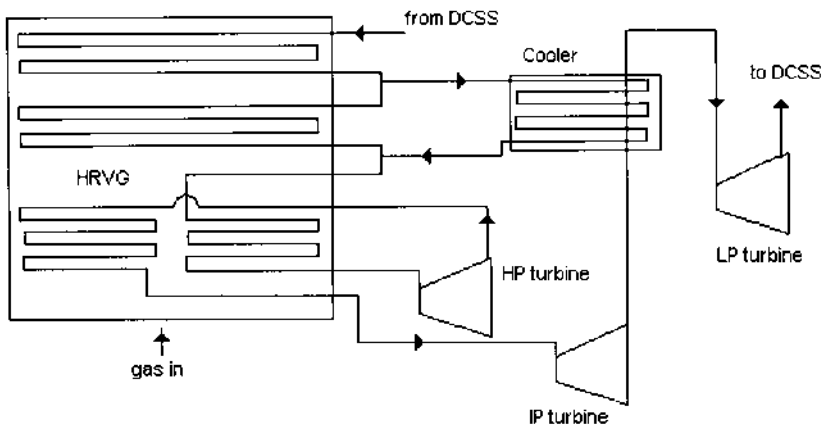

FIGURE 1.8 Kalina system to improve energy recovery in a combined cycle plant.

Iceland. It may be noted that as the temperature of the heat source is reduced, the Kalina system offers more efficiency than a steam or organic vapor system.

ORGANIC RANKINE CYCLE

The Rankine cycle is a thermodynamic cycle used to generate electricity in many power stations and is the practical approach to the Carnot cycle. Superheated steam is generated in a boiler, then expanded in a steam turbine. The turbine drives a generator to convert the work into electricity. The remaining steam is then condensed and recycled as feedwater to the boiler. A disadvantage of using the water–steam mixture is that superheated steam has to be generated; otherwise the moisture content after expansion might be too high, which would erode the turbine blades. Organic substances that can be used below a temperature of 400°C do not have to be overheated. For many organic compounds superheating is not necessary, resulting in a more efficient cycle. In a heat recovery system, it may be shown that if the degree of superheating is reduced, more steam can be generated and hence more energy can be recovered from the heat source as shown in Q8.36.* The working fluid superheats as the pressure is reduced, unlike steam, which becomes wet during the expansion process. Organic fluids also have low freezing points and hence even at low temperatures there is no freezing. The ratio of latent heat to sensible heat allows for greater heat recovery than in steam systems.

An Organic Rankine Cycle (ORC) can make use of low temperature waste heat such as geothermal heat to generate electricity. At these low temperatures a steam cycle would be inefficient, because of the enormous volume of low pressure steam, which would require very voluminous and costly piping resulting in inefficient plants. Small-scale ORCs have been used commercially or as pilot plants in the last two decades. Several organic compounds have been used in ORCs (e.g., CFCs, Freon, isopentane, or ammonia) to match the temperature of the available waste heat. Waste heat temperatures can be as low as 70–80°C. The efficiency of an ORC is estimated to be between 10% and 20%, depending on temperature levels. To minimize costs and energy losses it is necessary to locate an ORC near the heat source. It is also necessary to condense the working vapor; therefore, a cooling medium should be available on site. These site characteristics will limit the potential application. Condensing pressure is higher than atmospheric, so there is no need for vacuum equipment. ORC is expensive on the basis of cost per kilowatt-hour compared to other systems, but the main advantage is that it can generate power from low temperature heat sources. ORC plants can also be of large capacity. A 14 MW power plant using Flurinol 85 as the working

*Q8.36 refers to the Q and A section in [Chapter 8](#). This nomenclature will be used throughout.

fluid is in operation in Japan, using the energy recovered from the effluents of a sintering plant. The low boiling point and low latent heat of this fluid compared to steam help recover a significantly greater amount of energy from the hot gases.

COMBINED CYCLE AND COGENERATION PLANTS

Gas turbine plants operate in both combined cycle and cogeneration mode (Fig. 1.9). [Figure 1.10](#) shows the arrangement of an unfired HRSG used in such plants. Large combined cycle plants with thousands of megawatts in capacity are being built today. Chemical plants, refineries, and process plants use HRSGs in cogeneration mode to supply steam for various purposes. The combined cycle plant with a gas turbine exhausting into an HRSG that supplies steam to a steam turbine is the most efficient electric generating system available today. It exhibits lower capital costs than fossil power plants. [Table 1.1](#) shows the average cost of a gas turbine. The HRSG price ranges from about \$80 to \$130 per kilowatt. Combining the Brayton and Rankine cycles results in efficiencies significantly above the 40% level, which was an upper limit of large coal-fired utility plants built 30–50 years ago. Distillate oils and natural gas are typically fired in the gas turbines. Combined cycle plants have a number of advantages:

Modular designs enable increases in plant capacity as time passes.

These plants have short start-up periods. They come on-line in a couple of hours from the cold.

Combined cycle plants can be built within 12–20 months, unlike a large utility plant, which takes 3–4 years.

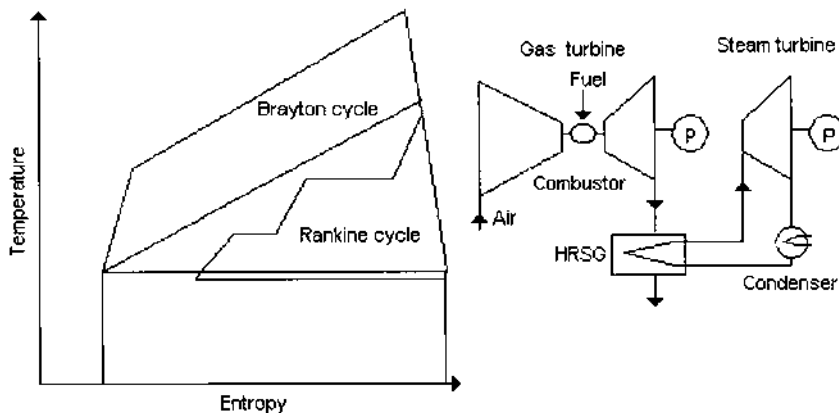

FIGURE 1.9a Combined cycle system showing the Brayton–Rankine cycle.

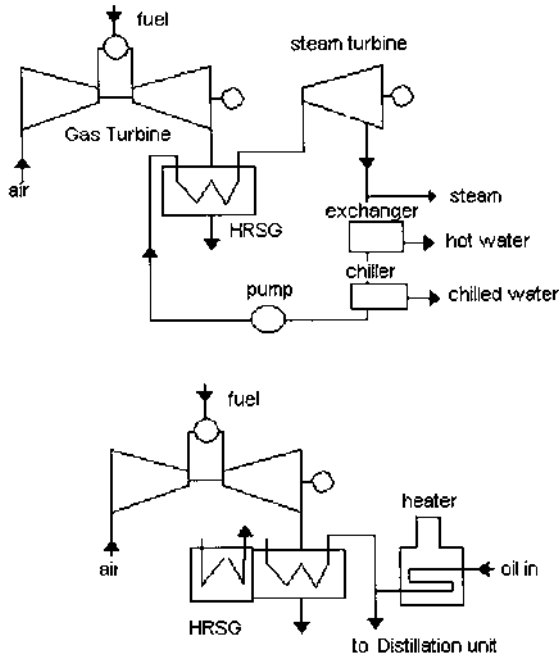

FIGURE 1.9b Cogeneration systems.

Advances in gas turbine technology and cooling systems can be made use of to improve the overall system efficiency. We are close to 60% LHV efficiency with recent developments such as high pressure, multiple-pressure steam systems and reheat steam cycles.

Emissions of NO_x and CO for plants burning natural gas are in single-digit plants per million (ppm).

Cooling water requirements are low due to higher efficiency and the small ratio of Rankine cycle power to total power output. The Brayton cycle portion does not require cooling water.

Large-capacity additions are feasible. Today's combined cycle plant is rated in thousands of megawatts, which is otherwise feasible only with coal-fired power plants.

Recent developments in gas turbine technology such as closed steam cooling of blades enable firing temperatures to be increased, thus increasing the simple cycle efficiency. Every 100°F increase in firing temperature increases the turbine power output by 10% and gives a 4% gain in simple cycle efficiency. In large systems, an HRSG with three pressure levels and reheat is used,

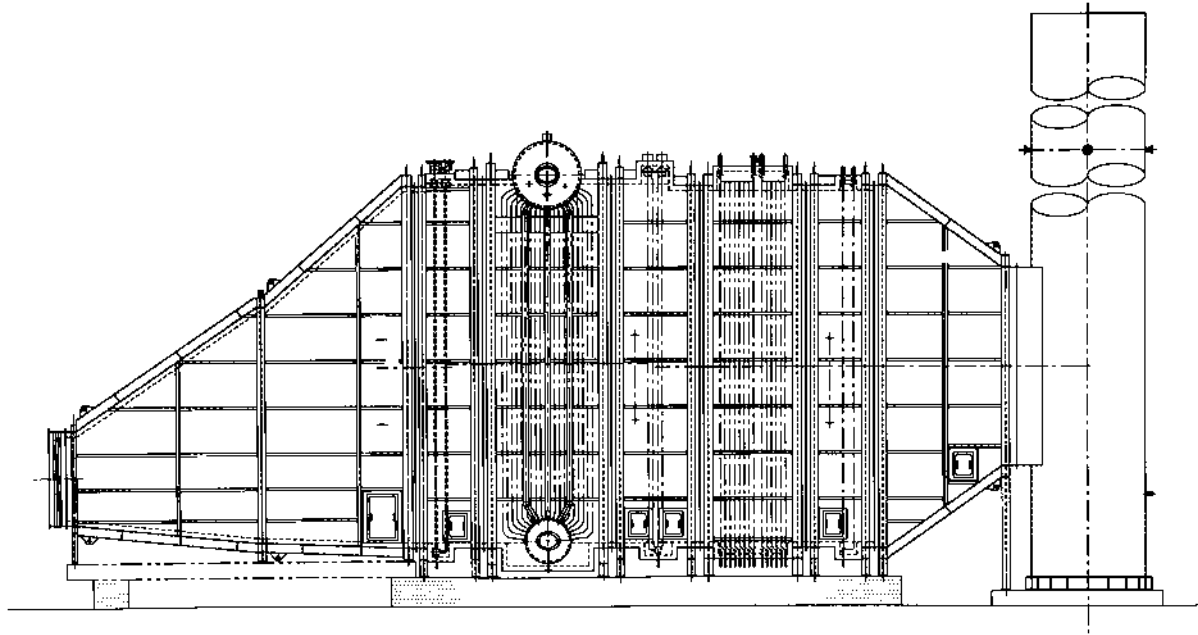

FIGURE 1.10 Unfired HRSG in a gas turbine plant.

TABLE 1.1 Gas Turbine Pricing

Machine size (MW)	Cost (\$/kW)
1–2	600–650
5	400–450
50	275–300
150	180–190
250	175–185
260–340	175–180

Note: A host of factors affect pricing, and the above numbers give an idea only and should be used with caution.

Source: Ref. 14.

increasing the plant efficiency to 55% LHV. Table 1.2 presents data for a few systems that are being commercially offered. The data are typical only.

In spite of all the advantages mentioned, it should be noted that the output of a gas turbine decreases significantly as the ambient temperature increases. The lower density of warm air reduces the mass flow through the turbine and the exhaust gas flow through the HRSG, which in turn reduces its steam generation and hence the steam turbine power output. Unfortunately, hot weather also corresponds to peak electrical loads in many areas of the world. Hence a few methods are used to improve the gas turbine power output in summer. The three most common methods of increasing the gas turbine (GT) output are [7]

- Injection of steam into the gas turbine
- Precooling of the inlet air
- Supplementary firing in the HRSG

Steam Injection

Injecting steam into the gas turbine has been a strategy adopted by turbine users for a long time to increase its power output. The increased mass flow coupled with the higher thermal conductivity and specific heat of the exhaust gases (due to the higher percent by volume of water vapor) generates more power in the gas turbine and higher steam output in the HRSG. The Cheng cycle, discussed later, is a good example of this technique. Besides increasing the power output, it reduces the turbine NO_x levels.

Precooling of the Inlet Air

Evaporative cooling boosts the output of the gas turbine by increasing the density and mass flow of the air. Water sprayed into the inlet air stream cools the air to

TABLE 1.2 Typical Combined Cycle Plants

Simple cycle data	System			
	7FA	9FA	6FA	W501F
Simple cycle output, kW	159,000	226,500	70,140	187,000
Simple cycle heat rate (LHV)	9500	9570	9980	9235
Simple cycle efficiency, % LHV	35.9	35.7	34.2	36.9
Pressure ratio	14.7	14.7	14.6	15
Firing temperature, °F	2350	2350	2350	—
Exhaust gas flow, lb/h	3,387,000	4,877,000	1,591,000	1,645,200
Exhaust gas temperature, °F	1093	1093	1107	1008
HRSG system	3 press, reheat	3 press, reheat	3 press, reheat	Multipress, reheat
1 × GT net output, MW	241.4	348.5	108.4	274
Net heat rate (LHV), Btu/kWh	6260	6220	6455	6150
1 × GT net efficiency, %	54.5	54.8	52.8	55.5
2 × GT net output, MW	483.2	700.8	219.3	550
2 × GT net heat rate, Btu/kWh	6250	6190	6385	6120
2 × GT net efficiency, %	54.6	55.1	53.4	55.8

Source: Ref. 9.

near its wet bulb temperature. The effectiveness of the evaporative cooling systems is limited by the relative humidity of the air. At 95°F dry bulb temperature and 60% relative humidity, an 85% effective evaporative cooler can alter the air inlet temperature and moisture content to 85°F dry bulb and 92% humidity, respectively. This boosts the gas turbine output and the HRSG steam generation (due to the larger gas mass flow). The incremental cost of this system is about \$180/kW. The cost of treated water, which is lost to the atmosphere, must also be considered in evaluating this system. The effectiveness of the same system in less humid conditions, say 95°F and 40% relative humidity, is much higher. The same evaporative cooler can reduce the inlet air temperature to 75°F dry bulb and 88% humidity. The combined cycle plant output increases by 7%, and the heat rate by about 1.9%. With evaporative coolers, the air cannot be cooled below the wet bulb temperature, so chillers are used for this purpose.

Chillers can be mechanical or absorption systems. Water is the refrigerant, and lithium bromide (LiBr) is the absorber in single-effect LiBr absorption systems. A low grade heat source such as low pressure steam drives the absorption process, which produces chilled water. Absorbers draw little electrical power and are well suited to cogeneration plants where steam is readily available. Sometimes the HRSG generates the low pressure steam required for chilling, or it can be taken from some low pressure steam header. Unlike mechanical chillers, the efficiency of an absorber is unchanged as its load is decreased. Chilled water output is limited to around 44°F, yielding inlet air at 52°F.

A mechanical chiller can easily reduce the temperature of GT inlet air from 95°F to 60°F dry bulb and achieve 100% humidity. This increases the plant output by 8.9% but also degrades the net combined cycle heat rate by 0.8% and results in a 1.5 in. WC inlet air pressure drop due to the heat exchanger located at the chilling section. Costs could be about \$165/kW. Absorption systems are more complex than mechanical chillers.

Off-peak thermal storage is another method of chilling inlet air. A portion of the plant's electrical or thermal output is used to make ice or cool water during lean periods. During peak periods, the chilling system is turned off and the stored ice is used to chill the inlet air.

The performance of HRSGs with varying ambient temperatures is discussed later. One can appreciate from the example why inlet air cooling is necessary, particularly in locations where ambient temperatures are very high.

Improvements in Gas Turbines

In order to handle the high firing temperatures, in the range of 2500–2600°F, gas turbine suppliers are doing research and development work on turbine blades for protection against corrosion and thermal stresses. Thermal barrier coatings have been used on turbine blades for several years. The base high alloy material

ensures the mechanical integrity, while the coatings protect against oxidation and corrosion as well as reducing the blade surface temperature. The rotating blades are manufactured by using single-crystal casting technology, which allows the chemical composition of the alloys to be modified to improve their resistance to fatigue and creep. Thermal barrier coatings comprise two layers: the outer ceramic layer, which prevents flow of heat into the turbine blade, and a metallic bond coating, which is a nickel- or cobalt-based material.

General Electric uses closed loop steam cooling for the blades in its quest for higher firing temperatures. This unique cooling system allows the turbine to fire a higher temperature, around 2600°F, for higher performance. Earlier designs were cooled by compressor discharge air, which causes a large temperature drop in the first-stage nozzle. Cooling with steam systems has been found to be more effective because it picks up heat for use in the steam turbine, transforming what was waste heat to usable heat. In conventional gas turbines, compressor air is also used to cool rotational and stationary components downstream of the stage 1 nozzle. This is called chargeable air because it reduces performance. In advanced systems, this air is replaced by steam, which enhances performance by 2% and increases the gas turbine output because all the compressor air can be channeled through the turbine path to do useful work in the turbine as well as in the HRSG [9]. The high pressure steam from the HRSG is expanded through the steam turbine's high pressure section. The exhaust steam from this turbine section is then split. One part is returned to the HRSG while the other is combined with the intermediate pressure steam and used for cooling in the gas turbine. Steam is used to cool the stationary and rotational parts of the turbine. In turn, the heat transferred from the gas turbine increases the steam temperature to approximately reheat temperature. The gas turbine cooling steam is mixed with the reheat steam from the HRSG and introduced into the intermediate pressure steam turbine section [8].

COAL-BASED SYSTEMS

Though combined cycle plants based on natural gas (Fig. 1.9a) are widely used, with the increasing cost of natural gas several coal gasification technologies are gaining acceptance. The technology is proven, and there are several plants in operation throughout the world. The advantages of integrated coal gasification combined cycle (IGCC) are

- Ability to use of low grade fuels such as coal and biomass.

- High efficiency, about 7–8% higher than conventional coal-based plants. A net efficiency of 45% is not impossible. With improvements in gasification and gas turbine technologies, the efficiency can reach 50% by 2010.

Fuel flexibility. The combined cycle portion of the plant can be fueled by natural gas, oil, or coal. A plant can switch from gas to coal as gas becomes unavailable or very expensive. Most gasifiers can handle different grades of coal. Gas turbine combustors can also handle different fuels with different heating values and gas analysis from low to high Btu.

Low SO₂, NO_x, and CO₂ emissions. In an IGCC, 90% of the coal's sulfur is removed before combustion. NO_x is reduced by 90%, as is also the CO₂ on lb/kWh basis. The coal gas is purified before combustion, unlike in a conventional coal-fired plant, where the flue gases are cleaned. Hence the quantity of effluent to be handled is much smaller. The composition of the fuel gas also allows for better chemistry while cleaning.

Low water consumption due to higher efficiency and lower heat losses.

Marketable by-products such as sulfur, sulfuric acid, and carbon dioxide.

A wide range of technologies such as fixed bed, fluidized bed, and entrained bed gasification.

Ability to make use of advances in gas turbine technology.

Availability of IGCC plants, which has been in excess of 90% and is improving.

Higher gas turbine power output possible due to about 14% larger mass flow of flue gases at the same combustion temperature compared to natural gas.

Decreasing installation costs due to advances in technology. \$1000/kW will be achievable in the near future. Unit sizes range from 100 to 500 MW.

In an IGCC, coal is gasified in a gasifier by using steam and either air or oxygen to generate a low or high Btu gas, which is cleaned and fired in a gas turbine combustor. There are three processes for gasifying coal: fixed bed, fluidized bed, and entrained bed. [Figure 1.3](#) shows an IGCC plant. Typically, coal is gasified in the gasifier at pressure using steam, oxygen or air, and coal. The coal gas is cooled in a synthesis gas cooler, which also generates steam or superheats the steam generated elsewhere. It is then cleaned in a gas cleaning system, where the particulates and sulfur are removed. Hot gas cleaning methods are also being developed, which can improve the efficiency of the system even more. The clean coal gas is fired in the gas turbine combustor. The exhaust gases generate high pressure steam for the steam turbine and also for gasification. A portion of the air from the gas turbine compressor is also sent to the gasifier. There are several plants in operation throughout the world. In the United States the Wabash River plant, which began operation in 1995 ([Fig. 1.3](#)) generates 262 MW using the Destec process for gasification, which uses an entrained flow

oxygen-blown gasifier. Coal is slurried, combined with 95% pure oxygen, and injected into the first stage of the gasifier, which operates at 400 psig and 2600°F. The coal slurry undergoes a partial oxidation reaction at temperatures that bring the coal's ash above its melting point. From the gasifier the fluidized ash falls through a tap hole at the bottom. The synthesis gas flows into the second stage, where additional coal slurry is injected. At this stage the coal is pyrolyzed in an endothermic reaction with the hot synthesis gas. This enhances the heating value of the synthesis gas.

After leaving the second stage the synthesis gas flows into a gas cooler, which is a waste heat boiler that generates high pressure saturated steam at 1600 psia. After cooling, any remaining particulates are removed in a hot/dry filter. Further cooling of gas takes place in a series of exchangers. It is scrubbed to remove chlorides and passed through a catalyst that hydrolyzes the carbonyl sulfide into hydrogen sulfide. The H₂S is removed by an acid gas removal system. A marketable elemental sulfur is produced as a by-product. Finally the sweet gas is moisturized and preheated before being sent to the gas turbine. The power block consists of a GE 192 MW MS7001A gas turbine, The exhaust gases generate steam in the HRSG, which generates power via a steam turbine. This is presently the largest gasification repowering project. The heat rate is around 8910 Btu/kWh (HHV) with SO₂ emissions around 0.1 lb/MM Btu, NO_x 0.15, and particulates below detectable limits [10].

Coal will remain a major fuel, more so with the significant run-up in the price of gas, and IGCC plants have earned a permanent place in power generation technology. The heat exchanger and the HRSG are designed to meet the special requirements of this process. Oxygen-blown gasification has dominated commercial gasification processes, because these plants produce chemicals based on synthesis gas (H₂ and CO) and premium fuels. Air-blown gasifiers, which generate low Btu gas, are also widely used in the industry. Air-blown gasification produces a gas in which the desirable chemical reactants are diluted by massive amounts of nitrogen. The gasifier capacity is cut in half when it is air-blown. The efficiency of conversion of feed to fuel gas is higher with oxygen-blown gasification. The air-blown gasification produces over twice as much gas as is generated by oxygen-blown operation; hence investment costs for air-blown systems and cleanup systems are higher. Cleanup costs are also higher because the partial pressures of the pollutants are higher in air-blown system raw gas. Compression costs are lower because the mass flow of an oxygen-blown system is smaller by 20–40%.

The Sierra Pacific Power Company's Pinon-Pine project employs an air-blown system and a fluidized bed gasification process that uses low sulfur coal, most of which is captured in the bed itself by the use of limestone injection methods. A low Btu gas is generated, on the order of 130 Btu/scf.

EFFECT OF AMBIENT TEMPERATURE ON HRSG PERFORMANCE

The power output of a gas turbine without inlet air temperature cooling or conditioning suffers at high ambient temperature owing to the effect of lower air density, which in turn reduces the mass flow of air. The power output could drop by as much as 15–25% between the coldest and hottest temperatures. The exhaust gas flow, temperature, and gas analysis also vary with ambient temperature, which affects the HRSG performance. Table 1.3 shows the data for a typical LM 5000 gas turbine.

Naturally, the performance of an unfired HRSG behind the gas turbine would be affected by the changes in exhaust gas flow and temperature. Using the “HRSGS” program (see Chap. 2), one can evaluate the HRSG performance under varying ambient conditions; the results are shown in Fig. 1.11. One can see the large variation in the HRSG performance between summer and winter months. In order to minimize the effect of ambient temperature on power output, several methods are resorted to, such as the use of evaporative coolers, mechanical chillers, absorption chillers, and thermal storage systems as discussed above.

EFFECT OF GAS TURBINE LOAD ON HRSG PERFORMANCE

Generally gas turbines perform poorly at low loads, which affect not only their [11, 12] performance but also that of the HRSG located behind them. Because of the low exit gas temperature at lower loads, the HRSG generates less steam and also has the potential for steaming in the economizer. Table 1.4 shows the exhaust flow and temperature of a small gas turbine as a function of load. It should be noted that the data are typical, presented to illustrate the point that at low gas

TABLE 1.3 Gas Turbine Performance at Selected Ambient Temperatures

	20°F	40°F	60°F	80°F	100°F	120°F
Power, kW	38,150	38,600	35,020	30,820	27,360	24,040
Heat rate, Btu/kWh	9,384	9,442	9,649	9,960	10,257	10,598
Exhaust temp, °F	734	780	797	820	843	870
Exhaust flow, lb/h	1,123,200	1,094,400	1,029,600	950,400	878,400	810,000
Vol% CO ₂	2.7	2.9	2.8	2.8	2.7	2.7
H ₂ O	7.6	8.2	8.5	9.2	10.5	12.8
O ₂	14.6	14.3	14.3	14.2	14.0	13.7
N ₂	75.1	74.7	74.4	73.8	72.8	70.8

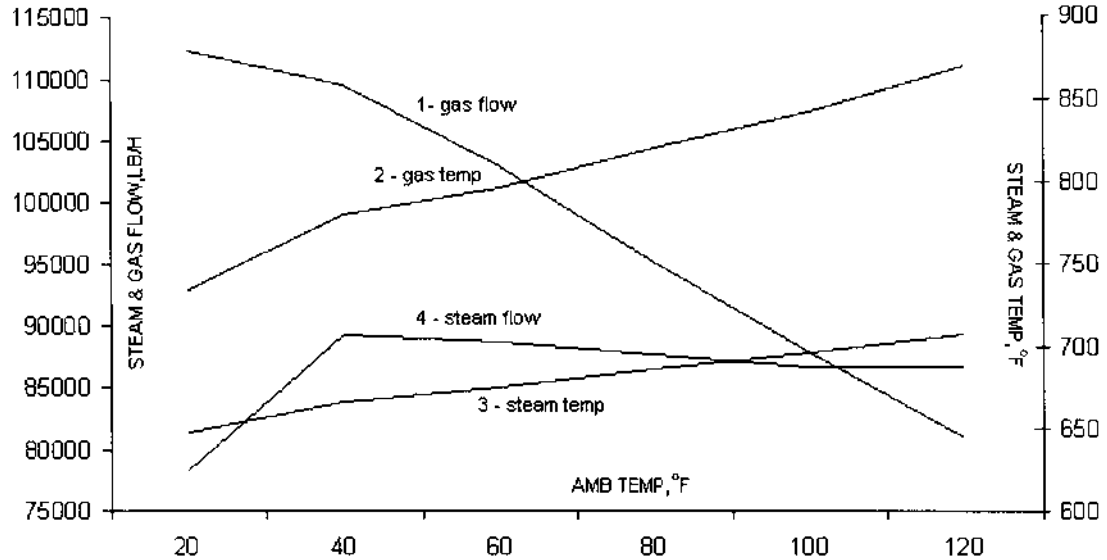

FIGURE 1.11 HRSG performance versus ambient temperature. Gas flow shown has a multiplication factor of 0.1.

TABLE 1.4 Typical Gas Turbine Performance at Low Loads

	Load (%)				
	10	20	30	40	100
Generator kW	415	830	1244	1659	4147
Heat rate, Btu/kWh	48,605	28,595	21,960	18,649	12,882
Efficiency, %	7	12	15.54	18.3	26.5
Exhaust gas, lb/h	147,960	148,068	148,170	148,320	148,768
Exhaust temp, °F	562	612	662	712	1019
Vol% CO ₂	1.18	1.38	1.59	1.79	3.04
H ₂ O	3.76	4.14	4.53	4.93	7.33
O ₂	18.18	17.78	17.28	16.88	14.13
N ₂	76.9	76.7	76.6	76.4	75.5

turbine loads the HRSG performance will be poor. Note that at low loads the exhaust temperature is lower but the mass flow changes little.

The HRSG performance at 100% and 40% loads is given in Figs. 1.12a and 1.12b. The HRSG was designed for the 100% case, and its performance was checked at 40% load using the “HRSGS” program. It may be seen that the economizer generates some steam. Also, the exit gas temperature from the HRSG at low load is very high compared to the normal case. This is due to the fact that less steam is generated in the evaporator and hence the flow through the economizer is also small, resulting in only a small gas temperature drop; the heat sink at the economizer is not large enough to cool the gases to a low temperature. Thus it is recommended that the HRSG not be operated at low loads of the gas turbine for long durations. If it is absolutely required, then a gas bypass damper should be used, or methods suggested in Q8.41, may be tried to minimize economizer steaming.

EFFECT OF STEAM PRESSURE ON HRSG PERFORMANCE

Combined cycle plants today operate in sliding pressure mode; if extraction steam is desired at a given pressure for process reasons, then a constant pressure may be required at the steam turbine inlet. Typically the steam pressure is allowed to float by keeping the turbine throttling valves fully open and ensuring full arc admission. The load range over which sliding operation is allowed varies from about 40% or 50% to 100%. Large variations in steam pressure affect the specific volume of steam, which in turn affects the velocity and pressure drop through superheater tubes and pipes, valves, etc. Large variations in steam pressure also affect the saturation temperature at the drum and hence thermal stresses across

HRSG PERFORMANCE - Design case



Project - study-100% Units - British Case - 100 % load Remarks - unfired

amb temp - F= 60 heat loss-%= 1 gas temp to HRSG F= 1019 gas flow - Lb/h= 148768
 % vol CO2 =3.04 H2O =7.33 N2 =75.5 O2 =14.13 SO2=. ASME eff-% =68.75 tot duty-MM Btu/h=25.9

Surf	gas temp in/out -F	wat/stm in/out -F	duty MMB/h	pres psia	flow lb/h	pstrn %	pinch F	apprch F	US Btu/hF	module no
sh	1019 924	492 750	3.87	615	21941	100			11238	1
evap	924 512	472 492	16.39	635	21941	100	20	20	122275	1
eco	512 365	230 472	5.68	645	22161	0			72658	1

Gas-Steam Temperature profiles

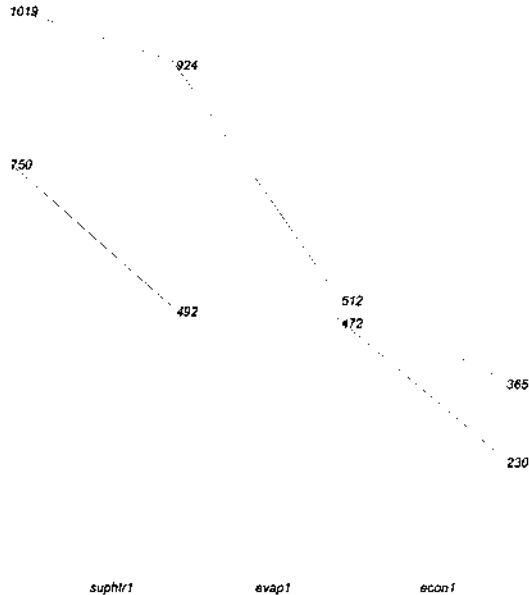

FIGURE 1.12a HRSG performance at 100% load of gas turbine.

thick components such as drum and superheater headers, which in turn limits the rate of load changes. Sliding pressure operation increases the efficiency of the turbine at low loads due to lower throttling losses and also lowers the cost of pumping if variable-speed pumps are used.

The steam pressure at turbine inlet increases linearly as the load increases; however, the unfired HRSG steam output decreases as the steam pressure increases. By matching the steam turbine and HRSG characteristics, one can

HRSG PERFORMANCE - Off-Design case



Project - study-100% Units - BRITISH Case - 40% load Remarks -

amb temp - F= 60 heat loss-%= 1 gas temp to HRSG F= 712 gas flow - Lb/h= 148320
 % vol CO2 =1.79 H2O =4.93 N2 =76.4 O2 =16.88 SO2= ASME eff-% =44.8 tot duty-MM Btu/h=11.1

Surf	gas temp		wat/stm		duty	pres	flow	pstrn	pinch	apprch	US	module no
	in/out -F		in/out -F		MMB/h	psia	lb/h	%	F	F	Btu/hF	
sh	712	683	489	642	1.12	615.	9937	100			9189	1
evap	683	498	489	489	7.07	618.8	9937	100	9	0	116777	1
eco	498	421	230	489	2.91	628.8	10036	2.01			72593	1

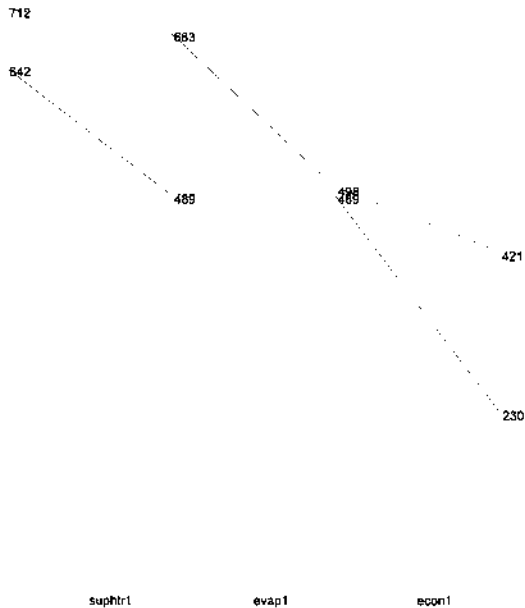

FIGURE 1.12b HRSG performance at 40% load of gas turbine.

arrive at the operating points at various loads. Because of the large variations that occur in drum pressure during sliding pressure operation, the drum level controls should be pressure-compensated.

As an example, using the HRSG simulation program, the effect of steam pressure on a single-pressure unfired HRSG was evaluated; the results are shown in [Table 1.5](#). Note that when multiple-pressure HRSGs are involved, the

TABLE 1.5 Effect of Steam Pressure on HRSG Performance^a

	Pressure (psia)			
	400	600	800	1000
Steam flow, lb/h	69,900	68,225	67,320	66,800
Steam temp, °F	799	802	800	800
Exit gas temp, °F	354	373	388	401
Duty, MM Btu/h	85.2	82.9	81.0	79.6

^aFeedwater temperature = 230°F, heat loss = 1%, blowdown = 1%.

performance of a given module is affected by the module preceding it, so unless the configuration is known it is difficult to make generalized observations.

In the case for which data are given in Table 1.5, the HRSG was designed to generate steam at 1000 psia and 800°F and the off-design performance was evaluated at selected pressures.

The steam flow decreases as the pressure increases due to the higher saturation temperature, which limits the temperature profiles.

The exit gas temperature increases as the pressure increases, again due to the higher saturation temperature.

The steam temperature does not vary by much.

The duty or energy absorbed by steam decreases as pressure increases due to the higher exit gas temperature.

AUXILIARY FIRING IN HRSGs

Supplementary firing is an efficient way to increase the steam generation in HRSGs. Additional steam in the HRSG is generated at an efficiency of nearly 100% as shown in Q8.38. Typically, HRSGs in combined cycle plants are unfired and those in cogeneration plants are fired. The merits of auxiliary firing in HRSGs are discussed in Q8.38. [Figure 1.13](#) shows the arrangement of a supplementary-fired HRSG, which can handle a firing temperature of about 1600°F. Typically, oil or natural gas is the fuel used. [Figure 1.14](#) shows a furnace-fired HRSG, which can be fired up to 3000°F. The superheater is shielded from the flame by a screen section. The furnace should be large enough to enclose the flame. In furnace-fired HRSGs even a solid fuel can be fired and the HRSG design approaches that of a conventional steam generator. Water-cooled membrane walls ensure that the casing is kept cool. A large amount of steam can be generated in this system. [Table 1.6](#) compares the features of unfired, supplementary-fired, and furnace-fired HRSGs.

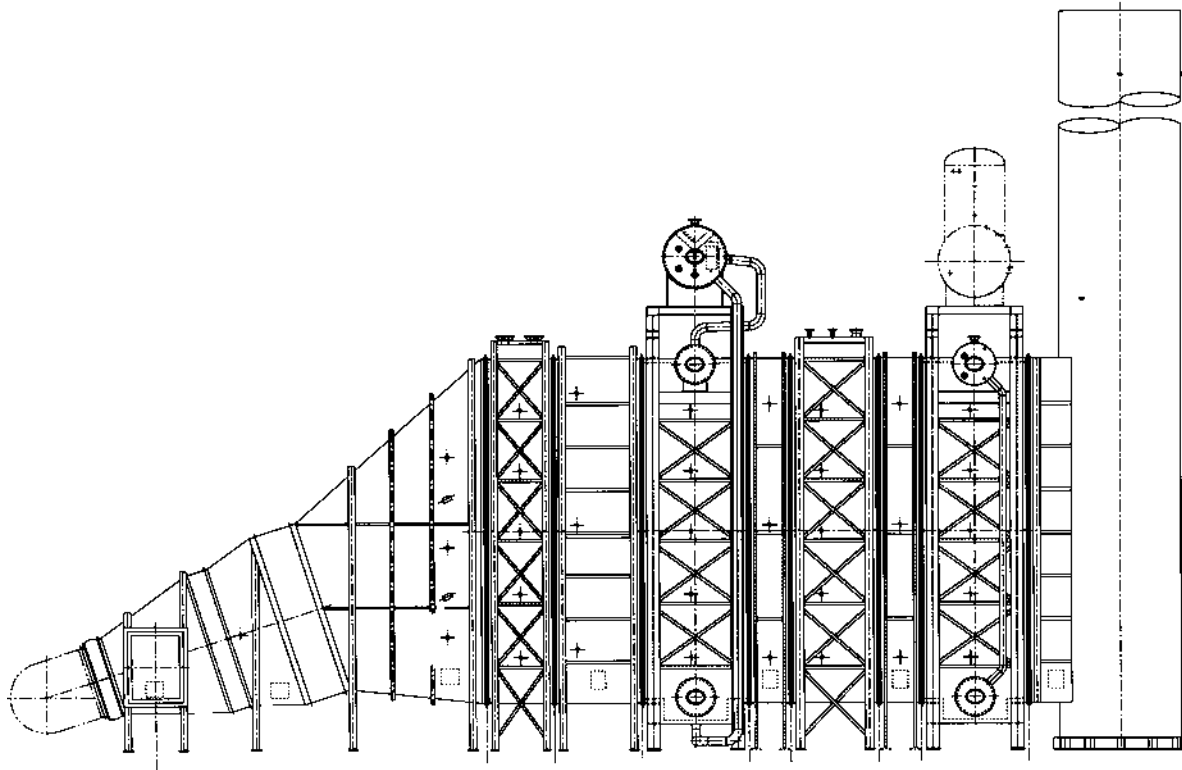

FIGURE 1.13 Multipressure supplementary-fired HRSG.

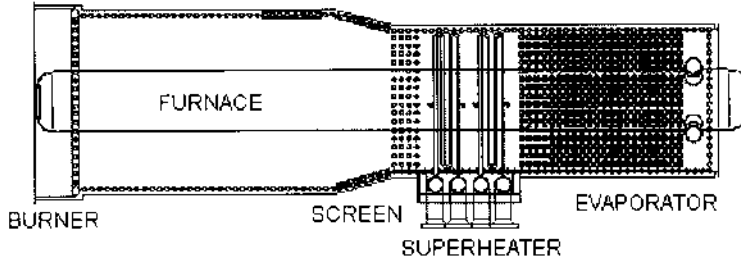

FIGURE 1.14a Furnace-fired HRSG arrangement.

Combined Cycle Plants and Fired HRSGs

It is generally believed that combined cycle plant efficiencies with fired HRSGs are lower than those with unfired HRSGs. The reason is not the poor performance of the HRSG. In fact, a fired HRSG by itself is efficient. However, the large losses associated with the Rankine cycle, particularly when the steam turbine power is a large fraction of the overall power output, distorts the results slightly as the following example shows.



FIGURE 1.14b Photograph of a furnace-fired ABCO HRSG in a cogeneration plant.

TABLE 1.6 General Features of Fired and Unfired HRSGs

	Unfired	Supplementary-fired	Furnace-fired
Gas inlet temp to HRSG, °F	800–1000	1000–1700	1700–3200
Gas/steam ratio	5.5–7.0	2.5–5.5	1.2–2.5
Burner type	No burner	Duct burner	Duct or register
Fuel	None	Oil or gas	Oil, gas, solid
Casing	Internally insulated, 4 in. ceramic fiber	Insulated or membrane wall	Membrane wall, external insulation
Circulation	Natural, forced, once-through	Natural, forced, once-through	Natural
Backpressure, in. WC	6–10	8–14	10–20
Configuration	Single- or multiple- pressure steam	Single- or multiple-pressure steam	Single-pressure
Other	Convective design, finned tubes	Convective design, finned tubes	Radiant furnace, generally bare tubes

Example 1

A combined cycle plant uses a fired HRSG. The gas turbine used is LM 5000. At 59°F,

Exhaust gas flow = 1,030,000 lb/h at 800°F.

Gas analysis, vol%: CO₂ = 2.8, H₂O = 8.5, N₂ = 74.4, O₂ = 14.3

Power output = 35 MW; heat rate = 9649 Btu/kWh

Steam turbine data:

Inlet pressure = 650 psia at 750°F

Exhaust pressure = 1 psia

Efficiency = 80%, dropping off by 2–3% at 40% load.

HRSG data:

230°F feedwater, 2% blowdown, 1% heat loss

Steam is generated at 665 psia and 750°F.

The HRSG generates 84,400 lb/h in the unfired mode and a maximum of 186,500 lb/h when fired up to 1200°F. The HRSG performance was simulated by using the HRSGS program. The system efficiency in both cogeneration and combined cycle mode are calculated as follows:

Gas turbine fuel input = $35,000 \times 9649 = 337.71$ MM Btu/h,
lower heating value (LHV) basis.

Cogeneration mode efficiency at 900°F, from first principles (or fundamentals) =

$$\frac{(35 \times 3.413 + 129.9)}{337.71 + 29.6} \times 100 = 67.9\%$$

where 129.9 MM Btu/h is the HRSG output and 29.6 MM Btu/h is the HRSG burner input in LHV (lower heating value basis).

Combined cycle mode efficiency:

$$\frac{(35 + 12.1) \times 3.413}{337.71 + 29.6} \times 100 = 43.8\%$$

where 12.1 MW is the power output from the steam turbine.

Table 1.7 shows the results at various HRSG firing temperatures.

Cogeneration plant efficiency improves with firing in the HRSG as discussed earlier. The combined cycle plant efficiency drops only because of the lower efficiency of the Rankine system as the proportion of power from the Rankine cycle increases. The HRSG, as can be seen, is efficient in the fired mode with a slightly lower stack gas temperature.

TABLE 1.7 Cogeneration and Combined Cycle Efficiency with Fired HRSG

Gas inlet temp (°F)	HRSG exit gas temp (°F)	Boiler duty ^a	Burner duty ^b	Turbine power (MW)	Cogen. effic. (%)	Comb. cycle effic. (%)	Steam (lb/h)
800	435	99.8	0	9.2	64.9	44.7	84,400
900	427	129.9	29.6	12.1	67.9	43.8	109,700
1000	423	160.0	59.1	15.3	70.4	43.2	135,200
1100	420	190.4	90.7	18.2	72.3	42.4	160,960
1200	418	221.0	121.0	21.1	74.2	41.75	186,500

^aBoiler duty is the energy absorbed by steam, MM Btu/h.

^bBurner duty is the fuel input to HRSG, MM Btu/h, LHV basis.

Generating Steam Efficiently in Cogeneration Plants

Today's cogeneration plants have both HRSGs and packaged steam generators. To generate a desired quantity of steam efficiently, the load vs. efficiency characteristics of both the HRSG and steam generator should be known. Although the generation of steam with the least fuel input is the objective, it may not always be feasible, for reasons of plant loading, availability or maintenance. However the information is helpful for planning purposes [13].

To explain the concept, an HRSG and a packaged boiler both capable of generating up to 100,000 lb/h of 400 psig saturated steam on natural gas are considered. In order to understand how the cogeneration system performs, one should know how the HRSG and the steam generator perform as a function of load. [Figure 1.15](#) shows the load vs. efficiency characteristics of both the HRSG and packaged boiler. The following points may be noted.

1. The exit gas temperature from the HRSG decreases as the steam generation is increased. This is due to the fact that the gas flow remains the same while the steam flow increases, thus providing a larger heat sink at the economizer as discussed earlier. On the other hand, the exit gas temperature from the steam generator increases as the load increases because a larger quantity of flue gas is handled by a given heat transfer surface.
2. The ASME HRSG efficiency increases as firing increases as explained in Q8.38. The range between the lowest and highest load is significant. The steam generator efficiency increases slightly with load, peaks around 60–75%, and drops off. The variation between 25% and 100% loads is marginal. This is due to the combination of exit gas losses and casing heat losses. The casing loss is nearly unchanged with load in Btu/h but increases as a percentage of total loss at lower loads. The

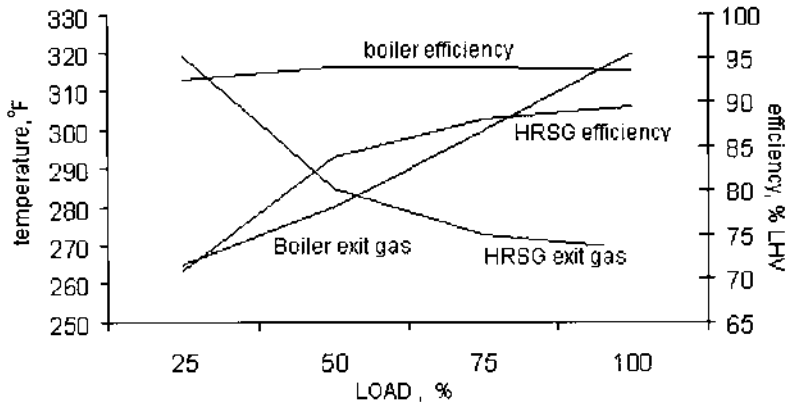

FIGURE 1.15 Load versus efficiency characteristics of HRSG and steam generator.

flue gas heat loss is lower at lower loads due to the lower exit gas temperature and mass flow.

Performance calculations were done at loads ranging from 25% to 100% for both the steam generator and the HRSG. Results are presented in Tables 1.8 and

TABLE 1.8 Steam Generator Performance at Various Loads^a

	Load (%)			
	25	50	75	100
Steam flow, lb/h	25,000	50,000	75,000	100,000
Excess air, %	30	10	10	10
Duty, MM Btu/h	25.4	50.8	76.3	101.6
Flue gas, lb/h	30,140	50,600	76,150	101,750
Exit gas temp, °F	265	280	300	320
Dry gas loss, %	3.93	3.56	3.91	4.27
Air moisture, %	0.1	0.09	0.1	0.11
Fuel moisture, %	10.43	10.49	10.58	10.66
Casing loss, %	2.00	1.0	0.7	0.5
Efficiency, HHV %	83.54	84.86	84.7	84.46
Efficiency, LHV %	92.58	94.05	93.87	93.60
Fuel, MM Btu/h (LHV)	27.5	54.0	81.3	108.6

^aSteam pressure = 400 psig; feedwater = 230°F, blowdown = 5%.
 Fuel: natural gas. C₁ = 97, C₂ = 2, C₃ = 1 vol%

TABLE 1.9 HRSG Performance at Various Loads^a

	Load			
	25	50	75	100
Steam generation, lb/h	25,000	50,000	75,000	100,000
Duty, MM Btu/h	25.4	50.8	76.3	101.6
Exhaust gas flow, lb/h	152,000	153,140	154,330	155,570
Exit gas temp °F	319	285	273	269
Fuel fired, MM Btu/h (L)	0	24.5	50.0	76.5
ASME efficiency, %	70.8	83.79	88.0	89.53

^aSteam pressure = 400 psig; feedwater = 230°F; 5% blowdown.
Fuel input is on LHV basis.

1.9. Additional performance calculations may also be done for intermediate steam generation values. Table 1.10 presents the total fuel required for a given total steam output and shows the split between the boiler and HRSG steam generation.

It is obvious that the HRSG should be used first to make any additional steam, because its fuel utilization is the best. However, if for some reason we cannot operate the HRSG, then information on how the total fuel consumption varies with the loading of each type of boiler helps in planning. For example, if 100,000 lb/h of steam is required, the steam generator can be shut off completely and the HRSG can be fully fired; the next best mode is to run the HRSG at

TABLE 1.10 Fuel Consumption at Various Loads

Total steam (lb/h)	HRSG steam	Boiler steam	HRSG fuel (MM Btu/h)	Boiler fuel (MM Btu/h)	Total fuel (MM Btu/h)
200,000	100,000	100,000	76.5	108.5	185
150,000	50,000	100,000	24.5	108.5	133.0
150,000	75,000	75,000	50.0	81.3	131.3
150,000	100,000	50,000	76.5	54.0	130.5
100,000	0	100,000	0	108.5	108.5
100,000	25,000	75,000	0	81.3	81.3
100,000	50,000	50,000	24.5	54.0	78.5
100,000	75,000	25,000	50.0	27.4	77.4
100,000	100,000	0	76.5	0	76.5
50,000	0	50,000	0	54.0	54.0
50,000	25,000	25,000	0	27.4	27.4
50,000	50,000	0	24.5	0	24.5

75,000 lb/h and the boiler at 25,000 lb/h or in that range. A similar table may be prepared if there are multiple units in the plant, and by studying the various combinations a plan for efficient fuel utilization can be developed. Note that a typical packaged boiler generates steam at about 92% efficiency on LHV basis, whereas it is nearly 100% if the same amount of fuel (gas or oil) is fired in an HRSG.

Cogeneration Plant Applications

The steam parameters of combined cycle and cogeneration plants differ significantly.

Combined cycle plants typically use unfired HRSGs and generate multiple-pressure-level steam with a complex arrangement of heating surfaces to maximize energy recovery. Fired HRSGs in combined cycle plants are often the exception to the rule owing to their impact on cycle efficiency as discussed above.

In cogeneration plants, a large amount of steam is required and hence supplementary or furnace-fired HRSGs are common. With a high gas inlet temperature, a single-pressure HRSG can often cool the gases to a reasonably low temperature, so single-pressure steam generation is often adequate.

In cogeneration plants, saturated steam is often imported from other boilers to the HRSG to be superheated; steam may also be exported from the HRSG to other plants.

Combined cycle plant HRSGs often operate at steady loads, cogeneration plant steam demand often fluctuates and is a function of the process. Given below is an example of an HRSG simulation in a cogeneration plant. Note the effect on steam temperature with and without the export steam.

Example 2

Exhaust gas flow from a gas turbine is 250,000 lb/h at 1000°F. Gas analysis in percent by volume (vol %) is $\text{CO}_2 = 3$, $\text{H}_2\text{O} = 7$, $\text{N}_2 = 75$, and $\text{O}_2 = 15$. Superheated steam is generated at 600 psia at 875°F, and about 20,000 lb/h of saturated steam is required for process, which is taken off the steam drum. Predict the HRSG gas/steam profiles. Use 20°F pinch and approach points, 230°F feedwater, and 1% blowdown and heat loss.

In the off-design mode, process steam is not required. Steam pressure is 650 psia. Determine the HRSG performance. Steam temperature is uncontrolled.

Solution. The design mode run is shown in Fig. 1.16a. The evaporator generates 37,883 lb/h, and 17,883 lb/h is sent through the superheater as 20,000 lb/h is taken off for process from the drum.

In the off-design mode, almost all of the steam, 35,270 lb/h, is sent through the superheater. As a result the steam temperature is lower, only 749°F, as shown in Fig. 1.16b. Note that without the program it would be tedious to perform this

HRSG PERFORMANCE - Design case



Project - study1 Units - British Case - b Remarks -

amb temp - F= 60 heat loss-%= 1 gas temp to HRSG F= 1000 gas flow - Lb/h= 250000
 % vol CO2 =3. H2O =7. N2 =75. O2 =15. SO2= . ASME eff-% =68.69 tot duty-MM Btu/h=42.5

Surf	gas temp in/out -F	wat/strm in/out -F	duty MMB/h	pres psia	flow lb/h	pstm %	pinch F	approch F	US Btu/hF	module no
sh	1000 935	488 875	4.4	600.	17883	100			17407	1
evap	935 508	468 488	28.46	615.	37883	100	20	20	207256	1
eco	508 359	230 468	9.65	625.	38262	0			126686	1

Gas-Steam Temperature profiles

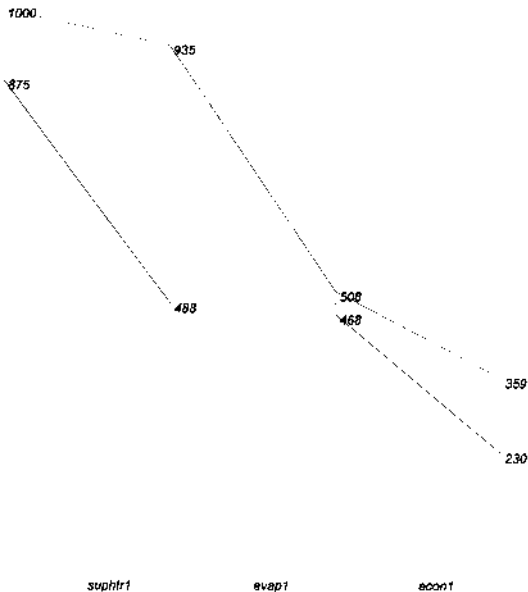

FIGURE 1.16a Performance of a HRSG with process steam use.

HRSG PERFORMANCE - Off-Design case



Project - study1 Units - BRITISH Case - b Remarks -

amb temp - F= 60 heat loss-%= 1 gas temp to HRSG F= 1000 gas flow - Lb/h= 250000
 % vol CO2 =3. H2O =7. N2 =75. O2 =15. SO2=. ASME eff-% =67.22 tot duty-MM Btu/h=41.6

Surf	gas temp in/out -F	wat/strm in/out -F	duty MMB/h	pres psia	flow lb/h	pstrm %	pinch F	apprch F	US Btu/hF	module no
sh	1000 909	503 749	6.19	650.	35270	100			19210	1
evap	909 521	486 503	25.73	698.5	35270	100	17	17	206829	1
eco	521 370	230 486	9.68	708.5	35623	.			127179	1

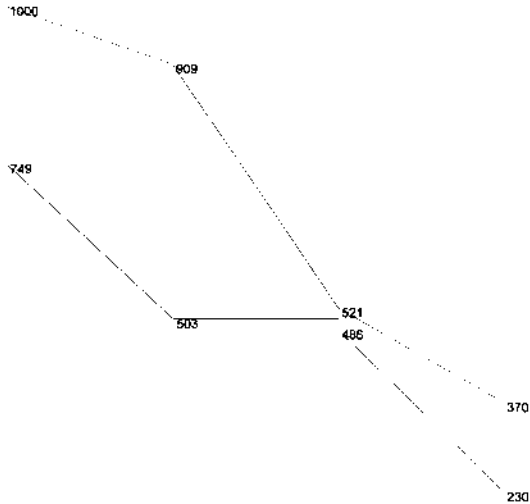

FIGURE 1.16b Performance of the HRSG when process steam is not required.

calculation, because we have no idea of the exit gas temperature in the design mode.

COMBINED CYCLE PLANT HRSG SIMULATION

The HRSG simulation concept is helpful in predicting the performance of an HRSG at various modes of operation. The HRSG need not be designed to perform this study. [Figure 1.17a](#) shows a multiple-pressure HRSG used in a combined cycle plant with nine modules. Module 1 superheater is fed by module 3, which consists of a superheater, evaporator, and economizer. Module 2 is a reheater. Module 7 evaporator feeds module 4 superheater. Module 5 economizer

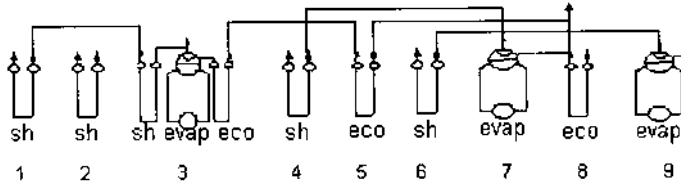
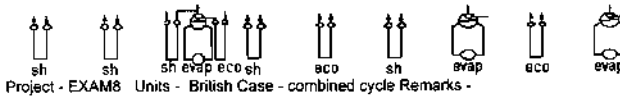

FIGURE 1.17a HRSG scheme in a combined cycle plant. Modules 1, 3, and 5 are HP sections. Modules 6, 8, and 9 are LP sections. Modules 4 and 7 are IP sections. Module 2 is a reheater.

HRSG PERFORMANCE - Design case



Project - EXAM8 Units - British Case - combined cycle Remarks -

amb temp - F= 60 heat loss-%= 1 gas temp to HRSG F= 1135 gas flow - Lb/h= 6563000
 % vol CO2 =3.8 H2O =9.15 N2 =74.54 O2 =12.51 SO2=. ASME eff-% =78.63 tot duty-MM Btu/h=1498.2

Surf	gas temp in/out-F	wat/stm in/out-F	duty MMB/h	pres psia	flow lb/h	pstrn %	pinch F	apprch F	US Btu/hF	module no
sh	1135 1093	900 1054	77.48	1825	796305	100			599975	1
sh	1093 987	630 1032	195.85	350	917000	100			1165015	2
sh	987 871	825 900	212.19	1840	796305	100			1382638	3
evap	871 640	610 625	413.48	1855	796305	100	15	15	5008280	3
eco	640 607	558 610	57.21	1865	796305	0			1474682	3
sh	607 599	439 575	13.45	375	148982	100			168690	4
eco	599 530	430 558	118.48	1900	796305	0			1775908	5
sh	530 522	305 485	14.26	70	153162	100			129762	6
evap	522 454	430 439	118.53	380	148916	100	15	9	2974070	7
eco	454 379	310 430	128.58	1900	1021000	0			2991608	8
evap	379 291	235 284	148.7	53	153162	100	7	49	4407354	9

Gas-Steam Temperature profiles

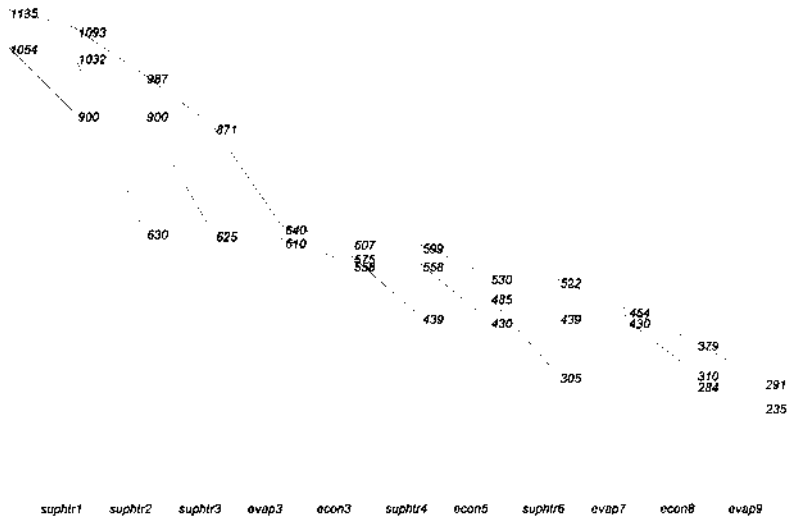

FIGURE 1.17b Temperature profiles and performance of the HRSG.

feeds module 2, and module 9 evaporator feeds module 6 superheater. Module 8 economizer feeds both modules 5 and 7.

The HRSGS program can be used to arrive at the design case performance as shown in Fig 1.17b. The US value (product of overall heat transfer coefficient and surface area) for each surface is also shown. One may also use this information to predict the HRSG performance at other off-design cases and study, for example, the effect of steam pressure or the feedwater temperature on the HRSG performance.

IMPROVING HRSG PERFORMANCE

By nature, HRSGs are inefficient, particularly the unfired units, because of the large gas mass flow associated with the low exit gas temperature from the gas turbine. The large mass flow forces one to use a boiler with a large cross section, though the steam generation may not be compatible with the size of the HRSG. The low ratio of steam to gas flow (15–18%) also results in a small heat sink at the economizer leading to higher stack gas temperature. Hence single-pressure units are inefficient. In addition,

- 1 Gas/steam temperature profiles are dictated by the steam pressure and steam temperature, unlike in a steam generator, where one can easily attain about 300°F stack gas temperature in a single-pressure unit even with high steam pressures on the order of 2000–2500 psi. In a single-pressure HRSG, the exit gas temperature is a function of the steam pressure and temperature. With 600 psig steam superheated to 700°F, it is difficult to get the economizer exit gas temperature below 380°F in an unfired HRSG.
- 2 The higher the steam pressure, the lower the exit gas temperature (single-pressure unit). This point is explained under HRSG simulation: see Q8.36.
- 3 The higher the steam temperature, the lower the steam generation and the higher the exit gas temperature. This is due to the smaller amount of steam generated with higher steam temperature and hence a smaller heat sink at the economizer.
- 4 Partial load operation of a gas turbine also results in poor HRSG performance, as shown above.

So how can we improve the HRSG performance? There are several options.

Designs with Low Pinch and Approach Points

Pinch and approach points determine HRSG temperature profiles. If we have to work with only a single-pressure HRSG and there is no additional heat recovery

equipment such as a deaerator coil or condensate heater, we can use low pinch and approach points to maximize steam generation. However, the surface area requirements increase due to the low log-mean temperatures in the evaporator and economizer, which adds to the cost of the HRSG slightly and increases the gas pressure drop. The major components of the HRSG such as controls and instrumentation, drum size, casing, and insulation do not change in a big way, and the additional cost of heating surfaces may not be that significant if we look at the overall picture. However, an economic evaluation may be done as shown in Q8.40.

Fired HRSGs

The advantages of fired HRSGs were discussed earlier. Firing increases the steam generation and lowers the HRSG exit gas temperature with a fuel utilization of nearly 100%. The additional fuel fired increases the HRSG duty by the same amount compared to, say, 92% in a steam generator.

Using Secondary Surfaces

Because single-pressure HRSGs are not very efficient, one may consider adding secondary surfaces such as a deaerator coil or condensate heater or a heat exchanger as shown in [Fig. 1.18](#) to lower the stack gas temperature.

Multiple-Pressure HRSGs

Before going into this option, one should clearly understand when multiple-pressure options are justified. From the discussion on HRSG simulation, it can be seen that the exit gas temperature in an HRSG depends on the steam pressure and temperature. The higher the steam pressure, the higher the exit gas temperature. Hence when high pressure steam is generated, it will not be possible to cool the exhaust gases to an economically justifiable level with a single-pressure HRSG. Hence multiple-pressure steam generation is warranted. Also, one can maximize energy recovery by doing several things such as rearranging heat transfer surfaces, splitting up economizers, superheaters, and evaporators so that the gas temperature profiles match the steam and water temperatures and no large imbalance exists between the gas and steam temperatures. This can be done by using a program such as the HRSGS program (see Q8.37). In small HRSGs, multiple-pressure steam generation may not often be viable due to the complexity of the HRSG design and cost.

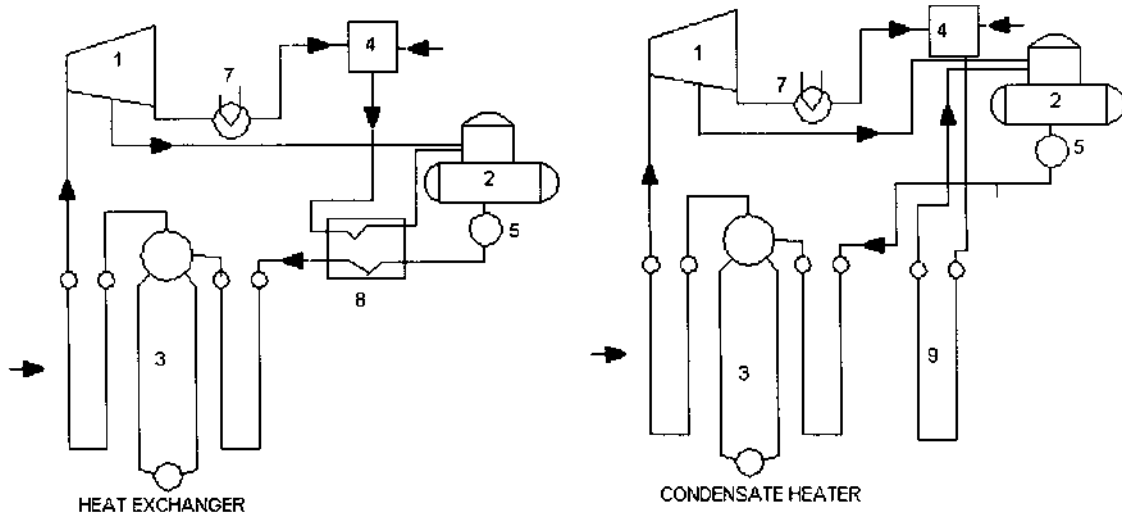

FIGURE 1.18a Secondary surfaces to improve HRSG efficiency. 1, turbine; 2, deaerator; 3, HRSG; 4, mixing tank; 5, pump; 6, deaerator coil; 7, condenser; 8, heat exchange; 9, condensate heater.

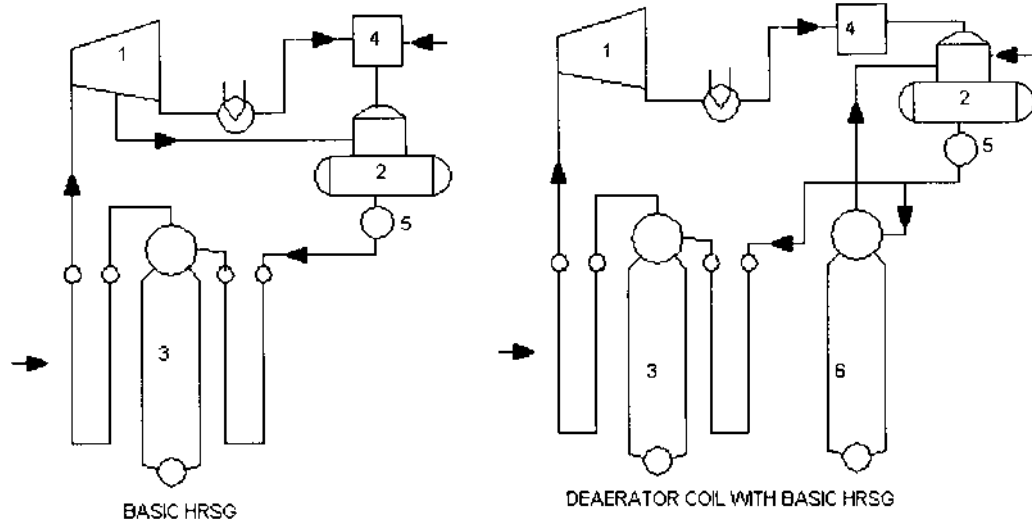

FIGURE 1.18b Continued

HIPPS

Several teams of large companies in the United States are developing a coal-fired high performance system, also called HIPPS. In this combined cycle plant, a fluid bed air-blown pyrolyzer converts coal into fuel gas and char. The char is fired in a high temperature advanced furnace, which heats up both air for a gas turbine and steam for a steam turbine. The air is heated to 1400°F. The gas turbine combustor raises the air temperature to 2350°F and generates power in the gas turbine. High pressure steam is also generated in the HRSG [11].

CHENG CYCLE

One of the variations in cogeneration systems using gas turbines is the Cheng cycle. This system is ideal for plants with varying electrical and steam loads. It consists of a gas turbine with an HRSG, which has a superheater, evaporator, and economizer (Fig. 1.19). A duct burner is located between the superheater and evaporator. The HRSG generates saturated steam, which is superheated in the superheater and injected into the gas turbine, which increases its electrical power output significantly. The figure shows an Allison 501K machine, which normally generates 3.5 MW, in injection mode about 6 MW. The superheater is capable of running dry, that is, without steam. When only process steam is required, saturated steam from the evaporator is used. When additional process steam is required, the duct burner is fired. Hence the HRSG can operate in a variety of modes and at various points as shown in the figure by varying the amount of steam injected into the gas turbine and by varying the amount of fuel fired in the duct burner. Thus the plant can vary the ratio of power to process steam significantly according to the cost of fuel or electricity and thus optimize the overall efficiency. Cogeneration plants with fluctuating steam and power demands are ideal candidates for the Cheng cycle. The system's proven success in small-scale plants is now being applied to midsized gas turbines ranging from 50 to 125 MW. Cheng cycle systems are in operation in over 50 installations worldwide.

HAT CYCLE

Another concept that is being studied is the humidified air turbine (HAT) cycle. This is an intercooled, regenerated cycle with a saturator that adds a considerable amount of moisture to the compressor discharge as shown in Fig. 1.20. The combustor inlet contains 20–40% water vapor, depending on whether the fuel is natural gas or gasified coal gas. The intercooling reduces the compressor work, while the water vapor in the exhaust gases increases the turbine output. Capital cost is lowered by the absence of steam turbine and condenser system. The gas

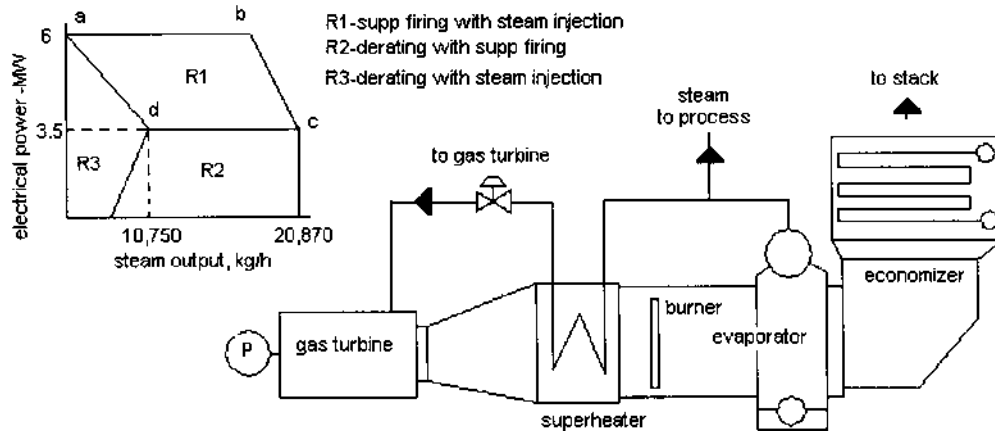

FIGURE 1.19 Cheng cycle scheme.

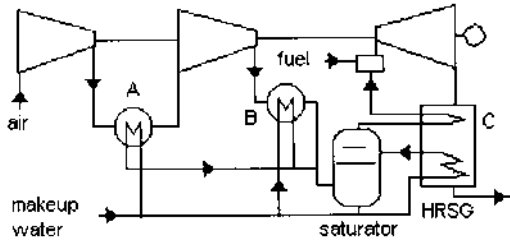

FIGURE 1.20 HAT cycle scheme. A, intercooler; B, aftercooler; C, recuperator.

turbine combustor design is modified to handle the large amount of water vapor in the incoming air. Cycle efficiency is expected to be in the range of 55% LHV with a significant increase in power output.

DIESEL ENGINE HEAT RECOVERY

Diesel engines are widely used as sources of power when an electrical utility supply is not available. They may be fired on gaseous or liquid fuels. They are mostly employed in low and medium power cogeneration units, typically 50 kW to 10 MW for natural gas firing, 50 kW to 50 MW for diesel, and 2.5–50 MW for heavy fuel oils. They are widely used in countries where the electricity supply is not reliable. Diesel plants have several advantages and features:

- Medium-sized reciprocating engines have substantially higher electrical efficiencies than gas turbines of similar size (34–40% vs. 25–30%).

- Partial load efficiencies are also higher.

- They require lower fuel gas pressure for operation—20–40 psig compared to 180–400 psig for gas turbines.

- Electrical power output is less sensitive to ambient air temperature. The output of a gas turbine drops off at higher ambient temperatures as discussed above.

- Capital costs are higher than these for gas turbines by 10–25%. Operating and maintenance costs are also higher, but diesel engines can be used on heavy fuel oils, so fuel costs are lower. Developing countries use diesel engine sets for on-site power needs because the power supply is not dependable in many locations.

- In applications calling for high power to heat recovery, hot water or low-pressure steam, reciprocating engines are preferred to gas turbines. A lower exhaust gas temperature (650–800°F) makes them less suitable for high pressure heat recovery systems than gas turbines; also, the exhaust

gas contains less oxygen, on the order of 10–12% compared to 14–15% for turbine exhaust, making supplementary firing difficult, though not impossible.

There are two main sources of heat available in diesel engines. One is the engine cooling water, and the other is the exhaust gas (Fig. 1.21). The exhaust gas temperature is often below 750°F, hence only low pressure saturated or superheated steam is generated. Depending on the cleanliness of the gas stream, water tube boilers with extended surfaces could be used for heat recovery, though bare tube boilers with soot blower provisions are often used. Fire tube boilers are used if the gas flow is small, less than 50,000 lb/h. In many plants several diesel engines are used at the same time; hence by combining the exhaust gas flow into a single large duct, a single waste heat boiler could be built. The gas is often pulsating, so the boiler and casing design has to be rugged. Work is also being done to supplementary fire the diesel engine exhaust by using solid fuels to generate high pressure steam for combined cycle operation.

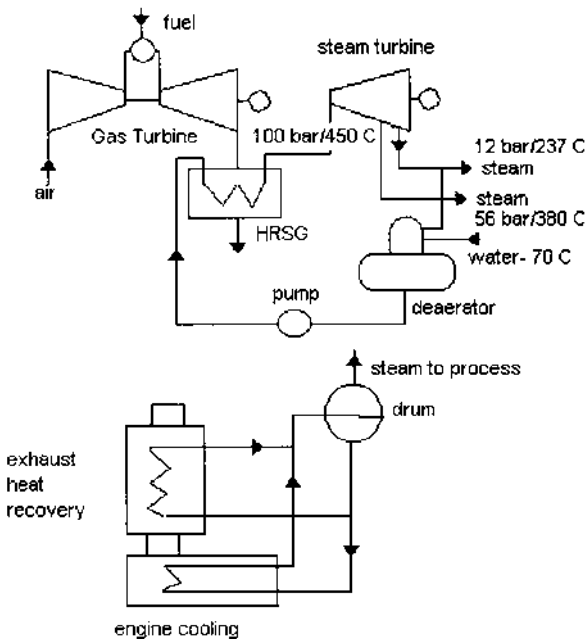

FIGURE 1.21 Diesel engine heat recovery system. Top: Combined cycle plant. Bottom: Diesel cogeneration.

REFERENCES

1. JB Kitto. Developments in pulverized coal-fired boiler technology. Presented to Missouri Valley Electric Association Engineering Conference, Apr 10–12, 1996, Kansas City.
2. Supercritical Steam Power Cycles for Power Generation Applications. Report, Dept of Trade & Industry, London, UK, Jan 1999.
3. I Stambler. Kalina bottoming cycle 3.2 MW demo plant rated 26.9% efficiency. *Gas Turbine World*, March-April 1992.
4. J Corman. Kalina cycle looks good for combined cycle generation. *Modern Power Systems Review*, July 1995.
5. A Kalina. Kalina cycle promises improved efficiency. *MPS Review*, January 1987.
6. Editor. Enhancing gas turbine performance. *Power*, September 1995.
7. Boswell. Choose best options for enhancing combined cycle output. *Power*, September 1993.
8. GE Report. Advanced Technology Combined Cycles. General Electric Corp, October 2000.
9. Editor. Advanced gas turbines provide high efficiency and low emission. *Power Engineering*, March 1994.
10. US Dept of Energy. Clean Coal Technology Report—Wabash River Coal Gasification Repowering Project, November 1996.
11. V Ganapathy. Understand boiler performance characteristics. *Hydrocarbon Processing*, August 1994.
12. V Ganapathy. Heat-recovery steam generators: understand the basics. *Chemical Engineering Progress*, August 1996.
13. V Ganapathy. Efficiently generate steam from cogeneration plants. *Chemical Engineering*, May 1997.
14. D Franus. The gas turbine powered electrical power generation market 2001–2010. *Cogeneration and On-Site Power Production*, July–August 2001.

2

Heat Recovery Boilers

INTRODUCTION

Heat recovery boilers, also known as waste heat recovery boilers or heat recovery steam generators (HRSGs), form an inevitable part of chemical plants, refineries, power plants, and process systems. They are classified in several ways, as can be seen in Fig. 2.1, according to the application, the type of boiler used, whether the flue gas is used for process or mainly for energy recovery, cleanliness of the gas, and boiler configuration, to mention a few. The main classification is based on whether the boiler is used for process purposes or for energy recovery. Process waste heat boilers are used to cool waste gas streams from a given inlet temperature to a desired exit temperature for further processing purposes. An example can be found in the chemical industry in a sulfuric acid or hydrogen plant where the gas stream is cooled to a particular gas temperature and then taken to a reactor for further processing. The exit gas temperature from the boiler is an important parameter affecting the downstream process reactions and hence is controlled by using a gas bypass system. Steam generation is of secondary importance in such plants. In energy recovery applications, on the other hand, the gas is cooled as much as possible while avoiding low temperature corrosion. Examples can be found in gas turbine exhaust heat recovery or flue gas heat

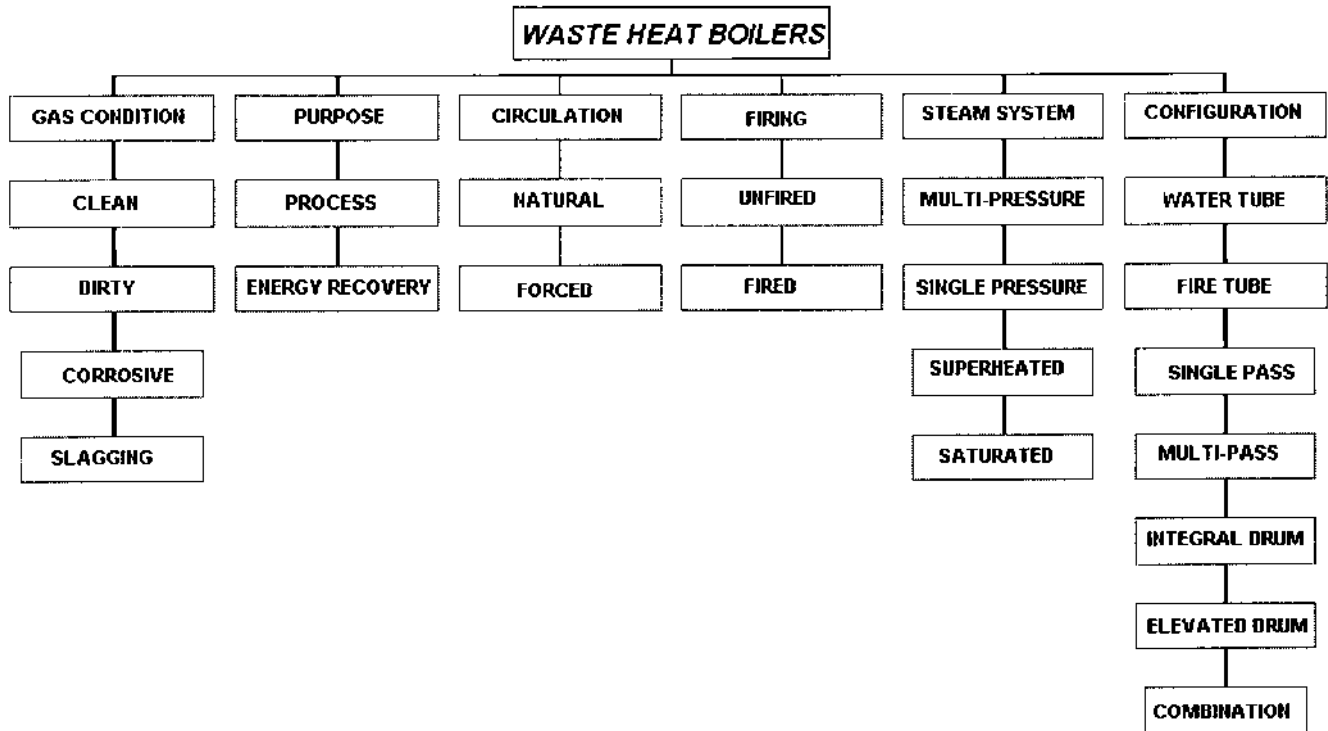

FIGURE 2.1 Classification of waste heat boilers.

recovery from incinerators, furnaces, and kilns. The objective here is to maximize energy recovery.

If the gas stream is clean, water tube boilers with extended surfaces may be used. In solid or liquid waste incineration applications, the gas is generally dirty and may contain corrosive compounds, acid vapors, ash, and particulates. If the ash contains compounds of sodium, potassium, or nonferrous metals, slagging is likely on heat transfer surfaces if these compounds become molten. In these cases, bare tube boilers with provision for cleaning the tubes with soot blowers or a rapping mechanism are used. A water-cooled furnace, which cools the gas stream to a temperature below the ash melting temperature and hence minimizes slagging on the convective surfaces, may also be necessary.

Generally if the gas inlet temperature is high, say above 1400°F, a single-pressure heat recovery system is adequate to cool the gases to about 300–350°F. In gas turbine exhaust heat recovery applications with a low inlet gas temperature to the HRSG of 900–1000°F, a single-pressure heat recovery system cannot cool the gases adequately and a multipressure steam system is often required.

In the United States HRSGs are generally of natural circulation design, whereas in Europe it is very common to see once-through and forced circulation designs. The features of these boilers are discussed later.

Flue gas analysis is important to the design of the boiler. A large amount of water vapor or hydrogen increases the specific heat and thermal conductivity of the gas and hence the boiler duty and heat flux. For example, the reformed gas in hydrogen plants has a large volume of hydrogen and water vapor, which increases the heat transfer coefficient by 500–800% compared to typical flue gases. Hence heat flux is of concern in these types of boilers. Hydrogen chloride (HCl) vapor in the flue gases indicates corrosive potential, particularly if a superheater operating at high metal temperatures, say exceeding 900°F, is present. The presence of sulfur trioxide (SO₃) vapor and HCl also suggests low temperature corrosion problems due to their low acid dew points. Flue gas pressure in waste heat boilers is typically atmospheric or a few inches of water column (in. WC) above or below atmospheric pressure; however, there are applications such as the use of a reformed gas boiler or synthesis gas boiler in hydrogen or ammonia plants where the gas pressure could be as high as 300–1500 psig (see [Chap. 8, Table 8.46](#)). Fire tube boilers are generally preferred for these applications, though special water tube boiler designed with heat transfer surfaces located inside pressure vessels have been built.

A common classification of boilers is based on whether the gas flows inside or outside the tubes. In fire tube boilers, the flue gases flow inside the tubes ([Fig. 2.2](#)), whereas in water tube boilers, the gas flows outside the tubes as shown in [Fig. 2.3](#). The features of each type are discussed in the following section.

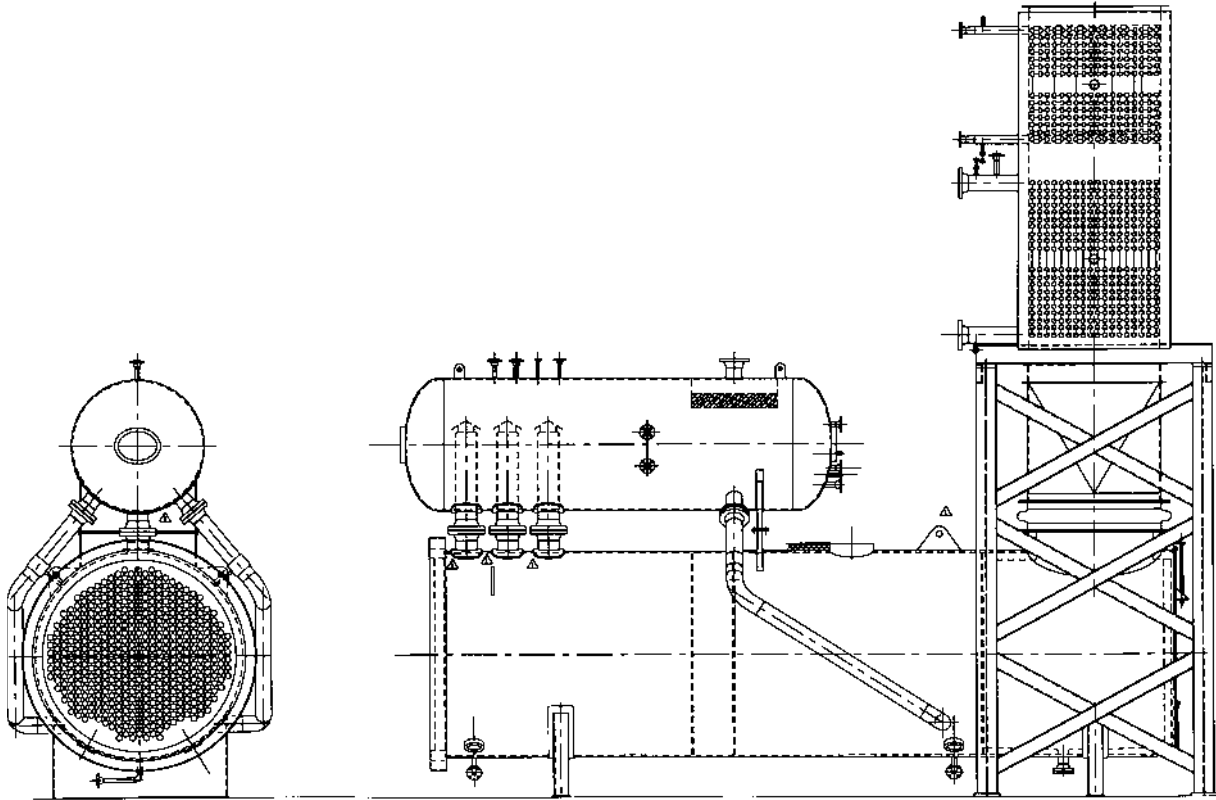

FIGURE 2.2 Fire tube waste heat boiler with superheater and economizer. (Courtesy of ABCO Industries, Abilene, TX.)

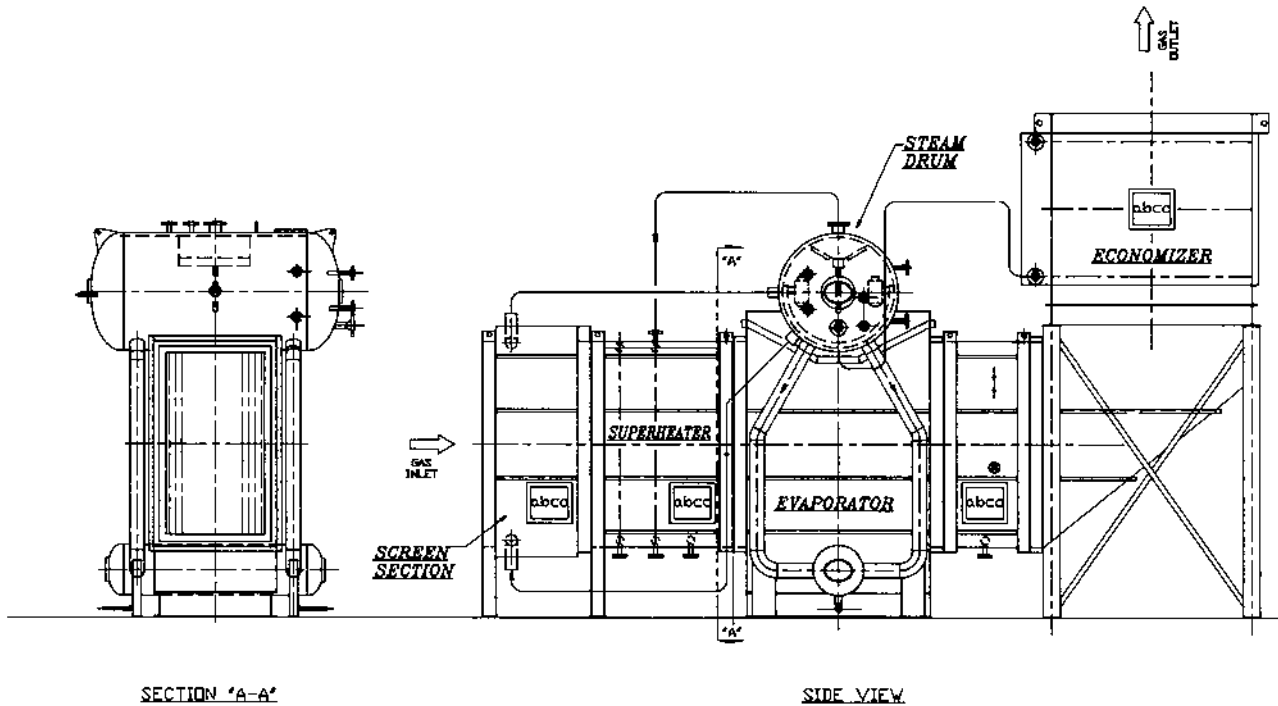

FIGURE 2.3 Water tube waste heat boiler with superheater and economizer. (Courtesy of ABCO Industries, Abilene, TX.)

WATER TUBE VERSUS FIRE TUBE BOILERS

Table 2.1 shows a few aspects of fire tube and water tube waste heat boilers. Generally water tube boilers are suitable for large gas flows exceeding millions of pounds per hour and can handle high steam pressures and temperatures. Fire tube boilers are suitable for low steam pressures, generally below 500 psig. Table 2.2 shows the effect of pressure on tube thickness in both types of boilers, and one can see why fire tube boilers are not suggested for high steam pressure applications.

In water tube boilers, extended surfaces can be used to make them compact if the gas stream is clean, as discussed in Q8.21. Flue gas pressure drop will also be lower than for an equivalent fire tube boiler owing to the compactness of the design. Water tube boilers can be smaller and weigh less, particularly if the gas flow is large, exceeding 100,000 lb/h. Superheaters can be used in both types. In a water tube boiler they can be located in an optimum gas temperature zone. A shield screen section or a large convection section precedes the superheater. In a fire tube boiler, the superheater has to be located at either the gas inlet or exit, making the design less flexible and vulnerable to slagging or corrosion. If the waste gas is slagging in nature, a water tube boiler is desired because the surfaces can be cleaned by using retractable soot blowers. In general, the type of boiler to

TABLE 2.1 A Comparison of Fire Tube and Water Tube Boilers

Variable	Fire tube boiler	Water tube boiler
Gas flow	Small—less than 50,000 lb/h	50,000 to millions of lb/h
Gas inlet temperature	Low to adiabatic combustion	Low to adiabatic combustion
Gas pressure	High—even as high as 2000 psig	Generally less than 2 psig
Firing	Possible	Possible
Type of heating surface	Bare tube	Bare and finned tubes
Superheater location	At inlet or exit of boiler	Anywhere in the gas path using screen section
Water inventory	High	Low
Heat flux-steam side	Generally low	Can be high with finned tubes
Multiple steam pressure	No	Yes
Soot blower location	Inlet or exit of boiler	Anywhere inside boiler surfaces
Multiple modules	No	Yes

TABLE 2.2 Tube Thickness vs. Steam Pressure—ASME Sec 1

Tube thickness ^a (in.)	External pressure (psig)	Internal pressure (psig)
0.105	575	1147
0.120	686	1339
0.135	800	1533
0.150	921	1730
0.180	1172	2137

^a2 in. OD, SA 178a and SA 192 carbon steel tubes at 700°F.

be used for a particular case is determined by the experience of the manufacturer. Sometimes a combination of fire and water tube boilers is used to suit special needs.

HEAT RECOVERY IN SULFUR PLANTS

A sulfur plant forms an important part of a gas processing system in a refinery. Sulfur is present in natural gas as hydrogen sulfide (H₂S); it is the by-product of processing natural gas and refining high sulfur crude oils. For process and combustion applications, the sulfur in the natural gas has to be removed. Sulfur recovery refers to the conversion of hydrogen sulfide to elemental sulfur. The most common process for sulfur removal is the Claus process, which recovers about 95–97% of the hydrogen sulfide in the feedstream. Waste heat boilers are an important part of this process (Fig. 2.4).

The Claus process used today is a modification of a process first used in 1883, in which H₂S was reacted over a catalyst with air to form elemental sulfur and water. The reaction is expressed as

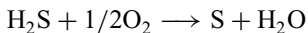

Control of this exothermic reaction was difficult, and sulfur recovery efficiency was low. Modifications later included burning one third of the H₂S to produce sulfur dioxide, SO₂, which is reacted with the remaining H₂S to produce elemental sulfur. This process consists of multistage catalytic oxidation of hydrogen sulfide according to the reactions

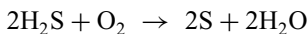
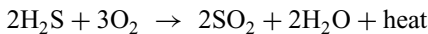

Each catalytic stage consists of a gas reheater, a catalyst chamber, and a condenser as shown in Fig. 2.4.

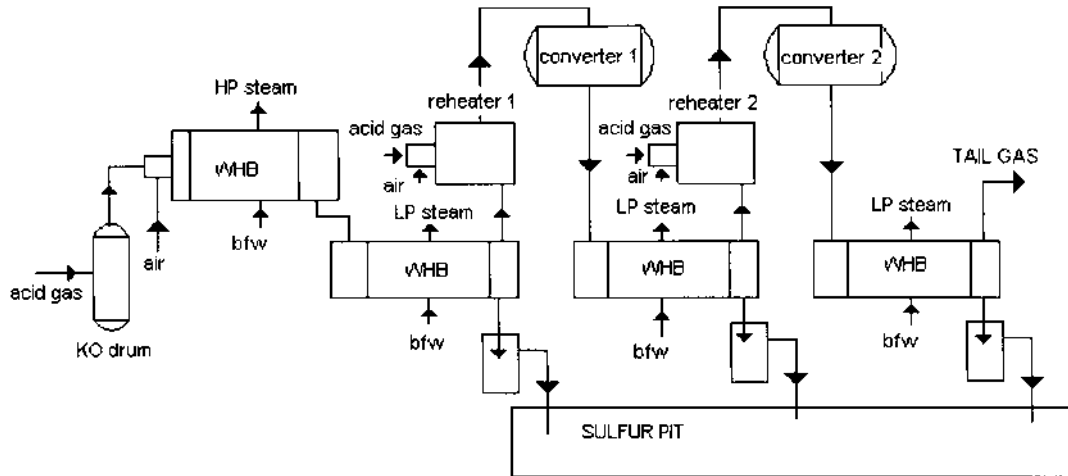
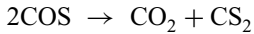
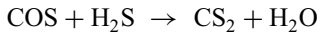
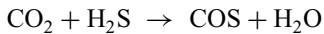

FIGURE 2.4 Claus process for sulfur recovery.

In addition to the oxidation of H_2S to SO_2 and the reaction of SO_2 with H_2S in the reaction furnace, many other side reactions occur, such as



The gas stream contains CO_2 , H_2S , SO_2 , H_2 , CH_4 , and water vapor in addition to various species of sulfur. The duty of the boiler behind the sulfur combustor includes both sensible heat from cooling of the gas stream from 2600°F to about 650°F and the duty associated with the transformation of various species of sulfur. The reaction furnace normally operates at $1800\text{--}2800^\circ\text{F}$, and the flue gases are cooled in a waste heat boiler (Fig. 2.5), in which saturated steam at about 600 psig is generated. This is typically of two-gas-pass design, though single-pass designs have been used. The gas is cooled to about 1200°F in the first pass and finally to about 650°F in the two-pass boiler.

Figure 2.6 shows the boiler for a large sulfur recovery plant, which consists of two separate shells for each pass connected to a common steam drum. The steam drum is external to the boiler. The external downcomer and riser system ensures adequate cooling of the tubes and the tube sheet, which is refractory-lined; ferrules are also used for further protection of the tube sheet. Ferrules are generally made of ceramic material and are used to transfer the heat from the hot flue gases (at about 2800°F) to the tubes, which are cooled by water. The refractory on the tube sheet, which is about 4 in. thick and made of a high grade, high density castable, lowers the tube sheet temperature at the hot end and thus limits the thermal stress across it. The inlet gas chamber is also refractory-lined. The casing is kept above $350\text{--}400^\circ\text{F}$ through a combination of internal and external insulation to minimize concerns regarding acid dew point corrosion. This is often referred to as “hot casing.” Q8.56 discusses this concept. The exit gas chamber is externally insulated, as are also the drum, downcomer, riser pipes, and exchanger. The high pressure saturated steam, which is generated at about 600–650 psig, is purified by using steam drum internals and sent for process use. About 65–70% of the sulfur is removed in the boiler as liquid sulfur by using heated drains.

Though the boiler generally operates above the sulfur dew point, some sulfur may condense at partial loads and during transient start-up or shutdown mode. The cooled gases exiting the exchanger are reheated to maintain acceptable reaction rates and to ensure that process gases remain above the sulfur dew point and are sent to the catalyst beds for further conversion as shown in Fig. 2.4. The catalytic reactors using alumina or bauxite catalysts operate at lower temperatures, ranging from 200 to 315°C . Because this reaction represents an equilibrium chemical reaction, it is not possible for a Claus plant to convert all of the

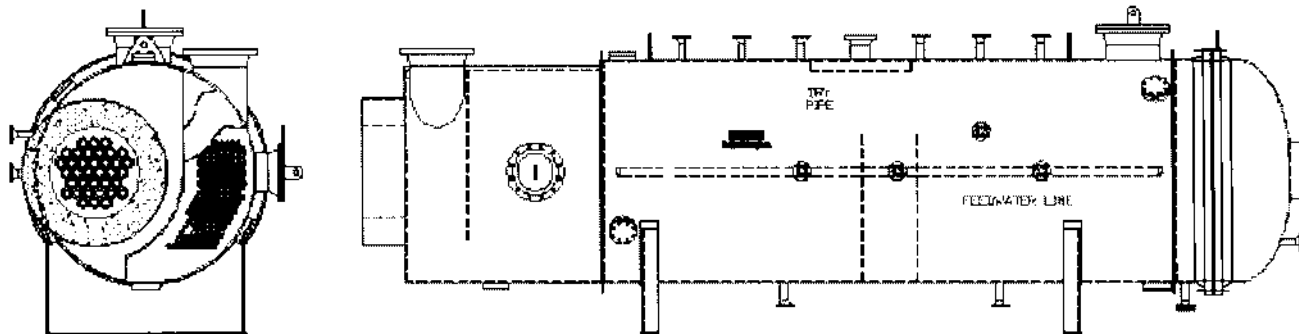

FIGURE 2.5 Waste heat boiler for sulfur recovery plant. (Courtesy of ABCO Industries, Abilene, TX.)

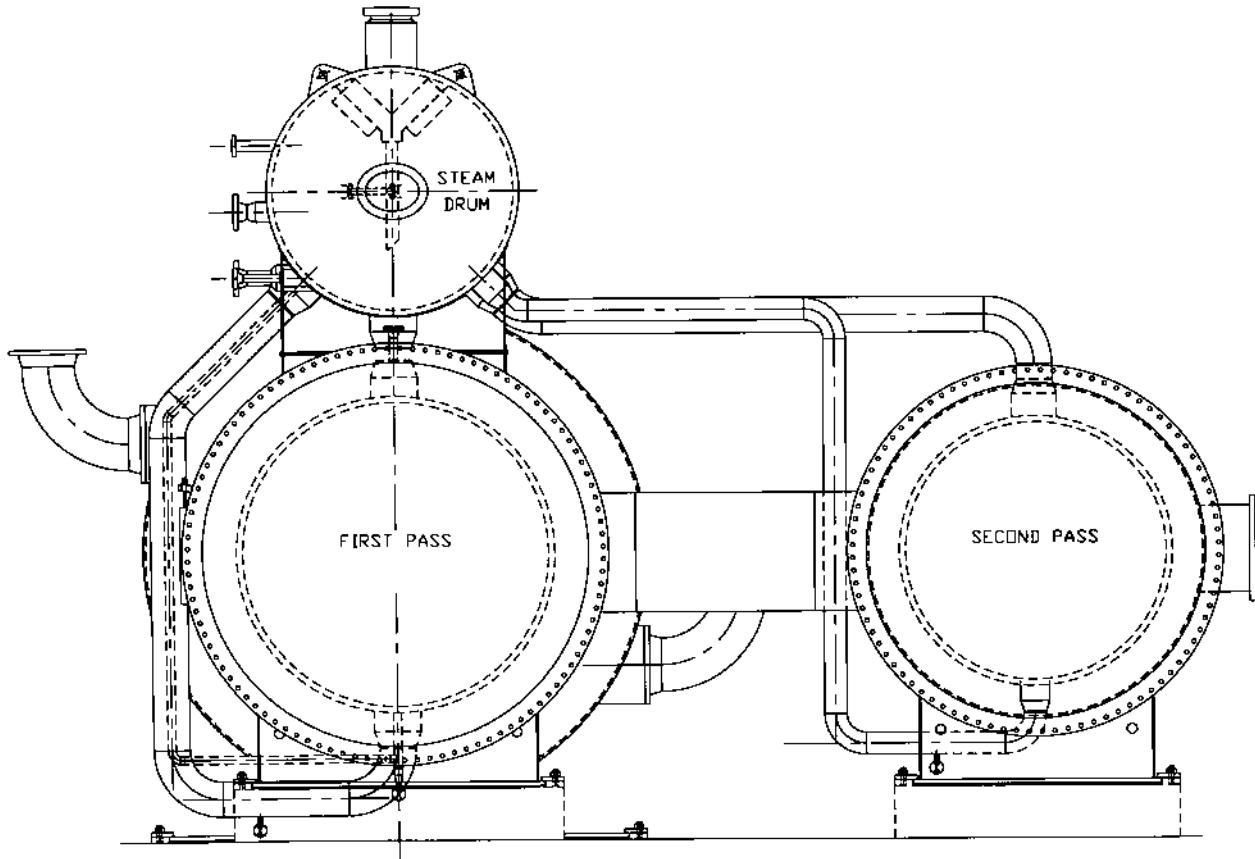

FIGURE 2.6 Multiple boiler passes connected to a common steam drum. (Courtesy of ABCO Industries, Abilene, TX.)

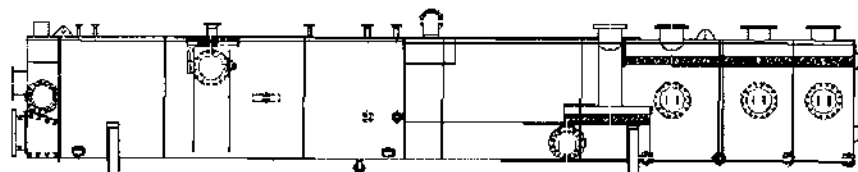
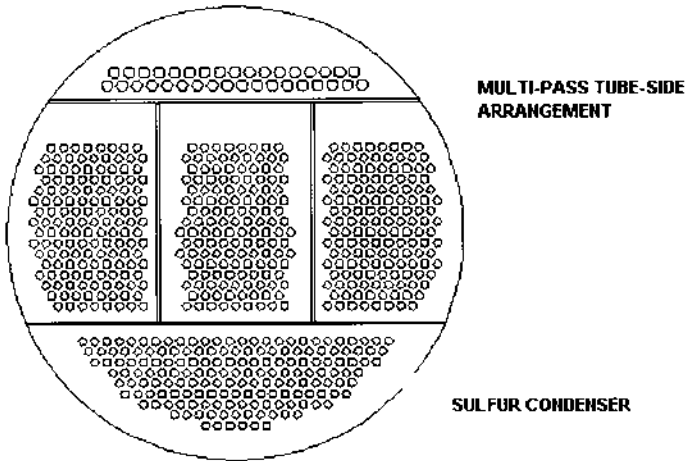

FIGURE 2.7 Sulfur condenser. (Courtesy of ABCO Industries, Abilene, TX.)

incoming sulfur to elemental sulfur. Therefore two or more stages are used. Each catalytic stage can recover one half to two-thirds of the incoming sulfur. Acid gas is also introduced at each catalyst stage as shown. The gas stream from each stage is cooled in another low pressure boiler, called the sulfur condenser, which condenses some of the sulfur. These gas streams generate low pressure steam at about 50–70 psig in the sulfur condenser.

If the flue gas quantity is small, a single-shell fire tube boiler handles all the streams from the reactors (Fig. 2.7). Each stage has its own gas inlet and exit connections. The outlet gas temperatures of these exchangers are around 330–360°F. From the condenser of the final catalytic stage the process stream passes on to some form of tail gas treatment process. The tail gas contains H_2S , SO_2 , sulfur vapor, and traces of other sulfur compounds and is further treated downstream and vented.

SULFURIC ACID PLANT HEAT RECOVERY

Sulfuric acid is an important chemical that is manufactured using the contact process. Heat recovery plays a significant role in this system, whose main objective, is to cool the gas stream to a desired temperature for further processing.

Raw sulfur is burned with air in a combustion chamber, generating sulfur dioxide, oxygen, and nitrogen. The gases, at about 1900°F and at a pressure of about 50 in. WC, pass through a waste heat boiler generating saturated or superheated steam. The boiler could be of fire tube or water tube design. The gases are cooled to about 800°F, which is the optimum temperature for conversion of SO₂ to SO₃. The exit gas temperature from the boiler decreases as the load decreases.

In order to maintain the exit gas temperature at 800°F at varying loads, a gas bypass system is incorporated into the boiler, either internally or externally (Fig. 2.8). The gases then pass through a converter where SO₂ gets converted to SO₃ in a few stages in the presence of catalyst beds. The reactions are exothermic, and the gas temperature increases by 40–100°F. Air heating or superheating of steam is necessary to cool the gases back to 800°F. After the last stage of conversion, most of the SO₂ has been converted to SO₃. The gas stream containing SO₃ gases at about 900°F is cooled in an economizer before being sent to an absorption tower. The flue gas stream is absorbed in dilute sulfuric acid to form concentrated sulfuric acid. The scheme is shown in Fig. 2.9. The steam thus generated in these waste heat boilers is used for process as well as for power generation.

The main boiler behind the sulfur combustor could be of fire tube or water tube design, depending on gas flow. Extended surfaces may also be used if the gas stream has no dust. Sometimes, owing to inadequate air filtration and poor

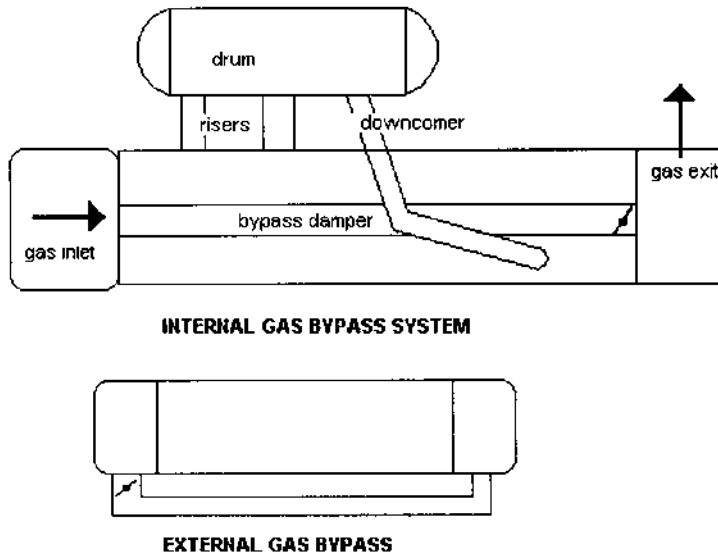

FIGURE 2.8 Gas bypass systems for HRSG exit gas temperature control.

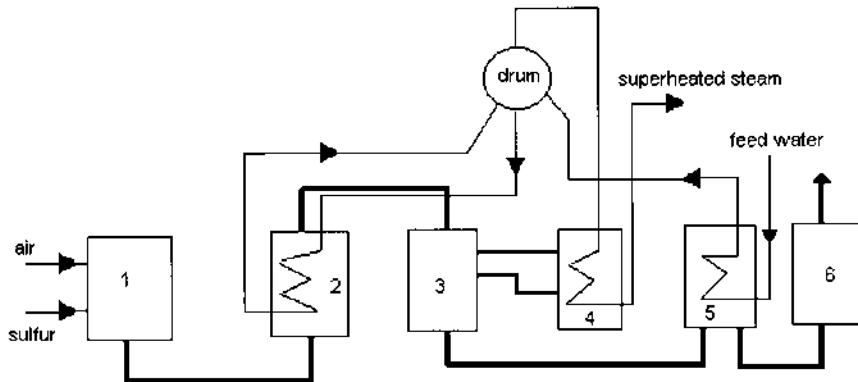

FIGURE 2.9 Scheme of a sulfuric acid plant. 1, sulfur combustion furnace; 2, waste heat boiler; 3, contact apparatus; 4, superheater; 5, economizer; 6, absorption tower.

combustion, particulates are present in the flue gases, which could preclude the use of finned tubes. One has to be concerned about the casing design because of the possibility of sulfur condensation and corrosion. Soot blowing is not recommended, because it affects the gas analysis and adds moisture to the flue gases and may cause acid condensation.

Water-cooled furnace designs have an advantage in that the casing operates at the saturation temperature of steam, hence acid corrosion is unlikely. The main concern in sulfuric acid plants is corrosion due to acid condensation from moisture reacting with SO_3 . This is minimized by starting up and shutting down the plants on clean fuels if possible and avoiding frequent start-ups and shutdowns, which induce a cooler environment for possible acid condensation over the exchanger or economizer tubes. The boiler and exchanger casings must also be maintained above the dew point by using a “hot casing” design, which reduces the heat loss to the surroundings while at the same time keeping the casing hot, above $350\text{--}400^\circ\text{F}$, as required. Boilers may be kept in hot standby if frequent shutdowns and start-ups are likely.

The feedwater temperature as it enters the economizer has to be high, often above 320°F , to minimize acid dew point corrosion because the gas contains SO_3 . Carbon steel tubes with continuously welded solid fins have been used in several plants in the United States, whereas in Europe and Asia cast iron gilled tubes shrunk over carbon steel tubes are widely used. In a few projects, the sulfur deposits found their way between the gilled iron rings and the tubes and caused corrosion problems. The choice of tube materials is based on the preference and experience of the end user and the boiler supplier.

The internal gas bypass system increases the shell diameter compared to the external bypass system. The bypass pipe also cools the gases to some extent, so the damper is not exposed to the high temperature gases as in the external bypass system, where the damper is located in a refractory-lined pipe and handles the hot inlet gases. Operability and maintenance of the damper are important aspects of boiler operation. Both internal and external gas bypass systems have been used in the industry.

In fire tube boilers, ferrules and the refractory lining on the tube sheet protect the tube sheet from the hot gases. An external steam drum with down-comers and risers ensures adequate circulation of the steam–water mixture inside the shell.

HEAT RECOVERY IN HYDROGEN PLANTS

Hydrogen and ammonia are valuable chemicals in various processes. The steam reforming process is widely used to produce hydrogen from fossil fuels such as natural gas, oil, or even coal as shown in Fig. 2.10. There are several variations of the process, but basically the steam reforming process converts a mixture of hydrocarbons and steam into hydrogen, methane, and carbon dioxide in the presence of nickel catalyst inside tubes. Before entering the reformer, the natural gas has to be desulfurized in order to protect the reformer tubes and catalysts from sulfur poisoning. The desulfurized gas is mixed with process steam, preheated to about 500°C in the flue gas boiler, then sent through the tubes of the reformer. Reactions occur inside the tubes of the reformer at 800–950°C.

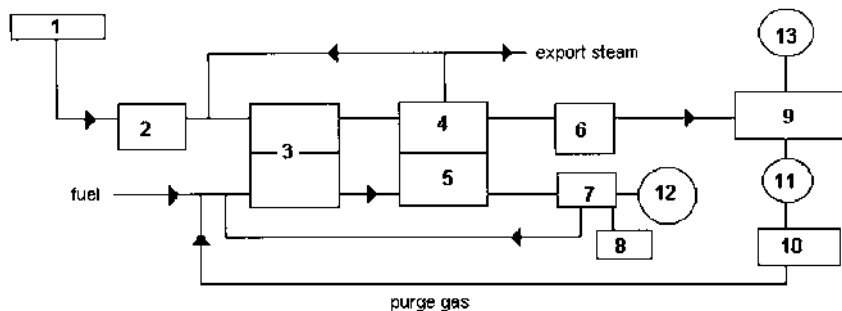
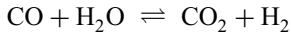
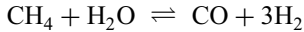
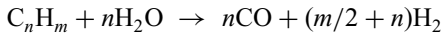

FIGURE 2.10 Steam reforming process in hydrogen plants. 1, natural gas; 2, sulfur removal; 3, reformer; 4, reformed gas boiler; 5, flue gas boiler; 6, shift converter; 7, air preheater; 8, air; 9, CO₂ removal and methanation; 10, Pressure Swing Adsorption (PSA); 11, H₂ product; 12, stack; 13, CO₂ by-product.

Reforming pressures range from 20 to 40 atm, depending on the process equipment supplier.



The overall reaction is highly endothermic, so the reaction heat has to be provided from outside by firing fuel such as natural gas or naphtha outside the tubes. This generates flue gases, typically at 1800°F and atmospheric pressure, that are used to generate high pressure superheated steam in a water tube waste heat boiler, generally referred to as a flue gas boiler. The flue gases also preheat the steam–fuel mixture and air.

In some processes the effluents of the primary reformer are led to the secondary reformer, where they are mixed with preheated air. Chemical reactions occur, and the catalysts convert the methane partly to hydrogen. The effluent from the reformer, called reformed gas, is at a high gas pressure, typically 20–40 atm, and contains hydrogen, water vapor, methane, carbon dioxide, and carbon monoxide. This gas stream is then cooled from about 1600°F to 600°F in a reformed gas boiler, which is generally an elevated drum fire tube boiler (Fig. 2.11) with provision for gas bypass control to maintain the exit gas temperature constant at all loads. The exit gas temperature from the boiler decreases as the duty of the boiler decreases, and the bypass valve adjusts the flow between the incoming hot gases and the cool exit gases to maintain a constant exit gas temperature at all loads. The cooled gases then enter a shift converter, where CO is converted to CO₂ in the presence of catalyst and steam. Additional hydrogen is also produced. The exothermic reaction raises the gas temperature to about 800°F. The CO content is reduced from about 13% to 3%. A waste heat boiler referred to as a converted gas boiler cools the gas stream before it enters the next stage of conversion, where CO is reduced to less than 0.3%. The next stage is the methanator, in which catalysts convert traces of CO and CO₂ to methane and water vapor. The H₂, CO, and unreacted methane are then separated. This produces a gas stream that can be recycled to process feed and produce hydrogen of 98–99% purity that is further purified by the pressure swing adsorption method. In older plants carbon dioxide is removed in a liquid absorption system and finally the gas goes through a methanation step to remove residual traces of carbon oxides.

In large plants, the flue gas and reformed gas boilers are separate units but have a common steam system, whereas in small hydrogen plants these boilers can be combined into a single module. The flue gas boiler is a water tube unit; the reformed and converted gas boilers are fire tube units connected to the same steam drum. The flue gas boiler contains various heating surfaces such as the feed



FIGURE 2.11 Reformed gas boiler with internal gas bypass system. (Courtesy of ABCO Industries, Abilene, TX.)

preheat coil, evaporator, superheater, economizer, and air heater. The casing is refractory-lined, and extended surfaces are used where feasible because the gas stream is generally clean. The steam generated in the reformed gas boiler is often combined with the saturated steam generated in the flue gas boiler and then superheated in the superheater of the flue gas boiler. This is a substantial quantity of steam (often referred to as import steam), so the performance of the superheater must be checked for cases when the import steam quantity diminishes or is reduced to zero for various reasons.

The reformed gas boiler, which handles gases containing a large volume of hydrogen and water at high pressure, operates at high heat flux; the heat transfer coefficient with reformed gases is about 6–8 times higher than those of typical flue gases from combustion of natural gas; see Q8.64. Hence the heat flux at the inlet to the reformed gas boiler is limited to less than $100,000 \text{ Btu/ft}^2\text{h}$ to minimize concerns about vapor formation over the tubes and possible departure from nucleate boiling conditions (DNB). The gas properties for typical reformed gas and flue gases are listed in [Table 8.45 \(Chap. 8\)](#). The higher thermal conductivity and specific heat and lower viscosity coupled with higher mass

flow per tube leads to higher heat transfer rates and hence higher heat flux in reformed gas boilers. Note that the heat transfer coefficient is proportional to

$$\left(\frac{\text{specific heat}}{\text{viscosity}}\right)^{0.4} \times (\text{thermal conductivity})^{0.6}$$

as discussed in Q8.02.

Generally fire tube boilers are ideal for high gas pressures, though a few European suppliers have built water tube designs for this application.

GAS TURBINE HRSGs

Gas turbine-based combined cycle and cogeneration plants are springing up throughout the world. The advantages of gas turbine plants are discussed in [Chapter 1](#). Though gas turbine exhaust is used to heat industrial heat transfer fluids and gases, the emphasis here will be on steam generation. Gas turbine exhaust is clean; therefore water tube boilers with extended surfaces are the natural choice for heat recovery applications. It is also relevant here to mention briefly a few peculiar aspects of gas turbine exhaust gases in order to understand the design features of HRSGs better.

As discussed in Chapter 1, gas turbine combustor temperature is limited to about 2400–2500°F for metallurgical reasons. Therefore a large amount of compressed air is used to cool the flame, which in turn increases the exhaust gas flow from the turbine. After expansion in the turbine, the gas exits at about 1000°F and at a few inches of water column above atmospheric pressure. The exhaust gas contains about 6–10% by volume (vol%) of water vapor and about 14 vol% of oxygen. Gas turbines that are heavily injected with steam have a different exhaust gas analysis, which is discussed later. The large amount of oxygen in the exhaust gases enables fuel to be fired in the exhaust gases without the addition of air; the higher gas inlet temperature to the HRSG in turn generates more steam in the HRSG. Because of these large ratio of gas to steam flow compared to steam generators, HRSGs are huge in comparison. For example, the cross section of an unfired HRSG generating, say, 100,000 lb/h of steam will be about 6 times as large as that of a packaged boiler generating the same amount of steam.

Another important aspect of gas turbine HRSGs is that the exhaust gas flow remains nearly constant, and increasing the gas inlet temperature through auxiliary fuel firing increases the steam generation. Unlike in a conventional steam generator, the ratio of gas to steam flow in an HRSG varies significantly with steam generation. This in turn affects the gas and steam temperature profiles in the HRSG.

A water–steam mixture boils at a constant temperature at a given steam pressure; hence the gas temperature distribution across the HRSG surfaces is influenced by the saturation temperature of steam. Generally, the lower the gas

inlet temperature to the HRSG, the lower will be the steam generation and the higher the exit gas temperature. This is due to fact that the heat sink in the form of an economizer does not have the ability to bring the exhaust gas stream to a lower temperature. In order to cool the gas stream to a reasonably low temperature, on the order of 250–300°F, multiple-pressure steam generation is usually required.

Heat recovery steam generators are generally of the water tube type with extended surfaces. This makes their design compact. Because of the large duty and low log-mean temperature differences at the various heating surfaces, plain tubes cannot serve the purpose effectively. The resulting HRSG design would be huge and uneconomical; the gas pressure drop also would be very high. One exception is the furnace-fired HRSG, which is very close in design to a conventional steam generator operating at much higher log-mean temperature differences; bare tubes may be used in this case. Fire tube boilers are rare in gas turbine heat recovery applications because they use plain tubes, which makes them large and unwieldy. They are sometimes used behind small gas turbines, often less than 3 MW in size, for generating low pressure saturated steam for use in chillers.

HRSGs AND CIRCULATION

Heat recovery steam generators are generally categorized according to the type of circulation system used, which could be natural, forced, or once-through as illustrated in Fig. 2.12. Natural circulation units have vertical tubes and horizontal gas flow orientation, whereas the forced circulation HRSG uses horizontal tubes and gases flow in the vertical direction. Once-through units can have either a horizontal or vertical gas flow path. In natural circulation units, the difference in density between water and steam drives the steam–water mixture through the evaporator tubes and risers and back to the steam drum. In forced circulation units, a pump is used to drive the steam–water mixture through the horizontal evaporator tubes. At the steam drum, steam separates from the steam–water mixture and dry saturated steam flows through the superheater. In once-through designs, there is no circulation system. Water enters at one end and leaves as steam at the other end of the tube bundle.

In Europe, vertical gas flow forced circulation units are common. These require a circulation pump for maintaining flow through the evaporator tubes. A recent design in Belgium has natural circulation with vertical gas flow. The pressure drop through the evaporator tubes is limited by using an adequate number of streams or parallel paths.

Once-Through Units

A once-through HRSG (called an OTSG) does not have a steam drum like a natural or forced circulation unit (Fig. 2.12). An OTSG is simply made up of serpentine coils like an economizer. Because water is converted to steam inside

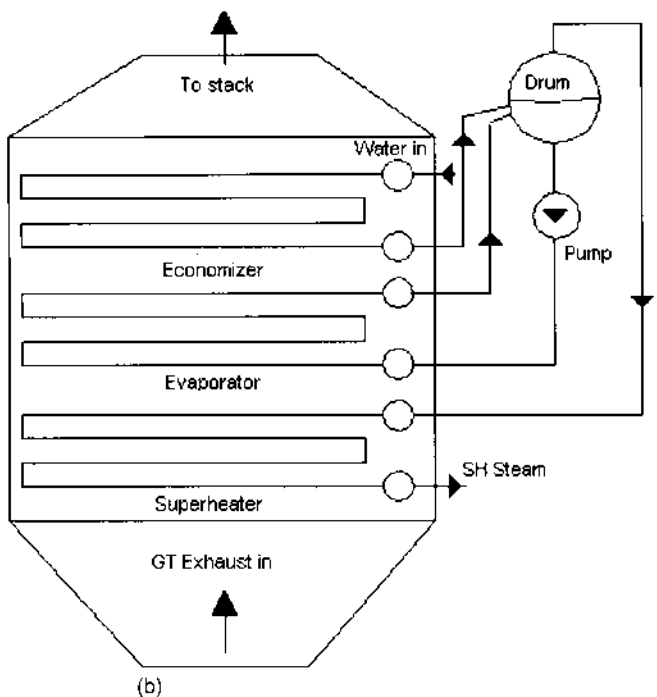
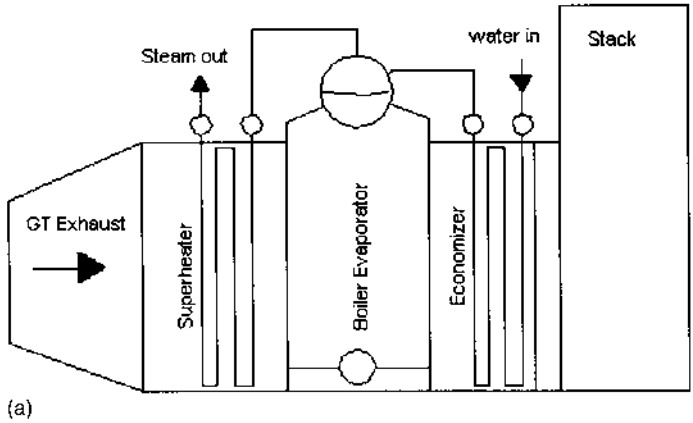
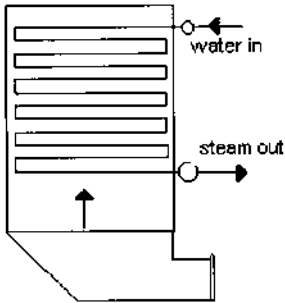

FIGURE 2.12 HRSGs with different type of circulation systems: (a) Natural circulation, (b) forced circulation. (c) Once-through.



(c)

FIGURE 2.12 Continued.

the tubes, the water should have nearly zero solids. Otherwise deposition of solids can occur inside the tubes to the complete evaporation process. This in turn can lead to overheating of the tubes and consequent tube failure, particularly if the heat flux inside the tubes is high. Like natural or forced circulation units, these units generate single- or multiple-pressure saturated or superheated steam.

The concept of once-through steam generation is not new. Supercritical boilers in Europe have been using once-through designs for over half a century. A once-through unit does not have a defined economizer, evaporator, and superheater section. The location at which boiling starts keeps moving depending upon the gas flow, inlet gas temperature, and duty. The single-point control for the OTSG is the feedwater control valve; valve actuation depends on predefined operating conditions that are set through the distributed control system (DCS). The DCS is connected to a feedforward and feedback control loop, which monitors the transients in the gas turbine load and steam conditions. If a transient in the gas turbine load is monitored, the feedforward control sets the feedwater flow to a predicted value based on the turbine exhaust temperature, producing steady-state superheated steam conditions.

Because there is no steam drum, the water holdup is much less than in drum-type units. Often Alloy 800 or 825 tubes are used to ensure dry running and also to limit the sensitivity to oxygen in the water, avoiding the need for active chemical treatment. A gas bypass diverter system is not required, because of the dry operability. The use of high grade alloy tubes minimizes exfoliation concerns, which are likely with carbon steel or low grade alloy superheater tubes. When boiler tubes are heated, they form an oxide layer inside the tubes, and when cooler steam flows through them the oxide particles are dislodged and carried off to be deposited inside the steam turbine. This process, called exfoliation, occurs when the tubes are cycled frequently between hot and cold conditions.

Once-through units can also be started up or shut down very fast compared to natural or forced circulation boilers, because the weight of steel and holdup of water are much smaller. On the flip side, the steam pressure decay when the gas turbine trips is likely to be faster than in designs that have much larger metal heat and a large water inventory. It must be kept in mind that a typical gas turbine HRSG can generally be started up in 80–100 min from cold, so the saving in start-up time may not be a significant issue unless the unit is designed for frequent cycling. There are also a few advantages of once-through units such as absence of downcomer and riser piping and drum and related material costs and fabrication concerns. From the heat transfer viewpoint there should not be much of a difference between once-through units and the natural or forced circulation units; hence the cross section and size of the HRSG or the areas of various heating surfaces should all be nearly the same. The flow configuration of the heating surfaces is generally counterflow except for the evaporator, which could be in parallel flow as in forced circulation units.

The two-phase steam-side pressure drop in the evaporator tubes is, however, quite large and could be in the range of a few hundred psi, which is an operating cost and must be considered in evaluating the design. In the natural and forced circulation unit, there is no additional pressure loss associated with the evaporator circuit, because the circulation system handles the losses and the static head available or the circulating pump balances this loss, considering other losses associated with the downcomer, evaporator tubes, and riser piping.

Another type of once-through unit is used in oil fields for secondary oil recovery operations (Fig. 2.13). These generate high pressure steam ranging from 1500 to 3000 psig at 80% quality for injection into used oil fields in order to recover additional oil. The steam pressure depends on the depth at which oil is available. The hot, wet steam dislodges the viscous layers of oil in the ground beneath, and thus more oil is recovered. This HRSG is also of once-through design, with water entering at one end of the coil and leaving as wet steam at the

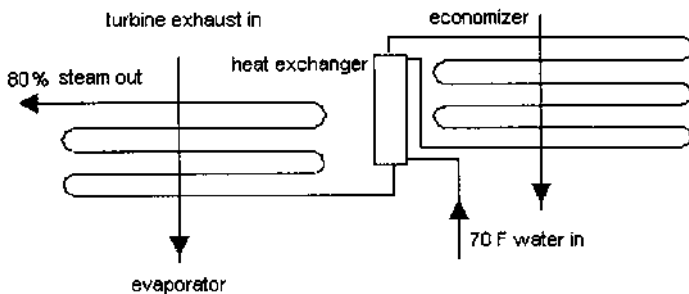

FIGURE 2.13 HRSG used in oil field applications.

other. Because of concerns with departure from nucleate boiling (DNB), the final portions of the coil are in parallel flow and not in counterflow and are located behind tubes having lower steam quality. This feature helps to lower the heat flux inside the tubes where the quality of steam is high. The allowable heat flux to avoid DNB decreases as the steam quality increases, hence this measure. The feedwater in these generators is generally of poor quality and has high solids content, exceeding thousands of ppm of salts, because the water is taken from the fields nearby and basic, inexpensive softening methods are used in its treatment. Because sodium salts are soluble in water, the 80% quality steam, which still has 20% water, is often adequate to ensure that the salts are dissolved and are not deposited inside the tubes during the evaporation process. Single-stream designs, in which a single tube handles the entire steam flow, are used for up to 100,000 lb/h capacity, whereas with higher steam flows, multiple streams are employed. Due to instability problems associated with two-phase boiling of fluids with multiple streams, a flow resistance at the inlet to each stream in the form of orifices or control valves, as explained in Q7.36, is used. Because water at ambient temperature is often used as feedwater, a heat exchanger is used to preheat the incoming water, using the hotter water at the exit of the economizer portion to minimize acid dew point concerns.

Natural and Forced Circulation HRSGs

Figures 2.12b and 2.12c show the arrangement of natural and forced circulation HRSGs. In the natural circulation unit the differential head between the cold water in the downcomer circuit and the hotter, less dense mixture in the riser tubes drives the steam–water mixture through the evaporator tubes. The circulation ratio (CR), which is discussed in Q7.29, is typically on the order of 8–20 depending on the system, the layout, and the size of downcomers, evaporator tubes, and risers. The forced circulation units are sized for a particular CR, typically 3–6. The circulation pumps provide the additional differential head to ensure flow through the evaporator tubes. The following are some of the features of these types of HRSGs.

1. Natural circulation units do not require a pump for maintaining circulation through the evaporator tubes. The circulation is ensured through natural gravity principles. The use of circulating pumps in forced circulation units involves an operational and maintenance cost, and their failure for some reason such as power outage or pump failure could shut down the HRSG.
2. The water boils inside vertical tubes in natural circulation units, and the steam bubbles formed move upward, which is the natural path for them; hence the tube walls are completely wetted by water. As a result, tube failures are rare, whereas with horizontal tubes there is a

difference in temperature between the top and bottom portions of the tubes, which could cause thermal fatigue. Also, if the steam–water mixture velocity is not high enough, the vapor can separate from the water inside the horizontal tubes, leading to steam blanketing and possibly overheating the tubes. This is a possibility when the heat flux inside the evaporator tubes is high, for example, in fired conditions, particularly when a high fin density is used for the evaporator tubes.

3. Natural circulation units can tolerate higher heat flux, generally 50–80% more than horizontal tube designs due to the vertical configuration of the tubes. Also, in the event of nonuniform gas temperature or heat flux across the cross section (which is often likely due to maldistribution of gas flow), the tube receiving the higher heat flux in a natural circulation unit has a higher circulation ratio or higher steam–water mixture flow. This is due to the greater differential in fluid densities between the more dense fluid in the downcomer circuit and the less dense fluid inside the evaporator tubes, which is helpful and evens out flow imbalances. In a forced circulation unit, all the evaporator tubes receive the same steam–water flow, irrespective of their location, unless special efforts are taken to design the orifice in each tube as in controlled circulation utility boilers. Therefore severe gas-side flow and temperature maldistributions can lead to the possibility of tube failures or overheating in some tubes.
4. Natural circulation units require more real estate than forced circulation units, because heating surfaces are laid out one behind the other. The floor space occupied often runs into a few hundred square feet, particularly with multipressure units with catalysts for NO_x and CO reduction. In forced circulation units the floor space may be small but the height of the HRSG will be large, requiring a large amount of supporting structural steel, ladders, and platforms.
5. During warm starts, the vertical, readily drainable superheater–reheater arrangement in natural circulation designs eliminates concerns over condensate carryover and impingement on hot headers and piping, which would result in thermal stresses at the headers.
6. The horizontal gas flow configuration of natural circulation HRSG provides an easy way to water wash the highly soluble ammonia compounds formed downstream of the SCR when operating with a sulfur-bearing fuel. A major deficiency of forced circulation or once-through units with their vertical gas path arrangement is the lack of a procedure to water wash deposits from heat transfer surfaces downstream of the SCR without damage to the SCR catalysts.
7. During start-up and low load periods, steam bubbles generated in the economizer section have to flow down in the counterflow direction in

once-through and forced circulation units, which is not their natural path. To overcome steaming concerns, the feedwater control is sometimes located between the economizer and the evaporator. This increases the design pressure of the economizer. A safety valve is also required at the economizer.

8. The casing design for forced circulation units is typically “hot,” that is, it is insulated on the outside. Hence the designer is required to use alloy steel material for the casing, and one has to evaluate the impact of thermal expansion.

Despite their differences and the pros and cons, all three types of HRSGs are used throughout the world. Selection is generally based on the experience of the plant managers, their consultants, and the end users.

INCINERATION APPLICATIONS

In chemical and industrial plants, several by-products are generated in solid, liquid, and gaseous forms that have to be safely destroyed to prevent potential environmental damage. These by-products come from petroleum refining and petrochemical, pharmaceutical, paper and pulp, and plastics production. Small quantities of by-products are stored in drums and placed in landfills, but the most effective method of rapidly destroying a high percentage of hydrocarbon contaminants is to oxidize the organic materials at elevated temperatures (1500–1800°C). For some vapor streams, effective destruction of contaminants can be achieved at lower temperatures. The carbon and hydrogen in the waste are converted to CO₂ and H₂O. If the gas stream contains sulfur or chlorine or similar substances they must be recovered or removed before venting the flue gases to the atmosphere according to local air quality regulations. Particulates are also generated that have to be removed.

The process of thermal oxidation of fumes, liquids, and gaseous wastes is often carried out in thermal oxidizers or incinerators. If the waste stream has a low heating value or low concentration, often natural gas or liquid fuels are fired alongside to improve the combustion process. In order to destroy most of the pollutants, incineration is carried out at temperatures ranging from 1500 to 1800°F with proper residence times, typically 1–2 s. The exhaust gas stream contains a significant amount of energy and is recovered in the form of steam in waste heat boilers.

If the gas stream is greater than 100,000 lb/h and clean, then a water tube boiler with extended surfaces is the ideal choice. Fire tube boilers are also used in incineration plants if the gas is not likely to cause slagging. A superheater and economizer may also be used in fire tube boilers as shown in Fig. 2.2. Because of

the high gas temperature at the inlet to the boiler, 1500–2000°F, the superheater is often located downstream of the boiler as shown. The superheater steam temperature cannot be very high, obviously, with such an arrangement; it is typically 500–550°F depending on the steam pressure. The disadvantage of the fire tube design is that it is difficult to have two fire tube boilers with a superheater in between such as can be done with water tube designs. Hence we have to live with a steam temperature that is slightly lower than those feasible with water tube designs. Locating the superheater at the gas inlet can lead to corrosion due to the presence of corrosive gases in the gas stream.

Bare and finned tubes are used in the design of water tube boilers, depending upon the cleanliness of the gas, its fouling tendencies, and the gas temperature. Simple two-drum designs, such as those shown in Chapter 8 in Fig. 8.3, in which the steam drum and mud drum are connected by plain or finned tubes rolled into the steam and mud drums, are common. This design can have either a refractory-lined casing or a water-cooled casing. With the refractory-lined design, casing corrosion is a possibility if the gas stream contains corrosive acid vapors that can seep through the refractory. Access doors or lanes can be easily incorporated into this design. The water-cooled casing operates at the saturation temperature of steam and ensures that corrosion concerns are minimal. The two-drum crossflow design is suitable for small capacities, generally about 50,000–75,000 lb/h of steam. When the amount of steam generated is much greater say above 100,000 lb/h, an elevated steam drum with external downcomers and risers may be justified. The steam drum should have the volume or holdup to handle a few minutes of residence time from normal level to empty. Some plants require this residence time to be 3–4 min, and a few plants require 10–12 min. In large plants, multiple evaporators are connected to a common steam drum and circulation system.

Figure 2.3 shows a water tube boiler consisting of a screen section, followed by a two-stage superheater with interstage attemperation, an evaporator, and an economizer that is used in large incineration projects handling clean effluents. The screen section is similar to the shield section used in a fired heater and protects the superheater from the hot gases and from external radiation from the incinerator flame. A minimum of four rows are required to absorb the external radiation from the cavity or flame, as discussed in Q8.09. The evaporator and the screen sections are in parallel and are connected to the same steam drum by external downcomers and risers. If the gas enters at a temperature in excess of 1500°F, the screen section is often designed with bare tubes. The superheater may or may not have fins, depending on the steam and tube wall temperatures. The evaporator has finned surfaces, which can vary from a low fin density section at the inlet (two fins per inch) to a high fin density section (four to five fins per inch) as the gas is cooled. This is done to minimize the heat flux inside the tubes and also to minimize fin tip temperatures.

The economizer uses a fin density of four to six fins per inch. The tubes of all the sections are generally vertical with horizontal gas flow, as in gas turbine HRSG plants. Superheaters are of T11, T22, or T91 material if the tube wall temperatures are close to 1000–1100°F.

In plants with large steam requirements, energy from the waste gas stream is augmented by firing natural gas or fuel oil. In these designs, a D-type boiler (Fig. 2.14) is an ideal choice. The burner is fitted at the front wall of the boiler and fires into a water-cooled furnace; the waste gas stream enters the convection bank, mixes with the furnace flue gases, then flows through the convection and economizer sections. A superheater can be located in the convection bank behind screen tubes. If the flue gases are clean, extended surfaces may be used in the cooler sections of the convection bank.

Various modes of operation have to be considered in these boilers, particularly if a superheater is used. If the waste gas stream supply is cut off, the steam generation is reduced. Hence the total steam flow is reduced which affects the steam temperature and the superheater tube wall temperatures. In some cases only the waste gas stream is used, and in some other modes only the burner is fired for generating steam. All these different cases generate different quantities of steam and flue gases at different temperatures that enter the convection section; hence the superheater performance has to be evaluated carefully in all these modes. The furnace pressure is maintained at nearly zero, and an induced draft fan handles the flow of the flue gases from the burner and the waste gas stream. The forced draft fan just handles the combustion air to the burner.

Figure 2.15 is the schematic of a waste heat boiler for a dirty gas from a carbon black incineration system. A D-type boiler was also used for this application. The hot gas coming in at about 2100°F is cooled in the furnace and then enters the convection bank. A screen section with widely spaced bare tubes helps to minimize slagging concerns with ash particulates that have low melting temperatures. A retractable blower also helps to clean the front end. As the gas cools, the tube spacing can be closer.

Slagging is a serious concern when flue gases containing ash particulates with low melting point salts are used in heat recovery applications. The slag is a rocklike deposit that forms on cool surfaces such as tubes and solidifies as soon as it is formed. Retractable blowers can help minimize this problem but cannot eliminate it completely. The wide tube spacing ensures that tubes are not bridged by the molten mass of deposits, thus preventing the flow of gases. Ash particles, if any, are collected in hoppers located beneath the convection bank.

FOULING IN WASTE HEAT BOILERS

Fouling is a serious concern in both fire tube and water tube boilers, particularly with dirty gas streams. It affects not only the waste heat boiler performance but

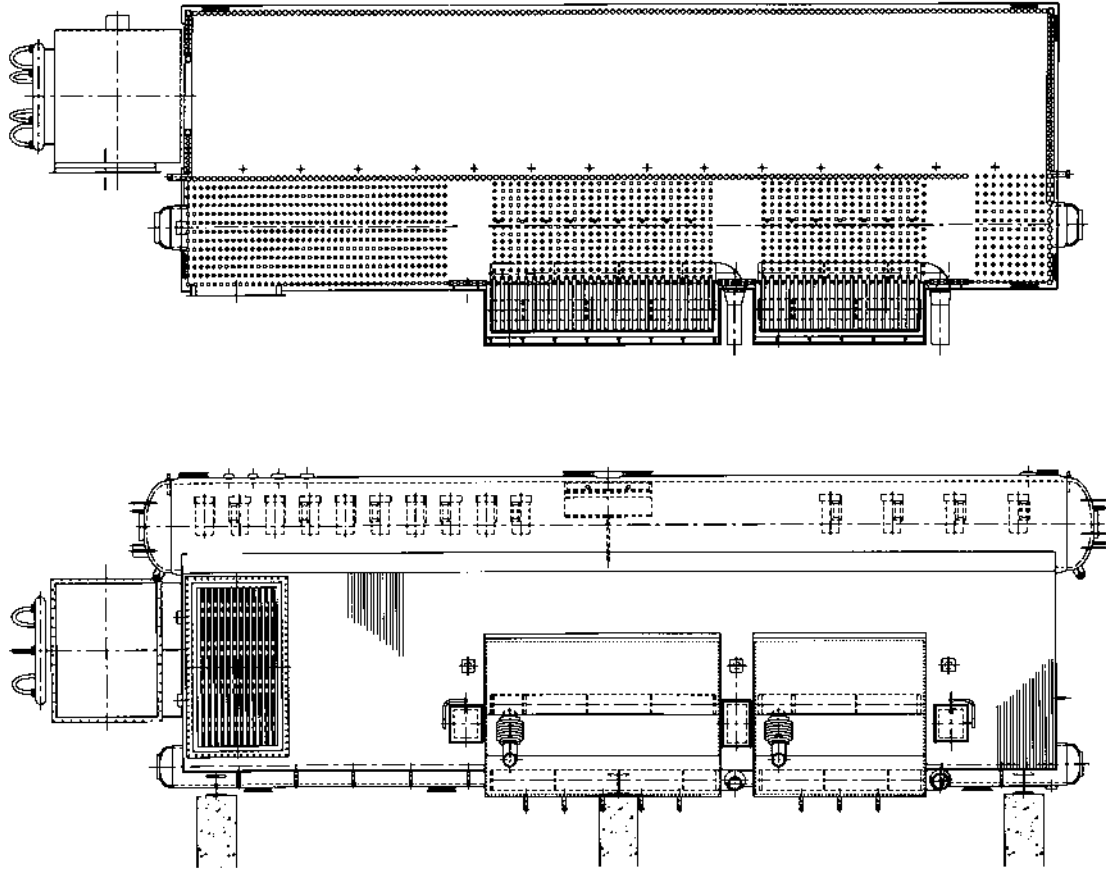

FIGURE 2.14 D-type waste heat boiler for operation with burner and waste heat. (Courtesy of ABCO Industries, Abilene, TX.)

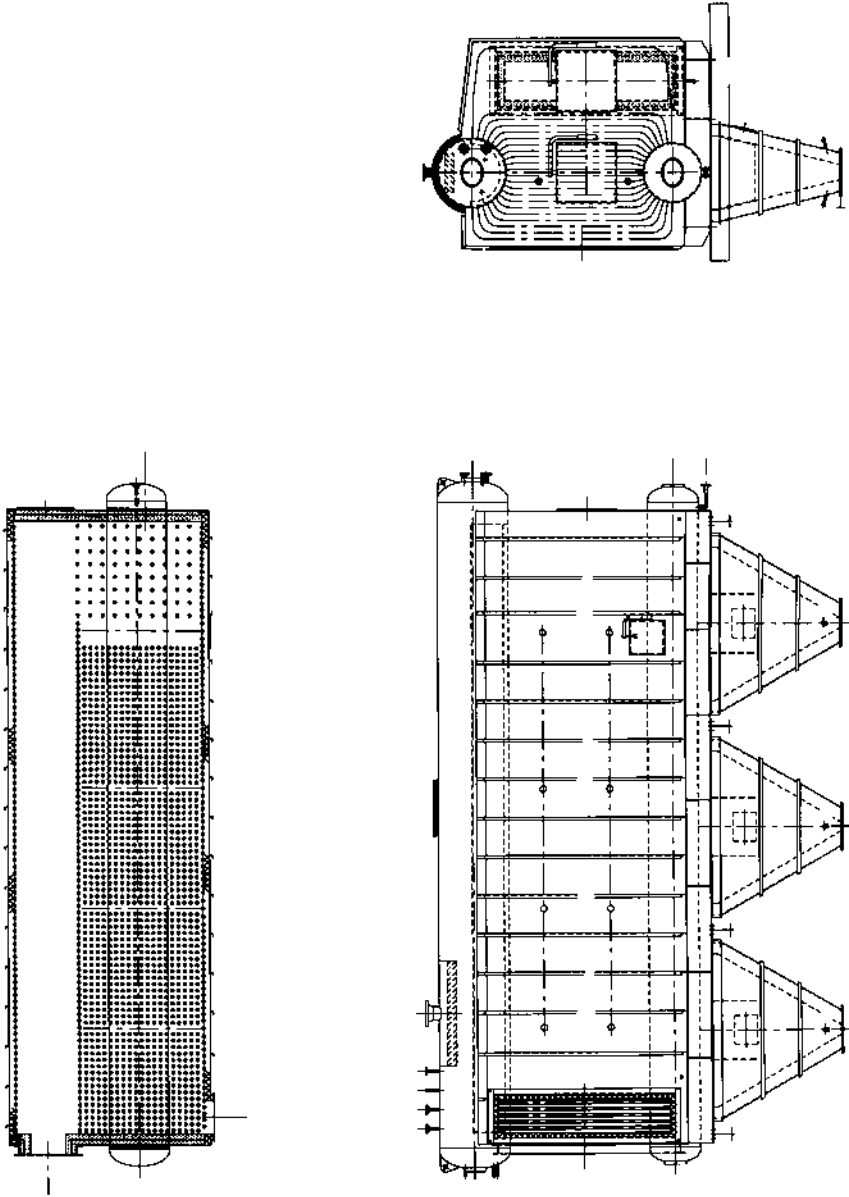

FIGURE 2.15 Waste heat boiler in carbon black plant. (Courtesy of ABCO Industries, Abilene, TX.)

also equipment such as scrubbers downstream of the boiler. When fouling sets in, the steam generation decreases and the gas pressure drop increases over a period of time. There are a few ways to infer if the fouling has become severe:

1. The exit gas temperature from the boiler will increase over a period of time; if, say, the normal exit gas temperature from the convection bank is 550°F and we observe 570–600°F for the same load, then we can infer that fouling has set in. Fouling deposits build up over heat transfer surfaces (whether inside or outside), and the fouling factor increases exponentially and then tapers off as shown in Fig. 2.16. With periodic cleaning some of the deposits are removed, which decreases the fouling factor, but a base layer builds up and increases the exit gas temperature and decreases the boiler duty. A complete shutdown and cleaning may help restore the original boiler performance or close to it.
2. The gas pressure drop across the convection section increases. If the fan power consumption increases over a period of time, then one can infer that there is some blockage of the gas path and that fouling has set in.
3. Steam generation naturally decreases with fouling.
4. Superheated steam temperature, if a superheater is present, has to be looked at carefully, because fouling in different sections may be different, and one cannot conclude that there is fouling at a given surface without having data on the gas inlet and exit temperatures and steam inlet and exit temperatures and flows. Sometimes steam-side fouling is caused by deposition of salts from steam. Steam-side fouling can increase the tube wall temperatures and cause overheating as discussed in Q8.13. Steam-side fouling is more critical in finned water tube boilers, as discussed in Q8.24.

One has to shut down the boiler and perform an investigation if fouling is severe. Normal fouling may be acceptable between maintenance shutdowns. Heat transfer calculations backed up with field data and tube wall temperature

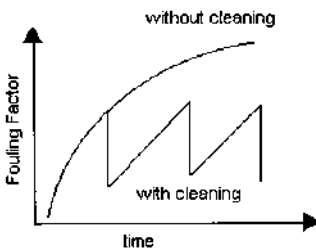

FIGURE 2.16 Fouling in waste heat boilers versus time.

measurements can also show if the fouling is on the gas side or steam side or both. With gas-side fouling the tube wall temperatures will not increase, whereas with steam-side fouling the tube wall temperatures can increase significantly. With a combination of gas- and steam-side fouling, the measurement of operating data on each side, followed by elaborate calculations, can reveal the extent of fouling.

Because both fire tube and water tube boilers are used in HRSGs, a few guidelines on their sizing are in order.

FIRE TUBE BOILER DESIGN CONSIDERATIONS

The sizing procedures for fire tube boilers are discussed in Q8.10. It may be noted that the tube size plays a significant role in minimizing the length of the boiler. With small gas flows, one may consider multi-gas-pass design, which can reduce the overall length. Tube sizes vary from 1.5 to 2.5 in. OD; smaller tubes generally have lower tube wall temperatures and also require less surface area and shorter tube length. Hence a comparison of surface areas of two or more designs should be made with caution. Heat fluxes are quite low in fire tube boilers owing to low gas-side heat transfer coefficients, an exception being gas streams in hydrogen plants, as discussed earlier. SA 178a carbon steel tubes are typically used for evaporators handling common flue gases. In reformed gas applications, T11 or T22 tubes are preferred. Gas pressure drop can range from 3 to 6 in. WC in flue gas heat recovery boilers and about 1 psi in high gas pressure applications such as reformed gas boilers.

Boiler circulation may be checked using methods discussed in Q7.32. With poor water quality, fouling and scale formation are of concern, and tube wall temperatures can increase significantly with scale thickness as discussed in Q8.13.

Elevated steam drum design is generally used if the steam purity has to be less than 1 ppm. External downcomers and risers help cool the tubes and tube sheet by circulating the water–steam mixture over them. If the flue gas temperature is below 1500°F, then an elevated drum design may be dispensed with and a single-shell fire tube boiler may be used. The steam purity without internals is low, on the order of 5–15 ppm, which may be adequate for low pressure process heating applications.

Owing to the large inventory of water, fire tube boilers respond slowly to load changes compared with water tube units. However, the pressure decay on loss of heat input will also be smaller.

WATER TUBE BOILER DESIGN CONSIDERATIONS

The design procedure for waste heat boilers is quite involved. With a given set of inlet gas conditions such as flow and temperature, we have to see how the various

heating surfaces respond. The surfaces could consist of bare or finned tubes. The superheater could have one or more stages; a screen section may or may not be used. Import steam could come from another boiler to be superheated in the boiler in question, or saturated steam may be drawn off the steam drum for deaeration or process purposes. The feedwater temperature or steam pressure could vary depending on plant facilities.

Before attempting to evaluate the performance of a complete waste heat boiler, one must first know how to obtain the performance of individual components such as the superheater, evaporator, and economizer by using the number of transfer units (NTU) method or through trial and error. This is discussed in Q8.29 and Q8.30. Once we know how to evaluate the performance of each surface, evaluating the overall performance of a waste heat boiler is simple. Figure 2.17 shows the logic for a simple waste heat boiler consisting of a superheater, evaporator, and economizer. A few iterations may be required, because we have to first assume a steam flow and completely solve all the other sections and then check on whether the assumed steam flow was fine. A

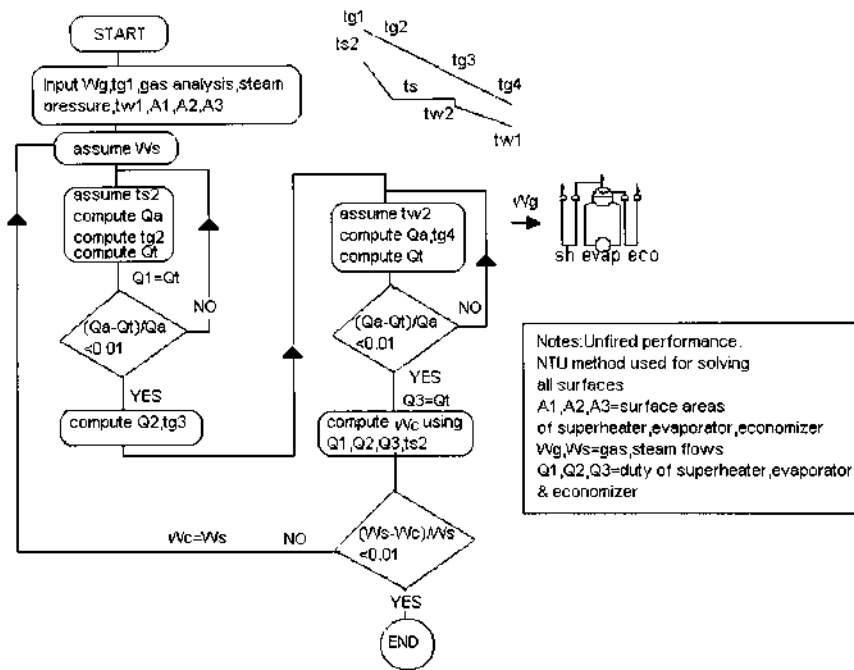

FIGURE 2.17 Logic used for evaluating HRSG performance.

computer program is required, because these calculations become tedious with two-stage superheaters with attemperation, a combination of bare and finned tubes in evaporators, and the use of import or export steam, to mention a few variables. Also the incinerator may operate at different combinations of gas flows, temperatures, and gas analysis. The performance has to be checked at different operating points before finalizing it.

Figure 2.18 shows the printout of results for a water tube waste heat boiler for a gas turbine exhaust consisting of a furnace section, a screen section, a two-stage superheater, an evaporator consisting of bare and finned tubes, and a finned tube economizer. In the unfired mode this HRSG makes about 45,000 lb/h of steam. The turbine exhaust enters the HRSG at 980°F, which is raised to 2175°F by the burner located at the HRSG inlet to generate 150,000 lb/h of steam at 620 psig and 750°F. The oxygen content has decreased from 15% to 8.39% by volume and the burner duty is 123 MM Btu/h on LHV basis. The gas temperature drops to 2063°F in the furnace section and is cooled to 1852°F in the screen section before entering the superheater. The gas pressure drop in the HRSG is about 6 in. WC. To this must be added the burner, selective catalytic reduction (SCR), and duct losses. The printout also shows the tube wall temperatures, fin tip temperatures, heat transfer coefficients at various sections both inside and outside the tubes, and the gas- and steam/water-side pressure drops. The amount of spray water used for attemperation is also computed. Several variables can be changed to check the effect on performance. The evaporator uses different fin configurations. This is done to minimize the heat flux inside the evaporator tubes and also the tube wall and fin tip temperatures. The boiler duty is 177 MM Btu/h. The fuel used is typically natural gas.

Boiler tube sizes typically range from 1.5 to 2.5 in. and fin density can vary from 2 to 6 fins/in. depending upon the design. Bare tube boilers are used in dirty gas applications. Sometimes multipass designs offer a compact design. Whereas with finned tubes, both in-line and staggered arrangements are used, an in-line arrangement is generally used with bare tubes because it is inefficient to use a staggered arrangement, as discussed in Q8.22. Tube spacing can vary depending on gas velocity, dirtiness of the gas stream, and heat transfer considerations. A radiant furnace is also used if the incoming gas is at a high temperature and has the potential to cause slagging problems. Superheaters can be of bare tube or finned tube design, depending upon the gas temperature and cleanliness. Generally a low fin density is preferred for superheaters owing to the low heat transfer coefficient inside tubes, as discussed in Q8.22 and Q8.27. Superheater tubes can be vertical or horizontal depending on size or layout considerations. Economizers are of bare tube design in dirty gas applications and use finned tubes in clean gas applications. In sulfuric acid plants, a few suppliers use cast iron gilled tubes.

WASTE HEAT BOILER PERFORMANCE Project: MYBOILER
Remarks ... units: British case : fired case * Date : 21-09-01**

Gas flow -lb/h=317370 Gas Temp in -F=980 GAS MW =28. Gas pres -psia=14.5
 drum pres-psia=658 sat temp-F=497 % blow down= 1. fw temp-F=230
 ext duty -MMBtu/h=11.6 % heat loss= 1. foul ftr in-ft²hF/Btu=.001 pros stm -lb/h=
 furnace cools the gases before entering the convection section
 furnace width=-ft=9.5 depth=-ft=11. length=-ft=18. proj area=-ft²=760
 Firing temperature is -F= 2175
 Fuel -GAS tot gas-lb/h=323084 bur duty-MMBtu/h=122.52 fuel LHV-Btu/lb=21439
 % gas flow to scm= 100 sh= 100 evap= 100 econ= 100

CO2	H2O	N2	O2	SO2	HCL	H2S	H2	CO	CH4	SO3
3.	7.	75.	15.							
6.01	12.8772	71	8.39							

EVAPORATOR

OD	ID	TG1	TG2	CPG	DUTY	U	SURFP	DELT	DELPG	MAXVL
2.	1.7382063	1853	.318	21.39	17.81	824	1458	.37	93	

NW	ND	L	N	H	B	WS	ST	SL	TFIN	TWAL	WT
21	7	10.7					5.5	4.	567	567	4451

argt=IN com= 1 foul ftr-ft²hF/Btu=.001 duty-MMBtu/h=21.39 gas dp -in wc= 37

SUPERHEATER

TG1	TG2	CPG	DUTY	U	SURFP	DELT	DELPG	MAXVL	WT
1853	1758	.314	9.51	20.67	415	1109	.59	136	2494
1758	1550	.31	20.65	20.5	949	1062	.831	134	3385

NW	ND	L	N	H	B	WS	ST	SL	PDRP	STRMS
22	4	9.			.075		4.5	4.	12.8	22
22	4	9.	1.	.5	.075		4.5	4.	10.4	22

CONF	OD	ID	DUTY	STM IN	STM OUT	HTC	TWAL	TFIN
CF	2.	1.706	9.5	645	750	344	883	883
CF	2.	1.706	20.6	497	692	375	963	1266

com= 1 Foul ftr-ft²hF/Btu=.001 stm pr -psia=635 argt IN stm flow-lb/h=146233
 spray wat flow -lb/h=3767 spray water temp -F=230
 steam vel1-ft/s= 116 steam vel2-ft/s= 97

EVAPORATOR

OD	ID	TG1	TG2	CPG	DUTY	U	SURFP	DELT	DELPG	MAXVL
2.	1.7381550	1490	.306	5.84	16.17	353	1023	.13	74	
2.	1.7381490	1299	.302	18.48	12.56	1645	895	.37	86	
2.	1.7381299	569	.287	67.1	7.89	27991	304	2.89	81	

NW	ND	L	N	H	B	WS	ST	SL	TFIN	TWAL	WT
21	3	10.7					5.5	4.	539	539	1908
20	3	10.	2.	.75	.075		5.5	4.	1086	659	3883
20	27	10.	4.5	.75	.05	.157	5.5	4.	909	652	3885

argt=IN com= 1 foul ftr-ft²hF/Btu=.001 duty -MMBtu/h=91.42 gas dp -in wc=3.38

ECONOMISER

OD	ID	TG1	TG2	CPG	DUTY	U	SURFP	DELT	DELPG	MAXVL	WT
2.	1.738569	306	.269	22.57	6.05	29857	125	.89	37	41477	

NW	ND	L	N	H	B	WS	ST	SL	PRDP	STRMS
30	12	16.	4.5	.75	.05	.157	4.	4.	13.42	10

wat temp in -F=230 wat temp out-F=378 wat htc -Btu/ft²hF=1572
 water inlet: tube wall temp-F= 241 fin tip temp-F= 261
 water exit: tube wall temp-F= 410 fin tip temp-F= 462
 com= .95 foul ftr -ft²hF/Btu=.001 argt=IN water vel-ft/s=4.5
 econ-counter flow
 blr duty -MMBtu/h=165.54 tot duty-MMBtu/h=177.14 tot gas prdp-in wc=6.06
 steam -lb/h=150000 wat flow -lb/h=147695

For clarifications or for more information, please contact: V.Ganapathy

FIGURE 2.18 Printout of HRSG performance.

PREDICTING HRSG DESIGN AND OFF-DESIGN PERFORMANCE USING HRSG SIMULATION

It is possible to predict the performance of water tube HRSGs in clean gas applications by using a simulation process instead of physically designing the unit. Thus anyone familiar with heat balances such as consultants and those planning cogeneration or combined cycle plants can obtain a good idea of the performance of the HRSG under various modes of operation. This information may be used to arrive at the HRSG configuration and optimize the major parameters for the steam system. Several “what if” scenarios may be looked at. The performance of an existing HRSG may also be evaluated to see if its performance is reasonable, as discussed in Q8.45. Though simulation may be used for any clean gas convective type of HRSG, it is particularly useful in gas turbine applications, because the HRSG designs involving multiple-pressure, multiple-module designs are more complex as discussed in [Chapter 1](#).

Because of the large amount of exhaust gases and the low inlet gas temperature of an HRSG, one cannot arbitrarily assume an exit gas temperature and compute the steam generation. The problem of evaluating steam generation and temperature profiles gets complicated further as it is not often possible to recover a substantial amount of energy from the exhaust gases with steam at a single pressure level. Multiple-pressure steam generation with split modules alone can optimize energy recovery, makes the task of performing energy balance calculations very tedious. Gas and steam temperature profiles and hence energy balance in an HRSG are governed by what are called pinch and approach points ([Fig. 2.17](#)) Q8.34 and Q8.37 explain this in greater detail.

Basically, we estimate the term UA , the product of the overall heat transfer coefficient and the surface area, for each heating surface in the design mode and then correct it for the effect of gas flow, temperature, and analysis. Using this corrected UA , one can use the NTU method to evaluate the performance of any exchanger and then the overall performance.

The HRSGS Program

I have developed a simulation program called HRSGS to perform these complex design and off-design performance calculations. Basically the desired HRSG configuration is built up by using the six basic modules shown in [Fig. 2.19](#). By using the common economizer or common superheater concept, one can configure complex multiple-pressure HRSGs, as shown in the examples in the figure. Up to 10 modules or nine pressure levels can be evaluated. The program automatically arrives at the firing temperature and the fuel requirement if the desired steam quantity is known with both turbine exhaust and fresh air cases. It checks for steaming in the economizer and handles import or export steam from evaporators as illustrated by a few examples in [Chapter 1](#) (See p. 26 and 36). It

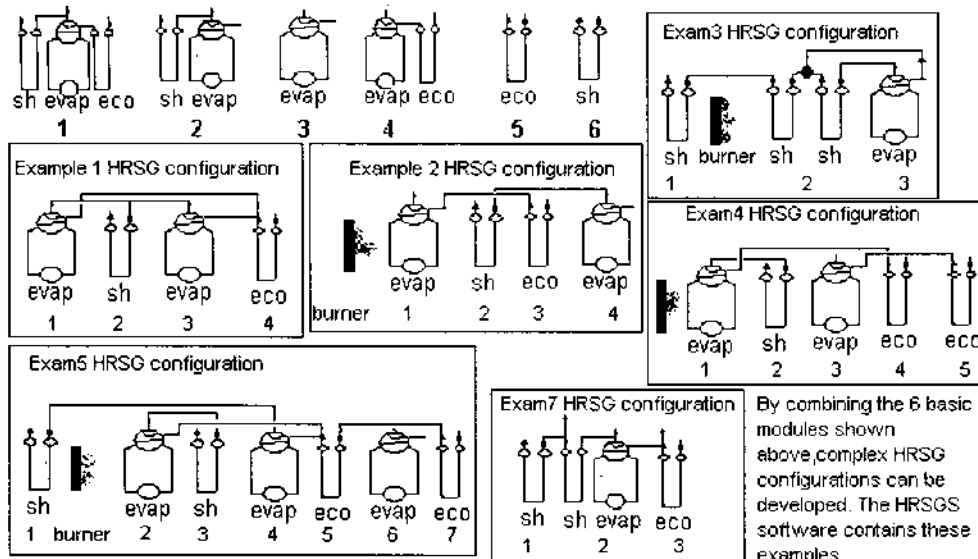

FIGURE 2.19 How basic modules may be combined to arrive at complex HRSG configurations.

computes the ASME efficiency and prints out the US values for each surface in the design and off-design modes as shown in several examples in [Chap. 1](#).

The simulation program is generally used for convective-type HRSGs and waste heat boilers, which operate on clean gas streams. If a radiant furnace is used, there will be some variation between the actual and predicted values. Because of the large fouling factors involved in dirty gas applications, the heat transfer coefficients cannot be corrected for off-design conditions accurately; hence there will be some deviation between predicted and actual performance if this is used in, say, municipal waste applications. For more information about the program, please contact the author at v_ganapathy@yahoo.com or visit the web site <http://vganapathy.tripod.com/boilers.html>.

SPECIFYING WASTE HEAT BOILERS

The following points may be considered while developing specifications for heat recovery applications.

1. Because there are numerous applications of heat recovery, it is always good practice to start off the specifications by describing the process that generates the flue gases, because that gives an idea of the nature of the gas stream. With a clean gas stream, finned tubes could be used to make the boiler design compact, whereas a dirty gas with slagging potential must have bare tubes, with provision for cleaning the surfaces. Process gas applications such as hydrogen plants or sulfuric acid plant boilers require exit gas temperature control systems.
2. Desired steam purity should be mentioned, particularly if the steam generated is used in a gas or steam turbine. Also, based on load swings, one could arrive at the proper size for the steam drum.
3. The extent of optimization required and the cost of fuel, electricity, and steam should be indicated. For example, simply stating the inlet gas conditions and steam parameters may not be adequate. If design A cools the gas to, say, 450°F and design B cools it to, say, 400°F by using a larger boiler at higher cost, how is this to be evaluated? Also, if for the same steam parameters, one design has 6 in. WC pressure drop and another has 4 in. WC, is there any way to evaluate operating costs? Such an indication in the specifications will help the designer to review the design and balance the installed and operating costs.
4. Space availability and layout considerations should be indicated. Sometimes a boiler is built before the builder finds out that it has to be located inside a building that has already been constructed.
5. The steam system should be clearly described. Often only the makeup water conditions are given without an indication of where the steam to

the deaerator comes from. If the steam is taken from the boiler itself, then the design is likely to be affected, particularly if a superheater is present. Hence a scheme showing the complete steam–water system for the plant will be helpful. In waste heat boilers, sometimes import steam from another source is superheated in the boiler. This affects the superheater and boiler performance, particularly when the import steam supply is reduced or cut off.

6. Often feedwater is used for desuperheating steam to control its temperature. This water should have zero solids and should preferably be demineralized. Softened water will add solids to the steam if used directly as spray, so one may have problems with solid deposits, fouling, and overheating of superheater tubes and possible deposition of solids in the steam turbine blades. If demineralized water is not available and that is so stated up front, the designer could come up with a sweet water condensing system to obtain the desired spray water for steam temperature control (see [Chap. 3](#)). The feedwater analysis is also important because it affects blowdown rates.
7. Gas flow should be stated in mass units. Often volumetric units are given and the writer of the specifications has no idea if it is actual cubic feet per minute or standard cubic feet per minute; then without the gas analysis, it is difficult to evaluate the density or the mass flow. The ratio between standard and actual cubic feet per minute of flue gas could be nearly 4 depending on the gas temperature. The problem is resolved if the flue gas mass flow is given in pounds per hour or kilograms per hour.
8. Flue gas analysis is important. We have seen that the presence of water vapor or hydrogen in flue gases increases the heat transfer coefficient and also affects the specific heat and temperature profiles of the gas. The presence of corrosive gases such as hydrogen chloride, sulfur trioxide, and chlorine suggests the possibility of corrosion. The boiler duty for the same gas temperature drop and mass flow could be different if one designer assumes a particular flue gas analysis and another designer assumes another. Hence flue gas analysis should be stated as well as the gas pressure. High gas pressure, on the order of even 1–2 psi, affects the casing design and cost.
9. With HRSGs, one should perform a temperature profile analysis before arriving at the steam generation values. As shown in Q8.36, assuming an exit gas temperature and computing HRSG duty or steam generation on that basis can lead to errors.
10. Emission levels of NO_x, CO, and other pollutants required at the exit of the HRSG or waste heat boiler should be stated. In such cases, information on pollutants in the incoming gases should also be given.

11. Fuel analysis should be provided for a fired HRSG or boiler. Also, the cost of fuel helps to determine if a design can be optimized by using a larger boiler and smaller fuel consumption or vice versa.
12. If the boiler is likely to operate for a short period only or weekly or is being cycled, then this information should also be given. Frequent cycling requires some considerations in the design to minimize fatigue stresses. Provisions for keeping the boiler warm during shut-down may also be necessary.

In addition, local code requirements, site ambient conditions, and constructional features, if any, should be mentioned.

REFERENCES

1. V Ganapathy. Simulation aids cogeneration system analysis. *Chemical Engineering Progress*, October 1993.
2. V Ganapathy. Evaluating gas turbine heat recovery boilers. *Chemical Engineering*, Dec 7, 1987.
3. V Ganapathy. Evaluating waste heat boiler systems. *Plant Engineering*, Nov 22, 1990.
4. V Ganapathy. HRSG features and applications. *Heating, Piping, Air-Conditioning*, January 1989.
5. V Ganapathy. Simplify HRSG evaluation. *Hydrocarbon Processing*, March 1990.
6. V Ganapathy. Fouling—the silent heat transfer thief. *Hydrocarbon Processing*, October 1992.

3

Steam Generators

INTRODUCTION

Steam generators, or boilers as they are often called, form an essential part of any power plant or cogeneration system. The steam-based Rankine cycle has been synonymous with power generation for centuries. Though steam parameters such as pressure and temperature have been steadily increasing during the last several decades, the function of the boiler remains the same, namely, to generate steam at the desired conditions efficiently and with low operating costs. Low pressure steam is used in cogeneration plants for heating or process applications, and high pressure superheated steam is used for generating power via steam turbines. Steam is used in a variety of ways in process industries, so boilers form an important part of the plant utilities. In addition to efficiency and operating costs, another factor that has introduced several changes in the design of boilers and associated systems is the stringent emission regulations in various parts of the world. As discussed in [Chapter 5](#), the limits on emissions of NO_x, CO, SO_x, and particulates have impacted the design and features of steam generators and steam plants, not to mention their costs. Today's cogeneration systems and power plants resemble chemical plants with NO_x, SO_x, and particulate control systems forming a major portion of the plant equipment. Oil- and gas-fired packaged boilers used in cogeneration and combined cycle plants have also undergone significant changes during the last few decades. Selective catalytic reduction

systems (SCRs) are used even in packaged boilers for NO_x control, adding to their complexity and costs.

Steam pressure and temperature ratings of large utility boilers have been increasing in order to improve overall plant efficiency. Several supercritical plants have been built during the last decade. There have been improvements in the design of packaged boilers too. Figure 3.1 shows the general arrangement of a packaged steam generator. The standard refractory-lined packaged boilers of the last century are being slowly replaced by custom-designed boilers with completely water-cooled furnaces (Fig. 3.2). The air heater that was once an integral part of oil- and gas-fired boilers is now replaced by the economizer, which helps to

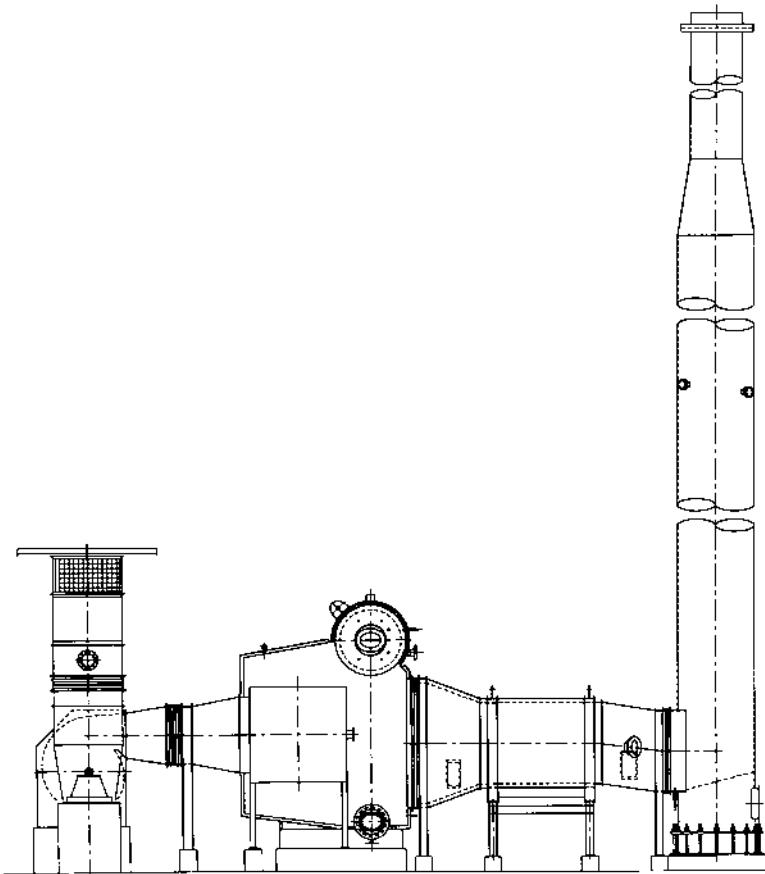

FIGURE 3.1 Package water tube boiler. (Courtesy of ABCO Industries, Abilene, TX.)

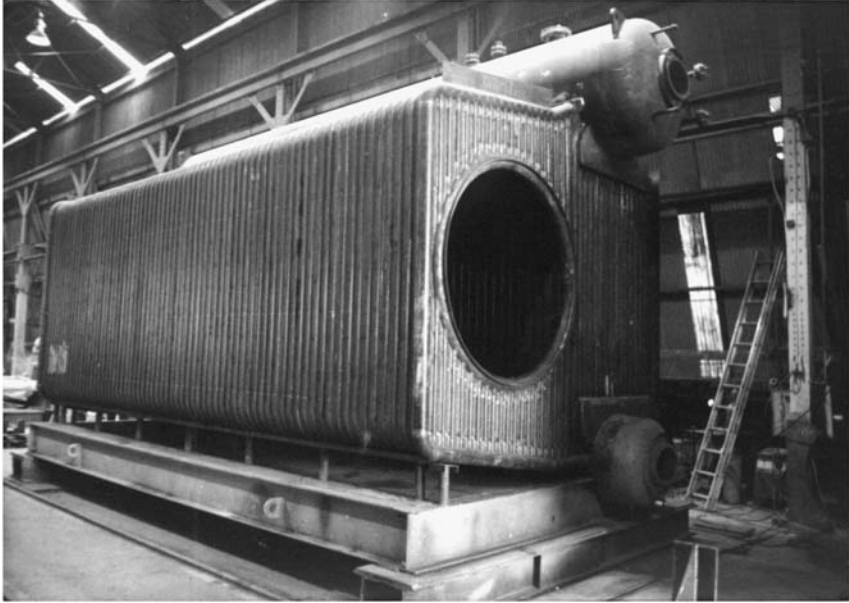

FIGURE 3.2 Completely water-cooled furnace design. (Courtesy of ABCO Industries, Abilene, TX.)

lower NO_x levels. To improve efficiency, a few plants are even considering the use of condensing economizers.

Though pulverized coal-fired boilers form the backbone of utility plants, fluidized bed boilers are finding increasing application when it comes to handling solid fuels with varying moisture, ash, and heating values; they also generate lower emissions of NO_x and SO_x. Oil- and gas-fired fire tube boilers (Fig. 3.3) are widely used in small process plants for generating low pressure saturated steam. Though different types of boilers are mentioned in this chapter, the emphasis is on the oil- and gas-fired packaged water tube steam generator, which is fast becoming a common sight in every cogeneration and combined cycle plant.

BOILER CLASSIFICATION

The terms boiler and steam generator are often used in the same context. Boilers may be classified into several categories as follows:

By Application: Utility, marine, or industrial boiler. Utility boilers are the large steam generators used in power plants generating 500–1000 MW of

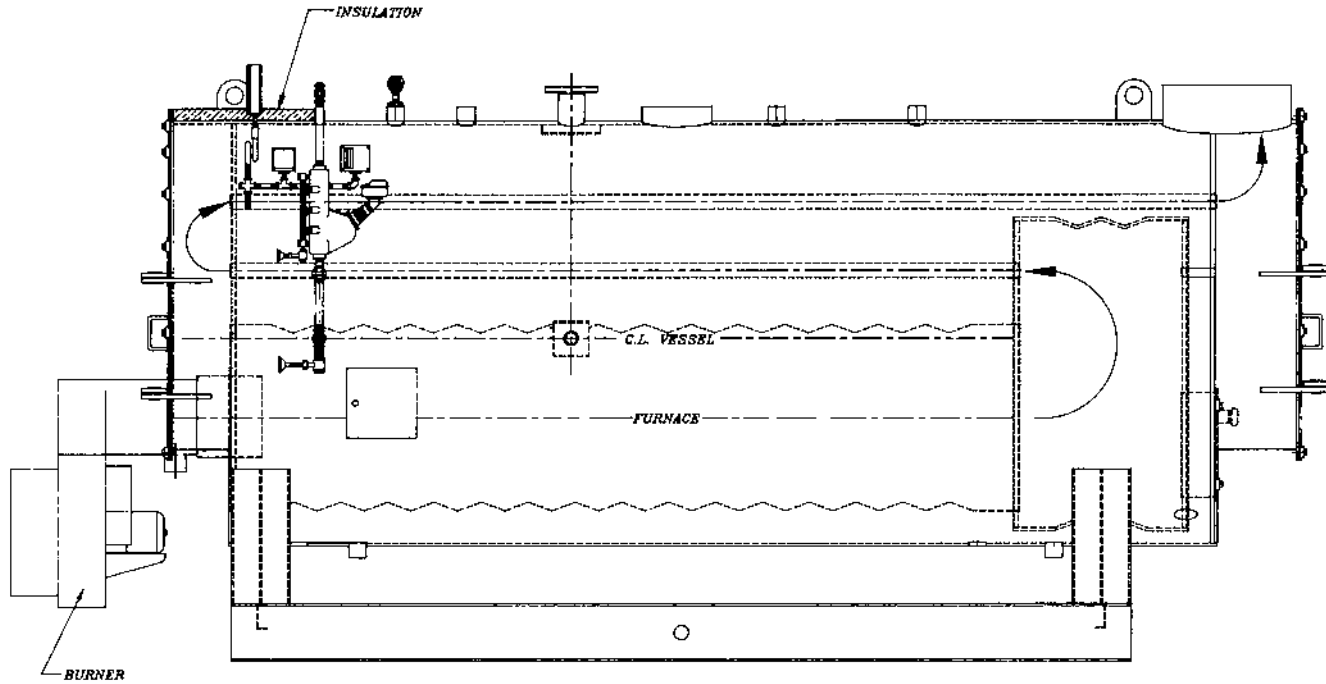

FIGURE 3.3a Fire tube boiler—wetback design.

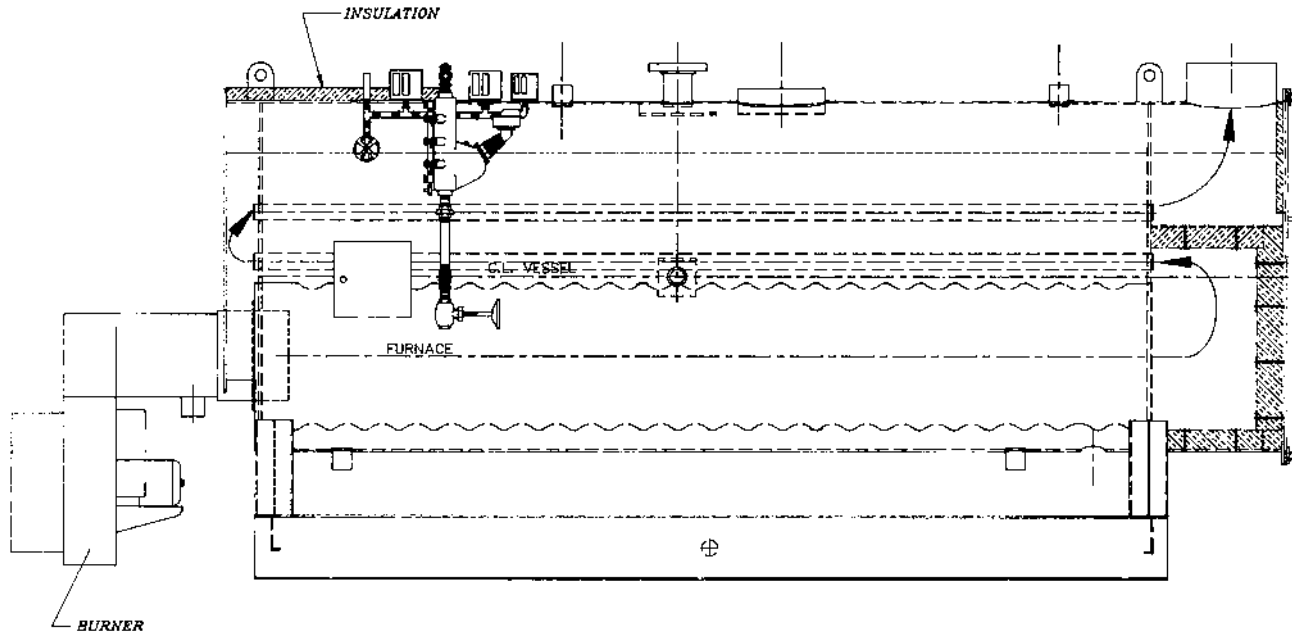

FIGURE 3.3b Fire tube boiler—dryback design.

electricity. They are generally fired with pulverized coal, though fluidized bed boilers are popping up in some plants. Utility boilers generate high pressure, high temperature superheated and reheat steam; typical parameters are 2400 psig, 1000/1000°F. A few utility boilers generate supercritical steam at pressures in excess of 3500 psig, 1100/1100/1100°F. Double reheat cycles are also in operation. Industrial boilers used in cogeneration plants generate low pressure steam at 150 psig to superheated steam at 1500 psig at temperatures ranging from 700 to 1000°F.

By Pressure: Low to medium pressure, high pressure, and supercritical pressure. Process plants need low to medium pressure steam in the range of 150–1500 psig, which is generated by field-erected or packaged boilers, whereas large utility boilers generate high pressure (above 2000 psig) and supercritical pressure steam.

By Circulation Method: Natural, controlled, once-through, or combined circulation. [Figure 3.4](#) illustrates these concepts. Natural circulation is widely used for up to 2400 psig steam pressure. There is no operating cost incurred for ensuring circulation through the furnace tubes, because gravity aids the circulation process. Controlled and combined circulation boilers use pumps to ensure circulation of a steam–water mixture through the evaporator tubes. Supercritical boilers are of the once-through type. It may be noted that once-through designs can be employed at any pressure, whereas supercritical pressure boilers must be of a once-through design.

By Firing Method: Stoker, cyclone furnace, fluidized bed, register burner, fixed or moving grate.

By Construction: Field-erected or shop-assembled. Large industrial and utility boilers are field-erected, whereas small packaged fire tube boilers up to 90,000 lb/h capacity and water tube boilers up to 250,000 lb/h are generally assembled in the shop. Depending on shipping dimensions, these capacities could vary slightly.

By Slag Removal Method: Dry or wet bottom, applicable to solid-fuel-fired boilers.

By Heat Source and Fuel: Solid, gaseous, or liquid fuels, waste fuel or waste heat. Waste heat boilers are discussed in [Chapter 2](#). The type of fuel used has a significant impact on boiler size. For example, coal-fired boiler furnaces are large, because a long residence time is required for coal combustion, whereas oil- and gas-fired boilers can be smaller, as shown in [Fig. 3.5](#).

According to Whether Steam is Generated Inside or Outside the Boiler Tubes: Fire tube boilers ([Fig. 3.3](#)), in which steam is generated outside the tubes, are used in small plants up to a capacity of about 60,000 lb/h

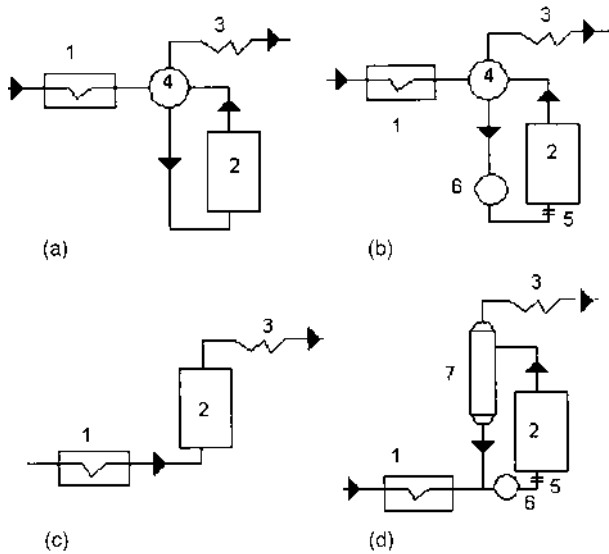

FIGURE 3.4 Boiler circulation methods. (a) Natural; (b) forced circulation; (c) once-through; (d) once-through with superimposed circulation. 1, Economizer; 2, furnace; 3, superheater; 4, drum; 5, orifice; 6, circulating pumps; 7, separator.

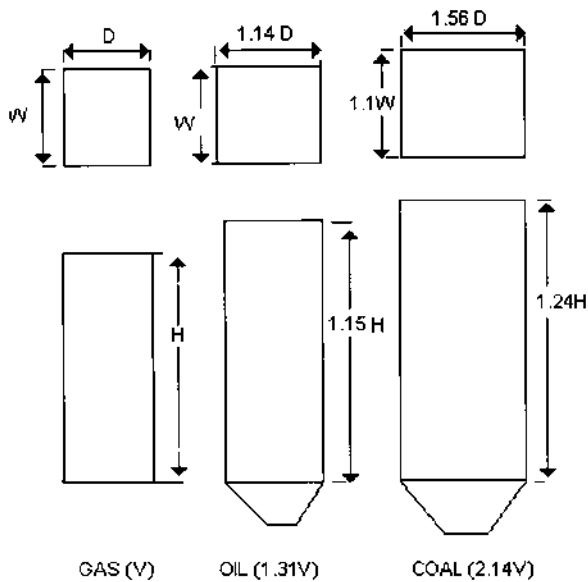

FIGURE 3.5 The impact of fuel on furnace size.

of saturated steam at 300 psig or less; they typically fire oil or gaseous fuels. Water tube boilers, in which steam is generated inside the tubes, can burn any fuel, be of any size, and operate at any pressure but are generally economical above 50,000 lb/h capacity. See [Chap. 2](#) for a comparison between fire tube and water tube waste heat boilers.

STEAM PRESSURE AND BOILER DESIGN

The energy absorbed by steam is distributed among feedwater heating (sensible heat), boiling (latent heat), superheating, and reheating functions. The distribution ratios are a function of steam pressure, as can be seen from steam tables or from Fig. 3.6. If the latent heat is large as in low pressure steam, a large furnace is required for the boiler; as the pressure of steam increases, the latent heat portion decreases and the superheat and reheat energy absorption increases. The boiler design accordingly varies with large surface areas required for the superheaters and reheaters and a small furnace with little or no convective evaporator surface in particular. The sensible heat, which is absorbed in the economizer, is also high at high pressure. The distribution of energy among the various surfaces—the furnace, evaporator, superheater, reheater, and economizer—is somewhat flexible, as will be shown later, but it must be emphasized that steam pressure plays a significant role in determining the sizes of these surfaces.

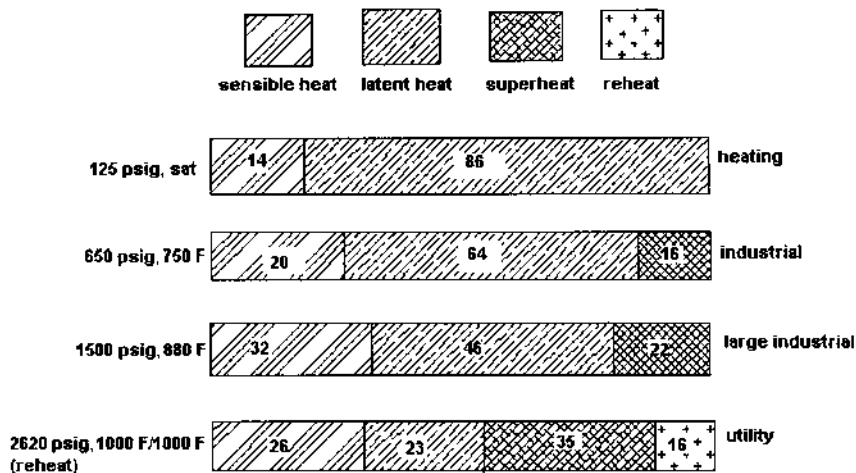

FIGURE 3.6 Distribution of energy in boilers as a function of steam pressure.

In natural circulation units the density differential between the cooler water in the downcomers and the less dense steam–water mixture in the riser tubes of the furnace provides the hydraulic head for circulation of the steam–water mixture through the evaporator tubes. The circulation ratio, CR, which is the ratio of the mixture flow to steam flow, could be in the range of 6–8 in high pressure boilers. In packaged boilers operating at low steam pressure, say 150–1000 psig, the CR could be higher, ranging from 10 to 20. Note that we are referring to an average value. The circulation ratio will differ for each parallel circuit, depending on its length, tube size, heat flux, and static head available, as discussed in Q7.29. The controlled circulation boiler is operated at a slightly higher steam pressure, around 2500–2600 psig, and flow is ensured through the furnace tubes by a circulating pump; which forces the boiler water through each circuit. The circulation ratio is preselected in the range of about 2–4. This is done to reduce the operating cost associated with the circulating pumps; also, the use of carefully selected orifices ensures the flow of the steam–water mixture through each circuit. Hence a low CR is used in these systems. The once-through unit with superimposed circulation requires the circulating pump during start-up and at low loads when flow through the circuits is not high and later switches to the once-through mode at higher loads.

PACKAGED STEAM GENERATORS

Packaged boilers are widely used in cogeneration and even in combined cycle plants as auxiliary boilers providing steam for turbine sealing and steam for other uses when the gas turbine trips and the HRSG is not in operation. These boilers are generally shop-assembled and custom-designed. Typically, boilers of up to 250,000 lb/h capacity can be shop-assembled and larger units are field-erected. Steam parameters vary from 150 psig saturated to 1500 psig, 1000°F. They typically burn natural gas, distillate fuel oils, and even heavy residual oils. Widely used methods for NO_x control are low-NO_x burners, flue gas recirculation, and selective catalytic reduction systems (SCRs). Carbon monoxide catalysts are also used if required. Emission control methods are discussed in [Chapter 4](#).

Packaged boilers could be further classified as D, A, or O-type depending on their construction, as shown in [Fig. 3.7](#). In the A- and O-type boilers, the flue gases exit the furnace and then make a 180° turn, split up into two parallel paths, and flow through the convection section, then recombine to flow through the economizer. Using a convective superheater in this type of boiler is tricky, because it has to be split into two halves. A radiant design may be located at the furnace exit, but it operates in a harsh environment as discussed later.

D-type boilers are widely used in industry. The flue gases generated in the furnace travel through the furnace, make a turn, and go through the convection

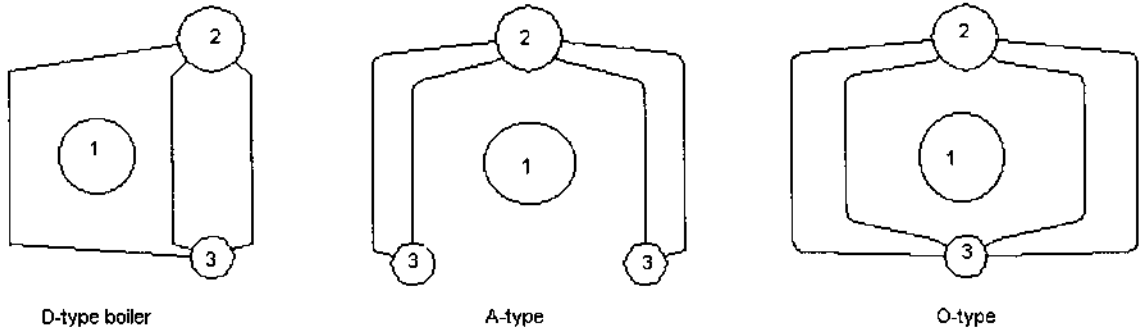

FIGURE 3.7 A-, D-, and O-type boiler configurations. 1, Burner; 2, steam drum; 3, mud drum.

bank and then through the economizer to the stack. The gas flow is not split into two parallel paths as in the A- or O-type designs. If a superheater has to be located in the convection bank, the D-type design is the most convenient, because there is no concern with maldistribution in gas flow between parallel paths as with the O- and A-type boilers, which may lead to thermal performance issues. However, the O- and A-type boilers are more suitable as mobile units, because they have balanced weight distribution; rental boilers, which move from location to location, are generally of A- and O-type designs.

The gas-fired O-type boiler shown in Fig. 3.8 is another variation of packaged boiler design. In this boiler the flue gases do not make a turn at the furnace end; the gases flow straight beyond the furnace to a convection section consisting of bare and finned tubes; the finned tubes make the convection section compact, thus reducing the overall length of the boiler. The advantage of this design is that the width required is not large, because the width of the furnace determines the width of the unit, whereas in a typical O- or A-type boiler the width of the furnace is added to that of the convection bank, making it difficult to ship the boiler to certain areas of the country or the world. Also, a convective type of superheater can be easily located behind a screen section. The advantages of the convective superheater over a radiant design are discussed later.

A recent application for packaged boilers has been in combined cycle plants. These plants require steam for turbine sealing purposes when the HRSG trips, and they need it at short notice, say, within 5–15 min. Packaged boilers with completely water-cooled furnace designs are well suited for fast start-ups, as discussed later.

Very high steam purity as in utility plants can be obtained in packaged boilers through proper design of steam drum internals. Depending on the application, steam purity in the range of 30–100 parts per billion (ppb) can be

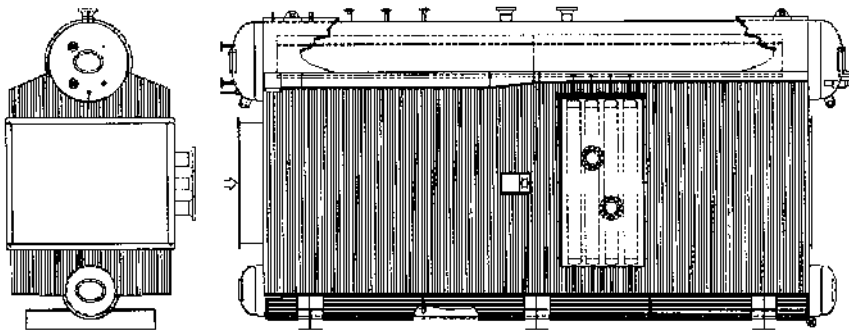

FIGURE 3.8 A gas-fired O-type package boiler with extended surfaces. (Courtesy of ABCO Industries, Abilene, TX.)

achieved. Packaged boiler designs have evolved over the years and have adapted well to the needs of the industry.

Standard Boilers

Standard boilers, which are pre-engineered packages, are inexpensive and are used in applications that are not very demanding in terms of process or emission limits. Decades ago, various manufacturers had developed so-called standard designs for boilers of 40,000–200,000 lb/h capacity with fixed dimensions of furnace, tubes, tube spacing, lengths, and surface areas. If someone wanted a boiler for a particular capacity that was not listed, the next or closest standard model would be offered. Standard models are less expensive than custom designs because no engineering is required to design and build them. It must be borne in mind that these designs were developed 30–50 years ago when the concept of flue gas recirculation and low-NO_x burners were unheard of. They also had a lot of refractory in their design—on the floor, front walls, and rear walls—because completely water-cooled furnace designs had not yet been developed. The concerns with refractory-lined boilers are discussed later. However, emission regulations are forcing suppliers to custom design the boilers.

As discussed in [Chapter 4](#), the effect of flue gas recirculation and changes in excess air levels have to be reviewed on a case-to-case basis depending on the NO_x and CO levels desired. Hence standard furnace dimensions may or may not be suitable for a given heat input, because the flame shape varies according to the NO_x control method used. Flame lengths with low-NO_x burners can be wider or even longer than with regular burners. Hence the use of low-NO_x burners makes it difficult to select a standard boiler that meets the same need and is also an economical option. The furnace size could be compromised, which may result in flame impingement concerns with the burners used, or the gas pressure drop across the convection surfaces could be very large due to the flue gas recirculation rates used; the efficiency also could be lower due to the higher exit gas temperature associated with the larger flue gas flow. The operating cost due to a higher gas pressure drop is discussed below and in [Chapter 4](#).

Often gaseous and oil fuels are fired at excess air ranging from 10% to 20%; flue gas recirculation could be in the range of 10–35%, depending on the NO_x level desired. In a few boilers, 9 ppmv NO_x has been achieved with the burner operating at 15% excess air and 35% flue gas recirculation rate on natural gas firing. Thus it is possible to have a “standard” steam generator handling nearly 30–40% more flue gases than it was designed for in the good old days when 5–10% excess air was used without gas recirculation: A 100,000 lb/h standard boiler could be operating at gas flow conditions equivalent to those of a 140,000 lb/h boiler if it is not custom-designed. Of course, one could select a larger standard boiler, but it may or may not meet all the requirements of furnace

dimensions, because developers of standard boilers generally increase furnace lengths for higher capacity but not the width or height, due to shipping constraints, particularly when the capacity is large. However, standard boilers are useful where one is not concerned about optimizing all the parameters such as efficiency, gas pressure drop, and emission levels and low initial cost is a primary objective.

Packaged steam generators of today are custom-designed with an eye on operating costs and emissions. The furnace design also has undergone major design innovations, the completely water-cooled furnace (Fig. 3.2) being one of them. This design offers several advantages over the refractory-lined boilers designed decades ago.

Advantages of Water-Cooled Furnaces

Water-cooled furnaces have a number of advantages over other types:

1. The front, rear, and side walls are completely water-cooled and are of membrane construction, resulting in a leakproof enclosure for the flame, as shown in Fig. 3.2. The entire furnace expands and contracts uniformly, thus avoiding casing expansion problems. When refractory is used on the front, side, or rear walls, the sealing between the hotter membrane walls and the cooler outer casing is a concern and hot gases can sometimes leak from the furnace to the outside. This can cause corrosion of the casing, particularly if oil fuels are fired.
2. Problems associated with refractory maintenance are eliminated. Also, there is no need for annual shutdown of the boiler plant to inspect the refractory or repair it, thus lowering the cost of owning the boiler.
3. Fast boiler start-up rates are difficult with refractory-lined boilers because of the possibility of causing cracks in the refractory. However, with completely water-cooled furnaces, start-up rates are limited only by thermal stresses in the drums and are generally quicker. The tubes may be welded to the drums instead of being rolled if the start-ups are frequent. With boilers maintained in hot standby conditions using steam-heated coils located in the mud drum, even 10–15 min start-ups are feasible. With a separate small burner whose capacity is 6–8% of the total heat input in operation during boiler standby conditions, the boiler can be maintained at pressure and can be ramped up to generate 100% steam within 3–5 min.
4. Heat release rate on an area basis is lower for the water-cooled furnace by about 7–15% compared to the refractory-lined boiler. Some gas-fired boilers designed decades ago still use refractory on the floor; replacing this with a water-cooled floor will increase the effective heating surface of the furnace and lower the heat flux inside the tubes

even further. The furnace exit gas temperature also decrease slightly due to the increased effective cooling surface of the furnace. A lower furnace exit gas temperature decreases the radiant energy transferred to a superheater located at the furnace exit and thus reduces the potential for superheater tube failures. A lower area heat release also helps reduce NO_x, as can be seen from the correlations developed by a few burner suppliers.

5. Reradiation from the refractory on the front wall, side walls, and a floor increases the flame temperatures locally, which results in higher NO_x formation. Of the total NO_x generated by the burner, a significant amount of NO_x is formed at the burner flame base, so providing a cooler environment for the flame near the burner helps minimize NO_x to some extent.
6. Circulation was one of the concerns about the use of refractory on the floor of even gas-fired boilers because the D tubes are longer than partition tubes of the dividing wall. Heat fluxes in packaged boilers are generally low compared to those of utility boilers. To further protect the floor and roof tubes, a small inclination to the horizontal is used; also, considering the low steam pressure, tube-side velocities, heat flux, and steam quality, departure from nucleate boiling (DNB) has never been an issue, as evidenced by the operation of hundreds of boilers at pressures as high as 1000–1500 psig. The tube-side velocities are also adequate to ensure that steam bubbles do not separate from the water. Hence refractory is not required on the floor or front or rear walls for oil and gas firing.
7. Packaged boilers use economizers as the heat recovery equipment instead of air heaters, which only serve to increase the flame temperature, thus increasing the NO_x formation. The gas- and air-side pressure drops are also higher with air heaters, thus adding to the fan size and power consumption. The heat flux inside the furnace tubes is also reduced owing to the smaller furnace duty.

Custom-Designed Boilers

Custom-designed boilers, as the term implies, are designed from scratch. Based on discussions with the burner supplier and the level of NO_x and CO desired, one first selects the type of burner to be used and the emission control strategy. A few options could be considered:

- Use a large amount of flue gas recirculation (FGR) and a low cost burner, which results in higher operating costs; one may use a large boiler with a wide convection bank to minimize gas pressure drop.
- Use an expensive burner, which uses fuel or air staging methods and requires little or no flue gas recirculation. A few burners can guarantee

about 20–30 ppmv NO_x (at 3% oxygen dry) on gas firing. Installation and operating costs associated with FGR are minimized.

One can also consider the possibility of using a selective catalytic reduction (SCR) system along with a less expensive burner, which has a low to nil FGR rate.

Steam injection may also be looked into, and the cost of steam versus FGR may be compared.

Depending on the NO_x and CO levels desired and the fuel analysis, the solution may vary from case to case, and no obvious solution exists for every situation. Thus one arrives at the best option from an emission control viewpoint and then starts developing the boiler design using the excess air and FGR rates for the fuels in consideration; the furnace dimensions to avoid flame impingement on the furnace walls are then arrived at. Assuming a specific exit gas temperature, the boiler efficiency calculations are done to arrive at the air and flue gas flow rates and the amount of flue gas recirculated. This is followed by an evaluation of furnace performance and design of the heating surfaces. The exit gas temperature from the economizer is arrived at and compared with the assumed value; efficiency is recalculated using the computed exit gas temperature, and revised air and flue gas flows are obtained. (Air and flue gas quantities depend on the amount of fuel fired, which in turn depends on efficiency.) Another iteration starting from the furnace is done to fine-tune the performance. The superheater performance is evaluated at various loads to determine whether the surface areas are adequate.

If different fuels are fired, these calculations are carried out for all the fuels. Efforts are then made to reduce the fuel consumption and also lower the fan power consumption, which are recurring expenses, by fine-tuning the design of the evaporator and economizer. A large economizer may be used to improve the boiler efficiency if the duration of operation warrants it. The designer also has the ability to change the dimensions of the convection section—for example, the number of tubes wide, length, tube spacing, or even tube diameter—to come up with low gas pressure drop and hence low fan operating cost as shown below. Based on partial load performance and gas temperature profiles, bypass dampers may be required if an SCR system is used. Hence it is likely that the steam parameters of several boilers could be the same but the designs different due to the emission control strategy used and degree of custom designing. A computer program is used to perform these tedious calculations.

Example 1

A 150,000 lb/h boiler firing standard natural gas and generating saturated steam at 285 psig with 230°F feedwater uses 15% excess air and 15% flue gas recirculation. The exit gas temperature is 323°F. Compare the performance of a standard boiler with that of a custom-designed unit. The flue gas flow through the

boiler is 184,300 lb/h. With 80°F ambient temperature, the efficiency is 83.38% HHV.

The results of the calculations are shown in Table 3.1. The following points may be noted from this table:

1. The efficiency is the same in both designs because the exit gas temperature and excess air are the same. Also, the furnace dimensions are the same. Hence the furnace exit gas temperature is the same in both designs.
2. The convection sections are different. In the standard boiler, we used a standard tube spacing of 4 in. In the custom-designed unit, we reduced the surface area significantly by using fewer rows and also made the convection bank tube transverse spacing 5 in. This reduces the gas pressure drop in the convection bank by 4 in. WC. It also reduces the duty of the evaporator section, as can be seen by the higher exit gas temperature of 683°F versus 550°F.
3. We added a few more rows to the economizer in the custom-designed unit and made its tubes longer to obtain the same exit gas temperature and also to handle the additional duty. Economizer steaming is not a

TABLE 3.1 Reducing Boiler Gas Pressure Drop Through Custom Designing

Item	Standard boiler		Custom boiler	
Furnace length × width × height	32 ft × 7 ft × 11 ft		32 ft × 7 ft × 11 ft	
Furnace exit gas temp, °F	2167		2167	
Gas temp leaving evaporator, °F	550		683	
Exit gas temperature, °F	323		323	
Boiler surface area, ft ²	8,920		6,710	
Economizer area, ft ²	10,076		14,107	
Geometry	<i>Evaporator</i>	<i>Economizer</i>	<i>Evaporator</i>	<i>Economizer</i>
Tubes/row	16	18	12	18
No. of rows deep	96	12	96	14
Effective length, ft	10	10	10	12
Gas pressure drop, in. WC	11.0	1.7	7.0	1.6
Transverse pitch, in.	4	4	5	4

concern in packaged boilers due to the small ratio of flue gas to steam flows (this aspect is discussed later). Hence we can absorb more energy in the economizer, which is a less expensive heating surface than the evaporator. The overall gas pressure drop saving of 4 in. WC results in a saving of 31 kW in fan power consumption (see Example 9.06b for fan power calculation). If energy costs 7 cents/kWh, for 8000 h of operation per year the annual saving is

$$31 \times 0.07 \times 8000 = \$17,360.$$

This is not an insignificant amount. Simply by manipulating the tube spacing of the convection bank, we have dramatically reduced the fan power consumption and the size of the fan. Also the boiler cost for the two designs should be nearly the same because the increase in economizer cost is offset by the smaller number of evaporator tubes, which reduces the material costs as well as labor costs. To improve the energy transfer in evaporators one can also use finned tubes if the boiler is fired with natural gas or distillate fuels. For example, if we desire good efficiency but do not want an economizer because of, say, shorter duration of operation or corrosion concerns, we may consider using extended surfaces in the convection bank to lower the evaporator exit gas temperature by about 40–100°F, which improves the efficiency by 1–2.5% compared to a standard boiler.

4. Another important point is that surface areas should be looked at with caution. One should not purchase boilers based on surface areas, which is still unfortunately being done. It is possible to distribute energy among the furnace, evaporator, and economizer in several ways and come up with the same overall efficiency and fan power consumption and yet have significantly different surface areas as shown in [Tables 3.1](#) and [3.2](#).

Comparing Surface Areas

Example 2

This example illustrates the point that surface areas can be misleading. A boiler generates 100,000 lb/h of saturated steam at 300 psig. Feedwater is at 230°F, and blowdown is 2%. Standard natural gas at 10% excess air is fired. Boiler duty = 100.8 MM Btu/h, efficiency = 84.3% HHV, furnace backpressure = 7 in. WC

It is seen from Table 3.2 that boiler 2 has about 10% more surface area than boiler 1 but the overall performance is the same for both boilers in terms of operating costs such as fuel consumption and fan power consumption. Also the

TABLE 3.2 Comparison of Boilers with Same Efficiency and Backpressure

Item ^a	Boiler 1		Boiler 2	
Heat release rate, Btu/ft ³ h	90,500		68,700	
Heat release rate, Btu/ft ² h	148,900		116,500	
Furnace length, ft	22		29	
Furnace width, ft	6		6	
Furnace height, ft	10		10	
Furnace exit gas temp, °F	2364		2255	
Evaporator exit gas temp, °F	683		611	
Economizer exit gas temp, °F	315		315	
Furnace proj area, ft ² (duty)	802 (36.6)		1026 (40.4)	
Evaporator surface, ft ²	3972 (53.7)		4760 (52.1)	
Economizer surface, ft ²	8384 (10.5)		8550 (8.3)	
Geometry	<i>Evaporator</i>	<i>Economizer</i>	<i>Evaporator</i>	<i>Economizer</i>
Tubes/row	11	15	10	15
Number deep	66	14	87	10
Length, ft	9.5	11	9.5	10
Economizer, fins/in. × ht × thickness × (serration)	3 × 0.75 × 0.05 × 0.157		5 × 0.75 × 0.05 × 0.157	
Transverse pitch, in.	4	4	4.375	4
Overall heat transfer coeff	18	7.35	17.0	6.25

^aDuty is in MM Btu/h, fin dimensions in inches, heat transfer coefficient in Btu/ft² h °F.

energy absorbed in different sections is different, hence comparing surface areas is difficult unless one can do the heat transfer calculations for each surface.

It has become a common practice (with the plethora of spreadsheet users) to compare surface areas of boilers and generally select the design that has the higher surface area. Surface areas should not be used for comparing two boiler designs for the following reasons:

1. Surface area is only a part of the simple equation $Q = UA \Delta T$, where U = overall heat transfer coefficient, A = surface area, ΔT = log-mean temperature difference, and Q = energy transferred. However, the Q and ΔT could be different for the two designs at different sections as shown in the above example. Hence unless one knows how to compute U , A values should not be compared.
2. Even if ΔT remains the same for a surface, U is a function of several variables such as the tube size, spacing, and gas velocity. With finned tubes, the heat transfer coefficient decreases as fin surface area increases, as discussed in Q8.19. Hence unless one is familiar with

all these issues, a simplistic tabulation of surface areas can be misleading.

EFFECT OF STEAM PRESSURE ON BOILER DESIGN AND PERFORMANCE

Another example of custom designing is shown in Example 3. In this example, we are asked to design a boiler for a lower pressure of operation for the first few years with the idea of operating at a higher steam pressure after that.

Example 3

An interesting requirement was placed on the design of a boiler. The 175,000 lb/h boiler was to generate steam at 150 psig and 680°F for the first few years and then operate at 650 psig and 760°F. The piping and superheater changes had to be minimal when the time came for modifications.

Operating a steam generator at two different pressures is a challenging task, particularly when a superheater is present. The reason is that the large difference in specific volume of steam affects the steam velocity inside the superheater tubes and the steam-side pressure drop, which in turn affect the flow distribution inside the tubes. The ratio of specific volume between the 150 and 650 psig steam is about 4. Hence for the same steam output, we could have a 4 times higher steam velocity at the lower pressure if the flow per tube were the same. Also, if the pressure drop at 650 psig were, say, 30 psi, it would be about 120 psi at the lower operating pressure if flow per tube were the same. Hence it was decided to manipulate the streams and steam flows as shown in [Fig. 3.9](#).

In the low pressure operation, there would be two inlets to the superheater from opposite ends of the headers as shown in [Fig. 3.9a](#). This would make the velocity and pressure drop inside the tubes more reasonable. The total length of tubing traveled by steam in the low pressure option would be nearly half that of the high pressure case, which also reduces the pressure drop. Part of the steam is in parallel flow and part in counterflow. At high gas temperatures, as in this case, the difference in performance between parallel and counterflow superheaters is marginal.

In the high pressure case, all the steam flows through the superheater tubes in counterflow. Because the specific volume is small, the steam can flow as shown with a reasonable steam velocity and without increasing the pressure drop. The performance in both, cases is shown in [Table 3.3](#). Thus with a minimal amount of reworking, the piping could be changed when high pressure operation is begun. The superheater per se was untouched, and only the nozzle connections were redone. This boiler will be in operation for several years. If custom designing were not done, the capacity at low pressure mode would have to be limited to

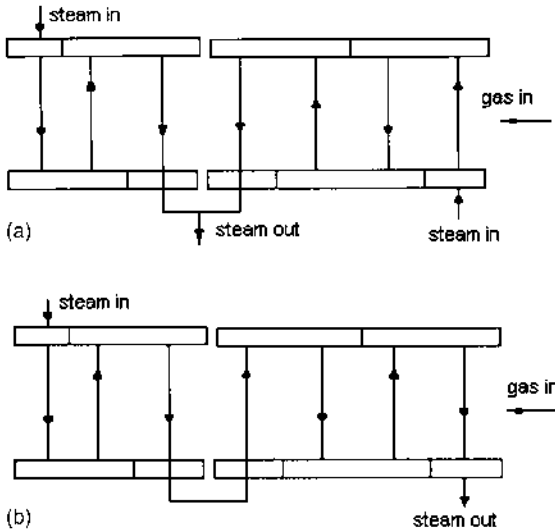

FIGURE 3.9 Superheater piping arrangement for (a) low and (b) high pressure operation.

about 50–60% of the boiler capacity in order to avoid unreasonable steam velocity or pressure drop values. The main steam line has two parallel valves in the low pressure mode and will be converted to single-valve operation in the high pressure mode.

BOILER FURNACE DESIGN

The furnace is considered the heart of the boiler. Both combustion and heat transfer to the boiling water occur here, so it should be carefully designed. If not, several problems may result, such as lower or higher steam temperature if a

TABLE 3.3 Boiler Performance at Low and High Steam Pressure^a

	Low pressure	High pressure
Steam flow, lb/h	175,000	175,000
Steam temperature, °F	680	760
Steam pressure, psig	150	650
Pressure drop, psi	23	46

^aFeedwater = 230°F; excess air = 15%; FGR = 17%; natural gas.

superheater is used; the heat flux should be such as to avoid from DNB concerns. Circulation inside the tubes should be good. There could be incomplete combustion, which leads to lower efficiency and, coupled with a poor burner design, higher emissions of NO_x and CO. Also, the flame should not impinge on the walls of the furnace enclosure. Hence it is always good practice to discuss emission control needs with potential burner suppliers who can model the flame shape and ensure that the furnace dimensions used can avoid flame impingement issues while ensuring the desired emission levels.

In boilers fired with fuels that produce ash, the furnace is sized so that the furnace exit gas temperature is below the ash softening temperature. This is to avoid potential slagging problems at the turnaround section. Slag or molten deposits from various salts and compounds in the ash can cause corrosion damage and also affect heat transfer to the surfaces. The gas pressure drop across the convection section is also increased when the flow path is blocked by slag deposits.

One of the parameters used in furnace sizing is the area heat release rate. This is the net heat input to the boiler divided by the effective projected area. This factor determines the furnace absorption and hence the duty and heat flux inside the tubes. Typically it varies from 100,000 to 200,000 Btu/ft² h for oil- and gas-fired boilers and from 70,000 to 120,000 Btu/ft² h for coal-fired units.

The volumetric heat release rate is another parameter, which is obtained by dividing the net heat input by the furnace volume. This is indicative of the residence time of the flue gases in the furnace and varies from 15,000 to 30,000 Btu/ft³ h for coal-fired boilers. For oil and gaseous fuels it is not as significant a parameter as for fuels that are difficult to burn such as solid fuels. However, this parameter ranges from 60,000 to 130,000 Btu/ft³ h for typical packaged oil- and gas-fired boilers.

From the steam side, the circulation of the steam-water mixture in the tubes should be good. As discussed in Q7.30, several variables affect circulation, including static head available, steam pressure, tube size, and steam generation. The circulation is said to be adequate when the heat flux does not cause DNB conditions for the steam quality in consideration. Packaged boilers have a low static head, unlike field-erected industrial boilers, and also have longer furnace tubes. However, packaged boilers operate at low pressures, on the order of 200–1200 psig, unlike large utility boilers, which operate at 2400–2600 psig, and circulation is better at lower pressures.

Today's boilers use completely welded membrane walls for the furnace enclosure (Fig. 3.2). Earlier designs were of tangent tube construction or had refractory behind the tubes (Fig. 3.10). With the refractory-lined casing, it is difficult to maintain a leakproof enclosure between the refractory walls and the water-cooled tubes, as a result flue gases can leak to the atmosphere, leading to corrosion, at the casing interfaces, particularly on oil firing. Balanced draft

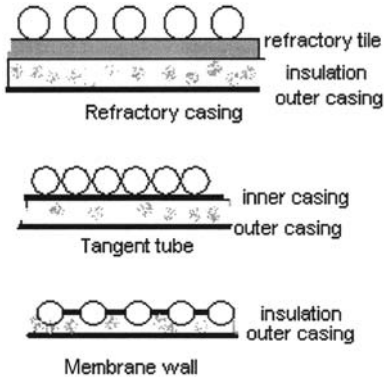

FIGURE 3.10 Furnace construction—membrane wall, tangent tube, and refractory wall.

furnace design is used to minimize this concern, where the furnace pressure is maintained near zero by using a combination of forced draft and induced draft fans.

The tangent tube design is an improvement over the refractory-lined casing. However, it has the potential for leakage across the partition wall. During operation the tubes in the partition wall are likely to flex or bend due to thermal expansion, paving the way for leakage of combustion gases from the furnace to the convection bank, resulting in higher CO emissions and also higher exit gas temperature from the evaporator and lower efficiency. Present-day boiler designs use forced draft fans, and the furnace is pressurized to 20–30 in. WC, depending on the backpressure. If SCR and CO catalysts are used, the back-pressure is likely to be even higher. With such a large differential pressure between the furnace and the convection bank, a leakproof combustion chamber is desired to ensure complete combustion. If gas bypassing occurs from the furnace to the convection side, the residence time of the flue gases in the furnace is reduced, thus increasing the formation of CO. Another concern with leakage of hot furnace gases from the furnace to the convection bank is the impact on superheater performance; the steam temperature is likely to be lower.

The present practice is to use membrane walls. These consist of tubes welded to each other by fins as shown in Figs. 3.2 and 3.10. A gastight enclosure is thus formed for the combustion products. The partition wall is also leakproof, hence gas bypassing is avoided between the furnace and convection sections. This ensures complete combustion in the furnace enclosure. Typical designs at low pressures use 2 in. OD tubes at intervals of 3.5–4 in. depending on membrane tip temperature. Three-inch tubes have also been swaged to 2 in. and used at 4 in.

pitch. This ensures a lower membrane temperature as well as reasonable ligament efficiency in the steam and mud drums. At pressures up to 700–750 psig, membranes using 2 in. tubes on 4 in. pitch have been found to be adequate due to the combination of low heat flux in the furnace and low saturation temperature, as evidenced by the operation of several hundred boilers. The 1 in. long membrane with appropriate thickness does not result in excessive fin tip temperatures or thermal stress concerns. At higher pressures, one may use 0.5 in. × 0.75 in. long membranes. Figure 3.11 shows how fin tip temperatures vary with heat flux and membrane length.

The furnace process is extremely complicated, because today’s burners have to deal with various aspects of burner designs such as staged fuel or staged air combustion, flue gas recirculation, and other NOx control methods; hence furnace performance should be arrived at on the basis of experience, field data, and calculations. The furnace exit gas temperature is the most important variable in this evaluation and is a function of heat input, flue gas recirculation rate, type of fuel used, effective cooling surface available, and excess air used. A gas-fired flame has less luminosity than an oil flame, so the furnace exit temperature is higher, as shown in Fig. 3.12. A coal-fired flame has an even higher furnace exit gas temperature. An oil flame is more luminous and the furnace absorbs more energy, resulting in higher heat flux in the furnace tubes.

Energy Absorbed by the Furnace

The energy transferred to the furnace is obtained from the equation

$$Q = A_p \varepsilon_1 \varepsilon_2 \sigma (T_g^4 - T_w^4) = W_f \text{LHV} - W_g h_e$$

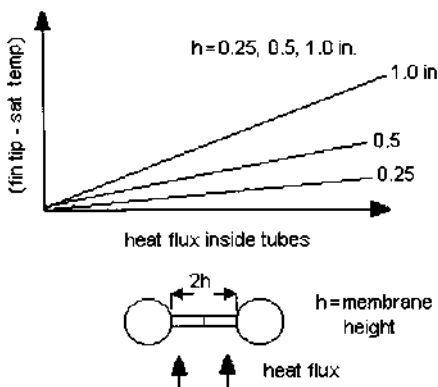

FIGURE 3.11 Relating fin tip temperature to heat flux in membrane wall furnace.

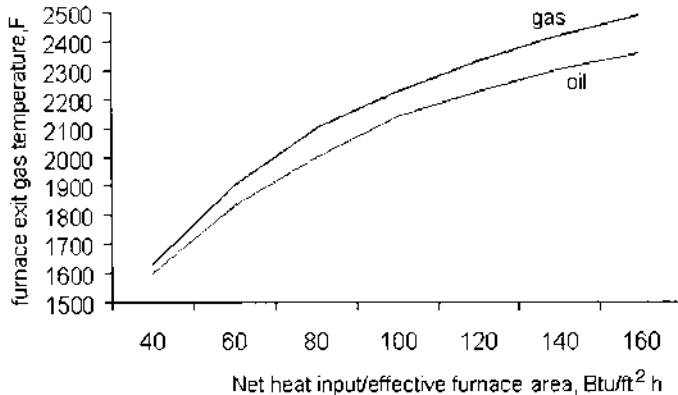

FIGURE 3.12 Furnace outlet temperature for gas and oil firing.

where

Q = energy transferred to the furnace, Btu/h

T_g = average gas temperature in the furnace, °R

h_e = enthalpy of flue gases corresponding to the furnace exit gas temperature T_e , Btu/lb

T_w = average furnace wall temperature, °R

A_p = effective projected area of the furnace, ft²

σ = radiation constant

$\varepsilon_1, \varepsilon_2$ = emissivity of flame and wall, respectively

LHV = lower heating value of the fuel, Btu/lb

W_f, W_g = fuel and flue gas quantity, lb/h

The emissivity of the flame may be determined by using methods discussed in Q8.08. The effective projected area includes the water-cooled surfaces and the opening to the furnace exit plane. If refractory is used on part of the surfaces, a correction factor of 0.3–0.5 has to be used for its effectiveness. Once the furnace duty is arrived at, the heat flux inside the tube may be estimated. Heat flux inside the tubes is a very important parameter because it affects the boiling process.

Example 4

Determine the energy absorbed by the packaged boiler furnace firing natural gas for which data are given in Table 3.4. At 100% load, boiler duty or energy absorbed by steam = 118.71 MM Btu/h. Flue gas flow = 125,246 lb/h at 100% load.

TABLE 3.4 Boiler Performance—Gas Firing^a

	Load (%)			
	25	50	75	100
Boiler duty, MM Btu/h	29.14	50.09	89.03	118.71
Excess air, %	30	15	15	15
Fuel input, MM Btu/h	34.68	69.79	105.69	141.89
Heat rel rate, Btu/ft ³ h	16,055	32,310	48,931	65,691
Heat rel rate, Btu/ft ² h	29,646	59,660	90,349	121,297
Steam flow, lb/h	25,000	50,000	75,000	100,000
Steam temperature, °F	711	740	750	750
Economizer exit water temp, °F	328	334	356	374
Boiler exit gas temp, °F	525	587	666	739
Economizer exit gas temp, °F	254	271	298	327
Air flow, lb/h	32,954	58,665	88,843	119,275
Flue gas, lb/h	34,413	61,602	93,290	125,246
Dry gas loss, %	3.71	3.58	4.08	4.62
Air moisture loss, %	0.1	0.1	0.1	0.12
Fuel moisture loss, %	10.48	10.55	10.67	10.79
Casing loss, %	1.2	0.6	0.4	0.3
Margin, %	0.5	0.5	0.5	0.5
Efficiency, % HHV	84.01	84.67	84.24	83.66
Efficiency, % LHV	93.12	93.85	93.37	92.73
Furnace back pressure, in. WC	0.8	2.61	6.21	11.49

^aSteam pressure 500 psig; feedwater 230°F, blowdown 1%, amb temp 80°F; RH 60%, fuel-standard natural gas. Flue gas analysis (vol%): CO₂ = 8.29, H₂O = 18.17, N₂ = 71, O₂ = 0.07, O₂ = 2.46. Boiler furnace projected area = 1169 ft², furnace width = 7.5 ft, length = 32 ft, height = 9 ft.

The net heat input to the furnace is

$$118.71 \times \frac{0.992}{0.9273} = 127 \text{ MM Btu/h}$$

where 0.992 = 1 – heat losses, and 0.9273 is the boiler efficiency on LHV basis.

$$\frac{\text{Net heat input}}{\text{Effective furnace area}} = \frac{127 \times 10^6}{1169} = 108,900 \text{ Btu/ft}^2 \text{ h}$$

The furnace exit gas temperature from Fig. 3.12 is 2235°F. It may be shown that the enthalpy of the flue gases at 2235°F is 661.4 Btu/lb based on the flue gas analysis. (See Appendix, Table A8.)

The furnace duty from (5) = $127 \times 10^6 - 125,246 \times 661.4 = 44.2$ MM Btu/h.

The average heat flux based on projected area is

$$\frac{44.2 \times 10^6}{1169} = 37,810 \text{ Btu/ft}^2 \text{ h}$$

However, what is of significance is the heat flux inside the boiler tubes, not the heat flux on a projected area basis. We can relate these two parameters as follows:

$$q_p S_t = q_c (\pi d/2 + 2h)$$

where

q_p = heat flux on projected area basis

S_t = transverse pitch of membrane walls, in.

q_c = heat flux on circumferential area basis, Btu/ft² h

d = OD of furnace tubes

h = membrane height, in.

Once q_c is obtained, we can relate it to q_i , the heat flux inside the tubes, as follows:

$$q_c d = q_i d_i$$

where d_i = tube inner diameter, in. Simplifying

$$q_i = \frac{q_p S_t (d/d_i)}{\pi d/2 + 2h}$$

In our example, $q_p = 37,810$ Btu/ft² h, $S_t = 4$ in., $h = 1$ in., $d = 2$, $d_i = 1.706$ in. Then

$$q_i = \frac{37,810 \times (2/1.706) \times 4}{3.14 \times 2/2 + 2 \times 1} = 34,500 \text{ Btu/ft}^2 \text{ h}$$

Note that if we did the same calculation for oil firing, the heat flux would be higher, because the furnace exit gas temperature is lower. Heat flux inside tubes is an important parameter, because allowable heat fluxes are limited by circulation rates. Large heat flux inside tubes can lead to departure from nucleate boiling conditions.

Estimating Fin Tip Temperatures

Fin tip temperatures in boilers of membrane wall design depend on several factors such as cleanliness of the water or tube-side fouling, fin geometry, and heat flux,

which is a function of the load and gas temperature. Assuming that membranes are longitudinal fins heated from one side, the following equation may be used to determine the fin tip temperature:

$$\frac{t_g - t_b}{\cosh(mh)} = t_g - t_t$$

where

t_g = gas temperature, °F

t_b = fin base temperature, °F

Due to the high boiling heat transfer coefficients, on the order of 3000–10,000 Btu/ft² h°F, fin base temperatures will be a few degrees higher than saturation temperature, assuming that tube-side fouling is minimal.

t_t = fin tip temperature, °F

h = membrane height, in. (see Fig. 3.11)

$m = (h_g C / KA)^{0.5}$

where

h_g = gas-side heat transfer coefficient, Btu/ft² h°F

C = perimeter of fin cross section = $2b + L$ in. (for heating from one side)
where b = fin thickness and L = fin length or furnace length

K = fin thermal conductivity, Btu/ft h°F

A = cross-section of fin = bL

C/A for long fins = $(2b + L)/bL = L/bL = 1/b$

Example 5

In a boiler furnace, gas temperature at one location is 2200°F. The gas-side heat transfer coefficient is estimated to be 30 Btu/ft² h°F. Fin height = 0.5 in. fin thickness = 0.375 in. Fin base temperature is 600°F. Thermal conductivity of fin is 20 Btu/ft h°F. Determine the fin tip temperature.

Solution: Using the above equation, we have

$$T_g = 2200^\circ\text{F}, \quad t_b = 600^\circ\text{F}, \quad h_g = 30, \quad h = 0.5 \text{ in.}, \quad b = 0.375 \text{ in.};$$

$$K = 20$$

$$mh = \frac{0.5}{12} \left(\frac{30 \times 12}{20 \times 0.25} \right)^{0.5} = 0.3536 \quad \text{or} \quad \cosh(0.3536) = 1.063$$

$$T_t = 2200 - \frac{2200 - 600}{1.063} = 695^\circ\text{F}$$

THE BOILING PROCESS

When thermal energy is applied to furnace tubes, the process of boiling is initiated. However, the fluid leaving the furnace tubes and going back to the steam drum is not 100% steam but is a mixture of water and steam. The ratio of the mixture flow to steam generated is known as the circulation ratio, CR. Typically the steam quality in the furnace tubes is 5–8%, which means that it is mostly water, which translates into a CR in the range from about 20 to 12. CR is the inverse of steam quality. Circulation calculations and the importance of heat fluxes are discussed in Q7.29.

Nucleate boiling is the process generally preferred in boilers. In this process, the steam bubbles generated by the thermal energy are removed by the flow of the mixture inside the tubes at the same rate, so the tubes are kept cool. Boiling heat transfer coefficients are very high, on the order of 5000–8000 Btu/ft² h °F as discussed in Q8.46. When the intensity of thermal energy or heat flux exceeds a value known as the critical heat flux, then the process of nucleate boiling is disrupted. The bubbles formed inside the tubes are not removed adequately by the cooler water; the bubbles interfere with the flow of water and form a film of superheated steam inside the tubes, which has a lower heat transfer coefficient and can therefore increase the tube wall temperatures significantly as illustrated in Fig. 3.13. It is the designer's job to ensure that we are

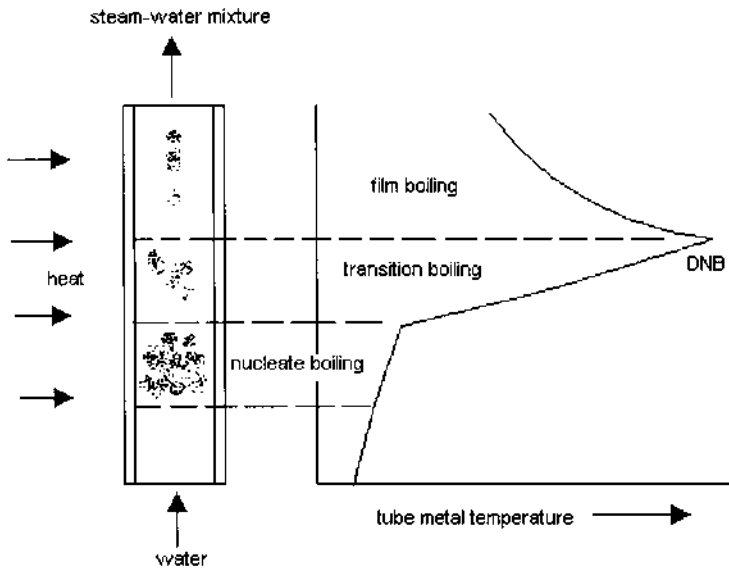

FIGURE 3.13 Boiling process and DNB in boiler tubes.

never close to critical heat flux conditions. Generally, packaged boilers operate at low pressures compared to utility boilers and therefore DNB is generally not a concern. The actual heat fluxes range from 40,000 to 70,000 Btu/ft² h, while critical heat flux could be in excess of 250,000 Btu/ft² h. However, one has to perform circulation calculations on all the parallel circuits in the boiler, particularly the front wall, which is exposed to the flame, to ensure that there is adequate flow in each tube. In the ABCO D-type boiler, carefully sized orifices are used to limit the flow of mixture through the D headers while ensuring flow through all the tubes in the front wall. Ribbed or rifled tubes are sometimes used as evaporator tubes. These tubes ensure that the wetting of the tube periphery is better than in plain tubes. They have spiral grooves cut into their inner wall surface. The swirl flow induced by the ribbed tubes not only forces more water outward onto the tube walls but also promotes general mixing between the phases to counteract the gravitational stratification effects in a nonvertical tube. Ribbed or twisted tubes can handle a much higher heat flux, often 50% higher than plain tubes. They are expensive to use but offer a safety net in regions of high heat flux, particularly in very high pressure boilers.

In fire tube boilers, the critical heat flux may be estimated as shown in Q8.47. Again owing to the low pressure of steam, the allowable heat flux to avoid DNB is much higher than the actual values; hence tube failures are rare unless tube deposits or scale formation is severe. As discussed later in this chapter, maintaining good boiler water chemistry, ensuring proper blowdown, and adding chemicals to maintain proper alkalinity and pH in the boiler should minimize scale formation and thus prevent tube failures.

BOILER EFFICIENCY CALCULATIONS

The boiler efficiency is an important variable that is impacted by the type of fuel, its analysis, the exit gas temperature, excess air used, and ambient reference conditions. The major losses due to flue gases and the method of computing efficiency are discussed in Q6.19. With rising fuel costs, plant engineers should try to aim for higher efficiency if the plant is base-loaded and operates continuously. Often less efficient and less expensive units are purchased owing to lack of funds, and this practice should be reviewed. One should look at the long-term benefits to the end user. Similarly, the fan operating costs should also be evaluated. A design with high gas pressure drop in the boiler may be less expensive, but if one considers the long-term operating costs, it may not be the better choice.

Table 3.5 shows the effect of excess air and exit gas temperatures on boiler efficiency and cost of operation. It is important to operate at as low an excess of air as possible; however, as discussed in Chapter 4, limits on NO_x and CO may force the burners to use higher values of excess air.

TABLE 3.5 Effect of Excess Air and Exit Gas Temperature on Efficiency^a

	Excess air (%)			
	5	20	5	20
Exit gas temp, °F	300	300	400	400
Vol% CO ₂	9	7.97	9	7.97
H ₂ O	19.57	17.56	19.57	17.56
N ₂	70.53	71.31	70.53	71.31
O ₂	0.89	3.16	0.89	3.16
Efficiency, % HHV	84.81	84.22	82.64	81.79
% LHV	94.11	93.46	91.71	90.70
Flue gas, lb/h	96,160	110,000	98,680	113,210
Annual fuel cost, MM\$/yr	2.854	2.873	2.928	2.959

^a Steam flow = 100,000 lb/h, 300 psig sat, feedwater temp = 230°F, 2% blowdown, ambient temp = 80°F, relative humidity = 60%, boiler duty = 100.8 MM Btu/h, fuel cost = \$3/MM Btu.

As shown in Tables 3.4 and 3.7, the efficiency of packaged boilers varies with load. This information may be used as a planning tool as discussed, particularly when the plant has HRSGs in addition to steam generators.

Combination Firing

Boiler efficiency calculations are done using ASME PTC 4.1 methods, as shown in Q6.19. When a combination of fuels is fired, the calculations can be involved. The results from a program developed are shown in Fig. 3.14. They show the performance of a boiler firing two different fuels *at the same time*. Based on the exit gas temperature and measured or predicted oxygen for the flue gas mixture, one can simulate the excess air and obtain the performance with individual fuels first and then obtain the combined effect on air and gas flows, flue gas analysis, combustion temperatures, heat losses, and efficiency.

BURNERS

The fuel burner is an important component of any boiler. Burner designs have undergone several iterations during the last decade. Burner suppliers such as Coen and Todd are offering burners that result in single-digit NO_x emissions and very low CO levels, competing with the SCR system presently used in the industry for single-digit NO_x emissions. However, these burners use a large amount of flue gas recirculation, and flame stability at low loads is a concern. Development work is going on to improve on these results. Fuel or air staging and

BOILER DUTY & EFFICIENCY CALCULATIONS

Combination firing - 2 fuels fired
PROJECT sample units - British

<p>1.boiler duty- MM Btu/h = 109.93 2.excess air- % = 18. 3.amb temp- F = 80 4.exit gas temp- F = 404 5.rel humidity- % = 60 Flue Gas Analysis - % vol (wet / dry) 6. co2 8.99 / 10.73 7. h2o 16.19 8. n2 71.92 / 85.81 [gas flow, analysis, air flow, efficiencies shown here 9. o2 2.9 / 3.46 pertain to effective average conditions if multiple fuels are fired..] 10. so2 / 11.total air - Lb/h = 115402 12.total flue gas - Lb/h = 121312 13.efficiency-% HHV =82.7 14.efficiency-% LHV =90.71 15.adiab comb temp - F = 3207</p>	<p>Boiler Parameters 1.steam press- psig = 400 2.steam temp- F = 750 3.steam flow- Lb/h = 100000 4.feed water temp- F = 320 5.blow down-% = 1. 6.process steam- Lb/h =</p>
--	---

air heated by boiler flue gas or no airheater

FUEL NO 1 gas - % volume [% duty = 71]
 methane= 97 ethane= 2 propane= 1
 fuel & air input HHV- MM Btu/h = 95.54 fuel fired- Lb/h = 4021 ad comb temp- F = 3164
 air/fuel ratio=20.5 gas/fuel =21.5 eff-lhv -% =90.55 eff-hhv -% =81.69
 losses: dry gas-%= 6.22 air moisture= .17 fuel moisture= 11.12 radiation= .3 unaccounted= .5
 flue gas analysis: % vol co2= 8.1 h2o= 17.8 n2= 71.22 o2= 2.89 so2= .
 LHV - Btu/lb = 21439 HHV - Btu/lb = 23764 fuel temp F = 80 air temp F = 80
 NOx- ppmv/0.1 lb per MM Btu HHV = 83.1 CO- ppmv/0.1 lb CO per MM Btu HHV = 136.6

FUEL NO 2 oil - % weight [% duty = 29]
 carbon= 87. hydrogen= 13. sulfur= . nitrogen= . oxygen= . deg API= 32 moisture= .
 fuel & air input HHV- MM Btu/h = 37.38 fuel fired- Lb/h = 1895 ad comb temp- F = 3288
 air/fuel ratio=17.41 gas/fuel =18.41 eff-lhv -% =91.12 eff-hhv -% =85.28
 losses: dry gas-%= 6.71 air moisture= .17 fuel moisture= 7.04 radiation= .3 unaccounted= .5
 flue gas analysis: % vol co2= 11.29 h2o= 12.04 n2= 73.73 o2= 2.94 so2= .
 LHV - Btu/lb = 18463 HHV - Btu/lb = 19727 fuel temp F = 80 air temp F = 80
 NOx- ppmv/0.1 lb per MM Btu HHV = 77.5 CO- ppmv/0.1 lb CO per MM Btu HHV = 127.4

FIGURE 3.14 Efficiency calculations for simultaneous firing of fuels.

steam injection are the other methods used by burner suppliers to control NOx. Today single burners are used for capacities up to 300–350 MM Btu/h on gas or oil firing.

Often more than one fuel is fired in the burner. When different gaseous fuels are fired in a burner, the fuel gas pressure has to be adjusted at the burner inlet to ensure proper fuel flow.

Example 6

Let us say that a burner is firing 5 MM Btu/h on LHV basis using a fuel of lower heating value, 1400 Btu/ft³, and molecular weight 25.8 at a pressure of 30 psig. Assuming the nozzles remain the same, what should be done when a fuel of

heating value 700 Btu/ft³ whose molecular weight is 11.6 is fired, the duty being the same?

Solution: The gas pressure should be adjusted; otherwise it would be difficult to control the heat input. The pressure drop across the nozzles is related to the flow of fuel as follows (Subscripts 1 and 2 refer to fuels 1 and 2):

$$\Delta P_1 = KW^2/MW = KQ^2MW$$

where Q = volumetric flow
 W = mass flow
 MW = molecular weight
 K is a constant = $30/Q_1^2$ MW

Basically we are converting the pressure drop equation from mass to volumetric flow.

Because the heat input by both fuels is the same,

$$Q_1 \text{ LHV}_1 = Q_2 \text{ LHV}_2$$

where LHV is the lower heating value of the fuel, Btu/ft³.

$$\Delta P_2 = \frac{30}{Q_1^2 MW_1} Q_2^2 MW_2$$

Rewriting Q_2 in terms of Q_1 and simplifying, we have

$$\Delta P_2 = 30 \times \left(\frac{700}{1400} \right)^2 \times \frac{25.8}{11.6} = 17 \text{ psi}$$

Thus we should have a lower fuel gas pressure to ensure the same heat input.

COMBUSTION CONTROLS

The function of a combustion control system is to ensure that the steam generation matches the steam demand. When the demand exceeds the supply, the steam pressure will decrease and vice versa. Although a few utility boilers generate steam at sliding pressures, packaged boilers typically generate steam at fixed pressure. The control system immediately adjusts the fuel input to maintain the steam pressure. The following methods are typically used for combustion control.

Single-Point Positioning: This is a simple and safe system for combustion control. A common jackshaft is modulated by a power unit based on variations in drum pressure and is mechanically linked to both the fuel control valve and the air control damper. This system is limited to small boilers, typically below 100,000 lb/h, that have an integral fan mounted

on top of the wind-box and are fired by a single fuel of nearly constant heating value. Fuel heating values should not vary, and only one fuel can be fired at a time. When low CO values are desired such as less than 70 ppmv, an oxygen trim is added.

Parallel Positioning System: This system is used on large boilers where a remote fan supplies air to the wind-box. It has separate pneumatic power units for controlling air and fuel.

Full Metering with Cross Limiting: This system is expensive but is recommended for accurate air/fuel ratios, for keeping oxygen levels optimized, and for its firing precision. Fuel and air flows are measured continuously and are adjusted as required to maintain the desired air/fuel ratio. Air leads on load increases, and fuel leads on load decreases. This system allows simultaneous firing of two or more fuels. When emission levels are stringent and a large flue gas recirculation rate is used, this method is used and offers better control over the combustion process.

As far as the boiler is concerned, a three-element-level control system is generally used to control the drum water level. Other controls would include steam temperature and master pressure control. [Figure 3.15a](#) and [3.15b](#) show typical schemes of gas-side and steam-side instrumentation and controls, respectively, used in packaged boilers.

FAN SELECTION

Packaged steam generators of today use a single fan for up to 250,000 lb/h of steam. The furnaces of oil- and gas-fired boilers are pressurized, hence the fan parameters should be selected with care. Estimating the flow or head inaccurately can force the fan to operate in an unstable region or result in the horsepower being too high and the operation inefficient. The density of air should be accurately estimated, so elevation and ambient temperature conditions should be considered. In some cold locations, a steam-air preheat coil is used to preheat the air before it enters the fan, and this adds to the pressure drop. When flue gas recirculation is required, usually the flue gases from the boiler exit are sucked in by the fan, which handles the resistance of the entire system. The density of the mixed air is lower, owing to the higher temperature of the air mixed with the flue gases. The fan should be selected for the lowest density case, as explained in Q9.06, because the mass flow of air is important for combustion and not the volumetric flow. The effect of gas density on fan performance is shown in [Fig. 3.16a](#).

Large margins on flow and head should not be specified, because this leads to oversizing of the fan and can force the fan operating point to the extreme right of the curve in [Fig. 3.16b](#), where the horsepower can be extremely high; a lot of energy is also wasted. Inlet vane control is typically used for controlling the flow

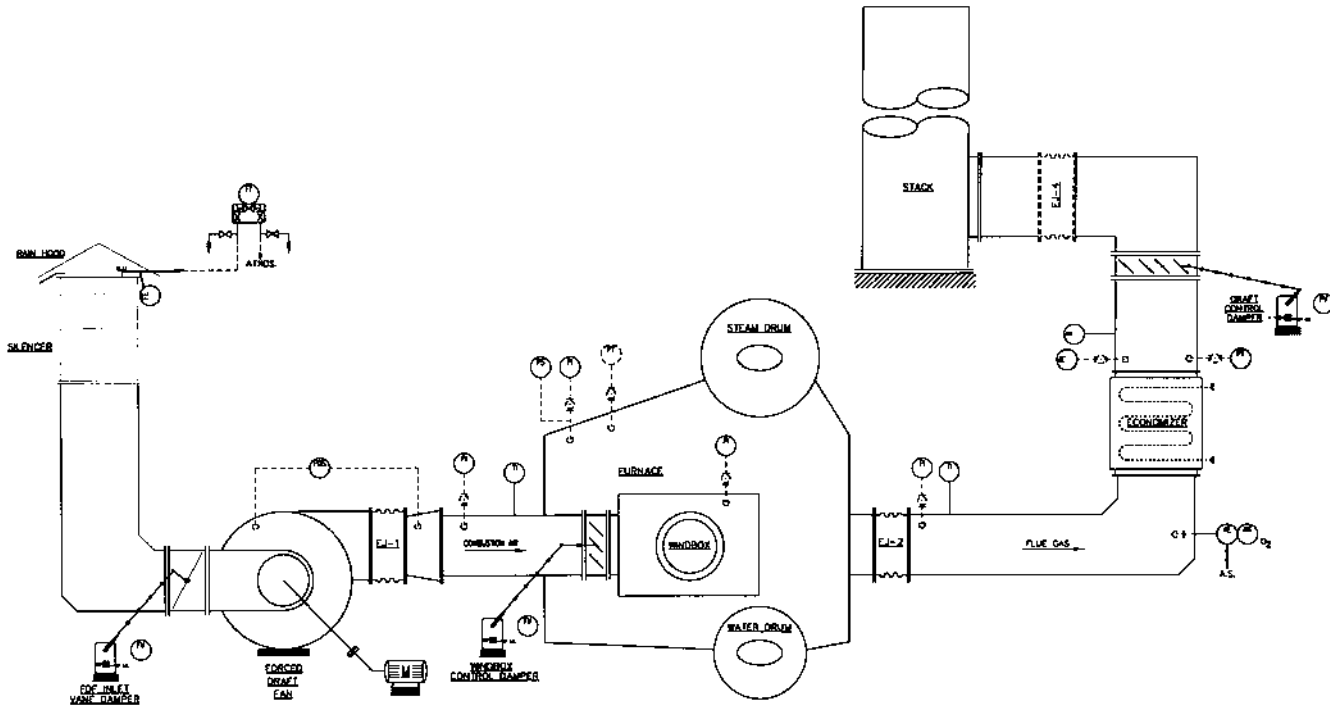

FIGURE 3.15a Scheme of boiler controls—gas side. (Courtesy of ABCO Industries, Abilene, TX.)

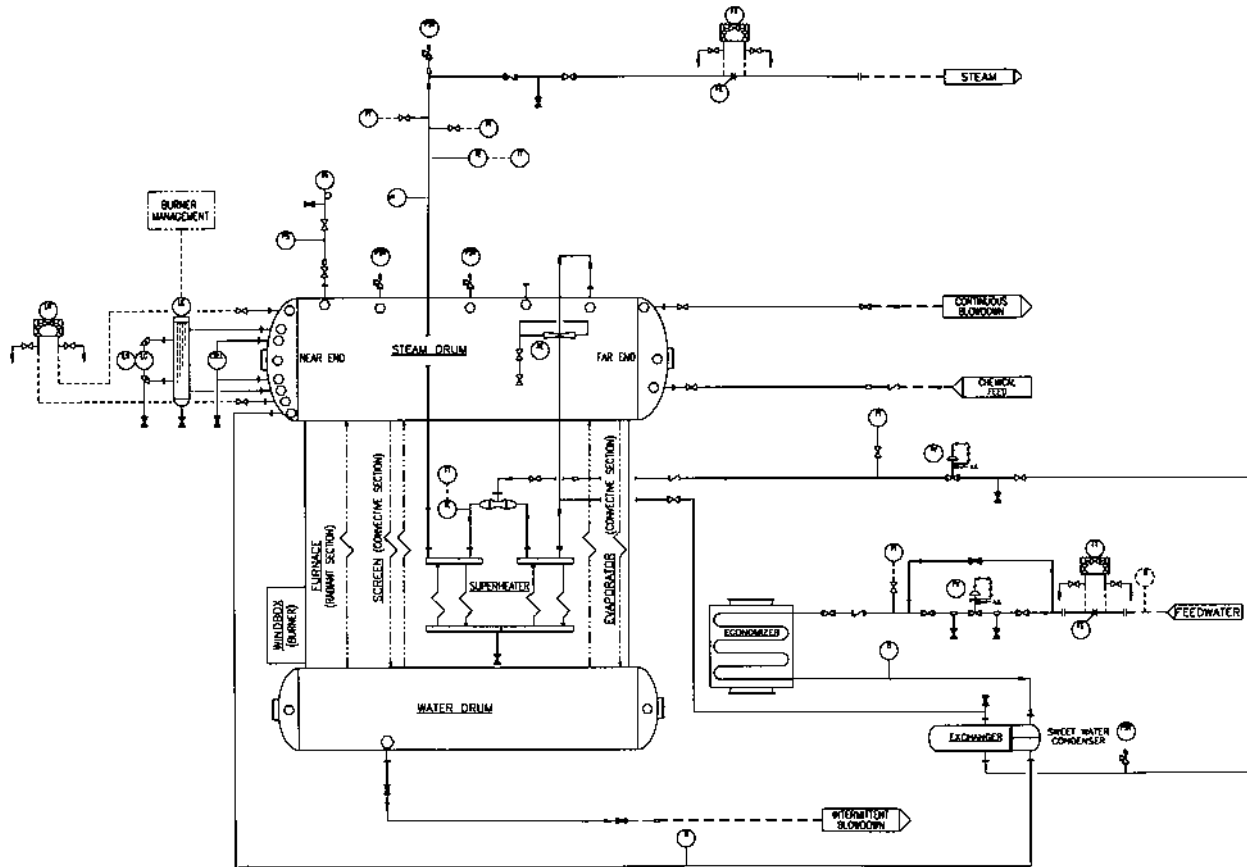
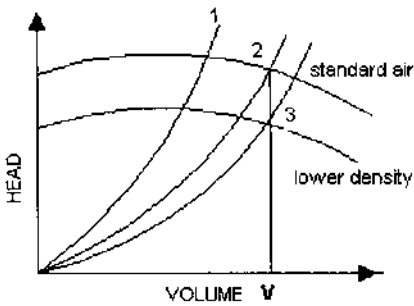
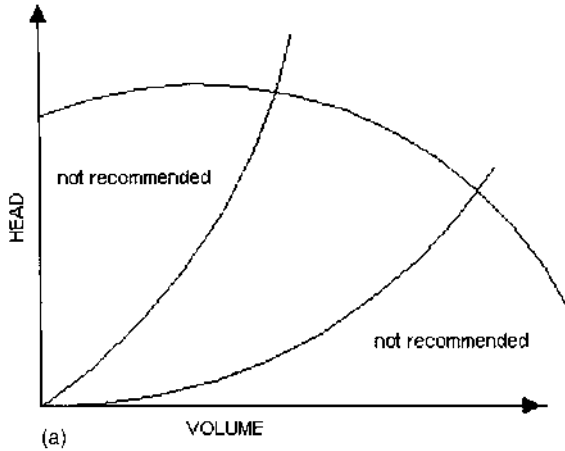

FIGURE 3.15b Scheme of boiler controls—steam side. (Courtesy of ABCO Industries, Abilene, TX.)



Curve 1 is the actual operating curve while curve 2 is the estimated. Operating at point 1 is not recommended.

Also, a fan delivers a lower head at lower density.

(b)

FIGURE 3.16 (a) Fan performance and range of operation. (b) Effect of system resistance on fan horsepower. (c) Effect of vane position on flow reduction in fans.

of air; this system typically operates stably between 20% and 100% vane opening, which does not translate into a large flow difference, as can be seen from Fig. 3.16c. Hence a small margin on flow and head is preferred—about 15% margin on flow and 20–25% on head is adequate; otherwise one may have to use a variable-speed drive or frequency modulation for control, which is expensive. Underestimating the fan head can also cause the fan to operate in the unstable

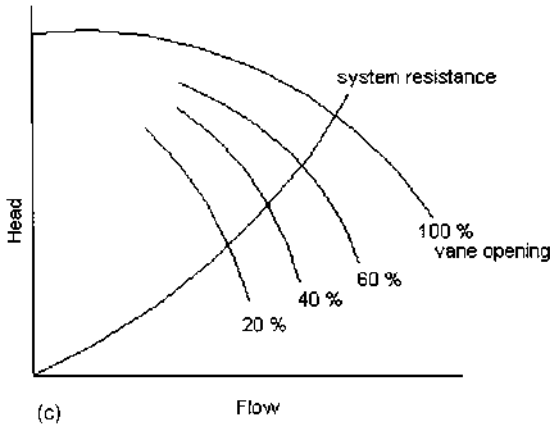

FIGURE 3.16 Continued.

region as shown in Fig. 3.16a. Curve 2 in Fig. 3.16b is the estimated curve, and the actual curve 1 is to the left, close to the unstable region with positive slope. It also delivers less flow than required. The fan operating point must preferably be in the negatively sloping portion of the head versus flow curve; otherwise the fan could operate in the unstable region, causing surges and vibration. The flue gas recirculation lines must be properly sized; typical air and flue gas velocity in ducts is about 40 ft/s.

The flue gas recirculation line is usually connected to the fan inlet in gas and distillate oil-fired boilers. This increases the size of the forced draft fan. The higher gas pressure drop in the boiler due to the increased mass flow should also be considered when selecting the fan. A separate recirculation fan is used occasionally when heavy fuel oils containing sulfur are fired and the flue gases are admitted into the burner wind-box. If the flue gases were allowed to mix with the cold air at the fan inlet, the mixture temperature could fall below the acid dew point, possibly leading to corrosion.

The fan inlet duct and downstream ductwork must have proper flow distribution. Pulsations and duct vibrations are likely if the inlet airflow to the fan blades is not smooth and the maldistribution in velocity is large. Similarly, the ductwork between the fan and wind-box should be designed to minimize flow maldistribution to ensure proper airflow to the burner.

SUPERHEATERS

The superheater is an important component of a packaged boiler. The degree of superheat could be very high, with steam temperatures up to 1000°F, or as low as

50°F. With a very low degree of superheat, one can locate the superheater behind the evaporator and ahead of the economizer. In this case, the superheater may require a large surface area due to the low log-mean temperature difference, but extended surfaces may be used (if distillate oils and gaseous fuels are fired) to make it compact.

Radiant superheaters, which are typically located in the furnace exit region, are widely used by several boiler manufacturers. Radiant superheaters have to be designed very carefully because they operate in a much harsher environment than convective superheaters, which are located in the convective zone behind screen tubes as shown in Fig. 3.17a. Radiant superheaters are located at the furnace exit or in the turning section (Fig. 3.17b). The furnace exit gas temperature is a difficult parameter to estimate. Variations in excess air, flue gas recirculation rates, and burner flame patterns can affect this value and the temperature distribution across the furnace exit plane. The gas temperature in operation could be off by 100–150°F from the predicted value. The turning section is also subject to nonuniformity in gas flow and turbulence, which can affect the superheater performance. Thus its duty can be either underestimated or overestimated by a large margin.

The convective superheater is shielded behind screen tubes as shown in Fig. 3.17a and often operates at 1800–1900°F in comparison with the 2200–2300°F for radiant designs. Because it operates at lower tube wall temperatures, its life can be longer, but it requires a greater surface area because of the lower log-mean temperature difference. However, owing to the lower operating temperatures, a convective superheater can use a lower grade material than the radiant design, and this helps balance the cost to some extent. Also, its location behind screen tubes helps reduce the gas flow nonuniformity to a great extent; hence predicting its performance is easier and more reliable than predicting the performance of the single-stage radiant superheater.

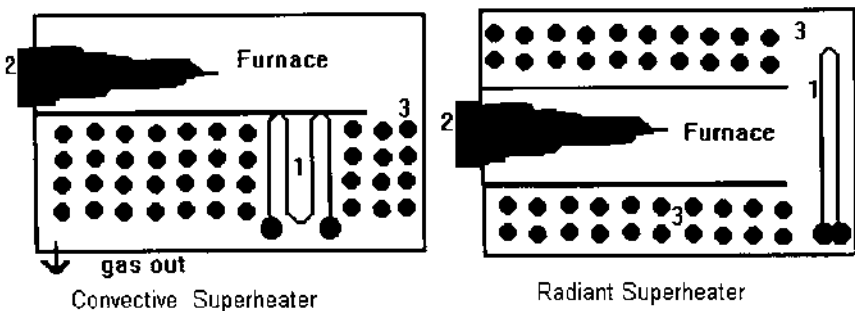

FIGURE 3.17 Location of convective and radiant superheater. 1, Superheater; 2, burner; 3, screen evaporator.

Several boilers operate at partial loads of less than 60% for large periods. The radiant superheater, by its nature, absorbs more enthalpy at lower loads, hence the steam temperature increases at lower loads. Convective heat transfer depends on mass flow of flue gases, so as the load decreases, the gas flow and temperature decrease at the superheater region, and therefore the steam temperature and the tube wall temperatures drop with load. Also if at 100% load the steam-side pressure drop in a radiant superheater is 50 psi, then at 30%, it will be about 5 psi, which can lead to concerns about steam flow distribution through the tubes when it is receiving more radiant energy per unit mass of steam. Coupled with nonuniform gas flow distribution at low loads and low gas velocities, the radiant superheater poses several concerns about its tube wall temperatures and hence its life.

The convective superheater is located behind several rows of screen tubes that shield it from furnace radiation. Gas flow entering the superheater is well mixed; hence it is easier to predict its performance and tube wall temperatures. As mentioned earlier, its surface area requirement may be more, but one is assured of low tube wall temperatures and hence longer life.

The steam temperature in a convective superheater generally decreases as the load falls off, whereas in a radiant design it remains within a small range over a larger load range. Hence the convective design has to be sized to ensure that the required steam temperature is achieved at the lowest load, which can increase its size and cost.

The choice of whether to use a radiant or a convective superheater is based on the experience of the supplier. Because the surface area requirements are significantly different due to the different log-mean temperature differences, this is yet another reason that a comparison of surface areas can be misleading.

If heavy oil is fired in the boiler, the problems associated with slagging and high temperature corrosion pose concerns for the longevity and operability of radiant superheaters as discussed below, so convective superheater designs are preferred in such cases. Packaged boilers use limited space compared to utility or field-erected boilers; with high gas velocities and slagging potential in the furnace exit region, the radiant design is vulnerable. Even with a convective superheater design, care should be taken to use retractable soot blowers, and there should be adequate space provided for cleaning and maintenance.

Steam Temperature Control

The steam temperature in packaged boilers is often controlled from 60% to 100% load by using a two-stage superheater design with interstage attemperation as shown in Fig. 3.18. Steam temperature can also be maintained from 10% to 100%; however, this calls for a much larger superheater surface area. Demineralized water should be used for attemperation, because it does not add solids to

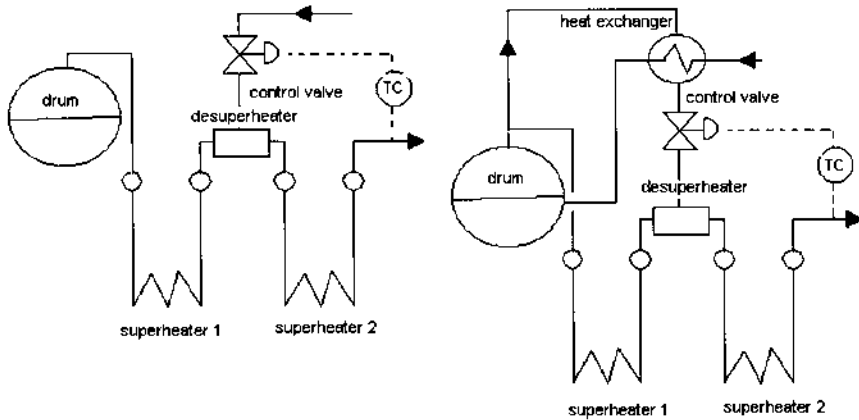

FIGURE 3.18 Steam temperature control methods.

the steam. The solids in the feedwater used for attenuation should be in the same range as the final steam purity desired, which could be as low as 30–100 ppb. If solids are deposited inside the superheater, the tubes can become overheated, particularly if operated at high loads and high heat flux conditions. The convective superheaters are generally oversized at 100% load as explained earlier. The quantity of water spray is larger at higher load. In the radiant design, the steam temperature remains nearly flat over the load range because the radiant component of energy increases at lower loads and decreases at higher loads. Thus many radiant superheaters do not use a two-stage design. However, reviewing other concerns such as possible overheating of tubes and higher tube wall temperatures, the choice is left to the user.

When demineralized water is not available, a portion of the saturated steam from the drum is taken and cooled in a heat exchanger, preheating the feedwater as shown in Fig. 3.18. The condensed water is then sprayed into the attenuator between the two stages of the superheater. Often, in order to balance the pressure drops in the two parallel paths, a resistance is introduced into each path or the exchanger is located vertically up, say 30–40 ft above the boiler, to provide additional head for the spray water control valve operation.

Spraying downstream of the superheater for steam temperature control is not recommended, because the steam temperature at the superheater exit increases with load, thus increasing the superheater tube wall temperature, which can lead to tube failures. For example, if 800°F is the final steam temperature desired, the steam temperature at the superheater exit may run as high as 875–925°F, which will diminish the life of the tubes over a period of time. Also, the water droplets

may not evaporate completely in the piping and the steam turbine could end up with water droplets and the solids present in the water, leading to deposits on turbine blades.

Design Aspects

Figures 3.19a and 3.19b show an inverted loop superheater commonly used in packaged boilers, and Fig. 3.19c shows a horizontal tube design with vertical headers. Superheaters operate at high tube wall temperatures; hence their design should be carefully evaluated. The convective superheater design located behind several rows of screen section operates at lower tube wall temperatures than the radiant design, though the steam temperatures may be the same. Figure 3.20 shows the results from a computer program for a superheater located very close to the furnace section and beyond several rows of screen tubes.

Option a shows the results for a packaged boiler generating 150,000 lb/h of steam at 650 psig when a 14-row screen section is used. The gas temperature entering the superheater is 1628°F. For the steam temperature of 758°F, the superheater tube wall temperature is 856°F. The surface area used is 1833 ft².

In option b, a nine-row screen section is used. The gas temperature entering the superheater is 1801°F. The superheater tube wall temperature is 882°F. However, owing to the higher log-mean temperature difference, the surface area required is smaller, namely 1466 ft². It can be shown, as discussed under life estimation below, that the difference in the life of the superheater for a 26°F difference for alloy steel tubes such as T11 can be several years. By the same token, one may wonder about the life of the radiant design with a gas inlet temperature of 2187°F. Tube sizes are typically 1.5–2 in. OD, and materials used range from T11, T22, and T91 to stainless steels, depending upon steam and tube wall temperatures. Generally, bare tubes are used; however, I have designed a few packaged boilers, which are in operation in gas-fired boilers, using finned superheaters to make the design compact.

Steam velocity inside the tubes ranges from about 50 ft/s at high steam pressure (say 1000–1500 psig) to about 150 ft/s at low pressure (150–200 psig). The turndown conditions and maximum tube wall temperatures determine the number of streams used and hence the steam pressure drop. In inverted loop superheaters, the headers are inside the gas path and are therefore protected by refractory. A few evaporator tubes are provided in the superheater region to ensure that steam blanketing does not occur at the mud drum and that steam bubbles can escape from the mud drum to the steam drum.

Flow distribution through tubes is another concern with superheater design. If long headers are used, multiple inlets can reduce the nonuniformity in steam flow distribution through the tubes as shown in Fig. 3.21. Inlet and exit connections from the ends of headers should be avoided because they can

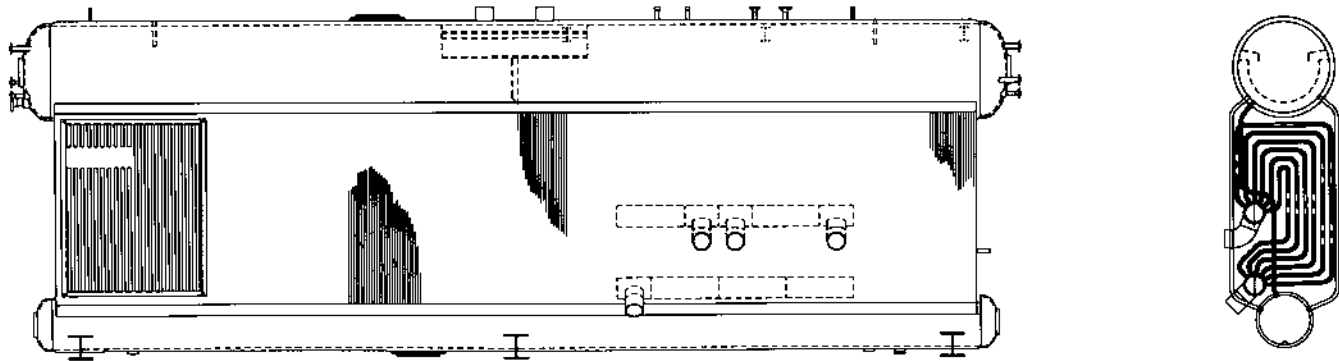

FIGURE 3.19a Inverted loop superheater arrangement. (Courtesy of ABCO Industries, Abilene, TX.)

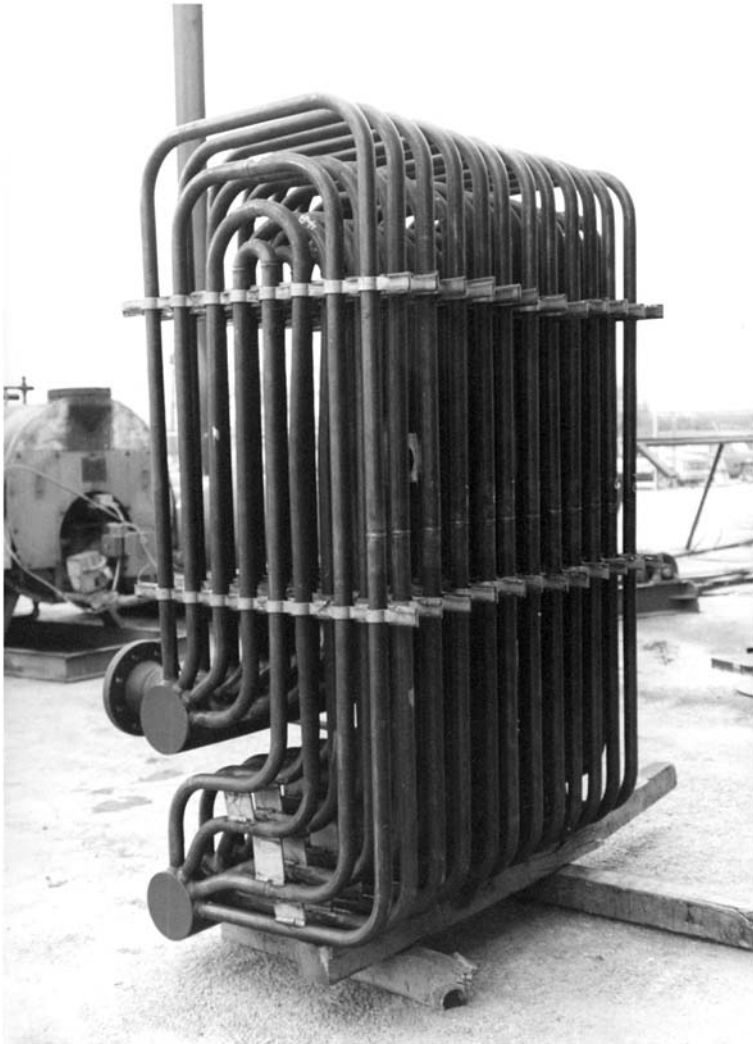

FIGURE 3.19b An inverted loop superheater. (Courtesy of ABCO Industries, Abilene, TX.)

result in flow distribution problems. In arrangement 1, the inlet and exit connections are on opposite ends, causing the greatest difference in static pressure at the ends of the headers, and should be avoided. Arrangement 2 is better than 1 because the flow distribution is more uniform. However, arrangement 3 is preferred, because the central inlet and exit reduce the differential static pressure values by one-fourth, so the flow maldistribution is minimal.

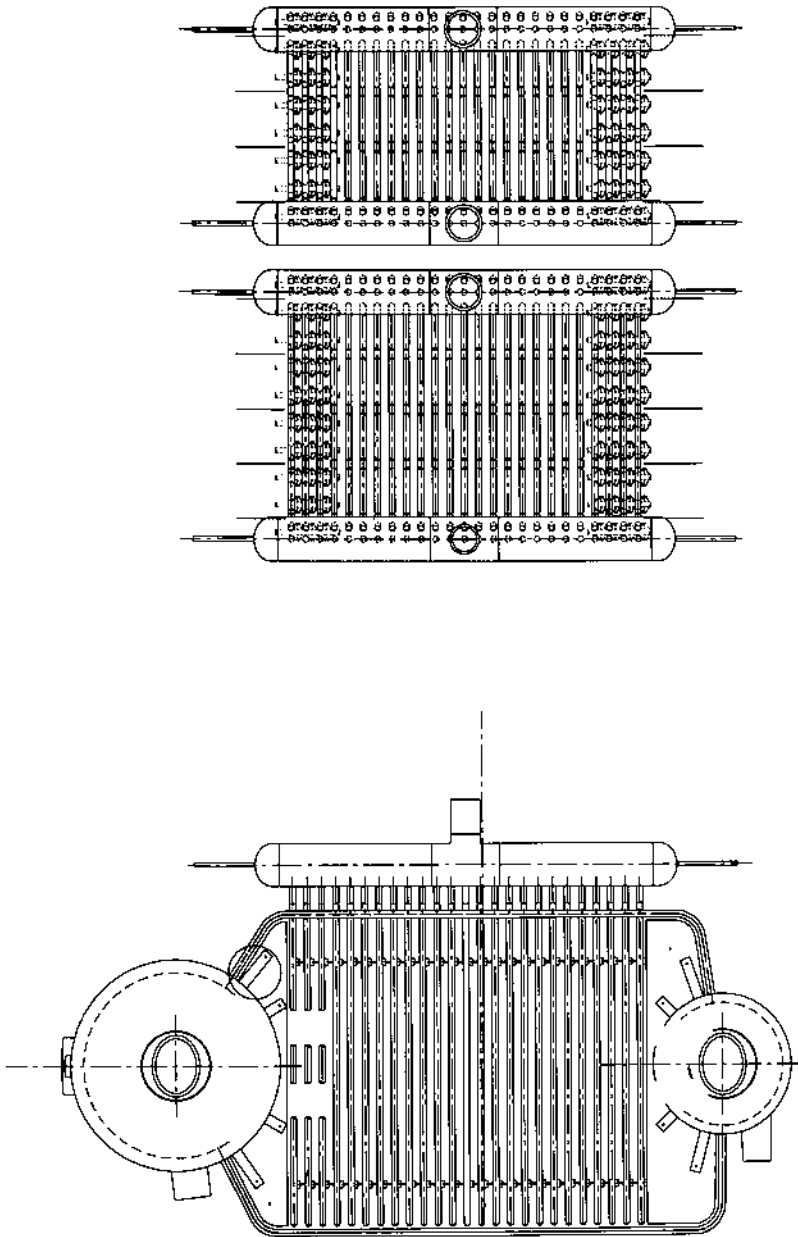
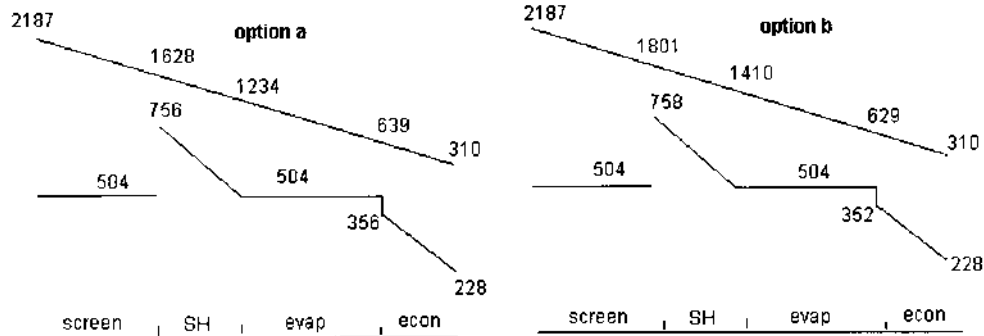

FIGURE 3.19c Horizontal tube superheater arrangement. (Courtesy of ABCO Industries, Abilene, TX.)



	Option a	Option b
surface area		
screen	1462	940
SH	1833	1466
evap	6432	7422
econ	20156	20156
SH tube wall temp		
	856	882

150,000 lb/h, 650 psig, 755 F , nat gas firing

Performance of Boiler with large (Option a) and small screen sections (Option b)

FIGURE 3.20 Results from boiler program showing effect of screen section on superheater performance. Option a: More screen rows; option b: fewer screen rows.

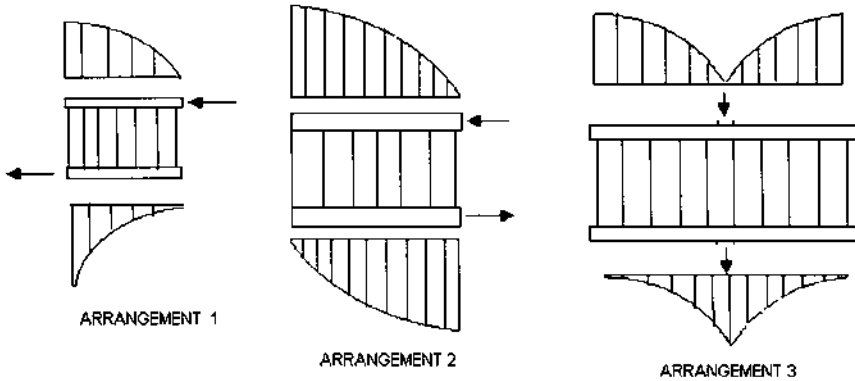

FIGURE 3.21 Flow nonuniformity due to header arrangements.

Two temperatures are of significance in the design of superheater tubes. One is the tube midwall temperature, which is used to evaluate the tube thickness per ASME code. (The published ASME stress values have increased during the last few years and therefore the latest information on stress values should be used in calculating the tube thickness.) The outer wall temperature determines the maximum allowable operating temperature, sometimes known as the oxidation limit. Table 3.6 gives typical maximum allowable temperatures for a few materials.

One can vary the tube thickness to handle the design pressure, but if the outermost tube temperature gets close to the oxidation limit, we have to review

TABLE 3.6 Maximum Allowable Temperatures

Material	Composition	Temp (°F)
SA 178A (erw)	Carbon steel	950
SA 178C (erw)	Carbon steel	950
SA 192 (seamless)	Carbon steel	950
SA 210A1	Carbon steel	950
SA 210C	Carbon steel	950
SA 213-T11	1.25Cr-0.5Mo-Si	1050
SA 213-T22	2.25Cr-1Mo	1125
SA 213-T91	9Cr-1Mo-V	1200
SA 213-TP304H	18Cr-8Ni	1400
SA 213-TP347H	18Cr-10Ni-Cb	1400
SA 213-TP321H	18Cr-10Ni-Ti	1400
SB 407-800H	33Ni-21Cr-42Fe	1500

the design. In large superheaters, different materials and tubes of different sizes may be used at different sections, depending on the tube midwall and outer wall temperatures. In all these calculations one has to consider the nonuniformity in gas flow, gas temperature across the cross section, and steam flow distribution through the tubes. Because of their shorter lengths, a few tubes could have higher flow and starve the longer tubes.

Life Estimation

High alloy steel tubes used in superheaters and reheaters, unlike carbon steel, fail by creep rupture. Creep refers to the permanent deformation of tubes that are operated at high temperatures. Carbon steel tubes operate in the elastic range where allowable stresses are based on yield stresses, whereas alloy tubes operate in the creep-rupture range, where allowable stresses are based on rupture strength. The life of superheater tubes is an important datum that helps plant engineers plan tube replacements or schedule maintenance work. When a new superheater tube is placed in service, it starts forming a layer of oxide scale on the inside. This layer gradually increases in thickness and also increases the tube wall temperature. Therefore, to predict the life of the tubes, information on the corrosion or the formation of the oxide layer is necessary. The corrosion of oxide formation also reduces the actual thickness of the tubes and increases the stresses in the tubes over time even if the pressure and temperature are the same. The data on oxide formation were once obtained by cutting tube samples and examining them but are now obtained through nondestructive methods. There are also methods to relate the oxide layer thickness with tube mean wall temperatures over a period of time.

Creep data are available for different materials in the form of the Larson Miller parameter, LMP. This relates the rupture stress value to temperature T and the remaining lifetime t , in hours.

$$\text{LMP} = (T + 460)(20 + \log t)$$

Every tube in operation has an LMP value that increases with time. LMP can be related to stress values and the relationship then used to predict remaining life. However, there are charts that give what is called the minimum and the average rupture stress versus LMP, and one can compute different life times with the different values. Also, it can be seen that even a few degrees difference, say 10°F in metal temperatures, can change the lifetime by a large amount, which shows how complex and difficult it is to interpret the results. [Figure 3.22](#) shows the relationships between LMP and minimum rupture stress values for T11 and T22 materials.

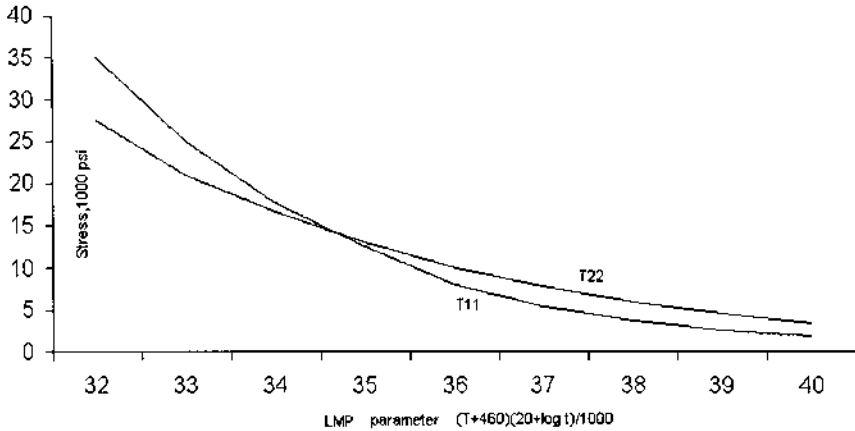

FIGURE 3.22 Larson–Miller parameters for T11 and T22 materials.

Example 7

Assume that a superheater of T11 material operates at 1000°F and at a hoop stress of 6000 psi. What is the predicted time to failure? From Fig. 3.22, the LMP at 6000 is 36,800.

Solution: From the above equation, we can see that

$$36,800 = (1460)(20 + \log t), \quad \text{or} \quad t = 160,500 \text{ h}$$

If a tube had operated at this temperature for 50,000 h, its life consumed would be $50,000/160,500 = 0.31$, or 0.69 of its life would remain. If after this period of 50,000 h, it operated at, say, 1020°F and at the same stress level, then

$$36,800 = (1480)(20 + \log t), \quad \text{or} \quad t = 73,250 \text{ h}$$

and the number of operating hours at this temperature would be $0.69 \times 73,250 = 50,728 \text{ h}$.

One can see from the above how sensitive these numbers are to temperatures and stress values. Hence we have to interpret the results with caution backed up by operational experience. Simplistic approaches to replacement of tube bundles are not recommended. It should also be noted that if the average rupture stress is used instead of the minimum value, the lifetime would be much higher, casting more uncertainty in these calculations.

ECONOMIZERS

Economizers are used as heat recovery equipment in packaged boilers instead of air heaters because of NO_x concerns as discussed in [Chapter 4](#). They are also less expensive and have lower gas pressure drops across them. Economizers for gas firing typically use serrated fins at four to five fins per inch. For distillate fuel, about 4 fins/in, solid fins are preferred. For heavy oil, bare tubes or a maximum of 2–3 fins/in. are used, depending upon the dirtiness of the flue gas and the ash content of the fuel.

Economizers are generally of vertical gas flow and counterflow configuration with horizontal tubes as shown in [Fig. 3.23](#). The water-side velocity ranges from 3 to 7 ft/s. Small packaged boilers, below 40,000 lb/h capacity, use circular economizers that can be fitted into the stack. Another variation is the horizontal gas flow configuration with vertical headers and horizontal tubes.

Generally, steaming in the economizer is not a concern, as discussed earlier. Feedwater temperatures of 230–320°F are common, depending on acid dew point concerns. The feedwater is sometimes preheated in a steam–water exchanger if the deaerator delivers a lower feedwater temperature than that desired to avoid acid corrosion in the case of oil-fired boilers.

BOILER PERFORMANCE ASPECTS

Plant engineers are interested in knowing how a given boiler performs at various loads. The variables affecting its performance are the fuel, amount of excess air, FGR rate, and steam parameters. [Tables 3.4](#) and [3.7](#) show how boiler performance varies with load on gas and oil firing. [Figure 3.24](#) shows the results in graph form. The following observations can be made:

1. As the load increases, the boiler exit gas temperature increases. This is due to the larger flue gas mass flow transferring energy to a given heating surface. The water temperature leaving the economizer is higher at loads owing to the higher gas temperature entering the economizer. The approach point (difference between saturation and water temperature entering evaporator) is lower at higher loads. Steaming in the economizer is not a concern in steam generators because the approach point is quite large at full load and increases at lower loads. The ratio of gas flow to steam generation is maintained at 1.2–1.3 at various loads. Hence the economizer does not absorb more energy at low loads as in the case of HRSGs.
2. The boiler efficiency increases as the load increases, peaks at about 50–70% of load, then drops off. The two major variables affecting the heat losses are the casing heat losses and heat loss due to flue gases. Q6.24 discusses this calculation. As the load increases, the flue gas heat losses

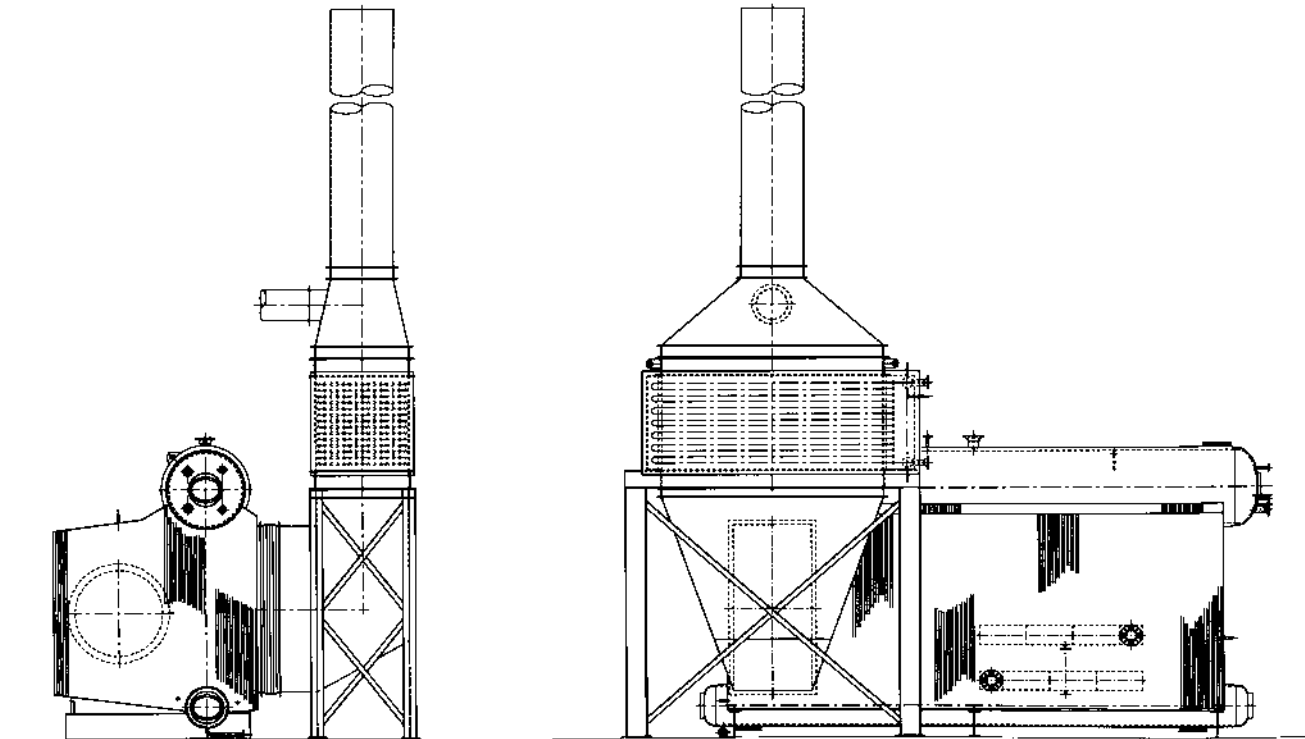

FIGURE 3.23a Economizer in a packaged boiler. (Courtesy of ABCO Industries, Abilene, TX.)

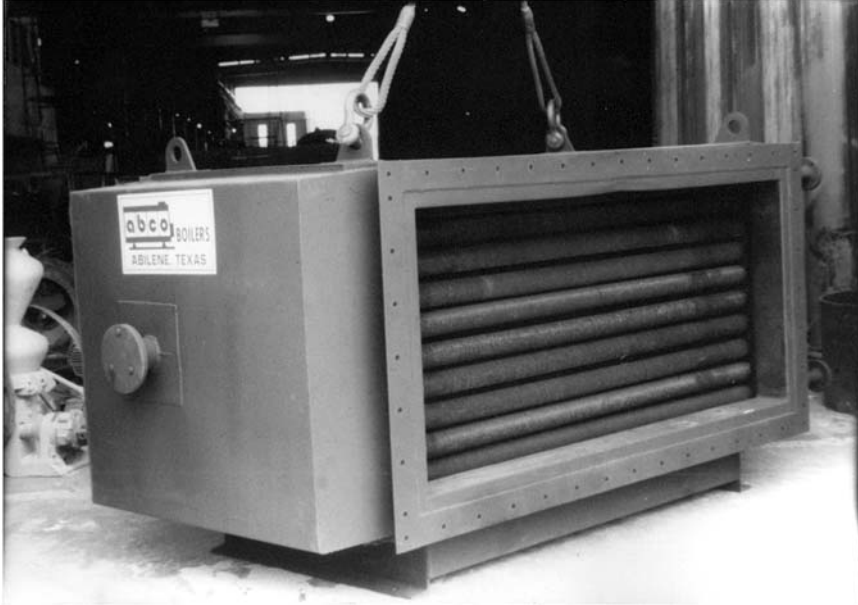

FIGURE 3.23b Photo of an economizer. (Courtesy of ABCO Industries, Abilene, TX.)

increase due to the higher exit gas temperature. The casing loss decreases as a percentage but, as explained in Q6.24, in terms of Btu/h it remains the same because the evaporator operates at saturation temperature, so heat losses in Btu/h are unaffected by boiler load except if ambient temperature or wind velocity changes. Thus the combination of these losses results in a parabolic shape for efficiency as a function of load.

3. The steam temperature generally increases with load owing to the convective nature of the superheater. If a radiant design were used, it would decrease slightly at higher loads.
4. It may also be seen that the gas temperature leaving the evaporator decreases as the load decreases. If an SCR is used between the evaporator and the economizer, the gas temperature should be maintained in the range of typically 650–780°F; hence one may have to use a gas bypass system to obtain a higher gas temperature at low loads. [Chapter 4](#) shows the arrangement of dampers to achieve this purpose.
5. The steam temperature on oil firing is lower than that in gas firing. This is due to the better absorption of energy from the oil flames in the

TABLE 3.7 Boiler Performance—Oil Firing

	Load (%)			
	25	50	75	100
Boiler duty, MM Btu/h	28.94	58.26	89.03	118.71
Excess air, %	30	15	15	15
Fuel input, MM Btu/h	32.98	65.95	101.25	135.9
Heat rel rate, Btu/ft ³ h	15,266	30,531	46,875	62,918
Heat rel rate, Btu/ft ² h	28,188	56,376	86,554	116,176
Steam flow, lb/h	25,000	50,000	75,000	100,000
Steam temp, °F	694	710	750	750
Economizer exit water temp, °F	324	329	350	368
Boiler exit gas temp, °F	526	588	671	748
Economizer exit gas temp, °F	254	269	296	325
Air flow, lb/h	32,064	56,728	87,096	116,903
Flue gas, lb/h	33,731	60,061	92,212	123,771
Dry gas loss, %	3.95	3.83	4.36	4.95
Air moisture loss, %	0.1	0.1	0.11	0.13
Fuel moisture loss, %	6.58	6.62	6.69	6.77
Casing loss, %	1.2	0.6	0.4	0.3
Margin, %	0.5	0.5	0.5	0.5
Efficiency, % HHV	87.67	88.35	87.93	87.35
Efficiency, % LHV	93.67	94.39	93.95	93.33
Furnace back pressure, in. WC	0.8	2.45	5.81	10.76

Steam pressure = 500 psig, oil firing. HHV = 19,727; LHV = 18,463 Btu/lb. Flue gas analysis (vol%): CO₂ = 10.76, H₂O = 11.57, N₂ = 73.63, O₂ = 2.51.

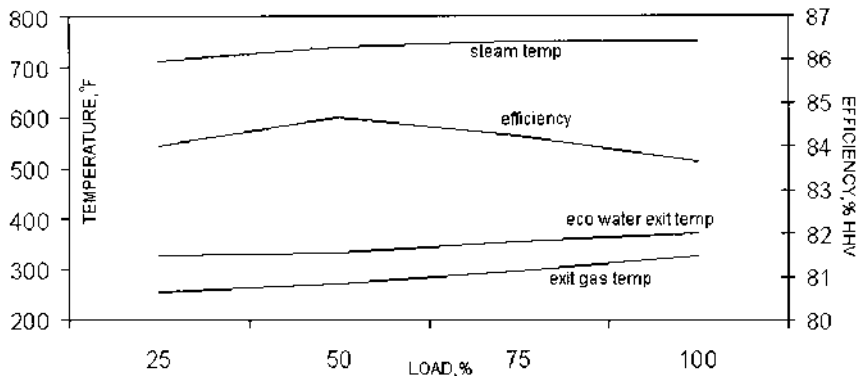
**FIGURE 3.24** Boiler performance versus load.

furnace, which results in a lower furnace exit gas temperature and lower gas temperature at the superheater in oil firing. Hence the steam temperature is lower. However, if we wanted to maintain the same steam temperature on both oil and gas firing, we would have to size the superheater so that it makes the steam temperature in the oil-firing case and then control it in gas firing by attemperation.

Performance Without an Economizer

If we look at [Table 3.4](#) for performance of a boiler at, say, 100% load, we see that the gas temperature leaving the evaporator is 739°F and leaving the economizer it is 327°F. Now if the economizer is removed from service, can we assume that the exit gas temperature will still be 739°F? The answer is No, for the following reasons:

1. The boiler efficiency drops significantly, by at least $(739 - 327)/40 = 10.3\%$. Hence the efficiency will be at best $83.66 - 10.3 = 73.36\%$ HHV.
2. The boiler fuel input increases by this ratio. The new heat input is $(118.71/0.7336) = 161.8$ MM Btu/h versus $(118.71/0.8366) = 141.9$ MM Btu/h. Hence the flue gas flow, which is proportional to heat input, will be higher by $161.8/141.9 = 1.14$ or 14%, or about $1.14 \times 125,246 = 142,800$ lb/h.
3. The furnace heat input and heat release rate will also be higher due to the lower efficiency and hence higher furnace exit gas temperature. The combination of higher gas flow and higher gas inlet temperature to the convection bank will increase the exit gas temperature from the evaporator from 739°F to a slightly higher value. Therefore another iteration will have to be performed to arrive at the exit gas temperature based on the revised efficiency and fuel input. The exit gas temperature could be close to 770–780°F.
4. Because of the larger flue gas flow and higher operating temperature in the evaporator bank, the gas pressure drop will also be higher; it could be as much as in the earlier case or even more. *Hence, the assumption that removing the economizer will reduce the total gas pressure drop is incorrect.* One has to do the performance calculations before arriving at any conclusion.

Why the Economizer Does Not Steam in Packaged Boilers

Unlike HRSGs, packaged boilers, fortunately, do not have to deal with the issue of steaming. The reason is illustrated in [Fig. 3.25](#), which shows the temperature

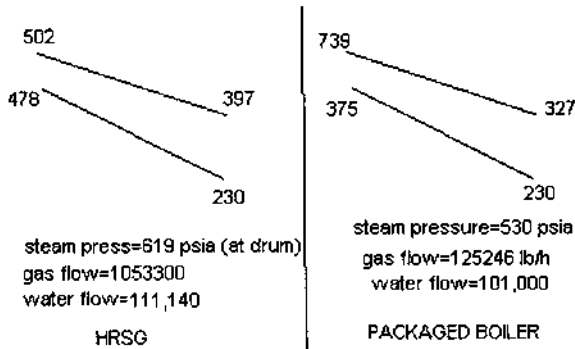

FIGURE 3.25 Economizer temperature pick-up in boiler versus HRSG.

profiles of the economizer of the boiler whose performance is given above and an HRSG.

Because of the small ratio of gas to water flow in packaged boilers, the temperature drop of the flue gas has to be large for a given water temperature increase. If the water temperature increases by, say, 145°F, the gas temperature drop is given by

$$1.23 \times 0.286 \times (T_1 - T_2) = 145$$

or

$$T_1 - T_2 = 412^\circ F$$

whereas in an unfired HRSG, the gas temperature drop of only 105°F accomplishes a water temperature increase of 248°F! Thus it is easy for the water to reach saturation temperature in HRSGs. Thus in spite of the fact that the gas entering temperature is quite large in packaged boilers (due to the high furnace exit gas temperature), the water temperature does not increase significantly.

If the water temperature approach is large at 100% load, it will be even larger at partial loads, because the gas temperature entering the economizer decreases.

Performance with Oil Firing

Steam generators have been fired with both distillate fuel oils and residual oils. The design of the boiler does not change much for distillate oil firing compared to gas firing. The fouling factor used is moderately higher, 0.003–0.005 ft² h °F/Btu, compared to 0.001 ft² h °F/Btu for gas firing; rotary soot blowers located at either end of the convection section are adequate for cleaning the surfaces for distillate oil firing. With heavy fuel oils, retractable soot blowers are required. Economizers

also use rotary blowers in oil-fired applications. Solid fin tubes of a fin density of three or four per inch may be used if distillate fuels are used, but if heavy oil is fired it is preferable to use bare tubes or at best 2–3 fins/in. The emissions of NO_x will be higher on the basis of fuel-bound nitrogen, because it can contribute to nearly 50% of the total NO_x. Flue gas recirculation has less effect on NO_x in oil firing than in gas firing.

With residual fuel oil firing, there are several aspects to be considered.

1. High temperature corrosion due to the formation of salts of sodium and vanadium in the ash has been a serious problem in with heavy oil boilers fired. The furnace exit region is a potentially dirty zone prone to deposition of molten ash on heating surfaces. The use of superheaters in such regions presents serious performance concerns. Retractable steam soot blowers are required, with access lanes for cleaning. Tubes should preferentially be widely spaced at the gas inlet region to avoid bridging of tubes by slag. Vanadium content in fuel oil ash should be restricted to about 100 ppm to minimize corrosion potential.
2. Superheater materials used in heavy oil firing applications should consider the high temperature corrosion problems associated with sodium and vanadium salts. The metallurgy of the tubes should be T22 or even higher if the tube wall temperature exceeds 1000°F. A large corrosion allowance on tube thickness is also preferred. This is yet another reason for preferring a convective superheater design to a radiant superheater.
3. Steam temperatures with oil firing will be lower than on gas firing as discussed above.
4. Furnace heat flux will be higher in oil firing than in gas firing. Therefore one has to check the circulation and the furnace design.
5. One of the problems with firing a fuel containing sulfur is the formation of sulfur dioxide and its conversion to sulfur trioxide in the presence of catalysts such as vanadium, which is present in fuel oil ash. Sulfur trioxide combines with water vapor to form sulfuric acid vapor, which can condense on surfaces whose temperature falls below the acid dew point. Q6.25 illustrates the estimation of dew points of various acid vapors. Sulfuric acid dew points can vary from 200 to 270°F depending on the amount of sulfur in the fuel. If the tube wall temperature of the economizer or air heater falls below the acid dew point, condensation and hence corrosion due to the acid vapor are likely. I have seen a few specifications where a parallel flow arrangement was suggested for the economizer to minimize acid dew point corrosion. Because the feedwater temperature governs the tube wall temperature and not the flue gas temperature, only maintaining a high

water temperature avoids this problem, as shown in Q6.25c. One could use steam to preheat the feedwater or use the water from the exit of the economizer to preheat the incoming water in a heat exchanger. Experience and research show that acid corrosion potential is maximum not at the dew point but at slightly lower values, about 15–20°C below the dew point. Hence one may use a feedwater temperature even slightly lower than the dew point of the acid vapor in order to recover more energy from the waste gas stream. In waste heat boiler economizers, other acid vapors such as hydrochloric acid or hydrobromic acid may be present. The dew points of these are much lower than that of sulfuric acid, as discussed in Q6.25, so care must be taken in the design of economizers or air heaters in heat recovery applications.

Table 3.7 shows the boiler performance with distillate oil firing. The efficiency on LHV basis is nearly the same as for gas firing, but on HHV basis there is a difference. The flue gas analysis with 15% excess air is shown. The flue gases have less water vapor but more carbon dioxide than flue gases from natural gas combustion.

Effect of FGR on Boiler Performance

Flue gas recirculation is widely used as a method of NO_x control because it reduces the flame temperature and thus lowers NO_x formation as discussed in Chapter 4. The effect of FGR on boiler performance is quite significant. Not only is the gas temperature profile across the boiler different, but the steam temperature and gas pressure drop are also affected.

Table 3.8 shows the performance of a 150,000 lb/h boiler with and without FGR. The following points may be noted:

1. The flue gas quantity increases with FGR; hence the backpressure increases at all loads.
2. The steam temperature is higher with FGR in both 100% and 50% load cases, but the difference is greater at low loads.
3. The furnace exit gas temperature is lower with FGR, and the gas temperature across the superheater is higher at 50% load than at 100%. Thus load plays a big role in the temperature profiles.
4. The efficiency naturally drops due to the higher stack gas temperature at both 100% and 50% loads.

Relating FGR and Oxygen in the Wind-Box

Flue gas recirculation affects the oxygen in the wind-box by diluting it. One may measure the oxygen values to evaluate the FGR rate used.

TABLE 3.8 Effect of FGR on Boiler Performance

	Load (%)			
	100	100	50	50
Excess air, %	15	15	15	15
FGR, %	0	15	0	15
Combustion, temp, °F	3,230	2,880	3,230	2,880
Furnace exit temp, °F	2,350	2,188	2,007	1,956
Gas temp to superheater, °F	1,695	1,630	1,323	1,334
Gas temp to evaporator, °F	1,250	1,240	944	973
Gas temp to economizer, °F	630	645	543	555
Gas temp leaving economizer, °F	300	315	263	270
Flue gas flow, lb/h	185,500	215,000	88,900	104,000
Efficiency, % HHV	84.26	83.9	85.1	84.9
Steam flow, lb/h	150,000	150,000	75,000	75,000
Steam temp, °F	748	756	686	711
Economizer exit water temp, °F	338	355	318	333
Boiler backpressure, in. WC	6.2	7.8	2.0	2.5
Feedwater temp, °F	228	228	228	228

Fuel: standard natural gas; 1% blowdown; steam pressure = 650 psig.

Example 8

A boiler firing natural gas at 15% excess air uses 119,275 lb/h of combustion air, and about 14,000 lb/h of flue gases is recirculated. Determine the oxygen levels in the wind-box. Let us assume that the air is dry and is 77% by weight nitrogen and 23% oxygen. Then the amount of nitrogen in air = $0.77 \times 119,275 = 91,842$ lb/h, and that of oxygen = 27,433 lb/h.

The flue gas analysis (vol%) is $\text{CO}_2 = 8.29$, $\text{H}_2\text{O} = 18.17$, $\text{N}_2 = 71.07$, and $\text{O}_2 = 2.47$.

To convert to percent by weight (wt%) basis, first obtain the molecular weight:

$$\text{MW} = (8.29 \times 44 + 18.17 \times 18 + 71.07 \times 28 + 2.47 \times 32)/100 = 27.61$$

$$\% \text{CO}_2 = 8.29 \times 44/27.61 = 13.21$$

Similarly, $\text{H}_2\text{O} = 11.84$ wt%, $\text{N}_2 = 72.07$, and $\text{O}_2 = 2.88$.

The individual constituents in the mixture of $14,000 + 119,275 = 133,275$ lb/h of gases are

$$\text{CO}_2 = 0.1321 \times 14,000 = 1849.4 \text{ lb/h}$$

$$\text{H}_2\text{O} = 0.1184 \times 14,000 = 1658 \text{ lb/h}$$

$$\text{N}_2 = 91,843 + 0.7207 \times 14,000 = 101,922 \text{ lb/h}$$

$$\text{O}_2 = 27,433 + 0.0288 \times 14,000 = 27,836 \text{ lb/h}$$

Converting this to percent by volume basis as we did earlier, we have

$$\text{CO}_2 = 0.9 \text{ vol } \%, \text{ H}_2\text{O} = 1.98, \text{ N}_2 = 78.37, \text{ and } \text{O}_2 = 18.75$$

SOOT BLOWING

Soot blowing is often resorted to in coal-fired or heavy oil-fired boilers. In packaged boilers, both steam and air have been used as the blowing media, and both have been effective with heavy oil firing. Rotary blowers are sometimes used with distillate oil firing. Steam-blowing systems must have a minimum blowing pressure of 170–200 psig to be effective. The steam system must be warmed up prior to blowing to minimize condensation. The steam must be dry. Increasing the capacity of a steam system is easier than increasing that of an air system. With an air system, the additional capacity of the compressor must be considered. Also, because steam has a higher heat transfer coefficient than air, more air is required for cooling the lances in high gas temperature regions compared to steam. Moisture droplets in steam can cause erosion of tubes, and often tube shields are required to protect the tubes. The intensity of the retractable blower jet is more than that of the rotary blower jet, and its blowing radius is larger, thus cleaning more surface area. However, one must be concerned about the erosion or wear on the tubes.

Sonic cleaning has been tried on a few boilers. In this system, low frequency high energy sound waves are produced when compressed air enters a sound generator and forces a diaphragm to flex. The resulting sound waves cause particulate deposits to resonate and dislodge from the surfaces. Once dislodged, they are removed by gravity or by the flowing gases. Typical frequencies range from 75 to 33 Hz. Sticky particles are difficult to clean. The nondirectional nature of the sound waves minimizes accumulation in blind spots where soot blowers are ineffective. Piping work is minimal. Sonic blowers operate on plant air at 40–90 psi and sound off for 10 s every 10–20 min.

WATER CHEMISTRY, CARRY OVER, AND STEAM PURITY

Good water chemistry is important for minimizing corrosion and the formation of scale in boilers. Steam-side cleanliness should be maintained in water tube as well as fire tube boilers. Plant engineers should do the following on a regular basis:

1. Maintain proper boiler water chemistry in the drum according to ABMA or ASME guidelines by using proper continuous blowdown rates. The calculation procedure for the blowdown rate based on feedwater and boiler water analysis is given in Q5.17.
2. Ensure that the feedwater analysis is fine and that there are no sudden changes in its conductivity or solids content.
3. Check steam purity to ensure that there are no sudden changes in its value. A sudden change may indicate carryover.
4. Watch superheated steam temperatures, particularly in boilers with large load swings. If slugs of water get carried into the steam during large load swings, the deposits are left behind after evaporation, potentially leading to tube failure. An indication of slugging, which is likely in boilers with small drums, is a sudden decrease in steam temperatures due to entrainment of water in the steam.

In the process of evaporating water to form steam, scale and sludge deposits form on the heated surfaces of a boiler tube. The chemical substances in the water concentrate in a film at the evaporation surface; the water displacing the bubbles of steam readily dissolves the soluble solids at the point of evaporation. Insoluble substances settle on the tube surfaces, forming a scale and leading to an increase in tube wall temperatures. Calcium bicarbonate, for example, decomposes in the boiler water to form calcium carbonate, carbon dioxide, and water. Calcium carbonate has limited solubility and will agglomerate at the heated surface to form a scale. Blowdown helps remove some of the deposits. Calcium sulfate is more soluble than calcium carbonate and will deposit as a heat-deterrent scale. Most scale-forming substances have a decreasing solubility in water with an increase in temperature.

In boilers that receive some hardness in the makeup water, deposits are generally compounds of calcium, sulfate, silica, magnesium, and phosphate. Depending on tube temperatures and heat flux and the solubility of these compounds as a function of temperature, these compounds can form deposits inside the boiler tubes. These scales, along with sludge and oils, form an insulating layer inside tubes at locations where the heat flux is intense. Alkalinity and pH of the water also affect the scale formation. Salts such as calcium sulfate and calcium phosphate deposit preferentially in hot regions. Boilers are considered generally clean if the deposits are less than 15 mg/cm^2 . Boilers having more than 40 mg/cm^2 are considered very dirty. The least soluble compounds deposit

first when boiling starts. Calcium carbonate deposits quickly, forming a white friable deposit. Magnesium phosphate is a binder that can produce very hard, adherent deposits. Insoluble silicates are present in many boilers. The presence of sodium hydroxide, phosphate, or sulfate may be considered proof that complete evaporation has occurred in the tubes, because these are easily soluble salts.

Sludge or easily removable deposits accumulate at the bottom of the tubes in the mud drum and should be removed by intermittent blowdown, generally once per shift. Based on conductivity readings, the frequency may be increased or decreased. Continuous blowdown is usually taken from the steam drum a few inches from above the waterline, where the concentration of solids is the highest.

Any boiler water treatment program should be reviewed with a water chemistry consultant, because this program can vary on a case-to-case basis. Generally the objective is to add chemicals to prevent scale formation caused by feedwater hardness constituents such as calcium and magnesium compounds and to provide pH control in the boiler to enhance maintenance of a protective oxide film on boiler water surfaces. There are methods such as phosphate-hydroxide, coordinated phosphate, chelant treatment, and polymer treatment methods. In medium and low pressure boilers, all these methods have been used.

Carryover of impurities with steam is a major concern in boilers having superheaters and also if steam is used in a steam turbine. Carryover results from both ineffective mechanical separation methods and vaporous carryover of certain salts. Vaporous carryover is a function of steam density and can be controlled only by controlling the boiler water solids, whereas mechanical carryover is governed by the efficiency of the steam separators used. Total solids carryover in steam is the sum of mechanical and vaporous carryover of impurities.

The steam purity requirements for saturated steam turbines are not stringent. Because the saturated steam begins to condense on the first stage of the turbine, water-soluble contaminants carried with the steam do not form deposits. Unless the steam is contaminated with solid particles or acidic gases, its purity does not significantly affect the turbine performance. However, there can be erosion concerns due to water droplets moving at high speeds.

With superheated steam, steam purity is critical to the turbine. Salts that are soluble in superheated steam may condense or precipitate and adhere to the metal surfaces as the steam is cooled when it expands. Deposition from steam can cause turbine valves to stick. Reduced efficiency and turbine imbalance are the other concerns. Deposition and corrosion occur in the "salt zone" just above the saturation line and on surfaces in the wet steam zone. The solubility of all low volatility impurities such as salts, hydroxides, silicon dioxide, and metal oxides decreases as steam expands in the turbine and is lowest at the saturation line. The moisture formed has the ability to dissolve most of the salts and carry them downstream. The critical region for deposition in turbines operating on superheated steam is the blade row located just upward of the Wilson line.

Mechanical carryover results from entrainment of small droplets of boiler water in the separated steam. Because the entrained water droplets contain the same concentration and proportions of solids as in the boiler water, the steam will also contain these solids as a function of its moisture content.

Foaming in the boiler water will also result in carryover. Common causes are excessive boiler water solids, excessive alkalinity, or the presence of organic matter such as oil. Continuous blowdown should be done to maintain the boiler water concentration below the ASME/ABMA levels.

Unlike mechanical carryover, vaporous carryover is selective because it depends on the solubility of the salts in steam. Silica is an example of a contaminant that has this tendency, particularly at high steam pressures, above 700 psig. Boiler water of a higher pH helps minimize the carryover. Drum internals (Fig. 3.26) serve to remove moisture from the steam as it leaves the drum and enters the superheater. Generally the belly pan collects the steam–water mixture from the riser tubes and directs it inside the drum, where a chevron separator consisting of multiple vanes with tortuous paths separates the moisture from the steam. The mass flow of the mixture is the circulation ratio times the steam generation. Hence the belly pan width must be sized to handle the flow of this mixture. The steam purity required depends on the application. Saturated steam used in process heating applications can have a large carryover of solids, as much as 3–5 ppm. Drum internals need not be elaborate in these cases. A few steam turbine suppliers demand steam purity in the range of parts per billion for superheated steam, whereas some accept even 100 ppb total dissolved solids.

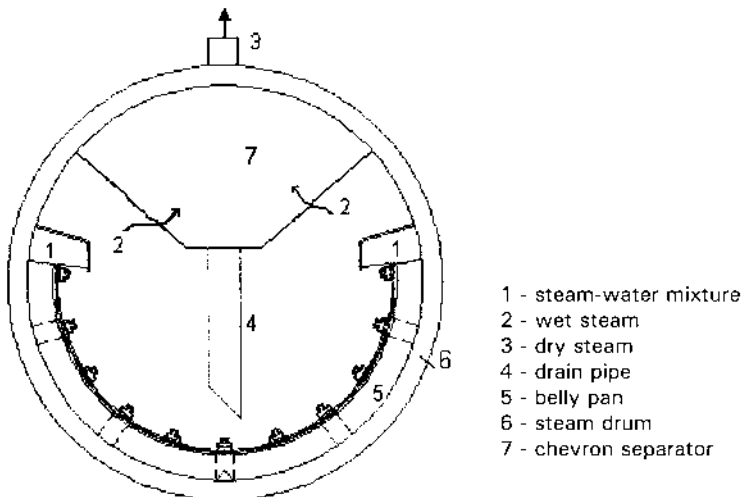

FIGURE 3.26 Arrangement of steam drum internals.

Restrictions are also placed on sodium and silica in steam. Typical silica levels are 20 ppb. By maintaining proper boiler water chemistry as suggested in Q5.17, per ABMA and ASME, one can ensure that the steam purity is acceptable. Maintaining an alkaline condition (pH about 10–11.5) in the boiler water minimizes corrosion in the boiler; however, the alkalinity should also not exceed 700 ppm CaCO₃. Above this level chemical reactions liberate CO₂ into steam, which results in the corrosion of steam and return lines.

As far as the feedwater is concerned, proper deaeration and the removal of oxygen by chemical methods helps. Demineralized water is required if it is used for attemperation to control the steam temperature. Once-through steam generators and HRSGs need zero solids because complete evaporation of water occurs inside the tubes. Dissolved oxygen is the factor most responsible for the corrosion of steel surfaces in contact with water. Oxygen should be less than 5–7 ppb to minimize these concerns. Chemicals such as hydrazine or sodium sulfite are added to minimize oxygen corrosion.

Scale formation can affect the tube wall temperatures in fire tube as well as water tube boilers; as discussed above.

A few plants do not spend sufficient money on water treatment facilities. Table 3.9 shows how a large amount of blowdown increases the cost of operation and why it pays to invest in a good water treatment system. Corrosion and steam purity problems result in additional costs, which cannot be quantified because they lead to unscheduled maintenance. The additional amount of fuel fired to generate the same amount of steam is significant over a period of time. I have seen blowdown on the order of 15–20% in a few refineries.

TABLE 3.9 Cost of Blowdown^a

	100,000		100,000	
	2	10	2	10
Steam flow, lb/h	100,000		100,000	
Steam pressure, psig	300		850	
Steam temperature, °F	Sat		850	
Feedwater temperature, °F	230		230	
Blowdown, %				
Boiler duty, MM Btu/h	100.8	102.4	123.1	125.7
Heat input, MM Btu/h	121.5	123.4	148.4	151.5
Flash steam recovery, %		20		33
Additional cost, \$/y		36,480		49,850

^a Boiler efficiency = 83% HHV; fuel cost = \$3/MM Btu. Operating for 8000 h/y.

FIRE TUBE BOILERS

Packaged fire tube boilers (Fig. 3.3) generate low pressure saturated steam, generally below 300 psig. Above this pressure, the thickness of the corrugated central furnace (referred to as Morrison pipe) becomes larger and it is difficult to make the corrugations. The corrugations help to reduce the thickness of the furnace, which operates at a high metal temperature because it contains the flame. The corrugations also help to handle the thermal expansion differences between the furnace and the smaller tubes in the second and third passes, which operate at lower tube wall temperatures. Note that the tube sheets are fixed at the ends of the tubes, and without this flexibility large stresses would be introduced into the tube sheets and the tubes. The thickness of a tube subjected to external pressure is higher than that subjected to internal pressure, as shown in Table 2.2. Fire tube boilers are typically rated in boiler horsepower (BHP); Q5.08 shows how one can relate BHP to steam generation. Often these boilers do not need an economizer, because the exit gas temperature, due to the low pressure of steam, is around 400–450°F. However, an economizer is used when high efficiency is desired.

The number of passes on the tube side depends upon the supplier. Typically three to four passes are used. In the wetback design the turnaround section is immersed in the water, so the hot gases leaving the furnace do not contact the refractory as in the dryback design, which is less expensive to build. However, the wetback design has fewer problems with refractory maintenance than the dryback design. Wet or water-cooled rear doors are also available that minimize refractory maintenance concerns in dryback boilers. The typical gas temperature at the furnace exit is about 2000–2200°F, hence the turnaround section with refractory often requires maintenance.

Oil and gaseous fuels are generally fired in packaged fire tube boilers. Solid fuels such as wood shavings have also been fired. The boiler capacity has been limited to about 80,000 lb/h, because it becomes more expensive to build these boilers as shop-assembled units as the capacity increases. The heat transfer coefficient with gas flowing inside the tubes is generally less than when it flows outside the tubes; hence fire tube boilers are large compared to water tube designs. They are considered economical below 50,000 lb/h of steam. It is generally difficult to install a superheater in these designs. NO_x control methods such as flue gas recirculation or the use of low-NO_x burners have also been used with these boilers. Due to the large amount of water inventory compared to equivalent water tube designs, these boilers take a little longer to start up. Steam purity is generally poor, because the steam is mainly used in heating applications where steam purity is not a concern and therefore no drum internals are used. Often single-shell fire tube boilers such as those shown in Fig. 3.3 generate steam with 3–15 ppm purity. Elevated drums have been used on fire tube boilers to

obtain steam with a very high purity if required. The design would be similar to the elevated drum waste heat boiler discussed in [Chapter 2](#).

When it comes to generating superheated steam, a water tube boiler has more options, because the superheater can be placed within a bank of tubes or in the radiant section or beyond the convection section as discussed above. However, in the case of a fire tube boiler, the options are limited; a possible location is between the tube passes, but the gas temperatures there are either too high or too low, making it difficult to design a reasonable superheater. Therefore, packaged fire tube boilers generally generate saturated steam.

The water inventory in a fire tube boiler is generally larger, thus requiring a longer start-up period. Heating surfaces can be cleaned by using retractable or rotary blowers at any location in a water tube boiler, whereas in a fire tube, access for cleaning is available either at the turnaround section or at the tube sheet ends.

AIR HEATERS

Air heaters are used in a few waste heat boilers for preheating combustion air. Incineration plants and reformer furnaces also use preheated air. Decades ago they were used in boilers that fired solid, liquid, and gaseous fuels. However, with NO_x limitations for all kinds of fuels, they are now used only if the combustion of the fuel warrants it. If the gaseous fuel has a low heating value or if the solid fuel has a significant amount of moisture, then hot air is required for drying the fuel and also to ensure combustion with a stable flame. A gas to gas heater, which is similar to an air heater, is also used in incineration heat recovery plants where waste fuel is heated by the flue gases from the incinerator before entering the thermal or catalytic incinerator. In gas-fired or liquid fuel-fired packaged boilers, air heaters are not generally used. An economizer is the main heat recovery equipment. There are several types of air heaters, including tubular, regenerative, and heat pipes, the latter being a recent development. In all these heat exchangers, air is preheated by using hot flue gases from the boiler or heater. The flue gases could flow outside or inside the tubes. If the flue gases contain dust or ash particles, it is preferable to make them flow inside the tubes so that the shell or casing is not fouled, because it is more difficult to clean the exterior surfaces. The air takes a multipass route outside the tubes as shown in [Fig. 3.27](#). Q8.28 shows the sizing procedures.

One of the concerns with air heaters is low temperature corrosion at the cold end. The tube wall temperature or the plate temperature at the cold end falls below the acid dew point of the flue gases if the incoming air temperature is low. Also, tube wall and plate temperatures are lower at lower loads because of their low heat transfer coefficients. Steam is often used to increase the incoming air temperature and thus mitigate this concern.

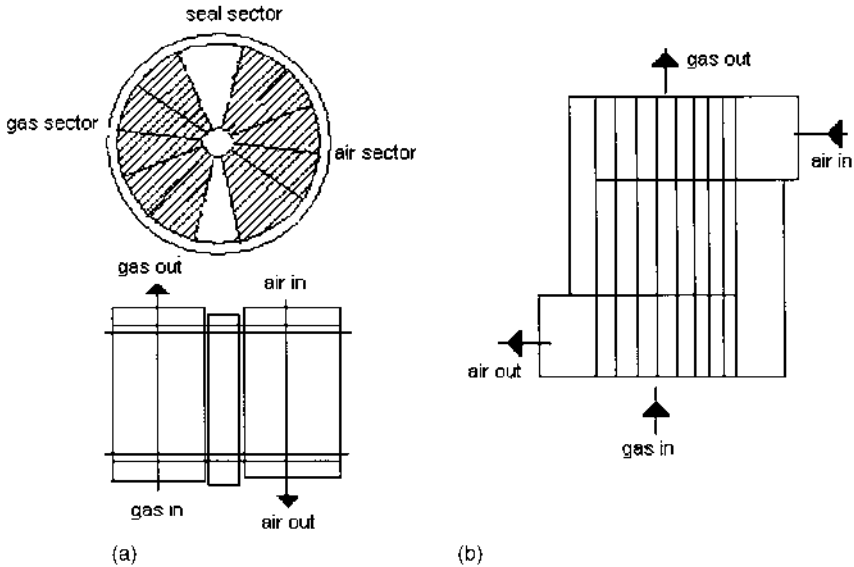

FIGURE 3.27 (a) Rotary regenerative air heater. (b) Tubular air heater.

There are two types of regenerative air heaters, one in which the heater matrix rotates, and one in which the connecting air and flue gas duct work rotate. The first type is called the Ljungstrom air heater. The energy from the hot flue gases is transferred to a slowly rotating matrix made of enamel or alloy/carbon steel material, which absorbs the heat and then transfers it to the cold air as it rotates. The elements are contained in baskets, which makes cleaning or replacement easier. Regenerative air heaters are more compact than tubular air heaters, which are heavy and occupy a lot of space. The gas- and air-side pressure drops are high in both these types of air heaters, adding to the fan power consumption. Due to the low heat transfer coefficients of air and flue gases and a low log-mean temperature difference (LMTD), surface area requirements are large for air heaters. However, a lot of surface area can be packed into each basket of a regenerative air heater, so they are more compact than the tubular heater.

One of the problems with regenerative air heaters is the leakage of air from the flue gas side that affects the power consumption and efficiency of the fan. Though the leakage may be low, on the order of 5–10% depending upon the seal design, it is significant in large plants. In tubular air heaters, failure of the tubes or expansion joints could result in leakage from the air side to the gas side, but this is minimal.

In regenerative air heaters, corrosion concerns are addressed by using enamel or corten materials at the cold end. In the case of tubular air heaters, the entire section of tubes may have to be replaced. In some designs of regenerative air heaters, a selective coating of catalytic materials is given to the heating elements to promote the reaction of NO_x with ammonia or urea, which is injected upstream of the air heater. NO_x is thus reduced. The ammonium bisulfate formed is removed periodically by online soot blowing.

Both tubular and regenerative air heaters are widely used in pulverized coal-fired or fluid bed coal-fired boiler plants.

HEAT PIPES

Heat pipes (Fig. 3.28) were introduced into the heat recovery market about 40 years ago. A heat pipe consists of a bundle of pipes filled with a working fluid such as toluene, naphthalene, or water and sealed. Heat from the flue gas evaporates the working fluid collected in the lower end of the slightly inclined pipes (6–10° from horizontal), and the vapor flows to the condensing section, where it gives up heat to the incoming combustion air.

Condensed fluid returns by gravity to the evaporative section assisted by an internal capillary wick, which is essentially a porous surfaces or circumferentially spiraled groove of proprietary design. The process of evaporation and condensa-

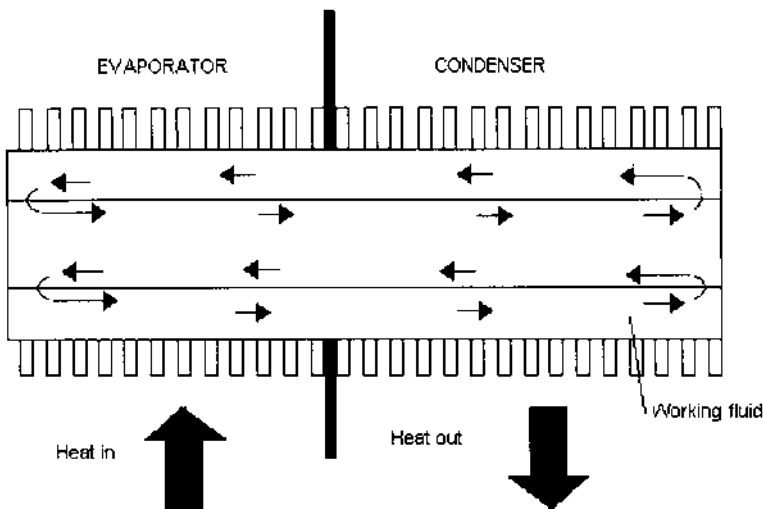

FIGURE 3.28 Arrangement of a heat pipe.

tion continues as long as there is a temperature difference between the air and flue gases.

In a typical design, there is a divider plate at the middle of the tube that supports the tube and also maintains a seal between the hot flue gases and the cold air. Pipe surfaces are finned to make the heat transfer surfaces compact. Finned surfaces are used because the heat transfer coefficient inside the tubes is very high due to the condensation and evaporation. Fin density is based on cleanliness of the gas stream.

Heat pipes offer several advantages over conventional air heaters:

1. They are compact and weigh less than other air heaters due to the use of extended surfaces.
2. They have zero leakage because the pipes are stationary and the divider plate is welded to the tubes.
3. No auxiliary power is needed, because heat pipes do not need a power source to operate.
4. Maintenance is low because there are no rotating parts.
5. They have low corrosion potential. Owing to the isothermal behavior of the pipes, the minimum tube metal temperature is higher than in other types of exchangers. By selecting proper working fluids, it is possible to maintain the cold end above the acid dew point. The tubes also operate at constant temperature along their entire length because of the phase transfer process.
6. They undergo only low stresses because the tubes are fixed at the midpoint and are allowed to expand at either end.
7. Individual pipe failure does not appreciably affect the overall performance of the unit.
8. Gas- and air-side pressure drops are generally lower than in tubular or regenerative air heaters owing to the compactness of the design.

CONDENSING HEAT EXCHANGERS

The conventional design of economizers and air heaters ensures that cold end corrosion due to condensing sulfuric acid or water vapor does not occur because the minimum tube wall temperature is maintained above the dew points. However, owing to this design philosophy, a significant amount of energy is lost or not recovered in boilers and HRSGs. The condensing heat exchanger is designed to allow for the condensation of acid and water vapor over the heat transfer surfaces, thus recovering a significant amount of sensible and latent heat from the flue gases. The efficiency of a boiler plant with a condensing heat recovery system can be close to 99%. With natural gas firing, the partial pressure of water vapor is about 18%, whereas with oil fuels it is about 12%. With the

condensation of this water vapor, significant improvement in efficiency can be obtained by using oil-fired boilers as shown in Fig. 3.29. Due to the improvement in the overall efficiency of the boiler or HRSG, the emissions of CO₂, NO_x and CO are also reduced.

Unlike conventional economizers and air heaters, which maintain temperatures above 270–300°F to prevent condensation, the condensing exchanger can operate with water or air at ambient temperatures. Hence condensate or makeup water at 60–80°F or so can be directly used to be heated up by the flue gases, whereas in a noncondensing exchanger the lowest feedwater temperature would vary from 230 to 270°F. Hence the exit flue gas temperature can be around 100–130°F versus 270–300°F. Because the exchanger tube surface and the exhaust section of the exchanger are below the dew point of water vapor, a rain of condensate is produced through dropwise condensation of the water vapor. This condensate passes around the tube array, carrying particulates and acids that have been scrubbed and washed from the tubes. A few designs handle the problem of heat recovery and scrubbing at the same time to remove particulates and acid gases from the waste gas stream from incineration plants.

The condensing exchanger consists of specially designed tubes coated with a 0.015 in. extruded layer of FEP Teflon. The inside surfaces of the heat exchanger are covered with a 0.06 in. thick sheet of PTFE Teflon. During fabrication, the tubes are pushed through extruded tube seals in the Teflon-covered tube sheet to form a resilient Teflon-to-Teflon seal. This ensures that all heat exchanger surfaces exposed to the flue gases are protected against acid corrosion. To protect the Teflon, the inlet gas temperature is limited to about 500°F. The tubes are generally made of Alloy C70600, which protects them

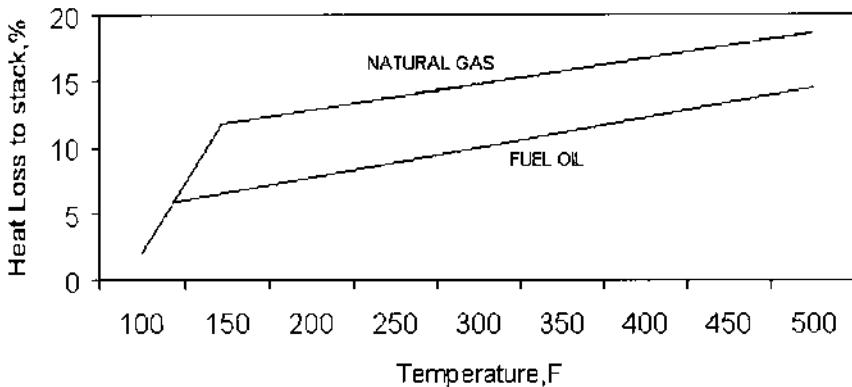

FIGURE 3.29 Efficiency improvement in oil and gas firing using a condensing exchanger.

against acid corrosion. The tube sheet and casing are coated with Teflon to prevent corrosion. The sub dew point condensing exchanger uses bare tubes due to the coating required and hence is larger than a finned tube bundle for the same duty.

Potential applications also include recovery of water from the gas turbine exhaust for recycle, reducing the amount of fresh makeup water required. The water could be redirected with proper treatment into the steam–water injection system for reducing NO_x emissions. Cheng cycle systems, in which a large amount of steam is injected into a gas turbine, are also candidates for condensing exchangers.

GLASS EXCHANGERS

Borosilicate glass (Pyrex) tubing has been used in heat recovery applications because it is most resistant to chemical attack and presents no corrosion problems. Fouling is minimal due to the smoothness of the surfaces. These tubes also have a low coefficient of expansion and are resistant to thermal shock, which makes them suitable as heat exchanger tubes. However, the temperature limit is about 500°F, and the pressure limit is also low, on the order of 60 psig or less. The thermal conductivity is lower than that of carbon steel, by about one-third; however, because the tube wall thickness is low, the wall resistance to heat transfer is also low. Thus, compared to carbon steel tubes the overall heat transfer coefficient is lower by only a small margin. Flue gas to water heat recovery has been accomplished by using glass exchangers.

SPECIFYING PACKAGED BOILERS

The following process data should be specified as a minimum.

1. Steam parameters such as flow, pressure, temperature, and feedwater temperature. If saturated steam is taken from the boiler for deaeration or for NO_x control, fuel oil heating, etc., it should be so stated. If the makeup water flow is 100%, the deaeration steam could be in the range of 15% of the steam generation and therefore not an insignificant amount.
2. If superheated steam is required, the steam temperature control range should be specified. Generally the steam temperature can be maintained from 50 to 100%. A larger range requires a larger superheater. Also, if several fuels were fired, the steam temperature would vary as discussed above.
3. Analysis of feedwater entering the economizer should be stated so that the blowdown requirements can be evaluated. An example is given in

Q5.17. In some refinery projects, I have seen very poor feedwater being used, which results in 10% to even 20% blowdown, which is a tremendous waste of energy; it also affects the boiler duty and heat input significantly. Heat input, in turn, affects the flue gas quantity and gas pressure drop.

4. Emission limits of NO_x and CO should be stated up front because they affect the burner design as well as the furnace design, the flue gas recirculation rates, and therefore the entire boiler design and performance. The use of SCR may also have to be looked into, and the cost implications are significant.
5. Fuels used and their analysis should be stated. Standard natural gas or fuel oil may not have significant variations in analysis within the United States, but for projects overseas the fuel analysis is important. Some natural gas fuels overseas contain a large percentage of hydrogen sulfide, which can cause acid dew point problems. Gaseous fuels should have the analysis in percent by volume and not in percent by weight, whereas liquid and solid fuels should have the analysis in percent by weight.
6. Surface areas should *not* be specified, for reasons discussed earlier.
7. Operating costs such as the cost of fuel and electricity should be stated as well as the norm for evaluating operating costs. Ignoring operating costs and selecting boilers based on initial costs alone (which is unfortunately being done even today!) is doing a disservice to the end user.
8. Furnace area heat release rates are more important than volumetric heat release rates for clean fuels, as mentioned earlier, therefore specifying volumetric heat release rates is not recommended for gas and oil fuels.
9. Large fan margins should not be used, and efforts must be made to estimate the gas pressure drop accurately. Large margins on flow (such as 20%) and on heat (40%) not only increase the operating horsepower, which is a waste of energy, but also make it difficult to operate the fan at low loads. In boilers with single fans, the margins should be small, say 10–12% on flow and 20–25% on head. Those familiar with utility boiler practice where multiple fans are used try to apply the same norms to packaged boilers, which can lead to operating concerns at low loads unless variable-speed drives or variable-frequency drives are used. The ambient temperature variations and elevation at which the boiler is likely to be used are important because this information helps in the selection of appropriate fans.

These points along with information on mechanical requirements such as materials, corrosion allowances, and future operational considerations, if any, are

important to the boiler designer. The proposal should also clearly state the required performance aspects.

REFERENCES

1. V Ganapathy. Understand the basics of packaged steam generators. *Hydrocarbon Processing*, July 1997.
2. V Ganapathy. Heat recovery steam generators: understand the basics. *Chemical Engineering Progress*, August 1996.
3. V Ganapathy, Customizing pays off in steam generators. *Chemical Engineering*, January 1995.
4. API Recommended Practice 530, 2nd. ed. Recommended Practice for Calculation of Heater Tube Thickness in Petroleum Refineries. May 1978.
5. V Ganapathy. Understand the basics of packaged steam generators. *Hydrocarbon Processing*, July 1997.
6. V Ganapathy. Superheaters: design and performance. *Hydrocarbon Processing*, July 2001.
7. V Ganapathy. 21st century packaged boilers will be larger and more environmentally friendly. *Power Engineering*, August 2001.
8. O Jones. Developing steam purity limits for industrial turbines. *Power*, May 1989.
9. J Robinson. A practical guide to avoiding steam purity problems in the industrial plant. *International Water Conference*, October 1992.
10. Nalco Corp. *The Nalco Guide to Boiler Failure Analysis*. New York: McGraw-Hill, 1991.
11. Editor. Attraction grows for heat pipe air heaters in flue gas streams. *Power*, February 1989.
12. V Ganapathy. How important is surface area? *Chemical Engineering Progress*, October 1992.
13. V Ganapathy. Understand steam generator performance. *Chemical Engineering Progress*, December 1994.

4

Emission Control in Boilers and HRSGs

INTRODUCTION

Boiler and HRSG designs have undergone significant changes during the last few decades with the enforcement of emission regulations in various parts of the world. Decades ago boiler and HRSG users were concerned about two issues only: the initial cost of the boiler or HRSG and the cost of operation. Low boiler efficiency, for example, meant higher fuel cost, and a large pressure drop across boiler heating surfaces resulted in increased fan power consumption. Each additional 1 in. WC pressure drop in a boiler of 100,000 lb/h capacity results in about 5 kW of additional fan power consumption. In a gas turbine HRSG, an additional 4 in. WC of gas pressure drop decreases the gas turbine power output by about 1.0%. At 320°F stack gas temperature, the difference in efficiency between 5% and 15% excess air operation on natural gas is about 0.4%. Therefore, steam generators were operated at the lowest possible excess air, about 5% or so, to maintain good efficiency. With strict emission regulations in vogue throughout the world, present-day steam generators or HRSGs, in addition to having low operating costs, must limit the emissions of CO₂, CO, NO_x, SO_x, and particulates. The expression “low NO_x, no SO_x, and no rocks” aptly describes the direction in which we are headed. However, several of the techniques used for emission control increase the cost of owning and operating

the boilers and HRSGs. For example, in order to meet the stringent levels of NO_x and CO, today's boilers have to operate at higher excess air and use some flue gas recirculation (FGR), which affects their efficiency as well as their operating costs significantly, as we discuss later.

One of the important changes is in the use of an economizer instead of an air heater for heat recovery in packaged boilers. Air heaters were used in industrial boilers several decades ago even if the fuel fired was natural gas. However, as the combustion air temperature to the boiler increases, the NO_x formation increases, because it is a function of flame temperature, as shown in Fig. 4.1. With natural gas at 15% excess air, each 100°F increase in combustion air temperature increases the flame temperature by about 65°F. Hence today's packaged oil- and gas-fired boilers do not use air heaters. Economizers are used to improve their efficiency. In addition to increasing NO_x, an air heater adds about 3–5 in. WC to the gas- and air-side pressure drop, while the typical gas pressure drop across the economizer is 1 in. WC. Therefore, with an economizer as the heat recovery equipment, substantial savings in operating cost can also be realized.

Owing to the use of low-NO_x burners, the furnace dimensions of standard boilers may have to be reviewed to avoid flame impingement concerns. The completely water-cooled furnace (Fig. 4.2) is another innovation that helps in lowering emissions. If the desired emission levels are in single digits, HRSGs and packaged boilers use catalysts to minimize NO_x and CO, which influences their design significantly. For example, a gas bypass system has to be provided in boilers, and the evaporator may have to be split up in the case of HRSGs to accommodate the selective catalytic reduction (SCR) system.

Thus, there are several variables that affect emissions and numerous options to minimize them, as indicated in Fig. 4.3, which will be addressed in this

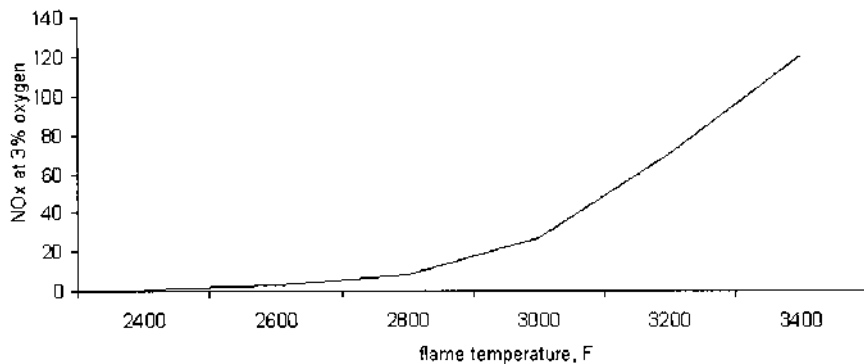

FIGURE 4.1 Typical NO_x formation versus flame temperature for natural gas.

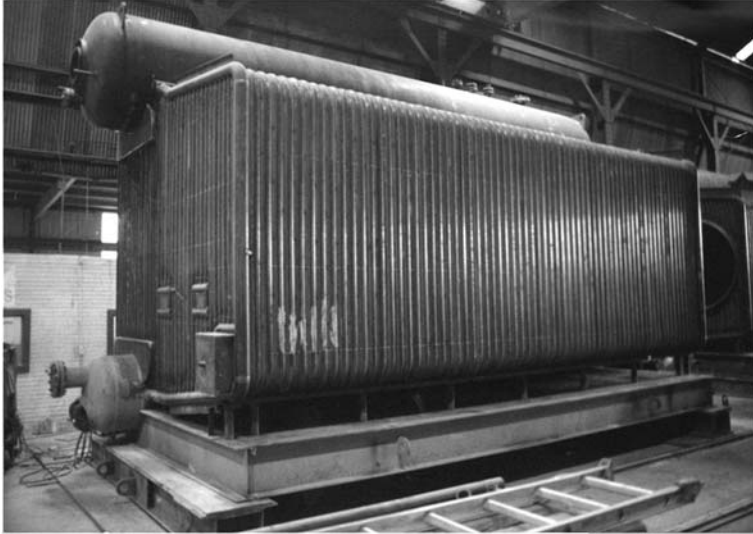

FIGURE 4.2 Water-cooled furnace. (Courtesy of ABCO Industries, Abilene, TX.)

chapter. These emission control strategies naturally add to the initial and operating costs of boilers and HRSGs and impact their design as well, a price we must pay for cleaner air.

HOW POLLUTANTS ARE GENERATED

Before going into further details of how the boiler or HRSG is impacted by emission regulations, one should first understand what the various pollutants are

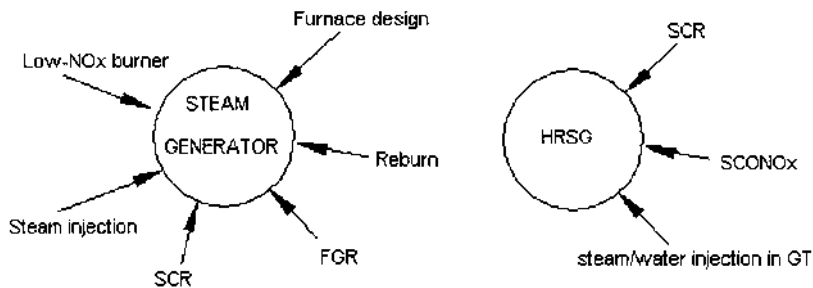

FIGURE 4.3 Options for NO_x removal in boilers and HRSGs.

and how they are formed. In the process of combustion of fossil fuels, be it in steam generators, gas turbines, or engines, several pollutants are released to the environment. These include carbon dioxide (CO_2), oxides of nitrogen (NO_x), carbon monoxide (CO), oxides of sulfur (SO_x), and volatile organic compounds (VOCs).

Carbon dioxide is considered to be responsible for the greenhouse effect and global warming. Concentrations of 3–6% can cause headaches; larger concentrations can lead to unconsciousness and possibly death. Coal generates about 200 lb CO_2 /MM Btu fired; oil generates 150 lb and natural gas about 100 lb per MM Btu. Hence one can see why natural gas is the preferred fuel in any fired equipment. CO_2 molecules retain infrared heat energy, preventing normal radiation from the earth and leading to warming of the atmosphere. There are several processes, such as amine-based systems that can remove CO_2 from flue gas streams, but these can be justified only in large plants.

The presence of carbon monoxide (CO) in flue gases is indicative of inefficient combustion and may be due to poor burner operation, improper settings, or even poor boiler design. CO is dangerous to the health of humans and other living creatures. It passes through the lungs directly into the bloodstream, where it reduces the ability of the red blood cells to carry oxygen. It can cause fainting and even death. At an exposure of only 0.1% by volume (1000 ppm) in air, a human being will be comatose in less than 2 h. A few regulations establish a maximum exposure of CO of 9 ppm for an 8 h average and 13 ppm for any 1 h period.

Oxides of nitrogen, NO_x , are predominantly NO and NO_2 . The majority of NO_x produced during combustion is NO (95%). NO_x is responsible for the formation of ground-level ozone or smog. Oxides of sulfur, SO_x , are formed when fuels containing sulfur are fired. Sulfur dioxide (SO_2) and sulfur trioxide (SO_3) are responsible for acid rain and can damage plant life and materials of construction. The Taj Mahal in India is a good example of what acid formation from nearby refineries emitting oxides of sulfur can do to the luster and beauty of marble over a period of time. Particulates are also formed during combustion that disperse in the air to form haze and smog, affecting visibility. Dangerous driving conditions are created in some places due to smog formation. Inhalation of particulates affects the lungs and the digestive system.

Volatile organic compounds (VOCs), which are generated in industrial processes such as those of chemical and petrochemical plants, also cause harmful ozone.

Tremendous efforts are being made to reduce these pollutants in power and process plants, refinery heaters, and combustion equipment.

NO_x FORMATION

Nitrogen oxides are of environmental concern because they initiate reactions that result in the formation of ozone and acid rain, which can cause health problems, damage buildings, and reduce visibility. The allowable NO_x emissions from boilers and HRSGs vary depending on local regulations but are gradually edging toward single-digit values in parts per million volume (ppmv) due to advances in combustion and pollution control technology. The principal nitrogen pollutants generated by boilers, gas turbines, and engines and other combustion equipment are nitric oxide (NO) and nitrogen dioxide (NO₂), collectively referred to as NO_x and reported as NO₂. Once released into the atmosphere, NO reacts to form NO₂, which reacts with other pollutants to form ozone (O₃). Oxides of nitrogen are produced during the combustion of fossil fuels through the oxidation of atmospheric nitrogen and fuel-bound nitrogen. These sources produce three kinds of NO_x: fuel NO_x, prompt NO_x, and thermal NO_x.

Fuel NO_x is generated when nitrogen in fuel combines with oxygen in combustion air. Gaseous fuels have little fuel-bound nitrogen, whereas coal and oil contain significant amounts. Fuel-bound nitrogen can account for about 50% of total NO_x emissions from coal and oil combustion. Most NO_x control technologies for industrial boilers reduce thermal NO_x and have little impact on fuel NO_x, which is economically reduced by fuel treatment methods or by switching to cleaner fuels. Fuel NO_x is relatively insensitive to flame temperature but is influenced by oxygen availability.

Prompt NO_x results when fuel hydrocarbons break down and recombine with nitrogen in air. Prompt NO_x is chemically produced by the reactions that occur during burning; specifically, it forms when intermediate hydrocarbon species react with nitrogen in air instead of oxygen. Prompt NO_x, so called because the reaction takes place ahead of the flame tip, accounts for about 15–20 ppm of the NO_x formed in the combustion process and is a concern only in low temperature situations.

Thermal NO_x forms when atmospheric nitrogen combines with oxygen under intense heat. This rate of formation increases exponentially with an increase in temperature and is directly proportional to oxygen concentration. Its formation is well understood and straightforward to control. Keeping the flame temperature low reduces it. Below a certain temperature, thermal NO_x is nonexistent, as indicated in Fig. 4.1. Combustion temperature, residence time, turbulence, and excess air are the other factors that affect the formation of thermal NO_x. Most NO_x is formed in this manner in gas turbines, industrial boilers, and heaters fueled by natural gas, propane, butane, and light fuel oils.

Common boiler fuels in the order of increasing NO_x potential are methanol, ethanol, natural gas, propane, butanes, distillate fuel oil, heavy fuel oils, and coal.

NO_x CONTROL METHODS

Methods for NO_x control can be classified into two broad categories:

1. Postcombustion methods: methods that are deployed after flue gases are generated.
2. Combustion control methods: methods that are deployed during the combustion process.

Postcombustion Methods

As the name implies, postcombustion methods deal with the flue gases obtained after combustion. They are more expensive than combustion control methods, because they handle large quantities of flue gases generated in the process of combustion. The ratio of flue gas to fuel on a weight basis is about 21 for natural gas and 18 for fuel oils in steam generators. In gas turbines, the exhaust gas quantity generated is very large because on the order of 200–300% excess air is used. The two commonly used methods of control are

1. Selective noncatalytic reduction (SNCR) methods
2. Selective catalytic reduction (SCR) methods

SNCR

In selective noncatalytic reduction a NO_x reduction agent such as ammonia or urea is injected into the boiler exhaust gases at a temperature of approximately 1400–1650°F. The ammonia or urea breaks down the NO_x in the exhaust gases into water and atmospheric nitrogen, plus CO₂ if urea is injected. This reaction takes place in a narrow range of temperatures; as shown in Fig. 4.4, ammonia is formed below a certain temperature, and above this temperature the NO_x level increases. SNCR reduces NO_x by about 70%. The SNCR method is used in large industrial and utility boilers, which have adequate residence times for the reduction reactions. In packaged boilers it is difficult to apply this method because the ammonia or urea must be injected into the flue gases at a specific flue gas temperature; however, the gas temperature profile varies with load, excess air, and fuel fired as shown in Fig. 4.5 and residence times in oil- and gas-fired packaged boilers are generally very small.

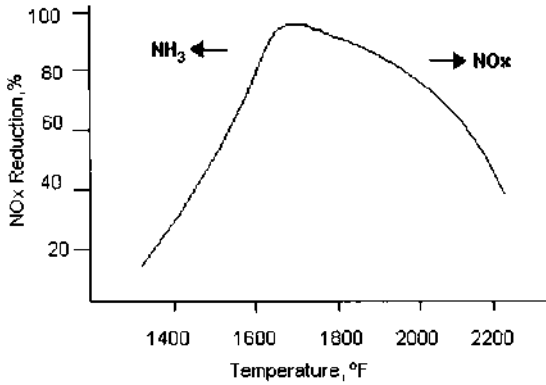

FIGURE 4.4 Range of temperatures for SNCR operation.

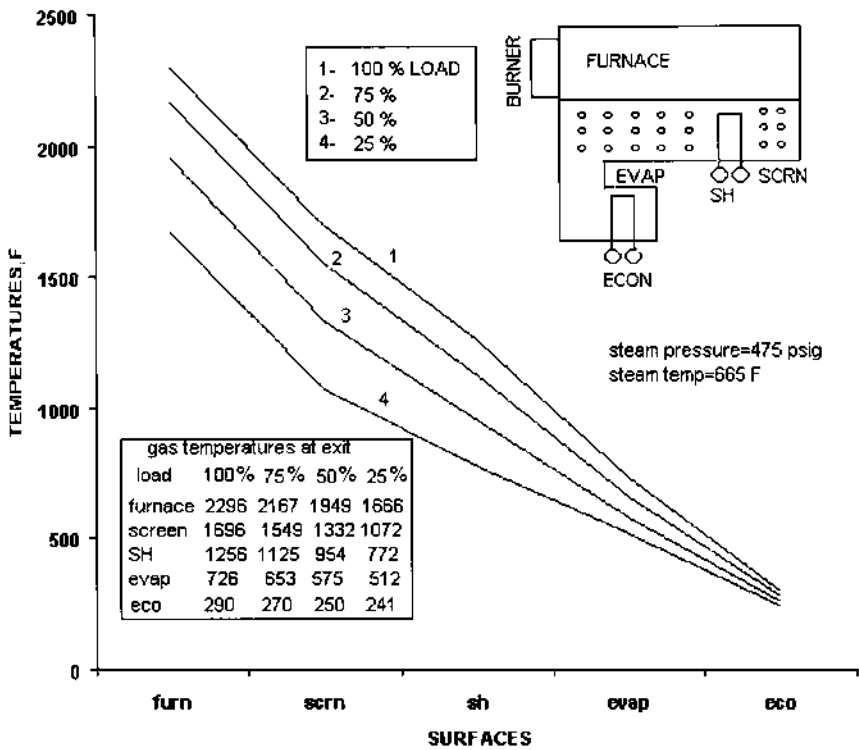
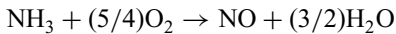
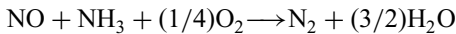

FIGURE 4.5 Boiler temperature profiles as a function of load. Furn, furnace; scrn, screen; SH, superheater evap, evaporators; econ, economizer.

Typical reactions, that take place with ammonia injection are:



Both oxidation and reduction take place. Ammonia oxidizes to form NO. Because reduction and oxidation reactions are temperature-sensitive, there is a narrow range of temperatures in which the conversions are efficient. An increase in ammonia increases the efficiency of conversion; however, excessive ammonia can slip through the reactions and cause plugging of components downstream. SNCR has a low cost of operation and may be used in conjunction with other methods such as a low-NO_x burner to improve the efficiency of NO_x reduction.

In large field-erected boilers, wall injectors are located at several locations to inject the ammonia or urea using specially designed lances. This method is not used in HRSGs because it is difficult to find such a temperature window and also have a suitable residence time.

Benefits of SNCR include

- Medium to high NO_x reduction.
- No by-products for disposal—minimizes waste management concerns,
- Easy to retrofit—little downtime required.
- Minimum space required.
- Can be used along with other NO_x reduction methods.
- Low energy consumption. Additional gas pressure drop of flue gases is zero, unlike in SCR method, where the catalyst could add about 3 to 4 in. WC to the gas pressure drop, adding to the operating cost.

SCR

If the desired CO and NO_x levels are very low, on the order of single digits, a selective catalytic reduction (SCR) system may have to be used in boilers and HRSGs. Because most catalysts operate efficiently within a temperature window, generally 650–780°F, the boiler should have a gas bypass system to accommodate the gas temperature window at all loads. One can see from Fig. 4.5 how the gas temperature profile across a packaged boiler varies with load. As the load decreases, the gas temperature at the various surfaces decreases because a smaller amount of flue gases is generated at lower load. Hence a gas bypass system, as shown in Fig. 4.6, that mixes the hot flue gases taken from the convection bank with the cooler gases at the evaporator exit ensures a higher gas temperature at the SCR at low loads. Heat recovery steam generators (HRSGs) also use the SCR system to limit NO_x, and, again, to match the gas temperature window of 650–780°F the evaporator is often split up as shown in Fig. 4.7. If we did not split up the evaporator, we would have a very low gas temperature at its exit; also we cannot locate the SCR system ahead of the evaporator, because the gas

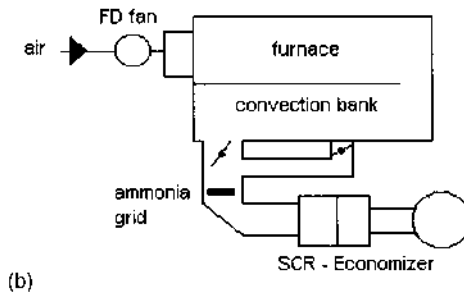
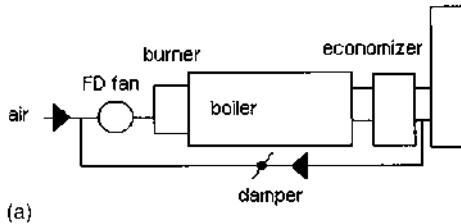

FIGURE 4.6 Gas bypass system in boiler using (a) FGR and (b) SCR methods for NO_x control.

temperature there is very high. As shown in Fig. 4.7, the two evaporator circuits are in parallel. External downcomers and risers are used to ensure adequate circulation through both the evaporator modules. Figure 4.8 shows the gas temperatures entering various sections of a fired HRSG—superheater, evaporator, economizer, and stack—at various steam flows. The gas temperature at the entrance of the second-stage evaporator section may be seen to be in the range of 650–800°F. The SCR system adds about 3–4 in. WC to the boiler or HRSG gas-side pressure drop, which is an operating expense as discussed earlier.

The selective catalytic reduction (SCR) method uses the same reaction process as SNCR except that a catalyst is employed to lower the temperature of operation and also increase the efficiency of conversion. Ammonia or urea is used in these reactions as the reagent. Figure 4.9 shows how ammonia is added in three different systems. The most common method uses anhydrous ammonia, which is pure ammonia. Anhydrous ammonia is toxic and hazardous, particularly if the neighborhood has a large population. It has a high vapor pressure at ordinary temperatures and thus requires thick shells for the storage tanks. Its release to the atmosphere can cause environmental problems, and extreme caution is required to handle such a situation. However, this is the least expensive way to feed ammonia into the HRSG.

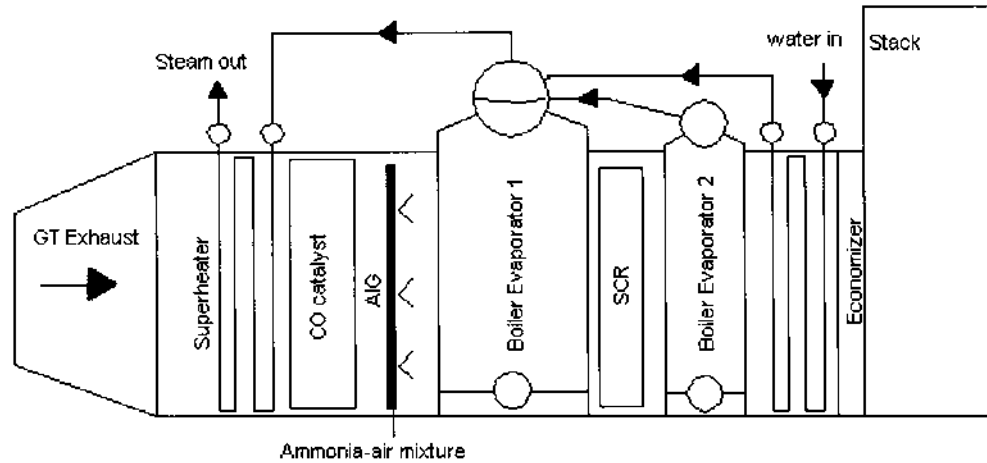

FIGURE 4.7 HRSG showing location of NO_x (SCR) and CO catalysts.

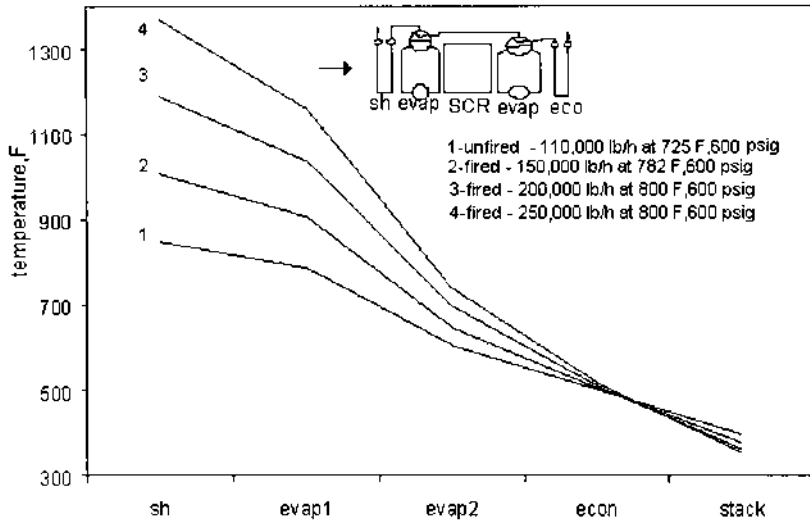

FIGURE 4.8 HRSG gas temperature profiles as a function of steam generation. sh, superheater; econ, economizer; evap, evaporator.

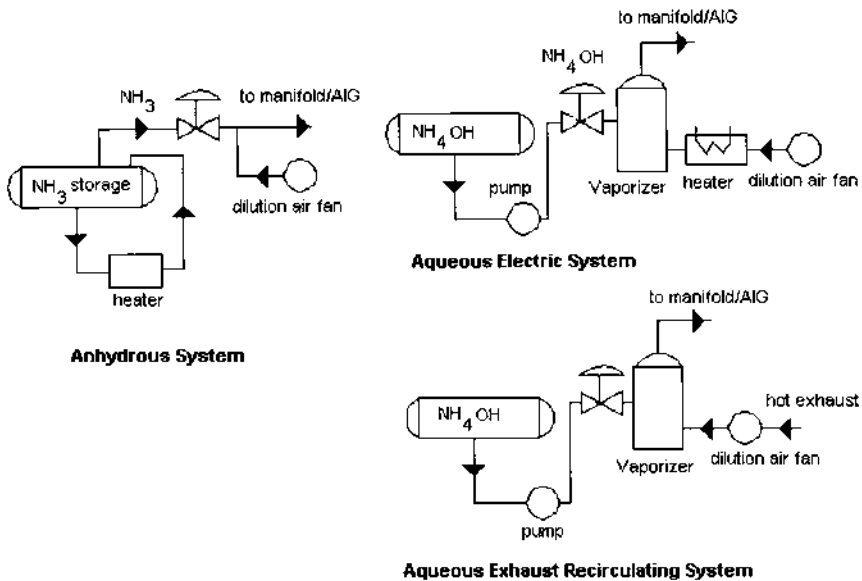
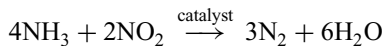
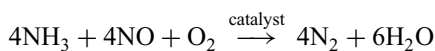

FIGURE 4.9 Ammonia injection methods. (Courtesy of Peerless Manufacturing, Dallas, TX.)

Aqueous $\text{NH}_3(\text{NH}_4\text{OH})$, which is a mixture of ammonia and water, is safer to handle. A typical grade contains 30% ammonia and 70% water. It has nearly atmospheric vapor pressure at ordinary temperatures. The liquid ammonia is pumped to a vaporizer and mixed with heated air before being sent to the mixing grid. Urea systems, which generate ammonia on-site, are also safer and have been recently introduced. Dry urea is dissolved to form an aqueous solution, which is fed to an in-line reactor to generate ammonia by hydrolysis. Heat is applied to carry out the reactions under controlled conditions. The ammonia is mixed with air and then injected through a grid into the gas stream.

Computational fluid dynamics (CFD) analysis is done to ensure that the gas velocity distribution across the boiler or HRSG cross section is uniform, with variations within 15%. The ammonia vapor is mixed with air and sprayed into the flue gas stream at the desired location before coming into contact with the catalyst. A heat transfer surface located immediately behind the ammonia injection grid ensures good mixing of ammonia vapor with the flue gases. The optimum gas temperature for the NO_x reduction reactions with most catalysts is 600–780°F as mentioned earlier. Below this temperature, chemical reactivity is impaired, and above it physical damage can occur to the catalyst through sintering. From the boiler or HRSG design viewpoint, a suitable location has to be found for the SCR so that at the wide range of loads, the temperature window is maintained, to ensure that undesirable oxidation of ammonia to NO does not take place. This is accomplished in a boiler by using a gas bypass system as discussed earlier. The ammonia injection system is located upstream of the SCR and should have sufficient mixing length that the flue gases can react with ammonia. SCR efficiency ratings are in excess of 90%. A gas pressure drop across the catalyst of about 3–4 in. WC adds to the fan power consumption in a steam generator and could be a significant power decrement in a gas turbine plant. Catalysts are typically platinum, vanadium, tungsten, and noble metals and zeolites, which are used at higher temperatures.

Typical reactions are



To complete these reactions, slightly more NH_3 than required is injected into the gas stream. This excess ammonia, which is called slip, is generally limited to a single-digit value (less than 5 ppm), through a control and emission monitoring system. The slip value increases gradually over a period of time as the catalyst nears the end of its service life.

Sulfur-containing flue gas streams present problems for boilers and HRSGs. The presence of vanadium in the SCR converts SO_2 to SO_3 , which

can react with excess ammonia to form ammonium sulfate or with water vapor to form sulfuric acid, causing problems such as fouling and plugging of tubes downstream of the boiler or HRSG. Distillate oil contains a small amount of sulfur, hence the only way to minimize this concern is to limit the operating hours on oil fuels. Lowering the ammonia slip also helps, but this can lower the NO_x reduction efficiency.

Environmentally ammonium sulfate and bisulfate are particulates that contribute to visible haze and acidify lakes and ground areas when they settle out of the air.

Sulfates are formed according to the equations

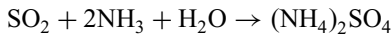
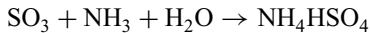

Ammonium sulfate is a sticky substance that can be deposited on heat transfer surfaces and cause fouling. The gas pressure drop across the heating surfaces also increases over a period of time. If the ammonia slip is less than 10 ppm and the SO₃ concentration is less than 5 ppm, expert opinion is that the probability of ammonium sulfate formation is practically nil unless the gas temperature is low, on the order of 200°C. Hence low gas temperatures should be avoided, particularly at the catalysts, because salt formation and deposits there would be detrimental to the life of the catalyst. Some suppliers require a minimum of 450–500°F at the catalyst to minimize these reactions. Either ammonium sulfate or ammonium bisulfate will be formed by the reaction of SO₃ and excess ammonia downstream of the SCR catalyst. In general, ammonium sulfate is considerably less corrosive than ammonium bisulfate.

One should keep the boiler or HRSG warm in standby conditions during brief shutdowns if fuel oils are fired. Shutdown and isolation of the HRSG after oil firing should be avoided because the SO₃ can condense during the cooling phase. For boilers or HRSGs firing natural gas fuels, fortunately, there are no such concerns as those just discussed. It may be noted that the presence of water vapor in the flue gases has an adverse effect on NO_x reduction efficiency.

Selective catalytic reduction systems have efficiencies of 90–95%. However, they are expensive and may cost from \$3000 to \$5000/MM Btu/h in gas or oil-fired packaged boilers. For gas turbines the cost could range from \$40 to 100/kW. In some coal-fired plants where regenerative air heaters are used, the hot end heating elements are coated with a catalyst material to convert NO_x to N₂ and H₂O.

SCONOX

The SCONOX system is a recent development that is claimed to reduce NO_x and CO levels to 2–5 ppmv with a single catalyst. It does not use ammonia or urea and

hence avoids the concerns associated with handling ammonia. The system can operate efficiently at 300–700°F, which is an advantage because the HRSG evaporator need not be split up. Typically the gas temperature between the evaporator and economizer of an HRSG is in this range. Dampers are not needed to control the gas temperature in steam generators at low loads. This method has been used in a few HRSGs but not in packaged boilers.

The SCONOX catalyst works by simultaneously oxidizing CO to CO₂, hydrocarbons to CO₂ + H₂O, and NO_x to NO₂ and then absorbing NO₂ onto its platinum surface through the use of a potassium carbonate absorber coating. These reactions, shown below, are referred to as the “oxidation/absorption cycle.”

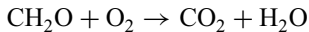
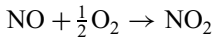
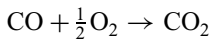

The CO₂ produced by these reactions is exhausted up the stack. The potassium carbonate coating reacts to form potassium nitrates and nitrites, which remain on the surface of the catalyst.

The SCONOX catalyst can be compared to a sponge absorbing water. It becomes saturated with NO_x and must be regenerated. When all of the carbonate absorber coating on the catalyst surface has reacted to form nitrogen compounds, NO_x will no longer be absorbed, and the catalyst must enter the regeneration cycle.

The unique regeneration cycle is accomplished by passing a dilute hydrogen reducing gas across the surface of the catalyst in the absence of oxygen. The hydrogen reacts with nitrites and nitrates to form water and elemental nitrogen. Carbon dioxide in the regeneration gas reacts with potassium nitrites and nitrates to form potassium carbonate, which is the absorber coating that was on the catalyst surface before the oxidation/absorption cycle began. This cycle is called the “regeneration cycle.”



Water and elemental nitrogen are exhausted up the stack instead of NO_x, and potassium carbonate is once again present on the catalyst surface, allowing the entire cycle to begin again.

Because the regeneration cycle must take place in an oxygen-free environment, a section of catalyst undergoing regeneration must be isolated from the exhaust gases, usually by a set of louvers, one upstream of the section being regenerated and one downstream. During the regeneration cycle, these louvers

close and a valve allows the regeneration gas into the section. Stainless steel strips on the louvers minimize leaks during operation. A SCONOx system has five to 15 sections of catalyst, depending on gas flow, design, etc. At any given time, 80% of the sections are in the oxidation/absorption cycle and 20% are in the regeneration mode. Because the same number of sections are always in the regeneration mode, the production of regeneration gas proceeds at a constant rate. A regeneration cycle lasts for 3–5 min, so each section is in oxidation/absorption mode for 9–15 min.

The SCONOx technology is still being developed and have yet to accumulate significant operational experience compared to the SCR system. It is also very expensive and is sensitive to sulfur, even the small amount in natural gas. For a 2.5 ppmv NOx limit from a 501°F Westinghouse gas turbine, studies show that the cost of SCONOx is more than that of the SCR system. However, with technological improvements, it could become an economically viable option.

Combustion Control Methods

The formation of NOx has been well understood by burner manufacturers, who are able to offer several methods to reduce the formation of NOx in steam generators. Gas turbine manufacturers also have come up with design improvements to lower NOx emissions.

During the combustion process, several complex reactions occur within the flame, and NOx formation is a function of temperature, oxygen, and time of residence in the high temperature zones. [Figure 4.1](#) shows the effect of temperature on NOx formation. As the combustion temperature is reduced from 2700°F to 2300°F, NOx is reduced by a factor of 10.

As the excess air increases, the NOx increases and drops off as shown in [Fig. 4.10](#) Because CO is another pollutant, its emissions should also be limited. As the excess air increases, CO decreases. Hence there is a band of excess air in which one can operate the burner to minimize both NOx and CO.

Gas turbine manufacturers have come up with dry low-NOx (DLN) combustors, which limit the NOx to single-digit levels. Most of the NOx emitted by a gas turbine firing natural gas is generated by the fixation of atmospheric nitrogen in the flame, and the amount of this “thermal NOx” is an exponential function of flame temperature. The DLN combustor lowers the flame temperature by burning a leaner mixture of fuel and air in premixed mode. To reduce NOx emissions in traditional combustors, steam or water is injected to reduce the flame temperature; benefits include additional power output. However, there is a loss in engine life and shortening of combustor life. CO formation also increases as the amount of water or steam increases, as shown in [Fig. 4.11](#).

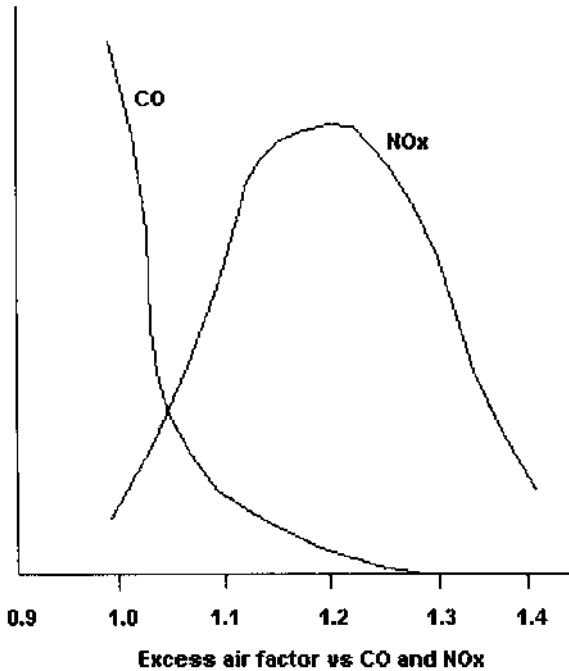

FIGURE 4.10 Typical NOx and CO levels versus excess air.

Oxygen Control

In steam generators, oxygen trim can be added to control the excess oxygen levels. Too little oxygen increases CO formation, and too much can increase the NOx. Also, the boiler efficiency is impacted by the excess air levels as discussed in [Chapter 3](#). The higher mass flow also affects the gas temperature distribution throughout the boiler and can affect the superheated steam temperature.

Steam–Water Injection

Boiler and burner suppliers sometimes use steam injection to reduce the flame temperature and thus decrease NOx. Steam generators as well as gas turbines use this method. In boilers the steam consumption could vary by 1–3% of the total steam generated, thus reducing the boiler output; however, the significant reduction in NOx may offset the need for FGR or other methods. The NOx reduction is more significant with gas firing than with oil firing. A side effect of water or steam injection is the increase in CO content. Hence there should be a compromise between the efforts to reduce NOx and CO.

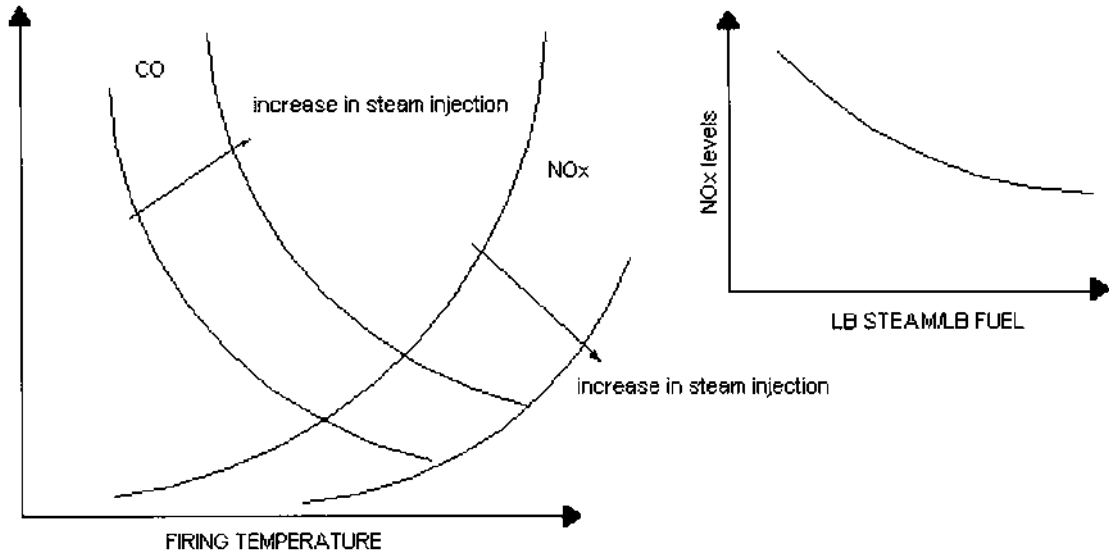

FIGURE 4.11 Effect of steam–water injection on NOx and CO.

In HRSGs, steam or water injection in to the gas turbine combustor is used along with catalysts located in the HRSG to limit NO_x to single digits. The increase in water vapor content on SCR performance has to be reviewed. Steam injection also increases the gas turbine power output due to the increased mass flow and higher specific heat of the gases with increased water vapor content. This concept is used in the Cheng cycle power system discussed in [Chapter 1](#).

Water or steam injected into gas turbines has to be treated to give high steam purity. Steam purity should be preferably in the parts per billion range. The treated water is lost to the atmosphere and has to be evaluated as an operating cost in such systems.

Burner Modifications

Staged combustion is widely used by burner suppliers to reduce NO_x. In this method, the fuel or air is added in increments (Fig. 4.12) so that at no point in the flame is an exceptionally high temperature obtained. In air staging, a fuel-rich mixture is initially created, followed by the addition of air at the burner tip to burn the remaining fuel. As little as 60% of the total combustion air is introduced into the primary combustion zone. The substoichiometric operation generates a high level of partial pressures of hydrogen and CO, and these reducing agents limit the NO_x formation. The second-stage air is introduced downstream to complete the combustion process after some heat has been transferred to the process, thereby limiting the formation of thermal NO_x. The staging of air does provide some control over both thermal and fuel NO_x.

A concept that is a little more effective for reducing thermal NO_x is fuel staging. Staged fuel burners are widely used. A portion of the fuel and all of the combustion air are introduced into the primary combustion zone. Rapid combus-

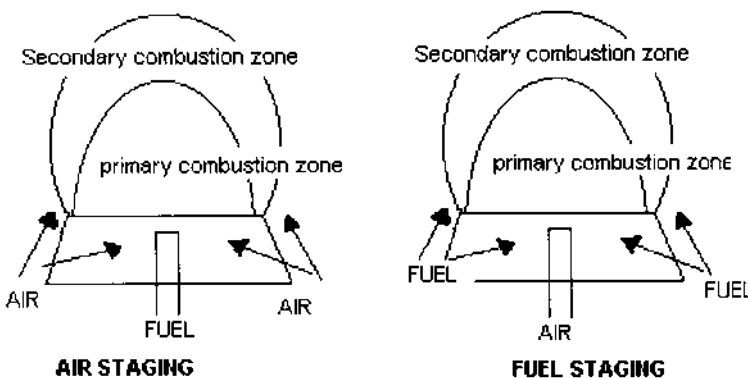

FIGURE 4.12 Staging of fuel and air in burners.

tion is achieved in the fuel-rich atmosphere with a high level of excess air, which reduces the peak flame temperature, thereby reducing thermal NO_x. The fuel for the second stage is introduced through a series of nozzles positioned around the burner perimeter. This fuel is introduced in such a manner that the final combustion occurs after heat has been transferred to the process, lowering the final combustion temperature. In addition, the secondary fuel is injected at a relatively high pressure, which, because of the position of the secondary tips, entrains flue gases; this simulates flue gas recirculation, which helps lower the combustion temperature. Although fuel staging helps lower thermal NO_x by up to 75%, it does not reduce the amount of fuel NO_x generated. However, this is a small portion of the overall NO_x in gas-fired boilers. Fuel staging is difficult with liquid fuels. Fuel staging also helps operation at lower excess air than air staging. A few burner suppliers are able to promise less than 30 ppmvd NO_x using this technique.

Furnace Modifications

The completely water-cooled furnace (Fig. 4.2) provides a cooler envelope for the flame than a refractory-lined front wall or floor and hence produces less NO_x. Most NO_x is generated at the flame front when combustion is initiated, and a water-cooled furnace absorbs some of the radiation from the flame, which helps cool it, whereas a refractory-lined boiler reradiates energy back to the flame, keeping it locally hotter, thus increasing its potential for forming thermal NO_x. The effective projected radiant surface for this design is greater than that of a refractory-lined boiler by 7–15%. Hence the net heat input per unit effective radiant area or the heat release rate on area basis is lower, which also helps lower NO_x.

Burner Emissions

Duct burners used in HRSGs also generate NO_x and CO, adding to the emissions from the turbine exhaust gases. The calculation procedure for estimating the NO_x and CO in ppmv after combustion is shown in Q6.26e. It may be noted that the values of NO_x and CO in lb/h are always higher after combustion; however, the values in ppmv may or may not be, depending on the initial ppmv values of NO_x and CO and the contribution by the burner. Typical NO_x and CO emissions from duct burners are listed in Table 4.1.

With distillate oils containing fuel-bound nitrogen in the range of 0.05%, nearly 80–90% of it is converted to NO_x, whereas with heavy fuel oils with 0.3% nitrogen, about 50% of it is converted to NO_x. In the case of packaged boiler burners, the emissions depend on burner design, on whether fuel is premixed with air, on whether fuel or air is staged, and on the combustion temperature as discussed below. NO_x emission ranges from 0.04 to 0.1 lb/Mm Btu for natural gas firing and increases if hydrogen or a fuel with a high combustion temperature

TABLE 4.1 Typical Emissions from Various Fuels

Gas	Nox (lb/MM Btu)	CO (lb/MM Btu)
Natural gas	0.1	0.08
Hydrogen gas	0.15	0
Refinery gas	0.1–0.15	0.03–0.08
Blast furnace gas	0.03–0.05	0.12
Producer gas	0.05–0.1	0.08

is fired. Typical CO emissions range from 30 to 100 ppmv. Combustion technology is improving day by day. Readers should note that significant changes in burner design or combustion techniques could be made available to the industry before this book is even published!

Flue Gas Recirculation and Excess Air

Present-day packaged steam generators operate at high excess air (15–20%) with flue gas recirculation (FGR) rates ranging from 0% to 30% to limit CO and NO_x. Flue gas recirculation refers to the admission of flue gases from the boiler exit back into the burner region in order to lower the combustion temperature, as shown in Fig. 4.6, which in turn lowers NO_x. See Table 4.2 for the effect of FGR on combustion temperature.

The reason for the use of high excess air can be seen from Fig. 4.10, which shows that as the excess air is increased, the NO_x level increases and then drops off. At substoichiometric conditions, the combustion temperature is not high and hence the NO_x formation is less; however, as the excess air increases, the combustion temperature increases, which results in higher NO_x. Further increase in excess air (or FGR) lowers the flame temperature and hence NO_x decreases. Also, at a low excess air rate, the CO generation is high due to poor mixing between fuel and air. Hence to meet both CO and NO_x levels, 15% excess air and 15% FGR rates are not unusual today in oil- and gas-fired steam generators. Some burner suppliers recommend 15% excess air and 30% FGR rates to limit the NO_x to less than 9 ppmv on natural gas firing. The FGR system naturally adds

TABLE 4.2 Effect of FGR on Combustion Temperatures with 15% Excess Air

	Natural gas			No. 2 oil		
	0	15	30	0	15	30
FGR, %						
Combustion temp, °F	3227	2892	2619	3354	2994	2713

to both the initial and operating costs of the boiler. Hence excess air on the order of 5%, which was typical decades ago, is not adequate to limit CO, though efficiencywise it makes sense. The combination of high FGR rate and excess air factor increases the mass flow of flue gases through the boiler, though the steam generation may be unchanged, making it necessary to use a larger boiler for the same duty. If the same boiler (designed several decades ago) were used, the flue gas mass flow through the boiler could be 20–25% higher, resulting in significant pressure drop across the heating surfaces and consequently higher fan power consumption.

Table 4.3 shows the effect of different excess air and FGR rates on the performance of a boiler of 100,000 lb/h capacity generating steam at 300 psig using feedwater at 230°F. Cases 1 and 2 use an economizer. Cases 3 and 4 show the results without the economizer. In all these calculations the boiler is assumed to be the same and the burner is changed to handle the higher excess air and FGR rate. The new burner is assumed to have the same pressure drop as the earlier one. The pressure drop differences shown are due to the difference in the flue gas flow rates through the boiler.

Using an electricity cost of 7 cents/kWh and fuel cost of \$3/MM Btu, the additional fuel and electricity costs due to the lower efficiency and higher gas pressure drop were computed and are shown below in Table 4.3. Due to the higher excess air and FGR rate, the annual operating cost increases by \$43,400 in case 2 over case 1. This does not include the cost of the bypass system, damper, and controls. When the economizer is not present, the differential operating cost is even more, \$69,000 per year. Two conclusions may be drawn from this study:

TABLE 4.3 Effect of Excess Air and Flue Gas Recirculation on Boiler Operating Costs

Item	Case 1 ^a	Case 2 ^a	Case 3 ^b	Case 4 ^b
Duty, MM Btu/h	101.4	101.4	101.4	101.4
Exit gas temp, °F	295	311	553	579
Excess air, %	10	15	10	15
FGR, %	0	15	0	15
Flue gas, lb/h	96,349	117,416	103,498	126,923
Fuel input, MM Btu/h	119.83	120.68	128.72	130.45
Gas drop, in. WC	16	21	17.6	21.5
Fan power, kW	60	101	71	120
Efficiency, % HHV	84.6	84.0	78.78	77.74
Fan cost, \$/yr	0	23,000	0	27,500
Fuel cost, \$/yr	0	20,400	0	41,500

^a With an economizer.

^b Without an economizer.

1. Modifying an existing boiler to handle new emission levels will be expensive in terms of operating costs.
2. Operating a boiler without the economizer results in a higher gas pressure drop even for the same excess air. Case 3 shows an increase of 1.6 in. WC over case 1. This is due to the larger flue gas flow in case 3 arising out of lower boiler efficiency.

As shown in Fig. 4.13, the effect of FGR on NO_x reduction gradually decreases as the FGR rate increases; that is, NO_x reduction is very high at low FGR rates and as the FGR rate increases the incremental NO_x reduction becomes smaller. On oil firing, the effect of FGR is less significant. Operators must consider the risk of operating a boiler near the limits of inflammability when using high amounts of FGR. Figure 4.14 shows the narrowing between the upper flammability limit and the lower ignition limit as FGR increases. Integrating control systems to maintain fuel/air ratios at high FGR rates is difficult because FGR dampens the combustion process to the ragged edges of flammability—flame-outs and flame instability. Full metering combustion control systems with good safety measures are necessary in such cases.

As the FGR rate increases, the gas pressure drop across the boiler increases, and the boiler must be made larger with wider tube spacing or the fan power consumption can be significant as shown in Table 4.3. A boiler using 20% FGR is equivalent to a 20% increase in its size compared to a boiler of the same capacity not using FGR. One has to be concerned about the flame stability at low loads and also the excess CO formed. Generally, in packaged boilers the FGR duct is connected to the fan inlet duct and a separate FGR fan is not required. Large

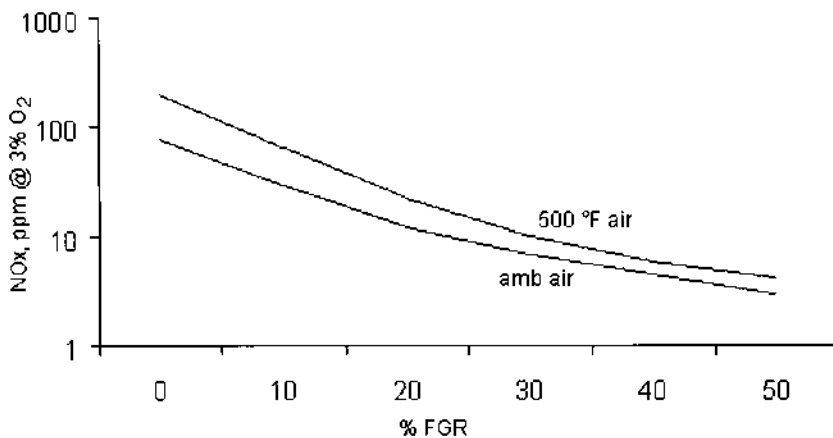

FIGURE 4.13 NO_x versus flue gas recirculation.

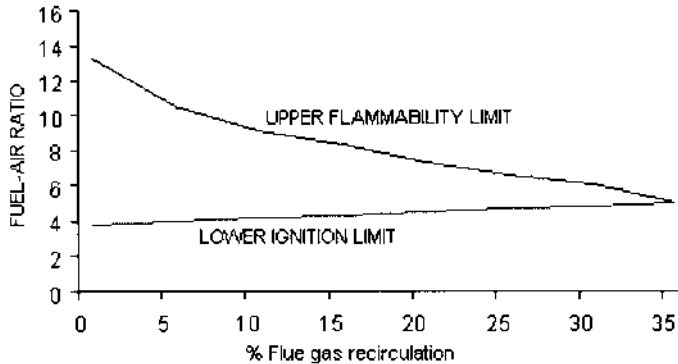

FIGURE 4.14 Flue gas recirculation and limits of inflammability. (Adapted from newsletter of Coen Co., Spring 1996, Burlingame, CA.)

industrial boilers use separate FGR fans. If the flue gases contain oxides of sulfur, then mixing the flue gases at the fan inlet may lower the temperature below the acid vapor point and risk potential corrosion at the fan and inlet ductwork; in such cases, a separate fan may be used to admit the flue gases directly near the burner throat. With induced FGR, the inlet temperature to the fan increases. With 80°F ambient temperature and 15% FGR at 320°F flue gas temperature, the mixed air temperature at the fan inlet is about 112°F. The air density decreases, which results in a slightly larger volume of air to be handled by the fan. FGR also affects the performance of steam generators because it affects the gas temperature profile throughout the boiler. This is illustrated in [Chapter 3](#).

Gas Reburn

One of the methods to reduce NO_x in large industrial boilers is natural gas reburning, which is capable of providing a 50–70% reduction in NO_x. In this method, natural gas is injected into the upper furnace region to convert the NO_x formed in the primary fuel's combustion gases to molecular nitrogen. The overall process occurs within three zones of the boiler as shown in [Fig. 4.15](#).

Primary Combustion Zone: Burners fueled by coal, oil, or gas are turned down by 10–20%. Low excess air is used to minimize NO_x.

Gas Reburning Zone: Natural gas between 10% and 20% of boiler heat input is injected above the primary combustion zone. This creates a fuel-rich region where hydrocarbon radicals react with NO_x to form molecular nitrogen. Recirculated flue gases may be mixed in with the gas before it is injected into the boiler.

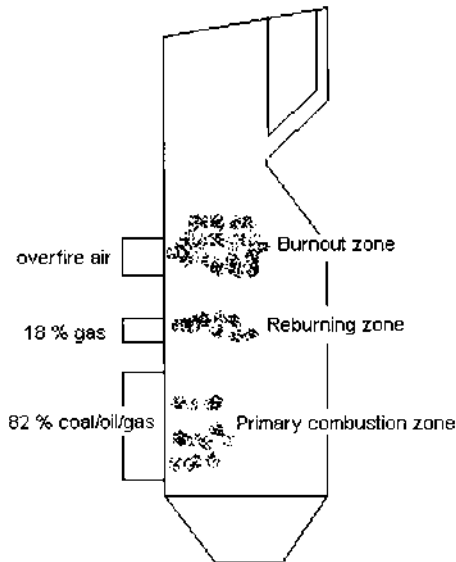

FIGURE 4.15 Reburning and NO_x reduction.

Burnout Zone: A separate overfire air system redirects air from the primary combustion zone to a location above the gas reburning reaction zone to ensure complete combustion of any unreacted fuel. All coal-, oil-, or gas-fired utility boilers are suitable for reburning. There must be enough room above the main firing zone for reburning and burnout. As the natural gas replaces the primary fuel (coal or oil), the emissions of SO_x, CO₂, and particulates are also reduced.

CARBON MONOXIDE REDUCTION

From Figs. 4.10 and 4.11 it can be seen that any effort to reduce NO_x such as reducing flame temperature or water/steam injection results in an increase in CO; therefore a balance must be struck between the efforts to reduce NO_x and CO. In packaged boilers, in addition to using proper excess air and FGR, ensuring that the combustion products do not leak to the convection pass from the furnace helps to lower CO. Some boilers that use the tangent tube construction instead of the membrane wall design for the partition between the furnace and the convection section have experienced leakage of hot furnace gases from the furnace side to the convection section; the tangent tubes are likely to warp due to thermal expansion during operation and allow gas to leak. The difference in gas

pressure between the furnace and the convection section can be on the order of 10–30 in. WC depending on the boiler design, so the leakage could be significant. In that case the flue gases do not have the residence time needed to complete the combustion process in the furnace, which can result in higher CO formation. The presence of water vapor also increases CO. Increasing the boiler size reduces both CO and NO_x because the furnace temperatures and heat release rates are reduced and the residence time for CO conversion to CO₂ is increased; however, this adds to the boiler cost.

Generally 30–100 ppmv of CO can be achieved with most packaged boiler burners in operation today and about 25–50 ppmv in gas turbines. If single-digit CO emissions are required, an oxidation catalyst is suggested in packaged boilers and HRSGs, which can add to their cost and operating gas-side pressure drop.

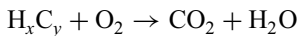
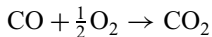

An oxidation catalyst increases the conversion of SO₂ to SO₃, which can react with ammonia to form ammonium sulfate. However, with natural gas fuel with a low sulfur content, this is not a serious concern. This conversion is higher at higher temperatures, say at 1100°F, and decreases to about 10% at 600°F without significantly affecting the efficiency of CO or formaldehyde removal. Good combustion controls can also help reduce CO formation. VOCs are also somewhat reduced by oxidation catalysts.

The dry low-NO_x (DLN) combustors used in gas turbines have demonstrated CO levels of less than 5 ppm.

Figure 4.7 shows the use of a CO catalyst in an HRSG. Generally, higher temperatures on the order of 600–1000°F are acceptable for CO catalysts, so the catalyst can be placed at the inlet of the unfired gas turbine HRSG. However, when a burner is used in the HRSG, it is advisable to have another heat transfer surface precede it so that the burner flame does not impinge on the catalyst. The CO catalyst should also precede the NO_x catalyst to keep it away from ammonia. Typical CO conversion efficiency can range from 60% to 85%, though higher values may be obtained. Depending on its size, the gas pressure drop across the CO catalyst can range from 2 to 3 in. WC. The cost of a typical CO catalyst is about 50% of that of a SCR catalyst.

SO_x REMOVAL

Sulfur present in fuels gets converted to SO₂, and in the presence of a catalyst the SO₂ is converted to SO₃, which reacts with water vapor to form sulfuric acid vapor. Sulfuric acid causes environmental damage through corrosion. SO₂ and SO₃ are together referred to as SO_x. The level of SO_x depends on the amount of

sulfur present in the fuel. Typically, 95% of the sulfur converts to SO_2 and 1–3% converts to SO_3 . Historically SO_x pollution has been controlled through dispersion through the use of tall stacks. However, in cases where this is not adequate, reduction methods such as flue gas desulfurization (FGD) are used. FGD involves the use of scrubbers to remove SO_x emissions from the flue gases. These are classified as either regenerable or nonregenerable, depending on how the by-products are disposed of. In regenerable systems, the sulfur or sulfuric acid is recovered. However, these are expensive processes and are justified only in large high-sulfur coal-fired plants. Wet scrubbers using chemicals such as lime soda, magnesium oxide, and limestone are widely used in large utility plants. Because many of these chemical processes occur beyond the boiler boundary, they are not discussed here.

PARTICULATES

Emission particulates from combustion sources consist of compounds such as sulfates, nitrates, and unburned compounds. Particulate matter emissions are classified into two categories, PM and PM_{10} , which refer to particulates $10\ \mu\text{m}$ or more and less than $10\ \mu\text{m}$ in diameter, respectively. All particulates pose health problems, but small particulates can be inhaled and can cause more damage to humans than larger ones. PM levels from natural gas are lower than those from oils and coals. High ash in fuel oils and coals can also increase the PM. In utility boilers, electrostatic precipitators, scrubbers, or bag houses are used to remove particulates. These systems increase the installation cost of the plant and may not be justified in small plants. Switching to low ash, low sulfur fuels also helps reduce PM but adds to the cost of fuel.

VOLATILE ORGANIC COMPOUNDS

Volatile organic compounds (VOCs) are unburned hydrocarbons of higher molecular weight than methane. Sources of VOCs include combustion products, automobile exhaust solvents, and paints, to mention a few. When released into the atmosphere, VOCs contribute to the formation of harmful ozone and are health hazards, particularly because of their high molecular weights. [Unburned hydrocarbons (UHCs) are similar to VOCs but are of lower molecular weight and characterized as methane.]

Good combustion techniques and the maintenance of high combustion temperatures minimize VOC formation; however, they also increase NO_x . In chemical plants, incineration is generally adopted to minimize the emission of VOCs. There are two types of oxidizers. Thermal oxidizers combust the VOCs along with natural gas and maintain a gas temperature of $1500\text{--}1800^\circ\text{F}$ with a few seconds of residence time, which destroys the VOCs. Catalytic oxidation

requires a lower temperature, 500–700°F, and therefore consumes less natural gas. Heat recovery boilers may be used behind incinerators for recovering energy from the flue gases, as discussed in [Chapter 2](#). VOCs in packaged boilers are reduced by using good combustion techniques. Oxidation catalysts also reduce VOCs but are expensive.

CONCLUSION

It is easier to design for a given NO_x or CO level in a new boiler or HRSG than in an older one, because we can design around the various options and size the boiler or HRSG accordingly. Modifying an existing boiler or HRSG to meet new emission levels presents more challenges. For example, the existing boiler furnace dimensions may not be adequate if a low-NO_x burner is retrofitted, owing to possible flame impingement concerns. The existing fan may not be able to handle the increase in pressure drop if FGR is used. If an air heater is used it must be replaced by an economizer. If a catalyst is required, an existing HRSG may have to operate in a gas temperature regime that may not be optimum for it unless the heating surfaces are split. A different catalyst material capable of operation at the gas temperature window available between the evaporator and economizer or capable of operating ahead of the evaporator may have to be used. If there are space limitations, the designer may even have to reduce the boiler capacity. Steam injection in the burner may be examined.

It is possible to improve the emissions of existing boilers through options such as replacing the refractory-lined boilers with water-cooled furnaces, using membrane walls where possible to minimize flue gas bypassing between the furnace and convection bank, and using a low-NO_x burner. With HRSGs, if steam injection is introduced to minimize NO_x, the effects of gas flow and temperature have to be reviewed because they may affect the HRSG performance. In a new boiler or HRSG project, there are fewer constraints.

There are several ways to control NO_x and CO in packaged boilers and HRSGs, some of which affect the quantity of flue gases flowing through the boiler, thus affecting the temperature profile, efficiency, and gas pressure drop. Catalysts require a specific gas temperature window for efficient operation, which is achieved by modifying the boiler or HRSG design as discussed above. These factors must be evaluated on a case-by-case basis, because no two boilers are identical. In the case of gas turbine HRSGs, optimum locations must be found for the SCR and the CO catalyst by considering the various loads and gas temperature profiles. The cost of meeting the emission limits is quite large, because boiler and HRSG designs have to be modified to incorporate catalysts, dampers, and low-NO_x burners. Operating costs are also increased due to the higher gas pressure drop across the heating surfaces and ducts. The fan may have to be replaced.

TABLE 4.4 Typical Allowable Emission Rates for a Combined Cycle Project in California

Unit	Pollutant	Allowable emission rate	
		lb/h	lb/MM Btu or pmvd
CTG/HRSG with duct firing	PM	28.2	0.012
	SOx	5.7	0.0023
	NOx	28.6	3 ppmvd at 15% O ₂
	VOCs	35.2	0.015
	CO	98.5	20 ppmvd at 15% O ₂
	Formaldehyde	5.0	0.002
Auxiliary boiler	PM	0.19	0.005
	SOx	0.09	0.0024
	NOx	3.5	0.092
	VOCs	0.49	0.013
	CO	2.1	0.055

New plants evaluate the best available control technology (BACT) for emissions on the basis of cost and environmental conditions. The cost per ton of pollutant removed is estimated, and the best technology to achieve this within the maximum cost allowable is chosen. Emission limits vary depending on location. Typical limits for a combined cycle plant in California that were both gas turbines and auxiliary boilers are listed in Table 4.4.

As the technology improves, it is hoped that the cost of emission control will also be reduced. For example, research work is going on to lower NOx and CO to single-digit percentages in gas-fired burners by using internal recirculation of partial combustion products without the use of flue gas recirculation and while using low excess air. This will lower operating costs and also improve the boiler efficiency.

REFERENCES

1. Catalogues. Coen Company, Burlingame, CA.
2. V Burd. Squeezing clean energy from boilers and heaters. Chemical Engineering, March 1992.
3. P Bancel et al. Gas turbine NOx controlled with steam and water injection. Power Engineering, June 1986.
4. Nalco Fuel Tech Brochure on NOx out process, 1992.
5. D Lambert and TF McGowan. Nox control techniques for the CPI. Chemical Engineering, June 1996.

6. S Drennen, V Lifshits. Developmental issues of ultra low NO_x burners for steam generation. Paper presented at the Fall Meeting of the Western States Section of the Combustion Institute, Diamond Bar, CA, Oct 23–24, 1997.
7. T Webster. Burner technology for single digit NO_x emissions in boiler applications, CIBO NO_x Control Conference, San Diego, CA, Mar 13, 2001.
8. Use of SCR for control of NO_x emissions from power plants in the US. Prepared by Synapse Energy Economics, Inc., Cambridge, MA, for the Ontario Clean Air Program, Canada (ONTAIR), campaign, February 2000.
9. S Naroozi. Urea enhances safety in SCR applications. Power Engineering, December 1993.
10. L Czarnecki. SCONO_x—ammonia-free NO_x removal technology for gas turbines. International Joint Power Generation Conference (IJPGC)-2000-15032, Florida, July 2000.

5

Basic Steam Plant Calculations

- 5.01 Converting liquid flow in lb/h to gpm, and vice versa; relating density, specific gravity, and specific volume
- 5.02 Relating head of liquid or gas column to pressure; converting feet of liquid to psi; relating inches of water column of gas to psi and feet of gas column
- 5.03 Estimating density of gases; relating molecular weight and density; effect of elevation on gas density; simplified formula for density of air and flue gases at sea level
- 5.04 Relating actual and standard cubic feet of gas per minute to lb/h
- 5.05 Computing density of gas mixture; relating mass to volumetric flow; computing velocity of gas in duct or pipe
- 5.06 Relating mass and linear velocities
- 5.07 Calculating velocity of wet and superheated steam in pipes; computing specific volume of wet steam; use of steam tables
- 5.08 Relating boiler horsepower to steam output
- 5.09 Calculating amount of moisture in air; relative humidity and saturation vapor pressure
- 5.10 Water dew point of air and flue gases; partial pressure of water vapor
- 5.11 Energy absorbed by wet and superheated steam in boilers; enthalpy of wet and dry steam; use of steam tables; converting MM Btu/h (million Btu/h) to kilowatts

- 5.12 Relating steam by volume, steam by weight, and steam quality; relating circulation ratio and quality
- 5.13a Determining steam quality using throttling calorimeter
- 5.13b Relating steam quality to steam purity
- 5.14 Water required for desuperheating steam; energy balance in attemperators, desuperheaters
- 5.15 Water required for cooling gas streams
- 5.16 Calculating steam volume after throttling process; use of steam tables
- 5.17 Determining blowdown and steam for deaeration
- 5.18 Calculating flash steam from boiler blowdown; economics of flash steam recovery
- 5.19a Estimating leakage of steam through openings; effect of wetness of steam on leakage
- 5.19b Estimating air flow through openings
- 5.20 Estimating leakage of gas across dampers; calculating energy loss of leakage flow; sealing efficiency of dampers on area and flow basis
- 5.21 Economics of waste heat recovery; annual cost of energy loss; simple payback period calculation
- 5.22 Life-cycle costing applied to equipment selection; interest and escalation factors; capitalized and life-cycle cost
- 5.23 Life-cycle costing applied to evaluation of heat recovery systems
- 5.24 Calculating thickness of boiler tubes to ASME Code; allowable stresses for various materials
- 5.25 Calculating maximum allowable working pressures for pipes
- 5.26 Sizing tubes subject to external pressure
- 5.27 On sound levels: OSHA permissible exposure levels
- 5.28 Adding decibels
- 5.29 Relating sound pressure and power levels
- 5.30 Effect of distance on noise level
- 5.31 Computing noise levels from engine exhaust
- 5.32 Holdup time in steam drum

5.01

Q:

Convert 50,000 lb/h of hot water at a pressure of 1000 psia and 390°F to gpm.

A:

To convert from lb/h to gpm, or vice versa, for any liquid, we can use the following expressions:

$$W = 8 \frac{q}{v} \quad (1)$$

$$\rho = 62.4s = \frac{1}{v} \quad (2)$$

where

- W = flow, lb/h
- q = flow, gpm (gallons per minute)
- ρ = density of liquid, lb/cu ft
- s = specific gravity of liquid
- v = specific volume of liquid, cu ft/lb

For hot water we can obtain the specific volume from the steam tables (see the Appendix). v at 1000 psia and 390°F is 0.0185 cu ft/lb. Then, from Eq. (1),

$$q = 50,000 \times \frac{0.0185}{8} = 115.6 \text{ gpm}$$

For water at temperatures of 40–100°F, for quick estimates we divide lb/h by 500 to obtain gpm. For example, 50,000 lb/h of water at 70°F would be 100 gpm.

5.02A

Q:

Estimate the head in feet developed by a pump when it is pumping oil with a specific gravity of 0.8 through a differential pressure of 150 psi.

A:

Conversion from feet of liquid to psi, or vice versa, is needed in pump calculations. The expression relating the variables is

$$H_1 = 144 \Delta P v = 2.3 \frac{\Delta P}{s} \quad (3)$$

where

- ΔP = differential pressure, psi
- H_1 = head, ft of liquid

Substituting for ΔP and s , we have

$$H_1 = 2.3 \times \frac{150}{0.8} = 431.2 \text{ ft}$$

5.02B

Q:

If a fan develops 8 in. WC (inches of water column) with a flue gas density of 0.05 lb/cu ft, what is the head in feet of gas and in psi?

A:

Use the expressions

$$H_g = 144 \frac{\Delta P}{\rho_g} \quad (4)$$

$$H_w = 27.7 \Delta P \quad (5)$$

where

H_g = head, ft of gas

H_w = head, in. WC

ρ_g = gas density, lb/cu ft

Combining Eqs. (4) and (5), we have

$$H_g = 144 \times \frac{8}{27.7 \times 0.05} = 835 \text{ ft}$$

$$\Delta P = \frac{8}{27.7} = 0.29 \text{ psi}$$

5.03

Q:

Estimate the density of air at 5000 ft elevation and 200°F.

A:

The density of any gas can be estimated from

$$\rho_g = 492 \times MW \times \frac{P}{359 \times (460 + t) \times 14.7} \quad (6)$$

where

P = gas pressure, psia

MW = gas molecular weight (Table 5.1)

t = gas temperature, °F

ρ_g = gas density, lb/cu ft

The pressure of air decreases as the elevation increases, as shown in Table 5.2, which gives the term $(P/14.7) \times MW$ of air = 29. Substituting the various terms, we have

$$\rho_g = 29 \times 492 \times \frac{0.832}{359 \times 660} = 0.05 \text{ lb/cu ft}$$

TABLE 5.1 Gas Molecular Weights

Gas	MW
Hydrogen	2.016
Oxygen	32.0
Nitrogen	28.016
Air	29.2
Methane	16.04
Ethane	30.07
Propane	44.09
<i>n</i> -Butane	58.12
Ammonia	17.03
Carbon dioxide	44.01
Carbon monoxide	28.01
Nitrous oxide	44.02
Nitric oxide	30.01
Nitrogen dioxide	46.01
Sulfur dioxide	64.06
Sulfur trioxide	80.06
Water	18.02

A simplified expression for air at atmospheric pressure and temperature t at sea level is

$$\rho_g = \frac{40}{460 + t} \quad (7)$$

For a gas mixture such as flue gas, the molecular weight (MW) can be obtained as discussed in Q5.05. In the absence of data on flue gas analysis, Eq. (7) also gives a good estimate of density.

TABLE 5.2 Density Correction for Altitude

Altitude (ft)	Factor
0	1.0
1000	0.964
2000	0.930
3000	0.896
4000	0.864
5000	0.832
6000	0.801
7000	0.772
8000	0.743

When sizing fans, it is the usual practice to refer to 70°F and sea level as standard conditions for air or flue gas density calculations.

5.04A

Q:

How is acfm (actual cubic feet per minute) computed, and how does it differ from scfm (standard cubic feet per minute)?

A:

acfm is computed using the density of the gas at given conditions of pressure and temperature, and scfm is computed using the gas density at 70°F and sea level (standard conditions).

$$q = \frac{W}{60\rho_g} \quad (8)$$

where

q = gas flow in acfm (at 70°F and sea level, scfm and acfm are equal; then

$$q = W/4.5)$$

ρ_g = gas density in lb/cu ft (at standard conditions $\rho_g = 0.075$ lb/cu ft)

W = gas flow in lb/h = 4.5 q at standard conditions

5.04B

Q:

Convert 10,000 lb/h of air to scfm.

A:

Using Eq. (6), it can be shown that at $P = 14.7$ and $t = 70$, for air $\rho_g = 0.075$ lb/cu ft.

Hence, from Eq. (8),

$$q = \frac{10,000}{60 \times 0.075} = 2222 \text{ scfm}$$

5.04C

Q:

Convert 3000 scfm to acfm at 35 psia and 275°F. What is the flow in lb/h? The fluid is air.

A:

Calculate the density at the actual conditions.

$$\rho_g = 29 \times 492 \times \frac{35}{359 \times 735 \times 14.7} = 0.129 \text{ lb/cu ft}$$

From the above,

$$W = 4.5 \times 3000 = 13,500 \text{ lb/h}$$

Hence

$$\text{acfm} = \frac{13,500}{60 \times 0.129} = 1744 \text{ cfm}$$

5.05

Q:

In a process plant, 35,000 lb/h of flue gas having a composition $N_2 = 75\%$, $O_2 = 2\%$, $CO_2 = 15\%$, and $H_2O = 8\%$, all by volume, flows through a duct of cross section 3 ft^2 at a temperature of 350°F . Estimate the gas density and velocity. Because the gas pressure is only a few inches of water column, for quick estimates the gas pressure may be taken as atmospheric.

A:

To compute the density of a gas, we need its molecular weight. For a gas mixture, molecular weight is calculated as follows:

$$MW = \sum(MW_i \times y_i)$$

where

y_i = volume fraction of gas i

MW_i = molecular weight of gas i

Hence

$$\begin{aligned} MW &= 0.75 \times 28 + 0.02 \times 32 + 0.15 \times 44 \\ &\quad + 0.08 \times 18 = 29.68 \end{aligned}$$

From Eq. (6),

$$\rho_g = 29.68 \times \frac{492}{359 \times 810} = 0.05 \text{ lb/cu ft}$$

The gas velocity V_g can be obtained as

$$V_g = \frac{W}{60\rho_g A} \tag{9}$$

where

$$V_g = \text{velocity, fpm (feet per minute)}$$
$$A = \text{cross section, ft}^2$$

Hence

$$V_g = \frac{35,000}{60 \times 0.05 \times 3} = 3888 \text{ fpm}$$

The normal range of air or flue gas velocities in ducts is 2000–4000 fpm. Equation (9) can also be used in estimating the duct size.

In the absence of flue gas analysis, we could have used Eq. (7) to estimate the gas density.

5.06

Q:

A term that is frequently used by engineers to describe the gas flow rate across heating surfaces is *gas mass velocity*. How do we convert this to linear velocity? Convert 5000 lb/ft² h of hot air flow at 130°F and atmospheric pressure to fpm.

A:

Use the expression

$$V_g = \frac{G}{60\rho_g} \tag{10}$$

where G is the gas mass velocity in lb/ft² h. Use Eq. (7) to calculate ρ_g .

$$\rho_g = \frac{40}{460 + 130} = 0.0678 \text{ lb/cu ft}$$

Hence

$$V_g = \frac{5000}{60 \times 0.0678} = 1230 \text{ fpm}$$

5.07A

Q:

What is the velocity when 25,000 lb/h of superheated steam at 800 psia and 900°F flows through a pipe of inner diameter 2.9 in.?

A:

Use expression (11) to determine the velocity of any fluid inside tubes, pipes, or cylindrical ducts.

$$V = 0.05 \times W \times \frac{v}{d_i^2} \quad (11)$$

where

V = velocity, fps

v = specific volume of the fluid, cu ft/lb

d_i = inner diameter of pipe, in.

For steam, v can be obtained from the steam tables in the Appendix.

$$v = 0.9633 \text{ cu ft/lb}$$

Hence

$$V = 0.05 \times 25,000 \times \frac{0.9633}{2.9^2} = 143 \text{ fps}$$

The normal ranges of fluid velocities are

Water: 3–12 fps

Steam: 100–200 fps

5.07B**Q:**

Estimate the velocity of 70% quality steam in a 3 in. schedule 80 pipe when the flow is 45,000 lb/h and steam pressure is 1000 psia.

A:

We need to estimate the specific volume of wet steam.

$$v = xv_g + (1 - x)v_f$$

where v_g and v_f are specific volumes of saturated vapor and liquid at the pressure in question, obtained from the steam tables, and x is the steam quality (see Q5.12 for a discussion of x). From the steam tables, at 1000 psia, $v_g = 0.4456$ and $v_f = 0.0216$ cu ft/lb. Hence the specific volume of wet steam is

$$v = 0.7 \times 0.4456 + 0.3 \times 0.0216 = 0.318 \text{ cu ft/lb}$$

The pipe inner diameter d_i from [Table 5.3](#) is 2.9 in. Hence, from Eq. (11),

$$V = 0.05 \times 45,000 \times \frac{0.318}{2.9^2} = 85 \text{ fps}$$

5.08

Q:

What is meant by *boiler horsepower*? How is it related to steam generation at different steam parameters?

A:

Packaged fire tube boilers are traditionally rated and purchased in terms of boiler horsepower (BHP). BHP refers to a steam capacity of 34.5 lb/h of steam at atmospheric pressure with feedwater at 212°F. However, a boiler plant operates at different pressures and with different feedwater temperatures. Hence conversion between BHP and steam generation becomes necessary.

$$W = \frac{33,475 \times \text{BHP}}{\Delta h} \quad (12)$$

where

W = steam flow, lb/h

Δh = enthalpy absorbed by steam and water = $(h_g - h_{fw}) + \text{BD}(h_f - h_{fw})$

where

h_g = enthalpy of saturated steam at operating steam pressure, Btu/lb

h_f = enthalpy of saturated liquid, Btu/lb

h_{fw} = enthalpy of feedwater, Btu/lb

BD = blowdown fraction

For example, if a 500 BHP boiler generates saturated steam at 125 psig with 5% blowdown and with feedwater at 230°F, the steam generation at 125 psig will be

$$\begin{aligned} W &= \frac{500 \times 33,475}{(1193 - 198) + 0.05 \times (325 - 198)} \\ &= 16,714 \text{ lb/h} \end{aligned}$$

where 1193, 198, and 325 are the enthalpies of saturated steam, feedwater, and saturated liquid, respectively, obtained from steam tables. (See Appendix.)

5.09A

Q:

Why do we need to know the amount of moisture in air?

A:

In combustion calculations (Chap. 6) we estimate the quantity of dry air required to burn a given amount of fuel. In reality, atmospheric air is never dry; it consists of some moisture, depending on the relative humidity and dry bulb temperature. To compute the partial pressure of water vapor in the flue gas, which is required

TABLE 5.3 Dimensions of Iron Steel Pipe (IPS)

Nominal pipe size, IPS (in.)	OD (in.)	Schedule no.	ID (in.)	Flow area per pipe (in. ²)	Surface per linear ft (ft ² /ft)		Weight per lin ft (lb steel)
					Outside	Inside	
$\frac{1}{3}$	0.405	40 ^a	0.269	0.058	0.106	0.070	0.25
		80 ^b	0.215	0.036		0.056	0.32
$\frac{1}{4}$	0.540	40 ^a	0.364	0.104	0.141	0.095	0.43
		80 ^b	0.302	0.072		0.079	0.54
$\frac{2}{3}$	0.675	40 ^a	0.493	0.192	0.177	0.129	0.57
		80 ^b	0.423	0.141		0.111	0.74
$\frac{1}{2}$	0.840	40 ^a	0.622	0.304	0.220	0.163	0.85
		80 ^b	0.546	0.235		0.143	1.09
$\frac{3}{4}$	1.05	40 ^a	0.824	0.534	0.275	0.216	1.13
		80 ^b	0.742	0.432		0.194	1.48
1	1.32	40 ^a	1.049	0.864	0.344	0.274	1.68
		80 ^b	0.957	0.718		0.250	2.17
$1\frac{1}{4}$	1.66	40 ^a	1.380	1.50	0.435	0.362	2.28
		80 ^b	1.278	1.28		0.335	3.00
$1\frac{1}{2}$	1.90	40 ^a	1.610	2.04	0.498	0.422	2.72
		80 ^b	1.500	1.76		0.393	3.64
2	2.38	40 ^a	2.067	3.35	0.622	0.542	3.66
		80 ^b	1.939	2.95		0.508	5.03
$2\frac{1}{2}$	2.88	40 ^a	2.469	4.79	0.753	0.647	5.80
		80 ^b	2.323	4.23		0.609	7.67
3	3.50	40 ^a	3.068	7.38	0.917	0.804	7.58
		80 ^b	2.900	6.61		0.760	10.3
4	4.50	40 ^a	4.026	12.7	1.178	1.055	10.8
		80 ^b	3.826	11.5		1.002	15.0
6	6.625	40 ^a	6.065	28.9	1.734	1.590	19.0
		80 ^b	5.761	26.1		1.510	28.6
8	8.625	40 ^a	7.981	50.0	2.258	2.090	28.6
		80 ^b	7.625	45.7		2.000	43.4
10	10.75	40 ^a	10.02	78.8	2.814	2.62	40.5
		60	9.75	74.6		2.55	54.8
12	12.75	30	12.09	115	3.338	3.17	43.8
14	14.0	30	13.25	138	3.665	3.47	54.5
16	16.0	30	15.25	183	4.189	4.00	62.6
18	18.0	20 ^c	17.25	234	4.712	4.52	72.7
20	20.0	20	19.25	291	5.236	5.05	78.6
22	22.0	20 ^c	21.25	355	5.747	5.56	84.0
24	24.0	20	23.25	425	6.283	6.09	94.7

^aCommonly known as standard.^bCommonly known as extra heavy.^cApproximately.

for calculating nonluminous heat transfer, we need to know the total quantity of water vapor in flue gases, a part of which comes from combustion air.

Also, when atmospheric air is compressed, the saturated vapor pressure (SVP) of water increases, and if the air is cooled below the corresponding water dew point temperature, water can condense. The amount of moisture in air or gas fixes the water dew point, so it is important to know the amount of water vapor in air or flue gas.

5.09B

Q:

Estimate the pounds of water vapor to pounds of dry air when the dry bulb temperature is 80°F and the relative humidity is 65%.

A:

Use the equation

$$M = 0.622 \times \frac{P_w}{14.7 - p_w} \quad (13)$$

where

M = lb water vapor/lb dry air

p_w = partial pressure of water vapor in air, psia

This may be estimated as the vol% of water vapor \times total air pressure or as the product of relative humidity and the saturated vapor pressure (SVP). From the steam tables we note that at 80°F, SVP = 0.5069 psia (at 212°F, SVP = 14.7 psia). Hence $p_w = 0.65 \times 0.5069$.

$$M = 0.622 \times 0.65 \times \frac{0.5069}{14.7 - 0.65 \times 0.5069} = 0.0142$$

Hence, if we needed 1000 lb of dry air for combustion, we would size the fan to deliver $1000 \times 1.0142 = 1014.2$ lb of atmospheric air.

5.10A

Q:

What is the water dew point of the flue gases discussed in Q5.05?

A:

The partial pressure of water vapor when the vol% is 8 and total pressure is 14.7 psia will be

$$p_w = 0.08 \times 14.7 = 1.19 \text{ psia}$$

From the steam tables, we note that the saturation temperature corresponding to 1.19 psia is 107°F. This is also the water dew point. If the gases are cooled below this temperature, water can condense, causing problems.

5.10B

Q:

What is the water dew point of compressed air when ambient air at 80°F, 14.7 psia, and a relative humidity of 65% is compressed to 35 psia?

A:

Use the following expression to get the partial pressure of water vapor after compression:

$$p_{w2} = p_{w1} \times \frac{P_2}{P_1} \quad (14)$$

where

$$p_w = \text{partial pressure, psia}$$
$$P = \text{total pressure, psia}$$

The subscripts 1 and 2 stand for initial and final conditions. From Q5.09b, $p_{w1} = 0.65 \times 0.5069$.

$$p_{w2} = 0.65 \times 0.5069 \times \frac{35}{14.7} = 0.784 \text{ psia}$$

From the steam tables, we note that corresponding to 0.784 psia, the saturation temperature is 93°F. This is also the dew point after compression. Cooling the air to below 93°F would result in its condensation.

5.11A

Q:

Calculate the energy absorbed by steam in a boiler if 400,000 lb/h of superheated steam at 1600 psia and 900°F is generated with feedwater at 250°F. What is the energy absorbed, in megawatts?

A:

The energy absorbed is given by

$$Q = W \times (h_2 - h_1) \quad (\text{neglecting blowdown}) \quad (15)$$

where

$$W = \text{steam flow, lb/h}$$
$$h_2, h_1 = \text{steam enthalpy and water enthalpy, Btu/lb}$$
$$Q = \text{duty, Btu/h}$$

From the steam tables, $h_2 = 1425.3$ Btu/lb and $h_1 = 224$ Btu/lb.

$$\begin{aligned} Q &= 400,000 \times (1425.3 - 224) \\ &= 480.5 \times 10^6 \text{ Btu/h} \\ &= 480.5 \text{ million Btu/h (MM Btu/h)} \end{aligned}$$

Using the fact that $3413 \text{ Btu/h} = 1 \text{ kW}$, we have

$$Q = 480.5 \times \frac{10^6}{3413 \times 10^3} = 141 \text{ MW}$$

5.11B

Q:

Estimate the energy absorbed by wet steam at 80% quality in a boiler at 1600 psia when the feedwater temperature is 250°F .

A:

The enthalpy of wet steam can be computed as

$$h = xh_g + (1 - x)h_f \quad (16)$$

where h is the enthalpy in Btu/lb. The subscripts g and f stand for saturated vapor and liquid at the referenced pressure, obtained from saturated steam properties. x is the steam quality fraction.

From the steam tables, $h_g = 1163$ Btu/lb and $h_f = 624$ Btu/lb at 1600 psia. The enthalpy of feedwater at 250°F is 226 Btu/lb.

$$\begin{aligned} h_2 &= 0.8 \times 1163 + 0.2 \times 624 = 1054 \text{ Btu/lb} \\ h_1 &= 226 \text{ Btu/lb} \\ Q &= 1054 - 226 = 828 \text{ Btu/lb} \end{aligned}$$

If steam flow were 400,000 lb/h, then

$$Q = 400,000 \times 828 = 331 \times 10^6 = 331 \text{ MM Btu/h}$$

5.12

Q:

How is the wetness in steam specified? How do we convert steam by volume (SBV) to steam by weight?

A:

A steam–water mixture is described by the term *quality*, x , or dryness fraction. $x = 80\%$ means that in 1 lb of wet steam, 0.8 lb is steam and 0.2 lb is water. To relate these two terms, we use the expression

$$SBV = \frac{100}{1 + [(100 - x)/x] \times v_f/v_g} \quad (17)$$

where

$$\begin{aligned} v_f, v_g &= \text{specific volumes of saturated liquid and vapor, cu ft/lb} \\ x &= \text{quality or dryness fraction} \end{aligned}$$

From the steam tables at 1000 psia, $v_f = 0.0216$ and $v_g = 0.4456$ cu ft/lb.

$$SBV = \frac{100}{1 + [(100 - 80)/80] \times 0.0216/0.4456} = 98.8\%$$

Circulation ratio (CR) is another term used by boiler engineers to describe the steam quality generated.

$$CR = \frac{1}{x} \quad (18)$$

A CR of 4 means that the steam quality is 0.25 or 25%; in other words, 1 lb of mixture would have 0.25 lb of steam and the remainder would be water.

5.13A**Q:**

How is the quality of steam determined using a throttling calorimeter?

A:

Throttling calorimeters (Fig. 5.1) are widely used in low pressure steam boilers for determining the moisture or wetness (quality) of steam. A sampling nozzle is located preferably in the vertical section of the saturated steam line far from bends or fittings. Steam enters the calorimeter through a throttling orifice and passes into a well-insulated expansion chamber. Knowing that throttling is an isenthalpic process, we can rewrite Eq. (16) for enthalpy balance as

$$h_s = h_m = xh_g + (1 - x)h_f$$

where

$$\begin{aligned} h_s, h_m, h_f, h_g &= \text{enthalpies of steam, mixture, saturated liquid, and saturated} \\ &\quad \text{steam, respectively} \\ x &= \text{steam quality fraction} \end{aligned}$$

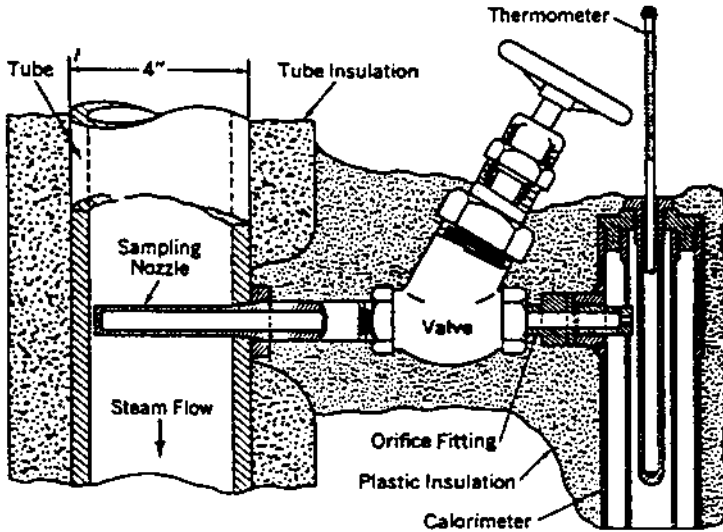

FIGURE 5.1 Throttling calorimeter.

The steam temperature after throttling is measured at atmospheric pressure, and then the enthalpy is obtained with the help of steam tables. The steam is usually in superheated condition after throttling.

Example

A throttling calorimeter measures a steam temperature of 250°F when connected to a boiler operating at 100 psia. Determine the steam quality.

Solution. h_s at atmospheric pressure and at 250°F = 1168.8 Btu/lb from steam tables; $h_g = 1187.2$ and $h_f = 298.5$ Btu/lb, also from steam tables. Hence

$$1168.8 = 1187.2x + (1 - x)298.5$$

or

$$x = 0.979 \text{ or } 97.9\% \text{ quality}$$

5.13B

Q:

How is steam quality related to steam purity?

A:

Steam purity refers to the impurities in wet steam, in ppm. A typical value in low pressure boilers would be 1 ppm of solids. However, quality refers to the moisture in steam.

The boiler drum maintains a certain concentration of solids depending on ABMA or ASME recommendations as discussed in Q5.17. If at 500 psig pressure the boiler water concentration is 2500 ppm, and if steam should have 0.5 ppm solids, then the quality can be estimated as follows:

$$\% \text{ Moisture in steam} = \frac{0.5}{2500} \times 100 = 0.02\%$$

or

$$\text{Steam quality} = 100 - 0.02 = 99.98\%$$

5.14**Q:**

How do we estimate the water required for desuperheating steam? Superheated steam at 700 psia and 800°F must be cooled to 700°F by using a spray of water at 300°F. Estimate the quantity of water needed to do this.

A:

From an energy balance across the desuperheater, we get

$$W_1 h_1 + W h_f = W_2 h_2 \quad (19a)$$

where

$$\begin{aligned} W_1, W_2 &= \text{steam flows before and after desuperheating} \\ W &= \text{water required} \\ h_1, h_2 &= \text{steam enthalpies before and after the process} \\ h_f &= \text{enthalpy of water} \end{aligned}$$

Also, from mass balance,

$$W_2 = W_1 + W$$

Hence we can show that

$$W = W_2 \times \frac{h_1 - h_2}{h_1 - h_f} \quad (19b)$$

Neglecting the pressure drop across the desuperheater, we have from the steam tables $h_1 = 1403$, $h_2 = 1346$, and $h_f = 271$, all in Btu/lb. Hence $W/W_2 = 0.05$. That is, 5% of the final steam flow is required for injection purposes.

5.15

Q:

How is the water requirement for cooling a gas stream estimated? Estimate the water quantity required to cool 100,000 lb/h of flue gas from 900°F to 400°F. What is the final volume of the gas?

A:

From an energy balance it can be shown [1] that

$$q = 5.39 \times 10^{-4} \times (t_1 - t_2) \times \frac{W}{1090 + 0.45 \times (t_2 - 150)} \quad (20)$$

where

$$\begin{aligned} q &= \text{water required, gpm} \\ t_1, t_2 &= \text{initial and final gas temperatures, } ^\circ\text{F} \\ W &= \text{gas flow entering the cooler, lb/h} \end{aligned}$$

Substitution yields

$$\begin{aligned} q &= 5.39 \times 10^{-4} \times (900 - 400) \\ &\quad \times \frac{100,000}{1090 + 0.45 \times (400 - 150)} \\ &= 23 \text{ gpm} \end{aligned}$$

The final gas volume is given by the expression

$$(460 + t_2) \times \left(\frac{W}{2361} + 0.341 \right)$$

The final volume is 43,000 acfm.

5.16

Q:

In selecting silencers for vents or safety valves, we need to figure the volume of steam after the throttling process. Estimate the volume of steam when 60,000 lb/h of superheated steam at 650 psia and 800°F is blown to the atmosphere through a safety valve.

A:

We have to find the final temperature of steam after throttling, which may be considered an isoenthalpic process; that is, the steam enthalpy remains the same at 650 and 15 psia.

From the steam tables, at 650 psia and 800°F, $h = 1402$ Btu/lb. At 15 psia (atmospheric conditions), the temperature corresponding to an enthalpy of 1402 Btu/lb is 745°F. Again from the steam tables, at a pressure of 15 psia and a temperature of 745°F, the specific volume of steam is 48 cu ft/lb. The total volume of steam is $60,000 \times 48 = 2,880,000$ cu ft/h.

5.17

Q:

How do we determine the steam required for deaeration and boiler blowdown water requirements?

A:

Steam plant engineers have to frequently perform energy and mass balance calculations around the deaerator and boiler to obtain the values of makeup water, blowdown, or deaeration steam flows. Boiler blowdown quantity depends on the total dissolved solids (TDS) of boiler water and the incoming makeup water. Figure 5.2 shows the scheme around a simple deaerator. Note that there could be several condensate returns. This analysis does not consider venting of steam from the deaerator or the heating of makeup using the blowdown water. These refinements can be done later to fine-tune the results.

The American Boiler Manufacturers Association (ABMA) and ASME provide guidelines on the TDS of boiler water as a function of pressure (see [Tables 5.4](#) and [5.5](#)). The drum solids concentration can be at or less than the value shown in these tables. Plant water chemists usually set these values after reviewing the complete plant chemistry.

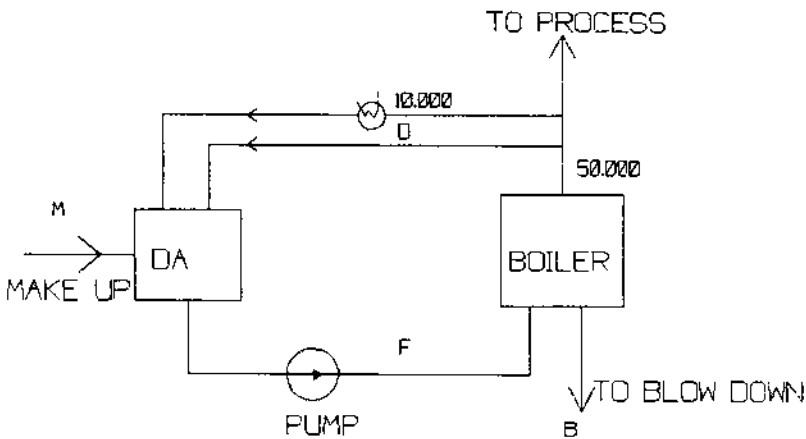

FIGURE 5.2 Scheme of deaeration system.

TABLE 5.4 Suggested Water Quality Limits^a

Boiler type: Industrial water tube, high duty, primary fuel fired, drum type

Makeup water percentage: Up to 100% of feedwater

Conditions: Includes superheater, turbine drives, or process restriction on steam purity

Drum operating pressure ^b , MPa (psig)	0–2.07 (0–300)	2.08–3.10 (301–450)	3.11–4.14 (451–600)	4.15–5.17 (601–750)	5.18–6.21 (751–900)	6.22–6.89 (901–1000)	6.90–10.34 (1001–1500)	10.35–13.79 (1501–2000)
<i>Feedwater^c</i>								
Dissolved oxygen (mg/L O ₂) measured before oxygen scavenger addition ^d	< 0.04	< 0.04	< 0.007	< 0.007	< 0.007	< 0.007	< 0.007	< 0.007
Total iron (mg/L Fe)	≤ 0.100	≤ 0.050	≤ 0.030	≤ 0.025	≤ 0.020	≤ 0.020	≤ 0.010	≤ 0.010
Total copper (mg/L Cu)	≤ 0.050	≤ 0.025	≤ 0.020	≤ 0.020	≤ 0.015	≤ 0.015	≤ 0.010	≤ 0.010
Total hardness (mg/L CaCO ₃)	≤ 0.300	≤ 0.300	≤ 0.200	≤ 0.200	≤ 0.100	≤ 0.050	n.d.	n.d.
pH range @25°C	7.5–10.0	7.5–10.0	7.5–10.0	7.5–10.0	7.5–10.0	8.5–9.5	9.0–9.6	9.0–9.6
Chemicals for preboiler system protection	Use only volatile alkaline materials							
Nonvolatile TOCs (mg/L C) ^e	< 1	< 1	< 0.5	< 0.5	< 0.5	—As low as possible, < 0.2—		
Oily matter (mg/L)	< 1	< 1	< 0.5	< 0.5	< 0.5	—As low as possible, < 0.2—		
<i>Boiler water</i>								
Silica (mg/L SiO ₂)	≤ 150	≤ 90	≤ 40	≤ 30	≤ 20	≤ 8	≤ 2	≤ 1
Total alkalinity (mg/L CaCO ₃)	< 350 ^f	< 300 ^f	< 250 ^f	< 200 ^f	< 150 ^f	< 100 ^f	n.s. ^g	n.s. ^g
Free hydroxide alkalinity (mg/L CaCO ₃) ^h	n.s.	n.s.	n.s.	n.s.	n.d. ^g	n.d. ^g	n.d. ^g	n.d. ^g
Specific conductance (μmho/cm) @ 25°C without neutralization	< 3500 ⁱ	< 3000 ⁱ	2500 ⁱ	< 2000 ⁱ	< 1500 ⁱ	< 1000 ⁱ	≤ 150	≤ 100

n.d. = not detectable; n.s. = not specified.

^aNo values are given for saturated steam purity target because steam purity achievable depends upon many variables, including boiler water total alkalinity and specific conductance as well as design of boiler, steam drum internals, and operating conditions (see footnote i). Because boilers in this category require a relatively high degree of steam purity, other operating parameters must be set as low as necessary to achieve this high purity for protection of the superheaters and turbines and/or to avoid process contamination.

^bWith local heat fluxes $> 473.2 \text{ kW/m}^2$ ($> 150,000 \text{ Btu/h ft}^2$), use values for the next higher pressure range.

^cBoilers below 6.21 MPa (900 psig) with large furnaces, large steam release space, and internal chelant, polymer, and/or antifoam treatment can sometimes tolerate higher levels of feedwater impurities than those in the table and still achieve adequate deposition control and steam purity. Removal of these impurities by external pretreatment is always a more positive solution. Alternatives must be evaluated as to practicality and economics in each case.

^dValues in table assume the existence of a deaerator.

^eNonvolatile TOCs are the organic carbon not intentionally added as part of the water treatment regime.

^fMaximum total alkalinity consistent with acceptable steam purity. If necessary, should override conductance as blowdown control parameter. If makeup is demineralized water at 4.14–6.89 MPa (600–1000 psig), boiler water alkalinity and conductance should be that in table for 6.90–10.34 MPa (1001–1500 psig) range.

^g“Not detectable” in these cases refers to free sodium or potassium hydroxide alkalinity. Some small variable amount of total alkalinity will be present and measurable with the assumed congruent or coordinated phosphate pH control or volatile treatment employed at these high pressure ranges.

^hMinimum level of OH^- alkalinity in boilers below 6.21 MPa (900 psig) must be individually specified with regard to silica solubility and other components of internal treatment.

ⁱMaximum values are often not achievable without exceeding suggested maximum total alkalinity values, especially in boilers below 6.21 MPa (900 psig) with $> 20\%$ makeup of water whose total alkalinity is $> 20\%$ of TDS naturally or after pretreatment with soda lime or sodium cycle ion-exchange softening. Actual permissible conductance values to achieve any desired steam purity must be established for each case by careful steam purity measurements. Relationship between conductance and steam purity is affected by too many variables to allow its reduction to a simple list of tabulated values.

Source: Adapted from ASME 1979 Consensus.

Example

A boiler generates 50,000 lb/h of saturated steam at 300 psia, out of which 10,000 lb/h is taken for process and returns to the deaerator as condensate at 180°F. The rest is consumed. Makeup water enters the deaerator at 70°F, and steam is available at 300 psia for deaeration. The deaerator operates at a pressure of 25 psia. The blowdown has a total dissolved solids (TDS) of 1500 ppm, and the makeup has 100 ppm TDS.

Evaluate the water requirements for deaeration steam and blowdown.

Solution. From mass balance around the deaerator,

$$10,000 + D + M = F = 50,000 + B \quad (21)$$

TABLE 5.5 Recommended Boiler Water Limits and Associated Steam Purity at Steady-State Full Load Operation—Water Tube Drum-Type Boilers

Drum pressure (psig)	TDS range, ^a boiler water (ppm)(max)	Range total alkalinity, ^b boiler water (ppm)	Suspended solids boiler water (ppm)(max)	TDS range, ^{b,c} steam (ppm) (max expected value)
0–300	700–3500	140–700	15	0.2–1.0
301–450	600–3000	120–600	10	0.2–1.0
451–600	500–2500	100–500	8	0.2–1.0
601–750	200–1000	40–200	3	0.1–0.5
751–900	150–750	30–150	2	0.1–0.5
901–1000	125–625	25–125	1	0.1–0.5
1001–1800	100	— ^d	1	0.1
1801–2350	50		n.a.	0.1
2351–2600	25		n.a.	0.05
2601–2900	15		n.a.	0.05
<i>Once-through boilers</i>				
1400 and above	0.05	n.a.	n.a.	0.05

n.a. = not available.

^aActual values within the range reflect the TDS in the feedwater. Higher values are for high solids in the feedwater, lower values for low solids.

^bActual values within the range are directly proportional to the actual value of TDS of boiler water. Higher values are for the high solids in the boiler water, lower values for low solids.

^cThese values are exclusive of silica.

^dDictated by boiler water treatment.

Source: American Boiler Manufacturers Association, 1982.

From an energy balance around the deaerator,

$$10,000 \times 148 + 1202.8 \times D + M \times 38 = 209 \times F = 209 \times (50,000 + B) \quad (22)$$

From a balance of solids concentration,

$$100 \times M = 1500 \times B \quad (23)$$

In Eq. (22), 1202.8 is the enthalpy of the steam used for deaeration, 209 the enthalpy of boiler feedwater, 148 the enthalpy of the condensate return, and 38 that of the makeup, all in Btu/lb. The equation assumes that the amount of solids in returning condensate and steam is negligible, which is true. Steam usually has a TDS of 1 ppm or less, and so does the condensate. Hence, for practical purposes we can neglect it. The net solids enter the system in the form of makeup water and leave as blowdown. There are three unknowns— D , M , and B —and three equations. From Eq. (21),

$$D + M = 40,000 + B \quad (24)$$

Substituting (23) into (24),

$$D + 15B = 40,000 + B$$

or

$$D + 14B = 40,000 \quad (25)$$

From (22),

$$\begin{aligned} 1,480,000 + 1202.8D + 38 \times 15B \\ = 209 \times 50,000 + 209B \end{aligned}$$

Solving this equation, we have $B = 2375$ lb/h, $D = 6750$ lb/h, $M = 35,625$ lb/h, and $F = 52,375$ lb/h. Considering venting of steam from the deaerator to expel dissolved gases and the heat losses, 1–3% more steam may be consumed.

5.18

Q:

How can the boiler blowdown be utilized? A 600 psia boiler operates for 6000 h annually and discharges 4000 lb/h of blowdown. If this is flashed to steam at 100 psia, how much steam is generated? If the cost of the blowdown system is \$8000, how long does payback take? Assume that the cost of steam is \$2/1000 lb.

A:

To estimate the flash steam produced we may use the expression

$$h = xh_g + (1 - x)h_f \quad (26)$$

where

- h = enthalpy of blowdown water at high pressure, Btu/lb
- h_g, h_f = enthalpies of saturated steam and water at the flash pressure, Btu/lb
- x = fraction of steam that is generated at the lower pressure

From the steam tables, at 600 psia, $h = 471.6$, and at 100 psia, $h_g = 1187$ and $h_f = 298$, all in Btu/lb. Using Eq. (26), we have

$$471.6 = 1187x + (1 - x) \times 298$$

or

$$x = 0.195$$

About 20% of the initial blowdown is converted to flash steam, the quantity being $0.2 \times 4000 = 800$ lb/h. This 800 lb/h of 100 psia steam can be used for process. The resulting savings annually will be

$$800 \times 2 \times \frac{6000}{1000} = \$9600$$

Simple payback will be $8000/9600 = 0.8$ year or about 10 months.

Tables are available that give the flash steam produced if the initial and flash pressures are known. [Table 5.6](#) is one such table.

5.19A**Q:**

Estimate the leakage of steam through a hole 1/8 in. in diameter in a pressure vessel at 100 psia, the steam being in a saturated condition.

A:

The hourly loss of steam in lb/h is given by [2]

$$W = 50 \frac{AP}{1 + 0.00065(t - t_{\text{sat}})} \quad (27)$$

where

- W = steam leakage, lb/h
- A = hole area, in.²
- P = steam pressure, psia
- t, t_{sat} = steam temperature and saturated steam temperature, °F

TABLE 5.6 Steam Flash and Heat Content at Differential Temperatures

Initial pressure (psig)	Temp. of liquid (°F)	Atm. pressure	Percent of flash at reduced pressures							
			5 lb	10 lb	15 lb	20 lb	25 lb	30 lb	35 lb	40 lb
100	338	13	11.5	10.3	9.3	8.4	7.6	6.9	6.3	5.5
125	353	14.5	13.3	11.8	10.9	10	9.2	8.5	7.9	7.2
150	366	16	14.6	13.2	12.3	11.4	10.6	9.9	9.3	8.5
175	377	17	15.8	14.4	13.4	12.5	11.6	11.1	10.4	9.7
200	388	18	16.9	15.5	14.6	13.7	12.9	12.2	11.6	10.9
225	397	19	17.8	16.5	15.5	14.7	13.9	13.2	12.6	11.9
250	406	20	18.8	17.4	16.5	15.6	14.9	14.2	13.6	12.9
300	421	21.5	20.3	19	18	17.2	16.5	15.8	15.2	14.5
350	435	23	21.8	20.5	19.5	18.7	18	17.3	16.7	16
400	448	24	23	21.8	21	20	19.3	18.7	18.1	17.5
450	459	25	24.3	23	22	21.3	20	19.9	19.3	18.7
500	470	26.5	25.4	24.1	23.2	22.4	21.7	21.1	20.5	19.9
550	480	27.5	26.5	25.2	24.3	23.5	22.8	22.2	21.6	20.9
600	488	28	27.3	26	25	24.3	23.6	23	22.4	21.8
Btu in flash per lb		1150	1155	1160	1164	1167	1169	1172	1174	1176
Temp. of liquid, °F		212	225	240	250	259	267	274	280	287
Steam volume, cu ft/lb		26.8	21	16.3	13.7	11.9	10.5	9.4	8.5	7.8

Source: Madden Corp. catalog.

If the steam is saturated, $t = t_{\text{sat}}$. If the steam is wet with a steam quality of x , then the leakage flow is obtained from Eq. (27) divided by \sqrt{x} . Because the steam is saturated ($x = 1$),

$$W = 50 \times 3.14 \times \left(\frac{1}{8}\right)^2 \times \frac{1}{4} \times 100 = 61 \text{ lb/h}$$

If the steam were superheated and at 900°F, then

$$W = \frac{61}{1 + 0.00065 \times (900 - 544)} = 50 \text{ lb/h}$$

544°F is the saturation temperature at 1000 psia. If the steam were wet with a quality of 80%, then

$$W = \frac{61}{\sqrt{0.8}} = 68 \text{ lb/h}$$

5.19B

Q:

How is the discharge flow of air from high pressure to atmospheric pressure determined?

A:

Critical flow conditions for air are found in several industrial applications such as flow through soot blower nozzles, spray guns, and safety valves and leakage through holes in pressure vessels. The expression that relates the variables is [8]

$$W = 356 \times AP \times \left(\frac{MW}{T} \right)^{0.5} \quad (28)$$

where

W = flow, lb/h

A = area of opening, in.²

MW = molecular weight of air, 28.9

T = absolute temperature, °R

P = relief or discharge pressure, psia

What is the leakage air flow from a pressure vessel at 40 psia if the hole is 0.25 in. in diameter? Air is at 60°F.

$$A = 3.14 \times 0.25 \times \frac{0.25}{4} = 0.049 \text{ in.}^2$$

Hence,

$$W = 356 \times 0.049 \times 40 \times \left(\frac{28.9}{520} \right)^{0.5} = 164 \text{ lb/h}$$

5.20A

Q:

Derive an expression for the leakage of gas across a damper, stating the assumptions made.

A:

Most of the dampers used for isolation of gas or air in ducts are not 100% leakproof. They have a certain percentage of leakage area, which causes a flow of

gas across the area. Considering the conditions to be similar to those of flow across an orifice, we have

$$V_g = C_d \sqrt{2gH_w \frac{\rho_w}{2\rho_g}} \quad (29)$$

where

- V_g = gas velocity through the leakage area, fps
- H_w = differential pressure across the damper, in. WC
- ρ_g, ρ_w = density of gas and water, lb/cu ft
- g = acceleration due to gravity, ft/s²
- C_d = coefficient of discharge, 0.61

The gas flow W in lb/h can be obtained from

$$W = 3600 \rho_g A (100 - E) \left(\frac{V_g}{100} \right) \quad (30)$$

where E is the sealing efficiency on an area basis (%). Most dampers have an E value of 95–99%. This figure is provided by the damper manufacturer. A is the duct cross section, ft². Substituting $C_d = 0.61$ and $\rho_g = 40/(460 + t)$ into Eqs. (29) and (30) and simplifying, we have

$$W = 2484A(100 - E) \sqrt{\frac{H_w}{460 + t}} \quad (31)$$

where t is the gas or air temperature, °F.

5.20B

Q:

A boiler flue gas duct with a diameter of 5 ft has a damper whose sealing efficiency is 99.5%. It operates under a differential pressure of 7 in. WC when closed. Gas temperature is 540°F. Estimate the leakage across the damper. If energy costs \$3/MM Btu, what is the hourly heat loss and the cost of leakage?

A:

Substitute $A = 3.14 \times 5^2/4$, $H_w = 7$, $t = 540$, and $E = 99.5$ into Eq. (31). Then

$$\begin{aligned} W &= 2484 \times 3.14 \times \frac{5^2}{4} \times (100 - 99.5) \times \frac{7}{\sqrt{1000}} \\ &= 2040 \text{ lb/h} \end{aligned}$$

The hourly heat loss can be obtained from

$$\begin{aligned} Q &= WC_p(t - t_a) = 2040 \times 0.26 \times (540 - 80) \\ &= 240,000 \text{ Btu/h} = 0.24 \text{ MM Btu/h} \end{aligned}$$

where C_p is the gas specific heat, Btu/lb °F. Values of 0.25–0.28 can be used for quick estimates, depending on gas temperature. t_a is the ambient temperature in °F. 80°F was assumed in this case. The cost of this leakage = $0.24 \times 3 = \$0.72/\text{h}$.

5.20C

Q:

How is the sealing efficiency of a damper defined?

A:

The sealing efficiency of a damper is defined on the basis of the area of cross section of the damper and also as a percentage of flow. The latter method of definition is a function of the actual gas flow condition.

In Q5.20b, the damper had an efficiency of 99.5% on an area basis. Assume that the actual gas flow was 230,000 lb/h. Then, on a flow basis, the efficiency would be

$$100 - \frac{2040}{230,000} = 99.12\%$$

If the flow were 115,000 lb/h and the differential pressure were maintained, the efficiency on an area basis would still be 99.5%, whereas on a flow basis it would be

$$100 - \frac{2040}{115,000} = 98.24\%$$

Plant engineers should be aware of these two methods of stating the efficiency of dampers.

5.21

Q:

50,000 lb/h of flue gas flows from a boiler at 800°F. If a waste heat recovery system is added to reduce its temperature to 350°F, how much energy is saved? If energy costs \$3/MM Btu and the plant operates for 6000 h/year, what is the annual savings? If the cost of the heat recovery system is \$115,000, what is the simple payback?

A:

The energy savings $Q = WC_p(t_1 - t_2)$, where t_1 and t_2 are gas temperatures before and after installation of the heat recovery system, °F. C_p is the gas specific heat, Btu/lb °F. Use a value of 0.265 when the gas temperature is in the range of 400–600°F.

$$Q = 50,000 \times 0.265 \times (800 - 350) = 5.85 \times 10^6 \\ = 5.85 \text{ MM Btu/h}$$

$$\text{Annual savings} = 5.85 \times 6000 \times 3 = \$105,000$$

Hence

$$\text{Simple payback} = \frac{115,000}{105,000} = 1.1 \text{ years, or 13 months}$$

5.22

Q:

What is life-cycle costing? Two bids are received for a fan as shown below. Which bid is better?

	Bid 1	Bid 2
Flow, acfm	10,000	10,000
Head, in. WC	8	8
Efficiency, %	60	75
Total cost, fan and motor, \$	17,000	21,000

A:

Life-cycle costing is a methodology that computes the total cost of owning and operating the equipment over its life. Several financing methods and tax factors would make this a complicated evaluation. However, let us use a simple approach to illustrate the concept. To begin with, the following data should be obtained.

Cost of electricity, $C_e = \$0.25/\text{kWh}$
Annual period of operation, $N = 8000 \text{ h}$
Life of equipment, $T = 15 \text{ years}$
Interest rate, $i = 0.13$ (13%)
Escalation rate, $e = 0.08$ (8%)

If the annual cost of operation is C_a , the life-cycle cost (LCC) is

$$\text{LCC} = C_c + C_a F \quad (32)$$

where C_c is the cost of equipment and F is a factor that capitalizes the operating cost over the life of the equipment. It can be shown [4,5] that

$$F = \frac{1+e}{1+i} \times \frac{1 - \left(\frac{1+e}{1+i}\right)^T}{1 - \frac{1+e}{1+i}} \quad (33)$$

The annual cost of operation is given by

$$C_a = PC_e N \quad (34)$$

where P is the electric power consumed, kW.

$$P = 1.17 \times 10^{-4} \times \frac{qH_w}{\eta_f} \quad (35)$$

where

$$\begin{aligned} H_w &= \text{head, in. WC} \\ \eta_f &= \text{efficiency, fraction} \\ q &= \text{flow, acfm} \end{aligned}$$

Let us use the subscripts 1 and 2 for bids 1 and 2.

$$P_1 = 1.17 \times 10^{-4} \times 10,000 \times \frac{8}{0.60} = 15.6 \text{ kW}$$

$$P_2 = 1.17 \times 10^{-4} \times 10,000 \times \frac{8}{0.75} = 12.48 \text{ kW}$$

From Eq. (33), substituting $e=0.08$, $i=0.13$, and $T=15$, we get $F=10.64$. Calculate C_a from Eq. (34):

$$C_{a1} = 15.6 \times 8000 \times 0.025 = \$3120$$

$$C_{a2} = 12.48 \times 8000 \times 0.025 = \$2500$$

Using Eq. (32), calculate the life-cycle cost.

$$LCC_1 = 17,000 + 3120 \times 10.64 = \$50,196$$

$$LCC_2 = 21,000 + 2500 \times 10.64 = \$47,600$$

We note that bid 2 has a lower LCC and thus may be chosen. However, we have to analyze other factors such as period of operation, future cost of energy, and so on, before deciding. If N were lower, it is likely that bid 1 would be better.

Hence, the choice of equipment should not be based only on the initial investment but on an evaluation of the life-cycle cost, especially as the cost of energy is continually increasing.

5.23

Q:

A process kiln omits 50,000 lb/h of flue gas at 800°F. Two bids were received for heat recovery systems, as follows:

	Bid 1	Bid 2
Gas temperature leaving system, °F	450	300
Investment, \$	215,000	450,000

If the plant operates for 6000 h/year and interest, escalation rates, and life of plant are as in Q5.22, evaluate the two bids if energy costs \$4/MM Btu.

A:

Let us calculate the capitalized savings and compare them with the investments. For bid 1:

$$\begin{aligned}\text{Energy recovered} &= 50,000 \times 0.25 \times (800 - 450) \\ &= 4.375 \text{ MM Btu/h}\end{aligned}$$

This energy is worth

$$\begin{aligned}4.375 \times 4 &= \$17.5/\text{h} \\ \text{Annual savings} &= 6000 \times 17.5 = \$105,000\end{aligned}$$

The capitalization factor from Q5.22 is 10.64. Hence capitalized savings (savings throughout the life of the plant) = $105,000 \times 10.64 = \$1.12 \times 10^6$. A similar calculation for bid 2 shows that the capitalized savings will be $\$1.6 \times 10^6$. The difference in capitalized savings of $\$0.48 \times 10^6$, or \$480,000, exceeds the difference in the investment of \$235,000. Hence bid 2 is more attractive.

If, however, energy costs \$3/MM Btu and the plant works for 2500 h/year, capitalized savings on bid 1 will be \$465,000 and that of bid 2 \$665,000. The difference of \$200,000 is less than the difference in investment of \$235,000. Hence under these conditions, bid 1 is better.

The cost of energy and period of operation are important factors in arriving at the best choice.

5.24

Q:

Determine the thickness of the tubes required for a boiler super-heater. The material is SA 213 T11; the metal temperature is 900°F (see Q8.16a for a

discussion of metal temperature calculation), and the tube outer diameter is 1.75 in. The design pressure is 1000 psig.

A:

Per ASME *Boiler and Pressure Vessel Code*, Sec. 1, 1980, p. 27, the following equation can be used to obtain the thickness or the allowable pressure for tubes. (A tube is specified by the outer diameter and minimum wall thickness, where as a pipe is specified by the nominal diameter and average wall thickness.) Typical pipe and tube materials used in boiler applications are shown in [Tables 5.3](#) and [5.7](#).

$$t_w = \frac{Pd}{2S_a + P} + 0.005d + e \tag{36}$$

$$P = S_a \times \frac{2t_w - 0.01d - 2e}{d - (t_w - 0.005d - e)} \tag{37}$$

where

- t_w = minimum wall thickness, in.
- P = design pressure, psig
- d = tube outer diameter, in.
- e = factor that accounts for compensation in screwed tubes, generally zero
- S_a = allowable stress, psi

TABLE 5.7 Allowable Stress Values, Ferrous Tubing, 1000 psi

Material specifications	Temperatures not exceeding (°F):									
	20–650	700	750	800	850	900	950	1000	1200	1400
SA 178 gr A	10.0	9.7	9.0	7.8	6.7	5.5	3.8	2.1	—	—
	12.8	12.2	11.0	9.2	7.4	5.5	3.8	2.1	—	—
SA 192 gr C	11.8	11.5	10.6	9.2	7.9	6.5	4.5	2.5	—	—
SA 210 gr A-1 SA 53 B	15	14.4	13.0	10.8	8.7	6.5	4.5	2.5	—	—
gr C	17.5	16.6	14.8	12.0	7.8	5.0	3.0	1.5	—	—
SA 213 T11, P11	15.0	15.0	15.0	15.0	14.4	13.1	11.0	7.8	1.2	—
T22, P22	15.0	15.0	15.0	15.0	14.4	13.1	11.0	7.8	1.6	—
T9	—	13.4	13.1	12.5	12.5	12.0	10.8	8.5	—	—
SA 213 TP 304 H	—	15.9	15.5	15.2	14.9	14.7	14.4	13.8	6.1	2.3
TP 316 H	—	16.3	16.1	15.9	15.7	15.5	15.4	15.3	7.4	2.3
TP 321 H	—	15.8	15.7	15.5	15.4	15.3	15.2	14.0	5.9	1.9
TP 347 H	—	14.7	14.7	14.7	14.7	14.7	14.6	14.4	7.9	2.5

Source: ASME, *Boiler and Pressure Vessel Code*, Sec. 1, Power boilers, 1980.

From Table 5.7, S_a is 13,100. Substituting into Eq. (36) yields

$$t_w = \frac{1000 \times 1.75}{2 \times 13,100 + 1000} + 0.005 \times 1.75 = 0.073 \text{ in.}$$

The tube with the next higher thickness would be chosen. A corrosion allowance, if required, may be added to t_w .

5.25

Q:

Determine the maximum pressure that an SA 53 B carbon steel pipe of size 3 in. schedule 80 can be subjected to at a metal temperature of 550°F. Use a corrosion allowance of 0.02 in.

A:

By the ASME Code, Sec. 1, 1980, p. 27, the formula for determining allowable pressures or thickness of pipes, drums, and headers is

$$t_w = \frac{Pd}{2S_aE + 0.8P} + c \quad (38)$$

where

E = ligament efficiency, 1 for seamless pipes

c = corrosion allowance

From Table 5.3, a 3 in. schedule 80 pipe has an outer diameter of 3.5 in. and a nominal wall thickness of 0.3 in. Considering the manufacturing tolerance of 12.5%, the minimum thickness available is $0.875 \times 0.3 = 0.2625$ in.

Substituting $S_a = 15,000$ psi (Table 5.7) and $c = 0.02$ into Eq. (38), we have

$$0.2625 = \frac{3.5P}{2 \times 15,000 + 0.8P} + 0.02$$

Solving for P , we have $P = 2200$ psig.

For alloy steels, the factor 0.8 in the denominator would be different. The ASME Code may be referred to for details [6]. Table 5.8 gives the maximum allowable pressures for carbon steel pipes up to a temperature of 650°F [7].

5.26

Q:

How is the maximum allowable external pressure for boiler tubes determined?

TABLE 5.8 Maximum Allowable Pressure^a

Nominal pipe size (in.)	Schedule 40	Schedule 80	Schedule 160
1/4	4830	6833	—
1/2	3750	5235	6928
1	2857	3947	5769
1½	2112	3000	4329
2	1782	2575	4225
2½	1948	2702	3749
3	1693	2394	3601
4	1435	2074	3370
5	1258	1857	3191
6	1145	1796	3076
8	1006	1587	2970

^aBased on allowable stress of 15,000 psi; corrosion allowance is zero.

Source: Ref. 7.

A:

According to ASME Code [9], the external pressures of tubes or pipes can be determined as follows.

For cylinders having $d_o/t > 10$,

$$P_a = \frac{4B}{3(d_o/t)} \quad (39)$$

where

P_a = maximum allowable external pressure, psi

A, B = factors obtained from ASME Code, Sec. 1, depending on values of d_o/t and L/d_o , where L, d_o , and t refer to tube length, external diameter, and thickness.

When $d_o/t < 10$, A and B are determined from tables or charts as in Q5.25. For $d_o/t < 4$, $A = 1.1/(d_o/t)^2$. Two values of allowable pressures are then computed, namely, P_{a1} and P_{a2} .

$$P_{a1} = \left(\frac{2.167}{d_o/t} - 0.0833 \right) \times B$$

and

$$P_{a2} = 2S_b \times \frac{1 - t/d_o}{d_o/t}$$

where S_b is the lesser of 2 times the maximum allowable stress values at design metal temperature from the code stress tables or 1.8 times the yield strength of the material at design metal temperature. Then the smaller of the P_{a1} or P_{a2} is used for P_a .

Example

Determine the maximum allowable external pressure at 600°F for 120 in. SA 192 tubes of outer diameter 2 in. and length 15 ft used in fire tube boilers.

Solution.

$$\frac{d_o}{L} = \frac{15 \times 12}{2.0} = 90$$

and

$$\frac{d_o}{t} = \frac{2}{0.120} = 16.7$$

From Fig. 5.3 factor $A = 0.004$. From Fig. 5.4, $B = 9500$. Since $d_o/t > 10$,

$$P_a = \frac{4B}{3(d_o/t)} = 4 \times \frac{9500}{3/16.7} = 758 \text{ psi}$$

5.27

Q:

What is a decibel? How is it expressed?

A:

The decibel (dB) is the unit of measure used in noise evaluation. It is a ratio (not an absolute value) of a sound level to a reference level and is stated as a sound pressure level (SPL) or a sound power level (PWL). The reference level for SPL is 0.0002 μ bar. A human ear can detect from about 20 dB to sound pressures 100,000 times higher, 120 dB.

Audible frequencies are divided into octave bands for analysis. The center frequencies in hertz (Hz) of the octave bands are 31.5, 63, 125, 250, 500, 1000, 2000, 4000, and 8000 Hz. The human ear is sensitive to frequencies between 500 and 3000 Hz and less sensitive to very high and low frequencies. At 1000 Hz, for example, 90 dB is louder than it is at 500 Hz.

The sound meter used in noise evaluation has three scales, A, B, and C, which selectively discriminate against low and high frequencies. The A scale (dBA) is the most heavily weighted scale and approximates the human ear's response to noise (500–6000 Hz). It is used in industry and in regulations regarding the evaluation of noise. Table 5.9 gives typical dBA levels of various

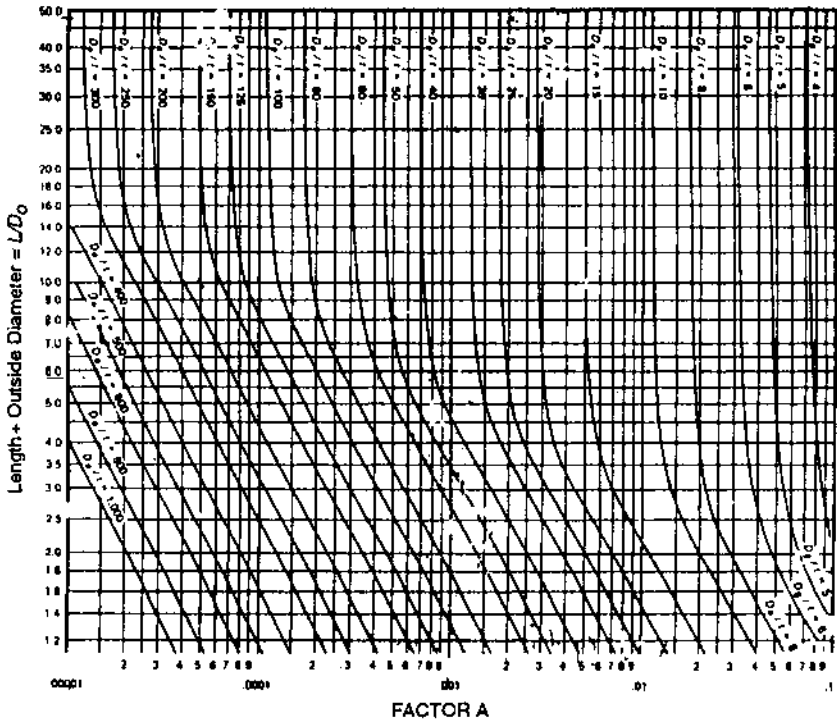

FIGURE 5.3 Factor A for use in external pressure calculation [9].

noise sources, and Table 5.10 gives the permissible Occupational Safety and Health Act (OSHA) noise exposure values.

5.28

Q:

How are decibels added? A noise source has the following dB values at center frequencies:

Hz	31.5	63	125	250	500	1000	2000	4000	8000
dB	97	97	95	91	84	82	80	85	85

What is the overall noise level?

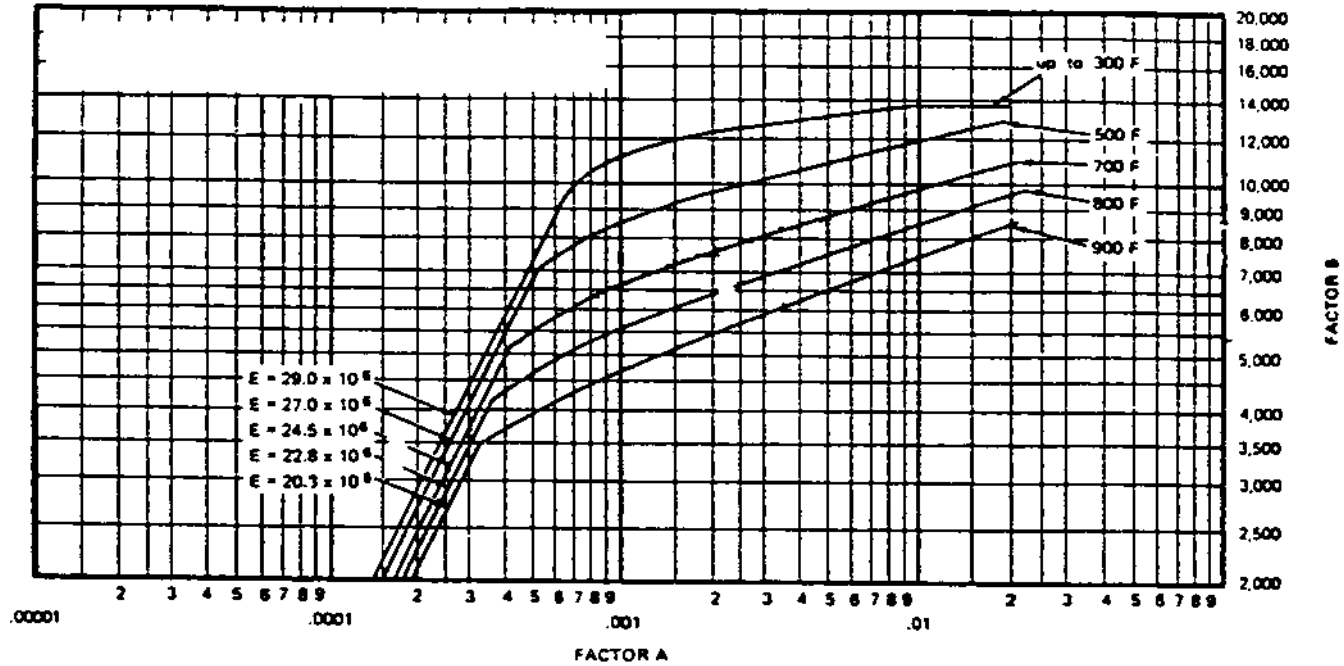

FIGURE 5.4 Factor *B* for use in external pressure calculation (SA 178A, SA 192 tubes) [9].

TABLE 5.9 Typical A-Weighted Sound Levels

dBA	Source	Perception/hearing
140	Jet engine at 25 ft	Unbearable
130	High pressure safety vent at 25 ft	Threshold of pain
120	Large forced draft fan plenum area	Uncomfortably loud
110	8000 hp engine exhaust at 25 ft	
100	Compressor building	Very loud
90	Boiler room	
80	Pneumatic drill	Loud
70	Commercial area	
60	Normal conversation	
50	Average home	Comfortable
40	Nighttime residential area	
30	Broadcast studio	
20	Whisper	Barely audible
10		
0		Threshold of hearing

A:

Decibels are added logarithmically and not algebraically. 97 dB plus 97 dB is not 194 dB but 102 dB.

$$\begin{aligned}
 P &= 10 \log(10^{P_1/10} + 10^{P_2/10} + 10^{P_3/10} + \dots) \\
 &= 10 \log(10^{9.7} + 10^{9.7} + 10^{9.5} + 10^{9.1} + 10^{8.4} + 10^{8.2} + 10^8 \\
 &\quad + 10^{8.5} + 10^{8.5}) \\
 &= 102 \text{ dB}
 \end{aligned}$$

TABLE 5.10 Permissible Noise Exposures (OSHA)

Duration per day (h)	Sound level (dBA) (slow response)
8	90
6	92
4	95
3	97
2	100
1½	102
1	105
½	110
¼ or less	115

5.29

Q:

What are SPL and PWL?

A:

SPL is sound pressure level, which is dependent on the distance and environment and is easily measured with a sound level meter. SPL values should be referred to distance. PWL is sound power level and is a measure of the total acoustic power radiated by a given source. It is defined as

$$\text{PWL} = 10 \log \left(\frac{W}{10^{-12}} \right) \text{dB} \quad (40)$$

PWL is a constant for a given source and is independent of the environment. It cannot be measured directly but must be calculated. PWL can be roughly described as being equal to the wattage rating of a bulb. Manufacturers of fans and gas turbines publish the values of PWL of their machines. When selecting silencers for these equipment, PWL may be converted to SPL depending on distance, and the attenuation desired at various frequencies may be obtained. A silencer that gives the desired attenuation can then be chosen.

5.30

Q:

A sound level of 120 dB is measured at a distance of 3 ft from a source. Find the value at 100 ft.

A:

The following formula relates the PWL and SPL with distance:

$$\text{SPL} = \text{PWL} - 20 \log L + 2.5 \text{ dB} \quad (41)$$

where L = distance, ft.

PWL is a constant for a given source. Hence

$$\text{SPL} + 20 \log L = \text{a constant}$$

$$120 + 20 \log 3 = \text{SPL}_2 + 20 \log 100$$

Hence

$$\text{SPL}_2 = 89.5 \text{ dB}$$

Thus we see that SPL has decreased by 30 dB with a change from 3 ft to 100 ft. When selecting silencers, one should be aware of the desired SPL at the desired distance. Neglecting the effect of distance can lead to specifying a larger and more costly silencer than necessary.

5.31

Q:

How is the noise level from the exhaust of engines computed?

A:

A gas turbine exhaust has the noise spectrum given in Table 5.11 at various octave bands. The exhaust gases flow through a heat recovery boiler into a stack that is 100 ft high. Determine the noise level 150 ft from the top of the stack (of diameter 60 in.) and in front of the boiler.

Assume that the boiler attenuation is 20 dB at all octave bands. In order to arrive at the noise levels at the boiler front, three corrections are required: (1) boiler attenuation, (2) effect of directivity, and (3) divergence at 150 ft. The effect of directivity is shown in Table 5.12. The divergence effect is given by $20 \log L - 2.5$, where L is the distance from the noise source.

Row 8 values are converted to dBA by adding the dB at various frequencies. The final value is 71 dBA.

5.32

Q:

How is the holdup or volume of water in boiler drums estimated? A boiler generating 10,000 lb/h of steam at 400 psig has a 42 in. drum 10 ft long with 2:1 ellipsoidal ends. Find the time between normal water level (NWL) and low level cutoff (LLCO) if NWL is at 2 in. below drum centerline and LLCO is 4 in. below NWL.

TABLE 5.11 Table of Noise Levels

1. Frequency, Hz	63	125	250	500	1000	2000	4000	8000
2. PWL, $\times 10^{-12}$ W dB (gas turbine)	130	134	136	136	132	130	131	133
3. Boiler attenuation, dB	-20	-20	-20	-20	-20	-20	-20	-20
4. Directivity, dB	0	-1	-2	-5	-8	-10	-13	-16
5. Divergence, dB	-41	-41	-41	-41	-41	-41	-41	-41
6. Resultant	69	72	73	70	63	59	57	56
7. A scale, dB	-25	-16	-9	-3	0	1	1	-1
8. Net	44	56	64	67	63	60	58	55
	56		69		65		60	
	69				66.5			
	71							

TABLE 5.12 Effect of Directivity Based on Angle to Direction of Flow and Size of Silencer Outlet

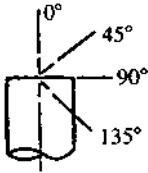
Angle to direction of flow	Silencer outlet diameter (in.)	Octave band center frequency (Hz)							
		63	125	250	500	1000	2000	3000	4000
	72-96	+4	+5	+5	+6	+6	+7	+7	+7
	54-66	+3	+4	+4	+5	+5	+5	+5	+5
	36-48	+2	+3	+3	+4	+4	+4	+4	+4
	26-32	+1	+1	+2	+2	+2	+2	+2	+2
	16-24	0	0	+1	+1	+1	+1	+1	+1
	8-14	0	0	0	0	0	0	0	0
	6	0	0	0	0	0	0	0	0
45°	72-96	+2	+3	+3	+4	+4	+5	+5	+5
	54-66	+1	+2	+2	+3	+3	+3	+3	+3
	36-48	0	+1	+1	+2	+2	+2	+2	+2
	26-32	0	0	0	+1	+1	+1	+1	+1
	16-24	0	0	0	0	0	0	0	0
	8-14	0	0	0	0	0	0	0	0
	6	0	0	0	0	0	0	0	0
90 and 135°	72-96	-1	-2	-5	-7	-10	-12	-15	-17
	54-66	0	-1	-2	-5	-8	-10	-13	-16
	36-48	0	0	-1	-3	-6	-7	-11	-15
	26-32	0	0	0	-1	-3	-5	-9	-14
	16-24	0	0	0	0	-1	-3	-7	-13
	8-14	0	0	0	0	-1	-2	-5	-11
	5-6	0	0	0	0	0	-1	-3	-6
	4	0	0	0	0	0	0	-1	-3

Source: Burgess Manning.

A:

The volume of water in the drum must include the volume due to the straight section plus the dished ends.

Volume in the straight section, V_s , is given by

$$V_s = L \times R^2 \times \left(\frac{a}{57.3} - \sin a \times \cos a \right)$$

where a is the angle shown in Fig. 5.5. The volume of liquid in each end is given by

$$V_e = 0.261 \times H^2 \times (3R - H)$$

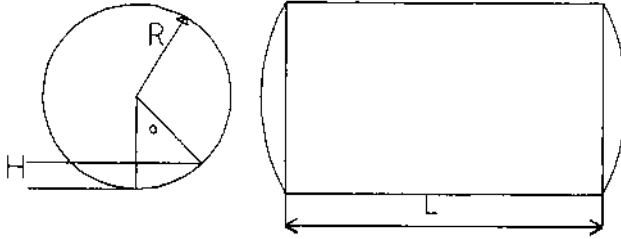

FIGURE 5.5 Partial volume of water in boiler drum.

where

H = straight length of drum
 R = drum radius

In this case, $H = 120$ in. and $R = 21$ in.

Let us compute V_{s1} and V_{e1} , the volume of the straight section and each end corresponding to the 19 in. level from the bottom of the drum.

$$\cos a = \frac{2}{21} = 0.09523$$

Hence

$$a = 84.5^\circ \text{ and } \sin a = 0.9954$$

$$v_{s1} = 120 \times 21 \times 21 \times \left(\frac{84.53}{57.3} - 0.0953 \times 0.9954 \right)$$

$$= 73,051 \text{ cu in.}$$

$$V_{e1} = 0.261 \times 19 \times 19 \times (3 \times 21 - 19) = 4146 \text{ cu in.}$$

Hence total volume of liquid up to 19 in. level = $73,051 + 2 \times 4146 = 81,343$ cu in. = 47.08 cu ft.

Similarly, we can show that total volume of water up to the 15 in. level = 34.1 cu ft. Hence the difference is 13 cu ft.

Specific volume of water at 400 psig = 0.0193 cu ft/lb.

$$\begin{aligned} \text{Normal evaporation rate} &= 10,000 \times \frac{0.0193}{60} \\ &= 3.2 \text{ cu ft/min} \end{aligned}$$

Hence the length of time between the levels assuming that the water supply has been discontinued = $13/3.21 = 4.05$ min.

NOMENCLATURE

A	Area of opening, in. ² , or duct cross section, ft ²
A, B	Factors used in Q5.26
BD	Blowdown, fraction
BHP	Boiler horsepower
c	Corrosion allowance, in.
C_c	Initial investment, \$
C_d	Coefficient of discharge
C_e	Cost of electricity, \$/kWh
C_p	Specific heat, Btu/lb °F
d	Tube or outer diameter, in.
d_i	Tube or pipe inner diameter, in.
e	Escalation factor
E	Sealing efficiency, %; ligament efficiency, fraction
F	Factor defined in Eq. (33)
G	Gas mass velocity, lb/ft ² h
h	Enthalpy, Btu/lb
H	Height of liquid column, in.
h_g, h_f	Enthalpy of saturated vapor and liquid, Btu/lb
H_g	Head of gas column, ft
H_l	Head of liquid, ft
H_w	Differential pressure across damper, in. WC
i	Interest rate
L	Distance, ft
LCC	Life-cycle cost, \$
M	Moisture in air, lb/lb
MW	Molecular weight
N	Annual period of operation, h
P_w	Partial pressure of water vapor, psia
P	Gas pressure, psia; design pressure, psig
ΔP	Differential pressure, psi
PWL	Sound power level
q	Volumetric flow, gpm or cfm
Q	Energy, Btu/h
R	Radius of drum, in.
RH	Relative humidity
s	Specific gravity
S_a	Allowable stress, psi
SBV	Steam by volume
SPL	Sound pressure level, dB
SVP	Saturated vapor pressure, psia

t	Fluid temperature, °F
t_w	Minimum wall thickness of pipe or tube, in.
T	Life of plant, years
v	Specific volume, cu ft; subscripts g and f stand for saturated vapor and liquid
V_e, V_s	Volume of drum ends, straight section, cu in.
V_g	Velocity of gas
W	Mass flow, lb/h
x	Steam quality
y	Volume fraction
ρ	Density, lb/cu ft; subscript g stands for gas

REFERENCES

1. V Ganapathy. Determining operating parameters for hot exhaust gas cooling systems. *Plant Engineering*, Mar 3, 1983, p 182.
2. V Ganapathy. Nomograph estimates steam leakage and cost. *Heating Piping and Air-Conditioning*, Nov 1982, p 101.
3. V Ganapathy. Quick estimates of damper leakage and cost energy loss. *Oil and Gas Journal*, Sept 21, 1981, p 124.
4. V Ganapathy. *Applied Heat Transfer*, Tulsa, OK: PennWell Books, 1982, p 186.
5. RJ Brown and RR Yanuck. *Life Cycle Costing*. Atlanta, GA: Fairmont Press, 1980, p 188.
6. ASME. *Boiler and Pressure Vessel Code*, Sec. 1. New York, 1980, p 119.
7. V Ganapathy. Estimate maximum allowable pressures for steel piping, *Chemical Engineering*, July 25, 1983, p 99.
8. ASME. *Boiler and Pressure Vessel Code*, Sec. 8, Div. 1, Para UG 131, 1980.
9. ASME. *Boiler and Pressure Vessel Code*, Sec. 1, Para PFT 51, 1989.

6

Fuels, Combustion, and Efficiency of Boilers and Heaters

- 6.01 Estimating HHV (higher heating value) and LHV (lower heating value) of fuels from ultimate analysis; relating heat inputs based on HHV and LHV; relating boiler efficiencies based on HHV and LHV
- 6.02 Estimating HHV and LHV of fuel oils if $^{\circ}$ API is known
- 6.03 Calculating cost of fuels on MM Btu (million Btu) basis; comparing electricity cost with cost of fuels
- 6.04 Estimating annual fuel cost for power plants; relating heat rates with efficiency of power plants
- 6.05 Determining gas regulator settings for different fuels
- 6.06 Correcting fuel flow meter readings for operating fuel gas pressures and temperatures
- 6.07 Determining energy, steam quantity, and electric heater capacity required for heating air
- 6.08 Determining energy, steam quantity, and electric heater capacity required for heating fuel oils
- 6.09 Combustion calculations from ultimate analysis of fuels; determining wet and dry air and flue gas quantities; volumetric analysis of flue gas on wet and dry basis; partial pressures of water vapor and carbon dioxide in flue gas; molecular weight and density of flue gas
- 6.10 Combustion calculations on MM Btu basis; determining air and flue gas quantities in the absence of fuel data

- 6.11 Estimating excess air from flue gas CO₂ readings
- 6.12 Estimating excess air from CO₂ and O₂ readings; estimating excess air from O₂ readings alone
- 6.13 Effect of reducing oxygen in flue gas; calculating flue gas produced; calculating energy saved and reduction in fuel cost
- 6.14 Effect of fuel heating values on air and flue gas produced in boilers
- 6.15 Determining combustion temperature of different fuels in the absence of fuel analysis
- 6.16a Calculating ash concentration in flue gases
- 6.16b Relating ash concentration between mass and volumetric units
- 6.17 Determining melting point of ash knowing ash analysis
- 6.18 Determining SO₂ and SO₃ in flue gases in lb/MM Btu and in ppm (volume)
- 6.19 Determining efficiency of boilers and heaters; efficiency on HHV basis; dry gas loss; loss due to moisture and combustion of hydrogen; loss due to moisture in air; radiation loss; efficiency on LHV basis; wet flue gas loss; relating efficiencies on HHV and LHV basis
- 6.20 Determining efficiency of boilers and heaters on HHV and LHV basis from flue gas analysis
- 6.21 Loss due to CO formation
- 6.22 Simple formula for efficiency determination
- 6.23 Determining radiation losses in boilers and heaters if casing temperature and wind velocity are known
- 6.24 Variation of heat losses and efficiency with boiler load
- 6.25a Sulfur dew point of flue gases
- 6.25b Computing acid dew points for various acid vapors
- 6.25c Effect of gas temperature on corrosion potential
- 6.25d Another correlation for sulfuric acid dew point
- 6.26a Converting NO_x and CO from lb/h to ppm for turbine exhaust gases
- 6.26b Converting NO_x and CO from lb/h to ppm for fired boilers
- 6.26c Converting UHC from lb/MM Btu to ppm
- 6.26d Converting SO_x from lb/MM Btu to ppm
- 6.26e Converting NO_x and CO from lb/h to ppm before and after auxiliary firing in an HRSG
- 6.26f Relating steam generator emission from measured oxygen value to 3% basis
- 6.27a Oxygen consumption versus fuel input for gas turbine exhaust gases
- 6.27b Determining gas turbine exhaust gas analysis after auxiliary firing
- 6.27c Determining turbine exhaust gas temperature after auxiliary firing
- 6.28 Relating heat rates of engines to fuel consumption

6.01

Q:

How are the HHV (higher heating value) and LHV (lower heating value) of fuels estimated when the ultimate analysis is known?

A:

We can use the expressions [1]

$$\text{HHV} = 14,500 \times C + 62,000 \times \left(\text{H}_2 - \frac{\text{O}_2}{8} \right) + 4000 \times S \quad (1)$$

$$\text{LHV} = \text{HHV} - 9720 \times \text{H}_2 - 1110W \quad (2)$$

where W is the fraction by weight of moisture in fuel, and C , H_2 , O_2 , and S are fractions by weight of carbon, hydrogen, oxygen, and sulfur in the fuel.

If a coal has $C = 0.80$, $\text{H}_2 = 0.003$, $\text{O}_2 = 0.005$, $W = 0.073$, $S = 0.006$, and the rest ash, find its HHV and LHV. Substituting into Eqs. (1) and (2), we have

$$\text{HHV} = 14,500 \times 0.80 + 62,000 \times \left(0.003 - \frac{0.005}{8} \right)$$

$$+ 4000 \times 0.006 = 11,771 \text{ Btu/lb}$$

$$\text{LHV} = 11,771 - 9720 \times 0.003 - 1110 \times 0.073$$

$$= 11,668 \text{ Btu/lb}$$

Fuel inputs to furnaces and boilers and efficiencies are often specified without reference to the heating values, whether HHV or LHV, which is misleading.

If a burner has a capacity of Q MM Btu/h (million Btu/h) on HHV basis, its capacity on LHV basis would be

$$Q_{\text{LHV}} = Q_{\text{HHV}} \times \frac{\text{LHV}}{\text{HHV}} \quad (3a)$$

Similarly, if η_{HHV} and η_{LHV} are the efficiencies of a boiler on HHV and LHV basis, respectively, they are related as follows:

$$\eta_{\text{HHV}} \times \text{HHV} = \eta_{\text{LHV}} \times \text{LHV} \quad (3b)$$

6.02a

Q:

How can we estimate the HHV and LHV of a fuel oil in the absence of its ultimate analysis?

A:

Generally, the °API of a fuel oil will be known, and the following expressions can be used:

$$\text{HHV} = 17,887 + 57.5 \times \text{°API} - 102.2 \times \%S \quad (4a)$$

$$\text{LHV} = \text{HHV} - 91.23 \times \%H_2 \quad (4b)$$

where %H₂ is the percent hydrogen by weight.

$$\%H_2 = F - \frac{2122.5}{\text{°API} + 131.5} \quad (5)$$

where

$$F = 24.50 \text{ for } 0 \leq \text{°API} \leq 9$$

$$F = 25.00 \text{ for } 9 \leq \text{°API} \leq 20$$

$$F = 25.20 \text{ for } 20 \leq \text{°API} \leq 30$$

$$F = 25.45 \text{ for } 30 \leq \text{°API} \leq 40$$

HHV and LHV are in Btu/lb.

6.02b**Q:**

Determine the HHV and LHV of 30 °API fuel oil in Btu/gal and in Btu/lb. Assume that %S is 0.5.

A:

From Eq. (4a),

$$\begin{aligned} \text{HHV} &= 17,887 + 57.5 \times 30 - 102.2 \times 0.5 \\ &= 19,651 \text{ Btu/lb} \end{aligned}$$

To calculate the density or specific gravity of fuel oils we can use the expression

$$s = \frac{141.5}{131.5 + \text{°API}} = \frac{141.5}{131.5 + 30} = 0.876 \quad (6)$$

Hence

$$\text{Density} = 0.876 \times 8.335 = 7.3 \text{ lb/gal}$$

8.335 is the density of liquids in lb/gal when $s = 1$.

$$\text{HHV in Btu/gal} = 19,561 \times 7.3 = 142,795$$

From Eq. (5),

$$\%H_2 = 25.2 - \frac{2122.5}{131.5 + 30} = 12.05$$

$$\begin{aligned} \text{LHV} &= 19,561 - 91.23 \times 12.05 = 18,460 \text{ Btu/lb} \\ &= 18,460 \times 7.3 = 134,758 \text{ Btu/gal} \end{aligned}$$

6.03a

Q:

A good way to compare fuel costs is to check their values per MM Btu fired. If coal having HHV = 9500 Btu/lb costs \$25/long ton, what is the cost in \$/MM Btu?

A:

1 long ton = 2240 lb. 1 MM Btu has $10^6/9500 = 105$ lb of coal. Hence 105 lb would cost

$$105 \times \frac{25}{2240} = \$1.17/\text{MM Btu}$$

6.03b

Q:

If No. 6 fuel oil costs 30 cents/gal, is it cheaper than the coal in Q6.03a?

A:

Table 6.1 gives the HHV of fuel oils. It is 152,400 Btu/gal. Hence 1 MM Btu would cost

$$\frac{10^6}{152,400} \times 0.30 = \$1.96/\text{MM Btu}$$

6.03c

Q:

Which is less expensive, electricity at 1.5 cents/kWh or gas at \$3/MM Btu?

A:

3413 Btu = 1 kWh. At 1.5 cents/kWh, 1 MM Btu of electricity costs $(10^6/3413) \times 1.5/100 = \4.4 . Hence in this case, electricity is costlier than gas. This example serves to illustrate the conversion of units and does not imply that this situation will prevail in all regions.

TABLE 6.1 Typical Heat Contents of Various Oils

Typical oil	Sp. gr. 60°F (15.6°C)	lb/gal	kg/m ³	Gross Btu/gal	Gross kcal/L	Wt% H	Net Btu/gal	Net kcal/L	Sp. heat at 40°F	Sp. heat at 300°F	Temp. corr. (°API/°F)	Air 60°F (ft ³ /gal)	Ult. %CO ₂	
	0	1.076	8.969	1,075	160,426	10,681	8.359	153,664	10,231	0.391	0.504	0.045	1581	—
	2	1.060	8.834	1,059	159,038	10,589	8.601	152,183	10,133	0.394	0.508	—	—	—
	4	1.044	8.704	1,043	157,692	10,499	8.836	150,752	10,037	0.397	0.512	—	—	18.0
	6	1.029	8.577	1,0028	156,384	10,412	9.064	149,368	9,945	0.400	0.516	0.048	1529	17.6
	8	1.014	8.454	1,013	155,115	10,328	9.285	148,028	9,856	0.403	0.519	0.050	1513	17.1
	10	1.000	8.335	1,000	153,881	10,246	10.00	146,351	9,744	0.406	0.523	0.051	1509	16.7
	12	0.986	8.219	985.0	152,681	10,166	10.21	145,100	9,661	0.409	0.527	0.052	1494	16.4
No. 6 oil	14	0.973	8.106	971.5	151,515	10,088	10.41	143,888	9,580	0.412	0.530	0.054	1478	16.1
	16	0.959	7.996	958.3	150,380	10,013	10.61	142,712	9,502	0.415	0.534	0.056	1463	15.8
	18	0.946	7.889	945.5	149,275	9,939	10.80	141,572	9,426	0.417	0.538	0.058	1448	15.5
No. 5 oil	20	0.934	7.785	933.0	148,200	9,867	10.99	140,466	9,353	0.420	0.541	0.060	1433	15.2
	22	0.922	7.683	920.9	147,153	9,798	11.37	139,251	9,272	0.423	0.545	0.061	1423	14.9
	24	0.910	7.585	909.9	146,132	9,730	11.55	138,210	9,202	0.426	0.548	0.063	1409	14.7
No. 4 oil	26	0.898	7.488	897.5	145,138	9,664	11.72	137,198	9,135	0.428	0.552	0.065	1395	14.5
	28	0.887	7.394	886.2	144,168	9,599	11.89	136,214	9,069	0.431	0.555	0.067	1381	14.3
No. 2 oil	30	0.876	7.303	875.2	143,223	9,536	12.06	135,258	9,006	0.434	0.559	0.089	1368	14.0
	32	0.865	7.213	864.5	142,300	9,475	12.47	134,163	8,933	0.436	0.562	0.072	1360	13.8
	34	0.855	7.126	854.1	141,400	9,415	12.63	133,259	8,873	0.439	0.566	0.074	1347	13.6
	36	0.845	7.041	843.9	140,521	9,356	12.78	132,380	8,814	0.442	0.569	0.076	1334	13.4
	38	0.835	6.958	833.9	139,664	9,299	12.93	131,524	8,757	0.444	0.572	0.079	1321	13.3
No. 1 oil	40	0.825	6.877	824.2	138,826	9,243	13.07	130,689	8,702	0.447	0.576	0.082	1309	13.1
	42	0.816	6.798	814.7	138,007	9,189	—	—	—	0.450	0.579	0.085	—	13.0
	44	0.806	6.720	805.4	137,207	9,136	—	—	—	0.452	0.582	0.088	—	12.8

6.04

Q:

Estimate the annual fuel cost for a 300 MW coal-fired power plant if the overall efficiency is 40% and the fuel cost is \$1.1/MM Btu. The plant operates for 6000 h/yr.

A:

Power plants have efficiencies in the range of 35–42%. Another way of expressing this is to use the term *heat rate*, defined as

$$\text{Heat rate} = \frac{3413}{\text{efficiency}} \text{ Btu/kWh}$$

In this case it is $3413/0.4 = 8530$ Btu/kWh.

$$\begin{aligned} \text{Annual fuel cost} &= 1000 \times \text{megawatt} \times \text{heat rate} \times (\text{h/yr}) \times \text{cost of fuel} \\ &\quad \text{in } \$/\text{MM Btu} \\ &= 1000 \times 300 \times 8530 \times 6000 \times \frac{1.1}{10^6} \\ &= \$16.9 \times 10^6 \end{aligned}$$

The fuel cost for any other type of power plant could be found in a similar fashion. Heat rates are provided by power plant suppliers.

6.05

Q:

A 20 MM Btu/h burner was firing natural gas of HHV = 1050 Btu/scf with a specific gravity of 0.6. If it is now required to burn propane having HHV = 2300 Btu/scf with a specific gravity of 1.5, and if the gas pressure to the burner was set at 4 psig earlier for the same duty, estimate the new gas pressure. Assume that the gas temperature in both cases is 60°F.

A:

The heat input to the burner is specified on HHV basis. The fuel flow rate would be Q/HHV , where Q is the duty in Btu/h. The gas pressure differential between the gas pressure regulator and the furnace is used to overcome the flow resistance according to the equation

$$\Delta P = \frac{KW_f^2}{\rho} \quad (7)$$

where

$$\Delta P = \text{pressure differential, psi}$$

$K = \text{a constant}$

$\rho = \text{gas density} = 0.075s$ (s is the gas specific gravity; $s = 1$ for air)

$W_f = \text{fuel flow rate in lb/h} = \text{flow in scfh} \times 0.075s$

Let the subscripts 1 and 2 denote natural gas and propane, respectively.

$$W_{f1} = \frac{20 \times 10^6}{1050} \times 0.075 \times 0.6$$

$$W_{f2} = \frac{20 \times 10^6}{2300} \times 0.075 \times 1.5$$

$\Delta P_1 = 4$, $\rho_1 = 0.075 \times 0.6$, and $\rho_2 = 0.075 \times 1.5$. Hence, from Eq. (7),

$$\frac{\Delta P_1}{\Delta P_2} = \frac{W_{f1}^2 \rho_2}{W_{f2}^2 \rho_1} = \frac{4}{\Delta P_2} = \frac{0.6}{(1050)^2} \times \frac{(2300)^2}{1.5}$$

or

$$\Delta P_2 = 2.08 \text{ psig}$$

Hence, if the gas pressure is set at about 2 psig, we can obtain the same duty. The calculation assumes that the backpressure has not changed.

6.06

Q:

Gas flow measurement using displacement meters indicates actual cubic feet of gas consumed. However, gas is billed, generally, at reference conditions of 60°F and 14.65 psia (4 oz). Hence gas flow has to be corrected for actual pressure and temperature. Plant engineers should be aware of this conversion.

In a gas-fired boiler plant, 1000 cu ft of gas per hour was measured, gas conditions being 60 psig and 80°F. If the gas has a higher calorific value of 1050 Btu/scf, what is the cost of fuel consumed if energy costs \$4/MM Btu?

A:

The fuel consumption at standard conditions is found as follows.

$$V_s = V_a P_a \frac{T_s}{P_s T_a} \quad (8)$$

where

V_s, V_a = fuel consumption, standard and actual, cu ft/h
 T_s = reference temperature of 520°R
 T_a = actual temperature, °R
 P_s, P_a = standard and actual pressures, psia

$$V_s = 100 \times (30 + 14.22) \times \frac{520}{14.65 \times 540}$$
$$= 2900 \text{ scfh}$$

Hence

Energy used = 2900 × 1050 = 3.05 MM Btu/h
Cost of fuel = 3.05 × 4 = \$12.2/h.

If pressure and temperature corrections are not used, the displacement meter reading can lead to incorrect fuel consumption data.

6.07

Q:

Estimate the energy in Btu/h and in kilowatts (kW) for heating 75,000 lb/h of air from 90°F to 225°F. What is the steam quantity required if 200 psia saturated steam is used to accomplish the duty noted above? What size of electric heater would be used?

A:

The energy required to heat the air can be expressed as

$$Q = W_a C_p \Delta T \quad (9)$$

where

Q = duty, Btu/h
 W_a = air flow, lb/h
 C_p = specific heat of air, Btu/lb°F
 ΔT = temperature rise, °F

C_p may be taken as 0.25 for the specified temperature range.

$$Q = 75,000 \times 0.25 \times (225 - 90) = 2.53 \times 10^6 \text{ Btu/h}$$

Using the conversion factor $3413 \text{ Btu} = 1 \text{ kWh}$, we have

$$Q = 2.53 \times \frac{10^6}{3413} = 741 \text{ kW}$$

A 750 kW heater or the next higher size could be chosen.

If steam is used, the quantity can be estimated by dividing Q in Btu/h by the latent heat obtained from the steam tables (see the Appendix). At 200 psia, the latent heat is 843 Btu/lb. Hence

$$\text{Steam required} = 2.55 \times \frac{10^6}{843} = 3046 \text{ lb/h}$$

6.08

Q:

Estimate the steam required at 25 psig to heat 20 gpm of 15 °API fuel oil from 40°F to 180°F. If an electric heater is used, what should be its capacity?

A:

Table 6.2 gives the heat content of fuel oils in Btu/gal [2]. At 180°F, enthalpy is 529 Btu/gal, and at 40°F it is 26 Btu/gal. Hence the energy absorbed by the fuel oil is

$$\begin{aligned} Q &= 20 \times 60 \times (529 - 26) = 0.6 \times 10^6 \text{ Btu/h} \\ &= 0.6 \times \frac{10^6}{3413} = 175 \text{ kW} \end{aligned}$$

The latent heat of steam (from the steam tables) is 934 Btu/lb at 25 psig or 40 psia. Hence

$$\text{Steam required} = 0.6 \times \frac{10^6}{934} = 646 \text{ lb/h}$$

If an electric heater is used, its capacity will be a minimum of 175 kW. Allowing for radiation losses, we may choose a 200 kW heater.

In the absence of information on fuel oil enthalpy, use a specific gravity of 0.9 and a specific heat of 0.5 Btu/lb °F. Hence the duty will be

$$\begin{aligned} Q &= 20 \times 60 \times 62.40 \times \frac{0.9}{7.48} \times 0.5 \times (180 - 40) \\ &= 0.63 \times 10^6 \text{ Btu/h} \end{aligned}$$

(7.48 is the conversion factor from cubic feet to gallons.)

TABLE 6.2 Heat Content (Btu/gal) of Various Oils^a

Temp. (°F)	Gravity, °API at 60°F (15.6°C)							
	10	15	20	25	30	35	40	45
	Specific gravity, 60°F/60°F							
	1.0000	0.9659	0.9340	0.9042	0.8762	0.8498	0.8251	0.8017
32	0	0	0	0	0	0	0	0
	0	0	0	0	0	0	0	0
60	95	93	92	90	89	87	86	85
								965
100	237	233	229	226	222	219	215	
							1065	1062
120	310	305	300	295	290	286	281	
							1116	1112
140	384	378	371	366	360	355	349	
							1169	1164
160	460	453	445	438	431	425	418	
					1236		1223	1217
180	538	529	520	511	503	496	488	
					1293		1278	1272
200	617	607	596	587	577	569	560	
			1371		1352		1335	1327
220	697	686	674	663	652	643	633	
			1434		1412		1393	1384
240	779	766	753	741	729	718	707	
			1498		1474		1452	1442
260	862	848	833	820	807	795	783	
			1563		1537		1513	1502
300	1034	1017	999	984	968	954	939	
			1699		1668		1639	1626
400	1489	1463	1439	1416	1393	1372	1352	1333
		2088	2064	2041	2018	1997	1977	1958
500	1981	1947	1914	1884	1854	1826	1799	1774
		2497	2464	2434	2404	2376	2349	2324
600	2511	2467	2426	2387	2350	2314	2281	2248
		2942	2901	2862	2825	2789	2756	2723
700	3078	3025	2974	2927	2881	2837	2796	2756
	3478	3425	3374	3327	3281	3237	3196	3156
800	3683	3619	3559	3502	3447	3395	3345	3297
	4008	3944	3884	3827	3772	3720	3670	3622

^aValues in regular type are for liquid; **bold values** are for vapor.

TABLE 6.3 Combustion Constants

No. Substance	Formula	Mol. wt ^a	Lb per cu ft ^b	Cu ft per lb ^b	Sp gr air = 1,000 ^b	Heat of combustion ^c			
						Btu/cu ft		Btu/lb	
						Gross	Net ^d	Gross	Net ^d
1 Carbon	C	12.01	—	—	—	—	—	14,093 ^g	14,093
2 Hydrogen	H ₂	2.016	0.005327	187.723	0.06959	325.0	275.0	61,100	51,623
3 Oxygen	O ₂	32.000	0.08461	11.819	1.1053	—	—	—	—
4 Nitrogen (atm)	N ₂	28.016	0.07439 ^c	13.443 ^c	0.9718 ^e	—	—	—	—
5 Carbon monoxide	CO	28.01	0.07404	13.506	0.9672	321.8	321.8	4,347	4,347
6 Carbon dioxide	CO ₂	44.01	0.1170	8.548	1.5282	—	—	—	—
Paraffin series C_nH_{2n+2}									
7 Methane	CH ₄	16.041	0.04243	23.565	0.5543	1013.2	913.1	23,879	21,520
8 Ethane	C ₂ H ₆	30.067	0.08029 ^c	12.455 ^c	1.04882 ^e	1792	1641	22,320	20,432
9 Propane	C ₃ H ₈	44.092	0.1196 ^c	8.365 ^c	1.5617 ^c	2590	2385	21,661	19,944
10 n-Butane	C ₄ H ₁₀	58.118	0.1582 ^c	6.321 ^c	2.06654 ^e	3370	3113	21,308	19,680
11 Isobutane	C ₄ H ₁₀	58.118	0.1582 ^e	6.321 ^e	2.06654 ^e	3363	3105	21,257	19,629
12 n-Pentane	C ₅ H ₁₂	72.144	0.1904 ^e	5.252 ^e	2.4872 ^e	4016	3709	21,091	19,517
13 Isopentane	C ₅ H ₁₂	72.144	0.1904 ^e	5.252 ^e	2.4972 ^e	4008	3716	21,052	19,479
14 Neopentane	C ₅ H ₁₂	72.144	0.1904 ^e	5.252 ^e	2.4872 ^e	3993	3693	20,970	19,396
15 n-Hexane	C ₆ H ₁₄	86.169	0.2274 ^e	4.399 ^e	2.9704 ^c	4762	4412	20,940	19,403
Olefin series C_nH_{2n}									
16 Ethylene	C ₂ H ₄	28.051	0.07456	13.412	0.9740	1613.8	1513.2	21,644	20,295
17 Propylene	C ₃ H ₆	42.077	0.1110 ^e	9.007 ^e	1.4504 ^e	2336	2186	21,041	19,691
18 n-Butene (butylene)	C ₄ H ₈	56.102	0.1480 ^e	6.756 ^e	1.9336 ^e	3084	2995	20,840	19,496
19 Isobutene	C ₄ H ₈	56.102	0.1480 ^e	6.756 ^e	1.9336 ^e	3068	2969	20,730	19,382
20 n-Pentene	C ₅ H ₁₀	70.128	0.1852 ^e	5.400 ^e	2.4190 ^e	3836	3586	20,712	19,363
Aromatic series C_nH_{2n-6}									
21 Benzene	C ₆ H ₆	76.107	0.2060 ^c	4.852 ^c	2.6920 ^e	3751	3601	19,210	17,480
22 Toluene	C ₇ H ₈	92.132	0.2431 ^c	4.113 ^c	3.1760 ^e	4484	4284	18,440	17,620
23 Xylene	C ₈ H ₁₀	106.158	0.2803 ^e	3.567 ^e	3.6618 ^e	5230	4980	18,650	17,760
Miscellaneous gases									
24 Acetylene	C ₂ H ₂	26.036	0.06971	14.344	0.9107	1499	1448	21,500	20,776
25 Naphthalene	C ₁₀ H ₈	128.162	0.3384 ^e	2.955 ^e	4.4208 ^e	5854 ^f	5654 ^f	17,298 ^f	16,708 ^f
26 Methyl alcohol	CH ₃ OH	32.041	0.0846 ^e	11.820 ^e	1.1052 ^e	967.9	768.0	10,259	9,078
27 Ethyl alcohol	C ₂ H ₅ OH	46.067	0.1216 ^e	8.221 ^e	1.5890 ^e	1600.3	1450.5	13,161	11,929
2g Ammonia	NH ₃	17.031	0.0456 ^e	21.914 ^e	0.5961 ^e	441.1	365.1	9,668	8,001
29 Sulfur	S	32.06	—	—	—	—	—	3,983	3,983
30 Hydrogen sulfide	H ₂ S	34.076	0.09109 ^e	10.979 ^e	1.1998 ^e	647	596	7,100	6,545
31 Sulfur dioxide	SO ₂	64.06	0.1733	5.770	2.264	—	—	—	—
32 Water vapor	H ₂ O	18.016	0.04758 ^e	21.017 ^e	0.6215 ^e	—	—	—	—
33 Air	—	26.9	0.07655	13.063	1.0000	—	—	—	—

All gas volumes corrected to 60° F and 30 in. Hg dry. For gases saturated with water at 60° F, 1.73% of the Btu value must be deducted.

^aCalculated from atomic weights given in Journal of the American Chemical Society, February 1937.

^bDensities calculated from values given in gL at 0° C and 760 mmH in the International Critical Tables allowing for the known deviations from the gas laws. Where the coefficient of expansion was not available, the assumed value was taken as 0.0037 per °C. Compare this with 0.003662, which is the coefficient for a perfect gas. Where no densities were available, the volume of the mole was taken as 22.4115L.

^cConverted to mean Btu per lb (1/180 of the heat per lb of water from 32 to 212° F) from data by Frederick D. Rossini, National Bureau of Standards, letter of April 10, 1937, except as noted.

Cu ft per cu ft of combustible						Lb per lb of combustible						Experimental error in heat of combustion (± %)
Required for combustion			Flue products			Required for combustion			Flue products			
O ₂	N ₂	Air	CO ₂	H ₂ O	N ₂	O ₂	N ₂	Air	CO ₂	H ₂ O	N ₂	
—	—	—	—	—	—	2.664	8.863	11.527	3.664	—	8.863	0.012
0.5	1.882	2.382	—	1.0	1.882	7.937	26.407	34.344	—	8.937	26.407	0.015
—	—	—	—	—	—	—	—	—	—	—	—	—
—	—	—	—	—	—	—	—	—	—	—	—	—
0.5	1.882	2.382	1.0	—	1.882	0.571	1.900	2.471	1.571	—	1.900	0.045
—	—	—	—	—	—	—	—	—	—	—	—	—
—	—	—	—	—	—	—	—	—	—	—	—	—
2.0	7.528	9.528	1.0	2.0	7.528	3.990	13.275	17.265	2.744	2.246	13.275	0.033
3.5	13.175	16.675	2.0	3.0	13.175	3.725	12.394	16.119	2.927	1.798	12.394	0.030
5.0	18.821	23.821	3.0	4.0	18.821	3.629	12.074	15.703	2.994	1.634	12.074	0.023
6.5	24.467	30.967	4.0	5.0	24.467	3.579	11.908	15.487	3.029	1.550	11.908	0.022
6.5	24.467	30.967	4.0	5.0	24.467	3.579	11.908	15.487	3.029	1.550	11.908	0.019
8.0	30.114	38.114	5.0	6.0	30.114	3.548	11.805	15.353	3.050	1.498	11.805	0.025
8.0	30.114	38.114	5.0	6.0	30.114	3.548	11.805	15.353	3.050	1.498	11.805	0.071
8.0	30.114	38.114	5.0	6.0	30.114	3.548	11.805	15.353	3.050	1.498	11.805	0.11
9.5	35.760	45.260	6.0	7.0	35.760	3.528	11.738	15.266	3.064	1.464	11.738	0.05
—	—	—	—	—	—	—	—	—	—	—	—	—
—	—	—	—	—	—	—	—	—	—	—	—	—
3.0	11.293	14.293	2.0	2.0	11.293	3.422	11.385	14.807	3.138	1.285	11.385	0.021
4.5	16.939	21.439	3.0	3.0	16.939	3.422	11.385	14.807	3.138	1.285	11.385	0.031
6.0	22.585	28.585	4.0	4.0	22.585	3.422	11.385	14.807	3.138	1.285	11.385	0.031
6.0	22.585	28.585	4.0	4.0	22.585	3.422	11.385	14.807	3.138	1.285	11.385	0.031
7.5	28.232	35.732	5.0	5.0	28.232	3.422	11.385	14.807	3.138	1.285	11.385	0.037
—	—	—	—	—	—	—	—	—	—	—	—	—
7.5	28.232	35.732	6.0	3.0	28.232	3.073	10.224	13.297	3.381	0.692	10.224	0.12
9.0	33.878	32.978	7.0	4.0	33.878	3.126	10.401	13.527	3.344	0.782	10.401	0.21
10.5	39.524	50.024	8.0	5.0	39.524	3.165	10.530	13.695	3.317	0.849	10.530	0.36
—	—	—	—	—	—	—	—	—	—	—	—	—
2.5	9.411	11.911	2.0	1.0	9.411	3.073	10.224	13.297	3.381	0.692	10.224	0.16
12.0	45.170	57.170	10.0	4.0	45.170	2.996	9.968	12.964	3.434	0.562	9.968	—
1.5	5.646	7.146	1.0	2.0	5.646	1.498	4.984	6.482	1.974	1.125	4.984	0.027
3.0	11.293	14.293	2.0	3.0	11.293	2.084	6.934	9.018	1.322	1.170	6.934	0.030
0.75	2.823	3.573	—	1.5	3.323	1.409	4.688	6.097	—	1.587	5.511	0.088
—	—	—	—	—	—	0.998	3.287	4.285	1.998	—	3.287	0.071
—	—	—	SO ₂	—	—	—	—	—	SO ₂	—	—	—
1.5	5.646	7.146	1.0	1.0	5.646	1.409	4.688	6.097	1.880	0.529	4.688	0.30
—	—	—	—	—	—	—	—	—	—	—	—	—
—	—	—	—	—	—	—	—	—	—	—	—	—
—	—	—	—	—	—	—	—	—	—	—	—	—

^dDeduction from gross to net heating value determined by deducting 18,919 Btu/lb mol water in the products of combustion. Osborne, Stimson and Ginnings, Mechanical Engineering, p. 163, March 1935, and Osborne, Stimson, and Flock, National Bureau of Standards Research Paper 209.

^eDenotes that either the density or the coefficient of expansion has been assumed. Some of the materials cannot exist as gases at 60°F and 30 in.Hg pressure, in which case the values are theoretical ones given for ease of calculation of gas problems. Under the actual concentrations in which these materials are present their partial pressure is low enough to keep them as gases.

^fFrom third edition of Combustion.

Adapted from Ref. 8.

6.09a

Q:

Natural gas having $\text{CH}_4 = 83.4\%$, $\text{C}_2\text{H}_6 = 15.8\%$, and $\text{N}_2 = 0.8\%$ by volume is fired in a boiler. Assuming 15% excess air, 70°F ambient temperature, and 80% relative humidity, perform detailed combustion calculations and determine flue gas analysis.

A:

From [Chapter 5](#) we know that air at 70°F and 80% RH has a moisture content of 0.012 lb/lb dry air. [Table 6.3](#) can be used to figure air requirements of various fuels. For example, we see that CH_4 requires 9.53 mol of air per mole of CH_4 , and C_2H_6 requires 16.68 mol.

Let us base our calculations on 100 mol of fuel. The theoretical dry air required will be

$$83.4 \times 9.53 + 16.68 \times 15.8 = 1058.3 \text{ mol}$$

Considering 15% excess,

$$\text{Actual dry air} = 1.15 \times 1058.3 = 1217 \text{ mol}$$

$$\text{Excess air} = 0.15 \times 1058.3 = 158.7 \text{ mol}$$

$$\text{Excess O}_2 = 158.7 \times 0.21 = 33.3 \text{ mol}$$

$$\text{Excess N}_2 = 1217 \times 0.79 = 961 \text{ mol}$$

(Air contains 21% by volume O_2 , and the rest is N_2 .)

$$\text{Moisture in air} = 1217 \times 29 \times \frac{0.012}{18} = 23.5 \text{ mol}$$

(We multiplied moles of air by 29 to get its weight, and then the water quantity was divided by 18 to get moles of water.)

[Table 6.3](#) can also be used to get the moles of CO_2 , H_2O , N_2 and O_2 [3].

$$\text{CO}_2 = 1 \times 83.4 + 2 \times 15.8 = 115 \text{ mol}$$

$$\text{H}_2\text{O} = 2 \times 83.4 + 3 \times 15.8 + 23.5 = 237.7 \text{ mol}$$

$$\text{O}_2 = 33.3 \text{ mol}$$

$$\text{N}_2 = 961 + 0.8 = 961.8 \text{ mol}$$

The total moles of flue gas produced is $115 + 237.7 + 33.3 + 961.8 = 1347.8$.
Hence

$$\% \text{CO}_2 = \frac{115}{1347.8} \times 100 = 8.5$$

Similarly,

$$\% \text{H}_2\text{O} = 17.7, \quad \% \text{O}_2 = 2.5, \quad \% \text{N}_2 = 71.3$$

The analysis above is on a wet basis. On a dry flue gas basis,

$$\%CO_2 = 8.5 \times \frac{100}{100 - 17.7} = 10.3\%$$

Similarly,

$$\%O_2 = 3.0\%, \quad \%N_2 = 86.7\%$$

To obtain w_{da} , w_{wa} , w_{dg} , and w_{wg} , we need the density of the fuel or the molecular weight, which is

$$\frac{1}{100} \times (83.4 \times 16 + 15.8 \times 30 + 0.8 \times 28) = 18.30$$

$$w_{da} = 1217 \times \frac{29}{100 \times 18.3} = 19.29 \text{ lb dry air/lb fuel}$$

$$w_{wa} = 19.29 + \frac{23.5 \times 18}{18.3 \times 100} = 19.52 \text{ lb wet air/lb fuel}$$

$$w_{dg} = \frac{115 \times 44 + 33.3 \times 32 + 961 \times 28}{1830}$$

$$= 18 \text{ lb dry gas/lb fuel}$$

$$w_{wg} = \frac{115 \times 44 + 33.3 \times 32 + 237.7 \times 18 + 961.8 \times 28}{1830}$$

$$= 20.40 \text{ lb wet gas/lb fuel}$$

This procedure can be used when the fuel analysis is given. More often, plant engineers will be required to estimate the air needed for combustion without a fuel analysis. In such situations, the MM Btu basis of combustion and calculations will come in handy. This is discussed in Q6.10a.

6.09b

Q:

For the case stated in Q6.09a, estimate the partial pressure of water vapor, p_w , and of carbon dioxide, p_c , in the flue gas. Also estimate the density of flue gas at 300°F.

A:

The partial pressures of water vapor and carbon dioxide are important in the determination of nonluminous heat transfer coefficients.

$$p_w = \frac{\text{volume of water vapor}}{\text{total flue gas volume}} = 0.177 \text{ atm} = 2.6 \text{ psia}$$

$$p_c = \frac{\text{volume of carbon dioxide}}{\text{total flue gas volume}} = 0.085 \text{ atm} = 1.27 \text{ psia}$$

To estimate the gas density, its molecular weight must be obtained (see Q5.05).

$$\begin{aligned} MW &= \sum(MW_i \times y_i) \\ &= \frac{28 \times 71.3 + 18 \times 17.7 + 32 \times 2.5 + 44 \times 8.5}{100} \\ &= 27.7 \end{aligned}$$

Hence, from Eq. (6),

$$\rho_g = 27.7 \times 492 \times \frac{14.7}{359 \times 760 \times 14.7} = 0.05 \text{ lb/cu ft}$$

The gas pressure was assumed to be 14.7 psia. In the absence of flue gas analysis, we can obtain the density as discussed in Q5.03.

$$\rho_g = \frac{40}{760} = 0.052 \text{ lb/cu ft}$$

6.10a

Q:

Discuss the basis for the million Btu method of combustion calculations.

A:

Each fuel such as natural gas, coal, or oil requires a certain amount of stoichiometric air per MM Btu fired (on HHV basis). This quantity does not vary much with the fuel analysis and has therefore become a valuable method of evaluating combustion air and flue gas quantities produced when fuel gas analysis is not available.

For solid fuels such as coal and oil, the dry stoichiometric air w_{da} in lb/lb fuel can be obtained from

$$w_{da} = 11.53 \times C + 34.34 \times \left(H_2 - \frac{O_2}{8} \right) + 4.29 \times S$$

where C, H₂, O₂, and S are carbon, hydrogen, oxygen, and sulfur in the fuel in fraction by weight.

For gaseous fuels, w_{da} is given by

$$\begin{aligned} w_{da} &= 2.47 \times CO + 34.34 \times H_2 + 17.27 \times CH_4 \\ &\quad + 13.3 \times C_2H_2 + 14.81 \times C_2H_4 \\ &\quad + 16.12 \times C_2H_6 - 4.32 \times O_2 \end{aligned}$$

Example 1

Let us compute the amount of air required per MM Btu fired for fuel oil. $C = 0.875$, $H = 0.125$, and $^{\circ}\text{API} = 28$.

Solution. From (4a),

$$\begin{aligned}\text{HHV} &= 17,887 + 57.5 \times 28 - 102.2 \times 0 \\ &= 19,497 \text{ Btu/lb}\end{aligned}$$

The amount of air in lb/lb fuel from the above equation is

$$\begin{aligned}w_{\text{da}} &= 11.53 \times 0.875 + 34.34 \times 0.125 \\ &= 14.38 \text{ lb/lb fuel}\end{aligned}$$

1 MM Btu of fuel fired requires $(1 \times 10^6)/19,497 = 51.28$ lb of fuel. Hence, from the above, 51.28 lb of fuel requires

$$51.28 \times 14.38 = 737 \text{ lb of dry air}$$

Table 6.4 shows a range of 735–750. To this must be added excess air; the effect of moisture in the air should also be considered.

Example 2

Let us take the case of natural gas with the following analysis: methane = 83.4%, ethane = 15.8%, and nitrogen = 0.8%.

Solution. Converting this to percent weight basis, we have

Fuel	% vol	MW	Col 2 \times col 3	% wt
CH ₄	18.3	16	1334.4	72.89
C ₂ H ₆	15.8	30	474	25.89
N ₂	0.8	28	22.4	1.22

Let us compute the air required in lb/lb fuel.

From Table 6.3,

$$\begin{aligned}\text{Air required} &= 17.265 \times 0.7289 + 16.119 \times 0.2589 \\ &= 16.75 \text{ lb/lb fuel}\end{aligned}$$

$$\begin{aligned}\text{HHV of fuel} &= 0.7289 \times 23,876 + 0.2589 \times 22,320 \\ &= 23,181 \text{ Btu/lb}\end{aligned}$$

where 23,876 and 22,320 are HHV of methane and ethane from Table 6.3.

TABLE 6.4 Combustion Constant *A* For Fuels

No.	Fuel	<i>A</i>
1	Blast furnace gas	575
2	Bagasse	650
3	Carbon monoxide gas	670
4	Refinery and oil gas	720
5	Natural gas	730
6	Furnace oil and lignite	745–750
7	Bituminous coals	760
8	Anthracite	780
9	Coke	800

The amount of fuel equivalent to 1 MM Btu would be $(1 \times 10^6)/23,181 = 43.1$ lb, which requires $43.1 \times 16.75 = 722$ lb of air, or 1 MM Btu fired would need 722 lb of dry air; this is close to the value indicated in Table 6.4.

Let us take the case of 100% methane and see how much air it needs for combustion. From Table 6.3, air required per pound of methane is 17.265 lb, and its heating value is 23,879 Btu/lb. In this case 1 MM Btu is equivalent to $(1 \times 10^6)/23,879 = 41.88$ lb of fuel, which requires $41.88 \times 17.265 = 723$ lb of dry air.

Taking the case of propane, 1 lb requires 15.703 lb of air.

$$1 \text{ MM Btu} = \frac{1 \times 10^6}{21,661} = 46.17 \text{ lb fuel}$$

This would require $46.17 \times 15.703 = 725$ lb of air.

Thus for all fossil fuels we can come up with a good estimate of theoretical dry air per MM Btu fired on HHV basis, and gas analysis does not affect this value significantly. The amount of air per MM Btu is termed *A* and is shown in Table 6.4 for various fuels.

6.10b

Q:

A fired heater is firing natural gas at an input of 75 MM Btu/h on HHV basis. Determine the dry combustion air required at 10% excess air and the amount of fuel gas produced if the HHV of fuel is 20,000 Btu/lb.

A:

From Table 6.4, *A* is 730 lb/MM Btu. Hence the total air required is

$$W_a = 75 \times 1.1 \times 730 = 60,200 \text{ lb/h}$$

The flue gas produced is

$$W_g = W_a + W_f = 60,200 + \frac{10^6}{20,000} = 60,250 \text{ lb/h}$$

These values can be converted to volume rates at any temperature using the procedure described in [Chapter 5](#).

The MM Btu method is quite accurate for engineering purposes such as fan selection and sizing of ducts and air and gas systems. Its advantage is that fuel analysis need not be known, which is generally the case in power and process plants. The efficiency of heaters and boilers can also be estimated using the MM Btu method of combustion calculations.

6.10c

Q:

A coal-fired boiler is firing coal of HHV = 9500 Btu/lb at 25% excess air. If ambient conditions are 80°F, relative humidity 80%, and flue gas temperature 300°F, estimate the combustion air in lb/lb fuel, the volume of combustion air in cu ft/lb fuel, the flue gas produced in lb/lb fuel, and the flue gas volume in cu ft/lb fuel.

A:

Because the fuel analysis is not known, let us use the MM Btu method. From [Table 6.4](#), $A = 760$ for coal. 1 MM Btu requires $760 \times 1.25 = 950$ lb of dry air. At 80% humidity and 80°F, air contains 0.018 lb of moisture per pound of air (Chap. 5). Hence the wet air required per MM Btu fired is 950×1.018 lb. Also, 1 MM Btu fired equals $10^6/9500 = 105$ lb of coal. Hence

$$\begin{aligned} w_{da} &= \text{dry air, lb/lb fuel} = \frac{950}{105} = 9.05 \\ w_{wa} &= \text{wet air, lb/lb fuel} = 950 \times \frac{1.018}{105} = 9.21 \\ \rho_a &= \text{density of air at } 80^\circ\text{F} = 29 \times \frac{492}{359 \times 540} \\ &= 0.0736 \text{ lb/cu ft (see Chap. 5, Q5.03).} \end{aligned}$$

Hence

$$\begin{aligned} \text{Volume of air} &= \frac{9.21}{0.0736} = 125 \text{ cu ft/lb fuel} \\ \rho_g &= \text{density of flue gas} = \frac{40}{760} = 0.0526 \text{ lb/cu ft} \\ w_{dg} &= \text{dry flue gas in lb/lb fuel} = \frac{950 + 105}{105} = 10.05 \\ \text{Volume of flue gas, cu ft/lb fuel} &= \frac{10.05}{0.0526} = 191 \end{aligned}$$

6.11

Q:

Is there a way to figure the excess air from flue gas CO₂ readings?

A:

Yes. A good estimate of excess air E in percent can be obtained from the equation

$$E = 100 \times \left(\frac{K_1}{\%CO_2} - 1 \right) \quad (10a)$$

%CO₂ is the percent of carbon dioxide in dry flue gas by volume, and K_1 is a constant depending on the type of fuel, as seen in Table 6.5. For example, if %CO₂ = 15 in flue gas in a coal-fired boiler, then for bituminous coal ($K_1 = 18.6$),

$$E = 100 \times \left(\frac{18.6}{15} - 1 \right) = 24\%$$

6.12

Q:

Discuss the significance of %CO₂ and %O₂ in flue gases.

A:

Excess air levels in flue gas can be estimated if the %CO₂ and %O₂ in dry flue gas by volume are known. The higher the excess air, the greater the flue gas quantity and the greater the losses. Plant engineers should control excess air levels to help control plant operating costs. The cost of operation with high excess air is discussed in Q6.13.

A formula that is widely used to figure the excess air is [1]

$$E = 100 \times \frac{O_2 - CO/2}{0.264 \times N_2 - (O_2 - CO/2)} \quad (10b)$$

TABLE 6.5 K_1 Factors for Fuels

Fuel type	K_1
Bituminous coals	18.6
Coke	20.5
Oil	15.5
Refinery gas and gas oil	13.4
Natural gas	12.5
Blast furnace gas	25.5

Source: Ref. 1.

where O_2 , CO, and N_2 are the oxygen, carbon monoxide, and nitrogen in dry flue gas, vol%, and E is the excess air, %.

Another formula that is quite accurate is [1]

$$E = K_2 \times \frac{O_2}{21 - O_2} \quad (10c)$$

where K_2 is a constant that depends on the type of fuel (see Table 6.6).

6.13

Q:

In a natural gas boiler of capacity 50 MM Btu/h (HHV basis), the oxygen level in the flue gas is reduced from 3.0% to 2.0%. What is the annual savings in operating costs if fuel costs \$4/MM Btu? The HHV of the fuel is 19,000 Btu/lb. The exit gas temperature is 500°F, and the ambient temperature is 80°F.

A:

The original excess air is $90 \times 3/(21 - 3) = 15\%$ (see Q6.12). The excess air is now

$$E = 90 \times \frac{2.0}{21 - 2} = 9.47\%$$

With 15% excess, the approximate air required (see Q6.10a) is $50 \times 746 \times 1.15 = 42,895$ lb/h.

$$\text{Flue gas} = 42,895 + 50 \times \frac{10^6}{19,000} = 45,256 \text{ lb/h}$$

TABLE 6.6 Constant k_2 Used in Eq. (10c)

Fuel	K_2
Carbon	100
Hydrogen	80
Carbon monoxide	121
Sulfur	100
Methane	90
Oil	94.5
Coal	97
Blast furnace gas	223
Coke oven gas	89.3

Source: Ref. 1.

With 9.47% excess air,

$$\text{Air required} = 50 \times 746 \times 1.0947 = 40,832 \text{ lb/h}$$

$$\begin{aligned} \text{Flue gas produced} &= 40,832 + 50 \times \frac{10^6}{19,000} \\ &= 43,463 \text{ lb/h} \end{aligned}$$

$$\begin{aligned} \text{Reduction in heat loss} &= (45,526 - 43,463) \times 0.25 \times (500 - 80) \\ &= 0.22 \text{ MM Btu/h} \end{aligned}$$

This is equivalent to an annual savings of $0.22 \times 4 \times 300 \times 24 = \6336 . (We assumed 300 days of operation a year.) This could be a significant savings considering the life of the plant. Hence plant engineers should operate the plant realizing the implications of high excess air and high exit gas temperature. Oxygen levels can be continuously monitored and recorded and hooked up to combustion air systems in order to operate the plant more efficiently. (It may be noted that exit gas temperature will also be reduced if excess air is reduced. The calculation above indicates the minimum savings that can be realized.)

6.14

Q:

Fuels are often interchanged in boiler plants because of relative availability and economics. It is desirable, then, to analyze the effect on the performance of the system. Discuss the implications of burning coal of 9800 Btu/lb in a boiler originally intended for 11,400 Btu/lb coal.

A:

Let us assume that the duty does not change and that the efficiency of the unit is not altered. However, the fuel quantity will change. Combustion air required, being a function of MM Btu fired, will not change, but the flue gas produced will increase. Let us prepare a table.

	Coal 1	Coal 2
Fuel HHV, Btu/lb	11,400	9800
Fuel fired per MM Btu (10^6 /HHV)	87	102
Air required per MM Btu (25% excess air)	$760 \times 1.25 = 950$	$760 \times 1.25 = 950$
Flue gas, lb	1037	1052
Ratio of flue gas	1	1.015

We can use the same fans, because the variation in flue gas produced is not significant enough to warrant higher gas pressure drops. We must look into other

aspects, such as the necessity of higher combustion air temperature (due to higher moisture in the fuel), ash concentration, and fouling characteristics of the new fuel. If a different type of fuel is going to be used, say oil, this will be a major change, and the fuel-handling system's burners and furnace design will have to be reviewed. The gas temperature profiles will change owing to radiation characteristics, and absorption of surfaces such as superheaters and economizers will be affected. A discussion with the boiler design engineers will help.

6.15

Q:

What is meant by combustion temperature of fuels? How is it estimated?

A:

The adiabatic combustion temperature is the maximum temperature that can be attained by the products of combustion of fuel and air. However, because of dissociation and radiation losses, this maximum is never attained. Estimation of temperature after dissociation requires solving several equations. For purposes of estimation, we may decrease the adiabatic combustion temperature by 3–5% to obtain the actual combustion temperature.

From an energy balance it can be shown that

$$t_c = \frac{\text{LHV} + A\alpha \times \text{HHV} \times C_{pa} \times (t_a - 80)/10^6}{(1 - \% \text{ash}/100 + A\alpha \times \text{HHV}/10^6) \times C_{pg}} \quad (11)$$

where

LHV, HHV = lower and higher calorific value of fuel, Btu/lb

A = theoretical air required per million Btu fired, lb

α = excess air factor = $1 + E/100$

t_a, t_c = temperature of air and combustion temperature, °F

C_{pa}, C_{pg} = specific heats of air and products of combustion, Btu/lb °F

For example, for fuel oil with combustion air at 300°F, LHV = 17,000 Btu/lb, HHV = 18,000 Btu/lb, $\alpha = 1.15$, and $A = 745$ (see Table 6.4). We have

$$\begin{aligned} t_c &= \frac{17,000 + 745 \times 1.15 \times 18,000 \times 0.25 \times (300 - 80)/10^6}{(1 + 745 \times 1.15 \times 18,000/10^6) \times 0.32} \\ &= 3400^\circ\text{F} \end{aligned}$$

C_{pa} and C_{pg} were taken as 0.25 and 0.32, respectively.

6.16a

Q:

How is the ash concentration in flue gases estimated?

A:

Particulate emission data are needed to size dust collectors for coal-fired boilers. In coal-fired boilers, about 75% of the ash is carried away by the flue gases and 25% drops into the ash pit. The following expression may be derived using the MM Btu method of combustion calculation [5]:

$$C_a = \frac{240,000 \times (\% \text{ ash}/100)}{T \times [7.6 \times 10^{-6} \times \text{HHV} \times (100 + E) + 1 - (\% \text{ ash}/100)]} \quad (12a)$$

where

C_a = ash concentration, grains/cu ft

E = excess air, %

T = gas temperature, °R

HHV = higher heating value, Btu/lb

Example

If coals of HHV = 11,000 Btu/lb having 11% ash are fired in a boiler with 25% excess air and the flue gas temperature is 850°R, determine the ash concentration.

Solution. Substituting into Eq. (12a), we have

$$\begin{aligned} C_a &= \frac{240,000 \times 0.11}{850 \times (7.6 \times 10^{-6} \times 11,000 \times 125 + 1 - 0.11)} \\ &= 2.75 \text{ grains/cu ft} \end{aligned}$$

6.16b

Q:

How do you convert the ash concentration in the flue gas in wt% to grains/acf or grains/scf?

A:

Flue gases from incineration plants or solid fuel boilers contain dust or ash, and often these components are expressed in mass units such as lb/h or wt%, whereas engineers involved in selection of pollution control equipment prefer to work in terms of grains/acf or grains/scf (actual and standard cubic feet). The relationship is

$$C_a = 0.01 \times A \times 7000 \times \rho = 70A \quad (12b)$$

where

ρ = gas density, lb/cu ft = $39.5/(460 + t)$

t = gas temperature, °F

C_a = ash content, grains/acf or grains/scf depending on whether density is computed at actual temperature or at 60°F

A = ash content, wt%

The expression for density is based on atmospheric flue gases having a molecular weight of 28.8 (see Q5.03).

Flue gases contain 1.5 wt% ash. The concentration in grains/acf at 400°F is

$$C_a = 70 \times 1.5 \times \frac{39.5}{860} = 4.8 \text{ grains/acf}$$

and at 60°F,

$$C_a = 70 \times 1.5 \times \frac{39.5}{520} = 7.98 \text{ grains/scf}$$

6.17

Q:

Discuss the importance of the melting point of ash in coal-fired boilers. How is it estimated?

A:

In the design of steam generators and ash removal systems, the ash fusion temperature is considered an important variable. Low ash fusion temperature may cause slagging and result in deposition of molten ash on surfaces such as superheaters and furnaces. The furnace will then absorb less energy, leading to higher furnace exit gas temperatures and overheating of superheaters.

A quick estimate of ash melting temperature in °C can be made using the expression [6]

$$t_m = 19 \times \text{Al}_2\text{O}_3 + 15 \times (\text{SiO}_2 + \text{TiO}_2) \\ + 10 \times (\text{CaO} + \text{MgO}) \\ + 6 \times (\text{Fe}_2\text{O}_3 + \text{Na}_2\text{O} + \text{K}_2\text{O})$$

where t_m is the fusion temperature in °C, and the rest of the terms are percent ash content of oxides of aluminum, silicon, titanium, calcium, magnesium, iron, sodium, and potassium.

Example

Analysis of a given ash indicates the following composition:

$$\begin{aligned} \text{Al}_2\text{O}_3 &= 20\%, & \text{SiO}_2 + \text{TiO}_2 &= 30\% \\ \text{Fe}_2\text{O}_3 + \text{Na}_2\text{O} + \text{K}_2\text{O} &= 20\%, & \text{CaO} + \text{MgO} &= 15\% \end{aligned}$$

Find the fusion temperature.

Solution. Substituting into Eq. (13), we find that $t_m = 1100^\circ\text{C}$.

6.18a

Q:

What is the emission of SO_2 in lb/MM Btu if coals of HHV = 11,000 Btu/lb and having 1.5% sulfur are fired in a boiler?

A:

The following expression gives e , the emission of SO_2 in lb/MM Btu:

$$e = 2 \times 10^4 \frac{S}{\text{HHV}} \quad (14)$$

where S is the percent sulfur in the fuel.

$$e = 2 \times 10^4 \times \frac{1.5}{11,000} = 2.73 \text{ lb/MM Btu}$$

If an SO_2 scrubbing system of 75% efficiency is installed, the exiting SO_2 concentration will be $0.25 \times 2.73 = 0.68$ lb/MM Btu.

6.18b

Q:

What is the SO_2 level in ppm (parts per million) by volume if the coals in Q6.18a are fired with 25% excess air?

A:

We have to estimate the flue gas produced. Using the MM Btu method,

$$w_g = \frac{10^6}{11,000} + 1.25 \times 760 = 1041 \text{ lb/MM Btu}$$

Let the molecular weight be 30, which is a good estimate in the absence of flue gas analysis. Then,

$$\text{Moles of flue gas} = \frac{1041}{30} = 34.7 \text{ per MM Btu fired}$$

$$\begin{aligned} \text{Moles of SO}_2 &= \frac{2.73}{64} \\ &= 0.042 \quad (\text{from Q6.18a and Table 5.1}) \end{aligned}$$

(64 is the molecular weight of SO_2 . Dividing weight by molecular weight gives the moles.)

$$\text{Hence ppm of SO}_2 \text{ in flue gas will be } 0.042 \times 10^6 / 34.7 = 1230 \text{ ppm.}$$

6.18c

Q:

If 5% of the SO_2 gets converted to SO_3 , estimate the ppm of SO_3 in the flue gas.

A:

$$\text{Moles of SO}_3 = 0.05 \times \frac{2.73}{80} = 0.0017 \text{ per MM Btu}$$

Hence

$$\text{ppm by volume of SO}_3 = \frac{0.0017}{34.7} \times 10^6 = 49 \text{ ppm}$$

(80 is the molecular weight of SO_3 .)

6.19a

Q:

How is the efficiency of a boiler or a fired heater determined?

A:

The estimation of the efficiency of a boiler or heater involves computation of several losses such as those due to flue gases leaving the unit, unburned fuel, radiation losses, heat loss due to molten ash, and so on. Readers may refer to the *ASME Power Test Code* [7] for details. Two methods are widely used, one based on the measurement of input and output and the other based on heat losses. The latter is preferred, because it is easy to use.

There are two ways of stating the efficiency, one based on HHV and the other on LHV. As discussed in Q6.01,

$$\eta_{\text{HHV}} \times \text{HHV} = \eta_{\text{LHV}} \times \text{LHV}$$

The various losses are [1], on an HHV basis,

1. Dry gas loss, L_1 :

$$L_1 = 24w_{\text{dg}} \frac{t_g - t_a}{\text{HHV}} \quad (15a)$$

2. Loss due to combustion of hydrogen and moisture in fuel, L_2 :

$$L_2 = (9 \times H_2 + W) \times (1080 + 0.46t_g - t_a) \times \frac{100}{\text{HHV}}$$

3. Loss due to moisture in air, L_3 :

$$L_3 = 46 M w_{\text{da}} \frac{t_g - t_a}{\text{HHV}} \quad (15c)$$

4. Radiation loss, L_4 . The American Boiler Manufacturers Association (ABMA) chart [7] may be referred to to obtain this value. A quick estimate of L_4 is

$$L_4 = 10^{0.62 - 0.42 \log Q} \quad (15d)$$

For Eqs. (15a)–(15d),

w_{dg} = dry flue gas produced, lb/lb fuel

w_{da} = dry air required, lb/lb fuel

H_2, W = hydrogen and moisture in fuel, fraction

M = moisture in air, lb/lb dry air (see Q5.09b)

t_g, t_a = temperatures of flue gas and air, °F

Q = duty in MM Btu/h

5. To losses L_1 – L_4 must be added a margin or unaccounted loss, L_5 . Hence efficiency becomes

$$\eta_{\text{HHV}} = 100 - (L_1 + L_2 + L_3 + L_4 + L_5) \quad (15e)$$

Note that combustion calculations are a prerequisite to efficiency determination. If the fuel analysis is not available, plant engineers can use the MM Btu method to estimate w_{dg} rather easily and then estimate the efficiency (see Q6.20).

The efficiency can also be estimated on LHV basis. The various losses considered are the following.

1. Wet flue gas loss:

$$w_{\text{wg}} C_p \frac{t_g - t_a}{\text{HHV}} \quad (15f)$$

(C_p , gas specific heat, will be in the range of 0.26–0.27 for wet flue gases.)

2. Radiation loss (see Q6.23)
3. Unaccounted loss, margin

Then

$$\eta_{\text{LHV}} = 100 - (\text{sum of the above three losses})$$

One can also convert η_{HHV} to η_{LHV} using Eq. (3b) (see Q6.01).

6.19b

Q:

Coals of HHV = 13,500 Btu/lb and LHV = 12,600 Btu/lb are fired in a boiler with 25% excess air. If the exit gas temperature is 300°F and ambient temperature is 80°F, determine the efficiency on HHV basis and on LHV basis.

A:

From the MM Btu method of combustion calculations, assuming that moisture in air is 0.013 lb/lb dry air,

$$\begin{aligned} w_{\text{wg}} &= \frac{1.013 \times 760 \times 1.25 + 10^6/13,500}{10^6/13,500} \\ &= \frac{1036}{74} = 14.0 \end{aligned}$$

(760 is the constant obtained from Table 6.4.) Hence

$$\begin{aligned} \text{wet flue gas loss} &= 100 \times 14.0 \times 0.26 \\ &\quad \times \frac{300 - 80}{12,600} \\ &= 6.35\% \end{aligned}$$

Let radiation and unaccounted losses be 1.3%. Then

$$\begin{aligned} \eta_{\text{LHV}} &= 100 - (6.35 + 1.3) = 92.34\% \\ \eta_{\text{HHV}} &= 92.34 \times \frac{12,600}{13,500} = 86.18\% \end{aligned}$$

(Radiation losses vary from 0.5% to 1.0% in large boilers and may go up to 2.0% in smaller units. The major loss is the flue gas loss.)

6.19c

Q:

Determine the efficiency of a boiler firing the fuel given in Q6.09a at 15% excess air. Assume radiation loss = 1%, exit gas temperature = 400°F, and ambient temperature = 70°F. Excess air and relative humidity are the same as in Q6.09a (15% and 80%).

A:

Results of combustion calculations are already available.

Dry flue gas = 18 lb/lb fuel

Moisture in air = 19.52 - 19.29 = 0.23 lb/lb fuel

Water vapor formed due to combustion of fuel =
20.4 - 18 - 0.23 = 2.17 lb/lb fuel

$$\text{HHV} = \frac{83.4 \times 1013.2 + 15.8 \times 1792}{100} = 1128 \text{ Btu/cu ft}$$

Fuel density at 60°F = 18.3/379 = 0.483 lb/cu ft, so

$$\text{HHV} = \frac{1128}{0.0483} = 23,364 \text{ Btu/lb}$$

The losses are

1. Dry gas loss,

$$L_1 = 100 \times 18 \times 0.24 \times \frac{400 - 70}{23,364} = 6.1\%$$

2. Loss due to combustion of hydrogen and moisture in fuel,

$$L_2 = 100 \times 2.17 \times \frac{1080 + 0.46 \times 400 - 70}{23,364} \\ = 11.1\%$$

3. Loss due to moisture in air,

$$L_3 = 100 \times 0.23 \times 0.46 \times \frac{400 - 70}{23,364} = 0.15\%$$

4. Radiation loss = 1.0%

5. Unaccounted losses and margin = 0%

$$\text{Total losses} = 6.1 + 11.1 + 0.15 + 1.0 = 18.35\%$$

Hence

$$\text{Efficiency on HHV basis} = 100 - 18.35 = 81.65\%$$

One can convert this to LHV basis after computing the LHV.

6.19d

Q:

How do excess air and boiler exit gas temperature affect the various losses and boiler efficiency?

A:

Table 6.7 shows the results of combustion calculations for various fuels at different excess air levels and boiler exit gas temperatures. It also shows the amount of CO₂ generated per MM Btu fired.

It can be seen that natural gas generates the lowest amount of CO₂.

$$\text{CO}_2/\text{MMBtu, natural, gas} = \frac{10^6}{23,789} \times 19.17 \times \frac{9.06 \times 44}{27.57 \times 100} = 116.5 \text{ lb}$$

TABLE 6.7 Combustion Calculations for Various Fuels

	Gas				Oil				Coal	
	<i>T</i> _{go} , °F	EA, %			<i>T</i> _{go} , °F	EA, %			<i>T</i> _{go} , °F	EA, %
	350	450	350	450	350	450	350	450	450	550
	5	5	15	15	5	5	15	15	25	25
CO ₂	9.06		8.34		12.88		11.82		13.38	
H ₂ O	19.11		17.70		12.37		11.47		7.10	
N ₂	70.93		71.48		73.83		74.19		75.43	
O ₂	0.90		2.48		0.92		2.53		3.94	
SO ₂									0.15	
<i>W</i> _g / <i>W</i> _f	19.17		20.9		16.31		17.77		13.42	
<i>L</i> ₁ , %	4.74	6.44	5.23	7.09	5.13	6.96	5.62	7.63	8.91	11.25
<i>L</i> ₂ , %	0.09	0.12	0.10	0.13	0.09	0.12	0.10	0.14	0.15	0.19
<i>L</i> ₃ , %	10.89	11.32	10.89	11.32	6.63	6.89	6.63	6.89	4.3	4.46
	<i>Gas</i>				<i>Oil</i>				<i>Coal</i>	
	350	450	350	450	350	450	350	450	450	550
	5	5	15	15	5	5	15	15	25	25
<i>L</i> ₄ , %					1.0					
<i>E</i> _n , %	83.2	81.1	82.9	80.5	87.1	85.0	86.7	84.3	85.6	83.0
<i>E</i> _t , %	92.3	89.9	91.7	89.2	92.8	90.0	92.3	89.9	89.0	86.4
MW	27.57		27.66		28.86		28.97		29.64	

Coal (wt%): C = 72.8, H₂ = 4.8, N₂ = 1.5, O₂ = 6.2, S = 2.2, H₂O = 3.5, ash = 9.0; HHV = 13139 Btu/lb; LHV = 12,634 Btu/lb.

Oil (wt%): C = 87.5, H₂ = 12.5, °API = 32; HHV = 19,727 Btu/lb; LHV = 18,512 Btu/lb.

Gas (vol%): CH₄ = 97; C₂H₆ = 2, C₃H₈ = 1; HHV = 23,789 Btu/lb; LHV = 21,462 Btu/lb.

(The above is obtained by converting the volumetric analysis to weight basis using the molecular weights of CO₂ and the flue gas.) For oil, CO₂ generated = 162.4 lb, and for coal, 202.9 lb.

6.20

Q:

A fired heater of duty 100 MM Btu/h (HHV basis) firing No. 6 oil shows the following dry flue gas analysis:

$$\text{CO}_2 = 13.5\%, \quad \text{O}_2 = 2.5\%, \quad \text{N}_2 = 84\%$$

The exit gas temperature and ambient temperature are 300°F and 80°F, respectively. If moisture in air is 0.013 lb/lb dry air, estimate the efficiency of the unit on LHV and HHV basis. LHV = 18,400 Btu/lb and HHV = 19,500 Btu/lb.

A:

Because the fuel analysis is not known, let us estimate the flue gas produced by the MM Btu method. First, compute the excess air, which is

$$E = 94.5 \times \frac{2.5}{21 - 2.5} = 12.8\%$$

The factor 94.5 is from Table 6.6 (see Q6.12). The wet flue gas produced is

$$\frac{745 \times 1.128 \times 1.013}{10^6} + \frac{10^6}{19,500}$$

$$\frac{10^6/19,500}{10^6/19,500}$$

$$= 17.6 \text{ lb/lb fuel}$$

Hence

$$\text{Wet gas loss} = 100 \times 17.6 \times 0.26 \times \frac{300 - 80}{18,400} = 5.47\%$$

The radiation loss on HHV basis can be approximated by Eq. (15d):

$$\text{Radiation loss} = 10^{0.62 - 0.42 \log Q} = 0.60\%$$

$$Q = 100 \text{ MM Btu/h}$$

Let us use 1.0% on LHV basis, although this may be a bit high. Hence the efficiency on LHV basis is $100 - 6.47 = 93.53\%$. The efficiency on HHV basis would be [Eq. (3b)]

$$\eta_{\text{HHV}} \times \text{HHV} = \eta_{\text{LHV}} \times \text{LHV}$$

or

$$\eta_{\text{HHV}} = 95.53 \times \frac{18,400}{19,500} = 88.25$$

Thus, even in the absence of fuel ultimate analysis, the plant personnel can check the efficiency of boilers and heaters based on operating data.

6.21

Q:

How is the loss due to incomplete combustion such as the formation of CO determined?

A:

Efforts must be made by the boiler and burner designers to ensure that complete combustion takes place in the furnace. However, because of various factors such as size of fuel particles, turbulence, and availability of air to fuel and the mixing process, some carbon monoxide will be formed, which means losses. If CO is formed from carbon instead of CO₂, 10,600 Btu/lb is lost. This is the difference between the heat of reaction of the two processes

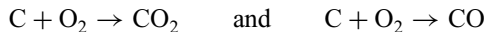

The loss in Btu/lb is given by [1]

$$L = \frac{\text{CO}}{\text{CO} + \text{CO}_2} \times 10,160 \times C$$

where C is the carbon in the fuel, fraction by weight, and CO and CO₂ are vol% of the gases.

Example

Determine the losses due to formation of CO if coal with HHV of 12,000 Btu/lb is fired in a boiler, given that CO and CO₂ in the flue gas are 1.5% and 17% and the fuel has a carbon content of 56%.

Solution. Substituting into the equation given above,

$$L = \frac{1.5}{18.5} \times 10,160 \times \frac{0.56}{12,000} = 0.038$$

or $L = 3.8\%$ on HHV basis (dividing loss in Btu/lb by HHV).

6.22

Q:

Is there a simple formula to estimate the efficiency of boilers and heaters if the excess air and exit gas temperature are known and the fuel analysis is not available?

A:

Boiler efficiency depends mainly on excess air and the difference between the flue gas exit temperature and the ambient temperature. The following expressions have been derived from combustion calculations for typical natural gas and oil fuels. These may be used for quick estimations.

For natural gas:

$$\eta_{\text{HHV}}, \% = 89.4 - (0.001123 + 0.0195 \times \text{EA}) \times \Delta T \quad (16a)$$

$$\eta_{\text{LHV}}, \% = 99.0 - (0.001244 + 0.0216 \times \text{EA}) \times \Delta T \quad (16b)$$

For fuel oils:

$$\eta_{\text{HHV}}, \% = 92.9 - (0.001298 + 0.01905 \times \text{EA}) \times \Delta T$$

$$\eta_{\text{LHV}}, \% = 99.0 - (0.001383 + 0.0203 \times \text{EA}) \times \Delta T$$

where

EA = excess air factor (EA = 1.15 means 15% excess air)

ΔT = difference between exit gas and ambient temperatures

Example

Natural gas at 15% excess air is fired in a boiler, with exit gas temperature 280°F and ambient temperature 80°F. Determine the boiler efficiency. EA = 1.15 and $\Delta T = 280 - 80 = 200^\circ\text{F}$.

Solution.

$$\begin{aligned} \eta_{\text{HHV}} &= 89.4 - (0.001123 + 0.0195 \times 1.15) \\ &\quad \times (280 - 80) = 84.64\% \end{aligned}$$

$$\begin{aligned} \eta_{\text{LHV}} &= 99.0 - (0.001244 + 0.0216 \times 1.15) \\ &\quad \times (280 - 80) = 93.78\% \end{aligned}$$

The above equations are based on 1% radiation plus unaccounted losses.

6.23

Q:

The average surface temperature of the aluminum casing of a gas-fired boiler was measured to be 180°F when the ambient temperature was 85°F and the wind velocity was 5 mph. The boiler was firing 50,000 scfh of natural gas with LHV = 1075 Btu/scf. Determine the radiation loss on LHV basis if the total surface area of the boiler was 2500 ft². Assume that the emissivity of the casing = 0.1.

A:

This example shows how radiation loss can be obtained from the measurement of casing temperatures. The wind velocity is 5 mph = 440 fpm. From Q8.51 we see that the heat loss q in Btu/ft² h will be

$$\begin{aligned} q &= 0.173 \times 10^{-8} \times 0.1 \times [(460 + 180)^4 - (460 + 85)^4] \\ &\quad + 0.296 \times (180 - 85)^{1.25} \times \sqrt{\frac{440 + 69}{69}} \\ &= 252 \text{ Btu/ft}^2 \text{ h} \end{aligned} \quad (17)$$

The total heat loss will be $2500 \times 252 = 0.63 \times 10^6$ Btu/h. The radiation loss on LHV basis will be $0.63 \times 10^6 \times 100 / (50,000 \times 1075) = 1.17\%$. If the HHV of the fuel were 1182 Btu/scf, the radiation loss on HHV basis would be $0.63 \times 1182 / 1075 = 1.06\%$.

6.24

Q:

How does the radiation loss vary with boiler duty or load? How does this affect the boiler efficiency?

A:

The heat losses from the surface of a boiler will be nearly the same at all loads if the ambient temperature and wind velocity are the same. Variations in heat losses can occur owing to differences in the gas temperature profile in the boiler, which varies with load. However, for practical purposes this variation can be considered minor. Hence the heat loss as a percent will increase as the boiler duty decreases.

The boiler exit gas temperature decreases with a decrease in load or duty and contributes to some improvement in efficiency, which is offset by the increase in radiation losses. Hence there will be a slight increase in efficiency as the load increases, and after a certain load, efficiency decreases.

The above discussion pertains to fired water tube or fire tube boilers and not waste heat boilers, which have to be analyzed for each load because the gas flow

and inlet gas temperature can vary significantly with load depending on the type of process or application.

6.25a

Q:

Discuss the importance of dew point corrosion in boilers and heaters fired with fuels containing sulfur.

A:

During the process of combustion, sulfur in fuels such as coal, oil, and gas is converted to sulfur dioxide. Some portion of it (1–5%) is converted to sulfur trioxide, which can combine with water vapor in the flue gas to form gaseous sulfuric acid. If the surface in contact with the gas is cooler than the acid dew point, sulfuric acid can condense on it, causing corrosion. ADP (acid dew point) is dependent on several factors, such as excess air, percent sulfur in fuel, percent conversion of SO_2 to SO_3 , and partial pressure of water vapor in the flue gas. Manufacturers of economizers and air heaters suggest minimum cold-end temperatures that are required to avoid corrosion. Figures 6.1 and 6.2 are typical. Sometimes the minimum fluid temperature, which affects the tube metal temperature, is suggested. The following equation gives a conservative estimate of the acid dew point [8]:

$$T_{\text{dp}} = 1.7842 + 0.0269 \log p_w - 0.129 \log p_{\text{SO}_3} + 0.329 \log p_w \times \log p_{\text{SO}_3} \quad (18a)$$

where

T_{dp} = acid dew point, K
 p_w = partial pressure of water vapor, atm
 p_{SO_3} = partial pressure of sulfur trioxide, atm

Table 6.8 gives typical p_{SO_3} values for various fuels and excess air. Q6.18c shows how ppm SO_3 can be computed from which p_{SO_3} is obtained.

A practical way to determine T_{dp} is to use a dew point meter. An estimation of the cold-end metal temperature can give an indication of possible corrosion.

6.25b

Q:

How is the dew point of an acid gas computed?

A:

Table 6.9 shows the dew point correlations for various acid gases [9,11].

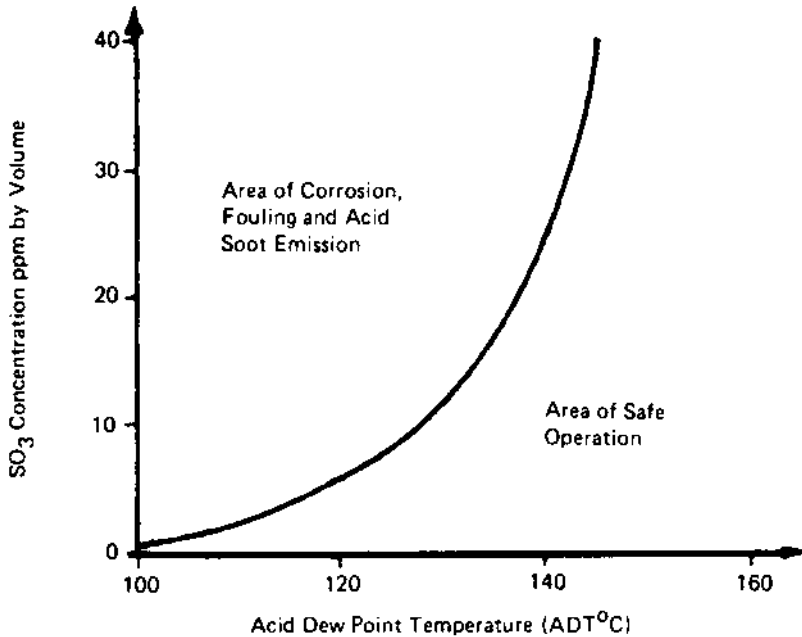

FIGURE 6.1 The relationship between SO₃ and ADT. (Courtesy of Land Combustion Inc.)

Flue gas from an incinerator has the following analysis (vol%): H₂O = 12, SO₂ = 0.02, HCl = 0.0015 and the rest oxygen and nitrogen. Gas pressure = 10 in. wg. Compute the dew points of sulfuric and hydrochloric acids given that 2% of SO₂ converts to SO₃. In order to use the correlations, the gas pressures must be converted to mmHg. Atmospheric pressure = 10 in. wg = 10/407 = 0.02457 atm or 1.02457 atm abs.

$$P_{\text{H}_2\text{O}} = 0.12 \times 1.02457 \times 760 = 93.44 \text{ mmHg}$$

$$\ln P_{\text{H}_2\text{O}} = 4.537$$

$$P_{\text{HCl}} = 0.0015 \times 1.0245 \times 760 = 0.1168 \text{ mmHg}$$

$$\ln P_{\text{HCl}} = -2.1473$$

Partial pressures of sulfuric acid and SO₃ are equal. Hence

$$P_{\text{SO}_3} = 0.02 \times 0.0002 \times 760 \times 1.0245 = 0.0031 \text{ mmHg}$$

$$\ln P_{\text{SO}_3} = -5.7716$$

Substituting into the equations, we obtain the following.

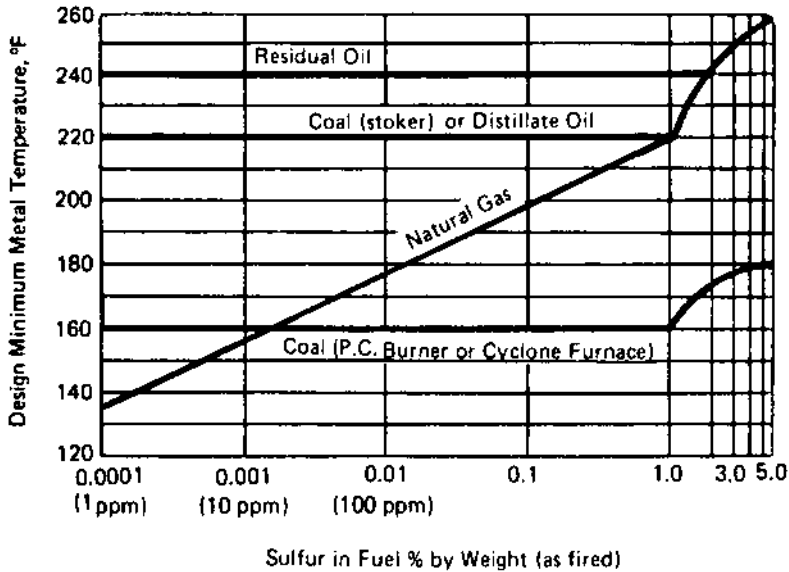

FIGURE 6.2 Limiting tube metal temperatures to avoid external corrosion in economizers and air heaters when burning fuels containing sulfur. (From Ref. 13, with permission.)

For hydrochloric acid:

$$\frac{1000}{T_{dp}} = 3.7368 - 0.1591 \times 4.537 + 0.0326 \times 2.1473 - 0.00269 \times 4.537 \times 2.1473 = 3.0588$$

or

$$T_{dp} = 327 \text{ K} = 54^\circ\text{C} = 129^\circ\text{F}$$

TABLE 6.8 SO₃ in Flue Gas (ppm)

Fuel	Excess air (%)	Sulfur (%)					
		0.5	1.0	2.0	3.0	4.0	5.0
Oil	5	2	3	3	4	5	6
	11	6	7	8	10	12	14
Coal	25	3–7	7–14	14–28	20–40	27–54	33–66

TABLE 6.9 Dew Points of Acid Gases^a

Hydrobromic acid

$$1000/T_{dp} = 3.5639 - 0.1350 \ln P_{H_2O} - 0.0398 \ln P_{HBr} \\ + 0.00235 \ln P_{H_2O} \ln \bar{P}_{HBr}$$

Hydrochloric acid

$$1000/T_{dp} = 3.7368 - 0.1591 \ln P_{H_2O} - 0.0326 \ln P_{HCl} \\ + 0.00269 \ln P_{H_2O} \ln \bar{P}_{HCl}$$

Nitric acid

$$1000/T_{dp} = 3.6614 - 0.1446 \ln P_{H_2O} - 0.0827 \ln P_{HNO_3} \\ + 0.00756 \ln P_{H_2O} \ln \bar{P}_{HNO_3}$$

Sulfurous acid

$$1000/T_{dp} = 3.9526 - 0.1863 \ln P_{H_2O} + 0.000867 \ln P_{SO_2} \\ - 0.000913 \ln P_{H_2O} \ln \bar{P}_{SO_2}$$

Sulfuric acid

$$1000/T_{dp} = 2.276 - 0.0294 \ln P_{H_2O} - 0.0858 \ln P_{H_2SO_4} \\ + 0.0062 \ln P_{H_2O} \ln \bar{P}_{H_2SO_4}$$

^a T_{dp} is dew point temperature (K), and P is partial pressure (mmHg). Compared with published data, the predicted dew points are within about 6 K of actual values except for H_2SO_4 , which is within about 9 K. *Source:* HCl, HBr, HNO_3 and SO_2 correlations were derived from vapor-liquid equilibrium data. The H_2SO_4 correlation is from Ref. 5.

For sulfuric acid:

$$\frac{1000}{T_{dp}} = 2.276 - 0.0294 \times 4.537 + 0.0858 \times 5.7716 \\ - 0.0062 \times 4.537 \times 5.7716 = 2.4755$$

or

$$T_{dp} = 404 \text{ K} = 131^\circ\text{C} = 268^\circ\text{F}$$

The dew points of other gases can be obtained in a similar manner.

6.25c**Q:**

Does the potential for acid dew point corrosion decrease if the gas temperature at the economizer is increased?

A:

Acid dew points were computed in Q6.25a. If the tube wall temperatures can be maintained above the dew point, then condensation of vapors is unlikely. However, the tube wall temperature in a gas-to-liquid heat exchanger such as the economizer is governed by the gas film heat transfer coefficient rather than the tube-side water coefficient, which is very high.

It can be shown by using the electrical analogy and neglecting the effects of fouling that [9]

$$t_m = t_o - (t_o - t_i) \frac{h_i}{h_i + h_o}$$

where

- t_m = tube wall temperature
- t_o = gas- and tube-side fluid temperature
- h_i = tube-side heat transfer coefficient
- h_o = gas-side heat transfer coefficient

In an economizer, h_i is typically about 1000 Btu/ft² h °F and h_o is about 15 Btu/ft² h °F.

Let us assume that water temperature $t_i = 250^\circ\text{F}$ and compute the wall temperature t_m for two gas temperatures, 350°F and 750°F.

$$t_{m1} = 350 - (350 - 250) \frac{1000}{1015} = 252^\circ\text{F}$$

$$t_{m2} = 750 - (750 - 250) \frac{1000}{1015} = 258^\circ\text{F}$$

Hence for a variation of 400°F in gas temperature, the tube wall temperature changes by only 6°F because the gas film heat transfer coefficient is so low compared to the water-side coefficient. Even with finned tubes the difference would be marginal.

We see that if we specify a higher stack gas temperature when selecting or designing an economizer we cannot avoid corrosion concerns if the water temperature is low or close to the acid dew point. A better way is to increase the water temperature entering the economizer by raising the deaerator pressure or by using a heat exchanger to preheat the water.

6.25d**Q:**

Using the correlation given below, evaluate the sulfuric acid dew point.

$$T_{dp} = 203.25 + 27.6 \log P_{\text{H}_2\text{O}} + 10.83 \log P_{\text{SO}_3} + 1.06 (\log P_{\text{SO}_3} + 8)^{2.19}$$

(18b)

The partial pressures are in atmospheres and dew point is in degrees Celsius.

A:

Using the data from Q6.25b [14],

$$P_{\text{SO}_3} = 0.0031 \text{ mmHg} = 4.1 \times 10^{-6} \text{ atm} \quad \log P_{\text{SO}_3} = -5.3872$$

$$P_{\text{H}_2\text{O}} = 93.44 \text{ mmHg} = 0.1229 \text{ atm} \quad \log P_{\text{H}_2\text{O}} = -0.9104$$

$$\begin{aligned} T_{\text{dp}} &= 203.25 - 27.6 \times 0.9104 - 10.83 \times 5.3872 + 1.06 \times (2.6128)^{2.19} \\ &= 128.4^\circ\text{C}, \text{ or } 263^\circ\text{F} \end{aligned}$$

which agrees with the other correlation. However, it should be mentioned that these calculations have some uncertainty, and experience should be taken as the guide.

6.26a

Q:

How do you convert pollutants such as NOx and CO from gas turbine exhaust gases from mass units such as lb/h to ppm?

A:

With strict emission regulations, plant engineers and consultants often find it necessary to relate mass and volumetric units of pollutants such as NOx and CO. In gas turbine cogeneration and combined cycle plants, in addition to the pollutants from the gas turbine itself, one has to consider the contributions from duct burners or auxiliary burners that are added to increase the steam generation from the HRSGs (heat recovery steam generators).

One can easily obtain the total lb/h of NOx or CO in the exhaust gas. However, regulations refer to NOx and CO in ppmvd (parts per million volume dry) referred to 15% oxygen in the gas. The conversion can be done as follows.

If w lb/h is the flow rate of NOx (usually reported as NO₂) in a turbine exhaust flow of W lb/h, the following expression gives NOx in volumetric units on dry basis [9].

$$V = 100 \times \frac{(w/46)/(W/MW)}{100 - \% \text{H}_2\text{O}} \quad (19)$$

where

$\% \text{H}_2\text{O}$ = volume of water vapor

MW = molecular weight of the exhaust gases

The value of V obtained with Eq. (19) must be converted to 15% oxygen on dry basis to give ppmvd of NOx:

$$V_n = \frac{V \times (21 - 15) \times 10^6}{21 - 100 \times \%O_2 / (100 - \%H_2O)} = V \times F \quad (20)$$

where $\%O_2$ is the oxygen present in the wet exhaust gases and factor F converts V to 15% oxygen basis, which is the usual basis of reporting emissions. Similarly, CO emission in ppmvd can be obtained as

$$V_c = 1.642 \times V_n \quad (\text{for the same } w \text{ lb/h rate})$$

because the ratio of the molecular weights of NO₂ and CO is 1.642.

Example

Determine the NOx and CO concentrations in ppmvd, 15% oxygen dry basis if 25 lb/h of NOx and 15 lb/h of CO are present in 550,000 lb/h of turbine exhaust gas that has the following analysis by volume percent (usually argon is added to the nitrogen content):

$$CO_2 = 3.5, \quad H_2O = 10, \quad N_2 = 75, \quad O_2 = 11.5$$

Solution. First,

$$MW = (3.5 \times 44 + 10 \times 18 + 75 \times 28 + 11.5 \times 32) / 100 = 28$$

Let us compute NOx on dry basis in the exhaust.

$$V = \frac{100 \times (25/46)}{(550,000/28)/(100 - 10)} = 0.00003074$$

$$F = \frac{10^6 \times (21 - 15)}{21 - [100/(100 - 10)] \times 11.5} = 0.73 \times 10^6$$

Hence

$$V_n = 0.00003074 \times 0.73 \times 10^6 = 22.4 \text{ ppmvd}$$

Similarly, $V_c = (15/25) \times 1.642 \times 22.4 = 22.0 \text{ ppmvd}$.

6.26b

Q:

How can the emissions due to NOx and CO in fired boilers be converted from ppm to lb/MM Btu or vice versa [10]?

A:

Packaged steam generators firing gas or oil must limit emissions of pollutants in order to meet state and federal regulations. Criteria on emissions of common

pollutants such as carbon monoxide (CO) and oxides of nitrogen (NO_x) are often specified in parts per million volume dry (ppmvd) at 3% oxygen. On the other hand, burner and boiler suppliers often cite or guarantee values in pounds per million Btu fired.

Table 6.10 demonstrates a simple method for calculating the conversion. It should be noted that excess air has little effect on the conversion factor.

Table 6.10 shows the results of combustion calculations for natural gas and No. 2 oil at various excess air levels. The table shows the flue gas analysis, molecular weight, and amount of flue gas produced per million Btu fired on higher heating value (HHV) basis. Using these, we will arrive at the relationship between ppmvd values of NO_x or CO and the corresponding values in lb/MM Btu fired.

Calculations for Natural Gas

From simple mass-to-mole conversions we have

$$V_n = 10^6 \times Y \times \frac{N}{46} \times \frac{MW}{W_{gm}} \times \frac{21 - 3}{21 - O_2 \times Y} \quad (21)$$

where

MW = molecular weight of wet flue gases

N = pounds of NO_x per million Btu fired

O₂ = vol% oxygen in wet flue gases

V_n = parts per million volume dry NO_x

W_{gm} = flue gas produced per MM Btu fired, lb

Y = 100/(100 - %H₂O), where H₂O is the volume of water vapor in wet flue gases

TABLE 6.10 Results of Combustion Calculations (Analysis in vol%)

Component	Percent excess air							
	0	10	20	30	0	10	20	30
	Natural gas ^a				No. 2 Oil ^b			
CO ₂	9.47	8.68	8.02	7.45	13.49	12.33	11.35	10.51
H ₂ O	19.91	18.38	17.08	15.96	12.88	11.90	11.07	10.36
N ₂	70.62	71.22	71.73	72.16	73.63	74.02	74.34	74.62
O ₂	0	1.72	3.18	4.43	0	1.76	3.24	4.50
MW	27.52	27.62	27.68	27.77	28.87	28.85	28.84	28.82
W _{gm}	768	841	914	966	790	864	938	1011

^aNatural gas analysis assumed: C₁ = 97, C₂ = 2, C₃ = 1 vol%. (HHV and LLV = 23,759 and 21,462 Btu/lb, respectively.)

^bNo. 2 oil analysis assumed: C = 87.5%, H₂ = 12.5%; °API = 32. (HHV and LLV = 19,727 and 18,512 Btu/lb, respectively.)

From Table 6.10; for zero excess air:

$$W_{\text{gm}} = (10^6/23,789) \times 18.3 = 769$$

$$Y = 100/(100 - 19.91) = 1.248$$

$$\text{MW} = 27.53, \quad \text{O}_2 = 0$$

Substituting these into Eq. (21) we have

$$V_n = 106 \times 1.248 \times N \times 27.52 \times \frac{18}{46 \times 769 \times 21} = 832 N$$

Similarly, to obtain ppmvd CO (parts per million volume dry CO), one would use 28 instead of 46 in the denominator. Thus the molecular weight of NO_x would be 46 and the calculated molecular weight of CO would be 28.

$$V_e = 1367 \text{ CO}$$

where CO is the pounds of CO per MM Btu fired on higher heating value (HHV) basis.

Now repeat the calculations for 30% excess air:

$$W_{\text{gm}} = 986.6, \quad Y = \frac{100}{100 - 15.96} = 1.189$$

$$\text{MW} = 27.77, \quad \text{O}_2 = 4.43$$

$$V_n = 10^6 \times 1.189 \times \frac{N}{46} \times \frac{27.77}{986.6}$$

$$\times \frac{18}{21 - (4.43 \times 1.189)} = 832N$$

Thus, independent of excess air, we obtain 832 as the conversion factor for NO_x and 1367 for CO.

Similarly, for No. 2 oil and using values from Table 6.10,

$$V_n = 783N \quad \text{and} \quad V_e = 1286 \text{ CO}$$

Example

If a natural gas burner generates 0.1 lb of NO_x per MM Btu fired, then the equivalent would equal $832 \times 0.1 = 83$ ppmvd.

6.26c

Q:

How can the emissions of unburned hydrocarbons (UHCs) be converted from lb/MM Btu to ppmv basis?

A:

Refer to Table 6.10, which shows the results of combustion calculations for oil and gaseous fuels at various excess air levels. We can obtain UHC emissions on ppmv basis if lb/MM Btu values are known.

Let us assume that U is the emission of UHC (treated as methane) in lb/MM Btu in flue gases of natural gas at 20% excess air. Using Eq. (21) for converting from mass to volume units,

$$V_u = \frac{10^6 \times Y \times MW \times (21 - 3)}{16 \times W_{gm} \times (21 - O_2 \times Y)}$$

MW = 16 for UHC and 27.68 for flue gases, water vapor in flue gases = 17.08 vol% at 20% excess air for natural gas, $W_{gm} = 914$ lb/MM Btu, and % oxygen wet = 3.18. Hence,

$$V_u = U \times 10^6 \times \frac{100}{82.92} \times \frac{27.68 \times 18}{16 \times 914 \times (21 - 3.18 \times 100/82.92)} = 2394U \text{ ppmvd}$$

For excess air at 10% excess air, MW = 27.62 for flue gases, water vapor = 18.38 vol%, oxygen wet = 1.72 vol% $W_{gm} = 841$.

$$V_u = U \times 10^6 \times \frac{100}{82.62} \times \frac{27.62 \times 18}{16 \times 841 \times (21 - 1.72 \times 100/82.62)} = 2365U \text{ ppmvd}$$

Hence, if the UHC value is 0.1 lb/MM Btu for natural gas, it is equivalent to about 237 ppmv.

For No. 2 oil at 20% excess air, $W_{gm} = 938$, oxygen = 3.24, MW flue gases = 28.84, water vapor = 11.07 vol%.

$$V_u = U \times 10^6 \times \frac{100}{88.93} \times \frac{28.84 \times 18}{16 \times 938 \times (21 - 3.24 \times 100/88.93)} = 2240U \text{ ppmvd}$$

6.26d**Q:**

Convert SOx values from lb/MM Btu to ppmvd.

A:

Each pound of sulfur in fuel converts to 2 lb of SO₂. Using natural gas at 20% excess air, *S* lb/MM Btu of SO₂ is equivalent to

$$V_s = S \times 10^6 \times \frac{100}{82.92} \times \frac{27.68 \times 18}{64 \times 914 \times (21 - 3.18 \times 100/82.92)}$$

$$= 598S \text{ ppmvd}$$

0.1 lb/MM Btu of SO_x is equivalent to 60 ppmv. [We are simply using Eq. (21) and substituting for MW and *Y*.]

Similarly, for No. 2 oil at 20% excess air;

$$V_s = S \times 10^6 \times \frac{100}{88.93} \times \frac{28.84 \times 18}{64 \times (21 - 3.24 \times 100/82.92)} = 534S \text{ ppmvd}$$

6.26e**Q:**

A gas turbine HRSG has the following data:

Exhaust gas flow = 500,000 lb/h at 900°F

Gas analysis vol%; CO₂ = 3, H₂O = 7, N₂ = 75, O₂ = 15. The exhaust gas has 9 lb/h of NO_x and CO. The HRSG is fired to 1500°F using natural gas consisting of vol% methane = 97, ethane = 2, propane = 1. Fuel input = 90 MM LHV. HHV of fuel = 23,790 Btu/lb, and LHV = 21,439 Btu/lb. The burner contributes 0.05 lb/MM Btu of NO_x and CO. Also see what happens when the burner contributes 0.1 lb/MM Btu of these pollutants. Flue gas analysis after combustion vol% CO₂ = 4.42, H₂O = 9.78, N₂ = 73.91, O₂ = 11.86, and flue gas flow = 504,198 lb/h. Compute the NO_x and CO levels in ppmvd corrected to 15% oxygen before and after the burner.

A:

We have to convert the mass flow of NO_x and CO to volumetric units and correct for 15% oxygen dry basis.

At the burner inlet, using Eqs. (19) and (20),

$$\text{ppmvd NO}_x = \frac{9}{46} \times \frac{100}{93} \times \frac{28.38}{500,000} \times 10^6 \times \frac{21 - 15}{21 - 15 \times 100/93} = 14.7$$

In this example, the molecular weights of NO_x = 46, flue gas = 28.38. The mass of CO remains the same, so ppmvd CO = (46/28) × 14.7 = 24.2.

At the burner exit; the mass of NO_x in the exhaust gases after combustion is

$$9 + 90 \times \frac{23,790}{21,439} \times 0.05 = 14 \text{ lb/h}$$

Because the burner heat input is on LHV basis and emissions are on HHV basis, we correct the values using the above expression.

$$\begin{aligned} \text{ppmvd NOx} &= \frac{14}{46} \times \frac{100}{90.22} \times \frac{28.2}{504,198} \times 10^6 \\ &\quad \times \frac{21 - 15}{21 - 11.86 \times 100/90.22} = 14.4 \\ \text{ppmvd CO} &= (46/28) \times 14 = 23.7 \end{aligned}$$

With 0.1 lb/MM Btu emissions from the burner, NOx ppmvd = 19.5 and CO ppmvd = 32.1. Thus both the burner contribution and the initial pollutant levels in the turbine exhaust gases affect the ppmv values after combustion. ppmvd values after the burner can be lower or higher than the inlet ppmvd values, though in terms of mass flow they will always be higher.

6.26f

Q:

Steam generator emissions are usually referred to 3% oxygen dry basis, and gas turbine or HRSG emissions are referred to 15% oxygen dry basis. However, in operation, different excess air rates are used that generate flue gases with different oxygen levels. What is the procedure for converting from actual to 3% oxygen basis?

A:

$$\text{ppm (@ 3% dry)} = \text{ppm (actual)} \times \frac{21 - 3}{21 - O_2 \text{ (actual)}}$$

If dry oxygen in flue gases is 1.7% and 12 ppm of a pollutant is measured, then at 3% oxygen,

$$\text{Emission} = 12 \times \frac{21 - 3}{21 - 1.7} = 11.2 \text{ ppm}$$

6.27a

Q:

In gas turbine cogeneration and combined cycle projects, the heat recovery steam generator may be fired with auxiliary fuel in order to generate additional steam. One of the frequently asked questions concerns the consumption of oxygen in the exhaust gas versus fuel quantity fired. Would there be sufficient oxygen in the exhaust to raise the exhaust gas to the desired temperature?

A:

Gas turbine exhaust gases typically contain 14–16% oxygen by volume compared to 21% in air. Hence generally there is no need for additional oxygen to fire auxiliary fuel such as gas or oil or even coal while raising its temperature. (If the gas turbine is injected with large amounts of steam, the oxygen content will be lower, and we should refer the analysis to a burner supplier.) Also, if the amount of fuel fired is very large, then we can run out of oxygen in the gas stream. Supplementary firing or auxiliary firing can double or even quadruple the steam generation in the boiler compared to its unfired mode of operation [1]. The energy Q in Btu/h required to raise W_g lb/h of exhaust gases from a temperature of t_1 to t_2 is given by

$$Q = W_g \times (h_2 - h_1)$$

where

h_1, h_2 = enthalpy of the gas at t_1 and t_2 , respectively

The fuel quantity in lb/h is W_f in Q/LHV , where LHV is the lower heating value of the fuel in Btu/lb.

If 0% volume of oxygen is available in the exhaust gases, the equivalent amount of air W_a in the exhaust is [9]

$$W_a = \frac{100 \times W_g \times \text{O} \times 32}{23 \times 100 \times 29.5}$$

In this equation we are merely converting the moles of oxygen from volume to weight basis. A molecular weight of 29.5 is used for the exhaust gases, and 32 for oxygen. The factor 100/23 converts the oxygen to air.

$$W_a = 0.0471 \times W_g \times \text{O} \quad (22)$$

Now let us relate the air required for combustion with fuel fired. From Q5.03–Q.5.05 we know that each MM Btu of fuel fired on HHV basis requires a constant amount A of air. A is 745 for oil and 730 for natural gas; thus, $10^6/\text{HHV}$ lb of fuel requires A lb of air. Hence Q/LHV lb of fuel requires

$$\frac{Q}{\text{LHV}} \times A \times \frac{\text{HHV}}{10^6} \text{ lb air}$$

and this equals W_a from (22).

$$\frac{Q}{\text{LHV}} \times A \times \frac{\text{HHV}}{10^6} = W_a = 0.0471 W_g \times \text{O} \quad (23)$$

or

$$Q = 0.0471 \times W_g \times \text{O} \times 10^6 \times \frac{\text{LHV}}{A \times \text{HHV}} \quad (24)$$

Now for natural gas and fuel oils, it can be shown that $LHV/(A \times HHV) = 0.00124$. Substituting into Eq. (24), we get

$$Q = 58.4 \times W_g \times O \quad (25)$$

This is a very important equation, because it relates the energy input by the fuel (on LHV basis) with oxygen consumed.

Example

It is desired to raise the temperature of 150,000 lb/h of turbine exhaust gases from 950°F to 1575°F in order to double the output of the waste heat boiler. If the exhaust gases contain 15 vol% of oxygen, and the fuel input is 29 MM Btu/h (LHV basis), determine the oxygen consumed.

Solution. From Eq. (24),

$$O = \frac{29 \times 10^6}{150,000 \times 58.4} = 3.32\%$$

Hence if the incoming gases had 15 vol% of oxygen, even after the firing of 29 MM Btu/h we would have $15 - 3.32 = 11.68\%$ oxygen in the exhaust gases.

A more accurate method would be to use a computer program [9], but the above equation clearly tells us if there is likely to be a shortage of oxygen.

6.27b

Q:

150,000 lb/h of turbine exhaust gases at 900°F having a gas analysis (vol%) of $CO_2 = 3$, $H_2O = 7$, $N_2 = 75$ and $O_2 = 15$ enters a duct burner, and 35 MM Btu/h (LHV) of natural gas is fired. Determine the exhaust gas analysis after the burner. Use 100% methane as fuel gas analysis for illustrative purposes.

A:

From Table 6.3, the $LHV = 21,520$ Btu/lb. Hence fuel fired $= 35 \times 10^6 / 21,520 = 1626$ lb/h.

From combustion basics,

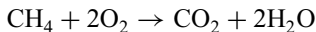

So 16 lb of methane requires 64 lb of oxygen and yields 44 lb of CO_2 and 36 lb of water vapor, using molecular weights of 16 for methane, 32 for oxygen, 44 for carbon dioxide, and 18 for water vapor. Hence 1626 lb/h of methane will consume

$$1626 \times (64/16) = 6504 \text{ lb/h of oxygen}$$

Also, it will increase CO₂ by

$$1626 \times (44/16) = 4471 \text{ lb/h}$$

H₂O will increase by

$$1626 \times (36/16) = 3659 \text{ lb/h}$$

Convert the volume percent in incoming exhaust gases to weight percent basis as follows. The molecular weight of incoming gases is $0.03 \times 44 + 0.07 \times 18 + 0.75 \times 28 + 0.15 \times 32 = 28.38$

$$\text{Fraction by weight of CO}_2 = 0.03 \times 44/28.38 = 0.0465$$

$$\text{H}_2\text{O} = 0.07 \times 18/28.38 = 0.0444$$

$$\text{N}_2 = 75 \times 28/28.38 = 0.74$$

$$\text{O}_2 = 0.15 \times 32/28.38 = 0.1691$$

The amounts of these gases in incoming exhaust gas in lb/h:

$$\text{CO}_2 = 150,000 \times 0.0465 = 6975 \text{ lb/h}$$

$$\text{H}_2\text{O} = 150,000 \times 0.0444 = 6660 \text{ lb/h}$$

$$\text{N}_2 = 150,000 \times 0.74 = 111,000 \text{ lb/h}$$

$$\text{O}_2 = 150,000 \times 0.1691 = 25,365 \text{ lb/h}$$

The final products of combustion will have

$$\text{CO}_2 = 6975 + 4471 = 11,446 \text{ lb/h}$$

$$\text{H}_2\text{O} = 6660 + 3659 = 10,319 \text{ lb/h}$$

$$\text{N}_2 = 111,000$$

$$\text{O}_2 = 25,365 - 6504 = 18,861 \text{ lb/h}$$

$$\begin{aligned} \text{Total exhaust gas flow} &= 11,446 + 10,319 + 111,000 + 18,861 \\ &= 151,626 \text{ lb/h} \end{aligned}$$

which matches the sum of exhaust gas flow and the fuel gas fired.

To convert the final exhaust gas to vol% analysis, we have to obtain the number of moles of each constituent.

$$\text{Moles of CO}_2 = 11,446/44 = 260.1$$

$$\text{H}_2\text{O} = 10,319/18 = 573.2$$

$$\text{N}_2 = 111,000/28 = 3964.3$$

$$\text{O}_2 = 18,861/32 = 589.4$$

$$\text{Total moles} = 5387$$

Hence

$$\text{CO}_2 = 260.1/5387 = 0.0483, \text{ or } 4.83\% \text{ by volume}$$

Similarly,

$$\text{H}_2\text{O} = 573.2/5387 = 0.1064, \text{ or } 10.64 \text{ vol}\%$$

$$\text{N}_2 = 3964.2/5387 = 0.7359, \text{ or } 73.59 \text{ vol}\%$$

$$\text{O}_2 = 589.4/5387 = 0.1094, \text{ or } 10.94 \text{ vol}\%$$

Using Eq. (25), we see that nearly 4% oxygen has been consumed $[(35 \times 10^6)(58.4/150,000) = 4\%]$ or final oxygen = $15 - 4 = 11\%$, which agrees with the detailed calculations.

When possible, detailed combustion calculations should be done because they also reveal the volume percent of water vapor, which has increased from 7% to 10.64%. This would naturally increase the gas specific heat or its enthalpy and affect the heat transfer calculations.

Table 6.11 shows the exhaust gas analysis at various firing temperatures.

6.27c

Q:

Determine the final exhaust gas temperature after combustion in the example in Q6.27b.

A:

To arrive at the final gas temperature, the enthalpy of the exhaust gases must be obtained. A simplistic specific heat assumption can also give an idea of the temperature but will not be accurate.

TABLE 6.11 Effect of Firing Temperature on Exhaust Gas Analysis

	Firing temperature, °F				
	1400	1800	2200	2600	3000
Burner duty, MM Btu/h	22.5	41.83	62.98	86.54	111.1
Total gas flow, lb/h	151,037	151,947	152,935	154,035	155,174
H ₂ O, vol%	9.33	11.29	13.39	15.67	18.00
CO ₂ , vol%	4.19	5.18	6.26	7.42	8.6
O ₂ , vol%	12.38	10.18	7.83	5.27	2.67

150,000 lb/h of exhaust gases at 900°F. Exhaust gas analysis (vol%): CO₂ = 3, H₂O = 7, N₂ = 75, O₂ = 15. Natural gas: C₁ = 97 vol%, C₂ = 3 vol%.

Using, say, 0.3 Btu/lb °F for the average gas specific heat for the temperature range in consideration, the increase in gas temperature is

$$35 \times 10^6 / (150,000 \times 0.3) = 777^\circ\text{F}$$

or

$$\text{Final gas temperature} = 900 + 777 = 1677^\circ\text{F}$$

However, let us use gas enthalpy calculations, which are more accurate. Figure 6.3 shows the gas enthalpy for the turbine exhaust gas at various temperatures. (A program was used to compute these values based on the enthalpy of individual constituents.) Enthalpy of exhaust gas at 900°F = 220 Btu/lb.

From an energy balance across the burner;

$$150,000 \times 220 + 35 \times 10^6 = 151,626 \times h_g$$

where h_g = enthalpy of final products of combustion. $h_g = 448.5$ Btu/lb. From the chart, the gas temperature = 1660°F.

A computer program probably gives more accurate results, because it can compute the gas temperature and enthalpy for any gas analysis and iterate for the actual enthalpy, whereas a chart can be developed only for a given exhaust gas analysis and a maximum firing temperature.

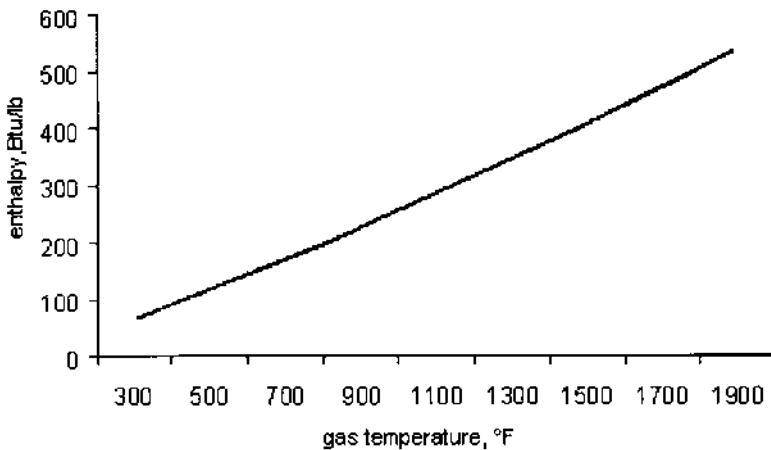

FIGURE 6.3 Enthalpy of turbine exhaust gas as a function of temperature.

6.28

Q:

How can the fuel consumption for power plant equipment such as gas turbines and diesel engines be determined if the heat rates are known?

A:

The heat rate (HR) of gas turbines or engines in Btu/kWh refers indirectly to the efficiency.

$$\text{Efficiency} = \frac{3413}{\text{HR}}$$

where 3413 is the conversion factor from Btu/h to kW. One has to be careful about the basis for the heat rate, whether it is on HHV or LHV basis. The efficiency will be on the same basis.

Example

If the heat rate for a gas turbine is 9000 Btu/kWh on LHV basis and the higher and lower heating values of the fuel are 20,000 and 22,000 Btu/lb, respectively, then

$$\text{Efficiency on LHV basis} = \frac{3413}{9000} = 0.379, \text{ or } 37.9\%$$

To convert this efficiency to HHV basis, simply multiply it by the ratio of the heating values:

$$\text{Efficiency on HHV basis} = 37.9 \times \frac{20,000}{22,000} = 34.45\%$$

NOMENCLATURE

A	Theoretical amount of air for combustion per MM Btu fired, lb
C, CO, CO_2	Carbon, carbon monoxide, and carbon dioxide
C_a	Ash concentration in flue gas, grains/cu ft
C_p	Specific heat, Btu/lb °F
e	Emission rate of sulfur dioxide, lb/MM Btu
E	Excess air, %
EA	Excess air factor
HHV	Higher heating value, Btu/lb or Btu/scf
HR	Heat rate, Btu/kWh
h_i, h_o	Inside and outside heat transfer coefficients, Btu/ft ² h °F
K	Constant used in Eq. (7)
K_1, K_2	Constants used in Eq. (10a) and (10c)

L_1-L_5	Losses in steam generator, %
LHV	Lower heating value, Btu/lb or Btu/scf
MW	Molecular weight
P_c, P_w, P_{H_2O}	Partial pressures of carbon dioxide and water vapor, atm
P_{SO_3}	Partial pressure of sulfur trioxide, atm
P_a, P_s	Actual and standard pressures, psia
ΔP	Differential pressure, psi
q	Heat loss, Btu/ft ² h
Q	Energy, Btu/h or kW
s	Specific gravity
S	Sulfur in fuel
t_a, t_g	Temperatures of air and gas, °F
t_m	Melting point of ash, °C; tube wall temperature, °C
T_{dp}	Acid dew point temperature, K
T_s, T_a	Standard and actual temperatures, °R
V_s, V_a	Standard and actual volumes, cu ft
V_c, V_n	CO and NOx ppmvd
w	Weight of air, lb/lb fuel; subscript da stands for dry air; wa, wet air; wg, wet gas; dg, dry gas
W	Moisture, lb/h
W_a, W_g, W_f	Flow rates of air, gas, and fuel, lb/h
η	Efficiency; subscripts HHV and LHV denote the basis
ρ	Density, lb/cu ft; subscript g stands for gas, f for fuel

REFERENCES

1. V Ganapathy. *Applied Heat Transfer*. Tulsa, OK: PennWell Books, 1982, pp 14–24.
2. *North American Combustion Handbook*. 2nd ed. Cleveland, OH: North American Mfg. Co., 1978, pp 9–40.
3. Babcock and Wilcox. *Steam: Its Generation and Use*. 38th ed. New York, 1978, p 6–2.
4. V Ganapathy, Use chart to estimate furnace parameters. *Hydrocarbon Processing*, Feb 1982, p 106.
5. V Ganapathy. Figure particulate emission rate quickly. *Chemical Engineering*, July 26, 1982, p 82.
6. V Ganapathy. Nomogram estimates melting point of ash. *Power Engineering*, March 1978, p 61.
7. ASME. *Power Test Code*. Performance test code for steam generating units, PTC 4.1. New York: ASME, 1974.
8. V Ganapathy. Estimate combustion gas dewpoint. *Oil and Gas Journal*, April 1978, p 105.
9. V Ganapathy. *Waste Heat Boiler Deskbook*. Atlanta, GA: Fairmont Press, 1991.

10. V Ganapathy. Converting ppm to lb/MM Btu; an easy method. *Power Engineering*, April 1992, p 32.
11. KY Hsiung. Predicting dew points of acid gases. *Chemical Engineering*, Feb 9, 1981, p 127.
12. C Baukal Jr. *The John Zink Combustion Handbook*. Boca Raton, FL: CRC Press, 2001.
13. Babcock and Wilcox, *Steam, its generation and use*, 40th ed. The Babcock and Wilcox Company, Barberton, Ohio, 1992.
14. AG Okkes. Get acid dew point of flue gas. *Hydrocarbon Processing*, July 1987.

7

Fluid Flow, Valve Sizing, and Pressure Drop Calculations

- 7.01 Sizing flow meters; discharge coefficients for orifices, venturis, and nozzles; permanent pressure drop across flow meters; correcting steam flow readings for different operating conditions
- 7.02 Sizing orifices for water flow measurement
- 7.03 Sizing orifices for steam flow measurement
- 7.04 Significance of permanent pressure drop in flow meters; cost of permanent pressure drop across flow meters
- 7.05 Converting pitot tube readings to air velocity, flow in ducts
- 7.06 Sizing safety valves for boilers; ASME Code procedure
- 7.07 Relieving capacities for steam service; orifice designations for safety valves; relating set and accumulated inlet pressures
- 7.08 Selecting safety valves for boiler superheater; actual and required relieving capacities
- 7.09 Relieving capacities of a given safety valve on different gases
- 7.10 Relieving capacity of safety relief valve for liquid service
- 7.11 Determining relieving capacity of a given safety valve on air and steam service
- 7.12 Sizing control valves; valve coefficient C_v
- 7.13 Calculating C_v for steam service; saturated and superheated steam; critical and noncritical flow
- 7.14 Calculating C_v for liquid service

- 7.15 On cavitation: recovery factors
- 7.16 Selecting valves for laminar flow
- 7.17 Calculating pressure loss in water line; determining friction factor for turbulent flow; equivalent length of piping; viscosity of water
- 7.18 Pressure loss in boiler superheater; estimating friction factor in smooth tubes; pressure drop in smooth tubing; Reynolds number for gases
- 7.19 Determining pressure drop under laminar conditions; pressure drop in fuel oil lines; effect of temperature on specific volume, viscosity of oils
- 7.20 Pressure drop for viscous liquids; friction factor under turbulent conditions
- 7.21 Calculating flow in gpm and in lb/h for fuel oils; expansion factors for fuel oils at different temperatures
- 7.22 Pressure loss in natural gas lines using Spitzglass formula
- 7.23 Calculating pressure drop of flue gas and air in ducts; friction factors; equivalent diameter for rectangular ducts; Reynolds number estimation
- 7.24 Determining Reynolds number for superheated steam in tubes; viscosity of steam; Reynolds number for air flowing over tube bundles.
- 7.25 Determining flow in parallel passes of a superheater
- 7.26 Equivalent length of piping system; equivalent length of valves and fittings
- 7.27 Pressure drop of air and flue gases over plain tube bundles; friction factor for in-line and staggered arrangements
- 7.28 Pressure drop of air and flue gases over finned tube bundles
- 7.29 Factors influencing boiler circulation
- 7.30 Purpose of determining circulation ratio
- 7.31 Determining circulation ratio in water tube boilers
- 7.32 Determining circulation ratio in fire tube boilers
- 7.33 Determining steam flow in blowoff lines
- 7.34 Sizing boiler blowdown lines
- 7.35 Stack height and friction losses
- 7.36 Flow instability in evaporators

7.01a

Q:

How are flow meters sized?

A:

The basic equation for pressure differential in head meters (venturis, nozzles, orifices) is [1]

$$W = 359YC_d d_o^2 \frac{\sqrt{h\rho}}{\sqrt{1 - \beta^4}} \quad (1a)$$

where

W = flow of the fluid, lb/h

Y = expansion factor, which allows for changes in density of compressible fluids (for liquids $Y = 1$, and for most gases it varies from 0.92 to 1.0)

C_d = a coefficient of charge

d_o = orifice diameter, in.

ρ = density of fluid, lb/cu ft

β = ratio of orifice to pipe inner diameter = d_o/d_i

h = differential pressure, in. WC

C_d may be taken as 0.61 for orifices and 0.95–0.98 for venturis and nozzles. It is a complicated function of Reynolds number and orifice size. The permanent pressure drop, Δp , across a flow meter is important, because it means loss in power or additional consumption of energy. It is the highest for orifices [2]:

$$\Delta P = h (1 - \beta^2) \quad (1b)$$

For nozzles,

$$\Delta P = h \frac{1 - \beta^2}{1 + \beta^2} \quad (1c)$$

and for venturis it depends on the angle of divergence but varies from 10% to 15% of h . Q7.04 discusses the significance of permanent pressure drop and the cost associated with it.

7.01b

Q:

The differential pressure across an orifice of a steam flow meter shows 180 in. WC when the upstream conditions are 1600 psia and 900°F. The steam flow was calibrated at 80,000 lb/h under these conditions. Because of different plant load requirements, the steam parameters are now 900 psia and 800°F. If the differential pressure is 200 in. WC, what is the steam flow?

A:

From Eq. (1a),

$$W \propto \sqrt{\rho h} \propto \sqrt{\frac{h}{v}}$$

where

W = steam flow, lb/h

v = specific volume, cu ft/lb

h = differential pressure, in. WC

ρ = density, lb/cu ft

From the steam tables (see the Appendix),

$$v_1 = 0.4553 \text{ cu ft/lb at 1600 psia, } 900^\circ\text{F}$$

$$v_2 = 0.7716 \text{ cu ft/lb at 900 psia, } 800^\circ\text{F}$$

$h_1 = 180$, $h_2 = 200$, and $W_1 = 80,000$. We need to find W_2 .

$$\frac{80,000}{W_2} = \sqrt{\frac{180 \times 0.7716}{200 \times 0.4553}} = 1.235$$

Hence $W_2 = 64,770 \text{ lb/h}$.

7.02

Q:

Determine the orifice size to limit the differential pressure to 100 in. WC when 700 lb/s of water at 60°F flows in a pipe of inner diameter 18 in. The density of water is 62.4 lb/cu ft.

A:

Equation (1a) is not handy to use when it is required to solve for the orifice diameter d_o . Hence, by substituting for $\beta = d_o/d_i$ and simplifying, we have

$$W = 359C_d Y d_i^2 \frac{\sqrt{\rho h \beta^2}}{\sqrt{1 - \beta^4}} \quad (2)$$

This equation is easy to use either when orifice size is needed or when flow through a given orifice is required. The term $\beta^2/\sqrt{1 - \beta^4}$ is a function of β and can be looked up from Table 7.1. Substituting for $W = 700 \times 3600$, $C_d = 0.61$, $Y = 1$, $\rho = 62.4$, and $h = 100$, we have

$$700 \times 3600 = 359 \times 0.61 \times 1 \times 18^2 \sqrt{62.4 \times 100} \times F(\beta)$$

or

$$F(\beta) = 0.45$$

From Table 7.1, by interpolation, we note that $\beta = 0.64$. Thus the orifice diameter $d_o = 0.64 \times 18 = 11.5 \text{ in}$.

7.03

Q:

What size of orifice is needed to pass a saturated steam flow of 26,480 lb/h when the upstream pressure is 1000 psia and line size is 2.9 in. and the differential is not to exceed 300 in. WC?

TABLE 7.1 $F(\beta)$ Values for Solving Eq. (2)

β	$F(\beta) = \beta^2 / \sqrt{1 - \beta^4}$
0.3	0.09
0.4	0.162
0.5	0.258
0.6	0.39
0.7	0.562
0.8	0.83

A:

Using Eq. (2) and substituting $Y = 0.95$, $\rho = 1/\nu = 1/0.4456 = 2.24$ lb/cu ft, and $d_i = 2.9$, we have

$$W = 26,480$$

$$= 359 \times 0.61 \times 0.95 \times 2.9^2 \times F(\beta) \times \sqrt{2.24 \times 300}$$

Hence

$$F(\beta) = 0.58$$

From Table 7.1, $\beta = 0.71$. Hence

$$d_o = 0.71 \times 2.9 = 2.03 \text{ in.}$$

7.04

Q:

What is the significance of a permanent pressure drop across the flow measurement device? 1.3 million scfh of natural gas with a specific gravity of 0.62 at 125 psia is metered using an orifice plate with a differential head of 100 in. WC. The line size is 12 in. What are the operating costs involved? Assume that electricity costs 20 mills/kWh.

A:

The first step is to size the orifice. Use a molecular weight of $0.62 \times 29 = 18$ to compute the density. (The molecular weight of any gas = specific gravity \times 29.) From Q5.03

$$\rho = 18 \times 492 \times \frac{125}{359 \times 520 \times 15} = 0.39 \text{ lb/cu ft}$$

(A temperature of 60°F was assumed.) The density at standard conditions of 60°F, 15 psia, is

$$\rho = 18 \times \frac{492}{359 \times 520} = 0.047 \text{ lb/cu ft}$$

Hence mass flow is

$$\begin{aligned} W &= 1.3 \times 10^6 \times 0.047 \\ &= 359 \times 0.61 \times 12^2 \times \sqrt{0.39 \times 100} \times F(\beta) \\ F(\beta) &= 0.31 \end{aligned}$$

From Table 7.1, $\beta = 0.55$, so $\beta^2 = 0.3$. The permanent pressure drop, from Q7.01, is

$$\Delta P = (1 - \beta^2)h = (1 - 0.3) \times 100 = 70 \text{ in. WC}$$

The horsepower consumed in developing this head is

$$\text{HP} = \text{scfh} \times (460 + t) \times \frac{\Delta P}{P \times 10^7} \quad (3)$$

It was assumed in the derivation of Eq. (3) that compressor efficiency was 75%. Substitution yields

$$\text{HP} = 1.3 \times 10^6 \times 520 \times \frac{70}{10^7 \times 125} = 38$$

The annual cost of operation is

$$38 \times 0.746 \times 8000 \times 0.02 = \$4535$$

(8000 hours of operation was assumed per year; 0.746 is the factor converting horsepower to kilowatts.)

7.05

Q:

Often, pitot tubes are used to measure air velocities in ducts in order to compute the air flow. A pitot tube in a duct handling air at 200°F shows a differential of 0.4 in. WC. If the duct cross section is 4 ft², estimate the air velocity and the flow rate.

A:

It can be shown [3] by substituting $\rho = 40/(460 + t)$ that for a pitot,

$$V = 2.85 \times \sqrt{h \times (460 + t)} \quad (4)$$

where

V = velocity, fps

h = differential pressure, in. WC

t = air or flue gas temperature, °F

$$V = 2.85 \times \sqrt{0.4 \times 660} = 46 \text{ fps}$$

The air flow rate in acfm will be $46 \times 4 \times 60 = 11,040$ acfm. The flow W in lb/h = $11,040 \times 60 \times 40/660 = 40,145$ lb/h. [$W = \text{acfm} \times 60 \times \text{density}$, and $\text{density} = 40/(460 + t)$.]

7.06

Q:

How are safety valves for boilers sized?

A:

The ASME Code for boilers and pressure vessels (Secs. 1 and 8) describes the procedure for sizing safety or relief valves. For boilers with 500 ft² or more of heating surface, two or more safety valves must be provided. Boilers with superheaters must have at least one valve on the superheater. The valves on the drum must relieve at least 75% of the total boiler capacity. Superheater valves must relieve at least 20%. Boilers that have reheaters must have at least one safety valve on the reheater outlet capable of handling a minimum of 15% of the flow. The remainder of the flow must be handled by valves at the reheater inlet.

If there are only two valves for a boiler, the capacity of the smaller one must be at least 50% of that of the larger one. The difference between drum pressure and the lowest valve setting may be at least 5% above drum pressure but never more than the design pressure and not less than 10 psi. The range between the lowest boiler valve setting and the highest set value is not to be greater than 10% of the set pressure of the highest set valve. After blowing, each valve is to close at 97% of its set pressure. The highest set boiler valve cannot be set higher than 3% over the design pressure.

The guidelines above are some of those used in selecting safety valves. For details the reader should refer to the ASME Code [4].

7.07

Q:

How are the capacities of safety valves for steam service determined?

A:

The relieving capacities of safety valves are given by the following expressions. ASME Code, Sec. 1 uses a 90% rating, whereas Sec. 8 uses a 100% rating [5].

$$W = 45AP_aK_{sh} \quad (5a)$$

$$W = 50AP_aK_{sh} \quad (5b)$$

where

W = lb/h of steam relieved

A = nozzle or throat area of valve, in.²

P_a = accumulated inlet pressure = $P_s \times (1 + \text{acc}) + 15$, psia (The factor acc is the fraction of pressure accumulation.)

P_s = set pressure, psig

K_{sh} = correction factor for superheat (see Fig. 7.1)

The nozzle areas of standard orifices are specified by letters D to T and are given in Table 7.2. For saturated steam, the degree of superheat is zero, so $K_{sh} = 1$. The boiler safety valves are sized for 3% accumulation.

7.08**Q:**

Determine the sizes of valves to be used on a boiler that has a superheater. The parameters are the following.

Total steam generation = 650,000 lb/h

Design pressure = 1500 psig

Drum operating pressure = 1400 psig

Steam outlet temperature = 950°F

Pressure accumulation = 3%

Superheater outlet operating pressure = 1340 psig

A:

The set pressure must be such that the superheater valve opens before the drum valves. Hence the set pressure can be $1500 - 60 - 40 = 1400$ psig (60 is the pressure drop and 40 is a margin). The inlet pressure $P_a = 1.03 \times 1400 + 15 = 1457$ psia. From Fig. 7.1, $K_{sh} = 0.79$.

$$A = \frac{W}{45K_{sh}P_a} = \frac{130,000}{45 \times 0.79 \times 1457} = 2.51 \text{ in.}^2$$

We used a value of 130,000 lb/h, which is 20% of the total boiler capacity. A K2 orifice is suitable. This relieves $(2.545/2.51) \times 130,000 = 131,550$ lb/h. The drum valves must relieve $650,000 - 131,550 = 518,450$ lb/h. About 260,000 lb/h may be handled by each drum valve if two are used. Let the first

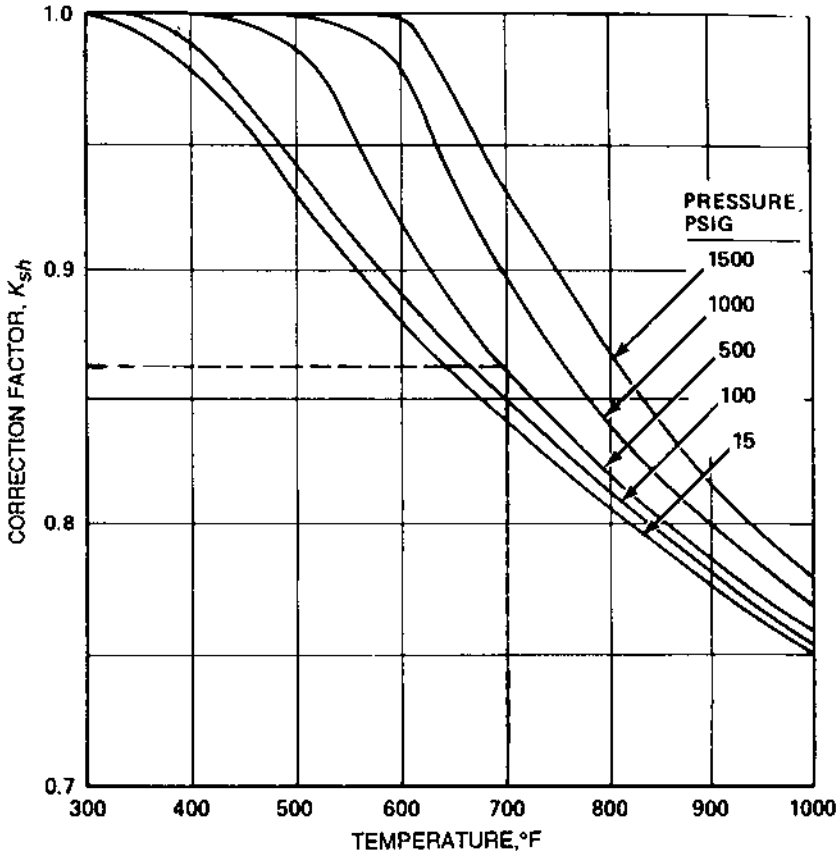

FIGURE 7.1 Correction factors for superheat.

valve be set at 1475 psig, or

$$P_a = 1.03 \times 1475 + 15 = 1535 \text{ psia}$$

and the next at $P_a = 1575$ psia.

$$\text{Area of first valve: } A = \frac{260,000}{45 \times 1535} = 3.76 \text{ in.}^2$$

$$\text{Area of second valve: } A = \frac{260,000}{45 \times 1575} = 3.67 \text{ in.}^2$$

Use two M2 orifices, which each have an area of 3.976 in.^2 . Relieving capacities are

$$\left(\frac{3.976}{3.76} + \frac{3.976}{3.67} \right) \times 260,000 = 556,000 \text{ lb/h}$$

which exceeds our requirement of 520,000 lb/h.

TABLE 7.2 Orifice Designation

Type	Area (in. ²)
D	0.110
E	0.196
F	0.307
G	0.503
H	0.785
J	1.287
K	1.838
K2	2.545
L	2.853
M	3.600
M2	3.976
N	4.340
P	6.380
Q	11.05
R	16.00

7.09a

Q:

How is the relieving capacity of safety valves for gaseous service found?

A:

The expression used for estimating the relieving capacity for gases and vapors [6] is

$$W = CKAP_a \sqrt{\frac{MW}{T}} \quad (6)$$

where

C = a function of the ratio k of specific heats of gases (Table 7.3)

K = valve discharge coefficient, varies from 0.96 to 0.98

P_a = accumulated inlet pressure = $P_s(1 + \text{acc}) + 15$, psia

P_s = set pressure, psig

MW = molecular weight of gas

T = absolute temperature, °R

7.09b

Q:

A safety valve is set for 100 psig for air service at 100°F and uses a G orifice. What is the relieving capacity if it is used on ammonia service at 50°F, pressure being the same?

TABLE 7.3 Constant C for Gas or Vapor Related to Ratio of Specific Heats ($k = C_p/C_v$)

k	Constant C	k	Constant C	k	Constant C
1.00	315	1.26	343	1.52	366
1.02	318	1.28	345	1.54	368
1.04	320	1.30	347	1.56	369
1.06	322	1.32	349	1.58	371
1.08	324	1.34	351	1.60	372
1.10	327	1.36	352	1.62	374
1.12	329	1.38	354	1.64	376
1.14	331	1.40	356	1.66	377
1.16	333	1.42	358	1.68	379
1.18	335	1.44	359	1.70	380
1.20	337	1.46	361	2.00	400
1.22	339	1.48	363	2.20	412
1.24	341	1.50	364		

Source: Ref. 5.

A:

Assume that k is nearly the same for both air and ammonia. Hence for the valve, $CKAP_a$ is a constant. For air, use $C = 356$, $K = 0.98$, $A = 0.503$, $MW = 29$, and $T = 560$.

$$W_a = 356 \times 0.98 \times 0.503 \times (1.1 \times 100 + 15) \sqrt{\frac{29}{560}}$$

$$= 4990 \text{ lb/h}$$

(An acc value of 0.10 was used above.) From Eq. (6), substituting $MW = 17$ and $T = 510$ for ammonia, we have

$$\frac{W_a}{W_{amm}} = \sqrt{\frac{29 \times 510}{17 \times 560}} = 1.246$$

Hence

$$W_{amm} = \frac{4990}{1.246} = 4006 \text{ lb/h}$$

7.10a

Q:

How are the relieving capacities for liquids determined?

A:

An expression for relieving capacity at 25% accumulation [5] is

$$q = 27.2AK_s \sqrt{P_1 - P_b} \quad (7)$$

where

P_1 = set pressure, psig

P_b = backpressure, psig

$K_s = \sqrt{1/s}$, s being the specific gravity

A = orifice area, in.²

q = capacity, gpm

7.10b

Q:

Determine the relieving capacity of a relief valve on an economizer if the set pressure is 300 psig, backpressure is 15 psig, and $s = 1$. The valve has a G orifice ($A = 0.503$ in.²).

A:

Using Eq. (7), we have

$$\begin{aligned} q &= 27.2 \times 0.503 \times 1 \times \sqrt{300 - 15} \\ &= 231 \text{ gpm} \\ &= 231 \times 500 = 115,000 \text{ lb/h} \end{aligned}$$

At 10% accumulation, q would be $0.6 \times 231 = 140$ gpm and the flow $W = 70,000$ lb/h (500 is the conversion factor from gpm to lb/h when $s = 1$.)

7.11

Q:

A safety valve bears a rating of 20,017 lb/h at a set pressure of 450 psig for saturated steam. If the same valve is to be used for air at the same set pressure and at 100°F, what is its relieving capacity?

A:

For a given valve, $CKAP_a$ is a constant if the set pressure is the same. (See Q7.09a for definition of these terms.)

For steam,

$$20,017 = 50 \times KAP_a$$

Hence

$$KAP_a = \frac{20,017}{50} = 400.3$$

For air,

$$W = CKAP_a \sqrt{\frac{MW}{T}}$$

$C = 356$, $MW = 29$, and $T = 560^\circ\text{R}$ for the case of air. Hence,

$$W_a = 356 \times 400.3 \times \sqrt{\frac{29}{560}} = 32,430 \text{ lb/h}$$

Converting to acfm, we have

$$\begin{aligned} q &= 32,430 \times 560 \times \frac{15}{0.081 \times 492 \times 465 \times 60} \\ &= 244 \text{ acfm} \end{aligned}$$

(The density of air was estimated at 465 psia and 100°F .)

7.12

Q:

How is the size of control valves for steam service determined?

A:

Control valves are specified by C_v or valve coefficients. The manufacturers of control valves provide these values (see [Table 7.4](#)). The C_v provided must exceed the C_v required. Also, C_v at several points of possible operation of the valve must be found, and the best C_v characteristics that meet the load requirements must be used, because controllability depends on this. For example, a quick-opening characteristic (see [Fig. 7.2](#)) is desired for on-off service. A linear characteristic is desired for general flow control and liquid-level control systems, whereas equal percentage trim is desired for pressure control or in systems where pressure varies. The control valve supplier must be contacted for the selection and for proper actuator sizing.

For the noncritical flow of steam ($P_1 < 2P_2$) [7],

$$C_v = \frac{W \times [1 + 0.00065 \times (t - t_s)]}{2.11 \times \sqrt{\Delta P \times P_t}} \quad (8)$$

TABLE 7.4 Flow Coefficient C_v

Body size (in.)	Port diameter (in.)	Total travel (in.)	Valve opening (% total travel)										K_m and C_f
			10	20	30	40	50	60	70	80	90	100	
3/4	1/4	3/4	0.075	0.115	0.165	0.230	0.321	0.448	0.625	0.870	1.15	1.47	0.70
	3/8	3/4	0.120	0.190	0.305	0.450	0.628	0.900	1.24	1.68	2.18	2.69	0.80
	1/2	3/4	0.235	0.400	0.600	0.860	1.16	1.65	2.15	2.85	3.40	3.66	0.70
1	1/4	3/4	0.075	0.115	0.165	0.230	0.321	0.448	0.625	0.870	1.20	1.56	0.80
	3/8	3/4	0.120	0.190	0.305	0.450	0.630	0.910	1.35	1.97	2.78	3.68	0.70
	1/2	3/4	0.235	0.410	0.610	0.900	1.26	1.80	2.50	3.45	4.50	5.36	0.70
11/2	3/4	3/4	0.380	0.700	1.10	1.57	2.36	3.40	5.00	6.30	6.67	6.95	0.75
	1/4	3/4	0.075	0.115	0.165	0.230	0.321	0.448	0.625	0.870	1.20	1.56	0.80
	3/8	3/4	0.120	0.190	0.305	0.450	0.630	0.910	1.35	1.97	2.78	3.68	0.70
2	1/2	3/4	0.265	0.420	0.620	0.915	1.31	1.90	2.64	3.65	4.56	6.04	0.80
	3/4	3/4	0.380	0.700	1.10	1.65	2.45	3.70	5.30	7.10	8.88	10.2	0.75
	1	3/4	0.930	1.39	2.12	3.10	4.44	6.12	8.13	10.1	11.5	12.2	0.75
	1/4	3/4	0.075	0.115	0.165	0.230	0.321	0.448	0.625	0.870	1.20	1.56	0.80
	3/8	3/4	0.120	0.190	0.305	0.450	0.630	0.910	1.35	1.97	2.78	3.68	0.70
3	1/2	3/4	0.265	0.420	0.620	0.915	1.31	1.90	2.64	3.65	4.89	6.44	0.70
	3/4	3/4	0.380	0.700	1.10	1.65	2.45	3.70	5.53	8.00	10.3	12.3	0.70
	1	3/4	0.930	1.39	2.12	3.10	4.50	6.45	9.31	12.9	15.7	17.8	0.75
	11/2	3/4	0.957	1.45	2.31	3.70	6.05	9.86	15.2	20.2	22.0	22.0	0.79
	1/4	3/4	0.075	0.115	0.165	0.230	0.321	0.448	0.625	0.870	1.20	1.56	0.80
3	3/8	3/4	0.120	0.190	0.305	0.450	0.630	0.910	1.35	1.97	2.78	3.68	0.70
	1/2	3/4	0.265	0.420	0.620	0.915	1.31	1.90	2.64	3.65	4.89	6.44	0.70
	3/4	3/4	0.380	0.700	1.10	1.65	2.45	3.70	5.70	8.66	12.3	14.8	0.65
	1	3/4	0.930	1.39	2.12	3.10	4.50	6.70	9.90	13.2	17.9	23.6	0.65
	11/2	11/8	1.15	2.29	3.41	4.77	6.44	8.69	12.5	19.2	26.7	32.2	0.74
	2	11/8	1.92	3.13	4.83	7.93	12.6	24.6	35.9	40.5	43.4	44.3	0.72

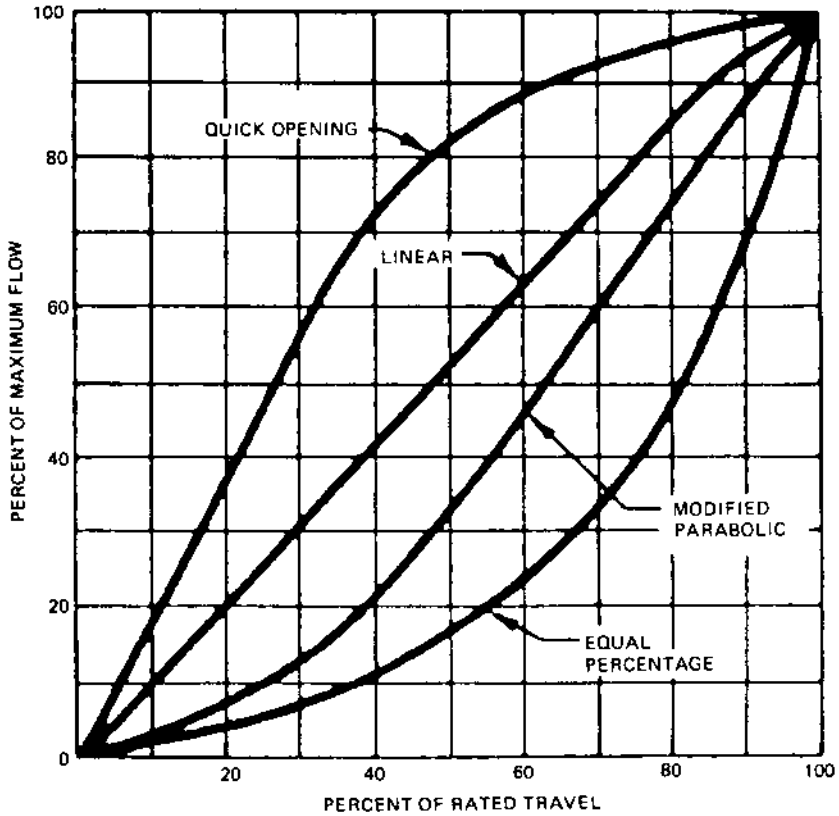

FIGURE 7.2 Typical control valve characteristics.

For critical flow ($P_1 \geq 2P_2$),

$$C_v = \frac{W \times [1 + 0.00065 \times (t - t_s)]}{1.85 \times P_1} \quad (9)$$

where

t, t_s = steam temperature and saturation temperature (for saturated steam,
 $t = t_s$)

W = steam flow, lb/h

P_t = total pressure ($P_1 + P_2$), psia

7.13a

Q:

Estimate the C_v required when 60,000 lb/h of superheated steam at 900°F, 1500 psia flows in a pipe. The allowable pressure drop is 30 psi.

A:

Since this is a case of noncritical flow, from Eq. (8), substituting $t = 800$ and $t_s = 596$, we have

$$\begin{aligned} C_v &= \frac{60,000 \times [1 + 0.00065 \times (900 - 596)]}{2.11 \times \sqrt{30 \times (1500 + 1470)}} \\ &= 114 \end{aligned}$$

If the steam is saturated, $t = t_s$ and $C_v = 95$. We have to choose from the valve supplier's catalog a valve that gives this C_v or more at 90–95% of the opening of the trim. This ensures that the valve is operating at about 90% of the trim opening and provides room for control.

7.13b

Q:

In a pressure-reducing station, 20,000 lb/h of steam at 200 psia, 500°F is to be reduced to 90 psia. Determine C_v .

A:

Use Eq. (9) for critical flow conditions:

$$C_v = \frac{20,000 \times [1 + 0.00065 \times (500 - 382)]}{1.85 \times 200} = 58$$

(382 is the saturation temperature at 200 psia.)

7.14

Q:

Determine the valve coefficient for liquids. A liquid with density 45 lb/cu ft flows at the rate of 100,000 lb/h. If the allowable pressure drop is 50 psi, determine C_v .

A:

The valve coefficient for liquid, C_v , is given by [8]

$$C_v = q \sqrt{\frac{s}{\Delta P}} \quad (10)$$

where

$$\begin{aligned}q &= \text{flow, gpm} \\ \Delta P &= \text{pressure drop, psi} \\ s &= \text{specific gravity}\end{aligned}$$

From Q5.01,

$$\begin{aligned}W &= 8q\rho \\ q &= \frac{100,000}{8 \times 45} = 278 \text{ gpm} \\ s &= \frac{45}{62.4} = 0.72 \\ \Delta P &= 50\end{aligned}$$

Hence

$$C_v = 278 \times \sqrt{\frac{0.72}{50}} = 34$$

7.15

Q:

How is cavitation caused? How is the valve sizing done to consider this aspect?

A:

Flashing and cavitation can limit the flow in a control valve for liquid. The pressure distribution through a valve explains the phenomenon. The pressure at the vena contracta is the lowest, and as the fluid flows it gains pressure but never reaches the upstream pressure. If the pressure at the port or vena contracta should drop below the vapor pressure corresponding to upstream conditions, bubbles will form. If the pressure at the exit remains below the vapor pressure, bubbles remain in the stream and flashing occurs.

A valve has a certain recovery factor associated with it. If the recovery of pressure is high enough to raise the outlet pressure above the vapor pressure of the liquid, the bubbles will collapse or implode, producing cavitation. High-recovery valves tend to be more subject to cavitation [9]. The formation of bubbles tends to limit the flow through the valve. Hence the pressure drop used in sizing the valve should allow for this reduced capacity. Allowable pressure drop ΔP_{all} is used in sizing,

$$\Delta P_{\text{all}} = K_m (P_1 - r_c P_v) \quad (11)$$

where

$$\begin{aligned}K_m &= \text{valve recovery coefficient (depends on valve make)} \\ P_1 &= \text{upstream pressure, psia} \\ r_c &= \text{critical pressure ratio (see Fig. 7.3)} \\ P_v &= \text{vapor pressure at inlet liquid temperature, psia}\end{aligned}$$

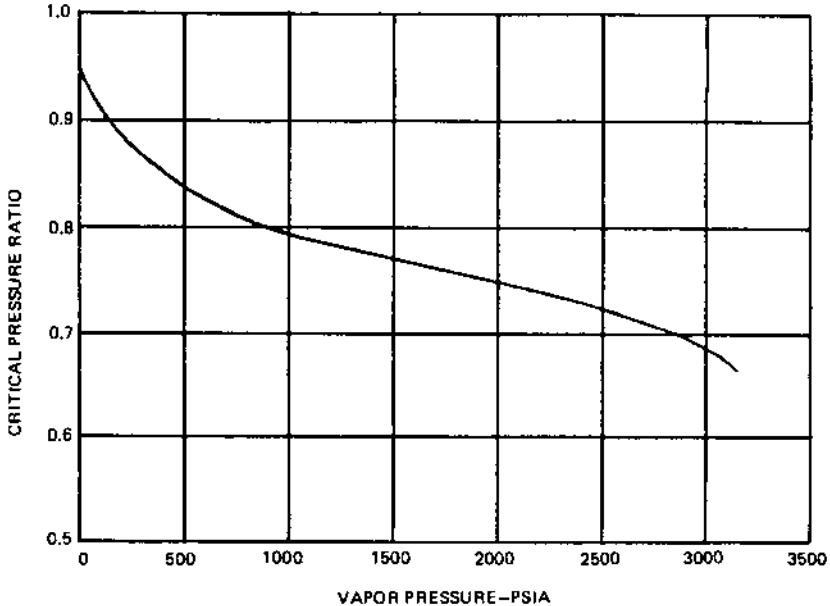

FIGURE 7.3 Critical pressure ratios for water.

Full cavitation will occur if the actual ΔP is greater than ΔP_{all} and if the outlet pressure is higher than the fluid vapor pressure. If the actual ΔP is less than ΔP_{all} , the actual ΔP should be used for valve sizing. To avoid cavitation, select a valve with a low recovery factor (a high K_m factor).

7.16

Q:

How are valves selected for laminar flow and viscous liquids?

A:

Calculate the turbulent flow C_v from Eq. (10) and the laminar C_v from [10]

$$\text{laminar } C_v = 0.072 \times \left(\frac{\mu q}{\Delta P} \right)^{2/3} \quad (12)$$

Use the larger C_v in the valve selection. (μ is the liquid viscosity in centipoise.)

7.17a

Q:

Determine the pressure loss in a 3 in. schedule 80 line carrying water at 100°F and 2000 psia if the total equivalent length is 1000 ft. Flow is 38,000 lb/h.

A:

The expression for turbulent flow pressure drop of fluids (Reynolds number > 2100) is [11]

$$\Delta P = 3.36 \times 10^{-6} \times f W^2 L_e \frac{v}{d_i^5} \quad (13)$$

where

ΔP = pressure loss, psi

f = Darcy friction factor

W = flow, lb/h

L_e = equivalent length, ft (Q7.26 shows how the equivalent length can be computed)

v = specific volume of fluid, cu ft/lb

d_i = tube inner diameter, in.

For water at 100°F and 2000 psia, from [Table A4 \(Appendix 3\)](#), $v = 0.016$. In industrial heat transfer equipment such as boilers, superheaters, economizers, and air heaters, the fluid flow is generally turbulent, and hence we need not check for Reynolds number. (Q7.24 shows how Re can be found.) However, let us quickly check Re here:

$$\text{Re} = 15.2 \frac{W}{d_i \mu} \quad (14)$$

Referring to [Table 7.5](#), water viscosity, μ , at 100°F is 1.645 lb/ft h

$$\text{Re} = 15.2 \times \frac{38,000}{2.9 \times 1.645} = 121,070$$

The inner diameter of 2.9 for the pipe was obtained from [Table 5.6](#). For turbulent flow and carbon or alloy steels of commercial grade, f may be obtained from [Table 7.6](#). Here f for a tube inner diameter of 2.9 in. is 0.0175. Substituting into Eq. (13) yields

$$\Delta P = 3.36 \times 10^{-6} \times 0.0175 \times (38,000)^2 \times 100 \times \frac{0.016}{2.9^5} = 6.6 \text{ psi}$$

TABLE 7.5 Viscosity of Steam and Water (lb_m/h ft)

Temp (°F)	Pressure (psia)											
	1	2	5	10	20	50	100	200	500	1000	2000	5000
1500	0.0996	0.0996	0.0996	0.0996	0.0996	0.0996	0.0996	0.0996	0.1008	0.1008	0.1019	0.1066
1400	0.0938	0.0938	0.0938	0.0938	0.0938	0.0938	0.0952	0.0952	0.0952	0.0961	0.0973	0.1019
1300	0.0892	0.0892	0.0892	0.0892	0.0892	0.0892	0.0892	0.0892	0.0892	0.0903	0.0915	0.0973
1200	0.0834	0.0834	0.0834	0.0834	0.0834	0.0834	0.0834	0.0834	0.0846	0.0846	0.0867	0.0926
1100	0.0776	0.0776	0.0776	0.0776	0.0776	0.0776	0.0776	0.0776	0.0788	0.0799	0.0811	0.0892
1000	0.0730	0.0730	0.0730	0.0730	0.0730	0.0730	0.0730	0.0730	0.0730	0.0741	0.0764	0.0857
900	0.0672	0.0672	0.0672	0.0672	0.0672	0.0672	0.0672	0.0672	0.0683	0.0683	0.0707	0.0846
800	0.0614	0.0614	0.0614	0.0614	0.0614	0.0614	0.0614	0.0614	0.0625	0.0637	0.0660	0.0973
700	0.0556	0.0556	0.0556	0.0556	0.0556	0.0556	0.0568	0.0568	0.0568	0.0579	0.0625	0.171
600	0.0510	0.0510	0.0510	0.0510	0.0510	0.0510	0.0510	0.0510	0.0510	0.0510	0.210	0.221
500	0.0452	0.0452	0.0452	0.0452	0.0452	0.0452	0.0452	0.0440	0.0440	0.250	0.255	0.268
400	0.0394	0.0394	0.0394	0.0394	0.0394	0.0394	0.0394	0.0382	0.317	0.320	0.323	0.335
300	0.0336	0.0336	0.0336	0.0336	0.0336	0.0336	0.441	0.442	0.444	0.445	0.448	0.460
250	0.0313	0.0313	0.0313	0.0313	0.0313	0.551	0.551	0.551	0.552	0.554	0.558	0.569
200	0.0290	0.0290	0.0290	0.0290	0.725	0.725	0.725	0.726	0.729	0.729	0.732	0.741
150	0.0255	0.0255	1.032	1.032	1.032	1.032	1.032	1.032	1.033	1.034	1.037	1.044
100	1.645	1.645	1.645	1.645	1.645	1.645	1.645	1.645	1.645	1.646	1.646	1.648
50	3.144	3.144	3.144	3.144	3.144	3.144	3.144	3.142	3.141	3.139	3.134	3.119
32	4.240	4.240	4.240	4.240	4.240	4.240	4.240	4.239	4.236	4.231	4.222	4.192

TABLE 7.6 Tube Diameter Versus Friction Factor (Darcy) for Turbulent Flow

d_i (in.)	f
0.5	0.028
0.75	0.0245
1.0	0.0230
1.5	0.0210
2.0	0.0195
2.5	0.0180
3.0	0.0175
4.0	0.0165
5.0	0.0160
8.0	0.0140
10.0	0.013

7.17b

Q:

Estimate the pressure drop in a superheater of a boiler that has an equivalent length of 200 ft. The tube inner diameter is 2.0 in., the flow per pass is 8000 lb/h, the steam pressure is 800 psia, and the temperature is 700°F.

A:

Using Eq. (13) and substituting $v = 0.78$ cu ft/lb and $f = 0.0195$ for turbulent flow from Table 7.6 (generally flow in superheaters, economizers, and piping would be turbulent), we obtain

$$\Delta P = 3.36 \times 10^{-6} \times 0.0195 \times 200 \times 8000^2 \times \frac{0.78}{2^5} = 21 \text{ psi}$$

7.18a

Q:

How does the friction factor depend on pipe roughness?

A:

For smooth tubes such as copper and other heat exchanger tubes, f is given by [12]

$$f = 0.133 \times \text{Re}^{-0.174} \tag{15}$$

Substituting this into Eq. (13) gives us

$$\frac{\Delta P}{L_e} = 0.0267 \rho^{0.8267} \mu^{0.174} \frac{V^{1.826}}{d_i^{1.174}} \quad (16)$$

(μ is the viscosity, lb/ft h; V is the velocity, fps.)

7.18b

Q:

Determine the pressure drop per 100 ft in a drawn copper tube of inner diameter 1.0 in. when 250 lb/h of air at a pressure of 30 psig and at 100°F flows through it.

A:

Calculate the density (see Chap. 5):

$$\rho = 29 \times 492 \times \frac{45}{359 \times 560 \times 15} = 0.213 \text{ lb/cu ft}$$

The effect of pressure can be neglected in the estimation of viscosity of gases up to 40 psig. For a detailed computation of viscosity as a function of pressure, readers may refer to Ref. 11. From Table 7.7, $\mu = 0.047$ lb/ft h. The velocity is

$$V = 250 \times \frac{576}{3600 \times 3.14 \times 0.213} = 60 \text{ fps}$$

$$\frac{\Delta P}{100} = 0.0267 \times 0.213^{0.8267} \times 0.047^{0.174} \times \frac{60^{1.826}}{1} = 7.7 \text{ psi}$$

TABLE 7.7 Viscosity of Air

Temperature (°F)	Viscosity (lb/ft h)
100	0.0459
200	0.0520
400	0.062
600	0.0772
800	0.0806
1000	0.0884
1200	0.0957
1400	0.1027
1600	0.1100
1800	0.1512

7.19a

Q:

Derive the expression for ΔP for laminar flow of fluids.

A:

For laminar flow of fluids in pipes such as that occurring with oils, the friction factor is

$$f = \frac{64}{\text{Re}} \quad (17a)$$

Substituting into Eq. (13) and using Eq. (14) gives us

$$\begin{aligned} \Delta P &= 3.36 \times 10^{-6} \times 64 \times d_i \mu W^2 \frac{L_e \times v}{15.2 \times W d_i^5} \\ &= 14.4 \times 10^{-6} \times W \times L_e \times \frac{v \mu}{d_i^4} \end{aligned} \quad (17b)$$

Converting lb/h to gph (gallons per hour), we can rewrite this as

$$\Delta P = 4.5 \times 10^{-6} \times L_e \times \text{cS} \times s \times \frac{\text{gph}}{d_i^4} \quad (18)$$

where

cS = viscosity, centistokes
s = specific gravity

Equation (18) is convenient for calculations for oil flow situations.

7.19b

Q:

Estimate the pressure drop per 100 ft in an oil line when the oil has a specific gravity of 16°API and is at 180°F. The line size is 1.0 in., and the flow is 7000 lb/h.

A:

We must estimate Re. To do this we need the viscosity [13] in centistokes:

$$\text{cS} = 0.226 \text{ SSU} - \frac{195}{\text{SSU}} \quad \text{for SSU } 32\text{--}100 \quad (19)$$

$$\text{cS} = 0.220 \text{ SSU} - \frac{135}{\text{SSU}} \quad \text{for SSU } > 100 \quad (20)$$

SSU represents the Saybolt seconds, a measure of viscosity. Also, $\text{cS} \times s = \text{cP}$, where cP is the viscosity in centipoise, and $0.413 \text{ cP} = 1 \text{ lb/ft h}$.

The specific gravity is to be found. At 180°F, from Eq. (23) (see Q7.21) it can be shown that the specific volume at 180°F is 0.0176 cu ft/lb. Then

$$s = \frac{1}{0.0176 \times 62.4} = 0.91$$

Hence $cP = 0.91 \times 24.83$, where

$$cS = 0.22 \times 118 - \frac{135}{118} = 24.83$$

and

$$\begin{aligned}\mu &= 2.42 \times 0.91 \times 24.83 = 54.6 \text{ lb/ft h} \\ \text{Re} &= 15.2 \times \frac{7000}{0.91 \times 24.83 \times 2.42} = 1948\end{aligned}$$

(2.42 was used to convert cP to lb/ft h.) From Eq. (17a),

$$f = \frac{64}{1948} = 0.0328$$

Substituting into Eq. (17b) yields

$$\Delta P = 14 \times 10^{-6} \times 54.6 \times 7000 \times 100 \times \frac{1}{0.91 \times 62.4} = 9.42 \text{ psi}$$

7.20a

Q:

For viscous fluids in turbulent flow, how is the pressure drop determined?

A:

For viscous fluids, the following expression can be used for the friction factor:

$$f = \frac{0.316}{\text{Re}^{0.22}} \quad (21)$$

Substituting into Eq. (13) gives us

$$\begin{aligned}\Delta P &= 3.36 \times 10^{-6} \times 0.361 \times (d_i \mu)^{0.22} L_e W^2 \times \frac{v}{(15.2W)^{0.22} d_i^5} \\ &= 0.58 \times 10^{-6} \times \mu^{0.22} W^{1.78} L_e \times \frac{v}{d_i^{4.78}}\end{aligned} \quad (22)$$

7.20b

Q:

A fuel oil system delivers 4500 lb/h of light oil at 70°F in a pipe. What is the flow that can be delivered at 30°F, assuming that $\mu_{70}/\mu_{30} = 0.5$, $v_{70}/v_{30} = 0.95$, and flow is turbulent?

A:

Using Eq. (22), we have

$$v_1 W_1^{1.78} \mu_1^{0.22} = v_2 W_2^{1.78} \mu_2^{0.22}$$
$$4500^{1.78} \times 0.5^{0.22} \times 0.95 = W_2^{1.78}$$

or

$$W_2 = 4013 \text{ lb/h}$$

7.21

Q:

What is the flow in gpm if 1000 lb/h of an oil of specific gravity (60/60°F) = 0.91 flows in a pipe at 60°F and at 168°F?

A:

We need to know the density at 60°F and at 168°F.

At 60°F:

$$\text{Density} = \rho = 0.91 \times 62.4 = 56.78 \text{ lb/cu ft}$$

$$v_{60} = \frac{1}{56.78} = 0.0176 \text{ cu ft/lb}$$

Hence at 60°F,

$$q = \frac{1000}{60 \times 56.78} = 0.293 \text{ cu ft/min (cfm)}$$
$$= 0.293 \times 7.48 = 2.2 \text{ gpm}$$

At 168°F, the specific volume of fuel oils increases with temperature:

$$v_t = v_{60}[1 + E(t - 60)] \quad (23)$$

where E is the coefficient of expansion as given in [Table 7.8](#) [13]. For this fuel oil, $E = 0.0004$. Hence,

$$v_{168} = 0.0176 \times (1 + 0.0004 \times 108) = 0.01836 \text{ cu ft/lb}$$

TABLE 7.8 Expansion Factor for Fuel Oils

$^{\circ}API$	E
14.9	0.00035
15–34.9	0.00040
35–50.9	0.00050
51–63.9	0.00060
64–78.9	0.00070
79–88.9	0.00080
89–93.9	0.00085
94–100	0.00090

Hence

$$\begin{aligned}
 q_{168} &= 1000 \times \frac{0.01836}{60} \\
 &= 0.306 \text{ cfm} = 0.306 \times 7.48 \\
 &= 2.29 \text{ gpm}
 \end{aligned}$$

7.22

Q:

How is the pressure loss in natural gas lines determined? Determine the line size to limit the gas pressure drop to 20 psi when 20,000 scfh of natural gas of specific gravity 0.7 flows with a source pressure of 80 psig. The length of the pipeline is 150 ft.

A:

The Spitzglass formula is widely used for compressible fluids [13]:

$$q = 3410 \times F \sqrt{\frac{P_1^2 - P_2^2}{sL}} \quad (24)$$

where

q = gas flow, scfh

s = gas specific gravity

P_1, P_2 = gas inlet and exit pressures, psia

F = a function of pipe inner diameter (see Table 7.9)

L = length of pipeline, ft

Substituting, we have

$$20,000 = 3410 \times F \sqrt{\frac{95^2 - 75^2}{0.7 \times 150}}$$

Hence $F = 1.03$. From Table 7.9 we see that d should be $1\frac{1}{4}$ in. Choosing the next higher standard F or d limits the pressure drop to desired values. Alternatively, if q , d , L , and P_1 are given, P_2 can be found.

7.23

Q:

Determine the pressure loss in a rectangular duct 2 ft \times 2.5 ft in cross section if 25,000 lb/h of flue gases at 300°F flow through it. The equivalent length is 1000 ft.

TABLE 7.9 Standard Steel Pipe^a Data (Black, Galvanized, Welded, and Seamless)

Nominal pipe size [in. (mm)]	Schedule ^b	Outside diameter [in. (mm)]	Inside diameter (in.)	Wall thickness (in.)	Functions of inside diameter, ^c F (in.)
1/8 (6)	40	0.405 (10.2)	0.269	0.068	0.00989
1/4 (8)	40	0.540 (13.6)	0.364	0.088	0.0242
3/8 (10)	40	0.675 (17.1)	0.493	0.091	0.0592
1/2 (15)	40	0.840 (21.4)	0.622	0.109	0.117
3/4 (20)	40	1.050 (26.9)	0.824	0.113	0.265
1 (25)	40	1.315 (33.8)	1.049	0.113	0.533
1 1/4 (32)	40	1.660 (42.4)	1.380	0.140	1.17
1 1/2 (40)	40	1.900 (48.4)	1.610	0.145	1.82
2 (50)	40	2.375 (60.2)	2.067	0.154	3.67
2 1/2 (65)	40	2.875 (76.0)	2.469	0.203	6.02
3 (80)	40	3.500 (88.8)	3.068	0.216	11.0
4 (100)	40	4.500 (114.0)	4.026	0.237	22.9
5 (125)	40	5.563 (139.6)	5.047	0.258	41.9
6 (150)	40	6.625 (165.2)	6.065	0.280	68.0
8 (200)	40	8.625 (219.1)	7.981	0.322	138
8 (200)	30	8.625	8.071	0.277	142
10 (250)	40	10.75 (273.0)	10.020	0.365	247
10 (250)	30	10.75	10.136	0.307	254
12 (300)	40	12.75 (323.9)	11.938	0.406	382
12 (300)	30	12.75	12.090	0.330	395

^a ASTM A53-68, standard pipe.

^b Schedule numbers are approx. values of $1000 \times \frac{\text{maximum internal service pressure, psig}}{\text{allowable stress in material, psi}}$

^c $F = \sqrt{d(1 + 0.03d + 3.6/d)}$ for use in Spitzglass formula = 5/23 for gas line pressure loss.

Source: Adapted from Ref. 13.

A:

The equivalent diameter of a rectangular duct is given by

$$\begin{aligned} d_i &= 2 \times a \times \frac{b}{a+b} = 2 \times 2 \times \frac{2.5}{4.5} \\ &= 2.22 \text{ ft} = 26.64 \text{ in.} \end{aligned}$$

The friction factor f in turbulent flow region for flow in ducts and pipes is given by [11]

$$f = \frac{0.316}{\text{Re}^{0.25}} \quad (25)$$

We make use of the equivalent diameter calculated earlier [Eq. (14)] while computing Re:

$$\text{Re} = 15.2 \frac{W}{d_i \mu}$$

From Table 7.7 at 300°F, $\mu = 0.05 \text{ lb/ft h}$.

$$\text{Re} = 15.2 \times \frac{25,000}{26.64 \times 0.05} = 285,285$$

Hence

$$f = \frac{0.316}{285,285^{0.25}} = 0.014$$

For air or flue gases, pressure loss is generally expressed in inches of water column and not in psi. The following equation gives ΔP_g [11]:

$$\Delta P_g = 93 \times 10^{-6} \times f W^2 v \frac{L_e}{d^5} \quad (26)$$

where d_i is in inches and the specific volume is $v = 1/\rho$.

$$\rho = \frac{40}{460 + 300} = 0.526 \text{ lb/cu ft}$$

Hence

$$v = \frac{1}{0.526} = 19 \text{ cu ft/lb}$$

Substituting into Eq. (26), we have

$$\Delta P_g = 93 \times 10^{-6} \times 0.014 \times 25,000^2 \times 19 \times \frac{1000}{(26.64)^5} = 1.16 \text{ in. WC}$$

7.24a

Q:

Determine the Reynolds number when 500,000 lb/h of superheated steam at 1600 psig and 750°F flows through a pipe of inner diameter 10 in.

A:

The viscosity of superheated steam does not vary as much with pressure as it does with temperature (see [Table 7.5](#)).

$$\mu = 0.062 \text{ lb/ft h}$$

Using Eq. (14), we have

$$\begin{aligned} \text{Re} &= 15.2 \times \frac{W}{d_i \mu} = 15.2 \times \frac{500,000}{10 \times 0.062} \\ &= 1.25 \times 10^7 \end{aligned}$$

7.24b

Q:

Determine the Reynolds number when hot air flows over a tube bundle.

$$\text{Air mass velocity} = 7000 \text{ lb/ft}^2 \text{ h}$$

$$\text{Temperature of air film} = 800^\circ\text{F}$$

$$\text{Tube size} = 2 \text{ in. OD}$$

$$\text{Transverse pitch} = 4.0 \text{ in.}$$

A:

The Reynolds number when gas or fluids flow over tube bundles is given by the expression

$$\text{Re} = \frac{Gd}{12\mu} \tag{27}$$

where

$$G = \text{fluid mass velocity, lb/ft}^2 \text{ h}$$

$$d = \text{tube outer diameter, in.}$$

$$\mu = \text{gas viscosity, lb/ft h}$$

At 800°F, the air viscosity from [Table 7.7](#) is 0.08 lb/ft h; thus

$$\text{Re} = 7000 \times \frac{2}{12 \times 0.08} = 14,580$$

7.25

Q:

There are three tubes connected between two headers of a super heater, and it is required to determine the flow in each parallel pass. The table gives the details of each pass.

Tube no. (pass no.)	Inner diameter (in.)	Equivalent length (ft)
1	2.0	400
2	1.75	350
3	2.0	370

Total steam flow is 15,000 lb/h, and average steam conditions are 800 psia and 750°F.

A:

Because the passes are connected between the same headers, the pressure drop in each will be the same. Also, the total steam flow will be equal to the sum of the flow in each. That is,

$$\Delta P_1 = \Delta P_2 = \Delta P_3$$

In other words, using the pressure drop correlation, we have

$$W_1^2 f_1 \frac{L_{e1}}{d_{i1}^5} = W_2^2 f_2 \frac{L_{e2}}{d_{i2}^5} = W_3^2 f_3 \frac{L_{e3}}{d_{i3}^5}$$

and

$$W_1 + W_2 + W_3 = \text{total flow}$$

The effect of variations in steam properties in the various tubes can be neglected, because it will not be very significant.

Substituting the data and using f from [Table 7.6](#), we obtain

$$W_1 + W_2 + W_3 = 15,000$$

$$\begin{aligned} W_1^2 \times 0.0195 \times \frac{400}{2^5} &= W_2^2 \times 0.02 \times \frac{350}{(1.75)^5} \\ &= W_3^2 \times 0.0195 \times \frac{370}{2^5} \\ &= \text{a constant} \end{aligned}$$

Simplifying and solving for flows, we have

$$W_1 = 5353 \text{ lb/h}, W_2 = 4054 \text{ lb/h}, W_3 = 5591 \text{ lb/h}$$

This type of calculation is done to check if each pass receives adequate steam flow to cool it. Note that pass 2 had the least flow, and a metal temperature check must be performed. If the metal temperature is high, the tube length or tube sizes must be modified to ensure that the tubes are protected from overheating.

7.26

Q:

How is the equivalent length of a piping system determined? 100 ft of a piping system has three globe valves, a check valve, and three 90° bends. If the line size is 2 in., determine the total equivalent length.

A:

The total equivalent length is the sum of the developed length of the piping plus the equivalent lengths of valves, fittings, and bends. Table 7.10 gives the equivalent length of valves and fittings. A globe valve has 58.6 ft, a check valve has 17.2 ft, and a 90° bend has 5.17 ft of equivalent length. The equivalent length of all valves and fittings is

$$3 \times 58.6 \times 17.2 + 3 \times 5.17 = 208.5 \text{ ft}$$

Hence the total equivalent length is $(100 + 208.5) = 308.5 \text{ ft}$.

TABLE 7.10 Equivalent Length L_e for Valves and Fittings^a

Pipe size (in.)	1 ^b	2 ^b	3 ^b	4 ^b
1	0.70	8.70	30.00	2.60
2	1.40	17.20	60.00	5.20
3	2.00	25.50	87.00	7.70
4	2.70	33.50	114.00	10.00
6	4.00	50.50	172.00	15.20
8	5.30	33.00	225.00	20.00
10	6.70	41.80	284.00	25.00
12	8.00	50.00	338.00	30.00
16	10.00	62.50	425.00	37.50
20	12.50	78.40	533.00	47.00

^a $L_e = Kd_i/12f$, where d_i is the pipe inner diameter (in.) and K is the number of velocity heads (adapted from Crane Technical Paper 410). f is the Darcy friction factor.

^b1, Gate valve, fully open; 2, swing check valve, fully open; 3, globe valve, fully open; 4, 90° elbow.

7.27

Q:

Determine the pressure drop of flue gases and air flowing over a tube bundle under the following conditions:

Gas mass velocity = 7000 lb/ft² h

Tube size = 2 in. OD

Transverse pitch = 4.0 in.

Longitudinal pitch = 3.6 in.

Arrangement: in-line

Average gas temperature = 800°F

Number of rows deep = 30

A:

The following procedure may be used to determine gas pressure drop over tube bundles in in-line and staggered arrangements [11].

$$\Delta P_g = 9.3 \times 10^{-10} \times f G^2 \times \frac{N_H}{\rho_g} \quad (28)$$

where

G = gas mass velocity, lb/ft² h

ΔP_g = gas pressure drop, in. WC

f = friction factor

ρ_g = gas density, lb/cu ft

N_H = number of rows deep

For an in-line arrangement for $S_T/d = 1.5-4.0$ and for $2000 < \text{Re} < 40,000$ [12],

$$f = \text{Re}^{-0.15} \left(0.044 + \frac{0.08 S_L/d}{(S_T/d - 1)^{0.43 + 1.13d/S_L}} \right) \quad (29)$$

where S_T is the transverse pitch and S_L is the longitudinal pitch, in.

For a staggered arrangement for $S_T/d = 1.5-4.0$,

$$f = \text{Re}^{-0.16} \left(0.25 + \frac{0.1175}{(S_T/d - 1)^{1.08}} \right) \quad (30)$$

In the absence of information on gas properties, use a molecular weight of 30 for flue gas. Then, from Chapter 5,

$$\rho_g = 30 \times \frac{492}{359 \times (460 + 800)} = 0.0326 \text{ lb/cu ft}$$

The viscosity is to be estimated at the gas film temperature. However, it can be computed at the average gas temperature, and the difference is not significant for Reynolds number computations.

From Table 7.7, $\mu = 0.08$ lb/ft h. From Eq. (27),

$$\text{Re} = \frac{Gd}{12\mu} = \frac{7000 \times 2}{12 \times 0.08} = 14,580$$

From Eq. (29),

$$f = (14,580)^{-0.15} \left(0.044 + \frac{0.08 \times 2}{1} \right) = 0.0484$$

$$\Delta P_g = 9.3 \times 10^{-0} \times 0.0484 \times 7000^2 \times \frac{30}{0.0326}$$

$$= 2.03 \text{ in. WC}$$

Similarly, using Eq. (30) we can estimate ΔP_g for a staggered arrangement.

Note: The foregoing procedure may be used in the absence of field-tested data or correlation.

7.28

Q:

Determine the gas pressure drop over a bundle of circumferentially finned tubes in an economizer when

Gas mass velocity of flue gas = 6000 lb/ft² h

(The method of computing G for plain and finned tubes is discussed in Chapter 8.)

Average gas temperature = 800°F

Tube size = 2.0 in.

Transverse pitch $S_T = 4.0$ in.

Longitudinal pitch $S_L = 3.6$ in.

Number of rows deep $N_H = 10$

A:

The equation of Robinson and Briggs [11] may be used in the absence of site-proven data or correlation provided by the manufacturer for staggered arrangement:

$$\Delta P_g = \frac{1.58 \times 10^{-8} \times G^{1.684} d^{0.611} \mu^{0.316} (460 + t) N_H}{S_T^{0.412} S_L^{0.515} \times \text{MW}} \quad (31)$$

where

G = gas mass velocity, lb/ft h

MW = gas molecular weight

d = tube outer diameter, in.

$F(t) = \mu^{0.316} \times (460 + t)$

S_T, S_L = transverse and longitudinal pitch, in.

$F(t)$ is given as a function of gas temperature in Table 7.11. Substituting into Eq. (31) gives us

$$\begin{aligned} \Delta P_g &= 1.58 \times 10^{-8} \times 6000^{1.684} \times 2^{0.611} \times 556 \\ &\quad \times \frac{10}{4^{0.412} \times 3.6^{0.515} \times 30} \\ &= 3.0 \text{ in. WC} \end{aligned}$$

7.29

Q:

What is boiler circulation, and how is it determined?

A:

The motive force driving the steam–water mixture through boiler tubes (water tube boilers) or over tubes (in fire tube boilers) is often the difference in density between the cooler water in the downcomer circuits and the steam–water mixture in the riser tubes (Fig. 7.4). A thermal head is developed because of this difference, which forces a certain amount of steam–water mixture through the system. This head overcomes several losses in the system such as

Friction loss in the downcomers

Friction loss and flow acceleration loss in the risers and connecting pipes to the drum

TABLE 7.11 $F(t)$
Versus t for Air or Flue
Gases

$t(F^\circ)$	$F(t)$
200	251
400	348
600	450
800	556
1000	664
1200	776
1600	1003

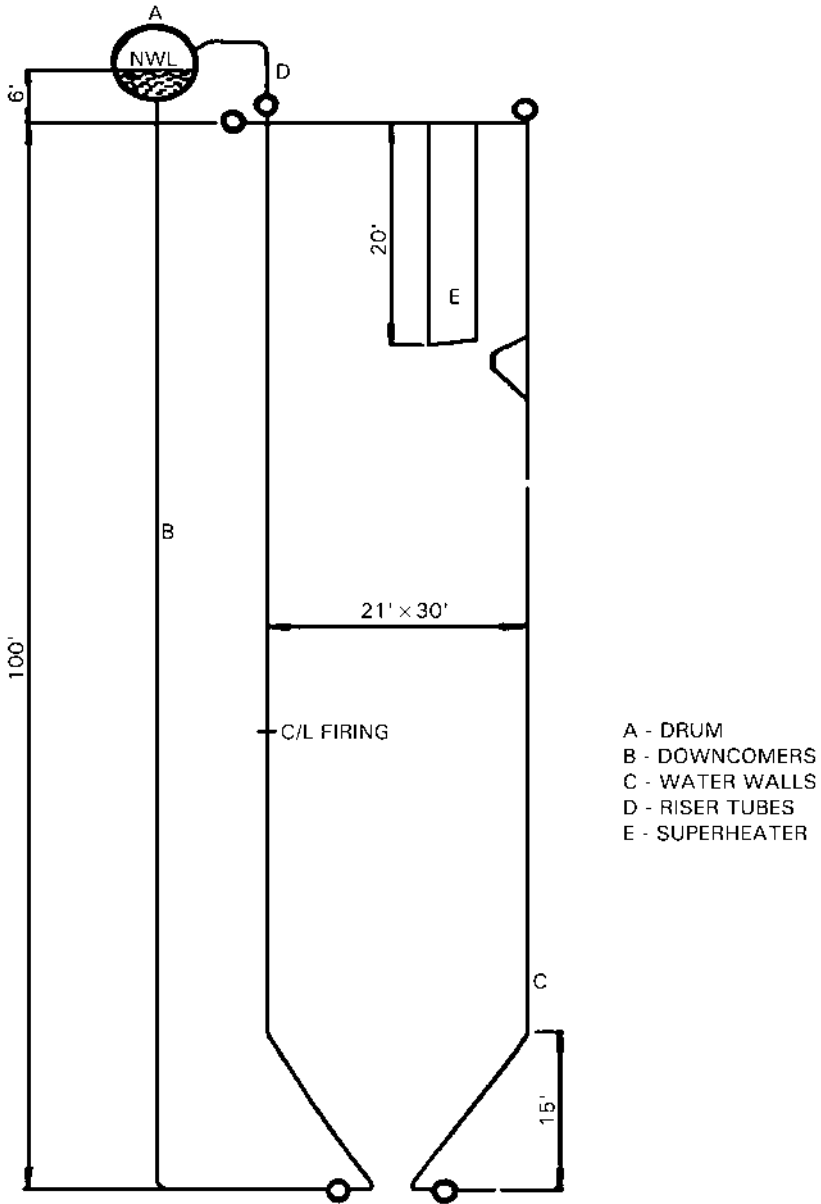

FIGURE 7.4 Scheme of natural circulation boiler showing furnace, drum, riser, and downcomer circuits.

Gravity loss in the evaporator tubes and the riser system
Losses in the drum internals

Generally, the higher the drum operating pressure, the less the difference between the densities of water and the steam–water mixture, and hence the lower the circulation rate.

Circulation ratio (CR) is defined as the ratio between the mass of the steam–water mixture flowing through the system and the mass of the steam generated. If $CR = 15$, then a boiler generating 10,000 lb/h of steam would have 150,000 lb/h of steam–water mixture flowing through the downcomers, risers, internals, etc. The quality of steam at the exit of the riser = $1/CR$, or 0.067 if $CR = 15$. In other words, 6.7% would be the average wetness of steam in the mixture. Low pressure systems have an average CR ranging from 10 to 40. If there are several parallel circuits for the steam–water mixture, each would have a different resistance to flow, and hence CR would vary from circuit to circuit. For natural circulation systems, CR is usually arrived at by trial and error or by iterative calculation, which first assumes a CR and computes all the losses and then balances the losses with the available thermal head. This computation is iterated until the available head and the losses balance.

Sometimes the difference in density between the water and the steam–water mixture is inadequate to circulate the mixture through the system. In such cases, a circulation pump is installed at the bottom of the steam drum, which circulates a desired quantity of mixture through the system (Fig. 7.5). This system is called a *forced circulation system*. One has to ensure that there are an adequate number of

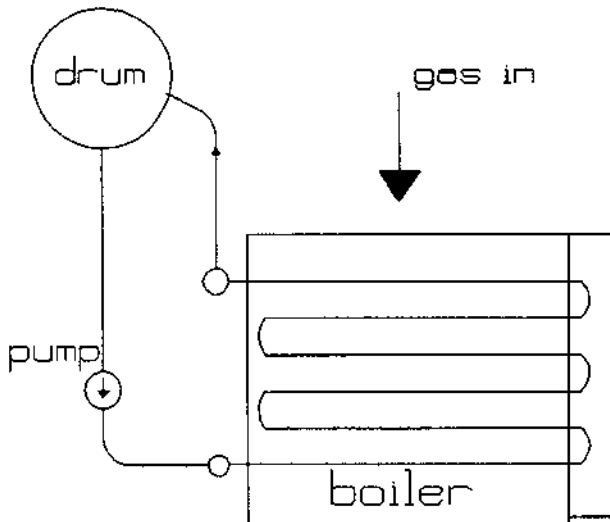

FIGURE 7.5 Scheme of forced circulation boiler.

pumps to ensure circulation, because the failure of the pump would mean starvation of flow in the evaporator tubes. Because we are forcing the mixture through the tubes, the CR is preselected, and the circulating pump is chosen accordingly. A CR of 3–10 is typical. This system is usually used when the pressure drop through the evaporator is likely to be high such as when horizontal tubes are used. When horizontal tubes are used, the critical heat flux to avoid DNB (departure from nucleate boiling) conditions is lower, so forced circulation helps to ensure adequate flow inside the tubes. Circulating pumps are also used when the boiler pressure is high owing to the lower difference in density between the water and the steam–water mixture.

7.30

Q:

What is the main purpose of determining CR?

A:

Determination of CR is not the end in itself. The CR value is used to determine whether a given circuit in the boiler has all the conditions necessary to avoid departure from nucleate boiling (DNB) problems. For each pressure and quality (or CR) there is a particular heat flux beyond which the type of boiling may change from nucleate boiling, which is preferred, to film boiling, which is to be avoided because it can cause the tube wall temperatures to rise significantly, resulting in tube failure. DNB occurs at heat fluxes of 100,000–400,000 Btu/ft² h depending on size and orientation of tubes, pressure, mass velocity, quality, and tube roughness. DNB occurs at a much lower heat flux in a horizontal tube than in an equivalent vertical tube because the steam bubble formation and release occurs more freely and rapidly in vertical tubes than in horizontal tubes, where there is a possibility of bubbles adhering to the top of the tube and causing overheating. More information on DNB and circulation can be found in references cited in Refs. 11 and 14.

Note that the heat flux in finned tubes is much higher than in bare tubes owing to the large ratio of external to internal surface area; this aspect is also discussed elsewhere. Hence one has to be careful in designing boilers with extended surfaces to ensure that the heat flux in the finned tubes does not reach critical levels or cause DNB. That is why boilers with very high gas inlet temperatures are designed with a few rows of bare tubes followed by a few rows of low-fin-density tubes and then high-fin-density tubes. As the gas cools, the heat flux decreases.

7.31a

Q:

Describe the procedure for analyzing the circulation system for the water tube boiler furnace shown in [Fig. 7.4](#).

A:

First, the thermal data such as energy absorbed, steam generated, pressure, and geometry of downcomers, evaporator tubes, and risers should be known. These are obtained from an analysis of furnace performance (see example in Chap. 8). The circulation ratio (CR) is assumed; then the flow through the system is computed, followed by estimation of various pressure losses. Thom's method is used for evaluating two-phase flow losses [15, 16].

The losses can be estimated as follows. ΔP_f , the friction loss in two-phase flow (evaporators/risers), is given by

$$\Delta P_f = 4 \times 10^{-10} \times v_f \frac{fL}{d_i} G_i^2 r_3 \quad (32)$$

The factor r_3 is shown in Fig. 7.6. G_i is the tube-side mass velocity in $\text{lb}/\text{ft}^2 \text{ h}$. The friction factor used is that of Fanning, which is 0.25 times the Moody friction factor.

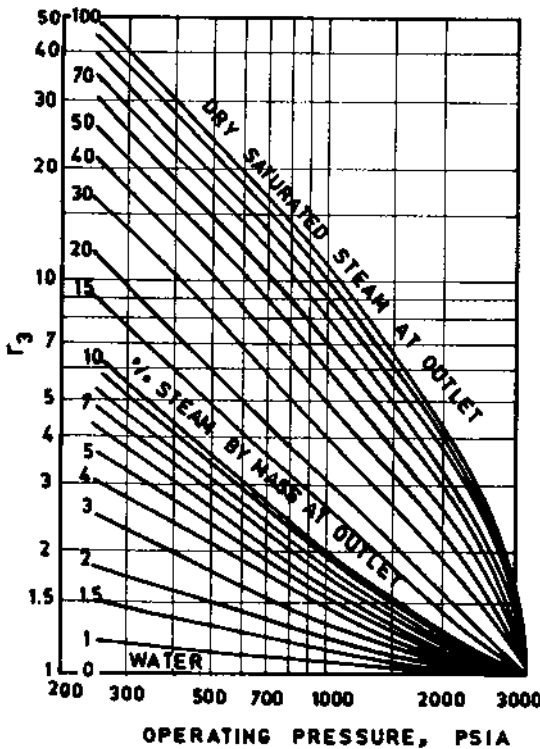

FIGURE 7.6 Thom's two-phase multiplication factor for friction loss. (See Refs. 11, 15, and 16.)

ΔP_g , the gravity loss in the heated riser/evaporator, is given by

$$\Delta P_g = 6.95 \times 10^{-3} \times L \frac{r_4}{v_f} \quad (33)$$

where r_4 is obtained from Fig. 7.7.

ΔP_a , the acceleration loss, which is significant at lower pressures and at high mass velocities, is given by

$$\Delta P_a = 1.664 \times 10^{-11} \times v_f \times G_i^2 \times r_2 \quad (34)$$

Figure 7.8 gives r_2 .

Single-phase pressure losses such as losses in downcomers are obtained from

$$\Delta P = 12 \times f L_e \rho \frac{V^2}{2g \times d_i}$$

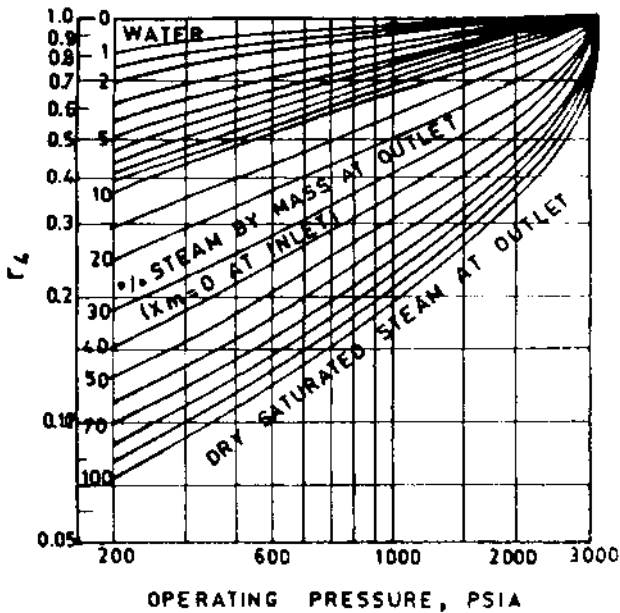

FIGURE 7.7 Thom's two-phase multiplication factor for gravity loss. (See Refs. 11, 15, and 16.)

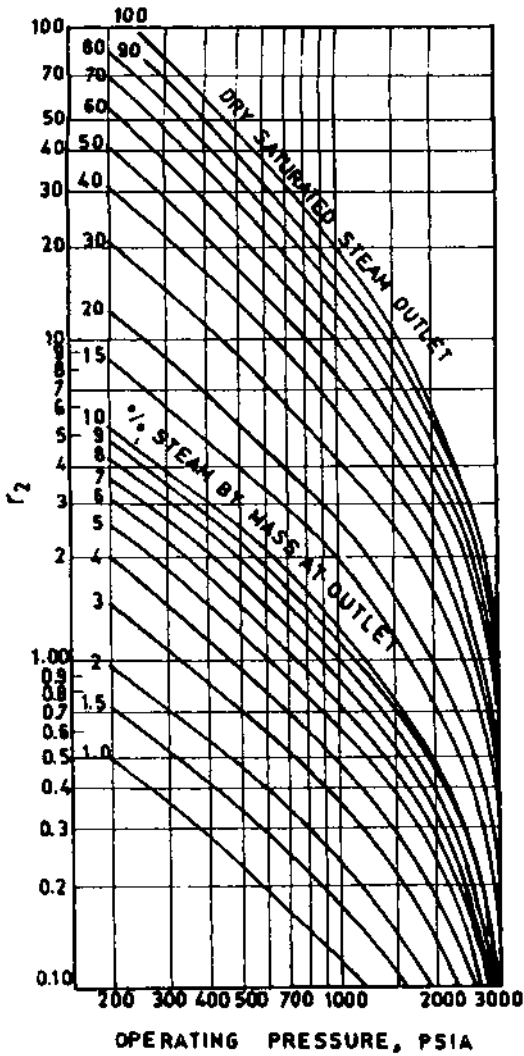

FIGURE 7.8 Thom's two-phase multiplication factor for acceleration loss. (See Refs. 11, 15, and 16.)

or

$$\Delta P = 3.36 \times 10^{-6} \times f L_e v \frac{W^2}{d_i^5}$$

where

W = flow per tube, lb/h

V = fluid velocity, fps

f = Moody's friction factor

L_e = effective or equivalent length of piping, ft

v = specific volume of the fluid, cu ft/lb

The unheated riser losses can be obtained from

$$\Delta P_f = f \times \frac{12L_e}{d_i} G_i^2 \frac{v_f r_f}{2g \times 144} \quad (35)$$

r_f is given in Fig. 7.9.

The equivalent lengths have to be obtained after considering the bends, elbows, etc., in the piping. See [Tables 7.10](#) and [7.12](#).

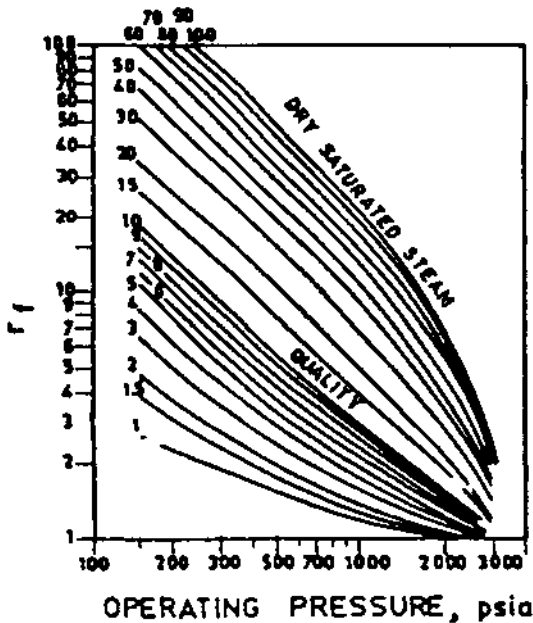

FIGURE 7.9 Two-phase friction factor for unheated tubes. (See Refs. 11, 15, and 16.)

TABLE 7.12 L_e/d_i , Ratios for Fitting Turbulent Flow

Fitting	L_e/d_i
45° elbow	15
90° elbow, standard radius	32
90° elbow, medium radius	26
90° elbow, long sweep	20
180° close-return bend	75
180° medium-radius return bend	50
Tee (used as elbow, entering run)	60
Tee (used as elbow, entering branch)	90
Gate valve, open	7
Gate valve, one-quarter closed	40
Gate valve, half-closed	200
Gate valve, three-quarters closed	800
Gate valve, open	300
Angle valve, open	170

A heat balance is first done around the steam drum to estimate the amount of liquid heat to be added to the steam–water mixture before the start of boiling. The mixture is considered to be water until boiling starts.

Once all of the losses are computed, the available head is compared with the losses. If they match, the assumed circulation rate is correct; otherwise another iteration is performed. As mentioned before, this method gives an average circulation rate for a particular circuit. If there are several parallel circuits, then the CR must be determined for each circuit. The circuit with the lowest CR and highest heat fluxes should be evaluated for DNB.

In order to analyze for DNB, one may compute the allowable steam quality at a given location in the evaporator with the actual quality. The system is considered safe if the allowable quality is higher than the actual quality. The allowable quality is based on the heat flux, pressure, mass velocity, and roughness and orientation of the tubes. Studies have been performed to arrive at these values. [Figure 7.10](#) shows a typical chart [14] that gives the allowable steam quality as a function of pressure and heat flux. It can be seen that as the pressure or heat flux increases, the allowable quality decreases. Another criterion for ensuring that a system is safe is that the actual heat flux on the steam side (inside tubes in water tube boilers and outside tubes in fire tube boilers) must be lower than the critical heat flux (CHF) for the particular conditions of pressure, flow, tube size, roughness, orientation, etc. CHF values are available in the literature; boiler manufacturers have developed their own CHF correlations based on their experience. See [Chapter 8](#) for an example.

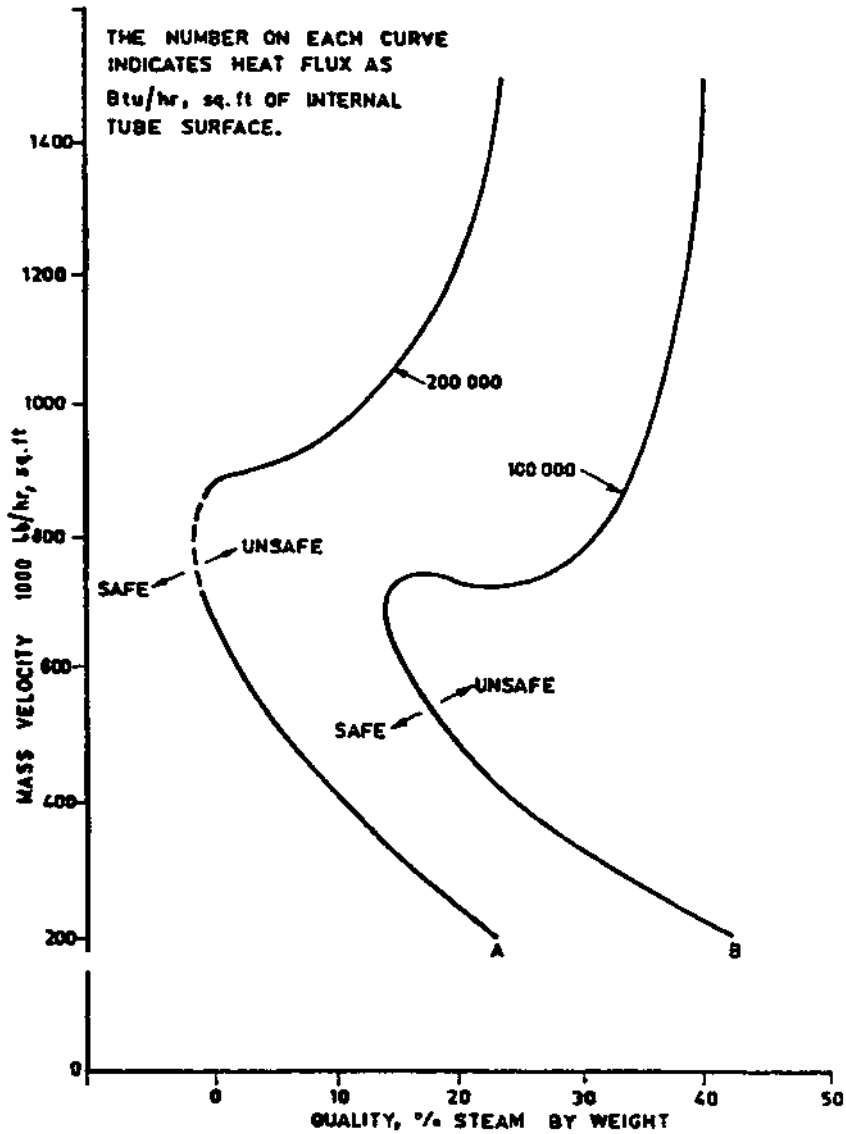

FIGURE 7.10 Allowable quality for nucleate boiling at 2700 psia, as a function of mass velocity and heat flux inside tubes. (From Ref. 14.)

7.31b

Q:

Compute the circulation ratio and check the system shown in Fig. 7.4 for DNB.

A:

Figure 7.4 shows a boiler schematic operating on natural circulation principles. The basis for estimating the flow through water walls is briefly as follows.

1. Assume a circulation ratio (CR) based on experience. For low pressure boilers (< 1000 psia), CR could be from 20 to 50. For high pressure boilers (1000–2700 psia), CR could range from 9 to 5. The following expression relates circulation ratio and dryness fraction, x :

$$CR = \frac{1}{x} \quad (36)$$

Hence, flow through the evaporator = CR \times the steam generated.

2. Furnace thermal performance data such as efficiency, furnace exit temperature, and feedwater temperature entering the drum should be known before the start of this exercise, in addition to details such as the location of the drum, bends, size, and length of various circuits.
3. Mixture enthalpy entering downcomers is calculated as follows through an energy balance at the drum.

$$h_{fw} + CR \times h_e = h_g + CR \times h_m \quad (37)$$

4. As the flow enters the water walls, it gets heated, and boiling starts after a particular distance from the bottom of the furnace. This distance is called boiling height, and it increases as the subcooling increases. It is calculated as follows.

$$L_b = L \times CR \times W_s \frac{h_f - h_m}{Q}$$

Beyond the boiling height, the two-phase flow situation begins.

5. Friction loss in various circuits such as downcomers, connecting headers, water wall tubes (single-phase, two-phase losses), riser pipes, and drums are calculated. Gravity losses, ΔP_g , are estimated along with the acceleration losses, ΔP_a , in a boiling regime. The head available in the downcomer is calculated and equated with the losses. If they balance, the assumed CR is correct; otherwise, a revised trial is made until they balance. Flow through the water wall tubes is thus estimated.
6. Checks for DNB are made. Actual quality distribution along furnace height is known. Based on the heat flux distribution (Fig. 7.11), the

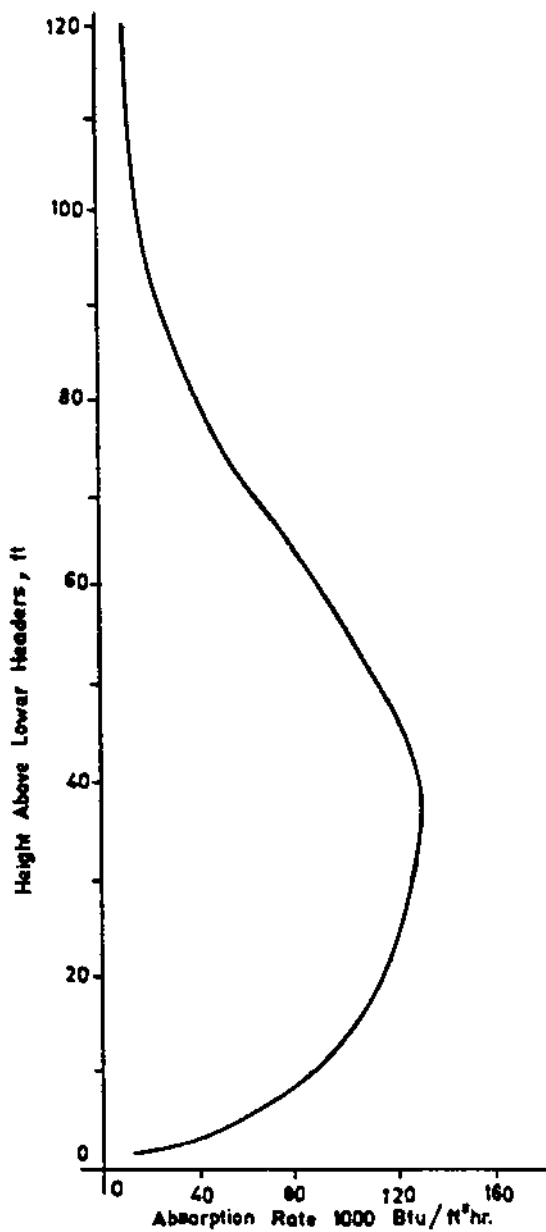

FIGURE 7.11 Typical heat absorption rates along furnace height.

allowable quality along the furnace height can be found. If the allowable quality exceeds actual quality, the design is satisfactory; otherwise, burnout possibilities exist, and efforts must be made to improve the flow through water wall tubes.

Example

A coal-fired boiler has a furnace configuration as shown in Fig. 7.4. Following are the parameters obtained after performing preliminary thermal design:

Steam generated	600,000 lb/h
Pressure at drum	2700 psia
Feedwater temperature entering drum from economizer	570°F
Furnace absorption	320×10^6 Btu/h
Number and size of downcomers	4, 12 in. ID
Number and size of water wall tubes	416, $2\frac{1}{2}$ in. OD \times 0.197 in. thick
Number and size of riser tubes	15, 6 in. ID
Drum ID	54 in.
Furnace projected area	8400 ft ²

Because it is difficult to estimate flow through parallel paths, let us assume that flow in each tube or circuit of downcomers, water walls, and risers may be near the average flow values. However, computer programs may be developed that take care of different circuits. The manual method gives a good idea of the solution procedure (though approximate).

Method

Let circulation ratio $CR = 8$. Then $x = 0.125$. From the steam tables,

$$\begin{aligned}
 t_{\text{sat}} &= 680^\circ\text{F} \\
 h_g &= 1069.7 \text{ Btu/lb} \\
 h_f &= 753.7 \text{ Btu/lb} \\
 v_f &= 0.0303 \text{ cu ft/lb} \\
 v_g &= 0.112 \text{ cu ft/lb} \\
 h_{\text{fw}} &= 568 \text{ Btu/lb}
 \end{aligned}$$

Enthalpy of steam leaving water walls is

$$h_e = 0.125 \times 1069.7 + 0.875 \times 753.7 = 793.2 \text{ Btu/lb}$$

Heat balance around the drum gives

$$\text{Steam flow} = 600,000 \text{ lb/h}$$

$$\begin{aligned}\text{Water wall, downcomer flow} &= 8 \times 600,000 \\ &= 4,800,000 \text{ lb/h}\end{aligned}$$

$$\begin{aligned}600,000 \times 568 + 8 \times 600,000 \times 793.2 &= \\ &600,000 \times 1069.7 + 8 \times 600,000 h_m\end{aligned}$$

Hence, $h_m = 731$ Btu/lb.

From the steam tables,

$$v_m = 0.0286 \text{ cu ft/lb}$$

$$\begin{aligned}v_e &= 0.125 \times 0.112 + 0.875 \times 0.0303 \\ &= 0.0405 \text{ cu ft/lb}\end{aligned}$$

- a. $\Delta P_g = \text{head available} = 106 / (0.0286 \times 144) = 25.7$ psi.
- b. $\Delta P_{dc} = \text{losses in downcomer circuit.}$

The downcomer has one 90° bend and one entrance and exit loss. Using an approximate equivalent length of $7d_i$,

$$L_e = 104 + 16 + (7 \times 12) = 204 \text{ ft}$$

The value f_i from [Table 7.6](#) is around 0.013.

$$V_{dc} = \frac{8 \times 600,000 \times 0.0286 \times 576}{3600 \times \pi \times 144 \times 4} = 12.1 \text{ fps}$$

$$\begin{aligned}\Delta P_{dc} &= \frac{0.013 \times 204 \times (12.1)^2 \times 12}{2 \times 32 \times 12 \times 0.0286 \times 144} \\ &= 1.47 \text{ psi}\end{aligned}$$

- c. Estimate boiling height:

$$\begin{aligned}L_b &= 100 \times 8 \times 600,000 \times \frac{753.7 - 731}{320 \times 10^6} \\ &= 31 \text{ ft}\end{aligned}$$

Hence, up to a height of 31 ft, preheating of water occurs. Boiling occurs over a length of only $100 - 31 = 69$ ft.

- d. Gravity loss in boiling height:

$$V_m, \text{ mean specific volume} = \frac{0.0286 + 0.0303}{2} \\ = 0.02945 \text{ cu ft/lb}$$

$$\Delta P_g = \frac{31}{0.02945 \times 144} = 7.3 \text{ psi}$$

- e. Friction loss in boiling height. Compute velocity through water wall tubes: $d_i = 2.1$ in.

$$V_w = \frac{8 \times 600,000 \times 576 \times 0.02945}{416 \times \pi \times (2.1)^2 \times 3600} \\ = 3.93 \text{ fps}$$

From Table 7.6, $f_i = 0.019$.

One exit loss, one 135° bend, and one 45° bend can be considered for computing an equivalent length. L_e works out to about 45 ft.

$$\Delta P_w = \frac{0.019 \times 45 \times (3.93)^2 \times 12}{2 \times 32 \times 2.1 \times 0.02945 \times 144} \\ = 0.28 \text{ psi}$$

- f. Compute losses in two-phase flow, from Figs. 7.6–7.8, for $x = 12.5\%$ and $P = 2700$ psi,

$$r_2 = 0.22, \quad r_3 = 1.15, \quad r_4 = 0.85$$

For computing two-phase losses:

$$\Delta P_a = 1.664 \times 10^{-11} \times v_f r_2 G_i^2 \\ G_i = \frac{8 \times 600,000 \times 576}{416 \times \pi \times (2.1)^2} = 480,000 \text{ lb/ft}^2 \text{ h}$$

$$\Delta P_a = 1.664 \times 10^{-11} \times 0.0303 \\ \times (4.8 \times 10^5)^2 \times 0.22 = 0.026 \text{ psi}$$

Friction loss,

$$\Delta P_f = 4 \times 10^{-10} \times 0.0303 \times \frac{0.0019}{4} \\ \times 69 \times (4.8 \times 10^5)^2 \times \frac{1.15}{2.1} \\ = 0.5 \text{ psi}$$

Gravity loss,

$$\Delta P_g = \frac{6.944 \times 10^{-3} \times 69 \times 0.85}{0.0303} = 13.4 \text{ psi}$$

$$\begin{aligned} \text{Total two-phase loss} &= 0.026 + 0.5 + 13.4 \\ &= 13.926 \text{ psi, or } 14.0 \text{ psi} \end{aligned}$$

- g. Riser circuit losses. Use Thom's method for two-phase unheated tubes. Let the total equivalent length, considering bends and inlet and exit losses, be 50 ft.

$$r_f = 1.4 \text{ (Fig. 7.9)}, \quad f_i = 0.015 \text{ from Table 7.6}$$

$$G_i = \frac{576 \times 8 \times 600,000}{\pi \times 36 \times 15} = 1.63 \times 10^6 \text{ lb/ft}^2 \text{ h}$$

$$\begin{aligned} \Delta P_f &= 0.015 \times \frac{50 \times 12}{6} \times \frac{(1.63 \times 10^6)^2}{2 \times 32 \times 3600^2} \\ &\quad \times \frac{1.4}{144} \times 0.0303 = 1.41 \text{ psi} \end{aligned}$$

Note that in estimating pressure drop by Thom's method for heated tubes, the Darcy friction factor was used. For unheated tubes, Moody's friction factor could be used. Void fraction α' from Fig. 7.12 = 0.36.

$$\Delta P_g = [\rho_f(1 - \alpha') + \rho_g\alpha'] \frac{L}{144} \quad (38)$$

$$\begin{aligned} \Delta P_g &= \left[\left(\frac{1}{0.0303} \times 0.64 \right) + \left(\frac{1}{0.112} \times 0.36 \right) \right] \\ &\quad \times \frac{5}{144} = 0.85 \text{ psi} \end{aligned}$$

$$\text{Total losses in riser circuit} = 1.41 + 0.85 = 2.26 \text{ psi.}$$

- h. Losses in drum. This is a negligible value; use 0.2 psi. (Generally the supplier of the drums should furnish this figure.)

$$\begin{aligned} \text{Total losses} &= b + d + e + f + g + h \\ &= 1.47 + 7.3 + 0.28 + 14.0 + 2.26 + 0.2 \\ &= 25.51 \text{ psi} \end{aligned}$$

$$\text{Available head} = a = 25.7 \text{ psi}$$

Hence, because these two match, an assumed circulation ratio of 8 is reasonable. This is only an average value for the entire system. If one is interested in a detailed analysis, the circuits should be separated

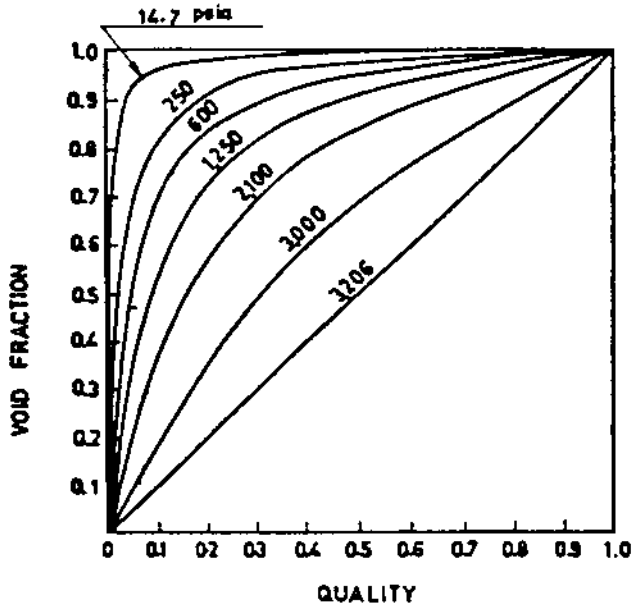

FIGURE 7.12 Void fraction as a function of quality and pressure for steam [See Refs. 11, 16].

according to heat loadings, and a rigorous computer analysis balancing flows and pressure drop in each circuit can be carried out.

Analysis for DNB

Typical furnace absorption profiles for the actual fuel fired are desirable for DNB analysis. These data are generally based on field tests, but for the problem at hand let us use Fig. 7.11, which gives typical absorption profiles for a boiler.

$$\begin{aligned} \text{Average heat flux} &= \frac{\text{furnace absorption}}{\text{furnace projected area}} = \frac{320 \times 10^6}{8400} \\ &= 38,095 \text{ Btu/ft}^2 \text{ h} \end{aligned}$$

There is a variation at any plan cross section of a boiler furnace between the maximum heat flux and the average heat flux, based on the burner location, burners in operation, excess air used, etc. This ratio between maximum and average could be 20–30%. Let us use 25%.

Again, the absorption profile along furnace height shows a peak at some distance above the burner where maximum heat release has occurred. It decreases as the products of combustion leave the furnace. The average for the entire profile

may be found, and the ratio of actual to average heat flux should be computed. For the sake of illustration, use the following ratios of actual to average heat flux at the locations mentioned.

Distance from bottom (ft)	Ratio of actual to average heat flux
40	1.4
56	1.6
70	1.0
80	0.9
100	0.4

We must determine the maximum inside heat flux at each of the locations and correct it for flux inside the tubes to check for DNB. Hence, considering the tube OD/ID ratio of 1.19 and the 25% nonuniformity at each furnace elevation, we have the following local maximum inside heat flux at the locations mentioned (q_i is taken as $q_p \times d/d_i$):

Location (ft)	q_i (Btu/ft ² h)
40	$1.4 \times 38,095 \times 1.25 \times 1.19 = 79,335$
56	90,440
70	56,525
80	50,872
100	22,600

It is desirable to obtain allowable quality of steam at each of these locations and check to be sure actual quality does not exceed it.

DNB tests based on particular tube profiles, roughness, and water quality as used in the operation give the most realistic data for checking furnace tube burnout. Correlations, though available in the literature, may give a completely wrong picture because they are based on tube size, heating pattern, water quality, and tube roughness that may not tally with actual operating conditions. However, they give the trend, which could be useful. For the sake of illustrating our example, let us use Fig. 7.10. This gives a good estimate only, because

extrapolation must be carried out for the low heat flux in our case. We see the following trend at $G_i = 480,000 \text{ lb/ft}^2 \text{ h}$ and 2700 psia:

Location (ft)	Allowable quality (%)
40	25
56	22
70	30
80	34
100	42

Figure 7.13 shows the actual quality (assuming linear variation, perhaps in reality quadratic) versus allowable quality. It shows that a large safety margin exists; hence, the design is safe. This exercise should be carried out at all loads (and for all circuits) before coming to a conclusion.

7.32a

Q:

How is the circulation system analyzed in fire tube boilers?

A:

The procedure is similar to that followed for water tube boilers in that the CR is assumed and the various losses are computed. If the losses associated with the assumed CR and the resulting mass flow are in balance with the available head, then the assumed CR is correct; otherwise another iteration is done. Because fire tube boilers in general use horizontal tubes, the allowable heat flux to avoid DNB is lower than when vertical tubes are used. With gas streams containing hydrogen and steam as in hydrogen plant waste heat boilers, the tube-side and hence the overall heat transfer coefficient and heat flux will be rather high compared to flue gas stream from combustion of fossil fuels. Typical allowable heat fluxes for horizontal tubes range from 100,000 to 150,000 Btu/ft² h.

7.32b

Q:

Perform the circulation calculations for the system shown in Fig. 7.14 with the following data:

$$\text{Steam flow} = 20,000 \text{ lb/h}, \quad \text{steam pressure} = 400 \text{ psig}$$

Assume that saturated water enters the drum.

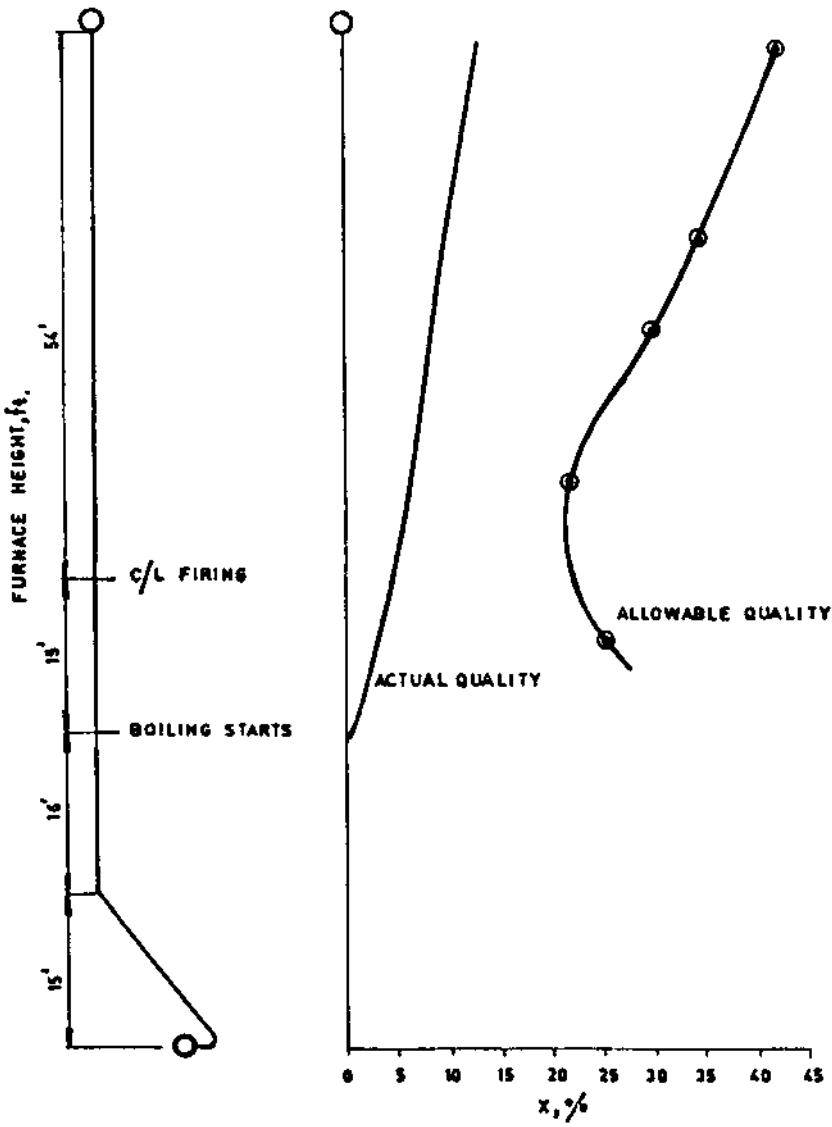

FIGURE 7.13 Actual quality vs. allowable quality along furnace height.

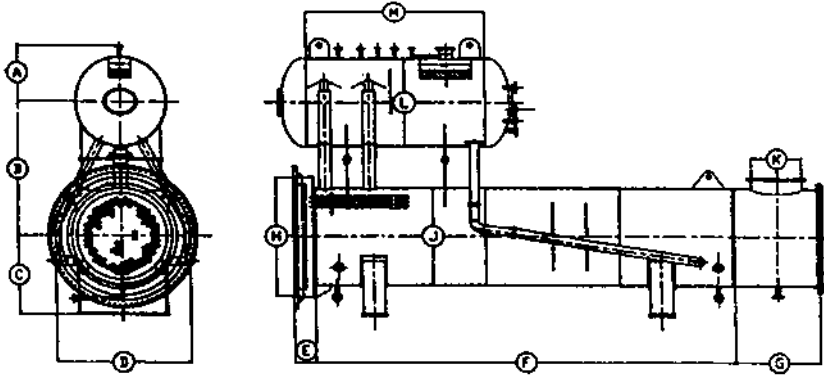

FIGURE 7.14 Circulation scheme in fire tube boiler.

A:

From steam tables, $v_f = 0.194$ and $v_g = 1.12$ cu ft/lb. Assume there are two downcomers of size 4 in schedule 40 ($d_i = 4.026$ in.) and two risers of size 8 in schedule 40 ($d_i = 7.981$ in.). The total developed length of each downcomer is 22.5 ft, and each has two 90° bends; the riser pipes have a total developed length of 5 ft. Exchanger diameter is 6 ft, and the center distance between the exchanger and the steam drum is 8 ft.

1. Assume $CR = 15$; then

$$\begin{aligned} \text{Mixture volume} &= 0.067 \times 1.12 + 0.933 \times 0.0194 \\ &= 0.0931 \end{aligned}$$

The head available due to the column of saturated water is $11 / (0.0194 \times 144) = 3.94$ psi, where 11 ft is the height of the water column.

2. Losses in downcomers:

- a. Water velocity $= 0.05 \times \left(15 \times \frac{20,000}{2} \right) \times \frac{0.0194}{(4.026)^2} = 9$ fps

Inlet plus exit losses = 1.5 velocity head

$$\begin{aligned} &= 1.5 \times 9 \times \frac{9}{2 \times 32 \times 144 \times 0.0194} \\ &= 0.68 \text{ psi} \end{aligned}$$

- b. Total developed length = $22.5 + 2 \times 10 = 42.5$ ft, where 10 ft is the equivalent length of a 90° bend from [Table 7.10](#).

$$\begin{aligned}\Delta P_f &= 3.36 \times 0.0165 \times \left(15 \times \frac{20}{2}\right)^2 \\ &\quad \times 42.5 \times \frac{0.0194}{(4.026)^5} \\ &= 0.98 \text{ psi}\end{aligned}$$

where 0.0165 is the friction factor. Equation (13) was used for pressure drop of single-phase flow.

$$\begin{aligned}\text{Total downcomer losses} &= 0.68 + 0.98 \\ &= 1.66 \text{ psi}\end{aligned}$$

3. Friction and acceleration losses in the exchanger may be neglected for this first trial, because in a fire tube boiler they will be negligible due to the low mass velocity.
4. Gravity losses in the exchanger: Using [Fig. 7.7](#), $r_4 = 0.57$.

$$\Delta P_g = 0.00695 \times 6 \times \frac{0.57}{0.0194} = 1.22 \text{ psi}$$

5. Gravity loss in riser pipe:

$$\Delta P_g = \frac{5}{0.0931 \times 144} = 0.37 \text{ psi}$$

6. Friction loss in riser:

$$\text{Velocity} = 0.05 \times \left(15 \times \frac{20,000}{2}\right) \times \frac{0.0931}{(7.981)^2} = 11 \text{ fps}$$

$$\begin{aligned}\text{Inlet plus exit losses} &= 1.5 \times \text{velocity head} \\ &= \frac{1.5 \times 11 \times 11}{2 \times 32 \times 0.0931 \times 144} = 0.21 \text{ psi}\end{aligned}$$

$$\begin{aligned}\text{Friction loss} &= 3.36 \times 0.014 \times \left(15 \times \frac{20}{2}\right)^2 \\ &\quad \times 5 \times \frac{0.0931}{(7.981)^5} = 0.02 \text{ psi}\end{aligned}$$

where 5 ft is the developed length of the riser.

Let the losses in drum internals = 0.5 psi. This can vary depending on the type of internals used. Then

$$\text{Total losses} = 1.66 + 1.22 + 0.37 + 0.21 + 0.02 + 0.50 = 3.98 \text{ psi}$$

This is close to the available head; hence CR = 15 is the circulation ratio for this system. The calculations can be fine-tuned with actual dimensions after the layout is done. One can compute the heat flux and compare it with the allowable heat flux to check if the circulation rate is adequate. Usually circulation is not a problem in this type of boiler, because the heat flux is low, on the order of 20,000–30,000 Btu/ft² h, whereas the allowable flux could be 100,000–150,000 Btu/ft² h. See [Chapter 8](#) for correlations for critical heat flux (CHF).

7.33

Q:

How is the flow in steam blowoff lines determined?

A:

Whenever steam flows to the atmosphere from a high pressure vessel, the flow reaches critical flow conditions, and beyond a certain pressure further lowering of pressure does not increase the steam discharge. The flow is given by the equation [17]

$$W = 1891 \times Y \times d^2 \times \left(\frac{\Delta P}{Kv} \right)^{0.5} \quad (39)$$

The value of ΔP to be chosen depends on K , the system resistance, where

$$K = 12 \times \frac{f L_e}{d}$$

where

L_e = total equivalent length of all downstream piping including valves and fittings, ft

f = Darcy friction factor

d = pipe inner diameter, in.

Y = expansion factor (see [Table 7.13](#))

v = specific volume of steam before expansion, cu ft/lb

ΔP = pressure drop, lower of actual upstream pressure minus downstream pressure or that obtained from [Table 7.13](#)

TABLE 7.13 Limiting Factors for Sonic Velocity $k = 1.3$

K	$\Delta P/P_1'$	Y
1.2	0.525	0.612
1.5	0.550	0.631
2.0	0.593	0.635
3	0.642	0.658
4	0.678	0.670
6	0.722	0.685
8	0.750	0.698
10	0.773	0.705
15	0.807	0.718
20	0.831	0.718
40	0.877	0.718
100	0.920	0.718

Example

Determine the flow of saturated steam from a vessel at 170 psia to the atmosphere if the total equivalent system resistance $K = 10$ and pipe inner diameter = 2.067 in.

Solution. Specific volume of steam at 170 psia = 2.674 ft³/lb. Actual $\Delta P = 170 - 14.7 = 155.3$ psia. From Table 7.13, for $K = 10$, $\Delta P/P_1 = 0.773$, or $\Delta P = 170 \times 0.773 = 131.5$ psia. Hence, use $\Delta P = 131.5$ psia. Also from Table 7.13 for $K = 10$, $Y = 0.705$. Hence

$$W = 1891.0 \times 0.705 \times (2.067)^2 \times \left(\frac{131.5}{10 \times 2.674} \right)^{0.5}$$

$$= 12,630 \text{ lb/h}$$

7.34

Q:

How is the flow through boiler blowdown lines determined?

A:

Sizing of blowdown or drain lines is very important in boiler or process plant operations.

The problem of estimating the discharge rates from a boiler drum or vessel to the atmosphere or to a vessel at low pressures involves two-phase flow calculations and is a lengthy procedure [18].

Presented below is a simplified approach to the problem that can save considerable time for engineers who are involved in sizing or estimating discharge rates from boiler drums, vessels, or similar applications involving water.

Several advantages are claimed for these charts, including the following.

No reference to steam tables is required.

No trial-and-error procedure is involved.

Effect of friction can be easily studied.

Obtaining pipe size to discharge a desired rate of fluid, the reverse problem, is simple.

Theory

The basic Bernoulli's equation can be written as follows for flow in a piping system:

$$10^4 v dp + \frac{V^2}{2g} dk + \frac{v}{g} dv + dH = 0 \quad (40)$$

Substituting mass flow rate $m = V/v$:

$$\frac{m^2}{2g} \left(dk + 2 \frac{dv}{v} \right) = -10^4 \times \frac{dP}{v} - \frac{dH}{v^2} \quad (41)$$

Integrating between conditions 1 and 2:

$$\frac{m^2}{2g} \left(k + 2 \ln \frac{v_2}{v_1} \right) = -10^4 \int_1^2 \frac{dP}{v} - \int_1^2 \frac{dH}{v^2} \quad (42a)$$

$$m = \left[\frac{2g}{k + 2 \ln(v_2/v_1)} \times \left(-10^4 \int_1^2 \frac{dP}{v} - \int_1^2 \frac{dH}{v^2} \right) \right]^{1/2} \quad (42b)$$

where $K = fl/d$, the equivalent pipe resistance.

When the pressure of the vessel to which the blowdown pipe is connected is decreased, the flow rate increases until critical pressure is reached at the end of the pipe. Reducing the vessel pressure below critical pressure does not increase the flow rate.

If the vessel pressure is less than the critical pressure, critical flow conditions are reached and sonic flow results.

From thermodynamics, the sonic velocity can be shown to be

$$V_c = \sqrt{-v^2 g \left(\frac{dP}{dv} \right)_s} \times 10^4 \quad (43)$$

and

$$m_c = 100 \sqrt{-g \left(\frac{dP}{dv} \right)_s} \quad (44)$$

The term $(dP/dv)_s$ refers to the change in pressure-to-volume ratio at critical flow conditions at constant entropy.

Hence, in order to estimate m_c , Eqs. (42) and (44) have to be solved. This is an iterative procedure. For the sake of simplicity, the term involving the height differences will be neglected. For high pressure systems the error in neglecting this term is marginal, on the order of 5%.

The problem is, then, given K and P_s , to estimate P_c and m . This is a trial-and-error procedure, and the steps are outlined below, followed by an example. Figs. 7.16 and 7.17 are two charts that can be used for quick sizing purposes.

1. Assume a value for P_c .
2. Calculate $(dP/dv)_s$ at P_c for constant-entropy conditions. The volume change corresponding to 2–3% of P_c can be calculated, and then $(dP/dv)_s$ can be obtained.
3. Calculate m_c using Eq. (44).
4. Solve Eq. (42b) for m .

The term $-10^{-4} \int_1^2 dP/v$ is computed as follows using Simpson's rule:

$$\begin{aligned} -10^4 \int_1^2 \frac{dP}{v} &= -10^4 \int_1^2 \rho \, dP \\ &= \frac{P_s - P_c}{6} \times (\rho_s + 4 \rho_m + \rho_c) \end{aligned}$$

where ρ_m = density at a mean pressure of $(P_s + P_c)/2$.

The densities are computed as isenthalpic conditions. The term $2 \ln (v_2/v_1) = 2 \ln (\rho_s/\rho_c)$ is then found.

Then m is computed using Eq. (42b). If the m values computed using Eqs. (42b) and (44) tally, then the assumed P_c and the resultant m_c are correct. Otherwise P_c has to be changed, and all steps have to be repeated until m and m_c agree.

Example

A boiler drum blowdown line is connected to a tank set at 8 atm. Drum pressure is 100 atm, and the resistance K of the blowdown line is 80. Estimate the critical mass flow rate m_c and the critical pressure P_c .

The procedure will be detailed for an assumed pressure P_c of 40 atm.

For steam table $P_s = 100$ atm, $s = 0.7983$ kcal/kg °C; $h_l = 334$ kcal/kg, $v_l = 0.001445$ m³/kg, or $\rho = 692$ kg/m³.

Let $\rho_c = 40$ atm; then $h_l = 258.2$ kcal/kg, $h_v = 669$ kcal/kg, $S_l = 0.6649$, $S_v = 1.4513$, $v_l = 0.001249$, $v_v = 0.05078$.

Hence:

$$x = \frac{S - S_l}{S_v - S_l} = \frac{0.7983 - 0.6649}{1.4513 - 0.6649} = 0.1696$$

$$\begin{aligned} v &= v_l + x(v_v - v_l) \\ &= 0.001249 + 0.1696 \times (0.05078 - 0.001249) \\ &= 0.009651 \text{ m}^3/\text{kg} \end{aligned}$$

Again, compute v at 41 atm (2.5% more than P_c). Using steps similar to those described above, $v = 0.0093 \text{ m}^3/\text{kg}$.

Hence,

$$\begin{aligned} m_c &= 100 \sqrt{-g \left(\frac{dP}{dv} \right)_s} \\ &= 100 \sqrt{\frac{9.8 \times 1}{0.00965 - 0.0093}} = 16,733 \text{ kg/m}^2 \text{ s} \end{aligned}$$

Compute the densities as

$$\rho_s = \frac{1}{0.001445} = 692 \text{ kg/m}^3$$

The dryness fraction at 40 atm at isenthalpic condition is

$$\begin{aligned} x &= \frac{334 - 258.2}{669 - 258.2} = 0.1845 \\ v_c &= 0.001249 + 0.1845 \times (0.05078 - 0.001249) \\ &= 0.010387 \text{ m}^3/\text{kg} \\ \rho_c &= 96.3 \text{ kg/m}^3 \end{aligned}$$

Similarly, at $P_m = (100 + 40)/2 = 70$ atm,

$$v_m = 0.03785 \text{ m}^3/\text{kg} \quad \text{or} \quad \rho_m = 264 \text{ kg/m}^3$$

$$\begin{aligned} -10^4 \int_1^2 \frac{dP}{v} &= \frac{100 - 40}{6} \times (692 + 4 \times 264 + 96.3) \\ &= 184 \times 10^6 \times 2 \times \ln \frac{v_2}{v_1} \\ &= 2 \times \ln \frac{\rho_s}{\rho_c} = 4.6 \end{aligned}$$

Substituting the various quantities into Eq. (42b),

$$m = \sqrt{\frac{2 \times 9.8}{80 + 4.6}} \times 184 \times 10^6$$

$$= 6530 \text{ kg/m}^2 \text{ s}$$

The two values m and m_c do not agree. Hence we have to repeat the calculations for another P_c .

This has been done for $P_c = 30$ and 15, and the results are presented in Fig. 7.15. At about 19 atm, the two curves intersect, and the mass flow rate is about 7000 kg/m² s. However, one may do the calculations at this pressure and check.

Use of Charts

As seen above, the procedure is lengthy and tedious, and trial and error is involved. Also, reference to steam tables makes it cumbersome. Hence with various K values and initial pressure P_s , a calculator was used to solve for P_c and m , and the results are presented in Figs. 7.16 and 7.17.

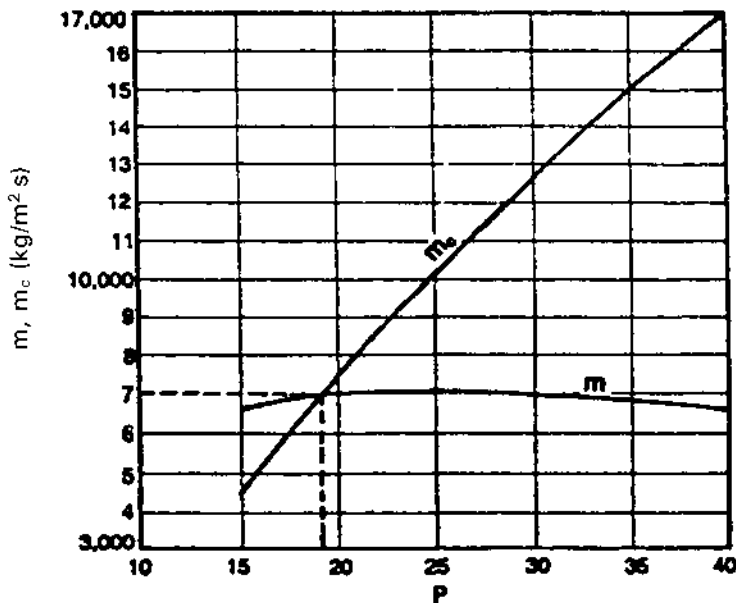

FIGURE 7.15 Calculation results.

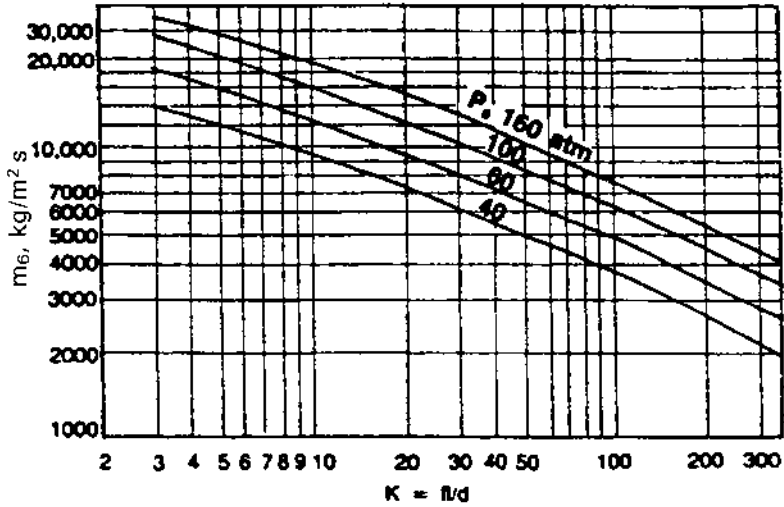

FIGURE 7.16 Solving for m .

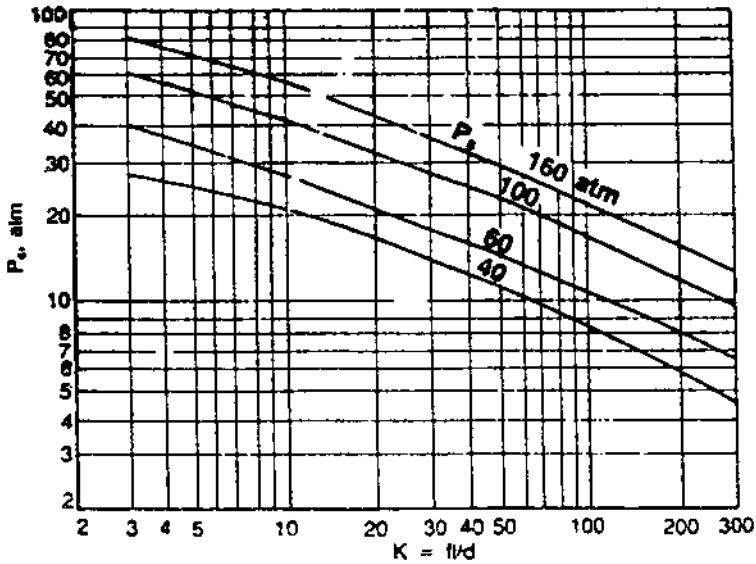

FIGURE 7.17 Solving for P .

7.35

Q:

What is the effect of stack height on friction loss and draft?

A:

Whenever hot flue gases flow in a vertical stack, a natural draft is created owing to the difference in density between the low density flue gases and ambient air, which has a higher density. However, due to the friction losses in the stack, this available draft is reduced.

Example

If 100,000 lb/h of flue gases at 400°F flow in a 48 in. ID stack of 50 ft height, determine the net stack effect. Ambient air temperature is 70°F.

Solution. Density of flue gases (see Q5.02) at 400°F = $39.5/860 = 0.0459$ lb/cu ft. Density of air at 70°F = $40/530 = 0.0755$ lb/cu ft. Hence

$$\begin{aligned}\text{Total draft available} &= (0.0755 - 0.0459) \times 50 \\ &= 1.48 \text{ lb/ft}^2 \\ &= (0.0755 - 0.0459) \times 50 \times \frac{12}{62.4} \\ &= 0.285 \text{ in. WC}\end{aligned}$$

(The factor 62.4 is density of water, and 12 converts ft to in.)

Let us see how much the friction loss per unit length is. From Eq. (26),

$$\Delta P = 93 \times 10^{-6} \times f \times W^2 \times \frac{v}{d^5}$$

$v = 1/0.0459 = 21.79$ cu ft/lb. To estimate the friction factor f , we need the Reynolds number. From the Appendix, $\mu = 0.058$ lb/ft h. Hence

$$\text{Re} = 15.2 \times \frac{100,000}{48 \times 0.058} = 546,000$$

$$f = \frac{0.316}{(546,000)^{0.25}} = 0.012$$

$$\begin{aligned}\Delta P &= 93 \times 10^{-6} \times 0.012 \times (100,000)^2 \times 50 \times \frac{21.79}{48^5} \\ &= 0.048 \text{ in. WC}\end{aligned}$$

Hence

$$\text{Net draft available} = 0.285 - 0.048 = 0.237 \text{ in. WC}$$

7.36

Q:

Discuss the flow instability problem in boiler evaporators.

A:

In once-through boilers or evaporators generating steam at high quality, the problem of flow instability is often a concern. This is due to the nature of the two-phase pressure drop characteristics inside tubes, which can have a negative slope with respect to flow under certain conditions. The problem is felt when multiple streams are connected to common header systems as in once-through or forced circulation systems. Small perturbations can cause large changes in flow through a few tubes, resulting in possible dryout or overheating conditions. Vibration can also occur. The problem has been observed in a few low pressure systems generating steam at high quality.

To illustrate the problem, let us take up the example of steam generation inside a tube. For the sake of analysis, a few assumptions will be made:

Heat flux is uniform along the length of the tube,

Steam at the exit of the tube has a quality x ,

Some subcooling of feedwater is present. That is, the feedwater enters the boiler at less than the saturation temperature.

We are considering a long straight tube without bends to describe the nature of the problem.

If a tube is supplied with subcooled water, the boiling starts after the enthalpy of the water has risen to the saturated liquid level. Thus the length of the boiler can be divided into two portions, the economizer portion and the evaporator, their lengths being determined by the heat input to their respective sections.

Let W be the flow of water entering in lb/h. Let $Q =$ total heat input to the evaporator and Q_l the heat input per unit length, Btu/ft h. The steam quality at the exit of the evaporator is x , fraction. Let the economizer length be L_1 ft. The pressure drop ΔP_1 in the economizer section is

$$\Delta P_1 = 3.36f L_1 W^2 v_f / d_i^5 \quad (45)$$

where

$$L_1 = W \Delta h / Q_l \quad (46)$$

$\Delta h =$ enthalpy absorbed by water in the economizer portion, Btu/lb

$v_f =$ average specific volume of water in the economizer, ft³/lb

In Eq. (46) we are simply using the fact that heat addition is uniform along the tube length.

$d_i =$ tube inner diameter, in.

The pressure drop in the evaporator region of length $L - L_1$ is given by

$$\Delta P_2 = 3.36f(L - L_1)W^2 \frac{v_f + x(v_g - v_f)/2}{d_i^5} \quad (47)$$

Now

$$\frac{xh_{fg}}{\Delta h} = \frac{L - L_1}{L_1} \quad (48)$$

because the heat applied is uniform along the evaporator length, and we are simply taking the ratio of energy absorbed in the evaporator and economizer, which is proportional to their lengths.

h_{fg} = latent heat of vaporization, Btu/lb

v_g, v_f = specific volume of saturated liquid and vapor, ft³/lb

Now substituting for x from Eq. (48) in. to Eq. (47) and for L_1 from Eq. (46) and simplifying the above equations, we can obtain the total pressure drop as follows.

$$\begin{aligned} \Delta P &= \Delta P_1 + \Delta P_2 \\ &= kW^3 \Delta h^2 \frac{v_g - v_f}{2Q_l h_{fg}} - kW^2 \left(\Delta h \frac{v_g - v_f}{h_{fg}} - v_f \right) + kWL^2 Q_l \frac{v_g - v_f}{2h_{fg}} \end{aligned} \quad (49)$$

or

$$\Delta P = AW^3 - BW^2 + CW \quad (50)$$

Though this is a simplistic analysis for two-phase flow pressure drop, it may be used to show the effect of the variables on the process.

Equation (50) is shown in Fig. 7.18. It is seen that the curve of pressure drop versus flow is not monotonic but has a negative slope. This is more so if the steam pressure is low. Hence it may lead to unstable conditions. For example, at the pressure drop condition shown by the horizontal line, there could be three possible operating points, which may cause oscillations and large variations in flow through the circuit. This is likely if multiple streams are connected between headers, where a few tubes can receive very small flows, causing tube overheating concerns and possible DNB conditions.

To improve the situation, one may add a restriction such as a control valve or orifice at the inlet to the economizer section. The orifice increases the resistance in proportion to the square of the flow as shown by the term R in Eq. (51). Figure 7.18a also shows the effect of the orifice, which makes the pressure drop curve monotonic.

$$\Delta P = AW^3 + (R - B)W^2 + CW \quad (51)$$

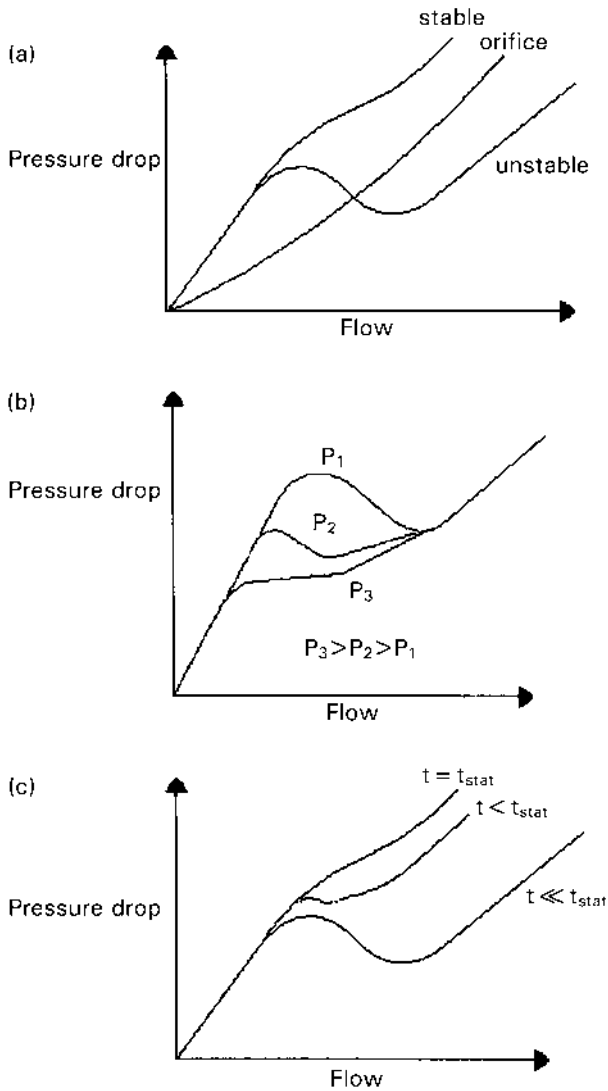

FIGURE 7.18 Effect of (a) orifice size, (b) pressure, and (c) inlet subcooling on the stability of two-phase boiling circuits.

Because the ratio of specific volumes of steam and water is much larger at low steam pressures and the latent heat is also large, the problem is more likely at low pressures than at high pressures, as indicated in Fig 7.18b. Decreasing the inlet subcooling by using a higher feedwater temperature also helps as shown in

Fig. 7.18c. If inlet subcooling is eliminated, $\Delta h = 0$ and then Eq. (50) becomes more stable as shown by the equation

$$\Delta P = BW^2 + CW \quad (52)$$

NOMENCLATURE

A	Area of orifice, in. ²
C	A constant depending on ratio of gas specific heats
CR	Circulation ratio
C_d	Discharge coefficient
C_v	Control valve coefficient
d	Tube or pipe outer diameter, in.
d_o, d_i	Orifice diameter and pipe or duct inner diameter, in.
E	Expansion factor for fuel oils
f	Friction factor
G	Gas mass velocity, lb/ft ² h
h	Differential pressure across flow meter, in. WC
h_e	Enthalpy of mixture at exit, Btu/lb
h_f, h_g, h_m, h_{fw}	Enthalpy of saturated liquid, saturated steam, mixture, and feedwater, Btu/lb
K	System resistance
K_m	Valve recovery coefficient
K_{sh}	Superheat correction factor
L	Length of pipe, ft
L_e	Equivalent length, ft
M	Constant used in Q7.25
m_c	mass flow at critical condition, kg/m ² s
MW	Molecular weight of gas or vapor
N_H	Number of rows deep in a tube bundle
P_a	Accumulated inlet pressure, psia
P_b	Backpressure, psig
P_s	Set pressure, psig
P_v	Vapor pressure, psia
P_1, P_2	Inlet and exit pressures, psia
ΔP	Pressure drop, psi
ΔP_g	Gas pressure drop, in. WC
$\Delta P_a, \Delta P_f, \Delta P_g$	Acceleration loss, friction loss, and loss due to gravity, psi
q	Fluid flow, gpm
Re	Reynolds number
r_2, r_3, r_4, r_f	Factors used in two-phase pressure drop calculation
S	Entropy
s	Specific gravity of fluid

S_T, S_L	Transverse and longitudinal pitch, in.
t, T	Fluid temperature, °F or °R
t_s	Saturation temperature, °F
v	Specific volume of fluid, cu ft/lb
V_c	Critical velocity, m/s
V	Fluid velocity, ft/s
v_f, v_g, v_m	Specific volume of saturated liquid, steam, and mixture, cu ft/lb
W	Flow, lb/h
x	Steam quality, fraction
y	Volume fraction of gas
Y	Expansion factor
β	d_o/d_i ratio
μ	Fluid viscosity, lb/ft h
ρ	Density of fluid, lb/cu ft; subscript g stands for gas
μ	Specific volume of fluid, m ³ /kg

REFERENCES

1. V Ganapathy. Determining flowmeter sizes. *Plant Engineering*, Sept 18, 1980, p 127.
2. *Chemical Engineers' Handbook*. 5th ed. New York: McGraw-Hill, 1974, pp 5–7.
3. V Ganapathy. Converting pitot tube readings. *Plant Engineering*, June 24, 1982, p 61.
4. ASME. Boiler and Pressure Vessel Code, Sec. 1. New York: ASME, 1980, pp 59, 67.
5. Crosby Valve Catalog 402. Crosby, Wrentham, MA, 1968, p 27.
6. ASME. Boiler and Pressure Vessel Code, Sec. 8. New York: ASME, 1980, Appendix 11, p 455.
7. V Ganapathy. Control valve coefficients. *Plant Engineering*, Aug 20, 1981, p 80.
8. V Ganapathy. Nomogram estimates control valve coefficients. *Power Engineering*, December 1978, p 60.
9. FD Jury. Fundamentals of Valve Sizing for Liquids. Fisher Tech Monograph 30. Marshalltown, IA: Fisher Controls Co., 1974, p 2.
10. Masoneilan. Handbook for Control Valve Sizing. 6th ed. Norwood, MA: 1977, p 3.
11. V Ganapathy. Applied Heat Transfer. Tulsa, OK: PennWell Books, 1982, pp 500–530.
12. V Ganapathy. Chart speeds estimates of gas pressure drop. *Oil and Gas Journal*, Feb 4, 1980, p 71.
13. North American Combustion Handbook. 2nd ed. Cleveland, OH: North American Mfg. Co., 1978, pp 20–25.
14. Babcock and Wilcox. Steam: Its Generation and Use. 38th ed.
15. JRS Thom. Prediction of pressure drop during forced circulation boiling of water. *International Journal of Heat Transfer* 7: 1964.
16. W Roshenow, JP Hartnett. Handbook of Heat Transfer. New York: McGraw-Hill, 1972.
17. Crane Company Technical Paper 410.
18. FJ Moody. Maximum two-phase vessel blowdown from pipes. *Transactions of ASME, Journal of Heat Transfer*, August 1966, p 285.

8

Heat Transfer Equipment Design and Performance

- 8.01 Estimating surface area of heat transfer equipment; overall heat transfer coefficient; approximating overall heat transfer coefficient in water tube boilers, fire tube boilers, and air heaters; log-mean temperature difference
- 8.02 Estimating tube-side heat transfer coefficient; simplified expression for estimating tube-side coefficient
- 8.03 Estimating tube-side coefficient for air, flue gas, water, and steam
- 8.04 Estimating heat transfer coefficient outside tubes
- 8.05 Estimating convective heat transfer coefficient outside tubes using Grimson's correlations
- 8.06 Effect of in-line vs. staggered arrangement
- 8.07a Evaluating nonluminous radiation heat transfer using Hottel's charts
- 8.07b Nonluminous radiation using equations
- 8.08a Predicting heat transfer in boiler furnaces
- 8.08b Design of radiant section for heat recovery application
- 8.09a Evaluating distribution of radiation to tube banks
- 8.09b Estimating the temperature of a lance inside boiler enclosure
- 8.10 Sizing fire tube boilers
- 8.11 Effect of gas velocity, tube size on fire tube boiler size

- 8.12 Computing heat flux, tube wall temperatures
- 8.13 Effect of scale formation on tube wall temperature and boiler performance
- 8.14 Design of water tube boilers
- 8.15a Predicting off-design performance
- 8.15b Logic for off-design performance evaluation for water tube boilers
- 8.16 Estimating metal temperature in a boiler superheater tube; thermal resistances in heat transfer; calculating heat flux
- 8.17 Predicting performance of fire tube and water tube boilers
- 8.18 Why finned tubes are used and their design aspects
- 8.19a Heat transfer and pressure drop in finned tubes using ESCOA correlations
- 8.19b Heat transfer in finned tubes using Briggs and Young correlation
- 8.19c Predicting the performance of a finned tube superheater
- 8.20 Sizing of finned tube evaporator
- 8.21 Comparison of bare tube and finned tube boilers
- 8.22 In-line versus staggered arrangement
- 8.23 Effect of tube-side heat transfer on fin configuration
- 8.24 Effect of tube-side fouling on bare and finned tube boilers
- 8.25 Estimating weight of finned tubes
- 8.26 Effect of fin thickness and conductivity on boiler performance and tube and fin tip temperatures
- 8.27a Is surface area an important criterion for boiler selection?
- 8.27b Optimization of a finned evaporator surface
- 8.28 Design of tubular air heaters
- 8.29 Off-design performance of air heaters
- 8.30 Predicting performance of economizers using NTU method
- 8.31 Evaluating natural convection heat transfer coefficients in air
- 8.32 Natural convection heat transfer in liquids
- 8.33 Determining size of coil/tube bundle immersed in liquids
- 8.34 Evaluating gas/steam temperature profiles in HRSGs
- 8.35a Simulating off-design performance
- 8.35b A simplified approach to determining auxiliary fuel requirement in an HRSG
- 8.36 Why gas exit temperature cannot be assumed in HRSGs
- 8.37 How to optimize temperature profiles in HRSGs
- 8.38 Efficiency of HRSGs according to ASME Power Test Code
- 8.39a Effect of fresh air fan size on HRSG performance
- 8.39b Performance of a multipressure HRSG in fresh air-fired mode
- 8.40 How to evaluate operating costs in HRSGs
- 8.41 Why economizer steaming occurs in gas turbine HRSGs

- 8.42 Why water tube boilers are preferred to fire tube boilers for gas turbine applications
- 8.43 Why 10% increase in surface area does not mean 10% more duty in boilers or heat transfer equipment
- 8.44a Time required to heat up boilers
- 8.44b Transient heating of a superheater bundle
- 8.44c Transient response of a water tube evaporator to cutoff in heat input and feedwater supply
- 8.44d Response of a water tube evaporator when steam demand increases and feedwater supply is cut off
- 8.45a Parameters to be considered in testing performance of HRSGs
- 8.45b Evaluating HRSG performance from operating data
- 8.46 Estimating boiling heat transfer coefficient and critical heat flux in water tube boilers
- 8.47a Relating heat flux, steam pressure, quality, flow in water tube boilers
- 8.47b Estimating critical heat flux in fire tube boilers
- 8.47c Estimating critical heat flux in a fire tube boiler; correcting for bundle geometry
- 8.48 Simplified approach to designing fire tube boilers
- 8.49 Simplified approach to designing water tube boilers
- 8.50 Estimating tube bundle size
- 8.51 Estimating thickness of insulation for flat and curved surfaces; effect of wind velocity; estimating thickness to limit surface temperatures
- 8.52 Estimating surface temperature of given thickness of insulation; trial-and-error procedure to determine casing temperature
- 8.53 Sizing insulation to prevent freezing; determining water dew point
- 8.54a Estimating heat loss from pipes for various insulation thicknesses
- 8.54b Estimating temperature drop of fluids in insulated piping
- 8.55 Optimum thickness of insulation; life-cycle costing; annual heat loss and capitalized cost; annual heat loss if no insulation is used
- 8.56 Design of hot casing
- 8.57 Temperature of duct or stack wall with and without insulation
- 8.58 Effect of wind velocity, casing emissivity on heat loss
- 8.59a Checking for noise and vibration problems in heat transfer equipment
- 8.59b Determining natural frequency of vibration of a tube bundle
- 8.59c Computing acoustic frequency
- 8.59d Determining vortex shedding frequency
- 8.59e Checking for bundle vibrations
- 8.59f Checks for tube bundle vibration using damping and fluid elastic instability criteria
- 8.60 Estimating specific heat, viscosity, and thermal conductivity for a gas mixture

- 8.61 Effect of gas analysis on heat transfer
- 8.62 Effect of gas pressure on heat transfer
- 8.63 Converting gas analysis from weight to volume basis
- 8.64 Effect of gas pressure and analysis on design of fire tube boiler

8.01

Q:

How is the surface area of heat transfer equipment determined? What terms can be neglected while evaluating the overall heat transfer coefficient in boilers, economizers, and superheaters?

A:

The energy transferred in heat transfer equipment, Q , is given by the basic equation

$$Q = U \times A \times \Delta T \quad (1)$$

Also,

$$W_h \Delta h_h = W_c \Delta h_c \quad (2)$$

where

- A = surface area, ft²
- W = fluid flow, lb/h
- Δh = change in enthalpy (subscripts h and c stand for hot and cold)
- ΔT = corrected log-mean temperature difference, °F
- U = overall heat transfer coefficient, Btu/ft² h °F

For extended surfaces, U can be obtained from [1]

$$\frac{1}{U} = \frac{A_t}{h_i A_i} + \text{ff}_i \times \frac{A_t}{A_i} + \text{ff}_o + \frac{A_t}{A_w} \times \frac{d}{24K_m} \times \ln \frac{d}{d_i} + \frac{1}{\eta h_o}$$

where

- A_t = surface area of finned tube, ft²/ft
- A_i = tube inner surface area = $\pi d_i/12$, ft²/ft
- A_w = average wall surface area = $\pi(d + d_i)/24$, ft²/ft
- K_m = thermal conductivity of the tube wall, Btu/ft h °F
- d, d_i = tube outer and inner diameter, in.
- ff_i, ff_o = fouling factors inside and outside the tubes, ft² h °F/Btu
- h_i, h_o = tube-side and gas-side coefficients, Btu/ft² h °F
- η = fin effectiveness

If bare tubes are used instead of finned tubes, $A_t = \pi d/12$.

Equation (3) can be simplified to

$$\frac{1}{U} = \frac{d}{h_i d_i} + \frac{1}{h_o} + \frac{d}{24 K_m} \times \ln \frac{d}{d_i} + ff_i \times \frac{d}{d_i} + ff_o \quad (4)$$

where h_o is the outside coefficient.

Now let us take the various cases.

Water Tube Boilers, Economizers, and Superheaters

The gas-side heat transfer coefficient h_o is significant; the other terms can be neglected. In a typical bare tube economizer, for example, $h_i = 1500 \text{ Btu/ft}^2 \text{ h } ^\circ\text{F}$, ff_i and $ff_o = 0.001 \text{ ft}^2 \text{ h } ^\circ\text{F/Btu}$, and $h_o = 12 \text{ Btu/ft}^2 \text{ h } ^\circ\text{F}$. $d = 2.0 \text{ in.}$, $d_i = 1.5 \text{ in.}$, and $K_m = 25 \text{ Btu/ft h } ^\circ\text{F}$.

Substituting into Eq. (4) yields

$$\begin{aligned} \frac{1}{U} &= \frac{2.0}{1500 \times 1.5} + \frac{1}{12} + \frac{2.0}{24 \times 25} \times \ln \frac{2}{1.5} \\ &\quad + 0.001 \times \frac{2.0}{1.5} + 0.001 \\ &= 0.0874 \end{aligned}$$

Hence,

$$U = 11.44 \text{ Btu/ft}^2 \text{ h } ^\circ\text{F}$$

Thus we see that the overall coefficient is close to the gas-side coefficient, which is the highest thermal resistance. The metal thermal resistance and the tube-side resistance are not high enough to change the resistance distribution much.

However, in a liquid-to-liquid heat exchanger, all the resistances will be of the same order, and hence none of the resistances can be neglected.

Even if finned tubes were used in the case above, with $A_t/A_i = 9$ substituted into Eq. (3), $U = 9.3 \text{ Btu/ft}^2 \text{ h } ^\circ\text{F}$, which is close to h_o . Thus, while trying to figure U for economizers, water tube boilers, or gas-to-liquid heat exchangers, U may be written as

$$U = 0.8 \text{ to } 0.9 \times h_o \quad (5)$$

Fire Tube Boilers, Gas Coolers, and Heat Exchangers with Gas Flow Inside Tubes with Liquid or Steam–Water Mixture on the Outside

h_o is large, on the order of 1000–1500 Btu/ft² h °F, whereas h_i will be about 10–12 Btu/ft² h °F. Again, using Eq. (4), it can be shown that

$$U \approx h_i \times \frac{d_i}{d} \quad (6)$$

All the other thermal resistances can be seen to be very small, and U approaches the tube-side coefficient h_i .

Gas-to-Gas Heat Exchangers (Example: Air Heater in Boiler Plant)

In gas-to-gas heat transfer equipment, both h_i and h_o are small and comparable, while the other coefficients are high.

Assuming that $h_o = 10$ and $h_i = 15$, and using the tube configuration above,

$$\begin{aligned} \frac{1}{U} &= \frac{2.0}{15 \times 1.5} + \frac{1}{10} + 0.001 + 9.6 \times 10^{-4} \\ &+ 0.001 \times \frac{2}{1.5} = 0.1922 \end{aligned}$$

or

$$U = 5.2 \text{ Btu/ft}^2 \text{ h } ^\circ\text{F}$$

Simplifying Eq. (4), neglecting the metal resistance term and fouling, we obtain

$$U = h_o \times \frac{h_i d_i / d}{h_o + h_i d_i / d} \quad (7)$$

Thus both h_o and h_i contribute to U .

ΔT , the corrected log-mean temperature difference, can be estimated from

$$\Delta T = F_T \times \frac{\Delta T_{\max} - \Delta T_{\min}}{\ln(\Delta T_{\max} / \Delta T_{\min})}$$

where F_T is the correction factor for flow arrangement. For counterflow cases, $F_T = 1.0$. For other types of flow, textbooks may be referred to for F_T . It varies from 0.6 to 0.95 [2]. ΔT_{\max} and ΔT_{\min} are the maximum and minimum terminal differences.

In a heat exchanger the hotter fluid enters at 1000°F and leaves at 400°F, while the colder fluid enters at 250°F and leaves at 450°F. Assuming counterflow, we have

$$\Delta T_{\max} = 1000 - 450 = 550^{\circ}\text{F}$$

$$\Delta T_{\min} = 400 - 250 = 150^{\circ}\text{F}$$

Then

$$\Delta T = \frac{550 - 150}{\ln(550/150)} = 307^{\circ}\text{F}$$

In boiler economizers and superheaters, F_T could be taken as 1. In tubular air heaters, F_T could vary from 0.8 to 0.9. If accurate values are needed, published charts can be consulted [1,2].

8.02

Q:

How is the tube-side heat transfer coefficient h_i estimated?

A:

The widely used expression for h_i is [1]

$$\text{Nu} = 0.023 \text{Re}^{0.8} \text{Pr}^{0.4} \quad (8)$$

where the Nusselt number is

$$\text{Nu} = \frac{h_i d_i}{12k} \quad (9)$$

the Reynolds number is

$$\text{Re} = 15.2 \frac{w d_i}{\mu} \quad (10)$$

where w is the flow in the tube in lb/h, and the Prandtl number is

$$\text{Pr} = \frac{\mu C_p}{k} \quad (11)$$

where

μ = viscosity, lb/ft h

C_p = specific heat, Btu/lb °F

k = thermal conductivity, Btu/ft h °F

all estimated at the fluid bulk temperature.

Substituting Eqs. (9)–(11) into Eq. (8) and simplifying, we have

$$h_i = 2.44 \times \frac{w^{0.8} k^{0.6} C_p^{0.4}}{d_i^{1.8} \mu^{0.4}} = 2.44 \times \frac{w^{0.8} C}{d_i^{1.8}} \quad (12)$$

where C is a factor given by

$$C = \frac{k^{0.6} C_p^{0.4}}{\mu^{0.4}}$$

C is available in the form of charts for various fluids [1] as a function of temperature. For air and flue gases, C may be taken from Table 8.1.

For hot water flowing inside tubes, Eq. (8) has been simplified and, for $t < 300^\circ\text{F}$, can be written as [3]

$$h_i = (150 + 1.55t) \frac{V^{0.8}}{d_i^{0.2}} \quad (13)$$

where

V = velocity, ft/s

t = water temperature, $^\circ\text{F}$

For very viscous fluids, Eq. (8) has to be corrected by the term involving viscosities at tube wall temperature and at bulk temperature [1].

8.03a

Q:

Estimate h_i when 200 lb/h of air at 800°F and atmospheric pressure flows in a tube of inner diameter 1.75 in.

TABLE 8.1 Factor C for Air and Flue Gases

Temp ($^\circ\text{F}$)	C
200	0.162
400	0.172
600	0.180
800	0.187
1000	0.194
1200	0.205

A:

Using Table 8.1 and Eq. (12), we have $C = 0.187$.

$$h_i = 2.44 \times 200^{0.8} \times \frac{0.187}{1.75^{1.8}} = 11.55 \text{ Btu/ft}^2 \text{ h } ^\circ\text{F}$$

where

w = flow, lb/h

d_i = inner diameter, in.

For gases at high pressures, Ref. 1 gives the C values. (See also p. 531.)

8.03b

Q:

In an economizer, 50,000 lb/h of water at an average temperature of 250°F flows in a pipe of inner diameter 2.9 in. Estimate h_i .

A:

Let us use Eq. (13). First the velocity has to be calculated. From Q5.07a, $V = 0.05(wv/d_i^2)$. v , the specific volume of hot water at 250°F, is 0.017 cu ft/lb. Then,

$$V = 0.05 \times 50,000 \times \frac{0.017}{2.9^2} = 5.05 \text{ ft/s}$$

Hence, from Eq. (13),

$$h_i = (150 + 1.55 \times 250) \times \frac{5.05^{0.8}}{2.9^{0.2}} = 1586 \text{ Btu/ft}^2 \text{ h } ^\circ\text{F}$$

8.03c

Q:

Estimate the heat transfer coefficient when 4000 lb/h of superheated steam at 500 psia and an average temperature of 750°F flows inside a tube of inner diameter 1.5 in.

A:

Using Table 8.2, we see that $C = 0.318$. From Eq (12)

$$h_i = 2.44 \times \frac{4000^{0.8} \times 0.318}{1.5^{1.8}} = 285 \text{ Btu/ft}^2 \text{ h } ^\circ\text{F}$$

If steam were saturated, $C = 0.383$ and $h_i = 343 \text{ Btu/ft}^2 \text{ h } ^\circ\text{F}$.

TABLE 8.2 Factor C for Steam

	Pressure (psia)				
	100	200	500 Saturation	1000	2000
Temperature (°F)	0.282	0.310	0.383	0.498	0.8733
400	0.2716	0.3059			
500	0.2737	0.2909	0.3595		
600	0.2813	0.2896	0.3228	0.413	
700	0.2917	0.2965	0.3161	0.3586	0.5206
800	0.3050	0.3090	0.3206	0.3453	0.4214
900	0.3161	0.3197	0.3277	0.3477	0.3946
1000	0.3276	0.3302	0.3392	0.3531	0.386

8.04

Q:

How is the outside gas heat transfer coefficient h_o in boilers, air heaters, economizers, and superheaters determined?

A:

The outside gas heat transfer coefficient h_o is the sum of the convective heat transfer coefficient h_c and nonluminous heat transfer coefficient h_N .

$$h_o = h_c + h_N \quad (14)$$

For finned tubes, h_o should be corrected for fin effectiveness. h_N is usually small if the gas temperature is less than 800°F and can be neglected.

Estimating h_c for Bare Tubes

A conservative estimate of h_c for flow of fluids over bare tubes in in-line and staggered arrangements is given by [1]

$$\text{Nu} = 0.33 \text{Re}^{0.6} \text{Pr}^{0.33} \quad (15)$$

Substituting, we have the Reynolds, Nusselt, and Prandtl numbers

$$\text{Re} = \frac{Gd}{12\mu} \quad (16)$$

$$\text{Nu} = \frac{h_c d}{12k} \quad (17)$$

and

$$\text{Pr} = \frac{\mu C_p}{k} \quad (18)$$

where

- G = gas mass velocity, lb/ft² h
- d = tube outer diameter, in.
- μ = gas viscosity, lb/ft h
- k = gas thermal conductivity, Btu/ft h °F
- C_p = gas specific heat, Btu/lb °F

All the gas properties above are to be evaluated at the gas film temperature. Substituting Eqs. (16)–(18) into Eq. (15) and simplifying, we have

$$h_c = 0.9G^{0.6} \frac{F}{d^{0.4}} \quad (19)$$

where

$$F = k^{0.67} \frac{C_p^{0.33}}{\mu^{0.27}} \quad (20)$$

Factor F has been computed for air and flue gases, and a good estimate is given in Table 8.3.

The gas mass velocity G is given by

$$G = 12 \frac{W_g}{N_w L (S_T - d)} \quad (21)$$

where

- N_w = number of tubes wide
- S_T = transverse pitch, in.
- L = tube length, ft
- W_g = gas flow, lb/h

TABLE 8.3 F Factor for Air and Flue Gases

Temp (°F)	F
200	0.094
400	0.103
600	0.110
800	0.116
1000	0.123
1200	0.130

For quick estimates, gas film temperature t_f can be taken as the average of gas and fluid temperature inside the tubes.

Example

Determine the gas-side convective heat transfer coefficient for a bare tube superheater tube of diameter 2.0 in. with the following parameters:

- Gas flow = 150,000 lb/h
- Gas temperature = 900°F
- Average steam temperature = 500°F
- Number of tubes wide = 12
- Length of the tubes = 10.5 ft
- Transverse pitch = 4.0 in.
- Longitudinal pitch = 3.5 in. (staggered)

Solution. Estimate G . From Eq. (21),

$$G = 12 \times \frac{150,000}{12 \times 10.5 \times (4 - 2)} = 7142 \text{ lb/ft}^2 \text{ h}$$

Using Table 8.3, at a film temperature of 700°F, $F = 0.113$. Hence,

$$h_c = 0.9 \times 7142^{0.6} \times \frac{0.113}{20.4} = 15.8 \text{ Btu/ft}^2 \text{ h } ^\circ\text{F}$$

Because the gas temperature is not high, the h_N value will be low, so

$$U \approx h_o \approx h_c = 15.8 \text{ Btu/ft}^2 \text{ h } ^\circ\text{F}$$

(Film temperature may be taken as the average of gas and steam temperatures, for preliminary estimates. If an accurate estimate is required, temperature drops across the various thermal resistances as discussed in Q8.16a must be determined.)

The convective heat transfer coefficient obtained by the above method or Grimson's method can be modified to include the effect of angle of attack a of the gas flow over the tubes. The correction factor F_n is 1 for perpendicular flow and decreases as shown in Table 8.4 for other angles [1].

If, for example, $h_c = 15$ and the angle of attack is 60°, then $h_c = 0.94 \times 15 = 14.1 \text{ Btu/ft}^2 \text{ h } ^\circ\text{F}$.

TABLE 8.4 Correction Factor for Angle of Attack

a , deg	90	80	70	60	50	40	30	20	10
F_n	1.0	1.0	0.98	0.94	0.88	0.78	0.67	0.52	0.42

8.05

Q:

How is the convective heat transfer coefficient for air and flue gases determined using Grimson's correlation?

A:

Grimson's correlation, which is widely used for estimating h_c [1], is

$$\text{Nu} = B \times \text{Re}^N \quad (22)$$

Coefficient B and power N are given in Table 8.5.

Example

150,000 lb/h of flue gases having an analysis (vol%) of $\text{CO}_2 = 12$, $\text{H}_2\text{O} = 12$, $\text{N}_2 = 70$, and $\text{O}_2 = 6$ flows over a tube bundle having 2 in. OD tubes at 4 in. square pitch. Tubes per row = 18; length = 10 ft. Determine h_c if the fluid temperature is 353°F and average gas temperature is 700°F . The Appendix tables give the properties of gases.

At a film temperature of $0.5 \times (353 + 700) = 526^\circ\text{F}$, $C_p = 0.2695$, $\mu = 0.0642$ and $k = 0.02344$. Then mass velocity G is

$$G = 12 \times \frac{150,000}{18 \times 10 \times (4 - 2)} = 5000 \text{ lb/ft}^2 \text{ h}$$

TABLE 8.5 Grimson's Values of B and N

S_L/d	$S_T/d = 1.25$		$S_T/d = 1.5$		$S_T/d = 2$		$S_T/d = 3$	
	B	N	B	N	B	N	B	N
Staggered								
1.25	0.518	0.556	0.505	0.554	0.519	0.556	0.522	0.562
1.50	0.451	0.568	0.460	0.562	0.452	0.568	0.488	0.568
2.0	0.404	0.572	0.416	0.568	0.482	0.556	0.449	0.570
3.0	0.310	0.592	0.356	0.580	0.44	0.562	0.421	0.574
In-line								
1.25	0.348	0.592	0.275	0.608	0.100	0.704	0.0633	0.752
1.50	0.367	0.586	0.250	0.620	0.101	0.702	0.0678	0.744
2.0	0.418	0.570	0.299	0.602	0.229	0.632	0.198	0.648
3.0	0.290	0.601	0.357	0.584	0.374	0.581	0.286	0.608

From Table 8.5, for $S_T/d = S_L/d = 2$, $B = 0.229$ and $N = 0.632$, so

$$Re = \frac{5000 \times 2}{12 \times 0.0642} = 12,980$$

$$Nu = 0.229 \times 12,980^{0.632} = 91 = \frac{h_c \times 2}{12 \times 0.02344}$$

or

$$h_c = 12.8 \text{ Btu/ft}^2 \text{ h } ^\circ\text{F}$$

8.06

Q:

Compare in-line versus staggered arrangements of plain tubes from the point of view of heat transfer and pressure drop considerations. In a waste heat boiler 180,000 lb/h of flue gases at 880°F are cooled to 450°F generating steam at 150 psig. The gas analysis is (vol%) CO₂ = 7, H₂O = 12, N₂ = 75, and O₂ = 6. Tube OD = 2 in.; tubes/row = 24; length = 7.5 ft. Compare the cases when tubes are arranged in in-line and staggered fashion with transverse pitch = 4 in. and longitudinal spacing varying from 1.5 to 3 in.

A:

Using Grimson's correlation, the convective heat transfer coefficient h_c was computed for the various cases. The nonluminous coefficient was neglected due to the low gas temperature. The surface area and the number of rows deep required were also computed along with gas pressure drop. The results are shown in Table 8.6.

$$\text{Gas mass velocity } G = \frac{180,000 \times 12}{24 \times (4 - 2) \times 7.5} = 6000 \text{ lb/ft}^2 \text{ h}$$

TABLE 8.6 In-Line Versus Staggered Arrangement of Bare Tubes

	$S_L/d = 1.5$		$S_L/d = 2.0$		$S_L/d = 3.0$	
	In-line	Staggered	In-line	Staggered	In-line	Staggered
Heat transfer coeff. h_c	12.5	15.34	14.43	14.59	14.43	14.10
Friction factor f	0.0386	0.0785	0.0480	0.0785	0.0668	0.0785
No. of rows deep	79	65	69	68	69	70
Gas pressure drop, in.WC	2.95	4.92	3.2	5.2	4.5	5.5

Average gas temperature = $0.5 \times (880 + 450)/2 = 665^\circ\text{F}$, and film temperature is about 525°F .

$C_p = 0.2706$, $\mu = 0.06479$, $k = 0.02367$ at gas film temperature and $C_p = 0.2753$ at the average gas temperature.

$$\text{Re} = \frac{6000 \times 2}{12 \times 0.06479} = 15,434$$

Duty $Q = 180,000 \times 0.99 \times 0.2753 \times (880 - 450) = 21 \text{ MM Btu/h}$

Saturation temperature = 366°F .

$$\begin{aligned} \Delta T &= \text{log-mean temperature difference} = \frac{(880 - 366) - (450 - 366)}{\ln[(880 - 366)/(450 - 366)]} \\ &= 237^\circ\text{F} \end{aligned}$$

With $S_L/d = 1.5$ in-line, we have the values for B and N from [Table 8.5](#):

$$B = 0.101 \quad \text{and} \quad N = 0.702$$

Hence

$$\text{Nu} = 0.101 \times 15,434^{0.702} = 88.0 = h_c \times \frac{2}{12 \times 0.02367}$$

or

$$h_c = 12.5$$

Because other resistances are small, $U = 0.95h_c = 11.87 \text{ Btu/ft}^2 \text{ h } ^\circ\text{F}$.

Hence

$$A = \frac{21 \times 10^6}{237 \times 11.87} = 7465 = 3.14 \times 2 \times 24 \times 7.5 N_d/12$$

or the number of rows deep $N_d = 79$.

The friction factor f , using the method discussed in Q7.27, is

$$f = 15,434^{-0.15} (0.044 + 0.08 \times 1.5) = 0.0386$$

Average gas density = 0.0347 lb/ft^3

$$\text{Gas pressure drop} = 9.3 \times 10^{-10} \times 6000^2 \times 79 \times \frac{0.0386}{0.0347} = 2.95 \text{ in. WC}$$

The calculations for the other cases are summarized in [Table 8.6](#).

1. The staggered arrangement of bare tubes does not have a significant impact on the heat transfer coefficient when the longitudinal spacing exceeds 2, which is typical in steam generators. Ratios lower than 1.5 are not used, owing to potential fouling concerns or low ligament efficiency.

2. The gas pressure drop is much higher for the staggered arrangement. Hence, with bare tube boilers the in-line arrangement is preferred. However, with finned tubes, the staggered arrangement is comparable with the in-line and slightly better in a few cases. This is discussed later.

8.07a

Q:

How is the nonluminous radiation heat transfer coefficient evaluated?

A:

In engineering heat transfer equipment such as boilers, fired heaters, and process steam superheaters where gases at high temperatures transfer energy to fluid inside tubes, nonluminous heat transfer plays a significant role. During combustion of fossil fuels such as coal oil, or gas—triatomic gases—for example, water vapor, carbon dioxide, and sulfur dioxide—are formed, which contribute to radiation. The emissivity pattern of these gases has been studied by Hottel, and charts are available to predict gas emissivity if gas temperature, partial pressure of gases, and beam length are known.

Net interchange of radiation between gases and surroundings (e.g., a wall or tube bundle or a cavity) can be written as

$$\frac{Q}{A} = \sigma(\varepsilon_g T_g^4 - \alpha_g T_o^4) \quad (23)$$

where

ε_g = emissivity of gases at T_g

α_g = absorptivity at T_o

T_g = absolute temperature of gas, °R

T_o = absolute temperature of tube surface, °R

ε_g is given by

$$\varepsilon_g = \varepsilon_c + \eta \varepsilon_w - \Delta\varepsilon \quad (24)$$

α_g is calculated similarly at T_o . η is the correction factor for the water pressure, and $\Delta\varepsilon$ is the decrease in emissivity due to the presence of water vapor and carbon dioxide.

Although it is desirable to calculate heat flux by (23), it is tedious to estimate α_g at temperature T_o . Considering the fact that T_o^4 will be much smaller

than T_g^4 , with a very small loss of accuracy we can use the following simplified equation, which lends itself to further manipulations.

$$\frac{Q}{A} = \sigma \epsilon_g (T_g^4 - T_o^4) = h_N (T_g - T_o) \quad (25)$$

The nonluminous heat transfer coefficient h_N can be written as

$$h_N = \sigma \epsilon_g \frac{T_g^4 - T_o^4}{T_g - T_o} \quad (26)$$

To estimate h_N , partial pressures of triatomic gases and beam length L are required. L is a characteristic dimension that depends on the shape of the enclosure. For a bundle of tubes interchanging radiation with gases, it can be shown that

$$L = 1.08 \times \frac{S_T S_L - 0.785 d^2}{d} \quad (27a)$$

L is taken approximately as 3.4–3.6 times the volume of the space divided by the surface area of the heat-receiving surface. For a cavity of dimensions a , b and c ,

$$L = \frac{3.4 \times abc}{2(ab + bc + ca)} = \frac{1.7}{1/a + 1/b + 1/c} \quad (27b)$$

In the case of fire tube boilers, $L = d_i$.

ϵ_g can be estimated using Figs. 8.1a–8.1d, which give ϵ_c , ϵ_w , η , and $\Delta\epsilon$, respectively. For purposes of engineering estimates, radiation effects of SO_2 can be taken as similar to those of CO_2 . Hence, partial pressures of CO_2 and SO_2 can be added and Fig. 8.1 used to get ϵ_c .

Example 1

Determine the beam length L if $S_T = 5$ in., $S_L = 3.5$ in., and $d = 2$ in.

Solution.

$$L = 1.08 \times \frac{5 \times 3.5 - 0.785 \times 4}{2} = 7.8 \text{ in.}$$

Example 2

In a fired heater firing a waste gas, CO_2 in flue gases = 12% and H_2O = 16%. The gases flow over a bank of tubes in the convective section where tubes are arranged as in Example 1 (hence $L = 7.8$). Determine h_N if $t_g = 1650^\circ\text{F}$ and $t_o = 600^\circ\text{F}$.

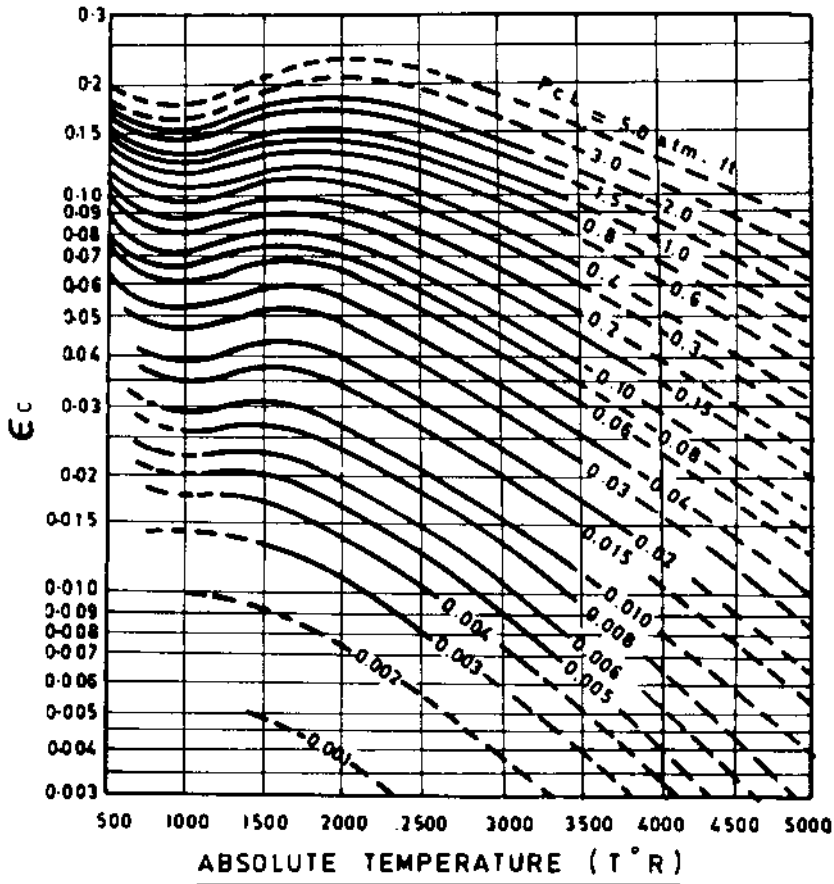

FIGURE 8.1a Emissivity of carbon dioxide. (From Ref 1.)

Solution.

$$P_c L = 0.12 \times \frac{7.8}{12} = 0.078 \text{ atm ft}$$

$$P_w L = 0.16 \times \frac{7.8}{12} = 0.104 \text{ atm ft}$$

In Fig. 8.1a at $T_g = (1650 + 460) = 2110^{\circ}R$ and $P_c L = 0.078$, $\epsilon_c = 0.065$. In Fig. 8.1b, at $T_g = 2110^{\circ}R$ and $P_w L = 0.104$, $\epsilon_w = 0.05$. In Fig. 8.1c, corresponding to $(P + P_w)/2 = 1.16/2 = 0.58$ and $P_w L = 0.104$, $\eta = 1.1$. In Fig. 8.1d,

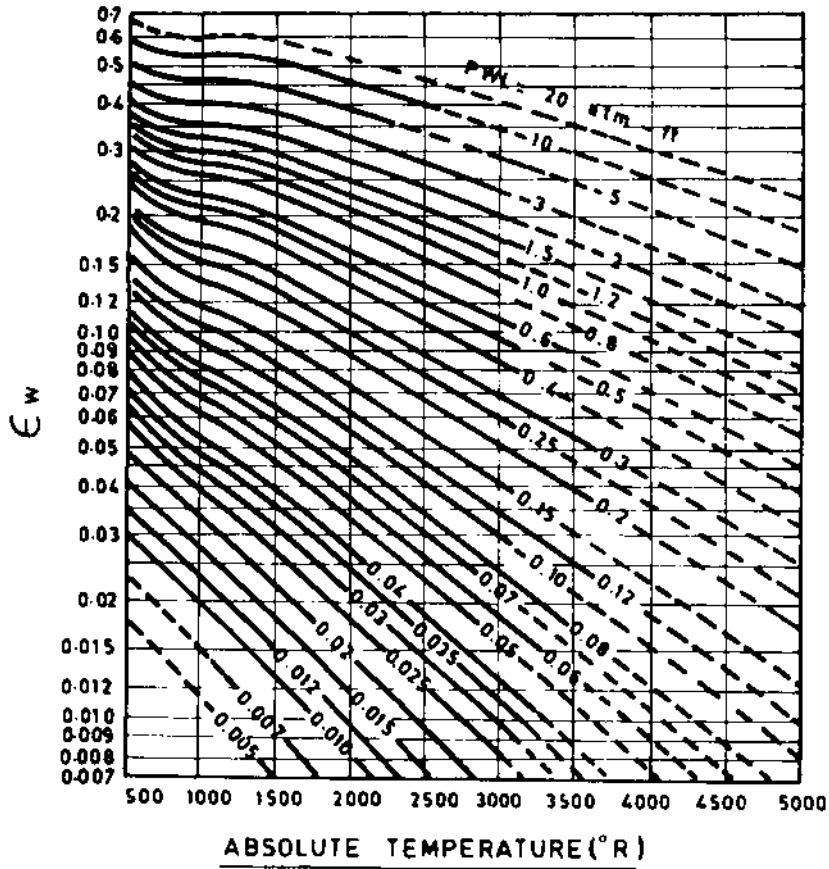

FIGURE 8.1b Emissivity of water vapor. (From Ref 1.)

corresponding to $P_w/(P_c + P_w) = 0.16/0.28$ and $(P_c + P_w)L = 0.182$, $\Delta\epsilon = 0.002$. Hence,

$$\epsilon_g = 0.065 + (1.1 \times 0.05) - 0.002 = 0.118$$

Using Eq. (26) with the Boltzmann constant $\sigma = 0.173 \times 10^{-8}$,

$$h_N = 0.173 \times 10^{-8} \times 0.118 \times \frac{2110^4 - 1060^4}{2110 - 1060} = 3.6 \text{ Btu/ft}^2 \text{ h } ^\circ\text{F}$$

Thus, h_N can be evaluated for gases.

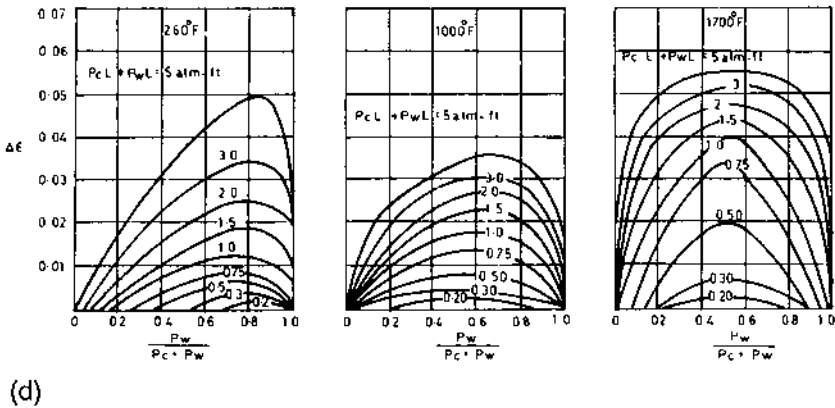
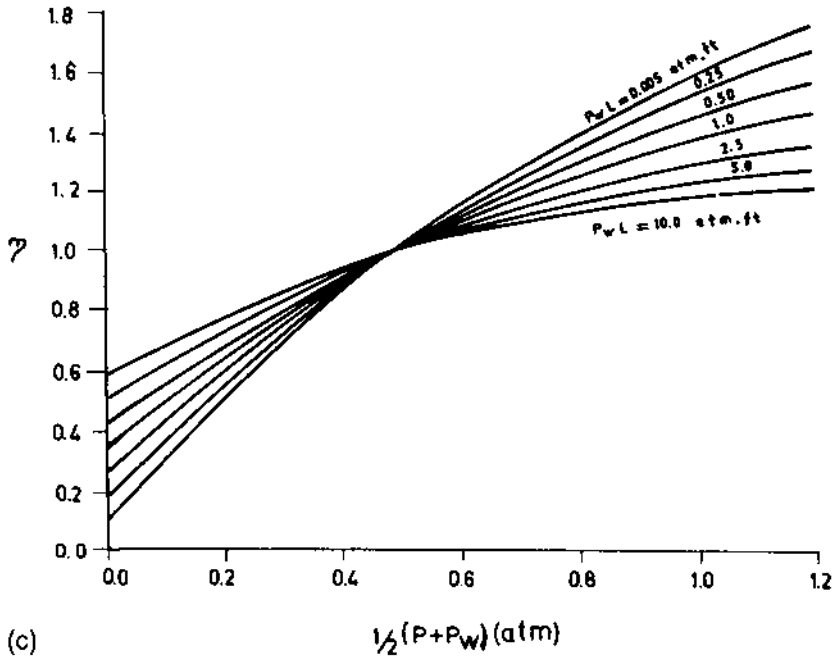

FIGURE 8.1c,d (c) Correction factor for emissivity of water vapor. (d) Correction term due to presence of water vapor and carbon dioxide. (From Ref 1.)

8.07b

Q:

Can gas emissivity be estimated using equations?

A:

Gas emissivity can be obtained as follows. h_N is given by Eq. (26),

$$h_N = \sigma \varepsilon_g \frac{T_g^4 - T_o^4}{T_g - T_o}$$

where

σ = Stefan–Boltzmann constant = 0.173×10^{-8}

T_g and T_o = gas and tube outer wall temperature, °R

ε_g , gas emissivity, is obtained from Hottel's charts or from the expression

[1]

$$\varepsilon_g = 0.9 \times (1 - e^{-KL}) \quad (28a)$$

$$K = \frac{(0.8 + 1.6p_w) \times (1 - 0.38T_g/1000)}{\sqrt{(p_c + p_w)L}} \times (p_c + p_w) \quad (28b)$$

T_g is in K. L is the beam length in meters, and p_c and p_w are the partial pressures of carbon dioxide and water vapor in atm. L , the beam length, can be estimated for a tube bundle by Eq. (27a),

$$L = 1.08 \times \frac{S_T \times S_L - 0.785d^2}{d}$$

S_T and S_L are the transverse pitch and longitudinal pitch. Methods of estimating p_c and p_w are given in [Chapter 5](#).

Example

In a boiler superheater with bare tubes, the average gas temperature is 1600°F and the tube metal temperature is 700°F. Tube size is 2.0 in., and transverse pitch S_T = longitudinal pitch S_L = 4.0 in. Partial pressures of water vapor and carbon dioxide are p_w = 0.12, p_c = 0.16. Determine the nonluminous heat transfer coefficient.

From Eq. (27a), the beam length L is calculated.

$$\begin{aligned} L &= 1.08 \times \frac{4 \times 4 - 0.785 \times 2 \times 2}{2} \\ &= 6.9 \text{ in.} = 0.176 \text{ m} \end{aligned}$$

Using Eq. (28b) with $T_g = (1600 - 32)/1.8 + 273 = 1114$ K, we obtain

$$K = \frac{(0.8 + 1.6 \times 0.12) \times (1 - 0.38 \times 1.114)}{\sqrt{0.28 \times 0.176}} \times 0.28$$

$$= 0.721$$

From Eq. (28a),

$$\varepsilon_g = 0.9 \times [1 - \exp(-0.721 \times 0.176)] = 0.107$$

Then, from Eq. (26),

$$h_N = 0.173 \times 0.107 \times 10^{-8} \times \frac{2060^4 - 1160^4}{1600 - 700}$$

$$= 3.33 \text{ Btu/ft}^2 \text{ h } ^\circ\text{F}$$

8.08a

Q:

How is heat transfer in a boiler furnace evaluated?

A:

Furnace heat transfer is a complex phenomenon, and a single formula or correlation cannot be prescribed for sizing furnaces of all types. Basically, it is an energy balance between two fluids—gas and a steam–water mixture. Heat transfer in a boiler furnace is predominantly radiation, partly due to the luminous part of the flame and partly due to nonluminous gases. A general approximate expression can be written for furnace absorption using an energy approach:

$$Q_F = A_p \varepsilon_w \varepsilon_f \sigma (T_g^4 - T_o^4)$$

$$= W_f \text{LHV} - W_g h_e \quad (29)$$

Gas temperature (T_g) is defined in many ways; some authors define it as the exit gas temperature itself. Some put it as the mean of the theoretical flame temperature and t_e . However, plant experience shows that better agreement between measured and calculated values prevails when $t_g = t_c + 300$ to 400°F [1].

The emissivity of a gaseous flame is evaluated as follows [1]:

$$\varepsilon_f = \beta(1 - e^{-KPL}) \quad (30)$$

β characterizes flame-filling volumes.

$$\beta = 1.0 \text{ for nonluminous flames}$$

$$= 0.75 \text{ for luminous sooty flames of liquid fuels}$$

$$= 0.65 \text{ for luminous and semiluminous flames of solid fuels}$$

$$L = \text{beam length, m}$$

K = attenuation factor, which depends on fuel type and presence of ash and its concentration. For a nonluminous flame it is

$$K = \frac{0.8 + 1.6p_w}{\sqrt{(p_c + p_w)L}} (1 - 0.38T_e/1000) (p_c + p_w) \quad (28b)$$

For a semiluminous flame, the ash particle size and concentration enter into the calculation:

$$K = \frac{0.8 + 1.6p_w}{\sqrt{(p_c + p_w)L}} (1 - 0.38T_e/1000) (p_c + p_w) + 7\mu \left(\frac{1}{d_m^2 \times T_e^2} \right)^{1/3} \quad (28c)$$

where

- d_m = the mean effective diameter of ash particles, in μm
- $d_m = 13$ for coals ground in ball mills
- $\quad = 16$ for coals ground in medium- and high-speed mills
- $\quad = 20$ for combustion of coals milled in hammer mills
- μ = ash concentration in g/N m^3
- T_e = furnace exit temperature, K

For a luminous oil or gas flame,

$$K = \frac{1.6T_e}{1000} - 0.5 \quad (28d)$$

p_w and p_c are partial pressures of water vapor and carbon dioxide in the flue gas.

The above equations give only a trend. A wide variation could exist due to the basic combustion phenomenon itself. Again, the flame does not fill the furnace fully. Unfilled portions are subjected to gas radiation only, the emissivity of which (0.15–0.30) is far below that of the flame. Hence, ϵ_f decreases. Godridge reports that in a pulverized coal-fired boiler, emissivity varied as follows with respect to location [3]:

Excess air	15%	25%
Furnace exit	0.6	0.5
Middle	0.7	0.6

Also, furnace tubes coated with ferric oxide have emissivities, ϵ_w , of the order of 0.8, depending on whether a slag layer covers them. Soot blowing changes ϵ_w considerably. Thus, only an estimate of ϵ_f and ϵ_w can be obtained, which varies with type of unit, fuel, and operation regimes.

To illustrate these concepts, a few examples are worked out. The purpose is only to show the effect of variables like excess air and heat release rates on furnace absorption and furnace exit gas temperature.

Example 1

Determine the approximate furnace exit gas temperature of a boiler when net heat input is about 2000×10^6 Btu/h, of which 1750×10^6 Btu/h is due to fuel and the rest is due to air. HHV and LHV of coals fired are 10,000 and 9000 Btu/lb, respectively, and a furnace heat release rate of 80,000 Btu/ft² h (projected area basis) has been used. The values ϵ_w and ϵ_f may be taken as 0.6 and 0.5, respectively; 25% is the excess air used. Water-wall outer temperature is 600°F. Ash content in coal is 10%.

Solution.

$$\frac{Q}{A_p} = 80,000 = W_f \frac{\text{LHV}}{A_p}$$

From combustion calculation methods discussed in [Chapter 5](#), using 1 MM Btu fired basis, we have the following ratio of flue gas to fuel:

$$\begin{aligned} \frac{W_g}{W_f} &= \frac{760 \times 1.24 \times 10^4}{10^6} + 1 - \frac{10}{100} \\ &= 10.4 \text{ lb/lb} \end{aligned}$$

$$Q = A_p \epsilon_w \epsilon_f \sigma (T_g^4 - T_o^4) = W_f \text{LHV} - W_g h_e$$

Dividing throughout by W_f gives

$$\frac{A_p}{W_f} \epsilon_w \epsilon_f \sigma (T_g^4 - T_o^4) = \text{LHV} - \frac{W_g}{W_f} h_e$$

$$A_p/W_f = \text{LHV}/80,000 = 0.1125$$

Assume $t_e = 1900^\circ\text{F}$. Then

$$C_{pm} = 0.3 \text{ Btu/lb } ^\circ\text{F}$$

$$t_g = 1900 + 300 = 2200^\circ\text{F} = 2660^\circ\text{R}$$

Let us see if the assumed t_e is correct. Substituting for A_p/W_f , ϵ_w , ϵ_f , σ , T_g , T_e in the above equation, we have (LHS = left-hand side; RHS = right-hand side)

$$\begin{aligned} \text{LHS} &= 0.1125 \times 0.6 \times 0.5 \times 0.173 \\ &\quad \times (26.6^4 - 10.6^4) = 2850 \end{aligned}$$

$$\text{RHS} = (9000 - 10.4 \times 1900 \times 0.3) = 3072$$

These do not tally, so we try $t_e = 1920^\circ\text{F}$. Neglect the effect of variation in C_{pm} :

$$\begin{aligned}\text{LHS} &= 0.1125 \times 0.6 \times 0.5 \times (26.8^4 - 10.6^4) \\ &\quad \times 0.173 = 2938 \\ \text{RHS} &= 9000 - 1920 \times 0.3 \times 10.4 = 3009\end{aligned}$$

These agree closely, so furnace exit gas temperature is around 1920°F . Note that the effect of external radiation to superheaters has been neglected in the energy balance. This may give rise to an error of 1.5–2.5% in t_e , but its omission greatly simplifies the calculation procedure. Also, losses occurring in the furnace were omitted to simplify the procedure. The error introduced is quite low.

Example 2

It is desired to use a heat loading of $100,000 \text{ Btu}/\text{ft}^2 \text{ h}$ in the furnace in Example 1. Other factors such as excess air and emissivities remain unaltered. Estimate the furnace exit gas temperature.

Solution.

$$\frac{Q}{A_p} = 100,000 = W_f \frac{\text{LHV}}{A_p}$$

$$\frac{A_p}{W_f} = \frac{\text{LHV}}{100,000} = 0.09$$

$$\frac{w_g}{w_f} = 10.4, \quad t_e = 2000^\circ\text{F}; \quad t_g = 2300^\circ\text{F}$$

$$C_{pm} = 0.3 \text{ Btu}/\text{lb } ^\circ\text{F}; \quad T_g = 2300 + 460 = 2760^\circ\text{R}$$

$$\begin{aligned}\text{LHS} &= 0.09 \times 0.6 \times 0.5 \times 0.173 \\ &\quad \times (27.6^4 - 10.6^4) = 2664\end{aligned}$$

$$\text{RHS} = (9000 - 10.4 \times 2000 \times 0.3) = 2760$$

From this it is seen that t_e will be higher than assumed. Let

$$t_e = 2030^\circ\text{F}, \quad T_g = 2790^\circ\text{R}$$

Then

$$\begin{aligned}\text{LHS} &= 0.09 \times 0.6 \times 0.5 \times 0.173 \\ &\quad \times [(27.9)^4 - (10.6)^4] = 2771 \\ \text{RHS} &= 9000 - 10.4 \times 2030 \times 0.3 = 2667\end{aligned}$$

Hence, t_e will lie between 2000 and 2030°F , perhaps 2015°F .

The exercise shows that the exit gas temperature in any steam generator will increase as more heat input is given to it; that is, the higher the load of the boiler, the higher the exit gas temperature. Example 3 shows the effect of excess air on t_e .

Example 3

What will be the furnace exit gas temperature when 40% excess air is used instead of 25%, heat loading remaining at about 100,000 Btu/ft² h in the furnace mentioned in earlier examples?

Solution.

$$\frac{Q}{A_p} = 100,000 = W_f \frac{\text{LHV}}{A_p}, \quad \frac{A_p}{W_f} = 0.09$$

$$\frac{W_g}{W_f} = \frac{760 \times 1.4 \times 10^4}{10^6} + 0.9 = 11.54 \text{ lb/lb}$$

$$t_e = 1950^\circ\text{F}, \quad C_{pm} = 0.3 \text{ Btu/lb } ^\circ\text{F}$$

$$T_g = 1950 + 300 + 460 = 2710^\circ\text{R}$$

$$\text{LHS} = 0.09 \times 0.6 \times 0.5 \times 0.173$$

$$\times [(27.1)^4 - (10.6)^4] = 2460$$

$$\text{RHS} = 9000 - (11.54 \times 1950 \times 0.3) = 2249$$

These nearly tally; hence, t_e is about 1950°F, compared to about 2030°F in Example 2. The effect of the higher excess air has been to lower t_e .

Example 4

If $\varepsilon_w \times \varepsilon_f = 0.5$ instead of 0.3, what will be the effect on t_e when heat loading is 100,000 Btu/ft² h and excess air is 40%?

Solution. Let

$$t_e = 1800^\circ\text{F}; \quad T_g = 1800 + 300 + 460 = 2560^\circ\text{R}$$

$$\begin{aligned} \text{LHS} &= 0.09 \times 0.5 \times 0.173 \times [(25.6)^4 - (10.6)^4] \\ &= 3245 \end{aligned}$$

$$\text{RHS} = 9000 - (11.54 \times 1800 \times 0.3) = 2768$$

Try

$$t_e = 1700^\circ\text{F}; \quad T_g = 2460^\circ\text{R}$$

Then

$$\begin{aligned}\text{LHS} &= 0.09 \times 0.5 \times 0.173 \times [(24.6)^4 - (10.6)^4] \\ &= 2752 \\ \text{RHS} &= 9000 - (11.54 \times 1700 \times 0.3) = 3115\end{aligned}$$

Try

$$t_e = 1770^\circ\text{F}; \quad T_g = 2530^\circ\text{R}$$

Then

$$\text{LHS} = 3091; \quad \text{RHS} = 2872$$

Hence, t_e will be around 1760°F . This example shows that when surfaces are cleaner and capable of absorbing more radiation, t_e decreases.

In practice, furnace heat transfer is not evaluated as simply as shown above because of the inadequacy of accurate data on soot emissivity, particle size, distribution, flame size, excess air, presence and effect of ash particles, etc. Hence, designers develop data based on field tests. Estimating t_e is the starting point for the design of superheaters, reheaters, and economizers.

Some boiler furnaces are equipped with tilting tangential burners, whereas some furnaces have only front or rear nontiltable wall burners. The location of the burners affects t_e significantly. Hence, in these situations, correlations with practical site data would help in establishing furnace absorption and temperature profiles. (See also p. 112, [Chapter 3](#).)

A promising technique for predicting furnace heat transfer performance is the zone method of analysis. It is assumed that the pattern of fluid flow, chemical heat release, and radiating gas concentration are known, and equations describing conservation of energy within the furnace are developed. The furnace is divided into many zones, and radiation exchange calculations are carried out.

8.08b

Q:

How is heat transfer evaluated in unfired furnaces?

A:

Radiant sections using partially or fully water-cooled membrane wall designs are used to cool gas streams at high gas temperatures ([Fig. 8.2](#)). They generate saturated steam and may operate in parallel with convective evaporators if any. The design procedure is simple and may involve an iteration or two. The higher the partial pressures of triatomic gases, the higher will be the nonluminous radiation and hence the duty.

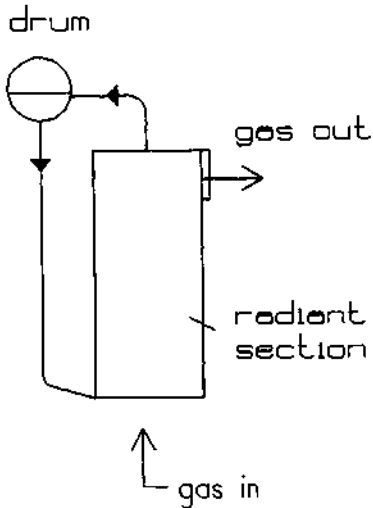

Figure 8.2 Radiant furnace in a water tube boiler.

If a burner is used as in the radiant section of a furnace-fired HRSG, the emissivity of the flame must also be considered. As explained elsewhere [8], radiant sections are necessary to cool the gases to below the softening points of any eutectics present so as to avoid bridging or slagging at the convection section. They are also required to cool gases to a reasonable temperature at the superheater if it is used.

Example

200,000 lb/h of flue gases at 1800°F has to be cooled to 1600°F in a radiant section of a waste heat boiler of cross section 9 ft × 11 ft. Saturated steam at 200 psig is generated. Determine the furnace length required. Flue gas analysis is (vol%) CO₂ = 8, H₂O = 18, N₂ = 72, O₂ = 2. Assume a length of 25 ft and that the furnace is completely water-cooled.

$$\text{Surface area for cooling} = (11 + 9) \times 2 \times 25 = 1000 \text{ ft}^2$$

$$\begin{aligned} \text{Beam length} &= 3.4 \times \frac{\text{volume}}{\text{surface area}} \\ &= 3.4 \times \frac{9 \times 11 \times 25}{2 \times (11 \times 9 + 9 \times 25 + 11 \times 25)} = 7.1 \text{ ft} = 2.15 \text{ m} \end{aligned}$$

Average gas temperature = 1700°F = 1200 K. Partial pressure of CO₂ = 0.08, and that of H₂O = 0.18. Using Eq. (28b),

$$K = (0.8 + 1.6 \times 0.18)(1 - 0.38 \times 1.2) \times \frac{0.26}{(0.26 \times 2.15)^{0.5}} = 0.2053$$

$$\text{Gas emissivity } \epsilon_g = 0.9 \times (1 - e^{-0.2053 \times 2.16}) = 0.3223$$

Let the average surface temperature of the furnace be 420°F (saturation temperature plus a margin). Then the energy transferred is

$$Q_r = 0.173 \times 0.9 \times 0.3223 \times (21.6^4 - 8.8^4) \times 1000 = 10.63 \text{ MM Btu/h}$$

$$\text{Required duty} = 200,000 \times 0.99 \times 0.32 \times 200 = 12.67 \text{ MM btu/h}$$

where 0.32 is the gas specific heat. Hence the furnace should be longer. The beam length and hence the gas emissivity will not change much with change in furnace length; therefore one may assume that the furnace length required = (12.67/10.63) × 25 = 29.8 or 30 ft.

If the performances at other gas conditions are required, a trial-and-error procedure is warranted. First the exit gas temperature is assumed; then the energy transferred is computed as shown above and compared with the assumed duty.

8.09a

Q:

How is the distribution of external radiation to tube bundles evaluated? Discuss the effect of tube spacing.

A:

Tube banks are exposed to direct or external radiation from flames, cavities, etc., in boilers. Depending on the tube pitch, the energy absorbed by each row of tubes varies, with the first row facing the radiation zone receiving the maximum energy. It is necessary to compute the energy absorbed by each row, particularly in superheaters, because the contribution of the radiation can result in high tube wall temperatures.

The following formula predicts the radiation to the tubes [8].

$$a = 3.14 \frac{d}{2S} - \frac{d}{S} \left[\sin^{-1} \left(\frac{d}{S} \right) + \sqrt{\left(\frac{S}{d} \right)^2 - 1} - \frac{S}{d} \right] \quad (31)$$

where a is the fraction of energy absorbed by the first row. The second row would then absorb $(1 - a)a$; the third row, $\{1 - [a + (1 - a)a]\}a$; and so on.

Example

1 MM Btu/h of energy from a cavity is radiated to a superheater tube bank that has 2 in. OD tubes at a pitch of 8 in. If there are six rows, estimate the distribution of energy to each row.

Solution. Substituting $d = 2$, $S = 8$ into Eq. (31), we have

$$a = 3.14 \left(\frac{2/8}{2} \right) - \frac{2}{8} \left[\sin^{-1} \left(\frac{2}{8} \right) + \sqrt{4 \times 4 - 1} - \frac{8}{2} \right]$$
$$= 0.3925 - 0.25(0.2526 + \sqrt{15} - 4) = 0.361$$

Hence the first row absorbs 0.361 MM Btu/h.

The second row would receive $(1 - 0.361) \times 0.361 = 0.231$ or 0.231 MM Btu/h.

The third row receives $[1 - (0.361 + 0.231)] \times 0.361 = 0.147$ MM Btu/h.

The fourth row, $[1 - (0.361 + 0.231 + 0.147)] \times 0.361 = 0.094$ MM Btu/h, and so on.

It can be seen that the first row receives the maximum energy and the amount lessens as the number of rows increases. For a tube pitch S of 4 in., $a = 0.6575$. The first row receives 0.6575 MM Btu/h; the second, 0.225 M Btu/h; and the third, 0.077 MM Btu/h. Hence if the tube pitch is small, a large amount of energy is absorbed within the first two to three rows, resulting in high heat flux in those tubes and consequently high tube wall temperatures. Hence it is better to use a wide pitch when the external radiation is large so that the radiation is spread over more tubes and the intensity is not concentrated within two or three tubes. Screen tubes in boilers and fired heaters perform this function.

8.09b

Q:

A soot blower lance is inserted in a boiler convection section where hot flue gases at 2000°F are flowing around the tubes. If the water wall enclosure is at 400°F, what will be the lance temperature? Assume that the heat transfer coefficient between the flue gas and the lance is 15 Btu/ft² h °F and the emissivity of the lance and the water wall tubes is 0.9.

A:

The energy transferred between the flue gases and lance and from the lance to the water wall enclosure in Btu/ft² h is given by

$$Q = h_c(2000 - T) \\ = 0.173 \times 0.9 \times 0.9 \times [(T + 460)^4 - (400 + 460)^4] \times 10^{-8}$$

where

T = lance temperature, °F
 0.173×10^{-8} is the radiation constant
Emissivity of lance and enclosure = 0.9

Actually, a trial-and-error procedure is required to solve the above equation. However, it may be shown that at $T = 1250^\circ\text{F}$, both sides balance and $Q = 11,250 \text{ Btu/ft}^2 \text{ h}$. At low loads, when $h_c = 5$ and with other parameters remaining the same, what will be the lance temperature? It can be shown to be about 970°F and $Q = 5150 \text{ btu/ft}^2 \text{ h}$.

Hence just as a thermocouple reads a lower temperature due to the radiation to the enclosure, the lance also will not reach the gas temperature. Its temperature will be lower than that of the gas.

8.10

Q:

Determine the size of a fire tube waste heat boiler required to cool 100,000 lb/h of flue gases from 1500°F to 500°F . Gas analysis is (vol%) $\text{CO}_2 = 12$, $\text{H}_2\text{O} = 12$, $\text{N}_2 = 70$, and $\text{O}_2 = 6$; gas pressure is 5 in.WC. Steam pressure is 150 psig, and feedwater enters at 220°F . Tubes used are in 2 in. OD \times 1.77 in. ID; fouling factors are gas-side fouling factor (ff); $0.002 \text{ ft}^2 \text{ h}^\circ\text{F/Btu}$ and steam-side $\text{ff} = 0.001 \text{ ft}^2 \text{ h}^\circ\text{F/Btu}$. Tube metal thermal conductivity = $25 \text{ Btu/ft h}^\circ\text{F}$. Steam-side boiling heat transfer coefficient = $2000 \text{ Btu/ft}^2 \text{ }^\circ\text{F}$. Assume that heat losses and margin = 2% and blowdown = 5%.

A:

Use Eq. (4) to compute the overall heat transfer coefficient, and then arrive at the size from Eq. (1).

$$\frac{1}{U} = \frac{d_o}{d_i h_i} + \text{ff}_o + \text{ff}_i \frac{d_o}{d_i} + d_o \frac{\ln(d_o/d_i)}{24K_m} + \frac{1}{h_o}$$

h_i , the tube-side coefficient, is actually the sum of a convective portion h_c plus a nonluminous coefficient h_n . h_c is obtained from Q8.04:

$$h_c = 2.44 \times w^{0.8} \times \frac{C}{d_i^{1.8}}$$

At the average gas temperature of 1000°F, the gas properties can be shown to be $C_p = 0.287$ Btu/lb °F, $\mu = 0.084$ lb/ft h, and $k = 0.0322$ Btu/ft h °F. Hence,

$$C = \left(\frac{0.287}{0.084} \right)^{0.4} \times (0.0322)^{0.6} = 0.208$$

$$\begin{aligned} \text{Boiler duty } Q &= 100,000 \times 0.98 \times 0.287 \times (1500 - 500) \\ &= 28.13 \times 10^6 \text{ Btu/h} \end{aligned}$$

Enthalpies of saturated steam, saturated water, and feedwater from steam tables are 1195.5, 338, and 188 Btu/lb, respectively. The enthalpy absorbed by steam is then $(1195.5 - 188) + 0.05 \times (338 - 188) = 1015$ Btu/lb, where 0.05 is the blowdown factor corresponding to 5% blowdown.

Hence,

$$\text{Steam generation} = \frac{28.13 \times 10^6}{1015} = 27,710 \text{ lb/h}$$

In order to compute h_i , the flow per tube w is required. Typically w ranges from 100 to 200 lb/h for a 2 in. tube. Let us start with 600 tubes; hence $w = 100,000/600 = 167$ lb/h.

$$h_c = 2.44 \times 0.208 \times \frac{167^{0.8}}{(1.77)^{1.8}} = 10.9 \text{ Btu/ft}^2 \text{ h } ^\circ\text{F}$$

The nonluminous coefficient is usually small in fire tube boilers because the beam length corresponds to the tube inner diameter. However, the procedure used in Q8.07 can also be used here. Let us assume that it is 0.45 Btu/ft² h °F. Then

$$h_i = 10.90 + 0.45 = 11.35 \text{ Btu/ft}^2 \text{ h } ^\circ\text{F}$$

Let us compute U . Because it is based on tube outside surface, let us call it U_o .

$$\begin{aligned}\frac{1}{U_o} &= \frac{2/1.77}{11.35} + 0.001 + 0.002 \times \frac{2}{1.77} \\ &\quad + \ln\left(\frac{2}{1.77}\right) \times \frac{2}{24 \times 25} + 0.0005 \\ &= 0.10 + 0.001 + 0.00226 + 0.00041 + 0.0005 \\ &= 0.10417\end{aligned}$$

Hence, $U_o = 9.6 \text{ Btu/ft}^2 \text{ h } ^\circ\text{F}$.

The various resistances in $\text{ft}^2 \text{ h } ^\circ\text{F/Btu}$ are

Gas-side heat transfer	0.10
Gas-side fouling	0.00226
Metal resistance	0.00041
Steam-side fouling	0.001
Steam-side heat transfer	0.0005

If U is computed on the basis of tube inner surface area, then U_i is given by the expression

$$A_i \times U_i = A_o \times U_o$$

Hence,

$$U_i = 9.6 \times \frac{2}{1.77} = 10.85 \text{ Btu/ft}^2 \text{ h } ^\circ\text{F}$$

Log-mean temperature difference is

$$\Delta T = \frac{(1500 - 366) - (500 - 366)}{\ln[(1500 - 366)/(500 - 366)]} = 468^\circ\text{F}$$

Hence

$$\begin{aligned}A_o &= \frac{28.13 \times 10^6}{468 \times 9.6} = 6261 \text{ ft}^2 \\ &= 3.14 \times 2 \times 600 \times \frac{L}{12}\end{aligned}$$

so required length L of the tubes = 19.93 ft. Use 20 ft. Then

$$\begin{aligned}A_o &= 3.14 \times 2 \times 600 \times \frac{20}{12} = 6280 \text{ ft}^2 \\ A_i &= 5558 \text{ ft}^2\end{aligned}$$

Let us compute the gas pressure drop using Eq. (12) of Chapter 7.

$$\Delta P_g = 93 \times 10^{-6} \times w^2 f L_e \frac{v}{d_i^5}$$

Friction factor f depends on tube inner diameter and can be taken as 0.02. The equivalent length L_e can be approximated by $L + 5d_i$ to include the tube inlet and exit losses.

Specific volume v obtained as $1/\text{density}$, or $v = 1/\rho$. Gas density at the average gas temperature of 1000°F is $\rho_g = 39/1460 = 0.0267 \text{ lb/cu ft}$. Therefore,

$$\begin{aligned} \Delta P_g &= 93 \times 10^{-6} \times 167^2 \times 0.02 \\ &\times \frac{20 + 5 \times 1.77}{0.0267 \times (1.77)^5} = 3.23 \text{ in. WC} \end{aligned}$$

This is only one design. Several variables such as tube size and mass flow could be changed to arrive at several options that could be reviewed for optimum operating and installed costs.

8.11

Q:

What is the effect of tube size and gas velocity on boiler size? Is surface area the sole criterion for boiler selection?

A:

Surface area should not be used as the sole criterion for selecting or purchasing boilers, because tube size and gas velocity affect this variable.

Shown in Table 8.7 are the design options for the same boiler duty using different gas velocities and tube sizes; the procedure described in Q8.10 was used to arrive at these options. The purpose behind this example is to bring out the fact that surface area can vary by as much as 50% for the same duty.

1. As the gas velocity increases, the surface area required decreases, which is obvious.
2. The smaller the tubes, the higher the heat transfer coefficient for the same gas velocity, which also decreases the surface area.
3. For the same gas pressure drop, the tube length is smaller if the tube size is smaller. This fact helps when we try to fit a boiler into a small space.
4. For the same tube size, increasing the gas velocity results in a longer boiler, a greater gas pressure drop, but smaller surface area.

In the case of water tube boilers, more variables such as tube spacing and in-line or staggered arrangement in addition to gas velocity and tube size can affect surface area. This is discussed elsewhere.

TABLE 8.7 Effect of Tube Size and Gas Velocity on Fire Tube Boiler Design

Tube size	1.75 × 1.521			2 × 1.773			2.5 × 2.238		
Velocity, ft/s	109	141	166	110	140	165	109	140	166
Tubes	1100	850	725	800	630	535	510	395	335
Length, ft	19	20	21	22.5	24	25	29.5	31.5	33
Surface area, ft ²	8318	6766	6059	8351	7015	6205	8811	7286	6474
<i>U</i> , Btu/ft ² h °F	9.74	11.78	13.25	9.6	11.43	12.89	9.15	11.02	12.43
Pressure drop in.WC	2.5	4.4	6.3	2.6	4.4	6.2	2.5	4.3	6.2

Gas flow = 110,000 lb/h; inlet temperature = 1450°F; exit temperature = 500°F; steam pressure = 300 psig; feedwater in = 230°F; blowdown = 5%; steam = 28,950 lb/h; gas analysis (vol%): CO₂ = 7, H₂O = 12, N₂ = 75, O₂ = 6; boiler duty = 29.4 MM Btu/h.

8.12

Q:

How is the tube wall temperature in fire tube boilers evaluated? Discuss the importance of heat flux.

A:

To compute the tube wall temperatures, heat flux must be known.

$$q_o = \text{heat flux outside tubes} = U_o \times (t_g - t_i) \text{ Btu/ft}^2 \text{ h}$$

Similarly, q_i (heat flux inside the tube) would be $U_i \times (t_g - t_i)$. However, heat flux outside the tubes is relevant in fire tube boilers because boiling occurs outside the tubes, whereas in water tube boilers the heat flux inside the tubes would be relevant. A high heat flux can result in a condition called departure from nucleate boiling (DNB), which will result in overheating of the tubes. It is preferable to keep the actual maximum heat flux below the critical heat flux, which varies from 150,000 to 250,000 Btu/ft² h depending on steam quality, pressure, and tube condition [1].

An electrical analogy can be used in determining the tube wall temperatures. Heat flux is analogous to current, electrical resistance to thermal resistance, and voltage drop to temperature drop. Using the example worked in Q8.10, we have that at average gas conditions the product of current (heat flux) and resistance (thermal resistance) gives the voltage drop (temperature drop):

$$q_o = \text{heat flux} = 9.6 \times (1000 - 366) = 6086 \text{ Btu/ft}^2 \text{ h}$$

$$\text{Temperature drop across gas film} = 6086 \times 0.1 = 609^\circ\text{F}$$

$$\text{Temperature drop across gas-side fouling} = 6086 \times 0.00226 = 14^\circ\text{F}$$

$$\text{Temperature drop across tube wall} = 6086 \times 0.00041 = 3^\circ\text{F}$$

$$\text{Temperature drop across steam-side fouling} = 6086 \times 0.001 = 6^\circ\text{F}$$

$$\text{Temperature drop across steam film} = 6085 \times 0.0005 = 3^\circ\text{F}$$

Hence,

$$\text{Average inside tube wall temperature} = 1000 - 609 - 14 = 377^\circ\text{F}$$

$$\text{Outside tube wall temperature} = 377 - 3 = 347^\circ\text{F}.$$

The same results are obtained working from the steam side.

$$\text{Outside tube wall temperature} = 366 + 6 + 3 = 375^\circ\text{F}$$

One can also compute the maximum tube wall temperature by obtaining the heat flux at the hot gas inlet end.

8.13

Q:

What is the effect of scale formation on tube wall temperatures?

A:

If nonsoluble salts such as calcium or magnesium salts or silica are present in the feedwater, they can deposit in a thin layer on tube surfaces during evaporation, thereby resulting in higher tube wall temperatures.

Table 8.8 lists the thermal conductivity k of a few scales. Outside fouling factor ff_o can be obtained if the scale information is available.

$$ff_o = \frac{\text{thickness of scale}}{\text{conductivity}}$$

Let us use the same example as in Q8.10 and check the effect of ff_o on boiler duty and tube wall temperatures. Let a silicate scale of thickness 0.03 in. be formed. Then,

$$ff_o = \frac{0.03}{0.6} = 0.05 \text{ ft}^2 \text{ h } ^\circ\text{F}/\text{Btu}$$

TABLE 8.8 Thermal Conductivities of Scale Materials

Material	Thermal conductivity [(Btu/ft ² h °F)/in.]
Analcite	8.8
Calcium phosphate	25
Calcium sulfate	16
Magnesium phosphate	15
Magnetic iron oxide	20
Silicate scale (porous)	0.6
Boiler steel	310
Firebrick	7
Insulating brick	0.7

Assume that other resistances have not changed. (Because of different duty and gas temperature profile, the gas-side heat transfer coefficient will be slightly different. However, for the sake of illustration, we neglect this.) We have

$$\begin{aligned}\frac{1}{U_o} &= 0.10 + 0.00226 + 0.00041 + 0.05 + 0.0005 \\ &= 0.15317\end{aligned}$$

Hence, $U_o = 6.52 \text{ Btu/ft}^2 \text{ h}^\circ\text{F}$

$$\text{Heat flux } q_o = 6.52 \times (1000 - 366) = 4133 \text{ Btu/ft}^2 \text{ h}$$

$$\begin{aligned}\text{Temperature drop across outside steam film} &= 0.0005 \times 4133 \\ &= 2^\circ\text{F}\end{aligned}$$

$$\begin{aligned}\text{Temperature drop across steam-side fouling layer or scale} &= 4133 \times 0.05 \\ &= 207^\circ\text{F}\end{aligned}$$

$$\begin{aligned}\text{Temperature drop across tube wall} &= 4133 \times 0.00041 \\ &= 2^\circ\text{F}\end{aligned}$$

We see that *average* tube wall temperature has risen to $366 + 2 + 207 + 2 = 577^\circ\text{F}$ from an earlier value of about 375°F . Scale formation is a serious problem. Note that the heat flux is now lower, but that does not help. *At the front end, where the heat flux is higher, the tubes would be much hotter.*

Now let us check the effect on boiler duty. It can be shown [1,8] that

$$\ln \frac{t_{g1} - t_{\text{sat}}}{t_{g2} - t_{\text{sat}}} = \frac{UA}{W_g \times C_p \times h_{\text{lf}}} \quad (32)$$

where h_{lf} is the heat loss factor. If 2% losses are assumed, then $h_{\text{lf}} = 0.98$.

We know that $U_o = 6.52$, $A_o = 6280$, $t_{g1} = 1500$, $t_{\text{sat}} = 366$. Hence,

$$\begin{aligned}\ln \frac{1500 - 366}{t_{g2} - 366} &= \frac{6.52 \times 6280}{100,000 \times 0.98 \times 0.287} \\ &= 1.456\end{aligned}$$

or

$$\frac{1500 - 366}{t_{g2} - 366} = 4.29$$

Hence $t_{g2} = 630^\circ\text{F}$ compared to 500°F earlier. The reason for t_{g2} going up is the lower U_o caused by scale formation.

Hence new duty $= 100,000 \times 0.98 \times 0.287 \times (1500 - 630) = 24.47 \times 10^6$ Btu/h. The decrease in duty is $28.13 - 24.47 = 3.66$ MM Btu/h. Even assuming

a modest energy cost of \$3/MM Btu, the annual loss due to increased fouling is $3.66 \times 3 \times 8000 = \$87,800$. The steam production in turn gets reduced.

Plant engineers should check the performance of their heat transfer equipment periodically to see if the exit gas temperature rises for the same inlet gas flow and temperature. If it does, then it is likely due to fouling on either the gas or steam side, which can be checked. Fouling on the gas side affects only the duty and steam production, but fouling on the steam side increases the tube wall temperature in addition to reducing the duty and steam production.

To ensure that variations in exit gas temperature are not due to fouling but are due to changes in gas flow or temperature, one can use simulation methods. For example, if, for the same gas flow, the inlet gas temperature is 1800°F, we can expect the exit gas temperature to rise. Under clean conditions, this can be estimated using the equation (32)

$$\frac{1500 - 366}{500 - 366} = \frac{1800 - 366}{t_{g2} - 366}, \quad \text{or} \quad t_{g2} = 535^\circ\text{F}$$

Now if, in operation, the exit gas temperature were 570–600°F, then fouling could be suspected; but if the gas temperature were only about 535°F, this would only be due to the increased gas inlet temperature. Similarly, one can consider the effect of gas flow and saturation temperature.

8.14

Q:

How is the size of a water tube boiler determined?

A:

The starting point in the design of an evaporator (Fig. 8.3) is the estimation of the overall heat transfer coefficient U . The cross-sectional data such as the number of tubes wide, spacing, and length of tubes are assumed. From the duty and log-mean temperature difference, the surface area is obtained. Then the number of rows deep is estimated. Tube wall temperature calculations and gas pressure drop evaluation then follow. A computer program is recommended to perform these tedious calculations, particularly if several alternatives have to be evaluated.

Example

200,000 lb/h of clean flue gas from an incinerator must be cooled from 1100°F to 600°F in a bare tube evaporator. Steam pressure = 250 psig saturated. Feedwater temperature = 230°F. Blowdown = 5%. Fouling factors on steam- and gas-side = 0.001 ft² h °F/Btu. Gas analysis (vol%): CO₂ = 7, H₂O = 12, N₂ = 75, O₂ = 6. Let heat loss from casing = 1%.

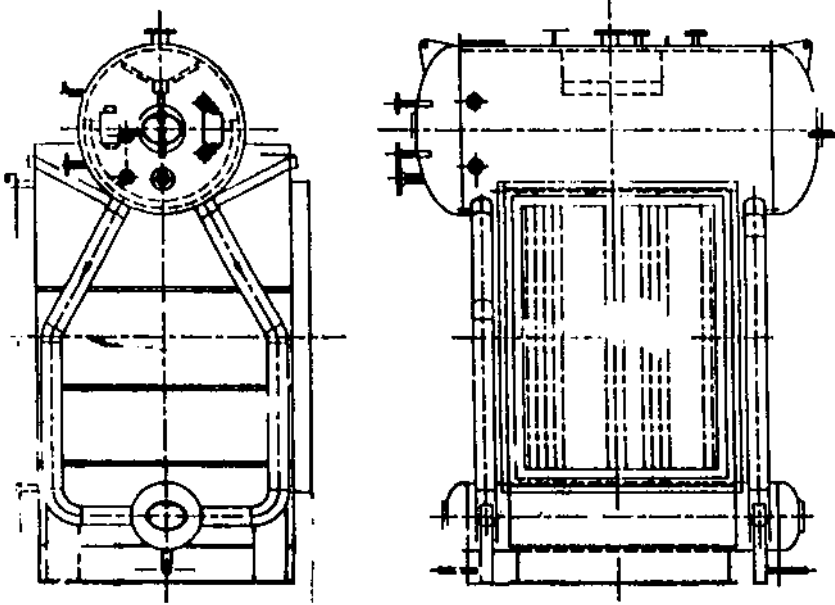

FIGURE 8.3 Boiler evaporator bundle.

Solution: Use 2×1.773 in carbon steel tubes; number wide = 24; length = 10 ft; tube spacing = 4 in. square.

$$\text{Average gas temperature} = 0.5 \times (1100 + 600) = 850^\circ\text{F}$$

Steam temperature inside tubes = 406°F . Assume tube wall temperature = 410°F (this should be checked again later).

$$\text{Film temperature} = 0.5 \times (850 + 410) = 630^\circ\text{F}$$

Gas properties at film temperature are (from Appendix) $C_p = 0.2741$, $\mu = 0.0693$, $k = 0.0255$

$$C_p \text{ at average gas temperature} = 0.282$$

$$\text{Duty } Q = 200,000 \times 0.99 \times 0.282 \times (1100 - 600) = 27.92 \text{ MM Btu/h}$$

$$\text{Steam enthalpy change} = (1201.7 - 199) + 0.05 \times (381.4 - 199) = 1011.82 \text{ Btu/lb}$$

Hence

$$\text{Steam generation} = 27.92 \times \frac{10^6}{1011.82} = 27,600 \text{ lb/h}$$

$$\text{Gas mass velocity } G = \frac{200,000 \times 12}{24 \times 12 \times (4 - 2)} = 4167 \text{ lb/ft}^2 \text{ h}$$

$$\text{Reynolds number } Re = Gd/12\mu = \frac{4167 \times 2}{12 \times 0.0693} = 10,021$$

Using Grimson's correlation,

$$Nu = 0.229 \times (10,021)^{0.632} = 77.3$$

The convective heat transfer coefficient

$$h_c = Nu \times 12 \frac{k}{d} = 77.3 \times 12 \times \frac{0.0255}{2} = 11.83 \text{ Btu/ft}^2 \text{ h } ^\circ\text{F}$$

Let us compute the nonluminous heat transfer coefficient h_N . Partial pressures of CO_2 and H_2O are 0.06 and 0.12, respectively; beam length $L = 1.08 \times (4 \times 4 - 0.785 \times 4)/2 = 6.95 \text{ in.} = 0.176 \text{ m}$.

$$\text{Average gas temperature} = 850^\circ\text{F} = 727 \text{ K}$$

Using Eq. (28b),

$$K = \frac{(0.8 + 1.6 \times 0.12) \times (1 - 0.38 \times 0.727) \times 0.19}{(0.19 \times 0.176)^{0.5}} = 0.746$$

$$\text{Gas emissivity } \varepsilon_g = 0.9 \times (1 - e^{-0.746 \times 0.176}) = 0.1107$$

Assuming that the tube wall is at 420°F (to be checked later)

$$h_N = 0.173 \times 0.9 \times 0.1107 \times \frac{13.1^4 - 8.8^4}{1310 - 880} = 0.94 \text{ Btu/ft}^2 \text{ h } ^\circ\text{F}$$

Using a conservative boiling heat transfer coefficient of $2000 \text{ Btu/ft}^2 \text{ h}$ and a tube thermal conductivity of $25 \text{ Btu/ft h } ^\circ\text{F}$; we have

$$\begin{aligned} \frac{1}{U} &= \frac{1}{0.94 + 11.83} + 0.001 + 0.001 \\ &\times \frac{2}{1.773} + \frac{2}{1.773 \times 2000} + 2 \frac{\ln(2/1.773)}{24 \times 25} \\ &= 0.0782 + 0.001 + 0.0011 + 0.000565 + 0.0004 = 0.0813 \end{aligned}$$

or

$$U = 12.3 \text{ Btu/ft}^2 \text{ h } ^\circ\text{F}$$

$$\begin{aligned} \text{Log-mean temperature difference} &= \frac{(1100 - 406) - (600 - 406)}{\ln[(1100 - 406)/(600 - 406)]} \\ &= 393^\circ\text{F} \end{aligned}$$

$$\text{Surface area required } A = \frac{27.92 \times 10^6}{12.3 \times 393} = 5776 \text{ ft}^2$$

$$A = 3.14 \times 2 \times N_d \times 24 \times 12/12 = 5776, \quad \text{or } N_d = 38.4$$

Use 40 rows deep. Surface provided = 6016 ft². Let us estimate the gas pressure drop.

$$\text{Gas density } \rho = \frac{28.2 \times 492}{359 \times (460 + 850)} = 0.0295 \text{ lb/ft}^3$$

$$\text{Friction factor } f = 10,020^{-0.15} \times (0.044 + 0.08 \times 2) = 0.0512$$

$$\Delta P_g = 9.3 \times 10^{-10} \times 4167^2 \times 40 \times \frac{0.0512}{0.0295} = 1.12 \text{ in. WC}$$

The average heat flux on tube ID basis is

$$q = 12.3 \times (850 - 406) \times 2/1.773 = 6160 \text{ Btu/ft}^2 \text{ h}$$

$$\text{Temperature drop across inside fouling layer} = 6160 \times 0.001 = 62^\circ\text{F}$$

$$\text{Temperature drop across inside film coefficient} = 6160/2000 = 3.1^\circ\text{F}$$

$$\text{Drop across tube wall} = 0.0004 \times 1.773 \times 6160/2 = 2.2^\circ\text{F}$$

Hence tube outer wall temperature = 406 + 6.2 + 3.1 + 2.2 = 418°F. Since this is close to the assumed value another iteration is not necessary.

Note that this is only the average tube wall temperature. The maximum heat flux is at the gas inlet, and one has to redo these calculations to obtain the maximum tube wall temperature. A computer program would help speed up these calculations.

8.15a

Q:

How is the off-design performance of a boiler evaluated? Predict the performance of the boiler designed earlier under the following conditions: Gas flow = 230,000 lb/h; gas inlet temperature = 1050°F; steam pressure = 200 psig. Gas analysis remains the same.

A:

Performance calculations are more involved than design calculations, because we do not know the gas exit temperature. The NTU method discussed in Q8.30 minimizes the number of iterations. However, for an evaporator, a simple procedure exists for predicting the performance.

The boiler duty Q is given by the expression

$$Q = W_g C_p (t_1 - t_2) = \frac{UA(t_1 - t_2)}{\ln[(t_1 - t_s)/(t_2 - t_s)]} \quad (33)$$

where

- t_1, t_2 = gas inlet and exit temperatures, °F
- t_s = saturation temperature, °F
- W_g = gas flow, lb/h (correcting for heat loss factor)
- C_p = gas specific heat at average gas temperature, Btu/lb °F
- U = overall heat transfer coefficient, Btu/ft² h °F
- A = surface area, ft²

Simplifying, we have

$$\ln \frac{t_1 - t_s}{t_2 - t_s} = \frac{UA}{W_g C_p} \quad (34)$$

First we have to estimate U . Assuming 580°F as the gas exit temperature, average gas temperature = 815°F and average film temperature = 613°F.

$$\mu = 0.06875, \quad k = 0.0252, \quad C_p = 0.2735$$

C_p at average gas temperature = 0.28 Btu/lb °F

$$G = 230,000 \times \frac{12}{24 \times 12 \times 2} = 4791 \text{ lb/ft}^2 \text{ h}$$

$$\text{Re} = \frac{4791 \times 2}{12 \times 0.06875} = 11,615$$

$$\text{Nu} = 0.229 \times 11,615^{0.632} = 84.9$$

or

$$h_c = 84.8 \times 12 \times 0.0252/2 = 12.9 \text{ Btu/ft}^2 \text{ h } ^\circ\text{F}$$

The nonluminous heat transfer coefficient may be computed as before and shown to be 0.895 Btu/ft² h °F.

$$\frac{1}{U} = 1/(0.895 + 12.9) + 0.001 + 0.0011 + 0.000565 + 0.0004 = 0.0756$$

$$U = 13.2 \text{ Btu/ft}^2 \text{ h } ^\circ\text{F}$$

Using Eq. (34) with saturation temperature of 388°F, we have

$$\ln \frac{1050 - 388}{t_2 - 388} = \frac{13.2 \times 6016}{230,000 \times 0.99 \times 0.28} = 1.2455$$

or

$$t_2 = 578^\circ\text{F}$$

From eq. (32)

$$Q = 230,000 \times 0.99 \times 0.28 \times (1050 - 578) = 30.0 \text{ MM Btu/h}$$

$$\text{Steam generation} = 29,770 \text{ lb/h}$$

The tube wall temperature and gas pressure drop may be computed as before. It may be shown that the gas pressure drop is 1.5 in.WC and the tube wall temperature is 408°F. Thus off-design performance is predicted for the evaporator. With an economizer or superheater, more calculations are involved as the water or steam temperature changes. Also, the duty is affected by the configuration of the exchanger, whether counterflow, parallel flow, or crossflow. The NTU method discussed in Q8.29 and Q8.30 may be used to predict the off-design performance of such an exchanger.

8.15b

Q:

Discuss the logic for determining the off-design performance of a water tube waste heat boiler with the configuration shown in Fig. 8.4.

A:

In the design procedure one calculates the size of the various heating surfaces such as superheaters, evaporators, and economizers by the methods discussed earlier based on the equation $A = Q/(U \times \Delta T)$. In this situation, the duty Q , log-mean temperature difference ΔT , and overall heat transfer coefficient U are known or can be obtained easily for a given configuration.

In the off-design procedure, which is more involved, the purpose is to predict the performance of a given boiler under different conditions of gas flow, inlet gas temperature, and steam parameters. In these calculations several trial-and-error steps are required before arriving at the final heat balance and duty, because the surface area is now known. The procedure is discussed for a simple case, configuration 1 of Fig. 8.4, which consists of a screen section, superheater, evaporator, and economizer.

1. Assume a steam flow W_s based on gas conditions.
2. Solve for the screen section, which is actually an evaporator, by using the methods discussed in Q8.15a.

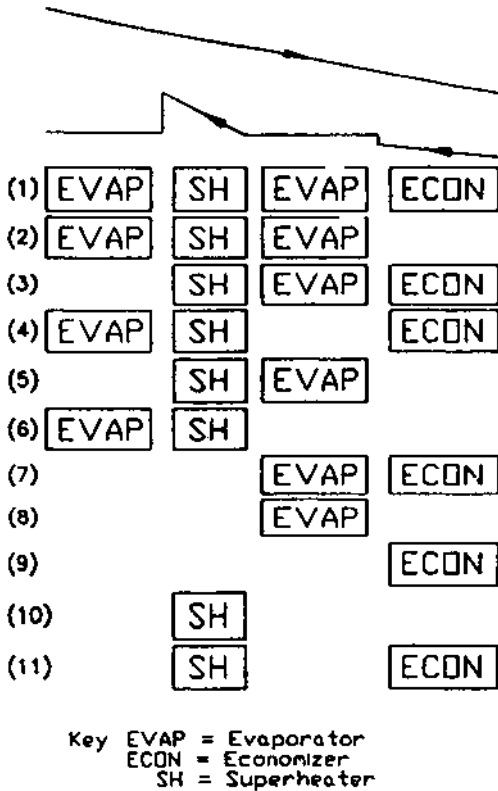

FIGURE 8.4 Configurations for water tube boiler.

- Solve for the superheater section, either using the NTU method or by trial and error. Assume a value for the duty and compute the exit gas/steam temperatures and then ΔT .

$$\begin{aligned} \text{Assumed duty } Q_a &= W_g C_p (T_{gi} - T_{go}) h_{lf} \\ &= W_s (h_{so} - h_{si}) \end{aligned}$$

where

$$\begin{aligned} h_{so}, h_{si} &= \text{enthalpies of steam at exit and inlet} \\ T_{gi}, T_{go} &= \text{gas inlet and exit temperatures.} \end{aligned}$$

Compute U . Then transferred duty is $Q_i = U \times A \times \Delta T$. If Q_a and Q_i are close, then the assumed duty and gas/steam temperatures are correct; proceed to the next step. Otherwise assume another duty and repeat step 3.

4. Solve for the evaporator section as in step 1. No trial and error is required, because the steam temperature is constant.
5. Solve for the economizer as in step 3. Assume a value for the duty and then compute exit gas/water temperatures, ΔT , and Q_t . Iteration proceeds until Q_a and Q_t match. The NTU method can also be used to avoid several iterations.
6. The entire HRSG duty is now obtained by adding the transferred duty of the four sections. The steam flow is corrected based on the actual total duty and enthalpy rise.
7. If the actual steam flow from step 6 equals that assumed in step 1, then the iterations are complete and the solution is over; if not, go back to step 1 with the revised steam flow.

The calculations become more complex if supplementary firing is added to generate a desired quantity of steam; the gas flow and analysis change as the firing temperature changes, and the calculations for U and the gas/steam temperature profile must take this into consideration. Again, if multipressure HRSGs are involved, the calculations are even more complex and cannot be done without a computer.

8.16a

Q:

Determine the tube metal temperature for the case of a superheater under the following conditions:

Average gas temperature = 1200°F

Average steam temperature = 620°F

Outside gas heat transfer coefficient = 15 Btu/ft² h °F

Steam-side coefficient = 900 Btu/ft² h °F

(Estimation of steam and gas heat transfer coefficients is discussed in Q8.03 and Q8.04.)

Tube size = 2 × 0.142 in. (2 in. OD and 0.142 in. thick)

Tube thermal conductivity = 21 Btu/ft h °F (carbon steel)

(Thermal conductivity of metals can be looked up in [Table 8.9](#).)

A:

Because the average conditions are given and the average tube metal temperature is desired, we must have the parameters noted above under the most severe conditions of operation—the highest gas temperature, steam temperature, heat flux, and so on.

TABLE 8.9 Thermal Conductivity of Metals, Btu/ft h °F

Material	Temperature (°F)														
	200	300	400	500	600	700	800	900	1000	1100	1200	1300	1400	1500	
Aluminum (annealed)															
Type 1100-0	126	124	123	122	121	120	118								
Type 3003-0	111	111	111	111	111	111	111								
Type 3004-0	97	98	99	100	102	103	104								
Type 6061-0	102	103	104	105	106	106	106								
Aluminum (tempered)															
Type 1100 (all tempers)	123	122	121	120	118	118	118								
Type 3003 (all tempers)	96	97	98	99	100	102	104								
Type 3004 (all tempers)	97	98	99	100	102	103	104								
Type 6061-T4 and T6	95	96	97	98	99	100	102								
Type 6063-T5 and T6	116	116	116	116	116	115	114								
Type 6063-T42	111	111	111	111	111	111	111								
Cast iron	31	31	30	29	28	27	26	25							
Carbon steel	30	29	28	27	26	25	24	23							
Carbon moly ($\frac{1}{2}$ %) steel	29	28	27	26	25	25	24	23							
Chrome moly steels															
1% Cr, $\frac{1}{2}$ % Mo	27	27	26	25	24	24	23	21	21						
$2\frac{1}{4}$ % Cr, 1% Mo	25	24	23	23	22	22	21	21	20	20					
5% Cr, $\frac{1}{2}$ % Mo	21	21	21	20	20	20	20	19	19	19					
12% Cr	14	15	15	15	16	16	16	16	17	17	17	18			
Austenitic stainless steels															
18% Cr, 8% Ni	9.3	9.8	10	11	11	12	12	13	13	14	14	14	15	15	
25% Cr, 20% Ni	7.8	8.4	8.9	9.5	10	11	11	12	12	13	14	14	15	15	

(continued)

TABLE 8.9 *Continued*

Material	Temperature (°F)													
	200	300	400	500	600	700	800	900	1000	1100	1200	1300	1400	1500
Admiralty metal	70	75	79	84	89									
Naval brass	71	74	77	80	83									
Copper (electrolytic)	225	225	224	224	223									
Copper and nickel alloys														
90% Cu, 10% Ni	30	31	34	37	42	47	49	51	53					
80% Cu, 20% Ni	22	23	25	27	29	31	34	37	40					
70% Cu, 30% Ni	18	19	21	23	25	27	30	33	37					
30% Cu, 70% Ni (Monel)	15	16	16	16	17	18	18	19	20	20				
Nickel	38	36	33	31	29	28	28	29	31	33				
Nickel-chrome-iron	9.4	9.7	9.9	10	10	11	11	11	12	12	12	13	13	13
Titanium (gr B)	10.9		10.4		10.5									

Let us use the concept of electrical analogy, in which the thermal and electrical resistances, heat flux and current, and temperature difference and voltage are analogous. For the thermal resistance of the tube metal,

$$R_m = \frac{d}{24K_m} \ln \frac{d}{d_i} = \frac{2}{24 \times 21} \times \ln \frac{2}{1.72}$$

$$= 0.0006 \text{ ft}^2 \text{ h } ^\circ\text{F/Btu}$$

Outside gas film resistance

$$R_o = \frac{1}{15} = 0.067 \text{ ft}^2 \text{ h } ^\circ\text{F/Btu}$$

$$\text{Inside film resistance } R_i = \frac{1}{900} = 0.0011 \text{ ft}^2 \text{ hr } ^\circ\text{F/Btu}$$

$$\text{Total resistance } R_t = 0.067 + 0.0006 + 0.0011$$

$$= 0.0687 \text{ ft}^2 \text{ h } ^\circ\text{F/Btu}$$

Hence

$$\text{Heat flux } Q = \frac{1200 - 620}{0.0687} = 8443 \text{ Btu/ft}^2 \text{ h}$$

$$\text{Temperature drop across the gas film} = 8443 \times 0.067 = 565^\circ\text{F}$$

$$\text{Temperature drop across the tube metal} = 8443 \times 0.0006 = 5^\circ\text{F}$$

$$\text{Temperature drop across steam film} = 8443 \times 0.0011 = 9.3^\circ\text{F}$$

(Here we have applied the electrical analogy, where voltage drop is equal to the product of current and resistance.) Hence,

$$\text{Average tube metal temperature} = \frac{(1200 - 565) + (620 + 9.3)}{2} = 632^\circ\text{F}$$

We note that the tube metal temperature is close to the tube-side fluid temperature. This is because the tube-side coefficient is high compared to the gas heat transfer coefficient. This trend would prevail in equipment such as water tube boilers, superheaters, economizers, or any gas–liquid heat transfer equipment.

An approximation of the tube metal temperature for bare tubes in a gas–liquid or gas–gas heat transfer device is

$$t_m = t_o - \frac{h_i}{h_i + h_o} (t_o - t_i) \quad (35)$$

where

h_i, h_o = heat transfer coefficients inside and outside the tubes, Btu/ft² h °F
 t_i, t_o = fluid temperatures inside and outside, °F

8.16b

Q:

In a boiler air heater, $h_o = 9$, $h_i = 12$, $t_i = 200^\circ\text{F}$, and $t_o = 800^\circ\text{F}$. Estimate the average tube wall temperature t_m .

A:

Using Eq. (35), we have

$$t_m = 800 - \frac{12}{12 + 9} \times (800 - 200) = 457^\circ\text{F}$$

8.17

Q:

How is the performance of fire tube and water tube boilers evaluated? Can we infer the extent of fouling from operational data? A water tube waste heat boiler as shown in Fig. 8.5 generates 10,000 lb/h of saturated steam at 300 psia when the gas flow is 75,000 lb/h and gas temperatures in and out are 1000°F and 500°F. What should the steam generation and exit gas temperature be when 50,000 lb/h of gas at 950°F enters the boiler?

A:

It can be shown as discussed in Q8.15a that in equipment with a phase change [1,8],

$$\ln \frac{t_1 - t_{\text{sat}}}{t_2 - t_{\text{sat}}} = \frac{UA}{W_g C_p}$$

which was given there as Eq. (34).

For fire tube boilers, the overall heat transfer coefficient is dependent on the gas coefficient inside the tubes; that is, U is proportional to $W_g^{0.8}$. In a water tube boiler, U is proportional to $W_g^{0.6}$. Substituting these into Eq. (34) gives us the following.

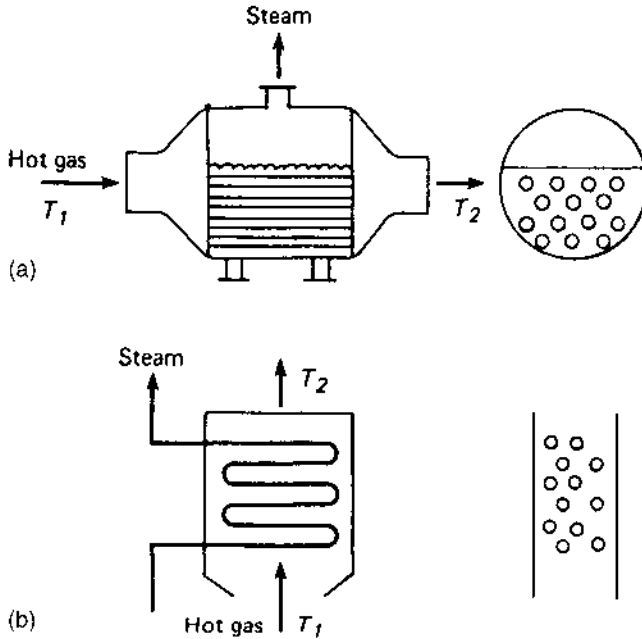

FIGURE 8.5 Sketch of (a) fire tube and (b) water tube boilers.

For fire tube boilers:

$$\ln \frac{t_1 - t_{\text{sat}}}{t_2 - t_{\text{sat}}} = \frac{K_1}{W_g^{0.2}} \quad (36)$$

For water tube boilers:

$$\ln \frac{t_1 - t_{\text{sat}}}{t_2 - t_{\text{sat}}} = \frac{K_2}{W_g^{0.4}} \quad (37)$$

As long as the fouling is not severe, Eqs. (36) and (37) predict the exit gas temperatures correctly. If t_2 is greater than predicted, we can infer that fouling has occurred. Also, if the gas pressure drop across the boiler is more than the calculated value (see [Chap. 7](#) for pressure drop calculations), we can infer that fouling has taken place.

Calculate K_2 from Eq. (37). $t_{\text{sat}} = 417$ from the steam tables (see the Appendix).

$$K_2 = \ln \left(\frac{1000 - 417}{500 - 417} \right) \times (75,000)^{0.4} = 173$$

Let us predict the exit gas temperature when $W_g = 50,000$.

$$\ln \left(\frac{950 - 417}{t_2 - 417} \right) = \frac{(50,000)^{0.4}}{173} = 2.29$$

$$t_2 = 417 + \frac{950 - 417}{\exp(2.29)} = 471^\circ\text{F}$$

Now the actual exit gas temperature is 520°F , which means that the fouling is severe.

The energy loss due to fouling is

$$\begin{aligned} Q &= 50,000 \times 0.26 \times (520 - 471) \\ &= 0.63 \times 10^6 \text{ Btu/h} \end{aligned}$$

If energy costs $\$3/\text{MM Btu}$, the annual loss of energy due to fouling will be $3 \times 0.63 \times 8000 = \$15,120$ (assuming 8000 hours of operation a year).

8.18

Q:

When and where are finned tubes used? What are their advantages over bare tubes?

A:

Finned tubes are used extensively in boilers, superheaters, economizers, and heaters for recovering energy from clean gas streams such as gas turbine exhaust or flue gas from combustion of premium fossil fuels. If the particulate concentration in the gas stream is very low, finned tubes with a low fin density may be used. However, the choice of fin configuration, particularly in clean gas applications, is determined by several factors such as tube-side heat transfer coefficient, overall size, cost, and gas pressure drop, which affects the operating cost.

Solid and serrated fins (Fig. 8.6) are used in boilers and heaters. Finned surfaces are attractive when the ratio between the heat transfer coefficients on the outside of the tubes to that inside is very small. In boiler evaporators or economizers, the tube-side coefficient could be in the range of 1500–3000 Btu/ft²h °F, and the gas-side coefficient could be in the range of 10–

Serrated fins

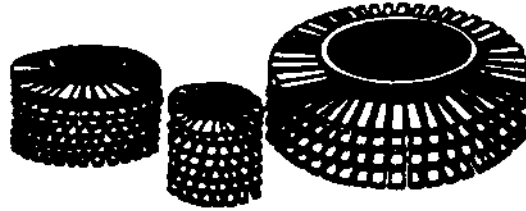

Solid fins

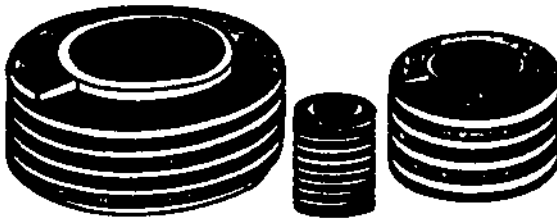

Figure 8.6 Solid and serrated fins.

20 Btu/ft² h °F. A large fin density or a large ratio of external to internal surface area is justified in this case. As the ratio between the outside and inside coefficients decreases, the effectiveness of using a large ratio of external to internal surface areas decreases. For example, in superheaters or high pressure air heaters, where the tube-side coefficient could be in the range of 30–300 Btu/ft² h °F, it does not pay to use a large fin surface; in fact, it is counter-productive, as will be shown later. A moderate fin density such as two or three fins per inch would be adequate, whereas for economizers or evaporators, five or even six fins per inch may be justified if cleanliness permits.

The other important fact to be kept in mind is that more surface area does not necessarily mean more energy transfer. It is possible, through poor choice of fin configuration, to have more surface area and yet transfer less energy. One has to look at the product of surface area and overall heat transfer coefficient and not at surface area alone. The overall heat transfer coefficient is significantly reduced as we increase the fin surface or use more fins per inch.

Finned tubes offer several advantages over bare tubes such as a compact design that occupies less space, lower gas pressure drop, lower tube-side pressure drop due to the fewer rows of tubes, and smaller overall weight and cost.

Solid fins offer slightly lower gas pressure drop than serrated fins, which have a higher heat transfer coefficient for the same fin density and configuration. Particulates, if present, are likely to accumulate on serrated finned tubes, which may be difficult to clean.

8.19a

Q:

How are the heat transfer and pressure drop over finned tubes and tube and fin wall temperatures evaluated?

A:

The widely used ESCOA correlations developed by ESCOA Corporation [9] will be used to evaluate the heat transfer and pressure drop over solid and serrated finned tubes in in-line and staggered arrangements. The basic equation for heat transfer coefficient with finned tubes is given by Eq. (3).

The calculation for tube-side coefficient h_i was discussed earlier. h_o consists of two parts, a nonluminous coefficient h_N , which is computed as discussed in Q8.07, and h_c , the convective heat transfer coefficient. Computation of h_c involves an elaborate procedure and the solving of several equations, as detailed below.

Determination of h_c [9]

$$h_c = C_3 C_1 C_5 \left(\frac{d + 2h}{d} \right)^{0.5} \times \left(\frac{t_g + 460}{t_a + 460} \right)^{0.25} \times GC_p \times \left(\frac{k}{\mu C_p} \right)^{0.67} \quad (38)$$

$$G = \frac{W_g}{[(S_T/12) - A_o]N_w L} \quad (39)$$

$$A_o = \frac{d}{12} + \frac{nbh}{6} \quad (40)$$

C_1 , C_2 , and C_3 are obtained from [Table 8.10](#).

$$\text{Re} = \frac{Gd}{12\mu} \quad (41)$$

$$s = \frac{1}{n} - b \quad (42)$$

Fin Efficiency and Effectiveness

For both solid and serrated fins, effectiveness η is

$$\eta = 1 - (1 - E) \frac{A_f}{A_t} \quad (43)$$

TABLE 8.10a Factors C_1 – C_6 for Solid and Serrated Fins in In-Line and Staggered Arrangements—old ESCOA Correlations.

Solid fins

$$C_1 = 0.25 \text{Re}^{-0.35} \quad C_2 = 0.07 + 8 \text{Re}^{-0.45}$$

In-line

$$C_3 = 0.2 + 0.65e^{-0.25h/s} \quad C_4 = 0.08(0.15S_T/d)^{-1.1(h/s)^{0.15}}$$

$$C_5 = 1.1 - (0.75 - 1.5e^{-0.7Nd})e^{-2.0S_L/S_T}$$

$$C_6 = 1.6 - (0.75 - 1.5e^{-0.7Nd})e^{-0.2(S_L/S_T)^2}$$

Staggered

$$C_3 = 0.35 + 0.65e^{-0.25h/s} \quad C_4 = 0.11(0.15S_T/d)^{-0.7(h/s)^{0.20}}$$

$$C_5 = 0.7 + (0.7 - 0.8e^{-0.15Nd^2})e^{-1.0S_L/S_T}$$

$$C_6 = 1.1 + (1.8 - 2.1e^{-0.15Nd^2})e^{-2.0(S_L/S_T)} - (0.7 - 0.8e^{-0.15Nd^2})e^{-0.6(S_L/S_T)}$$

Serrated fins

$$C_1 = 0.25 \text{Re}^{-0.35} \quad C_2 = 0.07 + 8.0 \text{Re}^{-0.45}$$

In-line

$$C_3 = 0.35 + 0.5e^{-0.35h/s} \quad C_4 = 0.08(0.15S_T/d)^{-1.1(h/s)^{0.2}}$$

$$C_5 = 1.1 - (0.75 - 1.5e^{-0.7Nd})e^{-2.0S_L/S_T}$$

$$C_6 = 1.6 - (0.75 - 1.5e^{-0.7Nd})e^{-0.2(S_L/S_T)^2}$$

Staggered

$$C_3 = 0.55 + 0.45e^{-0.35h/s} \quad C_4 = 0.11(0.05S_T/d)^{-0.7(h/s)^{0.23}}$$

$$C_5 = 0.7 + (0.7 - 0.8e^{-0.15Nd^2})e^{-1.0S_L/S_T}$$

$$C_6 = 1.1 + (1.8 - 2.1e^{-0.15Nd^2})e^{-2.0(S_L/S_T)} - (0.7 - 0.8e^{-0.15Nd^2})e^{-0.6(S_L/S_T)}$$

Source: Fintube Technologies, Tulsa, OK.

For solid fins,

$$A_f = \pi n \times \frac{4dh + 4h^2 + 2bd + 4bh}{24} \quad (44)$$

$$A_t = A_f + \pi \frac{d(1 - nb)}{12} \quad (45)$$

$$E = 1/\{1 + 0.002292 m^2 h^2 [(d + 2h)/d]^{0.5}\} \quad (46)$$

where

$$m = (24h_o/Kb)^{0.5} \quad (47)$$

For serrated fins,

$$A_f = \pi dn \frac{2h(ws + b) + bws}{12ws} \quad (48)$$

$$A_t = A_f + \pi d \frac{(1 - nb)}{12} \quad (49)$$

$$E = \frac{\tanh(mh)}{mh} \quad (50)$$

TABLE 8.10b Factors $C_1 - C_6$ for Solid and Serrated Fins in In-line and Staggered Arrangements—Revised Correlations

Solid fins

In-line

$$C_1 = 0.053(1.45 - 2.9S_L/d)^{-2.3} \text{Re}^{-0.21} \quad C_2 = 0.11 + 1.4 \text{Re}^{-0.4}$$

$$C_3 = 0.20 + 0.65e^{-0.25h/s} \quad C_4 = 0.08(0.15S_T/d)^{-1.1(h/s)^{0.15}}$$

$$C_5 = 1.1 - (0.75 - 1.5e^{-0.7Nd})e^{-2.0S_L/S_T} \quad C_6 = 1.6 - (0.75 - 1.5e^{-0.7Nd})e^{-0.2(S_L/S_T)^2}$$

$$J = C_1 C_3 C_5 [(d + 2h)/d]^{0.5} [(t_g + 460)/(t_a + 460)]^{0.5}$$

$$f = C_2 C_4 C_6 [(d + 2h)/d] [(t_g + 460)/(t_a + 460)]^{0.25}$$

Staggered

$$C_1 = 0.091 \text{Re}^{-0.25} \quad C_2 = 0.075 + 1.85 \text{Re}^{-0.3}$$

$$C_3 = 0.35 + 0.65e^{-0.25h/s} \quad C_4 = 0.11(0.05S_T/d)^{-0.7(h/s)^{0.20}}$$

$$C_5 = 0.7 + (0.7 - 0.8e^{-0.15Nd^2})[e^{-1.0S_L/S_T}] \quad C_6 = 1.1 + (1.8 - 2.1e^{-0.15Nd^2})e^{-2.0(S_L/S_T)} - [0.7 - 0.8e^{-0.15Nd^2}]e^{-0.6(S_L/S_T)}$$

$$J = C_1 C_3 C_5 [(d + 2h)/d]^{0.5} [(t_g + 460)/(t_a + 460)]^{0.5}$$

$$f = C_2 C_4 C_6 [(d + 2h)/d]^{0.5} [(t_g + 460)/(t_a + 460)]^{-0.25}$$

Serrated fins

In-line

$$C_1 = 0.053(1.45 - 2.9S_L/d)^{-2.3} \text{Re}^{-0.21} \quad C_2 = 0.11 + 1.4 \text{Re}^{-0.4}$$

$$C_3 = 0.25 + 0.6e^{-0.26h/s} \quad C_4 = 0.08(0.15S_T/d)^{-1.1(h/s)^{0.15}}$$

$$C_5 = 1.1 - (0.75 - 1.5e^{-0.7Nd})e^{-2.0S_L/S_T} \quad C_6 = 1.6 - (0.75 - 1.5e^{-0.7Nd})e^{-0.2(S_L/S_T)^2}$$

$$J = C_1 C_3 C_5 [(d + 2h)/d]^{0.5} [(t_g + 460)/(t_a + 460)]^{0.5}$$

$$f = C_2 C_4 C_6 [(d + 2h)/d] [(t_g + 460)/(t_a + 460)]^{0.25}$$

Staggered

$$C_1 = 0.091 \text{Re}^{-0.25} \quad C_2 = 0.075 + 1.85 \text{Re}^{-0.3}$$

$$C_3 = 0.35 + 0.65e^{-0.17h/s} \quad C_4 = 0.11(0.05S_T/d)^{-0.7(h/s)^{0.2}}$$

$$C_5 = 0.7 + (0.7 - 0.8e^{-0.15Nd^2})e^{-1.0S_L/S_T} \quad C_6 = 1.1 + (1.8 - 2.1e^{-0.15Nd^2})e^{-2.0(S_L/S_T)} - (0.7 - 0.8e^{-0.15Nd^2})e^{-0.6(S_L/S_T)}$$

$$J = C_1 C_3 C_5 [(d + 2h)/d]^{0.5} [(t_g + 460)/(t_a + 460)]^{0.25}$$

$$f = C_2 C_4 C_6 [(d + 2h)/d]^{0.5} [(t_g + 460)/(t_a + 460)]^{-0.25}$$

Source: Fintube Technologies, Tulsa, OK.

where

$$m = \left[\frac{24 \times h_o(b + ws)}{Kbws} \right]^{0.5} \quad (51)$$

Gas pressure drop ΔP_g is

$$\Delta P_g = (f + a) \frac{G^2 N_d}{\rho_g \times 1.083 \times 10^9} \quad (52)$$

where

$$f = C_2 C_4 C_6 \times \left(\frac{d + 2h}{d} \right)^{0.5} \quad \text{for staggered arrangement} \quad (53)$$

$$= C_2 C_4 C_6 \times \frac{d + 2h}{d} \quad \text{for in-line arrangement} \quad (54)$$

$$a = \frac{1 + B^2}{4N_d} \times \frac{t_{g2} - t_{g1}}{460 + t_g} \quad (55)$$

$$B = \left(\frac{\text{free gas area}}{\text{total area}} \right)^2 \quad (56)$$

C_2, C_4, C_6 are given in [Table 8.10](#) for solid and serrated fins.

Tube Wall and Fin Tip Temperatures

For solid fins the relationship between tube wall and fin tip temperatures is given by

$$\frac{t_g - t_f}{t_g - t_b} = \frac{K_1(mr_e) \times I_0(mr_e) + I_1(mr_e) \times K_0(mr_e)}{K_1(mr_e) \times I_0(mr_0) + K_0(mr_0) \times I_1(mr_e)} \quad (57)$$

The various Bessel functional data are shown in [Table 8.11](#) for serrated fins, treated as longitudinal fins:

$$\frac{t_g - t_f}{t_g - t_b} = \frac{1}{\cosh(mb)} \quad (58)$$

A good estimate of t_f can also be obtained for either type of fin as follows:

$$t_f = t_b + (t_g - t_b) \times (1.42 - 1.4 E) \quad (59)$$

t_b , the fin base temperature, is estimated as follows:

$$t_b = t_i + q (R_3 + R_4 + R_5) \quad (60)$$

where $R_3, R_4,$ and R_5 are resistances to heat transfer of the inside film, fouling layer, and tube wall, respectively, and heat flux q_o is given by

$$q_o = U_o(t_g - t_i) \quad (61)$$

The following example illustrates the use of the equations.

TABLE 8.11 I_0 , I_1 , K_0 , and K_1 Values for Various Arguments

x	$I_0(x)$	$I_1(x)$	$K_0(x)$	$K_1(x)$
0	1.0	0	8	8
0.1	1.002	0.05	2.427	9.854
0.2	1.010	0.10	1.753	4.776
0.3	1.023	0.152	1.372	3.056
0.4	1.040	0.204	1.114	2.184
0.5	1.063	0.258	0.924	1.656
0.6	1.092	0.314	0.778	1.303
0.7	1.126	0.372	0.66	1.05
0.8	1.166	0.433	0.565	0.862
0.9	1.213	0.497	0.487	0.716
1.0	1.266	0.565	0.421	0.602
1.2	1.394	0.715	0.318	0.434
1.4	1.553	0.886	0.244	0.321
1.6	1.75	1.085	0.188	0.241
1.8	1.99	1.317	0.146	0.183
2.0	2.28	1.591	0.114	0.140
2.2	2.629	1.914	0.0893	0.108
2.4	3.049	2.298	0.0702	0.0837
2.6	3.553	2.755	0.554	0.0653
2.8	4.157	3.301	0.0438	0.0511
3.0	4.881	3.953	0.0347	0.0402
3.2	5.747	4.734	0.0276	0.0316
3.4	6.785	5.670	0.0220	0.0250
3.6	8.028	6.793	0.0175	0.0198
3.8	9.517	8.140	0.0140	0.0157
4.0	11.30	9.759	0.0112	0.0125
4.2	13.44	11.70	0.0089	0.0099
4.4	16.01	14.04	0.0071	0.0079
4.6	19.09	16.86	0.0057	0.0063
4.8	22.79	20.25	0.0046	0.0050
5.0	27.24	24.34	0.0037	0.0040

Example

A steam superheater is designed for the following conditions.

Gas flow = 225,000 pph

Gas inlet temperature = 1050°F

Gas exit temperature = 904°F

Gas analysis (vol%): CO₂ = 3, H₂O = 7, N₂ = 75, O₂ = 15

Steam flow = 50,000 pph
 Steam temperature in = 501°F (sat)
 Steam exit temperature = 758°F
 Steam pressure (exit) = 650 psig

Tubes used: 2 × 0.120 low alloy steel tubes; 18 tubes/row, 6 deep, 10 ft long, in-line arrangement with 4 in. square pitch and nine streams. Tube inner diameter = 1.738 in.; outer diameter = 2 in.

Fins used: solid stainless steel, 2 fins/in., 0.5 in. high and 0.075 in. thick. Fin thermal conductivity $K = 15 \text{ Btu/ft h } ^\circ\text{F}$.

Determine the heat transfer coefficient and pressure drop.

Solution.

$$A_o = \frac{2}{12} + \frac{2 \times 0.5 \times 0.075}{6} = 0.17917 \text{ ft}^2/\text{ft}$$

$$G = \frac{225,000}{18 \times 10 \times [(4/12) - 0.17917]} = 8127 \text{ lb/ft}^2 \text{ h}$$

The gas properties at the average gas temperature (from the Appendix) are

$$C_p = 0.276, \quad \mu = 0.086, \quad k = 0.03172$$

$$\text{Re} = \frac{8127 \times 2}{12 \times 0.086} = 15,750$$

$$C_1 = 0.25 \times (15,750)^{-0.35} = 0.0085$$

$$s = 1/2 - 0.075 = 0.425$$

$$C_3 = 0.2 + 0.65 e^{-0.25 \times 0.5 / 0.425} = 0.6843$$

$$C_5 = 1.1 - (0.75 - 1.5 e^{-0.7 \times 6}) (e^{-2 \times 4 / 4}) = 1.0015$$

Assume that the average fin temperature is 750°F. The average gas temperature = 977°F, and steam temperature = 630°F. The fin thermal conductivity K is assumed to be 15 Btu/ft h °F. Then,

$$\begin{aligned}
 h_c &= 0.0085 \times 0.6843 \times 1.0015 \times \left(\frac{3}{2}\right)^{0.5} \\
 &\quad \times \left(\frac{977 + 460}{750 + 460}\right)^{0.25} \times 8127 \times 0.276 \\
 &\quad \times \left(\frac{0.03172}{0.276 \times 0.086}\right)^{0.67} = 20.29
 \end{aligned}$$

Using methods discussed in Q8.07, we find $h_N = 1.0$. The beam length for finned tubes is computed as $3.4 \times \text{volume/surface area}$. Hence

$$h_o = 20.29 + 1.0 = 21.29$$

$$m = \left(\frac{24 \times 21.29}{15 \times 0.075} \right)^{0.5} = 21.31$$

$$E = 1 / (1 + 0.002292 \times 21.31 \times 21.31 \times 0.5 \times 0.5 \times \sqrt{1.5}) \\ = 0.758$$

$$A_f = 3.14 \times 2 \\ \times \frac{4 \times 2 \times 0.5 + 4 \times 0.5 \times 0.5 + 2 \times 0.075 \times 2 + 4 \times 0.075 \times 5}{24} \\ = 1.426$$

$$A_t = 1.426 + 3.14 \times 2 \times \frac{1 - 2 \times 0.075}{12} = 1.871$$

Hence

$$\eta = 1 - (1 - 0.758) \frac{1.426}{1.871} = 0.8156$$

Let us compute h_i for steam. $w = 50,000/9 = 5555$ lb/h per tube. From [Table 8.2](#), factor $C = 0.34$.

$$h_i = 2.44 \times 0.34 \times \frac{(5555)^{0.8}}{(1.738)^{1.8}} = 303 \text{ Btu/ft}^2 \text{ h } ^\circ\text{F}$$

$$\frac{1}{U} = \frac{1}{21.29 \times 0.816} + 12 \times \frac{1.871}{303 \times 3.14 \times 1.738} \\ + 0.001 + 0.001 \times \frac{1.871 \times 12}{3.14 \times 1.738} + 24 \ln \left(\frac{2}{1.738} \right) \\ \times \frac{1.871}{24 \times 20 \times 3.14 \times 1.738} \\ = 0.0576 + 0.01358 + 0.001 + 0.0041 + 0.0032 \\ = 0.0795 \text{ or } U = 12.58 \text{ Btu/ft}^2 \text{ hF}$$

Calculation of Tube Wall and Fin Tip Temperature

$$\text{Heat flux } q = 12.58 \times (977 - 630) = 4365 \text{ Btu/ft}^2 \text{ h}$$

$$t_b = 630 + 4365 \times (0.0032 + 0.0041 + 0.01358) \\ = 722^\circ\text{F}$$

Using the elaborate Bessel functions, from Table 8.11,

$$mr_e = 21.29 \times \frac{1.5}{12} = 2.661 \text{ ft}, \quad mr_o = 1.7742 \text{ ft}$$

$$K_0(2.661) = 0.0517 \quad K_1(2.661) = 0.061$$

$$I_0(2.661) = 3.737, \quad I_1(2.661) = 2.921$$

$$K_0(1.7742) = 0.1515, \quad I_0(1.7742) = 1.959$$

Hence,

$$\frac{977 - t_f}{977 - 722} = \frac{0.061 \times 3.737 + 2.921 \times 0.0517}{0.061 \times 1.959 + 0.1515 \times 2.921} = 0.6743$$

$$t_f = 805^\circ\text{F}$$

Using the approximation

$$t_f = t_b + (1.42 - 1.4 \times 0.758) \times (977 - 722) = 813^\circ\text{F}$$

Note that this is only an average base and fin tip temperature. For material selection purposes one should look at the maximum heat flux, which occurs, for instance, at the gas inlet in a counterflow arrangement, and also consider the nonuniformity or maldistribution in gas and steam flow. A computer program can be developed to compute the tube wall and fin tip temperatures at various points along the tube length and the results used to select appropriate materials.

It can be noted from the above that there are a few ways to reduce the fin tip temperature:

1. Increase fin thickness. This reduces the factor m and hence t_f .
2. Increase the thermal conductivity of the fin material. This may be difficult, because the thermal conductivity of carbon steels is higher than that of alloy steels, and carbon steels can withstand temperatures only up to 850°F , whereas alloy steels can withstand up to 1300°F depending on the alloy composition.
3. Reduce h_o or the gas-side coefficient by using a lower gas mass velocity.
4. Reduce fin height or density.
5. In designs where the gas inlet temperature is very high, use a combination of bare and finned rows. The first few rows could be bare, followed by tubes with a low fin density or height or increased thickness and then followed by tubes with higher fin density or height or smaller thickness to obtain the desired boiler performance. A row-by-row analysis of the finned bundle is necessary, which requires the use of a computer program.

Computation of Gas Pressure Drop

$$C_2 = 0.07 + 8 \times (15,750)^{-0.45} = 0.1734$$

$$C_4 = 0.08 \times (0.15 \times 2)^{-1.11 \times (0.5/0.425)^{0.15}} = 0.3107$$

$$C_6 = 1$$

$$f = 0.1734 \times 0.3107 \times 1 \times \frac{3}{2} = 0.0808$$

$$B^2 = \left(\frac{0.333 - 0.17917}{0.333} \right)^2 = 0.2134$$

$$a = \frac{904 - 1050}{460 + 977} \times \frac{1 + 0.2134}{24} = -0.005$$

$$\begin{aligned} \Delta P_g &= (0.0808 - 0.0051) \times 8120 \times 8120 \times \frac{6}{0.0271 \times 1.083 \times 10^9} \\ &= 1.02 \text{ in. WC} \end{aligned}$$

(Gas density = 0.0271.)

Computer solution of the above system of equations saves a lot of time. However, I have developed a chart (Fig. 8.7) that can be used to obtain h_c (or h_g) and η values for serrated fins and an in-line arrangement for various fin configurations and gas mass velocities for gas turbine exhaust gases at an average gas temperature of 700°F. Although a computer program is the best tool, the chart can be used to show trends and the effect of fin configuration on the performance of finned surfaces. The use of the chart is explained later with an example. The following points should be noted.

1. From Fig. 8.7, it can be seen that for a given mass velocity, the higher the fin density or height, the lower the gas-side coefficient or effectiveness, which results in lower U_o . The amount of energy transferred in heat transfer equipment depends on the product of the overall heat transfer coefficient and surface area and not on the surface area alone. We will see later that one can have more surface area and yet transfer less duty due to poor choice of fin configuration.
2. Higher fin density or height results in higher ΔP_g . Even after adjusting for the increased surface area per row, it can be shown that the higher the fin density or the greater the height, the higher the gas pressure drop will be for a given mass velocity.

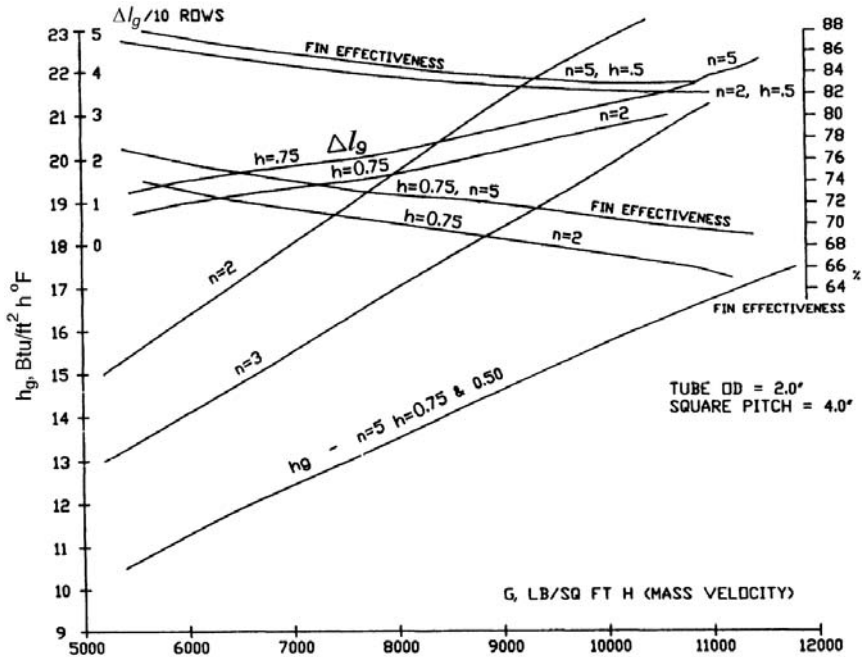

Figure 8.7 Chart of convective heat transfer coefficient and pressure drop versus fin geometry. (Data from Ref. 10)

8.19b

Q:

Describe Briggs and Young's correlation.

A:

Charts and equations provided by the manufacturer of finned tubes can be used to obtain h_c . In the absence of such data, the following equation of Briggs and Young for circular or helical finned tubes in staggered arrangement [4] can be used.

$$\frac{h_c d}{12k} = 0.134 \left(\frac{Gd}{12\mu} \right)^{0.681} \left(\frac{\mu C_p}{k} \right)^{0.33} \left(\frac{S}{h} \right)^{0.2} \left(\frac{S}{b} \right)^{0.113} \quad (62)$$

Simplifying, we have

$$h_c = 0.295 \left(\frac{G^{0.681}}{d^{0.319}} \right) \left(\frac{k^{0.67} C_p^{0.33}}{\mu^{0.351}} \right) \left(\frac{S^{0.313}}{h^{0.2} b^{0.113}} \right) \quad (63)$$

where

$$G = \text{gas mass velocity} \\ = \frac{W_g}{N_w L (S_T/12 - A_o)} \quad [\text{Eq. (39)}]$$

$$S = \text{fin clearance} = 1/n - b, \text{ in} \quad [\text{Eq. (42)}]$$

$d, h, b =$ tube outer diameter, height, and thickness, in.

$$A_o = \text{fin obstruction area} = \frac{d}{12} + \frac{nb d}{6}, \text{ ft}^2/\text{ft} \quad [\text{Eq. (40)}]$$

The gas properties $C_p, \mu,$ and k are evaluated at the average gas temperature.

The gas heat transfer coefficient h_c has to be corrected for the temperature distribution along the fin height by the fin efficiency

$$E = \frac{1}{1 + \frac{1}{3} \left(\frac{mh}{12} \right)^2 \sqrt{\frac{d+2h}{d}}} \quad (64)$$

where

$$m = \sqrt{\frac{24h_c}{K_m b}} \quad [\text{Eq. (47)}]$$

K_m is the fin metal thermal conductivity, in Btu/ft h °F.

In order to correct for the effect of finned area, a term called fin effectiveness is used. This term, η , is given by

$$\eta = 1 - (1 - E) \times \frac{A_f}{A_t} \quad [\text{Eq. 43}]$$

where the finned area A_f and total area A_t are given by

$$A_f = \frac{\pi n}{24} (4dh + 4h^2 + 2bd + 4bh) \quad [\text{Eq. (44)}]$$

$$A_t = A_f + \frac{\pi d}{12} (1 - nb) \quad [\text{Eq. (45)}]$$

n is the fin density in fins/in. The factor

$$F = \frac{k^{0.67} C_p^{0.33}}{\mu^{0.35}} \quad (65)$$

is given in [Table 8.12](#).

The overall heat transfer coefficient with finned tubes, U , can be estimated as $U = 0.85\eta h_c$, neglecting the effect of the non-luminous heat transfer coefficient.

TABLE 8.12 Factor F for
Finned Tubes

Temp (°F)	F
200	0.0978
400	0.1250
600	0.1340
800	0.1439
1000	0.1473
1200	0.1540
1600	0.1650

Example

Determine the gas-side heat transfer coefficient when 150,000 lb/h of flue gases at an average temperature of 900°F flow over helically finned economizer tubes with the following parameters:

- d = tube outer diameter = 2.0 in.
- n = fins/in. = 3
- h = fin height = 1 in.
- b = fin thickness = 0.06 in.
- L = effective length of tubes = 10.5 ft
- N_w = number of tubes wide = 12
- S_T = transverse pitch = 4.5 in. (staggered)

Calculate A_o , A_f , and A_t . From Eq. (40),

$$A_o = \frac{2}{12} + 3 \times 0.06 \times \frac{1}{6} = 0.2 \text{ ft}^2/\text{ft}$$

From Eq. (44),

$$A_f = \left(\pi \times \frac{3}{24} \right) \times (4 \times 2 \times 1 + 4 \times 1 \times 1 + 2 \times 0.06 \times 2 + 4 \times 0.06) = 4.9 \text{ ft}^2/\text{ft}$$

From Eq. (45),

$$A_t = 4.9 + \pi \frac{2 \times (1 - 3 \times 0.06)}{12} = 5.33 \text{ ft}^2/\text{ft}$$

From Eq. (39),

$$G = \frac{150,000}{12 \times 10.5 \times (4.5/12 - 0.2)} = 6800 \text{ lb/ft}^2 \text{ h}$$

$$\text{Fin pitch } S = \frac{1}{3} - 0.06 = 0.27$$

Using Eq. (65) with $F = 0.145$ from Table 8.12 gives us

$$h_c = 0.295 \times 6880^{0.681} \times 0.145 \\ \times \frac{0.27^{0.313}}{2^{0.319} \times 1^{0.2} \times 0.06^{0.113}} = 12.74 \text{ Btu/ft}^2 \text{ h } ^\circ\text{F}$$

Calculate fin efficiency from Eq. (64). Let metal thermal conductivity of fins (carbon steel) = 24 Btu/ft h °F.

$$m = \sqrt{\frac{24 \times 12.74}{24 \times 0.06}} = 14.57$$

$$E = \frac{1}{1 + 0.33 \times (14.57 \times 1/12)^2 \times \sqrt{(2 + 2)/2}} = 0.6$$

$$\text{Fin effectiveness } \eta = 1 - (1 - 0.6) \frac{4.9}{5.33} = 0.63$$

Hence,

$$\eta h_c = 0.63 \times 12.74 = 8 \text{ Btu/ft}^2 \text{ h } ^\circ\text{F}$$

K_m ranges from 23 to 27 Btu/ft h °F for carbon steels, depending on temperature [1]. For alloy steels it is lower.

8.19c

Q:

This example shows how one can predict the performance of a given heat transfer surface. A superheater is designed for the following conditions: 18 tubes/row, 6 rows deep, 10 ft long with 2 fins/in., 0.5 in. high and 0.075 in. thick solid fins. It has 18 streams. Surface area = 2022 ft². Tube spacing = 4 in. square.

Predict the performance of the superheater under the following conditions:

Gas flow = 150,000 lb/h at 1030°F

Steam flow = 35,000 lb/h at 615 psig sat

Flue gas analysis (vol%): CO₂ = 7, H₂O = 12, N₂ = 75, O₂ = 6

Heat loss = 2%

Surface area $A = 2022 \text{ ft}^2$

Let us say that U has been estimated as $10.6 \text{ Btu/ft}^2 \text{ h } ^\circ\text{F}$ using methods discussed earlier.

A:

Let us use the NTU method to predict the performance of the superheater. This is discussed in Q8.30. The superheater is in counterflow arrangement.

$$\text{Energy transferred } Q = \varepsilon C_{\min}(t_{g_1} - t_{s_1})$$

where

$$\varepsilon = \frac{1 - \exp[-NTU(1 - C)]}{1 - C \exp[-NTU(1 - C)]}$$

$$C = C_{\min}/C_{\max}$$

C_{\min} is the lower of (mass \times specific heat of the fluid) on gas and steam sides.

T_{g_1}, t_{s_1} = gas and steam temperature at inlet to superheater, $^\circ\text{F}$

Use 491°F for steam saturation temperature.

Though NTU methods generally require no iterations, a few rounds are necessary in this case to evaluate the specific heat for steam and gas, which are functions of temperature. However, let us assume that the steam-side specific heat = 0.6679 and that of gas = $0.286 \text{ Btu/lb } ^\circ\text{F}$.

$$C_{\text{gas}} = 150,000 \times 0.98 \times 0.286 = 42,042$$

$$C_{\text{steam}} = 35,000 \times 0.6679 = 23,376$$

Hence, $C_{\min} = 23,376$.

$$C = \frac{23,376}{42,042} = 0.556$$

$$NTU = UA/C_{\min} = \frac{10.62 \times 2022}{23,376} = 0.9186$$

Hence

$$\varepsilon = \frac{1 - \exp[-0.9186 \times (1 - 0.556)]}{1 - 0.556 \exp[-0.9186 \times (1 - 0.556)]} = 0.5873$$

Hence

$$\text{Energy transferred } Q = 0.5873 \times 23,376 \times (1030 - 491) = 6.7 \text{ MM Btu/h}$$

$$\text{Exit steam temperature} = \frac{6,700,000}{35,000 \times 0.06679} + 491 = 287 + 491 = 778^\circ\text{F}$$

$$\text{Exit gas temperature} = 1030 - \frac{6,700,000}{150,000 \times 0.286 \times 0.98} = 871^\circ\text{F}$$

Steam-side pressure drop is obtained as follows:

$$\begin{aligned} \text{Equivalent length of tube} &= (18/9) \times 6 \times 10 + (18/9) \times 6 \times 2.5 \times 2 \\ &= 180 \text{ ft} \end{aligned}$$

Use 185 ft for estimation. Specific volume of steam at the average steam conditions of 620 psia and 635°F is 0.956 ft³/lb.

$$\text{Pressure drop} = 3.36 \times 0.02 \times 0.956 \times \left(\frac{35}{9}\right)^2 \times \frac{185}{1.738^5} = 11.4 \text{ psi}$$

Gas-side pressure drop may be estimated using the chart in Fig. 8.7 and is about 0.6 in. WC.

8.20

Q:

A gas turbine HRSG evaporator operates under the following conditions:

$$\text{Gas flow} = 230,000 \text{ lb h (vol \% CO}_2 = 3, \text{ H}_2\text{O} = 7, \text{ N}_2 = 75, \text{ O}_2 = 15)$$

$$\text{Gas inlet temperature} = 1050^\circ\text{F}$$

$$\text{Exit gas temperature} = 406^\circ\text{F}$$

$$\text{Duty} = 230,000 \times 0.99 \times 0.27 \times (1050 - 406) = 39.6 \text{ MM Btu/h}$$

$$\text{Steam pressure} = 200 \text{ psig}$$

$$\text{Feedwater temperature} = 230^\circ\text{F}$$

$$\text{Blowdown} = 5\%$$

$$\text{Fouling factors} = 0.001 \text{ ft}^2 \text{ h }^\circ\text{F/Btu on both gas and steam sides}$$

$$\text{Arrangement: 4 in. square pitch}$$

$$\text{Tubes used: } 2 \times 1.773 \text{ in., 24 tubes/row, 11 ft long}$$

$$\text{Fins: 5 fins/in., 0.75 in. high, 0.05 in. thick, serrated}$$

Determine the overall heat transfer coefficient and pressure drop using the chart.

A:

The chart shown in Fig. 8.7 has been developed for serrated fins in in-line arrangement for the above gas analysis. Users may develop their charts for

various configurations or use a computer program. The chart is based on an average gas temperature of 700°F and a gas analysis (vol%) of CO₂ = 3, H₂O = 7, N₂ = 75, O₂ = 15.

$$A_o = \frac{2}{12} + \left(5 \times 0.75 \times \frac{0.05}{6} \right) = 0.1979 \text{ ft}^2/\text{ft}$$

$$G = \frac{230,000}{24 \times 11 \times (0.3333 - 0.1979)} = 6434 \text{ lb}/\text{ft}^2 \text{ h}$$

Average gas temperature = 728°F. From Table 8.12, the correction factor is 0.1402/0.139 = 1.008.

For $G = 6434$, h_c from the chart = 11.6 Btu/ft² h °F, Gas pressure drop over 10 rows = 1.7 in.WC.

Fin effectiveness = 0.75

h_N is small, about 0.4 Btu/ft² h °F

$$h_o = 0.75 \times (0.4 + 1.008 \times 11.6) = 9.07 \text{ Btu}/\text{ft}^2 \text{ h } ^\circ\text{F}$$

The fin total surface area can be shown to be 5.7 ft²/ft.

Hence

$$\frac{A_f}{A_i} = \frac{5.7 \times 12}{3.14 \times 1.773} = 12.29$$

Let tube-side boiling coefficient = 2000 Btu/ft² h °F and fin thermal conductivity = 25 Btu/ft h °F

$$\frac{1}{U} = \frac{1}{9.07} + 0.001 \times 12.29 + 0.001 + \frac{12.29}{2000} + 12.29 \times 2 \times \frac{\ln(2/1.773)}{24/25}$$

$$= 0.110 + 0.01229 + 0.001 + 0.006145 + 0.004935 = 0.1344$$

$$U = 7.4 \text{ Btu}/\text{ft}^2 \text{ h } ^\circ\text{F}$$

$$\begin{aligned} \text{Log-mean temperature difference} &= \frac{(1050 - 388) - (406 - 388)}{\ln[(1050 - 388)/(406 - 388)]} \\ &= 178^\circ\text{F} \end{aligned}$$

$$\text{Surface area required} = \frac{39.6 \times 10^6}{178 \times 7.4} = 30,063 \text{ ft}^2$$

$$\text{Number of rows deep required} = \frac{30,063}{24 \times 11 \times 5.7} = 20$$

$$\text{Gas pressure drop} = 1.7 \times 2 = 3.4 \text{ in. Wc}$$

8.21

Q:

How does a finned surface compare with a bare tube bundle for the same duty?

A:

Let us try to design a bare tube boiler for the same duty as above. Use the same tube size and spacing, tubes per row, and length. Use 2×1.773 in. bare tubes.

Using the procedure described in Q8.14, we can show that $U = 13.05$ Btu/ft² h °F and that 124 rows are required for the same duty. The results are shown in Table 8.13.

It may be seen that the finned tube bundle is much more compact and has fewer rows and also a lower gas pressure drop. It also weighs less and should cost less. Therefore, in clean gas applications such as gas turbine exhaust or fume incineration plants, extended surfaces may be used for evaporators. In dirty gas applications such as municipal waste incineration or with flue gases containing ash or solid particles, bare tubes are preferred. Finned tubes may also be used in packaged boiler evaporators.

However, the heat flux inside the finned tubes is much larger, which is a concern in high gas temperature situations. The tube wall temperature is also higher. Hence when the gas temperature is high, say 1400–1700°F, we use a few

TABLE 8.13 Comparison of Bare Tube and Finned Tube Boilers

	Bare tube	Finned tube
Gas flow, lb/h		230,000
Inlet gas temperature, °F		1050
Exit gas temperature, °F		407
Duty, MM Btu/h		39.5
Steam pressure, psig		200
Feedwater temperature, °F		230
Steam flow, lb/h		39,200
Surface area, ft ²	17,141	30,102
Overall heat transfer coeff, Btu/ft ² h °F	13.0	7.39
Gas pressure drop, in. WC	5.0	3.5
Number of rows deep	124	20
Heat flux, Btu/ft ² h	9707	60,120
Tube wall temperature, °F	409	516
Weight of tubes, lb	81,100	38,800

Tubes/row = 24; effective length = 11 ft; 4 in. square spacing. Gas analysis (vol%) CO₂ = 3 H₂ = 7, N₂ = 75, O₂ = 15. Blowdown = 5%.

bare tubes followed by tubes with, say, 2 fins/in. fin density and then go back to four or more fins per inch. This ensures that the gas stream is cooled before entering tube bundles with a high fin density and that the tubes are operating at reasonable temperatures, which should also lower the fin tip temperatures.

When the tube-side fouling is large, it has the same effect as a low tube-side heat transfer coefficient, resulting in poor performance when a high fin density is used. See Q8.24. One may also note the significant difference in surface areas and not be misled by this value.

8.22

Q:

Which is the preferred arrangement for finned tubes, in-line or staggered?

A:

Both in-line and staggered arrangements have been used with extended surfaces. The advantages of the staggered arrangement are higher overall heat transfer coefficients and smaller surface area. Cost could be marginally lower depending on the configuration. Gas pressure drop could be higher or lower depending on the gas mass velocity used. If cleaning lanes are required for soot blowing, an in-line arrangement is preferred.

Both solid and serrated fins are used in the industry. Generally, solid fins are used in applications where the deposition of solids is likely.

The following example illustrates the effect of arrangement on boiler performance.

Example

150,000 lb/h of turbine exhaust gases at 1000°F enter an evaporator of a waste heat boiler generating steam at 235 psig. Determine the performance using solid and serrated fins and in-line versus staggered arrangements. Tube size is 2×1.77 in.

Solution. Using the ESCOA correlations and the methodology discussed above for evaporator performance, the results shown in [Table 8.14](#) were arrived at.

8.23

Q:

How does the tube-side heat transfer coefficient or fouling factor affect the selection of fin configuration such as fin density, height, and thickness?

TABLE 8.14 Comparison Between Staggered and In-Line Designs for Nearly Same Duty and Pressure Drop^a

	Serrated fins		Solid fins	
	In-line	Staggered	In-line	Staggered
Fin config.	5 × 0.75 × 0.05 × 0.157		2 × 0.75 × 0.05 × 0	
Tubes/row	18	20	18	20
No. of fins deep	20	16	20	16
Length	10	10	10	11
U_o	7.18	8.36	9.75	10.02
ΔP_g	3.19	3.62	1.72	1.42
Q	23.24	23.31	21.68	21.71
Surface	20,524	18,244	9802	9584

^a Duty, MM Btu/h; ΔP_g , in. WC; surface, ft²; temperature, °F; U_o , Btu/ft² h °F.

A:

Fin density, height, and thickness affect the overall heat transfer coefficient as can be seen in Fig. 8.7. However, the tube-side coefficient also has an important bearing on the selection of fin configuration.

A simple calculation can be done to show the effect of the tube-side coefficient on U_o . It was mentioned earlier that the higher the tube-side coefficient, the higher the ratio of external to internal surface area can be. In other words, it makes no sense to use the same fin configuration, say 5 fins/in. fin density, for a superheater as for an evaporator.

Rewriting Eq. (3) based on tube-side area and neglecting other resistances,

$$\frac{1}{U_i} = \frac{1}{h_i} + \frac{A_i/A_t}{h_o \eta} \tag{66}$$

Using the data from Fig. 8.7, U_i values have been computed for different fin densities and for different h_i values for the configuration indicated in Table 8.15. The results are shown in Table 8.15. Also shown are the ratio of U_i values between the 5 and 2 fins/in. designs as well as their surface area.

The following conclusions can be drawn [10].

1. As the tube-side coefficient decreases, the ratio of U_i values (between 5 and 2 fins/in.) decreases. With $h_i = 20$, the U_i ratio is only 1.11. With an h_i of 2000, the U_i ratio is 1.74. What this means is that as h_i decreases, the benefit of increasing the external surface becomes less attractive. With 2.325 times the surface area we have only 1.11-fold improvement in U_i . With a higher h_i of 2000, the increase is better, 1.74.

TABLE 8.15 Effect of h_i on U_i

h_i	20		100		1000	
n , fins/in.	2	5	2	5	2	5
G , lb/ft ² h	5591	6366	5591	6366	5591	6366
$A_t/A_i\eta h_o^a$	0.01546	0.00867	0.01546	0.00867	0.01546	0.00867
U_o	2.73	1.31	7.03	4.12	11.21	8.38
U_i	15.28	17.00	39.28	53.55	62.66	109
Ratio U_i	1.11		1.363		1.74	
Ratio ΔP_g	1.6		1.3		1.02	

Calculations based on 2.0×0.105 tubes, 29 tubes/row, 6 ft long, 0.05 in. thick serrated fins; tubes on 4.0 in. square pitch; fin height = 0.75 in.; gas flow = 150,000 pph; gas inlet temp = 1000°F.

^a Surface area A_t of 2 fins/in. tube = 2.59 ft²/ft, and for 5 fins/in., $A_t = 6.02$ ft²/ft.

2. A simple estimation of tube wall temperature can tell us that the higher the fin density, the higher the tube wall temperature will be. For the case of $h_i = 100$, with $n = 2$, $U_i = 39.28$, gas temperature = 900°F, and fluid temperature of 600°F,

$$\begin{aligned} \text{Heat flux } q_i &= (900 - 600) \times 39.28 \\ &= 11,784 \text{ Btu/ft}^2 \text{ h} \end{aligned}$$

The temperature drop across the tube-side film ($h_i = 100$) = $11,784/100 = 118^\circ\text{F}$. The wall temperature = $600 + 118 = 718^\circ\text{F}$.

With $n = 5$, $U_i = 53.55$, $q_i = 53.55 \times 300 = 16,065 \text{ Btu/ft}^2 \text{ h}$. Tube wall temperature = $600 + 16,065/100 = 761^\circ\text{F}$. Note that we are comparing for the same height. The increase in wall temperature is 43°F .

3. The ratio of the gas pressure drop between the 5 and 2 fins/in. designs (after adjusting for the effect of U_i values and differences in surface area for the same energy transfer) increases as the tube-side coefficient reduces. It is 1.6 for $h_i = 20$ and 1.02 for $h_i = 2000$. That is, when h_i is smaller, it is prudent to use a smaller fin surface.

Effect of Fouling Factors

The effects of inside and outside fouling factors ff_i and ff_o are shown in [Tables 8.16](#) and [8.17](#). The following observations can be made.

1. With a smaller fin density, the effect of ff_i is less. With 0.01 fouling and 2 fins/in., $U_o = 6.89$ compared with 10.54 with 0.001 fouling. The ratio is 0.65. With 5 fins/in., the corresponding values are 4.01 and

TABLE 8.16 Effect of ff_i , Tube-Side Fouling Factor^a

Fins/in., n	2	2	5	5
U_o , clean	11.21	11.21	8.38	8.38
ff_i	0.001	0.01	0.001	0.01
U_o , dirty	10.54	6.89	7.56	4.01
U_o as %	100	65	100	53

^a Tube-side coefficient = 2000.

7.46, the ratio being 0.53. That means that with increased tube-side fouling it makes sense to use a lower fin density or smaller ratio of external to internal surface area. The same conclusion was reached with a smaller tube-side coefficient.

2. The effect of ff_o is less significant, because it is not enhanced by the ratio of external to internal surface area. A review of Eq. (1) tells us that the tube-side heat transfer coefficient or fouling factor is increased by the ratio of the external to internal surface area, and hence its effect is easily magnified.

8.24

Q:

Compare the effect of tube-side fouling on bare, low, and high finned tubes.

A:

Three boiler evaporators were designed using bare tubes, 2 fins/in. and 5 fins/in., to cool 150,000 lb/h of clean flue gases from 1000°F to 520°F. The effect of fouling factors of 0.001 and 0.01 on duty, tube wall temperatures, and steam production are shown in [Table 8.18](#). The following points may be observed [11].

1. With bare tubes, the higher tube-side fouling results in the lowest reduction in duty, from 19.65 to 18.65 MM Btu/h, with the exit gas

TABLE 8.17 Effect of ff_o , Outside Fouling Factor^a

Fins/in., m	2	2	5	5
U_o , clean	11.21	11.21	8.38	8.38
ff_o	0.001	0.01	0.001	0.01
U_o , dirty	11.08	10.08	8.31	7.73
U_o as %	100	91	100	93

^a Tube-side coefficient = 2000.

TABLE 8.18 Effect of Fouling Factors

Case	1	2	3	4	5	6
1. Gas temp in, °F	1000	1000	1000	1000	1000	1000
2. Exit temp, °F	520	545	520	604	520	646
3. Duty, MM Btu/h	19.65	18.65	19.65	16.30	19.65	14.60
4. Steam flow, lb/h	19,390	18,400	19,390	16,110	19,390	14,400
5. ff_i , ft ² h °F/Btu	0.001	0.01	0.001	0.01	0.001	0.01
6. Heat flux, Btu/ft ² h	9314	8162	35,360	23,080	55,790	30,260
7. Wall temp, °F	437	516	490	680	530	760
8. Fin temp, °F	—	—	730	840	725	861
9. A_t/A_i	1.13	1.13	5.6	5.6	12.3	12.3
10. Fins	bare	bare	(2 × 0.75 × 0.05 × 0.157)		(5 × 0.75 × 0.05 × 0.157)	
11. Tubes per row	20	20	20	20	20	20
12. No. deep	60	60	16	16	10	10
13. Length, ft	8	8	8	8	8	8
14. Surface area, ft ²	5024	5024	6642	6642	9122	9122
15. Gas Δp , in. WC	3.0	3.1	1.80	1.90	2.0	2.1

temperature going up to 545°F from 520°F—see columns 1 and 2. With 2 fins/in., the exit gas temperature increases from 520°F to 604°F, with the duty reducing to 16.3 from 19.65 MM Btu/h. The steam generation is about 3200 lb/h lower. With 5 fins/in., the reduction in duty and steam generation are the greatest.

- The heat flux increases with fin density. Therefore, with high temperature units one has to be concerned with DNB conditions; however, heat flux decreases because of fouling.
- The tube wall temperature increases significantly with fin density. The same fouling factor results in a much higher tube wall temperature for finned tubes than for bare tubes. The tube wall temperature increases from 530°F to 760°F with 5 fins/in., and from 437°F to 516°F for bare tubes. The effect of fouling is more pronounced in tubes of high fin density, which means that high fin density tubes have to be kept cleaner than bare tubes. Demineralized water and good water treatment are recommended in such situations.

8.25

Q:

How is the weight of solid and serrated fins determined?

A: The weight of fins is given by the formulas

$$W_f = 10.68 \times Fbn \times (d_o + h) \times (h + 0.03) \quad \text{for solid fins}$$

$$W_f = 10.68 \times Fbnd_o \times (h + 0.12) \quad \text{for serrated fins}$$

where

W_f = the fin weight, lb/ft (The segment width does not affect the weight.)

b = fin thickness, in.

n = fin density, fins/in.

h = fin height, in.

d_o = tube outer diameter, in.

Factor F corrects for material of fins and is given in Table 8.19 [9].

The weight of the tubes has to be added to the fin weight to give the total weight of the finned tube. Tube weight per unit length is given by

$$W_t = 10.68 \times F \times d_m \times t_m \quad (68)$$

where

d_m = mean diameter of tube, in.

t_m = average wall thickness, in.

Example

Determine the weight of solid carbon steel fins on a 2 in. OD tube if the fin density is 5 fins/in., height = 0.75 in., and thickness = 0.05 in. Average tube wall thickness is 0.120 in.

TABLE 8.19 Table of F Factors

Material	F
Carbon steel	1
Type 304, 316, 321 alloys	1.024
Type 409, 410, 430	0.978
Nickel 200	1.133
Inconel 600, 625	1.073
Incoloy 800	1.013
Incoloy 825	1.038
Hastelloy B	1.179

Solution. F from Table 8.19 = 1. Using Eq. (67a), we have

$$W_f = 10.68 \times 1 \times 0.05 \times 5 \times (2 + 0.75) \\ \times (0.75 + 0.03) = 5.725 \text{ lb/ft}$$

The tube weight has to be added to this. The tube weight is given by

$$W_t = 10.68 \times 1.94 \times 0.12 = 2.49 \text{ lb/ft}$$

Hence the total weight of the finned tube = $2.49 + 5.725 = 8.215 \text{ lb/ft}$.

8.26

Q:

What is the effect of fin thickness and conductivity on boiler performance and tube and fin tip temperatures?

A:

Table 8.20 gives the performance of a boiler evaporator using different fins.

2×0.120 carbon steel tubes; 26 tubes/row, 14 deep, 20 ft long

$4 \times 0.75 \times 0.05$ thick solid fins; surface area = 35,831 ft²

$4 \times 0.75 \times 0.102$ thick solid fins; surface area = 36,426 ft²

In-line arrangement, 4 in. square pitch.

Gas flow = 430,000 lb/h at 1400°F in; vol%, CO₂ = 8.2, H₂O = 20.9,

N₂ = 67.51, O₂ = 3.1

Steam pressure = 635 psig

Fouling factors = 0.001 ft² h °F/Btu on both gas and steam.

It can be seen that

1. Due to the slightly larger surface area and higher heat transfer coefficient, more duty is transferred with higher fin thickness.

TABLE 8.20 Fin Configuration and Performance

Fin cond. (Btu/ft h °F)	Fin thickness (in.)	Duty (MM Btu/h)	Tube temp. (°F)	Fin temp. (°F)	U (Btu/ft ² h °F)
25	0.05	104	673	996	8.27
25	0.102	106.35	692	874	9.00
15	0.05	98.35	642	1164	6.78
15	0.102	103.48	670	990	7.98

2. The overall heat transfer coefficient is increased owing to higher fin effectiveness for the same fin conductivity and greater fin thickness.
3. Lower fin conductivity reduces the fin effectiveness and the overall heat transfer coefficient U , and hence less duty is transferred.
4. Though fin tip temperature is reduced with greater fin thickness, owing to improved effectiveness the tube wall temperature increases. This is due to the additional resistance imposed by the larger surface area.

8.27a

Q:

Is surface area an important criterion for evaluating different boiler designs?

A:

The answer is yes if the person evaluating the designs is knowledgeable in heat transfer-related aspects and no if the person simply compares different designs looking only for surface area information. We have seen this in the case of fire tube boilers (Q8.11), where, due to variations in tube size and gas velocity, different designs with over 40–50% difference in surface areas were obtained for the same duty. In the case of water tube boilers also, due to variations in tube size, pitch, and gas velocity, one can have different surface areas for the same duty; hence one has to be careful in evaluating boilers based only on surface areas.

In the case of finned tube boilers, in addition to tube size, pitch, and arrangement (staggered or in-line), one has to review the fin configuration—the height, thickness, and fin density. The higher the fin density or ratio of external to internal surface area, the lower the overall heat transfer coefficient will be even though the surface area can be 100–200% greater. It is also possible to transfer more duty with less surface area by proper selection of fin geometry.

Example

A superheater is to be designed for the conditions shown in [Table 8.21](#). Study the different designs possible with varying fin configurations.

Solution. Using the methods discussed above, various designs were arrived at, with the results shown in [Table 8.22](#) [10]. Several interesting observations can be made. In cases 1 and 2, the same energy of 19.8 MM Btu/h is transferred; however, the surface area of case 2 is much higher because of the high fin density, which decreases U , the overall heat transfer coefficient. Also, the tube wall and fin tip temperatures are higher because of the large ratio of external to internal surface area.

TABLE 8.21 Data for HRSG Superheater

Gas flow = 240,000 lb/h
Gas inlet temperature = 1300°F
Gas analysis (vol%)
CO ₂ = 7
H ₂ O = 12
N ₂ = 75
O ₂ = 6

Comparing cases 3 and 4, we see that case 3 transfers more energy with less surface area because of better fin selection. Thus it is not a good idea to select or evaluate designs based on surface area alone, because this can be misleading. In addition, excessive fin surface can lead to higher tube wall and fin tip temperatures, forcing one to use better materials and increasing the cost. Some purchasing managers believe incorrectly that if they can get more surface area for the same price, they are getting a good deal. Nothing could be further from the truth.

8.27b**Q:**

When extended surfaces are used, the choice of fin density is generally arrived at based on optimization studies as illustrated below. Varying the fin density affects

TABLE 8.22 Effect of Fin Geometry on Superheater Performance

	Case 1	Case 2	Case 3	Case 4
Duty, MM Btu/h	19.8	19.87	22.62	22.44
Exit steam temperature, °F	729	730	770	768
Gas pressure drop, in. WC	0.8	1.3	1.2	1.5
Exit gas temp, °F	1017	1016	976	979
Fins/in.	2	4.5	2.5	5.5
Fin height, in.	0.5	0.75	0.75	0.625
Fin thickness, in.	0.075	0.075	0.075	0.075
Surface area, ft ²	2965	5825	5223	7106
Max tube wall temp, °F	890	968	956	988
Fin tip temperature, °F	996	1095	1115	1069
Overall heat transfer coeff, °F	12.1	6.19	8.49	6.16
Tube-side pressure drop, psi	12	8	12.3	10
Number of rows deep	6	4	6	5

the gas pressure drop, surface area, and weight of the boiler, not to mention the tube wall and fin tip temperatures. An incineration plant evaporator is to be designed to cool 550,000 lb/h of clean flues gases from 1000°F to about 460°F. Steam pressure is 250 psig sat. Feedwater enters the evaporator at 230°F. Flue gas analysis (vol%) is CO₂ = 7, H₂O = 12, N₂ = 75 O₂ = 6. Fouling factors are 0.001 ft² h °F/Btu on both the gas and steam sides. Study the effect of fin configuration on the design.

A:

The calculation procedure for finned tubes is detailed in Q8.19a–Q8.19c. Only the results from using a computer program will be discussed here. Using serrated fins of density 2, 4, and 6 fins/in., 0.75 in. high, 0.05 in. thick with 30 tubes/row, 4 in. square pitch configuration, the lengths were varied to obtain different gas mass velocities. The number of rows deep was adjusted to obtain an exit gas temperature of about 460°F or a duty of about 82 MM Btu/h. Figure 8.8 shows the results from the study.

As the gas mass velocity increases we see that the gas pressure drop increases, whereas the surface area decreases for both 2 and 6 fins/in. designs, which should be obvious. The surface area required for the 6 fins/in. design is much larger than with 2 fins/in. As discussed in Q8.27a, the heat transfer coefficient with higher fin density or large external fin surface area is lower. The weight of the tube bundle is also higher with higher fin density.

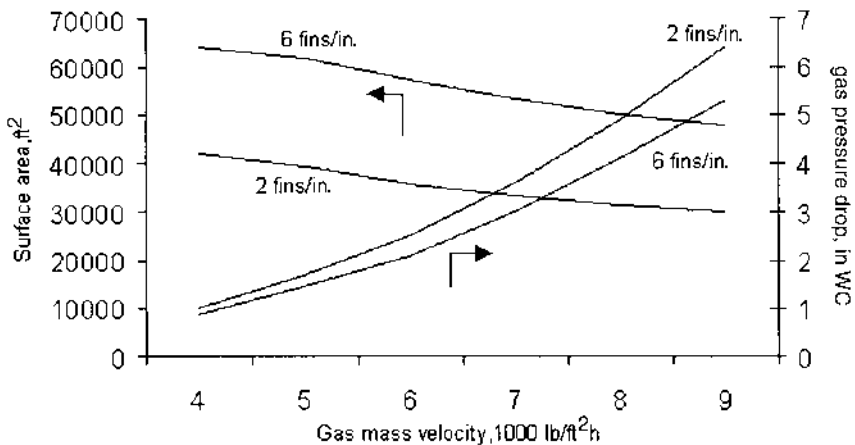

FIGURE 8.8 Effect of fin geometry on HRSG surface area and gas pressure drop.

Table 8.23 summarizes the designs for the 2 and 6 fins/in. cases for the same duty and gas pressure drop of 4 in.WC. It is seen that the surface area is much larger with the 6 fins/in. design. The tube wall temperature is also higher due to the higher heat flux, and the weight is slightly more. However, the fabrication cost may be less due to the smaller number of rows deep. Depending on the design, the drum length could also be smaller due to this. One may evaluate these factors and select the optimum design.

Note on Surface Areas

As discussed earlier, surface areas from different designs should be interpreted carefully. *One should not select a design based on surface area considerations.* With higher fin density, the heat transfer coefficient will be lower and vice versa. Simply looking at a spreadsheet that shows surface areas of tubes of different suppliers and deciding that the design with more surface area is better is technically incorrect. As can be seen below, the higher surface area option has higher tube wall temperature and heat flux inside the tubes. If one wants to compare alternative designs, one should look at UA , the product of overall heat transfer coefficient U and surface area A and not the surface area alone. The equation for energy transfer is $Q = UA\Delta T$. Q and ΔT being the same, UA should be constant for the various options. Unless one knows how to calculate the heat transfer coefficients, comparison of surface areas alone should not be attempted, because it can be misleading. Factors such as tube size, spacing, geometry, and fin configuration affect U . The discussion also applies to fire tube boilers, where tube sizes and gas velocities can impact surface areas.

TABLE 8.23 Design of a Boiler with 2 and 6 Fins/in.

Fins/in.	2	6
Gas mass velocity, lb/ft ² h	7500	8000
Surface area, ft ²	32,500	50,020
Tube wall temp, °F	488	542
Fin tip temp, °F	745	724
Tubes wide	30	30
Tube length, ft	16	17.6
No. of rows deep	26	14
Weight, lb	59,650	64,290

8.28

Q:

How are tubular air heaters designed?

A:

Let W_g , and W_a be the gas and air quantities. Normally, flue gas flows inside the tubes while air flows across the tubes in crossflow fashion, as shown in Fig. 8.9. Carbon steel tubes of $1\frac{1}{2}$ –3.0 in. OD are generally used. Thickness ranges from 0.06 to 0.09 in. because high pressures are not involved. The tubes are arranged in in-line fashion and are connected to the tube sheets at the ends. More than one block may be used in series; in this case, air flows across the tube bundles with a few turns. Hence, while calculating log-mean temperature difference, we must consider correction factors F_T .

Flue gas velocity is in the range of 40–70 fps, and air-side mass velocities range from 4000 to 8000 lb/ft² h. N_w and N_d , the numbers of tubes wide and deep, can be decided on the basis of duct dimensions leading to the air heater. In the case of a separate heater, we have the choice of N_w or N_d . In a boiler, for example, duct dimensions at the economizer section fix dimensions of the air heater also, because the air heater is located below the economizer.

To size the air heater, first determine the total number of tubes N_t [1]:

$$N_t = \frac{0.05W_g}{d_i^2 \rho_g V_g} \quad (69)$$

S_T/d and S_L/d range from 1.25 to 2.0. For the gas-side heat transfer coefficient h_i , Eq. (12) is used:

$$h_i = 2.44 \times w^{0.8} \frac{C}{d_i^{1.8}}$$

Values of C are evaluated at average flue gas temperature.

The air-side heat transfer coefficient h_o is given by Eq. (19) (variation in h_o between staggered and in-line arrangements is small in the range of Reynolds number and pitches one comes across),

$$h_o = 0.9 \times G^{0.6} \frac{F}{d^{0.4}}$$

The value h_o is calculated at air film temperature.

Because the temperature drops across the gas and air films are nearly the same, unlike in an evaporator or superheater, film temperature is approximated as

$$t_f = (3t_g + t_a)/4 \quad (70)$$

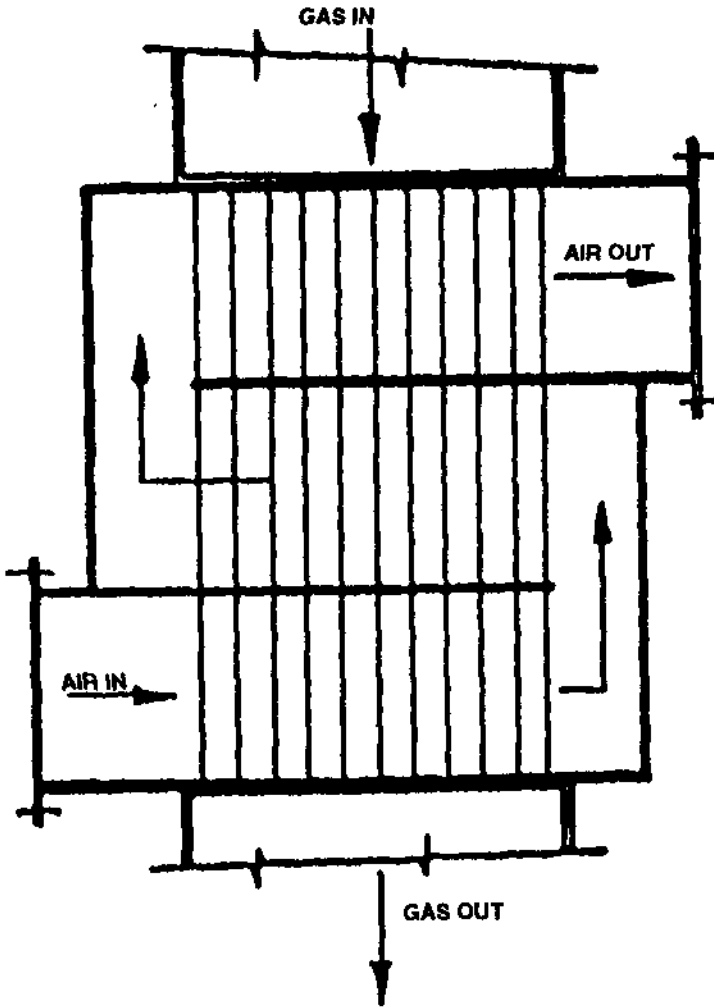

FIGURE 8.9 Tubular air heater.

where t_g and t_a refer to the average of gas and air temperatures. Calculate U using

$$\frac{1}{U} = \frac{1 \times d}{h_i d_i} + \frac{1}{h_o} \quad (71)$$

Metal resistance is neglected. Air- and gas-side pressure drops can be computed by Eqs. (26) and (28) of Chapter 7, after surfacing is done:

$$\Delta P_g = 93 \times 10^{-6} \times f w^2 \frac{L + 5d_i}{\rho_g d_i^5}$$

$$\Delta P_{\text{air}} = 9.3 \times 10^{-10} \times f G^2 \frac{N_d}{\rho_{\text{air}}}$$

It is also good to check for partial load performance to see if dew point corrosion problems are likely. Methods like air bypass or steam-air heating must be considered. Vibration of tube bundles must also be checked.

C and F are given in Table 8.24 for easy reference.

Example

A quantity of 500,000 lb/h of flue gas from a boiler is cooled from 700°F; 400,000 lb/h of air at 80°F is heated to 400°F. Design a suitable tubular air heater. Carbon steel tubes of 2 in. OD and 0.087 in. thickness are available.

Solution. Assume that duct dimensions are not a limitation. Hence, the bundle arrangement is quite flexible. Choose $S_T/d = 1.5$ and $S_L/d = 1.25$ in. in-line; use a maximum flue gas velocity of 50 ft/s.

From an energy balance, assuming negligible losses and for a specific heat of 0.25 for gas and 0.24 for the air side,

$$\begin{aligned} Q &= 500,000 \times 0.25 \times (700 - t) \\ &= 400,000 \times 0.24 \times (400 - 80) \\ &= 30.7 \times 10^6 \text{ Btu/h} \end{aligned}$$

TABLE 8.24 C and F Factors for Calculating h_i and h_o of Tubular Air

Temp (°F)	C	F
200	0.162	0.094
400	0.172	0.103
600	0.18	0.110
800	0.187	0.116

Hence, the gas temperature leaving the air heater is 454°F. The average flue gas temperature is $(700 + 454)/2 = 577^\circ\text{F}$. Let the molecular weight of the flue gas be 30. Then

$$\rho_g = \frac{30}{359} \times \frac{492}{460 + 577} = 0.0396 \text{ lb/cu ft}$$

From Eq. (69),

$$N_t = \frac{0.05 \times 500,000}{1.826^2 \times 0.0396 \times 50} = 3800$$

$$S_T = 3.0 \text{ in.}, \quad S_L = 2.5 \text{ in.}$$

Let $N_w = 60$. Hence, the width of the air heater is

$$60 \times \frac{3.0}{12} = 15 \text{ ft}$$

$N_d = 63$ because $N_t = N_w \times N_d$, so

$$\text{Depth} = 63 \times 2.5/12 = 13.2 \text{ ft}$$

At 577°F, from Table 8.24 we have $C = 0.178$:

$$\begin{aligned} h_i &= 2.44 \times \left(\frac{500,000}{3780} \right)^{0.8} \times \frac{0.178}{(1.826)^{1.8}} \\ &= 7.2 \text{ Btu/ft}^2 \text{ h } ^\circ\text{F} \end{aligned}$$

To estimate h_o , G is required. This requires an idea of L . We must assume a value for the length and check later to see if it is sufficient. Hence, it is a trial-and-error approach. Try $L = 15$ ft:

$$FGA = \frac{S_T - d}{12} \times N_w L = \frac{1}{12} \times 60 \times 15 = 75 \text{ ft}^2$$

$$G = 400,000/75 = 5333 \text{ lb/ft}^2 \text{ h}$$

Average gas and air temperatures are

$$t_g = 577^\circ\text{F}, \quad t_a = 240^\circ\text{F}$$

$$t_f = \frac{3 \times 577 + 240}{4} = 492^\circ\text{F}$$

From Table 8.24, F is 0.105. Then

$$h_o = 0.9 \times 5333^{0.6} \times 0.105/2^{0.4} = 12.3 \text{ Btu/ft}^2 \text{ h } ^\circ\text{F}$$

$$\begin{aligned}\frac{1}{U} &= \frac{1}{7.2} \times \frac{2.0}{1.826} + \frac{1}{12.3} \\ &= 0.152 + 0.081 = 0.233\end{aligned}$$

$$U = 4.3 \text{ Btu/ft}^2 \text{ h } ^\circ\text{F}$$

We must calculate F_T , the correction factor for ΔT , for the case of one fluid mixed and the other unmixed. From Fig. 8.10 (single-pass crossflow),

$$R = \frac{700 - 454}{400 - 80} = 0.77$$

$$P = \frac{400 - 80}{700 - 80} = 0.516$$

$$F_T = 0.9$$

Therefore,

$$\Delta T = 0.9 \times \frac{(454 - 80) - (700 - 400)}{\ln(374/300)} = 302^\circ\text{F}$$

$$\begin{aligned}A &= \frac{Q}{U \times \Delta T} = \frac{30.7 \times 10^6}{4.3 \times 302} = 23,641 \text{ ft}^2 \\ &= \frac{\pi \times 2}{12} \times 3780 L \\ L &= 11.95 \text{ ft}\end{aligned}$$

Hence, the assumed L is not correct. Try $L = 11.0$ ft.

$$FGA = \frac{11}{15} \times 75 = 55 \text{ ft}^2$$

$$G = 7272 \text{ lb/ft}^2 \text{ h}$$

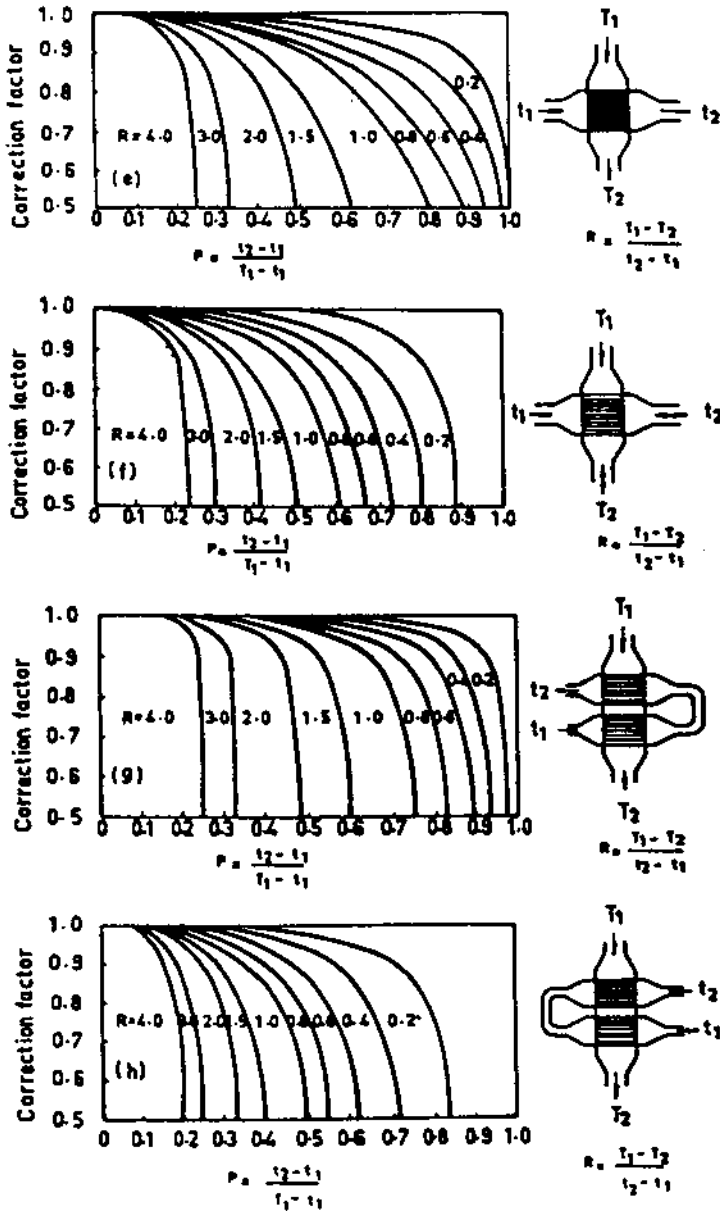

FIGURE 8.10 Crossflow correction factors (From Refs. 1 and 2).

Taking ratios,

$$h_o = \left(\frac{7272}{5333}\right)^{0.6} \times 12.3 = 14.8 \text{ Btu/ft}^2 \text{ h } ^\circ\text{F}$$

$$\frac{1}{U} = \frac{1 \times 2.0}{7.2 \times 1.826} + \frac{1}{14.8} = 0.152 + 0.067 \\ = 0.219$$

$$U = 4.56 \text{ Btu/ft}^2 \text{ h } ^\circ\text{F}$$

$$A = \frac{30.7 \times 10^6}{4.56 \times 302} = 22,293 \text{ ft}^2, \quad L = 11.25 \text{ ft}$$

The calculated and assumed lengths are close to each other, and the design may be frozen. Check the metal temperature at the exit portion. Because the gas-side resistance and air film resistances are 0.152 and 0.067, the metal temperature at the exit of the air heater can be calculated as follows. The drop across the gas film will be

$$\frac{0.152(454 - 80)}{0.152 + 0.067} = 260^\circ\text{F}$$

Metal temperature will be $454 - 260 = 194^\circ\text{F}$.

If the flue gas contains sulfur, dew point corrosion may occur at the exit. The air-side heat transfer coefficient is high, so the drop across its film is low compared to the gas-side film drop. If we increase the flue gas heat transfer coefficient, the drop across its film will be low and the metal temperature will be higher.

8.29

Q:

How is the off-design performance evaluated?

The air heater described in Q8.28 works at partial loads. $W_g = 300,000 \text{ lb/h}$, and flue gas enters the air heater at 620°F . $W_a = 250,000 \text{ lb/h}$, and the air temperature is 80°F . Check the exit gas temperatures of gas and air.

A:

Assume the gas leaves the air heater at 400°F . Then

$$Q = 300,000 \times 0.25 \times (620 - 400) \\ = 250,000 \times 0.24(t - 80) = 16.5 \times 10^6$$

Air temperature leaving = 355°F

To calculate h_i and h_o , see Table 8.24. At an average flue gas temperature of $(620 + 400)/2 = 510^\circ\text{F}$, $C = 0.175$. And at a film temperature of $[3 \times 510 + (355 + 80)/2]/4 = 437^\circ\text{F}$, $F = 0.104$.

$$h_i = 2.44 \times \left(\frac{300,000}{3825}\right)^{0.8} \times \frac{0.175}{(1.826)^{1.8}}$$

$$= 4.75 \text{ Btu/ft}^2 \text{ h } ^\circ\text{F}$$

$$G = \frac{250,000}{75} = 3333 \text{ lb/ft}^2 \text{ h}$$

$$h_o = 0.9 \times \frac{(3333)^{0.6}}{2^{0.4}} \times 0.104 = 9.22 \text{ Btu/ft}^2 \text{ h } ^\circ\text{F}$$

$$\frac{1}{U} = \frac{2}{1.826 \times 4.73} + \frac{1}{9.22} = 0.238$$

$$U = 4.22 \text{ Btu/ft}^2 \text{ h } ^\circ\text{F}$$

From Fig. 8.10,

$$P = \frac{355 - 80}{620 - 80} = 0.51$$

$$R = \frac{620 - 400}{355 - 80} = 0.8$$

$$F_T = 0.9$$

$$\Delta T = 0.9 \times \frac{(400 - 80) - (620 - 355)}{\ln(320/265)} = 262^\circ\text{F}$$

Transferred $Q = 4.2 \times 262 \times 23,640 = 26 \times 10^6 \text{ Btu/h}$, and assumed $Q = 16.5 \times 10^6 \text{ Btu/h}$. They don't tally.

Since the air heater can transfer more energy, assume a higher air temperature, 390°F , at the exit:

$$Q = 250,000 \times 0.24(390 - 80) = 18.6 \times 10^6$$

$$= 300,000 \times 0.25 \times (620 - t)$$

Then gas temperature leaving = 372°F .

Assume U remains the same at $4.2 \text{ Btu/ft}^2 \text{ h } ^\circ\text{F}$. Then

$$R = 0.8, \quad P = 0.574, \quad F_T = 0.82$$

$$\Delta T = 213^\circ\text{F}$$

$$\text{Transferred } Q = 4.2 \times 23,640 \times 213$$

$$= 21.1 \times 10^6 \text{ Btu/h}$$

Again, they don't tally. Next, try $Q = 20 \times 10^6$ Btu/h.

Air temperature leaving = 410°F

Gas temperature leaving = 353°F

$$F_T = 0.75, \quad \Delta T = 0.75 \times 242 = 182^\circ\text{F}$$

$$\text{Transferred } Q = 4.2 \times 23,640 \times 182 = 18 \times 10^6 \text{ Btu/h}$$

Again, try an exit air temperature at 400°F. Then

$$\begin{aligned} Q &= 250,000 \times 0.24 \times (400 - 80) \\ &= 19.2 \times 10^6 \text{ Btu/h} \end{aligned}$$

$$\begin{aligned} \text{Exit gas temperature} &= 620 - \frac{19.2 \times 10^6}{300,000 \times 0.25} \\ &= 364^\circ\text{F} \end{aligned}$$

$$R = 0.8, \quad P = \frac{320}{540} = 0.593, \quad F_T = 0.77$$

$$\Delta T = 0.77 \times \frac{284 - 220}{\ln(284/220)} = 193^\circ\text{F}$$

$$\text{Transferred } Q = 4.2 \times 193 \times 23,640 = 19.16 \times 10^6 \text{ Btu/h}$$

$$Q = 19.2 \times 10^6 \text{ Btu/h}$$

The gas leaves at 364°F against 454°F at full load.

Metal temperature can be computed as before. At lower loads, metal temperature is lower, and the air heater should be given some protection. This protection may take two forms: Bypass part of the air or use steam to heat the air entering the heater to 100–120°F. Either of these will increase the average metal temperature of the air heater. In the first case, the air-side heat transfer coefficient will fall. Because U decreases, the gas temperature leaving the air heater will increase and less Q will be transferred. Hence, metal temperature will increase. In the second case, air temperature entering increases, so protection of the metal is ensured. Again, the gas temperature differential at the exit will be higher, causing a higher exit gas temperature.

Example

Solve the problem using the NTU method.

Solution. Often the NTU method is convenient when trial-and-error calculations of the type shown above are involved.

$$NTU = \frac{UA}{C_{\min}} = \frac{4.2 \times 23,640}{250,000 \times 0.24} = 1.65$$

$$\frac{C_{\text{mixed}}}{C_{\text{unmixed}}} = \frac{250,000 \times 0.24}{300,000 \times 0.25} = 0.80$$

ε = effectiveness

$$= 1 - \exp\left\{-\frac{C_{\max}}{C_{\min}}[1 - \exp(-NTU \times C)]\right\} \quad (72)$$

$$= 1 - \exp\{-1.25[1 - \exp(-1.65 \times 0.8)]\}$$

$$= 0.59$$

$$\text{Effectiveness} = 0.59 = \frac{\text{air temperature rise}}{620 - 80}$$

Air temperature rise = 319°F

Air temperature leaving = 319 + 80 = 399°F

This compares well with the answer of 400°F. When U does not change much, this method is very handy.

8.30

Q:

Predict the exit gas and water temperatures and the energy transferred in an economizer under the following conditions:

t_{g1} = gas temperature in = 1000°F

t_{w1} = water temperature in = 250°F

A = surface area = 6000 ft²

W_g = gas flow = 75,000 lb/h

W_w = water flow = 67,000 lb/h

U = overall heat transfer coefficient = 8 Btu/ft² h °F

C_{pg} = gas specific heat = 0.265 Btu/lb °F

C_{pw} = water specific heat = 1 Btu/lb °F

A:

Figure 8.11 shows the arrangement of an economizer. A trial-and-error method is usually adopted to solve for the duty of any heat transfer equipment if the surface area is known. This procedure is detailed in Q8.29. Alternatively, the *number of transfer units (NTU) method* predicts the exit temperatures and duty. For more on

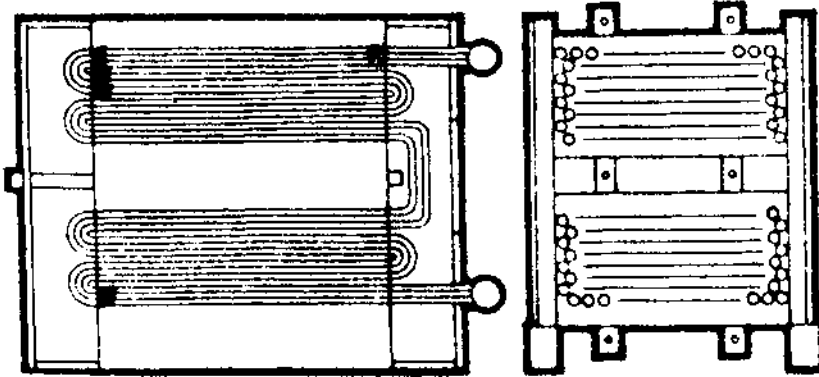

FIGURE 8.11 Economizer.

this theory, the reader is referred to any textbook on heat transfer [2]. Basically, the duty Q is given by

$$Q = \varepsilon C_{\min}(t_{g1} - t_{w1}) \quad (73)$$

where ε depends on the type of flow, whether counterflow, parallel flow, or crossflow. In economizers, usually a counterflow arrangement is adopted. ε for this is given by

$$\varepsilon = \frac{1 - \exp[-NTU \times (1 - C)]}{1 - C \exp[-NTU \times (1 - C)]} \quad (74)$$

where

$$NTU = \frac{UA}{C_{\min}} \quad \text{and} \quad C = \frac{(WC_p)_{\min}}{(WC_p)_{\max}}$$

$$(WC_p)_{\min} = 75,000 \times 0.265 = 19,875$$

$$(WC_p)_{\max} = 67,000 \times 1 = 67,000$$

$$C = \frac{19,875}{67,000} = 0.3$$

$$NTU = 8 \times \frac{6000}{19,875} = 2.42$$

Substituting into Eq. (74) yields

$$\varepsilon = \frac{1 - \exp(-2.42 \times 0.7)}{1 - 0.3 \times \exp(-2.42 \times 0.7)} = 0.86$$

From Eq. (73),

$$Q = 0.86 \times 19,875 \times (1000 - 250) \\ = 12.8 \times 10^6 \text{ Btu/h}$$

Let us calculate the exit water and gas temperatures.

$$Q = W_w C_{pw}(t_{w2} - t_{w1}) = W_g C_{pg}(t_{g1} - t_{g2})$$

Hence,

$$t_{w2} = 250 + 12.8 \times \frac{10^6}{67,000 \times 1} = 441^\circ\text{F}$$

$$t_{g2} = 1000 - 12.8 \times \frac{10^6}{75,000 \times 0.265} = 355^\circ\text{F}$$

The NTU method can be used to evaluate the performance of other types of heat transfer equipment, Table 8.25 gives the effectiveness factor ε .

TABLE 8.25 Effectiveness Factors

Exchanger type	Effectiveness
Parallel flow, single-pass	$\varepsilon = \frac{1 - \exp[-NTU \times (1 + C)]}{1 + C}$
Counterflow, single-pass	$\varepsilon = \frac{1 - \exp[-NTU \times (1 - C)]}{1 - C \exp[-NTU \times (1 - C)]}$
Shell-and-tube (one shell pass; 2, 4, 6, etc., tube passes)	$\varepsilon_1 = 2 \left[1 + C + \frac{1 + \exp[-NTU \times (1 + C^2)^{1/2}]}{1 - \exp[-NTU \times (1 + C^2)^{1/2}]} \times (1 + C^2)^{1/2} \right]^{-1}$
Shell-and-tube (n shell passes; 2n, 4n, 6n, etc., tube passes)	$\varepsilon_n = \left[\left(\frac{1 - \varepsilon_1 C}{1 - \varepsilon_1} \right)^n - 1 \right] \left[\left(\frac{1 - \varepsilon_1 C}{1 - \varepsilon_1} \right)^n - C \right]^{-1}$
Crossflow, both streams unmixed	$\varepsilon \approx 1 - \exp\{C \times NTU^{0.22} [\exp(-C \times NTU^{0.78}) - 1]\}$
Crossflow, both streams mixed	$\varepsilon = NTU \left[\frac{NTU}{1 - \exp(-NTU)} + \frac{NTU \times C}{1 - \exp(-NTU \times C)} - 1 \right]^{-1}$
Crossflow, stream C_{\min} unmixed	$\varepsilon = C \{1 - \exp[-C \{1 - \exp(-NTU)\}]\}$
Crossflow, stream C_{\max} unmixed	$\varepsilon = 1 - \exp\{-C \{1 - \exp(-NTU \times C)\}\}$

8.31

Q:

How is the natural or free convection heat transfer coefficient in air determined?

A:

The situations of interest to steam plant engineers would be those involving heat transfer between pipes or tubes and air as when an insulated pipe runs across a room or outside it and heat transfer can take place with the atmosphere.

Simplified forms of these equations are the following [12].

1. Horizontal pipes in air:

$$h_c = 0.5 \times \left(\frac{\Delta T}{d_o} \right)^{0.25} \quad (75a)$$

where

ΔT = temperature difference between the hot surface and cold fluid, °F

d_o = tube outside diameter, in.

2. Long vertical pipes:

$$h_c = 0.4 \times \left(\frac{\Delta T}{d_o} \right)^{0.25} \quad (75b)$$

3. Vertical plates less than 2 ft high:

$$h_c = 0.28 \left(\frac{\Delta T}{z} \right)^{0.25} \quad (75c)$$

where z = height, ft.

4. Vertical plates more than 2 ft high:

$$h_c = 0.3 \times (\Delta T)^{0.25} \quad (75d)$$

5. Horizontal plates facing upward:

$$h_c = 0.38 \times (\Delta T)^{0.25} \quad (75e)$$

6. Horizontal plates facing downward:

$$h_c = 0.2 \times (\Delta T)^{0.25} \quad (75f)$$

Example

Determine the heat transfer coefficient between a horizontal bare pipe of diameter 4.5 in. at 500°F and atmospheric air at 80°F.

Solution.

$$h_c = 0.5 \times \left(\frac{500 - 80}{4.5} \right)^{0.25} = 1.55 \text{ Btu/ft}^2 \text{ h } ^\circ\text{F}$$

Note that the above equations have been modified to include the effect of wind velocity in the insulation calculations; see Q8.51.

8.32

Q:

How is the natural or free convection heat transfer coefficient between tube bundles and liquids determined?

A:

One has to determine the free convection heat transfer coefficient when tube bundles such as desuperheater coils or drum preheat coils are immersed in boiler water in order to arrive at the overall heat transfer coefficient and then the surface area. Drum coil desuperheaters are used instead of spray desuperheaters when solids are not permitted to be injected into steam. The heat exchanger is used to cool superheated steam (Fig. 8.12), which flows inside the tubes while the cooler water is outside the tubes in the drum. Drum heating coils are used to keep boiler water hot for quick restart or to prevent freezing.

In this heat exchanger, steam condenses inside tubes while the cooler water is outside the tubes. The natural convection coefficient between the coil and drum water has to be determined to arrive at the overall heat transfer coefficient and then the size or surface area.

The equation that relates h_c with other parameters is [2]

$$\text{Nu} = 0.54 \left(\frac{d^3 \rho^2 g \beta \Delta T}{\mu^2} \times \frac{\mu C_p}{k} \right)^{0.25} \quad (76)$$

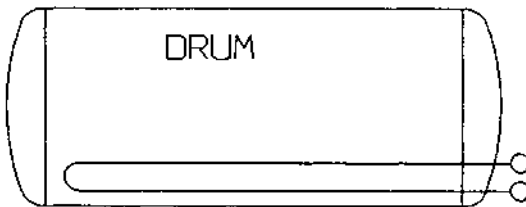

FIGURE 8.12 Exchanger inside boiler drum.

Simplifying the above we have

$$h_c = 144 \times \left(k^3 \times \frac{\rho^2 \beta \Delta T C_p}{\mu d_o} \right)^{0.25} \quad (77)$$

where

d_o = tube outer diameter, in.

k = fluid thermal conductivity, Btu/ft h °F

C_p = fluid specific heat, Btu/lb °F

β = volumetric expansion coefficient, °R⁻¹

ΔT = temperature difference between tubes and liquid, °F

μ = viscosity of fluid, lb/ft h

ρ = fluid density, lb/ft³

In Eq. (77) all the fluid properties are evaluated at the mean temperature between fluid and tubes except for the expansion coefficient, which is evaluated at the fluid temperature.

Fluid properties at saturation conditions are given in [Table 8.26](#).

Example

1 in. pipes are used to maintain boiler water at 100°F in a tank using steam at 212°F, which is condensed inside the tubes. Assume that the pipes are at 200°F, and estimate the free convection heat transfer coefficient between pipes and water.

Solution. From [Table 8.26](#), at a mean temperature of 150°F,

$$k = 0.381, \quad \mu = 1.04, \quad \beta = 0.0002, \quad \rho_f = 61.2$$

$$C_p = 1.0, \quad \Delta T = 100, \quad d_o = 1.32$$

$$\begin{aligned} h_c &= 144 \times \left(0.381^3 \times \frac{61.2^2 \times 1.0 \times 0.0002 \times 100}{1.04 \times 1.32} \right)^{0.25} \\ &= 188 \text{ Btu/ft}^2 \text{ h } ^\circ\text{F} \end{aligned}$$

8.33

Q:

Estimate the surface area of the heat exchanger required to maintain water in a boiler at 100°F using steam at 212°F as in the example of Q8.32. Assume that the heat loss to the cold ambient from the boiler is 0.5 MM Btu/h. Steam is condensed inside the tubes. 1 in. schedule 40 pipes are used.

TABLE 8.26 Properties of Saturated Water

t (°F)	C_p (Btu/lb °F)	ρ (lb/ft ³)	μ (lb/ft h)	ν (ft ² /h)	k (Btu/h ft °F)	α (ft ² /h)	β (°R ⁻¹)	N
32	1.009	62.42	4.33	0.0694	0.327	0.0052	0.03×10^{-3}	13.37
40	1.005	62.42	3.75	0.0601	0.332	0.0053	0.045	11.36
50	1.002	62.38	3.17	0.0508	0.338	0.0054	0.070	9.41
60	1.000	62.34	2.71	0.0435	0.344	0.0055	0.10	7.88
70	0.998	62.27	2.37	0.0381	0.349	0.0056	0.13	6.78
80	0.998	62.17	2.08	0.0334	0.355	0.0057	0.15	5.85
90	0.997	62.11	1.85	0.0298	0.360	0.0058	0.18	5.13
100	0.997	61.99	1.65	0.0266	0.364	0.0059	0.20	4.52
110	0.997	61.84	1.49	0.0241	0.368	0.0060	0.22	4.04
120	0.997	61.73	1.36	0.0220	0.372	0.0060	0.24	3.65
130	0.998	61.54	1.24	0.0202	0.375	0.0061	0.27	3.30
140	0.998	61.39	1.14	0.0186	0.378	0.0062	0.29	3.01
150	0.999	61.20	1.04	0.0170	0.381	0.0063	0.31	2.72
160	1.000	61.01	0.97	0.0159	0.384	0.0063	0.33	2.53
170	1.001	60.79	0.90	0.0148	0.386	0.0064	0.35	2.33
180	1.002	60.57	0.84	0.0139	0.389	0.0064	0.37	2.16
190	1.003	60.35	0.79	0.0131	0.390	0.0065	0.39	2.03
200	1.004	60.13	0.74	0.0123	0.392	0.0065	0.41	1.90
210	1.005	59.88	0.69	0.0115	0.393	0.0065	0.43	1.76
220	1.007	59.63	0.65	0.0109	0.395	0.0066	0.45	1.66
230	1.009	59.38	0.62	0.0104	0.395	0.0066	0.47	1.58
240	1.011	59.10	0.59	0.0100	0.396	0.0066	0.48	1.51
250	1.013	58.82	0.56	0.0095	0.396	0.0066	0.50	1.43
260	1.015	58.51	0.53	0.0091	0.396	0.0067	0.51	1.36
270	1.017	58.24	0.50	0.0086	0.396	0.0067	0.53	1.28
280	1.020	57.94	0.48	0.0083	0.396	0.0067	0.55	1.24
290	1.023	57.64	0.46	0.0080	0.396	0.0067	0.56	1.19
300	1.026	57.31	0.45	0.0079	0.395	0.0067	0.58	1.17
350	1.044	55.59	0.38	0.0068	0.391	0.0067	0.62	1.01
400	1.067	53.65	0.33	0.0062	0.384	0.0068	0.72	0.91
450	1.095	51.55	0.29	0.0056	0.373	0.0066	0.93	0.85
500	1.130	49.02	0.26	0.0053	0.356	0.0064	1.18	0.83
550	1.200	45.92	0.23	0.0050	0.330	0.0060	1.63	0.84
600	1.362	42.37	0.21	0.0050	0.298	0.0052	—	0.96

A:

The overall heat transfer coefficient can be estimated from

$$\frac{1}{U_o} = \frac{1}{h_o} + \frac{1}{h_i} + R_m + ff_i + ff_o$$

where R_m = metal resistance, and ff_i and ff_o are inside and outside fouling factors; see Eq. (3).

h_o , the free convection heat transfer coefficient between the tubes and boiler water, obtained from Q8.32, = 188 Btu/ft² h °F. Assume $h_i = 1500$, $ff_i = ff_o = 0.001$, and

$$\text{Metal resistance } R_m = \frac{d_o}{24K} \ln \frac{d_o}{d_i} = 0.0005$$

Then

$$\frac{1}{U_o} = \frac{1}{188} + \frac{1}{1500} + 0.0025 = 0.00849$$

or

$$U_o = 177 \text{ Btu/ft}^2 \text{ h } ^\circ\text{F}$$

$$\Delta T = \text{log-mean temperature difference} = 212 - 100 = 112^\circ\text{F}$$

Then,

$$\text{Surface area } A = \frac{Q}{U_o \Delta T} = \frac{500,000}{117 \times 112} = 38 \text{ ft}^2$$

8.34

Q:

Can we determine gas or steam temperature profiles in a heat recovery steam generator (HRSG) without actually designing it?

A:

Yes. One can simulate the design as well as the off-design performance of an HRSG without designing it in terms of tube size, surface area, etc. The methodology has several applications. Consultants and plant engineers can determine for a given set of gas inlet conditions for an HRSG how much steam can be generated and what the gas/steam temperature profile will look like, and hence write better specifications for the HRSG or select auxiliaries based on this simulation without going to a boiler firm for this information. Thus several options can be ruled out or ruled in depending on the HRSG performance. The methodology has applications in complex, multipressure cogeneration or combined cycle plant evaluation with gas turbines. More information on HRSG simulation can be found in [Chapters 1 and 3](#) and Refs. 11, 12.

Example

140,000 lb/h of turbine exhaust gases at 980°F enter an HRSG generating saturated steam at 200 psig. Determine the steam generation and temperature profiles if feedwater temperature is 230°F and blowdown = 5%. Assume that average gas specific heat is 0.27 at the evaporator and 0.253 at the economizer.

Two important terms that determine the design should be defined here (see Fig. 8.13). *Pinch point* is the difference between the gas temperature leaving the evaporator and saturation temperature. *Approach point* is the difference between the saturation temperature and the water temperature entering the evaporator. More information on how to select these important values and how they are influenced by gas inlet conditions is discussed in examples below.

For unfired gas turbine HRSGs, pinch and approach points lie in the range of 15–30°F. The higher these values, the smaller will be the boiler size and cost, and vice versa.

Let us choose a pinch point of 20°F and an approach point of 15°F. Saturation temperature = 388°F. Figure 8.14 shows the temperature profile. The gas temperature leaving the evaporator = 388 + 20 = 408°F, and water temperature entering it = 388 – 15 = 373°F.

$$\begin{aligned}\text{Evaporator duty} &= 140,000 \times 0.99 \times 0.27 \times (980 - 408) \\ &= 21.4 \text{ MM Btu/h}\end{aligned}$$

(0.99 is the heat loss factor with a 1% loss.)

$$\begin{aligned}\text{Enthalpy absorbed by steam in evaporator} &= (1199.3 - 345) + 0.05 \times (362.2 - 345) \\ &= 855.2 \text{ Btu/lb}\end{aligned}$$

(1199.3, 345, and 362.2 are the enthalpies of saturated steam, water entering the evaporator, and saturated water, respectively. 0.05 is the blowdown factor for 5% blowdown.)

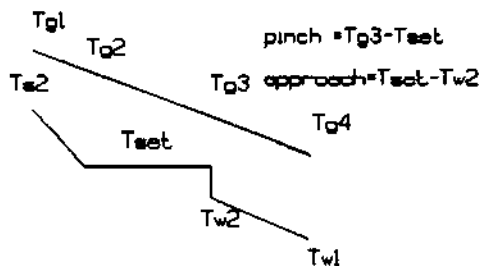

FIGURE 8.13 Pinch and approach points.

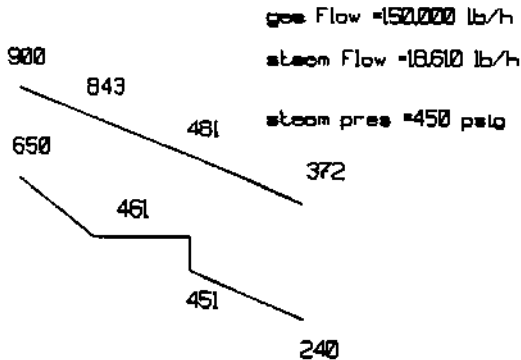

FIGURE 8.14 Temperature profile in an HRSG.

Hence

$$\text{Steam generated} = \frac{21.4 \times 10^6}{855.2} = 25,000 \text{ lb/h}$$

$$\begin{aligned} \text{Economizer duty} &= 25,000 \times 1.05 \times (345 - 198.5) \\ &= 3.84 \text{ MM Btu/h} \end{aligned}$$

$$\begin{aligned} \text{Gas temperature drop} &= \frac{3,840,000}{140,000 \times 0.253 \times 0.99} \\ &= 109^\circ\text{F} \end{aligned}$$

Hence gas temperature leaving economizer = $408 - 109 = 299^\circ\text{F}$. Thus the thermal design of the HRSG is simulated.

8.35a

Q:

Simulate the performance of the HRSG designed in Q8.34 when a gas flow of 165,000 lb/h enters the HRSG at 880°F . The HRSG will operate at 150 psig. Feedwater temperature remains at 230°F .

A:

Gas turbine exhaust flow and temperature change with ambient conditions and load. As a result the HRSG has to operate at different gas parameters, and hence simulation is necessary to determine how the HRSG behaves under different gas and steam parameters.

The evaporator performance can be determined by using Eq. (37). Based on design conditions, compute K .

$$\ln \left[\frac{980 - 388}{408 - 388} \right] = K \times (140,000)^{-0.4} = 3.388$$

$$K = 387.6$$

Under the new conditions,

$$\ln \left[\frac{880 - 366}{t_{g2} - 366} \right] = 387.6 \times (165,000)^{-0.4} = 3.1724$$

Hence $t_{g2} = 388^\circ\text{F}$.

$$\begin{aligned} \text{Evaporator duty} &= 165,000 \times 0.99 \times 0.27 \times (880 - 388) \\ &= 21.70 \text{ MM Btu/h} \end{aligned}$$

In order to estimate the steam flow, the feedwater temperature leaving the economizer must be known. This is arrived at through a series of iterations. Try $t_{w2} = 360^\circ\text{F}$. Then

$$\begin{aligned} \text{Steam flow} &= \frac{21.70 \times 10^6}{(1195.7 - 332) + 0.05 \times (338.5 - 332)} \\ &= 25,110 \text{ lb/h} \end{aligned}$$

$$\begin{aligned} \text{Economizer assumed duty } Q_a &= 25,110 \times 1.05 \\ &\quad \times (332 - 198.5) \\ &= 3.52 \text{ MM Btu/h} \end{aligned}$$

Compute the term $(US)_{\text{design}} = Q/\Delta T$ for the economizer based on design conditions.

$$\begin{aligned} Q &= 3.84 \times 10^6 \\ \Delta T &= \frac{(299 - 230) - (408 - 373)}{\ln(69/35)} = 50^\circ\text{F} \end{aligned}$$

Hence $(US)_{\text{design}} = 3,840,000/50 = 76,800$. Correct this for off-design conditions.

$$\begin{aligned} (US)_{\text{perf}} &= (US)_{\text{design}} \times \left(\frac{\text{gas flow, perf}}{\text{gas flow, design}} \right)^{0.65} \\ &= 76,800 \times \left(\frac{165,000}{140,000} \right) = 85,200 \end{aligned}$$

The economizer transferred duty is then $(US)_{\text{perf}} \times \Delta T$. Based on 360°F water leaving the economizer, $Q_a = 3.52 \text{ MBtu/h}$ and the exit gas temperature is

$$t_{g2} = \frac{3,520,000}{165,000 \times 0.99 \times 0.253} = 85^\circ\text{F}$$

Hence $t_{g2} = 388 - 85 = 303^\circ\text{F}$, and

$$\Delta T = \frac{(303 - 230) - (388 - 360)}{\ln(73/28)} = 47^\circ\text{F}$$

$$\text{Transferred duty } Q_t = 85,200 \times 47 = 4.00 \text{ MM Btu/h}$$

Because the assumed and transferred duty do not match, another iteration is required. We can show that at duty of 3.55 MM Btu/h the, assumed and transferred duty match. Water temperature leaving the economizer = 366°F (saturation); exit gas temperature = 301°F. Steam generation = 25,310 lb/h.

Because the calculations are quite involved, I have developed a software program called HRSGS that can simulate the design and off-design performance of complex, multipressure fired and unfired HRSGs. More information can be had by writing to V. Ganapathy, P.O. Box 673, Abilene, TX 79604.

8.35b

Q:

In the above case, how much fuel is required and at what firing temperature if 35,000 lb/h steam at 200 psig is to be generated? Gas flow is 140,000 lb/h at 980°F as in Q8.35a.

A:

A simple solution is given here, though the HRSG simulation would provide more accurate evaluation and temperature profiles. We make use of the concept that the fuel efficiency is 100% and all of that goes to generating the additional steam as discussed earlier.

$$\begin{aligned} \text{Energy absorbed by steam} &= 35,000 \times (1199.3 - 198.5) \\ &= 35.1 \text{ MM Btu/h} \end{aligned}$$

Additional energy to be provided by the burner = 35.1 - 25.24 = 9.86 MM Btu/h (the HRSG absorbs 25.24 as shown in Q8.34).

The oxygen consumed in the process of combustion (see Q6.27) is

$$9.86 \times 10^6 / (140,000 \times 58.4) = 1.2\%$$

The firing temperature T is obtained as follows:

$$9.86 \times 10^6 = 140,000 \times 0.3 \times (T - 980)$$

or

$$T = 1215^\circ\text{F}$$

Thus, by using a few simple concepts, preliminary information about the HRSG may be obtained. However, a complete temperature profile analysis requires a computer program such as the HRSG simulation software.

8.36

Q:

Can we assume that a particular exit gas temperature can be obtained in gas turbine HRSGs without doing a temperature profile analysis?

A:

No. It is not good practice to assume the HRSG exit gas temperature and compute the duty or steam generation as some consultants and engineers do. The problem is that, depending on the steam pressure and temperature, the exit gas temperature will vary significantly. Often, consultants and plant engineers assume that any stack gas temperature can be achieved. For example, I have seen catalogs published by reputable gas turbine firms suggesting that 300°F stack gas temperature can be obtained irrespective of the steam pressure or parameters. Now this may be possible at low pressures but not at all steam conditions. In order to arrive at the correct temperature profile, several heat balance calculations have to be performed, as explained below.

It will be shown that one cannot arbitrarily fix the stack gas temperature or the pinch point.

Looking at the superheater and evaporator of [Fig. 8.13](#),

$$W_g \times C_{pg} \times (T_{g1} - T_{g3}) = W_s \times (h_{s0} - h_{w2}) \quad (78)$$

Looking at the entire HRSG,

$$W_g \times C_{pg} \times (T_{g1} - T_{g4}) = W_s \times (h_{s0} - h_{w1}) \quad (79)$$

Blowdown was neglected in the above equations for simplicity. Dividing Eq. (78) by Eq. (79) and neglecting variations in C_{pg} , we have

$$\frac{T_{g1} - T_{g3}}{T_{g1} - T_{g4}} = \frac{h_{s0} - h_{w2}}{h_{s0} - h_{w1}} = X \quad (80)$$

Factor X depends only on steam parameters and on the approach point used. T_{g3} depends on the pinch point selected. Hence if T_{g1} is known, T_{g4} can be calculated.

It can be concluded from the above analysis that one cannot assume that any HRSG exit gas temperature can be obtained. To illustrate, Table 8.27 shows several operating steam conditions and X values and exit gas temperatures. As the steam pressure or steam temperature increases, so does the exit gas temperature, with the result that less energy is transferred to steam. This also tells us why we need to go in for multiple-pressure-level HRSGs when the main steam pressure is high. Note that even with infinite surface areas we cannot achieve low temperatures, because this is a thermodynamic limitation.

Example 1

Determine the HRSG exit gas temperature when the gas inlet temperature is 900°F and the steam pressure is 100 psig sat.

Solution. $X = 0.904$. Saturation temperature = 338°F. Hence with a 20°F pinch point, $T_{g3} = 358^\circ\text{F}$, and $t_{w2} = 323^\circ\text{F}$ with a 15°F approach point,

$$\frac{900 - T_{g4}}{900 - 358} = 0.904, \quad \text{or} \quad T_{g4} = 300^\circ\text{F}$$

Example 2

What is T_{g4} when steam pressure is 600 psig and temperature is 750°F?

TABLE 8.27 HRSG Exit Gas Temperatures^a

Pressure (psig)	Steam temp (°F)	Sat. temp (°F)	X	Exit gas temp (°F)
100	sat	338	0.904	300
150	sat	366	0.8754	313
250	sat	406	0.8337	332
400	sat	448	0.7895	353
400	600	450	0.8063	367
600	sat	490	0.740	373
600	750	492	0.7728	398

^aBased on 15°F approach point, 20°F pinch point, 900°F gas inlet temperature, and no blowdown. Feedwater temperature is 230°F. Similar data can be generated for other conditions.

Solution. $X = 0.7728$. Saturation temperature = 492°F; $t_{w2} = 477^\circ\text{F}$; $T_{g3} = 512^\circ\text{F}$.

$$\frac{900 - 512}{900 - T_{g4}} = 0.7728, \quad \text{or } T_{g4} = 398^\circ\text{F}$$

So a 300°F stack temperature is not thermodynamically feasible. Let us see what happens if we try to achieve that.

Example 3

Can you obtain a 300°F stack gas temperature with 900°F inlet gas temperature and at 600 psig, 750°F, and 15°F approach temperature?

Solution. $X = 0.7728$. Let us see, using Eq. (80), what T_{g3} results in a T_{g4} of 300°F, because that is the only unknown.

$$(900 - T_{g3})/(900 - 300) = 0.7728, \quad \text{or } T_{g3} = 436^\circ\text{F}$$

which is not thermodynamically feasible because the saturation temperature at 615 psig is 492°F! This is the reason one has to be careful in specifying HRSG exit gas temperatures or computing steam generation based on a particular exit gas temperature.

Example 4

What should be done to obtain a stack gas temperature of 300°F in the situation described in Example 3?

Solution. One of the options is to increase the gas inlet temperature to the HRSG by supplementary firing. If T_{g1} is increased, then it is possible to get a lower T_{g4} . Say $T_{g1} = 1600^\circ\text{F}$. Then

$$\frac{1600 - T_{g3}}{1600 - 300} = 0.7728, \quad \text{or } T_{g3} = 595^\circ\text{F}$$

This is a feasible temperature because the pinch point is now $(595 - 492) = 103^\circ\text{F}$. This brings us to another important rule: *Pinch point and exit gas temperature cannot be arbitrarily selected in the fired mode*. It is preferable to analyze the temperature profiles in the unfired mode and evaluate the off-design performance using available simulation methods discussed earlier.

Example 5

If gas inlet temperature in Example 1 is 800°F instead of 900°F, what happens to the exit gas temperature at 100 psig sat?

Solution.

$$\frac{800 - 358}{800 - T_{g4}} = 0.904$$

or $T_{g4} = 312^\circ\text{F}$ versus the 300°F when the inlet gas temperature was 900°F . We note that the exit gas temperature increases when the gas inlet temperature decreases, and vice versa. This is another important basic fact.

Once the exit gas temperature is arrived at, one can use Eq. (79) to determine how much steam can be generated.

8.37

Q:

How can HRSG simulation be used to optimize gas and steam temperature profiles?

A:

HRSG simulation is a method of arriving at the design or off-design performance of HRSGs without physically designing them as shown in Q8.34. By using different pinch and approach points and different configurations, particularly in multipressure HRSGs, one can maximize heat recovery. We will illustrate this with an example [12].

Example

A gas turbine exhausts 300,000 lb/h of gas at 900°F . It is desired to generate about 20,500 lb/h of superheated steam at 600 psig and 650°F and as much as 200 psig saturated steam using feedwater at 230°F . Using the method discussed in Q8.34, we can arrive at the gas/steam temperature profiles and steam flows. Figure 8.15 shows results obtained with HRSGS software. In option 1, we have the high pressure (HP) section consisting of the superheater, evaporator, and economizer followed by the low pressure (LP) section consisting of the LP evaporator and economizer. By using a pinch point of 190°F and approach point of 15°F , we generate 20,438 lb/h of high pressure steam at 650°F . Then, using a pinch point of 20°F and approach point of 12°F , we make 18,670 lb/h low pressure steam. The stack gas temperature is 370°F . In option 2, we have the HP section consisting of the superheater and evaporator and the LP section consisting of only the evaporator. A common economizer feeds both the HP and LP sections with feedwater at 375°F . Because of the larger heat sink available beyond the LP evaporator, the stack gas temperature decreases to 321°F . The HP steam generation is adjusted using the pinch point to make 20,488 lb/h while the LP steam is allowed to float. With a pinch point of 20°F , we see that we can make

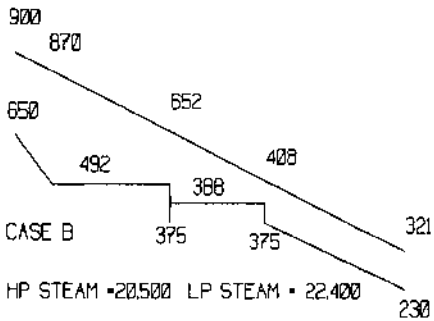
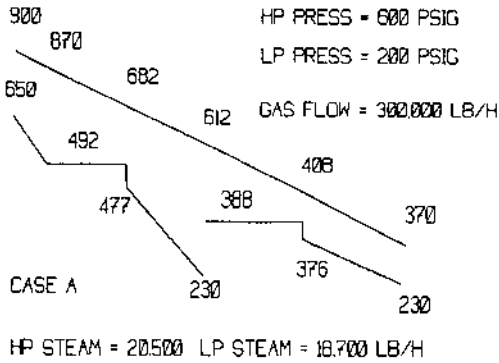

Figure 8.15 Optimizing temperature profiles.

22,400 lb/h in comparison with the 18,673 lb/h earlier. The ASME system efficiency is much higher now. Thus by manipulating the HRSG configuration, one can maximize the heat recovery.

8.38

Q:

How is the HRSG efficiency determined according to ASME Power Test Code 4.4?

A:

The efficiency E is given by

$$E = \frac{\text{energy given to steam/water/fluids}}{\text{gas flow} \times \text{inlet enthalpy} + \text{fuel input on LHV basis}}$$

To evaluate the efficiency, the enthalpy of the turbine exhaust gas should be known. The Appendix gives the enthalpy based on a particular gas analysis. Fuel input on LHV basis should also be known if auxiliary firing is used.

In Q8.37 the efficiency in the design case is

$$E = \frac{(21.4 + 3.84) \times 10^6}{140,000 \times 242} = 0.715, \text{ or } 71.5\%$$

If steam or water injection is resorted to, then the gas analysis will change, and the enthalpy has to be computed based on the actual analysis.

The HRSG system efficiency in gas turbine plants will improve with the addition of auxiliary fuel, which increases the gas temperature to the HRSG and hence increases its steam generation. There are two reasons for this.

1. Addition of auxiliary fuel reduces the effective excess air in the exhaust gases, because no air is added, only fuel. Hence the exhaust gas loss in relation to steam production is reduced.
2. With increased steam generation, usually the HRSG exhaust gas temperature decreases. This is due to the increased flow of water in the economizer, which offers a larger heat sink, which in turn pulls down the gas temperature further. In gas turbine units, the gas flow does not vary much with steam output as in conventional steam generators, which accounts for the larger temperature drop.

More information on HRSG temperature profiles can be found in [Chapters 1 and 2](#).

Table 8.28 shows the performance of an HRSG under various operating conditions. Case 1 is the unfired case; cases 2 and 3 have different firing conditions. It can be seen that the system efficiency is higher when more fuel is fired, for reasons explained above.

TABLE 8.28 Data for Supplementary-Fired HRSG

	Case 1	Case 2	Case 3
Gas flow, lb/h	250,000	250,000	250,000
Inlet gas temperature, °F	1000	1000	1000
Firing temperature, °F	1000	1257	1642
Burner duty, MM Btu/h	0	19.3	49.8
Steam flow, lb/h	45,700	65,000	95,000
Steam pressure, psig	300	300	300
Feedwater temperature, °F	230	230	230
Exit gas temperature, °F	298	278	265
Boiler duty, MM Btu/h	46.3	66.1	96.7
ASME efficiency, %	74.91	80.95	85.65

8.39a

Q:

In some cogeneration plants with gas turbines, a forced draft fan is used to send atmospheric air to the HRSG into which fuel is fired to generate steam when the gas turbine is not in operation. What should the criteria be for the fan size?

A:

The air flow should be large enough to have turbulent flow regimes in the HRSG and at the same time be small enough to minimize the loss due to exiting gases. If the air flow is high, the firing temperature will be low, but the system efficiency will be lower and the fuel input will be higher. This is illustrated for a simple case of two fans generating 250,000 and 210,000 lb/h of air flow in the HRSG. The HRSGS program was used in the simulation. See Table 8.29.

It can be seen that though the firing temperature is higher with the smaller fan, the efficiency is higher due to the lower exit gas losses considering the lower mass flow and exit gas temperature. It should be noted that as the firing temperature increases, the exit gas temperature will decrease when an economizer is used. Also, with the smaller fan the initial and operating costs are lower. One should ensure that the firing temperature does not increase to the point of changing the basic design concept of the HRSG. For example, an insulated casing design is used up to 1700°F firing temperature, beyond which a water-cooled membrane wall design is required. See [Chapter 1](#).

8.39b

Q:

How is the performance of an HRSG determined in fresh air fired mode?

A:

In this example, a multiple pressure HRSG with a common economizer is simulated in the design unfired mode and we are predicting its performance in the fired mode with fresh air firing using the HRSGS program.

TABLE 8.29 Fresh Air Firing Performance

Air flow, lb/h	250,000	210,000
Inlet temperature, °F	80	80
Firing temperature, °F	1258	1417
Exit gas temp, °F	278	267
Steam flow, lb/h	65,000	65,000
Burner duty, MM Btu/h	79.7	76.88
ASME efficiency, %	81.66	84.82

This is a three pressure level HRSG with HP steam at 600 psig, IP steam at 200 psig, and LP steam at 10 psig. (HP = high pressure, IP = intermediate pressure, LP = low pressure.) A common economizer feeds the HP and IP steam. Once the pinch points for the HP, IP, and LP evaporators are suggested, the program arrives at the steam flows and temperature profiles as shown in Figs. 8.16a and 8.16b. The flow through the common economizer is arrived at after a

HRSG PERFORMANCE - Design case



Project - 3preshrsg Units - British Case - unfired Remarks -

amb temp - F= 60 heat loss-%= 1 gas temp to HRSG F= 900 gas flow - Lb/h= 1215000
 % vol CO2 =2.5 H2O =10. N2 =73.5 O2 =14. SO2= ASME eff-% =76.93 tot duty-MM Btu/h=209.3

Surf	gas temp in/out -F	wat/stm in/out -F	duty MMB/h	pres psia	flow lb/h	pstm %	pinch F	apprch F	US Btu/hF	module no
sh	900 875	491 600	7.82	615.	91324	100			23002	1
evap	875 641	375 491	78.04	630.	91324	100	150	116	313578	1
sh	641 624	391 500	5.44	215.	80855	100			29665	2
evap	624 411	375 391	68.79	225.	80855	100	20	16	793324	2
eco	411 323	220 375	27.69	700.	173901	0			429302	3
evap	323 254	120 239	21.53	25.	20072	100	15	119	538830	4

Gas-Steam Temperature profiles

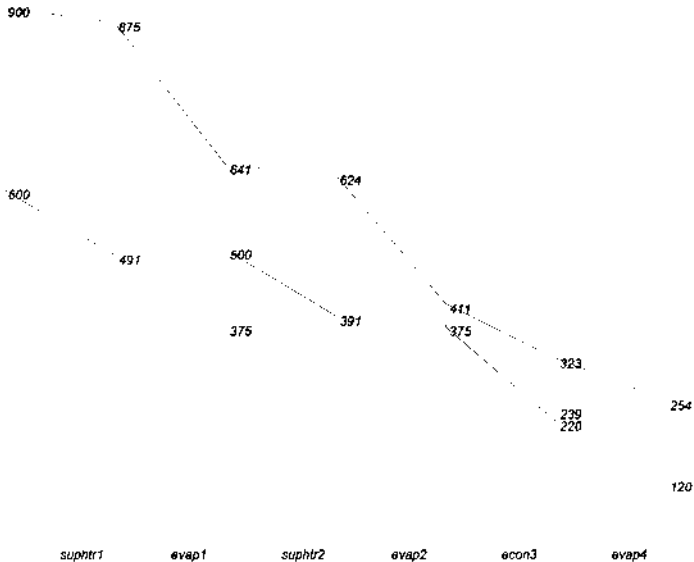
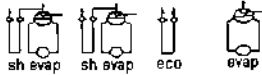

FIGURE 8.16a Unfired multipressure HRSG temperature profile.

HRSG PERFORMANCE - Off-Design case



Project - 3preshrsg Units - BRITISH Case - fresh air Remarks -

amb temp - F= 90 heat loss-%= 1 gas temp to HRSG F= 90 gas flow - Lb/h= 975000
 % vol CO2 = . H2O =1. N2 =78. O2 =21. SO2=. ASME eff-% =84.53 tot duty-MM Btu/h=279.4

Surf	gas temp in/out -F	wat/stm in/out -F	duty MMB/h	pres psia	flow lb/h	pstm %	pinch F	apprch F	US Btu/hF	module no
burn	90 1308	0 0	323.36	0	15083	0				
sh	1308 1248	496 639	16.67	615.	149674	100			23471	1
evap	1248 754	337 496	133.57	655.8	149674	100	258	158	288822	1
sh	754 726	392 528	7.45	215.	90175	100			26910	2
evap	726 414	337 392	80.22	227.5	90175	100	22	55	698895	2
eco	414 299	220 337	29.05	700.	242249				371537	3
evap	299 249	120 239	12.47	25.	11617	100	9	119	465986	4

stack gas flow =990083 % CO2 =2.71 H2O=6.29 N2=75.92 O2=15.07 SO2=.

Fuel gas vol %
 methane= 57 ethane= 2 propane= 1
 LHV -Btu/cu ft = 842 LHV -Btu/lb = 21436 aug air - Lb/h= 0

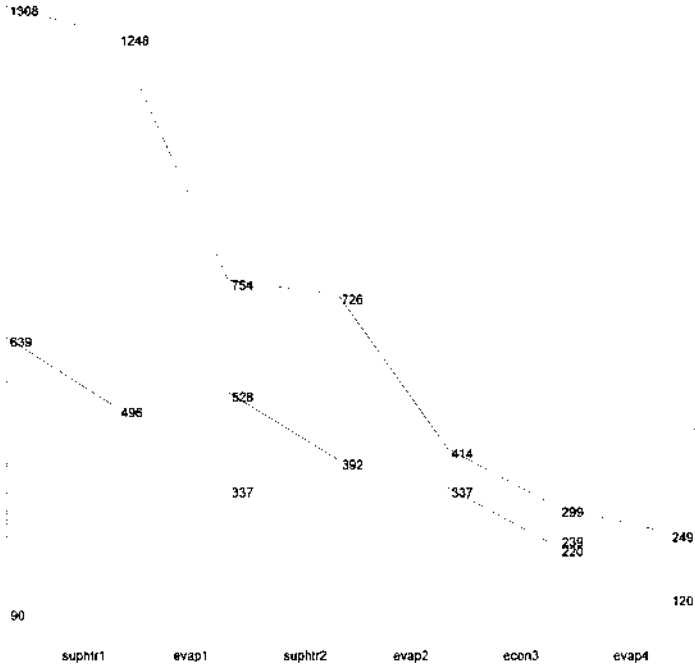

FIGURE 8.16b Fresh air fired temperature profile.

few complex iterations. Figure 8.16a shows the design mode results from the HRSGS program.

In the off-design or fired mode, fresh air is used instead of turbine exhaust. The air flow used is close to the design exhaust gas flow. We input the ambient air flow and the desired HP steam flow, and the program asks for fuel analysis and automatically arrives at the firing temperature. The off-design performance is shown in Fig. 8.16b.

The efficiency according to ASME Power Test Code 4.4, *US* values of each surface in both the design and off-design modes may also be seen, as well as the exhaust gas analysis after combustion.

This is yet another example of how simulation may be used to perform various studies without a physical design of an HRSG. Consultants and planners of cogeneration or combined cycle projects should find this a valuable tool.

8.40

Q:

How do we evaluate alternative HRSG designs if the operating costs are different?

A:

Let us consider the design of two HRSGs, one with low pinch and approach points (and hence more surface area and gas pressure drop), called design A, and another with higher pinch and approach points, called design B, which costs less. These HRSGs operate in both unfired and fired modes for 50% of the time. In the fired mode, both HRSGs generate 70,000 lb/h of steam; in the unfired mode, design A naturally generates more steam. Table 8.30 shows the performance of the HRSGs in unfired and fired modes.

Let fuel cost \$3/MMBtu (LHV). Cost of steam = \$3.5/1000 lb and electricity = 6 cents/kWh. Assume that an additional 4 in.WC of gas pressure drop is equivalent to a 1% decrease in gas turbine power output, which is a nominal 8000 kW. The HRSG operates in unfired and fired modes for 4000 h/y each.

Design A has the following edge over design B in operating costs. Due to higher steam generation in unfired mode:

$$(50,000 - 47,230) \times 3 \times \frac{4000}{1000} = \$33,240$$

Due to lower fuel consumption:

$$(22.55 - 19.23) \times 3.5 \times 4000 = \$46,480$$

TABLE 8.30 Performance of Alternative HRSG Designs

	Design A		Design B	
	Unfired	Fired	Unfired	Fired
Gas temp to HRSG	980	1208	980	1248
Gas temp to economizer, °F	437	441	466	483
Exit gas temperature, °F	314	298	353	343
Gas pressure drop, in. WC	4.0	4.3	2.75	3.0
Steam flow, lb/h	50,000	70,000	47,230	70,000
Water temp to economizer, °F	398	373	396	370
Burner duty, Mm Btu/h	0	19.23	0	22.55
Evaporator surface area ft ²		39,809		27,866
Economizer surface area, ft ²		24,383		13,933
Pinch point, °F	16	20	45	62
Approach point, °F	23	48	25	51

Gas flow = 287,000 lb/h; Gas analysis (vol%) CO₂ = 3, H₂O = 7, N₂ = 75, O₂ = 15. Steam pressure = 300 psig sat; gas turbine power = 8000 kW.

Due to higher gas pressure drop of 1.3 in.WC:

$$1.3 \times 8000 \times 0.07 \times \frac{8000}{100 \times 4} = \$14,560$$

Thus the net benefit of using design A over B is \$(33,240 + 46,480 - 14,560) = \\$65,160\$ per year.

If the additional cost of design A over B due to its size is, say, \$50,000, the payback of using design A is less than 1 year. However, if the HRSG operates for less than, say, 3000 h/year, the payback will be longer and has to be reviewed.

8.41

Q:

What is steaming, and why is it likely in gas turbine HRSGs and not in conventional fossil fuel fired boilers?

A:

When the economizer in a boiler or HRSG starts generating steam, particularly with downward flow of water, problems can arise in the form of water hammer, vibration, etc. With upward water flow design, a certain amount of steaming, 3–5%, can be tolerated because the bubbles have a natural tendency to go upward along with the water. However, steaming should generally be avoided.

TABLE 8.31 Typical Exhaust Gas Flow, Temperature Characteristics of a Gas Turbine

Ambient temp, °F	20.0	40.0	59.0	80.0	100.0	120.0
Power output, kW	38,150	38,600	35,020	30,820	27,360	24,040
Heat rate, Btu/kWh	9384	9442	9649	9960	10,257	10,598
Water flow rate lb/h	16,520	17,230	15,590	13,240	10,540	6990
Turbine inlet temp, °F	1304	1363	1363	1363	1363	1363
Exhaust temp, °F	734	780	797	820	843	870
Exhaust flow, lb/s	312	304	286	264	244	225

Fuel: natural gas; elevation: sea level; relative humidity 60%; inlet loss 4 in.H₂O; exhaust loss 15 in.H₂O; speed: 3600 rpm; output terminal: generator.

To understand why the economizer is likely to steam, we should first look at the characteristics of a gas turbine as a function of ambient temperature and load (see Tables 8.31 and 1.4).

In single-shaft machines, which are widely used, as the ambient temperature or load decreases, the exhaust gas temperature decreases. The variation in mass flow is marginal compared to fossil fuel fired boilers, while the steam or water flow drops off significantly. (The effect of mass flow increase in most cases does not offset the effect of lower exhaust gas temperature.) The energy-transferring ability of the economizer, which is governed by the gas-side heat transfer coefficient, does not change much with gas turbine load or ambient temperature; hence nearly the same duty is transferred with a smaller water flow through the economizer, which results in a water exit temperature approaching saturation temperature as seen in Q8.35. Hence we should design the economizer such that it does not steam in the lowest unfired ambient case, which will ensure that steaming does not occur at other ambient conditions. A few other steps may also be taken, such as designing the economizer [8] with a horizontal gas flow with horizontal tubes (Fig. 8.17). This ensures that the last few rows of the economizer, which are likely to steam, have a vertical flow of steam–water mixture.

In conventional fossil fuel fired boilers the gas flow decreases in proportion to the water flow, and the energy-transferring ability of the economizer is also lower at lower loads. Therefore steaming is not a concern in these boilers; usually the approach point increases at lower loads in fired boilers, whereas it is a concern in HRSGs.

The other measures that may be considered to minimize steaming in an economizer are

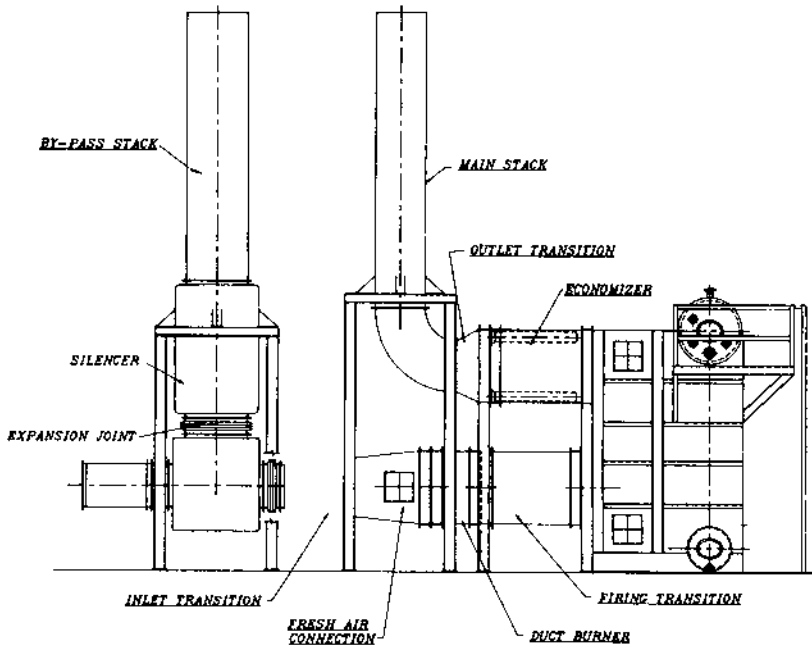

FIGURE 8.17 Horizontal gas flow economizer.

Increase the water flow through the economizer during these conditions by increasing the blowdown flow. This solution works only if small amounts of steam are formed and the period of operation in this mode is small. Blowdown results in a waste of energy.

Increasing the inlet gas temperature either by supplementary firing or by increasing the turbine load helps to generate more steam and thus more water flow through the economizer, which will prevent steaming. As we saw in [Chapter 1](#), the economizer steams at low loads of the turbine.

Exhaust gases can be bypassed around the HRSG during such steaming conditions. This minimizes the amount of energy transferred at the economizer as well as the evaporator. Gas can also be bypassed around the economizer, mitigating the steaming concerns.

Water can also be bypassed around the economizer during steaming conditions, but this is not a good solution. When the gas turbine load picks up, it will be difficult to put the water back into the economizer while the tubes are hot. The cold water inside hot tubes can flash and cause vibration and thermal stresses and can even damage the economizer tub.

8.42

Q:

Why are water tube boilers generally preferred to fire tube boilers for gas turbine exhaust applications?

A:

Fire tube boilers require a lot of surface area to reduce the temperature of gas leaving the evaporator to within 15–25°F of saturation temperature (pinch point). They have lower heat transfer coefficients than those of bare tube water tube boilers (see Q8.10), which do not compare well with finned tube boilers. Water tube boilers can use extended surfaces to reduce the pinch point to 15–25°F in the unfired mode and hence be compact. The tubes will be very long if fire tube boilers are used; hence the gas pressure drop will be higher. (A fire tube boiler can be made into a two-pass boiler to reduce the length; however, this will increase the shell diameter and the labor cost, because twice the number of tubes will have to be welded to the tube sheets.) The fire tube boiler will have to be even larger if the same gas pressure drop is to be maintained. Table 8.32 compares the performance of water tube and fire tube boilers for the same duty and pressure drop.

It can be seen from the table footnotes that the water tube boiler is very compact. If the gas flow is very small, say less than 50,000 lb/h, then a fire tube boiler may be considered.

TABLE 8.32 Water Tube vs. Fire Tube Boiler for Gas Turbine Exhaust

	Water tube ^a	Fire tube ^b
Gas flow, lb/h	100,000	100,000
Inlet temp, °F	900	900
Exit temp, °F	373	373
Duty, MM Btu/h	13.72	13.72
Gas pressure drop, in. WC	2.75	2.75
Feedwater temp, °F	220	220
Steam pressure, psig	125	125
Steam flow, lb/h	13,500	13,500
Surface area, ft ²	12,315	9798

^aWater tube boiler: 2 × 0.105 in. tubes, 20 wide, 18 deep, 6 ft long, with 5 serrated fins/in., 0.75 in. high, 0.05 in. thick.

^bFire tube boiler: 1400 1.5 × 0.105 in. tubes, 21 ft long.

8.43

Q:

Does the addition of 10% surface area to a boiler increase its duty by 10%?

A:

No. The additional surface area increases the duty only slightly. The increased temperature drop across the boiler and the temperature rise of water or steam (if single-phase) due to the higher duty results in a lower log-mean temperature difference. This results in lower transferred duty, even assuming that the overall heat transfer coefficient U remains unchanged. If the larger surface area results in lower gas velocities, the increase in duty will be marginal as U is further reduced.

As an example, consider the performance of a fire tube boiler with 10% and 20% increase in surface area as shown in Table 8.33. As can be seen, a 10% increase in surface area increases the duty by only 3%, and a 20% increase in surface area increases the duty by only 6%. Similar trends may be shown for water tube boilers, superheaters, economizers, etc.

8.44a

Q:

How do we estimate the time required to heat a boiler?

A:

A boiler can take a long time to heat up, depending on the initial temperature of the system, mass of steel, and amount of water stored. The following procedure gives a quick estimate of the time required to warm up a boiler. The methodology is applicable to either fire tube or water tube boilers.

TABLE 8.33 Boiler Performance with Increased Surface Area^a

Case	No. of tubes	Length (ft)	Surface (ft ²)	Duty (MM Btu/h)	Exit gas temp (°F)
1	390	16	2839	20.53	567
2	390	17.6	3123	21.16	533
3	390	19.2	3407	21.68	505

^aGas flow = 70,000 lb/h; inlet gas temperature = 1600°F. Gas analysis (vol%): CO₂ = 7, H₂O = 12, N₂ = 75, O₂ = 6; steam pressure = 125 psig saturated. Tubes: 2 × 0.120 carbon steel.

Gas at a temperature of T_{g1} enters the unit, which is initially at a temperature of t_1 (both the water and the boiler tubes). The following energy balance equation can then be written neglecting heat losses:

$$M_c \frac{dt}{dz} = W_g C_{pg} \times (T_{g1} - T_{g2}) = UA \Delta T \quad (81)$$

where

M_c = water equivalent of the boiler
 = mass of steel \times specific heat of steel + mass of water \times specific heat of water (Weight of the boiler tubes, drum, casing, etc., is included in the steel weight.)

dt/dz = rate of change of temperature, $^{\circ}\text{F}/\text{h}$

W_g = gas flow, lb/h

C_{pg} = gas specific heat, Btu/lb $^{\circ}\text{F}$

T_{g1}, T_{g2} = entering and exit boiler gas temperature, $^{\circ}\text{F}$

U = overall heat transfer coefficient, Btu/ft² h $^{\circ}\text{F}$

A = surface area, ft²

ΔT = log-mean temperature difference, $^{\circ}\text{F}$

$$= \frac{(T_{g1} - t) - (T_{g2} - t)}{\ln[(T_{g1} - t)/(T_{g2} - t)]}$$

t = temperature of the water/steam in boiler, $^{\circ}\text{F}$

From Eq. (81) we have

$$\ln \left[\frac{T_{g1} - t}{T_{g2} - t} \right] = \frac{UA}{W_g C_{pg}} \quad (82)$$

or

$$T_{g2} = t + \frac{T_{g1} - t}{e^{UA/W_g C_{pg}}} = t + \frac{T_{g1} - t}{K} \quad (83)$$

Substituting Eq. (83) into Eq. (81), we get

$$M_c \frac{dt}{dz} = W_g C_{pg} (T_{g1} - t) \frac{K - 1}{K}$$

or

$$\frac{dt}{T_{g1} - t} = \frac{W_g C_{pg}}{M_c} \times \frac{K - 1}{K} dz \quad (84)$$

To estimate the time to heat up the boiler from an initial temperature t_1 to t_2 , we have to integrate dt between the limits t_1 and t_2 .

$$\ln \frac{T_{g1} - t_1}{T_{g1} - t_2} = \frac{W_g C_{pg}}{M_c} \times \frac{(K - 1)z}{K} \quad (85)$$

The above equation can be used to estimate the time required to heat the boiler from a temperature of t_1 to t_2 , using flue gases entering at T_{g1} . However, in order to generate steam, we must first bring the boiler to the boiling point at atmospheric pressure and slowly raise the steam pressure through manipulation of vent valves, drains, etc; the first term of Eq. (81) would involve the term for steam generation and flow in addition to metal heating.

Example

A water tube waste heat boiler of weight 50,000 lb and containing 30,000 lb of water is initially at a temperature of 100°F. 130,000 lb of flue gases at 1400°F enter the unit. Assume the following:

Gas specific heat = 0.3 Btu/lb °F

Steel specific heat = 0.12 Btu/lb °F

Surface area of boiler = 21,000 ft²

Overall heat transfer coefficient = 8 Btu/ft² h °F

Estimate the time required to bring the boiler to 212°F.

Solution.

$$\frac{U}{W_g C_{pg}} = \frac{8 \times 21,000}{130,000 \times 0.3} = 4.3$$

$$K = e^{4.3} = 74$$

$$M_c = 50,000 \times 0.12 + 30,000 \times 1 = 36,000$$

$$\ln \frac{1400 - 100}{1400 - 212} = 0.09 = \frac{130,000 \times 0.3}{36,000} \times \frac{73}{74} z$$

or $z = 0.084 \text{ h} = 5.1 \text{ min}$.

One could develop a computer program to solve Eq. (81) to include steam generation and pressure-raising terms. In real-life boiler operation, the procedure is corrected by factors based on operating data of similar units.

It can also be noted that, in general, fire tube boilers with the same capacity as water tube boilers would have a larger water equivalent and hence the start-up time for fire tube boilers would be longer.

8.44b

Q:

Assuming that the superheater in Q8.19c is dry, how long does it take to heat the metal from 80°F to 900°F? Assume that the gas-side heat transfer coefficient is 12 Btu/ft² h °F. Gas flow and temperature are the same as before. The weight of the superheater is 5700 lb. 150,000 lb/h of exhaust gases enter the superheater at 1030°F.

A:

Let us use Eq. (85),

$$\ln \frac{t_{g1} - t_1}{t_{g1} - t_2} = \frac{W_g C_{p_g} (K - 1)z}{M_c \times K}$$

$$K = \exp \left[\frac{UA}{W_g C_{p_g}} \right] = \exp \left[\frac{12 \times 2022}{150,000 \times 0.286} \right] = 1.76$$

$$M_c = 5700 \times 0.12 = 684$$

$$\ln \frac{1030 - 80}{1030 - 900} = \frac{150,000 \times 0.286 \times 0.76z}{1.76 \times 684} = 27z = 1.99$$

or

$$z = 0.0737 \text{ h} = 4.5 \text{ min}$$

This is an estimate only but gives an idea of how fast the metal gets heated up. This is important in gas turbine plants without a gas bypass system. A large quantity of exhaust gases can increase the metal temperatures quickly. Hence if frequent start-ups and shutdowns are planned, a stress analysis is required to ensure that critical components are not subjected to undue stresses due to quick changes in tube wall or header temperatures.

By the same token, the superheater tubes cool fast when the exhaust gas is shut off compared to, say, evaporator tubes, which are still hot due to the inventory of hot saturated liquid. This can lead to condensation of steam when the HRSG is restarted, leading to blockage of flow inside the superheater tubes unless adequate drains are provided.

8.44c

Q:

A large mass of metal and water inventory in a boiler results in a longer start-up period, but the residual energy in the metal also helps to respond to load changes faster when the heat input to the boiler is shut off. Drum level fluctuations also are

smoothed out by a large water inventory. In order to understand the dynamics, let us look at an evaporator in a waste heat boiler with the following data:

Gas flow = 350,000 lb/h
 Gas inlet temp = 1000°F
 Gas exit temp = 510°F
 Steam pressure = 600 psig sat
 Feedwater temp = 222°F
 Tubes: 2 × 0.105, 30 tubes/row, 20 deep, 12 ft long with 4.5 × 0.75 × 0.05 in. serrated fins
 Steam drum = 54 in., mud drum = 36 in; both are 13 ft long. Boiler generates 45,000 lb/h of steam.
 Weight of steel including drums = 75,000 lb
 Weight of water in evaporator = 18,000 lb
 Volume of steam space = 115 ft³
 Feedwater temperature = 220°F
 Energy transferred by gas to evaporator = 45.9 MM Btu/h

What happens to the steam pressure and steam generation when the heat input and the feedwater supply are turned off?

A:

The basic equation for energy transfer to an evaporator is

$$Q = W_s h_{fg} + (h_l - h_f) W_f + \left(W_m C_p \frac{dT}{dp} + W_w \frac{dh}{dp} \right) \frac{dp}{dz} \quad (86a)$$

where

W_m = mass of metal, lb
 W_s = steam generated, lb/h
 W_f = feedwater flow, lb/h
 W_w = amount of water inventory in boiler system including drums, tubes, pipes, lb
 dh/dp = change of enthalpy to change in pressure, Btu/lb psi
 dT/dp = change of saturation temperature to change in pressure, °F/psi
 Q = energy transferred to evaporator, Btu/h
 dp/dz = rate of pressure change, psi/h

Now assuming that the volume of space between the drum level and the valve = V ft³, we can write the following expression for change in pressure using the perfect gas law:

$$pV = C = pV/m$$

where

$C = \text{a constant}$
 $m = \text{mass of steam, lb, in volume } V$

or

$$\frac{pV}{m} = C \quad \text{or} \quad p = \frac{Cm}{V}$$

$$\frac{dp}{dz} = \frac{pV}{V} (W_s - W_l) \quad (86b)$$

where

$p = \text{pressure, psia}$
 $W_s, W_l = \text{steam generated and steam withdrawn, lb/h}$

For steam at 600–630 psia, we have from the steam tables that the saturation temperature = 486°F and 492°F, respectively.

Enthalpy of water = 471.6 and 477.9 Btu/lb
 Average latent heat $h_{fg} = 730$ Btu/lb
 Specific volume = 0.75 ft³/lb

Hence

$$\frac{dh}{dp} = \frac{477.9 - 471.6}{30} = 0.21 \text{ Btu/lb psi}$$

$$\frac{dT}{dp} = \frac{492 - 486}{30} = 0.2^\circ\text{F/psi}$$

When $Q = 0$ and $W_f = 0$, we have from Eq. (86) that

$$W_s \times 730 + (75,000 \times 0.12 \times 0.2 + 18,000 \times 0.21) \frac{dp}{dz} = 0$$

$$\frac{dp}{dz} = \frac{615 \times 0.75}{115} (W_s - W_l) = 4 \times (W_s - W_l)$$

or, combining this with the previous equation,

$$W_s \times 730 + (5580) \times 4 \times (W_s - W_l) = 0 \quad \text{or} \quad W_s = 43,570 \text{ lb/h}$$

Using Eq. (87),

$$\frac{dp}{dz} = 4 \times (43,570 - 45,000) = -5720 \text{ psi/h or } -1.59 \text{ psi/s}$$

The pressure decay will be about 1.59 psi/s if this situation continues without correcting feedback such as matching heat input and feedwater flow.

These calculations, though simplistic, give an idea of what happens when, for example, the turbine exhaust gas is switched off. In fresh air fired HRSGs, there is a small time delay, on the order of a minute, before the fresh air fired

burner can come on and fire to full capacity. The steam pressure decay during this period can be evaluated by this procedure.

8.44d

Q:

Let us assume that the boiler is operating at 45,000 lb/h and suddenly the demand goes to 50,000 lb/h.

Case 1: What happens to the steam pressure if we maintain the same heat input to the evaporator and the feedwater supply?

Case 2: What happens if the feedwater is cut off but heat input remains the same?

A:

Case 1: $Q = 45.0 \times 10^6$ Btu/h; $W_f = 45,000$ lb/h; $W_l = 50,000$ lb/h. First let us compute the steam generation. Using Eq. (86a),

$$h_1 = 471.6 \text{ Btu/lb} \quad \text{and} \quad h_f = 189.5 \text{ Btu/lb}$$

From Eq. (86a),

$$45,000 \times (471.6 - 189.6) + W_s \times 730 + 5580 \frac{dp}{dz} = Q$$

also, $dp/dz = 4(W_s - 50,000)$,

Simplifying,

$$12.69 \times 10^6 + W_s \times 730 + 5580 \times 4(W_s - 50,000) = 45.9 \times 10^6$$

$$W_s = 49,857 \text{ lb/h}$$

Thus,

$$\frac{dp}{dz} = 4 \times (49,857 - 50,000) = -572 \text{ psi/h} = -0.159 \text{ psi/s}$$

Case 2: $W_f = 0$ and $Q = 45.9$ MM Btu/h. Using the above equations,

$$W_s \times 730 + 5580 \times 4(W_s - 50,000) = 45.9 \times 10^6, \text{ or } W_s = 50,405 \text{ lb/h}$$

$$\frac{dp}{dz} = 1620 \text{ psi/h} = 0.45 \text{ psi/s}$$

The pressure actually increases, because the cooling effect of the feedwater is not sensed.

In practice, controls respond fast and restore the balance among heat input, feedwater flow, and steam generation to match the demand. If we cannot adjust the heat input, as in unfired waste heat boilers, the pressure will slide as shown if we withdraw more steam than can be supplied by the boiler.

8.45a

Q:

Discuss the parameters influencing the test results of an HRSG during performance testing.

A:

The main variables affecting the performance of an HRSG are the gas flow, inlet gas temperature, gas analysis, and steam parameters. Assuming that an HRSG has been designed for a given set of gas conditions, in reality several of the parameters could be different at the time of testing. In the case of a gas turbine HRSG in particular, ambient temperature also influences the exhaust gas conditions. The HRSG could, as a result, be receiving a different gas flow at a different temperature, in which case the steam production would be different from that predicted.

Even if the ambient temperature and the gas turbine load were to remain the same, it is difficult to ensure that the HRSG would receive the design gas flow at the design temperature. This is due to instrument errors. Typically, in large ducts, the gas measurement could be off by 3–5% and the gas temperatures could differ by 10–20°F according to ASME Power Test Code 4.4. As a result it is possible that the HRSG would receive 5% less flow at 10°F lower gas temperature than design conditions, even though the instruments recorded design conditions. As a result, the HRSG steam generation and steam temperature would be less than predicted through no fault of the HRSG design. [Figure 8.18](#) shows the performance of an HRSG designed for 500,000 lb/h gas flow at 900°F; steam generation is 57,000 lb/h at 650 psig and 750°F. The graph shows how the same HRSG behaves when the mass flow changes from 485,000 to 515,000 lb/h while the exhaust temperature varies from 880°F to 902°F. The steam temperature falls to 741°F with 880°F gas temperature, whereas it is 758°F at 920°F. The steam flow increases from 52,900 to 60,900 lb/h as the gas mass flow increases. Thus the figure shows the map of performance of the HRSG for possible instrumental error variations only. Hence HRSG designers and plant users should mutually agree upon possible variations in gas parameters and their influence on HRSG performance before conducting such tests.

8.45b

Q:

Based on operating data, can we determine whether an HRSG is operating well?

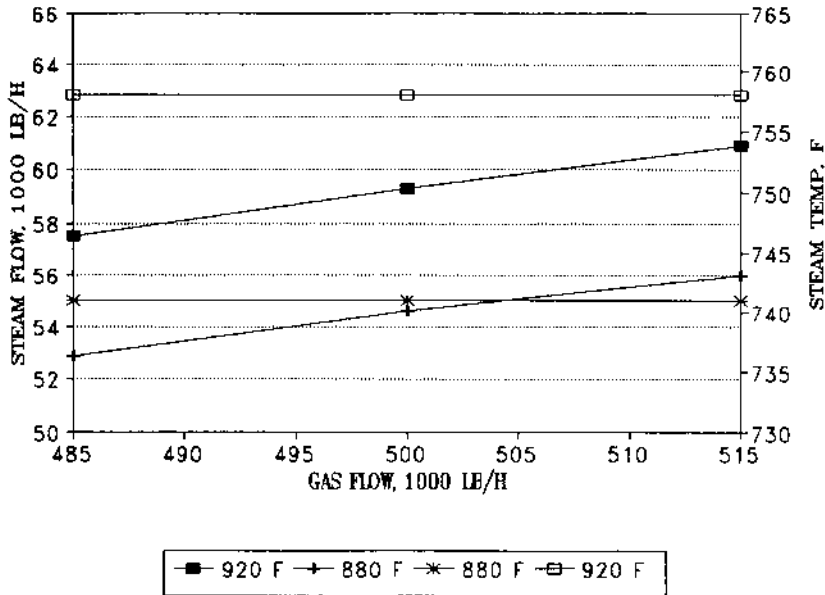

FIGURE 8.18 HRSG performance as a function of gas flow and temperature.

A:

It is possible to evaluate the operating data for possible deviations from predicted or guaranteed data as shown below. An HRSG supplier has guaranteed certain data for his HRSG in his proposal, which are shown alongside the measured data in Table 8.34. How are these data to be reconciled?

Note that the actual gas flow is difficult to measure and is not shown. However, using an energy balance, one can obtain the gas flow based on energy

TABLE 8.34 Proposed and Actual HRSG Performance

Data	Proposal guarantee	Actual data
Gas flow, lb/h	550,000	?
Exhaust gas temp, °F	1000	970
Exit gas temp, °F	372	380
Steam pressure, psig	600	500
Steam temp, °F	700	690
Feedwater temp, °F	230	230
Blowdown, %	2	0
Steam flow, lb/h	79,400	68,700

absorbed by steam and the difference between gas temperatures at the inlet and exit. Note that the operating steam pressure is lower than that called for in the design.

From the energy balance, we have

$$W_g \times (h_i - h_o) \times 0.99 = W_s \Delta h$$

where h_i, h_o refer to the enthalpy of gas at the inlet and exit of the HRSG corresponding to the gas temperatures measured. The steam flow, W_s , and the enthalpy absorbed by steam, Δh , are known from steam tables. Hence W_g , the gas flow, can be calculated. It can be shown to be 501,300 lb/h.

Now using the HRSGS program, one can simulate the design mode using the proposal data as shown in Fig. 8.19a. Then, using the calculated gas flow and the inlet temperature, run the HRSGS program in the off-design mode at the lower steam pressure. The results are shown in Fig. 8.19b. It may be seen that 69,520 lb/h of steam should have been generated at 690°F and the exit gas temperature should be 364°F, whereas we measured only 68,700 lb/h and exit gas at 380°F. Hence more analysis is required, but there is a prima facie concern with the HRSG performance.

8.46

Q:

Estimate the boiling heat transfer coefficient inside tubes for water and the tube wall temperature rise for a given heat flux and steam pressure.

A:

Subcooled boiling heat transfer coefficient inside tubes for water can be estimated by the following equations.

According to Collier [13],

$$\Delta T = 0.072e^{-P/1260} q^{0.5} \quad (87a)$$

According to Jens and Lottes [13],

$$\Delta T = 1.9e^{-P/900} q^{0.25} \quad (87b)$$

where

ΔT = difference between saturation temperature and tube wall temperature,
°F

P = steam pressure, psia

q = heat flux inside tubes, Btu/ft² h

HRSG PERFORMANCE - Design case



Project - test Units - British Case - proposal Remarks -

amb temp - F= 60 heat loss-%= 1 gas temp to HRSG F= 1000 gas flow - Lb/h= 550000
 % vol CO2 =3. H2O =7. N2 =75. O2 =15. SO2= ASME eff-% =67.45 tot duty-MM Btu/h=91.8

Surf	gas temp		wat/stm		duty	pres	flow	pstm	pinch	apprch	US	module no
	in/out -F		in/out -F		MMB/h	psia	lb/h	%	F	F	Btu/hF	
sh	1000	921	492	700	11.71	615	79440	100			32454	1
evap	921	517	472	492	59.36	635	79440	100	25	20	417377	1
eco	517	371	230	472	20.77	645	81029	0			246432	1

Gas-Steam Temperature profiles

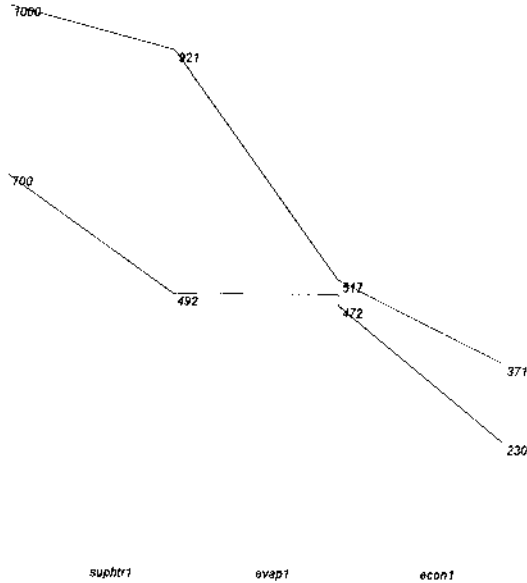

FIGURE 8.19a Simulation of HRSG design data.

HRSG PERFORMANCE - Off-Design case



Project - test Units - BRITISH Case - operation Remarks -

amb temp - F= 60 heat loss-%= 1 gas temp to HRSG F= 970 gas flow - Lb/h= 501300
 % vol CO2 =3. H2O =7. N2 =75. O2 =15. SO2=- ASME eff-% =66.82 tot duty-MM Btu/h=80.2

Surf	gas temp		wat/stm		duty	pres	flow	pstm	pinch	apprch	US	module no
	in/out -F		in/out -F		MMB/h	psia	lb/h	%	F	F	Btu/hF	
sh	970	894	473	691	10.26	515	69522	100			29735	1
evap	894	495	461	473	52.97	533.3	69522	100	22	12	390258	1
eco	495	364	230	461	16.93	543.3	69522				230911	1

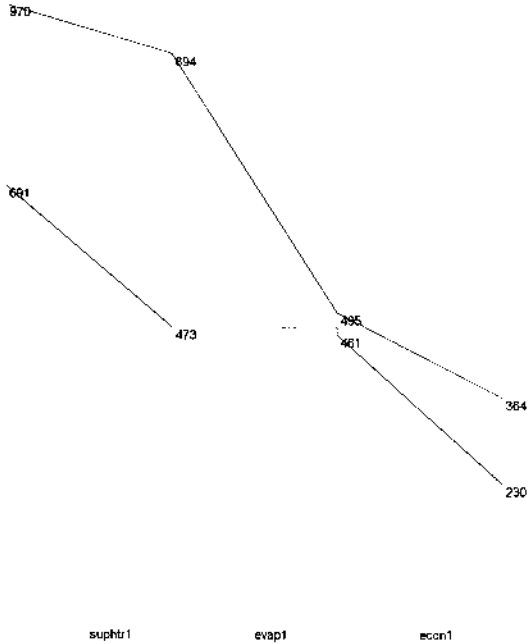

FIGURE 8.19b Simulation of HRSG operating data.

The heat transfer coefficient is then given by

$$h_i = q/\Delta T$$

Example

What is the boiling heat transfer coefficient inside the tubes, and what is the tube wall temperature if the heat flux inside boiler tubes is 60,000 Btu/ft² h and steam pressure = 1200 psia?

Solution. Using Collier's equation,

$$\Delta T = 0.072 \times e^{-1200/1260} \times 60,000^{0.5} = 6.8^\circ\text{F}$$

$$h_i = 60,000/6.8 = 8817 \text{ Btu/ft}^2 \text{ h } ^\circ\text{F}$$

Using Jens and Lottes's equation,

$$\Delta T = 1.9 \times e^{-1200/900} \times 60,000^{0.25} = 7.8^\circ\text{F}$$

$$h_i = 60,000/7.8 = 7650 \text{ Btu/ft}^2 \text{ h } ^\circ\text{F}$$

The above expressions assume that the tube surface where boiling occurs is smooth and clean.

8.47a

Q:

What is the relationship among critical heat flux, steam pressure, quality, and flow in water tube boilers?

A:

Several variables influence the critical heat flux or the departure from nucleate boiling (DNB) condition. These are

Steam pressure

Mass velocity of mixing inside the tubes

Steam quality

Tube roughness and cleanliness

Tube size and orientation

Correlations such as the Macbeth correlation are available in the literature [13].

The Macbeth correlation is

$$q_c = 0.00633 \times 10^6 \times h_{fg} d_i^{-0.1} (G_i/10^6)^{0.51} \times (1 - x) \quad (88a)$$

where

- q_c = critical heat flux, Btu/ft² h
- h_{fg} = latent heat of steam, Btu/lb
- G_i = mass velocity inside tubes, lb/ft² h
- x = steam quality, expressed as a fraction
- d_i = tube inner diameter, in.

Example

Estimate the critical heat flux under the following conditions:

- Steam pressure = 1000 psia
- Tube inner diameter = 1.5 in.
- Mass velocity = 600,000 lb/ft² h
- Steam quality = 0.20

$$q_c = 0.00633 \times 10^6 \times 650 \times 1.50^{-0.1} \times 0.6^{0.51} \\ \times (1 - 0.2) = 2.43 \times 10^6 \text{ Btu/ft}^2 \text{ h}$$

In real-life boilers, the allowable heat flux to avoid DNB is much lower, say 20–30% lower, than the values obtained by laboratory tests under controlled conditions due to factors such as roughness of tubes, water quality, and safety considerations. Boiler suppliers have their own data and design boilers accordingly.

8.47b

Q:

How is the critical heat flux q_c determined in pool boiling situations as in fire tube boilers?

A:

Several correlations are available in the literature, but only two will be cited. Motesinko suggests the simple equation [13]

$$q_c = 803P_c \left(\frac{P_s}{P_c} \right)^{0.35} \left(\frac{1 - P_s}{P_c} \right)^{0.9} \quad (88b)$$

where P_s, P_c are the steam pressure and critical pressure, both in psia.

Zuber's correlation takes the form [13]

$$\frac{q_c}{\rho_g h_{fg}} = 0.13 \times \left(\frac{\sigma(\rho_f - \rho_g) g g_0}{\rho_g^2} \right)^{0.25} \times \left(\frac{\rho_f}{\rho_g + \rho_f} \right)^{0.5}$$

where

σ = surface tension

ρ = density

h_{fg} = latent heat

g, g_0 = acceleration due to gravity and conversion factor g in force units

all in metric units.

Example

Determine the critical heat flux for steam at 400 psia under pool boiling conditions.

Solution. The following data can be obtained from steam tables:

Saturation temperature at 400 psia = 445°F

Density of liquid = 51 lb/cu ft (827 kg/m³)

Density of vapor = 0.86 lb/cu ft (13.8 kg/m³)

Latent heat of vaporization = 780 Btu/lb (433 kcal/kg)

From [Table 8.26](#) at a saturation temperature of 445°F, surface tension is 0.0021 lb_f/ft (0.31 kg_f/m).

$$g = 9.8 \times 3600^2 \text{ m/h}^2$$

$$g_0 = 9.8 \times 3600^2 \text{ kg}_m/\text{Kg}_f \text{ h}^2$$

Substituting into (88b):

$$q_c = 803 \times 3208 \times \left(\frac{400}{3208} \right)^{0.35} \times \left(1 - \frac{400}{3208} \right)^{0.9} \\ = 1.102 \text{ MM Btu/ft}^2 \text{ h}$$

Using Eq. (88c),

$$\begin{aligned}q_c &= 13.8 \times 433 \times 0.13 \times (0.0031 \times 813 \times 9.8^2 \\ &\quad \times \frac{3600^4}{(13.8)^2})^{0.25} \times \left(\frac{827}{827 + 13.8}\right)^{0.5} \\ &= 2.95 \times 10^6 \text{ kcal/m}^2 = 1.083 \text{ MM Btu/ft}^2 \text{ h}\end{aligned}$$

Again, as before, factors such as surface roughness, water quality, scale formation, and bundle configuration play a role, and for conservative estimates, boiler designers use a value that is 20–30% of these values.

8.47c

Q:

Estimate the critical heat flux for a tube bundle of a fire tube boiler with the following data:

Tube OD = 2 in.

Number of tubes = 590

Length = 29.5 ft

Tube spacing = 2.75 in., triangular

Surface area = 9113 ft²

Tube bundle diameter = 78 in.

A:

The heat flux for a tube bundle is obtained by correcting the heat flux for pool boiling obtained from Q8.47b.

First compute a factor $\Psi = D_b L / A$

where

D_b = bundle diameter, ft

L = length of tubes, ft

A = surface area of bundle, ft²

$$\Psi = \frac{78 \times 29.5}{12 \times 9113} = 0.021$$

The correction factor F is obtained from the correlation

$$\log F = 0.8452 + 0.994 \log \Psi$$

For $\Psi = 0.021$, $\log F = -0.8224$, or $F = 0.15$.

Hence,

$$\text{Corrected heat flux} = 1.083 \times 10^6 \times 0.15 = 162,500 \text{ Btu/ft}^2 \text{ h}$$

Typically a value such as 70–80% of this is used for tube bundles.

8.48

Q:

Discuss the simplified approach to designing fire tube boilers.

A:

Engineers often must estimate the size of heat transfer equipment such as heat exchangers, gas coolers, boilers, and economizers for preliminary costing and to check space requirements. With the approach presented here, one can quickly determine one or more configurations to accomplish a certain amount of heat transfer. One can also size equipment so as to limit the pressure drop without performing lengthy calculations. Life-cycle costing can then be applied to select the optimum design.

Two situations will be discussed [8].

1. The tube-side heat transfer coefficient governs the overall heat transfer. Examples: Fire tube boilers; gas coolers; heat exchangers in which a medium such as air or flue gas flows on the tube side and a fluid with a high heat transfer coefficient flows on the outside. Phase changes can also occur on the outside of the tubes.
2. The shell side governs. Examples: Water tube boilers, steam-air exchangers, and gas-liquid heat transfer equipment. See Q8.49.

Tube-Side Transfer Governs

In a fire tube boiler, gas flows inside the tubes and a steam-water mixture flows on the outside. The gas heat transfer coefficient is small, about 10–20 Btu/ft² h °F, compared to the outside coefficient of 2000–3000 Btu/ft² h °F. The metal resistance is also small; hence the gas-side coefficient governs the overall coefficient and the size of the equipment.

The energy transferred is given by

$$Q = UA \Delta T = W_i C_p \times (T_1 - T_2) \quad (89)$$

The overall heat transfer coefficient is obtained from Eq. (4),

$$\frac{1}{U} = \frac{d_o}{h_i d_i} + \frac{1}{h_o} + \frac{d}{24K_m} \ln \frac{d_o}{d_i} + ff_i \frac{d_o}{d_i} + ff_o$$

Because the inside coefficient governs U , we can rewrite Eq. (4) as follows (neglecting lower order resistances, such as h_o , metal resistance, and fouling factors, which contribute to about 5% of U):

$$U = 0.95 h_i \frac{d_i}{d_o} \quad (90)$$

The value of the tube-side coefficient is obtained from the familiar Dittus–Boelter equation, Eq. (8),

$$\text{Nu} = 0.023 \text{Re}^{0.8} \text{Pr}^{0.4}$$

where

$$\text{Nu} = \frac{h_i d_i}{12k}, \quad \text{Re} = 15.2 \frac{w}{d_i \mu}$$

The fluid transport properties are evaluated at the bulk temperature.

Substituting Eqs. (8)–(11) into Eq. (90) and simplifying, we have the following expression [Eq. (12)]:

$$h_i = 2.44w^{0.8}F_1/d_i^{1.8}$$

where

$$F_1 = (C_p/\mu)^{0.4}k^{0.6} \quad (91)$$

Combining Eqs. (89)–(91) we have, after substituting $A = 3.14d_iLN/12$ and for flow per tube $w = W_i/N$,

$$\frac{Q}{\Delta T F_1 W_i^{0.8}} = 0.606 \times \frac{LN^{0.2}}{d_i^{0.8}} \quad (92)$$

This simple equation relates several important variables. Given Q , ΔT , W_i , and F_1 , one can try combinations of L , d_i , and N to arrive at a suitable configuration. Also, for given thermal data, $LN^{0.2}/d_i^{0.8}$ is constant in Eq. (92).

F_1 is shown in Table 8.35 for flue gas and air. For other gases, F_1 can be computed from Eq. (91).

When a phase change occurs, as in a boiler, ΔT is written as

$$\Delta T = \frac{(T_1 - t_s) - (T_2 - t_s)}{\ln[(T_1 - t_s) - (T_2 - t_s)]} \quad (93)$$

Combining Eqs. (92) and (93) and simplifying, we arrive at the expression

$$\ln \frac{T_1 - t_s}{T_2 - t_s} = 0.606 \times \frac{F_1}{C_p} \times N^{0.2} \times \frac{L}{W_i^{0.2} d_i^{0.8}} \quad (94)$$

Factor F_1/C_p is also given in Table 8.35.

Equation (94) relates the major geometric parameters to thermal performance. Using this method, one need not evaluate heat transfer coefficients.

TABLE 8.35 Factors F_1/C_p , F_2/C_p , F_2 , and F_3 for Air and Flue Gas^a

Temp (°F)	F_1/C_p	F_2	F_2/C_p	F_3
Air				
100	0.6660	0.0897	0.3730	0.5920
200	0.6870	0.0952	0.3945	0.6146
300	0.7068	0.1006	0.4140	0.6350
400	0.7225	0.1056	0.4308	0.6528
600	0.7446	0.1150	0.4591	0.6810
1000	0.7680	0.1220	0.4890	0.6930
1200	0.7760	0.1318	0.5030	0.7030
		0.1353		0.7150
Flue gas^a				
200	0.6590	0.0954	0.3698	0.5851
300	0.6780	0.1015	0.3890	0.6059
400	0.6920	0.1071	0.4041	0.6208
600	0.7140	0.1170	0.4300	0.6457
800	0.7300	0.1264	0.4498	0.6632
1000	0.7390	0.1340	0.4636	0.6735
1200	0.7480	0.1413	0.4773	0.6849

^aFlue gas is assumed to have 12% water vapor by volume.

Gas Pressure Drop

Now consider gas pressure drop. The equation that relates the geometry to tube-side pressure drop in in.H₂O is

$$\begin{aligned} \Delta P_i &= 9.3 \times 10^{-5} f \times \left(\frac{W_i}{N}\right)^2 (L + 5d_i) \times \frac{v}{d_i^5} \\ &= 9.3 \times 10^{-5} \times \left(\frac{W_i}{N}\right)^2 K_2 v \end{aligned} \quad (95)$$

where

$$K_2 = f(L + 5d_i)/d_i^5 \quad (96)$$

Combining Eqs. (94)–(96) and eliminating N ,

$$\ln \frac{T_1 - t_s}{T_2 - t_s} = 0.24 \times \frac{F_1}{C_p} \times K_1 \frac{v^{0.1}}{\Delta P_i^{0.1}} \quad (97)$$

where

$$K_1 = (L + 5d_i)^{0.1} L f^{0.1} / d_i^{1.3} \quad (98)$$

TABLE 8.36 Values of K_1 as a Function of Tube Diameter and Length

L (ft)	d_i (in.)								
	1.00	1.25	1.50	1.75	2.00	2.25	2.50	2.75	3.00
8	7.09	5.33	4.22	3.46	2.92	2.52	2.20	1.95	1.75
10	8.99	6.75	5.34	4.38	3.70	3.17	2.78	2.46	2.21
12	10.92	8.20	6.48	5.31	4.48	3.85	3.36	2.98	2.67
14	12.89	9.66	7.63	6.25	5.27	4.53	3.95	3.50	3.14
16	14.88	11.14	8.80	7.21	6.07	5.21	4.55	4.02	3.61
18	16.89	12.65	9.98	8.17	6.88	5.91	5.15	4.56	4.10
20	18.92	14.16	11.17	9.14	7.70	6.60	5.76	5.10	4.56
22	20.98	15.70	12.38	10.12	8.52	7.31	6.37	5.64	5.05
24	23.05	17.24	13.59	11.11	9.35	8.02	6.99	6.19	5.54
26	25.13	18.80	14.81	12.11	10.19	8.74	7.61	6.74	6.03
28	27.24	20.37	16.05	13.11	11.00	9.46	8.74	7.30	6.52

TABLE 8.37 Values of K_2 as a Function of Tube Diameter and Length

L (ft)	d_i (in.)								
	1.00	1.25	1.50	1.75	2.00	2.25	2.50	2.75	3.00
8	0.2990	0.1027	0.0428	0.0424	0.0109	0.0062	0.0037	0.0024	0.0016
10	0.3450	0.1171	0.0484	0.0229	0.0121	0.0069	0.0041	0.0027	0.0018
12	0.3910	0.1315	0.0539	0.0252	0.0134	0.0075	0.0045	0.0029	0.0019
14	0.4370	0.1460	0.0595	0.0277	0.0146	0.0082	0.0049	0.0031	0.0021
16	0.4830	0.1603	0.0650	0.0302	0.0158	0.0088	0.0053	0.0033	0.0022
20	0.5750	0.1892	0.0760	0.0350	0.0183	0.0101	0.0060	0.0038	0.0025
22	0.6210	0.2036	0.0816	0.0375	0.0195	0.0108	0.0064	0.0040	0.0027
24	0.6670	0.2180	0.0870	0.0400	0.0207	0.0114	0.0067	0.0042	0.0028
26	0.7130	0.2320	0.0926	0.0423	0.0219	0.0121	0.0071	0.0045	0.0030
28	0.7590	0.2469	0.0982	0.0447	0.0231	0.0217	0.0075	0.0047	0.0031

K_1 and K_2 appear in Tables 8.36 and 8.37 respectively, as a function of tube ID and length. In the turbulent range, the friction factor for cold-drawn tubes is a function of inner diameter.

Using Eq. (97), one can quickly figure the tube diameter and length that limit tube pressure drop to a desired value. Any two of the three variables N , L , and d_i determine thermal performance as well as gas pressure drop. Let us discuss the conventional design procedure:

1. Assume w , calculate N .
2. Calculate U , using Eqs. (4) and (90).
3. Calculate L after obtaining A from Eq. (89).
4. Calculate ΔP_i from Eq. (95).

If the geometry or pressure drop obtained is unsuitable, repeat steps 1–4. This procedure is lengthy.

Some examples will illustrate the simplified approach. The preceding equations are valid for single-pass design. However, with minor changes one can derive the relationships for multipass units (e.g., use length = $L/2$ for two-pass units).

Example 1

A fire tube waste heat boiler will cool 66,000 lb/h of flue gas from 1160°F to 440°F. Saturation temperature is 350°F. Molecular weight is 28.5, and gas pressure is atmospheric. If L is to be limited to 20 ft due to layout, determine N and ΔP_i for two tube sizes: (1) 2×1.77 in. (2 in. OD, 1.77 in. ID) and (2) 1.75×1.521 in.

Solution. Use Eq. (92) to find N . Use 2 in. tubes. F_1/C_p from Table 8.35 is 0.73 for flue gas at the average gas temperature of $0.5 \times (1160 + 440) = 800^\circ\text{F}$.

$$\ln\left[\frac{1160 - 350}{440 - 350}\right] = 2.197$$

$$2.197 = 0.606 \times 0.73 \times N^{0.2} \times \frac{20}{(66,000)^{0.2} \times (1.77)^{0.8}}$$

$$= 0.6089N^{0.2}, \quad N = 611$$

Compute ΔP_i using Eq. (95). From Table 8.37, K_2 is 0.035. Compute the gas specific volume.

$$\text{Density } (\rho) = 28.5 \times \frac{492}{359 \times (460 + 800)} = 0.031 \text{ lb/ft}^3$$

$$v = 32.25 \text{ ft}^3/\text{lb}$$

Substituting into Eq. (95), we have

$$\Delta P_i = 9.3 \times 10^{-5} \times \left(\frac{66,000}{611}\right)^2 \times 0.035 \times 32.25$$

$$= 1.23 \text{ in.H}_2\text{O}$$

Repeat the exercise with 1.75 in. tubes; length remains at 20 ft. From Eq. (92) we note that for the same thermal performance and gas flow, $N^{0.2}L/d_i^{0.8} =$

a constant. The above concept comes in handy when one wants to quickly figure the effect of geometry on performance. Hence,

$$611^{0.2} \times \frac{20}{(1.77)^{0.8}} = N^{0.2} \times \frac{20}{(1.521)^{0.8}}$$

$$N = 333$$

With smaller tubes, one needs fewer tubes for the same duty. This is due to a higher heat transfer coefficient; however, the gas pressure drop would be higher. From Table 8.37, $K_2 = 0.076$ for 1.521 in. tubes. From Eq. (95),

$$\Delta P_i = 9.3 \times 10^{-5} \times \left(\frac{66,000}{333} \right)^2 \times 0.076 \times 32.25$$

$$= 8.95 \text{ in.H}_2\text{O}$$

Example 2

Size the heat exchanger for 2.0 in. tubes with a pressure drop of 3.0 in.H₂O. For the same thermal performance, determine the geometry.

Solution. The conventional approach would take several trials to arrive at the right combination. However, with Eq. (97), one can determine the geometry rather easily:

$$\ln \frac{1160 - 350}{440 - 350} = 2.197 = 0.24 \times \frac{F_1}{C_p} \times \frac{K_1 v^{0.1}}{\Delta P_i^{0.1}}$$

From Table 8.35, $F_1/C_p = 0.73$; $\Delta P_i = 3$, $v = 32.25$. Then

$$\ln \frac{1160 - 350}{440 - 350} = 2.197 = 0.24 K_1 \times (32.25)^{0.1}$$

$$\times \frac{0.73}{3^{0.1}} = 0.222 K_1$$

$$K_1 = 9.89$$

From Table 8.36, we can obtain several combinations of tube diameter and length that have the same K_1 value and would yield the same thermal performance and pressure drop. For the 1.77 in. ID tube, L is 21.75 ft. Use Eq. (92) to calculate the number of tubes.

$$2.197 = 0.606 \times 0.73 \times 21.75 \times \frac{N^{0.2}}{(66,000)^{0.2} \times (1.77)^{0.8}}$$

$$N = 402$$

Thus, several alternative tube geometries can be arrived at for the same performance, using the preceding approach. One saves a lot of time by not calculating heat transfer coefficients and gas properties.

Life-Cycle Costing

Such techniques determine the optimum design, given several alternatives. Here, the major operating cost is from moving the gas through the system, and the installed cost is that of the equipment and auxiliaries such as the fan. The life-cycle cost is the sum of the capitalized cost of operation and the installed cost:

$$LCC = C_{co} + I_c$$

The capitalized cost of operation is

$$C_{co} = C_a Y \frac{1 - Y^T}{1 - Y}$$

where $Y = (1 + e)/(1 + i)$.

The annual cost of operating the fan is estimated as

$$C_a = 0.001 \times PHC_e$$

where the fan power consumption in kW is

$$P = 1.9 \times 10^{-6} \times W_i \times \frac{\Delta P_i}{\rho \eta}$$

The above procedure is used to evaluate LCC. The alternative with the lowest LCC is usually chosen if the geometry is acceptable. (C_e is cost of electricity.) and H is the number of hours of operation per year.

8.49

Q:

Discuss the simplified approach to designing water tube boilers.

A:

Whenever gas flows outside a tube bundle—as in water tube boilers, economizers, and heat exchangers with high heat transfer coefficients on the tube side—the overall coefficient is governed by the gas-side resistance. Assuming that the other resistances contribute about 5% to the total, and neglecting the effect of nonluminous transfer coefficients, one may write the expression for U as

$$U = 0.95h_o \quad (99a)$$

where the outside coefficient, h_o , is obtained from

$$Nu = 0.35 Re^{0.6} Pr^{0.3} \quad (99b)$$

where, using Eqs. (16)–(18) and (21),

$$\text{Nu} = \frac{h_o d_o}{12k}, \quad \text{Re} = \frac{Gd}{12\mu}, \quad \text{Pr} = \frac{\mu C_p}{k}$$

$$G = 12 \frac{W_o}{N_w L (S_T - d_o)}$$

Equation (99) is valid for both in-line (square or rectangular pitch) and staggered (triangular pitch) arrangements. For bare tubes, the difference in h_o between in-line and staggered arrangements at Reynolds numbers and pitches found in practice is 3–5%. For finned tubes, the variation is significant.

Substituting Eqs. (17)–(21) into Eq. (99a) and (99b) and simplifying,

$$h_o = 0.945 G^{0.6} F_2 / d_o^{0.4} \quad (100)$$

$$U = 0.9 G^{0.6} F_2 / d_o^{0.4} \quad (101)$$

where

$$F_2 = k^{0.7} (C_p / \mu)^{0.3} \quad (102)$$

F_2 is given in [Table 8.35](#). Gas transport properties are computed at the film temperature.

$$A = \pi d_o N_w N_d L / 12$$

Combining the above with Eq. (89) and simplifying gives

$$\begin{aligned} Q / \Delta T = UA &= \pi 0.9 G^{0.6} F_2 d_o N_w N_d L / 12 d_o^{0.4} \\ &= 0.235 F_2 G^{0.6} N_w N_d L d_o^{0.6} \end{aligned}$$

Substituting for G from Eq. (21),

$$\frac{Q}{\Delta T} = 1.036 F_2 W_o^{0.6} \frac{N_w^{0.4} L^{0.4} N_d}{(S_T / d_o - 1)^{0.6}} \quad (103)$$

The above equation relates thermal performance to geometry. When there is a phase change, as in a boiler, further simplification leads to

$$\ln \frac{T_1 - t_s}{T_2 - t_s} = 2.82 \frac{F_2}{C_p} \times \frac{N_d}{G^{0.4} (S_T / d_o - 1) d_o^{0.4}} \quad (104)$$

If the tube diameter and pitch are known, one can estimate N_d or G for a desired thermal performance.

Let us now account for gas pressure drop. The equation that relates the gas pressure drop to G is Eq. (28) of [Chapter 7](#):

$$\Delta P_o = 9.3 \times 10^{-10} \times G^2 f \frac{N_d}{\rho}$$

For in-line arrangements, the friction factor is obtained from Eq. (29) of Chapter 7:

$$f = \text{Re}^{-0.15} X$$

where

$$X = 0.044 + \frac{0.08S_L/d_o}{(S_T/d_o - 1)^{0.43+1.13d_o/S_L}}$$

Another form of Eq. (28) of Chapter 7 is

$$\Delta P_o = 1.34 \times 10^{-7} \times \frac{W_o^{1.85} v N_d^{2.85} \mu^{0.15} X}{N_w^{1.85} L^{1.85} d_o^{0.15} (S_T - d_o)^{1.85}} \quad (105)$$

Substituting for f in Eq. (28) of Chapter 7 and combining with Eq. (104) we can relate ΔP_o to performance in a single equation:

$$\begin{aligned} \Delta P_o &= 4.78 \times 10^{-10} \times G^{2.25} (S_T - d_o) \\ &\times \ln \left[\frac{T_1 - t_s}{T_2 - t_s} \right] \times \frac{X}{d_o^{0.75} F_3 \rho} \end{aligned} \quad (106)$$

where

$$F_3 = (F_2/C_p) \mu^{-0.15} \quad (107)$$

F_3 is given in Table 8.35. With Eq. (107), one can easily calculate the geometry for a given tube bank so as to limit the pressure drop to a desired value. An example will illustrate the versatility of the technique.

Example

In a water tube boiler, 66,000 lb/h of flue gas is cooled from 1160°F to 440°F. Saturation temperature is 350°F. Tube outside diameter is 2 in., and an in-line arrangement is used with $S_T = S_L = 4$ in. Determine a suitable configuration to limit the gas pressure to 3 in.H₂O.

Let us use Eq. (106). Film temperature is $0.5 \times (800 + 350) = 575^\circ\text{F}$. Interpolating from Table 8.35 at 475°F, $F_3 = 0.643$. Gas density at 800°F is 0.031 lb/ft³ from Example 1.

$$\begin{aligned} \Delta P_o &= 4.78 \times 10^{-10} \times G^{2.25} (4 - 2) \\ &\times \ln \left[\frac{1160 - 350}{440 - 350} \right] \\ &\times \frac{(0.044 + 0.08 \times 2)}{2^{0.75} \times 0.643 \times 0.031} \\ &= 128 \times 10^{-10} \times G^{2.25} = 3 \end{aligned}$$

Hence, $G = 5200 \text{ lb/ft}^2 \text{ h}$. From Eq. (21) one can choose different combinations of N_w and L :

$$N_w L = 66,000 \times 12 / (2 \times 5200) = 76$$

If $N_w = 8$, then $L = 9.5 \text{ ft}$.

Calculate N_d from Eq. (104):

$$\begin{aligned} \ln \left[\frac{1160 - 350}{440 - 350} \right] &= 2.197 \\ &= 2.82 \frac{F_2}{C_p} \times \frac{N_d}{G^{0.4} (S_T d_o - 1) d_o^{0.4}} \end{aligned}$$

$$2.197 = 2.82 \times 0.426 N_d / (5200^{0.4} \times 1 \times 2^{0.4}) \text{ or } N_d = 74$$

Thus, the entire geometry has been arrived at.

8.50

Q:

How is the bundle diameter of heat exchangers or fire tube boilers determined?

A:

Tubes of heat exchangers and fire tube boilers are typically arranged in square or triangular pitch (Fig. 8.20). The ratio of tube pitch to diameter could range from 1.25 to 2 depending on the tube size and the manufacturer's past practice.

Looking at the triangular pitch arrangement, we see that *half* of a tube area is located within the triangle, whose area is given by

$$\text{Area of triangle} = 0.5 \times 0.866p^2 = 0.433p^2$$

If there are N tubes in the bundle, then

$$\text{Total area occupied} = 0.866Np^2$$

If the bundle diameter is D , then $3.14 \times D^2/4 = \text{area of bundle} = 0.866Np^2$, or

$$D = 1.05pN^{0.5} \tag{108}$$

Similarly, for the square pitch, the area occupied by one tube = p^2 . Hence bundle area = $3.14 \times D^2/4 = Np^2$, or

$$D = 1.128pN^{0.5} \tag{109}$$

In practice, a small clearance is added to the above number for manufacturing purposes.

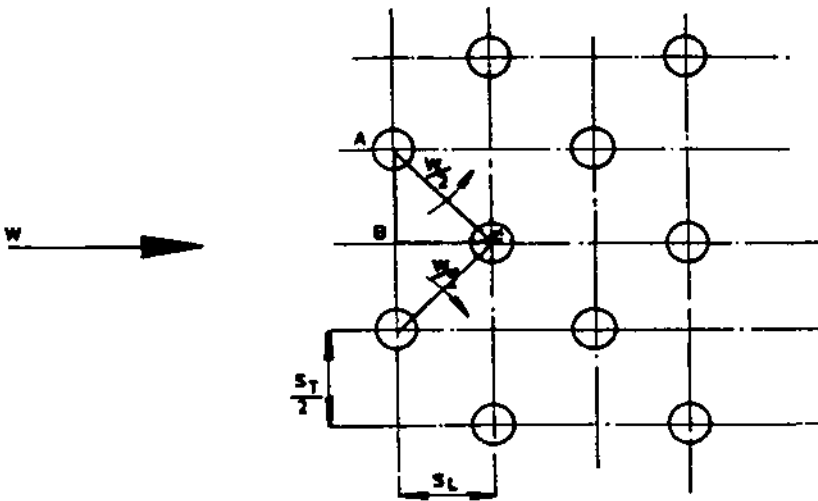
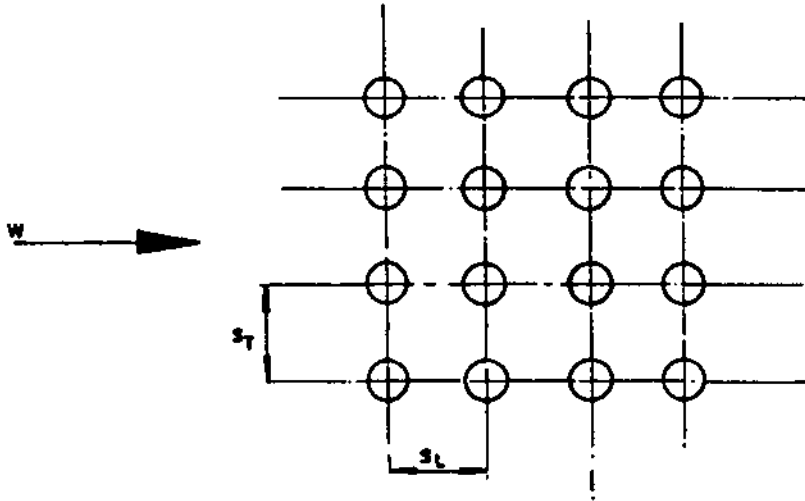

FIGURE 8.20 Square (top) and triangular (bottom) pitch for boiler/exchanger tubes.

Example

If 500 tubes of 2 in. diameter are located in a fire tube boiler shell at a triangular pitch of 3 in., the bundle diameter would be

$$D = 1.05 \times 3 \times 500^{0.5} = 70.5 \text{ in.}$$

If the pitch were square, the bundle diameter would be

$$D = 1.128 \times 3 \times 500^{0.5} = 75.7 \text{ in.}$$

Sometimes tubes have to be located within a given sector of a circle. In such cases, it is helpful to know the area of a sector of a circle given its height and diameter. Table 8.38 gives the factor C , which when multiplied by D^2 gives the sector area.

Example

Find the area of a sector of height 10 in. and diameter 24 in.

Solution. For $h/D = 10/24 = 0.4167$, C from Table 8.38 = 0.309. Hence,

$$\text{Area} = C \times D^2 = 0.309 \times 24 \times 24 = 178 \text{ in.}^2$$

8.51

Q:

How is the thickness of insulation for a flat or curved surface determined? Determine the thickness of insulation to limit the casing surface temperature of a pipe operating from 800°F to 200°F, when

Ambient temperature $t_a = 80^\circ\text{F}$

Thermal conductivity of insulation K_m at average temperature of 500°F =
0.35 Btu in./ft² h °F

Pipe outer diameter $d = 12$ in.

Wind velocity $V = 264$ ft/min (3 mph)

Emissivity of casing = 0.15 (oxidized)

TABLE 8.38 *C* Factors for Finding Area of Sector of a Circle (Area = CD^2)

<i>h/D</i>	<i>C</i>	<i>h/D</i>	<i>C</i>	<i>h/D</i>	<i>C</i>	<i>h/D</i>	<i>C</i>	<i>h/D</i>	<i>C</i>
0.001	0.00004	0.050	0.01468	0.100	0.04087	0.150	0.07387	0.200	0.11182
0.002	0.00012	0.051	0.01512	0.101	0.04148	0.151	0.07459	0.201	0.11262
0.003	0.00022	0.052	0.01556	0.102	0.04208	0.152	0.07531	0.202	0.11343
0.004	0.00034	0.053	0.01601	0.103	0.04269	0.153	0.07603	0.203	0.11423
0.005	0.00047	0.054	0.01646	0.104	0.04330	0.154	0.07675	0.204	0.11504
0.006	0.00062	0.055	0.01691	0.105	0.04391	0.155	0.07747	0.205	0.11584
0.007	0.00078	0.056	0.01737	0.106	0.04452	0.156	0.07819	0.206	0.11665
0.008	0.00095	0.057	0.01783	0.107	0.04514	0.157	0.07892	0.207	0.11746
0.009	0.00113	0.058	0.01830	0.108	0.04578	0.158	0.07965	0.208	0.11827
0.010	0.00133	0.059	0.01877	0.109	0.04638	0.159	0.08038	0.209	0.11908
0.011	0.00153	0.060	0.01924	0.110	0.04701	0.160	0.08111	0.210	0.11990
0.012	0.00175	0.061	0.01972	0.111	0.04763	0.161	0.08185	0.211	0.12071
0.013	0.00197	0.062	0.02020	0.112	0.04826	0.162	0.08258	0.212	0.12153
0.014	0.00220	0.063	0.02068	0.113	0.04889	0.163	0.08332	0.213	0.12235
0.015	0.00244	0.064	0.02117	0.114	0.04953	0.164	0.08406	0.214	0.12317
0.016	0.00268	0.065	0.02166	0.115	0.05016	0.165	0.08480	0.215	0.02399
0.017	0.00294	0.066	0.02215	0.116	0.05080	0.166	0.08554	0.216	0.12481
0.018	0.00320	0.067	0.02265	0.117	0.05145	0.167	0.08629	0.217	0.12563
0.019	0.00347	0.068	0.02315	0.118	0.05209	0.168	0.08704	0.218	0.12646
0.020	0.00375	0.069	0.02366	0.119	0.05274	0.169	0.08779	0.219	0.12729
0.021	0.00403	0.070	0.02417	0.120	0.05338	0.170	0.08854	0.220	0.12811
0.022	0.00432	0.071	0.02468	0.121	0.05404	0.171	0.08929	0.221	0.12894
0.023	0.00462	0.072	0.02520	0.122	0.05469	0.172	0.09004	0.222	0.12977
0.024	0.00492	0.073	0.02571	0.123	0.05535	0.173	0.09080	0.223	0.13060
		0.074	0.02624	0.124	0.05600	0.174	0.09155	0.224	0.13144

(continued)

TABLE 8.38 (continued)

h/D	C	h/D	C	h/D	C	h/D	C	h/D	C
0.025	0.00523	0.075	0.02676	0.125	0.05666	0.175	0.09231	0.225	0.13277
0.026	0.00555	0.076	0.02729	0.126	0.05733	0.176	0.09307	0.226	0.13311
0.027	0.00587	0.077	0.02782	0.127	0.05799	0.177	0.09384	0.227	0.13395
0.028	0.00619	0.078	0.02836	0.128	0.05866	0.178	0.09460	0.228	0.13478
0.029	0.00653	0.079	0.02889	0.129	0.05933	0.179	0.09537	0.229	0.13562
0.030	0.00687	0.080	0.02943	0.130	0.06000	0.180	0.09613	0.230	0.13646
0.031	0.00721	0.081	0.02998	0.131	0.06067	0.181	0.09690	0.231	0.13731
0.032	0.00756	0.082	0.03053	0.132	0.06135	0.182	0.09767	0.232	0.13815
0.033	0.00791	0.083	0.03108	0.133	0.06203	0.183	0.09845	0.233	0.13900
0.034	0.00827	0.084	0.03163	0.134	0.06271	0.184	0.09922	0.234	0.13984
0.035	0.00864	0.085	0.03219	0.135	0.06339	0.185	0.10000	0.235	0.14069
0.036	0.00901	0.086	0.03275	0.136	0.06407	0.186	0.10077	0.236	0.14154
0.037	0.00938	0.087	0.03331	0.137	0.06476	0.187	0.10155	0.237	0.14239
0.038	0.00976	0.088	0.03387	0.138	0.06545	0.188	0.10233	0.238	0.14324
0.039	0.01015	0.089	0.03444	0.139	0.06614	0.189	0.10312	0.239	0.14409
0.040	0.01054	0.090	0.03501	0.140	0.06683	0.190	0.10390	0.240	0.14494
0.041	0.01093	0.091	0.03559	0.141	0.06753	0.191	0.10469	0.241	0.14580
0.042	0.01133	0.092	0.03616	0.142	0.06822	0.192	0.10547	0.292	0.14666
0.043	0.01173	0.093	0.03674	0.143	0.06892	0.193	0.10626	0.243	0.14751
0.044	0.01214	0.094	0.03732	0.144	0.06963	0.194	0.10705	0.244	0.14837
0.045	0.01255	0.095	0.03791	0.145	0.07033	0.195	0.10784	0.245	0.14923
0.046	0.01297	0.096	0.03850	0.146	0.07103	0.196	0.10864	0.246	0.15009
0.047	0.01339	0.097	0.03909	0.147	0.07174	0.197	0.10943	0.247	0.15095
0.048	0.01382	0.098	0.03968	0.148	0.07245	0.198	0.11023	0.248	0.15182
0.049	0.01425	0.099	0.04028	0.149	0.07316	0.199	0.11102	0.249	0.15268
0.250	0.15355	0.300	0.19817	0.350	0.24498	0.400	0.29337	0.450	0.34278

0.251	0.15441	0.301	0.19908	0.351	0.24593	0.401	0.29435	0.451	0.34378
0.252	0.15528	0.302	0.20000	0.352	0.24689	0.402	0.29533	0.452	0.34477
0.253	0.15615	0.303	0.20092	0.353	0.24784	0.403	0.29631	0.453	0.34577
0.254	0.15702	0.304	0.20184	0.354	0.24880	0.404	0.29729	0.454	0.34676
0.255	0.15789	0.305	0.20276	0.355	0.24976	0.405	0.29827	0.455	0.34776
0.256	0.15876	0.306	0.20368	0.356	0.25071	0.406	0.29926	0.456	0.34876
0.257	0.15964	0.307	0.20460	0.357	0.25167	0.407	0.30024	0.457	0.34975
0.258	0.16501	0.308	0.20553	0.358	0.25263	0.408	0.30122	0.458	0.35075
0.259	0.16139	0.309	0.20645	0.359	0.25359	0.409	0.30220	0.459	0.35175
0.260	0.16226	0.310	0.20738	0.360	0.25455	0.410	0.30319	0.460	0.35274
0.261	0.16314	0.311	0.20830	0.361	0.25551	0.411	0.30417	0.461	0.35374
0.262	0.16402	0.312	0.20923	0.362	0.25647	0.412	0.30516	0.462	0.35474
0.263	0.16490	0.313	0.21015	0.363	0.25743	0.413	0.30614	0.463	0.35573
0.264	0.16578	0.314	0.21108	0.364	0.25839	0.414	0.30712	0.464	0.35673
0.265	0.16666	0.315	0.21201	0.365	0.25936	0.415	0.30811	0.465	0.35773
0.266	0.16755	0.316	0.21294	0.366	0.26032	0.416	0.30910	0.466	0.35873
0.267	0.16843	0.317	0.21387	0.367	0.26128	0.417	0.31008	0.467	0.35972
0.268	0.16932	0.318	0.21480	0.368	0.26225	0.418	0.31107	0.468	0.36072
0.269	0.17020	0.319	0.21573	0.369	0.26321	0.419	0.31205	0.469	0.36172
0.270	0.17109	0.320	0.21667	0.370	0.26418	0.420	0.31304	0.470	0.36272
0.271	0.17198	0.321	0.21760	0.371	0.26514	0.421	0.31403	0.471	0.36372
0.272	0.17287	0.322	0.21853	0.372	0.26611	0.422	0.31502	0.472	0.36471
0.273	0.17376	0.323	0.21947	0.373	0.26708	0.423	0.31600	0.473	0.36571
0.274	0.17465	0.324	0.22040	0.374	0.26805	0.424	0.31699	0.474	0.36671
0.275	0.17554	0.325	0.22134	0.375	0.26901	0.425	0.31798	0.475	0.36771
0.276	0.17644	0.326	0.22228	0.376	0.26998	0.426	0.31897	0.476	0.36871
0.277	0.17733	0.327	0.22322	0.377	0.27095	0.427	0.31996	0.477	0.36971
0.278	0.17823	0.328	0.22415	0.378	0.27192	0.428	0.32095	0.478	0.37071

(continued)

TABLE 8.38 (continued)

h/D	C	h/D	C	h/D	C	h/D	C	h/D	C
0.279	0.17912	0.329	0.22509	0.379	0.27289	0.429	0.32194	0.479	0.37171
0.280	0.18002	0.330	0.22603	0.380	0.27386	0.430	0.32293	0.480	0.37270
0.281	0.18092	0.331	0.22697	0.381	0.27483	0.431	0.32392	0.481	0.37370
0.282	0.18182	0.332	0.22792	0.382	0.27580	0.432	0.32491	0.482	0.37470
0.283	0.18272	0.333	0.22886	0.383	0.27678	0.433	0.32590	0.483	0.37570
0.284	0.18362	0.334	0.22980	0.384	0.27775	0.434	0.32689	0.484	0.37670
0.285	0.18452	0.335	0.23074	0.385	0.27872	0.435	0.32788	0.485	0.37770
0.286	0.18542	0.336	0.23169	0.386	0.27969	0.436	0.32887	0.486	0.37870
0.287	0.18633	0.337	0.23263	0.387	0.28067	0.437	0.32987	0.487	0.37970
0.288	0.18723	0.338	0.23358	0.388	0.28164	0.438	0.33086	0.488	0.38070
0.289	0.18814	0.339	0.23453	0.389	0.28262	0.439	0.33185	0.489	0.38170
0.290	0.18905	0.340	0.23547	0.390	0.28359	0.440	0.33284	0.490	0.38270
0.291	0.18996	0.341	0.23642	0.391	0.28457	0.441	0.33384	0.491	0.38370
0.292	0.19086	0.342	0.23737	0.392	0.28554	0.442	0.33483	0.492	0.38470
0.293	0.19177	0.343	0.23832	0.393	0.28652	0.443	0.33582	0.493	0.38570
0.294	0.19268	0.344	0.23927	0.394	0.28750	0.444	0.33682	0.494	0.38670
0.295	0.19360	0.345	0.24022	0.395	0.28848	0.445	0.33781	0.495	0.38770
0.296	0.19451	0.346	0.24117	0.396	0.28945	0.446	0.33880	0.496	0.38870
0.297	0.19542	0.347	0.24212	0.397	0.29043	0.447	0.33980	0.497	0.38970
0.298	0.19634	0.348	0.24307	0.398	0.29141	0.448	0.34079	0.498	0.39070
0.299	0.19725	0.349	0.24403	0.399	0.29239	0.449	0.34179	0.499	0.38170
								0.500	0.39270

A:

The heat loss q from the surface is given by [7]

$$q = 0.174\varepsilon \left[\left(\frac{t_s + 459.6}{100} \right)^4 - \left(\frac{t_a + 459.6}{100} \right)^4 \right] + 0.296 (t_s - t_a)^{1.25} \times \left(\frac{V + 68.9}{68.9} \right)^{1/2} \quad (110)$$

ε may be taken as 0.9 for oxidized steel, 0.05 for polished aluminum, and 0.15 for oxidized aluminum. Also,

$$q = \frac{K_m(t - t_s)}{[(d + 2L)/2] \times \ln[(d + 2L)/d]} = \frac{K_m(t - t_s)}{L_e} \quad (111)$$

where t is the hot face temperature, °F, and L_e is the equivalent thickness of insulation for a curved surface such as a pipe or tube.

$$L_e = \frac{d + 2L}{2} \ln \frac{d + 2L}{d} \quad (112)$$

Substituting $t_s = 200$, $t_a = 80$, $V = 264$, and $\varepsilon = 0.15$ into Eq. (110), we have

$$q = 0.173 \times 0.15 \times (6.6^4 - 5.4^4) + 0.296 \times (660 - 540)^{1.25} \times \left(\frac{264 + 69}{69} \right)^{0.5} = 285 \text{ Btu/ft}^2 \text{ h}$$

From Eq. (111),

$$L_e = 0.35 \times \frac{800 - 200}{285} = 0.74 \text{ in.}$$

We can solve for L given L_e and d by using Eq. (112) and trial and error, or we can use [Table 8.39](#). It can be shown that $L = 0.75$ in. The next standard thickness available will be chosen. A trial-and-error method as discussed next will be needed to solve for the surface temperature t_s . (Note that L is the actual thickness of insulation.)

8.52

Q:

Determine the surface temperature of insulation in Q8.51 when 1.0 in. thick insulation is used on the pipe. Other data are as given earlier.

TABLE 8.39 Equivalent Thickness of Insulation,^a L_e

Tube diam. d (in.)	Thickness of insulation L (in.)							
	0.5	1	1.5	2.0	3.0	4.0	5.0	6.0
1	0.69	1.65	2.77	4.0	6.80	9.90	13.2	16.7
2	0.61	1.39	2.29	3.30	5.50	8.05	10.75	13.62
3	0.57	1.28	2.08	2.97	4.94	7.15	9.53	12.07
4	0.56	1.22	1.96	2.77	4.55	6.60	8.76	11.10
5	0.55	1.18	1.88	2.65	4.34	6.21	8.24	10.40
6	0.54	1.15	1.82	2.55	4.16	5.93	7.85	9.80
8	0.53	1.12	1.75	2.43	3.92	5.55	7.50	9.15
10	0.52	1.09	1.70	2.35	3.76	5.29	6.93	8.57
12	0.52	1.08	1.67	2.30	3.65	5.11	6.65	8.31
16	0.52	1.06	1.63	2.23	3.50	4.86	6.31	7.83
20	0.51	1.05	1.61	2.19	3.41	4.70	6.10	7.52

^a $L_e = \frac{d + 2L}{2} \ln \frac{d + 2L}{d}$. For example, for $d = 3$ and $L = 1.5$, $L_e = 2.08$.

A:

Calculate the equivalent thickness L_e . From Eq. (112),

$$L_e = \frac{12 + 2}{2} \ln \frac{14}{12} = 1.08 \text{ in.}$$

Assume that for the first trial $t_s = 150^\circ\text{F}$. Let K_m at a mean temperature of $(800 + 150)/2 = 475^\circ\text{F}$ be $0.34 \text{ Btu in./ft}^2 \text{ h } ^\circ\text{F}$. From Eq. (110),

$$\begin{aligned} q &= 0.173 \times 0.15 \times (6.1^4 - 5.4^4) + 0.296 \\ &\quad \times (610 - 540)^{1.25} \times \left(\frac{264 + 69}{69} \right)^{0.5} \\ &= 145 \text{ Btu/ft}^2 \text{ h} \end{aligned}$$

From Eq. (111),

$$q = 0.34 \times \frac{800 - 150}{1.08} = 205 \text{ Btu/ft}^2 \text{ h}$$

Because these two values of q do not agree, we must go for another trial. Try $t_s = 170^\circ\text{F}$. Then, from Eq. (110),

$$q = 200 \text{ Btu/ft}^2 \text{ h}$$

and from Eq. (111),

$$q = 198 \text{ Btu/ft}^2 \text{ h}$$

These two are quite close. Hence the final surface temperature is 170°F, and the heat loss is about 200 Btu/ft² h.

8.53

Q:

A horizontal flat surface is at 10°F. The ambient dry bulb temperature is 80°F, and the relative humidity is 80%. Determine the thickness of fibrous insulation that will prevent condensation of water vapor on the surface. Use $K_m = 0.28 \text{ Btu/ft h } ^\circ\text{F}$. The wind velocity is zero. Use a surface emissivity of 0.9 for the casing.

A:

The surface temperature must be above the dew point of water to prevent condensation of water vapor. Q5.10 shows how the dew point can be calculated. The saturated vapor pressure at 80°F, from the steam tables in the Appendix, is 0.51 psia. At 80% relative humidity, the vapor pressure will be $0.8 \times 0.51 = 0.408$ psia. From the steam tables, this corresponds to a saturation temperature of 73°F, which is also the dew point. Hence we must design the insulation so the casing temperature is above 73°F.

From Eq. (110),

$$q = 0.173 \times 0.9 \times (5.4^4 - 5.33^4) + 0.296 \times (80 - 73)^{1.25} = 10.1 \text{ Btu/ft}^2 \text{ h}$$

Also, from Eq. (111),

$$q = (t_d - t_s) \times \frac{K_m}{L} = (73 - 10) \times \frac{0.28}{L}$$

(In this case of a flat surface, $L_e = L$.)

Note that the heat flow is from the atmosphere to the surface. t_d and t_s are the dew point and surface temperature, °F. Solving for L , we get $L = 1.75$ in.

Hence, by using the next standard insulation thickness available, we can ensure that the casing is above the dew point. To obtain the exact casing temperature with the standard thickness of insulation, a trial-and-error procedure as discussed in Q8.52 may be used. But this is not really necessary, because we have provided a safe design thickness.

8.54a

Q:

A $1\frac{1}{2}$ in. schedule 40 pipe 1000 ft long carries hot water at 300°F . What is the heat loss from its surface if it is not insulated (case 1) or if it has 1 in., 2 in., and 3 in. thick insulation (case 2)?

The thermal conductivity of insulation may be assumed to be $0.25 \text{ Btu in.}/\text{ft}^2 \text{ h } ^\circ\text{F}$. The ambient temperature is 80°F , and the wind velocity is zero.

A:

Case 1. Equation (110) can be used to determine the heat loss. For the bare pipe surface, assume that ε is 0.90. Then

$$q = 0.173 \times 0.9 \times (7.6^4 - 5.4^4) + 0.296 \times (300 - 80)^{1.25} = 638 \text{ Btu}/\text{ft}^2 \text{ h}$$

Case 2. Determination of the surface temperature given the insulation thickness involves a trial-and-error procedure as discussed in Q8.52 and will be done in detail for the 1 in. case.

Various surface temperatures are assumed, and q is computed from Eqs. (110) and (111). Let us use a ε value of 0.15. The following table gives the results of the calculations.

t_s	q from Eq. (110)	q from Eq. (111)
110	26	34
120	37	32
140	61	28

We can draw a graph of t_s versus q with these values and obtain the correct t_s . However, we see from the table, by interpolation, that at $t_s = 115^\circ\text{F}$, q , from both equations, is about $33 \text{ Btu}/\text{ft}^2 \text{ h}$.

$$\begin{aligned} \text{Total heat loss} &= 3.14 \times \frac{3.9}{12} \times 1000 \times 33 \\ &= 33,675 \text{ Btu}/\text{h} \end{aligned}$$

Similarly, we may solve for q when the thicknesses are 2 and 3 in. It can be shown that at $L = 2$ in., $q = 15 \text{ Btu}/\text{ft}^2 \text{ h}$, and at $L = 3$ in., $q = 9 \text{ Btu}/\text{ft}^2 \text{ h}$. Also, when $L = 2$ in., $t_s = 98^\circ\text{F}$ and total heat loss = $23,157 \text{ Btu}/\text{h}$. When $L = 3$ in., $t_s = 92^\circ\text{F}$ and total loss = $18,604 \text{ Btu}/\text{h}$.

8.54b

Q:

Estimate the drop in water temperature of 1 in. thick insulation used in Q8.54a. The water flow is 7500 lb/h.

A:

The total heat loss has been shown to be 33,675 Btu/h. This is lost by the water and can be written as $7500 \Delta T$, where ΔT is the drop in temperature, assuming that the specific heat is 1. Hence

$$\Delta T = \frac{33,675}{7500} = 4.5^\circ\text{F}$$

By equating the heat loss from insulation to the heat lost by the fluid, be it air, oil, steam, or water, one can compute the drop in temperature in the pipe or duct. This calculation is particularly important when oil lines are involved, because viscosity is affected, leading to pumping and atomization problems.

8.55

Q:

In Q8.54 determine the optimum thickness of insulation with the following data.

Cost of energy = \$3/MM Btu

Cost of operation = \$8000/year

Interest and escalation rates = 12% and 7%

Life of the plant = 15 years

Total cost of 1 in. thick insulation, including labor and material, = \$5200;
for 2 in. insulation, \$7100; and for 3 in. insulation, \$10,500

A:

Let us calculate the capitalization factor F from Q5.22.

$$F = \frac{1.07}{1.12} \times \frac{1 - (1.07/1.12)^{15}}{1 - 1.07/1.12} = 10.5$$

Let us calculate the annual heat loss.

For $L = 1$ in.,

$$C_a = 33,675 \times 3 \times \frac{8000}{10^6} = \$808$$

For $L = 2$ in.,

$$C_a = 23,157 \times 3 \times \frac{8000}{10^6} = \$555$$

For $L = 3$ in.,

$$C_a = 18,604 \times 3 \times \frac{8000}{10^6} = \$446$$

Calculate capitalized cost $C_a F$.

For $L = 1$ in.,

$$C_a F = 808 \times 10.5 = \$8484$$

For $L = 2$ in.,

$$C_a F = 555 \times 10.5 = \$5827$$

For $L = 3$ in.,

$$C_a F = 446 \times 10.5 = \$4683$$

Calculate total capitalized cost or life-cycle cost (LCC):

For $L = 1$ in.,

$$LCC = 8484 + 5200 = \$13,684$$

For $L = 2$ in., $LCC = \$12,927$; and for $L = 3$ in., $LCC = \$15,183$.

Hence we see that the optimum thickness is about 2 in. With higher thicknesses, the capital cost becomes more than the benefits from savings in heat loss. A trade-off would be to go for 2 in. thick insulation.

Several factors enter into calculations of this type. If the period of operation were less, probably a lesser thickness would be adequate. If the cost of energy were more, we might have to go for a greater thickness. Thus each case must be evaluated before we decide on the optimum thickness. This example gives only a methodology, and the evaluation can be as detailed as desired by the plant engineering personnel.

If there were no insulation, the annual heat loss would be

$$3.14 \times \frac{1.9}{12} \times 1000 \times 638 \times 3 \times \frac{8000}{10^6} = \$7600$$

Hence simple payback with even 1 in. thick insulation is $5200 / (7600 - 808) = 0.76$ year, or 9 months.

8.56

Q:

What is a hot casing? What are its uses?

A:

Whenever hot gases are contained in an internally refractory-lined (or insulated) duct, the casing temperature can fall below the dew point of acid gases, which can seep through the refractory cracks and cause acid condensation, which is a potential problem. To avoid this, some engineers prefer a “hot casing” design, which ensures that the casing or the vessel or duct containing the gases is maintained at a high enough temperature to minimize or prevent acid condensation. At the same time, the casing is also externally insulated to minimize the heat losses to the ambient (see Fig. 8.21). A “hot casing” is a combination of internal plus external insulation used to maintain the casing at a high enough temperature to avoid acid condensation while ensuring that the heat losses to the atmosphere are low.

Consider the use of a combination of two refractories inside the boiler casing: 4 in. of KS4 and 2 in. of CBM. The hot gases are at 1000°F. Ambient temperature = 60°F, and wind velocity is 100 ft/min. Casing emissivity is 0.9. To keep the boiler casing hot, an external 0.5 in. of mineral fiber is added. Determine the boiler casing temperature, the outer casing temperature, and the heat loss.

One can perform the calculations discussed earlier to arrive at the temperatures and heat loss. For the sake of illustrating the point, a computer printout of the result is shown in Fig. 8.22. It can be seen that the boiler casing is at 392°F, and the outermost casing is at 142°F. The heat loss is 180 Btu/ft² h. The boiler casing is hot enough to avoid acid condensation, while the heat losses are kept low.

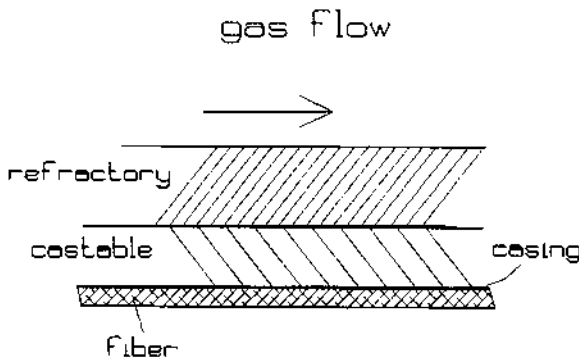

FIGURE 8.21 Arrangement of hot casing.

RESULTS-INSULATION PERFORMANCE-

flat surface

Project: HOT CASING

NAME	THICK-IN	TEMP-F	TEMP1	COND1	TEMP2	COND2
Casing	0.00	142.27	0.00	0.00	0.00	0.00
deltbd/mf/fib	0.50	392.02	200.00	0.32	400.00	0.45
cbm	2.00	880.12	200.00	0.57	600.00	0.72
ks4	4.00	1001.42	800.00	6.02	1600.00	6.20

HEAT LOSS -BTU/ft2h- 179.5997 Number of layers of insulation- 3
 AMB TEMP- 70 WIND VEL-fpm- 100 EMISS- .9 MAX LOSS-BTU/FT2H- 9330.736

FIGURE 8.22 Printout on casing temperatures.

8.57

Q:

What happens if ducts or stacks handling flue gases are not insulated? What would the gas or stack wall temperature be?

A:

This question faces engineers involved in engineering of boiler plants. If ducts and stacks are not insulated, the heat loss from the casing can be substantial. Also, the stack wall temperature can drop low enough to cause acid dew point corrosion.

Let the flue gas flow be W lb/h at a temperature of t_{g1} at the inlet to the duct or stack (Fig. 8.23). The heat loss from the casing wall is given by Eq. (110),

$$q = 0.174\epsilon \times \left[\left(\frac{t_c + 460}{100} \right)^4 - \left(\frac{t_a + 460}{100} \right)^4 \right] + 0.296(t_c - t_a)^{1.25} \times \left[\frac{V + 69}{69} \right]^{0.5}$$

The temperature drop across the gas film is given by

$$t_g - t_{w1} = q \frac{d_o/d_i}{h_c}$$

where

h_c = convective heat transfer coefficient Btu/ft² h °F
 d_o, d_i = outer and inner diameter of the stack, in.

$$h_c = 2.44 \times \frac{W^{0.8} C}{d_i^{1.8}}$$

where, from Eq. (12),

$$C = \left(\frac{C_p}{\mu} \right)^{0.4} k^{0.6}$$

The duct wall temperature drop is given by Eq. (111), which can be rearranged to give

$$t_{w1} - t_{wo} = q d_o \frac{\ln(d_o/d_i)}{24K_m}$$

where t_{w1}, t_{wo} are the inner and outer wall temperatures, °F.

The total heat loss from the duct or stack is $Q = 3.14d_o \times H/12$ where H is the height, ft. The exit gas temperature is then

$$t_{g2} = t_{g1} - \frac{Q}{W_g \times C_p} \quad (113)$$

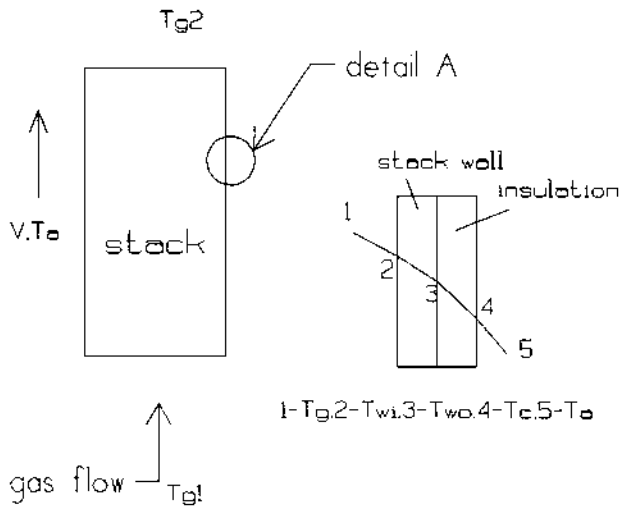

FIGURE 8.23 Stack wall temperature.

The above equations have to be solved iteratively. A trial value for t_{g2} is assumed, and the gas properties are computed at the average gas temperature. The casing temperature is also obtained through an iterative process. The total heat loss is computed and t_{g2} is again evaluated. If the assumed and calculated t_{g2} values agree, then iteration stops. A computer program can be developed to obtain accurate results, particularly if the stack is tall and calculations are better done in several segments.

Example

110,000 lb/h of flue gases at 410°F enter a 48 in. ID stack that is 50 ft long and 1 in. thick. If the ambient temperature is 70°F and wind velocity is 125 ft/min, determine the casing temperature, total heat loss, and exit gas temperature.

Flue gas properties can be assumed to be as follows at 400°F (or computed from methods discussed in Q8.12 if analysis is known): $C_p = 0.265$, $\mu = 0.058$ lb/ft h, $k = 0.0211$ Btu/ft h °F. Let the gas temperature drop in the stack = 20°F; hence the exit gas temperature = 390°F.

The gas-side heat transfer coefficient is

$$2.44 \times (110,000)^{0.8} \times \left(\frac{0.265}{0.058}\right)^{0.4} \times (0.0211)^{0.6} = 4.5 \text{ Btu/ft}^2 \text{ h } ^\circ\text{F}$$

Let the casing temperature t_c ($= t_{wo}$ without insulation) be 250°F.

$$\begin{aligned} q &= 0.174 \times 0.9 \times [(7.1)^4 - (5.3)^4] \\ &\quad + 0.296 \times (710 - 530)^{1.25} \times \left(\frac{125 + 69}{69}\right)^{0.5} \\ &= 601 \text{ Btu/ft}^2 \text{ h} \end{aligned}$$

Gas temperature drop across gas film = $601/4.5 = 134^\circ\text{F}$.

Temperature drop across the stack wall =

$$601 \times 50 \times \frac{\ln(50/48)}{24 \times 25} = 2^\circ\text{F}$$

Hence stack wall outer temperature = $400 - 134 - 2 = 264^\circ\text{F}$.

It can be shown that at a casing or wall temperature of 256°F, the heat loss through gas film matches the loss through the stack wall. The heat loss = 629 Btu/ft² h, and total heat loss = 411,400 Btu/h.

$$\text{Gas temperature drop} = \frac{411,400}{110,000 \times 0.265} = 14^\circ\text{F}$$

The average gas temperature = $410 - 14 = 396^\circ\text{F}$, which is close to the 400°F assumed. With a computer program, one can fine-tune the calculations to include fouling factors.

8.58

Q:

What are the effects of wind velocity and casing emissivity on heat loss and casing temperature?

A:

Using the method described earlier, the casing temperature and heat loss were determined for the case of an insulated surface at 600°F using 3 in. of mineral fiber insulation. (Aluminum casing has an emissivity of about 0.15, and oxidized steel, 0.9.) The results are shown in Table 8.40.

It can be seen that the wind velocity does not result in reduction of heat losses though the casing temperature is significantly reduced. Also, the use of lower emissivity casing does not affect the heat loss, though the casing temperature is increased, particularly at low wind velocity.

8.59a

Q:

How does one check heat transfer equipment for possible noise and vibration problems?

A:

A detailed procedure is outlined in Refs. 1 and 8. Here only a brief reference to the methodology will be made.

Whenever a fluid flows across a tube bundle such as boiler tubes in an economizer, air heater, or superheater (see Fig. 8.24), vortices are formed and shed in the wake beyond the tubes. This shedding on alternate sides of the tubes causes a harmonically varying force on the tube perpendicular to the normal flow of the fluid. It is a self-excited vibration. If the frequency of the von Karman vortices, as they are called, coincides with the natural frequency of vibration of the tubes, resonance occurs and the tubes vibrate, leading to leakage and damage

TABLE 8.40 Results of Insulation Performance

Casing	Emissivity	Wind vel. (fpm)	Heat loss	Casing temp (°F)
Aluminum	0.15	0	67	135
Aluminum	0.15	1760	71	91
Steel	0.90	0	70	109
Steel	0.90	1760	70	88

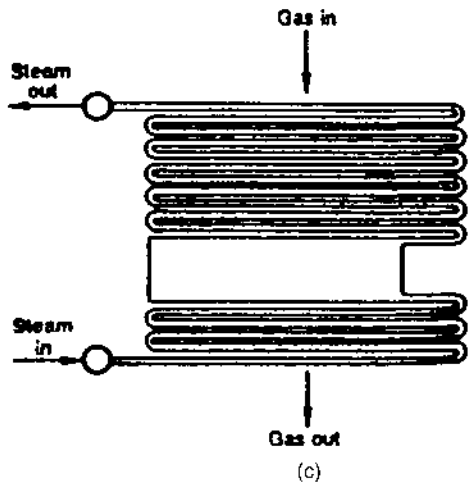
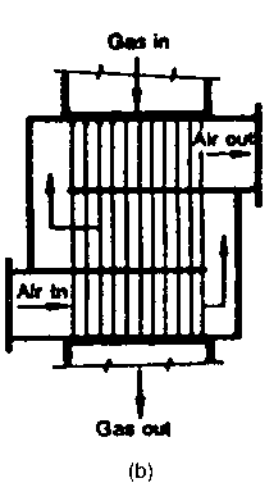
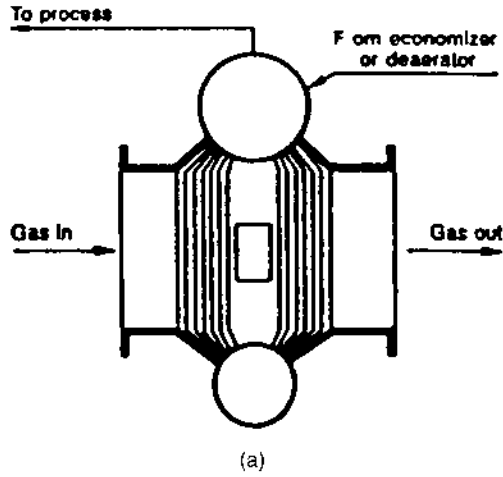

FIGURE 8.24 Crossflow of gas over tube bundles. (a) Water tube boiler design; (b) air heater; (c) superheater.

at supports. Vortex shedding is more prevalent in the range of Reynolds numbers from 300 to 2×10^5 . This is the range in which many boilers, economizers, and superheaters operate. Another mechanism associated with vortex shedding is acoustic oscillation, which is normal to both fluid flow and tube length. This is observed only with gases and vapors. These oscillations coupled with vortex shedding lead to resonance and excessive noise. Standing waves are formed inside the duct.

Hence in order to analyze tube bundle vibration and noise, three frequencies must be computed: natural frequency of vibration of tubes, vortex shedding frequency, and acoustic frequency. When these are apart by at least 20%, vibration and noise may be absent. Q8.59b–Q8.59e show how these values are computed and evaluated.

8.59b

Q:

How is the natural frequency of vibration of a tube bundle determined?

A:

The natural frequency of transverse vibrations of a uniform beam supported at each end is given by

$$f_n = \frac{C}{2\pi} \left(\frac{Elg_o}{M_e L^4} \right)^{0.5} \quad (114a)$$

where

C = a factor determined by end conditions

E = Young's modulus of elasticity

I = moment of inertia = $\pi(d_o^4 - d_i^4)/64$

M_e = mass per unit length of tube, lb/ft (including ash deposits, if any, on the tube)

L = tube length, ft

Simplifying (114a), we have for steel tubes

$$f_n = \frac{90C}{L^2} \left(\frac{d_o^4 - d_i^4}{M_e} \right)^{0.5} \quad (114b)$$

where d_o and d_i are in inches.

Table 8.41 gives C for various end conditions.

TABLE 8.41 Values of C for Eq. (114b)

End support conditions	Mode of vibration		
	1	2	3
Both ends clamped	22.37	61.67	120.9
One clamped, one hinged	15.42	49.97	104.2
Both hinged	9.87	39.48	88.8

8.59c**Q:**

How is the acoustic frequency computed?

A:

f_a is given by V_s/λ , where V_s = velocity of sound at the gas temperature in the duct or shell, ft/s. It is given by the expression $V_s = (g_0 \nu RT)^{0.5}$. For flue gases and air, sonic velocity is obtained by substituting 32 for g_0 , 1.4 for ν , and 1546/MW for R , where the molecular weight for flue gases is nearly 29. Hence,

$$V_s = 49 \times T^{0.5} \quad (115)$$

Wavelength $\lambda = 2W/n$, where W is the duct width, ft, and n is the mode of vibration.

8.59d**Q:**

How is the vortex shedding frequency f_e determined?

A:

f_e is obtained from the Strouhal number S :

$$S = f_e d_o / 12V \quad (116)$$

where

d_o = tube outer diameter, in.

V = gas velocity, ft/s

S is available in the form of charts for various tube pitches; it typically ranges from 0.2 to 0.3 (see Fig. 8.25) [1].

Q8.59e shows how a tube bundle is analyzed for noise and vibration.

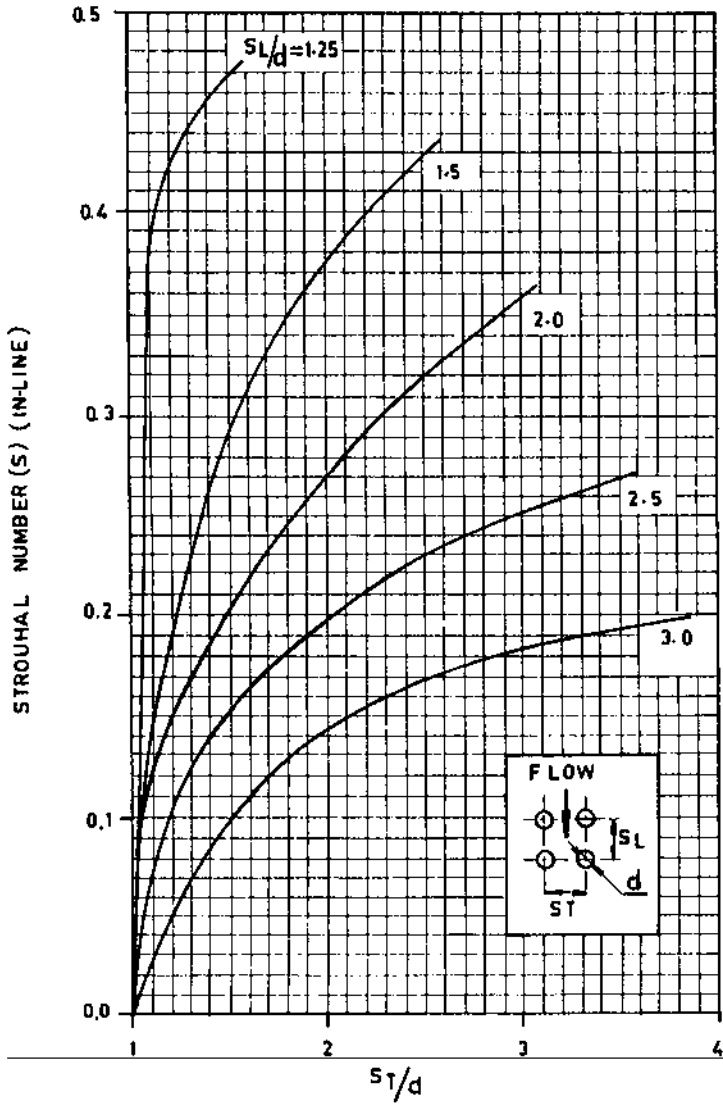

FIGURE 8.25a Strouhal number for in-line bank of tubes.

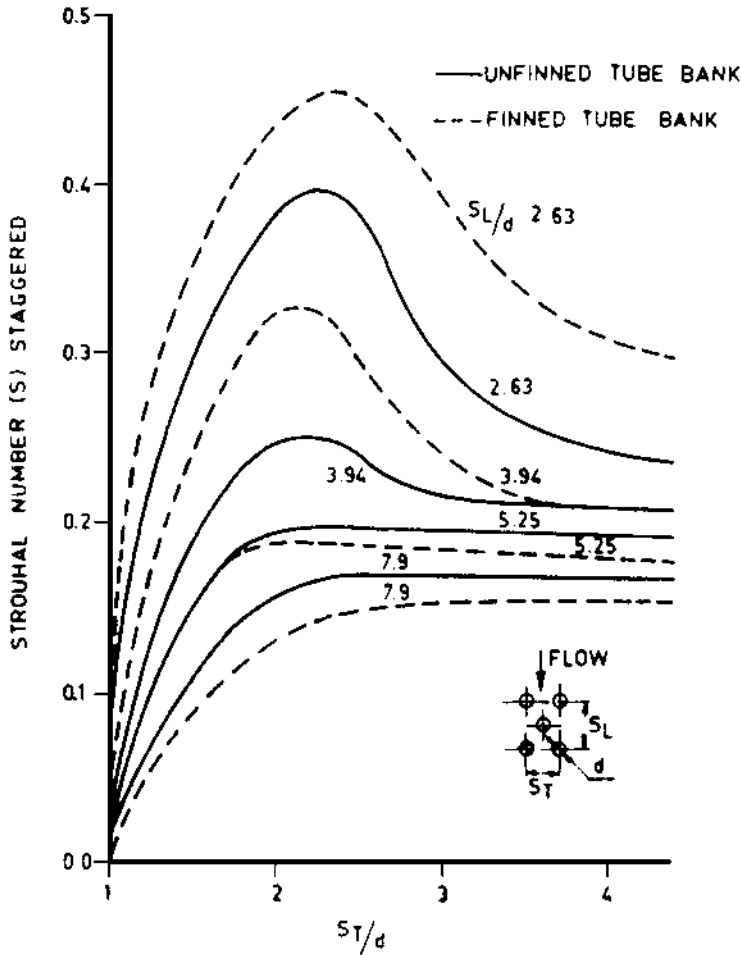

FIGURE 8.25b Strouhal number for staggered bank of tubes.

8.59e

Q:

A tubular air heater 11.7 ft wide, 12.5 ft deep, and 13.5 ft high is used in a boiler. Carbon steel tubes of 2 in. OD and 0.08 in. thickness are used in in-line fashion with a transverse pitch of 3.5 in. and longitudinal pitch of 3.0 in. The heater is 40 tubes wide (3.5 in. pitch) and 60 tubes deep (2.5 in. pitch). Air flow across the

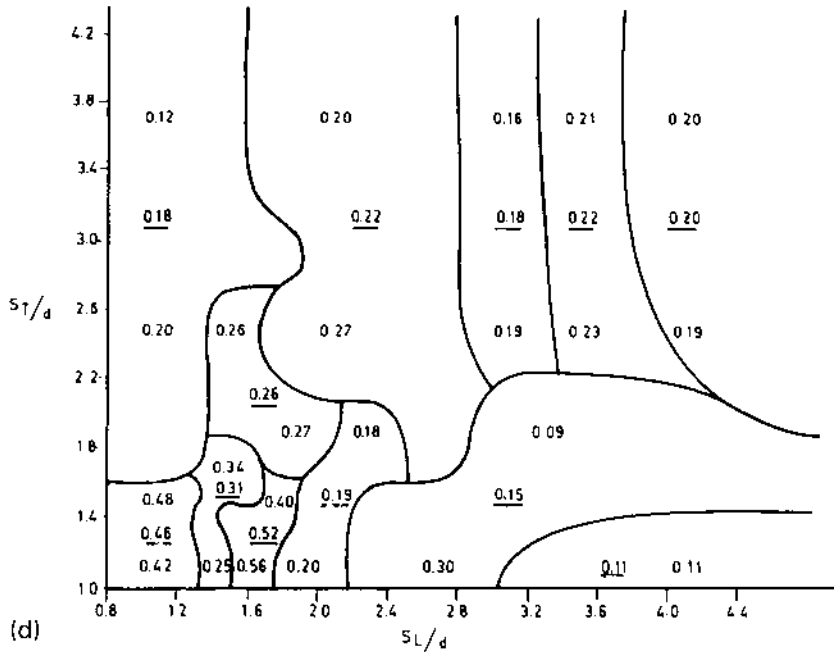
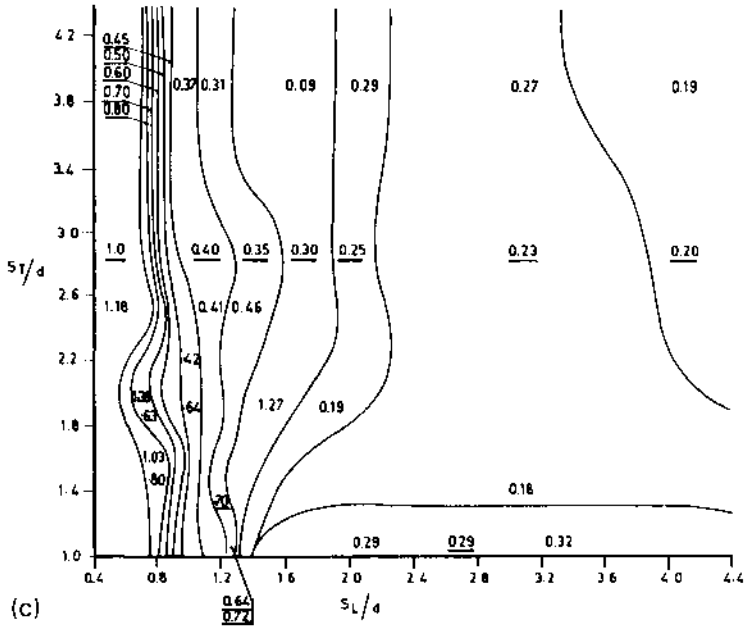

FIGURE 8.25c,d Strouhal number (c) for staggered bank of tubes (top), (d) for in-line bank of tubes (bottom).

tubes is 300,000 lb/h at an average temperature of 219°F. The tubes are fixed at both ends in tube sheets. Check whether bundle vibrations are likely. Tube mass per unit length = 1.67 lb/ft.

A:

First compute f_a , f_e , and f_n . $L = 13.5$ ft, $d_o = 2$ in., $d_i = 1.84$ in., $M_e = 1.67$ lb/ft, and, from Table 8.41, $C = 22.37$.

Using Eq. (114b), we have

$$f_n = \frac{90 \times 22.37}{(13.5)^2} \times \frac{(2^4 - 1.84^4)^{0.5}}{(1.67)^{0.5}} = 18.2 \text{ Hz}$$

This is in mode 1. In mode 2, $C = 61.67$; hence f_{n2} is 50.2 Hz. (The first two modes are important.)

Let us compute f_e . S from Fig. 8.25 for $S_T/d_o = 3.5/2 = 1.75$ and a longitudinal pitch of $3.0/2 = 1.5$ is 0.33.

From Eq. (1) of Chapter 5, $\rho = 40/(219 + 460) = 0.059$ lb/cu ft.

$$\text{Free gas area} = 40 \times (3.5 - 2) \times 13.5/12 = 67.5 \text{ lb/ft}^2 \text{ h}$$

(13.5 is the tube length, and 40 tubes wide is used with a pitch of 3.5 in.) Hence air velocity across tubes is

$$V = \frac{300,000}{67.5 \times 3600 \times 0.059} = 21 \text{ ft/s}$$

Hence

$$f_e = \frac{12SV}{d_o} = 12 \times \frac{0.33 \times 21}{2} = 41.6 \text{ Hz}$$

Let us compute f_a . $T = (219 + 460) = 679^\circ\text{R}$. Hence $V_s = 49 \times 679^{0.5} = 1277$ ft/s. Width $W = 11.7$ ft, and $\lambda = 2 \times 11.7 = 23.4$ ft. For mode 1 or $n = 1$,

$$f_{a1} = 1277/23.4 = 54.5 \text{ Hz}$$

For $n = 2$,

$$f_{a2} = 54.5 \times 2 = 109 \text{ Hz}$$

The results for modes 1 and 2 are summarized in Table 8.42. It can be seen that without baffles the frequencies f_a and f_e are within 20% of each other. Hence noise problems are likely to arise. If a baffle or plate is used to divide the duct width into two regions, the acoustic frequency is doubled as the wavelength or width is halved. This is a practical solution to acoustic vibration problems.

TABLE 8.42 Summary of Frequencies for Modes 1 and 2

Mode of vibration n	1	2
f_n (cps or Hz)	18.2	50.2
f_e (cps or Hz)	41.6	41.6
f_a (without baffles)	54.5	109
f_a (with one baffle)	109	218

8.59f**Q:**

What are the other checks for ensuring that tube bundle vibrations are minimized? The vortex shedding frequencies often coincide with acoustic frequency, and often no standing waves develop and the transverse gas column does not vibrate. Resonance is more the exception than the rule. Chen proposed a damping criterion Ψ based on tube geometry as follows [1]:

$$\Psi = \frac{\text{Re}}{S} \left(\frac{S_l/d - 1}{S_l/d} \right)^2 \frac{d}{S_t} \quad (117)$$

where S_t and S_l are the transverse and longitudinal spacing and d is the tube diameter. The method of calculating the Strouhal number S is given in Q8.59d. For an in-line bank of tubes without fins, Chen stated that Ψ must exceed 600 before a standing wave develops. A large variation in Ψ exists in practice. According to one study, in spiral finned economizers Ψ reached 15,000 before a sonic vibration developed. If Ψ is less than 2000, then vibrations due to vortex shedding may not occur. Vibration analysis is not an exact science, and a lot of it is based on experience operating units of similar design. In some cases the calculations showed that the vortex shedding and acoustic frequencies were matching but no damaging vibrations occurred.

ASME Sec. 3 Appendix N 1330, 1995 on flow-induced vibration suggests that if the reduced damping factor C exceeds 64 where

$$C = 4\pi m \xi / \rho d^2 \quad (118)$$

then vortex shedding is unlikely to cause damage. This is due to the large mass of the system compared to the low energy in the gas stream. In Eq. (118),

m = mass per unit length of tube, lb/ft

ξ = damping factor (typically 0.001 for systems with no intermediate support and 0.01 for systems with intermediate supports)

ρ = gas density, lb/ft³

d = tube OD, in.

Table 8.43 shows the results of calculations for a waste heat boiler that has both bare and finned tubes. The high gas temperature region at the entrance section has bare tubes, and the cooler section has finned tubes.

Coincidence of vortex shedding frequency with the natural frequency in the fourth mode is not a concern. Due to the low amplitudes at lower modes, tube damage is unlikely. Also, owing to the high value of C , which exceeds 64, vortex shedding is unlikely to cause tube damage.

Fluid Elastic Instability

The need for intermediate tube supports is governed by fluid elastic instability considerations. ASME Sec. 3 gives an idea of the stability of tube bundles. If the nondimensional flow velocity as a function of mass damping factor is above the curve shown in Fig. 8.26, then intermediate supports are required; without them fretting and wear of tubes due to vibration is possible. Basically this criterion tells us that if we have a tall tube bundle without intermediate supports, it can oscillate due to the gas flow; intermediate supports help to increase the natural frequency of the tubes and thus reduce the nondimensional flow velocity, making the bundle design more stable. Using the criterion showed that intermediate supports are required even for short boilers (under 12 ft high). However, based on my experience designing several hundred water tube waste heat boilers that are now in operation, the boilers operated well without intermediate supports, indicating once again the generality of these types of analysis. One has to consider operational experience of a similar unit along with these calculation procedures before modifying any boiler design.

TABLE 8.43 Damping Factors for Evaporator Tubes

Item	Bare tube section	Finned section
Gas temperature, °F	1600	510
Gas density, lb/ft ³	0.0188	0.0394
Gas velocity, ft/s	53.9	25.8
Fins	No	2 × 0.75 × 0.075 in.
Tube mass, lb/ft	3.132	7.33
Tube span, ft	17.33	17.33
Strouhal number S	0.25	0.25
Vortex shedding frequency, Hz	80.85	38.66
Damping factor	0.01	0.01
Factor C	753	845
Tube natural freq, Hz	8.8, 24, 48, 79	5.7, 16, 31, 51.6
Amplitude, in.	0.0018	0.00167

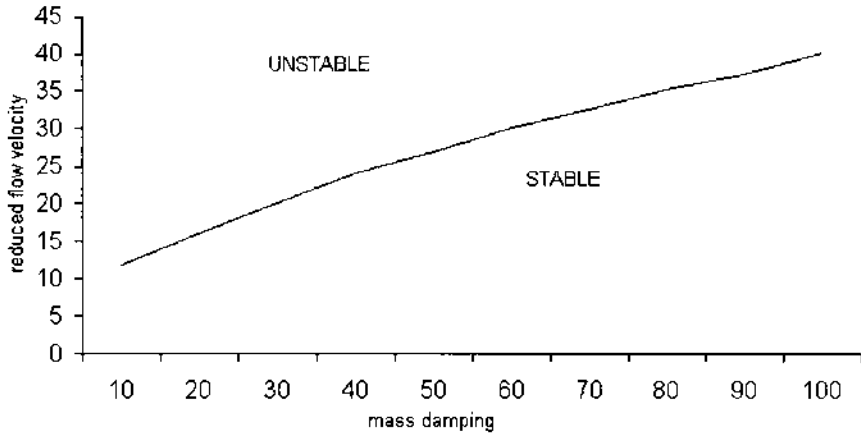

FIGURE 8.26 Damping factor versus nondimensional flow velocity.

Example

In a boiler with mass per unit length $m = 3.132$ lb/ft, damping factor $\xi = 0.001$, gas velocity = 87 ft/s, and gas density $\rho = 0.0188$ lb/ft³, $d = 2$ in.

$$\begin{aligned} \text{Mass damping factor} &= \frac{2\pi m \xi}{d^2 \rho} = 2\pi \times 3.132 \times 0.001 \times 144 / (0.0188 \times 2^2) \\ &= 37.7 \end{aligned}$$

Nondimensional velocity = $12U/fd$, where f = natural frequency of vibration, Hz; U = gas velocity, ft/s; and d = tube outer diameter, in.

Based on previous calculations, $f = 20.6$ Hz. Hence

$$\text{Flow velocity} = 87 \times 12 / (20.6 \times 2) = 25.5$$

It can be seen from Fig. 8.26 that this is a borderline case and that an intermediate support would have further increased the natural frequency and made the flow velocity fall within the stable region. In practice, for tall tube bundles, intermediate supports at 11–15 ft intervals are used.

8.60

Q:

How are the gas properties C_p , μ , and k estimated for a gaseous mixture? Determine C_p , μ , and k for a gas mixture having the following analysis at 1650°F and 14.7 psia.

Gas	Vol%	C_p	μ	k	MW
N ₂	80	0.286	0.108	0.030	28
O ₂	12	0.270	0.125	0.043	32
SO ₂	8	0.210	0.105	0.040	64

Mixture properties are needed to evaluate heat transfer coefficients. For flue gas obtained from the combustion of fossil fuels, in the absence of flue gas analysis, one can use the data on air.

A:

For a gaseous mixture at atmospheric pressure, the following relations apply. For high gas pressures, readers are referred to Ref. 1.

$$\mu_m = \frac{\sum y_i \mu_i \sqrt{MW_i}}{\sum y_i \sqrt{MW_i}} \quad (119a)$$

$$k_m = \frac{\sum y_i k_i \sqrt[3]{MW_i}}{y_i \sqrt[3]{MW_i}} \quad (119b)$$

$$C_{pm} = \frac{\sum C_{pi} MW \times y_i}{\sum MW \times y_i} \quad (119c)$$

where

MW = molecular weight

y = volume fraction of any constituent

Subscript m stands for mixture.

Substituting into Eqs. (119), we have

$$C_{pm} = \frac{0.286 \times 0.8 \times 28 + 0.27 \times 0.12 \times 32 + 0.21 \times 0.08 \times 64}{0.8 \times 28 + 0.12 \times 32 + 0.08 \times 64}$$

$$= 0.272 \text{ Btu/lb } ^\circ\text{F}$$

$$k_m = \frac{0.03 \times 28^{1/3} \times 0.80 + 0.043 \times 32^{1/3} \times 0.12 + 0.04 \times 64^{1/3} \times 0.08}{28^{1/3} \times 0.80 + 32^{1/3} \times 0.12 + 64^{1/3} \times 0.08}$$

$$= 0.032 \text{ Btu/ft } ^\circ\text{F}$$

$$\mu_m = \frac{0.108 \times \sqrt{28} \times 0.8 + 0.125 \times \sqrt{32} \times 0.12 + 0.105 \times \sqrt{64} \times 0.08}{\sqrt{28} \times 0.8 + \sqrt{32} \times 0.12 + \sqrt{64} \times 0.105}$$

$$= 0.109 \text{ lb/ft h}$$

8.61

Q:

How do gas analysis and pressure affect heat transfer performance?

A:

The presence of gases such as hydrogen and water vapor increases the heat transfer coefficient significantly, which can affect the heat flux and the boiler size. Also, if the gas is at high pressure, say 100 psi or more, the mass velocity inside the tubes (fire tube boilers) or outside the boiler tubes (water tube boilers) can be much higher because of the higher density, which also contributes to the higher heat transfer coefficients. Table 8.44 compares two gas streams, reformed gases from a hydrogen plant and flue gases from combustion of natural gas.

Factors C and F used in the estimation of heat transfer coefficients inside and outside the tubes are also given in Table 8.44. It can be seen that the effect of gas analysis is very significant. Even at low gas pressures of reformed gases (50–100 psig), the factors C and F would be very close to the values shown, within 2–5%.

8.62

Q:

How does gas pressure affect the heat transfer coefficient?

TABLE 8.44 Effect of Gas Analysis on Heat Transfer

	<i>Reformed gas</i>		<i>Flue gas</i>	
CO ₂ , vol%	5.0		17.45	
H ₂ O, vol%	38.0		18.76	
N ₂ , vol%	—		62.27	
O ₂ , vol%	—		1.52	
CO, vol%	9.0		—	
H ₂ , vol%	45.0		—	
CH ₄ , vol%	3.0		—	
Gas pressure, psia	400		15	
Temp, °F	1550	675	1540	700
C_p , Btu/lb °F	0.686	0.615	0.320	0.286
μ , lb/ft h	0.087	0.056	0.109	0.070
k , Btu/ft h °F	0.109	0.069	0.046	0.028
Factor C^a	0.571		0.225	
Factor F^a	0.352		0.142	

$$^a C = (C_p/\mu)^{0.4} k^{0.6}; \quad F = C_p^{0.33} k^{0.67} / \mu^{0.27}.$$

A:

The effect of gas pressure on factors C and F for some common gases is shown in Figs. 8.27 and 8.28. It can be seen that the pressure effect becomes smaller at high gas temperatures, while at low temperatures there is a significant difference. Also, the pressure effect is small and can be ignored up to a gas pressure of 200 psia.

8.63

Q:

How do we convert gas analysis in percent by weight to percent by volume?

A:

One of the frequent calculations performed by heat transfer engineers is the conversion from weight to volume basis and vice versa. The following example shows how this is done.

Example

A gas contains 3% CO₂, 6% H₂O, 74% N₂, and 17% O₂ by weight. Determine the gas analysis in volume percent.

Solution. Moles of a gas are obtained by dividing the weight by the molecular weight; moles of CO₂ = $3/44 = 0.06818$.

The volume of each gas, then, is the mole fraction $\times 100$. Percent volume of O₂ = $(0.5312/3.57563) \times 100 = 14.86$, and so on. One can work in reverse and convert from volume (or mole) basis to weight basis.

Gas	W%	MW	Moles	Vol%
CO ₂	3	44	0.06818	1.91
H ₂ O	6	18	0.3333	9.32
N ₂	74	28	2.6429	73.91
O ₂	17	32	0.5312	14.86
Total			3.57563	100

8.64

Q:

What is the effect of gas pressure and gas analysis on design of a fire tube waste heat boiler? Compare the following two cases. In case 1, reformed gas in a

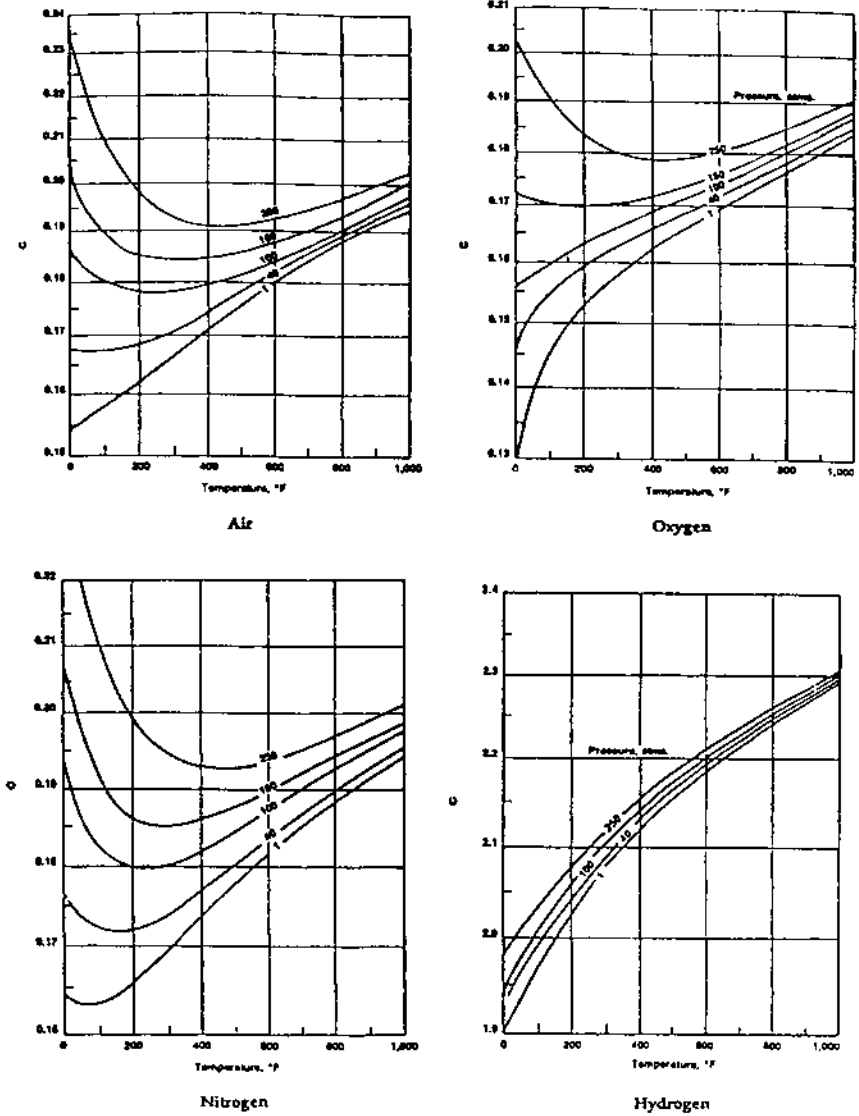

FIGURE 8.27 Effect of gas pressure on heat transfer—flow inside tubes. (From Ref. 1.)

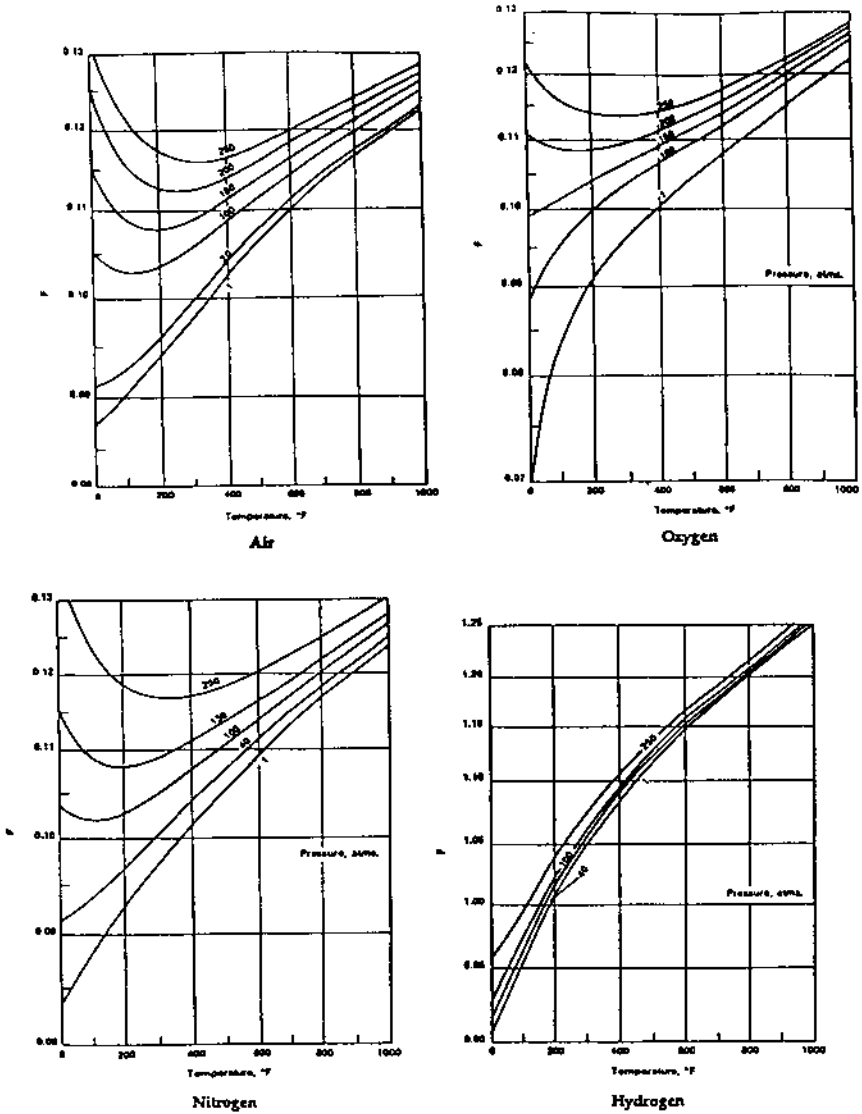

FIGURE 8.28 Effect of gas pressure on heat transfer—flow outside tubes. (From Ref. 1.)

hydrogen plant is cooled in a waste heat boiler, whereas in case 2, flue gas in an incineration plant is cooled. Maximum allowable heat flux is 100,000 Btu/ft² h.

Case 1. Reformed gas. Flow = 100,000 lb/h; gas pressure = 300 psig; gas analysis (vol%):

CO₂ = 5, H₂O = 30, N₂ = 0.1, H₂ = 52, CH₄ = 2.9, CO = 10.

Case 2. Flue gas. Flow = 100,000 lb/h; gas pressure = atmospheric; gas analysis (vol%):

CO₂ = 7, H₂O = 12, N₂ = 75, O₂ = 6.

Steam is generated at 500 psig using 230°F feedwater. Blowdown = 2%. Use fouling factors of 0.001 on both gas and steam sides. Tubes are 1.5 in. OD and 1.14 in. ID. Material is T11 for reformed gas boiler and carbon steel for flue gas boiler. Saturation temperature is 470°F.

A:

Calculations were done using the procedure discussed in Q8.10. The results are presented in Table 8.45. The following points may be noted:

The boiler is much smaller when the gas pressure is higher because of the high gas density.

The heat transfer coefficient is much higher for the reformed gas owing to the presence of hydrogen and water vapor. The heat flux is also very high compared to that in the flue gas boiler.

TABLE 8.45 Effect of Gas Analysis and Pressure on Design of Fire Tube Boiler

Item	Reformed gas	Flue gas
Gas flow, lb/h	100,000	100,000
Gas inlet temp, °F	1650	1650
Gas exit temp, °F	650	650
Gas pressure, psia	315	15
Duty, MM Btu/h	70.00	28.85
Steam generation, lb/h	69,310	28,570
Gas pressure drop, in.WC	9	5
Heat flux, Btu/ft ² h	92,200	12,300
Surface area, ft ²	1566	4266
No. of tubes	350	1300
Length, ft	15	11
Heat transfer coeff, <i>U</i>	87	13.4
Max gas velocity, ft/s	68	165
Tube wall temp, °F	653	498

TABLE 8.46 Composition of Typical Waste Gases

Waste gas ^a	Temp (°C)	Pressure (psig)	vol% component													
			N ₂	NO	H ₂ O	O ₂	SO ₂	SO ₃	CO ₂	CO	CH ₄	H ₂ S	H ₂	NH ₃	HCL	
1	300–1000	1	80			10	10									
2	250–500	1	81			11	1	7								
3	250–850	3–10	66	9	19	6										
4	200–1100	1	70		18	3				9						
5	300–1100	30–50	0.5		37					6	8	5.5		43		
6	200–500	200–450	20										60	20		
7	100–600	1	75		7	15				3						
8	175–1000	1	72		10	6				12						trace
9	250–1350	1	76		8	4				7						5
10	150–1000	1	73		20	2				5						
11	300–1450	1.5	55		23			6		6	3		3	4		

^a1, Raw sulfur gases; 2, SO₃ gases after converter; 3, nitrous gases; 4, reformer flue gases; 5, reformed gas; 6, synthesis gas; 7, gas turbine exhaust; 8, MSW incinerator exhaust; 9, chlorinated plastics incineration; 10, fume or VOC incinerator exhaust; 11, sulfur condenser effluent.

The tube wall temperature is also higher with reformed gas. Hence steam-side fouling should be low in these boilers.

It is obvious that gas analysis and pressure play a significant role in the design of boilers. Table 8.46 gives the analysis and gas pressure for typical waste gas streams.

NOMENCLATURE

A	Surface area, ft^2
A_f, A_t, A_i, A_o	Fin, total, inside, and obstruction surface areas, ft^2/ft
A_w	Area of tube wall, ft^2/ft
B	Factor used in Grimson's correlation
b	Fin thickness, in.
C	Factor used to estimate heat transfer coefficient
C_p	Specific heat, $\text{Btu}/\text{lb } ^\circ\text{F}$; subscripts g, w, m stand for gas, water, and mixture
C_1-C_6	Factors used in heat transfer and pressure drop calculations for finned tubes
D	Exchanger diameter, in.
d, d_i	Tube outer and inner diameter, in.
e	Escalation factor used in life-cycle costing calculations; base of natural logarithm
E	Efficiency of HRSG or fins
f	Frequency, Hz or cps; subscripts a, e, n stand for acoustic, vortex shedding, and natural
ff	Fouling factor, $\text{ft}^2 \text{h } ^\circ\text{F}/\text{Btu}$; subscripts i and o stand for inside and outside
F	Factor used in the estimation of outside heat transfer coefficient and in the estimation of capitalized costs
G	Gas mass velocity, $\text{lb}/\text{ft}^2 \text{h}$
h	Fin height, in.
h_c	Convective heat transfer coefficient, $\text{Btu}/\text{ft}^2 \text{h } ^\circ\text{F}$
h_i, h_o	Heat transfer coefficients inside and outside tubes, $\text{Btu}/\text{ft}^2 \text{h } ^\circ\text{F}$
h_{lf}	Heat loss factor, fraction
h_N	Nonluminous heat transfer coefficient, $\text{Btu}/\text{ft}^2 \text{h } ^\circ\text{F}$
Δh	Change in enthalpy, Btu/lb
i	Interest rate
k	Thermal conductivity, $\text{Btu}/\text{ft h } ^\circ\text{F}$ or $\text{Btu in.}/\text{ft}^2 \text{h } ^\circ\text{F}$; subscript m stands for mixture
K_m	Metal thermal conductivity, $\text{Btu}/\text{ft h } ^\circ\text{F}$
K_1, K_2	Constants

L	Length, ft; thickness of insulation, in.; or beam length
L_e	Equivalent thickness of insulation, in.
m	Factor used in Eq. (47, 51)
M_c	Water equivalent, Btu/°F
M_e	Weight of tube, lb/ft
MW	Molecular weight
n	Number of fins per inch
N	Constant used in Grimson's correlation; also number of tubes
Nu	Nusselt number
NTU	Number of transfer units
P	Term used in temperature cross-correction
P_w, P_c	Partial pressure of water vapor and carbon dioxide
Pr	Prandtl number
Q	Energy transferred, Btu/h; heat flux, Btu/ft ² h
q	Heat flux, heat loss, Btu/ft ² h
q_c	Critical heat flux, Btu/ft ² h
R	Thermal resistance, ft ² h °F/Btu; subscripts $i, o,$ and t stand for inside, outside, and total
Re	Reynolds number
R_m	Metal thermal resistance, ft ² h °F/Btu
S	Fin clearance, in.; Strouhal number; surface area, ft ²
S_T, S_L	Transverse and longitudinal pitch, in.
t	Fluid temperature, °F; subscripts a, s, b stand for ambient, surface, fin base
t_f	Fin tip temperature, °F
t_m	Metal temperature, °F
t_{sat}	Saturation temperature, °F
T	Absolute temperature, K or °R; subscripts g and w stand for gas and wall
ΔT	Log-mean temperature difference, °F
U	Overall heat transfer coefficient, Btu/ft ² h °F
V	Fluid velocity, ft/s or ft/min
V_s	Sonic velocity, ft/s
W	Fluid flow, lb/h; subscripts g, s, w stand for gas, steam, and water
w	Flow per tube, lb/h
x	Steam quality, fraction
y	Volume fraction of gas
ε	Effectiveness factor
$\varepsilon_c, \varepsilon_w, \varepsilon_g$	Emissivity of CO ₂ , water, gas emissivity
$\Delta\varepsilon$	Emissivity correction term

η	Fin effectiveness
μ	Viscosity, lb/ft h; subscript <i>m</i> stands for mixture
ρ	gas density, lb/cu ft
λ	wavelength, ft
v	ratio of specific heats

REFERENCES

1. V Ganapathy. Applied Heat Transfer. Tulsa, OK: PennWell Books, 1982.
2. DQ Kern. Process Heat Transfer. New York: McGraw-Hill, 1950.
3. V Ganapathy. Nomogram determines heat transfer coefficient for water flowing in pipes or tubes. Power Engineering, July 1977, p 69.
4. V Ganapathy. Charts simplify spiral finned tube calculations. Chemical Engineering, Apr 25, 1977, p 117.
5. V Ganapathy. Estimate nonluminous radiation heat transfer coefficients. Hydrocarbon Processing, April 1981, p 235.
6. V Ganapathy. Evaluate the performance of waste heat boilers. Chemical Engineering, Nov 16, 1981, p 291.
7. WC Turner, JF Malloy. Thermal Insulation Handbook. New York: McGraw-Hill, 1981, pp 40–45.
8. V Ganapathy. Waste Heat Boiler Deskbook. Atlanta, GA: Fairmont Press, 1991.
9. ESCOA Corp. ESCOA Fintube Manual. Tulsa, OK: ESCOA, 1979.
10. V Ganapathy. Evaluate extended surfaces carefully. Hydrocarbon Processing, October 1990, p 65.
11. V Ganapathy. Fouling—the silent heat transfer thief. Hydrocarbon Processing, October 1992, p 49.
12. V Ganapathy. HRSG temperature profiles guide energy recovery. Power, September 1988.
13. W Roshenow, JP Hartnett. Handbook of Heat Transfer. New York: McGraw-Hill, 1972, pp 13–56.

9

Fans, Pumps, and Steam Turbines

- 9.01 Determining steam rates in steam turbines; actual and theoretical steam rates; determining steam quantity required to generate electricity; calculating enthalpy of steam after isentropic and actual expansion
- 9.02a Cogeneration and its advantages
- 9.02b Comparison of energy utilization between a cogeneration plant and a power plant
- 9.03 Which is the better location for tapping deaeration steam, boiler or turbine?
- 9.04 Determining fan power requirements and cost of operation; calculating BHP (brake horsepower) of fans; actual horsepower consumed if motor efficiency is known; annual cost of operation of fan
- 9.05 Effect of elevation and air density on fan performance
- 9.06a Density of air and selection of fan capacity
- 9.06b How fan horsepower varies with density for forced draft fans
- 9.07 Determining power requirements of pumps
- 9.08 Electric and steam turbine drives for pumps; annual cost of operation using steam turbine drive; annual cost of operation with motor
- 9.09a How specific gravity of liquid affects pump performance; BHP required at different temperatures
- 9.09b How water temperature affects boiler feed pump power requirements
- 9.10 Effect of speed on pump performance; effect of change in supply frequency

- 9.11 Effect of viscosity on pump flow, head, and efficiency
- 9.12 Determining temperature rise of liquids through pumps
- 9.13 Estimating minimum recirculation flow through pumps
- 9.14 Net positive suction head (NPSH) and its determination
- 9.15 Effect of pump suction conditions on $NPSH_a$ (available NPSH)
- 9.16 Estimating $NPSH_r$ (required NPSH) for centrifugal pumps
- 9.17 Determining $NPSH_a$ for reciprocating pumps
- 9.18 Checking performance of pumps from motor readings; relating motor current consumption to pump flow and head; analyzing for pump problems
- 9.19 Checking performance of fan from motor data; relating motor current consumption to fan flow and head
- 9.20 Evaluating performance of pumps in series and in parallel
- 9.21 Parameters affecting Brayton cycle efficiency
- 9.22 How to improve the efficiency of the Brayton cycle

9.01

Q:

How is the steam rate for steam turbines determined?

A:

The actual steam rate (ASR) for a turbine is given by the equation

$$ASR = \frac{3413}{\eta_t \times (h_1 - h_{2s})} \quad (1)$$

where ASR is the actual steam rate in lb/kWh. This is the steam flow in lb/h required to generate 1 kW of electricity. h_1 is the steam enthalpy at the inlet to the turbine, Btu/lb, and h_{2s} is the steam enthalpy at turbine exhaust pressure if the expansion is assumed to be isentropic, Btu/lb. That is, the entropy is the same at inlet condition and at exit. Given h_1 , h_{2s} can be obtained either from the Mollier chart or by calculation using steam table data (see the Appendix). η_t is the efficiency of the turbine, expressed as a fraction. Typically, η_t ranges from 0.65 to 0.80.

Another way to estimate ASR is to use published data on turbine theoretical steam rates (TSRs) (see [Table 9.1](#)).

$$TSR = \frac{3413}{h_1 - h_{2s}} \quad (2)$$

TSR divided by η_t gives ASR. The following example shows how the steam rate can be used to find required steam flow.

TABLE 9.1 Theoretical Steam Rates for Steam Turbines at Some Common Conditions (lb/kWh)

Exhaust pressure	Inlet						
	150 psig 366°F saturated	200 psig 388°F saturated	200 psig 500°F 94°F superheat	400 psig 750°F 302°F superheat	600 psig 750°F 261°F superheat	600 psig 825°F 336°F superheat	850 psig, 825°F, 298°F, superheat
2 in.Hg	10.52	10.01	9.07	7.37	7.09	6.77	6.58
4 in.Hg	11.76	11.12	10.00	7.99	7.65	7.28	7.06
0 psig	19.37	17.51	15.16	11.20	10.40	9.82	9.31
10 psig	23.96	21.09	17.90	12.72	11.64	10.96	10.29
30 psig	33.6	28.05	22.94	15.23	13.62	12.75	11.80
50 psig	46.0	36.0	28.20	17.57	15.36	14.31	13.07
60 psig	53.9	40.4	31.10	18.75	16.19	15.05	13.66
70 psig	63.5	45.6	34.1	19.96	17.00	15.79	14.22
75 psig	69.3	48.5	35.8	20.59	17.40	16.17	14.50

Source: Ref. 4.

Example

How many lb/h of superheated steam at 1000 psia, 900°F, is required to generate 7500 kW in a steam turbine if the backpressure is 200 psia and the overall efficiency of the turbine generator system is 70%?

Solution. From the steam tables, at 1000 psia, 900°F, $h_1 = 1448.2$ Btu/lb and entropy $s_1 = 1.6121$ Btu/lb °F. At 200 psia, corresponding to the same entropy, we must calculate h_{2s} by interpolation. We can note that steam is in superheated condition. $h_{2s} = 1257.7$ Btu/lb. Then

$$\text{ASR} = \frac{3413}{0.70 \times (1448 - 1257.7)} = 25.6 \text{ lb/kWh}$$

Hence, to generate 7500 kW, the steam flow required is

$$W_s = 25.6 \times 7500 = 192,000 \text{ lb/h}$$

9.02a

Q:

What is cogeneration? How does it improve the efficiency of the plant?

A:

Cogeneration is the term used for simultaneous generation of power and process steam from a single full source, as in a system of gas turbine and process waste heat boiler, wherein the gas turbine generates electricity and the boiler generates steam for process (see Fig. 9.1).

In a typical power plant that operates at 35–43% overall efficiency, the steam pressure in the condenser is about 2–4 in.Hg. A lot of energy is wasted in the cooling water, which condenses the steam in the condenser.

If, instead, the steam is generated at a high pressure and expanded in a steam turbine to the process steam pressure, we can use the steam for process, and electricity is also generated. A full credit for the process steam can be given if the steam is used—hence the improvement in overall energy utilization. Q9.02b explains this in detail.

9.02b

Q:

50,000 lb/h of superheated steam at 1000 psia and 900°F is available in a process plant. One alternative is to expand this in a steam turbine to 200 psia and use the 200 psia steam for process (cogeneration). Another alternative is to expand the

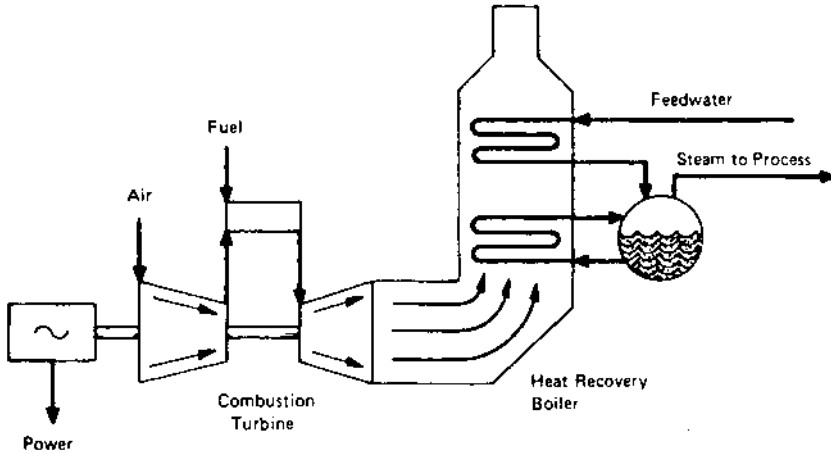

FIGURE 9.1 Cogeneration produces power and steam from the same fuel source by converting the turbine exhaust heat in a boiler, which produces steam for process.

superheated steam in a steam turbine to 1 psia, generating electricity alone in a power plant. Evaluate each scheme.

A:

Scheme 1. The steam conditions are as in Q9.01, so let us use the data on enthalpy. Assume that the turbine efficiency is 70%. The electricity produced can be written as follows using Eq. (1):

$$P = W_s \eta_t \times \frac{h_1 - h_{2s}}{3413} \quad (3)$$

P is in kilowatts. $h_1 = 1448$ Btu/lb and $h_{2s} = 1257.7$ Btu/lb, from Q 9.01. Substituting into Eq. (3), we have

$$P = 50,000 \times (1448 - 1257.7) \times \frac{0.70}{3413} = 1954 \text{ kW}$$

Now let us calculate the final enthalpy at condition 2, h_2 . Using the equation

$$\eta_t(h_1 - h_{2s}) = h_1 - h_2 \quad (4)$$

we obtain

$$0.70 \times (1448 - 1257.7) = 1448 - h_2$$

or

$$h_2 = 1315 \text{ Btu/lb}$$

This enthalpy is available for process in the cogeneration mode. The energy Q available in the cogeneration mode is the sum of the electricity produced and the energy to process, all in Btu/h. Hence the total energy is

$$Q = 1954 \times 3413 + 50,000 \times 1315 = 72.4 \times 10^6 \text{ Btu/h}$$

Scheme 2. Let us take the case when electricity alone is generated. Let us calculate the final steam conditions at a pressure of 1 psia. $s_1 = 1.6121 = s_{2s}$. At 1 psia, from the steam tables, at saturated conditions, $s_f = 0.1326$ and $s_g = 1.9782$. s_f and s_g are entropies of saturated liquid and vapor. Since the entropy s_{2s} is in between s_f and s_g , the steam at isentropic conditions is wet. Let us estimate the quality x . From basics,

$$0.1326(1 - x) + 1.9782x = 1.6121$$

Hence

$$x = 0.80$$

The enthalpy corresponding to this condition is

$$h = (1 - x)h_f + xh_g$$

or

$$h_{2s} = 0.80 \times 1106 + 0.2 \times 70 = 900 \text{ Btu/lb}$$

(h_f and h_g are 70 and 1106 at 1 psia.) Using a turbine efficiency of 75%, from Eq. (3) we have

$$\begin{aligned} P &= 50,000 \times (1448 - 900) \times \frac{0.75}{3413} = 6023 \text{ kW} \\ &= 20.55 \times 10^6 \text{ Btu/h} \end{aligned}$$

Hence we note that there is a lot of difference between the energy patterns of the two cases, with the cogeneration scheme using much more energy than that used in Scheme 2.

Even if the steam in Scheme 1 were used for oil heating, the latent heat of 834 Btu/lb at 200 psia could be used.

$$\begin{aligned} \text{Total output} &= 1954 \times 3413 + 50,000 \times 834 \\ &= 48.3 \times 10^6 \text{ Btu/h} \end{aligned}$$

This is still more than the output in the case of power generation alone.

Note, however, that if the plant electricity requirement were more than 2000 kW, Scheme 1 should have more steam available, which means that a bigger boiler should be available. Evaluation of capital investment is necessary before a

particular scheme is chosen. However, it is clear that in cogeneration the utilization of energy is better.

9.03

Q:

Which is a better location for tapping steam for deaeration in a cogeneration plant with an extraction turbine, the HRSG or the steam turbine?

A:

When steam is taken for deaeration from the HRSG and not from an extraction point in a steam turbine, there is a net loss to the system power output because the steam is throttled and not expanded to the lower deaerator pressure. Throttling is a mere waste of energy, whereas steam generates power while it expands to a lower pressure. To illustrate, consider the following example.

Example

An HRSG generates 80,000 lb/h of steam at 620 psig and 650°F from 550,000 lb/h of turbine exhaust gases at 975°F. The steam is expanded in an extraction-condensing steam turbine. Figure 9.2 shows the two schemes. The

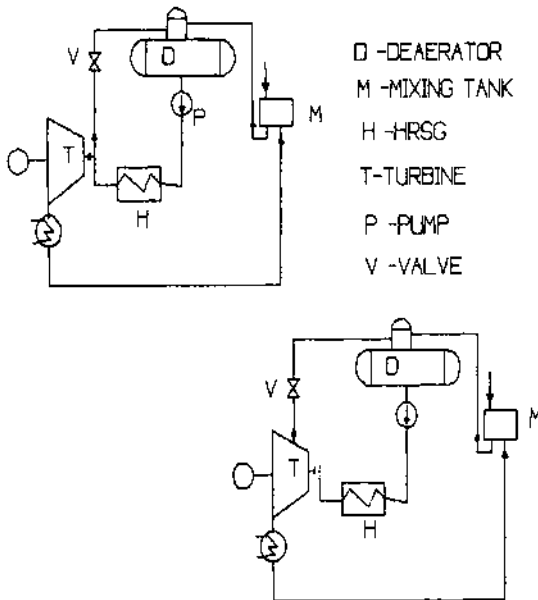

FIGURE 9.2 Options for taking steam for deaeration.

condenser operates at 2.5 in.Hg abs. The deaerator is at 10 psig. Blowdown losses = 2%. Neglecting flash steam and vent flow, we can show that when steam is taken for deaeration from the HRSG,

$$81,700 \times 208 = 1700 \times 28 + (80,000 - X) \times 76 + 1319X$$

where 208, 28, 76, and 1319 are enthalpies of feedwater at 240°F, makeup water at 60°F, condensate at 108°F, and steam at 620 psig, 650°F.

The deaeration steam $X = 8741$ lb/h; use 8785 to account for losses. Now compute the actual steam rate (ASR) in the steam turbine (see Q9.01). It can be shown that $ASR = 11.14$ lb/kWh at 70% expansion efficiency; hence power output of the turbine generator = $0.96 \times (80,000 - 8785)/11.14 = 6137$ kW, assuming 4% loss in the generator.

Similarly, when steam is taken at 30 psia from the extraction point in the steam turbine, the enthalpy of steam for deaeration is 1140.6 Btu/lb. An energy balance around the deaerator shows

$$81,700 \times 208 = 1140.6X + (80,000 - X) \times 76 + 1700 \times 28$$

Hence $X = 10,250$ lb/h. Then ASR for expansion from 620 psig to 30 psia = 19 lb/kWh and 11.14 for the remaining flow. The power output is

$$P = 0.96 \times \left(\frac{10,250}{19} + \frac{80,000 - 10,250}{11.14} \right) = 6528 \text{ kW}$$

Thus a significant difference in power output can be seen. However, one has to review the cost of extraction machine versus the straight condensing type and associated piping, valves, etc.

9.04

Q:

A fan develops an 18 in. WC static head when the flow is 18,000 acfm and static efficiency of the fan is 75%. Determine the brake horsepower required, the horsepower consumed when the motor has an efficiency of 90%, and the annual cost of operation if electricity costs 5 cents/kWh and the annual period of operation is 7500 h.

A:

The power required when the flow is q acfm and the head is H_w in. WC is

$$\text{BHP} = q \frac{H_w}{6356\eta_f} \quad (5)$$

where η_f is the efficiency of the fan, fraction; in this case, $\eta_f = 0.75$.

The horsepower consumed is

$$\text{HP} = \frac{\text{BHP}}{\eta_m} \quad (6)$$

where η_m is the motor efficiency, fraction. Substituting the data, we have

$$\text{BHP} = 18,000 \times \frac{18}{0.75 \times 6356} = 68 \text{ hp}$$

and

$$\text{HP} = \frac{68}{0.9} = 76 \text{ hp}$$

The annual cost of operation will be

$$76 \times 0.74 \times 0.05 \times 7500 = \$21,261$$

(0.74 is the conversion factor from hp to kW.)

9.05

Q:

A fan develops 18,000 acfm at 18 in. WC when the ambient conditions are 80°F and the elevation is 1000 ft (case 1). What are the flow and the head developed by the fan when the temperature is 60°F and the elevation is 5000 ft (case 2)?

A:

The head developed by a fan would vary with density as follows:

$$\frac{H_{w1}}{\rho_1} = \frac{H_{w2}}{\rho_2} \quad (7)$$

where ρ is the density, lb/cu ft, and the subscripts 1 and 2 refer to any two ambient conditions.

The flow q in acfm developed by a fan would remain the same for different ambient conditions; however, the flow in lb/h would vary as the density changes.

Let us use [Table 9.2](#) for quick estimation of density as a function of elevation and temperature. $\rho = 0.075/\text{factor}$ from Table 9.2. At 80°F and 1000 ft elevation,

$$\rho_1 = \frac{0.075}{1.06} = 0.0707 \text{ lb/cu ft}$$

At 60°F and 5000 ft,

$$\rho_2 = \frac{0.075}{1.18} = 0.0636 \text{ lb/cu ft}$$

TABLE 9.2 Temperature and Elevation Factors

Temp. (°F)	Altitude (ft) and barometric pressure (in.Hg)												
	0 (29.92)	500 (29.38)	1000 (28.86)	1500 (28.33)	2000 (27.82)	2500 (27.31)	3000 (26.82)	3500 (26.32)	4000 (25.84)	4500 (25.36)	5000 (24.90)	5500 (24.43)	6000 (23.96)
-40	.79	.81	.82	.84	.85	.87	.88	.90	.92	.93	.95	.97	.99
0	.87	.88	.90	.92	.93	.95	.97	.99	1.00	1.02	1.04	1.06	1.08
40	.94	.96	.98	1.00	1.01	1.03	1.05	1.07	1.09	1.11	1.13	1.16	1.18
70	1.00	1.02	1.04	1.06	1.08	1.10	1.12	1.14	1.16	1.18	1.20	1.22	1.25
80	1.02	1.04	1.06	1.08	1.10	1.12	1.14	1.16	1.18	1.20	1.22	1.25	1.27
100	1.06	1.08	1.10	1.12	1.14	1.16	1.18	1.20	1.22	1.25	1.27	1.29	1.32
120	1.09	1.11	1.13	1.16	1.18	1.20	1.22	1.24	1.27	1.29	1.31	1.34	1.37
140	1.13	1.15	1.17	1.20	1.22	1.24	1.26	1.29	1.31	1.34	1.36	1.39	1.41
160	1.17	1.19	1.21	1.24	1.26	1.28	1.31	1.33	1.35	1.38	1.41	1.43	1.46
180	1.21	1.23	1.25	1.28	1.30	1.32	1.35	1.37	1.40	1.42	1.45	1.48	1.51
200	1.25	1.27	1.29	1.32	1.34	1.36	1.39	1.42	1.44	1.47	1.50	1.53	1.55
250	1.34	1.36	1.39	1.41	1.44	1.47	1.49	1.52	1.55	1.58	1.61	1.64	1.67
300	1.43	1.46	1.49	1.51	1.54	1.57	1.60	1.63	1.66	1.69	1.72	1.76	1.79
350	1.53	1.56	1.58	1.61	1.64	1.67	1.70	1.74	1.77	1.80	1.84	1.87	1.91
400	1.62	1.65	1.68	1.71	1.75	1.78	1.81	1.84	1.88	1.91	1.95	1.99	2.02
450	1.72	1.75	1.78	1.81	1.85	1.88	1.92	1.95	1.99	2.03	2.06	2.10	2.14
500	1.81	1.84	1.88	1.91	1.95	1.98	2.02	2.06	2.10	2.14	2.18	2.22	2.26
550	1.91	1.94	1.98	2.01	2.05	2.09	2.13	2.17	2.21	2.25	2.29	2.33	2.38
600	2.00	2.04	2.07	2.11	2.15	2.19	2.23	2.27	2.32	2.36	2.40	2.45	2.50
650	2.09	2.13	2.17	2.21	2.25	2.29	2.34	2.38	2.43	2.47	2.52	2.56	2.61
700	2.19	2.23	2.27	2.31	2.35	2.40	2.44	2.49	2.53	2.58	2.63	2.68	2.73
750	2.28	2.32	2.37	2.41	2.46	2.50	2.55	2.60	2.64	2.69	2.74	2.80	2.85
800	2.38	2.42	2.46	2.51	2.56	2.60	2.65	2.70	2.75	2.80	2.86	2.91	2.97
850	2.47	2.52	2.56	2.61	2.66	2.71	2.76	2.81	2.86	2.92	2.97	3.03	3.08
900	2.57	2.61	2.66	2.71	2.76	2.81	2.86	2.92	2.97	3.03	3.08	3.14	3.20
950	2.66	2.71	2.76	2.81	2.86	2.91	2.97	3.02	3.08	3.14	3.20	3.26	3.32
1000	2.76	2.81	2.86	2.91	2.96	3.02	3.07	3.13	3.19	3.25	3.31	3.37	3.44

Substitution into Eq. (7) yields

$$\frac{18}{0.0707} = \frac{H_{w2}}{0.0636}$$
$$H_{w2} = 16.1 \text{ in. WC}$$

In case 1 flow will be

$$18,000 \times 0.0707 \times 60 = 76,356 \text{ lb/h}$$

and in case 2 the flow will be

$$18,000 \times 0.0636 \times 60 = 68,638 \text{ lb/h}$$

The exact operating point of the fan can be obtained after plotting the new H_w versus q characteristic and noting the point of intersection of the new curve with the system resistance curve.

9.06a

Q:

Why should the capacity of forced draft fans for boilers be reviewed at the lowest density condition?

A:

For the same heat input to boilers, the air quantity required in mass flow units (lb/h) remains the same irrespective of the ambient conditions.

$$W = 60\rho q$$

where

$$W = \text{mass flow, lb/h}$$

$$\rho = \text{density, lb/cu ft}$$

$$q = \text{volumetric flow, acfm}$$

Fans discharge constant volumetric flow at any density. Hence if the fan is sized to give a particular volumetric flow at the high density condition, the mass flow would decrease when density decreases as can be seen in the equation above. Hence the fan must be sized to deliver the volumetric flow at the lowest density condition, in which case the output in lb/h will be higher at the higher density condition, which can be then controlled.

Also, the gas pressure drop ΔP in in. WC across the wind-box is proportional to W^2/ρ . If the air density decreases as at high temperature conditions, the pressure drop increases, because W remains unchanged for a given heat input. Considering the fact that H/ρ is a constant for a given fan,

where H is the static head in in. WC, using the lowest ρ ensures that the head available at higher density will be larger.

9.06b

Q:

How does the horsepower of a forced draft fan for boilers or heaters change with density?

A:

Equation (5) gives the fan horsepower:

$$\text{BHP} = \frac{qH_w}{6356\eta_f}$$

Using the relation $W = 60q\rho$, we can rewrite the above as

$$\text{BHP} = \frac{WH_w}{381,360 \rho\eta_f}$$

For a boiler at a given duty, the air flow in lb/h and the head in in. WC, H_w , remain unchanged; hence as the density decreases, the horsepower increases. This is yet another reason to check the fan power at the lowest density condition. However, if the application involves an uncontrolled fan that delivers a given volume of air at all densities, then the horsepower should be evaluated at the highest density case because the mass flow would be higher as well as the gas pressure drop.

9.07

Q:

A triplex reciprocating pump is used for pumping 40 gpm (gallons per minute) of water at 100°F. The suction pressure is 4 psig and the discharge pressure is 1000 psig. Determine the BHP required.

A:

Use the expression

$$\text{BHP} = q \times \frac{\Delta P}{1715\eta_p} \quad (8)$$

where

q = flow, gpm

ΔP = differential pressure, psi

η_p = pump efficiency, fraction

In the absence of data on pumps, use 0.9 for triplex and 0.92 for quintuplex pumps.

$$\text{BHP} = 40 \times \frac{1000 - 4}{1715 \times 0.90} = 25.8 \text{ hp}$$

A 30 hp motor can be used.

The same expression can be used for centrifugal pumps. The efficiency can be obtained from the pump characteristic curve at the desired operating point.

9.08

Q:

A pump is required to develop 230 gpm of water at 60°F at a head of 970 ft. Its efficiency is 70%. There are two options for the drive: an electric motor with an efficiency of 90% or a steam turbine drive with a mechanical efficiency of 95%. Assume that the exhaust is used for process and not wasted.

If electricity costs 50 mills/kWh, steam for the turbine is generated in a boiler with an efficiency of 85% (HHV basis), and fuel costs \$3/MM Btu (HHV basis), determine the annual cost of operation of each drive if the plant operates for 6000 h/year.

A:

Another form of Eq. (8) is

$$\text{BHP} = W \times \frac{H}{1,980,000\eta_p} \quad (9)$$

where

W = flow, lb/h

H = head developed by the pump, ft of liquid

For relating head in ft with differential pressure in psi or flow in lb/h with gpm, refer to Q5.01. Substituting into Eq. (9) and assuming that $s = 1$, $W = 230 \times 500$ lb/h,

$$\text{BHP} = 230 \times 500 \times \frac{970}{0.70 \times 1,980,000} = 81 \text{ hp}$$

The annual cost of operation with an electric motor drive will be

$$81 \times 0.746 \times 0.05 \times \frac{6000}{0.90} = \$20,142$$

(0.746 is the conversion factor from hp to kW.)

If steam is used, the annual cost of operation will be

$$81 \times 2545 \times 6000 \times \frac{3}{0.85 \times 0.90 \times 10^6} = \$4595$$

(2545 Btu/h = 1 hp; 0.85 is the boiler efficiency; 0.95 is the mechanical efficiency.) Hence the savings in cost of operation is $20,142 - 4545 = \$15,547/\text{year}$.

Depending on the difference in investment between the two drives, payback can be worked out. In the calculation above it was assumed that the backpressure steam was used for process. If it was wasted, the economics may not work out the same way.

9.09a

Q:

How does the specific gravity or density of liquid pumped affect the BHP, flow, and head developed?

A:

A pump always delivers the same flow in gpm (assuming that viscosity effects can be neglected) and head in feet of liquid at any temperature. However, due to changes in density, the flow in lb/h, pressure in psi, and BHP would change. A variation of Eq. (9) is

$$\text{BHP} = \frac{q \Delta P}{1715 \eta_p} = \frac{W \Delta P}{857,000 \eta_p s} \quad (10)$$

where

q = liquid flow, gpm

W = liquid flow, lb/h

s = specific gravity

ΔP = pressure developed, psi

H = head developed, ft of liquid

Also,

$$H = 2.31 \frac{\Delta P}{s} \quad (11)$$

Example

If a pump can develop 1000 gpm of water at 40°F through 1000 ft, what flow and head can it develop when the water is at 120°F? Assume that pump efficiency is 75% in both cases.

Solution. s_1 at 40°F is 1 (from the steam tables; see the Appendix). s_2 at 120°F is 0.988.

$$\Delta P_1 = 1000 \times \frac{1}{2.31} = 433 \text{ psi}$$

From Eq. (11),

$$\text{BHP}_1 = 1000 \times \frac{433}{0.75 \times 1715} = 337 \text{ hp}$$

$$W_1 = 500q_1s_1 = 500 \times 1000 \times 1 = 500,000 \text{ lb/h}$$

At 120°F,

$$\Delta P_2 = 1000 \times \frac{0.988}{2.31} = 427 \text{ psi}$$

$$\text{BHP}_2 = 1000 \times \frac{427}{0.75 \times 1715} = 332 \text{ hp}$$

$$W_2 = 500 \times 0.988 \times 1000 = 494,000 \text{ lb/h}$$

If the same W is to be maintained, BHP must increase.

9.09b

Q:

How does the temperature of water affect pump power consumption?

A:

The answer can be obtained by analyzing the following equations for pump power consumption. One is based on flow in gpm and the other in lb/h.

$$\text{BHP} = \frac{QHs}{3960\eta_p} \quad (12)$$

where

Q = flow, gpm

H = head, ft of water

s = specific gravity

η_p = efficiency

In boilers, one would like to maintain a constant flow in lb/h, *not* in gpm, and at a particular pressure in psi. The relationships are

$$Q = \frac{W}{500s} \quad \text{and} \quad H = 2.31 \times \frac{\Delta P}{s}$$

where

W = flow, lb/h

ΔP = pump differential, psi

Substituting these terms into (1), we have

$$\text{BHP} = W \frac{\Delta P}{857,000\eta_p s} \quad (13)$$

As s decreases with temperature, BHP will increase if we want to maintain the flow in lb/h and head or pressure in psi. However, if the flow in gpm and head in ft should be maintained, then the BHP will decrease with a decrease in s , which in turn is lower at lower temperatures.

A similar analogy can be drawn with fans in boiler plants, which require a certain amount of air in lb/h for combustion and a particular head in in. WC.

9.10

Q:

A centrifugal pump delivers 100 gpm at 155 ft of water with a 60 Hz supply. If the electric supply is changed to 50 Hz, how will the pump perform?

A:

For variations in speed or impeller size, the following equation applies:

$$\frac{q_1}{q_2} = \frac{N_1}{N_2} = \frac{\sqrt{H_1}}{\sqrt{H_2}} \quad (14)$$

where

q = pump flow, gpm

H = head developed, ft

N = speed, rpm

Use of Eq. (14) gives us the head and the flow characteristics of a pump at different speeds. However, to get the actual operating point, one must plot the

new head versus flow curve and note the point of intersection of this curve with the system resistance curve. In the case above,

$$q_2 = 100 \times \frac{50}{60} = 83 \text{ gpm}$$
$$H_2 = 155 \times \left(\frac{50}{60}\right)^2 = 107 \text{ ft}$$

In this fashion, the new H versus q curve can be obtained. The new operating point can then be found.

9.11

Q:

How does the performance of a pump change with the viscosity of the fluids pumped?

A:

The Hydraulic Institute has published charts that give correction factors for head, flow, and efficiency for viscous fluids when the performance with water is known (see Figs. 9.3a and 9.3b).

Example

A pump delivers 750 gpm at 100 ft head when water is pumped. What is the performance when it pumps oil with viscosity 1000 SSU? Assume that efficiency with water is 82%.

Solution. In Fig. 9.3b, go up from capacity 750 gpm to cut the head line at 100 ft and move horizontally to cut viscosity at 1000 SSU; move up to cut the various correction factors.

$$C_Q = 0.94, \quad C_H = 0.92, \quad C_E = 0.64$$

Hence the new data are

$$q = 0.94 \times 750 = 705 \text{ gpm}$$
$$H = 0.92 \times 100 = 92 \text{ ft}$$
$$\eta_p = 0.64 \times 92 = 52\%$$

The new H versus q data can be plotted for various flows to obtain the characteristic curve. The operating point can be obtained by noting the point of intersection of the system resistance curve with the H versus q curve. C_Q , C_H , and C_E are correction factors for flow, head, and efficiency.

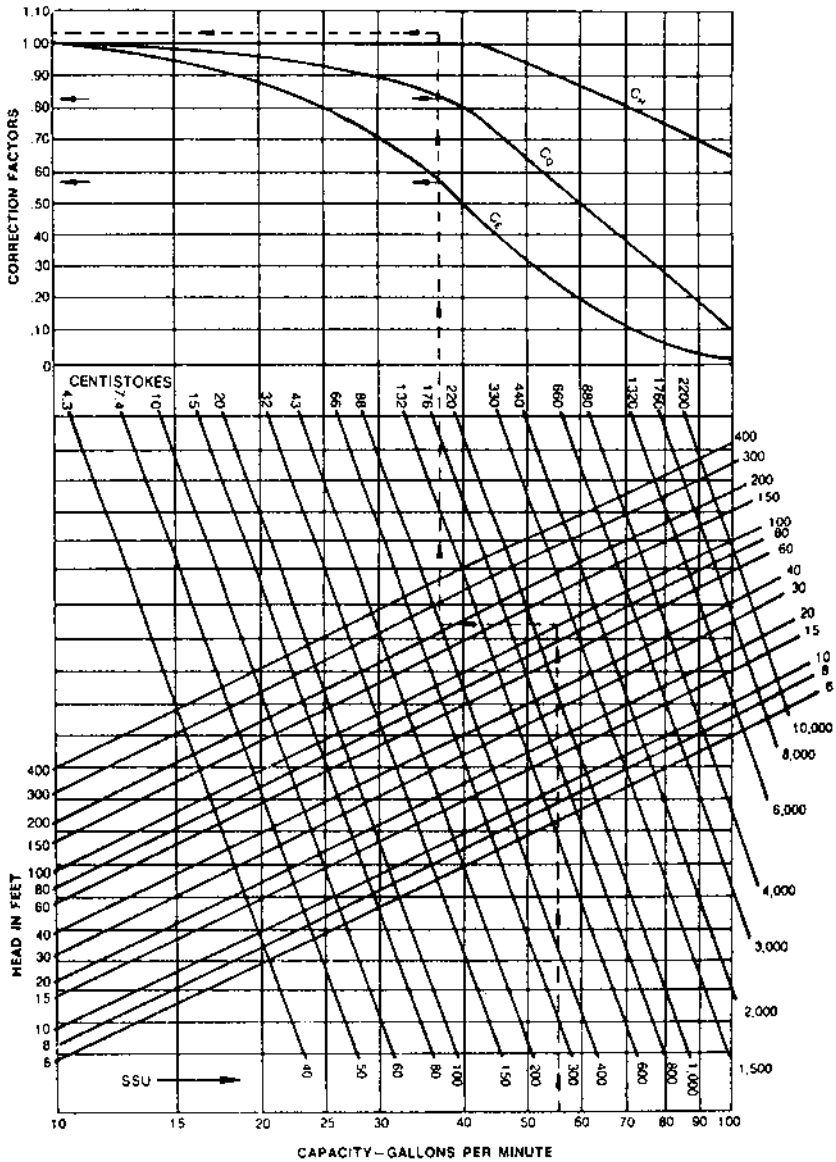

FIGURE 9.3a Viscosity corrections. (Courtesy of Hydraulic Institute/Gould Pump Manual.)

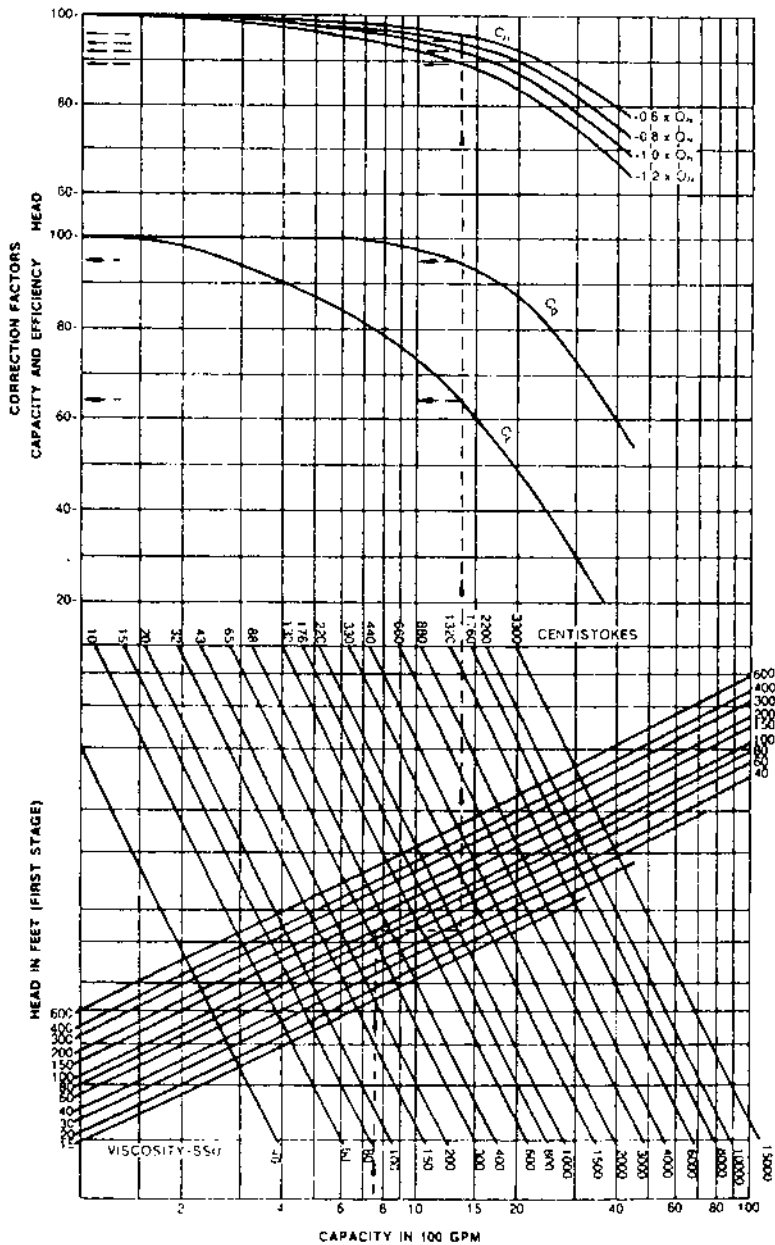

FIGURE 9.3b Determination of pump performance when handling viscous liquids. (Courtesy of Hydraulic Institute/Gould Pump Manual.)

9.12

Q:

What is the temperature rise of water when a pump delivers 100 gpm at 1000 ft at an efficiency of 60%?

A:

The temperature rise of fluids through the pump is an important factor in pump maintenance and performance considerations and must be limited. The recirculation valve is used to ensure that the desired flow goes through the pump at low load conditions of the plant, thus cooling it.

From energy balance, the friction losses are equated to the energy absorbed by the fluid.

$$\Delta T = (\text{BHP} - \text{theoretical power}) \times \frac{2545}{WC_p} \quad (15a)$$

where

ΔT = temperature rise of the fluid, °F

BHP = brake horsepower

W = flow of the fluid, lb/h

C_p = specific heat of the fluid, Btu/lb °F

For water, $C_p = 1$.

From Eq. (9),

$$\text{BHP} = W \times \frac{H}{\eta_p \times 3600 \times 550}$$

where η_p is the pump efficiency, fraction. Substituting into Eqs. (15a) and (9) and simplifying, we have

$$\Delta T = H \times \frac{1/\eta_p - 1}{778} \quad (15b)$$

If $H = 100$ ft of water and $\eta_p = 0.6$, then

$$\Delta T = 1000 \times \frac{1.66 - 1}{778} \approx 1^\circ\text{F}$$

9.13

Q:

How is the minimum recirculation flow through a centrifugal pump determined?

A:

Let us illustrate this with the case of a pump whose characteristics are as shown in Fig. 9.4. We need to plot the ΔT versus Q characteristics first. Note that at low flows when the efficiency is low, we can expect a large temperature rise. At 100 gpm, for example,

$$\eta_p = 0.23 \quad \text{and} \quad H = 2150 \text{ ft}$$

Then

$$\Delta T = 2150 \times \frac{1/0.23 - 1}{778} = 9^\circ\text{F}$$

In a similar fashion, ΔT is estimated at various flows. Note that ΔT is higher at low flows owing to the low efficiency and also because of the lesser cooling capacity.

The maximum temperature rise is generally limited to about 20°F , depending on the recommendations of the pump manufacturer. This means that at least 40 gpm must be circulated through the pump in this case. If the load is only 30 gpm, then depending on the recirculation control logic, 10–70 gpm could be recirculated through the pump.

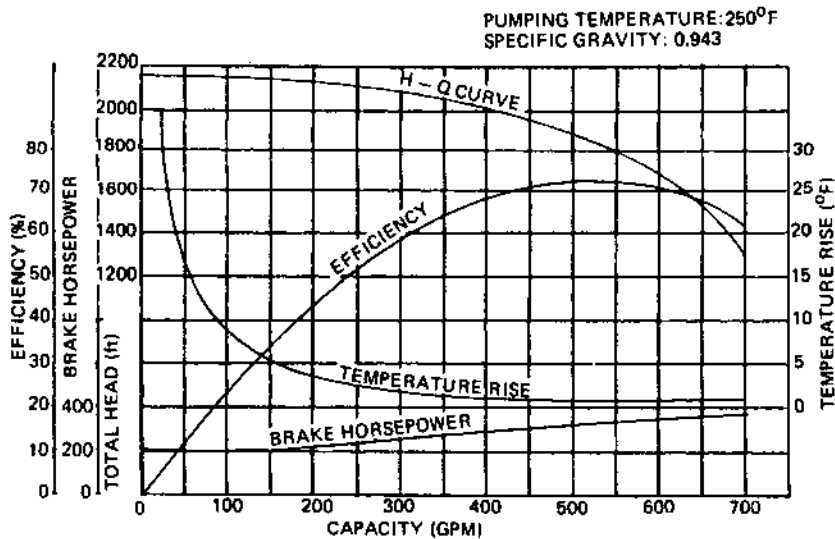

FIGURE 9.4 Typical characteristic curve of a multistage pump also showing temperature rise versus capacity.

9.14

Q:

What is net positive suction head (NPSH), and how is it calculated?

A:

The NPSH is the net positive suction head in feet absolute determined at the pump suction after accounting for suction piping losses (friction) and vapor pressure. NPSH helps one to check if there is a possibility of cavitation at pump suction. This is likely when the liquid vaporizes or flashes due to low local pressure and collapses at the pump as soon as the pressure increases. NPSH determined from pump layout in this manner is $NPSH_a$ (NPSH available). This will vary depending on pump location as shown in Fig. 9.5.

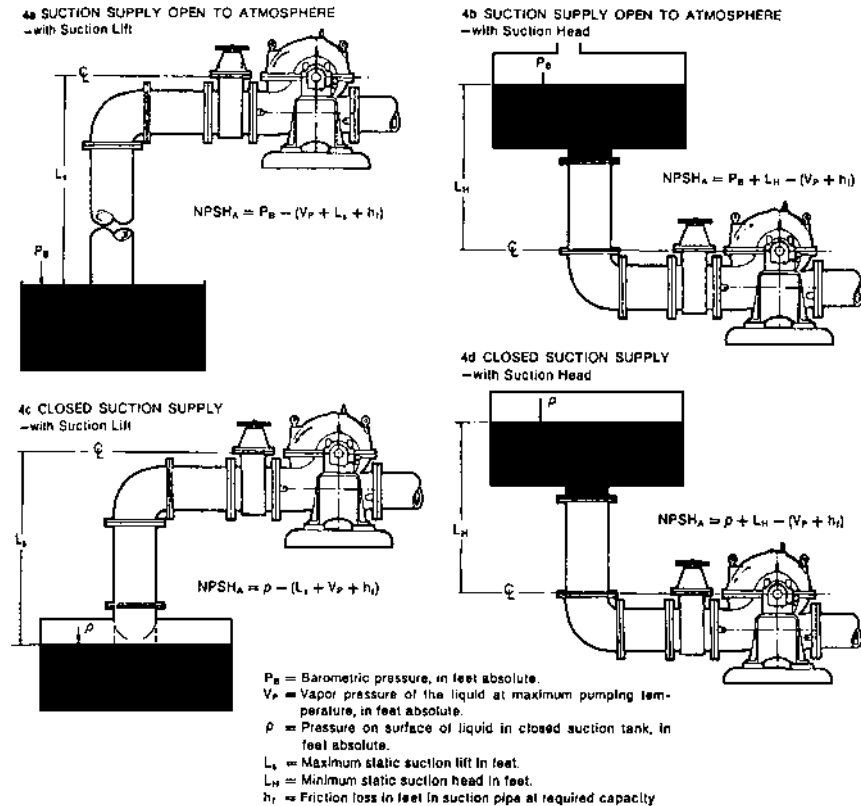

FIGURE 9.5 Calculation of system NPSH available for typical suction conditions.

$NPSH_r$ (NPSH required) is the positive head in feet absolute required to overcome the pressure drop due to fluid flow from the pump suction to the eye of the impeller and maintain the liquid above its vapor pressure. $NPSH_r$ varies with pump speed and capacity. Pump suppliers generally provide this information.

$NPSH_a$ can be determined by a gauge reading at pump suction:

$$NPSH_a = P_B - VP \pm PG + VH \quad (16)$$

where

VH = velocity head at the gauge connection, ft

PG = pressure gauge reading, converted to ft

VP = vapor pressure, ft absolute

P_B = barometric pressure, ft (if suction is atmospheric)

To avoid cavitation, $NPSH_a$ must be greater than $NPSH_r$.

9.15

Q:

Does the pump suction pressure change $NPSH_a$?

A:

$NPSH_a$ is given by

$$NPSH_a = P_s + H - VP - H_f \quad (17)$$

where

P_s = suction pressure, ft of liquid

H = head of liquid, ft

VP = vapor pressure of the liquid at operating temperature, ft

H_f = friction loss in the suction line, ft

For saturated liquids, $VP \approx P_s$, so changes in suction pressure do not significantly change $NPSH_a$.

Example

Determine the $NPSH_a$ for the system shown in Fig. 9.5b when $H = 10$ ft, $H_f = 3$ ft, and $VP = 0.4$ psia (from the steam tables). Assume that the water has a density of 62 lb/cu ft.

Solution.

$$VP = 0.4 \times \frac{144}{62} = 0.93 \text{ ft}$$

$$\text{Suction pressure} = 14.6 \text{ psia} = 14.6 \times \frac{166}{62} = 33.9 \text{ ft}$$

$$NPSH_a = 33.9 - 3 - 0.93 + 10 = 40 \text{ ft}$$

9.16

Q:

In the absence of information from the pump supplier, can we estimate $NPSH_r$?

A:

A good estimate of $NPSH_r$ can be made from the expression for specific speed S .

$$S = N \times \frac{\sqrt{q}}{NPSH_r^{0.75}} \quad (18)$$

S ranges from 7000 to 12,000 for water.

For example, when $q = 100$ gpm, $N = 1770$, and assuming that $S = 10,000$ for water,

$$NPSH_r = 1770 \times \left(\frac{\sqrt{100}}{10,000} \right)^{1.33} = 2.2 \text{ ft}$$

Even if we took a conservative value of 7000 for S , we would get

$$NPSH_r = 3.43 \text{ ft}$$

This information can be used in making preliminary layouts for systems involving pumps.

9.17

Q:

How is $NPSH_a$ for a reciprocating pump arrived at?

A:

$NPSH_a$ for a reciprocating pump is calculated in the same way as for a centrifugal pump except that the acceleration head H_a is included with the friction losses. This is the head required to accelerate the liquid column on each suction stroke so

that there will be no separation of this column in the pump suction line or in the pump [1]:

$$H_a = \frac{LNVC}{K_g} \quad (19)$$

where

L = length of the suction line, ft (actual length, not developed)

V = velocity in the suction line, ft/s

N = pump speed, rpm

C is a constant: 0.066 for triplex pump, 0.04 for quintuplex, and 0.2 for duplex pumps. K is a factor: 2.5 for hot oil, 2.0 for most hydrocarbons, 1.5 for water, and 1.4 for deaerated water. $g = 32 \text{ ft/s}^2$. Pulsation dampeners are used to reduce L significantly. By proper selection, L can be reduced to nearly zero.

Example

A triplex pump running at 360 rpm and displacing 36 gpm has a 3 in. suction line 8 ft long and a 2 in. line 18 ft long. Estimate the acceleration head required.

Solution. First obtain the velocity of water in each part of the line. In the 3 in. line, which has an inner diameter of 3.068 in.,

$$V = 0.41 \frac{q}{d_i^2} = 0.41 \times \frac{36}{(3.068)^2} = 1.57 \text{ ft/s}$$

In the 2 in. line, which has an inner diameter of 2.067 in.,

$$V = 0.41 \times \frac{36}{(2.067)^2} = 3.45 \text{ ft/s}$$

The acceleration head in the 3 in. line is

$$H_a = 8 \times 360 \times 1.57 \times \frac{0.066}{1.4 \times 32} = 6.7 \text{ ft}$$

In the 2 in. line,

$$H_a = 18 \times 3.45 \times 360 \times \frac{0.066}{1.4 \times 32} = 32.9 \text{ ft}$$

The total acceleration head is $32.9 + 6.7 = 39.6 \text{ ft}$.

9.18

Q:

How can we check the performance of a pump from the motor data?

A:

A good estimate of the efficiency of a pump or a fan can be obtained from the current reading if we make a few reasonable assumptions. The efficiency of a motor is more predictable than that of a pump owing to its small variations with duty. The pump differential pressure and flow can be obtained rather easily and accurately. By relating the power consumed by the pump with that delivered by the motor, the following can be derived. The pump power consumption, P , in kW from Eq. (8) is

$$P = 0.00043q \times \frac{\Delta P}{\eta_p} \quad (20)$$

$$\text{Motor power output} = 0.001732EI \cos \phi \eta_m \quad (21)$$

Equating Eqs. (20) and (21) and simplifying, we have

$$q\Delta P = 4EI \cos \phi \eta_p \eta_m \quad (22)$$

where

q = flow, gpm

ΔP = differential pressure, psi

E = voltage, V

I = current, A

η_p, η_m = efficiency of pump and motor, fraction

$\cos \phi$ = power factor

From Eq. (22) we can solve for pump efficiency given the other variables. Alternatively, we can solve for the flow by making a reasonable estimate of η_p and check whether the flow reading is good. The power factor $\cos \phi$ typically varies between 0.8 and 0.9, and the motor efficiency between 0.90 and 0.95.

Example

A plant engineer observes that at a 90 gpm flow of water and 1000 psi differential, the motor current is 100 A. Assuming that the voltage is 460 V, the power factor is 0.85, and the motor efficiency is 0.90, estimate the pump efficiency.

Solution. Substituting the data into Eq. (22), we obtain

$$90 \times 1000 = 4 \times 460 \times 100 \times 0.85 \times 0.90 \times \eta_p$$

Solving for η_p , we have $\eta_p = 0.65$.

We can use this figure to check whether something is wrong with the system. For instance, if the pump has been operating at this flow for some time but the current drawn is more, one can infer that the machine needs attention. One

can also check the pump efficiency from its characteristic curve and compare the calculated and predicted efficiencies.

9.19

Q:

Derive an expression similar to (22) relating fan and motor.

A:

Equating the power consumption of a fan with that delivered by its motor,

$$P = 1.17 \times 10^{-4} \times q H_w = 0.001732 EI \cos \phi \eta_m \quad (23)$$

where

q = flow, acfm

H_w = static head of fan, in. WC

Other terms are as in Q9.18.

If the efficiency of a fan is assumed to be 65% when its differential head is 4 in. WC, the motor voltage is 460, and the current is 7 A, then the power factor is 0.8 and the motor efficiency is 85%. Solving for q , we have

$$1.17 \times 10^{-4} \times q \times 4 = 0.001732 \times 460 \times 7 \times 0.80 \times 0.85 \times 0.65$$

or

$$q = 5267 \text{ acfm}$$

One can check from the fan curve whether the flow is reasonable. Alternatively, if the flow is known, one can check the head from Eq. (23) and compare it with the measured value. If the measured head is lower, for example, we can infer that something is wrong with the fan or its drive or that the flow measured is not correct.

9.20

Q:

How is the performance of pumps in series and in parallel evaluated?

A:

For parallel operation of two or more pumps, the combined performance curve (H versus q) is obtained by adding horizontally the capacities of the same heads. For series operation, the combined performance curve is obtained by adding vertically the heads at the same capacities.

The operating point is the intersection of the combined performance curve with the system resistance curve. Figure 9.6 explains this. Head and flow are shown as percentages [2]. *ABC* is the *H* versus *q* curve for a single pump, *DEF* is the *H* versus *q* curve for two such pumps in series, and *AGH* is the *H* versus *q* curve for two such pumps in parallel. To obtain the curve *DEF*, we add the heads at a given flow. For example, at *q* = 100%, *H* with one pump is 100%, and with two pumps *H* will be 200%. Similarly, *AGH* is obtained by adding flows at a given head. At *H* = 100, *q* for two pumps will be 200%.

Let the system resistance curve be *KBGE*. When one pump alone operates, the operating point is *B*. With two pumps in series, *E* is the operating point. With two pumps in parallel, *G* is the operating point.

BHP curves also have been plotted and reveal that with series operation *BHP* = 250% and with pumps in parallel *BHP* = 164%, indicating that *BHP*/*q* is larger in series operation than in parallel. This varies with pump and system resistance characteristics. *NPSH_r* also increases with pump capacity.

Note that if the full capacity of the plant were handled by two pumps in parallel and one tripped, the operating *BHP* would not be 50% of that with two pumps, but more, depending on the nature of the *H* versus *q* curve and the system resistance curve. In the case above, with *KBGE* as the system resistance, *G* is the operating point with two pumps, and if one trips *B* would be the operating point.

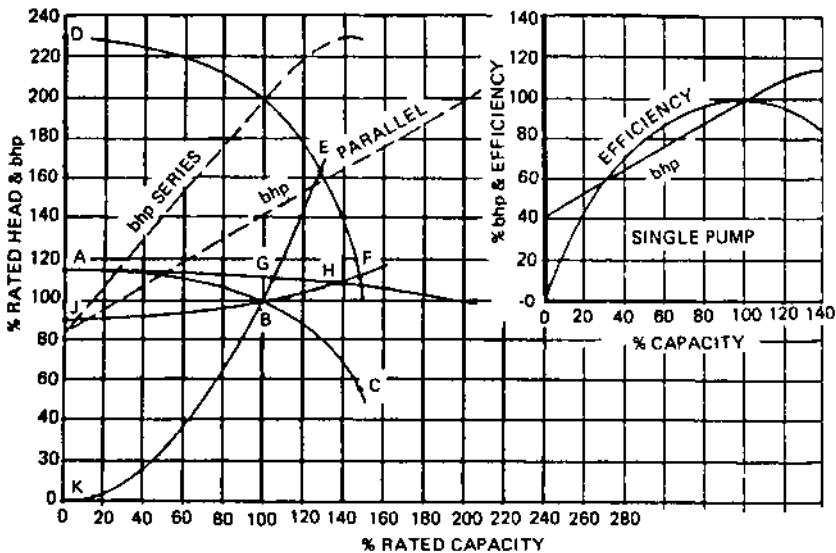

FIGURE 9.6 Series and parallel operations of pumps with flat head capacity curves. (From Ref. 2.)

BHP at G is 142%, whereas at B it is 100% (see the inset of Fig. 9.6). Hence in sizing drives for pumps in parallel, this fact must be taken into account. It is a good idea to check on whether the pump has an adequately sized drive.

A similar procedure can be adopted for determining the performance of fans in series and in parallel and for sizing drives.

9.21

Q:

Determine the parameters affecting the efficiency of the Brayton cycle [3].

A:

Figure 9.7a shows a simple reversible Brayton cycle used in gas turbine plants. Air is taken at a temperature T_1 absolute and compressed, and the temperature after compression is T_2 . Heat is added in the combustor, raising the gas temperature to T_3 ; the hot gases expand to T_4 in the turbine, performing work. Following are some of the terms used to describe the performance.

$$\text{Thermal efficiency TE} = \frac{Q_a - Q_r}{Q_a} \quad (24)$$

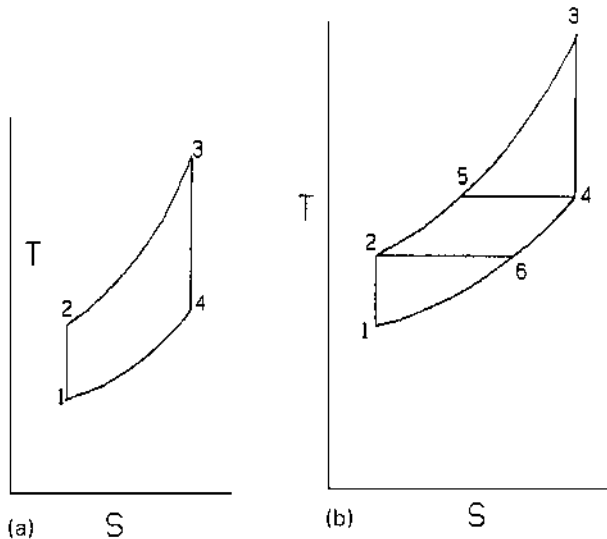

FIGURE 9.7 (a) Simple and (b) regenerative Brayton cycle.

where

Q_a = heat added to cycle, Btu/lb

Q_r = heat rejected, Btu/lb

$$Q_a = C_p(T_3 - T_2) \quad (25)$$

$$Q_r = C_p(T_4 - T_1) \quad (26)$$

$$P_2 = P_3 \quad \text{and} \quad P_1 = P_4 \quad (27)$$

Also,

$$\frac{T_2}{T_1} = \frac{T_3}{T_4} = r^{(k-1)/k} \quad (28)$$

where

$$r = \text{pressure ratio} = \frac{P_2}{P_1} = \frac{P_3}{P_4} \quad (29)$$

k = ratio of gas specific heats

C_p = gas specific heat, Btu/lb

$T_1 - T_4$ = temperatures, °R

$P_1 - P_4$ = pressure, psia

Using the above, we can write

$$\begin{aligned} \text{TE} &= 1 - \frac{Q_r}{Q_a} = 1 - \frac{T_4 - T_1}{T_3 - T_2} \\ &= 1 - \frac{T_1}{T_2} \times \frac{T_4/T_1 - 1}{T_3/T_2 - 1} \end{aligned} \quad (30a)$$

Since, from Eq. (28), $T_4/T_1 = T_3/T_2$, we have

$$\text{TE} = 1 - \frac{T_1}{T_2} = 1 - 1/r^{(k-1)/k} \quad (30b)$$

Example

A simple cycle takes in air at 80°F and 14.7 psia and compresses it at constant entropy through a pressure ratio of 4. The combustor raises the gas temperature to 1500°F. The heated air expands to 14.7 psia at constant entropy in the turbine. Assume $k = 1.3$ and $C_p = 0.28$. Find (1) compression work, W_c ; (2) heat input to cycle, Q_a ; (3) expansion work, Q_e ; (4) thermal efficiency, TE.

Solution. From Eq. (28),

$$T_2 = (80 + 460) \times 4^{(1.3-1)/1.3} = 742^\circ\text{R}$$

Note that $4^{(1.3-1)/1.3} = 1.375$. Hence

$$\begin{aligned} W_c &= C_p \times (T_2 - T_1) = 0.28 \times (742 - 540) \\ &= 56.6 \text{ Btu/lb} \end{aligned}$$

$$\begin{aligned} \text{Heat input to cycle} &= Q_a \\ &= C_p \times (T_3 - T_2) \\ &= 0.28 \times (1500 + 460 - 742) \\ &= 341 \text{ Btu/lb} \end{aligned}$$

$$T_4 = \frac{T_3}{1.375} = \frac{1960}{1.375} = 1425^\circ\text{R}$$

$$\text{Expansion work } Q_e = 0.28 \times (1960 - 1425) = 150 \text{ Btu/lb}$$

$$\text{TE} = \frac{150 - 56.6}{341} = 0.273, \text{ or } 27.3\%$$

Using Eq. (30b), $\text{TE} = 1 - 1/1.375 = 0.273$.

It can be seen that as the pressure ratio increases, TE increases. Also, as inlet air temperature decreases, the efficiency increases. That is why some gas turbine suppliers install chillers or air coolers at the compressor inlet so that during summer months the turbine output does not fall off compared to the winter months.

9.22

Q:

How can the efficiency of a simple Brayton cycle be improved?

A:

One of the ways of improving the cycle efficiency is to use the energy in the exhaust gases (Fig. 9.7b) to preheat the air entering the combustor. This is called regeneration.

Assuming 100% regeneration, the exhaust gas at temperature T_4 preheats air from T_2 to T_5 while cooling it to T_6 . The actual heat rejected corresponds to a temperature drop of $T_6 - T_1$, while the heat added corresponds to $T_3 - T_5$, and hence the cycle is more efficient. Assuming constant C_p ,

$$\text{TE} = 1 - \frac{Q_r}{Q_a} = 1 - \frac{T_6 - T_1}{T_3 - T_5}$$

Now $P_2 = P_5 = P_3$ and $P_4 = P_6 = P_1$. Also,

$$\begin{aligned}\frac{T_2}{T_1} &= \frac{T_6}{T_1} = r^{(k-1)/k} = \frac{T_3}{T_4} = \frac{T_3}{T_5} \\ \text{TE} &= 1 - T_1 \frac{T_6/T_1 - 1}{T_5(T_3/T_5 - 1)} \\ &= 1 - \frac{T_1}{T_5} \quad (T_6/T_1 = T_3/T_5, \text{ from above}) \\ \frac{T_1}{T_5} &= \frac{T_1}{T_3} \times \frac{T_3}{T_5} = \frac{T_1}{T_3} \times r^{(k-1)/k}\end{aligned}$$

Hence

$$\text{TE} = 1 - \frac{T_1}{T_3} \times r^{(k-1)/k} \quad (31)$$

Example

Using the same data as above, compute the following for the ideal regenerative cycle: (1) Work of compression, W_c ; (2) heat added to cycle; (3) heat added to regenerator; (4) expansion work in turbine; (5) cycle efficiency.

Solution. For the same inlet temperature and pressure ratio, $W_c = 56.6$ and $T_2 = 742^\circ\text{R}$. Exhaust temperature from above $= 1425^\circ\text{R} = T_5$.

$$\begin{aligned}\text{Heat added in regenerator} &= C_p \times (T_5 - T_2) \\ &= 0.28 \\ &\quad \times (1425 - 742) = 191.3 \text{ Btu/lb}\end{aligned}$$

$$\begin{aligned}\text{Heat added in combustor} &= Q_a = C_p \times (T_3 - T_5) \\ &= 0.28 \times (1960 - 1425) \\ &= 150 \text{ Btu/lb}\end{aligned}$$

$$\begin{aligned}\text{Heat rejected} &= Q_r = C_p \times (T_6 - T_1) \\ &= 0.28 \times (742 - 540) = 56.6 \text{ Btu/lb}\end{aligned}$$

$$\text{TE} = 1 - \frac{Q_r}{Q_a} = 1 - \frac{56.6}{150} = 0.622, \text{ or } 62.2\%$$

Using (31)

$$\text{TE} = 1 - \frac{540}{1960} \times 4^{(1.3-1)/1.3} = 0.621, \text{ or } 62.1\%$$

It is interesting to note that as the pressure ratio increases, the efficiency decreases. As the combustor temperature increases, the efficiency increases. However, it can be shown that the power output increases with increases in the

pressure ratio. Hence industrial gas turbines operate at a pressure ratio between 9 and 18 and an inlet gas temperature of 1800–2200°F.

NOMENCLATURE

ASR	Actual steam rate, lb/kWh
BHP	Brake horsepower, hp
C_Q, C_H, C_E	Factors correcting viscosity effects for flow, head, and efficiency
C_p	Specific heat, Btu/lb °F
d	Tube or pipe diameter, in.; subscript i stands for inner diameter
E	Voltage
h	Enthalpy, Btu/lb; subscripts f and g stand for saturated liquid and vapor
H	Head developed by pump, ft; subscript a stands for acceleration
HP	Horsepower
H_w	Head developed by fan, in. WC
I	Current, A
k	Ratio of gas specific heats, C_p/C_v
L	Length, ft
N	Speed of pump or fan, rpm
NPSH	Net positive suction head, ft; subscripts a and r stand for available and required
P	Power, kW
ΔP	Differential pressure, psi
q	Flow, gpm or acfm
Q_a, Q_r	Heat added, rejected, Btu/lb
r	Pressure ratio
s	Specific gravity
s_f, s_g	Entropy of saturated liquid and vapor, Btu/lb °R
S	Specific speed
ΔT	Temperature rise, °F
TE	Thermal efficiency
T	Temperature, °R
TSR	Theoretical steam rate, lb/kWh
V	Velocity, ft/s
W	Flow, lb/h
W_c	Work of compression, Btu/lb
η	Efficiency, fraction; subscripts $f, m, p,$ and t stand for fan, motor, pump, and turbine
ρ	Density, lb/cu ft

REFERENCES

1. Cameron Hydraulic Data. 16th ed. Woodcliff Lake, NJ: Ingersoll Rand, 1981, p 5.1.
2. I Karassik. Centrifugal Pump Clinic. New York: Marcel Dekker, 1981, p 102.
3. Power Magazine, Power Handbook. New York: McGraw-Hill, 1983.
4. RH Perry, CH Chilton. Chemical Engineers Handbook. 5th ed. New York: McGraw-Hill, 1974.