



Connectix Cabling Systems

Structured Cabling
Introduction & Installation Guide



General Structure - Cat5e/Cat6 Cabling

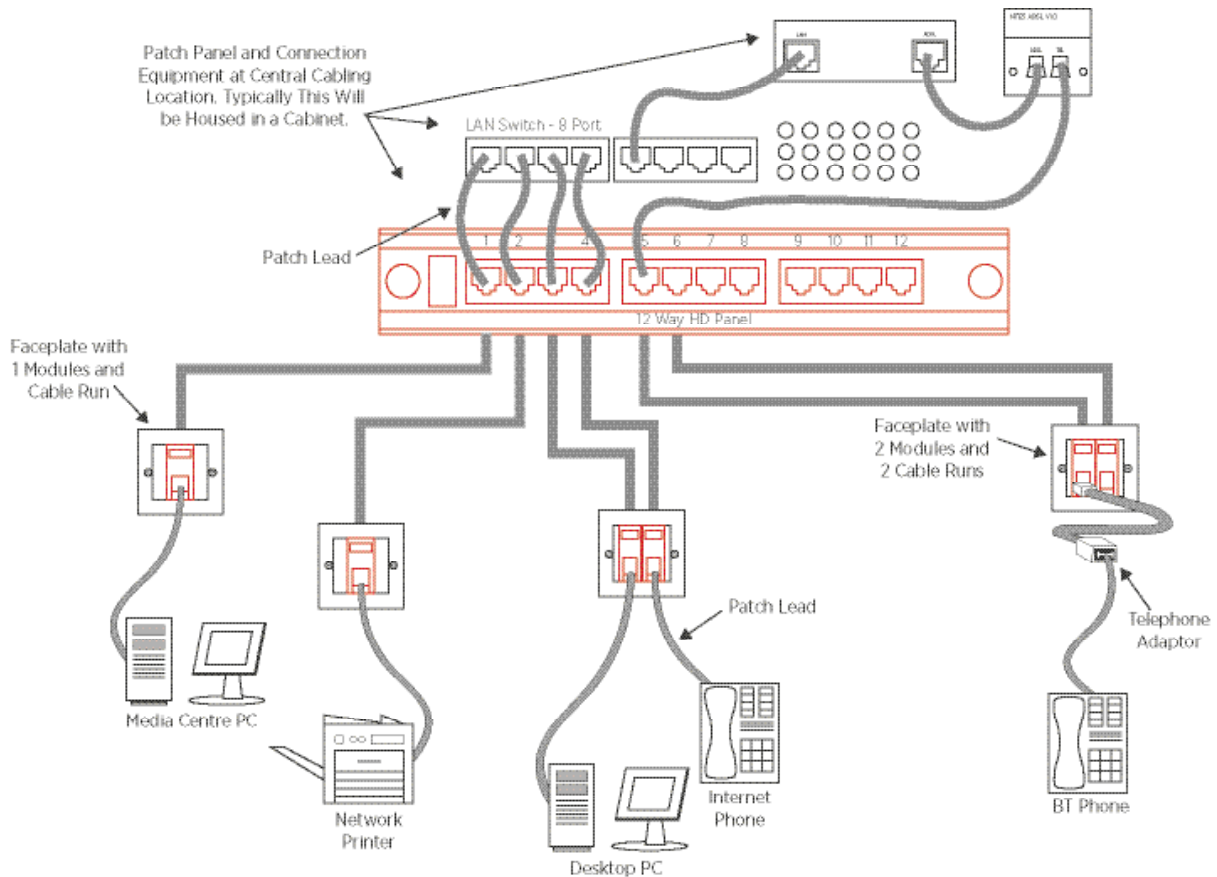

The structure illustrated has the following key points:

- Face plates present outlet modules where PCs, phones & other devices will be connected.
- Each module is connected to its own run of cable (two modules in one place; two cables.)
- Installed cable terminates onto the back of the outlet module
- All cables connected to outlet modules head back to a common point.
- All cables terminate onto a patch panel at the common point.
- Cables from modules terminate onto the back of the patch panel.
- Typically a cabinet is used at the common point to house the patch panel(s).
- Connectivity equipment may also be installed in the cabinet.
- Patch leads are used to connect devices and equipment to the cabling system.
- Patch leads connected between patch panel ports may be used to link one wall outlet to another.
- Adaptors or converters may be required for certain signal types.

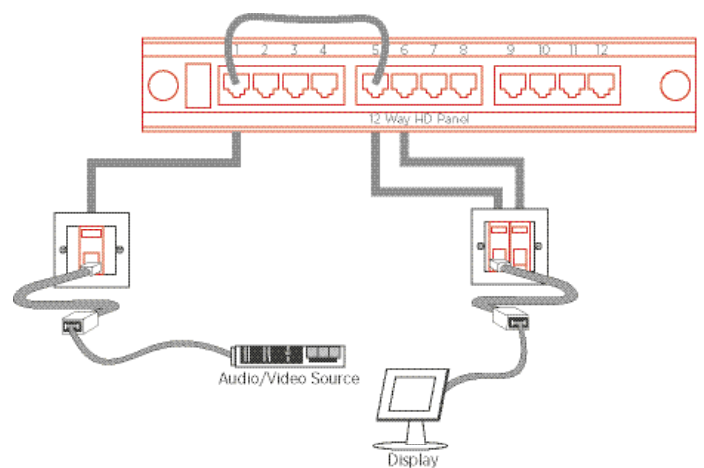



Wall Outlet Features

Double module installed in faceplate

Mounting screw hole



Single Gang Faceplate
Will hold one or two modules
Dual gang available for four modules

Mounting Back Box

Standard electrical type 85mm*85mm back box For standard modules (as shown) a minimum of 39mm front face to back face clearance is required.

With a standard 15mm face plate a 24mm backbox is acceptable. The compact Net5e module requires 24mm minimum. With a 9mm compact face plate a 15mm back box is acceptable.

* Connectix standard face plates and modules are not compatible with EuroMod (50mm*50mm) plates or modules. Connectix manufacturers EuroMod modules for use with EuroMod faceplates.

Wall Outlet Module Features

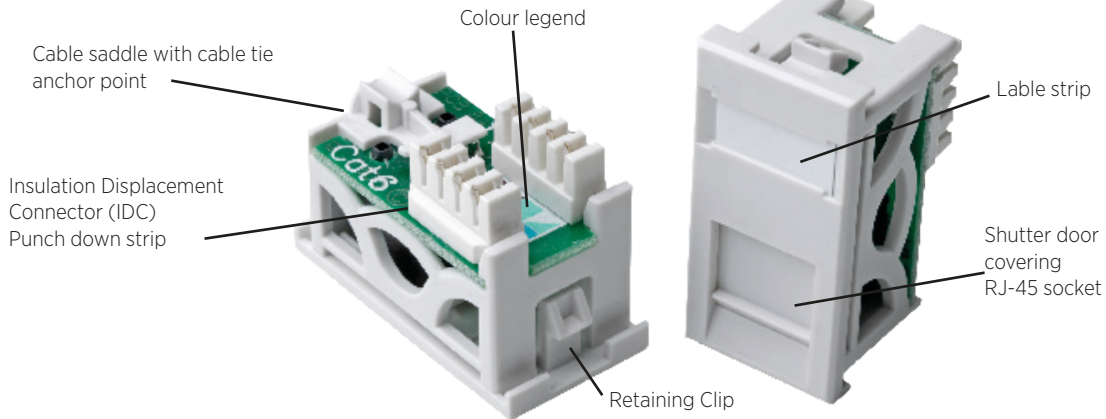

* A number of module size formats exist, certain combinations of faceplate and module are incompatible. Connectix modules are available to fit in a range of face plates including Connectix, LJ6C and EuroMod standards.

Examples Uses

A telephone with BT type plug may be connected to a wall outlet using a Line Adaptor Unit (LAU)



A Local Area Network (LAN) can be used for data connectivity between PCs and other data devices. A patch lead is used to connect the device to the wall outlet



10" Small Office / Home Cabling Cabinets

10" cabinets are designed to be used with 10" format patch panels and other cabinet hardware such as shelves and blank panels. As a space saving alternative to commercial 19" cabinets the 10" range is ideally suited to small office and home installations.

Connectix Home Cabinet

Designed for home cabling system use the Home Cabinet range is low profile, compact and able to accommodate typical home cabling system hardware requirements using minimal space.

The ability to house larger pieces of equipment has been sacrificed against the need for space saving aesthetic design. Typically phone and cabling system panels, RF TV distribution, data networking and broadband equipment can be installed.

19" Full Size Structured Cabling Cabinets - Commercial / Advanced Home

19" cabinets are typically used in commercial or advanced home installations where either a high number of cabling system connections are required or where there will be a lot of equipment installed in the cabinet.

Cabinet height is measured in cabinet Units (U) with one 24 port patch panel typically requiring 1U. (1U = 44mm). Floor standing cabinets are used where lots of space is required for cabling system hardware or heavy equipment. In situations where 19" equipment is to be accommodated without the need for lots of U space a wall mounted cabinet may be used if a suitable mounting surface exists. Where there is no need for security and if the U space requirement is low a wall mount frame may be used.



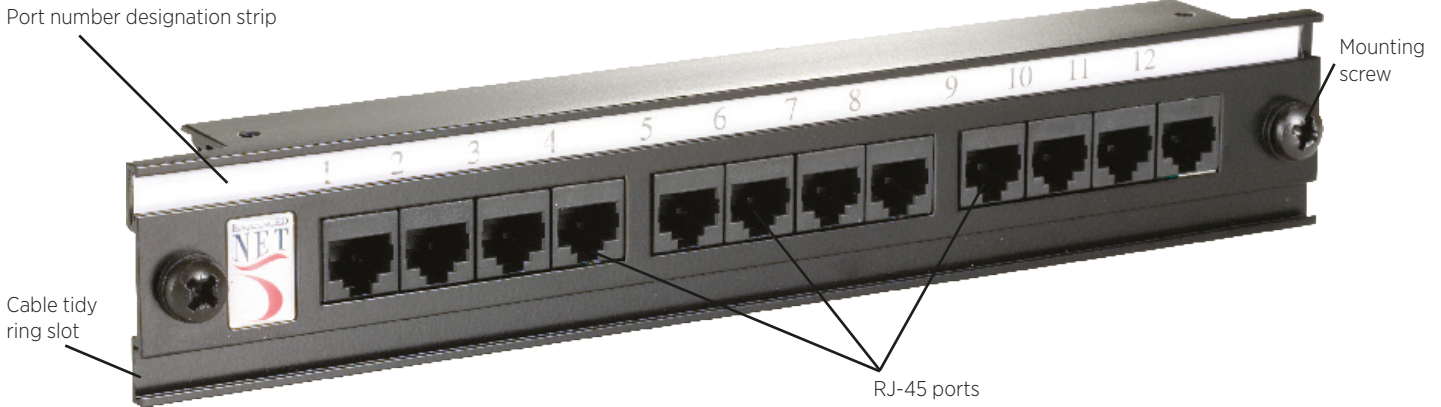

Patch Cable Tidy Ring

Patch panels are available in 10" and 19" formats giving 12 and 24 ports respectively. Each port connects to a single Cat 5e / Cat 6 cable using an Insulation Displacement Connector (IDC) punch down strip on the rear of the panel. RJ-45 ports on the front of the panel are used to connect wall outlet ports to equipment or other wall outlet ports by using patch cables.

The mounting screws fix the panel into a cabinet or enclosure using cage nuts supplied with the panel. Cable tidy rings may be fitted to the panel in either a horizontal or vertical orientation. When installed patch cables may be routed through the rings for tidy patch cable management.



Installation Features



Insulation Displacement Connector (IDC) Punch Down Strip

Wire position legend



Cable tie points (Velcro ties NOT on 10" panels)

Example Uses

Cables to BT type wall outlet modules have been terminated onto a patch panel and are connected to a telephone distribution panel with blue patch leads.



Cables terminated onto RJ-45 wall outlets have been terminated onto a patch panel and are connected to a LAN switch with red patch leads.

8U Slim Line Cabinet

Designed with ease of installation in mind the external case is removable revealing the surface mounted frame with 10" rack profiles for easy access to cabling.

A Network 8 port 10/100Mbps Ethernet switch for LAN devices can be installed horizontally using the space saving bracket. The Connectix TV distribution amplifier can be installed on to the back plate of the frame leaving the rack profiles free for other components requiring ease of access.

The door hinges on retractable sprung hinge pins allowing easy removal. Door opening orientation may be chosen by selecting cabinet external case orientation.

Specifications

Overall Dimensions (mm)	
Height	385
Width	275
Depth	150

Internal clearance

Back panel-profile	88
TV unit-profile	52
Profile to door	45(min) 54(max)

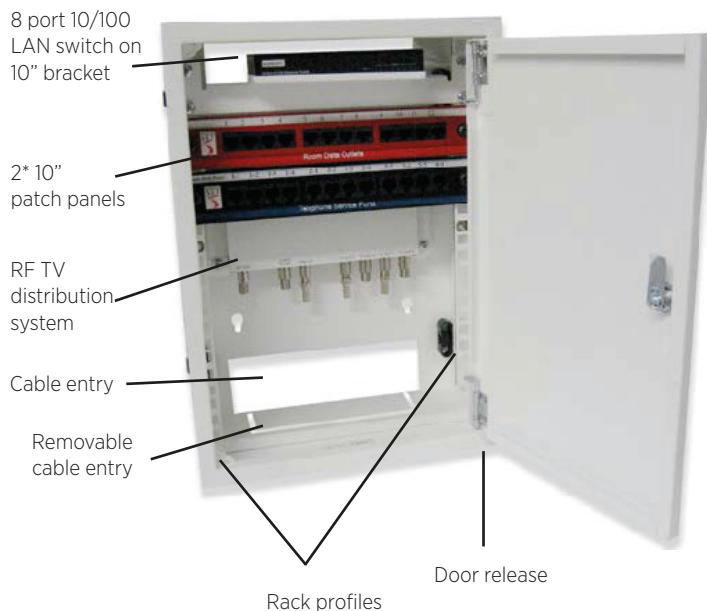

Cabinet Features

The cabinet outer case slides forwards to reveal surface mounted frame with 10" rack profiles. Back plate provides mounting location for RF TV, FM and Satellite distribution system. Up to eight 1U panels can be accommodated on the 10" rack profiles for up to 96 ports. Blank plates can be used to cover unused rack space and provide mounting surfaces for equipment such as broadband routers.

The external case fixes to the frame with 4 quick release fixings positioned toward the rear of the cabinet on the sides. Cable entry options allow hidden wiring to enter using the cut outs in the back plate. Alternatively removable case sections from the top and bottom allow surface mounted cabling to enter. Screw head keyways for surface mounting.

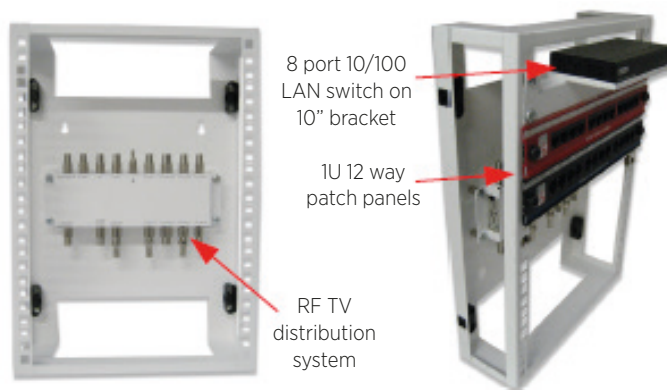



Connectix Office System 8U Cabinet

The Connectix Office System cabinet shares the same frame with removable outer carcass design as the slim line cabinet. The carcass may be removed during installation allowing improved access to cabling hardware and installed equipment. The door hinge position is selected by choosing the orientation of the carcass when affixed onto the frame.

Compared to the Slim Line version, increased depth typically allows installation of more equipment which may be accommodated on optional shelves. The smoked polycarbonate door allows visual inspection of equipment operation inside the cabinet. The lock provides a basic level of security reducing the chance of casual tampering when installed in occupied or public spaces. All 10" cabinet hardware can be installed in the Connectix Office System Cabinet. An extensive range of cabinet accessories are available, this includes shelves, blank panels, brush strip panels and cable tidy panels.

Specifications

Overall Dimensions	
Height	360mm
Width	263mm
Depth	360mm

Connectix 10U Home Cabinet

The Connectix Home Cabinet has been designed to consider the requirements of a typical domestic cabling system addressing data networking, voice service and RF TV/FM radio signal distribution. Its 10U height can accommodate any components from the 10" range including patch & telephone host panels, 8 room TV distribution system and blanking panels. The low profile space saving design allows installation in utility areas, under stairs or within a cupboard without looking out of place. An enclosed section on the right hand side (shown with lid removed) containing a 4 way socket strip will house a power supply for items such as the TV distribution amplifier, a LAN switch or broadband router.

The enclosed section on the left hand side (shown with lid removed) can be used for cable routing to either the front or rear of the profiles. Fixed wiring or patch cables may be kept tidy using this space. The flap down front door makes access easy and is fitted with a key lock for added security.

Specifications

Overall Dimensions (mm)	
Height	450
Width	415
Depth	105
Internal clearance	
Back panel-profile	48
Profile to door	45

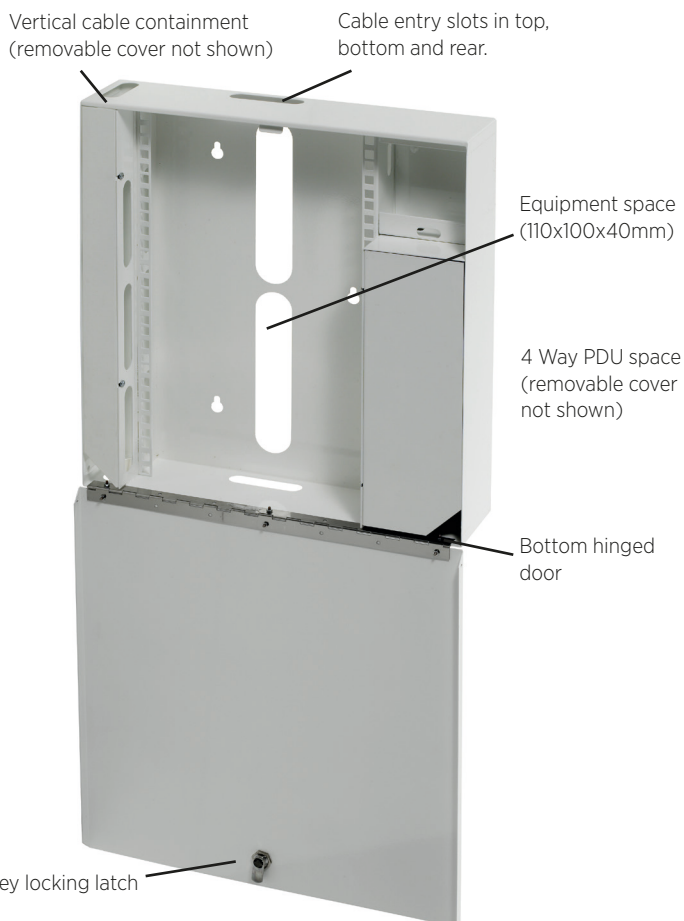

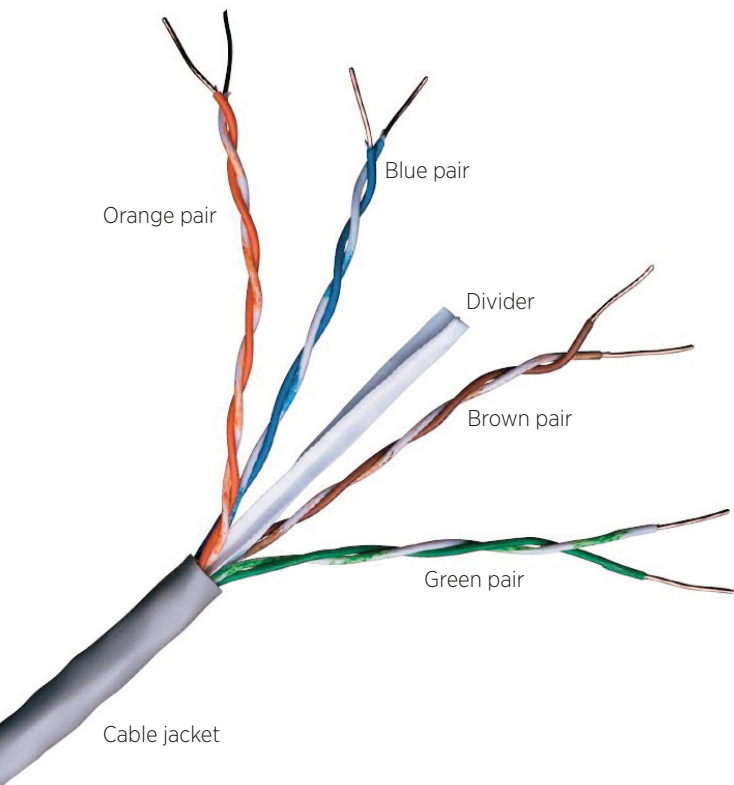

Cable and Connector detail

Each pair consists of a solid colour insulated conductor twisted with an associated white with same colour stripe. Cat5e is similar but without the divider signals sent over Cat5e / Cat6 must use the wires in their correct pairs for proper operation. Equipment designed for Cat5e / Cat6 connection routes signals to RJ-45 socket contacts using specific wired pairs. A signal should not be split across the Orange and Green wires, for example. Termination errors can result in wires connected to the wrong patch panel / module IDC positions. Use of the 8 wires is defined in two ways, T568A and T568B. Connectix IDC products use the 'B' version as shown above. When installing Cat5e / Cat6 follow the component colour legend to ensure correct termination.

T568B Wiring Scheme

RJ-45 Plug	Pin No.	Wire Colour	Colour Symbols
	1	White/Orange Stripe	
	2	Orange	
	3	White/Green Stripe	
	4	Blue	
	5	White/Blue Stripe	
	6	Green	
	7	White/Brown Stripe	
	8	Brown	

Tools used in structured cabling installation

- IDC Punch Down Tool**
 Used for terminating cables onto module and Patch panel IDC strips. All Connectix products use a Krone type contact. Failure to use a Krone type tool will result in permanent damage to the component or failure to operate reliably. The tip of the punch down tool consists of an insertion blade designed for Krone contacts and a pair of snips which cut away excess cable all in one operation.
- Maximum cut cable stripper**
 Aids cable jacket removal without damaging conductor insulation.
- Screw Driver**
 Cross head for panel mounting screws. Flat head for faceplates and module removal from face plate.
- Continuity Tester**
 Used to test terminated cabling or patch leads for basic wiring faults such as incorrect wire position, open and short circuit connections.
- Wire cutters**
 Used for cutting installed cable from reel / box. Removal of cable tie excess.



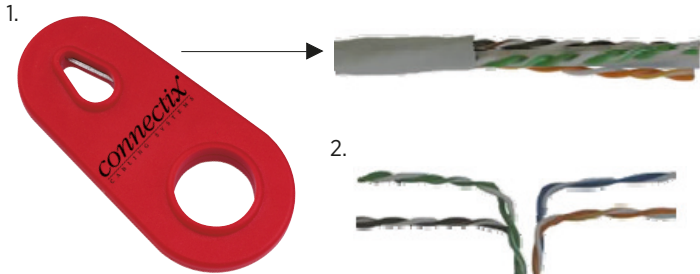

1. **Strip outer jacket.**
Do not nick conductor insulation with tool use to cut outer jacket. Use a purpose designed maximum cut stripping tool.



2. **Fan out conductors.**
A tidy termination will be achieved if the cable is rotated so that the pairs exit on the right side of the cable for the relevant IDC positions on the module/patch panel. Snip away any excess rip cord and cable divider. (There will be no divider in Cat5e cable.)

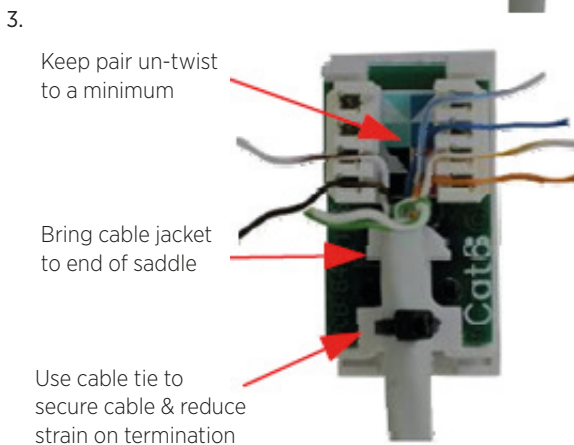

3. **Lay conductors into IDCs**
Use the strain relief cable tie point to secure the cable for easier handling. Do not deform the cable by over tightening the cable tie. Follow the colour legend to identify the correct IDC position for each wire.

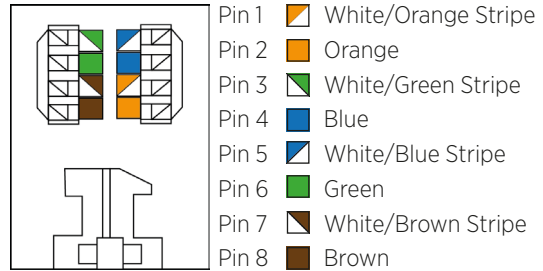

* Some IDC layout/cable lay combinations do not allow for punch down of all conductors during the same operation. In the example shown the green pair falls above the brown pair and gets in the way if laid into the IDC before the browns are punched.

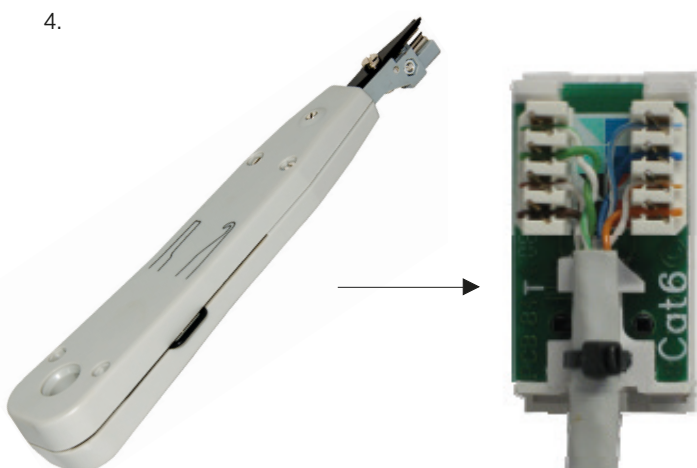

4. **Punch down conductors**
Only use a Krone type punch down tool with Connectix IDC based products.

* Use the tool with the cutter blades facing out away from the IDC so as to remove excess cable and not cut the incoming. Ensure the cut end is not bent around where it could short with the next contact.

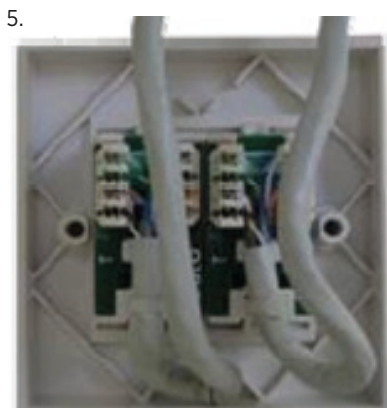

5. **Clip module into faceplate.**
Manage excess cable behind module to avoid crush and cable deformation. Exceeding minimum bend radii (25mm) will result in performance degradation.

* Trim cable tie excess off carefully to avoid leaving sharp exposed points

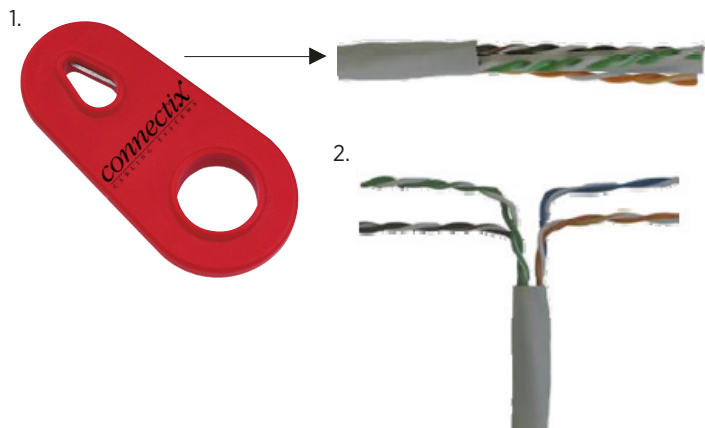

- Strip outer jacket.**
Do not nick conductor insulation while stripping outer jacket. Use a purpose designed maximum cut stripping tool.
- Fan out conductors.**
Rotate the cable for correct pair alignment with patch panel IDC positions. Need for pairs to cross each other should be non-existent or at a minimum. Snip away any excess rip cord and cable divider. (There will be no divider in Cat5e cable.)

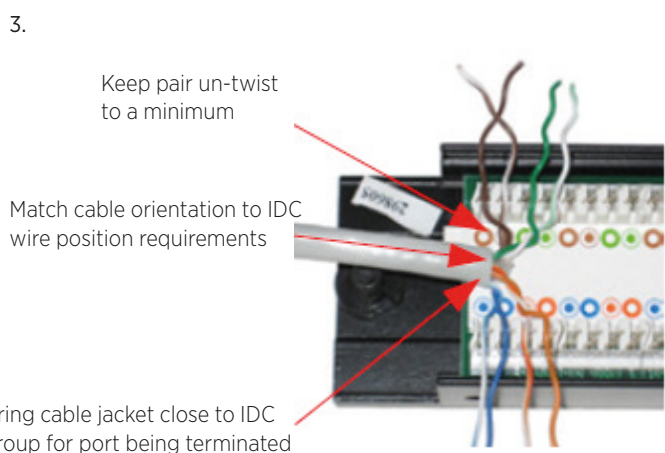

- Lay conductors into IDCs**
Follow the colour legend to identify the correct IDC position for each wire.

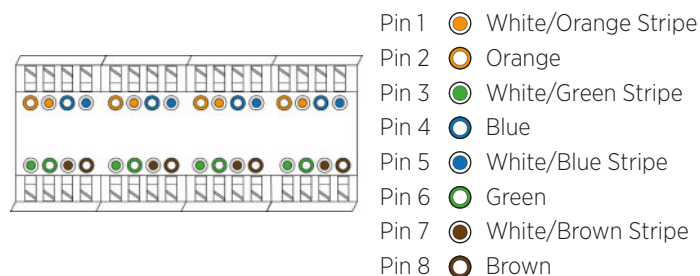

* Some IDC layout / cable lay combinations will require pairs to be crossed for correct positioning. Typically if pulling cable with the box at the panel location, pulling out to the wall outlets, the cable will have the correct orientation not to require crossing of pairs at the panel.

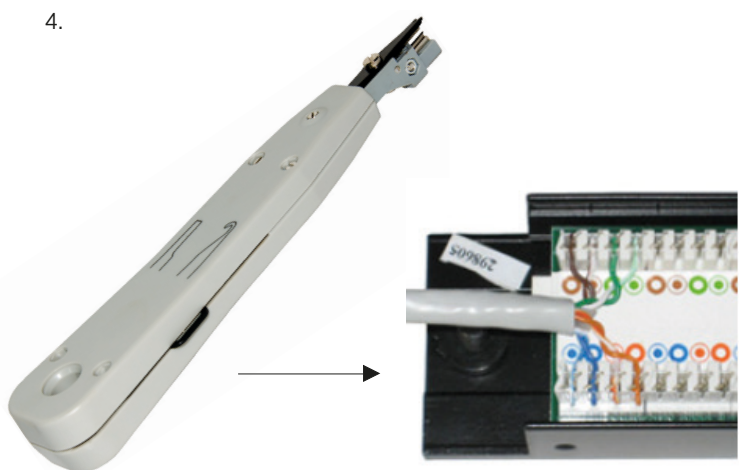

- Punch down conductors**
Only use a Krone type punch down tool with Connectix IDC based products.

* Use the tool with the cutter blades facing out away from the IDC so as to remove excess cable and not cut the incoming. Ensure the cut end is not bent around where it could short with the next contact.

- Bundle and tie cables.**
IDC connections can be pulled from their contact fairly easily. Use the cable tie points to secure the cables before installing the panel in a cabinet or enclosure. Ensure the tie does not deform the shape of the cables through over tightening.

* Trim cable tie excess off carefully to avoid leaving sharp exposed points

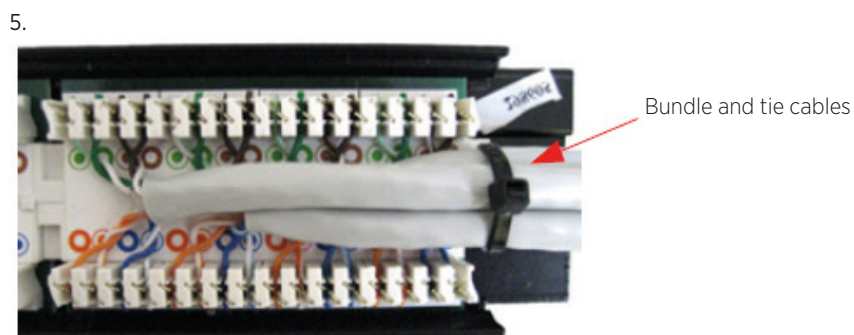



What is the maximum length run of Cat5e or Cat6 that I can install?

An installation compliant to structured cabling system standards can have up to 90m installed cable and a further 10m of patch cable for equipment connection. Typical data applications for Local Area Networking (such as Fast Ethernet and Gigabit Ethernet) have this as a design limit in their specifications. Other applications for video, audio, security system or telephone connection allow much longer lengths. If you want all typical applications to work stick to the 90m limit. Alternatively check with the equipment manufacturer (some high definition video systems for Cat5e/6 may have a lower limit)

Should I use Cat5e or Cat6?

Cat6 is a higher performance cabling system compared to Cat5e. If installed correctly it can provide higher performance and better immunity to interference depending on the signals being carried. Currently all typical applications function with Cat5e just as well as with Cat6. However, the latest version of Ethernet (operating at 10Gbps) will not function on Cat5e but it may function on Cat6 for cable lengths up to 30m. The decision between Cat5e and Cat6 is usually based on requirements of the equipment to be connected, personal point of view and cost.

What happens if I mix Cat5e / Cat6 patch panels, modules and cable?

The cabling system will operate at the performance level of the lowest performance component, in this case Cat5e.

What is Cat7 and Cat8?

Cat7 and Cat8 are terms used to refer to proprietary cabling systems which claim performance better than standards based Cat5e and Cat6.

Should I consider a Cat7 / Cat8 cabling system?

Systems referred to with these terms usually offer more functionality than Cat5e or Cat6; for example the ability to transmit RF TV signals on structured cabling. However, to compare with Cat5e / Cat6, remember that the cost of such systems is typically two or three times that of combined CatX and co-ax systems offering similar functionality. Also proprietary cabling systems only available from one source.

Can I use Cat5e or Cat6 for audio or video signals?

It is sometimes possible to send AV signals without conversion over Cat5e/Cat6. Signal loss and interference can result in poor video images or audio combined with hum or other interference, particularly on line level signals. Signal conditioning converters are available for low loss noise free transmission of AV signals over Cat5e / Cat6 cabling. The cost of these converters depends on the signals to be carried. Composite or component AV (including surround sound) and HD video on HDMI can be carried on Cat5e / Cat6.

Can I make patch leads using solid cable?

Crimping RJ-45 connectors onto solid cable is possible but not recommended. Small amounts of movement on the cable can break the conductors in the plug. The result is intermittent failures which are difficult to find. Patch leads are normally made from stranded cable having greater flexibility than solid cable with lower likelihood of breaking.

What do I need to make my own patch leads?

You will need some stranded patch cable, RJ-45 connectors and an RJ-45 crimp tool. Ensure that you have the correct tool for the brand of connector otherwise an under or over crimped plug will result. Under crimped plugs will permanently damage RJ-45 sockets. Over crimped plugs will cause intermittent connection failures.

Option 1. - Telephone distributed to general purpose RJ-45 wall outlets

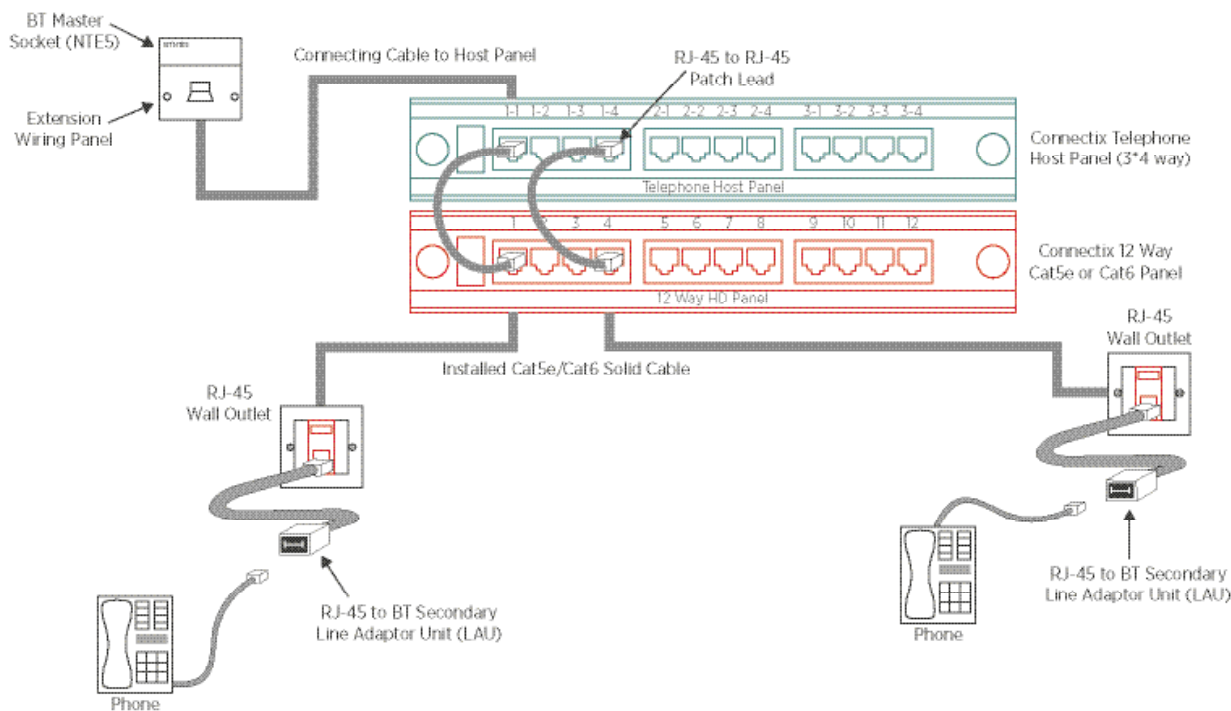

RJ-45 modules at room outlet locations require the use of a Line Adaptor Unit (LAU) to convert from RJ-45 to BT type connectors if typical telephones are to be connected.

Option 2. - Telephone distributed to dedicated BT type wall outlets

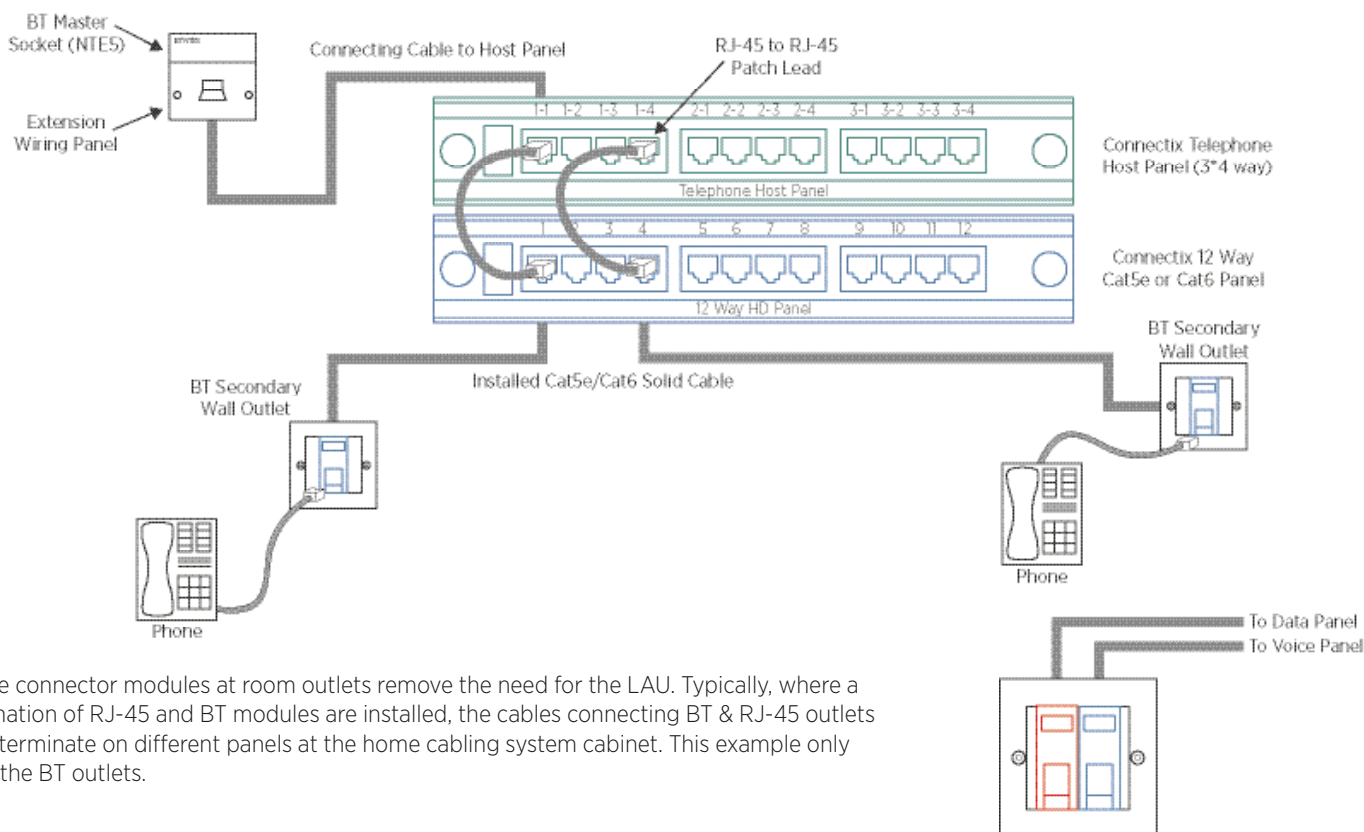

BT type connector modules at room outlets remove the need for the LAU. Typically, where a combination of RJ-45 and BT modules are installed, the cables connecting BT & RJ-45 outlets would terminate on different panels at the home cabling system cabinet. This example only shows the BT outlets.



The Connectix Telephone Host Panel installs in the home cabling system cabinet and allows distribution of up to three individual telephone lines. It has three separate modules each with six points of connection, four of which are typically used for connection to room outlets. Modules may be linked where one line is to be connected to more than four locations.



Each module has four front presented RJ-45 sockets with a fifth one and an 8 way Krone type Insulation Displacement Connector (IDC) punch down strip on the rear.

All module connection points are interconnected; a telephone service connected on the rear IDC is available for connection to 4 locations using a patch cable and the RJ-45 ports available on the front of the panel.

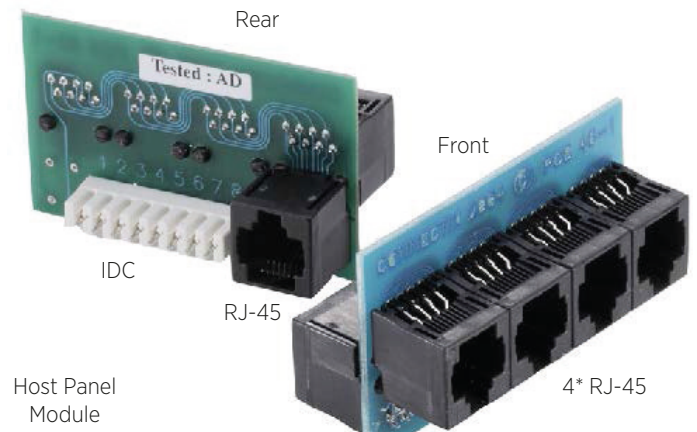
The rear RJ-45 socket may be used to connect the service with a suitably terminated lead. Either the rear presented RJ-45 or the IDC can be used for inter-linking modules to provide more connection points for a single telephone service.



Connectix Home Cabling System - Telephone Distribution Components

	Description	Part Nuber
	12 Port (3 * 4 way) 10" Telephone Host Panel 12 Port (3 * 4 way) 19" Telephone Host Panel 24 Port (6 * 4 way) 19" Telephone Host Panel	009-003-001-01 12 009-003-001-07 12 009-003-001-10
	Secondary BT Module Module for Connectix Cabling System Faceplate	008-001-001-50
	Secondary BT Module Module for EuroMod 50*50mm Standard Faceplate	008-001-000-80
	Secondary BT/RJ-45 Line Adaptor Unit	007-006-003-15
	BT/RJ-45 Link Lead 2m	000-000-000-000

Option 1. - BT to RJ-45 lead to Connectix Telephone Host panel Module

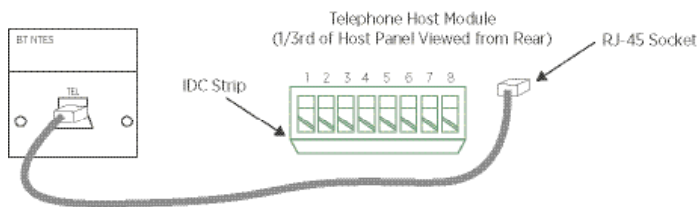

*Host panel modules may be connected together to provide 8 or 12 connections for a single line. Either of the rear presented RJ-45/IDC or front presented RJ-45s may be used to link modules. If using the RJ-45 sockets a standard patch lead is required. When using the IDC link with 1:1, 2:2 etc continuity.

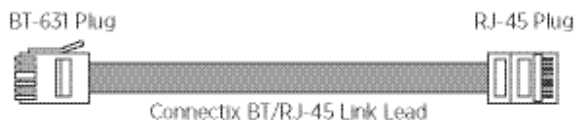

Option 2. - BT extension wiring facility to Host panel module IDC

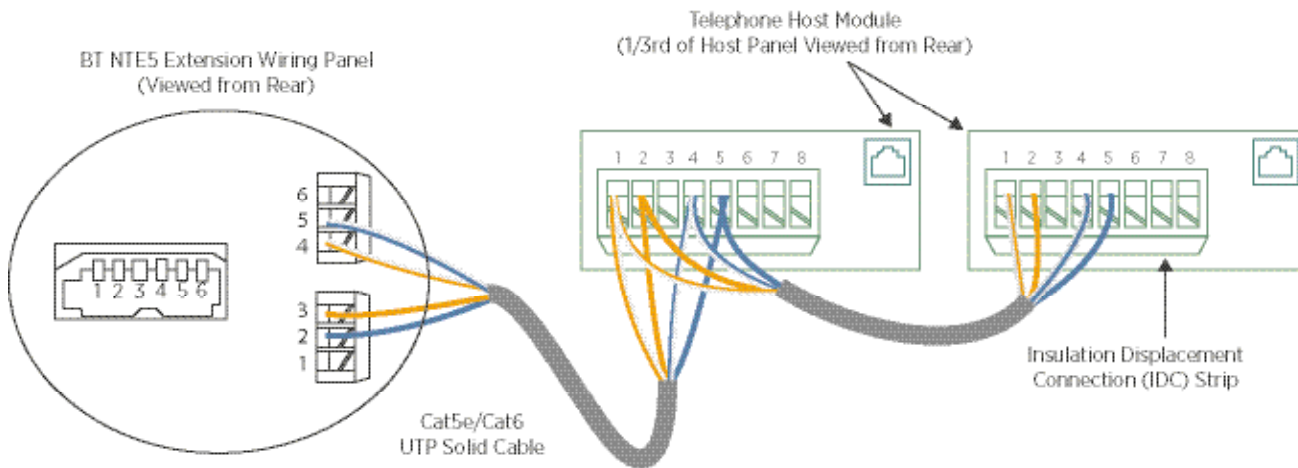

*This example follows the BT colour code. If using a standard patch panel at the home cabinet the blue pair must be reversed at the patch panel. The T568B/258A wiring scheme must be used. All Connectix patch panels are labelled to T568B. This example also shows how multiple modules may be connected to present a service on more ports than made available by one module.

Option 3. Phone service routed to Host Panel via installed cabling

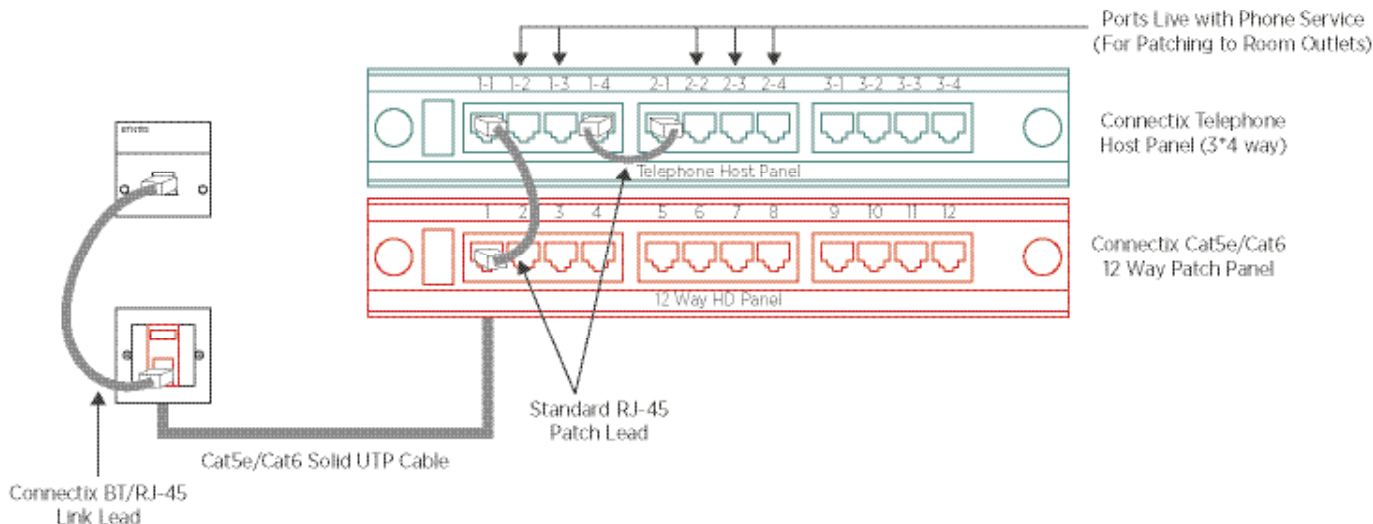

*The RJ-45 face plate to patch panel ink is wired using the standard T568B colour code as shown on the IDC colour legend presented on the rear of the module and panel. The example does not use the rear presented connections of the host panel leading to a reduced number of available ports (3 for a single line to one module, 5 for a single line to 2 connected modules.)

Option 1. - Telephone distributed to general purpose RJ-45 wall outlets

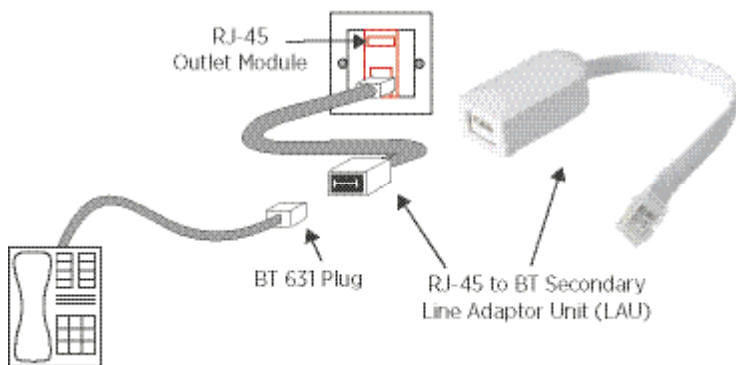

*When using a Connectix BT / RJ-45 link lead or the wiring as detailed in the 'connection of telephone service to Connectix home cabling system' section a Connectix Secondary Line Adaptor Unit (LAU) will be required at the wall outlet if RJ-45 type connector modules are installed.

Follow the standard termination procedures and colour code for T568B at both the patch panel and wall outlet module ends of installed cabling.

Option 2. - BT Type Wall Outlet Module - Wiring Detail

When using any of the schemes presented in the 'connection of telephone service' section with BT type wall outlet modules, wiring as noted below must be used.

Cable runs connected to BT type outlets should be terminated onto their own panel at the home cabling cabinet for to aid clarity of purpose and ease of use.

Use Cat5e/6 cable and terminate all pairs at the panel. Tie back the brown and green pairs at the wall outlet. This arrangement allows future upgrade based on simple re-termination with RJ-45 modules.

Follow the standard termination procedures and colour code for T568B at patch panel.

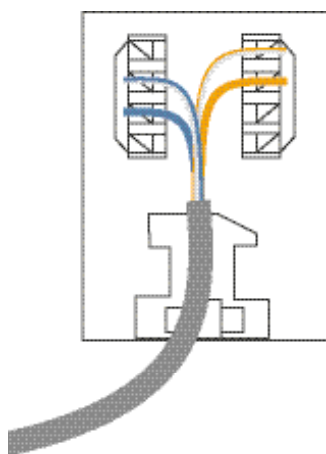
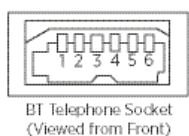
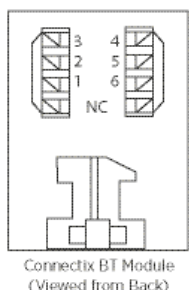
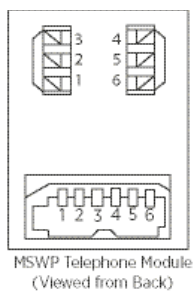
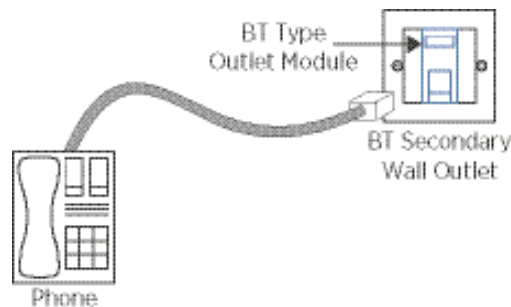

Pin 1	No Connection
Pin 2	White/Blue Stripe
Pin 3	Orange
Pin 4	White/Orange Stripe
Pin 5	Blue
Pin 6	No Connection

