

Modern Diesel Technology

Diesel Engines

Sean Bennett



We Support
ASE Program Certification
Through



MODERN DIESEL TECHNOLOGY: DIESEL ENGINES

Sean Bennett



Australia • Brazil • Japan • Korea • Mexico • Singapore • Spain • United Kingdom • United States

Modern Diesel Technology: Diesel Engines

Sean Bennett

Vice President, Editorial: Dave Garza

Director of Learning Solutions: Sandy Clark

Executive Editor: David Boelio

Managing Editor: Larry Main

Senior Product Manager: Sharon Chambliss

Editorial Assistant: Lauren Stone

Vice President, Marketing: Jennifer McAvey

Executive Marketing Manager: Deborah
S. Yarnell

Marketing Manager: Jimmy Stephens

Marketing Specialist: Mark Pierro

Production Director: Wendy Troeger

Production Manager: Mark Bernard

Content Project Manager: Barbara LeFleur

Art Director: Benj Gleeksman

Technology Project Manager: Christopher
Catalina

Production Technology Analyst: Thomas Stover

© 2010 Delmar, Cengage Learning

ALL RIGHTS RESERVED. No part of this work covered by the copyright herein may be reproduced, transmitted, stored, or used in any form or by any means graphic, electronic, or mechanical, including but not limited to photocopying, recording, scanning, digitizing, taping, Web distribution, information networks, or information storage and retrieval systems, except as permitted under Section 107 or 108 of the 1976 United States Copyright Act, without the prior written permission of the publisher.

For product information and technology assistance, contact us at
Professional & Career Group Customer Support, 1-800-648-7450

For permission to use material from this text or product,
submit all requests online at cengage.com/permissions

Further permissions questions can be e-mailed to
permissionrequest@cengage.com

Library of Congress Control Number: 2008937971

Hardcover Edition ISBN-13: 978-1-4354-4044-9

Hardcover Edition ISBN-10: 1-4354-4044-7

Softcover Edition ISBN-13: 978-1-4018-9809-0

Softcover Edition ISBN-10: 1-4018-9809-2

Delmar

5 Maxwell Drive

Clifton Park, NY 12065-2919

USA

Cengage Learning products are represented in Canada by Nelson Education, Ltd.

For your lifelong learning solutions, visit delmar.cengage.comVisit our corporate website at cengage.com**Notice to the Reader**

Publisher does not warrant or guarantee any of the products described herein or perform any independent analysis in connection with any of the product information contained herein. Publisher does not assume, and expressly disclaims, any obligation to obtain and include information other than that provided to it by the manufacturer. The reader is expressly warned to consider and adopt all safety precautions that might be indicated by the activities described herein and to avoid all potential hazards. By following the instructions contained herein, the reader willingly assumes all risks in connection with such instructions. The publisher makes no representations or warranties of any kind, including but not limited to, the warranties of fitness for particular purpose or merchantability, nor are any such representations implied with respect to the material set forth herein, and the publisher takes no responsibility with respect to such material. The publisher shall not be liable for any special, consequential, or exemplary damages resulting, in whole or part, from the readers' use of, or reliance upon, this material.

Brief Contents

	Preface	xvii
CHAPTER 1	Shop and Personal Safety	1
CHAPTER 2	Hand and Shop Tools, Precision Tools, and Units of Measurement	17
CHAPTER 3	Engine Basics	39
CHAPTER 4	Piston Assemblies, Crankshafts, Flywheels, and Dampers	53
CHAPTER 5	Timing Geartrains, Camshafts, Tappets, Rockers, and Cylinder Valves	81
CHAPTER 6	Cylinder Blocks, Liners, Cylinder Heads, Rocker Housings, Oil Pans, and Manifolds	101
CHAPTER 7	Engine Lubrication Systems	117
CHAPTER 8	Engine Cooling Systems	139
CHAPTER 9	Engine Breathing	163
CHAPTER 10	Engine Retarders	183
CHAPTER 11	Engine Removal, Disassembly, Cleaning, Inspection, and Reassembly Guidelines	197
CHAPTER 12	Fuel Subsystems	217
CHAPTER 13	Injector Nozzles	233
CHAPTER 14	Engine Management Electronics	245
CHAPTER 15	Electronic Diesel Fuel Injection Systems	263
CHAPTER 16	Emissions	289
	Glossary	305
	Acronyms	333
	Index	337

This page intentionally left blank

Contents

	Preface	xvii
CHAPTER 1	Shop and Personal Safety	1
	Introduction	1
	<i>Safety Rules</i>	1
	<i>Experience and Injuries</i>	2
	<i>Safety Awareness</i>	2
	<i>A Healthy Lifestyle</i>	2
	<i>Physical Fitness</i>	2
	Personal Safety Equipment	2
	<i>Safety Boots</i>	2
	<i>Safety Glasses</i>	3
	<i>Hearing Protection</i>	3
	<i>Gloves</i>	4
	<i>Back Care</i>	4
	<i>Coveralls and Shop Coats</i>	5
	<i>Butane Lighters</i>	5
	<i>Hair and Jewelry</i>	6
	Fire Safety	6
	<i>Fire Extinguishers</i>	6
	Shop Equipment	6
	<i>Lifting Devices</i>	6
	General Shop Precautions	8
	<i>Exhaust Extraction</i>	8
	<i>Workplace Housekeeping</i>	9
	<i>Components Under Tension</i>	9
	<i>Compressed Fluids</i>	9
	<i>Pneumatics Safety</i>	9
	Chassis and Shop Electrical Safety	10
	<i>Arc Welding Abuse</i>	10
	<i>Static Discharge</i>	11
	<i>Chassis Wiring and Connectors</i>	11
	<i>Mains Electrical Equipment</i>	11
	<i>Oxyacetylene Equipment</i>	12
	<i>Electric Arc Welding</i>	15
	Summary	15
	Review Questions	16

CHAPTER 2	Hand and Shop Tools, Precision Tools, and Units of Measurement	17
	Introduction	18
	Hand Tools	18
	<i>Open-End Wrenches</i>	18
	<i>Combination Wrenches</i>	19
	<i>Box-End Wrenches</i>	19
	<i>Adjustable Wrenches</i>	19
	<i>Line Wrenches</i>	19
	<i>Socket Wrenches</i>	19
	<i>Ratchets and Breaker/Flex Bars</i>	19
	<i>Torque Wrenches</i>	19
	<i>Hammers</i>	20
	<i>Pliers</i>	20
	<i>Screw Extractors</i>	21
	<i>Stud Extractors</i>	21
	<i>Taps</i>	21
	<i>Dies</i>	21
	<i>Reamers</i>	22
	<i>Drill Bits</i>	22
	<i>Hacksaws</i>	22
	<i>Cutting Fluids</i>	22
	Precision Measuring Tools	22
	<i>Electronic Digital Calipers</i>	22
	<i>Standard Micrometers</i>	22
	<i>Metric Micrometers</i>	23
	<i>Dial Indicators</i>	24
	<i>Dial Bore Gauges</i>	25
	<i>Depth Gauges</i>	27
	<i>Combination Square</i>	27
	<i>Telescoping Gauges (Snap Gauges)</i>	27
	<i>Small-Hole Gauges</i>	28
	<i>Plastigage</i>	28
	<i>Dividers and Calipers</i>	29
	<i>Precision Straightedge</i>	29
	<i>Feeler Gauges</i>	29
	<i>Truck Technician's Toolbox</i>	29
	Shop Tools	30
	<i>Sledgehammers</i>	31
	<i>Presses</i>	31
	<i>Scissor Jacks</i>	31
	<i>A-Frame Hoists</i>	31
	<i>Cherry Pickers</i>	31
	<i>Transmission and Clutch Jacks</i>	31
	<i>Spreader Bars</i>	32
	<i>Load Rotor</i>	32
	<i>Chains</i>	32
	<i>Slings</i>	32
	<i>Air Tools</i>	32
	<i>Oxyacetylene Equipment</i>	33
	<i>Steam and High-Pressure Washers</i>	33
	<i>Pullers</i>	33

	<i>Bushing Drivers</i>	33
	<i>Glass Bead Blasters/Sandblasters</i>	33
	<i>Tachometers</i>	34
	Fastener Grades and Torques	34
	<i>Clamping Force</i>	35
	<i>Tensile Strength and Yield Strength</i>	35
	<i>Shear Strength</i>	35
	Metric System and English/Metric Conversion	35
	<i>Metric Weights and Measures</i>	35
	<i>Metric to Standard Conversions</i>	36
	<i>Pressure Conversions</i>	36
	Summary	37
	Review Questions	37
CHAPTER 3	Engine Basics	39
	Introduction	40
	Key Engine Terms	40
	<i>Building Block Definitions</i>	40
	The Diesel Cycle	41
	<i>Direct Injection, Compression Ignition Engine</i>	41
	Two-Stroke Cycle Diesel Engine	45
	Engine Systems and Circuits	46
	<i>Diesel Fuel</i>	46
	More Engine Terms	46
	Two Key Principles	49
	<i>Mean Effective Pressure</i>	49
	<i>Cylinder Pressure and Throw Leverage</i>	49
	Summary	50
	Review Questions	50
CHAPTER 4	Piston Assemblies, Crankshafts, Flywheels, and Dampers	53
	Introduction	54
	<i>Function of the Powertrain</i>	54
	<i>Bicycle Powertrain</i>	54
	Piston Assemblies	54
	<i>Piston Terminology</i>	54
	<i>Trunk-Type Pistons</i>	55
	<i>Articulating Pistons</i>	58
	<i>Piston Thrust Faces</i>	59
	<i>Combustion Chamber Designs</i>	59
	<i>Piston Cooling</i>	60
	Piston Rings	61
	<i>Roles of Piston Rings</i>	61
	<i>Ring Materials</i>	61
	<i>Ring Action</i>	61
	<i>Number of Rings</i>	61
	<i>Piston Ring Types</i>	62
	<i>Piston Ring Designs</i>	63
	<i>Ring Joint Geometry</i>	63
	<i>Installing Piston Rings</i>	63
	<i>Piston and Cylinder Wall Lubrication</i>	64

<i>Wrist Pins</i>	65
<i>Assembling Piston and Rings</i>	65
<i>Reusing Piston Assemblies</i>	65
Connecting Rods	65
<i>Cracked Rods</i>	66
<i>Connecting Rod Construction</i>	66
<i>Compressional Loading</i>	67
<i>Tensional Loading</i>	67
<i>Inspecting Rods</i>	67
Crankshafts and Bearings	68
<i>Hydrodynamic Suspension</i>	68
<i>Dynamic Balance</i>	68
<i>Crankshaft Construction</i>	69
<i>Removing of Crankshaft from Cylinder Block</i>	70
<i>Crankshaft Failures</i>	70
<i>Crankshaft Inspection</i>	71
<i>Reconditioning Crankshafts</i>	71
Rod and Main Bearings	72
<i>Construction and Design</i>	72
<i>Bearing Clearance</i>	72
<i>Crankshaft End Play</i>	73
<i>Bearing Retention</i>	73
<i>Bearing Removal and Installation</i>	73
Vibration Dampers	74
<i>Vibration Damper Construction</i>	74
Flywheels	76
<i>Inertia</i>	76
<i>Types of Flywheels</i>	76
<i>Ring Gear Replacement</i>	76
<i>Reconditioning and Inspecting Flywheels</i>	77
Summary	77
Internet Exercises	78
Shop Tasks	79
Review Questions	79
CHAPTER 5 Timing Geartrains, Camshafts, Tappets, Rockers, and Cylinder Valves	81
Introduction	82
Timing Gears	82
<i>Timing Gear Construction</i>	82
<i>Timing Gear Inspection and Removal</i>	83
<i>Timing Overhead Camshafts</i>	83
Camshafts	83
<i>Cam Profile</i>	84
<i>Construction and Design</i>	84
<i>Removing and Installing the Camshaft from the Engine</i>	85
<i>Camshaft Inspection</i>	86
<i>Camshaft Bushings/Bearings</i>	87
<i>Camshaft End Play</i>	87
Valve and Injector Trains	87
<i>Followers</i>	88
<i>Pushrods and Tubes</i>	88
<i>Rocker Arms</i>	89

Cylinder Head Valves	90
<i>Valve Design and Materials</i>	90
<i>Valve Operation</i>	91
<i>Inspecting Valve Springs and Retainers</i>	91
<i>Valve Servicing</i>	92
<i>Valve Seat Inserts</i>	92
<i>Valve Lash Adjustment</i>	93
<i>Valve Adjustment Procedure</i>	93
<i>Variable Valve Timing</i>	97
<i>Valves: Conclusion</i>	97
<i>Other Feedback Assembly Functions</i>	97
<i>Creating a Valve Polar Diagram</i>	98
Summary	98
Internet Exercises	99
Shop Tasks	99
Review Questions	100

CHAPTER 6

Cylinder Blocks, Liners, Cylinder Heads, Rocker Housings, Oil Pans, and Manifolds	101
Introduction	102
Engine Cylinder Block	102
<i>Cylinder Block Forces</i>	102
<i>Cylinder Block Design and Construction</i>	102
<i>Cylinder Block Functions</i>	103
<i>Categories of Cylinder Block</i>	103
<i>Checking a Cylinder Block</i>	106
<i>Liner and Sleeve Reconditioning</i>	107
<i>Flywheel Housings</i>	108
Cylinder Heads	108
<i>Cylinder Head Disassembly, Inspection, and Reconditioning</i>	108
<i>Cylinder Head Installation</i>	110
<i>Rocker Housing Covers</i>	111
Intake and Exhaust Manifolds	112
<i>Exhaust Manifold</i>	112
Oil Pans or Sumps	113
<i>Oil Pan Functions</i>	113
<i>Removing an Oil Pan</i>	113
<i>Oil Pan Inspection</i>	115
Summary	115
Review Questions	115

CHAPTER 7

Engine Lubrication Systems	117
Introduction	118
<i>Friction</i>	118
Engine Lubricating Oil	119
<i>How Oil Works</i>	119
<i>Principle of Hydrodynamic Suspension</i>	119
<i>Engine Oil Classification and Terminology</i>	120
<i>Oil Contamination and Degradation</i>	121
<i>API Classifications</i>	122
<i>SAE Viscosity Grades</i>	123

<i>Synthetic Oils</i>	124
<i>What Oil Should Be Used?</i>	124
Lubrication System Components	125
<i>Oil Pan</i>	125
<i>Dipsticks</i>	125
<i>Oil Pump</i>	125
<i>Scavenge Pumps/Scavenge Pickups</i>	127
<i>Pressure-Regulating Valves</i>	127
<i>Filters</i>	127
<i>Oil Coolers</i>	129
<i>Oil Pressure Measurement</i>	130
Interpreting Oil Analyses	133
<i>Types of Testing</i>	133
Lubricating Circuit Problems	134
<i>Extended Oil Changes</i>	134
Summary	135
Internet Exercises	136
Shop Tasks	136
Review Questions	136

CHAPTER 8 Engine Cooling Systems	139
Introduction	140
<i>Functions of the Cooling System</i>	140
<i>Heat Transfer</i>	140
<i>Antiboil Properties</i>	141
Engine Coolant	143
<i>Types of Antifreeze</i>	143
<i>Coolant Expansion and Contraction</i>	143
<i>What Makes a Good Antifreeze</i>	143
<i>Toxicity of Coolants</i>	143
<i>Antifreeze Protection</i>	143
<i>Compatibility of EG and PG</i>	144
<i>Antifreeze Color</i>	144
<i>Measuring Coolant Mixture Strength</i>	144
<i>Supplemental Coolant Additives</i>	144
<i>Testing SCA Levels</i>	145
<i>Blending Heavy-Duty Coolant</i>	146
<i>Extended Life Coolants</i>	147
Cooling System Components	147
<i>Radiators</i>	148
<i>Auxiliary Heat Exchangers</i>	150
<i>Radiator Cap</i>	150
<i>Water Manifold</i>	151
<i>Water Pumps/Coolant Pumps</i>	151
Filters	152
Coolant Monitoring Circuit	152
<i>Thermistors</i>	153
<i>Electric Sensors</i>	153
<i>Expansion-Sensing Gauges</i>	153
<i>Coolant Level Indicators</i>	153
Thermostats	153
<i>Operating Principle</i>	153

<i>Testing Thermostats</i>	155
<i>Shutters</i>	155
Cooling Fans	155
<i>Variable Pitch Blades</i>	155
<i>Fan Cycles</i>	156
<i>Winter Fronts</i>	156
<i>Fan Shrouds</i>	156
<i>Fan Belts and Pulleys</i>	157
<i>Water Manifolds</i>	157
Cooling System Problems	157
<i>Leaks</i>	157
<i>Stray Voltage Damage</i>	158
Cooling System Management	158
<i>Actively Pressurized Cooling Systems</i>	158
Coolant Heaters	159
<i>Diesel Fired Coolant Heater</i>	160
Summary	160
Internet Exercises	161
Shop Tasks	161
Review Questions	161

CHAPTER 9

Engine Breathing	163
Introduction	164
<i>Gas Flow in Breathing Circuit</i>	164
<i>Role of Intake System</i>	164
<i>Role of the Exhaust System</i>	164
Breathing Components	164
<i>Current Four-Stroke Cycle</i>	164
Air Intake System Components	166
<i>Air Cleaners</i>	166
Turbochargers	167
<i>Principles of Operation</i>	168
<i>Types of Turbochargers</i>	168
<i>Turbocharger Precautions</i>	172
<i>Turbocharger Failures</i>	172
Charge Air Coolers	173
<i>Types of Charge Air Coolers</i>	173
<i>Boost Circuit Troubleshooting</i>	174
Exhaust Gas Recirculation	175
<i>EGR Operation</i>	175
<i>Clean Gas Induction</i>	175
<i>Cooled EGR</i>	175
<i>EGR Components</i>	175
<i>Intake Manifold Design</i>	176
Valve Design and Breathing	176
<i>Crossflow Configurations</i>	176
<i>Parallel Port Configurations</i>	176
<i>Valve Seat Angle</i>	176
<i>Variable Valve Timing</i>	177
Exhaust System Components	177
<i>Exhaust Manifold</i>	177
<i>Pyrometer</i>	177

<i>Exhaust Piping</i>	177
<i>Engine Exhaust Aftertreatment</i>	178
<i>Sonic Emission Control</i>	178
Breathing Circuit Sensors	179
Summary	179
Internet Exercises	180
Shop Tasks	180
Review Questions	180

CHAPTER 10 Engine Retarders	183
Introduction	183
<i>How Air Brakes Work</i>	184
<i>Supplementary Brake Systems</i>	184
<i>Retarding Principle</i>	184
<i>Today's Engine Brakes</i>	184
<i>Engine Brake Controls</i>	185
Principles of Operation	185
<i>Internal Engine Compression Brakes</i>	185
<i>External Engine Compression Brakes</i>	185
<i>Hydraulic Engine Brakes</i>	186
<i>Control Circuits</i>	186
Exhaust Brakes	187
<i>Williams Brakes</i>	187
<i>Exhaust Pressure Governor</i>	187
Internal Compression Brakes	187
<i>Electric-over-Hydraulic Compression Brakes</i>	188
<i>ECM Controlled Compression Brakes</i>	188
<i>Jacobs Brakes</i>	188
<i>Caterpillar Compression Brakes</i>	190
<i>Progressive Step Engine Braking</i>	190
<i>Constant Throttle Valves</i>	191
<i>Other Internal Retarders</i>	192
Caterpillar BrakeSaver	193
<i>Control Valves</i>	194
Summary	194
Internet Exercises	195
Shop Tasks	195
Review Questions	195

CHAPTER 11 Engine Removal, Disassembly, Cleaning, Inspection, and Reassembly Guidelines	197
Introduction	198
<i>Service Literature</i>	198
Removal of an Engine from a Vehicle	198
<i>Getting Ready</i>	198
<i>Removing the Engine from the Chassis</i>	199
Engine Disassembly	200
Cleaning and Inspecting Components	203
<i>Magnetic Flux Test</i>	203
Engine Reassembly Guidelines	204
<i>O-Rings on Wet Liners</i>	204
<i>Use of Anaerobic Sealants (Silicone, Silastic/RTV, Etc.)</i>	204

<i>Test the Cylinder Block Line Bore</i>	204
<i>Cylinder Block Fretting and Warpage</i>	204
<i>Sleeve Height Protrusion Specification</i>	204
<i>Machining Counter Bore</i>	204
<i>Inspect Crankshaft</i>	204
<i>Checking Main Bearing Clearance</i>	205
<i>Piston Cooling Jets</i>	205
<i>Piston Assembly</i>	205
<i>Measuring Connecting Rods</i>	205
<i>Assessing Pistons and Rings</i>	205
<i>Rod Assembly</i>	206
<i>Ring End Gap</i>	206
<i>Piston Wrist Pin Retainer Snap Rings</i>	207
<i>Ring Stagger</i>	207
<i>Installing the Piston Assembly</i>	207
<i>Buttress Screws on Main Bearing Caps</i>	208
<i>Timing Geartrain Assembly</i>	208
<i>Rear Cam Bushings</i>	209
<i>Cylinder Head Servicing</i>	209
<i>Measure and Recut the Cylinder Head Fire Ring Groove</i>	210
<i>Cylinder Head Valves</i>	210
<i>Cylinder Head Alignment</i>	210
<i>Setting Valves and Injectors</i>	210
<i>Injector Installation</i>	210
<i>Finding True TDC</i>	211
<i>Flywheel Housing Concentricity</i>	211
<i>Reinstall Engine to Chassis</i>	215
Summary	215
Shop Tasks	215
Review Questions	216
CHAPTER 12 Fuel Subsystems	217
Introduction	218
Fuel Subsystem Objectives	218
Fuel Tanks	219
<i>Fuel Tank Design</i>	219
<i>Dual Tanks</i>	220
<i>Pickup Tubes</i>	221
<i>Fuel Tank Sending Units</i>	221
Fuel Filters	222
<i>Primary Filters</i>	222
<i>Secondary Filters</i>	222
<i>Servicing Filters</i>	223
<i>Priming</i>	224
<i>Replacement Procedure</i>	224
<i>Water Separators</i>	225
<i>Fuel Heaters</i>	226
<i>Water-in-Fuel Sensors</i>	227
Fuel Charging/Transfer Pumps	227
<i>Pumping Principle</i>	228
<i>Plunger-Type Pumps</i>	228
<i>Gear-Type Pumps</i>	228

	<i>Hand Primer Pumps</i>	229
	<i>Electric Primer Pumps</i>	230
	<i>Priming a Fuel System</i>	230
	<i>Refueling</i>	230
	Complete Fuel Circuit	230
	Summary	230
	Review Questions	231
CHAPTER 13	Injector Nozzles	233
	Introduction	234
	<i>Multiple-Orifice Nozzles</i>	234
	<i>Electrohydraulic Nozzles</i>	234
	Multiple-Orifice Nozzles	235
	<i>Droplet Sizing</i>	235
	<i>Action</i>	236
	<i>Nozzle Differential Ratio</i>	237
	<i>VCO Nozzles</i>	237
	Electrohydraulic Nozzles	238
	<i>EHI Operation</i>	238
	<i>Piezoelectric Injectors</i>	239
	<i>Summary of EHIs</i>	240
	Nozzle Testing	240
	<i>Removal of Injectors from the Cylinder Head</i>	241
	<i>Flanged Injectors</i>	241
	<i>Cylindrical Injectors</i>	241
	<i>Nozzle Spacer</i>	241
	<i>Seal Lines and Injectors</i>	241
	<i>Seized Injectors</i>	241
	<i>Testing</i>	241
	<i>Reinstallation of Injectors</i>	242
	<i>Testing EHIs</i>	242
	Summary	243
	Internet Exercises	243
	Shop Tasks	243
	Review Questions	243
CHAPTER 14	Engine Management Electronics	245
	Introduction	246
	<i>Engine Controller</i>	246
	<i>Data Processing</i>	246
	Input Circuit	246
	<i>Sensors</i>	246
	<i>Reference Voltage</i>	246
	<i>Sensors Using V-Ref</i>	248
	<i>Switches</i>	251
	The ECM	252
	<i>Central Processing Unit</i>	252
	<i>ECM Memory</i>	254
	<i>ECM Outputs</i>	255
	Output Circuit	255
	Multiplexing	255
	<i>Serial Bus</i>	255

	<i>Packets</i>	256
	<i>Standardization</i>	256
	<i>J-Standards</i>	256
	<i>Connecting to the Chassis Data Bus</i>	256
	ECM Programming	257
	<i>Customer Data Programming</i>	257
	<i>Proprietary Data Programming</i>	259
	Summary	260
	Internet Exercises	261
	Shop Tasks	261
	Review Questions	261
CHAPTER 15	Electronic Diesel Fuel Injection Systems	263
	Introduction	264
	<i>Brief History of EUIs</i>	264
	<i>Brief History of CR Fueling</i>	264
	EUI System Overview	264
	Fuel Subsystem	265
	<i>Fuel Subsystem Routing</i>	265
	Input Circuit	266
	Management Electronics	267
	<i>ECM Responsibilities</i>	268
	Output Circuit	268
	<i>Electronic Unit Injectors</i>	269
	Common Rail Fuel Systems	274
	<i>Function of the Rail</i>	274
	<i>Engines Using CR Diesel Systems</i>	274
	<i>CR System Manufacturers</i>	275
	<i>Advantages of CR Diesel Fuel Systems</i>	275
	CR Subsystems and Components	275
	<i>CR Features</i>	276
	<i>Engine Controller Acronym</i>	276
	CR Management Electronics	276
	<i>Input Circuit</i>	276
	<i>Processing Circuit</i>	276
	<i>Output Circuit</i>	277
	CR Fuel Routing Circuit	277
	<i>Fuel Subsystem</i>	278
	<i>High-Pressure Pumps</i>	278
	<i>Rail Pressure Control Valves</i>	279
	<i>Electrohydraulic Injectors</i>	283
	<i>Timing Pumps</i>	285
	Fuel-Amplified CR System	285
	<i>Amplification Principle</i>	285
	<i>FACR Components</i>	285
	Summary	286
	Review Questions	287
CHAPTER 16	Emissions	289
	Introduction	290
	<i>Importance of CARB</i>	290
	<i>Understanding the Impact of Diesel Emissions</i>	290

What Is Smog?	291
<i>Photochemical Smog</i>	291
<i>Ingredients of Smog</i>	291
<i>Smog Summary</i>	293
<i>History of Emissions Controls</i>	293
Diesel Engine Emission Controls	294
<i>Engine Control Module</i>	294
<i>External Emission Controls</i>	294
<i>Cooled-EGR</i>	294
<i>Clean Gas Induction (CGI)</i>	294
<i>Catalytic Converters</i>	295
<i>NO_x Adsorber Catalysts</i>	296
<i>Diesel Particulate Filters (DPFs)</i>	296
<i>Selective Catalytic Reduction (SCR)</i>	298
<i>Closed Crankcase Ventilation</i>	299
Field Testing of Smoke Density	300
<i>Visible Smoke Emissions</i>	300
<i>Opacity Meters</i>	300
<i>Performing J1667 Testing</i>	301
Smoke Analysis	302
Summary	302
Internet Exercises	303
Shop Tasks	303
Review Questions	303
Glossary	305
Acronyms	333
Index	337

Preface

ABOUT THIS TEXT

The *Modern Diesel Technology: Diesel Engines* text was conceived because of the need for a technically accurate introduction to diesel engine technology suitable for use at high school- and entry-level college programs. The objectives, from my perspective, were twofold. The first was to create a book that would act as a primer for my textbook, *Truck Diesel Engines, Fuel, and Computerized Management Systems* which has become the standard in college programs targeting NATEF/ASE competency levels along with associate degree program outcomes. The second was to adopt a more general approach to diesel engines rather than one with a specific focus on truck engines. As diesel engines gain acceptance in smaller vehicles, including some noncommercial applications, specialist automotive technicians will be increasingly required to service and repair diesel engines. Most programs of study recognize this and are in the process of introducing diesel engines into syllabi.

To achieve these goals, I attempted to retain some of the basic structure of the larger work because I believe this to be an effective model. However, I adopted the following key differences in this book:

- Simplification of the reading level
- Elimination of all but the most frequently used original equipment manufacturer (OEM) acronyms
- Use of a more general approach to diesel engines by reducing the focus on truck diesel engines
- Minimization of all but the most basic repair procedures
- Simplification of explanations of operating principles
- Removal of all coverage of hydromechanical diesel fuel systems
- Restriction of fuel system coverage to the most current electronically controlled fuel systems

A secondary objective was to make this book dovetail with the more technical approach used in *Truck*

Diesel Engines, Fuel, and Computerized Management Systems so that those students graduating to more advanced studies in diesel engine technology would have a firm foundation. It is a fact that most students targeting careers as diesel technicians learn best by *doing* rather than by *reading*. To be effective, any program of study must take this learning style into account. However, it is important to dispel the notion that anyone can competently repair modern diesel engines without a solid understanding of their operating principles. In addition, a sound level of technical literacy is required to navigate manufacturer service literature, almost all of which is in electronic formats today. Both technical and computer skills are reinforced throughout this book. Students using this textbook along with a balanced approach to the hands-on skills required of the modern technician should find themselves with a solid backbone of competencies with which they can launch a career.

Modern Diesel Technology: Diesel Engines uses a systems approach to diesel technology. After a general introduction to engine operating principles, a building-block approach is used to study each engine subsystem. This is followed by the outlining of a typical diesel engine reconditioning procedure. The final chapters of the book examine engine management with a look at fuel systems, computer controls, and emissions. The study of diesel fuel systems can be especially intimidating to entry-level learners. For this reason, the focus on diesel fuel systems is limited to basics, the “need-to-know” understanding of any diesel technician on the shop floor. Only post-2010 fuel systems are described.

There has never been a better time to launch a career as a diesel technician. Both short and long term labor forecasts indicate a shortage of skilled diesel technicians to meet existing service and repair volumes. The shortage is extreme in some areas. This is compounded by the reality that sales of diesel engines are expected to rise exponentially as

they gain acceptance as power plants in small bore, noncommercial applications. In some European countries, diesel engines are the engine of choice in more than 50 percent of passenger automobiles. While this degree of dominance is unlikely in our automobile market, there is no doubt that sales will increase. After all, the diesel engine is a proven technology with a track record of fuel efficiency and longevity. A betting person would suggest that when pitted against the limitations of hybrid drive and electric motive power, diesels are more likely to win the day.

Sean Bennett, October 2008

ACKNOWLEDGMENTS

The author and publisher would like to thank the following individuals for their contributions during the preparation of the manuscript:

Darren Smith, Centennial College, Ontario,
Canada

Brent Delfel, Sno-Isle Technical. Skills Center,
Everett,
Washington

ABOUT THE SERIES

The Modern Diesel Technology (MDT) series has been developed to address a need for *modern*, system-specific textbooks in the field of truck and heavy equipment technology. This focused approach gives schools more flexibility in designing programs that target specific ASE certifications. Because each textbook in the series focuses exclusively on the competencies identified by its title, the series is an ideal review and study vehicle for technicians preparing for certification examinations.

Titles in the Modern Diesel Technology Series include:

MDT: Electricity and Electronics, by Joe Bell;
ISBN: 1401880134

MDT: Heating, Ventilation, Air Conditioning and Refrigeration, by John Dixon; ISBN: 1401878490

MDT: Electronic Diesel Engine Diagnosis, by Sean Bennett; ISBN: 1401870791

MDT: Brakes, Suspension, and Steering Systems, by Sean Bennett; ISBN: 1418013722

MDT: Heavy Equipment Systems, by Robert Huzij, Angelo Spano, and Sean Bennett; ISBN: 1418009504

MDT: Preventive Maintenance and Inspection, by John Dixon; ISBN: 1418053910

SUPPLEMENTS

Prepared by the author, the *Workbook to Accompany Modern Diesel Technology: Diesel Engines* includes reference material, test preparation suggestions, study tips, chapter-by-chapter objectives, end of chapter review questions, Internet tasks, and job sheets. The job sheets in the workbook are designed to help students tackle some of the routine tasks expected of rookie technicians in a diesel repair facility. They are designed to be performed in a learning environment such as high school or college. In some cases, the tasks may require equipment or data hub access not readily available in a learning environment. Students may still derive some benefit by reviewing these tasks and perhaps observing others perform them in a repair facility.

The *Instructor Resources to Accompany Modern Diesel Technology: Diesel Engines* CD contains an electronic version of the Instructor's Guide; an Image Library, which includes images from the text; a PowerPoint presentation including selected images from the text; and an ExamView® computerized test bank.

CHAPTER

1

Shop and Personal Safety

Learning Objectives

After studying this chapter, you should be able to:

- Identify potential danger in the workplace.
- Describe the importance of maintaining a healthy personal lifestyle.
- Outline the personal safety clothing and equipment required when working in a service garage.
- Distinguish between different types of fire.
- Identify the fire extinguishers required to suppress small-scale fires.
- Describe how to use jacks and hoisting equipment safely.
- Explain the importance of using exhaust extraction piping.
- Identify what is required to work safely with chassis electrical systems and shop mains electrical systems.
- Outline the safety procedures required to work with oxyacetylene torches.

Key Terms

chain hoist

cherry picker

come-along

digital multimeter (DMM)

electronic service tool (EST)

ground strap

original equipment manufacturer
(OEM)

scissor jack

single-phase mains

static charge

static discharge

three-phase mains

Underwriter's Laboratories (UL)

INTRODUCTION

The mechanical repair trades are physical by nature and those employed as technicians probably have higher than average levels of personal fitness. There are many heavy components on a commercial vehicle but technicians in the modern workplace are never required to lift excessive weights. They are required to understand when and how to use shop jacks and hoisting equipment. Technicians should also make it their business to

safely handle materials that can be hazardous. It goes without saying that employers are required to ensure that the shop floor is a safe working environment. An employer who fails to ensure a safe working environment is breaking the law and endangering the profitability of the business.

Safety Rules

If you look at any service repair shop today, you will notice safety rules and regulations posted on walls and

bulletin boards. Although these are posted for maximum exposure, the bottom line of safe working practice rests with the individual. A large part of safe working practice is common sense. But it is up to individuals to observe these commonsense rules and regulations. It simply does not make sense to take risks when safety is an issue. Persons who do sooner or later get burned by poor decisions, sometimes fatally.

Experience and Injuries

Most technicians do not want to get hurt in the workplace or anywhere else. But knowing something about potential danger minimizes the risk of injury. A major truck **original equipment manufacturer (OEM)** monitored accidents over a 5-year period in one of its assembly plants and came up with the following conclusion: a line-production employee's risk of serious injury (defined as one that required some time off work) during the first year of employment was equal to that of years 2 through 6 combined. In simple terms, if you can survive your first year injury-free, thereafter your risk will diminish significantly.

Safety Awareness

Teachers of mechanical technology often complain that it is difficult to teach safe work practices to entry-level students. When students enroll in a transportation technology program, they are hopefully well motivated to learn the technology but tend to turn off when it comes to learning the health and safety issues that accompany working life. The sad truth is that it is difficult to teach safe work practices to persons who have never been injured. On the other hand, an injured person probably acquires, with the injury, powerful motivation to avoid a repeat.

A Healthy Lifestyle

Repairing diesel engines and trucks requires more physical strength than working at a desk all day but it would be a mistake to say it is a healthy occupation. Lifting a 150 lb (70 kg) clutch pack or pulling a high load on a torque wrench requires some muscle power, but you cannot compare this with lifting weights in a gym. In the weight room, the repetitions, conditions, and movements are carefully coordinated to develop muscle power. Jerking on a torque wrench while attempting to establish final torque on main caps during an in-chassis engine job can tear muscle as easily as develop it.

It pays to think about how you use your body and to use your surroundings to maximize leverage and minimize wear and tear. Make a practice of using

hoists to move heavier components even if you know you can manually lift the component. You may believe it is macho to lift a cylinder head off a block by hand, but a slight twist of the back while doing so can mean that you sustain an injury lasting a lifetime. There is nothing especially macho about hobbling around with chronic back pain for years.

Physical Fitness

Part of maintaining a healthy lifestyle means eating properly and making physical activity a part of your lifestyle. You can achieve this in many different ways. Team sports are not just for kids and teenagers. Whether your sport is hockey, baseball, basketball, or football, plenty of opportunities exist to compete at all ages and levels. If team sports are not your thing, you can explore individual pursuits. Working out in a gym, hiking, and canoeing are good for your mind as well as your body, and even golf gets you outside and walking. Because of the physical nature of repair technology, it makes sense to routinely practice some form of weight conditioning, especially as you get older.

PERSONAL SAFETY EQUIPMENT

Personal safety equipment refers to anything you wear on your body in the workplace. Some items of personal safety should be worn continually in the workplace. One of these essential items is safety shoes or footwear. Other personal safety equipment such as hearing protection may be worn only when required, for instance, when noise levels are high.

Safety Boots

Safety boots or shoes are required footwear in a repair shop. Most jurisdictions require technicians to wear safety footwear. It is an employer responsibility to make sure this happens. Safety footwear is manufactured with steel shanks, steel toes, and **UL (Underwriter's Laboratories: <http://www.ul.com>)** certification. Keep in mind that safety is about you. If you lose a limb in the workplace, your whole life will be affected by the event. Even if the law did not require you to wear safety footwear, common sense should tell you that your feet should be protected in a shop environment. Given the choice, especially in a diesel or truck repair facility, safety boots (see **Figure 1-1**) are a better choice than safety shoes because of the additional support and protection to the ankle area.

You have a range of options from which to choose when it comes to selecting a pair of safety boots, as well as a wide range of prices. If you are going to work on a car under a tree over a weekend, a low-cost pair of



Figure 1-1 UL approved safety boots.

safety shoes may be all you will require. However, it pays for the professional technician who wears this footwear daily for the lifetime of the boot to invest a little more. Better quality safety footwear will last longer and be more comfortable.

Safety Glasses

Many shops today require all their employees to wear safety glasses while on the shop floor. This is really just common sense. Eyes are sensitive to dust, metal shavings, grinding and machining particulates, fluids, and fumes. They are also more complex to repair than feet when an injury is sustained. It also makes sense to wear safety glasses when working with chassis electrical equipment because of potential danger represented by battery acid and arcing at terminals.

Perhaps the major problem when it comes to making a habit of using safety glasses is the poor quality of most shop-supplied eyewear. Shops supply safety glasses because in many cases they are legally liable if they do not. All too often, this means they provide low-cost, mass-produced, and easily scratched plastic safety glasses. If you have a pair of safety glasses that impairs vision, you will probably want to wear them as little as possible. A pair of safety glasses in your pocket is not going to protect you from eye injuries.

Don't Be Cheap! The solution is to not depend on your employer to provide safety glasses. Get out of the mind-set that safety glasses should be provided to you at no cost. As we have said, “free” safety glasses are uncomfortable and may actually impair vision. Buy your own. Spend a little more and purchase a good quality pair of safety glasses. These will be optically sound and scratchproof. Even if you do not normally wear eyeglasses, after a couple of days, you will forget



A



B



C

Figure 1-2 (A) Safety glasses, (B) splash goggles, and (C) face shield. (Courtesy of Goodson Tools & Supplies for Engine Builders)

you are wearing them. **Figure 1-2** shows some eye protection options available to technicians.

Hearing Protection

Two types of hearing protection are used in shops. Hearing muffs are connected by a spring-loaded band

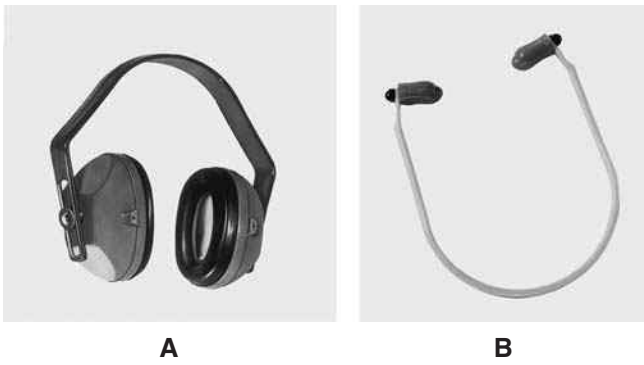

Figure 1-3 Typical (A) ear muffs and (B) ear plugs. (Courtesy of Dalloz Safety)

and enclose the complete outer ear. This type of hearing protection is available in a range of qualities. Cheaper versions may be almost useless but good quality hearing muffs can be very effective when noise levels are extreme. But be careful. Hearing muffs that almost completely suppress sound can be dangerous because they disorientate the wearer.

A cheaper and generally effective alternative to hearing muffs are ear sponges. Each sponge is a soft cylindrical or conical sponge. The sponge can be shaped for insertion into the outer ear cavity. Almost immediately after insertion, the sponge expands to fit the ear cavity. The disadvantage of hearing sponges is that they can be uncomfortable when worn for long periods. Technicians should also consider using other types of soft ear plugs most of which are wax based.

Figure 1-3 shows some ear muffs and ear plugs.

CAUTION *Damage to hearing is seldom the result of a single exposure to a high level of noise. More often, it results from years of exposure to excessive and repetitive noise levels. Protect your hearing! Listening to music at excessive volumes can damage your hearing as easily as exposure to buck riveting.*

Gloves

A wide range of gloves can be used in shop applications to protect the hands from exposure to dangerous or toxic materials and fluids. The following are some examples.

CAUTION *Never wear any type of gloves when using a bench-mounted, rotary grinding wheel. There have been cases where a glove has been snagged by the abrasive wheel, dragging the whole hand with it.*

Vinyl Disposable Gloves. Most shops today make vinyl disposable gloves available to service personnel. These protect the hands from direct exposure to fuel, oils, and grease. The disadvantage of vinyl gloves is that they do not breathe and some find the sweating hands that result to be uncomfortable. Most shop-use vinyl gloves today are made of thin gossamer that allows some touch sensation.

Cloth and Leather Multipurpose Gloves. A typical pair of multipurpose work gloves will have rough leather on the palms and cotton on the backs. They can be used for a variety of tasks ranging from lifting objects to general protection from cold when working outside. This type of work glove can provide some insulation for the hands when performing procedures such as using impact wrenches and buck riveting. You should not use this type of glove after saturation with grease or oil.

Welding Gloves. Welding gloves are manufactured from rough cured leather. They are designed to protect the hands from exposure to the high temperatures created in welding and flame cutting processes. You should only use these gloves for cutting and welding. The rough leather they are made from soaks up grease and oil. This reduces their ability to insulate and makes them a potential fire hazard. Avoid using welding gloves rather than tools to handle heated steel because the gloves will rapidly harden and require replacement.

Dangerous Materials Gloves. Gloves designed to handle acids or alkalines should be used for that task only. Gloves in this category are manufactured from unreactive, synthetic rubber compounds. Care should be taken when washing up after using this type of glove.

CAUTION *Never wear leather gloves to handle refrigerants: leather gloves rapidly absorb refrigerant and can adhere to the skin.*

Back Care

Back injuries are said to affect 50 percent of repair technicians at some point in their careers seriously enough for them to have to take time off work. A bad back does not have to be an occupational hazard. Most of us begin our careers in our twenties when we have sufficient upper body strength to handle plenty of abuse. As we age, this upper body strength decreases and bad lifting practices can take their toll. To avoid injury, observe some simple rules for lifting heavy items:

- Keep your back vertical while lifting (do not bend).

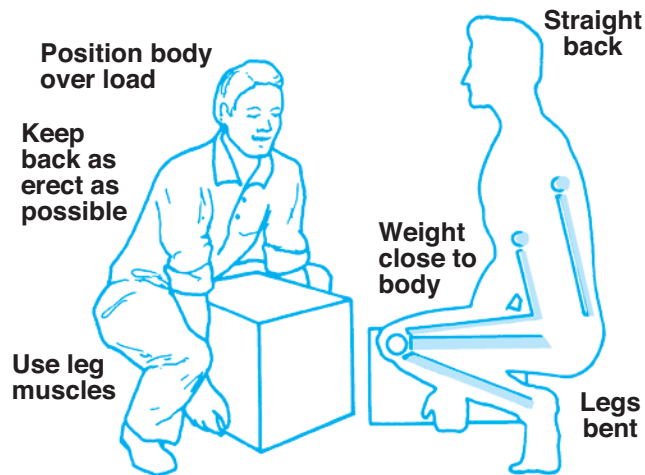

Figure 1-4 Use your leg muscles, never your back, when lifting any heavy load.

- Keep the weight you are lifting close to your body.
- Bend your legs and lift using the leg muscles.

Figure 1-4 shows how to protect your back when lifting heavy objects. One key is to hold the weight as close to your body as you can get it.

Back Braces. A back brace may help you avoid injuring your back. Wearing a back brace makes it more difficult to bend your back, so it “reminds” you to keep it straight when lifting. You may have noticed that the sales personnel in one national hardware and home goods chain are all required to wear back braces. As a diesel technician, you will be required to use your back for lifting so you should consider the use of a back brace. Body shape plays a role when it comes to back injuries: if you are either taller than average height or overweight, you will be more vulnerable to back injuries.

Coveralls and Shop Coats

Many shops today require their service employees to wear a uniform of some kind. This may be work shirts and pants, shop coats, or coveralls. Uniforms have a way of making service personnel look professional. The uniform of choice in truck and diesel service facilities should be coveralls given the nature of the work. The coveralls should preferably be made out of cotton for reasons of comfort and safety. When ordering cotton coveralls for personal use, remember to order at least a size larger than your usual nominal size: unless otherwise treated, cotton shrinks when washed. Shop coats can also be used but because these come pretty close to our definition of loose clothing they are a second-best choice to coveralls. **Figure 1-5** shows a technician wearing a shop coat.



Figure 1-5 Shop coats can be worn to protect clothing.

CAUTION Avoid wearing any type of loose-fitting clothing when working with machinery. Shop coats, neckties, and shirttails not tucked into pants can all be classified as loose-fitting clothing.

Artificial Fibers. When artificial fibers are used as material for coveralls, they should be treated with fire retardant. Cotton smolders a long time when exposed to fire if it is not saturated with oil, fuel, or grease. When any material is saturated with petroleum products, it becomes highly flammable. Cleanliness is essential: oily shop clothing not only looks unprofessional but also can be dangerous! Artificial fibers can be especially dangerous. When not treated with fire retardant, artificial fibers melt when exposed to high temperatures. This can cause them to fuse to the skin.

CAUTION Even when treated with fire retardant, some artificial fibers will burn vigorously when exposed to a direct flame for a period of time.

Butane Lighters

There are few more dangerous items routinely observed on the shop floor than the butane cigarette lighter. The explosive potential of the butane lighter is immense yet it is often stored in a pocket close to where it can do the most amount of damage. A chip of hot welding slag will almost instantly burn through the

plastic fuel cell of a butane lighter. Owners of these devices often compound the danger they represent by lighting torches with them. If you have to have a lighter on your person while working, purchase a Zippo!

Hair and Jewelry

Long hair and personal jewelry produce some of the same safety concerns as loose-fitting clothing. If it is your style to wear long hair, secure it behind the head and consider wearing a cap. If you are part of the recent trend of wearing more body jewelry, remove as much of it as possible while at work. Body jewelry is often made of conductive metals (such as gold, platinum, silver, and brass) and presents the possibility both of snagging the jewelry and of creating unwanted electrical short circuits.

FIRE SAFETY

Service and repair facilities are usually subject to regular inspections by fire departments. This means that obvious fire hazards are identified and neutralized. Although firefighting is a job for trained professionals, any person working in a service shop environment should be able to appropriately respond to a fire in its early stages. This requires some knowledge of the four types of fire extinguishers in current use.

Fire Extinguishers

Fire extinguishers are classified by the types of fire they are designed to suppress. Using the wrong type of fire extinguisher on certain types of fire can be extremely dangerous and actually worsen the fire you are attempting to control. Every fire extinguisher clearly indicates the types of fire it is designed to extinguish. This is done by using class letters. This means that it is important to identify each of the four types of fire that could occur in the workplace. The role of the technician in suppressing a fire is to estimate the risk required. Intervention should be considered only if there is minimal risk.

Class A A **Class A** fire is one involving combustible materials such as wood, paper, natural fibers, biodegradable waste, and dry agricultural waste. A class A fire can usually be extinguished with water. Fire extinguishers designed to suppress Class A fires use foam or a multipurpose dry chemical, usually sodium bicarbonate.

Class B **Class B** fires are those involving fuels, oil, grease, paint, and other volatile liquids, paint, flammable gases, and some petrochemical plastics. Water should not be used on Class B fires. Fire extinguishers designed to suppress

type B fires work by smothering: they use foam, dry chemicals, or carbon dioxide. Trained fire personnel may use extinguishers such as Purple K (potassium bicarbonate) or halogenated agents to control fuel and oil fires.

Class C **Class C** fires are those involving electrical equipment. First intervention with this type of fire should be to attempt to shut off the power supply: assess the risk before handling any switching devices. When a Class C fire occurs in a vehicle harness, combustible insulation and conduit can produce highly toxic fumes so great care is required when making any kind of intervention in vehicle chassis or building electrical fires. Fire extinguishers designed to suppress electrical fires use carbon dioxide, dry chemical powders, and Purple K.

Class D **Class D** fires are those involving flammable metals. Some metals when heated to their fire point begin to vaporize and combust. These metals include magnesium, aluminum, potassium, sodium, and zirconium. Dry powder extinguishers should be used to suppress Class D fires.





Figure 1-6 shows the symbols used to categorize each type of fire and the types of fire suppressants required to put each out.

SHOP EQUIPMENT

Technicians should become familiar with the extensive assortment of shop equipment. Some of this equipment can be dangerous if you are not trained in how to use it. Make a practice of asking for help before operating any equipment with which you are not familiar.

Lifting Devices

Many different types of hoists and jacks are used in diesel and truck shops. These can range from simple pulley and chain hoists to hydraulically actuated hoists. Weight bearing chains on hoists should be routinely inspected (this is usually required by law). Chain links with evidence of wear, bent links, and nicks should be placed out of service. Hydraulic hoists should be inspected for external leaks before using. Any drop-off observed in hydraulic lifting equipment while in operation is reason to take the equipment out of service. Never rely on the hydraulic circuit alone

Class of Fire		Typical Fuel Involved	Type of Extinguisher
Class  Fires (green)	For Ordinary Combustibles Put out a Class A fire by lowering its temperature or by coating the burning combustibles.	Wood Paper Cloth Rubber Plastics Rubbish Upholstery	Water* ¹ Foam* Multipurpose dry chemical ⁴
Class  Fires (red)	For Flammable Liquids Put out a Class B fire by smothering it. Use an extinguisher that gives a blanketing, flame-interrupting effect; cover whole flaming liquid surface.	Gasoline Oil Grease Paint Lighter fluid	Foam* Carbon dioxide ⁵ Halogenated agent ⁶ Standard dry chemical ² Purple K dry chemical ³ Multipurpose dry chemical ⁴
Class  Fires (blue)	For Electrical Equipment Put out a Class C fire by shutting off power as quickly as possible and by always using a nonconducting extinguishing agent to prevent electric shock.	Motors Appliances Wiring Fuse boxes Switchboards	Carbon dioxide ⁵ Halogenated agent ⁶ Standard dry chemical ² Purple K dry chemical ³ Multipurpose dry chemical ⁴
Class  Fires (yellow)	For Combustible Metals Put out a Class D fire of metal chips, turnings, or shavings by smothering or coating with a specially designed extinguishing agent.	Aluminum Magnesium Potassium Sodium Titanium Zirconium	Dry powder extinguishers and agents only

*Cartridge-operated water, foam, and soda-acid types of extinguishers are no longer manufactured. These extinguishers should be removed from service when they become due for their next hydrostatic pressure test.

Notes:

- (1) Freezes in low temperatures unless treated with antifreeze solution, usually weighs over 20 pounds (9 kg), and is heavier than any other extinguisher mentioned.
- (2) Also called ordinary or regular dry chemical (sodium bicarbonate).
- (3) Has the greatest initial fire-stopping power of the extinguishers mentioned for Class B fires. Be sure to clean residue immediately after using the extinguisher so sprayed surfaces will not be damaged (potassium bicarbonate).
- (4) The only extinguishers that fight A, B, and C classes of fires. However, they should not be used on fires in liquefied fat or oil of appreciable depth. Be sure to clean residue immediately after using the extinguisher so sprayed surfaces will not be damaged (ammonium phosphates).
- (5) Use with caution in unventilated, confined spaces.
- (6) May cause injury to the operator if the extinguishing agent (a gas) or the gases produced when the agent is applied to a fire are inhaled.

Figure 1-6 Guide to fire extinguisher selection.

when working under equipment on a hoist: after lifting, support the equipment using a mechanical sprag or stands. This also applies when working on a dump truck with the load box raised or a cab-over-engine (COE) truck with the cab raised.

CAUTION Never rely on a hydraulic circuit alone when working underneath raised equipment. Before going under anything raised by hydraulics, make sure it is mechanically supported by stands or a mechanical lock.

Jacks. Many types of jacks are used in truck and heavy equipment service facilities. Before using a jack to raise a load, make sure that the weight rating of the jack exceeds the supposed weight of the load. Most jacks used in service repair shops are hydraulic, and most use air-over-hydraulic actuation because this is faster and requires less effort. Bottle jacks are usually hand-actuated and designed to lift loads up to 10 tons: they are so named because they have the appearance of a bottle. Air-over-hydraulic jacks are capable of lifting up to 30 tons.

Using hydraulic piston jacks should be straightforward. They are designed for a straight uplift only.

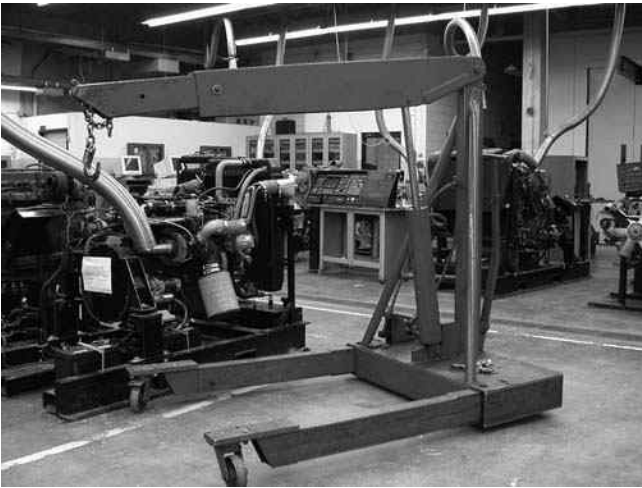

Figure 1-7 Typical heavy-duty cherry picker.

The jack base should be on a level floor and the lift piston should be located on a flat surface on the equipment to be lifted. Never place the lift piston on the arc of a leaf spring or the radius of any suspension device on the truck. After lifting the equipment, it should be supported mechanically using steel stands. An acceptable practice is to use a hardwood spacer with a shop jack: it should be exactly level and placed under the jack. Whenever using a jack to raise one end of a vehicle, make sure that the vehicle being jacked can roll either forward or backward during the lift. After the lift has been completed, the parking brakes should be applied and wheel chocks used on the axles not being raised.

Cherry Pickers. **Cherry pickers** come in many shapes and sizes. Light-duty cherry pickers can be used to raise a heavy component such as a cylinder head from an engine while heavy-duty cherry pickers (see **Figure 1-7**) can lift a large-bore diesel engine out of a chassis. Most cherry pickers have extendable booms. As the boom is lengthened the weight that the device can lift is reduced. Take care that the weight you are about to lift can be raised by the cherry picker without toppling.

CAUTION *As the boom of a cherry picker is lengthened, the weight it can lift is reduced significantly. Make sure that the weight you are about to lift is appropriate for the boom length you have set: failure to do this can cause the cherry picker to topple.*

Scissor Jacks. The popularity of **scissor jacks** has increased recently because of the need to raise trucks equipped with aerodynamic shrouding and foils higher in order to remove components such as clutches and

transmissions. Scissor jacks can be used only at either end of a vehicle: the end not being lifted has to be skidded as the lift angle increases, so it is important that the brakes are not applied during the lifting procedure. When the vehicle has been hoisted to the required height, engage the mechanical lock on the jack, then chock the set of wheels at the end of the vehicle still on the floor. Never chock the wheels of a vehicle being lifted on a scissor jack until after the lift is completed.

Chain Hoists. These are often called chain falls. **Chain hoists** can be suspended from a fixed rail or a beam that slides on rails, or they can be mounted on a number of different types of A-frames. Chain hoists in shops in most jurisdictions are required to be inspected periodically. An inspection on a mechanical chain hoist involves checking the chain link integrity and the ratchet teeth and lock. Electromechanical units require inspection of the mechanical and electrical components. Where a chain hoist beam runs on rails, brake operation becomes critical: some caution is required when braking the beam because aggressive braking can cause a pendulum effect on the object being lifted.

Come-Alongs. **Come-alongs** describe a number of different types of cable and chain lifting devices that are hand ratchet actuated. They are used to both lift objects and apply linear force to them. When used as a lift device, come-alongs should be simple to use providing the weight being lifted is within rated specification. However, come-alongs are more often used in truck shops to apply straight-line force to a component usually to separate flanges. Great care should be taken: make sure that the anchor and load are secure, and that the linear force does not exceed the weight rating of the device.

GENERAL SHOP PRECAUTIONS

Every service facility is different and therefore the potential dangers faced in each shop differ. In this section, we will outline some general rules and safety strategies to be observed in truck and heavy equipment shops.

Exhaust Extraction

Diesel engines should be run in a shop environment using an exhaust extraction system: in most cases this will be a flexible pipe or pipes that fit over the exhaust stack(s). Be careful when climbing up to fit an exhaust extraction pipe over the truck exhaust stack. Use a ladder when you cannot get a secure foothold elsewhere. When parking trucks in and out of service bays, park the unit in the bay and shut the engine off.

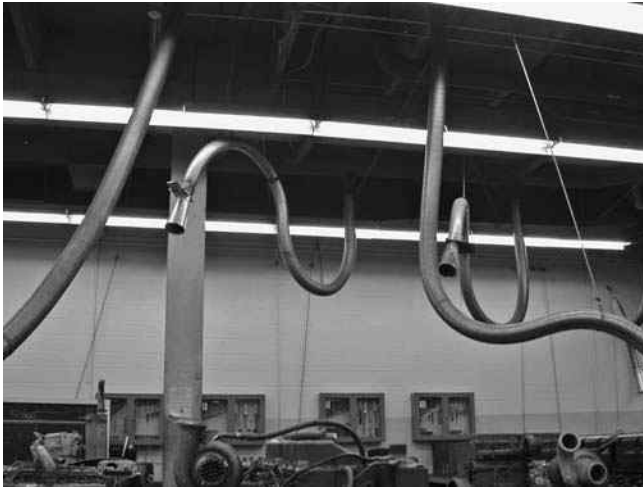

Figure 1-8 Shop exhaust extraction piping.

Avoid running an engine without the extraction pipe(s) fitted to the stack(s). **Figure 1-8** shows exhaust extraction piping used in a shop.

WARNING *The state of California has proven that diesel exhaust fumes cause respiratory problems, cancer, birth defects, and other reproductive harm in humans. Avoid operating diesel engines unless in a well-ventilated area. When starting an engine outside a shop, warm the engine before driving it into the shop to reduce the contaminants emitted directly into the shop while parking the unit.*

WARNING *When attempting to fit exhaust extraction pipes to a truck exhaust system, check the temperature of the exhaust gas aftertreatment piping before attempting to handle it: diesel particulate filters can retain heat long after a regeneration cycle and cause severe burns.*

Workplace Housekeeping

Sloppy housekeeping can make your workplace dangerous. Clean up oil spills quickly. You can do this by applying absorbent grit: this not only absorbs oil but makes it less likely that a person will slip and fall on an oil slick. Try to organize parts in bins and on benches when you are disassembling components. This not only makes reassembly easier but also makes your work environment a lot safer.

Components Under Tension

On trucks and other heavy mobile equipment, numerous components are under extreme tension,

sometimes deadly tensional loads. Never attempt to disassemble a component that you suspect is under high tensional load unless you are very sure about the exact procedure. Refer to service literature and ask more experienced coworkers when you are unsure about a procedure.

Compressed Fluids

Fluids in both liquid and gaseous states can be extremely dangerous when proper safety precautions are not observed. Equipment does not necessarily have to be running to produce high fluid pressures. Residual pressures in stationary circuits can represent a serious safety hazard. Technicians should also be aware of the potential danger represented by oxygen cylinders. When shops receive fire safety inspections, fire personnel are more concerned about the storage location of compressed oxygen cylinders than compressed fuels such as acetylene and propane.

Pneumatics Safety

Compressed air is used extensively on truck and heavy equipment chassis in both brake and auxiliary systems. Additionally, compressed air is used to drive both portable and nonportable shop tools and equipment.

WARNING *Always wear safety glasses when coupling or uncoupling and using pneumatic tools.*

Some examples of chassis systems that use compressed air:

- air brake circuits and actuators
- pneumatic suspensions
- pilot control systems on tankers
- air start systems

Some examples of shop equipment that use compressed air:

- pneumatic wrenches
- pneumatic drills
- shop air-over-hydraulic presses
- air-over-hydraulic jacks
- air-over-hydraulic cylinder hoists

Figure 1-9 shows a typical setup for a ½-inch drive impact gun used every day in diesel and truck repair shops.

Hydraulic System Safety. Vehicle and shop hydraulic systems use extremely high pressures that can be lethal when mishandled. Once again, never forget that idle circuits can hold residual pressures and many circuits use

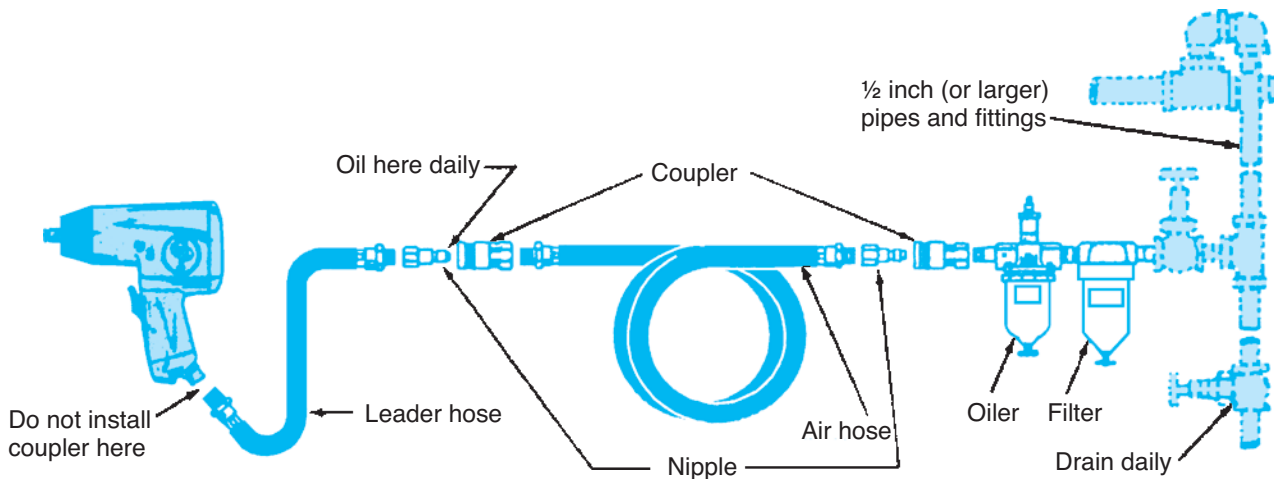

Figure 1-9 Typical setup for a 1/2-inch drive impact gun.

accumulators. The rule when working with hydraulic circuits is to be absolutely sure about potential dangers before attempting to disassemble a circuit or component.

WARNING *Always wear safety glasses when working close to shop or vehicle hydraulic circuits and check service literature before attempting a disassembly procedure. Ask someone if you are not sure rather than risk injury.*

Some examples of chassis systems that use hydraulic circuits:

- wet line kits for dump and auxiliary circuits
- high-pressure fuel management circuits
- automatic transmission control circuits
- air-over-hydraulic brake circuits
- clutch control circuits

Some examples of shop equipment using hydraulic circuits:

- jacks and hoists
- presses
- bearing and liner pullers
- suspension bushing presses

CHASSIS AND SHOP ELECTRICAL SAFETY

Trucks today use numerous computers. These computers are all networked to a central data backbone using multiplexing technology. The chassis subsystems controlled by computers include:

- engine
- transmission
- brakes
- traction control

- antirollover controller
- lights
- dash electronics
- collision warning systems
- satellite communications

These systems function on low-voltage electrical signals and use thousands of solid-state components. While some of these electronic subcircuits are protected against voltage overload spikes, others are not. An unwanted high-voltage spike caused by static discharge or careless placement of electric welding grounds can cause thousands of dollars worth of damage.

Arc Welding Abuse

Some truck chassis are equipped with electrical isolation switches. These should be opened any time major service or repair work is performed on a vehicle. When any type of electric welding is performed on a truck chassis, make sure that the ground clamp is placed close to the work. Placing a welding ground clamp on the front bumper when you are welding at the rear of the chassis can not only cause electronic damage but also destroy bearings and journals anywhere on the vehicle. While electricity can be relied on to take the shortest path to complete a circuit, sometimes it experiments while determining which is the shortest path. Pulsing electricity through crankshaft journals and transmission bearings causes arcing that results in costly damage.

CAUTION *Whenever performing electric arc welding or cutting on a chassis, make sure you place the ground clamp as close to the work area as possible to avoid creating chassis electronic or arcing damage.*

Static Discharge

When you walk across a plush carpet, your shoes “steal” electrons from the floor. This charge of electrons accumulates in your body and when you grab a door handle, this excess of stolen electrons discharges itself into the door handle, creating an arc that we see as a spark. Accumulation of a **static charge** is influenced by factors such as relative humidity and the type of footwear you are wearing. Getting a little zap from the static charge that can accumulate in the human body seldom produces any harmful effects to human health but it can damage sensitive solid-state circuits.

Dangers of Static Charge Accumulation. Picture a fuel tanker transport running down an interstate. In the same way your body steals electrons from a carpet, the tanker steals electrons from the atmosphere. However, the charge differential that can be accumulated by the tanker is much greater, and can exceed 50,000 volts. This type of charge differential can be highly dangerous and when discharged, producing a spark that can easily ignite fuel vapors. This potential danger accounts for the legal requirement to ground out a tanker chassis before undertaking any load or unload operation.

Static Discharge and Computers. Static charge accumulation in the human body can easily damage computer circuits. Because most trucks today have a dozen, and sometimes more, computer-controlled circuits, it is important for technicians to understand the effects of **static discharge**. The reason that static discharge has not caused more problems than it has in the service repair industry is due to:

- technicians’ footwear of choice, which is usually rubber-soled boots
- shop floors tending not to be carpeted

Rubber-soled footwear and concrete floors are not conducive to static charge accumulation.

Having said this, technicians should remember that the flooring in truck cabs and sleeper units is almost always carpeted. Therefore, when troubleshooting requires you to access electronic circuits, it is good practice to use a ground strap before separating sealed connectors and working on any truck electronic circuit, even if just connecting an **electronic service tool (EST)** to a data link. A **ground strap** “electrically” connects you to the device on which you are working so that an unwanted static discharge into a shielded circuit is unlikely. Special care should be taken when working with modules that require you to physically remove and replace solid-state components such as PROM chips from the motherboard.

Chassis Wiring and Connectors

Every year, millions of dollars worth of damage to trucks is created by truck technicians who ignore OEM precautions regarding working with chassis wiring systems. Perhaps the most common abuse is puncturing wiring insulation with test lights and **digital multi-meter (DMM)** leads. When you puncture the insulation on copper wiring, in an instant that wiring becomes exposed to both oxygen (in the air) and moisture (relative humidity!). The chemical reaction almost immediately produces copper oxides that then react with moisture to form corrosive cupric acid. The acid begins to eat away the wiring, first creating high resistance, and ultimately consuming the wire. The effect is accelerated when copper stranded wiring is used (it mostly is in truck applications) because the surface area over which the corrosion can act is so much greater.

CAUTION *Never puncture the insulation on chassis wiring. Read the section that immediately precedes this if you want to know why!*

The sad thing about this type of abuse is that it is so easily avoided. Since a truck technician can access wiring circuits in many ways by using the correct tools, it is just stupidity not to use them. Use breakout Ts, breakout boxes, and test lead spoons.

Mains Electrical Equipment

Mains electrical circuits, unlike vehicle electrical circuits, operate at pressures that can be lethal. Electrical pressures may be **single-phase mains** operating at pressure values between 110 and 120 volts or **three-phase mains**, operating at pressures between 400 and 600 volts. In most jurisdictions, repairs to mains electrical equipment and circuits are required to undertaken by qualified personnel. Be careful when working around any electrical equipment. If you undertake to repair electrical equipment, make sure you know what you are doing! **Figure 1-10** shows a three-phase outlet of the type commonly used in truck shops to power compressors, machine shop equipment, and arc welding stations. Learn how to identify these outlets with high electrical potential that can kill if mishandled.

Use electrically powered equipment with extra care when the area you are working in is wet. Remember that a discharge of AC voltage driven through a chassis data bus can knock out electronic equipment networked to it. Electrical equipment can also be dangerous around vehicles because of its potential to arc and initiate a fire or explosion.



Figure 1-10 High-voltage, three-phase electrical outlet.

CAUTION Do not undertake to repair mains electrical circuit and equipment problems unless you are qualified to do so.

Some examples of shop equipment using single-phase mains electricity:

- electric hand tools
- portable electric lights
- computer stations
- drill presses
- burnishing and broaching tools

CAUTION Take care when using trouble lights with incandescent bulbs around volatile liquids and flammable gases: these are capable of creating sufficient heat to ignite flammables. Many jurisdictions have banned the use of this type of trouble light and they should be never used in garages in which gasoline, propane, and natural gas fueled vehicles are present. Best bet: use a fluorescent type trouble light in rubber insulated housing!

Some examples of shop equipment using high-voltage, three-phase electricity:

- most welding equipment
- dynamometers
- lathes and mills
- large shop air compressors

Oxyacetylene Equipment

Technicians use oxyacetylene for heating and cutting probably on a daily basis. Less commonly this equipment is used for braising and welding. Some

basic instruction in the techniques of oxyacetylene equipment safety and handling is required. The following information should be understood by anyone working with oxyacetylene equipment.

Acetylene Cylinders. Acetylene regulators and hose couplings use a left-hand thread. Left-hand threads tighten counterclockwise (CCW). Acetylene regulator gauge working pressure should *never* be set at a value exceeding 15 psi (100 kPa). At pressures higher than this, acetylene becomes dangerously unstable. An acetylene cylinder should always be used in the upright position. Using an acetylene cylinder in a horizontal position will result in the acetone draining into the hoses.

The quantity of acetylene in a cylinder cannot be accurately determined by the pressure gauge reading because it is in a dissolved condition. The only real accurate way of determining the quantity of gas in the cylinder is to weigh it and subtract this from the weight of the full cylinder, often stamped on the side of the cylinder.

CAUTION It is a common malpractice to set acetylene pressure at high values. Check a welder's manual for the correct pressure values to set for the equipment and procedure you are using.

CAUTION Never operate an acetylene cylinder in anything but an upright condition. Using acetylene when the cylinder is horizontal results in acetone exiting with the acetylene that can destabilize the remaining contents of the cylinder.

Oxygen Cylinders. Oxygen cylinders present more problems than acetylene when exposed to fire. For this reason they should be stored upright and in the same location in a service shop when not in use. This location should be identified to the fire department during an inspection. They should never be left randomly on the shop floor.

Oxygen regulator and hose fittings use a right-hand thread. A right-hand thread tightens clockwise (CW). An oxygen cylinder pressure gauge accurately indicates the oxygen quantity in the cylinder, meaning that the volume of oxygen in the cylinder is approximately proportional to the pressure.

Oxygen is stored in the cylinders at a pressure of 2,200 psi (15 mPa) and the hand wheel actuated valve forward-seats to close the flow from the cylinder and back-seats when the cylinder is opened. It is important to ensure that the valve is fully opened when in use. If the valve is only partially opened, oxygen will leak past the valve threads. **Figure 1-11** shows a typical oxygen cylinder.



Figure 1-11 High-pressure oxygen cylinder.

CAUTION Never use oxygen as a substitute for compressed air when cleaning components in a shop environment. Oxygen can combine with solvents, oils, and grease, resulting in an explosion.

Regulators and Gauges. A regulator is a device used to reduce the pressure at which gas is delivered. It sets the working pressure of the oxygen or fuel. Both oxygen and fuel regulators function similarly. They

increase the working pressure when turned CW and close off the pressure when backed out CCW.

Pressure regulator assemblies are usually equipped with two gauges. The cylinder pressure gauge indicates the actual pressure in the cylinder. The working pressure gauge indicates the working pressure and this should be trimmed using the regulator valve to the required value while under flow.

Hoses and Fittings. The hoses used with oxyacetylene equipment are usually color-coded. Green is used to identify the oxygen hose and red identifies the fuel hose. Each hose connects the cylinder regulator assembly with the torch. Hoses may be single or paired (Siamese). Hoses should be routinely inspected and replaced when defective. A leaking hose should never be repaired by wrapping with tape. In fact, it is generally bad practice to consider repairing welding gas hoses by any method. They should be replaced when they fail.

Fittings couple the hoses to the regulators and the torch. Each fitting consists of a nut and gland. Oxygen fittings use a right-hand thread and fuel fittings use a left-hand thread. The fittings are machined out of brass that has a self-lubricating characteristic. Never lubricate the threads on oxyacetylene fittings. **Figure 1-12** shows a typical oxyacetylene station setup with a cutting torch.

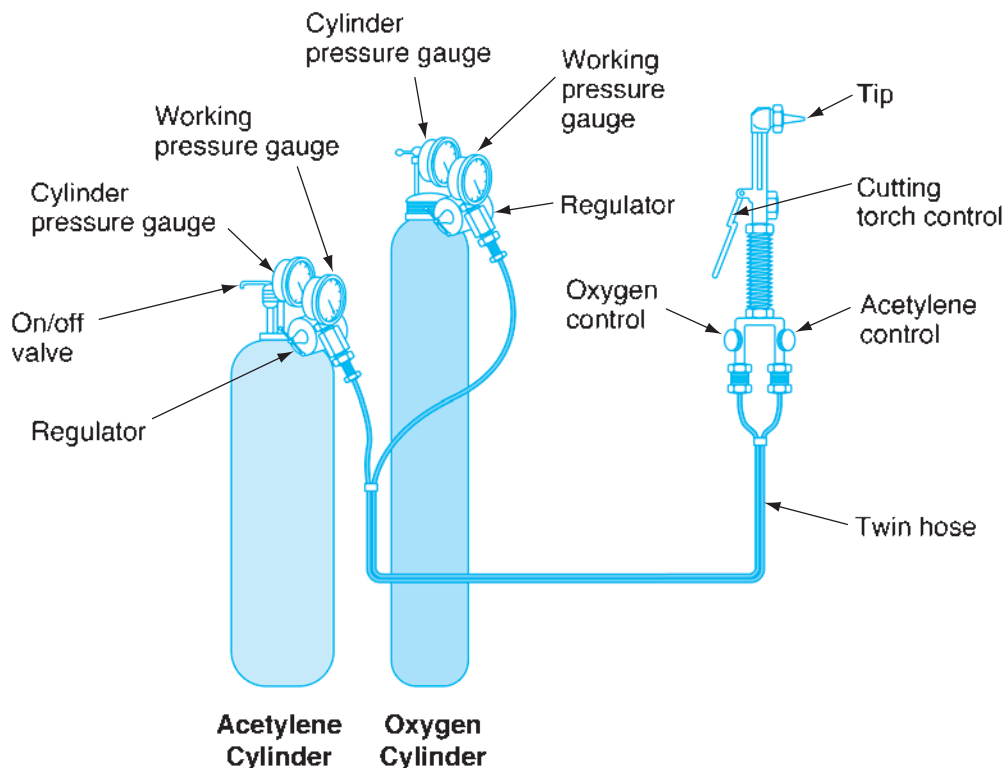

Figure 1-12 Oxyacetylene station setup with a cutting torch.

Torches and Tips. Torches should be ignited using the following sequence:

- Open the cylinder flow valve.
- Set the working pressure using the regulator valve for both gases under flow, then close.
- Next, open the fuel valve only and ignite the torch using a flint spark lighter.
- Set the acetylene flame to a clean burn (no soot) condition.
- Now open the oxygen valve to set the appropriate flame. When setting a cutting torch, set the cutting oxygen last.
- To extinguish a torch, close the fuel valve first, then the oxygen.
- Finally, the cylinders should be shut down using the main flow valve and the hoses purged.

Welding, cutting, and heating tips may be used with oxyacetylene equipment. Refer to a welder's manual to identify the specified working pressures for each type of tip. There is a tendency to set gas working pressure high. Even when using a large heating tip often described as a rosebud, the working pressure of both the acetylene and the oxygen is typically specified at 7 psi (50 kPa). **Figure 1-13** shows a typical oxyacetylene cutting torch.

Backfire. Backfire is a condition where the fuel ignites within the nozzle of the torch producing a popping or squealing noise: it often occurs when the torch nozzle overheats. Extinguish the torch and clean the nozzle with tip cleaners. Torches may be cooled by immersing in water briefly with the oxygen valve open.



Figure 1-13 Oxyacetylene cutting torch.

Flashback. Flashback is a much more severe condition than backfire: it takes place when the flame travels backward into the torch to the gas mixing chamber and beyond. Causes of flashback are inappropriate pressure settings (especially low-pressure settings) and leaking hoses/fittings. When a backfire or flashback condition is suspected, close the cylinder valves immediately beginning with the fuel valve. Flashback arresters are usually fitted to the torch and will limit the extent of damage when a flashback occurs.

Eye Protection. Safety requires that a #4 to #6 grade filter be used whenever using an oxyacetylene torch. The flame radiates ultraviolet (U/V) light that can damage eyesight. Even when U/V rated, sunglasses are not sufficient protection. Eyesight can be damaged by short exposure to an oxyacetylene flame.

Oxyacetylene Precautions. Things to do and not to do:

- Store oxygen and acetylene upright in a well-ventilated, fireproof room.
- Protect cylinders from snow, ice, and direct sunshine.
- Remember that oil and grease can spontaneously ignite in the presence of oxygen.
- Never use oxygen in place of compressed air.
- Avoid bumping and dropping cylinders.
- Keep cylinders away from electrical equipment where there is a danger of arcing.
- Never lubricate the regulator, gauge, cylinder, and hose fittings with oil or grease.
- Blow out cylinder fittings before connecting regulators: make sure the gas jet is directed away from equipment and other people.
- Use soapy water to check for leaks. *Never* use a flame to check for leaks.
- Thaw frozen spindle valves with warm water. *Never* use a flame.

Adjustment of the Oxyacetylene Flame. To adjust an oxyacetylene flame, first the torch acetylene valve is turned on and the gas ignited. At the point of ignition, the flame will be yellow and producing black smoke. Next the acetylene pressure should be increased using the torch fuel valve. This increases the brightness of the flame and reduces the smoking. At the point the smoking disappears, the acetylene working pressure can be assumed to be correct for the nozzle jet size used. Then the torch oxygen valve is turned on. This will cause the flame to become generally less luminous (bright) and an inner blue luminous cone surrounded by a white colored plume should form at the tip of the nozzle. The white colored plume indicates excess acetylene.

As more oxygen is supplied, this plume reduces until there is a clearly defined blue cone with no white plume visible. This indicates the *neutral* flame used for most welding and cutting operations.

Electric Arc Welding

Electric arc welding and cutting processes are used extensively in truck and heavy equipment service garages. Arc welding stations work on one of two principles:

- Transformer: this receives a high-voltage feed (mains electrical) then reduces it to a lower-voltage, high-current circuit.
- Generator: this generates a high-voltage charge, then conditions it to lower-voltage, high-current circuits.

Just as with oxyacetylene welding, before attempting to use any type of arc welding equipment, make sure you receive some basic instruction and training. Typical open-circuit voltages in industrial welding stations are around 70 volts while closed-circuit voltages are typically a little over 20 volts. The following types of welding stations are nonspecialized in application and are found in many truck shops:

- Arc welding: this uses a flux-coated, consumable electrode. Arc welding is often known as *stick welding*.
- MIG (metal inert gas) welding: this uses a continuous reel of wire that acts as the electrode



Figure 1-14 Arc welding electrode holder.

around which inert gas is fed to shield the weld from air and ambient moisture. *Flux-shielded reel welding* is closely related to MIG welding.

- TIG (tungsten inert gas) welding: this uses a nonconsumable tungsten electrodes surrounded by inert gas. Filler rods are dipped into the welding puddle that is created.
- Carbon arc cutting: an arc is ignited using carbon electrodes to melt base melt while a jet of compressed air blows through the puddle to make the cut.

Figure 1-14 shows a typical arc welding electrode holder used with an arc welding station.

Summary

- Diesel and truck shops are safe working environments but technicians must learn how to work safely.
- While all service shops play a role in ensuring a safe working environment, technicians should think of safety as a personal responsibility.
- Personal safety clothing and equipment such as safety boots, eye protection, coveralls, hearing protection, and different types of gloves are required when working in a service garage.
- Technicians should learn to distinguish between the four different types of fires and identify the fire extinguishers required to suppress them.
- Jacks and hoists are used extensively in service facilities and should be used properly and inspected routinely.
- The danger of inhaling diesel exhaust emissions should be recognized. When engines are run inside a garage, exhaust extraction piping must be fitted to the exhaust stacks.
- It is important to identify what is required to work safely with chassis electrical systems because of the costly damage made by simple errors.
- Shop mains electrical systems are used in portable power and stationary equipment and can be lethal if not handled properly.
- Oxyacetylene equipment is used for heating, cutting, and welding. Technicians should be taught how to work safely with oxyacetylene torches.
- Arc welding and cutting processes are also used in service facilities. This type of high-voltage equipment can be safely operated with some basic training.

Review Questions

- When is a worker more likely to be injured?
 - First day on the job
 - During the first year of employment
 - During the second to fourth year of employment
 - During the year before retirement
- When lifting a heavy object, which of the following should be true?
 - Keep your back straight while lifting.
 - Keep the weight you are lifting close to your body.
 - Bend your legs and lift using the leg muscles.
 - All of the above.
- What is Purple K?
 - A new type of stimulant
 - A dry powder fire suppressant
 - A toxic gas
 - A type of paint
- Which of the following is usually a requirement of a safety shoe or boot?
 - UL certification
 - Steel sole shank
 - Steel toe
 - All of the above
- What type of gloves should never be worn when working with refrigerants?
 - Synthetic rubber
 - Vinyl disposable
 - Leather welding gloves
 - Latex rubber gloves
- Which of the following is under the most pressure?
 - Oxygen cylinders
 - Acetylene cylinders
 - Diesel fuel tanks
 - Gasoline fuel tanks
- Which type of fire can usually be safely extinguished with water?
 - Class A
 - Class B
 - Class C
 - Class D
- When attempting to suppress a class C fire in a chassis, which of the following is good practice?
 - Disconnect the batteries.
 - Use a carbon dioxide fire extinguisher.
 - Avoid inhaling the fumes produced by burning conduit.
 - All of the above.
- What color is used to indicate the fuel hose in an oxyacetylene station?
 - Green
 - Red
 - Yellow
 - Blue
- In which direction do you tighten an oxygen cylinder fitting?
 - CW
 - CCW
 - Depends on the manufacturer

CHAPTER

2

Hand and Shop Tools, Precision Tools, and Units of Measurement

Learning Objectives

After studying this chapter, you should be able to:

- Identify the hand tools commonly used by truck technicians and describe their function.
- Categorize the various types of wrenches used in shop practice.
- Describe the precision measuring tools used by the engine and fuel system technician.
- Outline the operating principles of a standard micrometer and name the components.
- Identify different types of torque wrenches.
- Calculate torque specification compensation when a linear extension is used.
- Read a standard micrometer.
- Outline the operating principles of a metric micrometer and name the components.
- Read a metric micrometer.
- Understand how a dial indicator is read.
- Define TIR and how it is determined.
- Understand how a dial bore gauge operates.
- Outline the procedure for setting up a dial bore gauge.
- Perform accurate measurements using a dial bore gauge.
- Describe some typical shop hoisting equipment and its applications.

Key Terms

bar

calipers

chain hoist

dial bore gauge

dial indicator

dividers

electronic digital calipers (EDCs)

inside diameter (id)

inside micrometer

outside diameter (od)

outside micrometer

scissor jack

spreader bar
telescoping gauges

tensile strength
total indicated runout (TIR)

units of atmosphere (atms)
yield strength

INTRODUCTION

This chapter is intended to provide a guide to tools for novice truck technicians. The tools are loosely divided into the categories of hand tools, precision measuring, and shop tools (**Figure 2-1**). The chapter also provides a guide to the contents of a truck technician's toolbox. The rookie technician should invest in a minimum of tools before obtaining employment and then develop a tool collection with the job requirements in mind. Some guidance in standard to metric conversion units is also provided.

HAND TOOLS

Every technician requires a basic set of hand tools. This chapter provides some basic guidelines, but the tools you purchase should be determined by the nature of the work. Hand tools vary considerably in price. Before spending large sums of money, determine whether the cost is justified by the amount of use to

which they will be put. Almost all better quality hand tools carry lifetime warranties, although they may not cover tools that wear out, so always question the extent of any warranty offered. The reality is that technicians seldom wear out tools. The main problem is usually loss. Because of the high price of hand tools, most technicians learn to check the contents of their toolboxes carefully after completing each job. Most of the time loss of tools is the result of carelessness on the technician's part. Thousands of wrenches are lost every week because they are left on a truck, bus, or car chassis.

Open-End Wrenches

Open-end wrenches have open jaws on either side of the wrench, usually with different sizes at either end and slightly offset (**Figure 2-2A**). The wrench should be of sufficient quality that the jaws do not:

- spread when force is applied
- restrict access to difficult-to-get-at fasteners because they are too bulky

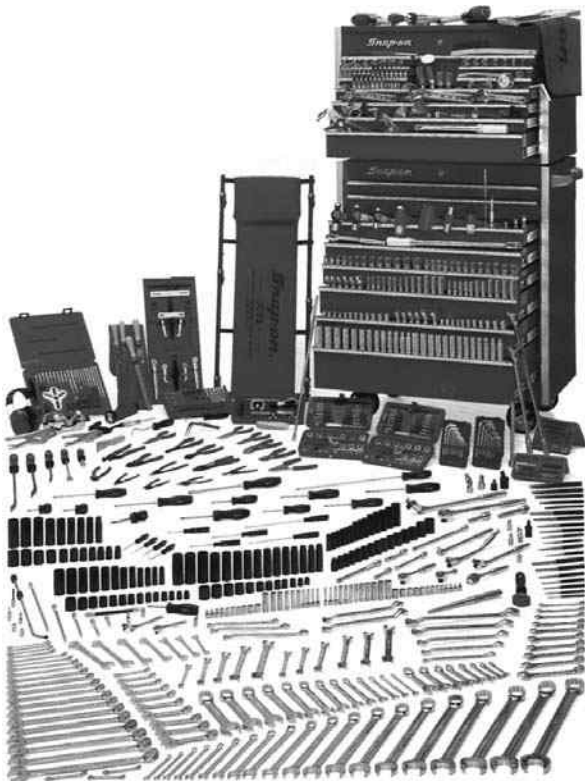

Figure 2-1 A complete tool kit. (Courtesy of Snap-on Tools Corporation)

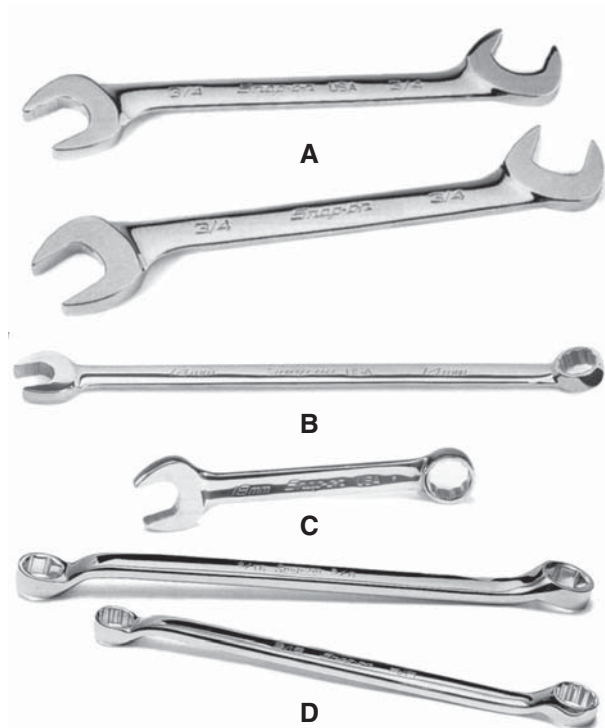

Figure 2-2 Wrenches: (A) open end; (B and C) combination; and (D) box end. (Courtesy of Snap-on Tools Corporation)

Open-end wrenches may damage softer fasteners (such as brass pipe nuts) because they act on only two of the six flats of a hex nut.

Combination Wrenches

A combination wrench is manufactured with a box end and an open end, both of the same nominal size (**Figure 2-2B** and **Figure 2-2C**). There are a wide range of prices when considering the purchase of a set of combination wrenches. It makes sense to own a set of top quality combination wrenches in sizes up to $\frac{3}{4}$ in. (19 mm): these tend to be lighter and slimmer than less expensive wrenches. Less costly wrenches tend to be heavier and clumsier. Less expensive but fully warranted wrenches can be considered for use on sizes larger than $\frac{3}{4}$ in. (19 mm). Many cheaper, poor quality wrenches are on the market, many of them imported. These are seldom guaranteed. Avoid using poor quality wrenches because they may be dangerous.

Box-End Wrenches

A box-end wrench surrounds the fastener. It may be hex (6-point) or double-hex (12-point) as shown in **Figure 2-2D**. Because most bolts and nuts use a hex or 6-point design, a hex box-end wrench grips more securely because it acts on all six flats of the fastener. However, it is less versatile where access is restricted as it can only fit on the fastener in 6 radial positions through a rotation rather than the 12 radial positions of the double-hex, box-end wrench.

Adjustable Wrenches

The adjustable wrench consists of a fixed jaw integral with the handle and an adjustable jaw moved by a worm adjuster screw. You should probably own a couple of these and then resolve to use them as little as possible. Their advantage is versatility. They can sometimes grip a worn fastener. Their disadvantage is that they cause wear because the adjustable jaw never fits tightly to the flats on a hex fastener and it tends to round them out. Never apply excessive force to an adjustable wrench.

Line Wrenches

A line wrench is designed to grip to a pipe or line hex nut and act on four of the six flats of its hex. It has the appearance of a box-end wrench with a small section removed so that it fits through the pipe to enclose the pipe nut. A line wrench should be used in place of the open-end wrench to avoid damaging pipe nuts.

Socket Wrenches

Diesel technicians will require complete socket sets in $\frac{1}{4}$ -inch, $\frac{3}{8}$ -inch, and $\frac{1}{2}$ -inch drive sizes. A $\frac{3}{4}$ -inch drive size may also be useful. Complete sets of socket wrenches will vary by manufacturer but the following is typical:

- $\frac{1}{4}$ in. drive: drives sockets up to $\frac{1}{2}$ in. (12 mm)
- $\frac{3}{8}$ in. drive: drives sockets up to $\frac{3}{4}$ in. (19 mm)
- $\frac{1}{2}$ in. drive: drives sockets up to $1\frac{1}{4}$ in. (30 mm)

Sockets may be of the hex or double-hex design and surround the fastener. The socket may be hand-rotated by a ratchet or flex bar and power-rotated by compressed air powered wrenches or impact wrenches.

Types of Sockets. Impact sockets are manufactured out of softer alloys than those designed to be turned by a ratchet or flex bar. Softer alloy sockets are less likely to fracture when driven by air tools. Deep sockets permit access to a nut in which a greater length of the bolt or stud is exposed. A crowsfoot socket is an open-end wrench that can be turned by a ratchet; it grips two of the six flats of a nut and is probably mostly used for final torquing a difficult-to-access nut. A line socket is the socket counterpart to the line wrench. It grips four of the six flats of a nut and its main use is to deliver final torque to a pipe nut.

Ratchets and Breaker/Flex Bars

Reversible ratchets used in conjunction with sockets are often used by any technician. They are used to rapidly turn fasteners by hand and should be of good quality because the consequence of failure is personal injury. Ratchets are not designed to accommodate high torque loads. The ratchet spur wheel is locked to one direction of rotation by a single or double cog. The spur and cog cannot be seen because they are enclosed in the ratchet head. However, the spur and cog determine the strength of the tool. A breaker bar (also known as a flex bar, power bar, and Johnson bar) has a grip bar and pivoting drive square to engage with a socket in the same way a ratchet does so they are available in $\frac{1}{4}$ -inch, $\frac{3}{8}$ -inch, $\frac{1}{2}$ -inch, $\frac{3}{4}$ -inch, and 1-inch sizes. A breaker/flex bar can be used to release fasteners that require considerably more force than could be safely applied to a ratchet; however, the use of “helpers” such as a pipe over the handle should be avoided.

Torque Wrenches

Torque wrenches measure resistance to turning effort (**Figure 2-3**). Fasteners are torqued to ensure that

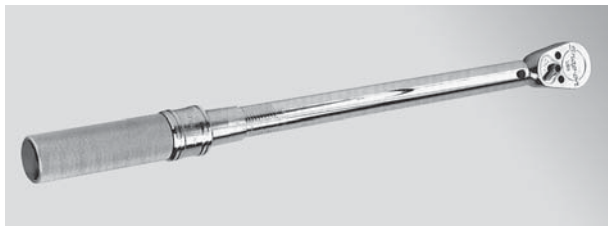

Fixed ratchet head



Swivel ratchet head

Figure 2-3 Types of click-type torque wrenches. (Courtesy of Snap-on Tools Corporation)

the correct clamping force between two components is achieved. In assembling engine and fuel system components, every fastener should be torqued to specification. (See **Figure 2-4.**) Studies indicate that when technicians fail to use torque wrenches, they overtorque fasteners to values 50 percent to 100 percent over the specification. This damages fasteners and distorts components including cylinder blocks and heads.

The commonly used torque wrench is the sensory or click-type: when the selected torque value is attained, the wrench produces a click. Diesel technicians are often required to torque large numbers of fasteners to the same specification such as when torquing cylinder heads to a cylinder block. It makes sense to use a click-type torque wrench when performing this type of procedure.

Types of Torque Wrenches. Click-type torque wrenches should always be backed off to a zero reading after use. Their calibration should be routinely checked because they rely on spring tension to produce a reading. Dial-type torque wrenches use a circular dial scale and a needle to display torque values. Dial-type torque wrenches are usually higher priced than click-type torque wrenches and usually require less frequent calibration. Beam-type torque wrenches use a

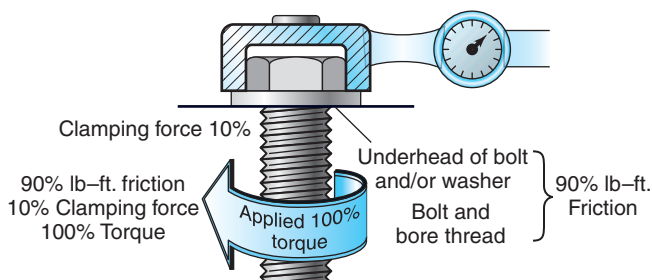

Figure 2-4 Torque to overcome friction. (Courtesy of Navistar International Corp.)

flexible, middle alloy steel shaft (beam) that deflects when torque is applied. A needle pointer is used to indicate the torque reading. Beam-type torque wrenches are the least costly but have good accuracy and seldom require calibrating. They should be stored carefully as the needle pointer is easily damaged.

Tech Tip: Sensory or click-type torque wrenches are set to a specified torque value by setting the internal spring tension by rotating either the handle or a dial and latch. On torque wrenches that use spring tension to define torque, the spring tension should be relieved after each use.

Torque wrenches can be calibrated in standard or metric systems, preferably both. To convert these values from one system to the other:

- 1 lb–ft. = 1.356 Newton-meters (Nm)
- 1 Nm = 0.7375 lb–ft.

Hammers

Mechanical technicians mostly use ball-peen hammers in various weights. The specified weight of a hammer is the head weight, which starts at ½ pound and should go up to about 4 pounds in weight. The engine specialist should also own a 5-pound rubber mallet and a couple of soft-faced or fiberglass hammers. Safety glasses should be worn whenever using any striking tool. The impact faces of hammers should be inspected regularly and discarded when the face becomes damaged. Hammer handles are also important, and a hammer should not be used when its handle is damaged. The handle may be made of hickory, in which case it is susceptible to damage, or steel and integral with the head with a rubber-cushioned grip. Some examples are shown in **Figure 2-5A** and **Figure 2-5B**.

WARNING Never strike a hammer with another hammer. The hardened impact surfaces can shatter and cause serious injury.

Pliers

Most technicians require a large selection of pliers. They are used for gripping and cutting. Pliers used for working on electrical circuits should have insulated handles. Pliers are named by type. Some examples are needle-nose, slip joint, lineman, and sidecutter pliers. **Figure 2-5C** shows some examples.

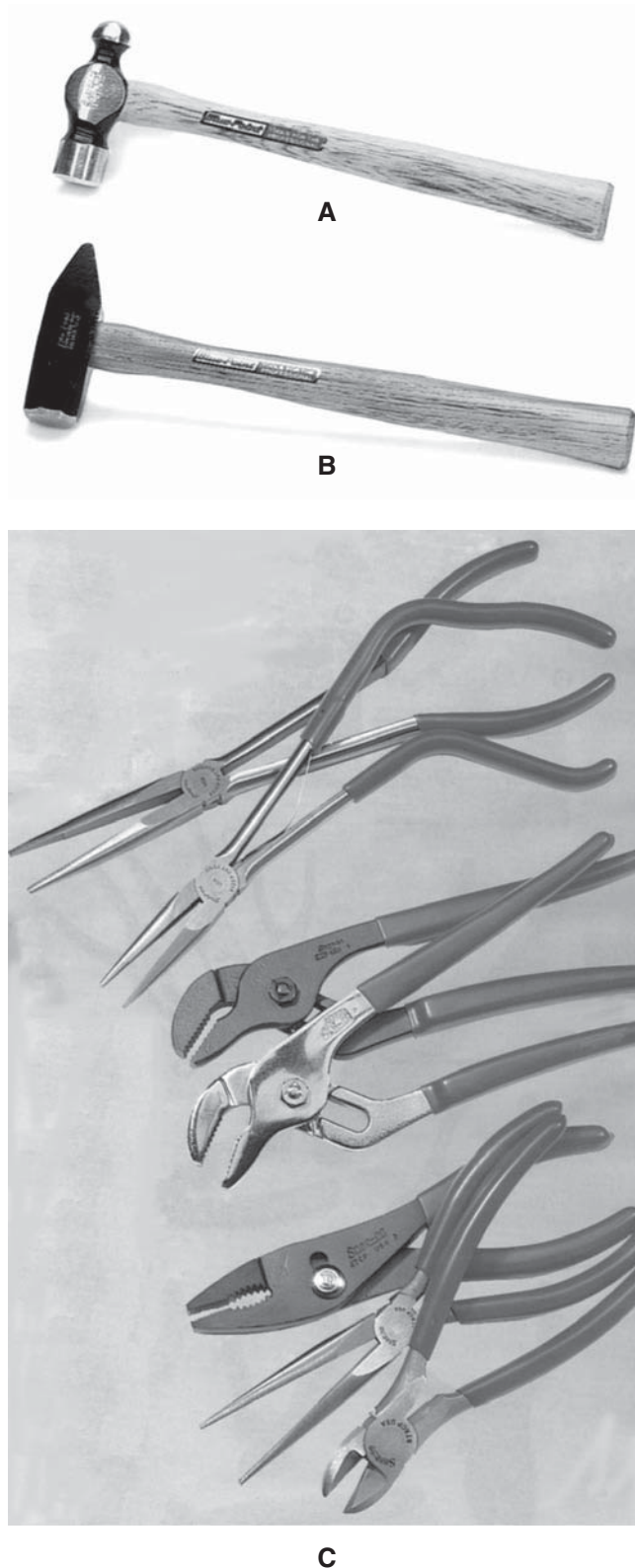

Figure 2-5 Types of hammers and pliers: (A) ball peen hammer; (B) cross peen hammer; and (C) selection of different types of pliers. (Courtesy of Snap-on Tools Corporation)

Screw Extractors

Fasteners occasionally fail when the fastener head sheers. When methods such as welding a nut onto a fastener that has had its hex head sheered off have failed, a screw extractor has to be used. First, the fastener has to be drilled dead-center to around 75 percent of its depth, and then the screw extractor has to be driven into the drilled hole. Two types exist. The taper square screw extractor is designed to bite into and grab the bore of the drilled hole; it can be progressively driven into the hole if the edges round out. The left-hand twist screw extractor works by self-tapping its way into the drilled hole in the fastener as it is turned counterclockwise.

Stud Extractors

Stud extractors can be used to extract a fastener when enough of it protrudes to grab onto its shank. Two types are used:

1. collet-type: fits over the exposed length of the stud and locks to it as it is rotated counterclockwise. Can be used with air tools.
2. wedge-type: consists of a splined-circular wedge that locks to the stud as it is rotated counterclockwise. Should only be used with hand tools as they are driven eccentrically.

Taps

Taps cut internal threads in both standard and metric specifications. They can be used either to cut virgin threads in bores or to repair damaged threads. Three types are used:

1. taper tap: used to cut threads to a virgin bore
2. plug tap: used to finish cut or repair threads
3. bottom tap: used to cut the final threads in a blind hole

Dies

Dies cut external threads. Most are designed with graduated teeth and a taper, enabling them to cut threads to a shaft. Technicians are most likely to use these to repair damaged threads. In fact, most toolbox quality taps and dies should not be used to cut virgin threads in hardened steels, especially if the fastener is critical.

Thread Chasers. A thread chaser is a die designed for the sole purpose of repairing minor damage to an existing thread. It cuts in much the same way a die does, but it is not designed to cut new threads.

TABLE 2-1: RECOMMENDED CUTTING FLUID PROCESSES

Metal	Drilling	Reaming	Tapping
Mild steel	Soluble oil/water	Lard	Lard
Middle alloy	Soluble oil/water	Lard	Lard
Cast iron	Dry	Dry	Lard
Brass	Dry	Water	Dry
Copper	Soluble oil/water	Soluble oil/water	Soluble oil/water
Aluminum	Kerosene	Kerosene	Soluble oil/water

Thread Pitch Gauges. Thread pitch gauges are designed to measure the thread pitch (angle) and number of threads per inch (tpi) of any thread pattern. They are used to determine which tap, die, or fastener is appropriate.

Reamers

Reamers are rotary cutting tools that enlarge an existing hole to an exact dimension. They are used in situations that require a greater degree of accuracy than a drill is capable of delivering. Reamers are available in several types, two of the most common of which are:

- adjustable: reamers that can cut holes through a range of sizes
- spiral-fluted, taper: reamers that are driven by air or electric power tools and enlarge a hole accurately to a specific size

Drill Bits

Drill bits are driven by an electric or pneumatic power tool. Twist drills must be machined to the correct cutting pitch (angle) normally by grinding on a fine abrasive wheel. The two cutting edges of a twist drill must be angled identically from the center point of the drill and have the same radial dimension. A slight difference results in a larger hole than the drill shank size. Drills sharpened by hand seldom produce exact-sized holes. Drill speeds should be adjusted for the material being cut and the size of the hole.

Hacksaws

A hacksaw is designed to cut metals. A hacksaw has a rigid frame and the blade selected should have the appropriate number of teeth per inch (tpi) for the metal to be cut. The harder the metal, the more tpi required. Better quality hacksaw blades tend to be cost-effective because they last until they wear out. Cheaper blades tend to break. Inspect the blades and replace them when they have dulled or missing teeth.

A hacksaw should be used with a light but firm grip. An even horizontal stroke with no rocking will produce the fastest cutting rates. Approaching the cutting task in a relaxed, calm way produces fast results, whereas attempting to power through the task often results in broken blades and lost tempers.

Cutting Fluids

Soluble oil is machinist's oil mixed with water according to the manufacturer's recommendations. Engine oil is not soluble and cannot be used as a substitute. See **Table 2-1**.

PRECISION MEASURING TOOLS

Several precision measuring instruments are used in a typical truck service garage. Precision measuring tools tend to be high-cost items. They are sometimes provided by employers but technicians who use specific tools frequently may wish to purchase their own.

Electronic Digital Calipers

Electronic digital calipers (EDCs) are a great addition to the toolbox especially if you work on engines. They measure dimensions. They can be used to measure:

- inside
- outside
- depth

measurements to within half-a-thousandth or 0.0005-inch accuracy. EDCs perform with good accuracy and have the advantage of being easier to read than micrometers. Additionally, they will perform metric to standard linear conversions at the push of a button. **Figure 2-6** shows some of the uses of an EDC.

Standard Micrometers

Since most of the dimensional specifications on a metric engine are still recorded using the standard

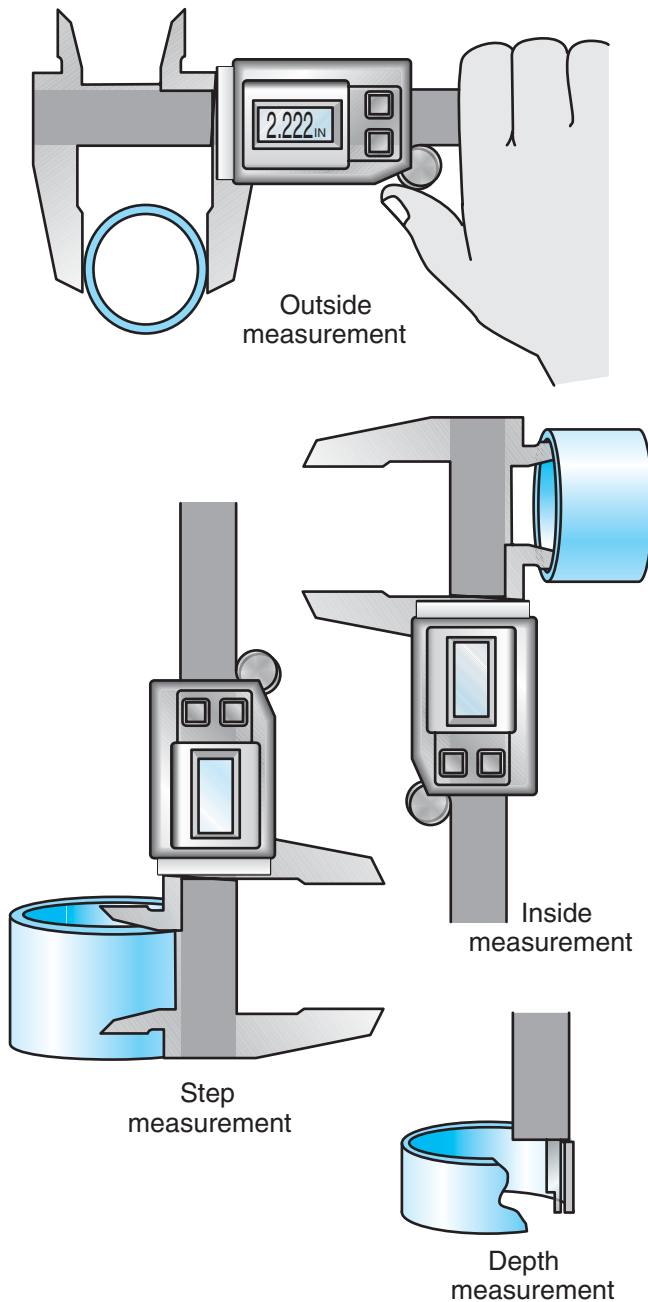

Figure 2-6 Various uses of a set of digital calipers. (Courtesy of Fred V. Fowler Co. Inc.)

system, every technician must know how to read a standard micrometer. A standard **outside micrometer** consists of a frame in the shape of the letter G: on one side of the frame is a fixed anvil and on the other is a spindle assembly. The spindle assembly consists of an accurately machined screw that rotates in the spindle nut. The spindle is hand-rotated by a thimble: the point at which the thimble registers on the micrometer sleeve calibration scale indicates the reading.

From the point at which the spindle contacts the anvil and the micrometer dimensional readout is zero,

the thimble must be rotated through 40 complete revolutions to produce a reading of 1 inch. This means that the inch is divided by 40. Therefore, each complete rotation of the thimble is represented by:

$$\frac{1.00}{40} \text{ in.} = 0.025 \text{ in.}$$

So, each full rotation of the thimble is equivalent to 0.025 inch. The calibration scale on the sleeve is calibrated in units of 0.025 inch and every fourth stroke equals 0.100 inch, usually indicated by single digits 1 through 10. The leading edge of the thimble is divided into 25 calibration strokes, each representing 0.001 inch.

Understanding exactly how the micrometer is calibrated enables the technician to read it easily. All standard micrometers measure dimensions through 1 inch and are read in the same manner. Changing the frame and anvil assembly permits the micrometer to be used for measuring dimensions larger than 1 inch but the readings are still confined to the 1-inch window of spindle travel.

An outside micrometer is used to measure the outside dimensions of a component such as a shaft or set of shims whereas an **inside micrometer** is used to measure internally such as a bore dimension. **Figure 2-7** shows both outside and inside micrometers and the terminology used to describe them. Study **Figure 2-8**, which shows how to read a standard micrometer.

Metric Micrometers

All metric micrometers have a scale that reads 25 mm. From the zero measurement when the spindle contacts the anvil, the metric micrometer must be

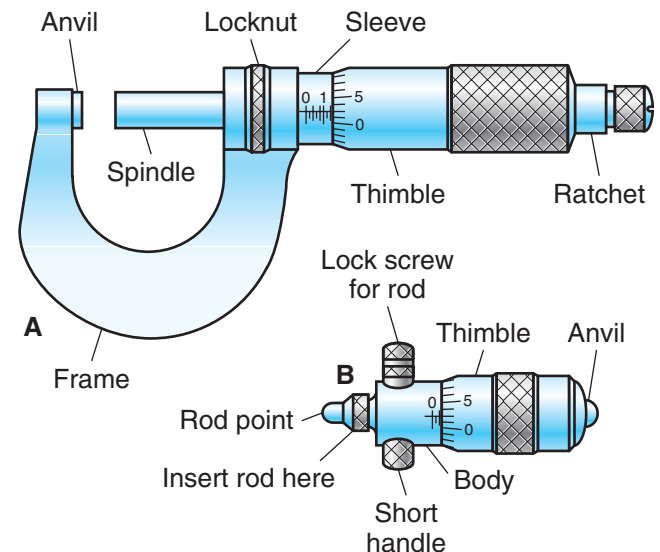

Figure 2-7 Terminology and components of (A) an outside and (B) an inside micrometer.

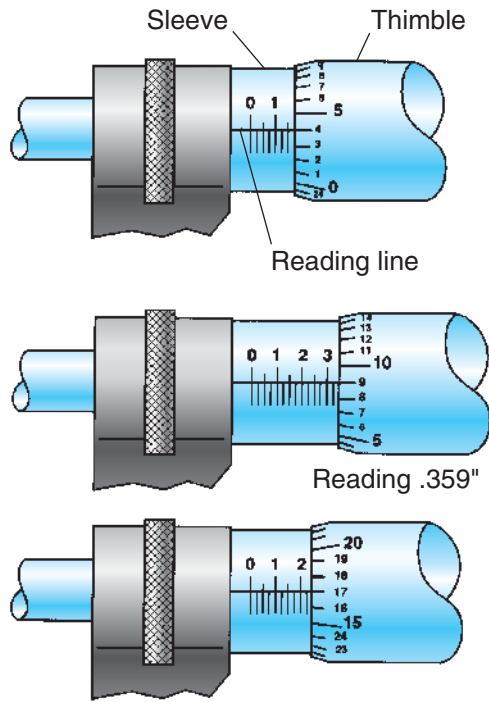

Figure 2-8 How to read a micrometer. (Courtesy of Navistar International Corp.)

turned through 50 rotations. Therefore, each revolution of the thimble is represented by:

$$\frac{25.0 \text{ mm}}{50} = 0.5 \text{ mm}$$

The thimble on a metric micrometer is divided into 50 graduations so:

$$\frac{0.5 \text{ mm}}{50} = 0.01 \text{ mm}$$

As all metric micrometers measure dimensions from 0 through 25 mm, once again changing the frame and anvil assembly permits the micrometer to be used for measuring dimensions larger than 25 mm, in which the readings will be confined to the 25 mm window of spindle travel. Metric micrometers are as easy to read as standard micrometers, especially when the technician understands how they are calibrated.

Dial Indicators

Dial indicators are used to measure travel or movement in values of thousandths to one hundred thousandths of an inch. Metric dial indicators are calibrated to read in tenths to thousandths of a millimeter. Dial indicators are used for many general and job-specific functions in the diesel engine shop. Most have a total travel range of 1 in. (25 mm), although job-specific indicators may have a total travel range exceeding that, and some have much less. Dial indicators may

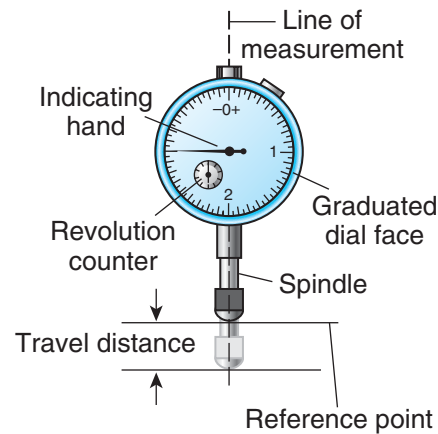

Figure 2-9 Dial Indicator terminology. (Courtesy of C. Thomas Olivo Associates)

have a balanced dial, in which case, in an indicator in which one revolution of the indicator needle represents 0.100 inch, the dial would be calibrated in units of 0.001 inch to 0.050 inch through 180 degrees of the dial and then graduate back down to 0.001 inch through the other side of the dial. The zero at the center of the dial face would be marked with a plus (+) on one side and a minus (-) on the other. This type of dial indicator is useful in determining the **total indicated runout (TIR)** of a rotating component. **Figure 2-9** demonstrates dial indicator terminology.

TIR. The method for measuring TIR can be demonstrated using the example of measuring flywheel concentricity. A magnetic base dial indicator is placed on the engine crankshaft after removing the flywheel. Using chalk on the flywheel housing face, the indicator dial is set to zero at a start point. As the engine is rotated through 360 degrees, four readings each 90 degrees apart are made as shown in **Figure 2-10**. The first reading is always zero because this is where you set the indicator scale. Rotate the engine in its correct direction of rotation, recording the indicator measurements in 90-degree steps as shown in **Figure 2-10**. When you return to the original position where you set the first reading, the indicator should read exactly zero again. If it does not, the indicator has moved and you will have to repeat the procedure. The TIR is calculated by adding the highest positive reading to the highest negative reading. **Figure 2-11** shows the various positions of a universal dial indicator.

Tech Tip: The TIR is always the sum of the highest positive and the highest negative reading.

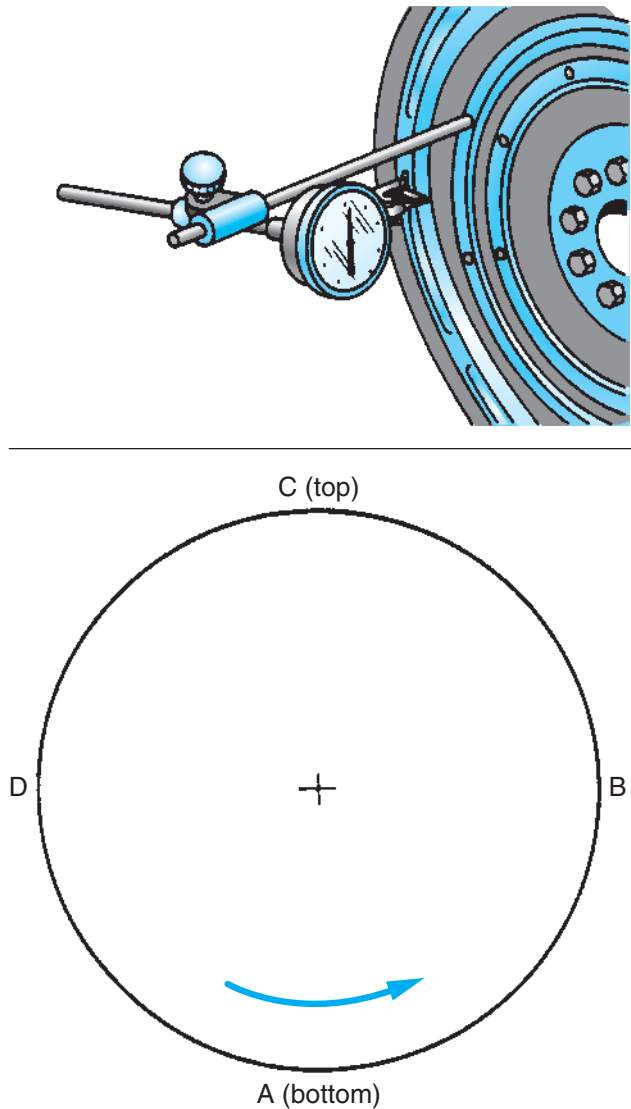

Figure 2-10 Locations of the four readings required to measure the TIR of a flywheel housing. (Courtesy of Caterpillar Inc.)

Dial Bore Gauges

Dial bore gauges are used to measure bore dimensions such as **inside diameter (id)**, taper, and out-of-round. They are calibrated in increments of 0.001 in. (0.025 mm) or 0.0001 in. (0.0025 mm). Using a dial bore gauge is a fast way of rapidly assessing cylinder bore dimensions. The typical dial bore gauge consists of a shaft on top of which is the dial indicator; at the base of the shaft is a measuring sled consisting of guides and an actuating plunger. One of the three guides is located diametrically opposite to the actuating plunger. The actuating plunger is responsible for producing the indicator readings. **Figure 2-12** shows a dial bore gauge being used to measure cylinder bore.

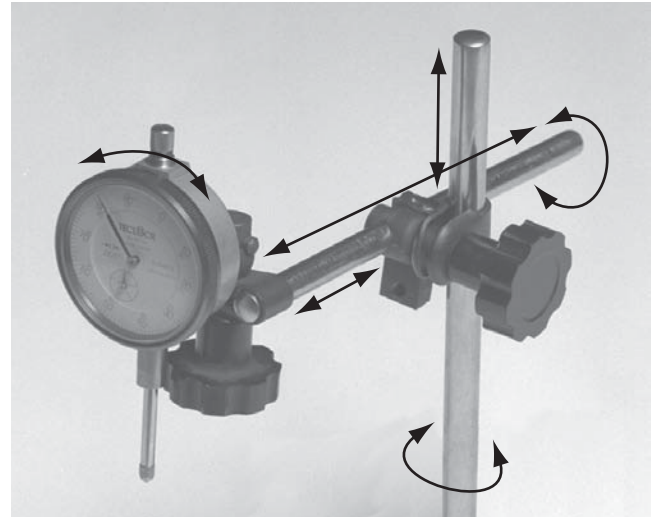

Figure 2-11 Adjustment features of a dial indicator. (Courtesy of C. Thomas Olivo Associates)

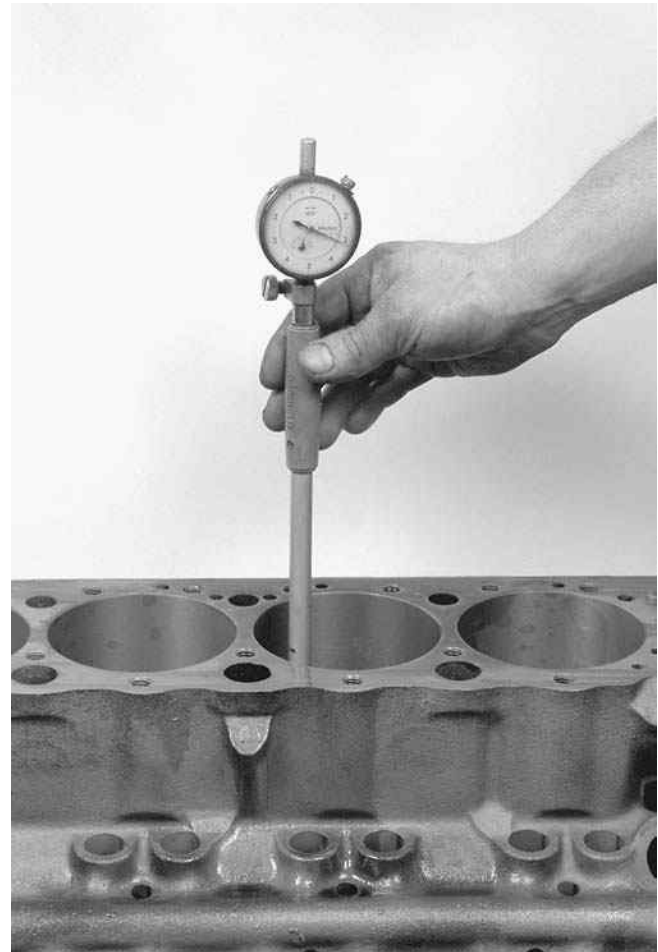

Figure 2-12 Dial bore gauge being used to measure a cylinder bore. (Courtesy of Sunnen Products Co.)

Setup Options. The guide located diametrically opposite to the actuating plunger is both removable (to permit the dial bore gauge to measure different bore

dimensions) and adjustable within a range. A number of different methods exist for setting up a dial bore gauge and each technician will, in time, develop a preference for a particular method. In addition, some original equipment manufacturers (OEMs) have very specific methods that they want used. For instance, one OEM prefers that a C-tram is used: the dimension of the C-tram is exactly that of the maximum permitted bore size, meaning that every within-specification measurement should read on the *minus* side of the indicator scale.

.....
Tech Tip: Take the time to learn how to use a dial bore gauge properly. *Never* use telescoping gauges to make critical bore measurements. This indirect measurement method produces inaccuracies.

Dial Bore Gauge Procedure. Many students experience some difficulty in setting up and making measurements using a dial bore gauge, primarily because so many different methods are used. The following method works well if you do not have a lot of experience in setting up dial bore gauges. The steps are:

1. Identify the specification window.
2. Set the micrometer.

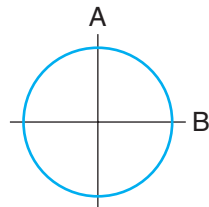

3. Set the dial bore gauge.
4. Make the bore measurements.
5. Record the measurements.

IDENTIFY THE SPECIFICATION WINDOW

Most OEMs use units of 0.0001 inch to express cylinder bore specifications. They provide a range of acceptable specifications, called a window. When you make a measure that falls outside that window, you have an out-of-spec bore. Diesel engine technicians should get used to working in units of 1/2 thousands of an inch. This means that 0.0027 inch can be rounded to 0.0025 inch and expressed as 2 1/2 thousandths inch. If the spec is 0.0028 inch, you would round to 0.003 inch and express this as 3 thousandths inch. This makes recording the data you measure much easier to handle. When you take a look at the OEM specification window for a bore, round to the nearest 1/2-thousand and identify the *maximum* bore specification. This is important. It means that when you start making measurements, every acceptable specification will read on the *minus* side of the dial bore gauge zero.

SET THE MICROMETER

Set the micrometer reading to the maximum permitted bore specification. Lock the micrometer. Record the maximum specification on the bore data chart shown in **Figure 2-13**. Now wrap the micrometer frame in a wiper and gently but firmly clamp it into a vise.

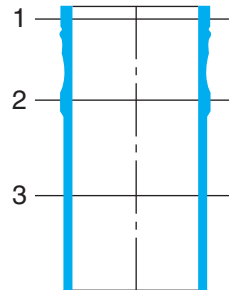

1 A1 _____	B1 _____	2 A1 _____	B1 _____	3 A1 _____	B1 _____
A2 _____	B2 _____	A2 _____	B2 _____	A2 _____	B2 _____
A3 _____	B3 _____	A3 _____	B3 _____	A3 _____	B3 _____
4 A1 _____	B1 _____	5 A1 _____	B1 _____	6 A1 _____	B1 _____
A2 _____	B2 _____	A2 _____	B2 _____	A2 _____	B2 _____
A3 _____	B3 _____	A3 _____	B3 _____	A3 _____	B3 _____

Maximum specification _____ (Set micrometer to this dimension.)

Minimum specification _____

Figure 2-13 Cylinder bore data recording chart for a 6-cylinder engine. Note the locations for taking longitudinal and transverse measurements.

SET THE DIAL BORE GAUGE

Now set the dial bore gauge to the mike dimension. Select the appropriate length adjustable guide and screw inward into the sled until the dimension between the adjustable guide and the measuring plunger is less than the micrometer setting. Supporting the measuring plunger against the micrometer anvil, begin to screw the adjustable guide counterclockwise (CCW) until it makes contact with the micrometer spindle. As you continue to rotate the adjustable guide CCW, the indicator reading needle will begin to rotate: make sure that it rotates at least one full revolution (on a typical indicator, this will be 100 thousandths). Remove the dial bore gauge. Lock the jam nut on the adjustable guide. It does not matter if the adjustable guide moves slightly as you are engaging the jam nut. Next, insert the dial bore gauge back into the mike. Make sure the dial bore indicator turns through approximately one rotation of travel, then zero the indicator and lock the setting. Having set the dial bore gauge, remove and reinstall it a couple of times to check your measurement.

Each time you install the dial bore gauge into the mike it should read exactly zero. When it does, the zero corresponds to the *maximum* permitted bore specification. This means that *any* positive reading on the indicator is out-of-spec. It also means that when you record your data, every in-spec reading should be a minus reading.

MAKE THE BORE MEASUREMENTS

If you are making measurements to determine the serviceability of cylinder liners they should be made in the following locations:

1. top of the ring belt sweep
2. bottom of the ring belt sweep
3. midway between measurement 2 and the bottom of the liner

These locations are shown in **Figure 2-13**. To make a bore measurement, gently hold the dial bore gauge between two fingers on the grip of the handle above the indicator. Allow the measuring sled to pivot in the bore using the dial bore handle to sweep the device through an arc. Watch the needle as you move the dial bore gauge through each sweep. You are looking for the stroke-over point—or, in other words, the point at which the needle reverses.

RECORD THE MEASUREMENTS

This is where you want to keep things as simple as possible. Think in terms of relative thousandths. Avoid recording the specification and complete the chart as we have done. On this engine, the OEM defines the

specification tolerance as 4.8744 inches to 4.8768 inches. First, round these values to the nearest half thousandth of an inch. Now record the following specs onto the bore chart shown in **Figure 2-13**:

- Minimum specified bore size: 4.874½
- Maximum specified bore size: 4.877

The specification window within which this cylinder sleeve should measure is 2½ thousandths of an inch. Observe the way in which the bore chart shown in **Figure 2-14** has been completed, and notice the out-of-spec cylinder.

Tech Tip: Always use a bore chart when measuring bore to specification. It is the only effective means of organizing the stream of data that you will generate from making at least six measurements per cylinder on an inline 6-cylinder engine.

Depth Gauges

Depth gauges may be of the micrometer or dial gauge type. In each case, the instrument consists of a block to which either a micrometer assembly or dial indicator mechanism is attached. The micrometer depth gauge is read opposite from the standard micrometer: when the spindle is flush with the block (that is, in its most retracted position), the micrometer reads zero. As the thimble is rotated, the plunger extends beyond the flush position on the block to produce readings on the sleeve calibration scale. The calibration scales on both standard and metric depth micrometers are read in the same way as regular micrometers. The dial-type depth gauge is simply a dial indicator mounted on a block. It is read in the same manner as a dial indicator.

Combination Square

The combination square consists of a right-angle square, a protractor, and a center gauge assembled on a steel ruler. A good quality, precision combination square may be used as a square, protractor, center gauge, depth gauge, height gauge, level, straightedge, and ruler. It is a valuable addition to the technician's toolbox.

Telescoping Gauges (Snap Gauges)

Telescoping gauges are used to measure internal dimensions. They do not display readings so they have to be used in conjunction with a standard outside micrometer. A set of telescoping gauges is usually

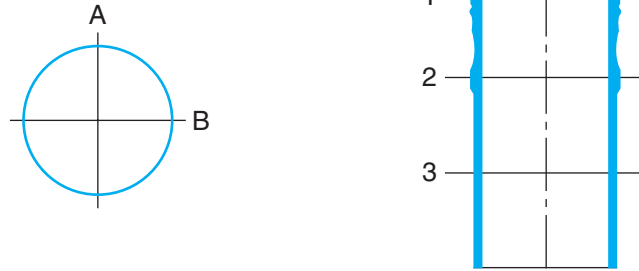

1	A1	<u>-1</u>	B1	<u>$-\frac{1}{2}$</u>	2	A1	<u>-1</u>	B1	<u>$-\frac{1}{2}$</u>	3	A1	<u>$+\frac{1}{2}$</u>	B1	<u>$+1$</u>
	A2	<u>$-\frac{1}{2}$</u>	B2	<u>$-\frac{1}{2}$</u>		A2	<u>$-\frac{1}{2}$</u>	B2	<u>-2</u>		A2	<u>$-\frac{1}{2}$</u>	B2	<u>$-\frac{1}{2}$</u>
	A3	<u>-2</u>	B3	<u>-2</u>		A3	<u>-2</u>	B3	<u>-2</u>		A3	<u>-1</u>	B3	<u>$-\frac{1}{2}$</u>
4	A1	<u>$-\frac{1}{2}$</u>	B1	<u>-1</u>	5	A1	<u>$-\frac{1}{2}$</u>	B1	<u>$-\frac{1}{2}$</u>	6	A1	<u>$-\frac{1}{2}$</u>	B1	<u>-1</u>
	A2	<u>$-\frac{1}{2}$</u>	B2	<u>-1</u>		A2	<u>-1</u>	B2	<u>$-\frac{1}{2}$</u>		A2	<u>-1</u>	B2	<u>-1</u>
	A3	<u>-2</u>	B3	<u>-2</u>		A3	<u>$-\frac{1}{2}$</u>	B3	<u>-2</u>		A3	<u>$-\frac{1}{2}$</u>	B3	<u>-2</u>

Maximum specification 4.877" (Set micrometer to this dimension.)

Minimum specification $4.874\frac{1}{2}$ "

Figure 2-14 Completed cylinder bore data recording chart using the method outlined in this chapter: note the out-of-spec data on the #3 cylinder.

capable of measuring dimensions from 1/2 inch up to 6 inches. The gauge has the appearance of a T: the T bar is equipped with a spring-loaded plunger, which, when released by the locking handle, expands to the dimension to be measured because it is spring-loaded. The gauge may then be locked by the locking handle and removed from the bore; an outside micrometer is then used to measure the T bar dimension.

Telescoping gauges are indirect measuring instruments, which means they tend to be less accurate. If you need to work with some precision, avoid using telescoping gauges. They should not be used to measure cylinder bores for two reasons:

1. They are more likely to produce inaccurate measurements.
2. They are much slower than using a dial bore gauge.

Small-Hole Gauges

Small-hole gauges, like telescoping gauges, are indirect measuring instruments used to measure small cylindrical bores in conjunction with an outside micrometer. In the typical small-hole gauge, a tapered spindle is rotated by a handle to spread split ball halves, moving them outward to contact the bore walls of the hole being measured. The gauge is adjusted for minimal

drag in the bore, and then measured with an outside micrometer. A typical application of a split ball gauge would be the measuring of valve guide bores.

Plastigage

Plastigage™ is used to check friction-bearing clearances. It consists of a cylindrical plastic thread wrapped in an envelope calibrated in the dimensions that the Plastigage is designed to measure. To measure bearing-to-shaft clearance, cut a small strip and place it across the width of the bearing shell. Next, torque the cap to specification, which will flatten the Plastigage. Then remove the cap and measure the width that the Plastigage has been squished to against the calibration scale on the envelope. The wider the flattened dimension of the Plastigage, the less the bearing clearance. Plastigage is used to measure rod and main bearing clearance on engines. When crankshaft main journal clearance is measured, the engine must be inverted so that the weight of the crankshaft is fully supported by the cylinder block and not by the main caps. Plastigage is available in four size ranges, but the following three are generally used in engine technology:

- Green: clearance range -0.001 in. to 0.003 in.
- Red: clearance range -0.002 in. to 0.006 in.
- Blue: clearance range -0.004 in. to 0.009 in.

Carefully remove Plastigage from the shaft when the measurement is complete. A Plastigage test strip that is flattened irregularly indicates journal taper.

Dividers and Calipers

Dividers are used for measuring dimensions between lines or points and scribing reference points and arcs. **Calipers** are designed with internally or externally arced legs to perform internal and external measurements. Dividers and calipers are comparison measuring instruments that require the use of a calibrated measuring instrument such as a micrometer or ruler to produce a specific dimension.

Precision Straightedge

A precision straightedge is manufactured from middle alloy carbon steel. It should be encased in a protective wood or plastic cover and hung vertically when stored. A precision straightedge is used for such tasks as measuring cylinder block wear and warpage in conjunction with a set of thickness gauges.

Feeler Gauges

Feeler or thickness gauges are precisely machined blades of tool steel usually packaged in sets. They are available in standard and metric dimensions and tend to be one of the most used items in the technician's toolbox. Thickness gauges are used for setting valve lash, checking connecting rod end-play, checking backlash on gear sets, checking ring end gap and, used with a precision straightedge, checking cylinder head and cylinder block warpage and wear.

Be aware that thickness gauges wear with frequent use. They should be measured from time to time with a micrometer. Individual blades can be easily replaced in a thickness gauge set.

Truck Technician's Toolbox

Not every technician's toolbox will be equipped as shown in **Figure 2-1**, but the following list provides a guideline for purchasing tools. Begin with the safety items:

Safety glasses (Make a practice of wearing these while at work. See **Chapter 3**.)

Hearing protection muffs and plugs

Uncured leather gloves (Use for heavy lifting.)

Latex gloves (These provide the hands with protection against oil and grease.)

¼ in. drive ratchet

⅜ in. drive ratchet

½ in. drive ratchet; ½ in. drive flex/breaker bar

¾ in. drive ratchet; ¾ in. drive flex/breaker bar

Sockets (Purchasing in sets is usually more economical. See **Table 2-2**.)

Allen sockets—an assortment of sizes

½ in. drive torque wrench—click or dial type to 250 lb–ft. (Swivel/flex head is useful for engine work in tight locations.)

⅜ in. drive torque wrench—preferably dial type to 120 in.–lb

¾ in. and 1 in. drive torque wrenches—usually provided by shops

4:1 torque multiplier—usually provided by shops

Combination wrenches—standard: ⅝ in. to 1¼ in.; metric: 4 mm to 30 mm

Open- and box-end wrenches—standard: ⅝ in. to 1¼ in.; metric: 4 mm to 30 mm

(Note: Purchasing wrenches in sets, rather than individually, is usually significantly more economical.)

Allen keys—standard and metric sets

Screwdrivers (Purchase in sets: slotted, Phillips, torx to #30.)

TABLE 2-2: RATCHET DRIVES AND SOCKET SIZES

	Double Hex	Hex	Hex Deep	Soft Impact
¼ in. drive		4 mm to 12 mm ⅜ in. to ½ in.	4 mm to 12 mm ⅝ in. to ½ in.	
⅜ in. drive	10 mm to 19 mm ⅜ in. to ¾ in.	10 mm to 19 mm ⅜ in. to ¾ in.	10 mm to 19 mm ⅜ in. to ¾ in.	
½ in. drive	½ in. to 1⅝ in. 12 mm to 19 mm	½ in. to 1¼ in. 12 mm to 24 mm	½ in. to ⅝ in. 12 mm to 19 mm	½ in. to 1¼ in. 12 mm to 24 mm
¾ in. drive		⅞ in. to 1½ in. 20 mm to 30 mm		

- Digital multimeter (DDM)—2½- or 3½-digit resolution (Consider purchasing a rubber holster to protect the tool.)
- Circuit test light
- Circuit testing clips and cables
- Breakout Ts
- Breakout boxes (Specialty diagnostic breakout boxes are usually provided by shops.)
- Electronic service tools (ESTs)—usually provided by shops (Avoid investing in costly ESTs and software because they rapidly become obsolescent.)
- Coolant hydrometer (not a recommended instrument)
- Refractometer (for coolant and battery electrolyte)—usually provided by shops (Ensure that it is calibrated for electrolyte, ethylene glycol [EG], and propylene glycol [PG].)
- 4 lb cross-peen hammer (optional)
- 1½ lb ball-peen hammer (wood handle)
- 1½ lb nylon/rubber head
- Hacksaw (Selecting a good quality frame with high rigidity and using the best blades can pay off by saving frustration and sweat.)
- Prybar set—to 18-in. size (length)
- Cold chisel set—to 1 in.
- Set of punches—to 1 in.
- Brass drift—1 in. × 8 in.
- Mild steel drift—1 in. × 12 in.
- Stud extractor set plus wheel stud extractor collar
- Nut splitter
- Bolt cutter
- Seal and bearing drivers—normally provided by shops
- Lineman pliers—8 in. and 12 in.
- Terminal crimpers—bent-nose electronic pliers
- Specialty terminal crimpers/connector disassembly tools—usually provided by shops
- Wire strippers—needle-nose pliers
- Side cutters
- Tin snips—straight cut
- Slip joint/water-pump pliers—12 in., 24 in., 36 in.
- Vise grips (Never let anyone kid you that these are the tools of an amateur. There are thousands of valid uses for them in the truck shop.)
- 10 in. pipe jaw, 10 in. straight jaw, 8 in. needle-nose vise grips
- 18 in. pipe wrench
- Adjustable wrenches—6 in., 8 in., 12 in.
- ½ in. chuck pneumatic drill
- HS (high speed steel) drill bits to ⅜ in. size
- ⅜ in. drive air ratchet
- ½ in. drive impact gun (See **Figure 2-17.**)
- Pneumatic chisel/hammer
- Truck tire air chuck
- Tire gauge to 150 psi (1mPa)
- Air blower nozzle
- Air hose—often provided by shops (See **Figure 2-17.**)
- Hand primer pump coupled into #8 hydraulic hose and fittings
- Variable focus flashlight
- Soldering gun
- Telescoping mirror
- Telescoping magnet
- 0 to 1 in. micrometer
- 0 to 1 in. depth micrometer
- 0 to 25 mm micrometer
- 0 to 25 mm depth micrometer
- Micrometer (Sets exceeding 1 in. are provided by shops.)
- 6 in. or 150 mm vernier caliper—digital preferred
- 12 in. tape measure
- Dial bore gauge; telescoping gauges—usually provided by shops
- Stethoscope—usually provided by shops
- Infrared thermometer—usually provided by shops
- Fluorescent trouble light—often provided by shops
- Heavy-duty hand tools (Wrenches sized over 1¼ in. or 30 mm, ⅜ in. and 1 in. drive sockets, and other heavy-duty specialty tools are normally provided by shops.)
- Roller cabinet (Many shallow drawers are preferable to fewer deep ones.)
- Top box (Also consider a side cabinet for shop manuals and fluid containers.)
- Creeper—often provided by shops

SHOP TOOLS

Shop tools are those tools generally provided by the employer. Tools that are too large to fit into a toolbox, high in cost, or highly specialized to a specific procedure should be provided by the service garage.

Sledgehammers

Sledgehammers are designed so that the weight of the head (and perhaps the length of the arms holding the hammer) defines the force imparted. Sledgehammers have a variety of functions in the truck shop and while they are unlikely to be needed in engine reconditioning, they may be required in some of the procedures required to remove components from a chassis. They are usually manufactured in 8-, 12-, and 16-pound weights.

Before using a sledgehammer, inspect the handle for damage and check that the head-to-handle attachment is secure. When swinging a sledgehammer, use a firm but relaxed hand grip and allow the weight of the head to define the amount of force delivered. Never attempt to amplify the force with muscle power as this usually results in missing the target. If the force is insufficient to achieve the objective, select a heavier hammer.

.....
Tech Tip: The neck of a sledgehammer handle is vulnerable when its operator misses the target. Help protect the neck of the sledgehammer handle against accidental damage by binding it with a split section of appropriately sized rubber coolant hose.

Presses

Most truck and bus garages have at least one power press. Extreme caution is required when operating a power press: components should be properly supported, and mandrels/drivers should be used when required. Arbor presses are hand-actuated. Whenever pressing components using any kind of power press, always consider both the consequences of component slippage and where separated components will fall. Personal safety and that of those working in the vicinity must always be considered. **Figure 2-15** shows a press driving a bearing onto a shaft.

Scissor Jacks

Scissor jacks are designed to quickly raise one end of a truck to heights of up to 8 feet above the shop floor. Clevises on the jack fit under each frame rail and the truck is raised by an air-actuated piston. Scissor jacks are an invaluable shop tool but they must be safely used. Ensure that the lift clevises are positioned at a safe location on the frame rails and that allowance is made for the relative movement between the truck and jack during raising and lowering. When the truck has been raised, engage the mechanical stops and make sure that the

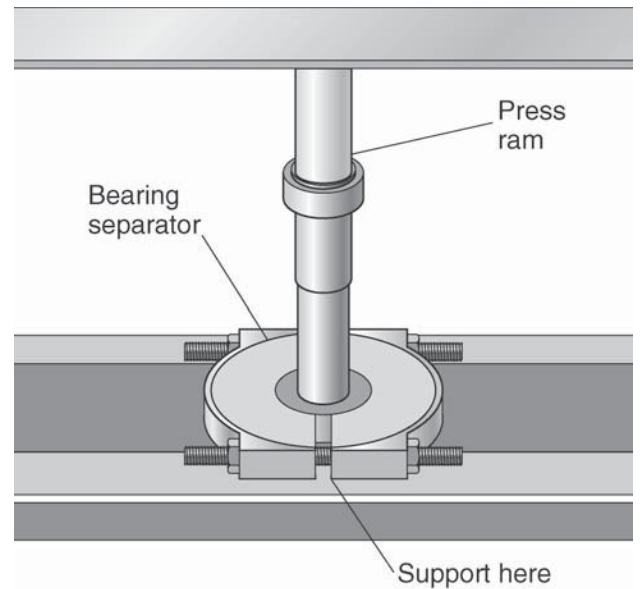

Figure 2-15 Press and bearing puller used to install a bearing on a shaft. (Courtesy of Ford Motor Company)

weight is supported on them and not the power piston. Also check the weight of the vehicle to be lifted and the load capacity of the scissor jack. Chock the wheels on the end of the chassis not being raised after lifting.

A-Frame Hoists

A-frame hoists are often large enough to pass over the top of a truck. They use a block and tackle (chain falls) lift mechanism. A-frame hoists can be used to lift components such as an engine or a cab from the chassis. They also may be capable of hoisting one end of the chassis, but extreme caution should be exercised because of the tendency of anything lifted by chains to swing. The hoist mechanism should be inspected annually whether or not local regulations require the inspection.

Cherry Pickers

These are portable, hydraulically actuated, one-arm boom hoists that have many uses in the truck and bus garage. The term *cherry picker* is commonly used in the industry though the device is also known as an *engine hoist*. They are available in a variety of sizes and load-carrying ratings. The pickup arm is usually adjustable in length, and the longer the adjustment arm setting, the less the load lift potential. If the load-carrying ability is exceeded, they will topple. **Figure 2-16** shows a cherry picker.

Transmission and Clutch Jacks

Transmission and clutch jacks are usually hydraulically actuated and designed to fit under the truck

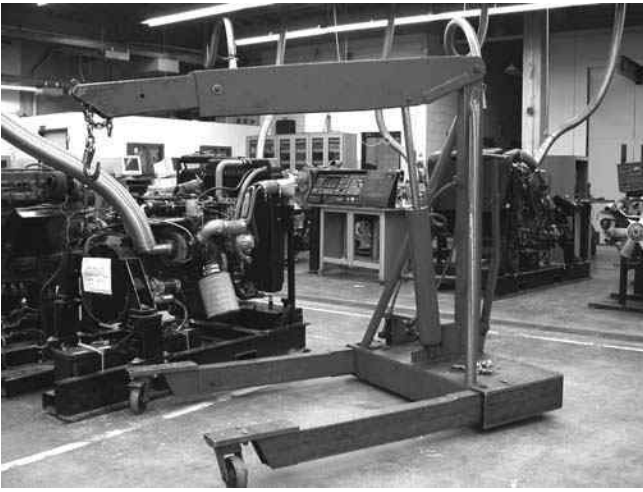

Figure 2-16 Cherry picker or engine hoist.

frame and support the transmission/clutch. It is important to ensure that transmissions are chained securely to these jacks, especially when the mass of a unit is top-heavy such as in triple countershaft units. When the jack must hold the transmission in a stationary position such as when removing an engine from a chassis, ensure that the transmission jack load is supported mechanically. Clutch jacks should be used when installing heavy-duty clutches: a 15½-inch clutch pack can weigh somewhere around 175 pounds (80 kilograms [kg]) and should never be handled without some kind of assistance.

Spreader Bars

A **spreader bar** is a rigid bar, usually adjustable in length, used for lifting engines out of a chassis. The spreader bar is adjusted to the length of the engine, and then attached to the engine on three or four points: the bar should be close to level before a lift is attempted. Chains should be installed so that the chain length is at a minimum with the spreader bar clear of the engine. The chains should be attached to the engine by means of hooks to lifting eyes located on either the cylinder head or cylinder block assembly. Never fit lifting eyes to the rocker housing fasteners. Some engines have just two permanently fitted lifting eyes. It is usually safe to lift these engines using the spreader bar on a two-point lift.

Load Rotor

The load rotor is an alternate to the spreader bar when it comes to hoisting an engine: it permits a limited ability to tilt the load during the lift. Load

rotors consist of a ratcheting chain block with a single chain equipped with hooks at either end. The hooks fit to the engine lift eyes and the load rotor chain block locks the chain, permitting a different length of chain on either side of the block. This feature often permits the chains to be fitted to the engine and clear the upper engine components.

Chains

Chains are rated by working load limit—a value that is normally equivalent to about 25 percent of the tensile strength of the chain material. Many jurisdictions require that chains be inspected annually. Additionally, technicians should visually inspect all chains before using them. The saying that every chain is only as strong as its weakest link bears true. Truck diesel engines can weigh more than a ton and while relying on a chain to support this kind of weight, the technician should try to avoid working under the load. Apart from inspecting the **chain hoists** and checking their load rating, the technician should check the hooks, lifting eyes, lifting eye fasteners, and connecting links.

Slings

Slings may have to be used to hoist engines from the chassis in some applications. These are normally manufactured from synthetic fibers or braided steel wire. Again, the load capacity must be checked and the sling integrity inspected. Avoid using steel cable slings unless also using the engine lift eyes.

Air Tools

Air tools are used extensively in all truck service locations. Some of the air tools are owned by the technicians; others are provided by the shops. Technicians working around pneumatic equipment sometimes forget that it can be dangerous. Always wear eye protection and be aware that dusts driven into the air by pneumatic tools can cause breathing problems. Most shops provide heavy-duty pneumatic tools such as 1-inch drive air guns. A ½-inch drive impact wrench such as that shown in **Figure 2-17** will be one of the most frequently used tools in the truck technician's cabinet. The engine technician primarily uses this for disassembly. Buying a good quality air gun and properly maintaining it by keeping it moisture-free and oiled (observe the oiler and filter in **Figure 2-17**) will help ensure that it functions well for a number of years.

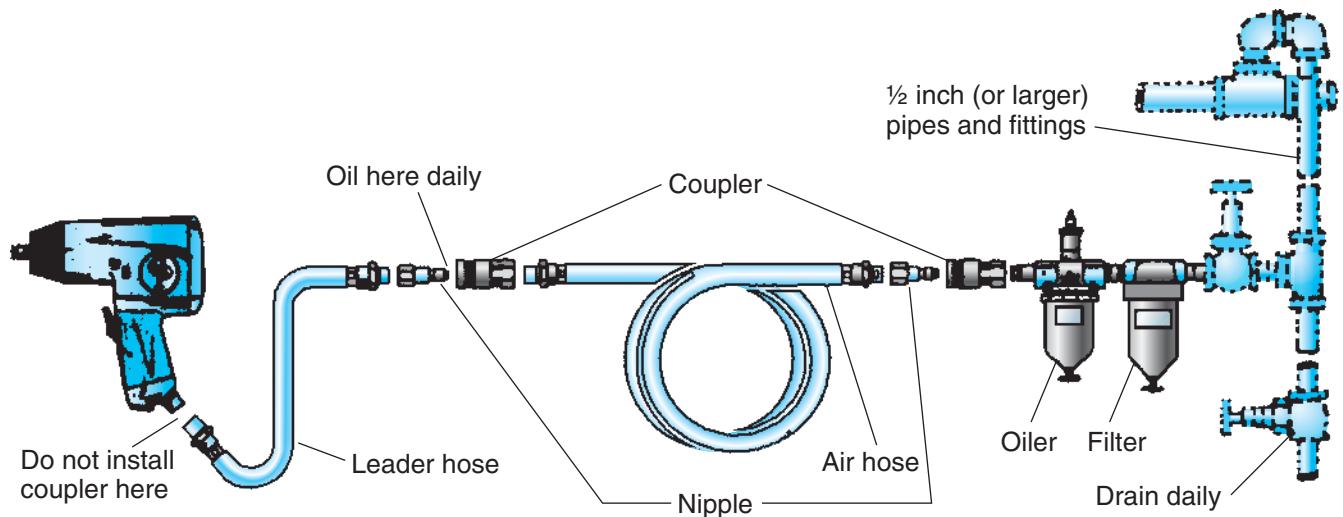

Figure 2-17 Typical setup for a 1/2-inch drive, impact gun. (Courtesy of Chicago Pneumatic)

Tech Tip: Purchase a good quality 1/2-inch drive air impact wrench. With proper care, it should last for many years. Low-cost impact guns are generally a poor investment for a truck technician who uses one daily.

Oxyacetylene Equipment

Truck and bus technicians generally use oxyacetylene for heating and cutting on a daily basis. Less commonly, this equipment is used for brazing and welding. Technicians using oxyacetylene stations require some basic hands-on instruction in the safety requirements and handling of this equipment. (See **Chapter 1** for a detailed explanation of oxyacetylene handling and safety.)

Steam and High-Pressure Washers

Hot water, high-pressure washers have generally replaced the steam cleaners more commonly used a decade ago. Hot water, high-pressure washers are safer and usually require less maintenance than steam washers. Be aware of the potential for damage when using any type of high-temperature, high-pressure washers; eye protection and gloves should be worn when operating this equipment. Environmental regulations in most jurisdictions mandate that the runoff from this type of cleaning operation not be permitted to directly enter sewage systems. Power wash runoff should be filtered through a water separator system, and the separator tanks should be pumped out regularly. Heavy fines may be imposed when sewage is

contaminated with oil and road dirt washed off trucks, buses, and their engines.

Pullers

Shops usually have a selection of general use and specialty pullers that can be power or mechanically actuated. Ensure that puller jaws and legs are capable of handling the force to which they will be subject. Always wear safety glasses when operating pullers.

Pullers are often used in conjunction with a bearing puller clamp. A typical bearing puller clamp is shown in **Figure 2-15**.

Bushing Drivers

Bushing drivers consist of a mandrel, which should fit tightly in the bushing bore with the shoulder having an identical **outside diameter (od)** to the bore that the bushing is pressed into. This should enable bushings to be removed and installed without damaging either the bushing or the bore to which it is fitted. Bushings may be installed using direct mechanical force, such as a hammer or slide hammer, or by using hydraulic or pneumatic power drivers. Always wear safety glasses when using bushing drivers. Some bushings must be reamed for final fit after installation.

Glass Bead Blasters/Sandblasters

Most shops rebuilding engines are equipped with a glass bead blaster or sandblaster. Usually these are encased in an enclosed housing and powered pneumatically. They are ideal for cleaning components, especially those coated with high-tack adhesives or gasket remains that can be difficult to remove. In

enclosed housing glass bead blasters, protective gloves are integral with the unit and in most cases the blaster can be actuated only when the component is placed inside and the cover sealed. Armored glass permits the technician to observe the object being blasted. Consider using hearing protection when operating blasters, as these units are capable of producing high noise levels.

Tech Tip: Following any bead or sandblasting procedure; all the beading material must be completely removed from the components treated. Special attention must be paid to bolt holes, oil galleries, and bearing surfaces.

Tachometers

Tachometers measure rotational speed. Mechanical tachometers consist of a pickup button that directly contacts the rotating component (it should be held close to its axis) and produces a direct rotations per minute (rpm) reading. Electronic tachometers use a sensor that reads a magnetic strip and reports the rpm digitally. These tachometers should be capable of producing mean (average) readings when reading rotational speed on components whose rpm is fluctuating.

FASTENER GRADES AND TORQUES

Diesel engine technicians should be able to identify SAE (Society of Automotive Engineers) cap screw (bolt) and nut identification grades (**Figure 2-18**).

However, most engine OEMs use a large quantity of special fasteners that the OEM classifies by a part number. This is often done with the specific objective of discouraging crossover to any other than OEM fasteners either because of some very specific metallurgical properties of the fastener, which make crossover impossible, or simply to prevent the use of substandard quality fasteners. In recent years, the North American market has been subject to bogus fasteners mostly originating in Asia with the appropriate SAE markings that have found their way onto aircraft and highway equipment at both manufacturing and repair facilities. Unfortunately, these dangerous and illegal fasteners are not usually discovered until analysis by accident investigators. It is important to purchase fasteners from reputable suppliers and perform destructive testing on fastener samples at random intervals.

The SAE fastener grades commonly used on trucks and their engines are:

- Grade 5 category—manufactured from medium carbon steels and heat treated to provide:

	<i>Proof Loads</i>	<i>Tensile Strength</i>
to ¾ in.	85,000 psi	120,000 psi
¾ in. to 1 in.	78,000 psi	115,000 psi
1 in. to 1½ in.	74,000 psi	105,000 psi

- Grade 8 category—manufactured from medium carbon alloyed steels and heat treated and roll threaded to provide:

	<i>Proof Loads</i>	<i>Tensile Strength</i>
to 1½ in.	120,000 psi	150,000 psi

Standard bolts—Identification marks correspond to bolt strength—increasing numbers represent increasing strength.

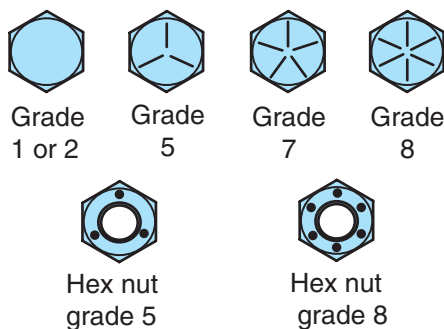

Increasing dots represent increasing strength.

Metric bolts—Identification class numbers correspond to bolt strength—increasing numbers represent increasing strength.

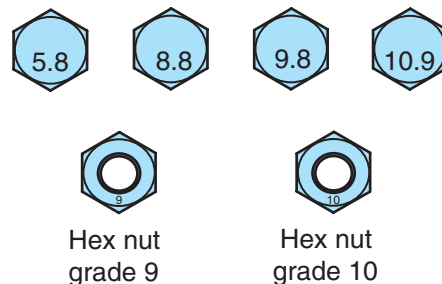

Can also have a blue finish or paint dab on hex flat. Increasing numbers represent increasing strength.

Figure 2-18 Bolt head identification chart. (Courtesy of Navistar International Corp.)

SAE grade 5 fasteners are identified by three radial strokes. SAE grade 8 fasteners are identified by six radial strokes.

Tech Tip: Replacing an SAE grade 5 fastener with one of grade 8 may be inviting problems in certain fastener applications. Grade 8 fasteners have lower elasticity (flexibility) and can fail or cause the components they are fastening to fail. Always use the OEM-recommended fastener.

Clamping Force

Fasteners are designed to provide clamping force. When the fasteners responsible for clamping a cylinder head to a cylinder block are torqued to a common torque value, the objective is to ensure a consistent clamping force throughout the assembly. Fasteners such as Huck™ fasteners provide a more reliable clamping force value because they are set by defining the clamping force and eliminating the variables encountered when using a torque value to set the clamping force.

Tensile Strength and Yield Strength

Fasteners are rated by **tensile strength**, the amount of force that must be exacted on a round bar of 1-inch sectional area to make it fracture. The **yield strength** is the amount of force that must be exerted using the same test to cause the bar to permanently deform; typically this force is about 10 percent lower than the tensile strength value in steels. The difference between the tensile strength and yield strength is sometimes used to denote the elasticity of a material.

Shear Strength

Shear strength is a measure of a fastener's ability to withstand force applied at a 90-degree angle to the axis of the bolt. Some bolts are made to withstand shear forces such as body-bound bolts, manufactured with an interference fit shank: the interference fit shank consists of an extended shoulder that should be driven home with a hammer before applying torque to the nut.

METRIC SYSTEM AND ENGLISH/ METRIC CONVERSION

The metric system has been authorized by an act of Congress in the United States and by federal legislation

in Canada. The metric system is used by most countries in the world, and has been generally adopted by industry for use in the United States as a replacement for the standard system. For example, every truck diesel engine engineered in the United States since 1980 has been a metric engine. However, the specifications reproduced in service literature are usually presented in both standard and metric systems and as a consequence most mechanical technicians are forced to have an understanding of both. The British replaced the "English" system of weights and measures with the metric system more than 40 years ago.

The metric system is a decimal system, the meter being the basis of all measures, whether of length, surface, capacity, volume, or weight. The meter measures 39.37 inches and is theoretically one ten-millionth of the distance from the equator to the pole. The unit of weight is the gram (15.432 grains), and is the weight of a cubic centimeter of water at its greatest density at about 39°F (3.9°C).

Multiples of the units are expressed by the Greek prefixes meaning:

- deca = tens
- hecto = hundreds
- kilo = thousands
- mega = millions
- giga = billions

Decimal parts of the units are indicated by the Latin prefixes meaning:

- deci = tenths
- centi = hundredths
- milli = thousandths
- micro = millionths
- nano = thousand millionths
- pico = billionths

Metric Weights and Measures

Listings of the commonly used metric weights and measures as well as a conversion table for common metric measurements to standard units follow.

Metric Weights

Milligram	(1/1,000 gm)	= 0.0154 grain (gr.)
Centigram	(1/100 gm)	= 0.1543 gr.
Decigram	(1/10 gm)	= 1.5432 gr.
Gram		= 15.432 gr.
Decagram	(10 gm)	= 0.3527 ounce (oz.)
Hectogram	(100 gm)	= 3.5274 oz.
Kilogram	(1,000 gm)	= 2.2046 lb
Myriagram	(10,000 gm)	= 22.046 lb

Metric Dry Measures

Milliliter	(1/1,000 L)	= 0.061 cubic inch (cu. in.)
Centiliter	(1/100 L)	= 0.6102 cu. in.
Deciliter	(1/10 L)	= 6.1022 cu. in.
Liter		= 0.908 quart (qt.)
Decaliter	(10 L)	= 9.08 qt.
Hectoliter	(100 L)	= 2.838 bushels (bu.)
Kiloliter	(1,000 L)	= 1.308 cubic yard (cu. yd.)

Metric Liquid Measures

Milliliter	(1/1,000 L)	= 0.0338 fluid ounce (fl. oz.)
Centiliter	(1/100 L)	= 0.338 fl. oz.
Deciliter	(1/10 L)	= 3.380 fl. oz.
Liter		= 1.0567 qt.
Decaliter	(10 L)	= 2.6418 gallons (gal.)
Hectoliter	(100 L)	= 26.417 gal.
Kiloliter	(1,000 L)	= 264.18 gal.

Metric Measures of Length

Millimeter	(1/1,000 m)	= 0.0394 in.
Centimeter	(1/100 m)	= 0.3937 in.
Decimeter	(1/10 m)	= 3.937 in.
Meter		= 39.37 in.
Decameter	(10 m)	= 393.7 in.
Hectometer	(100 m)	= 328.1 ft.
Kilometer	(1,000 m)	= 0.62137 mile (mi.)
	(1 mi. = 1.6093 km)	
Myriameter	(10,000 m)	= 6.2137 mi.

Metric Surface Measures

Centare (1 sq. m)	= 1,550 sq. in.
Are (100 sq. m)	= 119.6 square yard (sq. yd.)
Hectare (10,000 sq. m)	= 2.471 acre

Metric to Standard Conversions

The following formulae can be used to translate metric values to standard and vice versa.

Linear Measurements

Centimeters	$\times 0.3937 =$ in.
Meters	$= 39.37$ in.
Kilometers	$= 0.621$ mi.
Kilometers	$\times 3280.89 =$ ft.
Square centimeters	$\times 0.155 =$ sq. in.
Cubic centimeters	$\times 0.06102 =$ cu. in.
Cubic meters	$\times 35.3144 =$ cu. ft.
Liters	$\times 0.2642 =$ gal. (231 cu. in.)
Kilograms	$\times 2.2046 =$ lb

Kilograms (kg) per square millimeter (sq. mm.)	$\times 1,422.3 =$ lb per sq. in. (psi)
Kg per sq. in.	$\times 14,223 =$ lb psi

Torque Conversion

1 lb–ft.	$= 1.355$ Newton-meters (Nm)
1 Nm	$= 0.738$ lb–ft.

Temperature Conversion

$$\text{Degrees Fahrenheit} = \frac{9 \times C}{5} + 32$$

$$\text{Degrees Celsius} = \frac{5 \times (F - 32)}{9}$$

Pressure Conversions

Older fuel injection test instruments were often calibrated in **units of atmosphere (atms)**. Technicians should become familiar with the process of converting units of pressure into the metric and standard systems. This is an easy way:

$$\begin{aligned} \text{Atmospheric pressure @ sea level} &= 14.7 \text{ psi} \\ &= 101.3 \text{ kiloPascal (kPa)} \\ &= 1 \text{ unit of atmosphere or 1 atms} \end{aligned}$$

The following fast method of converting pressure values is not as mathematically accurate as the previous equivalent but is accurate enough for quick conversions:

$$15 \text{ psi} = 100 \text{ kPa} = 1 \text{ atms}$$

So, to convert 45 psi to kPa:

$$\frac{45}{15} = 3 \text{ units of atmosphere or 3 atms}$$

$$3 \text{ atms} \times 100 \text{ kPa} = 300 \text{ kPa}$$

In Europe, a unit of pressure measurement known as **bar** is used. As our domestic market becomes more international we are increasingly using the bar as a unit of pressure measurement. One bar is equivalent to 105 Newtons per square meter, not precisely equivalent to one unit of atmosphere. Although units of bar and atms are often used as if they were exactly equivalent, this is not so, and, where precise values are required, they should not be confused.

$$\begin{aligned} 1 \text{ atms} &= 14.7 \text{ psi} = 101.3 \text{ kPa} = 1.033 \text{ bar} \\ &= 29.92 \text{ inches of mercury (in. Hg)} \\ &= 407.19 \text{ in. H}_2\text{O} \end{aligned}$$

Power Conversion

$$\begin{aligned} 1 \text{ horsepower (HP)} &= 550 \text{ ft.–lb per second} \\ &= 0.746 \text{ kilowatt (kW)} \\ &= 42.4 \text{ British thermal unit (Btu) per minute} \end{aligned}$$

Summary

- The actual contents of a truck or diesel technician's toolbox should be determined by the type of work performed.
- Cheaper tools are often more bulky and more prone to breakage.
- The personal safety of the user is always on the line when hand tools are being used, so it makes sense for the professional to invest in reliable tools.
- The technician should acquire some knowledge of precision measuring tools before using them on a critical job. This is best done by using the instruments and measuring actual engine components.
- Reading both standard and metric micrometers becomes much easier when the technician understands exactly how they are constructed and calibrated.
- A standard micrometer rotates through 40 complete revolutions from the point at which the spindle contacts the anvil producing a zero reading to the point at which it reads 1 inch. Each complete revolution of the thimble therefore represents 0.025 inch.
- A metric micrometer must be rotated through 50 complete revolutions from the point at which the spindle contacts the anvil producing a zero reading to the point at which it reads 25 mm. Each complete revolution of the thimble therefore represents 0.05 mm.
- Diesel engine technicians should be familiar with setting up and using dial bore gauges.
- Shop hoisting apparatus should be routinely inspected by qualified personnel and by the technician before using it. This may be a legal requirement in some jurisdictions.
- Shop power equipment must be checked out by the technician before each use.
- The technician should know how to identify SAE fastener grades and understand the importance of selecting the correct grade for the job being performed.
- Engine OEMs use many specialty fasteners on their engines: these usually have special metal properties and should not be replaced by SAE fasteners.
- The technician should be prepared to work in either the standard or the metric system. It is not necessary to memorize the formulae, but the technician should get used to rapidly converting values from one system to the other.

Review Questions

1. When the spindle contacts the anvil on a standard 0- to 1-inch micrometer, it should read:
A. Zero
B. One thousandth of an inch
C. 0.025 inch
D. 1 inch
2. How many complete rotations must the thimble of a standard micrometer be turned to travel through a reading of zero to a reading of 1 inch?
A. 25
B. 40
C. 50
D. 100
3. How many complete rotations must the thimble of a standard metric micrometer be turned to travel through a reading of zero to a reading of 25 mm?
A. 25
B. 40
C. 50
D. 100
4. When the thimble of a metric micrometer is turned through one full revolution, the dimension between the anvil and the spindle has changed by:
A. 0.1 mm
B. 0.5 mm
C. 2.5 mm
D. 5.0 mm

5. When using a dial indicator to check the concentricity of a flywheel housing, during a single rotation of the flywheel, the reading on the positive side of the zero on the dial peaks at 0.002 inch while the reading on the negative side peaks at 0.005 inch. What is the TIR?
 - A. 0.003 inch
 - B. 0.005 inch
 - C. 0.007 inch
 - D. 0.010 inch

6. Which of the following precision measuring instruments would be required to measure a valve guide bore?
 - A. Dial indicator
 - B. Inside micrometer
 - C. Split ball gauge and micrometer
 - D. Dial bore gauge

7. How many radial strokes on the cap-screw head indicate that a bolt is an SAE grade 5 bolt?
 - A. 3
 - B. 5
 - C. 6
 - D. 8

8. The cutting fluid recommended for use when cutting threads in mild steel is:
 - A. Soluble oil and water
 - B. Lard
 - C. Dry
 - D. Kerosene

9. When drilling into cast iron, the correct method calls for the procedure to be performed:
 - A. With kerosene
 - B. With lard
 - C. Preheated
 - D. Dry

10. Which Plastigage color code should be selected to measure a main bearing clearance that the manufacturer specifies must be between 0.0023 inch and 0.0038 inch?
 - A. Red
 - B. Green
 - C. Blue

CHAPTER

3

Engine Basics

Learning Objectives

After studying this chapter, you should be able to:

- Interpret basic engine terminology.
- Identify the subsystems that make up a diesel engine.
- Calculate engine displacement.
- Define the term *mean effective pressure*.
- Describe the differences between a *naturally aspirated* and *manifold-boosted* engine.
- Explain how volumetric efficiency affects cylinder breathing.
- Define *rejected heat* and explain thermal efficiency in diesel engines.
- Outline the operation of a diesel four-stroke cycle.
- Outline the operation of a diesel two-stroke cycle.
- Interpret the term *cetane number* and relate it to ignition temperature.

Key Terms

after top dead center (ATDC)	direct injection (DI)	oversquare engine
before top dead center (BTDC)	engine displacement	ratio
bore	fire point	rejected heat
bottom dead center (BDC)	friction	spark ignited (SI)
clearance volume	heat energy	square engine
combustion pressure	ignition lag	stroke
compression	ignition temperature	swept volume
compression ignition (CI)	indirect injection (IDI)	thermal efficiency
compression pressure	inertia	top dead center (TDC)
compression ratio	manifold-boost	torque
cylinder volume	mean effective pressure (MEP)	undersquare engine
diesel cycle	naturally aspirated (NA)	volumetric efficiency

INTRODUCTION

This chapter begins with an explanation of some basic engine terminology. Before you can properly understand how any engine functions, you have to become familiar with the language used to describe its operation. After introducing the basic terminology, the chapter describes first the four-stroke diesel cycle and then the two-stroke diesel cycle. The basic engine terminology and principles introduced in this chapter are used repeatedly throughout the textbook. As you progress through it, use the glossary to check the definitions of any words with which you are not familiar.

KEY ENGINE TERMS

The terms explained in this chapter are the building blocks required to understand engine technology. In most cases, technically correct terms are used in this textbook, but remember that the terminology used on the shop floor might differ. When you reference manufacturers' service literature, you will be expected to have a basic understanding of the key terms introduced in this chapter. The following text simply interprets many of the words that are later used to describe the various engine cycles and key events within those cycles. We introduce these terms in two sections within this chapter.

Building Block Definitions

You probably are already familiar with some of the terms introduced in this section, but even if you are, read through the definitions because those given here may differ in small ways from those with which you are familiar.

Engine. The term *engine* describes a machine that converts one energy form to another. A waterwheel driving a mill could be described as an engine. When this book refers to an engine, we will be referring to an engine that converts the heat energy of a fuel into useable mechanical energy.

Internal Combustion Engine. The term *internal combustion engine* describes a heat engine in which the combustion of fuel is contained within a cylinder. A spark-ignited, gasoline-fueled engine such as the one powering most cars is an internal combustion engine. So is a diesel engine. Internal combustion engines differ from steam engines (these are *external* combustion engines) in which the fuel is combusted outside of the engine.

Diesel Engine. A *diesel engine* is a type of internal combustion engine in which the fuel/air charge is ignited by the heat of compression. It differs from a spark-ignited engine in which the fuel/air charge is ignited by a spark from a spark plug.

Kinetic Energy. *Kinetic energy* is the energy of motion. Kinetic energy is a form of mechanical energy. When an engine attempts to convert the energy available in a fuel to mechanical work, some heat losses result. Kinetic energy describes the percentage of a fuel's potential energy that actually gets converted to usable mechanical energy in an engine.

Air. *Air* is a gaseous mixture of nitrogen and oxygen. We breathe this mixture we call air and so does a diesel engine. Air is composed of a little under 80 percent nitrogen and a little over 20 percent oxygen. The oxygen available in air is used as the reactant to combust the fuel in most internal combustion engines.

Fuel. The *fuels* we use in diesel engines are hydrocarbons (HC). The source of most diesel fuel used today is petroleum. However, other hydrocarbon-based fuels (such as soy-based biodiesels) are used and under some conditions can work as efficiently as petroleum-based fuels.

Heat Energy. *Heat energy* is a rating of the available energy in any given fuel. As the heat energy of a fuel increases, so does the potential for converting this heat energy into useful kinetic energy. For instance, a gasoline contains less heat energy by weight than a diesel fuel. Because of this, the power potential of diesel fuel per unit of fuel used is usually greater than that for an equivalent gasoline-fueled engine.

Naturally Aspirated. The term **naturally aspirated (NA)** is used to describe an engine in which air (or air/fuel mixture) is induced into its cylinders by low cylinder pressure created by the downstroke of the piston. Not too many diesels today are naturally aspirated; most are turbo-boosted. An engine that has no turbocharger or supercharger is naturally aspirated.

Turbo-Boost. As mentioned earlier, most diesel engines are *turbo-boosted*. Another way of saying turbo-boost is **manifold-boost**. Manifold-boosted describes any engine whose cylinders are charged at pressures above atmospheric.

Volumetric Efficiency. The term **volumetric efficiency** is defined as a measure of an engine's breathing efficiency. It is the ratio between the volume of actual fresh air taken into the engine cylinder before the intake valves close versus the cylinder swept volume. Volumetric efficiency is usually expressed as a percentage. In turbocharged engines, volumetric efficiency often greatly exceeds 100 percent. The best way to define the term is as the amount of air charged to the engine cylinder in an actual cycle versus the amount it would contain if it were at atmospheric pressure.

THE DIESEL CYCLE

The definitions of terms given so far in this chapter should be sufficient for understanding the operation of the diesel cycle. Toward the end of the chapter, we will examine another group of terms that are the building blocks required for understanding the diesel engine.

A cycle is a sequence of events. The **diesel cycle** is best introduced by outlining the four strokes of the pistons made as an engine is turned through two revolutions. A full cycle of a diesel engine requires two complete rotations. Each rotation requires turning the engine through 360 degrees, so a complete diesel cycle translates into 720 crankshaft degrees.

Each of the four strokes that make up the diesel cycle involves moving a piston either from the top of its travel to its lowest point of travel or vice versa; each stroke of the cycle therefore translates into 180 crankshaft degrees. The four strokes that comprise the four-stroke cycle are:

1. Intake
2. Compression
3. Power
4. Exhaust

The four strokes of the diesel cycle are shown in **Figure 3-1**.

The diesel cycle is by definition a four-stroke cycle. Two-stroke cycle diesel engines do exist but always have to be qualified as *two-stroke cycle* diesel engines. These are described later in this chapter. Most modern diesel engines are four-stroke cycle engines. This is necessary to meet current emissions standards.

Direct Injection, Compression Ignition Engine

Now we will take a closer look at what happens during the four-stroke diesel cycle. Refer to **Figure 3-2** to help you understand the description provided here.

1. Intake Stroke. The piston is connected to the crankshaft throw by means of a wrist pin and connecting rod. The throw is an offset journal on the crankshaft. Therefore, as the crankshaft rotates the piston is drawn from top dead center (TDC) to bottom dead center (BDC): while the piston moves through its downstroke, the cylinder head intake valves are held open. The downstroke of the piston creates lower atmospheric pressure in the cylinder and in a naturally aspirated engine, this pulls a charge of fresh, filtered air into the cylinder. Because most current truck and bus engines are turbocharged, the cylinder will actually be

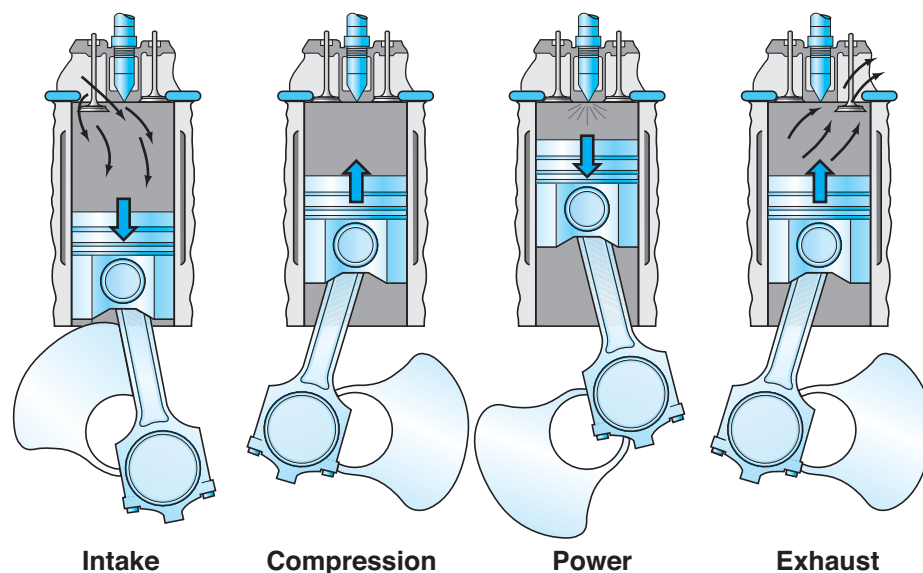

Figure 3-1 The four-stroke, diesel cycle.

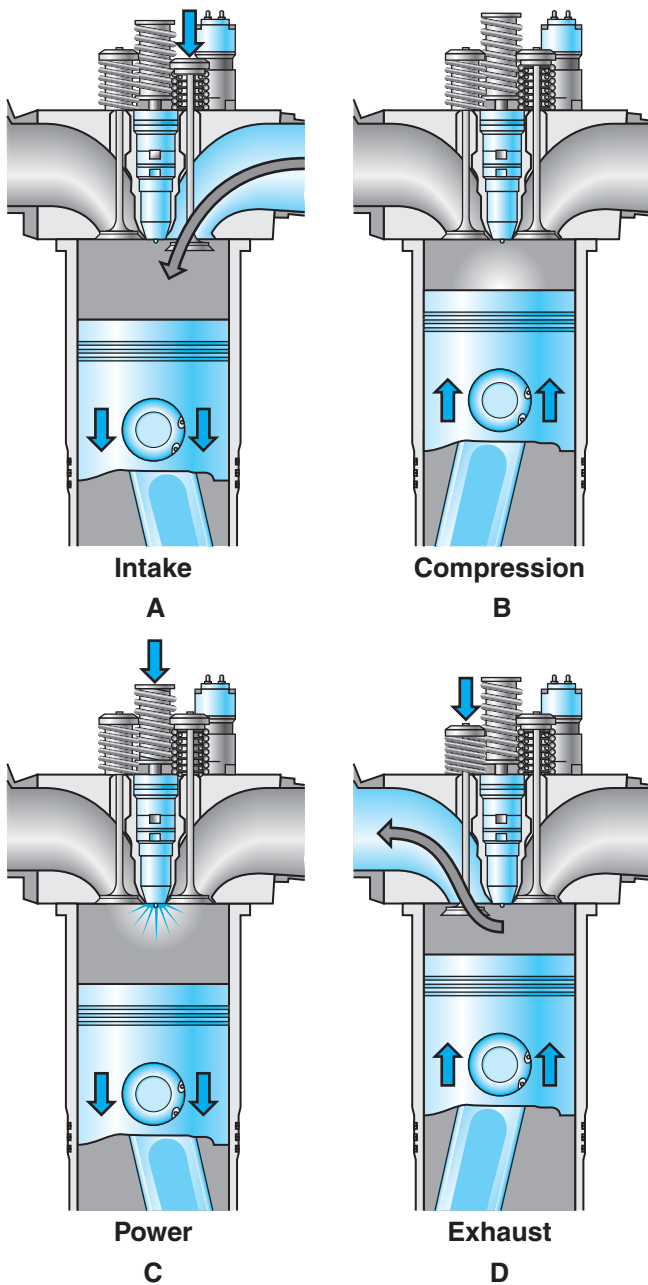

Figure 3-2 (A) Intake stroke: turbo-boosted air is charged to the engine cylinder. (B) Compression stroke: piston is driven upward, compressing the air charge. (C) Power stroke: fuel is injected to cylinder and resulting gas expansion drives the piston downward. (D) Exhaust stroke: piston is driven upward, displacing end gas through the exhaust valves. (Courtesy of Caterpillar)

filled with charged air (turbo-boosted) when the intake valves open and the piston travels downward. This means that at the completion of the intake stroke when the intake valves close, the cylinder will be filled with a charge of filtered air. The actual quantity of air in the cylinder will depend on the extent of turbo-boost.

Turbo-boost varies with how the engine is being operated. **Figure 3-2A** illustrates the intake stroke.

The *air* that is taken into the cylinder is a mixture of approximately four-fifths nitrogen and one-fifth oxygen. The oxygen is required to combust the fuel. Note that no fuel is introduced into the engine cylinder during the intake stroke. When the air charged to the engine cylinder is pressurized using a turbocharger, more oxygen can be forced into the cylinder. All diesel engines are designed for lean burn operation; that is, the cylinder will be charged with much more air than that required to combust the fuel. Volumetric efficiency in most phases of engine operation usually exceeds 100 percent in turbocharged engines.

2. Compression Stroke. At the completion of the intake stroke, the intake valves close, sealing the engine cylinder. The piston is now driven upward from BDC to TDC with the intake and exhaust valves closed. The quantity of air in the cylinder does not change, but compressing the charge of air in the cylinder gives it much less space and heats it up considerably. Compression pressures in diesel engines vary from 400 pounds per square inch (psi) (2,750 kiloPascal [kPa]) to 700 psi (4,822 kPa). The actual amount of heat generated from these compression pressures also varies, but it usually substantially exceeds the minimum ignition temperature values of the fuel. Compression ratios used to achieve the compression pressure required of diesel engines generally vary from a low of 14:1 to a high of 25:1. However, in modern turbocharged, highway diesel engines, compression ratios are typically around 16:1 to 17:1. **Figure 3-2B** illustrates the compression stroke.

3. Power Stroke. Shortly before the completion of the compression stroke, atomized fuel is introduced directly into the engine cylinder by a multi-orifice (multiple-hole) nozzle assembly. The fuel exits the nozzle orifices at very high pressures and in a liquid state. The liquid droplets emitted by the injector must be sized appropriately for ignition and combustion. Once exposed to the heated air charge in the cylinder, these fuel droplets are first vaporized (their state changes from that of a liquid to a gas), and then ignited. The ignition point of the fuel is usually designed to occur just before the piston is positioned at TDC: you can compare the ignition point of diesel fuel in the cylinder with spark timing in a gasoline-fueled engine. However, in the diesel engine the cylinder pressures that result from combusting fuel in the cylinder can be managed with more precision than in indirect-injected gasoline engines. This is because fuel can be injected at

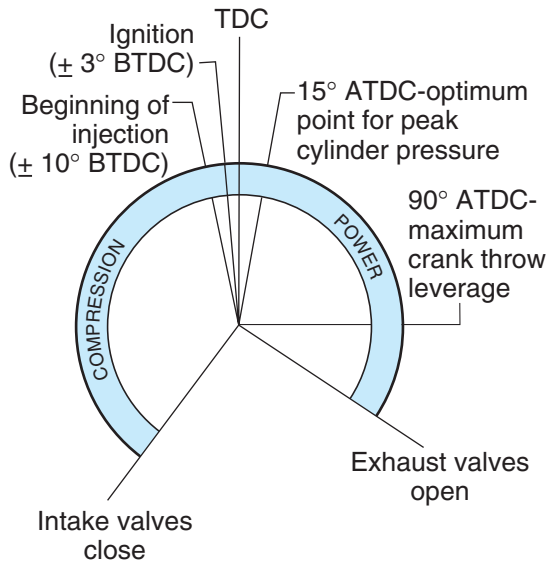

Figure 3-3 Events of the compression and power strokes.

high pressures into the cylinder during combustion. **Figure 3-2C** illustrates the power stroke.

During the power stroke, cylinder pressure resulting from the combusting of fuel acts on the piston driving it downward through its downstroke. The piston moves linearly, that is, in a straight line. It is connected to the crankshaft throw which rotates. In this way, cylinder pressures are converted into a twisting force known as **torque**. Because the crank throw is offset from the crankshaft centerline it acts as a lever. For this reason, in managing the power stroke, it is desirable to have little pressure acting on the piston at TDC because it has zero leverage at this specific location. As the piston moves downward, the leverage increases incrementally until the angle between the crank throw and connecting rod is 90 degrees (maximum leverage). By getting cylinder pressure (managed by the fuel system) and throw leverage (a hard value dependent on the rotational position of the engine) to work together, it is possible to deliver a relatively constant torque from around 15 degrees after top dead center (ATDC) to 90 degrees ATDC. This relationship between pressure and throw leverage helps to transmit the energy produced in the engine cylinder as smoothly as possible to the flywheel (**Figure 3-3**).

4. Exhaust Stroke. Somewhere after 90 degrees ATDC during the expansion stroke, most of the heat energy that can be converted to kinetic energy has been converted and the exhaust valves open. The products of cylinder combustion are known as end gas. The exhausting of combustion end gases occurs in four

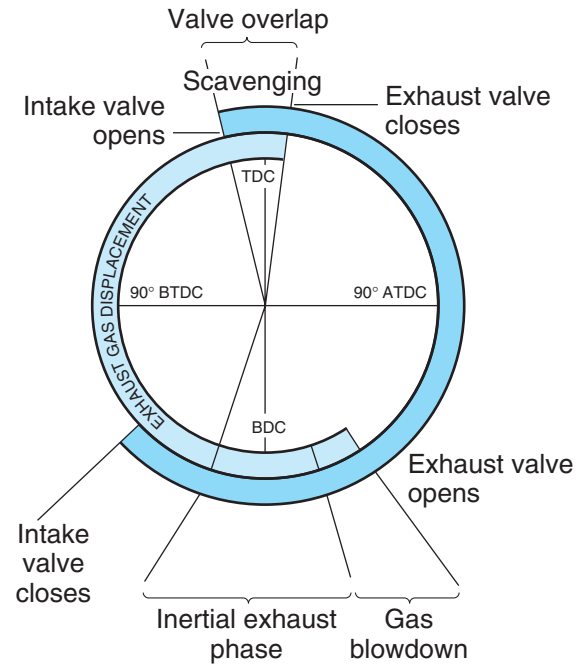

Figure 3-4 Events of the intake and exhaust strokes.

distinct phases and the process begins toward the end of the power stroke as the piston is traveling downward (**Figure 3-4**):

1. Pressure differential—At the moment the exhaust valves open during the latter portion of the power stroke, pressure is higher in the cylinder than in the exhaust manifold. High-pressure end gas in the cylinder will therefore flow to the lower pressure in the exhaust manifold.
2. Inertial—Next the piston comes to a standstill at BDC at the completion of the power stroke. However, gas inertia established during the pressure differential phase results in the end gases continuing to flow from the cylinder to the exhaust manifold while the piston is in a stationary state and near stationary state of motion.
3. Displacement—As the piston is forced upward through its stroke, it positively displaces the combustion end gases above it.
4. Scavenging—Toward the end of the exhaust stroke, as the exhaust valves begin to close, the intake valves begin to open with the piston near TDC. The scavenging phase takes place during valve overlap and can be highly effective in expelling end gases and providing some piston crown cooling. The efficiency of the scavenging process is greatest with turbocharged engines. Photosequence 1 shows piston and valve movements on a cutway, 4-stroke cycle diesel engine.

PHOTO
SEQUENCE

1

Four Stroke Diesel Cycle and Valve Status

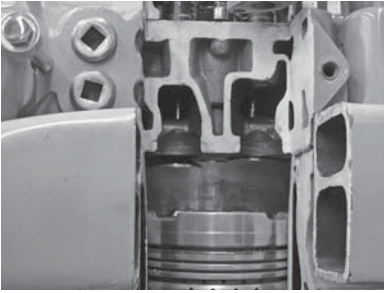

P1-1 Piston travels downward. Intake valve is open. Exhaust valve is closed. Filtered air enters the cylinder.

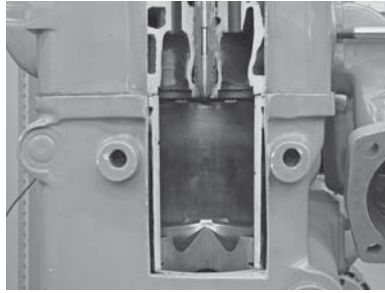

P1-2 Piston bottoms (BDC) at the end of the intake stroke. Intake valve closes. Both the intake and exhaust valves are closed, sealing the engine cylinder.

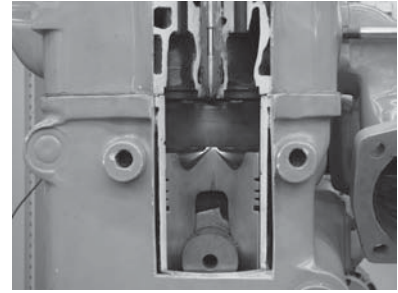

P1-3 Compression stroke: the piston is driven upward. Because the cylinder is sealed (both intake and exhaust valves closed), the air in the cylinder is compressed. As the air is compressed, it heats.

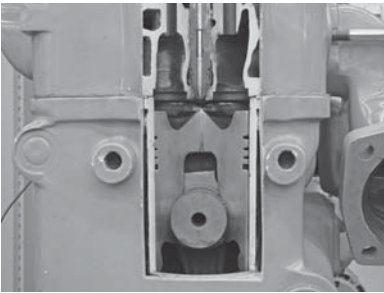

P1-4 Power stroke: high pressure fuel is injected into the engine cylinder. The heat of the compressed air in the cylinder ignites the fuel. Combustion pressure acting on the piston forces it downward through the power stroke.

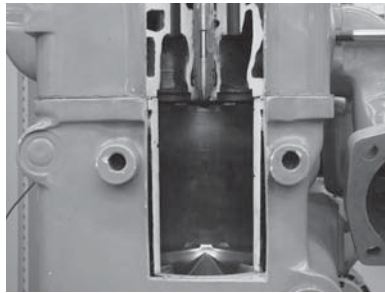

P1-5 Exhaust valve opens. This unseals the engine cylinder. Higher pressure exhaust gases escape to the exhaust system through the open exhaust valve.

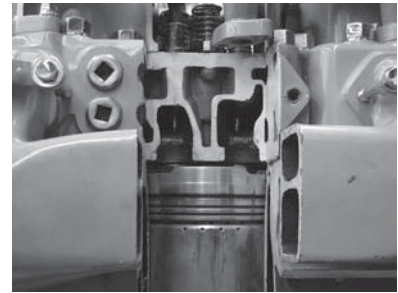

P1-6 Exhaust stroke: the piston is driven upward in the engine cylinder displacing the end gases out to the exhaust system.

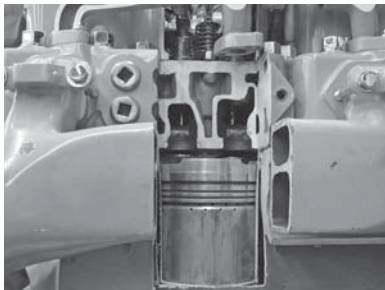

P1-7 Valve overlap: before the exhaust valve closes, the intake valve opens. This allows filtered air from the turbocharger compressor to scavenge the engine cylinder of any remaining exhaust gas. This is known as cylinder scavenging.

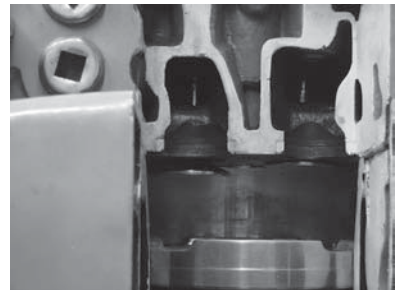

P1-8 Exhaust valve closes, intake valve remains open. As the piston is pulled downward, the cycle repeats itself, with a new charge of fresh, filtered air forced into the cylinder.

TWO-STROKE CYCLE DIESEL ENGINE

The two-stroke cycle engine eliminates the intake and exhaust strokes. This means that in 360 degrees of rotation, each engine cylinder must fire once. Theoretically, the two-stroke cycle diesel engine should develop twice as much power as a four-stroke cycle engine of the same displacement, but in reality this is not achieved mainly due to reduced cylinder breathing efficiency. The two-stroke cycle diesel engine principle is widely used but the only examples in the truck and bus industry are manufactured by the Detroit Diesel Corporation. These engines have not been able to meet Environmental Protection Agency (EPA) noxious emissions standards for some time, but for more than a generation they have been popular as bus engines: buses can have a working life of up to 30 years so some of these engines will be around for a few years to come. Many of the two-stroke cycle engines in existence are managed electronically; retrofitting electronic controls on some Detroit Diesel hydromechanical engines can make them more fuel-efficient. They also have been adapted to burn fuels other than diesel with some success.

Two-stroke cycle engines differ from four-stroke cycle diesel engines mainly because cylinder breathing must take place in less than one-fifth of the time. All the valves in the cylinder head, usually four per cylinder, are exhaust valves. After combustion, the cylinder end gases must be expelled and to enable this, air must be pumped through the cylinder from an air box charged by a Roots blower, sometimes aided by a turbocharger. In truck and bus applications, because of widely variable speed and load variations, engine breathing requires the use of a Roots blower. A Roots blower is a positive displacement pump that works efficiently at all rotational speeds. Its disadvantage is that it is gear driven and leeches engine power.

A turbocharger may be used in applications such as a genset in which engine loading would result in adequate exhaust gas heat to drive the turbine with sufficient efficiency for it to act as the air box pump. The cylinder liners are machined with ports designed to be exposed when the piston is in the lower portion of its downstroke; when these ports are exposed to the air box by the downward traveling piston, the cylinder is charged with air for scavenging and breathing. The ports are usually angled to encourage vortex (cyclonic) airflow movement.

The two-stroke cycle sequence begins with the piston at BDC when what is termed cylinder *scavenging* takes place. At this moment, the piston has fully exposed the canted intake ports and the exhaust valves are fully opened. Air from the air box rushes into the cylinder and displaces the combustion end gases, spiraling them upward to exit through the exhaust valves. Air from the air box continues to charge the cylinder until the piston reverses and its upward travel closes off the intake ports; the exhaust valves close almost simultaneously. Every upward stroke of the piston is therefore a compression stroke. If all the end gases were effectively expelled, only air is compressed; however, scavenging efficiency is a problem with these engines and any end gases remaining in the cylinder after the exhaust valves close will dilute the incoming air change.

Shortly before TDC, the fueling of the cylinder begins directly into the engine cylinder. After a short delay, ignition occurs and expanding combustion gases act on the piston and drive it downward through the power stroke. Every downward stroke of the piston is a power stroke. Shortly before the liner intake ports are exposed by the piston, the exhaust valves open, beginning the exhaust process, which must take place quickly and in two stages: pressure differential and scavenging. The two-stroke cycle engine is shown in **Figure 3-5** and the events are detailed in **Figure 3-6**.

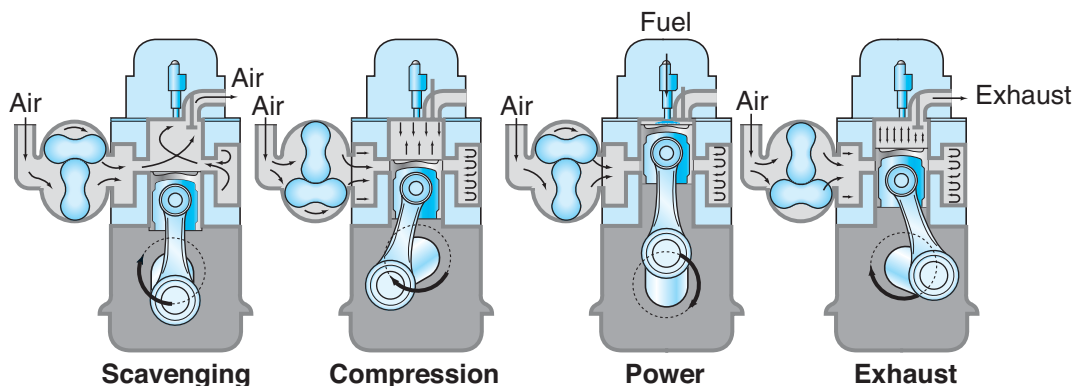

Figure 3-5 The two-stroke diesel cycle.

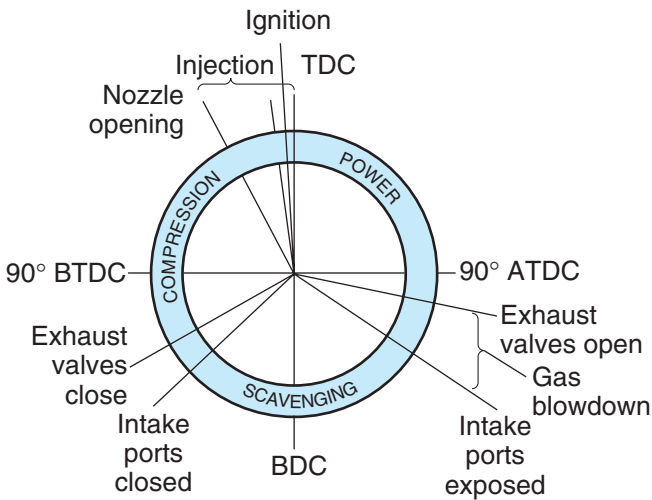

Figure 3-6 Two stroke diesel cycle events.

ENGINE SYSTEMS AND CIRCUITS

Many of the components in the diesel (compression ignition or CI) engine are identical to those in the Otto (spark ignition or SI) cycle engine. For study purposes, the engine components are divided as follows:

1. Engine housing components—the cylinder block, cylinder head(s), oil pan, rocker covers, timing gear covers, manifolds, and flywheel housing.
2. Engine power train—the components directly responsible for power delivery to the drivetrain including the piston assemblies, connecting rods, crankshaft assembly, vibration damper, and flywheel.
3. Engine feedback assembly—the engine's self-management components also known as the valvetrain assembly. This term is used to describe the diesel engine timing geartrain, camshaft, valvetrains, valves, fueling apparatus, and accessory drive components.
4. Engine lubrication circuit—the oil pump, relief valve, lubrication circuitry, full flow filter(s), bypass filters, and heat exchangers.
5. Engine cooling circuit—the coolant pump, thermostat(s), water jacket, coolant manifold, filter, shutters, fan assembly, radiator, and other heat exchangers.
6. Engine breathing system—the engine intake and exhaust system components including pre-cleaners, air cleaners, ducting, turbocharger, Roots blower, charge air heat exchangers, tip turbine assemblies, intake and exhaust manifolds, pyrometer, exhaust gas recirculation (EGR) system, diesel particulate filter (DPF), exhaust

pipings, engine silencer, catalytic converter, and other external emission control apparatus.

7. Engine fuel management system—the fuel storage, pumping, metering, and quantity control apparatus including a management computer, sensors and actuators, hydraulic injectors, mechanical unit injectors (MUIs), electronic unit injectors (EUIs), hydraulically actuated electronic unit injectors (HEUIs), electronic unit pumps (EUPs), common rail (CR) injection, hydromechanical injection pumps, fuel tanks, filters, and transfer pumps.

Diesel Fuel

It helps to know a little bit about the diesel fuel used to fuel compression ignited engines. The fuel used in modern diesel engines on North American highways is composed of roughly 85 percent carbon and 12 to 15 percent hydrogen, not too much different from the chemical composition of gasoline. Unlike gasoline, diesel fuel does not vaporize easily at ambient temperatures, so it is less likely to form combustible mixtures of fuel and air. The heat required to ignite the fuel oil is defined by the most volatile fractions of the fuel: this is determined by the fuel's cetane number (CN). The ignition temperature of highway diesel fuel is usually around 482°F (250°C); this is equivalent to a CN of around 45. The ignition temperature would be higher, around 550°F (290°C), using fuel with the poorest ignition quality (rated with a CN of 40) that can be legally sold for use on North American highways.

Using the example of a diesel fuel with a fire point of 482°F (250°C), this indicates the *minimum* temperature that must be achieved in the engine cylinder if the fuel is to be ignited. In fact, actual cylinder temperatures generated on the compression stroke tend to be considerably higher than the minimum required to ignite the fuel. The greater the difference between these two temperature values, the shorter the ignition lag. **Ignition lag** is the time between the entry of the first droplets of fuel into the engine cylinder and actual ignition that begins combustion.

MORE ENGINE TERMS

Now that you have an understanding of some basic engine terms and know how the different engine cycles function, you should be ready for some more terms and definitions. We have already used some of these terms in describing the engine cycles, but reviewing them here will reinforce them.

Top dead center (TDC): the highest point of piston travel in an engine cylinder.

Bottom dead center (BDC): the lowest point of piston travel in an engine cylinder.

Before top dead center (BTDC): a point of piston travel through its upstroke.

After top dead center (ATDC): a point of piston travel through its downstroke.

Bore: cylinder diameter. Bore is how we express the piston sectional area over which the cylinder pressures act.

Stroke: the distance through which a piston travels from BDC to TDC. Stroke is established by the crank throw offset; that is, the distance from the crankshaft centerline to the throw centerline multiplied by 2 equals the stroke dimension. The relationship between the bore and stroke is shown in **Figure 3-7**.

Swept volume: the volume displaced by the piston in the cylinder as it moves from BDC to TDC. It can be calculated if both stroke and bore are known.

Clearance volume: the remaining volume in an engine cylinder when the piston is at the top of its travel or TDC. The clearance volume on older indirect injection (IDI) diesel engines was considerable but it is much less on today's direct injected (DI) engines.

Cylinder volume: the total volume in the cylinder when the piston is at BDC. You can calculate

the cylinder volume by adding the cylinder swept volume to the cylinder clearance volume.

Engine displacement: the *swept volume* of all the engine cylinders expressed in cubic inches or cubic centimeters/liters. It is one way of expressing engine size. To calculate engine displacement you do the following:

$$\begin{aligned} \text{Engine displacement} &= \text{bore} \times \text{bore} \times \text{stroke} \\ &\quad \times 0.7854 \\ &\quad \times \text{number of cylinders} \end{aligned}$$

Example

Navistar International MaxxForce 13

Engine displacement calculation data:

6-cylinder engine, bore 126 mm, stroke 166 mm

$$\begin{aligned} \text{Engine displacement} &= 126 \times 126 \times 166 \times 0.7854 \times 6 \\ &= 12,419,134 \text{ cubic millimeters} \\ &= 12.4 \text{ liters (rounded)} \end{aligned}$$

Tech Tip: To convert liters to cubic inches or cubic inches to liters, use the following simple formula in which 61 is either multiplied or divided into the value to be converted:

$$\begin{aligned} 12.4 \text{ liters} \times 61 &= 756.4 \text{ cubic inches or} \\ &756 \text{ cubic inches (rounded)} \end{aligned}$$

To change cubic inches into liters, you do the opposite:

$$\begin{aligned} 893 \text{ cubic inches} \div 61 &= 14.639 \text{ liters or} \\ &14.6 \text{ liters} \end{aligned}$$

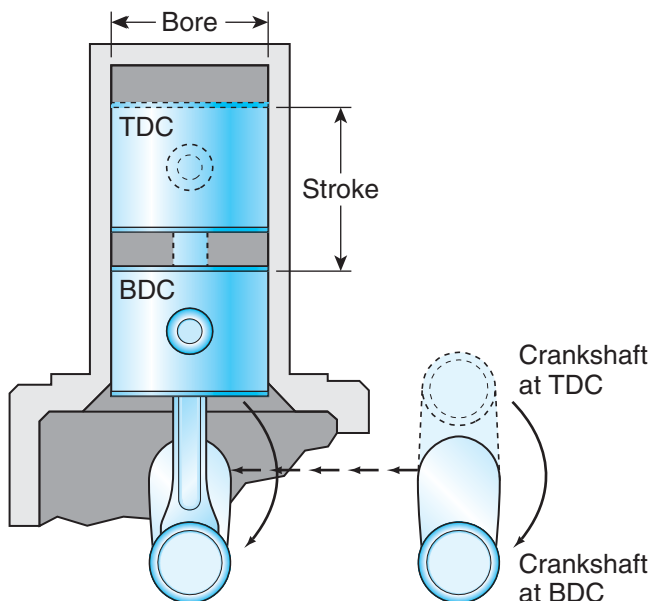

Figure 3-7 Bore and stroke.

Square engine: an engine in which the cylinder bore diameter is exactly equal to the piston stroke dimension. For instance, an engine with a 4-inch piston diameter and a 4-inch stroke is classified as *square*. When bore and stroke values are expressed, bore always appears before stroke.

Oversquare engine: describes an engine in which the cylinder bore diameter is larger than the stroke dimension. Most indirect injected, gasoline-fueled, spark-ignited engines are oversquare.

Undersquare engine: describes an engine in which the cylinder bore diameter is smaller than stroke dimension. Most high-compression diesel engines are undersquare.

Compression: when a gas is squeezed by driving a piston into a sealed cylinder, heat is created. For instance, when you use a hand-actuated bicycle pump to inflate tires, the pump cylinder heats up.

Compression ignition (CI): a high-compression engine in which the heat required to ignite the fuel in its cylinders is sourced from compression; more commonly known as a *diesel engine*. The acronym CI is often used to describe a diesel engine.

Spark ignited (SI): an engine in which the fuel/air charge is ignited by a timed electrical spark.

Direct injection (DI): either a CI or SI engine in which the fuel charge is injected directly into the engine cylinder rather than to a precombustion chamber or part of the intake manifold.

Indirect injection (IDI): a CI or SI engine in which the fuel charge is introduced outside of the engine cylinder to a precombustion chamber, cylinder head intake tract, or intake manifold.

Ratio: the relationship between two values expressed by the number of times one contains the other. We use ratios in automotive technology to describe the drive/driven relationships of two meshed gears, the mechanical advantage of levers, and cylinder compression.

Compression ratio: a measure of the cylinder volume when the piston is at BDC versus cylinder volume when the piston is at TDC. Theoretically, compression ratios in diesel engines range between 14:1 and 24:1. In reality, most modern diesel engines have compression ratios typically between 16:1 and 17:1.

Compression pressure: the actual cylinder pressure developed on the compression stroke. Actual compression pressures in diesel engines range from 350 psi (2.40 mPa) to 700 psi (4.80 mPa) in CI engines. The higher the compression pressure, the more heat developed in the cylinder. Modern diesel engines typically produce compression pressures of ± 600 psi.

Combustion pressure: the highest pressure developed in an engine cylinder during the power stroke. In today's efficient, electronically controlled diesel engines, combustion pressures may peak at up to five times the compression pressure.

Fire point: the temperature at which a flammable liquid gives off sufficient vapor for continuous combustion to take place; also known as **ignition temperature**. The fire point or ignition

temperature of a diesel fuel is specified by a cetane number (CN). We will explain the importance of CN later on in this textbook.

Friction: force is required to move an object over the surface of another; *friction* is the resistance to motion between two objects in contact with each other. Smooth surfaces produce less friction than rough surfaces. Lubricants coat and separate two surfaces from each other and reduce friction.

Inertia: describes the tendency of an object in motion to stay in motion or, conversely, an object at rest to remain that way. For example, an engine piston moving in one direction must be stopped at its travel limit and its kinetic inertia must be absorbed by the crankshaft and connecting rod. The inertia principle is used by the engine harmonic balancer and the flywheel—the inertial mass (that is, weight) represented by the flywheel has to be greatest in a single cylinder, four-stroke cycle engine. As the number of cylinders increases, the flywheel weight can be reduced due to the greater mass of rotating components and the higher frequency of power strokes.

Thermal efficiency: a measure of the combustion efficiency of an engine calculated by comparing the heat energy potential of a fuel (calorific value) with the amount of usable mechanical work produced. Electronically controlled CI engines can have thermal efficiency values exceeding 40 percent. A typical gasoline-fueled car engine has a thermal efficiency of just over 30 percent. A rocket engine produces thermal efficiencies of over 60 percent.

Rejected heat: that percentage of the heat potential of the fuel (see the *thermal efficiency* definition) that is not converted into useful work by an engine. If a CI engine operating at optimum efficiency can be said to have a thermal efficiency of 40 percent, then 60 percent of the heat energy of the fuel has to be dissipated as *rejected heat*. Half of the rejected heat is typically transferred to the engine hardware to be dissipated to the atmosphere by the engine cooling system, and the other half exits in the exhaust gas. A turbocharger makes use of rejected heat by compressing the intake air forced into the engine cylinders, thereby increasing the thermal efficiency of the engine. **Figure 3-8** shows how the potential heat energy of fuel is released when combusted in a diesel engine.

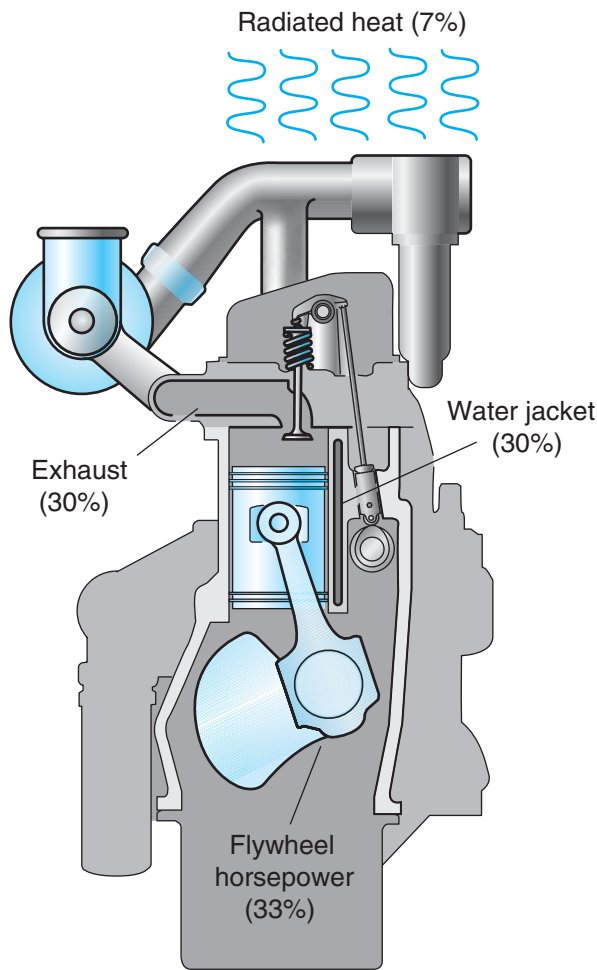

Figure 3-8 An example of how the potential energy of diesel fuel is released in a diesel engine.

TWO KEY PRINCIPLES

We finish this chapter by looking at some principles that are key to understanding the operation of any engine: mean effective pressure, cylinder pressure, and throw leverage.

Mean Effective Pressure

Mean effective pressure (MEP) is a way of describing the engine cylinder pressure that can actually be converted into useable torque. Simply, it is peak combustion pressure (produced during the power stroke) minus peak compression pressure (produced during the compression stroke). MEP describes the relationship between the *work performed* by the piston (in compressing the air charge) and the *work received* by the piston (through its downstroke on the power stroke). If the engine is going to continue to rotate, there has to be a net gain in terms of work. MEP is an important definition.

Modern, computer-controlled diesel engines can manipulate MEP by varying valve opening and closing. For instance, diesel engines using an internal compression brake open the exhaust valve(s) under engine braking just as the compression stroke is being completed. This means that when the engine brake is actuated, the piston is required to do its normal amount of work in compressing the air in the cylinder during the compression stroke: but just at the point the power stroke would normally begin, the exhaust valves open, and the cylinder charge is dumped. The result is that the piston does its normal work on its upstroke, but is denied receiving any work during the power stroke. The role of the engine is therefore reversed. It becomes a power absorbing pump rather than a power receiving pump.

Another way of managing the MEP is to use variable valve timing. In diesel engines this is used as an emission control strategy. The closure of the intake valves can be delayed by the computer managing the engine under some running conditions to make it perform like a smaller engine. In other words, the MEP equation becomes a *soft* value managed by the engine controller computer.

Cylinder Pressure and Throw Leverage

The objective of any engine is to transfer the power developed in its cylinders as smoothly and evenly as possible to the power take-off mechanism, usually a flywheel. The relationship between the crankshaft throw (to which the piston assembly is connected) and the crankshaft centerline is that of a lever. A lever is a device that provides a mechanical advantage. The amount of leverage (mechanical advantage) depends on the rotational position of the throw, which ranges from zero or no leverage when the throw is positioned at TDC to maximum leverage when the throw is positioned at a 90-degree angle with the connecting rod after TDC. This makes the relationship between cylinder pressure (gas pressure acting on the piston) and throw leverage (the position of the piston) critical in meeting the objective of smooth/even transfer of power from the engine cylinders to drivetrain.

Let us take a look at this principle in operation. When the piston is at TDC beginning a power stroke, it is desirable to have minimum cylinder pressure, because in this position throw leverage is zero; therefore, no power transfer is possible. A properly set up fuel system attempts to manage cylinder pressure so that in any given performance mode it peaks somewhere between 10 degrees and 20 degrees ATDC when there is some but nevertheless a small

amount of throw leverage. As the piston is forced down through the power stroke, gas pressure acting on the piston diminishes but as it does so, throw leverage increases. Ideally, this relationship between cylinder pressure and crank throw leverage should be

managed in a way that results in consistent torque delivery from an engine cylinder through the power stroke until the throw forms a 90-degree angle with the connecting rod: this occurs a little before true 90 degrees ATDC.

Summary

- Most diesel engines are rated by their ability to produce power and torque. The tendency is to rate gasoline-fueled auto engines by their total displacement.
- Diesel engines have high compression ratios so they tend to be undersquare.
- Almost every medium- and large-bore highway diesel engine is manifold-boosted, that is, turbocharged.
- The diesel cycle is a four-stroke cycle consisting of four separate strokes of the piston occurring over two revolutions; a complete engine cycle is therefore extended over 720 degrees.
- The two-stroke diesel cycle enables every downstroke of a piston to be a power stroke, so in theory, it has the potential to produce more power than the four-stroke cycle.
- Mean effective pressure (MEP) is the average pressure acting on the piston through the four strokes of the cycle. Usually, the intake and exhaust strokes are discounted, so MEP is equal to the average pressure acting on the piston through the compression stroke subtracted from the average pressure acting on the piston through the power stroke.
- Ideally, engine fueling should be managed to produce peak cylinder pressures at somewhere around 10 to 20 degrees ATDC when the relative mechanical advantage provided by the crank throw position is low. This means that as cylinder pressure drops through the power stroke, throw mechanical advantage increases peaking at 90 degrees ATDC, providing a smooth unloading of force to the engine flywheel.
- An engine attempts to convert the potential heat energy of a fuel into useful kinetic energy: the degree to which it succeeds is rated by its thermal efficiency.
- That portion of the heat energy of a fuel not converted to kinetic energy is known as *rejected heat*. Rejected heat must be dissipated to the atmosphere by means of the engine cooling and exhaust systems.

Review Questions

1. A diesel engine has a bore of 4.5 inches and a stroke of 5.25 inches. Which of the following correctly describes the engine?

A. 10-inch displacement	C. Oversquare
B. 10-liter displacement	D. Undersquare
2. Which of the following best describes the term *engine displacement*?

A. Total piston swept volume	C. Peak horsepower
B. Mean effective pressure	D. Peak torque
3. Engine breathing in the two-stroke cycle is sometimes referred to as:

A. Inertial	C. Exhaust blowdown
B. Scavenging	
4. The tendency of an object in motion to stay in motion is known as:

A. Kinetic energy	C. Inertia
B. Dynamic friction	D. Mechanical force

-
5. What percentage of the potential heat energy of the fuel does the modern diesel engine convert to useful mechanical energy when it is operating at its best efficiency?
 - A. 20 percent
 - B. 40 percent
 - C. 60 percent
 - D. 80 percent

 6. Where does scavenging take place on a four-stroke cycle diesel engine?
 - A. BDC after the power stroke
 - B. TDC after the compression stroke
 - C. Valve overlap
 - D. 10 to 20 degrees ATDC on the power stroke

 7. Ideally, where should peak cylinder pressure occur during the power stroke?
 - A. TDC
 - B. 10 to 20 degrees ATDC
 - C. 90 degrees ATDC
 - D. At gas blowdown

 8. When running an engine at any speed or load, which of the following would be the best location to produce peak cylinder pressure?
 - A. 20 degrees BTDC
 - B. 10 degrees BTDC
 - C. TDC
 - D. 15 degrees ATDC

 9. At which point in the engine cycle does the crank throw leverage peak?
 - A. TDC
 - B. 15 degrees ATDC
 - C. 90 degrees ATDC
 - D. BTDC

 10. The energy of motion is known as:
 - A. Inertia
 - B. Kinetic
 - C. Thermal
 - D. Potential

This page intentionally left blank

CHAPTER

4

Piston Assemblies, Crankshafts, Flywheels, and Dampers

Learning Objectives

After studying this chapter, you should be able to:

- Identify the engine powertrain components.
- Define the roles of piston assemblies, crankshafts, flywheels, and dampers.
- Identify the different types of pistons used in current diesel engines.
- Describe the combustion chamber designs used in diesel engines.
- Explain the function of piston rings.
- Classify piston wrist pins by type.
- Describe the role of connecting rods and outline the stresses they are subject to.
- Identify common crankshaft throw arrangements.
- Outline the forces a crankshaft is subjected to under normal operation.
- Identify some typical crankshaft failures and their causes.
- Outline the procedure for an in-chassis rod and main bearing rollover.
- Measure friction bearing clearance using Plastigage.
- Define the term *hydrodynamic suspension*.
- Outline the roles played by vibration dampers and flywheel assemblies.
- Describe how vibration dampers function.
- Remove and replace a ring gear on a flywheel.

Key Terms

antithrust side
articulating piston
bearing shell
big end

buttress screws
cam ground
composite steel trunk pistons
compression ring

compressional load
connecting rod
cracked rod
crosshead piston

crown	lugging	ring groove
Ferrotherm™ pistons	major thrust side	rod eye
forged steel trunk pistons	Mexican hat piston crown	scraper ring
fractured rods	minor thrust side	small end
friction bearing	Monocomp™ pistons	thrust bearing
headland volume	Monotherm™ pistons	thrust face
hone	Ni-Resist™ insert	torsion
hydrodynamic suspension	pin boss	torsional stress
keystone ring	piston pin	trunk type piston
keystone rod	Plastigage™	wrist pin
lands	ring belt	

INTRODUCTION

In an internal combustion engine, the burning of fuel in an engine cylinder produces cylinder gas pressure. This pressure has to be converted into useful mechanical energy. This chapter addresses the engine components responsible for converting the gas pressures developed in engine cylinders to torque at the flywheel. We call this group of components the engine powertrain. The engine powertrain includes:

- pistons
- piston rings
- wrist pins
- connecting rods
- crankshafts
- friction bearings
- flywheels
- vibration dampers

Function of the Powertrain

The powertrain is actuated by cylinder gas pressure. This pressure acts on the piston and drives through its stroke. A piston moves straight up or down in the engine cylinder. This vertical movement has to be converted into torque. We accomplish this by connecting the piston assembly to an offset throw on the crankshaft. In this way we convert the linear force produced by the piston into rotary force we call torque. As pistons travel up and down in the cylinder bore, the crankshaft rotates. Connecting rods pivot on both the piston and crankshaft throw. Torque from the crankshaft is transferred to a flywheel bolted to the crankshaft. The flywheel acts as a coupling to transfer engine torque to the vehicle drivetrain.

Bicycle Powertrain

You can compare what happens in a typical engine with what happens with another type of engine, a bicycle. A bicycle is an engine driven by muscle power. The powertrain of a bicycle consists of offset throws (we call them pedals), a crankshaft, and a bull gear: cogs on the bull gear allow torque to be transferred to a driven gear and wheel assembly. When a bicycle is ridden, linear force is applied to the pedals by the rider's legs. Just as it does in a diesel engine, the crankshaft converts the linear force applied to the pedals into torque so the rider can power the bicycle down a road.

PISTON ASSEMBLIES

A piston is a circular plug. It is required to fill and seal the engine cylinder bore while moving within it. A piston is connected to the crankshaft by means of a connecting rod and moves up and down in the cylinder bore. The role of the piston in the cylinder bore is to:

- Deliver force: it does this when traveling upward on its compression stroke.
- Receive force: it receives force when combustion pressures act on it during the power stroke.

A piston assembly consists of the piston, piston rings, a wrist pin, and connecting rods. Piston rings seal the cylinder and lubricate the cylinder walls. The wrist pin is installed through a boss in the piston: it connects the piston to the connecting rod.

Piston Terminology

A diesel engine piston is shown in **Figure 4-1** along with the terminology used to describe it. The type of

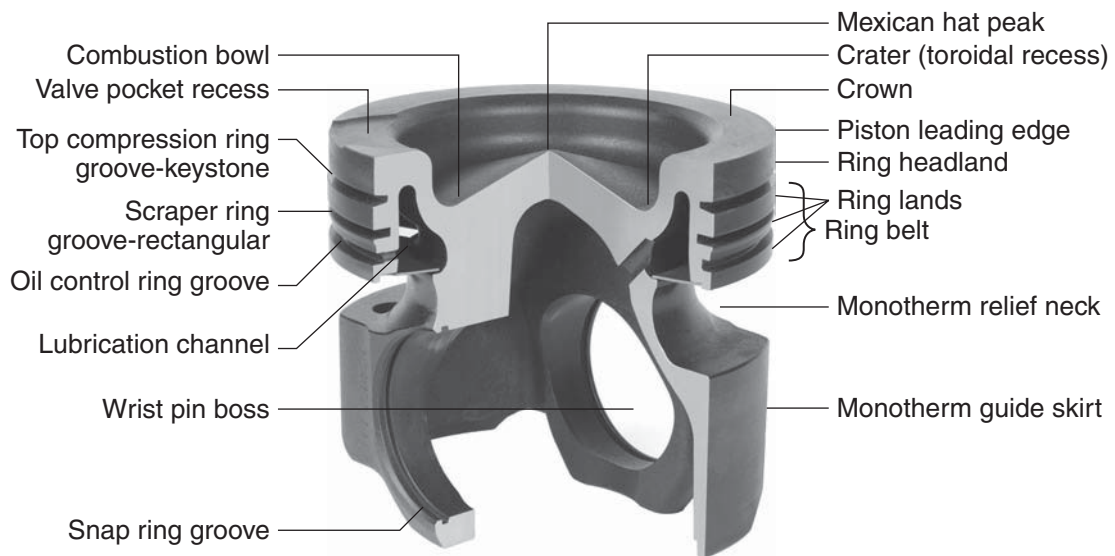

Figure 4-1 Piston terminology. (Courtesy of Mahle)

piston shown is a forged steel trunk piston used in many current diesels. However, four general categories of pistons are used in diesel engines, which we will look at later. By following the callouts in **Figure 4-1**, you will be able to make sense of the description that follows.

Piston Crown. The upper face of the piston is called the **crown**. The crown or top of the piston is exposed directly to the cylinder chamber and therefore the effects of combustion. Because of this, a piston should be capable of rapidly transferring the combustion heat it is exposed to. This ability to transfer heat is especially important when aluminum pistons are used. Aluminum has a much lower melting point than alloy steels. Many pistons have cooling jets that spray lubricating oil on the underside of the piston. This helps remove heat and keep piston crown temperatures lower.

The shape of the piston crown is important. This shape determines how swirl and squish is generated in an engine. Swirl and squish determine how injected fuel mixes with the air in the cylinder. A large majority of modern diesel engines use a Mexican hat piston crown design such as that shown in **Figure 4-1**. The upper edge of the piston around the crown is known as its leading edge. Most modern diesel engines have low clearance volumes. This means that at top dead center (TDC), the piston rises in the cylinder bore just short of protruding above the cylinder block preventing contact with the valves and the cylinder head.

Two basic piston designs are used in current commercial and off-highway diesel engines:

1. trunk type pistons
2. articulating pistons

We will subdivide each design into additional categories.

Trunk Type Pistons

Trunk type pistons are single-piece pistons. Three categories of trunk type pistons are used in diesel engines today:

1. aluminum alloy
2. forged steel
3. composite steel

Aluminum Trunk Type Pistons. Until the 1990s, most commercial diesel engines used single-piece pistons manufactured from aluminum alloys. Aluminum alloy pistons are lightweight and transfer heat easily. However, because of a lower melting temperature and lack of toughness when compared with forged steels or cast irons, aluminum trunk pistons use a ring groove insert for at least the top compression ring groove. The insert is usually a **Ni-Resist™ insert**. Ni-Resist has a much higher melting temperature than aluminum and in addition, it expands and contracts in the same way. **Figure 4-2** is an image of an aluminum trunk type piston: note the location of the Ni-Resist insert.

Another method of increasing the toughness and high-temperature performance of an aluminum trunk type piston is to reinforce it with ceramic fiber alumina (CFA). A CFA reinforced process is used on some smaller-bore diesels. The CFA process eliminates the requirement for a Ni-Resist insert because it reinforces the piston at the top of the ring belt extending up into the top of the crown. This allows placement of the top

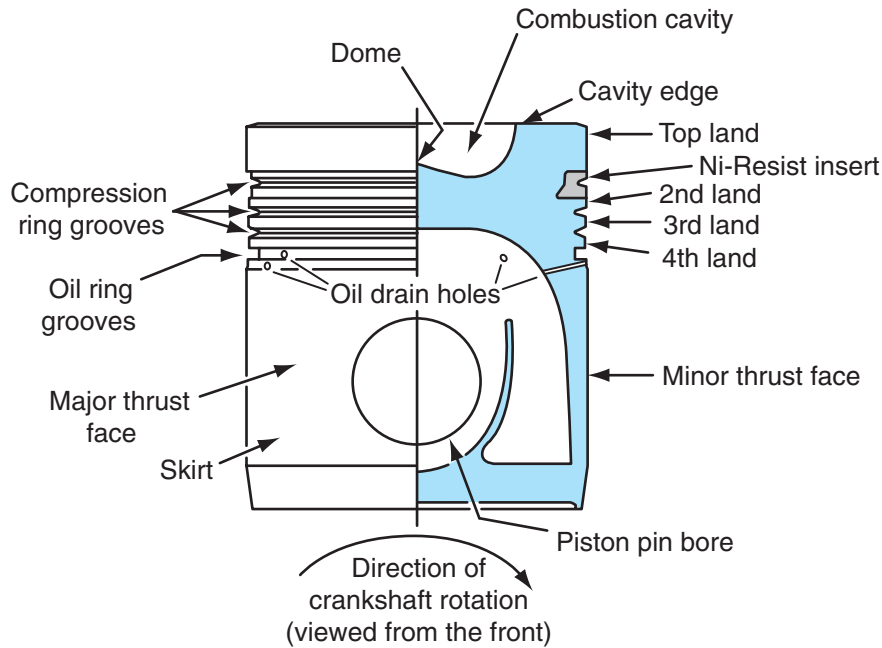

Figure 4-2 Aluminum trunk piston and ring terminology.

compression ring close to the leading edge and reduces *headland volume* (see **Figure 4-1**). High location of the top compression ring is almost a requirement for today's low emissions diesels because it reduces the dead gas zone between the upper compression ring and piston leading edge. Another fiber reinforcement manufacturing practice known as squeeze cast, fiber reinforced (SCFR) is used by some manufacturers to toughen the crown area of the piston. This is an alumina fiber manufacturing process.

CAM GROUND

Aluminum pistons are light in weight and transfer heat efficiently but they also expand and contract much more than steels. This means that they have to be designed with much more clearance in the cylinder bore when cold. It also means that they have to be **cam ground**. A cam ground piston is slightly oval in shape when cold. As the piston warms up, the area around the **pin boss** expands relatively more than the thinner skirt area between the pin bosses. The idea behind a cam ground piston is that at running temperatures, the piston should expand to a circular shape.

A big disadvantage of cam ground pistons is that they should be warmed to operating temperature before being subjected to high cylinder pressures. Failing to warm up a cam ground piston before loading an engine can overstress the piston rings and lands. Aluminum trunk pistons are shaped to beef up the piston where it is at its weakest. So in addition to having reinforcement at the pin boss, an aluminum trunk

piston has increased material around the crown as you can see in **Figure 4-2**.

WRIST PINS AND RING BELT

Piston wrist pins when not full-floating are usually press fit to the piston boss and float on the rod eye. Heating the piston to 95°C (200°F) in boiling water facilitates pin assembly. Aluminum trunk pistons are prone to piston slap especially during engine warmup. Piston slap is the tilting action of the piston when the piston is thrust-loaded by cylinder combustion pressure. It can be minimized by tapering the piston so that the outside diameter at the lower skirt slightly exceeds the outside diameter over the ring belt region. The ring belt region is exposed to more heat and expands more as the piston heats to operating temperatures.

ADVANTAGES OF ALUMINUM TRUNK PISTONS

Aluminum trunk pistons have the following advantages:

- **Lightweight.** This reduces the overall piston weight. Lightweight pistons reduce the inertia forces to which the connecting rod and crankshaft are subject. This permits the use of lighter-weight components throughout the engine powertrain.
- **Cooler piston crown temperatures.** Because aluminum alloy pistons transfer heat so rapidly, they run cooler than equivalent iron- or steel-based pistons.



Figure 4-3 Two views of a forged steel trunk piston (Monotherm). (Courtesy of Mahle)

- Quieter. Engines using aluminum alloy, trunk type pistons generally produce less non-combustion-related noise.

Forged Steel Trunk Type Pistons. Although **forged steel trunk type pistons** were used half a century ago in drag racing applications, they are a relatively new introduction to diesel engine technology. However, they have caught on fast with diesel engine designers and many of today's commercial diesel engines use them. The brand name use for these pistons is **Monotherm™**. They are manufactured by Mahle. We have called them *forged steel trunk type pistons* to avoid using the brand name but you will find them commonly referred to as Monotherm pistons. **Figure 4-3** shows two views of a forged steel trunk piston.

DESIGN AND CONSTRUCTION

The single-piece steel trunk piston has the appearance of an aluminum trunk piston with a large circumferential slot cut away between the pin boss and the ring belt. The skirt is designed to guide the piston during its vertical travel using the surface area over the thrust sides of the piston. The skirt is recessed across the pin boss. This permits the use of shorter, lower-weight wrist pins. It also allows the piston pin boss support area to be increased making the design well suited to engines producing very high cylinder pressures.

The problem of cold-start, piston slap in aluminum trunk pistons has been overcome with the Monotherm design. Monotherm steel alloy pistons expand much less than aluminum trunk pistons when heated from cold to operating temperatures because steel expands less than aluminum. This means they can be manufactured with a much tighter fit to the liner bore. The

lubricating oil cooling gallery used in a Monotherm piston is closed with cover plates: this allows higher oil feed and flow-back volumes. The oil feed to the underside of the piston is delivered by a precisely targeted, cooling jet. In some cases, the connecting rods used with Monotherm pistons are not rifle-drilled with a lubrication passage. This means that the piston and wrist pin depend almost entirely on the oil cooling jet for lubrication and cooling.

The Monotherm's micro-alloyed steel construction provides very high strength so much less material has to be used. The result is a tough steel piston of about the same weight as the older aluminum trunk pistons. Monotherm pistons also feature a bushingless wrist pin bore. The pin boss is phosphate treated over the pin bearing bore. **Figures 4-1** and **4-3** both show forged steel trunk pistons typical to that used in a majority of current, high-horsepower highway diesel engines.

ADVANTAGES OF FORGED STEEL TRUNK PISTONS

Many engine original equipment manufacturers (OEMs) have adopted forged steel trunk type pistons in the past few years because we are using much higher cylinder combustion pressures and temperatures today. Some of the advantages of Monotherm pistons are:

- Reduction of headland volume. **Headland volume** is the volume in the cylinder above the top compression ring and below the piston crown leading edge. This volume is less affected by cylinder turbulence and the effects of cylinder scavenging so it collects dead end gas and soot. Headland volume can be minimized by placing the top compression ring as close as possible to the crown leading edge. Because forged steel is much stronger than aluminum, steel trunk pistons require no groove insert and the upper ring groove can be located close to the crown leading edge. Reducing headland volume helps lower emissions and helps prevent soot saturation of the engine lube. Monotherm pistons place the top compression ring just slightly under the leading edge of the piston.
- Thermal expansion factors. Thermal expansion is simply how a material responds to heat. Forged steel expands and contracts much less than aluminum as temperature changes, so cam ground designs are not required in steel trunk pistons.
- Long life. Micro-alloyed forged steel coated with phosphate provides much longer service life than equivalent aluminum trunk pistons.
- Lightweight. Monotherm pistons are as light in weight as aluminum trunk pistons but have much



Figure 4-4 Composite steel piston (Monocomp). (Courtesy of Mahle)

higher strength. Some forged steel trunk pistons are specified to sustain cylinder pressures that reach 3,500 pounds per square inch (psi) (250 bar).

COMPOSITE STEEL TRUNK PISTONS

The industry is in the process of introducing **composite steel trunk pistons**. These are a variation on the forged steel trunk type pistons in that the crown and skirt sections of the piston are manufactured separately. The two sections are then screwed together using a special process. The piston crown section is manufactured from high-temperature steel then screwed into a steel skirt assembly. Mahle manufactured versions of these pistons will be known as **Monocomp™**. **Figure 4-4** shows a composite steel trunk piston: if you study it closely, you can see where the two sections are joined.

Articulating Pistons

Articulating pistons were adopted by most engine OEMs during the 1990s and up until 2004. More recently, the use of articulating pistons in diesel engines has dropped off as OEMs have opted to use forged steel and composite steel, trunk type pistons. Articulating pistons are two-piece pistons. Specifically, the crown and skirt are manufactured separately, usually out of different materials. Two types of articulating piston assemblies are used in commercial diesel engines:

1. Crosshead pistons: semifloating wrist pin bolted to the connecting rod.

2. Full articulating piston: full-floating wrist pin that pivots on the connecting rod eye, crown, and skirt assemblies.

Crosshead Pistons. Detroit Diesel Corporation (DDC) used **crosshead pistons** for many years. The crosshead piston is a two-piece piston assembly consisting of a crown and a skirt linked by a semifloating wrist pin. The semifloating wrist pin is bolted directly to the connecting rod. Because this design allows both the crown and skirt assemblies some degree of independent movement (each can pivot on the wrist pin), the assembly articulates. The key difference between the crosshead and true articulating piston is that crosshead wrist pins are bolted directly to the connecting rods. In other words, the wrist pins used on crosshead pistons are semifloating rather than full-floating.

Full Articulating Pistons. The articulating piston consists of a crown usually manufactured of forged steel or cast-iron alloy and a separate skirt, usually (but not always) manufactured of aluminum alloy. A full-floating wrist pin permits both the crown and skirt to pivot independently while also linking them to the connecting rod eye. The true articulating piston assembly always uses a free-floating wrist pin and therefore shares bearing surface with both the pin boss and the connecting rod eye. This requires a heavier wrist pin and helps to disadvantage the articulating piston with higher weight.

Mahle's **Ferrotherm™** articulating pistons were used by a number of diesel engine OEMs in their medium- and large-bore highway engines until 2007. **Figure 4-5** shows a three-ring articulating piston assembly: the crown has been raised slightly from the skirt assembly.

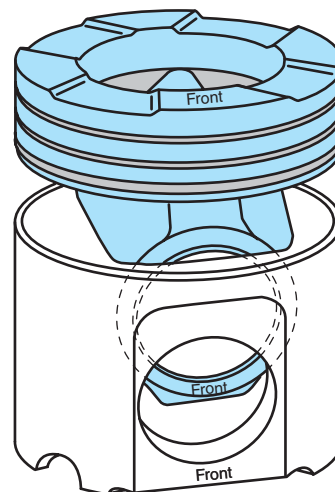

Figure 4-5 Articulating piston.

Advantages of Articulating Pistons. The crown assembly used in articulating pistons is usually manufactured from either forged steel or a cast iron alloy. Both forged steel and cast iron materials are suitable for the high pressures and temperatures they are directly exposed to, while the skirt can be made out of a lighter material, usually an aluminum alloy. Two-piece articulating piston assemblies were widely adopted during the early 1990s, despite their heavier weight than the aluminum trunk pistons they replaced because they offered:

- Longer service life. The industry was promising greatly increased engine life and that the forged steel crown assembly was tougher and much more durable than aluminum.
- Reduced piston slap. This reduced both noise and wear but also provided better performance during the cold-start to engine operating temperature phase.
- Tougher crown assembly. With increased combustion pressures and temperatures of high-efficiency, low-emission diesel engines entering the 1990s, using an aluminum alloy crown material was insufficient.
- Reduced headland volume. Another significant reason that diesel engine OEMs adopted articulating pistons despite the extra weight penalty was it allowed the headland volume to be reduced: in other words, the top piston ring could be moved close to the piston leading edge.

Disadvantages of Articulating Pistons. A major disadvantage of articulating piston assemblies over trunk designs is significantly increased weight. This increased weight increases tensional loading (stretching forces) on the powertrain. When articulating pistons were adopted, OEMs had to beef-up the engine powertrain components, especially the connecting rods and crankshaft.

Piston Thrust Faces

When cylinder gas pressure acts on a piston especially during the initial stage of combustion, it tends to cock (pivot off a vertical centerline) in the cylinder bore because it pivots on the wrist pin. This action creates thrust faces on either side of the piston. The major thrust face is on the inboard side of the piston as its throw rotates through the power stroke. The minor thrust face is on the outboard side of the piston as its throw rotates through its power stroke. Take a close look at **Figure 4-2** in which the piston thrust faces are identified. The major thrust face is sometimes simply called the **thrust face** while the minor thrust face is called the antithrust face. You should learn to identify

the thrust faces of a piston for purposes of failure analysis. On modern steel trunk type pistons such as the Monotherm, only the thrust faces are skirted. This allows the piston to be guided true in its bore while also reducing the weight of the piston.

Combustion Chamber Designs

In direct-injected diesel engines, the shape of the piston crown determines what happens to gas in the cylinder on the compression and power strokes. Until around 1990, most diesel engines used crown designs that developed high turbulence. More recently however, diesel fuel injection pressures have greatly increased, reducing the need for high cylinder turbulence.

High Turbulence. Direct-injected (DI) engines use an open combustion chamber principle. In an open combustion chamber, the injector is usually located in the cylinder head and positioned directly over the piston crown. Because the mixing of the fuel charge with air takes place within the engine cylinder, the swirl and turbulence generated by piston movement are critical in determining the mixing efficiency and the actual location where ignition occurs. Because the piston is the only moving component in the cylinder after the intake valves close, the shape of the piston crown along with piston speed determines how much squish and swirl takes place in the cylinder. A sharp peak and deeper recess around it in a Mexican hat piston crown will produce more swirl than one that is less “aggressive.”

Low Turbulence. High turbulence can be a disadvantage for emissions because clusters of fuel droplets can be thrown outside the main flame front. These small clusters of fuel ignite late and sometimes do not completely burn. So, as diesel engine designers got serious about reducing emissions, they introduced engines that produced less turbulence. Many modern engines use these lower-turbulence designs. Most DI engines use one of three basic piston crown designs: Mexican hat, Mann type (M-type), or dished.

MEXICAN HAT

The **Mexican hat piston crown** design is by far the most common and the title perfectly describes its shape. The central area of piston crown is recessed below the piston leading edge, forming a crater (also known as a *toroidal recess*). Rising from the center of the crater is a cone-shaped protrusion (see **Figures 4-1** and **4-2**). The aggressiveness of the cone shape produces

the required turbulence as the piston moves through its strokes. In most cases, the fuel injector is positioned directly above the center of the cone. This allows it to direct atomized fuel toward the crater where the swirl effect is greatest.

Another reason diesel engine OEMs frequently use Mexican hat pistons is that diesel fuel droplets can be directed into the crater and this allows them to ignite before contacting the crown material. This provides a low risk of fuel burnout scorching on the piston crown directly below the injector, and lengthens service life.

MANN TYPE (OR M-TYPE)

The Mann type piston crown is named after the German company that first designed it. It is usually used with older trunk type pistons and consists of a rounded bowl located directly under the injector, though not necessarily in the center of the piston crown. Depending on the depth of this bowl, the Mann type combustion chamber produces high turbulence.

DISHED

The dished piston crown has a slightly concaved to almost flat design that produces low turbulence when compared with the previous types. You see this design in some current small-bore and offshore manufactured diesel engines.

Piston Cooling

Engine oil plays a major role in managing piston temperatures. Lube oil is routed to the pistons directly through rifled bores in connecting rods and by piston cooling jets. Things such as the size of the piston, peak cylinder pressures, and whether the engine is turbocharged determine what type of piston cooling is required. Within the same engine family, you may find that engines with lower-horsepower specifications do not use cooling jets while those rated at higher-horsepower do. Because combustion temperatures may sometimes be higher than the melting temperature of the piston materials (especially where aluminum is used), it is essential to get rid of any heat that has not been converted to usable energy as fast as possible. A percentage of cylinder heat is always transferred through the piston assembly. Three methods are used to cool pistons. Engines may use one or a combination of these piston cooling methods.

1. Shaker—Oil is delivered through the connecting rod to a gallery machined into the underside of the piston crown. This oil is distributed by the

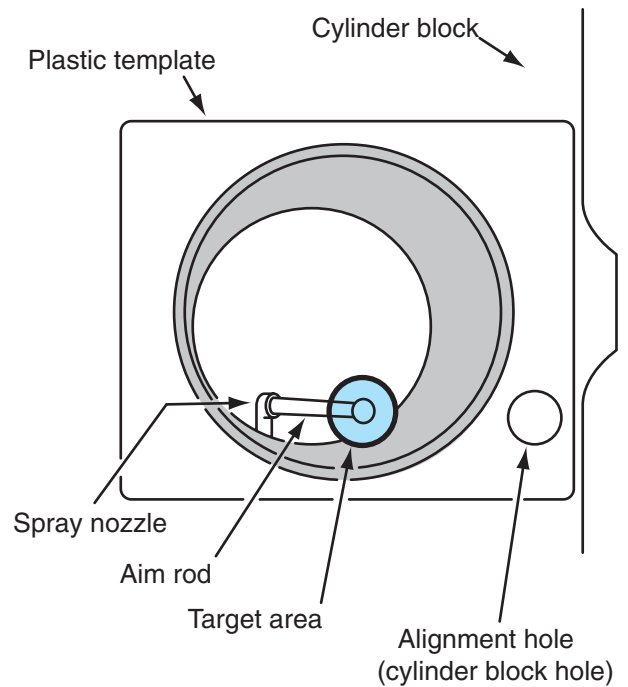

Figure 4-6 Spray nozzle targeting.

motion of the piston after which it drains to the crankcase.

2. Circulation—Oil is delivered through the connecting rod rifling, through the wrist pin, and then circulated through a series of grooves machined into the underside of the piston crown. It then drains back into the crankcase.
3. Spray—A stationary cooling jet is located in the cylinder block just below the cylinder liner. This jet is fed by engine lube under pressure. The oil cooling jet is then aimed so that the spray is directed at the underside of the piston. This oil cools the piston crown and may also lubricate the wrist pin. Aiming cooling jets is usually done using a clear perspex template that fits over the fire ring groove on the cylinder block deck: an aim rod is inserted in the jet orifice. A target window is scribed in the perspex template and the aim rod has to be positioned within the window as shown in **Figure 4-6**. The spray cooling method is used in a majority of current diesel engines.

CAUTION A piston cooling jet that is misaimed can destroy the piston it is supposed to cool. You have to take special care when assembling an engine to avoid clunking a cooling jet when installing piston/rod assemblies. During disassembly, the cooling jets should be removed before removing the piston assemblies.

PISTON RINGS

The function of piston rings is to seal the piston in the cylinder bore. Most pistons require rings to effectively seal, and those that do not are usually found in automobile racing applications. Ringless pistons use special piston materials and are run at high rpms. Running engines at high rpms permits little *time* for cylinder leakage or blowby to occur. Rings have three important functions:

1. Sealing: They are designed to seal compression and combustion gases within the engine cylinder.
2. Lubrication: They are designed to apply and regulate a film of lubricant to the cylinder walls.
3. Cooling: Rings provide a path for heat to be transferred from the piston to the cylinder walls.

Piston rings are located in recesses in the piston known as **ring grooves**. Ring grooves are located between **lands**. Check out **Figure 4-1** paying special attention to the ring area.

Roles of Piston Rings

Piston rings may be broadly categorized as:

- compression
- oil control rings

Compression rings are responsible for sealing the engine cylinder and play a role in helping to transfer piston heat to the cylinder walls. The term **scraper ring** is used to describe rings below the top compression ring that play a role in sealing cylinder gas as well as managing the oil film on the cylinder wall. Oil control rings are responsible for lubricating the cylinder walls and also provide a path to dissipate piston heat to the cylinder walls.

Ring Materials

Piston rings are designed with an uninstalled diameter larger than the cylinder bore, so that when they are installed, radial pressure is applied to the cylinder wall. Older piston compression rings were manufactured from cast iron alloys. These were more brittle than today's versions. Today, most piston rings have some flexibility and will not fracture like cast iron. Most current diesels use these much tougher and more flexible rings that often show little wear at engine overhaul. The wall section of the piston in which the set of rings is located is known as the **ring belt**.

Ring Action

The major sealing force of piston rings is high-pressure gas. Piston rings have a small side clearance.

The result of this minimal side clearance is that when cylinder pressure acts on the upper sectional area of the ring, three things happen to make it seal:

1. Pressure forces the ring downward into the land.
2. Forcing the ring into the land allows cylinder pressure to get behind the ring.
3. When cylinder pressure gets behind the ring between it and the groove wall, it gets driven outward into the cylinder wall, creating the seal.

The lower right side of **Figure 4-7** explains ring action in diagram form. Make sure you understand this. What this tells us is that cylinder sealing efficiencies increase with cylinder pressure. The higher the cylinder pressure, the more effectively rings seal the cylinder.

Number of Rings

The number of rings used is determined by the engine manufacturer and factors to be considered are:

- bore size
- engine speed
- engine configuration

Time is probably the major factor in determining the number of compression rings. The slower the maximum running speed of the engine, the greater the total number of rings because there is more time for gas blowby to occur. Most current truck and bus medium- and large-bore diesel engines have rated speeds that are in the 2,000 rotations per minute (rpm) range. Highway diesel engine OEMs commonly use a three-ring configuration of two compression rings and a single oil control ring. Go back a little in time, and you might have seen a greater number of rings. You can still sometimes see four- and five-ring configurations, usually in offshore, off-highway products or larger, slower diesels.

Gas Blowby. The top compression ring gets the greatest sealing assist from cylinder pressures. Gas blowby from the top compression ring passes downward to seal the second compression ring, and so on. Gas that blows by all the rings enters the crankcase, so high crankcase pressures are often an indication that an engine is wearing out. Because an engine cylinder is sealed by rings, some cylinder leakage past the ring belt is inevitable. The limiting factor is time. When an engine is operated at 2,000 rpm, one full stroke of a piston takes place in 15 milliseconds (0.015), so there is quite simply insufficient time for significant cylinder leakage to take place.

You are likely to see the most gas blowby when an engine is lugged. When an engine is lugged, cylinder

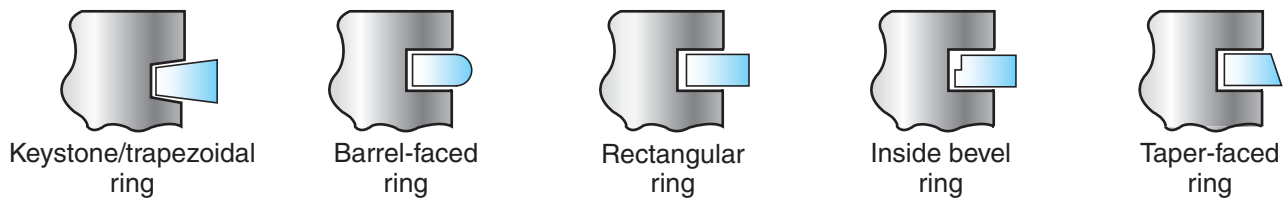

Rings may use combinations of the above geometry

Compression Ring Types

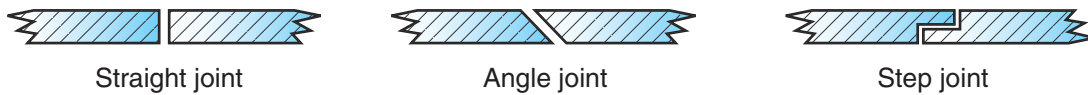

Types of Ring Joints

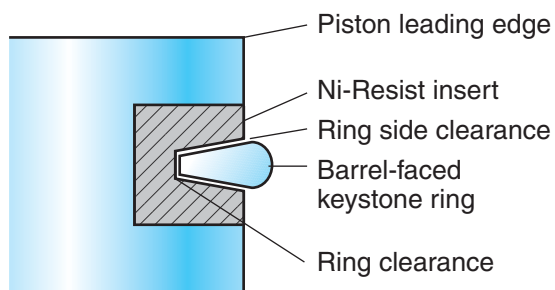

Ring Geometry Terminology

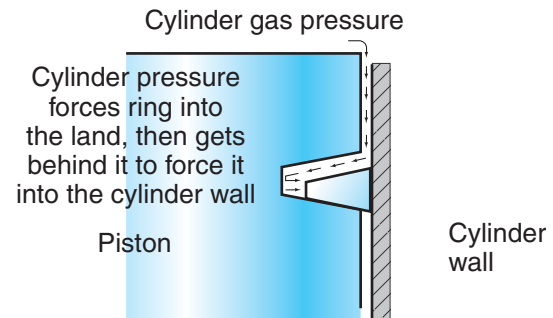

Compression Ring Action

Figure 4-7 Piston ring geometry and action.

pressures are high and the engine is running at a lower rpm. All the piston rings play a role in controlling the oil film on the cylinder wall including the top ring. The role the rings play in controlling the oil film on the cylinder wall becomes increasingly more important as emissions standards get tougher. Any excess oil on cylinder walls is combusted and exhausted as unwanted emissions.

Piston Ring Types

There are many different types of piston rings. We name them by function and shape. Make sure you reference **Figure 4-7** as you read the following explanation.

Compression Rings. Compression rings seal cylinder compression and combustion pressures. They also play a role in managing the oil film applied to the cylinder wall. Most current diesel engine piston rings can be substantially deformed without fracturing. Diesel engine compression rings are usually coated by tinning, plasma, and chrome cladding to reduce friction.

Some ring coatings are break-in coatings. These temporary coatings wear off and end up in the crankcase lube, something that has to be taken into account

when studying an oil sample analysis. Sometimes the upper compression ring is known as the *fire ring*, but more often this term is used to describe the cylinder ring seal at the top of the liner that is often integral with the cylinder head gasket.

Combination Compression and Scrapper Rings. *Combination compression and scrapper rings* assist in sealing combustion gases and controlling the oil film on the cylinder wall. Manufacturers who use this term are referring to a ring or rings located in the middle of the ring belt, between the top compression ring and oil control ring(s).

Oil Control Rings. Oil control rings are designed to control the oil film on the cylinder wall. Too much oil on the cylinder wall will end up being combusted. Too little oil on the cylinder wall will result in scoring and scuffing of the cylinder wall. The action of first applying (piston traveling upward) and then wiping (piston traveling downward) lubricant from the cylinder wall helps remove heat from the cylinder by transferring it to the engine oil. Most oil control rings

use circular scraper rails that are forced into the cylinder wall by a coiled spring expander. This spiral expander ring is responsible for radially loading the oil control ring to contact the cylinder wall: this is necessary because unlike compression rings, oil control rings get no assistance from cylinder pressures in creating a seal. Oil control rings are sometimes known as *conformable* rings, because they flex to conform to a moderately distorted liner bore.

Piston Ring Designs

Piston rings are described by their sectional shape: the term *ring geometry* is often used to describe this sectional shape. **Figure 4-7** shows some examples of ring geometry used in diesel engines today. Most piston rings use combinations of the characteristics outlined here. Following are some examples.

Keystone Rings. **Keystone rings** (sometimes known as *trapezoidal rings*) are wedge-shaped. A keystone ring is fitted to a wedge-shaped ring groove in the piston. This design is very common especially for the top compression ring. The shape of a keystone ring allows cylinder pressure that first acts on its upper sectional area to get behind the ring, and then forces it against the cylinder wall. Keystone rings are also less likely to form carbon deposits due to the scraping action that takes place as the ring twists within its groove. They are also less likely to stick.

Rectangular Rings. The sectional shape of the ring is rectangular as you can see in **Figure 4-7**. Rectangular rings were more common in the days when diesel engines used cast iron rings. This ring design is loaded evenly (they do not twist so much) into the cylinder wall when cylinder pressure acts on it. Some pistons that use a keystone top compression ring use rectangular second or third compression rings as you can see in **Figure 4-1**.

Barrel Faced. A barrel faced piston ring is one in which the outer face is “barreled” with a radius (rounded). This increases the service life. The downside is that they do not seal quite as well because there is no sharp edge to bite into the cylinder wall when the ring twists within the groove. Keystone rings are often barrel faced. **Figure 4-7** shows an example of a barrel faced keystone ring.

Inside Bevel. An inside bevel ring is one in which a recess is machined into the inner circumference of the ring as shown in **Figure 4-7**. This helps cylinder

pressure to get behind the ring and causes it to twist in the groove. This twisting action produces high unit-sealing pressures because the ring bites into the cylinder wall providing an effective seal.

Taper Faced. The design is similar to the rectangular ring but its outer face is angled, giving it a sharp lower edge. Once again, this enables the ring to achieve high unit-sealing pressures, that is, to bite into the cylinder wall when loaded with cylinder gas pressure. A taper faced ring is shown in **Figure 4-7**.

Channel Section. Channel section rings are used as oil control rings. They usually consist of a grooved ring with a number of slots to allow oil to be first applied, and then scraped from the cylinder walls. In most cases, an expander ring is used with channel section rings. This spring-loads the ring into the cylinder wall allowing it to adapt to minor variations in the liner bore. The expander ring is a coiled or trussed spring installed to a groove behind the rails of the channel section. See the channel section oil control rings shown in the lower right corner of **Figure 4-2**.

Ring Joint Geometry

Piston rings must be designed so that when heated to operating temperatures, the ring does not expand so much that the joint edges come into contact. If this was to happen, the ring would buckle. A ring must also be capable of sealing with some efficiency when cold and cylinder pressures are low. **Figure 4-7** shows the three types of joint design described in the text:

1. Straight. The split edges of the ring abut. This design is more likely to leak blowby gas, especially during cold engine operation. It is, however, the most commonly used.
2. Stepped. This design uses an L-shaped step at the joint. It is least likely to leak blowby gas at the ring joint.
3. Angled. The ring is faced with complementary angles at the joint. It seals fairly efficiently at the ring joint.

Installing Piston Rings

Rings should be installed to the piston using the correct installation tool. Stretching rings over the piston by hand can crack the plating and cladding materials. Try to avoid using multipurpose ring expanders. This is one case where the engine OEM’s special tool is usually the best bet: an example of an OEM ring expander is shown in **Figure 4-8**. You

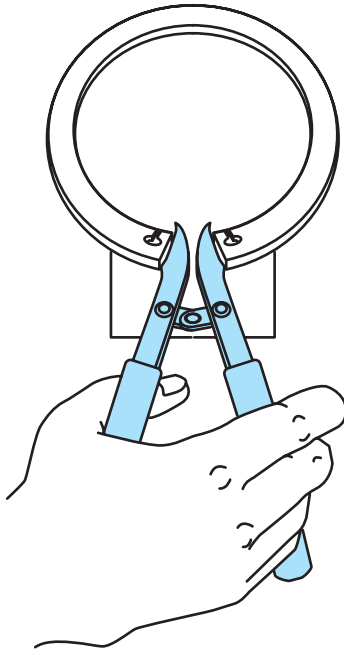

Figure 4-8 Ring expander.

should not install a piston ring in which the coating appears cracked or chipped. Most rings must be correctly installed and that means they usually have an upside, so check the service literature before installation. Most rings are marked, typically by using a dot to indicate the upside.

Ring End Gap. The ring end gap is checked by installing a new ring into the cylinder bore making sure it is within the ring belt swept area. You then measure the gap using feeler gauges. The specification is usually 0.003 to 0.004 in. per 1 in. of cylinder diameter (0.3 to 0.4 mm per 100 mm). Install a cold ring into a cold engine to check ring end gap: this will make the end gap appear larger than you might think. Remember that most engine specifications are established for performance at engine operating temperature and a warm ring will expand to almost close the gap you measure. Never use a ring that measures out of specification. In certain cases where the OEM permits (this is almost never on diesel engines), ring end gap can be adjusted by filing.

Ring Gap Spacing or Stagger. Observe OEM instructions. The gaps are usually offset by dividing the number of rings into 360 degrees, so if there were three rings, the stagger would be 120 degrees offset. In the case of four rings, the stagger should be 90 degrees offset as shown in **Figure 4-9**. It is not recommended that ring gaps are placed directly over the thrust or antithrust faces of the piston.

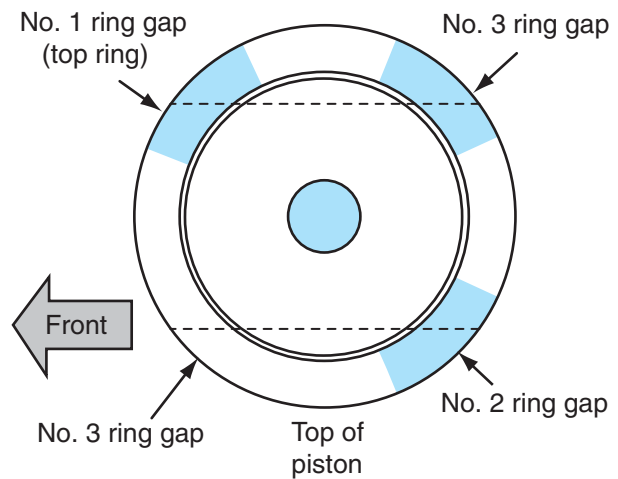

Figure 4-9 Ring stagger.

Ring Side Clearance. Ring side clearance is the installed clearance between the ring and the groove it is fitted to. The dimension is measured using feeler gauges. **Figure 4-10** shows the ring side clearance dimension. Ring side clearance must be within specification for the ring to seal properly.

Tech Tip: Most piston rings have an up side that is often not easy to see at a glance. Check the OEM instructions for installing rings and locate the means used to identify the up side of their rings.

Piston and Cylinder Wall Lubrication

Oil control rings are designed to maintain a precisely managed film of oil on the engine cylinder wall. On the downstroke of the piston, when not loaded by cylinder pressure, lubricating oil is forced into the lower part of the ring groove while the ring is contacting the upper

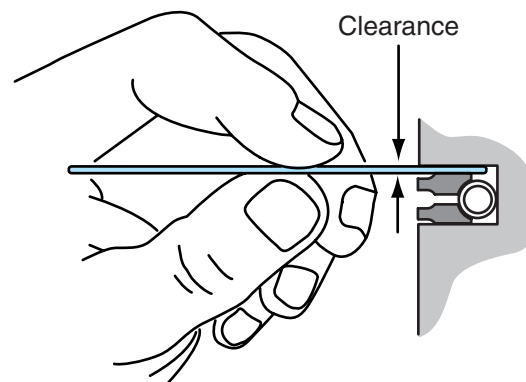

Figure 4-10 Oil ring side clearance.

ledge of the land. When the piston changes direction to travel upward, the ring is forced into the lower land of the ring groove, allowing the lubricating oil to pass around the ring and be applied to the liner wall. While the action of simultaneously applying and scraping oil from the cylinder walls ensures that the applied film thickness is minimal, all engines will burn some oil. In the latest generation of low-emissions engines the amount of burned oil is minimal: this is due both to the ring design and properties of CJ-4 lube oil.

Wrist Pins

The function of **wrist** or **piston pins** is to connect the piston assembly with the connecting rod eye or small end. In the two-piece, articulating piston assembly, they also link the crown with the skirt allowing both the crown and skirt to pivot independently. The highest expected cylinder pressures determine whether the pin is solid or bored through. Because the weight of the wrist pin adds to the piston total weight, it is designed to be as light as possible while handling the forces to which it is subjected. One of the reasons that forged steel trunk pistons have replaced articulating pistons in more recent engines is that the wrist pin can be reduced in length and weight because there is no separate skirt to support.

The bearing surfaces of wrist pins are lubricated by engine oil in two ways:

1. Directed upward through a rifle bore in the connecting rod, the method used in most engines until recently.
2. Sprayed upward by a piston cooling jet targeted at a gallery entry port, the method used on some forged steel trunk (Monotherm) pistons.

Full-floating piston pins are fitted to both the rod eye and the piston boss with minimal clearance. Some newer piston bosses are bushingless.

Piston Pin Retention. All full-floating piston pins require a means of preventing the pin from exiting the pin boss and contacting the cylinder walls. Snap rings and plugs are used. When installing the internal snap rings used by most engine OEMs you must observe the installation instructions. In most cases, the split joint of the snap ring should be located downward. Semifloating wrist pins such as those used in cross-head piston assemblies are bolted directly to the connecting rod. In older, DDC, two-stroke cycle engines, a press fit sealing cap was used: this component should be leak-tested when assembled using the OEM method.

Assembling Piston and Rings

When clamping a piston/connecting rod assembly in a vise, use brass jaws or a generous wrapping of rags around the connecting rod. The slightest nick or abrasion may cause a stress point from which a failure could develop in a connecting rod. It is also important to handle rings with the specified tools during reassembly. Overflexing of piston rings during assembly can damage the surface coatings of rings while the rings ends can score an aluminum piston during installation.

Reusing Piston Assemblies

Reusing piston assemblies is not a common practice with aluminum alloy trunk type pistons, but it is becoming more common with some of the latest pistons that use forged steels in the crown assembly. You should observe OEM recommended practice, but routine replacement of pistons at an engine overhaul may not always be justified. For engines under warranty, always check to see whether piston replacement is covered. If you are planning to reuse a piston, here are some common practices:

- Clean crystallized carbon out of the ring groove using a correctly sized ring groove cleaner. If a used top compression ring can be broken (many cannot, use a grinder!), file it square and use this.
- The ring groove is correctly measured with a new ring installed square in the cylinder bore using feeler gauges and measuring to OEM specification.
- Ring end gap is measured by inserting the ring by itself into the cylinder bore and measuring gap with feeler gauges. Remember, check OEM specifications and *always* measure new rings before installation.

Piston Thrust and Antithrust Side Identification. The piston thrust side is that half of the piston divided at the wrist pin pivot on the inboard side of the crank throw during the downstroke. For a typical engine that rotates clockwise viewed from the front, the major thrust side is the right side of the piston observed from the rear of the engine. The opposite side is known as the **antithrust side**. The terms **major thrust side** and **minor thrust side** are also used. Check out **Figure 4-2** and make sure you understand this: it can be a key to effective troubleshooting in the future.

CONNECTING RODS

Connecting rods are also known as *conn rods*. They connect the piston with the throw on the crankshaft. (See **Figure 4-11**.) The end of the connecting rod that

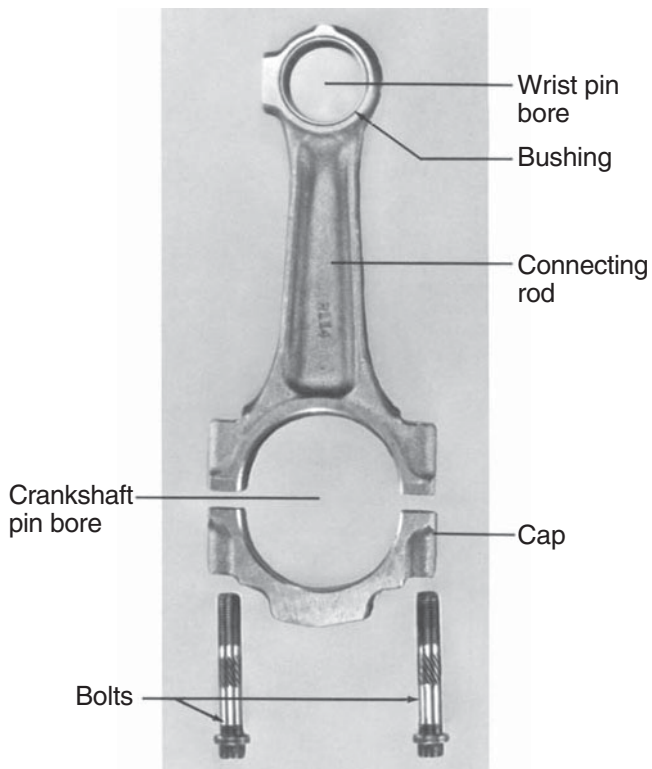
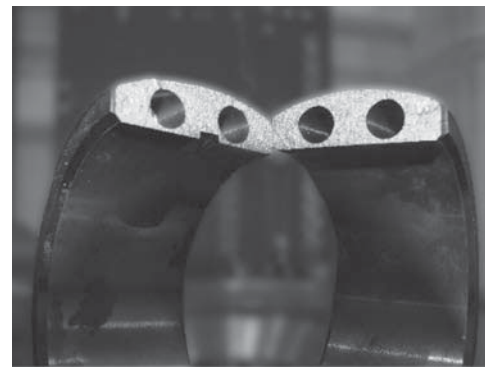

Figure 4-11 Connecting rod terminology. (Specifications are subject to change without notice. Detroit Diesel Corporation is registered to ISO 9001:2001. Courtesy © Detroit Diesel Corporation. All rights reserved. Detroit Diesel is a Daimler company)

links to the piston wrist pin is known as either the **rod eye** or the **small end**. The other end of the connecting rod, which links it to the crankshaft throw, is known as the **big end**. Both the rod eye and big end have bearing surfaces. In this way, the linear force that acts on the piston (cylinder pressure) can be converted to torque by the crank throw. Connecting rods used with crosshead type pistons differ in that they have no rod eye; instead, they have a saddle that bolts directly to the wrist pin. This means that upper bearing action has to be provided by the piston pin boss bushing. A two-piece connecting rod is one in which the rod is forged in one piece, after which the big end cap is cut or fractured off, faced, and fastened (bolted) for machining.

Cracked Rods

For many years, **cracked rod** technology has been used in auto racing applications but now it has become common in diesel engines. Some diesel OEMs refer to this as **fractured rod** technology. Cracked rods have a big end that is machined in one piece. After machining, the rod big end is fractured. Depending on the materials used, the fracture process may take place at



A



B

Figure 4-12 Cracked rod from a Volvo D16 showing the mating faces disassembled (A) and assembled (B).

room temperatures or the rod is frozen to subzero temperatures. Fracturing requires a separation across the diameter of the rod big end. This produces rod and rod cap mating faces that appear rough but form a perfect final-fit alignment. (See **Figure 4-12.**) Providing they are assembled properly, cracked rods make the procedure of checking rod sideplay after assembly unnecessary. Most diesel engine OEMs are using cracked rods in at least some of their engines.

Connecting Rod Construction

Most rods use an I-beam section design but around section has been used in larger-bore diesels. The majority are rifle drilled from big to small ends to carry engine oil from the crank throw up to the wrist pin for lubrication purposes. This oil is used for lubrication and cooling. **Keystone** rods have become commonplace because they increase the area of the small end on which the most amount of force has to act. A keystone rod has a wedge-shaped rod eye or small end. The conn rods shown in **Figure 4-13** have a keystone small end. Connecting rods are subjected to two types of loading: compressional and tensional.

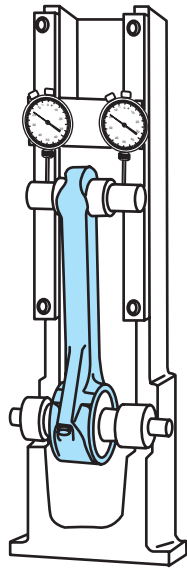

Figure 4-13 Connecting rod fixture.

Compressional Loading

During the compression and power strokes of the cycle, the connecting rod is subjected to **compressional loads**. When something is under compression, it is squeezed. Compressional loads on a rod can be calculated by knowing the cylinder pressure and the piston sectional area. Because of this, connecting rods seldom fail due to compressional overloading. When they do, it is usually coincidental with another failure such as hydraulic lock. Hydraulic lock is rare and usually results from cylinder head-gasket failure that has allowed coolant to leak into the cylinder.

Tensional Loading

Tensional loading is stretching force. At the completion of each stroke, the piston has to stop each time it passes through TDC or bottom dead center (BDC). This reversal of motion occurs nearly 70 times per second in each connecting rod when an engine is run at 2,000 rpm. The heavier the piston, the greater the tensile stress on the rod and crank throw. Tensile stresses on connecting rods increases with engine rpm because piston speeds increase. Any time an engine is overspeeded, the increased tensile loading on conn rods can result in a tensile failure.

Offset Big End Caps. Many OEMs offset (from horizontal) the mating faces of the two halves of the big end. Doing this ensures that the rod cap fasteners do not have to sustain the full tensile loading of rod. The conn rod shown in the rod fixture in **Figure 4-13** uses an offset big end.

Inspecting Rods

Connecting rods should be handled with care. When assembling the rod to the piston, a brass jaw vise and light clamping pressure should be used. Slight nicks and scratches on connecting rods can turn into stress points that eventually cause a separation failure. Most diesel engine OEMs suggest that connecting rods be electromagnetic flux tested *every* time they are removed from the engine. The cost of magnetic flux examination is small compared to the damage caused by a rod failure. When a connecting rod fails in a running engine, the result is often a rod driven through the cylinder block casting. OEMs recommend that connecting rods that fail the inspection procedure be replaced rather than reconditioned. Note that when rods are reconditioned, removing material from a conn rod changes its weight. This changes the dynamic balance of the engine.

Replacing Rods. Because reconditioning of rods is not widely practiced, connecting rods should be inspected using OEM guidelines, and if rejected, replaced. When replacing rods, they should be weight matched. Because most diesel engines are relatively slow running compared with gasoline engines, some OEMs permit flexibility here. However, the consequence of replacing a connecting rod with one of either greater or lesser weight is an unbalanced engine. Manufacturers usually code connecting rods to a weight class and typically each weight class will have a window of about 1.4 ounce (40 grams). When replacing defective connecting rods, always try to match the weight codes.

Rod Cap Fasteners. Most OEMs require that rod cap fasteners be replaced at each reassembly. They should be replaced with the correct OEM fastener and not cross-matched to an Society of Automotive Engineers (SAE)-graded bolt. Deformed threads and stretching make these bolts a poor reuse risk, considering the consequences of fastener failure at the rod cap. The actual chances of failure are low, but remember, the consequences of a conn rod failure are severe. If the work is being performed for a customer, recommend that the rod cap fasteners be replaced and leave any decision to reuse fasteners to the customer. If you are a betting person, your odds are better when reusing fasteners with an offset big end cap.

Connecting Rod Bearings. Most engine OEMs use a single-piece bushing, press fit to the rod eye, and two-piece friction **bearing shells** at the big end. Rod eye bearings should be removed using an appropriately

sized driver and press. Using a hammer and any type of driver that is not sized to the rod eye bore is not recommended because the chances of damage are high. New one-piece bushings should be installed using a press and mandrel, ensuring that the oil hole is properly aligned, and then sized using a broach or hone. Split big end bearings should also be installed respecting the oil hole location. Bearing shells and rod eye bushings should both be installed to a clean dry bore: remove any packing protective coating from the bearings by washing them in solvent, followed by compressed air drying.

.....
Tech Tip: Rod sideplay has to be checked after a rod cap has been torqued to the rod. Cocking of the rod cap on the big end can cause an engine to bind and damage the crankshaft by scoring the web cheeks. In applications in which cracked rods are used, this check is unnecessary as a perfect rod cap to rod fit can be assumed. Snapping the assembly fore and aft on the journal should produce a clacking noise indicating sideplay.

CRANKSHAFTS AND BEARINGS

A crankshaft is a shaft with offset throws or journals to which piston assemblies are connected by means of connecting rods. **Figure 4-14** shows some typical crank throw configurations. Note that in the case of V-configured engines, OEMs may use different numbering sequences than those shown here. When a crankshaft is rotated, the offset crank throws convert the linear, back-and-forth movement of the pistons into rotary motion at the crankshaft. This works in the same way as the pedals function on a bicycle crankshaft. Crankshafts are supported by bearings at main journals. These main bearings require pressurized lubrication any time the engine is running because crankshafts rely on **hydrodynamic suspension**.

Hydrodynamic Suspension

Hydrodynamic suspension is the supporting of a rotating shaft on a fluid wedge of constantly changing, pressurized engine oil. In this way, shaft main journal-to-bearing bore contact is avoided. When the engine is stationary, an oil film coats and protects the bearing shell. It should also prevent metal-to-metal contact when the engine is cold cranked. When the crankshaft begins to turn, lube oil is supplied to each journal from oil passages in the cylinder block. This oil is pumped into the bearing and the main journals of the crankshaft. As the crankshaft rotates, its journals are rolled into this oil creating the wedge required to hydrodynamically support the crankshaft. Angling the oil hole in the journal can help develop a thicker wedge of oil that better supports the crankshaft.

Dynamic Balance

Crankshafts are designed for dynamic balance and use counterweights to oppose the unbalancing forces generated by the pistons. These unbalancing forces reduce as the number of cylinders in an engine increases and companion throws (for example, in an inline 6-cylinder engine, 1 and 6, 5 and 2, 3 and 4) have a counterbalancing effect. Crankshafts are subjected to two types of force: bending forces and torsional forces.

Bending Forces. Bending stress occurs between the main journals between each power stroke. Crankshafts are designed to withstand the bending forces that result from the compression and combustion pressures developed in the cylinder. This normal bending stress takes place between the main journals any time the crank throw between them is loaded by cylinder pressure. Normal bending forces are at their highest when engine cylinder pressures are at their highest. An example of abnormal bending forces would occur if a crankshaft main bearing failed.

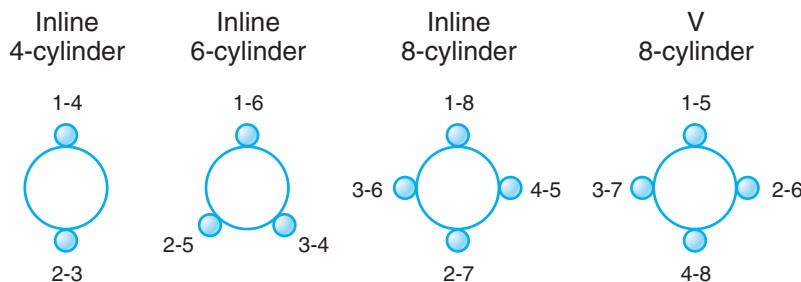

Figure 4-14 Crank throw configurations.

Torsional Forces. **Torsion** is twisting. **Torsional stresses** are the high-speed twisting vibrations that occur in a crankshaft. Crankshaft torsional vibration occurs because when a crank throw is under compression (that is, driving the piston upward on the compression stroke) it slows to a speed just a little less than average crank speed. This same throw on receiving power stroke forces (from the piston) accelerates to a speed just a little higher than average crank speed. These twisting vibrations take place at high frequencies and crankshaft design, materials, and hardening methods must take them into account.

Torsional stresses on a crankshaft tend to peak at crank journal oil holes at the flywheel end of the shaft. Torsional vibrations are amplified when an engine is run at slower speeds with high cylinder pressures because the real-time interval between cylinder firing pulses is longer. Running an engine at lower speeds with high cylinder pressures is known as **lugging**. Torsional vibrations from the crankshaft can be amplified through the chassis drivetrain. This makes proper matching of transmissions and final drive carriers essential.

Crankshaft Construction

Figure 4-15 is a guide to crankshaft terminology. Understanding these terms is critical when measuring and machining crankshafts. Most diesel engine crankshafts today are made of steel forgings. All crankshafts are tempered (heat treated) to provide a tough core with the ability to flex just enough to take the bending and torsional punishment to which they are subject. Most diesel engine OEMs use special processes to forge crankshafts. Most maintain some secrecy about the details of the process. An understanding of journal

hardening procedures is important as the reconditionability of the crankshaft depends on this.

Journal Surface Hardening Methods. Basically three methods are used to surface harden main and rod journals:

1. Flame hardening. Used on plain carbon and sometimes middle alloy steels, flame hardening consists of the direct application of heat followed by quenching in oil or water. This produces relatively shallow surface hardening. The actual hardness of the crankshaft depends on the amount of carbon and other alloys in the steel. Note: flame is sometimes used as protection in induction hardening treatment ovens because it prevents air exposure to the crankshaft during the induction hardening process.
2. Nitriding. Used on alloy steels, this involves higher temperatures than flame hardening and surface hardens to a greater depth—around 0.65 mm (0.025 in.). This method provides a small margin for machining but the process is mostly used on smaller-bore diesel crankshafts.
3. Induction hardening. The area to be hardened is enclosed by an applicator coil through which the alternating current (AC) is pulsed, heating the surface; tempering is achieved by blast air or liquid quenching. This process results in hardening to depths of up to 1.75 mm (0.085 in.), providing a much wider wear and machinability margin than the previous two methods. Most current diesel crankshafts are surface hardened by this method. Sometimes during the process, a flame is used in the induction oven to prevent

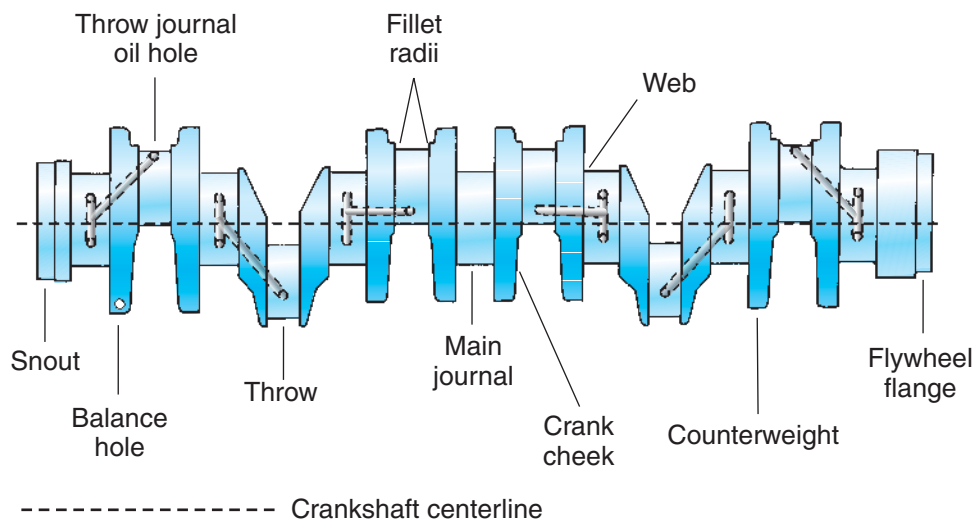

Figure 4-15 Crankshaft terminology. (Courtesy of Caterpillar)

air exposure to the crankshaft while it is being induction hardened.

Removing of Crankshaft from Cylinder Block

The cylinder block should be in an engine stand and in an upside-down position. After the main bearing caps and any other obstructions have been removed, a rigid crankshaft yoke should be fitted to a hoist. The yoke prongs should be fitted with rubber hose (to prevent damage to the journals) and hooked to a pair of throws in the center of the crankshaft (for weight balance). **Figure 4-16** demonstrates how a yoke connects the crankshaft to a hoist.

Torque Twist Control Devices. To reduce engine weight, engine OEMs have used tougher, lighter alloys in cylinder block manufacture. This makes a cylinder block more likely to torque twist when the engine is under extreme loads. To limit cylinder block torque flexing, OEMs have installed bolster plates across the lower cylinder block flange. Another method is to install transverse bolts known as **buttress screws** into the main caps. When buttress screws are used, the main cap is bolted to the cylinder block in the usual manner but in addition, transverse buttress screws are installed from outside the block. If you are experiencing difficulty removing a main cap on a diesel engine after removing the main cap screws, check on the outside of the cylinder block for buttress screws. Buttress screws have to be removed before you can remove a buttressed main cap.

Crankshaft Failures

Only a small percentage of crankshaft failures result from manufacturing and design problems. Because

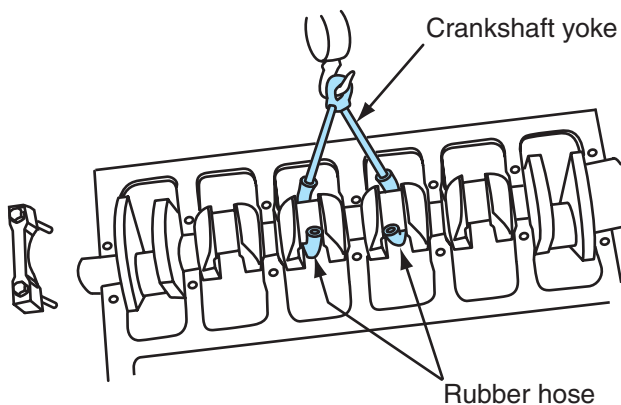

Figure 4-16 Crankshaft removal from cylinder block.

research, development, and testing of new engine series are so thorough in today's engines, when crankshaft failures occur, the cause will most likely fall into one of these categories: bending failures, torsional failures, spun bearings, or etched main bearings.

Bending Failures. Abnormal bending stresses occur when:

- Main bearing bores are misaligned. Any kind of cylinder block irregularity can cause abnormal stress.
- Main bearings fail or become unevenly worn.
- Main caps are broken or loose.
- Standard specification main bearing shells are installed where an oversize is required.
- Flywheel housing is eccentrically (relative to the crankshaft) positioned on the cylinder block. This produces a broken back effect on the drivetrain. The condition usually results from a failure to (dial) indicate a flywheel housing on reinstallation.
- Crankshaft is not properly supported either out of the engine before installation or while replacing main bearings in-chassis. The last problem is more likely to damage the block line bore but it can also deform the crankshaft.

Bending failures tend to initiate at the main journal fillet and extend through to the throw journal fillet at 90 degrees to the crankshaft axis.

Torsional Failures. Causes of crankshaft torsional failures are:

- Loose, damaged, or defective vibration damper or flywheel assembly.
- Unbalanced engine-driven components such as fan pulleys and couplings, fan assembly, idler components, compressors, and power take-offs (PTOs).
- Engine overspeed. Even a slight engine overspeed can create enough torsional stress to cause a crankshaft failure.
- Unbalanced cylinder loading. A dead cylinder or fuel injection malfunction of over- or underfueling a cylinder can result in a torsional failure.
- Defective engine mounts. This can produce a "shock load" effect on the whole powertrain.

When performing failure analysis, remember that the event that caused the failure and the actual failure may be separated by a considerable amount of time. High torsional stress produces fractures occurring from a point beginning in a journal oil hole extending through

the fillet at a 45-degree angle or circular severing right through a fillet. In an inline 6-cylinder engine, the #5 and #6 journal oil holes are more likely to suffer from torsional failures when the crankshaft is torsionally overloaded.

Spun Bearing(s). Spun bearings are lubrication-related failures. They are caused by a lack of oil in one or all of the crank journals. The friction created in the bearing causes it to surface weld itself to the crank journal; then it either rotates with the journal in the bore or continues to scuff the journal to destruction. When a crankshaft fractures as a result of bearing seizure, the surface of the journal is destroyed by excessive heat, and it fails because it is unable to handle the torsional loading. Causes of spun bearings and bearing seizure are:

- Misaligned bearing shell oil hole.
- Improper bearing-to-journal clearance. This produces excessive bearing oil throwoff, which starves journals farthest from the supply of oil.
- Sludged lube oil causing restrictions in oil passages.
- Contaminated engine oil. Fuel or coolant in lube oil will destroy its lubricity.

Etched Main Bearings. Etched main bearings are caused by the chemical action of contaminated engine lubricant. Chemical contamination of engine oil by fuel, coolant, or sulfur compounds can result in high acidity levels that can corrode all metals. The condition is usually first noticed in engine main bearings. It may result from extending oil change intervals well beyond those recommended. Etching appears initially as uneven, erosion pock marks, or channels.

Crankshaft Inspection

Most diesel engine OEMs recommend that a crankshaft be magnetic flux tested at every out-of-chassis overhaul. This process requires that the component to be tested be magnetized and then coated with minute iron filings. When AC is pulsed through the shaft, the magnetic lines of force that result will bend into a crack or nick, causing the iron filings to collect in the flaw.

.....

Tech Tip: Most small cracks observed when magnetic flux testing crankshafts are harmless but beware of fillet cracks and cracks extending into oil holes.

.....

Visual Inspection. Following magnetic flux inspection, the crankshaft thrust surfaces should be checked for wear and roughness. It is usually only necessary to polish or dress these areas using the appropriate crank machining equipment. The front and rear main seal contact areas of the crankshaft should be checked for wear. Wear sleeves, interference-fit to the seal race, are available for most engines and can be easily installed without special tools. Most crankshafts in current medium- and large-bore highway diesel engines require no special attention during the life of the engine.

Crankshaft Measuring Practices. Specifications listed here are *typical* maximums. The OEM service literature should always be consulted when determining the serviceability of a specific crankshaft. Journals should be measured across axes 90 degrees apart in three places, usually at either end and in the center of the journal, and the results matched to OEM specification. Using a measuring chart is the best method of organizing the measurements made.

- *Journal out of roundness:* 0.025–0.050 mm (0.001–0.002 in.)
- *Journal taper:* 0.0375 mm (0.0015 in.)
- *Bent crankshaft:* Check in V-blocks with a dial indicator while smoothly rotating by hand—out of service (OOS) specifications differ widely due to differing crankshaft materials and lengths.

Reconditioning Crankshafts

Most truck and bus engine OEMs do not approve of the reconditioning of crankshafts. However, the practice is widespread. In most cases, the reconditioning procedures attempt to preserve the original surface hardening but where the damage is severe, for example, with a spun bearing, journal damage can be deeper than the hard surfacing. While journal surfaces can be rehardened, this practice is not so common.

The reconditioning methods are simply outlined here, but the technician should be aware that most OEMs regard them as bad practice. Four basic methods of crankshaft reconditioning are used:

1. Grinding to undersize, which may require oversize bearings (these are not always available from engine OEMs).
2. Metallizing journal surfaces followed by grinding to the original size.
3. Chroming surface to original size.
4. Submerged arc welding buildup followed by grinding to original size.

ROD AND MAIN BEARINGS

You should have a basic understanding of bearing construction (Figure 4-17) because it can help you diagnose failures. Most diesel engine manufacturers make available excellent bearing failure analysis charts and booklets, some of which are available on online service information systems (SIS).

Construction and Design

Two basic designs are used in current applications:

1. concentric wall—uniform wall thickness
2. eccentric wall—wall thickness is greater at the crown than parting faces; also known as delta-wall bearings

Materials. Rod and main friction bearings usually have a steel base or backing plate. Onto this is layered copper, lead, tin, aluminum, and other alloys. **Friction bearings** are designed to have embedability. This means that the outer face of the bearing must be soft enough to allow small abrasives to penetrate the outer shell, known as the overlay, to a depth at which they will cause a minimum amount of scoring to the crank journals that rotate in the bearing.

Bearing Clearance

The engine OEM's specification for bearing clearance must be observed. Bearing clearance is measured

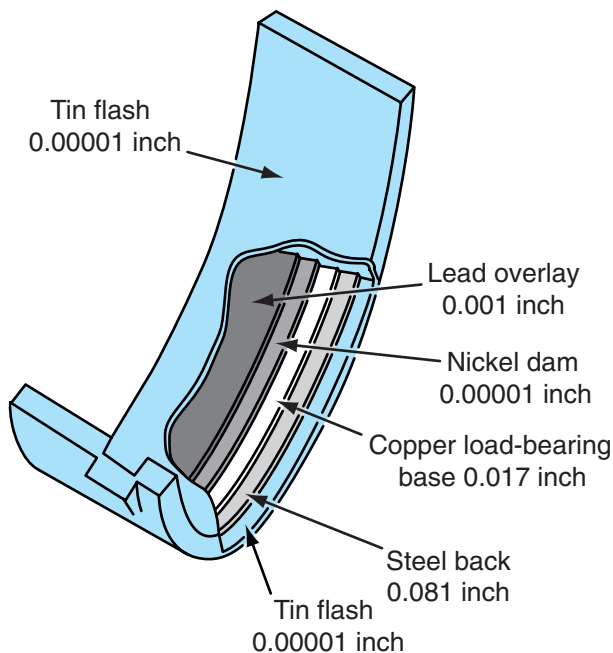

Figure 4-17 Construction of a typical bearing. (Courtesy of Navistar)

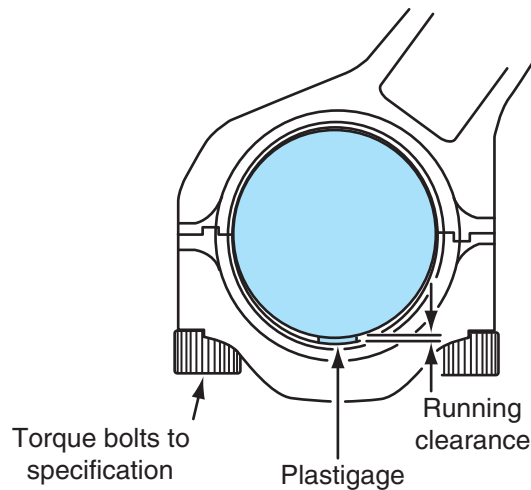

Figure 4-18 Checking bearing clearance using Plastigage.

with Plastigage using the methods shown in Figure 4-18 and Figure 4-19. Most manufacturers make several oversizes (of bearings) to accommodate a small amount of crankshaft journal wear or machining. Do not assume that a new engine will always have standard size bearings. Typical bearing clearances in highway diesel engine applications run from 0.050–0.100 mm (0.002–0.004 in.). The ability to maintain hydrodynamic suspension of the crankshaft decreases as bearing clearances increase. When bearing clearance increases above specification, a drop in oil pressure results that may indicate the need for an in-chassis bearing rollover. Increased bearing clearance also increases oil throw-off, and this may result in excessive lube being thrown up onto cylinder walls.

Do not attempt to measure bearing clearance when the engine is in-chassis because the results are not that accurate. This is because of the flexibility of crankshafts when not fully supported at each main bearing.

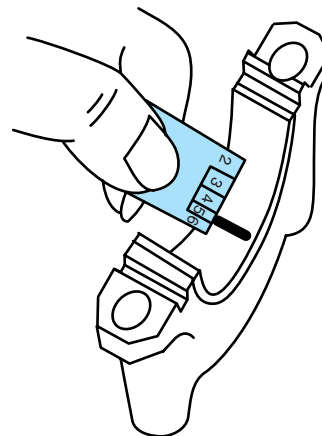

Figure 4-19 Correct method of locating Plastigage.

The engine should be upside-down and level so that there is no weight load acting on the retaining cap of the bearing being measured.

Check the bearing clearance specifications first. Sometimes bearing clearances are expressed in ten thousandths of an inch because engineering specs are used. When they are, round the value to the nearest half thousandth (0.0005 inch) and try to work in units of thousandths. For instance, an OEM bearing clearance spec of 0.0027 inch can be expressed as 2½ thousandths. Next select the Plastigage color code capable of measuring in the range of specifications. **Plastigage™** is soft plastic thread that easily squishes to conform to whatever clearance space is available when compressed between a bearing and journal. The crushed width can then be measured against a scale on the Plastigage packaging. The lower the clearance, the wider the Plastigage strip will be flattened. The measuring process is shown in **Figure 4-19**.

Using Plastigage. A short strip of Plastigage should be cut and placed across the center of the bearing in line with the crankshaft. The bearing cap with the bearing shell in place can then be installed and torqued to specification. Do not rotate the engine with the Plastigage in place. Next the bearing cap and shell should be removed and the width of the flattened Plastigage checked against the dimensional gauge on the Plastigage packaging. If clearance is within specifications, carefully remove the Plastigage from the journal before reinstalling the cap and shell assembly.

Selecting the Correct Plastigage Strip. Plastigage is manufactured in four sizes, each color-coded for the range of clearances it is capable of measuring. **Table 4-1** identifies each Plastigage color-coded size window in both standard and metric dimensions. While most diesel OEMs still display their specifications using standard measurements, some display in both standard and metric, and one uses only metric specifications.

Tech Tip: Always ensure that all Plastigage residue is removed from a bearing after measuring. Use a mild solvent and never an abrasive object to perform this.

Crankshaft Endplay

One of the main bearings is usually flanged to define crankshaft endplay. This is known as the **thrust bearing** and it is available in several sizes to accommodate some thrust surface wear as well as some thrust face dressing in the crankshaft. Another way of defining crankshaft endplay is to use split rings known as thrust washers. Endplay specifications would typically be in the 0.2 to 0.3 mm (0.008 to 0.012 in.) range. Use a dial indicator to measure endplay. A lever should be used that is not going to damage the crankshaft. The crankshaft should be levered fore and aft while observing the indicator measurement.

Bearing Retention

Bearings are retained primarily by *crush*. The outside diameter of a pair of uninstalled bearing shells slightly exceeds the bore into which it is installed (**Figure 4-20**). This creates radial pressure that acts against the bearing halves and provides good heat transfer. The bearing halves are also slightly elliptical, which helps the bearing to be held in place during installation and provides what is known as bearing spread (**Figure 4-20**). Tangs in bearings (**Figure 4-21**) are inserted into notches in the bearing bore: the tangs reduce movement, prevent bearing rotation, and align oil holes.

Bearing Removal and Installation

Service literature should always be consulted and their procedures observed. This operation is very straightforward when performed out of chassis because the crankshaft is removed when installing the cylinder block side bearing shell and the technician is working

TABLE 4-1: PLASTIGAGE CODE IDENTIFICATION

Part Number	Color	Standard Dimension Window	Metric Dimension Window
HPG1	Green	0.001 to 0.003 in.	0.025 to 0.76 mm
HPR1	Red	0.002 to 0.006 in.	0.051 to 0.152 mm
HPB1	Blue	0.004 to 0.009 in.	0.102 to 0.229 mm
HPY1	Yellow	0.009 to 0.020 in.	0.230 to 0.510 mm

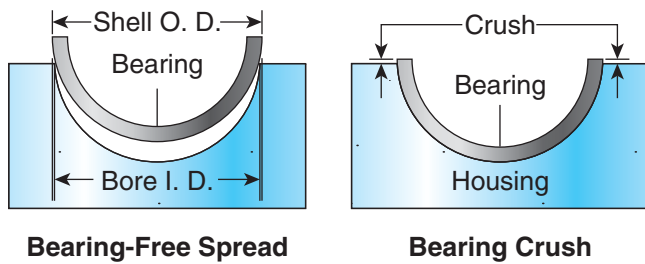

Figure 4-20 Bearing spread and crush. (Specifications are subject to change without notice. Detroit Diesel Corporation is registered to ISO 9001:2001. Courtesy © Detroit Diesel Corporation. All rights reserved. Detroit Diesel is a Daimler company)

above the engine with perfect visibility and accessibility for the remainder of the procedure.

Bearing Rollover. For many rookie truck technicians, their first experience of engine work will be performing what is known as an in-chassis bearing rollover. Though this is a simple procedure, it can be messy, especially on a hot engine that may drip oil for hours. It is not unusual today when performing a bearing rollover to remove a set of bearings in near perfect condition. This is due to the quality of today's bearings compared with those of a generation ago.

In-chassis, main bearings are rolled out using a capped dowel (often "homemade" by machining a bolt) inserted into the journal oil hole. Make sure that the dowel cap does not exceed the thickness of the bearing because if it does, it will destroy the journal. You begin by removing the main cap, and then insert the dowel cap. Next, rotate the crank to roll the bearing out, tang side first. Using a screwdriver or similar method will almost certainly result in scratch and score

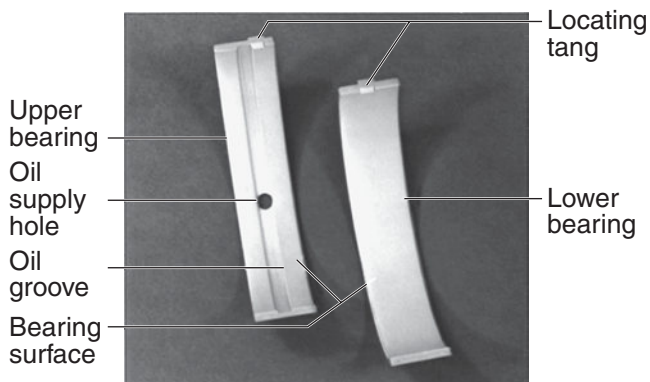

Figure 4-21 Upper and lower bearing shells. (Specifications are subject to change without notice. Detroit Diesel Corporation is registered to ISO 9001:2001. Courtesy © Detroit Diesel Corporation. All rights reserved. Detroit Diesel is a Daimler company)

damage to the journal. New bearing halves are installed clean, dry, and with as little handling as possible. If a new bearing is coated with a protective film of grease or light wax, this should be removed using a bristle brush and solvent followed by air drying.

The new bearing backing should be installed clean, dry, and preferably without finger contact. Trace quantities of lubricant, moisture, or dirt will reduce its ability to transfer heat. The facing may be lightly coated with clean engine lubricant applied by finger. After performing any procedure that involves the draining of lubricant from the oil galleries and passages that supply the bearings, it is good practice to prime the engine lubrication circuit using a remote pump before cranking.

Bedplate Main Bearings. Some recent small-bore engines usually of offshore origins have introduced a lower cylinder block bedplate. The bedplate replaces a set of main bearing caps with a single casting plate that bolts to the engine cylinder block. This design can enable a lighter cylinder block to withstand higher resistance to acceleration and deceleration torsionals. It goes without saying that when a bedplate design is used, in-chassis overhauls cannot be done.

VIBRATION DAMPERS

Vibration damper and *harmonic balancer* both refer to the same component, but the term *vibration damper* is used by most diesel engine OEMs so we will use it in this text. A vibration damper is mounted on the free end of the crankshaft, usually at the front of the engine. Its function is to reduce twisting vibrations as well as add to flywheel mass in establishing rotary inertia. In other words, its main function is to reduce crankshaft torsional vibration. (See the full explanation of crankshaft torsional vibration earlier in this chapter under crankshafts.)

Vibration Damper Construction

A typical vibration damper consists of a damper drive or housing and inertia ring (see **Figure 4-22** and **Figure 4-23**). The housing is coupled to the crankshaft and, using springs, rubber, or viscous medium, drives the inertia ring: the objective is to drive the inertia ring at *average* crankshaft speed. Vibration dampers therefore have three main components:

1. drive member: bolted to crankshaft
2. drive medium: either a fluid (silicone gel) or solid rubber
3. driven member: an inertia ring

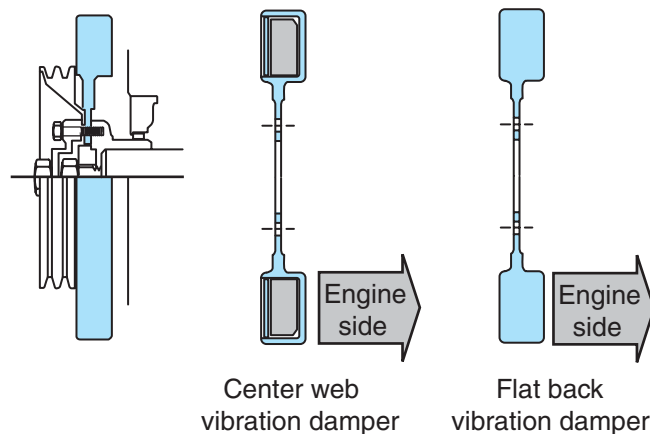

Figure 4-22 Sectional view of a vibration damper.

Two types are used in current diesel engines:

1. viscous drive type
2. solid rubber drive type

Viscous Drive Operating Principle. Viscous drive type vibration dampers are more common in truck and bus diesels. The drive member is bolted to the crankshaft and consists of a ring-shaped, hollow housing. Inside the hollow housing is a solid-steel inertia ring. This inertia ring is suspended in, and driven by, silicone gel, at least when cold. But as it warms to operating temperature, the silicone drive medium becomes more fluid. Because the drive member is bolted to the front of the crankshaft, it

moves with whatever torsional vibrations occur in this location. When the drive member rotates, it drives the drive medium (silicone gel) and inertia ring inside of it. Because the inertia ring contains most of the weight of the vibration damper, it rotates at *average* crankshaft speed. This means that it will be subject to the twisting effects occurring at the front of the crankshaft. Because the speeds of the drive member and inertia ring will differ, shear action will take place in the drive medium, the silicone gel. This shearing action of the viscous fluid film between the drive housing and the inertia ring will help smooth the twisting forces occurring at the front of the crankshaft. It would be correct to say that the inertia ring is hydrodynamically supported by the silicone medium.

REPLACING VISCOUS VIBRATION DAMPERS

Most OEMs recommend the replacement of a vibration damper at each major overhaul. This is not always observed due to the expense. The consequences of not replacing the damper when scheduled can be costly, as it can result in a failed crankshaft. Viscous vibration dampers usually fail for one of two reasons:

1. damage to the outside housing causing a leak or locking the inertia ring
2. breakdown of the viscosity of the silicone drive medium

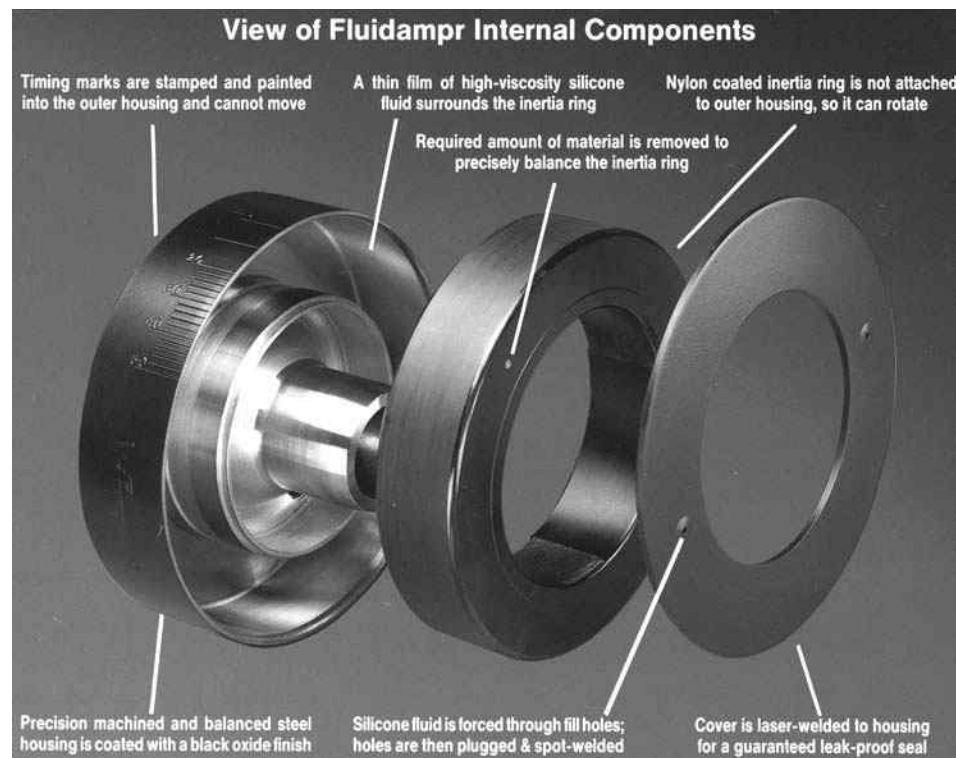

Figure 4-23 Exploded view of a viscous vibration damper. (Courtesy of Vibratech IDEX)

CAUTION Recommend that a viscous type vibration damper be replaced at engine overhaul regardless of its external appearance. Explain that this is an OEM recommendation. If customers decline, they have made the decision, not you. A failed vibration damper can cause crankshaft failure.

Solid Rubber Vibration Dampers. Solid rubber type vibration dampers are used less often on today's heavy truck diesel engines, because they tend to be less effective at dampening torsionals on modern high-torque, lower-speed engines. This type consists of a drive hub bolted to the crankshaft: a rubber ring is bonded to both the drive hub and the outer inertia ring which contains most of the mass. The rubber ring therefore acts as both the drive and the damping medium. The elasticity of rubber enables it to function as a damping medium, but the internal friction generates heat, which eventually hardens the rubber and renders it less effective and vulnerable to shear failures. Cracks appearing in the rubber are usually an indication that it is time to replace it.

FLYWHEELS

The engine flywheel in a typical commercial diesel engine is normally mounted at the rear of the engine. It has three basic functions:

1. To store kinetic energy (the energy of motion) in the form of inertia. This helps smooth out the power pulses that occur in an engine as each cylinder fires and establish an even crankshaft rotational speed.
2. To provide a mounting for engine output: it is the power take-off device to which a clutch or torque converter is bolted.
3. To provide a means of rotating the engine by starter motor.

In addition, a flywheel may be marked with an index for timing purposes and increasingly, it may be used as an ECM input to signal engine speed and position.

Inertia

The inertia role of a flywheel relates to its ability to store energy. As an energy storage device, the flywheel plays a major role in smoothing the twisting vibrations that act on the rear of the crankshaft during engine operation. The weight of the flywheel helps rotate the engine between firing pulses. The actual weight of a flywheel depends on a number of factors:

- two- or four-stroke cycle engine
- number of engine cylinders
- engine operating rpm range

Because the number of crank angle degrees between power strokes is half that on a two-stroke cycle compared to a four-stroke cycle of the equivalent number of cylinders, less flywheel weight is required. Engines designed to be run at consistently high rpms also require less flywheel weight. Having a heavy flywheel slows a response to a sudden demand for acceleration. While you will be unlikely to find a four-stroke cycle, single-cylinder diesel engine powering a modern truck, you should take a look at one of these engines if you can come across one. You can sometimes find a single-cylinder diesel on a farm. Typically, these engines use a pair of flywheels that, combined, weigh more than the remainder of the engine.

Types of Flywheels

The flywheels (and flywheel housings) used on all North American-built engines are categorized by the SAE by size, shape, and bolt configuration. This allows engines to be easily coupled to different OEM clutch and transmissions. Two designs are used: the *flat face* design and the *pot* design. **Figure 4-24** shows a flat face truck flywheel. Most trucks equipped with current medium- and large-bore highway diesel engines use one of two SAE flywheel sizes:

- SAE #4—accommodates a 15½-inch clutch assembly
- SAE #5—accommodates a 14-inch clutch assembly

Ring Gear Replacement

A ring gear is shrunk fit around the outside of the flywheel. The ring gear is machined with external teeth. This allows the pinion on the starter motor to connect with the flywheel and rotate it to crank the engine. A worn or defective ring gear can be removed from the flywheel by first removing the flywheel from the engine and then using an oxyacetylene torch to partially cut through the ring gear working from the outside on a single tooth. Cutting of a single tooth is usually sufficient to expand the ring gear so that the removal can be completed using a hammer and chisel. Care should be taken to avoid heating the flywheel any more than absolutely necessary or damaging the flywheel itself by careless use of the oxyacetylene flame. A hacksaw and chisel may also do the job but this will require some care and a lot of sweat if no heat is to be used.

Installing a New Ring Gear. To install a new ring gear, place the flywheel on a flat, level surface, and check that the ring gear seating surface is free from dirt, nicks, and burrs. Ensure that the new ring gear is the correct one and if its teeth are chamfered on one side, that they will face the cranking motor pinion after

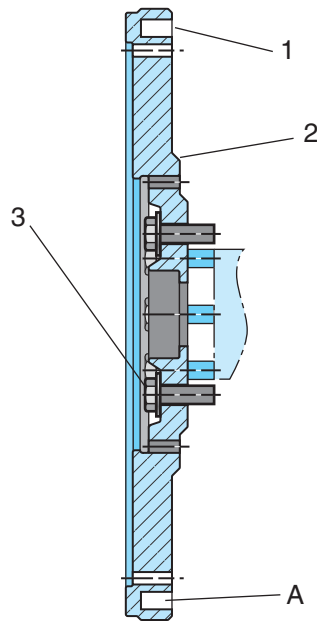

Typical Example

Make reference to flywheel runout for correct method of flywheel inspection

- (1) Flywheel ring gear. Gear must be assembled against shoulder (A) of flywheel. Maximum temperature of gear before shrinking 315°C (599°F)
- (2) Flywheel.
- (3) Apply thread sealant to bolts and torque to 300 ± 30 Nm (220 ± 22 ft.-lb)

Figure 4-24 Sectional view of a flywheel. (Courtesy of Caterpillar)

installation. Next, the ring gear must be expanded using heat so that it can be shrunk to the flywheel. Most OEMs specify a specific heat value because ring

gears are heat treated, and overheating will damage the tempering and substantially reduce the hardness. A typical temperature specification would be around 400°F (200°C) but it may be as high as the 600°F (315°C) recommended by Caterpillar (**Figure 4-24**).

Because of its size, the only practical method of heating a ring gear for installation is using a rosebud type (high gas flow) oxyacetylene heating tip. To ensure that the ring gear is heated evenly to the specified temperature and especially to ensure that it is not overheated, the use of temperature indicating crayon such as Tempilstick is recommended. When the ring gear has been heated evenly to the correct temperature, it will usually drop into position and almost instantly contract to the (cold) flywheel. Handle a hot ring gear with blacksmith tongs.

Reconditioning and Inspecting Flywheels

Flywheels are commonly removed from engines for reasons such as clutch damage, leaking rear main seals, or leaking cam plugs. Care should be taken when both inspecting and reinstalling the flywheel and the flywheel housing. Flywheels should be inspected for:

- face warpage (straightedge and thickness gauges)
- heat checks (visual)
- scoring (visual)
- intermediate plate drive lugs (right angle square)
- axial and radial runout (dial indicator)
- thickness (micrometer)

Damaged flywheel faces may be machined using a flywheel resurfacing lathe to OEM tolerances. Typical maximum machining tolerances range from 0.060 in. to 0.090 in. (1.50 to 2.30 mm). Note that when resurfacing pot-type flywheel faces, the pot face must have the same amount of material ground away as the flywheel face. If you do not do this, the clutch will not function.

Summary

- For purposes of study, the engine powertrain refers to those engine components responsible for delivering power developed in the engine cylinders to the power take-off mechanism, usually a flywheel.
- Aluminum trunk type pistons were widely used in medium- and large-bore diesel engines until the late 1980s because of their light weight and ability to rapidly transfer heat. They are still used today but mostly in light-duty diesel engines.
- Aluminum alloy trunk type pistons used in diesel engines support the top compression ring with a Ni-Resist insert. They are also cam ground and tapered due to the way they expand in operation.
- Two-piece articulating piston assemblies replaced aluminum trunk pistons and until recently were the favored piston assembly design by engine OEMs.
- Articulating pistons usually consist of a forged steel crown and aluminum alloy skirt. The two pieces pivot on the wrist pin, which allows each of the two components that make up the piston-independent movement.

- Today, diesel engine OEMs favor single-piece forged or composite steel trunk pistons. These pistons are known as Monotherm and Monocomp pistons.
- In direct-injection engines, the shape of the piston crown determines the type of combustion chamber. The Mexican hat piston crown, open combustion chamber is the most common in today's low-emission diesel engines.
- Engine oil is used to help cool pistons in three ways: shaker, circulation, and spray jet methods.
- Piston rings seal when cylinder pressure acts on the exposed sectional area of the ring: this pressure first forces the ring down into the land, then gets behind it to load the ring face into the cylinder wall. Because of this, piston rings seal with best efficiency when engine cylinder pressures are at their highest.
- Any cylinder gas that passes by the piston rings enters the crankcase. These are known as blowby gases. High crankcase pressure can indicate worn piston rings.
- A keystone is wedge-shaped. Keystone rings are commonly used for the top compression ring in today's highway diesel engines. They may also be used for the rings below the top compression ring.
- Oil control rings are designed to apply a film of oil to the cylinder wall on the upstroke of the piston and "scrape" it on the downstroke. All the piston rings play a role in controlling the oil film on the cylinder because oil that remains on the cylinder walls during the power stroke is combusted.
- Full-floating wrist pins have a bearing surface with both the piston boss and the connecting rod eye. Crosshead pistons articulate but have a semi-floating wrist pin that bolts directly to the rod small end.
- Full-floating wrist pins are retained in the piston boss by snap rings.
- Connecting rods are subjected to compressional and tensional loads. Most connecting rods will outlast the engine. That said, they should be carefully inspected at each overhaul using the OEM procedure.
- Crankshafts have to be flexible because they receive considerable bending and torsional stress.
- Most commercial diesel engines use induction-hardened crankshafts.
- Most engine OEMs do not approve of reconditioning failed crankshafts. However, the practice is widespread due to the high cost of new crankshafts.
- The term *friction bearings* is used to describe the half shell bearings used to support crankshafts and on rod big ends. The term *friction* refers to the fluid friction created by the hydrodynamics of the lube oil.
- Friction bearings used in crankshaft throw and main journals are retained by crush.
- Vibration dampers consist of a drive member, drive medium, and inertia ring.
- The viscous-type damper is common on today's commercial diesels. A hollow drive ring bolts directly to the crankshaft: inside this is a solid-steel inertia ring suspended in silicone gel. The hydrodynamic shear of the silicone drive medium between the drive ring and the inertia ring produces the damping effect.
- Some OEMs use solid rubber vibration dampers. In these, the inertia ring is exposed and driven by solid rubber that is bonded to both the inertia ring and drive hub.
- The flywheel uses inertia to help smooth out the power pulses delivered to the engine powertrain.
- Flywheels are classified by size and shape by the SAE.

Internet Exercises

1. Use a search engine to log onto the Mahle website. Identify some of their products.
2. Log onto some engine OEMs, such as Caterpillar, Cummins, DDC, and Volvo, and within the site search out these key words: Ferrotherm, Monotherm, and Monocomp.
3. Check out the following websites: <http://www.clevite.com> and <http://www.piomach.com>.
4. Compare pricing of OEM and aftermarket diesel engine piston rings.
5. Use a search engine to research machine shops that will recondition diesel engine crankshafts: investigate the warranty offered with the repair.

Shop Tasks

1. Measure a piston ring end gap in a liner using feeler gauges.
2. Identify rod weight class using one OEM method. Explain how other OEMs do this.
3. Assemble a set of rings onto a piston, identify the thrust faces, and set an end gap stagger.
4. Install a piston assembly: torque rod caps to specification and check rod sideplay.
5. Measure main bearing clearance using Plastigage.

Review Questions

1. Where would you likely find a Ni-Resist insert?
 - A. Upper ring belt, aluminum trunk piston
 - B. Lower ring belt, articulating piston
 - C. Upper ring belt, crosshead piston
 - D. Trunk piston, pin boss
2. Under which of the following conditions would a piston ring seal more effectively?
 - A. Low engine temps
 - B. High engine temps
 - C. Low cylinder pressures
 - D. High cylinder pressures
3. Which of the following crankshaft journal surface hardening method provides the highest machinability margin?
 - A. Nitriding
 - B. Shot peening
 - C. Flame hardening
 - D. Induction hardening
4. What should you use to measure rod and main journal bearing clearances?
 - A. Tram gauges
 - B. Dial indicators
 - C. Plastigage
 - D. Snap gauges
5. What type of piston is favored by diesel engine OEMs in recent commercial vehicle diesel engines?
 - A. Aluminum trunk
 - B. Forged steel trunk
 - C. Two-piece articulating
 - D. Two-piece crosshead
6. Which of the following types of pistons use bushingless pin bosses?
 - A. Crosshead
 - B. Ferrotherm
 - C. Monotherm
 - D. Aluminum alloy
7. Technician A says that keystone rings are the most common in current diesel engines. Technician B says that keystone conn rods have a wedge-shaped small end. Who is correct?
 - A. Technician A only
 - B. Technician B only
 - C. Both A and B
 - D. Neither A nor B
8. Which of the following would be the more likely if an engine was run underload with a failed vibration damper?
 - A. Increased fuel consumption
 - B. Increased cylinder blowby
 - C. Camshaft failure
 - D. Crankshaft failure

9. What is the upper face of a piston assembly known as?
- A. Crown
 - B. Skirt
 - C. Boss
 - D. Trunk
10. Which term is used to describe the cylinder volume between the piston upper compression ring and its leading edge?
- A. Dead volume
 - B. Headland volume
 - C. Toroidal recess
 - D. Clearance volume

CHAPTER

5

Timing Geartrains, Camshafts, Tappets, Rockers, and Cylinder Valves

Learning Objectives

After studying this chapter, you should be able to:

- Identify the engine feedback assembly components.
- Identify the engine timing geartrain components.
- Outline the procedure required to time an engine geartrain.
- Define the role of the camshaft in a typical diesel engine.
- Interpret camshaft terminology.
- Perform a camshaft inspection.
- Identify the role valvetrain components play in running an engine.
- List the types of tappet/cam followers used in diesel engines.
- Inspect a set of push tubes or rods.
- Describe the function of rockers.
- Define the role played by cylinder head valves.
- Interpret the valve terminology.
- Outline the procedure required to recondition cylinder head valves.
- Describe how valve rotators operate.
- Perform a valve lash adjustment.
- Outline the consequences of either too much or too little valve lash.
- Create a valve polar diagram.

Key Terms

base circle (BC)

cam geometry

cam profile

camshaft

clevis

companion cylinders

concept gear

feedback assembly

followers

helical gear	periphery	valve
inner base circle (IBC)	ramps	valve float
interference angle	rockers	valve margin
keepers	split locks	valve polar diagram
lifters	spur gear	valvetrain
outer base circle (OBC)	tappets	variable valve timing (VVT)
overhead adjustment	Tempilstick™	
pallet	train	

INTRODUCTION

Timing geartrains, camshafts, tappets, rockers, and cylinder valves together form what is known as the engine **feedback assembly**. It is the engine's mechanical management train. The feedback assembly of an engine includes:

- timing and accessory drive gearing
- the camshaft
- tappets
- valve and unit injector trains
- fuel pumping mechanisms

Its components are driven by, and often timed to, the engine crankshaft. The drive mechanism for most commercial diesel engine feedback assemblies is almost always a gearset. In lighter-duty engines, pulleys and belts, chains, and sprockets may be used as drives. A typical timing gearset is illustrated in **Figure 5-1**.

TIMING GEARS

Diesel engine timing gears are normally located at the front of the engine. These gears are responsible for turning the camshaft and most of the engine accessories. Some larger engines may locate the timing geartrain in the rear or both the front and rear.

Timing Gear Construction

Diesel engine gears are cast or forged alloys that are heat tempered and then surface hardened. The gear teeth are milled in manufacture to spur and helical designs. Combinations of both these gear designs are used in engine geartrains. The noise produced by the geartrain is a factor and for this reason, helical cut gears tend to be more common because they are quieter. **Helical gears** provide increased tooth contact area, which lowers contact forces. The disadvantage of helical gears is that they have high thrust loads: this means that thrust forces have to be contained by thrust plates and bearings.

The **spur gear** design offers much lower thrust loads but at the cost of greater noise and faster wear. Both helical and spur gear designs are used. The gears are commonly press fit to the shafts that they drive and

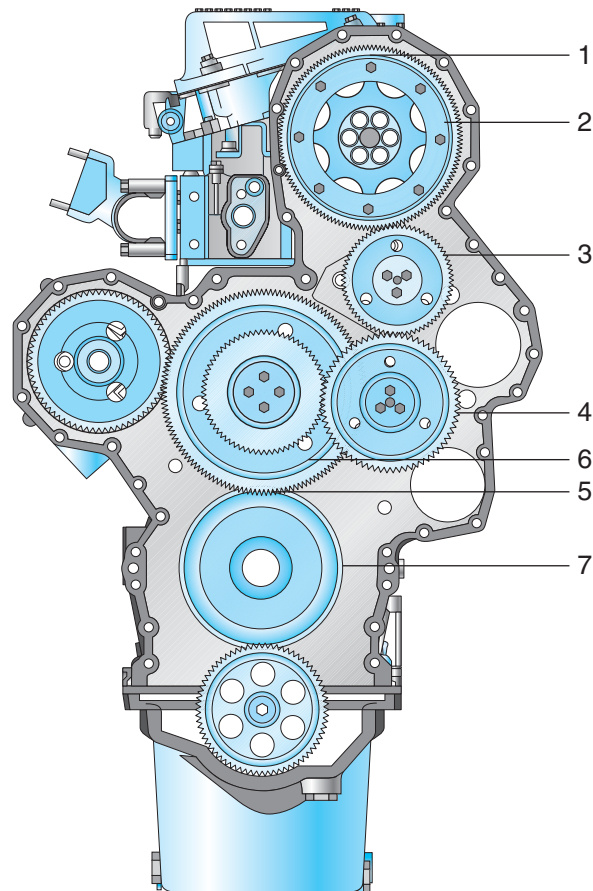

FRONT GEARTRAIN

- | | |
|--------------------------|--------------------|
| 1. Timing mark | 5. Timing mark |
| 2. Camshaft gear | 6. Cluster gear |
| 3. Adjustable idler gear | 7. Crankshaft gear |
| 4. Idler gear | |

Figure 5-1 Caterpillar 2007 ACERT C13 engine timing geartrain featuring an overhead camshaft. (Courtesy of Caterpillar)

are positioned on the shaft by means of keys and keyways.

Timing Gear Inspection and Removal

Visual inspection can usually determine the condition of timing gears. Indications of cracks, pitting, heat discoloration, or lipping of the gear teeth usually require the replacement of a gear. Press-fit gears have to be removed from gear shafts using mechanical, pneumatic, or hydraulic pullers. When the shaft and gear can be removed from the engine, a shop air-over-hydraulic press can be used. Make sure you take the usual safety precautions and support the components on separation. When a gear has to be separated from a shaft while on the engine, a portable hydraulic press is usually required; while using the press, ensure that it is mounted in such a way that it will not damage either the cylinder block or other gears.

Installation. Install the new gear to the shaft by heating to the original equipment manufacturer's (OEM's) specified temperature. The best way to heat the gear to the specified temperature is to use a thermostatically regulated oven or hot plate. If a bearing hot plate is used, make sure that it is large enough to fit the entire surface of the gear. Typical specified temperatures are around 150°C (300°F). Overheating a gear can destroy the heat treatment and possibly the surface hardening, resulting in premature failure. Heat indicating crayon such as **Tempilstick™** may be used to determine the exact temperature. At the specified temperature, the gear can be dropped over the shaft and allowed to air cool. The engine geartrain should be timed according to the OEM procedure. Some current engines have a timing geartrain at the rear of the engine, such as engines in the Detroit Diesel DD family and Volvo engines.

A number of gears are used in the engine geartrain especially when an overhead camshaft (OHC) is used. If the camshaft is to be rotated in the same direction of rotation as the crankshaft, an idler gear must be used between the crankshaft and camshaft gears. It is not necessary that the camshaft be turned in the same direction as the crankshaft.

Timing the Engine Geartrain. The timing procedure is simple but must be performed accurately. When timing the engine geartrain, you are phasing the crankshaft with the camshaft. In other words, you are phasing the engine powertrain with its feedback assembly. In most cases, you are required to locate the crankshaft in a specific position. The camshaft and other timing gears are then timed to the crankshaft gear. It is essential that

you reference OEM service literature when performing this procedure.

Gears that have to be timed to each other are identified by stamped markings on the teeth that intermesh. Engine timing geartrains may be designed with one or more idler gears. Some engines use offset gear-to-shaft keys. These offset keys are used to adjust timing.

.....
Tech Tip: A quick check for proper timing gear alignment can be made by locating the #1 piston at TDC (top dead center) on the compression stroke. In this position, the **valves** on #1 cylinder should be closed, while those on its companion #6 cylinder should be at overlap.

Gear backlash is the relative movement between two gears in mesh. It should be checked after the engine geartrain has been assembled and timed. A dial indicator (preferred) or feeler gauges should be used. A typical geartrain backlash specification would be in the region of 200 μm (0.008 in.), but the OEM specifications should be consulted. A backlash specification higher than the OEM specification is an indication of gear contact face wear and usually requires that a gear or gears be replaced. A lower than specified backlash factor often indicates an assembly or timing problem.

Timing Overhead Camshafts

The procedure for timing OHCs varies and depends on the engine. **Figure 5-2** shows the engine timing geartrain used in a pre-2010 Cummins ISX engine. Each camshaft has different functions. The left-side camshaft is responsible for actuating the mechanical injectors used on these engines. The right-side camshaft takes care of valve actuation and engine braking. Two **concept gears** are used.

Concept Gears. A concept gear uses coaxial springs between the drive hub and the gear to dampen geartrain oscillation. Geartrain oscillations are the vibrations that result when shafts in the geartrain have fractionally different rotational speeds. In effect, a concept gear allows a zero lash condition to exist between intermeshing gears regardless of engine temperature. The ISX engine uses two concept gears. The lower concept gear acts as an idler gear and uses seven coaxial springs. The upper concept gear is located on the injector camshaft and drives the valve/brake camshaft.

CAMSHAFTS

The **camshaft** in most commercial diesel engines is gear driven by the crankshaft through one revolution

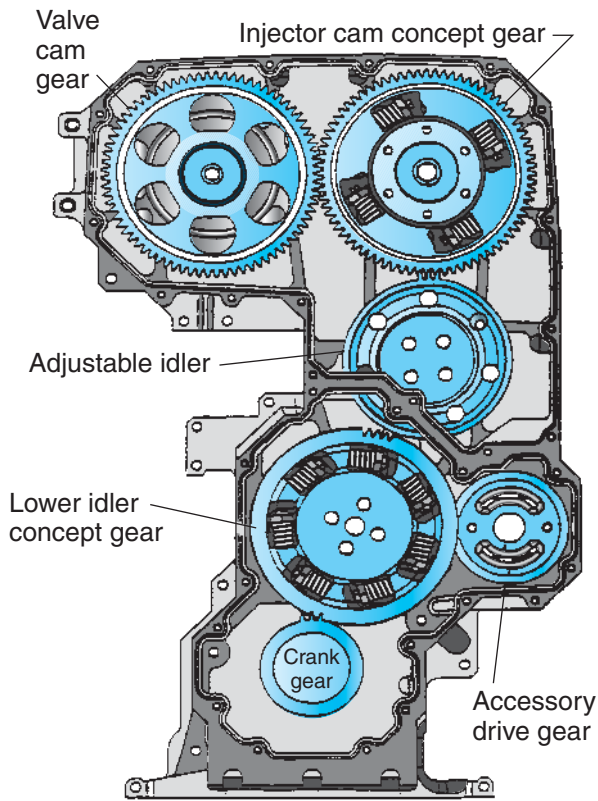

Figure 5-2 Cummins ISX timing geartrain used until 2010. (Courtesy of Cummins)

per complete cycle of the engine. In a four-stroke cycle engine, to complete a full cycle the engine must be turned through two revolutions or 720 degrees. During this time the camshaft would turn one revolution. Camshaft speed is therefore one-half engine speed. In a two-stroke cycle engine, the full cycle is completed in a single rotation or 360 degrees. Camshaft speed and crankshaft (engine) speed is therefore geared so each completes a full cycle in sync with the other.

Cam Profile

The camshaft in a diesel engine actuates the **valvetrains**. The term **train** can describe any components that ride a cam profile and are actuated by it. In many diesel engines, the mechanical means of achieving injection pressures is provided by an injector train riding a cam profile. The camshaft is supported at its journals by bushings or bearings that are in most cases pressure lubricated. **Cam geometry** refers to the physical shape of the cams: the term **cam profile** is also used. The profile outside of base circle will actuate the trains riding the cam and convert the rotary movement of the camshaft into reciprocating motion.

Overhead camshafts are becoming more common in current truck diesel engines—Cummins ISX, Caterpillar

C15, Navistar MaxxForce 13, and the current Volvo/Mack family of engines are examples. Valvetrain timing and unit injection pump or unit injector stroke are determined by cam geometry so this is dependent on the camshaft gear timing to the engine crankshaft. **Figure 5-3** shows the sequence of camshaft-actuated events during an engine cycle.

Rotary and Linear Motion. Camshafts rotate. The cams machined on the camshaft therefore have rotary motion. Positioned to ride the cam profiles are the followers. As a camshaft rotates, the followers that ride the cam profiles move linearly, that is, in a straight line. Followers therefore convert rotary motion into linear motion. Using the example of a cylinder block-mounted camshaft, the followers actuated by cam profile move up and down. Push rods or tubes fitted to the followers also move linearly. These connect to rockers. Rockers pivot on a shaft. They are actuated linearly either directly by cam profiles or by push tubes. Rockers have rotary motion. Because of this, they have a linear input and produce a linear output. In doing this, they change the direction of the input. The valves or unit injectors actuated by rockers move linearly.

Construction and Design

Camshafts are manufactured from middle alloy steels. They are then treated to provide surface-hardened journals and cams. Surface hardening is usually done by nitriding or other hard facing processes, followed by finish grinding. Diesel engine camshafts are not usually reconditioned. Resurfacing of the journals is possible but most camshaft failures are cam lobe related. Camshafts are supported by bearing journals within a lengthwise bore in the cylinder block or on a pedestal arrangement on the cylinder head as in the case of an overhead cam.

Base and Outer Base Circle. Cams are designed to convert rotary motion to linear movement. The smallest radius of a cam is known as the **base circle (BC)** or **inner base circle (IBC)**. The largest radial dimension from the camshaft centerline is known as **outer base circle (OBC)**. The shaping of the profile that connects the cam base circle with its outer base circle is described as ramping. A cam may be designed so that the larger percentage of its circumference is base circle: in this case, the train it actuates will be unloaded for most of the cycle. For instance, cams used to actuate engine cylinder valves use a mostly IBC design.

Alternatively, cams may be designed so that most of their circumference is an OBC. In this case, the train

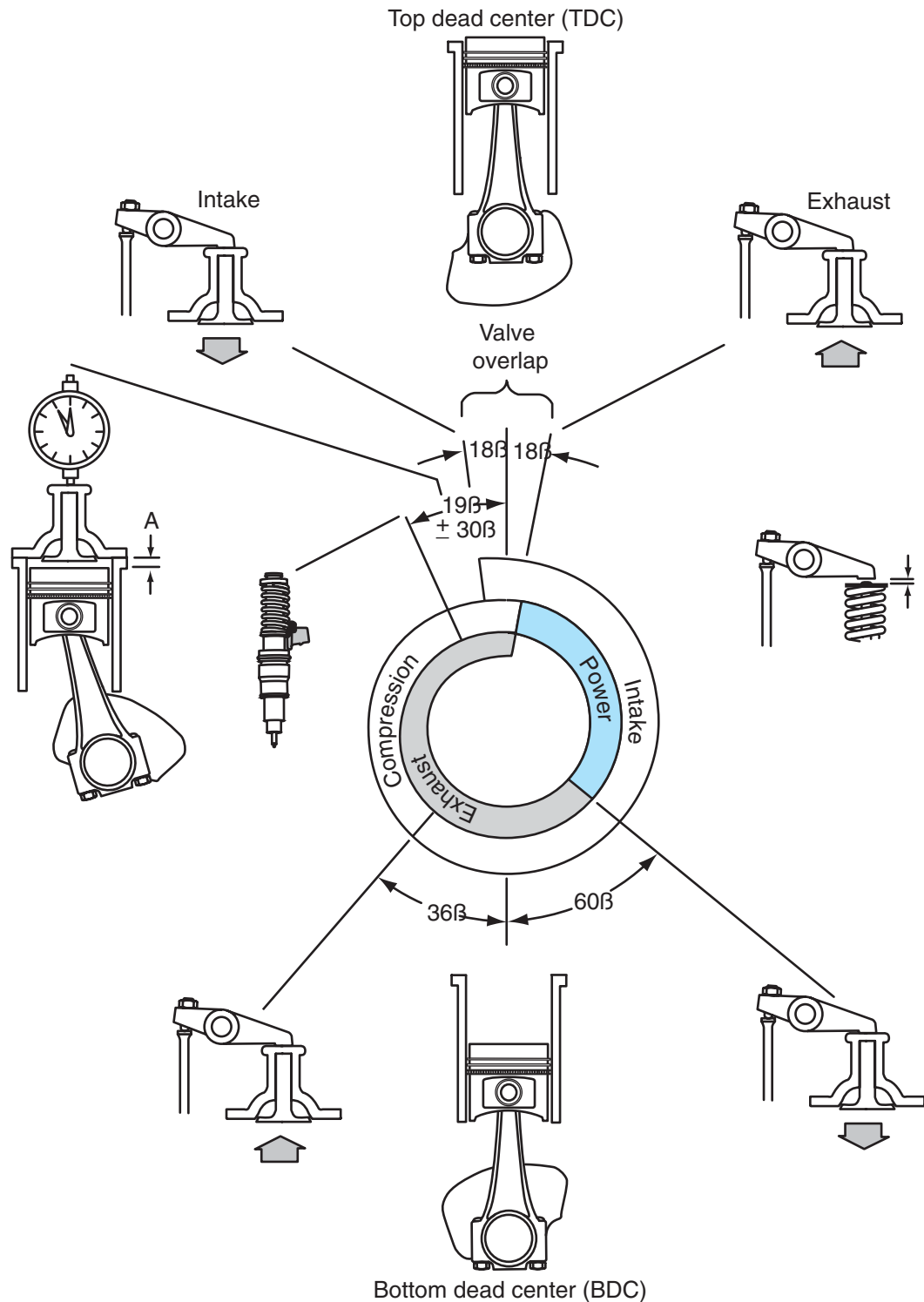

Figure 5-3 Camshaft timing events.

it actuates will be loaded for most of the cycle. What a cam profile is required to do, determines whether it uses a mostly IBC or mostly OBC design. In some cases, you will come across a design that is a mix of both. **Figure 5-4** explains some cam terminology as it applies to a cam whose profile is mostly IBC.

Removing and Installing the Camshaft from the Engine

The procedure for removing the camshaft from a cylinder head-mounted OHC is relatively straightforward. Usually this requires the cam caps to be removed

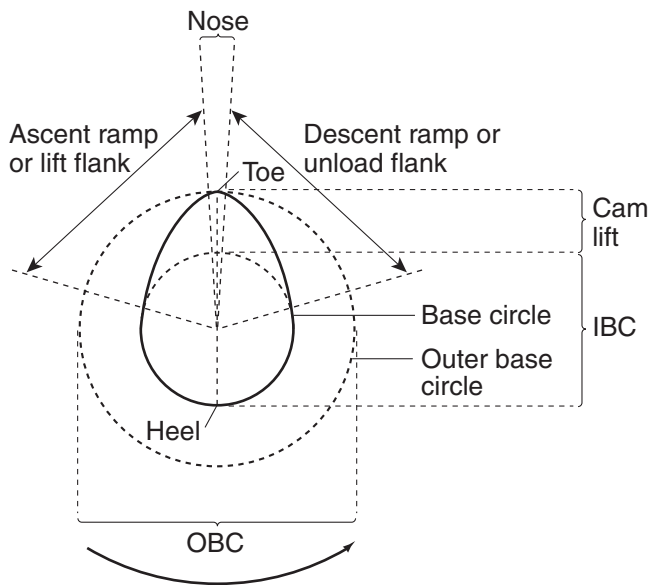

Figure 5-4 Camshaft terminology.

from the cam pedestals. When a block-mounted, camshaft has to be removed from a cylinder block, the tappet/follower assemblies will not permit the camshaft to be simply withdrawn while the engine is in an upright position. If the engine cannot be turned upside down, such as when removing the camshaft from an engine in-chassis, the tappet/follower mechanisms must be raised sufficiently so that they do not obstruct the camshaft as it is withdrawn. Most engine OEMs provide special tools to perform this procedure—usually magnets on a shaft that lift the follower after which the shaft is locked to the train bore in the cylinder head. All the followers must be raised in this fashion so that the cam lobes and journals do not interfere with them as the camshaft is withdrawn from the block.

When the correct tools are not available, the OEM special tools may be improvised by using coat hanger wire (mechanic's wire is not usually substantial enough) to first hook the follower and then lift it by bending the wire at the top. When withdrawing or installing the camshaft from a cylinder block bore, it is important that it never be forced because the result will almost certainly be damage to the camshaft or its support bearings. In certain engines, powertrain components, such as the crank web and crank throws, may interfere with the camshaft lobes. This means that the engine has to be rotated at intervals while the camshaft is being removed and installed.

Camshaft Inspection

Camshaft inspection consists of the following steps:

1. Visually inspect the camshaft, watching for pitting, scoring, peeling of lobes and scoring, wear,

or blueing of journals. Check the drive gear keyway for distortion and key retention ability. Any visible deterioration of the hard surfacing on the journal or cam profile indicates a need to replace the camshaft. The inspection can be by touch. A fingernail stroked over a suspected hard surfacing failure can identify hard surfacing failure in its early stages better than the eye.

2. Referencing **Figure 5-4**, mike the cam profile heel-to-toe dimension and check to OEM specifications. Mike the base circle dimension and check to specifications. Subtract the base circle dimension from the heel-to-toe dimension to calculate the cam lift dimension. Check to specifications. Cam lift can also be measured using a dial indicator with the camshaft mounted in V-blocks. Zero the dial indicator on the cam base circle and rotate the camshaft to record the lift. Ensure that a dial indicator with sufficient total travel to measure the specified lift is used. When checking the cam lift dimension with the camshaft in-engine using a dial indicator, the measurement may not exactly match the OEM spec, even when the cam profile is in good condition. This variance is usually due to the lie of the camshaft in the support journals.
3. Check for cam lobe surface wear using a straightedge and thickness gauges sized to the maximum wear specification.
4. Place the camshaft in V-blocks (**Figure 5-5**) and check for a bent camshaft using a dial indicator. It is unusual for camshafts to bend in normal service. Bending a camshaft is usually caused by the failure of another engine component.

Failure to meet the OEM specifications in any of the previous categories indicates that the camshaft should be replaced. The technician should be aware that the smallest indication of a hard surfacing failure on the

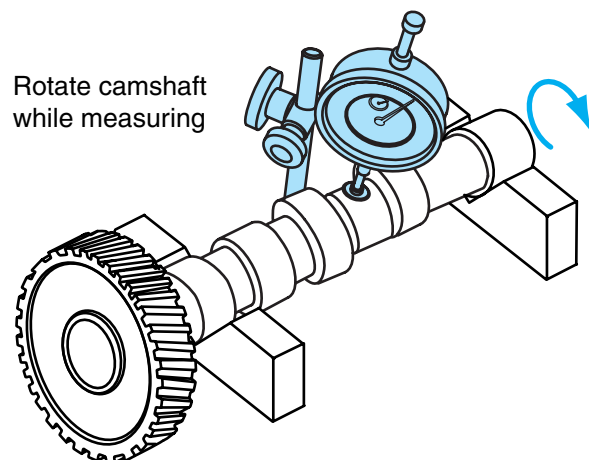

Figure 5-5 Checking a camshaft on V-blocks.

cam profile requires little time to create a total failure. Probably the most important inspection is the visual inspection that begins the listed sequence.

Camshaft Bushings/Bearings

The camshaft is supported by pressure lubricated, friction bearings at main journals. In other words, it is hydrodynamically supported. A camshaft is loaded whenever one of its cams is actuating the train that rides its profile. This loading can be considerable, especially when engine compression brake hydraulics and fuel injection pumping components are actuated by the camshaft. Cam bushings are normally routinely replaced during engine overhaul, but if they are to be reused they must be measured with a dial bore gauge (Figure 5-6) or telescoping gauge and micrometer to make sure that they are within the OEM reuse specifications.

Interference fit camshaft bushings located on the cylinder block should be removed in sequence starting usually at the front and working to the back of the cylinder block. The correct sized bushing driver (mandrel) and slide hammer should be used. Cam bearing split shells are retained either by cam cap crush (overhead camshafts) or lock rings. Interference fit cam bushings are installed using the same driver tools used to remove them. Care should be taken to properly align the oil holes. When installing bushings to a cylinder block in-chassis where access and visibility are restricted, painting the oil hole location on the bushing rim with a shop paintstick may help align the bushing before driving it. Ensure that the correct bushing is driven into each bore.

Bushings and their support bores vary in size and bushings rarely survive being driven into a bore and

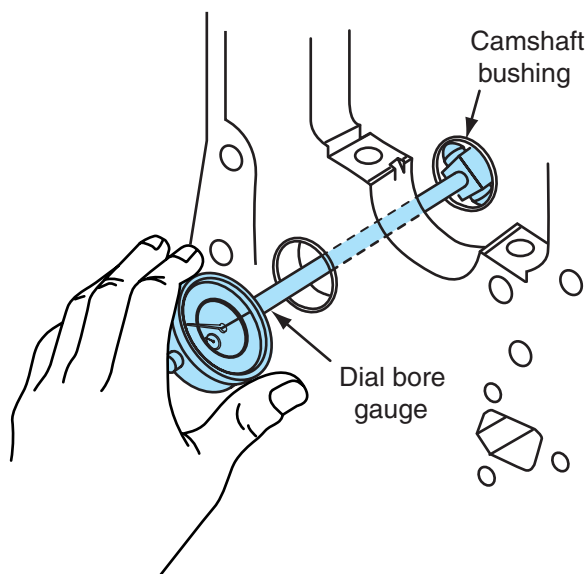

Figure 5-6 Measuring a cam bushing bore.

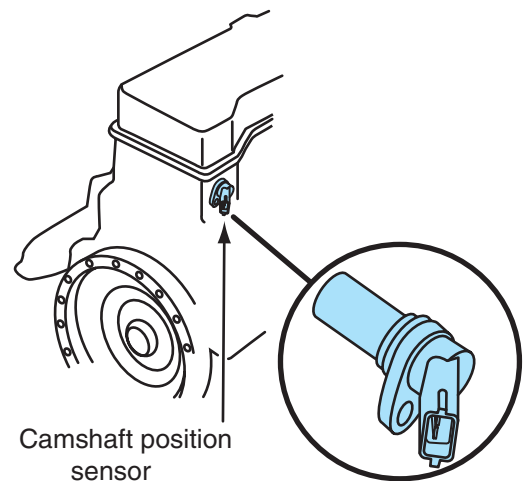

Figure 5-7 Camshaft position sensor.

then removed. Bearing clearance is the difference in size between the outside diameter of the camshaft journal and the inside diameter of the bushing. Prolonged use of certain types of engine compression brakes can be especially hard on camshaft bearings.

Camshaft Endplay

Camshaft endplay is its end-to-end or linear movement after installation. It is defined either by free or captured thrust washers/plates. Thrust loads are not normally excessive unless the camshaft is driven by a helical toothed gear. In this case the thrust is produced by the helical drive gear. When wear occurs, it is more likely to be observed at the thrust faces. Endplay is best measured with a dial indicator. The camshaft should be gently forced backward then forward and the total travel measured.

Camshaft Position Sensors. Camshaft position sensors (CPSs) are used in all current engines. They signal shaft speed and position data to the engine control module (ECM). CPS may use either an inductive pulse generator or Hall-effect electrical principle. The operating principles of camshaft position sensors are studied in some detail in Chapter 14. Figure 5-7 shows a typical inductive pulse generator CPS. It signals a frequency value (for engine speed) and the irregular tooth at #1 cylinder indicates TDC.

VALVE AND INJECTOR TRAINS

While a camshaft rotates, the trains it actuates move linearly. Followers ride the cam profiles to actuate trains. The linear movement of the train that rides the cam profile is converted to rotary motion once again at the rocker. It is its rocking action that reverses the linear direction of the train to open and close valves. Cylinder valves

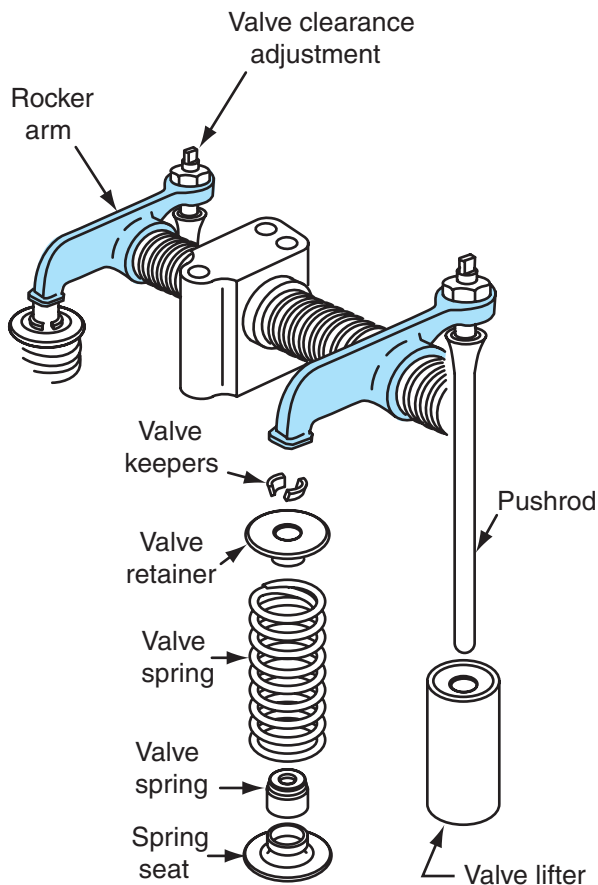

Figure 5-8 Typical valvetrain assembly.

move linearly. Rockers may be used in both cylinder block-mounted camshaft engines (shown in **Figure 5-8**) and those with overhead camshafts.

Followers

Tappet, *lifter*, and *follower* may all mean the same thing depending on which OEM is using the term. These terms describe components that are usually positioned to directly ride, or at least be actuated by, a cam profile. The term **tappet** has a broader definition and is sometimes used to describe what is more often referred to as a **rocker** lever. In this text, we use the terms *cam follower* or *lifter* to describe a component that rides the cam profile. The function of the cam **follower** is to reduce friction and evenly distribute the force imparted from the cam's profile to the train it is responsible for actuating. Diesel engines using cylinder block-mounted camshafts use two categories of follower while those using overhead camshafts use either direct-actuated rockers or roller type cam followers.

Solid Lifters. **Lifters** are manufactured from cast iron and middle alloy steels and are usually located in guide bores in the cylinder block so they ride the cam profile

over which they are positioned. Pushrods or push tubes are fitted to lifter sockets. The critical surface of a solid lifter is the face that directly contacts the cam profile. This face must be durable and may either be chemically hardened, plated with a toughened alloy, or have a disc of special alloy steel molecularly bonded to the face.

LIFTER INSPECTION

Solid lifters should be carefully inspected at engine overhaul. Look for thrust face wear, as well as for stem and socket wear. The lifter guide bores in the cylinder block should be measured using digital calipers or a telescoping gauge and micrometer. When they wear to an oversize dimension they can be sleeved. Sleeving lifter guide bores is simple. The procedure involves boring out to the new sleeve outside diameter; this is installed with a slight interference fit. Check that the lifters do not drag or cock in newly sleeved guide bores.

Roller Type Cam Followers. Roller type cam follower assemblies can handle much higher mechanical forces so they are commonly used in engines that use the camshaft to actuate injector unit injectors. They are used with both OHC and cylinder block-mounted camshafts. Roller type cam followers usually consist of a roller supported by a pin mounted to a **clevis** (yoke). The clevis can either be cylindrical and mounted in a cylinder block guide bore or be a pivot arm fitted to either the cylinder block or cylinder head.

ROLLER CAM FOLLOWER INSPECTION

In the case of some OHC designs, a roller type cam follower assembly and the rocker arm are used. Roller type cam followers distribute forces more evenly than solid followers. They also outlast them. The roller faces are usually chemically hard-surfaced. Roller contact faces should be inspected for pitting, scoring, and other surface flaws. The roller assembly should also be checked for axial and radial runout. **Figure 5-9** shows a Caterpillar valvetrain actuated by roller type cam follower.

Pushrods and Tubes

Engines using cylinder block-mounted camshafts require a means of transferring cam action to the rockers in the cylinder head. Push tubes and pushrods act as links in the train. They are located between the cam followers and rocker assemblies. They are subject to shock loads that occur each time the cam ramps or de-ramps onto the follower. These shock loads increase proportionally with engine rotations per minute (rpm). For this reason, they are manufactured from alloyed steels to handle these shock loads and also keep their weight to a minimum.

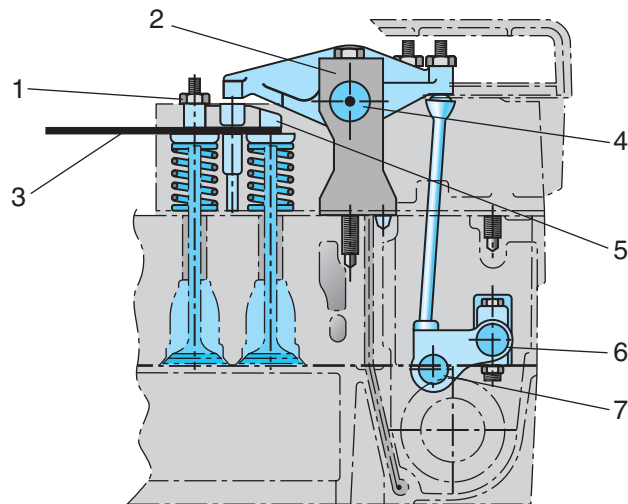

1. Adjusting screw and locknut
2. Rocker pedestal
3. Valve lash—valve stem to rocker pallet clearance
4. Rocker shaft
5. Valve bridge/yoke assembly
6. Cam follower pivot
7. Roller-type cam follower/lifter

Figure 5-9 Roller-actuated valvetrain. (Courtesy of Caterpillar)

Hollow push tubes are more commonly used than solid pushrods, especially in cases where the camshaft is mounted low in the cylinder block. A typical push tube is a cylindrical, hollow shaft fitted with a solid ball or socket at either end. Balls and sockets form bearing surfaces at the follower and rocker. The bearing contact surfaces are usually lubed by engine oil. This is especially important at the rocker end as the rocker moves through an arc while the push tube moves in linearly. Balls and sockets are usually hard-surfaced. Push tubes are preferred over solid pushrods because the tubular shape provides high strength along with less weight. Pushrods are cylindrical and solid. They are used mostly in applications that permit them to be short and relatively low in weight.

Inspecting Push Tubes. Both pushrods and push tubes seldom fail under normal operation. When they do fail, there are two main causes:

1. inaccurate valve lash or injector train adjustments
2. engine overspeeding

Ball and socket wear should first be checked visually. Reject if there is evidence of hard-surface flaking or disintegration. Reject a push tube if it feels heavier

than others in the set: they can fill with lube oil if cracked or the ball socket has loosened. Next check:

1. Ball/socket to tube integrity: Test by dropping onto a concrete floor from a height of 2 inches. A separating ball will always ring flat. *Never* reuse a push tube with a separating ball or socket.
2. Straightness: Roll the push tube on a known true flat surface such as a (new) toolbox deck. The slightest bend (wobble as it is rolled) is reason to reject a push tube.

CAUTION *It does not make economic sense to ever straighten a push tube or pushrod. The failure will recur—it is only a question of when. Even as a “temporary” repair, it makes little sense as the consequences of push-tube failure can be much more expensive than the cost of replacing it.*

Rocker Arms

Rockers are levers. They transfer camshaft motion to the valves and mechanically actuated injectors. They are used in both in-block camshaft and overhead camshaft configurations. The rocker pivots on a rocker shaft. When a cam **ramps** off its base circle, it acts on the train that rides the cam profile and “rocks” the rocker arm: this movement actuates the components on the opposite side of the rocker arm, either valves or unit injectors. Lubricating oil is supplied through the rocker shaft to each rocker arm.

Rocker Ratio. Rocker ratio may be used to increase the input cam lift to a greater amount of output travel. This requires that the distance from the centerline of rocker pivot bore to the input (pushrod) side be less than its distance to the output side. Rocker ratio increases mechanical advantage. A rocker ratio of 1:2 converts a cam lift dimension of 1 inch into 2 inches of valve opening travel. In the case of a rocker with equal distance either side of its centerline (center of pivot), the rocker ratio is 1:1 meaning equal cam and valve lift.

Inspecting Rockers. The rocker arms should be inspected for wear at the push tube end cup or ball socket, the pivot bore (usually a bushing), and the **pallet** end. The pallet end of a rocker is the bearing surface that contacts and actuates the valve stem or valve bridge. If the hard-surfacing at either end of a rocker shows signs of deteriorating, the rocker arm should be replaced. The pivot bore bearing/bushing can be replaced if it shows signs of wear, as can the adjusting screw ball.

The rocker shafts should be checked for straightness and wear at the rocker bearing race.

Pallet Links. Because a rocker moves radially and whatever it actuates moves linearly, the “bearing” or pallet end of the rocker is subject to friction. This friction can be considerable when actuation forces are high such as when a mechanically actuated fuel injector is used. A link provides a little forgiveness at the point radial motion is converted into linear motion. Links may clip onto the rocker pallet or be inserted into a bore in the injector tappet. It makes sense to use a link between the rocker pallet and the injector tappet. Links should be inspected for wear at overhaul.

CYLINDER HEAD VALVES

Cylinder head valves provide the means of admitting air into, and exhausting end gas out of, engine cylinders. Although any movement of cylinder valves in current engines is due to cam profile, the timing of engine valve movement depends on whether the engine is equipped with a compression brake or uses variable valve timing (VVT). With a VVT or engine brake equipped engine, the engine management electronics can manage valve lift and alter valve timing.

Valve Design and Materials

Cylinder head valves are mushroom-shaped, poppet type valves. The stems are fitted to cylindrical guides in the cylinder head and loaded by a spring or springs to seal to a seat. A disc-shaped spring retainer locks the spring(s) in position. **Split locks**, also known as **keepers**, are fitted to grooves at the top of the valve stem to hold the spring retainer in position. Valves rely on transferring heat through seat contact. This means that exhaust valves run at their highest temperatures when held open for the longest time. For this reason, exhaust valves are made of materials that do not distort when exposed to high temperatures and often the valve head is manufactured using different alloys from the stem. The two sections are then inertia welded. Inertia welding is a type of friction welding that requires spinning the stem at high speed while also applying pressure. **Figure 5-10** identifies valve components and terminology.

Intake Valves. Intake valves do not have to sustain the high temperatures to which exhaust valves are exposed. They are actuated at high speeds and so must have some flexibility. This flexibility is required so that at high engine speeds when valve closing speeds are at their highest, the valves do not hammer out their seats. While most diesel engine designers use a valve seat

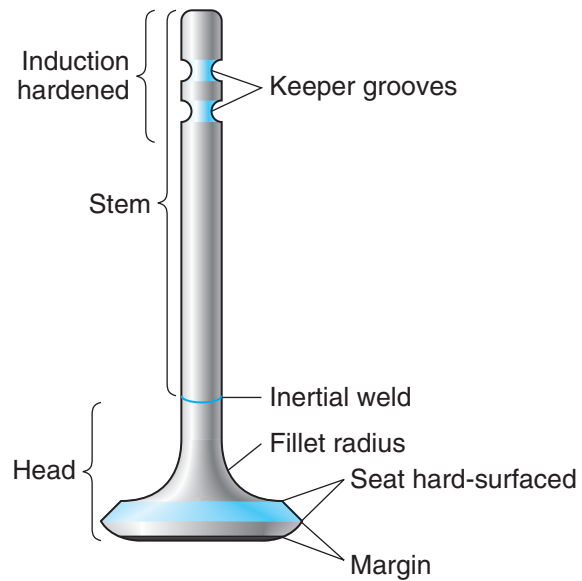

Figure 5-10 Valve terminology.

angle of 45 degrees due to greater toughness, some use 30-degree cut seats on just the intake valves. This takes advantage of the better breathing efficiency of 30-degree over 45-degree seat angles.

Exhaust Valves. Running temperatures of exhaust valves are much higher than those of intake valves. When the exhaust valve is first opened at the end of the power stroke, cylinder temperatures are very high. Only about 20 percent of the heat the valve is exposed to can be transferred through the stem: this means that the exhaust valves are exposed to high temperatures until they seat.

Exhaust valves are manufactured out of special ferrous alloys. They may be clad (coated) at the head and often use chromium, nickel, manganese, tungsten, cobalt, and molybdenum to improve flexibility, toughness, and heat resistance. Exhaust valves are cooled by:

- transferring heat to the valve seats (when closed)
- intake air (during valve overlap)
- stem-to-guide contact

Inertia welding is commonly used to manufacture exhaust valves using separate alloys for the stem and head. In this way, the stem can be made out of a tough, hard alloy while the head can be manufactured from an alloy with extreme heat resistance and flexibility. The separate stem and head are friction welded. If you look at **Figure 5-11** you can see the location where the stem and head are joined on a typical inertia welded valve.

Valve Breathing Efficiency. Valves machined with 45-degree seats have lower breathing efficiencies than those with 30-degree seats given identical lift. Valve seats

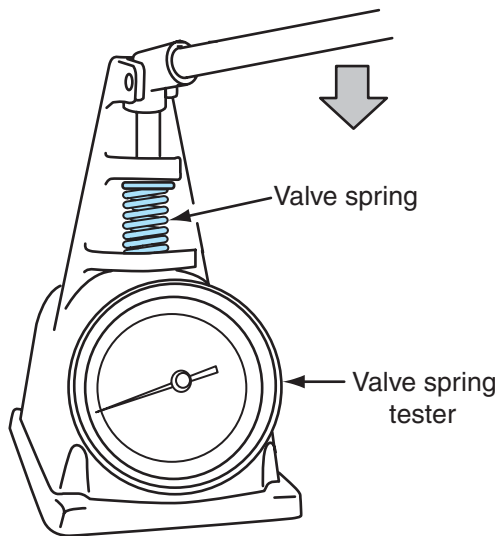

Figure 5-11 Valve spring tension tester.

with 45-degree seats are widely used in commercial diesel applications simply because they tend to last longer. Valves machined with 30-degree seats tend to run hotter than those with 45-degree seats because they have less material at the head. They also have less distortion resistance and lower unit seating force. To get around this problem, some engine OEMs use a 30-degree valve seat angle on their intake valves and a 45-degree seat angle on the exhaust valves.

Valve Operation

Current diesel engine valves rely on maximizing the seat contact area for cooling purposes and, as a consequence, **interference angles** are seldom machined. An interference angle requires that the valve be machined at 0.5 degree to 1.0 degree more acute angle than the seat. This results in the valve biting into its seat with high unit forces. Interference angles also break up carbon formations on the valve seat. A majority of current diesel engines use valve rotators to minimize carbon buildup on the seat and promote even wear. An interference angle is not machined to valves using valve rotators.

Valve Rotators. Valve rotators use a ratchet principle or a ball and coaxial spring to fractionally rotate the valve each time it is actuated. Valve rotation should be checked after assembly by marking an edge of the stem and guide with a marker pen and then tapping the valve stem with a light nylon hammer a number of times. The valve should visibly rotate each time the stem is struck with the nylon hammer.

Valve Harmonics. Cylinder head valves are seated by a spring or pair of springs. When a pair of springs is

used, they are often wound in different directions (one clockwise [CW], the other counterclockwise [CCW]). This helps cancel the coincidence of vibration harmonics that may contribute to valve flutter or float. **Valve float** can occur at higher engine speeds when valve spring force is not sufficient to close the valve fast enough. This may result in out-of-time valve closing. Springs are a key component of the valvetrain. Their importance increases as engine rpm increases.

Inspecting Valve Springs and Retainers

To inspect valve springs and retainers, follow these steps:

1. Once the cylinder head has been removed from the cylinder block, remove the valves using a valve spring compressor. Check the keepers and the valve keeper grooves for wear. Inspect the retainers.
2. Measure the spring vertical height and compare to specifications. Minor differences do not matter.
3. Test valve spring tension using a tension gauge (**Figure 5-11**). The valve spring tension should be within 10 percent of the original tension specification. If not, replace the valve spring.
4. Check the spring(s) for abrasive wear at each end.
5. Use a straightedge to make certain the spring is not cocked.
6. Check valve spring operation with the valve installed in the cylinder head. Remember that as the cylinder head valve seat material is ground away, the spring operating height is lengthened, reducing spring tension. Valve protrusion and recession must be checked to specification as shown in **Figure 5-12**.

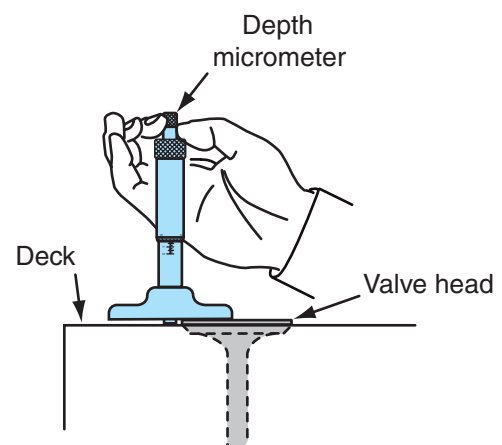

Figure 5-12 Measuring valve protrusion with a depth micrometer.

Valve Servicing

The rocker assembly including engine brake and VVT actuators should be removed from the cylinder head(s). Use a valve spring compressor to remove valves from the cylinder head. The valves should be tagged by location. Valves should first be cleaned on a buffer wheel, taking great care not to remove any metal. A glass bead blaster may be used to remove carbon deposits from the seat face, fillet, and head, but avoid blasting the stem.

Valve inspection should begin with visually checking for dishing, burning, cracks, and pits. Evidence of any of these conditions requires that the valve be replaced. Check the valve fillet for cracks and nicks—using a portable magnetic flux crack detector may help here—and again, reject the valve if cracks are evident in this critical area. Next, the valve should be measured. Using a micrometer, mark the valve stem at three points through the valve guide bushing sweep and check to specifications. Valve stem straightness should be checked with a vertical runout indicator.

Valve Margin. Measure the **valve margin** (see **Figure 5-10**). Valve margin is the dimension between the valve seat and the flat face of the valve head mushroom. This specification is critical when machining valves: it must exceed the minimum specified value after the grinding process has been completed. A valve margin that is lower than the specification will result in valve failures caused by overheating. The split lock keeper grooves on the valve stem should also be checked for wear, nicks, and cracks.

Valve Dressing/Grinding. Before servicing a set of valves, the previously outlined checks and measurements should be completed. It is pointless machining valves that have failed in any of the previous categories. First, dress the grinding stone using a diamond dressing tool. Adjust the valve grinder chuck to the specified angle and the carriage stop to limit travel so the stone cannot contact the stem. Run the coolant (soluble machine oil and water solution), and make a single shallow pass. When machining valves, try to make the minimum number of passes to produce a valve seat face surface free of ridging and pitting. The final step should be to check that the valve margin is still within specification.

In cases in which the valve has been loosely adjusted, the stem end may be slightly mushroomed due to hammering from the rocker. Grind a new chamfer, taking care to remove as little material as possible. Too much chamfer will reduce the rocker-to-stem contact area and may damage the rocker pallet. When valves must be replaced, the new valves must be inspected, measured,

and sometimes ground using the same procedure as that for used valves.

Valve Seat Inserts

Most commercial diesel engines use valve seat inserts. The advantage of valve seat inserts is that they can be manufactured from tough, temperature-resistant material and then easily replaced when the cylinder head is serviced. Valve seat inserts are press fit to a machined recess in the cylinder head. Sometimes they are staked to position (with a punch) after installation. Since most of the heat of the valve must be transferred from the valve to the seat, it is essential that the contact area of the seat and the cylinder head be maximized.

Valve Seat Removal and Installation. Valve guides must be removed using a removal tool. The removal tool is designed to expand into the valve seat after which it can be either levered out or driven out with a slide hammer. When installing new valve seats, the seat counterbore must first be cleaned using low-abrasive emery cloth. The new insert should be inserted into the OEM specified driver: this has a pilot shaft that fits tight to the valve guide bore. Use a hammer to drive the insert into its bore until it bottoms. Next check the concentricity of the valve seat with the valve guide bore using a dial gauge. This is a critical specification (**Figure 5-13**). In most cases the seat will have to be ground a small amount, even when new seats are finish-ground. It is

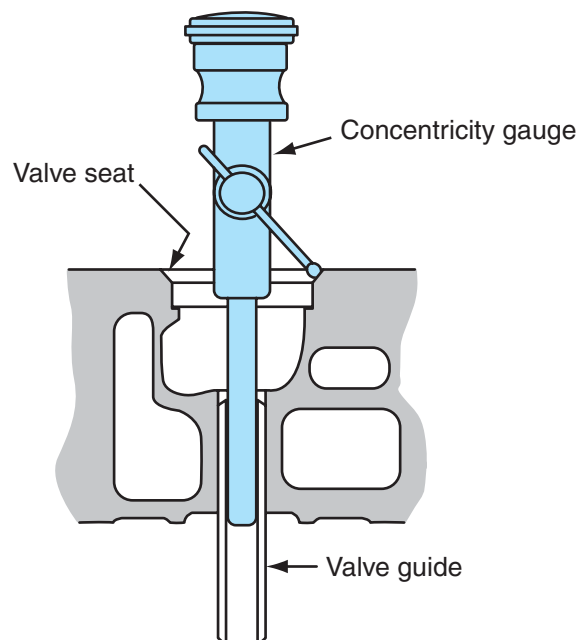

Figure 5-13 Measuring valve seat concentricity with a concentricity gauge.

important that the valve grinders are serviced before fitting and machining the valve seats so that the new seats are machined to be concentric with the guides that will be put in service.

Valve Seat Grinding. Valve seats are ground using a specified grit abrasive stone, dressed to the appropriate angle, with a pilot shaft that fits to the valve guide. The valve head protrusion or recess dimension specifications must be respected when grinding valve seats. In cases in which the cylinder head deck surface has been machined, undersize valve seat inserts are available from most OEMs. Whenever a cylinder head deck has been machined, the valve stem height, which is determined by the specific valve seat insert location, must be within specification.

Valve Lash Adjustment

When valves are properly adjusted, there should be clearance between the pallet end of the rocker arm and the top of the valve stem. Valve lash is required because as the moving parts heat up in an engine, they expand. If clearance were not factored somewhere in the valvetrain, the valves would remain constantly open by the time an engine reached operating temperature. Actual valve lash values depend on factors such as the length of the push tubes and the materials used in valve manufacture. Exhaust valves run hotter and as a consequence expand more than intake valves when at operating temperature. Valve lash specifications for exhaust valves are usually greater than the intake valve lash setting specification.

Maladjusted Valves. Loose valve adjustment retards valve opening and advances valve closing. This reduces cylinder breathing time and results in low power. Cam ramp shaping is designed to provide some “forgiveness” to the train at valve opening and valve closure to reduce the shock loading. When valves are set loose, the valvetrain is loaded at a point on the cam ramp beyond the intended point. The same occurs at valve closure as the valve is seated. High valve opening and closing speeds hammer the valve and its seat: this results in cracking, failure at the head-to-stem fillet, and scuffing to the cam and its follower.

Valve Adjustment Procedure

This section outlines the steps of the valve adjustment procedure on a typical four-stroke cycle, inline, 6-cylinder diesel engine. Valves should always be adjusted using the OEM’s specifications and procedures.

Photo Sequence 2 demonstrates how valve lash is measured and adjusted on one type of diesel engine.

CAUTION *Shortcutting the engine OEM recommended valve (and injector) settings can result in engine damage unless the technician knows the engine well. Cam profiles are not always symmetrical and some engines may have camshaft profiles designed with ramps between the base circle and outer base circle for purposes such as actuating engine compression brakes. Similarly, a valve rocker that shows what appears to be excessive lash when not in its setting position is not necessarily defective.*

6-cylinder engine firing order: 1–5–3–6–2–4

Companion cylinders or cylinder throw pairings:

1–6 at TDC

5–2 at 120 degrees BTDC

3–4 at 120 degrees ATDC

Companion Cylinders. Cylinder throw pairings are called **companion cylinders**. In other words, when #1 piston is at TDC completing its compression stroke, #6 piston (its companion) is also at TDC having just completed its exhaust stroke. If the engine is viewed from overhead with the rocker covers removed, engine position can be identified by observing the valves over a pair of companion cylinders. For instance, when the engine timing marker indicates that the pistons in cylinders #1 and #6 are approaching TDC and the valves over #6 are both closed (lash is evident), then the point at which the valves over #1 cylinder rock (exhaust closing, intake opening) at valve overlap will indicate that #1 is at TDC having completed its exhaust stroke and #6 is at TDC having completed its compression stroke. This method of orienting engine location is commonly used for valve adjustment.

Adjustment. The valve adjustment procedure consists of the following steps:

1. Locate the valve lash specifications. These are often located on the engine ID plate on the rocker housing cover or cylinder block. The lash specification for the exhaust valve(s) is usually (but not always) greater than that for the inlet valve.
2. The valves on current diesel engine should usually be set to engine off and with the engine coolant at 100°F (37°C) or less. Locate the stationary engine timing indicator rotating indexes: these are set 120 degrees apart and may be located on a vibration damper, any pulley driven at engine speed, or the flywheel.

PHOTO
SEQUENCE

2

Valve Adjustment



P2-1 Begin by identifying the cylinder firing sequence. On this inline 6-cylinder engine, the firing order is cast into the cylinder block.

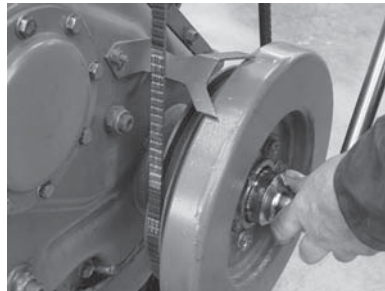

P2-2 Next, manually bar the engine in its correct direction of rotation to position #1 piston at TDC on its compression stroke. In this position, the valvetrain over #1 cylinder should show lash, while those on #6 cylinder should be rocking.

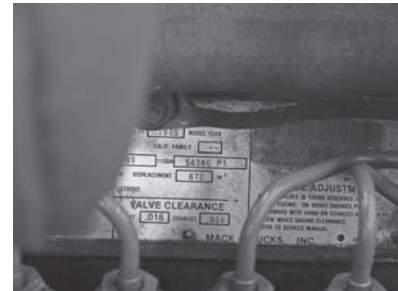

P2-3 Locate the valve lash specifications. These are often indicated on the engine ID and specification plate but you may have to reference the manufacturer service literature. On the above engine, the exhaust valve lash is 0.24 inch and the intake valve lash is 0.16 inch.

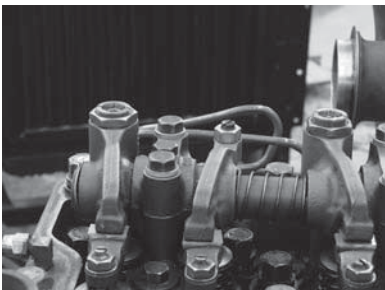

P2-4 The above engine is equipped with a compression brake. The exhaust valve rocker is located in front (to the left) of the intake valve rocker on this engine.

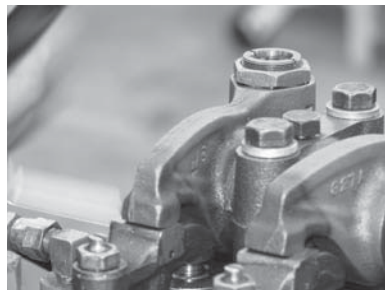

P2-5 Begin by adjusting the exhaust valve. Loosen the jam nut. This frees up the adjusting screw that sets the valve lash.

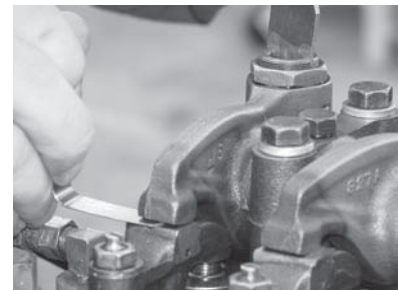

P2-6 Turn the adjusting screw CW to bottom and load the exhaust valve. Then back it off. Lightly oil and insert the specified feeler gauge. To adjust the exhaust valves on this engine either a special tool (shown) or large slotted screwdriver is required.



P2-7 Turn the adjusting screw so that it clamps the feeler gauge. Release the gauge. Now turn the adjusting screw so that it applies a little pressure to the valve: typically this requires an additional turn of about 1/2 a flat (of a hex nut).

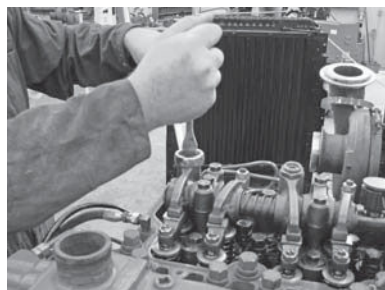

P2-8 Hold the adjusting screw still and torque the jam nut. Remove the feeler gauge.

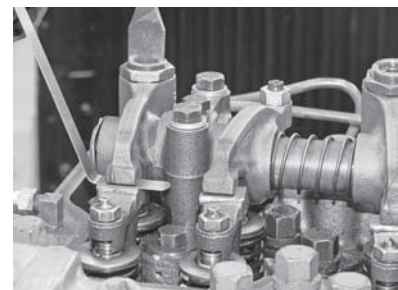

P2-9 Reinsert the feeler gauge. If the lash has been properly set, you should feel a small amount of drag on the feeler gauge as you attempt to slide it back and forth. If it is either too tight or loose, repeat the preceding steps.

(Continued)

PHOTO
SEQUENCE

2

Valve Adjustment (Continued)

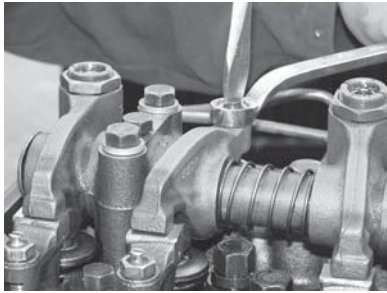

P2-10 After the exhaust valve lash has been properly set, you can move onto the intake valve. Begin by loosening the jam nut to free up the adjusting screw.

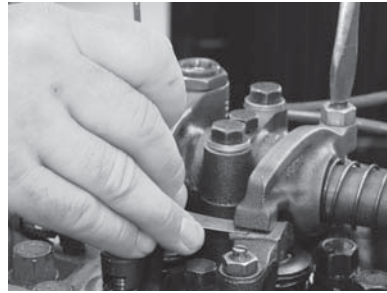

P2-11 Set the intake valve lash to spec using the same method you used for the exhaust valve. Remember, intake valve lash is typically less than exhaust valve lash: this is because they run cooler and expand less at engine operating temperature.

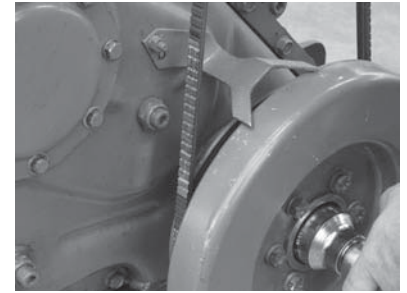

P2-12 Now you can bar the engine over 120-degrees to adjust the valve over the next cylinder in the firing order. If you began at #1 cylinder, this will be #5. If you did not begin at #1, use a chalk mark on each set of valves you adjust to indicate that you have set them to spec.

3. Ensure that the engine is prevented from starting by mechanically or electronically no-fueling the engine. The engine will have to be manually barred in its normal direction of rotation through two revolutions during the valve-setting procedure requiring the engine to be no-fueled to avoid an unwanted startup.
4. If the engine is equipped with valve bridges or yokes (**Figure 5-14**) that require adjustment, this procedure should be performed before the valve adjustment. To adjust a valve yoke, back off the rocker arm then loosen the yoke adjusting screw locknut and back off the yoke adjusting screw. Using finger pressure on the rocker arm (or yoke), load the pallet end (opposite to the adjusting

screw) of the yoke until it just makes contact with the valve. Next, screw the yoke adjusting screw clockwise until it bottoms on the other valve stem. Turn an additional one flat of a nut (60 degrees) as shown in **Figure 5-15**, then lock to position by torquing the jam nut.

CAUTION When loosening and tightening the valve yoke adjusting screw locknut, the guide on the cylinder head can be easily bent. Most OEMs recommend that the yoke be removed from the guide and placed in a vise to backoff and final torque the adjusting screw locknut.

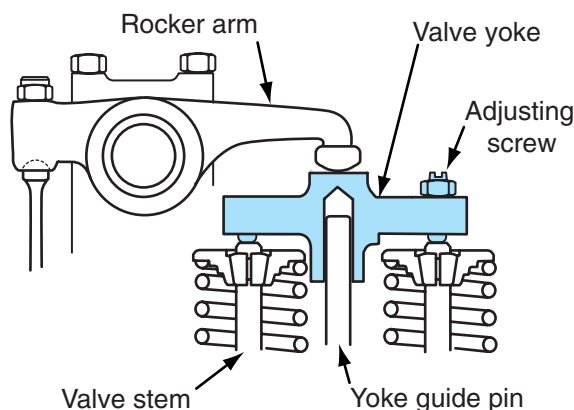

Figure 5-14 Valve bridge/yoke assembly.

5. To check that the yoke is properly adjusted, insert two similarly sized thickness gauges of 0.010 inch or less between each valve stem and the yoke. Load the yoke with finger pressure on the rocker arm and simultaneously withdraw both thickness gauges. They should produce equal drag as they are withdrawn. If the yokes are to be adjusted, do this in sequence as each valve is adjusted. In some engines, valve yokes can be adjusted only after removing the rocker assemblies.
6. If the instructions in the OEM literature indicate that valves must be adjusted in a specific engine location, make sure you observe this. The cams that actuate the valves may only have a small

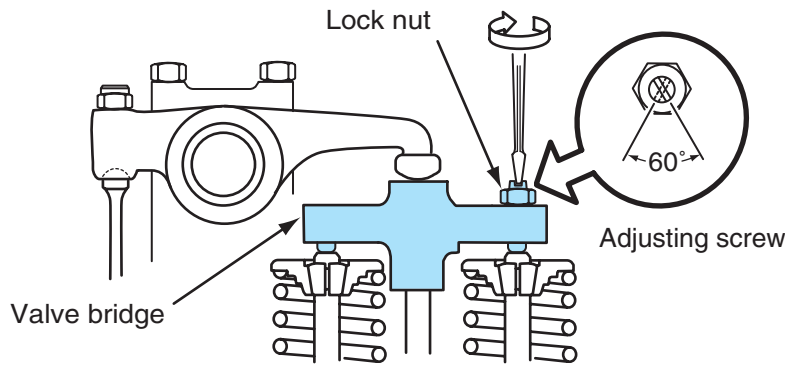

Figure 5-15 Adjusting a valve bridge/yoke assembly: the procedure on this engine is to bottom the adjusting screw, turn one flat, then torque the jam nut.

percentage of base circle. Setting valves requires the lash between the rocker arm and the valve stem to be set. To do this, back off the valve adjusting screw jam nut first, then loosen the adjusting screw. Next, insert the specified size of feeler gauge between the rocker and the valve stem/yoke. Let go of the feeler gauge. Now turn the adjusting screw clockwise until it bottoms. Turn it an additional one-half flat of a hex nut (30 degrees). Hold the adjusting screw with a screwdriver and torque the jam nut to spec. Now for the first time since inserting the thickness gauge, handle it once again and withdraw the thickness gauge. A light drag indicates that the valve is properly set. If the valve lash setting is either too loose or too tight, repeat the setting procedure. Do *not* set valves too tight. Set all the valves in cylinder firing order sequence rotating the engine 120 degrees between settings. It is preferable to begin at #1 cylinder and proceed through the engine in firing order sequence. **Figure 5-16** shows this procedure: note how the feeler gauge is not being held during the adjustment.

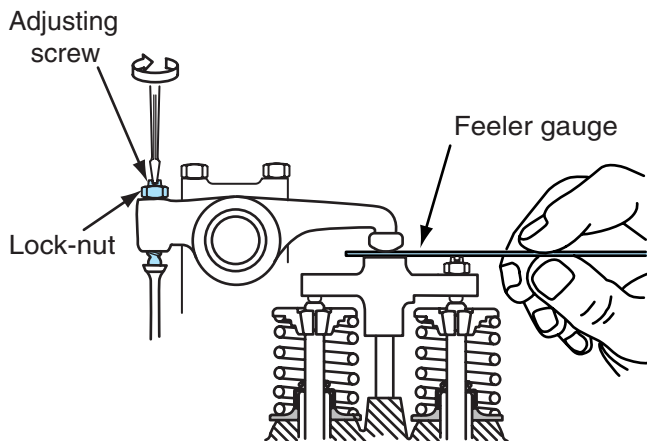

Figure 5-16 Adjusting the intake valve lash.

Tech Tip: Never attempt to adjust valve lash while simultaneously checking it with a feeler gauge. Allow the gauge blade to be clamped by the rocker, and then release it. Make the adjustment at the rocker screw; then check the gauge blade drag. This should reduce the time you spend performing this simple engine maintenance adjustment.

Shortcuts. When experienced technicians perform diesel top end tune-ups, they often take shortcuts not shown in the service literature procedures. Once you know a specific engine like the back of your hand, you will get a sense of which shortcuts involve zero risk. Until you do, avoid falling into the trap of thinking that a shortcut on one engine will work on another. The best shortcuts are those of which the OEM approves and outlines in their service literature. For instance, you can set the top end on a Navistar International DT466E using just two engine positions, #1 piston at TDC on compression, followed by #6 piston at TDC on compression as shown in **Figure 5-17**. Most other engines have similar “shortcuts” and it is fine to use them when approved by the engine OEM.

CAUTION Do not be persuaded that cylinder head valves should be set tighter than specified. This might have been acceptable in a different age when engine technology used wider specification margins, but not today. A feeler gauge used properly should define minimal drag: this is what you are attempting to achieve. Setting valves tight can result in low power (valves not seating properly at operating temperature), burned valves, and physical engine damage.

Barring Engines. When you are setting valves, you will have to rotate the engine. With older engines

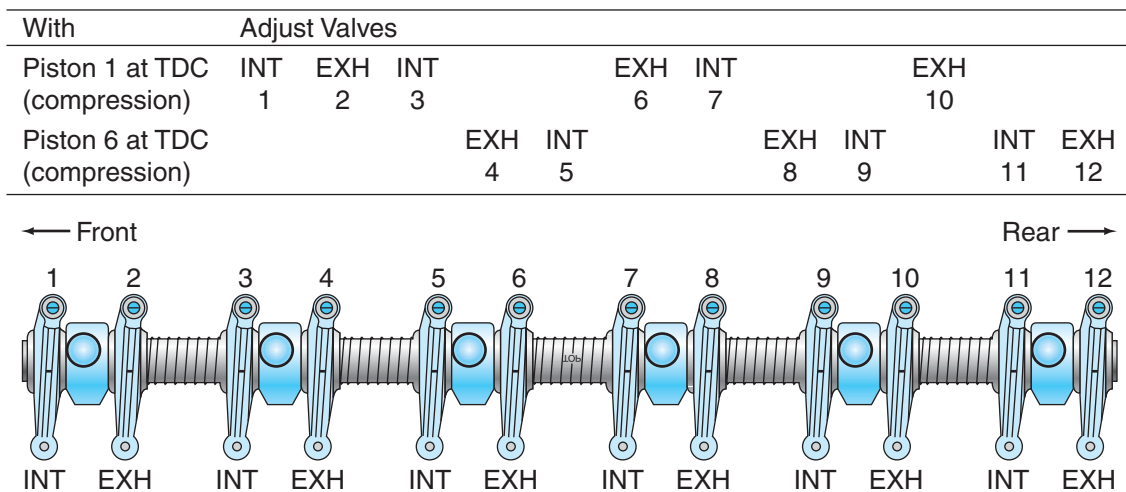

Figure 5-17 Valve lash adjustment positions on a Navistar International DT-466E. (Courtesy of Navistar International)

using symmetrical cam profiles, you may be able to bunt the engine over using a remote starter switch providing the engine is no-fueled. With today’s engines, you should use the OEM approved method in their service literature. Manually barring an engine into overhead setting positions can be made easier if a tool such as that shown in **Figure 5-18** is used: this engages with the flywheel ring gear teeth allowing the engine to be easily rotated with a ½-drive ratchet.

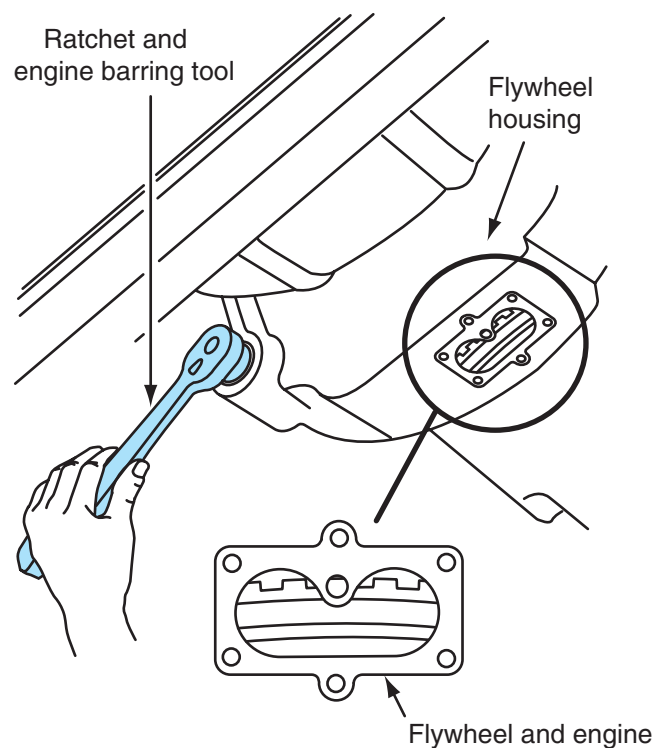

Figure 5-18 Barring an engine using a toothed barring tool while observing the engine position scale.

Variable Valve Timing

Variable valve timing (VVT) refers simply to any means used to vary either the opening or closing of cylinder valves. Highway diesel engines have used engine compression brakes for five decades. Engine brake controls were initially hydromechanically controlled and actuated. Today, they tend to be electronically controlled and hydraulically (engine lube) actuated. We will take a look at diesel engine compression brakes in **Chapter 10**. More recently, VVT of intake valves has been introduced. Having the ability to manage the moment of intake valve closure delays the beginning of the compression stroke. This means that the ECM can determine exactly how much intake gas is admitted to the engine cylinder. The net result is to enable a large engine to behave like a smaller engine when power output requirement is lower along with a bonus of reducing emissions.

Valves: Conclusion

Valves are normally, but not always, set when the piston is at TDC on the cylinder being set. Some very critical exceptions to this rule exist, however, so always refer to the OEM service literature when adjusting cylinder valves. The procedure for setting valves in an engine is sometimes referred to as **overhead adjustment** or tune-up. In most cases, the valve setting procedure is accompanied by procedures such as injector timing and/or lash setting/train loading.

Other Feedback Assembly Functions

The engine feedback assembly in many modern engines is responsible for actuating the pumping of fuel to injection pressure values. Some current and many older engines are fueled by mechanically actuated injectors.

These include different types of mechanical unit injectors (MUIs), electronic unit injectors (EUIs), and electronic unit pumps (EUPs). Pumping fuel pressures to the required injection pressures on all of these engines is accomplished by the engine camshaft. This requires considerable mechanical force to be delivered by the camshaft so in these cases, camshafts have considerable bulk.

Every OEM has different requirements for setting injector trains. This means you should assume nothing and always consult OEM service literature. Some injection pumping actuation trains are set at zero lash or even a slight load when the actuating cam profile is on its IBC. Injector train settings usually have to be precisely set because they help define injection timing.

Creating a Valve Polar Diagram

If you look at **Figure 5-3** captioned *Camshaft timing events* earlier in this chapter, you can observe the key cylinder head valve opening and closing

events during a typical diesel cycle. A **valve polar diagram** is a somewhat simplified version of this illustration that can be performed on any engine. You make the valve polar diagram specific to the engine you are mapping. This can be an especially useful learning tool because you have to closely observe the engine you are mapping through an entire effective cycle. The objective is to map the valve opening and closing events by observation of the tappets as an engine is barred over. You can perform this exercise by first mapping the valves only. Then you can advance to including injector actuation train activity on engines equipped with mechanically actuated injection systems such as those using pressure-time (PT), MUI, EUI, EUP, and high pressure injection pressure-time (HPI-PT) fuel systems. When you perform this exercise, try to be as precise as possible. You should end up with a diagram similar to that shown in **Figure 5-4** but with the exact specifications for the engine you are working on.

Summary

- Engine feedback components include the engine timing geartrain, the camshaft, valve and unit injector trains, and in some cases the injection pumping apparatus.
- Camshaft drive gears must be precisely timed to the crankshaft-driven, engine geartrain.
- Timing the engine geartrain synchronizes the engine powertrain with the engine feedback assembly.
- The camshaft drive gear is usually interference-fit to the camshaft. It is positioned by a keyway.
- Camshaft gears are heat-treated. To fit them to camshafts they must be heated up so it is essential that they are heated evenly to a precise temperature. Overheating can destroy the gear.
- Camshafts may be rotated either CW or CCW.
- Camshaft gears may use spur or helical cut gear teeth. Thrust loads are much higher when helical gears are used.
- Gear backlash should be measured using feeler gauges or dial indicators.
- Cam lift on block-located camshafts may be checked using a dial indicator mounted above the push tube or rod.
- Cam base circle or IBC is that portion of the cam circumference with the smallest radial dimension.
- Cam OBC is that portion of the cam **periphery** with the largest radial dimension.
- Critical cam dimensions can be checked on an overhead camshaft or an out-of-engine camshaft with a micrometer. Cam lift can be checked with a dial indicator in a block-mounted camshaft.
- Visual inspection of a camshaft should identify most cam failures. Cam profile wear may be checked to specification using straightedge and feeler gauges. The camshaft should be mounted in V-blocks to test for straightness.
- Out-of-engine camshafts should be supported on pedestals, on V-blocks, or hung vertically to prevent damage.
- Medium- and large-bore diesel engine cam followers are of the solid or roller types. Hydraulic lifters are not used.
- A cam train consists of the series of components it is responsible for actuating.
- A diesel engine with a block-mounted camshaft uses trains consisting of a follower assembly, push tubes, and a rocker. The rocker actuates cylinder valves or an injector pump.
- Valve lash allows for expansion of the valvetrain materials as the engine heats to operating temperature.

- Some injection pumping actuation trains are set at zero lash or even a slight load when the actuating cam profile is on its IBC. Injector train settings may have to be precisely set because they help define injection timing.
- Rocker assemblies provide a means of reversing the direction of linear movement of the push tube or follower, and in some cases providing a mechanical advantage.
- Cylinder head valves are used to breathe the engine cylinders. They are actuated by cam profiles and time the gas (air and exhaust gas recirculation [EGR]) into, and end gases out of, the engine cylinders.
- When reconditioning valves by regrinding, a critical specification is the valve margin.
- Most diesel engines do not use an interference angle to seat valves because it reduces the seating contact surface area. In addition, valve rotators are widely used and these cannot be used when valves are machined with an interference angle.
- A 45-degree valve has higher seating force but lower gas flow than a 30-degree valve .
- Valve seats are usually interference fit into the cylinder head. After installation they must be ground concentric to the valve guide bore.
- When setting valve lash, the OEM specifications must be adhered to. The engine position for setting the valves over each cylinder must also be observed.
- Valve lash should be set using feeler gauges. Valves in current engines are set cold.
- Loose set valves produce lower cylinder breathing efficiencies. They can also produce top end clatter and damage cam profiles.
- Variable valve timing is commonly used to control exhaust valves for engine braking and also to delay intake valve closing for purposes of reducing emissions.
- Creating a valve polar diagram is an effective way to map the valve opening and closing events in any engine you choose. You can also map how mechanically actuated injectors are phased into the cycle.

Internet Exercises

1. Use a search engine to check out the QuickWay and Sioux Tools websites. Examine each company's valve servicing equipment.
2. Use a search engine and punch in <tempilstick> to see what you come up with.
3. Identify three currently manufactured diesel engines made by different OEMs: use the Web to identify valve lash specifications for intake and exhaust valves. Cross-check this information with the OEM specs if available to you.
4. Use the Web to research VVT on diesel engines. Make a list of OEMs using or about to use VVT on their engines.

Shop Tasks

1. Check and set, if necessary, valve lash on a diesel engine equipped with a cylinder block located camshaft.
2. Check and set, if necessary, valve lash on a diesel engine equipped with an overhead camshaft.
3. Set a complete top end on a diesel engine equipped with mechanically actuated injectors (such as EUIs). Note what method is required to set injector height.
4. Use a dial indicator to check out cam lift on an engine equipped with a cylinder block located camshaft.
5. Place a diesel engine camshaft in V-blocks: check cam profile dimensions to specification using the OEM recommended methods.
6. Use the information in this chapter to perform a valve polar diagram on a specific engine: include injector actuation if appropriate on the map you produce.
7. Select an engine and map a valve polar diagram.

Review Questions

- The location on a cam profile that is exactly opposite the toe is referred to as the:
A. Sole
B. Nose
C. Ramp
D. Heel
- On a cam profile described as mostly inner base circle, the profiles between IBC and OBC are known as:
A. Cam geometry
B. Ridges
C. Ramps
D. Heels
- In which direction must a camshaft be rotated on a diesel engine with a crankshaft that is rotated clockwise?
A. Clockwise (CW)
B. Counterclockwise (CCW)
C. Either CW or CCW depending on the engine
- Which tool would be required to measure the cam lift of a cylinder block-mounted camshaft in position?
A. Dial indicator
B. Outside micrometer
C. Depth micrometer
D. Thickness gauges
- A camshaft gear is usually precisely positioned on the camshaft using a(n):
A. Dial indicator
B. Interference fit
C. Key and keyway
D. Captured thrust washer
- When grinding a valve face to remove pitting, the critical specification to monitor during machining would be the:
A. Shank diameter
B. Stem
C. Poppet diameter
D. Margin
- Which of the following engine running conditions would be more likely to cause a valve float condition?
A. Engine lug down
B. Engine overspeed
C. Operating in the torque rise profile
D. Operating in the droop curve
- When grinding a new set of cylinder valve seats, which of the following should be performed before the machining?
A. Install the valves.
B. Install the rockers.
C. Adjust the valve yokes.
D. Install the valve guides.
- Which of the following methods is used to transfer drive torque from the crankshaft to the camshaft on most commercial diesel engines?
A. Gears
B. Belt and pulley
C. Fluid coupling
D. Timing chain and sprocket
- What type of cam geometry is required if the objective is to load the train that rides it for most of the cycle?
A. Mostly OBC profile
B. Mostly IBC profile
C. Symmetrical OBC and IBC profiles

CHAPTER

6

Cylinder Blocks, Liners, Cylinder Heads, Rocker Housings, Oil Pans, and Manifolds

Learning Objectives

After studying this chapter, you should be able to:

- Identify the components classified as engine housing components.
- Identify the types of cylinder blocks used in diesel engines.
- Outline the procedure required to inspect a cylinder block.
- Measure an engine block to specifications using service literature.
- Identify the types of cylinder liners used in diesel engines.
- Explain the procedure required to remove dry, wet, and midstop liners.
- Perform selective fitting of a set of dry liners to a cylinder block.
- Explain how cavitation erosion occurs on wet liners.
- Identify the types of cylinder heads used in diesel engines.
- Describe the component parts of a cylinder head.
- Define component creep and gasket yield.
- Explain the procedure required to measure, test, and recondition a cylinder head.
- Describe the role of the intake and exhaust manifolds.
- Describe the function of the oil pan in the engine.

Key Terms

bubble collapse

cavitation

compacted graphite iron (CGI)

crankcase

creep

cylinder block

cylinder head

dry liners

exhaust manifold

fire rings

gasket

intake manifold

interference fit

liners

oil pan

parent bore	sump	wet liners
scavenging pump	template torque	yield point
sleeves		

INTRODUCTION

The engine housing encloses the internal engine components. The cylinder block acts as the central frame of the engine. All the other engine components are in some way attached to it including the remaining engine housing components. The components examined in this chapter are as follows:

1. engine cylinder block and cylinder liners
2. cylinder head assemblies
3. intake and exhaust manifolds
4. oil pans

ENGINE CYLINDER BLOCK

The engine **cylinder block** is the frame of the engine around which all the other components are assembled in much the same way that subcomponents are assembled around a truck frame. The cylinder block houses the engine cylinders and the engine crankcase. Most high-way diesel engines use an inline, 6-cylinder configuration. Some V-cylinder configurations are used but you are more likely to see them in small-bore automotive or off-highway diesels. Whether inline or V-configurations are used, in most cases a single crankshaft is required and cylinder blocks are usually cast as a single unit. **Figure 6-1** shows a stripped-down cylinder block used in the MaxxForce 13 engine.

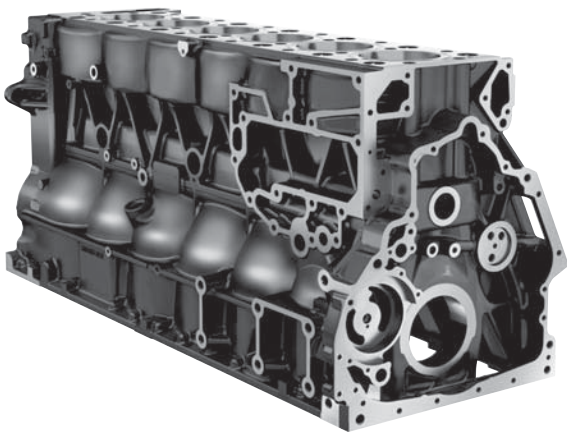

Figure 6-1 Navistar MaxxForce 13 compacted graphite iron (CGI) cylinder block. (Courtesy of Navistar International)

Cylinder Block Forces

Cylinder blocks today have to be lighter and stronger than those of a generation ago. Because of this, the cast irons from which they are manufactured are alloyed with toughening materials. However, reducing cylinder block weight has resulted in some undesirable flexibility. For this reason, some modern cylinder blocks are braced to limit this flexibility. The forces that a cylinder block is subject to are:

- **Torque twist:** This occurs when twisting force from the crankshaft anchors through the cylinder block. A cylinder block can be subject to torque twist from either crankshaft input or output. The condition can occur at high cylinder pressures, or oppositely, can be generated through the drivetrain.
- **Cylinder pressures:** Excessively high cylinder pressures, especially in small parent bore engines, can generate failures. Today, combustion pressures tend to be approximately double those in engines of a generation ago.
- **Sudden changes in temperature:** This occurs when a hot cylinder block is cooled rapidly either when immediately shutdown after a hard run cycle or from cold water in a wash bay.

Cylinder Block Design and Construction

Most current diesel engines use cylinder **liners** or **sleeves**. Unlike the majority of automobile engines, diesel engines are commonly reconditioned. Reconditioning requires that an engine is completely disassembled and reassembled, replacing any worn or defective parts. Cylinder liners or sleeves tend to wear during engine operation and can easily be replaced when the engine is overhauled.

Liners and Parent Bore. Engines that do not use liners or sleeves have what are called integral cylinder bores. That is, the cylinder bore is machined directly into the cylinder block. Engines with no cylinder liners are known as a **parent bore** engines. Until recently, parent bore diesel engines were usually found in light-duty engines such as those used to power automobiles and pick-up trucks. However, heavier duty parent bore engines have more recently been available. The life of heavy-duty parent bore engines can be increased by

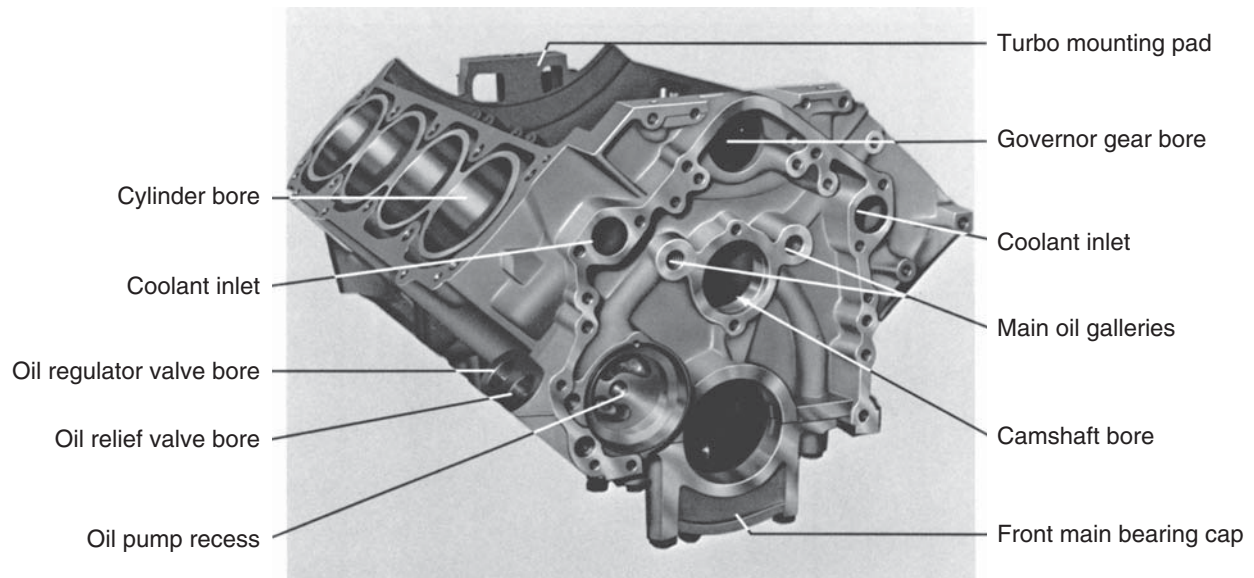

Figure 6-2 Cylinder block terminology. (Specifications are subject to change without notice. Detroit Diesel Corporation is registered to ISO 9001:2001. Courtesy © Detroit Diesel Corporation. All rights reserved. Detroit Diesel is a Daimler company)

induction, hardening the surface of the bore. **Figure 6-2** shows an older Detroit Diesel, V-configured cylinder block and identifies some of the terms we will be using in this chapter.

Crankcase. In addition to supporting the cylinders, a cylinder block must also support the crankshaft and flywheel. The crankshaft is located in a lengthwise bore in the cylinder block and is supported in a cradle of main bearings in what is usually called the **crankcase**. The flywheel housing is bolted to the rear of the cylinder block. The flywheel is bolted to the crankshaft and rotates within the flywheel housing.

Cylinder Block Design. Cylinder blocks may be bored to support the camshaft or camshafts and are cast with coolant passages and a water jacket. Even in a liquid-cooled engine, the cylinder block frame plays a major role in transferring engine heat to the atmosphere. Because all the other engine housing components are attached either directly or indirectly to the cylinder block, it must be designed to accommodate them. Twenty years ago most diesel engines were manufactured from simple cast irons. Because of the thrust toward lighter, much tougher cylinder blocks, the base cast iron used today is alloyed with other materials. **Compacted graphite iron (CGI)** cylinder blocks (see **Figure 6-1**) have been a key to reducing engine weight. High-horsepower diesel engines today often weigh less than half the weight of equivalent power engines of just 10 years ago. **Figure 6-3** shows an exploded view of a DDC cylinder block assembly.

Cylinder Block Functions

Although there are some differences between manufacturers, a diesel engine cylinder block must perform some or all of the following:

- house the piston cylinder bores
- support the crankshaft in main bearing bores
- support a cylinder block-located camshaft(s)
- incorporate coolant passages and a water jacket
- incorporate lubricant passages/drillings
- incorporate mounting locations for other engine components

Categories of Cylinder Block

Cylinder blocks used in commercial diesel engines can be categorized by type:

- integral cylinder bore or parent bore
- wet sleeve/liner
- dry sleeve/liner
- combination wet/dry liners

Other factors such as two-stroke cycle and air-cooled are also reflected in the block design.

Parent Bore. Most automobile and small-bore engines use parent bore cylinder blocks. They are seen less often in truck diesel engines, especially those of large-bore dimensions. Parent bore cylinder blocks are usually less costly to manufacture but they can present problems when they have to be rebuilt. When a parent bore design uses cylinder bores set close to each other,

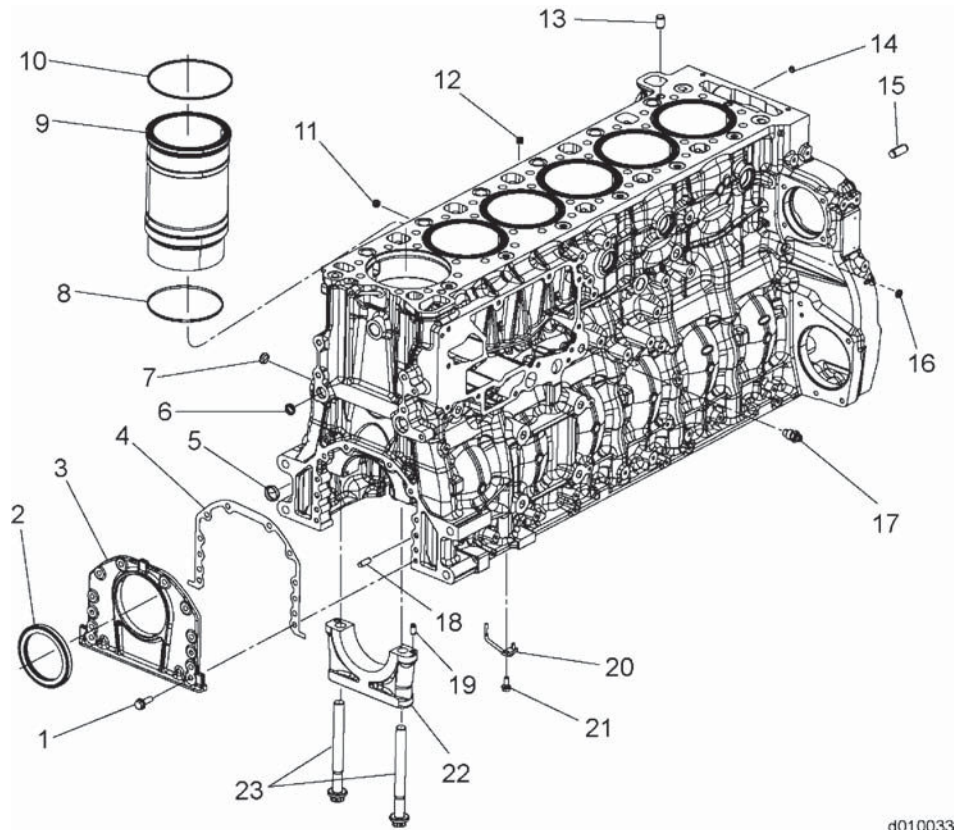

d010033

- | | |
|---|--|
| 1. Bolt, front cover to cylinder block | 13. Pin |
| 2. Sealing ring, front crankshaft sealing | 14. Expansion plug, cooling water duct |
| 3. Front cover | 15. Pin |
| 4. Gasket, front cover to cylinder block | 16. Expansion plug |
| 5. Expansion plug, front oil duct intake | 17. Connector pipe |
| 6. Expansion plug, front oil duct outlet | 18. Pin, front cover |
| 7. Expansion plug, connector front oil duct outlet | 19. Dowel pin, crankshaft bearing cap |
| 8. Bottom cylinder liner seal ring | 20. Piston oil spray nozzle |
| 9. Cylinder liner | 21. Bolt, oil spray nozzle |
| 10. Top cylinder liner seal ring | 22. Main bearing cap |
| 11. Expansion plug, connector crankcase ventilation | 23. Bolt, crankshaft bearing cap to cylinder block |
| 12. Plug | |

Figure 6-3 Exploded view of a DD15 cylinder block. (Specifications are subject to change without notice. Detroit Diesel Corporation is registered to ISO 9001:2001. Courtesy © Detroit Diesel Corporation. All rights reserved. Detroit Diesel is a Daimler company)

it can be difficult to bore for sleeves if the engine has to be rebuilt. Two examples of diesel engines using a parent bore design are:

- Caterpillar 3208 (an old V-8 engine)
- MB-900 (a current family of inline 4- and 6-cylinder engines)

The cost savings in purchasing a parent bore cylinder block can be lost if the engine ever has to be reconditioned.

Parent bores in cylinder blocks can be bored to an oversize and fitted with sleeves but this is obviously more costly than simply replacing a set of sleeves. The advantages of parent bore engines are:

- lower initial cost
- no liner O-rings to fail
- no liner protrusion specs to adhere to on reassembly

INDUCTION HARDENED PARENT BORE

The MB-900 engine families of 4- and 6-cylinder engines use a unique, helical-striped, induction-hardening feature in the upper ring belt sweep. This provides the cylinder bores longer service life when compared with other parent bore engines. If the cylinder bores are worn to oversize, they can be bored and sleeved, but Mercedes-Benz recommends that this procedure be performed only by them. This engine has become very successful in both on- and off-highway applications.

Wet Liner/Sleeve. When a cylinder block is designed with wet liners or sleeves, the water jacket comes into direct contact with the outside of the liner in the block bore. This means that the liner must be tough enough to contain the highest combustion pressures the engine produces. **Wet liners** transfer heat efficiently into the coolant and are easily replaced at overhaul. Their main disadvantage is that a seal must be maintained for the life of the liner and that an O-ring failure results in coolant contaminated engine lube. **Figure 6-4** shows the wet liner used in a DD15 engine.

CAVITATION

Wet liners can fail due to a condition known as **cavitation**. A cavitation failure is caused by vapor bubble implosion. Despite the fact that a wet liner is

constructed from a sizeable mass of cast iron or steel, it is relatively easily flexed when subjected to cylinder pressures. This flexing movement of the liner walls can shorten the life of wet liners if the engine coolant is allowed to degrade.

HOW CAVITATION EROSION OCCURS

Cylinder combustion pressures in today's engines can be as high as 3,000 psi (24 mPa). This massive pressure acts directly on the wall of a wet liner, expanding it outward into the wall of coolant. Immediately after the expansion, the wall then contracts: as it does so, it leaves a low-pressure bubble. This "bubble" is actually boiled-off coolant vapor. It almost immediately collapses, causing the wall of coolant to collide on the liner exterior wall. This condition repeats itself at high frequency (17 times per second on each liner at 2,000 rpm). **Bubble collapse** has been tested to produce pressures of up to 60,000 pounds per square inch (psi) (4,137 bar), enough to start pecking away at the liner. Coolants designed for use in diesel engines with wet liners protect the outside wall of the liner from bubble collapse by forming a coating on the exterior of the liner wall. Cavitation can be identified by pitting/erosion that usually appears on the liner outside the thrust faces of the piston.

LINER O-RINGS

The O-rings used to seal wet liners are made from a variety of rubber type compounds. When installing these, it is important that the original equipment manufacturer (OEM) installation recommendations be observed. OEM recommendations can be to install them dry or coated in coolant, soap, engine oil, and various other substances. The reason is that some O-rings are designed to react to the coating substance and swell, creating a perfect seal.

Dry Sleeves. The dry sleeve uses a thinner-walled sleeve than the wet liner. The dry sleeve is installed into the block bore usually with a marginally loose fit and retained by the cylinder head. The dry sleeve does not transfer heat as efficiently as the wet liner, but it is easily replaced and does not present coolant sealing problems.

In older diesel engines, **dry liners** were made of cast iron material almost identical to that of the engine block. This generation of dry liners was installed into the cylinder bore with an interference fit. The interference fit allowed the cast iron liner to effectively transfer combustion heat to the cylinder block. Current dry liners are alloyed so they provide longer service life. Because the ability of dry liners to transfer heat

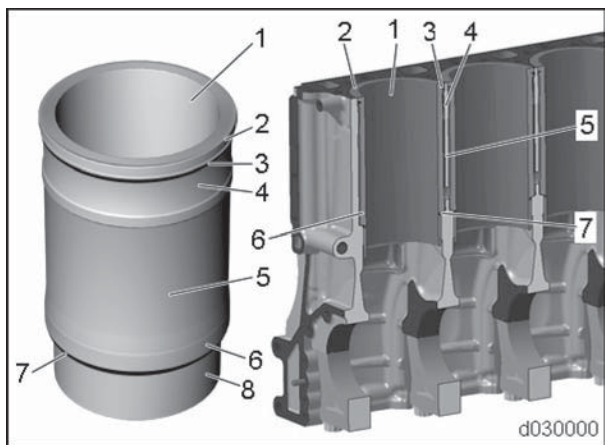

- | | |
|--------------------------|-----------------------------|
| 1. Cylinder liner | 5. Lower coolant jacket |
| 2. Top of cylinder liner | 6. Lower collar |
| 3. Upper sealing ring | 7. Lower sealing ring |
| 4. Upper coolant jacket | 8. Bottom of cylinder liner |

Figure 6-4 Wet liner from a DD15 engine. (Specifications are subject to change without notice. Detroit Diesel Corporation is registered to ISO 9001:2001. Courtesy © Detroit Diesel Corporation. All rights reserved. Detroit Diesel is a Daimler company)

depends on having the best surface contact area in the cylinder block bore, they are designed to expand slightly more than unalloyed cast iron when they heat to operating temperature. For this reason, they should be installed loose; this allows them to expand into the block bore as they warm to operating temperature. If this type of liner is installed with an interference fit, it can buckle in use, which reduces its service life. Always use the OEM service specifications when installing dry liners.

Combination Wet/Dry Sleeves. The wet/dry sleeve is designed so that the hottest part of the liner at the top is in direct contact with the coolant in the water jacket and the lower portion fits directly to the cylinder block with a fractional loose fit. For this reason the upper part of the liner has to have thicker walls because it has to contain the cylinder combustion pressures. Wet/dry liners must also seal the water jacket. This is usually done with O-rings. Some OEMs prefer to call wet/dry liners *midstop liners*. **Figure 6-5** shows a typical wet/dry sleeve assembly.

Cylinder Sleeve Removal. Sleeves should be removed with a puller and adaptor plate or shoe. The shoe or adaptor plate is required to be fitted into the lower portion of the liner and, while doing this, have an outside diameter just a little less than the inside diameter (ID) of the cylinder bore. Some wet sleeves can be removed with the puller attached to a slide hammer. Dry sleeves often require the use of mechanical, hydraulic, or air-over-hydraulic pullers.

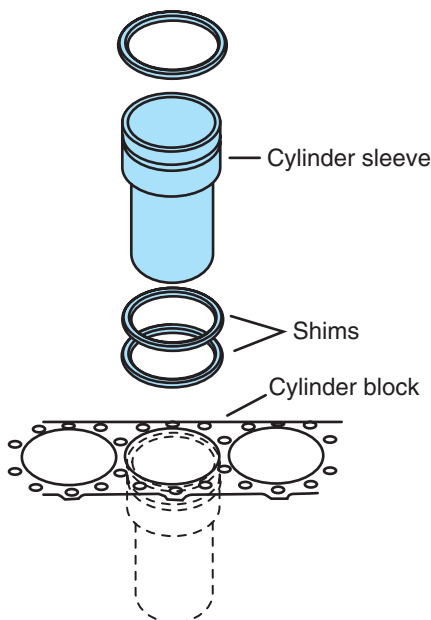

Figure 6-5 Wet or wet/dry liner assembly.

Tech Tip: Removing pistons from cylinder liners can be made much easier by removing the carbon around the cylinder wear ridge that forms in use (**Figure 6-6**). The carbon in the wear ridge can be removed using a flexible knife blade followed by the gentle use of an emery cloth.

Checking a Cylinder Block

Follow these steps in checking a cylinder block:

1. Strip the block completely including the cup expansion and gallery plugs.
2. Soak in a hot or cold tank with the correct cleaning solution.
3. Check for scaling in the water jacket not removed by soaking. One OEM reports that 0.060 in. (1.5 mm) scale buildup has the insulating effect of 4 in. (100 mm) cast iron.
4. Check for wear/erosion around the deck coolant ports and fire ring seats.
5. Electromagnetic flux test the block for cracks at each out-of-chassis overhaul.

Final Inspection and Assembly. Final inspection and assembly consists of these steps:

1. Check for deck warpage using a straightedge and thickness gauge. A typical maximum specification is approximately 0.004 inch but be sure to check the OEM tolerances; this spec is usually less on new tech blocks using single slab cylinder heads.
2. Check the main bearing bore and alignment. Consult the engine service history to ensure that the engine has not been previously line bored. A master bar is used to check alignment for a specific engine series. Check that the correct bar has been

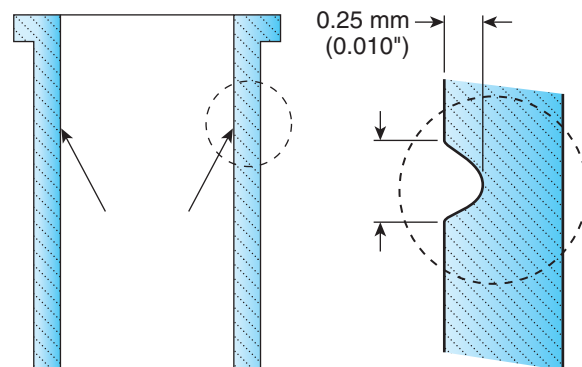

Figure 6-6 Cylinder wear ridge. (Courtesy of Caterpillar)

selected for the engine being tested. Lube the master bar with engine oil. Then clamp to position by torquing down the main caps minus the main bearings. The master bar should rotate in the cylinder block main bearing line bore without binding. Should it bind, the cylinder block should be line-bored.

3. Check the cylinder sleeve counter bore for the correct depth and circumference. Counter bore depth should typically not vary by more than 0.001 in. (0.025 mm). Counter bore depth can be subtracted from the sleeve flange dimension to calculate sleeve protrusion. Recut and shim the counter bore using the OEM recommended tools and specifications (**Figure 6-7**).
4. Check the cam bore dimensions with a T-gauge and install the cam bushings with the correct cam bushing installation equipment. Use drivers with great care as the bushings may easily be damaged and ensure that the oil holes are lined up before driving each bushing home.
5. Install gallery and expansion plugs. These are often interference-fitted and sealed with silicone, thread sealants, and hydraulic dope.

Liner and Sleeve Reconditioning

Liner and sleeve reconditioning is not a common current practice because of the time it takes and the relative low cost of new liners. It is probably good practice to advise customers against reconditioning

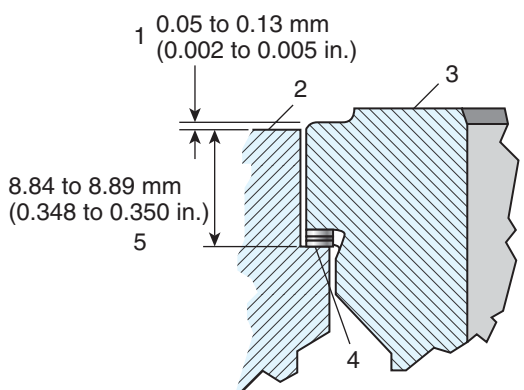

Maximum allowable variation of counter bore between four points—0.025 mm (0.001 in.)

1. Sleeve protrusion
2. Crankcase top surface
3. Sleeve
4. Shim to suit
5. Maximum allowable counter bore—10.49 mm (0.413 in.)

Figure 6-7 Installing counter bore shims on a Navistar DT 466E engine. (Courtesy of Navistar International)

liners, citing the fact that it will probably cost them more in the long-term. OEMs make oversize liners when the block bores are damaged and have to be rebored. Two basic methods of liner reconditioning are used: glaze busting and honing.

Glaze Busting. When checked to be within serviceability specs, the liner should be deglazed. Deglazing involves the least amount of material removal. A power driven (heavy-duty electric drill with accurate low rpm control) flex hone or rigid hone with 200- to 250-grit stones can be used for deglazing. The best type of glaze buster is the flex hone, typically a conical (Christmas tree shaped) or cylindrically shaped shaft with flexible branches of carbon/abrasive balls.

PRESERVING CROSSHATCH

The objective of glaze busting is to machine away the cylinder ridge above the ring belt travel and reestablish the crosshatch. The drill speed should be set at 120 to 180 rpm. When glaze busting, the flex hone should be used rhythmically. Short in-out sequences, stopping frequently to inspect the finish, produce the best results. A 60- to 70-degree horizontal crossover angle (some OEMs express this as 120- to 130-degree vertical crosshatch), and a 15- to 20-micron (3.8- to 5-micron) depth crosshatch, should be observed (**Figure 6-8**). Faster results can be produced by using a spring-loaded hone to deglaze liners, but there is also more chance of damaging the cylinder liner. **Figure 6-8** shows the crosshatch on a Volvo D16 engine after machining.

Honing. Honing is performed with a rigid hone, powered once again at low speeds by either a drill or overhead boring jig. The typical cylinder hone consists

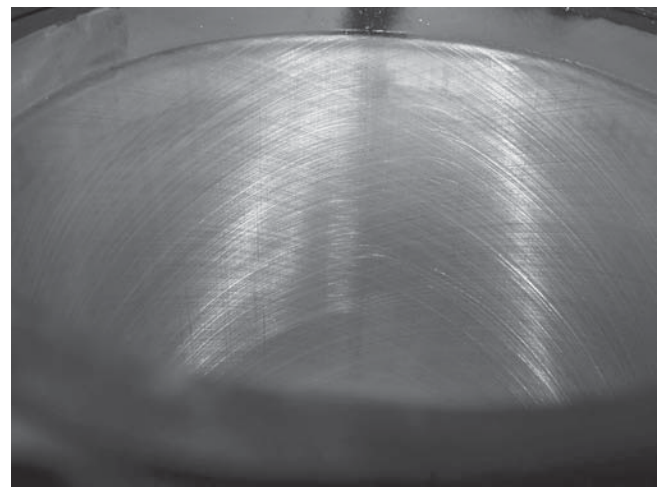

Figure 6-8 Cylinder crosshatch on a Volvo D16 after machining.

of three legs. These are set before machining to produce a radial load into the liner wall. The abrasive grit rating of the stones determines the aggressiveness of the tool: 200- to 250-grit stones are typical. Overhead boring tools can be programmed to produce the required stroke rate for the specified crosshatch, but if using a hand-held tool, remember that a few short strokes with a moderate radial load tend to produce a better crosshatch pattern than many strokes with a light radial load.

CREATING CROSSHATCH

Once again, a 60- to 70-degree horizontal crossover angle, and 15–20 microinch (3.8- to 5-micron) crosshatch should be observed. It should be clearly visible by eye as shown in **Figure 6-8**. Honing is designed to produce the specified crosshatch. This means that the liner contact surface retains oil required to allow the piston rings to seal. When installing wet liners, observe the OEM installation procedure.

Selective Fitting of Liners. Selective fitting of liners to block bores is good practice whether or not the block bore has been machined. Make a practice of measuring all new liners. To selective fit a set of dry liners to a cylinder block, measure the inside diameter (ID) of each block bore across the North–South and East–West faces. Then grade in order of size. Next, get the set of new liners and measure the outside diameter (OD) of each. Again, grade in order of size. Ensure that *every* measurement falls within the OEM specifications. Then fit the liner with the largest OD to the block bore with the largest ID and so on, down in sequence.

Flywheel Housings

Flywheel housings bolt to the rear of the cylinder block. They house the engine flywheel and enable the transmission bell housing to be coupled to the engine. Flywheel housings used in most diesel drivetrains are classified by SAE codes such as those mentioned in **Chapter 4**. This allows some interchangeability between similarly coded bell housings and flywheel housings. In the trucking industry, this is important because it allows transmission OEMs to fit their product to a range of different OEM engines. The flywheel housing encloses the flywheel and clutch pack. It encloses the mechanical coupling of the engine and transmission. In some cases, the rear engine mounts may be located on the flywheel housing. Rear engine mounts may also be located on the transmission bell housing. The starter motor is usually flange-mounted to the front of the flywheel housing.

Flywheel housings are precision-located to the engine cylinder block by cylindrical or diamond dowels.

The clamping force between the flywheel housing and cylinder block is provided by fasteners, usually grade 8 bolts. Flywheel housings should be checked for:

- Flange ID radial concentricity. This is an important check; it is covered in some detail in **Chapter 11**. If it does not meet specification, it produces a broken-back effect imparting drive torque to the transmission that can take out clutches, clutch shafts, crankshafts, and transmissions.
- Outer flange face runout. This is the mating face to the transmission bell housing. It seldom fails to meet specification but should be checked at engine overhaul.

CYLINDER HEADS

Cylinder heads seal the engine cylinders. They also contain the cylinder valves that manage engine breathing. Most diesel engines use cast iron cylinder heads. The cylinder head is machined with breathing tracts and ports, cooling and lubrication circuit manifolds, fuel manifolds, and injector bores. They may also support rocker assemblies and camshafts when overhead camshaft design is used. Several configurations are used in diesel engines:

1. multicylinder, single-slab casting (most common today)
2. multicylinder, multiple-cast units (a 6-cylinder engine may have two or three cylinder heads)
3. single cylinder (a 6-cylinder engine would require six cylinder heads)

Cylinder heads usually contain the valve assemblies, breathing ports, injector bores, and coolant and lubricant passages. A detailed exploded view of a cylinder head from a DD15 engine is shown in **Figure 6-9**.

Cylinder Head Disassembly, Inspection, and Reconditioning

Cylinder heads are often reconditioned in specialty machine shops. If you are required to disassemble and recondition a cylinder head, make sure you reference the OEM service literature. When removing variable valve timing and engine brake actuators there is usually a very specific procedure to observe. The following is a general procedure and we will assume that the injectors have already been removed (it is good practice to remove injectors before removing the cylinder head from the engine):

1. Remove the valves with a C-type spring compressor and gently tap each valve with a nylon hammer to loosen the keepers and retainers.

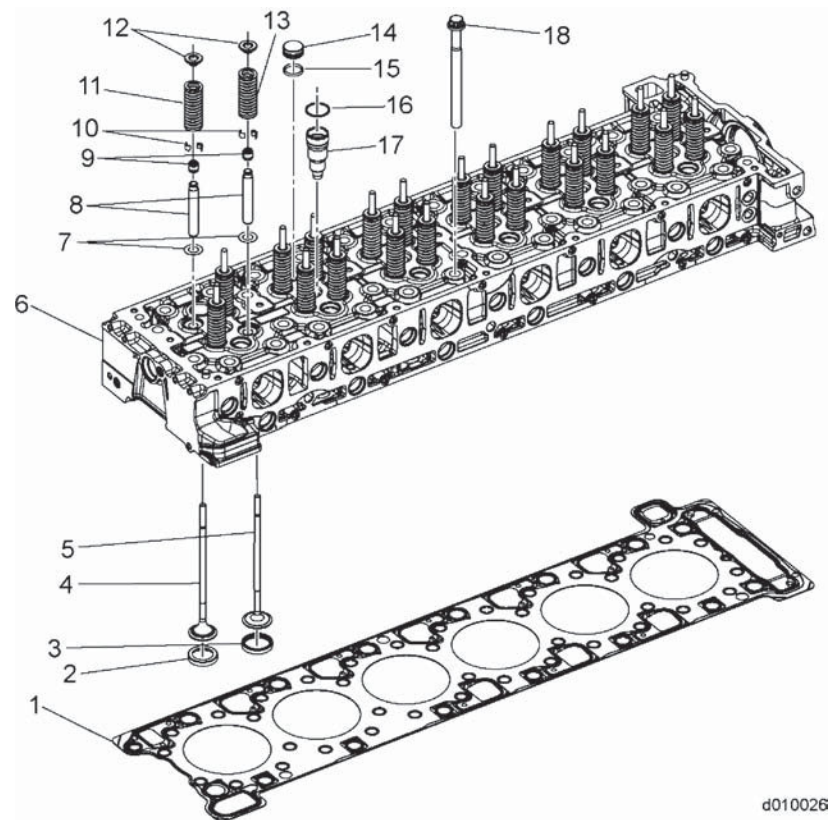

d010026

- | | |
|----------------------------|--|
| 1. Cylinder head gasket | 10. Valve keeper |
| 2. Exhaust valve seat ring | 11. Exhaust valve spring |
| 3. Intake valve seat ring | 12. Spring retainer |
| 4. Exhaust valve | 13. Intake valve spring |
| 5. Intake valve | 14. Water jacket cover plug |
| 6. Cylinder head | 15. Water jacket seal ring plug |
| 7. Washer | 16. Water protection sleeve seal ring |
| 8. Valve guide | 17. Injector cup |
| 9. Seal holder | 18. Cylinder head-to-cylinder block bolt |

Figure 6-9 Exploded view of a DD15 cylinder head. (Specifications are subject to change without notice. Detroit Diesel Corporation is registered to ISO 9001:2001. Courtesy © Detroit Diesel Corporation. All rights reserved. Detroit Diesel is a Daimler company)

2. Clean cylinder heads in a soak tank (preferably hot).
3. Check the cylinder head height dimension. Each OEM has its own preference on where to make this, so consult the service literature.
4. Clean up the head gasket surface with a fine-grit emery cloth.
5. Electromagnetic flux test head for cracks. Optionally dye penetrant testing can be used, but this is messy and inaccurate.
6. Hydrostatic pressure test. Cap and plug all the coolant ports. Place the cylinder head on a test bench and heat by running hot water through it. When hot to the touch, hydrostatically test

- using shop air at around 100 psi (7 bar). Areas to watch are valve seats and injector sleeves. When brass injector sleeves are used (usually older engines), perform the hydrostatic test both cold and hot. If injector sleeves have to be replaced, use appropriate removal and installation tools and repeat a pressure test after the operation. These are sometimes swaged and sometimes threaded into the injector bore. Some have internal threads that allow a removal tool to be threaded into them: these are pulled using a slide hammer.
7. Check for warpage using a straightedge and feeler gauges. The specification will vary according to the size of the head.

8. Check valve guide bore to specs with a ball gauge. If in need of replacement, the guide must be pressed or driven out with the correct driver. Damage to the guide bore may require reaming to fit an oversize guide. Integral guides can be repaired by machining for guide sleeves or knurling. Installation of new guides can be made easier by freezing (dry ice) or use of a press fit lubricant.
9. New guides may require reaming after installation, but some OEMs use cladded guides that should *never* be reamed: check the service literature.
10. Check valve seats for looseness using a light ball-peen hammer and listening—a loose seat resonates at a much higher pitch. To recondition, select the appropriate mandrel pilot and insert into the guide, then match valve seat to the mandrel grinding stone. Stellite-faced seats require special grinding stones. Dress the stone to achieve the required seat angle. Interference angles are seldom used in current applications because this lowers a valve's ability to transfer heat. An interference angle is usually not required when valve rotators are used. New valve seats are installed with an **interference fit** and require the use of the correct driver; after installation the seat is usually knurled or staked in position. Most

current diesels use alloy steel seats. When cast iron seats are used do not stake: this may fracture the seat. After valve and seat reconditioning, check the valve head height (valve protrusion) with a dial indicator.

11. Recondition valves by cleaning them with a wire wheel or glass bead blaster, and then check for stretching, cupping, burning, or pitting. When refacing (dressing) valves, ensure that the valve margins remain within OEM specifications. Check the valve seating using Prussian blue (aka machinist's blue). Lapping is not required if the grinding has been done properly.
12. Check the valve springs for straightness, height, and tension using a right-angle square, tram gauge, and tension gauge.
13. Check the positive valve rotators (rotocoil) after hand assembly by tapping the valve open with a nylon hammer to simulate valvetrain action—they should rotate.

Cylinder Head Installation

Most current cylinder head gaskets are one piece. This means that cylinder pressures, coolant ports, and oil passages are all sealed by the cylinder head gasket as shown in **Figure 6-10**. Grommets are used to seal coolant ports and oil passages. Grommets are commonly

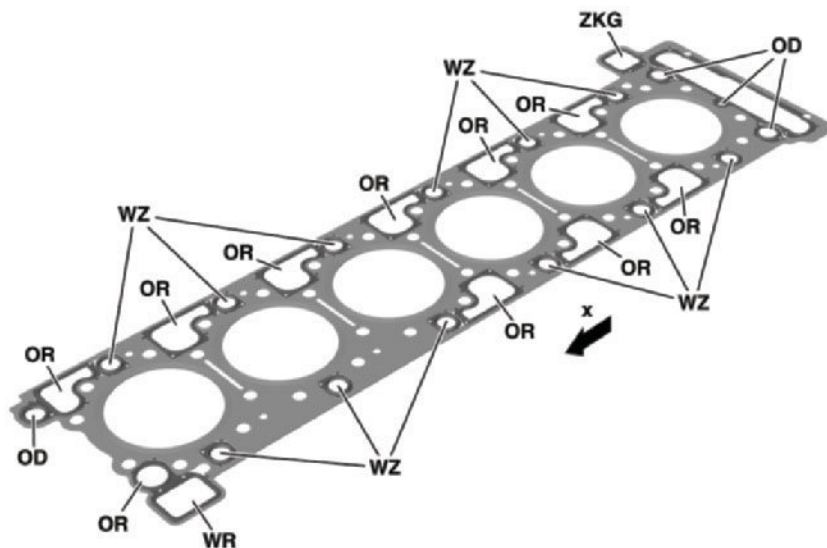

d010015

- | | |
|-------------------------------|--|
| OD. Engine oil feed hole | WR. Coolant return opening |
| OR. Engine oil return opening | ZKG. Opening for blowby duct to crankcase vent |
| WZ. Coolant feed hole | |

Figure 6-10 DD15 cylinder head gasket. (Specifications are subject to change without notice. Detroit Diesel Corporation is registered to ISO 9001:2001. Courtesy © Detroit Diesel Corporation. All rights reserved. Detroit Diesel is a Daimler company)

made of rubber: the rubber is fused into a one-piece cylinder head gasket. **Fire rings** are ring-shaped and are used to seal cylinder gases at the liner flange. Fire rings are manufactured from alloy steels: they have to effectively seal through a wide range of temperatures and cylinder pressures. Whether fire rings are incorporated into a one-piece head gasket or are separate components, they can be regarded as a one-off use component. This is because when a cylinder head is torqued onto the cylinder block, the fire rings are designed to deform so they form the best possible seal.

Gasket Yield Point. All gaskets are designed to yield to conform to two clamped components. Some gaskets and grommets can be safely reused but many cannot. A head **gasket** must be properly torqued to ensure that its **yield point** is achieved. Yield point means that the gasket is crushed to conform to the mating faces of two clamped components to produce the best possible seal. The fire rings used in most cylinder heads are made from embossed and often tubular alloy steels. When a cylinder head is properly torqued (correct increments and sequencing), the fire rings are literally crushed into the liner flange. Failure to observe the incremental steps can damage gaskets and fire rings by deforming them so, at final torque, they fail to seal. Cylinder head gaskets must be carefully torqued to make sure that the required amount of clamping force is obtained and the gaskets yield to effectively seal.

Component Creep. Most head gaskets require no applied sealant. In fact, if sealants are used they can fail. Because head gaskets have to seal engine components where both the temperature and pressure are at their highest, they have to accommodate a large amount of component creep. **Creep** is the relative movement of clamped engine components due to different rates of expansion and contraction as they are heated or cooled. Because a cylinder head has much less material than the cylinder block, it expands more rapidly as it is heated. It also contracts more rapidly as

it cools. While doing this it is clamped to the cylinder block and must maintain a good enough seal to contain cylinder combustion pressures that can exceed 3,000 psi (207 bar). The head gasket is the key to ensuring this seal is effective under all the operating conditions of the engine. It is essential that OEM torque increments and sequences be observed. Cylinder head bolts should be lightly lubed with engine oil before installation. Oil should never be poured into the block threads because a hydraulic lock may result. The torque sequence for a Mercedes-Benz MB-906 cylinder head is shown in **Figure 6-11**.

Incremental Torque Sequence. On inline, multi-cylinder heads, it is usually required that separate heads be aligned with a straightedge across the intake manifold faces before torquing. Failure to observe torquing increments and sequencing can result in cracked cylinder heads, failed head gaskets, and fire rings that will not seal. Because of the large number of fasteners involved, a click-type torque wrench should be used. Some OEMs require that a **template torque** method be used. Typically this requires setting a torque value first and then turning a set number of degrees beyond the torque spec using a template or protractor. This is also known as *torque-to-yield*. The torque sequence used on a DD15 engine is shown in **Figure 6-12**.

Tech Tip: Installing a cylinder head onto an engine that uses individual fire rings for each cylinder can be made easier by using four guide studs inserted into cylinder bolt holes. This reduces the chances of a fire ring misalignment occurring during head installation.

Rocker Housing Covers

Rocker housing or valve covers seal the upper portion of the engine above the cylinder head. Because valve and injector trains have become more complex

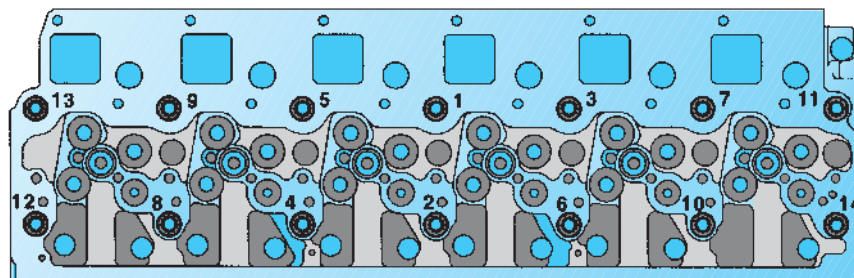
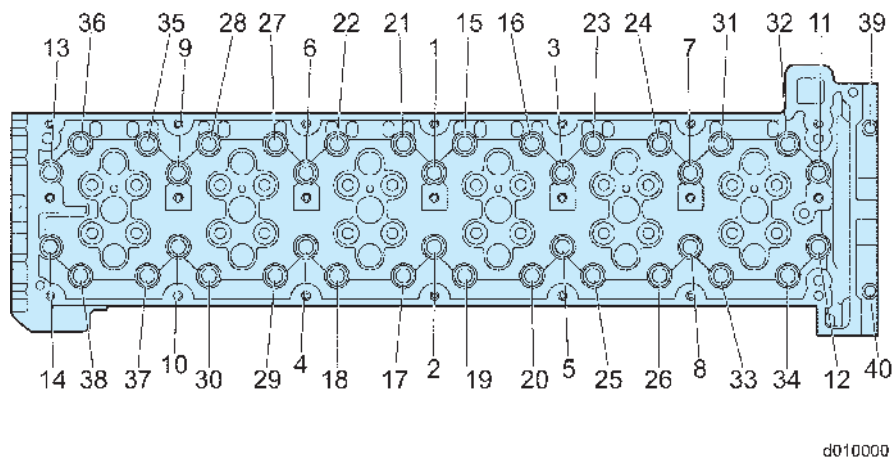

Figure 6-11 Cylinder head torque sequence. (Courtesy of Mercedes Benz)



d010000

Figure 6-12 DD15 cylinder head torque sequence. (Specifications are subject to change without notice. Detroit Diesel Corporation is registered to ISO 9001:2001. Courtesy © Detroit Diesel Corporation. All rights reserved. Detroit Diesel is a Daimler company)

over the years, the physical size of rocker housing covers has increased especially on engines equipped with variable valve timing and engine brakes. Rocker housing covers are the most frequently removed engine component. They have to be removed to access the valves and injectors for purposes of tune-up and injector timing. For this reason, many engine OEMs have adopted the use of multiuse, rubber compound sealing gaskets usually fitted to a captured groove in the rocker housing cover.

Rocker housing covers also reduce the noise produced by the rockers. Make sure you observe the OEM recommendations for installing these gaskets especially if you want to use them more than once. Usually a light coating of engine oil is all that should be applied. Try to avoid using aggressive adhesives such as weatherstrip glue because it ruins these rubber gaskets which tend to be much more costly than the older fiber type. When removing the remains of fiber gaskets, a jackknife with a flexible blade does a good job. If you have to resort to using a pneumatic scraper, bear in mind that the sealing faces are easily damaged.

INTAKE AND EXHAUST MANIFOLDS

In current diesel engines, the **intake manifold** is required to deliver both air and recirculated exhaust gas (EGR) to the engine cylinders. The intake manifold is bolted to the cylinder head(s) enclosing the intake passages to the valve ports. Because most diesel engines are turbocharged, the runners that extend from the intake plenum can be of unequal lengths without reducing engine breathing efficiency. EGR mixing

with boost air may take place in the region of the intake manifold plenum.

Intake manifolds can either be wet (coolant ports) or dry. That said, most current diesel engines in mobile equipment use dry intake manifolds. Materials used for intake manifolds are usually aluminum alloy or cast iron, but some OEMs are experimenting with plastics and carbon-based fibers. The gaskets used are usually fiber-based. Fiber gaskets can accommodate the small amount of component creep that takes place and peak turbocharger boost pressures. When a single section cast aluminum intake manifold is bolted to an engine with multiple inline cylinder heads, the cylinder heads must be aligned with a straightedge before they are torqued down. **Figure 6-13** shows a sectional view of an engine: try to identify the engine housing components.

Exhaust Manifold

The function of the **exhaust manifold** is to collect and contain cylinder end gases and deliver them to the turbocharger. In the case of a naturally aspirated engine, the exhaust manifold routes cylinder end gas directly to the exhaust piping. They are usually manufactured in single or multiple sections of cast iron. The exhaust manifold assembly is bolted to the cylinder head and in engines using multiple cylinder heads, it should be aligned before torquing.

Tuned Manifolds. Most current diesel engine exhaust manifolds are described as tuned. A tuned exhaust manifold means that exhaust gas is routed to the turbine housing of the turbocharger with low flow resistance. The term *tuned* can be applied to any exhaust system

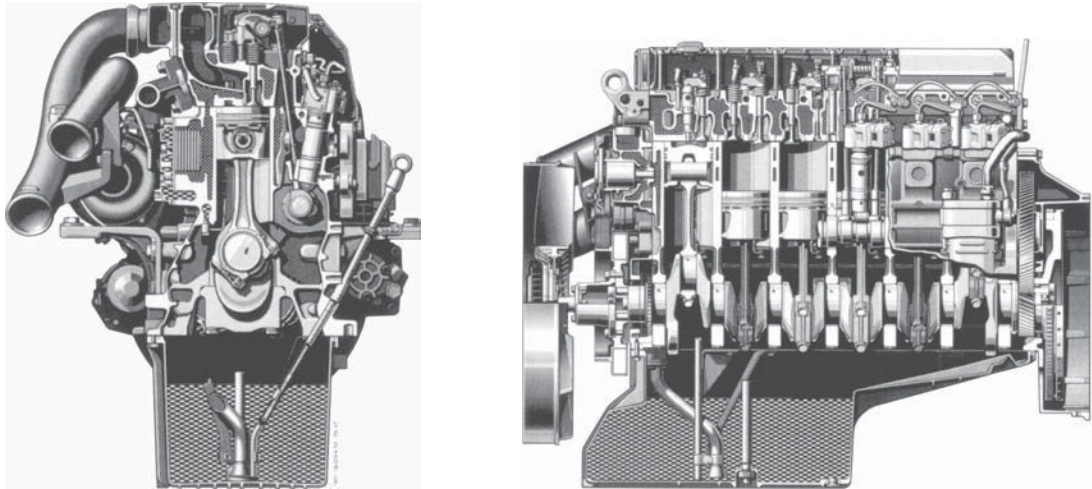

Figure 6-13 Sectional view of a MB-906: note the location of the engine housing components. (Courtesy of Mercedes Benz)

designed with at least some thought given to ensuring that exhaust gases flow without restriction to the turbine housing. If the exhaust manifold and piping are properly designed, as each slug of cylinder exhaust is discharged by a cylinder, it flows into the tail stream of the cylinder that fired before it.

Exhaust Manifold Gaskets. Exhaust manifold gaskets in diesel engines are usually manufactured from embossed steel. Embossed steel is stamped with protrusions in manufacture. Exhaust manifold gaskets have to be able to seal during high levels of component creep along with high temperatures. Embossed steel exhaust manifold gaskets are almost always installed dry and should be used once only because when torqued, the embossed protrusions are crushed. In many cases, the studs and bolts used to fasten exhaust manifolds to cylinder heads are manufactured from highly alloyed steels. This helps seal the manifold through a wide range of temperatures along with plenty of expansion and contraction.

OIL PANS OR SUMPS

The **sump** is a reservoir usually located at the crankcase flange below the engine cylinder block. It encloses the crankcase. **Oil pans** are manufactured from:

- cast aluminum
- stamped mild steels
- laminated steels
- plastics
- mineral and synthetic fibers

The oil pan is a reservoir. It collects engine lube oil that drains down into it by gravity. The oil pump

pickup is positioned low in the oil pan. This allows the oil pump to pick up and pump oil through the lubrication circuit. An oil pan from a DD15 engine is shown in **Figure 6-14**.

Oil Pan Functions

Oil pans can act as a sort of boom box and amplify engine noise, so they are usually designed to minimize noise. Laminated steels effectively reduce engine noise and also toughen an oil pan. The oil pan also plays a role in transferring lube oil heat to atmosphere. The effectiveness of this role obviously has a lot to do with the material from which it is manufactured. Aluminum will transfer heat more effectively than a fiber-reinforced plastic. In new generation diesel engines, lube oil is playing a greater role in cooling the engine so oil pan design and materials matter a lot. Some off-highway trucks and heavy equipment use deep, large-capacity oil pans with a scavenging pump. **Scavenging pumps** are secondary oil pumps designed to ensure that the engine is not starved for oil when the vehicle is operating on steep grades.

Removing an Oil Pan

Oil pans are usually located in the airflow under the frame rails. They are therefore easily damaged by objects on the road such as rocks on rough pavement and small animals on the highway. Most highway diesel engines have oil pans that can be removed from the engine while it is in chassis. It is recommended that you drain the oil sump before removing it. Oil pans that seal to the engine block using fiber gaskets can be difficult to remove, especially where adhesives have been used to ensure a seal. A 4 lb (2 kg) rubber mallet

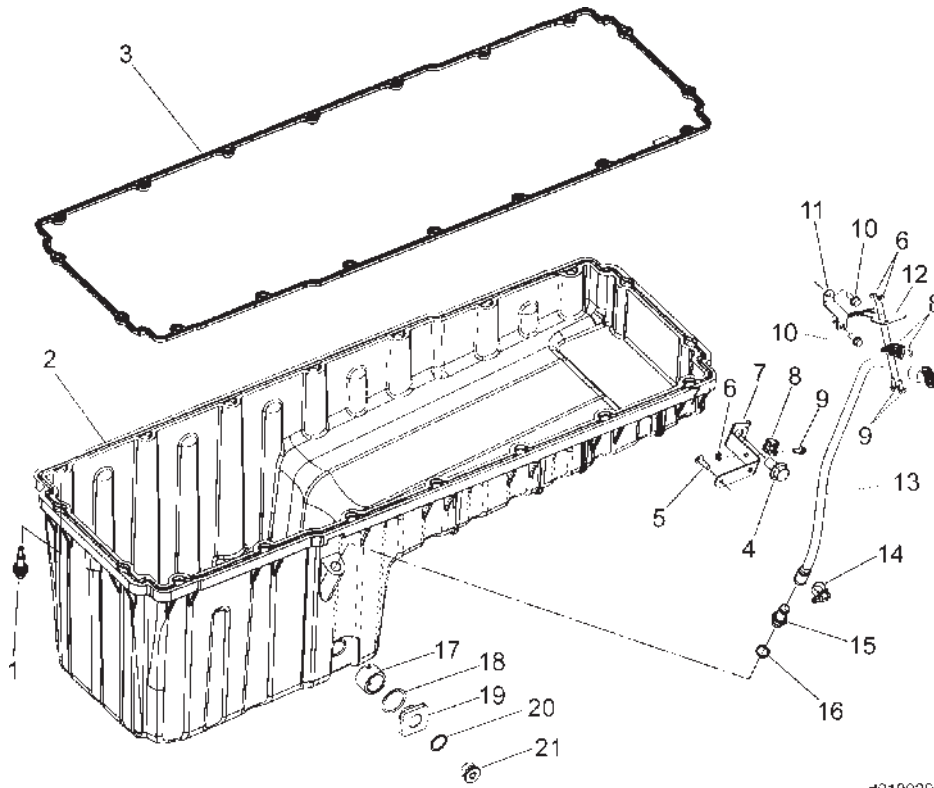

d010029

- | | |
|----------------------|-------------------|
| 1. Bolt and isolater | 12. Bracket |
| 2. Oil pan | 13. Dipstick tube |
| 3. Gasket | 14. Clamp |
| 4. Bolt | 15. Adapter |
| 5. Bolt | 16. Seal |
| 6. Nut | 17. Nut |
| 7. Bracket | 18. Seal ring |
| 8. Clamp | 19. Nut |
| 9. Bolt | 20. Seal ring |
| 10. Bolt | 21. Screw plug |
| 11. Bracket | |

Figure 6-14 DD15 oil pan. (Specifications are subject to change without notice. Detroit Diesel Corporation is registered to ISO 9001:2001. Courtesy ©Detroit Diesel Corporation. All rights reserved. Detroit Diesel is a Daimler company)

may make removal easier. Avoid driving screwdrivers between the oil pan and crankcase flange because it is easy to damage the sealing faces.

Tech Tip: A pneumatic gasket scraper is a great way to remove gasket residue from the engine block oil pan flange face but you must take care. It is easy to gouge the sealing surfaces. Avoid using pneumatic gasket scrapers on aluminum, glass fiber, or carbon fiber oil pans.

Tech Tip: Use the OEM recommended sealant on pan gaskets. With rubber compound gaskets, smeared engine oil does the job. Sprayed Hi-Tack adhesive works well with paper, fiber, and cork gaskets. Avoid using weatherstrip adhesive. No OEMs recommend it and it can be difficult to remove. It can also produce failures because it does not have great ability to allow creep between the oil pan and the crankcase flange.

Oil Pan Inspection

Oil pans that use rubber isolator seals tend not to present removal problems. In fact, sometimes rubber isolator seals can be reused if they are inspected and found to be in good condition. After removal, the oil pan should be cleaned of gasket residues and washed with a pressure washer. Inspect the oil pan sealing

flanges, check for cracks, and test the drain plug threads. Cast aluminum oil pans that fasten both to the cylinder block and to the flywheel housing are prone to stress cracking in the rear due to cylinder block torque twist. Carefully inspect them before returning them to service. When torquing aluminum oil pans, always meticulously observe torque sequences and values.

Summary

- The engine cylinder block can be considered to be the main frame of an engine, the component to which all others are attached.
- Cylinder blocks are manufactured from cast iron or compacted graphite iron (CGI).
- Most truck diesel engines use wet, dry, or wet/dry liners. Liners help make engine overhaul easier and faster, and extend engine life.
- Parent bore engines do not use liners. The cylinder bore is machined into the engine cylinder block. Some parent bores are induction hardened.
- Dry liners are usually fitted to the cylinder block with a fractionally loose fit.
- Dry liners do not transfer heat from the engine cylinder to the coolant in the water jacket as efficiently as wet liners.
- Selective fitting of dry liners to cylinder block bores ensures the best liner-to-bore fit.
- Wet liners transfer heat to the water jacket efficiently because they are surrounded by the coolant. Wet liners have thicker walls because they must also support combustion pressures.
- Wet liners seal the water jacket using O-rings.
- Liners are clamped into position by cylinder heads. Therefore, the protrusion of liner flanges is a critical specification.
- Liner protrusion is set by shimming the counter bore.
- Engine cylinder blocks should be boiled in a tank, have every critical dimension measured, especially deck straightness and line bore, and be magnetic flux tested at every major engine overhaul.
- The cylinder head houses the valvetrain assemblies, the injectors, and the engine breathing passages.
- The engine cylinder block should be pressure tested hydrostatically. The head should first be heated by running hot water through it, and then hydrostatically tested using pressurized shop air over water. Common locations for cracks in cylinder heads are the injector bore tubes and the valve seats.
- Cylinder heads must be torqued in sequence to ensure even clamping pressure.
- Torquing cylinder heads in increments (steps) is designed to achieve the cylinder head gasket yield point by evenly achieving the required clamping force.
- Cylinder head bolts should be lightly lubed with engine oil before installation.
- The intake manifold is responsible for directing intake air and recirculated exhaust gas into the cylinder head intake passages.
- Most truck diesel engines use the term *tuned* to describe their exhaust manifolds because they are designed to supply the turbine housing of the turbocharger with unrestricted end gas flow.
- Gaskets used to seal the engine housing components must be able to accommodate creep without failing. For this reason, most gaskets can be regarded as single-use items.

Review Questions

1. Which of the following cylinder block designs would be the most common in commercial diesel engines?
 - A. 8-cylinder, 90-degree, V-configuration
 - B. Inline, 6-cylinder
 - C. 6-cylinder, 60-degree, V-configuration
 - D. Inline, 8-cylinder

2. The main reason for bench pressure testing a diesel engine cylinder head is to:
 - A. Test cylinder gas leakage
 - B. Check for air leaks
 - C. Check for exhaust leaks
 - D. Check for coolant leaks
3. When selective fitting a set of dry liners to a cylinder block, which of the following statements should be true?
 - A. The liner with the largest OD is fitted to the bore with the largest ID.
 - B. The liners are installed with an interference fit.
 - C. The liner with the smallest OD is fitted to the bore with the largest ID.
 - D. The liners are installed with a fractionally loose fit.
4. Which of the following is the recommended method of pulling dry liners from a cylinder block?
 - A. A puller and shoe assembly
 - B. Heat and shock cool method
 - C. Fracturing the liner in position
 - D. Oxyacetylene torch
5. Which of the following tools is recommended for checking a cylinder block line bore?
 - A. Straightedge and thickness gauges
 - B. Dial bore gauge
 - C. Dial indicator
 - D. Master line bore bar
6. When boiling out a cylinder block, why is it critical that all the scale in the water jacket be removed?
 - A. Scale is an effective insulator.
 - B. Scale may contaminate the engine lubricant.
 - C. Scale can accelerate coolant silicate drop-out.
 - D. Scale causes cavitation of wet liners.
7. Which of the following tools should be used to check a cylinder block deck for warpage?
 - A. Master bar
 - B. Dial indicator
 - C. Laser
 - D. Straightedge and feeler gauges
8. Which of the following tools should be used to check a cylinder head for warpage?
 - A. Master bar
 - B. Dial indicator
 - C. Laser
 - D. Straightedge and thickness gauges
9. When cavitation damage can be observed on a set of wet liners, which of the following is more likely to be responsible?
 - A. Lubrication breakdown
 - B. High cylinder pressures
 - C. Coolant breakdown
 - D. Cold engine operation
10. Once a cylinder head gasket fire ring has been torqued to its yield point, it should:
 - A. Not be reused after removal
 - B. Be immediately heated to operating temperature
 - C. Deform and no longer seal effectively
 - D. Be pressure tested with shop air

CHAPTER

7

Engine Lubrication Systems

Prerequisites

Chapters 3, 4, 5, and 6.

Learning Objectives

After studying this chapter, you should be able to:

- Identify the main components of a typical diesel engine lubrication circuit.
- List the properties of heavy-duty engine oils.
- Define the term *hydrodynamic suspension*.
- Describe the difference between thin film and thick film lubrication.
- Interpret the terminology used to classify lubrication oil.
- Interpret API classifications and SAE viscosity grades.
- Replace and properly calibrate a lube oil dipstick.
- Describe the two types of oil pumps commonly used on diesel engines.
- Describe the operation of an oil pressure regulating valve.
- Define the term *positive filtration*.
- Outline the differences between *full flow* and *bypass* filters.
- Service a set of oil filters.
- Outline the role of an oil cooler in the lubrication circuit.
- Test an oil cooler core using vacuum or pressure testing.
- Identify the methods used to signal oil pressure in current diesel engines.
- Outline the procedure for taking an engine oil sample for analysis.
- Interpret the results of a laboratory oil analysis.

Key Terms

American Petroleum
Institute (API)

blotter test

boundary lubrication

bundle

bypass filter

bypass valve

centrifugal filter	inhibitors	spectrographic testing
dry sump	lubricity	synthetic oil
flash point	oil cooler	thick film lubrication
fluid friction	positive filtration	thin film lubrication
full flow filter	pour point	viscosity
gerotor	relief valve	
hydrodynamic suspension	shear	

INTRODUCTION

Most commercial diesel engines currently used on North American highways use a pressure lubrication system. This lube circuit supplies the bearings and other moving components with engine oil. Engine oil is formulated to fulfill the lubrication and service life requirements of diesel engines. In addition to lubricating an engine's moving parts, lube oil is also increasingly used to cool engine components. The basic components required of a diesel engine lubrication system are shown in **Figure 7-1**. In this chapter we will examine:

- Functions of a lubrication circuit.
- Lubricants: petroleum-based, liquid medium used to lubricate and cool engine components.
- Oil pan: oil storage space that encloses the crankcase, often called a sump.

- Oil pump: responsible for moving the oil through the lubrication circuit.
- Filters: commercial diesel engine lubrication systems usually require multistage filtration.
- **Oil cooler**: a means of transferring heat from engine lube to engine coolant.
- Piston cooling requirements: spray nozzles.

Friction

Friction is a common element in our lives that we simply take for granted. For instance, we can walk up a steep hill without slipping because of high friction between the soles of our feet and the ground surface. When that same hill is covered with packed snow, we can ski down it. In the first instance, the coefficient of friction is high, and in the second it is low. Another

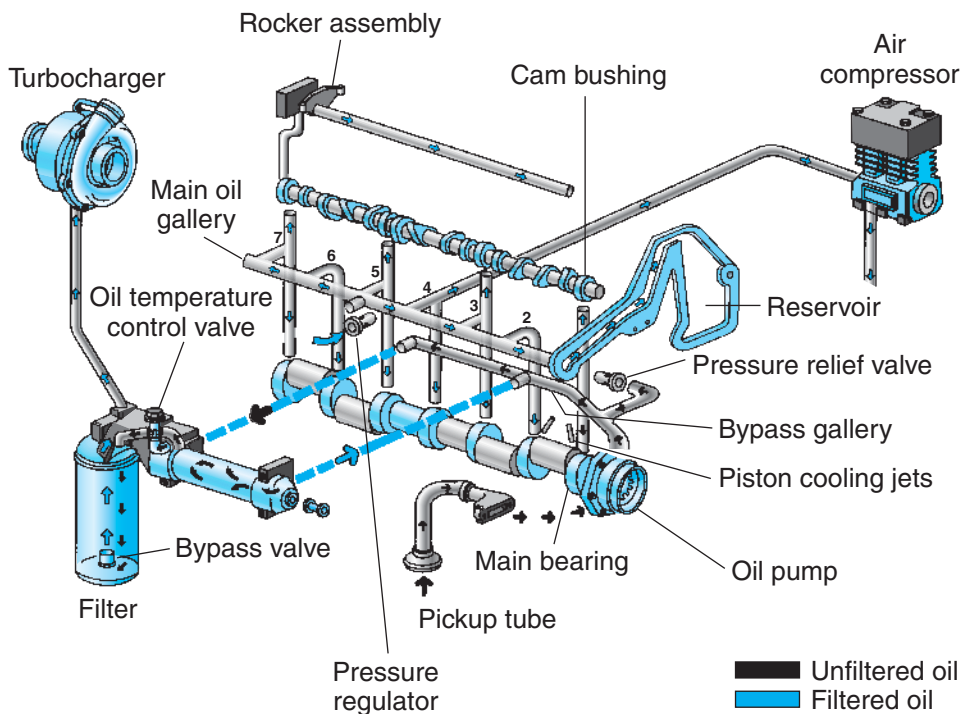

Figure 7-1 Navistar lubrication circuit. (Courtesy of Navistar)

way of thinking about the coefficient of friction is as a means of rating the aggressiveness of friction surfaces. Rubber soles have a higher coefficient of friction than skis. Lubricants are designed to reduce friction between surfaces that are, or could be, in contact with one another, creating wear at the contact points.

ENGINE LUBRICATING OIL

The main functions of a diesel engine lubricating system are:

1. Lubrication: to minimize friction and hydrodynamically support rotating shafts (the primary task of an engine oil).
2. Sealant: to help the piston rings in the engine cylinder.
3. Coolant: to remove heat from hot engine components.
4. Cleaning agent: to neutralize acids and sludge formed by blowby gases.
5. Coating: to cover engine moving components with an oil film even when they are subjected to high thrust loads.

Lubricating oils are usually petroleum products that are complex mixtures made up of many different fractions. The fractionated compounds that make up an engine oil are refined from petroleum and asphalt bases. Some synthetic oils are used but these have not yet proven to be cost-effective.

How Oil Works

Theoretically an engine oil is designed to form a film between moving surfaces. If it achieves this effectively, any friction that results occurs in the oil itself preventing direct metal-to-metal contact. We call this **fluid friction**. Fluid friction generates a lot less heat than dry friction. The lubricating requirements of an engine oil can be classified as:

- **Thick film lubrication**, which occurs where the distances between two moving surfaces are wider, such as that between a rotating crankshaft and its main bearings.
- **Boundary lubrication (thin film lubrication)**, which is required where two metal surfaces are narrow, such as would occur between a crankshaft and its main bearings when the engine is not running. A breakdown of boundary lubrication results in metal-to-metal contact.

Good quality engine oil should be capable of performing both thick film and boundary lubrication.

Because engine lube oil is usually petroleum based, it is flammable.

Principle of Hydrodynamic Suspension

When a shaft is rotated within friction bearings such as those used to support an engine crankshaft, and that shaft is stationary, a crescent-shaped gap is formed on either side of the line of direct contact due to the clearance between the journal and the inside diameter of the friction bearing. A static film of oil prevents shaft-to-bearing contact when stationary. When the shaft is rotated and the bearing is charged with engine oil under pressure, a crescent-shaped wedge of lubricant is formed between the journal and its bearing. The oil is introduced to the bearing where the shaft clearance is greatest, usually at the top. This wedge of oil is driven ahead of the direction of rotation in a manner that permits the shaft to be “floated” on a bed of constantly changing, pressurized oil. This principle, known as **hydrodynamic suspension**, is used to support crankshafts and camshafts in operation.

In hydrodynamic suspension, the key is to maintain a liquid film between moving surfaces by pumping lubricant through a circuit. In the case of a rotating shaft and a stationary friction bearing, the shaft acts as a pump to maintain the lubricant film. The result is that the shaft journal floats on a film of oil the thickness of which depends on:

- Oil input: the rate at which oil is delivered to the bearing. This is why you will have a problem if oil pressure is low.
- Oil leakage rate: the oil that spills from a bearing during operation. This is why low oil pressure is an indication of worn engine main bearings.

The thickness of the oil wedge created by hydrodynamic suspension depends on the following four factors:

1. Load increase: causes oil to be squeezed out of the bearing at a faster rate.
2. Temperature increase: causes oil leakage rate from bearing to increase.
3. Lower-viscosity oil: flows with less resistance creating higher leakage.
4. Changing shaft speed: speed reduction (remember, the shaft is the “pump”) results in a thinner film. An increase in speed provides a thicker film.

Figure 7-2 shows how hydrodynamic lubrication functions.

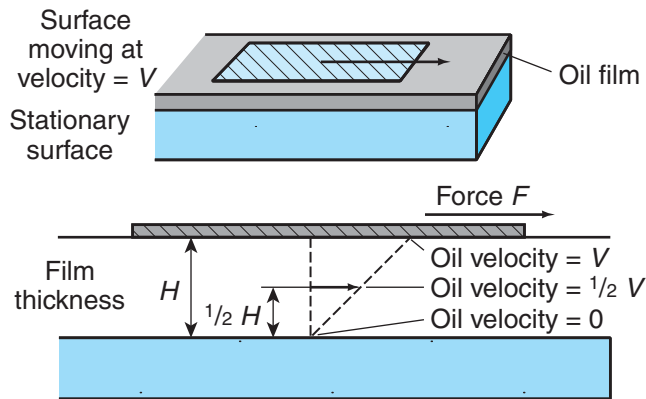

Figure 7-2 Concept of dynamic viscosity.

Engine Oil Classification and Terminology

Every technician should have a basic understanding of the codes and terms used to describe engine oils. This section introduces some of the basic language of lubricants.

Viscosity. The **viscosity** rating of an oil usually describes its resistance to flow. High-viscosity oils are thicker and have less fluidity than low-viscosity oils. However, the true definition of viscosity is that it is a measure of resistance to **shear**. When moving components are separated by engine oil, the oil film closest to each metal surface has the least fluid velocity while the fluid in the center has the greatest fluid velocity. Shear occurs when the fluid velocity is so high that it pulls the surface film away from the moving components.

Viscosity Index. Oils generally thin out as temperature increases. The viscosity index (VI) is a measure of the oil's tendency to thin as temperature rises. Viscosity may be reduced as temperature rises. The greater the VI, the less of an effect temperature has on the actual viscosity of the oil. In other words, oils that show relatively small viscosity changes with changes in temperature can be said to have high VI.

SAE Numbers and Viscosity. The viscosity of engine oils is graded by the Society of Automotive Engineers (SAE). These grades and their recommendations are listed later in this chapter. SAE grades specify the temperature window within which the engine oil can function to provide adequate shear resistance under boundary lubrication conditions.

Multiviscosity Oils. Multiviscosity engine oils are the lubricating oil of choice in commercial diesel engines. The biggest advantage of multiviscosity oils

over straight grade oils is that they provide proper lubrication to the engine over a much wider temperature range. In other words, they have a relatively flat viscosity-to-temperature curve.

Multiviscosity oils are produced by special refining processes and the addition of VI improvers. The objective is to provide them with good cold cranking features and show as little change in viscosity as possible over a wide range of operating temperatures. Synthetic oils, when marketed with an SAE grade, usually greatly exceed the SAE grade specification.

Lubricity. Two oils with identical viscosity grades can possess different lubricity. The **lubricity** of an oil properly describes its flow characteristics. Lubricity is also affected by temperature: hotter oils flow more easily, colder oils less easily. In comparing two engine oils, the one that has the lowest resistance to flow has the greater lubricity. Lubricity is an expression of the “oiliness” of an engine oil.

Flash Point. **Flash point** is the temperature at which a flammable liquid gives off enough vapor to ignite momentarily. The **fire point** of the same flammable liquid is usually about 10°C higher and is the temperature at which a flammable liquid gives off sufficient vapor for continuous combustion. The flash point specification has some significance for diesel engine lube oils because a large portion of the cylinder wall is swept by flame every other revolution. However, actual cylinder wall temperatures are lower than the temperatures of the combustion gases and the oil is only exposed to these high temperatures for very short periods of time. Most diesel engine lubricating oils have flash points of 400°F (205°C) or higher.

Pour Point. The temperature at which a lubricant ceases to flow is known as the **pour point**. Engine lube oils suited for extreme cold weather operation have pour point depressants that act as “antifreeze” for lubrication oils. Pour point is an important engine oil specification especially where operators use multigrade engine oil viscosities not suited for midwinter conditions in the northern part of the continent. **Figure 7-3** demonstrates the cold weather flow ability of some common engine lubes.

Inhibitors. **Inhibitors** in an engine lubricant protect the oil itself against corrosion, oxidation, and acidity. They function to make the oil less likely to react with any contaminants that find their way into the crankcase, such as combustion by-products, moisture, and raw fuel. When lube oil inhibitors fail to work properly

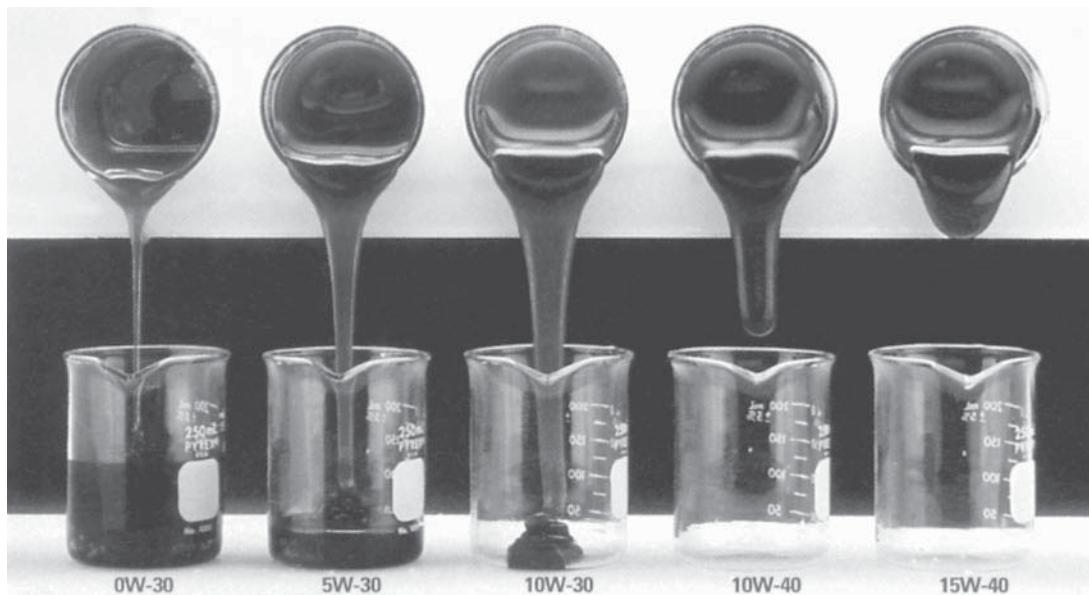

Figure 7-3 Demonstration of cold-weather flow ability of different oil viscosity grades. (Courtesy of Esso/Imperial Oil)

(usually due to extended service), the oil lacks protection and begins to degrade.

Ash. Ash in lubricant is mineral residue that results from oxide and sulfate incineration. Some ash content in diesel engine lube oils was desirable in the past because it checked the formation of some acids. However, in the latest CJ-4 diesel oils (described in detail later in this chapter), the objective is to keep ash levels at a minimum because they can plug emission control devices. Higher than specified ash levels in oil analyses are usually caused by high-temperature operation.

Film Strength. Most engine oils possess adequate film strength to prevent seizure and galling of contacting metal surfaces. However, those formulated for high-speed, high-output diesel engines usually contain additives to improve the film strength of the oil. The idea is that the film does not break down when pressure is applied. Synthetic oils generally provide superior film strength to mineral oils. You can test this by applying a couple of drops of each to a smooth surface: when you attempt to clean them off the surface, the mineral oil is usually easily wiped away while the synthetic oil leaves a waxy film.

Detergents. Detergents are added to engine oils to prevent the formation of deposits on internal engine components. They also help reduce sludge formation. Some engine oils require a higher percentage of detergent, especially those recommended for newer diesels

with exhaust gas recirculation (EGR). Other engine oils may have almost no detergent.

Dispersants. Dispersants are added to engine oils to help keep insoluble contaminants in suspension and prevent them from forming into sludge and deposits. When sludge and deposits do form in the crankcase, the capability of the dispersants in the engine oil has been exceeded. This is usually an indication that the oil change interval should be reduced because the result is lube oil degradation.

Oil Contamination and Degradation

When oil becomes contaminated, it can lead to complete engine failure. Contaminated engine oil has some characteristic tattletales. These can be quickly identified by visual and odor testing, and confirmed, if required, by oil analysis. Some common contaminants include: fuel, coolant, oil aeration, and cold sludge.

Fuel. When fuel contaminates engine oil, the oil loses its lubricity and it appears thinner and blacker in color. The condition is usually easy to detect because small amounts of fuel in oil can be recognized by odor. When fuel is found in significant quantities in engine oil, the cylinder head(s) and fuel injectors, and in some cases, fuel pumps are possible sources.

Coolant. Coolant in the engine lubricant gives it a milky, cloudy appearance when churned into the oil. After settling, the coolant usually collects at the

bottom of the oil sump. When the drain plug is removed, the heavier coolant exits first as long as sufficient time has passed for it to settle. When coolant is found in the engine oil, the cylinder head(s), wet liner seals, and cylinder head gasket are the most likely source. Within the cylinder head, the injector cup seals are usually the culprit.

Oil Aeration. Aerated engine oil occurs when engine oil is whipped into foam by moving engine components. Aerated engine oil cannot properly lubricate the engine. It can be caused either by the breakdown of the oil itself (such as detergent additives) or by contaminants such as water. The conditions that aerate oil in the crankcase are the churning action of the crankshaft (overfilled crankcase), sucking of air into the oil pump inlet, and the free fall of oil into the crankcase from the oil pump **relief valve** and cylinder walls. Antifoaming additives reduce the tendency to oil aeration.

Cold Sludge. Cold sludge is caused by lube oil breakdown that occurs when an engine is operated under low loads at low temperatures for extended periods. Once formed, the sludge settles in the engine crankcase and can accelerate engine wear rates. When a diesel engine is operated with its coolant thermostat(s) removed, the result can be the formation of cold sludge. In extreme cold, cold sludge can also form when the engine cooling fan runs constantly not allowing the engine to achieve its specified minimum operating temperature.

API Classifications

The **American Petroleum Institute**, usually known as **API**, classifies all engine oil sold in North America. The two main classifications are designated by the prefix letters GF and C. The GF classes of engine oil designate those oils suitable for gasoline-fueled passenger cars and light trucks. The C classes of engine oils designate oils suitable for heavy-duty trucks, buses, and industrial and agricultural equipment powered by diesel engines. The C represents CI or compression-ignited engines. The most recent C and GF category oil classifications are listed and described here because many fleets use engine oils that claim to be suitable for both C and GF classifications. In most cases, original equipment manufacturers (OEMs) have specific requirements for engine lubricants that should be observed because failure to do so could result in higher hydrocarbon (HC) emissions. Also note that using inappropriate oil in current diesel engines can damage emission control hardware.

CF—May be used in diesel engines exposed to fuels that may have a sulfur content greater than 0.05 percent. Effective in controlling piston deposits, wear, and bearing corrosion. May be used where API Service Category CD is recommended.

CF-2—Service typical of two-stroke cycle engines that require effective control over cylinder and ring face scuffing and deposits. May be used where API Service Category CD-II is recommended.

CF-4—Service typical of on-highway, heavy-duty truck applications. Designated for multigraded oils and introduced in 1991. Oils meeting this category will also meet API Service Category CE.

CG-4—For use in high-speed, four-stroke cycle diesel engines used on both heavy-duty, on-highway and off-highway applications (with less than 0.05 percent wt. sulfur fuel). CG-4 oils provide effective control over high-temperature piston deposits, wear, and soot accumulation. Effective in meeting 1994 exhaust emission standards and may also be used where API Service Categories CD, CE, and CF-4 are specified.

CH-4—For use in high-speed, four-stroke cycle diesel engines used in on- and off-highway applications that are fueled with fuels containing less than 0.05 percent sulfur. Supercedes CD, CE, CF, and CG category oils.

CI-4—Introduced in September 2002 for use in high-speed, highway diesel engines meeting 2004 exhaust emission standards, implemented in October 2002 by EPA agreement with engine OEMs. CI-4 oil is specially formulated for engines using fuels containing less than 0.05 percent sulfur and maximizes lube oil and engine longevity when exhaust gas recirculation (EGR) devices are used. CI-4 engine oil supercedes CD, CE, CF, CG, and CH category oils. Unless authorized by the OEM, it should not be used in any post-2007 diesel engines. CI-4 should be available until around 2010, and will probably be used by some operators due to its lower cost than CJ-4.

CJ-4—Formulated for use in 2007 diesel engines equipped with cooled-EGR and diesel particulate filters (DPFs), but is also backward compatible. The main difference between CJ-4 and CI-4 is a change in the additive package

designed to reduce ash generated when the oil is combusted in the cylinder. This ash in the exhaust gas can produce a negative effect on the DPFs, and may plug or poison the catalyst.

Impact of Using CJ-4 Engine Oil. The change to CJ-4 requires some changes in the way we interpret diesel engine oil analysis reports discussed later in this chapter. CJ-4 is a low ash oil and because ash had the effect of reducing acidity, oil analysis acidity counts will increase. Post-combustion acids were mostly produced when the sulfur component in diesel fuel was burned and the use of ultra low sulfur (ULS) fuel should reduce this.

Although CJ-4 has backward compatibility, it will cost more. This means that some operators may continue to use CI-4 for pre-2007 engines, until they are forced to change. Use of other than CJ-4 engine oil post-2007 engines may result in voiding of engine and emission hardware warranty. CJ-4 engine oil will be around for awhile. **Figure 7-4** shows the chemical limits required of CJ-4 diesel engine lubes.

Oils for Gasoline-Fueled Engines. Oils formulated for use in gasoline-fueled engines are categorized in much the same way and they are no longer of much importance to diesel technicians because the days of dual fuel application engine lubes are past. The most recent engine oils formulated for service in gasoline engines areas are as follows:

- SH 1993
- GF-2 1996

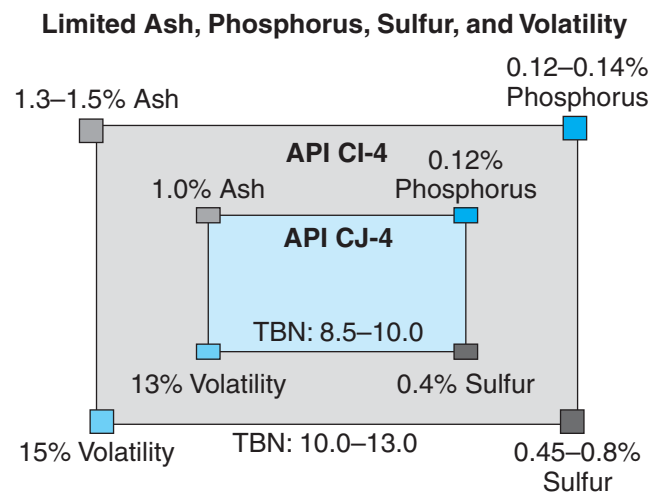

Figure 7-4 Chemical limits of API CJ-4 engine lube. (Courtesy of Caterpillar)

- GF-3 2001
- GF-4 2004

A few engine oils are formulated that claim to meet the needs for both SI gasoline-fueled and diesel fuel engines. These are relics from the years when some fleets (such as schoolbus operators) had a mix of diesel and gasoline-fueled vehicles. Most diesel engine OEMs recommend that multipurpose, multifuel specified oils be avoided: this is because such oils tend to be loaded with excessive additives in an effort to meet too wide a range of lube specs.

SAE Viscosity Grades

The following list contains the SAE engine oil grades and the recommended temperature operating ranges. **Figure 7-5** shows the temperature range for some common SAE viscosity grades. The W denotes a winter grade lubricant.

Multigrade Engine Oils

- 0W-30 Recommended for use in arctic and sub-arctic winter conditions.
- 5W-30 Recommended for winter use where temperatures frequently fall below 0°F (-18°C) and seldom exceed 60°F (15°C).
- 5W-40 Recommended for severe-duty winter use where temperatures frequently fall below 0°F (-18°C).

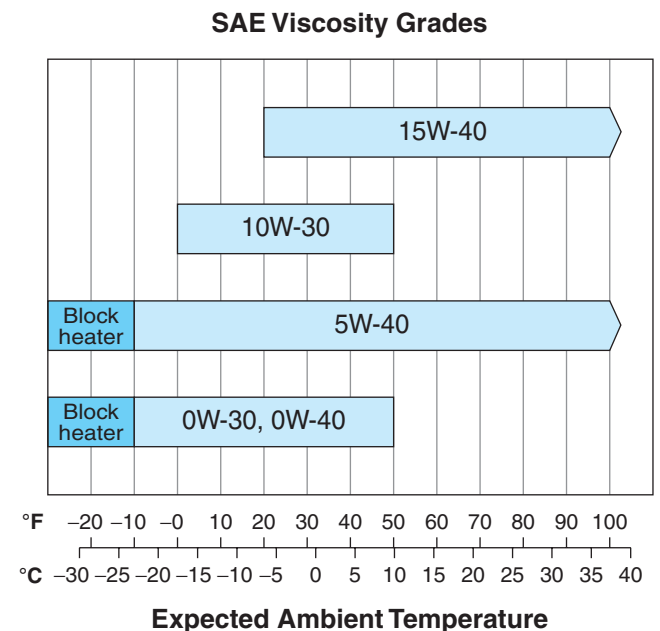

Figure 7-5 SAE viscosity grades and temperature ranges for 2007 engines. (Courtesy of Navistar International Trucks)

- 5W-50 Recommended for severe-duty winter use in Arctic and sub-Arctic conditions where temperatures frequently fall below 0°F (−18°C). A synthetic oil viscosity grade.
- 10W-30 Recommended for winter use where temperatures never fall below 0°F (−18°C).
- 10W-40 Recommended for severe-duty winter use where temperatures never fall below 0°F (−18°C).
- 15W-40 Recommended for use in climates where temperatures never fall below 15°F (−9°C). Despite this and diesel engine OEM recommendations that support the use of lighter multigrades in winter conditions, this is by far the most commonly used viscosity grade for commercial diesel engines year-round, often in climates that have severe winters. A true 15W-40 engine oil will freeze to a grease-like consistency in subzero conditions, making the engine almost impossible to crank; additionally, engine wear is accelerated during the warmup phase of operation. **Figure 7-5** is a Navistar schematic showing their recommended viscosity grades by temperatures: note that 15W-40 lube is not recommended by Navistar for engines operating below 20°F (−6°C).
- 20W-40 Recommended for use in high-performance engines in climates where temperatures never fall below 20°F (−6°C).
- 20W-50 Recommended for use in high-performance engines in climates where temperatures never fall below 20°F (−6°C).

Straight Grades

- 10W Recommended for winter use in climates where temperatures never fall below 0°F (−18°C) and never exceed 60°F (15°C).
- 20W-20 Recommended for use in climates where temperatures never fall below 20°F (−6°C).
- 30 Recommended for use in climates where temperatures never fall below 32°F (0°C). This grade of oil is the most widely used in truck and bus diesel engines in operations that persist in using straight grade oils.
- 40 Recommended for severe-duty use in climates where temperatures never fall below 40°F (4°C).
- 50 Recommended for severe-duty use in climates where temperatures never fall below 60°F (15°C). Often used to disguise engine problems, especially oil burners and leakage.

Synthetic Oils

Most diesel engine OEMs approve of the use of **synthetic oils** and often recommend them for severe-duty applications such as extreme cold weather operation, providing the oil used meets their specifications. The problem is that OEMs have not sanctioned increased service intervals when synthetic lubricants are used. This makes them uneconomical at this moment in time because synthetics are significantly higher in cost.

Only the high cost of synthetic lubricants is limiting their use in diesel engines. Synthetics have already become the oil of choice in transmissions and final drive carriers, but the frequency of service required of diesel engine lubes have limited their application. That said, most of the indicators suggest that synthetics substantially outperform conventional lubricants. The wide viscosity range of synthetics (5W-40) makes it an ideal all weather diesel lube oil.

What Oil Should Be Used?

Each engine OEM has specific requirements for the engine oils it wants you to put in its engines. These requirements are outlined in tests that engine oils are subjected to prior to an approval. Oil refiners attempt to meet as many standards as possible when marketing engine oils for the obvious reason that they can service more potential buyers with a single product. The problem is, oil is like a brew and you do not necessarily improve it by throwing in more additives. For instance, if your preference is to drink orange juice, you probably will not consider it a better drink if some apple and grape juice are added to it. For this reason, general-purpose, heavy-duty engine oil is not necessarily an improvement on the OEM labeled oil, although of course it will be both cheaper and more advertised.

Developing a Formula. The best choice for the engine is to use the manufacturer-recommended engine oil. After all, the research and performance profiles have all been performed on the engine using this oil. This may not be the best choice for the pocketbook, and in fairness there are general-purpose diesel engine oils proven to perform well in engines over time. Be aware that engine OEMs usually do not “engineer” their own oils. This development is done by specialist oil research companies contracted by the OEM such as Lubrizol (<http://www.lubrizol.com>). A company such as Lubrizol neither manufactures nor markets oil. They are paid by an OEM to develop a formula (a “recipe” if you like). After the formula has been developed, the OEM takes it to an oil refiner who then manufactures

the product to specification. Developing the right additive package for an engine oil is a science in itself and is usually the result of extensive testing.

LUBRICATION SYSTEM COMPONENTS

Engine lubricant must be stored and collected in a reservoir, pumped through the lubrication circuit, filtered, cooled, and have its pressure and temperature monitored. The group of components that performs these tasks is known as the lubricating circuit. The components in a diesel engine lube circuit vary little from one engine to another but OEM service literature should be consulted before servicing and reconditioning any components.

Oil Pan

The oil pan or sump is a reservoir usually located at the base of the engine cylinder block enclosing the crankcase (**Figure 7-6**). Oil pans are manufactured from cast aluminum, stamped mild steel, and various plastics and fibers. The oil pan acts as the reservoir used to collect the lubrication oil, which gravity causes to drain to the crankcase, and from which the oil pump pickup can recycle it through the lubrication circuit. A more complete description of an oil pan is provided in **Chapter 6**.

Tech Tip: Observe the torque sequence when fitting an oil pan, especially those designed to bolt both to the engine cylinder block and the flywheel housing. The consequences of not doing so can be leaks at the pan gasket or stress cracks to the oil pan.

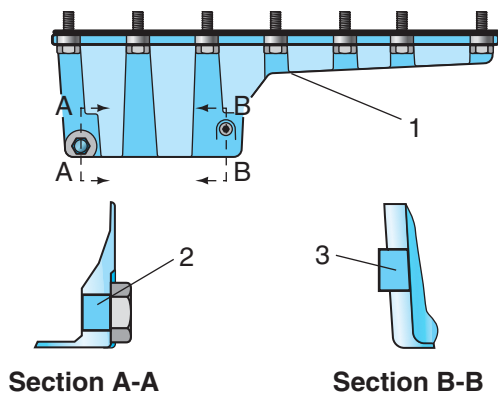

Figure 7-6 A Caterpillar oil pan. (Courtesy of Caterpillar)

Dipsticks

The dipstick is a rigid band of hardened steel that is inserted into a round tube to extend into the oil sump. Checking the engine oil level should be performed daily by the vehicle operator, so its location is always accessible. In a cab-over-engine (COE) chassis, the dipstick must be accessible without raising the cab, so it may be of considerable length. It is crucial that the correct dipstick be used for an engine. When replacing a missing or defective dipstick, replace the engine oil and filters, installing the exact OEM specified quantity. Run the engine for a couple of minutes then shut down and leave for 10 minutes. Dip the oil sump with the new dipstick and scribe the high level graduation with an electric pencil. Measure the distance from the high-level to low-level graduations on the old dipstick and then duplicate on the replacement. Remember, the consequences of low or high engine oil levels can be equally serious, so perform this operation accurately. Some electronically managed engines have an oil level sensor that signals a low oil level condition to the engine control module (ECM), which can then initiate whatever failure strategy it is programmed for.

Tech Tip: To obtain an accurate oil level reading, ensure that an engine has been shut down for at least 5 minutes before reading the dipstick-indicated level.

Oil Pump

Engine oil pumps are classified as positive displacement and have pumping capacities that greatly exceed the requirements of the engine. They are gear driven and usually located in the crankcase close to the oil they pump, though in some Cummins and Caterpillar applications they are external. Oil pumps are driven either directly or indirectly by the engine geartrain. In cases where the oil pump is located in the crankcase, the drive source is a vertical shaft and pinion that engages with a drive gear on the camshaft. **Figure 7-7** shows the oil pump assembly along with the pickup circuit used on a DD15 engine. Two basic types of oil pumps are used: external gear, and gerotor.

External Gear. External gear pumps consist of two meshed gears, one driving the other within a housing machined with an inlet (suction) port and outlet (charge) port. As the gears rotate, the teeth entrap inlet oil and force it outside between the gear teeth and the gear

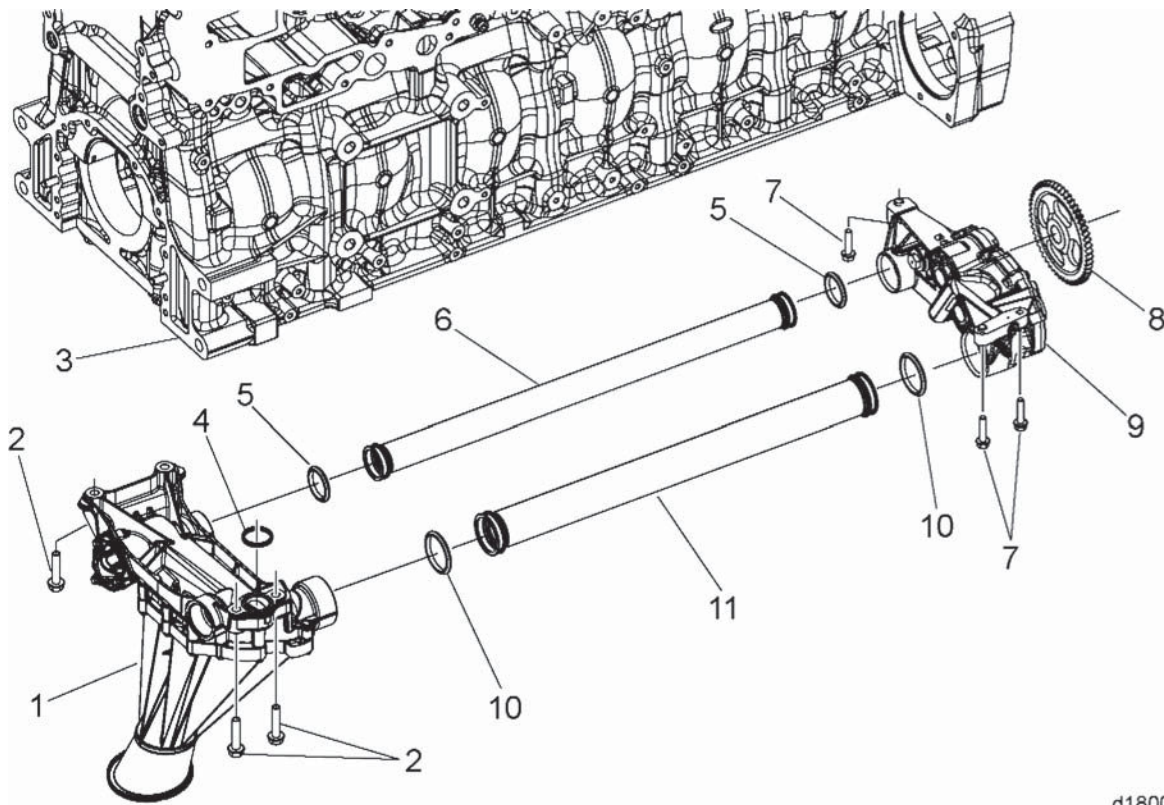

- | | |
|--|---|
| 1. Oil pump to intake manifold | 7. Bolt, oil pump to cylinder block |
| 2. Bolt, suction pipe to cylinder head | 8. Oil pump drive gear |
| 3. Cylinder block | 9. Oil pump |
| 4. Gasket, suction pipe to cylinder block | 10. Gasket, intake pipe at oil pump and oil intake manifold |
| 5. Gasket, pressure pipe at oil pump and oil intake manifold | 11. Oil line, oil pump to oil intake manifold |
| 6. Oil line, oil pump to oil pressure intake manifold | |

Figure 7-7 Oil pump assembly used on a DD15 engine. (Specifications are subject to change without notice. Detroit Diesel Corporation is registered to ISO 9001:2001. Courtesy © Detroit Diesel Corporation. All rights reserved. Detroit Diesel is a Daimler company)

housing to the outlet port. Where the teeth mesh in the center, a seal is formed that prevents any backflow of oil to the inlet. This is by far the most common oil pump design on current engines. **Figure 7-8** demonstrates the operating principle of a typical external gear type oil pump.

Gerotor. Gerotor type oil pumps use an internal crescent gear pumping principle. An internal impeller with external crescent vanes is rotated within an internal crescent gear also known as a rotor ring. The inner rotor or impeller has one less lobe than the rotor ring. The result is that as the inner rotor is driven within the outer rotor, only one lobe is engaged at any given moment of operation. In this way, oil from the

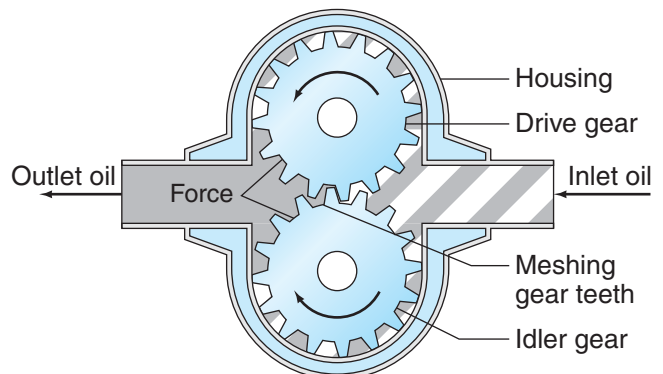

Figure 7-8 Operating principle of an external gear type oil pump.

inlet port is picked up in the crescent formed between two lobes on the impeller and, as the impeller rotates, forced out through the outlet port as the lead lobe once again engages. The assembly is rotated within the gerotor pump body.

Gerotor pumps tend to wear most between the lobes on the impeller and on the apex of the lobes on the rotor ring. These dimensions should be checked to OEM specifications using a micrometer. The rotor ring-to-body clearance should be checked with a thickness gauge sized to the OEM maximum clearance specification and the axial clearance of the rotor ring and impeller measured with a straightedge and thickness gauges.

Scavenge Pumps/Scavenge Pickups

Scavenge pumps are used in the crankcase of some off-highway trucks (and other mobile heavy equipment) required to work on inclinations that could cause the oil pump to suck air. They are designed with a pickup located at either end of the oil pan. Scavenge pumps and pickups are often spec'd into offhighway construction vehicles and equipment.

Pressure-Regulating Valves

Pressure-regulating valves are responsible for defining maximum system oil pressure. Most are adjustable. Typically, an oil pressure regulating valve consists of valve body with an inlet sealed with a spring-loaded, ball check valve. Other types of poppet valves are also used but the principle is the same. The regulating valve body is connected in parallel to the main oil pump discharge line. When oil pressure rise is sufficient to unseat the regulator spring-loaded check ball, it unseats. Unseating the regulator check ball permits oil to pass through the valve and spill to the oil sump dropping the oil pressure. The regulating pressure value is adjusted by setting the spring tension of the spring usually by shims or adjusting screw. Some OEMs use color-coded springs to define the oil pressure values.

.....
Tech Tip: When testing pressure-regulating valve operation, always use a master pressure gauge to accurately check the oil pressure.

Filters

Oil filters in a diesel engine lube system remove and hold contaminants. They must accomplish this while providing the least amount of flow restriction.

Filters use several different principles to accomplish this objective. In general oil filters can be classified as:

- full flow: in series between the oil pump and lube circuit
- bypass: ported off a lube gallery in parallel

The term **positive filtration** describes a filter that operates by forcing all the fluid to be filtered through the filtering medium. Most engine oil filters use a positive filtration principle. Filters function at higher efficiencies when the engine oil is at operating temperature. Filters work to clean the engine oil by using the following methods: mechanical straining, absorbent filtration, and adsorbent filtration.

Mechanical Straining. Mechanical straining is accomplished by forcing the lubricant through a filtering medium, which if greatly enlarged would have the appearance of a grid. The size of the grid openings determines whether a solid particle passes through or is entrapped by the filtering medium. Most current diesel engine oil filters make use of mechanical straining. Straining media includes rosin-impregnated paper often pleated to increase the effective area, and cotton fibers.

Absorbent Filtration. These filters work by absorbing or sucking up engine contaminants as a sponge would. Effective absorbent filtering mediums include cotton pulp, mineral wools, wool yarn, and felt. These filters not only absorb coarse particles but may also remove moisture and acids.

Adsorbent Filtration. Filters adsorb by holding (by adhesion) dissolved liquids to the surface of the filtering medium. Adsorbent filtering mediums include charcoal, Fuller's earth, and chemically treated papers. Because adsorbent filters may remove oil additives, they are usually used only where low-additive engine oils are specified.

Filter Types and Efficiencies. Most current filters are spin-on disposable cartridges. Older engines may have permanent canisters enclosing a replaceable element; the canister was mounted to the filter pad with a long threaded shaft that extended through the length of the canister. They are seldom seen today as most OEMs made conversion adapters so that disposable spin-on cartridges could replace them. Oil filters are categorized by the manner in which they are plumbed into the lubrication circuit so we divide them into two categories:

1. full flow
2. bypass

FULL FLOW

The filter mounting pad is usually plumbed into the lubrication circuit close to the oil pump outlet, and all the oil exiting the pump is forced through the filter. This means it is in series. The filtering media is usually rosin or otherwise treated paper or cotton fiber. The filters use a mechanical straining principle, so the particles entrapped by the element are those too large to pass through it. All **full flow filters** used on current commercial diesel engines use positive filtration and are rated to entrap any particles larger than their nominal specifications which range between 25 and 60 microns. **Bypass valves** located on full flow filter mounting pad(s) protect the engine should a filter become plugged. In this event, the oil exiting the oil pump would be routed around the plugged filter directly to the lubrication circuit. **Figure 7-9** shows a Volvo filter pad assembly. This lubrication circuit uses a pair of full flow filters, a bypass filter, and lube circuit flow control valves.

BYPASS

Bypass filters are used to complement the full flow filters on current highway diesel engines. These are plumbed in parallel in the lubrication circuit, usually by porting them into the main engine oil gallery. They filter more slowly, but are rated to entrap particles down to 10 microns in size. Two types are used:

- Luber-finer™ filter
- centrifugal filter

LUBER-FINER FILTER

These are large canister-type filters designed to entrap much smaller particles than full flow filters. Luber-finer filters are supplied from any point in the engine lubrication circuit and gravity-return filtered lubricant directly to the oil pan. They also play a role as an oil cooler and for that reason they are often mounted in the airflow. Luber-finer filters are large-volume filters that substantially increase the amount of engine oil required, which is important to remember when servicing the engine because more oil will be required than that specified by the engine OEM. Drain the filter housing before attempting to remove the filter cartridge. The replaceable filter element is installed by dropping it into the filter housing. After replacing a filter element, the housing should be purged of air: after engine startup, crack the bleed nut until air ceases to exit and lube oil begins to flow.

.....
Tech Tip: Always crack the bleed nut or pipe nut on the exit line of a Luber-finer filter after each oil change to purge the air. Failure to do this can result in an air-locked filter.

CENTRIFUGAL FILTER

Centrifugal filters are used to entrap smaller particles than most full flow filters so they are usually, but not always, of the bypass type. The filter consists of a canister within which a cylindrical rotor is supported on bearings. It is plumbed into the lubrication circuit

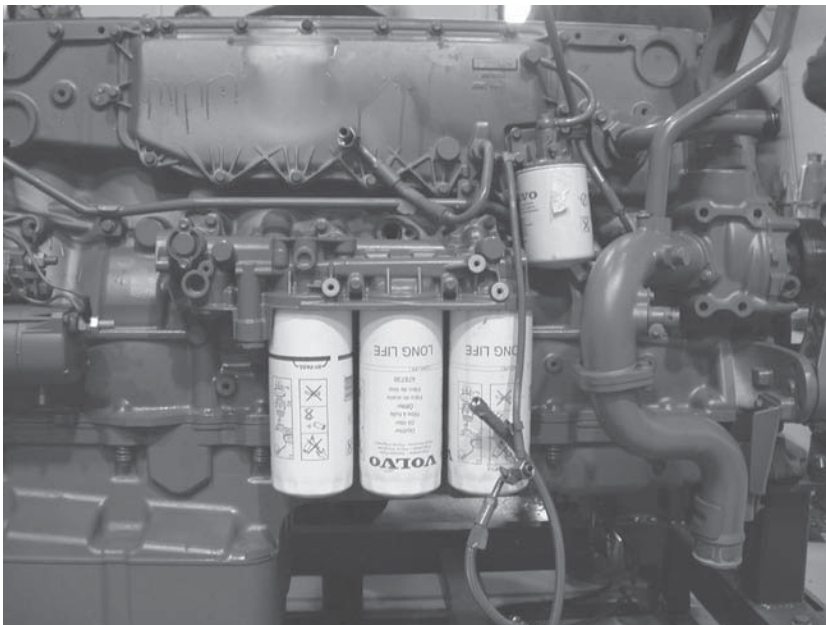

Figure 7-9 Volvo VD-16 filter pad assembly with a pair of full flow filters, a bypass filter, and lube circuit valves.

so that the rotor is charged with engine oil at lube system pressure. Oil exits the rotor via two thrust jets, angled to rotate the assembly at high velocity. The centrifuge forces the engine oil through a stationary cylindrical filtering medium wrapped outside the rotor. The filtering medium is usually a rosin-coated paper element. The filtered oil drains back to the oil sump.

.....
Tech Tip: Bypass filters have high filtering efficiencies, and failure to observe scheduled maintenance can result in plugged filters.

CAUTION *The OEM specified oil capacity of an engine seldom includes the volume of oil stored in the bypass filter housing. Purge bypass filters of air where required, and check the oil level after running the engine following the oil change.*

Filter Bypass Valves. Filter mounting pad bypass valves operate in much the same way as the oil pressure regulating valves, except that their objective is to route the lubricant around a restricted full flow filter to prevent engine damage by oil starvation. When a filter bypass valve is actuated and the check valve unseated, instead of spilling the oil to the crankcase it reroutes the oil directly to the lubrication circuit. This shorts out the filter assembly. So, when a bypass valve trips, unfiltered oil is pumped through the lubrication circuit.

Replacing Filters. Filters are removed using a band, strap, or socket wrench. Ensure that the filter gasket and seal (if used) are removed with the filter: these have a tendency to adhere to the mounting pad. Take precautions to capture oil that spills when the filter is removed. Disposable filters and elements are loaded with toxins and must be disposed of in accordance with federal and local jurisdiction legislation that applies to used engine oils and filters.

CAUTION *When performing lube service on a vehicle that comes in off the road, expect the engine oil you drain from the oil pan and filters to be hot. In fact, it will be hot enough to cause serious burns, so take great care in dropping oil and filters from warm engines.*

Most OEMs require that new oil filters be primed. If this is not done, in some cases, the lag required to

charge the oil filters on startup is sufficient to generate a fault code. Priming an oil filter requires that it be filled with new engine oil on the inlet side of the filter until it is just short of the top of the filter; this will take some time, as the oil must pass through the filtering media to fill the outlet area inside the element. The sealing gasket should be lightly coated with engine oil. OEMs usually caution against over-tightening. In most cases, the filter should be tightened by rotating it one-half to a full turn after the gasket and filter pad mounting face contact.

Oil Coolers

Oil coolers are heat exchangers consisting of a housing and cooling core through which coolant is pumped and around which oil is circulated. Operating oil temperatures in diesel engines run higher than coolant temperatures, typically around 230°F (110°C). However, the engine coolant reaches its operating temperature more rapidly than the oil and plays a role in heating the oil to operating temperature in cold weather startup/warmup conditions. Two types of oil coolers are in current use: bundle-type and plate-type.

Bundle-Type Oil Cooler. The **bundle**-type oil cooler is the most common design. It consists of a cylindrical “bundle” of tubes with headers at either end, enclosed in a housing. Engine coolant is flowed through the tubes and the oil is spiral-circulated around the tubes by helical baffles. The assembly is designed so that the oil inlet is at the opposite end to the coolant inlet. This arrangement means that the engine oil at its hottest is first exposed to the coolant at its coolest, slightly increasing cooling efficiency. **Figure 7-10** shows the routing flow through a typical bundle-type oil cooler.

The consequence of a failed cooler bundle or the header O-rings is oil charged to the cooling circuit. Most OEMs prefer that bundles be leak tested by vacuum because this tests the assembly in the direction of fluid flow in the event of a leak. One header should be capped with a dummy (blocking) plate and the other fitted with the vacuum adaptor. Set the OEM recommended vacuum value and leave for the required amount of time to observe any drop-off.

Alternatively, the bundle can be pressure tested using regulated shop air pressure and a bucket of water. This is known as reverse-flow testing. Whenever oil has leaked into the coolant circuit, the engine cooling system must be flushed with an approved detergent and water with the engine run at its operating temperature for at least 15 minutes.

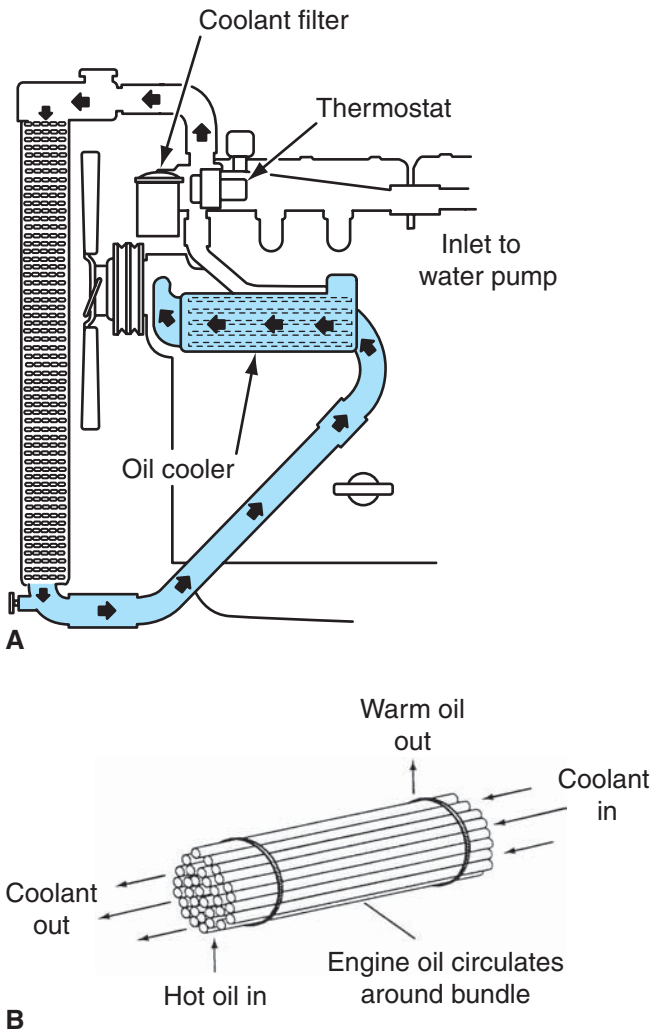
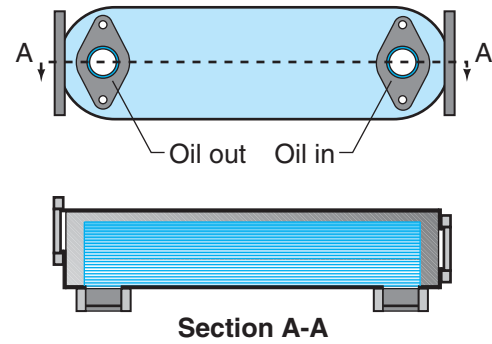

Figure 7-10 Oil flow through a bundle-type cooler.

Plate-Type Oil Cooler. In the plate-type oil cooler, the oil circulates within a series of flat plates and the coolant flows around them within a housing assembly. They have lower cooling efficiencies than bundle element coolers, but they are usually easier to clean and repair. **Figure 7-11** shows a typical low-maintenance, plate-type oil cooler. Lower cost, lower maintenance, and more compact design means that plate-type oil coolers are preferred by some engine OEMs.

Oil Cooling Jets. Piston oil cooling jets have always been a critical component of the engine lubrication circuit. They are plumbed into a cylinder block oil gallery and spray engine lube onto the underside of each piston. They play a critical role in managing piston temperatures especially in some more modern engines that may have no other means of delivering oil to the pistons. Bushingless piston bosses such as those



With SAE 30W oil, the oil flow through the cooler assembly is 110 liter/min (29 U.S. gpm). The maximum water flow through the cooler assembly is 190 liter/min (50 U.S. gpm).

Figure 7-11 A plate-type oil cooler. (Courtesy of Caterpillar)

used in Monotherm pistons and conn rods with no delivery rifling have both added to the already important role played by piston cooling jets.

TARGETING PISTON COOLING JETS

Piston cooling jets have to be targeted to a specific area on the underside of the piston crown. As indicated earlier in **Chapter 4**, a slightly misdirected cooling jet can result in rapid torching of a piston due to overheating. By targeting the cooling jet, oil is delivered to a circulation gallery machined in the underside of the piston. This enables engine lube to be routed to those areas of the piston that require lubrication and cooling. The procedure used to target piston cooling jets is covered in **Chapter 4**. Make sure you understand the consequences of an improperly targeted cooling jet. Just to make things more confusing, OEMs frequently alter the target window, so make sure you consult OEM service literature before undertaking the procedure. With each change, the target zone of the piston cooling jet also changes. **Figure 7-12** shows the oil cooling nozzle alignment targeting on an MB-4000 engine.

Oil Pressure Measurement

Of all the engine monitoring devices used on an engine, the oil pressure is one of the most critical. Loss of engine oil pressure will, in most cases, cause a nearly immediate engine failure. Back in the days when few of an engine's operating conditions were monitored and displayed to the operator, there was always a means of signaling a loss of oil pressure. Several types of sensors are used in today's engines.

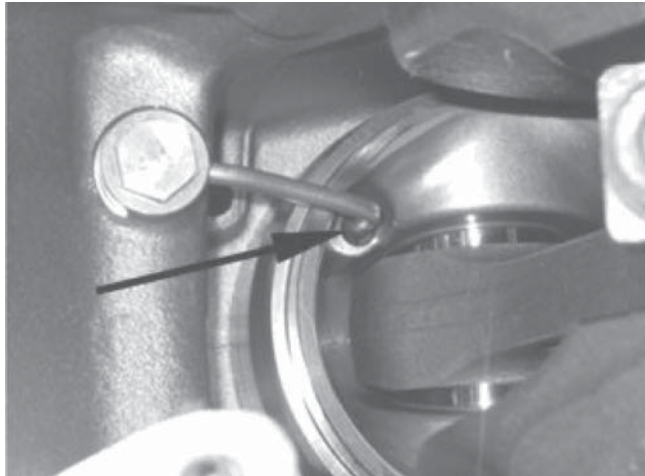

Figure 7-12 Oil cooling nozzle alignment on an MB-4000 engine. (Specifications are subject to change without notice. Detroit Diesel Corporation is registered to ISO 9001:2001. Courtesy © Detroit Diesel Corporation. All rights reserved. Detroit Diesel is a Daimler company/Mercedes Benz)

Variable Capacitance (Pressure) Sensor. Most current commercial diesel engines managed electronically use variable capacitance type sensors. These are supplied with reference voltage output from the engine

ECM. Oil pressure acts on a ceramic disc and moves it either closer or farther away from a stationary steel disc, varying the capacitance of the device and thus the voltage signal value returned to the ECM. The ECM is responsible for outputting the signal that activates the dash display or gauge. Engine oil pressure usually has to fall to dangerously low levels before programmed failure strategies are triggered. **Figure 7-13** is a Navistar schematic showing how a variable capacitance oil pressure sensor signals the engine ECM. The fault codes shown in the schematic are Navistar specific.

Bourdon Gauge. A flexible, coiled bourdon tube is filled with oil under pressure. The bourdon tube will attempt to uncoil and straighten incrementally as it is subjected to pressure rise. This action of somewhat bending the bourdon tube rotates a gear by means of a sector and pinion. A pointer is attached at the gear across a calibrated scale and provides a means of reading it. A bourdon gauge is also known as a mechanical gauge. They are the commonly used pressure gauges in engines that are not ECM controlled.

Electrical. Engine oil pressure acts on a sending unit diaphragm, which in turn moves a sliding wiper

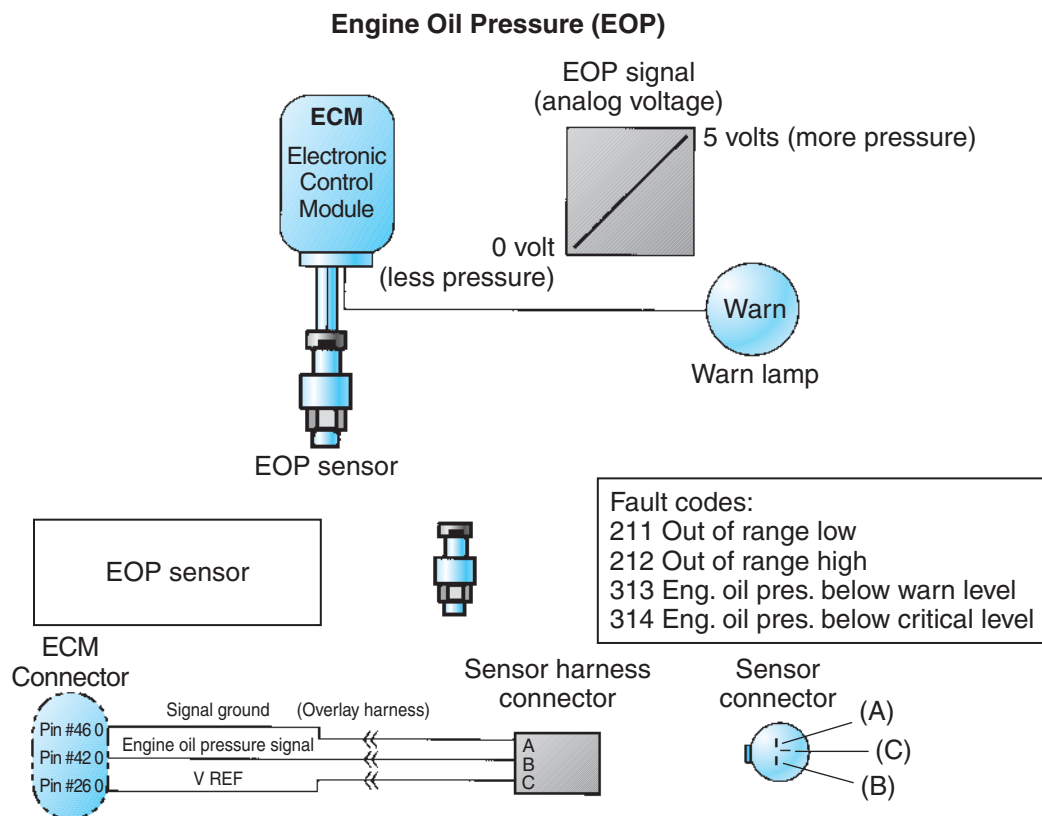

Figure 7-13 A Navistar oil pressure sensing circuit. (Courtesy of Navistar)

arm across a variable resistor that incrementally grounds out a feed from the electric gauge. The gauge is a simple armature and coil assembly that receives its electrical supply from the vehicle ignition switch.

Tech Tip: No single gauge should be used as the only means of diagnosing a low oil pressure complaint. Use a good quality master gauge, usually a bourdon gauge with a fluid-filled display dial, to verify the dash gauge reading. Ensure that the engine oil is at operating temperature before recording a reading.

Oil Temperature Management. As EPA noxious emission standards become increasingly tougher, there is an ever greater requirement to manage the combustion temperatures to a tight operating window. Engine oil temperatures are one of the most accurate indicators of engine temperature. Engine oil also plays a major role as a coolant in engines, especially in managing piston temperatures. In addition, when engine oil is used as a hydraulic medium as it is in variable valve timing, engine brakes, and the hydraulic electronic unit injector (HEUI) fuel system, its performance is to some extent dependent on its operating temperature. On the other end of the scale, the time required to heat engine oil to operating temperature is a factor in the higher emissions output during a warmup phase. **Figure 7-14** shows a Navistar

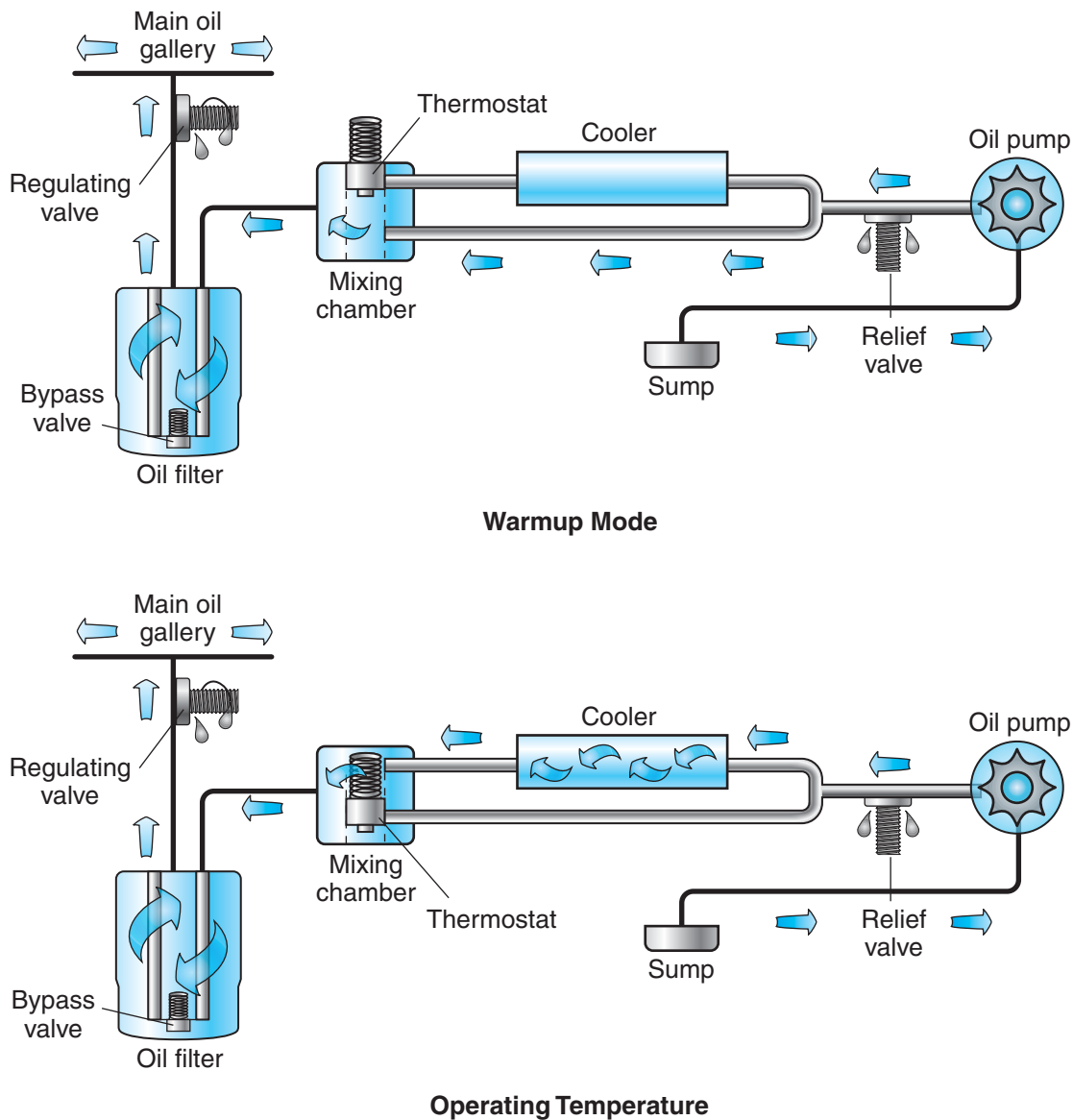

Figure 7-14 Navistar temperature control circuit. (Courtesy of Navistar)

temperature control circuit that enables the engine oil to bypass the oil cooler while the engine is warming up.

INTERPRETING OIL ANALYSES

Oil analysis has become a key component of good preventative maintenance (PM) practice. This is because it can save operators money. Performing the analyses at each PM and responding appropriately to the lab reports is key to making them cost-effective. An oil analysis is performed to determine:

- viscosity
- presence of coolant
- dirt contamination
- abnormal wear contamination

The engine oil temperature should be close to operating temperature when drawing a sample. Although the Technical and Maintenance Council (TMC) has guidelines on how to draw off oil samples (RP 1417), they are not always easy to observe. The TMC recommends that an oil sample syringe be ported directly into the main lube gallery being especially careful to avoid dead zones. The engine oil should be at operating temperature with the engine running before drawing the sample. However, in practice most oil samples are taken from diesel engines during routine PM oil change operations while draining oil from the engine.

Avoid taking the sample from either the beginning or end of the drain-off: midway through the runoff is preferred. Take precautions to avoid burns from the oil while obtaining the sample by wearing insulated rubber chemical-handling gloves. Also avoid contaminating the sample after it has been taken. Label the container and complete the engine identification form that accompanies the sample to the laboratory. If the objective of the sample is diagnosis of a condition, you have no choice but to syringe the sample either from the oil pan or a lubrication gallery. Again the oil should be at running temperature when the sample is drawn.

Types of Testing

When used engine oil is analyzed, the objective is to produce a report card on the rate of engine wear and the suitability of the oil change interval to the application, and perhaps to identify a potential engine failure before it becomes an actual failure. Oil-testing laboratories use blotter and spectrographic testing to produce reports that reference the engine OEM limit specifications.

A blotter test kit is available for nonlaboratory testing of engine oil. A **blotter test** is a relatively crude means of testing some of the oil's characteristics.

A change in the oil's viscosity can be determined using a flow comparator. A significant increase in the engine oil's viscosity can be caused by prolonged high-temperature operation, aerated lubricant, extended service intervals, or coolant contamination. A decrease in viscosity is normally attributable to fuel contamination. All commercial diesel engine oil is affected by a small amount of fuel contamination; however, this should not be sufficient to cause any significant alteration in viscosity. Next, a measured drop of used oil is dropped on a test paper or blotter. The darkness of the sample relative to that on a code chart is used to indicate the amount of soot, dirt, and other suspended material in the sample. On some blotter test kits, the acidity can also be read on the test paper by a change of color.

Laboratories perform more comprehensive testing usually involving the use of spectrochemical analyses. **Spectrographic testing** produces more specific results and is used to identify metallic and organic contaminants in oil. A quantity of the sample is boiled off, and then subjected to ultraviolet radiation. Contaminants are identified by the way they react to the radiation.

Oil sample analyses must be interpreted comparatively not only with the OEM maximum specifications but also with the vehicle's service application. They are most meaningful when interpreted by a fleet equipped with identical engines in units engaged in similar operating modes. The following list includes some of the elements found on a typical oil analysis report:

- Al—aluminum. A constituent of many friction bearings, pistons, turbo impeller housings, Roots blowers.
- B—boron. An engine coolant SCA (supplemental cooling additive) and an engine oil additive.
- Cr—chromium. A common piston ring coating.
- Cu—copper. A constituent of many oil cooler bundles, friction bearings, engine bushings, and thrust washers. Copper levels tend to be higher when an engine is new (100 ppm) and should drop down to lower levels (20 ppm) after 100,000 miles (160,000 km).
- Fe—iron. Most of the engine components are iron-based alloys. High Fe readings could be an indication of rapid wear on almost any engine component exposed to the lube oil; engine cylinder and valvetrain components should be suspected first.
- Pb—lead. A constituent of most friction bearings.
- Si—silicon. Silicon dioxide from airborne fine sands and dusts ingested by the engine intake

system often indicate malfunctioning air filter or intake ducting leaks. Silicon is a constituent of new engine oil in which it serves as an antifoam agent, so the silicon level reported by the laboratory is corrected to read only externally acquired silicon.

Na—sodium. Found in some lubricants as an additive, so the laboratory reading must be corrected to read acquired sodium. When the source is other than the engine oil, the culprit is usually coolant SCAs.

Sn—tin. A constituent of most friction bearings and occasionally used to coat pistons.

Soot—also known as total solids. Soot is a form of fine carbon particle, a combustion by-product that is not readily identifiable in routine lab testing; in fact, some laboratories report total suspended particles as soot level. Fuel soot is present in all engine oil. It can generally be regarded as nonabrasive but in the presence of moisture may crystallize when it becomes abrasive. Accumulated soot loads may increase the oil's viscosity.

.....
Tech Tip: Whenever a high reading in an oil analysis chart cannot be explained, contact the National Service Operations Department of the engine OEM before taking any other action. Their experience of failure feedback from across the continent may produce a simple explanation of the problem that could avoid an unnecessary engine teardown.

LUBRICATING CIRCUIT PROBLEMS

The following are some guidelines for troubleshooting lubrication circuit complaints. Be aware of the sequencing. You would be amazed at how many lubrication circuit problems are root-sourced by insufficient oil in the oil pan.

- When investigating a low oil pressure complaint, first check the oil pan level. Next, check the appearance and odor of the oil.
- Low oil pressure complaints must be verified with a master gauge.
- High oil pan levels aerate engine oil causing low pressure and fluctuations or surging.

- After an engine rebuild, it is good practice to pressure prime the engine lubrication system with an external pump.
- Most OEMs recommend priming full flow filters on all turbocharged engines. Oil filters should be primed by filling them with new engine oil poured into the inlet side of the oil filter. One OEM (Caterpillar) prefers that oil filters not be primed before installation, due to the risk of dirt contamination caused by careless handling of the filter during priming and improper priming technique.
- It is not necessary to prime bypass filters, although it may be necessary to purge air from them as the engine is started up after an oil change.
- When taking an oil sample, draw off midway through the sump runoff, never at the beginning or end. If an oil sample is required outside the normal oil change interval, use a syringe. Oil samples should be taken shortly after an engine has been run to obtain the most reliable results.
- Oil change intervals are usually determined primarily by mileage in line-haul applications.

As with *all* troubleshooting on electronic engines, make sure that you connect to the chassis data bus: today this is just part of sound shop practice.

Extended Oil Changes

Servicing trucks costs money. When oil change intervals can be extended, it saves money. Engine OEMs along with those who research their oil requirements are continually working on developing engine oils that will provide longer service intervals because this is what their customers are asking for. And until the almost universal adoption of EGR on diesel engines in 2004 they were doing a great job. However, rerouting soot particles back into the engine with the intake charge in an EGR mixing chamber has a way of shortening the life of engine oils. The API CI-4 and CJ-4 engine lube categories are formulated to reduce the effect of minute soot particles, but OEM recommended oil service intervals have not been raised much in recent years. You can expect that diesel engine OEMs will work toward increasing oil change intervals over the next few years, but nothing dramatic is likely to happen in the near future. The clean gas induction (CGI) system used by Caterpillar ACERT engines produces cleaner combustion and the key may be in developing this technology.

Summary

- A diesel engine lubricant performs a number of roles including minimizing friction, supporting hydrodynamic suspension, cooling, and cleaning.
- Viscosity describes a liquid fluid's resistance to shear.
- Lubricity describes the flow characteristics of a liquid fluid. Lubricity in engine oils is affected by temperature. Hot oils tend to flow more readily than cold oils.
- Diesel engine OEMs recommend the use of multi-grade oils over straight grades and approve the use of synthetic engine oils, especially for operation in conditions of extreme cold.
- The pour point of engine oil is the temperature at which the oil starts to change into a solid state. Oils formulated for winter use have pour point depressant additives.
- Sludged oil is usually a result of oil degradation caused by prolonged low-load, cold weather operation.
- High ash levels in used engine oils may indicate prolonged high-temperature operation.
- Oil aeration can be caused by high oil sump levels.
- When interpreting API oil classifications, the GF prefix identifies oil formulated for gasoline-fueled engines and the C identifies oil formulated for compression-ignition engines.
- Post-2007 diesel engines with EGR and DPFs are required to use SAE CJ-4 rated engine lube unless the OEM sanctions the use of CI-4.
- Most research indicates that synthetic oils outperform traditional oils. However, because they cost much more they will probably not be extensively used by operators until engine OEMs endorse extended oil change intervals.
- It is important to maintain the correct engine oil level. Be aware that the consequences of an excessively high oil level can be as severe as those for low oil levels.
- Positive displacement pumps of the external gear and gerotor types are used as oil pumps in diesel engines. Most current commercial diesel engines use the external gear pump design.
- Oil pumps are designed to pump much greater volumes of oil than that required to lubricate the engine. An adjustable, pressure-regulating valve defines the peak system pressure.
- The filters used on a heavy-duty lubrication system may be classified as *full flow* and *bypass*.
- Full flow filters are located in series between the oil pump and the lubrication circuit.
- Bypass filters are located in parallel receiving oil ported from an oil gallery and returning it directly to the oil pan.
- Most OEMs prefer that filters are primed before installation. This helps prevent oil starvation to critical components in the lube circuit. Filters should always be primed by filling from the inlet side only.
- Filters are usually rated by their mechanical straining specification in microns.
- Oil coolers are heat exchangers used on most heavy-duty, highway diesel engines; the cooling medium used is engine coolant.
- There are two types of oil cooler: the bundle type and plate type.
- A bundle-type oil cooler consists of a housing within which coolant is pumped through a cylindrical "bundle" of copper tubes in one direction while engine oil is pumped around the tubes flowing in the opposite direction. A bundle can be known as a core.
- Most OEMs prefer that bundles be vacuum tested for leaks before assembly. Pressure testing may also be used.
- Plate-type oil coolers have slightly lower cooling efficiencies but offer fewer in-service maintenance problems.
- Engine oil pressure measurement is usually performed by a variable capacitance type sensor. The sensor signals the ECM. The dash gauge or display is therefore an ECM output.
- Engine oil pressures usually have to fall to very low levels before programmed electronic failure strategies are triggered. Actual oil pressure has a relationship with rpm because the engine drives the oil pump.
- A low oil pressure at idle speed represents a less serious condition than the same oil pressure reading when the engine is run at rated rpm.
- Laboratory testing of used engine oil samples is an inexpensive method of tracking engine wear rates

- and providing early warning indicators to engine malfunctions.
- Routine engine oil samples should be taken when the engine oil is changed, preferably at the midflow point when draining the sump.
 - When interpreting oil sample analyses, it should be noted that a high silicon reading is often an indication of a leak in the air cleaner or suction side of the air intake system.

Internet Exercises

Do you want to know more? Try these websites:

1. <http://www.api.org> (American Petroleum Institute)
2. <http://www.dieselnet.com> (EPA diesel emissions news)
3. <http://www.lubrizon.com> (Lubrizon home page)
4. <http://www.wearcheck.com> (*oil analysis*)

Shop Tasks

1. Identify a full flow oil filter on a diesel engine.
2. Identify bypass filter(s) on a diesel engine.
3. Check the oil level using the dipstick. Research what the total oil capacity on that engine is.
4. Identify the type of oil cooler used on the engine.
5. Outline the procedure required by the manufacturer to service engine fluids. Make a note of the recommended lube oil and viscosity for the season you are in.

Review Questions

1. Which of the following SAE multigrade oils would likely be recommended by most highway diesel engine OEMs for North American summertime conditions?

A. 5W-30	C. 20W-20
B. 15W-40	D. 20W-50
2. Which of the following API classifications would indicate that the oil was formulated for diesel engines meeting 2007 emission standards?

A. SF	C. CI-4
B. CC	D. CJ-4
3. Which of the following conditions could result from a high crankcase oil level?

A. Lube oil aeration	C. Friction bearing damage
B. Oil pressure gauge fluctuations	D. All of the above
4. A full flow oil filter has become completely plugged. Which of the following is likely if the engine is running?

A. A bypass valve diverts the oil around the filter.	C. Oil pump hydraulically locks.
B. Engine lubrication ceases.	D. Engine seizure occurs.

-
5. Which type of oil pump is most commonly used in current highway diesel engines?
 - A. External gear
 - B. Plunger
 - C. Centrifugal
 - D. Vane

 6. Which of the following is usually the preferred OEM method of testing an oil cooler bundle?
 - A. Vacuum test
 - B. Die penetrant test
 - C. Hydrostatic test
 - D. Pressure test using shop air and a bucket of water

 7. When interpreting a used engine oil analysis profile, which of the following conditions would be most likely to cause high silicon levels?
 - A. Plugged air cleaner
 - B. A hole in the air cleaner
 - C. Turbocharger bearing failure
 - D. Oil cooler bundle disintegration

 8. Oil that has a milky, clouded appearance is probably contaminated with:
 - A. Fuel
 - B. Dust
 - C. Engine coolant
 - D. Air

 9. Which of the following statements correctly describes viscosity?
 - A. Lubricity
 - B. Resistance to flow
 - C. Resistance to shear
 - D. Breakdown resistance

 10. Technician A states that 15W-40 is the most commonly used truck engine oil. Technician B states that 15W-40 oil is not an appropriate all-season oil because winter temperatures are often much lower than the SAE recommended ambient temperature window for this oil. Who is correct?
 - A. Technician A only
 - B. Technician B only
 - C. Both A and B
 - D. Neither A nor B

This page intentionally left blank

CHAPTER

8

Engine Cooling Systems

Prerequisites

Chapters 3, 4, and 6.

Learning Objectives

After studying this chapter, you should be able to:

- Identify diesel engine cooling system components and their principles of operation.
- Define the terms *conduction*, *convection*, and *radiation*.
- Identify the three types of coolant used in current highway diesel engines.
- Outline the properties of a heavy-duty antifreeze.
- Calculate the boil and freeze points of a coolant mixture.
- Mix coolant using the correct proportions of water, antifreeze, and SCAs.
- Perform standard SCA tests and measure antifreeze protection.
- Identify the problems scale buildup can create in an engine cooling system.
- List the advantages claimed for extended life coolants.
- Outline the causes of wet liner cavitation and the steps required to minimize it.
- Identify the types of heavy-duty radiators including *downflow*, *crossflow*, and *counterflow*.
- Test a radiator for external leakage using a standard cooling system pressure tester.
- Test a radiator cap.
- Identify the different types of thermostats in use and describe their principle of operation.
- Describe the role of the coolant pump.
- Define the role of the coolant filters and their servicing requirements.
- List the types of temperature gauges used in highway diesel engines.
- Describe how a coolant level warning indicator operates.
- Define the roles played by the shutters and engine fan in managing engine temperatures.
- Outline the operation of an actively pressurized cooling system (APCS).
- Diagnose basic cooling system malfunctions.

Key Terms

actively pressurized cooling system (APCS)	extended life coolant (ELC)	ram air
antifreeze	fanstat	refraction
cavitation	headers	refractometer
conduction	heat exchanger	rejected heat
convection	hydrometer	shutterstat
counterflow radiator	kinetic energy	single pass
crossflow radiator	Nalcool™	supplemental cooling additives (SCA)
diesel coolant additive (DCA)	pH	thermatic fan
double pass	propylene glycol (PG)	thermostat
downflow radiator	radiation	total dissolved solids (TDS)
ethylene glycol (EG)	radiator	

INTRODUCTION

Cooling systems have to transfer a percentage of engine **rejected heat**. *Rejected heat* (see **Chapter 3**) is that percentage of the potential heat energy of a fuel that the engine is unable to convert into useful mechanical energy. Engine rejected heat has to be transferred to atmosphere, either in the exhaust gas or indirectly using the engine cooling system. If an engine is operating at 40 percent thermal efficiency, 60 percent of the potential heat energy is rejected. Approximately half of the rejected heat leaves the engine in the form of exhaust gas, which leaves the engine cooling system responsible for transferring the other half to atmosphere.

This task of safely transferring rejected heat is complicated by the extremes of our climate and the fact that it is necessary to manage a consistent engine-operating temperature at all engine speeds and loads. Failure to manage engine operating temperatures has a negative effective on engine performance and emissions. Liquid cooling systems are universal in North American commercial diesel engine applications, and only they will be addressed in this section. The Deutz engine company of Germany manufactures air-cooled engines but in North America, their engines are generally only found in agricultural and mining applications. **Figure 8-1** shows the components that make up the cooling circuit in a DD15 engine.

Functions of the Cooling System

The functions of a diesel engine liquid cooling system are to:

- absorb heat from engine components.
- absorb heat from engine support systems such as EGR and transmission coolers.

- transfer the absorbed heat by circulating the coolant.
- supply heat to cab and bunk heaters.
- transfer the heat to atmosphere by means of heat exchangers.
- manage engine operating temperatures.

The actual coolant temperature at any given moment of operation is one means the engine control module (ECM) uses to determine engine temperature. In fact, in older hydromechanical engines the cooling system was entirely responsible for managing engine and under hood temperatures. In today's engines, ECMs use both coolant and oil temperature readings to determine *engine* temperature. Note the following:

- Engine coolant warms to operating temperature faster than engine oil.
- Engine oil is regarded as being a better indicator of *actual* engine temperature.
- When both coolant and lube oil are at operating temperature, engine coolant temperatures tend to be lower than oil temperatures.

Heat Transfer

Combustion heat can be transferred by the cooling system to atmosphere in three ways:

1. **Conduction:** The transfer of heat through solid matter, such as the transfer of heat through the cast iron material of a cylinder block.
2. **Convection:** The transfer of heat by currents of gas or liquids, such as in the movement of ambient air through an engine compartment.
3. **Radiation:** The transfer of heat by means of heat rays not requiring matter, such as a fluid or solid. The turbine housing of a turbocharger radiates a considerable amount of heat.

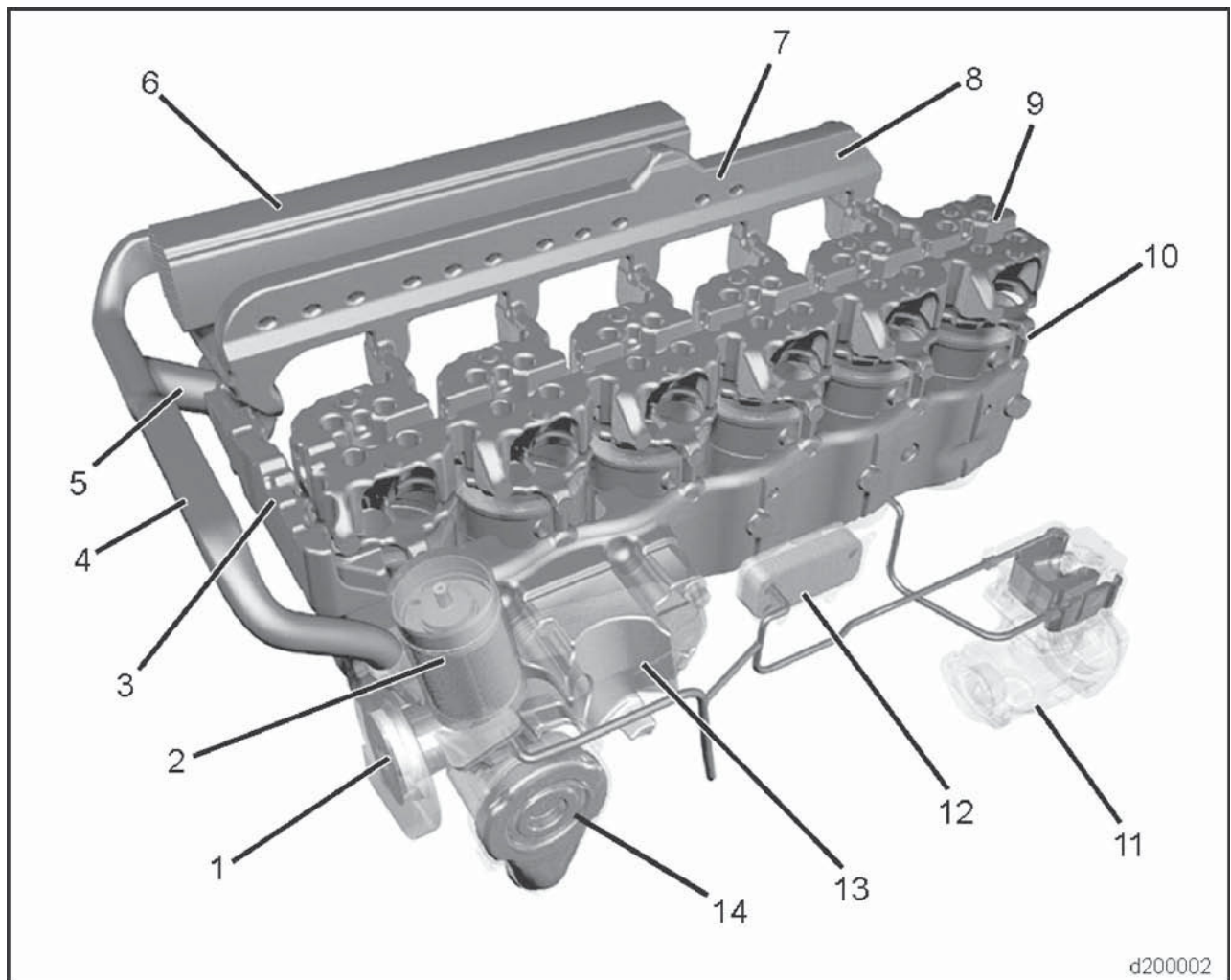

- | | |
|-------------------------------------|------------------------------|
| 1. Water pump | 8. Water manifold |
| 2. Coolant filter | 9. Cylinder head |
| 3. Short circuit line | 10. Cylinder block |
| 4. Coolant return flow | 11. Air compressor |
| 5. Coolant outlet to cooler circuit | 12. Fuel cooler |
| 6. Exhaust gas recirculation cooler | 13. Oil/water heat exchanger |
| 7. Coolant return flow | 14. Thermostat |

Figure 8-1 Cooling circuit components on a DD15 engine. (Specifications are subject to change without notice. Detroit Diesel Corporation is registered to ISO 9001:2001. Courtesy © Detroit Diesel Corporation. All rights reserved. Detroit Diesel is a Daimler company)

Antiboil Properties

Cooling systems are sealed and maintained under pressure. By confining a liquid under pressure, its boil point is increased. Most cooling systems are designed to manage coolant temperatures at just below their boil points. The chemistry of the **antifreeze** and its concentration in the coolant will define the actual boil point of a coolant. Most antifreeze doubles as antiboil agents. When an engine is approaching an overheat condition, the

coolant will first boil at the location within the system where the pressure is lowest. In most cases, coolant boiling will occur first at the inlet (suction side) of the system water pump for the very reason that pressure is slightly lower in that location. **Figure 8-2** and **Figure 8-3** illustrate a couple of diesel engine cooling circuits, the first without and the second with a water manifold: the role of water manifolds will be discussed later in this chapter.

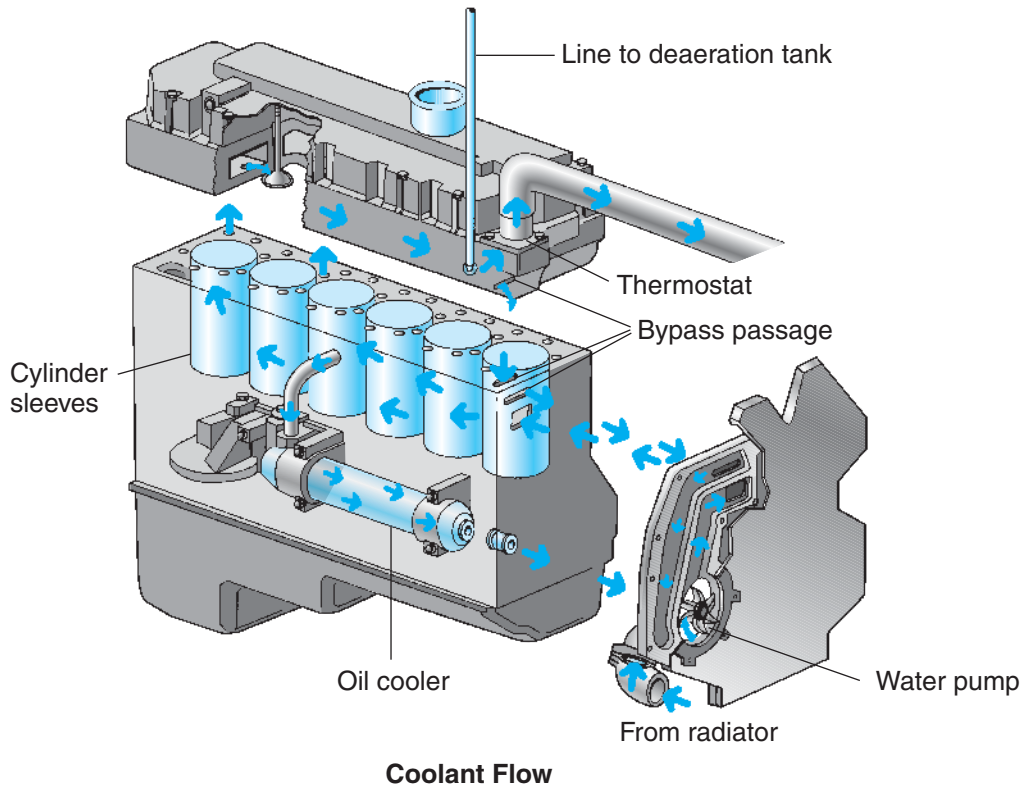
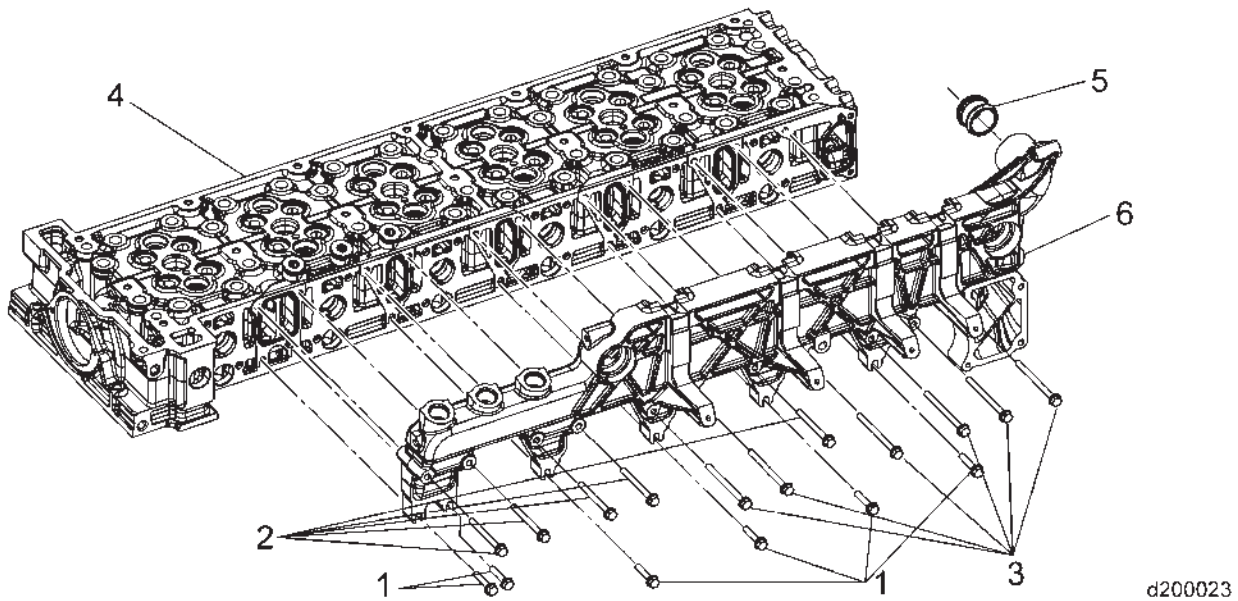

Figure 8-2 Coolant flow through a Navistar 6-cylinder engine with no water manifold: flow routing is from the front to back. (Courtesy of Navistar)



- | | |
|--------------------------|-------------------|
| 1. Bolt M8 x 40 (6 qty) | 4. Cylinder head |
| 2. Bolt M8 x 80 (5 qty) | 5. Insert |
| 3. Bolt M8 x 100 (6 qty) | 6. Water manifold |

d200023

Figure 8-3 Coolant manifold on a DD15 engine: this design allows for more even cooling throughout the engine. (Courtesy of Navistar)

ENGINE COOLANT

Water-based coolant is the medium used to absorb engine rejected heat and transfer that heat to atmosphere via a **heat exchanger**. The coolant is circulated through the engine water jacket to absorb the heat of combustion in the manner shown in **Figure 8-3**. Engine coolant is a mixture of water, antifreeze, and **supplemental cooling additives (SCAs)**. If the only objective of diesel engine coolant was to transfer heat, pure water would accomplish this more efficiently than any currently used antifreeze mixture. However, water possesses inconvenient boil and freeze points, poor lubricating properties, and furthermore promotes oxidation and scaling activity.

Types of Antifreeze

Almost all current truck and bus engines use a mixture of **ethylene glycol (EG)**, or **propylene glycol (PG)** plus water as coolant, or a premix of carboxylate, EG-based **extended life coolant (ELC)**. Alcohol-based solutions are no longer used because they evaporate at low temperatures. A properly formulated diesel engine coolant is always made up of the correct proportions of water, antifreeze, and supplemental coolant additives or SCAs. When the antifreeze is an EG- or PG-based mixture with water, the SCAs require monitoring and routine replenishing. ELC is low maintenance in that the coolant life can be up to 6 years, with only one SCA charge required in that period.

Coolant Expansion and Contraction

Water expands about 9 percent in volume as it freezes. This means that it can distort or fracture any container in which it is stored even when this container is a cast iron engine block. Water occupies the least volume when it is in the liquid state and close to its freezing point of 0°C or 32°F. As water is heated from a near freezing point to a near boiling point, it expands approximately 3 percent. A 50/50 mixture of water and EG expands even more, approximately 4 percent through the same temperature range. This means that cooling systems must be designed to accommodate the expansion and contraction of the engine coolant while it is in the liquid state. Just as important to its operation, antifreeze must also be antiboil.

What Makes a Good Antifreeze?

The mixture of water, antifreeze, and SCAs that is referred to as engine coolant should perform the following:

1. Corrosion protection. Special anticorrosion ingredients in the antifreeze and the SCA package

- protect the metals, plastics, and rubber compounds in the engine cooling system.
2. Freeze protection. The freeze protection provided by any coolant relates to the proportion of antifreeze in the coolant mixture.
3. Antiboil protection. The antiboil protection provided by coolant relates to the proportion of antifreeze in the mixture.
4. Antiscale protection. Diesel engine antifreeze mixtures contain additives to prevent scale buildup in the engine: scaling is caused by hard water mineral deposits.
5. Acidity protection. A pH buffer is used to control acid formation in the coolant, which would result in corrosion.
6. Antifoam protection. The action of pumping coolant through an engine can cause aeration or foaming of the coolant so this must be controlled.
7. Antidispersant protection. This prevents insoluble matter from coagulating and plugging cooling system passages.

Toxicity of Coolants

Except for the antifreeze and antiboil characteristics of a glycol-based coolant mixture, the remaining protection additives tend to degrade with engine operation, especially at high temperatures. Because coolant degrades, the protection additives must be tested and restored on a regular preventative maintenance schedule. EG has been used as the standard antifreeze for some time, but the Federal Clean Air Act and OSHA regard EG as a toxic hazard. When new to an engine, PG is said to be less toxic than EG. For this reason it has gained some acceptance as an antifreeze. However, leaks and spillage of both EG- and PG-based coolants should be regarded as dangerous to mammals (including humans) and plant life. Engine coolant becomes more toxic as it ages. Although ELC uses an EG base, it is regarded as safer because it requires less handling (it is premixed and does not require routine testing) in service.

Antifreeze Protection

The temperature at which a glycol-based coolant solution stops protecting against freezing depends on:

- whether the antifreeze is EG or PG
- the percentage of antifreeze to water in the mixture

Table 8-1 shows how coolant mixture percentages compare with the freezing point temperatures in both EG and PG antifreeze solutions. In the case of EG,

TABLE 8-1: COMPARISON OF ANTIFREEZE CONCENTRATION AND FREEZING POINT TEMPERATURE

Concentration of Antifreeze by Percent Volume	Freezing Point of Coolant (EG/PG)			
	EG (°F)	PG (°F)	EG (°C)	PG (°C)
0 percent (water only)	32°F	32°F	0°C	0°C
20 percent	16°F	19°F	-0°C	-7°C
30 percent	4°F	10°F	-16°C	-12°C
40 percent	-12°F	-6°F	-24°C	-21°C
50 percent	-34°F	-27°F	-37°C	-33°C
60 percent	-62°F	-56°F	-52°C	-49°C
80 percent	57°F	-71°F	-49°C	-57°C
100 percent	-5°F	-76°F	-22°C	-60°C

when its percentage in the coolant is increased above 60 percent, the freezing point protection starts to drop off. The freezing point of a PG is at its maximum at 100 percent so it is often used as coolant in extreme low-temperature conditions.

Compatibility of EG and PG

Propylene and ethylene glycol based coolants should *never* be mixed. The mixture in itself will not cause any immediate engine or cooling system problems, but it will be impossible to measure the level of antifreeze protection with either a refractometer or a **hydrometer**. If a mixture of EG and PG is known to have taken place and the coolant, for whatever reasons, cannot be immediately replaced, use a refractometer with an EG and a PG scale and average the two readings. However, the cooling system should be drained and refilled with either aqueous PG or EG when practical to avoid problems later on. ELC is only sold premixed. Only ELC premix should be added to the cooling system, or in conditions of extreme cold, ELC concentrate. ELC is incompatible with PG and EG.

Antifreeze Color

Antifreeze is colored with dye. The color appearance of antifreeze is meaningless. Antifreeze may be dyed green, yellow, blue, orange, red, pink, or any other color in the spectrum. Chemically identical antifreezes can be sold in a number of different colors under different OEM brand names. When green EG is mixed with orange EG, the result is a mud-colored solution. Nevertheless, it will perform as specified.

Measuring Coolant Mixture Strength

Standard antifreeze hydrometers are calibrated to measure EG mixtures; however, the readings are not

accurate and require temperature correction. Today the use of a **refractometer** is recommended to test the antifreeze protection of a coolant. A refractometer produces an accuracy of within 7°F (4°C) of the actual freeze point of the coolant. Refractometers designed for measuring diesel engine coolant usually have both PG and EG calibration scales.

.....
Tech Tip: Always use a refractometer to test the freeze protection of coolant solution and ensure that the correct scale is used for the type of antifreeze being tested.

Supplemental Coolant Additives

Supplemental coolant additives (SCAs) are key ingredients of the coolant mixture. The SCA package recommended by an engine OEM depends on whether wet or dry cylinder liners are used, the materials used in the cooling system components, and whether the cooling system is high or low flow. An SCA package may have to be adjusted to suit an abnormal operating environment or set of conditions. An example is where hard water is used. In this case, the coolant requires a greater degree of antiscaling protection.

Depending on the manufacturer, SCA may be added to a cooling system in a number of ways. Installing the SCAs in the system coolant filter is less common today because it results in higher levels of additives than required. An excess of additives can create problems. Today, most OEMs suggest testing the SCA levels in the coolant, and then adding SCA such as **Nalcool™** or **diesel coolant additive (DCA)** to adjust to the required values. You should not dump unmeasured quantities of SCAs into the cooling system at each PM.

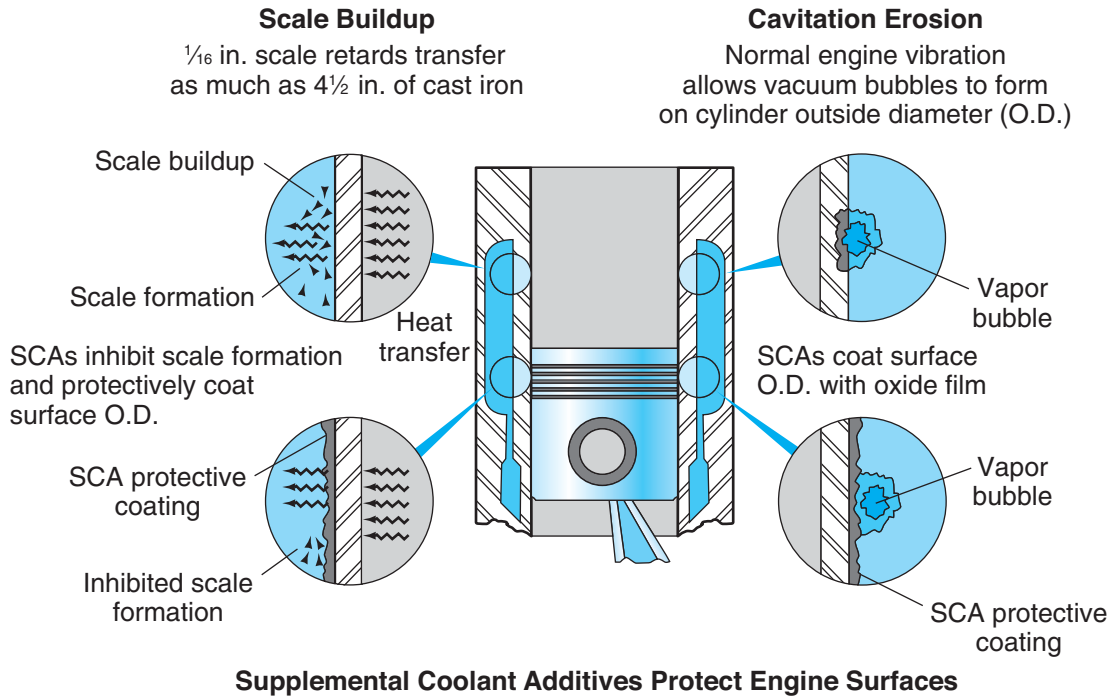

Supplemental Coolant Additives Protect Engine Surfaces

Figure 8-4 How SCAs help scaling and cavitation problems in wet liners. (Courtesy of Navistar)

Cavitation. SCAs are especially important to controlling cavitation on engines that use wet liners. **Cavitation** is caused by vapor bubble collapse. This results in pitting erosion on the outside of the liner wall, usually across the thrust faces of the piston. When a liner has to contain normal combustion pressures, it first expands and then contracts, forming a low-pressure vapor bubble on the outside of the liner. This vapor bubble almost immediately collapses (implodes). When the implosion occurs, the wall of coolant slams into the liner wall creating surface pressures exceeding 4,000 bar (60,000 pounds per square inch [psi]). This can cause pitting and erosion on the outside of the liner usually across the thrust faces of the piston.

Liner pitting caused by cavitation can be controlled by adding special ingredients to coolant. These ingredients form an invisible but very tough protective oxide film on the liner wall. The vapor bubbles will still form, but the liner is shielded by the oxide film. The bad news is that this film breaks down as the coolant ages. **Figure 8-4** shows how vapor bubbles are formed on wet liners.

Scaling. Navistar International Trucks state that a scale buildup of 1.5 mm (1/16 in.) had the equivalent insulating effect of 100 mm (4 in.) of cast iron. Scaling is caused by hard water mineral deposits (especially magnesium and calcium) forming on the surfaces of the cooling system where temperatures are highest. Scale formation on wet liners is an especially serious

condition because it acts as an insulator and limits the liner’s ability to transfer heat. High temperatures result and may cause buckling and other distortions to the liner. Left unchecked, scale buildup insulates engine components designed to transfer heat, resulting in overheating and subsequent failure as shown in **Figure 8-4**.

DESCALING ENGINES

There are commercially available descalants that can sometimes remove minor scale buildup in the engine cooling system. After descaling, the cooling system should be flushed. However, by the time scale buildup has progressed to the point that it is causing an engine to overheat, it is usually too late to rescue it with descalant. In most cases the engine will have to be disassembled and the cylinder block and heads boiled in a soak tank.

Testing SCA Levels

Generally OEMs recommend that the coolant SCA level be tested at each oil change interval. Additionally, whenever there is a substantial loss of coolant and the system has to be replenished, the SCA level should be tested. The test kits consist of test strips that have to be stored in air-tight containers; they have expiration dates that should be observed. Standard coolant test kits permit the technician to test for the appropriate SCA concentration.

Test Procedure. The coolant sample should be taken from the radiator, and not from the recovery or overflow system. The coolant temperature should be between 50°F (10°C) and 130°F (55°C) during testing and the test should be completed within 75 seconds.

1. Remove a strip from the package or bottle without touching the pads. Discard if the nitrite test pad has turned brown.
2. Dip the strip into the coolant for 1 second, remove and shake to remove excess coolant.
3. Wait 45 seconds, and then match the colors of the test pads to the colors on the chart.

- End pad A Tests freeze point. Low accuracy (about 10 percent).
- Middle pad B Tests molybdates. Buffers the formation of acids.
- Top pad C Tests nitrites. Helps protect liner walls against cavitation.

Figure 8-5 shows an example of the test card used with a three-way Fleetguard™ coolant test strip.

Testing Coolant pH. The pH level is a measure of the acidity of the coolant. Acids may form in engine coolant exposed to combustion gases, or in some cases, when cooling system metals start to corrode. The pH test is a litmus test in which a test strip is first inserted into a sample of the coolant, and then removed, and the color of the test strip is compared to a color chart provided with the kit. The acceptable pH level is defined by each OEM: this is usually between 7.5 and 11.0 on the pH scale. A pH of 9.5 is typical. Higher acidity readings (below 8.0 on the pH scale) indicate that corrosion of engine copper and iron based materials is taking place. Higher than normal alkalinity readings indicate aluminum corrosion or that low-silicate antifreeze is being used where a high-silicate antifreeze is required.

Testing TDS. Testing for **total dissolved solids (TDS)** requires using a TDS probe. A TDS probe measures the conductivity of the coolant by conducting a current between two electrodes. Distilled water does *not* conduct electricity. The ability of water to conduct electricity increases with its TDS content. The TDS test is performed by inserting the probe into the top radiator tank. A reading higher than the OEM specified TDS measured in parts per million is an indication the condition of the coolant may be conducive to scale buildup.

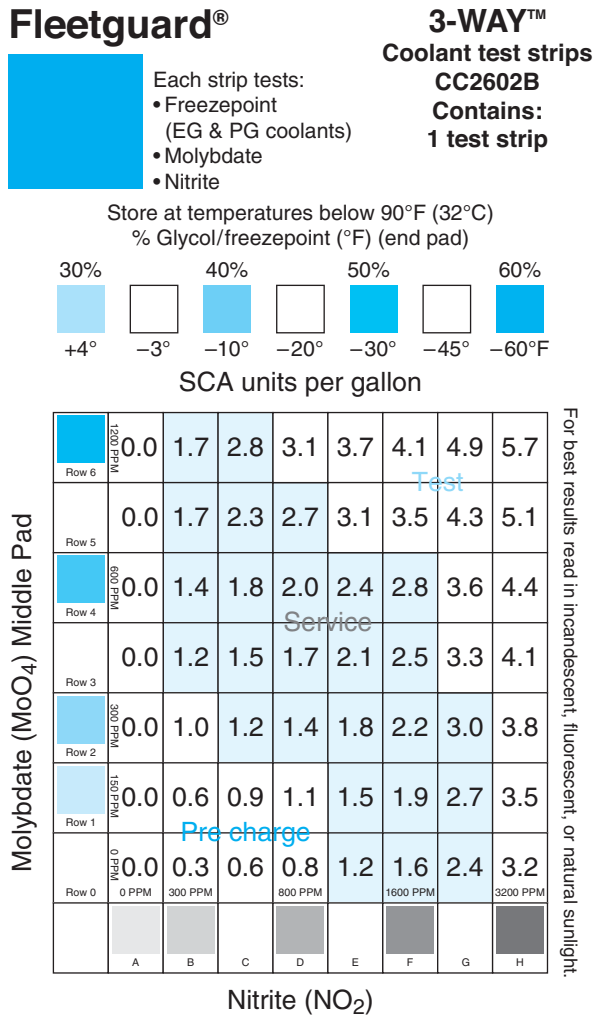

Figure 8-5 Test card used with a three-way Fleetguard coolant test strip. (Courtesy of Fleetguard)

Blending Heavy-Duty Coolant

Coolant for use in heavy-duty diesel engines should not be blended in the engine cooling system. It should be mixed in a container before pouring or pumping it into the engine. Good quality water (known to be not excessively hard and to have no iron content; it should not appear reddish) should always be poured into the container first, followed by the correct proportions of antifreeze and finally the SCA package. Mix the solution before adding to the engine cooling system. When adding coolant to compensate for a low coolant level, some OEMs manufacture premixed, heavy-duty coolant. This shifts the responsibility of mixing coolant from the technician because the water, antifreeze, and SCA are premixed in the correct proportions. It also eliminates the problems associated with poor quality water.

Good Quality Water. One of the reasons premixed ELC significantly outlasts EG and PG solutions is that

distilled water is used in the solution. There are so many variables associated with tap water that it does not make sense to use anything but distilled water when mixing antifreeze solution. Distilled water is not costly, but it is not as easily available on the shop floor as tap water. Fleetguard defines good quality water with the following specifications:

- less than 40 ppm chloride
- less than 100 ppm sulfate
- less than 170 ppm calcium/magnesium (hardness)

High-Silicate Antifreeze. High-silicate concentrations are used in less costly antifreezes to protect aluminum components exposed to the engine coolant. However, most diesel OEMs require that low- or no-silicate coolant be used in their engines. High-silicate and low-silicate antifreeze should not be mixed. ELCs do not use silicates, nitrates, borates, phosphates, or amines to inhibit scaling, but instead use a carboxylate additive.

Extended Life Coolants

Premixed *Extended life coolants (ELC)* use an EG base and promise a service life of up to 600,000 miles (960,000 km) or 6 years with one additive recharge at 300,000 miles (480,000 km) or 3 years. This compares with a typical service life of 2 years during which up to 20 recharges of SCA would be required for conventional EGs and PGs. A true ELCs is only available as a premixed solution: this ensures that the water quality (contaminant level) is within specification. However, the term ELC has recently been applied to non-premixed antifreezes: in this text we will only consider premixed ELC to be true ELC. The pricing of premixed ELCs by quantity is generally comparable with EGs and PGs, but because of reduced cooling system maintenance and extended service life, it is fast becoming the coolant of choice among engine OEMs. No test kits are required to monitor the ELC SCA level. Notable among the advantages claimed for premixed ELCs are:

- long service life—6 years or 600,000 miles (966,000 km)
- no SCA testing required
- long water pump life due to much lower TDS content (TDSs are abrasive)
- reduced cooling system scaling
- improved cavitation protection
- improved corrosion protection
- improved heat transfer ability
- no gelling problems

- improved aluminum corrosion inhibitors
- better high-temperature performance than EGs and PGs

ELCs may be used in engine cooling systems that have previously used either EG or PG solutions. The EG and PG should be drained from the cooling system, which should then be flushed with clean water. The ELC can then be installed. If a coolant filter is used, replace the existing filter with an SCA-free filter. For midwinter Northern United States and Canadian operation, the ELC premix should be strengthened with concentrate; check with the ELC manufacturer. Most engine OEMs endorse the use of ELCs in their products.

Tech Tip: In an emergency, an ELC cooling system can be topped up using EG mixture. However, the cooling system should be flushed and refilled with a fresh antifreeze mixture at the first opportunity.

WARNING *When running a truck in severe winter conditions, the thermostats will close-cycle coolant through the engine: this isolates the radiator, which is exposed to frigid ram air, and icing can occur if there is insufficient freeze protection. Ensure that coolant freeze protection accounts for the lowest ambient temperature with a margin of at least -10°F.*

CAUTION *After coming into contact with any antifreeze or coolant solution, wash the affected skin areas immediately and thoroughly.*

COOLING SYSTEM COMPONENTS

The components used to store, pump, condition, and manage engine coolant flow and temperature are known as the cooling system components (**Figure 8-1**). These components vary little from one diesel engine manufacturer to the next but the way in which coolant is circulated through these components is specific to each OEM. In **Figure 8-1** and **Figure 8-2** two quite different diesel engine cooling circuits are shown. Note the location of the oil cooler in each figure. Oil coolers, while integrated into the cooling circuit, were studied in this book as part of the lubrication system in **Chapter 7**. When servicing and repairing cooling system components, always consult the appropriate service literature.

Radiators

Radiators are heat exchangers. The engine power rating determines the size of a radiator required by a diesel engine. In a truck application, the cooling medium is **ram air**. Ram air is air forced through the radiator core as the truck moves down the highway. Vehicle speed and ambient temperatures determine the radiator's efficiency as a heat exchanger. Fan shrouds improve airflow through the radiator core and the efficiency of the fan.

Radiator Materials and Construction. Most truck diesel engine radiators are fabricated mainly from copper and brass components, but the use of aluminum and plastics is increasing. Radiators typically consist of bundled rows of round or elliptical tubes through which the coolant is flowed. Fins increase the sectional area to which ram air is exposed. The tubes are usually brass and the fins are copper in truck applications but OEMs are experimenting with aluminum, widely used in automobile radiator construction, due to lower cost and lighter weight. Copper, brass (an alloy of copper and zinc), and aluminum all transfer heat efficiently and are ideal as materials for radiators. Aluminum corrodes more easily than copper and brass. The corrosion occurs both inside (coolant breakdown, poor water quality) and outside (ambient salt, road salt). Plastics are being increasingly used in the construction of radiator tanks

replacing metal tanks. Plastic tanks are usually crimped onto the main radiator core, enclosing the **headers**.

All radiators are equipped with a drain valve located at their lowest point, inlet and outlet piping, and a filler opening sealed with a radiator cap. Most use a **single-pass**, downflow principle, which requires that the cooling tubes run vertically from the top tank to the bottom tank. Radiators are classified by their flow characteristics. The following types may be found in current truck applications:

- **Downflow radiators:** Coolant enters the radiator through the top tank and flows, aided by gravity, to the bottom tank by means of vertical tubes. These tubes connect the upper and lower tanks. Downflow radiators are a single-pass design. Coolant is routed from the engine to the top tank, flows to the bottom tank, and then exits. The location of a typical downflow radiator is shown in **Figure 8-6** and the coolant routing is illustrated in **Figure 8-7**.
- **Crossflow radiators:** The headers and tanks are positioned on either side of the radiator core. Coolant enters through one of the side tanks and then flows through horizontal tubes to the tank at its opposite side. This design can have a lower profile than the downflow design so it is used by chassis OEMs using low-nose, aerodynamic designs of trucks. Flow is single pass.

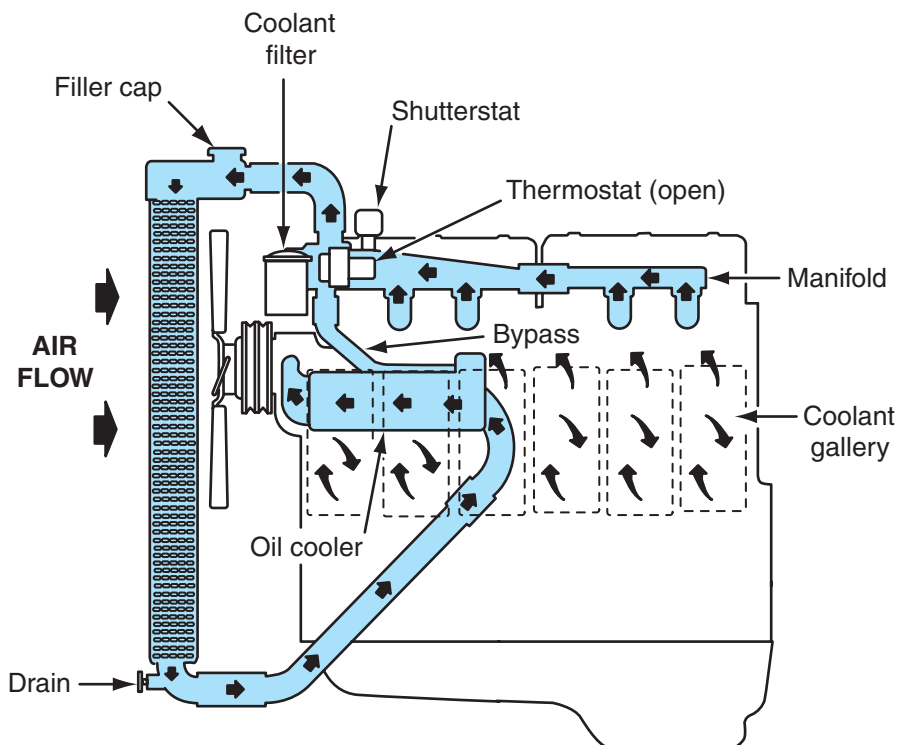

Figure 8-6 Cooling system flow with a downflow radiator.

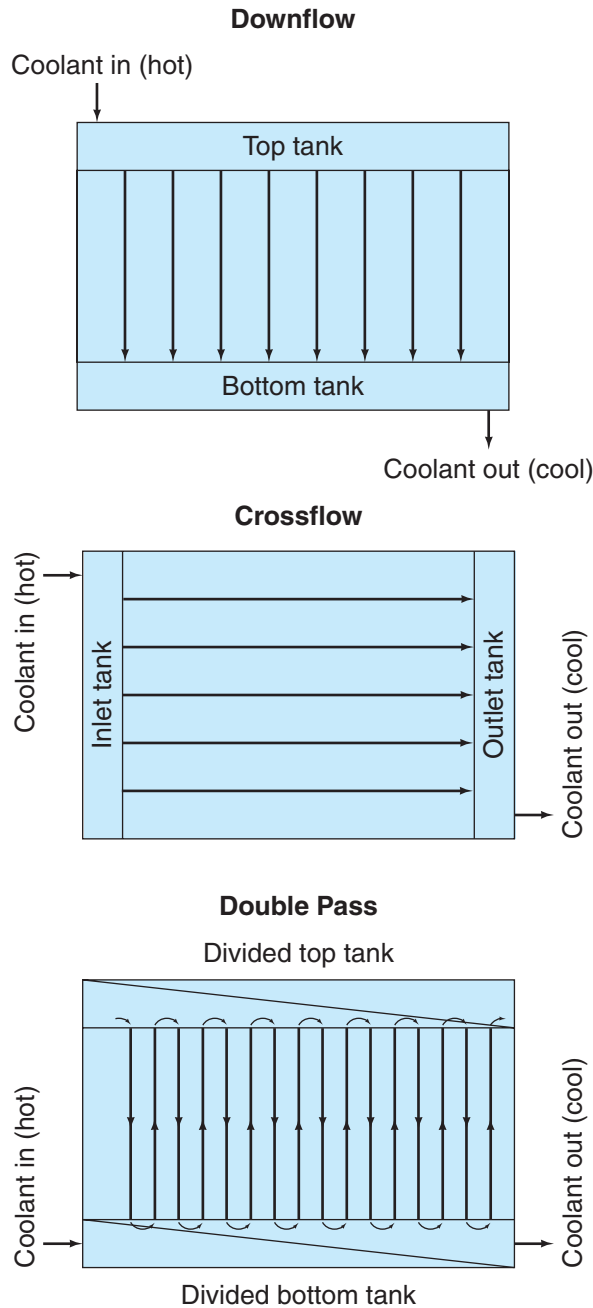

Figure 8-7 Coolant flow shown on downflow, cross-flow, and double pass radiators.

- **Counterflow radiators:** The coolant usually enters through a bottom tank that is divided into inlet and outlet sections. The coolant flows vertically upward from the inlet section of the bottom tank to the top tank, then downward to the outlet section of the bottom tank before being returned to the engine cooling circuit. The cooling efficiencies of this design are improved because the coolant is held in the radiator for a longer period. The flow of coolant through the radiator is **double pass**. The design was popular

when liquid-cooled, charge-air heat exchangers were common.

Aeration. Air in a cooling system can cause many problems. It reduces the coolant’s ability to transfer heat, may promote corrosion, and may cause a cooling system to become air bound. An air-bound system occurs when air becomes trapped in the inlet to the coolant pump. The result is that the coolant pump loses its prime. Most cooling systems are designed to limit aeration problems. Some radiators have a divided top tank in which coolant enters the lower section from the cylinder head and the upper section from a standpipe; the two sections are separated by a baffle. This design reduces cooling system aeration problems. Also, vent lines help to de-aerate the cooling system.

Servicing and Testing Radiators. Radiators in highway trucks tend to be left in the chassis with no maintenance until they fail, either because they leak or fail to adequately cool. An often overlooked PM practice is the external cleanliness of the radiator; buildup of road dirt and summer bugs can reduce the radiator’s ability to properly cool. Radiators should be cleaned externally using either a low-pressure steamer or regular hose, detergent, and a soft nylon bristle brush. Never use a high-pressure washer because this will almost certainly result in damaging the cooling fins.

Repairing Leaks. Leaks are more often the result of external damage than corrosion failure. The location of a leak is often indicated by white or reddish streaks. Radiators are commonly pressure tested at around 10 percent above normal operating pressure, but ensure that the OEM test specifications are consulted, especially where plastic tanks are used. Pressure testing may help identify the locations of leaks. It is important that radiator leaks are promptly repaired. If the leak has been caused by external damage and the radiator is in otherwise good condition, the radiator may be repaired by shorting out the affected tubes. This usually involves removing the top and bottom tanks and plugging the damaged tube(s) at the headers. If a leaking tube is accessible, a soldering repair may be possible.

Soldering radiators can be a risky job. Before beginning, assess how the heat will affect any nearby soldered joints. Low melt point solder has little structural strength and although it may be used to seal a hairline crack or small impact leak, it should not be used otherwise. Silver solder is a preferred solder repair medium, but much more heat is required to apply it than 50% lead-tin solder so make sure you know what you are doing.

Radiator Flushing and Major Repairs. Most commercially available in-chassis radiator descaling solutions are a poor risk as they are seldom 100 percent effective and can dislodge scale. The loosened scale then plugs up somewhere else in the cooling circuit. For the same reasons, reverse flow flushing of the cooling system makes little sense. When OEMs recommend radiator flushing, it is generally performed in the normal direction of flow often aided by a cleaning solution.

Major radiator repairs should be referred to a radiator specialty shop. A scaled radiator falls into the classification of major repair. An ultrasonic bath will remove most scale rapidly and effectively. A properly equipped radiator repair shop will also be able to determine the extent of repairs required and whether recoring is necessary. One of the problems of performing radiator repairs without the proper test equipment is the inability to test the radiator until it is assembled and reinstalled in the chassis. Removing and installing radiators can be a labor intensive operation in some chassis.

Auxiliary Heat Exchangers

The engine cooling system is required to cool other heat exchangers plumbed into the cooling system. Other heat exchangers that can be plumbed into the cooling circuit include:

- aftercoolers and intercoolers
- tip turbine heat exchangers
- EGR heat exchangers
- oil coolers
- CGI heat exchangers
- cab and bunk heaters
- transmission oil coolers

The principles required to diagnose and repair these heat exchangers are similar to those for radiators. We covered oil coolers in **Chapter 7** dealing with engine lubrication systems, but most OEMs require you to replace rather than repair heat exchangers.

Radiator Cap

Radiators are usually equipped with a pressure cap whose function it is to maintain a fixed operating

pressure while the engine is running. This cap is additionally equipped with a vacuum valve to admit surge tank coolant (or air) into the cooling circuit (the upper radiator tank) when the engine is shut down and the coolant contracts. Radiator caps allow sealed cooling systems to be safely pressurized. For each 1 psi (7 kPa) above atmospheric pressure, coolant boil point is raised by 3°F (1.67°C) at sea level; for every 1,000 feet of elevation, the boil point decreases by 1.25°F (0.5°C). System pressures are seldom designed to exceed 25 psi (172 kPa) and more typically they range between 7 psi (50 kPa) and 15 psi (100 kPa).

Radiator caps are identified by the pressure required to overcome the cap spring pressure and unseat the seal: when this occurs, the coolant is routed to a surge tank. The surge tank coolant level is always at its highest when the engine is running hottest. As the engine cools, the pressure within the cooling system drops, and when it falls to a “vacuum” value of about ¼ psi, the radiator cap vacuum valve is unseated: this allows coolant from the surge tank to be pulled back into the radiator. **Table 8-2** shows how much the coolant boil point is raised correlated with rad cap trip pressure.

Tech Tip: When radiator hoses collapse as the engine cools, it indicates that the vacuum-relief valve in the radiator cap has failed. Collapsing hoses on diesel engines may destroy them internally so they should be checked after this type of rad cap failure.

CAUTION Great care should be exercised when removing a radiator cap from the radiator. If the system is pressurized, hot coolant may escape from the filler neck with great force. Most filler necks are fitted with double cap lock stops to prevent the radiator cap from being removed in a single counterclockwise motion: if the radiator is still pressurized, the cap will jam on the intermediate stops. Never attempt to remove a radiator cap until the cooling system pressure is equalized.

TABLE 8-2: SYSTEM PRESSURE AND BOIL POINT

Cooling System Maximum Pressure	Increase in Boil Point	Temperature at Which Coolant Boils
7 psi (52 kPa)	21°F (12°C)	233°F (112°C)
10 psi (79 kPa)	30°F (17°C)	242°F (117°C)
15 psi (105 kPa)	40°F (22°C)	252°F (122°C)

Testing Radiator Caps. Radiator caps can be performance tested using a standard cooling system pressure testing kit. First install the radiator cap to an appropriately sized adapter on the hand pump, and then pump to the seal crack value (this should exceed the cap rated value by 1 psi [7 kPa]). Next, release the pressure and once again recharge to the exact rated pressure value of the cap and observe the pump gauge: pressure drop-off should not exceed 2 psi over 60 seconds.

Water Manifold

Most diesel engines are equipped with a water manifold. A water manifold ensures an even distribution of coolant through the engine block, resulting in more consistent cylinder temperatures. For instance, if you study the coolant routing on an engine with no water manifold shown in **Figure 8-1** you can observe that coolant flows from the front to the rear of the engine. This results in higher temperatures at the rear of the engine. In the coolant system with a water manifold illustrated in **Figure 8-3**, note how coolant is routed through the cylinder block to cool the midstop cylinder liners. This ensures more even cylinder block temperatures.

Water Pumps/Coolant Pumps

Water pumps are usually nonpositive, centrifugal pumps driven directly by a gear or by belts. When the engine rotates the coolant pump, an impeller is driven within the housing, creating low pressure at its inlet, usually located at or close to the center of the impeller. The impeller vanes throw the coolant outward and centrifugal force accelerates it into the spiraled pump housing and out toward the pump outlet. Because the cooling system pressure at the inlet to the coolant pump is at its lowest (because of low-pressure pull of impeller at inlet), system boiling always occurs at this location first. This will very rapidly accelerate the overheating condition as the pump impeller will be acting on vapor. Coolant pumps are the main reason that engine coolants should have some lubricating properties, because they are vulnerable to abrasion damage when the coolant TDS levels are high. A sectional view of a Navistar water pump is shown in **Figure 8-8**.

Coolant pumps fail for the following reasons:

- overloading of the bearings and seals caused by misalignment or tight drive belts
- high TDS levels in the coolant that erode the impeller

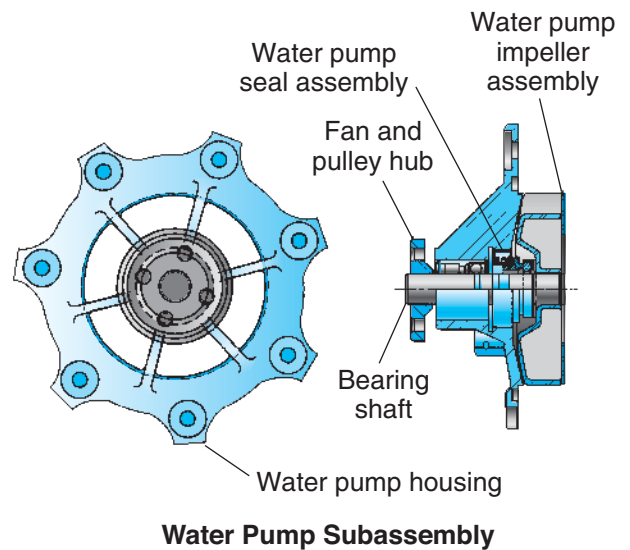

Figure 8-8 Sectional view of a water pump and housing. (Courtesy of Navistar)

- mineral scale buildup on the pump housing
- overheating—boiling usually occurs first at the inlet to the water pump causing vapor lock: this results in rapid temperature rise and hot, shutdown.

Inspecting, Replacing, and Rebuilding Coolant Pumps.

A defective coolant pump should first be removed from the engine. It should be carefully inspected to determine the cause of the failure to avoid a repetition. Water pumps are seldom reconditioned in the modern service garage. When defective, they are replaced as a unit with a rebuilt/exchange unit. Rebuilding of water pumps is usually performed at a rebuild center equipped with the proper equipment by persons who specialize in the process.

Although the technician who reconditions one or two coolant pumps a year may not be able to compete with the time of the specialist rebuilder, it is certainly possible to perform the work to the same standard. A slide hammer is usually required to remove the pulley from the impeller drive shaft, and an arbor press is generally preferred over power presses both for disassembly and reassembly. The pump is one of the more simple subcomponents of the engine. It consists of a housing, impeller, impeller shaft, bearings, and seals. When a pump is rebuilt, inspect the components thoroughly; in many cases, especially where plastic impellers are used, only the housing and shaft are reused. Examine the shaft seal contact surfaces for wear. When gear-driven coolant pumps are reconditioned, pay special attention to the drive gear teeth. The OEM instructions should be observed, and where ceramic seals are used, great care is required to avoid cracking them

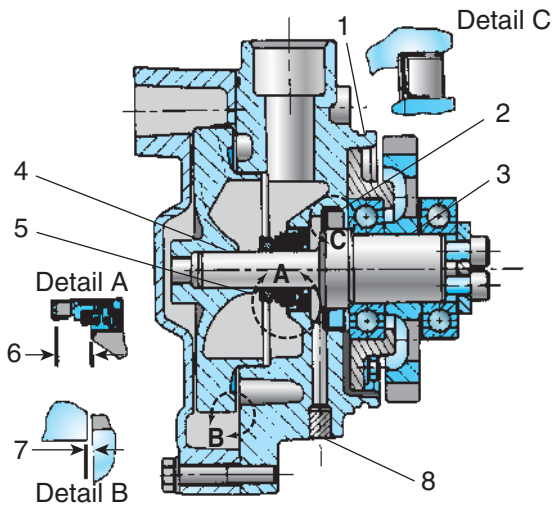

1. Seal groove
2. Lip-type seal
3. Shaft diameter on drive gear end
4. Shaft diameter on impeller end
5. Seal assembly
6. Clearance from surface in pump housing to top of seal assembly
7. Clearance between impeller and pump housing
8. Filter. Install filter flush with pump housing

Figure 8-9 Sectional view of a water pump and sub-components. (Courtesy of Caterpillar)

during installation. A critical specification is the impeller-to-housing clearance; failure to meet this will reduce pumping efficiency. **Figure 8-9** is a sectional view of a Caterpillar water pump with the rebuild specs and tolerances.

FILTERS

Coolant filters are usually of the spin-on cartridge type. They are connected in parallel to coolant flow. Coolant enters the cartridge through outer ports and exits through a central single port. **Figure 8-10** shows the flow routing through a typical coolant filter. As we said earlier in the chapter, SCAs may also be packaged within the OEM coolant filter, so take care to avoid over-servicing.

When coolant filters have to be changed, check the type of shutoff mechanism used. Most current diesel engines use an automatic check valve as shown in **Figure 8-11**. This means that no spillage results when a filter is removed for servicing because a lock-off ball engages. Some engines have manual shutoff valves which must be turned off before removal. New coolant filters do not

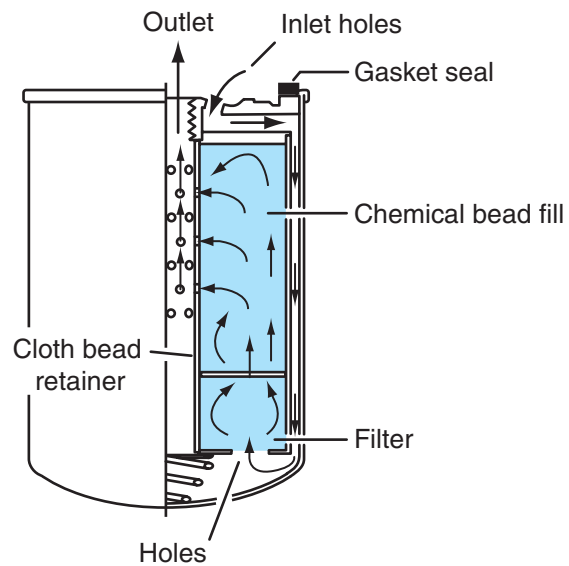

Figure 8-10 Cutaway view of a coolant filter.

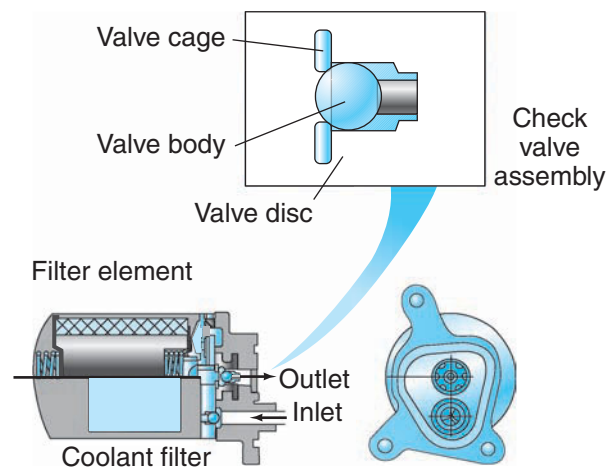

Figure 8-11 Coolant filter with a mounting pad check valve. (Courtesy of Navistar)

require priming. Some coolant filters are equipped with a zinc electrode to neutralize the electrolytic effect of the coolant, although these are more likely to be found in marine and off-highway applications.

CAUTION Where ELC is being used as coolant, blank filters (no SCA charge) may be required. Check the OEM or fleet service schedules.

COOLANT MONITORING CIRCUIT

A diesel engine cooling system is monitored in different ways according to the generation of the system. Coolant temperature is often a primary reference

to the engine management software with factoring timing and air/fuel ratio parameters on electronically managed engine systems, so the temperature display to the operator is secondary in importance. All current electronically managed engines can be programmed to default to failure strategies, which may include engine shutdown based on the coolant temperature or level readings. Thermistors are almost universally used to sense the temperature of the cooling system as well as other engine fluid temperatures, including ambient air, boost air, and lubricating oil. The following methods are used to sense coolant temperature: thermistors, electric sensors, expansion-sensing gauges, and coolant level indicators.

Thermistors

Thermistors are solid-state, semiconductor devices whose internal resistance varies with temperature change. They are supplied with a specific reference voltage, almost always around 5V-DC, and return a signal to the ECM based on temperature. Negative temperature coefficient (NTC) thermistors are commonly used. The internal resistance in an NTC thermistor decreases as temperature rises. Because the internal resistance in a NTC thermistor decreases as temperature increases, the signal voltage (returned to the ECM) goes up proportionally with temperature rise. The engine ECM broadcasts engine coolant temperature information to the data bus so that it can be displayed on a dash digital display or gauge.

Electric Sensors

Electric sensors use a bimetal arm in conjunction with a resistor supplied by a modulated electrical signal from the temperature gauge: when the bimetal arm is heated, the greater linear expansion of one of the bimetal strips causes it to bend one way and, as it cools and contracts, bend in the opposite direction. Connected to the bimetal strip is a wiper, which short-circuits the current flow through the resistor to ground, thereby altering the gauge value.

Expansion-Sensing Gauges

An expansion-sensing gauge consists of a tube filled with a liquid that expands as it is heated and, in expanding, activates the gauge indicator needle. This gauge tends not to be used much in today's engines but you will likely come across a few examples in older truck engines and many off-highway, heavy equipment applications.

Coolant Level Indicators

Almost all current electronically managed engines have radiators equipped with low coolant level warning systems. Most operate using the same principles. The ECM outputs a signal to a probe (or sensor), usually located in the top radiator tank, which grounds through the coolant. When the probe fails to ground through the coolant, a low coolant level warning is generated; the outcome depends on how the ECM has been programmed (this is usually a customer data program option). In most cases, a lag (somewhere around 5 to 12 seconds) is required before the ECM resorts to a programmed failure strategy. This may be simply to alert the operator, ramp down to a default rpm/engine load, or shut down the engine after a suitable warning period. Some radiators are equipped with two probes used to signal low and dangerously low coolant levels.

THERMOSTATS

Thermostats function as a type of automatic valve that senses changes in engine temperature and regulate coolant flow to maintain an optimum engine-operating temperature. To function effectively, a thermostat must:

- start to open at a specified temperature.
- be fully open at a set number of degrees above the start-to-open temperature.
- define a flow area through the thermostat in the fully open position.
- permit zero coolant flow or a defined small volume of flow when in the fully closed position.

The cooling system thermostat is normally located either in the coolant manifold or in a housing attached to the coolant manifold such as that shown in **Figure 8-12**. It has two primary functions:

- to permit a rapid engine warmup by of the engine by limiting flow to the in-engine cooling circuit
- to maintain a consistent temperature once the engine has attained its normal operating temperature by optioning flow to the radiator

The thermostat therefore functions by optioning flow to either the in-engine circuit or the radiator circuit. It opens and closes based on temperature. As it opens and closes, it defines a flow area so, for instance, a partially open thermostat limits the flow area of coolant routed to the radiator.

Operating Principle

Because a thermostat defines the flow area for circulating the coolant, there is often more than one.

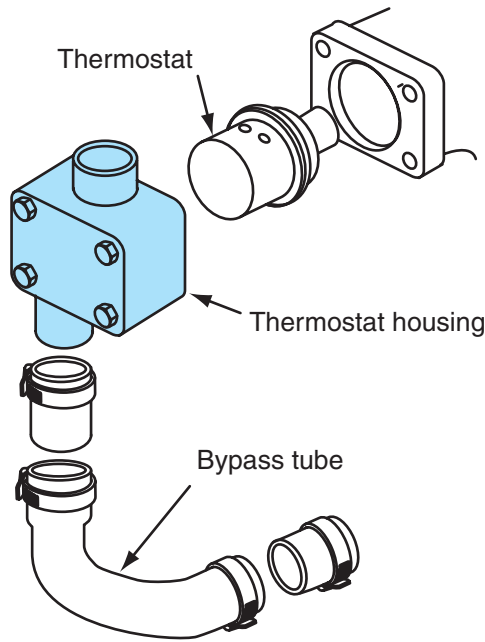

Figure 8-12 Exploded view of a thermostat housing.

A heat-sensing element actuates a piston attached to the seal cylinder. When the engine is cold, coolant is routed back to the coolant pump to be recirculated through the engine. When the engine heats to operating temperature, the seal cylinder gates off the passage to the coolant pump and routes the coolant to the radiator circuit. The

heat-sensing element consists of a hydrocarbon or wax pellet into which the actuating shaft of the thermostat is immersed. As the hydrocarbon or wax medium expands, the actuating shaft is forced outward in the pellet, opening the thermostat. Thermostats can be full blocking or partial blocking. **Figure 8-13** shows a typical engine thermostat in its engine warm and engine cold positions.

Top Bypass Thermostat. The top bypass thermostat controls the flow of coolant to both the radiator and the bypass circuit. During engine warmup, all of the engine coolant is directed to flow through the bypass circuit. As the temperature rises to operating temperature, the thermostat begins to open and coolant flow is routed to the radiator, increasing in proportion to temperature rise.

Poppet or Choke Thermostats. Poppet-type thermostats control the flow of coolant to the radiator only, with the result that the bypass circuit is open continuously. Flow to the radiator is discharged through the top of the thermostat valve.

Side Bypass or Partial Blocking Thermostat. The side bypass thermostat functions similarly to the poppet type. It has a circular sleeve below the valve that moves with the valve as it opens. This partially blocks

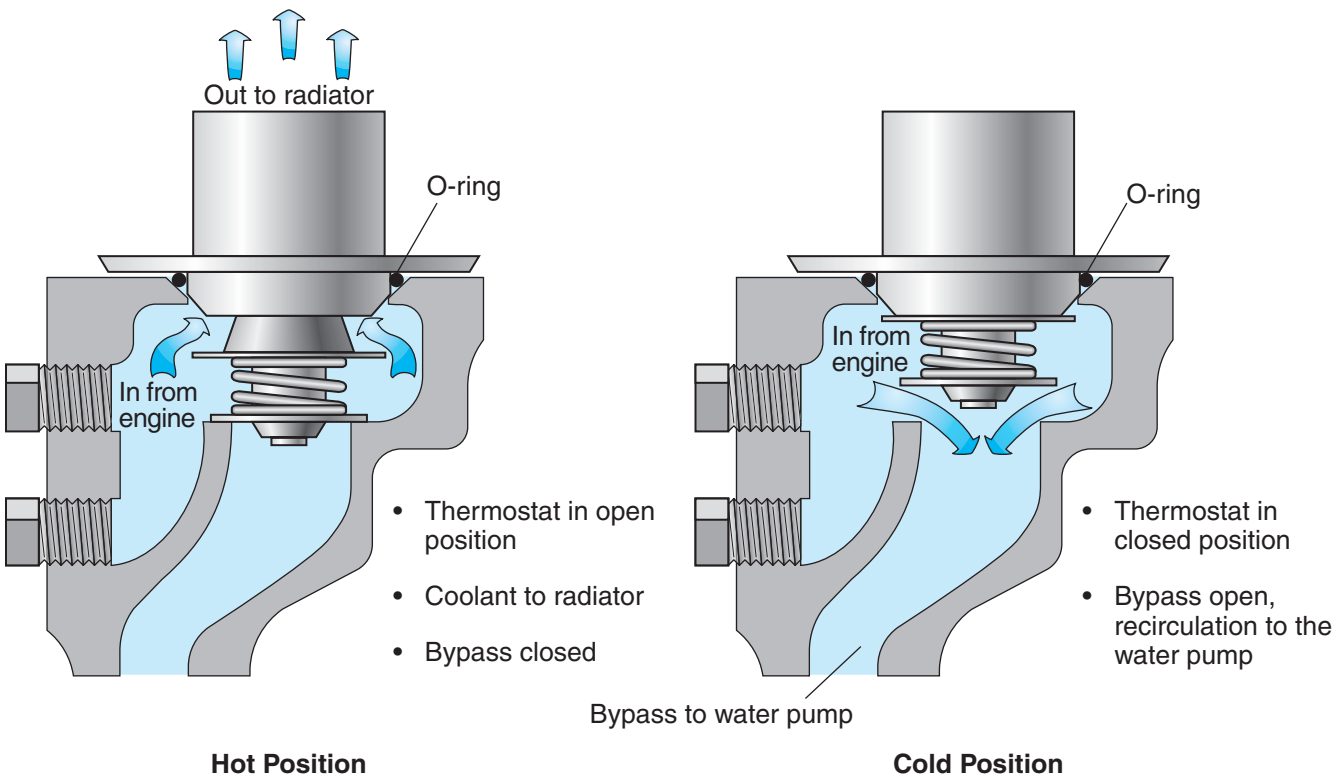

Figure 8-13 Sectional view showing thermostat operation. (Courtesy of Navistar)

the bypass circuit and, in doing so, directs most of the coolant flow to the radiator.

Vented and Unvented Thermostats. Vented thermostats have a small orifice in the valve itself or a notch in the seat; usually this must be positioned in an upright position on installation. The function of the vent orifice is to help de-aerate the coolant by routing air bubbles out of the bypass circuit. Positive de-aeration type systems usually require nonvented thermostats.

Bypass Circuit. The term *bypass circuit* describes the routing of the coolant before the thermostat opens. When flow is confined to the bypass circuit, coolant flow is limited to the engine cylinder block and head. The flow of bypass coolant permits rapid engine warmup to the required operating temperature.

Running without a Thermostat. This practice is not recommended and engine OEMs may void warranty. It also violates the EPA requirements regarding tampering with emission control components. Removing the thermostat invariably results in the engine running too cool. This can cause vaporized moisture in the crankcase to condense and result in developing corrosive acids and sludge in the crankcase. Additionally, low engine running temperatures will increase the emission of HC. On the other hand, engines that should use top bypass or partial bypass type thermostats may overheat when the thermostat is removed as most of the coolant will be routed through the bypass circuit with little being routed through the radiator.

Testing Thermostats

Testing a thermostat can be performed using a specialized tool consisting of a tank, heating element, and accurate thermometer. You can make such a test device from an open top electric kettle. Check the OEM specifications for testing thermostats. Remember, there is a difference between start-to-open and fully open temperature values.

CAUTION Exercise extreme care when handling close to boiling water in a thermostat test tank. Use eye protection, gloves, and tongs.

Shutters

Shutters used to be common on highway trucks. They are seldom used today because of the sudden temperature changes that result from opening and

closing them. Shutters were used to control the airflow through the radiator and into the engine compartment. A **shutterstat** was used to manage the system, and it was usually located in the coolant manifold. Shutters have are sets of horizontal slats that open and close in the same way as a set of Venetian blinds. The shutterstat measures coolant temperature and uses system air pressure to close the slats and block air from entering the engine compartment.

Shutters are on the radiator. They are spring loaded to the opened position. For this reason we can say that they default to the open position. When air from the shutterstat is delivered to the shutter cylinder, the plunger extends to actuate a lever and close the shutters. When no air is available at the shutter cylinder, the shutters are held open by spring force.

COOLING FANS

Either suction or pusher fans can be used to move air through an engine compartment. Suction fans pull outside air into the engine compartment. Pusher fans do the opposite so they push heated air out. Highway vehicles that receive ram air assist are best suited to using suction fans. Off-highway and some vocational trucks that cannot benefit from ram air use pusher fans to remove heated air from the engine compartment. In highway diesel engine applications, ram air is often sufficient to perform cooling 95 percent of operating time. This is good for both fuel economy and engine power because it requires energy to drive a fan.

Modern engine cooling fans do not require nearly as much energy to drive them as the heavy steel fans of a generation ago. Lightweight, variable pitch fans are manufactured from carbon composites and plastics. This new generation of engine fans requires as little as 6 BHP to drive them.

Variable Pitch Blades

Fan design is important, and fans should draw as little engine power as possible. Most current designs use flexible fan blades. Pitch means angle. Because the blades are flexible, the pitch is at its most aggressive when the fan assembly is being driven at a slow speed. As the fan's driven speed increases, air resistance begins to decrease the blade pitch. Flexible pitch blades have variable efficiency. They are aggressive (and efficient) at low rpms but as they are speeded up, the blade pitch flexes and reduces efficiency (decreasing the engine power required to drive them). **Figure 8-14** shows some examples of fan blades used in some current trucks.

Windmaster plastic standard fans



Windmaster plastic ring fans



Windmaster composite standard fans



Windmaster metal standard fans



Figure 8-14 Various diesel engine fan blades used in current trucks. (Courtesy of Horton)

CAUTION Fan assemblies must be precisely balanced. An out-of-balance fan (even a small fragment missing from one blade) can unbalance the engine driving it. This type of out-of-balance condition can result in a failure of the crankshaft.

Fan Cycles

Because a fan assembly draws engine power, most diesel engines use lightweight, temperature-controlled fans. **Fanstat**, air/electric/oil pressure engaged clutch fans of the on-off type, are used as well as temperature controlled, viscous drive fans. The objective is usually to have the fan running as little as possible. In today's electronically controlled diesel engines, fan cycles (on or off) are usually managed by the engine ECM which can use sensor input from a variety of sources, some of which may be associated with nonengine systems such as heating, ventilation, and air-conditioning (HVAC).

Winter Fronts

Winter fronts, which are installed on the hood grill to limit the amount of ram air driven through the engine compartment, can load a fan off its axis and create an unbalancing effect whenever the fan is engaged. A winter front should not be necessary on most engines produced after 1990. When one is installed, ensure that it is approved by the truck chassis OEM. Never completely close a winter front.

Fan Shrouds

Fan shrouds are usually molded fiber or plastic devices bolted to the inside of the radiator. The shroud usually partially encloses the fan. This provides some safety if the fan engages when the hood is open and the engine is running. Shrouds play an important role in directing airflow through the engine compartment. A missing or damaged shroud can result in temperature

management problems. In hot weather conditions, fan efficiencies can be lowered by a defective or missing shroud, so they should be examined at each inspection.

Fan Belts and Pulleys

Fan pulleys use external-V or poly-V grooves and internal bearings. Belts should be adjusted using a belt tensioner. If belts are not properly adjusted they will fail.

- too tight: excessively loads the bearings and shortens bearing and belt life
- too loose: causes slippage and destroys belts even more rapidly than a too tight adjustment

Belts should be inspected as part of a PM routine. Replace belts when glazed, cracked, or nicked. Replacing belts with early indicators of failure costs much less in the long run than the breakdowns that may be caused by belts that fail in service. **Figure 8-15** shows a poly-V fan hub drive favored by Caterpillar.

Water Manifolds

The water manifold acts as a sort of main artery for the cooling system. It is usually a cast iron or aluminum assembly fitted to the cylinder heads. In some cases, it may house the thermostat(s). Both single-piece and

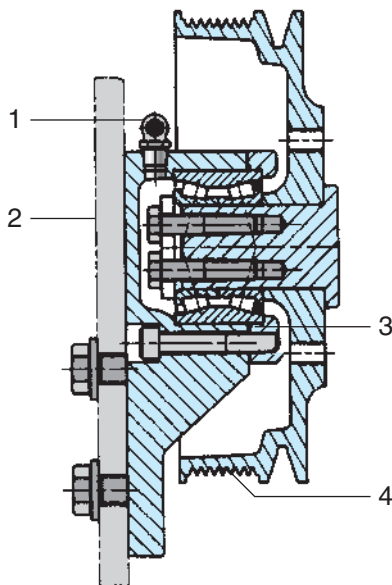

1. Fitting. Fill seal cavity with 2S3230 bearing lubricant
2. Fan drive mounting plate
3. O-ring seal
4. Poly-V belt pulley

Figure 8-15 Sectional view of a Poly-V fan drive. (Courtesy of Caterpillar)

multiple-section water manifolds are used. Water manifolds play an essential role in keeping the engine cylinders at a consistent temperature so they are used on most medium- to high-output diesel engines. Refer to **Figure 8-2** and **Figure 8-3** to compare engines that use coolant manifolds versus those that do not.

COOLING SYSTEM PROBLEMS

When a problem occurs in the cooling system, it can result in an engine failure if not repaired. What initially appears as a minor leak can quickly progress to a condition that can destroy an engine. Cooling system performance problems can be grouped into the following categories:

- overheating
- overcooling
- loss of coolant
- defective radiator cap
- defective thermostat

Leaks

Cooling system leakage is common. Most leaks are minor in nature and can be quickly repaired. A visual inspection of the cooling system is part of the driver or operator daily inspection. Cold leaks may be caused by the contraction of components at joints as an engine cools. Hose clamps are common sources of leaks. Cold leaks often cease to leak at operating temperatures because everything expands. Some fleet operators replace all the coolant hoses after a scheduled in-service period for no other reason than to avoid the costs of an over-the-road breakdown.

External Leaks. Silicone hoses are more expensive than the rubber compound type but they usually have longer service life. Silicone hoses require special clamps. Take care to torque these hose clamps to specification and remember that over-tightening can cause them to leak. Pressure testing a cooling system will locate most external cooling system leaks. A typical cooling system pressure-testing kit consists of a hand pump and gauge assembly. The gauge is calibrated from zero to around 25 psi (170 kPa). The kit contains various adapters for the different types of fill neck and radiator cap. Some are capable of vacuum testing.

Internal Leaks. Internal leaks can be more difficult to locate. When coolant is present in the engine oil, it forms a milky sludge that settles to the bottom of the oil pan. It is the first fluid to exit the oil pan when the drain plug is removed because it is heavier than oil. When an

internal leak is caused by a failed wet liner seal, the cylinder responsible has to be identified. To locate the engine cylinder, remove the oil pan, allow the oil to drip for a period, and then pressurize the cooling system using a standard hand pump testing kit. Place a sheet of cardboard under the engine and leave the cooling system under pressure. Wet liner O-ring seals may leak either cold or hot and even this method is not surefire.

Bubbles in Coolant. The appearance of bubbles may indicate that combustion gases are leaking into the coolant or that the engine is being run without thermostat(s). There are a couple of ways to determine whether combustion gases are leaking into the cooling circuit and the best method varies according to the engine you are testing. Pressure testing of the cooling system using the method outlined previously is the preferred method. On some engines, disconnecting the water pump drive, removing the piping to the upper radiator tank and the thermostat, filling the engine with coolant (water will do), and running the engine can identify cylinder leakage to the cooling system. The cooling circuit may also be pressurized by air from sources other than the engine: this could be from the air compressor, an auxiliary power unit (APU), or air-over-electric heater control valve.

WARNING *The use of cooling system agents that claim to stop leaks should generally be avoided even in a situation that might be described as an emergency. They may work temporarily, but they have been known to plug thermostats, radiator/heater cores, and oil cooler bundles. Generally, they cause more trouble than they cure.*

Stray Voltage Damage

Stray voltage grounding through engine coolant can result in electrolytic action that can cause considerable engine damage in unbelievably short periods of time. This electrolytic damage ranges from pinholes in heat exchangers to erosion pitting failures of cast iron liners and cylinder blocks. Stray voltage damage has become more commonplace due to the increase in electrical and electronic components combined with the introduction of nonconducting components such as plastic radiator tanks. Chassis static voltage buildup can also discharge through engine coolant.

One fleet hauling both tankers and flatbed trailers, using tractors with identical powertrains, reported that engine failures attributed to coolant electrolysis were only occurring in the tractors assigned to flatbeds. Trailer technicians will know that tankers have a dedicated ground circuit (known as *bonded ground*)

whereas flatbeds do not. Use the following method to identify stray voltage and eliminate it.

Testing for Stray Voltage. Stray voltage can be AC (alternator diode bridge leakage) or DC. It is more likely to be DC voltage. Use a DMM on autorange to perform the following tests, checking for DC first.

1. Run the engine and turn on all the vehicle electrical loads.
2. Place the negative DMM lead directly on the battery negative terminal and the other into the coolant at the neck of the radiator without touching metal.
3. Record voltage reading. A reading of 0.1 V-DC is acceptable; the maximum acceptable to most OEMs is 0.3 V-DC. If higher, you must locate the leakage source. A leakage of 0.5 V-DC is capable of eating out a cast iron engine block.
4. Shut down each electrical component in sequence while checking the voltage reading. When the leaking component or circuit has been identified, repair its ground. Attempting to ground the coolant at the radiator will not repair the problem.

COOLING SYSTEM MANAGEMENT

Most truck engine cooling systems are managed so that heating controls kick in the following sequence:

1. thermostat opens
2. shutterstat (if equipped) opens shutters
3. fan engages

You should remember this sequence, because this is usually what you are required to remember when tested on the subject. Because the fan consumes power, most OEMs manage the cooling system so that it is driven as little as possible. However, some open shutters before opening the thermostat to allow the thermostat full control of engine temperature and avoid sudden changes in engine compartment temperature caused by cycling the shutters. **Thermatic fans** sense underhood or engine compartment temperature. An underhood temperature of 155°F (68°C) can be generally reckoned to an engine coolant equivalent of 190°F (88°C).

Actively Pressurized Cooling Systems

As diesel engines have evolved to reduce exhaust emissions, the amount of heat an engine has to transfer to atmosphere has increased. Because the cooling system handles a large percentage of this heat, this has required some changes. C-EGR heat exchangers in particular

have increased the heat unloaded into the cooling system and in early systems (2004) some engines experienced coolant boiling in the C-EGR heat exchanger.

In the past, engine OEMs addressed increased heat unload into the cooling system by increasing the size of the radiator, increasing coolant capacity, and improving underhood airflow. The limiting factors of this approach were the physical space required by larger radiators and the higher energy consumption required by increased coolant volumes. Recently, some engine OEMs have opted to increase diesel engine cooling capacity by using an external means of pressurizing the cooling system and thereby raising the boiling point of the antifreeze mixture. The system is known as **actively pressurized cooling system (APCS)**.

An APCS is managed by the ECM and introduces air under pressure from an external pressurized source. This source is usually the intake manifold on turbo-charged engines. This pressurized air from the engine intake manifold is plumbed into a cooling system expansion tank by means of a flow control check valve. The flow control valve is a spring loaded non-return valve located in the connection plumbing for unidirectional flow between the intake manifold to the expansion tank.

Using higher system coolant temperatures requires proper pressurization under all operating conditions in

order to manage engine temperatures, ensure adequate coolant flow, and especially to prevent coolant boiling and possible overflow. An independent control module (separate from the engine ECM) is used to manage the APCS system. The functions of the APCS controller are to monitor:

- coolant level
- coolant pressure
- coolant temperature
- system malfunctions

The APCS controller manages:

- pressurization solenoid of the cooling system tank
- broadcast of system status and faults to the chassis data bus

COOLANT HEATERS

With many jurisdictions imposing anti-idling legislation, and many more proposing to, there is suddenly some urgency about installing climate control devices on trucks. These units keep the cab either warm enough or cool enough, depending on the season. Some of them work independently from the diesel engine HVAC circuit, such as Webasto's Blue Cool system which is A/C based on the old icebox system. However, most are

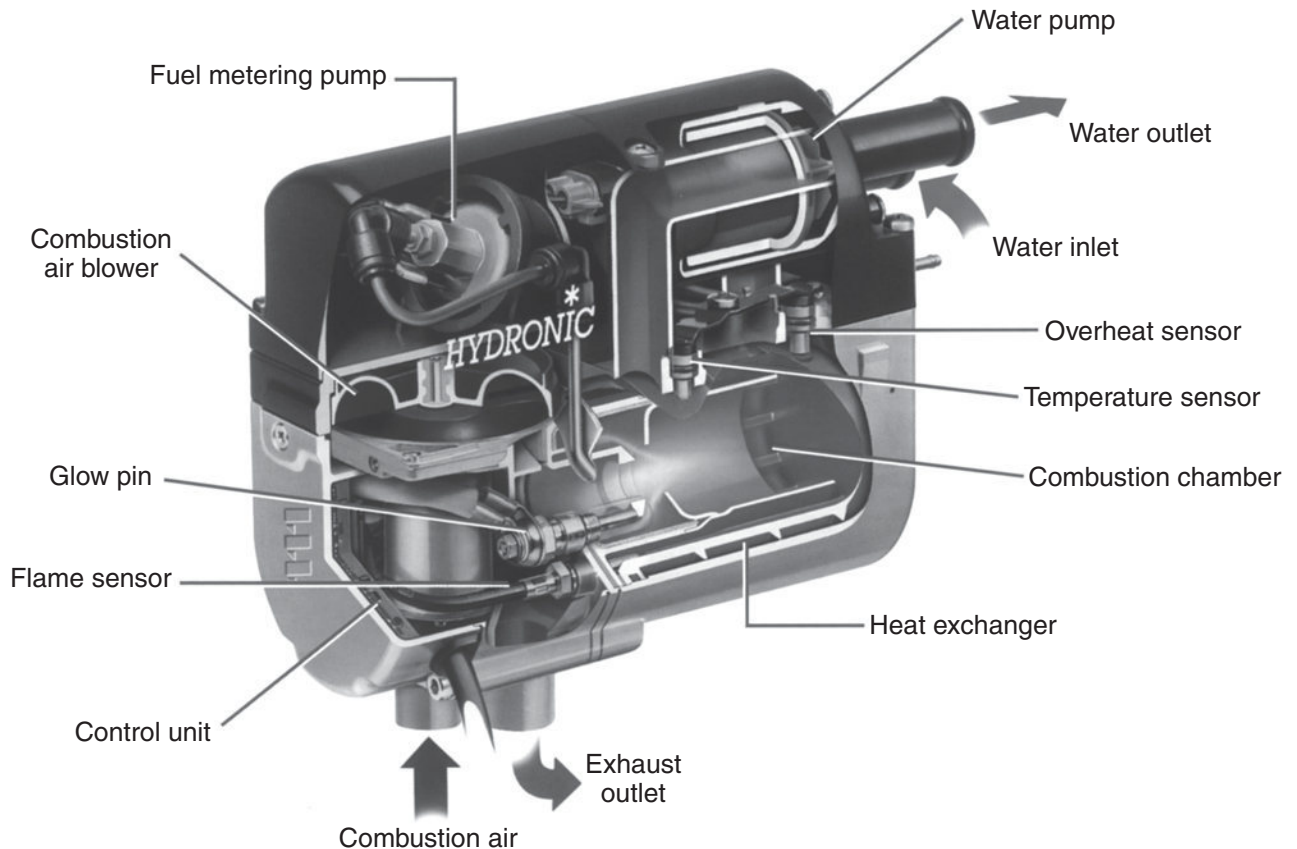

Figure 8-16 Espar hydronic coolant heater. (Courtesy of Espar)

integrated in some way into the engine HVAC circuit. Let us look at how a typical coolant heater operates.

Diesel Fired Coolant Heater

A diesel fired coolant heater sources the main fuel system for its supply of fuel. These units are intended to be operated only when the vehicle is parked with the

engine off. A typical coolant heater consists of a burner nozzle, combustion chamber, heat exchanger, and coolant circulation pump. System control is electronic and key sensors in the system are a coolant temperature sensor, overheat sensor, and flame sensor. Some use spark ignition but the unit shown in **Figure 8-16** uses a glow pin. Heat regulation can usually be managed at several different levels.

Summary

- At its best, a diesel engine converts about 40 percent of the heat energy released by burning fuel into useful mechanical energy. The remaining 60 percent of the potential energy of the fuel is released as *rejected heat*.
- Approximately half of the *rejected heat* of combustion is transferred to the engine cooling system. The cooling system is responsible for transferring this heat to the atmosphere.
- The cooling system uses the principles of *conduction*, *convection*, and *radiation* to transfer heat from the coolant to the atmosphere.
- A diesel engine cooling system has four main functions: to absorb combustion heat, to transfer the heat using coolant to heat exchangers, to transfer the heat from the heat exchangers to atmosphere, and to manage engine operating temperatures.
- The main components of a diesel engine cooling system are the water jacket, coolant, a coolant pump, a radiator, thermostat(s), filter(s), shutters, temperature sensing circuit, and a fan assembly.
- Water expands in volume both as it freezes and as it approaches its boil point. The engine cooling system must accommodate this change in volume.
- Engine coolant is a mixture of water, antifreeze, and supplemental coolant additives (SCAs).
- Three types of diesel engine coolant are in current use: ethylene glycol (EG), propylene glycol (PG), and premixed extended life coolant (ELC).
- Diesel engine coolant should protect against freezing, boiling, corrosion, scaling, and foaming. It should neutralize acid buildup.
- The correct instrument for reading the degree of antifreeze protection of a coolant is a refractometer.
- Mixing coolant solutions should be performed in a container outside of the engine cooling system and then added.
- Supplemental coolant additives (SCAs) are a vital component of engine coolant. The SCA levels must be routinely tested in EG and PG coolants because their strength reduces in service.
- Premixed ELC is claimed to have a service life of 600,000 miles (966,000 km) or 6 years, during which a single SCA recharge is required.
- Where possible, the radiator is located in the airflow at the front of the chassis to take advantage of ram air cooling.
- Most radiators are of the single-pass, downflow type, but crossflow and double-pass routing is also used.
- Radiator caps are equipped with a pressure valve used to define maximum cooling system operating pressure. They are also equipped with a vacuum valve to prevent hose collapse as the system cools and pressure drops.
- Coolant pumps are either belt or gear driven. They use a centrifugal operating principle.
- Coolant pumps are lubricated by the coolant. When antifreeze is mixed with hard water, abrasive damage can occur at the impeller.
- Care should be taken when servicing coolant filters because some are precharged with SCAs. SCA overload into the system can cause coolant problems.
- The commonly used coolant temperature sensor on today's electronically managed engines is the thermistor. A thermistor is a temperature sensitive, variable resistor.
- Coolant level sensors ground a reference signal into the coolant in the top radiator tank. An alert is triggered when the ground circuit is broken.
- Thermostats manage the engine temperature to ensure fast warmup, good performance, fuel economy, and minimum noxious emissions.

- Thermostats route the coolant through the bypass circuit to permit rapid engine warmup.
- Shutters control the airflow through the engine compartment by means of slats that open and close like Venetian blinds.
- Shutters are controlled by a shutterstat, which is located in the water manifold and uses chassis system air pressure to open and close the shutters.
- Shutters are usually designed to default to a fully open position.
- Most engine compartment fans are temperature controlled, either directly on the basis of coolant temperature measured by a thermistor or fanstat, or indirectly based on engine compartment temperature.
- Flex blade composite, plastic, or fiberglass fan blades alter their pitch based on engine rpm. This permits higher fan efficiencies at low rpm when coolant is being moved through the engine at a low rate.
- Viscous type, thermatic fans sense underhood temperatures and are driven by a fluid coupling designed to produce minimum slip at their nominal operating temperature.
- Fan assemblies are driven by external-V or poly-V belts. Belt tension should be adjusted using a belt tension gauge to avoid bearing and slippage problems.
- Testing a cooling system for external leaks is performed using a hand-actuated pressure-testing kit. The kit consists of a pump, pressure gauge, and a variety of fill neck and radiator cap adaptors.
- Because modern diesel engines run hotter than those of a generation ago, some OEMs use APCS. An APCS pressurizes the cooling system to raise the boil point of the engine coolant.
- Recent anti-idling legislation has led to the increased use of engine coolant heaters. These are electronically controlled, diesel-fired heaters that keep coolant warm and circulating during engine-off in cool temperatures.

Internet Exercises

Use a search engine and research what comes up when you enter the following key words:

1. ethylene glycol
2. propylene glycol
3. long life antifreeze
4. Texaco antifreeze products
5. cavitation on wet liners

Shop Tasks

1. See if you can identify the engine coolant used in a specific engine.
2. Use a refractometer or hydrometer to measure the antifreeze protection of a coolant.
3. Use a litmus paper to measure the acidity of an antifreeze.
4. Pressure test a diesel engine cooling system and check for leaks.
5. Outline the procedure required to test SCAs for the engine you are working on.

Review Questions

1. Which type of diesel engine coolant is regarded as potentially the most harmful?
 - A. EG
 - B. PG
 - C. Pure water
 - D. ELC
2. What causes wet liner cavitation?
 - A. Aerated coolant
 - B. Combustion gas leakage
 - C. Air in the radiator
 - D. Vapor bubble collapse

3. What causes cooling system hoses on an engine to collapse when the unit is left parked overnight?
 - A. This is normal.
 - B. Defective thermostat
 - C. Improper coolant
 - D. Defective radiator cap
4. When a radiator cap pressure valve fails to seal, which of the following would be more likely to occur?
 - A. Coolant boil-off
 - B. Cooler operating temperatures
 - C. Higher HC emissions
 - D. Cavitated cylinder liners
5. In a typical diesel-powered highway truck at operating temperature, which of the following should be true?
 - A. Coolant temperatures run cooler than lube oil temperatures.
 - B. Coolant temperatures run warmer than lube oil temperatures.
 - C. Coolant temperatures should be equal to lube oil temperatures.
6. What operating principle is used by a typical diesel engine coolant pump?
 - A. Positive displacement
 - B. Centrifugal
 - C. Constant volume
 - D. Gear type
7. When the thermostat routes the coolant through the bypass circuit, what is happening?
 - A. The coolant is cycled primarily through the radiator.
 - B. The coolant is cycled primarily through the engine.
 - C. The coolant is cycled primarily through auxiliary heat exchangers.
8. Fiberglass fans with flexible pitch blades are designed to drive air at greatest efficiency at:
 - A. Low speeds
 - B. All speeds
 - C. High speeds
9. In the event of an engine overheating, where is the coolant likely to boil first?
 - A. Engine water jacket
 - B. Top radiator tank
 - C. Inlet to the coolant pump
 - D. Thermostat housing
10. What instrument do most engine OEMs recommend for checking the degree of antifreeze protection in a heavy-duty diesel engine coolant?
 - A. Hydrometer
 - B. Refractometer
 - C. Spectrographic analyzer
 - D. Color-coded test coupon

CHAPTER

9

Engine Breathing

Prerequisites

Chapters 3, 4, and 5.

Learning Objectives

After studying this chapter, you should be able to:

- Identify the intake and exhaust system components.
- Describe how intake air is routed to the engine's cylinders.
- Describe how exhaust gases are routed out to aftertreatment devices.
- Define the term *positive filtration*.
- Outline the operating principle of an air precleaner.
- Service a dry, positive air cleaner.
- Perform an inlet restriction test.
- Identify the subcomponents on a truck diesel engine turbocharger.
- Define constant and variable geometry turbochargers.
- Outline the operating principles of turbochargers.
- Troubleshoot common turbocharger problems.
- Define the role of a charge air cooler in the intake circuit.
- Test a charge air heat exchanger for leaks.
- Relate valve configurations and seat angles to breathing efficiency.
- Outline the role of a diesel engine muffler device.
- Identify the different types of catalytic converters used on current diesels.
- Describe the operation of EGR and DPF systems.

Key Terms

catalytic converter

cooled exhaust gas recirculation
(C-EGR)

charge air cooler (CACs)

clean gas induction (CGI)

compressor housing

constant geometry (CG)

crossflow valve configuration

exhaust gas recirculation (EGR)

heat exchanger

internal exhaust gas recirculation (I-EGR)	parallel port valve configuration	turbine
impeller	positive filtration	turbocharger
inlet restriction gauge	ram air	variable geometry (VG)
intake circuit	rejected heat	variable nozzle (VN)
manifold boost	resonation	variable valve actuator (VVA)
naturally aspirated	sound absorption	

INTRODUCTION

Diesel engine intake and exhaust systems share common components in the turbocharger and exhaust gas recirculation (EGR) system. For this reason, it makes sense to study intake and exhaust systems together. Turbochargers boost the intake manifold at pressures above atmospheric and they use **rejected heat** from the exhaust system to do it. EGR systems reroute exhaust gas back into the **intake circuit** to reduce emissions so they also have a role in both intake and exhaust systems.

Turbocharged diesel engine cylinders are *charged* with air in most current diesel engines. In a **naturally aspirated** diesel engine, air is drawn into the engine cylinder by the lower than atmospheric pressure created in the engine cylinder on the downstroke of the piston on its intake stroke. In reality, you will seldom see a naturally aspirated commercial diesel engine today. For this reason, when discussing the intake circuit in this chapter, we make the assumption that the engine is turbocharged. Turbocharging provides manifold-boost. A manifold-boosted engine charges its cylinders with air at pressures above atmospheric in most phases of operation.

Gas Flow in the Breathing Circuit

Figure 9-1 is an overview of the gas flow of a typical post-2007 engine breathing circuit. We have used a series turbocharged (twin turbo) system because this has become common in modern diesel engines. The figure looks complicated and it is. The reality is that this schematic simplifies the circuits shown, which are ECM-controlled and monitored by numerous sensors. In this chapter we will follow the gas flow through the engine breathing circuit beginning at the air cleaner and ending at the exhaust stack.

Role of the Intake System

The role of the intake system in a diesel engine is to supply a charge of air or air/dead gas mixture to the engine cylinders. This gas mixture is used for combustion,

cooling, and cylinder scavenging. Even when naturally aspirated and especially when turbocharged, diesel engines are designed for lean burn operation. This means that under most operating phases, there is significantly more air present in the engine cylinder than that required to burn the fuel. A generation ago, the objective of diesel engines was to cram as much air into the engine cylinders as possible. This was great for performance but bad news for emissions. Today engines must be managed so that they achieve the best fuel economy while producing a minimum of harmful emissions.

Role of the Exhaust System

The role of the exhaust system is to minimize engine noise while keeping harmful exhaust emissions at a minimum. As stated earlier, the turbocharger is common to both intake and exhaust systems. Its function is to use the exhaust system to recapture some of the waste heat from engine cylinders by pressurizing the air delivered to the engine cylinders from the intake circuit. Current certified highway diesel engines have complicated exhaust aftertreatment systems to minimize emissions. Diesel intake and exhaust systems have to work together to achieve the best fuel economy while minimizing emissions. For this reason, the breathing circuit is managed by the engine electronics. This was not so in older engines. **Figure 9-2** shows the components of a more simple diesel engine breathing circuit commonly used before 2004 emissions standards.

BREATHING COMPONENTS

We begin by identifying the breathing components used on a current four-stroke cycle, highway-certified diesel engine.

Current Four-Stroke Cycle

Bear in mind that older engines may not be equipped with all of the components listed here. EGR became commonplace in 2004 and diesel particulate filters (DPFs) in 2007.

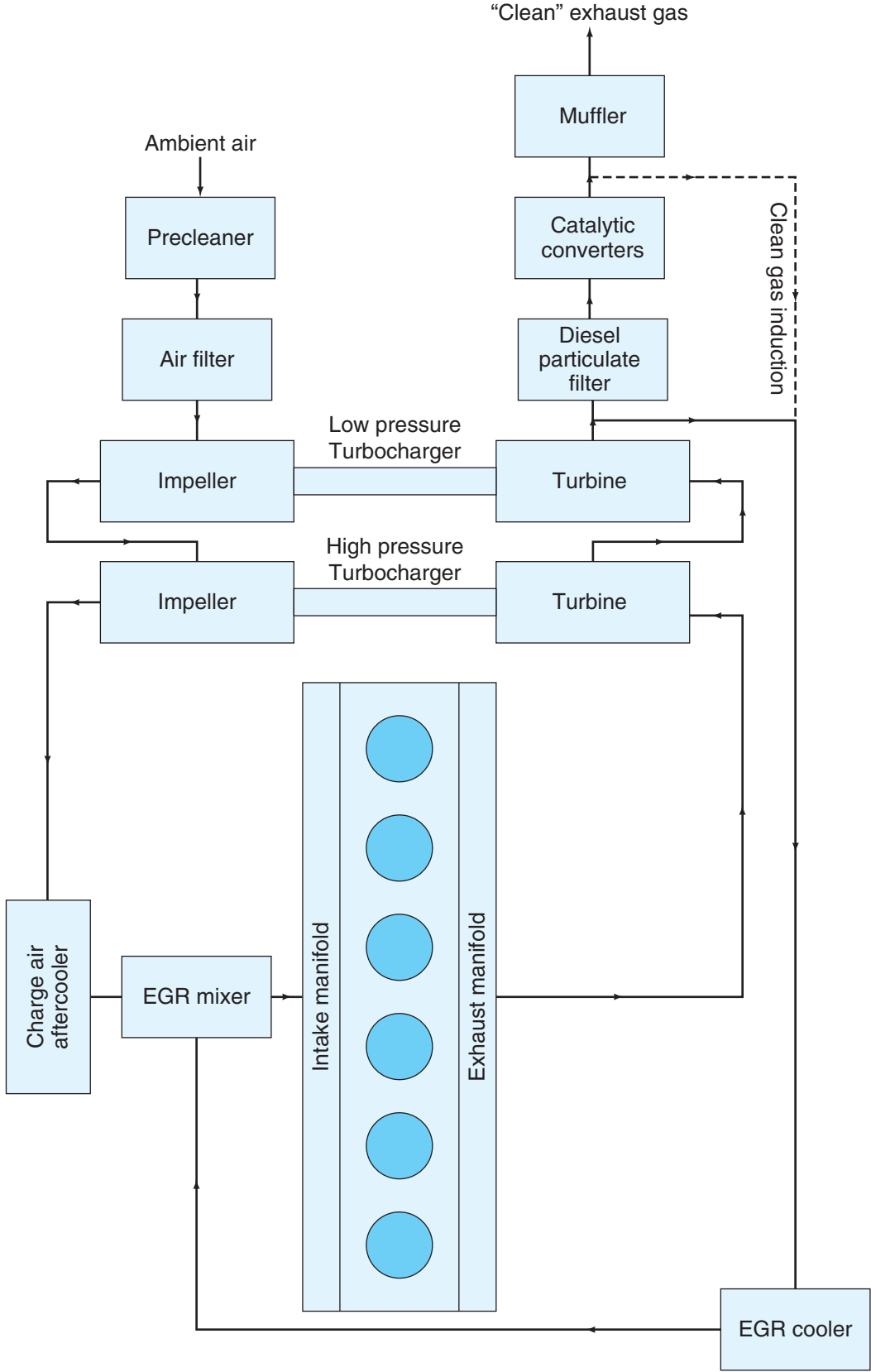

Figure 9-1 Schematic showing gas flow through a typical post-2007 engine breathing circuit.

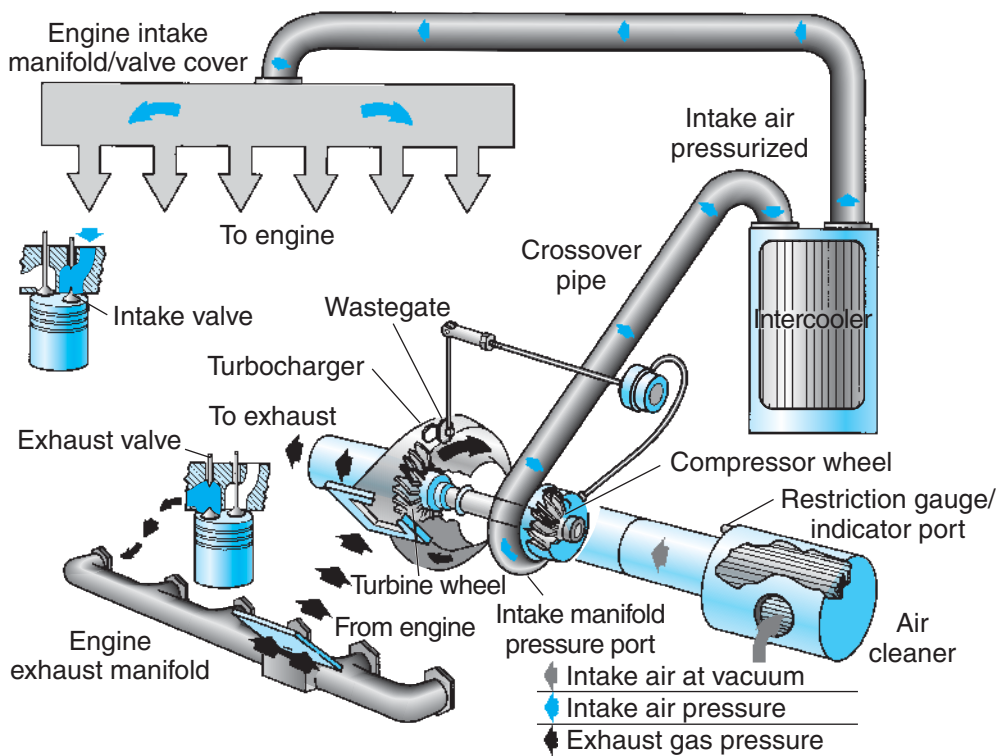

Figure 9-2 Typical pre-2004 diesel engine breathing circuit. (Courtesy of Navistar)

Intake System Components

1. precleaner
2. main filter
3. intake ducting/piping
4. turbocharger(s) and turbocharger controls
5. charge air cooling circuit
6. intake module for mixture management of EGR
7. intake manifold
8. valve porting and cylinder head design

Exhaust System Components

1. valve configuration and exhaust tract geometry
2. exhaust manifold
3. turbocharger(s) and turbocharger controls
4. EGR system
5. exhaust piping
6. diesel particulate filter
7. pyrometer(s)
8. catalytic converter(s)
9. selective catalytic reduction (SCR)
10. muffler

AIR INTAKE SYSTEM COMPONENTS

The air intake system components are those responsible for delivering ambient air and dead gas rerouted from the exhaust system to the engine's

cylinders. The ambient air is filtered upstream from the turbocharger(s). Turbochargers pressurize intake air well above atmospheric pressure values to increase the oxygen density of the intake charge. In pressurizing the air, the temperature increases and this has a reducing effect on its density. To counter this, most turbo-charged engines use some form of **heat exchanger** to cool the boost air (while maintaining the pressure) before it is directed into the engine cylinders. The term used to describe this heat exchanger is *charge air cooler (CAC)*. When the air exits the CAC it is routed to an engine ECM controlled EGR mixer. Depending on how the engine is being operated, the boost air is mixed with dead gas routed from the exhaust system. We will follow the intake circuit component by component in this section.

Air Cleaners

The function of the air cleaner system on a highway diesel engine is to filter airborne particles from the air before it is routed to the engine cylinders. Airborne dirt can be highly abrasive and when it finds its way past the air cleaner system, it can destroy an engine in a very short period.

Precleaners. Precleaners are required in trucks operating in dusty conditions. This is especially true in winter conditions when highways are gridded and salted.

A precleaner can triple the service life of the main engine air filterer. Air filters use turbulence to separate heavier particulates by centrifugal force. After being separated, these heavier particles can either be exhausted or collected in a dust bowl. In addition to a precleaner, trucks operating in extremely dusty conditions may use precleaner screens. However, pre-cleaner screens can easily plug so they have to be used with inlet restriction gauges. In agricultural and mining applications, a precleaner can be connected to the exhaust system so that exhaust back pressure pulls particles into the exhaust gas.

Dry, Positive Filters. Dry, **positive filtration** air cleaners are commonly used today. Because they use a positive filtration principle, *all* of the air entering the intake system must pass through the filtering element. The filter element is usually pleated paper surrounded by a perforated steel mesh. It should be noted that a small dent in the surrounding mesh is enough to cause leakage past the filter. An element that fails to seal in the filter housing should be replaced. Filtering efficiencies in modern filters are usually stated to be better than 99 percent.

Servicing Air Filters. Dry paper element filters are designed to last for as long as 12 months in a line-haul application. This means they do not have to be replaced unless the inlet restriction specification exceeds the OEM specification. When this happens, the filter has become plugged. Inlet restriction is a measure of how much airflow resistance occurs upstream from the turbocharger compressor. It is measured by a negative pressure gauge. Most truck air filter housings are equipped with on-board inlet restriction gauges. These are not accurate instruments. When a filter mounted inlet restriction gauge indicates that the filter element is plugging before a scheduled service, the reading should be checked using an accurate negative pressure gauge. Never remove an air filter from its canister unnecessarily. Every time a filter is serviced, some dust will be admitted beyond the filter assembly, no matter how much care is taken.

Checking filter restriction with a trouble light is not recommended. To perform this test the filter element has to be removed from its housing. The only reason for inspecting a dry filter with a trouble light is to locate a perforation through which larger particles can pass. Inlet restriction is measured in inches of water vacuum. OEM specifications should always be consulted but typical *maximum* inlet restriction specifications are:

- 15 in. H₂O vacuum for NA engines
- 25 in. H₂O vacuum for boosted engines

The practice of removing and attempting to clean a dirt-laden, dry filter on the shop floor should be avoided. A dirt-laden filter weighs many times the weight of a new filter and dropping it onto a concrete floor to shake dust free is usually sufficient to damage the filter element (by crumpling the perforated mesh) sufficiently to prevent it from sealing in the housing. A worse practice is reverse blowing out of filters using compressed air. This may loosen sharp particles but leaves enlarged openings through which other larger particles can pass.

.....
Tech Tip: One of the first tests that should be performed when troubleshooting black smoke emission from an engine is to check inlet restriction. If the on-board restriction gauge is reading high, connect a negative pressure gauge to confirm the reading. The engine should ideally be tested under load, but a throttle snap to high idle should give a close indication.

Laundering Dry Element Filters. When a dry filter element has become plugged the ideal solution is to replace it. However, dry filter elements are expensive and in some operations, such as on construction sites, mining, and aggregate hauling, a filter can become restricted in a couple of working days even when pre-cleaners are used. Professional laundering is a second-best option to replacement. The laundering process usually requires that the filter element be soaked in a detergent solution for a period of time, followed by reverse flushing with low-pressure clean water. The element is next dried with warm air and inspected for perforations in the element. When professionally laundered filter elements are tested, filtering efficiencies are reduced with each successive laundering.

Inlet Restriction Gauges. **Inlet restriction gauges** are resettable gauges mounted either on the filter canister or remotely in the vehicle dash. They provide a readout in inches of water vacuum in the same way the manometer does. Inlet restriction gauges are not noted for their accuracy. However, they provide an indication of when filter service is required. You can see the location of the inlet restriction gauge in **Figure 9-2**.

TURBOCHARGERS

Turbochargers are used on most domestic medium- and large-bore, highway diesel engines. By definition, a **turbocharger** is an exhaust gas-driven, centrifugal

pump that “recycles” some of the rejected heat from the engine’s cylinders. Turbochargers may be driven to speeds exceeding 200,000 rpm in certain race car engine applications but maximum speeds are about 30 percent lower in diesel engines. Turbochargers are used to add to engine power in two ways:

- by delivering a pressurized charge of intake air to the engine’s cylinders
- by delivering drive torque to the engine drivetrain

Principles of Operation

When a turbocharger is used to pressurize the intake air supplied to the engine cylinders, exhaust gas heat is directed onto a **turbine**. This exhaust gas heat rotates the turbine. Connected by means of a shaft to the other end of the turbine is a compressor wheel. When the compressor wheel is driven by the turbine, pressurized air is developed. This increases the oxygen density in the air charge. In more recently introduced highway diesel engines, the exhaust gas-driven turbine is used with a fluid coupling to drive reduction gearing. The reduction gearing connects with the engine drivetrain. In this way, the turbocharger assists in driving the crankshaft.

Construction. Another way of describing a turbocharger is to call it an exhaust gas-driven air pump consisting of a turbine and an **impeller**. The turbine and impeller are connected by a common shaft. The shaft is supported by bearings supplied with pressurized lube oil. The turbine wheel turns in the turbine housing. Engine exhaust gas is routed through the turbine housing. The impeller is enclosed in a separate **compressor housing**. When it is turned by the turbine, it pumps intake air from the air filter pressurizing it. The exhaust gas that drives the turbine and the intake air the impeller pressurizes do not come into contact. **Figure 9-3** shows the gas flow through a simple turbocharger.

Compressor Operation. Filtered intake air is pulled into the compressor housing by the impeller. The turbine drives the impeller on the other side of the turbine shaft: this means that the actual speed of the impeller is determined by what is happening in the turbine housing. As the impeller rotates, the air in the intake system is accelerated to high speeds. High-speed air flows from the impeller to a restricted flow area. This restriction in the impeller housing converts the high-speed air into compressed air.

Turbine Operation. Exhaust gas is routed to the turbine housing. The greater the amount of heat in the

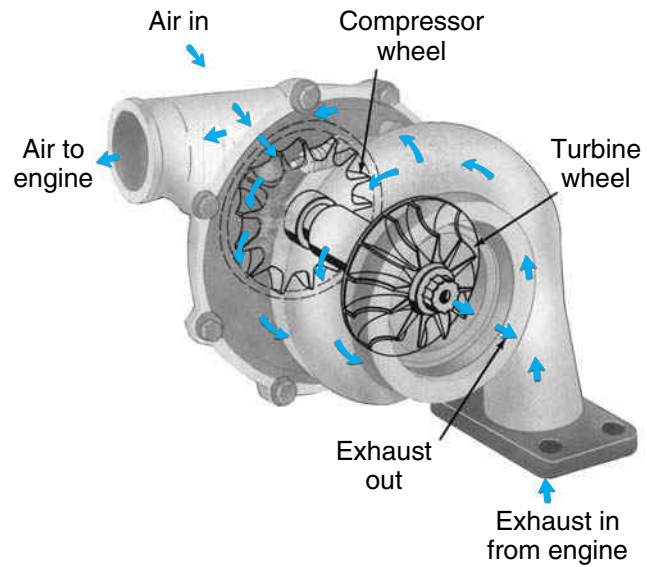

Figure 9-3 Gas flow through a turbocharger. (Courtesy of Schwitzer Engine Components, Schwitzer Group)

exhaust gas, the faster the turbine rotates. This means that turbine speeds are highest when engine loads are high. Exhaust gas enters the turbine housing radially. It is routed into a reduced flow area known as a volute. The volute restricts flow. However, as the exhaust gas exits the volute it expands, acting on the turbine vanes before being routed into the exhaust. The amount the exhaust gas expands depends on the amount of exhaust gas heat. The more exhaust gas heat, the more gas expansion and the faster the turbine rotates. Turbocharger speeds depend mainly on the exhaust gas heat and less on exhaust gas pressure.

The role of the volute should be understood. The smaller the volute size, the greater the restriction to exhaust gas flow. However, the smaller the volute, the greater the gas expansion as this gas exits to act on the turbine. The best arrangement is to be able to control the volute flow area, which we will look at next. **Figure 9-4** shows turbocharger gas flow. In the schematic you can see the key roles played by the volute and diffuser: note how gas flow enters and exits the turbine and compressor housings.

Types of Turbochargers

It is important to identify the two general categories of turbocharger. The definitions we use in this textbook are as follows:

- **Constant geometry:** a turbocharger in which all of the exhaust flow is routed through the turbine housing regardless of how the engine is being operated.

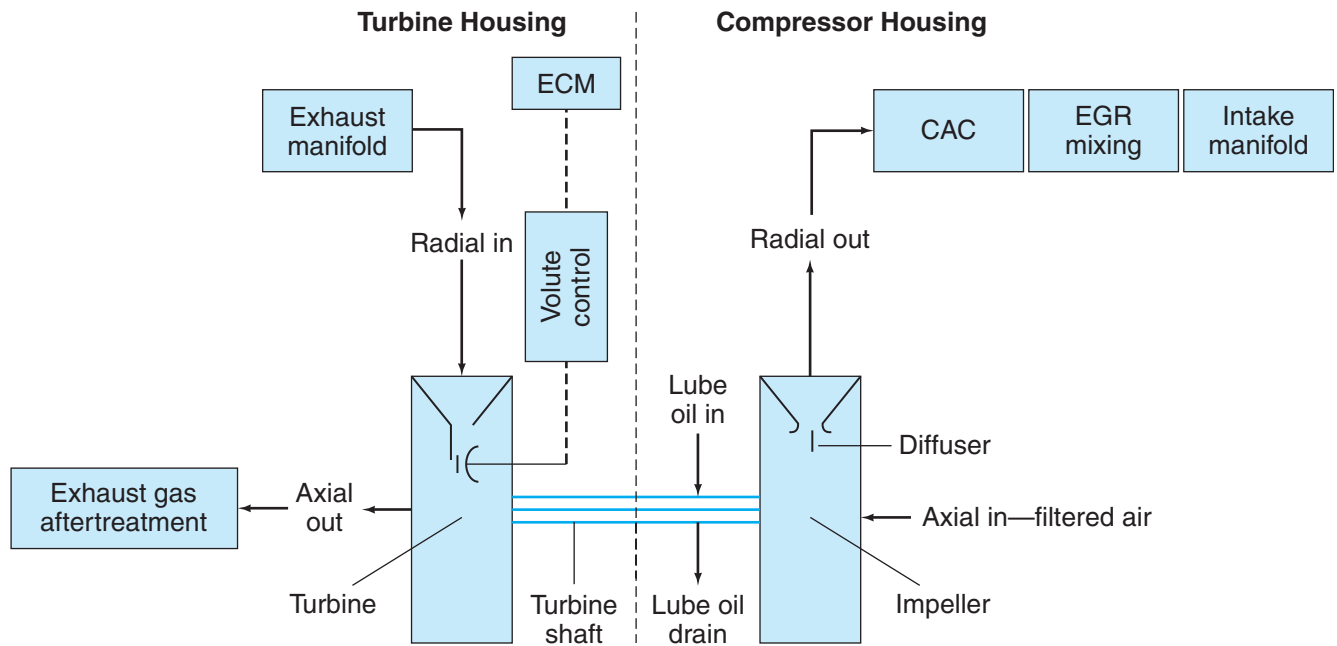

Figure 9-4 Turbocharger gas flow schematic indicating the roles played by the volute and diffuser.

- Variable geometry: a turbo that uses either external or internal controls to determine how the exhaust gas passes through or around the turbine housing.

Constant geometry turbochargers were common a generation ago. Today, almost all turbochargers use one of a couple of types based on the variable geometry principle.

Constant Geometry Turbos. **Constant geometry (CG)** turbos are designed to produce their best performance at a specific rpm and engine load. They are not versatile. This limits their output. Highway engines that used CG turbos were usually spec'd to produce peak efficiency under full load and at peak torque rpm. This meant that whenever the engine was operated outside that specified point, a performance shortfall would result. An advantage of CG turbos is that they are simple, so there is little that can go wrong. **Figure 9-4** shows a typical CG turbocharger.

WARNING *Mismatching of CG turbochargers to an engine can result in damaging diesel engines either by producing high engine cylinder pressures or by causing low power, smoking, and high emissions.*

Variable Geometry Turbos. Earlier in this chapter we defined a **variable geometry (VG)** turbocharger as one that uses either external or internal controls to determine how exhaust gas flows either through or

around the turbine housing. For purposes of studying VG turbos they can be divided as follows:

- wastegate controlled
- volute controlled

The objective of VG turbos is to:

- allow the turbo to act like a small turbocharger when engine loads are light.
- allow the turbo to act like a large turbocharger when engine loading is high.

Today's ECM controlled turbochargers can adapt to produce good performance however the engine is being operated. In addition, they can do this with almost no turbo lag (response to a change in conditions) and while keeping emissions at a minimum.

Wastegate Controlled VG. Wastegated turbochargers have been around for many years. They can either allow all the exhaust gas to be routed through the turbine housing, similar to a CG turbocharger, or allow a percentage of the exhaust gas to bypass the turbine. When this happens, the wastegate routes exhaust directly to the exhaust circuit. The *gate* in the wastegate functions as the exhaust gas control door. Two methods are used to control the gate:

- Manifold pressure: Wastegate movement depends on the amount of turbo-boost.
- Electronic: Wastegate is positioned by the engine ECM.

MANIFOLD PRESSURE WASTEGATE

A manifold pressure wastegate is often known as a pneumatically controlled wastegate. It uses a wastegate actuator that has the appearance of a can with an actuator rod protruding from one end. The actuator rod moves the gate. The actuator rod connects to the wastegate door at one end. The other end connects to a bellows inside the can. An internal spring within the can holds the actuator to its closed position. In the closed position, all the exhaust gas is routed through the turbine housing. On the other side of the bellows, intake manifold-boost acts against the spring. When intake manifold-boost reaches a specified value, it begins to overcome the spring pressure, moving the actuator rod to allow some of the exhaust gas to bypass the turbine housing.

ELECTRONIC WASTEGATE

The engine ECM manages electronically controlled wastegates. This means that exhaust gas can either be full-flowed or a percentage can bypass the turbine housing. With an ECM controlled wastegate, the wastegate door is controlled according to how the ECM is managing engine performance and emissions: it is not limited by how much intake manifold-boost is being produced. In other words, an electronically managed wastegate provides much more flexibility than a pneumatic wastegate.

Volute Controlled VG. Volute controlled VG turbochargers have become more common on today's diesel engines. Race car engines have used variable nozzles to control the volute flow area for many years. Diesel engines successfully adapted this technology about 10 years ago. The first volute controlled diesel engine turbochargers appeared in the early 1990s with limited success, but today most diesel engine OEMs are using variable volute in preference to wastegated turbochargers. **Figure 9-5** shows a volute controlled VG turbocharger on the system used on a post-2007 Caterpillar ACERT C7 engine.

Variable Nozzle Turbocharger. **Figure 9-5** shows a sectioned view of what Caterpillar call a **variable nozzle (VN)** turbo. This type of variable volute technology has become popular with OEM post-2007 engines. Identify the turbine, pin wheel, vanes, and unison ring by cross-referencing this figure with **Figure 9-6**.

The VN turbocharger alters the volute flow area by moving the vane pitch. This means it can be managed to produce exactly the amount of boost required for any engine load or rpm. Vane pitch movement is accomplished when oil pressure acts on the piston: the piston is tooth-meshed to the cam gear and crankshaft.



Figure 9-5 Caterpillar C7 variable nozzle turbocharger cutaway. (Courtesy of Caterpillar)

This movement “cranks” (turns) the unison ring. The unison ring supports the vane assemblies. Each vane has a spiral slot. When the unison ring rotational position changes, vane pitch angle changes. This is because each vane pivots on wheel pins. Whenever the crankshaft moves the unison ring, the vane pitch is altered simultaneously. In this way, the volute (inflow) flow area can be increased or decreased. As we have

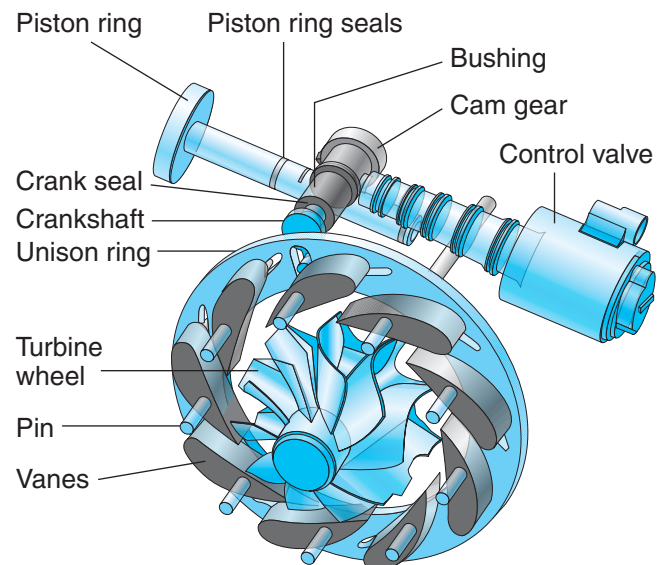

Figure 9-6 Component operation of a VN turbocharger. (Courtesy of Caterpillar)

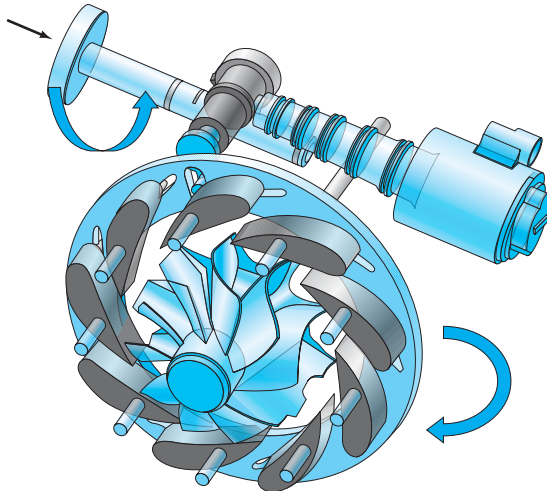

Figure 9-7 VN turbocharger: opening vane pitch to reduce turbine efficiency. (Courtesy of Caterpillar)

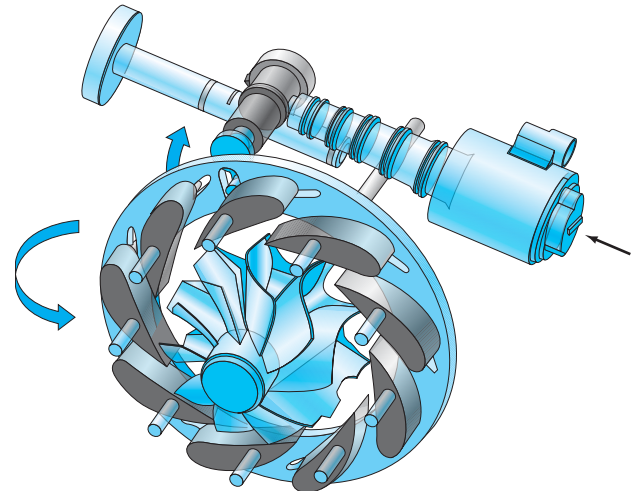

Figure 9-8 VN turbocharger: closing down vane pitch to produce maximum boost. (Courtesy of Caterpillar)

said previously, controlling the volute flow area onto the turbine has a lot to do with determining how fast the turbine rotates. Because this defines turbine speed, it is capable of managing boost pressure.

VN ACTUATOR

The VN turbocharger is controlled by the VN control valve. The VN control valve is a proportioning solenoid managed by the ECM. It converts the current delivered to the actuator into a specific piston ring position. Maximum boost is produced when the vanes are held in the nearly closed position: they are never fully closed.

Boost air is managed by vane position because vane pitch determines how exhaust gas acts on the turbine. In **Figure 9-7**, oil pressure acting on the piston ring moves the cam and crank assembly, turning the unison ring clockwise. Moving the unison ring clockwise opens the vanes, reducing turbine gas efficiency. This has the effect of reducing manifold-boost. When oil pushes the piston to the left (see **Figure 9-8**), the unison ring turns counterclockwise, moving the vane pitch to their nearly closed position and increasing turbine efficiency to provide maximum boost. You can see this action in **Figure 9-9**.

The rotational speed of the VN turbocharger is signaled to the ECM by a shaft speed sensor. The shaft speed sensor uses an inductive pulse generator principle (explained in **Chapter 14**); the trigger is a flat on one section of the turbine shaft.

Sliding Ring Volute Turbos. Another way of varying the volute flow area is by having the VG actuator move a sliding ring. As the ring moves, it determines flow unload area. The objective is identical to that used on the variable nozzle turbos. **Figure 9-10** shows an overhead

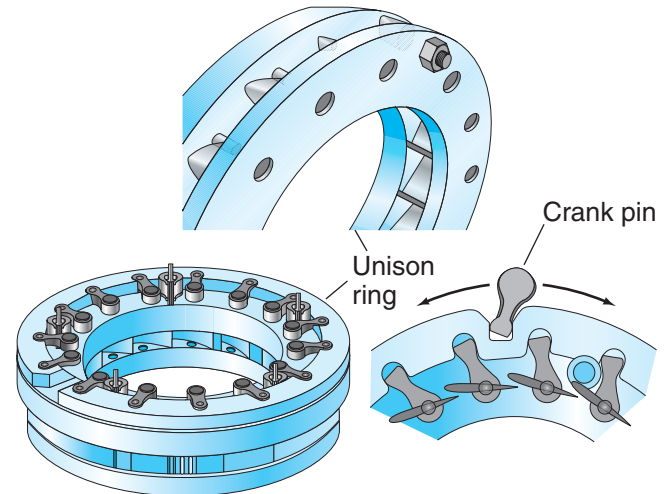

Figure 9-9 Action of unison ring in controlling vane pitch. (Courtesy of Caterpillar)

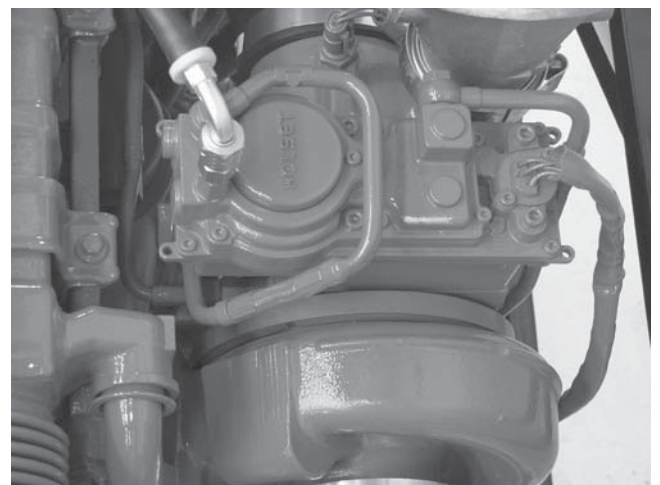

Figure 9-10 Overhead view of the VG actuator module used on a post-2007 Cummins ISC engine.

view of the VG actuator module used on a post-2007 Cummins ISC engine.

.....
Tech Tip: At no time should technicians tamper with turbocharger wastegates or actuators. It is not only illegal (emission control device) but could result in catastrophic engine damage.

Turbocharger Lubrication. All current turbochargers use floating friction bearings. Turbo bearings are designed to rotate in operation and do so at about one-third shaft speed floated with a film of oil on either side of the bearing. The operating principle is that of friction bearings. This means that the turbine shaft is hydrodynamically supported during operation. Accordingly, the radial play specification is a critical determination of bearing and/or shaft wear.

Turbine shaft radial play can be measured using a dial indicator. A thrust bearing defines the endplay of the turbine shaft. Gas pressure on both the turbine and compressor housings is sealed by a pair of piston rings. The oil that pressure feeds the bearings spills to an oil drain cavity and then drains to the crankcase by gravity through a return hose. The lubricating oil required for the bearings also plays a major role in cooling the turbocharger components.

Common Manifold Turbocharging. A single-pipe manifold is flange mounted to the exhaust tract of each engine cylinder. A single turbocharger turbine housing flange is located at the center of the assembly. This represents the single exit flange in the exhaust manifold. This manifold design creates certain problems. First, gas flow from each engine cylinder is not even to the turbocharger and the exhaust dump from one engine cylinder can conflict with that from other engine cylinders. Next, the effective heat per exhaust slug discharged into the manifold is not balanced. For instance, each exhaust slug volume discharge from cylinders 1 and 6 (on an inline, six-configured engine) has to travel much farther than those from cylinders 3 and 4 before entering the turbine housing.

Pulse/Tuned Exhaust Manifold. Most current diesel engines use tuned exhaust manifolds. This means that the pipes from the cylinder heads that direct the exhaust gas from each cylinder are matched for minimum flow interference at most engine operating phases and are designed to complement each other at peak power. Tuned exhaust manifolds reduce turbo lag

(turbocharger response time) and may increase low engine load performance.

TWO-STAGE OR SERIES TURBOCHARGING

Series turbocharging requires use of two turbochargers in series. The terms *primary and secondary turbochargers* or *low- and high-pressure turbochargers* are used. In series turbocharging, one turbo may be CG and the other VG.

PARALLELING

Paralleling describes the use of multiple turbochargers to charge each bank of a V configuration engine. Parallel turbocharger configurations are not used on any current truck diesel engines, but they are used extensively in larger, off-highway applications. You also see paralleling used in railway locomotive applications.

COMPOUNDING

The term *compounding* is often incorrectly used to describe two-stage turbocharging. In place of being connected to an impeller, the turbine is connected to a fluid coupling: the fluid coupling is connected to reduction gearing with an output shaft connected to the engine timing geartrain. This means that the turbocharger unloads drive torque directly to the crankshaft. Detroit Diesel Corporation has used compounding in their recently released DD15 engine: they claim that it can add 50 horsepower to engine output (see **Figure 9-11**).

Turbocharger Precautions

Make sure to follow these precautions regarding turbochargers:

1. Avoid hot shutdown: allow at least 5 minutes of idling before shutting down an engine after a hard run.
2. Prelubing: remove the turbo oil supply line and directly pour oil onto the turbine shaft. This should be done when installing a turbocharger before connecting the lube supply line or after an engine overhaul.
3. Prime oil filters: most OEMs require that the oil filters be primed when replacing them at service intervals.

Turbocharger Failures

Common reasons for turbocharger failure include:

1. Hot shutdown: high-temperature failures can result in warped shafts and bores.
2. Turbocharger overspeed: this can be caused by fuel rate tampering, high-altitude operation with a

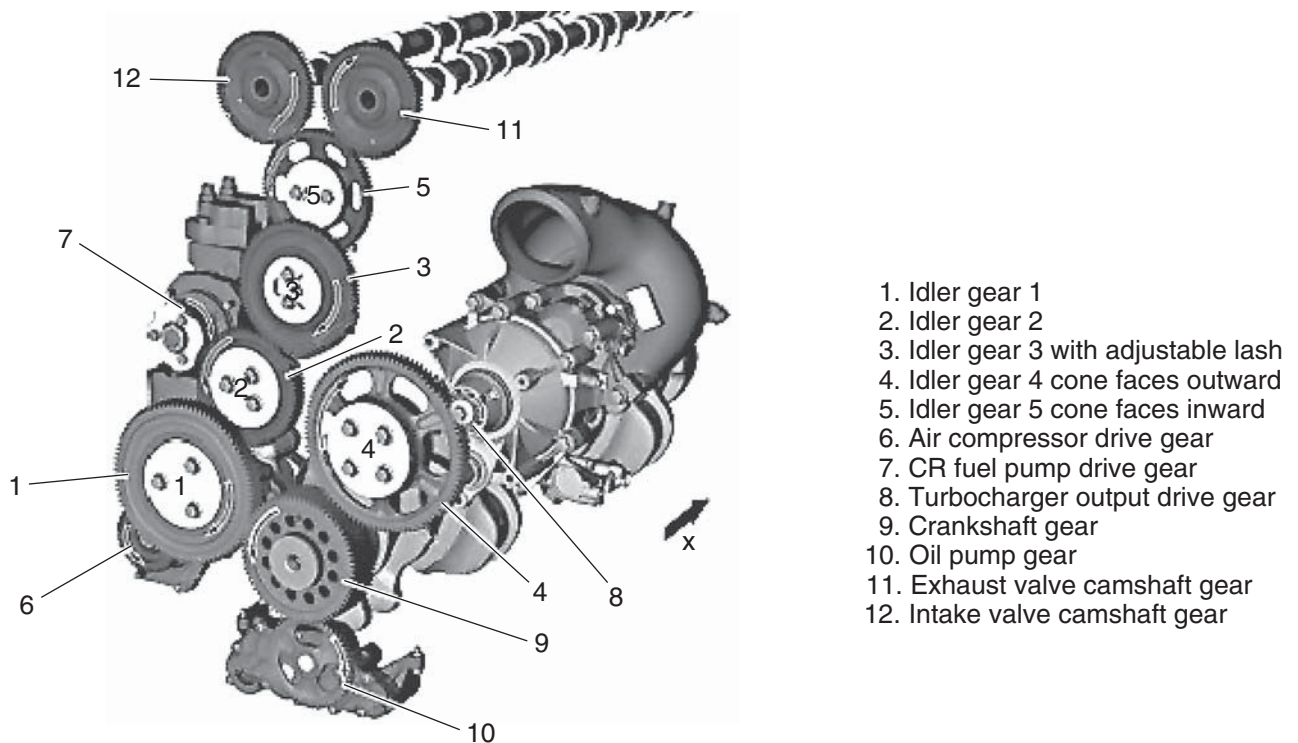

Figure 9-11 Coupling arrangement of a compound turbocharger to the engine drivetrain located at the rear of the engine.

defective altitude compensation fuel control, and mismatching of complete turbocharger units.

3. Air intake system leaks: these allow dirt to enter the compressor housing, causing the impeller vanes to be worn wafer thin.
4. Lubrication-related failure: this is caused by abrasives in the engine oil, improper oil, broken-down oil, or restricted oil supply.

CHARGE AIR COOLERS

Compressing the intake air charge by a turbocharger can produce air temperatures of up to 300°F (150°C) when the ambient temperature is 70°F (21°C). These temperatures become proportionally more at higher ambient temperatures. The objective of **charge air coolers (CACs)** is to cool the air pressurized by the turbocharger as much as possible while maintaining the pressure. As intake air temperature increases, air density decreases. Less dense air contains less of the oxygen that is required in the cylinder to burn fuel. Less dense air results in lower power—along with higher cylinder temperatures. A charge air cooler is a heat exchanger and, as such, its role is to reduce the temperature of boost air.

Charge air coolers use a couple of different principles to reduce boost air temperatures. These heat exchanger devices are a key component in a diesel

engine management system for controlling emissions. Because the performance of charge air coolers influences combustion temperatures if they fail to perform at a specified efficiency, the result can be increased emissions, engine overheating, and lack of power. For this reason, most turbo-boosted diesel engines use some type of heat exchanger to cool intake air.

Types of Charge Air Coolers

For purposes of study, we divide boost air coolers as follows:

- air-to-air: cooled by ram air
- aftercoolers and intercoolers: cooled by engine coolant

Air-to-Air Heat Exchangers. Air-to-air charge air coolers have the appearance of a coolant radiator. They are often chassis mounted in front of the radiator. As the vehicle moves down the highway, ambient air is forced through the fins and element tubing: we use the term **ram air** to describe this. Ram air cooling efficiencies are highest when the vehicle is moving at higher speeds. When the vehicle is not moving, they have low efficiency. The engine fan may provide a little help, but generally air-to-air cooling is not going to suit vehicles that are not primarily run on the highway. When run down the highway air-to-air

coolers have better efficiency than any type of liquid-cooled heat exchangers: this is because the faster the vehicle is traveling, the greater the ram air effect.

TESTING AIR-TO-AIR COOLERS

When an engine is operating at close to rated speeds and loads, turbo compressed air enters a charge air cooler at around 300°F (150°C). When an air-to-air heat exchanger is used, the boost air typically exits at around 110°F (44°C) when ambient temperatures are 75°F (24°C). CACs are designed so that they can leak small amounts of air without any performance drop-off. To test the air leak-off rate, plug the inlet and outlets of the charge air cooler and then pressurize it using a regulator to the OEM recommended test value. Some examples of OEM recommended test values are shown in the following table.

Engine OEM	psi Start Test Value	psi Drop-Off over 15 Seconds
Caterpillar	30 psi	5 psi
Cummins	30 psi	7 psi
Detroit Diesel	25 psi	5 psi

If the pressure drop-off exceeds specifications, drop the pressure down to 5 psi and hold. Then attempt to locate the leak using a soap and water solution. **Figure 9-12** shows the equipment and method Caterpillar recommends to test their CACs.

Aftercoolers and Intercoolers. The terms *aftercoolers* and *intercoolers* normally refer to heat exchangers that use liquid engine coolant as the cooling medium. Boosted air is forced through an element containing tubing through which coolant from the engine cooling system is pumped. Cooling efficiencies are lower than with air-to-air heat exchangers due to the relatively high temperature of the liquid coolant. Aftercoolers and intercoolers continue to be used in applications in which low airflow through the engine housing rules out the use of an air-to-air exchanger.

Boost Circuit Troubleshooting

When manifold-boost is either too high or too low, engine performance complaints result. Common causes of low manifold-boost are:

- intake circuit restriction
- air leakage downstream from turbocharger impeller
- low fuel delivery
- mismatched turbocharger

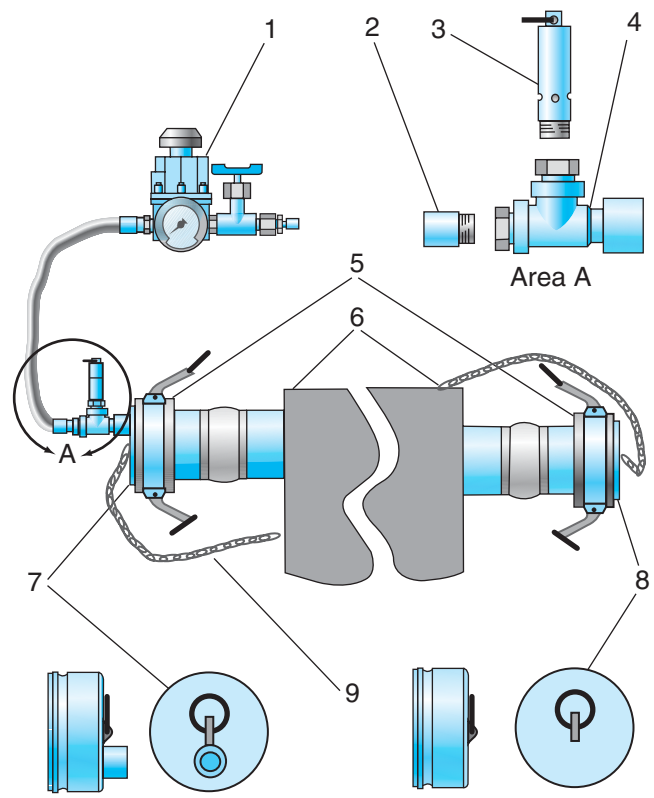

1. Regulator and valve assembly
2. Nipple
3. Relief valve
4. Tee
5. Coupler
6. Aftercooler
7. Dust plug
8. Dust plug
9. Chain

g01134323

Figure 9-12 CAC test kit: charge CAC to 30 psi (200 kPa). Pressure drop-off should not exceed 5 psi (35 kPa) after 5 minutes. (Specifications are subject to change without notice. Detroit Diesel Corporation is registered to ISO 9001:2001. Courtesy of Detroit Diesel Corporation)

Common causes of high manifold-boost are:

- mismatched turbocharger
- sticking unison ring on VGT turbos
- high inlet air temperatures
- deposits on internal turbocharger components
- overfueling
- advanced fuel injection timing

CAUTION Never regulate the air pressure at a value above 30 psi (200 kPa) when testing for boost side leaks because this may result in personal injury and damage to the components under pressure.

EXHAUST GAS RECIRCULATION

Until the introduction of the EPA 2004 emission standards, truck diesel engine manufacturers had successfully avoided using **exhaust gas recirculation (EGR)** systems. Things have changed. From 2007 onward, all the diesel engine OEMs are using some form of EGR though they may not call it EGR. Because the role of EGR concerns emissions control, we will take just a brief look at it in this chapter and address EGR in more depth in **Chapter 16**.

EGR Operation

Oxides of nitrogen, or NO_x is produced when engine combustion temperatures are high, a condition that occurs during lean burn combustion. Diesels run lean. Although EGR reduces engine power and fuel economy, by 2004 diesel engine manufacturers had no option but to turn to EGR. An EGR system redirects some of the exhaust gas back into the intake system. Exhaust gas is “dead” gas. That means it does not react with either the fuel or air in the engine cylinder. Dead gas is routed back into engine cylinders to occupy some space. In doing so, it reduces the lean burn factor and this makes NO_x emission less likely. In other words, EGR dilutes the intake charge of oxygen. It is not popular for the following reasons:

- Putting end gas back into the engine cylinder in place of fresh filtered air adds wear-inducing contaminants and increases engine oil acidity.
- EGR reduces engine power. However, the effect of this has been reduced by better control of combustion in modern engines.
- EGR reduces fuel economy. Again, the effect of EGR on fuel economy has been minimized due to improvements in engine technology.

Clean Gas Induction

Caterpillar adopted a type of EGR for their post-2007 generation engines. The Caterpillar system is called **clean gas induction (CGI)** because it sources the exhaust gas after it has exited the exhaust gas aftertreatment process. This explains the use of the term *clean*. EGR and CGI are the most effective means of reducing NO_x emission because they function during combustion and not after NO_x has been created. Because dead or unreactive gas is required to make EGR work, there is no better source (it has no cost) of dead gas than the exhaust system. It can be argued that EGR defeats what took years of engineering to accomplish, the diesel engine with high engine breathing efficiency. But if the diesel is going to survive another generation,

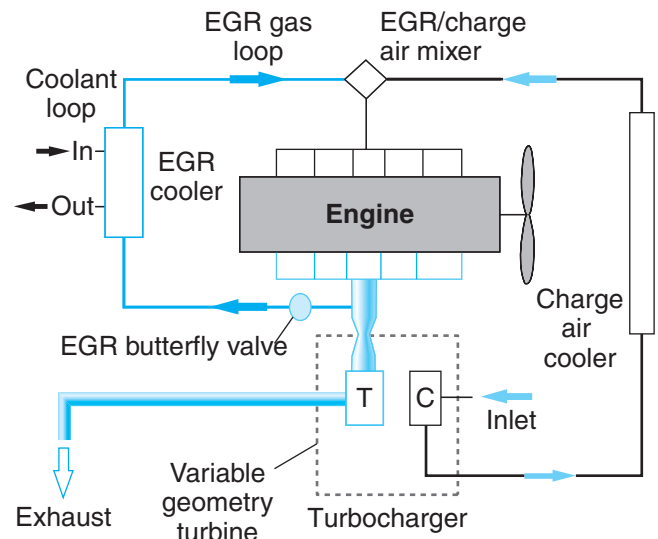

Figure 9-13 C-EGR: Schematic of a Detroit Diesel Company (DDC) Series 60 C-EGR system identifying flow routing and main components. (Specifications are subject to change without notice. Detroit Diesel Corporation is registered to ISO 9001:2001. Courtesy of Detroit Diesel Corporation)

it will do so only by minimizing the emissions it produces.

Cooled EGR

Most diesel engine EGR systems cool the end gas using a heat exchanger before rerouting it back into the engine cylinders. The ECM controls the cycling of the EGR gas. *Cooled EGR* systems have produced the acronym **C-EGR**. Some OEMs use *internal exhaust gas recirculation* or **I-EGR** in engines powering vocational trucks. I-EGR functions by using the valvetrain to allow some of the combustion end gas to remain in the cylinder. It does the same thing as C-EGR: it dilutes the cylinder charge of oxygen by simply occupying space with *dead* gas. **Figure 9-13** is a schematic of a Detroit Diesel cooled EGR circuit on a Series 60 diesel engine.

EGR Components

A typical C-EGR system is made up of the components identified in **Figure 9-13** which you should reference while reading through this description. In current commercial diesel engines, the control of EGR is by the engine ECM. Components and their functions are as follows:

- ECM. Receives inputs from system sensors. The ECM output circuit drivers manage the operation of EGR flow gates and mixing.
- Sensors. Key sensors in the EGR circuit are ambient temperature, barometric pressure (altitude),

boost pressure, mass airflow (MAF), coolant temperature, and oil temperature.

- Butterfly valve. Manages flow rate from exhaust circuit to EGR circuit.
- C-EGR cooler. The C-EGR heat exchanger uses engine coolant to reduce the temperature of EGR gases to be recirculated back to the engine cylinders.
- EGR mixer. Combines exhaust gas with charge air from intake system to be routed into engine cylinders. ECM controlled. In systems using a differential pressure type MAF sensors, the venturi is usually built into the EGR mixer assembly.

The MAF sensors used in diesel engine EGR breathing systems can use either hot wire or differential pressure operating principles. These are explained in **Chapter 14** of this book.

Intake Manifold Design

Because of the use of turbochargers on diesel engines, intake manifold design can be simple. This usually means that the runners that extend from the plenum can be of unequal lengths, without effecting engine breathing efficiency. A single box manifold supplied with boost air and EGR gas is usually all that is required to meet the engine's breathing requirements. Intake manifolds can either be wet (coolant ports) or dry, but dry are used in highway diesel applications. Materials used are aluminum alloys, cast irons, poly-plastics, and carbon-based fibers.

VALVE DESIGN AND BREATHING

Cylinder head valves were studied in some detail in **Chapter 5** so here we will examine them only insofar as they influence engine breathing. Most current diesel engines use multivalve configurations consisting of two

inlet and two exhaust valves, but other arrangements are possible such as two inlet and one exhaust. Two basic breathing configurations are used for the more common four-valve cylinder heads: crossflow and parallel port.

Crossflow Configurations

Until the electronic era, most diesel engines used **crossflow valve configurations**. Crossflow breathing locates both sets of valves transversely. This means that in-flow of intake air to the inboard valve interferes with that from the outboard valve. This is good if the idea is to create as much turbulence in the cylinder as possible. Back in the days when diesel engines produced lower fuel injection pressures, they were designed to maximize cylinder turbulence and crossflow four-valve configurations did the job. **Figure 9-14** compares crossflow with parallel port valve configurations.

Parallel Port Configurations

Breathing efficiencies can be improved by using **parallel port valve configurations**. This allows each pair of cylinder valves to be responsible for an equal amount of gas flow without crossflow interference, which generally results in lower cylinder turbulence. Parallel port valve configuration improves both cylinder charging and scavenging, but with the disadvantage of requiring a more complicated camshaft assembly (or dual camshafts). Reducing cylinder turbulence is desirable in some more recent engine designs that use high fuel injection pressures.

Valve Seat Angle

The valve seat angle also affects cylinder breathing. Valve seats in diesel engines are usually cut and machined at either 30 degrees or 45 degrees. The features of each are discussed in the text that follows.

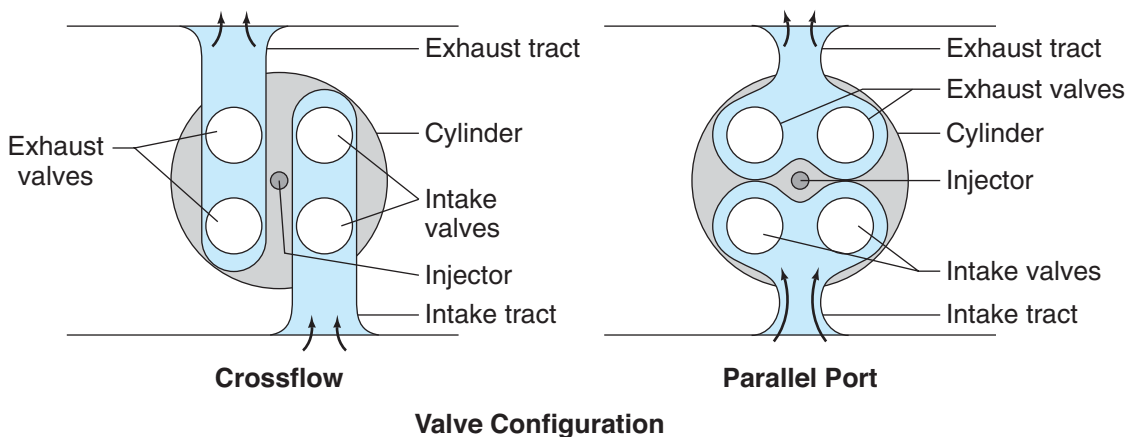

Figure 9-14 Crossflow and parallel port valve configurations.

30-Degree Valve Seats. Gas flow both into and out of the engine cylinder is 20 percent greater using a 30-degree valve seat angle when compared with a 45-degree valve seat angle when each have equal lift. However, a 30-degree valve has less material around the seat area: this means that they do not last as long as valves cut with 45-degree valve seats.

45-Degree Valve Seats. The 45-degree seats tend to be used more in diesel engines due to:

- higher seating force
- better distortion resistance

Some engines use a mixture of 30- and 45-degree valve seats. One popular engine uses a valve design in which the intake valves are machined at a 30-degree seat angle while the (hotter running) exhaust valves are machined at a 45-degree angle.

Variable Valve Timing

Recently diesel engine manufacturers have introduced variable valve timing managed by the ECM. This allows the ECM to reduce the compression ratio and therefore the actual air in the cylinder. Managing the compression ratio means that the engine breathes like a small engine when engine loads are light and breathes like a large engine when more power is required. The electronically controlled, hydraulically actuated, **variable valve actuator (VVA)** assembly is mounted over the rocker assembly.

EXHAUST SYSTEM COMPONENTS

Diesel engine exhaust systems have become much more complicated in recent years because of the exhaust aftertreatment devices required of diesel engines since 2007. Refer to **Chapter 16** in this textbook for a more detailed study of emissions control equipment. This chapter presents only a brief look at emissions controls. Typically, an exhaust system is required to perform the following:

- assist cylinder scavenging
- minimize engine noise
- minimize emissions
- route heat, noise, and end gases safely to the atmosphere

Exhaust Manifold

The exhaust manifold collects cylinder end gases and delivers them to the turbocharger. The exhaust manifold is usually manufactured in single or multiple

sections of cast iron. Most diesel engine exhaust manifolds are “tuned.” A tuned exhaust manifold is one that has been designed to efficiently route exhaust gas to the turbocharger without creating flow resistance. If the exhaust manifold and piping is properly designed, as each slug of cylinder exhaust gas is discharged, it will not “collide” with that from another cylinder but instead will be timed to unload into its tailstream. The pulsed manifolds discussed earlier in this section in the context of turbochargers are an example of a tuned exhaust system.

Exhaust backpressure factors in a diesel engine are the turbocharger turbine assembly, the exhaust after-treatment apparatus, and the engine silencer. Exhaust manifold gaskets in truck/bus engine applications are usually of the embossed steel type, although occasionally fiber gaskets are used. Exhaust manifold gaskets are usually installed dry. Embossed steel exhaust manifold gaskets are designed for one-off usage because they yield to seal when they are clamped between a pair of mated components. Attempting to reuse them will almost certainly result in a leak, sooner or later.

Pyrometer

Pyrometers are used in emissions control components, especially those built to meet 2007 emissions standards. A pyrometer is a bimetal thermocouple that is used to signal high temperatures. Two dissimilar metal wires are used: they are connected at the “hot” end known as the sensing bulb. When the hot end is heated a small voltage is produced. This voltage is measured using a millivoltmeter at the opposite end. Each voltage value indicates a specific temperature. The practice of locating one pyrometer in the exhaust tract on each engine cylinder to indicate cylinder balance is used on larger diesels but seldom on highway commercial diesel engines. Most diesel particulate filters use several pyrometers to signal temperature conditions to the ECM.

Exhaust Piping

Diesel engine exhaust systems are manufactured primarily from steel components. The steel is corrosion protected usually by galvanizing (zinc coating) or stainless steels are used which doubles the service life of exhaust components. Exhaust piping consists of:

- mild steel pipes
- stainless steel pipes
- flex steel pipes
- band clamps

Stainless steel band clamps have been used for many years and are an effective means of sealing flex pipe to

straight pipe because they yield to shape at installation. They are not designed to be reused.

The function of exhaust piping is to collect the engine exhaust gases discharged by the turbine housing and route them to the engine aftertreatment canister. After discharge from the aftertreatment canister, the exhaust should be discharged to atmosphere clear of the tractor cab and the trailer structure. If rain caps are used on vertical straight pipes, they should be mounted transversely, opening away from the chassis. They should never be mounted so they open either front-to-back or back-to-front because this can affect exhaust gas flow.

Engine Exhaust Aftertreatment

Today's diesel engines have complex exhaust gas aftertreatment canisters. A typical aftertreatment canister may incorporate:

- muffler or engine silencer
- diesel particulate filter (DPF)
- oxidation catalytic converter
- reduction catalytic converter
- clean air induction piping (routes “dead” gas back to intake)
- selective catalytic reduction (aqueous urea injection)
- diffuser (redirects DPF heat away from trailer/reefer, etc.)

These aftertreatment devices are usually contained within a single canister with many different sensors. The aftertreatment device is usually manufactured by the engine OEM and *must* be replaced with an OEM approved equivalent. Because they are engine computer-controlled and part of the emissions control circuit, we address them in detail in **Chapter 16** of this textbook. In this chapter, we address only the principles of a muffler or engine silencer on a diesel engine. The design of the aftertreatment canister attempts to minimize restriction in routing “clean” exhaust gas to atmosphere.

CAUTION *It is illegal to tamper with emissions control hardware. Diesel exhaust aftertreatment canisters must be replaced with an OEM approved equivalent that allows the engine to meet the emissions controls that prevailed in the year of the engine's manufacture.*

Sonic Emission Control

Sound is an energy form and it is produced in an engine by the firing pulses in engine cylinders. The noise produced by a running engine is generally

considered to be unpleasant to the human ear. The function of the silencer or muffler is to alter the frequency of engine noise to legally acceptable levels.

Before the tougher sonic emissions standards of the 1990s, a turbocharger along with piping design was in some cases able to meet the minimum noise emissions standards, but this is no longer so. Engine silencers use two basic principles to achieve their objective of dampening sound:

1. **Resonation.** **Resonation** requires reflecting sound waves back toward the source: this process multiplies the number of sound emission points, changing the frequency. Separate chambers connected by offset pipes are used to achieve this. The idea is to reduce the noise while minimizing gas flow restriction. One of the reasons that the muffler section (usually the last section of the device) of a post-2007 aftertreatment canister looks more simple is that diesel particulate filters and **catalytic converters** have a significant resonance effect.
2. **Sound absorption.** Exhaust gases pass through a perforated pipe enclosed in a canister filled with sound-absorbing material. Sound absorption involves converting sound energy into heat by friction. The efficiency of these devices depends on the packing density of the sound-absorbing material. Sound absorption mufflers generally have improved flow resistance when compared with resonator mufflers but are usually insufficient to lower noise to legal levels without the help of a resonator.

Muffler Volume. Muffler volume required in pre-2007 truck engine systems was typically around five times the total exhaust slug discharge volume per cycle. Since the universal adoption of DPFs and multi-stage catalytic converters into the exhaust gas aftertreatment canister, there are no easy rules regarding muffler volume. In most cases, it is much less in newer engines due to the resonance effect created by the emissions control devices upstream from the muffler. In other words, the mufflers used with post-2007 diesel engines are often more simple than their predecessors.

Diffusers. Because of the amount of heat generated by DPFs during regeneration cycles, it is necessary to fit a heat diffuser on stanchion-mounted, exhaust gas aftertreatment canisters. The heat diffuser simply redirects heat away from a trailing load that may be heat sensitive.

BREATHING CIRCUIT SENSORS

Although the operating principles of sensors are not discussed until **Chapter 14**, this chapter identifies those used in a typical system. Both intake and exhaust circuits are monitored in current diesel engines mainly because of the need to manage emissions within legal limits. The following is a list of sensors you may find on a diesel engine (the text in parenthesis identifies the electrical principles on which they operate):

- ambient temperature (thermistor)
- barometric pressure (variable capacitance)
- CAC in temperature
- CAC out temperature
- boost circuit temperature (thermistor)
- manifold-boost pressure (variable capacitance or piezo-resistive)

- mass airflow (MAF) (hot-wire or delta pressure differential)
- turbocharger shaft speed (inductive pulse generator)
- exhaust gas back pressure (variable capacitance)
- DPF in temperature (pyrometer)
- DPF combustion temperature (pyrometer)
- DPF out temperature (pyrometer)
- NO_x sensor (density or galvanic)
- aftertreatment canister mass flow (delta pressure sensor)

Many sensors on today's engines are multifunctional, which means they perform multiple tasks—so what appears to be one sensor may read both temperature and pressure.

Summary

- Most current trucks use a dry, positive filter system.
- Trucks operated in environments with airborne particulates such as grain chaff dust, construction, and road dust should use some kind of precleaner. Precleaners extend air cleaner element service life.
- Dry, positive type filters have highest efficiencies just before they become completely plugged.
- It is important not to over-service air filters, because every time the canister is opened, some dust will find its way downstream from the filter assembly. Many air filters last for up to a year in a line-haul application.
- Air inlet restriction should be tested with a water manometer or negative pressure gauge.
- Charge air heat exchangers cool the turbo-boosted air charge and therefore increase its density.
- Air-to-air charge air coolers have higher cooling efficiencies but must have adequate ram airflow: this makes them ideal for use in highway applications but not in high-load, low road speed vocational applications.
- All current diesel engines use some type of EGR to dilute the intake charge with dead gas. Cooled EGR (C-EGR) systems use engine coolant to reduce the temperature of exhaust gases before readmission to the engine.
- C-EGR and Caterpillar's cooled gas induction (CGI) are ECM managed. They minimize NO_x emissions. Both systems use mixing chambers to combine dead gas from the exhaust system with boost air from the intake circuit.
- Valve configuration affects both the cylinder breathing efficiency and the cylinder turbulence.
- Parallel port valve configurations generally produce better and more balanced cylinder breathing efficiency but also produce lower swirl.
- Valve seats cut at a 45-degree angle produce greater flow restriction and higher seating force than valves cut at a 30-degree angle, assuming identical lift. They are usually preferred in commercial diesel engines.
- Turbochargers increase exhaust backpressure. Their objective is to recapture some of the engine rejected heat by using it to pressurize the intake charge to the cylinders.
- Turbochargers are driven by the *heat* in the exhaust gas, so the more heat, the faster the turbine speeds.
- Turbochargers in truck diesel engine applications may wind out at up to 150,000 rpm with mean running speeds in the 70,000 to 80,000 rpm range.
- Truck diesel engine OEMs use variable geometry turbochargers to increase the efficient operating range and reduce the turbo lag duration. VG turbos may be managed internally by variable volute or externally by wastegates.
- Turbocharger radial and axial runouts should be routinely inspected at engine preventive maintenance (PM) intervals.

- Hot shutdowns are a primary cause of turbocharger failures. After prolonged high-load operation and especially after a dynamometer test, a cool-down period of at least 5 minutes is required.
- Engine silencers use resonance and sound absorption principles to alter the frequency of the sound emitted from the engine; most use a combination of both principles.
- The exhaust aftertreatment canister on today's engines contains a DPF, oxidation and reduction catalytic converters, and a muffler device.

Internet Exercises

Use a search engine and informative sites such as <http://www.wikipedia.com> and <http://www.howstuffworks.com>, and key in the following prompts:

1. Donaldson air filters
2. Donaldson exhaust aftertreatment devices
3. Schwitzer turbochargers
4. Holset turbochargers
5. Exhaust gas recirculation

Shop Tasks

1. Use a manometer or negative pressure gauge to measure the inlet restriction of an air filter with the engine at idle and high idle.
2. Find manufacturer specifications for radial and axial turbine shaft play. Measure both with a dial indicator.
3. Fit a negative pressure gauge to an exhaust port. Measure the exhaust back pressure.
4. Disassemble a cylinder head, removing the valves. Determine the seat angle on each. Note any differences between the angles on the intake and exhaust valves.
5. Examine a diesel engine "muffler." Determine exactly what components are contained within it; this will vary considerably depending on the age of the engine.

Review Questions

1. Which tool should be used to accurately check the inlet restriction of a dry air filter?

A. Mercury manometer	C. Negative pressure gauge
B. Trouble light	D. Restriction gauge
2. Which of the following would be a typical maximum specified inlet restriction for an air filter on a turbocharged diesel?

A. 25 in. water	C. 25 psi
B. 25 in. mercury	D. 25 kPa
3. Which of the following type of filter has the highest filtering efficiencies?

A. Centrifugal precleaners	C. Dry, positive
B. Oil bath	
4. Which of the following should be performed first when checking an engine that produces black smoke under load?

A. Injection timing	C. Fuel chemistry analysis
B. Plugged particulate trap	D. Air filter restriction test

5. Which of the following best describes the function of a C-EGR system on a diesel engine?
- A. Increases engine breathing efficiency
 - B. Dilutes intake charge with cooled dead gas
 - C. Preheats the intake charge to the cylinder
 - D. Assists the turbocharger in boosting intake pressure
6. Which of the following best describes the function of a wastegate in a current turbo-boosted diesel engine?
- A. Bleeds down intake boost air when excessively high
 - B. Options exhaust gas to bypass the turbine
 - C. Adjusts the volute flow area
 - D. Holds the exhaust valves open when turbo-boost is low boost
7. What is the critical flow area managed by a VG turbo using a variable nozzle operating principle?
- A. Compressor diffuser
 - B. Impeller inlet throat
 - C. Turbine volute
 - D. EGR gate
8. The constant geometry turbocharger used with a high torque rise highway diesel engine is usually designed to produce its best efficiency at which rpm?
- A. Rated
 - B. Top engine limit (TEL)
 - C. Peak torque
 - D. High idle
9. Which of the following components would be located in a diesel exhaust gas aftertreatment canister?
- A. Diesel particulate filter
 - B. Catalytic converter(s)
 - C. Muffler
 - D. Any or all of the above
10. Which of the following best describes the function of a VG turbocharger?
- A. Behaves like a large turbocharger when engine load is high
 - B. Behaves like a small turbocharger when engine load is high
 - C. Reroutes NO_x back into the engine cylinders
 - D. Reroutes EGR gas into the DPF

This page intentionally left blank

CHAPTER

10

Engine Retarders

Prerequisites

Chapters 3, 4, and 9.

Learning Objectives

After studying this chapter, you should be able to:

- Identify some of the different types of engine brakes used on highway diesel engines.
- Describe the operating principles of each type of engine brake.
- Outline the controls used to manage engine brakes.
- Describe how the hydraulic actuation of internal engine compression brakes is managed and timed.
- Explain how a progressive, multicylinder engine braking system is managed.
- Describe the operation of a constant throttle valve (CTV) brake.
- Outline the differences in automatic and manual control of the Caterpillar BrakeSaver.

Key Terms

brake fade

BrakeSaver™

coefficient of friction

constant throttle valve (CTV)
brake

exhaust brake

exhaust pressure governor (EPG)

external engine compression
brake

Intebrate™

internal engine compression
brake

Jacobs brake

Jake brake

retarder

INTRODUCTION

Engine compression brakes are widely used on North American truck diesel engines. On a typical loaded tractor trailer combination, a large percentage of vehicle braking requires application pressures of 20 pounds per square inch (psi) or less in a typical air brake system. This means that for the majority of vehicle braking requirements, less than a fifth of the air brake system's peak potential is being used. Engine brakes are supplementary

to the service brake system. A supplementary brake system such as an engine compression brake is designed to perform some of the light-duty braking required by the rig. This supplementary braking role can be especially important when a vehicle is running downhill on a long downgrade: although this usually requires only light-duty braking, because braking may be required for a prolonged period, the service brake system can be easily overheated. Engine brakes can play a major role in backing up the service brake system on trucks.

How Air Brakes Work

Most trucks use air brakes. A typical truck braking system uses the stored energy in compressed air to convert the energy of motion of the vehicle to friction which is then released as heat energy. Braking effort takes place at the brake foundation assembly located at each wheel on the vehicle. Foundation brakes consist of drums or rotors both of which rotate with the wheel assembly. Braking effort is applied by brake shoes or calipers that do not rotate with the wheel. Actuators apply force to the brake shoes or calipers. The actuators receive modulated compressed air. They function to convert the potential energy of compressed air into mechanical force when the brakes are applied and the friction facings on the brake shoes or calipers are loaded into a rotating drum or rotor. The result is friction that slows or stops the movement of the rotating drum or rotor.

Friction produces heat. This means that the brake system produces high temperatures and this heat has to be transferred away from the foundation brakes as rapidly as possible. The **coefficient of friction** describes the aggressiveness of friction materials such as brake drums and linings. However, coefficient of friction is altered by changes in temperature. It is also changed when friction faces become wet with rainwater. If a brake system is going to function at its best efficiency, it is desirable to have a relatively constant coefficient of friction. When the foundation brake system is in constant use, such as when a truck is traveling downhill, it has to get rid of the most amount of heat by transferring it to atmosphere. When a brake system fails to transfer the heat generated, foundation brake temperatures increase. This results in:

- reducing the coefficient of friction of brake components.
- expanding the size of brake drums.

When a tractor-trailer combination has to run downhill for prolonged periods, even though brake application pressures may be light, high foundation brake temperatures result. This reduces braking efficiency just when it is most needed. It can produce a condition known as **brake fade**. A supplementary brake system such as an engine compression brake can help the primary service brake system on a rig by sharing some of the braking.

Supplementary Brake Systems

A supplementary braking system such as an engine brake helps out the main vehicle braking system. It does not come close to replacing it. However, it

will improve peak braking performance, and when electronic control module (ECM) managed, reduce some of the driver-actuated braking. The first engine compression brakes were manufactured by the Jacobs Manufacturing Company. Until recently, Jacobs manufactured an engine brake for almost every highway diesel engine. In doing this they managed to establish some pretty good brand identification. Today, the term *Jake brake* is used to refer to any engine compression brake by many drivers.

Highway trucks may also use hydraulic retarders. These can be located anywhere in the driveline, but more often than not are built into the engine or transmission. Hydraulic driveline retarders absorb torque. They use principles similar to those used in a torque converter. Electric driveline retarders are also currently available and one of them is marketed by Jacobs. The Caterpillar BrakeSaver, which is coupled to the engine, is covered in this chapter because it is an engine component rather than a transmission or driveline component.

Retarding Principle

The term **retarder** can be applied to any component or system connected with the brakes. Retarders slow movement; however, the primary vehicle braking system is seldom referred to as a vehicle retarder system. On the other hand, engine compression brakes and driveline brakes are commonly described as retarders. Compression and driveline brakes do no more than supplement the primary braking system. The braking or retarding powerflow that results from an engine brake is limited to just those axles connected directly linked to the drivetrain. On trucks, that means engine braking effort is confined to the drive axle wheels.

The engine brake system attempts to achieve exactly what the main vehicle braking system does. The energy of vehicle motion is converted to heat energy. In the engine compression brake, the energy of vehicle motion is converted first to the potential energy of compressed air. The heated compressed air is then released into the exhaust system as heat.

Today's Engine Brakes

In recent years as engine control electronics have become more complex, engine manufacturers have on the whole preferred to manufacture their own engine brakes. This makes sense. Managing the engine brakes has come a long way from the days when the only way to actuate them was for the driver to toggle a dash switch.

Engine Brake Controls

Because all of today's highway diesel engines are computer controlled, the engine controllers tend to manage engine braking more often than the driver. An obvious use of a computer-controlled engine brake is by the cruise control system to help maintain a consistent road speed. However, because the engine controller is networked by multiplexing to other controllers on the chassis, the engine brake plays a role in supporting other chassis systems such as:

- collision warning system
- electronic lane tracking system
- yaw and stability control systems
- smart braking systems

Engine braking makes a lot of sense from both a safety and a maintenance point of view. Electronics have enabled engine brakes to do more than simply extend foundation brake service life. They help improve rig safety and reduce driver fatigue. Engine brakes absorb inertial energy from a moving tractor trailer combination. The braking powerflow therefore exactly reverses the powerflow of the engine when it drives the rig in this sequence:

- moving mass of vehicle
- drive axle tires
- final drive unit
- driveshaft
- transmission
- clutch
- engine cylinder gas pressure

PRINCIPLES OF OPERATION

The term *engine brake* is used to describe three different types of brakes:

1. internal engine compression brakes
2. external engine compression brakes
3. hydraulic engine brakes

Internal Engine Compression Brakes

In the four-stroke cycle diesel engine, the piston is required to:

- perform work (compression stroke)
- receive work (power stroke)

On its upward travel during the compression stroke, the piston compresses the cylinder air charge. This is immediately followed by the power stroke. During the power stroke, the piston is forced downward by combustion pressure. For an engine to continue to rotate

and provide turning effort to the powertrain, the work received by a piston during the power stroke must exceed the work it has to produce during the compression stroke. In other words, there has to be a net pressure gain in favor of the power stroke over the compression stroke.

The **internal engine compression brake** operates by making the piston perform all of its usual work of compressing the air charge on the compression stroke. Then, just as the power stroke is about to take place, it releases cylinder pressure by opening the exhaust valves. This has the effect of canceling the power stroke by releasing the compressed cylinder gases to the exhaust system somewhere around top dead center (TDC). You could say that the internal engine compression brake reverses the normal engine function: It converts the engine role from that of an energy-producing pump to an energy-absorbing compressor.

All engine compression brakes use this principle of operation; however, they operate in a number of different ways. The braking powerflow of the vehicle during engine braking follows this sequence:

1. begins at the drive axle wheels
2. continues through the final drive carrier
3. transfers to the driveshafts
4. transfers to the transmission
5. passes to the engine crankshaft
6. drive torque is converted by the crankshaft and pistons to cylinder pressure and heat
7. heat and pressure are unloaded into the exhaust system

Braking efficiencies are highest when engine rotations per minute (rpm) is highest, because the number of compression strokes per second is highest when the engine rpm is at its highest. Each piston compression stroke is a retarding stroke.

External Engine Compression Brakes

The operating principle of the **external engine compression brake** is not that different from that of the internal compression brake. External engine compression brakes are also known as **exhaust brakes**. They consist of a housing located downstream from the exhaust side of the turbocharger. The principle is simple. Inside the exhaust brake housing is a valve. When this valve is actuated, it chokes off the exhaust flow. The result is that the piston on its exhaust stroke is being made to perform compressive work.

Restricting exhaust gas flow in this way once again reverses the role of the engine, converting it into an energy-absorbing pump. However, in the internal engine compression brake, the effective pumping stroke is

the compression stroke, whereas in the exhaust brake, the effective retarding stroke becomes the exhaust stroke. And because of this, just like the internal engine compression brake, braking efficiency increases with engine rpm.

Dual Stage. Retarding efficiency of an engine brake is reduced by pressure losses to the intake during valve overlap. In many current diesel engines, engine braking efficiencies can be increased by combining internal and external engine compression brakes. This means that both upward strokes of the piston are “braking” strokes. In this way, many current engines are able to absorb (during retarding cycles) nearly as much power as they are capable of producing—at least when engine rpms are close to rated speed. Operation of the engine brakes is managed so that the engine is not fueled during braking.

Hydraulic Engine Brakes

Many types of electric and hydraulic driveline brakes exist, but it is not appropriate to cover these in an engines book. However, the Caterpillar **BrakeSaver™** is a hydraulic retarder that is coupled to the rear of the engine and uses engine lubrication oil as its medium. A rotor is coupled directly to the engine crankshaft, so it rotates at any time the engine is running. The rotor is turned within the BrakeSaver housing: this housing is coupled to the flywheel housing onto which the transmission is mounted. The engine flywheel is bolted through to the crankshaft, but because of the BrakeSaver, the starter motor must crank the engine by means of a ring gear on a ring gear plate mounted to the crankshaft behind the BrakeSaver rotor. The rotor is therefore driven by the crankshaft between the BrakeSaver housing and a stator.

When the BrakeSaver is actuated, the housing is charged with pressurized engine oil. Vaned pockets on the rotor mean that when the BrakeSaver is charged with oil, the rotor encounters fluid resistance: the amount of resistance is defined by the shape of the stator vanes and the actual speed the rotor is turning. Once again, braking efficiencies are greatest when engine rpm is greatest. The oil that acts as the BrakeSaver hydraulic medium is engine oil. The oil supplied to the BrakeSaver is drawn from the engine oil pan by a section of the oil pump used only for that purpose.

Control Circuits

Engine brakes use electrical control switches. These electrical control switches use engine lube oil to hydraulically control the actuators in the brake

circuit. Engine braking cycles may occur in three different ways:

- switched by the direct driver command
- switched by the engine management ECM for cruise control management
- switched by the engine management ECM using networked commands from other modules on the data bus, such as in an antirollover strategy

Electrohydraulic. When engine brakes are used in hydromechanically managed engines, the switching circuit of the engine brake is usually electrical. However, engine braking cycles have to be actuated either hydraulically or pneumatically. In such engines, a control circuit requires that a series of switches be closed before engine braking can be effected. The first of this series of switches would be the driver control switch. This is located on the vehicle dash or may be floor mounted. Engine braking is usually proportional depending on the system. In a proportional engine brake system, typical driver options are:

- off
- low: 2-cylinder retarding
- medium: 4-cylinder retarding
- high: 6-cylinder retarding

Switch Sequence. Once the dash switch has been closed (ON position), the next switch in the series is located at the clutch. The clutch must be fully engaged to operate engine braking so the clutch switch closes when the clutch pedal is in the fully released position. The third essential switch in the series verifies that the accelerator pedal is not depressed. This is sometimes known as the idle validation switch. It helps confirm that the engine is not being fueled. This is a requirement of all engines certified on our highways since 1994. Since then, federal regulations have prohibited exhausting raw fuel to atmosphere.

Electronic Management. Today’s engines use ECM control of engine brake cycles. The driver may still have the option of switching the engine brake on or off, but depending on the system, the engine may manage braking cycles in ways of which the driver may be entirely unaware. Because many of today’s engine brakes option many different levels of power absorption, they can be used to complement cruise control logic and be made to work in conjunction with data bus driven strategies such as yaw (directional stability), tailgating avoidance, and antirollover electronics. Although today’s engines brakes are electronically

managed, the ECM switches actuators to produce electrical (solenoids), air (chassis system air pressure), and hydraulic (engine lube) outcomes in managing the brakes.

EXHAUST BRAKES

As stated earlier, all external engine compression brakes use the same operating principles. We describe a couple of these here.

Williams Brakes

Williams exhaust brakes are classified as external engine compression brakes. **Figure 10-1** shows two schematics of how this type of engine brake is managed, one mechanical, and the other electronic. These

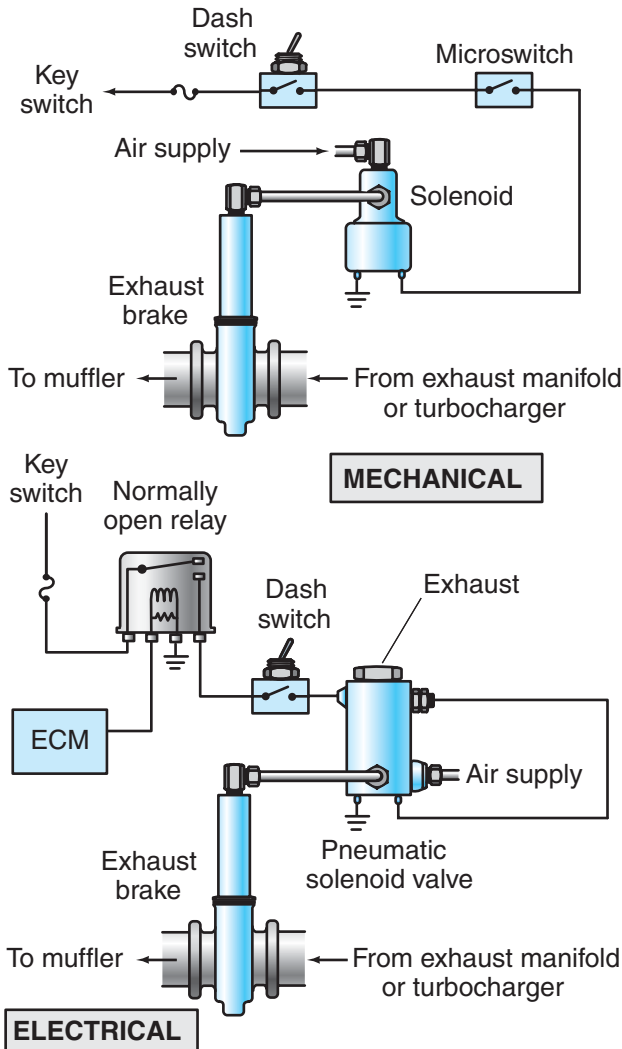

Figure 10-1 Mechanical and electrical control and actuation circuits on a typical exhaust compression brake.

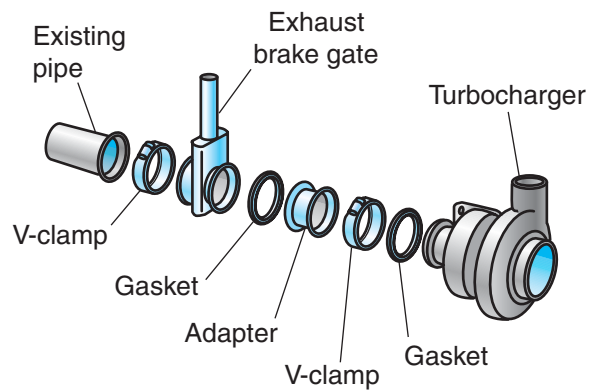

Figure 10-2 Choke gate used on a typical exhaust compression brake.

brakes were very popular as an aftermarket engine brake but are not so common today. Control of the brake is electric over air. The electrical circuit required to actuate the engine brake consists of three switches:

- control switch (dash mounted)
- clutch switch (clutch must be fully engaged)
- accelerator switch (accelerator must be fully released)

To switch the engine brake on, all three switches must be closed. Closing the brake control circuit energizes a pilot valve. The pilot valve uses air pressure to force a sliding gate to close off the exhaust flow area. The gate is equipped with an aperture. This aperture allows a minimal amount of exhaust flow through the brake gate during engine braking. There is also a butterfly valve version of this brake that operates similarly. **Figure 10-2** shows the gate-type version of this engine brake.

Exhaust Pressure Governor

An **exhaust pressure governor (EPG)** is a variation on the external engine compression brake. This uses the principles of exhaust engine brakes we have just described but the device doubles as an engine warmup device. When the EPG is actuated during engine warmup, the high back pressure created by choking of the exhaust flow results in a rapid rise to operating temperatures. The EPG is built into the turbine housing of the turbocharger.

INTERNAL COMPRESSION BRAKES

We will examine both electrical-over-hydraulic and ECM controlled internal engine compression brakes. The power absorption equation is the same in all

internal engine compression brakes regardless of how they are controlled. The energy of vehicle inertia is transferred in the following sequence:

1. First to the drive axle tires/drive wheels, which transfers to
2. chassis drivetrain components routing through final drive carriers, driveshafts, transmission, and clutch, and transferring to
3. engine crankshaft torque, which then transfers to
4. pistons (on compression stroke), which produce
5. torque at crankshaft that is converted to linear force at the piston, which in turn results in cylinder pressure and heat.
6. Finally, pressure and heat are discharged to the exhaust system.

Electric-over-Hydraulic Compression Brakes

Electrical-over-hydraulic internal engine compression braking triggers the following sequence:

1. The electromechanical switch on the dash controls circuit.
2. This energizes an electric solenoid in the cylinder head piloting the opening of a hydraulic valve.
3. The hydraulic valve opens to allow the engine oil under pressure to charge to the engine brake hydraulic circuit.
4. Mechanical movement of an injector or valve-train forces a master piston inboard. This action traps oil in the engine brake hydraulic circuit, creating pressure rise as the master piston is driven inboard.
5. Pressure rise in engine brake hydraulic circuit acts on the slave piston.
6. The slave piston actuated by hydraulic pressure mechanically acts on the exhaust valve or exhaust valve yoke causing them to open somewhere around the completion of the compression stroke on that cylinder.

ECM-Controlled Compression Brakes

ECM control over internal engine compression braking opens up the control options so that driver initiated braking events are added to by ECM and data bus driven requests for engine braking. It greatly improves cruise control options. A driver initiated request for engine braking is signaled to the ECM by means of an electromechanical or smart switch. ECM logic is

used to process the request and manage braking. The sequence occurs as follows:

1. ECM processes a request for engine braking. The source of the “request” can be the driver (dash switch), the engine ECM (cruise control management), or the chassis data bus (networked system controllers such as antirollover electronics).
2. ECM drivers switch the cylinder head engine brake solenoid(s).
3. This energizes electric solenoid(s) in the cylinder head piloting the opening of a hydraulic valve.
4. The hydraulic valve opens to allow the engine oil under pressure to charge to the engine brake hydraulic circuit.
5. Mechanical movement of an injector or valve-train forces a master piston inboard. This action traps oil in the engine brake hydraulic circuit, creating pressure rise as the master piston is driven inboard.
6. Pressure rise in engine brake hydraulic circuit acts on the slave piston.
7. The slave piston actuated by hydraulic pressure mechanically acts on exhaust valve or exhaust valve yoke causing them to open somewhere around the completion of the compression stroke on that cylinder.

Jacobs Brakes

People in the trucking industry use the term **Jake brake** to refer to any internal engine compression brake because for a number of years, this manufacturer dominated the marketplace by designing its engine brakes for most of the major original equipment manufacturers (OEMs). There were other manufacturers of similar devices, but that did not stop the adoption of the general term *Jake brakes*.

Operating Principle. As an internal engine compression brake, a **Jacobs brake** operates by having the piston perform its usual work of compressing the cylinder air charge on the compression stroke and then negating the power stroke by opening the exhaust valves somewhere around TDC and releasing the cylinder compressed air to the exhaust. Jacobs engine brakes use electric switching of a hydraulic actuating circuit, so they adapt readily to electronic management. They have been used as an integral component in “smart” cruise control systems.

Jacobs brakes hydraulically actuate the opening of the exhaust valve(s) in the engine cylinder performing the braking. The manner in which this hydraulic circuit is timed and actuated varies with the engine; however,

the mechanical force required to actuate the hydraulic circuit is typically provided by the engine camshaft. This means that the timing of the exhaust valve opening is also governed by cam profile, either the injector actuating cam profile or that on an adjacent exhaust valvetrain.

An example of an engine brake actuated by movement from an adjacent exhaust valve is shown in **Figure 10-3**. When you study this illustration, note that the image shows two different rocker arms. In this circuit, once oil is trapped in the engine brake hydraulic circuit, the master piston is forced inboard by exhaust rocker upward (opening) movement that creates pressure rise. Pressure in the engine brake actuation circuit acts on the

sectional area of the slave piston, which in turn acts on the exhaust valve bridge on the cylinder being braked. The slave piston thereby forces the valve bridge downward, opening both exhaust valves, dumping cylinder pressure created by the piston compression stroke.

Remember that all internal engine compression brakes use the same general principles, although you should expect to see minor differences in the hardware. **Figure 10-4** shows the setup of a Jacobs brake used on an engine that uses valvetrain movement to actuate the master cylinder piston. The system would function similarly if movement of the injector train were used to actuate the master cylinder piston.

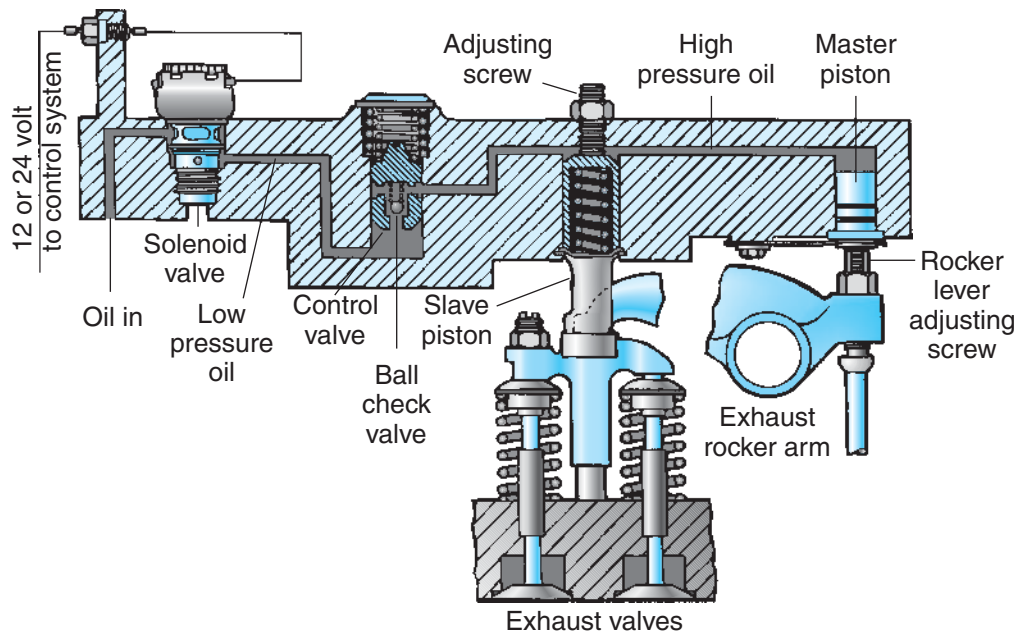

The blowdown of compressed air to atmospheric pressure prevents the return of energy to the engine piston on the expansion stroke, the effect being a net energy loss since the work done in compressing the cylinder charge is not returned during the expansion process.

Exhaust blowdown of the braking cylinder is accomplished by utilizing the pushrod motion of an exhaust valve of another cylinder during its normal exhaust cycle as follows:

1. Energizing the solenoid valve permits engine lube oil to flow under pressure through the control valve to both the master piston and the slave piston.
2. Oil pressure causes the master piston to move down and come to rest on the corresponding exhaust rocker arm adjusting screw.

3. The exhaust rocker pushrod begins upward travel (as in normal exhaust cycle), forcing the master piston upward and directing high-pressure oil to the slave piston of the braking cylinder. The ball check in the control valve traps high-pressure oil in the master/slave piston circuit.
4. The slave piston (under the influence of the high-pressure oil) moves down, momentarily opening the exhaust valves while the engine piston is near its top dead center position, releasing compressed cylinder air to the exhaust manifold.
5. Compressed air escapes to the atmosphere, completing a compression braking cycle.

The level of engine braking is controlled by using the solenoid to turn each housing ON or OFF. The above figure shows the relationships between master pistons, slave pistons, and control valves within the housing.

Figure 10-3 Jacobs compression brake schematic (on Caterpillar) and operating description. (Courtesy of Jacobs Vehicle Systems)

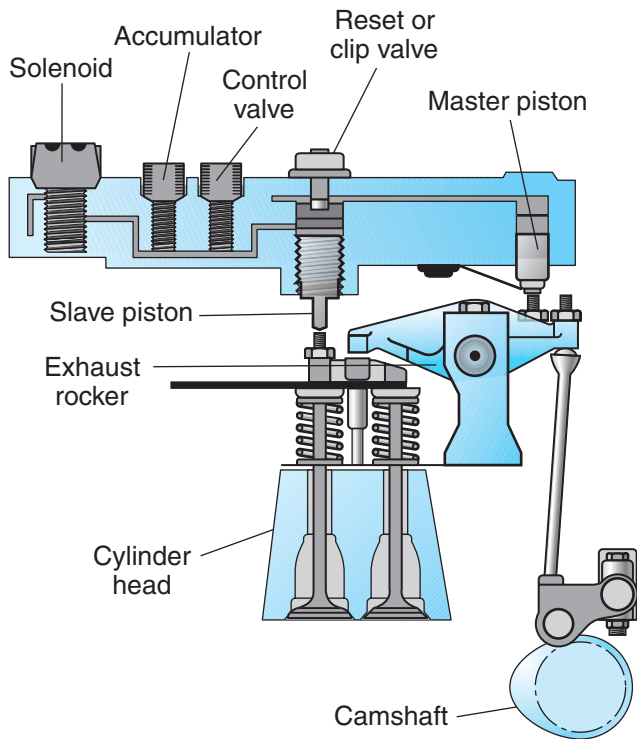

Figure 10-4 Sectional view of Jacobs engine brake components.

Caterpillar Compression Brakes

Caterpillar uses their in-house design of engine compression brakes on their C13 and C15 family of electronic unit injector (EUI)-fueled engines. Refer to **Figure 10-5** as you read the following text outlining the operating principles of this device. The Caterpillar (Cat) compression brake sources engine oil to use as hydraulic actuation media from around the studs of the rocker shaft pedestals. The actuator valve (**Figure 10-5 #5**) controls oil flow in the compression brake housing. When the control valve is switched by the ECM, oil at lube system pressure passes from the actuator spool supply port (**Figure 10-5 P**) to the actuation port (**Figure 10-5 A**). The resulting oil flow opens the check valve (**Figure 10-5 #1**) and passes into the high-pressure oil

passage (**Figure 10-5 #2**): this routes oil to both the slave (**Figure 10-5 #7**) and master pistons (**Figure 10-5 #4**).

As oil pressure overcomes the spring (**Figure 10-5 #8**), the master piston moves toward the injector rocker arm which is in its unactuated position (base circle): oil charges the circuit between the master and slave pistons. When the injector rocker train ramps off the base circle, the master piston is driven into the high-pressure oil circuit, closing the check valve (traps oil in the circuit), and actuating the slave piston. This results in the opening of the exhaust valves, dumping the compressed air from the compression stroke into the exhaust.

Progressive Step Engine Braking

Engine braking can be used most effectively when the greatest number of levels (steps) of braking is available. Until recently, internal engine compression brakes operated on steps that consisted of braking those cylinders located under one cylinder head. For instance, an inline 6-cylinder engine with two cylinder heads would have two steps, while one with three cylinder heads had three steps. In the Cummins ISX engine, engine braking can be achieved in six steps, meaning that under a braking cycle, one cylinder progressing to all six can be used. Cummins calls this **Intebrate™**.

The Intebrate system is achieved using engine oil as the hydraulic medium and three solenoids. When one cylinder is selected for braking, only the solenoid between cylinders 1 and 2 (S1) is energized. The solenoid between 2 and 3 actuates braking for cylinders 2 and 3. The solenoid between cylinders 4 and 5 (S2) actuates engine braking on cylinders 4, 5, and 6 (S3). **Table 10-1** shows how the Intebrate progressive braking is effected.

Intebrate is still an internal engine compression brake and functions hydromechanically like other versions, but because it options from one to all six cylinders for engine braking, it will probably be copied. A real advantage of Intebrate on ISX is that this engine uses two separate function camshafts, one dedicated to

TABLE 10-1: ISX INTEBRAKE STEPPED BRAKING OPTIONS

Number of Braked Cylinders	Solenoids Energized	Actual Braked Cylinder Number	Percentage of Total Braking
1	S1	1	17
2	S2	2 and 3	33
3	S3	4, 5, and 6	50
4	S1 and S3	1, 4, 5, and 6	67
5	S2 and S3	2, 3, 4, 5, and 6	83
6	S1, S2, and S3	1, 2, 3, 4, 5, and 6	100

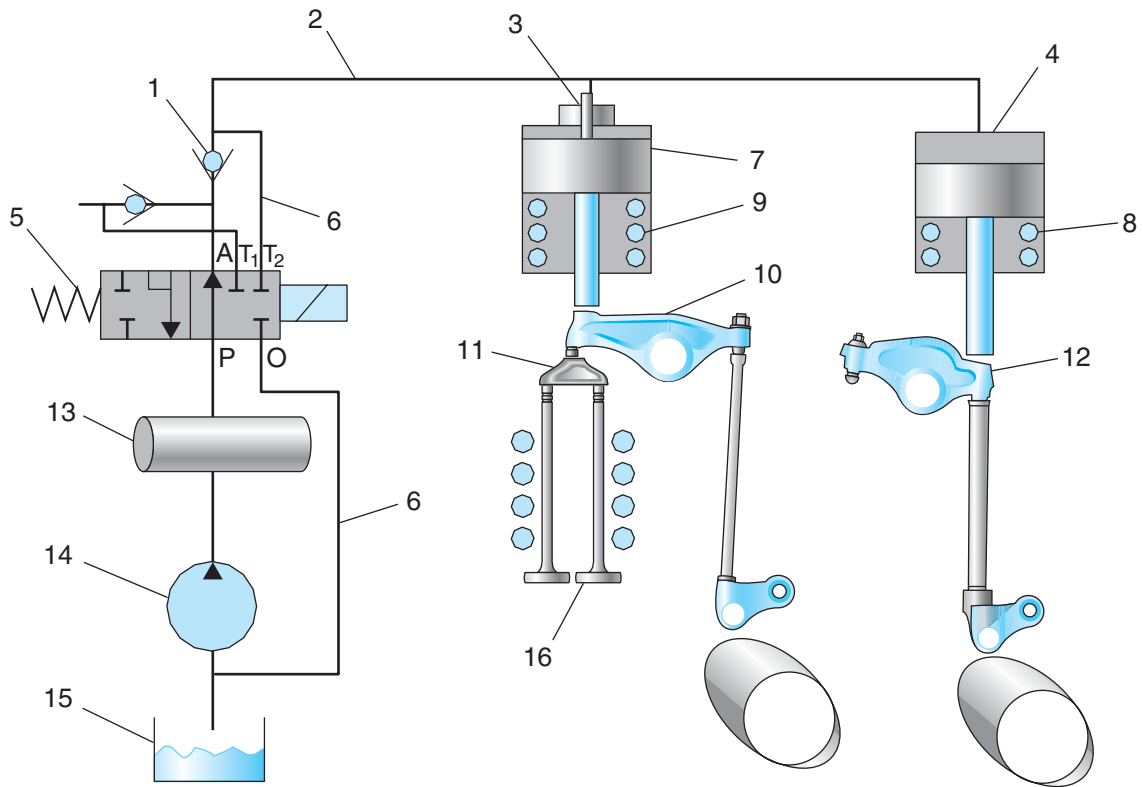

- | | | |
|----------------------------------|----------------------------------|-----------------------------------|
| 1. Check valve | 8. Master piston spring | 15. Engine oil pan |
| 2. High-pressure oil passage | 9. Spring for the slave piston | 16. Exhaust valve |
| 3. Slave piston adjustment screw | 10. Exhaust rocker arm | A. Actuation port |
| 4. Master piston | 11. Exhaust bridge | T ₁ . Drain port |
| 5. Actuator valve | 12. Fuel injector rocker arm | T ₂ . Drain port |
| 6. Oil drain passage | 13. Rocker arm shaft oil passage | P. Actuator spool for supply port |
| 7. Slave piston | 14. Engine oil pump | |

Figure 10-5 Operation of a Caterpillar C13 internal engine compression brake. (Courtesy of Caterpillar)

valve actuation and engine braking and the other one dedicated to injector actuation. This reduces the frequency of cam train-related, engine-braking problems.

Constant Throttle Valves

Mercedes-Benz (Daimler Freightliner) has introduced a variation on the internal engine compression brake called the constantly open throttle valve or **CTV brake**. Small valves (the CTVs) are fitted into the engine cylinder head. These valves allow some cylinder leakage to the exhaust during both the compression and exhaust strokes. The result is that although some braking ability is lost, the engine brake is considerably quieter than comparable systems that use the exhaust valves to dump compression gas into the exhaust system.

A CTV is fitted to each engine cylinder and the system is managed electrohydraulically using engine oil as the medium. When activated, the CTVs remain open throughout the braking cycle. Actuation of the

CTV brake requires that the accelerator pedal is at zero travel and the clutch is fully engaged. The system is designed to cease braking when engine rpm drops below 1,100 rpm (factory preset), but this value can be reprogrammed up or down depending on application. **Figure 10-6** shows an MB-906 CTV.

When the CTV circuit is actuated on the compression stroke, the constantly open throttle valve permits cylinder compressed air to bleed through the valve into the exhaust circuit. By the time the piston moves away from TDC at the completion of the compression stroke, most of the compression charge has been dumped into the exhaust circuit. **Figure 10-7** will help guide you through the following explanation. After the electrical actuation of the solenoid slide valve (**Figure 10-7** #4) by the control module, the 3/2-way valve spool (**Figure 10-7** #5) opens, allowing engine oil to be directed into the cylinder head to each CTV, holding each open. Unintentional closure (fluttering) of the CTV by cylinder back pressure is prevented by a

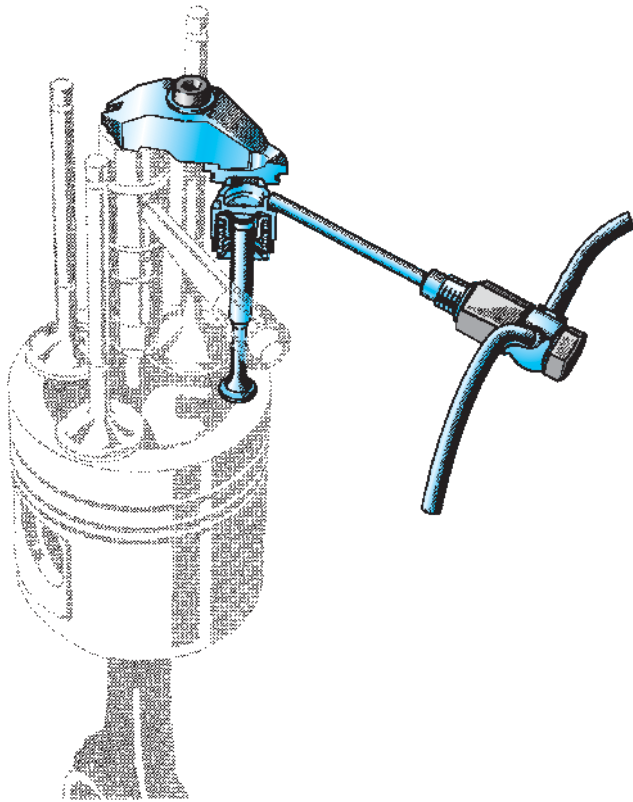

Figure 10-6 Location of a CTV on the engine. (Courtesy of Mercedes-Benz)

pressure holding valve (**Figure 10-7** #6). To take the system out of braking cycle, the solenoid slide valve is deenergized, closing the oil supply at the $\frac{3}{2}$ valve spool and routing the oil back to the sump. This causes oil pressure in the pressure chambers above the CTV pistons (**Figure 10-7** #1.1) to collapse, and the CTVs close to seal the cylinder by spring force. The normal engine cycle resumes at this point.

The constant throttle valve retarder is internal engine compression braking with a difference. By not using the engine camshaft to manage the engine braking, camshaft problems associated with engine braking are eliminated. The system is also notably quiet in operation.

Other Internal Retarders

Although they may be referred to as Jake brakes, there are other internal engine compression brakes available on diesel engines marketed in North America, many of them manufactured offshore. Some OEMs use a two-stage engine brake on their engines. Two-stage braking combines an internal engine compression brake with an exhaust brake that can be classified as an internal/external engine retarder. Pacific Diesel Brake, known as PACBrake, also offers an aftermarket engine brake. Any engine brake described as an internal engine

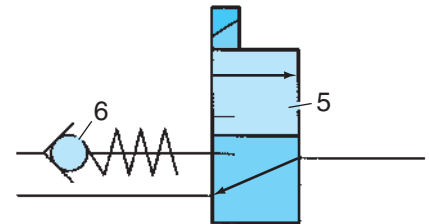
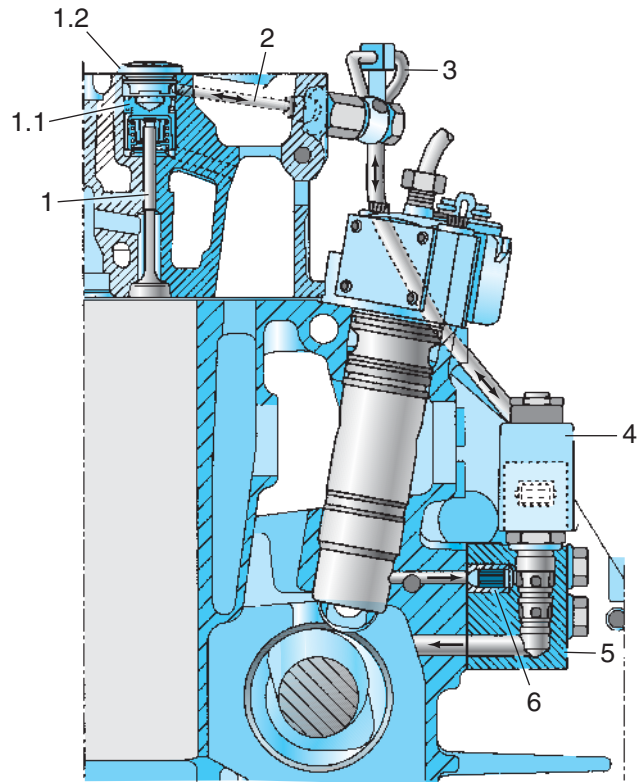

- | | |
|---|-------------------------------------|
| 1. Constantly open throttle valve | 2. Oil port |
| 1.1. Constantly open throttle piston | 3. Oil line |
| 1.2. Constantly open throttle valve cover | 4. Solenoid slide valve |
| | 5. $\frac{3}{2}$ -way valve |
| | 6. Pressure holding valve (0.2 bar) |

Figure 10-7 Components in a CTV engine brake on an electronic unit pump (EUP)-fueled engine. (Courtesy of Mercedes-Benz)

compression brake uses almost identical principles, so the only factor that changes is the means of managing the braking cycle.

Tech Tip: Engine brake operation can be tough on camshafts on some engines, especially older ones. Where there are low-power complaints and repeated top-end adjustments are required on an engine, a camshaft failure could be the cause. Check cam lift to specifications.

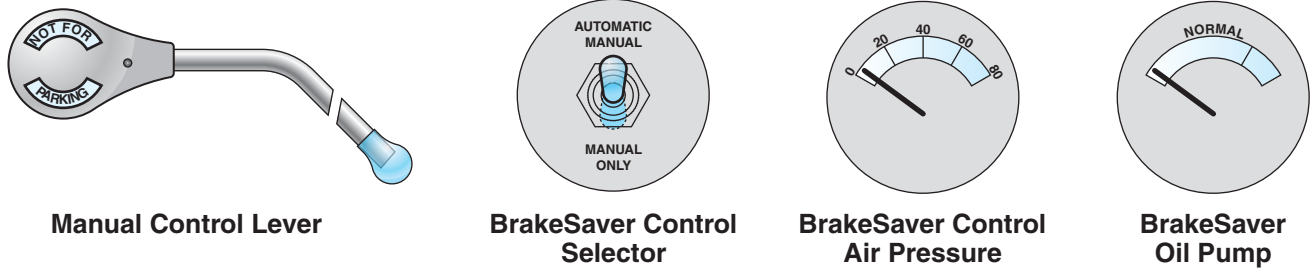
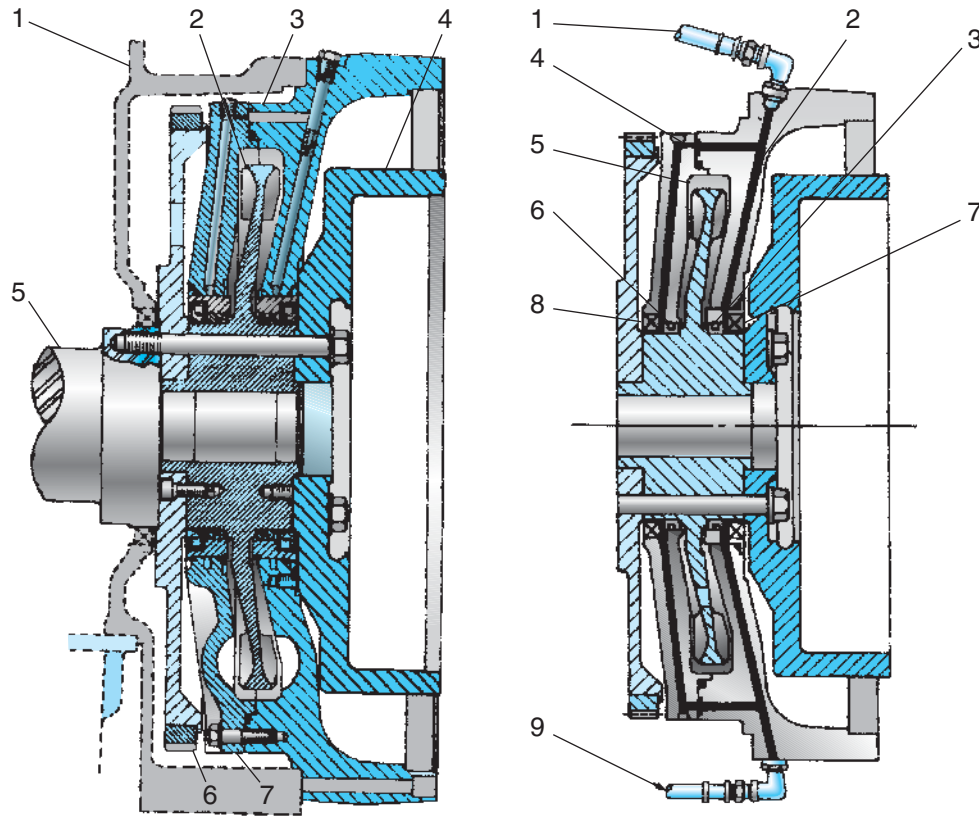

Figure 10-8 Caterpillar BrakeSaver controls. (Courtesy of Caterpillar)

CATERPILLAR BRAKESAVER

BrakeSaver is a hydraulic retarding device whose operation can be compared to a torque converter operating in reverse. The BrakeSaver rotor is coupled directly to the rear of the crankshaft and driven within

the BrakeSaver housing. When the BrakeSaver is not applied, the housing is not charged with pressurized engine oil, and the rotor can easily turn in the housing. When the BrakeSaver is applied, the housing is charged with pressurized engine oil, and the rotor’s ability to turn is limited by a combination of fluid



BRAKESAVER COMPONENTS

- | | |
|--|---|
| <ul style="list-style-type: none"> 1. Flywheel housing 2. Rotor 3. BrakeSaver housing 4. Flywheel 5. Crankshaft flange 6. Ring gear plate 7. Stator | <ul style="list-style-type: none"> 1. Oil line 2. Orifice 3. Piston-type ring seal 4. Orifice 5. Chamber 6. Piston ring seal 7. Lip-type seal 8. Lip-type seal 9. Oil line |
|--|---|

Figure 10-9 Sectional view of the Caterpillar BrakeSaver. (Courtesy of Caterpillar)

resistance and vane blades that have to churn through the oil. This produces the braking effect.

The BrakeSaver is electrically or manually controlled and pneumatically actuated. Chassis system air pressure is reduced by a pressure-reducing valve, which drops the pressure to a maximum value of 50 psi (345 kiloPascal [kPa]): this feeds the manual control valve and the solenoid control valve. Both the automatic solenoid valve and the manual control valve use air to control the flywheel-mounted oil control valve. The function of the oil control valve is to meter the flow of oil to the BrakeSaver housing.

Control Valves

The automatic control circuit requires an electrical circuit consisting of the ignition switch, mode selection switch, clutch switch, and accelerator switch. When the automatic option is toggled on the mode selection switch (manual/automatic), the BrakeSaver is actuated whenever the accelerator is released and the clutch and accelerator switches are closed. The automatic control circuit is “on/off.” The steering column-mounted (usually) manual control valve meters the air delivered to the

oil control valve. This controls the flow of engine oil to the BrakeSaver housing and thus the braking effort. A pneumatic two-way check valve prioritizes delivery of the actuation signal at the highest pressure to the oil control valve.

Oil Flow. Engine oil is used as the hydraulic medium by the BrakeSaver. It is supplied to the oil control valve by the engine oil pump, which is designed with a front and a rear section. The front section feeds the engine lube circuit while the rear section feeds exclusively the BrakeSaver oil control valve. BrakeSaver-equipped engines require larger capacity oil sumps. When pneumatically actuated by either the automatic or manual control valve, the oil control valve routes oil to the BrakeSaver housing at a high rate of flow and at a pressure value of around 70 psi (480 kPa). Because of the pumping action within the BrakeSaver, pressures at the outlet increase 50 percent over the charge pressure. When the BrakeSaver is not actuated, a small amount of oil is pumped through the housing to lubricate the seals. Oil exiting the housing is routed directly to the oil cooler (**Figure 10-8** and **Figure 10-9**).

Summary

- Engine brakes are designed to supplement the service brake system, not replace it.
- Engine brakes can greatly extend the life of the vehicle foundation brakes.
- Engine brake cycles can be managed by either electromechanical (dash) switches or electronically.
- Engine brakes are controlled by an electric circuit that requires a series of switches to be closed: at minimum the control switch, a clutch switch (drive-line disengagement), and an accelerator (idle validation) or governor switch must be closed.
- Internal engine compression brakes use an electronic/electric control circuit to manage the engine brake hydraulic circuit.
- The operating principle of an internal engine compression brake is to make the piston perform all the work of compressing the cylinder air charge on the compression stroke. Having done that, the power stroke is canceled by releasing the cylinder charge by opening the exhaust valves at TDC on the compression stroke.
- An engine internal compression brake changes the engine’s role from that of a power-producing pump to that of a power-absorbing pump.
- The mechanical force used to time and actuate the hydraulic circuit of a Jacobs-type internal engine compression brake is rocker movement. This may be the movement of an injector rocker or adjacent exhaust valve rocker.
- Engine external or exhaust compression brakes operate by choking down the exhaust flow: this makes the exhaust stroke of the piston a braking stroke.
- Exhaust brakes can be managed electronically (ECM) or electrically (dash switches). They may be actuated by air pressure or hydraulically.
- Some engines use both an internal engine compression brake combined with an exhaust brake: this means that both upward strokes of the piston are braking strokes. This increases engine braking capacity significantly.

- The BrakeSaver uses principles similar to a torque converter operating in reverse: engine oil is used as its hydraulic medium.
- Because the BrakeSaver uses engine oil as its braking medium, a larger-capacity oil pan is required: the BrakeSaver circuit is supplied by a dedicated section of the oil pump.
- All engine retarders operate at their highest efficiency when engine rpm is highest.

Internet Exercises

Use “engine brakes” as a prompt and access:

1. <http://www.howstuffworks.com>
2. <http://www.wikipedia.com>
3. Jacobs retarders
4. Internal compression brakes
5. External compression brakes

Shop Tasks

1. Locate a truck with an engine brake and see if you can actuate it while the vehicle is stationary with the engine running. Explain why this is not possible on more recent truck chassis.
2. Locate an engine with an internal compression brake. Remove the rocker cover housing and make a note of what is used to time the actuation of the brake.
3. Draw an electrical/mechanical/hydraulic schematic of one manufacturer’s internal engine compression brake.

Review Questions

1. Which type of engine brake uses the compression stroke of the piston as its retarding stroke?
 - A. Internal compression brake
 - B. External compression brake
 - C. Hydraulic retarder
 - D. Exhaust pressure governor
2. Which type of engine brake uses the exhaust stroke of the piston as its retarding stroke?
 - A. Internal compression brake
 - B. External compression brake
 - C. Hydraulic retarder
3. Technician A says that the Cummins ISX Intebrake options engine braking on just one engine cylinder. Technician B says that the Cummins ISX Intebrake can option engine braking on all six cylinders. Who is correct?
 - A. Technician A only
 - B. Technician B only
 - C. Both A and B
 - D. Neither A nor B
4. An engine brake on most current diesel engines is switched by which of the following?
 - A. Electromechanically by the driver using a dash switch
 - B. Electromechanically by the driver using a pedal switch
 - C. By the ECM based on input signals
 - D. By a dedicated electronic controller networked to the data bus
5. When will any kind of engine brake usually operate at peak efficiency?
 - A. At idle rpm
 - B. At peak torque rpm
 - C. At rated speed rpm
 - D. At the highest rpm

6. Technician A states that on most internal engine compression brakes, the effective braking stroke of the piston is the compression stroke. Technician B states that on some engine brake systems, both the compression and exhaust strokes can deliver engine braking. Who is correct?
- A. Technician A only C. Both A and B
B. Technician B only D. Neither A nor B
7. The operating principle of an internal engine compression brake is to convert the engine into an:
- A. energy-absorbing compressor C. inertia-absorbing device
B. energy-releasing machine D. inertia-producing device
8. When an engine brake is used, what is the energy of vehicle motion ultimately converted to?
- A. Kinetic energy C. Chemical energy
B. Heat energy D. Potential energy
9. Which of the following engine brakes offers progressive step braking using from one to all six cylinders?
- A. Cummins Intebrake C. Jacobs brakes on Caterpillar engines
B. Mercedes-Benz CTV D. Caterpillar BrakeSaver
10. When a Caterpillar BrakeSaver is used, which of the following is true?
- A. External exhaust brake principles apply. C. It must be controlled by the vehicle ECM.
B. A larger capacity engine oil sump is used. D. Braking efficiency can never be modulated.

CHAPTER

11

Engine Removal, Disassembly, Cleaning, Inspection, and Reassembly Guidelines

Prerequisites

Chapters 4 through 10.

Learning Objectives

After studying this chapter, you should be able to:

- Remove an engine from a typical truck chassis.
- Disassemble a typical diesel engine.
- Outline the process of cleaning and inspecting engine components.
- Tag and organize components and connectors during engine disassembly.
- Describe some key reconditioning procedures.
- Develop good inspection and failure analysis habits.
- Evaluate components for repair or replacement.
- Describe the procedure required to reassemble a diesel engine.

Key Terms

air conditioning (A/C)

anaerobic sealant

buttress

cab-over-engine (COE)

communications adapter (CA)

diamond dowels

electronic service tool (EST)

flywheel housing concentricity

high-pressure washer

magnetic flux test

master bar

service information systems (SIS)

service literature

soak tank

spreader bar

Tempilstick™

INTRODUCTION

This chapter will guide you through a typical diesel engine disassembly. Most of the procedures and terms used in this chapter have been introduced earlier in this textbook. The general objective of this chapter is to consolidate the previous information in a sequence. We can batch the steps together as follows:

- disassembly
- cleaning
- inspection
- diagnosis
- reassembly

A textbook chapter such as this should never be used as a replacement for original equipment manufacturer (OEM) service literature. Every truck chassis presents distinct challenges when it comes to removal of an engine and every engine OEM tends to be very specific about how it organizes disassembly and reassembly procedure. For these reasons, technicians today must learn to use the product-specific guidelines found in the service literature.

Service Literature

In this textbook we use the term **service literature** to refer to what used to be known as a service manual. Service literature today is seldom available in hard format. Most manufacturers provide service literature using their online **service information systems (SIS)**. The reason for using SIS in preference to hard copy service manuals is that information can be easily corrected and updated. In consequence, we use the term *service literature* to include any of the following:

- hard (paper) service manuals
- data disk (CD, DVD) service literature
- online service information systems
- technical service literature

REMOVAL OF AN ENGINE FROM A VEHICLE

First, identify the engine you are working on. Determine whether the engine is:

- hydromechanically managed: part of the class of older diesels that were controlled by a governor
- electronically managed: most diesel engines today, which are computer controlled

Identifying the engine is the first step in a disassembly procedure. You will need to do this to obtain the appropriate service literature.

Getting Ready

The initial preparations include the following:

1. Pressure wash or steam clean the engine and engine compartment. This will remove road grime, grease, and oil. Ensuring the work area is clean will help you when it comes to inspecting the components as you take them apart. It will also make a statement about your professionalism as a technician.
2. Park the vehicle on a clean, level surface. Next, make sure that the engine compartment can be accessed by whatever hoist you are planning to use to remove the engine from the chassis. Engage the vehicle parking brakes and block the wheels. Make sure that there is sufficient bench space or a mobile steel cart on which removed components can be placed. Ensure that some adhesive labels, tie tags, and masking tape are at hand so that electrical wiring and fluid hoses can be identified.
3. If the truck is of the **cab-over-engine (COE)** design, make sure that the cab lift hydraulics operate properly and that the positional locks are in place. With the COE chassis, the cab usually has to be raised to its extreme travel position. This means you have to check that the mechanical stops are in place so that the extended lift rams are not supporting the whole weight of the cab alone.
4. If the engine is electronically managed, download the engine/chassis identification data and the customer data programmable options using an appropriate electronic service tool (EST) and OEM software. The EST is usually a laptop PC loaded with the OEM software. In most cases, a **communications adapter (CA)** will be required to enable the EST to communicate with the chassis data bus. After downloading the required information from the engine ECM, disconnect the main battery leads at the battery terminals.

WARNING *On electronic engines with a nonvolatile RAM component, all NV-RAM data is lost the instant that the batteries are disconnected. Check the OEM instructions before disconnecting the batteries.*

5. Remove the radiator cap. To avoid injury when removing a radiator cap, rotate it counterclockwise (CCW) to the first stop, but do not depress. This will allow any residual pressure to bleed from the cooling system. After the pressure has equalized, press the cap downward and continue turning to remove. Open the cooling system drain

cocks usually located on the lower radiator tank and somewhere on the engine block to drain the coolant. If the coolant is to be reused, store it in a sealed container. Do not leave coolant in drainage tubs exposed to the shop atmosphere. If the coolant is to be replaced (and it really should be at an engine overhaul), ensure that the used coolant is disposed of in an environmentally safe manner consistent with federal and local jurisdictional regulations.

6. Shut off the air supply to any engine air system controls. Air system controls include devices such as shutterstats, fan controls, puff limiters, and air-controlled exhaust brakes.
7. Remove the oil pan plug and drain the engine oil. Remove the oil, fuel, and coolant filters and dispose of them and the engine oil. This must be done in an environmentally safe manner consistent with federal and local jurisdictional regulations.

Removing the Engine from the Chassis

To remove the engine from the chassis, follow these steps:

1. Disconnect the piping/ducting to charge air coolers (CACs). This includes heat exchanger components such as aftercoolers, intercoolers, air-to-air coolers, and tip turbine assemblies. Label any plumbing that could be a problem during reassembly. Remove the intake ducting. Cap the turbocharger intake and exhaust porting. Ensure that all intake ducts, air hoses, and the air filter assembly are capped to prevent dirt from entering the intake system.
2. On vehicles with **air conditioning (A/C)**, it is often possible to remove the engine without losing the refrigerant charge. Remove the condenser from the heat exchanger cluster at the front of the engine housing and fully support it so that it is not hanging by its hoses. Remove the A/C compressor, again without disconnecting its plumbing, and fully support it someplace where it is not going to hinder further work in the engine compartment. If the refrigerant must be discharged, connect the appropriate recovery station and evacuate the system, plugging any open hoses.
3. Usually, the radiator should be removed. In most cases, the radiator tie rods make access to the engine difficult, so at minimum these should be removed. To remove the radiator, when possible, leave the air-to-air type, charge air coolers attached to the rad assembly: remove as a unit

by attaching chains to the radiator tie-rod upper brackets. Support the assembly using a shop crane (chain hoist or cherry picker). Next, disconnect the upper and lower radiator hoses. Inspect the hoses for cracks and general overall condition to note whether replacement is required. It is very important that you do this on disassembly so that quotes to customers are reliable and parts can be ordered when necessary. Remove the radiator lower mounting support bolts and rubber insulators. Lift radiator/air-to-air charge air cooler assembly from the chassis using the shop crane. Lift slowly and carefully to avoid damaging any components.

4. When the assembly is out of chassis, separate the two heat exchangers. Carefully, place the radiator upright on a flat surface. Use extreme care when handling heat exchanger cores—they are easily damaged. Remove the fan shroud, brackets, and other hardware if the radiator is to be recored.
5. Remove fan and fan hub assembly.
6. Tag all the electrical leads before disconnection. Do the same with fuel lines, all linkages, oil lines, and water hoses. Cap all disconnected fuel lines to keep out dust.
7. Locate the rear engine mounts. These are either on the engine flywheel housing or on the transmission bell housing. When the rear engine mounts are located on the flywheel housing, the transmission must be fully and safely supported. Position a mechanical transmission jack or blocks under the transmission. In some vehicles it may be necessary to completely separate the transmission from the engine *before* attempting to remove the engine.
8. Loosen and remove the cap screws that hold the transmission bell housing to the engine flywheel housing.
9. Use a suitable **spreader bar** and lifting chain so that the engine can be lifted without lift chain contact to critical engine components. Fit engine lifting eyes to the OEM-recommended location on the engine. Move into position the hoist to be used to lift the engine from the chassis. Attach lifting chain hooks to the engine lifting eyes.

CAUTION *Never attempt to lift an engine using only rope slings or cable slings. Never support the engine on its oil pan and never place any kind of sling around the oil pan.*

10. After the hoist is chained to the engine lift eyes, apply a slight load to the lifting chain.

11. Remove the engine mounting bolts. Perform a thorough visual inspection to ensure that everything that has to be uncoupled is and that nothing is obstructing the planned removal path of the engine.
12. Separate the engine from the transmission, taking care not to force anything or overload the transmission input shaft. Use the hoist to remove the engine from the chassis. This may be a two-person operation, depending on the chassis. If unfamiliar with the chassis, ensure that someone is around to assist, even if it means just having an extra pair of eyes.
13. Remove external accessories as required: alternator, starter, power steering pump, oil, coolant and fuel filter mounting pads, and anything else on the block that might obstruct the engine overhaul mount stand.
14. Bolt the engine into the overhaul stand and do not release the weight from the hoist until the engine stand mounting plate bolts are tight.
15. Remove the hoist chain hooks and then the lifting eyes from the engine unless they were originally on the engine.
16. Remove the turbocharger oil supply and return lines. Remove the turbocharger and assess its condition.
17. Remove the crankcase breather assembly if fitted.

Tech Tip: Work on every engine assuming it may have to be reinstalled by someone other than you. Tag every electrical wire and hose coupling. Failure to do this can result in greatly increased reassembly times.

Tech Tip: Work cleanly and methodically. Use several containers to put fasteners in and label each container by component and location. Inspect every disassembled component for reusability: by doing this, you make it possible to issue an accurate repair quote to the customer.

ENGINE DISASSEMBLY

In most cases, the engine should be removed from the area of the chassis it was pulled from before it is disassembled. If an engine is to be rebuilt in a general area of the shop floor, you should make sure that no work, such as welding or other work that can create a lot of airborne dust, is going to take place close to the engine work.

1. For electronic engines using injectors or pump units with programmable fuel flow codes, you must tag each unit by cylinder number if you intend to reuse them. On engines that use integral or unit high-pressure injection pumps, remove the injection lines and any electrical wiring by separating the connectors. On engines using integral hydraulic injectors accessible without removing the valve covers, remove the injectors, capping the leak-off and feed ports. On some engines the high-pressure pipe is connected to a cylindrical injector through a port in the rocker housing. The two nuts that locate and seal this connector pipe must be backed off and the pipe removed before any attempt is made to remove the injector.

CAUTION You must refer to the OEM service literature before removing injectors and pumps from engines, especially those controlled by a computer. The consequences of not doing this can be costly fuel system damage and extended reassembly times.

Tech Tip: As you disassemble any engine, make a habit of inspecting every component you remove to evaluate whether it should be reused or replaced. This is essential if an accurate quote is required once the engine is completely disassembled. Such an inspection requires three steps:

1. Thoroughly clean the component using solvent, detergents, and/or compressed air as appropriate.
2. Decide whether a component can be reused: if replacement is required, immediately note this on work order.
3. After inspection, seal any component that you are going to reuse: protect each component by sealing it using clear plastic wrap. This will help ensure that the product does not get damaged during the time required to rebuild the engine.

2. Remove the exhaust and intake manifolds plus the exhaust gas recirculation (EGR) assembly. Carefully observe the location of sensors and actuators, tagging each for location. Be especially cautious when disassembling EGR components. The sensors and actuators located in the EGR heat exchanger(s), venturi, and mixing chamber(s) are sensitive and easily damaged.

3. Remove the water manifold assembly (if equipped), complete with the thermostat housing when possible. Sometimes the EGR heat exchanger is integrated into the water manifold and it may be easier to remove both as a unit.
4. Separate the vibration damper using great care, especially with viscous-type units. Inspect the vibration damper to assess whether it can be reused. Next, remove the crank pulley and crankshaft hub assembly. Usually this requires removing the hub retaining cap screw(s) and then using a universal T-puller (**Figure 11-1**).

WARNING Take care when pulling the hub and damper from a crankshaft. If you damage either a crankshaft or a vibration damper, that will likely erase any profit that might be earned on the engine overhaul. Always consult the engine OEM service literature.

5. Remove the engine timing gear cover. If the timing gear cover has thrust buttons fitted, back these off before removing. On engines where the timing indicator is bolted on by the timing gear

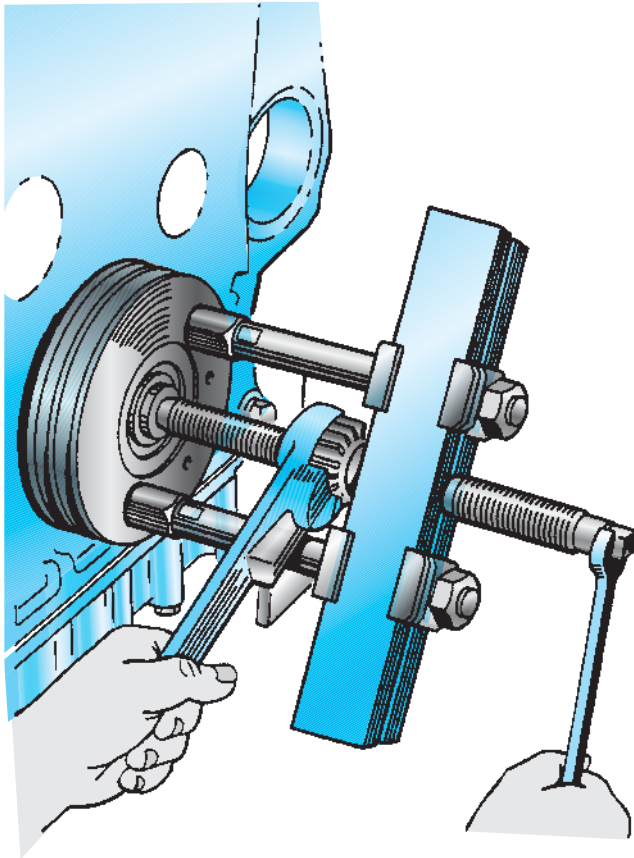

Figure 11-1 Removing a pulley using a T-puller. (Courtesy of Caterpillar)

- cover screws, remove them first and ensure that they are not damaged.
6. Remove the oil cooler assembly. With bundle-type oil coolers, test the core using either the pressure or vacuum methods outlined in **Chapter 7** and then seal using plastic wrap.
7. Disconnect any plumbing to the water pump not already removed, and then remove the water pump itself. It has become almost standard practice to replace water pumps with a rebuilt exchange unit when reconditioning engines today. But if you plan to reuse the water pump, visually check it for evidence of weeping at the ceramic seal, and check the seal itself for cracks.
8. Remove the clutch pack assembly from the flywheel and decide whether it will be reused. Anything more than 50 percent wear of clutch friction faces probably justifies a clutch pack replacement. Remember that as the technician, you are responsible for making the recommendation, not for deciding to replace rather than reuse components.
9. Remove the flywheel assembly using a suitable hoist.
10. Remove the flywheel housing and any attached components, checking for sensors and connecting wires. Check for eccentricity at the locating dowel holes.
11. Remove all accessory drive components not already removed, such as power steering pumps, air compressors, and so forth. Remove accessory drive pulleys using a suitable puller (**Figure 11-1**).
12. Remove the oil filler and dipstick tubes.
13. Remove the mechanical tachometer drive, if fitted.
14. If the engine is fitted with electronic unit pumps (EUPs), remove them and store them as per OEM recommendations. If the engine has an inline injection pump, remove any electrical wiring from the rack actuator housing (electronically managed, port-helix metering), transducer module, or governor housing. Disconnect the throttle arm and fuel stop arm from hydromechanical pumps. Check that all the plumbing is disconnected from both sides of the pump and remove any support brackets: loosen the pump mounting cap screws, and using a smooth motion, pull the injection pump away from its mounting flange. The various types of transfer pumps used with the electronic unit injector (EUIs) systems are relatively straightforward to remove, but the OEM literature should be consulted. When performing a complete engine overhaul, it may be part of the procedure to

recondition or replace with rebuilt/exchange fuel injection components, so check with the OEM and shop work-order instructions.

15. Remove the rocker housing covers.
16. Remove the rocker shaft assemblies including valve bridges where used. On overhead camshaft engines, remove the camshaft assembly.

.....
Tech Tip: Most OEMs recommend that rocker arm shaft assemblies and valve bridges/yokes be tagged for position to help maintain the same wear surfaces if they are to be reused.

17. Remove the injectors, using the appropriate puller. When cylindrical hydraulic injectors are used, make sure that all the plumbing is clear of the injector seat before attempting to remove them. Where EUIs, electrohydraulic injectors (EHIs), EUPs, and hydraulic electronic unit injectors (HEUIs) are used, ensure that all electrical and hydraulic connections are removed: this is especially important where transverse cylinder head, high-pressure pipes are used.
18. Check the injector nozzle seal/gasket. If it is not on a removed injector, remove from the injector bore with a magnet or small tapered rod. Do not leave nozzle seal/gaskets in the cylinder head on disassembly because this could cause problems on reassembly.
19. Remove the push tubes or push rods where fitted. It is good practice to inspect each for serviceability on disassembly. Some OEMs recommend that the push tubes be tagged for position in the engine.
20. Remove fuel manifolds (internal charge and return lines) where fitted, jumper pipes, and crossover pipes.
21. Remove all the cylinder head cap screws and washers. Remove the cylinder head(s).
22. Remove the cylinder head gasket and the sealing grommets and fire rings if not built into the cylinder head gasket assembly. Inspect the cylinder head gasket for signs of failure, paying special attention to the fire rings.
23. Remove the oil pan cap screws and the oil pan.
24. Remove the oil pump, which may be located in the crankcase or bolted outside the engine cylinder block.
25. Before removing each piston and connecting rod assemblies, scrape carbon deposits (ring ridge) from the upper inside wall of each cylinder liner using a flexible knife. This will make removal of the pistons much easier.
26. Plan to remove the pistons on an inline 6-cylinder engine in companion pairs, that is, 1 and 6, 2 and 5, 3 and 4.
27. Remove the connecting rod bearing bolts and separate each rod cap from the rod by tapping with a light-duty nylon hammer. Use as little hammering force as possible, especially where cracked/fractured rod assemblies are used.
28. Remove each connecting rod and piston assembly carefully, guiding the rod bottom end clear of the piston cooling oil nozzle and avoiding contact with the liner wall. Arrange the piston assemblies sequentially on a bench, making note of anything unusual.
29. Remove the cylinder block located piston cooling nozzles. Oil will be trapped in the gallery that supplies the piston cooling jets, so be prepared to capture it. If the engine is rotated to an angle on the stand, remove either 1 or 6 first and allow the oil in the gallery to drain into a container.
30. Disassemble the engine timing geartrain. Remove accessory drive gears, idler gears, and an in-block camshaft gear and camshaft as an assembly. Rotating the engine upside down will ease the removal of an in-block camshaft because this will drop the cam follower/lifter assemblies out of the way so they do not interfere with the cam lobes and journals as the shaft is withdrawn.
31. Remove the cam follower/tappets/valve lifter assemblies. If the camshaft is to be reused, inspect and tag individual lifters for reassembly to position. Where cam follower housings are used, tag for position. In engines where the cam follower housing shims are used to help define engine timing, make sure you measure and record the shim (gasket thickness) with a micrometer: you should do this even when the engine is to be retimed on reassembly because you can use the previous measurements as a starting point for the timing procedure.
32. Disassemble any remaining gears in the engine geartrain and remove any auxiliary or balance shafts remaining in the engine cylinder block.
33. Remove the crankshaft rear seal housing assembly.
34. Remove all the camshaft bushings using the correct sized driver and slide hammer.
35. With the engine still upside down, remove the main bearing cap screws, the cap brackets, and the main bearing caps by gently tapping with a nylon hammer. Tag the bearings by location for inspection and failure analysis purposes.

CAUTION Some lightweight cylinder blocks use transverse buttress screws in the main caps. You will not be able to remove the main caps with these in place and attempting to do so can damage both the cap and cylinder block.

- 36. Fit a crank-lifting yoke to the crank throws on a pair of companion cylinders (preferably 2 and 5 on an inline six). The lift yoke should have rubber insulation installed over the throw hooks to prevent damage to the throw journals. Lift the crankshaft free from the cylinder block using a hoist.

Tech Tip: Due to the weight of the crankshaft, extreme care must be observed during removal. Lift the crankshaft straight up to avoid damage. No scratches, nicks, burrs, or any other kinds of distress are permitted on the main or throw journals and their fillets.

- 37. Remove the cylinder liners using a suitable puller as shown in **Figure 11-2**. Wet liners are sealed by O-rings and do not usually require a great amount of force to separate them from the block. Dry liners and combination wet/dry liners may require considerable force and hydraulic and air-over-hydraulic pullers along with adapter plates are usually required.
- 38. All expansion (frost) press fit plugs and threaded oil passage plugs must be removed from the cylinder block before cleaning.

Tech Tip: Although cleaning and inspection are covered in the following section, it is important that an engine not be simply ripped

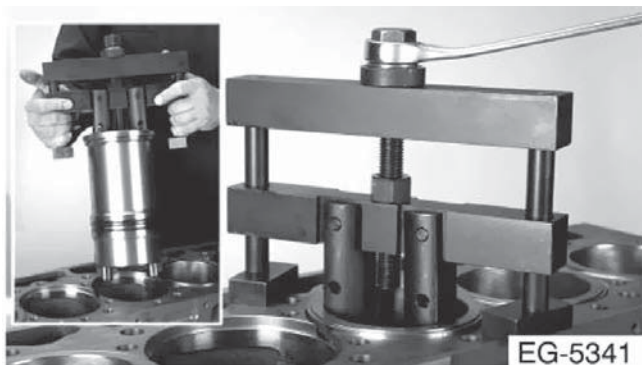

Figure 11-2 Removing a cylinder sleeve. (Courtesy of Navistar)

apart. Technicians should get in the habit of inspecting every component as it is removed and tagging it when it is important for it to be reinstalled in the same location. Cleaning, inspecting, and making the decision on whether a component can be reused on disassembly helps produce accurate quotes. Nothing is worse to a customer than costly surprises that inflate a bill way beyond the quoted dollar value.

CLEANING AND INSPECTING COMPONENTS

The cleaning and inspection of an engine is probably the most important stage in the engine reconditioning procedure. If the reason for the engine rebuild is a failure, ensure that the cause is identified before any attempt at reassembly is made.

1. Use a gasket scraper to remove all the gasket material and heavy dirt from the cylinder block. Install the cylinder block into a preferably heated, **soak tank** using a heavy-duty alkaline soak cleaner for a period of one to two hours. One OEM reports that 1/16 inch of coolant scale has the insulating properties of 4 inches of cast iron. It is therefore important not to skip this procedure.

CAUTION Use extreme care and wear protective clothing when working with the alkaline solutions used in soak tanks, as they may be caustic.

2. Remove the cylinder block from the cleaning or soak tank. Flush the cylinder block using a shop **high-pressure washer**. Make sure all particles and sludge produced by the block boiling are removed.
3. Visually inspect the cylinder block. Check all the coolant passages making sure that they are clean and unobstructed. Ream or drill out if necessary to dislodge any deposits.
4. Check to see that there are no casting fins or residues that might obstruct coolant flow. You can remove any casting irregularities with a pry bar.
5. Run a cylindrical wire brush through the oil passages to make sure there are no blockages.
6. Flush the oil passages with air and solvent.

Magnetic Flux Test

A **magnetic flux test** should be performed on engine cylinder blocks, crankshafts, and all connecting rods at

every major engine overhaul. Magnetic flux testing is inexpensive and takes little time to perform. Technicians should remind themselves that the cost of a single warranted engine failure can be greater than the profits of many other engine overhauls. This is an expense passed on to the customer, so make sure it is the customer who decides whether to skip it. Get a refusal in writing. The usual excuse for skipping magnetic flux testing of key components is that of not having the equipment on site. In most cases, the equipment is accessible and machine shops usually pick up and deliver.

ENGINE REASSEMBLY GUIDELINES

Although engines may be disassembled with little or no reference to service literature (not recommended practice), they should be reassembled step by step according to the OEM service literature. Even for the most experienced engine overhaul technician, using service literature as a guide is simply good practice. For the rookie engine overhauler, the service literature should guide every move: it is important that shortcuts never be experimented with. As you develop experience as an engine rebuilder, you will learn a few shortcuts to some procedures, but be aware that every shortcut must involve zero risk. This requires an in-depth knowledge of the engine that only comes with experience.

A general guide to an engine reassembly reverses the disassembly procedure; however, as already pointed out, engines should be reassembled exactly as outlined by the OEM service literature. In this chapter we list some general precautions that the engine rebuilder should observe when reassembling engines.

CAUTION *At present, the off-the-shelf cost of a current commercial diesel engine used in a typical heavy-duty truck exceeds the cost of the average automobile sold in the United States. Do not take any risks when working on diesel engines! In doing so, you could end up destroying an engine and losing your job.*

O-Rings on Wet Liners

Use the lubricant recommended by the manufacturer when installing full wet and midstop, wet/dry liners. The lubricant recommended may be antifreeze, engine oil, silastic, or nothing at all. An inappropriate lubricant may chemically interact with the O-ring material and cause it to swell, contract, or disintegrate, generating a premature failure.

Use of Anaerobic Sealants (Silicone, Silastic/RTV, and So Forth)

The use of **anaerobic sealants** has become popular in recent years. Any anaerobic sealant cures (sets) without exposure to air. Only use where specified, and do not overuse. Anaerobic sealants set to a rubber-like consistency and can plug up holes and passages.

.....
Note: Many sealants do not cure when in contact with any type of oil or grease.

Test the Cylinder Block Line Bore

This check is easily performed using a **master bar**. The master bar should be lubed with engine oil and clamped into the cylinder block line bore. The main caps are torqued to the cylinder block without the bearings in place. If after torquing the main caps the master bar can be rotated, the line bore can be assumed to be okay. When available, a master bar can be obtained from the OEM specialty tool supplier. The test is used to determine whether the cylinder block line bore must be machined. Binding indicates that line boring is required because the cylinder block has become distorted.

Cylinder Block Fretting and Warpage

This should be checked to specification using a straightedge and feeler gauges. This test is especially important with today's lightweight engines. Though these lightweight cylinder blocks are much harder, they are also more likely to twist under high torque loads.

Sleeve Height Protrusion Specification

This is a critical specification. The protrusion variance of the liners under one cylinder head determines how evenly each liner is clamped to the cylinder block. A liner protrusion error can damage a cylinder head and/or cause an immediate head gasket failure. To check liner protrusion, the liner should be installed using the proper OEM method as shown in **Figure 11-3**. In this example, a dial sled gauge is used to measure the protrusion.

Machining Counter Bore

When a liner protrusion is out of spec, this will usually require recutting the counter bore and then shimming to set specified protrusion. The general procedure for recutting a liner counter bore is shown in

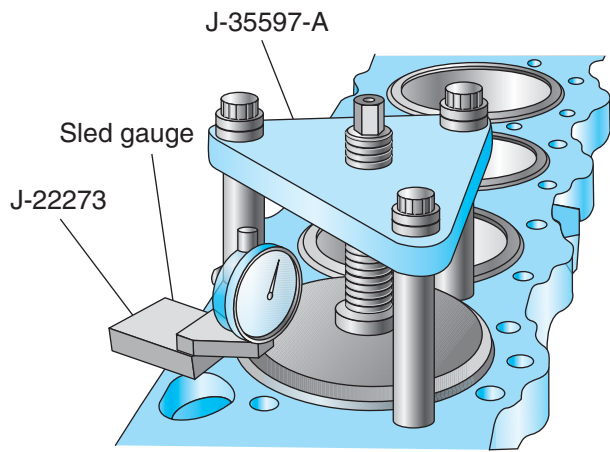
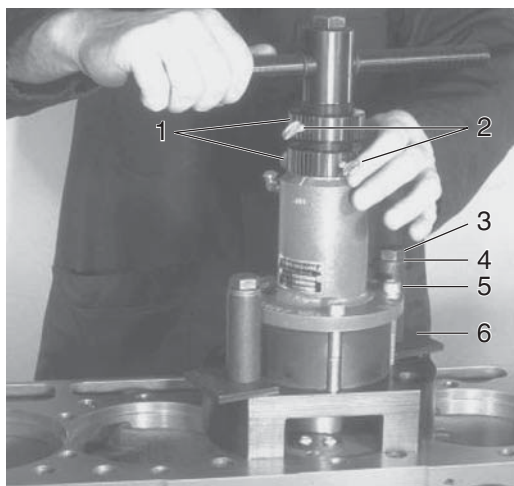

Figure 11-3 Measuring cylinder sleeve protrusion. (Courtesy of Navistar)

Figure 11-4 but always check the OEM service literature. Some diesel engines use angled or stepped counter bores that require specialized tooling.

Inspect Crankshaft

Crankshafts should be inspected using the OEM service literature and the procedures outlined in **Chapter 4**. Some OEMs emphasize the importance of magnetic flux testing crankshafts at each major overhaul. Others do not. This reflects the fact that crankshaft manufacturing technology since the early 1990s has developed to the point that very few crankshaft failures occur.



- 1. Turn knuckles
- 2. Locking screws
- 3. Mounting bolts (2)
- 4. Spacers (2)
- 5. Washers (2)
- 6. Locking plates (2)

Figure 11-4 Machining a cylinder block counter bore. (Courtesy of Navistar)

Checking Main Bearing Clearance

This procedure is designed to be performed with the engine upside down using Plastigage™; in other words, when the engine is being overhauled outside of the chassis. Performing this procedure when the engine is in-chassis will not produce accurate results. This is because crankshafts flex when not fully supported by their mains. Identify the OEM specification first, and then select the appropriate Plastigage color code. When making the measurement, ensure that the main bearing cap is torqued to specification. The procedure for using Plastigage is illustrated **Figure 4-18** and **Figure 4-19** in **Chapter 4**.

Piston Cooling Jets

Always check cooling jet aim using the appropriate tooling. This is usually a clear plastic template and rod. Some cooling jets may be bent to correct aim, but some may not be, so check the OEM service literature. The general procedure for targeting spray jets is illustrated in **Chapter 4**, **Figure 4-6**.

Piston Assembly

Piston assemblies must be checked before installation. It is important to do this whether the piston assembly is new or whether one is being reused. We will look at some of the critical steps in checking out piston and connecting rod assemblies. The components of a piston assembly are shown in **Figure 11-5**. Be aware that what is often referred to as a *piston kit* includes the liner in some OEM's terminology. **Figure 11-6** shows the procedure used to measure the big end of a connecting rod: note the rod cap is assembled and torqued into position.

Measuring Connecting Rods

The procedure for checking out conn rods is outlined by OEM service literature and some of the steps are covered in **Chapter 4** of this book. Make sure that connecting rods are completely clean before attempting to perform any measurements. Also be aware of the importance some OEMs place on magnetic flux testing of conn rods at each major overhaul.

Connecting Rod Weight Classifications. Connecting rod weights are coded by manufacturers. When replacing connecting rods, it may be possible to either increase or decrease the weight class by one increment, but not more. The consequence of an overweight or underweight rod is to unbalance the engine and generate a premature failure. Always check OEM service literature.

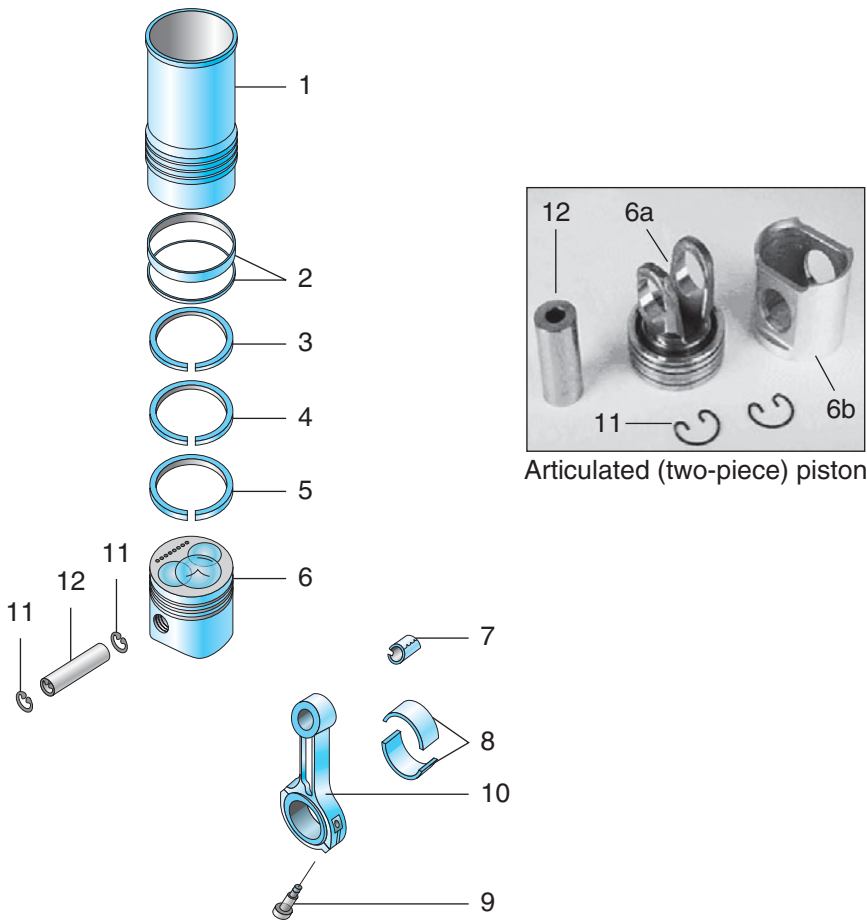

CONNECTING RODS, PISTONS, RING, AND SLEEVES

- | | | |
|---|-----------------------------------|--------------------------------|
| 1. Sleeve (6) | 5. Piston ring—oil regulating (6) | 8. Connecting rod bearing (12) |
| 2. Sleeve seals | 6. Piston (6) | 9. Bolt (12) |
| 3. Piston ring—top compression (6) | a. Piston crown (6) | 10. Connecting rod and cap (6) |
| 4. Piston ring—intermediate compression (6) | b. Piston skirt (6) | 11. Piston pin retainers (12) |
| | 7. Piston pin bushing (6) | 12. Piston pin (6) |

Figure 11-5 Connecting rods, pistons, rings, and sleeves. (Courtesy of Navistar)

Assessing Pistons and Rings

More recent piston assemblies such as Ferrotherm (articulating) and Monotherm™ (steel trunk) can often be safely reused providing they are properly inspected. When you come across aluminum truck pistons from older engines, remember that this generation of pistons was designed to be replaced at each major engine overhaul. If you are asked to inspect them, you must be very careful to consult OEM service specs and not take any risks.

Rod Assembly

Rod caps should never be mismatched. Each OEM identifies cap to rod matching in different ways so observe the instructions in service literature. Figure 11-7

shows the code number alignment of a properly matched Navistar rod and cap assembly. It is more difficult to mismatch a cracked rod assembly but you can bet it has been done. Figure 11-8 shows a mismatched cracked rod assembly.

Ring End Gap

This fast procedure is often overlooked by experienced diesel technicians probably due to the reliability of machining and packaging today. More often than not the nominal dimensions are correct. Checking the ring end gap specification takes little time, however, and should be always be done. Insert the ring into the cylinder bore (liner) and measure the gap with a feeler gauge. The specifications used by OEMs are based on a room temperature liner and room temperature ring.

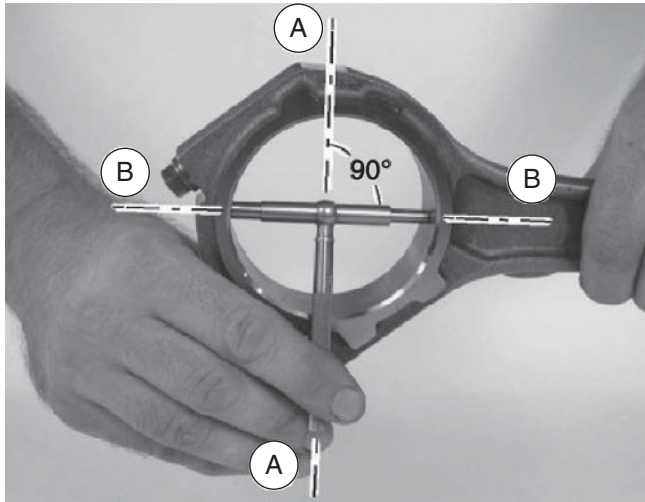
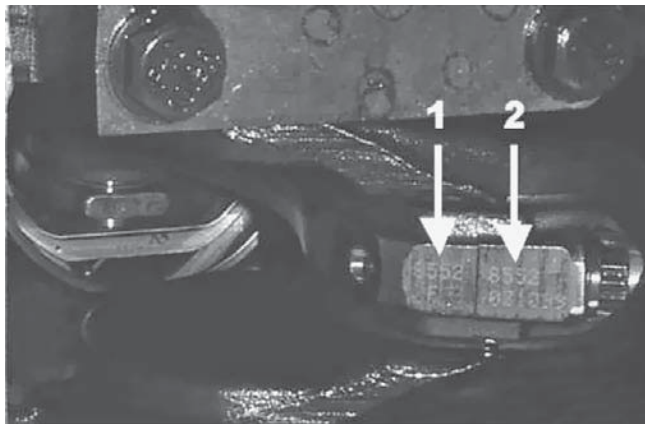

Figure 11-6 Measuring for out-of-round big end. (Courtesy of Navistar)



- 1. Numbers on connecting rod
- 2. Numbers on connecting rod cap

Figure 11-7 Match and align numbers on a connecting rod and cap. (Courtesy of Navistar)

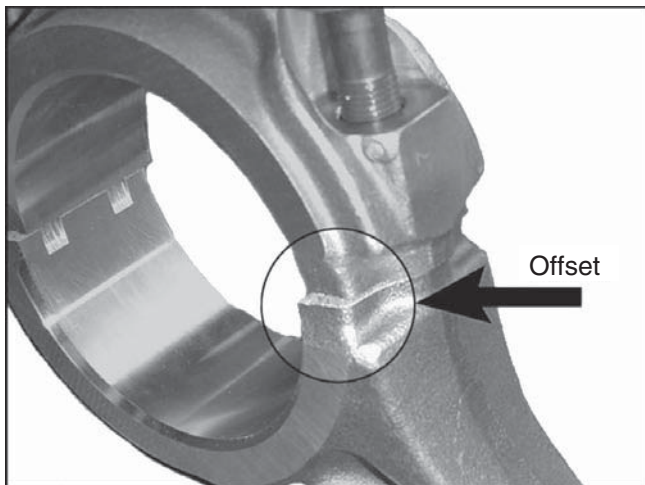

Figure 11-8 Incorrect rod cap assembly on a cracked/fractured rod assembly. (Courtesy of Navistar)

Piston Wrist Pin Retainer Snap Rings

These should be installed flat side out and with the gap either up or down (this varies with OEMs, but usually it is down), and never crossways to the direction of piston travel. Believe it or not, the inertia forces on acceleration or deceleration acting on the snap ring have been known to unseat them.

Ring Stagger

Ring stagger is crucially important when reassembling engines. Most engine OEMs prefer that no end gap is placed across either thrust face of the piston. **Figure 11-9** shows Detroit Diesel Corporation (DDC)'s preferred method for installing and staggering ring end gap on recent model Series 60 engines using Mono-therm pistons.

Installing the Piston Assembly

Make sure that both the piston and connecting rod are facing the right direction before installation. Most OEMs identify this by stamping the components with an arrow or front. Try to avoid using multipurpose band-type ring compressors when installing piston assemblies into the cylinder block. Band-type ring compressors are more likely than not going to damage piston rings. **Figure 11-10** and **Figure 11-11** show two common types of ring compressor. One uses a clamp, and the other a taper principle. You can actually machine the taper-type ring compressor using a discarded liner out of the same engine series. Ensure that the piston assembly and ring compressor are well oiled (with engine lube) before installing the unit.

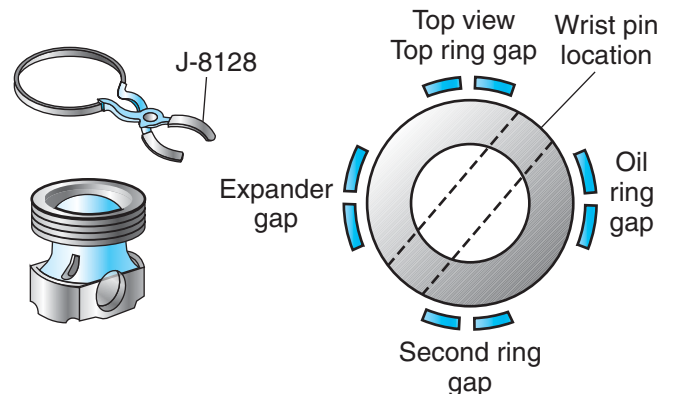

Figure 11-9 DDC Mono-therm piston ring stagger. (Specifications are subject to change without notice. Detroit Diesel Corporation is registered to ISO 9001:2001. Courtesy ©Detroit Diesel Corporation. All rights reserved. Detroit Diesel is a Daimler company)



Figure 11-10 Clamp-type ring compressor. (Courtesy of Navistar)

Install Rod Cap. In the case of cracked or fractured rods, eyeball the orientation before you install the rod cap. Although cracked rod caps will only fit when correctly orientated, it is easy enough to damage the mating faces by attempting to fit them improperly. In the case of stepped or clean face machined rod caps, make sure that you fit the clamp as indicated by the directional arrow or number on the cap. **Figure 11-12** shows the directional arrow on a typical rod cap.

Rod Sideplay. This is a critical specification on any rods with machined big end faces. Slightly cocked rod caps can damage crankshafts and destroy big end bearings. The use of a pair of equal-sized feeler gauge blades just under the rod side play spec can help installation. Insert the two feeler blades (they *must* be equally sized) on one side of the cap and then torque the rod cap to specification. Remove the feeler gauge blades. Now you can check the side play spec using

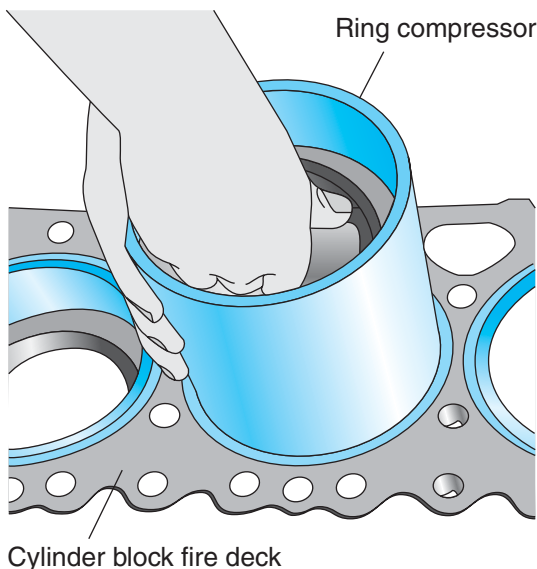

Figure 11-11 Taper-type ring compressor. (Specifications are subject to change without notice. Detroit Diesel Corporation is registered to ISO 9001:2001. Courtesy © Detroit Diesel Corporation. All rights reserved. Detroit Diesel is a Daimler company)

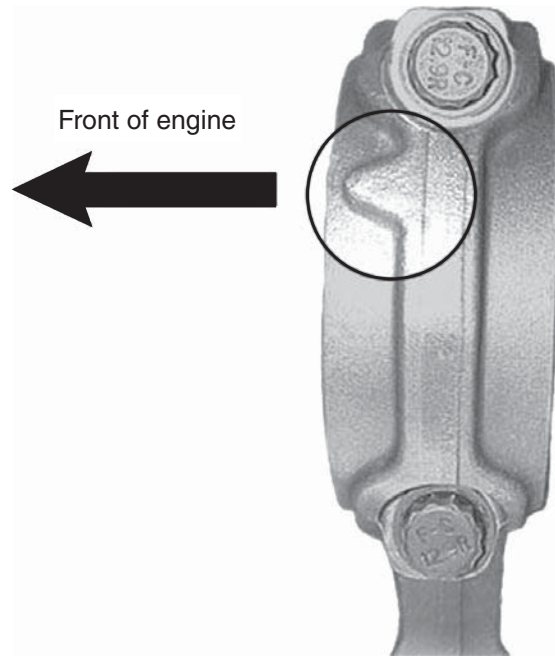

Figure 11-12 Correct orientation. (Courtesy of Navistar)

feeler gauges. Cracked rods used on some engines make this check unnecessary.

Buttress Screws on Main Bearing Caps

Some engines use **buttress** screws on some of the main bearing caps. This can help make the cylinder block more rigid. Buttress screws are usually installed after the main cap bolts have been torqued. Do not forget to install them. Cylinder blocks for the high-horsepower engines of today are made from castings of higher strength and lower weights: this makes them more likely to twist when producing high torque. Buttress screws are designed to limit cylinder block flexing.

Timing Geartrain Assembly

The procedure for setting up and timing the engine geartrain varies considerably from engine to engine. It can be a simple procedure but in some of today's overhead cam (OHC) engines, such as the Cummins ISX with its double OHCs, some specialized tooling (and training) is required. Some of the procedures you may be required to follow are listed next.

Camshaft Inspection. You should be familiar with camshaft terminology and inspection as we outlined it in **Chapter 5**. The camshaft should first be visually inspected and if it appears to be okay, then mount in V-blocks as shown in **Figure 5-6** in **Chapter 5**.

The journals should be miked and the profiles dial indicated. Pay special attention to areas of the cam profile that are more likely to wear. This would include peak cam lift on cam profiles. Another critical location is the portion of the cam profile just ahead of peak cam lift on injector train cam profiles.

Heat Shrinking Gears to Shafts. A bearing hot plate may be used to heat interference-fit gears to the OEM specified temperature. A kitchen toaster oven (dedicated to the purpose of heating engine components) has an accurate thermostat and works better: the gear is more evenly heated. **Tempilstick™** crayon may be used to check the temperature of a heated component. Using Tempilstick is required if you are using the hotplate method. Do not use an oxyacetylene torch to heat components because the steel may carburize. Gears should not be heated for periods exceeding 45 minutes.

Timing procedure. You must follow the OEM procedure when timing engine geartrains. Some guidelines are provided in **Chapter 5** of this book but this is a procedure that varies considerably by engine OEM and can be a little tricky when performing on OHC engines. **Figure 11-13** shows the location of the timing gear marks on a Caterpillar C15 engine. The crankshaft drives a bull gear immediately above it on this

engine. The bull gear masters the driving of all other gears in the timing geartrain. The timing marks are indicated by the callouts (**Figure 11-13**). Circles are also commonly used by OEMs.

Rear Cam Bushings

When performing an in-chassis engine overhaul, when the cam bushings are removed, it should be noted that the rear cam bushing in some engines cannot be removed without unseating the rear cam plug. In this case, replacement of the rear cam plug involves the removal of the transmission/clutch assembly and flywheel housing. This is not a procedure you will want to undertake if you are working on a quote that reckons for an in-chassis overhaul. The good news is that you can leave the rear cam bushing in place and not worry about replacing the rearmost cam bushing. Record the fact that it was not replaced on the hard copy of the work order.

Cylinder Head Servicing

Because OEMs have adopted single slab cylinder heads manufactured from lighter (and stronger) base metal, a cylinder head must be measured and pressure-tested before returning it to service. Some of the required checks are outlined here.

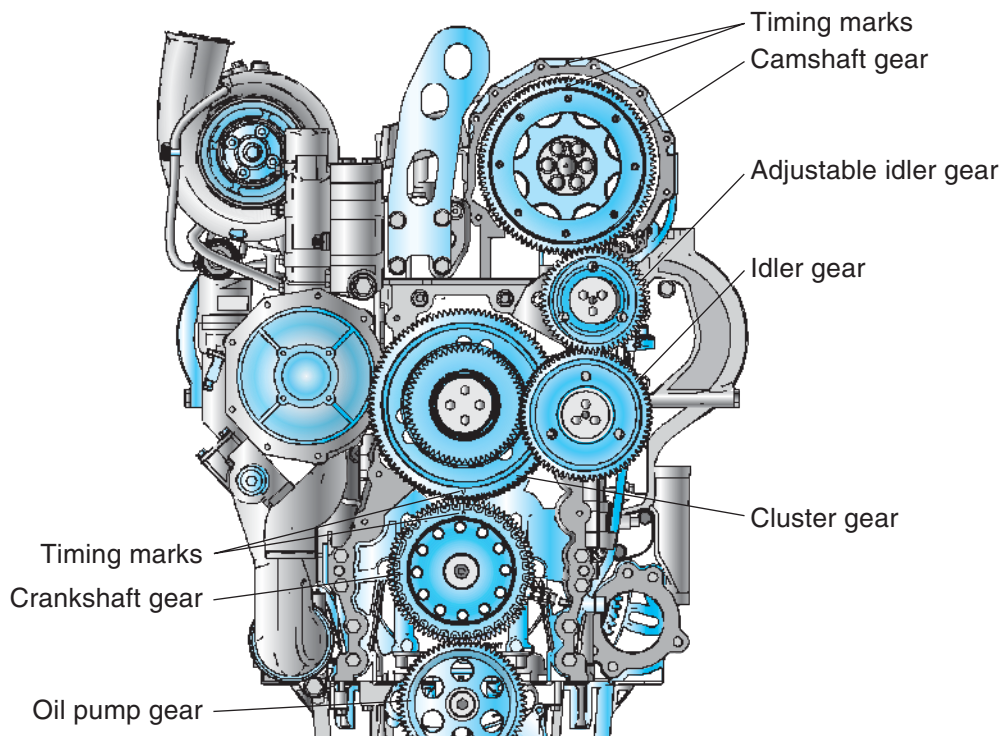

Figure 11-13 Timing a DDC Series 60 geartrain. (Specifications are subject to change without notice. Detroit Diesel Corporation is registered to ISO 9001:2001. Courtesy © Detroit Diesel Corporation. All rights reserved. Detroit Diesel is a Daimler company)

Cylinder Head Warpage. Check the cylinder for head warpage with a machinist's straightedge and feeler gauges. Check the OEM maximum warpage spec. This is usually expressed in thousands of an inch or decimals of millimeters. Select a feeler gauge equivalent to the maximum spec. Next, place the straightedge corner to corner over an upside down cylinder head. Then attempt to insert the gauge under the straightedge. If it can be inserted, this fails the cylinder head and it should be machined.

Pressure Testing Cylinder Heads. First, run hot water through cylinder heads for about 10 minutes to heat them up close to their operating temperature. Next, they should be hydrostatically tested. This requires that you trap hot water in the cylinder head, and then pressurize the trapped water using compressed air. Hot water and shop air regulated at 100 pounds per square inch (psi) should locate any leakage problems. Ask an experienced technician if the engine series has a track record of cylinder head problems and where leakage problems occur. The number one source of cylinder head leaks is the injector sleeve. Because the injector sleeve is in direct contact with the cylinder head water jacket, coolant leakage into the engine cylinder can occur. The problem is less frequent today because copper injector sleeves have been replaced by stainless steel (SS) sleeves.

CAUTION *Some injector sleeves are swaged into position and can be tough to remove. In some cases, these are threaded so they can be pulled out with a slide hammer. Do not attempt to cut them out. This may have worked with copper injector sleeves but the SS is harder than the cylinder head material and damage will result.*

Measure and Recut the Cylinder Head Fire Ring Groove

Measure to specification and recut when necessary. This is not a difficult procedure but it does require the correct tooling. In engines that use a cylinder head fire ring groove, the fire ring (usually built into the cylinder head gasket) is designed to deform into the groove when the cylinder head is torqued to spec. This fire ring yield deformation is a key to creating a good seal.

Cylinder Head Valves

You should be familiar with the procedure required to inspect and service valves as outlined in **Chapter 5**. Never take any risks with cylinder head valves. They have to be able to handle a lot of high temperature and hammering punishment. What appears as a small nick

of little importance can result in a dropped valve. When valves are “dressed” at cylinder head overhaul, the process is more about cleaning off deposits than removing material. However, the term is also used for more aggressive machining procedures.

Valve Margin. When dressing valves, remember that the valve margin specification is critical, and if it cannot be met, the valve should be replaced. Reference **Chapter 5** if you are uncertain what the valve margin spec represents. If you use a valve with insufficient margin it may either deform or overheat. Either condition will result in major engine damage.

Valve Interference Angle. Valves are seldom designed with an interference angle in today's diesel engines. This is because it reduces the valve's seating contact surface area. Valves depend on seating contact surface area for cooling. Additionally, most diesel engines use valve rotators and when they are used, an interference angle is never machined into the valve.

Cylinder Head Alignment

When installing multiple heads on an engine block deck, align the heads before torquing using a straight-edge. Perform this even when the cylinder block has cylinder head alignment dowels. This enables improved sealing and lower stress loads on the manifolds.

Most current cylinder head gaskets are of the integral design. An integral cylinder head gasket is one in which the fire rings and sealing grommets are built into the head gasket template. However, in nonintegral gasket designs, especially those installed on a cylinder block deck that is angled (such as on a V engine), you should use alignment dowels to install the cylinder head(s). Carefully lower the cylinder head onto the cylinder block making sure all the grommets and fire rings stay in position.

Setting Valves and Injectors

When setting cylinder valves and cam-actuated injectors, always use the correct engine locations to perform the adjustment. Novice technicians may observe experienced technicians taking shortcuts that save time and do not endanger the engine. However, until you are completely familiar with a specific engine series, always go by the book. The general procedure for setting valves is outlined in **Chapter 5**.

Injector Installation

When installing hydraulic, EHIs, EUIs, and HEUIs, always use the OEM recommended procedure. Where O-rings are used to seal supply and return fuel galleries, they must be lubricated with the correct medium. Usually this is diesel fuel. Avoid using any sealants or lubricants

on injector and O-rings that are not approved: this includes silicone, lithium grease, and antiseize compounds. Note that when injectors are removed and replaced either or both of the following may be required:

- Mechanically actuated injectors may have to be timed (height adjusted).
- Calibration codes may need to be reprogrammed to ECM.

These procedures are covered in a later section of this textbook.

Torque High Pressure Pipe Nuts. Injection pressures on today's engines frequently exceed 30,000 psi (2,000 bar). Because of this many of the high-pressure pipes are designed for one-off use only. When the pipe nut is torqued, it is designed to deform slightly. This helps create a more effective seal. A torque wrench must be used. Overtorquing high-pressure pipe nuts can ridge the nipple seat and, more significantly, collapse the nipple, creating a flow restriction. Torquing injector lines using a line wrench socket and torque wrench is required practice

CAUTION *Some OEMs require that the high-pressure pipes used with CR fuel systems be replaced every time they are removed. They are one-off use components because they yield to deform to seat the first time they are torqued.*

Finding True Top Dead Center (TDC)

When a piston reaches the top of its travel on its upstroke, it remains stationary while the crank throw turns over center before beginning the downstroke. True top dead center is the exact midpoint between the moment the piston stops moving upward and the moment it begins its downstroke. Engines that use a timing indicator must have this set at true TDC. Timing accuracy in many modern engines should be within a half crank angle degree and not simply at any point where the piston is at the top of its travel. This ensures that components such as injection pumps are accurately timed to the engine. The following list identifies the procedure used to determine true TDC for a typical four-stroke cycle, inline, 6-cylinder engine.

1. Locate the fixed engine timing marker and rotating calibration scale. The calibration scale (this rotates) may be on the vibration damper, any pulley driven at engine speed, or on the flywheel. The procedure may be performed on either 1 or 6 engine cylinder. Make sure that the engine is no-fueled either mechanically or electrically, whichever is appropriate. Manually bar the engine in its

normal direction of rotation to locate cylinders 1 and 6 at indicated TDC using:

- the fixed timing indicator already on the engine, or
- make one out of mechanic's wire and clamp it close to where the fixed timing indicator is to be positioned.

The flywheel (using a gear and ratchet barring tool) or crank hub (using a barring fixture) should be used to rotate the engine.

2. If the cylinder heads are installed, remove the 1 or 6 injector and install in its place a dial indicator fitted with an extension probe long enough to contact the piston crown. In cases where the cylinder heads are removed from the engine, the dial indicator may be positioned on the cylinder block with the probe contacting the piston crown. Next, zero the indicator at the highest point of piston travel by barring the engine slightly both sides of TDC.
3. Cut a 4-inch strip of masking tape and place it on the flywheel or pulley calibration scale.
4. If the dial indicator was properly zeroed, barring the engine in either direction (before top dead center [BTDC] or after top dead center [ATDC]) will produce a reading on the negative side of the indicator scale. Take a look at the indicator scale to determine how much travel is required to turn the needle through a complete revolution. This should be either 0.050 inch or 0.100 inch. For the purposes of the explanation of the procedure, 0.050 inch is used. Now bar the engine BTDC until the chosen value is exceeded by 0.030 inch, that is, until the indicator reads 0.080 inch. Next, bar the engine back in the normal direction of rotation until 0.050 inch is read at the dial indicator. With a pencil, draw a line on the masking tape under the fixed (or temporary) timing indicator. Then reverse bar the engine until 0.050 inch is read at the dial indicator. Draw a second line under the fixed or temporary timing marker. The reason for turning the engine 0.030 inch beyond the selected value is to eliminate backlash factors while performing this procedure.
5. Next, place a third mark exactly between the first two. One way of accurately performing this is with a knife. Neatly cut the masking tape at both of the two lines drawn on the masking tape: fold back one end of the masking tape so that the two cut ends align. Rotate the engine until the fold crease is positioned under the fixed or temporary timing marker. When the engine is rotated back

to the exact midpoint between the two lines, it will be positioned at true TDC.

6. With the engine located at true TDC, the tape can be removed and the fixed timing marker adjusted to the TDC point on the engine calibration scale.

Flywheel Housing Concentricity

Never take any risks with flywheel housings. They are regarded as indestructible by many technicians but can cause more problems than you might think. Flywheel housings are subjected to high torque shock loads and minor misalignment problems can create a range of problems. *Always* observe the OEM measurements when reinstalling flywheels anytime they are removed.

Diamond Dowels. Diamond dowels retain the alignment of mated components much better than cylindrical dowels. Some OEMs use them on flywheel housings. However, all the critical alignment checks should still be performed. For instance, if a flywheel housing has been removed, the housing should be radially indicated (dial indicator) for its concentricity to the crankshaft even when diamond dowels are used. If they are used, there is much less chance of an eccentric measurement.

Indicating a Flywheel Housing. Anytime a flywheel is removed from the cylinder block, the housing inner flange face concentricity with the crankshaft should be checked using a dial indicator. The maximum tolerance for the crankshaft to flywheel housing eccentricity is low, typically around 0.012 in. (0.3 mm) total indicated runout (TIR). It may be less.

The consequences of installing a flywheel housing that exceeds the allowable specification are severe. When this occurs the drive axis is broken, a condition that can result in clutch, engine mount, transmission, and engine failures. The flywheel housing to crankshaft concentricity is preserved by dowels. These may be relied on to properly realign the flywheel housing on the cylinder block at each reinstallation, but the specification is so critical, it should be checked. The following procedure outlines a method of checking **flywheel housing concentricity**, along with a couple of methods for correcting an out-of-specification condition. The procedure is demonstrated in Photo Sequence 3.

1. Make sure that the engine is properly supported. Indicating a flywheel housing may be performed with the engine in-chassis or out. It is a lot easier if the engine is out of chassis. First locate the flywheel inner flange face to crankshaft

concentricity TIR tolerance in the OEM technical literature. Either mechanically or electronically make sure the engine fuel system is no-fueled.

2. Mount the flywheel housing to the engine cylinder block using the dowels to align the assembly. Snug the flywheel bolts at about half of the OEM specified torque value.
3. Using chalk, mark the flywheel flange face with strokes in the following positions around the flywheel housing face: NE, NW, SW, SE, or N W S E (shown in **Figure 11-14**).
4. Next, clean the inside face of the flywheel housing with emery cloth. Fix a magnetic base dial indicator to any position on the crankshaft,

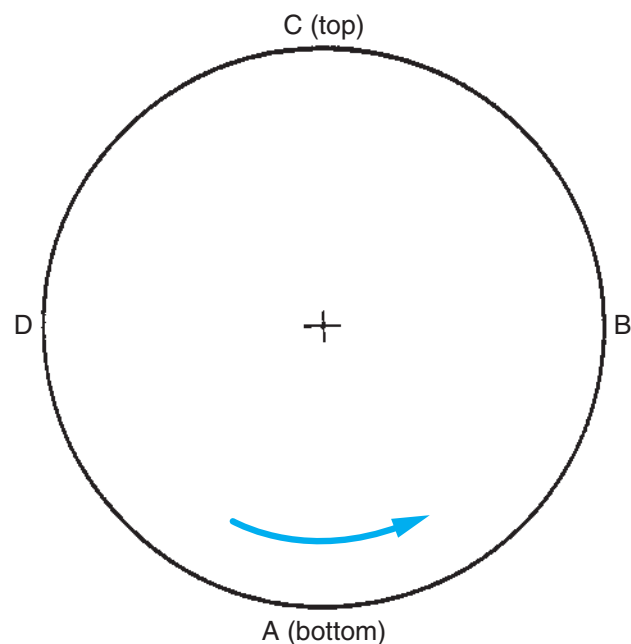
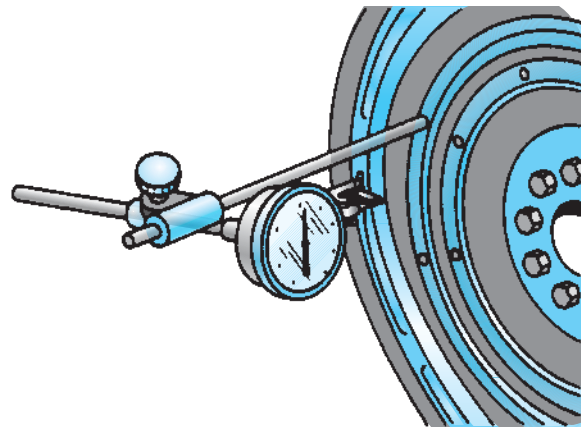
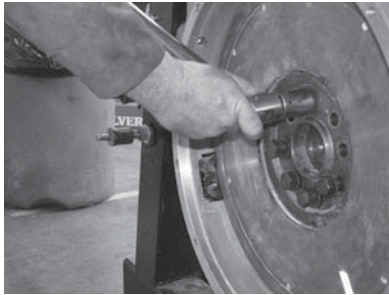

Figure 11-14 Caterpillar-recommended method for checking flywheel housing radial concentricity. (Courtesy of Caterpillar)

PHOTO SEQUENCE
3

Indicating a Flywheel Housing



P3-1 Hold the engine in a fixed position (so it cannot rotate) and remove the flywheel bolts.

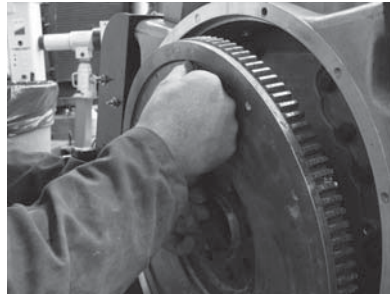

P3-2 When the flywheel fasteners have been removed, remove the flywheel from the flywheel housing. Place on hardwood blocks taking care not to damage the ring gear teeth.

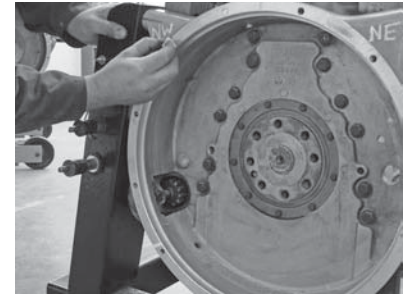

P3-3 Next, use chalk to mark four reference points on the flange face of the flywheel housing approximately 90 degrees apart. Use an emery cloth to clean up the inside bore of the flywheel housing removing any dirt or scratches: this must be clean to ensure accurate measurements.

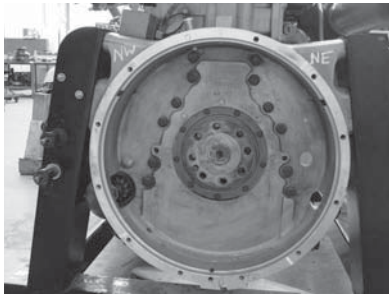

P3-4 On this engine we have marked reference points at NW, SW, SE, and NE. You may also use N, W, S, and E but check with the manufacturer service literature for their recommended method.



P3-5 Now fit a dial indicator with a magnetic base at any secure location on the crankshaft. Choose one of the four reference points and zero the indicator to it. Here we have chosen to begin at the NW reference location.

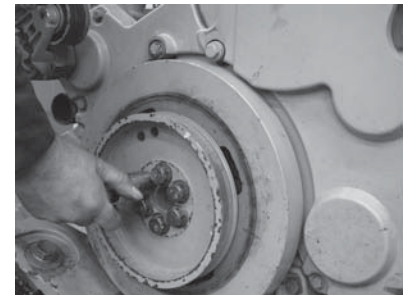

P3-6 Bar the engine in its correct direction of rotation (CCW from rear of engine, clockwise [CW] from front of engine) exactly 90 degrees to the SW reference point.

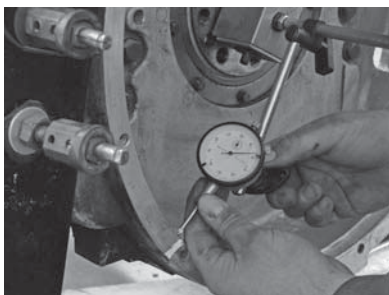

P3-7 Record the indicator reading at the SW location. Make sure you note whether this reading occurs on the plus or minus side of the indicator zero point. Bar the engine to the next reference point.



P3-8 Record the indicator reading at the SE location. Once again, make sure you note whether this reading occurs on the plus or minus side of the indicator zero point. Bar the engine to the NE reference point.

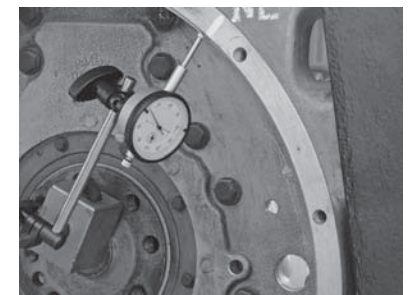

P3-9 Record the indicator reading at the NE location. Make sure you note whether this reading occurs on the plus or minus side of the indicator zero point. Now bar the engine back to the starting reference point at NW.

(Continued)

PHOTO
SEQUENCE
3

Indicating a Flywheel Housing (Continued)

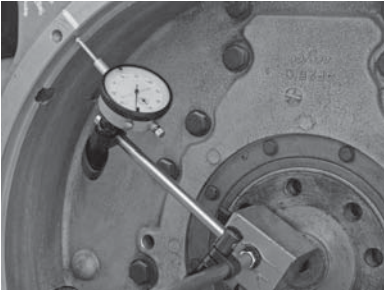

P3-10 Important: the indicator **MUST** read zero. If it does not, the dial indicator has moved and you will have to repeat the process.

P3-11 Check the manufacturer's total indicated runout (TIR) specification. This is a tight specification that may range between 0.004 inch and 0.015 inch. Exceeding the TIR specification can result in severe engine or drivetrain damage. On the engine we used in this example, the TIR spec was 0.006 inch.

P3-12 To calculate TIR, you take the highest reading on the positive side of the indicator dial zero point and add it to the highest reading on the negative side of the zero point. So using an example in which the highest plus reading was 0.003 inch and the highest negative reading was 0.004 inch, the TIR is calculated as follows:

Highest plus side reading: 0.003 inch

Highest negative side reading: 0.004 inch

TIR equals: $0.003 + 0.004 = 0.007$ inch

If the TIR is outside of specification, then you will have to adjust the flywheel housing using the manufacturer's recommended procedure.

setting the probe to contact the flywheel housing inside face as shown in **Figure 11-14**. Using an engine barring tool, rotate the engine in its normal direction of rotation until the indicator probe is positioned at any one of the chalk strokes you made. Set the indicator at zero.

5. Bar the engine through a full rotation, stopping at each chalk stroke to record the indicator reading. You can write this in chalk on the flywheel housing face. The indicator should once again read exactly zero when the revolution is complete. If this is not the case, the indicator has moved and you must repeat the procedure.
6. If the readings were NE: 0 (start point), NW: minus 0.003 inch, SW: minus 0.005 inch, and SE: plus 0.004 inch, the TIR would be the highest negative reading (0.005 inch) added to the highest positive reading (0.004 inch) giving a reading of 0.009 inch. If the OEM TIR maximum specification were 0.012 inch, this reading would be within it.

Correct Flywheel Housing Radial Runout. If the flywheel housing to crankshaft concentricity is outside of the specification, it must be reset. The following outlines this procedure for an engine that aligns the flywheel housing using cylindrical locating dowels. These are by far the most common.

1. Begin by removing the dowels. There are usually two.

2. Check the availability of oversize locating dowels with the parts department. Loosen the flywheel mounting bolts until they are just barely snug. This should allow the flywheel housing to be moved slightly when struck with a rubber mallet.
3. Perform the flywheel housing concentricity procedure as outlined just before this procedure. After writing the runout data in chalk on the housing, adjust the position of the flywheel housing by tapping with the rubber mallet. You will have to repeat the procedure until the readings fall within specification. This may take some time.
4. When the runout readings fall within specification, torque the flywheel housing bolts to OEM specification.
5. Next, the locating dowel holes in the cylinder block and flywheel housing have to be reamed to an oversize specification. Flywheel housing dowels are specified to an interference fit. This means that the dowel size will slightly exceed the size of the hole reamed for it. You will have to account for this.
6. Drive the oversize dowels into the reamed holes. Use a 3-pound hammer and make sure you strike the dowels evenly.

Checking the Flywheel Housing Axial Runout. Flywheel housing axial runout failures are rare but you should still perform the check. You are checking

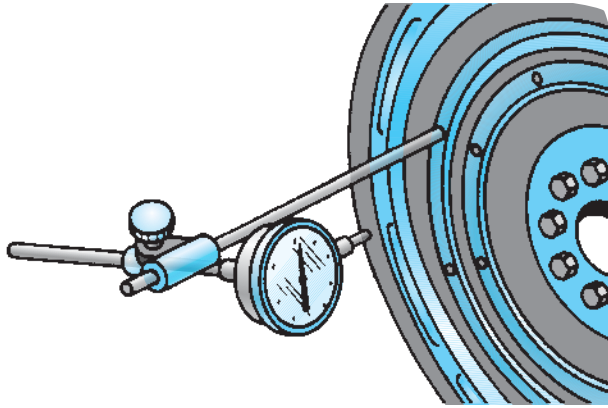

Figure 11-15 Checking flywheel housing axial concentricity. (Courtesy of Caterpillar)

the flywheel housing mating face runout as shown in **Figure 11-15**. When a failure to meet specification occurs, it is most likely coincidental damage or some other problem such as missing fasteners. If measured out of specification, machining or replacement is required.

Summary

- Most of the procedures outlined in this chapter are covered in greater detail elsewhere in the book. The contents in this chapter are general in nature.
- Make sure the work area around the chassis and the engine during rebuild is clean, organized, and uncluttered.
- You must tag components, lines, linkages, and connectors so that you do not create reassembly problems.
- Always work on an engine in such a way that another technician taking over the rebuild or reinstallation at any point in the sequence would have

Reinstall Engine to Chassis

If an adequate amount of care was taken in removing the engine from the chassis, the reinstallation should be straightforward. Usually, this takes less time than the removal because the components are clean and the hoses and connectors tagged. Never hesitate to obtain assistance, especially in snub nose conventional chassis with an engine compartment that extends into the cab.

Note: The contents of this chapter are practical. It puts together some of the theory introduced in earlier chapters. At this point, it is probably essential to take down and reassemble a diesel engine and put to practice some of the theory covered thus far. The following Shop Tasks and Review Questions will help prepare you for the experience.

- no problem in determining at what point you left off and where to begin.
- Remember to note the condition of every engine component as it is removed for failure analysis, especially until the root cause of the failure has been diagnosed.
- When the reason for the engine rebuild is a failure, never begin the engine reassembly before defining the failure.
- Always use the OEM technical service literature when undertaking engine overhaul.

Shop Tasks

1. Identify an engine to be worked on. Record the engine identification data and determine how to obtain the required OEM service literature: for example, online, a hard-copy service manual, and so on.
2. Review the disassembly procedure for the diesel engine according to the OEM service literature. Make sure you have something on which to record any observations, especially those procedures that are not common to all engines.
3. Review the OEM recommended cleaning and testing procedure for all the engine components including the cylinder heads, cylinder block, connecting rods, and crankshaft. List all those procedures requiring the use of specialized equipment.
4. Review the OEM recommended reassembly procedure for the same engine, once again noting those procedures that are distinct to that particular engine.
5. Review the OEM requirements for initial startup of the engine following an engine overhaul. Make a list of each step in the procedure. Take special notice of the recommended break-in procedure.

Review Questions

- When hoisting a crankshaft from an inverted engine cylinder block using a yoke, which of the following would be the preferred location to attach the yoke hooks?
 - Throw journals numbers 2 and 5
 - Throw journals numbers 3 and 4
 - Main journals numbers 1 and 6
 - Main journals numbers 3 and 4
- When measuring piston ring end gap, which of the following should be true?
 - The piston should be at operating temperature.
 - The ring and liner should be at operating temperature.
 - The ring and liner should be at room temperature.
 - The ring should be installed into its piston ring groove.
- While indicating flywheel housing concentricity on a housing specified to be within 0.008 inch, you record the following measurements:

NE	SE	SW	NW	NE
0.000 in.	+0.003 in.	+0.005 in.	-0.004 in.	-0.004 in.

What should you do?

 - Calculate that the TIR is within specification.
 - Repeat the procedure; the indicator has moved.
 - Calculate that the TIR is close enough to spec to leave as is.
 - Remove dowels and reset flywheel housing concentricity.
- While indicating flywheel housing concentricity on a housing that must be within 0.012 inch TIR, you record the following measurements:

NE	SE	SW	NW	NE
0.000 in.	+0.006 in.	+0.003 in.	-0.005 in.	0.000 in.

What should you do?

 - Calculate that the TIR is within specification.
 - Repeat the procedure; the indicator has moved.
 - Calculate that the TIR is close enough to spec to leave as is.
 - Remove dowels and reset flywheel housing concentricity.
- When calculating true TDC on a diesel engine, which of the following instruments should be used?
 - Straightedge
 - Micrometer
 - Feeler gauges
 - Dial indicator

CHAPTER

12

Fuel Subsystems

Learning Objectives

After studying this chapter, you should be able to:

- Identify fuel subsystem components on a typical diesel engine.
- Describe the construction of a fuel tank.
- Explain the operation of and troubleshoot a fuel sending unit.
- Define the role of primary and secondary fuel filters.
- Service primary and secondary fuel filters.
- Explain how a water separator functions.
- Service a water separator.
- Define the operating principles of a transfer pump.
- Prime a fuel subsystem.
- Test the low-pressure side of the fuel subsystem for inlet restriction.
- Test the charge side of the fuel subsystem for charging pressure.
- Identify the some typical sensors used in diesel fuel subsystems.

Key Terms

canister

cartridge

centrifuge

charging circuit

charging pressure

charging pump

clockwise (CW)

crossover pipe

emulsify

fuel filter

fuel heater

fuel subsystem

fuel tank

gear pump

Hg manometer

inlet restriction

micron (m)

pickup tube

plunger pump

positive displacement

primary filter

secondary filter

sending unit

suction circuit

transfer pump

venting

ultra low sulfur (ULS) fuel

water-in-fuel (WIF)

water separator

INTRODUCTION

The diesel **fuel subsystem** on a commercial vehicle is the group of components responsible for fuel storage and its transfer to the high-pressure injection circuit. Although high-pressure injection circuits can differ greatly from manufacturer to manufacturer, the fuel subsystems that supply them have much in common. Many of the problems that you will experience as a rookie diesel technician will be connected to the fuel subsystem. That makes this chapter one of the key chapters in this textbook.

A thorough knowledge of fuel subsystem components and how they can affect the performance of the high-pressure injection circuit is essential. The basic components used in a fuel subsystem have not changed much over the years; however, the way in which the fuel subsystem is monitored has changed. A generation ago, the fuel subsystem had one monitoring sensor called a sending unit. Today, depending on the original equipment manufacturer OEM, system pressure and temperature are monitored at different locations in the circuit.

Fuel tanks, fuel filters, water separators, transfer pumps, fuel heaters, and all the plumbing that connects these components are discussed in this chapter. **Figure 12-1** shows the main fuel system components used on C7 and C9 common rail (CR)-fueled engines while **Figure 12-2** shows a Navistar fuel subsystem schematic. Study the fuel routing in both systems.

FUEL SUBSYSTEM OBJECTIVES

As you study the fuel systems shown in **Figure 12-1** and **Figure 12-2**, you will notice that in each the low-pressure side and the charge side of the fuel subsystem are divided by a fuel transfer pump. Most (but not all) fuel subsystems are of this type. We describe the circuits on each side of the fuel transfer pump as:

- the **suction circuit** (low-pressure side)
- the **charging circuit** (high-pressure side—do not confuse with injection pressures which are much higher)

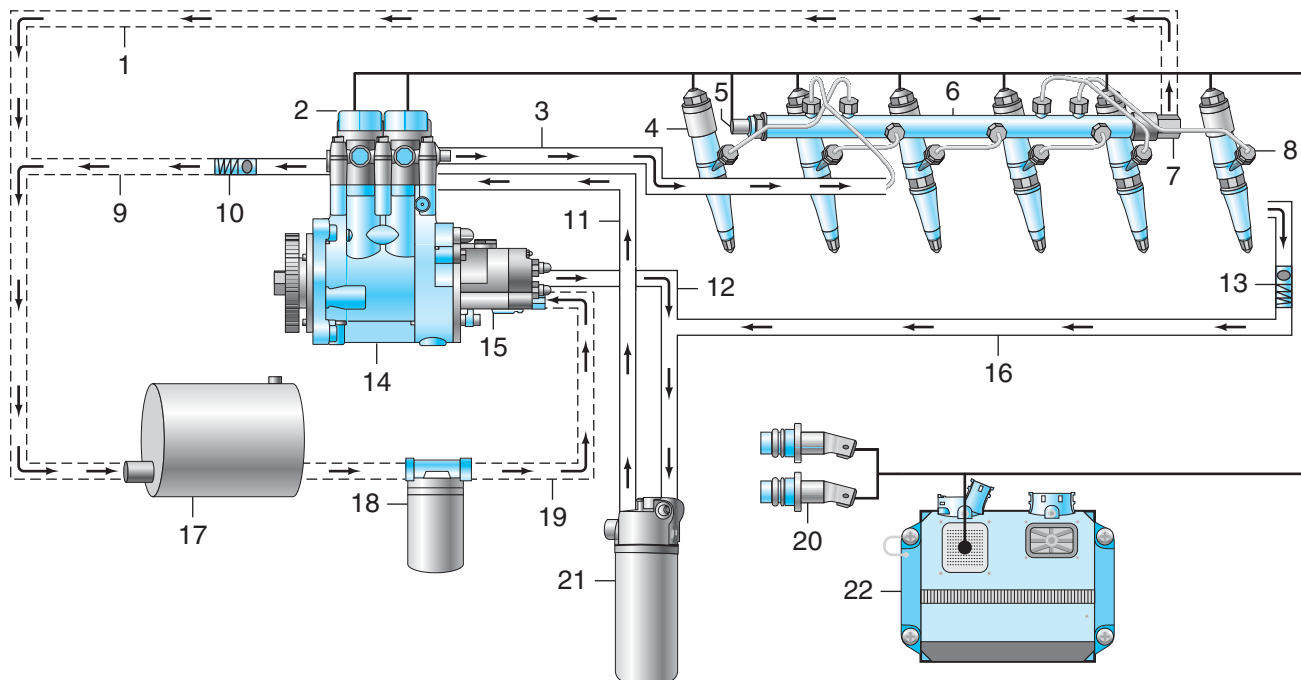

FUEL SYSTEM DIAGRAM

- | | | |
|---|--|--|
| 1. Return line from pressure relief valve to tank | 8. Quill tube | 16. Fuel line for the drain back to the filter |
| 2. Solenoid for the fuel pump | 9. Return line from fuel pump to tank | 17. Fuel tank |
| 3. High-pressure supply line | 10. Pressure relief valve for the fuel pump | 18. Primary fuel filter |
| 4. Electrohydraulic injector (EHI) | 11. Fuel line from secondary filter to fuel pump | 19. Fuel line from the primary filter to the transfer pump |
| 5. Fuel pressure sensor | 12. Fuel line from transfer pump to fuel filter | 20. Speed/timing sensor |
| 6. Fuel rail | 13. Pressure regulator for the drain line | 21. Secondary fuel filter |
| 7. Pressure relief valve for the fuel rail | 14. Fuel pump | 22. Engine control module (ECM) |
| | 15. Transfer pump | |

Figure 12-1 Fuel system components and routing used on C7 and C9 CR-fueled engines. (Courtesy of Caterpillar)

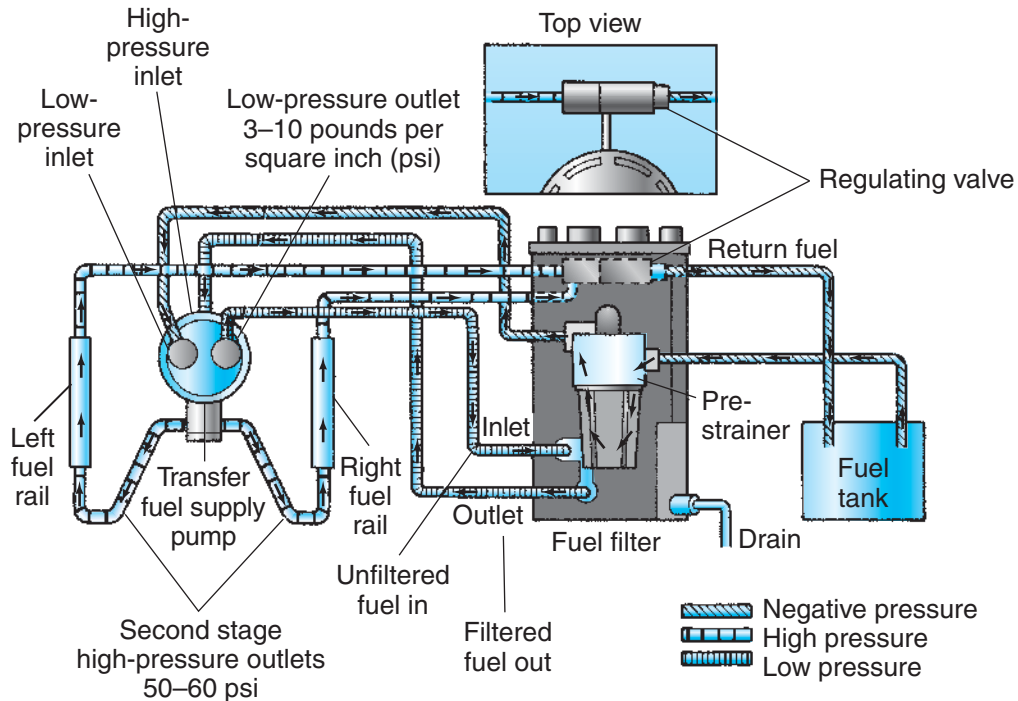

Figure 12-2 Fuel subsystem schematic. (Courtesy of Navistar)

A full explanation of how fuel is moved through the fuel subsystem appears later in this chapter under the heading “Fuel Charging/Transfer Pumps.”

A **primary filter** is most often located on the suction side of the transfer pump while the **secondary filter** is located on its charge side. However, in some fuel systems all movement of fuel through the fuel subsystem is under suction. When this type of fuel system uses multiple filters, the terms *primary* and *secondary* are not used. The objectives of a typical fuel subsystem are as follows:

- stores fuel in tanks until required
- removes moisture from the fuel
- filters fuel to remove abrasive particulates
- delivers fuel to the injection components at the proper temperature

Diesel fuel

Ultra low sulfur (ULS) was required to be sold in 80 percent of highway fuel outlets from 2007 on. This will change to 100 percent of outlets beginning in 2010. ULS contains a maximum sulfur content of 0.0015 percent. Note that the use of anything but ULS fuel in a truck manufactured after 2007 can cause costly damage to emission control devices.

FUEL TANKS

Fuel is stored on commercial vehicles in fuel tanks. In most highway trucks, fuel tanks are mounted to the frame. It is common to use a pair of fuel tanks. This

balances the considerable weight of onboard fuel as it is consumed. A typical fuel tank arrangement is shown in **Figure 12-3**. Many diesel fuel management systems are designed to pump much greater quantities of fuel through the system than that required to actually fuel the engine. The excess fuel is used to:

- lubricate high-pressure injection components
- cool high-pressure injection components (especially those exposed to extreme temperatures)
- cool electronic components such as ECMs and injector drivers

In its role as a cooling medium, the fuel transfers heat from engine components to the fuel tank. This means that one of the roles of the fuel tank(s) is to transfer heat from the fuel to atmosphere.

Fuel Tank Design

The fuel tank is always a chassis OEM-supplied component. **Figure 12-3** shows a typical truck fuel tank. Because one of the roles of a fuel tank is to transfer heat from the fuel it circulates to atmosphere, it plays a role as a heat exchanger. A vehicle fuel tank will function most effectively as a heat exchanger if the following is true:

1. Located in the airflow. Truck fuel tanks tend to be mounted in cradle brackets bolted to the outboard side of laddered frame rails such as those shown in **Figure 12-3**. This ensures fairly

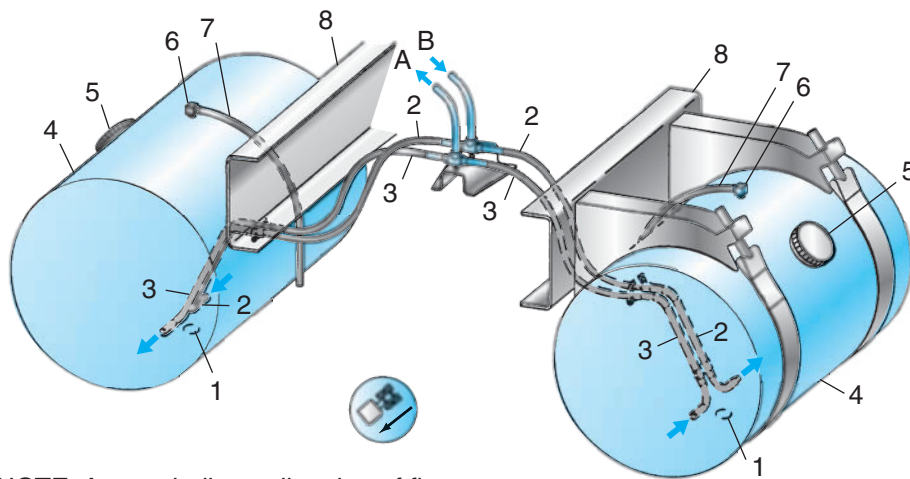

NOTE: Arrows indicate direction of flow.

- | | | | |
|-----------------|--------------------------|--------------|---------------|
| A. To fuel pump | 1. Drain | 4. Fuel tank | 7. Vent line |
| B. From engine | 2. Supply (suction) line | 5. Fuel cap | 8. Frame rail |
| | 3. Return line | 6. Vent | |

Figure 12-3 Dual fuel tank arrangement that eliminates the fuel crossover pipe. (Courtesy of Freightliner)

good airflow around the tank into which heat removed from the cylinder head by the fuel can be dissipated.

2. Cylindrically shaped. A cylindrically shaped container as shown in **Figure 12-3** exposes a greater percentage of its surface area to the air-flow. A cylindrical shaped tank is less flexible than one that is rectangular in shape. This means that cylindrical tanks can be made with a thinner wall thickness, resulting in a lighter fuel tank.
3. Aluminum construction. Aluminum transfers heat much more quickly than steel. This means that aluminum tanks transfer heat to atmosphere faster than equivalent steel tanks.
4. Aluminum is less likely than steel to corrode when exposed to water.
5. Maintained 25 percent full or better. Manufacturers of high-flow fuel system often caution that running tanks low on fuel overheats the fuel, causing it to lose lubricity. It is good practice in such systems to maintain the tank level at better than 25 percent full.

are of equal volume, fuel level is automatically equalized. Most of today’s trucks use a Y (sometimes known as a T-type) fuel pickup but you still see plenty of older style fuel tank arrangements with single pickup and crossover pipes.

Each tank requires a fuel cap (**Figure 12-4**) and must be filled separately when no crossover pipe is used. Older style crossover pipes can cause problems.

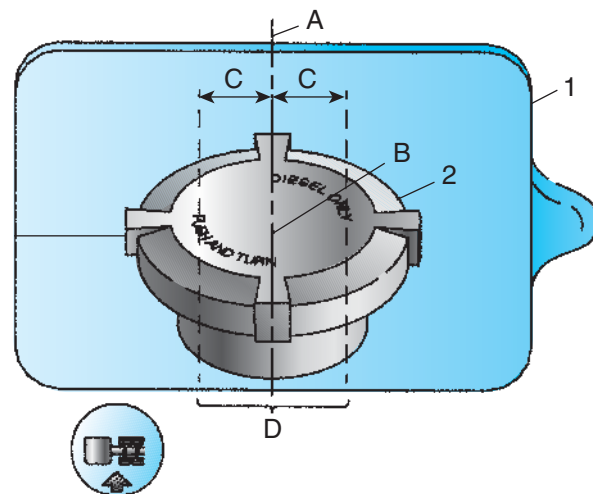

- | | |
|---|----------------------|
| A. Centerline of fill door opening | 1. Fill door opening |
| B. Centerline of fuel cap | 2. Fuel cap |
| C. 1 inch (25 mm) | |
| D. Fuel cap centerline to be within this area | |

Dual Tanks

Most heavy highway trucks use multiple fuel tanks (usually two) to increase onboard fuel capacity and also to evenly distribute fuel weight. One hundred gallons of a typical diesel fuel weighs between 700 and 730 pounds. To maintain even weight distribution as fuel is consumed, a Y-type **pickup tube** pulls fuel from both tanks simultaneously. Providing the tanks

Figure 12-4 Fuel tank cap. (Courtesy of Freightliner)

A **crossover pipe** connects a pair of fuel tanks at their lowest point. This means that they have low road clearance and can be damaged by road debris and animals. Although the crossover pipe is protected by an angle iron bracket this does not provide much protection. In addition, the crossover is also exposed to the airflow under the truck, which means that in the middle of winter, any water collected in the crossover pipe can freeze. When crossover lines freeze up, alcohol (methyl hydrate) has to be added to the fuel tanks. Because of these disadvantages, most current trucks use the dual fuel tank design shown in **Figure 12-3** that eliminates the crossover pipe. Y- or T-type pickups are used on today's fuel subsystems.

Pickup Tubes

A fuel pickup tube is located inside the fuel tank. It is positioned so it can draw on fuel slightly above the base of the tank: in this way it avoids picking up water and sediment. Pickup tubes are quite often welded into the tank; in this case, if they fail the tank may have to be replaced. Fuel pickup tubes seldom fail but when they do it is usually by metal fatigue crack at the neck; this results in no fuel being drawn out of the tank by the transfer pump whenever the fuel level is below the location of the crack.

Fuel Tank Sending Units

Most commercial truck fuel subsystems use fuel transfer pumps located outside of the fuel tank. This means that they use a stand-alone **sending unit** usually flange fitted to the top of a fuel tank. The function of a sending unit is to signal the fuel level to a dash located gauge. It consists of a float and arm connected to a variable resistor. The float is suspended by whatever amount of fuel is in the tank. It moves a wiper over a variable resistor. The position of the wiper on the variable resistor determines how much control current flows back to a cab dash gauge. The gauge displays the fuel level in the tank(s).

In older dual fuel tanks that were connected underneath by a crossover pipe, a single sending unit was located in one of the tanks. The tank with the sending unit was that opposite the tank with the pickup tube. It is preferable to locate a sending unit in each tank and provide a dash gauge for each, providing the operator with some advance warning of a crossover pipe restriction.

Testing Sending Units. Fuel sending unit problems are easily diagnosed. Disconnect the terminals and use a DMM (digital multimeter) in resistance mode. Use

service literature to find out the resistance of the sending unit: we list the two most common below. When the float arm is moved through its stroke, the readings observed should change as the arm angle changes.

TESTING A 240-OHM FUEL SENDING UNIT

1. Remove the wire lead from sensor terminal.
2. Connect the ohmmeter across the sensor terminal and mounting flange (ground).
3. Estimate the amount of fuel in the tank either visually or by using a stick.
4. Your fuel level estimate should connect with the following values:

Full tank	About 20 to 50 ohms
Half tank	About 80 to 120 ohms
Empty tank	About 220 to 260 ohms

5. Values that differ widely from those listed here indicate a defective sending unit.

DIAGNOSTIC PROCEDURE FOR A 90-OHM FUEL SENDING UNIT

1. Remove wire lead from sensor terminal.
2. Connect ohmmeter across the sensor terminal and mounting flange (ground).
3. Estimate the amount of fuel in the tank either visually or by using a stick.
4. Your fuel level estimate should connect with the following values:

Full tank	About 86 to 94 ohms
Half tank	About 40 to 50 ohms
Empty tank	About 0 to 4 ohms

5. Values that differ widely from those listed here indicate a defective sending unit.

Venting. Currently, most jurisdictions in North America permit **venting** of diesel fuel tanks to atmosphere. A vent or breather permits gas (either air or fuel vapors) to enter and exit the tank. As fuel is pumped out of a tank to fuel the engine, it is replaced by air drawn in through a vent. The gas movement can be reversed if the fuel becomes heated. In hot weather conditions, some of the lighter fuel fractions evaporate. Evaporated fuel vapors are vented to atmosphere.

Fuel tank vents or breathers should be routinely inspected for restrictions and should be protected from ice buildup. A plugged fuel tank vent or breather will rapidly shut down an engine, creating a suction side **inlet restriction**. The transfer pump cannot usually compensate for a plugged breather so the result is an engine shutdown caused by fuel starvation.

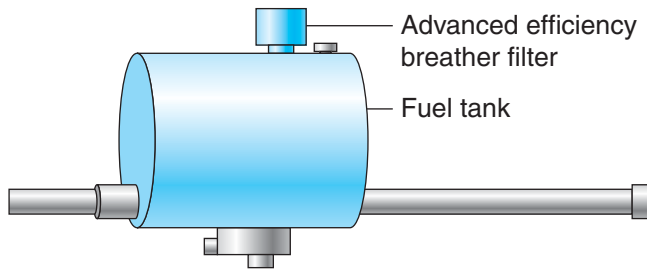

Figure 12-5 Fuel tank breather filter recommended by Caterpillar. (Courtesy of Caterpillar)

Breather Filters. As fuel is drawn out of a fuel tank, air is drawn in. This air contains whatever dust and dirt contaminants happen to be suspended in the air. One OEM has determined that over 60 percent of the dirt trapped by a 4-micron secondary fuel filter has passed through unfiltered fuel cap vents or breathers. For this reason, some manufacturers recommend the use of a high-efficiency fuel tank breather similar to that shown in **Figure 12-5**.

Water-in-Fuel Checking. Diesel fuel tanks should be routinely checked for **water-in-fuel (WIF)**. To check for water in fuel tanks, first allow the fuel tanks to settle. Next, insert a probe (a clean aluminum welding rod) lightly coated with water detection paste through the tank fill neck until it bottoms in the base of the tank; withdraw the rod and examine the water detection paste for a change in color. This test will give you some idea of the quantity of water in the tank by indicating the height on the probe where the color has changed. Trace quantities (just the tip of the probe changes color) in fuel tanks are not unusual and are nothing to worry about.

FUEL FILTERS

Diesel fuel injection equipment is manufactured with very low clearances. Impurities in fuel, if not removed by the fuel subsystem, can result in failures. Most dirt found in fuel is a result of conditions in stationary fuel storage tanks, refueling practices, and improper fuel filter priming techniques by service technicians. The function of a fuel filter is to prevent fine sediment in the diesel fuel from entering the fuel injection circuit. While some current secondary filters filter to the extent that water in its free state will not pass through the filter, a water separator is often used to remove H₂O before it gets to the secondary filter. All diesel fuel systems require clean fuel and the function of the filters in a fuel system is to ensure that the fuel is as clean as possible before it is delivered to the injection pumping components.

A typical fuel subsystem with a primary circuit and a secondary circuit in most cases uses a two-filter arrangement, one in each circuit. Two basic types of filter are used:

1. disposable **cartridge** type (most common)
2. permanent **canister** type fitted with disposable element

Spin-on filters are obviously easier to service and are the filter design of choice by most manufacturers. **Figure 12-6** shows the flow routing in some typical filters.

Primary Filters

Primary filters are the first-stage filter in a typical two-stage filtering fuel subsystem. Primary filters are therefore usually under lower than atmospheric pressure in operation. They are plumbed in series between the fuel tank and the fuel transfer pump. They are designed to entrap particles larger than 10 to 30 μ depending on the fuel system. They achieve this using pleated cotton threaded fibers and resin-impregnated paper. **Figure 12-7** shows a typical spin-on type primary filter.

Secondary Filters

Secondary filters represent the second filter in a typical two-stage filtering fuel subsystem. The secondary filter is charged by the transfer pump. Because this is at higher pressure the filtering element used can be more restrictive. The secondary filter is located in series between the transfer or **charging pump**. The charging pump is responsible for pulling fuel from the fuel tank and charging the high-pressure fuel injection circuit. In some diesel fuel subsystems using two-stage filtering, a primary and secondary filter may be both located on the same circuit, usually the charge circuit. In such cases, both filters are mounted on the same base pad with the primary filter feeding the secondary filter in series. You are more likely to see this in off-highway diesel engines. Current secondary filters trap much smaller particulates than primary filters. Similar to primary filters, they use chemically treated pleated papers and cotton fibers.

Water and Secondary Filters. Water cannot be pumped through most current secondary fuel filters. This results in the filter plugging on water and shutting down the engine by starving it for fuel. Water-plugged filters should be replaced. As an emergency measure you can clean out the filter using methyl hydrate or other pure alcohol, and then reprime it with fuel.



Fuel Filter
Two-stage box-type filter

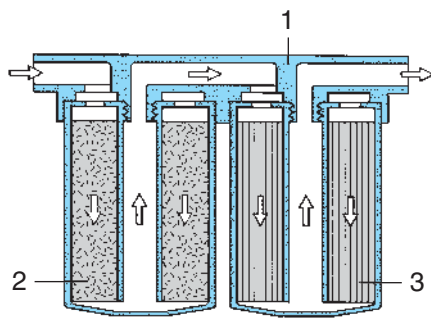

Multistage Filter
With spiral V-form filter element

1. Filter cover with mounting
2. Coarse filter
3. Fine filter

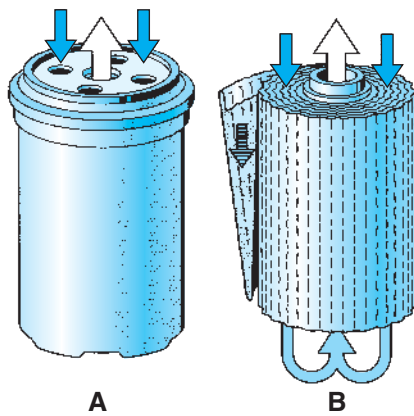

Fuel Filter

- A. Easy-charge filter
- B. Spiral V-form filter element

Figure 12-6 Types of fuel filters. (Courtesy of Robert Bosch GmbH, www.bosch-presse.de)

Single-Circuit Subsystems. In a fuel subsystem that is entirely under suction, the terms *primary* and *secondary* are not used to describe multiple filters in the circuit. Every filtering device used in the fuel subsystem



Primary filters on modern engines are typically rated at 10–15 microns

Figure 12-7 Typical spin-on type primary filter. (Courtesy of Caterpillar)

therefore is upstream from the transfer pump. This means that the filter or filters are held at a lower than atmospheric pressure (that is, under “suction”) anytime the engine is running. In this type of fuel subsystem, the inlet restriction specification is critical. If the inlet restriction value is exceeded, the result is fuel starvation.

Servicing Filters

Most fuel filters are routinely changed on preventative maintenance (PM) schedules. These PM schedules are determined by highway miles, engine hours, or calendar months. Filters are seldom *tested* to measure serviceability. When filters are tested, it is usually to determine if they are restricted (plugged) to the extent they are reducing engine power by causing fuel starvation.

Primary filters should be tested for inlet restriction using an electronic transducer, negative pressure gauge, or a mercury (**Hg**) filled **manometer**. A manometer is a clear tubular column formed in a U shape around a calibration scale marked off in inches. The U-shaped column is then filled with either mercury or water to a zero point on a measuring scale. When the manometer is connected to a fluid circuit, it produces a reading according to the pull (vacuum circuit) or pressure acting on the fluid in the column. Digital multimeter (DMM) manufacturers make available transducers that can measure both restriction and pressure so these can be a

useful diagnostic accessory. Actual inlet restriction values vary a lot according to which fuel system is being tested. Always refer to OEM specifications.

The Hg manometer or low-pressure gauge should be connected into the circuit between the filter mounting pad and the transfer pump. Transfer pumps are **positive displacement**. This means they unload a constant slug volume of fluid per cycle. The faster these cycles go by, the more fuel they pump meaning that accurate test results can be obtained without loading the engine. When testing circuit restriction on a fuel subsystem that is entirely under suction, the OEM specifications are usually pretty tight. Exceeding them by a margin as small as 1 inch of mercury may result in fuel starvation.

Secondary filters are usually charged by the transfer pump. Testing **charging pressure** (the pressure downstream from the charging/transfer pump) should be performed with an accurate, fluid-filled pressure gauge (see **Figure 12-8**) or electronic transducer (to DMM), which should be connected in series between the transfer pump and the high-pressure injection circuit. This is not generally used as a method of determining the serviceability of a secondary filter. Like primary filters, secondary filters tend to be changed by preventative maintenance schedule rather than by testing, or when they plug on water or midwinter fuel waxing and shut down an engine.

In summary:

- Primary filters are tested for inlet restriction measured in inches of Hg.
- Secondary filters are restriction tested using a pressure gauge or transducer specified in psi.

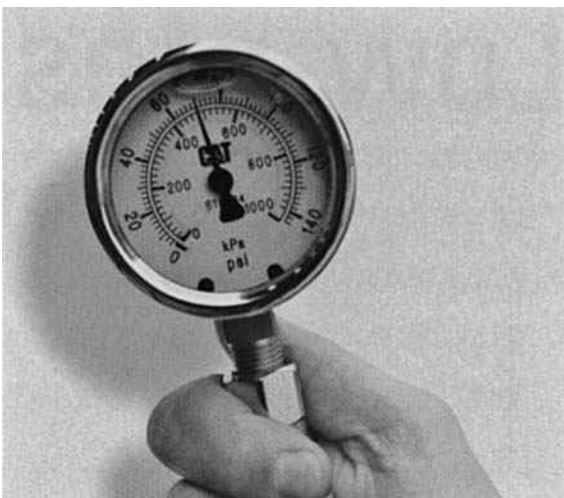

Figure 12-8 Fluid-filled pressure gauge used to measure charging pressure. (Courtesy of Caterpillar)

- Pressure gauges are used to measure fuel pressure downstream from the transfer pump known as charging pressure.

Procedure for Servicing Spin-On Filter Cartridges. Dirt gets into diesel fuel systems by technicians using improper service techniques. Diesel fuel replacement filters should be primed, that is, filled with fuel, before installation. Filters should be primed with filtered fuel. Shops performing regular engine services should have a reservoir of clean fuel. Any process that requires a technician to remove fuel from vehicle tanks will probably result in it becoming contaminated no matter how much care is exercised. The container used to transport the fuel from the tank to the filter should be cleaned immediately before it is filled with fuel. Paint filters (the paper cone-shaped type) can be used to filter fuel. The inlet and outlet sections of the filter cartridge should be identified.

Priming

The filter being primed should be filled only through the inlet ports usually located in the outer annulus (ring) of the cartridge and never directly through the outlet port, usually located at the center. Most manufacturers prefer that only the primary filters be primed before installation during servicing. After the primary filter(s) has been primed and installed, the secondary filter should be installed dry and primed with a hand primer pump or inline electric primer pump if equipped. Many current diesel fuel subsystems are equipped with electric priming pumps. An electric priming pump when fitted should always be used to prime the secondary filter.

Replacement Procedure

1. Remove the old filter cartridge from the filter base pad using a filter wrench.
2. Drain the fuel to an oil disposal container.
3. Ensure that the old filter cartridge gasket(s) have been removed. Wipe the filter pad gasket face clean with a lint-free wiper.
4. Remove the new filter cartridge from the shipping wrapping. Fill the filter cartridge with clean, filtered fuel poured carefully into the inlet section. The inlet ports are usually located in the outer ring of the cartridge. Fuel poured into the filter inlet ports passes through the filtering media and fills the center or outlet section of the filter; this method will take a little longer because it requires some time for the fuel to see through the filtration medium.

5. The fuel oil itself should provide the gasket and/or O-ring and mounting threads with adequate lubricant; it is not necessary or good practice to use grease or white lube on filter gaskets.
6. Screw the filter cartridge **CW** (**clockwise**: right-hand threads are used) onto the mounting pad; after the gasket contacts the pad face, a further rotation of the cartridge is usually required. In most cases, hand tightening is sufficient but each filter manufacturer has its own specific recommendations on the tightening procedure and these should be referenced.

.....
Tech Tip: When a hand primer pump is fitted to a fuel subsystem, prime the primary filter: make sure that all the fuel is poured through the filter inlet side only. Install the secondary filter dry, and prime using the hand primer pump. When an electric primer pump is fitted to the circuit, use it.

WARNING *When removing filter cartridges, ensure that the gasket is removed with the old filter. A common cause of air being sucked into the fuel subsystem is double gasketing of the primary filter. If you were to double gasket a secondary filter, the result would be an external fuel leak.*

Water Separators

Most current diesel engine powered highway vehicles have fuel subsystems with fairly sophisticated water removal devices. Water appears in diesel fuel in three forms:

1. free state
2. emulsified
3. semiabsorbed

Removing Free State Water. Water in its free state appears in large globules and because it is heavier than diesel fuel it collects in puddles at the bottom of fuel tanks or storage containers. Water separators can easily separate free state water if it happens to be pulled into the fuel subsystem.

Removing Emulsified Water. Water emulsified in fuel appears in small droplets. Because of the small size of these droplets they may be suspended for some time in the fuel before gravity takes them to the bottom of the fuel tank. When free state water collects at the bottom

of a fuel tank, 3 miles (5 km) of driving on a class B road is enough to **emulsify** it (finely dispersing it into the fuel), making it more of a problem.

Semiabsorbed Water. Semiabsorbed water is usually water in solution that is mixed with alcohol. Semi-absorbed water in diesel fuel is a direct result of adding methyl hydrate to fuel tanks. Methyl hydrate is a type of alcohol added to fuel tanks as deicer. Methyl hydrate either in pure form or as diesel fuel conditioner is added to fuel tanks to prevent winter freeze-up. Water that is semiabsorbed in diesel fuel is in its most dangerous form because it may emulsify in the fuel injection system where it can seriously damage components.

Why Water Damages Fuel Systems. Generally, water damages fuel systems for three reasons. Water:

1. has little ability to lubricate moving components
2. promotes corrosion
3. flows less readily than diesel fuel

Modern fuel injection systems pump diesel fuel at very high pressures. When even a small amount of water is pumped through the system, severe damage to fuel injectors may result. When you see a modern fuel injector with its tip blown off, the cause can often be traced to a water-in-fuel condition.

H₂O Separator Operating Principle. Water separators have been used in diesel fuel systems for many years. Often these were simple units that used gravity to separate the heavier water from the fuel. Today, a water separator often combines a primary filter and water separator. Many of these combination primary filter/water separators are manufactured by aftermarket suppliers such as Racor, CR, Davco, Dahl, and others. These use a variety of means to separate and remove water in free and emulsified states; they will not remove water from fuel in its semiabsorbed state.

Water separators use combinations of several principles to separate and remove water from fuel. The first is gravity. Water in its free state or emulsified water, if allowed to settle, will sink to the bottom of any container because it is heavier than diesel fuel. Some water separators use a **centrifuge** to help separate both larger globules of water and emulsified water from fuel. The centrifuge subjects fuel passing through it to centrifugal force: this throws the heavier water to the side walls of the separator allowing gravity to pull it into the sump drain. A centrifuge acts to separate particulate from the fuel in the same way so sediment also can be removed in this manner.

Positive filtration can also remove water from fuel. When fuel is forced through a fine resin-coated, pleated paper medium, it passes through it more easily than water. Water becomes trapped by this type of filtering medium. Once trapped, it collects in large enough droplets to allow gravity to pull it down into the sump drain. In many cases, aftermarket water separator/fuel filters are designed to replace the OEM's fuel system primary filter; in others this unit may work in conjunction with the primary filter. **Figure 12-9** shows an assortment of combination fuel filter/water separators used on diesel engines.

All water separators are equipped with a drain valve. The drain valve may be manual or electrically operated. The purpose of this valve is to siphon water from the

sump. Water should be routinely removed from the sump using the drain valve. The filter elements used in combination water separator/primary filter units should be replaced in most instances with the other engine and fuel filters at each full service. However, some manufacturers claim their filter elements have an in-service life that may exceed the oil change interval by two or more times. Whenever a water separator is fully drained, it should be primed before attempting to start the engine.

Tech Tip: To troubleshoot the source of air admission to the fuel subsystem, a diagnostic sight glass can be used; it consists of a clear section of tubing with hydraulic hose couplers at either end, and it is fitted in series with the fuel flow. However, the process of uncoupling the fuel hoses will always admit some air into the fuel subsystem, so the engine should be run for a while before the sight glass is read.

Fuel Heaters

In recent years it is more common to find fuel subsystems equipped with fuel heaters. There is some debate about the use of fuel heaters, and the fuel system/engine manufacturer should always be consulted when fitting such a device. One engine manufacturer warns that its warranty is voided if electric element-type fuel heaters are used in its system.

Two types of fuel preheaters are in current use:

1. Electric element type. An electric heating element uses battery current to heat fuel in the subsystem. This type offers a number of advantages, most notable of which is that the heater can be energized before startup so that cranking fuel is warmed up. Electric element fuel heaters may be thermostatically managed so that fuel is only heated as much as required and not to a point that compromises some of its lubricating properties.
2. Engine coolant heat exchanger type. This type of fuel heater consists of a housing within which coolant is circulated in a bundle (heat exchanger core) and over which the fuel is passed. A disadvantage of this type is that the engine cooling system must be at operating temperature before the fuel can be heated.

Fuel heaters exist that use both electric heating elements and coolant medium heat exchangers. This type of fuel heater can often manage the fuel temperature. Fuel temperatures should not exceed 90°F (32°C). Once fuel exceeds this temperature its lubricating



Figure 12-9 An assortment of water separators used on diesel engines. (Courtesy of Parker Hannefin Corporation, Racor Division)

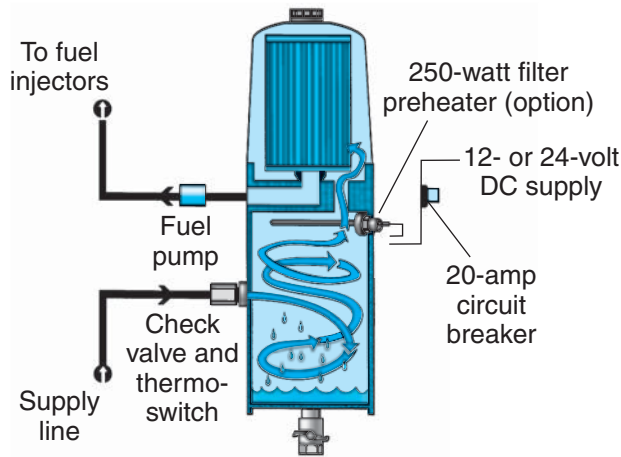

Figure 12-10 Detroit Diesel Fuel Pro assembly that combines a filter, water separator, and thermostatically controlled heating element. (Specifications are subject to change without notice. Detroit Diesel Corporation is registered to ISO 9001:2001. Courtesy © Detroit Diesel Corporation. All rights reserved. Detroit Diesel is a Daimler company)

properties start to diminish and the result is reduced service life of fuel injection components. **Figure 12-10** shows a Detroit Diesel Fuel Pro assembly: this combines a filter, water separator, and thermostatically controlled heating element.

Water-in-Fuel Sensors

Most current systems use a water-in-fuel (WIF) sensor to warn the operator of water contamination of fuel. A WIF sensor can be built into a replaceable filter cartridge or be integrated into a combination filter/water separator assembly. The sensor uses a couple of probes and a 12-volt supply. Because water has different electrical resistance to fuel, a signal from the WIF sensor can be triggered when the electrical path across the probes acts through water rather than fuel. At this point the WIF broadcasts a service alert. Note that sometimes a WIF can produce a service alert immediately after draining the water sump: the reason is that water-resident bacteria can coat the probes after draining and trigger a false signal. **Figure 12-11** shows a typical WIF sensor and its circuit.

FUEL CHARGING/TRANSFER PUMPS

Fuel charging or transfer pumps are positive displacement pumps driven directly or indirectly by the engine. A positive displacement pump displaces the same volume of fluid per cycle, and therefore fuel quantity

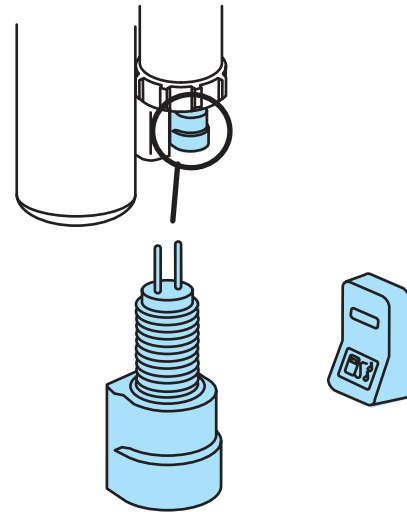
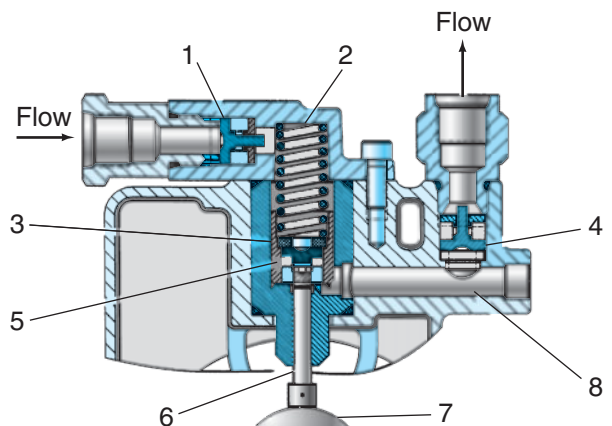

Figure 12-11 Water-in-fuel (WIF) sensor and its circuit.

pumped increases proportionately with rotational speed. Because of this, if a positive displacement pump unloads to a defined flow area, pressure rise is proportional with rotations per minute (rpm) increase. On most current diesel fuel systems, two types of transfer pumps are used:

1. plunger-type pumps
2. gear-type pumps

Plunger-type pumps are less commonly used today. **Figure 12-12** shows a typical plunger-type pump in a Caterpillar fuel subsystem. **Gear pumps** are the most commonly used fuel transfer pumps today. The gear pumps used as fuel transfer pumps share common



FUEL TRANSFER PUMP

- | | |
|----------------------|-----------------------|
| 1. Inlet check valve | 5. Piston check valve |
| 2. Spring | 6. Tappet assembly |
| 3. Piston assembly | 7. Cam |
| 4. Outlet | 8. Passage |

Figure 12-12 Caterpillar plunger-type transfer pump. (Courtesy of Caterpillar)

operating principles with other external gear pumps such as oil pumps.

Pumping Principle

In describing pump operation in the fuel subsystem, in common with most truck OEMs we use the terms *suction circuit* and *charge circuit*. Fuel movement through a fuel subsystem is created by a positive displacement pump. The way a transfer pump works is by creating flow that forces fuel out its discharge circuit. When this happens, lower than atmospheric pressure at the pump is created at the pump inlet. This allows atmospheric pressure acting on the fuel in the tank to “push” on the fuel, forcing it toward the pump inlet. In this way, fuel is moved through the fuel subsystem.

Plunger-Type Pumps

Plunger-type pumps (such as that shown in **Figure 12-13**) are usually flange mounted to a housing and cam driven. Single-acting and double-acting plungers may be used. Double-acting plungers are often used in higher-output engines requiring more fuel.

Single-Acting Plunger Pumps. A single-acting **plunger pump** (with a plunger that pumps in one direction only) has a single pump chamber and an inlet and outlet valve. Fuel is drawn into the pump chamber on the inboard stroke. It is pressurized on the outboard or cam stroke. The principle of a single-acting plunger pump is shown in **Figure 12-14**.

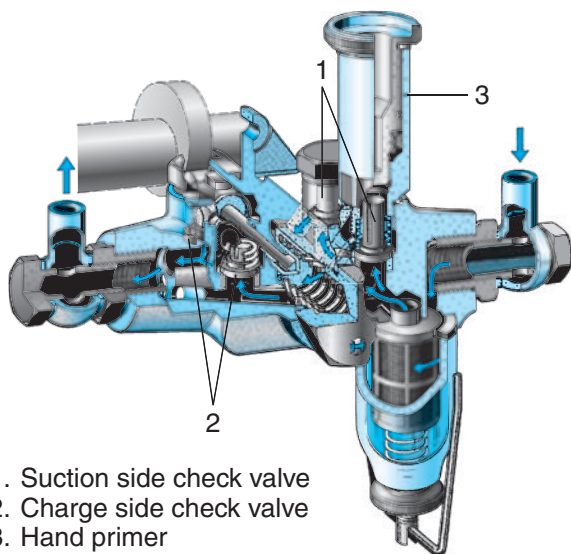

1. Suction side check valve
2. Charge side check valve
3. Hand primer

Figure 12-13 Bosch charging pump with integral hand primer and primary filter. (Courtesy of Robert Bosch GmbH, www.bosch-presse.de)

Operating Principle (Single-Acting)

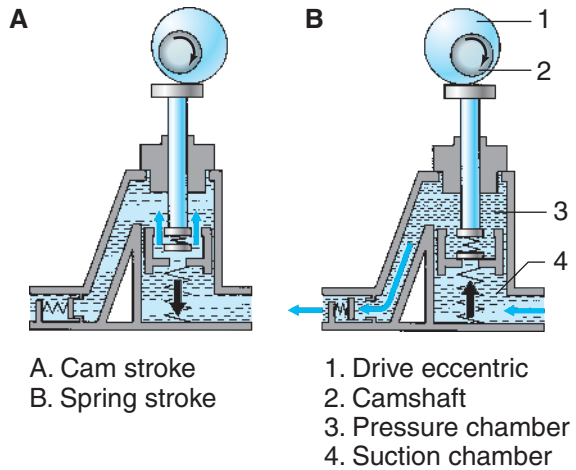

Operating Principle (Double-Acting)

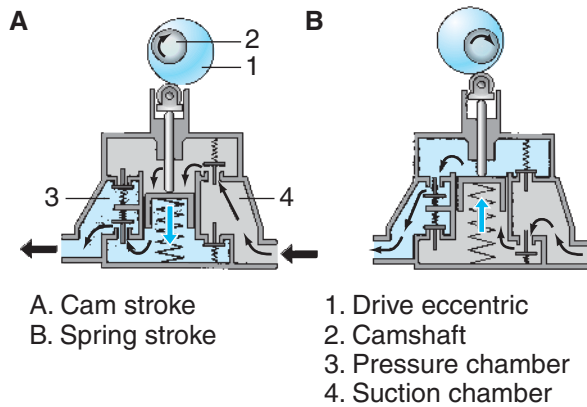

Figure 12-14 Action of single- and double-acting plunger pumps. (Courtesy of Robert Bosch GmbH, www.bosch-presse.de)

Double-Acting Plunger Pumps. A double-acting pump has twin chambers each equipped with its own inlet and outlet valve. This permits the plunger to pump on both strokes. On the cam stroke, a two-way plunger pulls fuel in behind the plunger while discharging fuel in front of the plunger. The reverse occurs as the plunger is pulled back on its retraction stroke. The principle of a double-acting plunger pump is shown in **Figure 12-14**.

Gear-Type Pumps

Gear pumps are the most commonly used transfer pumps. You will find them on most electronically managed engines, such as that shown in the schematic in **Figure 12-15**. These are normally driven from an engine accessory drive and are located wherever convenient. Gear pumps usually have a built-in relief valve that defines the system charging pressure. One of the reasons a majority of the full authority, electronic management fuel systems use gear-type transfer pumps

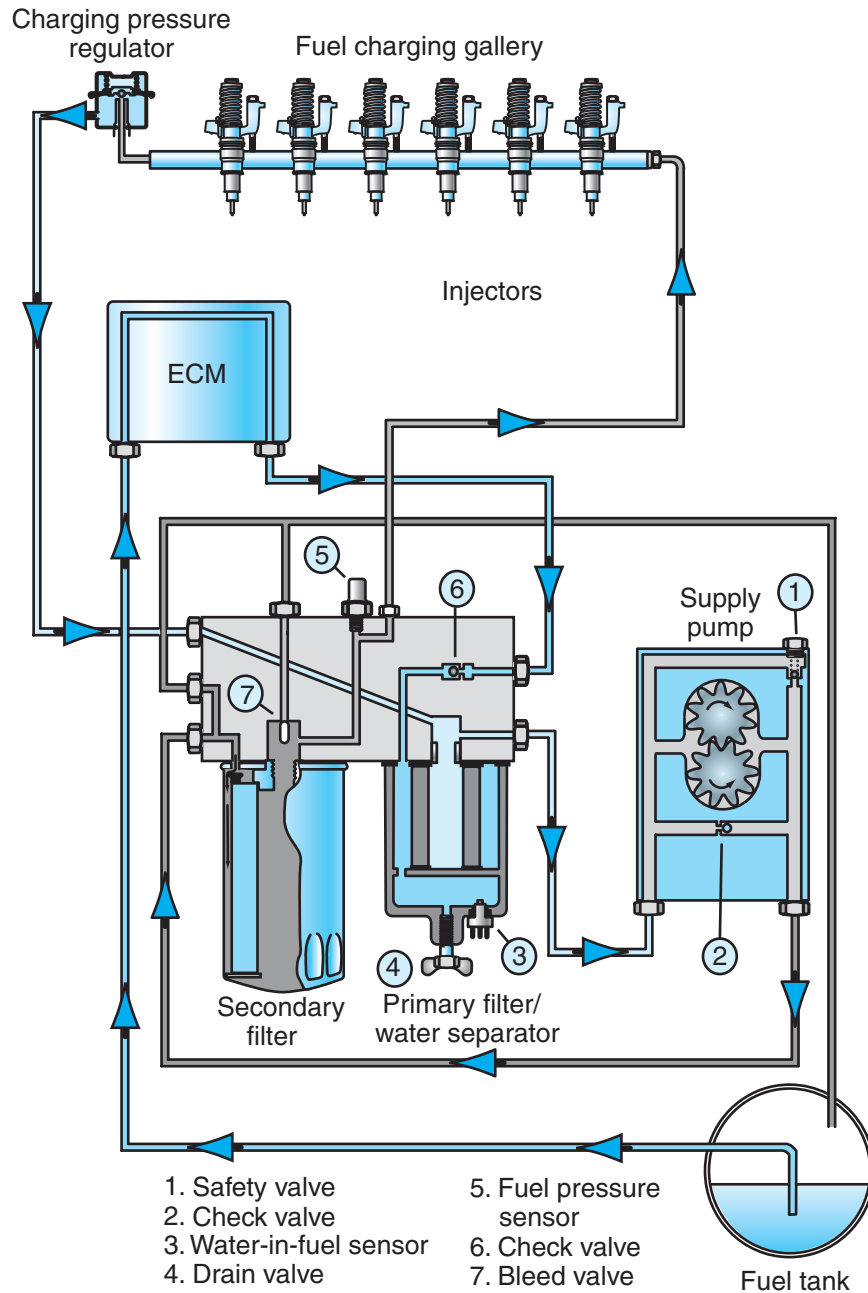

Figure 12-15 Fuel subsystem supplying electronic unit injectors (EUIs).

is that they can easily produce the much higher flow required by modern fuel injection systems. In addition to fueling the engine, the fuel subsystem uses excess fuel to remove heat from the cylinder head. The more recent addition of diesel particulate filter (DPF) dosing systems to highway diesel engines has further increased the fuel flow requirement of the fuel subsystem.

Hand Primer Pumps

A hand primer pump may be permanently fitted into the fuel subsystem. When it is, it is located either

on the fuel transfer pump body or a filter mounting pad (**Figure 12-13**). Some fuel subsystems are not equipped with a hand primer pump, so a hand primer pump can be a useful addition to a toolbox because it can be fitted to a fuel subsystem when priming is required.

A hand primer pump consists of a hand-actuated plunger and pump chamber. Most use a single-acting pumping principle. On the outward stroke, the plunger exerts suction on the inlet side, drawing in a charge of fuel to the pump chamber. On the downward stroke, the inlet valve closes and fuel is discharged to the outlet. When using a hand primer pump, it is important

to purge air downstream from the pump on its charge side. Some fuel subsystems mount a hand primer to the transfer pump housing.

Electric Primer Pumps

More and more truck diesel engines today are equipped with self-contained, electric primer pumps. These electric pumps are used mainly to prime the fuel subsystem system after servicing but can also be used when a loss of prime occurs. Electric primer pumps are a means of quickly and safely priming secondary fuel filters. Some more recent filters are designed to discourage any external priming methods, making it more likely that the electric prime feature will be used.

Priming a Fuel System

Although priming a fuel system is a simple procedure, you should still consult the OEM service literature. Most OEMs prefer that the technician avoid pressurizing air tanks with regulated air pressure to prime a diesel fuel system. Diesel fuel is easily vaporized and fuel vapors may ignite. Especially avoid pressurizing fuel tanks with compressed air in extreme hot weather conditions.

Recommended Procedure. When a vehicle runs out of fuel and it is determined that the fuel subsystem requires priming, follow these steps:

1. Remove the filters and fill with filtered fuel. If the system is equipped with a primer pump, fill only the primary filter with fuel, and then use the primer pump to fill the secondary filter.
2. Locate a bleed point in the system—this bleed point should be upstream from the injection circuit—and crack open the coupling.
3. Next, if the system is equipped with a primer pump, actuate it until air bubbles cease to exit

from the cracked open coupling. If the system is not equipped with a hand primer pump, fit one upstream from the transfer pump and actuate it until air bubbles cease to exit from the cracked open coupling.

4. Retorque the coupling. Crank the engine for 30 continuous seconds. If the engine fails to start allow at least a 2-minute interval before cranking again. This allows for starter motor cool-down. In most diesel engine systems, the high-pressure circuit will self-prime once the subsystem is primed.

Refueling

It is good practice to refuel tanks immediately on returning from a trip. Filling the tanks with fuel removes most of the air in the tank. When tanks are left in a near-empty condition for any length of time (overnight is long enough), the moisture in the air condenses and contaminates the fuel.

CAUTION *When refueling tanks, many drivers and technicians overlook the fact that diesel fuel vaporizes and combines with air to form combustible mixtures that only require an ignition source to cause an explosion. Diesel fuel is less volatile than gasoline but it should always be handled with care, especially in the heat of summer.*

COMPLETE FUEL CIRCUIT

Now that we have examined all the individual components that make up a fuel subsystem, we should take a brief look at how they interact as a system. **Figure 12-15** shows how a typical EUI fueled engine routes fuel through the fuel subsystem. See if you can identify the sensors used in the circuit.

Summary

- The fuel subsystem is the group of components responsible for fuel storage and its transfer to the high-injection circuit.
- The typical fuel transfer system can be divided into a primary (aka *suction*) circuit and a secondary (aka *charge*) circuit. The primary and secondary circuits are separated by a transfer or charge pump.
- Some light-duty diesel fuel systems may locate a transfer pump in the tank. Other fuel subsystems are entirely under suction. It is important to know this when priming a fuel subsystem.
- The secondary filter entraps smaller-sized particles than a primary filter. Secondary filters are subject to charging pressure.
- Aluminum alloy, cylindrical fuel tanks located in the airflow on truck chassis can act as heat exchangers. Most trucks use dual fuel tanks mounted on either side of the chassis. This helps evenly balance the weight of the fuel in the tanks.

- Most diesel fuel tanks are vented to atmosphere. Some current systems use breather filters.
- Many current secondary filters will plug on water and shut down the engine.
- Water may be found in fuel in three forms: free state, emulsified, and semiabsorbed.
- Many fuel subsystems are equipped with a water separator. Water separators remove free state and emulsified water from fuel. WIF sensors signal water buildup in a water separator or primary filter.
- Fuel system inlet restriction valves are tested on the suction side of the fuel subsystem using an electronic transducer (with DMM), negative pressure gauge or Hg manometer.
- A common source of air in the fuel subsystem is double gasketing of a filter under suction.
- Two types of fuel heaters are in current use: the electric element and coolant medium, and the heat exchanger.
- Diesel fuel systems commonly use one of two different fuel transfer or charge pumps: plunger-type or gear-type. Both of these pumps use a positive displacement pumping principle.
- Some fuel subsystems are equipped with a hand primer pump; the function of a hand primer pump is to eliminate air from the fuel subsystem.
- It is good practice to prime secondary filters after installation using a hand or electric primer pump.

Review Questions

1. On the typical truck diesel fuel subsystem, which of the following is at the lowest pressure in the circuit?
 - A. Fuel heater
 - B. Primary filter
 - C. Secondary filter
 - D. Charging circuit
2. Where is a secondary filter located?
 - A. Upstream from the transfer pump
 - B. On the charge side of the transfer pump
 - C. In the fuel rail
 - D. In the return gallery
3. What is the main reason for filling vehicle fuel tanks before overnight parking?
 - A. To minimize moisture condensation in the tanks
 - B. To minimize fuel evaporation
 - C. To help cool down onboard fuel
 - D. Drivers may forget the next morning
4. Besides fuel storage, the fuel tank may play an important role in a high-flow fuel system as a(n):
 - A. Heat exchanger
 - B. Fuel heating device
 - C. Ballast equalizer
 - D. Aerodynamic aid
5. Which of the following could be used to test the low-pressure side of fuel subsystems for inlet restriction?
 - A. Diagnostic sight glass
 - B. H₂O manometer
 - C. Negative pressure gauge
 - D. Accurate high-pressure gauge
6. Which of the following should fuel subsystem charging pressures be measured with?
 - A. Diagnostic sight glass
 - B. H₂O manometer
 - C. Hg manometer
 - D. Accurate pressure gauge

-
7. What should be used to check for air being pulled into a fuel subsystem?
 - A. Diagnostic sight glass
 - B. H₂O manometer
 - C. Hg manometer
 - D. Accurate pressure gauge

 8. Which type of fuel transfer pump is more commonly used by electronically managed engine/fuel systems?
 - A. Plunger pump
 - B. Centrifugal pump
 - C. Diaphragm pump
 - D. Gear pump

 9. Which type of pump is used by a typical hand primer pump?
 - A. Single-acting plunger
 - B. Double-acting plunger
 - C. Rotary gear
 - D. Cam-actuated diaphragm

 10. Charging pressure rise is usually directly related to which of the following?
 - A. Throttle position
 - B. Engine load
 - C. Peak power
 - D. Increased rpm

CHAPTER

13

Injector Nozzles

Prerequisites

A good understanding of diesel engine operation.

Learning Objectives

After studying this chapter, you should be able to:

- Identify the subcomponents of a nozzle assembly.
- Describe the injector nozzle's role in system pressure management.
- Identify two types of injector nozzles.
- Describe the principles of operation of multiple-orifice and electrohydraulic nozzles.
- Define nozzle differential ratio.
- Describe a valve closes orifice (VCO) nozzle.
- Bench (pop) test a hydraulic injector nozzle.
- Test a nozzle for forward leakage.
- Test a nozzle for back leakage.
- Outline the procedure required to test an electrohydraulic injector.
- Outline the procedure required to remove, inspect, and reconnect high-pressure lines.

Key Terms

atomization

back leakage

chatter

common rail (CR)

direct injection (DI)

electrohydraulic injectors (EHIs)

electronic unit injectors (EUIs)

forward leakage

hard value

hydraulic injectors

injector nozzle

mechanical injectors

multiple-orifice nozzle

nozzle differential ratio (NDR)

nozzle opening pressure (NOP)

nozzle seat

peak pressure

piezo injectors

piezoelectric actuators

pop tester

popping pressure

soft value

valve closes orifice
(VCO) nozzle

INTRODUCTION

All current diesel engines are direct injected. In a **direct injection (DI)** diesel engine, the fuel is injected into the cylinder immediately above the piston. Injected fuel must be atomized. **Atomization** of the fuel requires breaking it up into very small liquid droplets. These small droplets are produced by forcing very high-pressure fuel through minutely sized holes or orifices. The smaller the droplet exiting the injector, the faster it will vaporize and ignite when it is propelled into the engine cylinder. The actual size of droplets that exit the injector depends on:

- Orifice size: the hole size in nozzles obviously does not change after it has been manufactured.
- Pressure: the pressure a nozzle is subject to is managed by the injection pump. The higher the pressure, the smaller the fuel droplets exiting the nozzle.

The means used to inject fuel into the cylinder is an **injector nozzle**. An injector nozzle may be a stand-alone device or it may be a subcomponent of an electronically controlled pump and injector component. Although many different designs of injector nozzle have been used in the past, almost all of today's engines use one of the following two types of injector nozzle:

1. multiple-orifice (multiple-hole) hydraulic nozzles
2. electrohydraulic nozzles

All of the injector nozzles covered in this chapter are closed nozzle systems. One highway diesel engine manufacturer uses open nozzle injectors and will continue to do so until 2010. Open nozzle injectors use very different principles and are not discussed in this textbook. You will find open nozzle systems on Cummins ISX engines built up to model year 2010.

Multiple-Orifice Nozzles

When manufacturers describe multiple-orifice injectors, they are usually called:

- **hydraulic injectors**
- **mechanical injectors**

Perhaps the better of the terms is *hydraulic injector*. A **multiple-orifice nozzle** is opened and closed hydraulically. In fact, it really functions as a hydraulic switch. As a switch, the multiple-orifice nozzle is designed to open and close at a specific pressure. Once the pressure is set when the device is calibrated, it is unlikely to change unless it is due to old age or wear.

The opening pressure of multiple-orifice nozzles is described as **nozzle opening pressure (NOP)**. Another way of saying NOP is to use the term **popping pressure**. Because NOP in hydraulic injectors is a set value that cannot be controlled by the engine management electronics, we describe them as **hard value** NOPs. Hydraulic injectors with multiple-orifice nozzles can be divided into two general categories:

1. Integral injectors: a single function nozzle device used to atomize fuel and also set the NOP. Integral injectors are connected to an injection pump by a high-pressure line.
2. Subcomponent nozzles: a subassembly built into a more complex injector assembly that also pumps and controls injection fuel quantity.

In general terms, we can describe a hydraulic injector nozzle as a device with the following functions:

- to open and close a valve to begin or end fuel injection
- to define nozzle opening pressure (NOP) (hydraulic nozzles only)
- to atomize fuel to the correct size for combustion

Until the 2007 model year, almost all the nozzles used in highway diesel engines were hydraulic nozzles. This changed in the 2007 model year. Today's diesel engines require injector nozzles that can be controlled by the engine management electronics, so hydraulic nozzles are rapidly becoming a thing of the past. **Figure 13-1** shows an external view of a hydraulic injector nozzle.

Electrohydraulic Nozzles

The key feature to electrohydraulic nozzles is that they do not have fixed pressure opening and closing values. In other words, NOP becomes a **soft value**. We use the term *soft value* because both opening and closing

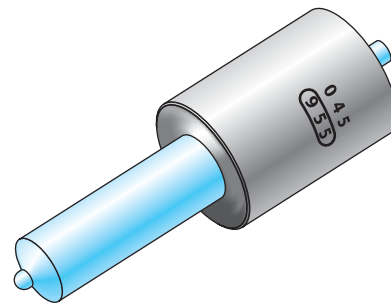

Figure 13-1 External view of a multi-orifice injector nozzle. (Courtesy of Robert Bosch GmbH, www.bosch-presse.de)



Figure 13-2 External view of an EHI used in a modern CR-fuel system.

of the injector valve is directly controlled by the ECM managing the engine. Electrohydraulic nozzles are found in two general types of current diesel injection systems:

- **Common rail (CR)** injection: CR diesel fuel injection uses stand-alone electrohydraulic injectors (EHIs). Each EHI is supplied by rail pressure fuel and is switched open and closed by the ECM.
- Dual actuator, **electronic unit injectors (EUIs)**: In a dual actuator EUI, the electrohydraulic nozzle is an ECM controlled subcomponent. It operates almost identically to the EHI except that the pumping of fuel to injection pressures takes place immediately above the nozzle assembly.

We will study both the CR and EUI fuel systems in **Chapter 15**. **Figure 13-2** shows an external view of an EHI from a Cummins ISC engine.

MULTIPLE-ORIFICE NOZZLES

As we said in the introduction to this chapter, until 2007, most diesel injector nozzles could be classified as multiple-orifice. They were used in:

- pump-line-nozzle (PLN) diesel injection pumps
- mechanical unit injectors (MUIs) as a subcomponent

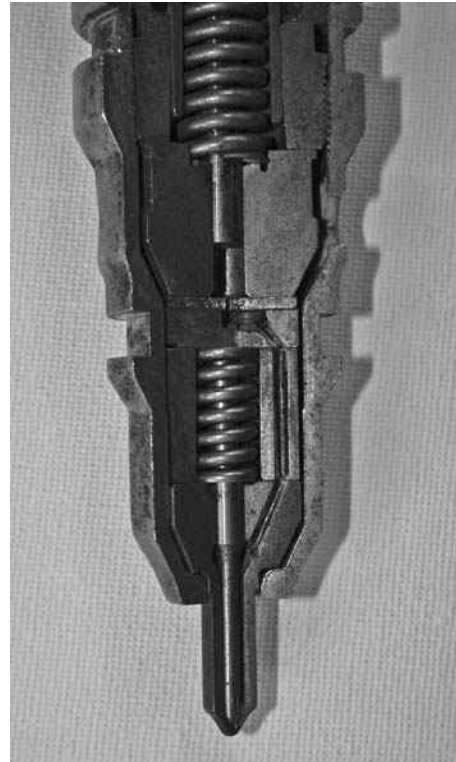

Figure 13-3 Sectional view of the hydraulic nozzle subassembly in a HEUI injector assembly: in this, the hydraulic nozzle is a subcomponent.

- single actuator, electronic unit injectors as a subcomponent
- hydraulically actuated, electronic unit injectors (HEUIs) as a subcomponent (see **Figure 13-3** for a sectional view of a HEUI, focusing on the multiple-orifice nozzle assembly)
- electronic unit pump (EUP) systems until 2007

A multiple-orifice nozzle is a hydraulically actuated switch machined with several tiny holes. The number of holes varies but it is typically between four and eight. **Figure 13-4** shows a sectional view of a typical multi-orifii injector. It should be stressed that when EUIs or HEUIs use hydraulic nozzles as a subassembly, the operating principles are identical to those of the injector shown in **Figure 13-4**.

Droplet Sizing

The size of droplets injected by a hydraulic nozzle depends on two factors:

1. flow area (size of nozzle holes)
2. pressure (managed by the injection pump)

Because flow area depends on the actual size of the holes machined into the nozzle, this remains constant. The pressure values vary. Actual pressure values range

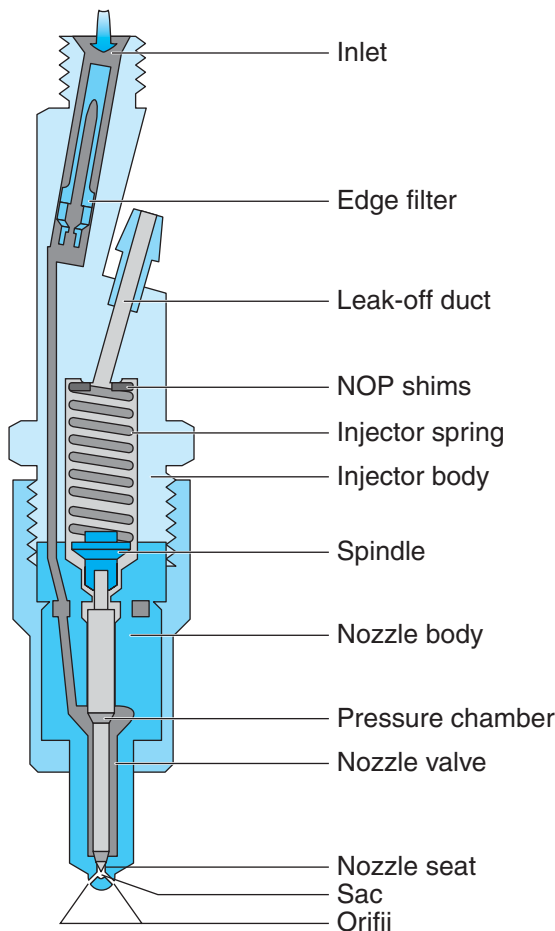

Figure 13-4 Sectional view of a multi-orifii injector nozzle. (Courtesy of Robert Bosch GmbH, www.bosch-presse.de)

from values lower than NOP up to the **peak pressure** (the highest pressure a fuel injection system can produce). Because the flow area remains constant, as pressure increases, the droplet sizing decreases. Generally, the longer the injection pulse (more fuel injected to the cylinder), the higher the pressure peak. What this means is that the largest atomized fuel droplets are produced at the beginning of the injection pulse just after the nozzle opens. This is generally good for performance. Fuel droplets burn from the outside inward, toward the center. When large droplets are injected early on in combustion, there is plenty of time to combust them.

Because the injection pressure is designed to rise during the injection pulse, the droplet size reduces. The reduction in droplet sizing that occurs as the fueling pulse is extended generally favors the complete combustion of the fuel injected into the cylinder. Fuel droplets burn from the outside inward. Larger droplets require more burn time, smaller droplets shorter burn times. This means that as a fuel pulse is extended, the

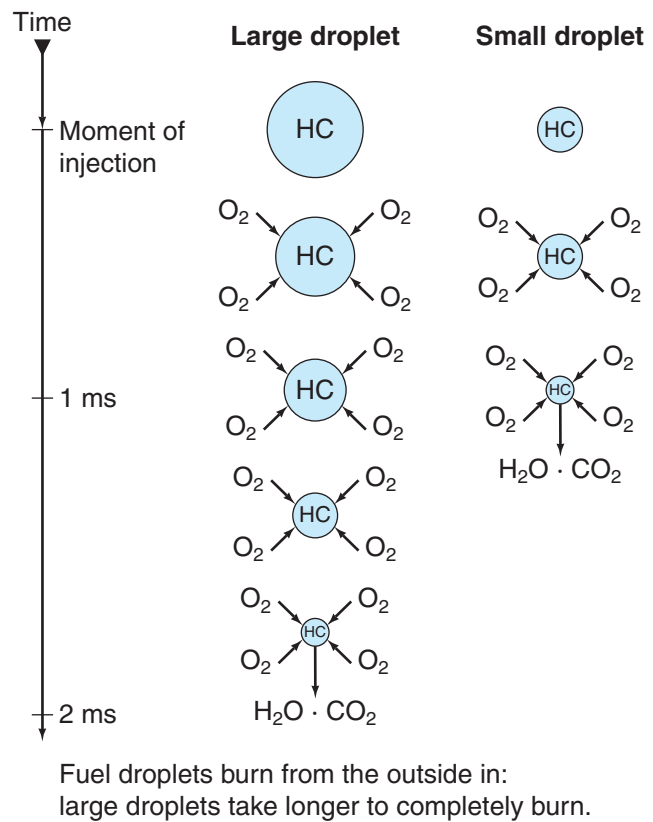

Figure 13-5 Atomized droplet size and speed of combustion.

injected droplet size in the atomized fuel reduces. This reduction in droplet size coincides with the reduction in real time available to burn the droplets injected late in the injection pulse. **Figure 13-5** shows how the size of an injected fuel droplet influences the speed of combustion: the fuel droplet is identified as hydrocarbon (HC) and the air it reacts with as oxygen (O₂) in this image.

Action

The multiple-orifice nozzle is located in the injector body by a dowel. The injector body is also usually positioned in its bore by a guide lug. This ensures that the atomized fuel spray pattern is directed toward an exact location of the engine cylinder. In a typical diesel engine with a Mexican hat peak in each piston, the correct location is in the crater that surrounds the Mexican hat peak. Fuel from the injection pump is delivered to the nozzle body. This fuel is then routed by a duct or ducts to the nozzle pressure chamber holder (see **Figure 13-4**) and then ducted to a circular recess known as the pressure chamber.

For most of the cycle, the nozzle valve is held closed by the injector spring. This spring pressure can be either directly or indirectly applied to the

nozzle valve. When pressure is applied directly, the nozzle spring contacts the nozzle valve. When pressure is applied indirectly, spring pressure is relayed to the nozzle valve by a spindle. The spring tension that acts on the nozzle valve holds it closed. It sets the NOP value so it is adjustable either by a screw or by shims.

Opening Pressure. When line pressure is driven upward by the injection pump, pressure increases in the nozzle pressure chamber. As soon as this hydraulic pressure in the nozzle pressure chamber is greater than that of the mechanical force of the injector spring, the nozzle valve lifts. This instantly opens the nozzle. At this point, fuel flows around the **nozzle seat**. At the center of the nozzle valve seat, a single duct connects to the nozzle sac. The nozzle sac is a hollow circular cavity. Each nozzle orifice is machined into the sac. As the nozzle valve lifts, fuel passes around the nozzle seat and enters the sac. The function of the sac is to hydraulically balance the fuel about to be injected. The idea is that droplets start to exit from each orifice at the same time. When fuel begins to exit the nozzle, the fuel injection pulse begins.

Nozzle Closing. The injection pulse continues for as long as the nozzle valve remains open. Anytime the nozzle valve is open, the engine is being fueled. A fueling or injection pulse ends when the pressure is collapsed by the injection pressure pumping element. The collapse phase takes time. Because this type of nozzle is controlled hydraulically, the collapse phase takes longer when peak pressures are high. For the nozzle valve to close, the pressure in the nozzle pressure chamber must collapse enough so that the mechanical force of the injector spring can take over once again. This pressure will be below NOP by a small margin. At the point that the nozzle spring closes the nozzle valve, the nozzle valve is held on its seat by spring pressure.

Nozzle Differential Ratio

Nozzle differential ratio (NDR) tells us why it takes more pressure to open a hydraulic nozzle valve than the pressure required to hold it open. Nozzle valves are opened by hydraulic pressure acting on the sectional area represented by the pressure chamber. When this hydraulic pressure is sufficient to overcome the spring pressure holding the valve seated, it opens. The instant the nozzle valve opens, hydraulic pressure passes around the seat. This means that hydraulic pressure now acts over the whole sectional area of the

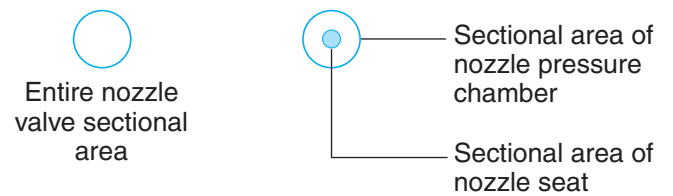

Figure 13-6 Nozzle differential ratio: sectional areas of a nozzle valve.

nozzle valve. The whole sectional area of the nozzle valve consists of both:

- the seat
- the pressure chamber

The principle of nozzle differential ratio is shown in **Figure 13-6**.

Summary of NDR. Nozzle differential ratio explains why more pressure is required to unseat a nozzle valve than that required to hold it off its seat due to nozzle differential ratio. In older diesel injection systems, when a high-pressure pump element began to increase pressure for an injection pulse, it did so by acting on a closed hydraulic circuit, sealed by the nozzle valve seat. However, the instant NOP was achieved, the hydraulic circuit opened. Opening the circuit resulted in a dip in pressure: without NDR, the nozzle valve would have closed. Because of NDR, less pressure was required to hold the nozzle valve open when the pressure dipped. Almost instantly after NOP was achieved, the restriction represented by the nozzle orifices came into play, meaning that pressure rise continued being controlled by the pump element.

Typical hydraulic injectors were specified with nozzle closing pressures that were between 10 percent and 20 percent lower than their specified NOP. A real disadvantage of NDR was that the largest droplets were injected into the engine cylinder when they were least wanted, at the very end of the injection pulse.

VCO Nozzles

Valve closes orifice (VCO) nozzles eliminated the sac. The function of the sac in the nozzle was to provide balanced fuel injection at the moment of NOP. This helped keep the interval between the delivery of the first fuel droplets and the moment they ignited consistent. The disadvantage of the sac was at the end of injection pulse, the volume of fuel in the sac was wasted fuel that added to HC emissions. Most current injector nozzles have either reduced the sac volume or eliminated it entirely. They have been replaced by

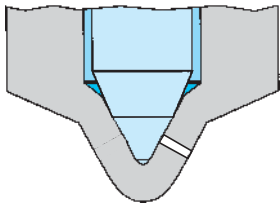

Figure 13-7 Valve closes orifice (VCO) nozzle. (Courtesy of Robert Bosch GmbH, www.bosch-presse.de)

valve closes orifice (VCO) nozzles. In a VCO nozzle, each orifice is bored directly into the nozzle seat. VCO nozzles are most often used on electronically managed injection systems that use high NOP values. Because of the much higher pressures used, hydraulic balance is achieved anyway. **Figure 13-7** shows a VCO nozzle design.

ELECTROHYDRAULIC NOZZLES

Electrohydraulic nozzles were introduced when **electrohydraulic injectors (EHIs)** were introduced on the first generation of common rail (CR), diesel fuel injection systems. As indicated earlier in this chapter, electrohydraulic nozzles are used in:

- CR electrohydraulic injectors
- dual actuator EUIs

Unlike hydraulic injector nozzles, EHIs are controlled electrically. The first generation of EHIs was switched by solenoids. More recently, **piezoelectric actuators** have been introduced.

The operating principles of solenoid-actuated and piezo-actuated injectors are almost identical. The **piezo injectors** (most manufacturers use this term) respond faster than solenoids to switching commands because they do not depend on creating and collapsing a magnetic field to open and close. They also require less current than solenoid-actuated EHIs. We will look at the general operating principles first, and then examine piezoelectric actuators afterward. Although this description is based on an EHI, the way the electrohydraulic nozzle functions as a subcomponent of a dual actuator EUI is identical.

Both solenoid-actuated and piezoelectric-actuated EHIs use hydraulic force from a rail or pump chamber to open and close the nozzle valve. The ECM precisely controls opening and closing events. An EHI (**Figure 13-8**) can be subdivided as follows:

- nozzle assembly
- hydraulic servo system
- actuator valve (either a solenoid or piezoelectric actuator)

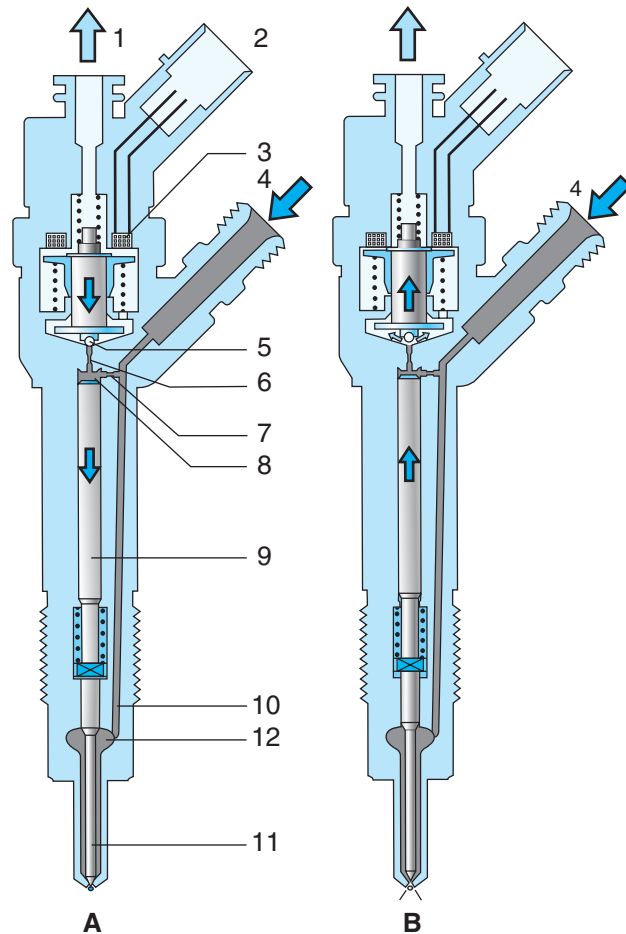

INJECTOR (schematic)

- | | |
|---|---|
| <p>A. Injector closed (at-rest status)</p> <p>B. Injector opened (injection)</p> <p>1. Fuel return</p> <p>2. Electrical connection</p> <p>3. Triggering element (solenoid valve)</p> <p>4. Fuel inlet (high pressure) from the rail</p> | <p>5. Valve ball</p> <p>6. Bleed orifice</p> <p>7. Feed orifice</p> <p>8. Valve control chamber upper pressure field</p> <p>9. Valve control plunger</p> <p>10. Feed passage to the nozzle</p> <p>11. Nozzle needle</p> <p>12. Lower pressure field</p> |
|---|---|

Figure 13-8 Electrohydraulic injector (EHI). (Courtesy of Robert Bosch GmbH, www.bosch-presse.de)

EHI Operation

Referencing **Figure 13-8**, fuel at rail pressure is supplied to the high-pressure connection (4), to the nozzle through the fuel duct (10), and to the control chamber (8) through the feed orifice (7). The control chamber (upper pressure field) is connected to the fuel return (1) via a bleed orifice (6) that is opened by the actuator valve. With the bleed orifice closed, hydraulic force acts on the valve control plunger (9), exceeding that at the nozzle-needle pressure chamber (located

between the shank and the needle of the nozzle valve). Although the actual hydraulic pressure values acting on the top of the nozzle valve (upper pressure field) (8) and those in the lower pressure field (12) are identical, the sectional area at the top of the nozzle valve is greater. As a result, the nozzle needle is loaded into its seated position, meaning that the injector is closed. The primary force holding the nozzle valve closed is hydraulic whenever the (common) rail is at operating pressure.

When an ECM signal triggers the actuator valve, the bleed orifice opens. This immediately collapses the control chamber pressure (upper pressure field), and as a result the hydraulic pressure acting on the top of the valve control plunger (9) also drops. Because the hydraulic force acting on top of the valve control plunger collapses and the pressure in the lower pressure field remains, the nozzle needle lifts. Lifting the nozzle needle allows fuel to pass around its seat. This opens the orifices allowing fuel to be injected into the combustion chamber. The nozzle needle remains open until de-energizing the actuator reestablishes the upper pressure field at rail pressure.

EHI Operating Phases. When the engine is stopped, all injector nozzles are closed, meaning that their nozzle valves are loaded onto their seats by spring pressure. In a running engine, injector operation takes place in three phases.

INJECTOR CLOSED

In the at-rest state, the actuator valve is not energized. In this state, the nozzle needle is seated by the injector spring combined with hydraulic pressure (from the rail). Although the hydraulic pressure in both the upper (control) and lower pressure fields is identical, the sectional area of the upper pressure field exceeds that of the lower pressure field by a considerable margin. With the bleed orifice closed (**Figure 13-8** #6), the actuator valve spring forces the armature ball check onto the bleed-orifice seat. This seals and holds intact the upper pressure field. The upper pressure field is the control field. Whenever the upper pressure field is held at rail pressure, the EHI is closed.

NOZZLE OPENING

Again referencing **Figure 13-8**, when the actuator is energized by the ECM injector driver, the bleed orifice (6) opens. As the bleed orifice opens, fuel flows from the valve control chamber into the return circuit. This collapses the hydraulic pressure in the upper pressure field (8). Because pressure in the lower pressure field (12) remains at rail pressure, the nozzle needle is forced open. The instant the EHI needle lifts it exposes the injector orifices, beginning the injection pulse. Fuel

continues to enter the valve control chamber (12) at rail pressure when the EHI opens but spills immediately to the return circuit. Note in **Figure 13-8** that the flow area at the bleed orifice is very small. This means that the actual volume of spill fuel from the control chamber is small. This spilled fuel is designed to be small enough not to affect the rail pressure.

The nozzle needle (11) opening speed is determined by the difference in the flow rate through the bleed and feed orifices. When the actuator control plunger reaches its upper stop, it is cushioned by fuel generated by flow between the bleed and feed orifices. When the injector nozzle needle has fully opened, fuel is injected into the combustion chamber at a pressure very close to that in the fuel rail.

NOZZLE CLOSING

When the actuator valve is de-energized by the ECM, its spring forces the valve downward. This forces the check ball downward to close the bleed orifice. Closing the bleed orifice allows the upper pressure field to be reestablished. Almost instantly, the pressure in the upper pressure field is at rail pressure. This means that pressure acting in both the upper (8) and lower (12) pressure fields is equal. However, because the upper pressure field (8) has a much greater sectional area, the valve control plunger (9) drives the nozzle needle downward until it seats. Seating the nozzle needle ends injection and seals the EHI. Once again, the primary seating force of the nozzle needle (11) is hydraulic relayed to it by the valve control plunger (9).

Piezoelectric Injectors

Piezoelectric actuators are based on reversibility of piezoelectric effect. When certain crystals are subjected to pressure, a voltage is produced in a process we know as piezoelectricity. These same crystals are capable of reversing the process, so when we subject them to a voltage, they almost instantly react, resulting in either expansion or contraction. This mechanical reaction produces a powerful force making it possible for them to be used as actuators. They have an advantage over equivalent solenoid actuators. Solenoids use electromagnetism and respond more slowly due to the time required to build and collapse electromagnetic fields. Piezo actuators respond almost instantly when triggered by a voltage pulse. They are therefore ideal for multipulse injection events. Multipulse injection means the breaking up of an injection pulse into up to seven mini-injections during a single cycle. This results in giving the ECM much better control of combustion. In addition it results in quieter diesel engine operation and lower emissions.

Summary of EHIs

Because of their soft opening and closing pressures and their capability of providing high injection pressures at low engine rpms, electrohydraulic nozzles are a requirement in most post-2007 diesel engines. Their advantages include:

- Ability to open and close almost instantly when signaled by the ECM.
- EHI injection pressures remain consistent through a fueling pulse.
- Ability to close instantly eliminates the collapse phase of older hydraulic injectors.
- Suited to multipulse injection.
- May use either solenoid or piezoelectric actuators.
- May be integrated as a subcomponent of an EUI to provide it with soft opening and closing values.

.....

Tech Tip: Practice special care when working with diesel fuel injectors. Use protective caps to seal the nozzle and the injector in-out ports after removing an injector.

.....

NOZZLE TESTING

Consult original equipment manufacturer (OEM) service literature before attempting to service injectors. Almost without exception, troubleshooting of engines with a

suspected injector problem is performed with the injector in-engine using diagnostic software. Most manufacturers today do not include fuel injectors in preventive maintenance schedules. This means that in most cases when you are asked to service fuel injectors, you are working on older engines. You should know how to test hydraulic injectors because this is a procedure you will be tested on in certification exams. Testing hydraulic injector nozzles requires a simple bench test fixture (or **pop tester**). (See **Figure 13-9.**) In this textbook, the description will be limited to the testing of hydraulic injectors only. Servicing of injectors is covered in more advanced textbooks and manufacturer service literature.

.....

Tech Tip: This section references the testing of hydraulic injectors only. Most OEMs require that EHIs are not field serviced. When a diagnostic routine identifies a defective EHI, it should be replaced.

.....

CAUTION *Eye protection should be worn when working with high-pressure fluids.*

- *High-pressure atomized fuel is extremely dangerous and no part of the body should be in danger of contacting it.*



Figure 13-9 Hydraulic injector pop tester.

- *Never touch an injector on the pop tester when it is at any pressure above atmospheric. Remember also that the entire injector assembly is under pressure.*
- *Diesel fuel oil is a known cancer-causing agent. Hands should always be washed after contact with it.*

Removal of Injectors from the Cylinder Head

You must follow the manufacturer recommended method of removing an injector from a cylinder head. Before attempting to remove injectors, clean the surrounding area: any dirt around the injector bore can end up in the engine cylinder below it. It is also good practice to drain high-pressure lines when removing the pipe fittings. Use a line wrench or socket to loosen line nuts; they are easy to round-out and if you damage the line you will end up replacing it. Injector nozzles may be damaged if subjected to any side load force. This means you should always use the correct pullers.

Flanged Injectors

Many hydraulic injector assemblies are flanged, which means you should first remove the hold-down fasteners and clamps. Next, use an injector heel bar under the clamp to lever it out of the injector bore. An injector heel bar is 8 to 12 in. (20 to 30 cm) in length. The idea is to prevent using excessive force that could damage the injector.

Cylindrical Injectors

Some engines use recessed cylindrical injectors. To pull a recessed cylindrical injector, a slide hammer and puller nut has to be used. This tool threads into the high-pressure inlet of the injector. Also, with some types of cylindrical hydraulic injectors, the high-pressure delivery pipe or a quill tube connects to a recess in the injector through a transverse bore in the cylinder head. The high-pressure pipe or quill tube must be backed away from the cylinder head before attempting to remove the injector. Failure to do this can damage the injector, the pipe or quill, and the cylinder head.

Nozzle Spacer

When removing injectors from cylinder heads, make sure you also remove the injector nozzle *gasket*,

spacer, or *washer* at the same time. Manufacturers use all three of these terms but for this description we will use *spacer*. A nozzle spacer is made out of soft steel or copper and has two functions:

1. to define the exact distance the nozzle tip protrudes into the cylinder
2. to seal the injector cup from the engine cylinder

The nozzle spacer has an id (inside diameter) just fractionally less than the cylinder head injector hole. This means that providing the piston is not at TDC, it can usually be removed by one of two methods:

1. inserting an O-ring pick
2. inserting the tapered end of the injector heel bar and jamming it into the washer

Do not reuse injector washers. Both steel and copper washers harden in service. They should be replaced because it is unlikely they will reseal properly.

Seal Lines and Injectors

After an injector has been removed, use the appropriate sized plastic caps to seal all of the following components:

- transverse cylinder head injector bores
- the inlet and return ports on the injector
- high-pressure injector lines

If you are removing a set of injectors, make sure you mark each by cylinder number. Use an injector tray if you have one because this protects the injectors. Wrap the injectors in shop rags if no injector tray is available.

Seized Injectors

Occasionally, an injector may seize in a cylinder head. Almost always this will result in damaging the injector: the trick is to finally remove it without damaging anything else. Once the injector becomes damaged (for instance, the line threads that fit the injector to the puller are destroyed), you have no option but to remove the cylinder head. Never risk damaging a cylinder head in attempting to remove an injector. With the cylinder head removed, a seized injector can usually be removed with a punch and hammer.

Testing

Manufacturer specifications and service literature should be referenced before testing a hydraulic nozzle. In using a nozzle test procedure such as the one outlined here, the first failed step FAILs the nozzle. Failing the nozzle means that it should be either

replaced (best option) or reconditioned. A typical procedure for testing nozzle assemblies is as follows:

1. Locate the manufacturer's test specifications and service literature.
2. Clean the injector externally with a brass wire brush
3. Mount the injector in a pop test fixture. Check for leaks. Build pressure slowly using the pump arm, watching for external leakage.
4. Bench test the NOP value and record. Actuate to NOP three times. Record the average NOP spec. A variation of NOP greater than 10 bar (150 pounds per square inch [psi]) fails the nozzle.
5. Test **forward leakage** by pumping the pop tester to 10 bar (150 psi) below the average NOP value. Hold this pressure by observing the gauge and using the pump handle just enough to prevent any drop-off. While doing this, observe the nozzle. It should be dry. Any leakage at the tip fails the nozzle because it is leaking at the seat.
6. Check **back leakage** by pumping the pop tester to 10 bar (150 psi) below the average NOP value. Now release the pump handle and observe the gauge. Pressure drop values should typically be in the range of 50 to 70 bar (700 to 1,000 psi) over a 10-second test period. The pressure drops because fuel leaks by the nozzle shank to the return circuit. A rapid pressure drop exceeding the OEM specification suggests the nozzle is worn out.
7. Check the nozzle spray pattern. Pump the pop tester to NOP, this time closely watching the spray pattern. It should be exactly even from each orifice. Ignore nozzle **chatter** (rapid pulsing of the nozzle valve), as this sometimes happens when bench testing hydraulic nozzles and is nothing to worry about.

A hydraulic injector that passes the above test cycle can be regarded as okay. If the injector fails the test, then either the injector nozzle or the injector should be replaced. Injectors and injector nozzles can be reconditioned but this is becoming an obsolete practice, since reconditioned nozzles seldom perform to the standards required of new injectors.

Reinstallation of Injectors

The injector bore should be cleaned before installation. A bore reamer can be used to remove carbon deposits. Blow out the injector bore using an air nozzle. Where injector sleeves are used, service/replace as per OEM instructions. In most cases, you will leave the

injector sleeves in place when removing hydraulic injectors for purposes of testing them. Most diesel engine OEMs prefer that hydraulic injectors are installed dry. Pasting them with lubricants such as Never-Seize™ can limit the injector's ability to transfer heat to the cylinder head.

Reconnecting Lines. It is good practice to turn the engine over and pump a little fuel through the high-pressure pipe before reconnecting it to the injector. This eliminates air and flushes dirt from the pipe. Check the high-pressure line nut torque specs. Failure to torque to specification can choke down on the flow area at the line nipple. Always torque the nut on the high-pressure pipe with a line socket. Failure to use a line socket can result in damage to both the line nut and the nipple and seat. Ensure that each injector line is of identical length. A longer than specified injector line can produce retarded injection timing in the affected cylinder. A shorter than specified injector line will result in advanced timing in the affected cylinder.

WARNING *Whenever fuel has spilled over an engine, ensure that the engine is pressure-washed afterward.*

Testing EHIs

As indicated earlier in this chapter, the procedure for testing EHIs requires using manufacturer electronic service tools (ESTs) and software-driven diagnostic routines. The idea is to identify a defective injector and then remove and replace it. At this moment in time, EHIs are not bench tested and reconditioned in general service facilities. This is unlikely to change. When working with common rail (CR) fuel systems, *never* crack the high-pressure pipe nuts attempting to bleed them. It could prove to be dangerous and you may have problems in getting them to reseal. Most manufacturers state that their CR high-pressure lines are single-use devices. The seats are torque-to-yield. This means that they yield to deform and create a perfect seal on initial torque. Like most modern high-pressure diesel fuel injection systems, CR fuel systems are designed to self-prime.

CAUTION *The high-pressure lines that connect EHIs to the rail in CR systems are expensive. Because these lines are designed for one-off use, avoid disconnecting them unnecessarily. Each time a line is disconnected it should be replaced with a new one.*

Summary

- Injector nozzles act as switches to begin and end injection pulses.
- The injector nozzle is responsible for atomizing diesel fuel.
- Atomized diesel fuel is in a liquid state: after injection to the cylinder, it must be vaporized and then ignited.
- Today's diesel engines use multiple-orifice or electrohydraulic nozzles.
- Injector spring tension defines the NOP value in hydraulic nozzles.
- Injector spring tension is set by adjusting either screws or shims.
- Dowels are used to position a nozzle in the injector body; this ensures correct spray dispersal into the engine cylinder.
- Electrohydraulic nozzles are required in current diesel engines. An electrohydraulic nozzle may be stand-alone in an EHI or a subcomponent of an EUI.
- EHI nozzles are designed to open and close precisely when the ECM electrically switches them to do so.
- EHIs produce pressures that remain relatively consistent through a fueling pulse. The pressure depends on rail pressure.
- EHIs may use either solenoid or piezoelectric actuators.
- Piezoelectric actuators respond rapidly to control signals. They tend to be used in fuel systems requiring multipulse injection.
- Nozzle sac volumes have been either decreased or eliminated (VCO nozzle). This reduces emissions.
- Hydraulic injector nozzles are tested out of engine using a pop tester. Testing requires working through a simple test procedure. Nozzles tend not to be fully reconditioned in current trade practice.
- EHI injectors are diagnosed using the manufacturer EST and software-guided diagnostic routines.
- When diagnosed defective, EHIs should be removed and sent for factory reconditioning.
- Torquing of high-pressure pipe union nuts at both the injection pump and injector ends is important to avoid damaging the nipple seat and hole size.
- Testing a hydraulic injector nozzle requires a pop tester.
- A hydraulic injector nozzle test sequence checks NOP, forward leakage, back leakage, and the spray pattern.
- Most OEMs regard the high-pressure pipes that supply EHIs as single-use devices: this is because when torqued, they deform to create a perfect seal.

Internet Exercises

Check out some of the terms used in this chapter on <http://www.wikipedia.com> and <http://www.howstuffworks.com>. Then use a search engine to see what you can discover with the following key words:

1. Robert Bosch diesel injectors
2. Caterpillar common rail injectors
3. Electrohydraulic injectors
4. Piezoelectric actuators

Shop Tasks

1. Download the procedure for removing and re-installing a CR injector.
2. Identify a hydraulic diesel injector: Access the service literature for bench testing it.
3. Using a pop tester, perform NOP verification, back leakage, forward leakage, and spray pattern tests on a hydraulic injector nozzle.

Review Questions

1. Which type of injection nozzle provides *soft* opening and closing pressures?
 - A. Hydraulic multiple-orifice injector
 - B. Electrohydraulic injector (EHI)
 - C. Any hydraulically switched injector
 - D. Any electronically switched injector

2. When injector *back leakage* is bench checked and higher than specified, which of the following is the usual cause?
 - A. Low NOP setting
 - B. High NOP setting
 - C. Sticking nozzle valve
 - D. Wear
3. When nozzle *forward leakage* is bench checked, which of the following is being tested?
 - A. NOP
 - B. The seal at the nozzle seat
 - C. Nozzle valve-to-body clearance
 - D. Injector spring
4. Replacing a single high-pressure injection line on a multicylinder engine by one of shorter length would likely have what effect on injection timing in the affected cylinder?
 - A. Advance
 - B. Retard
 - C. None
 - D. Decrease the fuel pulse width
5. As injection pressure increases to a hydraulic injector nozzle, which of the following is likely to occur?
 - A. Injected droplets decrease in size.
 - B. Injection droplets increase in size.
 - C. Ignition delay increases.
 - D. Nozzle valve is more likely to unintentionally close.
6. Which type of injector nozzle would be used in most diesel engine fuel systems built after 2007?
 - A. Pintle valve
 - B. Hard opening valve
 - C. Multiple-orifice
 - D. Electrohydraulic
7. What should be used to remove the nut on a high-pressure injection line?
 - A. Torque wrench
 - B. Hex socket
 - C. Line wrench
 - D. Open-end wrench
8. Which of the following is another way of stating the NOP specification?
 - A. Not operating properly
 - B. Residual line pressure
 - C. Peak pressure
 - D. Popping pressure
9. Most diesel engine OEMs recommend that injectors are installed into the cylinder head injector bore:
 - A. Dry
 - B. Coated with engine oil
 - C. Coated with Never-Seize
 - D. Coated with Lubriplate
10. Which of the following types of injector would be best suited to multipulse injection?
 - A. Hydraulic poppet
 - B. Hydraulic multi-orifii
 - C. EHI with solenoid actuator
 - D. EHI with piezoelectric actuator

CHAPTER

14

Engine Management Electronics

Prerequisites

Good understanding of basic electricity.

Learning Objectives

After studying this chapter, you should be able to:

- Describe the circuit layout of an electronically managed diesel engine.
- Explain what is meant by the input, processing, and output circuits in engine management electronics.
- Identify and explain the operation of some input circuit devices.
- Outline the stages of a computer processing cycle.
- Describe how memory is managed in a diesel engine ECM.
- Identify the different types of memory used in vehicle electronics.
- Define the role played by output circuit devices in a typical diesel engine management system.
- Explain the differences between customer and proprietary data programming.
- Define *multiplexing* and describe how it is used to network the engine electronics with other chassis systems.
- Describe the procedure required to connect an electronic service tool (EST) to the chassis data bus.

Key Terms

actuator	electronically erasable, program- mable read-only memory (EEPROM)	microprocessor
central processing unit (CPU)	engine/electronic control module (ECM)	monitoring sensors
chopper wheel	engine/electronic control unit (ECU)	multiplexing
command sensors	injector driver	potentiometer
communications adapter (CA)	mass airflow (MAF) sensors	programmable read-only memory (PROM)
critical flow venturi (CFV)		proprietary data programming
customer data programming		pulse wheel
download		

pyrometer	J1587/J1708	throttle position sensors (TPS)
random-access memory (RAM)	SAE J1939	tone wheel
read-only memory (ROM)	SAE J standards	upload
reference voltage (V-Ref)	strategy	variable capacitance
reprogram	thermistor	

INTRODUCTION

Almost every diesel engine today is controlled by computer. Any engine certified for on-highway use since 1998 has been computer controlled. Onboard vehicle computers are referred to as **engine/electronic control modules (ECM)** or **engine/electronic control units (ECU)**. We are going to use the acronym ECM in this book; however, be aware that some manufacturers use ECU and other terms.

Engine Controller

The ECM is the engine controller. It is packaged into a small box. The ECM contains a **microprocessor**, computer memory, and usually an output or switching apparatus. It is usually but not always mounted somewhere on the engine. Pretty much everything we say about the ECM that manages an engine can also be applied to home computer systems.

In the early days of vehicle computers the only system that was electronically managed was the engine. This is not true today. Most chassis systems are computer controlled. They are also networked to each other by means of a data bus. Every controller with an address on the data bus can communicate with other modules on the bus. We use the term **multiplexing** to refer to networking between modules on a vehicle data bus.

Data Processing

Vehicle computers do exactly what your home computer does. They manage information. A vehicle computer may be very simple such as that required to manage a pulse wiper circuit. On the other hand, it may be more complicated if it manages the many systems required to run a diesel engine. In a typical computer, information is managed in three distinct stages:

1. Data input
2. Data processing
3. Outputs

Figure 14-1 shows a schematic layout of the management system used by Caterpillar ACERT C13 and C15

engines. This circuit manages all the engine and emissions control systems on the vehicle. It is also networked to the chassis data bus. You can use this figure as a sort of roadmap to the contents in this chapter. We will go through the input, processing, and output circuits on a typical ECM managed diesel engine.

INPUT CIRCUIT

ECM inputs can be divided into sensor inputs and switched inputs. The good news about the way in which engine input circuits operate is that they vary little between manufacturers. In this section we will identify the operating principles without explaining them in detail. Inputs to the ECM can be divided into:

- monitoring
- command

Monitoring sensors are responsible for watching over circuit conditions such as:

- temperature
- pressure
- speed

Command sensors and switches are used by the operator to tell the management electronics what to do. The oil pressure signal sent to the ECM is an example of a monitoring input. The throttle position sensor is an example of a command input.

Sensors

Anything that signals input data to a computer system can be described as a sensor. Sensors may be simple switches that an operator toggles open or closed. Or they may be devices that are supplied with a reference voltage, and then send a portion of that back to the ECM. To begin with we should understand what is meant by reference voltage.

Reference Voltage

The term **reference voltage** is almost always referred to as **V-Ref**. Actually V-Ref is an ECM output.

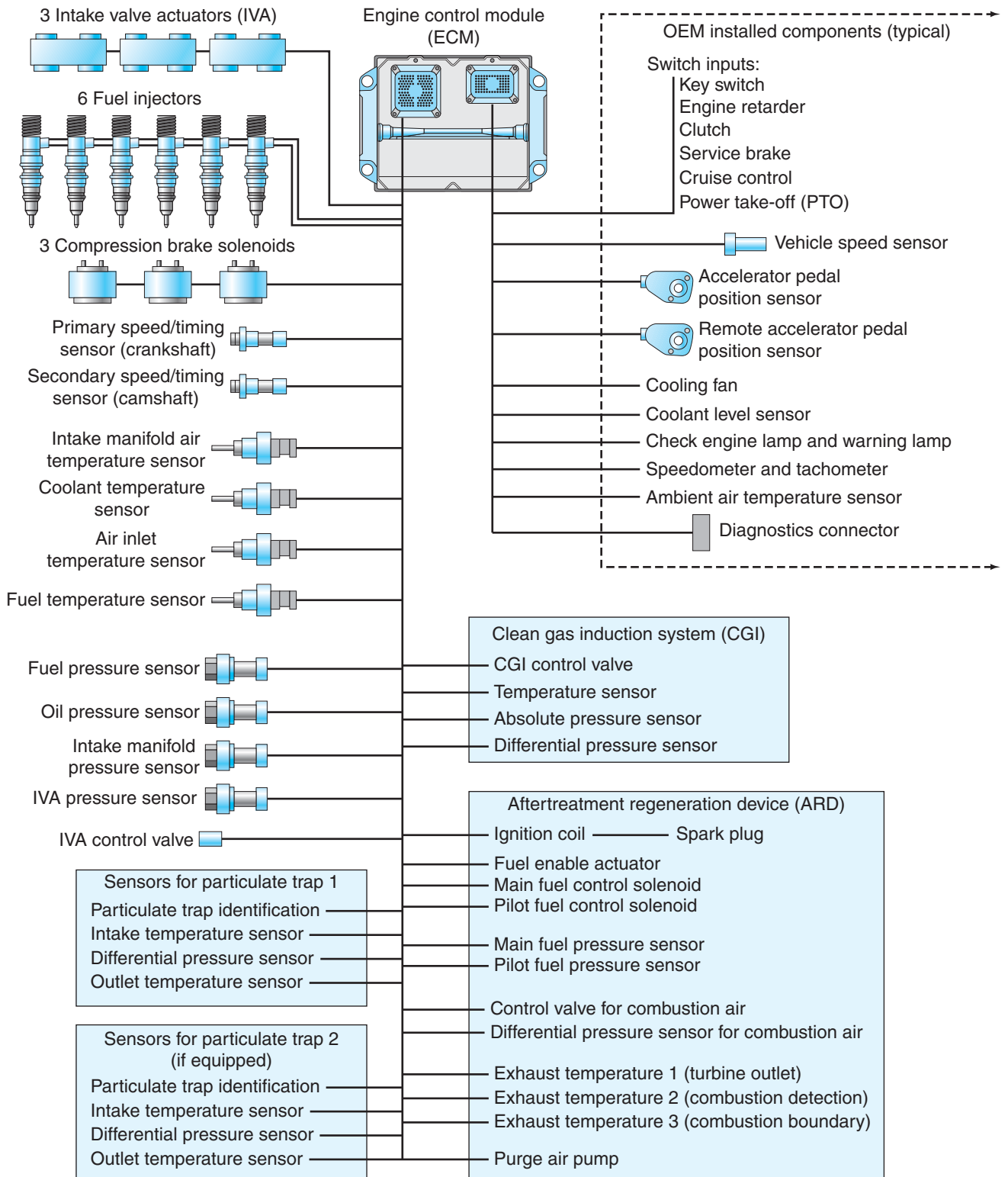

Figure 14-1 Schematic of a Caterpillar ACERT system used to manage C13 and C15 engines. (Courtesy of Caterpillar)

Regardless of manufacturer, V-Ref is specified as 5 V-DC. More correctly, it is a voltage as close to 5 V-DC as the ECM can maintain through conditions that vary, such as temperature and battery voltage (V-Bat). If you were to measure V-Ref with an accurate digital multimeter

(DMM), you might measure a value such as 5.014 V-DC when the engine is cold and 4.987 V-DC when at operating temperature. Because the ECM knows exactly what the V-Ref is at any given moment of operation, it knows how to interpret the signals that are returned to it.

Tech Tip: In addition to V-Ref and battery voltage (V-Bat), some original equipment manufacturers (OEMs) use an ECM-modulated voltage to power-up certain electronic components. An example is the 8 V-DC power-up voltage that Caterpillar uses to power-up their digital throttle position sensor circuit.

Sensors Using V-Ref

We will begin by examining some sensors that receive V-Ref. There are four types: (1) thermistors, (2) pressure sensors, (3) position sensors, and (4) induction pulse generators.

Thermistors. Thermistors precisely measure temperature. To do this they use a variable resistor. The resistance varies according to temperature. The voltage supplied to the thermistor is V-Ref. Thermistors are two-wire devices:

1. V-Ref
2. signal

The two types of thermistors are classified by whether resistance increases or decreases when a temperature rise occurs:

1. NTC (negative temperature coefficient): temperature goes up, resistance goes down
2. PTC (positive temperature coefficient): temperature goes up, resistance goes up

Some examples of thermistors used on diesel engines are:

- coolant temperature sensor
- ambient temperature sensor
- oil temperature sensor
- boost air temperature sensor

Almost without exception, NTC-type temperature sensors are used on diesel engine systems. This means that as temperature increases, resistance decreases, and therefore signal voltage (to the ECM) increases. In summary, we can say that in an NTC thermistor:

- As temperature rises, the output voltage signal rises proportionally.

Figure 14-2 shows how a typical NTC-type thermistor operates to signal temperatures on a diesel engine.

Pressure Sensors. Most pressure sensors used in engine management electronics operate on a **variable capacitance** principle. These are three-wire sensors that are supplied with V-Ref. In addition to V-Ref, they also have ground and signal terminals. The device consists of a ceramic disc behind which is a flat conductive spring and steel disc. Pressure acts on the ceramic disc and moves it either closer or farther away from the steel disc. This varies the capacitance of the device and therefore that portion of V-Ref that is returned as a signal to the ECM.

Variable capacitance pressure sensors are used as:

- oil pressure sensors
- turbo-boost pressure sensors

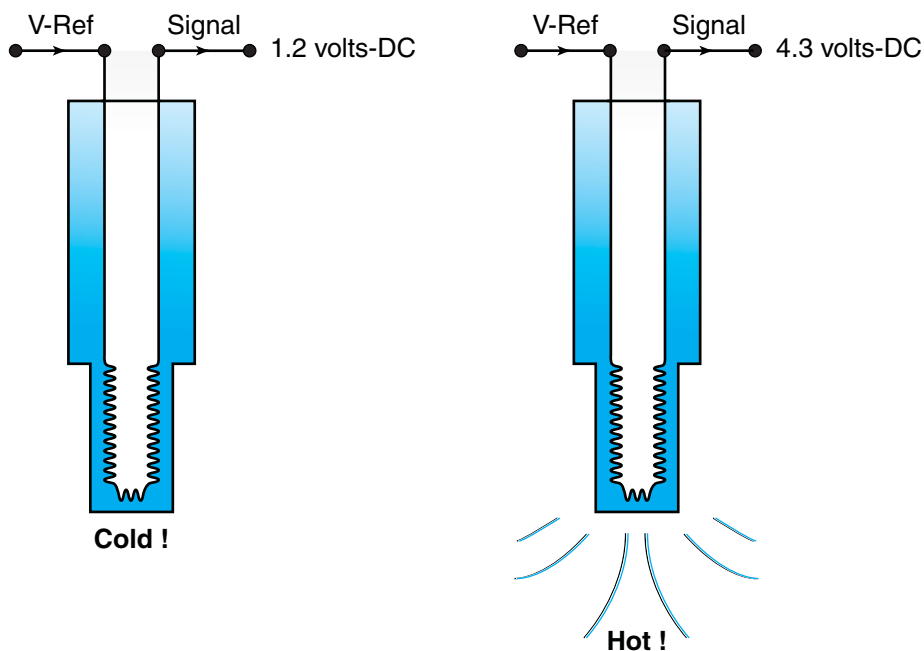

Figure 14-2 Operation of an NTC thermistor.

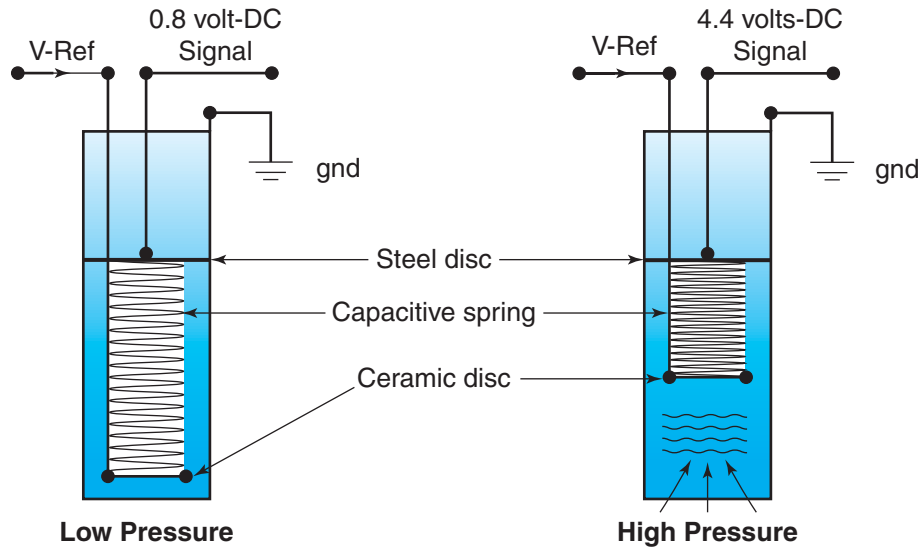

Figure 14-3 Operation of a variable capacitance pressure sensor. Note how the signal voltage changes in response to a rise in pressure.

- barometric pressure sensors
- fuel pressure sensors
- mass airflow sensors (in pairs)

Figure 14-3 shows how a variable capacitance-type pressure sensor responds to low and high pressure by outputting different return signals.

Piezo-resistive sensors may be used to signal pressure values. This type of pressure sensor is often used to measure and signal turbo-boost pressure. They provide greater accuracy than an equivalent variable capacitance sensor. Piezo-resistive pressure sensors are sometimes referred to as Wheatstone bridge sensors, a reference to the digital chip that outputs the signal. The operating principles of this type of sensor are more complex, so we are not going to address them in this textbook.

Position Sensors. A **potentiometer** is commonly used to signal position to the ECM. They are three-wire devices:

1. V-Ref
2. ground
3. signal

The output signal portion of the potentiometer is proportional to the movement of a mechanical device. Potentiometers are voltage dividers. The moving mechanical device (say, an accelerator pedal) moves a contact wiper over a variable resistor. As the wiper is moved over the variable resistor, the resistance path changes. This means that V-Ref is divided between the signal (sent to the ECM) and ground. Until 2007,

almost all **throttle position sensors (TPS)** used a potentiometer operating principle. A disadvantage of a potentiometer-type TPS is the mechanical contact between the wiper (moved with accelerator pedal) and the variable resistor. This mechanical contact results in wear that may eventually cause failures. **Figure 14-4** shows a TPS that uses a potentiometer principle of operation.

Induction Pulse Generator. An induction pulse generator does not require a V-Ref input to function. Instead it generates its own signal using the same principles as those of an electric motor. Induction pulse generators are used to signal the speed and sometimes position of anything that rotates. These types of sensors are used in many nonengine systems for functions such as wheel speed signaling.

Their operation is simple enough. A toothed disc known as a **pulse wheel**, tone wheel, or **chopper wheel** is connected to the rotating component. The pulse wheel is manufactured with evenly spaced teeth. As the wheel rotates, it is driven through a stationary magnetic field. This induces an alternating current (AC) voltage in the signal circuit as the magnetic field builds and collapses. The analog AC voltage pulses that are generated are signaled to the ECM. The ECM is not so much interested in the actual voltage value as the frequency. The faster the pulse wheel rotates, the higher the frequency of the wave signal produced. The frequency is used to identify a specific rotational speed. **Figure 14-5** shows the operating principle of an induction pulse generator.

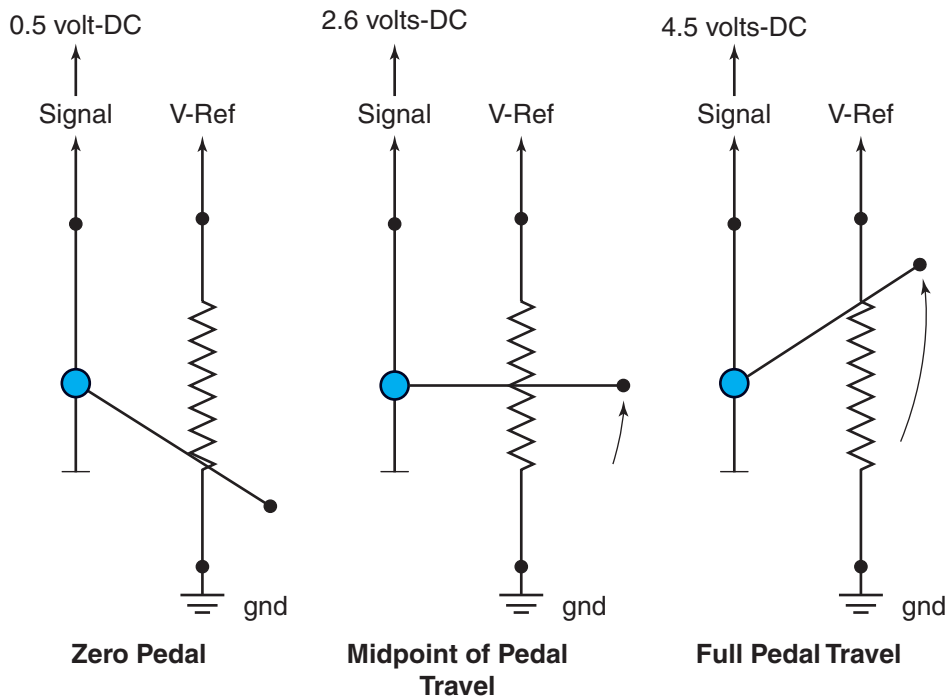

Figure 14-4 An accelerator position sensor of the potentiometer-type shown at zero, mid, and full travel positions.

SIGNALING POSITION

Inductive pulse generators can also be used to signal position. Simply by adding a tooth in one position on the pulse wheel, a specific position can be signaled by the change in frequency. An example would be on a camshaft position sensor. By adding a tooth to the pulse at the #1TDC position, the ECM is able to reference this for fuel injection timing purposes.

Hall-Effect Sensors. Hall-effect sensors generate a digital signal and may used to signal both speed and position. They may be used to accurately signal both linear and rotational position. A rotary Hall-effect sensor has a rotating disc machined with timing windows or vanes. The rotating disc is positioned to pass through a magnetic field by alternately blocking and opening a

magnetic field. This produces an on/off effect. In a rotary Hall-effect sensor, the rotating disc is known as a *pulse wheel* or **tone wheel**. Because these terms are also used to describe the rotating disc of an induction pulse generator, care should be taken to avoid confusion. We will use the term *tone wheel* here. The frequency and width of the signal provides the ECM with speed and position data. To signal position data, the tone wheel uses a single narrow window or vane at one specific position.

POWER-UP

A Hall-effect circuit has to be powered-up. Some OEMs power-up a Hall-effect circuit using V-Ref. Others power-up a Hall-effect circuit using either V-Bat or an ECM modulated voltage such as 8 V-DC. A Hall-effect sensor outputs a digital square wave signal as opposed to the analog signal of the inductive pulse (AC) generator.

Noncontact TPS. Hall-effect sensors can also be used as throttle position sensors. Their advantage over a potentiometer TPS is that there is no mechanical contact between the moving components. The result is that they tend to be more reliable. In a Hall-effect TPS, a noncontact sliding shutter alternately blocks and exposes the Hall-effect magnetic field to the signaling semiconductor sensor.

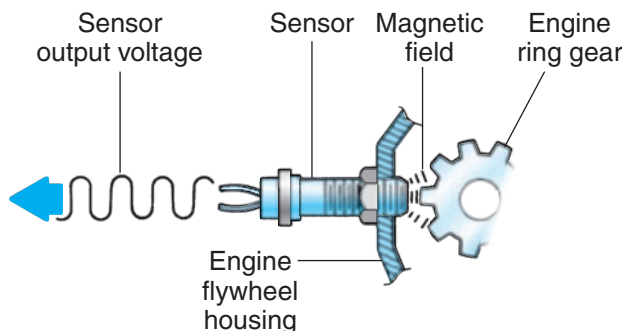

Figure 14-5 Induction pulse generator shaft speed sensor. (Courtesy of Navistar)

MAF Sensors. **Mass airflow (MAF) sensors** are required on all current diesel engines. They have been

used for decades in automobile applications. Their objective is to provide the ECM with accurate measurement of the weight of air delivered to the engine cylinders. MAF sensors may be classified as:

- hot wire
- vortex flow
- critical flow venturi (CFV)

In current diesel engines, the most common type of MAF sensor is the CFV.

Critical Flow Venturi. A **critical flow venturi (CFV)** MAF sensor is also known as a pressure differential flow sensor. It works based on the relationship between inlet pressure and flow rate through a venturi. A venturi is a throat-like device located in a flow passage that is designed to accelerate gas flow and decrease pressure. It uses the same flow principle that made a carburetor operate. When the pressure is known at the entry point to the venturi and at its exit point, the differential pressures can be used by the ECM to calculate the weight of the airflow. Some manufacturers refer to these as delta pressure sensors. The venturi and pressure sensing points on a Detroit Diesel Series 60 are shown in **Figure 14-6**.

SUMMARY OF MAF OPERATION

MAF sensors are designed to work with other temperature and pressure sensors in the intake circuit. This allows the ECM to compensate for changing conditions such as:

- outside air temperature
- humidity
- barometric pressure (altitude)
- turbo-boost

For instance, cool air is denser than warm air, so the signal from an NTC-type ambient temperature sensor is used by the ECM to accurately compute actual

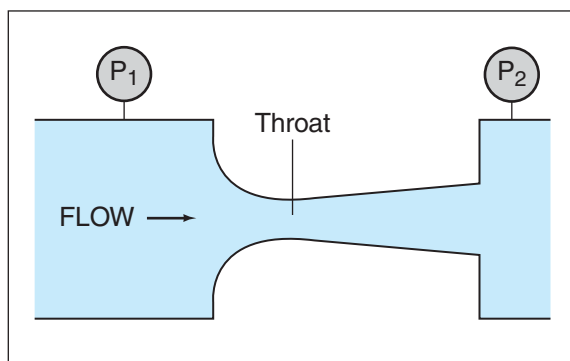

Figure 14-6 Critical flow venturi, pressure differential MAF sensor.

airflow data. Humidity always affects air density because humid air is denser than dry air. However, because humid air has increased cooling effect on the sensing element, no other compensation is required.

Water-in-Fuel Sensors. A water-in-fuel (WIF) sensor detects water contamination of fuel. A WIF sensor uses a couple of probes and a 12-volt supply. Because water responds differently to the presence of electricity than fuel, when water is present in fuel it can be detected when the electrical path across the probes acts through water rather than fuel. At this point the WIF broadcasts a service alert turning on a warning lamp to warn the driver to drain any accumulated water from the filter.

Pyrometers. A **pyrometer** measures temperature. In an earlier generation of truck diesel engines, a pyrometer was often located downstream from the turbocharger in the exhaust. It provided the driver with an indication of engine load based on exhaust temperature. When pyrometer readings rose to a certain level, the driver could downshift to avoid overheating the engine. In more recent engines, pyrometers are used to monitor the high temperatures that result from operating diesel particulate filters (DPFs).

THERMOCOUPLE PRINCIPLE

A pyrometer uses a thermocouple principle. This requires that two dissimilar insulated wires (often pure iron and constantin [55 percent copper, 45 percent nickel]) be connected at each end to form a continuous circuit. The two junctions are known as the hot end and the reference end. The two dissimilar wires are wound together at the hot end where temperature sensing is required. At the other end, the wires connect to a millivoltmeter. Whenever the junctions are at different temperatures, a small current flow takes place, the voltage increasing with difference in temperature. At the reference end where the millivoltmeter is located, the display gauge reads the temperature to which the voltage correlates. **Figure 14-7** shows the construction of a typical pyrometer.

Switches

Switches that signal a request of change of status to the ECM can usually be classified as command inputs. Switches may be:

- Electromechanical: switching alters the electrical status of output.
- Smart: signals, rather than a change in analog voltage values, signal a change in status.

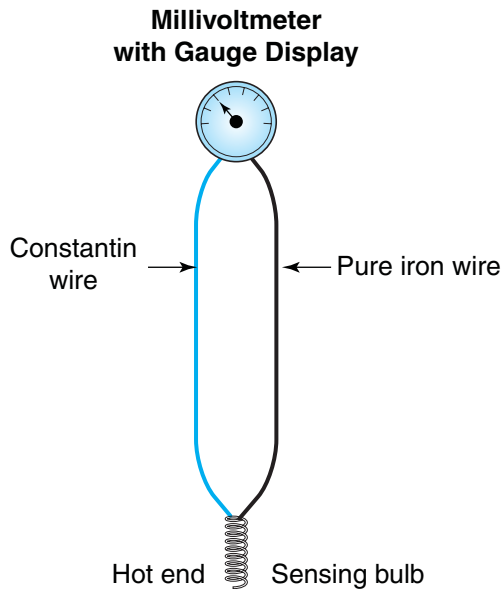

Figure 14-7 A thermocouple pyrometer.

Switches can be classified into the following categories: switches grounding V-Ref, manual electromechanical switches, and smart switches.

Switches Grounding V-Ref. An example of a switch that grounds a V-Ref input would be a coolant level sensor. This switch is designed to warn an operator that the engine coolant level is becoming dangerously low. It receives a V-Ref signal from the ECM that grounds through the coolant in the upper radiator tank. Should the coolant level drop below the sensor level, the reference signal loses its ground. After a preprogrammed time period, for example, 8 seconds, an alert is displayed. The time lag is required to prevent a temporary loss of ground caused by braking to open the circuit and trigger an ECM response. The ECM responds with whatever action it is programmed with—electronic malfunction alert or engine shutdown. **Figure 14-8** is an electrical schematic of grounding switch operation.

Manual Electromechanical Switches. Manual electromechanical switches control electrical circuit activity by opening and closing circuits. There are many examples of electromechanical switches on the dash of a vehicle. They are used by the operator to control vehicle functions. Some examples would be the ignition key, engine retarder mode switches, and the cruise control switches. Switches that are controlled by the driver are sometimes called command switches.

Smart Switches. Smart switches use digital signals to indicate a change in status. The signal produced by a smart switch may be automatically generated by a

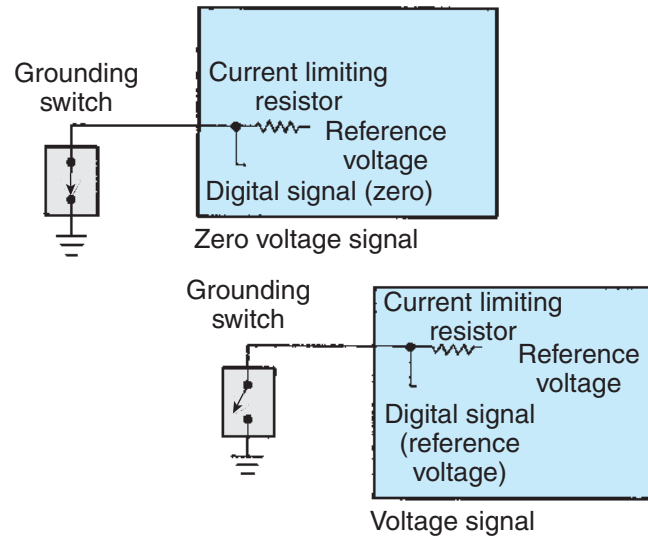

Figure 14-8 Grounding-type switch operation. (Courtesy of Navistar)

change in status condition or be generated by a mechanical action such as an operator toggling a switch. The advantage of smart switches is that they are responsible for sending a message rather than changing electrical status. This means that several switches can share a single wire to send their messages. The messages are sent to the ECM, which then computes how those messages will be used. Smart switches can significantly reduce the number of wires required by an electronic management system. Some truck manufacturers primarily rely on smart switches while others make almost no use of them. This is expected to change.

THE ECM

The electronic/engine control module (ECM) has the following functions:

- filter and prepare input signals for processing
- house the data memory required by the system
- house the processing hardware
- convert the results of processing into action using drivers

In most cases, the ECM is located on the engine. This is not always the case but it does make sense to keep it close to the systems it is monitoring and controlling. **Figure 14-9** shows the location of the ECM on a Navistar International engine and some of the intake circuit devices.

Central Processing Unit

The “brain” of the processing cycle is the **central processing unit (CPU)**. It manages the processing

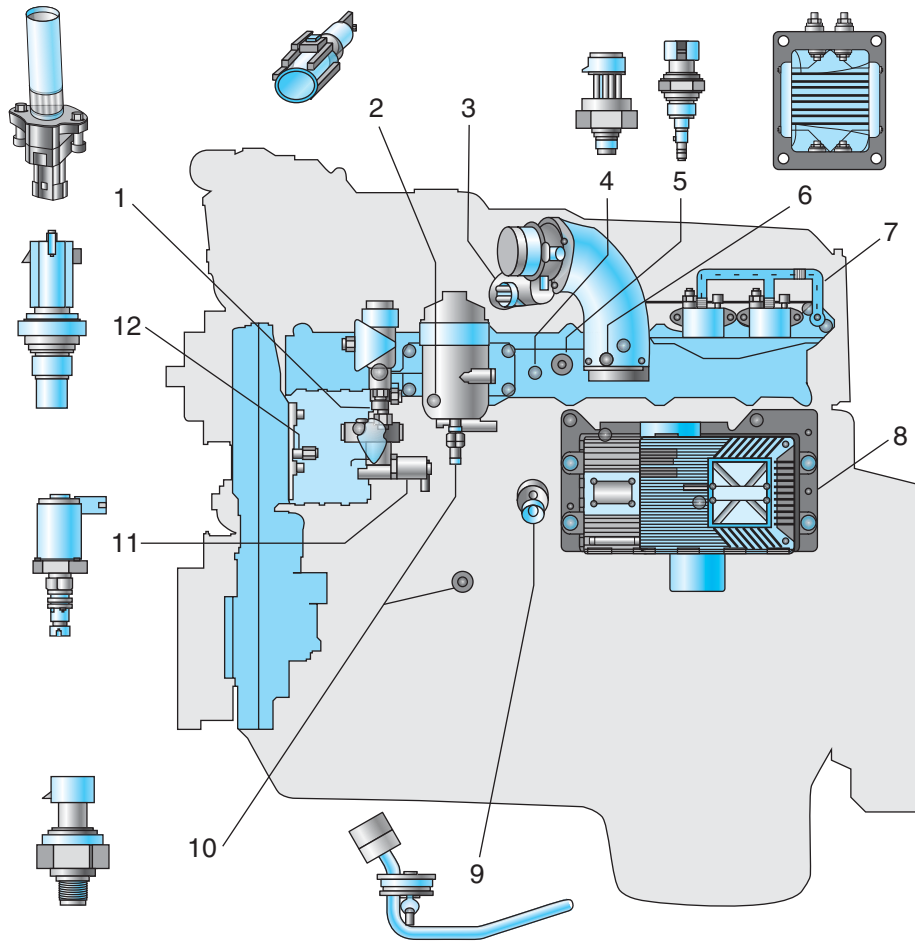

ELECTRONIC COMPONENTS—INTAKE SIDE

- | | |
|--|--|
| 1. Fuel heater (optional) | 8. Electronic control module (ECM) |
| 2. Water-in-fuel (WIF) sensor | 9. Coolant heater |
| 3. Intake throttle assembly | 10. Engine oil pressure (EOP) and engine fuel pressure (EFP) sensors |
| 4. Manifold absolute pressure (MAP) sensor | 11. Injection pressure regulator (IPR) valve |
| 5. Manifold air temperature (MAT) sensor | 12. Engine oil temperature (EOT) sensor |
| 6. Intake air heater (IAH) grid | |
| 7. Intake air heater relay assembly | |

Figure 14-9 Navistar International engine viewed from the intake side showing the location of the ECM and some sensors. (Courtesy of Navistar)

cycle and performs all the program instructions and high-speed calculations required by the system. We are going to use the word *processing* to describe the various functions of a CPU. The instructions the CPU relies on are retained in memory banks in the same way that your home computer retains memory on chips and a hard drive. Memory in an ECM can be classified as:

- nonvolatile: permanent and semipermanent memory
- volatile: electronic memory that requires an electrically active circuit only functional in real time.

Just like your home computer, when an ECM is booted by a wake-up signal or ignition key, the CPU has to transfer data from nonvolatile to electronic memory. You can bet that this has to happen a lot faster on a vehicle ECM than on your home computer. Drivers would become impatient if they had to wait for 2 minutes to launch Windows! The primary functions of the CPU are:

- manage the processing cycle
- organize incoming input data in main memory
- fetch and carry data from memory
- process data to produce outcomes
- generate switching commands to output drivers

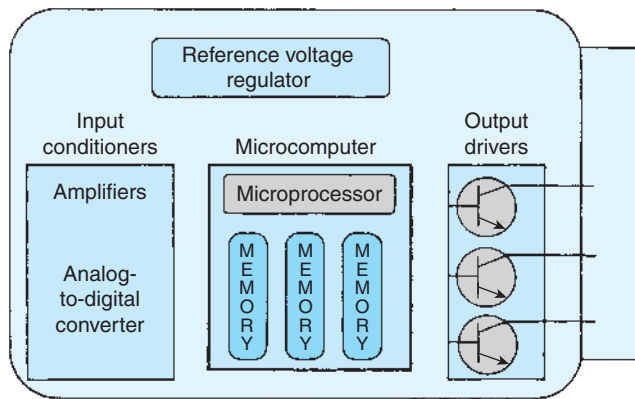

Figure 14-10 ECM functions. (Courtesy of Navistar)

Figure 14-10 is a schematic showing some of the functions of a typical diesel engine ECM. Note that the output drivers are shown as transistors: these enable a very small signal current from the processor to control the high-current circuits required to manage the ECM output circuit.

ECM Memory

Data simply means information. Data is retained electronically, magnetically, and optically in diesel engine ECMs. We will take a basic look at data by type and function in this section. We categorize data in vehicle ECMs as follows: random-access memory, read-only memory, programmable ROM, and electronically erasable PROM.

Random-Access Memory. **Random-access memory (RAM)** is often called *main memory*. This is because the CPU can only manipulate data when it is retained electronically. The amount of RAM data that a computer system can retain plays a major role in determining total computing power. At startup, RAM is electronically loaded with the vehicle management operating system instructions and all necessary running data retained in other data categories (ROM/PROM/EEPROM). The CPU can access RAM at high speed so all the key program instructions have to be logged in this memory segment.

VOLATILITY

Because RAM data is electronically retained, it is volatile. Another way of saying this is that RAM data storage is temporary. It requires power-up. If the circuit that supplies the RAM chip(s) is opened (ignition switch turned off), the data in RAM is lost. Most truck ECMs use only fully volatile RAM; in other words, when the ignition circuit is opened, all RAM data is dumped.

Sensor data such as coolant temperature, oil pressure, and boost pressure are also logged into RAM while

the engine is running. Providing the values inputted by all these sensors fall within a normal range, they are simply monitored. If they fall out of a normal range (as defined by program instructions), then other action is required. This other action might include changing the power output of an engine, alerting the driver to a possible failure condition, and logging a code.

NONVOLATILE RAM

A second category of RAM is used in some truck and older automobile systems. This is known as non-volatile RAM (NV-RAM) or keep-alive memory (KAM). Like RAM, NV-RAM is electronically retained. That means that NV-RAM requires power-up to retain its memory. The power-up circuit usually functions outside the ignition circuit, most often using a direct feed from the battery. For instance, when you disconnect a vehicle battery in some vehicles, the preset station selections are recorded in NV-RAM so these have to be reestablished after the battery has been reconnected. Codes and failure **strategy** are the type of data written to NV-RAM in systems that use it.

Read-Only Memory. **Read-only memory (ROM)** data is magnetically or optically retained. It is designed not to be overwritten, that is, it can be regarded as permanent. A majority of the total data retained in the ECM is held in ROM. In an engine ECM, the master program for running the engine is loaded into ROM. ROM chips can be mass produced and designed to manage a whole family of engines built by one manufacturer. However, engines within that family cannot be run by ROM data alone. To actually make an engine run in a specific chassis application, the ROM data requires further qualification from data loaded into PROM and EEPROM.

Programmable ROM. **Programmable ROM (PROM)** is magnetically or optically retained data. It can be a chip, set of chips, or card socketed into the ECM motherboard. PROM can sometimes be removed and replaced especially in early systems when it was the only method of changing programming. PROM qualifies ROM to a specific chassis application. In the earliest diesel engine management systems, programming options, such as idle shutdown time, could only be altered by replacing the PROM chip. This is not the case today.

Electronically Erasable PROM. The **electronically erasable, programmable read-only memory (EEPROM)** data category holds all the data that might have to be changed on a routine basis. It is usually magnetically retained in current systems but this will probably change in the near future. EEPROM provides the ECM with a write-to-self capability. This allows it to log fault

codes, audit trails, tattletales, and failure strategies in a way that is more permanent than NV-RAM. Other examples of the type of data programmed to EEPROM are tire rolling radius, governor options (LS, VS), cruise control limits, road speed limit, and many others. EEPROM data can be rewritten on an as-needed basis. Usually, only the owner password is required to access the EEPROM and make any required changes.

ECM Outputs

The results of processing operations have to be converted to action. This is accomplished by switching units usually located within the ECM and **actuators** located on the component to be switched. In an ECM managing a diesel engine, **injector drivers** are required to switch injectors on and off. This means that ECM processing commands have to be converted to electrical signals. These electrical signals are used to control injector output. We will take a closer look at injectors in the chapter that follows.

OUTPUT CIRCUIT

What happens in the output circuit is what really makes each manufacturer’s system different from their competitors. The ECM uses a combination of signals and electrical impulses to put the results of processing into action. The output circuit always begins in the ECM or in a module bus-connected to it. To make devices such as injectors and pressure valves operate under ECM control, actuators are required. Some examples of actuators are:

- Solenoids: consist of a coil and an armature. The coil is usually stationary and the armature moves within it. A simple solenoid has two status conditions, OFF or ON, and is usually spring-loaded to default to the OFF position when no current is flowing through the coil.
- Proportioning solenoids: coil and armature devices capable of precise linear or rotary positioning. To ensure the accuracy of the position, most proportioning solenoids are equipped with a means of signaling *actual* position while the ECM driver

attempts to control current flow to the proportioning solenoid to maintain desired position. An example of a linear proportioning solenoid would be the rail pressure control valve used in the high-pressure pumps on common rail (CR) fuel systems.

- Stepper motors: brushless electric motors capable of precision positioning of a shaft (and whatever is connected to it). Gas flow gates and doors such as those used in EGR systems are controlled by stepper motors.
- Piezoelectric actuators: much used in recent years in diesel fuel injection systems. These can be used to replace any solenoid, providing faster response times and requiring less current, but at this moment in time they tend to be a little bulkier.
- Field effect transistors (FETs): these act as relays. When signaled with a very low current signal, they can switch high-current circuits.

MULTIPLEXING

Earlier in this chapter we defined *multiplexing* as the networking of multiple controllers on a data bus. *Networking* is a term we use to describe communications. The communications may be one- or two-way. Multiplex communications consist of messages sent between different ECMs connected to a data bus. A data bus consists of just two wires. The two wires are used to carry digitally coded messages.

Serial Bus

The data bus we use in current truck chassis is a serial bus. This means that only one message can be pumped down the bus at one time. The fact that the message travels down the bus at nearly the speed of light means that a great number of messages can be broadcast on the bus in a time frame of one second. **Figure 14-11** is a schematic showing a typical serial data bus to which a number of ECMs are connected. Each ECM connected to the bus is said to have an address on that bus.

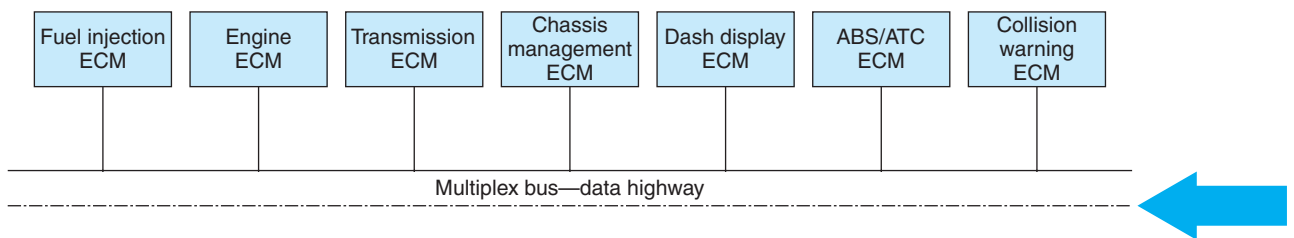

Figure 14-11 ECMs connected to a truck chassis serial data bus.

Packets

The messages broadcast on the bus are known as packets. This digital structure of a packet is standardized so that electronic systems made by different manufacturers can communicate with each other. One of the first fields built into a packet is a declaration of how important it is. This is known as its arbitration field. It is key to making a data bus function. Many of the messages broadcast on the bus are not that important. But when a chassis event such as a panic brake stop occurs, in order to put into effect evasive strategies, such as chassis antirollover strategies, messages from the brake control electronics get some very high priority on the data bus. Because the bus is a serial bus, the chances of message conflict occurring are kept at a minimum.

Standardization

Data bus and electronic protocols are standardized in highway heavy equipment markets. This standardization has been managed by the SAE and ATA-TMC, a cooperation that has been necessary because truck chassis OEMs almost always provide more than one engine, transmission, and brake option—and because the powertrain electronics have to communicate with the brakes, collision warning systems, and so on. This means that all the electronic systems manufactured by different manufacturers have to be able to speak to each other. In the automobile world this has never been so necessary, because it is not possible to order a GM chassis and have it spec'd with a Ford engine and a Chrysler transmission. Standardization of vehicle electronics is covered by J-standards.

J-Standards

Two standard data buses are used on current trucks, buses, and heavy equipment. They are referred to as:

- SAE J1587/1708
- SAE J1939

In addition, manufacturers of truck chassis may use proprietary data buses. A proprietary data bus is usually designed to communicate with just one other controller. The other controller is likely networked to one of the two primary data buses.

SAE J standards (surface vehicle recommended practice) dictate the hardware and software rules that apply to multiplexing data exchanges between modules. The rules are covered by the following J standards:

- **SAE J1587/J1708.** The first-generation multiplexing data bus, J1587 covered the communication *rules* while J1708 covered the *hardware*

compatibility. Data access to the J1587 bus is by a J1708 data socket; this is a 6-pin Deutsch connector.

- **SAE J1939.** This covers the set of standards that incorporate both *software rules* and *hardware standards*. It is based on a high-speed CAN 2.0 (Controller Area Network generation 2.0) data bus. The light-duty/automotive equivalent of J1939 is J1850: both are based on CAN 2.0 vehicle communication rules.

To work with any controllers with an address on the data bus you must first connect to the bus. The data connector used to access J1939 is a 9-pin Deutsch connector. This connector is usually located somewhere on the left side of the steering column. In order to add a module to the bus, it must be connected to a stub. J1939 data and stub connectors are shown in **Figure 14-12**.

Connecting to the Chassis Data Bus

With modern trucks, the technician is usually required to access the chassis data bus even for something as simple as performing a preventative maintenance service. Connecting to a truck chassis data bus requires the following:

- a Windows environment PC loaded with manufacturer-specific software
- a **communications adapter (CA)** to act as a serial link
- USB to CA cable
- CA to J1939 data link connector

Depending on what you are attempting to achieve while connected to the data bus, it may also be necessary to be connected to the manufacturer's data hub via the Internet. (See **Figure 14-13**.)

After connecting to the chassis data bus, you will see a menu identifying all of the electronic systems networked to the bus. Each electronic system is identified as a Message Identifier (MID). MIDs have numeric values which you are not required to remember, though perhaps you should know that an engine ECM has a MID 128 address on the bus. To work with the engine electronics, you have to first enter MID 128, and then use the menu options as appropriate. Some of the options are:

- parameters (means *values*: if the engine was running you would be able to monitor engine rotations per minute [rpm], coolant temperature, boost pressure, etc.)
- active faults: identifies any current faults
- inactive or historic faults: identifies any logged codes that are no longer active

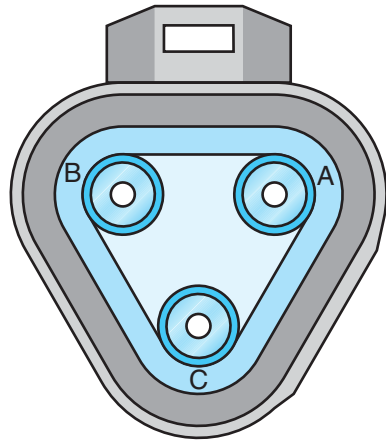

3-Pin J1939 Connector

- A. CAN bus line, dominant high (+)
- B. CAN bus line, dominant low (-)
- C. CAN shield

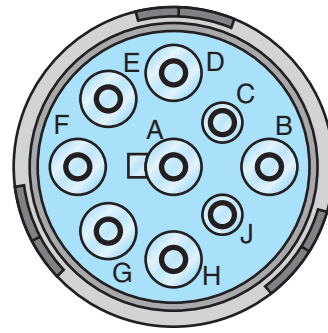

9-Pin J1939 Connector

- A. Battery negative
- B. Battery positive
- C. J1939 CAN bus line, dominant high (+)
- D. J1939 CAN bus line, dominant low (-)
- E. CAN shield
- F. J1587 bus line, dominant high (+)
- G. J1587 bus line, dominant low (-)

Figure 14-12 J1939 connectors: note the cavity pin assignments in the data connector.

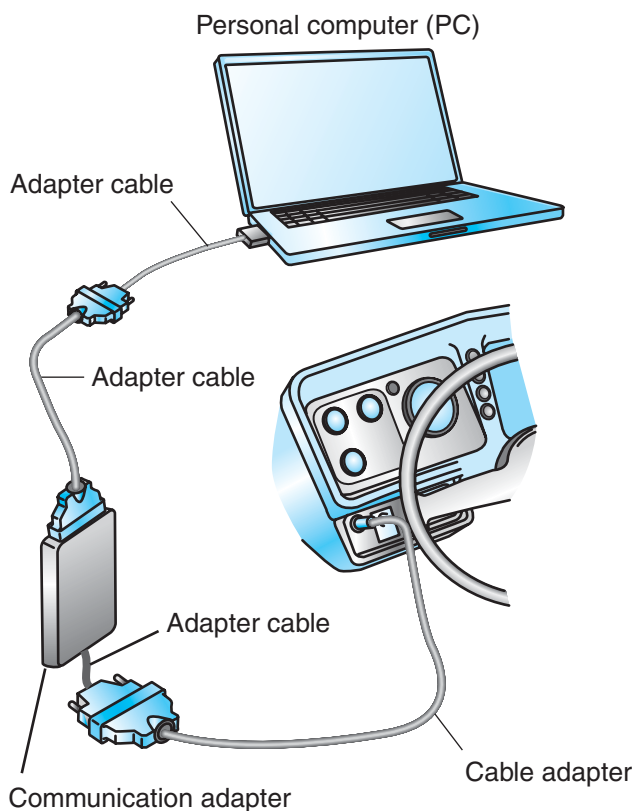

Figure 14-13 Connecting an EST to the chassis data bus using a CA. (Courtesy of Caterpillar)

- audit trails: view previous monitored parameters
- diagnostic routines: used to troubleshoot engine problems
- customer programming (see the next section)
- proprietary programming (see the next section)

Photo Sequence 4 demonstrates the procedure required to connect an EST to a J1939 data bus.

ECM PROGRAMMING

Just like your home computer, vehicle ECMs can be programmed and reprogrammed. Vehicle ECM programming can be divided into two categories:

1. customer data programming
2. proprietary data programming

In a general sense, the programming category indicates who owns the right to make the change. **Customer data programming** is owned by the owner of the vehicle. **Proprietary data programming** is owned by the manufacturer of the vehicle.

Customer Data Programming

Customer data programming refers to any information that may have to be changed on a routine basis. This means that the vehicle owner can make changes due to such things as driver preference or change in hardware. Usually all that is required to make a change

PHOTO
SEQUENCE
4

Connecting an Electronic Service Tool (EST) to a Chassis Data Bus



P4-1 The truck we are going to use for this exercise is a Navistar International 4200 series powered by a VT-365 engine.



P4-2 The EST required to connect to this chassis bus is a Navistar EZ-Tech laptop computer. Begin by booting the EZ-Tech.

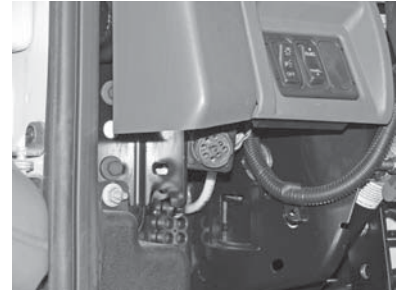

P4-3 Locate the chassis data connector. One is required to be located on the left side of the driver position. The data connector on this truck is located under the dash but you may find it located on the floor at the rear of the driver seat.

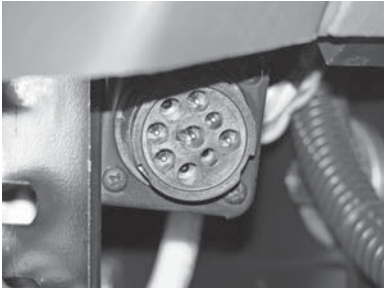

P4-4 Identify the data connector. Either a 6-pin or 9-pin Deutsch connector is used. In the example above, a 9-pin Deutsch connector is used indicating the chassis is equipped with a J1939 data bus.

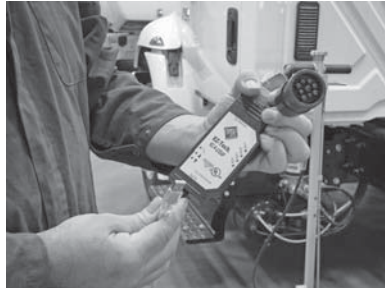

P4-5 Connect the appropriate serial communications adapter (CA). The CA module has a pair of cables extending from either side. At the end of one cable is a J1939 plug. At the end of the other is a USB plug.



P4-6 Make the connection between the CA and the laptop USB port.



P4-7 Make the connection between the CA and the chassis data bus via J1939.



P4-8 Turn the ignition key ON. This will launch a key-on, self-test cycle during which you will hear actuators cycle producing clicking noises.

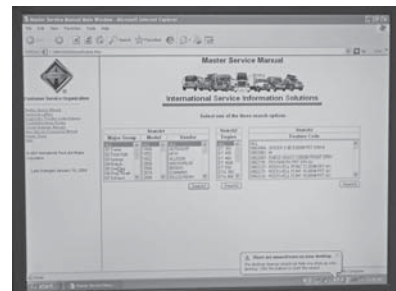

P4-9 After the self-test cycle, the EST software will display onscreen options for diagnostic routines (Master Diagnostics), international (trucks) (online) service information system (ISIS), and master service literature. The above screen shows the graphical user interface (GUI) from which you can launch service literature.

to customer data is the ECM customer password. Fleets sometimes do not provide their drivers with the vehicle ECM password.

Typical Customer Programming Options. Customer programming options define limits, such as road speed limit (RSL) or idle shutdown time limit. Some state jurisdictions mandate idle shutdown times and fleets often use this option to ensure that their drivers are not ticketed. Examples of typical customer data programming options offered by OEMs are:

- *Road speed limit.* If you look at how trucks are driven on our highways, you will note that this is a popular option with large fleets. It makes sense because limiting road speed saves fuel and improves safety. Although you do not see many owner-operators taking advantage of this feature, with rising fuel costs this becomes an increasingly important feature. This programming field is commonly referred to as vehicle speed limit (VSL).
- *PTO governing/limits.* Precise governing of the engine when it is run in power take-off mode means that the engine can safely run auxiliary equipment such as mechanical pumps, hydraulic pumps, compressors, and generators. This means that if a change in PTO device load occurs, the engine will adjust so the set PTO speed is maintained.
- *Cruise control parameters.* This feature allows the upper and lower cruise limits to be programmed. Actual values are programmed by the driver operating the vehicle using dash switches. Some chassis/engine management systems allow a higher cruise speed limit than the set vehicle speed limit.
- *Smart/soft cruise.* Most trucks today offer some type of flexible cruise programming. The idea is to run the vehicle in as fuel-efficient manner as possible. Smart cruise learns from the terrain over which the vehicle is being run. For instance, when being run through rolling hills, the cruise logic will allow the vehicle to speed up a certain percentage above set cruise speed on a downhill, and slow on an upgrade. This can greatly improve fuel-to-mileage figures, especially when multiplied through many vehicles in a fleet of trucks. Smart cruise programming can also “reward” a driver who improves on vehicle fuel economy: the reward is usually a slight increase in governed road speed.

- *Failure strategy.* When a key engine sensor sends a signal to the ECM that could indicate a serious problem, the way in which the electronics respond to the condition depends on the programming. Signals indicating high coolant temperature or low oil pressure can be typically responded to at three levels:
 1. sending a warning alert to the driver (first level)
 2. reducing engine rpm and/or engine load (second level)
 3. engine shutdown (third level)
- Although manufacturers recommend that all three levels of failure response be programmed, this may not be appropriate in a fire truck. An owner/operator may decide to go with second-level programming. On the other hand, fleets tend to opt for third-level programming. Running a vehicle under a failure strategy would probably be a bad idea that could void any warranty.
- *Tire size.* Tire size on the drive axle wheels has to be programmed to the ECM. This is usually programmed to the ECM in revolutions per mile or revolutions per kilometer. Note that two nominal 22.5-inch tires of different tread code ratings (even if they are manufactured by the same manufacturer) may produce a different number of rotations per mile. Incorrectly programmed tire data will result in false road speed data signaled to the ECM. This will result in inaccurate speedometer and mileage information.

Additional examples of typical customer data programming options offered by OEMs include:

- transmission ratio
- carrier ratio
- progressive shifting limits
- idle speed
- torque rise profile
- peak brake power
- idle shutdown duration

Proprietary Data Programming

The technician enables proprietary data programming but does not actually perform the reprogramming. Proprietary data includes any ECM programmed data that the manufacturer does not want the customer to alter. A good example is the engine horsepower rating. If after purchasing a truck a customer determines that more power is required,

in many cases this is possible with new programming without making any hardware changes. However, increasing power is a proprietary programming field that requires a **download** of a new set of engine files. In most cases there would be a fee. The manufacturer would justify the fee by stating that there would be a greater warranty liability. Proprietary data programming normally takes place in three distinct stages:

1. **Download**: a new set of files is downloaded from the manufacturer data hub.
2. **Reprogram** the ECM: the newly downloaded engine files are transferred to the ECM.

3. **Upload** verification: a confirmation is made verifying that the new set of engine files has been successfully transferred to the ECM.

Proprietary data reprogramming is a simple set of procedures. These procedures require some familiarity with PCs loaded with manufacturer software; however, most of the sequencing is menu driven and easy to follow. In fact, as each new software version is released, reprogramming becomes progressively simpler.

Summary

- All current on-highway trucks use computers to manage the engine and many other chassis systems.
- We call computers on trucks ECMs and ECUs.
- A truck with multiple ECM managed systems networks them to a chassis data bus. This allows different system ECMs to talk with each other.
- ECM processing takes place in three stages: (1) data input, (2) data processing, and (3) outputs.
- RAM or main memory is electronically retained. It is therefore volatile.
- The master program for engine management is usually written to ROM.
- PROM data is used to qualify the ROM data to a specific chassis application.
- EEPROM is used for write-to-self capability, retaining customer and proprietary programming, holding failure strategy, logging codes, and recording audit trails.
- *Multiplexing* is the term used to describe communications between two or more ECMs.
- Multiplexing reduces hardware and makes vehicle operation more efficient.
- Input data is divided into command data and system monitoring data.
- Thermistors precisely measure temperature.
- Variable capacitance-type sensors are used to measure pressure.
- Throttle position sensors use either potentiometer or Hall-effect operating principle.
- Hall-effect sensors generate a digital signal and are used to signal either rotating or linear position and speed data.
- Induction pulse generators are used to signal rotational speed data.
- Truck engine management ECMs are responsible for regulating reference voltage, conditioning input data, processing, and driving outputs.
- Engine management ECMs can be mounted on the engine itself or in a remote location such as under the dash.
- ECM outputs require drivers to actuate a range of output devices. Output devices are known as actuators. Some examples of actuators are solenoids, proportioning solenoids, stepper motors, and piezo-actuators.
- Customer data programming is owned by the vehicle owner. It includes information that may have to be changed on a routine basis.
- Proprietary data reprogramming is usually performed in these three stages: (1) downloading system files, (2) reprogramming the ECM, and (3) uploading verification.
- Connecting to the chassis data bus requires an EST loaded with manufacturer software, a CA, and a J1939 connector.

Internet Exercises

Check out some of the terms used in this chapter on <http://www.Wikipedia.com> and <http://www.howstuffworks.com>. Then use a search engine to see what you can discover with the following key words:

1. International Diamond Plus
2. Caterpillar ADEM
3. Detroit Diesel DDEC
4. Cummins Interact System (IS)
5. Piezoelectricity

Shop Tasks

1. Identify an EST, CA, and J1939 connector.
2. Establish an EST connection to a truck chassis data bus.
3. Identify all the MIDs networked to the chassis data bus.
4. Enter the 128 MID address, start the engine, and select the following parameters and record the values: engine rpm, coolant temperature, ambient pressure, and boost pressure.
5. Stop the engine. With key-on, enter the *customer data programming* field (this may be password protected). Reprogram the engine idle rpm. Restart engine and observe whether the new idle speed has been logged. Stop the engine and reprogram engine idle to the original specification.

Review Questions

1. Which of the following internal ECM components manages the processing cycle?
 - A. CRT
 - B. RAM
 - C. CPU
 - D. ROM
2. Which of the following memory types is volatile?
 - A. RAM
 - B. ROM
 - C. PROM
 - D. EEPROM
3. In which memory component would you find the master program for engine management in a typical ECM?
 - A. RAM
 - B. ROM
 - C. PROM
 - D. EEPROM
4. To which of the following memory categories would customer data programming be written from an electronic service tool (EST)?
 - A. RAM
 - B. ROM
 - C. PROM
 - D. EEPROM
5. Which of the following components conditions V-Ref?
 - A. ECM
 - B. Voltage regulator
 - C. EUI
 - D. Personality module

6. What type of data does a thermistor produce?
 - A. Pressure data
 - B. Temperature data
 - C. Rotational speed data
 - D. Rotational position data

7. What is a Hall-effect sensor most likely to be used for?
 - A. Pressure data
 - B. Temperature data
 - C. Fluid flow data
 - D. Rotational or linear position data

8. What type of information is produced by an induction pulse generator?
 - A. Pressure data
 - B. Temperature data
 - C. Rotational speed data
 - D. Altitude data

9. Which of the following components could be used to signal accelerator pedal travel?
 - A. Pulse generator
 - B. Potentiometer
 - C. Thermistor
 - D. Variable capacitance sensor

10. Which of the following words best explains what *multiplexing* is on a truck chassis?
 - A. Wi-fi
 - B. Handshaking
 - C. Networking
 - D. Broadband communication

CHAPTER

15

Electronic Diesel Fuel Injection Systems

Prerequisites

Chapters 12, 13, and 14.

Learning Objectives

After studying this chapter, you should be able to:

- Describe the system layout and the primary components in current full authority, electronic fuel management systems.
- Identify the key features of electronic unit injector (EUI) and common rail (CR) diesel fuel injection systems.
- Outline the role the four primary subsystems play in managing an EUI-fueled engine.
- Describe the operating principles of two-terminal (single actuator) EUIs.
- Describe the operating principles of four-terminal (two-actuator) Delphi EUIs.
- Describe how the electronic/engine control module (ECM) manages EUI duty cycle to control engine fueling.
- Outline some of the factors that govern the EUI fueling and engine output.
- Identify common rail (CR) diesel fuel systems.
- Identify some of the diesel engines currently using common rail diesel fuel injection.
- Trace fuel flow routing from tank to injector on common rail diesel fueled engines.
- Describe the electronic management circuit components used in common rail fuel systems.
- Describe the operation of the inline and radial piston pumps used to achieve sufficient flow to produce rail and injection pressures in a typical CR system.
- Understand how rail pressures are managed in an electronically managed, common rail diesel fuel system.
- Outline the operation of an electrohydraulic injector (EHI).
- Identify some of the characteristics of different original equipment manufacturer (OEM) common rail diesel fuel injection systems.
- Describe the operation of a fuel amplified common rail (FACR) system.

Key Terms

accumulator	engine management system (EMS)	radial piston pump
common rail (CR)	four-terminal EUIs	rail
dual actuator EUI	fuel-amplified common rail (FACR) system	rail pressure control valve
E-trim	injector drivers	rail pressure sensor
electrohydraulic injector (EHI)	multipulse injection	single actuator EUI
electronic control module (ECM)		two-terminal EUIs
electronic unit injector (EUI)		

INTRODUCTION

A generation ago more than a dozen different diesel fuel systems were used to manage commercial diesel engines. Things are simpler today. Although a wide range of diesel engines manufactured by many different companies exists, almost all diesels are managed by one of two fuel systems. We can classify these systems as:

1. electronic unit injector (EUI) fuel system
2. common rail (CR) fuel system

Even though there are differences within each of these fuel systems, they can be studied at an elementary level with little referencing to individual manufacturers' systems.

Brief History of EUIs

Diesel EUI systems have been used since the 1980s. The EUIs used today are fundamentally similar to those used earlier with the key difference being the introduction of dual actuator EUIs in 2007. From the mid-1990s until 2007, EUI fueling was the most common means of managing diesel engines. Original equipment manufacturers (OEMs) that relied on EUI fueling until 2007 were:

- Detroit Diesel Corporation (DDC)
- Caterpillar
- Cummins
- Volvo Trucks

Before 2007, diesel EUIs relied on hydraulic injector nozzles. These were simple hydraulic switches and as such were limited. Hydraulic injectors had hard opening and closing valves that could not be altered by computer controls. In order to meet 2007 emission standards, EUIs used to fuel on-highway trucks underwent a key change. The hydraulic injector nozzle was replaced by an **electrohydraulic injector (EHI)** nozzle assembly. EHIs permitted soft opening and

closing values. In other words, they could be controlled by the engine management computer. In this chapter, we begin by taking a look at EUIs.

Brief History of CR Fueling

Electronically controlled, **common rail (CR)** diesel fuel injection systems were introduced on small-bore and automobile diesel engines in the late 1990s. A CR fuel system actually has a lot in common with the fuel injection system used on most current gasoline-fueled automobile engines with the following exceptions:

- Fuel is direct injected to the engine cylinder.
- Injection pressures are much higher, some exceeding 30,000 pounds per square inch (psi) (2,000 bar).
- Injection pressure is controlled by the engine controller.

By 2010, almost every major diesel OEM will be using a CR system on at least one of their engine families. CR fueling provides the engine control module (ECM) much better control over injection. More precise control over injection means better management of combustion in the engine cylinder. The result is an improved ability to meet:

- diesel emissions standards
- fuel economy expectations

This chapter takes a close look at CR fuel systems following the discussion of EUI fuel systems.

EUI SYSTEM OVERVIEW

EUIs are mechanically actuated. The mechanical force required to produce injection pressures comes from a camshaft. The camshaft can be either cylinder block-mounted or overhead. Mechanically actuated EUIs have an effective pumping stroke managed and switched by an electronic control module (ECM). Because actual EUI plunger stroke is cam actuated, the

ECM can only switch an effective pumping stroke while its plunger is being driven downward. This fact means that the ECM has a hard limit window (represented by cam profile) within which it can select an effective stroke. EUI fueled engines can be divided into the following subsystems for purposes of study:

- fuel subsystem
- electronic input circuit
- management electronics (ECM)
- output circuit

FUEL SUBSYSTEM

The fuel subsystem incorporates those components we studied in **Chapter 12**. In short, it is made up of those components that enable onboard fuel storage and the transfer of fuel from the fuel tank to the EUIs. In most systems, the fuel subsystem incorporates a return circuit. This means that the fuel that is delivered to the EUIs, in addition to fueling the engine, is also used for:

- cooling the EUI and surround area of the cylinder head
- lubricating the EUI internal components

It is best introduced by looking at the fuel system schematic shown in **Figure 15-1**.

Fuel Subsystem Routing

A fixed clearance gear pump is responsible for all movement of fuel through the fuel subsystem. This pump uses an external gear pumping principle. It is

located on the engine and directly driven by it. A typical EUI fuel subsystem can be divided into:

- primary circuit: also known as a pull circuit or a suction circuit
- secondary circuit: also known as the charging circuit

The gear pump that moves fuel through the fuel subsystem is usually described as a:

- transfer pump
- supply pump

The transfer pump divides the primary and secondary circuits. The primary circuit is upstream from the gear pump. When the engine is running, the primary circuit is under negative pressure. This means that it is lower than atmospheric pressure. The secondary circuit is downstream from the transfer pump. It produces charging pressure, which means that it is at a pressure higher than atmospheric pressure.

Primary Circuit. Diesel fuel is stored in onboard tanks. When the transfer pump is rotated, low pressure is created at its inlet and in the circuit upstream from it. This lower than atmospheric pressure allows atmospheric pressure to act on the fuel in the fuel tank and push it through the primary circuit. Fuel is next pulled through a primary filter assembly that can have up to three functions:

1. primary filter
2. water separator
3. fuel heater

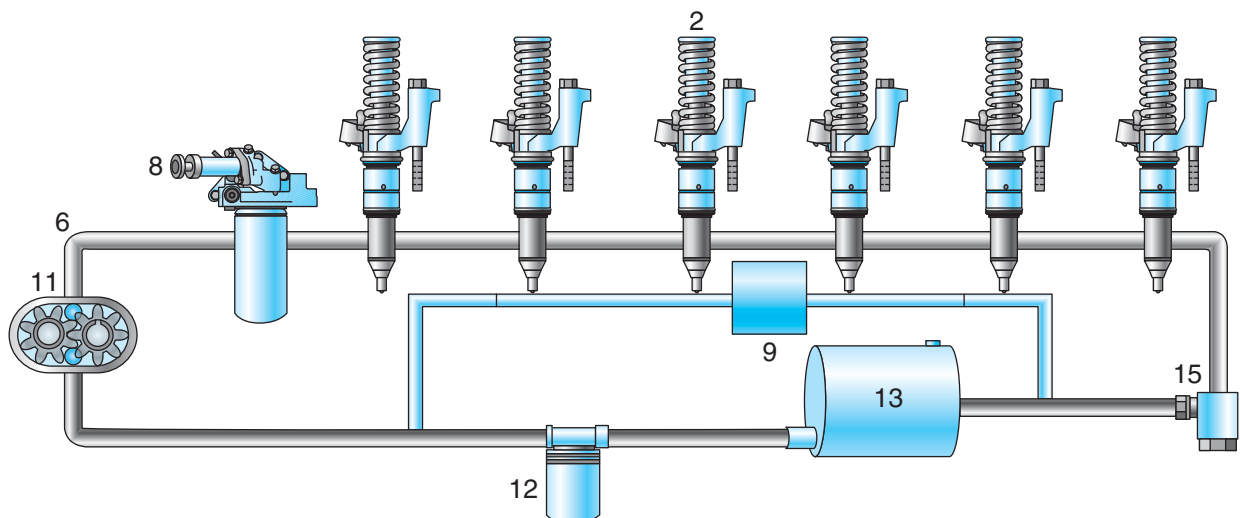

- | | | |
|------------------------------|--|-----------------------------|
| 2. Injectors | 9. Temperature regulator (if equipped) | 13. Fuel tank |
| 6. Fuel supply rail | 11. Fuel pump | 15. Fuel pressure regulator |
| 8. 2 micron secondary filter | 12. Primary fuel filter | |

Figure 15-1 Fuel system schematic for a typical EUI-fueled engine. (Courtesy of Caterpillar)

The primary filter uses a positive-type filter element to entrap larger particles suspended in the fuel. It is a disposable canister that screws onto the primary filter pad. The primary filter pad has a built-in one-way check valve known as a nonreturn valve. The nonreturn valve prevents fuel siphon from the primary circuit when the engine is shut down.

In most cases, the primary circuit is equipped with a water-in-fuel (WIF) sensor. The WIF sensor signals the operator when it detects accumulated water. A drain valve in the filter/separator is used to remove any accumulated water. A centrifuge in the water separator is used to separate the heavier water from the fuel. Water is spun to the outside of the separator and drains down to a sump at its base. Some fuel subsystems are equipped with a fuel heater that may be integrated into the primary filter assembly. Heaters may also be used in a water separator sump to prevent any separated water from freezing before it can be drained.

Supply Pump. The supply pump is an external gear pump. It is usually flange mounted to a location on the engine so it can be gear driven. This driving force may be from the engine camshaft, any accessory drive gear, or by coupling it to another engine driven component such as a power steering pump. Fuel from the supply pump is discharged to the secondary circuit. It therefore produces charging pressures. Actual charge pressure values are defined by the fuel pressure supply control valve which represents the most restricted portion of the circuit. Charging pressures vary by OEM. They typically vary from around 60 psi (4 bar) to 300 psi (20 bar).

Secondary Circuit. Fuel discharged by the supply pump is routed to the secondary circuit. Fuel in the secondary circuit is at charging pressures of around 60 psi (4 bar) to 300 psi (20 bar). In most systems, a charging pressure regulator defines maximum charging pressure. A charging pressure regulator is a simple spring-loaded ball-check valve. If the maximum charge pressure is exceeded, the ball check unseats and options fuel to the return circuit. The secondary circuit routes fuel to the secondary filter and from there to the EUI supply gallery in the cylinder head(s).

Like the primary filter, the secondary filter also uses a positive filtration principle. Modern secondary filters are designed to entrap particles as small as 2 microns. Fuel from the transfer pump enters the secondary filter inlet located on the outside of the filter canister. Filtered fuel exits through the center of the secondary filter. Fuel exiting the secondary filter pad is routed up to the fuel gallery that runs through the cylinder head. The fuel gallery supplies the EUIs with fuel at the charging pressure.

Auxiliary Fuel Subsystem Components. Fuel subsystems may be equipped with a range of auxiliary components that are designed to eliminate common maintenance problems. We will describe some of these here, but note that not all engines are equipped with them.

AUTOMATIC BLEEDING

An automatic bleeding valve purges any air in the fuel charge circuit on startup. During bleeding, any air in the charge circuit is routed to the return circuit.

SAFETY RELIEF VALVE

When used, a safety relief valve is usually located in the supply pump. It is designed to trip in the event of a blockage or partial restriction in the secondary circuit. When the pressure safety valve trips, it diverts fuel back into the primary circuit.

WATER DRAINAGE VALVE

A water drainage valve is located at the sump in the water separator. When water is detected by the WIF sensor (WIF sensor operation is explained in **Chapter 14**), a dash warning light is illuminated. In most cases, an alert is posted on the digital dash display. When this occurs, the driver can activate a dash located water drainage switch providing the following conditions are met:

- the ignition key is ON
- the engine is not running
- the parking brake is applied

In older applications, it may be necessary to manually drain the water separator when a WIF alert is signaled. In this case, the driver will obviously have to exit the cab to open the drain valve.

INPUT CIRCUIT

Command and monitoring sensors and switches used by EUI fueled engines do not vary much between the various OEMs. Current engine platforms require one of two different types of throttle position sensors (TPS):

- A standard potentiometer-type TPS supplied with V-Ref. This type of TPS uses a contact principle in which a wiper moves against a resistor. It returns an analog voltage signal representing a portion of the V-Ref that varies with accelerator pedal travel.
- A Hall-effect TPS known as a noncontact TPS. These output a digital signal. The output signal returned to the ECM is pulse width modulation (PWM).

Most input circuit components used by EUI fueled engines are similar, and mostly generic. The more recent the year of manufacture, the greater the number

of input sensors used. The operating principles of input circuit components are described in detail in **Chapter 14** and you may want to refer to that chapter. **Figure 15-2** shows the location of some of the input circuit sensors and other electronic components on a typical EUI fueled engine and **Figure 15-3** shows a wiring schematic from a Detroit Diesel electronic controls (DDEC) managed EUI fuel system identifying some of the engine sensors and actuators.

MANAGEMENT ELECTRONICS

The engine management controller used on EUI engines is usually known as an ECM. It occupies the message identifier (MID) 128 address on a truck data bus. In this way it networks with all of the other controllers connected to the data bus. The operating principles of chassis computers are explained in **Chapter 14** and you may wish to reference this once again. Most EUI

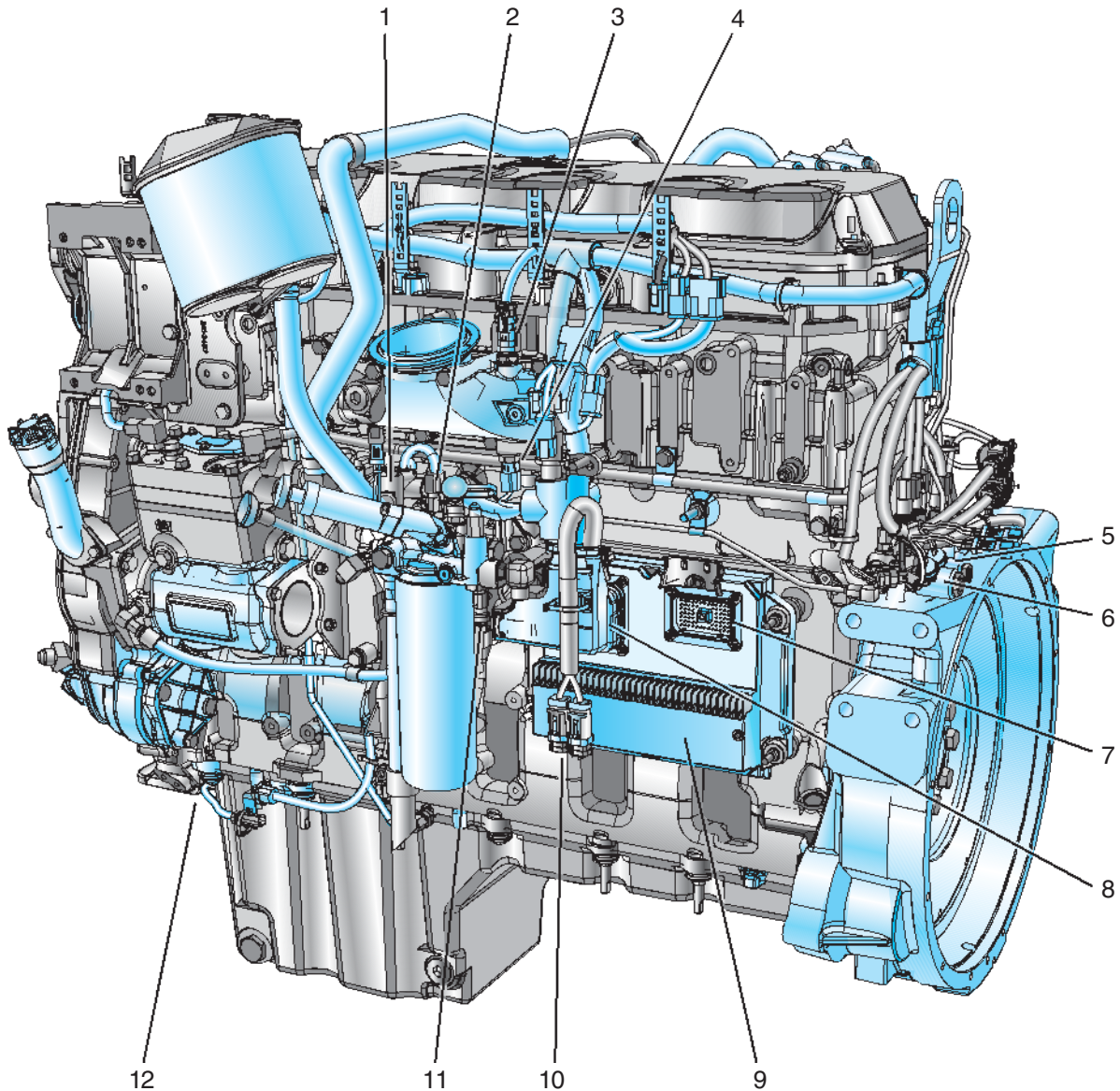

TYPICAL VIEW OF THE LEFT SIDE OF THE ENGINE

- | | |
|---|--|
| 1. Fuel enable actuator | 7. P1 connector |
| 2. Fuel temperature sensor | 8. P2 connector |
| 3. Intake manifold air temperature sensor | 9. ECM |
| 4. Intake manifold pressure sensor | 10. Connectors for the OEM wiring harness to the particulate trap or traps |
| 5. Main fuel control solenoid | 11. Oil pressure sensor |
| 6. Pilot fuel control solenoid | 12. Primary speed/timing sensor (crankshaft) |

Figure 15-2 Location of electronic components on a Caterpillar C13 engine. (Courtesy of Caterpillar)

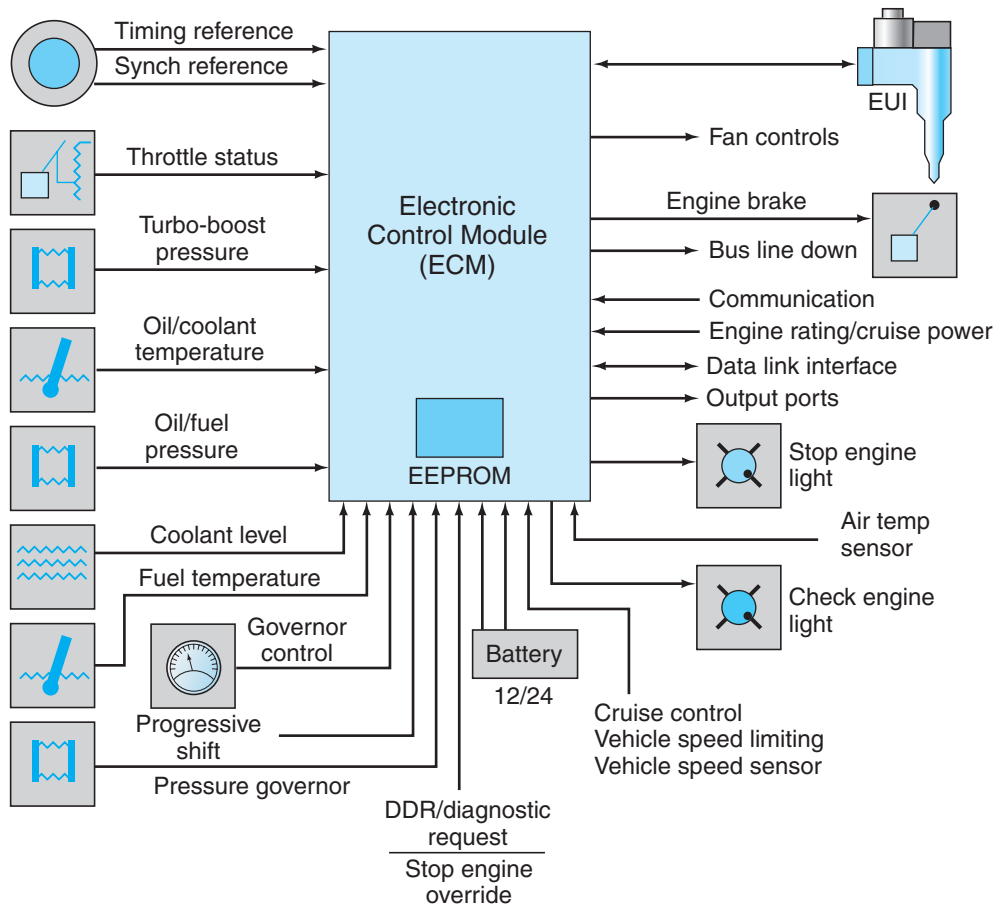

Figure 15-3 Component and wiring used on a DDEC EUI-fueled diesel engine. (Specifications are subject to change without notice. Detroit Diesel Corporation is registered to ISO 9001:2001. Courtesy © Detroit Diesel Corporation. All rights reserved. Detroit Diesel is a Daimler company)

fueled engines use a single ECM to perform both the processing and switching requirements of the system. In some cases, a two-module system is used. One module usually called the ECM occupies the MID 128 address on the data bus and performs the processing required of the system. It is also networked to the other chassis controllers and can be communicated with by the technician using an EST. The second module performs limited processing and all of the switching requirements. It connects to the ECM by means of a proprietary bus.

ECM Responsibilities

ECMs are programmable with customer and proprietary data. Current ECUs are resistant to radio frequency (RF), electromagnetic interference, and other low-level radiation experienced during normal driving. The ECM is responsible for:

- outputting system reference voltages (V-Ref)
- receiving inputs from engine monitoring sensors
- receiving and broadcasting on the J1587 and J1939 data backbones

- logging proprietary data programming
- logging customer data programming
- performing all the switching of actuators on the engine

ECMs incorporate the injector driver units usually within the housing or in a separate module connected by a proprietary data bus. The driver units simply switch the EUIs on and off. In most cases, coils are used to increase the actuation voltage to values around 100 V-DC. A typical ECM is shown in **Figure 15-4**: This unit manages the sixth generation of Detroit Diesel electronics and is known as a DDEC VI module.

OUTPUT CIRCUIT

The output circuit of the ECM is used to convert the results of the ECM processing cycle into action. In an EUI fuel system, the primary engine outputs are the EUIs and the exhaust aftertreatment devices. Other outputs are V-Ref and any information broadcast to the data backbone, such as instrument cluster displays and powertrain management.

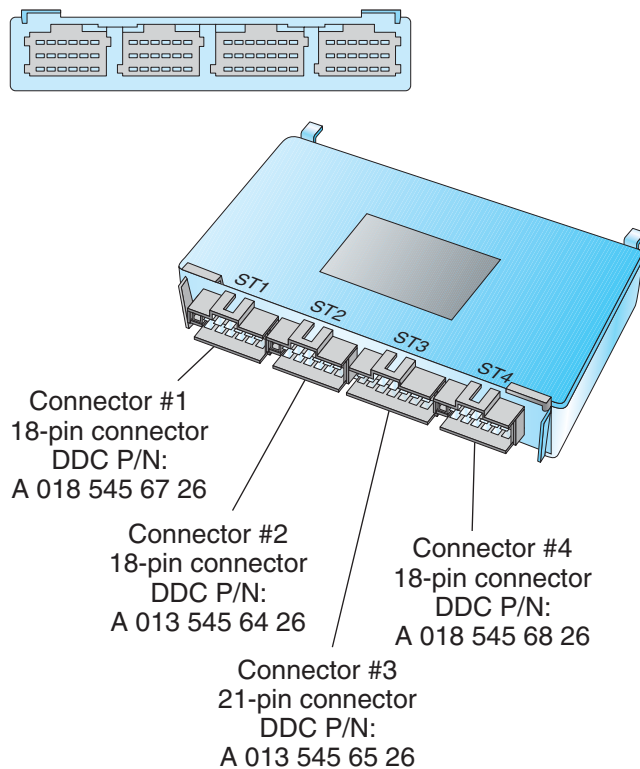

Figure 15-4 The ECM used on a Detroit Diesel DDEC VI management system. (Specifications are subject to change without notice. Detroit Diesel Corporation is registered to ISO 9001:2001. Courtesy © Detroit Diesel Corporation. All rights reserved. Detroit Diesel is a Daimler company)

ELECTRONIC UNIT INJECTORS

Electronic unit injectors (EUIs) have been used since the 1980s and until 2007 changed little in terms of their operating principles. However, those used in engines manufactured after 2007 use different operating principles, so we will divide our description of EUIs into:

- single actuator units (two-terminal) used until 2007
- dual actuator units (four-terminal) used after 2007

Both **two-terminal EUIs** and **four-terminal EUIs** are mechanically actuated by an injector train in the same way cylinder valves are actuated. In an engine with an overhead camshaft, a rocker is used to actuate the EUI as shown in the **Figure 15-5** example. Effective stroke of the EUI is electronically controlled by the ECM. This is what is known as switching and is the responsibility of the injector drivers.

Single Actuator EUI Operation

The **single actuator EUI** is fitted to a cylindrical bore in the engine cylinder head. In terms

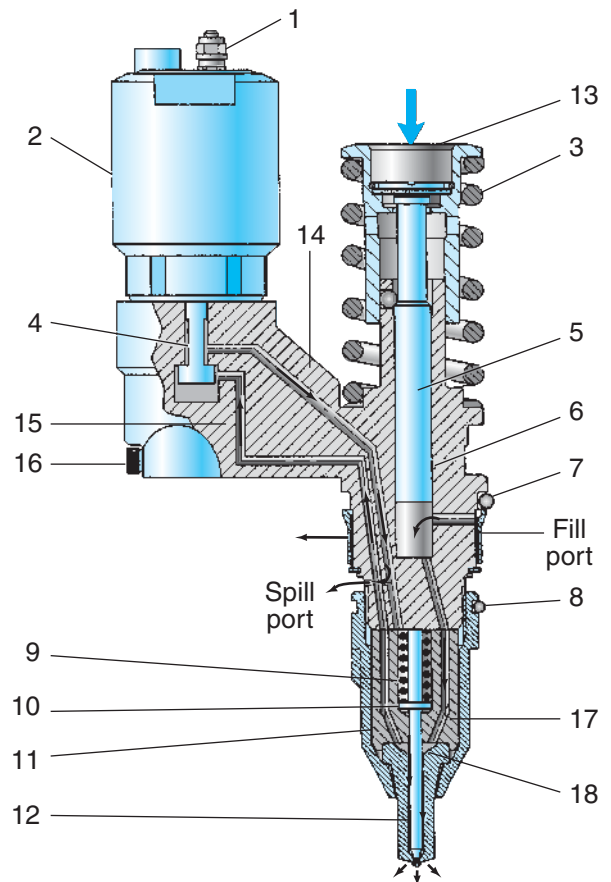

- | | |
|--|---------------------------|
| 1. Solenoid connection (to the multiplex enable circuit) | 8. O-ring |
| 2. Solenoid valve assembly | 9. Spring |
| 3. Spring | 10. Spacer |
| 4. Valve (shown in the closed position) | 11. Body |
| 5. Plunger | 12. Check |
| 6. Barrel | 13. Tappet |
| 7. O-ring | 14. Spill duct |
| | 15. Spill control circuit |
| | 16. Calibration port |
| | 17. Fuel duct |
| | 18. Pressure chamber |

Figure 15-5 Sectional view of a Delphi two-terminal EUI. (Courtesy of Caterpillar)

of its functions, the EUI can be divided into three subsystems:

1. pumping circuit: mechanically actuated by cam profile
2. control circuit: electronic engine control unit (EECU) switched to manage effective stroke
3. injector circuit: hydraulic multi-orifice nozzle

Charging pressure fuel from the fuel supply manifold (drilled passages in the cylinder head) enters the EUI through the fill port. This fuel circulates through the EUI and exits anytime the engine is running. The EUI pump chamber is formed by the cam actuated plunger and the stationary barrel. The EUI is actuated by cam profile. When the injector actuating cam is ramped off

inner base circle (IBC) toward the cam nose, the EUI plunger is driven downward. This allows the plunger to act on the fuel in the EUI pump chamber. As the plunger is forced downward, it first closes off the fill passage and then starts to displace fuel in the EUI pump chamber. To begin with, this forces fuel out through the spill circuit. When the EUI solenoid is energized by the injector driver circuit in the ECM the spill circuit is blocked, trapping fuel in the EUI. This begins an effective stroke.

An effective stroke can only occur when the EUI solenoid is energized. With the EUI solenoid energized and the plunger being driven downward, pressure rise takes place. Located below and connected by a passage to the EUI pump chamber is a hydraulic injector nozzle. When sufficient pressure rise has been created in the EUI pump chamber to open the nozzle, it opens to begin injection. Injection continues as long as the EUI solenoid is energized and the EUI plunger is being forced downward. The effective stroke ends when the ECM switches the EUI solenoid open. This opens the spill circuit, initiating a rapid pressure collapse. When there is insufficient pressure to hold the nozzle valve open, it closes, ending injection.

Single Actuator EUI Subcomponents

Figure 15-5 shows a sectional view of a two-terminal Delphi EUI with the subcomponents labeled. Refer to the callout codes in that figure as you read the following description of the single actuator EUI subcomponents:

1. Terminals: connect to the injector drivers in the ECM.
2. Control cartridge: the actuator, a solenoid consisting of a coil and armature with an integral poppet control valve (4). A spring loads the armature open. Energizing the solenoid closes the armature/poppet control valve. These actions open and close the EUI spill circuit.
3. EUI tappet spring: loads the EUI tappet upward. This enables the tappet/plunger actuation train to ride the cam profile and retract the tappet after a mechanical stroke.
4. Poppet control valve: a valve integral with the solenoid armature. In **Figure 15-5**, the control valve is shown closed (solenoid energized). In this closed position, fuel is prevented from exiting the EUI through the spill port. This traps it in the EUI, enabling an effective stroke.
5. Plunger: the moving member of the pump element. The plunger is lugged to the tappet, so moves with it. In **Figure 15-5**, the plunger is shown in its upward position.
6. Barrel: the fixed member of the EUI pumping element. It is machined with the fill port, pump chamber, and a duct that connects the pump chamber with the injector nozzle.
7. Upper O-ring: seals the upper fuel charging gallery.
8. Lower O-ring: seals the lower fuel charging gallery.
9. Nozzle spring: defines the nozzle opening pressure (NOP). The NOP is typically around 5,000 psi.
10. Spacer or shims: define nozzle spring tension and are used to set the NOP value.
11. Upper nozzle assembly body: machined with the ducts that feed fuel to the pressure chamber of the nozzle valve.
12. Nozzle valve: the hydraulically actuated moving component of the nozzle. A full description of nozzle operation is provided in **Chapter 14**.
13. Tappet: cam actuated.
14. Spill duct: the path through which fuel exits the EUI. Must be closed for an effective stroke to take place.
15. Spill control circuit: open when the control solenoid is de-energized, allowing fuel to spill from EUI. When the ECM energizes the control solenoid, the spill circuit is blocked, trapping fuel in the EUI. Blocking off the spill circuit allows an effective stroke to take place.
16. Calibration port: used only for factory bench setup.
17. Fuel duct: connects the EUI pump chamber with the injector circuit.
18. Pressure chamber: the sectional area of the nozzle valve over which pressurized fuel acts to open the nozzle valve and begin injection.

Two-terminal EUI NOPs are typically around 5,000 psi and they close at about 4,000 psi. When the EUI actuating cam reaches peak lift, the injector train is unloaded. As the injector train ramps down the cam flank, the EUI spring lifts the plunger once again exposing the fill port. Charging pressure fuel is then permitted to circulate throughout the EUI passages for purposes of cooling. In its lifted position, the plunger is ready for the next effective stroke.

Dual Actuator EUIs

Engines using EUI fueling built after 2007 use dual actuator EUIs such as the Delphi E3. You can identify these by taking a look at the electrical connector. **Dual actuator EUIs** have four electrical terminals in the connector. In fact, dual actuator EUIs are commonly referred to as *four-terminal EUIs*. Although they use a sleeker and lighter design, a

four-terminal EUI has a pair of actuators with quite different functions:

- Spill valve (SV) actuator: an ECM switched control cartridge identical to the control solenoid in a single actuator EUI; in other words, it opens and closes the spill circuit to manage EUI effective stroke.
- Nozzle control valve (NCV) actuator: this is built into the EUI body as shown in **Figure 15-6**. The NCV actuator is an electrohydraulic nozzle that allows soft NOP values. In other words, the pressure at the beginning of injection is controlled by the ECM.

Dual Actuator EUI Construction

Dual actuator EUIs have eliminated the major disadvantages of first generation EUIs:

- bulky assembly with protruding control cartridge
- hard value NOP due to the hydraulic injector nozzle

- hard value nozzle closure at the end of injection resulting in prolonged pressure collapse phase at the end of injection.

Although they are a little more complicated, dual actuator EUIs weigh about one-half of an equivalent two-terminal EUI. In addition, the obstruction to the injector and valvetrains created by the external control solenoid cartridge has been reduced. **Figure 15-6** shows the terminology used to describe a dual actuator EUI. Use that figure to guide you through the following description of its operating principles.

Dual Actuator EUI Operating Principles

In terms of general operating principles, four-terminal EUIs such as the Delphi E3 injectors are essentially a two-terminal EUI fitted with an ECM controlled electrohydraulic injector nozzle. Electrohydraulic injector nozzles were studied in the

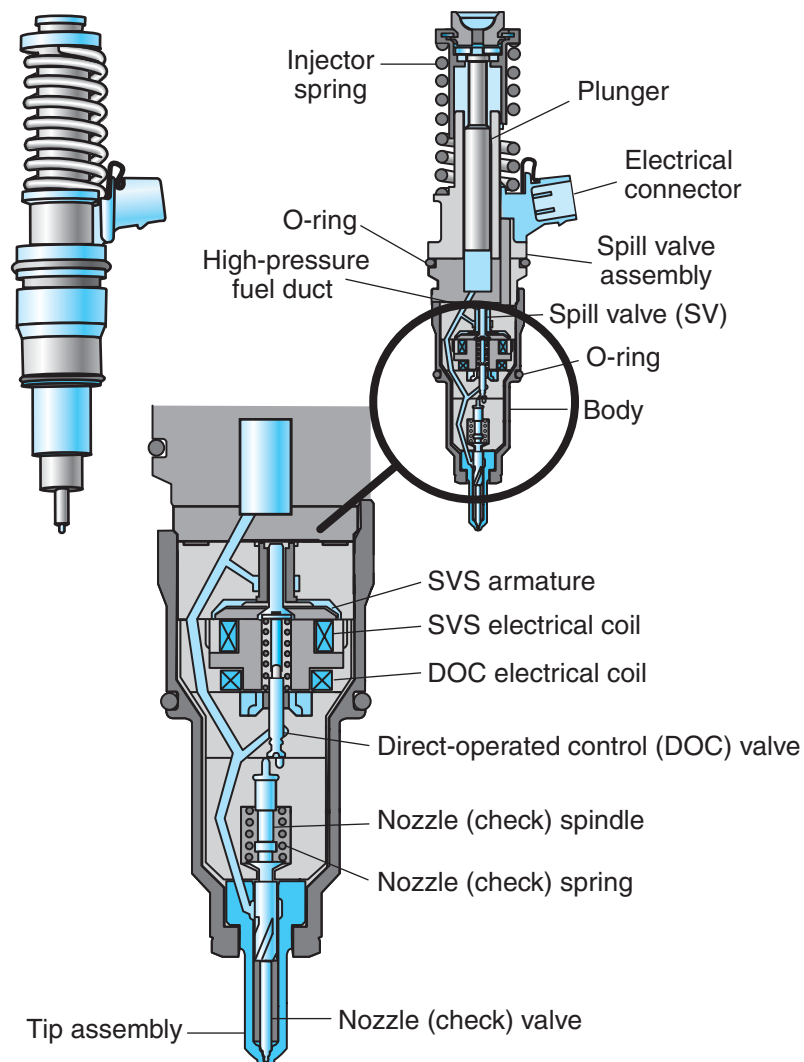

Figure 15-6 Dual actuator EUI terminology.

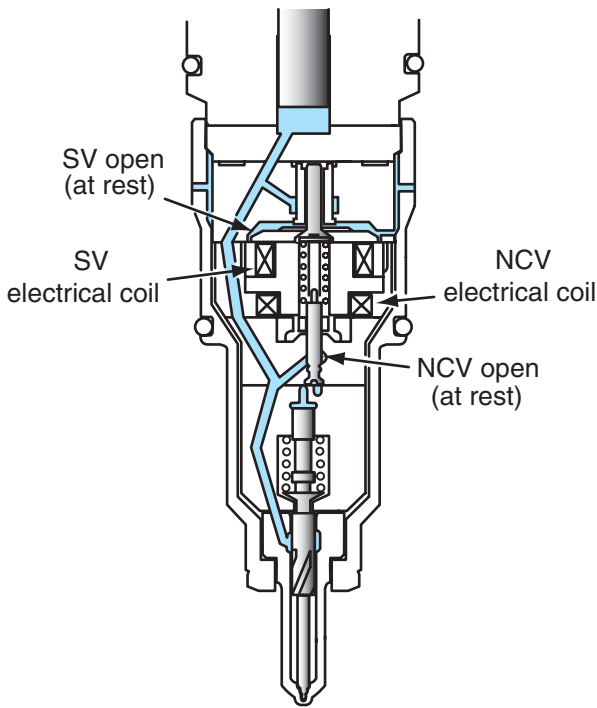

Figure 15-7 Four terminal EUI: at rest.

previous chapter so you may want to refer to that discussion again. We will reference **Figure 15-7**, **Figure 15-8**, and **Figure 15-9** to describe the operation of dual actuator EUIs, but it will help if you fully understand how electrohydraulic injectors (EHIs) operate.

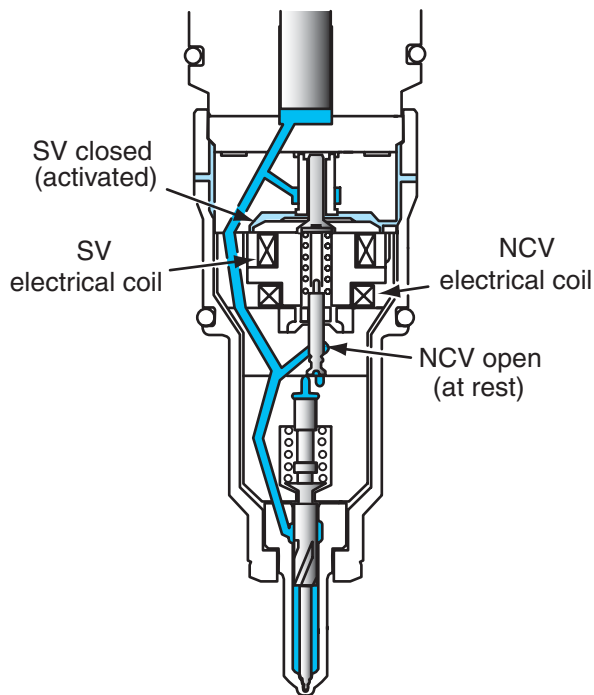

Figure 15-8 Four terminal EUI: pressurizing.

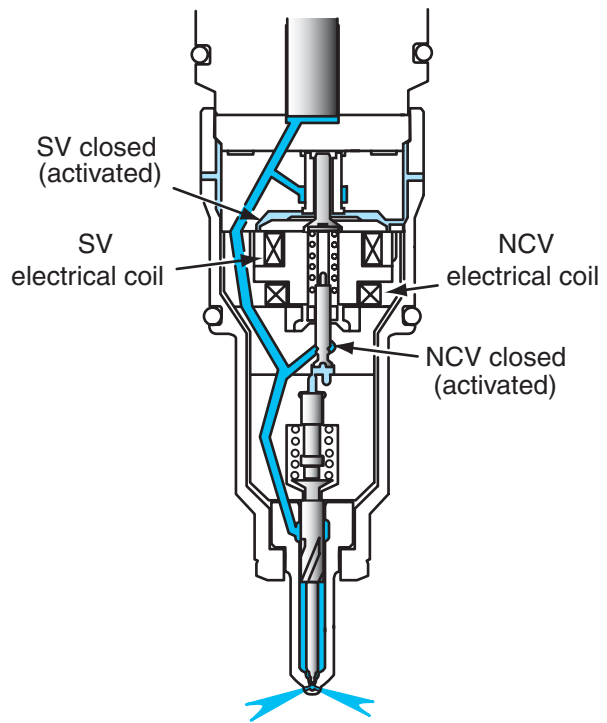

Figure 15-9 Four terminal EUI: injection.

AT REST

For most of the cycle, the dual actuator EUI will appear as it is shown in **Figure 15-7**. Fuel at the charge pressure flows into the EUI and circulates through the pump chamber and nozzle assembly, exiting through the spill circuit. Note that both the actuators are de-energized and the EUI pump plunger is in its raised position because the injector cam is on its IBC. In this phase, the nozzle needle valve is held seated by spring force. **Figure 15-7** shows a four-terminal EUI in its at-rest phase.

Actuator Status

- SV actuator: de-energized
- NCV actuator: de-energized

PRESSURIZING

Pressurizing begins when the injector cam profile begins to ramp off its base circle. This movement actuates the EUI plunger driving it downward in its bore. When the ECM energizes the SV actuator, the spill circuit closes. Closing the spill circuit traps fuel in the pump chamber underneath the plunger. As the plunger is driven into the pump chamber, pressure rise is created in the EUI fuel circuit. Equal pressure acts on both the upper and lower pressure field of the EHI assembly. However, because the sectional area of the upper pressure field (acting on the nozzle control piston) exceeds that of the lower pressure field (acting on the needle pressure chamber sectional area), the

nozzle needle valve remains firmly seated. In this phase the nozzle needle valve is held seated by a combination of spring force and hydraulic force acting on the needle control piston. **Figure 15-8** shows a four-terminal EUI during the pressurizing phase.

Actuator Status

- SV actuator: energized
- NCV actuator: de-energized

INJECTION

When the desired NOP is achieved within the EUI circuit (calculated by the ECM), the ECM energizes the NCV actuator. This pulls the NCV valve into the NCV actuator, collapsing the upper pressure chamber field. Because the upper pressure chamber field collapses and the lower pressure chamber field remains the same, hydraulic force lifts the nozzle needle valve beginning injection. While injection continues, the NCV valve remains lifted, which means no pressure can build in the upper pressure chamber. The exit flow area spilling fuel from the upper chamber is very small so spilling fuel from the upper pressure field has little effect on the pressure in the remainder of the EUI circuit. **Figure 15-9** shows a four-terminal EUI during injection: note that both actuators are energized.

Actuator Status

- SV actuator: energized
- NCV actuator: energized

END OF INJECTION PULSE

The ECM ends an injection pulse by de-energizing the NCV. Spring force slams the NCV downward, closing the NCV spill passage. This action permits almost instant reestablishing of the upper pressure field. The resulting hydraulic force acting on the nozzle needle control piston abruptly closes the nozzle needle valve ending the injection pulse.

Actuator Status

- SV actuator: energized
- NCV actuator: de-energized

MULTIPULSE INJECTION

The dual actuator EUI lends itself to multipulse injection especially when fast response, piezo-type NCV actuators are used. For multipulse injection to take place, the NCV actuator is energized more than once during a single mechanical downstroke of the EUI plunger. Multipulse injection provides better combustion efficiency and lower emissions. Dual actuator EUIs better suit multiple pulse injection events because the injection

pressure can be made to rise during combustion with each successive pulse. This produces the smallest droplets later on during the power stroke when there is less time to combust them.

Actuator Status

- SV actuator: energized
- NCV actuator: cycling ON and OFF

END OF INJECTION PHASE

The injection phase ends when both the SV and NCV actuators are de-energized by the ECM drivers. This always occurs before peak lift is achieved by the injector cam. Because EUIs are mechanically actuated by cam profile, the ECM can only switch effective strokes while the EUI plunger is descending. This means that when the ECM is managing multiple injection pulses during one cycle, these have to take place within a hard window defined by cam profile. At the completion of the injection phase, the actuating cam profile ramps back down to base circle and both actuators are de-energized. The at-rest status resumes.

Actuator Status

- SV actuator: de-energized
- NCV actuator: de-energized

Advantages of the Dual Actuator EUI

The key advantage of the dual actuator EUI over the older two-terminal version is the electrohydraulic nozzle. This feature allows the ECM to control injection pressures. Remember that hydraulic pressure at each nozzle orifice determines the size of the fuel droplets that exit the nozzle. Because the ECM can control the pressure, it removes the hard opening and closing values of the injector nozzle in older single actuator EUIs. Additionally, the dual actuator version uses more advanced manufacturing technology that makes it lighter and much less bulky.

FUEL CALIBRATION CODES

In common with single actuator EUIs, dual actuator EUIs injectors have a fuel flow code that has to be programmed to the engine ECM. This fuel flow code is printed on the side of the unit. The fuel flow code may be known by such terms as Cal-code or **E-trim**. The fuel flow code numeric value is established when an EUI is factory bench tested. This data is required by the ECM to ensure that the fueling to each engine cylinder is balanced. Once the fuel flow codes have been programmed to the ECM, it can compensate for minor hydraulic differences between injectors. The fuel calibration code

for each injector must be programmed to ECM memory each time an injector is changed out.

CAUTION Failure to reprogram fuel calibration codes when EUIs are replaced will result in the electronic engine control unit (ECM) using fuel flow data of the previous injector, which can result in unbalanced engine fueling.

CAUTION Always observe OEM instructions for draining the fuel manifold when removing EUIs from an engine cylinder head. When an EUI is removed, the contents of the fuel charging rail end up in the engine cylinder if the cylinder head fuel gallery is not first drained.

COMMON RAIL FUEL SYSTEMS

We are going to define a diesel common rail (CR) fuel system as one in which fuel injection pressure values are held in the **rail** that directly feeds the injectors. Fuel in the rail is pressurized to injection pressure values by an ECM controlled pump. The pump is located upstream from the rail. The injectors used in a CR fuel system are EHIs such as those described in **Chapter 14**. At this time, there are two generations of CR diesel fuel systems:

1. simple CR systems in which the EHI does nothing more than open or close
2. amplified CR systems in which the EHI increases the rail pressure using an intensifier

Simple CR systems have been used in commercial diesel engines since the end of the 1990s. Second generation CR fueling in which rail pressures could be amplified was introduced in 2008. We will begin by describing simple CR systems, and then describe amplified CR at the end of this chapter. **Figure 15-10** shows a current Bosch CR system; reference that figure during this introductory explanation.

Function of the Rail

In this text, the term *rail* will be used to describe the supply manifold or gallery that directly feeds all of the diesel fuel injectors. The basic principle of diesel common rail can be compared to the way in which automotive gasoline fuel injection (GFI) systems operate. The major differences between GFI and diesel CR is that the diesel systems:

- operate at much higher pressures, some exceeding 30,000 psi (2,068 bar)

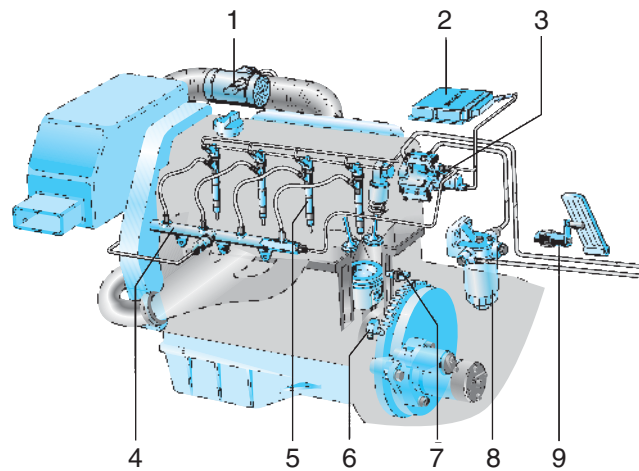

- | | |
|-------------------------------------|-------------------------------|
| 1. Air-mass meter | 6. Crankshaft-speed sensor |
| 2. ECU | 7. Coolant-temperature sensor |
| 3. High-pressure pump | 8. Fuel filter |
| 4. High-pressure accumulator (rail) | 9. Accelerator-pedal sensor |
| 5. Injectors | |

Figure 15-10 Common rail injection system on a 4-cylinder diesel engine. (Courtesy of Robert Bosch GmbH, www.bosch-presse.de)

- precisely manage rail pressure within a wide range of values

In terms of managing and switching the injectors, there are many similarities between diesel and gasoline common rail injection. The similarities increase when the comparison is made between diesel CR and current direct injection (DI) gasoline fuel injection systems.

Engines Using CR Diesel Systems

As indicated earlier, CR diesel fuel systems have been used since the end of the 1990s. This means that diesel engine manufacturers have already progressed through a first generation of the technology. Some current applications of diesel CR fuel systems are shown in **Table 15-1**.

You might notice in **Table 15-1** that most of the engines listed are classified as medium to small bore. However, the MaxxForce 11 and 13 engines (produced jointly by Navistar International and MAN of Germany) in 2007 introduced break this trend. Maxxforce 11 and 13 engines are using the Bosch CR system. Cummins has already announced that their 2010 version of the ISX Series (15-liter) will use a CR fuel system, and the recent Detroit Diesel DD-series family of engines uses the amplified CR fueling described at the end of this chapter.

TABLE 15-1: EXAMPLES OF POST-2007 ENGINES WITH CR-FUEL SYSTEMS

OEM	Series	Displacement in liters (L)	Peak power bhp (kW)	Maximum Torque lb-ft. (Nm)
Audi	Q7-V12	6.0 L	490 bhp (365 kW)	730 lb-ft. (990 Nm)
Caterpillar	C7 ACERT	7.2 L	330 bhp (246 kW)	860 lb-ft. (1,166 Nm)
Caterpillar	C9 ACERT	9.3 L	350 bhp (260 kW)	1,250 lb-ft. (1,695 Nm)
Cummins	ISB	6.7 L	325 bhp (242 kW)	750 lb-ft. (1,017 Nm)
Cummins	ISC	8.3 L	325 bhp (242 kW)	1,000 lb-ft. (1,356 Nm)
Cummins	ISL	8.9 L	325 bhp (242 kW)	750 lb-ft. (1,017 Nm)
Deere	Power Tech 6.8	6.8 L	200 bhp (150 kW)	500 lb-ft. (678 Nm)
GM Isuzu	6600 V-8	6.6 L	360 bhp (268 kW)	650 lb-ft. (880 Nm)
GM Isuzu	7800	7.8 L	300 bhp (224 kW)	860 lb-ft. (1,156 Nm)
Hino	J08E TB	7.7 L	260 bhp (193 kW)	585 lb-ft. (794 Nm)
Navistar	MaxxForce 7 (V-8)	6.4 L	350 bhp (260 kW)	650 lb-ft. (880 Nm)
Navistar	MaxxForce 9	8.6 L	330 bhp (246 kW)	950 lb-ft. (1,288 Nm)
Navistar	MaxxForce 10	9.3 L	350 bhp (260 kW)	1,150 lb-ft. (1,560 Nm)
Navistar	MaxxForce 11	10.5 L	390 bhp (290 kW)	1,450 lb-ft. (1,966 Nm)
Navistar	MaxxForce 13	12.4 L	475 bhp (354 kW)	1,700 lb-ft. (2,305 Nm)
Paccar	PX-6	6.7 L	325 bhp (242 kW)	750 lb-ft. (1,017 Nm)
Paccar	PX-8	8.3 L	325 bhp (242 kW)	1,000 lb-ft. (1,356 Nm)

Note: All the engines are I-6 configured unless otherwise indicated.

CR System Manufacturers

CR fuel system technology was launched by Bosch and Delphi Lucas but these companies have been joined by others. In most cases, diesel engine OEMs have opted to use one of the CR systems manufactured by a specialty diesel fuel system manufacturer rather than develop their own. The exception is Caterpillar, which manufactures their own CR system. Current systems are manufactured by:

- Bosch
- Caterpillar
- Delphi Lucas
- Denso
- Siemens

Advantages of CR Diesel Fuel Systems

CR diesel fuel systems are simple. They use fewer components and consequently produce fewer failures. Not only is CR diesel fueling less complicated but the system also allows the engine control electronics better control of the power stroke. Better control over combustion results in:

- lower emissions
- improved fuel economy

- lower engine noise levels
- balanced engine cylinder pressures

CR SUBSYSTEMS AND COMPONENTS

A typical diesel CR system consists of the following key components:

- Fuel subsystem: stores and supplies fuel to the high-pressure rail pump.
- High-pressure pump: an engine-driven pump capable of sufficient flow to produce injection pressures up to and exceeding 30,000 psi (2,000 bar). Either a radial piston or multicylinder in-line piston pump is used.
- ECM-controlled, **rail pressure control valve**: a linear proportioning solenoid with an integral spool valve is typically used.
- A V-Ref supplied **rail pressure sensor**: a variable capacitance electronic device that signals “actual” rail pressure to the ECM at any given moment of operation.
- Common rail: stores fuel at injection pressures. Distribution lines connect the rail with EHIs.
- Electrohydraulic injectors (EHIs): these ECM switched hydraulic valves inject fuel directly into the engine cylinders.

CR Features

Some of the reasons the CR diesel fueling systems have become common today are:

- They produce high injection pressures independent of engine speed.
- By controlling injection pressure, they control the size of the atomized droplets that exit the EHIs.
- EHIs can be switched on and off at high speeds. This allows up to seven injection “events” during a single power stroke.

Engine Controller Acronym

In this chapter, we reference a number of different engine OEMs that use CR fueling. Because diesel CR systems are used by the smallest to the largest diesel engines on our highways, some of the automobile diesel OEMs use acronyms such as ECU (electronic control unit) or PCM (powertrain control module) in preference to **ECM (electronic control module)**. We will use the acronym ECM when referring to engine system controllers to avoid creating confusion.

CR MANAGEMENT ELECTRONICS

Common rail fuel systems feature full authority electronic controls. These do not vary too much regardless of OEM. We will reference the Bosch CR system more often because it was the first to be introduced and is currently the market leader.

In all CR fuel systems, injected fuel quantity is defined by the engine management computer. Injected fuel quantity determines engine output. The actual output of a CR managed engine depends on a range of input variables. These include:

- accelerator pedal angle (fuel *request*)
- operating temperatures
- emissions requirements

As in all full authority **engine management systems (EMSs)**, the engine electronics can be divided into:

- input circuit (sensors and switches)
- processing circuit (the ECM)
- output circuit (actuators, such as EHIs)

CR systems are networked to the J1939 data bus. This allows the engine ECM to network with other powertrain and chassis components.

Input Circuit

The input circuit consists of sensors and switches. These signal data to the ECM. Sensors and switches can be divided into:

- command devices, which include the TPS, ignition control, and cruise switches
- monitoring devices, which include the means used to signal pressure, temperature, engine speed, and low fluid levels to the ECM

Both analog and digital signals are sent to the ECM.

Analog Inputs. Mass air flow, engine fluid and intake-air temperatures, engine pressure values, DPF pyrometer, and battery voltage are examples of analog signals. Analog signals have to be converted to digital values by an A/D converter in the ECM.

Digital Inputs. Digital input signals include on/off signals and digital sensor signals such as Hall-effect sensors. Digital signals can generally be responded to faster by the ECM because they bypass the A/D unit. Depending on the manufacturer, the TPS signal may use either an older style analog signature or produce a digital signal using one of two types of devices:

1. Hall-effect (noncontact) TPS broadcasting PWM signal
2. Potentiometer with built-in I/C (integrated circuit) broadcasting PWM signal

Processing Circuit

The processing circuit is a function of the ECM. Input signals, stored memory, and the way an ECM has been programmed all play a role in the processing cycle. In operation, the ECM maps an output strategy. This output strategy is put into effect by ECM located drivers. These drivers switch actuators such as EHIs and the rail pressure control valve. All of today’s ECMs have a write-to-self capability. This means that they can record fault codes and audit trails to internal memory or electronically erasable, programmable read-only memory (EEPROM). Because the ECM is networked to the J1939 data bus, it also can communicate with other chassis controllers.

Fuel Mapping. Managing injected fuel quantity in diesel engines is complex but we can simplify it by saying that fueling uses a “closed” loop cycle. The cycle attempts to keep *desired* rail pressure and *actual* rail pressure as close to each other as possible. Desired and actual rail pressure can be defined as follows:

- Desired rail pressure: calculated by the ECM. It is based on sensor inputs, emissions monitoring, and stored instructions in memory.

- Actual rail pressure: measured by a pressure sensor and signaled to the ECM.

By continually comparing the desired and actual rail pressures, the ECM attempts to maintain desired rail pressure by controlling the rail pressure control valve.

Output Circuit

The output driver system insofar as the fuel system management is concerned is not that complex. The key components of the output circuit are the:

- rail pressure management control valve
- EHIs

Rail Pressure Management Control. The rail pressure management control (RPMC) valve, as its name suggests, manages rail pressure. The RPMC valve is located downstream from the high-pressure pump and upstream from the rail. RPMC valves are spool valves. They are controlled by pulse width modulation (PWM) to control their linear position. This has to be done with some precision. The valve is spring loaded to default to no-fuel status. At no-fuel, the RPMC valve routes all fuel exiting the high-pressure pump directly to the return circuit. When energized by ECM output drivers, depending on the current flowed through its coil, a RPMC spool options fuel

from the high-pressure pump to either the rail or the fuel return circuit. In order to precisely maintain desired rail pressure, it has to be capable of fast correction response times. These valves function at high frequency (60 kHz).

Injector Drivers. ECM located **injector drivers** are used to switch the EHIs. They function similarly to drivers used to switch EUIs. The ECM outputs a PWM control current. This control pulse is usually spiked to around 100 V-DC. Current draw during actuation depends on whether solenoid or piezoelectric actuators are used in the EHI. The EHIs with piezo-actuators require less current and lower voltage.

CR FUEL ROUTING CIRCUIT

Common rail fuel routing is modular. We can divide it as follows:

- Fuel subsystem
- High-pressure pump
- Pressure accumulator or rail
- High-pressure distribution system
- Electrohydraulic injectors (EHIs)

Figure 15-11 shows the layout of the Caterpillar CR system used on their post-2007 C7 and C8 engines.

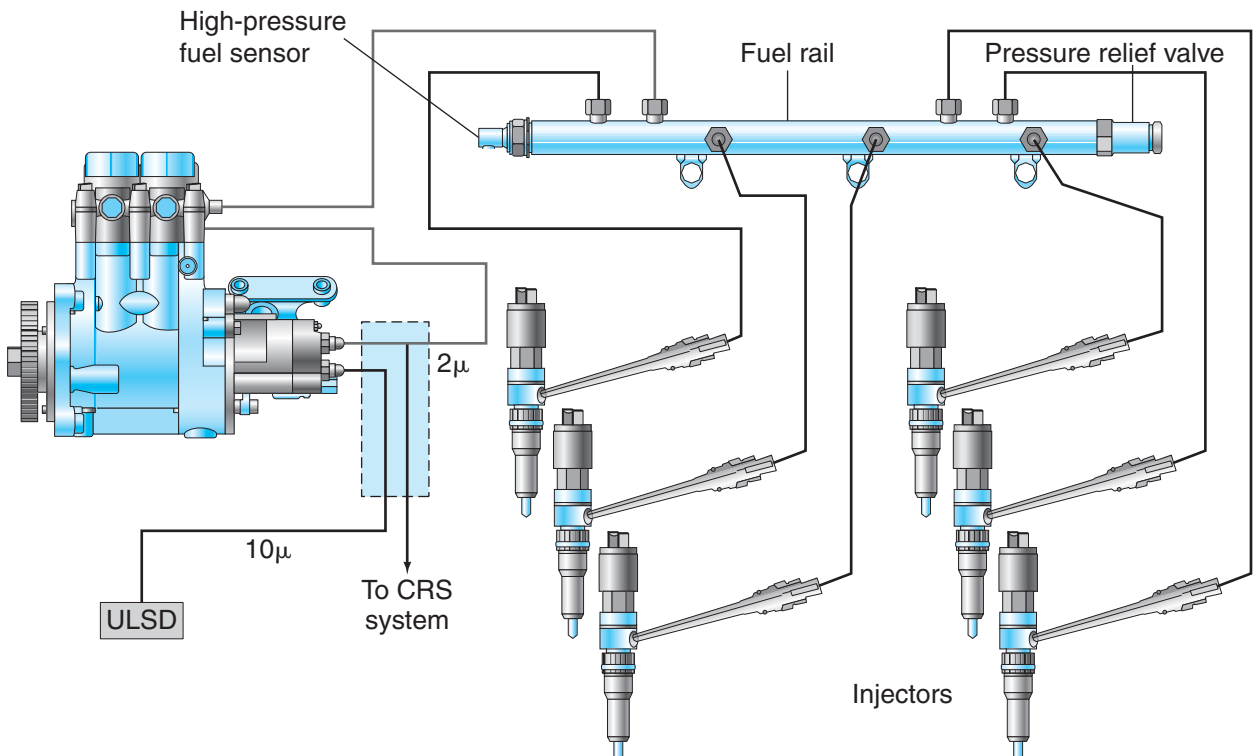

Figure 15-11 Key components of the Caterpillar CR system used on C7 and C8 engines: the micron ratings shown are the fuel filtration requirements of the system. (Courtesy of Caterpillar)

Fuel Subsystem

The fuel subsystem varies by OEM but the Bosch example shown in **Figure 15-12** is typical. All CR systems use a transfer pump. Bosch calls their transfer pump a presupply pump. In some small-bore diesels this can be located in the fuel tank. Caterpillar's transfer pump is a gear-type pump flange mounted to the high-pressure pump.

Transfer Pump. The transfer or presupply pump may be located within the fuel tank or inline. At present, there are two possible versions:

1. Electric roller-cell fuel pump located in the fuel tank. It functions similarly to the fuel supply pump in a gasoline-fueled automobile.
2. External gear pump mechanically driven by the engine. The gear pump is often located behind, and driven by, the CR high-pressure pump.

In both cases, the fuel transfer pump is positive displacement and functions to push fuel through the fuel subsystem to deliver it to the high-pressure stage.

Fuel Filter(s). The fuel filter is an OEM responsibility but it should meet the specifications of the CR fuel

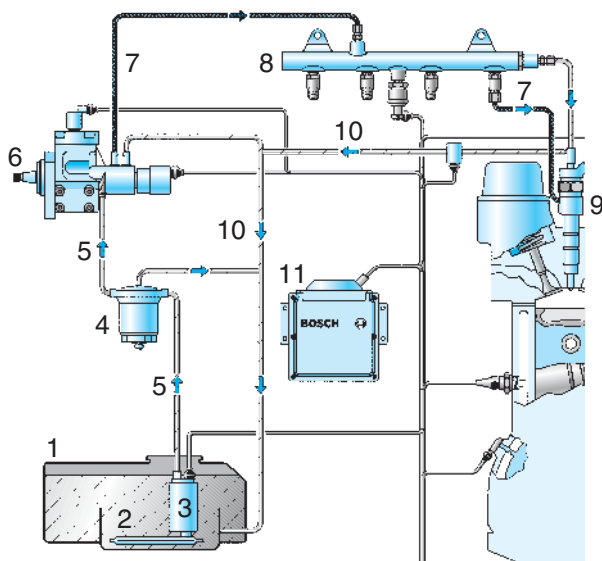

- | | |
|----------------------------|-----------------------------|
| 1. Fuel tank | 7. High-pressure fuel lines |
| 2. Prefilter | 8. Rail |
| 3. Presupply pump | 9. Injector |
| 4. Fuel filter | 10. Fuel-return line |
| 5. Low-pressure fuel lines | 11. ECU |
| 6. High-pressure pump | |

Figure 15-12 Schematic layout of a Bosch common rail diesel fuel system. (Courtesy of Robert Bosch GmbH, www.bosch-press.de)

system manufacturer. In a Bosch CR application, the fuel filter should have a nominal entrapment capability of 8 microns. Caterpillar requires the use of their high-efficiency secondary filter with a nominal entrapment capability of 2 microns. All fuel filtration must occur upstream from the high-pressure pump. CR fuel systems should either use a fuel filter with a water separator or integrate a separate water separator into the fuel subsystem. Collected water should be drained at regular intervals in systems equipped only with manual drains. Some water separators are equipped with a WIF sensor that triggers a warning lamp indicating that water should be drained.

High-Pressure Pumps

There are some differences between the types of high-pressure pumps used by CR manufacturers. We can classify them as:

- radial piston pumps
- inline piston pumps

The high-pressure pumps used in a CR diesel fuel system are simple in terms of the role they play. All they are required to do is create sufficient high flow volume so that when subject to flow restriction, they achieve the required rail pressures. Pump output is unloaded to the rail. The high-pressure pump plays no role in metering and timing of the fuel delivery. **Figure 15-13** shows all the high-pressure stage components in a typical CR diesel injection system.

Radial Piston Pumps. Bosch and Denso use a 3-cylinder **radial piston pump** to produce the rail pressures required for system operation. Pressurized fuel from the high-pressure pump is unloaded by means of a high-pressure line into a tubular, high-pressure fuel accumulator that we call the common rail. The high-pressure pump continually generates the ECM desired pressure at the rail, with the result that in contrast to conventional systems, fuel does not have to be specially compressed for each individual injection pulse. The advantage of using a radial piston pump is its compact design.

The high-pressure pump is installed on a diesel engine so that it can be driven by the engine timing geartrain. It may be driven at either camshaft or crankshaft speed depending on the system, but camshaft speed is more common. The high-pressure pump is usually drive-coupled to the timing geartrain using a dedicated gear, but both chain and toothed belt drives may be used in light-duty applications. The pump is internally lubricated by the diesel fuel it pumps. **Figure 15-14** shows a schematic cross-section of a radial piston, high-pressure

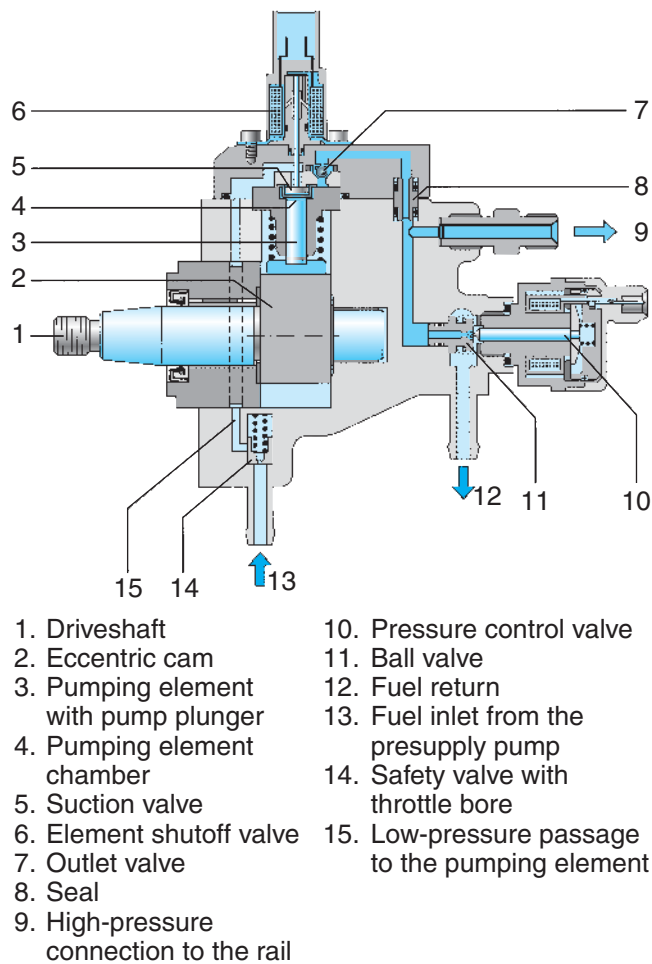

Figure 15-13 Radial piston, high-pressure pump (schematic, longitudinal section). (Courtesy of Robert Bosch GmbH, www.bosch-presse.de)

pump: note how the pumping elements are actuated by the central camshaft.

Radial Piston Pump Components. Pressure rise is created in the high-pressure pump by three radially arranged pump elements, evenly offset at an angle of 120 degrees around the pump driveshaft. This means that each pump element is actuated once during a single pump rotation. This reduces stress on the pump drive mechanism. Each pump piston is actuated by cams machined to the driveshaft (see **Figure 15-14**). Fuel from the pump element is discharged through an outlet valve.

Fuel Delivery Rate. Because the high-pressure pump is designed to deliver the required volume of fuel for rated speed and load performance, excess fuel is delivered to the rail during idle and low-load operation. Excess fuel is returned to the tank by means of the RPMC valve, which routes the fuel back to the tank. This results in wasted energy because of the mechanical

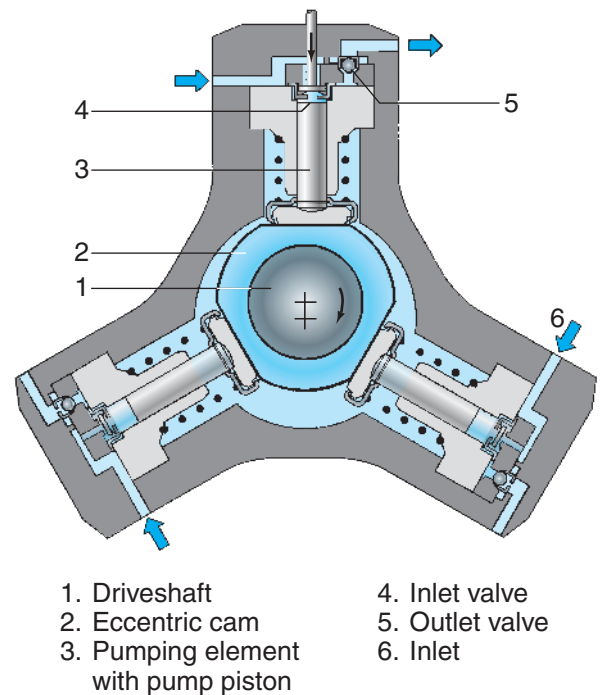

Figure 15-14 Radial piston, high-pressure pump (schematic, cross-section). (Courtesy of Robert Bosch, LLC)

effort required to actuate the pumping elements. Some of this parasitic loss can be recovered by switching off one of the pumping elements. When one of the pumping elements (**Figure 15-14**, # 3) is switched off, the fuel volume delivered into the rail is reduced. With one pumping element switched off when less engine power is required, the high-pressure pump operates on two cylinders.

Inline Piston Pumps. Caterpillar uses a 2-cylinder inline piston pump to produce rail pressures in their post-2007 C7 and C9 engines. The pump is flange mounted and direct-driven by an accessory drive gear. It is lubricated with engine oil. Fuel from the secondary filter is routed to an inlet on the upper outboard face of the pump. This fuel is then routed to the two high-pressure fuel pump elements. The transfer pump that moves fuel through the fuel subsystem is a gear-type pump coupled directly to the high-pressure pump. This low-pressure pump also supplies the fuel for dosing the Caterpillar Regeneration System (CRS). **Figure 15-15** shows an external view of the Caterpillar CR system high-pressure pump: note how the transfer pump is coupled to, and driven by, the high-pressure pump.

Rail Pressure Control Valves

The rail pressure control valve (RPCV) is PWM actuated by the ECM. The ECM uses it to define the

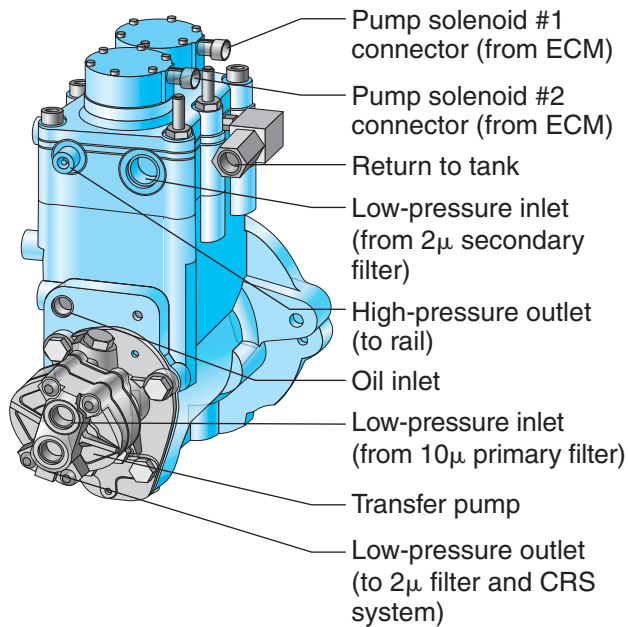

Figure 15-15 Caterpillar CR system high-pressure pump. (Courtesy of Caterpillar)

“desired” pressure in the rail at any given moment of operation. As stated earlier, it is a linear proportioning solenoid and spool valve that can option fuel unloaded by the high-pressure pump either to the rail or into the return circuit. Its operation can be summarized as follows:

- If *actual* rail pressure (signaled to the ECM by the rail pressure sensor) is higher than *desired* rail pressure, the RPCV opens to divert fuel from the rail, optioning it to the return circuit.
- If *actual* rail pressure is lower than *desired* rail pressure, the pressure control valve closes, sealing the rail and permitting pressure to rise.

A sectional view of the ECM controlled rail pressure control valve is shown in **Figure 15-16**.

The Bosch rail pressure control valve is located on the high-pressure pump (**Figure 15-16**) and is flange mounted to it. Some systems use a pressure control valve located at the rail inlet. To seal the high-pressure rail from the return circuit, the control valve armature forces a ball into a seat to create a seal. Two forces act on the armature. Mechanical force is provided by a spring, and opposing this, electromagnetic force is created by the solenoid coil when energized. Two control loops are used to manage pressure control valve operation:

- a slow-response electrical control loop for setting (variable) mean pressure in the rail
- a fast-response mechanical control loop to compensate for the high-frequency pressure fluctuations

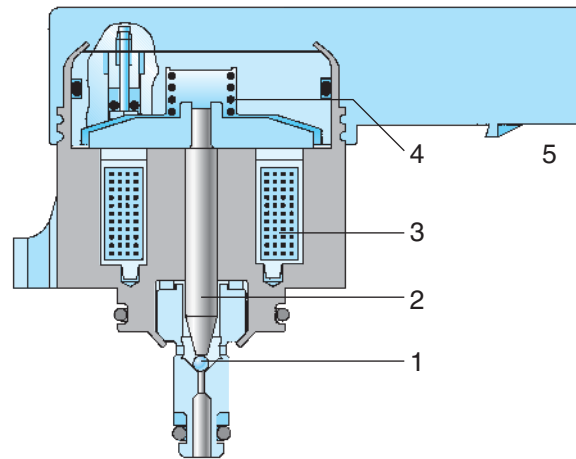

- | | |
|------------------|--------------------------|
| 1. Valve ball | 4. Spring |
| 2. Armature | 5. Electrical connection |
| 3. Electromagnet | |

Figure 15-16 Bosch-type, rail pressure-control valve. (Courtesy of Robert Bosch GmbH, www.bosch-press.de)

Pressure Control Valve Nonenergized. When desired rail pressure is higher than actual rail pressure, the rail pressure control valve must drop rail pressure. High pressure at the rail or at the high-pressure pump outlet acts on the pressure control valve via the high-pressure input. Because the nonenergized electromagnet in the control valve exerts no force, high-pressure fuel exceeds the spring force, opening the control valve and spilling rail fuel to the return circuit.

Pressure Control Valve Energized. When desired rail pressure is lower than actual rail pressure, the pressure control valve must allow rail pressure to rise. If the pressure in the high-pressure circuit is to be increased, the force of the electromagnet must combine with the mechanical force of the spring. The ECM energizes the pressure control valve, causing it to close and remain closed until equilibrium is established between desired and actual rail pressures. This means that a balance is reached between the high-pressure fuel forces on the one side and the combined forces of the spring and the electromagnet on the other. The valve then remains open and maintains rail pressure constant. Any change in the pump delivery quantity/engine load is compensated for by the valve assuming a different setting.

Caterpillar Rail Pressure Controls. Rail pressure control in the Caterpillar high-pressure pump is achieved by a pair of solenoids located above the pump elements. The operating principle is simple. Depending on the solenoid status, fuel is optioned either to charge the rail or routed to the low-pressure fuel

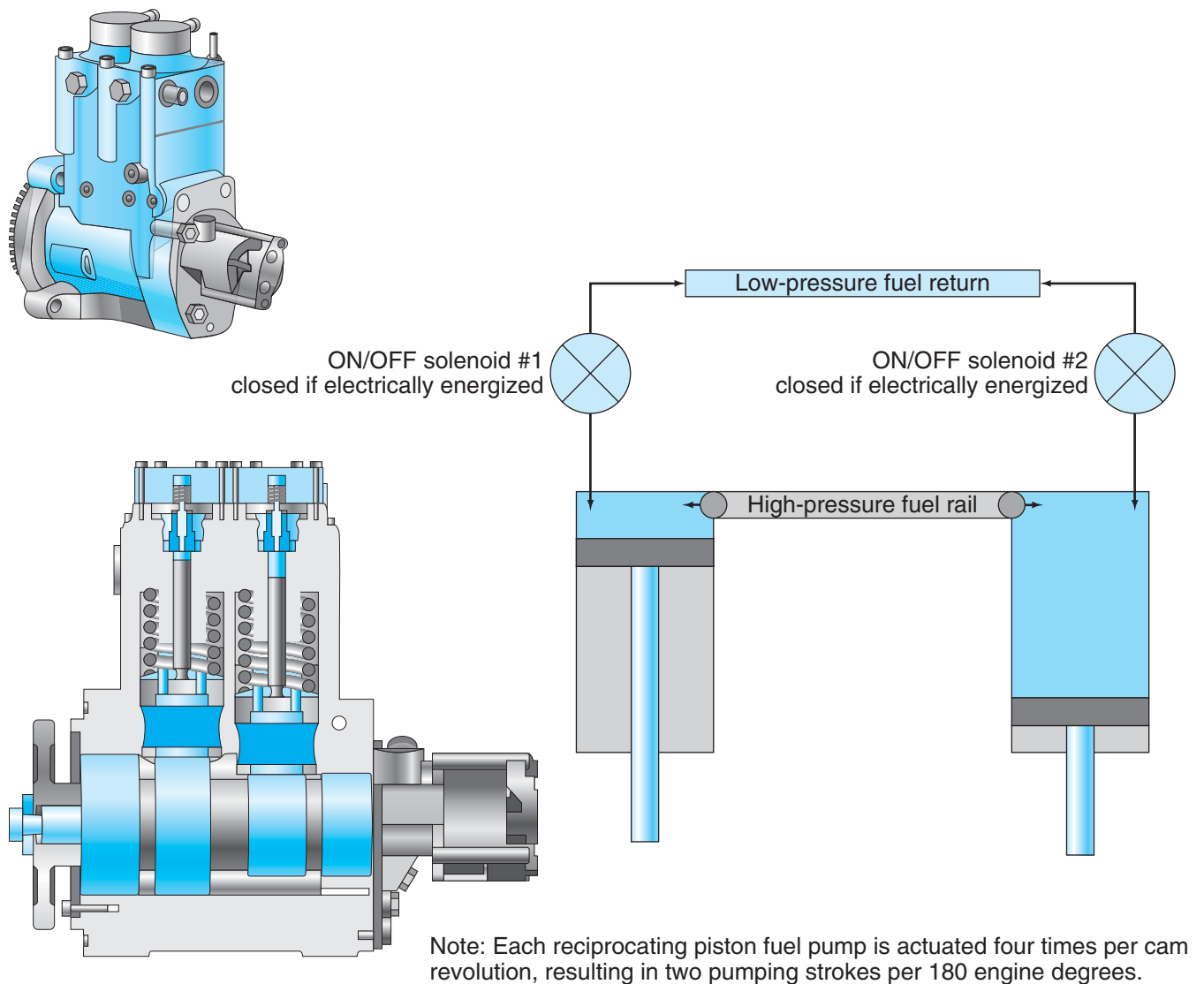

Figure 15-17 Sectioned view of a Caterpillar CR high-pressure pump and the solenoids that act as rail pressure control valves. (Courtesy of Caterpillar)

return circuit. **Figure 15-17** shows how the pump elements work in conjunction with the Caterpillar high-pressure pump.

Common Rail. The common rail or accumulator receives fuel from the high-pressure pump and, by means of dedicated lines, makes it available to the ECM controlled EHIs. The **accumulator** feature of the rail means that even after an injector has discharged a pulse of fuel into the engine, the fuel pressure in the rail remains almost constant. The volume of fuel in the rail has a dampening effect on the changes in rail pressure that occur as the injectors are actuated and the RPCV kicks in and out. The dampening ability of the rail can be accounted for by its accumulator effect resulting from the compressibility factor of the fuel. **Figure 15-18** is a line drawing of the Bosch common rail used on a 4-cylinder engine

and **Figure 15-19** shows the Caterpillar common rail used on a C7 engine.

RAIL PRESSURE LIMITS

Rail pressure is monitored by the rail pressure sensor and maintained at the desired value by the ECM pressure control valve. A pressure limiter valve acts to limit the maximum fuel pressure in the rail to a specification that usually exceeds the intended peak rail pressure by a small margin. For instance, in the current Caterpillar CR system the highest specified rail pressure is 27,550 psi (1,900 bar) so the pressure limiter valve is designed to trip at 33,300 psi (2,300 bar). Fuel in the rail is made available to the injectors by means of flow limiters, which prevent excess fuel from being injected. The rail and its critical components on a Bosch CR system are shown in **Figure 15-18**.

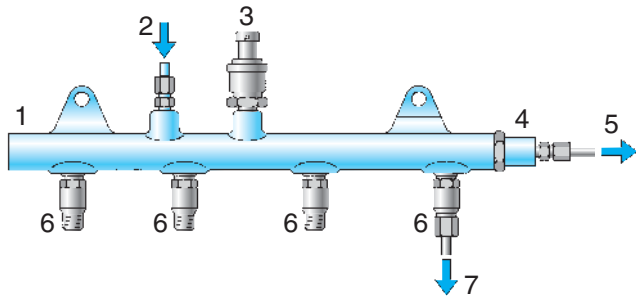

- 1. Rail
- 2. Inlet from the high-pressure pump
- 3. Rail pressure sensor
- 4. Pressure limiter valve
- 5. Return from the rail to the fuel tank
- 6. Flow limiter
- 7. Line to the injector

Figure 15-18 Bosch common rail. (Courtesy of Robert Bosch GmbH, www.bosch-presse.de)

Rail Pressure Sensor. The rail pressure sensor consists of a sensor housing, integral printed circuit, and sensor element. Two types of rail pressure sensors are used. One type uses a piezo-resistive operating principle. This is

more common. Variable capacitance type sensors are also used. Both sensors are usually supplied with a 5-volt V-Ref. They are fully explained in **Chapter 14**.

Flow Limiter. The flow limiter prevents continuous injection in the event that an EHI sticks in the open position. Once the fuel quantity leaving the rail exceeds a predetermined volume, the flow limiter shuts off the line to the problem injector. The flow limiter is a fail-safe device that is rarely engaged. When an EHI sticks in the open position, it is usually due to contaminated fuel.

High-Pressure Fuel Lines. The fuel lines used in CR systems must be capable of handling the maximum system pressures with a wide margin of safety. The injection lines are required to be of identical length and internal diameter. They are designed for one-off use. Because they are expensive, some thought should be given to the decision to remove them. They should never be cracked open when troubleshooting an engine miss.

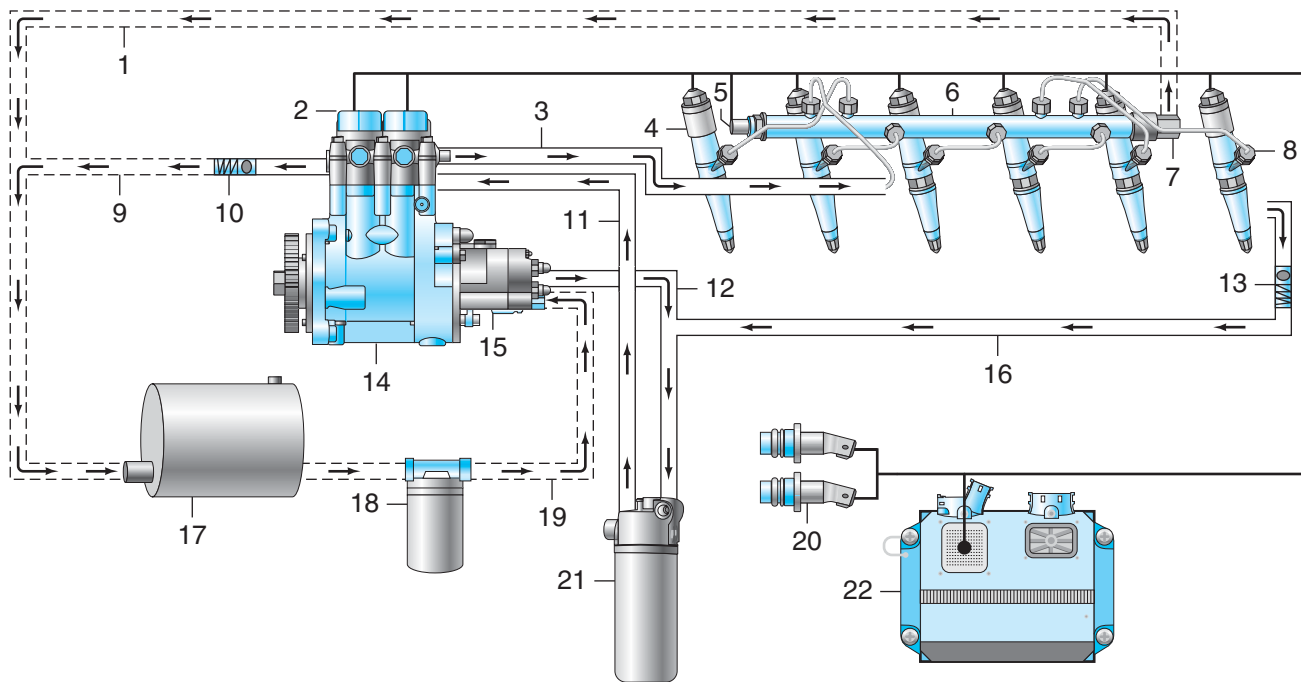

FUEL SYSTEM DIAGRAM

- 1. Return line from pressure relief valve to tank
- 2. Solenoid for the fuel pump
- 3. High-pressure supply line
- 4. Electrohydraulic injector (EHI)
- 5. Fuel pressure sensor
- 6. Fuel rail
- 7. Pressure relief valve for the fuel rail
- 8. Quill tube
- 9. Return line from fuel pump to tank
- 10. Pressure relief valve for the fuel pump
- 11. Fuel line from secondary filter to fuel pump
- 12. Fuel line from transfer pump to fuel filter
- 13. Pressure regulator for the drain line
- 14. Fuel pump
- 15. Transfer pump
- 16. Fuel line for the drain back to filter
- 17. Fuel tank
- 18. Primary fuel filter
- 19. Fuel line from the primary filter to the transfer pump
- 20. Speed/timing sensor
- 21. Secondary fuel filter
- 22. Engine control module (ECM)

Figure 15-19 Common rail on a Caterpillar C7 engine. (Courtesy of Caterpillar)

Caterpillar High-Pressure Lines. The high-pressure lines used in CR diesel fuel systems may directly connect the rail with the injector or, in the case of Caterpillar applications, use a high-pressure pipe that connects with a quill tube. Caterpillar EHIs are cylindrical in shape and vertically positioned in the cylinder head. Rail fuel is routed into the EHI by machining a recess into the side of the injector: a nipple on the quill tube fits into and seals the inlet recess. You can see how this works by studying **Figure 15-20** and **Figure 15-21**. Torque values at the quill tube nut are critical and must be observed.

WARNING Never crack the high-pressure pipe nuts attempting to bleed them. It could prove to be dangerous and OEMs prefer CR high-pressure lines to be single-use devices (they yield to deform to shape on initial torque). CR fuel systems are designed to self-prime.

Electrohydraulic Injectors

Electrohydraulic injectors (EHIs) were first introduced in **Chapter 13**. Two general types of EHIs are

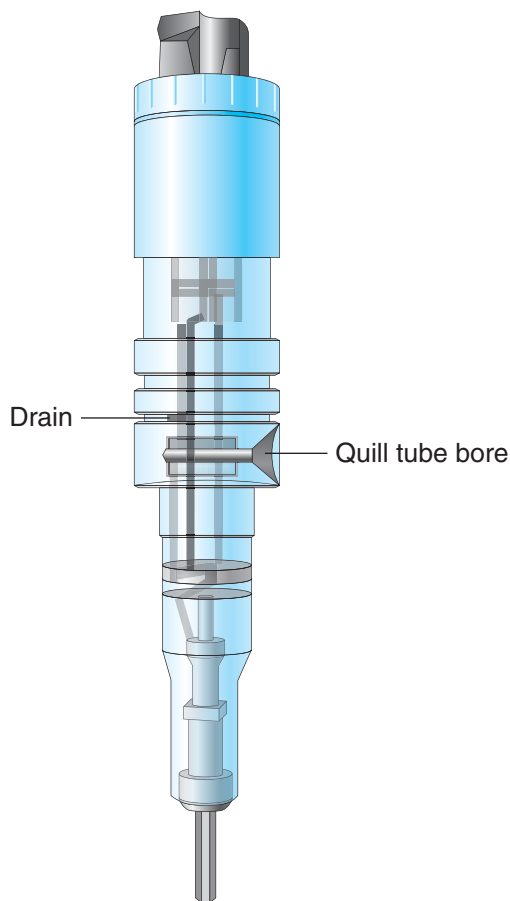

Figure 15-20 Location of quill tube recess on a cylindrical Caterpillar EHI. (Courtesy of Caterpillar)

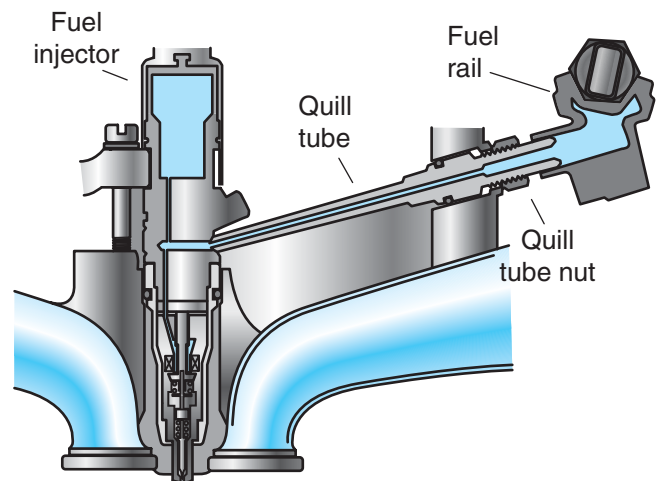

Figure 15-21 Sectional view of a Caterpillar C9 engine showing how the fuel quill mates into the EHI recess: the rail pipe connects to the quill tube. (Courtesy of Caterpillar)

used in CR fuel systems. First generation EHIs used a solenoid control valve, while more recent types use piezoelectric actuators. However, the general principles used by each type remain identical. We are going to use a Bosch EHI (see **Figure 15-22**) for purposes of the description here. An EHI can be subdivided as follows:

- nozzle assembly
- hydraulic servo-system
- actuator valve

Overview of Operation. Reference the callouts in **Figure 15-22** as you read the following description. Fuel at rail pressure is supplied to the high-pressure connection (4), to the nozzle through the fuel duct (10), and to the control chamber (8) through the feed orifice (7). The control chamber is connected to the fuel return (1) via a bleed orifice (6) that is opened by the actuator valve. With the bleed orifice closed, hydraulic force acts on the valve control plunger (9) exceeding that at the nozzle-needle pressure chamber (located between the shank and the needle of the nozzle valve). Although the hydraulic pressure values acting on the top of the nozzle valve and that in the pressure chamber are identical, the sectional area at the top of the nozzle valve is greater. As a result, the nozzle needle is loaded into its seated position, meaning that the injector is closed.

When an ECM signal triggers the injector control actuator valve, the bleed orifice opens. This immediately drops the control chamber pressure and, as a result, the hydraulic pressure acting on the top of the nozzle valve (11) also drops. When hydraulic force

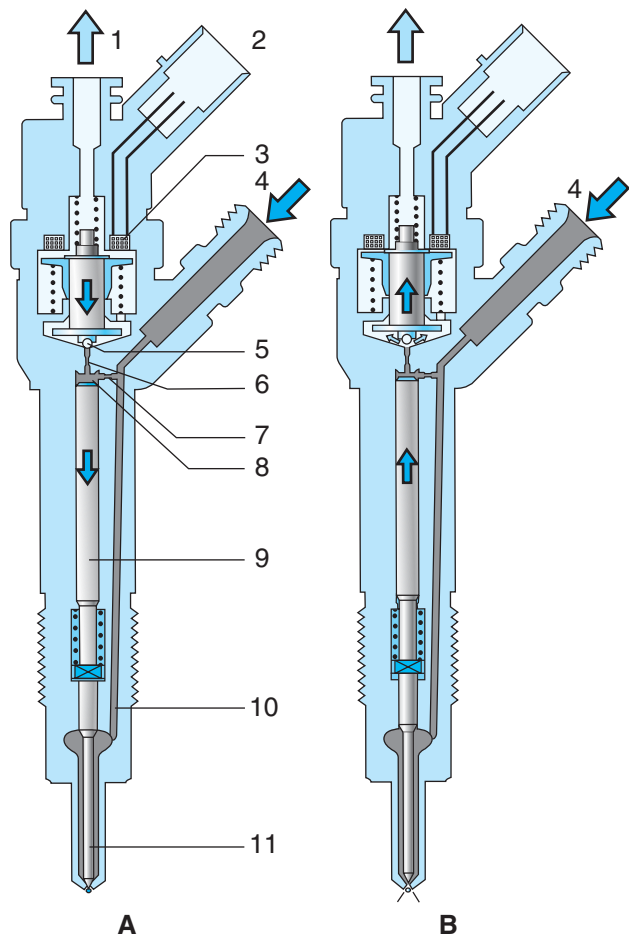

- A. Injector closed (at-rest status)
- B. Injector opened (injection)
- 1. Fuel return
- 2. Electrical connection
- 3. Triggering element (solenoid valve)
- 4. Fuel inlet (high pressure) from the rail
- 5. Valve ball
- 6. Bleed orifice
- 7. Feed orifice
- 8. Valve control chamber
- 9. Valve control plunger
- 10. Feed passage to the nozzle
- 11. Nozzle needle

Figure 15-22 EHI. (Courtesy of Robert Bosch GmbH, www.bosch-presse.de)

acting on top of the nozzle valve drops below the force on the nozzle-needle pressure shoulder, the nozzle valve retracts and allows fuel to pass around the seat to be injected through orifices into the combustion chamber.

The hydraulic assist and amplification factor are required in this system because the forces necessary for rapid nozzle valve opening cannot be directly generated by an actuator valve alone. Fuel used as a hydraulic medium to open the nozzle valve is in addition to the injected fuel quantity so this excess fuel is routed back to the tank. In addition to this fuel, some leak-by fuel losses occur at the nozzle valve to body clearance and the valve plunger guides clearance. This

leak-off fuel volume is also returned to the fuel tank via the fuel return circuit.

Injector Operating Phases. When the engine is stopped, all injector nozzles are closed meaning that their nozzle valves are loaded onto their seats by spring pressure. In a running engine, injector operation takes place in three phases.

INJECTOR CLOSED

In the at-rest state, the actuator valve is not energized and therefore the nozzle valve is loaded onto its seat by the injector spring combined with hydraulic pressure (from the rail) acting on the sectional area of the valve control plunger. With the bleed orifice closed, the actuator valve spring forces the armature ball check onto the bleed orifice seat. Rail pressure builds in the injector control chamber, but identical pressure will be present in the nozzle pressure chamber. Given equal pressure acting on the larger sectional area of the nozzle control plunger (which is mechanically connected to the nozzle valve) and in the nozzle pressure chamber, this and the force of the nozzle spring combine to load the nozzle valve on its seat, holding the injector closed.

NOZZLE OPENING

The injector actuator valve is PWM energized by the ECM injector driver. The actuation voltage varies by OEM but typically is spiked at around 100 V-DC. The current draw during injector energization depends on whether a solenoid or piezoelectric actuator is used: current draw is lower when piezoelectric actuators are used. Force exerted by the triggered actuator now exceeds that of the valve spring and the control valve opens the bleed orifice. Almost instantly, the high-level pickup current to the actuator drops off to a lower hold-in current flow. As the bleed orifice opens, fuel flows from the valve control chamber into the cavity above it and out to the return circuit. This collapses the hydraulic pressure acting on the valve control plunger that was helping to hold the nozzle valve closed. Now pressure in the valve-control chamber is much lower than that in the nozzle pressure chamber that is maintained at the rail pressure. The result is a collapsing of the force that was holding the nozzle valve closed and the result is that the nozzle valve opens, beginning the injection pulse.

The speed at which the nozzle needle opens is determined by the difference in the flow rate through the bleed and feed orifices. When the control plunger reaches its upper stop it is cushioned by fuel generated by flow between the bleed and feed orifices. When the injector nozzle valve has fully opened, fuel is injected into the combustion chamber at a pressure very close to that in the fuel rail.

NOZZLE CLOSING

When the actuator valve is de-energized by the ECM, its spring forces the control valve downward and the check ball closes the bleed orifice. The closing of the bleed orifice creates pressure buildup in the control chamber via the input from the feed orifice. This pressure should be the same as that in the rail and now it exerts an increased force on the nozzle valve control plunger through its end face. This force, combined with that of the nozzle spring, exceeds the hydraulic force acting on the nozzle valve sectional area and the nozzle valve closes, ending injection. Nozzle valve closing velocity is determined by the flow through the feed orifice. The injection pulse ceases the instant the nozzle valve seats.

CAUTION *Never attempt to locate an engine miss by cracking open the high-pressure lines that feed the EHs. Use OEM technical literature to troubleshoot engine as well as fuel system malfunctions.*

Multipulse Injection. EHIs lend themselves to **multi-pulse injection**. Multipulse injection is required in post-2007 diesel engines. Multipulse injection is multiple-shot injection during a single powerstroke. The number of injection pulses that take place will depend on how the engine is being operated and the type of actuator used in the EHI. Piezoelectric actuators allow for much faster responses so are often used in CR injectors. Injection pressures produced during each injection pulse during multipulse injection events remain pretty stable during a single cycle regardless of duration or volume. These pressures directly depend on the rail pressure that is being managed by the ECM at any given moment of operation. The action of opening and closing injectors during multipulse events causes little deviation in actual rail pressures.

Timing Pumps

High-pressure pumps used on CR systems may have to be timed to the engine they fuel. Timing the pump is required for reasons of mechanical balance. Refer to OEM service literature when timing a pump to the engine. Caterpillar requires you to use a variation of the timing pin method similar to that used on their older port-helix metering pumps when timing CR high-pressure pumps. The timing pin locks the pump into position so it can be coupled in balance with the engine. **Figure 15-23** shows a timing pin locked into position in the pump.

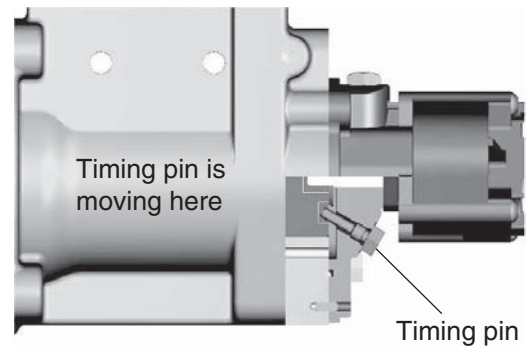

Figure 15-23 Caterpillar high pressure pump timing pin locked into position. (Courtesy of Caterpillar)

FUEL-AMPLIFIED CR SYSTEM

Fuel-amplified common rail (FACR) systems in their current format are manufactured by Bosch and Siemens. The FACR system is used on the DDC DD family of engines. This family of engines is available in the following displacements:

- DD16 (15.6 liters)
- DD15 (14.8 liters)
- DD13 (12.8 liters)
- DD11 (10.6 liters)

In FACR systems currently in production, the high-pressure pump produces approximately 50 percent of the system peak injection pressure. In fact, the FACR electrohydraulic injector functions somewhat similarly to a HEUI injector. The hydraulic amplifier medium in the FACR EHI is rail fuel pressure rather than stepped oil pressure.

Amplification Principle

In the FACR EHI, a fuel pressure amplifier or intensifier piston within the injector body is actuated by common rail sourced fuel (pressure managed by ECM), and acts on fuel contained in a separate pump chamber (supplied by common rail) to amplify the pressure. In current systems, the amplification ratio is usually 2:1 enabling the rail pressure to be approximately doubled. The extent of amplification depends on the sectional area of the EHI located amplifier piston, so in theory there is nothing to limit the current 2:1 amplification ratio in future applications.

FACR Components

The general layout of an FACR system is not that different from any other CR system. Rail pressures are produced using an engine-driven, cam-actuated

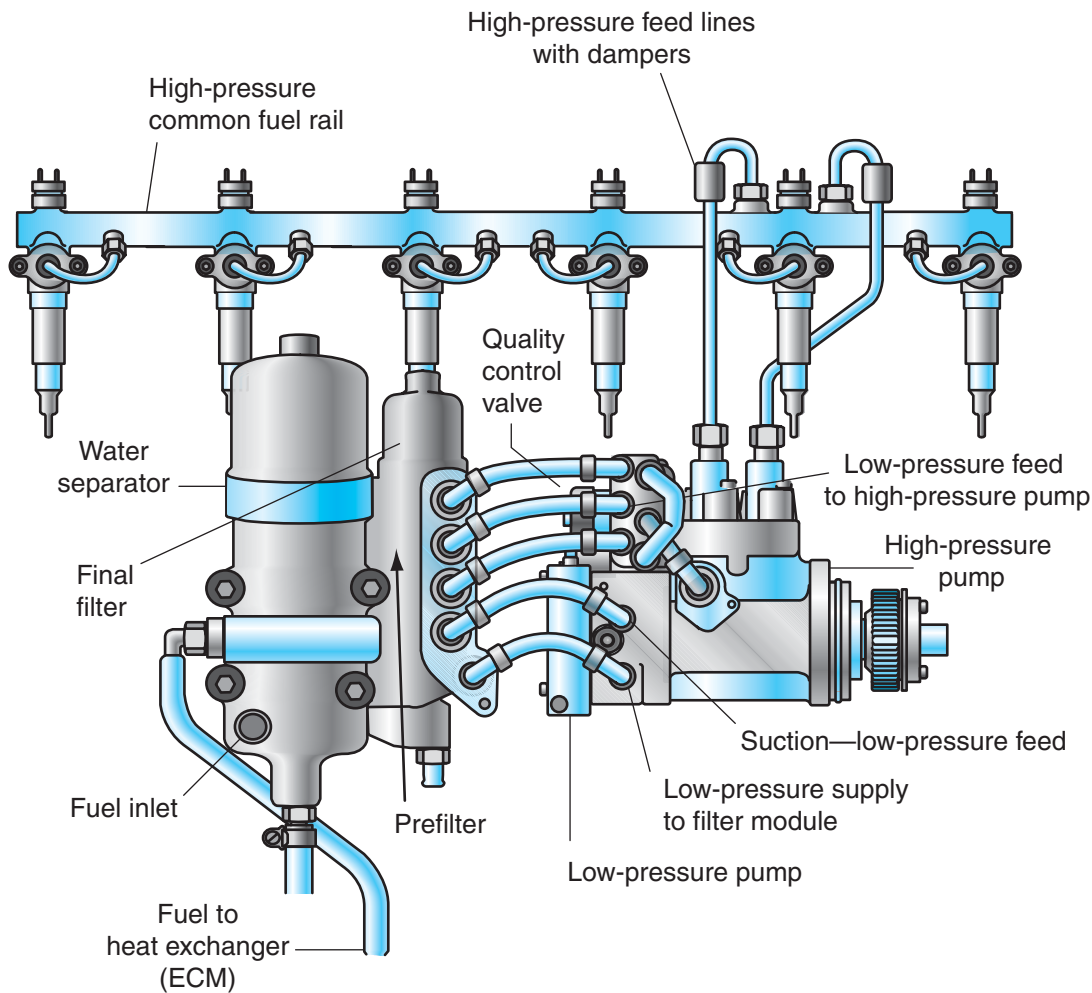

Figure 15-24 Components of a typical FACR system.

inline piston pump such as the Bosch pump shown in **Figure 15-24**. The high-pressure pump feeds the rail by means of a pair of outlet pipes. The schematic in **Figure 15-24** shows an FACR system that uses a low-pressure fuel module incorporating a transfer pump, two-stage filtering, and water separator. The low-pressure fuel module supplies the high-pressure pump with fuel.

A key advantage of an FACR system is that it permits lower rail pressures while generating high injection pressures. This reduces the chances for both internal and external leakage. A common reason for EHI change-outs was failure of the nozzle to seal at its seat. Halving the pressure acting on the seat while the EHI is in a closed position is expected to reduce the incidence of failures.

Summary

- Most current diesel fuel injection systems use either EUI or CR fueling.
- EUI fuel systems are mechanically actuated and electronically controlled.
- The fuel subsystems supplying the EUI charge circuit use a gear-type transfer pump to create charging pressures. Charging pressure is the pressure of the fuel upstream from the EUIs.
- The ECMs used to manage EUI-fueled engines are usually housed in a single module.
- Until 2007, EUIs used a single actuator. The single actuator controlled the spill circuit.
- Single actuator EUIs are often called two-terminal EUIs.
- From 2007 onward, EUIs use dual actuators. Dual actuator EUIs are often called four-terminal EUIs.
- Dual actuator EHIs have replaced hydraulic nozzles with an EHI.

- In a dual actuator EUI, one actuator controls the spill circuit. The second actuator controls an EHI.
- Dual actuator EUIs allow the ECM to control the opening and closing pressure of the device.
- Common rail (CR) diesel fuel systems are currently used on a wide range of engines that extend from small- to large-bore highway diesels.
- CR diesel fuel systems have full authority, engine management capability, and are networked to J1939 data buses.
- The fuel subsystems that supply CR fuel systems have few differences when compared with other current fuel supply circuits.
- The electronic controls on a typical CR system consist of an input circuit, processing hardware, and an actuator circuit.
- The primary outputs that manage fueling on a CR system are the rail pressure control valve and the switching of the EHI actuators.
- Most Bosch CR systems use radial piston high-pressure pumps to supply the rail.
- The Caterpillar CR system uses an inline piston high-pressure pump to supply the rail.
- Rail pressures on CR diesel fuel systems are managed by the ECM using a rail pressure control valve. The rail pressure control valve applies flow restriction to fuel discharged by the high-pressure pump and options it to either the rail or the return circuit.
- The rail pressure control valve is a linear proportioning solenoid. It uses a spool valve to option fuel exiting the high-pressure pump outlet either to the rail or to the fuel return circuit.
- Actual rail pressures are signaled to the ECM by the rail pressure sensor.
- The ECM managing rail pressures in a typical CR system does so by calculating *desired* rail pressure. By monitoring *actual* rail pressure, the ECM attempts to keep desired and actual rail pressures as close to each other as possible.
- EHIs are used in CR systems because they can be switched at faster speeds than hydraulically actuated injectors. This suits the current requirement for multipulse fuel injection events.
- EHIs are not limited by hard value opening and closing pressures. Because they are opened and closed by ECM injector drivers, the actual pressure at nozzle opening is determined by the CR pressure.
- The actuators used in EHIs may be solenoid or piezo-operated. Piezo-actuators are used in the latest CR systems because of super-fast response times to ECM driver signals.
- The actuators in EHIs are PWM switched by the ECM.
- Some CR high-pressure pumps must be timed to the engine. The timing method used is usually pin timing.
- In a fuel-amplified common rail (FACR)-type EHI, an intensifier piston inside the injector body is actuated by common rail sourced fuel. This increases the injection pressure.
- In a typical FACR system, the rail pressure is approximately doubled prior to injection.
- An FACR system permits lower rail pressures along with high injection pressures. This greatly reduces the possibility of internal and external leakage.

Review Questions

1. Which type of EUIs were used by most OEMs before 2007?
 - A. Twin actuator
 - B. Two-terminal
 - C. Four-terminal
 - D. Mechanically switched
2. When EUIs are used after 2007 on highway engines, which type of injector is required?
 - A. Two-terminal EUI
 - B. Two-terminal EUP
 - C. Four-terminal EUI
 - D. Four-terminal EUP
3. How many actuators are used in a four-terminal EUI?
 - A. None
 - B. One
 - C. Two
 - D. Four

4. Which of the following values would represent a typical NOP for a four-terminal EUI equipped with an EHI?
 - A. Soft value NOPs controlled by ECM
 - B. 3,800 psi
 - C. 5,000 psi
 - D. 22,000 psi
5. Technician A says that when a four-terminal EUI is injecting fuel into the engine cylinder the SV actuator must energized. Technician B says that for fuel injection to take place in a four-terminal EUI, the NCV actuator must be energized. Who is correct?
 - A. Technician A only
 - B. Technician B only
 - C. Both A and B
 - D. Neither A nor B
6. Which of the following best describes the type of injectors used with CR fuel systems?
 - A. Pintle injectors
 - B. Electrohydraulic injectors (EHIs)
 - C. Poppet injectors
 - D. Electronic unit injectors (EUIs)
7. How many high-pressure pump elements are used on a Bosch radial piston pump fueling a 6-cylinder engine with a CR (common rail) fuel system?
 - A. One
 - B. Two
 - C. Three
 - D. Six
8. Which of the following are advantages of multipulse injection cycles?
 - A. Lower cold-start emissions
 - B. Lower noise levels
 - C. Better fuel economy
 - D. All of the above
9. Which of the following best describes the means by which the ECM drivers control the actuation of CR EHIs?
 - A. V-Ref signal
 - B. V-Bat signal
 - C. Distributor spike
 - D. Pulse width modulation (PWM)
10. Which of the following is the key component used to signal actual rail pressure to the ECM?
 - A. Rail pressure sensor
 - B. Rail pressure control valve
 - C. Pressure limiter valve
 - D. Flow limiter valve
11. What device on a typical CR system prevents constant fueling of a cylinder if one of the EHIs sticks in the open position?
 - A. Flow limiter
 - B. Pressure limiter valve
 - C. Pressure control valve
 - D. Collapse of accumulator
12. What force is used to hold a CR EHI nozzle valve in its closed and seated position when the engine is running?
 - A. Spring force only
 - B. Electrical force only
 - C. Combined hydraulic and electrical force
 - D. Combined hydraulic and spring force

CHAPTER

16

Emissions

Learning Objectives

After studying this chapter, you should be able to:

- Define the origin of the word *smog*.
- Define photochemical smog and describe the conditions required to create it.
- Identify some common tailpipe emissions.
- Outline the operating principles of C-EGR, oxidation catalytic converters, reduction catalytic converters, diesel particulate filters, and selective catalytic reduction (SCR).
- Explain how an opacity meter functions.
- Describe the SAE J1667 test procedure.
- Analyze diesel engine smoke.

Key Terms

active regeneration

AdBlue™

aqueous urea

California Air Resources Board (CARB)

carbon dioxide (CO₂)

carbon monoxide (CO)

catalyst

clean gas induction (CGI)

closed crankcase ventilation (CCV)

cooled exhaust gas recirculation (C-EGR)

diesel particulate filter (DPF)

dosing

Environmental Protection Agency (EPA)

greenhouse gases (GHGs)

hydrocarbons (HC)

nitrogen dioxide (NO₂)

NO_x adsorber catalyst (NAC)

opacity meter

oxides of nitrogen (NO_x)

ozone

particulate traps

passive regeneration

photochemical smog

positive crankcase ventilation (PCV)

regeneration cycle

SAE J1667

selective catalytic reduction (SCR)

self-regeneration

SmartWaySM

smog

sulfur dioxide (SO₂)

ultraviolet (UV)

urea

volatile organic compounds (VOCs)

INTRODUCTION

The standards that apply to diesel engine tailpipe emissions fall under the jurisdiction of the **Environmental Protection Agency (EPA)**. Before 1991, the focus was mainly on the emissions produced by new engines before certification, but more recently state and local jurisdictions have regulated and enforced emissions standards operating in cities and on our highways. Although these local standards are not usually as tough as the original EPA certification standards, they shift the responsibility of meeting the standards onto the owners of vehicles.

The state of California has traditionally led the way for the rest of the jurisdictions in North America when it comes to defining vehicle emissions standards and enforcing them. The California agency responsible for emissions legislation and enforcement is the **California Air Resources Board, or CARB**. Any new engine introduced to the marketplace requires testing to EPA and CARB standards prior to certification. With the introduction of “clean” post-2007 diesel engines, the emphasis on CARB is beginning to shift to focus on greenhouse gases (GHGs). Reducing GHGs at this moment in time is fundamentally about improving fuel economy. In other words, burn less fuel. Programs such as SmartWaySM are designed to help trucking achieve better use of fuel by investing in low rolling resistance tires, aerodynamic fairings, and idle reduction logic. Most SmartWay programs pay for themselves within a year.

Importance of CARB

For many years CARB (<http://www.arb.ca.gov/>) was important to engine manufacturers. Obviously they wanted to sell engines in the state with the most powerful economy and largest population. Recently the influence of CARB has increased, with other states adopting CARB standards. This list of “green” states includes Maine, Vermont, Rhode Island, Massachusetts, Connecticut, Pennsylvania, Washington, Oregon, and New York—with Maryland and New Jersey planning to adopt CARB certification standards in the near future. Because this list now represents more than half of the U.S. economy, it is becoming unlikely that engine manufacturers can afford to make engines that do not meet CARB standards. **Figure 16-1** shows the impact EPA emissions standards have had on the diesel engine in recent years. The dirty diesel engines of a generation ago have been squeezed into the *almost* clean diesel engines of our world today!

Understanding the Impact of Diesel Emissions

We will begin by looking at some of the causes of smog and providing an introduction to diesel exhaust smoke. Next, we will discuss some of the components used on diesel engines that help reduce harmful emissions. Finally, we will examine an emissions test used by many jurisdictions for vehicles that are operating on our roads.

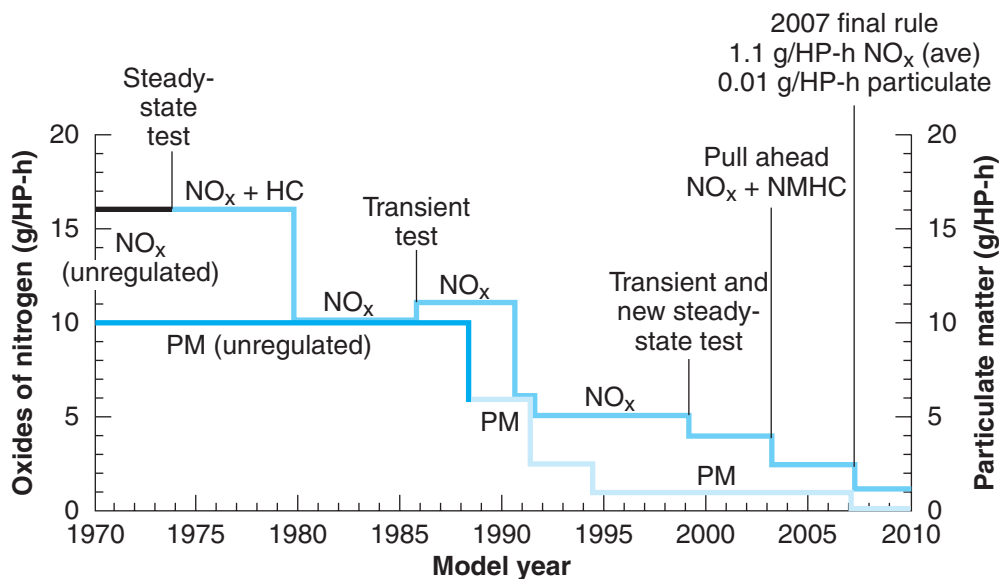

Figure 16-1 EPA heavy-duty engine emission standards.

WHAT IS SMOG?

The word **smog** comes from the words *fog* and *smoke*. Throughout the world there are two main types of smog. The first type is **sulfur dioxide (SO₂)** smog produced by the burning of sulfurous fuels such as coal and heavy oils. Sulfurous smog conditions are aggravated by dampness so foggy conditions can make it worse. Today, it is produced mostly by industry, especially in areas burning industrial coals and heavy oils. Forty years ago, diesel fuel contained enough sulfur to make diesel powered highway trucks a contributor. However, over the years the sulfur in diesel fuel has been gradually reduced to almost nothing, so that today, diesel powered highway vehicles using ultralow sulfur (ULS) fuels contribute little to sulfur dioxide smog formation. The second type of smog is what we know as **photochemical smog**. All internal combustion engines contribute to the formation of photochemical smog, as we will see in the next section, despite many years of fairly tough emissions controls.

Photochemical Smog

Photochemical smog (also known as photosynthetic and photoelectric smog) is produced mainly by vehicle tailpipe gases. After it has been formed, photochemical smog can be seen as yellowish/light brown haze. The effects of photochemical smog are just as serious as those produced by sulfurous smog. They include crop damage, eye irritation, and breathing problems in animals and humans.

Formation. Photochemical smog is produced in two stages. First, **hydrocarbons (HC)** and nitrogen oxides from vehicle tailpipes react with sunlight. This produces **ozone**. Ozone then begins to react with hydrocarbon gas to produce smog. Ozone by itself is highly toxic in low concentrations, and the smog that results from exposure to light is a major problem in America today.

Geographical Factors. Most large cities have experienced problems with photochemical smog especially during the summer months. The location most noted for the problem is Los Angeles, California. Conditions in Los Angeles are ideal for producing photochemical smog. It is the second largest population center in the United States, per capita automobile ownership is the highest in the world, the area experiences a high ratio of sunny days all year-round, and the San Gabriel Mountains act as a wall that helps trap the flow of air that tends to move from the west to the east.

Despite the fact that California has for many years required the toughest emissions standards in the world, smog problems in Southern California continue. In fact, throughout North America, photochemical smog problems have become slightly worse since the introduction of emissions control legislation. This is because the number of automobiles and trucks on our roads has greatly increased, along with average yearly distance traveled. It remains to be seen whether recent increases in the cost of all petroleum products will have any effect on this trend.

Economics of Emissions Controls. Doing something about tailpipe emissions is not simple. Money is the problem. There is a cost attached to developing low emissions engines. Next, fueling low emissions engines with environmentally friendlier fuels usually turns out to be more costly and less fuel-efficient. Environmentalists would argue that the “hidden” costs of polluting the environment are much greater. However, these costs are less direct because they are borne by health care and the generations that follow ours.

Global Warming. **Carbon dioxide (CO₂)** is classified as a greenhouse gas (GHG). It is *not* by definition a harmful emission; after all, we expel it from our lungs every time we exhale. However, carbon dioxide emissions are associated with global warming and many legislators want to regulate them. This is a problem. Reducing carbon dioxide emissions will mean taking a serious look at the chemical composition of the fuels we burn. At present, most of the fuels we use are carbon based. Because both gasoline and diesel fuel are composed of approximately 85 percent carbon, when legislators talk about reducing (or taxing) CO₂ emissions, the only current methods involve increasing fuel efficiency with voluntary programs such as SmartWaySM. However, the expectation is that the current voluntary programs will give way to mandatory GHG reduction strategies on the part of governments.

Ingredients of Smog

Knowing a little basic chemistry helps in understanding the nature of smog. Combustion is a chemical reaction. When diesel fuel is burned, it uses whatever oxygen is available in ground-level air. This oxygen is known as the reactant. When oxygen reacts with diesel fuel it is oxidized. This oxidation reaction forms:

- H₂O (water)
- CO₂ (carbon dioxide)

Neither the water nor the carbon dioxide is a harmful result of the combustion process. For this reason, if

these two gases were the only products of burning fuel in an engine cylinder, the term *perfect* combustion could be used to describe what has happened. Harmful emissions are what is produced when the combustion of an HC fuel is not “perfect.”

Imperfect Combustion. When a hydrocarbon fuel is not completely oxidized, gaseous HC, particulate HC, and **carbon monoxide (CO)** result. When emitted from the tailpipe of a vehicle, these chemicals are all classified as noxious emissions. Nitrogen can become involved in the combustion process under certain conditions. Within the normal combustion temperature range of typical diesel engines, this tends to be when temperatures are higher. When nitrogen is oxidized, it forms a number of different compounds known collectively as NO_x , but **nitrogen dioxide (NO_2)** presents the most problems. Nitrogen dioxide is a key to the formation of ozone and acid rain. All NO_x emissions are classified as noxious emissions by the EPA.

Sulfur. In recent years, the maximum sulfur content of diesel fuels has been dramatically reduced. The current maximum permitted sulfur content in an ASTM 1D or 2D fuel is 0.0015 percent (15 ppm). This standard was introduced in October 2006 and applies to 80 percent of the total fuel dispensed at the pumps in North America. This standard has come close to eliminating the tendency of diesel fuel to contribute to the sulfurous combustion emissions.

When sulfur is oxidized in the combustion process, it forms sulfur dioxide (SO_2), an ingredient of sulfurous but not photochemical smog. Sulfur is acidic, toxic, and an ingredient of acid rain. Although sulfur compound emissions from the combustion process are serious, highway trucks are no longer a major contributor. Sulfur emissions produce an unpleasant, acidic odor. Because of the acidity, high sulfur emissions from a diesel engine will usually produce tattletales such as rust-out of exhaust piping.

Hydrocarbons. The HCs emitted in the combustion process of an internal combustion engine burning liquid or gaseous petroleum product may be in a gaseous, liquid, or solid (particulate) state. They are only observable in liquid or solid states when they may be seen as white smoke (liquid emission) or black smoke (particulate emission). A more detailed analysis of diesel engine smoke emission appears toward the end of this chapter. In the days before rigid emissions standards, a truck diesel engine commonly emitted HC in a liquid state (that is, condensing in the exhaust gas) at

cold startup and in a particulate state under conditions of overfueling or air starvation.

Particulate Matter. Anything in the exhaust gas that is in the solid state can be classified as particulate matter (PM). Carbon soot and dust form particulate matter. Incomplete combustion is the main culprit in the formation of PM. These minute particulate compounds can cause respiratory problems in human and animal life. The EPA classifies particulates into two general categories:

1. inhalable particulates that range between 2.5 and 10 microns in diameter
2. respirable particulates that tend to be 2.5 microns or less in diameter

Respirable particulates are not entrapped by nasal filters and are small enough to get deep into the lungs, causing wheezing, coughing, and shortness of breath. PM emission is always visible from a diesel engine and is easily detected with smoke density measuring equipment such as opacity meters. The objective of diesel particulate filters (DPFs) studied later in this chapter is to minimize PM.

Volatile Organic Compounds. **Volatile organic compounds** or **VOCs** are hydrocarbons in the gaseous state that boil off fuels during production, distribution, and pumping. Diesel-fueled vehicles contribute VOCs in a small way: fuel tanks exposed to the high heat of a summer's day vaporize the more volatile fuel fractions to the extent that the CN can degrade. The transportation sector accounts for approximately 30 percent of the VOCs found around population centers. VOCs are more likely to be an atmospheric problem in hot weather conditions when the most volatile fractions of fuels more readily boil off. VOCs react with sunlight to produce ground-level ozone.

Carbon Monoxide. Carbon monoxide is a colorless, odorless, tasteless, and highly poisonous gas. It is a result of the incomplete combustion of a hydrocarbon fuel. Carbon monoxide can be combusted to form harmless CO_2 . Approximately two-thirds of the atmospheric levels of CO in North America can be attributed to vehicle emissions. Exposure to CO can impair brain function, cause fatigue, and may be fatal in high concentrations.

Ozone. Atmospheric oxygen is diatomic, that is, it combines to form molecules consisting of two oxygen atoms (O_2). Ozone is triatomic, that is, three oxygen atoms covalently bond to form a molecule of ozone (O_3).

It occurs naturally in small quantities in the Earth's stratosphere where it absorbs solar **ultraviolet (UV)** radiation. Ozone can be produced by passing a high-voltage electrical discharge (arc) through air: you can sometimes smell it during a thunderstorm. It is manufactured commercially using an electric arc process. As a pollutant, ozone results from the photochemical reaction between NO_x and various hydrocarbons (especially those categorized as VOCs). It is known to irritate the eyes and mucous membranes. Exposure to ozone at low-level concentrations can be a health threat.

Oxides of Nitrogen. Nitrogen makes up nearly 80 percent of what we call *air* at ground level. Combustion in an engine cylinder requires only the oxygen contained in the mixture we call air. Ideally, we would like the nitrogen contained in air to enter the engine cylinder as nitrogen and to exit as pure nitrogen. However, given the wrong conditions, nitrogen may become involved in the combustion process, and when it does, it oxidizes.

Despite the fact that nitrogen under usual atmospheric conditions and temperatures is *inert* (unlikely to participate in chemical reactions), there are certain conditions in which it may react. When it does react, just like the HC fuel, it oxidizes. It forms nitrous oxide (N_2O), nitric oxide (NO), and nitrogen dioxide (NO_2) when oxidized. All **oxides of nitrogen** produced in the cylinders of engines are known as **NO_x** . On- and off-highway vehicle engines are the source of about 60 percent of the NO_x in our atmosphere. NO_x directly affects persons with respiratory problems. This is why the EPA has so aggressively attacked NO_x emissions from diesel engines in its certification requirements.

Smog Summary

We can summarize the consequences of vehicle emissions as follows:

$$\text{NO}_x + \text{VOCs} + \text{Sunlight} = \text{Ozone}$$

$$\text{Ozone} + \text{PM} = \text{Smog}$$

Because the costs of doing something about vehicle emissions are upfront and levied on big business, they tend to be resisted by powerful political lobbying. However, the cost effects of pollution are delayed. They affect the health of individuals who then have to resort to the big business of our health care system. Whether you are an environmentalist or antienvironmentalist probably has much to do with where you live. Residents of geographical areas that are susceptible to smog tend to argue for stronger emissions legislation. Those in relatively unaffected areas probably do not care as much and might dismiss emissions controls as unwanted government interference. That said, you can expect emissions controls to become more aggressive as each year goes by. This is because there are more voters in big cities than rural areas who are demanding such controls.

History of Emissions Controls

In 1970, a typical diesel engine emitted 16 grams per hp/hr of NO_x and 10 grams of PM per hp/hr. The NO_x emission standard required in 2007 is 0.2 grams per hp/hr or an 8,000 percent reduction. Similarly, the PM standard required for 2007 has been reduced to 0.01 grams per hp/hr, a 10,000 percent reduction. **Table 16-1** outlines the progress of heavy-duty highway truck EPA emission standards from 1990 to 2010. **Figure 16-1** shows the EPA diesel emissions story over the 40-year period extending from 1970 to 2010.

TABLE 16-1: EPA EMISSIONS REQUIREMENTS BY YEAR

YEAR	HC (GRAMS BH/HR)*	PM (GRAMS BH/HR)	NO_x (GRAMS BH/HR)
1990	1.3	0.60	6.0
1991	1.3	0.25	5.0
1994	1.3	0.10	5.0
1996	1.3	0.10	5.0
1998	1.3	0.10	4.0
2004	0.5	0.05	0.5
2007	0.28	0.01	0.2
2010	0.14	0.01	0.2

*BH/HR = brake horsepower per hour

DIESEL ENGINE EMISSION CONTROLS

All engines today rely primarily on computers to manage emissions to acceptable levels. In fact, for many years, highway diesel engines primarily relied on computerized management of combustion. This meant that truck diesel engines were equipped with powerful computers ahead of their automobile counterparts which relied on external controls to a greater extent. The external devices used on automobiles beginning in the 1970s included catalytic converters, air pump units, EGR systems, and PCV systems. This has changed. Now the diesel engine relies on a full range of external emission control devices that include oxidation catalysts, reduction catalysts, particulate filters, and urea injection systems. Diesel fuel has changed over the years. Today's diesel engines have to operate on ultra low sulfur (ULS) fuel introduced for the 2007 EPA year (see **Chapter 12**). In this next section, we will look at some of the devices used on today's diesel engines to limit noxious emissions.

Engine Control Module

Diesel engine control modules (ECMs) manage the engine electronics. They receive a wide range of monitoring and command inputs, and process these using programmed rules and procedures to produce the desired performance and emissions from the engine at any given moment of operation. A simple way of describing what happens in the ECM processing cycle is to call it mapping. A more detailed study of how an ECM operates is covered in **Chapter 14**.

Factors Influencing Emissions. Injection timing and the ignition timing it controls have a major influence on emissions. The study of combustion in engine cylinders can become complicated but we can say the following:

- Retarded timing tends to reduce tailpipe NO_x. Severely retarded timing can greatly increase HC emissions.
- Advanced timing tends to reduce HC. Severely advanced timing can greatly increase NO_x emissions.

Timing that is out of spec by as little as 1-degree crank angle can increase NO_x or HC emissions by as much as 10 percent depending on whether it is advanced or retarding. This is one of the key reasons computer management of diesel engines became essential from the late 1980s onward. Temperature also has a major effect on exhaust emissions and, once again, managing engines in respect of temperature variables becomes a job that can be done only by electronic controls.

External Emission Controls

If you take a look at any truck diesel engine series manufactured in the year 2001 and compare it with its series equivalent today, you would have difficulty in identifying them as being of the same series of engine. Today's diesel engines use many different external emission controls. The next sections examine some of these devices.

Cooled-EGR

Until 2004, diesel engine manufacturers had been able to meet NO_x emissions requirements without the use of exhaust gas recirculation (EGR) systems. Today, almost all highway diesels use some form of EGR, usually **cooled exhaust gas recirculation (C-EGR)**. EGR dilutes the intake charge with “dead” gas. The dead gas is routed into the engine cylinders from the exhaust system. This dead gas creates a dead zone inside the engine cylinder. The idea is to reduce NO_x emissions by lowering combustion heat. It makes the cylinder volume available for combustion smaller. When rerouting (hot) exhaust gas back into the engine cylinders, it makes sense to cool it as much as possible. For this reason, most engine original equipment manufacturers (OEMs) use cooled-EGR, usually known by its acronym of C-EGR.

C-EGR Components. A typical C-EGR system on a diesel engine has to be ECM-controlled because the mixture percentage varies according to how the engine is being operated. This percentage ranges between 0 percent and, depending on the manufacturer, may be as high as 50 percent. Typically, a C-EGR system consists of:

- a heat exchanger (engine coolant is used)
- ECM-controlled mixing chamber (mixes boosted air with exhaust gas)
- mass airflow sensor
- plumbing to route engine coolant through the heat exchanger
- piping to route exhaust gas to the mixing chamber

Figure 16-2 shows a schematic of a typical C-EGR system.

Clean Gas Induction (CGI)

Caterpillar uses a modification of EGR on the engines they will manufacture up to 2010. Earlier we said that the objective of an EGR system is to dilute the intake charge with “dead” gas. In some ways this is almost like reducing the engine displacement. By reducing the cylinder volume available for combustion to take place, engine temperatures are lowered along

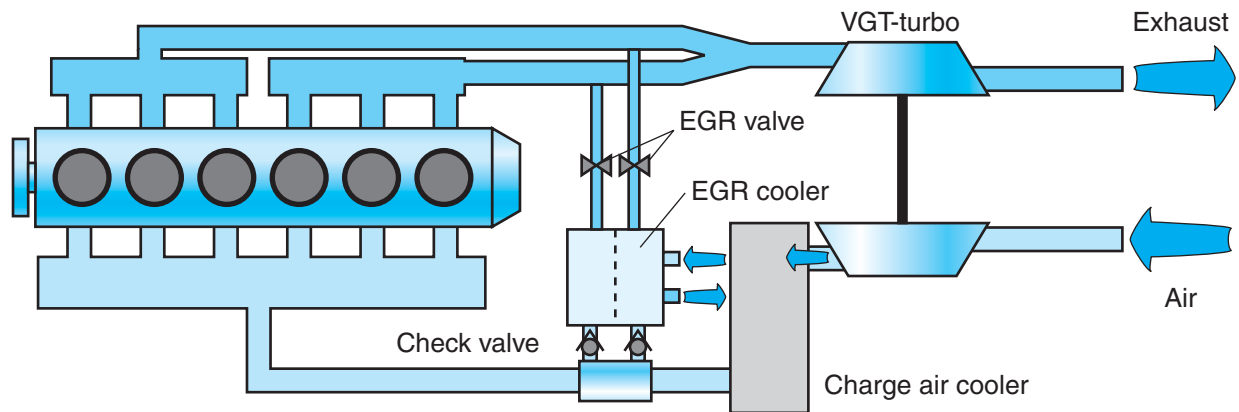

Figure 16-2 Typical C-EGR system.

with NO_x emissions. EGR needs dead gas to operate and there is no better source of dead gas than the engine exhaust system. It produces dead gas anytime the engine is running.

Clean gas induction (CGI) is a variation on EGR used exclusively on Caterpillar's post-2007 ACERT family of highway engines. The key difference between EGR and CGI is in where exhaust gas is sourced. In a typical EGR system, dead gas is sourced upstream from the exhaust gas aftertreatment canister. CGI sources its dead exhaust gas downstream from exhaust gas aftertreatment. More important, it is downstream from the diesel particulate filter (DPF).

Caterpillar likes to call their system "clean EGR." CGI is monitored by a mass airflow sensor (MAF) and, just like its competitors' EGRs, the objective is to keep combustion temperatures lower to reduce NO_x . It is easy to identify a Cat CGI engine because the CGI pipe can be seen to exit the muffler/converter/DPF assembly close to its exit. This pipe routes the theoretically clean dead gas back to the intake. **Figure 16-3** is a Caterpillar schematic of their CGI system.

Catalytic Converters

A few truck and bus diesel engines used catalytic converters before 2002, but almost all current engines use oxidation converters. Some use both oxidation and reduction converters. By definition, a **catalyst** is a substance that enables a chemical reaction without itself undergoing any change. For many years, automobile catalytic converters have been two-stage, three-way converters and it is only since 2007 that truck diesels have incorporated two-stage devices. The two stages are as follows:

1. oxidation stage: attempts to oxidize HC and CO not oxidized in the engine cylinder

2. reduction stage: attempts to reduce NO_x back to elemental nitrogen and oxygen when NO_x compounds have been formed during combustion

Oxidation Stage. When cylinder end gas contains HC and CO, the oxidizing stage of the catalytic converter attempts to oxidize (combust/burn) these to harmless H_2O and CO_2 . *Platinum* and *palladium* are both oxidation catalysts. They are expensive. Oxidizing catalysts enable what is called catalytic afterburning. This sometimes requires the addition of fresh air into the converter assembly. Peak temperatures in oxidation converters can be as high as 1,000 degrees Celsius. Oxidation catalytic converters first began to appear on highway diesels in the late 1990s but today almost all diesel engines are required to use them. Because of the high operating temperatures, it is not unusual for an oxidation converter to glow red during nighttime operation, especially when engines are under load.

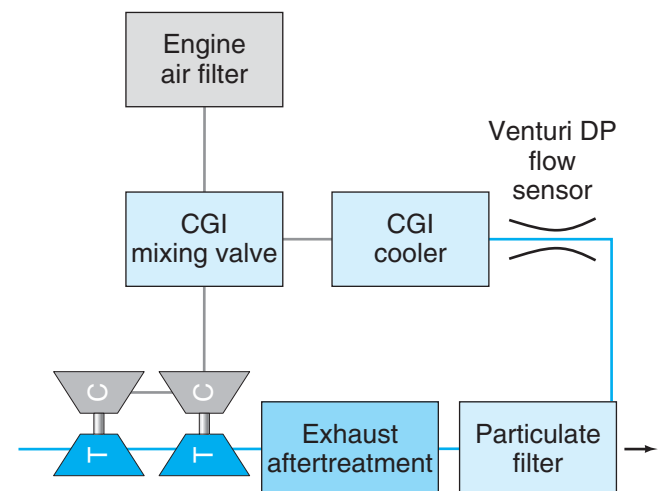

Figure 16-3 Caterpillar schematic of a CGI system. (Courtesy of Caterpillar)

Reduction Stage. Where NO_x is present in the exhaust gas, the reduction stage in a catalytic converter attempts to reduce this back to nitrogen and oxygen. *Rhodium* is the usual reduction catalyst and has been used by automobile manufacturers since the 1970s. A disadvantage of rhodium is that it can only function as a reduction catalyst when the cylinder burn is close to a stoichiometric ratio. This means that to use a rhodium catalytic converter in a lean burn diesel engine, you cannot have excess air. All diesel engines operate with excess air. Manufacturers that use rhodium-based catalytic converters “enrich” the mixture locally in the reduction converter. They do this by dosing. **Dosing** requires excess fuel to be injected into the exhaust gas. This has to happen upstream from the reduction converter.

NO_x Adsorber Catalysts

As we said earlier, rhodium-based reduction catalysts have been used on gasoline-fueled automobile engines for many years. These used a rhodium catalyst to “reduce” NO_x compounds back to nitrogen and oxygen. Because rhodium only functions as a reduction catalyst when the air-fuel ratio is at stoichiometric or richer, it could not be used on lean burn diesels. An NO_x adsorber catalyst functions similarly to a reduction catalyst except that it does not operate continuously.

Adsorption is a chemical term that is best defined as *adhesion*. When a substance is adsorbed it does not undergo any chemical change. **NO_x adsorber catalysts (NACs)** use base metal oxides to initially collect or “store” NO_x . They then use a rhodium reduction catalyst to reduce NO_x back to nitrogen and oxygen during an ECM managed reduction phase. In other words, an NAC functions in two stages:

1. NO_x storage: NO_x is adsorbed to the base metal oxide substrate during the normal lean burn operation of the diesel engine.
2. NO_x reduction: the engine ECM temporarily operates the engine operation in a rich AFR mode or injects fuel into the exhaust system to simulate a rich AFR allowing a rhodium catalyst to reduce the NO_x to elemental nitrogen (N_2), elemental oxygen (O_2), and water vapor (H_2O).

NAC Regeneration Cycle. The key to enabling an NAC to function in its regeneration cycle is to temporarily eliminate excess oxygen from the exhaust. NACs require the use of the ULS fuel. Sulfur at any

levels can damage NACs. Some NACs require occasional de-sulfation even when only the appropriate ULS fuel has been used. De-sulfation temporarily requires raising the exhaust temperatures using fuel injected directly into the exhaust system.

Diesel Particulate Filters (DPFs)

Diesel particulate filters (DPFs) have been around in the industry for a number of years usually in special applications such as a garbage packer required to operate inside for long periods of time. On this type of application they were usually known as **particulate traps**. You will find a DPF on every highway diesel engine meeting 2007 emissions and beyond. A DPF is an aftertreatment device designed to eliminate soot produced by the engine cylinder combustion process.

Types of DPF. There are three general types of DPF in use:

1. Catalyzed. This is the most common type of DPF. It is built into the aftertreatment canister that also contains multistage catalytic converters and what used to be known as the muffler. Catalyzed DPFs will be found on most highway trucks and are capable of both passive and active regeneration cycles.
2. Noncatalyzed. This type of DPF is required in diesel-powered vocational vehicles that are operated under low engine loads for long periods. Typical applications are cement trucks, fire trucks, and garbage packers. Noncatalyzed DPFs may only be capable of active regeneration cycles that require the vehicle to be stopped.
3. Low-temperature particulate filters. These are usually aftermarket devices fitted to pre-2007 highway diesels. Many have been fitted to school buses. While being capable of significantly reducing PM, they usually do not achieve this to EPA 2007 standards.

DPF Operating Principles. The idea behind a DPF is that engine-emitted soot first collects on the walls of the device. Engine manufacturers design DPFs to function primarily in self-regeneration mode. This means that when soot collection reaches a threshold level, it is burned off in what is known as a **regeneration cycle**. In most cases, the regeneration cycle will occur when exhaust temperatures are sufficiently high during normal operation. When this regeneration takes place unassisted by additional fuel or air injection to the exhaust gas it is known as **self-regeneration**.

Self-regeneration is also known as **passive regeneration**. The terminology varies by engine OEM.

Operating temperatures of the combined oxidation converter and DPF can exceed 600 degrees Celsius so most of these devices have plenty of heat shielding. Depending on the engine and its power rating, both single and dual canister versions are used. Typically, single and dual canisters are specified by horsepower rating as follows:

- single canister: up to 600 BHP
- dual canister: over 600 BHP

Active Regeneration. When the operating environment is not conducive to a self-regeneration cycle, regeneration can also occur assisted by injection of some fuel (diesel) ignited by spark plug or induced high exhaust temperatures. This mode of regeneration is known as **active regeneration**. Fuel for an active regeneration cycle is usually sourced from the fuel subsystem and delivered at the specified charging pressure. Most diesel engine OEMs are using similar DPF but they are managed in different ways. **Figure 16-4** shows a cutaway core view of a Detroit Diesel DPF.

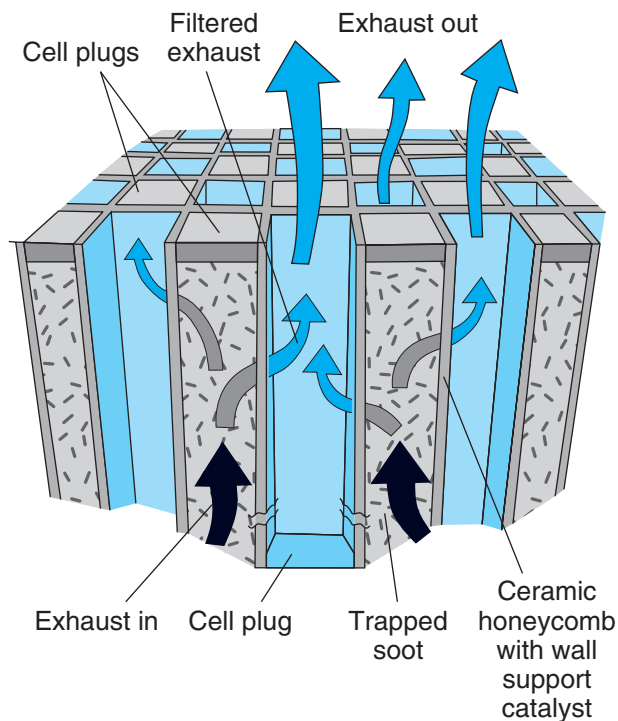

Figure 16-4 Cutaway view of a Detroit Diesel DPF core showing gas flow. (Specifications are subject to change without notice. Detroit Diesel Corporation is registered to ISO 9001:2001. Courtesy © Detroit Diesel Corporation. All rights reserved. Detroit Diesel is a Daimler company)

Frequency of Cycles. Regeneration cycles are designed to occur at set intervals. These set intervals may be as often as once every hour, or as infrequent as once every 8 hours of operation, depending on the engine and its power ratings, and how the engine is being operated. Truck drivers should be informed about the expected intervals of the regeneration cycles of the equipment they operate. During both passive and active regeneration, there will be an increase in exhaust gas temperatures.

Ash Residues. Regeneration leaves some ash residues. These ashes primarily originate from the additive package in the engine lube that is burned in the cylinder during normal combustion. Ash residues have to be removed manually. Federal law requires that this cleaning process occur no more frequently than once a year or 150,000 miles (whichever comes first). That said, some manufacturers are aiming to have DPF off-chassis service intervals that exceed 300,000 highway miles.

Temperature Monitoring. Temperature monitoring is by dual and single thermocouples (pyrometers). A thermocouple has a hot end and a sensing end. Two dissimilar wires are arranged to form a circuit: they are wound together at the hot end. When the hot end is exposed to heat, a small voltage is created. This small voltage is read by a millivoltmeter at the sensing end and displayed as temperature values. Thermocouple devices must be replaced as a complete unit when diagnosed as failed. The DPF is a complex assembly within which the regeneration cycles and temperatures have to be precisely managed.

DPF Cleaning Station. Most of the engine OEMs state that their DPFs will require routine in-shop cleaning using special equipment. Although some early systems could be cleaned while on chassis, all current systems require out-of-chassis cleaning stations. The DPF filter assembly is placed in the cleaning station. This high flow back-pressurizes the system for a period of around 20 minutes. The total time of the DPF cleaning procedure usually takes less than 2 hours. Skill levels required to perform the cleaning are not expected to be that high. **Figure 16-5** shows a Donaldson generic DPF cleaning cart but this will only function on certain designated DPFs.

CAUTION An appropriate respirator should be worn when servicing DPF components. Sub-micron ash particulate is known to cause respiratory problems.

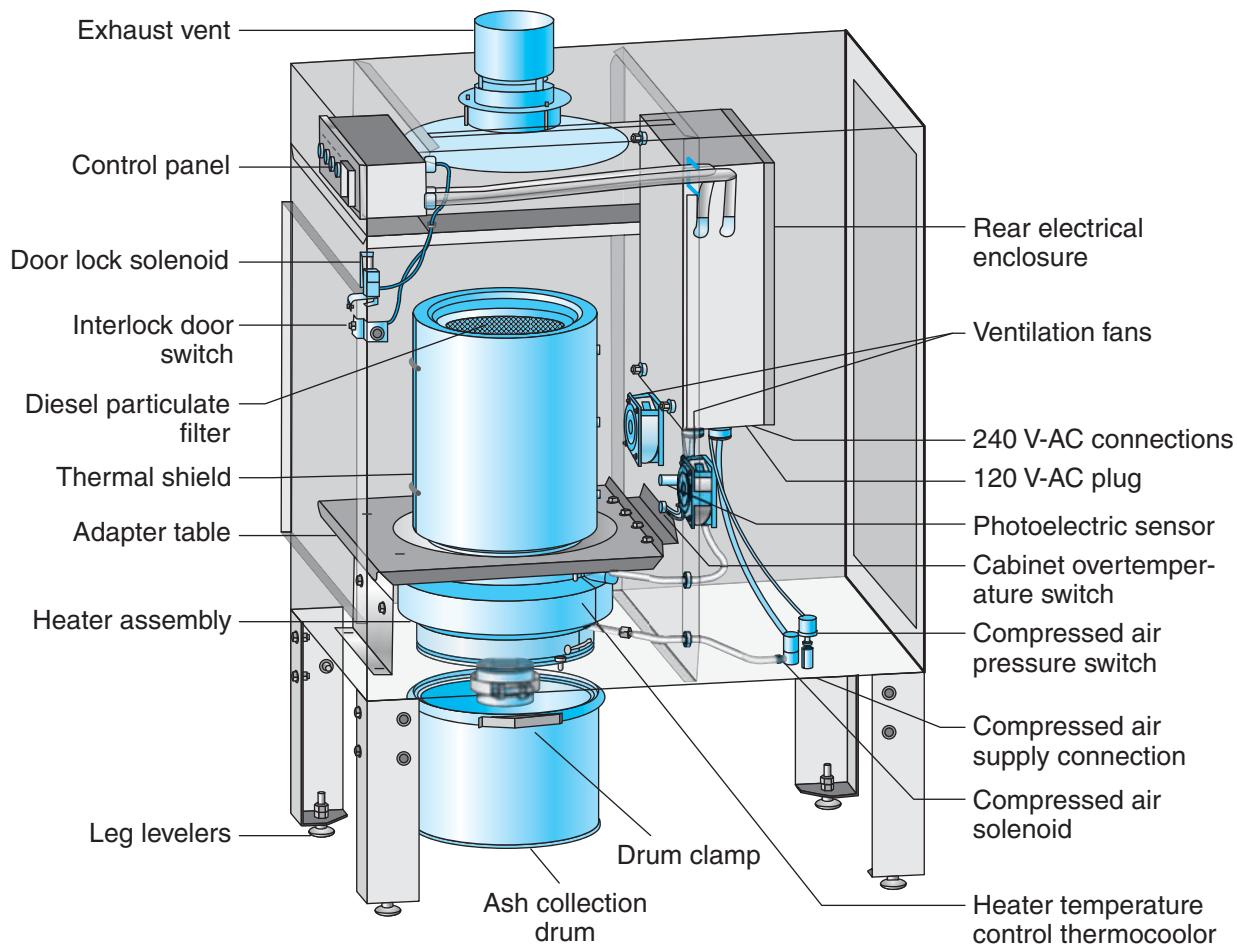

Figure 16-5 A Donaldson DPF cleaning system which will function on most DPFs. (Courtesy of Donaldson)

Selective Catalytic Reduction (SCR)

Like DPF, **selective catalytic reduction (SCR)** is also an exhaust gas after treatment process. While the DPF addresses particulate HC, an SCR system attempts to “reduce” oxides of nitrogen (NO_x) back to nitrogen and oxygen. Although SCR has been used in Europe for a decade, the EPA did not approve SCR use until 2007. The reason for the reluctance on the part of the EPA in approving SCR systems is that to function, this type of system depends on using a “consumable,” specifically urea. The urea that is in aqueous form has to be routinely refilled, just like fuel. This means that the EPA approval required some conditions.

Aqueous Urea. SCRs use consumable **urea** to achieve what the rhodium catalyst does in the gasoline-fueled engine. Urea is composed of crystallized nitrogen compounds sourced from natural gas. The urea is in a solution with water, known as **aqueous urea**. The aqueous urea is injected into the exhaust gas stream by a computer controlled injection system. After injection, the urea reduces to ammonia which itself reacts with

NO_x compounds, reducing them back to oxygen and nitrogen.

SCR Management. SCR is managed by the engine ECM. The urea is contained in aqueous/water form (32 percent) in a replenishable vessel. One manufacturer name for a 32 percent cut of aqueous urea is **AdBlue™**. It is injected upstream from the converter/DPF/muffler assembly sometimes assisted by on-chassis compressed air. The urea injection has to be precisely metered by the ECM. Too much urea can result in ammonia discharge through the exhaust system, while too little results in NO_x emissions. **Figure 16-6** shows a schematic of SCR components and operation.

Urea is carried onboard the truck in tanks with capacities of 20 to 50 gallons. An aqueous urea solution freezes at 12°F (minus 8°C) so it must be freeze-protected in winter operation. The urea is consumed at a rate that varies between approximately 1.5 percent and 10 percent of the fuel used, the variability depending on how the engine is being operated, that is, how much NO_x has to be reduced.

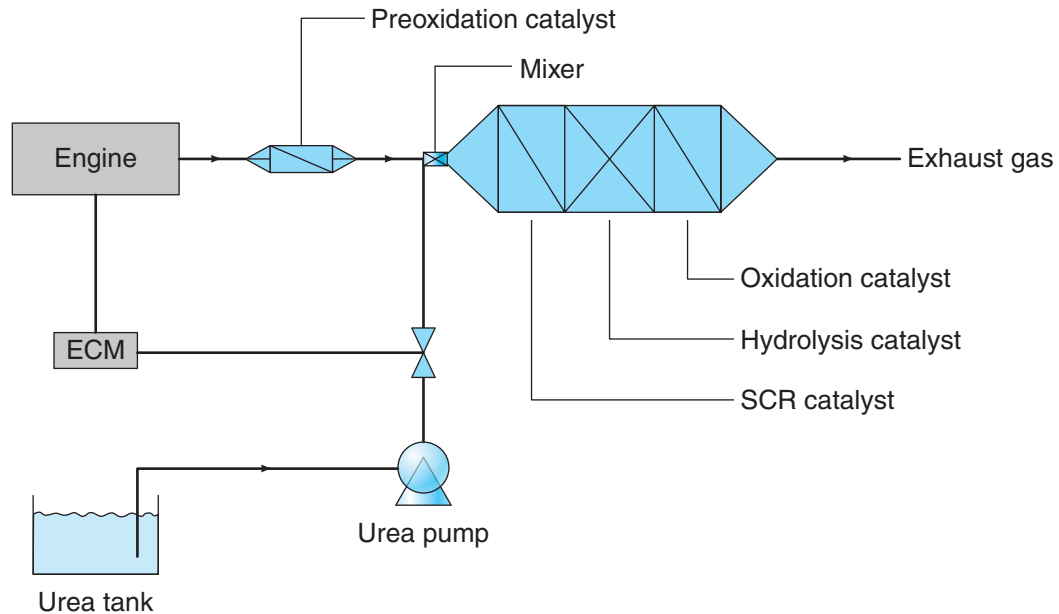

Figure 16-6 Schematic of SCR components and operation.

Closed Crankcase Ventilation

Highway diesel engines meeting 2007 emissions standards are required to have a **closed crankcase ventilation (CCV)** system. CCV is the diesel engine equivalent of automotive **positive crankcase ventilation (PCV)** systems. The objective of a CCV system is to prevent venting to atmosphere of crankcase gases. Crankcase gases consist of:

- blowby gas from engine cylinders
- boil-off gases from lubricant

CCV Operation. Diesel CCV systems can be directly compared with PCV circuits used on automobiles. The system is plumbed upstream from the turbocharger impeller housing so that some pull is exerted on the crankcase. The CCV piping is routed through a filter assembly, which in the case of the 2007 Cummins ISC engine shown in **Figure 16-7** is located on top of the rocker housing cover. OEM recommendations for CCV service intervals should be observed.

VCO Injectors. Valve closes orifice (VCO) injectors were introduced in **Chapter 14**. Elimination or reduction of nozzle sac volume in hydraulic injection injectors reduces the cylinder boil/dribble of sac fuel at the completion of injection. This nozzle design principle is used in all injectors today.

Charge Air Cooling. Effective cooling of intake air lowers combustion temperatures, making it less likely

that the nitrogen in the air mixture is oxidized to form NO_x . Air-to-air charge air coolers cool air more effectively than those that relied on engine coolant. Note that anything that compromises the charge air cooler's ability to cool will result in higher NO_x emissions. This is why codes are logged when charge air heat exchangers become plugged.

Variable Geometry Turbochargers. Variable geometry turbochargers (VGTs) that perform effectively over a much wider load and rpm range can make a significant difference to both HC and NO_x emissions, especially when ECM controlled, by providing the

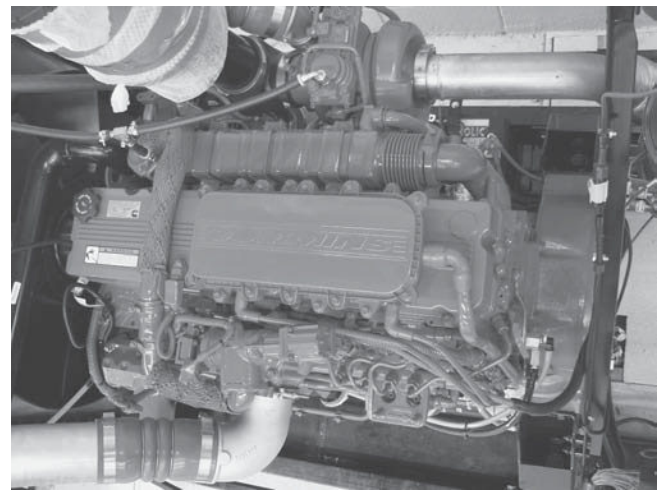

Figure 16-7 Overhead view of a Cummins 2007 ISC engine: note the location of the CCV filter on top of the rocker housing cover.

ability to manage boost on the basis of the fueling and emissions algorithms. VGTs are used rather than constant geometry turbos in almost every 2007 compliant highway diesel engine. When a constant geometry turbocharger is used today, it is usually as one of the pair used in series turbocharged engines.

Low Headland Volume Pistons. Low headland volume pistons raise the upper compression ring close to the leading edge of the piston crown. This keeps the headland gas volume close to minimum. Headland gas volume tends to be unclean and can increase HC emissions. The requirement for low headland volume pistons by engine designers has resulted in some radical design changes in diesel engine pistons within a short period of time. Most diesel engine manufacturers today favor trunk-type steel pistons such as the Mahle Monotherm, which features low headland volumes.

FIELD TESTING OF SMOKE DENSITY

Before an engine manufacturer can certify a diesel engine for use on a North American highway, it must meet some tough EPA certification standards. However, having been certified for on-highway use, the standards for field testing diesel engines for emissions once put in service change significantly. Most field testing currently used in North America is based on an outdated SAE standard known as J1667. Published in 1991, **SAE J1667** was based on a trucking world that used mostly hydromechanical diesel engines. Very few of these engines are around today.

Visible Smoke Emissions

Field testing at this moment in time relies on J1667 opacity tests. J1667 test requirements only address visible smoke emissions. Because the test procedures are entirely based on highway diesel engines commonly used back in the 1980s, the testing does little to identify polluting engines of this generation. Certification of diesel engines falls under the responsibility of the EPA. On the other hand, field enforcement of highway diesel engine emissions is left up to state and municipal jurisdictions. Their enforcement agencies are caught in a squeeze between the voting public who are requesting tougher standards and the hard fact that aggressive enforcement and tough penalties can hurt them economically. At present, few jurisdictions require exhaust gas analysis similar to EPA certification testing. Nevertheless, some transit operators undertake their own gas analysis profiles.

Opacity Meters

Opacity meters measure visible smoke emissions. They are simple to use and usually require that the unit's sensor head probe be fitted to the outlet of the exhaust pipe. Two different types are used:

1. partial flow
2. full flow

In the partial flow type, during the test procedure, a portion of the exhaust gas flow is diverted to a sensing chamber in which the opacity of the smoke can be read by the light sensor in the head assembly. A partial flow opacity meter is shown in **Figure 16-8**. The full flow type

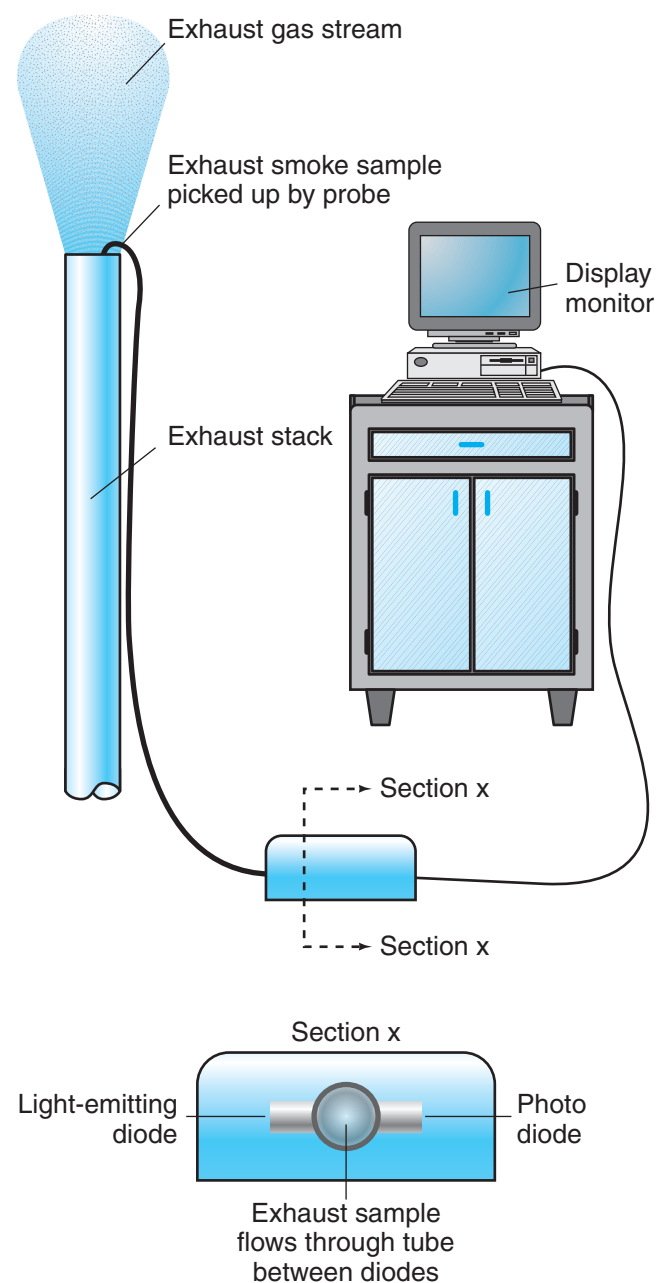

Figure 16-8 Partial flow opacity meter.

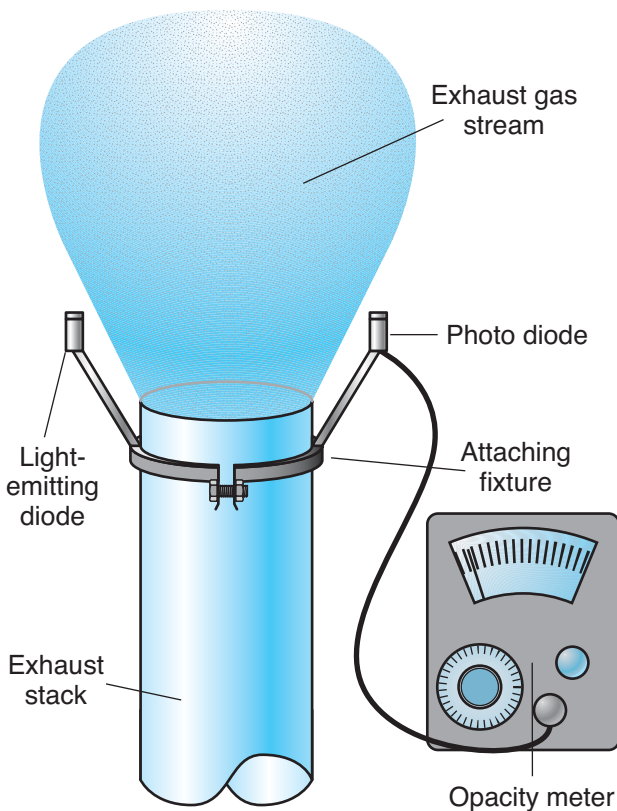

Figure 16-9 Full flow opacity meter.

is more commonly used and makes the opacity measurement directly at the stack outlet. **Figure 16-9** shows the operating principle of a full flow opacity test meter.

Light Extinction. Partial and full flow opacity meters are classified as light extinction test instruments. A beam of light from a light-emitting diode (LED) is directed at a photo diode sensor through the exhaust gas. The amount of light blocked from the photo diode sensor (by smoke) is determined by the density of the engine exhaust. The higher the density, the less light can pass through the smoke to be read by the sensor. Smoke density is expressed as a percentage reading by the opacity meter. In most cases, the opacity meter is equipped with an extension handle for the sensor head, so the device can be placed at the exhaust stack outlet by the technician working at ground level.

Opacity meter readings are displayed in percentages. The actual readings vary according to engine horsepower and the diameter of the exhaust pipe(s). Most should produce accurate results regardless of weather conditions and many will record the data electronically. Data recorded by the opacity meter can be hard-copy printed or transferred to PC- or Web-based systems for analysis. Any opacity meter can be used to evaluate smoke density in diesel smoke.

However, those used for official testing and to enforce compliance must be approved and have PC-managed and logged test sequences.

Performing J1667 Testing

In 1997, the EPA recommended that all jurisdictions adopt the SAE J1667 procedure for the testing of heavy-duty diesel vehicles, perhaps because it would promote some consistency in test standards between different jurisdictions. The test routine outlined here adheres closely to that performed by compliance enforcement agencies. While the emission standards do vary by jurisdiction and year of manufacture of the truck, there is some consistency nationwide and recently the maximum opacity standards have been reduced in many jurisdictions.

Weather Conditions. Weather conditions can have some impact on smoke density, and changes in air density influence the operation of any internal combustion engine. For this reason, SAE J1667 imposes restrictions on the environmental conditions during the administration of an “official” snap acceleration test.

Environmental Conditions. The following environmental conditions are required when performing a J1667 test:

- Temperature in the test area must be between 35°F and 86°F.
- Testing must not take place outdoors when there is visible precipitation such as rain, snow, or fog.
- Testing must not take place when the temperature is at or below the dew point, such as during fog or high-humidity conditions.
- Vehicles using downward-directed exhaust systems should be tested over ground surface conditions that are not dusty so that dirt particulates are not combined with the exhaust gas being measured.

Snap Test. Each J1667 throttle snap consists of a three-phase cycle that must be precisely executed by the test administrator:

1. Accelerator is snapped to high idle and held for 1 to 4 seconds or until prompted by the opacity meter to release.
2. Engine rpm must be allowed to drop to the specified low idle speed.
3. Engine must run at the specified low idle for a minimum of 5 seconds and a maximum of 45 seconds before initiating the next snap as prompted by the opacity meter.

SAE J1667 Test Cycle. The SAE J1667 test cycle consists of four phases and, again, these must be precisely executed by the test administrator:

1. Preliminary snaps. Three full snaps are required to clear the exhaust system of loose particles and precondition the vehicle.
2. Official snaps. Three official snaps should be undertaken as prompted by test instrument software.
3. Validation. The difference between the highest and the lowest maximum opacity readings of the three official test snaps should be within five opacity percentage points. If the difference is less than 5 percent, the meter software will compute the average. If the difference is greater than 5 percent, additional official snaps must be undertaken up to a maximum of nine.
4. Drift factor. Validation is required that the drift (rpm at full pedal travel) between three official test cycles does not exceed 2 percent opacity. A variation greater than ± 2 percent will result in an invalid test. This is not a tough spec to meet: 2 percent of 2,000 rpm translates to 40 rpm.

Stack Dimensions. Exhaust pipe diameter has an effect on the opacity reading of exhaust gas. Before undertaking a snap test, the diameter of the exhaust stack has to be known. For instance, an engine that tests at 30 percent opacity when tested with a 3-inch exhaust stack would only measure 20 percent opacity when tested with a 5-inch tailpipe. This is why you have to input the stack diameter into the opacity meter.

Summary

- Emissions standards that engine OEMs must meet are set nationwide by the EPA. The influence of CARB has greatly increased in recent years because their standards have been adopted by at least 10 other states.
- The word *smog* is derived from the words *smoke* and *fog*.
- Photochemical smog is formed by gaseous and particulate hydrocarbons (HC) combining with ozone and oxides of nitrogen (NO_x) followed by a period of exposure to sunlight.
- Because creating photochemical smog requires a period of exposure to sunlight, relatively still air mass is required for its formation.
- Vehicle emissions are the largest single contributor to the photochemical smog in most geographic areas

SMOKE ANALYSIS

Any truck diesel engine that fails an opacity snap test has a *severe* smoking problem, one that could not pass unnoticed under any circumstances. At this point we should say something about how tailpipe smoke looks to the observer's eye. The way we see smoke depends on the *state* of the emission. All matter has three states: vapor or gaseous, liquid, and solid. It is possible to emit matter in all three states from a diesel engine tailpipe.

1. Gaseous emission. To the observer's eye, this is "clean" exhaust smoke, but it may be either clean or contaminated with noxious pollutants in a vapor state. Because light is not affected by passing through a gas, we see nothing when we look at exhaust in a 100 percent gas state exiting the stack(s).
2. Liquid emission. To the observer's eye, liquid condensing in the exhaust gas stream appears white. When light attempts to pass through condensing liquid droplets in the exhaust, it either *reflects* or *refracts*, making it appear white to the observer. White smoke may be completely unburned fuel, or it may be water or antifreeze.
3. Solid emission. To the observer's eye, solids (we call these *particulates*) contained in the exhaust gas stream appear black. When light attempts to pass through particulate suspended in the exhaust gas it is blocked, making it appear black to the observer. Black smoke is caused by toasted fuel or oil exiting the exhaust.

of North America. Exhaust emissions for NO_x will have been reduced by 8,000 percent in a period extending from 1970 to 2010.

- Conditions in Southern California are ideal for the formation of photochemical smog. These include a high percentage of per capita vehicle ownership, plenty of sunlight, and a natural wall formed by the San Gabriel Mountains to the east that acts to trap air mass movement.
- The next challenge for diesel engine builders is GHG reduction. Reducing GHG emissions from diesel engines means improving fuel economy. At present GHG reduction programs such as SmartWay are voluntary but sooner or later it is expected that these will become mandatory.

- VOCs are hydrocarbon fractions boiled off fuels during their production, transportation, storage, and production. VOCs are a more severe problem in high-temperature climatic conditions.
- Ozone is known to be toxic in small concentrations.
- Diesel engines today rely on exhaust gas recirculation (EGR), NO_x adsorber catalysts, oxidation and reduction catalytic converters, diesel particulate filters (DPFs), along with computer control of combustion to meet emissions compliance standards.
- The DPF entraps soot particles. The entrapped soot is then combusted in what is known as a regeneration process.
- DPF regeneration can be passive (occurs during normal vehicle operation) or active (requires dosing fuel and sometimes spark ignition).
- Opacity meters use a light extinction method to measure visible tailpipe emissions.
- Opacity meters produce readings that indicate density: the higher the percentage reading, the higher the smoke density.
- Smoke density testing based on the SAE J1667 standards is used by many jurisdictions in North America as a compliance standard.

Internet Exercises

1. Download Al Gore's "An Inconvenient Truth" and make some notes.
2. Google some opposing points of view to Al Gore's.
3. Use a search engine and punch in Caterpillar ACERT.
4. Log on to <http://www.wikipedia.com> and see what you can learn about SCR.
5. Log on to <http://www.howstuffworks.com> and check out DPFs.

Shop Tasks

1. Select a truck chassis and make a list of the external emissions hardware used on that truck.
2. Using a truck equipped with a DPF, connect an EST to the data bus and perform an in-shop active regeneration.
3. Check out the air quality index (AQI) in your local area. Note whether it is lower or higher than usual. Next, compare the average seasonal AQI in your area with national averages. Explain why it might be higher or lower.

Review Questions

1. Which of the following compounds is not currently classified by the EPA as a harmful tailpipe emission?

A. Oxides of nitrogen	C. Sulfur dioxide
B. Hydrocarbons	D. Carbon dioxide
2. Which of the following is present in the largest quantity by weight in the diesel engine cylinder during combustion?

A. Oxygen	C. Fuel
B. Nitrogen	D. Carbon monoxide
3. Which tailpipe emission does an NO_x adsorber catalyst attempt to reduce?

A. Particulate matter (PM)	C. Hydrocarbons
B. Oxides of nitrogen	D. Ozone

4. Which of the following exhaust gas test instruments uses a *light extinction* principle to measure smoke density?
- A. CVA sampler
B. Seven-gas analyzer
C. Two-gas analyzer
D. Opacity meter
5. Which of the following best describes oxygen at ground level?
- A. O
B. O₂
C. O₃
D. O₄
6. Which of the following results from “perfect” combustion of an HC fuel when it is burned with oxygen?
- A. Carbon monoxide and carbon dioxide
B. Carbon dioxide and nitrogen dioxide
C. Nitrogen dioxide and water
D. Carbon dioxide and water
7. When a diesel engine is operated at lower than normal temperatures, which of the following tailpipe emissions is likely to increase?
- A. Oxides of nitrogen
B. Carbon dioxide
C. Ozone
D. Hydrocarbons
8. When a diesel engine is operated at higher than normal temperatures, which of the following tailpipe emissions is likely to increase?
- A. Oxides of nitrogen
B. Carbon dioxide
C. Ozone
D. Hydrocarbons
9. Which of the following compounds is classified as a greenhouse gas responsible for contributing to global warming?
- A. Oxides of nitrogen
B. Hydrocarbons
C. Carbon dioxide
D. Sulfur dioxide
10. Which of the following describes what happens in an *oxidation*-type catalytic converter?
- A. Nitrogen in NO_x is burned
B. CO and HCs are burned
C. HCs are filtered out
D. PM is filtered out

Glossary

accumulator device for storing energy. Often used to describe the high-pressure chamber or common rail used in some electronically controlled, fuel injection systems.

ACERT Caterpillar technology that uses a multiphase emissions reduction strategy to meet 2004 and 2007 EPA standards. Critical ACERT components include series turbocharging, variable valve timing, MEUI, CR, and HEUI injectors, and exhaust gas aftertreatment.

acronym a word formed by the initial letters of other words.

active code an electronically monitored system circuit, condition, or component that is malfunctioning and logs an ECM code, which may be displayed or read with an EST.

active DPF system a diesel particulate filter that actively generates the heat required to regenerate (burn off soot) the device. Heat is usually derived by injecting diesel fuel or from a heat grid.

actively pressurized cooling system (APCS) a means of raising cooling system pressure using controlled, onboard compressed air—the objective is to raise the boil point of the coolant.

active regeneration term used to describe diesel particulate filter regeneration aided by fuel dosing sometimes in combination with spark ignition.

actuators hardware that effects the results of computer processing into action. Examples of actuators would be the injector drivers in a diesel EUI system.

adaptive trim ECM software that evaluates fuel flow performance of electrohydraulic injector and EUIs at set engine operating hour intervals and makes corrections to ensure fueling balance. Sometimes abbreviated to *A-trim*.

AdBlue an aqueous urea solution of 68 percent water and 32 percent urea used for selective catalytic reduction (SCR)-type catalytic converters.

adsorption a chemical term that is best defined as *adhesion*: when a substance is adsorbed it does not undergo any significant chemical change. Adsorption is the principle used in diesel NO_x adsorber catalysts (NACs).

advanced combustion and emissions reduction technology (ACERT) Caterpillar combustion management approach to emissions reduction introduced in 2004. Currently used on all Caterpillar on-highway and most off-highway engines. See entry under *ACERT*.

advanced diesel engine management (ADEM) Caterpillar acronym used to describe its management electronics and associated hardware.

after top dead center (ATDC) any engine position during piston downstroke.

afterburn injection see *dosing injection*.

air/fuel ratio (AFR) the mass ratio of an air-to-fuel mixture.

air-to-air after cooling (ATAAC) alcohol any of a group of distillate hydrocarbon liquids containing at least one hydroxyl group; sometimes referred to as oxygenates.

algorithm software term that describes a programmed sequence of operating events.

alloy the mixing of a molten base metal with metallic or nonmetallic elements to alter the metallurgical characteristics.

American Petroleum Institute (API) classifies lubricants and sets standards in the petroleum-refining industry.

American Society for Testing Materials (ASTM) agency that sets industry standards and regulations including those for fuel and lube oils. Standards are set by accord and influence both recommended practice and legislated standards.

American Standard Code for Information Interchange (ASCII) widely used data-coding system found on PCs.

American Trucking Association (ATA) organization with a broad spectrum of representation responsible for setting standards in the U.S. trucking industry.

ampere unit of electrical current flow equivalent to 6.28×10^{18} electrons passing a given point in a circuit per second.

amplification term used in electronic circuits to describe what happens when very small currents are used to switch much larger ones using transistors.

anaerobic sealant a sealant designed to cure in the absence of oxygen.

analog the use of physical variables, such as voltage or length, to represent values.

analog signal a communication line signal consisting of a continuous electrical wave.

annulus a ring or something ring shaped.

anode positive electrode; the electrode toward which electrons flow.

antifreeze a liquid solution added to water to blend the engine coolant solution that raises the boil point and lowers the freeze point. Ethylene glycol (EG), propylene glycol (PG), and extended life coolants (ELC) are currently used.

antithrust face used to describe the minor thrust face of a piston; the outboard side of the piston as its throw rotates off the crankshaft centerline through the power stroke.

antithrust side piston term meaning minor thrust side.

app(s) widely used short form for (computer) applications.

application software programs that direct computer processing operations.

aqueous urea is the reducing agent used in SCR systems. Aqueous urea is a solution of 32 percent urea and distilled water.

articulating piston a two-piece piston with separate crown and skirt assemblies, linked by the piston wrist pin and afforded a degree of independent movement. The wrist pin is usually full floating or bolted directly to the conn rod, in which case it is known as a *crosshead piston*.

ash (1) the powdery/particulate residues of a combustion reaction. (2) solid residues found in crude oils. Present in trace quantities in engine lubricating oils and diesel fuels.

Association of Diesel Specialists (ADS) Organization to which fuel injection specialty shops belong and which monitors industry standards of practice and education.

ASTM 975 standard to which all petroleum base diesel fuels must conform.

ASTM 6751 standard to which pure biodiesel base diesel fuels must conform.

ASTM #1D fuel fuel recommended for use in high speed, on-highway diesel engines required to operate under variable load and variable speeds. Minimum CN must be above 40. In theory, the ideal fuel for highway truck and bus diesel engines but in practice, it is not used as often as #2D fuel because it has less heat energy by weight, making it less economical.

ASTM #2D fuel fuel recommended for use in high speed, on-highway diesel engines required to operate under constant loads and speeds. Like #1D fuel, the minimum CN is required to be above 40. Widely used in highway truck operations because it produces better fuel economy than #1D fuel due to its higher calorific value, albeit at the expense of slightly inferior performance.

asynchronous transfer mode (ATM) a method of transmission and switching that can handle vast amounts of data at a high speed.

ATA connector describes a J1708 data bus connector (6-pin Deutsch) but often used to reference either the J1708 or J1939 data link.

atom the smallest part of a chemical element that can take part in a chemical reaction; composed of electrons, protons, and neutrons.

atomization the process of breaking liquid fuel into small droplets by pumping it at a high pressure through a minute flow area.

atomized droplets the liquid droplets emitted from an injector nozzle.

A-trim see *adaptive trim*.

audit trail a means of electronically tracking electronically monitored problems in an engine management system. May

be discreet, that is, not read by some diagnostic ESTs and programs; also known as *tattletale*.

Automotive Service Excellence National Institute (ASE) organization dedicated to setting test standards for auto and truck technicians.

auxiliary power unit (APU) power supply unit used on many trucks to provide electrical power when the engine is not running. Gasoline, diesel, or fuel cell sourced.

axial power turbine (APT) term used by DDC to describe their compounded turbocharger that imparts drive torque directly to the engine powertrain.

axis the point about which a body rotates; the center point of a circle. Plural: axes.

B20 standard petroleum-based diesel fuel cut with 20 percent biodiesel.

B100 term used to describe pure biodiesel fuel meeting the ASTM standard D6751.

back leakage pumping plunger leak-off—a common indicator of plunger to barrel/cylinder wear.

back leakage test an injector bench fixture test in which nozzle valve to nozzle body leakage is measured.

backbone data bus consisting of a twisted wire pair.

background computations computer operating responses of lower priority than foreground operations, that while important do not require immediate response; monitoring of engine fluid temperatures would be classified as a background computation.

balanced atom an atom in which the number of electrons and protons are equal.

balanced rack setting infers that the rack adjustment of an MUI-fueled engine has been set so the fuel delivery in each injector is identical through the travel of the rack.

bandwidth volume or capacity of a data transmission medium; the number of packets that can be pumped down a channel or multiplex backbone.

bar a metric unit of pressure 105 Newtons per square meter; approximately, but not exactly one unit of atmosphere or 1 atm.

barometric pressure sensor (BARO) an electronic barometric pressure sensing device.

base circle the smallest radial dimension of an eccentric. Used to describe cam geometry, the train that the cam is responsible for actuating would be unloaded on the cam base circle; also known as an *inner base circle* or *IBC*.

basic input/output system (BIOS) when a computer is booted, the CPU looks to the BIOS chip for instructions on how to interface between the disk-operating system and the system hardware.

baud times per second that a data communications signal changes and permits one bit of data to be transmitted.

baud rate the speed of a data transmission.

bay a vacant location in the computer housing/system designed to accommodate system upgrades.

bearing shell a half segment of a friction bearing such as would be used as a crankshaft main bearing.

bedplate replaces a set of main bearing caps with a single casting plate that bolts to the engine cylinder block: enables a lighter cylinder block to withstand high resistance to torsionals.

before top dead center (BTDC) a piston location in the cycle before full piston travel usually abbreviated BTDC.

beginning of energizing (BOE) moment that an EUI or EUP is electrically energized.

beginning of injection (BOI) in engine management, a specific point at which injection begins.

big end the crankshaft throw end of a connecting rod.

binary system a two-digit arithmetic, numeric system commonly used in computer electronics.

biodiesel fuel derived from farm products with a vegetable and alcohol base; when used in current diesel engines should meet ASTM standard D6751.

bipolar transistor a three-terminal transistor that functions as a sort of switched diode.

bit a binary digit that can represent one of two values, on or off; presence of voltage or no voltage; the smallest piece of data a computer can manipulate. There are 8 bits to a byte.

bits per second (bps) a measure of the speed at which data can be transferred.

black smoke smoke that appears black to the observer is caused by particulate (solids) emission in the exhaust gas stream; light is blocked by the particulate, making it appear black.

blink codes fault codes blinked out using diagnostic lights; also known as *flash codes*.

blotter test a primitive oil analysis means in which a drop of oil is deposited on a blotter.

blue smoke usually associated with engine oil combusted in the engine cylinder; caused by the mixture of condensing droplets and particulate emitted when oil is burned in an engine.

Bluetooth a wireless network suited to applications where lower volumes of data have to be transferred: used primarily for phones, headsets, and PDAs.

boil point the temperature at which a liquid vaporizes.

boosted engine any turbocharged engine; turbo-boosted.

boot the process of loading an operating system into RAM or main memory.

boot-up to load an operating system into RAM, electronically reload a system program, or reset a computer.

bore an aperture. The internal diameter of a pump or engine cylinder or the act of machining a cylindrical aperture.

bottom dead center lowest point of travel of piston in an engine cylinder during its cycle. Usually abbreviated BDC.

boundary lubrication thin film lubrication characteristics of an oil.

brake horsepower standard expression for brake power commonly used in the truck industry. See definition for *brake power*.

brake power power developed by an engine measured at the flywheel measured by a dynamometer or brake. Factored by torque and rpm.

BrakeSaver a Caterpillar engine-mounted, hydraulic retarder.

breakout box a diagnostic device fitted with coded sockets that accesses an electrical or electronic circuit by teeing into it; used in conjunction with a DMM.

breakout T term used to describe a breakout box or in some cases a diagnostic device that tees into two- or three-wire circuits to enable diagnoses by DMM of a single component such as a sensor.

bridge the software and/or hardware used to make electronic connections such as that used to connect nodes in a network.

British thermal unit (Btu) The amount of heat required to raise the temperature of 1 pound of water, 1°F at 60°F. The standard unit of heat energy measurement.

brittle describes the property of a material that is unable to sustain any plastic deformation without fracturing: you could describe a china coffee cup as being brittle.

broach a boring bit used for final, accurate bore sizing.

bubble collapse the condition caused by wet liner combustion pressure impulses acting on the coolant resulting in vapor bubbles that collapse and cause cavitation.

buffers memory locations used to store processed data before it is sent to output devices.

bundle multiple arrangement of cooling tubes that form the core of a heat exchanger.

bus (1) a transit vehicle. (2) an electronic connection; transit lines that connect the CPU, memory, and input/output devices; increasingly used to mean “connected.”

bushing any of a number of types of friction bearings designed to support shafts.

bus systems term used to describe data highways.

butt splice the joining of two pieces in a series connection.

buttness a prop or support member of an assembly: used to increase the strength of a component.

buttness screws transverse main cap bolts installed from the outside of the cylinder block. Helps limit cylinder block torque twist.

bypass filter a filter assembly plumbed in parallel with the lubrication circuit, usually capable of high filtering efficiencies.

bypass valve a diverter valve fitted to full flow filter (series) mounting pads, designed to reroute lubricant around a plugged filter element to prevent a major engine failure.

byte unit of measure of computer data, comprised of 8 bits; used to quantify computer data memory.

cab-over-engine (COE) truck chassis in which the engine compartment is located directly underneath the driver cab, eliminating the hood. Usually abbreviated to COE.

cache high-speed RAM located between the CPU and main memory used to increase processing efficiency.

cage a computer system housing location accommodating two or more bays.

calibration adjusting performance specifications to a standard: fuel trimming of diesel fuel injection components is known as *calibration*.

California Air Resources Board (CARB) The state of California agency responsible for driving emissions legislation and enforcement. By establishing standards that exceed federal standards and effecting them earlier, CARB has led the emission control initiative throughout North America. CARB standards have now been adopted by at least 10 other states with more planning to follow.

calipers comparative measuring instrument used for measuring od or id.

calorific value the heating value of a fuel measured in Btu, calories, or joules.

cam an eccentric portion of a shaft, often used to convert rotary motion into reciprocating motion.

cam geometry the shaping of a cam profile and the effect it produces on the train it actuates.

cam ground trunk-type pistons that are machined slightly eccentrically. Because of the greater mass of material required at the wrist pin boss, this area will expand proportionally more when heated. Cam ground pistons are designed to assume a true circular shape at operating temperatures.

cam heel the point on a cam profile that is exactly opposite the toe or center point of the highest point on the cam.

cam nose the portion of the cam profile with the largest radial dimension; its center point would be the cam toe. That portion of the cam profile that is OBC.

cam profile the cam geometry; simply, the shape of the cam.

camshaft a crankshaft-driven shaft, machined with eccentrics (cams) designed to actuate trains positioned to ride the cam profiles; the engine feedback assembly actuator responsible for timing/actuating cylinder valves and fuel injection apparatus. Driven at half engine speed on four-stroke cycle engines and at engine speed on two-stroke cycles.

camshaft position sensor (CPS) any of a number of types of engine position sensors using either an inductive pulse generator or Hall effect electrical principle.

canister a cylindrical container.

capacitor an electrical device that can store an electrical charge or block AC and pass DC. Also known as a *condenser*.

carbon dioxide (CO₂) the product of combusting carbon in the oxidation reaction of a HC fuel. An odorless, tasteless gas that is nontoxic and not classified as a noxious engine emission, but that contributes to greenhouse gases that concern environmentalists.

carbon monoxide (CO) a colorless, odorless, and poisonous gas that is produced when carbon is not completely oxidized in combustion.

carcinogen a cancer-causing agent.

cartridge a removable container; used to describe the housing that encloses a filter.

cartridge tape data storage medium of the sequential type, currently used for PC data backup.

catalyst a substance that stimulates, accelerates, or enables a chemical reaction without itself undergoing any change.

catalytic converter an exhaust system device that enables oxidation and reduction reactions; in lean burn truck diesel engines, only oxidation catalytic converters are currently used.

cavitation describes metal erosion caused by the formation and subsequent collapse of vapor pockets (bubbles) produced by physical pulsing into a liquid such as that of a wet liner against the wall of coolant that surrounds it. Bubble collapse causes high unit pressures and can quickly erode wet liners when the protective properties of the coolant diminish.

CD-ROM an optically encoded data disk that is read by a laser in the same way an audio CD is read and is designed for read-only data.

central processing unit (CPU) computer subcomponent that executes program instructions and performs arithmetic and logic computations.

centrifugal filter a filter that uses a centrifuge consisting of a rotating cylinder charged with pressurized fluid and canted jets to drive it; centrifugal filters often have high efficiencies and are often of the bypass type.

centrifugal force the force acting outward on a rotating body.

centrifuge a device that uses centrifugal propulsion or a centrifugal force principle of operation.

cetane number (CN) the standard rating of a diesel fuel's ignition quality. It is a comparative rating method that measures the ignition quality of a diesel fuel versus that of a mixture of cetane (good ignition characteristics) and heptamethylnonane (poor ignition characteristics). A mixture of 45 percent cetane and 55 percent heptamethylnonane (another petroleum fraction of poor ignition quality) would have a CN of 45. Diesel fuels refined for use on North American highways are classified by the ASTM as 1D and 2D and must have a minimum CN of 40.

chain hoist a mechanical or power-operated ratcheting lifting device consisting of an actuating block, lift chains, and hook.

charge air cooler (CAC) the heat exchanger that effects charge air cooling: in truck engines, this is usually ram air assisted.

charge air cooling the cooling of turbo-boost air by means of ram air or coolant medium heat exchangers.

charging circuit the portion of the fuel subsystem that begins with the charging or transfer pump and is responsible for delivering fuel to the injection pumping/metering apparatus. In a port-helix metering pump, this extends through the charging gallery of the injection pump.

charging pressure a term used to describe the pressure on the charge side of the transfer pump in a fuel subsystem. Charging pressure parameters are defined by the cycle speed of the charging pump, the flow area it unloads to, and regulating valve.

charging pump the pump responsible for moving fuel through the fuel subsystem. Plunger, gear, and less commonly, vane-type pumps are used.

chassis dynamometer a test bed that measures brake power delivered to the vehicle wheels by having them drive roller(s) to which torque resistance is applied and accurately measured.

chassis-mounted charge air cooling (CMAC) method of cooling turbo-boost air using a ram air heat exchanger: effective in highway applications, less so in off-road service.

chatter a nozzle bench test characteristic in which a nozzle valve rapidly opens and closes; caused by the slow rate of pressure rise when testing nozzle valves.

check engine light (CEL) a dash warning light that is often used as a first level alert to the driver.

cherry picker a portable hydraulic boom hoist with a variety of shop floor functions. Also known as an *engine hoist*.

chip a complete electronic circuit that has been photo-infused to a semiconductor material such as silicon; also known as *I/C (integrated circuit)*, microchip.

chopper wheel the rotating disc that cuts a magnetic field to produce rotational speed or rotational position data to an ECM either by producing an AC voltage value or by pulse width modulation.

clean gas induction (CGI) a Caterpillar exhaust gas recirculation strategy that sources dead gas downstream from the exhaust aftertreatment circuit, hence, the term *clean*.

clearance volume the volume in an engine cylinder when the piston is at top dead center.

clevis a yoke machined with pin bosses with the objective of accommodating angular changes to a linkage.

client anything in a computer processing cycle or multiplex data transaction that can be described as having a need.

clipboard temporary storage location for data during cut, paste, and program transfer operations.

clock speed the measure of how fast a CPU can process data measured in MHz (megahertz) or millions of cycles per second.

clockwise (CW) right-hand rotation.

closed circuit an electrical circuit through which current is flowing.

closed circuit voltage (CCV) voltage measured in an energized circuit.

closed crankcase ventilation (CCV) an EPA requirement for diesel engine crankcases beginning in 2007 (off-highway 2008). Diesel engine OEMs have adopted positive-or centrifugal-type filtration of crankcase vapors prior to re-routing them to the intake upstream from the turbocharger impeller. Equivalent to the automotive *positive crankcase ventilation (PCV)*.

cloud point the temperature at which wax crystals present in all diesel fuels become large enough to make the fuel appear hazy. It is also the point at which plugging of fuel filters becomes a possibility. The cloud point is usually 5°F (3°C) above the fuel's pour point.

cluster the smallest data storage unit on a diskette.

CMP sensor camshaft position sensor.

coalesce to combine to form a single whole.

coefficient of friction a means of rating the aggressiveness of friction materials; alters with temperature and the presence of any kind of lubricant.

coils electromagnetic devices used as the basis of solenoids, transformers, and motors, and in electronics, to shape voltage waves.

cold-start strategy a programmed startup sequence in an electronic management system in which the timing, fuel quantity, and engine-operating parameters are managed on the basis of ambient and engine fluid temperatures. During this process, other inputs such as throttle position may be ignored by the ECM.

combustion the act of burning a substance. An oxidation reaction.

combustion pressure usually refers to peak cylinder pressure during the power stroke.

come-along a ratchet crank and chain or cable used to either lift or exert linear pull.

command circuit used to describe input sensors such as the TPS (throttle position sensor) that commands (requests) an output from the ECM.

command sensors driver-controlled input sensors that request a change in status. An example would be a *throttle position sensor (TPS)*.

common platform a term created to describe what happens when two major OEMs merge and proceed to develop common technology but for purposes of brand identification, badge and market the technology under different names. This has been the case for Volvo and Mack, and Detroit Diesel and Mercedes Benz engine development.

common powertrain controller (CPC) new (DDEC VI) DDC and MB term for their engine ECM (MID address 128).

compression literally *squeeze force*.

compression pressure the pressure produced in an engine cylinder as a piston is driven upward through its compression stroke.

common rail (CR) system fuel injection system in which injection pressures are created by a pump that then supplies fuel to an accumulator or common rail connected to fuel injectors. The fuel injectors are then electrically or electro-hydraulically actuated by the ECM.

communication adapter (CA) the serial communications adapter required to handshake PC software with the chassis data bus.

compacted graphite iron (CGI) a new generation cylinder block casting composite used because of its high strength, resistance to torque twist, and lightweight. One example of CGI is known as *GJV-450*.

companion cylinders term used to describe pistons paired by their respective crank throws to rotate together through the engine cycle such as #1 and #6 in an inline, 6-cylinder engine.

composite steel trunk piston a trunk-type piston in which the crown and skirt sections are manufactured separately and then screwed together using a proprietary process by Mahle; see *Monocomp pistons*.

compound (1) a substance consisting of two or more elements held together by chemical force and not necessarily retaining any characteristics of the composite elements. (2) the process of increasing the force acting on a plunger or piston by using both mechanical and fluid forces.

compound turbocharging a turbocharger circuit in which the turbine housing in place of driving an impeller, is

instead connected to a reduction gearing coupling with an output shaft indirectly connected to the engine crankshaft. This allows the turbocharger to directly transmit torque to the engine drivetrain. An example is the DDC D-Series with *axial power turbines* (APT).

compression ignition (CI) an engine in which the fuel/air mixture is ignited by the heat of compression.

compression ratio the ratio of piston swept volume to total cylinder volume with the piston at bottom dead center: a volumetric ratio not a pressure ratio.

compression ring the ring(s) designed to seal cylinder gas pressure located in the upper ring belt.

compressional load a force that attempts to compress or squeeze from diametrically opposite directions to a common point in the component underload.

compressor housing the section of a turbocharger responsible for compressing the intake air and feeding it into the intake circuit; also known as *impeller housing*.

concentric circles having a common center.

concept gear found in some diesel engine timing geartrains, a concept gear is a two-piece assembly that uses coaxial springs between the hub and outer toothed ring to maintain zero lash tooth contact with the gears it is in contact with.

condensation the changing of a vapor to a liquid by cooling.

conduction heat transmission through solid matter.

connecting rod the rigid mechanical link between the piston wrist pin and the crankshaft throw.

constant geometry (CG) usually used to describe a turbocharger in which all the exhaust gas is routed through the turbine housing which has no internal or external controls.

constant horsepower sometimes used to describe a high torque rise engine.

constant throttle valve (CTV) brake see *continuously open throttle valve (CTV) brake*.

continuity an unbroken circuit; used to describe a continuous electrical circuit. A continuity test would determine if a circuit or circuit component was capable of current flow.

continuously open throttle valve (CTV) brake Mercedes-Benz variation on the internal engine compression brake using small valves (the CTVs) are fitted into the engine cylinder head that allow some cylinder leakage to the exhaust during both the compression and exhaust strokes under braking.

control strategy the manner in which an ECM has been programmed to manage the engine especially in the event of an electronically monitored problem.

control unit the part of a computer CPU responsible for fetching, decoding, executing, and storing.

controller area network (CAN) a data bus system developed by Robert Bosch and Intel for vehicle applications. CAN is a serial data transmission network used as the basis for SAE J1850 (automotive) and SAE J1939 (truck) data backbones.

convection heat transfer by currents of gas or liquids.

conventional memory the first data logged into RAM on boot-up used primarily to retain the operating system.

cooled exhaust gas recirculation (C-EGR) introduced in 2002 to address EPA 2004 diesel emission standards. Dead-end gas is first cooled, then rerouted into the intake system to dilute the intake charge and lower temperatures, reducing NO_x emission.

cordierite ceramic material used for honeycomb flow-through substrates on diesel particulate filters and catalytic converters: not in itself a catalyst.

corrosion chemical change and deterioration of the metal surfaces: caused by acidic, alkaline, or electrolytic conditions.

corrosive alkaline or acidic substances that dissolve metals and skin tissue.

counterclockwise (CCW) left-hand rotation.

counterflow radiator a double pass radiator in which coolant is cycled through U column tubes from usually a bottom-located intake tank to a bottom located output tank; they have higher cooling efficiencies than other radiator designs.

covert term that means undercover, but is commonly used in vehicle electronics to describe the logging of data that cannot be read using the commonly available diagnostic software. Events such as engine overspeed conditions that could impact on the system warranty are often written covertly to an electronic system.

cracked rod connecting rod manufactured and machined in one piece following which the big end is separated by a precisely defined fracture. This ensures a cap-to-rod fit of the highest precision.

crank angle a location in an engine cycle noted by rotational degrees through the cycle.

crank axis center point about which a crankshaft rotates.

crank throw the offset journal on a crankshaft to which a connecting rod is connected.

crankcase the lower portion of the engine cylinder block in which the crankshaft is mounted and under which is the lubrication oil sump.

crankshaft a shaft with offset throws designed to convert the reciprocating movement of pistons into torque.

creep describes the independent movement of two components clamped by fasteners when they have different coefficients of thermal expansion or have different mass, which means their expansion and contraction rates do not concur. A function of a gasket is to accommodate component creep while maintaining an effective seal.

crimping pliers pliers designed to crimp a terminal to a wire without crushing or damaging the terminal.

critical flow venturi (CFV) one type of MAF sensor sometimes known as a *pressure differential flow sensor*. Its operating principle is based on the relationship between inlet pressure and flow rate through a venturi so it uses an inlet and outlet pressure sensor either side of a venturi: this enables the ECM to calculate flow mass.

crossflow radiator usually, a low profile design of radiator (used with aerodynamic hood/nose), in which the entry and output tanks are located at either end and coolant flow is horizontal.

crossflow valve configuration a cylinder head valve configuration in which the intake and exhaust valves are located in series in the cylinder head, meaning that gas flow from the inboard valve differs from (and may interfere with) that of the outboard valve.

crosshead piston an articulating piston with separate crown and skirt assemblies in which the connecting rod is bolted directly to the wrist pin.

crossover a pipe that connects a pair of fuel tanks mounted on either side of a truck frame at the sump level enabling fuel to be drawn from one tank while enabling equal fuel load in each tank.

crown the leading edge face of a piston or in articulating pistons, the upper section of the piston assembly. Crown geometry (shape) plays a large role in defining the cylinder gas dynamic.

crude oil the organic fossil fuel pumped from the ground from which diesel fuel, gasoline, and many other petroleum products are refined; raw petroleum.

current the flow of electrons in a closed electrical circuit.

customer data programming ECM programming *owned* by the vehicle operator and changed at the owner's discretion. An example would be *tire rolling radius programming*.

cycle (1) a sequence of events that recurs such as those of the diesel cycle. (2) one complete reversal of an alternating current from positive to negative.

cylinder block the main frame of any engine to which all the other components are attached.

cylinder head the components clamped to a cylinder block containing the engine breathing and fueling control mechanisms.

cylinder leakage tester device used to test cylinder leakage by applying regulated air to the cylinder at a controlled volume and pressure and producing a percentage of leakage specification.

cylinder volume total volume in an engine cylinder with the piston at BDC: the sum of swept volume and clearance volume.

data raw (unprocessed) information.

data bus multiplex backbone consisting of a twisted wire pair.

data frame a data tag consisting of 100 to 150 bits for transmission to the bus. Each tag codes a message for sequencing transmission to the data bus and also serves to limit the time it consumes on the bus.

data hub the hub of a network system. Used by most truck engine OEMs to log data such as warranty status, repair history, and proprietary programming of on-board ECMs.

data link the connection point or path for data transmission in networked devices.

data logging the tracking of computer data for later analysis.

data processing the production and manipulation of data by a computer.

database a data storage location or program.

default preselected option in computer processing outcomes that kicks in when a failure occurs outside the

programmed algorithm. Failure strategy that permits limited functionality when a critical input is lost. Revert to basics. Limp-home mode.

detonation combustion in an engine cylinder occurring at an explosive rate, accelerated by more than one flame front; caused by a number of different conditions but in diesel engines often by prolonged ignition lag when ambient temperatures are low when it is known as a *diesel knock*.

Detroit Diesel electronic controls (DDEC) DDEC I was introduced in 1985 and marketed in 1987. It was the first full authority engine management system available on a North American engine. DDEC has evolved through a number of versions.

Deutsch connector a widely used, weatherproof, proprietary electrical and electronic connector.

Dexcool a brand of EG base antifreeze.

Diagnostic Link a DDEC PC-based troubleshooting software package driven from MS Windows, designed to guide the technician through troubleshooting sequences, customer data programming, DDEC programming, and data analysis.

diagnostic trouble code (DTC) means of classifying log-coded codes either numerically or in text.

dial bore gauge an instrument designed to facilitate rapid bore comparative measurements, much used by the diesel engine rebuilders.

dial indicator an instrument designed to measure movement, travel, or precise relative dimensions. They consist of a dial face, needle, and spring-loaded plunger. They can measure values down to one hundred thousandth of an inch or thousandths of a millimeter.

Diamond Plus Navistar International's chassis data bus management software built on CAN 2.0/ J1939 architecture. Accessed using Navistar *EZ-Tech*.

diamond dowels flywheel housing alignment dowels shaped cylindrically to the cylinder block, and trapezoidally to the flywheel—capable of a higher precision fit.

dielectric insulator substance such as the separation plates used between the conductor plates in a typical capacitor.

diesel coolant additives (DCA) proprietary supplemental coolant additives.

diesel cycle the four-stroke, compression ignition cycle patented by Rudolf Diesel in 1892. Though the term diesel can be used to describe some two-stroke cycle CI engines, the diesel cycle is necessarily a four-stroke cycle.

diesel fuel a simple hydrocarbon fuel obtained from crude petroleum by means of fractioning and usually containing both residual and distillate fractions.

diesel knock a detonation condition caused by prolonged ignition lag.

diesel oxidation catalyst (DOC) single-stage oxidation catalysts that have been used on highway diesels from the mid-1990s.

diesel particulate filter (DPF) a diesel soot scrubber that physically traps particulate from the exhaust gas, then burns it off during regeneration cycles. Most are ECM managed to regenerate under passive (preferred) and active

cycles that require fuel dosing and a heat source. Heat is usually derived by upstream injection of diesel fuel or from a heat grid. Required in most highway post-2007 diesel engines.

diffuser the device in a turbocharger compressor housing that converts air velocity into air pressure.

digital the representing of data in form of digits or other discreet methods.

digital calipers a precise id and od measuring instrument with the appearance of Vernier calipers, the accuracy of a micrometer, and the ability to convert from the standard to metric system at the push of a button.

digital computer a calculating and computing device capable of processing data using coded digital formats.

digital diagnostic tool (DDT) term used to describe a reader/programmer EST.

digital micrometer a micrometer that displays dimensional readings digitally.

digital multimeter (DMM) A voltage, resistance (ohms), and current (amperes) reading instrument.

digital signals data interchange/retention signals limited to two discernable states; combinations of ones and zeros into which data, video, or human voice must be coded for transmission/storage and subsequently reconstructed.

direct current (DC) current flow through a circuit in one direction only.

direct injection (DI) describes any engine in which fuel is injected directly into the engine cylinder and not to any kind of external prechamber. Most current diesel engines are direct injected.

direct-operated check (DOC) the actuator on a four-terminal Caterpillar MEUI that controls the electrohydraulic nozzle and permits soft (ECM-controlled) NOPs.

discrete in computer technology, this means *coded*. For instance, coding analog values into binary values is expressing those values in a *discrete* format.

disk-operating system (DOS) The set of software commands that govern computer operations and enable functional software programs to be run.

displacement on demand (DOD) term used to describe the emission reduction and fuel consumption strategy of shutting down (by not fueling) engine cylinders. Used on diesel engines since the early 1990s.

distillate any of a wide range of distilled fractions of crude petroleum, some of which would be constituents of a diesel fuel. Refers to the more volatile fractions in a fuel. Sometimes used to refer to diesel fuels.

dividers a comparative-type measuring compass usually with an adjusting screw for setting precise dimensions.

doping the process of adding small quantities of impurities to semiconductor crystals to provide them with either P or N electrical characteristic.

dosing the process of injecting fuel usually from the fuel subsystem into the exhaust for purposes of regenerating a diesel particulate filter or for activating a NO_x adsorber catalyst.

dosing injection describes injection of fuel into an engine cylinder late in the power stroke that is not intended to be

combusted in the cylinder: dosing fuel vaporizes and is exhausted unreacted into the exhaust where it can participate in assisting DPF regeneration and NAC aftertreatment devices. Also known as *afterburn injection*.

double pass radiator a counterflow radiator in which the coolant is routed to make two passes, therefore, entering and exiting from separate tanks both located either at the top or the bottom of the radiator. A high-efficiency radiator.

downflow radiator a typical radiator in which hot coolant from the engine enters at the top tank, flows downward, and exits through a bottom tank.

downlink the transmission signal from a communications satellite to an Earth receiver or the receiver itself.

download data transfer from one computer system to another; often used to describe proprietary data transfer when reprogramming vehicle ECMs.

DPF pulse cleaner one type of off-vehicle DPF cleaning device; uses high volume, low pressure air pulses to remove contaminants.

driver another name for a power transistor. A transistor capable of switching high-current loads.

dry liners liners that are fitted either with fractional looseness or fractional interference that dissipate cylinder heat to the cylinder block bore and have no direct contact to the water jacket.

dry sump an engine that uses a remotely located oil sump; not often seen on highway diesel applications but used in some bus engines to reduce the profile of the engine.

dual actuator EUI a four-terminal EUI with one actuator to control effective pumping stroke and another to open and close the nozzle.

Duramax Isuzu-built, GM diesel engines available in 6600 and 7800 versions.

dynamometer a testing device that loads an engine by applying a resistance to turning effort (torque) and factors this against time to produce brake power values. Often used to performance test or break in engines after reconditioning.

eccentric not circular; axes that are not common.

EEPROM electronically erasable, programmable read-only memory. Vehicle computer memory category that can be rewritten or flashed with customer or proprietary reprogramming. Includes an ECMs write-to-self capability.

effective stroke describes that portion of a constant travel plunger or piston stroke used to actually pump fluid.

electricity a form of energy that results from charged particles, specifically electrons and protons, either statically (accumulated charge) or dynamically such as current flow in a circuit.

electrohydraulic injector (EHI) an ECM-switched injector used on CR and EUI injection systems: opening and closing values are soft, being controlled by the ECM.

electrolysis a chemical change produced in electrolyte by an electrical current often resulting in decomposition.

electrolyte a solution capable of conducting electrical current.

electromagnetic interference (EMI) Low level radiation (such as emitted from electrical power lines, vehicle radar,

etc.) that can interfere with signals on data buses unless suppressed.

electromagnetism describes any magnetic field created by current flow through a conductor.

electromechanical switch any switch in which output status is controlled by manually or automatically switching electrical circuits on and off: differentiated from *smart* or *ladder* switches.

electromotive force (EMF) voltage or charge differential.

electron a negatively charged component of an atom.

electron theory the theory that asserts that current flow through a circuit is by electron movement from a negatively charged point to a positively charged one. See *conventional theory*.

Electronic Diesel Controls (EDC) Bosch term for its engine ECMs.

electronic digital calipers (EDTs) a linear measuring caliper with internal and external jaws—capable of performing accurate measurements ranging from 0 to 6 inches (0–150 mm).

electronic/engine control module (ECM) refers to the computer and integral switching apparatus in an electronically controlled vehicle system. The SAE recommended term for describing the engine control electronics using the MID 128 address on the chassis data bus; most engine OEMs adhere to this recommendation but not all.

electronic distributor unit (EDU) DDC term for injector drivers.

electronic engine management computerized engine control.

electronic foot pedal assembly (EFPA) pedal mechanical travel managed by the TPS.

electronic governor any kind of governing using computer controls.

electronic management system management by computer or computers.

electronic service tool (EST) covers a range of instruments including DMMs, diagnostic lights, generic and proprietary reader-programmers, and PCs.

electronic technician (ET) Caterpillar PC-based software that enables the technician to diagnose system problems, reprogram ECMs, and access system data for analysis to produce fuel mileage figures and driver performance profiles.

electronic unit injector (EUI) The cam-actuated, electronically controlled pumping mechanism used to fuel most full authority, electronically controlled truck diesel engines.

electronic unit pump (EUP) a cam-actuated, ECM-controlled pumping and metering unit that supplies a hydraulic injector by means of a high-pressure line.

electronically erasable, programmable read-only memory see *EEPROM*.

electronics branch of electricity concerned with the study of the movement of electrons through hard-wire, semiconductor, gas, and vacuum circuits.

electrostatics the force field that surrounds an object with an electrical charge.

element (1) any of more than 100 substances (most naturally occurring, some man-made) that cannot be chemically resolved into simpler substances. (2) a component part of something such as a pump element.

emissions control device (ECD) term used to describe emission control hardware.

emulsify the dispersion of one liquid to another or the suspension of a fine particulate in a solution.

emulsion the dispersion of one liquid into another such as water in the form of fine droplets into diesel fuel.

end gas the gas that results from combusting fuel in engine cylinders; usually means the gases present at flame quench, that is, before any exhaust gas treatment so a mixture of CO₂, H₂O, and whatever noxious gases are present.

energized-to-run (ETR) any of a group of solenoids that must be electrically energized to remain in ON status, a non-latching-type solenoid.

energy best expressed as stored potential: its unit is kilowatt/hours (kW/h) or horsepower/hours (hp/h). In technology we more commonly use the term *potential energy*.

end of line (EOL) usually in reference to terminating a programming procedure.

engine a machine that converts one form of energy to another.

engine brake any type of engine retarder. The term usually describes an internal engine compression brake but may also refer to an exhaust compression brake or an enginemounted hydraulic retarder.

engine displacement the sum of the swept volume of all the engine cylinders.

engine dynamometer a dynamometer used for testing the engine on a test bed outside of the chassis.

engine hours a means of comparing engine service hours to highway mileage. Most engine OEMs equate 1 engine hour to 50 highway linehaul miles (80 km), so a service interval of 10,000 miles (16,000 km) would equal 200 engine hours. The term service hours is also used.

engine longevity the engine life span. In highway diesel engines it is usually reckoned in miles on highway engines and hours in off-highway applications.

engine management diagnostics (EMD) a term used to describe the onboard diagnostics (OBD) scheduled to become mandatory for 2010 on highway diesel engines.

engine management system (EMS) a term used to describe the engine management electronics hardware, software, or both.

engine position sensor (EPS) shaft position sensor using a reluctor pulse generator or Hall effect principle.

engine silencer a muffler that uses sound absorption and resonance principles to change the frequency of engine noise.

Environmental Protection Agency (EPA) Federal regulating body that sets and monitors noxious emission standards among other functions.

EPS engine position sensor.

etching bearing or other component failure caused by a chemical action.

ethylene glycol (EG) an antifreeze of higher toxicity that the EPA hopes to phase out.

E-Trim Caterpillar EUI fuel flow specification required to be programmed to the ADEM ECM whenever an EUI is removed and replaced. E-Trim data is important because it enables the ECM to balance fueling to each cylinder.

execute effect an operation or procedure.

executive the resident portion of a computer or program operating system.

exhaust blowdown the first part of the cylinder exhaust process that occurs at the moment the exhaust valves open.

exhaust brake an external engine compression brake that operates by choking down the exhaust gas flow area; sometimes used in conjunction with an internal engine compression brake, meaning that the piston is contributing to retarding effort on both its upward strokes.

exhaust gas recirculation (EGR) A means of routing “dead”-end gas back into the intake to “dilute” the intake charge of oxygen, reducing combustion heat and therefore NO_x . In most truck diesel engines EGR, exhaust gas is cooled by heat exchanger before rerouting to the intake.

exhaust manifold the cast-iron or steel component bolted to the cylinder exhaust tracts responsible for delivering the end gases to the turbocharger and the exhaust system.

exhaust pressure governor (EPG) a combination exhaust engine brake and engine warm-up device used on Volvo-Mack engines. When exhaust flow is partially choked-off downstream from the turbocharger, it creates high backpressure to warm engine when cold and provide engine braking when warm.

explosion an oxidation reaction that takes place rapidly; high-speed combustion.

extended life coolant (ELC) Coolant premix that claims a service life of up to six years with almost no maintenance.

external compression brake refers to an engine exhaust brake.

external engine compression brake see *external compression brake*.

EZ-Tech International Navistar PC to chassis data bus software and hardware. An EZ-Tech notebook (usually a Panasonic Toughbook) connects to the chassis data bus by means of a Navistar CA and J1939 data port (9-pin Deutsch).

failure analysis diagnosis of a failed component usually out of an engine.

fanstat a combination temperature sensor and switch (usually pneumatic) used to control the engine fan cycle.

fault mode indicator (FMI) defines a component or circuit failure numerically to an EST by ascribing to it one of twelve possible failure modes (SAE).

feedback assembly the engine’s mechanical, self management components consisting of a geartrain, camshaft, valve trains, injector actuating trains, fuel injection pumping apparatus and valves.

FerrothermTM piston a Mahle trademark for two-piece articulating piston assemblies consisting of a forged steel crown and aluminum skirt. Used by most commercial vehicle diesel OEMs from the early 1990s until the recent

introduction of single-piece, forged or composite steel, trunk pistons for the 2004 emissions year.

ferrous metals are composed primarily of iron and usually attracted by a magnet.

fetching CPU function that involves obtaining data from memory.

fiber optics the transmission of laser light waves through thin strands of fiber used to digitally pulse data more cheaply and at much higher speeds than copper wire.

field effect transistor (FET) group of transistors used to switch or amplify within a circuit.

field service bulletin (FSB) one OEM’s term for technical service bulletins (TSBs).

field service tips (FSTs) one OEM’s term for *technical service bulletins (TSBs)*.

fields specific items of (electronic) information.

file a collection of related data.

filter monitor a pressure sensing device that monitors DPF or after-treatment device backpressure and alerts the vehicle data bus when a plug-up condition is imminent. Some are also capable of signaling temperature.

fire point the temperature at which a combustible produces enough flammable vapor for a continuous burn; always a higher temperature than flash point.

fire ring normally used to refer to the fixed ring that may be integral with the cylinder head gasket responsible for sealing the cylinder. Sometimes used to refer to the top compression ring but this usage is uncommon.

FireWire a digital audio/video serial bus interface standard offering high-speed communications that can be used to network with vehicle data buses.

fixed disk a data storage device used in PCs and mainframe computers consisting of a spindle and multiple stacked data retention platters.

flame front during flame propagation, the leading edge of the flame in an engine cylinder.

flame propagation the flame pattern from ignition to quench during a power stroke in an engine cylinder.

flame quench the moment that the flame ceases to propagate or extinguishes in an internal combustion engine.

flammable any substance that can be combusted.

flash term used to describe the downloading of new software to EEPROM.

flash codes the ECM-generated fault codes that are usually displayed by means of diagnostic lights and alert the driver or technician as to the nature of an electronically monitored malfunction; also known as *fault codes*, *blink codes*.

flash memory nonvolatile computer memory that can be electrically erased and reprogrammed. It is primarily used in memory cards and USB flash drives (thumb drives, jump drives) and as data retention on vehicle ECM personality modules.

flash point the temperature at which a combustible produces enough flammable vapor for momentary ignition.

flash programming term that has come to mean any reprogramming procedure.

flash RAM nonvolatile RAM; NV-RAM.

flow area the most restricted portion of a fluid circuit; for instance, a water tap sets a flow area and as the tap is opened, the flow area increases, thereby increasing the volume flow of water.

flow control refers to any device that can proportionally control flow through a circuit. A thumb over the end of a hose is a flow control device.

fluid any substance that has fluidity. Both liquids and gases are fluids. Fluid power incorporates both hydraulics and pneumatics.

fluid friction the friction of dynamic fluids, always less than solid friction.

fluid power term used to describe both hydraulics and pneumatics.

flywheel an energy and momentum storage device usually bolted directly to the crankshaft.

flywheel housing concentricity a critical specification that ensures that the relationship of the flywheel and anything connected to it is concentric.

follower used to describe a variety of devices that ride a cam profile and transmit the effects of the cam geometry to the train to be actuated; also known as a *tappet*.

force the action of one body attempting to change the state of motion of another. The application of force does not necessarily result in any work accomplished.

foreground computations computer-operating responses that are prioritized, such as the response to a critical command input such as the TPS (throttle position sensor) whose signal must be acted on immediately to generate the appropriate outcome.

forged steel trunk pistons an open skirt, trunk-type piston assembly with an open skirt: manufactured by Mahle under the trade name *Monotherm*. First appeared for the 2004 model year but rapidly have become the piston of choice in medium and large bore truck diesel engines.

forward leakage an injector bench fixture test that tests the nozzle seat sealing integrity.

fossil fuel unrenewable, organically derived fuels such as petroleum and coal.

four-terminal EUI a more recently introduced, dual actuator EUI: operates on the same principles as a two-terminal EUI but has an ECM-controlled, electrohydraulic nozzle which allows soft (as opposed to fixed-value) NOPs.

fractions refers to separate compounds of crude petroleum separated by distillation and other fractioning methods such as catalytic and hydrocracking and classified by their volatility.

fractured rod a connecting rod manufacturing process: see *cracked rod*.

fretting occurs when two parts that fit tightly are allowed to move slightly against each other, sometimes resulting in microwelding creating small surface irregularities. Can result from a head gasket that fails to allow thermal creep as cylinder head and block pass through heat and cool cycles.

friction the resistance an object or fluid encounters in moving over or through another.

friction bearing a shaft-supporting bearing in which the rotating member can directly contact the bearing face or race.

fuel substance that can be used as source for heat energy.

fuel-amplified common rail (FACR) system the pressure amplified common rail system used in the DD family of engines—the objective is to reduce rail pressure while increasing injection pressure.

fuel conditioner usually unknown quantities of cetane improver and pour point depressants suspended in an alcohol base.

fuel filter device for filtering sediment from fuel rated by entrapment capability.

fuel heater a heat exchanger device used in extreme cold to prevent diesel fuel from waxing in the fuel subsystem.

fuel map a diagram or graph used to indicate fueling through the entire performance range of an engine; also used to describe the ECM fuel algorithm.

fuel pressure sensor (FPS) a pressure sensing mechanism usually of the variable capacitance-type that measures the charging pressure in the fuel subsystem and signals its value to the ECM.

fuel subsystem the fuel circuit used to pump fuel from the vehicle fuel tank and deliver it to the fuel metering/injection apparatus. The fuel subsystem typically comprises a fuel tank, water separator, primary filter, transfer or charge pump, secondary filter, and the interconnecting plumbing.

fuel tank the fuel storage reservoir on a vehicle.

full flow filter a filter plumbed in series on the charge side of the pump that feeds a circuit.

gas analyzer a test instrument for measuring and identifying the exhaust gas content.

gas dynamics the manner in which gases behave during the compression and combustion strokes and the processes of engine breathing.

gasket a sealing medium between a pair of clamped components.

gasket yield point the moment that a malleable gasket is crushed to its desired shape to conform to the required shape between two clamped components to provide optimum sealing.

gates routing switches with either digital or mechanical actuation.

gear pump a positive displacement pump consisting of intermeshing gears that uses the spaces between the teeth to move fluid through a circuit.

genset a complete electricity generating unit consisting of an internal combustion engine and an electricity generator.

geosynchronous orbit the park orbit of communications satellites 35,400 km (22,300 miles) from the Earth's equator.

gerotor a type of gear pump that uses an internal crescent gear pumping principle.

gigabyte a billion bytes; a measurement of digital memory capacity.

glazing friction wearing of a component to a mirror finish.

global positioning satellite (GPS) refers to communications using telecommunications satellites. Currently used for vehicle tracking, navigation, and data exchange.

governing algorithm the processing cycle map built on input circuit sensor status signals and programmed software instructions that manage fuel injector duty cycles.

governing map see *governing algorithm*.

governor a component that manages engine fueling on the basis of fuel demand (accelerator) and engine rpm; electronic on all current engines.

graphical user interface (GUI) software such as MS Windows that is icon and menu driven.

greenhouse gases (GHGs) references any potentially ozone-depleting gases emitted from vehicle systems. Examples are carbon dioxide (from engine) and chlorine dioxide (from A/C).

ground describes the point or region of lowest voltage potential in a circuit; the portion of a vehicle electrical circuit serving multiple system loads by providing a return path for the current drawn by the load. Used in vehicle systems using 48 V or less and ideal for the commonly used 12 V vehicle systems.

ground strap a conductive strap, usually braided wire, that extends a common ground electrical system.

gumming a term used to describe unburned fuel and lubrication oil residues when they sludge in piston ring grooves and other areas of the engine.

gusset a triangular bracket used to strengthen two perpendicularly joined beams.

Hall-effect a method of accurately sensing rotational or linear, position and speed. Normally used to produce a digital signal but may be configured to produce an analog signal using a DAC. A moving metallic shutter alternately blocks and exposes a magnetic field from a semiconductor sensor.

handshake establishing a communications connection especially where two electronic systems are concerned. The communication protocols must be compatible.

hard in electronics, this is a value that should not or cannot be changed. The term that has evolved in definition so that it references anything in computer technology that can be physically touched. An example would be service literature: this might be accessed online in which it would be called *soft* format, or printed out in which case it would be converted to a *hard* format.

hard drive a data storage device used in PCs and mainframe computers consisting of a spindle and multiple stacked data retention platters.

hard parameter a fixed value that cannot or should not be altered or rewritten. Maximum engine rpm would be an example of a hard parameter.

hard value term used to refer to a *constant* in computer technology.

hardware computer equipment excluding software.

headers the manifold deck to which the coolant tubes are attached in a heat exchanger bundle or the term used to describe low gas restriction, individual cylinder exhaust pipes that converge at a point calculated to maximize pulse effect.

headland the area above the uppermost compression ring and below the leading edge of the piston.

headland piston term used to describe a piston design that has minimized the headland volume.

headland volume the headland gas volume in a cylinder.

heat energy an expression of the energy potential a substance possesses. It is actually the amount of kinetic energy at the molecular level in an element or compound.

heat engine a mechanism that converts thermal energy into mechanical work.

heat exchanger any of a number of devices used to transfer heat from one fluid to another where there is a temperature difference using the principles of conduction and radiation.

heating value the potential heat energy of a fuel; also known as *calorific value*.

helical gear a gear with spiral cut teeth.

helices plural of helix.

Hg manometer a mercury (Hg) filled manometer.

high-idle speed the highest no-load speed of an engine.

high-pressure pipes the pipes or lines that deliver fuel from an injection pump element or common rail distributor to the injector nozzle.

high spring injector a type of hydraulic injector nozzle that locates the injector spring high in the injector/nozzle holder body. NOP is usually adjusted by an adjusting screw that acts directly on the spring.

high-pressure washer commonly used to clean trucks and engines: consists of a high pressure pump, accumulator, and nozzle assembly.

histogram a graphic display in which data is represented by rectangular columns used for comparative analysis.

historic codes fault codes that are no longer active but are retained in ECM memory (and displayed) for purposes of diagnosis until they are erased; also known as *inactive codes*.

hone any of a number of types of abrasive stones used for finishing metals. Rotary hones are electrically or pneumatically driven and are used for sizing and surface finishing cylinder liner bores.

horsepower the standard unit of power measurement used in North America defined as a work rate of 33,000 lb.-ft. per minute; equal to 0.746 kW.

H₂O manometer a water-filled manometer.

hunting rhythmic fluctuation of engine rpm usually caused by unbalanced cylinder fueling.

hunting gears an intermeshing gear relationship in which after timing, the gears may have to be turned through a large number of rotations before the timing indices realign.

hydraulic injectors any of a group of injectors that are opened and closed hydraulically as opposed to electronic: this would include the nozzle assemblies used in many EUI and HEUI units. One OEM uses the term *mechanical injector* in place of hydraulic injector.

hydraulically actuated electronic unit injector (HEUI) Caterpillar oil pressure actuated, high-pressure fuel pumping/injecting element.

hydraulics control and actuator circuits that use confined liquids under pressure: the science of fluid power circuits.

hydrocarbon (HC) describes substances primarily composed of elemental carbon and hydrogen. Fossil fuels and alcohols are both hydrocarbon fuels.

hydrodynamic suspension the principle used to float a rotating shaft on a bed of constantly changing, pressurized lubricant.

hydromechanical engine management all engines managed without computers.

hydromechanical governing engine governing without the use of a computer: requires a means of sensing engine speed (centrifugal force exacted by flyweights/fuel pressure) and a means of limiting fuel.

hydrometer an instrument designed to measure the specific gravity of liquids, usually battery electrolyte and coolant mixtures. Not recommended for measuring either in truck engine applications where a refractometer is the appropriate instrument due to greater accuracy.

icons pictorial/graphical representations of program menu options displayed on-screen.

idle speed the lowest speed that an engine is run at usually managed by the governor.

ignition accelerators easily ignited fuel fractions that are added to a fuel to decrease ignition delay. They increase CN.

ignition lag the time period between the entry of the first droplets of fuel to the engine cylinder and the moment of ignition based on the fuel chemistry and the actual temperatures of the engine components and the air charge.

ignition temperature the specific temperature at which any flammable substance begins to combust (oxidize).

impeller (1) the driven member of a turbocharger, responsible for compressing the air charge. (2) the power input member of a pump such as on a torque converter or hydraulic retarder.

inactive codes fault codes that are no longer active but are retained in ECM memory (and displayed) for purposes of diagnosis until they are erased; also known as *historic codes*.

indicated power expression of gross engine power usually determined by calculation: expressed as indicated horsepower.

induction circuit refers to the engine air intake circuit but more appropriately describes air intake on naturally aspirated engines than on boosted engines.

inert chemically unreactive. Any substance that is unlikely to participate in a chemical reaction.

inertia in physics, it describes the tendency of a body at rest or in motion to want to continue in that state unless influenced by an external force.

infrared thermometer accurate heat measuring instrument that can be used for checking cylinder fueling balance.

inhibitors substances that slow a chemical reaction especially an oxidation reaction.

injection lag a diesel fuel injection term describing the time lag between port closure in a pumping element and the actual opening of the injector.

injection quantity calibration data fuel flow specification assigned to EUIs, EUPs, and electrohydraulic injectors: also known by terms such as *QR* and *E-trim* programming.

injection rate a diesel fuel injection term that is defined as the fuel quantity pumped into an engine cylinder per crank angle degree.

injector a term broadly used to describe the holder of a hydraulic nozzle assembly.

injector drivers the ECM-controlled components that electrically switch EUI and HEUI assemblies. Injector drivers may be integral with the main ECM housing or contained in a separate module or housing.

injector nozzle the tip of an injector assembly which contains nozzle orifice or orifices.

injector response time (IRT) time in ms between injector driven signal and EUI control valve closure.

Injector Verification Test (IVT) Caterpillar ADEMs software that complements E-trim by evaluating injector performance 125 hours of engine operation to balance injector fueling.

inlet restriction a measure of the pressure value below atmospheric, developed on the pull side of a pumping mechanism. Air inlet restriction and fuel inlet restriction are common specifications used by the diesel technician.

inlet restriction gauge instrument that measures (usually air) inlet restriction often on-chassis.

inner base circle (IBC) in cam geometry, the portion of the cam profile with the smallest radial dimension; also known as *base circle/IBC*. When the train riding the cam profile is on IBC, it is unloaded.

input the process of entering data into a computer system.

input devices the hardware, such as a keyboard on a PC, or sensors on a vehicle system responsible for signaling/switching data to a computer system.

inside diameter (id) diametrical measurement across a bore.

inside micrometer standard or metric micrometer consisting of a spindle and thimble but no anvil: used for making internal and bore measurements.

InSite Cummins PC software.

insulators materials that either prevent or inhibit the flow of electrons; usually nonmetallic substances that contain more than four electrons in their outer shell.

intake circuit the series of components used to route ambient air into engine cylinders. In a diesel engine, includes filter(s), piping, turbo-compressor housing, charge air cooler and intake manifold.

intake manifold the piping that is clamped to the intake tract flange faces responsible for directing intake air into the engine cylinders.

intake module assembly of air guide components used in some post-2004, and most 2007 diesel engines consisting of intake manifold(s), EGR mixing chambers, and a heat exchanger.

InteBrake™ a six-progressive-step internal-engine-compression brake used on Cummins ISX engines.

integrated circuit (IC) an electronic circuit constructed on a semiconductor chip, such as silicon, that can replace many separate electrical components and circuits.

interface the point or device where an electronic interaction occurs. Separate vehicle system ECMs will sometimes require interface hardware.

interference angle used to provide aggressive valve to valve seat bite: achieved by machining a valve seat at ½-degree less than cylinder head mating seat. Not used when valve rotators are used therefore not common in diesel engines.

interference fit the fitting of two components so that the od of the inner component fractionally exceeds the id of the outer component. Liners are sometimes interference fit to cylinder bores. Interference fitting requires the use of a press, chilling, heating, or other forceful means.

internal compression brake any of a number of engine brakes that use the principle of making the piston perform its usual work through the compression stroke and then negate the power stroke by releasing the compression air to the exhaust system at TDC on the completion of the compression stroke.

internal exhaust gas recirculation (I-EGR) introduced by OEMs of smaller vocational diesels in 2002 to achieve EGR within the cylinder head using cylinder head valve timing.

International service information system (ISIS) see entry under *ISIS*.

iron (Fe) the primary constituent of steel.

ISIS acronym for International (online) service information system. ISIS is designed to interact with Master Diagnostics and Diamond Plus data bus management electronics.

J1667 SAE standards for emission testing of highway diesel engines manufactured before 1991 EPA standards. Currently used by many jurisdictions.

J1850 data backbone hardware and protocols used in light duty CAN multiplexing systems.

J1939 data backbone hardware and protocols used in heavy duty CAN multiplexing systems.

Jacobs brake Jacobs is known mainly for its internal engine compression brakes but also manufactures driveline retarders.

Jake brake a common term used to describe an internal engine compression brake: a slang term for a *Jacobs brake*.

Karman vortex flow MAF sensors See *vortex flow MAF sensors*. The upper inlet of the sensor has an obstruction in the airflow. As air passes around the obstruction, it generates a stream of vortices (like mini-tornadoes) that increase as the air flow velocity increases. By locating an ultrasonic speaker and pickup (microphone) across the stream of vortices which spin off in opposite directions, a frequency modulated shift can be signaled to the ECM. Frequency increases with air velocity.

keep alive memory (KAM) nonvolatile RAM.

keepers split locks fitted to a peripheral groove at the top of a cylinder valve stem: hold the spring retainer in position.

keystone the trapezoidal shape that gets its name from the trapezoidal stones used in a classic Roman arch bridge.

keystone ring a trapezoidally shaped piston ring commonly used in diesel engine compression ring design.

keystone rod a connecting rod with a trapezoidal eye (small end) to increase the loaded sectional area.

kilobyte a quantitative unit of data consisting of 1,024 bytes.

kilowatt a unit of power measurement equivalent to 1,000 watts. Equal to 1.34 BHP.

kinetic energy the energy of motion.

kPa kiloPascal. Metric unit of pressure measurement. Atmospheric pressure is equivalent to 101.3 kPa.

lacquering the process of baking a hard skin on engine components usually caused by high-sulfur fuels or engine oil contamination.

ladder switch a “smart” switch named because it contains a ladder of resistors, usually five per switch, known as a *ladder bridge*. The processor that receives data from the ladder switches on the data bus has a library of resistor values that enables it to identify switch status and its commands.

lamina a thin layer, plate, or film.

lands the raised areas between grooves especially on the ring belt of a piston.

large bore in the trucking industry describes diesel engines with displacements between 12 and up to 16 liters displacement.

latching solenoid a solenoid that locks to a position when actuated and usually remains in that position until the system is shut down.

latent heat thermal energy absorbed by a substance undergoing a change of state (such as melting or vaporization) at a constant temperature.

leak-off pipes/lines the low-pressure return circuit used in most current diesel fuel injection systems.

lean NO_x catalyst (LNC) a catalytic converter designed to reduce NO_x under conditions of excessive oxygen: usually ECM managed and requires HC injection to enable the reduction process using a rhodium catalyst.

lifters components that ride a cam profile and convert rotary motion of the camshaft into linear motion or lift. Lifters used in truck diesel engines are generally solid or roller types.

light-emitting diode (LED) diode that converts electrical current directly into light (photons) and therefore is highly efficient as there are no heat losses.

limiting speed governor (LSG) a standard automotive governor that defines the idle and high idle fuel quantities and leaves the intermediate fueling to be managed by the operator within the limitations of the fuel system.

limp-home see *default*.

linehaul terminal-to-terminal operation of a truck, meaning that most of its mileage is highway mileage.

liners the normally replaceable inserts into the cylinder block bores of most diesel engines that permit easy engine overhaul service and greatly extended cylinder block longevity.

liquid crystal display (LCD) flat panel display consisting of liquid crystal sandwiched between two layers of polarizing material. When a wire circuit below is energized, the liquid crystal media is aligned to block light

transmission from a light source producing a low-quality screen image.

load ratio of power developed versus rated peak power at the same rpm.

locking tang a tab on a component, such as a bearing, that may help position and lock it.

logical processing data comparison and mapping operations by the CPU.

log-on an access code or procedure used in network systems (such as truck OEM data hubs) used for security and identification.

longevity long life or lifespan.

low spring injector an injector design that locates the spring directly over the nozzle valve, thereby reducing the mass of moving components compared to a high spring model. Injector spring tension is usually defined by shims.

LS fuel low sulfur fuel required used on highway diesel engines: phase-out to ULS began in 2007: will not be available for on-highway use after 2010. LS contains a maximum of 0.05 percent sulfur.

lubricity literally, the oiliness of a substance.

lugging term used to describe an engine that is run at speeds lower than the base of the torque rise profile (peak torque) under high loads, that is, high cylinder pressures.

machine cycle the four steps that make up the CPU processing cycle: fetch, decode, execute, and store.

magnetic flux test magnetic flux crack detection used to identify defects in crankshafts, connecting rods, cylinder heads, and other parts. An electric current is flowed through the component being tested and iron particles suspended in liquid are then sprayed over the surface. The particles will concentrate where the magnetic flux lines are broken up by cracks.

magnetism the phenomenon that includes the physical attraction for iron observed in lodestone and associated with electric current flow. It is characterized by fields of force, which can exert a mechanical and electrical influence on anything within the boundaries of that field.

main memory RAM; electronically retained data pipelined to the CPU. Data must be loaded to RAM to be processed by a computer.

major thrust side when cylinder gas pressure acts on a piston, it tends to pivot off a vertical centerline: the major thrust side is the inboard side of the piston as its throw rotates through the cycle.

malleable possessing the ability to be deformed without breaking or cracking.

manifold boost turbo-boost.

manometer a tubular, U-shaped column mounted on a calibration scale. The tube is water or mercury filled to balance at 0 on the scale and the instrument is used to measure light pressure or vacuum conditions in fluid circuits.

mass the quantity of matter a body contains; weight.

mass airflow (MAF) sensors sensors that measure the weight of air forced into the engine cylinders.

master bar a test bar used to check the align bore in engine cylinder blocks.

Master Diagnostics (MD) Navistar International EZ-Tech driven software designed to troubleshoot Navistar engines and chassis components.

master gauge a diagnostic gauge of higher quality used to corroborate readings from an in-vehicle gauge.

master program the resident portion of an operating system. In a vehicle ECM, the master program for system management would be retained in ROM.

master pyrometer an accurate thermocouple pyrometer used when performing dynamometer testing.

material safety data sheets (MSDS) a data information sheet that must be displayed on any known hazardous substance: mandated by WHMIS.

matter physical substance; anything that has mass and occupies space.

mean average.

mean effective pressure average pressure acting on a piston through its complete cycle, the net gain of which, converts to work potential. Usually calculated by disregarding the intake and exhaust strokes, and subtracting mean compression pressure from mean combustion pressure.

mechanical efficiency a measure of how effectively indicated horsepower is converted into brake power: factors in pumping and friction losses.

mechanical injectors one OEM's term for *hydraulic injectors*.

mechanically-actuated, electronically-controlled, unit injector (MEUI) Caterpillar term for an *EUI*: see *electronic unit injector*.

medium bore in the trucking industry describes diesel engines with displacements between 8 and up to 12 liters displacement.

megabytes one million bytes. A quantitative measure of data. Often abbreviated to "meg."

megapascal (MPa) One million pascals. Metric pressure measurement unit.

memory address the location of a byte in memory.

menu a screen display of program or processing options.

message identifier (MID) identifies an on-vehicle electronic circuit by numeric code when read by an EST (SAE).

metals any of a group of chemical elements such as iron, aluminum, gold, silver, tin, and copper that are usually good conductors of heat and electricity and can usually form basic oxides.

metallurgy the science of the production, properties, and application of metals and their alloys.

meter resolution a measure of the power and accuracy of a DMM.

metering the process of precisely controlling fuel quantity.

Mexican hat piston a piston design in which the center of the crown peaks in the fashion of a sombrero. Commonly used in DI diesel engines.

micron one millionth of a meter equivalent to 0.000039 inch. The Greek letter *mu* is used to represent micron and is written as μ .

microorganism growth a condition that may result from water contamination in fuel storage tanks.

microprocessor a small processor. Sometimes used to describe a complete computer unit.

microwaves radio waves used to transmit voice, data, and video. Limited to line of sight transmission to distances not exceeding 30 km.

minor thrust face the outboard side of the piston as its throw rotates away from the crankshaft centerline on the power stroke. See *thrust faces*.

minor thrust side when cylinder gas pressure acts on a piston, it tends to pivot off a vertical centerline: the minor thrust side is the outboard side of the piston as its throw rotates through the cycle.

mixture the random distribution of one substance with another without any chemical reaction or bonding taking place. Air is a mixture of nitrogen and oxygen.

modem a communications device that converts digital output from a computer to the analog signal required by the phone system.

modulation in electronics, the altering of amplitude or frequency of a wave for purposes of signaling data.

module a housing that contains a microprocessor and switching apparatus or either of each.

monitor the common output screen display used by a computer system; a CRT or LCD screen.

monitoring sensors sensors that monitor status conditions and signal them to the ECM. An example would be *engine oil pressure*.

MonocompTM piston a Mahle trademark for a trunk-type piston in which the crown and skirt sections are manufactured separately. The two separate sections are then screwed together using a proprietary process. The piston crown section is manufactured from high temperature steel then screwed into the steel skirt assembly.

MonothermTM piston a Mahle trademark for forged steel, trunk-type piston assemblies with an open skirt.

motherboard the primary circuit board in the computer housing to which the other components are connected.

motive power automotive, transportation, marine, and aircraft.

motoring running an engine at 0 throttle, with chassis momentum driving engine.

mouse input device that controls the cursor location on the screen and switched program options.

muffler an engine silencer that uses sound absorption and resonance principles to alter the frequency of engine noise.

multimedia the combining of sound, graphics, and video in computer programs.

multi-orifice nozzle a typical hydraulic injector nozzle whose function it is to switch and atomize the fuel injected to an engine cylinder. Consists of a nozzle body machined with the orifices, a nozzle valve, and a spring.

multiple splice an electrical connection that joins a number of wires at a single junction.

multiplexing used to describe the networking of two or more electronic system controllers on a data backbone.

multi-pulse injection a feature of most current diesel fuel injection systems in which a fueling pulse can be divided into up to seven separate injection events within a single cycle.

multitasking the ability of a computer to simultaneously process multiple data streams.

Nalcool a brand of antifreeze coolant solution supplemental additive.

nanosecond one billionth of a second.

naturally aspirated refers to any engine that does not use a turbocharger.

naturally aspirated (NA) describes any engine in which intake air is induced into the cylinder by the lower-than-atmospheric pressure created on the downstroke of the piston and receives no assist from boost devices such as turbochargers.

network a series of connected computers designed to share data, programs, and resources.

networking the act of communicating using computers.

neutron a component part of an atom with the same mass as a proton, but with no electrical charge. Present in all atoms except the simplest form of hydrogen.

Newton unit of mechanical force defined as the force required to accelerate a mass of 1 kilogram through 1 meter in 1 second.

nibble four bits of data or half a byte.

Ni-Resist insert a high strength, nickel alloy piston ring support insert in an aluminum trunk-type piston with a similar coefficient of heat expansion as aluminum.

nitrogen (N) a colorless, tasteless, and odorless gas found elementally in air at a proportion of 76 percent by mass and 79 percent by volume. Atomic number 7.

nitrogen dioxide (NO₂) one of the oxides of nitrogen produced in vehicle engines and a significant contributor in the formation of photochemical smog.

noise in electronics, unwanted pulse or wave form interference that can scramble signals.

notebook computer briefcase-sized PC designed for portability.

NO_x adsorber catalyst (NACs) a two-stage exhaust after-treatment system that uses base metal oxides to initially adsorb (store) NO_x compounds, followed by the use of a rhodium reduction catalyst and *dosing* to reduce NO_x back to N₂.

NO_x sensor measures exhaust gas NO_x by essentially electrolytically reducing the compound and comparing the "reduced O₂" with the O₂ in the atmosphere.

noxious emissions engine end gases that are classified as harmful. Includes NO_x and HC but does not include CO₂ (a greenhouse gas) and H₂O.

nozzle the component of most hydraulic and electronic injector assemblies responsible for switching and atomizing fuel.

nozzle differential ratio the ratio of nozzle valve seat to nozzle valve shank sectional areas. This ratio defines the pressure difference between NOP and nozzle closure values.

nozzle opening pressure (NOP) the trigger pressure value of a hydraulic injector nozzle.

nozzle seat the seat in an injector nozzle body sealed by the nozzle valve in its closed position.

numeric data represented by number digits.

numeric keypad microprocessor-based instrument with numeric-only input keys such as on a ProLink or other hand-held ESTs.

Occupational Safety and Health Administration (OSHA) U.S. federal agency responsible for administering safety in the workplace.

ohm a unit for quantifying electrical resistance in a circuit.

Ohm's law the formula used to calculate electrical circuit performance. It asserts that it requires 1 V of potential to pump 1 A of current through a circuit resistance of 1 ohm. Named for Georg Ohm (1787–1854).

oil cooler a heat exchanger designed to cool oil usually using engine coolant as its medium.

oil pan the oil sump normally flange mounted directly under the engine cylinder block.

opacimeter see *opacity meter*.

opacity meter a light extinction means of testing exhaust gas particulate and liquid emission that rates density of exhaust smoke based on the percentage of emitted light that does not reach the sensor, so the higher the percentage reading, the more dense the exhaust smoke.

open circuit any electrical circuit through which no current is flowing whether intentional or not.

open circuit voltage (OCV) voltage measured in a device or circuit through which there is no current flow.

opens an electrical term referring to open circuits/no continuity in a circuit, portion of the circuit, or a component.

operating system (OS) core software programs that manage the operation of computer hardware and make it capable of running functional programs.

optical character recognition (OCR) scanners that read type by shape and convert it to a corresponding computer code.

optical disks digital data storage media consisting of rigid plastic disks on which lasers have burned microscopic holes. The disk can then be optically scanned (read) by a low power laser.

OR gate a multiple input circuit whose output is in the on or one state when any of the inputs is in the on state.

orifice a hole or aperture.

orifici plural of orifice.

orifice nozzle a hydraulic injector nozzle that uses a single orifice (unusual) or a number of orifici through which high-pressure fuel is pumped and atomized during injection.

original equipment manufacturer (OEM) term used to describe the manufacturer of original product, distinct from after-market manufacturer (replacement product).

oscilloscope an instrument designed to graphically display electrical waveforms on a CRT or other display medium.

outer base circle (OBC) the portion of a cam profile with the largest radial diameter.

output the result of any processing operation.

outside diameter (od) outside measurement of a shaft or cylindrical component, but can also be used to mean any outside dimension.

outside micrometer a standard micrometer designed to precisely measure od or thickness. Consists of an anvil, spindle, thimble, barrel, and calibration scales.

overhead adjustment term used to refer to setting cylinder head valves and timing injectors: also known as *tune-up*.

overspeed a governor condition in which the engine speed, for whatever reasons, exceeds the set high-idle speed or top engine limit.

oversquare engine an engine in which the piston bore dimension exceeds the cylinder stroke dimension. Most gasoline fueled engines are oversquare.

oxidation the act of oxidizing a material; can mean combusting or burning a substance.

oxidation catalyst a catalyst that enables an oxidation reaction. In the oxidation stage of a catalytic converter, the catalysts, platinum and palladium, are used.

oxidation stability describes the resistance of a substance to be oxidized. It is a desirable characteristic of an engine lubrication oil to resist oxidation so one of its specifications would be its oxidation stability.

oxides of nitrogen (NO_x) any of a number of oxides of nitrogen that may result from the combustion process: they are referred to collectively as NO_x. When combined with HC and sunlight, reacts to form photoelectric smog.

oxygen colorless, tasteless, odorless gas; the most abundant element on the Earth; occurs elementally in air and in many compounds including water.

ozone an oxygen molecule consisting of three oxygen atoms (triatomic). Exists naturally in the Earth's ozonosphere (6 to 30 miles altitude) where it absorbs ultraviolet light, but can be produced by lightning and by photochemical reactions between NO_x and HC. Explosive and toxic.

packet a data message delivered to the data bus when a ladder switch resistance changes indicating a change in switch status.

palladium an oxidation catalyst often used in catalytic converters.

pallet a bearing surface designed to interconvert rotary and reciprocating motion: the *pallet* of a cylinder valve rides the valve stem or valve bridge.

pallet the "bearing" end of a rocker that directly contacts a valve stem or yoke pad.

parallel circuits electrical circuits that permit more than a single path for current flow.

parallel hybrid term usually used to describe a commercial vehicle powertrain in which a diesel engine drives a genset producing electricity to drive electric motors that provide torque to the wheels.

parallel hydraulic drive (PHD) a drivetrain in which a diesel engine powers both a hydraulic motor/accumulator and mechanical drivetrain; this options hydrostatic drive or direct engine drive or any ratio combination of the two.

parallel hydraulic hybrid (PHH) an Eaton Corp. parallel drive system in which a conventional diesel driven drivetrain is assisted by a hydraulic system consisting of a reversible piston pump and motor coupled to the driveshaft by a clutch, accumulators, plumbing and a control circuit.

parallel port valve configuration a valve arrangement in which a pair of valves are located in parallel with the cylinder head breathing tract—a means of reducing cylinder turbulence.

parameter a value, specification, or limit.

parameter identifier (PID) codes components within a MID system.

parent bore term used to describe an engine with integral cylinder bores machined directly into the cylinder block. Not often used in diesel engines, and when used, the bore surface area may be induction hardened to provide improved longevity.

parity the even or odd quality of the number of 0s (zeros) and 1s (ones), a value that may have to be set to handshake two pieces of electronic equipment.

partial authority term widely used in truck technology to describe a hydromechanical system that has been adapted for management by computer.

particulate matter (PM) solid matter. Often refers to minute solids formed by incompletely combusted fuel and emitted in the exhaust gas.

particulate traps engine-emitted soot entrapment devices. More commonly known today as *diesel particulate filters*.

passive DPF a catalyzed DPF that uses latent diesel exhaust heat to burn off collected particulate (soot) from a wall flow-type filter.

passive DPF mode the primary regeneration cycle of a DPF capable of active and passive modes: it uses latent diesel exhaust heat to burn off collected particulate (soot).

passive regeneration usually the primary generation mode of a diesel particulate filter in which latent exhaust heat is used to combust accumulated soot.

password an alpha, numeric, or alpha–numeric value that either identifies a user to a system or enables access to data fields for purposes of download or reprogramming.

peak pressure the highest pressure attained in a hydraulic system.

peak torque maximum torque. In an internal combustion engine, peak torque always occurs at peak cylinder pressure and in most cases this will be achieved at a lower speed than rated power rpm.

peripherals input and output devices that support the basic computer system such as the CRT and the printer.

periphery in cam geometry, the entire outer boundary of the cam; cam profile.

personal computer (PC) any of a variety of small computers designed for full function in isolation from other units but which may be used to network with other systems.

personality module Caterpillar and Navistar PROM/EEPROM component.

petroleum any of a number of organic fossilized fuels found in the upper strata of the Earth's crust that can be refined into diesel fuel and gasoline among other fuels.

pH used to evaluate the acidity or alkalinity of a substance.

phasing the precise sequencing of events; often used in the context of phasing the pumping activity of individual elements in a multicylinder injection pump.

photochemical reaction a chemical reaction caused by radiant light energy acting on a substance.

photochemical smog formed from airborne HC and NO_x exposed to sunlight; also known as *photoelectric smog* or *photosynthetic smog*.

photoelectric smog see *photochemical smog*.

photons electromagnetic radiation energy; when visible, known as *light*.

pickup tube a suction tube or pipe in a fuel tank or oil sump.

piezo-actuators see *piezo-injectors*.

piezoelectricity some crystals become electrified when subjected to direct pressure producing a voltage increasing with pressure increase. In piezoelectricity, the direction of polarisation reverses if the direction of applied stress changes: that is, from compression to tension. The piezo effect is therefore reversible and this reversibility is the principle used in piezo-actuators.

piezo-injectors diesel fuel injectors that are switched by a piezo-actuator located in a control circuit or integrated directly into the injector valve shaft. A piezo-actuator is constructed of several hundred piezo crystals and mechanical movement occurs almost instantly when the wafer stack has voltage applied to it. They have faster response times than solenoid actuated injectors.

pilot ignition a means of igniting a fuel charge that might normally require a spark, by injecting a short pulse of diesel fuel into a cylinder to ignite a premixed charge of gaseous fuel and air.

pilot injection the injection of a short duration pulse of diesel fuel, followed by a pause to await ignition, followed by the resumption of the fuel pulse. Used as a cold start strategy in some systems to prevent diesel knock and throughout the fueling profile by others.

pin boss the wrist pin support bore in a piston assembly.

pintle nozzle a type of hydraulic injector nozzle used in some IDI automobile, small-bore diesel engines until recently.

piston the reciprocating plug in an engine cylinder bore that seals and transmits the effects of cylinder gas pressure to the crankshaft.

piston pin a wrist pin that links the piston assembly to the connecting rod eye.

piston speed the distance traveled by one piston in an engine per unit of time.

pitting a wear pattern that results in small pock marks or holes.

Plastigage™ a shaft-to-friction bearing clearance measuring system consisting of nylon cord that deforms to conform with the clearance dimension so it can be measured against a coded scale on the packaging envelope.

platinum an oxidation catalyst often used in catalytic converters.

plunger the reciprocating member of a plunger pump element.

plunger pump any pump that uses a reciprocating piston or plunger and, in most cases, is hydraulically classified a positive displacement.

pneumatics the science of the mechanical properties of gases, especially in confined circuits designed to provide motive power.

proprietary data programming ECM programming owned by the OEM and therefore only changed when authorized.

policy adjustment a polite way of describing a shop floor error that requires a service facility to write-off time on a repair invoice.

pop test the testing of NOP on a hydraulic injector nozzle using a bench or pop tester.

pop tester an injector bench test fixture used to *pop test* injectors.

poppet nozzle a forward opening nozzle valve used in older IDI diesel engines.

popping pressure see *nozzle opening pressure*.

port (1) an aperture or opening. (2) a computer connection socket used to link a computer with input and output devices.

positive crankcase ventilation (PCV) an EPA requirement for diesel engine crankcases beginning in 2007 (off-highway 2008). Diesel engine OEMs have adopted positive- or centrifugal-type filtration of crankcase vapors prior to re-routing them to the intake upstream from the turbocharger impeller. Usually called *closed crankcase ventilation (CCV)* in diesels.

positive displacement describes a pumping principle in which the quantity of fuel pumped (displaced) per cycle does not vary so the volume pumped depends on the rate of cycles per minute. When a positive displacement pump unloads to a defined flow area, pressure rise will increase in proportion to rpm or cycles per minute.

positive filtration a filter in which all of the fluid (gas or liquid) to be filtered is forced through the filtering medium. Most air, fuel, coolant, and oil filters used today employ a positive filtration principle.

potential difference electrical charge differential measured in voltage.

potentiometer a three-terminal variable resistor or voltage divider used to vary the voltage potential of a circuit. Commonly used as a throttle position sensor.

pour point a means of evaluating a fuel or lubricants low temperature flow characteristics. The pour point of a fuel is slightly higher in temperature than its gel point.

power the rate of accomplishing work, it is always dependent on time.

power line carrier term used to describe communication transactions delivered through a power line. Signals are

converted to radio frequencies for the transaction and subsequently decoded by the receiver ECM. An example is the power line carrier use of the auxiliary (blue) wire in a standard 7-pin trailer connector for trailer to tractor ABS communications.

power take-off (PTO) an engine or transmission located device used to provide auxiliary power. Can also mean the primary coupling between the engine and powertrain, so in a truck engine, this would be the flywheel.

power transistor a transistor used as the final switch in an electronic circuit to control a solenoid or other output; sometimes known as a *driver*.

powertrain the components of a system directly responsible for transmitting power to the output mechanisms. In an engine, the powertrain components are piston assemblies, connecting rods, crankshaft, and flywheel.

prefix addition of a syllable or letter(s) or numbers at the beginning of a word or acronym.

prelubricator a pump used to charge the lubrication circuit on a rebuilt engine before startup.

pressurizing the process of raising the pressure in a circuit.

preventative maintenance (PM) routine scheduled maintenance on vehicles.

primary filter usually describes a filter on the suction side of a fuel subsystem whereas the term *secondary filter* describes the filter on the charge side of the transfer pump.

processing the procedure required to compute information in a computer system. Input data is processed according to program instructions and outputs are plotted.

program set of detailed instructions that organize processing activity.

programmable read only memory (PROM) a chip or chips used to qualify ROM data to a specific chassis application. In early vehicle computers, this was usually the only method of reprogramming data to an ECM: this PROM function has now been superseded by the EEPROM capability found in most ECMs.

ProLink reader EST a hand-held generic reader/programmer capable of scanning the MIDs networked to a J 1850 or J 1939 data bus and performing diagnostic and limited programming operations on some systems.

propagate to breed, transmit, or multiply. The word is often used to describe the combustion process in an engine cylinder such as in flame propagation.

proportional solenoid a solenoid whose armature will be positioned according to how much current is flowed through its coil. Often an ECM-actuated output. Proportional solenoids may be linear or rotary.

proprietary OS OS that are privately owned and are specific to a manufacturer or operator.

propylene glycol (PG) A less toxic glycol base antifreeze solution than EG. PG mixture strength must be tested with a refractometer with a PG scale and not mixed with EG.

protocols sets of rules and regulations. Often used to define communication language.

proton positively charged component of an atom located within its nucleus.

psi pounds per square inch. Standard unit of pressure measurement.

pulse exhaust a tuned exhaust system used to optimize the gas dynamic of exhaust gas delivered to the turbocharger.

pulse wheel the rotating disc used to produce rpm or rotational position data to an ECM. The term is most often applied to the rotating member of a Hall effect sensor, but at least one manufacturer uses the term to describe an AC reductor wheel.

pulse width (PW) usually refers to EUI duty cycle measured in milliseconds.

pulse width modulation (PWM) constant frequency, digital signal in which ON/OFF time can be varied to modulate duty cycle.

pump drive gear the gear responsible for imparting drive force to a pump.

pump-line nozzle (PLN) the hydromechanical or electronically managed injection pump to line to nozzle fuel injection principle used in most diesel fuel systems until the introduction of EUI engines.

push tubes hollow, cylindrical tubes located between a follower and a rocker assembly that transmit the effects of cam profile to action at the rocker arm.

pushrods cylindrical solid rods located between a follower and a rocker assembly that transmit the effects of cam profile to action at the rocker arm.

pyrometer a thermocouple type, high temperature sensing device used to signal exhaust temperature. Consists of two dissimilar wires (pure iron and constantan) joined at the hot end with a millivoltmeter at the read end. Increase in temperature will cause a small current to flow, which is read at the voltmeter as a temperature value.

quick response (QR)code Denso electrohydraulic injector fuel flow calibration data specification that must be programmed to the ECM: allows the ECM to precisely balance fueling to the engine cylinders.

QuickServe OnLine (QSOL) Cummins on line engine and electronics server for repair, troubleshooting, and service bulletins.

quiescent a term used to describe any low turbulence engine cylinder dynamic. Its root is from the word *quiet*.

radial piston pump means of creating injection pressures in some current common rail diesel fuel injection systems. Multicam profiles actuate reciprocating plungers that unload to an accumulator or rail.

radiation the transfer of heat or energy by rays not requiring matter such as a liquid or a gas.

radiator a heat exchanger used in liquid-cooled engines designed to dissipate some of the engine's rejected heat to atmosphere.

rail a manifold.

rail actuator see *fueling actuator*.

rail pressure control valve (RPCV) a linear proportioning solenoid with integral spool valve used as an ECM output in a common rail injection system: its function is to precisely manage rail pressure. In ECM processing, it is looped with

the rail pressure sensor (inputs actual rail pressure) attempting to maintain "desired" rail pressure.

rail pressure sensor (CR) V-Ref supplied, variable capacitance-type pressure sensor that signals actual rail pressure to the ECM at any given moment of operation.

ram air air fed into engine cooling and intake circuits by the velocity of a moving vehicle; increases proportionally with vehicle speed.

ramps in cam geometry, the shaping of the cam profile between the IBC and the OBC. The ramp geometry defines the actuation/unload characteristics of the train that rides its profile.

random-access memory (RAM) main memory—electronically-retained memory held in the processing loop.

random access memory (RAM) electronically retained "main memory" of a computer system.

rated power the peak horsepower power produced by a diesel engine: often expressed as *rated speed* because it is always correlated to a specific rpm.

rated speed the rpm at which an engine produces peak power.

ratio quantitative relationship between two values expressed by the number of times one contains the other.

reactive substances that can become chemically reactive if they come into contact with other materials resulting in toxic fumes, combustion or explosion.

reader-programmer a generic or OEM electronic service tool (EST) designed to both scan, reprogram, and perform some diagnostics on an electronic system.

read-only memory (ROM) data that is retained either magnetically or by optical coding and designed to be both permanent and read-only.

ream the machining process of accurately enlarging an orifice using a steel boring bit with straight or spiral fluted cutting edges.

Recommended Practice (RP) a TMC standard practice published in the *TMC RP Manual* that sets technical standards in the trucking industry.

rectifier device used to convert AC into DC.

reference voltage (V-Ref) the ECM-controlled output to on-board sensors.

refraction the extent to which a light ray is deflected (bent) when it passes through mediums such as water, coolant or fog.

refractometer tests the refractive index of battery electrolyte and antifreeze—more accurate than hydrometer testing because it requires no temperature correction.

refractive index truly the ratio of the speed of light in a vacuum versus the speed of light through a specified medium, but in practice, is used to express natural light, refractometer readings in coolant or battery electrolyte.

regeneration cycle term used to describe the burn-off cycle of a diesel particulate filter in which accumulated soot is combusted.

regeneration system (RS) the *diesel particulate filter (DPF)* self-cleaning management system: the means used to manage and burn off accumulated DPF soot.

regenerative braking vehicle retarding effort achieved in a parallel hybrid drive unit when the drive electric motor magnetic field is reversed, both applying retarding torque and generating electricity that can be used to charge the batteries.

register alignment or track point of two components.

registers temporary storage locations in a CPU.

rejected heat that portion of the potential heat energy of a fuel not converted into useful kinetic energy.

relief valve a commonly used valve in hydraulic circuits (such as fuel subsystem and lubrication circuits) that defines maximum circuit pressure. The simplest type would consist of a ball check, loaded by a spring to seal a return line. When circuit pressure was sufficient to unseat the ball check, circuit fluid would be diverted from the main circuit to the return.

reluctance resistance to the movement of magnetic lines of force.

reluctor a term used to describe a number of devices that use magnetism and motion to produce an AC voltage.

reprogram general term used to cover a range of rewrite and overwrite procedures in computer technology.

resistance opposition to electrical current flow in a circuit.

resolution the smallest interval measurable by an instrument. In computer terminology, it usually describes the image clarity of a CRT display in pixels. It also defines range in a DMM.

resonation condition in which sound energy is reflected back toward its source thereby scrambling the frequency—used in some types of engine silencer.

resonation principle a noise-reducing principle used in engine silencers that scrambles sonic nodes and antinodes by reflecting sound back toward its source, thereby altering the frequency.

Resource Conservation and Recovery Act (RCRA) U.S. federal legislation that regulates the disposal of hazardous materials.

retarder generally refers to braking action, that is, the retarding of vehicle movement.

rhodium a hard white metal occurring naturally in platinum ores and used as a NO_x reduction catalyst in gasoline fueled engines.

Right to Know legislation a provision of the U.S. federal Hazard Communications legislation that imposes on employers the duty of fully revealing the potential dangers of hazardous materials to which their employees may be exposed.

ring belt the area of the piston in which the piston ring grooves are machined.

ring groove the piston recesses into which the piston compression and oil control rings are installed.

road speed governing (RSG) the managing of engine output on the basis of a specific road speed. Can also be used to mean the maximum programmed road speed limit.

road speed limit (RSL) usually the maximum programmed road speed value programmed to a vehicle management system meaning that the vehicle should not travel faster than this speed. However some OEMs permit maximum cruise speeds to be programmed above RSL to encourage drivers to use cruise control so this is not always true.

road speed sensor a sensor usually of the pulse generator type located at the transmission tailshaft or a wheel assembly that signals the ECM road speed data.

rocker arm see *rockers*.

rocker assemblies the entire rocker assembly consisting of rockers, rocker shaft, and pedestals.

rocker pallet the end of a rocker that contacts the injection pumping tappet, the valve stem, or the valve bridge.

rockers shaft-mounted, pivoting levers that transmit the effects of cam profile to valves and injection pumping apparatus.

rod eye the upper portion of a connecting rod that connects to the piston wrist pin; also known as a *small end*.

run-in usually describes the engine break-in procedure following a rebuild outlined by the OEM.

sac a spherical cavity. Refers to the chamber in some multi-orifice injector nozzles beyond the seat and from which the exit orifices extend.

SAE J standards standards developed by SAE industry committees and generally agreed to, usually without any statutory obligation.

SAE J1587 electronic data exchange protocols used in data exchange between heavy-duty, electronically managed systems.

SAE J1667 standards for emissions testing.

SAE J1708 serial communications and hardware compatibility protocols between microcomputer systems on a J1587 data bus. Its data link is a 6-pin Deutsch connector.

SAE J1939 the set of multiplexing standards that incorporate both J1587 and J1708. Both software and hardware protocols and compatibilities are covered by J1939, which is updated by simply adding a suffix. The standard SAE/ATA, 9-pin Deutsch connector is referred to as a J1939 diagnostic/data link. A CAN 2.0 data bus.

SAE viscosity grades the industry standard for grading lubricating oil viscosity.

scavenge term used generally to describe the process used to expel end gases from an engine cylinder and specifically to describe: (1) the final stage of the exhaust process in a four-stroke cycle engine that occurs at valve overlap. (2) cylinder breathing on a two-stroke cycle diesel engine.

scavenging pump an auxiliary oil pump used in some engines that may have to operate on steep inclines that may starve the primary oil pump.

scissor jack an air-actuated floor jack with a pair of clevises that lock to the truck frame rails and can lift one end of the chassis well clear of the floor.

scraper ring piston rings below the top compression ring that play a role in sealing cylinder gas as well as managing the oil film on the cylinder wall.

screen any computer output display from LCDs through CRTs.

scrolling the moving of lines of data up or down on a computer display screen.

scuffing a superficial scraping of metal against metal damage mode.

secondary filter usually refers to a filter downstream from the transfer or charge pump in a typical fuel subsystem. It is in most cases under pressure and capable of much finer filtration than a primary filter, which is usually under suction.

selective catalytic reduction (SCR) term used to describe NO_x reduction converters for truck applications using *aqueous urea* injection. On injection, the urea vaporizes to gaseous ammonia that reacts with NO_x compounds to reduce them back to elemental nitrogen and water.

self-regeneration term used to describe on-board regeneration (cleaning) cycles of a *diesel particulate filter (DPF)*: essentially, it refers to the combustion of accumulated soot during normal operation while on the vehicle.

semiconductor materials that neither conduct well nor insulate; they have four electrons in their outermost shell.

sending unit a variable resistor and float assembly that signals a gauge and/or ECM the liquid level in a tank.

sensor a term that covers a wide range of command and monitoring input (ECM) signal devices.

sequential troubleshooting chart commonly used by engine OEMs to structure electronic troubleshooting. The technician routes the troubleshooting path through the chart on the basis of test results in each step.

series circuit a circuit with a single path for electrical current flow.

service hours a means of comparing engine service hours to highway mileage. Most engine OEMs equate 1 engine hour to 50 highway linehaul miles (80 km), so a service interval of 10,000 miles (16,000 km) would equal 200 engine hours. The term *engine hours* is also used.

service information systems (SIS) term OEMs use to describe their service instructions, procedures and specifications: in most cases, SIS is online because of the ease of updating, correcting, and tagging information with TSBs.

service literature general term used to cover OEM service information regardless of whether it is hard (paper) copy, disk-based, or online sourced. Most truck OEMs use online service information systems today.

shear the stress produced in a substance or fluid when its layers are laterally shifted in relation to one another. Viscosity describes a fluid's resistance to shear.

shell term used to describe the concentric orbital paths of electrons in atomic structure.

shutdown solenoid an ETR or latching solenoid that functions to no-fuel the engine to shut it down.

shutterstat a temperature sensing, pneumatic switch used to manage air shutter operation.

sight glass see *diagnostic sight glass*.

signals codes, signs, or symbols used to convey information.

silicon a nonmetallic element found naturally in silica; silicone dioxide in the form of quartz.

silicone any of a number of polymeric organic compounds of the element silicon associated with good insulating and sealing characteristics.

single actuator term applied to pre-2007 EUIs—the single actuator controlled plunger effective stroke.

single pass radiator any radiator through which flow is unidirectional.

single-phase mains standard potential grid electricity at 110-130 V-AC in North America.

sinter a means of alloying metals in which the constituent materials are mixed in powdered form and then coalesced by subjecting them to heat and pressure. Produces more uniform metallurgical characteristics than alloying.

sintered steel a steel produced by a sintering process; used in certain engine and fuel system components to produce especially tough and durable material characteristics.

sleeves see *liners*.

small bore in the trucking industry describes diesel engines with displacements between 5.9 and up to 8 liters displacement.

small end the connecting rod eye.

smart general and some would say slang, term used to describe computer controls: see definition for *smart logic* that follows.

smart injector term used by some engine OEMs to describe an *electrohydraulic injector*.

smart logic used to describe computed outcomes that use a broad range of input and memory factors to produce “soft” outcomes rather than adhere to hard values. For instance, *smart* cruise control learns road terrain patterns and permits some latitude around the programmed road speed value to improve fuel economy and may “reward” drivers for exceeding fuel economy thresholds. The term is also used to describe computer peripherals that possess some processing capability.

smart switch so named because it contains a ladder of resistors, usually five per switch, known as a *ladder bridge*; switch status can be determined by the processor mastering the multiplex using a programmed resistance library that identifies the switch and its status.

SmartWaySM an EPA driven program that makes funds available to help reduce the carbon footprint of highway trucks—includes truck replacement, aerodynamics, and reduction of rolling drag initiatives.

smog a word formed by combining the words fog and smoke. A haze produced by suspended airborne particulates. Two major types exist: sulfurous smog produced by combusting sulfur-laden fuels such as coal and heavy oils and photochemical smog, a primary cause of which is vehicle emissions.

snapshot test a diagnostic test performed on a PC or Pro-Link that captures frames of running data before and after an event that can be identified by either an automatic (such as a fault code) or manual trigger.

soak tank a usually heated tank that is filled with a detergent or alkaline solution; used to clean engine components.

Society of Automotive Engineers (SAE) organization responsible for setting many of the manufacturing standards and protocols of the motive power industries and dedicated to educating and informing its members.

soft term used in electronics to indicate a flexible value. It has evolved to reference anything in electronic/computer technology that cannot be physically touched. An example would be service literature: this might be accessed online in which case it would be called *soft* format, or printed out in which case it would be converted to a *hard* format.

soft copy data that is retained electronically as opposed to being on paper.

soft cruise a cruise control mode programmed into some vehicle/engine management electronics in which the road speed is managed within a window extending both above and below the set speed. Soft cruise can increase fuel economy and is often used in conjunction with vehicle maximum speed programming below maximum cruise speed.

soft parameter a value that varies and depends on input and processing variables (see *fuzzy logic*). The term is often used to describe current cruise control systems that permit a cushion both above and below the set value. See *soft cruise*.

soft value term used to refer to virtual or variable conditions in computer technology.

software the programmed instructions that a computer requires to organize its activity to produce outcomes.

solar cells PN or NP silicon semiconductor junctions capable of producing up to 0.5 V when exposed to direct sunlight.

solenoid an electromagnet with a movable armature.

solid state components that use the electronic properties of solids such as semiconductors to replace the electrical functions of valves.

solid state storage volatile storage of data in RAM chips.

sound absorption principle a means of converting sound waves to friction then heat, which is then dissipated to atmosphere, used in engine silencers/mufflers.

spalling surface fatigue that occurs when chips, scales or flakes of two surfaces in contact with each other separate because of fatigue rather than wear. Also known as *contact stress fatigue*.

specific gravity the weight of a liquid or solid versus that of the same volume of water.

spectrographic analysis a low-level radiation test that can accurately identify trace quantities of matter in a fluid; used to analyze engine oils.

spectrographic testing oil analysis in which the oil is subjected to low level radiation to determine content.

spike an electrical (voltage) or hydraulic pressure surge.

spill valve solenoid (SVS) solenoid on a Caterpillar four-terminal MEUI that either spills or traps (when energized) fuel in the MEUI plunger pump chamber.

spindle an intermediary, responsible for transmitting force. In a hydraulic injector, it relays spring force to the nozzle valve.

splice to join.

split locks the keepers fitted to a peripheral groove at the top of a cylinder valve stem that hold the spring retainer in position.

split shot injection term used to describe pilot injection. Diesel fuel injection intentionally broken into more than one pulse during a single injection cycle to one engine cylinder.

spreader bar a rigid lifting aid permitting an engine to be raised on a single point chain hoist using two, three, or four lift points on the engine.

spur gear a gear with radial teeth.

square engine an engine in which the bore and stroke dimensions are the same or nearly the same.

stanchion a vertical bracket bolted to the chassis used to mount exhaust aftertreatment canisters, stack(s), and other equipment: usually reinforced with gussets and cross-struts.

star network network set up to operate from a central hub computer.

static charge capacitive (accumulated) charge resulting from electrostatic induction. When a conductor in motion steals electrons, they accumulate in the conductor and discharge when provided with a ground path.

static discharge the arcing that occurs when *static charge* finds a ground path.

static electricity accumulated electrical charge not flowing in a circuit.

static friction the characteristic of a body at rest to attempt to stay that way: see the definition of *inertia*.

steel an alloy of iron produced by the addition of a small percentage of carbon.

stiction stationary friction: an example would be thread contact friction during fastener torquing.

stoichiometric ratio an air-fuel ratio (AFR) term meaning that at ignition, the engine cylinder has the exact quantity of air (oxygen) present to combust the fuel charge: if more air is present, the AFR mixture is rich, if less air is present, it is lean.

stoichiometry the science of determining the ratio of reactants required to complete a chemical or physical reaction.

stop engine light (SEL) a driver alert indicating the driver should shut down the engine or if programmed to do so, the management system will shut down the engine. Usually illuminated 30 to 60 seconds before shutdown.

storage media any nonvolatile data retention device: floppy disks, data chips, CD-ROM, and PCMCIA cards are examples.

strategy action plan. In computer technology it relates to how a series of processing outcomes is put together: for instance, start-up strategy deals with how the sequence of events are switched by the ECM that results in the engine being cranked and started.

stroke linear travel of a piston or plunger from BDC to TDC. In an engine, piston stroke is defined by the crank throw dimension.

substrate (1) the supporting material on which an electric/electronic circuit is constructed/infused. (2) thermally stable, inert material on which active catalysts are embedded on a vehicle catalytic converter.

subsystem identifier (SID), branch circuit within a MID off the data bus used for diagnostic reporting.

suction circuit the portion of a lubrication or fuel sub-system that is on the pull side of the transfer pump.

suffix addition of a syllable or letter(s) or numbers at the end of a word or acronym.

sulfur an element present in most crude petroleum, but refined out of most current highway fuels. During combustion, it is oxidized to sulfur dioxide. Classified as a noxious emission.

sulfur dioxide the compound formed when sulfur is oxidized that is the primary contributor to sulfurous-type smog. Vehicles contribute little to sulfurous smog problems due to the use of low-sulfur fuels.

sump the lubricating oil storage device on an engine more commonly referred to as an oil pan.

supercharger technically any device capable of providing manifold boost, but in practice used to refer to gear-driven blowers such as the Roots blower.

supplemental cooling (system) additive (SCA) conditioning chemicals added to antifreeze mixtures.

swash plate pump a pump that uses a rotating, circular plate (the swash plate) set obliquely on a shaft to act as a cam and convert rotary motion into reciprocating movement to actuate pistons or plungers; also known as a *wobble plate*.

swept volume volume displaced by a piston as it travels from BDC to TDC.

synchronous reference sensor (SRS) DDEC engine location sensor consisting of a single dowel located on the cam gear.

synthetic oil petroleum-based and other elemental oils that have been chemically compounded by polymerization and other laboratory processes.

system pressure regulator a usually hydromechanical device responsible for maintaining a consistent line pressure; located downstream from a pump.

tang release tool a lock release tool required to service the sealed connector blocks on electronic engines.

tappets used to describe a variety of devices that ride a cam profile and transmit the effects of the cam geometry to the train to be actuated; also known as *followers*.

tattletale an audit trail that may be discreetly written to ECM data retention; the recording of electronic events for subsequent analysis.

Tech Central International Trucks central data hub.

Technical and Maintenance Council (TMC) division of the ATA that sets and recommends safety and operating standards.

technical service bulletin (TSB) the more common term used to describe up-to-date amendments and corrections to a service procedure or product recall.

telecommunications any distance communication regardless of transmission medium.

telematics information technology required for wireless networking of computers especially in mobile equipment such as trucks. For instance, telematics are used by fleets to network a truck chassis data bus with communications hubs.

telemetry the processes of obtaining and transmitting data from sensors for processing or display. For instance, the telemetry of a typical drive-by-wire, analog-type TPS, requires a V-Ref supply, potentiometer, and chassis ground, plus the connection wiring to connect the device to the ECM that requires the signal.

telescoping gauges spring loaded tram gauges used in conjunction with a micrometer or EDT to measure inside diameter.

Tempilstick a heat-sensing crayon used for precise determination of high temperatures.

template torque the procedure used to tighten a *torque-to-yield* fastener—requires using a torque wrench to a specified value, then turning the fastener a further specified number of degrees for final torque.

template torquing procedure used on torque-to-yield fasteners that usually involves torquing to a specified value with a torque wrench followed by turning the fastener through an arc of a specified number of degrees measured by a protractor or template. Produces more consistent clamping pressures than torque-only methods.

tensile strength unit force required to physically separate a material: in steels, tensile strength exceeds yield strength by around 10 percent.

terabyte a trillion bytes.

terminal (1) a computer station or network node. (2) an electrical connection point.

thermal efficiency measure of how efficiently an engine converts the potential heat energy of a fuel into usable mechanical energy, usually expressed as a percentage.

thermatic fan a fan with an integral temperature-sensing mechanism that controls its effective cycle.

thermistor a commonly used temperature sensor that is supplied with a reference voltage and by using a temperature sensitive variable resistor, signals back to the ECM a portion of it.

thermocouple a device made of two dissimilar metals, joined at the “hot” end and capable of producing a small voltage when heated. The principle used in pyrometers that monitor DPF and engine exhaust temperatures.

thermostat a self-contained, temperature-sensing/coolant flow modulating device used to manage coolant flow within the engine cooling system.

thick film lubrication lubrication of components where clearance factors tend to be large and unit pressures low.

thin film lubrication the ability of oil to form a cohesive film on contact with a material: more properly known as *boundary lubrication*.

Think Big a Caterpillar-sponsored associate degree program for technicians.

Think Bigger a Caterpillar-sponsored bachelor degree program for technicians.

three-phase mains high potential grid electricity provided in voltage values ranging from 210 to 600 V-AC.

three-way splice the uniting of three wires at junction.

threshold values outside limits or parameters.

throttle air flow to the intake manifold control mechanism used in SI gasoline and diesel engines with pneumatic governors. The term is commonly used to describe the speed control/accelerator/fuel control mechanism in a diesel engine.

throttle position sensor (TPS) device for signaling accelerator pedal angle to the TPS. One common type is designed to receive a V-Ref input delivered to a potentiometer which returns a portion of that voltage as a signal to the ECM that correlates with accelerator pedal angle. More recently, a Hall-effect-type TPSs have been introduced.

thrust linear force.

thrust bearing a bearing that defines the longitudinal or end play of a shaft.

thrust faces a term used to describe loading of surface area generally but most often of pistons. When the piston is subject to cylinder gas pressure there is a tendency for it to cock (pivot off a vertical centerline) and load the contact faces off its axis on the pin.

thrust washer see *thrust bearing*.

timing the manner in which events or actions are sequenced. The term is used in many applications in engines relating to valves, injection, ignition, and others.

timing bolt means of locking a component or engine to position for purposes of timing.

timing dimension tool a tune-up tool used to set the tappet height on MUIs and EUIs.

timing reference sensor (TRS) crankshaft position sensor. The acronym was originally used by DDC and current versions of DDEC use a 36-tooth tone wheel.

tone wheel the rotating disc used to produce rpm and rotational position data to an ECM. The term is most often applied to the rotating member of a Hall effect sensor, but at least one manufacturer uses the term to describe an AC retractor wheel.

top dead center outboard extremity of travel of a piston or plunger in a cylinder. Usually abbreviated to TDC.

top engine limit a Caterpillar term for *high idle*.

topology the configuration of a computer network; a network schematic.

torched piston a piston that has been overheated to the extent that meaningful analysis of cause is not possible.

torque twisting effort or force. Torque does not necessarily result in accomplishing work.

torque rise the increase in torque potential designed to occur in a diesel engine as it is lugged down from the rated power rpm to the peak torque rpm, during which the power curve remains relatively flat. High torque rise engines are sometimes described as constant horsepower engines.

torque rise profile diagrammatic representation of torque rise on a graph or fuel map.

torque-to-yield bolts with metallurgical properties that allow them to stretch to their yield point as they are tightened: used where more precise clamping loads are required such as on cylinder heads and connecting rods.

torque twist effect one way of describing the twist forces a cylinder block must sustain as engine torque is transferred to the drivetrain: increases as engine torque increases.

torsion twisting force.

torsional stress twisting stresses. A crankshaft is subject to torsional stress because a throw through its compression stroke will travel at a speed fractionally lower than mean crank speed, whereas a throw through its power stroke will accelerate to a speed fractionally higher than mean crank speed. These occur at high frequencies.

total base number (TBN) measure of lube oil acidity reported in lab lube oil analysis: will increase as low ash oils such as CJ-4 become commonplace.

total dissolved solids (TDS) dissolved minerals measured in a coolant by testing the conductivity with a current probe (TDS tester). High TDS counts can damage moving components in the cooling system such as water pumps.

total indicated runout (TIR) a measure of eccentricity of a shaft or bore usually measured by a dial indicator.

toxic materials that may cause death or illness if consumed, inhaled, or absorbed through the skin.

train a sequence of components with a common actuator. See *valve train*.

transducer an input circuit device that converts temperature, pressure, linear, and other mechanical signals into electrical signals to be sent to an ECM. A transducer may produce either analog or digital signals to be sent to control modules.

transfer pump describes the fuel subsystem pump used to pull fuel from the fuel tank and deliver it to the injection pumping/metering apparatus.

transformer an electrical device consisting of electromagnetic coils used to increase/decrease voltage/current values or isolate subcircuits.

transient short lived, temporary; often refers to an electrical spike or hydraulic pressure surge.

transistors any of a large group of semiconductor devices capable of amplifying or switching circuits.

transorb diode used to protect sensitive electronic circuits (such as an ECM) from the inductive kick that can be created by solenoids when their magnetic field collapses.

transponder a ground-based satellite uplink—can be either mobile or stationary.

trapezoid a quadrilateral with one pair of parallel sides.

trapezoidal ring see *keystone ring*.

trapezoidal rod a connecting rod with a trapezoidal small end or rod eye designed to maximize the sectional area of the rod subject to compressive pressures; more commonly referred to as a keystone rod.

triangulation see *trilateration*.

tribology the study of friction, wear, and lubrication.

trilateration the locating of a common intersection by using three circles each with different centers: the mathematical basis of GPS technology.

troubleshooting the procedures involved in diagnosing problems.

trunk-type piston a single piece piston assembly usually machined from aluminum alloys in diesel engine applications.

truth table a table constructed to represent the output of a multiswitch circuit, based on the switch status within the circuit.

tune-up term used to refer to the setting of valves and timing injectors in diesel engines: more commonly known as *overhead adjustment*.

turbine a rotary motor driven by fluid flow such as water, oil, or gas.

turbo commonly used short form for *turbocharger*.

turbo-boost sensor (TBS) a device used to signal manifold boost values to the ECM. An aneroid is used in hydro-mechanical engines and either a piezo-resistive or variable capacitance device is used in electronically controlled engines.

turbocharger an exhaust gas driven, centrifugal air pump used on most truck diesel engines to provide manifold boost. Consists of a turbine housing within which a turbine is driven by exhaust gas, and a compressor housing within which an impeller charges the air supply to the intake manifold.

twisted wire pair used as the data backbone in multiplex systems. The wires are twisted to minimize EMI.

two stage filtering any filtering process that takes place in separate stages.

two-terminal EUIs an older style EUI with a single actuator or control cartridge: this generation of EUIs were equipped with hydraulic injector nozzles which were limited to a fixed NOP.

ultraviolet (UV) black-light energy used to locate component defects (magnafluxing) or oil leaks in engines.

ultralow sulfur fuel (ULS) The current ULS diesel fuel standard requires it to have a maximum sulfur content of 0.0015 percent. Continent-wide, ULS accounts for 85 percent of all onhighway diesel fuel sold. From 2010, this becomes 100 percent.

undercrown the reverse side of a piston crown: in most current diesels, a lube oil cooling jet is targeted at a specific location on the undercrown.

undersquare engine an engine in which the bore dimension is smaller than its stroke dimension. Refers to high compression engines. Most diesel engines are undersquare.

unit injector a combined pumping, metering, and atomizing device.

universal serial bus (USB) a means of connecting peripherals (external devices) to a PC or network system.

uplink signal transmission from a stationary or mobile ground station to a telecommunications satellite.

upload the act of transferring data from one medium or computer system to another.

urea crystallized nitrogen base compounds in solution with distilled water: aqueous urea is injected into SCR-type reduction catalytic converters.

USB flash drives memory data storage devices integrated with a USB (universal serial bus) interface: they are small, portable, very lightweight, and rewritable by flashing.

user ID a password used for security and identification on multiuser computer systems.

valve any switch device that can open, close, or moderate flow through a circuit. For instance, engine valves open and close so that its cylinders can breathe and seal.

valve bridges a means of actuating a pair of cylinder valves with a single rocker; also known as a *valve yoke*.

valve closes orifice (VCO) (nozzle) a sacless hydraulic injector nozzle.

valve closing pressure (VCP) the specific pressure at which hydraulic injector nozzle closes, always lower than NOP due to nozzle differential ratio. Also known as *nozzle closing pressure*.

valve float a condition caused by running an engine at higher-than-specified rpms in which valve spring tension becomes insufficient, causing asynchronous (out of time) valve closing.

valve margin dimension between the valve seat and the flat face of the valve mushroom: critical valve machining specification.

valve pockets recesses machined into the crown of a piston designed to accommodate cylinder valve protrusion when the piston is at TDC.

valve polar diagram a valve mapping exercise that makes use of circles or a spiral configuration to map the valve closing and opening event during the engine cycle.

valve train all the components between the cam and the valve and typically would include followers/tappets, push tubes/rods, rocker assemblies and valve bridges/yokes.

valve yoke see *valve bridge*.

vaporization changing the state of a liquid to a gas.

variable capacitance a type of pressure sensor that outputs a voltage signal based on its capacitive status, which varies according to the pressure loaded onto it.

variable geometry (VG) term usually applied to turbochargers that have either external (wastegate) or internal means of managing the way in which exhaust gas acts on the turbine.

variable nozzle (VN) one type of VG turbocharger that uses an ECM controlled actuator to vary the turbine volute flow to determine turbo efficiencies.

variable speed governor (VSG) a governor in which the speed control/throttle mechanism inputs an engine speed value and the governor attempts to maintain that speed as the engine load changes.

variable speed limit (VSL) rpm limiting on a moving vehicle for PTO operation.

variable valve actuator (VVA) electronically-controlled and hydraulically (engine lube) actuated, variable valve timing: can delay intake valve closure reducing the compression charge and ratio.

variable valve timing (VVT) used by diesel engine OEMs to optimize power while minimizing emissions: ECM controlled and hydraulically-actuated (engine lube) when used.

vehicle control center (VCC) vehicle based communications and control center that organizes telematics, communications, and navigation. VCC is networked to the J 1939 data bus and controls connections to the outside world using

technologies such as GPS, Bluetooth, and two-way satellite communications.

vehicle control unit (VCU) a vehicle management module using the MID 144 address on the chassis data bus that is used by some OEMs optimize powertrain and chassis operations.

vehicle personality module (VPM) (Caterpillar/Navistar) term used to describe the PROM and EEPROM memory components in a chassis management module.

vehicle speed sensor (VSS) road speed sensor.

venting the act of breathing an enclosed vessel or circuit to atmosphere to moderate or equalize pressure.

viscosity often used to describe the fluidity of lubricant but correctly defined, it is a fluid's resistance to shear.

volatile memory RAM data that is only retained when a circuit is switched on.

volatile organic compounds (VOCs) the boiled-off, more volatile fractions of hydrocarbon fuels. The evaporation to atmosphere occurs during production, pumping, and refueling procedures; usually referred to as VOCs.

volatility the ability of a liquid to evaporate. Gasoline has greater volatility than diesel fuel.

volt a unit of electrical potential; named after Alessandro Volta (1745–1827).

voltage electrical pressure. A measure of charge differential.

voltage drop voltage drops in exact proportion to the resistance in a component or circuit. The voltage drop calculation is made to analyze component and circuit conditions.

volumetric efficiency the mass of air taken into an engine cylinder versus the mass that would be present in the cylinder at atmospheric pressure expressed as a percentage. Almost always less than 100 percent in naturally aspirated engines, may be well over 100 percent in turbocharged engines.

volute a snail-shaped diminishing sectional area such as used in turbocharger geometry.

vortex flow MAF sensors MAF sensor with an obstruction in the airflow that causes air passing around it to generate vortices (like mini-tornadoes): these increase with air flow velocity so by locating an ultrasonic speaker and pickup (microphone) across the stream of vortices which spin off in opposing directions, a frequency modulated shift can be signaled to the ECM: the frequency increases in proportion to air velocity.

VSS vehicle speed sensor.

water-in-fuel (WIF) sensor usually located in the filter/water separator sump, it signals an alert when covered with water.

water separator a canister located in a fuel subsystem used to separate water from fuel and prevent it from being pumped through the injection circuit.

watt a unit of power commonly used to measure mechanical and electrical power. Named after James Watt (1736–1819).

wavelength frequency or the distance between the nodes and antinodes of a radiated or otherwise transmitted wave.

Weather Pack connector a commonly used proprietary, sealed electric and electronic circuit connector system used in many electronically managed circuits.

wet liners cylinder block liners that have direct contact with the water jacket and therefore must support cylinder combustion pressures and seal the coolant to which they are exposed.

white smoke caused by liquid condensing into droplets in the exhaust gas stream. Light reflects or refracts from the droplets making them appear white to the observer.

wide open throttle (WOT) a term usually used in the context of SI gasoline-fueled engines to mean full fuel request. Used by one diesel OEM to describe high-idle speed.

Windows the Microsoft Corporation graphical user interface program manager widely used in PC systems.

wireless the use of radio frequencies to transmit analog or digital signals.

wireless fidelity (WiFi) wireless communications that conform to Institute of Electrical and Electronics Engineers (IEEE) protocol 802.11: the WiFi communications standard used in North America.

wobble plate pump slang term for a *swash plate pump*.

word processing using a computer system to produce mainly text in documents and files.

work when force produces a measurable result, work is accomplished.

Workplace Hazardous Materials Information System (WHMIS) the section of the Hazard Communications legislation that deals with tracking and labeling of hazardous workplace materials.

wrist pin the pin that links the connecting rod eye to the piston pin boss; also known as a *piston pin*.

yield strength unit force required to permanently deform a material: in steels, yield strength is approximately 10 percent less than tensile strength.

zener diode a diode that will block reverse bias current until a specific breakdown voltage is achieved.

This page intentionally left blank

Acronyms

AC alternating current	C carbon
A/C air conditioning	CA communications adapter (serial link)
ACC adaptive cruise control	CAC charge air cooling
ACERT Advanced Combustion Emissions Reduction Technology	CAN Controller Area Network
ADC analog to digital converter	CARB California Air Resources Board
ADEM advanced diesel engine management (system)	cc cubic centimeter
ADS Association of Diesel Specialists	CCV closed crankcase ventilation
AFC air/fuel control	CCW counterclockwise or left-hand rotation
AFR air/fuel ratio	C-EGR cooled exhaust gas recirculation
ANSI American National Standards Institute	CEL check engine light
API American Petroleum Institute	cfm cubic feet (per) minute
APT American pipe thread	CFR ceramic fiber reinforced
APT axial power turbine	CFV critical flow venturi
ASE (National Institute for) Automotive Service Excellence	CG constant geometry
ASME American Society of Mechanical Engineers	CGI clean gas induction (Caterpillar EGR)
ASTM American Society for Testing Materials	CGI compacted graphite iron
At ampere turns	CI compression ignition
ATA American Trucking Association	cid cubic inch displacement
ATAAC air-to-air after-cooling	CLM coolant level module
ATDC after top dead center	CMAC chassis mounted charge air cooling
atm unit of pressure equivalent to one unit of atmospheric pressure	CMP camshaft position
BDC bottom dead center	CN cetane number
BHP brake horsepower	CNG compressed natural gas
BIOS basic input/output system	CO carbon monoxide
BOE beginning of energizing	CO₂ carbon dioxide
BOI beginning of injection	COE cab-over-engine (truck chassis)
BP brake power	CPC common powertrain controller (DDC and MB)
BPS bits per second	CPL control parts list (Cummins part numbers)
BTDC before top dead center	CPS camshaft position sensor
BTM brushless torque motor	CPS characters per second
Btu British thermal unit	CPU central processing unit
	CR common rail
	CRS Caterpillar regeneration system (DPF)

CTS coolant temperature sensor	EMS engine management system
CTV continuously open throttle valve	EOE ending of energizing
CW clockwise	EOF end of frame (multiplexing packet)
DC direct current	EOI end of injection
DCA diesel coolant additives	EOL end of line (programming)
DDC Detroit Diesel Corporation	EPA Environmental Protection Agency
DDDL Detroit Diesel diagnostic link	EPS engine position sensor
DDEC Detroit Diesel electronic controls	ESS engine speed sensor
DDL diagnostic data link	EST electronic service tool
DDR digital diagnostic reader	ET Electronic Technician (Caterpillar diagnostic software)
DDT digital diagnostic tool	ETR energized to run
DI direct injection	EUI electronic unit injector
DID driver information display	EUP electronic unit pump
DIP dual inline package (chip)	FACR fuel-amplified common rail system
DMM digital multimeter	FET field effect transistor
DOC diesel oxidation catalyst	FM frequency modulation
DOC direct-operated check (valve)	FMI failure mode indicator (SAE)
DOD displacement on demand	FMVSS Federal Motor Vehicle Safety Standard
DOHC double overhead cam	FST field service tips
DOS disk operating system	GHGs greenhouse gases
DMF diesel multistage filter	gnd ground
DPF diesel particulate filter	gph gallons per hour
DTC diagnostic trouble code	GPS global positioning satellite
DVOM digital volt ohmmeter	GUI graphical user interface
ECI electronically controlled injection	H hydrogen
ECM electronic/engine control module	HC hydrocarbon
ECS evaporative (emission) control system	HDEO heavy-duty engine oil
ECT engine coolant temperature	HE hydroerosive (machining technology)
ECU electronic/engine control unit	HEUI hydraulically actuated electronic unit injector
EDU electronic distributor unit (DDEC)	HEV hybrid electric vehicle
EEC electronic engine control	Hg mercury
EECU electronic engine control unit	IBC inner base circle
EEPROM electronically erasable, programmable read-only memory	I/C integrated circuit
EFPA electronic foot pedal assembly	ICU instrument control unit
EG ethylene glycol	id inside diameter
EGR exhaust gas recirculation	ID identify
EHI electrohydraulic injector	IDI indirect injection
ELC extended life coolant	IDM injector driver module (Navistar)
EMA Engine Manufacturer's Association	I-EGR internal exhaust gas recirculation
EMF electromotive force	IHP indicated horsepower
EMI electromagnetic interference	INSITE Cummins PC software
EMI electromagnetic injector	IRT injector response time

ISIS international (trucks) (online) service information system	NTC negative temperature coefficient
ISO International Standards Organization	NV-RAM nonvolatile random-access memory
IVS idle verification switch	O oxygen
KAM keep-alive memory	OBC outer base circle
KAMPWR electrical circuit that powers KAM (Navistar)	OBD on-board diagnostics
km kilometers	OCR optical character recognition
KPa kiloPascals	OCV open circuit voltage
LAN local area network	od outside diameter
LCD liquid crystal display	OEM original equipment manufacturer
LED light-emitting diode	OOS out-of-service
LNC lean NO _x catalyst	OS operating system
LNG liquefied natural gas	OSHA Occupational Safety and Health Administration
LPG liquid petroleum gas	Pa Pascal
LS limiting speed	PC personal computer
LS low sulfur	PCM powertrain control module
LSG limiting speed governor	PCU powertrain control unit
MAF mass airflow sensors	PCV positive crankcase ventilation
MAP manifold actual pressure	PDI predelivery inspection
MCP motor control module	PDM power distribution module
MD Master Diagnostics (Navistar troubleshooting software)	PG propylene glycol
MEP mean effective pressure	pH power hydrogen (measure of acidity/alkalinity)
MEUI mechanically-actuated, electronically-controlled, electronic unit injector.	PHC partially-burned hydrocarbons
MHz megahertz	PID parameter identifier (SAE)
MID message identifier (SAE)	PLC power line carrier (multiplexing)
MIL malfunction indicator lamp	PLC programmable logic controller (smart relay)
mm millimeter	PLD German acronym meaning ECM (MB engines)
MPa megapascals	PLN pump-line nozzle (diesel fuel injection)
MPC multiprotocol cartridge/card (ProLink)	PM particulate matter
MSDS material safety data sheets	PM preventative maintenance
N nitrogen	PN positive–negative (junction semiconductor)
NAC NO _x adsorber catalyst	PNP positive–negative–positive (semiconductor)
NAFTA North American Free Trade Agreement (Mexico, USA, and Canada)	POST power-on self-test
NDR nozzle differential ratio	ppb parts per billion
Nm Newton-meter	ppm parts per million
NOP nozzle opening pressure	PROM programmable read-only memory
NO₂ nitrogen dioxide	psi pounds per square inch
NO_x oxides of nitrogen	PTC positive temperature coefficient
NPN negative–positive–negative (semiconductor)	PTO power take-off
	PW pulse width
	PWM pulse width modulation
	QSOL QuickServe OnLine (Cummins)
	R resistance

RAM random-access memory	TPS throttle position sensor
RCRA Resource Conservation and Recovery Act	TRS timing reference sensor (DDEC)
rms root mean square	TSB technical service bulletin
ROM read-only memory	ULEV ultralow emissions vehicle
RP recommended practice (ATA-TMC)	ULS ultralow sulfur (fuel)
RPCV rail pressure control valve	ULSD ultralow sulfur diesel
RS regeneration system (DPF operation)	UNC unified (thread) coarse
RSG road speed governing	UNF unified (thread) fine
RSL road speed limit	UPC universal product code
S sulfur	USB universal serial bus
SAE Society of Automotive Engineers	UV ultraviolet
SAE J1587 data bus software protocols	V volt
SAE J1667 emission testing standards	V-Bat battery system voltage
SAE J1708 data bus hardware protocols	VCO valve closes orifice (nozzle)
SAE J1939 data bus hardware/software protocols (CAN 2.0 HD)	VCP valve closing pressure
SCA supplemental cooling additive (system)	VCU vehicle control unit
VG variable geometry	VECTRO Volvo electronic controls
SCR selective catalytic reduction	VG variable geometry
SEL stop engine light	VGA video graphics array
SEO stop engine override	VI viscosity index
s.i. Système International (metric system)	VIN vehicle identification number
SI spark ignited	VIP vehicle interface program
SID subsystem identifier (SAE)	V-MAC vehicle management and control
SIS service information systems (generic and Caterpillar specific)	VN variable nozzle
SO₂ sulfur dioxide	VOC volatile organic compound
SOHC single overhead cam	VPM vehicle personality module (Caterpillar/Navistar)
SOI start of injection	VR voltage regulator
SRS synchronous reference sensor (DDEC)	V-Ref reference voltage (almost always ±5 VDC)
STEO stop engine override	VS variable speed
STOP stop engine light	VSC variable speed control
SVS spill valve solenoid (Cat MEUI)	VSG variable speed governor
TBN total base number (lubes)	VSL vehicle speed limit
TBS turbo-boost sensor	VSS vehicle speed sensor
TDC top dead center	VVA variable valve actuator
TDS total dissolved solids	VVT variable valve timing
TEL top engine limit (Cat: high idle)	W watt
TEM timing event marker	WHMIS Workplace Hazardous Materials Information System
TIR total indicated runout	WIF water in fuel (sensor)
TMC Technical and Maintenance Council	WiFi wireless fidelity
TP throttle position	WOT wide open throttle

Index

Note: Page numbers referencing figures are italicized and followed by an “f.” Page numbers referencing tables are italicized and followed by a “t.”

- Absorbent filtration, 127
- A/C. *See* Air conditioning
- Accumulator, 281
- Acetylene cylinders, 12
- Active regeneration, 297
- Actively pressurized cooling system (APCS), 158–159
- Actuators, 255
 - in dual actuator EUIs, 270–274, 271f–272f
 - piezoelectric, 238, 239, 249
 - in single actuator EUIs, 269–270, 269f
 - VVA, 177
- AdBlue, 298
- Adsorbent filtration, 127
- Aerated oil, 122
- A-frame hoists, 31
- After top dead center (ATDC), 47, 49–50
- Aftercoolers, 174
- Air, 40
- Air brakes, 184
- Air cleaners, 166–167
- Air conditioning (A/C), 199
- Air filters, 166–167
- Air tools, 32, 33f
- Air-to-air heat exchangers, 173–174
- Aluminum trunk type pistons, 55–56, 56f
- American Petroleum Institute (API), 122–123, 123f
- Anaerobic sealants, 204
- Antifreeze, 141, 143–144, 144t, 147
- Antithrust side, 65
- APCS. *See* Actively pressurized cooling system
- API. *See* American Petroleum Institute
- Aqueous urea, 298
- Arc welding abuse, 10. *See also* Electric arc welding
- Articulating pistons, 58–59, 58f
- Ash, 121, 123
- ATDC. *See* After top dead center
- atms. *See* Units of atmosphere
- Atomization, 234
- Automatic bleeding valve, 266
- Auxiliary heat exchangers, 150

- Back care, 4–5, 5f
- Back leakage, 242
- Backfire, 14
- Bar pressure measurement, 36
- Barrel faced rings, 62f, 63
- Base circle (BC), 84–85

- BDC. *See* Bottom dead center
- Bearing(s)
 - bedplate main, 74
 - camshaft, 87, 87f
 - clearance of, 72–73, 72f, 73t
 - construction and design of, 72, 72f
 - crankshaft end play and, 73
 - etched main, 71
 - friction, 72
 - removal and installation of, 73–74
 - retention, 73, 74f
 - rollover, 74
 - spun, 71
 - thrust, 73
- Bearing shells, 67–68, 73, 74f
- Bedplate main bearings, 74
- Before top dead center (BTDC), 47
- Bending forces, 68
- Big end, 66
- Blotter test, 133
- Boots, 2–3, 3f
- Bore
 - counter, 204–205
 - dial bore gauges and, 25–27, 25f–26f, 28f
 - parent bore engines and, 102–105
 - stroke and, 47, 47f
- Bottom dead center (BDC), 41–45, 47
- Boundary lubrication, 119
- Bourdon gauge, 131
- Brake fade, 184
- Brakes
 - air, 184
 - BrakeSaver, 193–194, 193f
 - engine compression, 183, 185–192, 187f, 189f, 190f, 191f, 190t
 - modern, 184
 - operation principles of, 185–187
 - supplementary systems of, 184
- Breaker/flex bars, 19
- Breather filter, 223, 223f
- Breathing circuit
 - charge air coolers in, 173–174, 174f
 - components of, 164–166
 - exhaust gas recirculation in, 175–176, 175f
 - exhaust system components in, 177–178
 - gas flow in, 164, 165f
 - intake system in, 164, 166–167, 166f
 - sensors, 179
 - turbochargers in, 167–173, 168f–171f, 173f
 - valve design and, 176–177, 176f

- BTDC. *See* Before top dead center
- Bubble collapse, 105
- Bundle-type oil cooler, 129–130, 130f
- Bushings, 33, 87, 87f, 209
- Butane lighters, 5–6
- Buttress screws, 208
- Bypass filters and valves, 128–129

- CA. *See* Communications adapter
- Cab-over-engine (COE), 198
- CACs. *See* Charge air coolers
- California Air Resources Board (CARB), 290, 290f
- Calipers, 22, 23f, 29
- Cam geometry, 84
- Cam ground, 56
- Cam profile, 84, 85f
- Camshaft(s)
 - bushings/bearings, 87, 87f
 - cam profile in, 84, 85f
 - construction and design of, 84–85, 86f
 - end play, 87, 87f
 - inspection of, 86–87, 86f, 208–209
 - removal and installation of, 85–86
 - role of, 83–84
 - timing overhead, 83, 83f
- Canister type fuel filters, 222
- CARB. *See* California Air Resources Board
- Carbon dioxide (CO₂), 291
- Carbon monoxide (CO), 292
- Cartridge fuel filters, 222
- Catalytic converters, 178, 295–296, 297f
- Caterpillar BrakeSaver, 193–194, 193f
- Caterpillar compression brakes, 190, 191f
- Cavitation, 105, 145, 145f
- CCV. *See* Closed crankcase ventilation
- C-EGR. *See* Cooled EGR
- Central processing unit (CPU), 252–254, 254f
- Centrifugal filters, 128–129
- Cetane number (CN), 46
- CFV. *See* Critical flow venturi
- CG turbochargers. *See* Constant geometry turbochargers
- CGI. *See* Clean gas induction
- CGI blocks. *See* Compacted graphite iron blocks
- Chain hoists, 8
- Chains, 32
- Channel section rings, 63
- Charge air coolers (CACs), 173–174, 174f, 299
- Charging circuit, 218

- Charging pressure, 224, 224f
- Charging pump, 222, 227–230, 227f–230f
- Chassis
 data bus, 256–258, 257f–258f
 engine reinstalled to, 215
 engine removed from, 199–200
 safety, 10–15, 12f–15f
- Chatter, 242
- Cherry pickers, 8, 8f, 31, 32f
- Chopper wheel. *See* Pulse wheel
- CI. *See* Compression ignition
- CJ-4 oil, 122–123, 123f, 134
- Clamping force, 35
- Classes, of fires, 6, 7f
- Clean gas induction (CGI), 175, 294–295, 295f
- Clearance volume, 47
- Clevis, 88
- Closed crankcase ventilation (CCV), 299–300, 299f
- Clothing, 5, 5f
- CN. *See* Cetane number
- CO. *See* Carbon monoxide
- CO₂. *See* Carbon dioxide
- COE. *See* Cab-over-engine
- Coefficient of friction, 184
- Cold sludge, 122
- Combination compression and scraper rings, 62, 62f
- Combination square, 27
- Combination wet/dry liners, 106
- Combustion chamber designs, 59–60
- Combustion pressure, 48
- Come-alongs, 8
- Command sensors, 246
- Common manifold turbocharging, 172
- Common rail (CR) fuel systems, 235, 242
 diesel, 274–275, 274f, 275t
 EHIs in, 283–285, 284f
 FACR, 285–286, 286f
 fuel subsystem of, 278, 278f
 history of, 264
 management electronics of, 276–277
 rail in, 274
 routing circuit of, 277–286, 277f–286f
 subsystems and components of, 275–276
- Communications adapter (CA), 198, 256
- Compacted graphite iron (CGI) blocks, 102f, 103
- Companion cylinders, 93
- Composite steel trunk pistons, 58, 58f
- Compressed fluids, 9
- Compression. *See also* Engine compression
 brakes
 pressure, 48
 ratio, 48
 rings, 61, 62, 62f
 stroke, 42, 42f–43f, 44
- Compression ignition (CI), 48
- Compressional loads, 67
- Compressor housing, 168
- Concept gears, 83
- Connecting rods
 compressional loading and, 67
 construction of, 66, 67f
 cracked, 66, 66f
 inspection of, 67–68
 keystone, 66
 reassembly of, 205–206, 205f, 207f
 role of, 65–66, 66f
 tensional loading and, 67
- Constant geometry (CG) turbochargers, 168–169
- Constant throttle valves (CTVs), 191–192, 192f
- Coolant, 121–122
 blending of, 146–147
 in cooling system, 143–147, 144t, 145f–146f, 152–153
 ELC, 143, 147
 filters, 152, 152f
 heaters, 159–160, 159f
 monitoring circuit, 152–153
 pumps, 151–152, 151f–152f
 SCAs and, 143, 144–147, 145f–146f
 types of, 143–144, 144t
- Cooled EGR (C-EGR), 175–176, 175f, 294, 295f
- Cooling system
 antiboil properties of, 141, 142f
 APCS, 158–159
 components of, 147–152, 148f–149f, 150t, 151f–152f
 coolant in, 143–147, 144t, 145f–146f, 152–153
 cooling fans in, 155–157, 156f–157f
 in DD15 engine, 140, 141f
 functions of, 140
 heat transfer and, 140
 management of, 158–159
 problems with, 157–158
 thermostats in, 153–155, 154f
- Counter bore, 204–205
- Counterflow radiators, 149
- CPU. *See* Central processing unit
- CR fuel systems. *See* Common rail fuel systems
- Cracked rods, 66, 66f
- Crankcase, 103, 299–300, 299f
- Crankshafts
 configurations of, 68, 68f
 construction of, 69–70, 69f
 dynamic balance and, 68–69
 end play of, 73
 failure of, 70–71
 hydrodynamic suspension and, 68
 inspection of, 71
 reconditioning of, 71
 removed from cylinder block, 70, 70f
- Creep, 111, 111f
- Critical flow venturi (CFV), 251, 251f
- Crossflow radiators, 148–149, 149f
- Crossflow valve configurations, 176, 176f
- Crosshatch, 107–108, 107f
- Crosshead pistons, 58
- Crossover pipe, 220–221, 220f
- Crown, piston, 55, 55f, 59–60
- CTVs. *See* Constant throttle valves
- Customer data programming, 257, 259
- Cutting fluids, 22, 22t
- Cutting torches, 14, 14f
- Cylinder block(s)
 categories of, 103–106
 checking of, 106–107, 107f
 crankshafts removed from, 70, 70f
 design and construction of, 102–103, 102f–104f
 flywheel housings and, 108
 forces, 102
 functions of, 102–103, 102f
 liner reconditioning and, 107–108, 107f
 reassembly of, 204–205
- Cylinder head valves
 design and materials of, 90–91, 90f–91f
 inspection of, 91, 91f
 operation of, 91
 servicing of, 92, 210
 valve lash adjustment and, 93–97, 94f–97f
 valve polar diagram and, 98
 valve seat inserts and, 92–93, 92f
 VVT and, 90, 97
- Cylinder heads
 disassembly, inspection, and reconditioning of, 108–110
 installation of, 110–111, 110f–111f
 reassembly of, 209–210
 rocker housing covers and, 111–112
 role of, 108, 109f
- Cylinder pressure, 49–50, 54
- Cylinder volume, 47
- Cylinder wall lubrication, 64–65
- Cylinder wear ridge, 106, 106f
- Dampers, 74–76, 75f
- Data bus, 256–258, 257f–258f
- DCA. *See* Diesel coolant additive
- Depth gauges, 27
- Detergents, 121
- DI. *See* Direct injection
- Dial bore gauges, 25–27, 25f–26f, 28f
- Dial indicators, 24, 24f–25f
- Diamond dowels, 212
- Dies, 21–22
- Diesel coolant additive (DCA), 144
- Diesel CR fuel systems, 274–275, 274f, 275t
- Diesel cycle
 four-stroke, 41–44, 42f–44f, 164
 two-stroke, 45, 45f–46f
- Diesel emissions, 290, 294–300, 295f, 297f–299f
- Diesel filters, 222–227, 223f–224f, 226f–227f, 296–297, 297f–298f
- Diesel fired coolant heater, 159f, 160
- Diesel fuel, 46, 219
- Diesel particulate filters (DPFs), 296–297, 297f–298f
- Diffusers, 178
- Digital multimeter (DMM), 11, 247
- Dipsticks, 125
- Direct injection (DI), 48, 59, 234
- Disassembly, engine, 200–203, 201f, 203f
- Dished piston crown, 60
- Dispersants, 121
- Dividers, 29
- DMM. *See* Digital multimeter
- Double pass radiators, 149, 149f
- Downflow radiators, 148, 148f–149f
- Download, 260
- DPFs. *See* Diesel particulate filters
- Drill bits, 22
- Droplet sizing, 235–236, 236f
- Dry element filters, 167
- Dry liners, 105–106, 106f
- Dual actuator EUIs, 270–274, 271f–272f
- ECM. *See* Engine/electronic control module
- EDCs. *See* Electronic digital calipers
- EEPROM. *See* Electronically erasable PROM
- EG. *See* Ethylene glycol

- EGR system. *See* Exhaust gas recirculation system
- EHIs. *See* Electrohydraulic injectors
- ELC. *See* Extended life coolant
- Electric arc welding, 10, 15, 15*f*
- Electric primer pumps, 230
- Electric sensors, 153
- Electrical safety, 10–15, 12*f*–15*f*
- Electric-over-hydraulic compression brakes, 188
- Electrohydraulic injectors (EHIs), 238–240, 238*f*, 242, 272, 275, 283–285, 284*f*
- Electrohydraulic nozzles, 238–240, 238*f*, 242
- Electronic control module. *See* Engine/electronic control module
- Electronic diesel fuel injection systems. *See* Common rail fuel systems; Electronic unit injector system
- Electronic digital calipers (EDCs), 22, 23*f*
- Electronic service tool (EST), 11, 258, 258*f*
- Electronic unit injector (EUI) system
fuel subsystem and, 265–266, 265*f*
history of, 264
injectors in, 98, 201–202, 235, 269–274, 269*f*, 271*f*–272*f*
input circuit and, 266–267, 267*f*–268*f*
management electronics of, 267–268, 268*f*
output circuit and, 268
overview of, 264–265
- Electronically erasable PROM (EEPROM), 254–255
- Emissions
CARB and, 290, 290*f*
diesel, 290, 294–300, 295*f*, 297*f*–299*f*
field testing of smoke density and, 300–302, 300*f*–301*f*
smog and, 291–294, 293*t*
smoke analysis and, 302
- EMS. *See* Engine management system
- End play, 73, 87, 87*f*
- Engine(s)
barring of, 96–97, 97*f*
cleaning and inspection of, 203–204
disassembly of, 200–203, 201*f*, 203*f*
displacement, 43, 47
key principles of, 49–50
reassembly of, 204–215, 205*f*–209*f*, 212*f*–215*f*
removal of, 198–200
systems and circuits, 46
terminology of, 40–41, 46–47, 48*f*
types of, 47, 102–105, 140, 141*f*
- Engine compression brakes, 183, 185–188, 187*f*
external, 185–187, 187*f*
internal, 185, 187–192, 189*f*–192*f*, 190*t*
- Engine/electronic control module (ECM), 140, 188, 276
CPU in, 252–254, 254*f*
diesel emissions and, 294
in EUI management electronics, 267–268, 268*f*
functions of, 246, 247*f*, 252, 253*f*, 268, 269*f*
input circuit and, 246–252, 247*f*–252*f*
memory of, 254–255
multiplexing and, 255–258, 255*f*, 257*f*–258*f*
outputs of, 255
programming of, 257–260
- Engine management system (EMS), 276
- Engine retarders. *See* Brakes
- English/metric conversion, 35–36
- Environmental Protection Agency (EPA), 290, 293*t*
- EPG. *See* Exhaust pressure governor
- Equipment safety, 6–8
- EST. *See* Electronic service tool
- Etched main bearings, 71
- Ethylene glycol (EG), 143, 144, 144*t*
- EUI. *See* Electronic unit injector system
- Exhaust
brakes, 185–187, 187*f*
extraction, 8–9, 9*f*
manifolds, 112–113, 172, 177
stroke, 43–44, 43*f*
system components, in breathing circuit, 177–178
valves, 90
- Exhaust gas recirculation (EGR) system, 164, 166, 175–176, 175*f*, 200, 294, 295*f*
- Exhaust pressure governor (EPG), 187
- Expansion-sensing gauges, 153
- Extended life coolant (ELC), 143, 147
- External engine compression brakes, 185–187, 187*f*
- External gear pumps, 125–126, 126*f*
- Eye protection, 3, 3*f*, 14, 29
- FACR system. *See* Fuel-amplified common rail system
- Fans, 155–157, 156*f*–157*f*
- Fanstat, 156
- Fastener grades and torques, 34–35, 34*f*
- Feedback assembly, 82, 97–98
- Feeler gauges, 29
- Ferrotherm articulating pistons, 58
- Film strength, 121
- Filter bypass valves, 128–129
- Filters
air, 166–167
coolant, 152, 152*f*
diesel, 222–227, 223*f*–224*f*, 226*f*–227*f*, 296–297, 297*f*–298*f*
fuel, 219, 219*f*, 222–227, 223*f*–224*f*, 226*f*–227*f*, 278
oil, 127–129, 128*f*
primary and secondary, 219, 222, 223*f*
servicing of, 223–224, 224*f*
- Fire point, 48, 120
- Fire rings, 210
- Fire safety, 6, 7*f*
- Flanged injectors, 241
- Flash point, 120
- Flashback, 14
- Flex bars, 19
- Fluid friction, 119
- Flywheel housing concentricity, 212
- Flywheel housings, 108, 212–215, 212*f*–215*f*
- Flywheels, 76–77, 77*f*
- Follower, 88, 89*f*
- Forged steel trunk type pistons, 57, 57*f*
- Forward leakage, 242
- Four-stroke diesel cycle, 41–44, 42*f*–44*f*, 164
- Friction, 48, 118–119, 184
- Friction bearings, 72
- Fuel
types of, 40, 46, 121, 219
water in, 223, 227, 227*f*, 251, 266
- Fuel-amplified common rail (FACR) system, 285–286, 286*f*
- Full articulating pistons, 58, 58*f*
- Fuel charging pumps, 227–230, 227*f*–230*f*
- Fuel filters, 219, 219*f*, 222–227, 223*f*–224*f*, 226*f*–227*f*, 278
- Fuel heaters, 219, 219*f*, 226–227, 227*f*
- Fuel sending units, 221
- Fuel subsystem
complete circuit of, 229*f*, 230
components of, 218, 218*f*–219*f*, 266
of CR systems, 278, 278*f*
EUI and, 265–266, 265*f*
fuel charging/transfer pumps in, 227–230, 227*f*–230*f*
fuel filters in, 219, 219*f*, 222–227, 223*f*–224*f*, 226*f*–227*f*
objectives of, 218–219, 218*f*–219*f*
tank in, 219–222, 219*f*, 222*f*–223*f*
- Fuel tanks, 219–222, 219*f*, 222*f*–223*f*
- Full flow filters, 128, 128*f*
- Gas blowby, 61–62
- Gasket yield point, 111
- Gauges, 22, 25–29, 25*f*–26*f*, 28*f*, 131, 166*f*, 167
- Gear pumps, 125–127, 126*f*, 227–229, 227*f*, 229*f*
- Gerotor pumps, 126–127
- Glass bead blasters, 33–34
- Glasses, 3, 3*f*, 29
- Glaze busting, 107
- Gloves, 4
- Ground strap, 11
- Hacksaws, 22
- Hall-effect sensors, 250
- Hammers, 20, 21*f*, 31
- Hand primer pumps, 228*f*, 229–230
- Hand tools, 18*f*, 19–22, 20*f*–21*f*
- Hard value NOPS, 234
- HC. *See* Hydrocarbons
- Head gasket, 111
- Headers, 148
- Headland volume, 56–57, 59
- Hearing protection, 3–4, 4*f*
- Heat energy, 40
- Heat exchanger, 143, 150, 166, 173–174
- Heat transfer, 140
- Helical gears, 82
- Hg manometer. *See* Mercury manometer
- High-pressure lines, 282–283, 283*f*
- High-pressure pumps, 278–283, 279*f*–283*f*, 285
- Honing, 68, 107–108
- Hydraulic engine brakes, 186–188
- Hydraulic injectors, 234, 234*f*
- Hydraulic system safety, 9–10
- Hydrocarbons (HC), 291
- Hydrodynamic suspension, 68, 119, 120*f*
- Hydrometer, 144
- IBC. *See* Inner base circle
- IDI. *See* Indirect injection
- I-EGR. *See* Internal exhaust gas recirculation
- Ignition temperature. *See* Fire point
- Impeller, 168
- Indirect injection (IDI), 48
- Induction hardened parent bore, 105
- Induction pulse generator, 249–250, 250*f*
- Inertia, 48

- Inhibitors, 120–121
- Injector drivers, 255
- Injector nozzles
 installation of, 210–211, 242
 multiple-orifice, 234–238, 234f–238f
 testing of, 240–242
- Injector train. *See* Valve and injector trains
- Injectors
 EHI, 238–240, 238f, 242, 272, 275, 283–285, 284f
 in EUI system, 98, 201–202, 235, 269–274, 269f, 271f–272f
 flanged, 241
 hydraulic, 234, 234f
 mechanical, 98, 234
 seized, 241
- Inlet restriction, 221
- Inlet restriction gauges, 166f, 167
- Inline piston pumps, 279, 280f
- Inner base circle (IBC), 84–85
- Input circuit, 276
 ECM and, 246–252, 247f–252f
 EUI system and, 266–267, 267f–268f
- Inside bevel rings, 62f, 63
- Intake circuit, 164, 166–167, 166f
- Intake manifolds, 112, 113f, 176
- Intake stroke, 41–42, 42f–43f, 44
- Intake system, 164, 166–167, 166f
- Intake valves, 90
- Intercoolers, 174
- Interference angles, 91
- Internal combustion engine, 40
- Internal engine compression brakes, 185, 187–192, 189f–192f, 190t
- Internal exhaust gas recirculation (I-EGR), 175
- J standards, 256, 257f, 301–302
- Jacks, 7–8, 31–32
- Jacobs brakes, 188–189, 189f–190f
- Journal surface hardening methods, 69–70
- Keepers. *See* Split locks
- Keystone rings, 62f, 63
- Keystone rods, 66
- Kinetic energy, 40
- Lands, 61
- Lifters, 88
- Lifting, 4–8, 5f, 8f
- Light extinction, 301
- Liners, 102
 combination wet/dry, 106
 dry, 105–106, 106f
 protrusion of, 204–205, 205f
 reconditioning of, 107–108, 107f
 removal of, 203, 203f
 wet, 105–106, 105f–106f, 145f, 204
- Load rotors, 32
- Luber-finer filters, 128
- Lubrication. *See also* Oil
 boundary, 119
 cylinder wall, 64–65
 thick film, 119
- Lubrication systems
 basic components of, 118, 118f
 dipsticks in, 125
 friction and, 118–119
 oil coolers in, 129–130, 130f–131f
 oil filter in, 127–129, 128f
 oil pan in, 125, 125f
 oil pressure measurement in, 130–133, 131f–132f
 oil pump in, 125–127, 126f
 pressure-regulating valves in, 127, 280
 problems with, 134
 scavange pumps in, 113, 127
 turbocharger, 172
- Lubricity, 120
- Lugging, 69
- MAF sensors. *See* Mass airflow sensors
- Magnetic flux test, 203–204
- Mains electrical equipment, 11–12, 12f
- Major thrust side, 65
- Manifold-boost. *See* Turbo-boost
- Mann type (M-type) piston crown, 60
- Manual electromechanical switches, 252
- Mass airflow (MAF) sensors, 250–251, 251f
- Master bar, 204
- Mean effective pressure (MEP), 49
- Mechanical injectors, 98, 234
- Mechanical straining, 127
- Mechanical unit injectors (MUIs), 98
- MEP. *See* Mean effective pressure
- Mercury (Hg) manometer, 223
- Message Identifier (MID), 256, 267
- Metric system, 35–36
- Mexican hat piston crown, 59–60
- Micrometers, 22, 23f–24f
- Microprocessor, 246
- MID. *See* Message Identifier
- Midstop liners. *See* Combination wet/dry liners
- Minor thrust side, 65
- Monitoring sensors, 246
- Monocomp, 58, 58f
- Monotherm piston, 57
- M-type piston crown. *See* Mann type piston crown
- Muffler volume, 178
- MUIs. *See* Mechanical unit injectors
- Multigrade oils, 120, 123–124, 123f
- Multiple-orifice injector nozzles, 234–238, 234f–238f
- Multiplexing, 246, 255–257, 255f, 257f
- Multipulse injection, 285
- NA. *See* Naturally aspirated
- NACs. *See* NO_x adsorber catalysts
- Nalcool, 144
- Naturally aspirated (NA), 40, 164
- NDR. *See* Nozzle differential ratio
- Negative temperature coefficient (NTC) thermistor, 153, 248
- Ni-Resist insert, 55, 56f, 62f
- Nitrogen compounds, 293, 296
- NOP. *See* Nozzle opening pressure
- NO_x adsorber catalysts (NACs), 296
- Nozzle differential ratio (NDR), 237
- Nozzle opening pressure (NOP), 234, 273
- Nozzle seat, 237
- NTC thermistor. *See* Negative temperature coefficient thermistor
- OBC. *See* Outer base circle
- OHC. *See* Overhead cam
- Oil
 analysis of, 133–134
 API classifications of, 122–123, 123f, 134
 BrakeSaver using, 194
 choice of, 124–125
 classification and terminology, 120–121, 121f
 contamination and degradation of, 121–122
 extended changes of, 134
 filters, 127–129, 128f
 hydrodynamic suspension and, 68, 119, 120f
 multigrade, 120, 123–124, 123f
 pressure measurement of, 130–133, 131f–132f
 role of, 119, 120f
 SAE viscosity grades of, 123–124, 123f
 synthetic, 124
- Oil control rings, 62–64, 64f
- Oil coolers, 129–130, 130f–131f
- Oil pans
 functions of, 113, 114f
 inspection of, 115
 in lubrication systems, 125, 125f
 removal of, 113–114
- Oil pump, 125–127, 126f
- Oil ring side clearance, 64, 64f
- Opacity meters, 300–301, 300f–301f
- O-rings, 105, 204
- Outer base circle (OBC), 84
- Output circuit, 268, 277
- Overhead cam (OHC), 208
- Oversquare engine, 47
- Oxyacetylene equipment, 12–15, 12f–14f, 33
- Ozone, 291, 292–293
- Packets, 256
- Pallet links, 90
- Parallel port valve configurations, 176
- Parent bore engines, 102–105
- Partial blocking thermostat. *See* Side bypass thermostat
- Particulate traps. *See* Diesel particulate filters
- Passive regeneration, 296
- PCV. *See* Positive crankcase ventilation
- Peak pressure, 236
- Personal safety, 2–6, 3f, 14, 29
- PG. *See* Propylene glycol
- pH level, 146
- Photochemical smog, 291
- Pickup tube, 220–221
- Piezoelectric actuators, 238, 239, 249
- Pin boss, 56
- Piston assemblies
 articulating, 58–59, 58f
 combustion chamber designs in, 59–60
 cylinder wall lubrication and, 64–65
 piston cooling in, 60, 60f
 reassembly of, 205–208, 205f–208f
 reuse of, 65
 rings in, 61–64, 62f, 64f
 role of, 54
 terminology of, 54–55, 55f
 thrust forces in, 59
 trunk type, 55–58, 56f–58f
 wrist pins in, 65
- Piston cooling jets, 130, 131f, 205
- Piston crown, 55, 55f, 59–60
- Piston pumps, 278–279, 279f–280f

- Piston rings, 61–64, 62*f*, 64*f*
Plastigage, 28–29, 72–73, 72*f*, 73*t*, 205
Plate-type oil cooler, 130, 130*f*
Pliers, 20, 21*f*
Plunger-type pumps, 228, 228*f*
PM. *See* Preventative maintenance
Pneumatics safety, 9–10, 10*f*
Popping pressure, 234
Position sensors, 249–250, 250*f*
Positive crankcase ventilation (PCV), 299
Positive displacement, 224
Positive filtration, 127, 167
Potentiometer, 249, 250*f*
Pour point, 120, 121*f*
Power stroke, 42–44, 42*f*–43*f*
Powertrain, 54
Precision measuring tools, 23*f*–26*f*,
24–29, 28*f*
Precleaners, 166–167
Presses, 31, 31*f*
Pressure
bar, 36
charging, 224, 224*f*
combustion, 48
compression, 48
conversions, 36
cylinder, 49–50, 54
exhaust, 187
mean effective, 49
nozzle opening, 234, 273
oil, 130–133, 131*f*–132*f*
peak, 236
popping, 234
rail, 275, 277, 279–283, 280*f*–283*f*
Pressure-regulating valves, 127, 275,
279–283, 280*f*–283*f*
Preventative maintenance (PM), 133
Primary filter, 219, 222, 223*f*
Processing circuit, 276
Programmable ROM (PROM), 254–255
Progressive step engine braking,
190–191, 190*t*
PROM. *See* Programmable ROM
Proprietary data programming, 257,
259–260
Propylene glycol (PG), 143, 144, 144*t*
Pullers, 33, 201, 201*f*
Pulse wheel, 249
Pumping principle, 228
Pumps
charging, 222, 227–230, 227*f*–230*f*
coolant, 151–152, 151*f*–152*f*
electric primer, 230
fuel charging, 227–230, 227*f*–230*f*
gear, 125–127, 126*f*; 227–229,
227*f*, 229*f*
hand primer, 228*f*; 229–230
high-pressure, 278–283, 279*f*–283*f*; 285
oil, 125–127, 126*f*
piston, 278–279, 279*f*–280*f*
plunger-type, 228, 228*f*
scavenge, 113, 127
supply, 266
timing, 285, 285*f*
transfer, 219, 219*f*; 227–230, 227*f*–230*f*
water, 151–152, 151*f*–152*f*
Pushrods and tubes, 88–89
Pyrometer, 177, 251, 252*f*
Radial piston pump, 278–279, 279*f*
Radiator cap, 150–151, 151*t*
Radiators, 148–150, 148*f*–149*f*
Rail pressure control valve, 275, 279–283,
280*f*–283*f*
Rail pressure management control (RPMC),
277
Rail pressure sensor, 275
RAM. *See* Random-access memory
Ram air, 148, 173
Random-access memory (RAM), 254
Ratchets, 19, 29*f*
Ratio, 48
Read-only memory (ROM), 254–255
Reamers, 22
Rear cam bushings, 209
Reassembly, 211–215, 212*f*–215*f*
of connecting rods, 205–206, 205*f*, 207*f*
of cylinder blocks, 204–205
of cylinder heads, 209–210
of piston assemblies, 205–208,
205*f*–208*f*
of timing geartrains, 208–209, 209*f*
Rectangular rings, 62*f*, 63
Reference voltage (V-Ref), 246–252,
248*f*–251*f*
Refueling, 230
Regeneration cycle, 296
Rejected heat, 48, 49*f*, 140, 164
Reprogramming, 257
Resonance, 178
Retarder, 184. *See also* Brakes
Ring belt, 56
Ring end gap, 206
Ring gear replacement, 76–77
Ring grooves, 61
Ring stagger, 207, 207*f*
Rings
fire, 210
O-rings, 105, 204
piston, 61–64, 62*f*, 64*f*
Rocker housing covers, 111–112
Rocker level, 88
Rod caps, 67, 208, 208*f*
Rod eye, 66
Rods. *See* Connecting rods
Roller type cam follower, 88, 89*f*
ROM. *See* Read-only memory
RPMC. *See* Rail pressure management control
SAE. *See* Society of Automotive Engineers
Safety
chassis and electrical, 10–15, 12*f*–15*f*
fire, 6, 7*f*
general shop precautions, 8–10, 9*f*–10*f*
lifting, 4–5, 5*f*
personal, 2–6, 3*f*, 14, 29
rules, 1–2
shop equipment, 6–8
Safety relief valve, 266
Sandblasters, 33–34
SCAs. *See* Supplemental cooling additives
Scavenge pumps, 113, 127
Scavenging, 43, 45, 45*f*
SCR. *See* Selective catalytic reduction
Scraper rings, 61, 62
Screw extractors, 21
Seal lines, 241
Secondary filter, 219, 222
Seized injectors, 241
Selective catalytic reduction (SCR), 298, 299*f*
Self-regeneration, 296
Sensors
breathing circuit, 179
command, 246
electric, 153
hall-effect, 250
MAF, 250–251, 251*f*
monitoring, 246
position, 249–250, 250*f*
rail pressure, 275
variable capacitance, 131, 131*f*,
248–249, 249*f*
Serial bus, 255–256, 255*f*
Service information systems (SIS), 198
Service literature, 198
Shear, 100
Shear strength, 35
Shop safety. *See* Safety
Shop tools, 8, 8*f*, 12–15, 12*f*–14*f*, 30–34, 31*f*–33*f*
Shrouds, 156–157
Shutters, 155
SI. *See* Spark ignited
Side bypass thermostat, 154
Single actuator EUI, 269–270, 269*f*
Single-pass principle, 148
SIS. *See* Service information systems
Sledgehammers, 31
Sleeves. *See* Liners
Sliding ring volute turbos, 171–172, 171*f*
Slings, 32
Small end. *See* Rod eye
Small-hole gauges, 28
Smart switches, 252
Smog, 291–294, 293*t*
Smoke analysis, 302
Smoke density, field testing of, 300–302,
300*f*–301*f*
Snap gauges. *See* Telescoping gauges
Snap test, 301
SO₂. *See* Sulfur dioxide
Soak tank, 203
Society of Automotive Engineers (SAE), 34,
34*f*, 120
J standards of, 256, 257*f*, 301–302
oil viscosity grades of, 123–124, 123*f*
Soft value, 234
Solid lifters, 88
Spark ignited (SI), 48
Spectrographic testing, 133
Split locks, 90
Spray nozzle targeting, 60, 60*f*
Spreader bars, 32, 199
Spun bearings, 71
Spur gears, 82
Square engine, 47
Standard conversions, 35–36
Static discharge, 11
Straight grades, 124
Stray voltage damage, 158
Stud extractors, 21
Suction circuit, 218
Sulfur dioxide (SO₂), 291
Sump, 113
Supplemental cooling additives (SCAs), 143,
144–147, 145*f*–146*f*

- Supply pump, 266
 Switches, 251–252, 252f
 Synthetic oil, 124
- Tachometers, 34
 Taper faced rings, 62f, 63
 Tappet. *See* Rocker level
 Taps, 21
 TDC. *See* Top dead center
 TDS. *See* Total dissolved solids
 Telescoping gauges, 27–28
 Tempilstick, 83, 209
 Template torque, 111, 112f
 Tensile strength, 35
 Tensional loads, 67
 Thermal efficiency, 48
 Thermal expansion, 57
 Thermistors, 153, 248, 248f
 Thermocouple principle, 251, 252f
 Thermostats, 153–155, 154f
 Thick film lubrication, 119
 Thin film lubrication. *See* Boundary lubrication
 Thread chasers, 21–22
 Thread pitch gauges, 22
 Throttle position sensors (TPS), 249–250, 250f
 Throw leverage, 49–50
 Thrust bearing, 73
 Thrust face, 59
 Timing geartrains, 82f–83f
 reassembly of, 208–209, 209f
 timing gears in, 82–83
 Timing overhead camshafts, 83, 83f
 Timing pumps, 285, 285f
 TIR. *See* Total indicated runout
 Tone wheel, 250
- Tools
 air, 32, 33f
 EST, 11, 258, 258f
 hand, 18f, 19–22, 20f–21f
 kit of, 18, 18f, 29–30, 29f
 precision measuring, 23f–26f, 24–29, 28f
 shop, 8, 8f, 12–15, 12f–14f, 30–34, 31f–33f
- Top bypass thermostat, 154
 Top dead center (TDC), 41–45, 47, 49, 93, 211–212
 Torque twist control devices, 70
 Torsional stresses, 69
 Total dissolved solids (TDS), 146, 146f
 Total indicated runout (TIR), 24, 25f
- TPS. *See* Throttle position sensors
 Train, 84. *See also* Timing geartrains; Valve and injector trains
 Transfer pumps, 219, 219f, 227–230, 227f–230f
 Trapezoidal rings. *See* Keystone rings
 Trunk type pistons, 55–58, 56f–58f
 Tuned manifolds, 112–113
 Turbine, 168
 Turbo-boost, 40, 174
 Turbochargers
 in breathing circuit, 167–173, 168f–171f, 173f
 variable geometry, 169–170, 299–300
 variable nozzle, 170–171, 170f–171f
 Turbulence, 59
 Two-stroke diesel cycle, 45, 45f–46f
- UL. *See* Underwriter's Laboratories
 Ultralow sulfur (ULS), 219
 Undersquare engine, 47
 Underwriter's Laboratories (UL), 2, 3f
 Units of atmosphere (atms), 36
 Upload verification, 260
 Urea, 298
- Valve(s). *See also* Cylinder head valves; Valve and injector trains
 automatic bleeding, 266
 bypass, 128–129
 constant throttle, 191–192, 192f
 crossflow, 176, 176f
 design of, 176–177, 176f
 exhaust, 90
 intake, 90
 parallel port configurations of, 176
 pressure-regulating, 127, 275, 279–283, 280f–283f
 safety relief, 266
 in VVA, 177
 in VVT, 90, 97, 177
 water drainage, 266
- Valve and injector trains
 followers in, 88, 89f
 pushrods and tubes in, 88–89
 rocker arms in, 89–90
 role of, 84, 87
 typical, 87–88, 88f
- Valve closes orifice (VCO) nozzles, 237–238, 238f, 299
 Valve float, 91
- Valve margin, 92
 Valve polar diagram, 98
 Valve seat inserts, 92–93, 92f
 Valve springs and retainers, 91, 91f
 Variable capacitance sensor, 131, 131f, 248–249, 249f
 Variable geometry (VG) turbocharger, 169–170, 299–300
 Variable nozzle (VN) turbocharger, 170–171, 170f–171f
 Variable pitch blades, 155, 155f
 Variable valve actuator (VVA), 177
 Variable valve timing (VVT), 90, 97, 177
 VCO nozzles. *See* Valve closes orifice nozzles
 Venting, 221
 VG turbocharger. *See* Variable geometry turbocharger
 VI. *See* Viscosity index
 Vibration dampers, 74–76, 75f
 Viscosity, 100, 123–124, 123f
 Viscosity index (VI), 120
 VN turbocharger. *See* Variable nozzle turbocharger
 VOCs. *See* Volatile organic compounds
 Volatile organic compounds (VOCs), 292
 Volumetric efficiency, 41
 Volute controlled VG, 170–172, 170f–171f
 V-Ref. *See* Reference voltage
 VVA. *See* Variable valve actuator
 VVT. *See* Variable valve timing
- Washers, 33, 203
 Wastegate controlled VG, 169–170
 Water drainage valve, 266
 Water manifold, 151, 157
 Water pumps, 151–152, 151f–152f
 Water separators, 219, 219f, 225–226, 227f
 Water-in-fuel (WIF), 223, 227, 227f, 251, 266
 Welding, 4, 10, 15, 15f
 Wet liners, 105–106, 105f–106f, 145f, 204
 WIF. *See* Water-in-fuel
 Williams exhaust brakes, 187, 187f
 Winter fronts, 156
 Wrenches, 18–20, 18f, 20f, 29, 29f
 Wrist pins, 56
- Yield point, 111
 Yield strength, 35