

Design of Low-Rise Reinforced Concrete Buildings

Based on the 2009 IBC®, ASCE/SEI 7-05, ACI 318-08



David A. Fanella, Ph.D., S.E., P.E., FASCE



Design of Low-Rise Reinforced Concrete Buildings

Based on the 2009 IBC[®], ASCE/SEI 7-05, ACI 318-08

David A. Fanella, Ph.D., S.E., P.E., F.ASCE



Design of Low-Rise Reinforced Concrete Buildings
Based on the 2009 IBC, ASCE/SEI 7-05, ACI 318-08

ISBN: 978-1-58001-797-8

Cover Design:	Duane Acoba
Manager of Development:	John Henry
Project Editor:	Jodi Tahsler
Publications Manager:	Mary Lou Luif
Typesetting:	Cheryl Smith

COPYRIGHT © 2009



Cover photo courtesy of Portland Cement Association.

ALL RIGHTS RESERVED. This publication is a copyrighted work owned by the International Code Council, Inc. Without advance written permission from the copyright owner, no part of this book may be reproduced, distributed or transmitted in any form or by any means, including, without limitation, electronic, optical or mechanical means (by way of example, and not limitation, photocopying or recording by or in an information storage retrieval system). For information on permission to copy material exceeding fair use, please contact: Publications, 4051 West Flossmoor Road, Country Club Hills, IL 60478. Phone 1-888-ICC-SAFE (422-7233).

The information contained in this document is believed to be accurate; however, it is being provided for informational purposes only and is intended for use only as a guide. Publication of this document by the ICC should not be construed as the ICC engaging in or rendering engineering, legal or other professional services. Use of the information contained in this workbook should not be considered by the user to be a substitute for the advice of a registered professional engineer, attorney or other professional. If such advice is required, it should be sought through the services of a registered professional engineer, licensed attorney or other professional.

First Printing: September 2009

PRINTED IN THE U.S.A.

TABLE OF CONTENTS

PREFACE

ACKNOWLEDGMENTS

CHAPTER 1 – INTRODUCTION	1-1
1.1 OVERVIEW	1-1
1.2 SCOPE	1-1
1.3 REFERENCES	1-4
CHAPTER 2 – FLOOR SYSTEMS	2-1
2.1 INTRODUCTION	2-1
2.2 GENERAL CONSIDERATIONS	2-1
2.3 FLOOR SYSTEMS	2-2
2.3.1 Flat Plate System	2-2
2.3.2 Flat Slab System	2-6
2.3.3 Beam-Supported Slab System	2-8
2.3.4 One-Way Joist System	2-9
CHAPTER 3 – LATERAL SYSTEMS	3-1
3.1 INTRODUCTION	3-1
3.2 RESPONSE OF LOW-RISE BUILDINGS TO LATERAL FORCES	3-1
3.2.1 Response to Wind Forces	3-1
3.2.2 Response to Earthquake Forces	3-3
3.3 SEISMIC DESIGN CATEGORY	3-4
3.4 LATERAL-FORCE-RESISTING SYSTEMS	3-5
3.4.1 Bearing Wall Systems	3-9
3.4.2 Building Frame Systems	3-10
3.4.3 Moment-resisting Frame Systems	3-11
3.4.3 Shear Wall-Frame Interactive Systems	3-11
3.4.5 Dual Systems	3-12
3.5 HORIZONTAL DISTRIBUTION OF LATERAL FORCES	3-12
3.5.1 Diaphragm Flexibility	3-13

3.5.2	Stiffness of Lateral-force-resisting Elements.....	3-14
3.5.3	Distribution of Lateral Forces	3-21
CHAPTER 4 – DESIGN AND DETAILING FOR SDCS A AND B.....		4-1
4.1	GENERAL REQUIREMENTS.....	4-1
4.1.1	Design and Detailing	4-1
4.1.2	Load Combinations	4-2
4.1.3	Materials	4-4
4.2	MEMBERS SUBJECTED TO BENDING	4-4
4.2.1	Beams and One-way Slabs.....	4-4
4.2.2	Two-way Slabs.....	4-34
4.3	MEMBERS SUBJECTED TO BENDING AND AXIAL FORCES.....	4-55
4.4	WALLS.....	4-60
4.5	FOOTINGS	4-69
4.6	EXAMPLES	4-78
4.6.1	Example 4.1—Four-story Residential Building.....	4-78
4.6.2	Example 4.2—One-story Retail Building	4-119
CHAPTER 5 – DESIGN AND DETAILING FOR SDC C		5-1
5.1	GENERAL REQUIREMENTS.....	5-1
5.1.1	Design and Detailing	5-1
5.1.2	Load Combinations	5-1
5.1.3	Materials	5-1
5.1.4	Anchoring to Concrete	5-1
5.2	MEMBERS SUBJECTED TO BENDING	5-1
5.2.1	Beams.....	5-1
5.2.2	Two-way Slabs without Beams	5-11
5.3	MEMBERS SUBJECTED TO BENDING AND AXIAL FORCES.....	5-13
5.4	EXAMPLES	5-20
5.4.1	Example 5.1 – Four-story Residential Building.....	5-20
5.4.2	Example 5.2 – One-story Retail Building.....	5-45
CHAPTER 6 – DESIGN AND DETAILING FOR SDCS D, E AND F.....		6-1
6.1	GENERAL REQUIREMENTS.....	6-1

6.1.1	Design and Detailing	6-1
6.1.2	Load Combinations and Strength Reduction Factors.....	6-1
6.1.3	Materials	6-1
6.1.4	Mechanical and Welded Splices	6-2
6.1.5	Anchoring to Concrete	6-2
6.2	FLEXURAL MEMBERS OF SPECIAL MOMENT FRAMES	6-3
6.2.1	General Requirements	6-5
6.2.2	Flexural Requirements	6-5
6.2.3	Splice Requirements	6-6
6.2.4	Transverse Reinforcement Requirements.....	6-8
6.2.5	Shear Requirements	6-8
6.3	SPECIAL MOMENT FRAME MEMBERS SUBJECTED TO BENDING AND AXIAL LOAD	6-18
6.3.1	General Requirements	6-21
6.3.2	Minimum Flexural Strength of Columns	6-21
6.3.3	Longitudinal Reinforcement Requirements	6-22
6.3.4	Transverse Reinforcement Requirements.....	6-23
6.3.5	Shear Requirements	6-25
6.4	JOINTS OF SPECIAL MOMENT FRAMES	6-35
6.4.1	General Requirements	6-37
6.4.2	Transverse Reinforcement Requirements.....	6-37
6.4.3	Shear Requirements	6-39
6.4.4	Development Length of Bars in Tension	6-40
6.5	SPECIAL STRUCTURAL WALLS.....	6-41
6.5.1	Reinforcement Requirements.....	6-41
6.5.2	Shear Strength Requirements.....	6-53
6.5.3	Flexure and Axial Load Requirements	6-53
6.5.4	Boundary Element Requirements	6-54
6.6	STRUCTURAL DIAPHRAGMS	6-64
6.6.1	Minimum Thickness Requirements	6-65
6.6.2	Reinforcement Requirements.....	6-65
6.6.3	Flexural Strength Requirements.....	6-66
6.6.4	Shear Strength Requirements.....	6-66

6.7	FOUNDATIONS.....	6-66
6.7.1	Requirements for Footings, Foundation Mats and Pile Caps	6-69
6.7.2	Requirements for Grade Beams and Slabs-on-ground	6-69
6.7.3	Requirements for Piles, Piers and Caissons	6-70
6.8	MEMBERS NOT DESIGNATED AS PART OF THE SEISMIC-FORCE-RESISTING SYSTEM.....	6-70
6.9	EXAMPLE	6-80

ABOUT THE AUTHOR

Preface

The purpose of *Design of Low-Rise Reinforced Concrete Buildings—based on the 2009 IBC/ASCE/SEI 7-05/ACI 318-08* is to help engineers analyze, design and detail low-rise cast-in-place conventionally reinforced concrete buildings in accordance with the 2009 edition of the *International Building Code*[®] (IBC[®]). Because the 2009 IBC references the 2008 edition of *Building Code Requirements for Structural Concrete (ACI 318-08)* and the 2005 edition of *ASCE/SEI 7, Minimum Design Loads for Buildings and Other Structures*, the narrative and examples are based on these current standards wherever applicable. Section numbers and equation numbers from the 2009 IBC, ACI 318-08 and ASCE/SEI 7-05 that pertain to the specific requirements are provided throughout the text.

Although the book is geared primarily for practicing structural engineers, engineers studying for licensing exams, structural plan check engineers and civil engineering students will find the book a valuable resource because of its straightforward approach.

Chapter 2 summarizes floor systems commonly used in concrete buildings with guidance on the advantages of various systems and practical framing layouts and formwork. Information on the selection of economical floor systems for various span and gravity load conditions is provided along with methods to determine preliminary member sizes.

Chapter 3 summarizes the typical lateral-force-resisting systems used in low-rise reinforced concrete buildings and describes how these buildings respond to wind and earthquake forces. The procedure used to determine Seismic Design Category is included as well as the limitations imposed on the various lateral-force-resisting systems in relation to the Seismic Design Category of the building. Approximate methods to determine stiffness of lateral-force-resisting elements and distribution of lateral forces to the vertical resisting elements are provided.

Chapters 4, 5 and 6 cover the comprehensive design and detailing requirements for various structural elements based on Seismic Design Category and summarize the requirements in many tables, figures and flowcharts.

Design of Low-Rise Reinforced Concrete Buildings According to the 2009 IBC is an excellent resource for practicing civil and structural engineers as well as plan check engineers, engineers preparing for licensing exams and civil engineering students.

ACKNOWLEDGMENTS

The writer is deeply grateful to John R. Henry, P.E., Principal Staff Engineer, International Code Council, Inc., for review of this document. His insightful comments and suggestions for improvement are most appreciated.

Thanks are also due to Adugna Fanuel, S.E., LEED AP, Christina Harber, S.E., and Majlinda Agojci, all of Klein and Hoffman, Inc., for their contributions and review of the manuscript. Their help was invaluable. Angelo Cicero of Klein and Hoffman, Inc., created some of the figures throughout the publication, and his efforts are also very appreciated.

1.1 OVERVIEW

The purpose of this publication is to assist in the analysis, design and detailing of low-rise reinforced concrete buildings in accordance with the 2009 edition of the *International Building Code*[®] (IBC[®]) [1.1].¹

Section 1901.2 of the IBC requires that structural concrete be designed and constructed in accordance with the provisions of Chapter 19 of the 2008 edition of *Building Code Requirements for Structural Concrete (ACI 318-08)* and *Commentary* as amended in IBC Section 1908.² Wherever applicable, the requirements of the 2005 edition of *ASCE/SEI 7 Minimum Design Loads for Buildings and Other Structures* [1.3], which is also referenced in the 2009 IBC, must be satisfied as well.

The general principles of design and construction are essentially the same for any size building. Code requirements for analysis, design and detailing are typically given in general terms, without regard to the overall size of a building. In the case of low-rise buildings, certain assumptions can often safely be made to simplify the overall design procedure.

1.2 SCOPE

This publication focuses on the design requirements for cast-in-place reinforced concrete buildings with members utilizing nonprestressed reinforcement. Requirements for prestressed, post-tensioned and precast members are not addressed.

For purposes of this publication, a low-rise building is defined as one that has one or more of the following characteristics: (1) no more than five stories above grade, (2) a height less than 60 feet (18 288 mm), and (3) a fundamental period less than or equal to 0.5 seconds.³ Usually, the less rigorous provisions in the IBC and ASCE/SEI 7 can be used to determine load effects on low-rise buildings. Also, simpler assumptions and procedures can be utilized in the structural analysis and in the methods of allocating lateral forces to the elements of the lateral-force-resisting system.



¹Numbers in brackets refer to references listed in Section 1.3 of this publication.

²ACI 318-05 is one of a number of codes and standards that is referenced by the IBC. These documents, which can be found in Chapter 35 of the 2009 IBC, are considered part of the requirements of the IBC to the prescribed extent of each reference (see Section 101.4 of the 2009 IBC).

³IBC 403 defines a high-rise building as a building with an occupied floor located more than 75 feet (22 860 mm) above the lowest level of fire department vehicle access. In such buildings assigned to Occupancy Category III or IV, the structural integrity requirements of IBC 1614 must be satisfied. Based on the types of buildings addressed in this publication, the requirements of IBC 1614 need not be satisfied.

Code provisions have been organized in tables, figures and comprehensive flowcharts, which provide a road map that guides the reader through the requirements. Included in the flowcharts are the applicable section numbers and equation numbers from the 2009 IBC, the 2008 ACI 318 and ASCE/SEI 7-05 that pertain to the specific requirements. A basic description of flowchart symbols used in this publication is provided in Table 1.1.

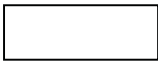
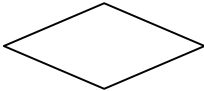
Table 1.1 Summary of Flowchart Symbols

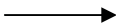
Symbol		Description
	Terminator	The terminator symbol represents the starting or ending point of a flowchart.
	Process	The process symbol indicates a particular step or action that is taken within a flowchart.
	Decision	The decision symbol represents a decision point, which requires a “yes” or “no” response.
	Off-page Connector	The off-page connector symbol is used to indicate continuation of the flowchart on another page.
	Or	The logical “Or” symbol is used when a process diverges in two or more branches. Any one of the branches attached to this symbol can be followed.
	Connector	The connector symbol indicates the sequence and direction of a process.

Although this publication focuses on low-rise buildings, it is evident that many of the design aids can be used in the design of reinforced concrete members in any building regardless of size.

The content of this publication is geared primarily to practicing structural engineers. The design and detailing requirements of the 2009 IBC and ACI 318-08 are presented in a straightforward manner with emphasis placed on the proper application of the provisions in everyday practice.

In addition to practicing structural engineers, engineers studying for licensing exams, structural plan checkers and others involved in structural engineering, such as advanced

undergraduate students and graduate students, will find the flowcharts and the worked-out design examples to be very useful.

Completely worked-out design examples are included in Chapters 4, 5 and 6 and illustrate the proper application of the code requirements. These examples follow the steps provided in the referenced flowcharts.

Throughout this publication, section numbers from the 2009 IBC are referenced as illustrated by the following: Section 1908 of the 2009 IBC is denoted as IBC 1908. Similarly, Section 21.1 from the 2008 ACI 318 is referenced as ACI 21.1 and Section 12.10 from the 2005 ASCE/SEI 7 is referenced as ASCE/SEI 12.10.

Chapter 2 contains a summary of the floor systems that are typically utilized in cast-in-place concrete buildings. General descriptions and basic information on the advantages of various systems as well as practical framing layouts and formwork are presented. Information is provided that can be used to select an economical floor system for various span and gravity load conditions. Methods on how to determine preliminary member sizes are also given.

A summary of the lateral-force-resisting systems that are commonly utilized in low-rise reinforced concrete buildings is given in Chapter 3. Included is a general description of how such buildings respond to wind and earthquake forces. A comprehensive procedure to determine the Seismic Design Category (SDC) is included, as are the limitations of the various lateral-force-resisting systems as a function of the SDC. Also provided are approximate methods to determine stiffness of lateral-force-resisting elements and equations to evaluate the allocation of lateral forces to the elements of the lateral-force-resisting system.

The remaining chapters of the publication present comprehensive design and detailing requirements for various structural elements based on the SDC of the building. Requirements are summarized in numerous tables, figures and flowcharts.

Chapter 4 contains the design and detailing requirements for buildings assigned to SDCs A and B. Requirements are summarized for the following: (1) members subjected to bending, (2) members subjected to bending and axial forces, (3) walls and (4) footings. The requirements are illustrated in two examples. A four-story residential building utilizing a flat plate and moment-resisting frame system is presented in the first example. The slab, beams, columns, footings and the diaphragm (including chords and collectors) are also designed and detailed according to code provisions. A one-story retail building utilizing a bearing wall system is presented in the second example.

The design and detailing requirements for buildings assigned to SDC C are given in Chapter 5. Requirements are presented for members subjected to bending (beams in intermediate moment frames and two-way slabs without beams) and for frame members subjected to bending and axial load in intermediate moment frames. The examples in

Chapter 4 are again utilized in Chapter 5 to illustrate the similarities and differences for the different SDCs.

Chapter 6 presents the design and detailing requirements for buildings assigned to SDC D, E and F. Requirements are summarized for (1) flexural members of special moment frames, (2) special moment frame members subjected to bending and axial load, (3) joints of special moment frames, (4) special structural walls, (5) structural diaphragms, (6) foundations and (7) members not designated as part of the seismic-force-resisting system. A three-story residential building utilizing special moment frames in one direction and a building frame system with special structural (shear) walls in the perpendicular direction is used to illustrate the requirements for beams, columns, walls, joints, members that are not part of the seismic-force-resisting system and the diaphragm (including chords and collectors).

1.3 REFERENCES

- 1.1 International Code Council, *International Building Code*, Washington, D.C., 2009.
- 1.2 American Concrete Institute, *Building Code Requirements for Structural Concrete (ACI 318-08) and Commentary*, Farmington Hills, MI, 2008.
- 1.3 Structural Engineering Institute of the American Society of Civil Engineers, *Minimum Design Loads for Buildings and Other Structures including Supplements No. 1 and 2*, ASCE/SEI 7-05, Reston, VA, 2006.

2.1 INTRODUCTION

In general, the cost of a floor system is often a major part of the overall structural cost of a building. Selecting the most effective system for a given set of constraints is vital to achieving overall economy. This is especially important for low-rise buildings, since the costs associated with lateral force resistance are usually nominal.

The information provided in the following sections can be used to select an economical cast-in-place concrete floor system with mild reinforcement for various span and gravity load conditions. General considerations that are applicable to all floor systems are presented first. Following the general considerations are a general description and basic information on the advantages of various systems as well as practical framing layouts and formwork. Methods on how to determine preliminary member sizes are also provided.

2.2 GENERAL CONSIDERATIONS

The three primary expenses in cast-in-place concrete floor system construction are concrete, reinforcement (mild and/or post-tensioned) and formwork. Of the three, formwork has the greatest influence, which accounts for about 50 percent of the total in-place costs. The following basic principles of formwork economy should be considered for site-cast concrete structures:

1. Specify readily available standard form sizes.

Most projects—especially low-rise projects—do not have the budget to accommodate the additional cost of custom formwork unless they are required in a quantity that allows for mass production.

2. Repeat sizes and shapes of concrete members wherever possible.

Maximum overall savings is achieved when formwork can be used from bay to bay and from floor to floor.

3. Strive for simple formwork.

Simple formwork and economical formwork are one in the same. The cost savings associated with a reduction in material quantities is negligible compared to the cost savings associated with simple formwork.

It is strongly recommended to consult with a concrete contractor during the early stages of a site-cast project. The type of forming system can have a major impact on the structural layout as well as on the schedule and time to completion.

A concrete mix with a specified compressive strength of 4,000 psi (27 580 kPa) yields the least expensive floor system where mild reinforcement is utilized. In post-tensioned floor systems, a concrete compressive strength of at least 5,000 psi (34 473 kPa) is usually specified to attain more cost-effective anchorages and higher resistance in tension and shear.

Fire resistance must also be considered in the preliminary design stage. Required fire-resistance ratings are a measure of the endurance needed to safeguard the structural stability of a building during a fire (i.e., structural members must be able to carry their own dead load and superimposed loads when subjected to the effects from fire) and to prevent the spread of fire to other parts of a building.

Concrete floor systems offer inherent fire resistance and no additional protective measures are required to achieve code-prescribed fire-resistance ratings when the floor system is completed (see Chapter 7 of the IBC).

Fire-resistance rating requirements depend on a number of factors and generally vary from 1 to 4 hours, with buildings typically requiring 2 hours. The concrete member thickness for structural purposes will usually be adequate to provide at least a 2-hour rating. In cases where a thicker member is required to satisfy fire-resistance requirements, consideration should be given to using a lightweight aggregate that provides higher fire resistance for the same thickness.

Adequate cover is needed to protect reinforcement from the effects of fire. The minimum cover requirements to the main reinforcement, which are in ACI 7.7, are adequate for at least a 2-hour fire-resistance rating.

It is good practice to consult the local building code governing the project at an early stage to ensure that minimum fire-resistance requirements are satisfied.

2.3 FLOOR SYSTEMS

The following sections describe the floor systems commonly used in concrete buildings, and the discussion is applicable to concrete buildings of any size. The information can be used as a guide in selecting an economical floor system.

2.3.1 Flat Plate System

A flat plate floor system is a two-way concrete slab supported directly on columns with reinforcement primarily in two orthogonal directions (see Figure 2.1). This system has the advantages of simple construction and formwork, and it is typically economical for span lengths between 15 feet (4572 mm) and 25 feet (7620 mm) when subjected to moderate live loads.

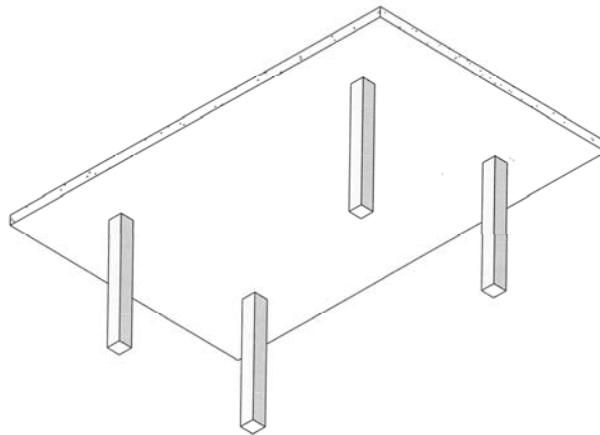
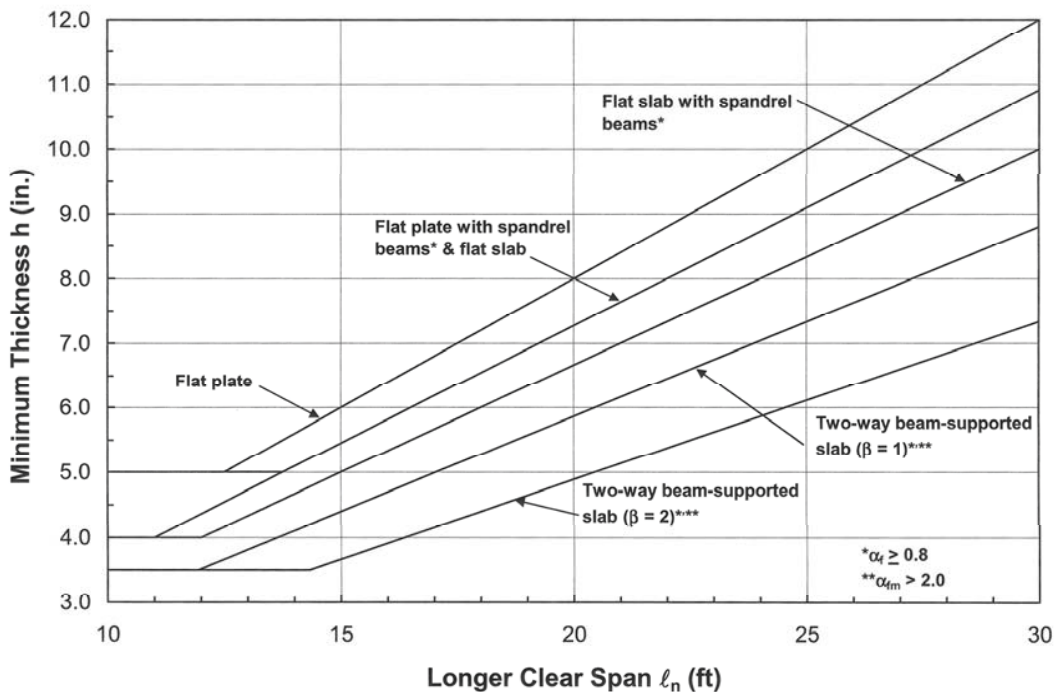

Figure 2.1 Flat Plate System

Minimum thickness requirements for flat plates are given in ACI 9.5.3. The thickness of flat plates without edge beams and containing mild reinforcement with a yield strength of 60,000 psi (413 685 kPa) must be greater than or equal to $\ell_n/30$ where ℓ_n is the length of the clear span (measured face-to-face of supports) in the long direction [see ACI Table 9.5(c)]. Minimum slab thickness is depicted in Figure 2.2, which includes the 5-inch (127 mm) minimum requirement of ACI 9.5.3.2.



For SI: 1 inch = 25.4 mm; 1 foot = 304.8 mm.

Figure 2.2 Minimum Slab Thickness in accordance with ACI 9.5.3

The thickness of a flat plate will usually be controlled by deflection requirements for relatively short spans and live loads of 50 psf (2.39 kPa) or less. In such cases, the flexural reinforcement at the critical sections in the column and middle strips will be about the minimum amount specified in ACI 13.3. Thus, using a slab thickness greater than the minimum required for serviceability is not economical, since a thicker slab requires more concrete without a reduction in reinforcement. Also, since the minimum slab thickness requirements are independent of the concrete compressive strength, specifying 4,000-psi (27 580 kPa) concrete is the most economical; using a concrete strength greater than 4,000 (27 580 kPa) psi increases cost without a reduction in slab thickness.

Two-way or punching shear also plays a key role in determining the thickness of a flat plate, especially where the spans are relatively long and/or the live load is 100 psf (4.79 kPa) or greater. To satisfy shear strength requirements, the thickness is usually greater than that required for serviceability. Shear stresses developed at edge and corner columns are particularly critical, since they are subjected to relatively large unbalanced moments.

Shear strength requirements for slabs are given in ACI 11.11. It is evident from Equations (11-31), (11-32) and (11-33) that using a higher concrete compressive strength, f'_c , is not the most effective way of increasing the nominal shear strength of the concrete, V_c , at the critical section around a column, since V_c is a function of the square root of f'_c . In lieu of using shear reinforcement, increasing the thickness of the slab and/or increasing the column dimensions are typically the most cost-effective solutions to two-way shear problems. Providing spandrel beams significantly increases shear strength at perimeter columns, but there is additional material and forming costs associated with such members and they may not fit into the architectural scheme.

Figure 2.3, which is based on the two-way shear strength requirements of ACI 318-08, can be used to determine a preliminary slab thickness, h , for a flat plate assuming the following:

- Square-edge column of size c_1 bending perpendicular to the slab edge with a three-sided critical section and $\alpha_s = 30$.
- Column supports a tributary area, A
- Square bays
- Gravity load moment transferred between the slab and edge column in accordance with the Direct Design Method requirement of ACI 13.6.3.6
- 4,000 psi (27 580 kPa) normal weight concrete

The total factored load, q_u , must include an estimate of the slab weight. The ratio d/c_1 is determined as a function of q_u and the area ratio A/c_1^2 . A preliminary slab thickness, h , can be obtained by adding 1 ¼ inches (32 mm) to d acquired from the figure. Figure 2.3 can help decrease the number of iterations that are needed to establish a viable slab

thickness based on shear strength. It can also be used to check the output from a computer program.

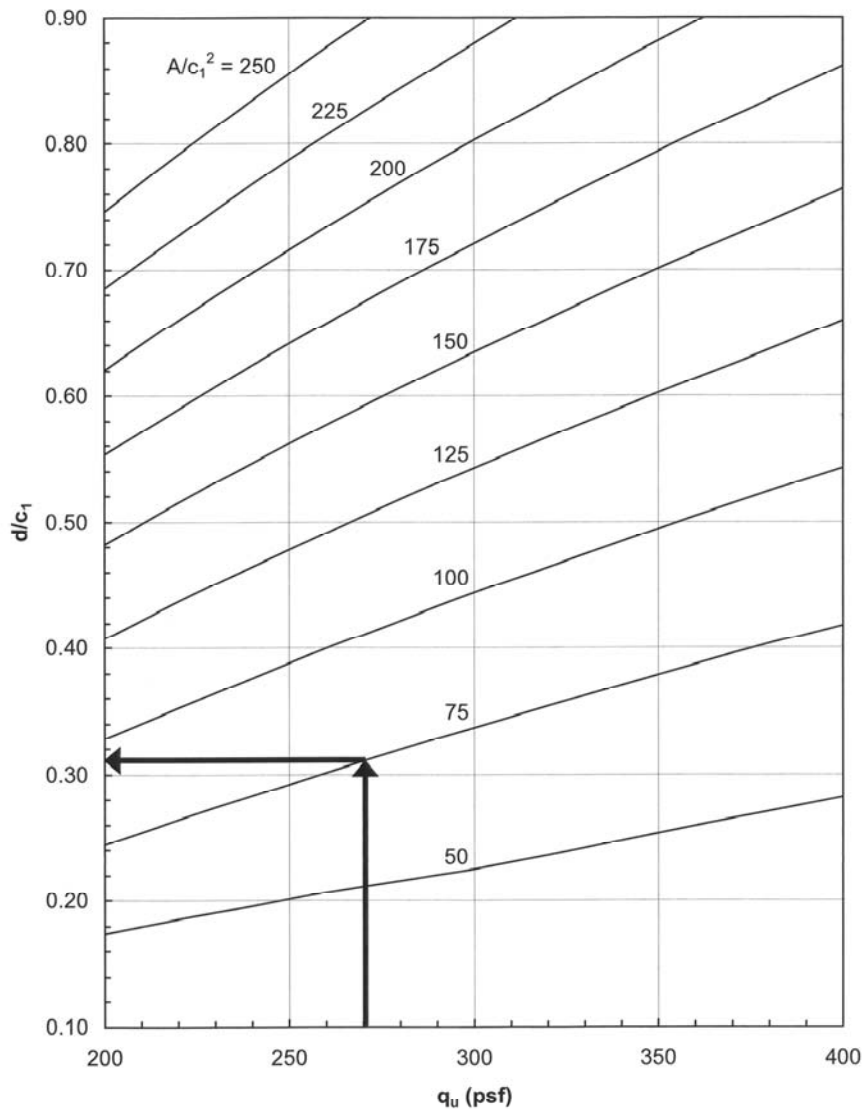

For SI: 1 pound per square foot = 47.88 Pa.

Figure 2.3 Preliminary Slab Thickness for Flat Plate Construction Based on Two-way Shear Strength at an Edge Column

As mentioned previously, slab thickness and/or column sizes can be increased where shear strength requirements are not satisfied. When these options are not viable, the slab can be thickened locally around the columns (commonly referred to as shear caps; see ACI 13.2.6) or shear reinforcement can be provided. Provisions for headed shear stud reinforcement are given in ACI 11.11.5; such reinforcement provides an economical means of resisting shear stresses and helps alleviate congestion at slab-column joints.

For a live load of 50 psf (2.39 kPa) or less, flat plates are economically viable for spans between 15 feet (4572 mm) and 25 feet (7620 mm). The economical range for live loads of 100 psf (4.79 kPa) is 15 feet (4752 mm) to 20 feet (6096 mm). A flat plate floor subjected to a 100-psf (4.79 kPa) live load is only about 8 percent more expensive than one subjected to a 50-psf (2.39 kPa) live load, primarily due to the minimum thickness requirements for deflection.

It will be shown later in this publication that flat plate systems are not permitted to be the primary seismic-force-resisting system in areas of high seismicity.

2.3.2 Flat Slab System

A flat slab floor system is similar to a flat plate floor system, with the exception that the slab is thickened around the columns, as depicted in Figure 2.4. These thickened portions of the slab are called drop panels. With relatively simple construction and formwork, this system is typically economical for spans between 20 feet (6096 mm) and 30 feet (9144 mm).

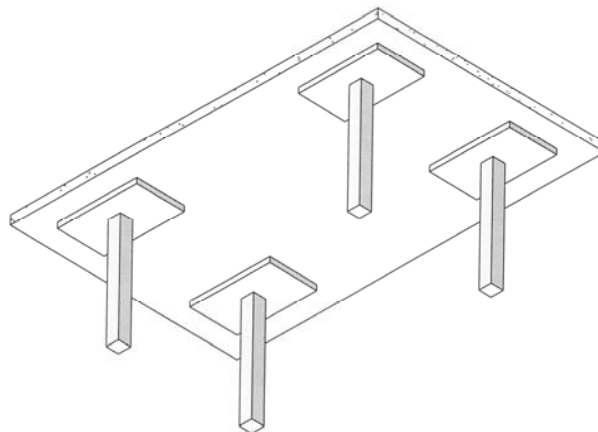

Figure 2.4 Flat Slab System

Unlike shear caps, which extend horizontally a minimum distance from the edge of the column equal to the thickness of the projection below the slab soffit and which are provided exclusively to increase shear strength, drop panels conform to the dimensional requirements of ACI 13.2.5. These requirements are illustrated in Figure 2.5. When drop panels are provided, the shear strength around the columns is increased and the amount of negative reinforcement and the overall thickness is reduced.

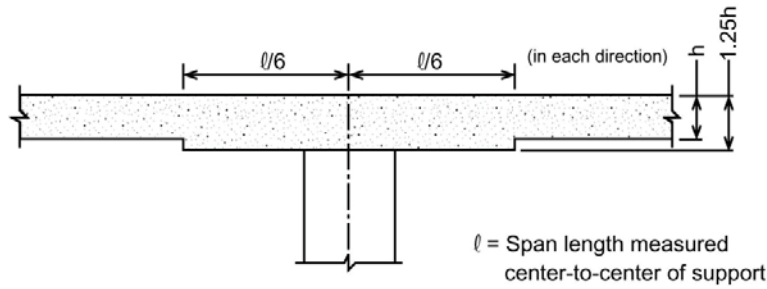
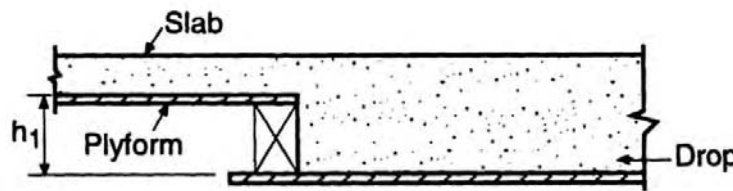

Figure 2.5 Drop Panel Dimensions (ACI 13.2.5)

The minimum slab thickness required by ACI 9.5.3 for flat slabs is 10 percent less than that required for flat plates (see Figure 2.2), and in no case can the slab thickness be less than 4 inches (102 mm) (ACI 9.5.3.2).

Drop panel dimensions are also controlled by formwork considerations. Using depths other than the standard depths indicated in Figure 2.6, which are dictated by lumber dimensions, will unnecessarily increase formwork costs.



Nominal lumber size	Actual lumber size (in.)	Plyform thickness (in.)	h_1 (in.)
2X	1 ¹ / ₂	3/4	2 ¹ / ₄
4X	3 ¹ / ₂	3/4	4 ¹ / ₄
6X	5 ¹ / ₂	3/4	6 ¹ / ₄
8X	7 ¹ / ₂	3/4	8 ¹ / ₄

For SI: 1 inch = 25.4 mm.

Figure 2.6 Drop Panel Formwork Details

For a live load of 50 psf (2.39 kPa) or less, flat slabs are economically viable for spans between 25 feet (7620 mm) and 30 feet (9144 mm). The economical range for live loads of around 100 psf (4.79 kPa) is 20 feet (6096 mm) to 25 feet (7620 mm). Total material costs increase by only about 4 percent when going from 50 psf (2.39 kPa) to 100 psf (4.79 kPa) because the material quantities are usually controlled by deflections.

2.3.3 Beam-Supported Slab System

The slab system supported on beams on all sides, which is depicted in Figure 2.7, was the original slab system in reinforced concrete. Where the ratio of the long side to the short side of a panel is two or more, load is transferred primarily by bending in the short direction and the panel acts as a one-way slab. Where the ratio of the sides is less than two, load is transferred by bending in both orthogonal directions and the panel acts as a two-way slab.

In a one-way system, the thickness of the beams and one-way slab is governed by the provisions of ACI 9.5.2. The largest applicable minimum value in ACI Table 9.5(a) should be used to determine the thickness of a slab or beam; for economy in formwork, this thickness should be used as much as possible over the floor area.

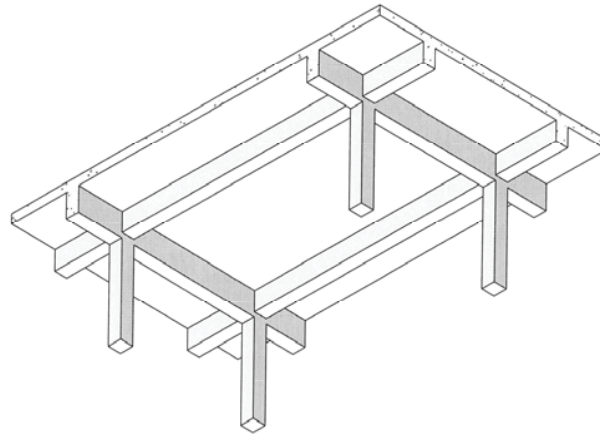

Figure 2.7 Beam-Supported Slab System

The minimum thickness, h , for a solid one-way slab with one end continuous is $\ell/24$, while the minimum thickness for a beam with one end continuous is $\ell/18.5$ where ℓ is the span length of the slab or beam defined by ACI 8.9 [see ACI Table 9.5(a)]. These values are for members with normal weight concrete and Grade 60 reinforcement that are not supporting or attached to partitions or other construction likely to be damaged by large deflections.

The minimum slab thickness for a two-way system is governed by ACI 9.5.3.3, and depends on the average value of α_f for all beams on the edges of a panel, α_{fm} , where α_f is the ratio of the flexural stiffness of a beam section to the flexural stiffness of a slab section bounded by centerlines of adjacent panels (if any) on each side of the beam. Minimum slab thickness based on the provisions of ACI 9.5.3.3 is depicted in Figure 2.2. The largest required slab thickness from all of the panels should be used wherever possible over the floor for economy in formwork.

Column-line beams are not used as often as they once were in concrete floor systems, except in cases where the demands for lateral-force resistance are relatively large. In such cases, and in lieu of other types of systems, moment-resisting frames with column-line beams must be used as the seismic-force-resisting system.

2.3.4 One-Way Joist System

A one-way joist system consists of evenly spaced concrete joists (ribs) spanning in one direction, a reinforced concrete slab that is cast integrally with the joists and beams that span between the columns perpendicular to the joists (see Figure 2.8). It is usually more cost-effective to frame the joists in the long direction.

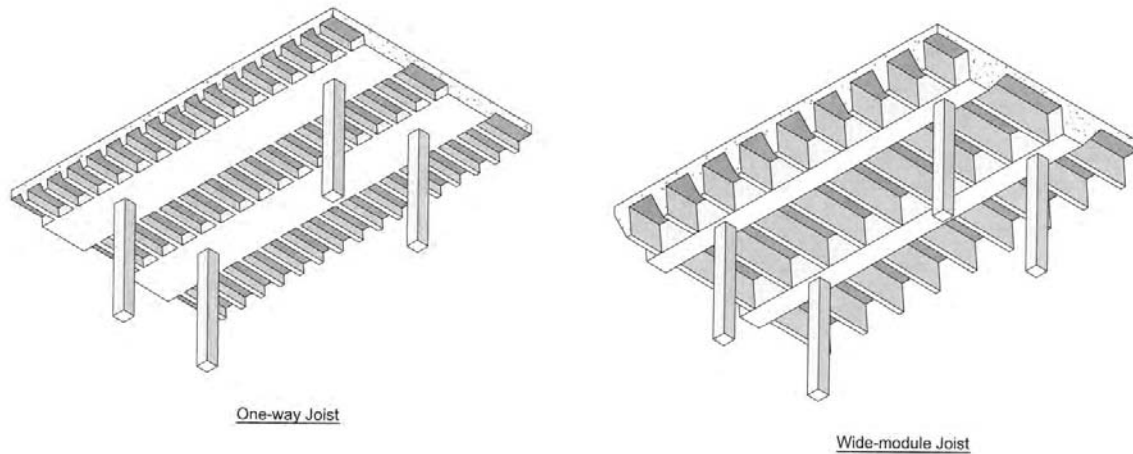
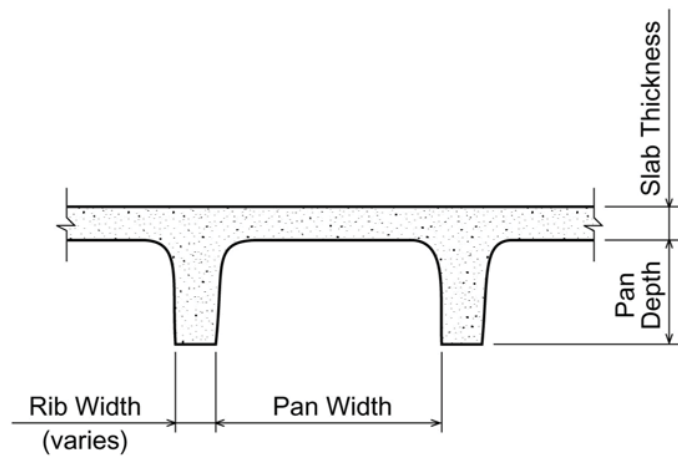

Figure 2.8 One-way Joist Systems

Standard joists, which are not commonly used any more, have pan forms that are 30 inches (762 mm) wide and range in depth from 8 inches to 24 inches (203 mm to 610 mm) (see Figure 2.9). The thickness of the slab spanning between the joists is usually controlled by fire-resistance requirements, since the structural requirements of the slab are minimal.



Pan Width (in.)	Pan Depth (in.)
30	8, 10, 12, 14, 16, 20, 24
53	16, 20, 24
66	14, 16, 20, 24

For SI: 1 inch = 25.4 mm.

Figure 2.9 Standard Form Dimensions for One-way Joist Construction

Wide-module joists, or “skip” joists, are similar to standard one-way joists, except the pans are 53 inches (1346 mm) or 66 inches (1676 mm) wide. The depths vary as shown in Figure 2.9. Wide-module joists are economical for long spans [30 feet to 50 feet (9144 mm to 15 240 mm)] and/or heavier loads.

In wide-module joist construction, the ribs and a portion of the slab must satisfy the requirements for beams, and the overall depth is governed by the deflection requirements of ACI 9.5.2. The longest span should be used to determine the required joist depth for the floor, if possible.

Joist width can be tailored to satisfy virtually any requirement. In usual situations, the thinnest practical width will usually be adequate for structural requirements. Column-line joists can be made part of the lateral-force-resisting system, and the width can be adjusted as needed to resist the combined load effects.

To achieve overall formwork economy, the depth of the supporting beam should be the same overall depth as the joists. If additional capacity is required, the beams should be made wider, not deeper. Also, beams should be as wide as, or wider than, the columns into which they frame (see Figure 2.10). Beams that are narrower than the columns require additional material and labor for formwork, which results in significant costs.

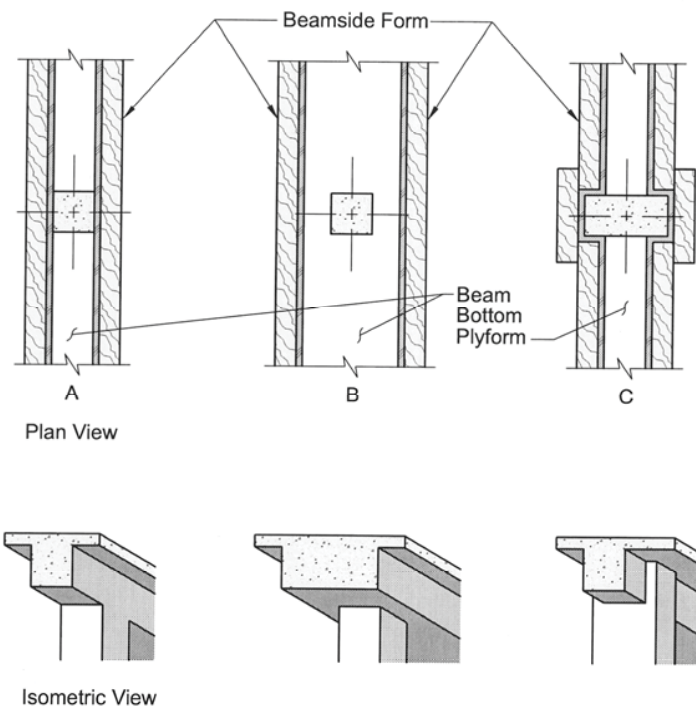

Figure 2.10 Formwork Considerations for Beam Construction

The depth of the one-way slab spanning between the ribs is governed by the deflection requirements of ACI 9.5.2. In most cases, minimum reinforcement for temperature and shrinkage is required for flexure.

An increase in live load from 50 psf (2.39 kPa) to 100 psf (4.79 kPa) results in approximately a 5 percent increase in total material costs.

3.1 INTRODUCTION

This chapter contains a summary of the lateral-force-resisting systems that are commonly utilized in low-rise reinforced concrete buildings. Included is a general description of how buildings respond to wind and earthquake forces.

A comprehensive procedure on how to determine the Seismic Design Category (SDC) is also included, as are the limitations of the various lateral-force-resisting systems as a function of the SDC.

Approximate methods to determine the stiffness of lateral-force-resisting elements for different types of low-rise systems are discussed and equations are provided that can be used to evaluate the allocation of lateral forces to the elements of the lateral-force-resisting system.

3.2 RESPONSE OF LOW-RISE BUILDINGS TO LATERAL FORCES

All buildings must be designed for the combined effects due to gravity, wind, earthquake and other applicable forces. For purposes of design, it is generally assumed that wind and earthquakes generate horizontal and vertical forces on a structure. These assumptions greatly simplify how the response of a building is treated when it is subjected to these complex natural occurrences.

The overall response of a building to wind is distinctly different than the overall response to earthquakes. Both response modes are examined below.

3.2.1 Response to Wind Forces

According to the 2009 IBC and ASCE/SEI 7-05, wind is applied to a structure in the form of pressures that act normal to the surfaces of a structure, as depicted in Figure 3.1 for a building with a gable or hip roof.¹ Positive wind pressure, which is commonly referred to as pressure, is above the ambient pressure at the site and acts towards the surface of the building. Negative wind pressure, or suction, is below the ambient pressure and acts away from the surface. As shown in Figure 3.1, which is adapted from Figure 6-6 of ASCE/SEI 7-05, positive pressure acts on the windward wall, while negative pressure acts on the leeward wall, the side walls and the leeward portion of the roof. Depending on the roof slope, either positive or negative wind pressure acts on the windward portion of the roof.

¹ Pressure distributions for buildings with other types of roofs are given in ASCE/SEI 7 Figure 6-6.

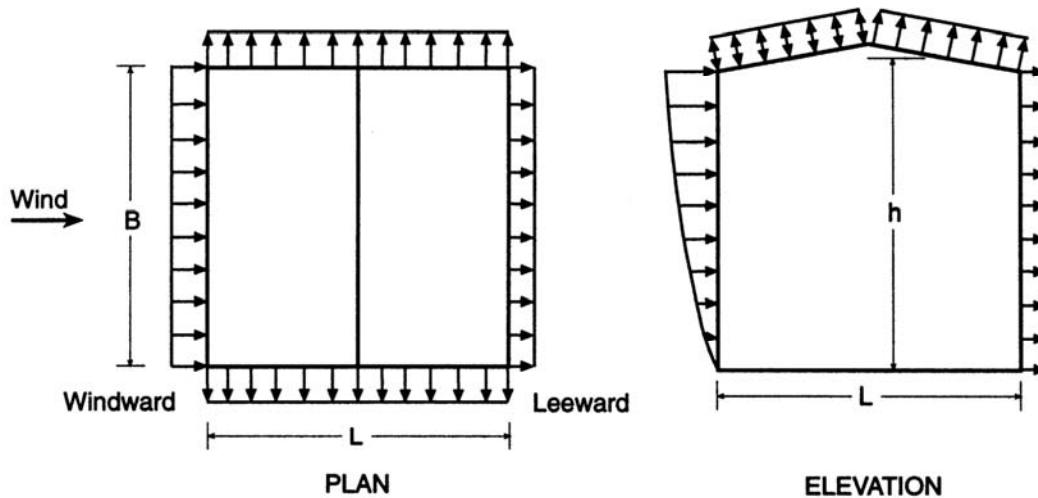

Figure 3.1 Wind Pressure Distribution on a Building with a Gable/Hip Roof

The methods for estimating wind pressures in Chapter 6 of ASCE/SEI 7 are essentially static methods and are based on the size, geometry, location (exposure), openness and importance of a building as well as on the height above ground level (pressure is assumed to vary with respect to height on the windward face, as shown in Figure 3.1). Gust and local extreme pressures at various locations over the faces of a building are also considered.

For most tall buildings, static methods cannot be used to estimate wind pressure because buildings respond dynamically to wind forces and inertial forces are generated. A dynamic analysis or a wind tunnel test is generally warranted in such cases (see ASCE/SEI 7 Section 6.6 for more information on wind tunnel procedures). For low-rise buildings, dynamic effects are typically negligible, so static methods are usually sufficient to determine wind pressures.

Design wind forces on the main wind-force-resisting system² can be determined by Method 1, Simplified Procedure, in Section 6.4 of ASCE/SEI 7 for low-rise buildings that satisfy the conditions of ASCE/SEI 6.4.1.1.³ Method 2, Analytical Procedure, can be used to determine design wind forces for a wide variety of buildings that meet the requirements of ASCE/SEI 6.5.1.⁴ In short, wind forces are external forces that are applied to, and hence are proportional to, the exposed surface of a structure.

²The main wind-force-resisting system is defined in Section 6.2 of ASCE/SEI 7 as the assemblage of structural elements assigned to provide support and stability for the overall structure and generally receives wind loading from more than one surface.

³Low-rise buildings are defined in Section 6.2 of ASCE/SEI 7 as buildings with a mean roof height less than 60 feet (18 288 mm) and with a mean roof height that does not exceed the least horizontal dimension of the building.

⁴Detailed information on how to determine wind forces by Methods 1 and 2 can be found in the ICC publication, *Structural Load Determination Under 2006 IBC and ASCE/SEI 7-05, 2008*.

It should be noted that Section 1609.6 of the 2009 IBC provides an alternate all-heights wind design method that is a simplification of the ASCE/SEI 7 analytical procedure.

The path of the externally applied, static wind forces through a building is straightforward. Wind pressure is applied on the windward surface, which transfers it to roof and floor decks acting as diaphragms. The diaphragms subsequently transmit these forces to the elements of the lateral-force-resisting system (such as walls, frames or a combination thereof). The elements of the lateral-force-resisting system in turn transfer their respective forces to the foundation. It is generally assumed that a structure remains elastic under the effects from design wind forces.

3.2.2 Response to Earthquake Forces

In short, seismic forces are generated by the dead weight of a building. These inertial forces are created by the motion of the ground that supports a building's foundation. The response of a structure resulting from such ground motion is influenced by the nature of the motion and the properties of the structure and its foundation.

The horizontal components of ground motion typically have a more significant effect on a building than the vertical components. Thus, earthquake-resistant design concentrates more on the effects of the horizontal forces although vertical load effects must also be considered as part of the earthquake load effect, E .

The general philosophy of earthquake-resistant design is to allow some structural and nonstructural damage while minimizing hazard to life. This is to be achieved by utilizing the inelastic deformability of a structure and allowing dissipation of the earthquake energy. It is expected that structures would undergo relatively large deformations when subjected to a design-basis earthquake and that yielding would occur in some members of the structure. Possessing sufficient inelastic deformability through ductile detailing of critical members enables the structure to survive without collapse when subjected to several cycles of deformation into the inelastic range.

Figure 11.4-1 of ASCE/SEI 7 shows the general shape of the design spectrum for seismic design. Low-rise buildings will typically have periods that correspond to maximum accelerations (the horizontal plateau of the design spectrum). These accelerations are translated directly into inertial forces, as described below.

Chapter 12 of ASCE/SEI 7-05 contains analytical procedures to determine seismic forces. In general, the procedure that is permitted to be used depends on a structure's Seismic Design Category (SDC), structural system, dynamic properties and regularity (see Section 12.6 of ASCE/SEI 7).

The Equivalent Lateral Force Procedure in ASCE/SEI 12.8 can be used to analyze all structures assigned to SDC B and C as well as some types of structures assigned to SDC D, E and F (see Table 12.6-1). In this method, a seismic base shear, V , is computed, which depends on the design response accelerations at the site and the structure's seismic-force-resisting system, period, importance and weight. The base shear is then

distributed over the height of the building; it is assumed that the effects from an earthquake can be modeled as a set of static forces, F_x , applied at the roof and floor levels of a structure that meet the requirements of this method.⁵ For a low-rise building where the fundamental period is less than or equal to 0.5 sec, the vertical distribution of seismic forces is triangular with the maximum force occurring at the roof level, as depicted in Figure 3.2.

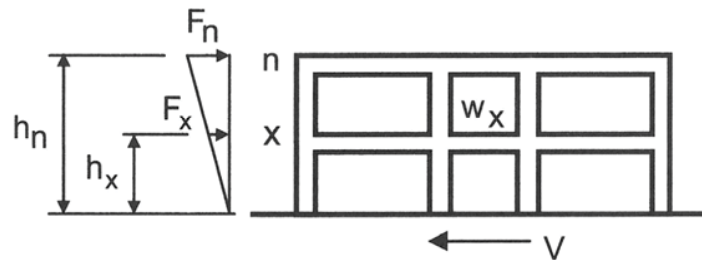

Figure 3.2 Vertical Distribution of Seismic Forces in a Low-rise Building ($T : 0.5 \text{ sec}$)

The simplified method presented in ASCE/SEI 12.14 can be used to determine seismic forces on simple bearing wall or building frame systems that meet the requirements of ASCE/SEI 12.14.1.1. This procedure is applicable to a wide range of relatively stiff, low-rise structures that fall under Occupancy Categories I and II and possess seismic-force-resisting systems that are arranged in a torsionally-resistant, regular layout.

It is essential that reinforced concrete structures be properly detailed in order to perform satisfactorily during earthquakes. It is especially important that stiff components of low-rise buildings (such as piers, short columns or walls) that may be prone to shear rather than flexural failures be designed and detailed to prevent such brittle failure. The proper level of seismic detailing must be provided even when the effects of wind forces govern the design. Detailing requirements are given in subsequent chapters of this publication as a function of SDC.

3.3 SEISMIC DESIGN CATEGORY

All buildings and structures must be assigned to a Seismic Design Category (SDC) in accordance with IBC 1613.5.6 or ASCE/SEI 11.6. In general, a SDC is a function of occupancy or use and the design spectral accelerations, S_{DS} and S_{D1} , at the site.

The SDC is determined twice: first as a function of S_{DS} by IBC Table 1613.5.6(1) or ASCE/SEI Table 11.6-1 and second as a function of S_{D1} by IBC Table 1613.5.6(2) or ASCE/SEI Table 11.6-2. The more severe of the two governs.

⁵Detailed information on how to determine seismic forces by the Equivalent Lateral Force Method and other methods can be found in the ICC publication, *Structural Load Determination Under 2006 IBC and ASCE/SEI 7-05, 2008*.

In locations where the mapped spectral acceleration parameter at a period of one second, S_1 , is less than 0.75, the SDC may be determined by IBC Table 1613.5.6(1) or ASCE/SEI Table 11.6-1 alone provided all of the four conditions listed under IBC 1613.5.6.1 or ASCE/SEI 11.6 are satisfied. This provision can be advantageous for low-rise buildings that meet these conditions, since the SDC determined by the short-period response alone can be lower than that determined by the more severe of the short-period and long-period responses. As will be shown later, this can have a large impact on the level of detailing that is required.

Conditions under which SDC E and SDC F are to be assigned are also given in IBC 1613.5.6 and ASCE/SEI 11.6.

The SDC is a trigger mechanism for many seismic requirements, including

- Permissible seismic-force-resisting systems
- Limitations on building height
- Consideration of structural irregularities
- The need for additional special inspections

The flowchart in Figure 3.3 can be used to determine the SDC in accordance with the IBC and ASCE/SEI 7. Referenced section numbers, tables and figures in the flowchart are from ASCE/SEI 7-05 unless noted otherwise.

3.4 LATERAL-FORCE-RESISTING SYSTEMS

Numerous types of reinforced concrete lateral-force-resisting systems are available to resist the effects from wind and earthquake forces, and this section focuses on those that are commonly used in low-rise buildings. This does not imply that the systems discussed here are the most suitable in every situation; other systems may be more appropriate in certain cases, and it is left to the judgment of the engineer to determine the system that is best for the given situation.

ASCE/SEI 7 essentially puts no limitations on the type of lateral-force-resisting system that can be used as the main wind-force-resisting system, even in hurricane-prone regions. However, ASCE/SEI 12.2.1 requires that seismic-force-resisting systems conform to those indicated in Table 12.2-1. Structural system limitations and building height limits are given in the table as a function of the SDC.

There are no system limitations for structures assigned to SDC A; such structures need only comply with ASCE/SEI 11.7.

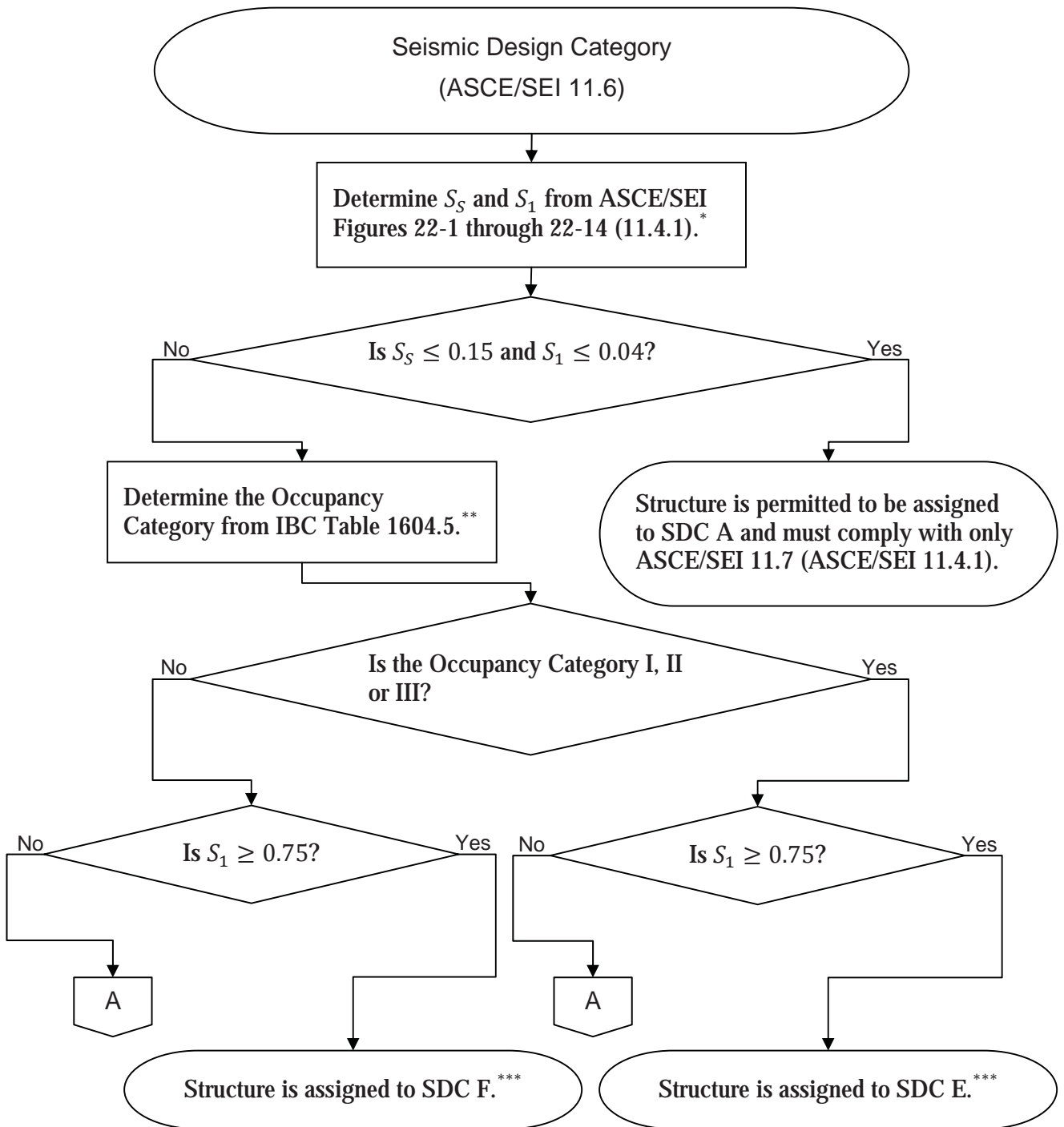

* Values of S_S and S_1 may be obtained from the USGS website (<http://earthquake.usgs.gov/research/hazmaps/design/>) for a particular site.

** Where the IBC is the legally adopted code, IBC Table 1604.5 should be used to determine occupancy category instead of ASCE/SEI Table 1-1.

*** A structure assigned to SDC E or F shall not be located where there is a known potential for an active fault to cause rupture of the ground surface at the structure (ASCE/SEI 11.8).

Figure 3.3 Determination of Seismic Design Category

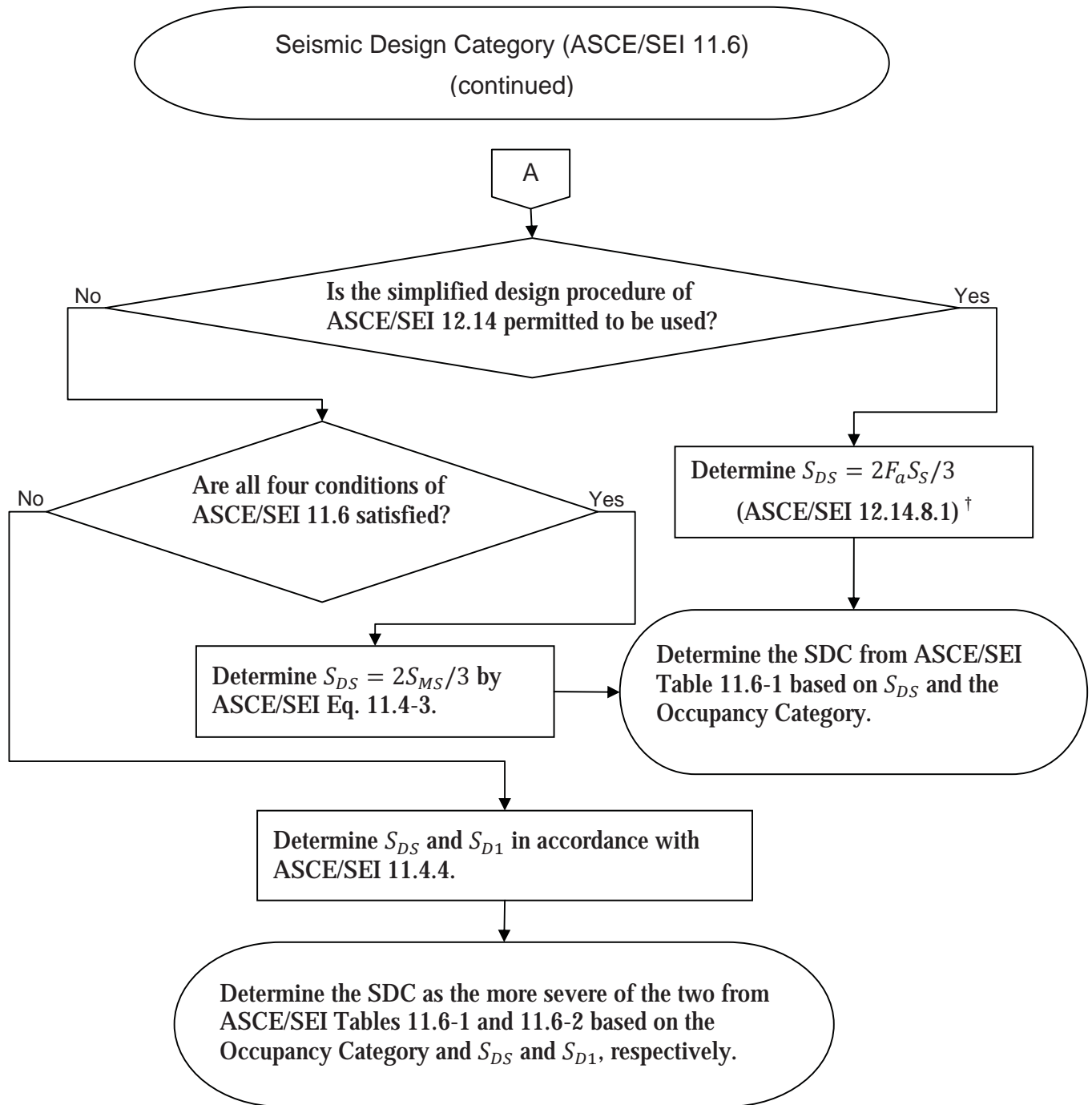

For SI: 1 foot = 304.8 mm.

† Short-period site coefficient, F_a , is permitted to be taken as 1.0 for rock sites, 1.4 for soil sites, or may be determined in accordance with ASCE/SEI 11.4.3. Rock sites have no more than 10 feet of soil between the rock surface and the bottom of spread footing or mat foundation. Mapped spectral response acceleration, S_S , is determined in accordance with ASCE/SEI 11.4.1 and need not be taken larger than 1.5 (ASCE/SEI 12.14.8.1).

Figure 3.3 Determination of Seismic Design Category (continued)

Bearing wall systems, building frame systems, moment-resisting frame systems, and shear wall-frame interactive systems are commonly utilized in low-rise buildings. Table 3.1 contains a summary of the information provided in ASCE/SEI Table 12.2-1 for these systems. Descriptions of each system are given in the following sections.

Table 3.1 Design Coefficients and Factors for Concrete Seismic-force-resisting Systems Typically Used in Low-rise Construction (adapted from ASCE/SEI Table 12.2-1)

Seismic-force-resisting System	R^*	Ω_o^{**}	C_d^\dagger	Structural System Limitations and Building Height (ft) Limit ^{††}				
				Seismic Design Category				
				B	C	D	E	F
A. Bearing Wall Systems								
1. Special reinforced concrete shear walls	5	2 ^{1/2}	5	NL	NL	160	160	100
2. Ordinary reinforced concrete shear walls	4	2 ^{1/2}	4	NL	NL	NP	NP	NP
3. Detailed plain concrete shear walls	2	2 ^{1/2}	2	NL	NP	NP	NP	NP
4. Ordinary plain concrete shear walls	1 ^{1/2}	2 ^{1/2}	1 ^{1/2}	NL	NP	NP	NP	NP
5. Intermediate precast shear walls	4	2 ^{1/2}	4	NL	NL	40 [‡]	40 [‡]	40 [‡]
6. Ordinary precast shear walls	3	2 ^{1/2}	3	NL	NP	NP	NP	NP
B. Building Frame Systems								
5. Special reinforced concrete shear walls	6	2 ^{1/2}	5	NL	NL	160	160	100
6. Ordinary reinforced concrete shear walls	5	2 ^{1/2}	4 ^{1/2}	NL	NL	NP	NP	NP
7. Detailed plain concrete shear walls	2	2 ^{1/2}	2	NL	NP	NP	NP	NP
8. Ordinary plain concrete shear walls	1 ^{1/2}	2 ^{1/2}	1 ^{1/2}	NL	NP	NP	NP	NP
9. Intermediate precast shear walls	5	2 ^{1/2}	4 ^{1/2}	NL	NL	40 [‡]	40 [‡]	40 [‡]
10. Ordinary precast shear walls	4	2 ^{1/2}	4	NL	NP	NP	NP	NP
C. Moment-resisting Frame Systems								
5. Special reinforced concrete moment frames	8	3	5 ^{1/2}	NL	NL	NL	NL	NL
6. Intermediate reinforced concrete moment frames	5	3	4 ^{1/2}	NL	NL	NP	NP	NP
7. Ordinary reinforced concrete moment frames	3	3	2 ^{1/2}	NL	NP	NP	NP	NP
F. Shear Wall-Frame Interactive System with Ordinary Reinforced Concrete Moment Frames and Ordinary Reinforced Concrete Shear Walls	4 ^{1/2}	2 ^{1/2}	4	NL	NP	NP	NP	NP

For SI: 1 foot = 304.8 mm.

* R = Response modification coefficient

** Ω_o = System overstrength factor

† C_d = Deflection amplification factor

†† NL = Not Limited and NP = Not Permitted

‡ Increase in height to 45 feet is permitted for single story storage warehouse facilities.

3.4.1 Bearing Wall Systems

In a bearing wall system, bearing walls provide support for all or most of the gravity loads, and resistance to lateral loads is provided by the same bearing walls acting as shear walls (see Figure 3.4). These systems do not have an essentially complete space frame that provides support for gravity loads.

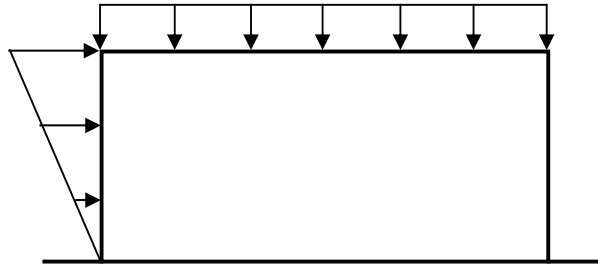

Figure 3.4 Bearing Wall System

SDC B. Ordinary reinforced concrete shear walls are permitted to be used in buildings assigned to SDC B without any limitations. Such walls must satisfy the applicable requirements of ACI Chapters 1 through 18; the provisions of Chapter 21 need not be satisfied. Detailed plain and ordinary plain concrete shear walls may also be used without limitations. According to ASCE/SEI 14.2.2.4, detailed plain concrete shear walls are walls complying with the requirements of ACI Chapter 22 and the additional reinforcement requirements of ASCE/SEI 14.2.2.15, and ordinary plain concrete shear walls are walls complying with the requirements of Chapter 22 only. Ordinary precast shear walls, which are precast walls complying with the requirements of ACI Chapters 1 through 18, are also permitted with no limitations.

SDC C. Ordinary or special reinforced concrete shear walls are to be used in buildings assigned to SDC C. Special reinforced concrete shear walls must conform to the requirements of ACI 21.9. Note that intermediate precast shear walls may also be used with no limitations as long as they comply with the additional requirements of ACI 21.4 and ASCE/SEI 14.2.2.14.

SDC D, E and F. Special reinforced concrete shear walls are required in buildings assigned to SDC D, E or F. The height of a building is limited to 160 feet (48 768 mm) for SDC D and E and is limited to 100 feet (30 480 mm) for SDC F. Although not listed in ASCE/SEI Table 12.2-1, special structural walls constructed using precast concrete may be used, provided the provisions of ACI 21.10 are satisfied. Intermediate precast shear walls are also permitted with a building height limit of 40 feet (12 192 mm), which can be increased to 45 feet (13 716 mm) for single-story storage warehouse facilities.

3.4.2 Building Frame Systems

A building frame system is a structural system with an essentially complete space frame that supports the gravity loads and shear walls that resist the lateral forces (see Figure 3.5). In the lateral load analysis, all of the lateral forces are allocated to the shear walls; no interaction is considered between the shear walls and the frames.

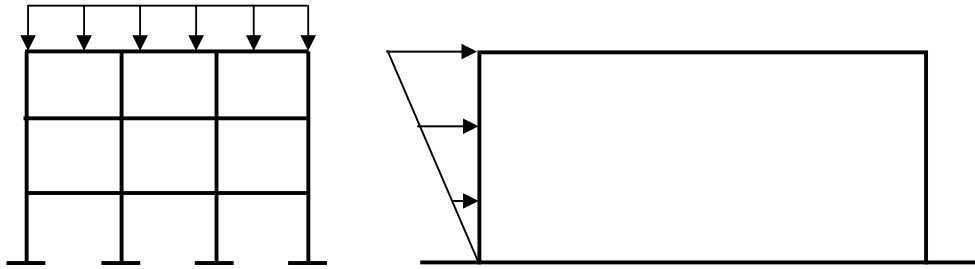

Figure 3.5 Building Frame System

SDC B. Ordinary plain, detailed plain and ordinary reinforced concrete shear walls and ordinary precast shear walls are permitted to be used in buildings assigned to SDC B with no limitations. Building frame systems are generally not used in buildings assigned to SDC B, since there is little to be gained from assigning the entire lateral resistance to the shear walls in absence of any special detailing requirements for the frames. A shear wall-frame interactive system, which is discussed in Section 3.4.4 of this publication, is usually more practical and economical in such cases.

SDC C. Buildings assigned to SDC C are permitted to utilize ordinary reinforced, special reinforced and intermediate precast concrete shear walls with no limitations. Like in the case of bearing wall systems, intermediate precast shear walls must comply with the additional requirements of ACI 21.4 and ASCE/SEI 14.2.2.14.

SDC D, E or F. The same systems (special reinforced, intermediate precast and special structural walls constructed using precast concrete) used in the bearing wall system can be used in the building frame system, along with the applicable building height limits. It is important to note that for these SDCs, the deformational compatibility requirements of ACI 21.13 must be satisfied. The beam-column frames must be designed to resist the effects caused by the lateral deflections due to the earthquake effects, since they are connected to the walls by the diaphragm at each level. The frame members, which are not designated as part of the seismic-force-resisting system, must be capable of supporting their gravity loads when subjected to the deformations caused by the seismic forces.

3.4.3 Moment-resisting Frame Systems

In a moment-resisting frame system, gravity loads are supported by an essentially complete space frame and lateral forces are resisted primarily by flexural action of designated frame members (the entire space frame or selected portions of the space frame may be designated as the seismic-force-resisting system). A typical moment-resisting frame system is illustrated in Figure 3.6.

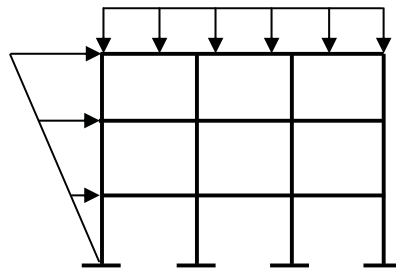

Figure 3.6 Moment-resisting Frame System

SDC B. An ordinary reinforced concrete moment can be used in buildings assigned to SDC B with no limitations. In addition to the requirements of ACI Chapters 1 to 19 and 22 (which must be satisfied for all members, regardless of SDC), the requirements of ACI 21.1.2 and 21.2 for ordinary moment frames must also be satisfied.

SDC C. Buildings assigned to SDC C are permitted to utilize intermediate reinforced concrete frames with no limitations. Such frames are to be designed and detailed in accordance with ACI 21.1.2, 21.1.8 and 21.3.

SDC D, E or F. Special reinforced concrete moment frames are required in buildings assigned to SDC D, E or F. These frames can be used without any limitations and must be designed and detailed in accordance with ACI 21.1.2, 21.1.8, 21.5 through 21.8, and 21.11 through 21.13.

3.4.4 Shear Wall-Frame Interactive Systems

In a shear wall-frame interactive system, an essentially complete space frame provides support for gravity loads and resistance to lateral forces is provided by moment-resisting frames and shear walls (see Figure 3.7). The frames and shear walls are designed to resist lateral forces in proportion to their relative rigidities.

Shear wall-frame interactive systems with ordinary reinforced concrete moment frames and ordinary reinforced concrete shear walls are permitted to be used in buildings assigned to SDC B with no limitations.

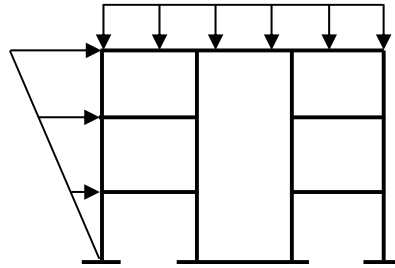

Figure 3.7 Shear Wall-Frame Interactive System

3.4.5 Dual Systems

For buildings assigned to SDC C and higher, dual systems must be utilized, which are similar to shear wall-frame interactive systems in that gravity loads are resisted by an essentially complete space frame and lateral forces are resisted by a combination of moment-resisting frames and shear walls. The main difference between the two systems is that in dual systems, the moment frames must be capable of resisting at least 25 percent of the seismic forces (i.e., the frames act as a backup to the shear walls). The concept of a dual system loses its validity for buildings assigned to SDC A or B, since it is questionable whether the moment frames with ordinary detailing can act as a backup to the ordinary reinforced concrete shear walls. It is for this reason that shear wall-frame interactive systems are used in such cases. Dual systems can be utilized in low-rise buildings, but it is generally more common to use the other types of systems described above.

3.5 HORIZONTAL DISTRIBUTION OF LATERAL FORCES

Lateral forces are transferred to the elements of the lateral-force-resisting system (shear walls and frames) by the roof and floor diaphragms at each level of the structure. The diaphragms distribute the lateral forces from above to the shear walls and frames below based on the degree of diaphragm flexibility and the relative rigidities of the shear walls and frames.

This section provides methods that can be used to estimate the allocation of lateral forces to the various members of the lateral-force-resisting system in low-rise structures with sufficiently regular plan and vertical configurations. Approximate methods to determine lateral stiffness of wall and frame systems are given, as are equations for the distribution of the lateral forces, which include building torsion. These methods are useful in preliminary design and can be used to verify the results from a computer program analysis.

3.5.1 Diaphragm Flexibility

Floor and roof framing systems support gravity loads and transfer these loads to columns and walls. In addition, they act as diaphragms that transfer the lateral forces to the elements of the lateral-force-resisting system. A three-dimensional analysis that considers the relative rigidities of the diaphragm and the elements of the lateral-force-resisting system would provide the most accurate distribution of the forces in these components. A more simple analysis is possible when assumptions are made concerning the flexibility, or rigidity, of a diaphragm.

ASCE/SEI 12.3 contains provisions on diaphragm flexibility that can be used to simplify the overall analysis of horizontal force distribution.⁶ ASCE/SEI 12.3.1.1 lists various types of floor systems that can be idealized as flexible. A definition of “Flexible diaphragm” is provided in ASCE/SEI 12.3.1.3 (also see ASCE/SEI Figure 12.3-1). Flexible diaphragms typically develop large deformations compared to those developed by the elements of the lateral-force-resisting system. In such cases, the amount of lateral force transferred to the elements of the lateral-force-resisting system can be based on the areas tributary to the elements. It is assumed that all of the lateral forces are taken by the elements of the lateral-force-resisting system parallel to the direction of analysis; flexible diaphragms are considered incapable of transferring forces to elements of the lateral-force-resisting system in the direction perpendicular to the direction of analysis. Consequently, torsional moments need not be considered.

According to ASCE/SEI 12.3.1.2, concrete slabs or concrete-filled metal deck with span-to-depth ratios less than or equal to 3 in structures that have no horizontal irregularities as defined in Table 12.3-1 are permitted to be idealized as rigid diaphragms. In the case of rigid diaphragms, lateral forces are distributed to the elements of the lateral-force-resisting system in proportion to their stiffness. The effects of torsion must be considered when applicable, which is usually the case. When rigid diaphragms rotate, lateral forces are transferred to all of the elements of the lateral-force-resisting system in both directions.

If a diaphragm cannot be idealized as either flexible or rigid by ASCE/SEI 12.3.1.1, 12.3.1.2 or 12.3.1.3, the diaphragm is classified as semi-rigid, and the actual stiffness of the diaphragm must be explicitly considered in the analysis in order to capture the correct distribution of horizontal forces.

Diaphragms must resist the design forces from the structural analysis. In the case of seismic design, diaphragm design forces must be greater than or equal to the design force computed by ASCE/SEI 12.10.1.1. Provisions for the design and detailing of structural reinforced concrete diaphragms in buildings assigned to SDC D and above are given in ACI 21.11. No special detailing is required for diaphragms in buildings assigned to SDC A, B or C.

⁶ Although these provisions are given in ASCE/SEI 7 with respect to seismic design, they are also applicable to wind design.

3.5.2 Stiffness of Lateral-force-resisting Elements

Wall Systems

Illustrated in Figure 3.8 is the deflection, δ_i , of a wall or pier subjected to a lateral force, V_i , in the plane of the element. In Figure 3.8(a), the wall or pier is assumed to be fixed at both ends and in Figure 3.8(b), the wall or pier is fixed at one end and is pinned at the other; the latter case is commonly referred to as a cantilevered wall or pier.

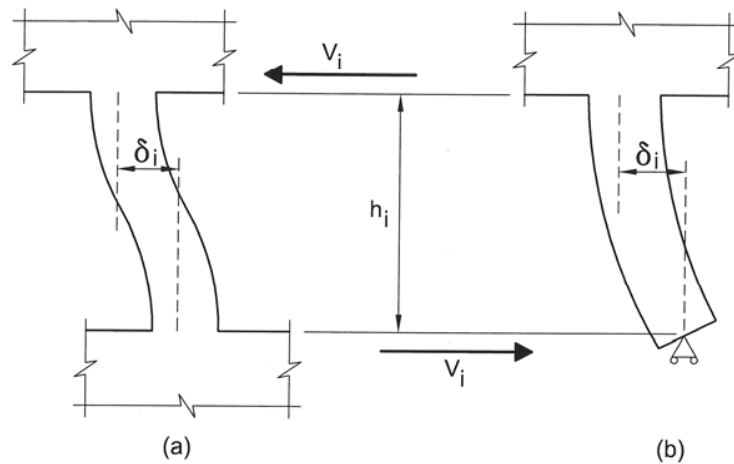

Figure 3.8 Lateral Displacement of a Wall or Pier

Due to their typical overall dimensions, most walls or piers act as short, deep beams, and displacements due to flexure and shear must both be considered. The total displacement, δ_i , is as follows:

- For both ends fixed (fixed wall or pier):

$$\delta_i = \delta_{Fi} + \delta_{Vi} = \frac{V_i h_i^3}{12E_c I_i} + \frac{1.2V_i h_i}{GA_i} = \frac{V_i}{k_{Fi}} + \frac{V_i}{k_{Vi}} \quad \text{Equation 3.1}$$

- For one end fixed, the other end pinned (cantilevered wall or pier):

$$\delta_i = \delta_{Fi} + \delta_{Vi} = \frac{V_i h_i^3}{3E_c I_i} + \frac{1.2V_i h_i}{GA_i} = \frac{V_i}{k_{Fi}} + \frac{V_i}{k_{Vi}} \quad \text{Equation 3.2}$$

The total stiffness of a wall or pier k_i is as follows:

$$k_i = \frac{V_i}{\delta_i} = \frac{k_{Fi} k_{Vi}}{k_{Fi} + k_{Vi}} \quad \text{Equation 3.3}$$

where δ_{Fi} = displacement due to flexure
 δ_{Vi} = displacement due to shear
 V_i = lateral force on wall or pier
 h_i = height of wall or pier
 I_i = moment of inertia of wall or pier cross-section in the direction of analysis
 A_i = cross-sectional area of wall or pier
 E_c = modulus of elasticity of concrete
 G = shear modulus of concrete
 k_{Fi} = flexural stiffness of wall or pier
 $= 12E_c I_i / h_i^3$ for fixed walls or piers
 $= 3E_c I_i / h_i^3$ for cantilevered walls or piers
 k_{Vi} = shear stiffness of wall or pier, which is equal to $GA_i / 1.2h_i$ for both fixed and cantilevered walls or piers

For columns of typical proportions, the contribution of shear to the total displacement is usually small. Thus, the total stiffness, k_i , can be set equal to the flexural stiffness, k_{Fi} .

The computation of stiffness and deflection are more complex for walls with door or window openings. In such cases, it is assumed that the walls consist of piers and spandrels, and the stiffness of these elements must be considered in the analysis.

For relatively flexible piers, the spandrels are assumed to be infinitely rigid, and the piers can be analyzed as having both ends fixed, as shown in Figure 3.9.

The deflection, δ , at the top of the wall can be obtained by determining the stiffness of the component piers, k_i . The deflection of a wall consisting of n piers (each with a lateral stiffness of k_i) connected by rigid spandrels is:

$$\delta = \frac{V}{\sum k_i} \quad \text{Equation 3.4}$$

where k_i for each pier is determined by Equation 3.3 using the appropriate stiffness components for piers that are fixed at both ends.

Thus, the total stiffness of a wall consisting of n piers connected by rigid spandrels is determined by adding the stiffness of each pier.

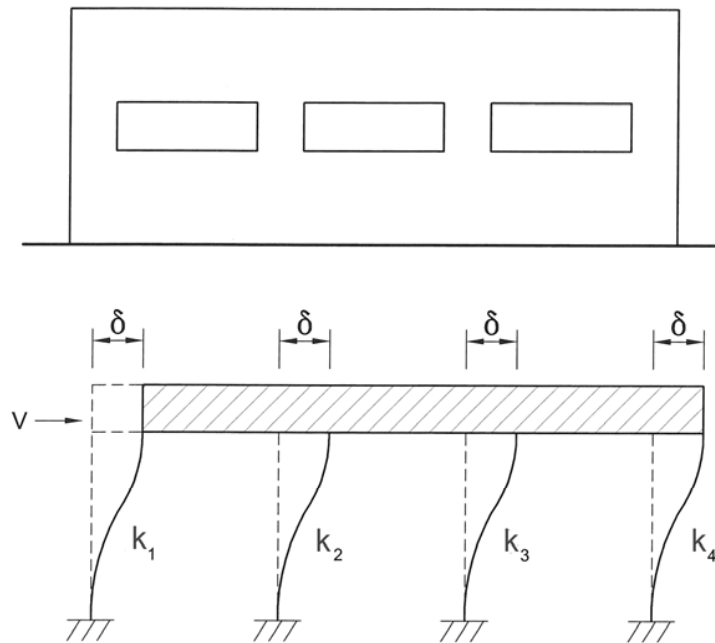

Figure 3.9 Lateral Displacement—Flexible Piers and Infinitely Rigid Spandrels

It is important to note that in some cases this approximate method can produce a total stiffness for a wall with openings greater than the stiffness of the same wall without openings. A more refined analysis is required when it is found that the total stiffness of the piers is greater than or approximately equal to the stiffness of the wall without openings.

For the situation shown in Figure 3.10, the piers are very rigid with respect to the spandrel. The piers essentially act as vertical cantilevers, and when a lateral force is applied, the spandrel deforms to be compatible with the deformation of the piers. It is relatively straightforward to determine the deflection of the piers if the deformation characteristics of the spandrel are ignored. For more substantial spandrels, the system needs to be analyzed as a coupled shear wall system, and the analysis must take into consideration the relative stiffness of the piers and the connecting spandrels.

In situations that are between the two extreme cases described above, the following method can be used to determine deflections (or stiffness) of walls with openings; this method is considered to be the most accurate of all the approximate methods developed for these situations.⁷ In this method, the deflection of a wall is first obtained by assuming that the wall is solid. The deflection of the section of the wall that contains the opening is

⁷This method is presented in *Seismic Design for Buildings*, United States Army Corps of Engineers, United States Government Printing Office, Washington, D.C., 1998.

then subtracted from the aforementioned deflection. Finally, the deflection of each pier that is formed by the opening is added back.

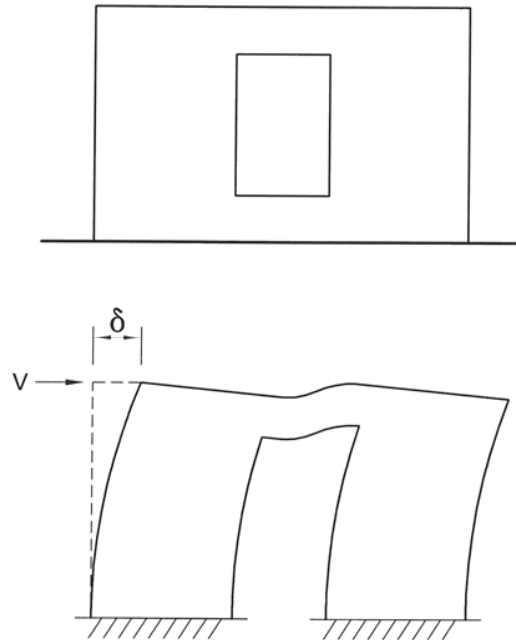

Figure 3.10 Lateral Displacement—Rigid Piers and Flexible Spandrel

As an example, consider the wall shown in Figure 3.11, which contains a generic opening. Assume that the wall has a constant thickness, t , and that a unit horizontal load is applied to the top of the wall.

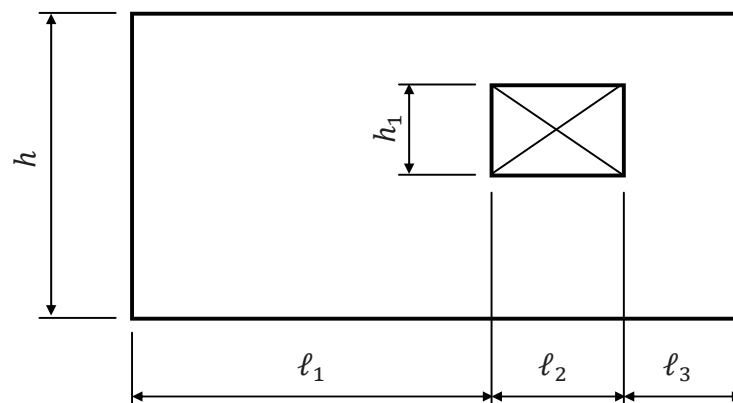

Figure 3.11 Example Wall with Opening

In the first step of the analysis, the deflection of the solid wall is obtained by Equation 3.2 for a cantilevered condition:

$$\delta_1 = \frac{12h^3}{3E_c t (\ell_1 + \ell_2 + \ell_3)^3} + \frac{1.2h}{Gt(\ell_1 + \ell_2 + \ell_3)}$$

In the next step, the deflection of the strip of the wall that contains the opening is computed by Equation 3.1 for fixed end conditions:

$$\delta_2 = \frac{12h_1^3}{12E_c t (\ell_1 + \ell_2 + \ell_3)^3} + \frac{1.2h_1}{Gt(\ell_1 + \ell_2 + \ell_3)}$$

The deflection of the strip is subtracted from the deflection of the solid wall:

$$\delta_{1-2} = \delta_1 - \delta_2$$

The deflection of the piers on each side of the opening is determined next by Equation 3.1:

- For the pier to the left of the opening:

$$\delta_{p1} = \frac{12h_1^3}{12E_c t \ell_1^3} + \frac{1.2h_1}{Gt\ell_1}$$

The corresponding rigidity of this pier is obtained by taking the inverse of this deflection:

$$R_{p1} = \frac{1}{\delta_{p1}}$$

- For the pier to the right of the opening:

$$\delta_{p2} = \frac{12h_1^3}{12E_c t \ell_3^3} + \frac{1.2h_1}{Gt\ell_3}$$

The corresponding rigidity of this pier is obtained by taking the inverse of this deflection:

$$R_{p2} = \frac{1}{\delta_{p2}}$$

The total deflection of the two piers is obtained by taking the inverse of the sum of the pier rigidities:

$$\delta_{p(1+2)} = \frac{1}{R_{p1} + R_{p2}}$$

The total wall deflection, considering the opening, is obtained by adding the net deflection, δ_{1-2} , to the total deflection of the piers:

$$\delta_{total} = \delta_{1-2} + \delta_{p(1+2)}$$

The inverse of δ_{total} is the relative rigidity of the wall, which is used in determining the amount of lateral force that is allocated to the wall in the case of a rigid diaphragm.

A similar analysis can be derived for walls with multiple openings.

Frame Systems

The rigid two-dimensional frame illustrated in Figure 3.12 is subjected to the lateral force, V_i , which produces the deflection, δ_i . The equivalent story stiffness, k_i , is obtained by combining the stiffness of all of the columns and the beams in a story:

$$k_i = \frac{12E_c}{h_i^2 \left(\frac{1}{\sum k_c + \sum k_b} \right)} \quad \text{Equation 3.5}$$

where k_c = column stiffness = I_c/h_i

I_c = cross-sectional moment of inertia of a column in the direction of analysis

h_i = length of column

k_b = beam stiffness = I_b/ℓ_i

I_b = cross-sectional moment of inertia of a beam

ℓ_i = length of beam

E_c = modulus of elasticity of concrete

The exact solution for story stiffness is obtained by Equation 3.5 for the case of rigid beams. Note that this equation underestimates the stiffness of the first story in cases where the lower ends of the column are assumed to be fixed.

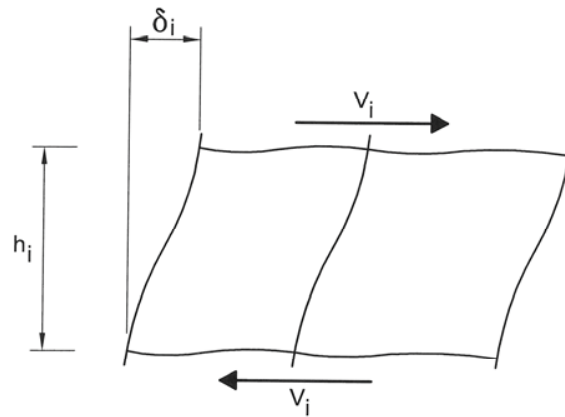

Figure 3.12 Lateral Displacement of a Story in a Rigid Frame

Flat plate structures behave like rigid frames when subjected to lateral loads. Numerous analytical procedures exist for modeling such systems, and any procedure that satisfies equilibrium and geometric compatibility may be utilized. Acceptable methods include finite element models, effective beam width models and equivalent frame models.

The effective beam width model can yield reasonably accurate results in routine situations. Since only a portion of the slab is effective across its full width in resisting the effects from lateral loads, the actual slab is replaced by a flexural element with the same thickness as the slab and an effective beam width, b_e , that is a fraction of the transverse width of the slab. The following equation can be used to determine b_e for an interior slab-column frame:⁸

$$b_e = 2c_1 + \frac{\ell_1}{3} \quad \text{Equation 3.6}$$

where c_1 is the column dimension in the direction of analysis and ℓ_1 is the span length in the direction of analysis. For an exterior frame, b_e is equal to one-half the value determined by Equation 3.6.

Combined Wall and Frame Systems

The approximate techniques presented above, as well as other approximate methods, can be used in structures where both walls and frames are part of the lateral-force-resisting system. In low-rise buildings, it is common for the walls to be stiff enough to attract most, if not all, of the lateral forces. In such cases, the interaction between the walls and frames can be neglected. Even though the walls may be designed to resist the entire effects from the lateral forces, the frames must be designed to carry their gravity loads

⁸ See "Models for Laterally Loaded Slab-Column Frames," by Hwang and Moehle, *ACI Structural Journal*, March-April 2000, pp. 345-352.

when subjected to the lateral deflections, since the walls and frames are tied together by the diaphragms. As noted previously, deformational compatibility requirements must be satisfied for all structures assigned to SDC D and higher.

3.5.3 Distribution of Lateral Forces

The distribution of lateral forces to the elements of the lateral-force-resisting system in a structure with rigid diaphragms depends on the relative stiffness of these elements on each floor level. The center of rigidity plays a key role in lateral force allocation.

Center of Rigidity

By definition, the center of rigidity is the point where the equivalent lateral story stiffness is assumed to act. In other words, the reaction to lateral forces acts through the center of rigidity. Depending on the structural layout, this point can be at different locations on different floor levels.

The following equations can be used to locate the center of rigidity (see Figure 3.13):

$$x_{cr} = \frac{\sum(k_i)_y x_i}{\sum(k_i)_y} \quad \text{Equation 3.7}$$

$$y_{cr} = \frac{\sum(k_i)_x y_i}{\sum(k_i)_x} \quad \text{Equation 3.8}$$

where $(k_i)_y$ = in-plane lateral stiffness of the lateral-force-resisting element, i , in the y -direction

$(k_i)_x$ = in-plane lateral stiffness of the lateral-force-resisting element, i , in the x -direction

x_i = distance in the x -direction from the origin to the centroid of lateral-force-resisting element, i

y_i = distance in the y -direction from the origin to the centroid of lateral-force-resisting element, i

The in-plane lateral stiffness, k_i , can be obtained by any rational method, including the approximate methods presented in Section 3.5.2 of this publication for wall and frame systems. The summation in Equations 3.7 and 3.8 is taken for all of the elements parallel to the direction of analysis only, since it is commonly assumed that out-of-plane resistance of a lateral-force-resisting element is negligible.

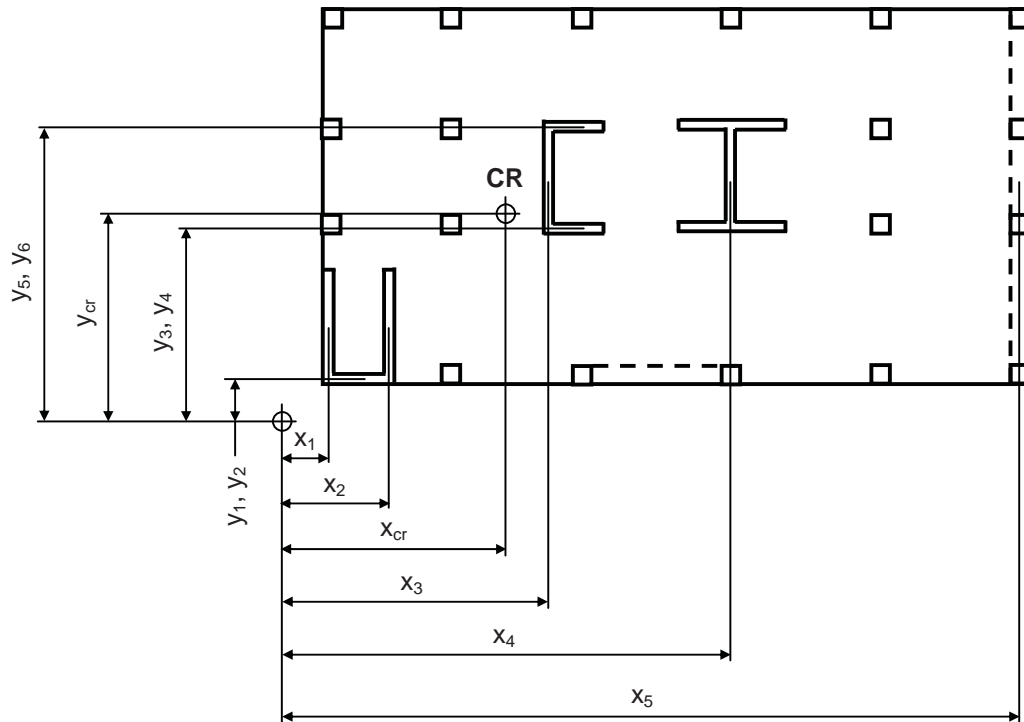

Figure 3.13 Location of Center of Rigidity (CR)

Wind Force Distribution: Wind Forces Acting through the Center of Rigidity

In the case of wind forces, it is generally assumed that the wind pressures acting over a tributary story height are uniformly distributed at that level over the width of the building that is perpendicular to the pressures. The resultant wind force acts through the geometric center of the building at that level (see ASCE/SEI 6.5.12.3).

When the resultant wind force acts through the center of rigidity at a floor level, a floor translates horizontally as a rigid body, as depicted in Figure 3.14. The elements of the lateral-force-resisting system all displace an equal amount horizontally⁹, and the story shear is distributed to these elements based on their relative rigidities.

The distribution of the story shear in the direction of analysis depends on the relative stiffness of the elements (walls, frames) of the lateral-force-resisting system in that direction, which is defined as follows:

$$\text{Relative stiffness of element } i = \frac{k_i}{\sum k_i} \quad \text{Equation 3.9}$$

⁹ Even in cases where the resultant of the wind force acts through the center of rigidity, torsional load cases must be investigated in accordance with ASCE/SEI 7 Chapter 6 (see Figures 6-2, 6-9 and 6-10).

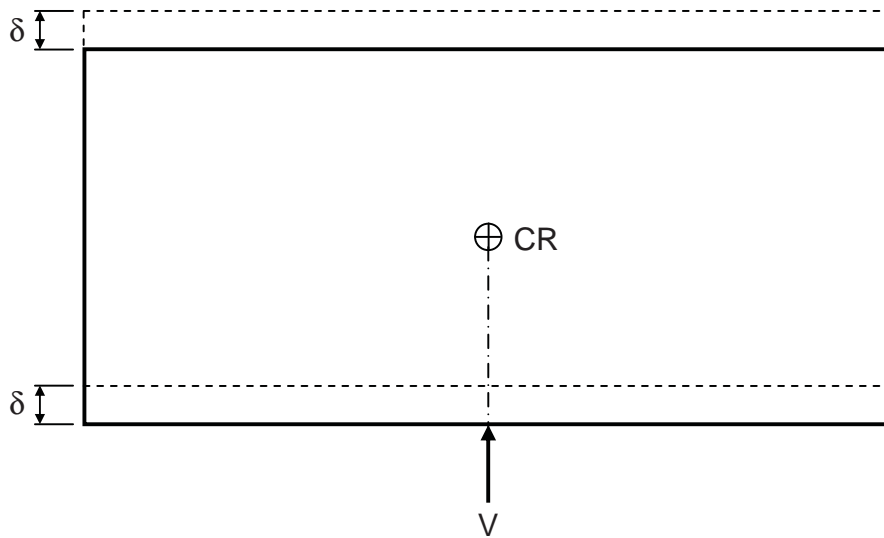

Figure 3.14 Resultant Wind Force Acting through the Center of Rigidity

where k_i is the stiffness of element i and the summation is over all of the elements in the direction of analysis.

The portion of the total story shear, V , in the direction of analysis that must be resisted by element i is:

$$V_i = \frac{k_i}{\sum k_i} V \quad \text{Equation 3.10}$$

Equation 3.10 can also be used to determine the amount of lateral force that is to be allocated to the piers of a wall that is connected at the top by a rigid diaphragm. This equation is used first to determine the total lateral force, V_i , that must be resisted by the wall based on its relative stiffness with respect to the other elements of the lateral-force-resisting system. It is then used a second time to determine the portion of V_i that is to be resisted by each pier based on the relative stiffness of all the piers in the wall.

Wind Force Distribution: Wind Forces Not Acting through the Center of Rigidity

When the resultant wind force does not act through the center of rigidity (either due to geometry or minimum eccentricity requirements of ASCE/SEI 7), a floor translates and rotates, as shown in Figure 3.15. The torsional moment, M_t , that is generated induces horizontal forces in the elements of the lateral-force-resisting system in the direction of analysis and in the direction perpendicular to analysis.

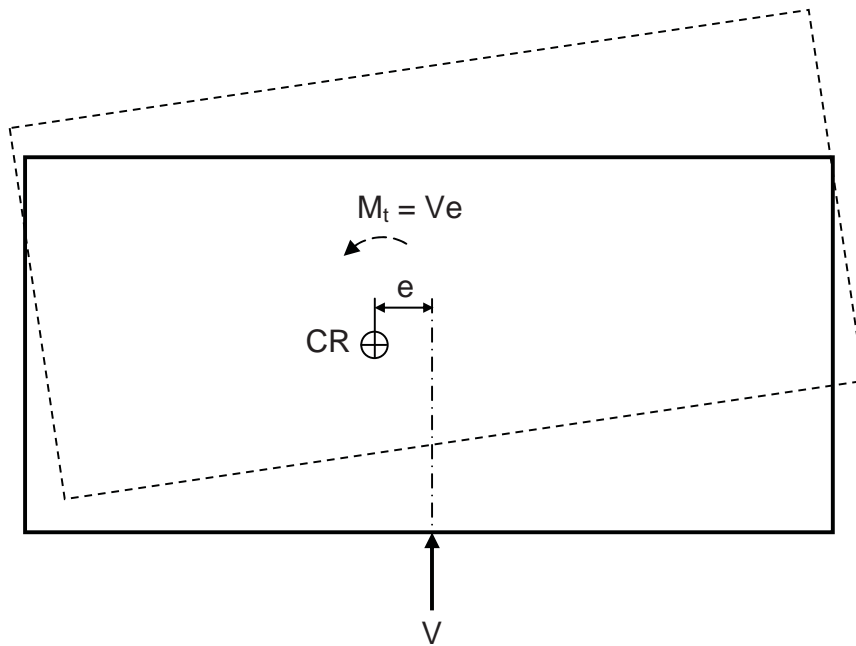

Figure 3.15 Resultant Wind Force Not Acting through the Center of Rigidity

The portion of the total story shear, V_y , in the y -direction that must be resisted by element i is:

$$(V_i)_y = \frac{(k_i)_y}{\sum (k_i)_y} V_y \pm \frac{\bar{x}_i (k_i)_y}{\sum \bar{x}_i^2 (k_i)_y + \sum \bar{y}_i^2 (k_i)_x} V_y e_x \quad \text{Equation 3.11}$$

Similarly, the portion of the total story shear, V_x , in the x -direction that must be resisted by element i is:

$$(V_i)_x = \frac{(k_i)_x}{\sum (k_i)_x} V_x \pm \frac{\bar{y}_i (k_i)_x}{\sum \bar{x}_i^2 (k_i)_y + \sum \bar{y}_i^2 (k_i)_x} V_x e_y \quad \text{Equation 3.12}$$

where \bar{x}_i = perpendicular distance from element i to the center of rigidity parallel to the x -axis

\bar{y}_i = perpendicular distance from element i to the center of rigidity parallel to the y -axis

Note that the second term in Equation 3.11 or 3.12 may be either positive or negative depending on the location of the element with respect to the center of rigidity.

Seismic Force Distribution: Centers of Mass and Rigidity Coincide

The center of mass is the location on a floor of a building where the mass of the entire story may be assumed to be concentrated. It is also the location where the seismic force for the story is assumed to act.

Similar to when a resultant wind force acts through the center of rigidity, a floor translates horizontally as a rigid body when the center of mass and center of rigidity coincide (see Figure 3.16).¹⁰ Equation 3.10 can be used to determine the portion of the seismic force that is to be resisted by the elements of the lateral-force-resisting system.

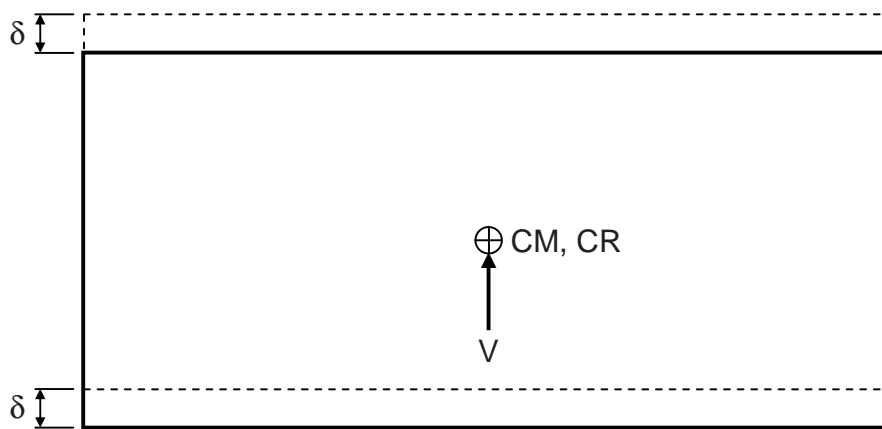

Figure 3.16 Center of Mass and Center of Rigidity at the Same Point

Seismic Force Distribution: Centers of Mass and Rigidity at Distinct Points

Where the center of mass and the center of rigidity do not coincide, the distribution of the seismic forces must consider the torsional moment, M_t , that is generated due to the eccentricity between the locations of the center of mass and the center of rigidity, as shown in Figure 3.17 (ASCE/SEI 12.8.4.1). Equations 3.11 and 3.12 can be used to distribute the seismic forces to the elements of the lateral-force-resisting system in each direction.

ASCE/SEI 12.8.4 requires consideration of inherent torsion due to the displacement between the center of mass and the center of rigidity, combined with accidental torsion due to an assumed displacement of the center of mass from its actual location.

¹⁰ Even in cases where the center of mass and the center rigidity coincide, the minimum eccentricity due to accidental torsion of ASCE/SEI 12.8.4.2 must be considered.

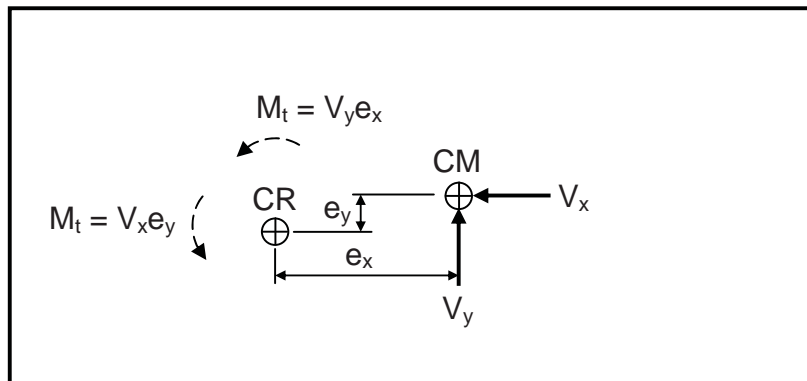

Figure 3.17 Center of Mass and Center of Rigidity at Distinct Points

CHAPTER 4

DESIGN AND DETAILING FOR SDCs A AND B

4.1 GENERAL REQUIREMENTS

4.1.1 Design and Detailing

For concrete buildings assigned to SDC A or B, all members must be designed and detailed in accordance with the general requirements of ACI 318 Chapters 1 to 19 and 22.¹ Ordinary moment frames that are part of the seismic-force-resisting system in buildings assigned to SDC B must also satisfy the provisions of ACI 21.2.

The general requirements in the aforementioned chapters of ACI 318 contain a number of provisions that are intended to increase the resistance of concrete buildings to all types of loading conditions. The following are examples of such provisions:

- Structural integrity reinforcement must be provided in accordance with ACI 7.13. The purpose of this reinforcement is to improve redundancy and ductility, especially in structures subjected to abnormal loading events where major supporting elements may be damaged.
- Minimum shear reinforcement must be provided in accordance with ACI 11.4.6. Such reinforcement is of great value in cases where a member is subjected to an unexpected tensile force or an overload.
- Beam-column connections must have a minimum amount of lateral reinforcement where such connections are not confined by beams on all four sides of a joint (ACI 11.10.2). Joints on the exterior of a building without lateral confinement need lateral reinforcement to prevent deterioration caused by shear cracking.
- Reinforcing bars must be spliced and anchored in accordance with the provisions of ACI Chapter 12. In order for a reinforced concrete structure to perform as intended, the reinforcing bars must be fully developed for all possible loading conditions.
- Beams that are part of the primary seismic-force-resisting system must contain positive reinforcement conforming to ACI 12.11.2. The proper anchorage of positive reinforcement at the supports helps ensure a ductile response in the event of overloading.

More information on these requirements is provided in subsequent sections of this chapter.

¹ IBC 1908.1.2, which modifies ACI 21.1.3, explicitly states that structures assigned to SDC A shall satisfy the requirements of ACI Chapters 1 to 19 and 22 and that the provisions of Chapter 21 do not apply.

4.1.2 Load Combinations

The load combinations for strength design (or load and resistance factor design) in IBC 1605.2 are to be used in the design of reinforced concrete members. According to IBC 1605.1, load combinations must be investigated with one or more of the variable loads set equal to zero.² It is possible that the most critical load effects on a member occur when variable loads are not present.

ASCE/SEI 2.3 contains load combinations using strength design that are essentially the same as those in IBC 1605.2 with the following exceptions:

- The variable, f_1 , that is present in IBC Equations 16-3, 16-4 and 16-5 is not found in ASCE/SEI combinations 3, 4 and 5. Instead, the load factor on the live load, L , in the ASCE/SEI combinations is equal to 1.0 with the exception that the load factor on L is permitted to equal 0.5 for all occupancies where the live load is less than or equal to 100 psf (4.79 kPa), except for parking garages or areas occupied as places of public assembly (see Exception 1 in ASCE/SEI 2.3.2). This exception makes these load combinations the same in ASCE/SEI 7 and the IBC.
- The variable, f_2 , that is present in IBC Equation 16-5 is not found in ASCE/SEI combination 5. Instead, a load factor of 0.2 is applied to S in the ASCE/SEI combination. The third exception in ASCE/SEI 2.3.2 states that in combinations 2, 4 and 5, S shall be taken as either the flat roof snow load, p_f , or the sloped roof snow load, p_s . This essentially means that the balanced snow load defined in ASCE/SEI 7.3 for flat roofs and 7.4 for sloped roofs can be used in combinations 2, 4 and 5. Drift loads and unbalanced snow loads are covered by combination 3.

The load effects that are included in the IBC and ASCE/SEI 7 load combinations are summarized in Table 4.1. Additional information can be found in the IBC and ASCE/SEI 7, as noted in the table.

The basic strength design load combinations given in IBC 1605.2 are summarized in Table 4.2. According to the exception at the end of IBC 1605.2, factored load combinations that are specified in other provisions of the IBC take precedence to those listed in IBC 1605.2. ACI 9.2 contains essentially the same strength design load combinations that are in the IBC and ASCE/SEI 7.

The load combinations of ASCE/SEI 2.3.3 are to be used where flood loads, F_a , must be considered in design (see IBC 1605.2.2).³

²By definition, a “variable load” is a load that is not considered to be a permanent load (see IBC 1602). Permanent loads are those loads that do not change or that change very slightly over time, such as dead loads. Live loads, roof live loads, snow loads, rain loads, wind loads and earthquake loads are all examples of variable loads.

³Flood loads are determined by Chapter 5 of ASCE/SEI 7-05.

Table 4.1 Summary of Load Effects

Notation	Load Effect	Notes
D	Dead load	See IBC 1606
D_i	Weight of ice	See Chapter 10 of ASCE/SEI 7
E	Combined effect of horizontal and vertical earthquake-induced forces as defined in ASCE/SEI 12.4.2	See IBC 1613, ASCE/SEI 12.4.2
E_m	Maximum seismic load effect of horizontal and vertical forces as set forth in ASCE/SEI 12.4.3	See IBC 1613, ASCE/SEI 12.4.3
F	Load due to fluids with well-defined pressures and maximum heights	—
F_a	Flood load	See IBC 1612
H	Load due to lateral earth pressures, ground water pressure or pressure of bulk materials	See IBC 1610 for soil lateral loads
L	Live load, except roof live load, including any permitted live load reduction	See IBC 1607
L_r	Roof live load including any permitted live load reduction	See IBC 1607
R	Rain load	See IBC 1611
S	Snow load	See IBC 1608
T	Self-straining force arising from contraction or expansion resulting from temperature change, shrinkage, moisture change, creep in component materials, movement due to differential settlement or combinations thereof	—
W	Load due to wind pressure	See IBC 1609
W_i	Wind-on-ice load	See Chapter 10 of ASCE/SEI 7

In particular, $1.6W$ in combinations 4 and 6 shall be replaced by $1.6W + 2.0F_a$ in V Zones or Coastal A Zones.⁴ In noncoastal A Zones, $1.6W$ in combinations 4 and 6 shall be replaced by $0.8W + 1.0F_a$.

ASCE/SEI 2.3.4 provides load combinations that include atmospheric ice loads, which are not found in the IBC. The following load combinations must be considered when a structure is subjected to atmospheric ice and wind-on-ice loads:⁵

- $0.5(L_r \text{ or } S \text{ or } R)$ in combination 2 shall be replaced by $0.2D_i + 0.5S$
- $1.6W + 0.5(L_r \text{ or } S \text{ or } R)$ in combination 4 shall be replaced by $D_i + W_i + 0.5S$
- $1.6W$ in combination 6 shall be replaced by $D_i + W_i$

⁴ Definitions of Coastal High Hazard Areas (V Zones) and Coastal A Zones are given in ASCE/SEI 5.2.

⁵ Atmospheric and wind-on-ice loads are determined by Chapter 10 of ASCE/SEI 7.

Table 4.2 Summary of Load Combinations Using Strength Design or Load and Resistance Factor Design (2009 IBC)

IBC Equation No.	Load Combination
16-1	$1.4(D + F)$
16-2	$1.2(D + F + T) + 1.6(L + H) + 0.5(L_r \text{ or } S \text{ or } R)$
16-3	$1.2D + 1.6(L_r \text{ or } S \text{ or } R) + (f_1L \text{ or } 0.8W)$
16-4	$1.2D + 1.6W + f_1L + 0.5(L_r \text{ or } S \text{ or } R)$
16-5	$1.2D + 1.0E + f_1L + f_2S$
16-6	$0.9D + 1.6W + 1.6H$
16-7	$0.9D + 1.0E + 1.6H$

For SI: 1 pound per square foot = 47.88 Pa.

Notes:

$f_1 = 1$ for floors in places of public assembly, for live loads in excess of 100 psf and for parking garage live load

= 0.5 for other live loads

$f_2 = 0.7$ for roof configurations (such as sawtooth) that do not shed snow off the structure

= 0.2 for other roof configurations

4.1.3 Materials

The specified compressive strength of concrete, f'_c , shall not be less than 2,500 psi (17 237 kPa) (ACI 1.1.1). Except for some specific provisions that are identified later, no maximum value of f'_c is prescribed. Requirements on the types of cementitious materials, aggregates, water and admixtures are given in ACI 3.2, 3.3, 3.4 and 3.6, respectively.

Materials permitted for use as reinforcement are specified in ACI 3.5. Included are provisions for deformed reinforcement, plain reinforcement, headed shear stud reinforcement, prestressing steel, structural steel, steel pipe, steel tubing, steel fiber reinforcement and headed deformed bars.

In short, there are no limitations on the types of materials that can be used in buildings assigned to SDC A or B other than those listed above.

4.2 MEMBERS SUBJECTED TO BENDING

4.2.1 Beams and One-way Slabs

Table 4.3 contains requirements for beams and one-way slabs. These apply to flexural members with negligible axial forces ($P_u \leq A_g f'_c / 10$).

Table 4.3 Summary of Requirements for Beams and One-way Slabs in Buildings Assigned to SDC A or B

	Requirement	ACI Section Number(s)
Serviceability	Minimum thickness in accordance with ACI Table 9.5(a) shall apply for beams and one-way slabs that are not supporting or are attached to partitions or other construction likely to be damaged by large deflections.	9.5.2.1
	A lesser thickness than that required by Table 9.5(a) is permitted to be used where calculation of deflections by the methods of ACI 9.5.2 do not exceed the limits in ACI Table 9.5(b).	9.5.2.6
Analysis Methods	All members of frames or continuous construction shall be designed for the maximum effects of factored loads determined by an elastic analysis. The assumptions specified in ACI 8.7 through 8.11 may be used.	8.3.1
	Approximate methods of analysis may be used for buildings of usual types of construction, spans and story heights.	8.3.2
	The approximate bending moments and shear forces of ACI 8.3.3 may be used for continuous beams and one-way slabs that satisfy the limitations given in that section.	8.3.3
Flexure	Design flexural members as tension-controlled sections.	10.3.4, 9.3.2.1
	Minimum flexural reinforcement shall not be less than: $\frac{3\sqrt{f'_c}b_wd}{f_y} \text{ and } \frac{200b_wd}{f_y}$ at every section of a flexural member where tensile reinforcement is required by analysis, except as provided by ACI 10.5.2, 10.5.3 and 10.5.4.	10.5.1
	The net tensile strain, ϵ_t , at nominal strength shall be greater than or equal to 0.004.	10.3.5
	Ensure that minimum and maximum spacing requirements for the flexural reinforcement are satisfied.	10.6, 7.6
	Positive and negative reinforcement must be developed.	12.10, 12.11, 12.12
	Provide minimum structural integrity reinforcement.	7.13

(continued)

Table 4.3 Summary of Requirements for Beams and One-way Slabs in Buildings Assigned to SDC A or B (continued)

	Requirement	ACI Section Number(s)
Development Length⁶	<p>For straight deformed bars, the development length, ℓ_d, shall be determined by the following:</p> $\ell_d = \left(\frac{3 f_y \psi_t \psi_e \psi_s}{40 \lambda \sqrt{f'_c} \left(\frac{c_b + K_{tr}}{d_b} \right)} \right) d_b \quad \text{ACI Eq. (12-1)}$ <p>where the term $(c_b + K_{tr})/d_b$ shall not be taken greater than 2.5.</p> <p>ψ_t = reinforcement location factor = 1.3 for horizontal reinforcement where 12 inches of concrete is cast below the development length or splice = 1.0 for other situations</p> <p>ψ_e = reinforcement coating factor = 1.5 for epoxy-coated bars or wires with cover less than $3d_b$ or clear spacing less than $6d_b$ = 1.2 for all other epoxy-coated bars or wires = 1.0 for uncoated and zinc-coated (galvanized) reinforcement</p> <p>The product of $\psi_t \psi_e$ need not be greater than 1.7.</p> <p>ψ_s = reinforcement size factor = 0.8 for No. 6 and smaller bars and deformed wires = 1.0 for No. 7 and larger bars</p> <p>λ = lightweight concrete factor = 0.75 for lightweight concrete unless f_{ct} is specified (see ACI 8.6.1) = 1.0 for normal weight concrete</p> <p>c_b = smaller of (a) distance from center of a bar or wire to nearest concrete surface and (b) one-half the center-to-center spacing of the bars or wires being developed</p> <p>K_{tr} = transverse reinforcement index = $40A_{tr}/sn$</p>	12.2.3

(continued)

⁶The provisions of ACI 12.2.2 may also be used.

Table 4.3 Summary of Requirements for Beams and One-way Slabs in Buildings Assigned to SDC A or B (continued)

	Requirement	ACI Section Number(s)
<p>Development Length (continued)</p>	<p>The standard development length, ℓ_{dh}, for a deformed bar in tension with a standard hook must not be less than:</p> <p>(a) $8d_b$ (b) 6 inches (c) $(0.02\psi_e f_y / \lambda \sqrt{f'_c}) d_b$</p> <p>where $\psi_e = 1.2$ for epoxy-coated reinforcement and $\lambda = 0.75$ for lightweight concrete. For other cases, ψ_e and λ shall be taken as 1.0.</p> <p>It is permitted to multiply ℓ_{dh} by the following factors, if applicable:</p> <ul style="list-style-type: none"> • For No. 11 bars and smaller with side cover (normal to plane of hook) greater than or equal to 2.5 inches, and for 90-degree hooks with cover on bar extension beyond the hook greater than or equal to 2 inches, a reduction multiplier of 0.7 is permitted. • For 90-degree hooks of No. 11 bars and smaller that are <ol style="list-style-type: none"> (1) enclosed within ties or stirrups perpendicular to the bar being developed and spaced less than or equal to $3d_b$, or (2) enclosed within ties or stirrups parallel to the bar being developed and spaced less than or equal to $3d_b$ along the full length of the tail extension of the hook plus bend, a reduction of 0.8 is permitted. • For 180-degree hooks of No. 11 bars and smaller, enclosed within ties or stirrups perpendicular to the bar being developed and spaced less than or equal to $3d_b$ along ℓ_{dh}, a reduction of 0.8 is permitted. • Where anchorage or development of f_y is not specifically required for reinforcement in excess of that required by analysis, a multiplier of $(A_s \text{ required} / A_s \text{ provided})$ can be used. 	<p>12.5</p>

(continued)

Table 4.3 Summary of Requirements for Beams and One-way Slabs in Buildings Assigned to SDC A or B (continued)

	Requirement	ACI Section Number(s)
Development Length (continued)	<p>For headed deformed bars satisfying ACI 3.5.9 and the conditions in ACI 12.6.1, the development length, ℓ_{dt}, in tension must not be less than:</p> <p>(a) $8d_b$</p> <p>(b) 6 inches</p> <p>(c) $(0.016\psi_e f_y / \lambda \sqrt{f'_c}) d_b$</p> <p>where $\psi_e = 1.2$ for epoxy-coated reinforcement and $f'_c \leq 6000$ psi. For other cases, ψ_e shall be taken as 1.0.</p> <p>A reduction factor of (A_s required/A_s provided) can be applied, if applicable.</p>	12.6
Splices	Provide Class A or Class B tension lap splices or mechanical and welded splices.	12.14, 12.15
	<p>Lap splices of deformed bars or wires in tension shall be Class B splices, except Class A splices are allowed where:</p> <p>(a) the area of reinforcement provided is at least twice that required by analysis over the entire length of the splice; and,</p> <p>(b) one-half or less of the total reinforcement is spliced within the required lap length.</p>	12.15.2
	<p>Class A splice length = $1.0\ell_d$</p> <p>Class B splice length = $1.3\ell_d$</p> <p>where ℓ_d is calculated in accordance with ACI 12.2, but without the 12 inches minimum of ACI 12.2.1 and without the modification factor of ACI 12.2.5.</p>	12.15.1
Confinement	Compression reinforcement in beams shall be enclosed by ties or stirrups satisfying the size and spacing limitations in ACI 7.10.5 or by welded wire reinforcement of equivalent area.	7.11.1
	Reinforcement of flexural members subject to stress reversals or to torsion shall consist of closed ties, closed stirrups or spirals extending around the flexural reinforcement.	7.11.2

(continued)

Table 4.3 Summary of Requirements for Beams and One-way Slabs in Buildings Assigned to SDC A or B (continued)

Requirement		ACI Section Number(s)
Shear	For one-way slabs, the following equation must be satisfied: $V_u \leq \phi V_c$ where $V_c = 2\lambda\sqrt{f'_c}b_wd$ and $\phi = 0.75$.	11.11.1, 11.2.1.1
	For beams, the following equation must be satisfied: $V_u \leq \phi V_c + \phi V_s$ where $V_c = 2\lambda\sqrt{f'_c}b_wd$, $V_s = A_v f_{yt} d/s$, and $\phi = 0.75$.	11.11.1, 11.2.1.1, 11.4.7
	For beams where $V_u > 0.5\phi V_c$, provide the following minimum shear reinforcement: $A_{v,min} = \frac{0.75\sqrt{f'_c}b_ws}{f_{yt}} \geq \frac{50b_ws}{f_{yt}}$ See ACI 11.4.6.1 for cases where minimum shear reinforcement is not required.	11.4.6.3
Torsion	For beams, the following equation must be satisfied: $T_u \leq \phi T_n$	11.5.3.5
	Provide required transverse and longitudinal torsion reinforcement in accordance with ACI 11.5.1 through 11.5.6.	11.5

For SI: 1 inch = 25.4 mm; 1 degree = 0.01745 rad; 1 pound per square inch = 6.895 kPa.

Serviceability. Chapter 9 of ACI 318 contains the general serviceability requirements for various types of reinforced concrete members, including beams and one-way slabs. Chapter 2 of this publication presents an overview of these requirements, which are summarized in Figure 4.1.

To achieve economy of formwork, the largest required depth should be used for all spans in a continuous system (see Chapter 2 of this publication).

It is permitted to use a thickness less than that required by ACI Table 9.5(a) provided the deflections computed in accordance with ACI 9.5.2 are less than the limiting deflections in ACI Table 9.5(b).

Analysis methods. In the strength design method, an elastic analysis is used to determine bending moments and shear forces for beams and one-way slabs. The assumptions for stiffness, effective stiffness for determination of lateral deflections, span length, columns and arrangement of live load in ACI 8.7 through 8.11 can be used in the analysis.

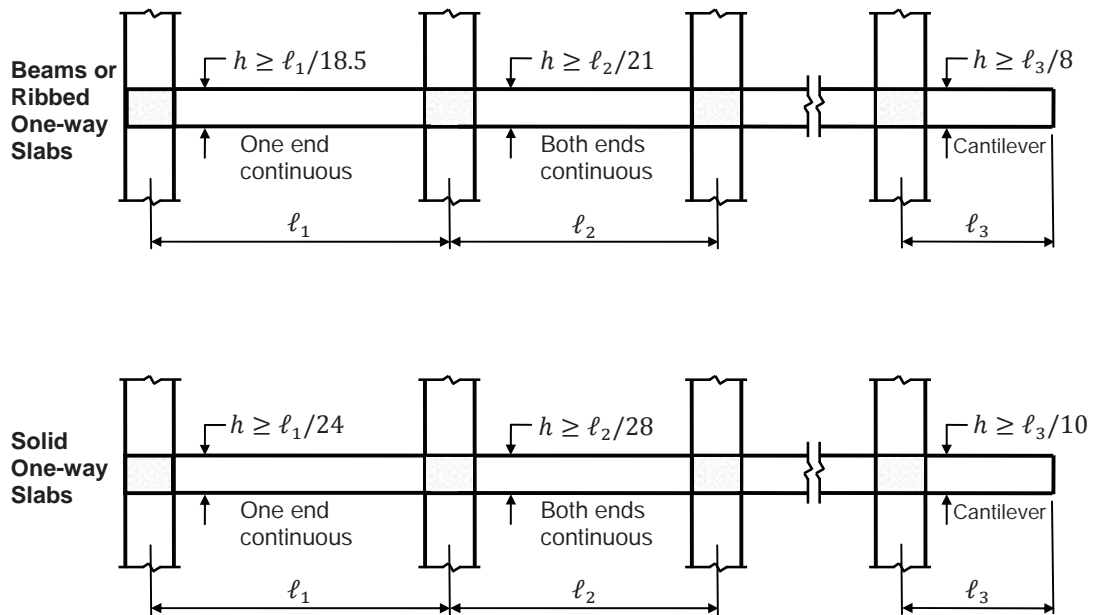

For SI: 1 pound per square inch = 6.895 kPa; 1 pound per cubic foot = 16.02 kg/m³.

Notes:

- Applicable to one-way construction not supporting or attached to partitions or other construction likely to be damaged by large deflections.
- Values shown are applicable to members with normal weight concrete ($w_c = 145$ pcf) and Grade 60 reinforcement. For other conditions, modify the values as follows:
 - For structural lightweight having w_c in the range 90-115 pcf, multiply the values by $(1.65 - 0.005w_c) \geq 1.09$.
 - For f_y other than 60,000 psi, multiply the values by $(0.4 + f_y/100,000)$.
- For simply-supported members, minimum $h = \ell/20$ for solid one-way slabs and $\ell/16$ for beams or ribbed one-way slabs.

Figure 4.1 Minimum Thickness, h , for Beams and One-Way Slabs Unless Deflections Are Calculated

Continuous beams and one-way slabs that meet the limitations in ACI 8.3.3 may be designed using the approximate bending moments and shear forces given in that section.

Figure 4.2 outlines a summary of the analysis requirements presented above. The approximate bending moments and shear forces of ACI 8.3.3 are given in Figure 4.3.

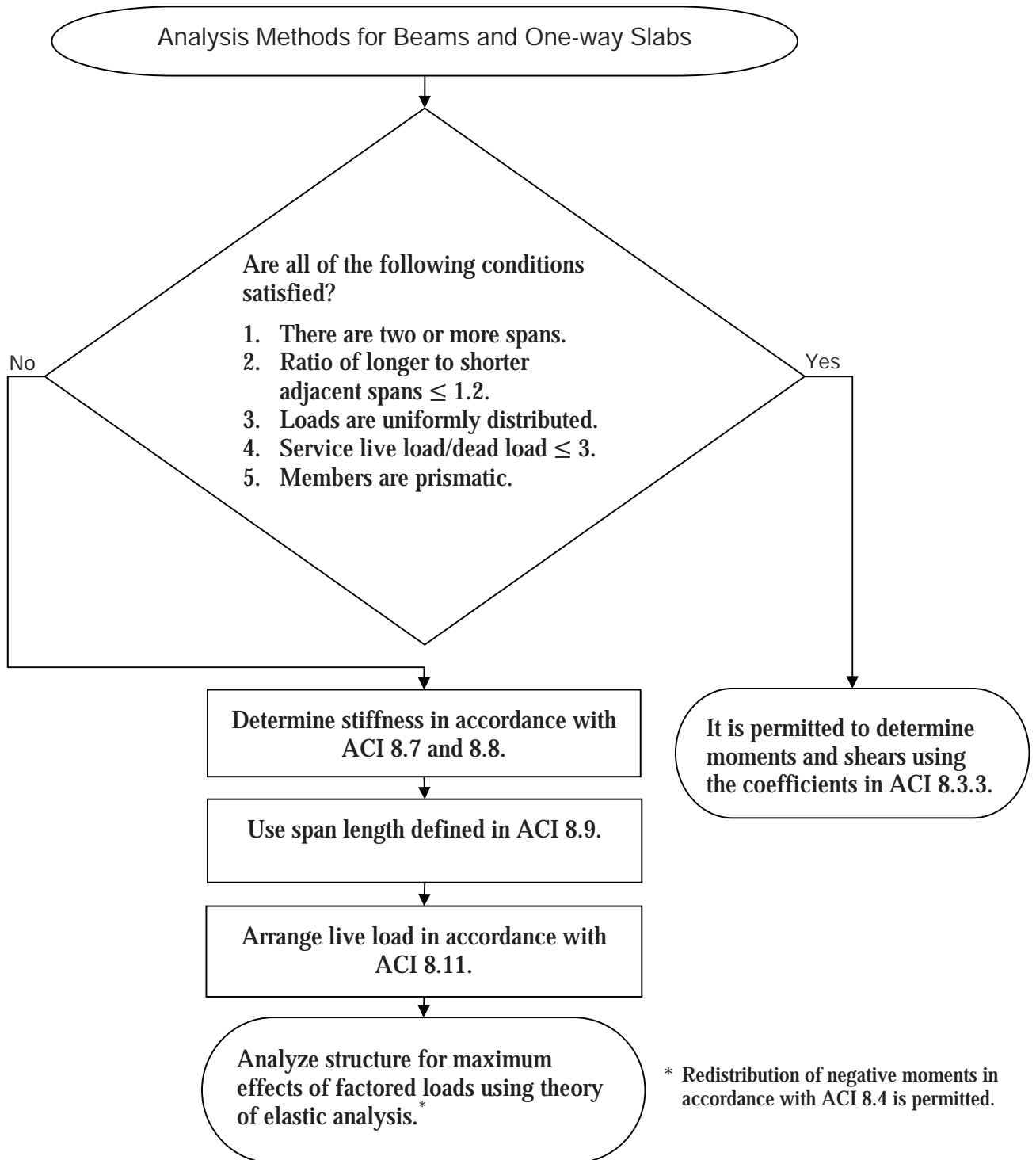
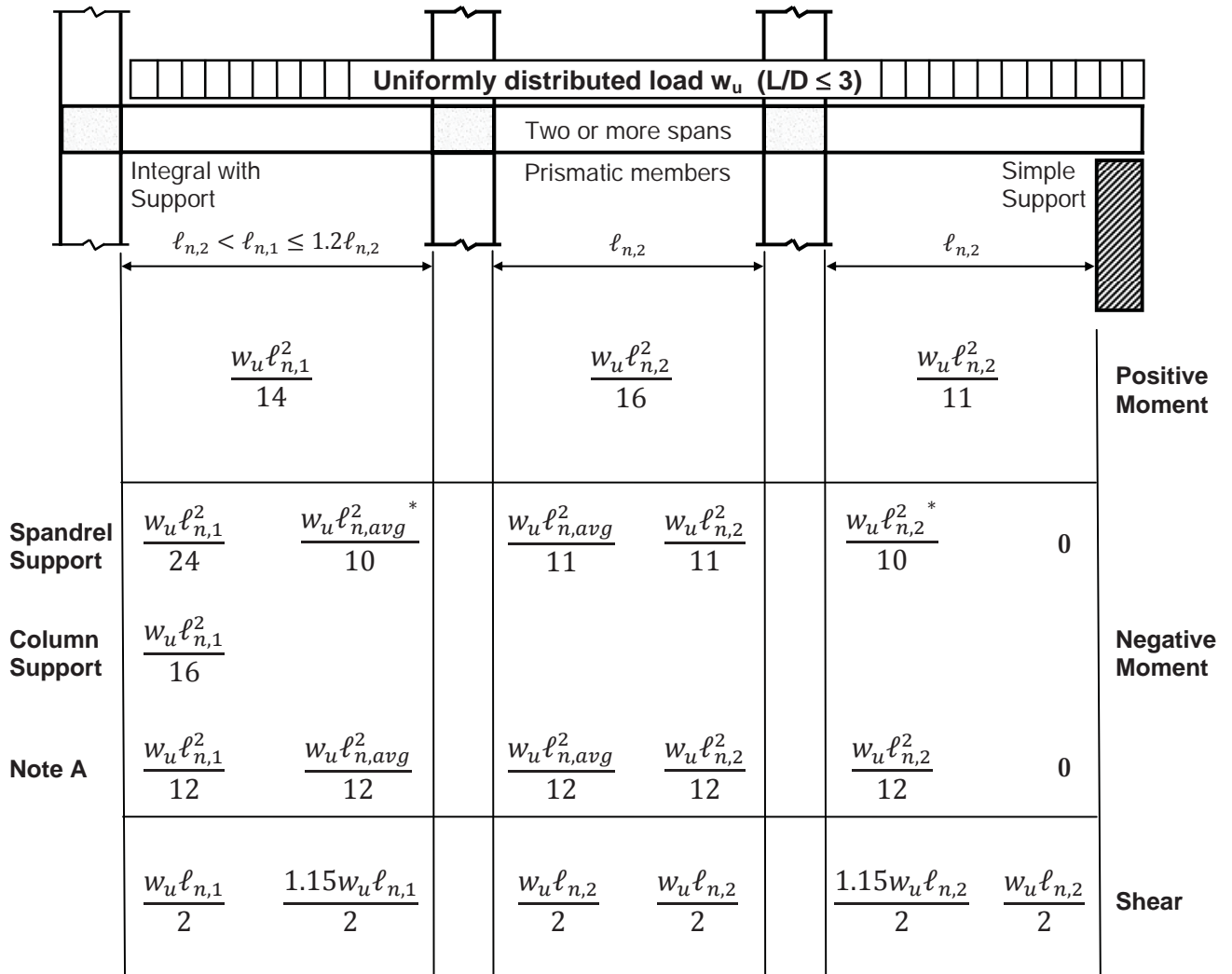

Figure 4.2 Analysis Methods for Beams and One-way Slabs



For SI: 1 foot = 304.8 mm.

* For 2-span condition, first interior negative moment = $w_u \ell_n^2 / 9$

$$\ell_{n,avg} = (\ell_{n,1} + \ell_{n,2}) / 2 \quad (\text{ACI 8.3.3})$$

Note A: Applicable to slabs with spans ≤ 10 feet and beams where the ratio of the sum of column stiffnesses to beam stiffness > 8 at each end of the span.

Figure 4.3 Approximate Bending Moments and Shear Forces for Beams and One-way Slabs (ACI 8.3.3)

Design methods for flexure. ACI Chapter 10 contains the general principles and requirements for flexural design. Included are provisions for minimum reinforcement and distribution of flexural reinforcement.

Figure 4.4 can be used to determine the depth of a beam or one-way slab, h , the width of a beam, b_w [one-way slabs are typically designed using a 12-inch-wide (305 mm) design strip], and the required flexural reinforcement, A_s , for a factored moment, M_u .⁷

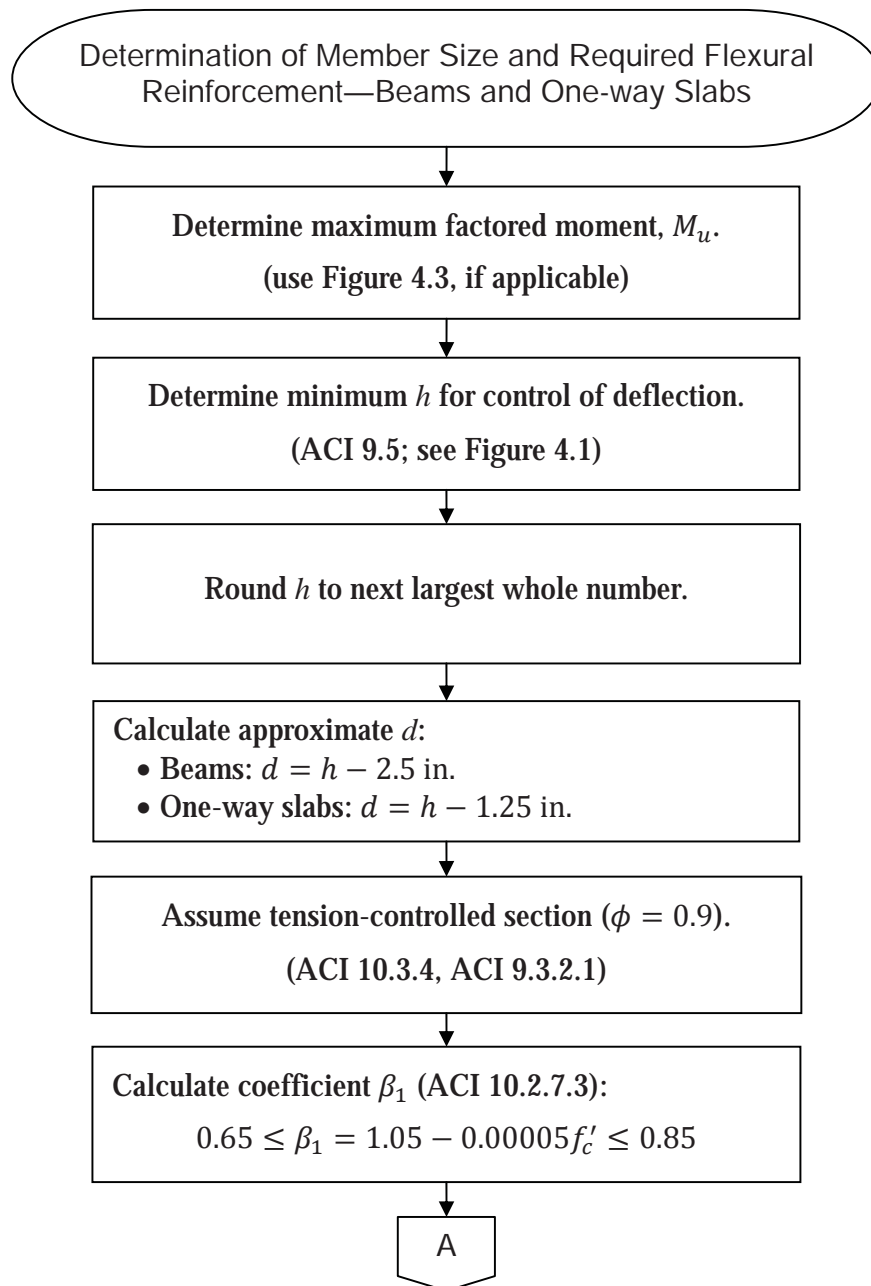
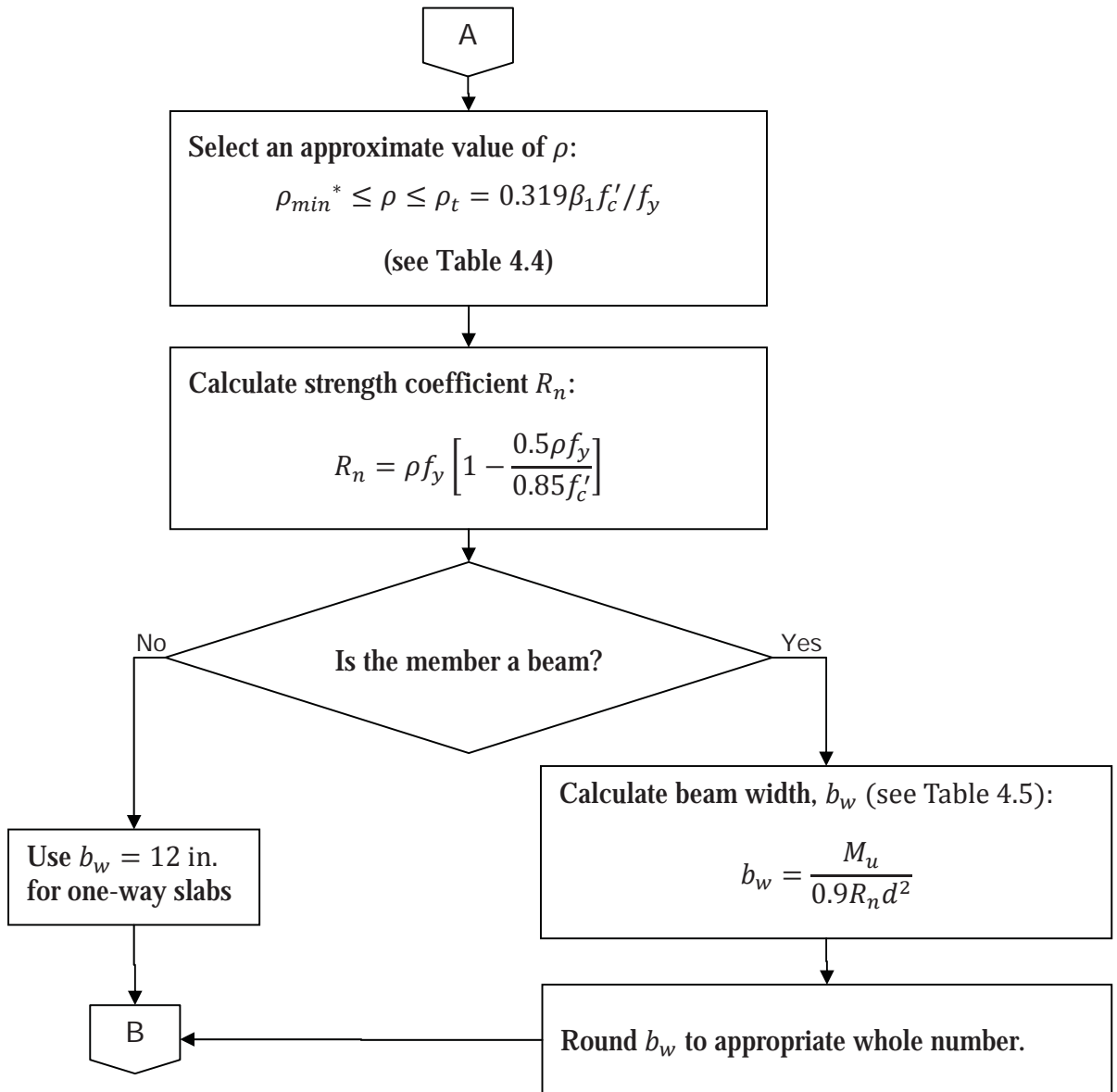

Figure 4.4 Determination of Member Size and Required Flexural Reinforcement—Beams and One-way Slabs

⁷ Figure 4.4 is applicable to beams that are not deep beams. Deep beams are defined in ACI 10.7.



* For beams: $\rho_{min} =$ greater of $3\sqrt{f'_c}/f_y$ and $200/f_y$ (ACI 10.5.1)

For slabs: $\rho_{min} = 0.0018$ (Grade 60 deformed bars) (ACI 10.5.4)

Figure 4.4 Determination of Member Size and Required Flexural Reinforcement—
Beams and One-way Slabs (continued)

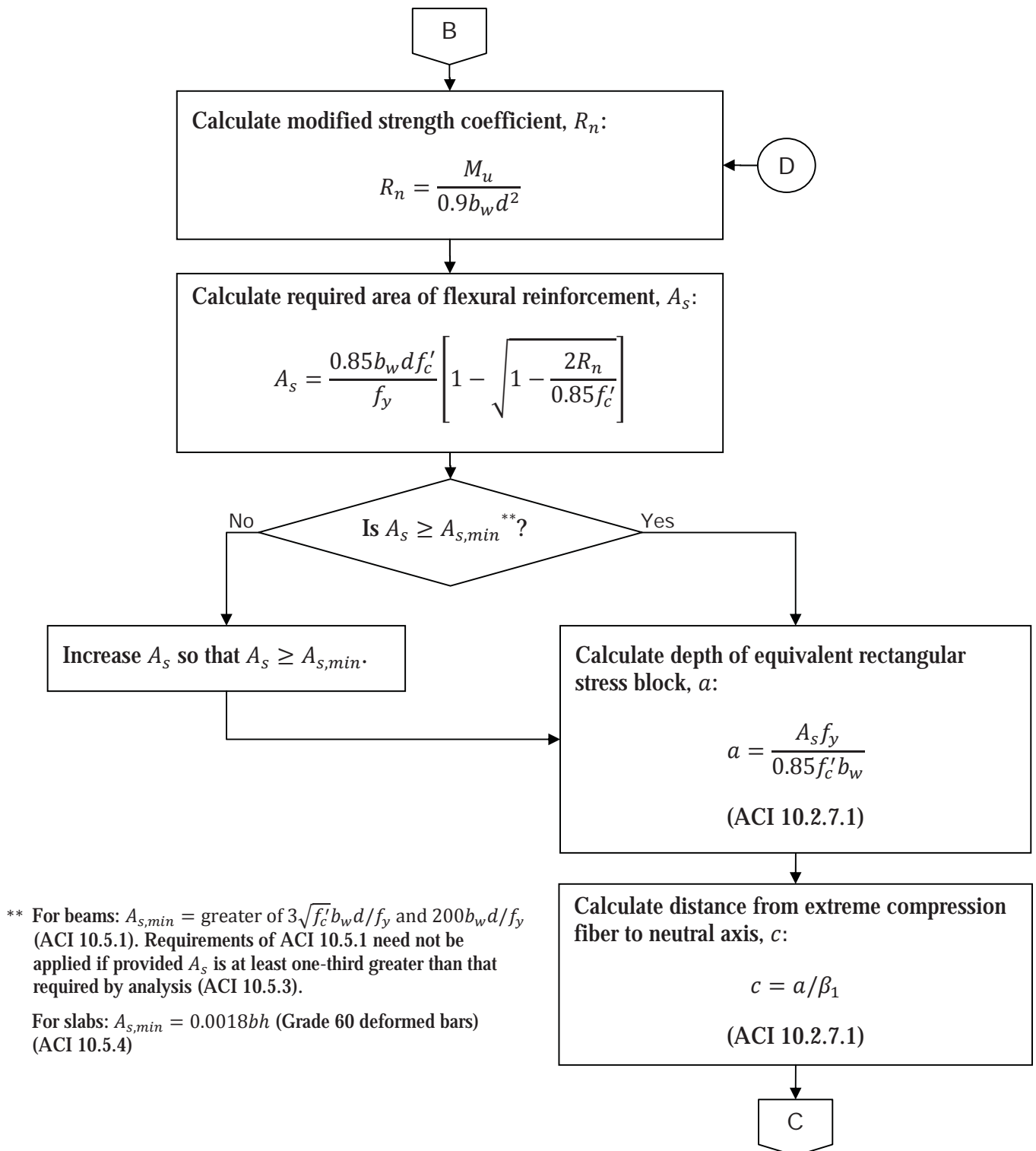
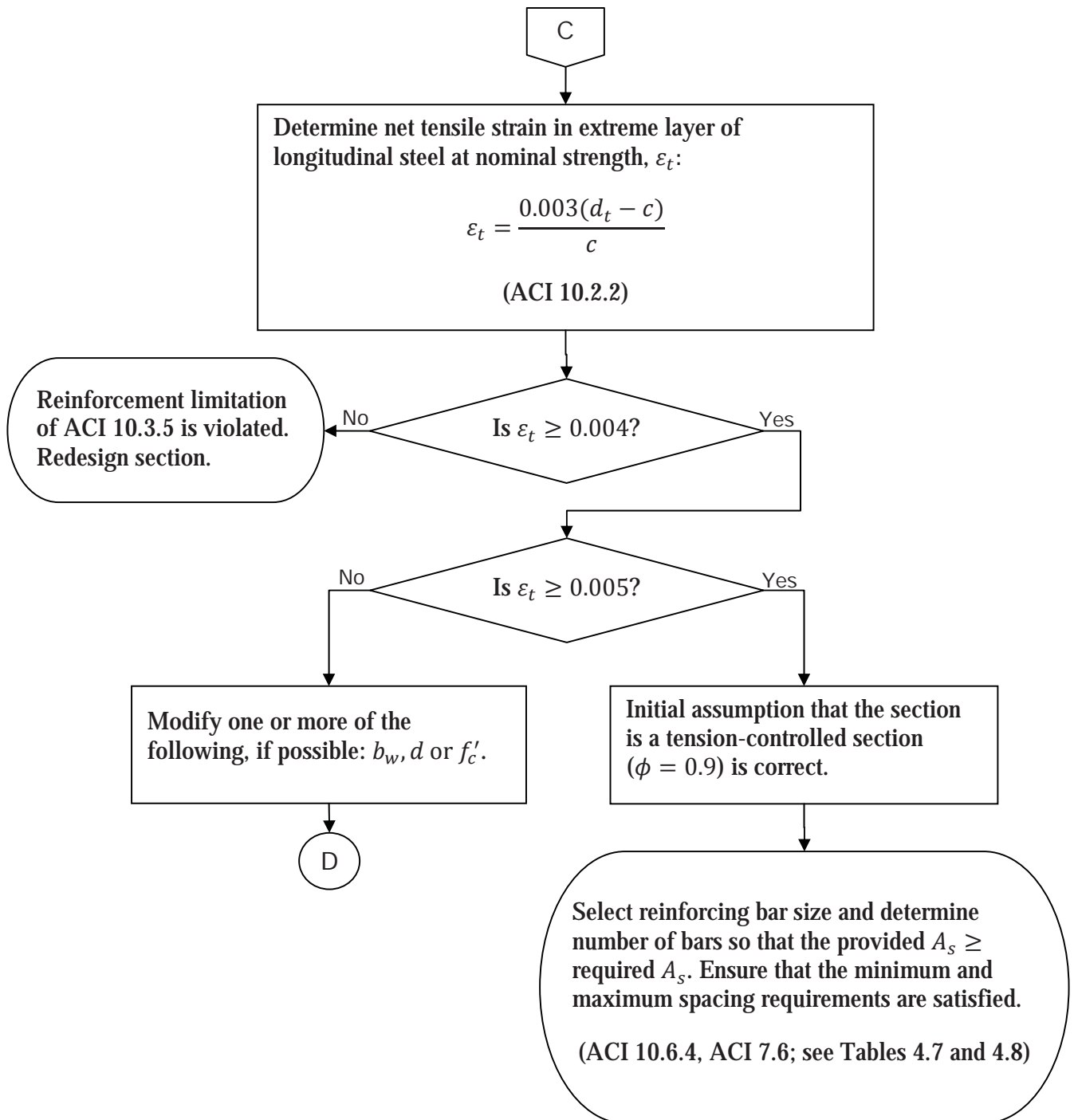

Figure 4.4 Determination of Member Size and Required Flexural Reinforcement—Beams and One-way Slabs (continued)



For SI: 1 inch = 25.4 mm.

Figure 4.4 Determination of Member Size and Required Flexural Reinforcement—Beams and One-way Slabs (continued)

The reinforcement ratio, ρ_t , at a strain limit of 0.005 for tension-controlled sections is given in Table 4.4 as a function of the concrete compressive strength and Grade 60 reinforcement.

Table 4.4 Reinforcement Ratio, ρ_t , at Strain Limit of 0.005 for Tension-Controlled Sections Assuming Grade 60 Reinforcement

f'_c (psi)	ρ_t
3000	0.01355
4000	0.01806
5000	0.02125

In general, beam width, b_w , can be determined from the following equation, which is derived from the basic strength equation for flexural members:

$$b_w = \frac{36,600M_u}{\bar{\rho}\beta_1 f'_c (1 - 0.2143\bar{\rho}\beta_1)d^2}$$

where $\bar{\rho} = \rho/\rho_{max}$, f'_c is in psi, d is in inches, M_u is in ft-kips and

$$\rho_{max} = \frac{0.85\beta_1 f'_c}{f_y} \frac{0.003}{0.004 + 0.003} \quad (\text{ACI 10.3.5})$$

Using $\bar{\rho} = 0.5$ will typically result in members of sufficient size so that deflections will be within acceptable limits. The equations in Table 4.5 can be used to determine b_w assuming Grade 60 reinforcement and $\bar{\rho} = 0.5$.

The calculation of the required flexural reinforcement can be simplified by using the equations in Table 4.6, which are also derived from the basic strength equation for reinforced concrete sections. It can be seen from the table that for concrete compressive strengths from 3,000 psi to 5,000 psi (20 684 kPa to 34 474 kPa), the required reinforcement can be expediently calculated by $A_s = M_u/4d$ where A_s is in square inches, M_u is in ft-kips and d is in inches.

The minimum and maximum number of reinforcing bars permitted in a cross-section are a function of the cover and spacing requirements in ACI 7.6.1 and ACI 3.3.2 (minimum spacing for concrete placement), ACI 7.7.1 (minimum cover for protection of nonprestressed reinforcement) and ACI 10.6 (maximum spacing for control of flexural cracking).

Table 4.5 Simplified Calculation of b_w Assuming Grade 60 Reinforcement and $\bar{\rho} = \rho/\rho_{max} = 0.5$

f'_c (psi)	b_w (in.) [*]
3000	$\frac{31.6M_u}{d^2}$
4000	$\frac{23.7M_u}{d^2}$
5000	$\frac{20.0M_u}{d^2}$

* M_u is in ft-kips and d is in inches.

For SI: 1 inch = 25.4 mm; 1 pound per square inch = 6.895 kPa; 1 ft-kip = 1.356 kN-m.

Table 4.6 Simplified Calculation of A_s Assuming Tension-Controlled Section and Grade 60 Reinforcement

f'_c (psi)	A_s (in. ²)
3000	$\frac{M_u}{3.95d}$
4000	$\frac{M_u}{3.96d}$
5000	$\frac{M_u}{3.99d}$

* M_u is in ft-kips and d is in inches

For SI: 1 inch = 25.4 mm; 1 square inch = 645.16 mm²; 1 pound per square inch = 6.895 kPa; 1 ft-kip = 1.356 kN-m.

Table 4.7 contains the minimum number of bars required in a single layer for beams of various widths, assuming Grade 60 reinforcement, clear cover to the tension reinforcement, c_c , equal to 2 inches (51 mm), and f'_s equal to 40 ksi (276 MPa). Table 4.8 contains the maximum number of bars permitted in a single layer assuming Grade 60 reinforcement, clear cover to the stirrups, c_s , equal to 1 1/2 inches (38 mm), and 3/4-inch (19 mm) aggregate. Also, it is assumed that No. 3 stirrups are utilized for No. 5 and No. 6 longitudinal bars, and No. 4 stirrups are used for No. 7 and larger bars.

Development Length. Flexural reinforcement must be developed in accordance with the provisions of ACI 12.10, 12.11 and 12.12. ACI Figure R12.10.2 depicts the requirements for development of flexural reinforcement in a typical continuous beam.

Table 4.7 Minimum Number of Reinforcing Bars Required in a Single Layer in accordance with ACI 10.6.4

Bar Size	Beam Width (in.)												
	12	14	16	18	20	22	24	26	28	30	36	42	48
No. 4	2	2	3	3	3	3	3	4	4	4	5	5	6
No. 5	2	2	3	3	3	3	3	4	4	4	5	5	6
No. 6	2	2	3	3	3	3	3	4	4	4	5	5	6
No. 7	2	2	3	3	3	3	3	4	4	4	5	5	6
No. 8	2	2	3	3	3	3	3	4	4	4	5	5	6
No. 9	2	2	3	3	3	3	3	4	4	4	5	5	6
No. 10	2	2	3	3	3	3	3	4	4	4	5	5	6
No. 11	2	2	3	3	3	3	3	4	4	4	5	5	6

For SI: 1 inch = 25.4 mm.

Table 4.8 Maximum Number of Reinforcing Bars Permitted in a Single Layer in accordance with ACI 7.6

Bar Size	Beam Width (in.)												
	12	14	16	18	20	22	24	26	28	30	36	42	48
No. 4	5	6	8	9	10	12	13	14	16	17	21	25	29
No. 5	5	6	7	8	10	11	12	13	15	16	19	23	27
No. 6	4	6	7	8	9	10	11	12	14	15	18	22	25
No. 7	4	5	6	7	8	9	10	11	12	13	17	20	23
No. 8	4	5	6	7	8	9	10	11	12	13	16	19	22
No. 9	3	4	5	6	7	8	8	9	10	11	14	17	19
No. 10	3	4	4	5	6	7	8	8	9	10	12	15	17
No. 11	3	3	4	5	5	6	7	8	8	9	11	13	15

For SI: 1 inch = 25.4 mm.

For beams subjected to uniformly distributed gravity loads where the shape of the moment diagram is known, the development lengths shown in Figure 4.5 can be used. These recommended details include the provisions for structural integrity reinforcement in ACI 7.13. Figure 4.6 depicts similar details for one-way slabs.

Cut-off points of the reinforcement need to be determined by the requirements of ACI Chapter 12 when combined gravity and lateral loads act on a member.

Splices. In general, flexural reinforcement is spliced at locations along the span where the bending moment is small or zero. Thus, positive (bottom) reinforcement is typically spliced over the supports and negative (top) reinforcement is spliced near or at midspan.

Tension lap splices are classified as either Class A or Class B, and the length of the lap splice is a multiple of the tensile development length, ℓ_d , defined in ACI 12.2

(ACI 12.15). Class B splices are required in all cases except for those given in ACI 12.15.2 where Class A splices may be used.

Mechanical or welded splices conforming to the requirements of ACI 12.14.3 may also be used.

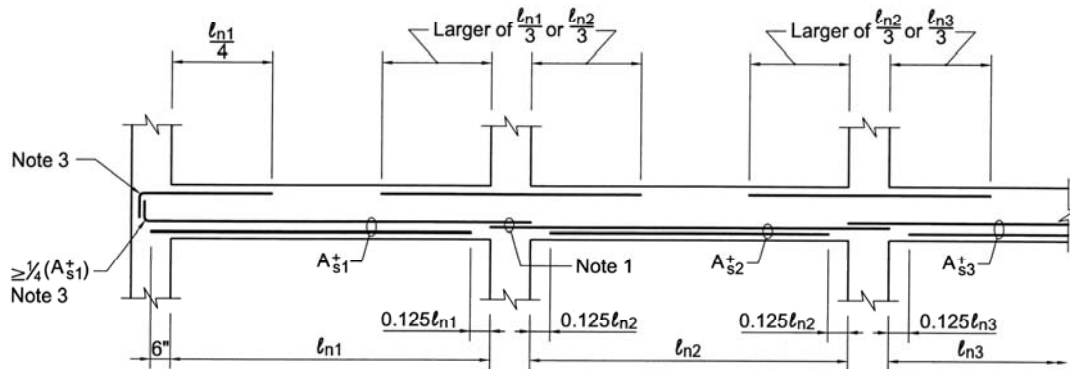

(a) Other than perimeter beams without transverse reinforcement defined in ACI 7.13.2.3

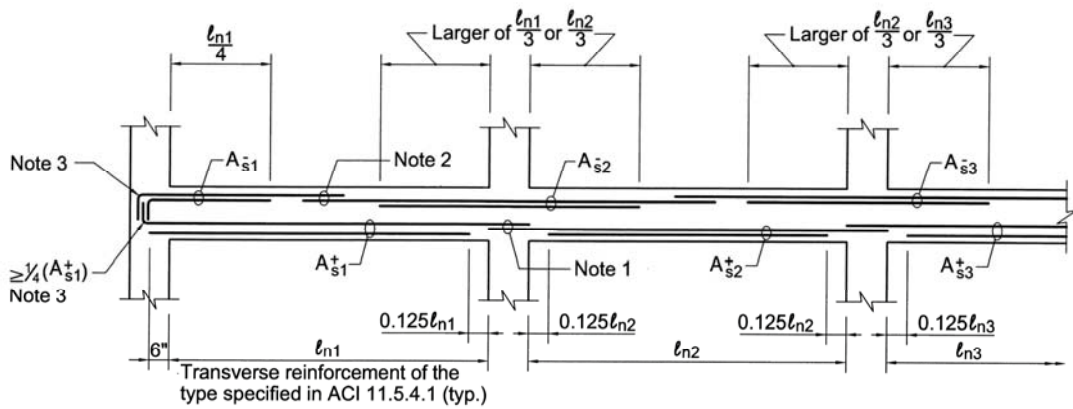

(b) Perimeter beams or other than perimeter beams where transverse reinforcement as defined in ACI 7.13.2.3 is provided

- Notes: (1) Larger of $\frac{1}{4} (A_{s1}^+)$ or $\frac{1}{4} (A_{s2}^+)$ but not less than two bars continuous or spliced with Class B splices or mechanical or welded splice satisfying ACI 12.14.3 (ACI 7.13.2.2 and 7.13.2.4)
- (2) Larger of $\frac{1}{6} (A_{s1}^-)$ or $\frac{1}{6} (A_{s2}^-)$ but not less than two bars continuous or spliced with Class B splices or mechanical or welded splice satisfying ACI 12.14.3 (ACI 7.13.2.2 and 7.13.2.4)
- (3) Use a standard hook satisfying ACI 12.5 or a headed deformed bar satisfying ACI 12.6
- (4) Beams shall have at least two of the longitudinal bars continuous along the top and bottom faces when they are part of the seismic-force-resisting system (ACI 21.2.2)

Figure 4.5 Recommended Bar Details for Beams

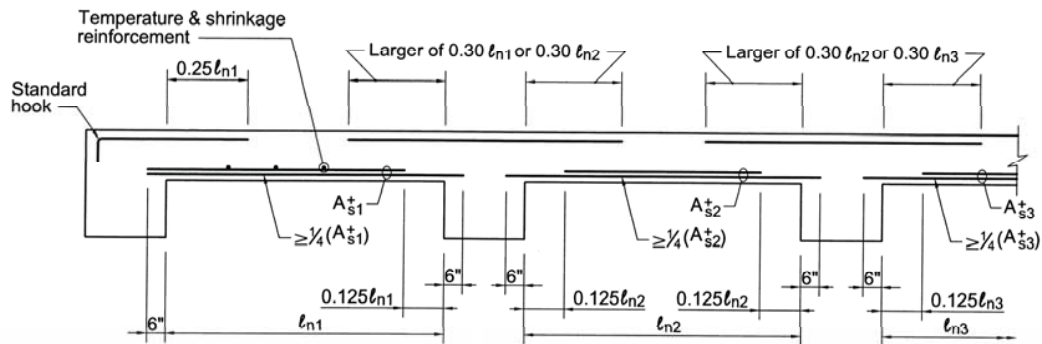

For SI: 1 inch = 25.4 mm.

Figure 4.6 Recommended Bar Details for One-way Slabs

Confinement. Lateral reinforcement for flexural members must satisfy the requirements of ACI 7.11. Closed ties or closed stirrups are required for members subject to stress reversals (e.g., members that are part of the lateral-force-resisting system subject to wind or seismic forces) or to torsion.

Shear. For one-way slabs where shear reinforcement is not used, the factored shear force, V_u , at the critical section located a distance, d , from the face of the support must not exceed the shear design strength for concrete, ϕV_c . Figure 4.7 outlines the requirements to determine ϕV_c for one-way slabs and for beams.

The required amount of shear reinforcement for beams can be determined by the information provided in Figure 4.8. Minimum shear reinforcement for Grade 60 reinforcing bars is given in Table 4.9 and the values of ϕV_s in Table 4.10 can be used to determine the required spacing of shear reinforcement.

Torsion. Torsional effects typically need to be considered for spandrel beams. However, other members can be subjected to torsion (for example, interior beams with adjoining spans perpendicular to the beam span that are not equal).

The factored torsion, T_u , at a section can be determined using Figure 4.9. It is assumed that the section is not subjected to significant axial compressive or tensile forces.

Torsional section properties for edge and interior members are given in Table 4.11.

Information on how to determine the required transverse reinforcement A_t/s and longitudinal reinforcement is provided in Figures 4.10 and 4.11, respectively, for solid sections.

The design procedure for members subjected to combined torsion, shear and bending moment is given in Figure 4.12.

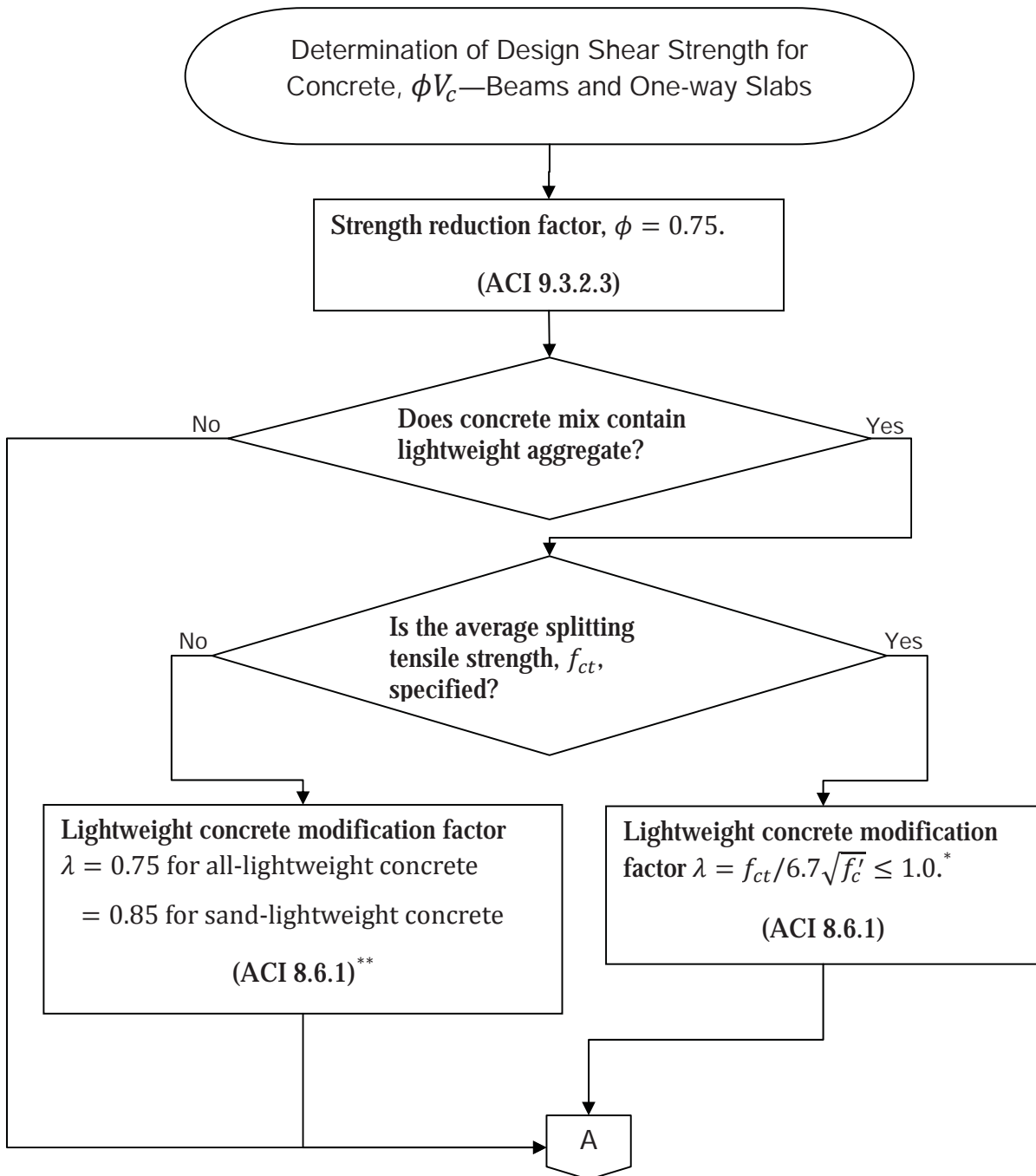

* Values of $\sqrt{f'_c}$ shall not exceed 100 psi except as allowed in ACI 11.1.2.1 (ACI 11.1.2).

**Linear interpolation shall be permitted when partial sand replacement is used (ACI 8.6.1).

Figure 4.7 Determination of Design Shear Strength for Concrete, ϕV_c —Beams and One-way Slabs

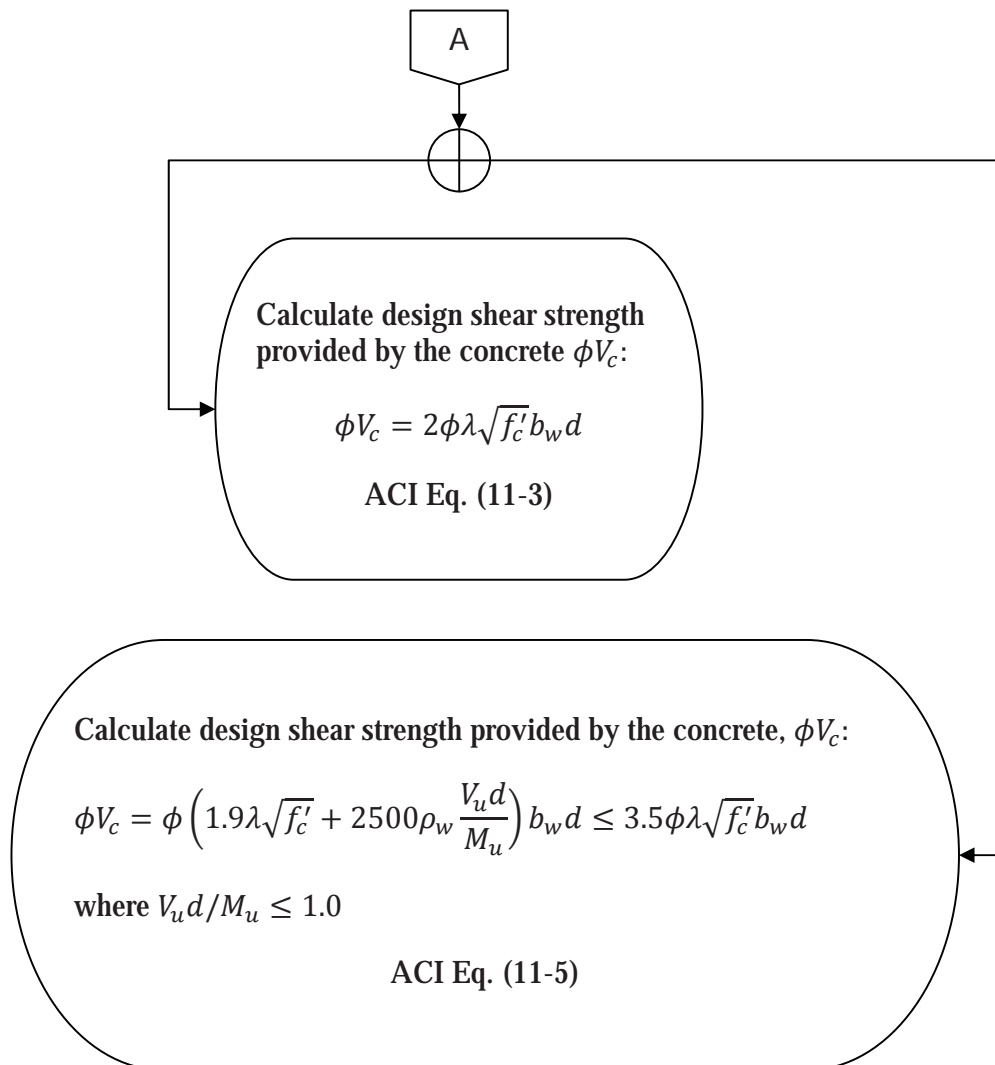

For SI: 1 pound per square inch = 6.895 kPa.

Figure 4.7 Determination of Design Shear Strength for Concrete, ϕV_c —Beams and One-way Slabs (continued)

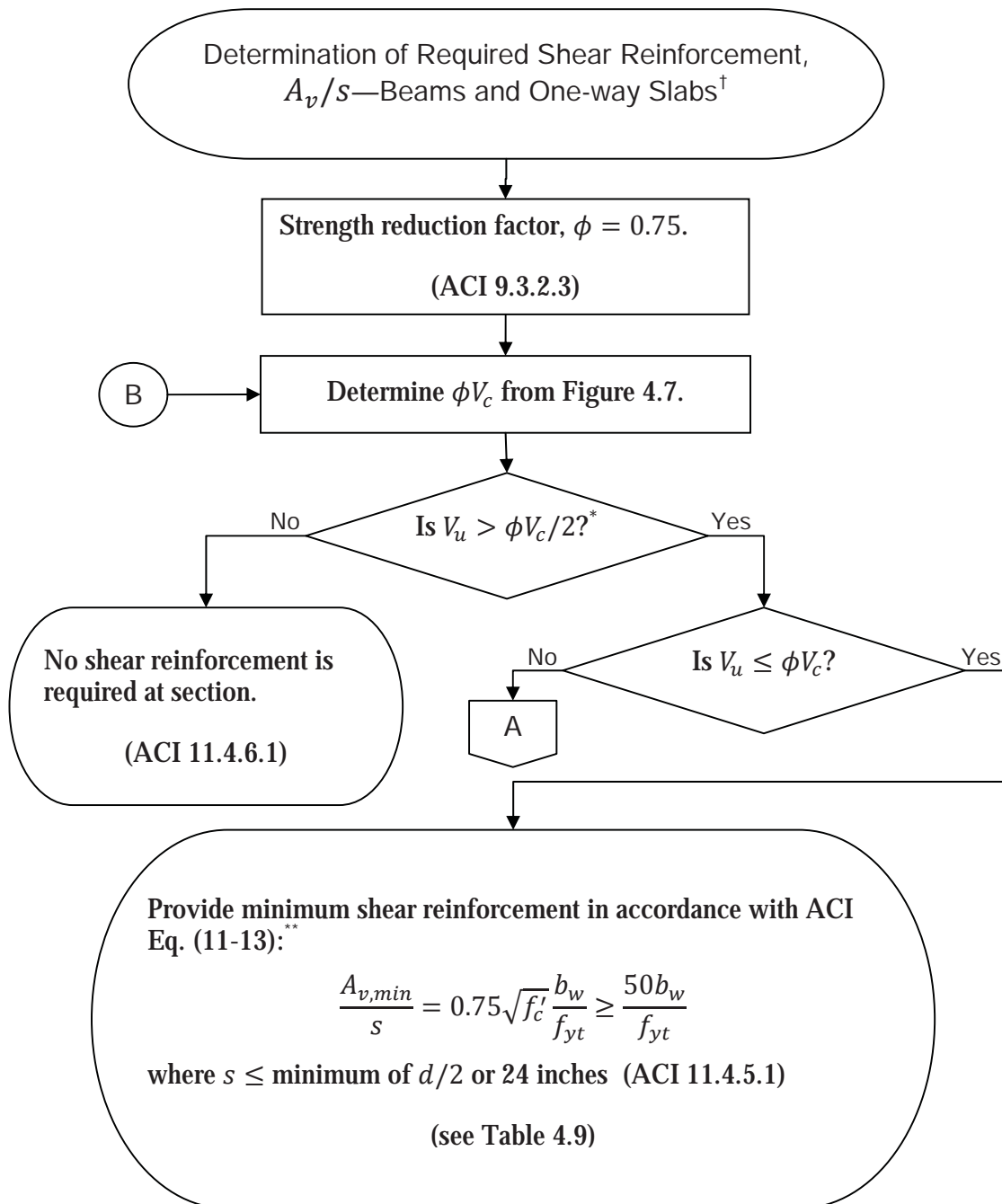

[†] Applicable to shear reinforcement perpendicular to axis of member (ACI 11.4.7.2); see ACI 11.4.7.3 through 11.4.7.8 for other cases.

* Sections located less than a distance, d , from face of support shall be permitted to be designed for V_u computed at a distance d provided all of the conditions of ACI 11.1.3 are satisfied (ACI 11.1.3.1).

** Minimum shear reinforcement need not be provided in the types of members listed in ACI 11.4.6.1.

Figure 4.8 Determination of Required Shear Reinforcement, A_v/s —Beams and One-way Slabs

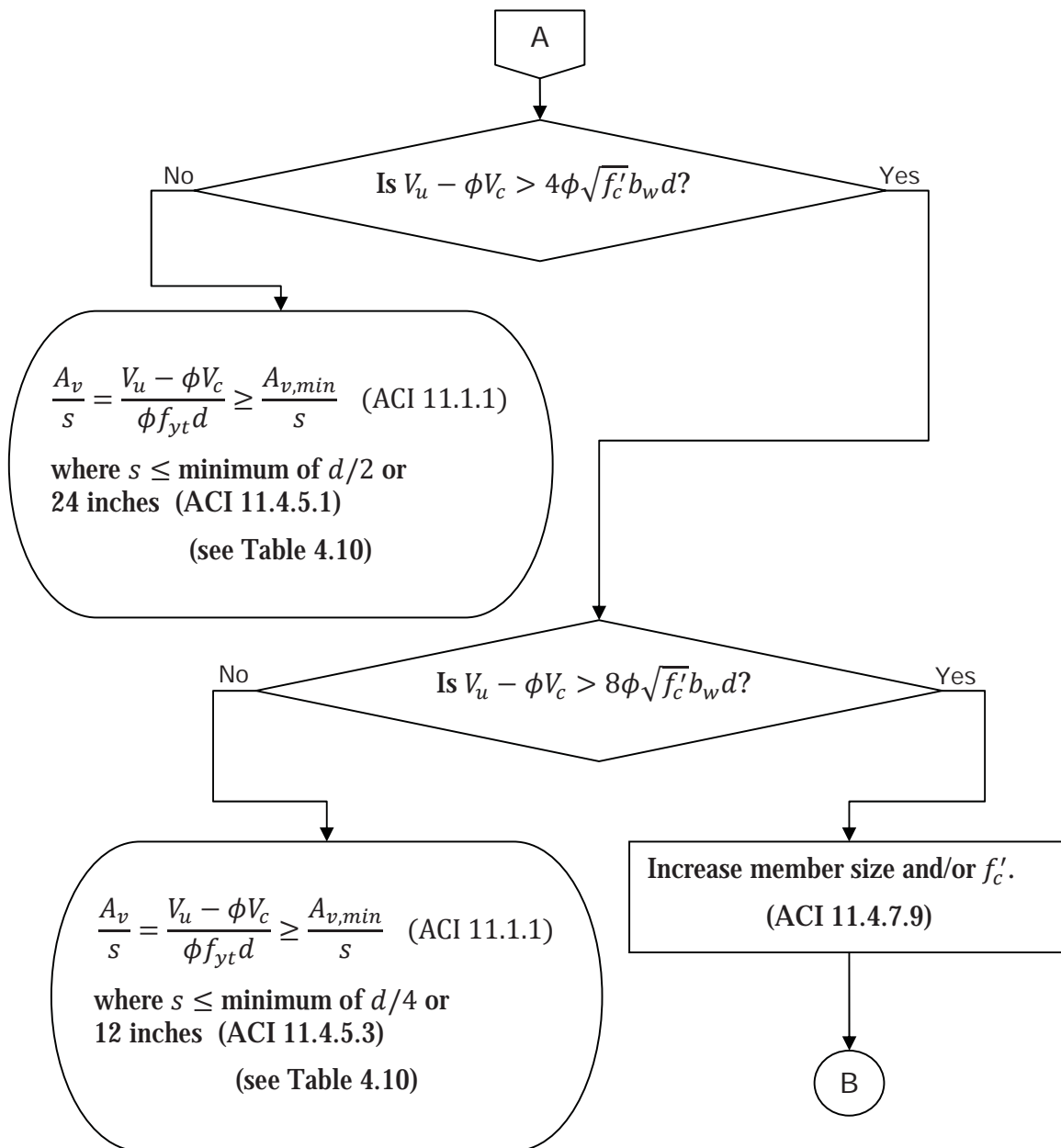

For SI: 1 inch = 25.4 mm.

Figure 4.8 Determination of Required Shear Reinforcement, A_v/s —Beams and One-way Slabs (continued)

Table 4.9 Minimum Shear Reinforcement, $A_{v,min}/s$, Assuming Grade 60 Reinforcement

f'_c (psi)	$A_{v,min}/s$ (in. ² /in.)
≤ 4000	0.00083 b_w
5000	0.00088 b_w

For SI: 1 inch = 25.4 mm; 1 square inch = 645.16 mm²; 1 pound per square inch = 6.895 kPa.

Table 4.10 Values of $\phi V_s = V_u - \phi V_c$ (kips) as a Function of Spacing, s *

s	No. 3 U-stirrups	No. 4 U-stirrups	No. 5 U-stirrups
$d/2$	19.8	36.0	55.8
$d/3$	29.7	54.0	83.7
$d/4$	39.6	72.0	111.6

* Valid for Grade 60 ($f_{yt} = 60$ ksi) stirrups with two legs (double the tabulated values for four legs, etc.).

For SI: 1 ksi = 6.8948 MPa.

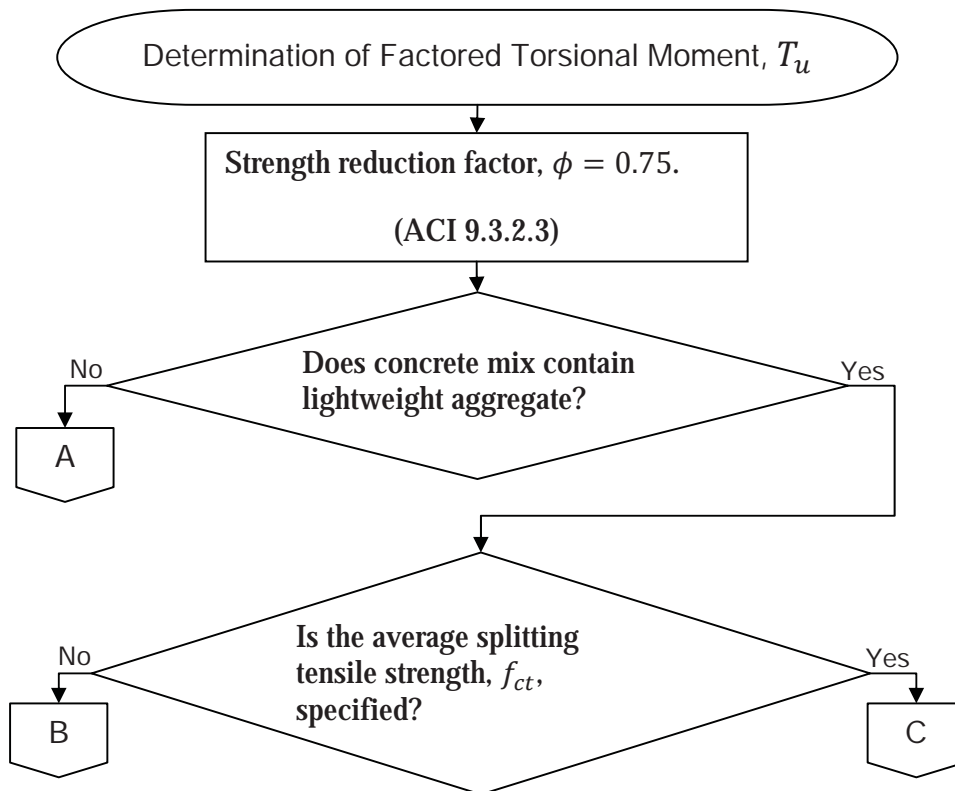
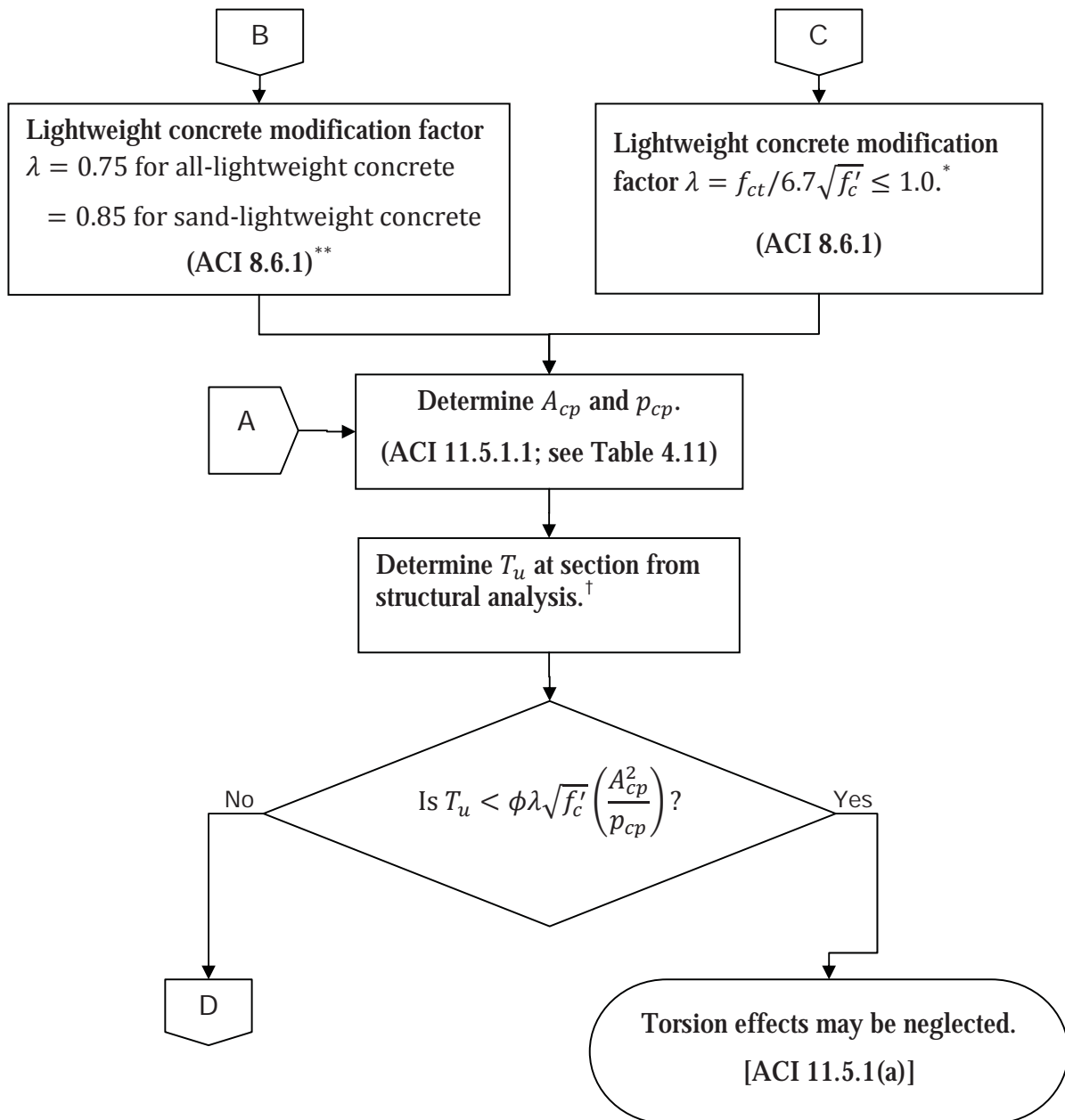

Figure 4.9 Determination of Factored Torsional Moment, T_u



* Values of $\sqrt{f'_c}$ shall not exceed 100 psi except as allowed in ACI 11.1.2.1 (ACI 11.1.2).

**Linear interpolation shall be permitted when partial sand replacement is used (ACI 8.6.1).

† Sections located less than a distance, d , from face of support shall be permitted to be designed for T_u computed at a distance, d . If a concentrated torque occurs within this distance, the critical section is at the face of the support (ACI 11.5.2.4). It is permitted to take the torsional loading from a slab as uniformly distributed along a member (ACI 11.5.2.3).

Figure 4.9 Determination of Factored Torsional Moment, T_u (continued)

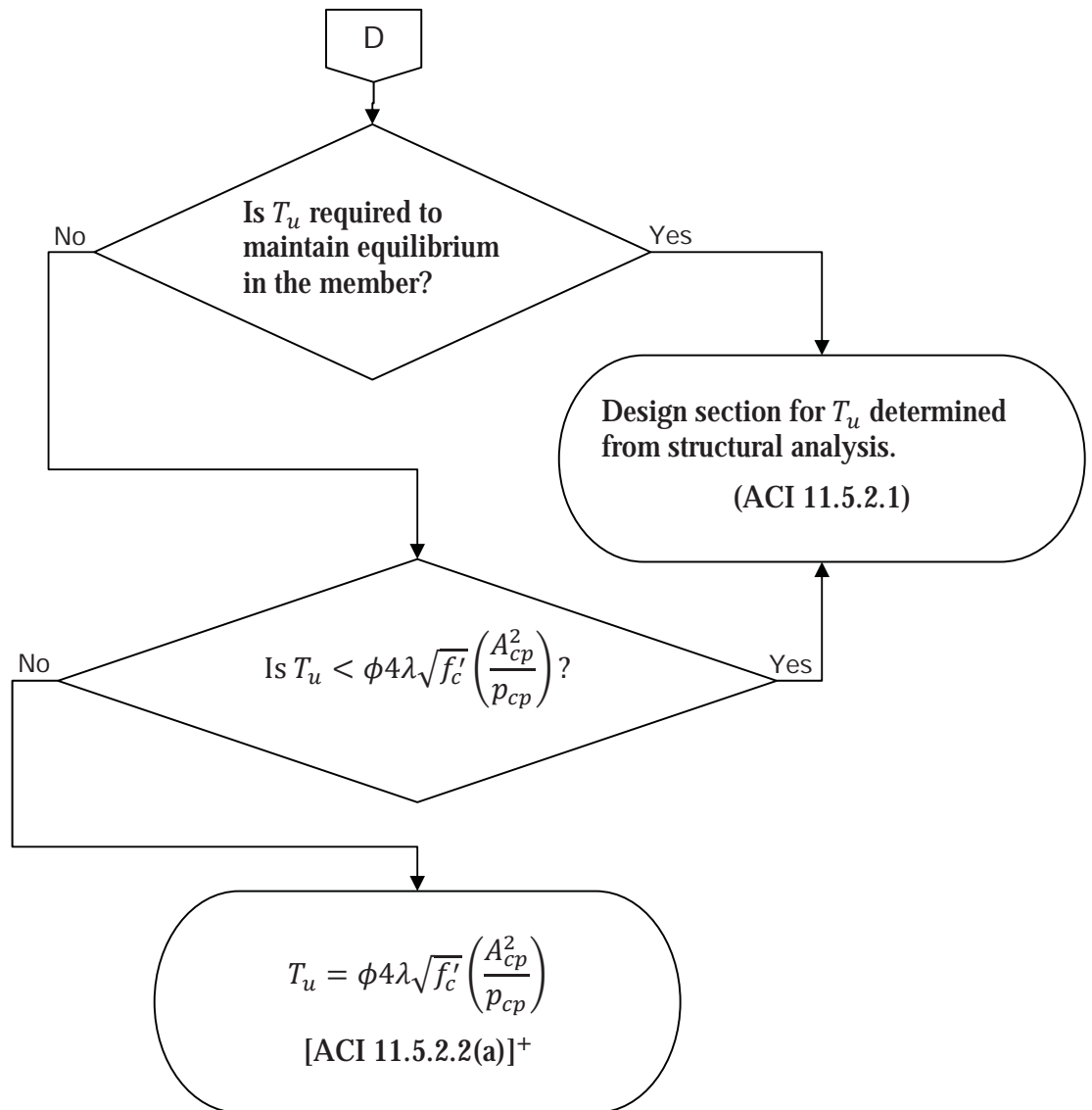

⁺ Adjoining members must be designed for the redistributed bending moments and shear forces corresponding to T_u (ACI 11.5.2.2).

For SI: 1 pound per square inch = 6.895 kPa.

Figure 4.9 Determination of Factored Torsional Moment, T_u (continued)

Table 4.11 Torsional Section Properties

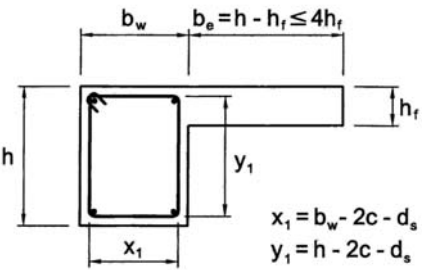
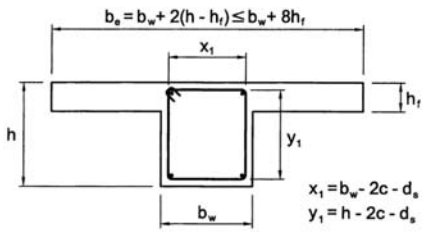
Section*	A_{cp}	p_{cp}	A_{oh}	p_h
 <p> b_w $b_e = h - h_f \leq 4h_f$ h h_f x_1 y_1 $x_1 = b_w - 2c - d_s$ $y_1 = h - 2c - d_s$ </p>	$b_w h + b_e h_f$	$2(h + b_w + b_e)$	$x_1 y_1$	$2(x_1 + y_1)$
 <p> $b_e = b_w + 2(h - h_f) \leq b_w + 8h_f$ h h_f x_1 y_1 $x_1 = b_w - 2c - d_s$ $y_1 = h - 2c - d_s$ </p>	$b_w(h - h_f) + b_e h_f$	$2(h + b_e)$	$x_1 y_1$	$2(x_1 + y_1)$

*Notes: x_1, y_1 = center-to-center dimension of closed rectangular stirrup
 c = clear cover to closed rectangular stirrup
 d_s = diameter of closed rectangular stirrup

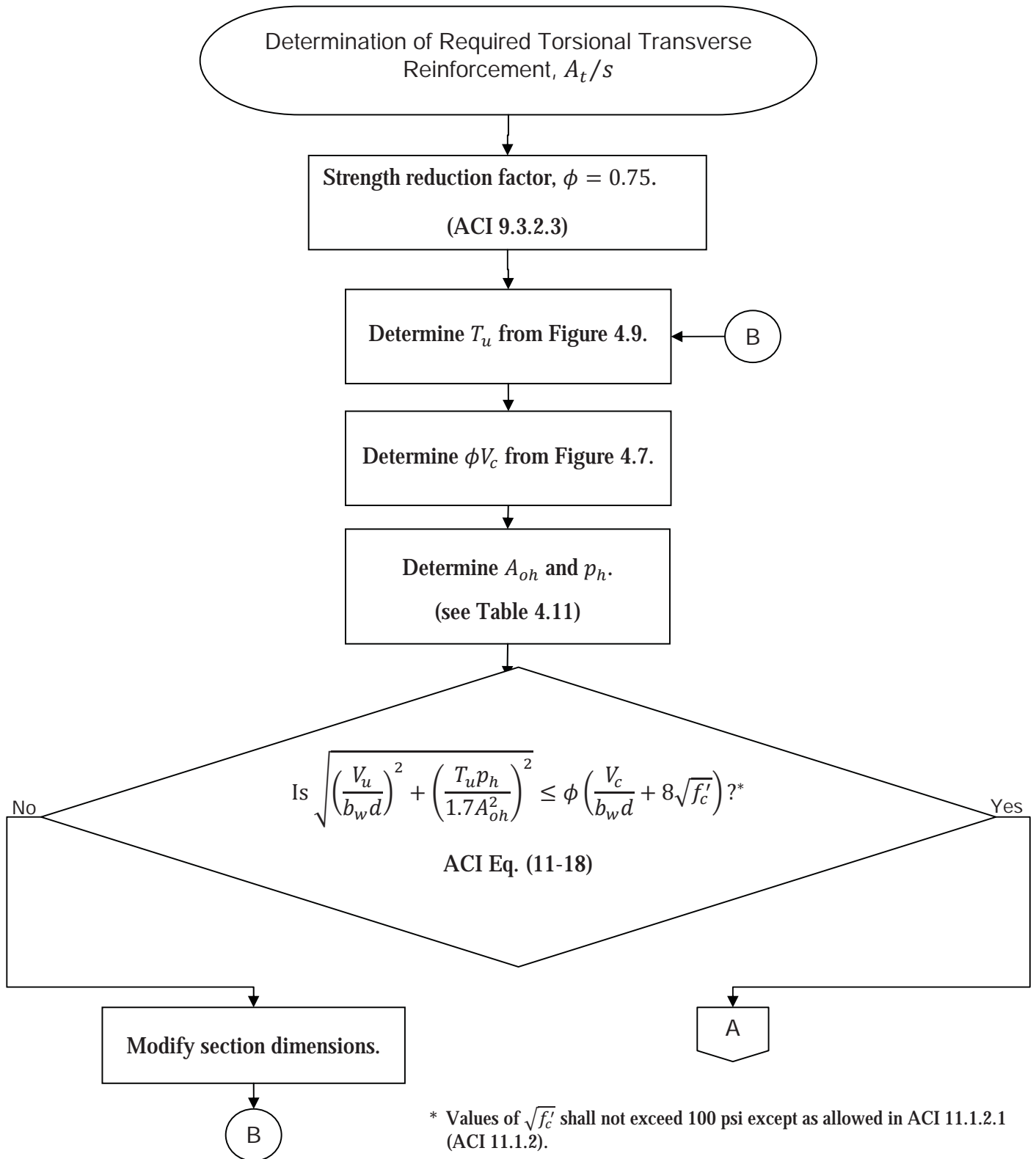
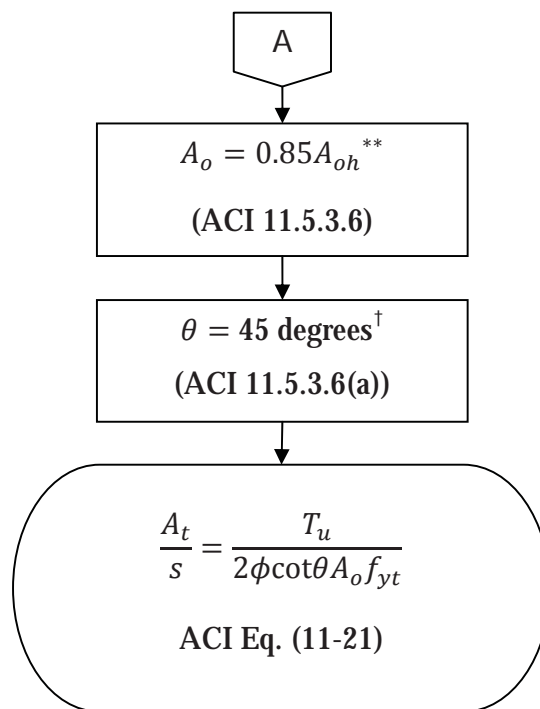

Figure 4.10 Determination of Required Torsional Transverse Reinforcement, A_t/s



** A_o can also be determined from analysis (ACI 11.5.3.6).

\dagger θ shall not be taken smaller than 30 degrees nor larger than 60 degrees (ACI 11.5.3.6).

For SI: 1 degree = 0.01745 rad; 1 pound per square inch = 6.895 kPa.

Figure 4.10 Determination of Required Torsional Transverse Reinforcement, A_t/s
(continued)

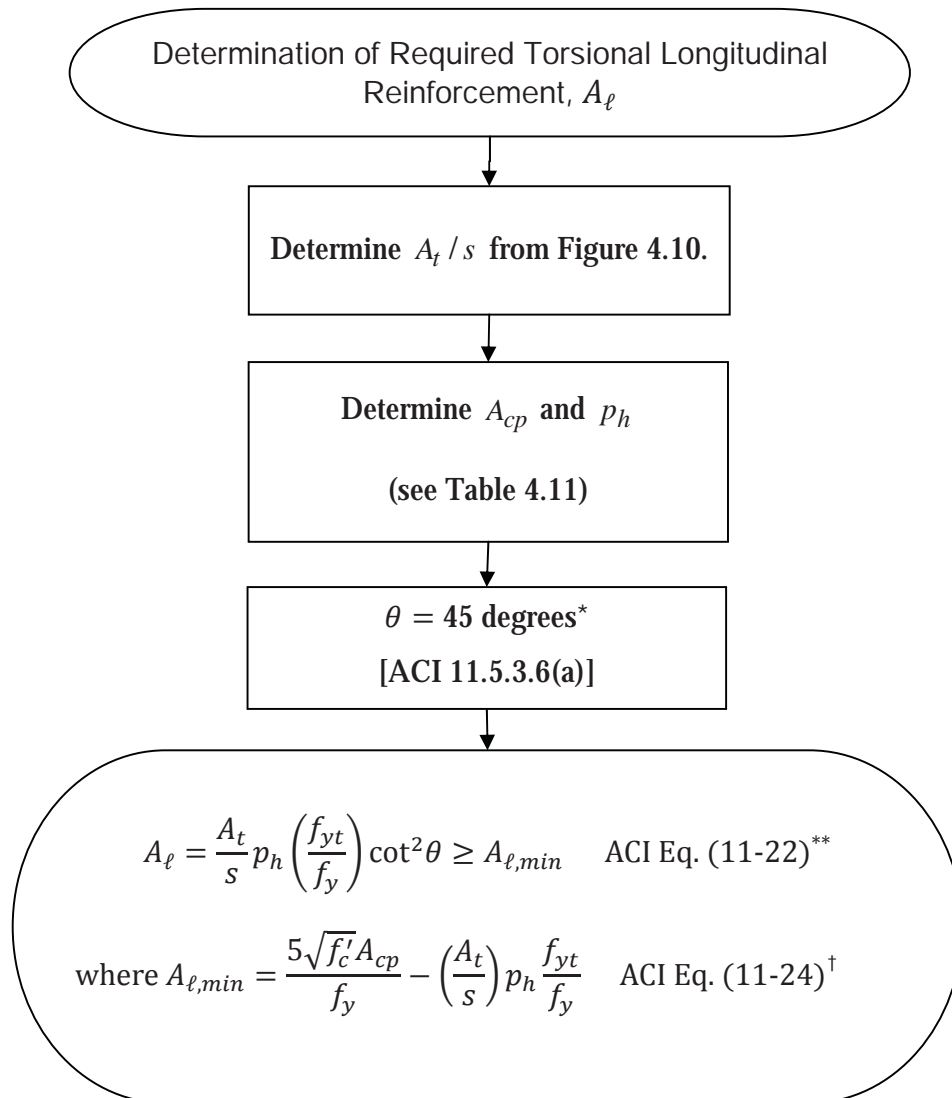

* θ shall not be taken smaller than 30 degrees nor larger than 60 degrees (ACI 11.5.3.6).

** A_t/s shall be taken as the amount computed from ACI Eq. (11-21) not modified in accordance with ACI 11.5.5.2 or 11.5.5.3.

† In ACI Eq. (11-24), $A_t/s \geq 25b_w/f_{vt}$ (ACI 11.5.5.3). Values of $\sqrt{f'_c}$ shall not exceed 100.

Figure 4.11 Determination of Required Torsional Longitudinal Reinforcement, A_ℓ

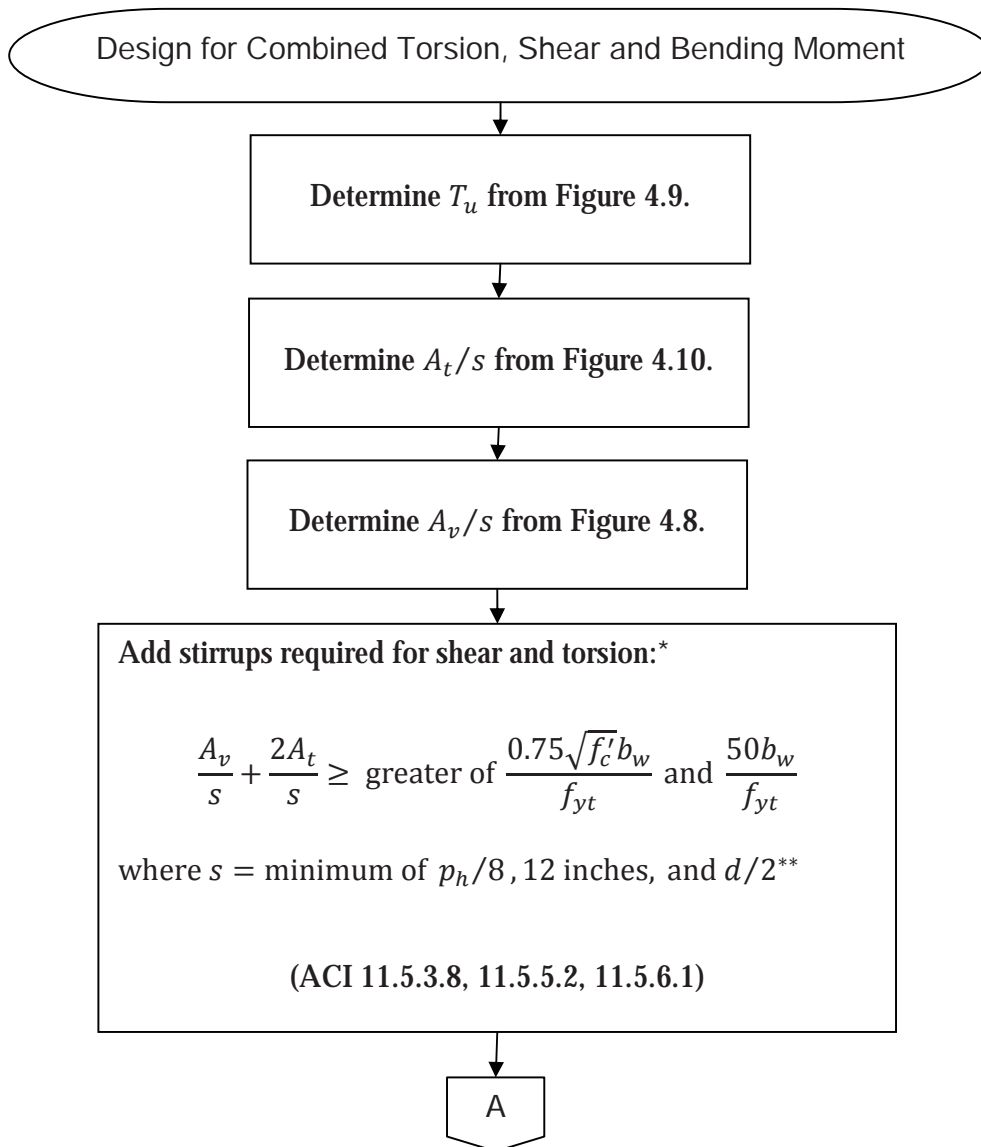

* For stirrup groups that have more than two legs for shear, only the legs adjacent to the sides of the beam would be included in this summation since the inner legs would be ineffective for torsion.

** Applicable where $V_s \leq 4\sqrt{f'_c}b_wd$. Where $V_s > 4\sqrt{f'_c}b_wd$, maximum spacing shall be reduced by one-half (ACI 11.4.5.1, 11.4.5.3).

Figure 4.12 Determination for Combined Torsion, Shear and Bending Moment

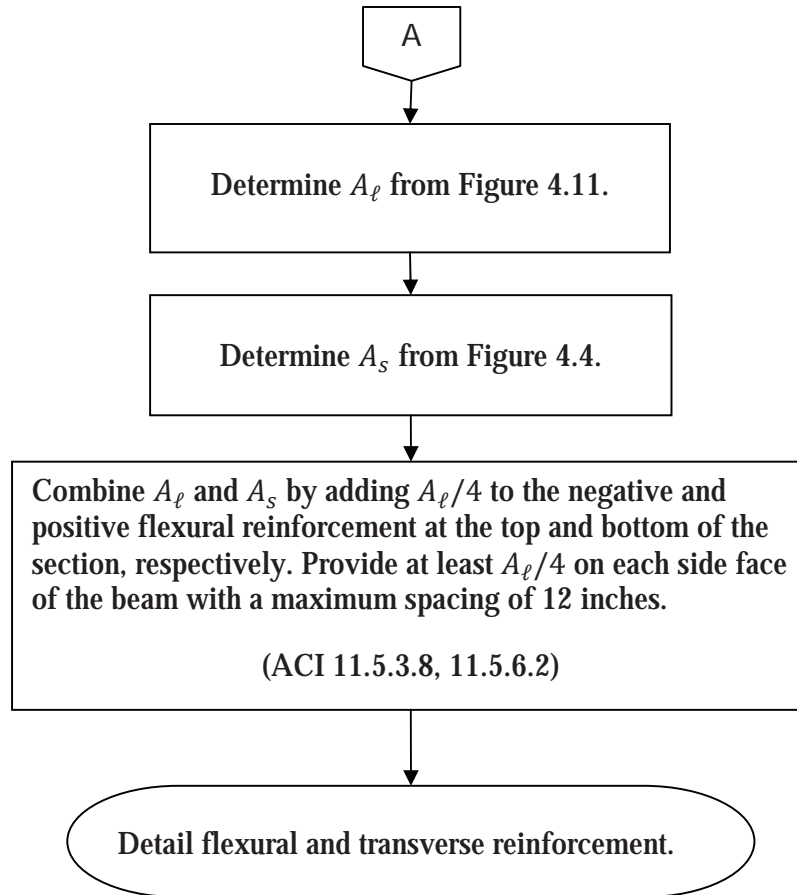

For SI: 1 inch = 25.4 mm; 1 degree = 0.01745 rad.

Figure 4.12 Determination for Combined Torsion, Shear and Bending Moment
(continued)

4.2.2 Two-way Slabs

A summary of the requirements for two-way slabs is given in Table 4.12.

Serviceability. Calculating deflections for two-way slabs is complicated even when linear elastic behavior is assumed. For routine designs, meeting the minimum thickness requirements of ACI 9.5.3 is usually sufficient. Section 2.3 of this publication provides an overview of these requirements for two-way systems with and without column-line beams. Also provided is a procedure to determine a preliminary slab thickness based on two-way shear requirements.

Table 4.12 Summary of Requirements for Two-way Slabs in Buildings Assigned to SDC A or B

	Requirement	ACI Section Number(s)
Serviceability	Minimum thickness of two-way slabs without interior beams shall be in accordance with the provisions of ACI Table 9.5(c) and shall not be less than 5 inches for slabs without drop panels as defined in ACI 13.2.5 or 4 inches for slabs with drop panels as defined in ACI 13.2.5.	9.5.3.2
	Minimum thickness of two-way slabs with beams spanning between the supports on all sides shall be determined in accordance with the following: <ul style="list-style-type: none"> • For $\alpha_{fm} \leq 0.2$, the provisions of ACI 9.5.3.2 apply. • For $0.2 < \alpha_{fm} \leq 2.0$: $h = \frac{\ell_n \left(0.8 + \frac{f_y}{200,000} \right)}{36 + 5\beta(\alpha_{fm} - 0.2)} \geq 5 \text{ in. ACI EQ. (9-12)}$ • For $\alpha_{fm} > 2.0$: $h = \frac{\ell_n \left(0.8 + \frac{f_y}{200,000} \right)}{36 + 9\beta} \geq 3.5 \text{ in. ACI EQ. (9-13)}$ At discontinuous edges, an edge beam shall be provided with a stiffness ratio $\alpha_f \geq 0.8$ or the minimum thickness required by ACI Eq. (9-12) or (9-13) shall be increased by at least 10 percent in the panel with a discontinuous edge.	9.5.3.3
	Slab thickness less than the minimum required by ACI 9.5.3.1, 9.5.3.2 and 9.5.3.3 is permitted where computed deflections do not exceed the limits of ACI Table 9.5(b).	9.5.3.4
	A slab system shall be designed by any procedure satisfying conditions of equilibrium and geometric compatibility.	13.5.1
Analysis Methods	It is permitted to design for gravity loads using the Direct Design Method of ACI 13.6 or the Equivalent Frame Method of ACI 13.7.	13.5.1.1
	Analysis for lateral loads shall take into account the effects of cracking and reinforcement on stiffness of members.	13.5.1.2
	Combining the results of the gravity load analysis with the results of the lateral load analysis is permitted.	13.5.1.3

(continued)

Table 4.12 Summary of Requirements for Two-way Slabs in Buildings Assigned to SDC A or B (continued)

	Requirement	ACI Section Number(s)
Flexure	Design flexural members as tension-controlled sections.	10.3.4, 9.3.2.1
	Minimum flexural reinforcement shall not be less than that required by ACI 7.12.2.1.	13.3.1
	Maximum spacing of flexural reinforcement is equal to $2h$.	13.3.2
	Positive moment reinforcement perpendicular to a discontinuous edge shall extend to the edge of the slab and shall have straight or hooked embedment of at least 6 inches into spandrel beams, columns or walls.	13.3.3
	Negative moment reinforcement perpendicular to a discontinuous edge shall be bent, hooked or otherwise anchored into spandrel beams, columns or walls. The reinforcement shall be developed at the face of the support in accordance with the provisions of ACI Chapter 12.	13.3.4
	Anchorage of reinforcement shall be permitted within a slab where a slab is not supported by a spandrel beam or a wall at a discontinuous edge or where a slab cantilevers beyond a support.	13.3.5
	Top and bottom reinforcement shall be provided at exterior corners in accordance with ACI 13.3.6.1 through 13.3.6.4 at exterior corners of slabs supported by edge walls or where one or more edge beams have a value of $\alpha_f > 1.0$.	13.3.6
	The amount of negative reinforcement over the column of a flat slab may be reduced provided the dimensions of the drop panel conform to ACI 13.2.5. For purposes of computing the required negative reinforcement, the thickness of the drop panel below the slab shall not be assumed to be greater than one-quarter the distance from the edge of the drop panel to the face of the column or the column capital.	13.3.7
	For two-way slabs without beams, reinforcement shall have minimum extensions prescribed in ACI Figure 13.3.8. Extension of negative reinforcement is based on the longer of adjacent spans.	13.3.8.1, 13.3.8.2
	Lengths of reinforcement shall be based on analysis where two-way slabs are part of the lateral-force-resisting system, but shall not be less than those in ACI Figure 13.3.8.	13.3.8.4

(continued)

Table 4.12 Summary of Requirements for Two-way Slabs in Buildings Assigned to SDC A or B (continued)

Requirement		ACI Section Number(s)
Flexure (continued)	All bottom bars within the column strip must be continuous or spliced with Class B tension splices or with mechanical or welded splices satisfying ACI 12.14.3. At least two bars must pass within the region bounded by the longitudinal reinforcement of the column and shall be anchored at exterior supports.	13.3.8.5
	The fraction of unbalanced moment given by $\gamma_f M_u$ is transferred by flexure within an effective slab width equal to $c_2 + 3h$ where $\gamma_f = \frac{1}{1 + (2/3)\sqrt{b_1/b_2}}$	13.5.3.2
	It is permitted to increase γ_f determined by ACI Eq. (13-1) in accordance with ACI 13.5.3.3.	13.5.3.3
Openings	Openings of any size are permitted if shown by analysis that requirements for strength and serviceability are satisfied.	13.4.1
	As an alternate to analysis, openings in slab systems without beams are permitted provided the requirements of ACI 13.4.2.1 through 13.4.2.4 are satisfied.	13.4.2
Shear	Beam action—For two-way slabs without shear reinforcement, the following must be satisfied at the critical section located a distance, d , from the face of the support: $V_u \leq \phi V_c$ where $V_c = 2\lambda\sqrt{f'_c}b_w d$ and $\phi = 0.75$.	11.11.1.1
	Two-way action—For two-way slabs without shear reinforcement, the following must be satisfied at the critical section located a distance $d/2$ from corners of columns, concentrated loads or reaction areas or from changes in slab thickness (capitals, drop panels or shear caps): $V_u \leq \phi V_c$ where V_c is the smallest of the following: $V_c = \left(2 + \frac{4}{\beta}\right)\lambda\sqrt{f'_c}b_o d \quad \text{ACI Eq. (11-31)}$ $V_c = \left(\frac{\alpha_s d}{b_o} + 2\right)\lambda\sqrt{f'_c}b_o d \quad \text{ACI Eq. (11-32)}$ $V_c = 4\lambda\sqrt{f'_c}b_o d \quad \text{ACI Eq. (11-33)}$	11.11.1.2, 11.11.2.1

(continued)

Table 4.12 Summary of Requirements for Two-way Slabs in Buildings Assigned to SDC A or B (continued)

	Requirement	ACI Section Number(s)
Shear (continued)	It is permitted to use shear reinforcement consisting of bars or wires and single- or multiple-leg stirrups, shearheads or headed shear studs to resist shear forces.	11.11.3, 11.11.4, 11.11.5
	Critical sections for shear defined in ACI 11.11.1.2 and 11.11.4.7 shall be modified to account for openings in slabs located at a distance less than $10h$ from a concentrated load or reaction area or when openings in flat slabs are located within column strips as defined in ACI Chapter 13.	11.11.6
	The fraction of unbalanced moment given by $\gamma_v M_u$ is transferred by eccentricity of shear about the centroid of the critical section defined in ACI 11.11.1.2 where $\gamma_v = 1 - \gamma_f \quad \text{ACI Eq. (11-37)}$	11.11.7.1
	The shear stress resulting from moment transfer by eccentricity of shear is assumed to vary linearly about the centroid of the critical section.	11.11.7.2
	For members without shear reinforcement, the following equations must be satisfied: $v_{u(AB)} = \frac{V_u}{A_c} + \frac{\gamma_v M_u c_{AB}}{J_c} \leq \frac{\phi V_c}{b_o d}$ $v_{u(CD)} = \frac{V_u}{A_c} - \frac{\gamma_v M_u c_{CD}}{J_c} \leq \frac{\phi V_c}{b_o d}$ where V_c is defined in ACI 11.11.2.1.	
For members with shear reinforcement other than shearheads: $v_{u(AB)} = \frac{V_u}{A_c} + \frac{\gamma_v M_u c_{AB}}{J_c} \leq \frac{\phi(V_c + V_s)}{b_o d}$ $v_{u(CD)} = \frac{V_u}{A_c} - \frac{\gamma_v M_u c_{CD}}{J_c} \leq \frac{\phi(V_c + V_s)}{b_o d}$ where $V_c \leq 2\lambda\sqrt{f'_c}b_o d$, V_s is calculated in accordance with ACI 11.4, and $V_c + V_s \leq 6\sqrt{f'_c}b_o d$. At the critical section located $d/2$ outside the outermost line of stirrup legs, the shear stress due to factored shear force and moment shall not exceed $\phi(2\lambda\sqrt{f'_c})$.	11.11.7.2, 11.11.3	

For SI: 1 inch = 25.4 mm.

Analysis methods. For purposes of analysis, two-way slab panels are generally divided into design strips consisting of column strips and middle strips, which are illustrated in Figure 4.13 (see ACI 13.2).

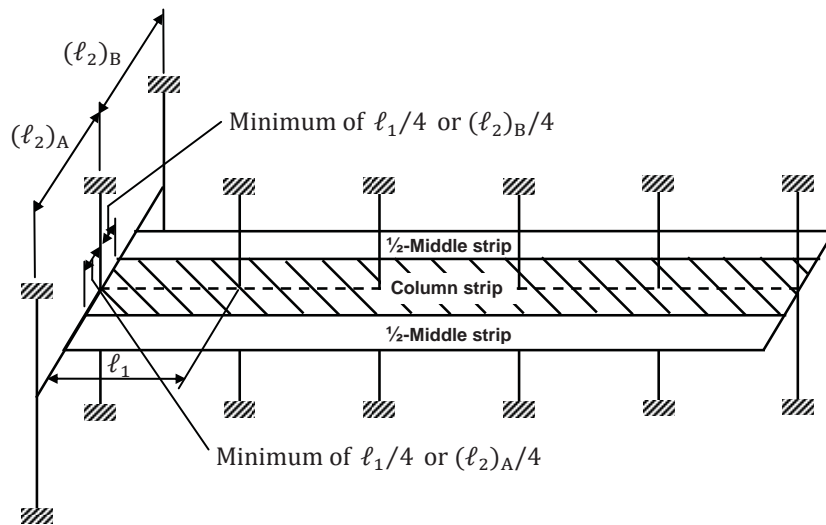

Figure 4.13 Definitions of Column Strips and Middle Strips in accordance with ACI 13.2

The Direct Design Method of ACI 13.6 can be used to determine approximate bending moments in column strips and middle strips of two-way slab systems that meet the limitations in ACI 13.6.1. The conditions for analysis by the Direct Design Method are given in Figure 4.14.

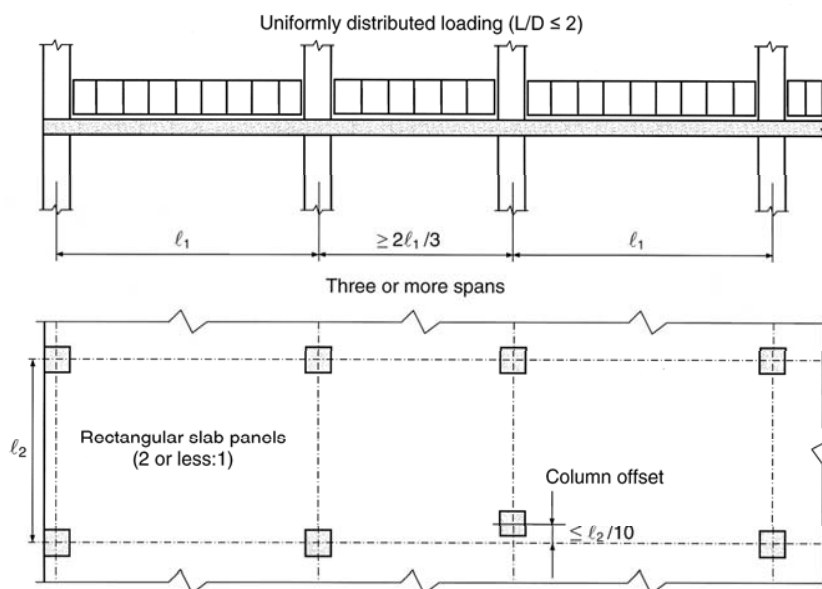

Figure 4.14 Conditions for Analysis by the Direct Design Method (ACI 13.6.1)

For a panel with beams between supports on all sides, ACI Eq. (13-2) must also be satisfied:

$$0.2 \leq \frac{\alpha_{f1} \ell_2^2}{\alpha_{f2} \ell_1^2} \leq 5.0$$

where $\alpha_f = \frac{E_{cb} I_b}{E_{cs} I_s}$ ACI Eq. (13-3)

$E_c =$ modulus of elasticity of concrete (ACI 8.5.1)

$= w_c^{1.5} 33 \sqrt{f'_c}$ for values of w_c between 90 and 160 pcf

$I_b, I_s =$ moment of inertia of beam and slab, respectively

The information in Figure 4.15 can be used to determine I_b and I_s for slabs and for interior and edge beams.

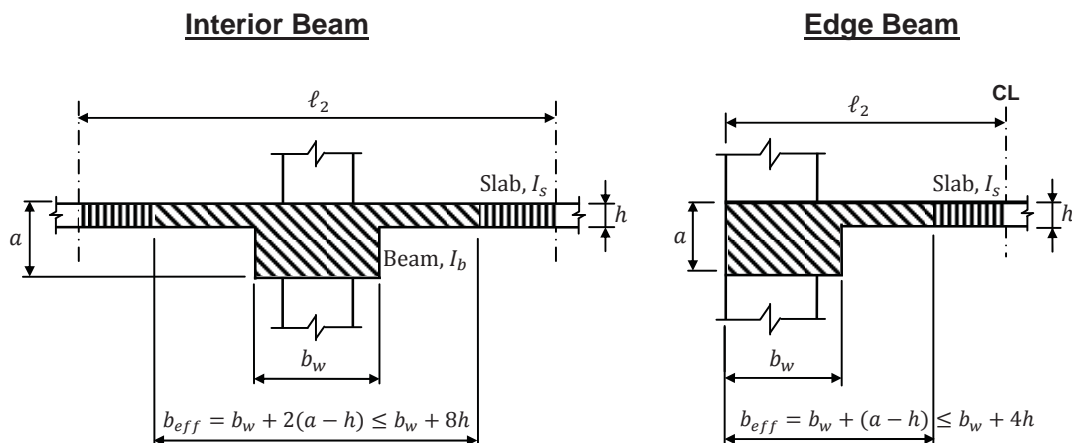

$$I_s = \frac{\ell_2 h^3}{12}$$

$$I_b = \frac{b_w (a - h)^3}{12} + b_w (a - h) \left(y_b - \frac{a - h}{2} \right)^2 + \frac{b_{eff} h^3}{12} + b_{eff} h \left(a - \frac{h}{2} - y_b \right)^2$$

where

$$y_b = \frac{b_{eff} h \left(a - \frac{h}{2} \right) + \frac{b_w (a - h)^2}{2}}{b_{eff} h + b_w (a - h)}$$

Figure 4.15 Effective Beam and Slab Sections for Computation of α_f

The Direct Design Method is essentially a three-step analysis procedure. First, the total static moment for a span, M_o , is determined by ACI Eq. (13-4):

$$M_o = \frac{q_u \ell_2 \ell_n^2}{8}$$

where q_u = factored load per unit area

ℓ_2 = length of span perpendicular to ℓ_1 (length of span in direction that moments are being determined), measured center-to-center of supports

ℓ_n = length of clear span measured face-to-face of supports

Figure 4.16 illustrates the determination of the clear span for various support conditions, based on the provisions of ACI 13.6.2.5.

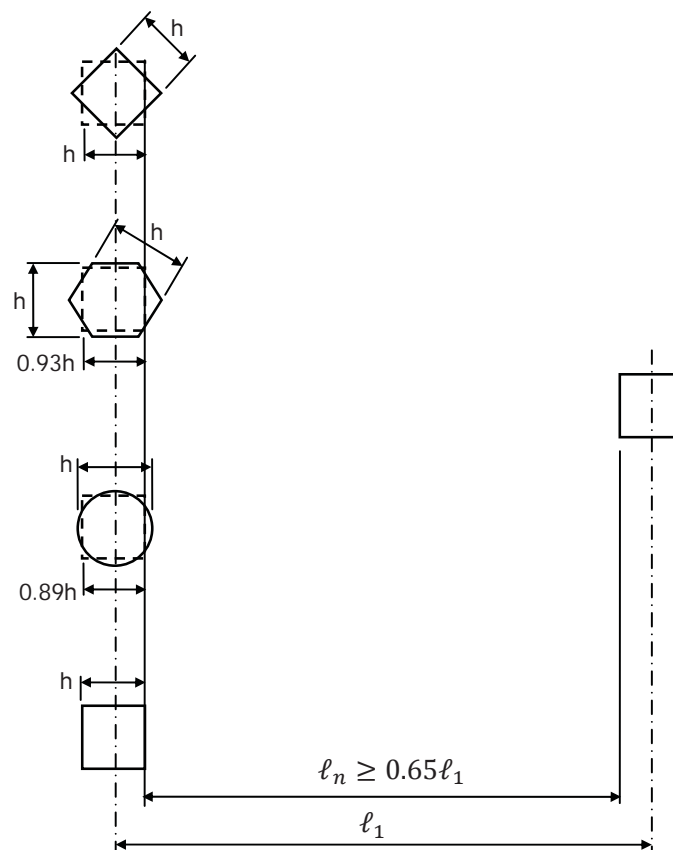

Figure 4.16 Determination of Clear Span, ℓ_n (ACI 13.6.2.5)

Second, M_o is distributed to negative and positive sections along the span length in accordance with ACI 13.6.3. Third, the negative and positive factored moments are distributed to column and middle strips and to beams, if any, using the requirements in ACI 13.6.4, 13.6.5 and 13.6.6.

Moment coefficients for typical two-way slab systems are given in Figure 4.17.

Equations for computing the torsional stiffness factor, β_t , for slab systems with T- and L-sections are given in Figure 4.18.

Slab-column frames that are considered to be part of the lateral-force-resisting system are subjected to the effects from wind and seismic forces in addition to gravity load effects. For slab systems without column-line beams, a portion of the slab is effective across its full width in resisting the effects from lateral forces. Section 3.5.2 of this publication contains an approximate method for determining the effective slab width that can be used in a lateral analysis (see Equation 3.6). In slab systems with relatively stiff column-line beams, the beams will resist the majority of the lateral force effects.

According to ACI 13.5.1.3, the results from the gravity load analysis by the Direct Design Method can be combined with the results from the lateral analysis using the appropriate load combinations given in ACI 9.2.

Design methods for flexure. Once the factored negative and positive factored moments are determined at the critical sections, the required reinforcement in the column strips and middle strips can be obtained using the simplified equation $A_s = M_u/4d$.

According to ACI 13.3, the minimum reinforcement at any critical section is equal to $0.0018bh$ for Grade 60 reinforcement and maximum bar spacing is the smaller of $2h$ or 18 inches (457 mm). Additional provisions for slab reinforcement, including details of reinforcement in slabs without beams, can be found in ACI 13.3.

Transfer of moment in slab-column connections takes place by a combination of flexure (ACI 13.5.3.2) and eccentricity of shear (ACI 11.11.7). The portion of total unbalanced moment, M_u , transferred by flexure is $\gamma_f M_u$ where γ_f is defined by ACI Eq. (13-1). It is assumed that $\gamma_f M_u$ is transferred within an effective slab width equal to $c_2 + 3h$. Reinforcement is concentrated in the effective slab width such that $\phi M_n \geq \gamma_f M_u$, or using the simplified equation for the area of reinforcement, $A_s \geq \gamma_f M_u/4d$. Under certain conditions, γ_f may be increased to values greater than those determined by ACI Eq. (13-1) (see ACI 13.5.3.3).

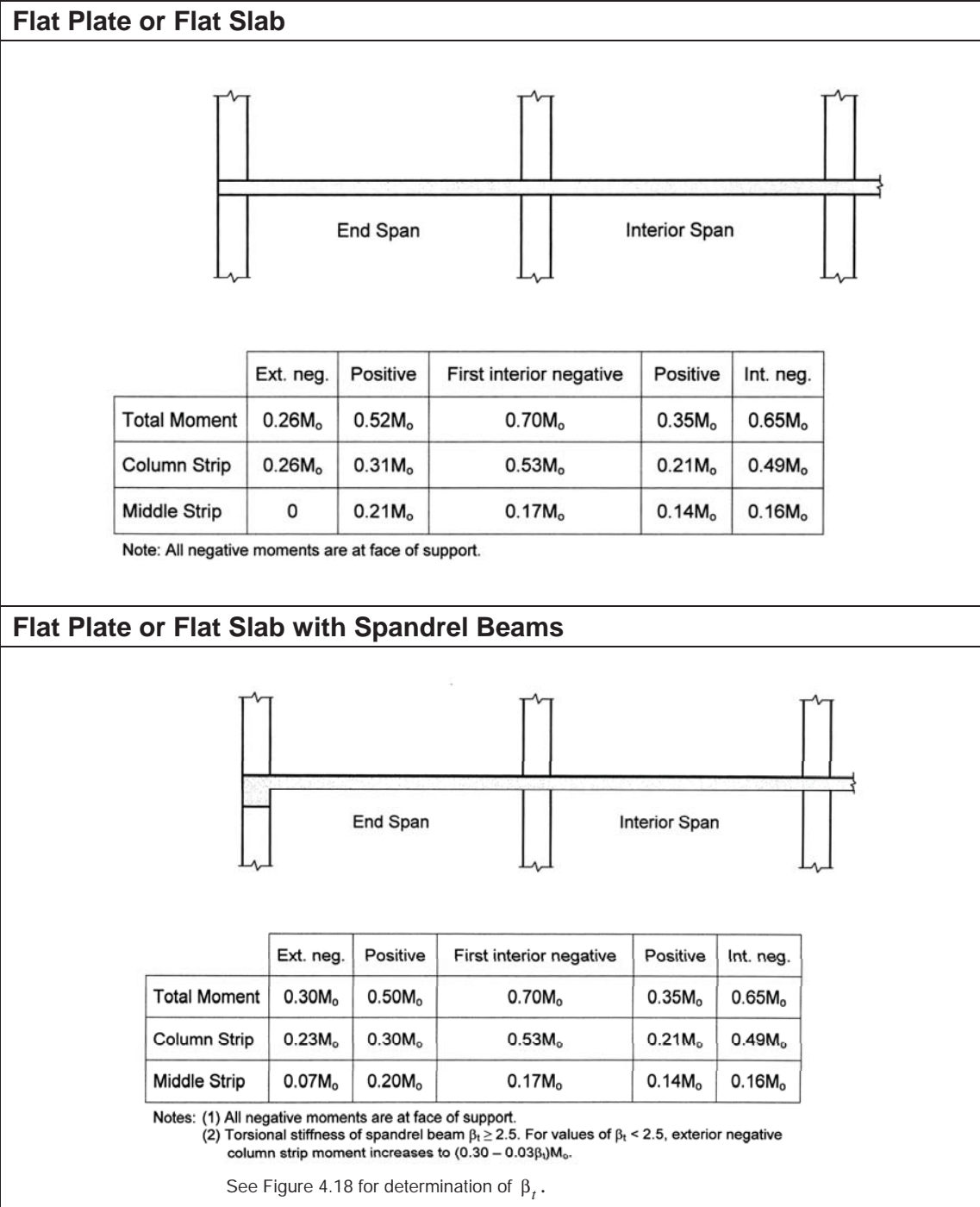

Figure 4.17 Design Moment Coefficients Used with the Direct Design Method (ACI 13.6.3–13.6.6)

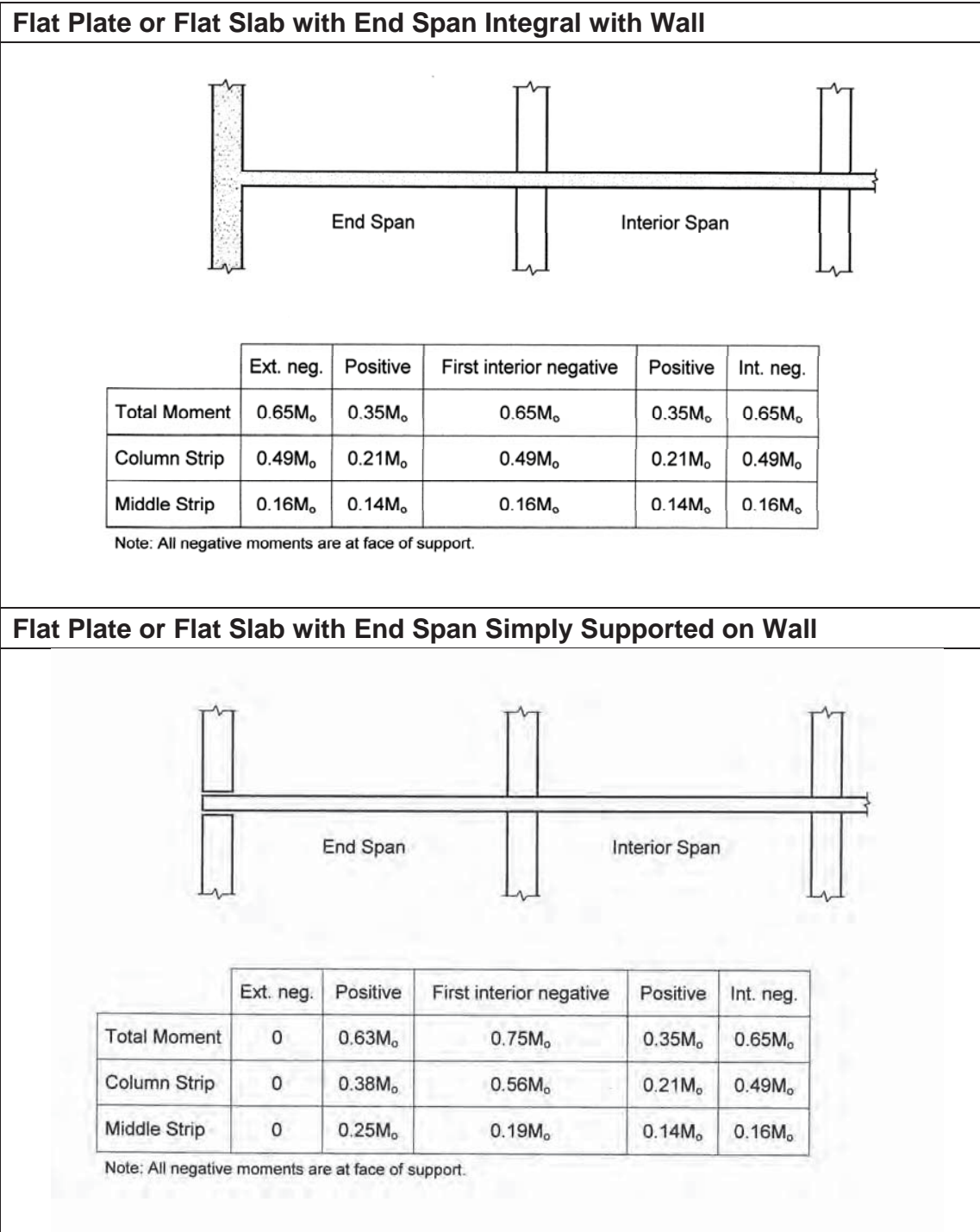

Figure 4.17 Design Moment Coefficients Used with the Direct Design Method (ACI 13.6.3–13.6.6) (continued)

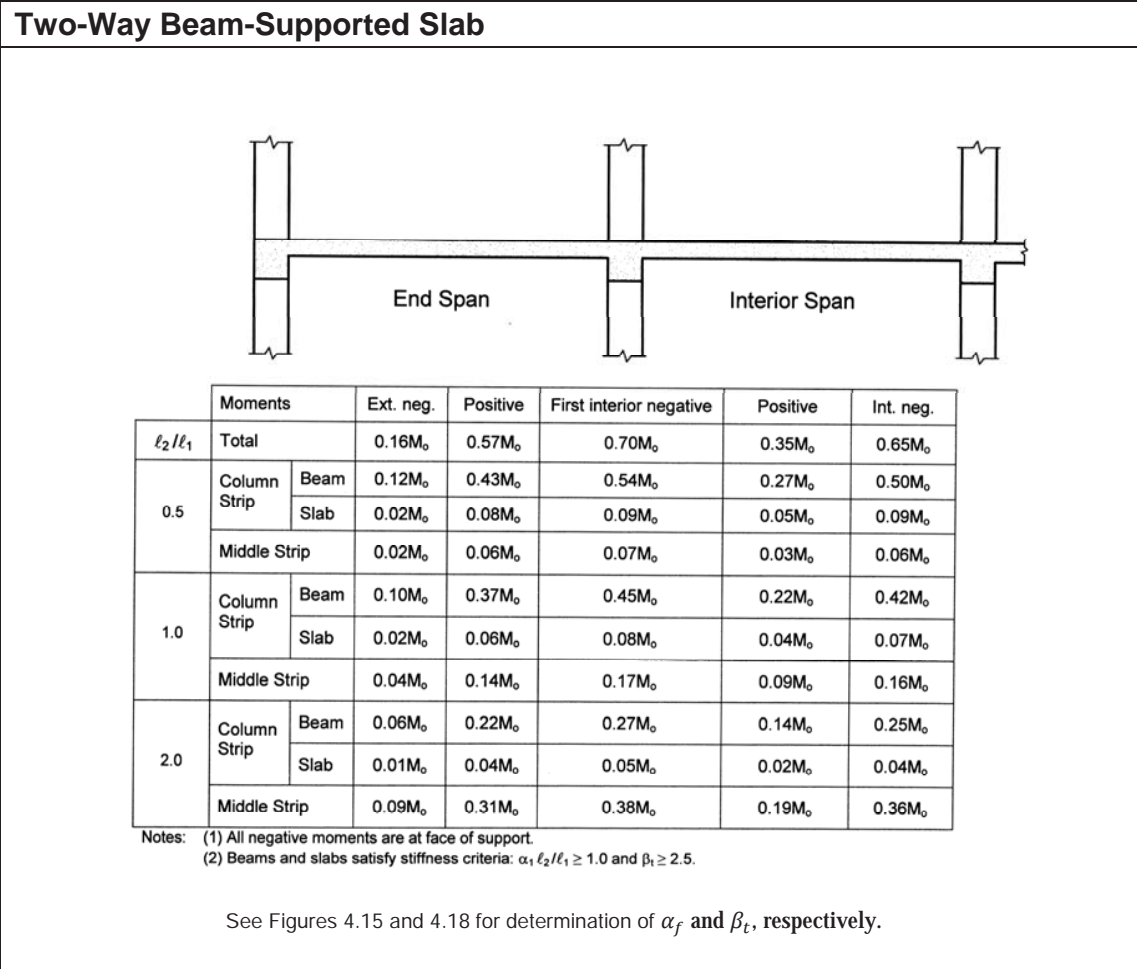
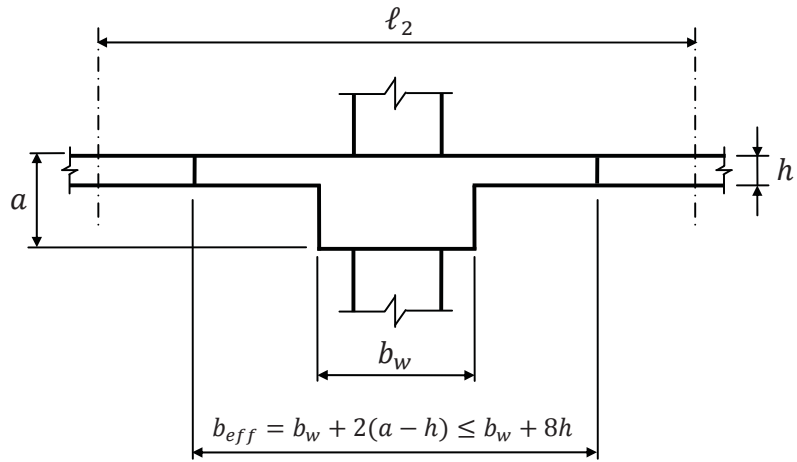

Figure 4.17 Design Moment Coefficients Used with the Direct Design Method
(ACI 13.6.3–13.6.6) (continued)

Interior Beam



Case A	
	$C_A = \left(1 - 0.63 \frac{x_1}{y_1}\right) \frac{x_1^3 y_1}{3} + 2 \left(1 - 0.63 \frac{x_2}{y_2}\right) \frac{x_2^3 y_2}{3}$
Case B	
	$C_B = \left(1 - 0.63 \frac{x_1}{y_1}\right) \frac{x_1^3 y_1}{3} + \left(1 - 0.63 \frac{x_2}{y_2}\right) \frac{x_2^3 y_2}{3}$

$C = \text{maximum of } C_A \text{ and } C_B$

$$\beta_t = \frac{E_{cb} C}{2E_{cs} I_s} \quad \text{ACI Eq. (13-5)}$$

where $I_s = \ell_2 h^3 / 12$ and $E_c = w_c^{1.5} 33 \sqrt{f'_c}$ for values of w_c between 90 and 160 pcf

Figure 4.18 Computation of Torsional Stiffness Factor, β_t , for T- and L-sections

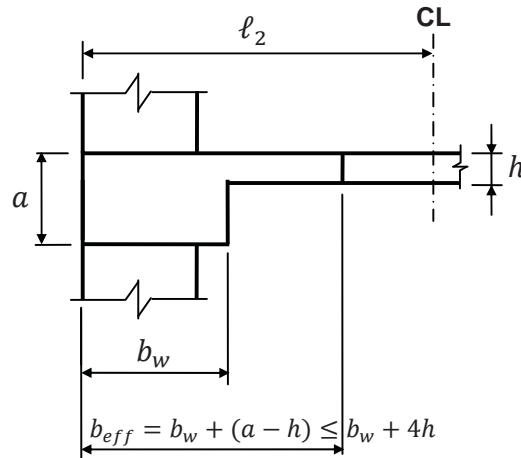
Edge Beam

Case A	
	$C_A = \left(1 - 0.63 \frac{x_1}{y_1}\right) \frac{x_1^3 y_1}{3} + \left(1 - 0.63 \frac{x_2}{y_2}\right) \frac{x_2^3 y_2}{3}$
Case B	
	$C_B = \left(1 - 0.63 \frac{x_1}{y_1}\right) \frac{x_1^3 y_1}{3} + \left(1 - 0.63 \frac{x_2}{y_2}\right) \frac{x_2^3 y_2}{3}$

For SI: 1 pound per cubic foot = 16.02 kg/m³.

$C =$ maximum of C_A and C_B

$$\beta_t = \frac{E_{cb} C}{2E_{cs} I_s} \quad \text{ACI Eq. (13-5)}$$

where $I_s = \ell_2 h^3 / 12$ and $E_c = w_c^{1.5} 33 \sqrt{f'_c}$ for values of w_c between 90 and 160 pcf

Figure 4.18 Computation of Torsional Stiffness Factor, β_t , for T- and L-sections (continued)

Openings. Openings of any size are permitted in a two-way slab system provided that strength and serviceability requirements are satisfied (ACI 13.4.1). For two-way slabs without beams, such an analysis is not required when the provisions of ACI 13.4.2 are met.

Reinforcement that is interrupted by an opening must be replaced on each side of the opening (ACI 13.4.2.3).

Shear. When two-way slab systems are supported directly by columns, shear stresses around the columns are of critical importance. In contrast, shear stresses are seldom a critical factor in design when two-way slabs are supported by beams or walls.

The total shear stress at the critical section around a column is a combination of shear stress due to direct shear forces and transfer of moment by eccentricity of shear. The moment, $\gamma_v M_u$, is transferred by eccentricity of shear where γ_v is defined by ACI Eq. (11-37).

Table 4.13 contains the equations that must be satisfied for systems with and without shear reinforcement. Numerous resources contain equations for determining the critical section properties, A_c , J_c , c_{AB} and c_{CD} . Tables 4.14 through 4.18 facilitate calculation of these quantities for rectangular and circular columns.

Openings in slabs for mechanical, electrical or plumbing equipment are almost invariably located in close proximity to columns. These openings have a direct impact on shear strength when they are located within a column strip or within a distance of $10h$ from a column. ACI Figure R11.11.6 illustrates the portion of the critical shear perimeter that is considered ineffective due to an opening.

Shear reinforcement can supplement the shear strength of concrete. Provisions for shear reinforcement consisting of bars or wires or single- and multiple-leg stirrups can be found in ACI 11.11.3.

Shearhead reinforcement, which is typically a structural steel section that is cast in the concrete at a slab-column joint (ACI 11.11.4), is rarely used any longer due to high labor and material costs.

Provisions for headed shear stud reinforcement are given in ACI 11.11.5. Shear studs consist of vertical rods that are mechanically anchored by heads on one end of the rod and a base rail at the other end. Rails are shared by more than one stud and are nailed to the formwork around the columns. The dimensions of the shear studs are such that they can develop their full yield strength in tension. Typical arrangements of headed shear stud reinforcement and critical sections are given in ACI Figure R11.11.5.

Table 4.13 Properties of Critical Sections

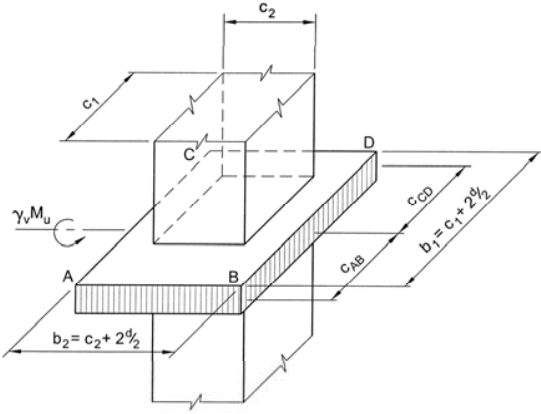
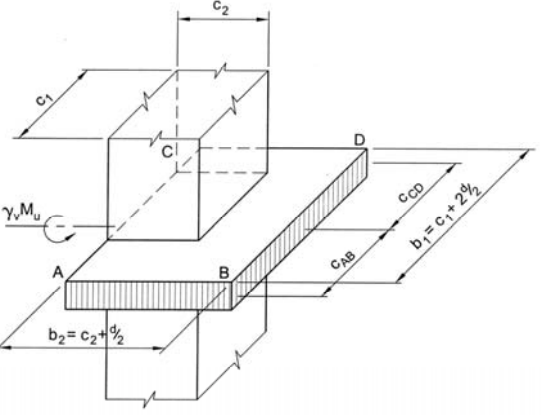
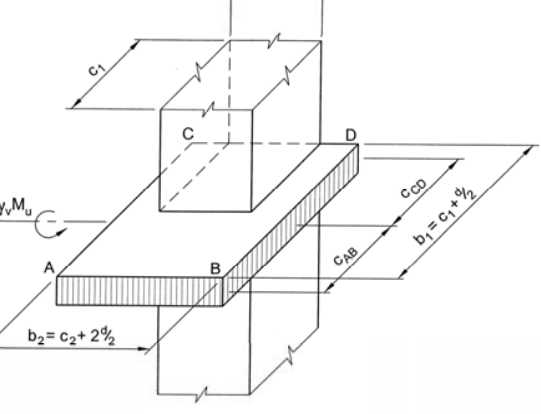
<p>Interior Rectangular Column (Table 4.14)</p>		$c_{AB} = c_{CD} = b_1/2$
<p>Edge Rectangular Column Bending Parallel to the Edge (Table 4.15)</p>		$A_c = f_1 d^2$ $J_c/c_{AB} = J_c/c_{CD} = 2f_2 d^3$
<p>Edge Rectangular Column Bending Perpendicular to the Edge (Table 4.16)</p>		$c_{AB} = [f_3/(f_2 + f_3)][c_1 + (d/2)]$ $c_{CD} = [f_2/(f_2 + f_3)][c_1 + (d/2)]$ $A_c = f_1 d^2$ $J_c/c_{AB} = 2f_2 d^3$ $J_c/c_{CD} = 2f_3 d^3$

(continued)

Table 4.13 Properties of Critical Sections (continued)

<p>Corner Rectangular Column (Table 4.17)</p>		$c_{AB} = [f_3 / (f_2 + f_3)] [c_1 + (d/2)]$ $c_{CD} = [f_2 / (f_2 + f_3)] [c_1 + (d/2)]$ $A_c = f_1 d^2$ $J_c / c_{AB} = 2f_2 d^3$ $J_c / c_{CD} = 2f_3 d^3$
<p>Circular Interior Column (Table 4.18)</p>		$c = c' = (D + d) / 2$ $A_c = f_1 d^2$ $J_c / c = J_c / c' = 2f_2 d^3$

Table 4.14 Properties of Critical Section—Interior Rectangular Column

c_1/d	f_1							f_2						
	c_2/c_1							c_2/c_1						
	0.50	0.75	1.00	1.25	1.50	1.75	2.00	0.50	0.75	1.00	1.25	1.50	1.75	2.00
1.00	7.00	7.50	8.00	8.50	9.00	9.50	10.00	2.33	2.58	2.83	3.08	3.33	3.58	3.83
1.50	8.50	9.25	10.00	10.75	11.50	12.25	13.00	3.40	3.86	4.33	4.80	5.27	5.74	6.21
2.00	10.00	11.00	12.00	13.00	14.00	15.00	16.00	4.67	5.42	6.17	6.92	7.67	8.42	9.17
2.50	11.50	12.75	14.00	15.25	16.50	17.75	19.00	6.15	7.24	8.33	9.43	10.52	11.61	12.71
3.00	13.00	14.50	16.00	17.50	19.00	20.50	22.00	7.83	9.33	10.83	12.33	13.83	15.33	16.83
3.50	14.50	16.25	18.00	19.75	21.50	23.25	25.00	9.73	11.70	13.67	15.64	17.60	19.57	21.54
4.00	16.00	18.00	20.00	22.00	24.00	26.00	28.00	11.83	14.33	16.83	19.33	21.83	24.33	26.83
4.50	17.50	19.75	22.00	24.25	26.50	28.75	31.00	14.15	17.24	20.33	23.43	26.52	29.61	32.71
5.00	19.00	21.50	24.00	26.50	29.00	31.50	34.00	16.67	20.42	24.17	27.92	31.67	35.42	39.17
5.50	20.50	23.25	26.00	28.75	31.50	34.25	37.00	19.40	23.86	28.33	32.80	37.27	41.74	46.21
6.00	22.00	25.00	28.00	31.00	34.00	37.00	40.00	22.33	27.58	32.83	38.08	43.33	48.58	53.83
7.00	25.00	28.50	32.00	35.50	39.00	42.50	46.00	28.83	35.83	42.83	49.83	56.83	63.83	70.83
7.50	26.50	30.25	34.00	37.75	41.50	45.25	49.00	32.40	40.36	48.33	56.30	64.27	72.24	80.21
8.00	28.00	32.00	36.00	40.00	44.00	48.00	52.00	36.17	45.17	54.17	63.17	72.17	81.17	90.17
8.50	29.50	33.75	38.00	42.25	46.50	50.75	55.00	40.15	50.24	60.33	70.43	80.52	90.61	100.71
9.00	31.00	35.50	40.00	44.50	49.00	53.50	58.00	44.33	55.58	66.83	78.08	89.33	100.58	111.83
9.50	32.50	37.25	42.00	46.75	51.50	56.25	61.00	48.73	61.20	73.67	86.14	98.60	111.07	123.54
10.00	34.00	39.00	44.00	49.00	54.00	59.00	64.00	53.33	67.08	80.83	94.58	108.33	122.08	135.83

Table 4.15 Properties of Critical Section—Edge Rectangular Column Bending Parallel to Edge

c_1/d	f_1							f_2						
	c_2/c_1							c_2/c_1						
	0.50	0.75	1.00	1.25	1.50	1.75	2.00	0.50	0.75	1.00	1.25	1.50	1.75	2.00
1.00	4.00	4.50	5.00	5.50	6.00	6.50	7.00	1.42	1.67	1.92	2.17	2.42	2.67	2.92
1.50	5.00	5.75	6.50	7.25	8.00	8.75	9.50	2.17	2.64	3.10	3.57	4.04	4.51	4.98
2.00	6.00	7.00	8.00	9.00	10.00	11.00	12.00	3.08	3.83	4.58	5.33	6.08	6.83	7.58
2.50	7.00	8.25	9.50	10.75	12.00	13.25	14.50	4.17	5.26	6.35	7.45	8.54	9.64	10.73
3.00	8.00	9.50	11.00	12.50	14.00	15.50	17.00	5.42	6.92	8.42	9.92	11.42	12.92	14.42
3.50	9.00	10.75	12.50	14.25	16.00	17.75	19.50	6.83	8.80	10.77	12.74	14.71	16.68	18.65
4.00	10.00	12.00	14.00	16.00	18.00	20.00	22.00	8.42	10.92	13.42	15.92	18.42	20.92	23.42
4.50	11.00	13.25	15.50	17.75	20.00	22.25	24.50	10.17	13.26	16.35	19.45	22.54	25.64	28.73
5.00	12.00	14.50	17.00	19.50	22.00	24.50	27.00	12.08	15.83	19.58	23.33	27.08	30.83	34.58
5.50	13.00	15.75	18.50	21.25	24.00	26.75	29.50	14.17	18.64	23.10	27.57	32.04	36.51	40.98
6.00	14.00	17.00	20.00	23.00	26.00	29.00	32.00	16.42	21.67	26.92	32.17	37.42	42.67	47.92
6.50	15.00	18.25	21.50	24.75	28.00	31.25	34.50	18.83	24.93	31.02	37.11	43.21	49.30	55.40
7.00	16.00	19.50	23.00	26.50	30.00	33.50	37.00	21.42	28.42	35.42	42.42	49.42	56.42	63.42
7.50	17.00	20.75	24.50	28.25	32.00	35.75	39.50	24.17	32.14	40.10	48.07	56.04	64.01	71.98
8.00	18.00	22.00	26.00	30.00	34.00	38.00	42.00	27.08	36.08	45.08	54.08	63.08	72.08	81.08
8.50	19.00	23.25	27.50	31.75	36.00	40.25	44.50	30.17	40.26	50.35	60.45	70.54	80.64	90.73
9.00	20.00	24.50	29.00	33.50	38.00	42.50	47.00	33.42	44.67	55.92	67.17	78.42	89.67	100.92
9.50	21.00	25.75	30.50	35.25	40.00	44.75	49.50	36.83	49.30	61.77	74.24	86.71	99.18	111.65
10.00	22.00	27.00	32.00	37.00	42.00	47.00	52.00	40.42	54.17	67.92	81.67	95.42	109.17	122.92

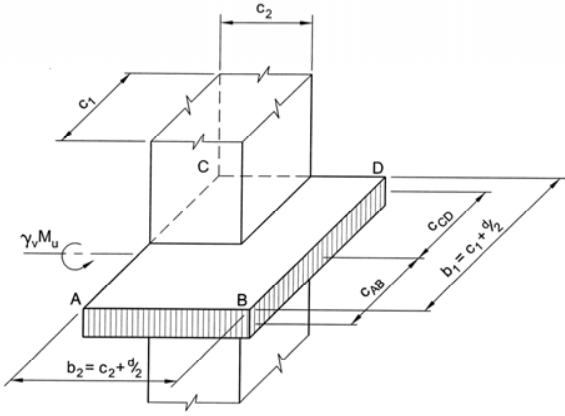
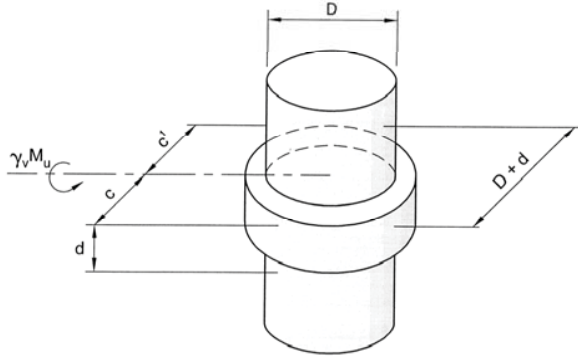
Table 4.16 Properties of Critical Section—Edge Rectangular Column Bending Perpendicular to Edge

c_1/d	f_1										f_2										f_3									
	c_2/c_1										c_2/c_1										c_2/c_1									
	0.50	0.75	1.00	1.25	1.50	1.75	2.00	0.50	0.75	1.00	1.25	1.50	1.75	2.00	0.50	0.75	1.00	1.25	1.50	1.75	2.00	0.50	0.75	1.00	1.25	1.50	1.75	2.00		
1.00	4.50	4.75	5.00	5.25	5.50	5.75	6.00	1.38	1.51	1.65	1.79	1.93	2.07	2.21	0.69	0.70	0.71	0.72	0.72	0.73	0.74									
1.50	5.75	6.13	6.50	6.88	7.25	7.63	8.00	2.07	2.34	2.60	2.87	3.14	3.40	3.67	1.11	1.13	1.16	1.18	1.19	1.21	1.22									
2.00	7.00	7.50	8.00	8.50	9.00	9.50	10.00	2.94	3.38	3.81	4.24	4.68	5.11	5.54	1.63	1.69	1.73	1.77	1.80	1.82	1.85									
2.50	8.25	8.87	9.50	10.13	10.75	11.38	12.00	3.98	4.62	5.26	5.91	6.55	7.19	7.83	2.27	2.36	2.43	2.49	2.53	2.58	2.61									
3.00	9.50	10.25	11.00	11.75	12.50	13.25	14.00	5.18	6.08	6.97	7.86	8.76	9.65	10.54	3.02	3.15	3.25	3.34	3.41	3.46	3.51									
3.50	10.75	11.62	12.50	13.37	14.25	15.12	16.00	6.56	7.74	8.93	10.11	11.30	12.48	13.67	3.89	4.06	4.20	4.31	4.41	4.49	4.56									
4.00	12.00	13.00	14.00	15.00	16.00	17.00	18.00	8.10	9.62	11.13	12.65	14.17	15.69	17.21	4.86	5.09	5.27	5.42	5.55	5.65	5.74									
4.50	13.25	14.37	15.50	16.62	17.75	18.87	20.00	9.80	11.70	13.59	15.49	17.38	19.27	21.17	5.94	6.24	6.47	6.66	6.82	6.95	7.06									
5.00	14.50	15.75	17.00	18.25	19.50	20.75	22.00	11.68	13.99	16.30	18.61	20.92	23.23	25.54	7.14	7.51	7.80	8.03	8.22	8.38	8.51									
5.50	15.75	17.12	18.50	19.87	21.25	22.62	24.00	13.72	16.49	19.26	22.03	24.80	27.56	30.33	8.44	8.89	9.24	9.52	9.76	9.95	10.11									
6.00	17.00	18.50	20.00	21.50	23.00	24.50	26.00	15.93	19.20	22.46	25.73	29.00	32.27	35.54	9.86	10.40	10.82	11.15	11.43	11.65	11.85									
6.50	18.25	19.87	21.50	23.12	24.75	26.37	28.00	18.30	22.11	25.92	29.73	33.54	37.36	41.17	11.39	12.02	12.51	12.91	13.23	13.50	13.72									
7.00	19.50	21.25	23.00	24.75	26.50	28.25	30.00	20.84	25.24	29.63	34.02	38.42	42.81	47.21	13.03	13.77	14.34	14.79	15.17	15.47	15.74									
7.50	20.75	22.62	24.50	26.37	28.25	30.12	32.00	23.55	28.57	33.59	38.61	43.63	48.65	53.67	14.78	15.63	16.29	16.81	17.24	17.59	17.89									
8.00	22.00	24.00	26.00	28.00	30.00	32.00	34.00	26.42	32.11	37.80	43.48	49.17	54.86	60.54	16.64	17.61	18.36	18.95	19.44	19.84	20.18									
8.50	23.25	25.37	27.50	29.62	31.75	33.87	36.00	29.47	35.86	42.25	48.65	55.04	61.44	67.83	18.61	19.71	20.56	21.23	21.78	22.23	22.61									
9.00	24.50	26.75	29.00	31.25	33.50	35.75	38.00	32.67	39.82	46.96	54.11	61.25	68.40	75.54	20.69	21.93	22.88	23.63	24.25	24.75	25.18									
9.50	25.75	28.12	30.50	32.87	35.25	37.62	40.00	36.05	43.98	51.92	59.86	67.79	75.73	83.67	22.89	24.27	25.33	26.17	26.85	27.41	27.89									
10.00	27.00	29.50	32.00	34.50	37.00	39.50	42.00	39.59	48.36	57.13	65.90	74.67	83.44	92.21	25.19	26.72	27.90	28.83	29.59	30.21	30.74									

Table 4.17 Properties of Critical Section—Corner Rectangular Column

c_1/d	f_1										f_2										f_3									
	c_2/c_1										c_2/c_1										c_2/c_1									
	0.50	0.75	1.00	1.25	1.50	1.75	2.00	0.50	0.75	1.00	1.25	1.50	1.75	2.00	0.50	0.75	1.00	1.25	1.50	1.75	2.00	0.50	0.75	1.00	1.25	1.50	1.75	2.00		
1.00	2.50	2.75	3.00	3.25	3.50	3.75	4.00	0.83	0.97	1.10	1.24	1.38	1.52	1.66	0.35	0.36	0.37	0.37	0.38	0.38	0.38	0.35	0.36	0.37	0.37	0.38	0.38	0.38		
1.50	3.25	3.63	4.00	4.38	4.75	5.13	5.50	1.30	1.57	1.83	2.10	2.36	2.63	2.90	0.58	0.60	0.61	0.62	0.63	0.64	0.64	0.58	0.60	0.61	0.62	0.63	0.64			
2.00	4.00	4.50	5.00	5.50	6.00	6.50	7.00	1.90	2.34	2.77	3.20	3.64	4.07	4.50	0.87	0.90	0.92	0.94	0.96	0.97	0.98	0.87	0.90	0.92	0.94	0.96	0.97			
2.50	4.75	5.37	6.00	6.62	7.25	7.87	8.50	2.63	3.27	3.92	4.56	5.20	5.84	6.49	1.21	1.27	1.31	1.33	1.36	1.37	1.39	1.21	1.27	1.31	1.33	1.36	1.37			
3.00	5.50	6.25	7.00	7.75	8.50	9.25	10.00	3.49	4.38	5.27	6.16	7.06	7.95	8.84	1.63	1.70	1.76	1.80	1.83	1.85	1.88	1.63	1.70	1.76	1.80	1.83	1.85			
3.50	6.25	7.12	8.00	8.87	9.75	10.62	11.50	4.46	5.65	6.83	8.02	9.20	10.39	11.57	2.10	2.20	2.28	2.33	2.37	2.41	2.44	2.10	2.20	2.28	2.33	2.37	2.41			
4.00	7.00	8.00	9.00	10.00	11.00	12.00	13.00	5.57	7.09	8.60	10.12	11.64	13.16	14.68	2.64	2.77	2.87	2.94	2.99	3.04	3.07	2.64	2.77	2.87	2.94	2.99	3.04			
4.50	7.75	8.87	10.00	11.12	12.25	13.37	14.50	6.80	8.69	10.58	12.48	14.37	16.26	18.16	3.24	3.41	3.53	3.62	3.68	3.74	3.78	3.24	3.41	3.53	3.62	3.68	3.74			
5.00	8.50	9.75	11.00	12.25	13.50	14.75	16.00	8.15	10.46	12.77	15.08	17.39	19.70	22.01	3.90	4.11	4.26	4.37	4.45	4.52	4.57	3.90	4.11	4.26	4.37	4.45	4.52			
5.50	9.25	10.62	12.00	13.37	14.75	16.12	17.50	9.63	12.40	15.17	17.94	20.70	23.47	26.24	4.62	4.88	5.06	5.19	5.29	5.37	5.43	4.62	4.88	5.06	5.19	5.29	5.37			
6.00	10.00	11.50	13.00	14.50	16.00	17.50	19.00	11.23	14.50	17.77	21.04	24.31	27.58	30.85	5.41	5.71	5.92	6.08	6.20	6.29	6.37	5.41	5.71	5.92	6.08	6.20	6.29			
6.50	10.75	12.37	14.00	15.62	17.25	18.87	20.50	12.96	16.77	20.58	24.39	28.21	32.02	35.83	6.26	6.61	6.86	7.04	7.18	7.29	7.38	6.26	6.61	6.86	7.04	7.18	7.29			
7.00	11.50	13.25	15.00	16.75	18.50	20.25	22.00	14.82	19.21	23.60	28.00	32.39	36.79	41.18	7.17	7.58	7.87	8.08	8.24	8.36	8.46	7.17	7.58	7.87	8.08	8.24	8.36			
7.50	12.25	14.12	16.00	17.87	19.75	21.62	23.50	16.79	21.81	26.83	31.85	36.87	41.89	46.91	8.14	8.62	8.94	9.18	9.36	9.51	9.62	8.14	8.62	8.94	9.18	9.36	9.51			
8.00	13.00	15.00	17.00	19.00	21.00	23.00	25.00	18.90	24.58	30.27	35.96	41.64	47.33	53.02	9.18	9.72	10.09	10.36	10.57	10.73	10.86	9.18	9.72	10.09	10.36	10.57	10.73			
8.50	13.75	15.87	18.00	20.12	22.25	24.37	26.50	21.13	27.52	33.92	40.31	46.71	53.10	59.50	10.28	10.89	11.31	11.61	11.84	12.02	12.17	10.28	10.89	11.31	11.61	11.84	12.02			
9.00	14.50	16.75	19.00	21.25	23.50	25.75	28.00	23.48	30.63	37.77	44.92	52.06	59.21	66.35	11.44	12.12	12.59	12.93	13.19	13.39	13.56	11.44	12.12	12.59	12.93	13.19	13.39			
9.50	15.25	17.62	20.00	22.37	24.75	27.12	29.50	25.96	33.90	41.83	49.77	57.71	65.64	73.58	12.66	13.42	13.94	14.32	14.61	14.83	15.02	12.66	13.42	13.94	14.32	14.61	14.83			
10.00	16.00	18.50	21.00	23.50	26.00	28.50	31.00	28.56	37.33	46.10	54.87	63.64	72.41	81.18	13.95	14.79	15.37	15.79	16.10	16.35	16.55	13.95	14.79	15.37	15.79	16.10	16.35			

Table 4.18 Properties of Critical Section—Interior Circular Column

D/d	f_1	f_2
1.00	6.28	1.74
1.50	7.85	2.62
2.00	9.42	3.70
2.50	11.00	4.98
3.00	12.57	6.45
3.50	14.14	8.12
4.00	15.71	9.98
4.50	17.28	12.05
5.00	18.85	14.30
5.50	20.42	16.76
6.00	21.99	19.41
6.50	23.56	22.26
7.00	25.13	25.30
7.50	26.70	28.54
8.00	28.27	31.98
8.50	29.85	35.61
9.00	31.42	39.44
9.50	32.99	43.46
10.00	34.56	47.68

4.3 MEMBERS SUBJECTED TO BENDING AND AXIAL FORCES

Table 4.19 contains requirements for frame members subjected to combined bending and axial forces. These would typically apply to columns of frames and flexural members that carry a factored axial force, $P_u > A_g f'_c / 10$.

Combined flexure and axial strength. Typically, columns must be designed for the combined effects from flexure and axial forces. Numerous design aids and computer programs are available for determining the size and reinforcement for such columns.

A preliminary column size can be obtained using a low percentage of reinforcement; it is then possible to provide additional reinforcement in the final design stage, if required, without having to change the column size.

Slenderness effects must also be considered in columns where the slenderness ratio is greater than the limits for members that are not braced and braced against sidesway in ACI 10.10.1(a) and 10.10.1(b), respectively.

Table 4.19 Summary of Requirements for Frame Members Subjected to Bending and Axial Forces in Buildings Assigned to SDC A or B

	Requirement	ACI Section Number(s)
Combined Flexural and Axial Strength	Members must be designed such that the following equations are satisfied for each load combination: $P_u \leq \phi P_n$ and $M_u \leq \phi M_n$.	9.2, 9.3, 10.2, 10.3
	Design axial strength, ϕP_n , shall not be taken greater than $\phi P_{n,max}$ where <ul style="list-style-type: none"> • $\phi P_{n,max} = 0.85\phi[0.85f'_c(A_g - A_{st}) + f_y A_{st}]$ for nonprestressed members with spiral reinforcement conforming to ACI 7.10.4. • $\phi P_{n,max} = 0.80\phi[0.85f'_c(A_g - A_{st}) + f_y A_{st}]$ for nonprestressed members with tie reinforcement conforming to ACI 7.10.5. 	10.3.6
	Area of longitudinal reinforcement, A_{st} , shall not be less than $0.01A_g$ or more than $0.08A_g$.	10.9.1
	The following minimum number of longitudinal bars must be provided: <ul style="list-style-type: none"> (a) four for bars within rectangular or circular ties (b) three for bars within triangular ties (c) six for bars enclosed by spirals conforming to ACI 10.9.3 	10.9.2
	Slenderness effects must be considered in the following situations: <ul style="list-style-type: none"> • For compression members not braced against sidesway: $k\ell_u/r > 22$ • For compression members braced against sidesway: $k\ell_u/r > 34 - 12(M_1/M_2)$ A nonlinear second-order analysis must be performed or moments must be magnified to account for second-order slenderness effects.	10.10

(continued)

Table 4.19 Summary of Requirements for Frame Members Subjected to Bending and Axial Forces in Buildings Assigned to SDC A or B (continued)

	Requirement	ACI Section Number(s)
Splices	Lap splices, mechanical splices, butt-welded splices and end-bearing splices must conform to the provisions of ACI 12.17.2 through 12.17.4. Splices shall satisfy requirements for all load combinations for the column.	12.17.1
	Where the bar stress due to factored loads is compressive, lap splices shall conform to ACI 12.16.1, ACI 12.16.2 and, where applicable, to ACI 12.17.2.4 or 12.17.2.5.	12.17.2.1
	Where the bar stress due to factored loads is tensile and is less than or equal to $0.5f_y$, the lap splices shall be: <ul style="list-style-type: none"> • Class B tension lap splices if more than one-half of the bars are spliced at any section. • Class A tension lap splices if half or fewer of the bars are spliced at any section and alternate lap splices are staggered by ℓ_d. 	12.17.2.2
	Where the bar stress due to factored loads is greater than $0.5f_y$, lap splices shall be Class B tension lap splices.	12.17.2.3
	Required lap splice length may be multiplied by 0.83 in tied reinforced compression members where ties throughout the lap splice length have an effective area greater than or equal to $0.0015hs$ in both directions. Minimum lap length is 12 inches.	12.17.2.4
	Lap splice length may be multiplied by 0.75 for bars within a spiral of a spirally reinforced compression member. Minimum lap length is 12 inches.	12.17.2.5
	Mechanical or welded splices must meet the requirements of ACI 12.14.3.2 or 12.14.3.4.	12.17.3
	End-bearing splices satisfying the requirements of 12.16.4 are permitted to be used for column bars stressed in compression provided the splices are staggered or additional bars are provided at splice locations. The continuing bars in each face shall have a tensile strength not less than $0.25f_y$ times the area of the vertical reinforcement in that face.	12.17.4

(continued)

Table 4.19 Summary of Requirements for Frame Members Subjected to Bending and Axial Forces in Buildings Assigned to SDC A or B (continued)

	Requirement	ACI Section Number(s)
Transverse Reinforcement	<p>Volumetric spiral reinforcement ratio, ρ_s, shall not be less than that given by:</p> $\rho_s = 0.45 \left(\frac{A_g}{A_{ch}} - 1 \right) \frac{f'_c}{f_{yt}}$ <p>where the value of f_{yt} shall not exceed 100,000 psi. Lap splices according to ACI 7.10.4.5(a) shall not be used where f_{yt} is greater than 60,000 psi.</p>	10.9.3
	<p>Spiral reinforcement must satisfy the following requirements:</p> <ul style="list-style-type: none"> (a) Minimum spiral diameter = $3/8$ inch. (b) Clear spacing between spirals shall not exceed 3 inches nor be less than 1 inch. Also see ACI 3.3.2. (c) Spiral reinforcement shall be spliced using lap splices conforming to ACI 7.10.4.5(a) or mechanical or welded splices conforming to ACI 7.10.4.5(b). (d) Spirals shall extend from top of footing or slab in any story to the level of the lowest horizontal reinforcement in members supported above. (e) Ties shall extend above termination of spiral to the bottom of a slab, drop panel or shear cap where beams or brackets do not frame into all sides of a column. (f) In columns with capitals, spirals shall extend to a level at which the diameter or width of capital is two times that of the column. 	7.10.4
	<p>Tie reinforcement must satisfy the following requirements:</p> <ul style="list-style-type: none"> (a) At least No. 3 ties shall enclose No. 10 or smaller longitudinal bars, and at least No. 4 ties shall enclose No. 11, No. 14, No. 18 and bundled longitudinal bars. (b) Vertical spacing of ties shall not exceed the smallest of (1) 48 tie bar diameters, (2) 16 longitudinal bar diameters or (3) the least dimension of the compression member. (c) Ties shall be arranged such that every corner or alternate longitudinal bar has lateral support provided by the corner of a tie with an included angle of not more than 135 degrees. No bar shall be farther than 6 inches clear on each side along the tie from a laterally supported bar. A complete circular tie is also permitted. 	7.10.5

(continued)

Table 4.19 Summary of Requirements for Frame Members Subjected to Bending and Axial Forces in Buildings Assigned to SDC A or B (continued)

Requirement		ACI Section Number(s)
Transverse Reinforcement (continued)	Ties shall be located vertically not more than one-half a tie spacing above the top of a footing or slab in any story and should be spaced to not more than one-half a tie spacing below the lowest horizontal reinforcement in a slab, drop panel or shear cap above.	7.10.5
	Where beams or brackets frame from four directions into a column, it is permitted to terminate the ties not more than 3 inches below the lowest reinforcement in the shallowest of the beams or brackets.	
Shear Strength	Provide sufficient transverse reinforcement for shear.	11.1, 11.2, 11.4
	Columns in ordinary moment frames that are part of the seismic-force-resisting system that have a clear height less than or equal to $5c_1$ shall be designed for shear in accordance with ACI 21.3.3.	21.2.3

For SI: 1 inch = 25.4 mm; 1 pound per square inch = 6.895 kPa; 1 degree = 0.01745 rad.

Splices. Splice requirements for columns are given in ACI 12.17. Column splices must satisfy requirements for all load combinations. For example, even though the strength requirements may govern for a gravity load combination where all of the longitudinal bars are in compression, a tension splice would be required if a load combination that includes wind or seismic produces tensile stresses in the reinforcing bars.

Where the bar stress due to factored loads is compressive, lap splices, mechanical splices, butt-welded splices and end-bearing splices are permitted. Table 4.20 contains minimum compression lap splice lengths for Grade 60 bars with $f'_c \geq 3,000$ psi (20 684 kPa). Lap splice lengths may be multiplied by 0.83 and 0.75 for tied reinforced compression members and spirally reinforced compression members, respectively, provided the requirements of ACI 12.17.2.4 and 12.17.2.5 are satisfied.

Lap splices, mechanical splices and welded splices are permitted where the bar stress is tensile. Mechanical and welded splices must conform to the provisions of ACI 12.14.3. Where the bar stress on the tension face of a column is less than or equal to $0.5f_y$, lap splices may be Class A if half or fewer of the longitudinal bars are spliced at one location and alternate splices are staggered by the tension development length, ℓ_d , or must be Class B if more than half of the bars are spliced at any section. Where the bar stress on the tension face of a column is greater than $0.5f_y$, Class B tension lap splices must be used.

Typical lap splice details for tied columns are shown in Figure 4.19. Lap splices are typically located just above the floor for ease of construction. There is no restriction on their location for buildings assigned to SDC A or B.

Table 4.20 Minimum Compression Lap Splice Lengths for Grade 60 Bars

Bar Size	Minimum Lap Length (in.)*
3	12.0
4	15.0
5	18.8
6	22.5
7	26.3
8	30.0
9	33.8
10	38.1
11	42.3

* $f'_c \geq 3000$ psi

For SI: 1 inch = 25.4 mm; 1 pound per square inch = 6.895 kPa.

Transverse Reinforcement. Provisions for lateral reinforcement of compression members are given in ACI 7.10 for spiral reinforcement and tie reinforcement. Maximum spacing of tie reinforcement is illustrated in Figure 4.19.

Shear strength. Sufficient transverse reinforcement must be provided for shear in accordance with the applicable provisions of ACI 11.1, 11.2 and 11.4. Figure 4.20 can be used to determine the design shear strength for concrete, ϕV_c , for members subjected to axial compression, shear and flexure.

Required spacing of tie reinforcement for shear is determined by ACI Eq. (11-15). This spacing is limited by the smaller of those given in ACI 7.10.5.

According to ACI 21.2.3, columns in ordinary moment frames that are part of the seismic-force-resisting system that have a clear height less than or equal to $5c_1$ shall be designed for shear in accordance with ACI 21.3.3. This requirement is intended to provide additional toughness to resist shear forces in columns with proportions that make them more susceptible to shear failure.

4.4 WALLS

Table 4.21 contains requirements for walls. ACI 2.2 defines a wall as a member, usually vertical, that is used to enclose or separate spaces. A definition based on the ratio of overall plan dimensions is not provided.

Combined flexural and axial strength. ACI 14.2.2 gives three methods that can be used for wall sections subjected to flexure and axial forces. In the first method, a wall is designed as a compression member in accordance with the provisions listed in ACI 14.4. This general method applies to any wall section. Reinforcement is developed and spliced in accordance with the provisions in ACI Chapter 12.

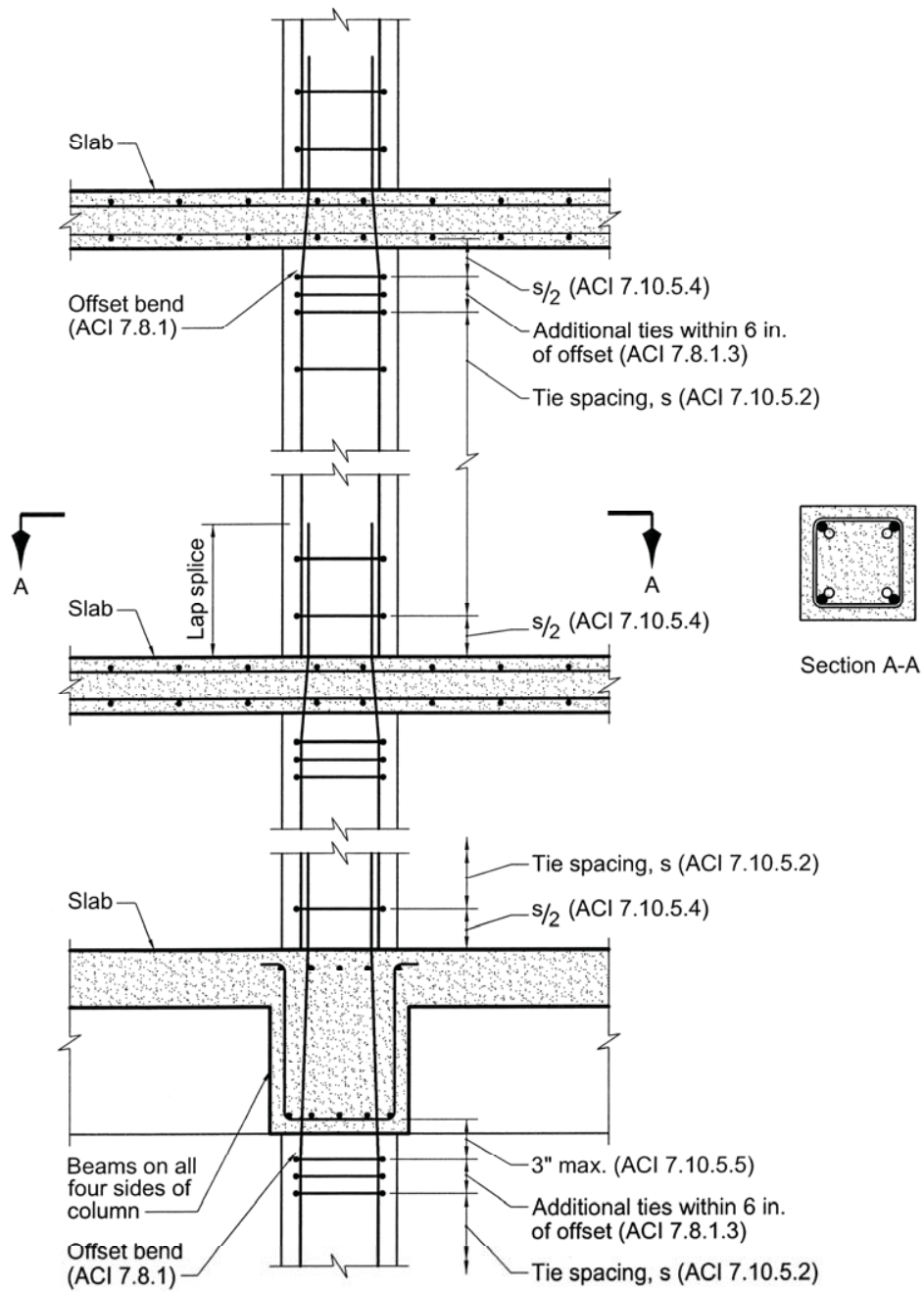

For SI: 1 inch = 25.4 mm.

Figure 4.19 Splice and Tie Details for Columns in Buildings Assigned to SDC A and B

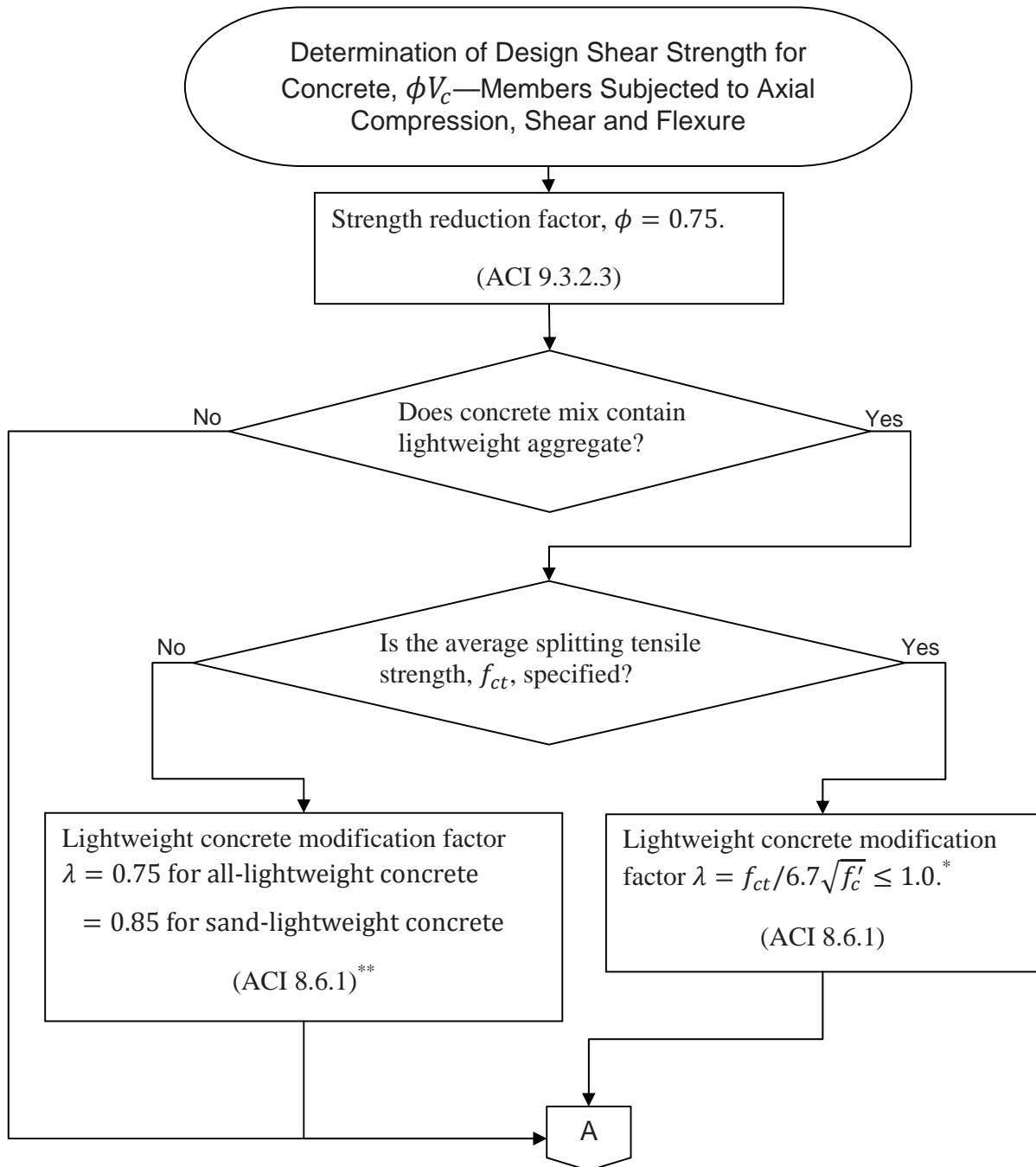

* Values of $\sqrt{f'_c}$ shall not exceed 100 psi except as allowed in ACI 11.1.2.1 (ACI 11.1.2).

**Linear interpolation shall be permitted when partial sand replacement is used (ACI 8.6.1).

Figure 4.20 Determination of Design Shear Strength for Concrete, ϕV_c —Members Subjected to Axial Compression, Shear and Flexure

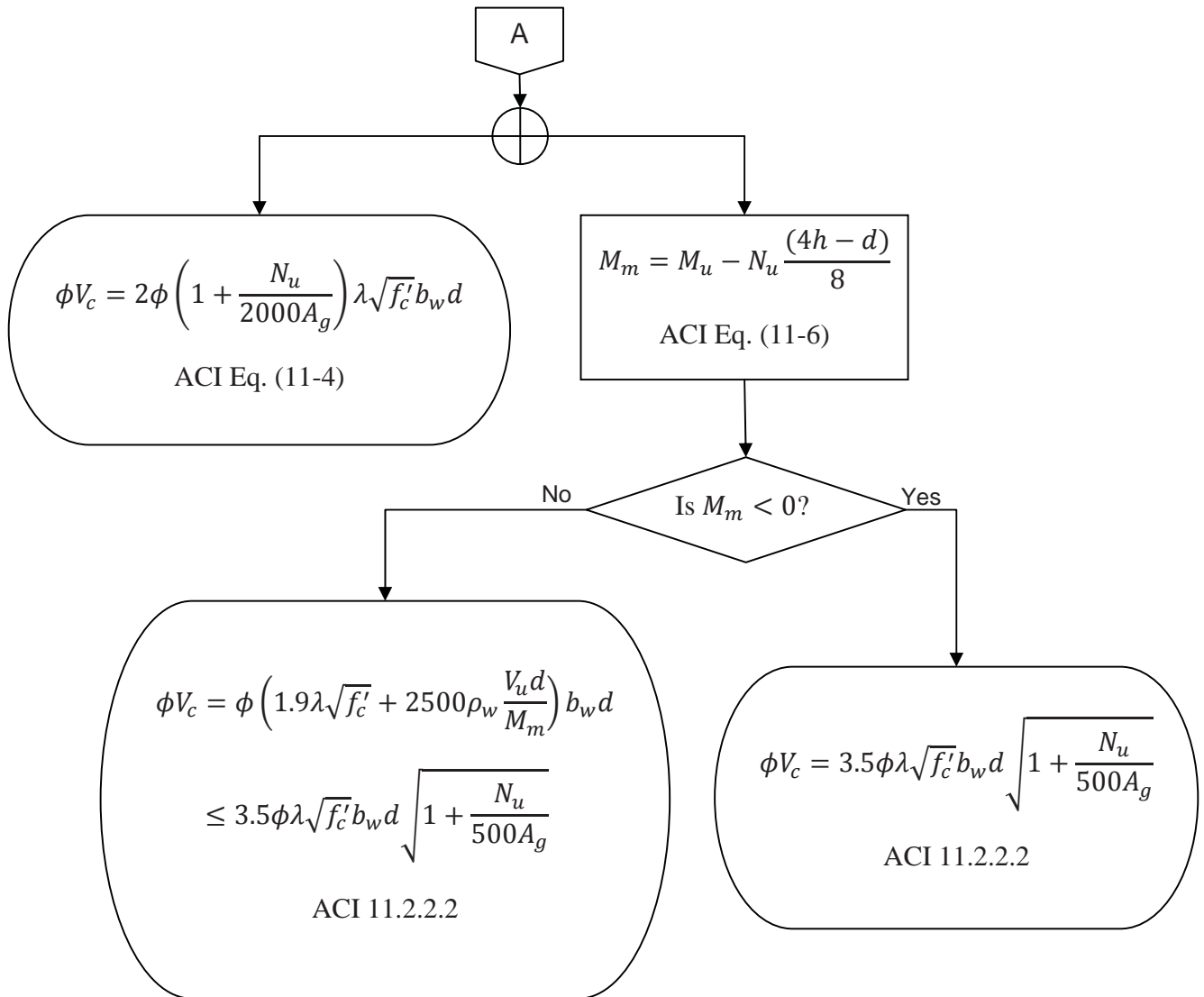

For SI: 1 pound per square inch = 6.895 kPa.

Figure 4.20 Determination of Design Shear Strength for Concrete, ϕV_c —Members Subjected to Axial Compression, Shear and Flexure (continued)

Table 4.21 Summary of Requirements for Walls in Buildings Assigned to SDC A or B

	Requirement	ACI Section Number(s)
Combined Flexural and Axial Strength	Walls subjected to axial force or to combined flexure and axial force are to be designed as compression members in accordance with ACI 10.2, 10.3, 10.10, 10.11, 10.14, 14.2 and 14.3.	14.4
	In lieu of ACI 14.4, walls that meet the requirements of ACI 14.5.1 may be designed using the Empirical Design Method.	14.5.1
	Where flexural tension controls the out-of-plane design of a wall, the alternate design requirements of ACI 14.8 are considered to satisfy the slenderness effects requirements of ACI 10.10.	14.8.1
Shear Strength	Design for shear shall be in accordance with ACI 11.9.	14.2.3
	Design for shear forces perpendicular to the face of a wall shall be in accordance with ACI 11.11.	11.9.1
	Design for horizontal in-plane shear forces shall be in accordance with ACI 11.9.2 through 11.9.9.	11.9.1
	Nominal shear strength $V_n = V_c + V_s \leq 10\sqrt{f'_c}hd$ where $d = 0.8\ell_w$ or is determined by a strain compatibility analysis.	11.9.2, 11.9.3, 11.9.4
	Unless a more detailed calculation is made in accordance with ACI 11.9.6, $V_c = 2\lambda\sqrt{f'_c}hd$ for walls subjected to axial compression.	11.9.5
	V_c shall be permitted to be the lesser determined by ACI Eq. (11-27) or (11-28): $V_c = 3.3\lambda\sqrt{f'_c}hd + \frac{N_u d}{4\ell_w}$ $V_c = \left[0.6\lambda\sqrt{f'_c} + \frac{\ell_w \left(1.25\lambda\sqrt{f'_c} + 0.2 \frac{N_u}{\ell_w h} \right)}{\frac{M_u}{V_u} - \frac{\ell_w}{2}} \right] hd$ ACI Eq. (11-28) does not apply when $(M_u/V_u) - (\ell_w/2)$ is negative.	11.9.6
	Values of V_c computed by ACI Eq. (11-27) or (11-28) at a section located a distance of $\ell_w/2$ or $h_w/2$, whichever is less, above the base apply to that and all sections between this section and the base.	11.9.7
	Where $V_u \leq 0.5\phi V_c$, provide reinforcement in accordance with ACI 11.9.9 or Chapter 14. Where $V_u > 0.5\phi V_c$, provide reinforcement in accordance with ACI 11.9.9.	11.9.8

(continued)

Table 4.21 Summary of Requirements for Walls in Buildings Assigned to SDC A or B
(continued)

	Requirement	ACI Section Number(s)
Shear Strength (continued)	Where $V_u > \phi V_c$, determine horizontal reinforcement in accordance with ACI Eq. (11-29): $\frac{A_v}{s} \geq \frac{V_s}{f_y d}$ Provide vertical reinforcement to satisfy ACI 11.9.9.4.	11.9.9.1
	Ratio of horizontal shear reinforcement area to gross concrete area of vertical section, ρ_t , must be greater than or equal to 0.0025.	11.9.9.2
	Spacing of horizontal shear reinforcement shall not exceed the smallest of $\ell_w/5$, $3h$, and 18 inches.	11.9.9.3
	Ratio of vertical shear reinforcement area to gross concrete area of horizontal section, ρ_ℓ , shall be greater than or equal to the larger of $0.0025 + 0.5[2.5 - (h_w/\ell_w)](\rho_t - 0.0025)$ and 0.0025. The value of ρ_ℓ need not be greater than ρ_t .	11.9.9.4
	Spacing of vertical shear reinforcement shall not exceed the smallest of $\ell_w/3$, $3h$ and 18 inches.	11.9.9.5

For SI: 1 inch = 25.4 mm.

The second method is the Empirical Design Method (ACI 14.5), which is applicable to solid rectangular cross-sections where the resultant load for all applicable load combinations falls within the middle third of the wall thickness (i.e., the eccentricity is less than or equal to $h/6$). The following equation, based on ACI Equation (14-1), must be satisfied:

$$P_u \leq \phi P_n = 0.55\phi f'_c A_g \sqrt{1 - \left(\frac{k\ell_c}{32h}\right)^2}$$

where $\phi = 0.65$ for compression-controlled sections (ACI 9.3.3.2) and the effective length factor, k , is defined in ACI 14.5.2. Minimum wall thicknesses are prescribed in ACI 14.5.3.

The third method is an alternate method for the out-of-plane design of slender walls that meet the criteria in ACI 14.8.2. The design moment strength for combined flexure and axial forces, ϕM_n , must be greater than or equal to the factored moment, M_u , which includes second-order effects [see ACI Eqs. (14-3) and (14-4)]. Limitations on maximum out-of-plane deflection are prescribed in ACI 14.8.4.

Shear strength. Provisions for the design of walls for shear are given in ACI 11.9. Design for shear forces perpendicular to the face of a wall must satisfy the provisions for slabs in ACI 11.11. Figure 4.21 can be used to determine the required vertical and horizontal reinforcement for shear.

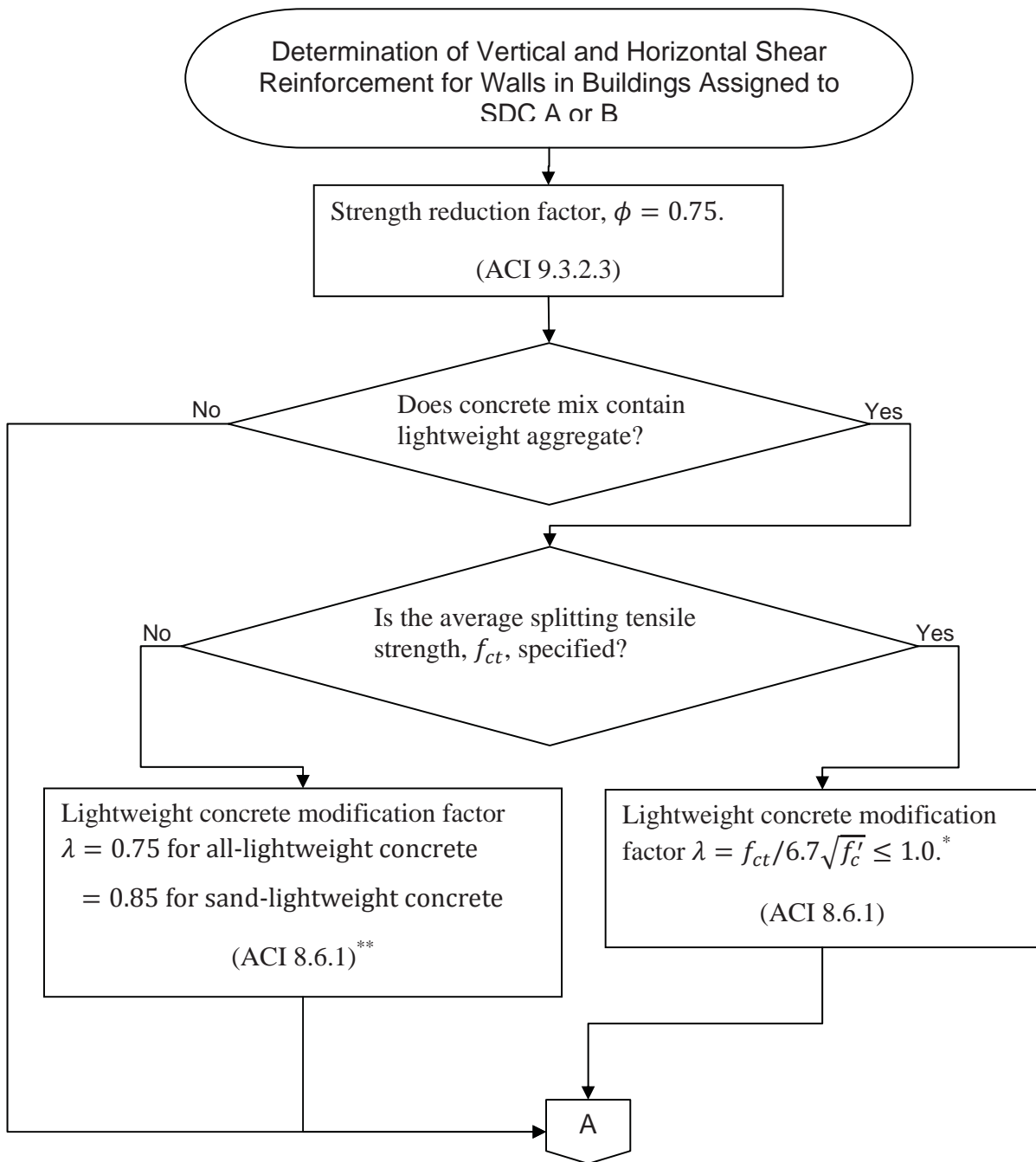

* Values of $\sqrt{f'_c}$ shall not exceed 100 psi except as allowed in ACI 11.1.2.1 (ACI 11.1.2).

**Linear interpolation shall be permitted when partial sand replacement is used (ACI 8.6.1).

Figure 4.21 Determination of Vertical and Horizontal Shear Reinforcement for Walls in Buildings Assigned to SDC A or B

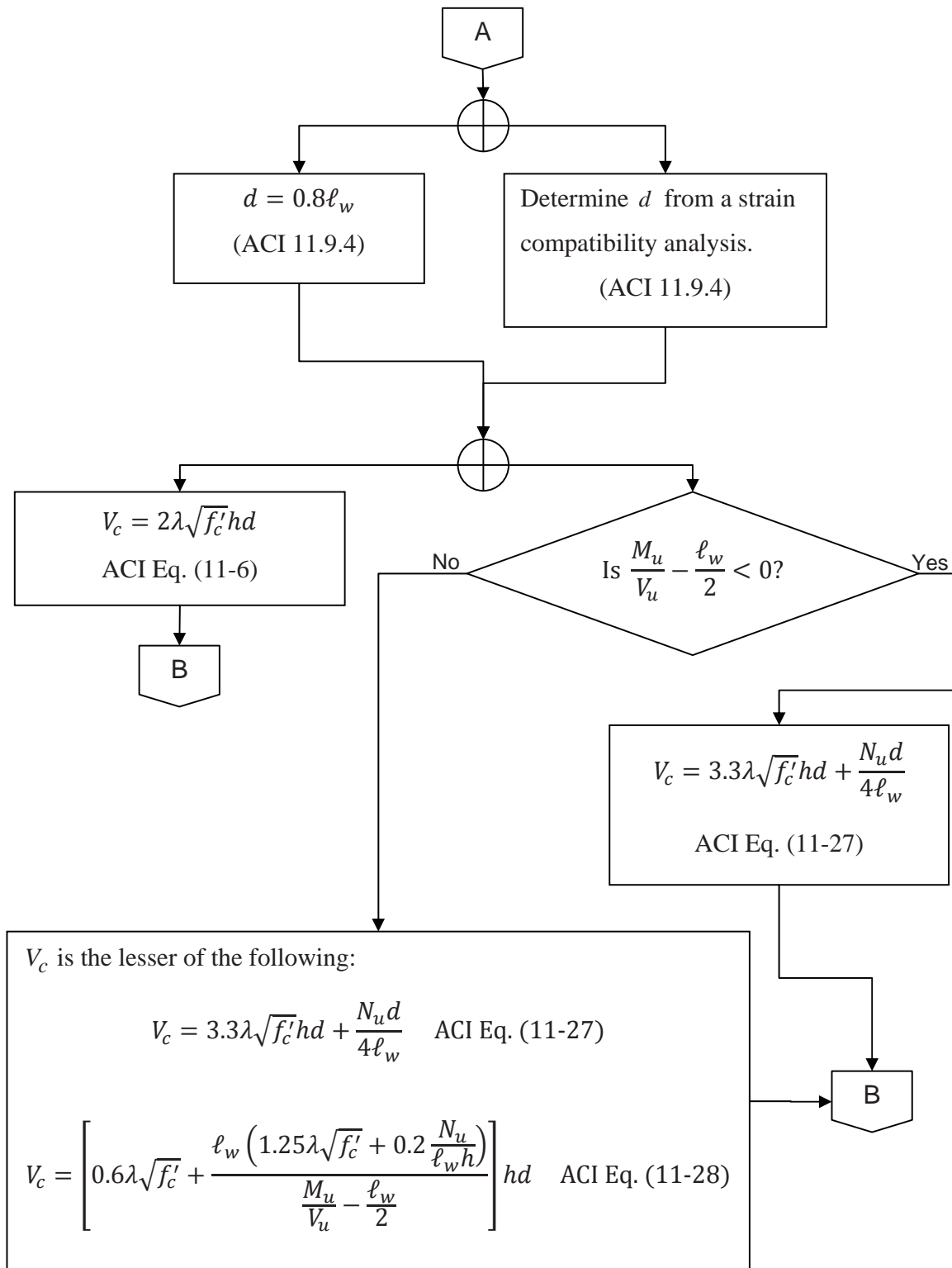

Figure 4.21 Determination of Vertical and Horizontal Shear Reinforcement for Walls in Buildings Assigned to SDC A or B (continued)

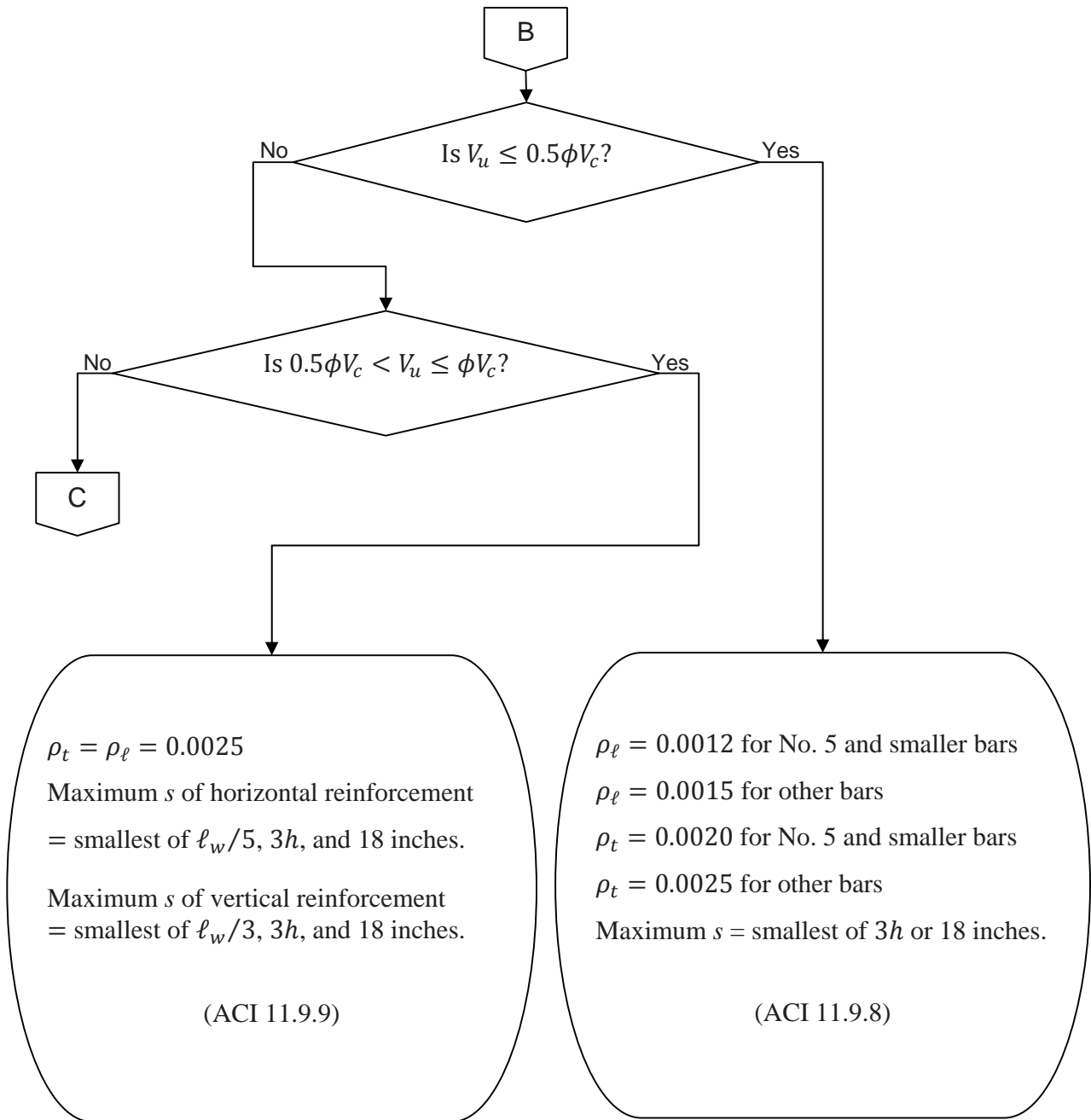
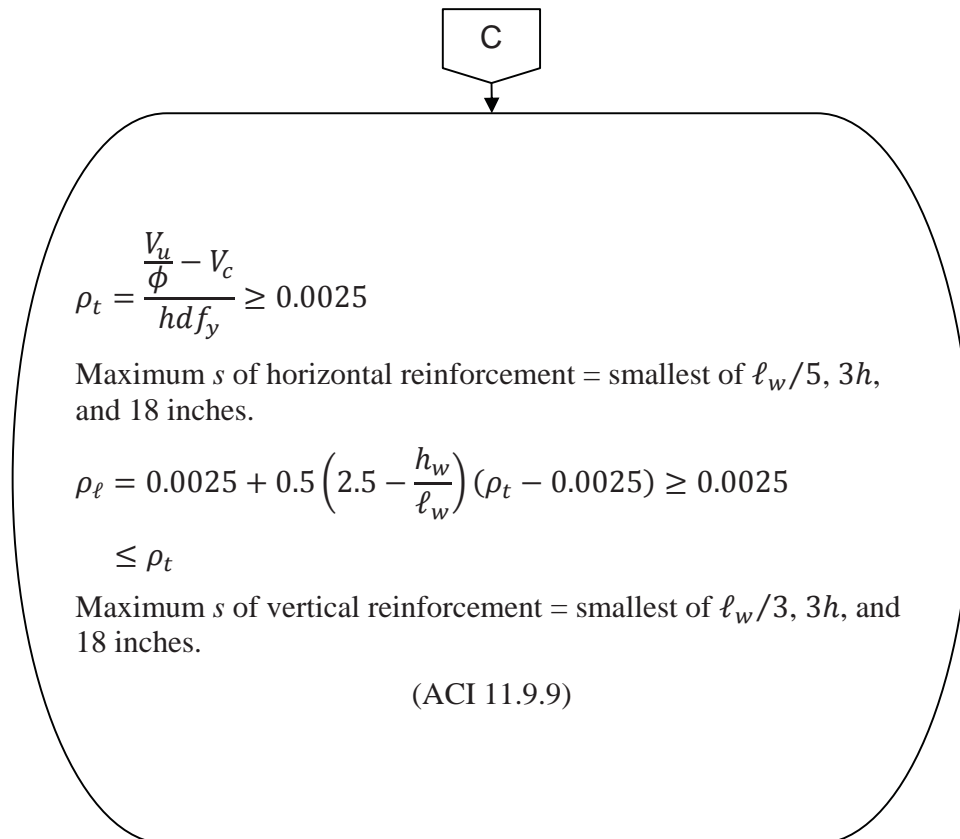

Figure 4.21 Determination of Vertical and Horizontal Shear Reinforcement for Walls in Buildings Assigned to SDC A or B (continued)



For SI: 1 inch = 25.4 mm; 1 pound per square inch = 6.985 kPa.

Figure 4.21 Determination of Vertical and Horizontal Shear Reinforcement for Walls in Buildings Assigned to SDC A or B (continued)

4.5 FOOTINGS

Depending on the soil conditions, reinforced concrete spread footings can be a viable foundation option, especially for low-rise buildings. Table 4.22 contains the requirements for footings based on ACI 318-08.

It should be noted that IBC 1809 contains requirements for shallow foundations (footings) that must also be met. For example, IBC 1809.4 requires footings to be a minimum of 12 inches (305 mm) in width. IBC 1809.8 requires plain concrete footings to be 8 inches (203 mm) thick except for footings in Group R-3 occupancies, which are permitted to be a minimum of 6 inches (152 mm) thick if the projection of the footing beyond the wall does not exceed the thickness of the footing. Additionally, IBC 1908.1.8 contains modifications to ACI 318 for plain concrete footings based on the SDC.

Table 4.22 Summary of Requirements for Footings in Buildings Assigned to SDC A or B

Requirement		ACI Section Number(s)
Loads and Reactions	Footings shall be proportioned to resist factored reactions in accordance with the appropriate flexure and shear requirements in ACI Chapters 9, 10, 11 and 15.	15.2.1
	Base area of footings shall be determined from unfactored forces and moments using the permissible soil pressure.	15.2.2
Moment	The critical section for the maximum factored moment, M_u , in an isolated footing is as follows: <ul style="list-style-type: none"> • For footings supporting a concrete column, pedestal or wall, the critical section is at the face of the concrete column, pedestal or wall. • For footings supporting a masonry wall, the critical section is halfway between the middle and the edge of the wall. • For footings supporting a column with a steel base plate, the critical section is halfway between the face of the column and the edge of the base plate. 	15.4.2
	Reinforcement shall be distributed uniformly across the entire width of a one-way footing and two-way square footings.	15.4.3
	In two-way rectangular footings, reinforcement in the long direction shall be distributed uniformly across the entire width of the footing. Reinforcement in the short direction shall be distributed in accordance with ACI 15.4.4.2.	15.4.4
	Minimum reinforcement = $0.0018bh$. Maximum spacing of reinforcement = smaller of $3h$ and 18 inches.	10.5.4
Shear	Shear strength of footings supported on soil or rock shall satisfy the one-way and two-way shear requirements of ACI 11.11.	15.5.1
	For footings supporting a column, pedestal or wall, the location of critical section for shear shall be measured from the face of the column, pedestal or wall. For footings supporting a column or pedestal with a steel base plate, the critical section is to be measured from the location defined in ACI 15.4.2(c).	15.5.2
Development of Reinforcement	Development of reinforcement is to be in accordance with ACI Chapter 12.	15.6.1
	Reinforcement is permitted to be developed at critical sections by embedment length, hooks (tension only), mechanical devices or a combination thereof.	15.6.2

(continued)

Table 4.22 Summary of Requirements for Footings in Buildings Assigned to SDC A or B
(continued)

	Requirement	ACI Section Number(s)
Development of Reinforcement (continued)	Critical sections for development of reinforcement shall occur at the same locations defined in ACI 15.4.2 for maximum factored moment, and at all other locations where changes of section or reinforcement occur. See also ACI 12.10.6 for provisions where reinforcement stress is not directly proportional to moment.	15.6.3
Minimum Footing Depth	Depth of footing above bottom reinforcement must be greater than or equal to 6 inches for footings supported on soil.	15.7
Transfer of Force at Base of Column, Wall or Reinforced Pedestal	Forces and moments at the base of a column, wall or pedestal are to be transferred to a supporting pedestal or footing by bearing and by reinforcement, dowels and mechanical connections.	15.8.1
	Bearing stress on concrete shall not exceed the concrete bearing strength given by ACI 10.14.	15.8.1.1
	Reinforcement dowels or mechanical connectors between supported and supporting members must be adequate to transfer all compressive forces that exceed the concrete bearing strength of either member or any tensile force across the interface.	15.8.1.2
	Reinforcement, dowels or mechanical connectors must be adequate to satisfy the provisions of ACI 12.17 where moments are transferred to a supporting pedestal or footing.	15.8.1.3
	Lateral forces shall be transferred to supporting pedestal or footing in accordance with the shear-friction provisions of ACI 11.6 or by other appropriate means.	15.8.1.4
	Area of reinforcement across the interface must be greater than or equal to $0.005A_g$ for cast-in-place columns and pedestals.	15.8.2.1
	For cast-in-place walls, area of reinforcement across the interface must be greater than or equal to the minimum reinforcement given in ACI 14.3.2.	15.8.2.2
It is permitted to lap splice No. 14 and No. 18 longitudinal bars in compression only to dowels from a footing where the dowel bars are No. 11 or smaller. The dowels must extend into the supported member a distance greater than or equal to the larger of ℓ_{dc} of the No. 14 or No. 18 bars and the compression lap splice length of the dowels. The dowels must extend into the footing a distance greater than or equal to ℓ_{dc} of the dowels.	15.8.2.3	

For SI: 1 inch = 25.4 mm.

Loads and reactions. In general, the base area of a footing is determined using unfactored loads and allowable soil pressures, while the thickness of the footing and the required reinforcement are obtained using factored loads.

Table 4.23 contains soil pressure distributions for various loading conditions. These distributions can be used to size the base area of the footing using service loads. Similarly, the footing thickness and reinforcement can be obtained using these distributions with factored loads.

Table 4.23 Soil Pressure Distributions for Various Loading Conditions

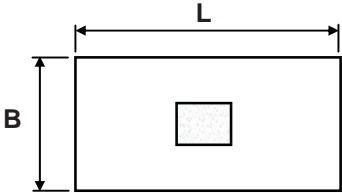
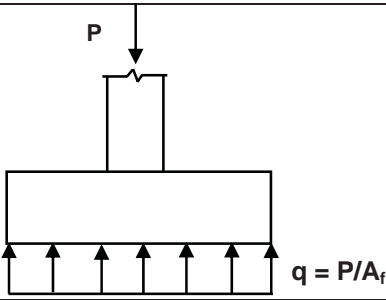
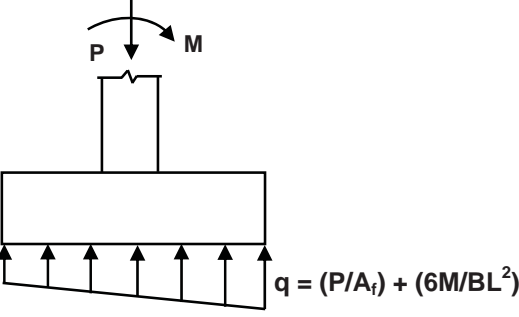
Eccentricity $e = M/P$	Soil Pressure Distribution
	
0	
< L/6	

(continued)

Table 4.23 Soil Pressure Distributions for Various Loading Conditions (continued)

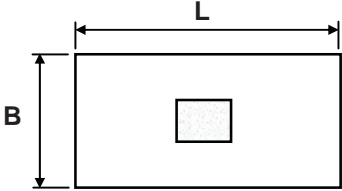
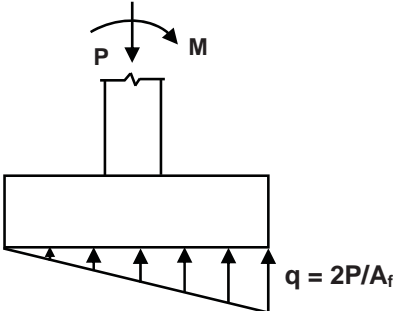
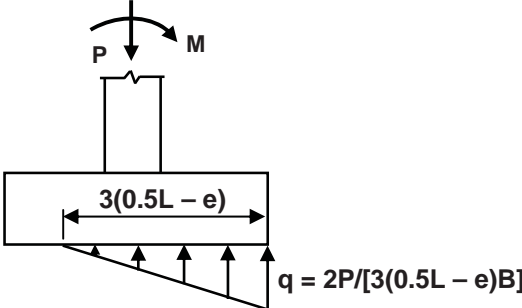
Eccentricity $e = M/P$	Soil Pressure Distribution
	
$= L/6$	
$> L/6$	

Design for Flexure. Once the required area of the footing has been established based on the service loads and the allowable bearing capacity of the soil, the thickness h of the footing must be determined considering both flexure and shear. In general, a spread footing must be designed for the bending moments that are induced due to the soil pressure developed at the base of the footing from the factored loads.

Critical sections for the maximum factored moment in an isolated footing are provided in ACI 15.4.2 and are illustrated in Figures 4.22, 4.23 and 4.24.

Figure 4.22 depicts an isolated spread footing subjected to a concentric factored axial load, P_u . The factored pressure, q_u , at the base of the footing is equal to the factored axial force, P_u , divided by the area of the footing, A_f . The maximum factored bending moment, M_u , at this critical section in this direction is equal to $q_u c^2/2$. Similar equations can be derived for other pressure distributions.

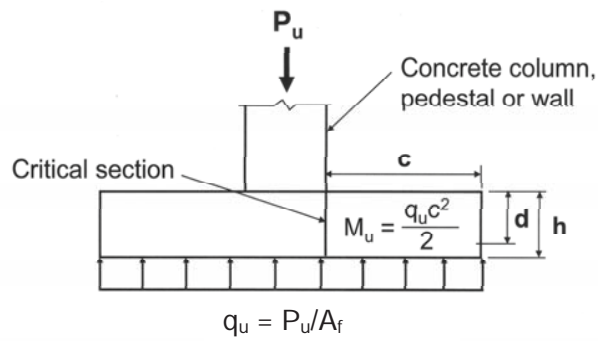

Figure 4.22 Critical Section for Flexure for an Isolated Footing Supporting a Concrete Column, Pedestal or Wall

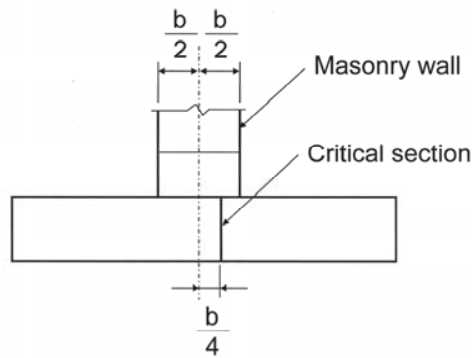

Figure 4.23 Critical Section for Flexure for an Isolated Footing Supporting a Masonry Wall

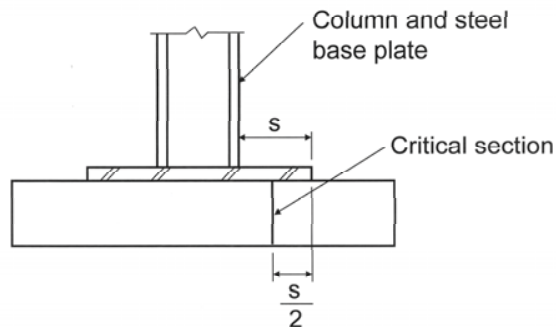

Figure 4.24 Critical Section for Flexure for an Isolated Footing Supporting a Column with a Steel Base Plate

Once M_u has been determined, the required area of reinforcing steel, A_s , can be calculated using the strength requirements of ACI Chapter 9. The required strength, M_u , must be less than or equal to the design strength, ϕM_n :

$$M_u = \frac{q_u c^2}{2} \leq \phi M_n = \phi A_s f_y \left(d - \frac{a}{2} \right)$$

In this equation, the expression for M_u is for a concentrically loaded isolated spread footing and the expression for ϕM_n is for a rectangular concrete section with tension reinforcement. An efficient design for footings would be one where the section is tension-controlled. Thus, in accordance with ACI 9.3.2, the strength reduction factor, ϕ , is equal to 0.9.

Alternatively, the above strength equation can be used to determine the minimum effective depth, d , of the footing using the minimum area of steel, $A_{s,min}$, which is equal to 0.18 percent of the gross area of the footing for Grade 60 reinforcement. For a square footing supporting a square concrete column:

$$d = 2.2c \sqrt{\frac{P_u}{A_f}} \quad \text{Equation 4.1}$$

where c is in feet, P_u is in kips, A_f is in square feet and d is in inches.

ACI 15.4.3 provides detailing requirements for one-way footings and two-way square footings. In such cases, the flexural reinforcement is to be distributed uniformly across the entire width of the footing.

Flexural reinforcement in two-way rectangular footings must be distributed in accordance with ACI 15.4.4. In the long direction, the flexural reinforcement is to be uniformly distributed across the entire width of the footing. In the short direction, a portion of the total reinforcement, $\gamma_s A_s$, is to be uniformly distributed over a band width centered on the column or pedestal equal to the length of the short side of the footing. The quantity, γ_s , is a function of the long to short sides of the footing, β . The remainder of the reinforcement must be uniformly distributed outside of the center band width of the footing (see Figure 4.25).

Shear strength. Provisions for shear strength of footings are given in ACI 11.11. Like two-way slabs, both one-way and two-way shear must be investigated for footings. The critical section for shear is measured from the face of a column, pedestal or wall for footings supporting such members or from the location defined in ACI 15.4.2(c) for footings supporting a column or pedestal with steel base plates.

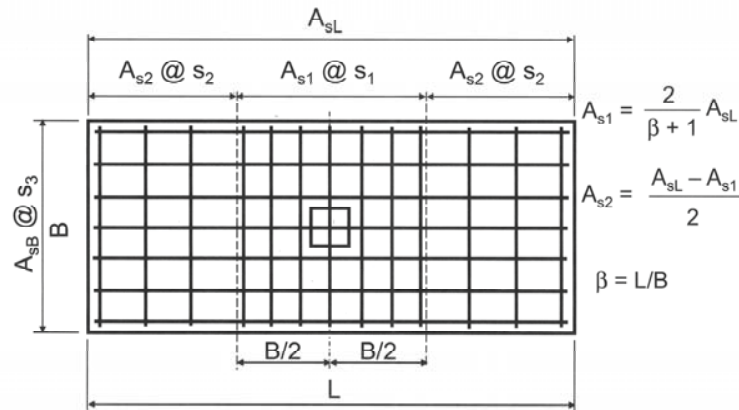

Figure 4.25 Distribution of Flexural Reinforcement in a Rectangular Footing

For a square concrete column supported by a square footing, the following equation can be used to determine the minimum effective depth, d , that is required to satisfy one-way shear requirements:

$$d = \frac{q_u c}{q_u + 2\phi\sqrt{f'_c}} \quad \text{Equation 4.2}$$

Two-way shear strength will be the lesser of the values obtained from ACI Eqs. (11-32) and (11-33) for a square concrete column supported by a square footing. Since Eq. (11-32) will govern where $d/c_1 \leq 0.25$, which is rare, it is reasonable to assume that Eq. (11-33) will govern in the majority of cases. Thus, the minimum effective d that is required to satisfy two-way shear requirements is:

$$d = c_1 \left[\frac{-a + \sqrt{a^2 + q_u bc}}{2b} \right] \quad \text{Equation 4.3}$$

where $a = \frac{q_u}{2} + \phi v_c$

$$b = \frac{q_u}{4} + \phi v_c$$

$$c = \frac{A_f}{c_1^2} - 1$$

$$v_c = 4\lambda\sqrt{f'_c}$$

The largest d computed by Equations 4.1, 4.2 and 4.3 should be used to determine the overall thickness of the footing.

Development of flexural reinforcement. Flexural reinforcement in footings must be fully developed in accordance with the applicable provisions of ACI Chapter 12. The bars must extend at least a tension development length, ℓ_d , beyond the critical section defined in ACI 15.4.2 (see Figures 4.22 through 4.24).

For a reinforced concrete column supported on an isolated footing, the available development length can be determined by the following:

$$\ell_d \leq \frac{L - c_1}{2} - 3$$

where L = length of footing in direction of analysis

c_1 = length of concrete column in direction of analysis

A minimum 3 inches (76 mm) cover is required for concrete cast against and permanently exposed to earth (ACI 7.7.1).

The reinforcing bar size and spacing must be chosen to satisfy the above equation so that the bars can become fully developed.

Force transfer at base of column. The interface between a supported element and a footing must be designed to adequately transfer any vertical and horizontal forces between the members.

In general, compression forces must be transferred by bearing. For the case of a concrete column supported on a footing with a total area considerably larger than the column area, bearing on the column concrete will govern in cases where the strength of the column concrete is less than or equal to twice that of the footing concrete.

If the factored axial compressive force exceeds the concrete bearing capacity given in ACI 10.14 for either surface, the excess compression must be transferred by reinforcement developed in the footing (extended column bars or dowels). The minimum area of reinforcement required across the interface is equal to 0.5 percent of the gross area of the supported member (ACI 15.8.2.1). Dowels extending into a footing must be developed in compression in accordance with ACI 12.3. The splice requirements of ACI 12.16 are to be satisfied for the dowel bars that are spliced to the column bars.

Tensile forces transferred from a supported element to a footing must be resisted entirely by reinforcement across the interface (ACI 15.8.1.2 and 15.8.1.3).

The shear-friction method of ACI 11.6 can be used to check for transfer of lateral forces from a supported member to a footing (ACI 15.8.1.4). In such cases, the reinforcement provided across the interface must satisfy the strength requirements of this method.

4.6 EXAMPLES

4.6.1 Example 4.1—Four-story Residential Building

For the four-story residential building depicted in Figure 4.26, determine the required reinforcement (1) in the slab along column line 4, (2) in the beams along column line 1 on the first floor, (3) in column B1 supporting the first floor level, (4) in footing B1, (5) in the diaphragm chords along column lines 1, 2, 6 and 7 at the second-floor level for lateral forces in the east-west direction and (6) in the collector element along column line F at the second floor level for lateral forces in the east-west direction.

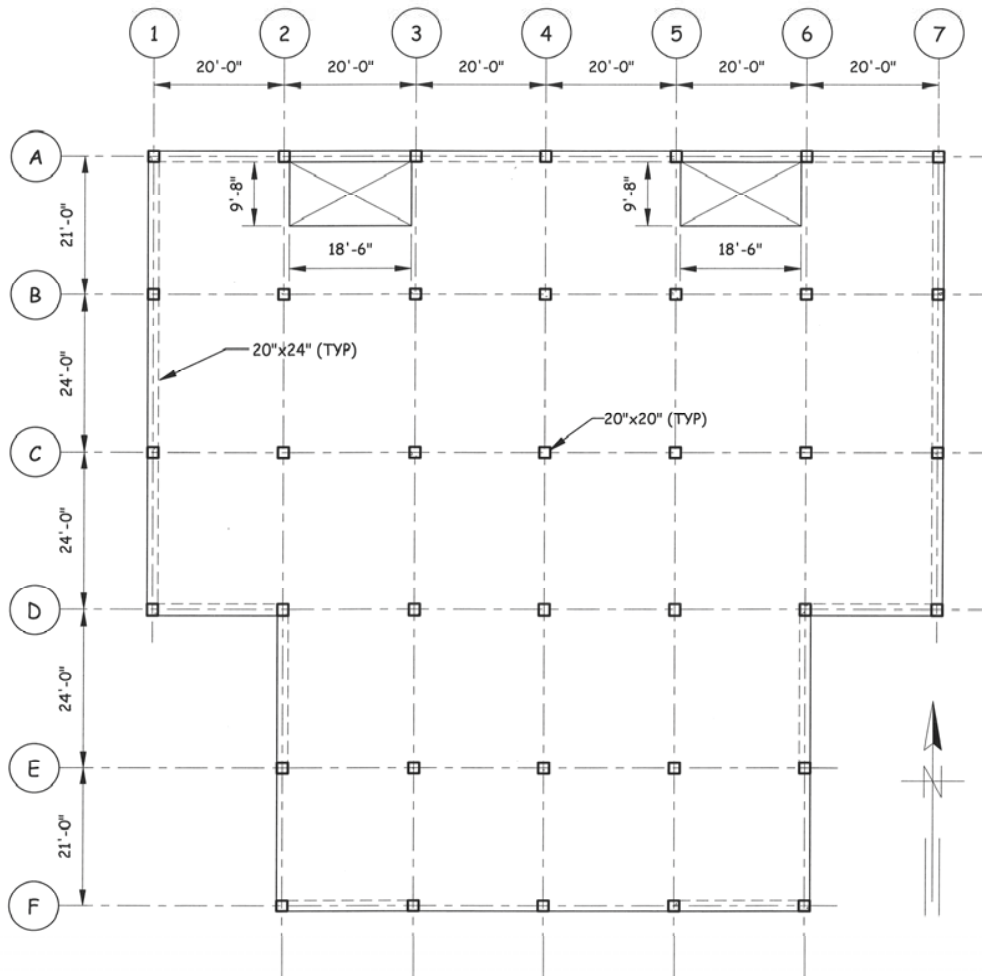

For SI: 1 inch = 25.4 mm; 1 foot = 304.8 mm.

Figure 4.26 Typical Floor Plan of Four-story Residential Building

DESIGN DATA

Concrete: $f'_c = 4000$ psi; reinforcement: $f_y = 60,000$ psi.

Roof live load = 20 psf; roof superimposed dead load = 10 psf

Floor average live load = 70 psf (40 psf outside of corridors, 100 psf for corridors)

Floor superimposed dead load = 30 psf

Glass curtain wall system: 8 psf

Net allowable bearing capacity of soil = 4000 psf

Lateral-force-resisting system: moment-resisting frames

Wind velocity = 90 mph, Exposure B

Seismic Design Category: B ($S_{DS} = 0.19$, $S_{D1} = 0.10$)

First story height = 12 feet, typical story height = 10 feet.

SOLUTION

Part 1: Determine reinforcement in slab along column line 4

Assuming that the two-way slab is not part of the lateral-force-resisting system, the slab needs to be designed for the effects of gravity loads only.

- Preliminary Slab Thickness

For serviceability, an interior panel without beams will govern in this example (ACI 9.5.3.2).

From ACI Table 9.5(c), minimum overall thickness, h , with Grade 60 reinforcement is:

$$\text{Minimum } h = \frac{\ell_n}{30} = \frac{(24 \times 12) - 20}{30} = 8.9 \text{ in.}$$

Use Figure 2.3 to estimate minimum slab thickness based on two-way shear strength at an edge column assuming a 9-inch-thick slab (112.5 psf).

$$\text{Total factored load } q_u = 1.2(112.5 + 30) + 1.6(70) = 283 \text{ psf}$$

$$\text{Tributary area } A = \frac{1}{2} \left(21 + \frac{20}{12} \right) \times 20 = 226.67 \text{ sq ft}$$

Area of edge column = $c_1^2 = 2.78$ sq ft

$$A/c_1^2 = 81.6$$

From Figure 2.3, $d/c_1 \cong 0.35$

Therefore, $d = 0.35 \times 20 = 7.0$ in.

$$h = 7.0 + 1.25 = 8.25 \text{ in.}$$

Try a 9-inch-thick slab.

Check one-way (beam) shear at a distance $d = 7.75$ inches from the face of an interior column (see Figure 4.27).

Factored shear force at critical section is:

$$V_u = 0.283 \times \left(\frac{24}{2} - \frac{20}{2 \times 12} - \frac{7.75}{12} \right) \times 20 = 59.6 \text{ kips}$$

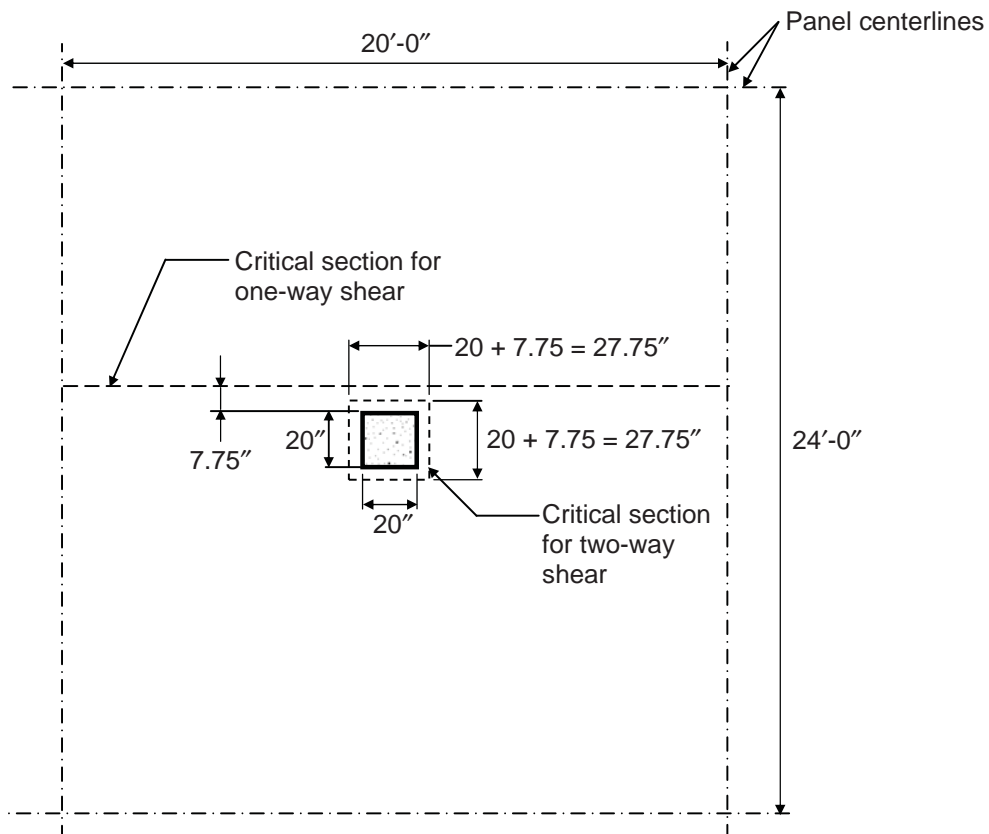

For SI: 1 inch = 25.4 mm; 1 foot = 304.8 mm.

Figure 4.27 Critical Sections for One-way and Two-way Shear at an Interior Column

Design shear strength is computed by ACI Eq. (11-3):

$$\begin{aligned}\phi V_c &= \phi 2\lambda\sqrt{f'_c}b_wd = 0.75 \times 2 \times 1.0\sqrt{4000} \times (20 \times 12) \times 7.75/1000 \\ &= 176.5 \text{ kips} > V_u = 59.6 \text{ kips} \quad \text{O.K.}\end{aligned}$$

Check two-way shear at a distance $d/2 = 3.875$ inches from the face of an interior column (see Figure 4.27).

Factored shear force at critical section is:

$$V_u = q_u(\ell_1\ell_2 - b_1b_2) = 0.283 \left[(24 \times 20) - \frac{27.75 \times 27.75}{144} \right] = 134.3 \text{ kips}$$

Design shear strength is the smallest value determined by ACI Eqs. (11-31), (11-32) and (11-33). For square columns, ACI Eq. (11-33) governs:

$$\begin{aligned}\phi V_c &= \phi 4\lambda\sqrt{f'_c}b_o d = 0.75 \times 4 \times 1.0\sqrt{4000} \times (4 \times 27.75) \times 7.75/1000 \\ &= 163.2 \text{ kips} > V_u = 134.3 \text{ kips} \quad \text{O.K.}\end{aligned}$$

A 9-inch-thick slab appears to be adequate for both serviceability and shear strength requirements. A more refined check for shear strength is made at a later stage.

- Design for Flexure

The Direct Design Method in ACI 13.6 is utilized in this example to determine the bending moments in the slab due to gravity loads. This method can be used only if certain geometric and loading criteria are met. All of the criteria are met in this example, as indicated below (see Figure 4.14):

- There shall be a minimum of three consecutive spans in each direction.
...Structure has at least three spans in each direction. O.K.
- Panels shall be rectangular with a center-to-center longer span to shorter span length ratio not greater than 2.
...Longer span/shorter span = $24/20 = 1.2 < 2$ O.K.
- Successive center-to-center span lengths in each direction shall not differ by more than one-third the longer span.
...In the north-south direction, $21/24 = 0.875 > 0.67$. O.K.
- Columns may be offset a maximum of 10 percent of the span in the direction of offset from either axis between centerlines of successive columns.
...No column offsets are present. O.K.

- Loads must be uniformly distributed gravity loads only and the live load must be less than or equal to 2 times the dead load.
...Uniform live to dead load ratio = $70/142.5 = 0.49 < 2$ O.K.
- For a panel with beams between supports on all sides, ACI Eq. (13-2) must be satisfied.
...Not applicable, since this design strip does not have beams. O.K.

Therefore, the Direct Design Method can be used for gravity load analysis.

Design Moments

The total static factored moments for spans in the interior design strip along column line 4 are computed by ACI Eq. (13-4):

$$M_o = \frac{q_u \ell_2 \ell_n^2}{8}$$

For an end span:

$$M_o = \frac{0.283 \times 20 \times 19.33^2}{8} = 264.5 \text{ ft-kips}$$

For an interior span:

$$M_o = \frac{0.283 \times 20 \times 22.33^2}{8} = 352.9 \text{ ft-kips}$$

These moments are divided into positive and negative moments, and then into column strip and middle strip moments according to the distribution factors in ACI 13.6.3, 13.6.4 and 13.6.6. The distribution factors for a flat plate system are given in Figure 4.17. A summary of the factored gravity load bending moments in the end span and an interior span is given in Table 4.24.

Table 4.24 Factored Moments in Design Strip Along Column Line 4

Slab Moments (ft-kips)	End Span			Interior Span	
	Exterior Negative	Positive	Interior Negative	Positive	Interior Negative
Total Moment	$0.26M_o$ = 68.8	$0.52M_o$ = 137.5	$0.70M_o$ = 185.2	$0.35M_o$ = 123.5	$0.65M_o$ = 229.4
Column Strip	$0.26M_o$ = 68.8	$0.31M_o$ = 82.0	$0.53M_o$ = 140.2	$0.21M_o$ = 74.1	$0.49M_o$ = 172.9
Middle Strip	0	$0.21M_o$ = 55.6	$0.17M_o$ = 45.0	$0.14M_o$ = 49.4	$0.16M_o$ = 56.5

It is evident from the table that the interior negative moment in an interior span is greater than the interior negative moment in an end span; the larger moment is used to compute the required flexural reinforcement at this location (ACI 13.6.3.4).

Required Flexural Reinforcement

The required flexural reinforcement is given in Table 4.25.⁸ The provided areas of steel are greater than the minimum required in accordance with ACI 13.3.1 and the provided spacing is less than the maximum allowed in accordance with ACI 13.3.2.

Table 4.25 Required Slab Reinforcement in Design Strip Along Column Line 4

Location		M_u (ft-kips)	b (in.)	A_s^* (in. ²)	Reinforcement*	
End Span	Column strip	Ext. neg.	-68.8	120	2.22	8-No. 5
		Positive	82.0	120	2.65	9-No. 5
		Int. neg.	-172.9	120	5.58	18-No. 5
	Middle strip	Ext. neg.	0.0	120	1.94	8-No. 5
		Positive	55.6	120	1.94	8-No. 5
		Int. neg.	-56.5	120	1.94	8-No. 5
Interior Span	Column strip	Positive	74.1	120	2.39	8-No. 5
		Negative	-172.9	120	5.58	18-No. 5
	Middle strip	Positive	49.4	120	1.94	8-No. 5
		Negative	-56.5	120	1.94	8-No. 5

* Minimum $A_s = 0.0018bh = 0.0018 \times 120 \times 9 = 1.94 \text{ in.}^2$ (ACI 13.3.1)
 Maximum spacing = $2h = 18 \text{ in.}$ (ACI 13.3.2). For $b = 120 \text{ in.}$, $120/18 = 6.7$ spaces, say 8 bars

For SI: 1 inch = 25.4 mm; 1 square inch = 645.16 mm².

Additional Flexural Reinforcement Required for Moment Transfer—End Support

The total unbalanced moment at the exterior slab-column connection is equal to 68.8 ft-kips (see Table 4.24). A fraction of this moment, $\gamma_f M_u$, must be transferred by flexure over an effective width equal to $c_2 + 3h = 20 + (3 \times 9) = 47 \text{ in.}$ (ACI 13.5.3.2) where γ_f is determined by ACI Eq. (13-1):

$$\gamma_f = \frac{1}{1 + (2/3)\sqrt{b_1/b_2}}$$

$$= \frac{1}{1 + (2/3)\sqrt{[20 + (7.75/2)]/(20 + 7.75)}} = 0.62$$

⁸Required reinforcement is computed by the following simplified equation: $A_s = M_u/4d$ where $d = 7.75 \text{ in.}$

For edge columns bending perpendicular to the edge, the value of γ_f computed by ACI Eq. (13-1) may be increased in accordance with the provisions of ACI 13.5.3.3. No adjustment is made to γ_f in this example.

Unbalanced moment transferred by flexure = $\gamma_f M_u = 0.62 \times 68.8 = 42.7$ ft-kips.
 The required area of steel to resist this moment in the 47-inch-wide strip = $42.7 / (4 \times 7.75) = 1.38$ in.², which is equivalent to five No. 5 bars. Provide the five No. 5 bars by concentrating five of the column strip bars (eight No. 5) within the 47-inch width over the column. For symmetry, add another bar in the column strip and check bar spacing:

For five No. 8 within the 47-inch width: $47/5 = 9.4$ in. < 18.0 in. O.K.

For four No. 5 within the $120 - 47 = 73$ inch width: $73/4 = 18.25$ in. > 18.0 in. N.G.

Therefore, add two more No. 5 bars to the 73-inch width: $73/6 = 12.2$ in. < 18.0 in. O.K.

Reinforcement details for the top bars at the exterior column are shown in Figure 4.28.

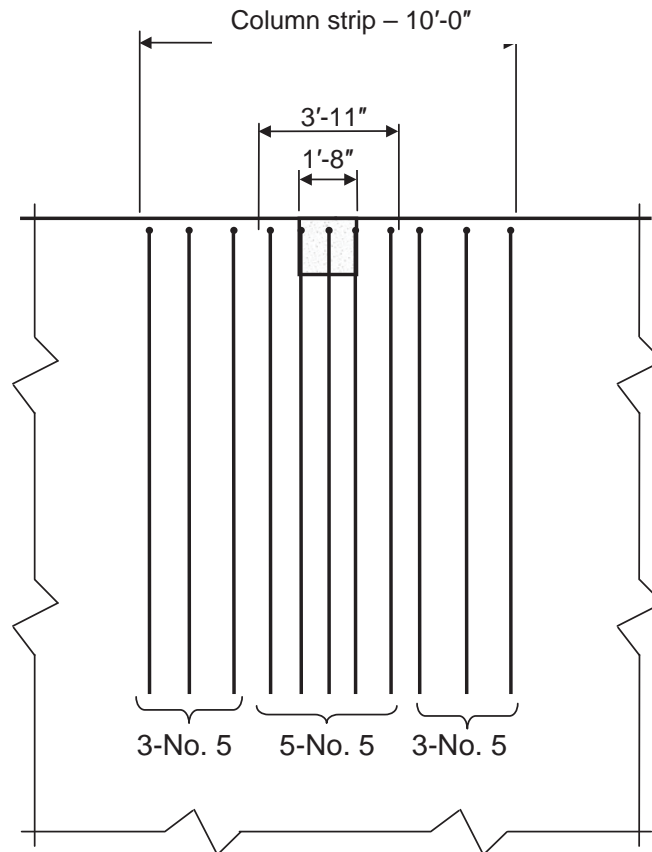

For SI: 1 inch = 25.4 mm; 1 foot = 304.8 mm.

Figure 4.28 Reinforcement Detail at Exterior Column

Similar analyses can be performed for additional flexural reinforcement requirements at interior columns.

- Design for Shear

The total shear stress is the sum of the direct shear stress plus the shear stress due to the fraction of the unbalanced moment transferred by eccentricity of shear (ACI 11.11.7).

The maximum shear stress is determined by the following equation, assuming shear stress due to moment transfer by eccentricity of shear varies linearly about the centroid of the critical section:

$$v_{u(AB)} = \frac{V_u}{A_c} + \frac{\gamma_v M_u c_{AB}}{J_c}$$

where A_c = area of concrete section resisting shear transfer

J_c = property of critical section analogous to polar moment of inertia of segments forming A_c

c_{AB} = distance from centroidal axis of critical section to perimeter of critical section in direction of analysis

γ_v = factor used to determine the unbalanced moment transferred by eccentricity of shear

$$= 1 - \gamma_f = 1 - \frac{1}{1 + (2/3)\sqrt{b_1/b_2}}$$

Shear Strength at End Support

At this location, the factored shear force due to gravity loads is

$$\begin{aligned} V_u &= q_u(A_t - b_1 b_2) - \frac{M_1 - M_2}{\ell_n} \\ &= 0.283 \left[226.67 - \frac{23.875 \times 27.75}{144} \right] - \frac{185.2 - 68.8}{21 - (20/12)} \\ &= 62.9 - 6.0 = 56.9 \text{ kips} \end{aligned}$$

where A_t = tributary area of column = $[(21/2) + (20/24)] \times 20 = 226.67$ sq ft

M_1 = total negative design strip moment at interior support (see Table 4.24)

M_2 = total negative design strip moment at exterior support (see Table 4.24)

The section properties of the critical section are determined using Tables 4.13 and 4.16 for an edge column bending perpendicular to the edge:

$$c_2/c_1 = 1.0$$

$$c_1/d = 20/7.75 = 2.58$$

From Table 4.16, $f_1 = 9.74$ and $f_2 = 5.52$ (by linear interpolation).

$$\text{Using Table 4.13, } A_c = f_1 d^2 = 9.74 \times 7.75^2 = 585.0 \text{ in.}^2 \text{ and} \\ J_c/c_{AB} = 2f_2 d^3 = 2 \times 5.52 \times 7.75^3 = 5139 \text{ in.}^3$$

According to ACI 13.6.3.6, the gravity load moment to be transferred between the slab and edge column by eccentricity of shear must be $0.3M_o = 0.3 \times 264.5 = 79.4$ ft-kips.

Therefore, the combined factored shear stress at the face of the critical section due to gravity loads is

$$v_{u(AB)} = \frac{56,900}{585.0} + \frac{(1 - 0.62) \times 79.4 \times 12,000}{5139} = 97.3 + 70.5 = 167.8 \text{ psi}$$

Design shear strength is the smallest value determined by ACI Eqs. (11-31), (11-32) and (11-33). For a square column, ACI Eq. (11-33) governs:

$$\phi v_c = \frac{\phi V_c}{b_o d} = \phi 4 \lambda \sqrt{f'_c} = 0.75 \times 4 \times 1.0 \sqrt{4000} = 189.7 \text{ psi} > 167.8 \text{ psi} \quad \text{O.K.}$$

Shear Strength at First Interior Support

At this location, the factored shear force due to gravity loads is

$$V_u = q_u (A_t - b_1 b_2) + \frac{M_1 - M_2}{\ell_n} \\ = 0.283 \left[450 - \frac{27.75^2}{144} \right] + \frac{185.2 - 68.8}{21 - (20/12)} \\ = 125.8 + 6.0 = 131.8 \text{ kips}$$

where $A_t =$ tributary area of column $= 22.5 \times 20 = 450$ sq ft

$M_1 =$ total negative design strip moment at interior support (see Table 4.24)

$M_2 =$ total negative design strip moment at exterior support (see Table 4.24)

The section properties of the critical section are determined using Tables 4.13 and 4.14 for an interior column:

$$c_2/c_1 = 1.0$$

$$c_1/d = 20/7.75 = 2.58$$

From Table 4.14, $f_1 = 14.32$ and $f_2 = 8.73$ (by linear interpolation).

$$\text{Using Table 4.13, } A_c = f_1 d^2 = 14.32 \times 7.75^2 = 860.1 \text{ in.}^2 \text{ and } J_c/c_{AB} = 2f_2 d^3 = 2 \times 8.73 \times 7.75^3 = 8127 \text{ in.}^3$$

The total unbalanced moment at the first interior support is equal to $229.4 - 185.2 = 44.2$ ft-kips (see Table 4.24).

Therefore, the combined factored shear stress at the face of the critical section due to gravity loads is

$$v_{u(AB)} = \frac{131,800}{860.1} + \frac{(1 - 0.62) \times 44.2 \times 12,000}{8127} = 153.2 + 24.8 = 178.0 \text{ psi}$$

$$< 189.7 \text{ psi O.K.}$$

- Reinforcement Details

Slab reinforcement must conform to the requirements of ACI 13.3. The minimum bar extensions in ACI Figure 13.3.8 are to be provided for reinforcement in the column and middle strips.

Splice lengths for the flexural bars are determined by ACI 12.15. Class B splices are required for the bottom bars in the column strip in accordance with ACI 13.3.8.

Class B splice = $1.3\ell_d$ where ℓ_d is determined by ACI Eq. (12-1):

$$\ell_d = \left(\frac{3}{40} \frac{f_y}{\lambda \sqrt{f'_c}} \frac{\psi_t \psi_e \psi_s}{\left(\frac{c_b + K_{tr}}{d_b} \right)} \right) d_b$$

where λ = modification factor for lightweight concrete = 1.0 for normal weight concrete

ψ_t = modification factor for reinforcement location = 1.0 for other than top bars

ψ_e = modification factor for reinforcement coating = 1.0 for uncoated reinforcement

ψ_s = modification factor for reinforcement size = 0.8 for No. 5 bars

c_b = spacing or cover dimension

$$= 0.75 + \frac{0.625}{2} = 1.1 \text{ in. (governs)}$$

$$= \frac{15}{2} = 7.5 \text{ in.}$$

K_{tr} = transverse reinforcement index = 0

$$\frac{c_b + K_{tr}}{d_b} = \frac{1.1 + 0}{0.625} = 1.8 < 2.5$$

Therefore,

$$\ell_d = \left(\frac{3}{40} \frac{60,000}{1.0\sqrt{4000}} \frac{1.0 \times 1.0 \times 0.8}{1.8} \right) \times 0.625 = 19.8 \text{ in.} = 1.7 \text{ ft}$$

Class B tension splice = $1.3 \times 1.7 = 2.2 \text{ ft}$

Use a 2 foot, 3 inch splice length.

Reinforcement details for the column strip and middle strip in the end span are shown in Figure 4.29.

Part 2: Determine reinforcement in beams along column line 1

The beams along column line 1 are part of the lateral-force-resisting system and must be designed for the combined effects due to gravity, wind and seismic forces.

- Design for Flexure

Bending moments due to the dead and live loads are determined using the Direct Design Method. The longest clear span is used to calculate bending moments due to gravity forces.

The bending moments due to gravity forces are combined with the bending moments due to the lateral forces to obtain the maximum factored moments at the critical sections.

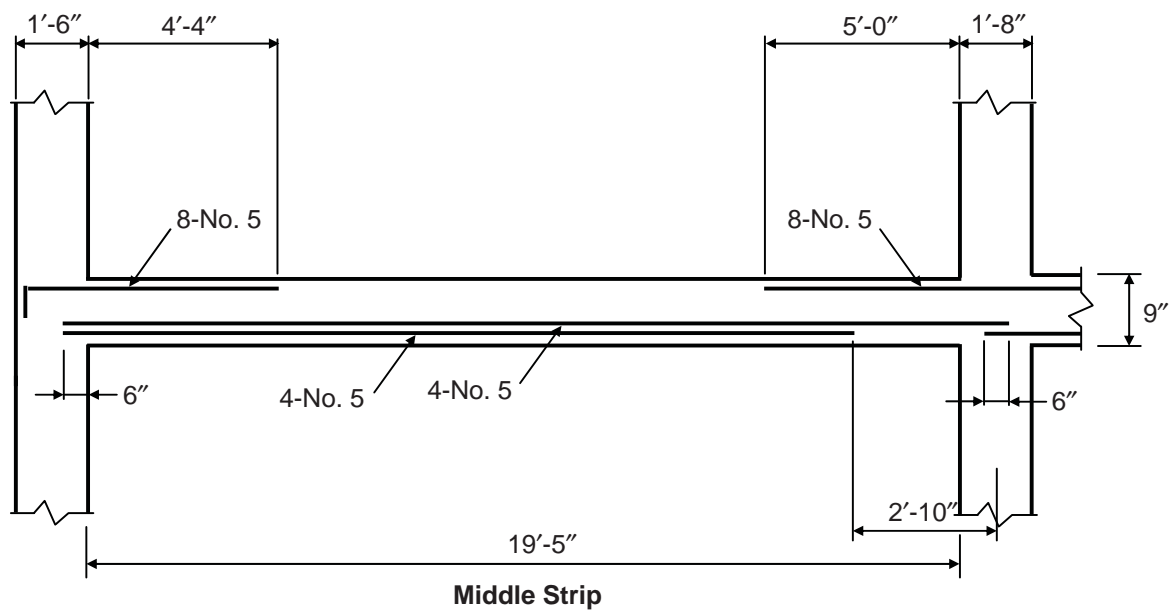
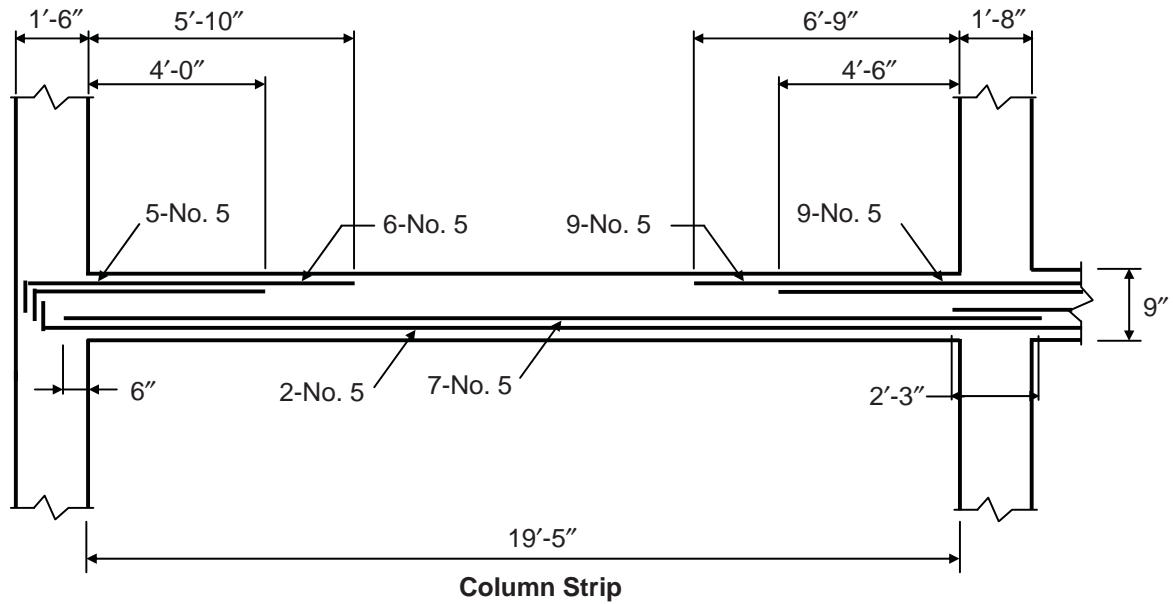

For SI: 1 inch = 25.4 mm; 1 foot = 304.8 mm.

Figure 4.29 Reinforcement Details for Design Strip Along Column Line 4

Bending Moments Due to Gravity Forces

According to ACI 13.6.5, beams are proportioned to resist a fraction of the column strip moment where the fraction depends on the value of $\alpha_{f1} \ell_2/\ell_1$.

Use ACI Eq. (13-3) and Figure 4.15 to determine α_{f1} .

Effective slab width $b_{eff} = 20 + (24 - 9) = 35$ in. $< 20 + (4 \times 9) = 56$ in.

$$y_b = \frac{\left[35 \times 9 \times \left(24 - \frac{9}{2}\right)\right] + \left[\frac{20}{2} \times (24 - 9)^2\right]}{[35 \times 9] + [20 \times (24 - 9)]} = 13.7 \text{ in.}$$

$$I_b = \frac{20 \times (24 - 9)^3}{12} + \left[20 \times (24 - 9) \times \left(13.7 - \frac{24 - 9}{2}\right)^2\right] + \frac{35 \times 9^3}{12} + \left[35 \times 9 \times \left(24 - \frac{9}{2} - 13.7\right)^2\right] = 29,880 \text{ in.}^4$$

$$I_s = \frac{(10.75 \times 12) \times 9^3}{12} = 7837 \text{ in.}^4$$

Thus,

$$\alpha_{f1} = \frac{29,880}{7837} = 3.81$$

$$\frac{\alpha_{f1} \ell_2}{\ell_1} = \frac{3.81 \times 20}{24} = 3.2$$

Since $\alpha_{f1} \ell_2/\ell_1 > 1.0$, the beam must be proportioned to resist 85 percent of the column strip moment (ACI 13.6.5.2).

ACI 13.6.2 is used to determine the bending moments in the column strip and the beam. A summary of the moments is given in Table 4.26.

The total static factored dead and live load moments are computed by ACI Eq. (13-4):

$$M_{oD} = \frac{q_D \ell_2 \ell_n^2}{8} = \frac{0.179 \times 10.83 \times 22.33^2}{8} = 120.8 \text{ ft-kips}$$

$$M_{oL} = \frac{q_L \ell_2 \ell_n^2}{8} = \frac{0.070 \times 10.83 \times 22.33^2}{8} = 47.3 \text{ ft-kips}$$

where

$$q_D = \left(\frac{9}{12} \times 150\right) + 30 + \left[\frac{(24 - 9) \times 20}{144} \times \frac{150}{10.83}\right] + \left(\frac{8 \times 11}{10.83}\right) = 179 \text{ psf}$$

$$\ell_2 = (20/2) + (20/24) = 10.83 \text{ ft (to be used when calculating } M_o \text{ for spans adjacent and parallel to an edge; see ACI 13.6.2.4)}$$

$$\ell_n = 24 - (20/12) = 22.33 \text{ ft}$$

Table 4.26 Service Gravity Bending Moments in Design Strip Along Column Line 1

Bending Moments (ft-kips)		End Span			Interior Span	
		Exterior Negative	Positive	Interior Negative	Positive	Interior Negative
Total Moment	Dead	36.4	60.4	84.6	42.3	78.5
	Live	14.2	23.7	33.1	16.6	30.8
Column Strip	Dead	33.1	48.3	67.7	33.8	62.8
	Live	12.9	19.0	26.5	13.3	24.6
Beam	Dead	28.1	41.1	57.6	28.7	53.4
	Live	11.0	16.2	22.5	11.3	20.9

In the interior span, the static moment, M_o , was distributed into total negative and positive moments using the distribution factors in ACI 13.6.3.2, and in the end span, M_o was distributed using the distribution factors in ACI 13.6.3.3 for slabs without beams between interior supports with an edge beam.⁹

Interior negative moments in the column strip were obtained by multiplying the total interior negative moments by the appropriate percentage in ACI 13.6.4.1. For $\ell_2/\ell_1 = 20/24 = 0.83$ and $\alpha_{f1}\ell_2/\ell_1 = 3.2 > 1$, the percentage of the total moment to be assigned to the column strip is 80 from linear interpolation. For example, the dead load moment in the column strip at this location is $0.80 \times 84.6 = 67.7$ ft-kips.

Exterior negative moments in the column strip were obtained by multiplying the total exterior negative moments by the appropriate percentage in ACI 13.6.4.2. The stiffness ratio, β_t , is calculated using ACI Eqs. (13-5) and (13-6) and Figure 4.18:

$$b_{eff} = 20 + (24 - 9) = 35 \text{ in.} < 20 + (4 \times 9) = 56 \text{ in.}$$

Case A:

$$C_A = \left(1 - 0.63 \frac{20}{24}\right) \frac{20^3 \times 24}{3} + \left(1 - 0.63 \frac{9}{15}\right) \frac{9^3 \times 15}{3} = 32,667 \text{ in.}^4 \text{ (governs)}$$

⁹ The distribution factors chosen for the end span resulted in bending moments very close to those obtained from a computer analysis.

Case B:

$$C_B = \left(1 - 0.63 \frac{15}{20}\right) \frac{15^3 \times 20}{3} + \left(1 - 0.63 \frac{9}{35}\right) \frac{9^3 \times 35}{3} = 18,996 \text{ in.}^4$$

Also,

$$I_s = \frac{20 \times 12 \times 9^3}{12} = 14,580 \text{ in.}^4$$

Therefore,

$$\beta_t = \frac{32,667}{2 \times 14,580} = 1.1$$

The percentage of the total moment to be assigned to the column strip is 91 from double linear interpolation of the values provided in ACI 13.6.4.2 using $\ell_2/\ell_1 = 0.83$ and $\beta_t = 1.1$. For example, the dead load moment in the column strip at this location is $0.91 \times 36.4 = 33.1$ ft-kips.

Positive moments in the column strip were obtained by multiplying the total positive moments by the appropriate percentage in ACI 13.6.4.4. For $\ell_2/\ell_1 = 0.83$ and $\alpha_{f1} \ell_2/\ell_1 = 3.2 > 1$, the percentage of the total moment to be assigned to the column strip is 80 from linear interpolation. For example, the dead load moment in the column strip in the end is $0.80 \times 60.4 = 48.3$ ft-kips.

As noted previously, the gravity bending moments in the beams are 85 percent of the column strip moments, since $\alpha_{f1} \ell_2/\ell_1 > 1.0$ (ACI 13.6.5.1).

Bending Moments Due to Lateral Forces

Wind and seismic forces were computed in accordance with ASCE/SEI Chapters 6, 11, 12, 20 and 21 given the design data above. The structure was analyzed for the lateral forces in the N-S direction, and the results are summarized in Table 4.27 for the beams along column line 1 at the first floor. Note that since the building is assigned to SDC B, ordinary reinforced concrete moment frames are utilized (see ASCE/SEI Table 12.2-1, system C7).

Factored Bending Moments

Basic strength design load combinations are given in ACI 9.2, which are essentially the same as those in ASCE/SEI 2.3.2. The applicable load combinations in this case are:

$$U = 1.4D$$

ACI Eq. (9-1)

$U = 1.2D + 1.6L$	ACI Eq. (9-2)
$U = 1.2D + 0.8W$	ACI Eq. (9-3)
$U = 1.2D + 0.5L + 1.6W$	ACI Eq. (9-4)
$U = 1.2D + 0.5L + 1.0E$	ACI Eq. (9-5)
$U = 0.9D + 1.6W$	ACI Eq. (9-6)
$U = 0.9D + 1.0E$	ACI Eq. (9-7)

Table 4.27 Bending Moments (ft-kips) in Beams at First Floor Level Along Column Line 1 Due to Wind and Seismic Forces

	End Span		Interior Span
	Exterior Negative	Interior Negative	Interior Negative
Wind (W)	54.0	49.0	40.4
Seismic (Q_E)	376.7	342.1	283.1

According to ASCE/SEI 12.4.2, the seismic load effect, E , is the combination of horizontal and vertical seismic load effects. The E for use in ACI Eq. (9-5) (or, equivalently, ASCE/SEI load combination 5) where the effects of gravity and seismic ground motion are additive is

$$E = \rho Q_E + 0.2S_{DS}D$$

The redundancy factor, ρ , is equal to 1.0 for structures assigned to SDC B (ASCE/SEI 12.3.4.1).

The E for use in ACI Eq. (9-7) (or, equivalently, ASCE/SEI load combination 7) where the effects of gravity and seismic ground motion counteract is

$$E = \rho Q_E - 0.2S_{DS}D$$

A summary of the governing factored bending moments is given in Table 4.28. The required flexural reinforcement is given in Table 4.29, and the provided areas of steel are within the limits prescribed in ACI 10.3.5 for maximum reinforcement (i.e., net tensile strain in the extreme tension steel at nominal strength, ϵ_t , shall be greater than or equal to 0.004) and ACI 10.5.1 for minimum reinforcement.

The selected reinforcement satisfies ACI 7.6.1 and 3.3.2 (minimum spacing for concrete placement), ACI 7.7.1 (minimum cover for protection of reinforcement) and ACI 10.6 (maximum spacing for control of flexural cracking). See Tables 4.7 and 4.8 for minimum and maximum number of reinforcing bars permitted in a single layer.

Table 4.28 Summary of Design Bending Moments and Shear Forces for Beam at First Floor Level Along Column Line 1

Load Case	Location	Bending Moment (ft-kips)	Shear Force (kips)
Dead (D)	Support	-57.6	11.8
	Midspan	41.1	
Live (L)	Support	-22.5	4.6
	Midspan	16.2	
Wind (W)	Support	± 54.0	± 4.8
Seismic (Q _E)	Support	± 376.7	± 33.7
Load Combination			
1.4D	Support	-80.6	16.5
	Midspan	57.5	
1.2D + 1.6L	Support	-105.1	21.5
	Midspan	75.2	
1.2D + 0.5L + 1.6W	Support	-166.8	24.1
	Midspan	57.4	
0.9D – 1.6W	Support	34.6	2.9
	Midspan	37.0	
1.24D + 0.5L + Q _E	Support	-459.4	50.7
	Midspan	59.1	
0.86D – Q _E	Support	327.2	23.6
	Midspan	35.3	

Table 4.29 Required Flexural Reinforcement for Beam at First Floor Level Along Column Line 1

Location	M _u (ft-kips)	A _s [*] (in. ²)	Reinforcement
Support	-459.4	5.33	6-No. 9
	327.2	3.66	4-No. 9
Midspan	75.2	1.43	2-No. 9
$*A_{s,min} = \frac{3\sqrt{f'_c}b_wd}{f_y} = \frac{3\sqrt{4000} \times 20 \times 21.5}{60,000} = 1.36 \text{ in.}^2$ $= \frac{200b_wd}{f_y} = \frac{200 \times 20 \times 21.5}{60,000} = 1.43 \text{ in.}^2 \text{ (governs) } \quad \text{ACI 10.5.1}$ $A_{s,max} = \frac{0.85\beta_1f'_cb_wd}{f_y} \frac{0.003}{0.003 + 0.004}$ $= \frac{0.85 \times 0.85 \times 4 \times 20 \times 21.5}{60} \times \frac{0.003}{0.007} = 8.88 \text{ in.}^2 \quad \text{ACI 10.3.5}$			

For SI: 1 square inch = 645.16 mm²; 1 foot-kip = 1.356 kN-m.

The final flexural reinforcement will be chosen after the effects of torsion are included in the analysis.

- Design for Combined Flexure, Shear and Torsion (see Figure 4.12)

Maximum Torsional Moment

In accordance with ACI 13.6.3.5, the beams along column line 1 must be designed to resist the torsional moments caused by the slab framing perpendicular to their span length. The applied uniform torsion, t_u , on the beams is equal to the total negative moment in the slab at column line 1 (which is equal to $0.3M_o$ for slabs without beams between interior supports and with an edge beam) divided by the span length:

$$t_u = \frac{0.3M_o}{\ell_1} = \frac{0.3 \times 0.283 \times 24 \times 18.33^2}{8 \times 24} = 3.6 \text{ ft-kips/ft}$$

The torsional moment at the critical section $T_u = 3.6 \times 24/2 = 43.2 \text{ ft-kips}^{10}$

Torsion can be neglected where T_u is less than

$$\phi \lambda \sqrt{f'_c} \left(\frac{A_{cp}^2}{p_{cp}} \right) = 0.75 \times 1.0 \sqrt{4000} \left(\frac{615^2}{118} \right) / 12,000 = 12.7 \text{ ft-kips}$$

where A_{cp} and p_{cp} are determined by Table 4.11 for an edge beam.

Thus, torsional effects must be considered since $T_u = 43.2 \text{ ft-kips} > 12.7 \text{ ft-kips}$.

Since the beams are part of an indeterminate framing system where redistribution of internal forces can occur following torsional cracking, the maximum factored torsional moment, T_u , at the critical section located at a distance, d , from the face of the support need not exceed the following [see ACI 11.5.2.2(a) and Figure 4.9]:

$$T_u = \phi 4 \lambda \sqrt{f'_c} \left(\frac{A_{cp}^2}{p_{cp}} \right) = 4 \times 12.7 = 50.8 \text{ ft-kips} > 43.2 \text{ ft-kips}$$

Therefore, design the beams for a torsional moment of 43.2 ft-kips.

Check the adequacy of the cross-sectional dimensions of the beam using ACI Eq. (11-18).

Maximum factored shear force at face of support $V_u = 50.7 \text{ kips}$ and factored shear force at critical section $V_u = 50.3 \text{ kips}$ (see Table 4.28 and Figure 4.30).

¹⁰ The factored torsional moment at the critical section based on a finite element analysis is equal to 26.7 ft-kips.

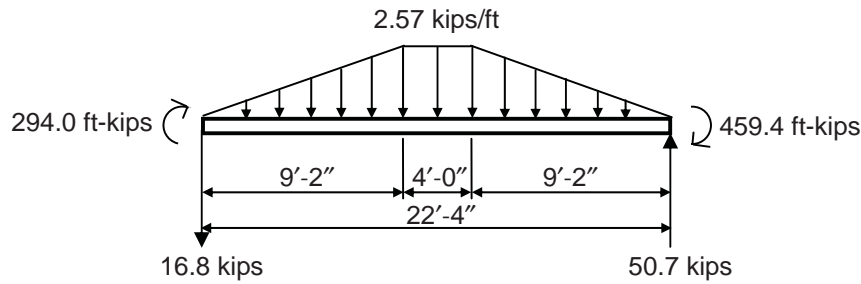

For SI: 1 inch = 25.4 mm; 1 foot = 304.8 mm; 1 ft-kip = 1.356 kN-m.

Figure 4.30 Factored Shear Forces on Beam at First Floor Level Along Column Line 1

Assuming a 1.5-inch clear cover to No. 4 closed stirrups in the beam web only, use Table 4.11 to determine the section properties A_{oh} and p_h :

$$A_{oh} = [20 - (2 \times 1.5) - 0.5] \times [24 - (2 \times 1.5) - 0.5] = 338.25 \text{ in.}^2$$

$$p_h = 2 \times \{[20 - (2 \times 1.5) - 0.5] + [24 - (2 \times 1.5) - 0.5]\} = 74 \text{ in.}$$

$$\sqrt{\left(\frac{V_u}{b_w d}\right)^2 + \left(\frac{T_u p_h}{1.7 A_{oh}^2}\right)^2} = \sqrt{\left(\frac{50,300}{20 \times 21.5}\right)^2 + \left(\frac{43.2 \times 12,000 \times 74}{1.7 \times 338.25^2}\right)^2} = 229.3 \text{ psi}$$

$$\phi \left(\frac{V_c}{b_w d} + 8\sqrt{f'_c} \right) = 0.75(2 + 8)\sqrt{4000} = 474.3 \text{ psi} > 229.3 \text{ psi} \quad \text{O.K.}$$

Required Transverse Reinforcement for Torsion

Determine transverse reinforcement required for torsion by ACI Eq. (11-21) (see Figure 4.10).

$$A_o = 0.85A_{oh} = 287.5 \text{ in.}^2$$

$$\frac{2A_t}{s} = \frac{2T_u}{2\phi \cot\theta A_o f_{yt}} = \frac{2 \times 43.2 \times 12,000}{2 \times 0.75 \times \cot 45^\circ \times 287.5 \times 60,000} = 0.040 \text{ in.}^2 / \text{in.}$$

Required Transverse Reinforcement for Shear

Determine transverse reinforcement required for shear by ACI Eqs. (11-1), (11-2) and (11-15) (see Figure 4.8).

$$\frac{A_v}{s} = \frac{V_u - \phi V_c}{\phi f_{yt} d} = \frac{50,300 - (0.75 \times 2 \times \sqrt{4000} \times 20 \times 21.5)}{0.75 \times 60,000 \times 21.5} = 0.010 \text{ in.}^2 / \text{in.}$$

Total Required Transverse Reinforcement

Total required transverse reinforcement = $0.040 + 0.010 = 0.050 \text{ in.}^2/\text{in.}$

Minimum transverse reinforcement is the greater of the following:

$$0.75\sqrt{f'_c} \frac{b_w}{f_{yt}} = 0.75\sqrt{4000} \frac{20}{60,000} = 0.016 \text{ in.}^2/\text{in.}$$

$$\frac{50b_w}{f_{yt}} = \frac{50 \times 20}{60,000} = 0.017 \text{ in.}^2/\text{in.} \quad (\text{governs})$$

Maximum spacing of transverse reinforcement is the smallest of the following:

$$\frac{p_h}{8} = \frac{74}{8} = 9.3 \text{ in.} \quad (\text{governs})$$

12 in.

$$\frac{d}{2} = \frac{21.5}{2} = 10.8 \text{ in.}$$

Assuming No. 4 closed stirrups, the required spacing, s , at the critical section = $2 \times 0.20/0.050 = 8.0 \text{ in.} < 9.3 \text{ in.}$

Provide No. 4 closed stirrups spaced at 8 inches on center at the critical section. Closed stirrups are required over the length of the continuous reinforcement (ACI 7.13.2.3).

Longitudinal Reinforcement Required for Torsion

Determine longitudinal reinforcement required for torsion by ACI Eq. (11-22) (see Figure 4.11).

$$A_\ell = \frac{A_t}{s} p_h \left(\frac{f_{yt}}{f_y} \right) \cot^2 \theta = \frac{0.040}{2} \times 74 = 1.48 \text{ in.}^2$$

$$A_{\ell, \min} = \frac{5\sqrt{f'_c} A_{cp}}{f_y} - \left(\frac{A_t}{s} \right) p_h \left(\frac{f_{yt}}{f_y} \right) = \frac{5\sqrt{4000} \times 615}{60,000} - \left(\frac{0.040}{2} \times 74 \right) = 1.76 \text{ in.}^2$$

Total Required Longitudinal Reinforcement

The longitudinal reinforcement required for torsion must be combined with the longitudinal reinforcement required for flexure. The longitudinal torsion reinforcement must be distributed around the perimeter of the section with a

maximum spacing of 12 inches (ACI 11.5.6.2). In order to have a uniform distribution of reinforcement around the perimeter, assign $1.76/4 = 0.44 \text{ in.}^2$ to each face.

Use one No. 6 bar on each side (area = 0.44 in.^2 , bar diameter = $0.75 \text{ in.} > 0.042s = 0.34 \text{ in.}$). This bar satisfies the maximum spacing requirement of 12 inches, since the spacing = $\{24 - 2[1.5 + 0.5 + (1.128/2)]\}/2 = 9.4 \text{ in.}$

The remaining 0.44 square inches of longitudinal steel required for torsion at the top and bottom of the section is added to the area of steel required for flexure (see Table 4.29):

- Face of support

$$5.37 + 0.44 = 5.81 \text{ in.}^2 < 6.00 \text{ in.}^2$$

$$3.65 + 0.44 = 4.09 \text{ in.}^2 \approx 4.00 \text{ in.}^2$$

- Midspan

$$1.43 + 0.44 = 1.87 \text{ in.}^2 < 2.00 \text{ in.}^2$$

Thus, the reinforcing bars in Table 4.29 can be used for combined flexure and torsion at the top and bottom of the section.

- Reinforcement Details

According to the structural integrity provisions in ACI 7.13.2.2, at least one-sixth of the tension reinforcement required for negative moment at the support (but not less than two bars) and at least one-quarter of the tension reinforcement required for positive moment at midspan (but not less than two bars) must be continuous and be enclosed by closed stirrups. Thus, at least two No. 9 top bars must be continuous or spliced by Class B tension splices near midspan, and at least two No. 9 bottom bars must be continuous or spliced by Class B tension splices at or near the supports. ACI 21.2.2 also requires that at least two of the top and bottom longitudinal bars be continuous.

Four of the six No. 9 top bars can be theoretically cut off at the location where the factored bending moment is equal to the design moment strength of the section based on a total area of steel equal to the area of two No. 9 bars. Thus, with $A_s = 2.00 \text{ in.}^2$, $\phi M_n = 185.6 \text{ ft-kips}$.

The load combination $0.86D - Q_E$ produces the longest bar lengths. The distance x from the face of the support where the factored bending moment is equal to 185.6 ft-kips is obtained by summing moments about section $a-a$ at this location (see Figure 4.31):

$$\left(\frac{x}{2} \times \frac{1.54x}{9.167} \times \frac{x}{3}\right) - 43.9x + 376.7 = 185.6$$

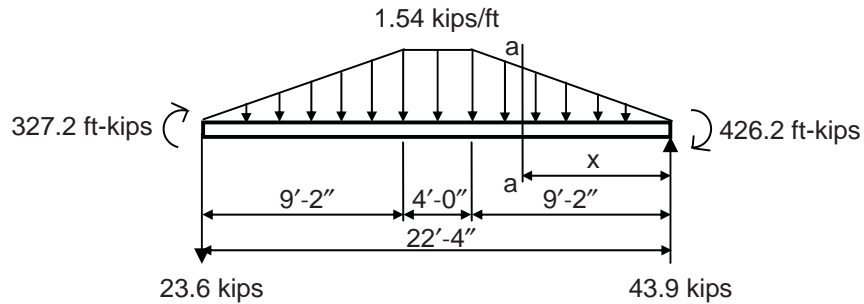

For SI: 1 inch = 25.4 mm; 1 foot = 304.8 mm; 1 ft-kip = 1.356 kN-m.

Figure 4.31 Cutoff Location of Negative Flexural Reinforcement

Solution of this equation gives $x = 5.6$ ft. The four No. 9 bars must extend a distance of $d = 21.5$ in. or $12d_b = 12 \times 1.128 = 13.5$ in. beyond the distance x (ACI 12.10.3). Thus, from the face of the support, the total bar length must be at least equal to $5.6 + (21.5/12) = 7.4$ ft. Also, the bars must extend a full development length, ℓ_d , beyond the face of the support (ACI 12.10.4). The development length for the No. 9 bars can be determined by ACI Eq. (12-1):

$$\ell_d = \left(\frac{3}{40} \frac{f_y}{\lambda \sqrt{f'_c}} \frac{\psi_t \psi_e \psi_s}{\left(\frac{c_b + K_{tr}}{d_b}\right)} \right) d_b$$

where $\lambda =$ modification factor for lightweight concrete = 1.0 for normal weight concrete

$\psi_t =$ modification factor for reinforcement location = 1.3 for top bars

$\psi_e =$ modification factor for reinforcement coating = 1.0 for uncoated reinforcement

$\psi_s =$ modification factor for reinforcement size = 1.0 for No. 9 bars

$c_b =$ spacing or cover dimension

$$= 1.5 + 0.5 + \frac{1.128}{2} = 2.6 \text{ in.}$$

$$= \frac{20 - 2(1.5 + 0.5) - 1.128}{2 \times 5} = 1.5 \text{ in. (governs)}$$

K_{tr} = transverse reinforcement index = 0 (conservative)

$$\frac{c_b + K_{tr}}{d_b} = \frac{1.5 + 0}{1.128} = 1.3 < 2.5$$

Therefore,

$$\ell_d = \left(\frac{3}{40} \frac{60,000}{1.0\sqrt{4000}} \frac{1.3 \times 1.0 \times 1.0}{1.3} \right) \times 1.128 = 80.3 \text{ in.} = 6.7 \text{ ft}$$

Thus, the total length of the four No. 9 bars must be at least 7.4 feet beyond the face of the support.

Flexural reinforcement shall not be terminated in a tension zone unless one or more of the conditions of ACI 12.10.5 are satisfied. In this case, the point of inflection is approximately 10.4 feet from the face of the support, which is greater than 7.4 feet. Thus, the No. 9 bars cannot be terminated here unless one of the conditions of ACI 12.10.5 is satisfied. In this case, check if the factored shear force, V_u , at the cutoff point does not exceed $2\phi V_n/3$ (ACI 12.10.5.1). With No. 4 stirrups at 8 inches on center, ϕV_n is determined by ACI Eqs. (11-1) and (11-2):

$$\phi V_n = \phi(V_c + V_s) = 0.75 \left(54.4 + \frac{0.4 \times 60 \times 21.5}{8} \right) = 89.2 \text{ kips}$$

At 7.4 feet from the face of the support, $V_u = 43.9 - (0.5 \times 1.24 \times 7.4) = 39.3$ kips, which is less than $2 \times 89.2/3 = 59.5$ kips. Therefore, the four No. 9 bars can be terminated at 7.4 feet from the face of the support.

It is assumed in this example that the four No. 9 positive bars are continuous with splices over the columns.

Figure 4.32 shows the reinforcement details for the beam.

Part 3: Determine reinforcement in column B1 supporting the first floor level

A summary of the axial forces, bending moments and shear forces on column B1 is given in Table 4.30. ACI Eq. (13-7) was used in determining the gravity load moments on the column where the full dead load is taken on adjoining spans and half of the live load is taken on the longer span. The bending moment determined by this equation was distributed to the column above and below inversely proportional to their lengths. Also given in Table 4.30 are the factored load combinations.¹¹

¹¹ It was assumed in the analysis that the base of the column is pinned and that only axial force is transmitted from the column to the footing.

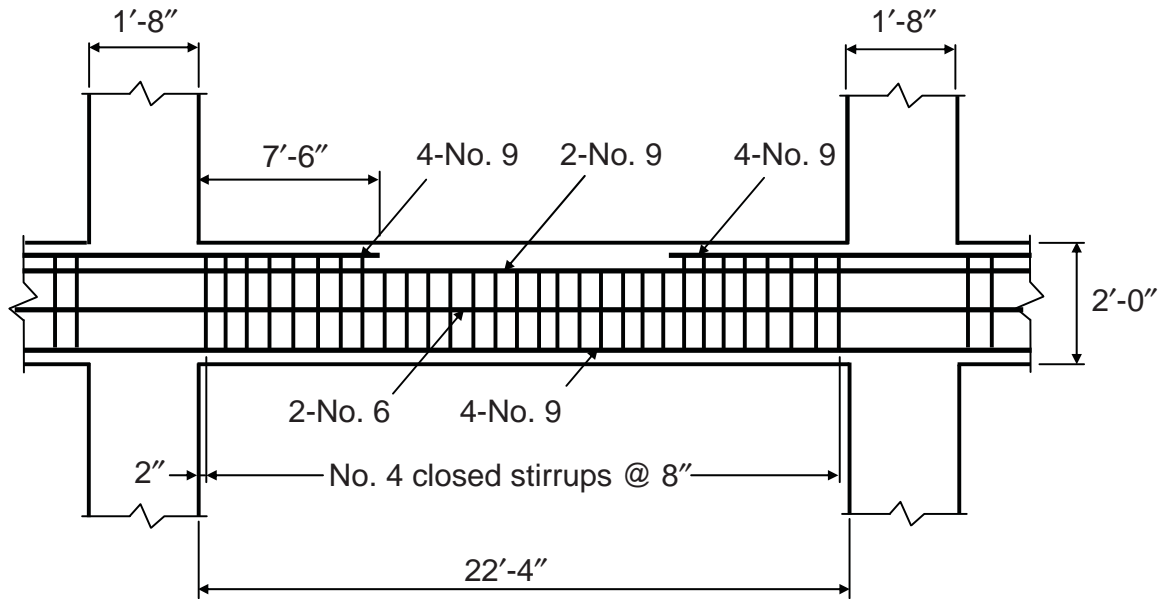

For SI: 1 inch = 25.4 mm; 1 foot = 304.8 mm.

Figure 4.32 Reinforcement Details for the Beam at First Floor Level Along Column Line 1

Table 4.30 Summary of Axial Forces, Bending Moments and Shear Forces on Column B1 Supporting the First Floor Level

Load Case	Axial Force (kips)	Bending Moment (ft-kips)	Shear Force (kips)
Dead (D)	157.9	11.3	± 2.3
Live (L)	31.5	11.0	± 2.2
Roof live (L_r)	4.9		
Wind (W)	± 3.6	± 111.0	± 11.1
Seismic (Q_E)	± 25.1	± 402.0	± 40.2
Load Combination			
$1.4D$	221.1	15.8	3.2
$1.2D + 1.6L + 0.5L_r$	242.3	31.2	6.3
$1.2D + 0.5(L + L_r) + 1.6W$	213.4	196.7	21.6
$0.9D - 1.6W$	136.4	167.4	15.7
$1.24D + 0.5L + Q_E$	236.7	421.5	44.2
$0.86D - Q_E$	110.7	392.3	38.2

For SI: 1 ft-kip = 1.356 kN-m.

- Design for Axial Force and Bending

Based on the governing load combinations in Table 4.30, a 20-inch by 20-inch column reinforced with 12 No. 9 bars ($A_{st} = 0.027A_g$) is adequate for column B1 supporting the first floor level. The interaction diagram for this column is shown in Figure 4.33. Since P-delta effects were considered in the analysis, slenderness effects need not be considered. The provided area of longitudinal reinforcement is within the allowable range specified in ACI 10.9.1.

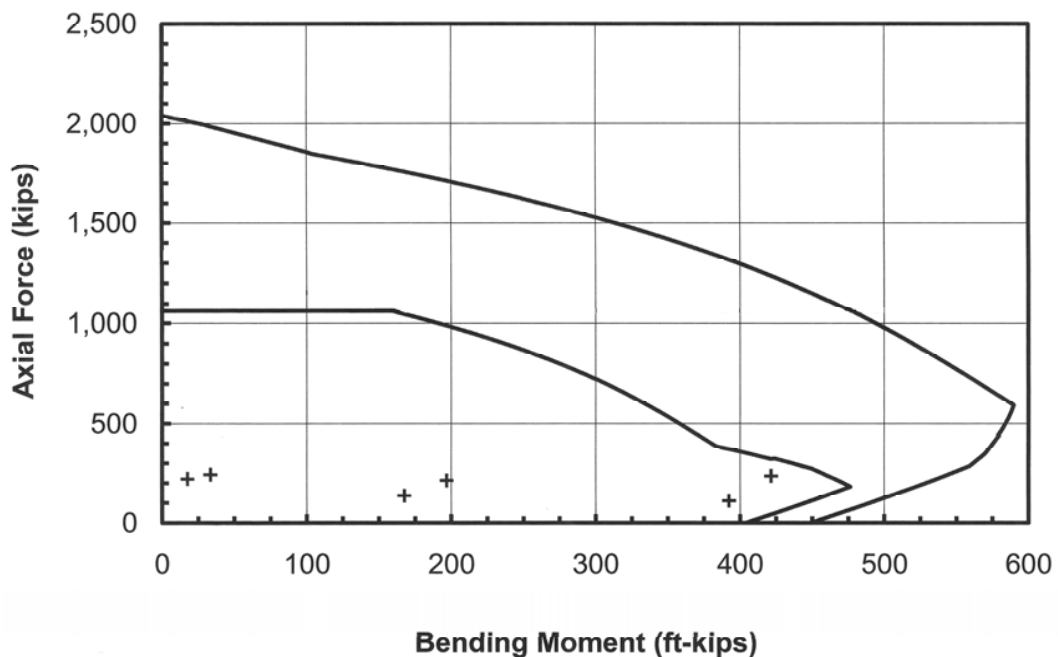

Figure 4.33 Design and Nominal Strength Interaction Diagrams for Column B1

In accordance with ACI 7.6.3, the distance between longitudinal bars must be greater than or equal to $1.5d_b = 1.5 \times 1.128 = 1.7$ in. (governs) or 1.5 inches. In this case, the clear distance is equal to

$$\frac{20 - 2 \left(1.5 + 0.375 + \frac{1.128}{2} \right)}{3} - 1.128 = 5.0 \text{ in.} > 1.7 \text{ in.} \quad \text{O.K.}$$

- Design for Shear

Since the clear height to plan dimension of the column = $[(12 \times 12) - 24]/20 = 6 > 5$, the column need not be designed for shear in accordance with ACI 21.3.3 (ACI 21.2.3).

The shear capacity of the column is checked in accordance with ACI Eq. (11-4) for members subjected to axial compression:

$$V_c = 2 \left(1 + \frac{N_u}{2000A_g} \right) \lambda \sqrt{f'_c} b_w d$$

$$= 2 \left(1 + \frac{236,700}{2000 \times 20^2} \right) \sqrt{4000} \times 20 \times 13.8/1000 = 45.2 \text{ kips}$$

where $N_u = 236.7$ kips, which is the factored axial compressive force on the column corresponding to the maximum shear force and $d = 13.8$ in. was obtained from a strain compatibility analysis.

Since $\phi V_c = 0.75 \times 45.2 = 33.9$ kips $< V_u = 44.2$ kips, provide shear reinforcement in accordance with ACI 11.4.7:

$$\frac{A_v}{s} = \frac{V_u - \phi V_c}{\phi f_{yt} d} = \frac{44.2 - 33.9}{0.75 \times 60 \times 13.8} = 0.017 \text{ in.}^2/\text{in.}$$

The required spacing of No. 3 ties and crossies is

$$s = \frac{4 \times 0.11}{0.017} = 25.9 \text{ in.} < \frac{A_v f_y}{50 b_w} = \frac{(4 \times 0.11) \times 60,000}{50 \times 20} = 26.4 \text{ in.}$$

The transverse reinforcement requirements of ACI 7.10.5 must also be satisfied. The vertical spacing of the No. 3 ties must not exceed the smallest of the following:

$$16(\text{longitudinal bar diameters}) = 16 \times 1.128 = 18.0 \text{ in.}$$

$$48(\text{tie bar diameters}) = 48 \times 0.375 = 18.0 \text{ in.}$$

$$\text{Least column dimension} = 20 \text{ in.}$$

Use No. 3 ties @ 18.0 in. on center with the first tie located vertically not more than $18/2 = 9.0$ in. above the top of the slab and not more than 3.0 inches below the lowest horizontal reinforcement in the beams (ACI 7.10.5.4 and 7.10.5.5).

- Reinforcement Details

ACI 12.17 contains the splice requirements for columns. It can be seen from the interaction diagram in Figure 4.33 that the bar stress corresponding to at least one factored load combination is greater than $0.5f_y$. Thus, Class B lap splices must be provided in accordance with ACI 12.17.2.3.

Determine the development length in tension by ACI Eq. (12-1):

$$\ell_d = \left(\frac{3}{40} \frac{f_y}{\lambda \sqrt{f'_c}} \frac{\psi_t \psi_e \psi_s}{\left(\frac{c_b + K_{tr}}{d_b} \right)} \right) d_b$$

where λ = modification factor for lightweight concrete = 1.0 for normal weight concrete

ψ_t = modification factor for reinforcement location = 1.0 for bars other than top bars

ψ_e = modification factor for reinforcement coating = 1.0 for uncoated reinforcement

ψ_s = modification factor for reinforcement size = 1.0 for No. 9 bars

c_b = spacing or cover dimension

$$= 1.5 + 0.5 + \frac{1.128}{2} = 2.6 \text{ in.}$$

$$= \frac{20 - 2(1.5 + 0.375) - 1.128}{2 \times 3} = 2.5 \text{ in. (governs)}$$

K_{tr} = transverse reinforcement index

$$= \frac{40A_{tr}}{sn} = \frac{40 \times 4 \times 0.11}{18 \times 4} = 0.2$$

$$\frac{c_b + K_{tr}}{d_b} = \frac{2.5 + 0.2}{1.128} = 2.4 < 2.5$$

Therefore,

$$\ell_d = \left(\frac{3}{40} \frac{60,000}{1.0 \sqrt{4000}} \frac{1.0 \times 1.0 \times 1.0}{2.4} \right) \times 1.128 = 33.4 \text{ in.} = 2.8 \text{ ft}$$

Class B splice length = $1.3\ell_d = 3.6 \text{ ft}$

Use a 3 foot, 8 inch splice length with the splice located just about the slab.

Reinforcement details for column B1 are given in Figure 4.34.

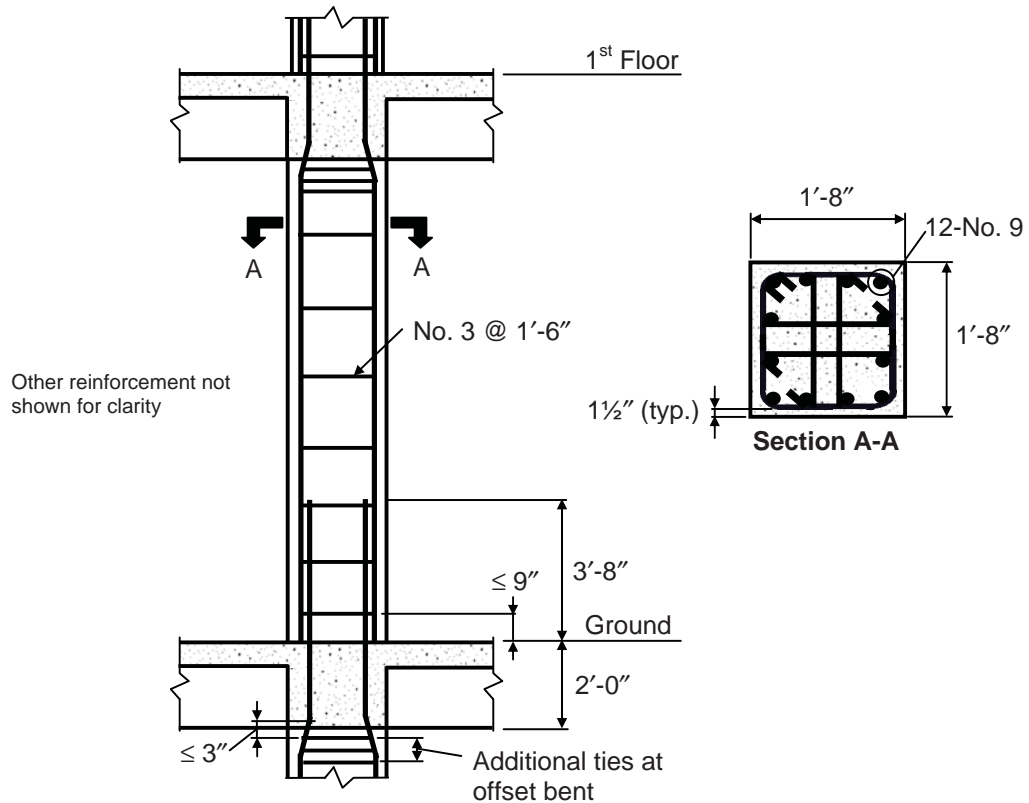

For SI: 1 inch = 25.4 mm; 1 foot = 304.8 mm.

Figure 4.34 Reinforcement Details for Column B1 Supporting the First Floor Level

Part 4: Determine reinforcement in footing B1

- Base Area of Footing

According to ACI 15.2.2, the base area of a footing is to be determined using service loads in whatever combination that governs the design. Basic load combination 6 in ASCE/SEI 2.4.1 is the critical load combination for footing B1 (see ASCE/SEI 12.4.2.3 and Table 4.30):

$$P = (1 + 0.105S_{DS})P_D + 0.75P_L + 0.75P_{Lr} + 0.525P_{QE} = 201.5 \text{ kips}$$

From Table 4.23, the required base area of the footing is

$$A_f = \frac{201,500}{4000} = 50.4 \text{ sq ft}$$

Use a 7 foot, 6 inch square footing ($A_f = 56.3 \text{ sq ft}$).

- Footing Thickness

The thickness of the footing must be determined using the factored pressure at the base of the footing considering both flexure and shear. The maximum factored pressure at the base of the footing is:

$$q_u = (1.2 + 0.2S_{DS})q_D + 0.5q_L + q_{QE}$$

$$= \left(1.24 \times \frac{157,900}{7.5^2}\right) + \left(0.5 \times \frac{31,500}{7.5^2}\right) + \frac{25,100}{7.5^2} = 4207 \text{ psf}$$

Design for Flexure

The critical section for flexure for a footing supporting a concrete column is at the face of the column (see Figure 4.22). Using Eq. 4.1, the required effective depth, d , of the footing for flexure, assuming minimum reinforcement, is

$$d = 2.2c\sqrt{q_u} = 2.2 \left(\frac{7.5}{2} - \frac{20}{24}\right) \sqrt{4207} = 13.2 \text{ in.}$$

The required reinforcement will be determined after the required effective depth is established, considering both flexure and shear strength.

Shear Strength

The minimum effective depth that is required to satisfy one-way shear requirements is determined by Eq. 4.2:

$$d = \frac{q_u c}{q_u + 2\phi\sqrt{f'_c}} = \frac{\frac{4207}{144} \times \left(\frac{7.5}{2} - \frac{20}{24}\right) \times 12}{\frac{4207}{144} + (2 \times 0.75\sqrt{4000})} = 8.2 \text{ in.}$$

Equation 4.3 is used to determine the minimum effective depth to satisfy two-way shear requirements:

$$d = c_1 \left[\frac{-a + \sqrt{a^2 + q_u bc}}{2b} \right]$$

$$= 20 \left[\frac{-204.4 + \sqrt{204.4^2 + \left(\frac{4207}{144} \times 197.1 \times 19.3\right)}}{2 \times 197.1} \right] = 9.5 \text{ in.}$$

where $a = \frac{q_u}{2} + \phi v_c = \frac{4207}{2} + (0.75 \times 253.0) = 204.4 \text{ psi}$

$$b = \frac{q_u}{4} + \phi v_c = \frac{4207}{4 \times 144} + (0.75 \times 253.0) = 197.1 \text{ psi}$$

$$c = \frac{A_f}{c_1^2} - 1 = \frac{7.5^2}{\left(\frac{20}{12}\right)^2} - 1 = 19.3$$

$$v_c = 4\lambda\sqrt{f'_c} = 4 \times 1.0\sqrt{4000} = 253.0 \text{ psi}$$

Therefore, an $13.2 + 4 = 17.2$ inch footing thickness is adequate for flexure and shear.

Try a 18-inch-thick footing ($d = 14$ in.).

Footing Reinforcement

Required area of reinforcement = $0.0018 \times 12 \times 18 = 0.39 \text{ in.}^2/\text{ft}$

Try No. 5 @ 9 in. ($A_s = 0.41 \text{ in.}^2/\text{ft}$)

Determine the development length of the No. 5 bars.

$$\begin{aligned} \ell_d &= \left(\frac{3}{40} \frac{f_y}{\lambda\sqrt{f'_c}} \frac{\psi_t\psi_e\psi_s}{\left(\frac{c_b + K_{tr}}{d_b}\right)} \right) d_b \\ &= \left(\frac{3}{40} \times \frac{60,000}{1.0\sqrt{4000}} \times \frac{1.0 \times 1.0 \times 0.8}{2.5} \right) \times 0.625 = 14.2 \text{ in.} = 1.2 \text{ ft} \end{aligned}$$

Available development length:

$$\frac{7.5 - \frac{20}{12}}{2} - \frac{3}{12} = 2.7 \text{ ft} > 1.2 \text{ ft} \quad \text{O.K.}$$

Use No. 5 @ 9 inches, 7 feet long each way.

Force Transfer at Base of Column

Check bearing stress on the concrete column and footing in accordance with ACI 15.8.1.1.

Bearing strength of column (ACI 10.14.1):

$$\phi P_{nb} = \phi 0.85 f'_c A_1 = 0.65 \times 0.85 \times 4 \times 20^2 = 884 \text{ kips} > P_u = 236.7 \text{ kips} \quad \text{O.K.}$$

Bearing strength of footing:

The bearing strength of the footing is permitted to be increased by the factor $\sqrt{A_2/A_1}$ where A_2 is the plan area of the lower base of the largest frustrum of a pyramid, cone or tapered wedge contained wholly within the support, and having for its upper base the loaded area and having side slopes of 1 vertical to 2 horizontal. In this case,

$$A_2 = (35 + 20 + 35)^2 = 8100 \text{ in.}^2$$

$$\sqrt{\frac{A_2}{A_1}} = \sqrt{\frac{8100}{20^2}} = 4.5 > 2.0, \text{ use } 2.0$$

$$\phi P_{nb} = 2\phi 0.85 f'_c A_1$$

$$= 0.65 \times 0.85 \times 4 \times 20^2 = 1768 \text{ kips} > P_u = 236.7 \text{ kips} \quad \text{O.K.}$$

In accordance with ACI 15.8.2.1, the following minimum area of reinforcement is required across the interface:

$$\text{Minimum } A_s = 0.005 A_g = 0.005 \times 20^2 = 2.0 \text{ in.}^2$$

Provide eight No. 5 bars as dowels ($A_s = 2.48 \text{ in.}^2$)

The required length of the dowel bars are determined below.

Transfer of Horizontal Force at Base of Column

According to ACI 15.8.1.4, the shear-friction provisions of ACI 11.6 can be used to check for transfer of lateral forces from the column to the footing.

Assuming that the footing surface is not intentionally roughened, the maximum shear transfer permitted is:

$$\phi V_n = \phi 0.2 f'_c A_c = 0.75 \times 0.2 \times 4 \times 20^2 = 240 \text{ kips} < 800 A_c = 320 \text{ kips}$$

From Table 4.30, $V_u = 67.8 \text{ kips} < 240 \text{ kips} \quad \text{O.K.}$

The required area of shear-friction reinforcement is determined by ACI Eq. (11-25):

$$A_{vf} = \frac{V_u}{\phi f_y \mu} = \frac{67.8}{0.75 \times 60 \times 0.6} = 2.51 \text{ in.}^2$$

Provided $A_{vf} = 2.48 \text{ in.}^2 \approx 2.51 \text{ in.}^2$ say O.K. (1.2 percent difference)

Since the shear-friction reinforcement acts in tension, it must be fully anchored for tension into the column and into the footing.

Tensile anchorage into the column:

$$\ell_d = \left(\frac{3}{40} \frac{f_y}{\lambda \sqrt{f'_c}} \frac{\psi_t \psi_e \psi_s}{\left(\frac{c_b + K_{tr}}{d_b} \right)} \right) d_b$$

where λ = modification factor for lightweight concrete = 1.0 for normal weight concrete

ψ_t = modification factor for reinforcement location = 1.0 for bars other than top bars

ψ_e = modification factor for reinforcement coating = 1.0 for uncoated reinforcement

ψ_s = modification factor for reinforcement size = 0.8 for No. 5 bars

c_b = spacing or cover dimension

$$= 1.5 + 0.5 + \frac{1.128}{2} + \left(\frac{1.128 + 0.625}{2} \right) \sin 45^\circ = 3.2 \text{ in.}$$

$$= \frac{1}{2} \left[\frac{20 - 2(1.5 + 0.375) - 1.128}{3} - \left(\frac{1.128 + 0.625}{2} \right) \sin 45^\circ \right]$$

$$= 2.2 \text{ in. (governs)}$$

K_{tr} = transverse reinforcement index

$$= \frac{40A_{tr}}{sn} = \frac{40 \times 4 \times 0.11}{6 \times 3} = 1.0$$

$$\frac{c_b + K_{tr}}{d_b} = \frac{2.2 + 1.0}{0.625} = 5.1 > 2.5, \text{ use } 2.5$$

Therefore,

$$\ell_d = \left(\frac{3}{40} \frac{60,000}{1.0 \sqrt{4000}} \frac{1.0 \times 1.0 \times 0.8}{2.5} \right) \times 0.625 = 14.2 \text{ in.}$$

Provide at least 14.2 inches of embedment into the column.

Tensile anchorage into the footing, assuming 90-degree standard hooks at the ends of the No. 5 dowel bars:

$$\ell_{dh} = \left(\frac{0.02\psi_e f_y}{\lambda\sqrt{f'_c}} \right) d_b = \left(\frac{0.02 \times 1.0 \times 60,000}{1.0\sqrt{4000}} \right) \times 0.625 = 11.9 \text{ in.}$$

Since the cover normal to the plane of the 90-degree hook is greater than 2.5 inches and the cover on the bar extension beyond the hook is greater than 2 inches, the required development length may be reduced in accordance with ACI 12.5.3(a):

$$\ell_{dh} = 0.7 \times 11.9 = 8.3 \text{ in.} > 8d_b = 5 \text{ in. and } 6 \text{ in.}$$

$$\text{Available footing depth} = 18 - 3 - (2 \times 0.625) = 13.75 \text{ in.} > 8.3 \text{ in.}$$

$$\text{Therefore minimum total length of dowel bars} = 14.2 + 8.3 = 22.5 \text{ in.}$$

Use 2 foot-long dowels.

Reinforcement details for footing B1 are given in Figure 4.35.

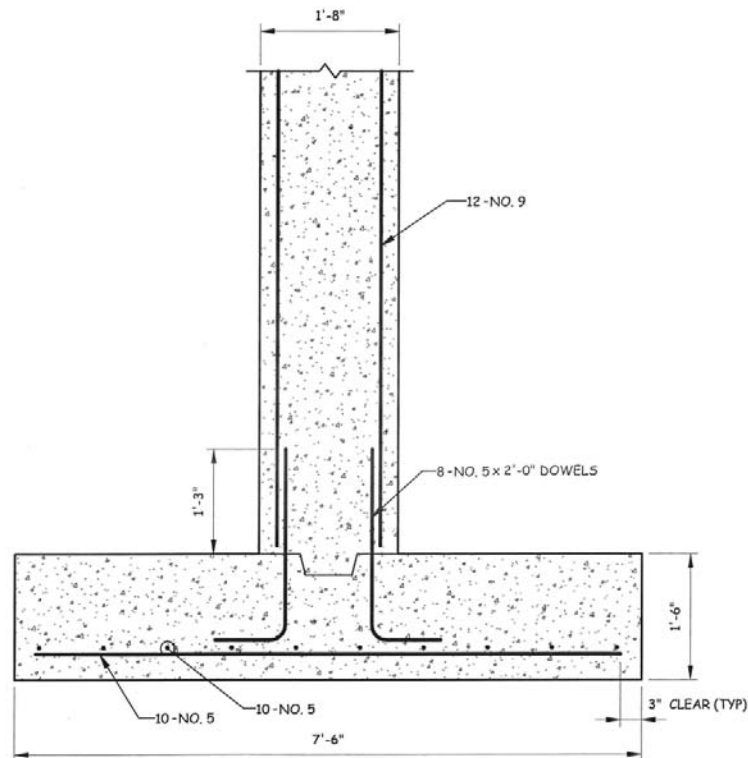

For SI: 1 inch = 25.4 mm; 1 foot = 304.8 mm.

Figure 4.35 Reinforcement Details for Footing B1

Part 5: Determine reinforcement in the diaphragm chords along column lines 1, 2, 6 and 7 at the second floor level for lateral forces in the east-west direction

Prior to determining the required reinforcement, the locations of the center of mass and center of rigidity will be determined.

Based on the member sizes and dimensions in Figure 4.26, the center of mass is located 60.0 feet to the east of column line 1 and 61.8 feet to the north of column line F.¹²

The stiffnesses of the frames are determined by Equation 3.5 in this publication. Using the beam and column cross-sectional dimensions and lengths in Figure 4.26, the relative stiffnesses of the frames are as follows:

One-bay frames on lines 2 and 6: 1.00

One-bay frames on line D: 1.06

Three-bay frames on lines 1 and 7: 2.35

Six-bay frame on line A: 4.62

By inspection, the center of rigidity in the east-west direction is located $x_{cr} = 60$ feet from column line 1 due to the symmetric distribution of the frame stiffnesses in the north-south direction. Equation 3.8 is used to determine the location of the center of rigidity in the north-south direction, which is measured from column line F:

$$y_{cr} = \frac{\sum(k_i)_x y_i}{\sum(k_i)_x}$$

$$= \frac{(4.62 \times 114) + (2 \times 1.06 \times 45)}{4.62 + (4 \times 1.06)} = 70.2 \text{ ft}$$

Diaphragm Design Forces

ASCE/SEI Equation (12.10-1) is used to determine the design seismic force, F_{px} , on the diaphragm.¹³

$$F_{px} = \left(\sum_{i=x}^n F_i / \sum_{i=x}^n w_i \right) w_{px}$$

$$\leq 0.4 S_{DS} I w_{px} = 0.076 w_{px}$$

$$\geq 0.2 S_{DS} I w_{px} = 0.038 w_{px}$$

¹² The center of mass is located 60.0 feet to the east of from column line 1 and 60.8 feet to the north of column line F when only the mass of the floor slab is considered.

¹³ The effects from wind forces do not govern in this example.

where F_i = the seismic design force applied at level i

w_i = the weight tributary to level i

w_{px} = the weight tributary to the diaphragm at level x

Table 4.31 contains a summary of the diaphragm forces at each level of the building.

Table 4.31 Design Seismic Diaphragm Forces

Level	w_x (kips)	$\sum w_x$ (kips)	F_x (kips)	$\sum F_x$ (kips)	$\frac{\sum F_x}{\sum w_x}$	w_{px} (kips)	F_{px} (kips)
4	1,667	1,667	172	172	0.076*	1,667	127
3	1,995	3,662	157	329	0.076*	1,995	152
2	1,995	5,657	108	437	0.076*	1,995	152
1	2,014	7,671	59	496	0.065	2,014	131

* Maximum value governs.

Since the diaphragm is rigid, the 152-kip diaphragm force at the second floor level is distributed to the frames in proportion to their relative stiffnesses. This force is applied at the location of the center of mass, which must be displaced from its actual location a distance of 5 percent of the dimension of the building perpendicular to the direction of the applied force = $0.05 \times 114 = 5.7$ ft (ASCE/SEI 12.8.4.2). Thus, two cases must be examined: (1) center of mass located at $61.8 + 5.7 = 67.5$ ft from column line F and (2) center of mass located at $61.8 - 5.7 = 56.1$ ft from column line F.

- Case 1: Center of mass located at 67.5 feet from column line F

In this case, the eccentricity, e_y , between the center of mass and the center of rigidity = $70.2 - 67.5 = 2.7$ ft

The forces applied to each frame are determined by Equation 3.12 of this publication:¹⁴

$$(V_i)_x = \frac{(k_i)_x}{\sum (k_i)_x} V_x + \frac{\bar{y}_i (k_i)_x}{\sum \bar{x}_i^2 (k_i)_y + \sum \bar{y}_i^2 (k_i)_x} V_x e_y$$

where \bar{x}_i = perpendicular distance from element i to the center of rigidity parallel to the x -axis

\bar{y}_i = perpendicular distance from element i to the center of rigidity parallel to the y -axis

¹⁴ The forces determined by this method are within 3 percent of those determined by a computer analysis of the diaphragm assuming that the diaphragm is rigid.

Frame on column line A between lines 1 and 7:

$$V_{A/1-7} = \frac{4.62 \times 152}{(4 \times 1.06) + 4.62} - \frac{(114 - 70.2) \times 4.62 \times (152 \times 2.7)}{40,777} = 77.2 \text{ kips}$$

Frames on column line D between lines 1 and 2 and between lines 6 and 7:

$$\begin{aligned} V_{D/1-2} = V_{D/6-7} &= \frac{1.06 \times 152}{(4 \times 1.06) + 4.62} + \frac{(70.2 - 45) \times 1.06 \times (152 \times 2.7)}{40,777} \\ &= 18.5 \text{ kips} \end{aligned}$$

Frames on column line F between lines 2 and 3 and between lines 5 and 6:

$$\begin{aligned} V_{F/2-3} = V_{D/5-6} &= \frac{1.06 \times 152}{(4 \times 1.06) + 4.62} + \frac{70.2 \times 1.06 \times (152 \times 2.7)}{40,777} \\ &= 18.9 \text{ kips} \end{aligned}$$

The maximum shear force per unit length in the slab occurs along column line A and is equal to 77.2 kips, which is distributed over a length of 80 feet.

The shear strength of the slab is determined by ACI Equation (11-3) using the full thickness of the slab:

$$\begin{aligned} \phi V_c &= \phi 2\lambda \sqrt{f'_c} b t = 0.75 \times 2 \times 1.0 \sqrt{4000} \times (80 \times 12) \times 9/1000 \\ &= 819.7 \text{ kips} > 77.2 \text{ kips} \quad \text{O.K.} \end{aligned}$$

- Case 2: Center of mass located at 56.1 feet from column line F

In this case, the eccentricity, e_y , between the center of mass and the center of rigidity
 $= 70.2 - 56.1 = 14.1 \text{ ft}$

Frame on column line A between lines 1 and 7:

$$V_{A/1-7} = \frac{4.62 \times 152}{(4 \times 1.06) + 4.62} - \frac{(114 - 70.2) \times 4.62 \times (152 \times 14.1)}{40,777} = 68.7 \text{ kips}$$

Frames on column line D between lines 1 and 2 and between lines 6 and 7:

$$\begin{aligned} V_{D/1-2} = V_{D/6-7} &= \frac{1.06 \times 152}{(4 \times 1.06) + 4.62} + \frac{(70.2 - 45) \times 1.06 \times (152 \times 14.1)}{40,777} \\ &= 19.6 \text{ kip} \end{aligned}$$

Frames on column line F between lines 2 and 3 and between lines 5 and 6:

$$V_{F/2-3} = V_{D/5-6} = \frac{1.06 \times 152}{(4 \times 1.06) + 4.62} + \frac{70.2 \times 1.06 \times (152 \times 14.1)}{40,777}$$

$$= 22.1 \text{ kips}$$

The maximum shear force per unit length in the slab occurs along column line A and is equal to 68.7 kips, which is distributed over a length of 80 feet. This maximum shear force is less than that determined in case 1, so the shear strength of the slab is adequate in this case as well.

Chord Forces and Reinforcement

Section 1602 of the IBC defines a diaphragm chord as a boundary element perpendicular to the applied lateral force that is assumed to resist the axial stresses due to the bending moments in the diaphragm.

In general, the diaphragm is assumed to act as a deep beam that spans between the vertical elements of the lateral-force-resisting system, which act as supports. The compressive or tensile chord force along the length of the diaphragm can be calculated by dividing the bending moment in the diaphragm due to the lateral forces by the diaphragm dimension parallel to the direction of the load.

The concrete diaphragm in this example is modeled as a continuous beam with supports along column lines A, D and F for seismic forces in the east-west direction. The total reactions at these supports can be determined from the forces in the frames. It is assumed that the diaphragm force can be represented by a trapezoidal distributed load as illustrated in Figure 4.36. Since the reactions at the supports are known, the distributed loads, w_1 and w_2 , can be determined from statics. Once the distributed loads have been established, the maximum bending moment is computed and is used to determine the maximum chord force in the diaphragm.

For the center of mass located at 67.5 feet from column line F, the reactions are as follows:

$$R_A = V_{A/1-7} = 77.2 \text{ kips}$$

$$R_D = V_{D/1-2} + V_{D/6-7} = 2 \times 18.5 = 37.0 \text{ kips}$$

$$R_F = V_{F/2-3} + V_{D/5-6} = 2 \times 18.9 = 37.8 \text{ kips}$$

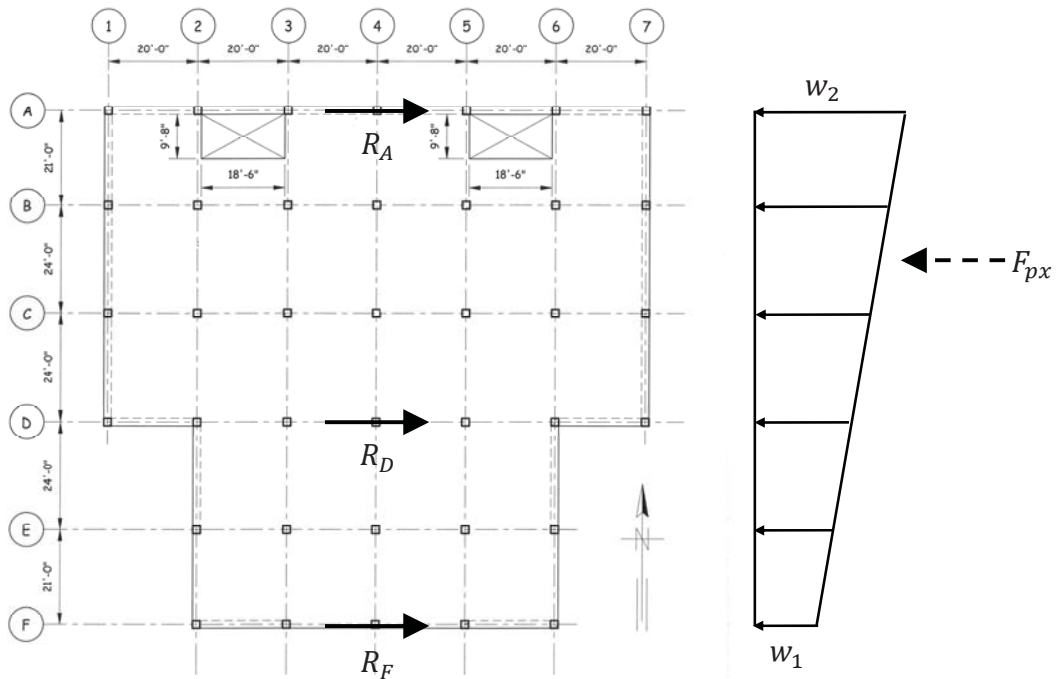

For SI: 1 inch = 25.4 mm; 1 foot = 304.8 mm.

Figure 4.36 Distributed Load on Diaphragm for Seismic Forces in the East-West Direction

Summing forces in the east-west direction and summing moments about column line A results in the following two equations for the diaphragm at the second floor level:

$$(w_1 \times 114) + \left[\frac{1}{2}(w_2 - w_1) \times 114 \right] = 152$$

$$\left(w_1 \times \frac{114^2}{2} \right) + \left[\frac{1}{2}(w_2 - w_1) \times 114 \times \left(\frac{1}{3} \times 114 \right) \right] = (37.0 \times 69) + (37.8 \times 114)$$

Solving these equations simultaneously results in $w_1 = 0.50$ kips/ft and $w_2 = 2.16$ kips/ft.

The shear and moment diagrams for this case are shown in Figure 4.37. The maximum bending moment in the portion of the diaphragm between column lines A and D is equal to 1513.2 ft-kips. Between column lines D and F, the maximum bending moment is equal to 970.7 ft-kips.

A similar analysis can be performed for the center of mass located at 56.1 feet from column line F. In that case, the maximum bending moment in the portion of the diaphragm between column lines A and D is equal to 1427.4 ft-kips. Between column lines D and F, the maximum bending moment is equal to 966.3 ft-kips. Thus, the

maximum chord forces are obtained for the case where the center of mass is located at 67.5 feet from column line F.

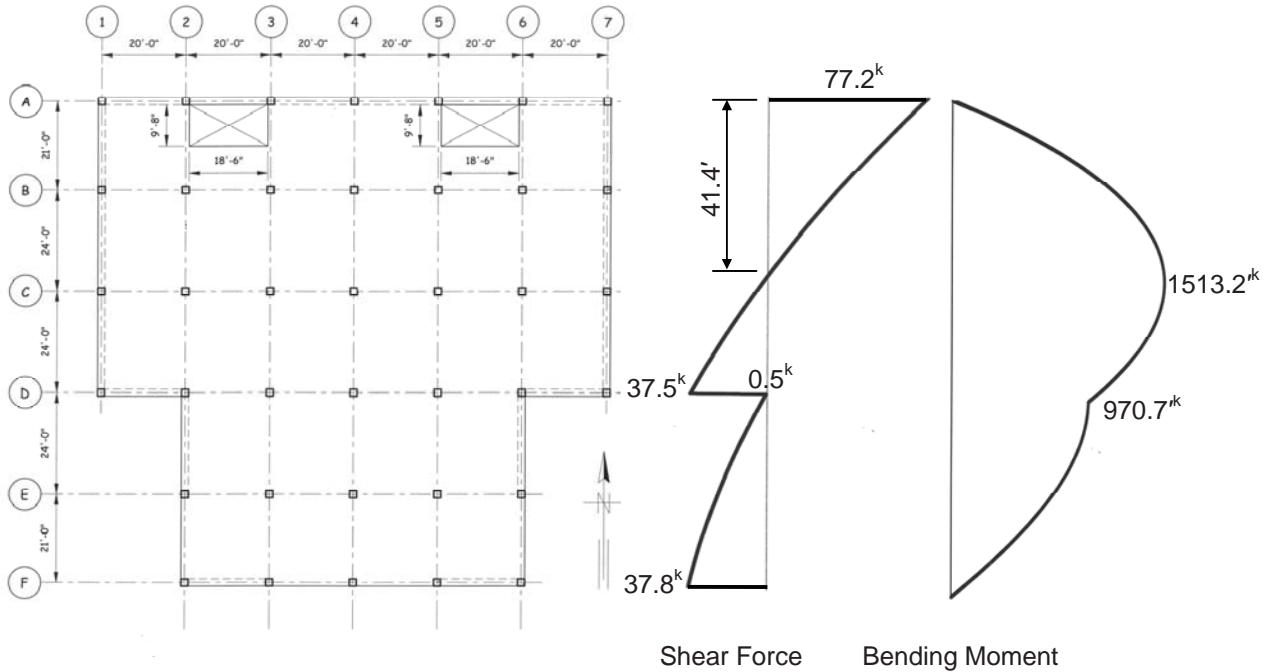

For SI: 1 inch = 25.4 mm; 1 foot = 304.8 mm.

Figure 4.37 Shear Force and Bending Moment Diagrams for the Diaphragm at the Second Floor Level for Seismic Forces in the East-West Direction

For the portion of the diaphragm between lines A and D, the maximum chord force is equal to the following:

$$T_u = C_u = \frac{M_u}{D} = \frac{1513.2}{120} = 12.6 \text{ kips}^{15}$$

The required area of tension reinforcement is

$$A_s = \frac{T_u}{\phi f_y} = \frac{12.6}{0.9 \times 60} = 0.23 \text{ in.}^2$$

Therefore, provide one No. 5 chord bar along the slab edges on column lines 1 and 7 between lines A and D.¹⁶

¹⁵ It can be shown that the 20-inch by 24-inch edge beams on column lines 1 and 7 are adequate for the combined effects due to bending and the 12.6-kip axial compressive force.

¹⁶ In lieu of providing an extra bar in the edge beams for chord reinforcement, any excess amount of provided reinforcement in the beams may be used to resist the tensile force in the chord. That option is not considered in this example.

For the portion of the diaphragm between lines D and F, the maximum chord force is:

$$T_u = C_u = \frac{M_u}{D} = \frac{970.7}{80} = 12.1 \text{ kips}$$

Therefore, provide one No. 5 chord bar along the slab edges on column lines 2 and 6 between lines D and F.¹⁷

Similar analyses can be performed for the required chord reinforcement due to seismic forces in the north-south direction.

It has been assumed in this example that the openings along column line A do not have a major influence on the overall analysis of the diaphragm. For typical stair and elevator openings, this is typically a good assumption. Additional reinforcement may be required around such openings to resist the secondary chord forces that are developed in these areas. In cases where the openings are relatively large compared to the area of the diaphragm, a more detailed analysis that takes into account the nonuniform distribution of seismic mass should be performed, especially in cases where a Type 3 diaphragm discontinuity irregularity is present (see ASCE/SEI Table 12.3-1).

Part 6: Determine reinforcement in the collector element along column line F at the second floor level for lateral forces in the east-west direction

The slab section between lines 3 and 5 is utilized in this example as the collector that pulls (or drags) the unit shear force in this segment of the diaphragm into the elements of the lateral-force-resisting system (frames) along line F. The concrete slab collector is designed in accordance with the recommendations in the SEAOC *Blue Book*.¹⁸ It is assumed that the effective width of the collector element is equal to the width of the beams in the moment frames, which is 20 inches.

It was determined in Part 5 of this example that the total diaphragm force along line F is equal to 37.8 kips. The unit shear force in the diaphragm is equal to $37.8/80 = 0.473$ kips/ft. Similarly, the unit shear force for the frames is $37.8/40 = 0.945$ kips/ft.

The unit shear forces and net unit shear forces are depicted in Figure 4.38. The collector force diagram is constructed by using the areas of the net unit shear force diagram as changes in the magnitude of the collector force. For example, between lines 2 and 3, the area of the net shear force diagram is $0.473 \times 20 = 9.5$ kips. This is the maximum value of the collector force (compression or tension) along the length between lines 2 and 6.

¹⁷ The portions of the chords on lines 2 and 6 between lines E and F also act as collector members for seismic forces in the north-south direction. Reinforcement needs to be provided that satisfies the more stringent of the two requirements.

¹⁸ SEAOC Seismology Committee, "Concrete slab collectors," *The SEAOC Blue Book: Seismic design recommendations*, Structural Engineers Association of California, Sacramento, CA, August 2008.

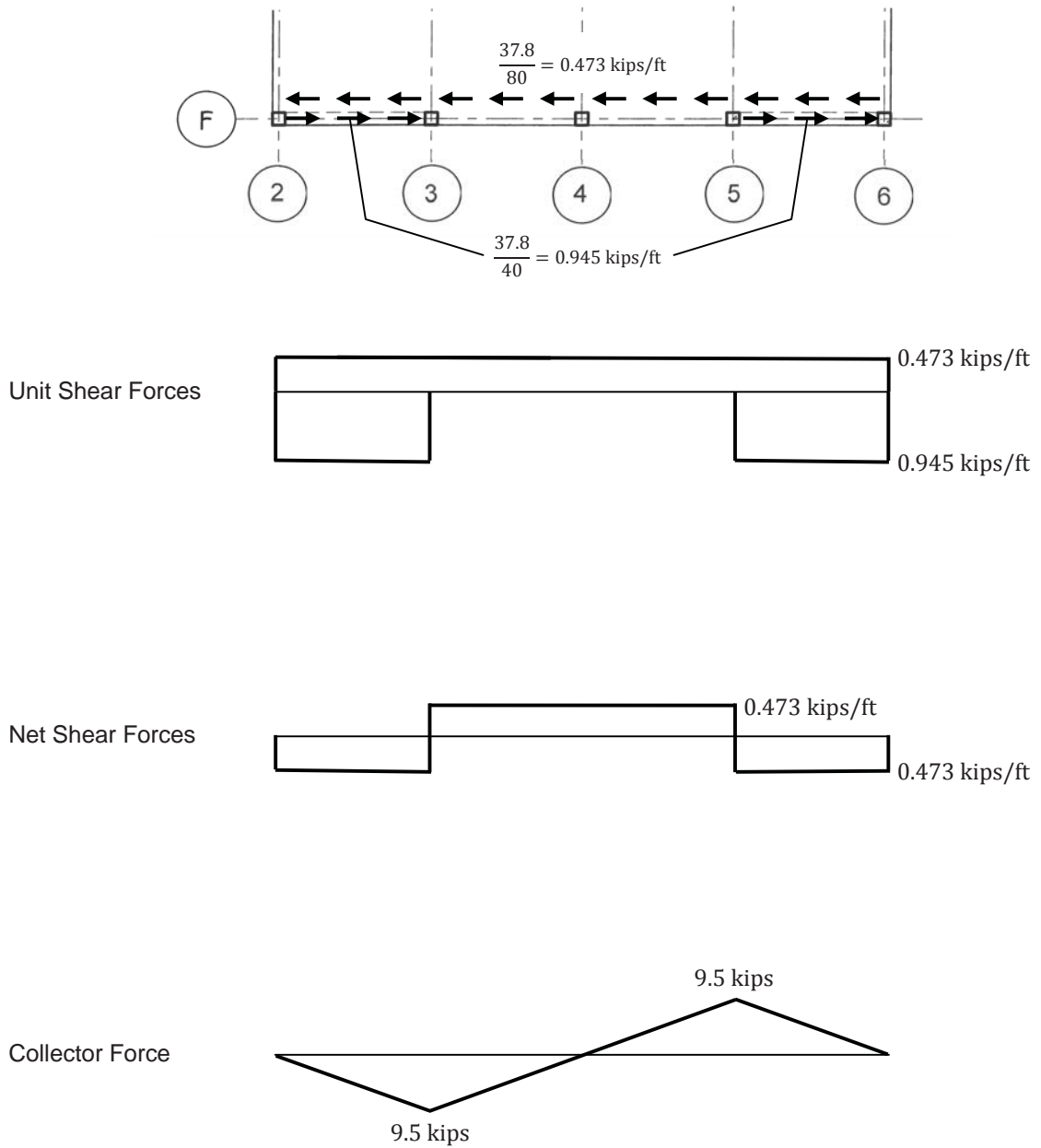

Figure 4.38 Unit Shear Forces, Net Shear Forces and Collector Force Diagram on Column Line F

Reinforcement Required to Resist Collector Tension

The required area of tension reinforcement is calculated based on the maximum collector force:

$$A_s = \frac{T_u}{\phi f_y} = \frac{9.5}{0.9 \times 60} = 0.18 \text{ in.}^2$$

Provide one No. 4 bar in addition to the reinforcement required for gravity loads. This reinforcement, which can be easily accommodated within the 20-inch-wide beams in the moment frames, should be placed at the mid-depth of the slab in order to prevent additional out-of-plane bending stresses in the slab. By developing the collector reinforcement within the width of beam, the collector forces are transmitted directly into the lateral-force-resisting system.

Collector Compressive Strength

The maximum compressive stress on the concrete slab collector, which is equal to $9500/(9 \times 20) = 53$ psi, is relatively low and the section is adequate without any additional reinforcement.

Diaphragm Segment Eccentricity

In cases where all or part of the collector reinforcement is placed at the sides of the lateral-force-resisting elements, which in this example are moment frames, the diaphragm section adjacent to the lateral-force-resisting elements must be designed to resist the seismic shear and in-plane bending resulting from the eccentricity of that part of the collector force that is not transferred directly into the end of the lateral-force-resisting elements. Since the collector force in this example is transferred directly into the beams of the moment frames, no eccentricity is present and no in-plane bending occurs.

4.6.2 Example 4.2—One-story Retail Building

For the one-story retail building depicted in Figure 4.39, (1) determine the location of the center of rigidity and distribute lateral forces to each wall and (2) design the wall on line A.

DESIGN DATA

Concrete: $f'_c = 4000$ psi; reinforcement: $f_y = 60,000$ psi.

Roof live load = 20 psf

Roof superimposed dead load = 10 psf

Lateral-force-resisting system: bearing walls (thickness = 8 inches)

Wind velocity = 90 mph, Exposure B

Seismic Design Category: A ($S_{DS} = 0.13$, $S_{D1} = 0.07$)

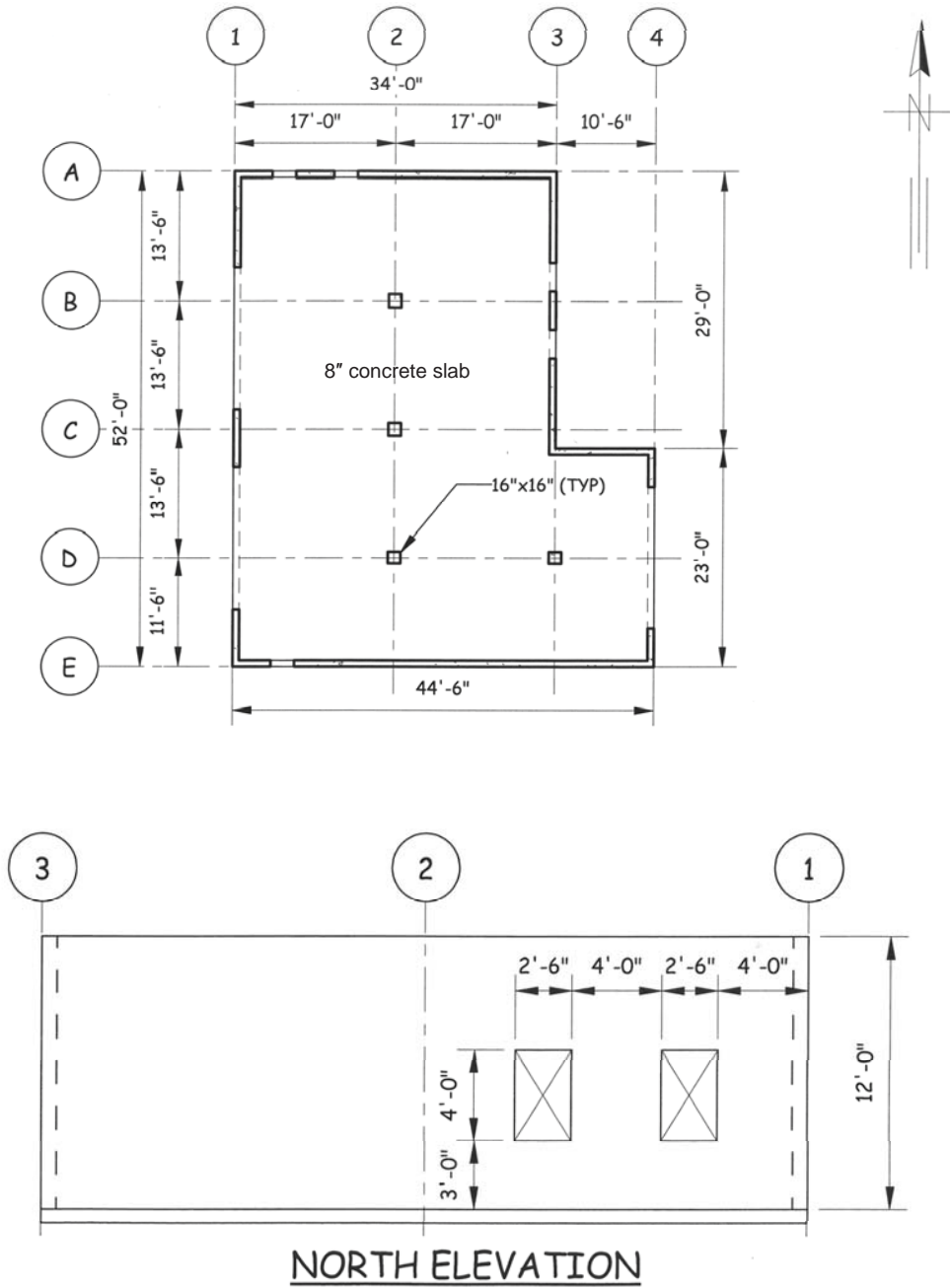
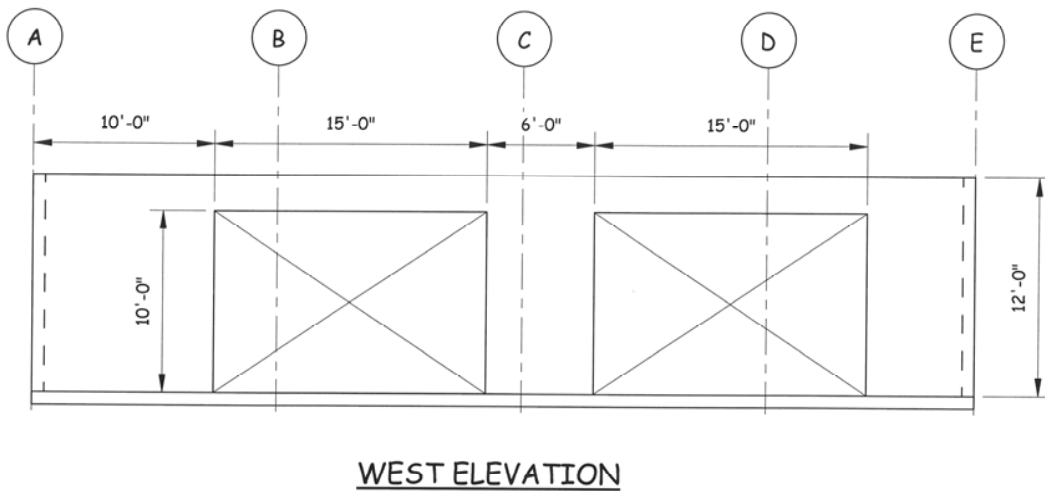
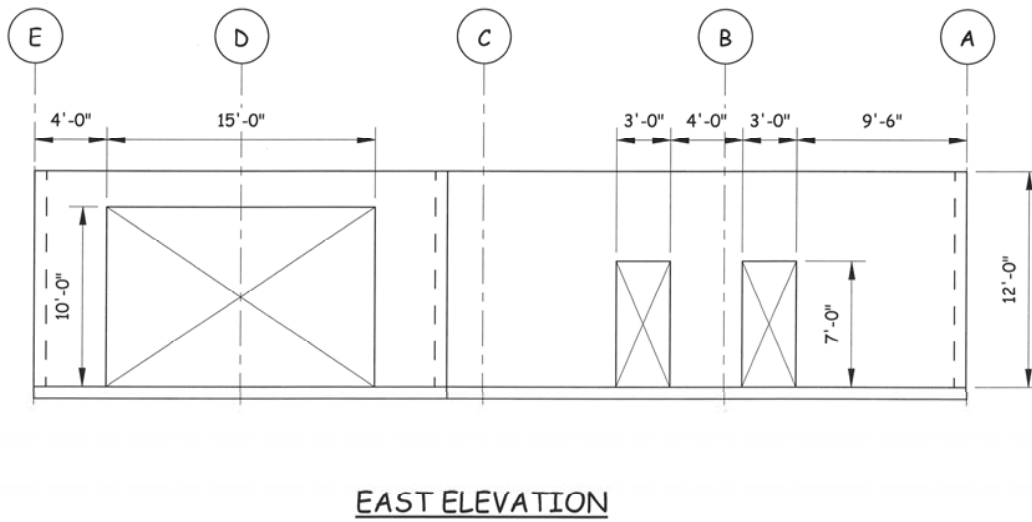
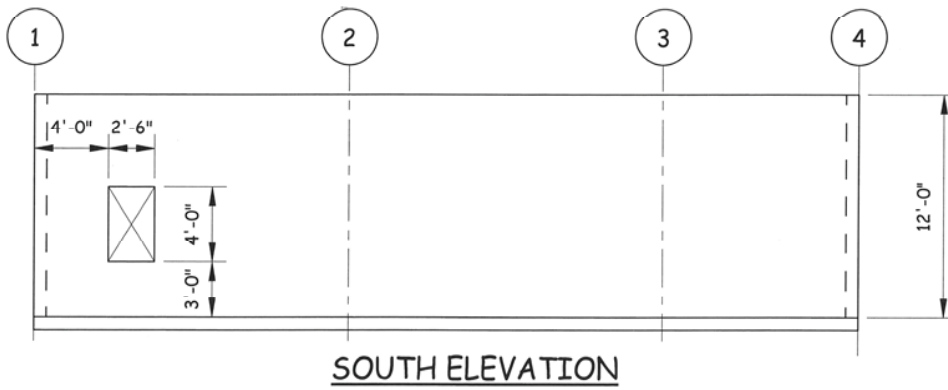

Figure 4.39 Roof Plan and Elevations of One-story Retail Building



For SI: 1 inch = 25.4 mm; 1 foot = 304.8 mm.

Figure 4.39 Roof Plan and Elevations of One-story Retail Building (continued)

SOLUTION

Part 1: Determine the location of the center of rigidity and distribute lateral forces to each wall

Since the building has a rigid diaphragm, the locations of the center of mass and the center of rigidity must be determined, and the lateral forces must be distributed to the walls in proportion to their relative rigidities.

Based on the member sizes and dimensions in Figure 4.39, the center of mass is located 21.4 feet from the centerline of the west wall and 22.4 feet from the centerline of the south wall.¹⁹

Equations 3.1 and 3.2 in Section 3.5.2 of this publication are used to determine the stiffnesses of the walls.

Total displacement of pier or wall i : $\delta_i = \delta_{Fi} + \delta_{Vi}$

δ_{Fi} = displacement due to bending

$$= \frac{\left(\frac{h_i}{\ell_i}\right)^3}{Et} \text{ for fixed walls or piers}$$

$$= \frac{4\left(\frac{h_i}{\ell_i}\right)^3}{Et} \text{ for cantilevered walls or piers}$$

δ_{Vi} = displacement due to shear

$$= \frac{3\left(\frac{h_i}{\ell_i}\right)}{Et} \text{ for fixed or cantilevered walls or piers}$$

where h_i = height of pier or wall

ℓ_i = length of pier or wall

t = thickness of pier or wall

E = modulus of elasticity of pier or wall = $G/0.4$

Stiffness of pier or wall $k_i = 1/\delta_i$

¹⁹ The center of mass is located 19.4 feet from the centerline of the west wall and 23.9 feet from the centerline of the south wall when only the mass of the floor slab is considered.

In lieu of a more rigorous analysis, the stiffness of a wall with openings is determined as follows (see Section 3.5.2): first, the deflection of the wall is obtained as though it were a solid wall with no openings. Next, the deflection of that portion of the wall that contains the openings is subtracted from the total deflection. Finally, the deflection of each pier surrounded by the openings is added back.

Tables 4.32 through 4.36 contain a summary of the stiffness calculations for the walls, and the pier designations are provided in Figure 4.40.

Table 4.32 Stiffness Calculations for North Wall

Pier/Wall	h_i (ft)	l_i (ft)	Type	$\delta_{Fi}Et$	$\delta_{Vi}Et$	δ_iEt	k_i/Et
1 + 2 + 3 + 4 + 5 + 6 + 7	12	34	Cant	0.176	1.059	1.235	—
1 + 2 + 3 + 6 + 7	4	34	Cant	-0.007	-0.353	-0.360	—
1	4	21	Fixed	0.007	0.571	—	1.729
2	4	4	Fixed	1.000	3.000	—	0.250
3	4	4	Fixed	1.000	3.000	—	0.250
1 + 2 + 3	—	—	—	—	—	0.449	2.229
						1.324	0.756

Table 4.33 Stiffness Calculations for South Wall

Pier/Wall	h_i (ft)	l_i (ft)	Type	$\delta_{Fi}Et$	$\delta_{Vi}Et$	δ_iEt	k_i/Et
1 + 2 + 3 + 4 + 5	12	44.5	Cant	0.078	0.809	0.887	—
1 + 2 + 5	4	44.5	Cant	-0.003	-0.270	-0.273	—
1	4	4	Fixed	1.000	3.000	—	0.250
2	4	38	Fixed	0.001	0.316	—	3.157
1 + 2	—	—	—	—	—	0.294	3.407
						0.908	1.101

Table 4.34 Stiffness Calculations for East Wall (Northern Segment)

Pier/Wall	h_i (ft)	ℓ_i (ft)	Type	$\delta_{Fi}Et$	$\delta_{Vi}Et$	δ_iEt	k_i/Et
1 + 2 + 3 + 4 + 5 + 6	12	29	Cant	0.283	1.241	1.524	—
1 + 2 + 3 + 5 + 6	7	29	Cant	-0.056	-0.724	-0.780	—
1	7	9.5	Fixed	0.400	2.211	—	0.383
2	7	4	Fixed	5.359	5.250	—	0.094
3	7	9.5	Fixed	0.400	2.211	—	0.383
1 + 2 + 3	—	—	—	—	—	1.163	0.860
						1.907	0.524

Table 4.35 Stiffness Calculations for East Wall (Southern Segment)

Pier/Wall	h_i (ft)	ℓ_i (ft)	Type	$\delta_{Fi}Et$	$\delta_{Vi}Et$	δ_iEt	k_i/Et
1 + 2 + 3 + 4	12	23	Cant	0.568	1.565	2.133	—
1 + 2 + 4	10	23	Cant	-0.329	-1.304	-1.633	—
1	10	4	Cant	62.500	7.500	—	0.014
2	10	4	Cant	62.500	7.500	—	0.014
1 + 2	—	—	—	—	—	35.71	0.028
						36.21	0.028

Table 4.36 Stiffness Calculations for West Wall

Pier/Wall	h_i (ft)	ℓ_i (ft)	Type	$\delta_{Fi}Et$	$\delta_{Vi}Et$	δ_iEt	k_i/Et
1 + 2 + 3 + 4 + 5 + 6	12	52	Cant	0.049	0.692	0.741	—
1 + 2 + 3 + 5 + 6	10	52	Cant	-0.028	--0.577	-0.605	—
1	10	10	Cant	4.000	3.000	—	0.143
2	10	6	Cant	18.519	5.000	—	0.043
3	10	6	Cant	18.519	5.000	—	0.043
1 + 2 + 3	—	—	—	—	—	4.367	0.229
						4.503	0.222

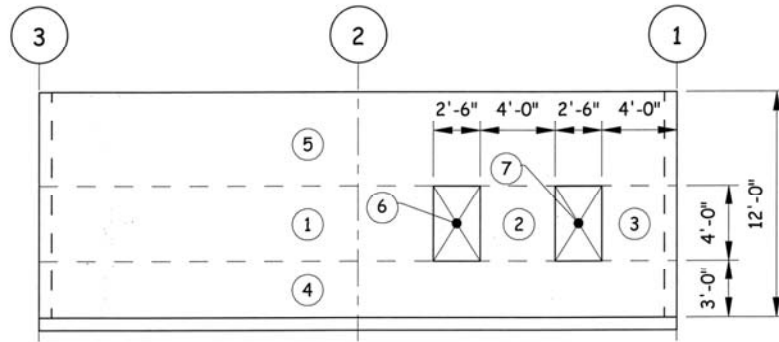

NORTH WALL

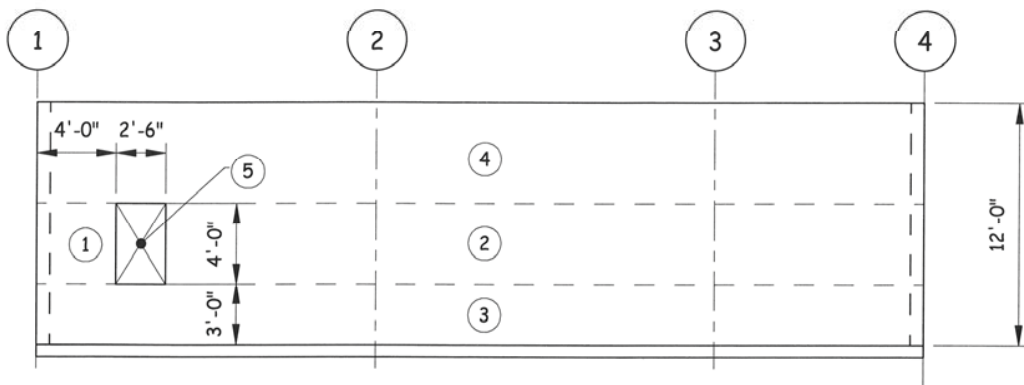

SOUTH WALL

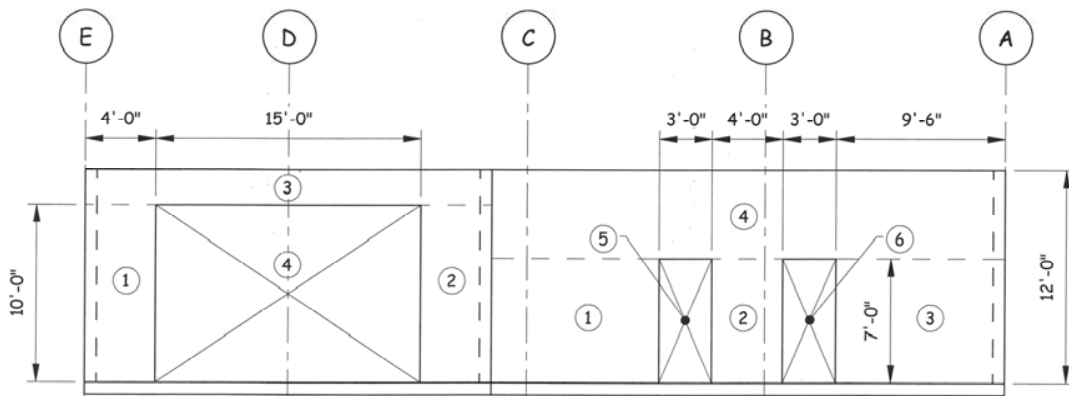

EAST WALL-SOUTHERN SEGMENT

EAST WALL-NORTHERN SEGMENT

Figure 4.40 Pier Designations for Stiffness Calculations

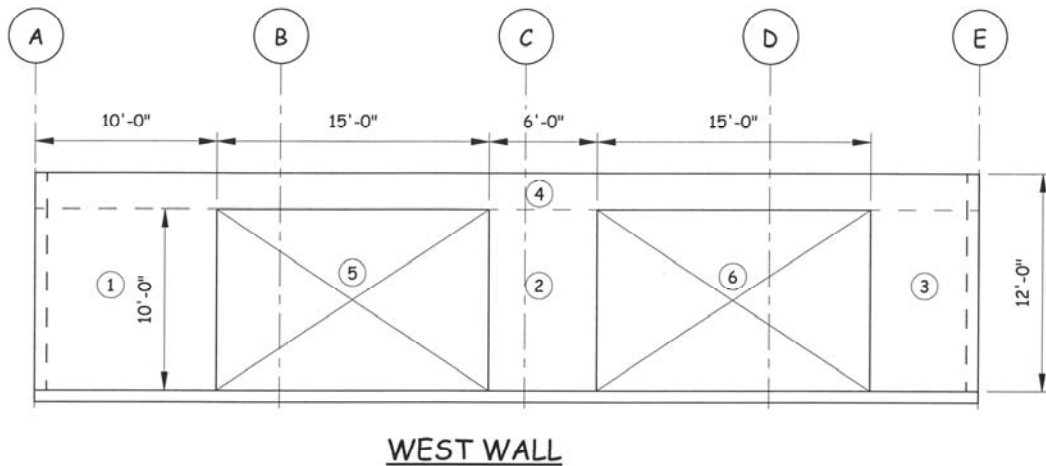

For SI: 1 inch = 25.4 mm; 1 foot = 304.8 mm.

Figure 4.40 Pier Designations for Stiffness Calculations (continued)

The stiffness of the solid wall between lines 3 and 4 is equal to

$$\frac{Et}{4\left(\frac{12}{10.5}\right)^3 + 3\left(\frac{12}{10.5}\right)} = 0.106Et$$

The location of the center of rigidity in the east-west direction measured from the centerline of the west wall can be determined by Equation 3.7 in Chapter 3 of this publication:

$$x_{cr} = \frac{\sum(k_i)_y x_i}{\sum(k_i)_y}$$

$$= \frac{\left[0.524Et \times \left(34 - \frac{8}{12}\right)\right] + \left[0.028Et \times \left(44.5 - \frac{8}{12}\right)\right]}{(0.222 + 0.524 + 0.028)Et} = 24.2 \text{ ft}$$

Similarly, the center of rigidity in the north-south direction measured from the centerline of the south wall can be determined by Equation 3.8 in Chapter 3 of this publication:

$$y_{cr} = \frac{\sum(k_i)_x y_i}{\sum(k_i)_x}$$

$$= \frac{\left[0.106Et \times \left(23 - \frac{8}{12}\right)\right] + \left[0.756Et \times \left(52 - \frac{8}{12}\right)\right]}{(1.101 + 0.106 + 0.756)Et} = 21.0 \text{ ft}$$

It can be shown that the effects from the wind forces govern in this example.²⁰ In the east-west direction, the base shear due to wind is equal to 3 kips, which is determined by the provisions in Chapter 6 of ASCE/SEI 7. The factored base shear is $1.6 \times 3 = 5$ kips (see ACI 9.2.1 or ASCE/SEI 2.3.2). This force is distributed to the walls in accordance with Equation 3.12.

North wall on line A:

$$V_A = \frac{0.756Et \times 5}{(0.756 + 0.106 + 1.101)Et} + \frac{(30.33 \times 12) \times 0.756Et \times (5 \times 4.67 \times 12)}{196,655Et}$$

$$= 1.9 + 0.4 = 2.3 \text{ kips}$$

where $\bar{y}_N = 52 - (8/12) - 21 = 30.33$ ft

$$e_y = [52 - (8/12)]/2 - 21 = 4.67 \text{ ft}$$

$$\begin{aligned} \sum \bar{x}_i^2 (k_i)_y + \sum \bar{y}_i^2 (k_i)_x &= 0.222Et \times (24.20 \times 12)^2 + 0.524Et \times (9.13 \times 12)^2 \\ &\quad + 0.028Et \times (19.63 \times 12)^2 + 1.101Et \times (21.0 \times 12)^2 \\ &\quad + 0.106Et \times (1.33 \times 12)^2 + 0.756Et \times (30.33 \times 12)^2 \\ &= 196,655Et \end{aligned}$$

South wall on line E:

$$V_E = \frac{1.101Et \times 5}{(0.756 + 0.106 + 1.101)Et} - \frac{(21.0 \times 12) \times 1.101Et \times (5 \times 4.67 \times 12)}{196,655Et}$$

$$= 2.8 - 0.4 = 2.4 \text{ kips}$$

Solid wall near line C:

$$V_C = \frac{0.106Et \times 5}{(0.756 + 0.106 + 1.101)Et} + \frac{(1.33 \times 12) \times 0.106Et \times (5 \times 4.67 \times 12)}{196,655Et}$$

$$= 0.3 + 0.0 = 0.3 \text{ kips}$$

West wall on line 1:

$$V_1 = \frac{(24.20 \times 12) \times 0.222Et \times (5 \times 4.67 \times 12)}{196,655Et} = 0.09 \text{ kips}$$

²⁰ The seismic base shear in this example can be determined by Equation (11.7-1) for SDC A.

East wall on line 3:

$$V_3 = \frac{-(9.13 \times 12) \times 0.524Et \times (5 \times 4.67 \times 12)}{196,655Et} = -0.08 \text{ kips}$$

East wall on line 4:

$$V_4 = \frac{-(19.63 \times 12) \times 0.028Et \times (5 \times 4.67 \times 12)}{196,655Et} = -0.01 \text{ kips}$$

A similar analysis can be performed for wind in the north-south direction.

Part 2: Design the wall on line A

Due to the relatively small in-plane shear force on this wall due to the governing lateral force on the building (see Part 1 of this example), the out-of-plane design forces are examined first.

The maximum wind pressure on this wall panel is 17 psf, which is determined by the provisions of Chapter 6 of ASCE/SEI 7 for components and cladding. The maximum factored wind pressure is equal to $1.6 \times 17 \times 12 = 326.4$ pounds per foot width of wall.

For structures assigned to SDC A, the provisions of ASCE/SEI 11.7 must be satisfied for seismic effects. In accordance with ASCE/SEI 11.7.3, the out-of-plane seismic force is equal to 5 percent of the weight of the wall. In accordance with ASCE/SEI 11.7.5, this force must not be taken less than 280 pounds per linear foot of wall. Thus, the out-of-plane seismic force is equal to the following:

$$F_p = 0.05w_w$$

where w_w = the weight of the wall = $(8/12) \times 150 \times 12 = 1200$ pounds/foot width of wall.

Thus, $F_p = 0.05 \times 1200 = 60 \text{ plf} < 280 \text{ plf}$ (governs)

Since the governing out-of-plane seismic force is less than the factored out-of-plane wind force, the wall will be designed for the combination of axial force due to the gravity loads and bending moment due to the out-of-plane wind force.

The provisions of ACI 14.8 are used to design the wall for the combined effects due to axial forces and bending moments. It is assumed that connection between the top of the wall and the concrete roof slab is detailed to transfer only shear forces and not bending moments, i.e., it is detailed as a simple support. It is also assumed that the gravity forces act through the centroid of the wall (i.e., no eccentricity). The wall is supported on a continuous wall footing, which is also a simple support.

Try a single layer of No. 5 @ 12 inches vertical reinforcement ($A_s = 0.31 \text{ in.}^2/\text{ft}$) at the centerline of the wall.

For a 1-foot-wide design strip, check minimum vertical reinforcement requirements of ACI 14.3.2:

$$\rho \text{ (gross)} = \frac{0.31}{12 \times 8} = 0.0032 > \text{minimum } \rho = 0.0012 \text{ O.K.}$$

The reinforcement is spaced less than the maximum spacing of 18 inches (ACI 14.3.5).

The wall on line A supports load over a tributary area equal to

$$2 \left[\frac{1}{2} \left(\frac{13.5}{2} \times \frac{17}{2} \right) \right] + \left[(34 - 17) \times \frac{13.5}{2} \right] = 172 \text{ sq ft}$$

$$\text{Dead load} = \left[\left(\frac{8}{12} \times 150 \right) + 10 \right] \times \frac{172}{34} = 557 \text{ plf}$$

$$\text{Live load} = 20 \times \frac{172}{34} = 101 \text{ plf}$$

$$\text{Wall dead load} = \frac{8}{12} \times 150 \times 12 = 1200 \text{ plf}$$

Factored load combinations at mid-height of wall:

- $U = 1.4D$

$$P_u = P_{u1} + \frac{P_{u2}}{2} = (1.4 \times 0.56) + \left(1.4 \times \frac{1.2}{2} \right) = 1.6 \text{ kips}$$

$$M_{ua} = 0$$

$$\frac{E_s}{E_c} = \frac{29,000}{57\sqrt{4000}} = 8.0 > 6.0 \text{ O.K. (ACI 14.8.3)}$$

$$I_{cr} = \frac{E_s}{E_c} \left(A_s + \frac{P_u h}{2f_y d} \right) (d - c)^2 + \frac{\ell_w c^3}{3} \quad (\text{ACI Eq. (14-7)})$$

$$\text{where } c = \frac{A_s f_y + \frac{P_u h}{2d}}{0.85\beta_1 f'_c \ell_w} = \frac{(0.31 \times 60) + \left(\frac{1.6 \times 8}{2 \times 4} \right)}{0.85 \times 0.85 \times 4 \times 12} = 0.58 \text{ in.}$$

$$I_{cr} = 8.0 \left(0.31 + \frac{1.6 \times 8}{2 \times 60 \times 4} \right) (4 - 0.58)^2 + \frac{12 \times 0.58^3}{3} = 32.3 \text{ in.}^4$$

$$\varepsilon_t = \left(\frac{0.003}{c}\right)d - 0.003 = \left(\frac{0.003}{0.58}\right)(4) - 0.003 = 0.018 > 0.005$$

Therefore, section is tension-controlled and $\phi = 0.9$ in accordance with ACI 10.3.4 and 9.3.2.

$$M_u = 0 \quad (\text{ACI Eq. (14-6)})$$

- $U = 1.2D + 1.6L_r + 0.8W$

$$P_u = P_{u1} + \frac{P_{u2}}{2} = (1.2 \times 0.56) + (1.6 \times 0.1) + \left(1.2 \times \frac{1.2}{2}\right) = 1.6 \text{ kips}$$

$$M_{ua} = \frac{w_u \ell_c^2}{8} = \frac{0.8 \times 0.017 \times 12^2}{8} = 0.25 \text{ ft-kips} = 2.9 \text{ in.-kips}$$

$$c = \frac{A_s f_y + \frac{P_u h}{2d}}{0.85 \beta_1 f'_c \ell_w} = \frac{(0.31 \times 60) + \left(\frac{1.6 \times 8}{2 \times 4}\right)}{0.85 \times 0.85 \times 4 \times 12} = 0.58 \text{ in.}$$

$$I_{cr} = 8.0 \left(0.31 + \frac{1.6 \times 8}{2 \times 60 \times 4}\right) (4 - 0.58)^2 + \frac{12 \times 0.58^3}{3} = 32.3 \text{ in.}^4$$

$$\varepsilon_t = \left(\frac{0.003}{c}\right)d - 0.003 = \left(\frac{0.003}{0.58}\right)(4) - 0.003 = 0.018 > 0.005$$

Therefore, section is tension-controlled and $\phi = 0.9$ in accordance with ACI 10.3.4 and 9.3.2.

$$M_u = \frac{M_{ua}}{1 - \frac{5P_u \ell_c^2}{(0.75)48E_c I_{cr}}} = \frac{2.9}{1 - \frac{5 \times 1.6 \times (12 \times 12)^2}{0.75 \times 48 \times 3605 \times 32.3}} = 3.0 \text{ in.-kips}$$

- $U = 1.2D + 0.5L_r + 1.6W$

$$P_u = P_{u1} + \frac{P_{u2}}{2} = (1.2 \times 0.56) + (0.5 \times 0.1) + \left(1.2 \times \frac{1.2}{2}\right) = 1.4 \text{ kips}$$

$$M_{ua} = \frac{w_u \ell_c^2}{8} = \frac{1.6 \times 0.017 \times 12^2}{8} = 0.49 \text{ ft-kips} = 5.9 \text{ in.-kips}$$

$$c = \frac{A_s f_y + \frac{P_u h}{2d}}{0.85 \beta_1 f'_c \ell_w} = \frac{(0.31 \times 60) + \left(\frac{1.4 \times 8}{2 \times 4}\right)}{0.85 \times 0.85 \times 4 \times 12} = 0.58 \text{ in.}$$

$$I_{cr} = 8.0 \left(0.31 + \frac{1.4 \times 8}{2 \times 60 \times 4} \right) (4 - 0.58)^2 + \frac{12 \times 0.58^3}{3} = 32.0 \text{ in.}^4$$

$$\varepsilon_t = \left(\frac{0.003}{c} \right) d - 0.003 = \left(\frac{0.003}{0.58} \right) (4) - 0.003 = 0.018 > 0.005$$

Therefore, section is tension-controlled and $\phi = 0.9$ in accordance with ACI 10.3.4 and 9.3.2.

$$M_u = \frac{M_{ua}}{1 - \frac{5P_u \ell_c^2}{(0.75)48E_c I_{cr}}} = \frac{5.9}{1 - \frac{5 \times 1.4 \times (12 \times 12)^2}{0.75 \times 48 \times 3605 \times 32.0}} = 6.1 \text{ in.-kips}$$

- $U = 0.9D + 1.6W$

$$P_u = P_{u1} + \frac{P_{u2}}{2} = (0.9 \times 0.56) + \left(0.9 \times \frac{1.2}{2} \right) = 1.0 \text{ kips}$$

$$M_{ua} = \frac{w_u \ell_c^2}{8} = \frac{1.6 \times 0.017 \times 12^2}{8} = 0.49 \text{ ft.-kips} = 5.9 \text{ in.-kips}$$

$$c = \frac{A_s f_y + \frac{P_u h}{2d}}{0.85 \beta_1 f'_c \ell_w} = \frac{(0.31 \times 60) + \left(\frac{1.0 \times 8}{2 \times 4} \right)}{0.85 \times 0.85 \times 4 \times 12} = 0.57 \text{ in.}$$

$$I_{cr} = 8.0 \left(0.31 + \frac{1.0 \times 8}{2 \times 60 \times 4} \right) (4 - 0.57)^2 + \frac{12 \times 0.57^3}{3} = 31.5 \text{ in.}^4$$

$$\varepsilon_t = \left(\frac{0.003}{c} \right) d - 0.003 = \left(\frac{0.003}{0.57} \right) (4) - 0.003 = 0.018 > 0.005$$

Therefore, section is tension-controlled and $\phi = 0.9$ per ACI 10.3.4 and 9.3.2.

$$M_u = \frac{M_{ua}}{1 - \frac{5P_u \ell_c^2}{(0.75)48E_c I_{cr}}} = \frac{5.9}{1 - \frac{5 \times 1.0 \times (12 \times 12)^2}{0.75 \times 48 \times 3605 \times 31.5}} = 6.1 \text{ in.-kips}$$

Determine the cracking moment, M_{cr} :

$$I_g = \frac{1}{12} \times 12 \times 8^3 = 512 \text{ in.}^4$$

$$f_r = 7.5 \lambda \sqrt{f'_c} = 7.5 \times 1.0 \sqrt{4000} = 474.3 \text{ psi}$$

$$M_{cr} = \frac{f_r I_g}{y_t} = \frac{474.3 \times 512}{4 \times 1000} = 60.7 \text{ in.-kips}$$

Check design moment strength, ϕM_n , for each load combination:

- $U = 1.4D$

$$M_n = \left(A_s + \frac{P_u h}{2 f_y d} \right) f_y \left(d - \frac{a}{2} \right)$$

$$= \left(0.31 + \frac{1.6 \times 8}{2 \times 60 \times 4} \right) \times 60 \times \left(4 - \frac{0.85 \times 0.58}{2} \right) = 75.8 \text{ in.-kips}$$

$$\phi M_n = 0.9 \times 75.8 = 68.2 \text{ in.-kips} > M_u = 0$$

$$> M_{cr} = 60.7 \text{ in.-kips} \quad \text{O.K.}$$

- $U = 1.2D + 1.6L_r + 0.8W$

$$M_n = \left(0.31 + \frac{1.6 \times 8}{2 \times 60 \times 4} \right) \times 60 \times \left(4 - \frac{0.85 \times 0.58}{2} \right) = 75.8 \text{ in.-kips}$$

$$\phi M_n = 0.9 \times 75.8 = 68.2 \text{ in.-kips} > M_u = 3.0 \text{ in.-kips}$$

$$> M_{cr} = 60.7 \text{ in.-kips} \quad \text{O.K.}$$

- $U = 1.2D + 0.5L_r + 1.6W$

$$M_n = \left(0.31 + \frac{1.4 \times 8}{2 \times 60 \times 4} \right) \times 60 \times \left(4 - \frac{0.85 \times 0.58}{2} \right) = 75.1 \text{ in.-kips}$$

$$\phi M_n = 0.9 \times 75.1 = 67.6 \text{ in.-kips} > M_u = 6.1 \text{ in.-kips}$$

$$> M_{cr} = 60.7 \text{ in.-kips} \quad \text{O.K.}$$

- $U = 0.9D + 1.6W$

$$M_n = \left(0.31 + \frac{1.0 \times 8}{2 \times 60 \times 4} \right) \times 60 \times \left(4 - \frac{0.85 \times 0.57}{2} \right) = 73.7 \text{ in.-kips}$$

$$\phi M_n = 0.9 \times 73.7 = 66.3 \text{ in.-kips} > M_u = 6.1 \text{ in.-kips}$$

$$> M_{cr} = 60.7 \text{ in.-kips} \quad \text{O.K.}$$

Check vertical stress at mid-height of wall using the maximum factored axial force from all of the combinations:

$$\frac{P_u}{A_g} = \frac{1600}{8 \times 12} = 17 \text{ psi} < 0.06f'_c = 240 \text{ psi} \quad \text{O.K.}$$

Check mid-height deflection, Δ_s :

$$M_a = \frac{w\ell_c^2}{8} = \frac{0.017 \times 12^2}{8} = 0.31 \text{ ft-kips} = 3.7 \text{ in.-kips} < 2M_{cr}/3 = 40.5 \text{ in.-kips}$$

Since $M_a < 2M_{cr}/3$, use ACI Eq. (14-9) to determine Δ_s :

$$\Delta_s = \left(\frac{M_a}{M_{cr}} \right) \Delta_{cr}$$

$$\text{where } \Delta_{cr} = \frac{5M_{cr}\ell_c^2}{48E_cI_g} = \frac{5 \times 60.7 \times (12 \times 12)^2}{48 \times 3605 \times 512} = 0.07 \text{ in. [ACI Equation (14-10)]}$$

Therefore,

$$\Delta_s = \left(\frac{3.7}{60.7} \right) \times 0.07 = 0.004 \text{ in.} < \frac{\ell_c}{150} = \frac{12 \times 12}{150} = 0.96 \text{ in.} \quad \text{O.K.}$$

The wall is adequate with No. 5 @ 12 inches vertical reinforcement for combined axial force and bending.

Check out-of-plane shear requirements of ACI 11.9.1.

$$V_u = 1.6 \times 0.017 \times 12 \times 1/2 = 0.2 \text{ kips}$$

$$< \phi 2\lambda\sqrt{f'_c}bd = 0.75 \times 2 \times 1.0\sqrt{4000} \times 12 \times 4/1000 = 4.6 \text{ kips} \quad \text{O.K.}$$

Check in-plane shear strength requirements of ACI 11.9.2.

$$\text{According to ACI 11.9.5, } \phi V_c = \phi 2\lambda\sqrt{f'_c}hd = 0.75 \times 2 \times 1.0\sqrt{4000} \times 8 \times (0.8 \times 34 \times 12)/1000 = 247.7 \text{ kips} \gg 2.3 \text{ kips.}^{21}$$

$$\text{Per ACI 14.3.3, minimum horizontal reinforcement} = 0.0020 \times 12 \times 8 = 0.19 \text{ in.}^2$$

Provide No. 4 @ 12 inches ($A_s=0.20 \text{ in.}^2/\text{ft}$) **horizontal reinforcement.**

²¹ According to ACI 11.9.4, the effective depth, d , is equal to 80 percent of the length of the wall.

In addition to the vertical and horizontal reinforcement noted above, the minimum reinforcement specified in ACI 14.3.7 must be provided around the two openings in the wall.

The design of the walls on lines C, E and 3 would be similar to that outlined above for the wall on line A. The walls on lines 1 and 4 should be designed and detailed similar to frames.

5.1 GENERAL REQUIREMENTS

5.1.1 Design and Detailing

For concrete buildings assigned to SDC C, all members must be designed and detailed in accordance with the general requirements of ACI 318 Chapters 1 to 19,¹ and intermediate moment frames that are part of the seismic-force-resisting system must also satisfy the provisions of ACI 21.3 [ACI 21.1.1.7(c) and IBC 1908.1.2].

5.1.2 Load Combinations

As noted in Chapter 4, the load combinations for strength design (or load and resistance factor design) in IBC 1605.2 are to be used in the design of reinforced concrete members. See Section 4.1.2 of this publication for detailed information on load combinations.

5.1.3 Materials

There are no limitations on the types of materials that can be used in buildings assigned to SDC C other than those given in Section 4.1.3 of this publication.

5.1.4 Anchoring to Concrete

The requirements of ACI D.3.3 must be satisfied for anchors resisting earthquake-induced forces in structures assigned to SDC C (ACI 21.1.8). It should be noted that IBC 1908.1.9 modifies ACI D.3.3.

5.2 MEMBERS SUBJECTED TO BENDING

5.2.1 Beams

Table 5.1 contains requirements for beams in intermediate moment frames. These apply to frame members with negligible axial forces, i.e., $P_u \leq A_g f'_c / 10$ (ACI 21.3.2).

Flexure. Reinforcement requirements for beams in structures assigned to SDC C are shown in Figure 5.1. Minimum moment capacity at any section of a beam is based on the

¹ According to IBC 1908.1.2, structural elements of plain concrete are prohibited in structures assigned to SDC C and above, except for those elements complying with IBC 1908.1.8.

moment capacity at the face of either support. These requirements, together with those for confinement, are meant to provide a minimum threshold level of toughness for beams.

Table 5.1 Summary of Requirements for Beams of Intermediate Moment Frames in Buildings Assigned to SDC C²

	Requirement	ACI Section Number(s)
Flexure	Design flexural members as tension-controlled sections.	10.3.4, 9.3.2.1
	Minimum flexural reinforcement shall not be less than: $\frac{3\sqrt{f'_c}b_wd}{f_y}$ and $\frac{200b_wd}{f_y}$ at every section of a flexural member where tensile reinforcement is required by analysis, except as provided by ACI 10.5.3.	10.5.1
	The net tensile strain, ϵ_t , at nominal strength shall be greater than or equal to 0.004.	10.3.5
	Positive moment strength at the face of a joint must be greater than or equal to one-third the negative moment strength at that face of the joint.	21.3.4.1
	Neither the negative nor the positive moment strength at any section along the length of the beam must be less than one-fifth the maximum moment strength at the face of either joint.	21.3.4.1
Confinement	Hoops are required over a length equal to at least twice the member depth from the face of the supporting member toward midspan at both ends of the beam.	21.3.4.2
	Where hoops are required, the spacing shall not exceed the smallest of: (a) $d/4$ (b) $8 \times$ diameter of smallest longitudinal bar (c) $24 \times$ diameter of hoop bar (d) 12 inches The first hoop shall be located not more than 2 inches from the face of the supporting member.	21.3.4.2
	Where hoops are not required, stirrups shall be spaced not more than $d/2$ throughout the length of the beam.	21.3.4.3
	Transverse reinforcement must also be proportioned to resist the design shear forces.	21.3.3

(continued)

² Additional requirements of ACI Chapters 1 to 19 must also be satisfied. See Chapter 4 of this publication for more details.

Table 5.1 Summary of Requirements for Beams of Intermediate Moment Frames in Buildings Assigned to SDC C (continued)

	Requirement	ACI Section Number(s)
Shear	<p>Design shear strength ϕV_n shall not be less than the smaller of:</p> <p>(a) The sum of the shear associated with the development of nominal moment strengths of the member at each restrained end of the clear span and the shear calculated for factored gravity forces.</p> <p>(b) The maximum shear obtained from the design load combinations that include E, with E assumed to be twice that prescribed by the legally adopted building code</p>	21.3.3

For SI: 1 inch = 25.4 mm.

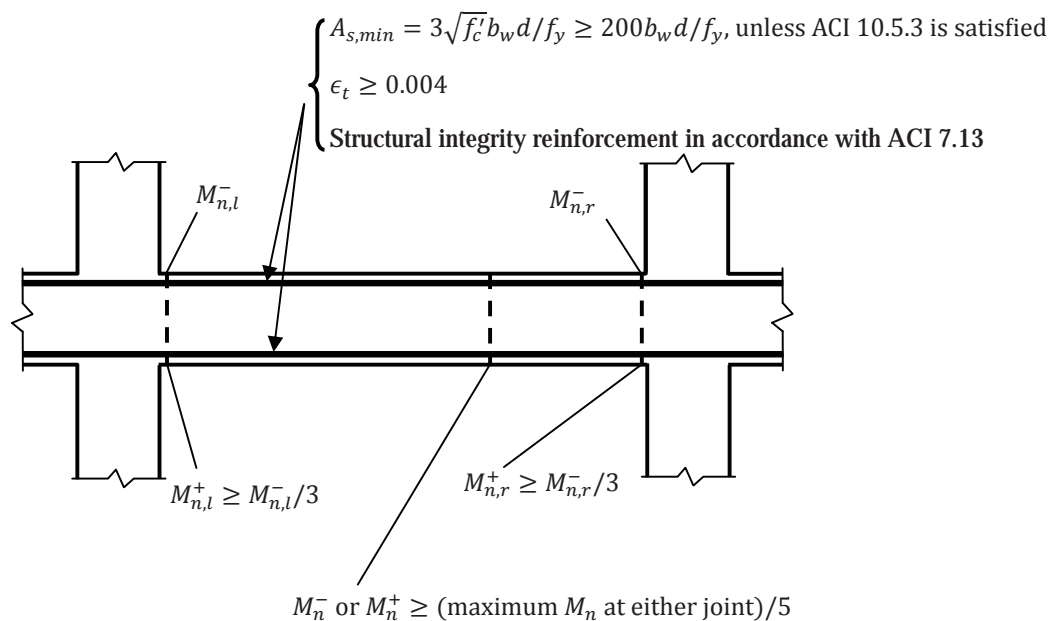

Note: transverse reinforcement not shown for clarity

Figure 5.1 Flexural Requirements for Beams in Buildings Assigned to SDC C

Confinement. Lateral reinforcement for beams must satisfy the requirements of ACI 21.3.4.2 and 21.3.4.3. Hoops must be provided at both ends of a beam over a minimum distance of $2h$ from the face of the supporting member with the first hoop located not more than 2 inches (51 mm) from the face of the support.³ The spacing of the hoops within these regions must be less than or equal to the smallest of the four values given in ACI 21.3.4.2. Stirrups spaced at a distance of no more than $d/2$ must be provided throughout the remaining length of the beam.

The transverse reinforcement requirements for confinement are illustrated in Figure 5.2.

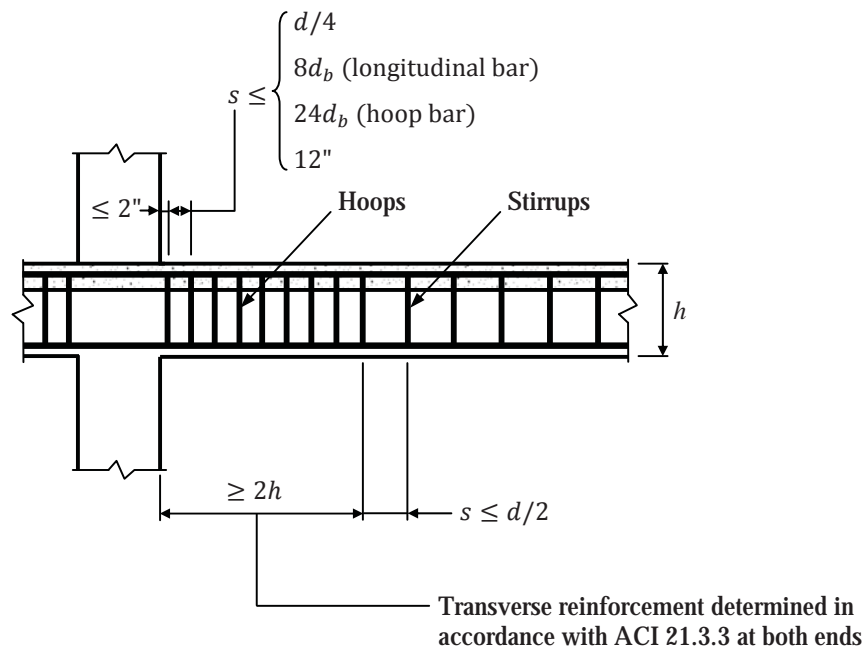

For SI: 1 inch = 25.4 mm.

Figure 5.2 Transverse Reinforcement Requirements for Beams in Buildings Assigned to SDC C

Shear. Two methods are provided in ACI 21.3.3 to determine the factored shear force for beams. According to the first method, the factored shear force, V_u , is determined by adding the shear effects associated with the application of the nominal moment strengths, M_n , at each end of the member to those associated with the factored gravity loads. This method is illustrated in Figure 5.3 for the cases of sidesway to the right and sidesway to the left.

³Requirements for hoops are given in ACI Figure R21.5.3. The likelihood of spalling and loss of shell concrete is high at the ends of a beam. Transverse reinforcement must be bent around longitudinal reinforcement and its ends must project into the core of the element in order to adequately confine the concrete in these regions.

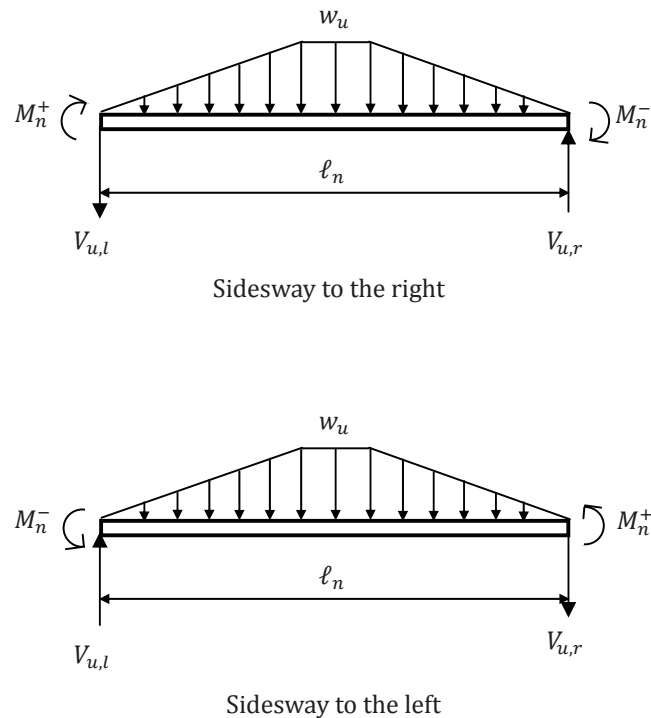

Figure 5.3 Design Shear Forces for Beams in Buildings Assigned to SDC C [ACI 21.3.3(a)]

In the second method, the factored shear force, V_u , is obtained from the design load combinations that include the earthquake load effects, E , where E is assumed to be twice that prescribed by the building code. In this option, the governing load combination for shear design is given by IBC Equation 16-5 (see Table 4.2):

$$1.2D + 2.0E + f_1L + f_2S$$

where $E = Q_E + 0.2S_{DS}D$.⁴

Design shear strength, ϕV_n , shall not be less than the smaller of those obtained by these two methods.

The required amount of shear reinforcement to resist V_u can be determined by the information provided in Figure 4.8. Minimum shear reinforcement for Grade 60 reinforcing bars is given in Table 4.9 and the values of ϕV_s in Table 4.10 can be used to determine the required spacing of the hoops. The required hoop spacing for V_u must be less than or equal to the limiting values in Figure 5.2.

⁴The redundancy factor, ρ , is equal to 1.0 for structures assigned to SDC B and C (ASCE/SEI 12.3.4.1).

A summary of the overall design procedure for beams in intermediate moment frames is given in Figure 5.4.

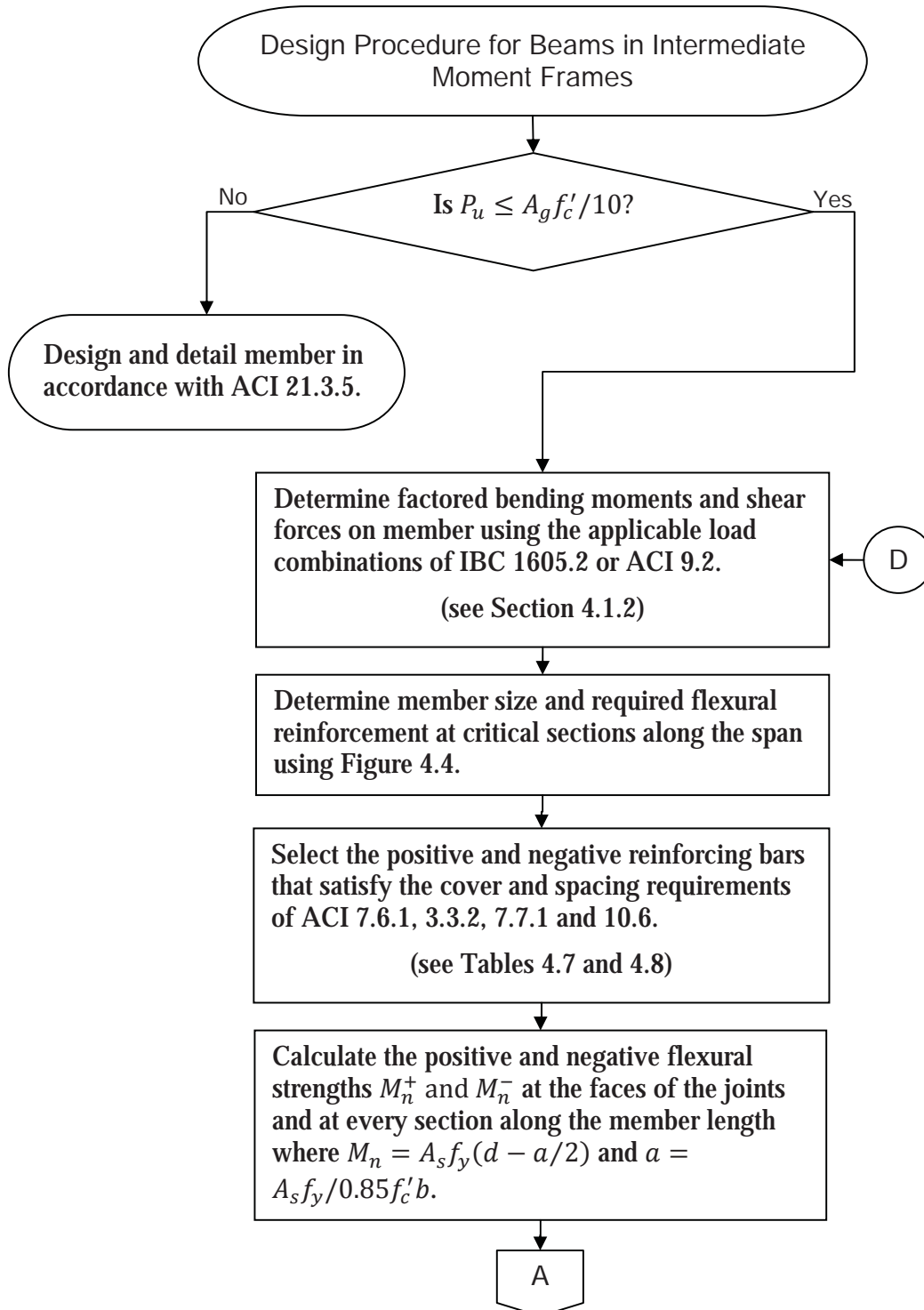

Figure 5.4 Design Procedure for Beams in Intermediate Moment Frames

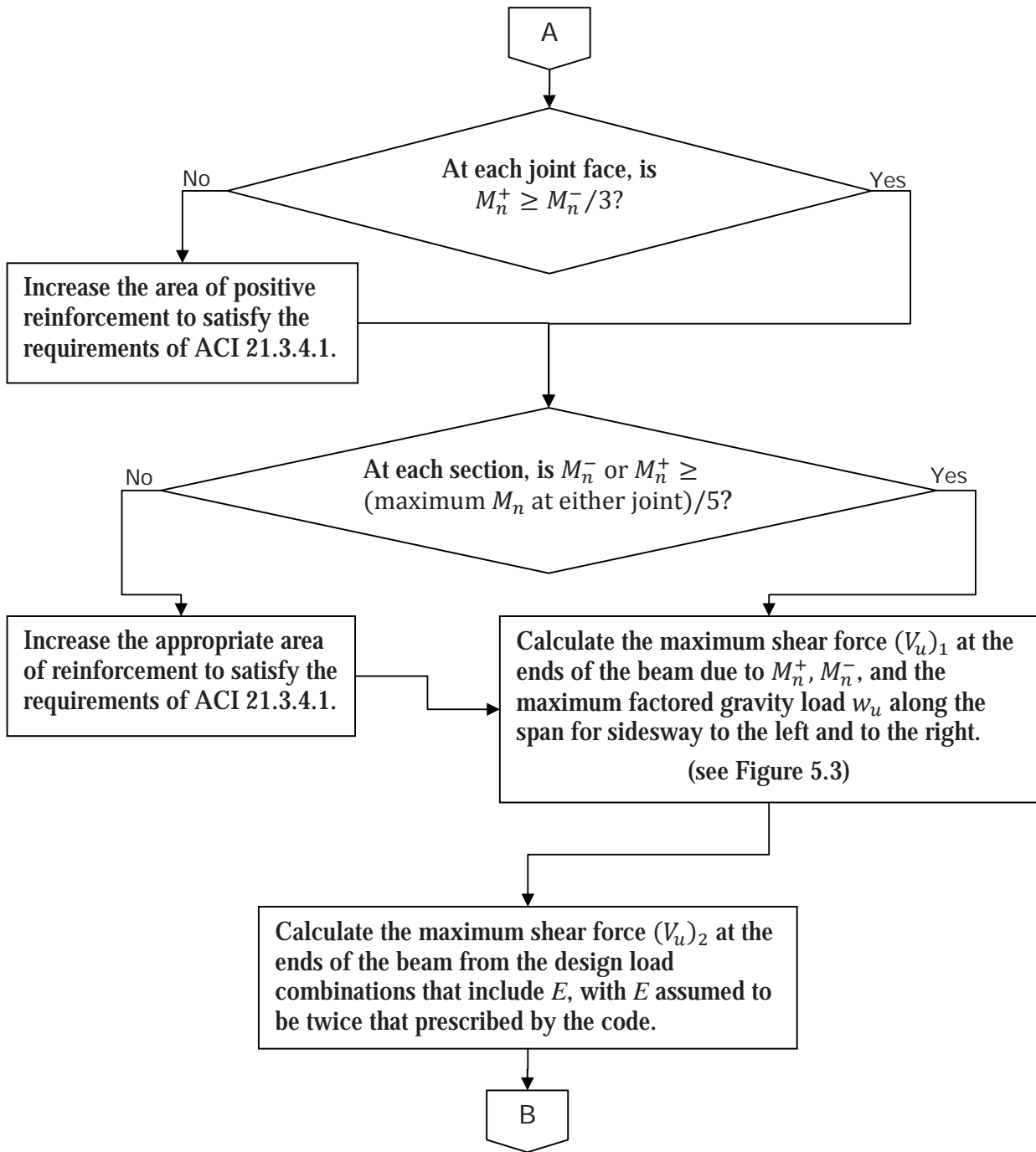

Figure 5.4 Design Procedure for Beams in Intermediate Moment Frames (continued)

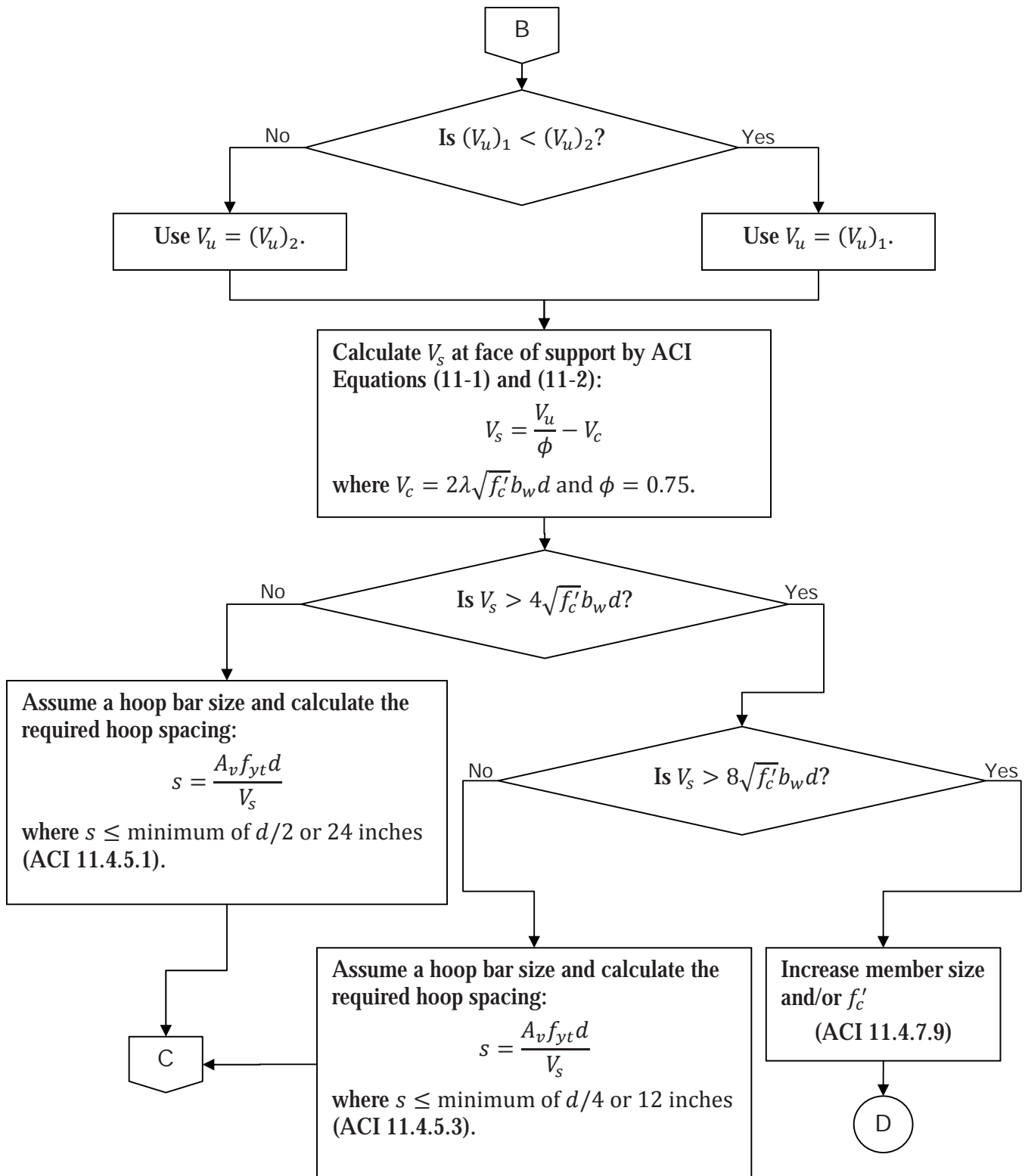

Figure 5.4 Design Procedure for Beams in Intermediate Moment Frames (continued)

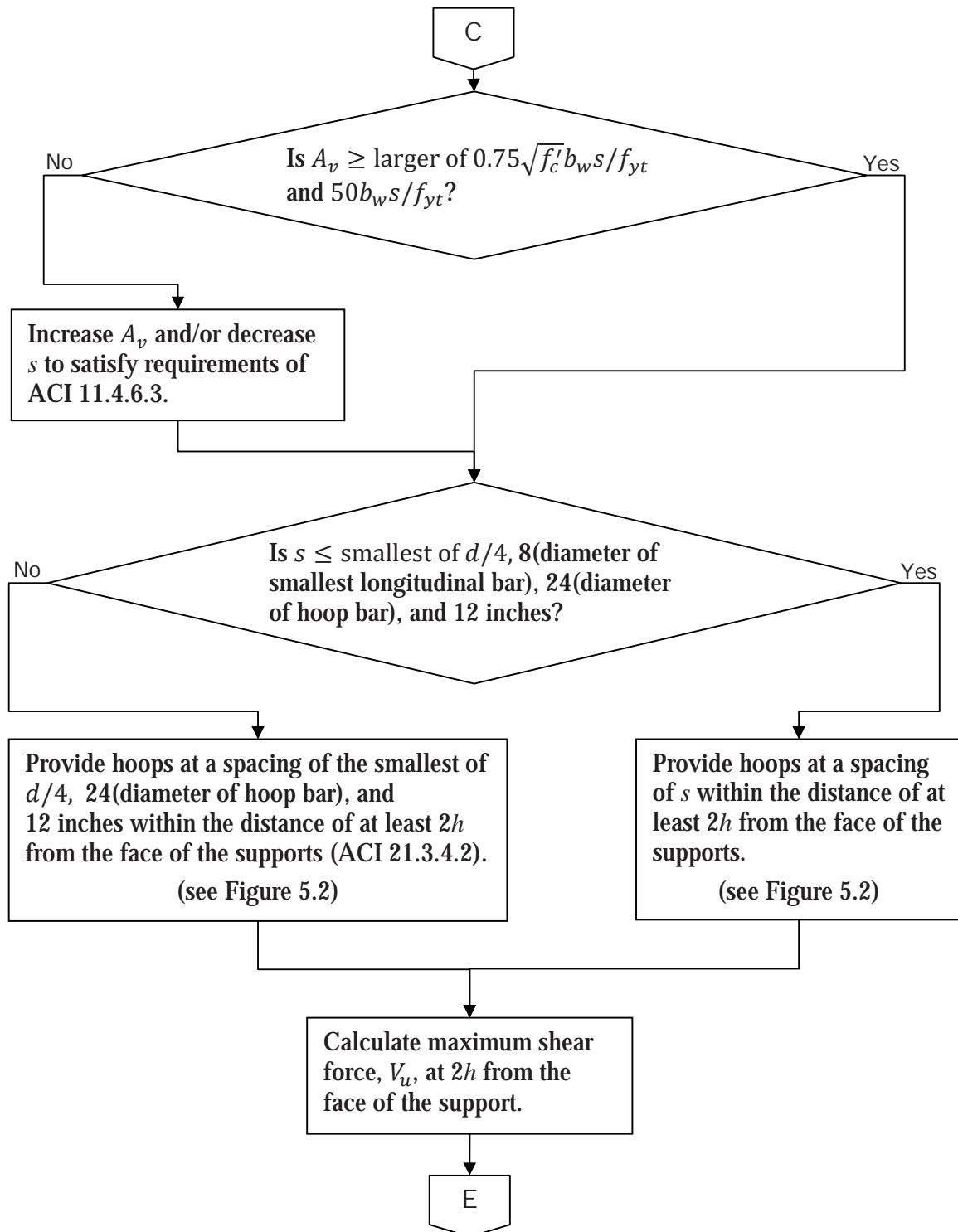

Figure 5.4 Design Procedure for Beams in Intermediate Moment Frames (continued)

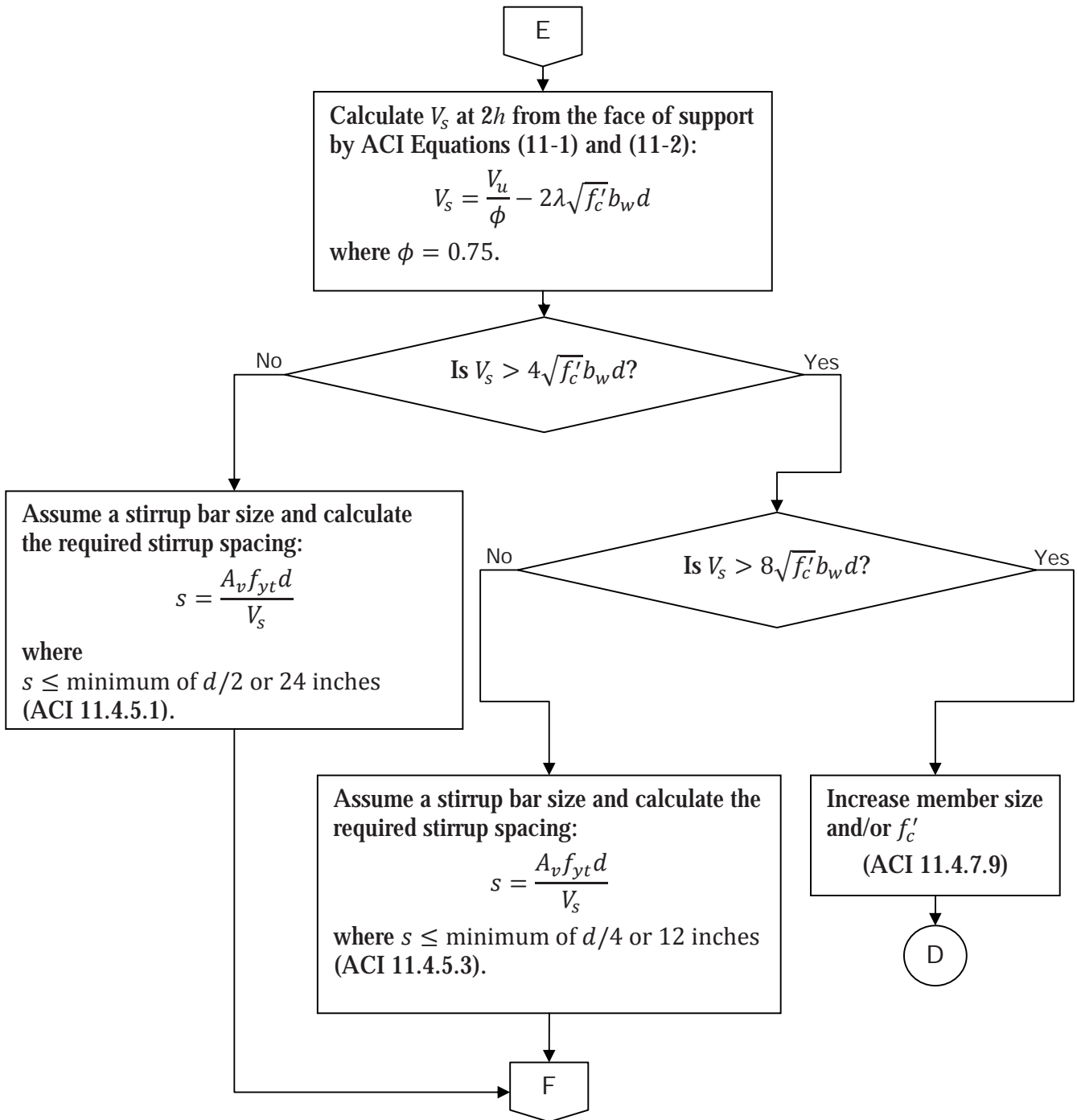
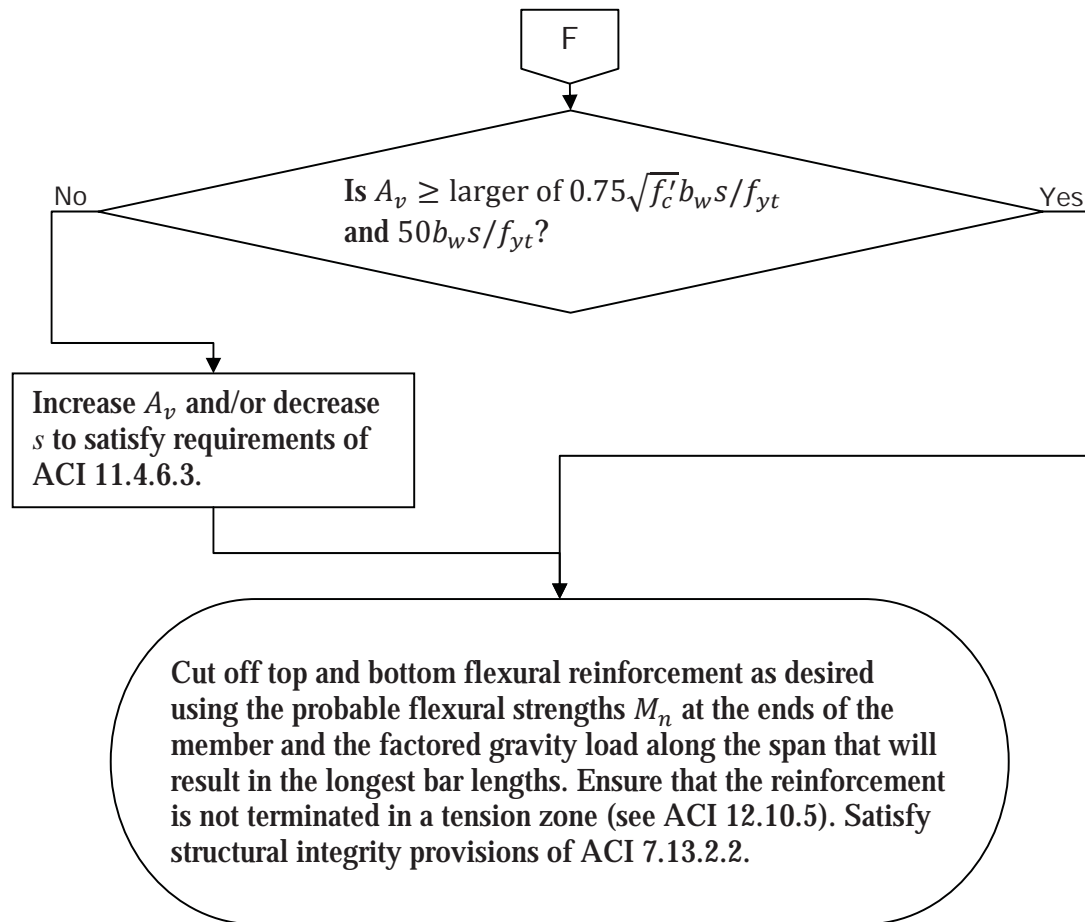

Figure 5.4 Design Procedure for Beams in Intermediate Moment Frames (continued)



For SI: 1 inch = 25.4 mm.

Figure 5.4 Design Procedure for Beams in Intermediate Moment Frames (continued)

5.2.2 Two-way Slabs without Beams

A summary of the requirements for two-way slabs without beams in intermediate moment frames is given in Table 5.2.

Two-way slabs without beams may be considered part of the seismic-force-resisting system in buildings assigned to SDC B and C, but are not permitted in SDC D or above.

The provisions for effective width for the reinforcement placement in edge and corner columns are illustrated in ACI Figure R21.3.6.1. Note that the moment, M_{slab} , refers to that portion of the factored slab moment that is balanced by the supporting members at a joint for a given design load combination with seismic load effect, E , acting in a particular horizontal direction. Flexural moment transfer reinforcement perpendicular to the edge is not considered fully effective unless it is placed within the specified band widths.

Table 5.2 Summary of Requirements for Two-way Slabs without Beams in Buildings Assigned to SDC C

Requirement	ACI Section Number(s)
All reinforcement provided to resist M_{slab} , the portion of the slab moment balanced by the support moment, must be placed within the column strip defined in ACI 13.2.1.	21.3.6.1
Reinforcement placed within an effective slab width defined in ACI 13.5.3.2 must be proportioned to resist the moment, $\gamma_f M_{slab}$, where γ_f is determined by ACI Equation (13-1). Effective slab widths for exterior and corner connections must not extend beyond the column face a distance greater than c_t measured perpendicular to the slab span.	21.3.6.2
Not less than one-half of the reinforcement in the column strip at the support shall be placed within the effective slab width defined in ACI 13.5.3.2.	21.3.6.3
Not less than one-quarter of the top reinforcement at the support in the column strip shall be continuous throughout the span.	21.3.6.4
Continuous bottom reinforcement in the column strip shall not be less than one-third of the top reinforcement at the support in the column strip.	21.3.6.5
Not less than one-half of all bottom middle strip reinforcement and all bottom column strip reinforcement at midspan shall be continuous and shall develop f_y at the face of the support defined in ACI 13.6.2.5.	21.3.6.6
At discontinuous edges of the slab, all top and bottom reinforcement at the support shall be developed at the face of the support as defined in ACI 13.6.2.5.	21.3.6.7
At the critical sections for columns defined in ACI 11.11.1.2, two-way shear caused by factored gravity loads shall not exceed $0.4\phi V_c$ where V_c is calculated by ACI 11.11.2.1 for nonprestressed slabs. This requirement may be waived if the slab design satisfies the provisions of ACI 21.13.6.	21.3.6.8

Requirements for location of reinforcement in slabs in accordance with ACI 21.3.6.1 through 21.3.6.3 are given in ACI Figure R21.3.6.2. The additional requirements in ACI 21.3.6 for the arrangement of reinforcement in slabs are illustrated in ACI Figure R21.3.6.3.

It has been shown that slab-column frames are susceptible to punching shear failures during seismic events where shear stresses due to gravity loads are relatively large. Thus, a limit of $0.4\phi V_c$ is prescribed in ACI 21.3.6.8 on the shear caused by factored gravity loads. This limit essentially permits the slab-column connection to have adequate toughness to withstand the anticipated inelastic moment transfer. The requirements of ACI 21.3.6.8 are permitted to be waived where the slab design satisfies the requirements of ACI 21.13.6, which are applicable to slab-column connections of two-way slabs without beams that are not designated as part of the seismic-force-resisting system.

5.3 MEMBERS SUBJECTED TO BENDING AND AXIAL FORCES

Table 5.3 contains requirements for frame members subjected to combined bending and axial forces in intermediate moment frames. These would typically apply to columns and flexural members that carry a factored axial force $P_u > A_g f'_c / 10$.

Transverse Reinforcement. Similar to the requirements for beams, the transverse reinforcement requirements of ACI 21.3.5 are meant to provide a minimum threshold level of toughness for columns in intermediate moment frames.

Column ends require adequate confinement (in the form of spirals or hoops) to ensure column ductility in the event of hinge formation during a seismic event. The transverse reinforcement requirements for columns with hoops and ties are illustrated in Figure 5.5.

Table 5.3 Summary of Requirements for Frame Members Subjected to Bending and Axial Forces of Intermediate Moment Frames in Buildings Assigned to SDC C⁵

	Requirement	ACI Section Number(s)
Transverse Reinforcement	Columns shall be spirally reinforced in accordance with ACI 7.10.4 or shall conform to the provisions of ACI 21.3.5.2 through 21.3.5.4.	21.3.5.1
	Hoops at a spacing of no more than s_o shall be provided at both ends of a column over a length, ℓ_o , measured from the joint face.	21.3.5.2
	The spacing, s_o , shall not exceed the smallest of: (a) $8 \times$ diameter of smallest longitudinal bar (b) $24 \times$ diameter of hoop bar (c) $0.5 \times$ smallest dimension of the column (d) 12 inches	
	The length, ℓ_o , shall not be less than the largest of: (a) (Clear span of the column)/6 (b) Maximum dimension of the column (c) 18 inches	
	The first hoop shall be located not more than $s_o/2$ from the joint face.	21.3.5.3
	Spacing of transverse reinforcement outside of the length, ℓ_o , shall conform to ACI 7.10 and 11.4.5.1.	21.3.5.4
Joint transverse reinforcement for all columns must conform to ACI 11.10.	21.3.5.5	

(continued)

⁵ Additional requirements of ACI Chapters 1 to 19 must also be satisfied. See Chapter 4 of this publication for more details.

Table 5.3 Summary of Requirements for Frame Members Subjected to Bending and Axial Forces of Intermediate Moment Frames in Buildings Assigned to SDC C (continued)

Requirement		ACI Section Number(s)
Transverse Reinforcement (continued)	<p>Columns supporting reactions from discontinuous stiff members, such as walls, shall have transverse reinforcement spaced at s_o (as defined in ACI 21.3.5.2) over their full length below the level at which the discontinuity occurs if the portion of the factored axial compressive force in these members related to earthquake effects exceeds $A_g f'_c / 10$.</p> <p>The limit of $A_g f'_c / 10$ shall be increased to $A_g f'_c / 4$ where design forces have been magnified to account for the overstrength of the vertical elements of the seismic-force-resisting system.</p> <p>Transverse reinforcement shall extend above and below the column as required in ACI 21.6.4.6(b).</p>	21.3.5.6
Shear Strength	<p>Design shear strength, ϕV_n, shall not be less than the smaller of:</p> <p>(a) The sum of the shear associated with the development of nominal moment strengths of the member at each restrained end of the clear span and the shear calculated for factored gravity forces.</p> <p>(b) The maximum shear obtained from the design load combinations that include E, with E assumed to be twice that prescribed by the legally adopted building code.</p>	21.3.3

For SI: 1 inch = 25.4 mm.

Transverse reinforcement conforming to ACI 11.10 must be provided within the joints of an intermediate moment frame. Such confinement is essential to ensure that the flexural strength of the beams and columns can be developed without deterioration of the joint under loading cycles from an earthquake.

The transverse reinforcement requirements of ACI 21.3.5.6 must be satisfied for columns that support reactions from discontinuous stiff members, such as walls. In cases where the factored axial compressive force related to earthquake effects in such columns exceeds $A_g f'_c / 4$,⁶ transverse reinforcement must be provided over the entire length of the column at a spacing of s_o , which is defined in ACI 21.3.5.2.

⁶The provisions of ASCE/SEI 12.3.3.3 apply to structural members that support discontinuous frames or shear walls systems where the discontinuity is severe enough to be deemed a structural irregularity. In such cases, the supporting members must be designed to resist the load combinations with overstrength factor, Ω_o , of ASCE/SEI 12.4.3.2. In such cases, the limit on the axial compressive force in ACI 21.3.5.6 is $A_g f'_c / 4$. Otherwise, the limit is $A_g f'_c / 10$.

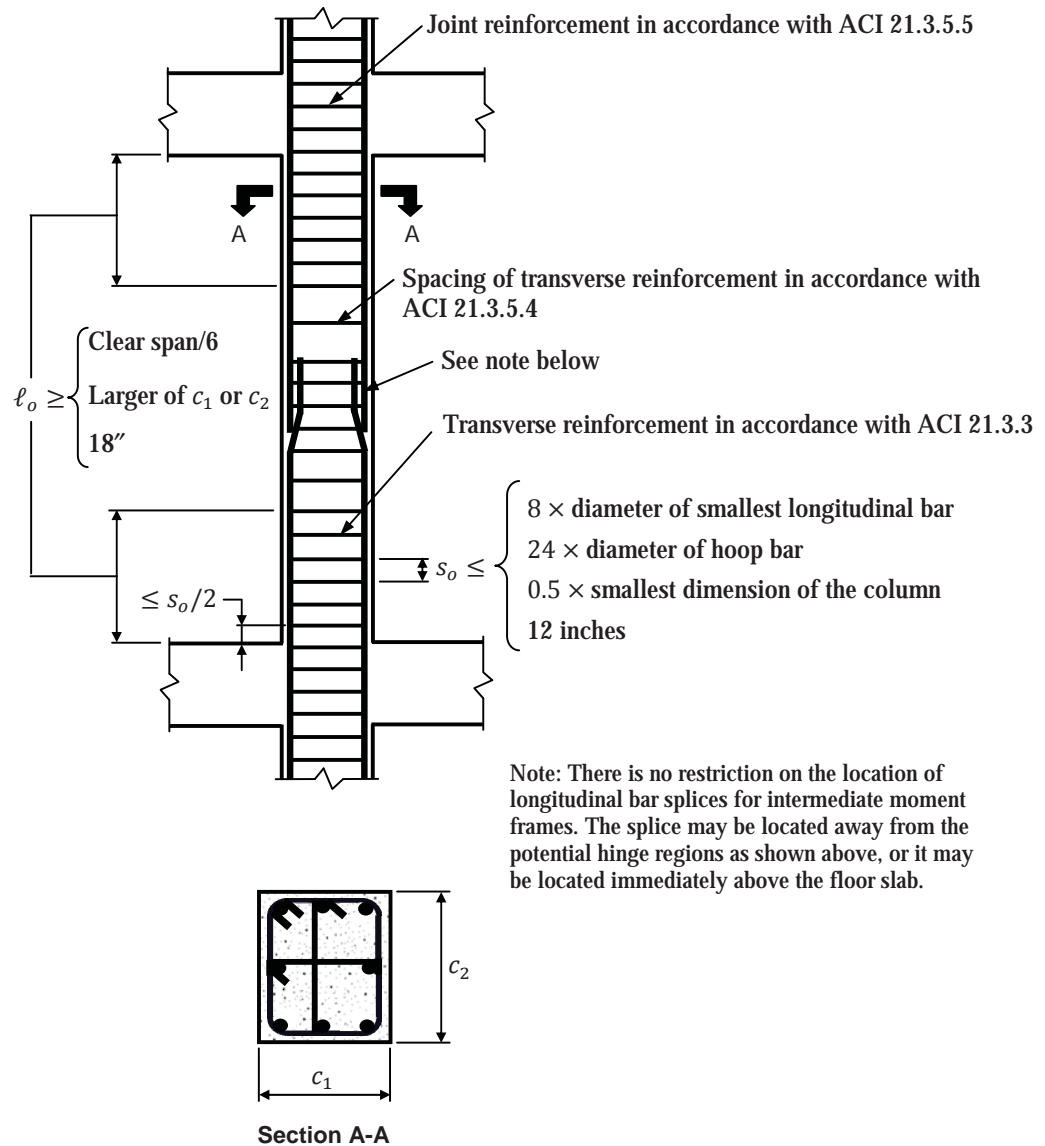

For SI: 1 inch = 25.4 mm.

Figure 5.5 Transverse Reinforcement Requirements for Columns of Intermediate Moment Frames in Buildings Assigned to SDC C

The transverse reinforcement must extend above into the discontinued member and below into the supporting element in accordance with the provisions of ACI 21.6.4.6(b), which are illustrated in Figure 5.6.

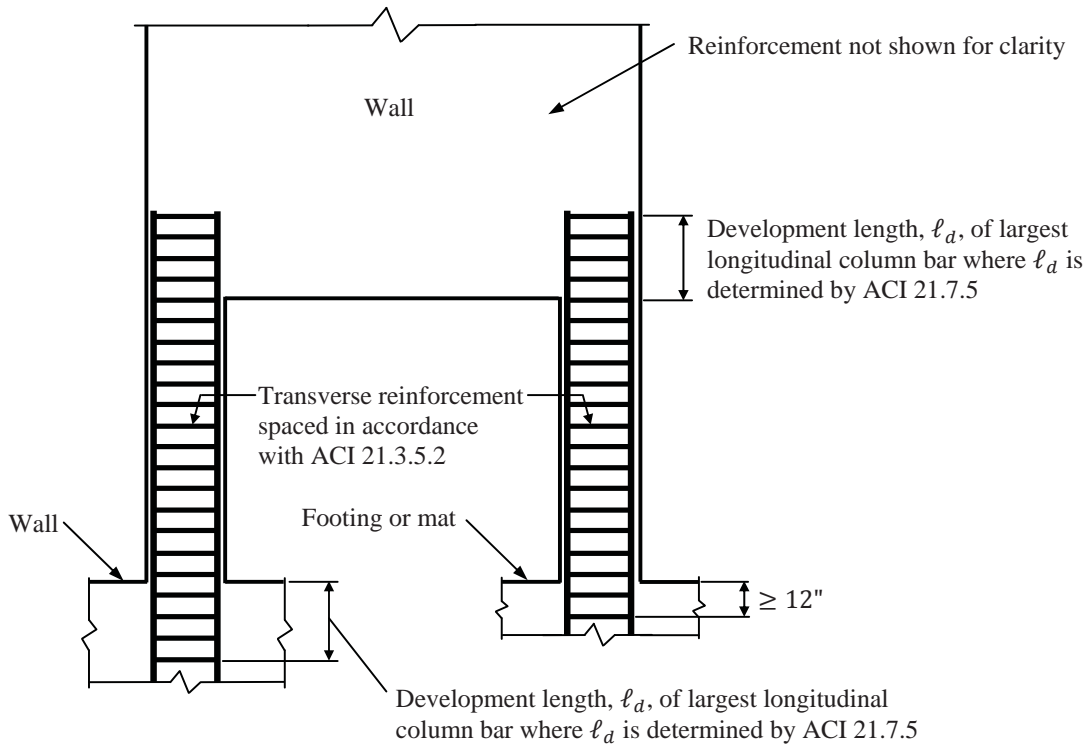

For SI: 1 inch = 25.4 mm.

Figure 5.6 Transverse Reinforcement Requirements for Columns Supporting Discontinued Stiff Members in Buildings Assigned to SDC C

Shear strength. The two methods provided in ACI 21.3.3 to determine the factored shear force for beams are also applicable to columns in intermediate moment frames. Both methods are discussed in Section 5.2.1 of this publication and ACI Figure R21.3.3 illustrates the design shear forces in columns according to the first of the two methods. The size and spacing of the transverse reinforcement must satisfy the applicable requirements of ACI 11.1, 11.2, 11.4 and 21.3.5 for the applicable design shear force, V_u , determined by ACI 21.3.3.

Outside of the anticipated plastic hinge length, ℓ_o , the spacing of the transverse reinforcement must conform to the lateral reinforcement for compression member provisions of ACI 7.10 and to the spacing limits for shear reinforcement provisions of ACI 11.4.5.1. The smallest spacing obtained from these requirements is to be used in the center region of a column.

A summary of the overall design procedure for frame members subjected to bending and axial load in intermediate moment frames is given in Figure 5.7.

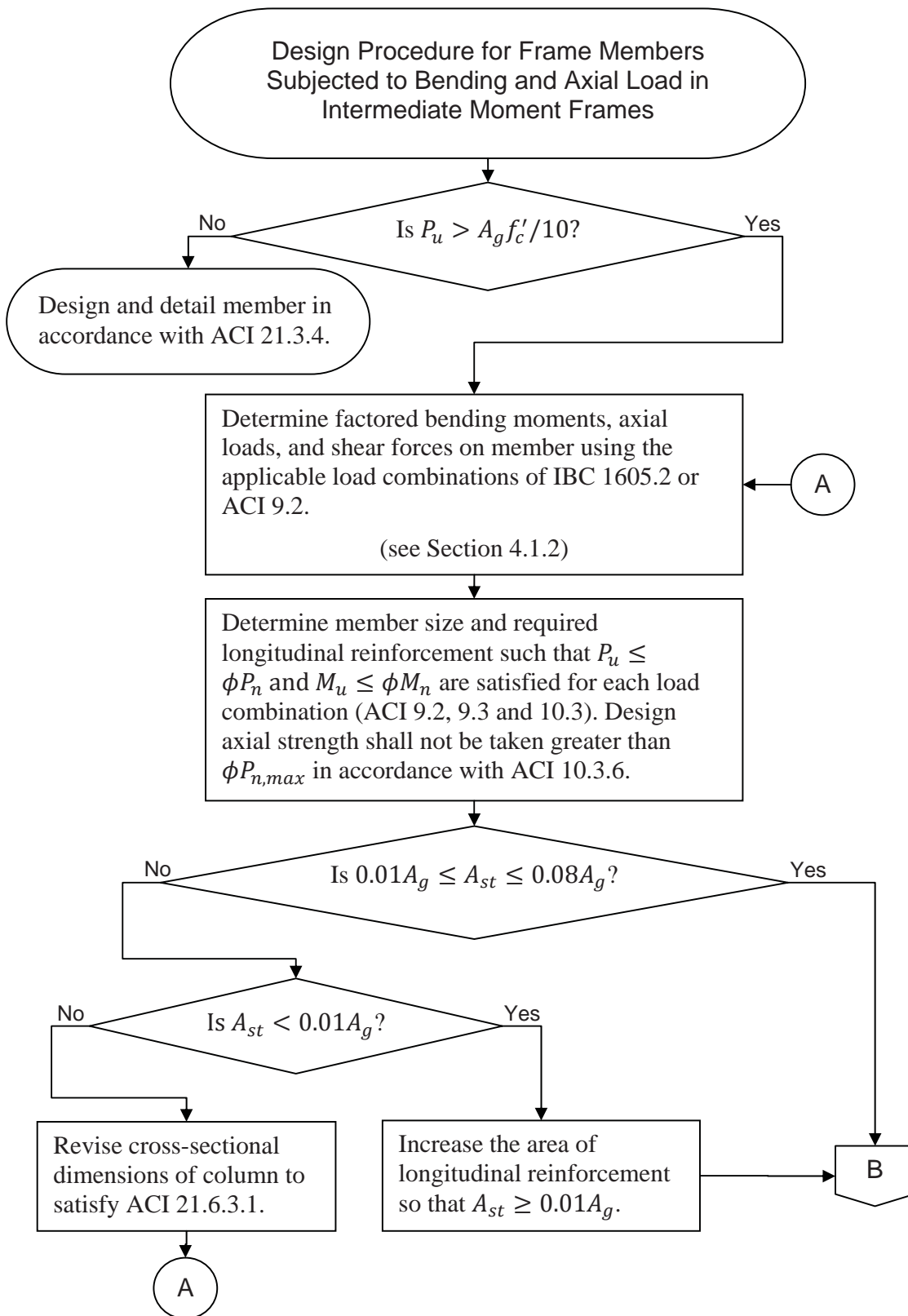

Figure 5.7 Design Procedure for Frame Members Subjected to Bending and Axial Load in Intermediate Moment Frames

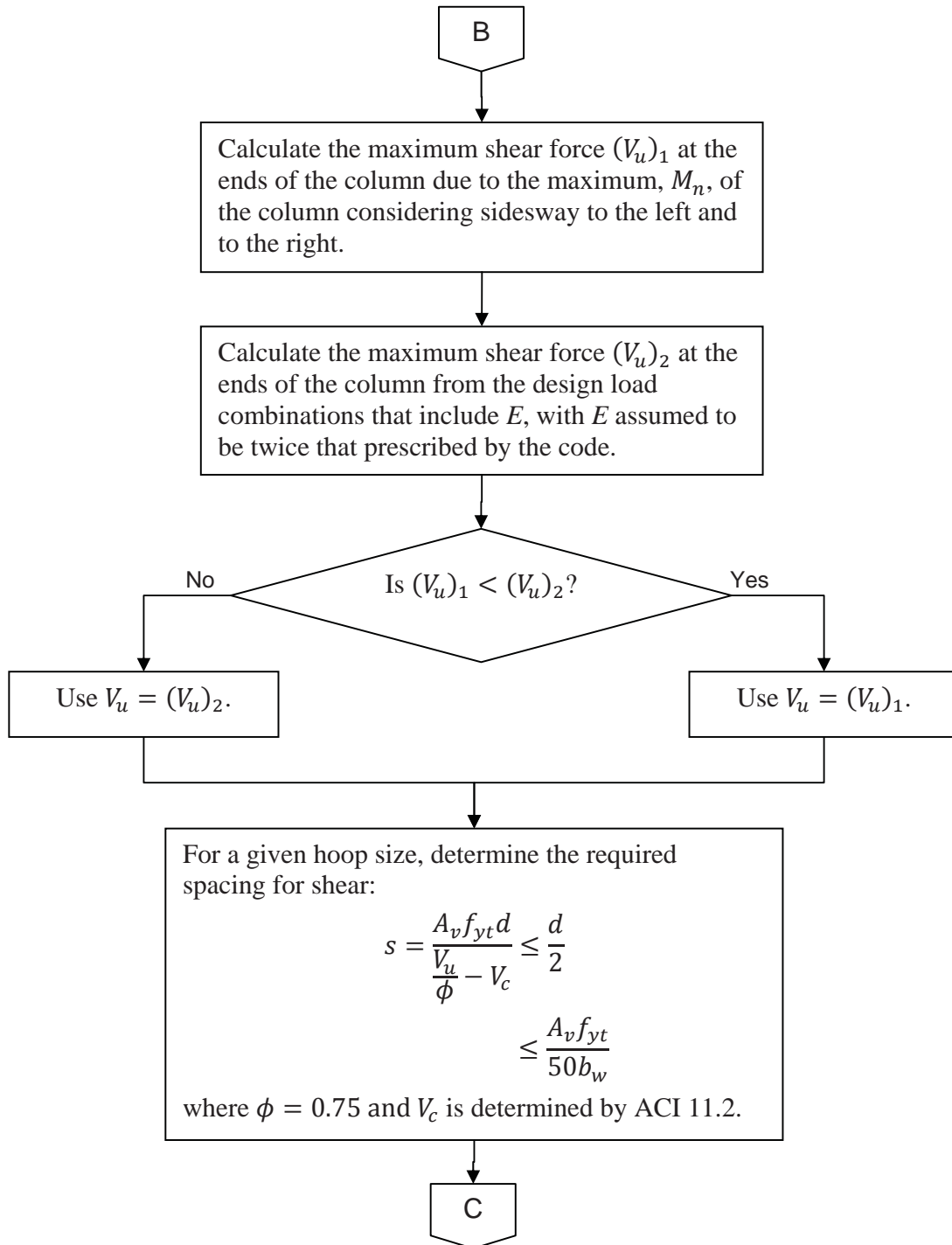

Figure 5.7 Design Procedure for Frame Members Subjected to Bending and Axial Load in Intermediate Moment Frames (continued)

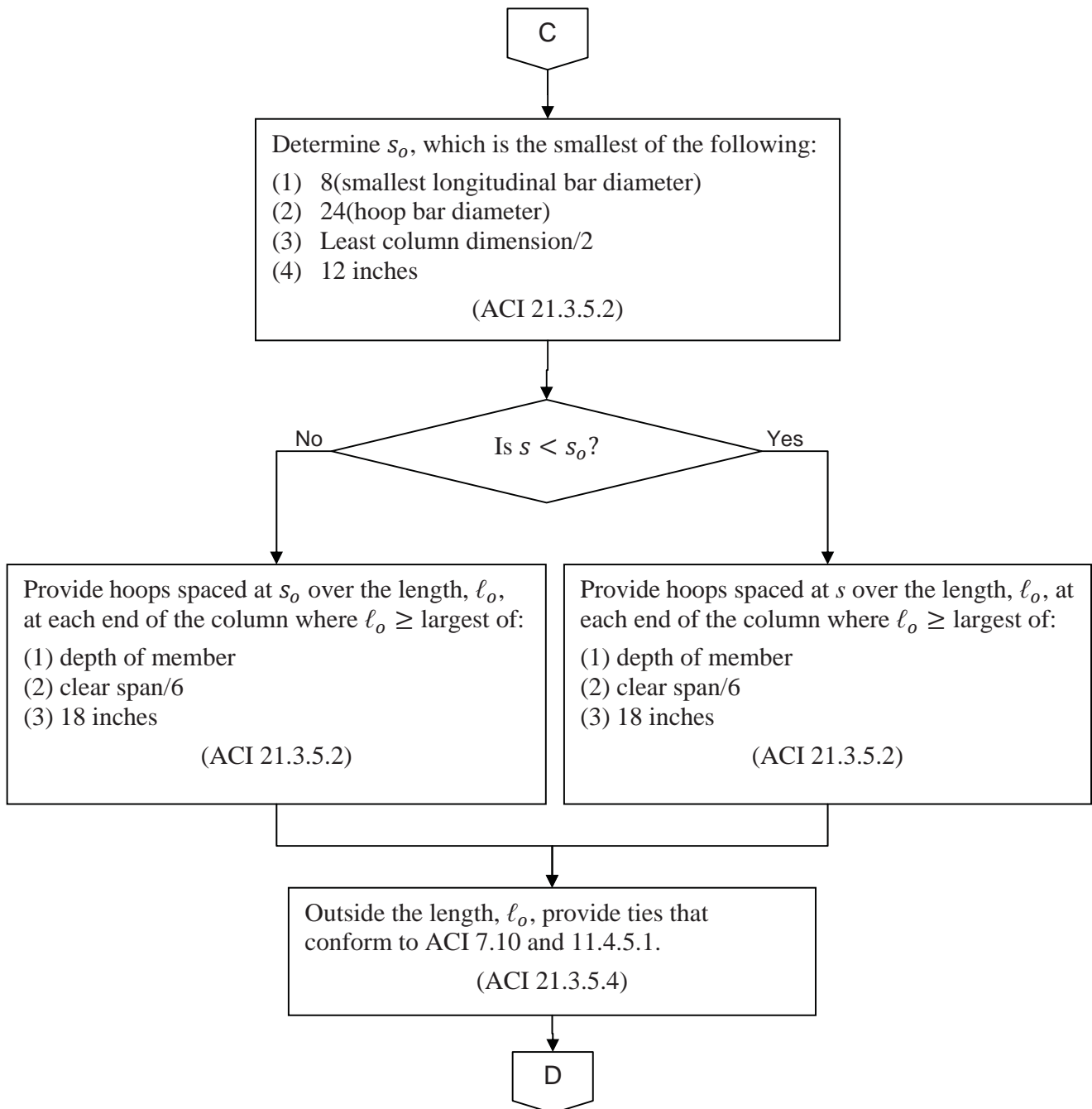
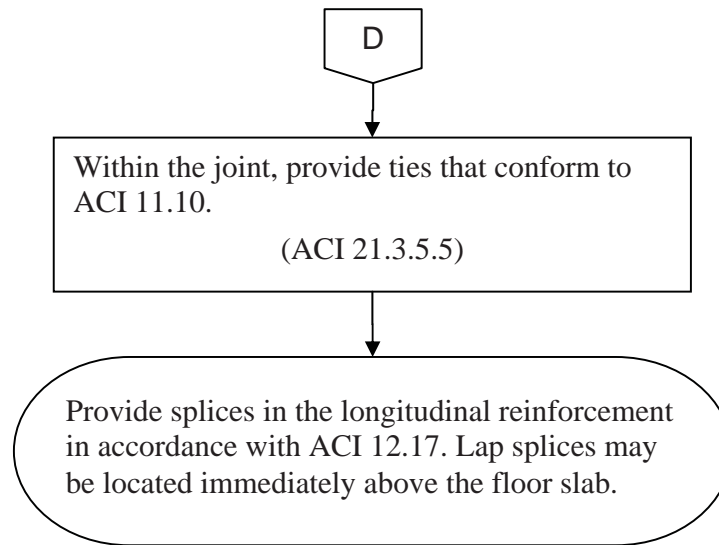

Figure 5.7 Design Procedure for Frame Members Subjected to Bending and Axial Load in Intermediate Moment Frames (continued)



For SI: 1 inch = 25.4 mm.

Figure 5.7 Design Procedure for Frame Members Subjected to Bending and Axial Load in Intermediate Moment Frames (continued)

5.4 EXAMPLES

5.4.1 Example 5.1—Four-story Residential Building

For the four-story residential building depicted in Figure 4.26, determine the required reinforcement (1) in the slab along column line 4, (2) in the beams along column line 1 on the first floor, (3) in column B1 supporting the first floor level, (4) in footing B1, (5) in the diaphragm chords along column lines 1, 2, 6 and 7 at the third floor level for lateral forces in the east-west direction and (6) in the collector element along column line F at the third floor level for lateral forces in the east-west direction.

DESIGN DATA

Concrete: $f'_c = 4000$ psi; reinforcement: $f_y = 60,000$ psi.

Roof live load = 20 psf; roof superimposed dead load = 10 psf

Floor average live load = 70 psf (40 psf outside of corridors, 100 psf for corridors)

Floor superimposed dead load = 30 psf

Glass curtain wall system: 8 psf

Net allowable bearing capacity of soil = 4000 psf

Lateral-force-resisting system: moment-resisting frames

Wind velocity = 90 mph, Exposure B

Seismic Design Category: C ($S_{DS} = 0.41$, $S_{D1} = 0.15$)

First story height = 12 feet, typical story height = 10 feet.

SOLUTION

Part 1: Determine reinforcement in slab along column line 4

Since the slab is not part of the lateral-force-resisting system, it is designed for the effects due to gravity loads only. Thus, the reinforcement details given in Part 1 of Example 4.1 for SDC B can be used for SDC C as well.

Part 2: Determine reinforcement in beams along column line 1

The beams along column line 1 are part of the lateral-force-resisting system, and must be designed for the combined effects due to gravity, wind and seismic forces.

- Design for Flexure

The bending moments due to gravity forces are combined with the bending moments due to the lateral forces to obtain the maximum factored moments at the critical sections.

Bending Moments Due to Gravity Forces

Bending moments due to the dead and live loads are determined using the Direct Design Method. The longest clear span is used to calculate bending moments. A summary of the service gravity bending moments in the design strip is given in Table 4.26 in Example 4.1.

Bending Moments Due to Lateral Forces

Wind and seismic forces were computed in accordance with ASCE/SEI Chapters 6, 11, 12, 20 and 21 based on the design data above, and the structure was analyzed for lateral forces in the N-S direction. The results of the analysis are summarized in Table 5.4 for the beams along column line 1 at the first floor. Since the building is assigned to SDC C, intermediate reinforced concrete moment frames are utilized (see ASCE/SEI Table 12.2-1, system C6).

Table 5.4 Bending Moments (ft-kips) in Beams at First Floor Level Along Column Line 1 Due to Wind and Seismic Forces

	End Span		Interior Span
	Exterior Negative	Interior Negative	Interior Negative
Wind (W)	54.0	49.0	40.4
Seismic (Q_E)	395.1	358.8	296.9

For SI: 1 ft-kip = 1.356 kN-m.

Factored Bending Moments

Basic strength design load combinations are given in ACI 9.2, which are essentially the same as those in ASCE/SEI 2.3.2. The applicable load combinations in this case are:

$$U = 1.4D \quad \text{ACI Eq. (9-1)}$$

$$U = 1.2D + 1.6L \quad \text{ACI Eq. (9-2)}$$

$$U = 1.2D + 0.8W \quad \text{ACI Eq. (9-3)}$$

$$U = 1.2D + 0.5L + 1.6W \quad \text{ACI Eq. (9-4)}$$

$$U = 1.2D + 0.5L + 1.0E \quad \text{ACI Eq. (9-5)}$$

$$U = 0.9D + 1.6W \quad \text{ACI Eq. (9-6)}$$

$$U = 0.9D + 1.0E \quad \text{ACI Eq. (9-7)}$$

According to ASCE/SEI 12.4.2, the seismic load effect, E , is the combination of horizontal and vertical seismic load effects. The E for use in ACI Equation (9-5) (or, equivalently, ASCE/SEI load combination 5) where the effects of gravity and seismic ground motion are additive is

$$E = \rho Q_E + 0.2S_{DS}D$$

The redundancy factor, ρ , is equal to 1.0 for structures assigned to SDC C (ASCE/SEI 12.3.4.1).

The E for use in ACI Equation (9-7) (or, equivalently, ASCE/SEI load combination 7) where the effects of gravity and seismic ground motion counteract is

$$E = \rho Q_E - 0.2S_{DS}D$$

A summary of the governing factored bending moments is given in Table 5.5. The required flexural reinforcement is presented in Table 5.6, and the provided areas of steel are within the limits prescribed in ACI 10.3.5 for maximum reinforcement (i.e.,

net tensile strain in the extreme tension steel at nominal strength, ϵ_t , shall be greater than or equal to 0.004) and ACI 10.5.1 for minimum reinforcement.

Table 5.5 Summary of Design Bending Moments and Shear Forces for Beam at First Floor Level Along Column Line 1

Load Case	Location	Bending Moment (ft-kips)	Shear Force (kips)
Dead (<i>D</i>)	Support	-57.6	11.8
	Midspan	41.1	
Live (<i>L</i>)	Support	-22.5	4.6
	Midspan	16.2	
Wind (<i>W</i>)	Support	± 54.0	± 4.8
Seismic (Q_E)	Support	± 395.1	± 35.4
Load Combination			
1.4 <i>D</i>	Support	-80.6	16.5
	Midspan	57.5	
1.2 <i>D</i> + 1.6 <i>L</i>	Support	-105.1	21.5
	Midspan	75.2	
1.2 <i>D</i> + 0.5 <i>L</i> + 1.6 <i>W</i>	Support	-166.8	24.1
	Midspan	57.4	
0.9 <i>D</i> - 1.6 <i>W</i>	Support	34.6	2.9
	Midspan	37.0	
1.28 <i>D</i> + 0.5 <i>L</i> + Q_E	Support	-480.1	52.8
	Midspan	60.7	
0.82 <i>D</i> - Q_E	Support	347.9	25.7
	Midspan	33.7	

Table 5.6 Required Flexural Reinforcement for Beam at First Floor Level Along Column Line 1

Location	M_u (ft-kips)	A_s^* (in. ²)	Reinforcement	ϕM_n (ft-kips)
Support	-480.1	5.61	6-No. 9	509.0
	347.9	3.91	4-No. 9	355.2
Midspan	75.2	1.43	2-No. 9	185.6
$* A_{s,min} = \frac{3\sqrt{f'_c} b_w d}{f_y} = \frac{3\sqrt{4,000} \times 20 \times 21.5}{60,000} = 1.36 \text{ in.}^2$ <p style="text-align: right;">ACI 10.5.1</p> $= \frac{200b_w d}{f_y} = \frac{200 \times 20 \times 21.5}{60,000} = 1.43 \text{ in.}^2 \text{ (governs)}$ $A_{s,max} = \frac{0.85\beta_1 f'_c b_w d}{f_y} \frac{0.003}{0.003 + 0.004} = \frac{0.85 \times 0.85 \times 4 \times 20 \times 21.5}{60} \times \frac{0.003}{0.007} = 8.88 \text{ in.}^2$ <p style="text-align: center;">ACI 10.3.5</p>				

The selected reinforcement satisfies ACI 7.6.1 and 3.3.2 (minimum spacing for concrete placement), ACI 7.7.1 (minimum cover for protection of reinforcement) and ACI 10.6 (maximum spacing for control of flexural cracking). See Tables 4.7 and 4.8 for minimum and maximum number of reinforcing bars permitted in a single layer.

ACI 21.3.4.1 requires that the positive moment strength at the face of a joint be greater than or equal to 33 percent of the negative moment strength at that location (see Figure 5.1). This is satisfied, since $355.2 \text{ ft-kips} > 509.0/3 = 169.7 \text{ ft-kips}$. Also, the negative or positive moment strength at any section of the beam must be greater than or equal to 20 percent of the maximum moment strength provided at the face of either joint. Twenty percent of the maximum moment strength in this case is equal to $509.0/5 = 101.8 \text{ ft-kips}$. Providing at least two No. 9 bars ($\phi M_n = 185.6 \text{ ft-kips}$) along the length of the beam satisfies this provision.

- Design for Combined Flexure, Shear and Torsion

Shear Requirements

Shear requirements for beams in intermediate moment frames are given in ACI 21.3.3. Design shear strength shall not be less than the smaller of the two values obtained by ACI 21.3.3(a) and ACI 21.3.3(b).

- Design shear strength by ACI 21.3.3(a)

The largest shear force associated with seismic effects is obtained from the fifth of the six load combinations in Table 5.5. Shear forces due to gravity loads plus nominal moment strengths for sidesway to the right are shown in Figure 5.8.⁷

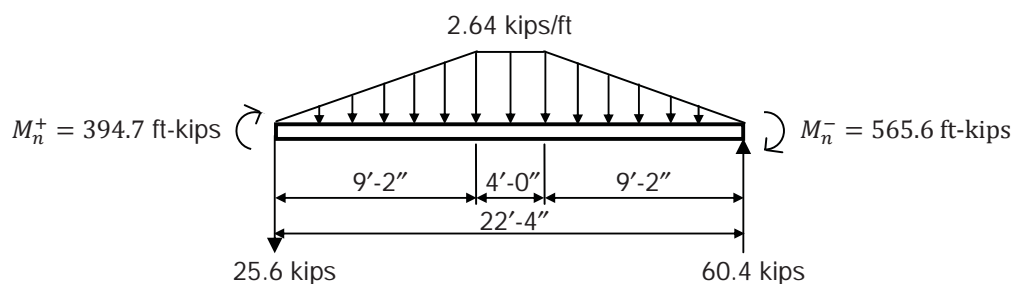

For SI: 1 inch = 25.4 mm; 1 foot = 304.8 mm.

Figure 5.8 Factored Shear Forces on Beam at First Floor Level Along Column Line 1

⁷ Sidesway to the left gives the same maximum shear force due to the symmetric distribution of the longitudinal reinforcement.

- Design shear strength by ACI 21.3.3(b)

As in the first method, the largest shear force associated with seismic effects is obtained from the fifth of the six load combinations in Table 5.5:

$$\begin{aligned} U &= 1.2D + 0.5L + 2.0E = 1.2D + 0.5L + 2.0(Q_E + 0.2S_{DS}D) \\ &= 1.36D + 0.5L + 2.0Q_E \end{aligned}$$

Using Table 5.5,

$$V_u = (1.36 \times 11.8) + (0.5 \times 4.6) + (2.0 \times 35.4) = 89.2 \text{ kips}$$

Therefore, use $V_u = 60.4$ kips.

- Required transverse reinforcement for shear

Determine transverse reinforcement required for shear by ACI Equations (11-1), (11-2) and (11-15) (see Figure 4.8).

$$\frac{A_v}{s} = \frac{V_u - \phi V_c}{\phi f_{yt} d} = \frac{60,400 - (0.75 \times 2 \times \sqrt{4000} \times 20 \times 21.5)}{0.75 \times 60,000 \times 21.5} = 0.020 \text{ in.}^2 / \text{in.}$$

Torsion Requirements

The torsional moments on the beam are due to gravity loads only. As shown in Example 4.1, the beam must be designed for a torsional moment of 43.2 ft-kips.

Check the adequacy of the cross-sectional dimensions of the beam using ACI Equation (11-18).

Assuming a 1.5-inch clear cover to No. 4 hoops/closed stirrups in the beam web only, use Table 4.11 to determine the section properties A_{oh} and p_h :

$$A_{oh} = [20 - (2 \times 1.5) - 0.5] \times [24 - (2 \times 1.5) - 0.5] = 338.25 \text{ in.}^2$$

$$p_h = 2 \times \{[20 - (2 \times 1.5) - 0.5] + [24 - (2 \times 1.5) - 0.5]\} = 74 \text{ in.}$$

$$\sqrt{\left(\frac{V_u}{b_w d}\right)^2 + \left(\frac{T_u p_h}{1.7 A_{oh}^2}\right)^2} = \sqrt{\left(\frac{60,400}{20 \times 21.5}\right)^2 + \left(\frac{43.2 \times 12,000 \times 74}{1.7 \times 338.25^2}\right)^2} = 242.1 \text{ psi}$$

$$\phi \left(\frac{V_c}{b_w d} + 8\sqrt{f'_c}\right) = 0.75(2 + 8)\sqrt{4000} = 474.3 \text{ psi} > 242.1 \text{ psi} \quad \text{O.K.}$$

- Required transverse reinforcement for torsion

It was shown in Example 4.1 that the required transverse reinforcement for torsion is

$$\frac{2A_t}{s} = \frac{2T_u}{2\phi \cot\theta A_o f_{yt}} = \frac{2 \times 43.2 \times 12,000}{2 \times 0.75 \times \cot 45^\circ \times 287.5 \times 60,000} = 0.040 \text{ in.}^2/\text{in.}$$

Total Transverse Reinforcement Requirements

Total required transverse reinforcement = 0.020 + 0.040 = 0.060 in.²/in.

Minimum transverse reinforcement is the greater of the following:

$$0.75\sqrt{f'_c} \frac{b_w}{f_{yt}} = 0.75\sqrt{4000} \frac{20}{60,000} = 0.016 \text{ in.}^2/\text{in.}$$

$$\frac{50b_w}{f_{yt}} = \frac{50 \times 20}{60,000} = 0.017 \text{ in.}^2/\text{in.} \quad (\text{governs})$$

According to ACI 21.3.4.2, the maximum spacing of hoops over the length $2h = 48$ in. is the smallest of the following (see Figure 5.2):

- (1) $d/4 = 21.5/4 = 5.4$ in. (governs)
- (2) $8 \times$ diameter of smallest longitudinal bar = $8 \times 1.128 = 9.0$ in.
- (3) $24 \times$ diameter of hoop bar = $24 \times 0.5 = 12$ in.
- (4) 12 inches

Maximum spacing of transverse reinforcement outside of the 48-inch segments at each end of the beam is the smallest of the following:

- (1) $\frac{p_h}{8} = \frac{74}{8} = 9.3$ in. (governs)
- (2) 12 inches
- (3) $\frac{d}{2} = \frac{21.5}{2} = 10.8$ in.

Assuming No. 4 hoops, the required spacing, s , at the critical section = $2 \times 0.20/0.060 = 6.7$ in. > 5.4 in.

Use 11 No. 4 hoops (two legs) at each end of the beam spaced at 5.0 inches on center with the first hook located 2 inches from the face of the support. For the remainder of the beam, provide No. 4 closed stirrups spaced at 6 inches.⁸

Longitudinal Reinforcement Required for Torsion

Determine longitudinal reinforcement required for torsion by ACI Equation (11-22) (see Figure 4.11):

$$A_\ell = \frac{A_t}{s} p_h \left(\frac{f_{yt}}{f_y} \right) \cot^2 \theta = \frac{0.040}{2} \times 74 = 1.48 \text{ in.}^2$$

$$A_{\ell, \min} = \frac{5\sqrt{f'_c} A_{cp}}{f_y} - \left(\frac{A_t}{s} \right) p_h \left(\frac{f_{yt}}{f_y} \right) = \frac{5\sqrt{4000} \times 615}{60,000} - \left(\frac{0.040}{2} \times 74 \right) = 1.76 \text{ in.}^2$$

Total Required Longitudinal Reinforcement

The longitudinal reinforcement required for torsion must be combined with the longitudinal reinforcement required for flexure. The longitudinal torsion reinforcement must be distributed around the perimeter of the section with a maximum spacing of 12 inches (ACI 11.5.6.2). In order to have a uniform distribution of reinforcement around the perimeter, assign $1.76/4 = 0.44 \text{ in.}^2$ to each face.

Use one No. 6 bar on each side (area = 0.44 in.^2 , bar diameter = 0.75 in. > $0.042s = 0.25 \text{ in.}$). This bar satisfies the maximum spacing requirement of 12 inches, since the spacing = $\{24 - 2[1.5 + 0.5 + (1.128/2)]\}/2 = 9.4 \text{ in.}$

The remaining 0.44 square inches of longitudinal steel required for torsion at the top and bottom of the section is added to the area of steel required for flexure (see Table 5.6):

- Face of support

$$5.61 + 0.44 = 6.05 \text{ in.}^2 \approx 6.00 \text{ in.}^2$$

$$3.91 + 0.44 = 4.35 \text{ in.}^2 > 4.00 \text{ in.}^2$$

- Midspan

$$1.43 + 0.44 = 1.87 \text{ in.}^2 < 2.00 \text{ in.}^2$$

⁸ Providing hoops and closed stirrups at a spacing of 5 inches over the entire length of the beam would result in simpler detailing.

Thus, the top reinforcing bars listed in Table 5.6 can be used for combined flexure and torsion. However, add one No. 9 bar to the bottom of the section for a total of five No. 9 bottom reinforcing bars to satisfy combined reinforcement requirements.

- Reinforcement Details

According to the structural integrity provisions in ACI 7.13.2.2, at least one-sixth of the tension reinforcement required for negative moment at the support (but not less than two bars) and at least one-quarter of the tension reinforcement required for positive moment at midspan (but not less than two bars) must be continuous and be enclosed by closed stirrups. Thus, at least two No. 9 tops bars must be continuous or spliced by Class B tension splices near midspan, and at least two No. 9 bottom bars must be continuous or spliced by Class B tension splices at or near the supports.

Four of the six No. 9 top bars can be theoretically cut off at the location where the factored bending moment is equal to the design moment strength of the section based on a total area of steel equal to the area of two No. 9 bars. Thus, with $A_s = 2.00 \text{ in.}^2$, $\phi M_n = 185.6 \text{ ft-kips}$.

The load combination, $0.82D$, plus the nominal flexural strengths, M_n , at each end of the beam produces the longest bar lengths. The distance, x , from the face of the support where the factored bending moment is equal to 185.6 ft-kips is obtained by summing moments about section $a-a$ at this location (see Figure 5.9):

$$\left(\frac{x}{2} \times \frac{1.47x}{9.167} \times \frac{x}{3}\right) - 52.7x + 565.6 = 185.6$$

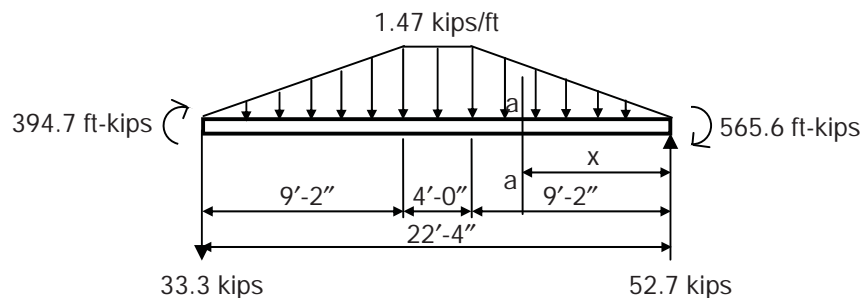

For SI: 1 inch = 25.4 mm; 1 foot = 304.8 mm.

Figure 5.9 Cutoff Location of Negative Flexural Reinforcement

Solution of this equation gives $x = 7.4$ feet. The four No. 9 bars must extend a distance of $d = 21.5 \text{ in.}$ or $12d_b = 12 \times 1.128 = 13.5 \text{ in.}$ beyond the distance, x (ACI 12.10.3). Thus, from the face of the support, the total bar length must be at least equal to $7.4 + (21.5/12) = 9.2 \text{ ft}$. Also, the bars must extend a full development length, ℓ_d , beyond the face of the support (ACI 12.10.4). The development length for the No. 9 bars can be determined by ACI Eq. (12-1):

$$\ell_d = \left(\frac{3}{40} \frac{f_y}{\lambda \sqrt{f'_c}} \frac{\psi_t \psi_e \psi_s}{\left(\frac{c_b + K_{tr}}{d_b} \right)} \right) d_b$$

where λ = modification factor for lightweight concrete = 1.0 for normal weight concrete

ψ_t = modification factor for reinforcement location = 1.3 for top bars

ψ_e = modification factor for reinforcement coating = 1.0 for uncoated reinforcement

ψ_s = modification factor for reinforcement size = 1.0 for No. 9 bars

c_b = spacing or cover dimension

$$= 1.5 + 0.5 + \frac{1.128}{2} = 2.6 \text{ in.}$$

$$= \frac{20 - 2(1.5 + 0.5) - 1.128}{2 \times 5} = 1.5 \text{ in. (governs)}$$

K_{tr} = transverse reinforcement index = 0 (conservative)

$$\frac{c_b + K_{tr}}{d_b} = \frac{1.5 + 0}{1.128} = 1.3 < 2.5$$

Therefore,

$$\ell_d = \left(\frac{3}{40} \frac{60,000}{1.0 \sqrt{4000}} \frac{1.3 \times 1.0 \times 1.0}{1.3} \right) \times 1.128 = 80.3 \text{ in.} = 6.7 \text{ ft}$$

Thus, the total length of the four -No. 9 bars must be at least 9.2 feet beyond the face of the support.

Flexural reinforcement shall not be terminated in a tension zone unless one or more of the conditions of ACI 12.10.5 are satisfied. In this case, the point of inflection is approximately 11.5 feet from the face of the support, which is greater than 9.2 feet. Thus, the No. 9 bars cannot be terminated here unless one of the conditions of ACI 12.10.5 is satisfied. In this case, check if the factored shear force, V_u , at the cutoff point does not exceed $2\phi V_n/3$ (ACI 12.10.5.1). With No. 4 stirrups at 10 inches on center, ϕV_n is determined by ACI Equations (11-1) and (11-2):

$$\phi V_n = \phi(V_c + V_s) = 0.75 \left(54.4 + \frac{0.4 \times 60 \times 21.5}{8} \right) = 89.2 \text{ kips}$$

At 9.2 feet from the face of the support, $V_u = 52.7 - (0.5 \times 1.47 \times 9.2) = 45.9$ kips, which is less than $2 \times 89.2/3 = 59.5$ kips. Therefore, the four No. 9 bars can be terminated at 9.2 feet from the face of the support.

It is assumed in this example that the five No. 9 positive bars are continuous with splices over the columns.

Figure 5.10 shows the reinforcement details for the beam.

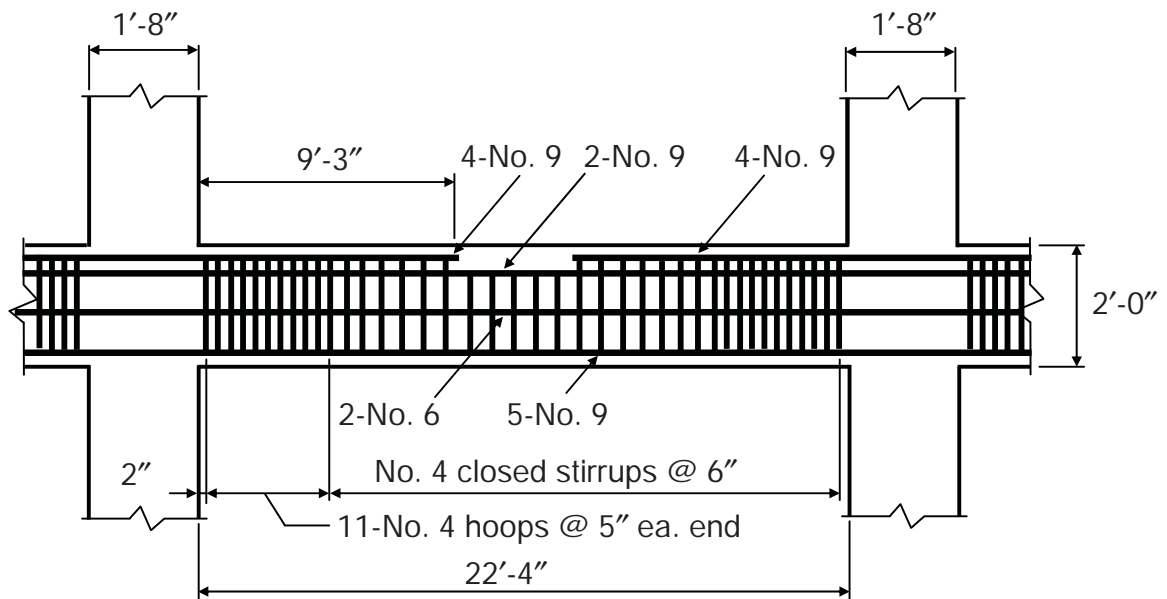

For SI: 1 inch = 25.4 mm; 1 foot = 304.8 mm.

Figure 5.10 Reinforcement Details for the Beam at First Floor Level Along Column Line 1

Part 3: Determine reinforcement in column B1 supporting the first floor level

A summary of the axial forces, bending moments and shear forces on column B1 is given in Table 5.7. ACI Equation (13-7) was used in determining the gravity load moments on the column where the full dead load is taken on adjoining spans and half of the live load is taken on the longer span. The bending moment determined by this equation was distributed to the column above and below inversely proportional to their lengths. Also given in Table 5.7 are the factored load combinations.⁹

According to ASCE/SEI 12.5.3, orthogonal load effects need not be considered on this member, since the building does not have horizontal structural irregularity Type 5 in ASCE/SEI Table 12.3-1 (nonparallel systems irregularity).

⁹ It was assumed in the analysis that the base of the column is pinned and that only axial force is transmitted from the column to the footing.

Table 5.7 Summary of Axial Forces, Bending Moments and Shear Forces on Column B1 Supporting the First Floor Level

Load Case	Axial Force (kips)	Bending Moment (ft-kips)	Shear Force (kips)
Dead (D)	157.9	11.3	± 2.3
Live (L)	31.5	11.0	± 2.2
Roof live (L_r)	4.9		
Wind (W)	± 3.6	± 111.0	± 11.1
Seismic (Q_E)	± 26.4	± 422.1	± 42.2
Load Combination			
$1.4D$	221.1	15.8	3.2
$1.2D + 1.6L + 0.5L_r$	242.3	31.2	6.3
$1.2D + 0.5(L + L_r) + 1.6W$	213.4	196.7	21.6
$0.9D - 1.6W$	136.4	167.4	15.7
$1.28D + 0.5L + Q_E$	244.3	442.1	46.2
$0.82D - Q_E$	103.1	412.8	40.3

- Design for Axial Force and Bending

Based on the governing load combinations in Table 5.7, a 20-inch by 20-inch column reinforced with 12 No. 9 bars ($A_{st} = 0.027A_g$) is adequate for column B1 supporting the first floor level. The interaction diagram for this column is shown in Figure 5.11. Since P-delta effects were considered in the analysis, slenderness effects need not be considered. The provided area of longitudinal reinforcement is within the allowable range specified in ACI 10.9.1.

In accordance with ACI 7.6.3, the distance between longitudinal bars must be greater than or equal to $1.5d_b = 1.5 \times 1.128 = 1.7$ in. (governs) or 1.5 inches. In this case, the clear distance is equal to

$$\frac{20 - 2 \left(1.5 + 0.375 + \frac{1.128}{2} \right)}{3} - 1.128 = 5.0 \text{ in.} > 1.7 \text{ in.} \quad \text{O.K.}$$

- Design for Shear

Similar to beams, columns in intermediate moment frames must satisfy the shear requirements of ACI 21.3.3.

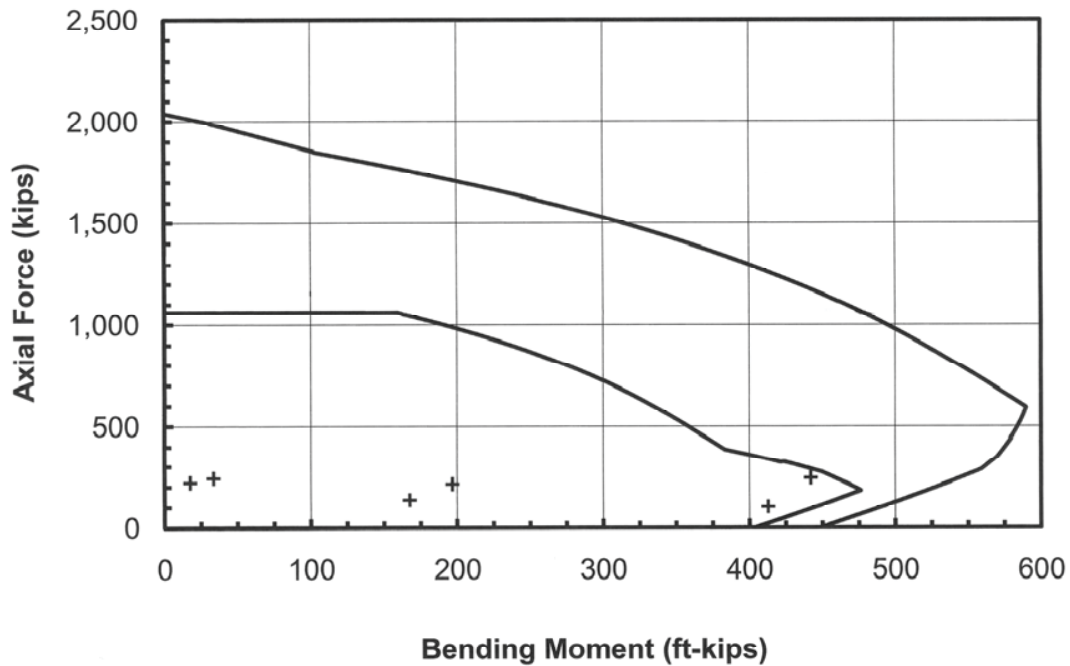

Figure 5.11 Design and Nominal Strength Interaction Diagrams for Column B1

- Design shear strength by ACI 21.3.3(a)

The largest moment strength, M_n , of the column is obtained using the fifth of the six load combinations in Table 5.7. For $P_n = P_u/\phi = 244.3/0.817 = 299.0$ kips, $M_n = 561.3$ ft-kips.

The shear force based on this nominal moment strength is equal to $M_n/\ell_u = 561.3/(12 - 2) = 56.1$ kips.

The maximum shear force, V_u , is obtained from the fifth load combination:

$$V_u = (1.28 \times 2.3) + (0.5 \times 2.2) + 56.1 = 60.1 \text{ kips}$$

- Design shear strength by ACI 21.3.3(b)

As in the first method, the largest shear force associated with seismic effects is obtained from the fifth of the six load combinations in Table 5.7:

$$\begin{aligned} U &= 1.2D + 0.5L + 2.0E = 1.2D + 0.5L + 2.0(Q_E + 0.2S_{DS}D) \\ &= 1.36D + 0.5L + 2.0Q_E \end{aligned}$$

Using Table 5.7,

$$V_u = (1.36 \times 2.3) + (0.5 \times 2.2) + (2.0 \times 46.2) = 96.6 \text{ kips}$$

Therefore, use $V_u = 60.1$ kips.

The shear capacity of the column is checked in accordance with ACI Equation (11-4) for members subjected to axial compression:

$$\begin{aligned} V_c &= 2 \left(1 + \frac{N_u}{2000A_g} \right) \lambda \sqrt{f'_c} b_w d \\ &= 2 \left(1 + \frac{244,300}{2000 \times 20^2} \right) \sqrt{4000} \times 20 \times 15.9/1000 = 52.5 \text{ kips} \end{aligned}$$

where $N_u = 244.3$ kips, which is the factored axial compressive force on the column corresponding to the maximum shear force and $d = 15.9$ in. was obtained from a strain compatibility analysis.

Since $\phi V_c = 0.75 \times 52.5 = 39.4$ kips $< V_u = 60.1$ kips, provide shear reinforcement in accordance with ACI 11.4.7:

$$\frac{A_v}{s} = \frac{V_u - \phi V_c}{\phi f_{yt} d} = \frac{60.1 - 39.4}{0.75 \times 60 \times 15.9} = 0.029 \text{ in.}^2/\text{in.}$$

The required spacing of No. 3 hoops and crossties is

$$s = \frac{4 \times 0.11}{0.029} = 15.2 \text{ in.} < \frac{A_v f_y}{50 b_w} = \frac{(4 \times 0.11) \times 60,000}{50 \times 20} = 26.4 \text{ in.}$$

The transverse reinforcement requirements of ACI 21.3.5.2 for intermediate moment frames must also be satisfied (see Table 5.3). The vertical spacing, s_o , of No. 3 hoops must not exceed the smallest of the following over a length, ℓ_o , at each end of the column:

- 8(smallest longitudinal bar diameter) = $8 \times 1.128 = 9.0$ in.
- 24(hoop bar diameter) = $24 \times 0.375 = 9.0$ in.
- Least column dimension/2 = 10 in.
- 12 inches

where ℓ_o is the largest of the following:

- Clear span/6 = $(12 - 2) \times 12/6 = 20$ in.

- Maximum cross-sectional dimension of the column = 20 inches
- 18 inches

According to the spacing requirements for shear reinforcement in ACI 11.4.5.1, the maximum spacing shall not exceed $d/2 = 15.9/2 \approx 8.0$ in.

Use four No. 3 hoops @ 8.0 in. on center with the first hoop located vertically not more than $s_o/2 = 8/2 = 4.0$ in. from the joint face (ACI 21.3.5.3). The 8.0-inch spacing is used over the lap splice length of 42 inches ($> \ell_o = 20$ in.), which is determined below. For the remainder of the column, tie spacing shall conform to ACI 7.10 and 11.4.5.1 (ACI 21.3.5.4). In this case, ACI 11.4.5.1 governs; therefore, use a spacing of 8.0 inches for the No. 3 ties and crossties in this region of the column.

ACI 21.3.5.5 requires that joint reinforcement in intermediate moment frames conform to the provisions of ACI 11.10. Lateral reinforcement in the joint must not be less than that computed by ACI Equation (11-13). For No. 3 ties with two crossties, the required spacing is equal to:

$$s = \frac{A_v f_{yt}}{0.75 \sqrt{f'_c} b_w} = \frac{(4 \times 0.11) \times 60,000}{0.75 \sqrt{4000} \times 20} = 27.8 \text{ in.}$$

$$> \frac{A_v f_y}{50 b_w} = \frac{(4 \times 0.11) \times 60,000}{50 \times 20} = 26.4 \text{ in. (governs)}$$

For simpler detailing, continue the 8.0-inch spacing at the column ends through the joint.

- Reinforcement Details

ACI 12.17 contains the splice requirements for columns. It can be seen from the interaction diagram in Figure 5.11 that the bar stress corresponding to at least one factored load combination is greater than $0.5f_y$. Thus, Class B lap splices must be provided in accordance with ACI 12.17.2.3.

Determine the development length in tension by ACI Eq. (12-1):

$$\ell_d = \left(\frac{3}{40} \frac{f_y}{\lambda \sqrt{f'_c}} \frac{\psi_t \psi_e \psi_s}{\left(\frac{c_b + K_{tr}}{d_b} \right)} \right) d_b$$

where $\lambda =$ modification factor for lightweight concrete = 1.0 for normal weight concrete

ψ_t = modification factor for reinforcement location = 1.0 for bars other than top bars

ψ_e = modification factor for reinforcement coating = 1.0 for uncoated reinforcement

ψ_s = modification factor for reinforcement size = 1.0 for No. 9 bars

c_b = spacing or cover dimension

$$= 1.5 + 0.5 + \frac{1.128}{2} = 2.6 \text{ in.}$$

$$= \frac{20 - 2(1.5 + 0.375) - 1.128}{2 \times 3} = 2.5 \text{ in. (governs)}$$

K_{tr} = transverse reinforcement index

$$= \frac{40A_{tr}}{sn} = \frac{40 \times 4 \times 0.11}{8 \times 4} = 0.6$$

$$\frac{c_b + K_{tr}}{d_b} = \frac{2.5 + 0.6}{1.128} = 2.8 > 2.5, \text{ use } 2.5$$

Therefore,

$$\ell_d = \left(\frac{3}{40} \frac{60,000}{1.0\sqrt{4000}} \frac{1.0 \times 1.0 \times 1.0}{2.5} \right) \times 1.128 = 32.1 \text{ in.} = 2.7 \text{ ft}$$

Class B splice length = $1.3\ell_d = 3.5 \text{ ft}$

Use a 3 foot, 6 inch splice length with the splice located just above the slab.

Reinforcement details for column B1 are given in Figure 5.12.

Part 4: Determine reinforcement in footing B1

It can be shown that the required footing size and reinforcement determined in Part 3 of Example 4.1 for SDC B can be used for SDC C as well.

Part 5: Determine reinforcement in the diaphragm chords along column lines 1, 2, 6 and 7 at the third-floor level for lateral forces in the east-west direction

It was determined in Part 5 of Example 4.1 that the center of mass is located 60.0 feet to the east of column line 1 and 61.8 feet to the north of column line F. It was also determined that the center of rigidity is located 60 feet to the east of column line 1 and 70.2 feet to the north of column line F.

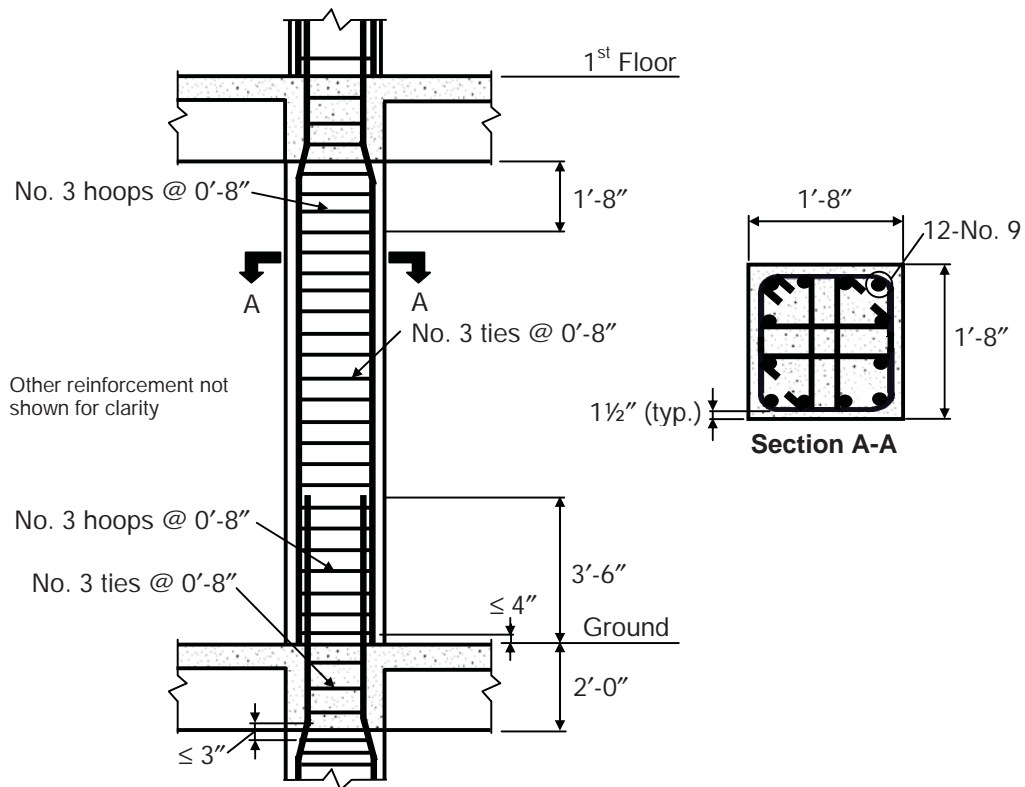

For SI: 1 inch = 25.4 mm; 1 foot = 304.8 mm.

Figure 5.12 Reinforcement Details for Column B1 Supporting the First-Floor Level

Diaphragm Design Forces

ASCE/SEI Equation (12.10-1) is used to determine the design seismic force, F_{px} , on the diaphragm:¹⁰

$$F_{px} = \left(\frac{\sum_{i=x}^n F_i}{\sum_{i=x}^n w_i} \right) w_{px}$$

$$\leq 0.4S_{DS}Iw_{px} = 0.164w_{px}$$

$$\geq 0.2S_{DS}Iw_{px} = 0.082w_{px}$$

where F_i = the seismic design force applied at level i

w_i = the weight tributary to level i

¹⁰ The effects from wind forces do not govern in this example.

w_{px} = the weight tributary to the diaphragm at level x

Table 5.8 contains a summary of the diaphragm forces at each level of the building.¹¹

Table 5.8 Design Seismic Diaphragm Forces

Level	w_x (kips)	Σw_x (kips)	F_x (kips)	ΣF_x (kips)	$\Sigma F_x / \Sigma w_x$	w_{px} (kips)	F_{px} (kips)
4	1,667	1,667	173	173	0.104	1,667	173
3	1,995	3,662	158	331	0.090	1,995	180
2	1,995	5,657	108	439	0.082*	1,995	164
1	2,014	7,671	60	499	0.082*	2,014	165

* Minimum value governs.

Since the diaphragm is rigid, the 180-kip diaphragm force at the third floor level is distributed to the frames in proportion to their relative stiffnesses. This force is applied at the location of the center of mass, which must be displaced from its actual location a distance of 5 percent of the dimension of the building perpendicular to the direction of the applied force = $0.05 \times 114 = 5.7$ ft (ASCE/SEI 12.8.4.2). Thus, two cases must be examined: (1) center of mass located at $61.8 + 5.7 = 67.5$ ft from column line F and (2) center of mass located at $61.8 - 5.7 = 56.1$ ft from column line F.

- Case 1: Center of mass located at 67.5 feet from column line F

In this case, the eccentricity, e_y , between the center of mass and the center of rigidity = $70.2 - 67.5 = 2.7$ ft.

The forces applied to each frame are determined by Equation 3.12 of this publication:¹²

$$(V_i)_x = \frac{(k_i)_x}{\sum (k_i)_x} V_x + \frac{\bar{y}_i (k_i)_x}{\sum \bar{x}_i^2 (k_i)_y + \sum \bar{y}_i^2 (k_i)_x} V_x e_y$$

where \bar{x}_i = perpendicular distance from element i to the center of rigidity parallel to the x -axis

¹¹ The base shear, V , for the building assigned to SDC C with an intermediate moment frame ($R = 5$) is equal to 499 kips compared to a base shear of 496 kips for the building assigned to SDC B with an ordinary moment frame ($R = 3$). The Equivalent Lateral Force Procedure of ASCE/SEI 12.8 was used to compute V in both cases using an approximate period equal to 0.46 sec and the appropriate design spectral response accelerations S_{DS} and S_{D1} .

¹² The forces determined by this method are within 3 percent of those determined by a computer analysis of the diaphragm assuming that the diaphragm is rigid.

\bar{y}_i = perpendicular distance from element i to the center of rigidity parallel to the y -axis

Frame on column line A between lines 1 and 7:

$$V_{A/1-7} = \frac{4.62 \times 180}{(4 \times 1.06) + 4.62} - \frac{(114 - 70.2) \times 4.62 \times (180 \times 2.7)}{40,777} = 91.5 \text{ kips}$$

Frames on column line D between lines 1 and 2 and between lines 6 and 7:

$$\begin{aligned} V_{D/1-2} = V_{D/6-7} &= \frac{1.06 \times 180}{(4 \times 1.06) + 4.62} + \frac{(70.2 - 45) \times 1.06 \times (180 \times 2.7)}{40,777} \\ &= 21.9 \text{ kips} \end{aligned}$$

Frames on column line F between lines 2 and 3 and between lines 5 and 6:

$$\begin{aligned} V_{F/2-3} = V_{D/5-6} &= \frac{1.06 \times 180}{(4 \times 1.06) + 4.62} + \frac{70.2 \times 1.06 \times (180 \times 2.7)}{40,777} \\ &= 22.4 \text{ kips} \end{aligned}$$

The maximum shear force per unit length in the slab occurs along column line A and is equal to 91.5 kips, which is distributed over a length of 80 feet.

The shear strength of the slab is determined by ACI Equation (11-3) using the full thickness of the slab:

$$\begin{aligned} \phi V_c &= \phi 2\lambda\sqrt{f'_c}bt = 0.75 \times 2 \times 1.0\sqrt{4000} \times (80 \times 12) \times 9/1000 \\ &= 819.7 \text{ kips} > 91.5 \text{ kips} \quad \text{O.K.} \end{aligned}$$

- Case 2: Center of mass located at 56.1 feet from column line F

In this case, the eccentricity, e_y , between the center of mass and the center of rigidity = $70.2 - 56.1 = 14.1$ ft.

Frame on column line A between lines 1 and 7:

$$V_{A/1-7} = \frac{4.62 \times 180}{(4 \times 1.06) + 4.62} - \frac{(114 - 70.2) \times 4.62 \times (180 \times 14.1)}{40,777} = 81.3 \text{ kips}$$

Frames on column line D between lines 1 and 2 and between lines 6 and 7:

$$V_{D/1-2} = V_{D/6-7} = \frac{1.06 \times 180}{(4 \times 1.06) + 4.62} + \frac{(70.2 - 45) \times 1.06 \times (180 \times 14.1)}{40,777}$$

$$= 23.2 \text{ kips}$$

Frames on column line F between lines 2 and 3 and between lines 5 and 6:

$$V_{F/2-3} = V_{D/5-6} = \frac{1.06 \times 180}{(4 \times 1.06) + 4.62} + \frac{70.2 \times 1.06 \times (180 \times 14.1)}{40,777}$$

$$= 26.2 \text{ kips}$$

The maximum shear force per unit length in the slab occurs along column line A and is equal to 81.3 kips, which is distributed over a length of 80 feet. This maximum shear force is less than that determined in case 1, so the shear strength of the slab is adequate in this case as well.

Chord Forces and Reinforcement

Section 1602 of the IBC defines a diaphragm chord as a boundary element perpendicular to the applied lateral force that is assumed to resist the axial stresses due to the bending moments in the diaphragm.

In general, the diaphragm is assumed to act as a deep beam that spans between the vertical elements of the lateral-force-resisting system, which act as supports. The compressive or tensile chord force along the length of the diaphragm can be calculated by dividing the bending moment in the diaphragm due to the lateral forces by the diaphragm dimension parallel to the direction of the load.

The concrete diaphragm in this example is modeled as a continuous beam with supports along column lines A, D and F for seismic forces in the east-west direction. The total reactions at these supports can be determined from the forces in the frames. It is assumed that the diaphragm force can be represented by a trapezoidal distributed load as illustrated in Figure 5.13. Since the reactions at the supports are known, the distributed loads, w_1 and w_2 , can be determined from statics. Once the distributed loads have been established, the maximum bending moment is computed and is used to determine the maximum chord force in the diaphragm.

For the center of mass located at 67.5 feet from column line F, the reactions are as follows:

$$R_A = V_{A/1-7} = 91.5 \text{ kips}$$

$$R_D = V_{D/1-2} + V_{D/6-7} = 2 \times 21.9 = 43.8 \text{ kips}$$

$$R_F = V_{F/2-3} + V_{D/5-6} = 2 \times 22.4 = 44.8 \text{ kips}$$

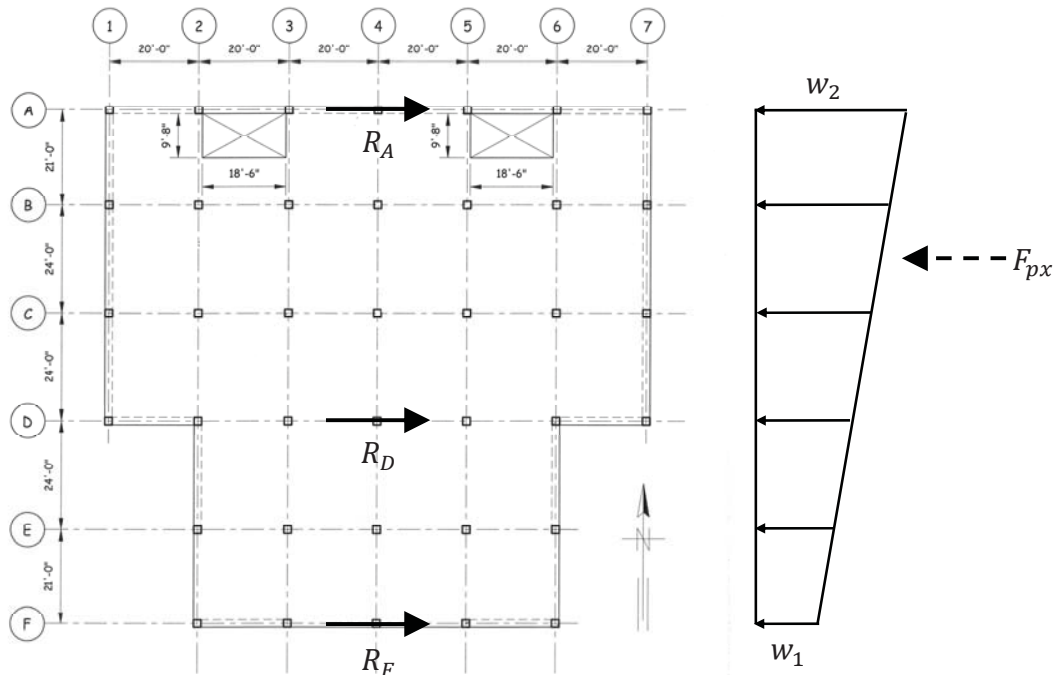

For SI: 1 inch = 25.4 mm; 1 foot = 304.8 mm.

Figure 5.13 Distributed Load on Diaphragm for Seismic Forces in the East-West Direction

Summing forces in the east-west direction and summing moments about column line A results in the following two equations for the diaphragm at the second floor level:

$$(w_1 \times 114) + \left[\frac{1}{2}(w_2 - w_1) \times 114 \right] = 180$$

$$\left(w_1 \times \frac{114^2}{2} \right) + \left[\frac{1}{2}(w_2 - w_1) \times 114 \times \left(\frac{1}{3} \times 114 \right) \right] = (43.8 \times 69) + (44.8 \times 114)$$

Solving these equations simultaneously results in $w_1 = 0.60$ kips/ft and $w_2 = 2.56$ kips/ft.

The shear and moment diagrams for this case are shown in Figure 5.14. The maximum bending moment in the portion of the diaphragm between column lines A and D is equal to 1796.1 ft-kips. Between column lines D and F, the maximum bending moment is equal to 1157.1 ft-kips.

A similar analysis can be performed for the center of mass located at 56.1 feet from column line F. In that case, the maximum bending moment in the portion of the diaphragm between column lines A and D is equal to 1689.6 ft-kips. Between column

lines D and F, the maximum bending moment is equal to 1143.9 ft-kips. Thus, the maximum chord forces are obtained for the case where the center of mass is located at 67.5 feet from column line F.

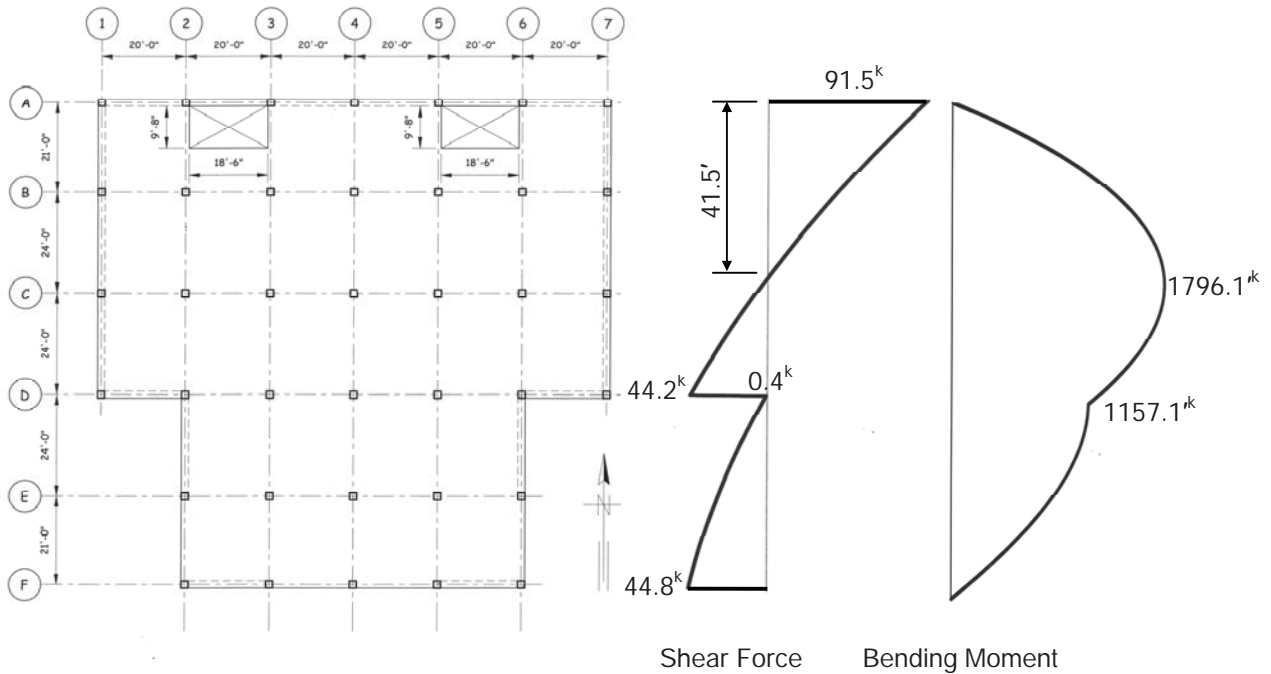

For SI: 1 inch = 25.4 mm; 1 foot = 304.8 mm.

Figure 5.14 Shear Force and Bending Moment Diagrams for the Diaphragm at the Third-Floor Level for Seismic Forces in the East-West Direction

For the portion of the diaphragm between lines A and D, the maximum chord force is equal to the following:

$$T_u = C_u = \frac{M_u}{D} = \frac{1796.1}{120} = 15.0 \text{ kips}^{13}$$

The required area of tension reinforcement is

$$A_s = \frac{T_u}{\phi f_y} = \frac{15.0}{0.9 \times 60} = 0.28 \text{ in.}^2$$

Therefore, provide one No. 5 chord bar along the slab edges on column lines 1 and 7 between lines A and D.¹⁴

¹³ It can be shown that the 20-inch by 24-inch edge beams on column lines 1 and 7 are adequate for the combined effects due to bending and a 15.0-kip axial compressive force.

¹⁴ In lieu of providing an extra bar in the edge beams for chord reinforcement, any excess amount of provided reinforcement in the beams may be used to resist the tensile force in the chord. That option is not considered in this example.

For the portion of the diaphragm between lines D and F, the maximum chord force is:

$$T_u = C_u = \frac{M_u}{D} = \frac{1157.1}{80} = 14.5 \text{ kips}$$

Therefore, provide one No. 5 chord bar along the slab edges on column lines 2 and 6 between lines D and F.¹⁵

Similar analyses can be performed for the required chord reinforcement due to seismic forces in the north-south direction.

It has been assumed in this example that the openings along column line A do not have a major influence on the overall analysis of the diaphragm. For typical stair and elevator openings, this is typically a good assumption. Additional reinforcement may be required around such openings to resist the secondary chord forces that are developed in these areas. In cases where the openings are relatively large compared to the area of the diaphragm, a more detailed analysis that takes into account the nonuniform distribution of seismic mass should be performed, especially in cases where a Type 3 diaphragm discontinuity irregularity is present (see ASCE/SEI Table 12.3-1). The example in Chapter 6 of this publication illustrates an approximate method to estimate the effects of openings in a diaphragm.

Part 6: Determine reinforcement in the collector element along column line F at the third-floor level for lateral forces in the east-west direction

The slab section between lines 3 and 5 is utilized in this example as the collector that pulls (or drags) the unit shear force in this segment of the diaphragm into the elements of the lateral-force-resisting system (frames) along line F. The concrete slab collector is designed in accordance with the recommendations in the SEAOC *Blue Book*.¹⁶ It is assumed that the effective width of the collector element is equal to the width of the beams in the moment frames, which is 20 inches.

It was determined in Part 5 of this example that the total diaphragm force along line F is equal to 44.8 kips. The unit shear force in the diaphragm is equal to $44.8/80 = 0.560$ kips/ft. Similarly, the unit shear force for the frames is $44.8/40 = 1.12$ kips/ft.

The unit shear forces and net unit shear forces are depicted in Figure 5.15. The collector force diagram is constructed by using the areas of the net unit shear force diagram as changes in the magnitude of the collector force. For example, between lines 2 and 3, the area of the net shear force diagram is $0.560 \times 20 = 11.2$ kips. This is the maximum

¹⁵ The portions of the chords on lines 2 and 6 between lines E and F also act as collector members for seismic forces in the north-south direction. Reinforcement needs to be provided that satisfies the more stringent of the two requirements.

¹⁶ SEAOC Seismology Committee, "Concrete slab collectors," *The SEAOC Blue Book: Seismic design recommendations*, Structural Engineers Association of California, Sacramento, CA, August 2008.

value of the collector force (compression or tension) along the length between lines 2 and 6.

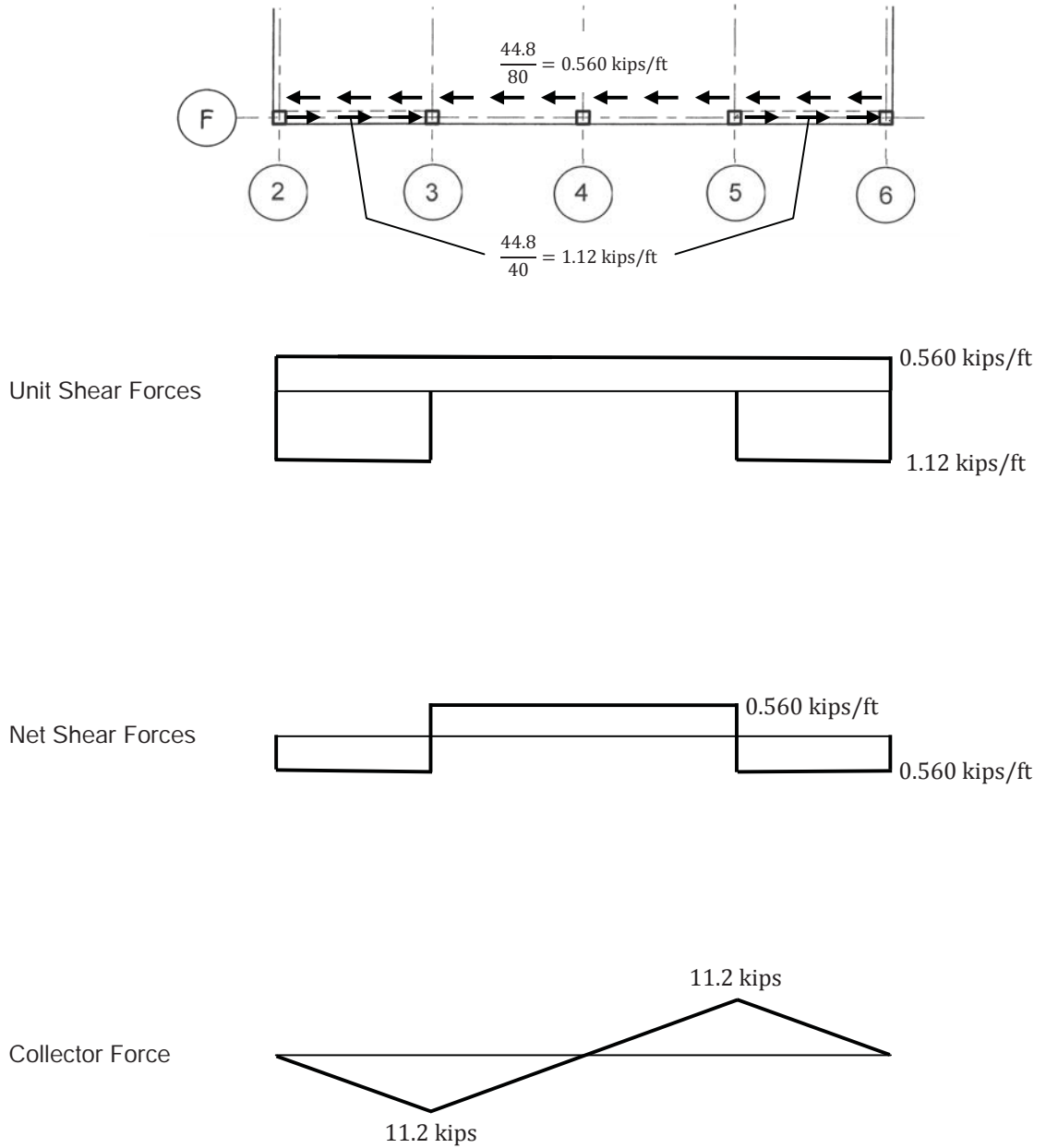

Figure 5.15 Unit Shear Forces, Net Shear Forces and Collector Force Diagram on Column Line F

Reinforcement Required to Resist Collector Tension

According to ASCE/SEI 12.10.2.1, collector elements, splices and their connections to the elements of the seismic-force-resisting system in structures assigned to SDC C, D, E or F must be designed to resist the load combinations with the overstrength factor, Ω_o , of ASCE/SEI 12.4.3.2. The overstrength factor, Ω_o , represents an upper bound lateral strength and is appropriate to use when estimating the maximum forces that can be developed in nonyielding elements of the seismic-force-resisting system during the design earthquake. The intent of this requirement is to ensure that collectors and their connections have adequate strength to transfer the seismic forces into the elements of the seismic-force-resisting system, which has been properly detailed to yield during the design basis ground motion.

According to the latest SEAOC Seismology Committee's draft recommendations, the collector is to be designed for the load combinations with the overstrength factor, Ω_o , in accordance with ASCE/SEI 12.4.3.2 where $\Omega_o Q_E$ is taken as the greatest of the following:

- $\Omega_o F_x$
- $\Omega_o F_{px}$ ignoring the $0.2S_{DS}I_{w_{px}}$ minimum
- Collector force based on $0.2S_{DS}I_{w_{px}}$ minimum value from ASCE/SEI 12.10.1.1

It is evident from Table 5.8 that the second of the three forces above is the greatest. Therefore, using the collector force diagram in Figure 5.15, the collector force is equal to $3 \times 11.2 = 33.6$ kips where $\Omega_o = 3$ from ASCE/SEI Table 12.2-1 for an intermediate reinforced concrete moment frame.

The required area of tension reinforcement is:

$$A_s = \frac{T_u}{\phi f_y} = \frac{33.6}{0.9 \times 60} = 0.62 \text{ in.}^2$$

Provide two No. 5 bar in addition to the reinforcement required for gravity loads. This reinforcement, which can be easily accommodated within the 20-inch-wide beams in the moment frames, should be placed at the mid-depth of the slab in order to prevent additional out-of-plane bending stresses in the slab. By developing the collector reinforcement within the width of beam, the collector forces are transmitted directly into the lateral-force-resisting system.

Collector Compressive Strength

The maximum compressive stress on the concrete slab collector, which is equal to $33,600/(9 \times 20) = 187$ psi, is relatively low and the section is adequate without any additional reinforcement.

Diaphragm Segment Eccentricity

In cases where all or part of the collector reinforcement is placed at the sides of the lateral-force-resisting elements, which in this example are moment frames, the diaphragm section adjacent to the lateral-force-resisting elements must be designed to resist the seismic shear and in-plane bending resulting from the eccentricity of that part of the collector force that is not transferred directly into the end of the lateral-force-resisting elements. Since the collector force in this example is transferred directly into the beams of the moment frames, no eccentricity is present and no in-plane bending occurs.

5.4.2 Example 5.2—One-story Retail Building

For the one-story retail building depicted in Figure 4.36, (1) determine the location of the center of rigidity and distribute lateral forces to each wall and (2) design the wall on line A.

DESIGN DATA

Concrete: $f'_c = 4000$ psi; reinforcement: $f_y = 60,000$ psi.

Roof live load = 20 psf

Roof superimposed dead load = 10 psf

Lateral-force-resisting system: bearing walls (thickness = 8 inches)

Wind velocity = 90 mph, Exposure B

Seismic Design Category: C ($S_{DS} = 0.27$, $S_{D1} = 0.14$)

SOLUTION

Part 1: Determine the location of the center of rigidity and distribute lateral forces to each wall

It was determined in Example 4.2 that the center of mass is located 21.4 feet from the centerline of the west wall and 22.4 feet from the centerline of the south wall.

It was also determined in Example 4.2 that the center of rigidity in the east-west direction is 24.2 feet from the centerline of the west wall and in the north-south direction is 21.0 feet from the centerline of the south wall.

It can be shown that the effects from the seismic forces govern in this example.¹⁷ The seismic base shear is equal to 22 kips, which is determined by the provisions in Chapters 11, 12 and 22 of ASCE/SEI 7.

In addition to the inherent torsional moment, M_t , resulting from eccentricity between the location of the center of mass and center of rigidity, ASCE/SEI 12.8.4.2 requires that an accidental torsional moment, M_{ta} , be considered. This accidental torsional moment, which is added to M_t , is caused by assuming that the center of mass is displaced each way from its actual location by a distance equal to 5 percent of the dimension of the structure perpendicular to the direction of the seismic base shear. For the seismic base shear acting in the east-west direction, the center of mass must be displaced $0.05 \times 52 = 2.6$ ft each way from its actual location. Thus, the center of mass must be located at $22.4 + 2.6 = 25.0$ ft and $22.4 - 2.6 = 19.8$ ft from the centerline of the south wall.

The accidental torsional moment, M_{ta} , must be amplified by the factor A_x , defined in ASCE/SEI Equation (12.8-14) for structures assigned to SDC C and above that have Type 1a or 1b torsional irregularity, which is defined in ASCE/SEI Table 12.3-1 (ASCE/SEI 12.8.4.3). Type 1a torsional irregularity exists where the maximum story drift, including accidental torsion, at one end of the structure is more than 1.2 times the average of the story drifts at the two ends of the structure (see ASCE/SEI Figure 12.8-1). In this example, it can be shown that the maximum story drift is less than 1.2 times the average story drift so that no torsional irregularities exist.

This seismic base shear in the east-west direction is distributed to the walls in accordance with Equation 3.12 in Chapter 3 of this publication. Two cases are examined: in the first case, the center of mass is located at 25.0 feet from the centerline of the south wall and in the second case, the center of mass is located at 19.8 feet from the centerline of the south wall.

- Case 1: Center of mass at 25.0 feet from the centerline of the south wall

North wall on line A:

$$V_A = \frac{0.756Et \times 22}{(0.756 + 0.106 + 1.101)Et} + \frac{(30.33 \times 12) \times 0.756Et \times (22 \times 4.0 \times 12)}{196,655Et}$$

$$= 8.5 + 1.5 = 10.0 \text{ kips}$$

where $\bar{y}_N = 52 - (8/12) - 21 = 30.33$ ft

$$e_y = 25 - 21 = 4.0 \text{ ft}$$

¹⁷ The Equivalent Lateral Force Procedure of ASCE/SEI 12.8 was used to determine the seismic base shear, which is the same in both the north-south and east-west directions.

$$\begin{aligned}
& \sum \bar{x}_i^2 (k_i)_y + \sum \bar{y}_i^2 (k_i)_x = \\
& 0.222Et \times (24.20 \times 12)^2 + 0.524Et \times (9.13 \times 12)^2 \\
& + 0.028Et \times (19.63 \times 12)^2 + 1.101Et \times (21.0 \times 12)^2 \\
& + 0.106Et \times (1.33 \times 12)^2 + 0.756Et \times (30.33 \times 12)^2 \\
& = 196,655Et
\end{aligned}$$

South wall on line E:

$$\begin{aligned}
V_E &= \frac{1.101Et \times 22}{(0.756 + 0.106 + 1.101)Et} - \frac{(21.0 \times 12) \times 1.101Et \times (22 \times 4.0 \times 12)}{196,655Et} \\
&= 12.3 - 1.5 = 10.8 \text{ kips}
\end{aligned}$$

Solid wall near line C:

$$\begin{aligned}
V_C &= \frac{0.106Et \times 22}{(0.756 + 0.106 + 1.101)Et} + \frac{(1.33 \times 12) \times 0.106Et \times (22 \times 4.0 \times 12)}{196,655Et} \\
&= 1.2 + 0.0 = 1.2 \text{ kips}
\end{aligned}$$

West wall on line 1:

$$V_1 = \frac{(24.20 \times 12) \times 0.222Et \times (22 \times 4.0 \times 12)}{196,655Et} = 0.4 \text{ kips}$$

East wall on line 3:

$$V_3 = \frac{-(9.13 \times 12) \times 0.524Et \times (22 \times 4.0 \times 12)}{196,655Et} = -0.3 \text{ kips}$$

East wall on line 4:

$$V_4 = \frac{-(19.63 \times 12) \times 0.028Et \times (22 \times 4.0 \times 12)}{196,655Et} = -0.04 \text{ kips}$$

- **Case 2: Center of mass at 19.8 feet from the centerline of the south wall**

North wall on line A:

$$V_A = \frac{0.756Et \times 22}{(0.756 + 0.106 + 1.101)Et} - \frac{(30.33 \times 12) \times 0.756Et \times (22 \times 1.2 \times 12)}{196,655Et}$$

$$= 8.5 - 0.4 = 8.1 \text{ kips}$$

$$\text{where } e_y = 21.0 - (22.4 - 2.6) = 1.2 \text{ ft}$$

South wall on line E:

$$V_E = \frac{1.101Et \times 22}{(0.756 + 0.106 + 1.101)Et} + \frac{(21.0 \times 12) \times 1.101Et \times (22 \times 1.2 \times 12)}{196,655Et}$$

$$= 12.3 + 0.4 = 12.7 \text{ kips}$$

Solid wall near line C:

$$V_C = \frac{0.106Et \times 22}{(0.756 + 0.106 + 1.101)Et} - \frac{(1.33 \times 12) \times 0.106Et \times (22 \times 1.2 \times 12)}{196,655Et}$$

$$= 1.2 - 0.0 = 1.2 \text{ kips}$$

West wall on line 1:

$$V_1 = \frac{-(24.20 \times 12) \times 0.222Et \times (22 \times 1.2 \times 12)}{196,655Et} = -0.1 \text{ kips}$$

East wall on line 3:

$$V_3 = \frac{(9.13 \times 12) \times 0.524Et \times (22 \times 1.2 \times 12)}{196,655Et} = 0.09 \text{ kips}$$

East wall on line 4:

$$V_4 = \frac{(19.63 \times 12) \times 0.028Et \times (22 \times 1.2 \times 12)}{196,655Et} = 0.01 \text{ kips}$$

A similar analysis can be performed for seismic forces in the north-south direction.

Part 2: Design the wall on line A

It was shown in Example 4.2 that the maximum out-of-plane wind pressure on this wall panel is 17 psf, which is determined by the provisions of Chapter 6 of ASCE/SEI 7 for components and cladding. For a 4-foot-wide design strip, the factored wind force is equal to $1.6 \times 17 \times 4 = 109$ plf.

For structures assigned to SDC C, structural walls shall be designed for an out-of-plane seismic force equal to the maximum of $0.4S_{DS}I$ or 10 percent of the weight of the wall (ASCE/SEI 12.11.1). In lieu of a more rigorous analysis, the pier width between the two openings is commonly defined as the design strip. The total weight used in determining

the out-of-plane design seismic force is taken as the weight of the design strip plus the weight of the wall tributary to the design strip above each opening (see Figure 5.16):

$$W_{p1} = \frac{8}{12} \times 150 \times 4 = 400 \text{ plf}$$

$$W_{p2} = W_{p3} = \frac{8}{12} \times 150 \times \frac{2.5}{2} = 125 \text{ plf}$$

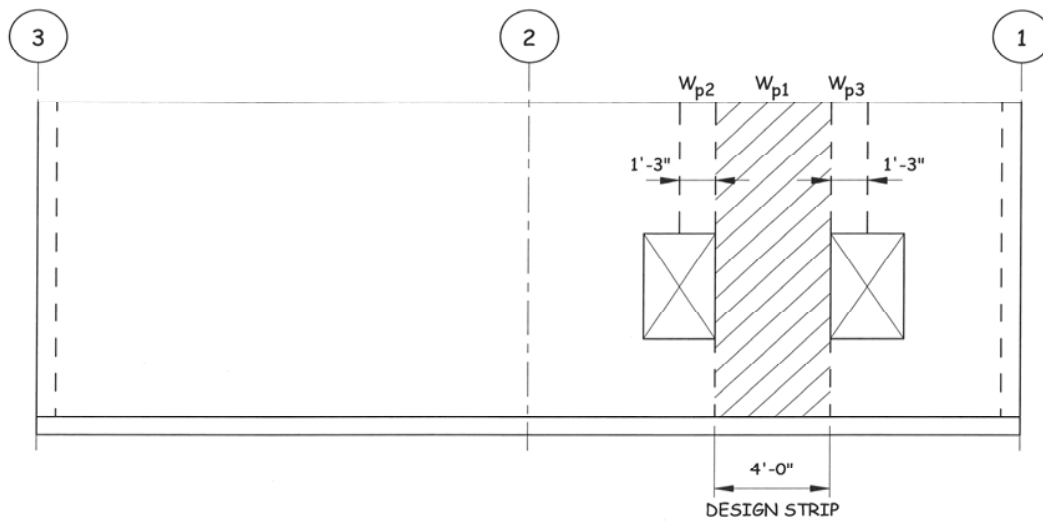

For SI: 1 inch = 25.4 mm; 1 foot = 304.8 mm.

Figure 5.16 Design Strip and Tributary Weights

The out-of-plane seismic forces are determined by ASCE/SEI 12.11.1:

$$F_{p1} = 0.4S_{DS}IW_{p1} = 0.4 \times 0.27 \times 1.0 \times 400 = 43.2 \text{ plf from 0 feet to 12 feet}$$

$$F_{p2} = F_{p3} = 0.4S_{DS}IW_{p2} = 0.4 \times 0.27 \times 1.0 \times 125 = 13.5 \text{ plf from 7 feet to 12 feet}$$

Thus, the wall is to be designed for the combination of axial force from the gravity forces and bending and shear for the out-of-plane wind forces.

Since the effects from the gravity forces and wind forces govern, the design of the wall is the same as that presented in Part 2 of Example 4.2.

CHAPTER 6

DESIGN AND DETAILING FOR SDCs D, E AND F

6.1 GENERAL REQUIREMENTS

6.1.1 Design and Detailing

For concrete buildings assigned to SDC D, E or F, all members must be designed and detailed in accordance with the general requirements of ACI 318 Chapters 1 to 19¹ and ACI 21.1.1.6, which references ACI 21.1.2 through 21.1.8 and 21.11 through 21.13. Also, where special moment frames and special structural walls² are utilized, the provisions of ACI 21.5 through 21.8 and ACI 21.9 must be satisfied, respectively. ACI Table R21.1.1 provides a summary of the sections of ACI Chapter 21 that must be satisfied as a function of the SDC.

6.1.2 Load Combinations and Strength Reduction Factors

As noted in Chapter 4, the load combinations for strength design (or load and resistance factor design) in IBC 1605.2 are to be used in the design of reinforced concrete members. See Section 4.1.2 of this publication for detailed information on load combinations. Strength reduction factors are given in ACI 9.3.4 (ACI 21.1.3).

6.1.3 Materials

In addition to the material limitations outlined in Section 4.1.3 of this publication, the requirements of ACI 21.1.4 and ACI 21.1.5 must be satisfied for concrete and reinforcement in special moment frames and special structural walls, respectively.

The minimum specified compressive strength of concrete is 3,000 psi (20 684 kPa), and the specified compressive strength of lightweight concrete is limited to 5,000 psi (34 474 kPa).

Deformed reinforcement must comply with ASTM A706. ASTM A615 (Grades 40 and 60) may be used if the two requirements in ACI 21.1.5.2 are satisfied.

ACI 21.1.5.4 limits the value of the specified yield strength of transverse reinforcement f_{yt} to 100,000 psi (689 476 kPa). This limit is based on research results that indicate that

¹ According to IBC 1908.1.2, structural elements of plain concrete are prohibited in structures assigned to SDC C and above, except for those elements complying with IBC 1908.1.8.

² According to IBC 1908.1, where ASCE/SEI 7 refers to a “special reinforced concrete structural wall,” it is equivalent to a “special structural wall” as defined in ACI Chapter 21.

higher yield strengths can be used effectively as confinement reinforcement. The value of f_y or f_{yt} used in the design of shear reinforcement is limited to 60,000 psi (413 685 kPa) for deformed reinforcing bars and 80,000 psi for welded deformed wire reinforcement in accordance with ACI 11.4.2 (ACI 21.1.5.5). The intent of this requirement is to limit the width of shear cracks.

6.1.4 Mechanical and Welded Splices

Requirements for mechanical and welded splices in special moment frames and special structural walls are given in ACI 21.1.6 and 21.1.7, respectively.

Mechanical splices are to be classified as either Type 1 or Type 2 mechanical splices. Type 1 mechanical splices are to conform to ACI 12.14.3.2, which requires that the splice develop in tension or compression 125 percent of the specified yield strength, f_y , of the reinforcing bar. Such splices are not permitted within a distance equal to twice the member depth from the column or beam face in special moment frames or from sections where yielding is likely to occur as a result of inelastic lateral displacements caused by the design basis earthquake. The locations of Type 1 splices are restricted since it is possible for the tensile stresses in the reinforcement in these yielding regions to be greater than the strength requirements of ACI 12.14.3.2.

Type 2 mechanical splices are required to conform to ACI 12.14.3.2 and must be able to develop in tension the specified tensile strength of the spliced reinforcing bar. There are no restrictions on where Type 2 splices can be located in a member.

Welded splices are to conform to ACI 12.14.3.4, which requires that the splice develop at least 125 percent of the specified yield strength, f_y , of the reinforcing bar. Like Type 1 mechanical splices, welded splices are not permitted within a distance equal to twice the member depth from the column or beam face in special moment frames or from sections where yielding is likely to occur as a result of inelastic lateral displacements caused by the design basis earthquake. Welded splices are not permitted within anticipated yield regions because the tension stresses in the reinforcement can exceed the strength requirements prescribed in ACI 12.14.3.4.

It is not permitted to weld stirrups, ties, inserts or other similar elements to longitudinal reinforcement that is required by design of the member. Such welding can lead to local embrittlement of the reinforcing steel.

6.1.5 Anchoring to Concrete

The requirements of ACI D.3.3 must be satisfied for anchors resisting earthquake-induced forces in structures assigned to SDC C, D, E or F (ACI 21.1.8).

6.2 FLEXURAL MEMBERS OF SPECIAL MOMENT FRAMES

Table 6.1 contains requirements for flexural members in special moment frames. These apply to frame members with negligible axial forces, i.e., $P_u \leq A_g f'_c / 10$ (ACI 21.5.1).

Table 6.1 Summary of Requirements for Flexural Members of Special Moment Frames³

	Requirement	ACI Section Number(s)
General	Factored axial compressive force $\leq A_g f'_c / 10$	21.5.1.1
	Clear span $\ell_n \geq 4d$	21.5.1.2
	Width of member $b_w \geq$ smaller of $0.3h$ and 10 inches	21.5.1.3
	Width of member $b_w \leq$ smaller of $3c_2$ and $c_2 + 1.5c_1$	21.5.1.4
Flexure	Design flexural members as tension-controlled sections.	10.3.4, 9.3.2.1
	Minimum flexural reinforcement shall not be less than: $\frac{3\sqrt{f'_c} b_w d}{f_y} \text{ and } \frac{200 b_w d}{f_y}$ at every section, top and bottom, of a flexural member, except as provided by ACI 10.5.3.	21.5.2.1
	The reinforcement ratio, ρ , shall not exceed 0.025.	21.5.2.1
	At least two bars shall be provided continuously at both the top and bottom of a section.	21.5.2.1
	Positive flexural strength at the face of a joint must be greater than or equal to one-half the negative flexural strength at that face of the joint.	21.5.2.2
	Neither the negative nor the positive flexural strength at any section along the length of the beam must be less than one-fourth the maximum moment strength at the face of either joint.	21.5.2.2
Splices	Lap splices of flexural reinforcement are permitted only if hoop or spiral reinforcement is provided over the lap length. Hoop or spiral reinforcement spacing shall not exceed the smaller of $d/4$ or 4 inches. Lap splices shall not be used: (a) within joints (b) within a distance of $2h$ from the face of the joint (c) where analysis indicates flexural yielding	21.5.2.3
	Mechanical splices shall conform to ACI 21.1.6 and welded splices shall conform to ACI 21.1.7.	21.5.2.4

(continued)

³ Additional requirements of ACI Chapters 1 to 19 must also be satisfied. See Chapter 4 of this publication for more details.

Table 6.1 Summary of Requirements for Flexural Members of Special Moment Frames
(continued)

	Requirement	ACI Section Number(s)
Transverse Reinforcement	<p>Hoops are required:</p> <p>(a) Over a length equal to at least $2h$ from the face of the supporting member toward midspan at both ends of the beam.</p> <p>(b) Over lengths equal to at least $2h$ on both sides of a section where flexural yielding is likely to occur due to inelastic lateral displacements of the frame.</p>	21.5.3.1
	<p>Where hoops are required, the spacing shall not exceed the smallest of:</p> <p>(a) $d/4$</p> <p>(b) $8 \times$ diameter of smallest longitudinal bar</p> <p>(c) $24 \times$ diameter of hoop bar</p> <p>(d) 12 inches</p> <p>The first hoop shall be located not more than 2 inches from the face of the supporting member.</p>	21.5.3.2
	<p>Where hoops are required, longitudinal bars on the perimeter shall have lateral support conforming to ACI 7.10.5.3.</p>	21.5.3.3
	<p>Where hoops are not required, stirrups with seismic hooks at both ends shall be spaced not more than $d/2$ throughout the length of the member.</p>	21.5.3.4
	<p>Stirrups or ties required to resist shear forces shall be hoops over the lengths of members prescribed in ACI 21.5.3.1.</p>	21.5.3.5
	<p>Hoops in flexural members may be made up of two pieces of reinforcement: (1) a stirrup having seismic hooks at both ends and (2) a crosstie as defined in ACI 2.2.</p> <p>Consecutive crossties engaging the same longitudinal bar shall have the 90-degree hooks at opposite sides of the flexural member.</p> <p>In cases where the longitudinal reinforcement secured by crossties is confined by a slab on only one side of the flexural member, the 90-degree hooks of the crossties shall be placed on that side.</p>	21.5.3.6

(continued)

Table 6.1 Summary of Requirements for Flexural Members of Special Moment Frames
(continued)

Requirement		ACI Section Number(s)
Shear	Design shear force, V_e , is to be determined from statics on the portion of the member between faces of the joints. It is assumed that moments of opposite sign corresponding to the probable flexural strength, M_{pr} , act at the joint faces and that the member is loaded with the factored tributary load along its span.	21.5.4.1
	Transverse reinforcement over the lengths defined in ACI 21.5.3.1 shall be proportioned to resist shear forces assuming $V_c = 0$ when both (a) and (b) occur: (a) The earthquake-induced shear force calculated by ACI 21.5.4.1 represents one-half or more of the maximum required shear strength within those lengths. (b) The factored axial compressive force, P_u , including earthquake effects, is less than $A_g f'_c / 20$.	21.5.4.2

For SI: 1 inch = 25.4 mm; 1 degree = 0.01745 rad.

6.2.1 General Requirements

ACI 21.5 typically refers to beams of special moment frames. In general, any frame member that is subjected to a factored axial compressive force that is greater than $A_g f'_c / 10$ under any load combination must be designed and detailed in accordance with the requirements of ACI 21.6 for frame members subjected to bending and axial load.

The geometric requirements of ACI 21.5.1.2 through 21.5.1.4, which are summarized in Figure 6.1, have been guided by experimental evidence and observations of reinforced concrete frames that have performed well in the past. ACI Figure R21.5.1 illustrates an example of maximum effective beam width where the beam is wider than the supporting column.

6.2.2 Flexural Requirements

Longitudinal reinforcement requirements for beams in special moment frames are shown in Figure 6.2. The requirement that the minimum positive flexural strength at the ends of the beam must be equal to at least 50 percent of the corresponding negative flexural strength allows for the possibility that the positive moment at the end of a beam due to earthquake-induced lateral displacements exceeds the negative moment due to gravity loads.

Minimum flexural capacity at any section of a beam is based on the flexural capacity at the face of either support. These requirements ensure strength and ductility under large lateral displacements. The maximum reinforcement ratio of 0.025 is based primarily on considerations of steel congestion and also on limiting shear stresses in beams of typical

proportions. The requirement that at least two bars be continuous at both the top and bottom of the section is for construction purposes.

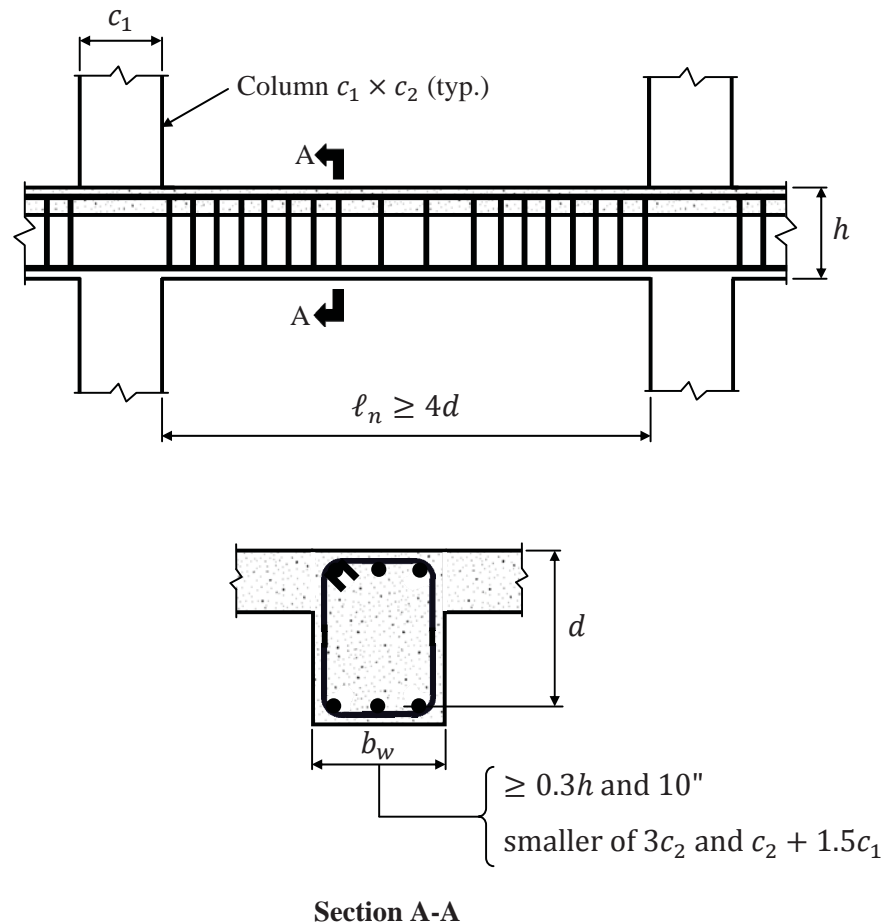

For SI: 1 inch = 25.4 mm.

Figure 6.1 Summary of General Requirements for Flexural Members of Special Moment Frames

6.2.3 Splice Requirements

Provisions for lap splices of flexural reinforcement are illustrated in Figure 6.3. Lap splices are permitted as long as they are properly confined with hoop or spiral reinforcement over the entire lap length and are located away from potential hinge areas (ACI 21.5.2.3).

In lieu of lap splices, mechanical and welded splices conforming to ACI 21.1.6 and 21.1.7, respectively, may be used (ACI 21.5.2.4).

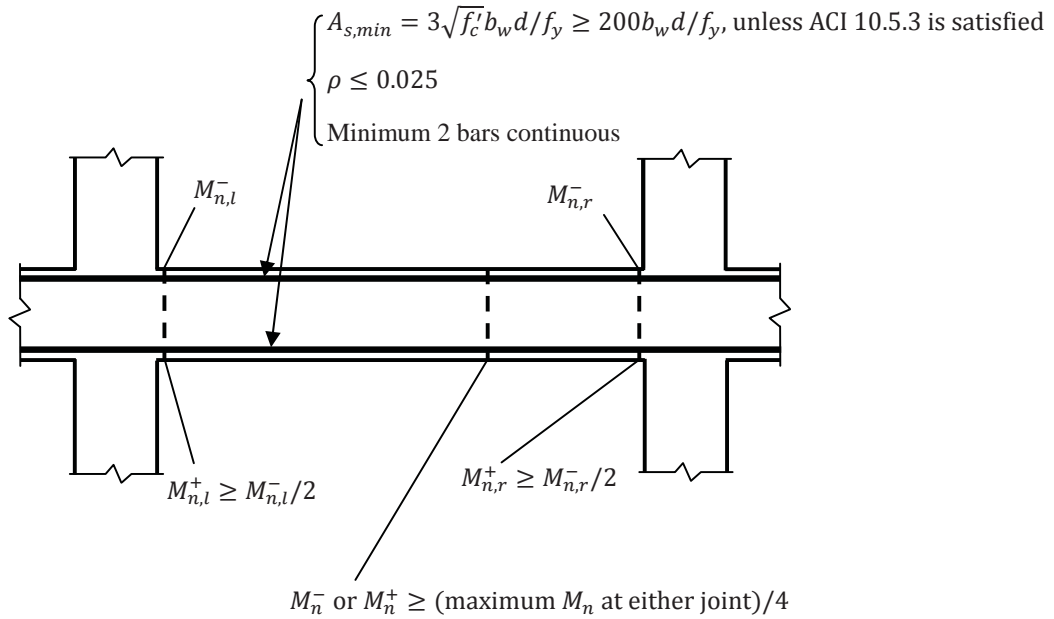

Note: transverse reinforcement not shown for clarity

Figure 6.2 Flexural Requirements for Flexural Members of Special Moment Frames

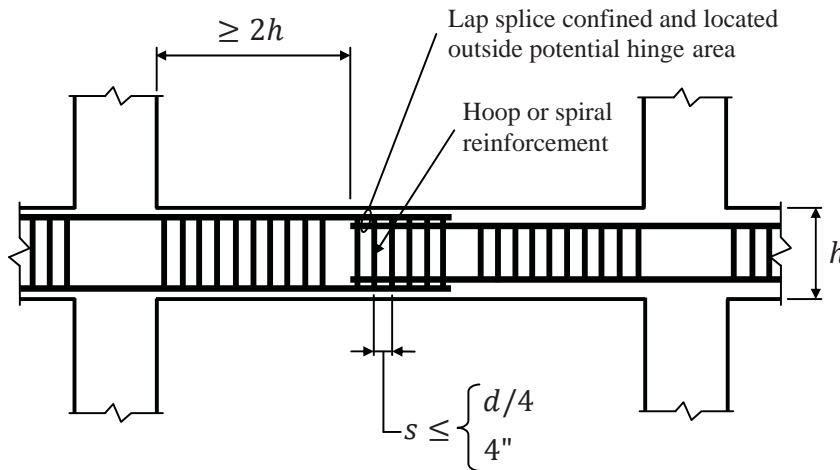

For SI: 1 inch = 25.4 mm.

Figure 6.3 Lap Splice Requirements for Flexural Members of Special Moment Frames

6.2.4 Transverse Reinforcement Requirements

A summary of the requirements of ACI 21.5.3 for transverse reinforcement is given in Figure 6.4. Adequate confinement is required at ends of flexural members where plastic hinges are likely to form to ensure sufficient ductility of the members. In addition to confining the concrete, transverse reinforcement also assists the concrete in resisting shear forces and maintains lateral support for the longitudinal reinforcing bars.

In regions where yielding is expected, hoops must be used. Hoops are defined in ACI 2.2 and are illustrated in ACI Figure R21.5.3.

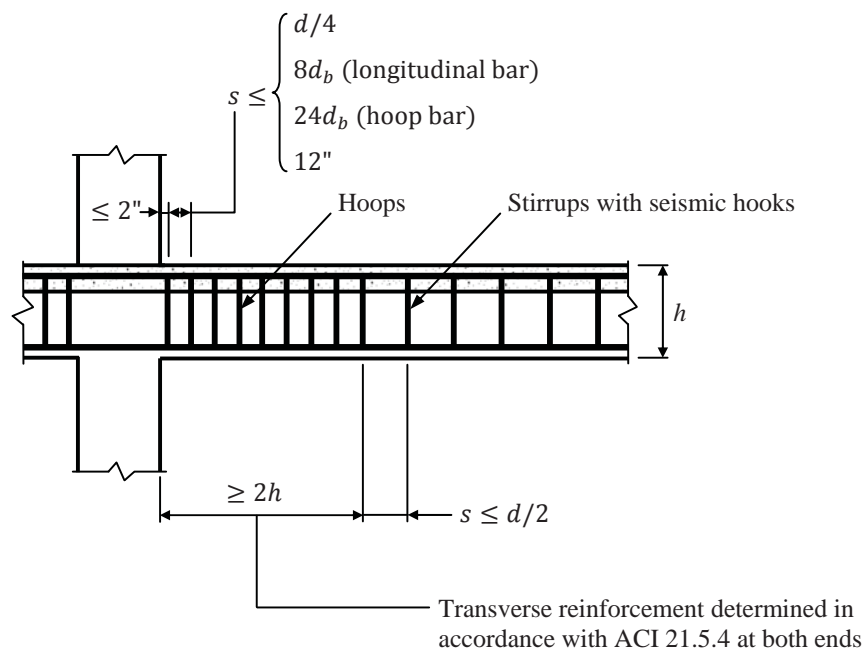

For SI: 1 inch = 25.4 mm.

Figure 6.4 Transverse Reinforcement Requirements for Flexural Members of Special Moment Frames

6.2.5 Shear Requirements

Flexural members of a special moment frames must be designed for the shear forces associated with probable flexural strengths, M_{pr} , acting at the ends of the member and the factored tributary gravity load along its span. The design shear force, which is related to the flexural strength of the member rather than to the shear forces obtained from the structural analysis, is a good approximation of the maximum shear force that can develop in a member.

The probable flexural strength, M_{pr} , is associated with plastic hinging in a flexural member, and is defined as the strength of a flexural member based on the properties of the member at the joint faces assuming the tensile stress in the longitudinal reinforcing steel is equal to $1.25f_y$ and a strength reduction factor, ϕ , of 1.0 (ACI 2.1):

$$M_{pr} = A_s(1.25f_y) \left(d - \frac{a}{2} \right)$$

where $a = A_s(1.25f_y)/0.85f'_c b$.

Sidesway to the right and sidesway to the left must both be considered to obtain the maximum shear force. Figure 6.5 illustrates these two conditions.

In order to help preclude shear failure prior to the development of plastic hinges at the ends of a flexural member, the contribution of concrete to shear strength must be taken equal to zero when the two conditions under ACI 21.5.4.2 are satisfied. Additional shear reinforcement in the form of hoops is deemed necessary at locations where potential flexural hinging may occur (i.e., at locations where spalling of the concrete shell is likely to occur).

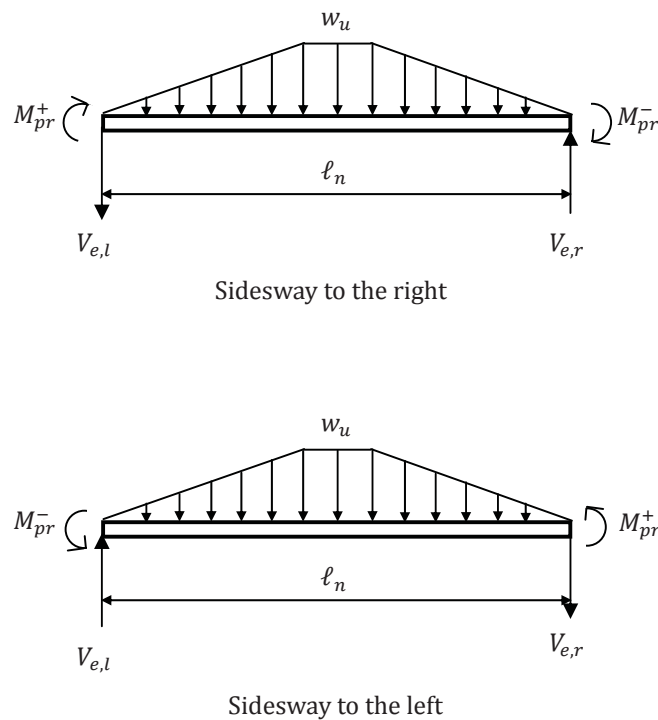

Figure 6.5 Design Shear Forces for Flexural Members in Special Moment Frames

A summary of the overall design procedure for flexural members in special moment frames is given in Figure 6.6.

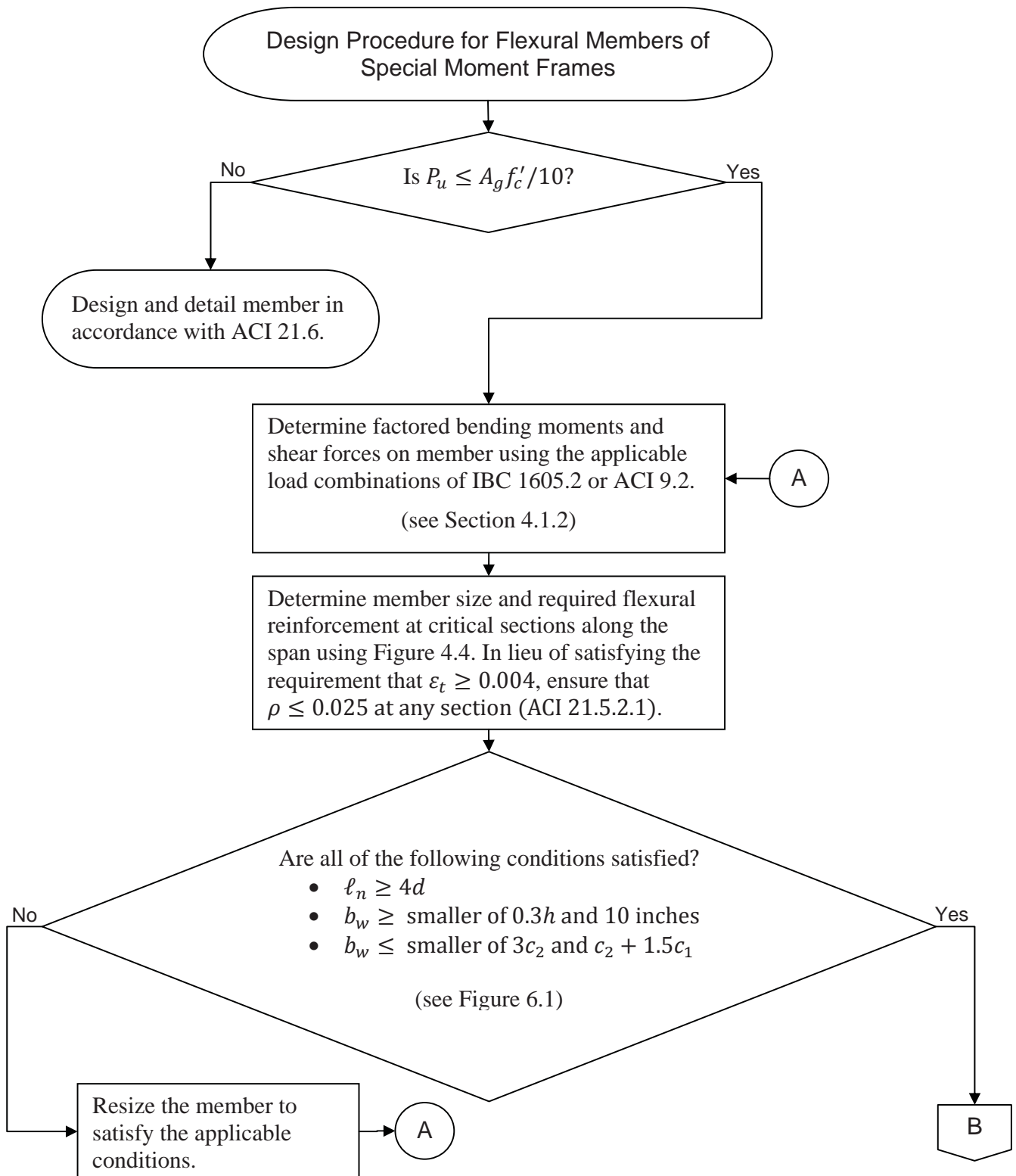

Figure 6.6 Design Procedure for Flexural Members in Special Moment Frames

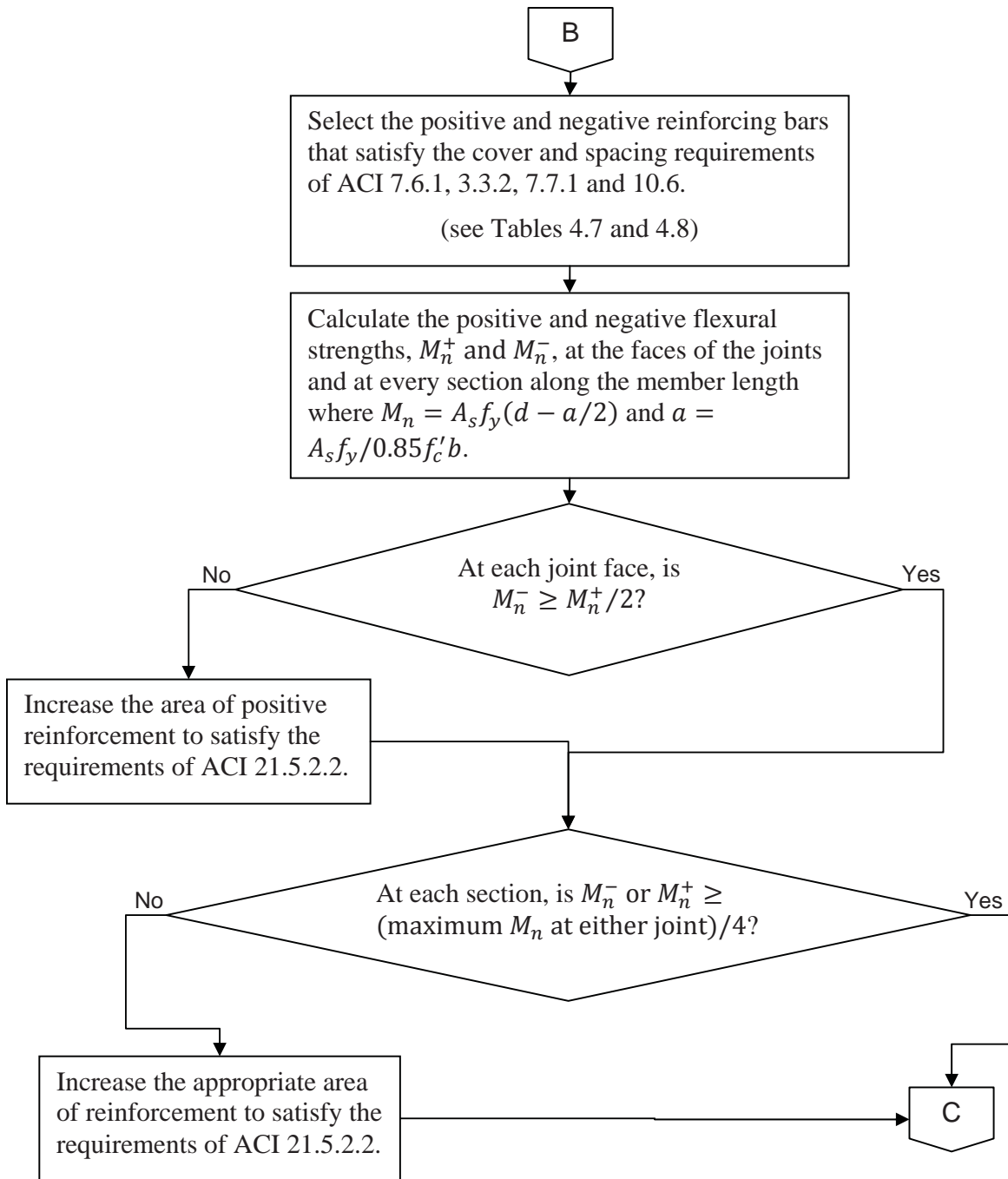

Figure 6.6 Design Procedure for Flexural Members in Special Moment Frames (continued)

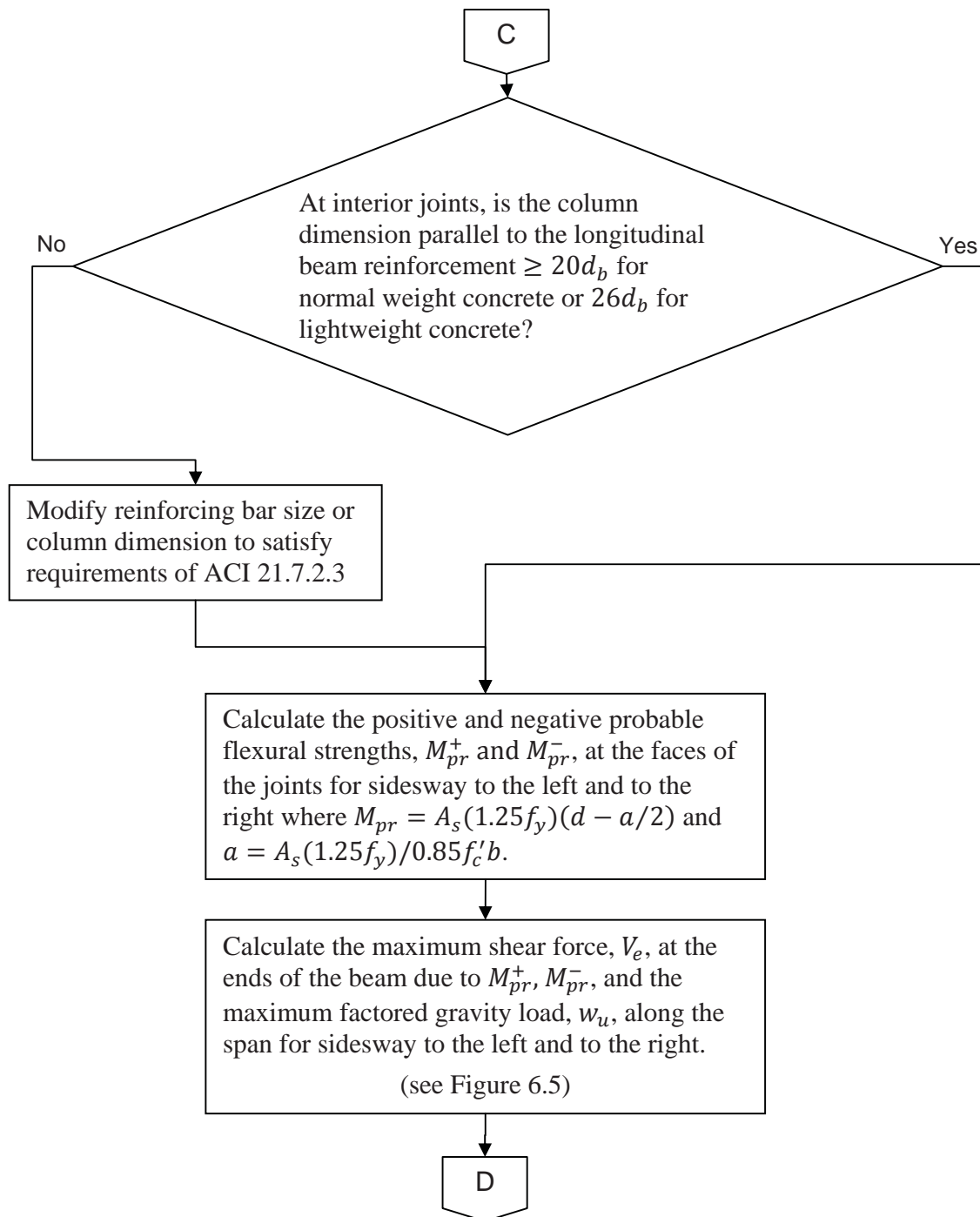

Figure 6.6 Design Procedure for Flexural Members in Special Moment Frames (continued)

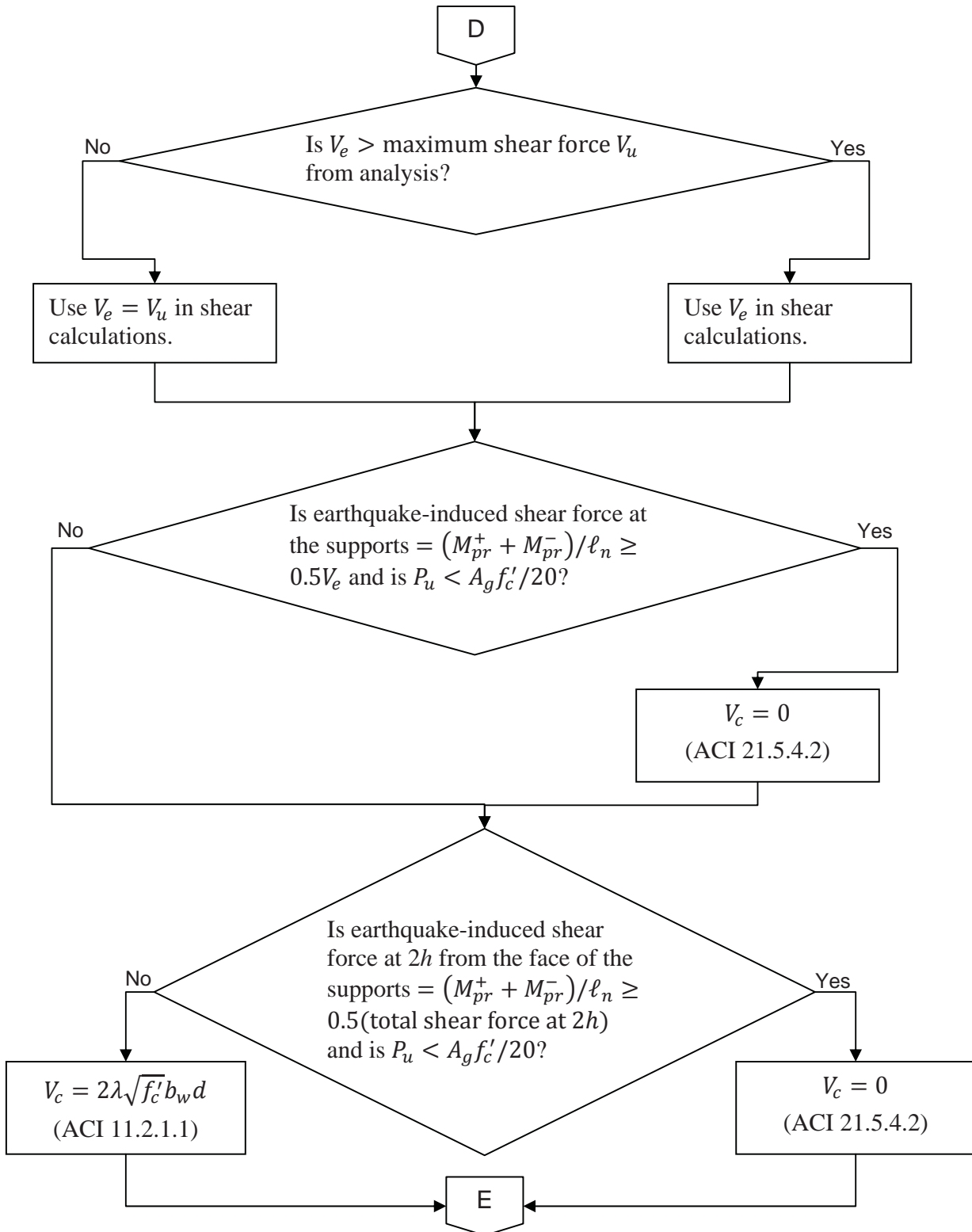

Figure 6.6 Design Procedure for Flexural Members in Special Moment Frames (continued)

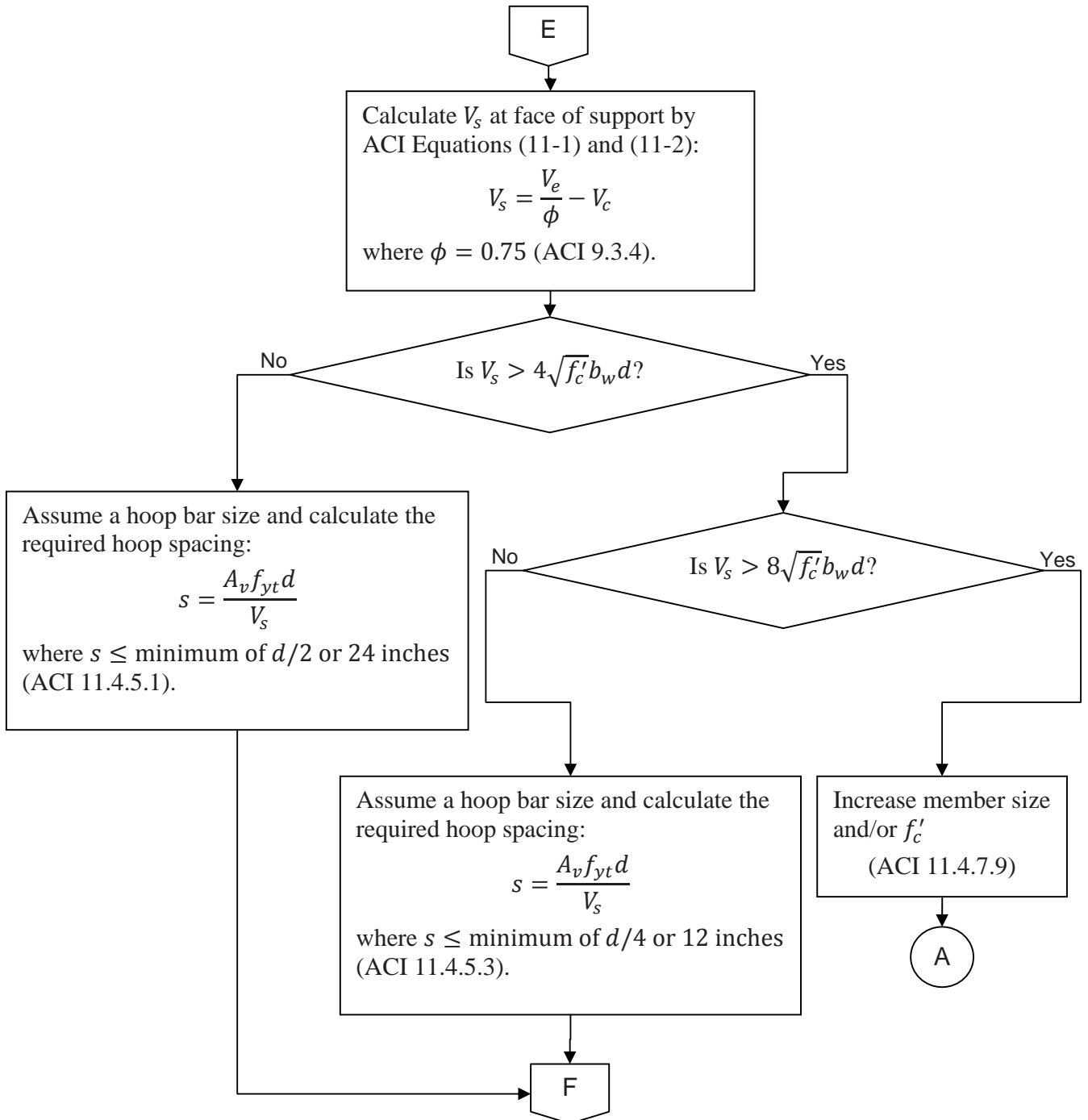

Figure 6.6 Design Procedure for Flexural Members in Special Moment Frames
(continued)

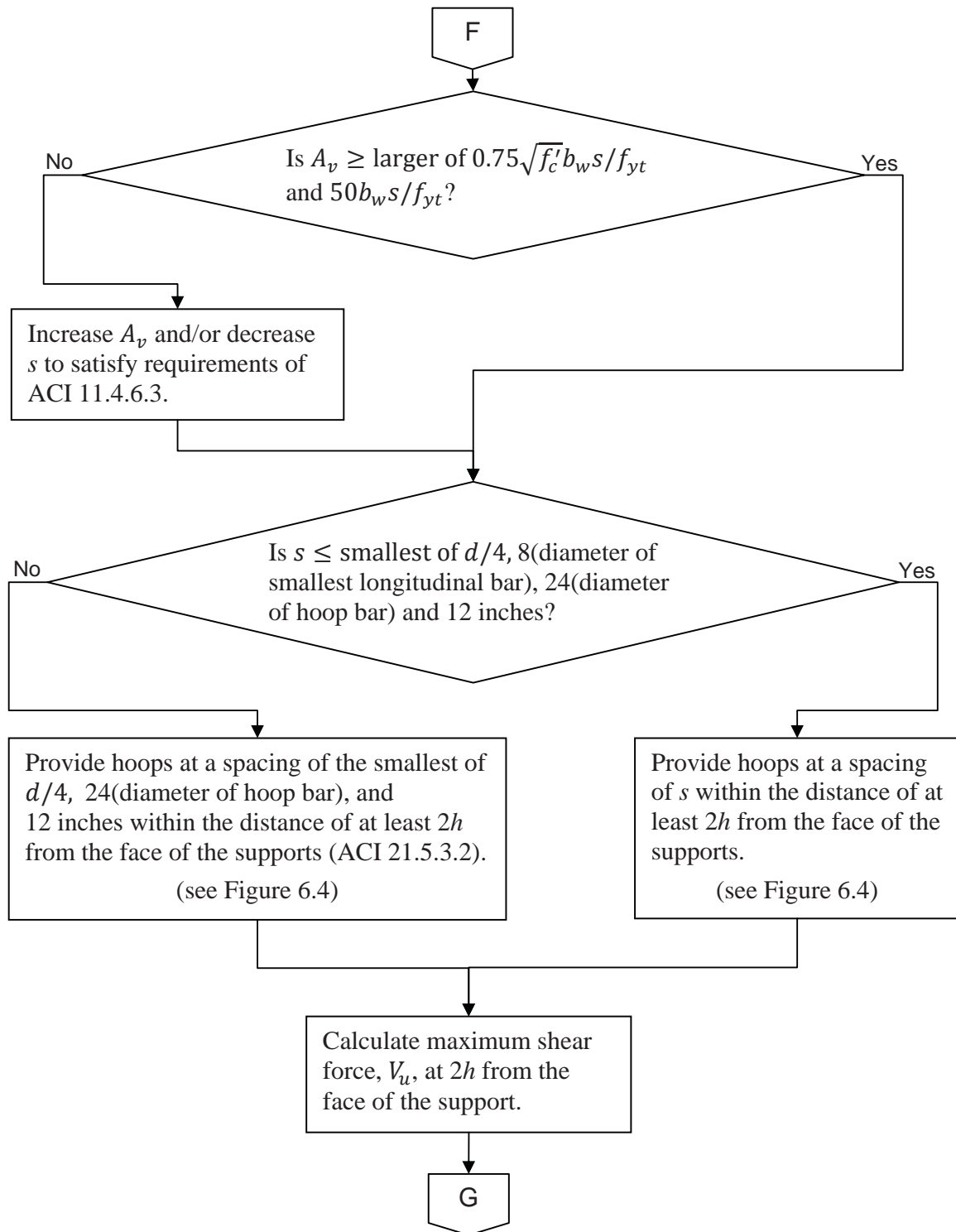

Figure 6.6 Design Procedure for Flexural Members in Special Moment Frames (continued)

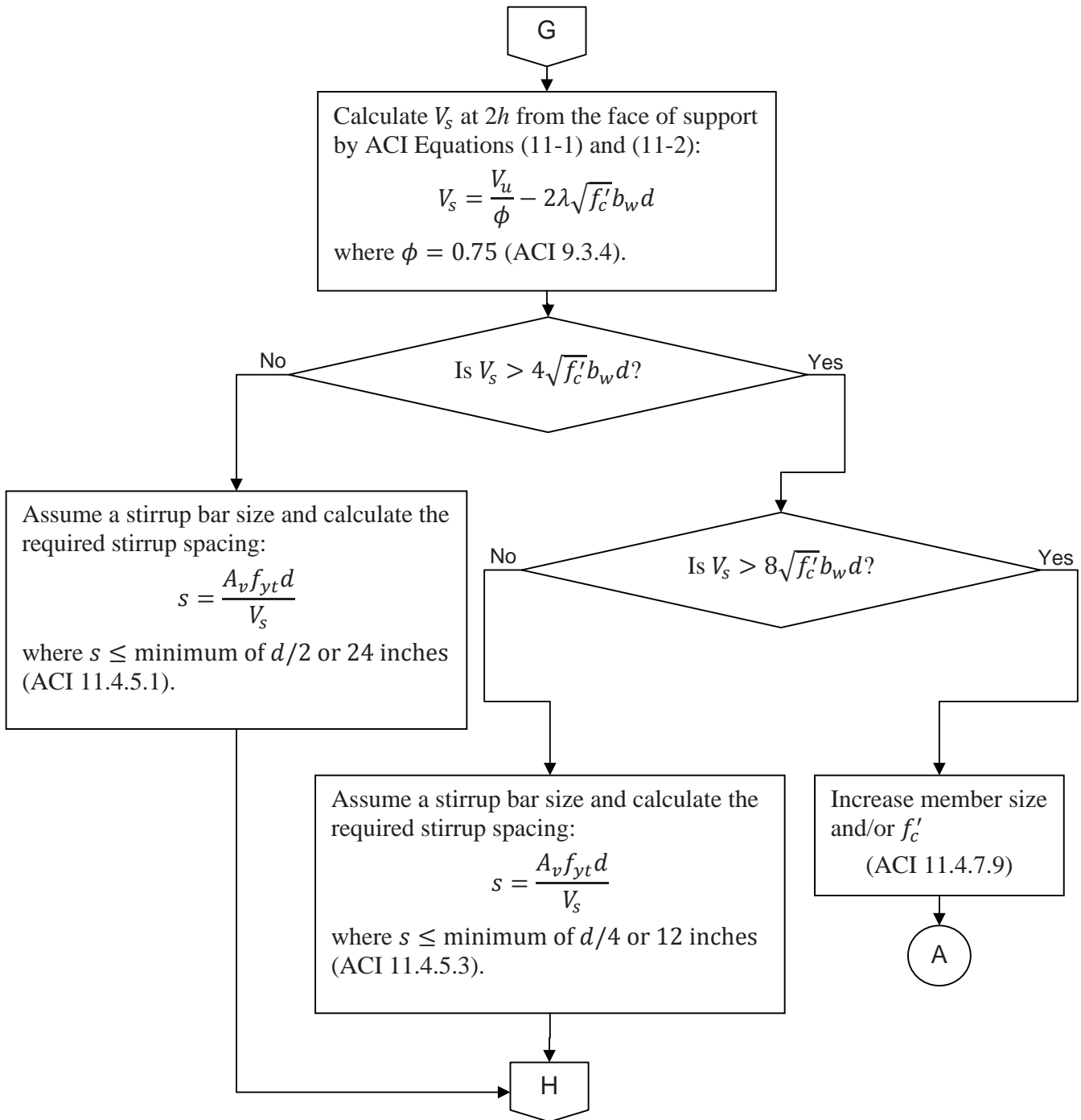
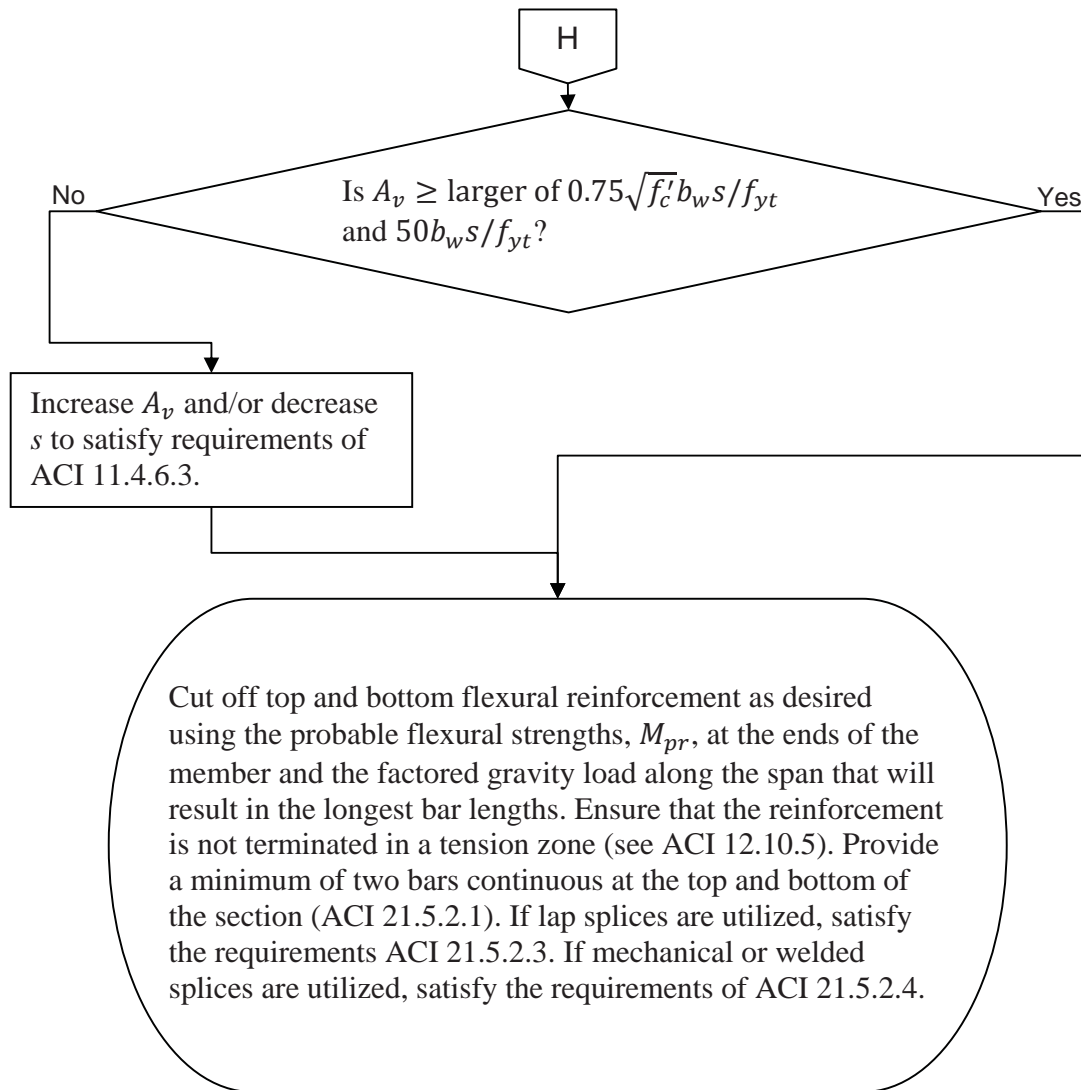

Figure 6.6 Design Procedure for Flexural Members in Special Moment Frames (continued)



For SI: 1 inch = 25.4 mm.

Figure 6.6 Design Procedure for Flexural Members in Special Moment Frames (continued)

6.3 SPECIAL MOMENT FRAME MEMBERS SUBJECTED TO BENDING AND AXIAL LOAD

Table 6.2 contains requirements for special moment frame members subjected to combined bending and axial forces. These requirements would typically apply to columns and flexural members that carry a factored axial force $P_u > A_g f'_c / 10$.

Table 6.2 Summary of Requirements for Special Moment Frame Members Subjected to Bending and Axial Load⁴

	Requirement	ACI Section Number(s)
General	Factored axial compressive force $> A_g f'_c / 10$.	21.6.1
	Shortest cross-sectional dimension measured on a straight line passing through the geometric centroid of the section ≥ 12 inches.	21.6.1.1
	Ratio of the shortest cross-sectional dimension to the perpendicular dimension ≥ 0.4 .	21.6.1.2
Flexure	Flexural strength of columns shall satisfy ACI Equation (21-1): $\Sigma M_{nc} \geq (6/5)\Sigma M_{nb}$ ΣM_{nc} = sum of nominal flexural strengths of columns framing into the joint, evaluated at the faces of the joint ΣM_{nb} = sum of nominal flexural strengths of the beams framing into the joint, evaluated at the faces of the joint. In T-beam construction, where the slab is in tension under moments at the face of the joint, slab reinforcement within an effective slab width defined in ACI 8.12 shall contribute to M_{nb} if the slab reinforcement is developed at the critical section for flexure	21.6.2.2
	If the requirements of ACI 21.6.2.2 are not satisfied at a joint, the lateral strength and stiffness of the columns framing into the joint are to be ignored when determining the strength and stiffness of the structure. These columns must satisfy the provisions of ACI 21.13.	21.6.2.3
Longitudinal Reinforcement	Area of longitudinal reinforcement, A_{st} , shall satisfy the following: $0.01A_g \leq A_{st} \leq 0.06A_g$.	21.6.3.1
	Mechanical splices shall conform to ACI 21.1.6 and welded splices shall conform to ACI 21.1.7.	21.6.3.2
	Lap splices are permitted only within the center half of the member length and shall be designed as tension lap splices. Lap splices must be enclosed by transverse reinforcement conforming to ACI 21.6.4.2 and 21.6.4.3.	21.6.3.2

(continued)

⁴ Additional requirements of ACI Chapters 1 to 19 must also be satisfied. See Chapter 4 of this publication for more details.

Table 6.2 Summary of Requirements for Special Moment Frame Members Subjected to Bending and Axial Load (continued)

	Requirement	ACI Section Number(s)
Transverse Reinforcement	Transverse reinforcement conforming to ACI 21.6.4.2 through 21.6.4.4 must be provided over the length, ℓ_o , from each joint face and on both sides of any section where flexural yielding is likely to occur. Length, ℓ_o , must be greater than or equal to the largest of the following: (a) Depth of member (b) Clear span/6 (c) 18 inches	21.6.4.1
	Transverse reinforcement is to be provided by: (a) Single or overlapping spirals conforming to ACI 7.10.4 (b) Circular hoops (c) Rectilinear hoops with or without crosssties	21.6.4.2
	Crossties of the same size or smaller size as the hoop bars are permitted.	21.6.4.2
	Each end of a crosstie must engage a peripheral longitudinal reinforcing bar.	
	Consecutive crossties shall be alternated end for end along the longitudinal reinforcement.	
	Spacing of crossties or legs of rectilinear hoops, h_x , shall not exceed 14 inches on center.	21.6.4.3
	The spacing of transverse reinforcement along the length, ℓ_o , shall not exceed the smallest of: (a) Minimum member dimension/4 (b) $6 \times$ diameter of smallest longitudinal bar (c) s_o defined in ACI Equation (21-2): $4 \text{ in.} \leq s_o = 4 + \left(\frac{14 - h_x}{3} \right) \leq 6 \text{ in.}$	
	Volumetric ratio of spiral or circular hoop reinforcement, ρ_s , shall not be less than that determined by ACI Equation (21-3): $\rho_s = \frac{0.12f'_c}{f_{yt}} \geq 0.45 \left(\frac{A_g}{A_{ch}} - 1 \right) \frac{f'_c}{f_{yt}}$	21.6.4.4(a)
Total cross-sectional area of rectangular hoop reinforcement, A_{sh} , shall not be less than that required by ACI Equations (21-4) and (21-5): $A_{sh} = 0.3 \left(\frac{sb_c f'_c}{f_{yt}} \right) \left[\left(\frac{A_g}{A_{ch}} \right) - 1 \right]$ $A_{sh} = 0.09 \left(\frac{sb_c f'_c}{f_{yt}} \right)$	21.6.4.4(b)	

(continued)

Table 6.2 Summary of Requirements for Special Moment Frame Members Subjected to Bending and Axial Load (continued)

	Requirement	ACI Section Number(s)
Transverse Reinforcement (continued)	Beyond the length, ℓ_o , spiral or hoop reinforcement satisfying the provisions of ACI 7.10 must be provided. The spacing of the transverse reinforcement, s , shall not exceed the smallest of: (a) $6 \times$ diameter of smallest longitudinal bar (b) 6 inches A larger amount of transverse reinforcement may be required based on the provisions of ACI 21.6.3.2 or 21.6.5.	21.6.4.5
	Columns supporting reactions from discontinuous stiff members, such as walls, shall have transverse reinforcement as required in ACI 21.6.4.2 through 21.6.4.4 over their full height below the level at which the discontinuity occurs if the portion of the factored axial compressive force in these members related to earthquake effects exceeds $A_g f'_c / 10$. The limit of $A_g f'_c / 10$ shall be increased to $A_g f'_c / 4$ where design forces have been magnified to account for the overstrength of the vertical elements of the seismic-force-resisting system. Transverse reinforcement shall extend above and below the column as required in ACI 21.6.4.6(b).	21.6.4.6
	Additional transverse reinforcement is required in members where the concrete cover outside of the transverse reinforcement specified in ACI 21.6.4.1, 21.6.4.5 and 21.6.4.6 exceeds 4 inches. Concrete cover for additional transverse reinforcement shall not exceed 4 inches and the spacing of the additional transverse reinforcement shall not exceed 12 inches.	21.6.4.7
Shear Strength	Design shear force, V_e , is to be determined considering the maximum forces that can be generated at the faces of the joints at each end of the member. The joint forces are to be determined using M_{pr} at each end of the member associated with the range of factored axial forces, P_u . Member shear forces need not exceed those determined from joint strengths based on M_{pr} of the transverse members framing into the joint.	21.6.5.1
	Transverse reinforcement over the lengths, ℓ_o , shall be proportioned to resist shear forces assuming $V_c = 0$ when both (a) and (b) occur: (a) The earthquake-induced shear force calculated by ACI 21.6.5.1 represents one-half or more of the maximum required shear strength within ℓ_o . (b) The factored axial compressive force P_u , including earthquake effects, is less than $A_g f'_c / 20$.	21.6.5.2

For SI: 1 inch = 25.4 mm.

6.3.1 General Requirements

ACI Section 21.6.1 is intended primarily for columns that are part of a special moment frame. Frame members other than columns that do not satisfy the general requirements of ACI 21.5.1 for flexural members of special moment frames are to be proportioned and detailed by the provisions of ACI 21.6.

The geometric constraints prescribed in ACI 21.6.1.1 and 21.6.1.2, which are illustrated in Figure 6.7, follow from previous practice.

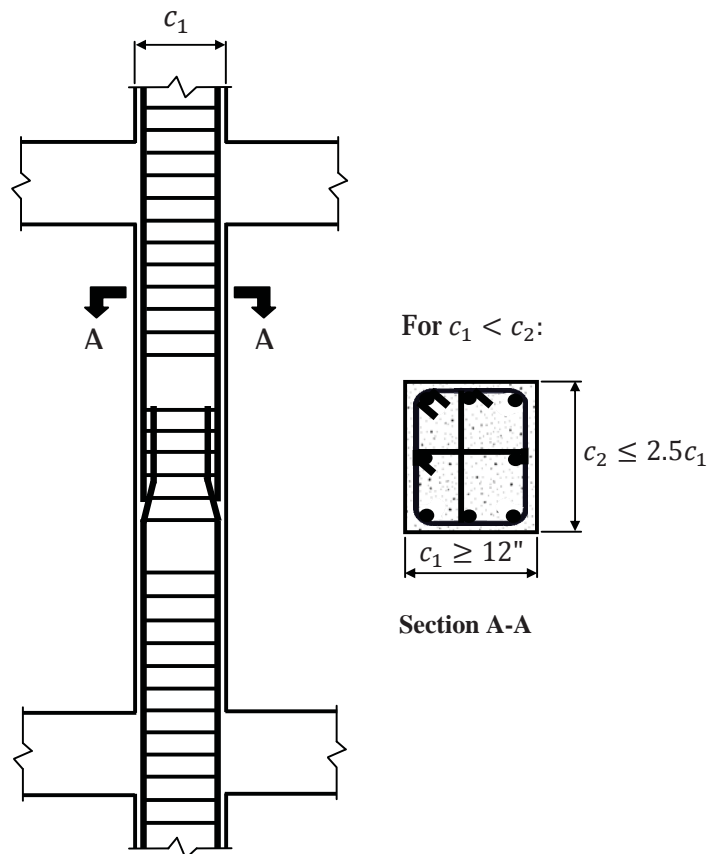

For SI: 1 inch = 25.4 mm.

Figure 6.7 Summary of General Requirements for Special Moment Frame Members Subjected to Bending and Axial Load

6.3.2 Minimum Flexural Strength of Columns

The intent of ACI 21.6.2 is to have columns in a special moment frame with sufficient strength so that they will not yield prior to the beams at a beam-column joint. Columns satisfying ACI Equation (21-1) are to be detailed in accordance with ACI 21.6.3 through 21.6.5.

If the provisions of ACI 21.6.2.2 are not satisfied at a joint, any positive contribution of a column at that joint to the lateral strength and stiffness of the structure is to be ignored, and the column must be designed and detailed in accordance with the requirements of ACI 21.13 for members that are not part of the seismic-force-resisting system.

6.3.3 Longitudinal Reinforcement Requirements

The longitudinal reinforcement requirements of ACI 21.6.3 are illustrated in Figure 6.8. The lower limit of the reinforcement ratio is to help in controlling time-dependent deformations and to ensure that the yield moment exceeds the cracking moment. The upper limit addresses concerns for steel congestion and high shear stresses that can be developed in columns with larger amounts of longitudinal reinforcement.

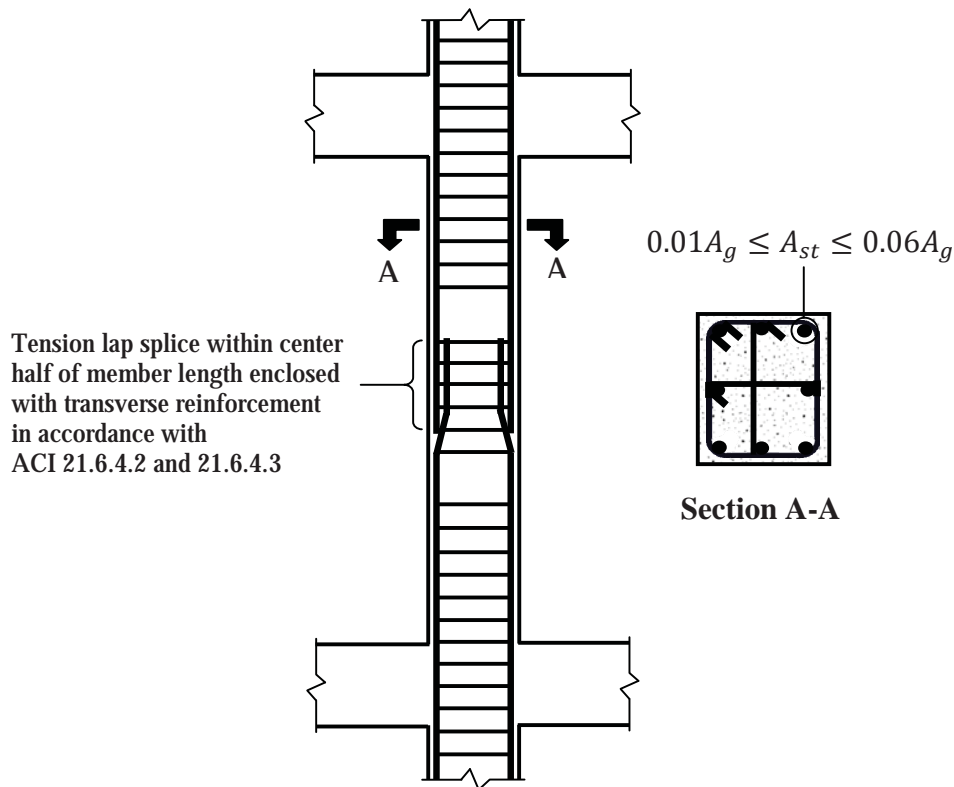

Figure 6.8 Longitudinal Reinforcement Requirements for Special Moment Frame Members Subjected to Bending and Axial Load

Requirements for splicing longitudinal reinforcement are also shown in Figure 6.8. Since spalling of the shell concrete is likely to occur at the column ends where stress reversal is expected to have a large stress range, lap splices must be located only within the center half of the member length. Special transverse reinforcement is required over the lap splice length due to the uncertainty in moment distributions along the height of the column and the need for confinement of lap splices subjected to stress reversals.

Mechanical and welded splices conforming to ACI 21.1.6 and 21.1.7, respectively, may be used as well.

6.3.4 Transverse Reinforcement Requirements

Closely spaced transverse reinforcement is required over the length, ℓ_o , from each joint face where flexural yielding normally occurs. To obtain adequate concrete confinement, the spacing of the transverse reinforcement at the ends of the member should not exceed one-quarter of the minimum column dimension. To restrain the longitudinal reinforcement from buckling after possible spalling of the shell concrete, the hoop spacing must be less than or equal to 6 times the diameter of the smallest longitudinal bar.

The spacing, s_o , is also related to concrete confinement. It is permitted to use a 6-inch (152 mm) spacing instead of a 4-inch (102 mm) spacing if crossties or legs of overlapping hoops are provided at a horizontal spacing no greater than 8 inches (203 mm).

Transverse reinforcement requirements are illustrated in Figure 6.9 for rectilinear hoops and in Figure 6.10 for spiral reinforcement. Spiral reinforcement is generally the most efficient form of confinement reinforcement; however, the extension of the spirals into the beam-column joint may cause some construction difficulties.

To ensure a relatively uniform toughness of the column along its full height, spiral or hoop reinforcement satisfying the lateral reinforcement requirements of ACI 7.10 must be spaced no more than 6 longitudinal bar diameters or 6 inches (152 mm) in the region beyond the length, ℓ_o .

The transverse reinforcement requirements of ACI 21.6.4.6 must be satisfied for columns that support reactions from discontinuous stiff members, such as walls. In cases where the factored axial compressive force related to earthquake effects in such columns exceeds $A_g f'_c / 4$,⁵ transverse reinforcement satisfying ACI 21.6.4.2 through 21.6.4.4 must be provided over the entire length of the column.

Transverse reinforcement must extend above into the discontinued member and below into the supporting element in accordance with the provisions of ACI 21.6.4.6(b), which are illustrated in Figure 6.11.

⁵The provisions of ASCE/SEI 12.3.3.3 apply to structural members that support discontinuous frames or shear walls systems where the discontinuity is severe enough to be deemed a structural irregularity. In such cases, the supporting members must be designed to resist the load combinations with overstrength factor, Ω_o , of ASCE/SEI 12.4.3.2, and the limit on the axial compressive force in ACI 21.6.4.6 is $A_g f'_c / 4$. Otherwise, the limit is $A_g f'_c / 10$.

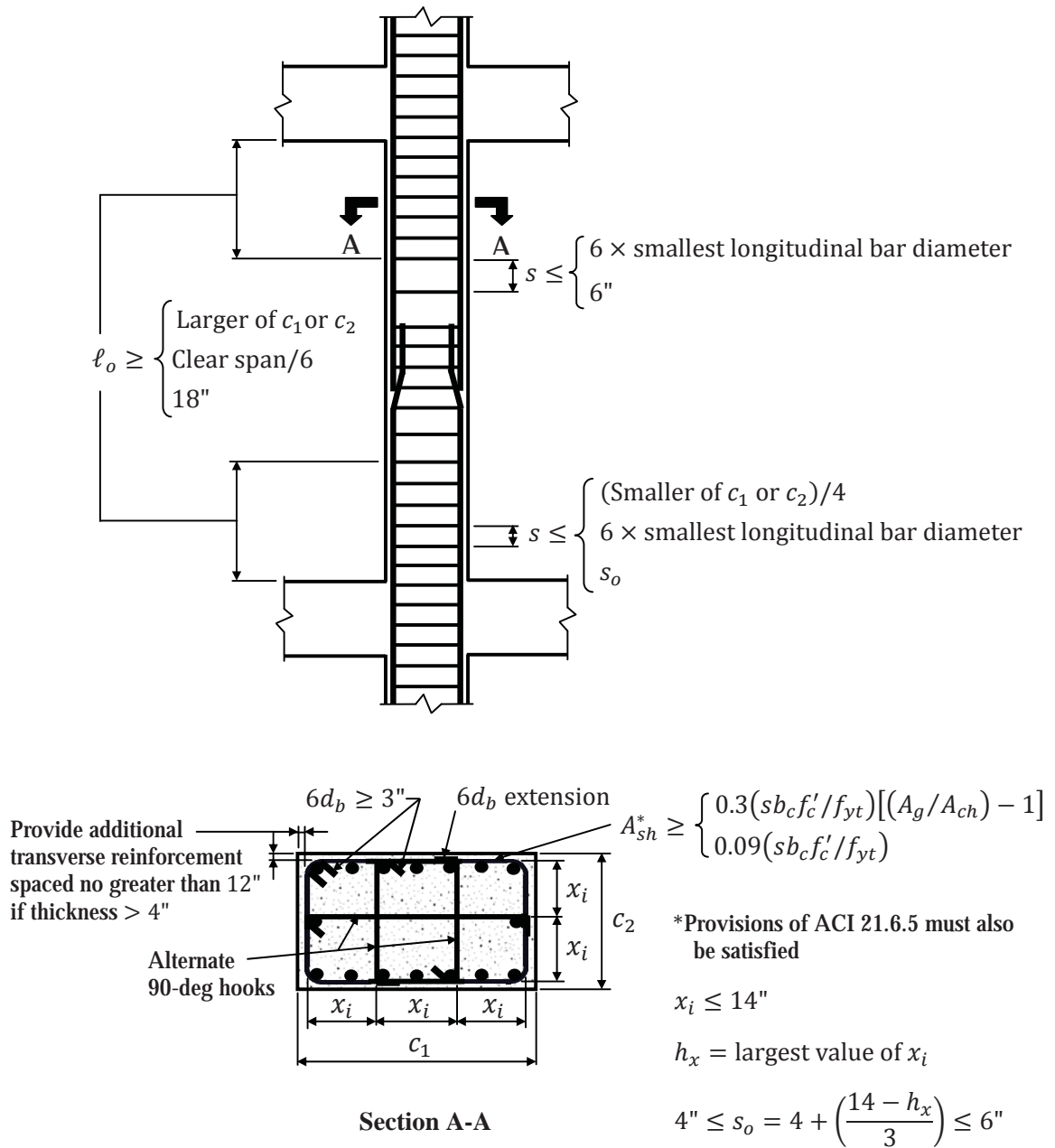

For SI: 1 inch = 25.4 mm; 1 degree = 0.01745 rad.

Figure 6.9 Transverse Reinforcement Requirements (Rectilinear Hoops) for Special Moment Frame Members Subjected to Bending and Axial Load

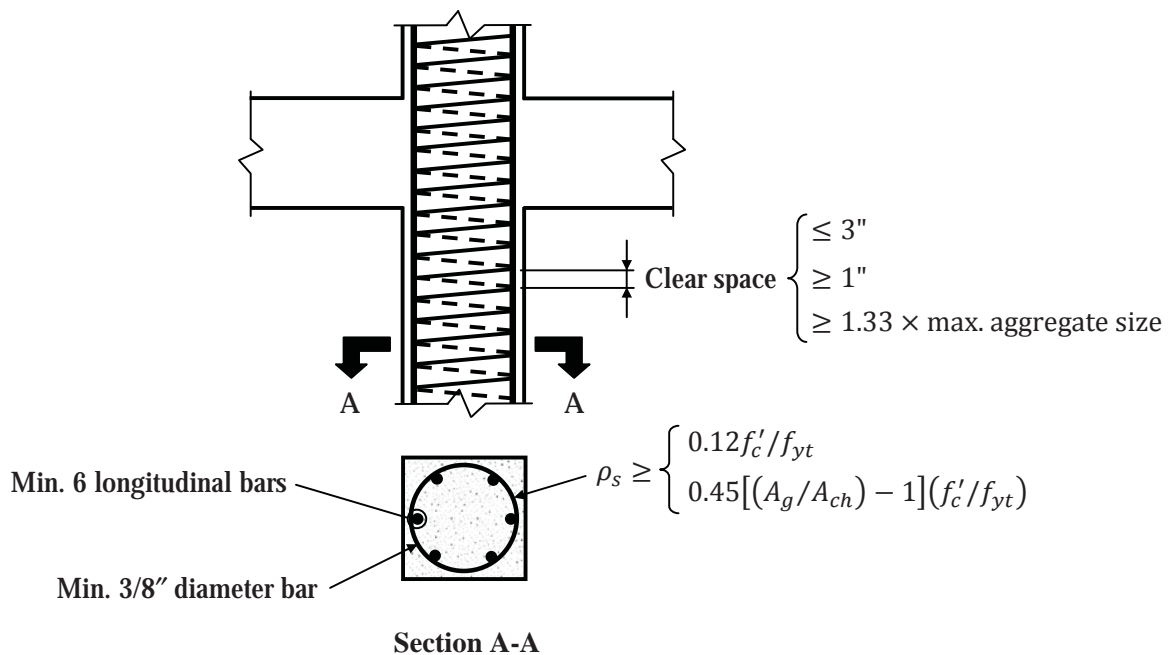

For SI: 1 inch = 25.4 mm.

Figure 6.10 Transverse Reinforcement Requirements (Spirals) for Special Moment Frame Members Subjected to Bending and Axial Load

6.3.5 Shear Requirements

Like flexural members of a special moment frames, members subjected to bending and axial load in special moment frames must be designed for the shear forces associated with probable moment strengths, M_{pr} , acting at the ends of the member associated with the range of factored axial loads, P_u , acting on the member. Sidesway to the left and sidesway to the right must both be considered to obtain the maximum shear force. One such case is illustrated in ACI Figure R21.5.4.

In lieu of computing M_{pr} based on the range of factored axial loads, it is conservative to use M_{pr} at the balanced point of the interaction diagram.

Above the ground floor level, the maximum shear force that can be induced in a column may be limited by the flexural strengths of the beams framing into the joint. In cases where beams frame on opposite sides of a joint, the combined probable moment strength may be taken as the sum of the negative probable moment strength of the beam on one side of the joint and the positive probable moment strength of the beam on the other side. The combined probable moment strength of the beams is then distributed to the columns above and below the joint based on relative stiffness, and the shear forces in the column are computed based on this distributed moment.

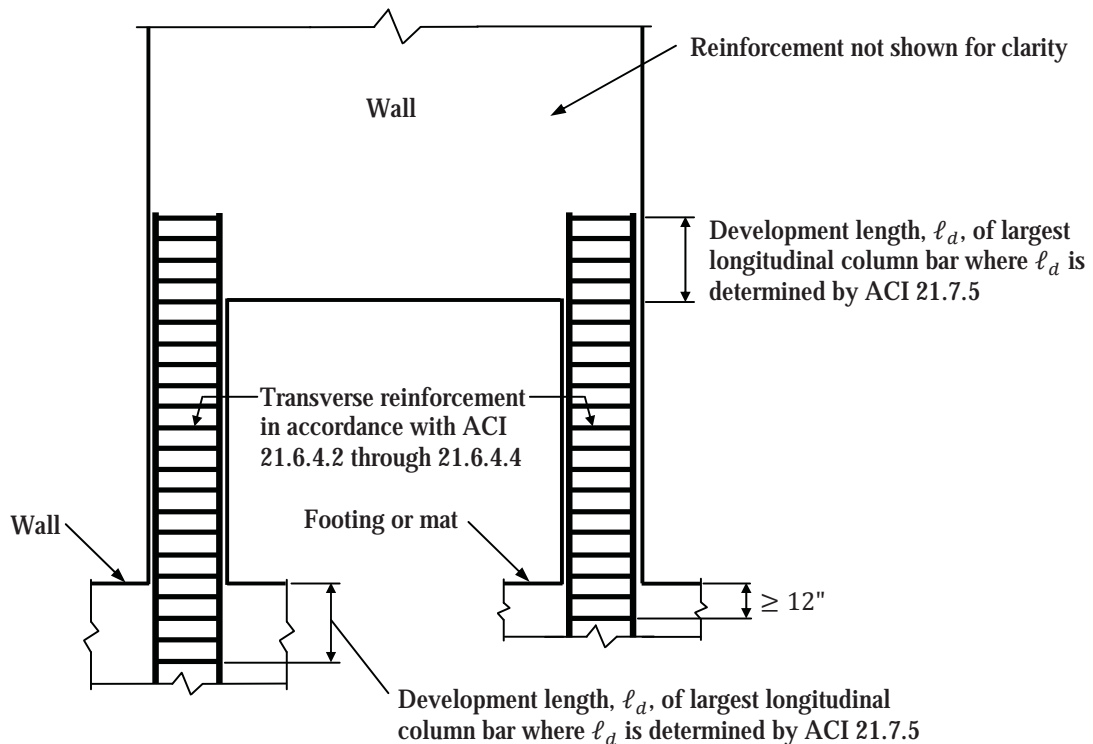

For SI: 1 inch = 25.4 mm.

Figure 6.11 Transverse Reinforcement Requirements for Columns Supporting Discontinued Stiff Members in Buildings Assigned to SDC D, E or F

For columns supporting the first elevated floor, it is possible to develop the probable flexural strength of the column at its base. Thus, for a first story column, shear forces are computed based on one of two ways: (1) the probable flexural strength of the column acting at both the top and bottom of the column and (2) the probable flexural strength of the column at the base and the probable flexural strengths of the beams at the top.

In general, the design shear force must not be taken less than that determined from the structural analysis of the building.

Like in the case of flexural members, the contribution of concrete to shear strength must be taken equal to zero when the two conditions under ACI 21.6.5.2 are satisfied.

A summary of the overall design procedure for special moment frame members subjected to bending and axial load is given in Figure 6.12.

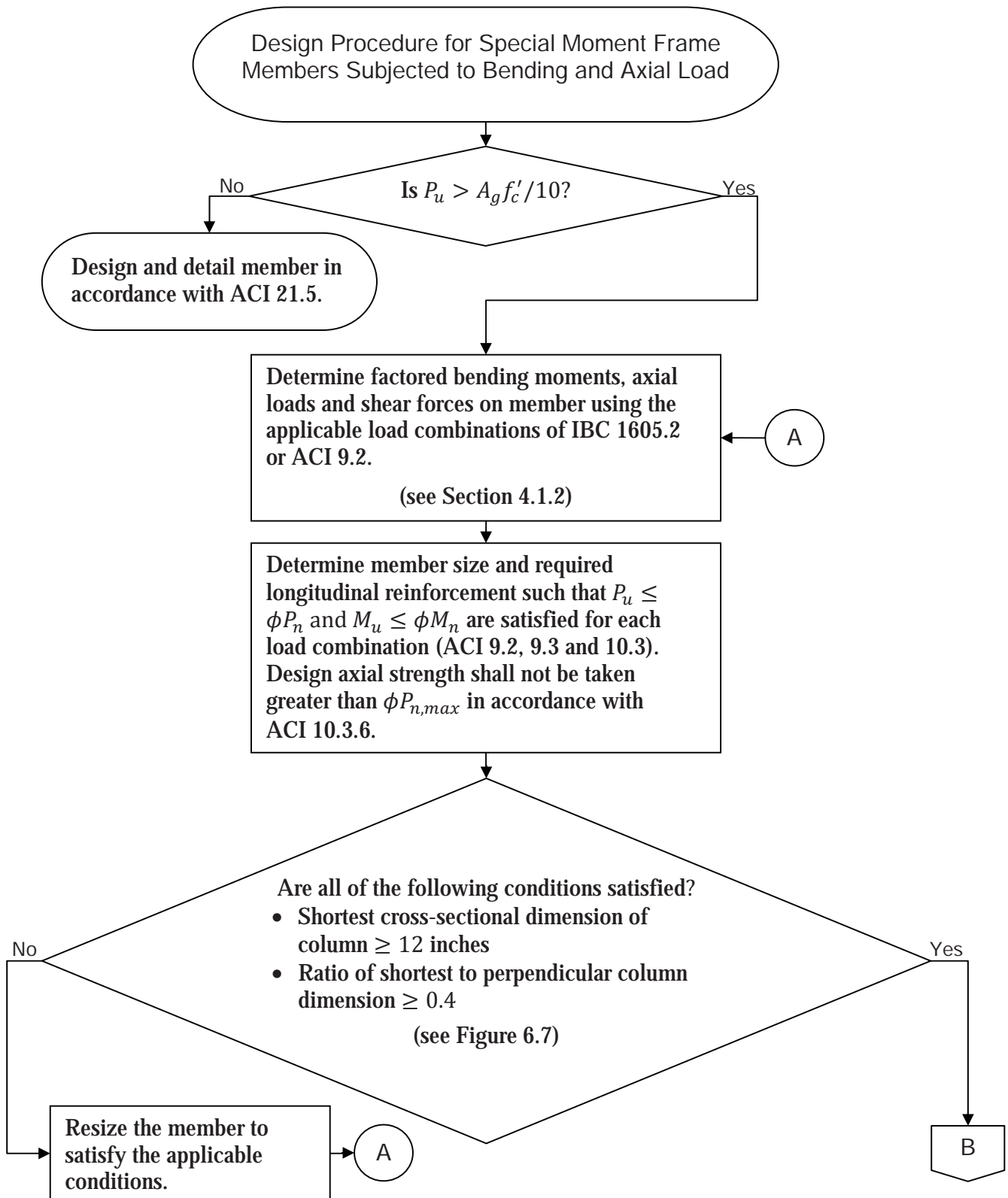

Figure 6.12 Design Procedure for Special Moment Frame Members Subjected to Bending and Axial Load

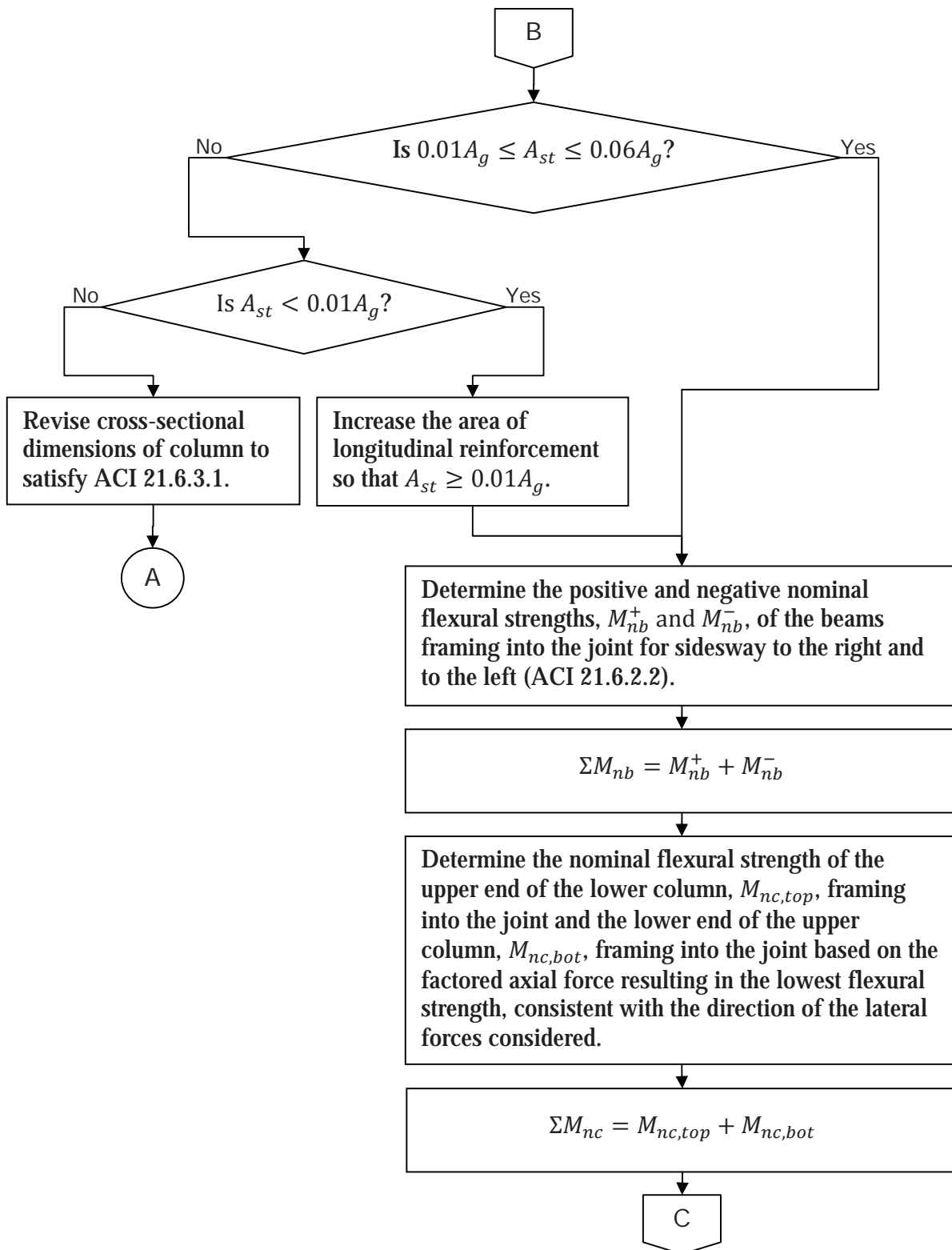

Figure 6.12 Design Procedure for Special Moment Frame Members Subjected to Bending and Axial Load (continued)

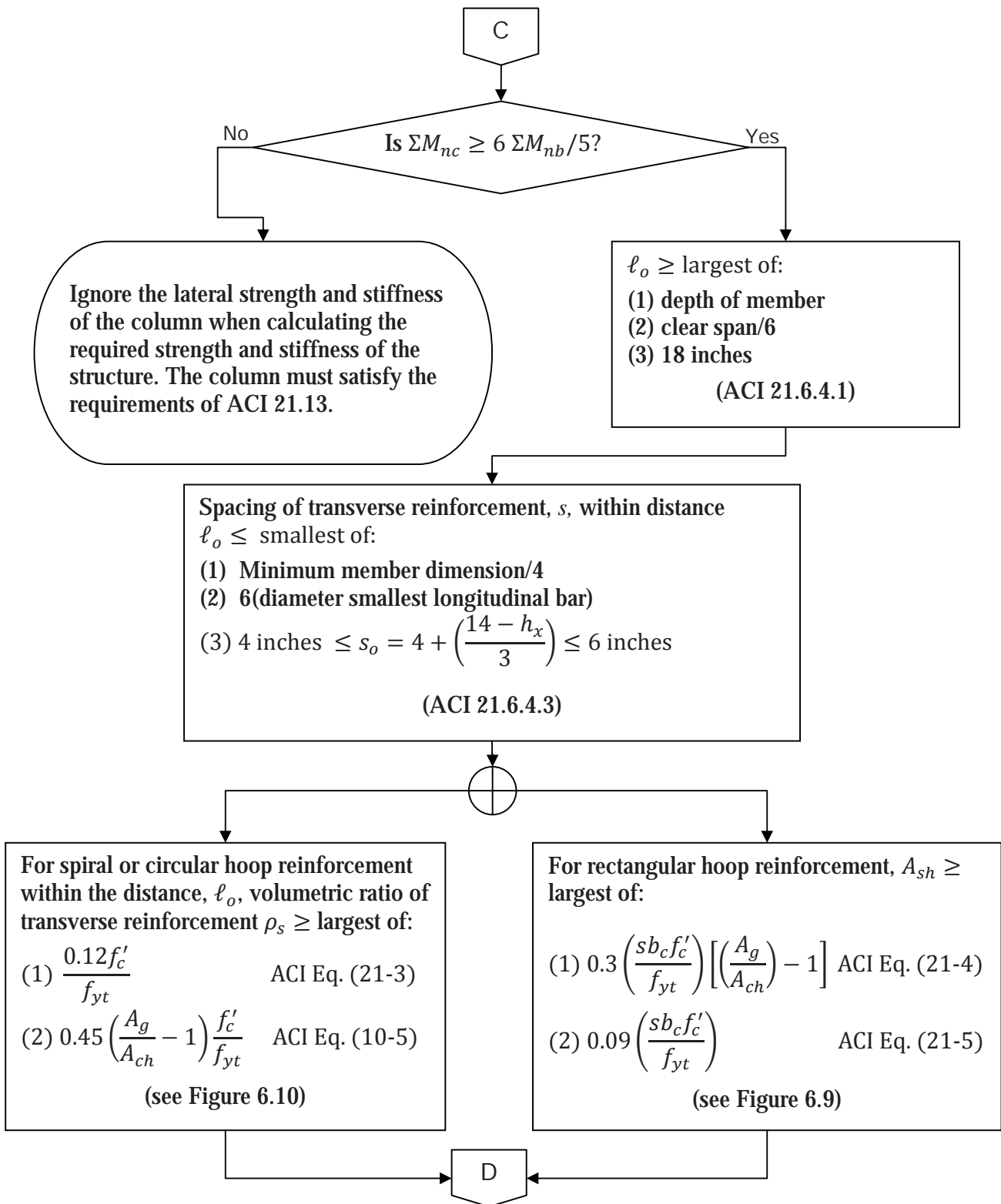

Figure 6.12 Design Procedure for Special Moment Frame Members Subjected to Bending and Axial Load (continued)

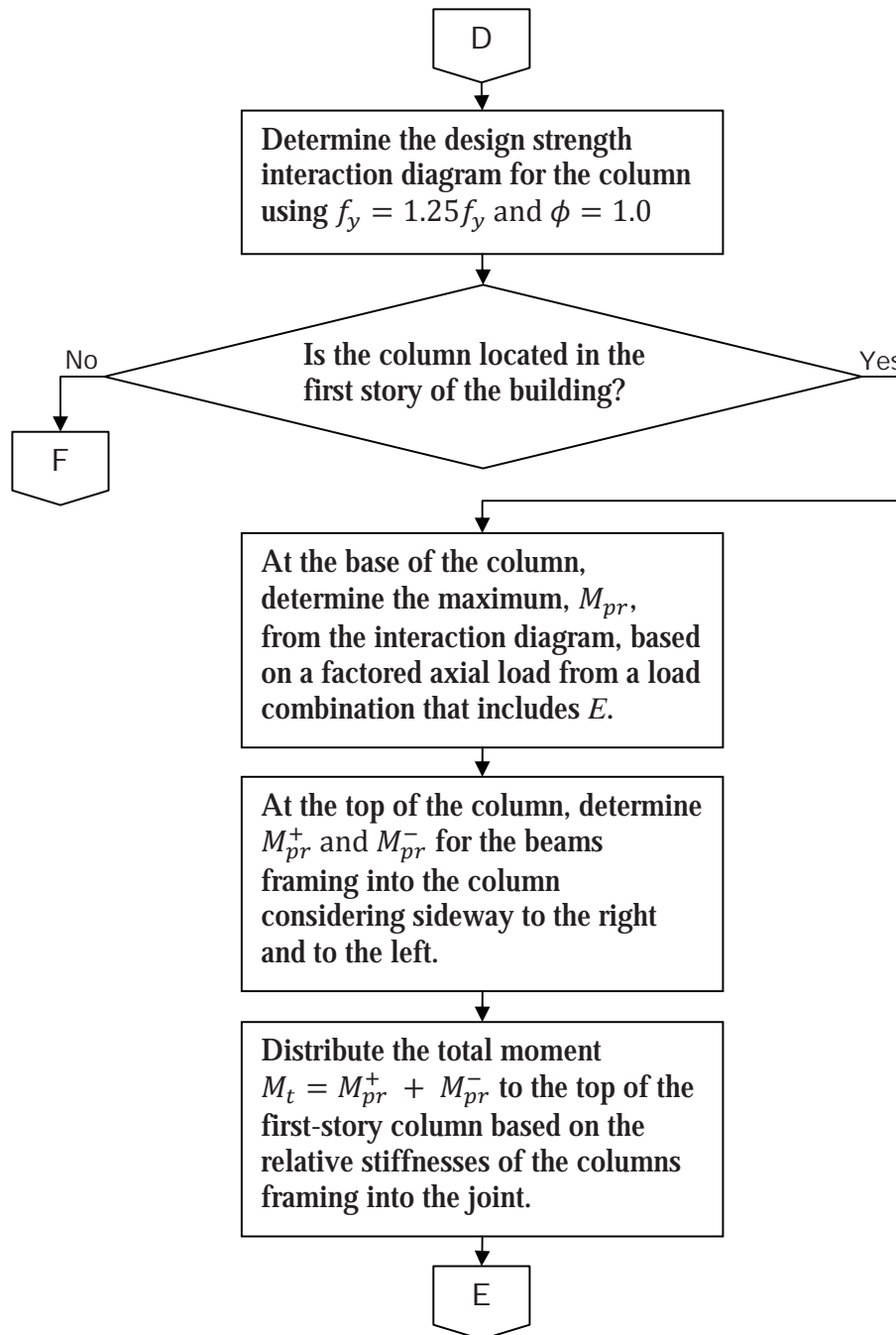

Figure 6.12 Design Procedure for Special Moment Frame Members Subjected to Bending and Axial Load (continued)

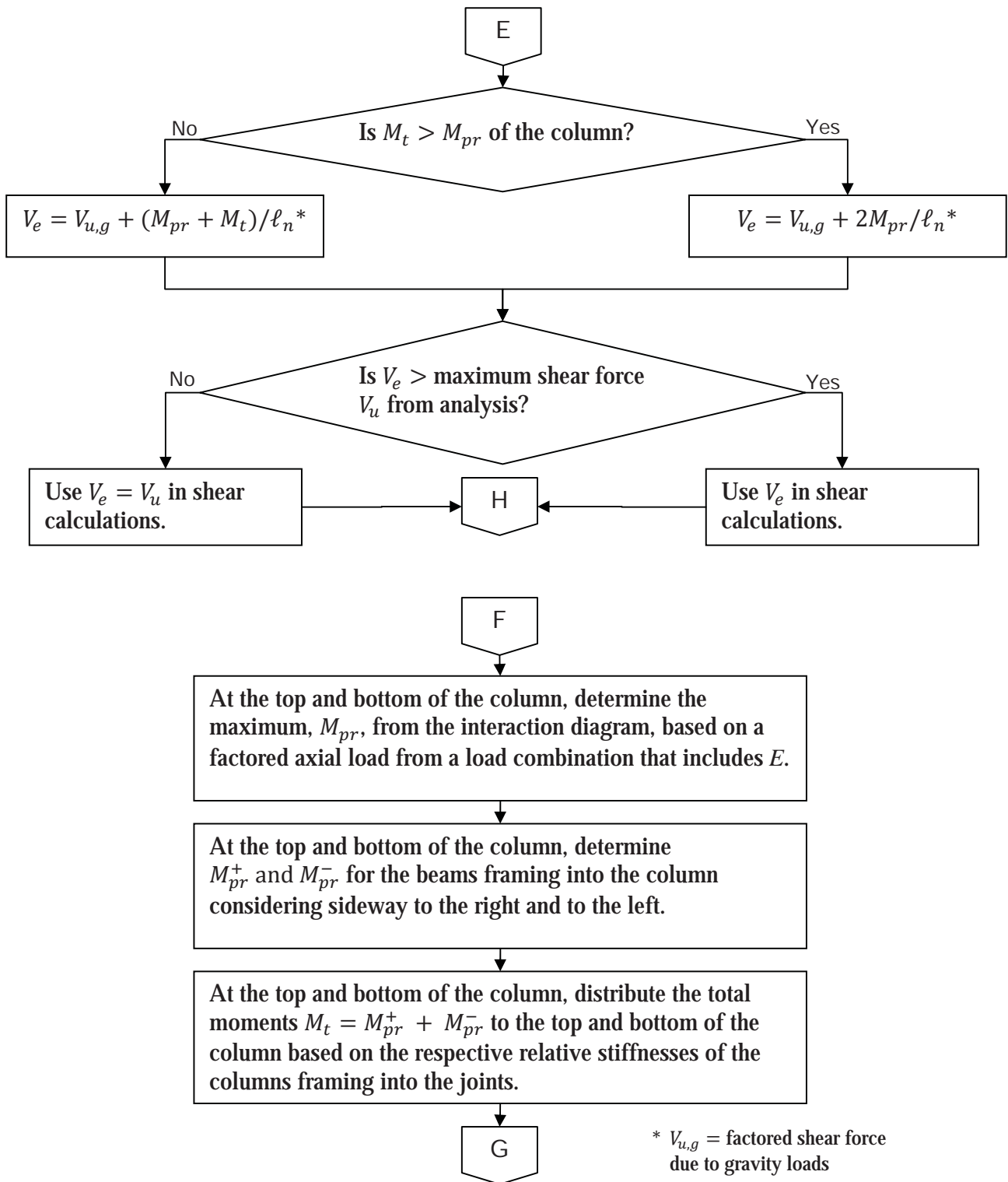

Figure 6.12 Design Procedure for Special Moment Frame Members Subjected to Bending and Axial Load (continued)

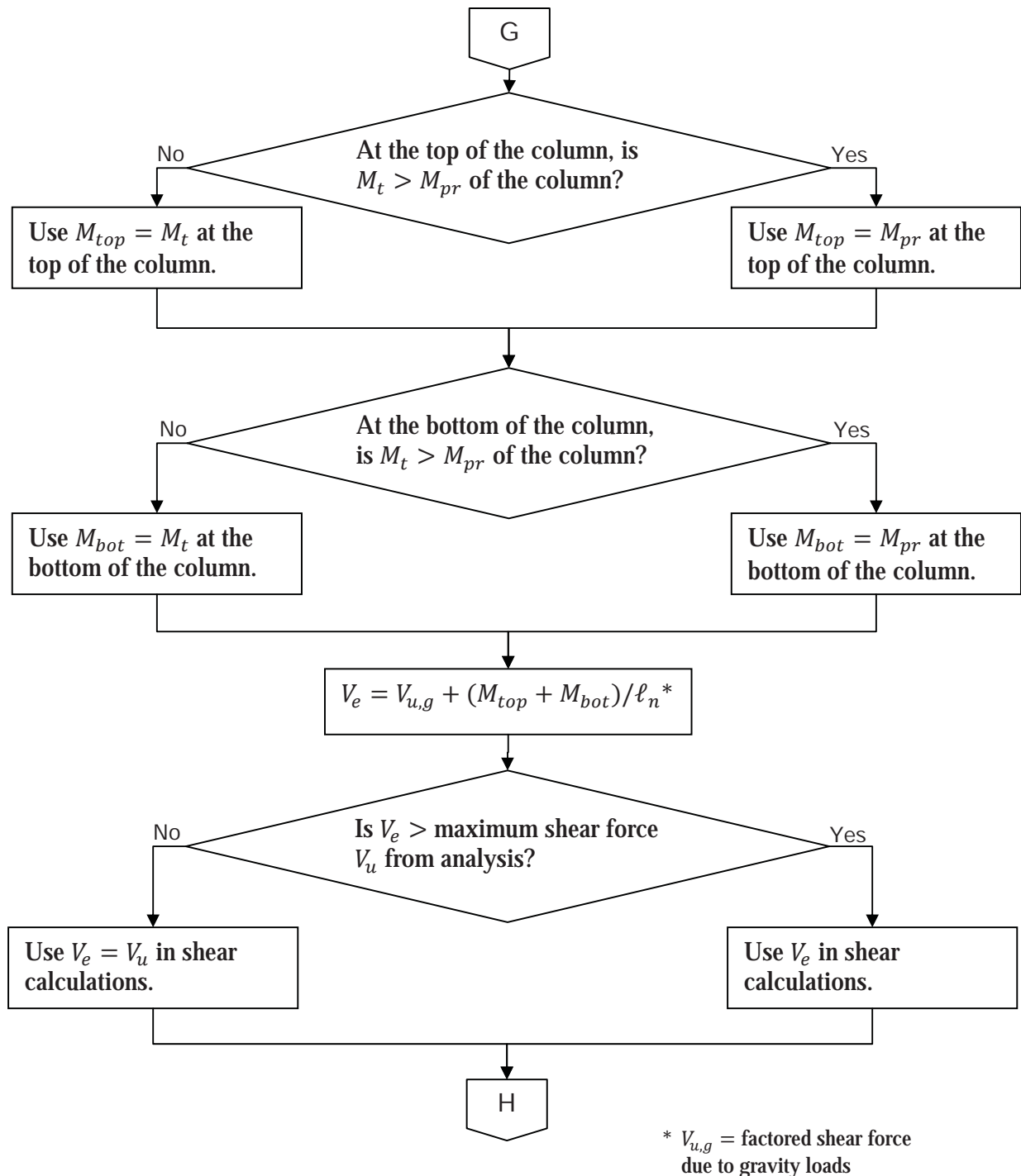

Figure 6.12 Design Procedure for Special Moment Frame Members Subjected to Bending and Axial Load (continued)

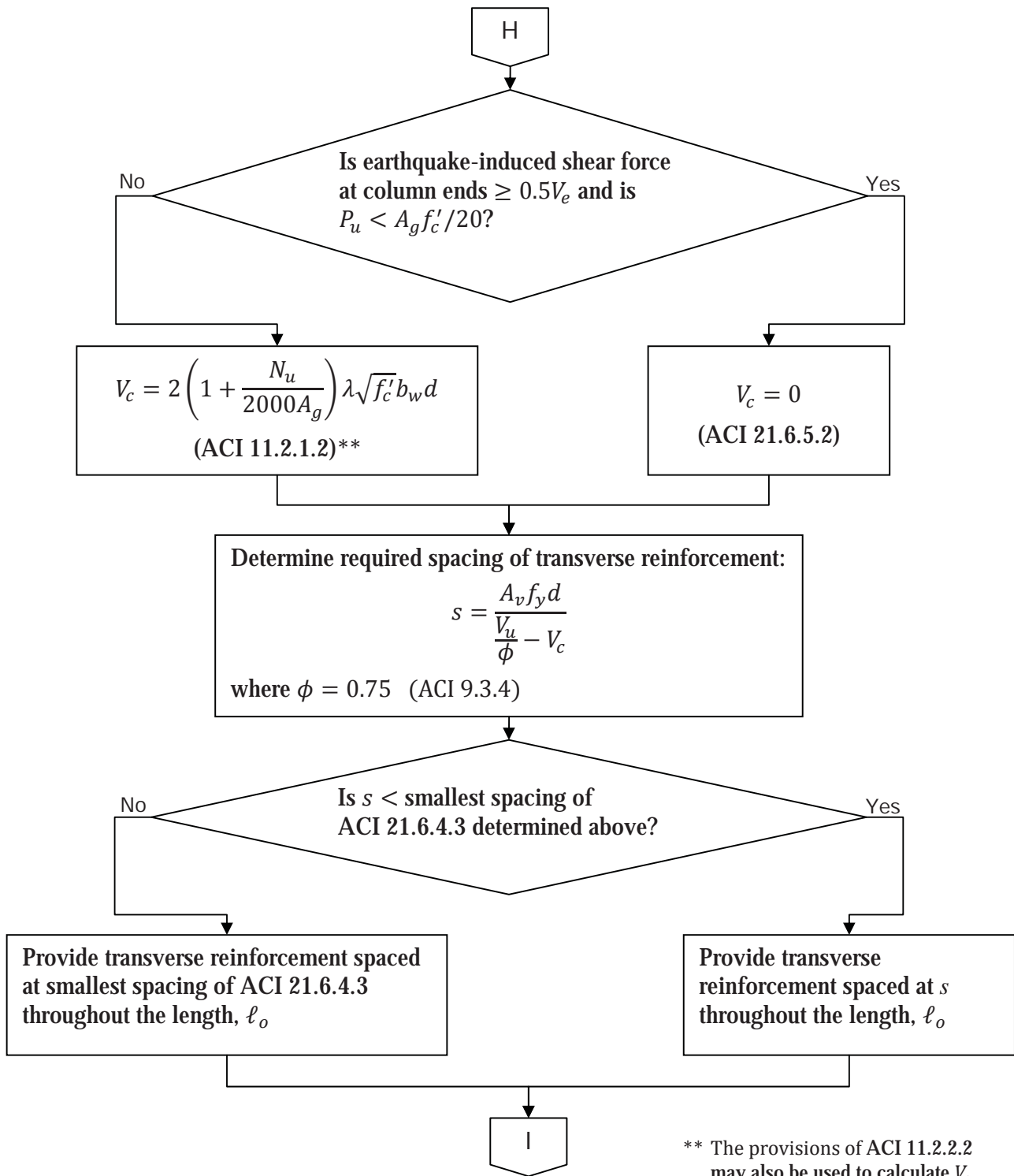

Figure 6.12 Design Procedure for Special Moment Frame Members Subjected to Bending and Axial Load (continued)

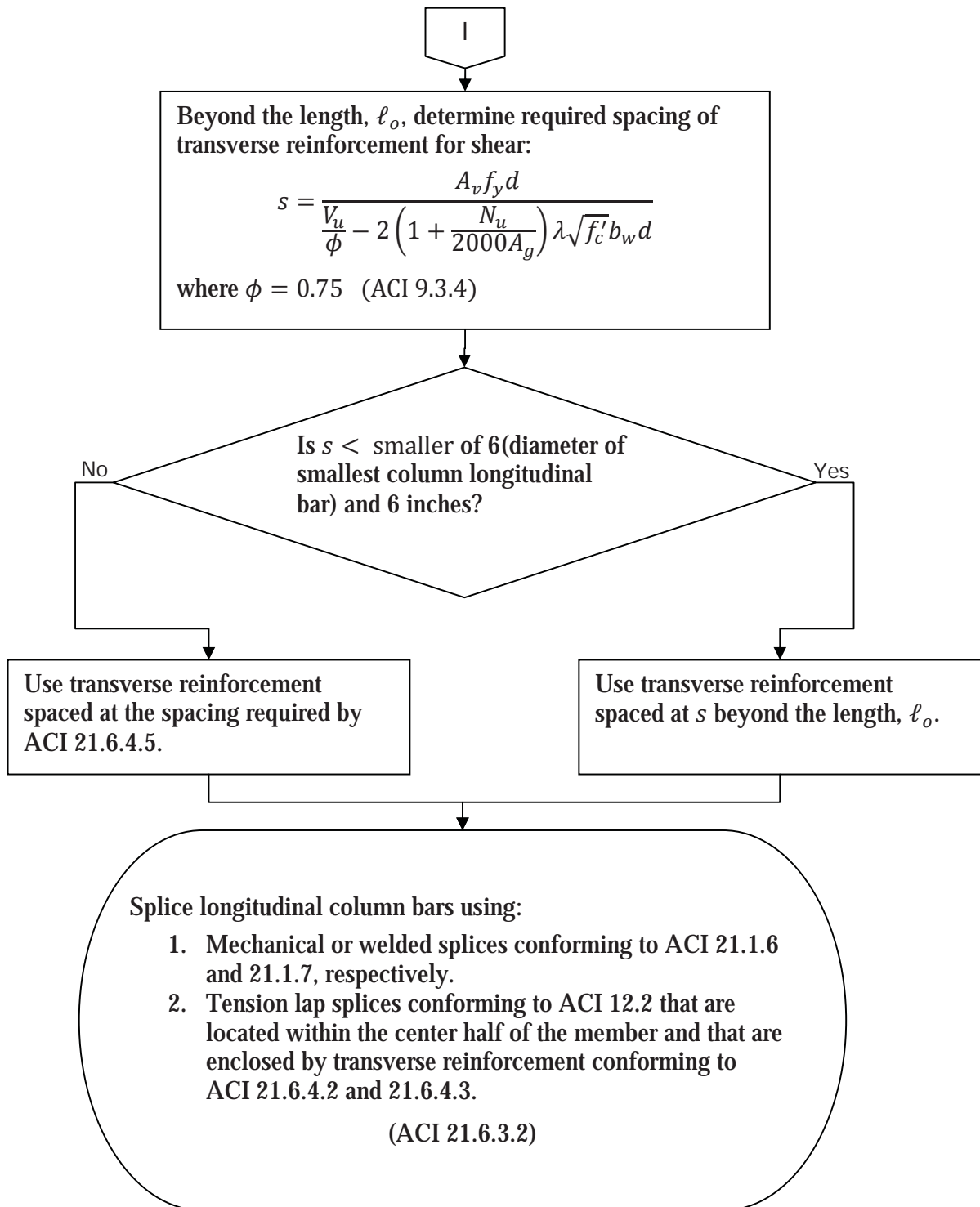

Figure 6.12 Design Procedure for Special Moment Frame Members Subjected to Bending and Axial Load (continued)

6.4 JOINTS OF SPECIAL MOMENT FRAMES

Table 6.3 contains requirements of ACI 21.7, which are applicable to beam-column joints of special moment frames that are part of the seismic-force-resisting system of the structure.

Table 6.3 Summary of Requirements for Joints of Special Moment Frames

	Requirement	ACI Section Number(s)
General	Forces in longitudinal beam reinforcement at joint faces shall be determined assuming the stress in the flexural tensile reinforcement = $1.25f_y$.	21.7.2.1
	Beam longitudinal reinforcement terminated in a column is to be extended to the far face of the confined column core and is to be anchored in tension in accordance with ACI 21.7.5 and in compression in accordance with ACI Chapter 12.	21.7.2.2
	Where longitudinal beam reinforcement extends through a beam-column joint, the column dimension parallel to the beam reinforcement must be greater than or equal to 20 times the diameter of the largest longitudinal bar in the beam for normal weight concrete. For lightweight concrete, the column dimension must be greater than or equal to 26 times the bar diameter.	21.7.2.3
Transverse Reinforcement	Transverse reinforcement required at column ends per ACI 21.6.4.4(a) or 21.6.4.4(b) must be provided through joints of special moment frames and must conform with the requirements of ACI 21.6.4.2, 21.6.4.3 and 21.6.4.7, unless the provisions of ACI 21.7.3.2 are satisfied.	21.7.3.1
	If members frame into all four sides of a joint and the width of the members are greater than or equal to three-quarters the width of the column, the amount of transverse reinforcement through the joint can be reduced to 50 percent of that required by ACI 21.6.4.4(a) or 21.6.4.4(b). The required spacing of the transverse reinforcement in accordance with ACI 21.6.4.3 is permitted to be increased to 6 inches within the overall depth, h , of the shallowest framing member.	21.7.3.2
	Longitudinal beam reinforcement outside of the column core shall be confined by transverse reinforcement passing through the column that satisfies ACI 21.5.3.2, 21.5.3.3 and 21.5.3.6, if such confinement is not provided by a beam framing into the joint.	21.7.3.3

(continued)

Table 6.3 Summary of Requirements for Joints of Special Moment Frames (continued)

	Requirement	ACI Section Number(s)
Shear	<p>The nominal shear strength of the joint V_n shall not exceed the following values for normal weight concrete:</p> <p>For joints confined on all four faces: $20\sqrt{f'_c}A_j$</p> <p>For joints confined on three faces or two opposite faces: $15\sqrt{f'_c}A_j$</p> <p>For all other cases: $12\sqrt{f'_c}A_j$</p> <p>A_j = effective cross-sectional area within a joint = joint depth \times effective joint width</p> <p>Joint depth = overall depth of column</p> <p>Effective joint width = overall width of column, except where a beam frames into a wider column, effective joint width shall not exceed the smaller of</p> <p>(a) beam width + joint depth</p> <p>(b) 2(smaller perpendicular distance from longitudinal axis of beam to column side)</p> <p>A member is considered to provide confinement to a joint if at least three-quarters of the joint is covered by a framing member. A joint is considered to be confined if confining members frame into all faces of the joint.</p> <p>Beam extensions that are at least one overall beam depth, h, beyond the joint face are permitted to be considered as confining members. Beam extensions shall satisfy ACI 21.5.1.3, 21.5.2.1, 21.5.3.2, 21.5.3.3 and 21.5.3.6.</p>	21.7.4.1
	<p>For lightweight concrete, the nominal shear strength of the joint shall not exceed three-quarters of the limits in ACI 21.7.4.1.</p>	21.7.4.2
Development Length of Bars in Tension	<p>For No. 3 through No. 11 bars with a standard 90-degree hook in normal weight concrete located within the confined core of a column or boundary element, the development length, ℓ_{dh}, should be greater than or equal to the largest of the following:</p> <p>(a) $8d_b$</p> <p>(b) 6 inches</p> <p>(c) $f_y d_b / (65\sqrt{f'_c})$</p> <p>For lightweight concrete, ℓ_{dh} is the largest of 1.25 times the length required for normal weight concrete.</p>	21.7.5.1

(continued)

Table 6.3 Summary of Requirements for Joints of Special Moment Frames (continued)

	Requirement	ACI Section Number(s)
Development Length of Bars in Tension (continued)	For No. 3 through No. 11 bars, the development length, ℓ_d , for a straight bar is the largest of the following: (a) 2.5 times the length required by ACI 21.7.5.1 if the depth of the concrete cast in one lift beneath the bar ≤ 12 inches (b) 3.25 times the length required by ACI 21.7.5.1 if the depth of the concrete cast in one lift beneath the bar > 12 inches	21.7.5.2
	Straight bars terminated at a joint shall pass through the confined core of a column or boundary element. Any portion of ℓ_d not within the confined core shall be increased by a factor of 1.6.	21.7.5.3
	Where epoxy-coated reinforcing bars are used, the development lengths prescribed in ACI 21.7.5.1 through 21.7.5.3 shall be multiplied by the applicable factors in ACI 12.2.4 or 12.5.2.	21.7.5.4

For SI: 1 inch = 25.4 mm; 1 degree = 0.01745 rad.

6.4.1 General Requirements

The overall integrity and performance of a special moment frame is dependent on the behavior of beam-column joints in the frames. The inelastic rotations at the faces of the joints produce strains in the reinforcement well in excess of the yield strain. Thus, the joint shear force is calculated using a stress of $1.25f_y$ in the beam longitudinal reinforcement passing through the joint.

Slippage of the longitudinal reinforcement through a joint can lead to an increase in joint rotation. Longitudinal bars must be continued through the joint or must be properly developed for tension in accordance with ACI 21.7.5 and compression according to ACI Chapter 12 in the confined column core. The minimum column size requirements of ACI 21.7.2.3 for both normal weight and lightweight concrete reduces the possibility of failure from loss of bond during load reversals that take the longitudinal reinforcement well beyond its yield point. The general requirements of ACI 21.7.2 are illustrated in Figure 6.13.

6.4.2 Transverse Reinforcement Requirements

Transverse reinforcement in a beam-column joint is required to adequately confine the concrete to ensure its ductile behavior and to allow it to maintain its vertical load-carrying capacity even after possible spalling of the outer shell. Minimum confinement reinforcement equal to the amount required for potential hinging regions in columns must be provided within a joint, unless the joint is confined by structural members as stipulated in ACI 21.7.3.2. Figure 6.13 illustrates the transverse reinforcement requirements for rectilinear hoops when less than four members frame into a beam-column joint.

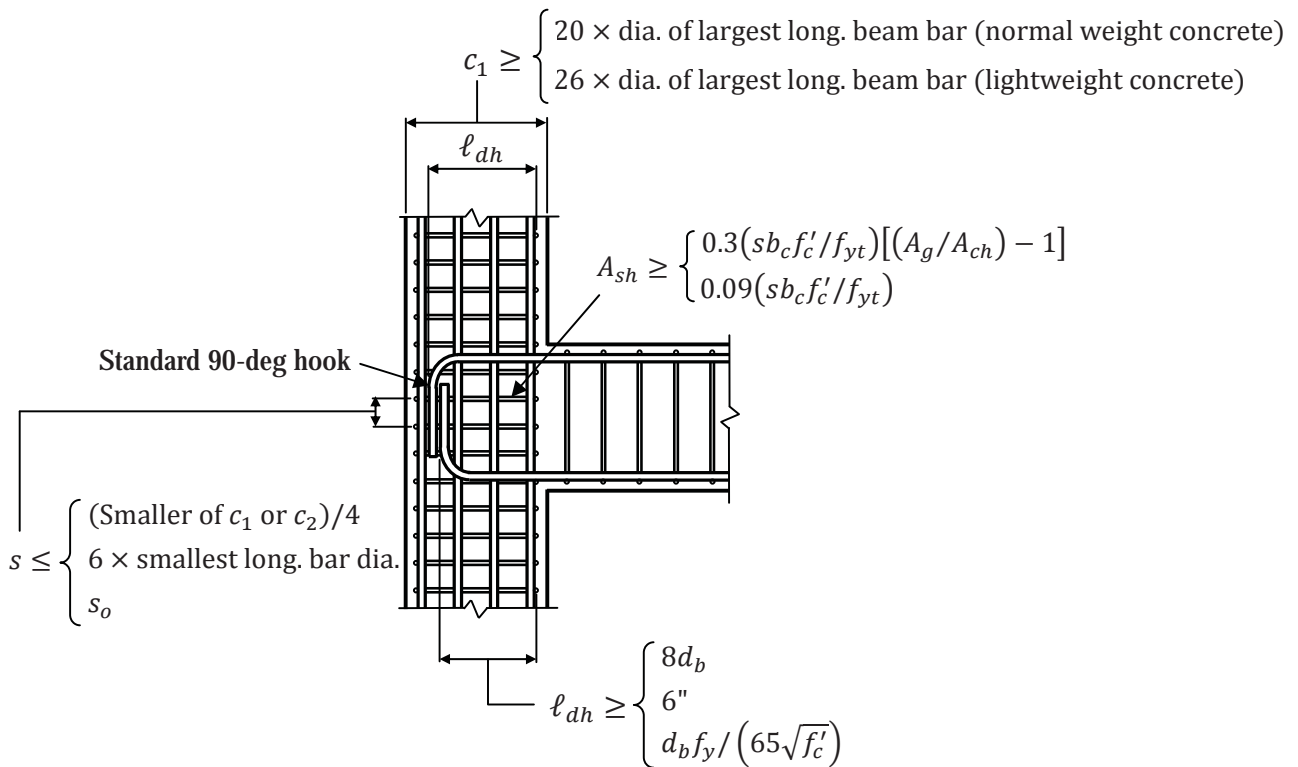

For lightweight concrete, multiply l_{dh} by 1.25

For epoxy-coated bars, multiply l_{dh} by 1.2

For SI: 1 inch = 25.4 mm; 1 degree = 0.01745 rad.

Figure 6.13 General Requirements and Transverse Reinforcement Requirements (Rectilinear Hoops) for Joints Not Confined by Structural Members

Fifty percent of the transverse reinforcement required by ACI 21.6.4.4(a) or 21.6.4.4(b) may be used when members frame into all four sides of a joint, provided the widths of the members are at least three-fourths the corresponding column widths. This reduction in the amount of transverse reinforcement recognizes the beneficial effect provided by these members in resisting bursting pressures that can be generated within a joint. The requirements of ACI 21.7.3.2 are shown in Figure 6.14.

Section 21.7.3.3 contains provisions for joints where the beam width is greater than the corresponding column width. Beam reinforcement that is not confined by column reinforcement must be confined by transverse reinforcement that satisfies ACI 21.5.3.2, 21.5.3.3 and 21.5.3.6, unless a beam framing into the joint provides confinement. ACI Figure R21.5.1 shows an example of the transverse reinforcement through a column that is required to confine the beam reinforcement that passes outside of the column core.

The minimum amount of transverse reinforcement for all of the cases noted above must be provided through the joint regardless of the magnitude of the calculated shear force in the joint.

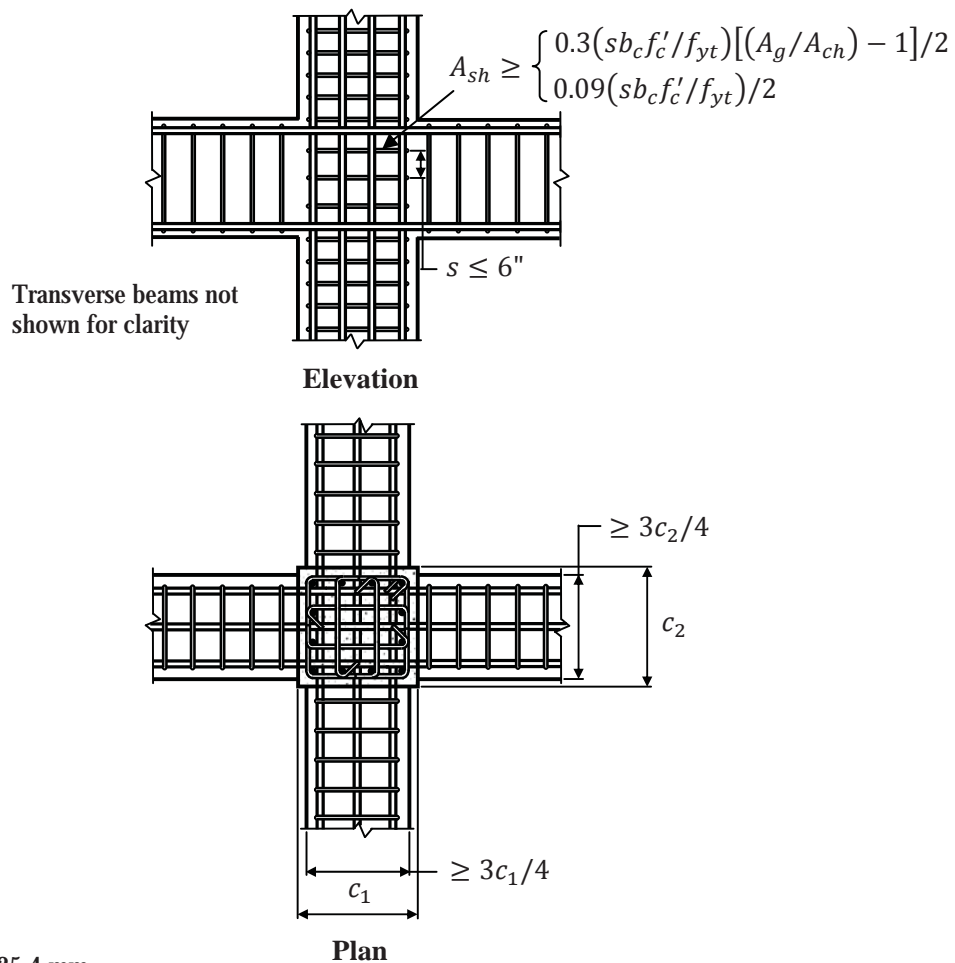

For SI: 1 inch = 25.4 mm.

Figure 6.14 Transverse Reinforcement Requirements (Rectilinear Hoops) for Joints Confined by Structural Members

6.4.3 Shear Requirements

Shear strength of a joint is a function of the concrete strength and the cross-sectional area of the joint, A_j , only. Tests of joints show that the shear strength of a joint is not altered significantly with changes in transverse reinforcement, provided a minimum amount of such reinforcement is present. ACI Figure R21.7.4 illustrates the effective joint area that is to be used in the calculation of the nominal shear strength of a joint.

As noted above, the stress in the longitudinal reinforcement of the beams is conservatively taken as $1.25f_y$. The multiplier of 1.25 takes into account the likelihood that due to strain hardening and actual strengths higher than the specified yield strengths, larger tensile forces may develop in the bars, resulting in a larger shear force in the joint.

6.4.4 Development Length of Bars in Tension

The detailing requirements of ACI 21.7.5 for reinforcing bars with standard 90-degree (1.57 rad) hooks located within a confined core of a column or boundary element are applicable for No. 3 through No. 11 bars, since information on the anchorage of No. 14 and No. 18 bars subjected to load reversals is very limited.

ACI Equation (21-6) for development length of bars in tension in normal weight concrete is based on the requirements of ACI 12.5 for reinforcing bars with $f_y = 60,000$ psi (413 685 kPa). Since it is stipulated in ACI 21.7.5.1 that the hook is to be embedded in confined concrete, the factors for hooks enclosed in ties that satisfy minimum cover requirements, which are 0.8 and 0.7, respectively, are incorporated into ACI Equation (21-6). Also incorporated into the equation are a 1.1-factor to reflect the effects of load reversals and a 1.25-factor for overstrength in the reinforcing steel.

For lightweight concrete, the development length is 25 percent greater than that required by ACI Equation (21-6) to compensate for variability of bond characteristics of reinforcing bars in various types of lightweight concrete.

Straight bars may also be utilized provided they are properly developed. Development lengths for straight bars are specified in ACI 21.7.5.2 as a multiple of the development length of hooked bars in accordance with ACI 21.7.5.1.

Straight bars that are terminated at a joint must pass through the confined core of a column or boundary element. Any portion of the required straight development length that extends beyond the confined core must be increased by a factor of 1.6. This increase is based on the premise that the limiting bond stress outside of the confined core is less than that inside the core.

Figure 6.15 illustrates the requirements of ACI 21.7.5.3 where ℓ_{dm} = required development length if the reinforcing bar is not entirely embedded in confined concrete; ℓ_d = required development length in tension for a straight reinforcing bar embedded in confined concrete; and, ℓ_{dc} = length of reinforcing bar embedded in confined concrete (i.e., length of confined core of column or boundary element).

A summary of the overall design procedure for joints of special moment frame is given in Figure 6.16.

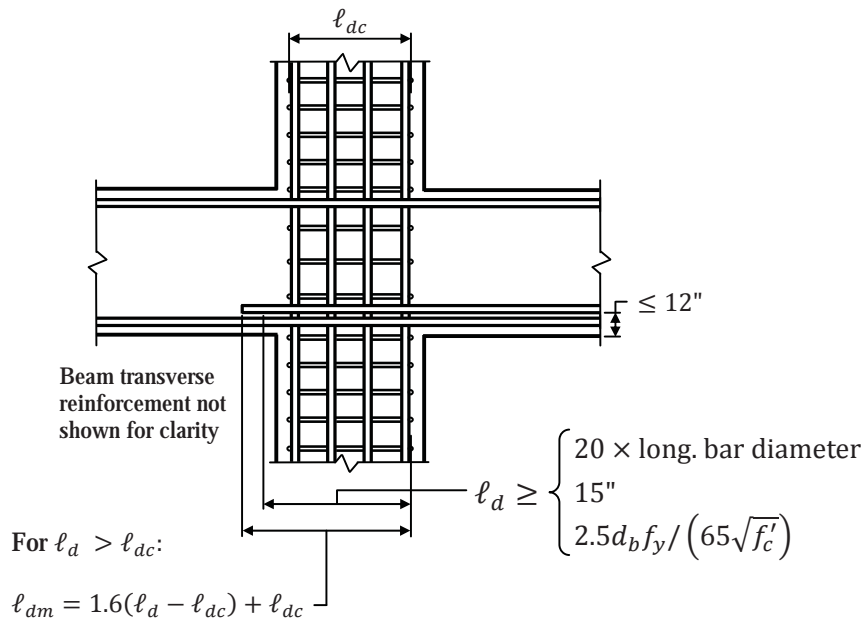

For lightweight concrete, multiply ℓ_d by 1.25

For epoxy-coated bars, multiply ℓ_d by

- 1.5 for bars with cover $< 3d_b$ or clear spacing $< 6d_b$
- 1.2 for all other bars

For depth of concrete cast in one lift beneath the bar > 12 in., multiply ℓ_d by 1.3

For SI: 1 inch = 25.4 mm.

Figure 6.15 Development Length of Straight Bars in Tension Passing through a Joint in a Special Moment Frame

6.5 SPECIAL STRUCTURAL WALLS

Requirements of ACI 21.9 for special structural walls are summarized in Table 6.4.⁶

6.5.1 Reinforcement Requirements

Special structural walls must have reinforcement in two orthogonal directions in the plane of the wall. The minimum reinforcement requirements of ACI 21.9.2.1 for longitudinal and transverse reinforcement follow from preceding codes.

Reinforcement that is provided for shear strength must be continuous and uniformly distributed across the shear plane. Uniform distribution of reinforcement across the height and horizontal length of the wall helps control the width of inclined cracks.

⁶ ACI 21.9 also contains requirements for coupling beams. Since coupling beams are typically not utilized in low-rise buildings, the requirements for these members are not covered here.

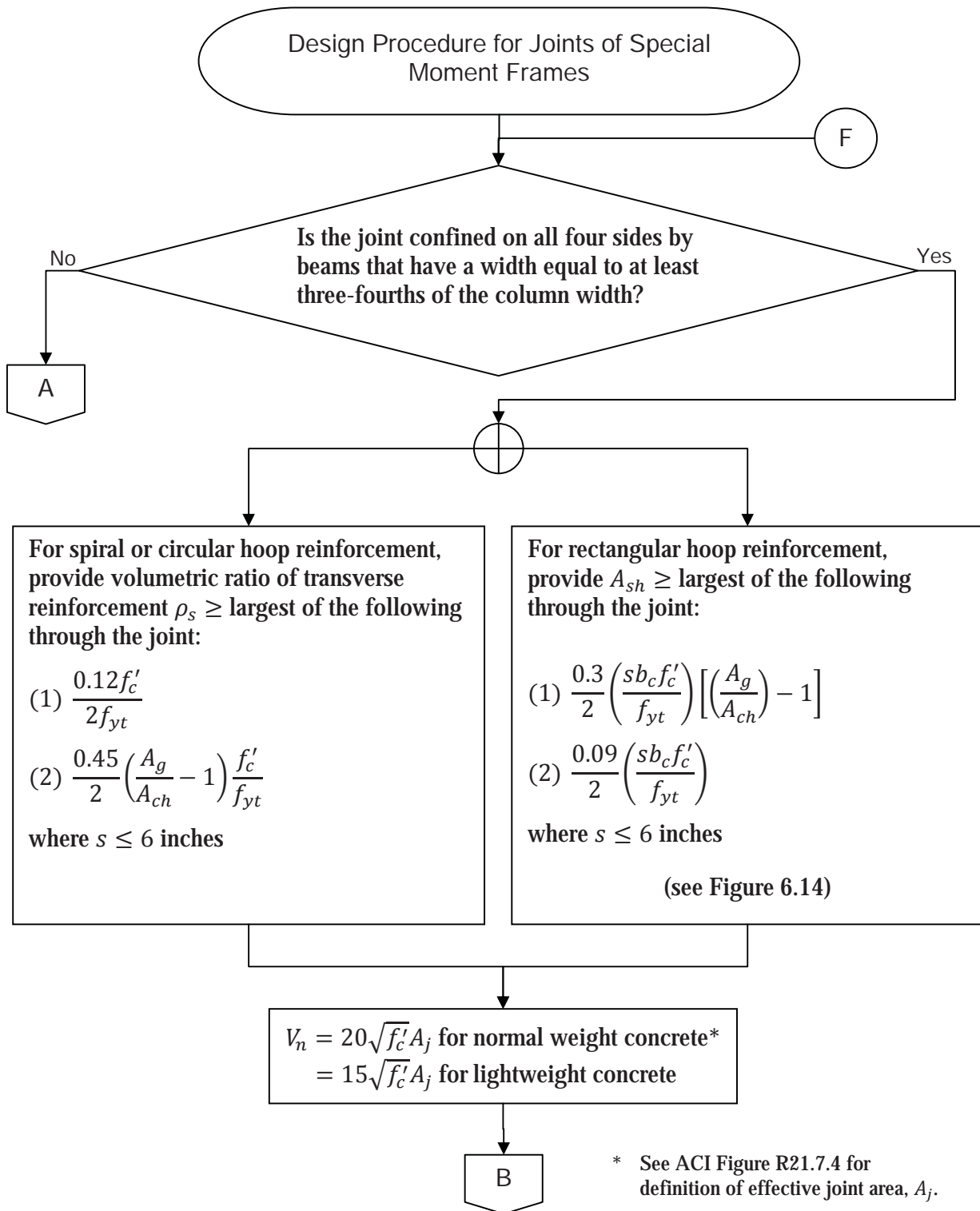

Figure 6.16 Design Procedure for Joints of Special Moment Frames

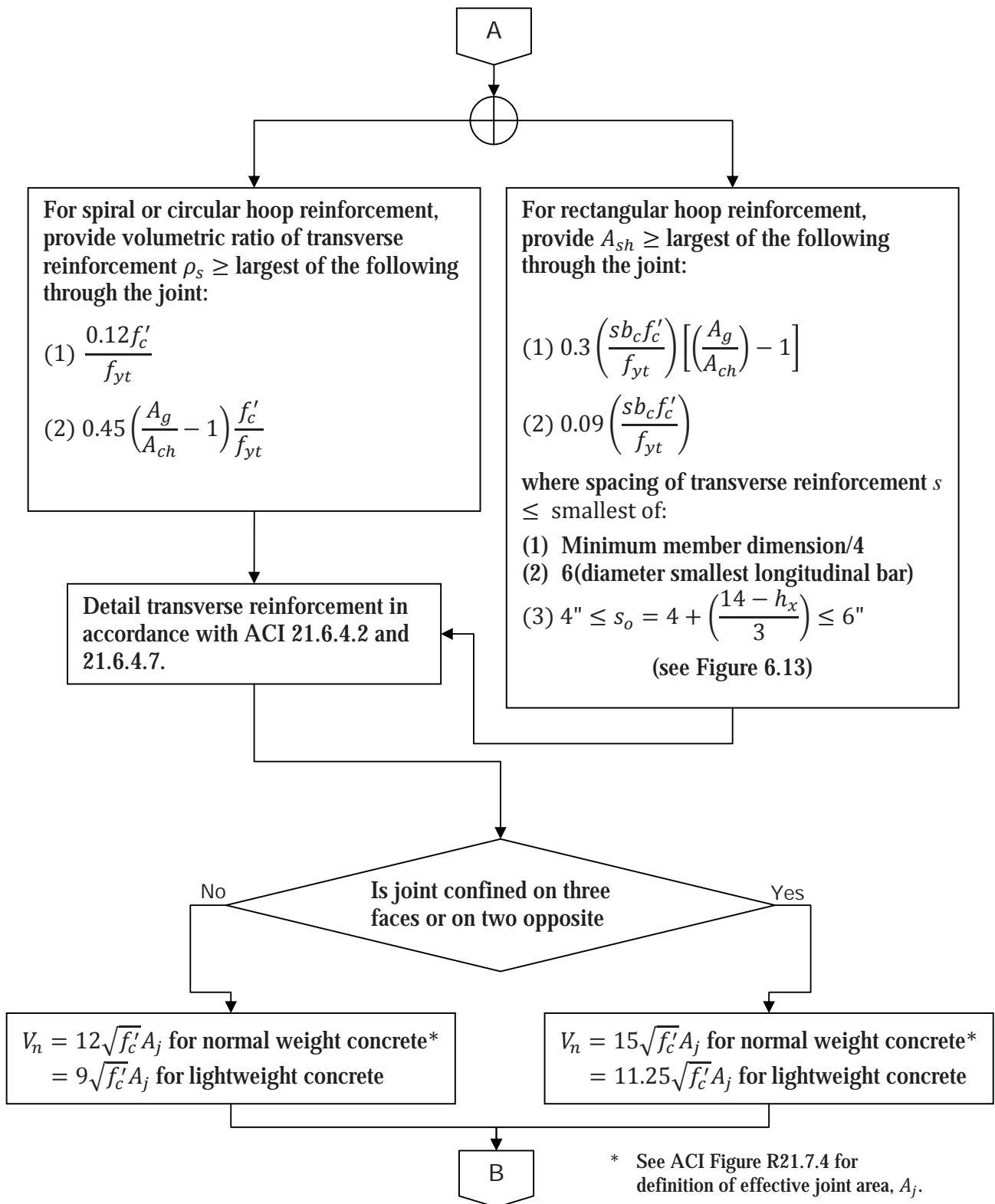

Figure 6.16 Design Procedure for Joints of Special Moment Frames (continued)

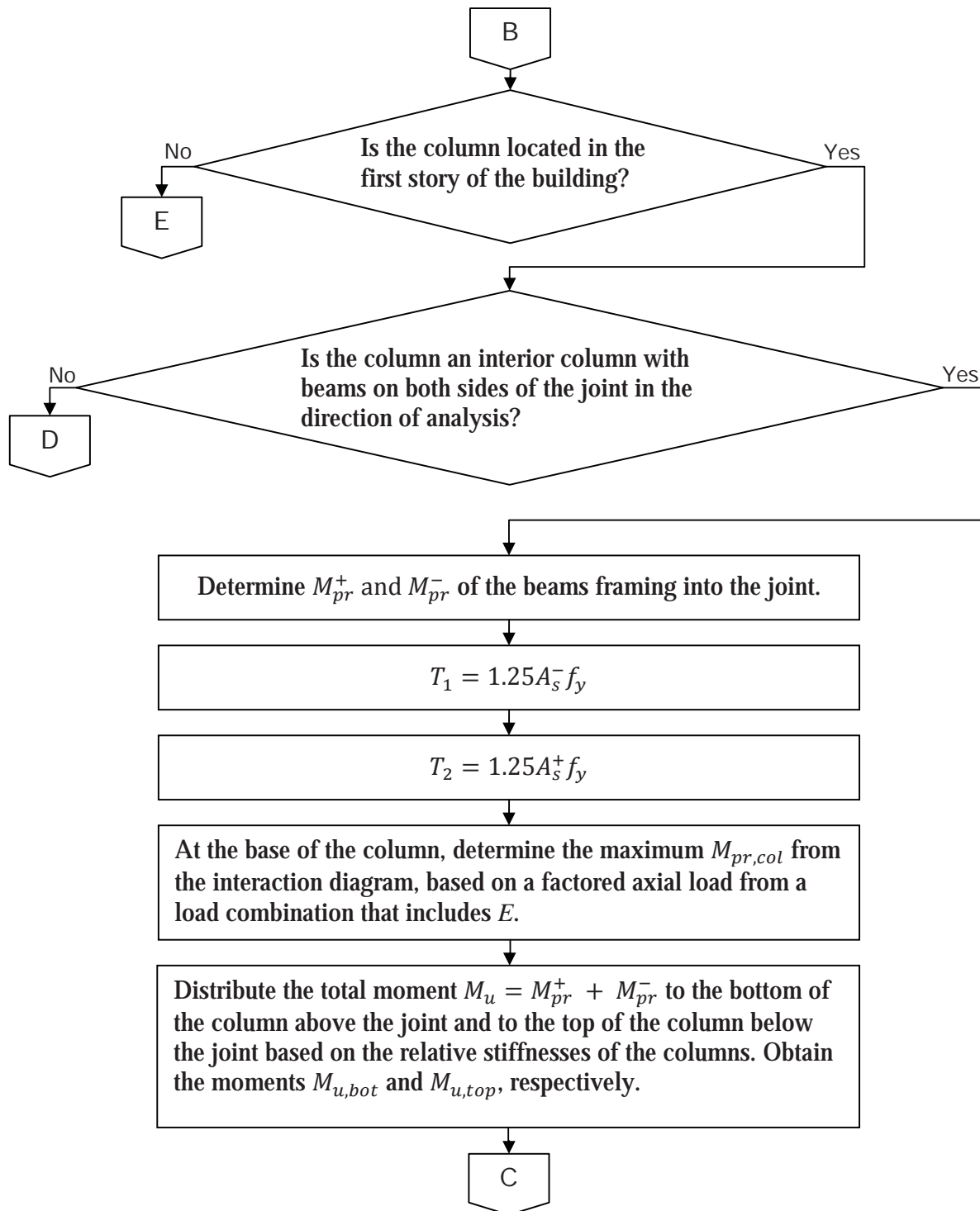

Figure 6.16 Design Procedure for Joints of Special Moment Frames (continued)

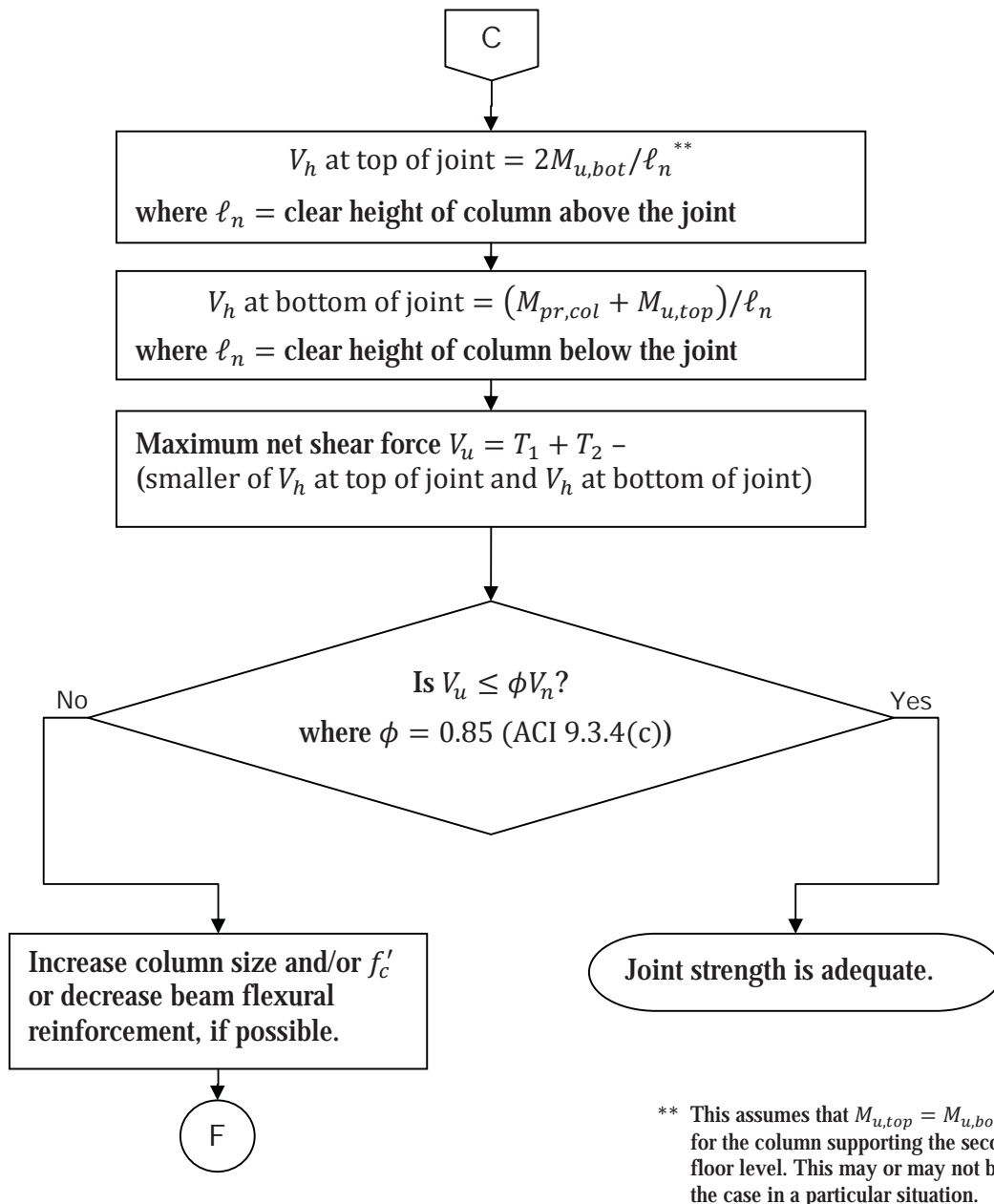

Figure 6.16 Design Procedure for Joints of Special Moment Frames (continued)

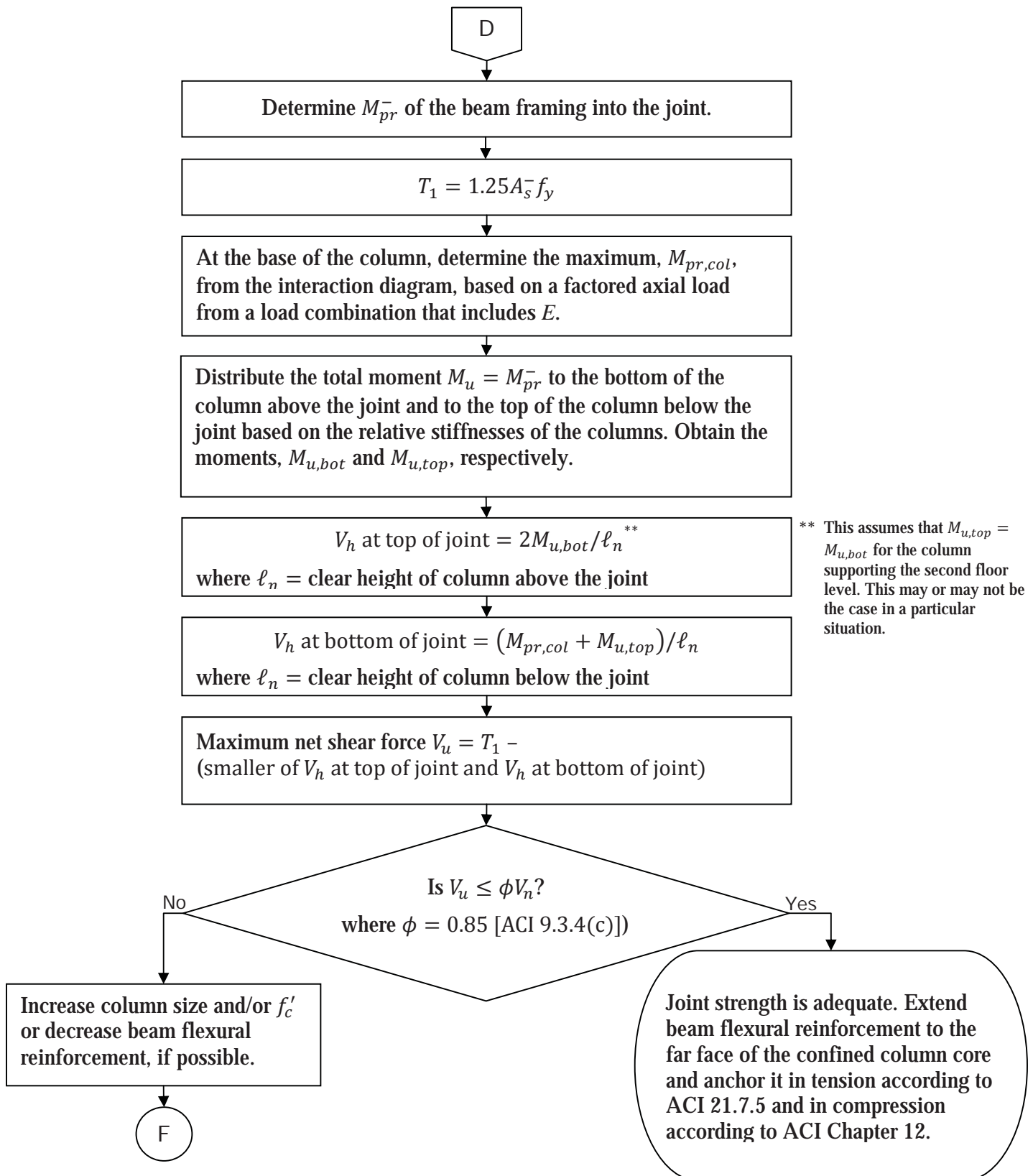

Figure 6.16 Design Procedure for Joints of Special Moment Frames (continued)

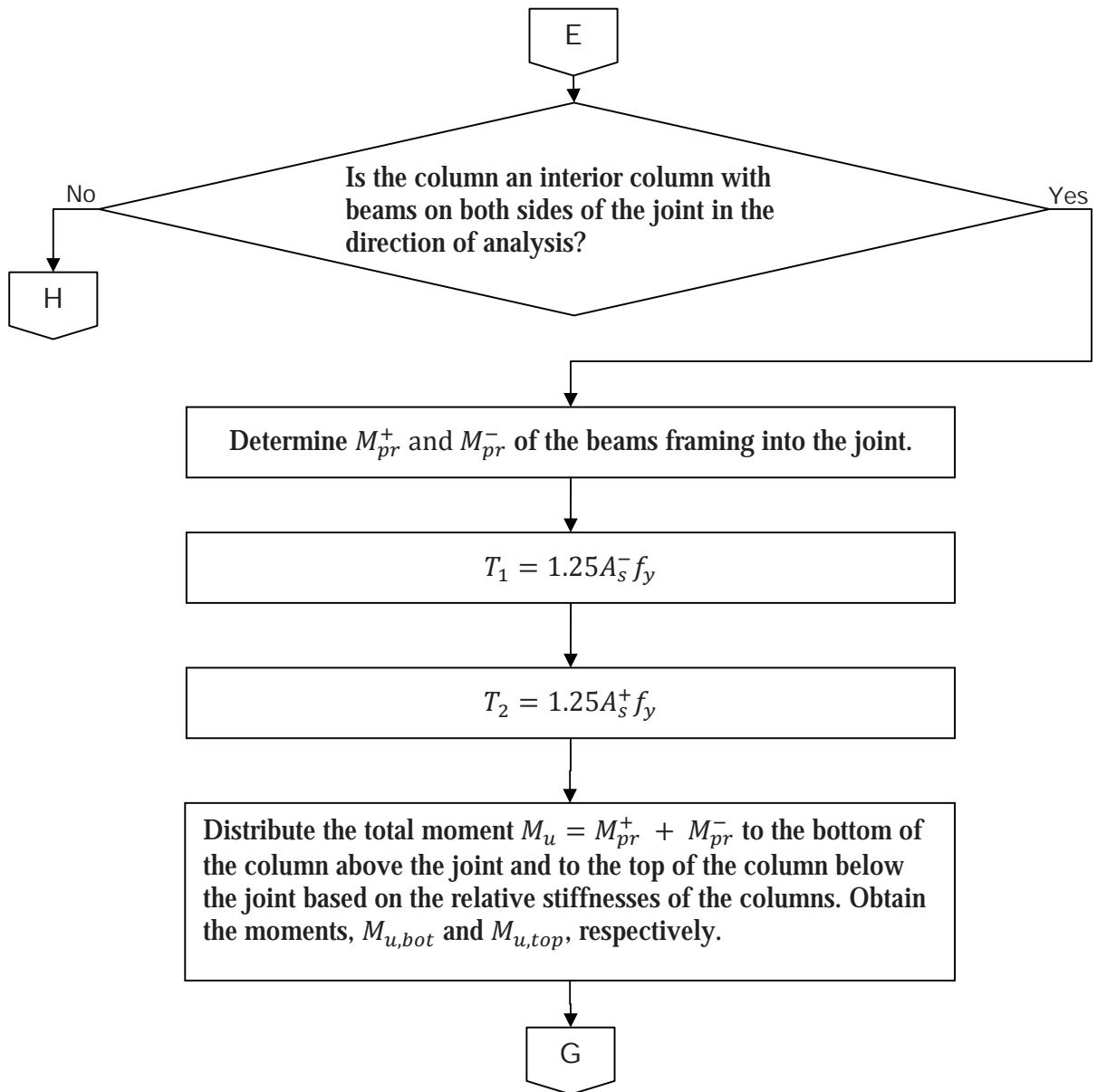

Figure 6.16 Design Procedure for Joints of Special Moment Frames (continued)

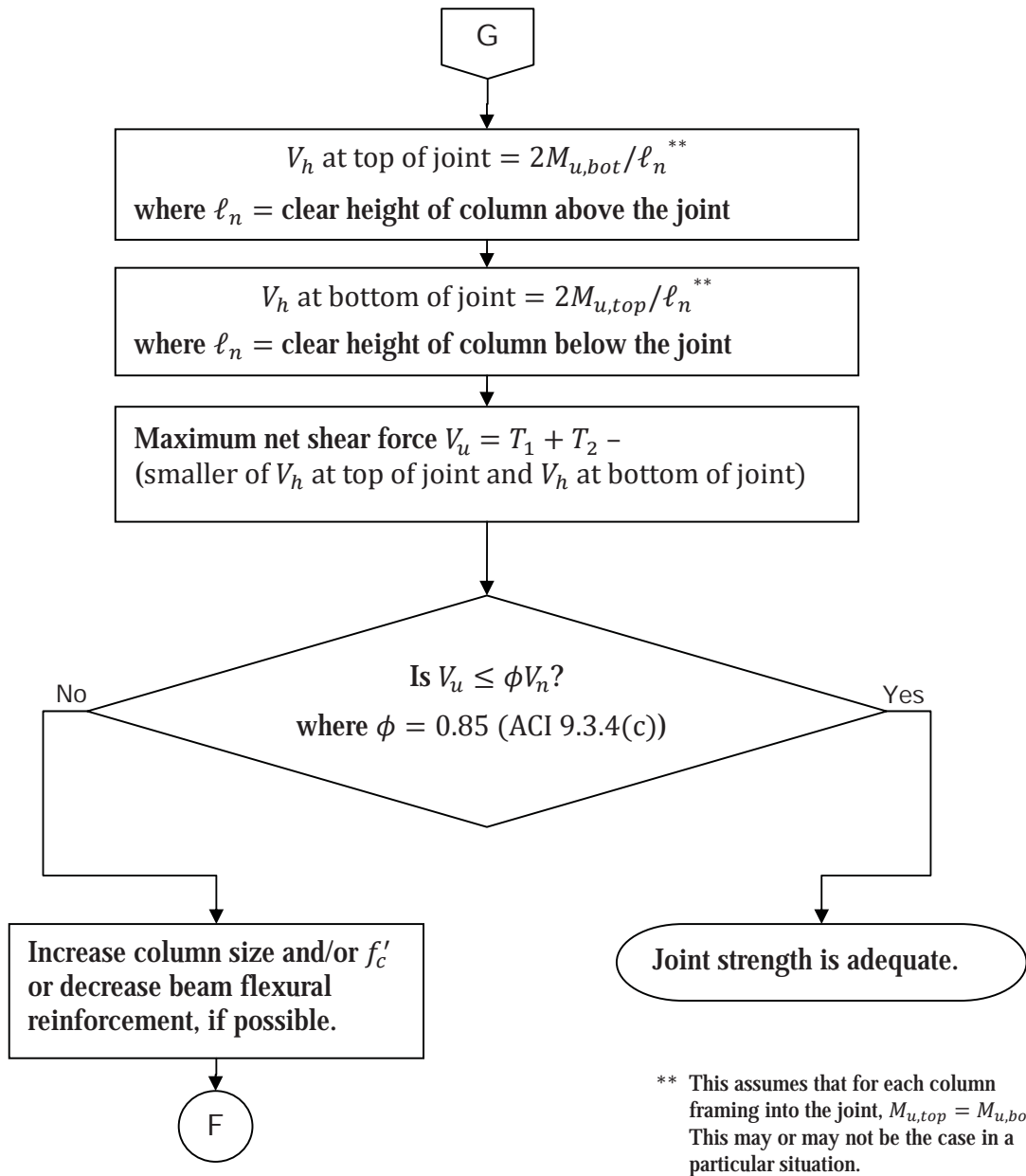
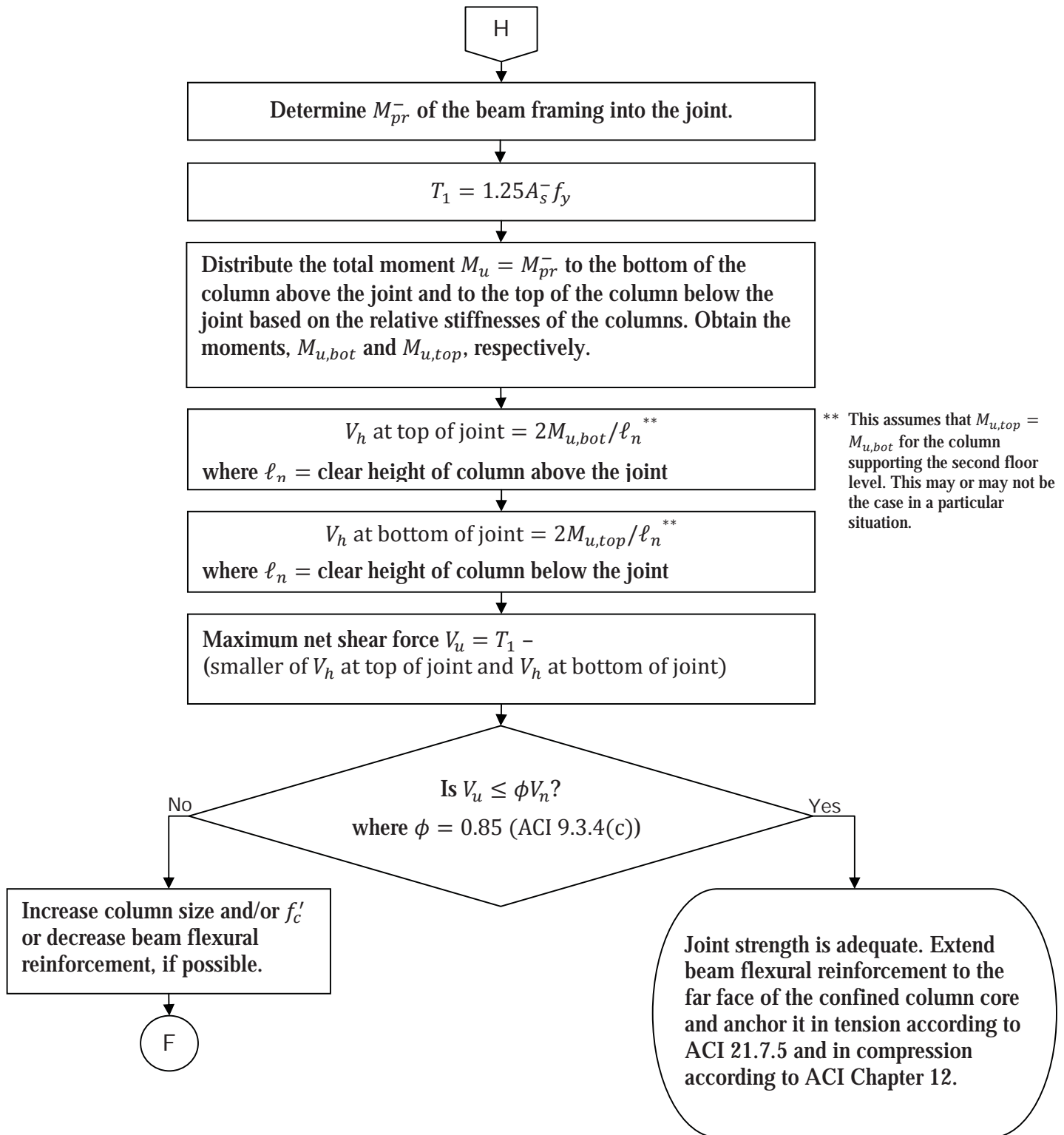

Figure 6.16 Design Procedure for Joints of Special Moment Frames (continued)



For SI: 1 inch = 25.4 mm.

Figure 6.16 Design Procedure for Joints of Special Moment Frames (continued)

Table 6.4 Summary of Requirements for Special Structural Walls

Requirement		ACI Section Number(s)
Reinforcement	Where $V_u > A_{cv}\lambda\sqrt{f'_c}$, distributed web reinforcement ratios, ρ_ℓ and ρ_t , must be greater than or equal to 0.0025. Where $V_u \leq A_{cv}\lambda\sqrt{f'_c}$, the minimum reinforcement ratio values of ACI 14.3 may be used. The spacing of reinforcement shall be less than or equal to 18 inches. Reinforcement shall be continuous and shall be distributed across the shear plane.	21.9.2.1
	Two curtains of reinforcement are required where $V_u > 2A_{cv}\lambda\sqrt{f'_c}$.	21.9.2.2
	Reinforcement shall be developed or spliced for f_y in tension in accordance with Chapter 12, except: (a) Effective depth may be taken as $0.8\ell_w$ (b) The requirements of ACI 12.11, 12.12 and 12.13 need not be satisfied. (c) Development lengths of longitudinal reinforcement shall be 1.25 times the values calculated for f_y in tension at locations where yielding of longitudinal reinforcement is likely to occur. (d) Mechanical and welded splices shall conform to ACI 21.1.6 and 21.1.7, respectively.	21.9.2.3
Shear Strength	The nominal shear strength shall not exceed that given by ACI Equation (21-7): $V_n = A_{cv}(\alpha_c\lambda\sqrt{f'_c} + \rho_t f_y)$ where $\alpha_c = 3$ for $h_w/\ell_w \leq 1.5$ $\alpha_c = 2$ for $h_w/\ell_w \geq 2.0$ α_c varies linearly between 3.0 and 2.0 for h_w/ℓ_w between 1.5 and 2.0	21.9.4.1
	The value of h_w/ℓ_w to be used when determining V_n by ACI Equation (21-7) for segments of a wall shall be the larger of the ratios for the entire wall and for the segment of wall considered.	21.9.4.2

(continued)

Table 6.4 Summary of Requirements for Special Structural Walls (continued)

	Requirement	ACI Section Number(s)
Shear Strength	Walls shall have distributed shear reinforcement in two orthogonal directions in the plane of the wall. Reinforcement ratio ρ_ℓ must be greater than or equal to reinforcement ratio ρ_t where $h_w/\ell_w \leq 2.0$.	21.9.4.3
	For all wall piers sharing a common lateral force, $V_n \leq 8A_{cv}\sqrt{f'_c}$.	21.9.4.4
	For any of the individual wall piers, $V_n \leq 10A_{cw}\sqrt{f'_c}$.	21.9.4.5
Flexure and Axial Loads	Structural walls and portions of structural walls subjected to combined flexure and axial loads shall be designed in accordance with ACI 10.2 and 10.3 except that the provisions of ACI 10.3.7 and the nonlinear strain requirements of ACI 10.2.2 shall not apply. Concrete and developed longitudinal reinforcement within effective flange widths, boundary elements and the wall web shall be considered effective. The effects of openings shall be considered.	21.9.5.1
	Effective flange widths of flanged sections shall extend from the face of the web a distance equal to the smaller of one-half the distance to an adjacent wall web and 25 percent of the total wall height, unless a more detailed analysis is performed.	21.9.5.2
Boundary Elements	The need for special boundary elements at the edges of structural walls shall be evaluated by ACI 21.9.6.2 or 21.9.6.3. The requirements of ACI 21.9.6.4 and 21.9.6.5 must also be satisfied.	21.9.6.1
	For walls or wall piers that are effectively continuous from the base of the structure to the top of the wall and that are designed to have a single critical section for flexure and axial loads, compression zones shall be reinforced with special boundary elements where $c \geq \frac{\ell_w}{600(\delta_u/h_w)}$ The special boundary element reinforcement shall extend vertically from the critical section a distance \geq the larger of ℓ_w or $M_u/4V_u$.	21.9.6.2
	Where walls are not designed to the provisions of ACI 21.9.6.2, special boundary elements are required at boundaries and edges around openings where the maximum extreme fiber compressive stress corresponding to load combinations including E exceeds $0.2f'_c$. Special boundary elements may be discontinued where the compressive stress is less than $0.15f'_c$. Stresses shall be calculated using a linearly elastic model and gross section properties.	21.9.6.3

(continued)

Table 6.4 Summary of Requirements for Special Structural Walls (continued)

	Requirement	ACI Section Number(s)
Boundary Elements (continued)	<p>Where special boundary elements are required by ACI 21.9.6.2 or 21.9.6.3, the following shall be satisfied:</p> <ul style="list-style-type: none"> (a) Boundary elements shall extend horizontally from the extreme compression fiber a distance greater than or equal to the larger of $c - 0.1\ell_w$ and $c/2$. (b) In flanged sections, the boundary element shall include the effective flange width and shall extend at least 12 inches into the web. (c) The boundary element transverse reinforcement shall satisfy ACI 21.6.4.2 through 21.6.4.4 except ACI Equation (21-4) need not be satisfied and the transverse reinforcement spacing limit of ACI 21.6.4.3(a) shall be one-third of the least dimension of the boundary element. (d) Boundary element transverse reinforcement at the base of the wall shall extend into the support at least the tension development length determined by ACI 21.9.2.3 of the largest longitudinal bar in the boundary element. Where special boundary elements terminate on a footing or mat, transverse reinforcement shall extend at least 12 inches into the footing or mat. (e) Horizontal reinforcement in the web of the wall shall be anchored to develop the specified yield strength of the reinforcement within the confined core of the boundary element. 	21.9.6.4
	<p>Where special boundary elements are not required by ACI 21.9.6.2 or 21.9.6.3, the following shall be satisfied:</p> <ul style="list-style-type: none"> (a) Boundary transverse reinforcement shall satisfy ACI 21.6.4.2 and 21.9.6.4(a) where the longitudinal reinforcement ratio at the wall boundary is greater than $400/f_y$. Longitudinal spacing of transverse reinforcement in the boundary shall be less than or equal to 8 inches. (b) Where $V_u \geq A_{cv}\lambda\sqrt{f'_c}$, horizontal reinforcement terminating at the edges of structural walls without boundary elements shall have a standard hook engaging the edge reinforcement or the edge reinforcement shall be enclosed in U-stirrups having the same size and spacing as, and spliced to, the horizontal reinforcement. 	21.9.6.5

For SI: 1 inch = 25.4 mm.

For walls that are subjected to substantial in-plane design shear forces (i.e., $V_u > 2A_{cv}\lambda\sqrt{f'_c}$), two layers of reinforcement must be provided. This serves to reduce fragmentation and premature deterioration of the concrete when the wall is subjected to load reversals into the inelastic range.

Reinforcement in structural walls must be developed or spliced in accordance with the provisions of ACI Chapter 12 (ACI 21.9.2.3). Since the actual force in the reinforcing bars may exceed the calculated forces, the reinforcement must be developed or spliced for the specified yield strength in tension.

At locations where yielding of the reinforcement is expected, the development lengths obtained by ACI Chapter 12 must be increased by a factor of 1.25 to account for the likelihood that the actual yield strength exceeds the specified yield strength and for strain hardening and cyclic load reversals.

Development lengths may be reduced as permitted in ACI 12.2 and 12.5 where closely spaced transverse reinforcement is utilized.

6.5.2 Shear Strength Requirements

The nominal shear strength of structural walls is given in ACI Equation (21-7). This equation recognizes that walls with high shear-to-moment ratios have higher shear strength.

Horizontal and vertical shear reinforcement must be appropriately distributed along the height and length of a wall to effectively restrain inclined cracks. Within practical limits, shear reinforcement should be uniformly distributed at a relatively small spacing. The reinforcement ratio ρ_ℓ shall be greater than or equal to the reinforcement ratio ρ_t where the overall wall height to length ratio h_w/ℓ_w is less than or equal to 2. Any concentrated chord reinforcement near wall edges provided primarily for resisting bending moments is not to be included when computing ρ_ℓ and ρ_t .

6.5.3 Flexure and Axial Load Requirements

Structural walls and portions of structural walls subjected to combined bending moments and axial loads are to be designed in accordance with the provisions of ACI 10.2 and 10.3 except that the nonlinear strain requirements of ACI 10.2.2 for deep members and the requirements of ACI 10.3.7 shall not apply. This design procedure is essentially the same as that used for columns subjected to bending moments and axial loads.

All reinforcement in the wall, including that in the boundary elements, web and effective flange widths as defined in ACI 21.9.5.2, must be included in the strain compatibility analysis of the wall. Openings in walls must also be considered.

6.5.4 Boundary Element Requirements

Boundary elements and corresponding detailing requirements may be required at the edges of structural walls to provide adequate confinement of the concrete at these locations. Two design approaches for evaluating the need of boundary elements are provided in ACI 21.9.6 and are discussed below.

ACI 21.9.6.2 permits the use of a displacement-based approach, which is applicable to walls or wall piers that are effectively continuous in cross-section over the entire height of the wall and designed to have one critical section for flexure and axial loads.⁷ The provisions of ACI 21.9.6.2 are summarized in Figure 6.17.

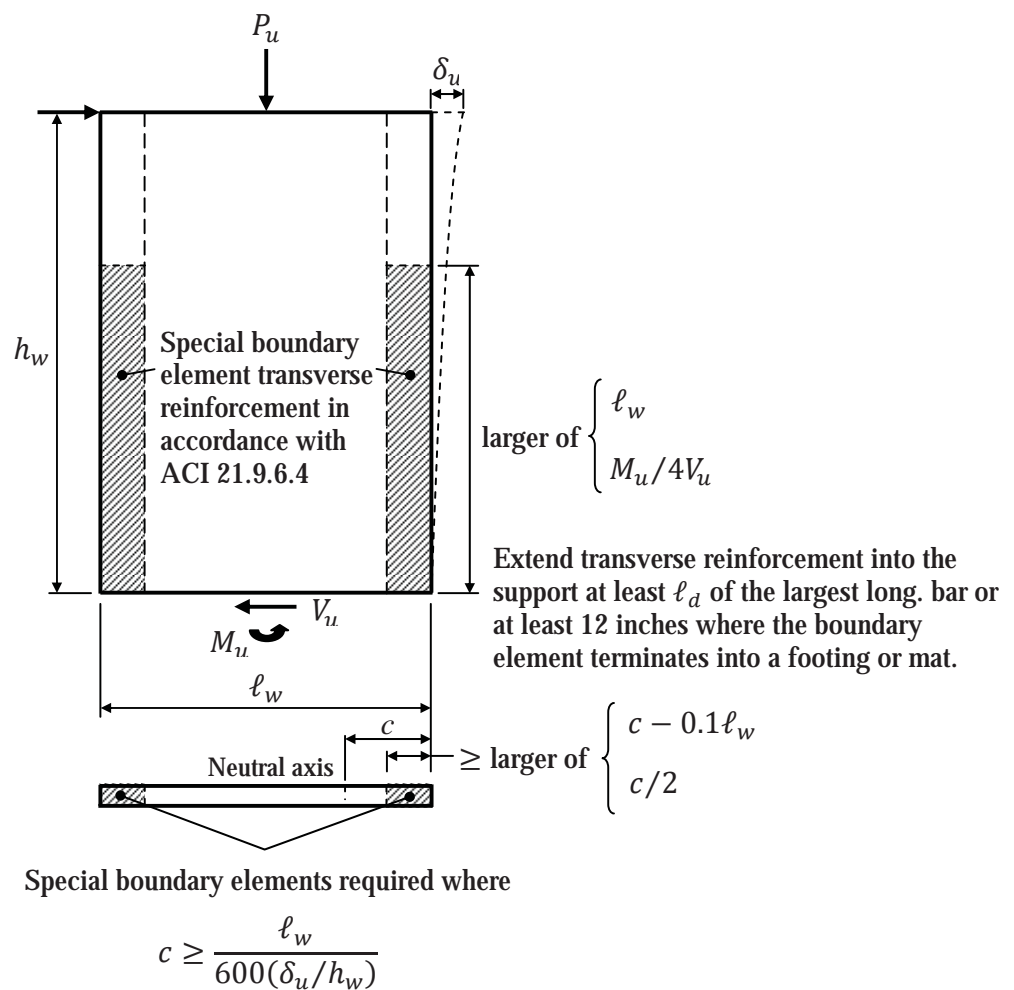

For SI: 1 inch = 25.4 mm.

Figure 6.17 Special Boundary Element Requirements of ACI 21.9.6.2

⁷These types of walls are common in low-rise concrete buildings.

Boundary elements are required to confine the concrete where the strain at the extreme compression fiber of the wall exceeds a critical value when the wall is subjected to the design displacement [see ACI Equation (21-8)]. The horizontal dimension of the boundary element extends over the length where the compression strain exceeds the critical value. The height of the boundary element is based on upper bound estimates of plastic hinge length and extends beyond the zone over which spalling is likely to occur. Boundary elements do not necessarily require an increase in wall thickness.

The second approach for evaluating the need of boundary elements is in ACI 21.9.6.3. These provisions, which are summarized in Figure 6.18, are conservative for assessing the need for transverse reinforcement at wall boundaries and at edges around openings for many types of walls. This approach must be used when walls do not satisfy the limitations of ACI 21.9.6.2.

The detailing requirements of ACI 21.9.6.4 must be satisfied where boundary elements are required by ACI 21.9.6.2 or 21.9.6.3. These requirements are illustrated in Figure 6.19 for walls without columns at the ends.

The required transverse reinforcement is the same as that for special moment frame members subjected to bending and axial load, except ACI Equation (21-4) need not be satisfied and the transverse reinforcement spacing limit of ACI 21.6.4.3(a) must be less than or equal to one-third of the least dimension of the boundary element.

Horizontal reinforcement in the wall web must be anchored within the confined core of the boundary element to develop its specified yield strength. To achieve this anchorage, standard 90-degree (1.57 rad) hooks or mechanical anchorage schemes are recommended in lieu of straight bar development.

Special transverse reinforcement at the ends of a wall may be necessary, even though boundary elements are not required according to ACI 21.9.6.2 or 21.9.6.3. For walls with moderate amounts of boundary longitudinal reinforcement, transverse reinforcement is required to help prevent buckling of the longitudinal reinforcement due to cyclic load reversals. The longitudinal reinforcement ratio includes only the reinforcement at the wall boundary as indicated in Figure 6.20 for the case where reinforcing bars are provided at the end of the wall that are larger than the uniformly distributed web longitudinal reinforcement (left portion of figure) and where uniformly distributed longitudinal bars of the same size and spacing are provided throughout the length of the wall (right portion of figure).

Hooks or U-stirrups at the ends of horizontal wall reinforcement are required to provide anchorage of the reinforcement so that it can effectively resist shear forces, and to help prevent buckling of vertical edge reinforcement. Development of horizontal reinforcement is not necessary for walls with relatively low in-plane shear forces.

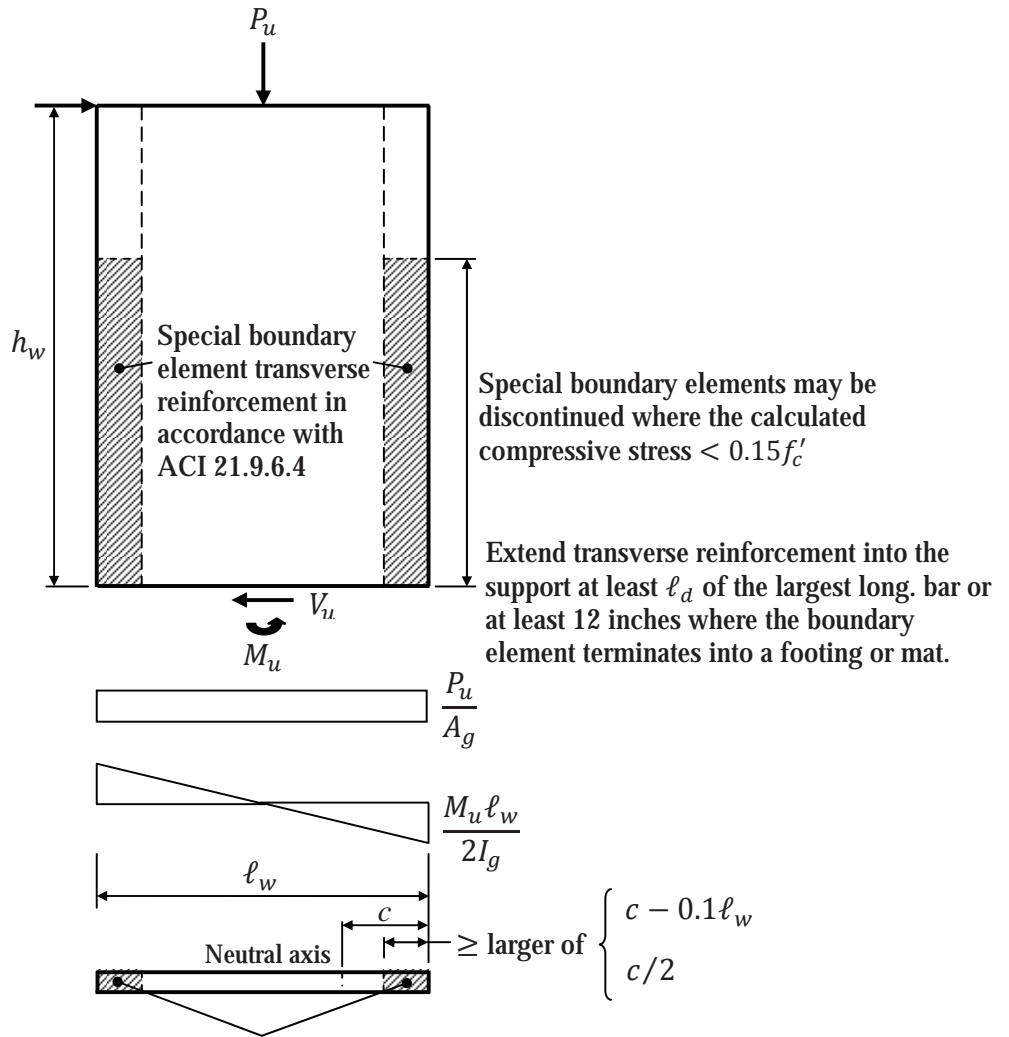

Special boundary elements required where

$$\frac{P_u}{A_g} + \frac{M_u \ell_w}{2I_g} > 0.2f'_c$$

For SI: 1 inch = 25.4 mm.

Figure 6.18 Special Boundary Element Requirements of ACI 21.9.6.3

IBC 1908.1.4 modifies ACI 21.9 by adding a new Section 21.9.10, which contains requirements for wall piers and wall segments.⁸ Wall piers that are not designated to be part of a special moment frame must have transverse reinforcement that satisfies the requirements in new Section 21.9.10.2. Walls segments with a horizontal length-to-thickness ratio less than 2.5 are to be designed as columns (new Section 21.9.10.3).

⁸IBC 1908.1.1 modifies ACI 2.2 by including a definition for a wall pier: a wall pier is defined as a wall segment that has a horizontal length-to-thickness ratio of at least 2.5, but not exceeding 6, whose clear height is at least two times its horizontal length.

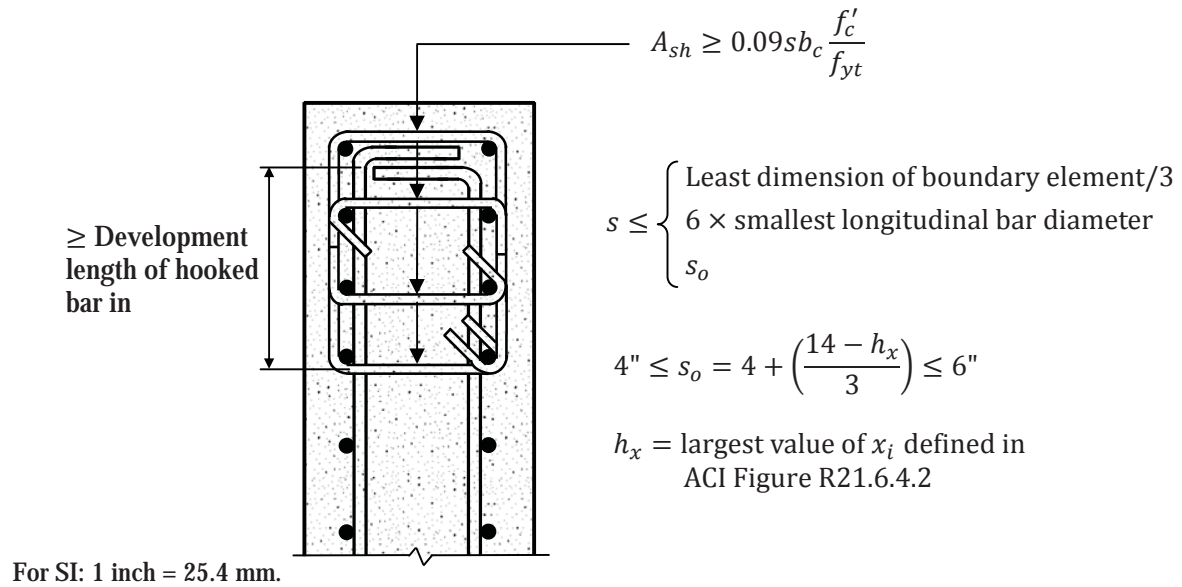

Figure 6.19 Reinforcement Details Where Special Boundary Elements Are Required (ACI 21.9.6.4)

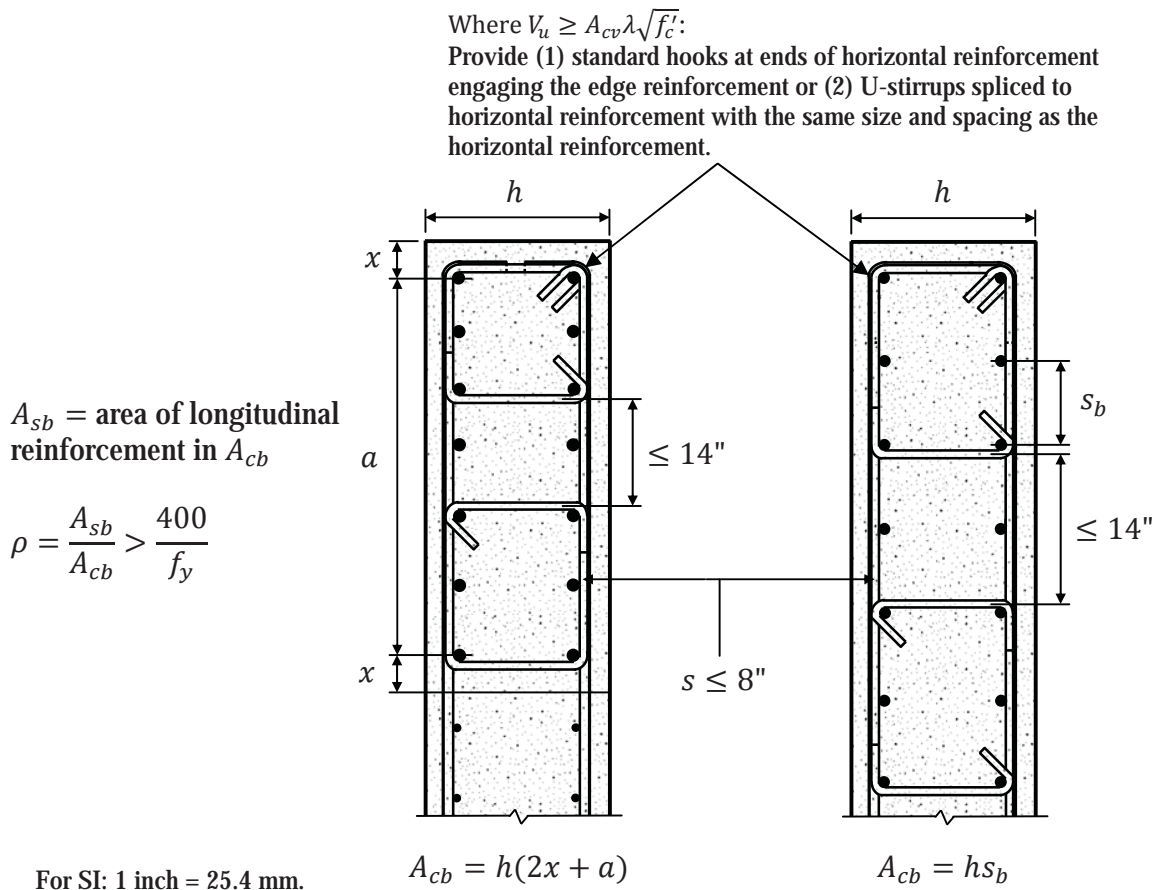

Figure 6.20 Reinforcement Details where Special Boundary Elements Are Not Required and $\rho > 400/f_y$ (ACI 21.9.6.5)

A summary of the overall design procedure for special structural walls is given in Figure 6.21.

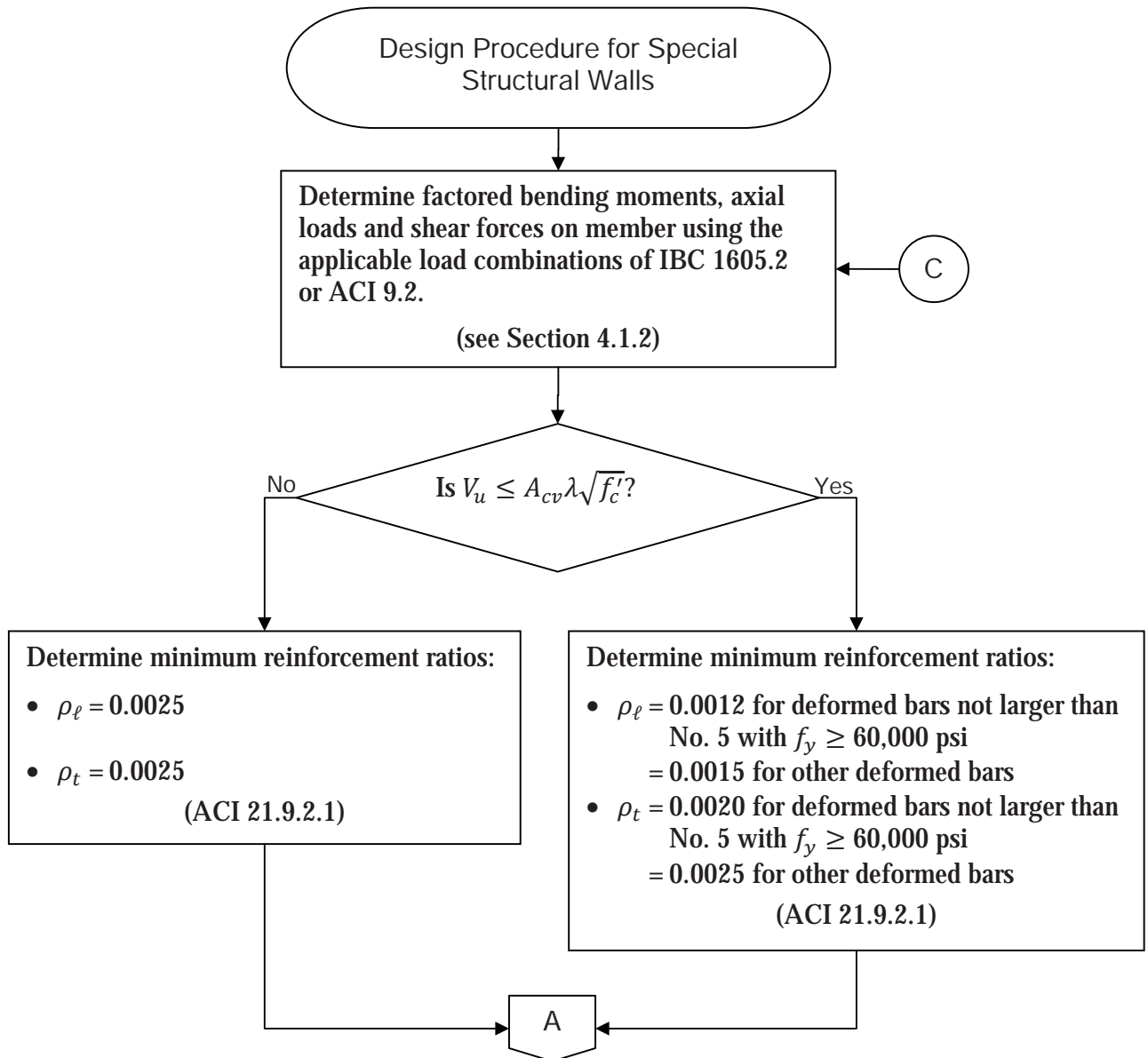

Figure 6.21 Design Procedure for Special Structural Walls

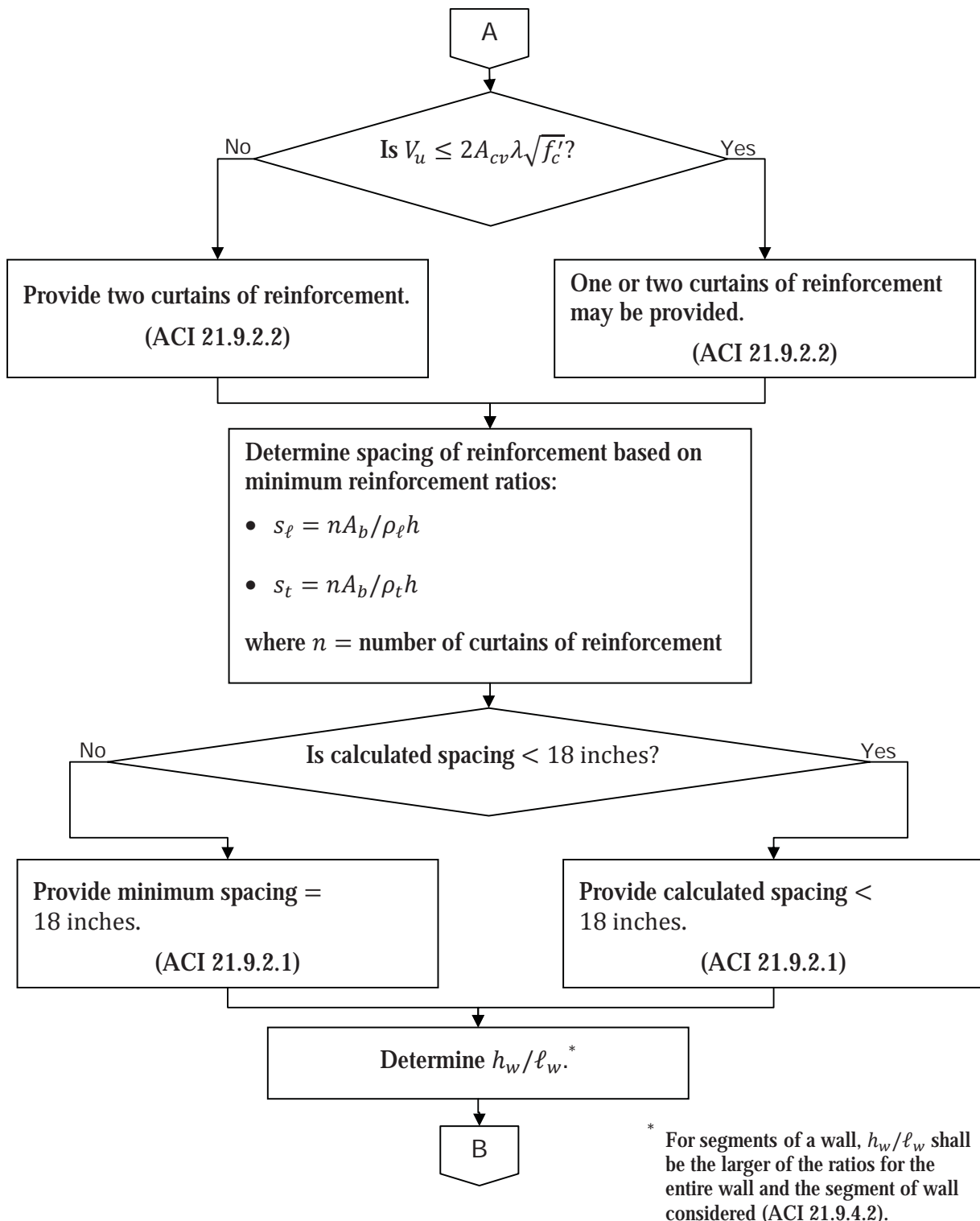

Figure 6.21 Design Procedure for Special Structural Walls (continued)

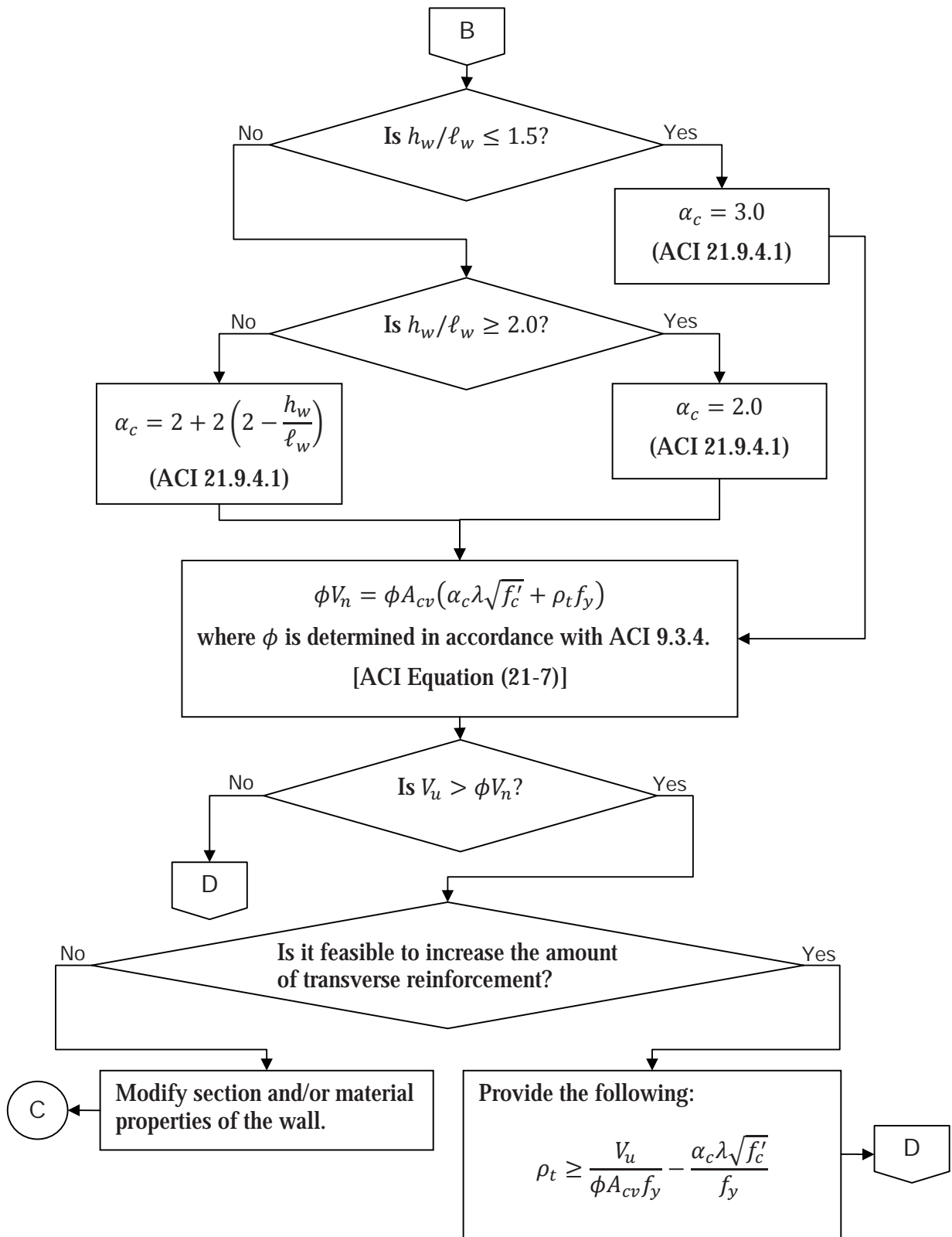

Figure 6.21 Design Procedure for Special Structural Walls (continued)

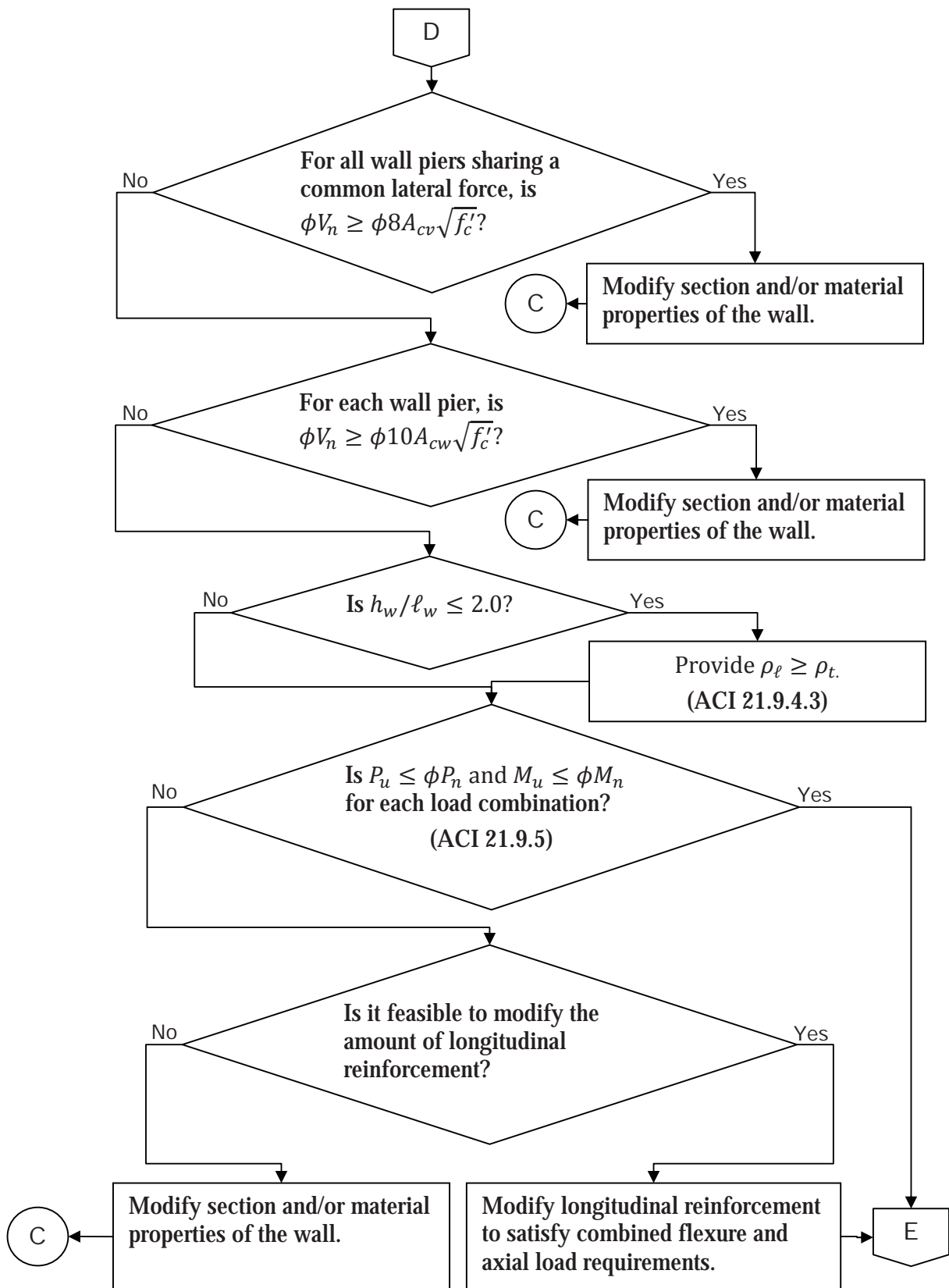

Figure 6.21 Design Procedure for Special Structural Walls (continued)

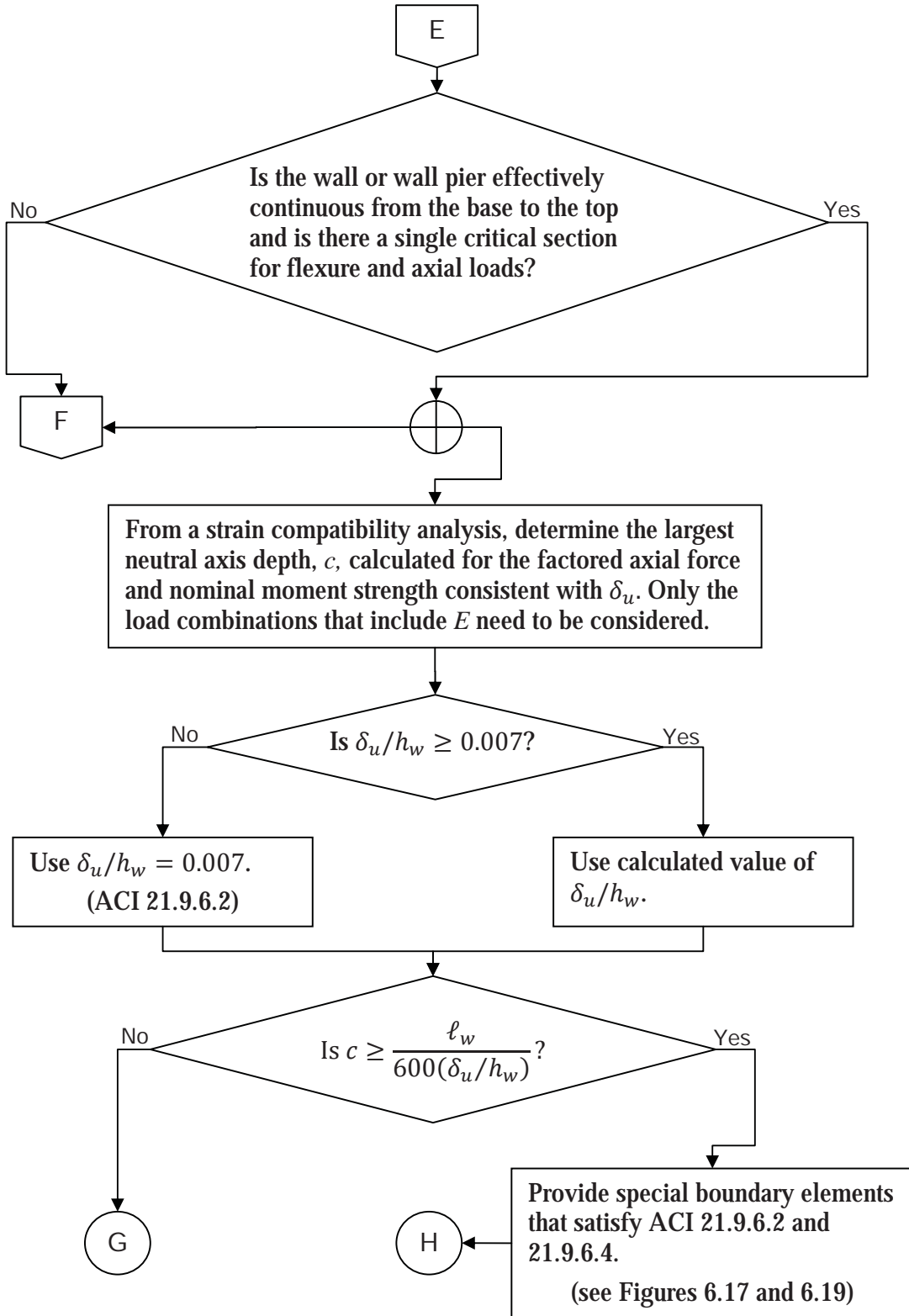
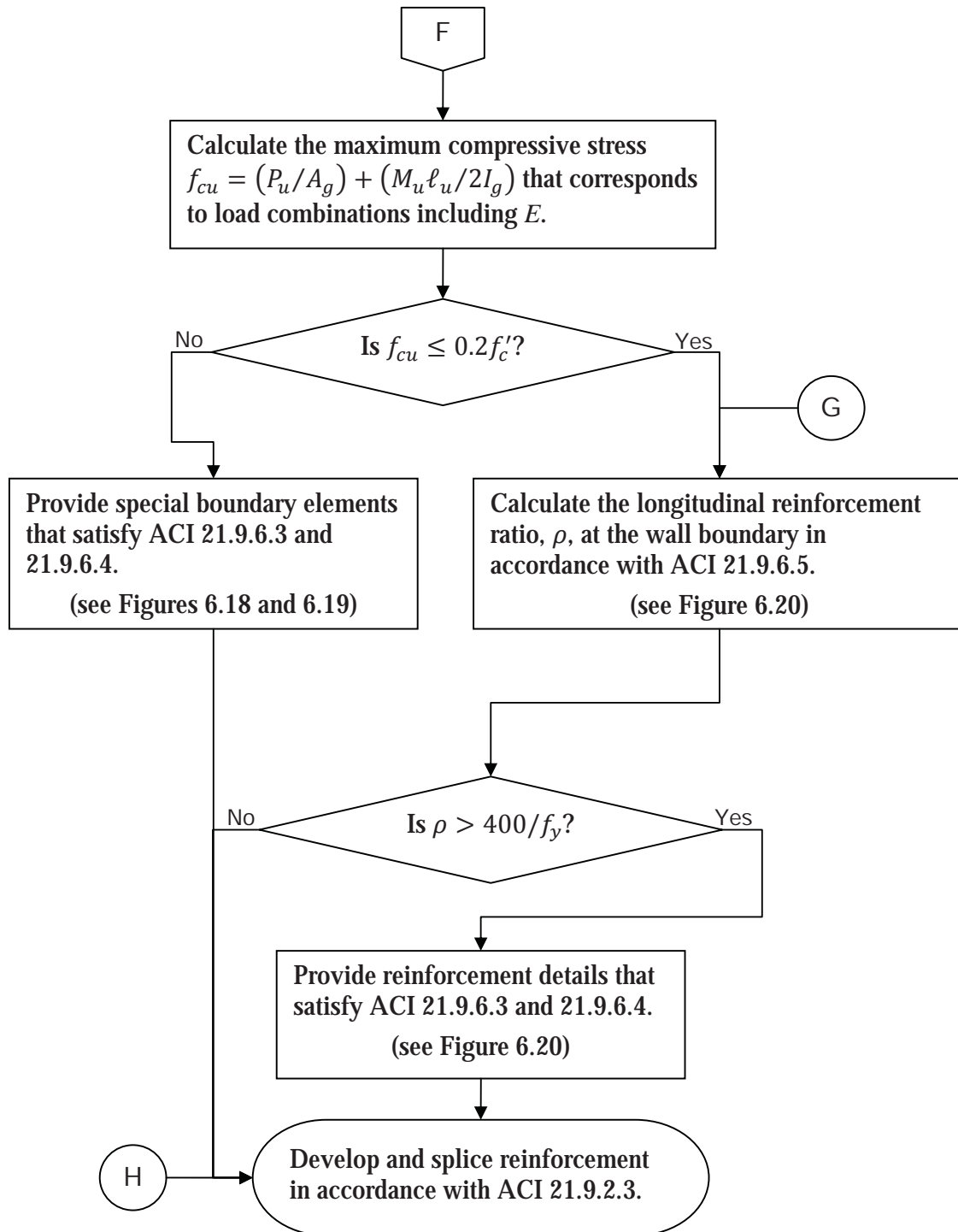

Figure 6.21 Design Procedure for Special Structural Walls (continued)



For SI: 1 inch = 25.4 mm.

Figure 6.21 Design Procedure for Special Structural Walls (continued)

6.6 STRUCTURAL DIAPHRAGMS

Requirements of ACI 21.11 for structural diaphragms are summarized in Table 6.5. As noted in Chapter 3, diaphragms and their components transfer lateral forces to the elements of the seismic-force-resisting system (also see ACI 21.11.3 and ACI Figure R21.11.3.2).

Table 6.5 Summary of Requirements for Structural Diaphragms

	Requirement	ACI Section Number(s)
Minimum Thickness	Concrete slabs serving as diaphragms used to transmit earthquake forces must be greater than or equal to 2 inches thick.	21.11.6
Reinforcement	Minimum reinforcement shall be in accordance with ACI 7.12.	21.11.7.1
	Spacing of reinforcement shall be less than or equal to 18 inches.	
	Reinforcement provided for shear strength shall be continuous and distributed uniformly across the shear plane.	
	All reinforcement used to resist collector forces, diaphragm shear or flexural tension shall be developed or spliced for the specified yield strength of the reinforcement in tension.	21.11.7.3
	Where mechanical splices are used to transfer forces between the diaphragm and the vertical elements of the seismic-force-resisting system, Type 2 splices are required.	21.11.7.4
	Transverse reinforcement in accordance with ACI 21.9.6.4(c) is required over the length of collector elements and other elements around openings or other discontinuities in diaphragms where the compressive strength exceeds $0.2f'_c$. Specified transverse reinforcement is permitted to be discontinued where the compressive stress is less than $0.15f'_c$. Where design forces have been amplified to account for the overstrength of the vertical elements of the seismic-force-resisting system, the limit of $0.2f'_c$ shall be increased to $0.5f'_c$ and the limit of $0.15f'_c$ shall be increased to $0.4f'_c$.	21.11.7.5, 21.11.3.2

(continued)

Table 6.5 Summary of Requirements for Structural Diaphragms (continued)

Requirement		ACI Section Number(s)
Reinforcement (continued)	Longitudinal reinforcement for collector elements and other elements around openings or other discontinuities in diaphragms at splices and anchorage zones shall have either:	21.11.7.6
	(a) A minimum center-to-center spacing of 3 longitudinal bar diameters, but not less than 1.5 inches and a minimum clear cover of 2.5 longitudinal bar diameters, but not less than 2 inches. (b) Transverse reinforcement as required by ACI 11.4.6.3, except as required in ACI 21.11.7.5.	
Flexural Strength	Diaphragms and portions of diaphragms shall be designed for flexure in accordance with ACI 10.2 and 10.3 except the nonlinear distribution of strain requirements of ACI 10.2.2 for deep beams need not apply. Effects of openings must also be considered.	21.11.8
Shear strength	Nominal shear strength V_n of structural diaphragms shall not exceed that given by ACI Equation (21-10): $V_n = A_{cv}(2\lambda\sqrt{f'_c} + \rho_t f_y)$	21.11.9.1
	Nominal shear strength V_n shall not exceed $8A_{cv}\sqrt{f'_c}$.	21.11.9.2

For SI: 1 inch = 25.4 mm.

6.6.1 Minimum Thickness Requirements

The minimum thickness of diaphragms prescribed in ACI 21.11.4 reflects current practice in concrete joist and waffle slab floor systems. Requirements for fire resistance will usually call for concrete slab thicknesses greater than 2 inches (51 mm).

6.6.2 Reinforcement Requirements

Provisions for minimum reinforcement in diaphragms are the same as those required in ACI 7.12 for temperature and shrinkage reinforcement. The maximum spacing of 18 inches (457 mm) is intended to control the width of inclined cracks that may form during a design-basis event.

All reinforcement in the diaphragm and its components must be developed and spliced for tension in accordance with the applicable provisions of ACI Chapter 12. A reduction in the development length or splice length in accordance with the excess reinforcement requirements of ACI 12.2.5 is not permitted.

Collector elements must contain the same transverse reinforcement as boundary elements in special structural walls at any section where the compressive stress, based on factored forces using a linearly elastic model and gross section properties, exceeds $0.5f'_c$. Such

transverse reinforcement is no longer required where the calculated compressive stress is less than $0.4f'_c$.⁹

The reinforcement details prescribed in ACI 21.11.7.6 at splices and anchorage zones of longitudinal reinforcement in collector elements is intended to reduce the possibility of longitudinal bar buckling and to provide adequate bar development conditions.

Elements around openings, diaphragm edges and at other discontinuities in diaphragms must comply with the aforementioned requirements for collectors in ACI 21.11.7.5 and 21.11.7.6.

6.6.3 Flexural Strength Requirements

Diaphragms are designed using the same assumptions as those for beams, columns and walls, except that the nonlinear distribution of strain for deep beams need not be considered.

The influence of slab openings on flexural and shear strength must also be considered.

6.6.4 Shear Strength Requirements

The shear strength requirements for monolithic diaphragms in ACI Equation (21-10) are similar to those for slender structural walls and are based on the shear provisions for beams. In this equation, the term A_{cv} refers to the thickness times the width of the diaphragm, which corresponds to the gross area of the deep beam that forms the diaphragm. Shear reinforcement should be placed perpendicular to the flexural reinforcement.

Design requirements for diaphragms and collectors are illustrated in the example at the end of this chapter.

6.7 FOUNDATIONS

Requirements of ACI 21.12 for foundations are summarized in Table 6.6. The provisions for piles, drilled piers, caissons and slab-on-ground supplement other criteria in ACI 318 (see ACI 1.1.6 and 1.1.7).

IBC 1908 1.6 modifies ACI 21.12.1.1 by requiring that the foundation requirements of ACI 21.12 be modified by the applicable provisions in IBC Chapter 18. For structures assigned to SDC D, E and F, the provisions of ACI 21.12.1 through 21.12.4 are applicable as long as they are not in conflict with the provisions in IBC 1808 through 1810.

⁹ ASCE/SEI 12.10.2.1 requires that collectors, splices and their connections in structures assigned to SDC C through F be designed to resist the load combinations with overstrength of ASCE/SEI 12.4.3.2. The limits of $0.5f'_c$ and $0.4f'_c$ are applicable in such cases. Otherwise, the limits are $0.2f'_c$ and $0.15f'_c$.

Table 6.6 Summary of Requirements for Foundations

	Requirement	ACI Section Number(s)
Footings, Foundation Mats and Pile Caps	Longitudinal reinforcement of columns and structural walls resisting forces induced by earthquake effects shall extend into the footing, mat or pile cap, and shall be fully developed for tension at the interface.	21.12.2.1
	Columns designed assuming fixed-end conditions at the foundation shall satisfy the requirements of ACI 21.12.2.1. If hooks are required at the ends of the longitudinal reinforcement, the hooks shall have a 90-degree bend and shall be located near the bottom of the foundation with the free end of the bars oriented toward the center of the column.	21.12.2.2
	Transverse reinforcement in accordance with ACI 21.6.4.2 through 21.6.4.4 shall be provided below the top of a footing where columns or boundary elements of special structural walls have an edge located within one-half the footing depth from an edge of a footing. The transverse reinforcement shall extend into the footing, mat or pile cap and be developed for the specified yield strength of the reinforcement in tension.	21.12.2.3
	Flexural reinforcement shall be provided in the top of a footing, mat or pile cap supporting columns or boundary elements of special structural walls that are subjected to uplift forces from earthquake effects. Provided flexural reinforcement must be greater than or equal to that required by ACI 10.5.	21.12.2.4
	Structures assigned to SDC D, E and F shall not have foundation elements of structural plain concrete, except for those cases provided in ACI 22.10.1.	21.12.2.5
Grade Beams and Slabs-on- ground	Grade beams acting as horizontal ties between pile caps or footings shall have continuous longitudinal reinforcement that shall be developed within or beyond the supported column. At all discontinuities, the longitudinal reinforcement must be anchored within the pile cap or footing.	21.12.3.1
	Grade beams acting as horizontal ties between pile caps or footings shall be proportioned such that the smallest cross-section dimension is greater than or equal to the clear spacing between connected columns divided by 20, but need not be greater than 18 inches. Closed ties shall be provided at a spacing not to exceed the lesser of one-half the smallest orthogonal cross-section dimension or 12 inches.	21.12.3.2
	Grade beams and beams that are part of a mat foundation subjected to flexure from columns that are part of the seismic-force-resisting system shall conform to ACI 21.5.	21.12.3.3

(continued)

Table 6.6 Summary of Requirements for Foundations (continued)

	Requirement	ACI Section Number(s)
Grade Beams and Slabs-on-ground (continued)	Slabs-on-ground that resist seismic forces from columns or walls that are part of the seismic-force-resisting system shall be designed as structural diaphragms in accordance with ACI 21.11.	21.12.3.4
	Design drawings shall clearly state that the slab-on-ground is a structural diaphragm that is part of the seismic-force-resisting system/	
Piles, Piers, and Caissons	Piles, piers or caissons resisting tension loads shall have continuous longitudinal reinforcement over the length resisting design tension forces. The longitudinal reinforcement shall be detailed to transfer tensile forces between the pile cap and the supported structural members.	21.12.4.2
	Where tension forces induced by earthquake effects are transferred between a pile cap or mat foundation and a precast pile by reinforcing bars that are grouted or post-installed in the top of the pile, the grouting system shall have been demonstrated by test that it can develop at least $1.25f_y$ of the bar.	21.12.4.3
	Piles, piers or caissons shall have transverse reinforcement in accordance with ACI 21.6.4.2 through 21.6.4.4 at the following locations: (a) At the top of a member for at least 5 times the member cross-section dimension, but not less than 6 feet below the bottom of the pile cap. (b) Along the entire unsupported length plus the length required in ACI 21.12.4.4(a) for portions of piles in soil that are not capable of providing lateral support, or in air or water.	21.12.4.4
	For precast concrete driven piles, the provided length of transverse reinforcement shall be sufficient to account for potential variations in the elevation in pile tips.	21.12.4.6
	Pile caps incorporating batter piles shall be designed to resist the full compressive strength of the batter piles acting as short columns. For portions of piles in soil that is not capable of providing lateral support, or in air or water, the slenderness effects of batter piles shall be considered.	21.12.4.7

For SI: 1 inch = 25.4 mm; 1 foot = 304.8 mm.

IBC 1808.8.6 points out that the provisions of ACI 21.12.4(a) for transverse reinforcement at the top of piles, piers and pile caps are not applicable.

Requirements for shallow foundations are contained in IBC 1809. Footing seismic ties must be provided for structures assigned to SDC D, E or F, and must satisfy the provisions of IBC 1809.13.

Design and detailing requirements for deep foundations are given in IBC 1810.

6.7.1 Requirements for Footings, Foundation Mats and Pile Caps

Detailing requirements for columns that have been designed assuming fixed-end conditions at the foundation are illustrated in Figure 6.22. Tests have demonstrated that column longitudinal reinforcement that is developed into the foundation from a supported flexural member (column or wall) should have hooks turned inwards towards the axis of the member in order for the joint to be able to resist the flexure at this location.

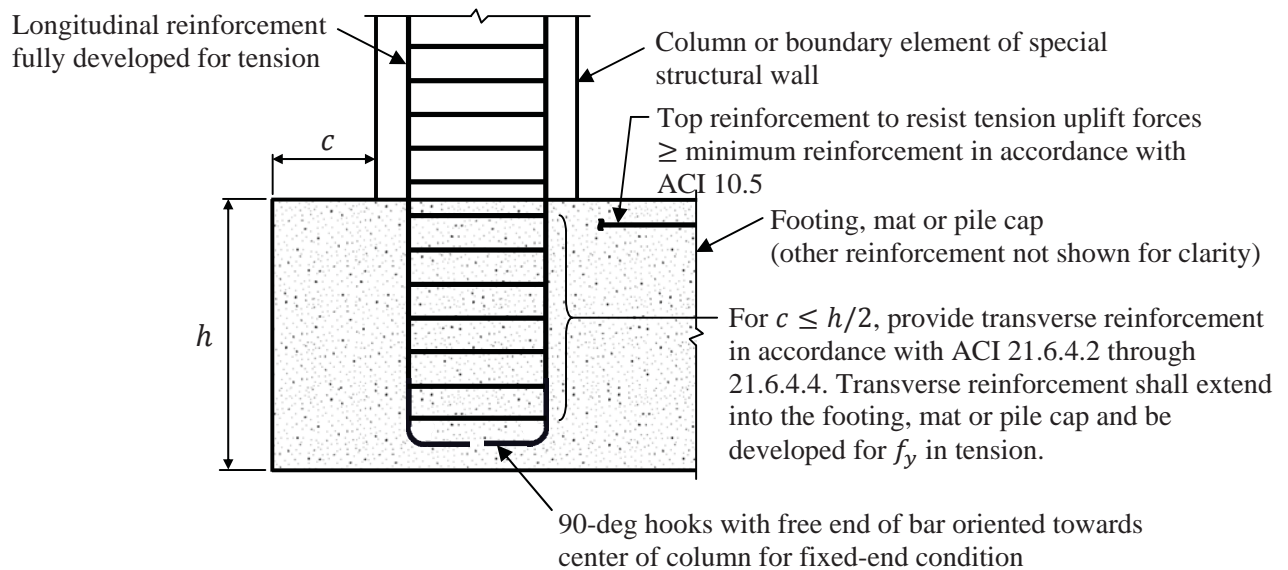

For SI: 1 degree = 0.01745 rad.

Figure 6.22 Requirements for Footings, Foundation Mats and Pile Caps

The detailing requirements of ACI 21.12.2.3, which are also illustrated in Figure 6.22, are provided to help prevent an edge failure where columns or boundary elements of special structural walls are supported close to an edge of a foundation, which can occur, for example, near property lines.

Structural plain concrete footings and basement walls supporting structures assigned to SDC D, E or F are prohibited, except for the specific cases cited in ACI 22.10. IBC 1908.1.8 modifies the exceptions in ACI 22.10.

6.7.2 Requirements for Grade Beams and Slabs-on-ground

The cross-section limitation and the minimum tie requirements of ACI 21.12.3.1 for grade beams between pile caps or footings are intended to provide reasonable beam proportions. Grade beams that are part of a mat foundation that resists flexural stresses from columns that are part of the seismic-force-resisting system must conform to the provisions of ACI 21.5 for flexural members of special moment frames.

A slab-on-ground that is not subjected to earthquake effects is generally considered nonstructural, and ACI 318 does not govern its design and construction (ACI 1.1.7). However, for structures assigned to SDC D, E or F, a slab-on-ground is often part of the seismic-force-resisting system, acting as a diaphragm that holds the structure together at the ground level and that minimizes the effects of out-of-phase ground motion that may occur over the footprint of the structure. In such cases, it must be designed and detailed in accordance with the provisions of ACI 21.11 for diaphragms.

6.7.3 Requirements for Piles, Piers and Caissons

The provisions of ACI 21.12.4 apply to concrete piles, piers and caissons that support structures subjected to earthquake effects. Adequate performance of these supporting members for seismic loads requires that these provisions be met, as well as other applicable standards and guidelines, which are contained in ACI R1.1.6.

For piles, piers or caissons resisting tension loads, a load path is necessary to transfer the tension forces from the longitudinal reinforcing bars in a column or boundary member of a special structural wall through the pile cap to the reinforcement of the pile, pier or caisson.

Piles can be subjected to extremely high flexural stresses just below the pile cap and near the base of soft or loose soil deposits during an earthquake. The requirement of ACI 21.12.4.4 for transverse reinforcement at the specified locations is based on numerous failures that were observed after recent earthquakes.¹⁰

It is important to consider that the tip of a precast pile may be driven to an elevation different than that specified in the design drawings. For example, a pile may reach refusal at a shallower depth than anticipated. When this occurs, the excess pile length needs to be cut off, which results in a portion of transverse reinforcement required by ACI 21.12.4.4 being cut off as well. If this possible situation is not anticipated, transverse reinforcement may not be provided over the length that is required.

Extensive structural damage has been observed at the junction of batter piles and buildings after some recent earthquakes. Pile caps and surrounding structure must be designed for the potentially large forces that can be developed in batter piles.

6.8 MEMBERS NOT DESIGNATED AS PART OF THE SEISMIC-FORCE-RESISTING SYSTEM

ASCE/SEI 12.12.4 requires that all structural members that are not designated to be part of the seismic-force-resisting system in structures assigned to SDC D and above shall be designed to support their respective gravity load effects when subjected to the design displacement from an earthquake. The provisions of ACI 21.13 satisfy this requirement for beams, columns and slabs.

¹⁰ Recall that IBC 1808.8.6 modifies ACI 21.12.4.4 in that the provisions of ACI 21.12.4.4(a) do not apply.

Requirements of ACI 21.13 for members that are not designated to be part of the seismic-force-resisting system are summarized in Table 6.7.

It is assumed in the provisions of ACI 21.13.2 through 21.13.4 that beams and columns yield if the combined effects of factored gravity loads and design displacements exceed the design moment and shear strengths of the members. Requirements for transverse reinforcement vary with the magnitude of the factored axial load and whether or not the member yields under the design displacement.

Table 6.7 Summary of Requirements for Members Not Designated as Part of the Seismic-force-resisting System

	Requirement	ACI Section Number(s)
Members where combined bending moments and shear forces due to factored gravity loads and design displacements are less than or equal to the design moment and shear strengths	Factored gravity load combinations to use in the design of beams and columns is the more critical of the following: (a) $1.2D + 1.0L + 0.2S$ (b) $0.9D$ The load factor on the live load, L , is permitted to be reduced to 0.5 except for garages, public assembly occupancies, and all areas where $L > 100$ psf.	21.13.3
	Members with factored axial forces $\leq A_g f'_c / 10$ shall satisfy ACI 21.5.2.1. Stirrups must be spaced $\leq d/2$ throughout the entire length.	21.13.3.1
	Members with factored axial forces $> A_g f'_c / 10$ shall satisfy ACI 21.6.3.1, 21.6.4.2 and 21.6.5. Maximum longitudinal spacing of ties over the entire length shall be s_o where s_o shall not exceed the smaller of 6 diameters of the smallest longitudinal bar enclosed and 6 inches.	21.13.3.2
	Members with factored axial forces $> 0.35P_o$ shall satisfy ACI 21.13.3.2 and 21.6.4.7. Required amount of transverse reinforcement must be at least one-half of that required by ACI 21.6.4.4 and the spacing must not exceed s_o for the full member length.	21.13.3.3
Members where combined bending moments and shear forces due to factored gravity loads and design displacements exceed the design moment and shear strengths, or if induced moments are not calculated	Materials shall satisfy ACI 21.1.4.2, 21.1.4.3, 21.1.5.2 and 21.1.5.5. Mechanical and welded splices shall satisfy 21.1.6 and 21.1.7.1, respectively.	21.13.4.1
	Members with factored axial forces $\leq A_g f'_c / 10$ shall satisfy ACI 21.5.2.1 and 21.5.4. Stirrups must be spaced $\leq d/2$ throughout the entire length.	21.13.4.2
	Members with factored axial forces $> A_g f'_c / 10$ shall satisfy ACI 21.6.3, 21.6.4, 21.6.5 and 21.7.3.1.	21.13.4.3

(continued)

Table 6.7 Summary of Requirements for Members not Designated as Part of the Seismic-force-resisting System (continued)

	Requirement	ACI Section Number(s)
Two-way slabs without beams	<p>Slab shear reinforcement conforming to ACI 11.11.3 and 11.11.5 that provides $V_s \geq 3.5\sqrt{f'_c}b_o d$ shall extend at least four times the slab thickness from the face of the support, unless either (a) or (b) is satisfied:</p> <p>(a) The requirements of ACI 11.11.7 using the design shear V_{ug} and the induced moment transferred between the slab and column under the design displacement.</p> <p>(b) The design story drift ratio is less than or equal to the larger of 0.005 and $[0.035 - 0.05(V_{ug}/\phi V_c)]$.</p> <p>Design story drift ratio shall be taken as the larger of the design story drift ratios of the adjacent stories above and below the slab-column connection. The quantity V_c is defined in ACI 11.11.2. The quantity V_{ug} is defined as the factored shear force on the slab critical section for two-way action, which is calculated for the load combination $1.2D + 1.0L + 0.2S$ where the load factor on the live load L is permitted to be reduced to 0.5 except for garages, public assembly occupancies, and all areas where $L > 100$ psf.</p>	21.13.6

For SI: 1 inch = 25.4 mm; 1 pound per square foot = 47.88 Pa.

Figures 6.23, 6.24 and 6.25 illustrate the requirements of ACI 21.13.3 and Figures 6.26 and 6.27 illustrate the requirements of ACI 21.13.4.

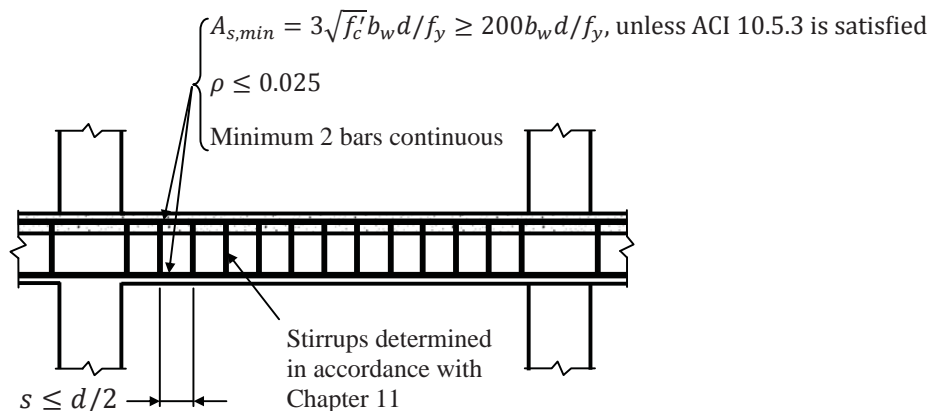

$$M_u \leq \phi M_n \text{ and } V_u \leq \phi V_n$$

$$P_u \leq A_g f'_c / 10$$

Figure 6.23 Requirements of ACI 21.13.3.1

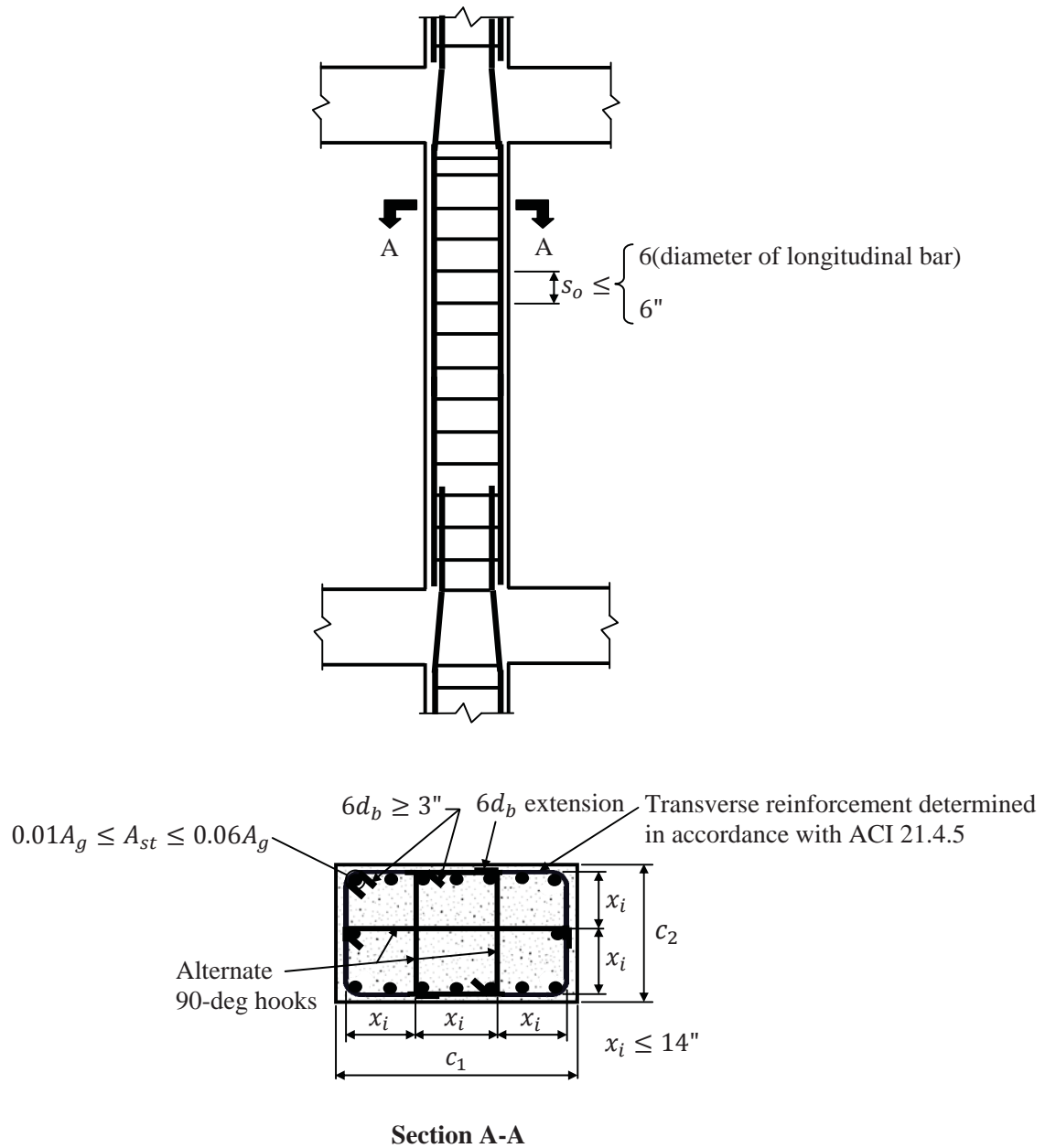

$$M_u \leq \phi M_n \text{ and } V_u \leq \phi V_n$$

$$A_g f'_c / 10 < P_u \leq 0.35 P_o$$

For SI: 1 inch = 24.5 mm; 1 degree = 0.01745 rad.

Figure 6.24 Requirements of ACI 21.13.3.2

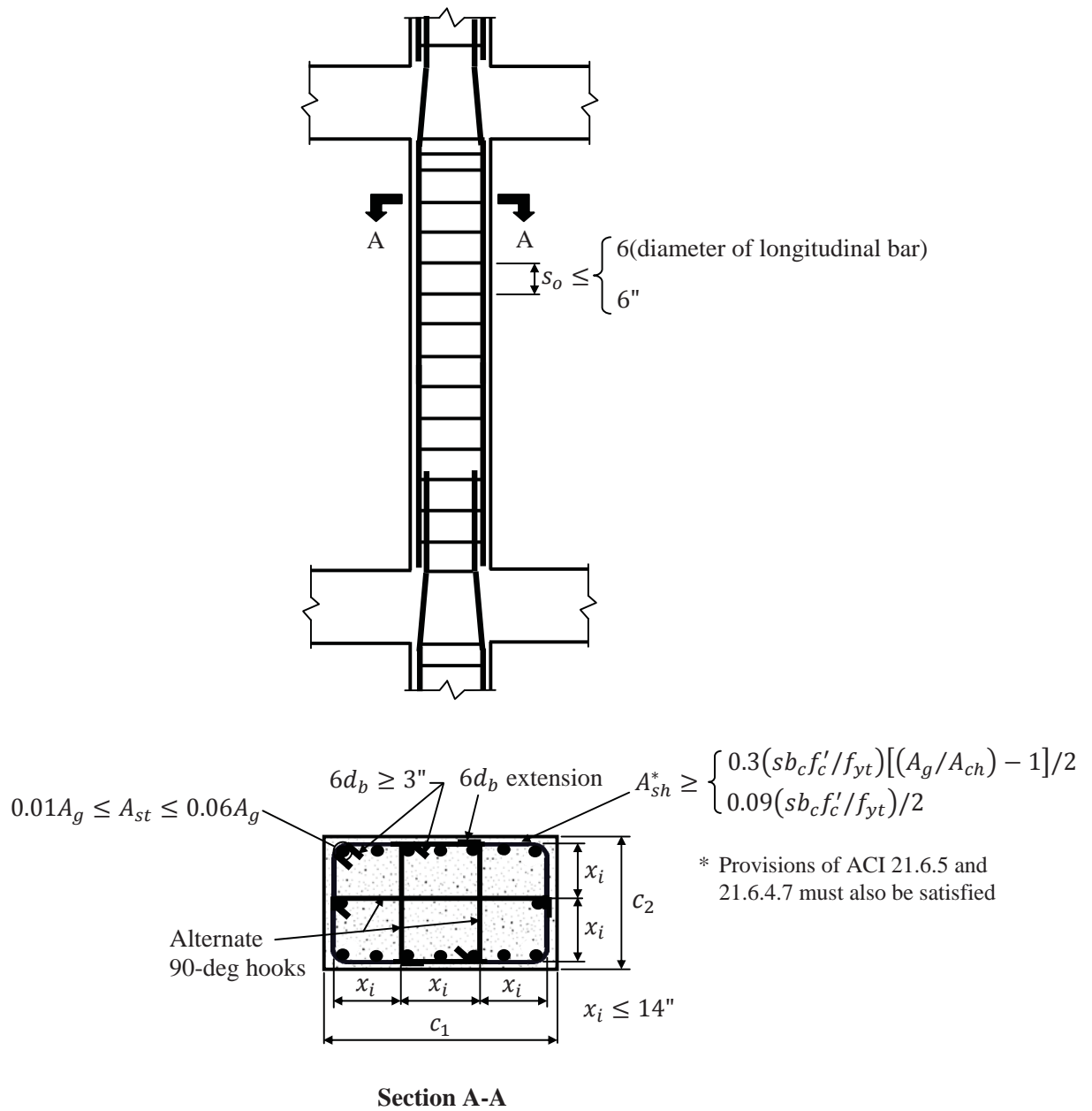

$$M_u \leq \phi M_n \text{ and } V_u \leq \phi V_n$$

$$P_u > 0.35 P_o$$

For SI: 1 inch = 24.5 mm; 1 degree = 0.01745 rad

Figure 6.25 Requirements of ACI 21.13.3.3

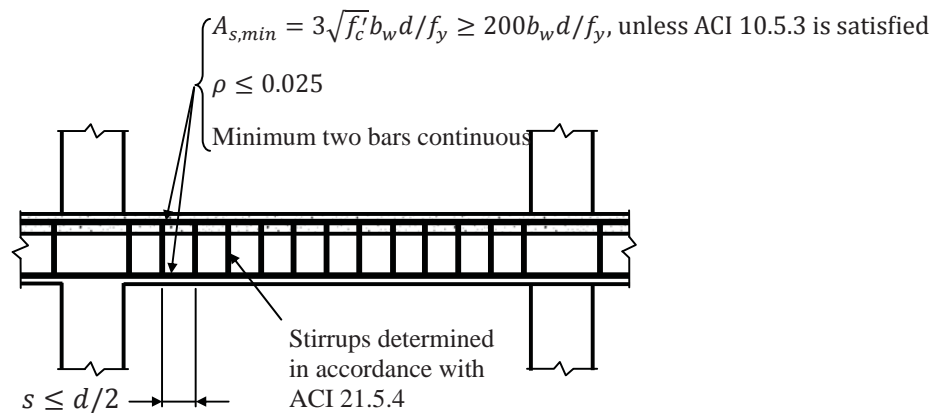

$M_u > \phi M_n$ or $V_u > \phi V_n$, or induced moments not calculated

$$P_u \leq A_g f'_c / 10$$

Figure 6.26 Requirements of ACI 21.13.4.2

Members must be detailed in accordance with ACI 21.13.4 when the effects of the design displacement are not determined.

Slab shear reinforcement conforming to ACI 11.11.3 and 11.11.5 and supplying a nominal shear strength, V_s , greater than or equal to $3.5\sqrt{f'_c}b_o d$ must be provided at all slab-column connections of two-way slabs without beams. Such reinforcement need not be provided where the requirements of ACI 11.11.7 are satisfied or where the design story drift ratio is less than or equal to the larger of 0.005 and $[0.035 - 0.05(V_{ug}/\phi V_c)]$. The latter exemption does not require the calculation of moments due to the design displacement and is based on research that identifies the likelihood of punching shear failure considering the story drift ratio and shear forces due to gravity loads.

A summary of the design procedure for members that are not designated as part of the seismic-force-resisting system is given in Figure 6.28.

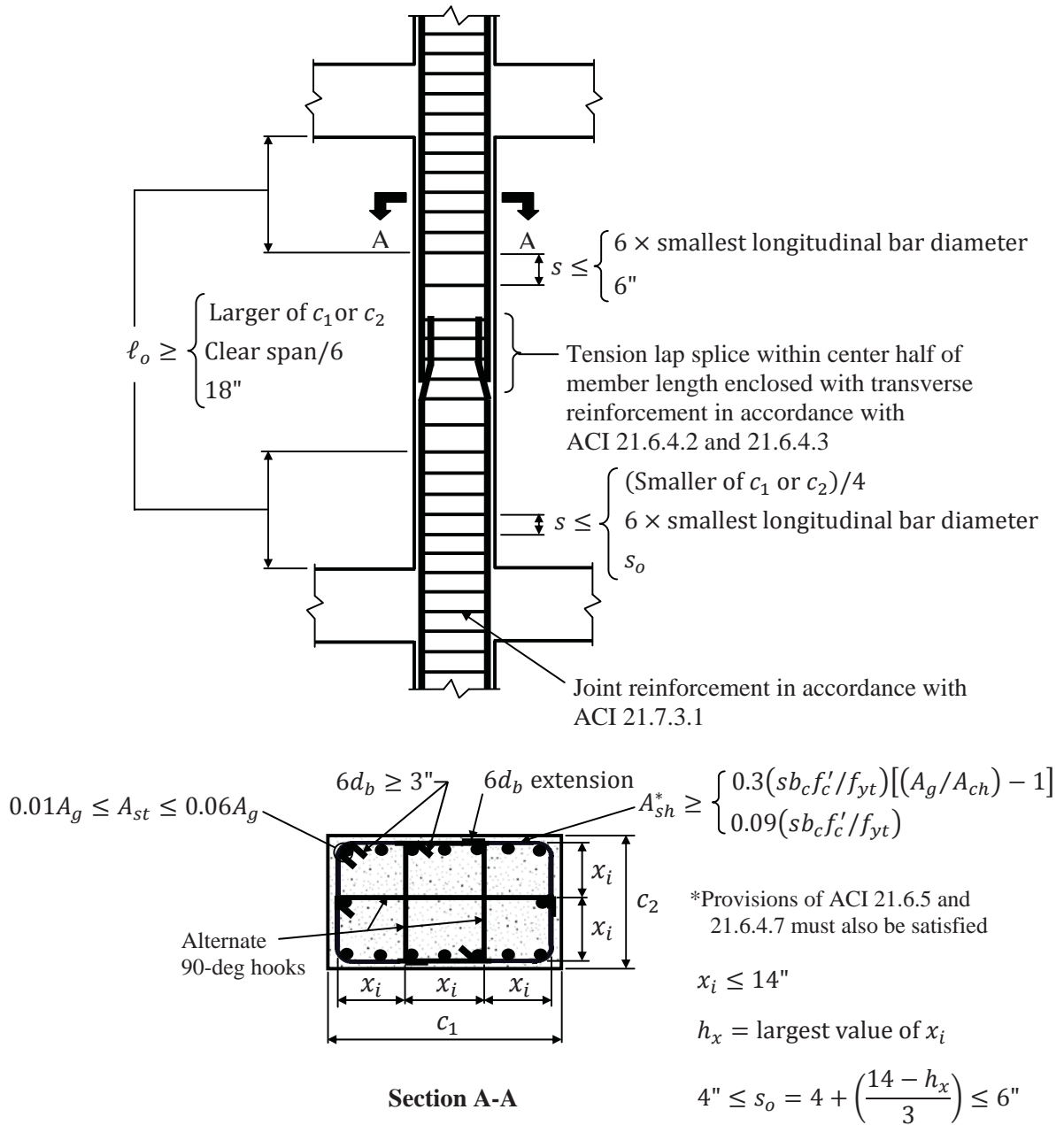

$M_u > \phi M_n$ or $V_u > \phi V_n$, or induced moments not calculated

$$P_u > A_g f'_c / 10$$

For SI: 1 inch = 24.5 mm; 1 degree = 0.01745 rad.

Figure 6.27 Requirements of ACI 21.13.4.3

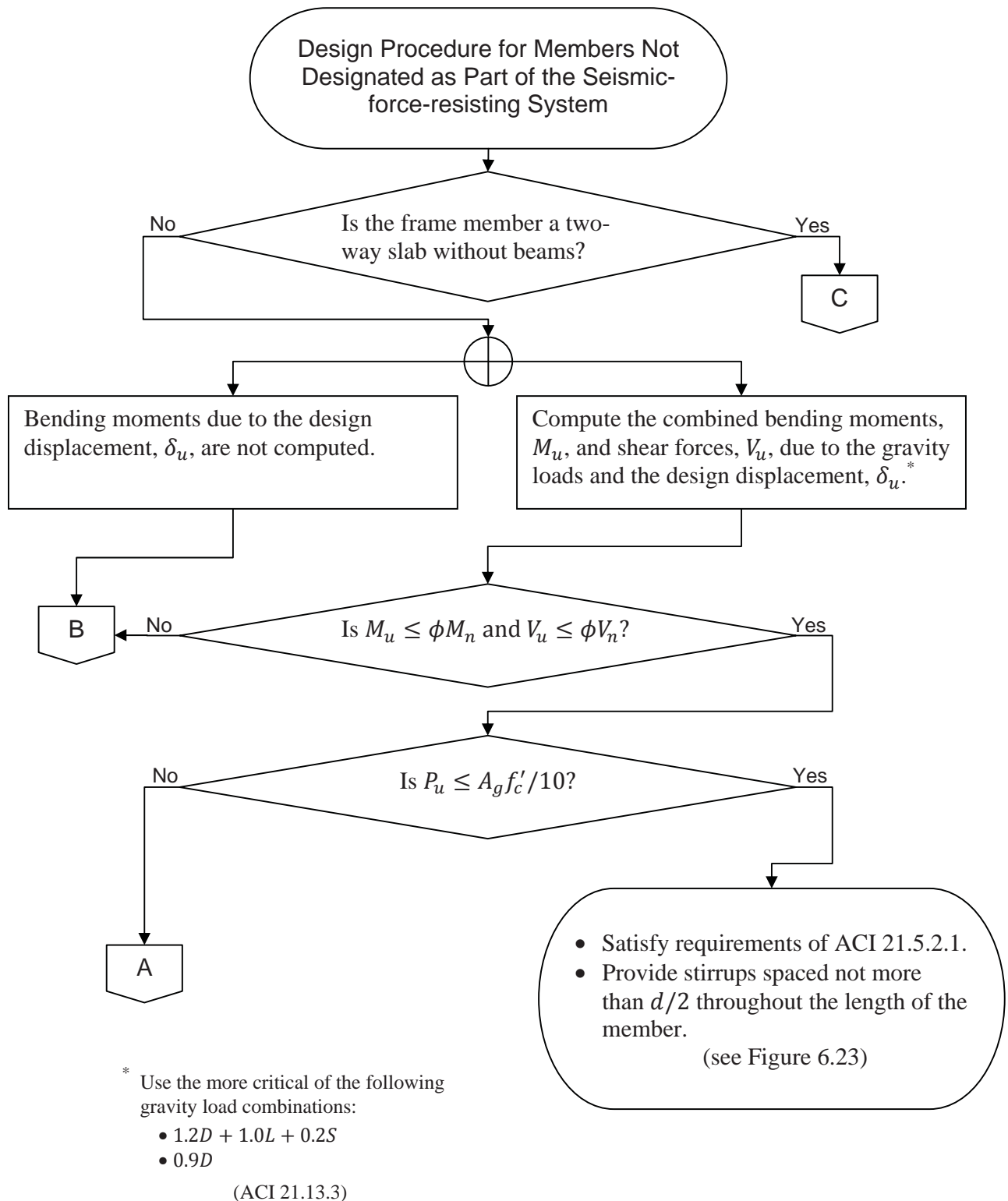

Figure 6.28 Design Procedure for Members Not Designated as Part of the Seismic-force-resisting System

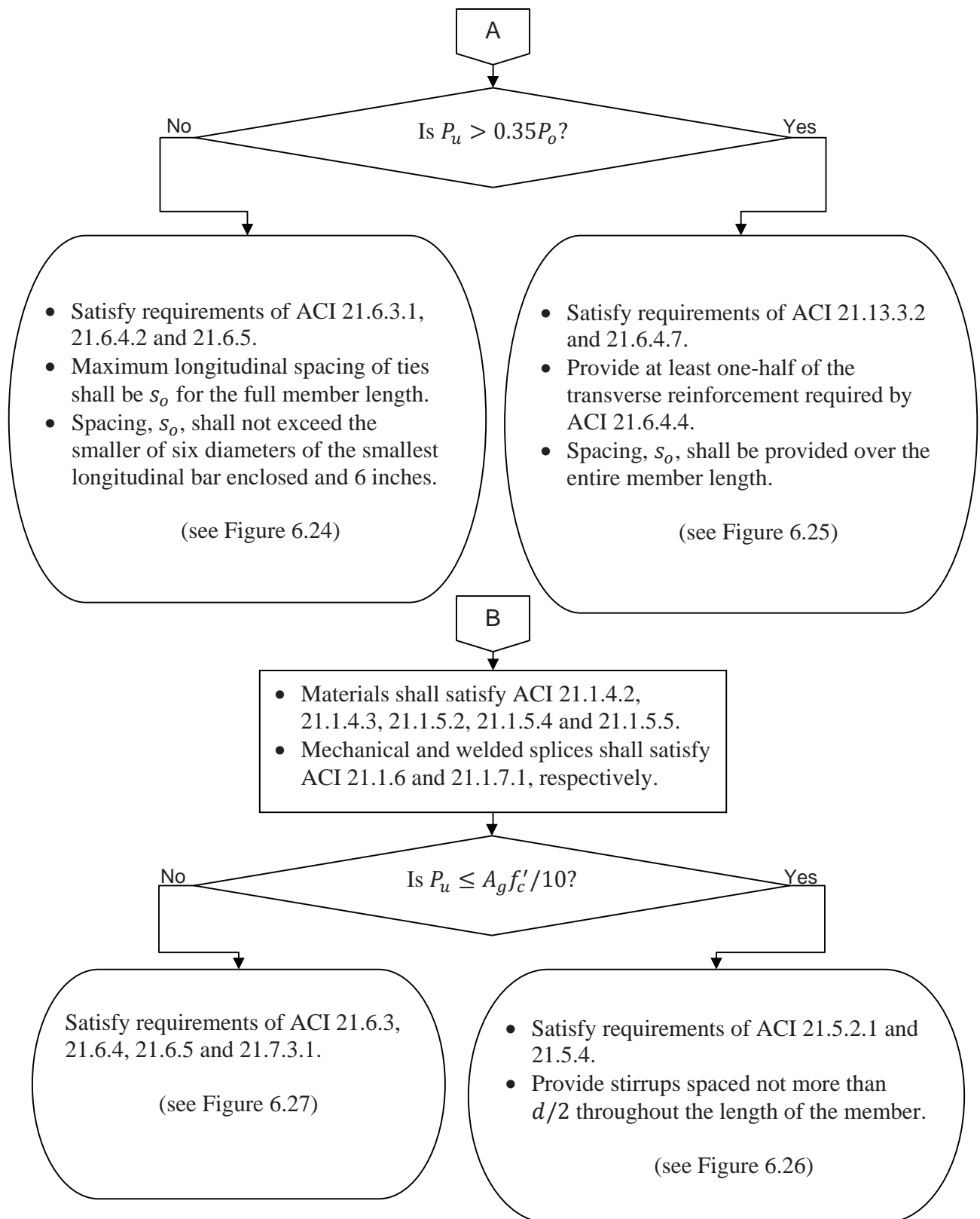
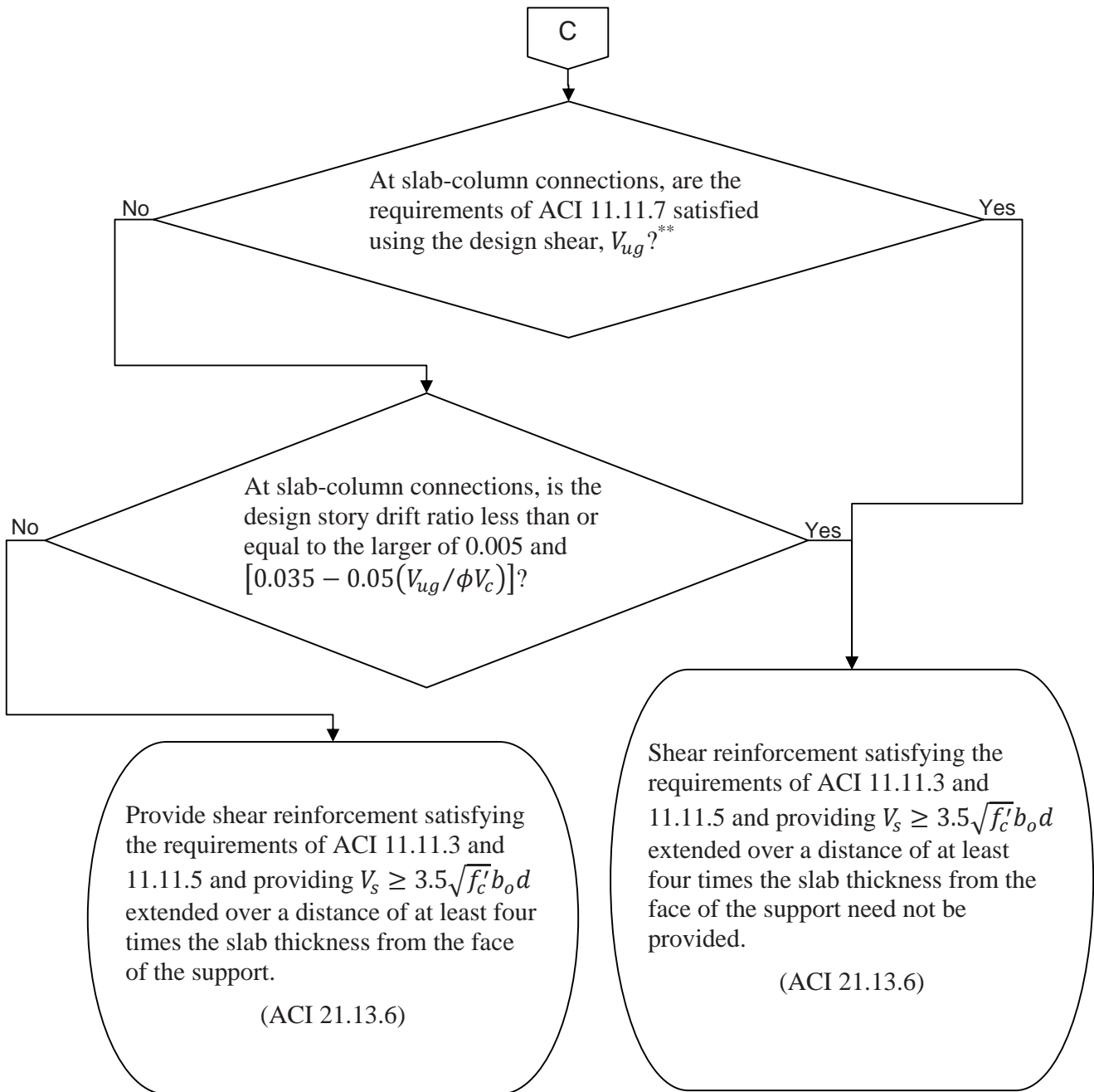

Figure 6.28 Design Procedure for Members Not Designated as Part of the Seismic-force-resisting System (continued)



^{**} The factored gravity shear force, V_{ug} , on the slab critical section is calculated for the load combination $1.2D + 1.0L + 0.2S$.

For SI: 1 inch = 25.4 mm.

Figure 6.28 Design Procedure for Members Not Designated as Part of the Seismic-force-resisting System (continued)

6.9 EXAMPLE

For the three-story residential building depicted in Figure 6.29, (1) design the beam on line 5 between A and B, (2) design column B5, (3) check the beam-column joint strengths at A5 and B5, (4) design the special structural wall on line C, (5) check the adequacy of the elements that are not part of the seismic-force-resisting system and (6) design the diaphragm and the collector elements in the N-S and E-W directions.

DESIGN DATA

Concrete: $f'_c = 4000$ psi; reinforcement: $f_y = 60,000$ psi.

Roof live load = 20 psf

Roof superimposed dead load = 10 psf

Floor live load = 80 psf

Floor superimposed dead load = 30 psf

Seismic-force-resisting system in north-south direction: special reinforced concrete moment frame ($R = 8, \Omega_o = 3, C_d = 5.5$)

Seismic-force-resisting system in east-west direction: building frame system with special reinforced concrete shear (structural) walls ($R = 6, \Omega_o = 2.5, C_d = 5$)

Wind velocity = 85 mph, Exposure B

Seismic Design Category: D ($S_{DS} = 1.00, S_{D1} = 0.61$)

First story height = 12 feet, typical story height = 12 feet.

SOLUTION¹¹

Seismic forces were computed in accordance with ASCE/SEI Chapters 6, 11, 12, 20 and 21 based on the design data above, and the structure was analyzed for seismic forces in the N-S and E-W directions. Since the building is assigned to SDC D, special reinforced concrete moment frames are utilized in the N-S direction (see ASCE/SEI Table 12.2-1, system C5) and a building frame system with special reinforced concrete shear (structural) walls are utilized in the E-W direction (see ASCE/SEI Table 12.2-1, system B5).

¹¹ The effects from the seismic forces govern in this example, and the effects from the wind forces are not considered.

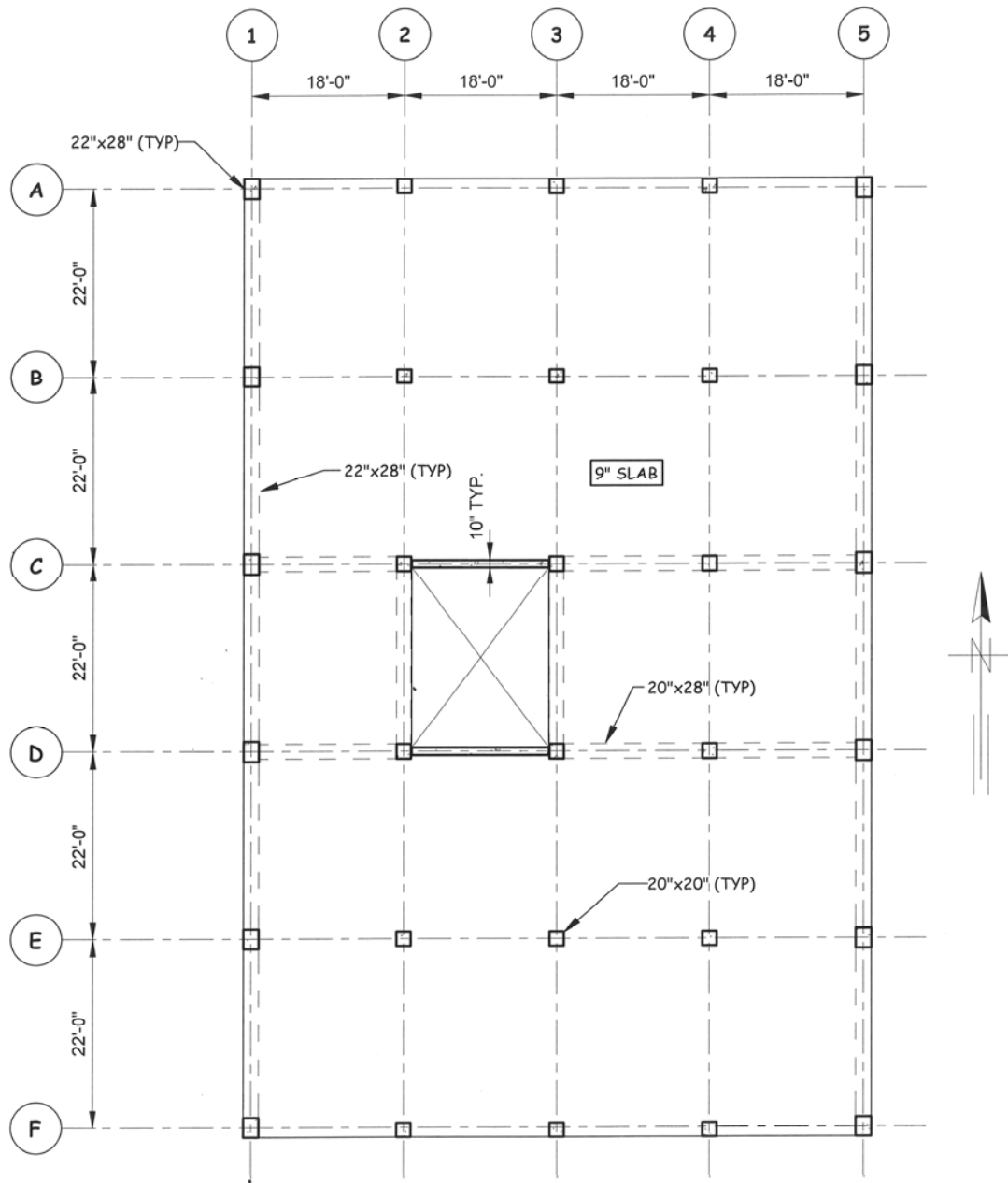

For SI: 1 inch = 25.4 mm; 1 foot = 304.8 mm.

Figure 6.29 Typical Floor Plan for Three-story Residential Building

Part 1: Design beam on line 5 between A and B

Deflection Control

Provisions for deflection control for reinforced concrete members subjected to flexure are given in ACI 9.5. Deflection requirements can be satisfied for nonprestressed beams by providing the minimum thickness in ACI Table 9.5(a).

The minimum thickness of beams made of normal weight concrete and Grade 60 reinforcement with one end continuous is:

$$\frac{\ell_n}{18.5} = \frac{(22 \times 12) - 28}{18.5} = 12.8 \text{ in.} < 28.0 \text{ in.} \quad \text{O.K.}$$

Flexural Design

A summary of the governing design bending moments and shear forces is given in Table 6.8 for the beam at the first floor level.

Table 6.8 Summary of Design Bending Moments and Shear Forces for Beam on Line 5 between A and B at First Floor Level

Load Case	Location	Bending Moment (ft-kips)	Shear Force (kips)
Dead (D)	Support	-45.6	21.4
	Midspan	33.1	
Live (L)	Support	-18.3	8.6
	Midspan	12.9	
Seismic (Q_E)	Support	± 101.3	± 10.3
Load Combination			
$1.4D$	Support	-63.8	30.0
	Midspan	46.3	
$1.2D + 1.6L$	Support	-84.0	39.4
	Midspan	60.4	
$1.4D + 0.5L + Q_E$	Support	-174.3	44.6
	Midspan	52.8	
$0.7D - Q_E$	Support	69.4	4.7
	Midspan	23.2	

Basic strength design load combinations are given in ACI 9.2, which are essentially the same as those in ASCE/SEI 2.3.2. The applicable load combinations in this case are:

$$U = 1.4D \quad \text{ACI Eq. (9-1)}$$

$$U = 1.2D + 1.6L \quad \text{ACI Eq. (9-2)}$$

$$U = 1.2D + 0.5L + 1.0E \quad \text{ACI Eq. (9-5)}$$

$$U = 0.9D + 1.0E \quad \text{ACI Eq. (9-7)}$$

According to ASCE/SEI 12.4.2, the seismic load effect, E , is the combination of horizontal and vertical seismic load effects. The E for use in ACI Equation (9-5) (or,

equivalently, ASCE/SEI load combination 5) where the effects of gravity and seismic ground motion are additive is

$$E = \rho Q_E + 0.2S_{DS}D$$

The E for use in ACI Equation (9-7) (or, equivalently, ASCE/SEI load combination 7) where the effects of gravity and seismic ground motion counteract is

$$E = \rho Q_E - 0.2S_{DS}D$$

The redundancy factor, ρ , is equal to 1.3 for structures assigned to SDC D and above unless one of the two conditions in ASCE/SEI 12.3.4.2 is met. In the N-S direction, the loss of moment resistance at both ends of a single beam in the special moment frames would not result in more than a 33 percent reduction in story strength, nor would the resulting system have a Type 1b extreme torsional irregularity (see ASCE/SEI Table 12.3-1). Thus, in the N-S direction, the first of the two conditions under ASCE/SEI 12.3.4.2 is met and $\rho = 1.0$.

Therefore,

$$E = \rho Q_E + 0.2S_{DS}D = Q_E + (0.2 \times 1.00)D = Q_E + 0.2D$$

$$E = \rho Q_E - 0.2S_{DS}D = Q_E - 0.2D$$

Check limitations on section dimensions in accordance with ACI 21.5.1:

- Clear span $\ell_n = 22 - (28/12) = 19.7 \text{ ft} > 4 \times (28 - 2.5)/12 = 8.5 \text{ ft}$ O.K.
- Width $b_w = 22 \text{ in.} > 0.3 \times 28 = 8.4 \text{ in.}$ (governs) and 10 in. O.K.
- Width $b_w = 22 \text{ in.} < 3 \times 22 = 66 \text{ in.}$ and $22 + (1.5 \times 28) = 64 \text{ in.}$ (governs) O.K.

The required flexural reinforcement is given in Table 6.9, and the provided areas of steel are within the limits prescribed in ACI 21.5.2.1 for maximum and minimum reinforcement.

The selected reinforcement satisfies ACI 7.6.1 and 3.3.2 (minimum spacing for concrete placement), ACI 7.7.1 (minimum cover for protection of reinforcement) and ACI 10.6 (maximum spacing for control of flexural cracking). See Tables 4.7 and 4.8 for minimum and maximum number of reinforcing bars permitted in a single layer.

Table 6.9 Required Flexural Reinforcement for Beam on Line 5 between A and B at First Floor Level

Location	M_u (ft-kips)	A_s^* (in. ²)	Reinforcement	ϕM_n (ft-kips)
Support	-174.3	1.87	3-No. 8	261.8
	69.4	1.87	3-No. 8	261.8
Midspan	60.4	1.87	3-No. 8	261.8

* $A_{s,min} = \frac{3\sqrt{f'_c} b_w d}{f_y} = \frac{3\sqrt{4,000} \times 22 \times 25.5}{60,000} = 1.77 \text{ in.}^2$

ACI 10.5.1

$= \frac{200 b_w d}{f_y} = \frac{200 \times 22 \times 25.5}{60,000} = 1.87 \text{ in.}^2$ (governs)

$A_{s,max} = \rho_{max} b_w d = 0.025 \times 22 \times 25.5 = 14.03 \text{ in.}^2$ ACI 21.5.2.1

For SI: 1 square inch = 645.16 mm².

ACI 21.5.2.2 requires that the positive moment strength at the face of a joint be greater than or equal to 50 percent of the negative moment strength at that location (see Figure 6.2). This is satisfied, since 261.8 ft-kips > 261.8/2 = 130.9 ft-kips. Also, the negative or positive moment strength at any section of the beam must be greater than or equal to 25 percent of the maximum moment strength provided at the face of either joint. Twenty-five percent of the maximum moment strength in this case is equal to 261.8/4 = 65.5 ft-kips. Providing at least two No. 8 bars ($\phi M_n = 176.8$ ft-kips) along the length of the beam satisfies this provision.

Where reinforcing bars extend through an interior joint, the column dimension parallel to the beam reinforcement must be at least 20 times the diameter of the largest longitudinal bar for normal weight concrete (ACI 21.7.2.3). The minimum required column dimension = 20 × 1.00 = 20.0 in., which is less than the 28.0-inch column width that is provided.

Shear Design

Shear requirements for beams in special moment frames are given in ACI 21.5.4. The method of determining design shear forces in beams in special moment frames takes into consideration the likelihood of plastic hinges forming at regions near the supports. Shear forces are determined assuming simultaneous hinging at the beam supports. To properly confine the concrete and to maintain lateral support of the longitudinal bars in regions where yielding is expected, the transverse reinforcement requirements of ACI 21.5.3 must also be satisfied.

Shear forces are computed from statics assuming that moments of opposite sign corresponding to the probable flexural strength, M_{pr} , act at the joint faces and that the member is loaded with tributary factored gravity load along its span. Sidesway to the right and to the left must be considered when calculating the maximum design shear forces.

The probable flexural strength, M_{pr} , for a section is determined using the stress in the tensile reinforcement equal to $1.25f_y$ and a strength reduction factor, ϕ , equal to 1.0 (see Figure 6.6). In this example, the positive and negative values of M_{pr} are the same:

$$M_{pr} = (3 \times 0.79)(1.25 \times 60) \left[25.5 - \frac{(3 \times 0.79)(1.25 \times 60)}{2 \times 0.85 \times 4 \times 22} \right] / 12 = 360.1 \text{ ft-kips}$$

The largest shear force including factored gravity effects and the effects from M_{pr} is depicted in Figure 6.30 for sidesway to the right.¹² Sidesway to the left yields the same maximum shear force due to the symmetric distribution of the longitudinal reinforcement in the beam. The maximum shear force of 67.1 kips is greater than the maximum shear force obtained from the structural analysis, which is equal to 44.6 kips (see Table 6.8).

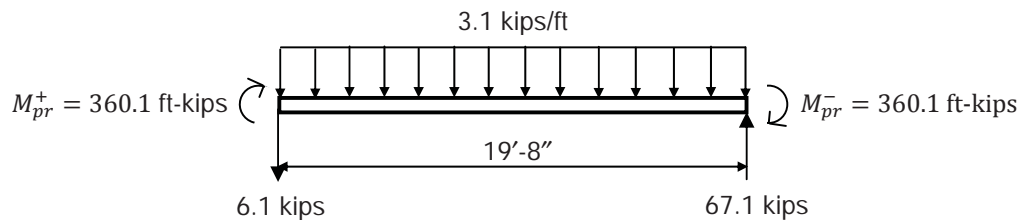

For SI: 1 inch = 25.4 mm; 1 foot = 304.8 mm.

Figure 6.30 Design Shear Forces for Beam on Line 5 between A and B at First Floor Level

The nominal shear strength provided by the concrete, V_c , must be taken as zero when the earthquake-induced shear force is greater than or equal to 50 percent of the total shear force and the factored axial compressive force including earthquake effects is less than $A_g f'_c / 20$ (ACI 21.5.4.2). The beam in this example carries negligible axial forces and the maximum earthquake-induced shear force at the face of the support is equal to $2 \times 360.1 / 19.67 = 36.6$ kips, which is greater than $0.5 \times 67.1 = 33.6$ kips. Thus, $V_c = 0$.

The maximum shear force, V_s , is

$$V_s = \frac{V_u}{\phi} - V_c = \frac{67.1}{0.75} - 0 = 89.5 \text{ kips}$$

where the strength reduction factor was taken as 0.75 in accordance with ACI 9.3.4. According to ACI 11.4.7.9, shear strength contributed by shear reinforcement, V_s , shall not exceed $8\sqrt{f'_c} b_w d = 283.9$ kips, which is satisfied in this case. Also, V_c is less than $4\sqrt{f'_c} b_w d = 142.0$ kips.

¹² The factored gravity load on the beam is an equivalent uniformly distributed load based on a finite element analysis of the floor system.

Required spacing, s , of No. 4 hoops for a factored shear force of 89.5 kips is determined by ACI Equation (11-15):

$$s = \frac{A_v f_{yt} d}{V_s} = \frac{(3 \times 0.2) \times 60 \times 25.5}{89.5} = 10.3 \text{ in.}$$

Note that three hoop legs are required for support of the longitudinal bars in order to satisfy the requirements of ACI 21.5.3.3.

Maximum allowable hoop spacing within a distance of $2h = 56.0$ in. from the face of the support at each end of the member is the smallest of the following (ACI 21.5.3.2):

- $d/4 = 25.5/4 = 6.4$ in. (governs)
- $8(\text{diameter of smallest longitudinal bar}) = 8 \times 1.0 = 8.0$ in.
- $24(\text{diameter of hoop bar}) = 24 \times 0.5 = 12.0$ in.
- 12 in.

Use 10 No. 4 hoops with three legs at each end of the beam spaced at 6 inches on center with the first hoop located 2 inches from the face of the support (ACI 21.5.3.2).

Where hoops are no longer required, stirrups with seismic hooks at both ends may be used (ACI 21.5.3.4). At a distance of 56 inches from the face of the support, $V_u = 52.6$ kips and shear strength contributed by shear reinforcement is¹³

$$V_s = \frac{V_u}{\phi} - V_c = \frac{52.6}{0.75} - \frac{2\sqrt{4000} \times 22 \times 25.5}{1000} < 0$$

The maximum allowable spacing of the stirrups is $d/2 = 12.75$ in. (ACI 21.5.3.4). A 12-inch spacing, starting at 56 inches from the face of the support, is sufficient for the remaining portion of the beam. Two stirrup legs are provided, since confinement of the longitudinal bars in accordance with ACI 21.5.3.3 must be satisfied only where hoops are required.

The provided shear reinforcement also satisfies the minimum shear requirements of ACI 11.4.6.3.

Reinforcing Bar Cutoff Points

The negative reinforcement at the supports is three No. 8 bars. The location where one of the three bars can be terminated will be determined.

¹³ At this location, the nominal strength provided by the concrete, V_c , may be used.

The load combination that is used to determine the cutoff point of the one No. 8 bar is 0.7 times the dead load in combination with the probable flexural strengths, M_{pr} , at the ends of the member, since this combination produces the longest bar lengths. The design flexural strength, ϕM_n , provided by two No. 8 bars is 176.8 ft-kips. Therefore, the one No. 8 bar can be terminated after the required moment strength, M_u , has been reduced to 176.8 ft-kips.

The distance, x , from the support to the location where the moment is equal to 176.8 ft-kips can readily be determined by summing moments about section $a-a$ in Figure 6.31:

$$\frac{1.35x^2}{2} - 49.9x + 360.1 - 176.8 = 0$$

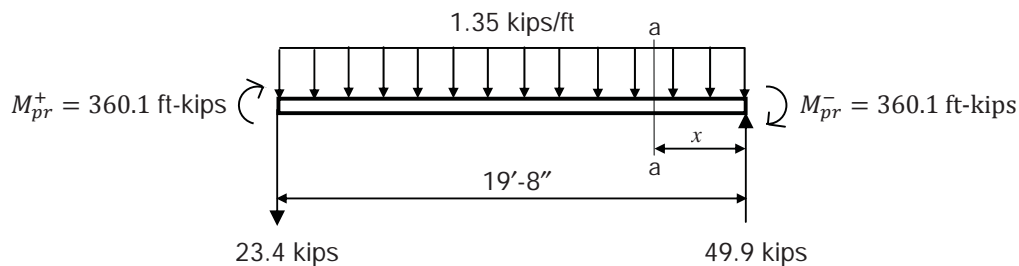

Figure 6.31 Cutoff Location of Negative Reinforcement

Solving for x gives a distance of 3.9 feet from the face of the support.

The one No. 8 bar must extend a distance $d = 25.5$ in. (governs) or $12d_b = 12$ in. beyond the distance x (ACI 12.10.3). Thus, from the face of the support, the total bar length must be at least equal to $3.9 + (25.5/12) = 6.0$ ft.

Also, the bars must extend a full development length, ℓ_d , beyond the face of the support (ACI 12.10.4), which is determined by ACI Equation (12-1):

$$\ell_d = \left(\frac{3}{40} \frac{f_y}{\lambda \sqrt{f'_c}} \frac{\psi_t \psi_e \psi_s}{\left(\frac{c_b + K_{tr}}{d_b} \right)} \right) d_b$$

where ψ_t = modification factor for reinforcement location = 1.3 for top bars

ψ_e = modification factor for reinforcement coating = 1.0 for uncoated bars

ψ_s = modification factor for reinforcement size = 1.0 for No. 8 bars

λ = modification factor for lightweight concrete = 1.0 for normal weight concrete

c_b = spacing or cover dimension

$$= 1.5 + 0.5 + \frac{1.0}{2} = 2.5 \text{ in. (governs)}$$

$$= \frac{22 - 2(1.5 + 0.5) - 1.0}{2 \times 2} = 4.25 \text{ in.}$$

K_{tr} = transverse reinforcement index

$$= \frac{40A_{tr}}{sn} = \frac{40 \times 3 \times 0.2}{6 \times 3} = 1.3$$

$$\frac{c_b + K_{tr}}{d_b} = \frac{2.5 + 1.3}{1.0} = 3.8 > 2.5, \text{ use } 2.5$$

Therefore,

$$\ell_d = \left(\frac{3}{40} \frac{60,000}{1.0\sqrt{4000}} \frac{1.3 \times 1.0 \times 1.0}{2.5} \right) \times 1.0 = 37.0 \text{ in.} = 3.1 \text{ ft} < 6.0 \text{ ft}$$

Thus, the total required length of the one No. 8 bars must be at least 6.0 feet beyond the face of the support.

Flexural reinforcement shall not be terminated in a tension zone unless one or more of the conditions of ACI 12.10.5 are satisfied. In this case, the point of inflection is approximately 11.6 feet from the face of the support, which is greater than 6.0 feet. Thus, the No. 8 bar cannot be terminated here unless one of the conditions of ACI 12.10.5 is satisfied. In this case, check if the factored shear force, V_u , at the cutoff point does not exceed $2\phi V_n/3$ (ACI 12.10.5.1). With No. 4 stirrups at 12 inches on center that are provided in this region of the beam, ϕV_n is determined by ACI Equations. (11-1) and (11-2):

$$\phi V_n = \phi(V_c + V_s) = 0.75 \left(\frac{2\sqrt{4000} \times 22 \times 25.5}{1000} + \frac{0.4 \times 60 \times 25.5}{12} \right) = 91.5 \text{ kips}$$

At 6.0 feet from the face of the support, $V_u = 41.8$ kips, which is less than $2 \times 91.5/3 = 61.0$ kips. Therefore, the one No. 8 bar can be terminated at 6.0 feet from the face of the support.

Flexural Reinforcement Splices

Lap splices of flexural reinforcement must not be placed within a joint, within a distance $2h$ from the face of the joint, or at locations where analysis indicates flexural yielding due to inelastic lateral displacements of the frame (ACI 21.5.2.3). Lap splices must be confined by hoops or spiral reinforcement along the entire lap length, and the maximum spacing of the transverse reinforcement is the smaller of $d/4$ or 4 inches. In lieu of lap splices, mechanical and welded splices conforming to ACI 21.1.6 and 21.1.7, respectively, may be used (ACI 21.5.2.4).

Lap splices are determined for the No. 8 bottom bars. Since all of the bars are to be spliced within the required length, a Class B splice must be used (ACI 12.15.1, 12.15.2):

$$\text{Class B splice length} = 1.3\ell_d$$

The development length, ℓ_d , is determined by ACI Equation (12-1):

$$\ell_d = \left(\frac{3}{40} \frac{f_y}{\lambda \sqrt{f'_c}} \frac{\psi_t \psi_e \psi_s}{\left(\frac{c_b + K_{tr}}{d_b} \right)} \right) d_b$$

where ψ_t = modification factor for reinforcement location = 1.0 for other than top bars

ψ_e = modification factor for reinforcement coating = 1.0 for uncoated bars

ψ_s = modification factor for reinforcement size = 1.0 for No. 8 bars

λ = modification factor for lightweight concrete = 1.0 for normal weight concrete

c_b = spacing or cover dimension

$$= 1.5 + 0.5 + \frac{1.0}{2} = 2.5 \text{ in. (governs)}$$

$$= \frac{22 - 2(1.5 + 0.5) - 1.0}{2 \times 2} = 4.25 \text{ in.}$$

K_{tr} = transverse reinforcement index

$$= \frac{40A_{tr}}{sn} = \frac{40 \times 2 \times 0.2}{4 \times 3} = 1.3$$

$$\frac{c_b + K_{tr}}{d_b} = \frac{2.5 + 1.3}{1.0} = 3.8 > 2.5, \text{ use } 2.5$$

Therefore,

$$l_d = \left(\frac{3}{40} \frac{60,000}{1.0\sqrt{4000}} \frac{1.0 \times 1.0 \times 1.0}{2.5} \right) \times 1.0 = 28.5 \text{ in.} = 2.4 \text{ ft}$$

Class B splice length = $1.3 \times 2.4 = 3.1 \text{ ft}$

Use a 3 foot, 4 inch. splice length with No. 4 hoops spaced at 4 inches.

Figure 6.32 shows the reinforcement details for this beam.

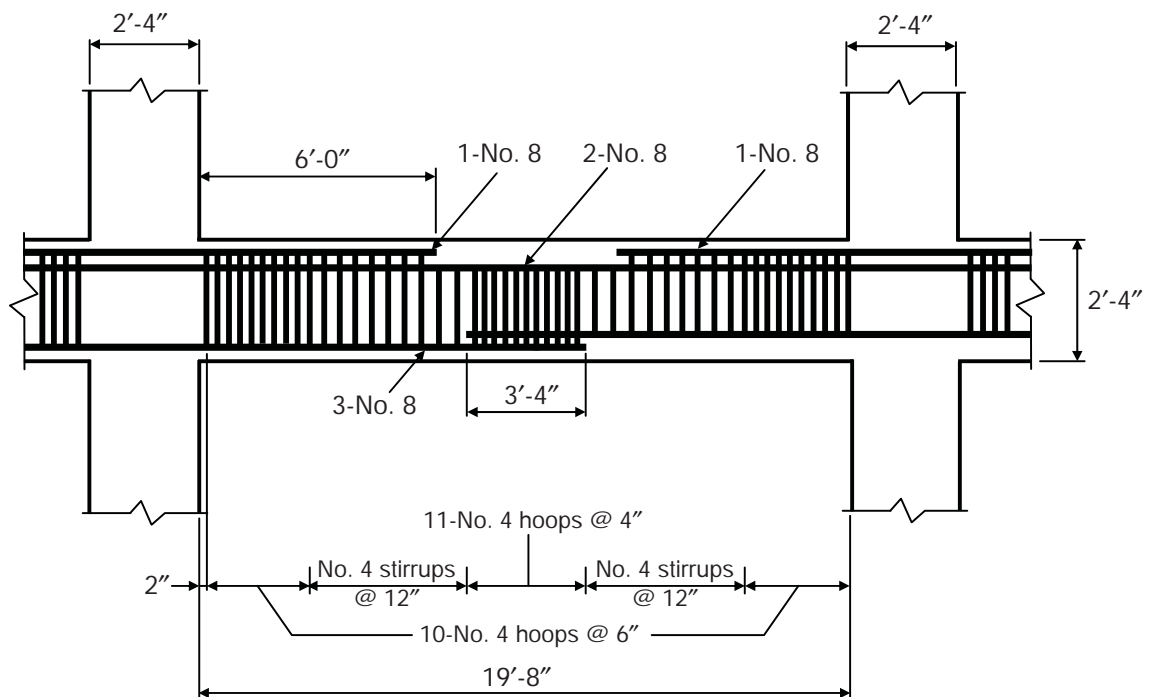

For SI: 1 inch = 25.4 mm; 1 foot = 304.8 mm.

Figure 6.32 Reinforcement Details for Beam on Line 5 between A and B at First Floor Level

Part 2: Design column B5

Design for Axial Force and Bending

A summary of the design axial forces, bending moments, and shear forces on column B5 for gravity and seismic loads is given in Table 6.10.

It was shown in Part 1 of this example that $\rho = 1.0$.

Since one of the factored axial force exceeds $A_g f'_c / 10 = 28 \times 22 \times 4 / 10 = 246.4$ kips, the provisions of ACI 21.6 are applicable, and the following two criteria of ACI 21.6.1 must be satisfied:

- Shortest cross-section dimension = 22 in. > 12 in. O.K.
- Ratio of shortest cross-sectional dimension to the perpendicular dimension = $22/28 = 0.8 > 0.4$ O.K.

Table 6.10 Summary of Axial Forces, Bending Moments and Shear Forces on Column B5 Supporting the First Floor Level

Load Case	Axial Force (kips)	Bending Moment (ft-kips)	Shear Force (kips)
Dead (D)	147.7	2.0	± 0.2
Live (L)	32.3	0.3	± 0.1
Roof live (L_r)	4.0		
Seismic (Q_E)	± 43.4	± 399.8	± 45.6
Load Combination			
$1.4D$	206.8	2.8	0.3
$1.2D + 1.6L + 0.5L_r$	230.9	31.2	0.4
$1.4D + 0.5L + Q_E$	266.3	402.8	45.9
$0.7D - Q_E$	60.0	398.4	45.5

Based on the load combinations in Table 6.10, a 22-inch by 28-inch column reinforced with 12 No. 8 bars ($A_{st} = 0.015A_g$) is adequate for column B5 supporting the first floor level. The interaction diagram for this column is shown in Figure 6.33.¹⁴ The provided area of longitudinal reinforcement is within the allowable range specified in ACI 21.6.3.1.

¹⁴ Slenderness effects in accordance with ACI 10.10 need not be considered in the design of this column. Also, P-Delta effects in accordance with ASCE/SEI 12.8.7 need not be considered.

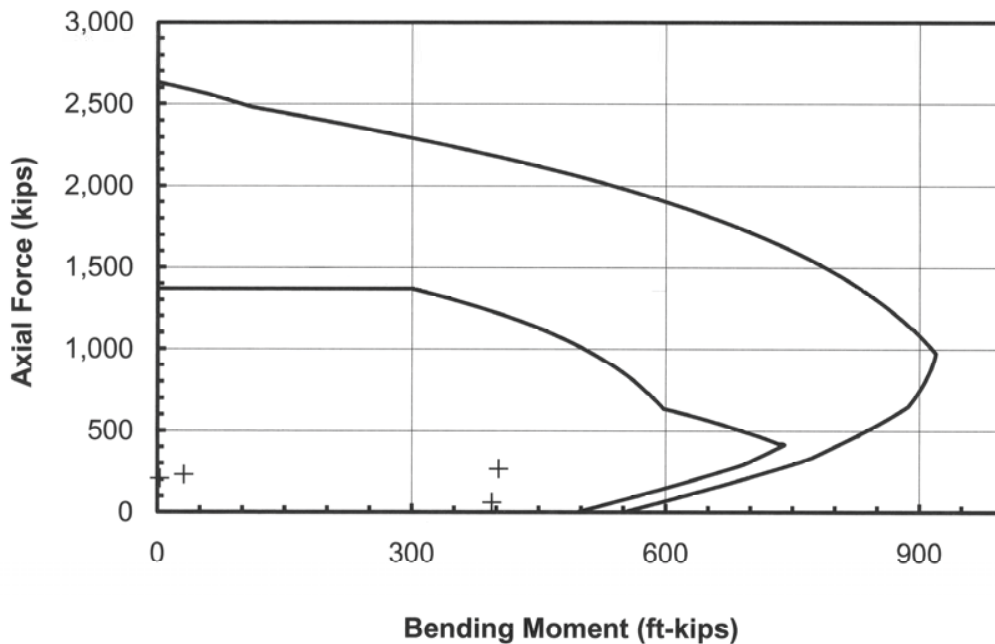

Figure 6.33 Design and Nominal Strength Interaction Diagrams for Column B5

In accordance with ACI 7.6.3, the distance between longitudinal bars must be greater than or equal to $1.5d_b = 1.5 \times 1.0 = 1.5$ in. In this case, the clear distance in the direction of analysis is equal to

$$\frac{28 - 2 \left(1.5 + 0.5 + \frac{1.0}{2} \right)}{4} - 1.0 = 4.75 \text{ in.} > 1.5 \text{ in.} \quad \text{O.K.}$$

This provision is also satisfied in the perpendicular direction.

Minimum Flexural Strength of Columns

ACI 21.6.2 requires that the sum of flexural strengths of columns at a joint must be greater than or equal to 6/5 times the sum of flexural strengths of beams framing into that joint. Only seismic load combinations need to be considered when checking the relative strengths of columns and girders.

The nominal flexural strength of the beam framing into the column must include the slab reinforcement within an effective slab width equal to the smallest of the following in accordance with ACI 8.12.3 (ACI 21.6.2.2):

- $(\text{Span}/12) + b_w = (22 \times 12/12) + 22 = 44.0$ in. (governs)

- $6h_s + b_w = (6 \times 9) + 22 = 76.0$ in.
- $(\text{Clear distance}/2) + b_w = (16.167 \times 12/2) + 22 = 119.0$ in.

The minimum required area of steel in the 44-inch width is equal to $0.0018 \times 44 \times 9 = 0.71$ in.², which corresponds to five No 4 bars at $44/4 = 11.0$ in. spacing. This spacing is less than the maximum bar spacing of 18.0 inches. Provide No. 4 @ 11 inches at both the top and bottom of the section.

A strain compatibility analysis of the 22-inch by 28-inch beam reinforced with three No. 8 bars with a 9-inch by 44-inch effective slab reinforced with No. 4 @ 11 inches at both the top and bottom of the section yields a negative nominal flexural strength $M_{nb}^- = 502.0$ ft-kips at the face of the joint.¹⁵ Also, the positive nominal flexural strength $M_{nb}^+ = 349.0$ ft-kips.

Thus, $\sum M_{nb} = 502.0 + 349.0 = 851.0$ ft-kips.

Column flexural strength is determined for the factored axial force resulting in the lowest flexural strength, consistent with the direction of lateral forces considered. For the upper end of the lower column framing into the joint (i.e., the column supporting floor level 1), the minimum $M_{nc} = 597.9$ ft-kips, which corresponds to $P_u = 60.0$ kips (see Table 6.10 and Figure 6.33). Similarly, for the lower end of the upper column framing into the joint (i.e., the column supporting floor level 2), $M_{nc} = 584.2$ ft-kips, which corresponds to $P_u = (0.7 \times 97.1) - 25.5 = 42.5$ kips. Therefore, $\sum M_{nc} = 597.9 + 584.2 = 1182.1$ ft-kips.

Check ACI Equation (21-1):

$$\sum M_{nc} = 1182.1 \text{ ft-kips} > (6/5) \sum M_{nb} = 6 \times 851.0/5 = 1021.2 \text{ ft-kips} \quad \text{O.K.}$$

Shear Strength

Special transverse reinforcement for confinement is required over a distance of ℓ_o from each joint face at both column ends where ℓ_o is the largest of (ACI 21.6.4.1):

- Clear span/6 = $(12 - 2.33) \times 12/6 = 19.3$ in.
- Maximum cross-sectional dimension of the column = 28 in. (governs)
- 18 inches

¹⁵ The negative nominal flexural strength $M_{nb}^- = 261.8/0.9 = 290.9$ ft-kips when the effective slab is not considered (see Table 6.9).

Transverse reinforcement within the distance, ℓ_o , shall not be spaced greater than the smallest of (ACI 21.6.4.3):

- Minimum member dimension/4 = $22/4 = 5.5$ in.
- 6(diameter of smallest longitudinal bar) = $6 \times 1.0 = 6.0$ in.
- $s_o = 4 + ((14 - h_x)/3) = 4 + ((14 - 10.0)/3) = 5.3$ in. (governs)

where

h_x = maximum spacing of hoop or crosstie legs on all faces of the 22-inch by 28-inch column

$$= \frac{22 - 2(1.5 + 0.5) - 1.0}{2} + 1.0 + 0.5 = 10.0 \text{ in.}$$

and assuming No. 4 rectangular hoops with crossties around every longitudinal bar.

Minimum required cross-sectional area of rectangular hoop reinforcement, A_{sh} , is the largest value obtained from ACI Equations (21-4) and (21-5):

$$A_{sh} = 0.3 \left(\frac{sb_c f'_c}{f_{yt}} \right) \left[\left(\frac{A_g}{A_{ch}} \right) - 1 \right]$$

$$A_{sh} = 0.09 \left(\frac{sb_c f'_c}{f_{yt}} \right)$$

where b_c = cross-sectional dimension of column core measured to the outside edges of the transverse reinforcement composing area, A_{sh}

A_{ch} = cross-sectional area of column core measured to the outside edges of the transverse reinforcement

In the N-S direction: $b_c = 22 - (2 \times 1.5) = 19.0$ in.

In the E-W direction: $b_c = 28 - (2 \times 1.5) = 25.0$ in.

Thus, $A_{ch} = 19.0 \times 25.0 = 475.0 \text{ in.}^2$

Minimum transverse reinforcement in the N-S direction:

$$A_{sh} = 0.3 \left(\frac{5 \times 19.0 \times 4}{60} \right) \left[\left(\frac{22 \times 28}{475.0} \right) - 1 \right] = 0.56 \text{ in.}^2$$

$$A_{sh} = 0.09 \left(\frac{5 \times 19.0 \times 4}{60} \right) = 0.57 \text{ in.}^2 \quad (\text{governs})$$

In the N-S direction, use No. 4 hoops with one cross-tie spaced at 5.0 inches ($A_{sh} = 0.60 \text{ in.}^2$).

Minimum transverse reinforcement in the E-W direction:

$$A_{sh} = 0.3 \left(\frac{5 \times 25.0 \times 4}{60} \right) \left[\left(\frac{22 \times 28}{475.0} \right) - 1 \right] = 0.74 \text{ in.}^2$$

$$A_{sh} = 0.09 \left(\frac{5 \times 25.0 \times 4}{60} \right) = 0.75 \text{ in.}^2 \quad (\text{governs})$$

In the E-W direction, use No. 4 hoops with three cross-ties spaced at 5.0 in. ($A_{sh} = 1.00 \text{ in.}^2$).

Shear forces are computed from statics assuming that moments of opposite sign act at the joint faces corresponding to the probable flexural strengths, M_{pr} , associated with the range of factored axial loads on the column (ACI 21.6.5.1).

For columns in the first story, it is possible to develop the probable flexural strength of the column at its base. At the top of a first floor column, probable flexural strengths of the beams framing into the joint will usually control. Thus, for a first story column, shear forces are computed based on the probable flexural strength of the column at the base and the probable flexural strengths of the beams at the top. Also, the design shear force must not be taken less than that determined from the structural analysis. Sidesway to the right and to the left must be considered when calculating the maximum design shear forces.

The design strength interaction diagram for this column with $f_y = 75 \text{ ksi}$ and $\phi = 1.0$ is shown in Figure 6.34. At the base of the column, the largest M_{pr} is equal to 828.2 ft-kips, which corresponds to an axial load equal to 266.3 kips (see Table 6.10).

At the top of the column, the positive and negative probable flexural strengths of the beam framing into the joint are equal to 360.1 ft-kips (see Figure 6.31). The moment transferred to the top of the column = $(2 \times 360.1)/2 = 360.1 \text{ ft-kips}$, which is less than 828.2 ft-kips.

The maximum shear force is

$$V_u = \frac{828.2 + 360.1}{12 - (28/12)} = 122.9 \text{ kips}$$

which is greater than the maximum shear force of 45.9 kips obtained from the structural analysis (see Table 6.10).

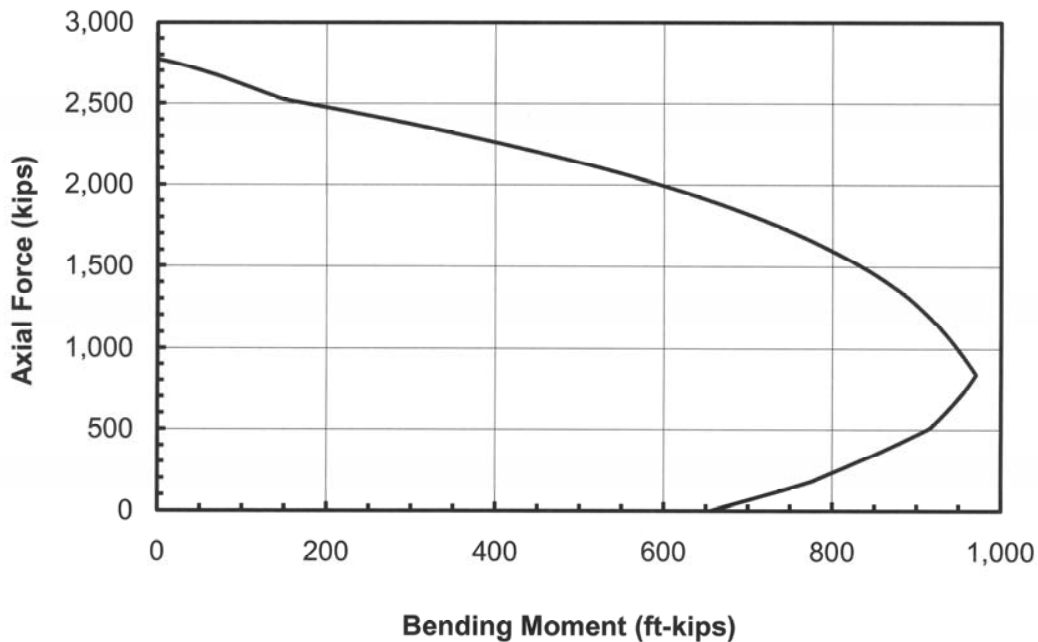

Figure 6.34 Design and Nominal Strength Interaction Diagrams for Column B5 with $f_y = 75$ ksi and $\phi = 1.0$

When determining the nominal shear strength of the column, the shear strength of the concrete, V_c , must be set equal to zero, since one of the factored axial forces including earthquake effects is less than $A_g f'_c / 20 = 123.2$ kips (ACI 21.6.5.2).

Determine the required spacing of transverse reinforcement by ACI Equation (11-15):

$$s = \frac{A_v f_y d}{\frac{V_u}{\phi} - V_c} = \frac{(3 \times 0.2) \times 60 \times 25.5}{\frac{122.9}{0.75} - 0} = 5.6 \text{ in.}$$

Thus, the No. 4 hoops at 5.0 inches at the column ends over the distance, ℓ_o , are also adequate for shear.

The remainder of the column must contain hoop reinforcement with spacing less than or equal to the larger of 6 times the diameter of the longitudinal bars = 6.0 in. or 6 inches (ACI 21.6.4.5). For simpler detailing, use a 5-inch spacing over the entire column length.

Splice Length of Longitudinal Reinforcement

Lap splices in columns of special moment frames are permitted only within the center half of the member and must be designed as tension lap splices (ACI 21.6.3.2). Such splices must be confined over the entire lap length with transverse reinforcement

conforming to ACI 21.6.4.2 and 21.6.4.3. In lieu of lap splices, mechanical splices conforming to ACI 21.1.6 and welded splices conforming to ACI 21.1.7 may be utilized. Since all of the bars are to be spliced at the same location, a Class B splice is required (ACI 12.15.1, 12.15.2).

Determine the development length in tension by ACI Eq. (12-1):

$$\ell_d = \left(\frac{3}{40} \frac{f_y}{\lambda \sqrt{f'_c}} \frac{\psi_t \psi_e \psi_s}{\left(\frac{c_b + K_{tr}}{d_b} \right)} \right) d_b$$

where $\lambda =$ modification factor for lightweight concrete = 1.0 for normal weight concrete

$\psi_t =$ modification factor for reinforcement location = 1.0 for bars other than top bars

$\psi_e =$ modification factor for reinforcement coating = 1.0 for uncoated reinforcement

$\psi_s =$ modification factor for reinforcement size = 1.0 for No. 8 bars

$c_b =$ spacing or cover dimension

$$= 1.5 + 0.5 + \frac{1.0}{2} = 2.5 \text{ in. (governs)}$$

$$= \frac{22 - 2(1.5 + 0.5) - 1.0}{2 \times 2} = 4.25 \text{ in.}$$

$K_{tr} =$ transverse reinforcement index

$$= \frac{40A_{tr}}{sn} = \frac{40 \times 3 \times 0.2}{5 \times 3} = 1.6$$

$$\frac{c_b + K_{tr}}{d_b} = \frac{2.5 + 1.6}{1.0} = 4.1 > 2.5, \text{ use } 2.5$$

Therefore,

$$\ell_d = \left(\frac{3}{40} \frac{60,000}{1.0 \sqrt{4000}} \frac{1.0 \times 1.0 \times 1.0}{2.5} \right) \times 1.0 = 28.5 \text{ in.} = 2.4 \text{ ft}$$

Class B splice length = $1.3\ell_d = 3.1 \text{ ft}$

$$V_h = \frac{2M_u}{\ell_n} = \frac{2 \times 180.1}{12 - \frac{28}{12}} = 37.3 \text{ kips}$$

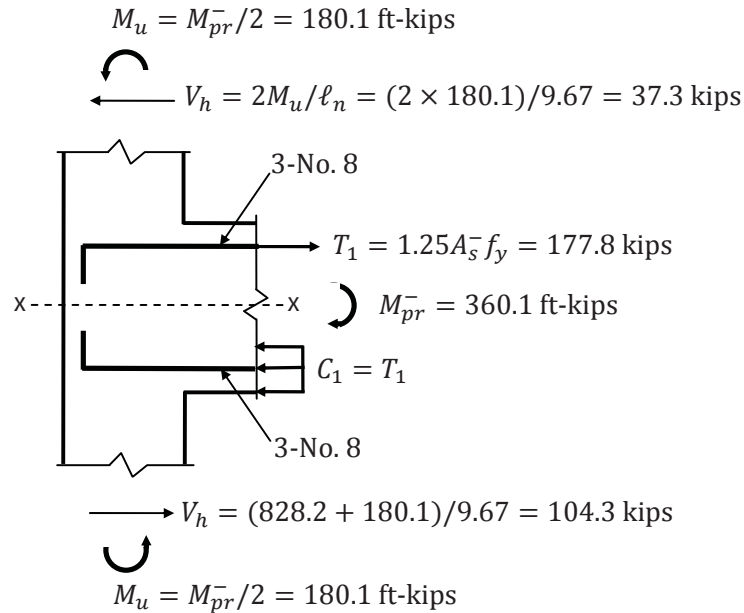

Figure 6.36 Shear Analysis of the Joint at A5

Assuming that the probable flexural strength of this corner column is the same as that of the interior column, the shear force V_h in the column at the bottom of the joint is:

$$V_h = \frac{M_{pr} + M_u}{\ell_n} = \frac{828.1 + 180.1}{12 - \frac{28}{12}} = 104.3 \text{ kips}$$

The largest net shear force at section $x-x$ is $T_1 - V_h = 177.8 - 37.3 = 140.5 \text{ kips}$.

For a joint confined on one face, the design shear strength is determined in accordance with ACI 21.7.4.1:

$$\begin{aligned} \phi V_c &= \phi 12 \sqrt{f'_c} A_j \\ &= 0.85 \times 12 \sqrt{4000} \times (22 \times 28)/1000 = 397.4 \text{ kips} > 140.5 \text{ kips} \quad \text{O.K.} \end{aligned}$$

Beam flexural reinforcement terminated in a column must extend to the far face of the confined column core and must be anchored in tension and compression in accordance with ACI 21.7.5 and ACI Chapter 12, respectively. The development length, ℓ_{dh} , for a

bar with a standard 90-degree hook in normal weight concrete is the largest of the following (ACI 21.7.5.1):

- $8(\text{diameter of beam longitudinal bar}) = 8 \times 1.0 = 8.0 \text{ in.}$
- 6 in.
- $f_y d_b / 65 \sqrt{f'_c} = (60,000 \times 1.0) / 65 \sqrt{4000} = 14.6 \text{ in. (governs)}$

The required development length can be accommodated in the confined core of the 28-inch column.

Reinforcement details of the exterior joint are shown in Figure 6.37.

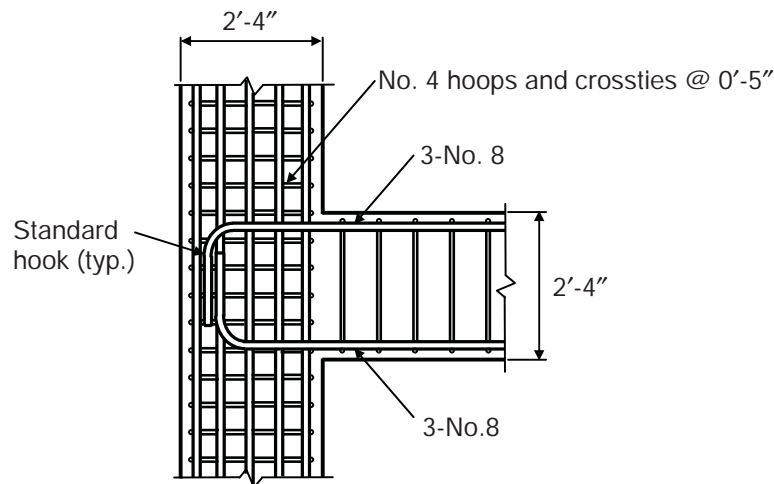

For SI: 1 inch = 25.4 mm; 1 foot = 304.8 mm.

Figure 6.37 Reinforcement Details of the Joint at A5

Interior Joint A5

Since this joint is not confined on all four sides, the transverse reinforcement at the column ends is provided through the joint (ACI 21.7.3.2).

Figure 6.38 shows the interior joint at level 1. The shear force at section $x-x$ is determined by subtracting the column shear force from the tensile force in the top beam reinforcement assuming that the stress in the reinforcement is equal to $1.25f_y$ and the compressive force at the top of the beam on the opposite face of the column (ACI 21.7.2.1).

Since the lengths of the column above and below the joint are equal, moments, M_u , in the columns above and below the joint are equal to one-half of the summation of the negative probable flexural strength and the positive probable flexural strength of the beams
 $= (360.1 + 360.1)/2 = 360.1$ ft-kips. Thus, the shear force, V_h , in the column at the top of the joint is:

$$V_h = \frac{2M_u}{\ell_n} = \frac{2 \times 360.1}{12 - \frac{28}{12}} = 74.5 \text{ kips}$$

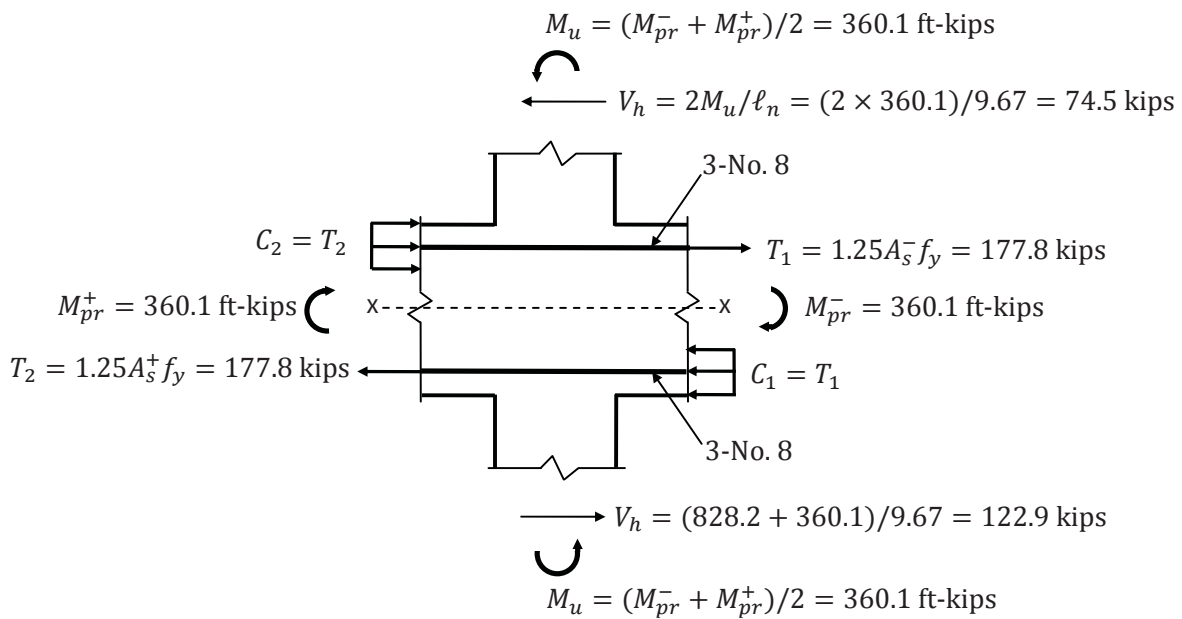

Figure 6.38 Shear Analysis of the Joint at B5

Using the probable flexural strength of the column, the shear force, V_h , in the column at the bottom of the joint is:

$$V_h = \frac{M_{pr} + M_u}{\ell_n} = \frac{828.1 + 360.1}{12 - \frac{28}{12}} = 122.9 \text{ kips}$$

The largest net shear force at section $x-x$ is $T_1 + C_2 - V_h = 177.8 + 177.8 - 74.5 = 281.1$ kips.

For a joint confined on two opposite face, the design shear strength is determined in accordance with ACI 21.7.4.1:

$$\phi V_c = \phi 15 \sqrt{f'_c} A_j$$

$$= 0.85 \times 15\sqrt{4000} \times (22 \times 28)/1000 = 496.7 \text{ kips} > 281.1 \text{ kips} \quad \text{O.K.}$$

Reinforcement details of the interior joint are shown in Figure 6.39.

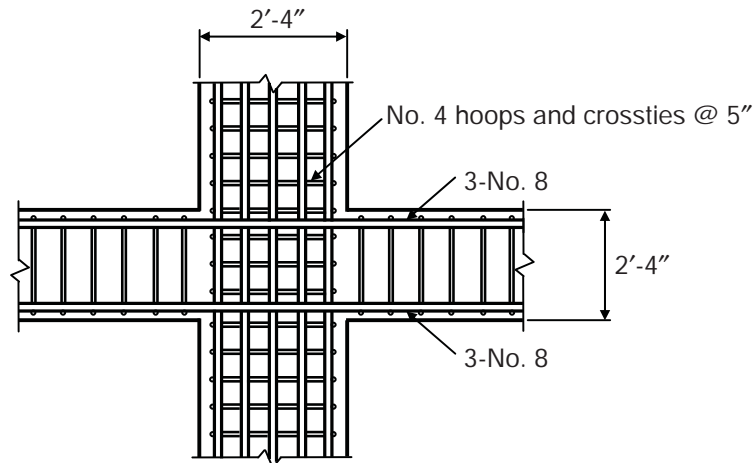

For SI: 1 inch = 25.4 mm; 1 foot = 304.8 mm.

Figure 6.39 Reinforcement Details of the Joint at B5

Part 4: Design the special structural wall on line C

A summary of the governing design axial forces, bending moments, and shear forces is given in Table 6.11 at the base of the structural wall on line C.

Table 6.10 Summary of Design Axial Forces, Bending Moments and Shear Forces for Structural Wall on Line C

Load Case	Axial Force (kips)	Bending Moment (ft-kips)	Shear Force (kips)
Dead (D)	375	0	0
Live (L)	49	0	0
Roof live (L_r)	12	0	0
Seismic (Q_E)	0	$\pm 9,660$	± 356
Load Combination			
$1.4D$	525	0	0
$1.2D + 1.6L + 0.5L_r$	534	0	0
$1.4D + 0.5L + 1.3Q_E$	550	12,558	463
$0.7D - 1.3Q_E$	263	-12,558	-463

The redundancy factor, ρ , is equal to 1.3 for structures assigned to SDC D and above unless one of the two conditions in ASCE/SEI 12.3.4.2 are met. In the east-west direction, the story to length ratio of a wall is equal to $12/19.83 = 0.6 < 1.0$, so there is no requirement that needs to be met under the condition of ASCE/SEI 12.3.4.2(a). However, the walls are not located at the perimeter of the building, so the condition of ASCE/SEI 12.3.4.2(b) is not met. Therefore, in the east-west direction, $\rho = 1.3$.

Shear Design

Special structural walls must be provided with reinforcement in two orthogonal directions in the plane of the wall in accordance with ACI 21.9.2.

The minimum web reinforcement ratio is 0.0025 unless the design shear force is less than or equal to $A_{cv}\lambda\sqrt{f'_c}$ where A_{cv} is the gross area of concrete bounded by the web thickness and the length of the wall in the direction of the shear force. In such cases, minimum reinforcement in accordance with ACI 14.3 must be provided. In this example,

$$A_{cv}\lambda\sqrt{f'_c} = (10 \times 19.67 \times 12)\sqrt{4000}/1000 = 149 \text{ kips} < V_u = 463 \text{ kips}$$

Therefore, the required minimum reinforcement ratio is 0.0025.

Since $V_u = 463 \text{ kips} > 2A_{cv}\lambda\sqrt{f'_c} = 298 \text{ kips}$, two curtains of reinforcement must be provided (ACI 21.9.2.2).

Minimum required area of steel per foot of wall for the horizontal and vertical reinforcement = $0.0025 \times 10 \times 12 = 0.30 \text{ in.}^2$ Try two layers of No. 4 bars @ 14 in. ($A_s = 0.34 \text{ in.}^2/\text{ft}$) in both directions.

The nominal shear strength of structural walls is determined by ACI Equation (21-7):

$$V_n = A_{cv}(\alpha_c\lambda\sqrt{f'_c} + \rho_t f_y)$$

where $\alpha_c = 2.4$ for $h_w/\ell_w = 36/19.67 = 1.8$ (ACI 21.9.4.1).

For two curtains of No. 4 horizontal bars spaced at 14 inches, $\rho_t = (2 \times 0.2)/(10 \times 14) = 0.0029$ and

$$\begin{aligned} \phi V_n &= 0.60 \times (10 \times 19.67 \times 12) \times [2.4\sqrt{4000} + (0.0029 \times 60,000)]/1000 \\ &= 461 \text{ kips} < V_u = 463 \text{ kips} \quad \text{N.G.} \end{aligned}$$

where $\phi = 0.60$ for low-rise walls (ACI 9.3.4(a)).

Therefore, provide two curtains of No. 4 horizontal bars spaced at 12 inches ($\phi V_n = 498$ kips). Note that $V_n = 830$ kips is less than the upper limit on shear strength $8A_{cv}\sqrt{f'_c} = 8 \times 149 = 1,192$ kips (ACI 21.9.4.4).

Reinforcement ratio, ρ_v , for the vertical reinforcement must not be less than ρ_t where $h_w/\ell_w < 2$ (ACI 21.9.4.3). Since $h_w/\ell_w = 1.8$, provide two curtains of No. 4 @ 12 inches vertical reinforcement in the web.

Design for Axial Force and Bending

The interaction diagram of the wall is shown in Figure 6.40. The 20-inch by 20-inch columns at the ends of the wall are reinforced with 12 No. 8 bars and the web is reinforced with two curtains of No. 4 bars @ 12 inches. As seen from the figure, the wall is adequate for the load combinations in Table 6.10.

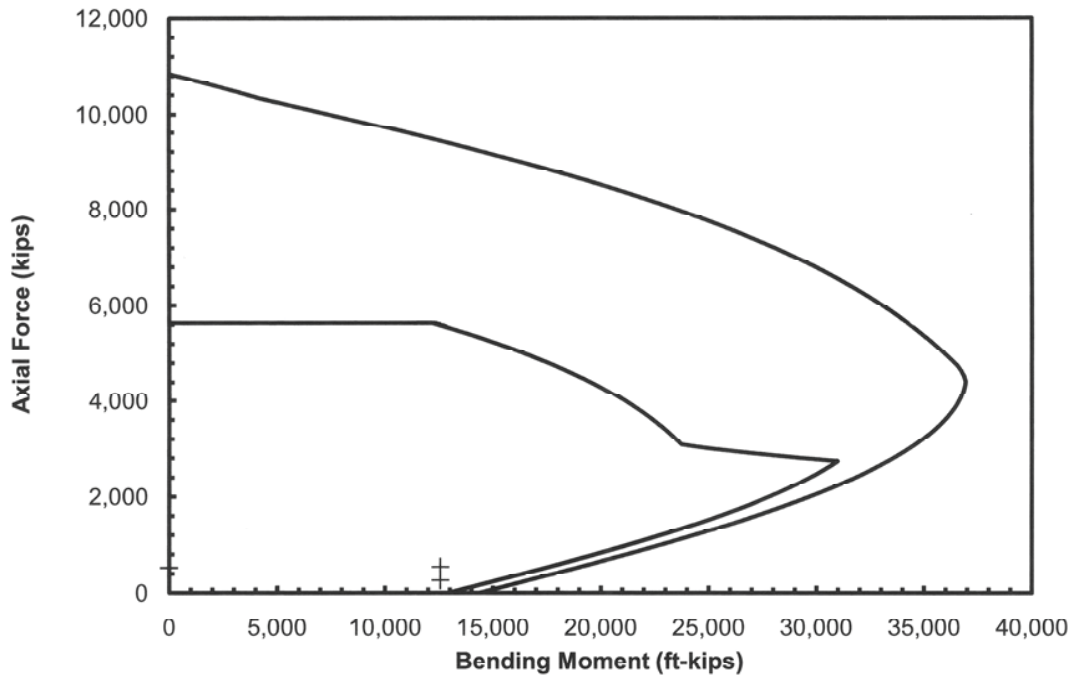

Figure 6.40 Design and Nominal Strength Interaction Diagrams for the Structural Wall on Line C

Boundary Elements

The need for special boundary elements at the edges of the walls is evaluated in accordance with ACI 21.9.6.2 or 21.9.6.3. The displacement-based approach of ACI 21.9.6.2 is utilized for this low-rise wall, since the wall is essentially continuous

over its entire height and it is designed at the base (one critical section) for flexure and axial forces.

Compression zones are to be reinforced with special boundary elements where ACI Equation (21-8) is satisfied:

$$c \geq \frac{\ell_w}{600(\delta_u/h_w)}, \quad \delta_u/h_w \geq 0.007$$

In this example, $\ell_w = 236$ in., $h_w = 432$ in., and the displacement at the top of the wall from the elastic analysis $\delta_{xe} = 0.18$ in. By definition,

$$\delta_u = \delta_x = \frac{C_d \delta_{xe}}{I} = \frac{5 \times 0.18}{1.0} = 0.90 \text{ in.}$$

where δ_x is determined by ASCE/SEI Equation (12.8-15) and the deflection amplification factor, C_d , is given in ASCE/SEI Table 12.2-1.

Since $\delta_u/h_w = 0.90/432 = 0.002 < 0.007$, use $\delta_u/h_w = 0.007$.

Therefore, special boundary elements are required if c is greater than or equal to $236/(600 \times 0.007) = 56.2$ in.

The distance, c , to be used in ACI Equation (21-8) is the largest neutral axis depth calculated for the factored axial force and nominal moment strength consistent with the design displacement, δ_u . From a strain compatibility analysis of the wall section, the largest c is equal to 21.0 inches, which corresponds to a factored axial force of 550 kips and nominal moment strength of 19,587 ft-kips, which is less than 56.2 inches. Therefore, special boundary elements are not required.

Where special boundary elements are not required by ACI 21.9.6.2, the provisions of ACI 21.9.6.5 must be satisfied.

Boundary element transverse reinforcement satisfying the requirements of ACI 21.6.4.2 and 21.9.6.4(a) must be provided at the ends of the wall where longitudinal reinforcement ratio at the wall boundary is greater than $400/f_y$. The reinforcement layout in this example is similar to that shown in the top portion of ACI Figure R21.9.6.5, and the longitudinal reinforcement ratio at the wall boundary is $(12 \times 0.79)/(20 \times 20) = 0.024 > 400/60,000 = 0.007$. Therefore, provide transverse reinforcement in the columns that satisfy ACI 21.6.4.2 and 21.9.6.4(a).

The boundary element must extend a minimum distance of $c - 0.1\ell_w < 0$ or $c/2 = 10.5$ inches. Provide No. 4 hoops and crossties spaced at 8 inches. in the columns.

Splice Length of Reinforcement

ACI 21.9.2.3 requires that reinforcement in structural walls be developed or spliced for the specified yield strength, f_y , in accordance with ACI Chapter 12.

Class B splices are utilized for the vertical bars in the columns and in the web. Mechanical connectors in accordance with ACI 21.1.6 or welded splices in accordance with ACI 21.1.7 may be considered as an alternative to lap splices [ACI 21.9.2.3(d)]. At locations where yielding of the reinforcement is likely to occur due to lateral displacements from the seismic forces, development lengths of longitudinal reinforcement must be 1.25 times the values calculated by Chapter 12 [ACI 21.9.2.3(c)].

The anticipated plastic hinge length at the base of a wall is the larger of $\ell_w = 19.67$ ft (governs) or $M_u/4V_u = 12,558/(4 \times 463) = 6.8$ ft. Therefore, the development lengths of the longitudinal reinforcement must be $1.25\ell_d$ over approximately two of the three stories of this building.

For the No. 8 vertical bars in the columns at the ends of the wall:

$$\ell_d = \left(\frac{3}{40} \frac{f_y}{\lambda \sqrt{f'_c}} \frac{\psi_t \psi_e \psi_s}{\left(\frac{c_b + K_{tr}}{d_b} \right)} \right) d_b$$

where $\lambda =$ modification factor for lightweight concrete = 1.0 for normal weight concrete

$\psi_t =$ modification factor for reinforcement location = 1.0 for bars other than top bars

$\psi_e =$ modification factor for reinforcement coating = 1.0 for uncoated reinforcement

$\psi_s =$ modification factor for reinforcement size = 1.0 for No. 8 bars

$c_b =$ spacing or cover dimension

$$= 1.5 + 0.5 + \frac{1.0}{2} = 2.5 \text{ in.}$$

$$= \frac{20 - 2(1.5 + 0.5) - 1.0}{2 \times 3} = 2.5 \text{ in.}$$

$K_{tr} =$ transverse reinforcement index

$$= \frac{40A_{tr}}{sn} = \frac{40 \times 3 \times 0.2}{8 \times 4} = 0.75$$

$$\frac{c_b + K_{tr}}{d_b} = \frac{2.5 + 0.75}{1.0} = 3.3 > 2.5, \text{ use } 2.5$$

Therefore,

$$\ell_d = \left(\frac{3}{40} \frac{60,000}{1.0\sqrt{4000}} \frac{1.0 \times 1.0 \times 1.0}{2.5} \right) \times 1.0 = 28.5 \text{ in.} = 2.4 \text{ ft}$$

In the plastic hinge zone, development length = $1.25 \times 2.4 = 3.0 \text{ ft}$

Class B splice length = $1.3\ell_d = 3.9 \text{ ft}$

Use a 4-foot splice length in the plastic hinge zone for the No. 8 vertical bars in the columns. For simpler detailing, this splice length can be used over the entire height of the building.

For the No. 4 vertical bars in the web of the wall:

$$\ell_d = \left(\frac{3}{40} \frac{f_y}{\lambda\sqrt{f'_c}} \frac{\psi_t\psi_e\psi_s}{\left(\frac{c_b + K_{tr}}{d_b}\right)} \right) d_b$$

where $\lambda =$ modification factor for lightweight concrete = 1.0 for normal weight concrete

$\psi_t =$ modification factor for reinforcement location = 1.0 for bars other than top bars

$\psi_e =$ modification factor for reinforcement coating = 1.0 for uncoated reinforcement

$\psi_s =$ modification factor for reinforcement size = 0.8 for No. 4 bars

$c_b =$ spacing or cover dimension

$$= 0.75 + 0.5 + \frac{0.5}{2} = 1.5 \text{ in. (governs)}$$

$$= \frac{12}{2} = 6.0 \text{ in.}$$

$K_{tr} =$ transverse reinforcement index = 0

$$\frac{c_b + K_{tr}}{d_b} = \frac{1.5 + 0}{0.5} = 3.0 > 2.5, \text{ use } 2.5$$

Therefore,

$$\ell_d = \left(\frac{3}{40} \frac{60,000}{1.0\sqrt{4000}} \frac{1.0 \times 1.0 \times 0.8}{2.5} \right) \times 0.5 = 11.4 \text{ in.} < 12.0 \text{ in., use } 12.0 \text{ in.}$$

In the plastic hinge zone, development length = $1.25 \times 1.0 = 1.25$ ft

Class B splice length = $1.3\ell_d = 1.6$ ft

Use a 1 foot, 8 inch splice length in the plastic hinge zone for the No. 4 vertical bars in the web. For simpler detailing, this splice length can be used over the entire height of the building.

The splice length of the No. 4 horizontal bars in the web is 1 foot, 4 inches. Since $V_u > A_{cv}\lambda\sqrt{f'_c}$, the No. 4 bars must have a standard hook that engages the No. 8 edge reinforcement, or the No. 8 edge reinforcement must be enclosed in No. 4 U-stirrups spaced at 12 inches that are spliced to the No. 4 horizontal bars in the web (ACI 21.9.6.5(b)). The first of the two options is provided in this example.

Reinforcement details for the structural wall along line C are shown in Figure 6.41.

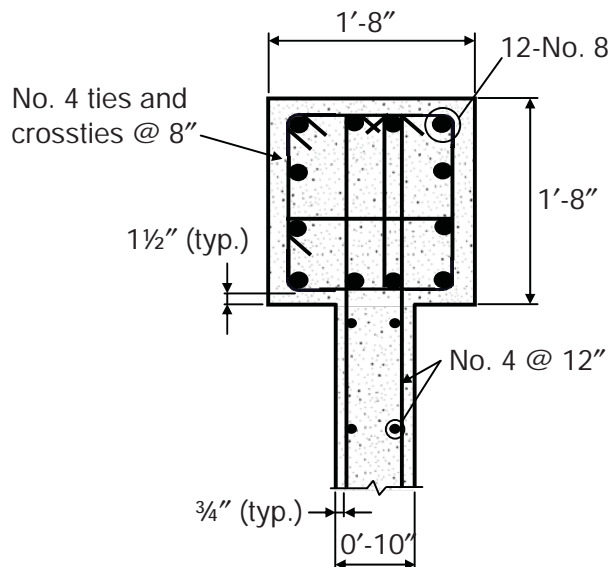

For SI: 1 inch = 25.4 mm; 1 foot = 304.8 mm.

Figure 6.41 Reinforcement Details for the Structural Wall on Line C

Part 5: Check the adequacy of the elements that are not part of the seismic-force-resisting system

The deformation compatibility requirements of ASCE/SEI 12.12.4 must be satisfied for structures assigned to SDC D and above. According to the exception in that section, the requirements of ACI 21.13 apply to reinforced concrete members not designated as part of the seismic-force-resisting system.

Frame Members Other Than the Two-way Slab without Beams

Frame members, except two-way slabs without beams, must be detailed according to ACI 21.13.3 or 21.13.4 depending on the magnitude of the moments induced in those members when subjected to the design displacement $\delta_u = \delta_x = C_d \delta_{xe}/I$. The design displacements, δ_u , are obtained from the analysis considering the code-prescribed seismic forces applied to only the elements of the seismic-force-resisting system.

In lieu of a more accurate analysis, the reactions, F_M , in the members that are not part of the seismic-force-resisting system due to the earthquake-induced displacements, δ_x , can be determined by the following equation:¹⁶

$$F_M = C_d \left(\frac{\delta_x}{\delta'_x} \right) F'_M = C_d \left(\frac{C_d \delta_{xe}/I}{C_d \delta'_{xe}/I} \right) F'_M = C_d \left(\frac{\delta_{xe}}{\delta'_{xe}} \right) F'_M$$

where F'_M = force in the member caused by the code-prescribed seismic forces applied to the entire structure

δ'_{xe} = displacements of the entire structure caused by the code-prescribed seismic forces

A three-dimensional analysis was performed on the entire structure subjected to the code-prescribed seismic forces in the north-south and east-west directions. The lateral displacement results are summarized in Tables 6.12 and 6.13 for analyses in the north-south and east-west directions, respectively.¹⁷

The forces on columns A3 and B3 in the first story are summarized in Tables 6.14 and 6.15, respectively, for seismic forces in the north-south and east-west directions.

¹⁶ This procedure is based on the method in *Seismic Design Manual—Volume 1, Code Application Examples*, Structural Engineers Association of California, Sacramento, CA, 1999. In lieu of using this approximate method, the forces in the members that are not part of the seismic-force-resisting system can be obtained by analyzing the structure subjected to the design displacements, δ_x , applied at each floor level.

¹⁷ The maximum story drift occurs in the north-south direction and is equal to 3.58 inches, which is less than the allowable story drift of $0.025 \times 12 \times 12 = 3.60$ in. for structures, other than masonry shear wall structures, four stories or less with interior walls, partitions, ceilings and exterior wall systems that have been designed to accommodate the story drifts (see ASCE/SEI Table 12.12-1). The following coefficients were applied to the gross moments of inertia in the analyses to account for cracking: 0.35 for the beams, 0.70 for the columns and 0.35 for the structural walls.

Table 6.12 Lateral Displacements / Drift (in.) Due to Seismic Forces in N-S Direction

Story	δ_{xe}	δ_x	Δ	δ'_{xe}	δ_{xe}/δ'_{xe}
3	1.57	8.64	2.64	0.56	2.81
2	1.09	6.00	3.58	0.41	2.66
1	0.44	2.42	2.42	0.20	2.20

Table 6.13 Lateral Displacements / Drift (in.) Due to Seismic Forces in E-W Direction

Story	δ_{xe}	δ_x	Δ	δ'_{xe}	δ_{xe}/δ'_{xe}
3	0.18	0.90	0.35	0.08	2.25
2	0.11	0.55	0.35	0.05	2.20
1	0.04	0.20	0.20	0.02	2.00

Table 6.14 Summary of Design Axial Forces, Bending Moments and Shear Forces for Column A3 in the First Story

Load Case	N-S Seismic Forces			E-W Seismic Forces		
	Axial Force (kips)	Bending Moment (ft-kips)	Shear Force (kips)	Axial Force (kips)	Bending Moment (ft-kips)	Shear Force (kips)
Dead (D)	90.9	18.1	1.5	90.9	18.1	1.5
Live (L)	31.7	9.1	0.8	31.7	9.1	0.8
Roof live (L_r)	4.0	0	0	4.0	0	0
Seismic (E)	81.7	20.6	3.4	1.0	8.6	1.4
Load Combination						
1.4 D	127.3	25.3	2.1	127.3	25.3	2.1
1.2 D + 1.6 L + 0.5 L_r	161.8	36.3	3.1	161.8	36.3	3.1
1.2 D + 0.5 L + E	206.6	46.9	5.6	125.9	34.9	3.6
0.9 D - E	0.1	4.3	2.1	80.8	7.7	0.1

In the load combinations that include seismic effects, which are prescribed in ACI 21.13.3, the values of E are the forces in the columns due to the displacements, δ_x . When the approximate method outlined above is utilized, $E = F_M$. The forces on the columns obtained from the analysis of the entire structure in the north-south direction in the first story are multiplied by $C_D(\delta_{xe}/\delta'_{xe}) = 5.5 \times 2.20 = 12.1$ to determine the forces due to the earthquake-induced displacements, where $(\delta_{xe}/\delta'_{xe})$ is given in Table 6.12.

Table 6.15 Summary of Design Axial Forces, Bending Moments and Shear Forces for Column B3 in the First Story

Load Case	N-S Seismic Forces			E-W Seismic Forces		
	Axial Force (kips)	Bending Moment (ft-kips)	Shear Force (kips)	Axial Force (kips)	Bending Moment (ft-kips)	Shear Force (kips)
Dead (D)	190.0	3.4	0.3	190.0	3.4	0.3
Live (L)	67.7	1.7	0.1	67.7	1.7	0.1
Roof live (L_r)	8.5	0	0	8.5	0	0
Seismic (E)	45.5	157.4	26.2	12.6	6.6	1.1
Load Combination						
1.4 D	266.0	4.8	0.4	266.0	4.8	0.4
1.2 D + 1.6 L + 0.5 L_r	340.6	6.8	0.5	340.6	6.8	0.5
1.2 D + 0.5 L + E	307.4	162.3	26.6	274.5	11.5	1.5
0.9 D - E	125.5	154.3	25.9	158.4	3.5	0.8

Similarly, in the east-west direction, $C_D(\delta_{xe}/\delta'_{xe}) = 5.0 \times 2.0 = 10.0$, where $(\delta_{xe}/\delta'_{xe})$ is given in Table 6.13.¹⁸ For example, the axial force in column A3 due to the code-prescribed seismic forces is equal to 6.75 kips at the first story from the analysis of the entire structure in the north-south direction. Thus, $E = F_M = 12.1 \times 6.75 = 81.7$ kips, which is shown in Table 6.14.

Column A3. Based on the governing load combinations in Table 6.14, a 20-inch by 20-inch column with eight No. 7 bars ($A_{st} = 0.012A_g$) is adequate for column A3 (see Figure 6.42).¹⁹ Since the maximum factored gravity axial force exceeds $A_g f'_c / 10 = 160.0$ kips, longitudinal reinforcement must satisfy ACI 21.6.3.1. This provision is satisfied, since the provided area of longitudinal reinforcement is between $0.01A_g$ and $0.06A_g$.

Transverse reinforcement requirements also depend on the magnitude of the factored gravity axial force. As noted above, it exceeds $A_g f'_c / 10$, but it is less than $0.35P_o = 0.35[0.85f'_c(A_g - A_{st}) + f_y A_{st}] = 571.1$ kips. Therefore, the transverse reinforcement requirements and shear requirements of ACI 21.6.4.2 and 21.6.5, respectively, must be satisfied (ACI 21.13.3.2).

¹⁸ Values of the deflection amplification factor, C_D , for the special moment frames and the building frame system with special structural walls are given in ASCE/SEI Table 12.2-1.

¹⁹ The 20-inch by 20-inch column size is needed primarily to resist two-way shear stresses in the slab. Slenderness effects in accordance with ACI 10.10 need not be considered in the design of this column. Also, P-Delta effects in accordance with ASCE/SEI 12.8.7 need not be considered.

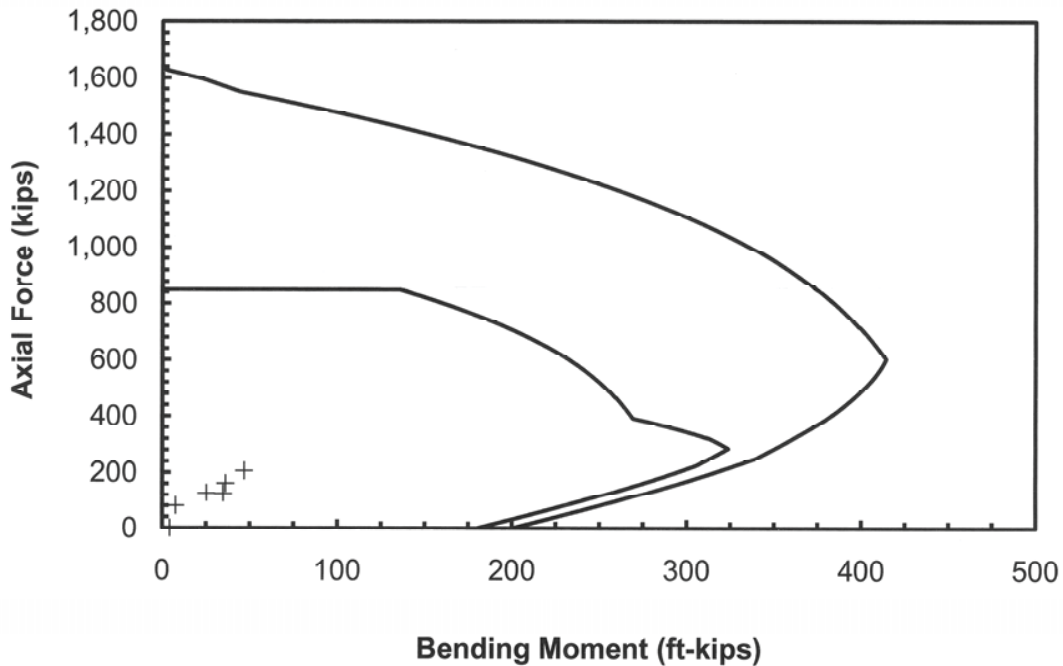

Figure 6.42 Design and Nominal Strength Interaction Diagrams for Column A3

According to ACI 21.13.3.2, longitudinal spacing of ties must be less than or equal to 6 times the diameter of the smallest longitudinal bar = $6 \times 0.875 = 5.3$ in. (governs) or 6.0 inches for the full height of the column.

Shear forces are computed from statics assuming that moments of opposite sign act at the joint faces corresponding to the probable flexural strengths, M_{pr} , associated with the range of factored axial loads on the column (ACI 21.6.5.1). The largest M_{pr} is equal to 358.7 ft-kips, which corresponds to an axial load equal to 206.6 kips (see Table 6.14).

Assuming that plastic hinges form simultaneously at the ends of the column, the maximum shear force is:

$$V_u = \frac{358.7 + 358.7}{12 - (9/12)} = 63.8 \text{ kips}$$

which is greater than the maximum shear force of 5.6 kips obtained from the structural analysis (see Table 6.14).

When determining the nominal shear strength of the column, the shear strength of the concrete, V_c , must be set equal to zero, since one of the factored axial forces including earthquake effects is less than $A_g f'_c / 20 = 80.0$ kips (ACI 21.6.5.2).

Determine the required spacing of transverse reinforcement by ACI Equation (11-15) assuming No. 4 ties and one crosstie:

$$s = \frac{A_v f_y d}{\frac{V_u}{\phi} - V_c} = \frac{(3 \times 0.2) \times 60 \times 17.5}{\frac{63.8}{0.75} - 0} = 7.4 \text{ in.}$$

Thus, the No. 4 ties spaced at 5.0 inches that are required by ACI 21.13.3.2 are also adequate for shear. Provide such ties and crossties over the full column length.

Column B3. Based on the governing load combinations in Table 6.15, a 20-inch by 20-inch column with eight No. 7 bars ($A_{st} = 0.012A_g$) is adequate for column B3 (see Figure 6.43). Since the maximum factored gravity axial force exceeds $A_g f'_c / 10 = 160.0$ kips, longitudinal reinforcement must satisfy ACI 21.6.3.1. This provision is satisfied, since the provided area of longitudinal reinforcement is between $0.01A_g$ and $0.06A_g$.

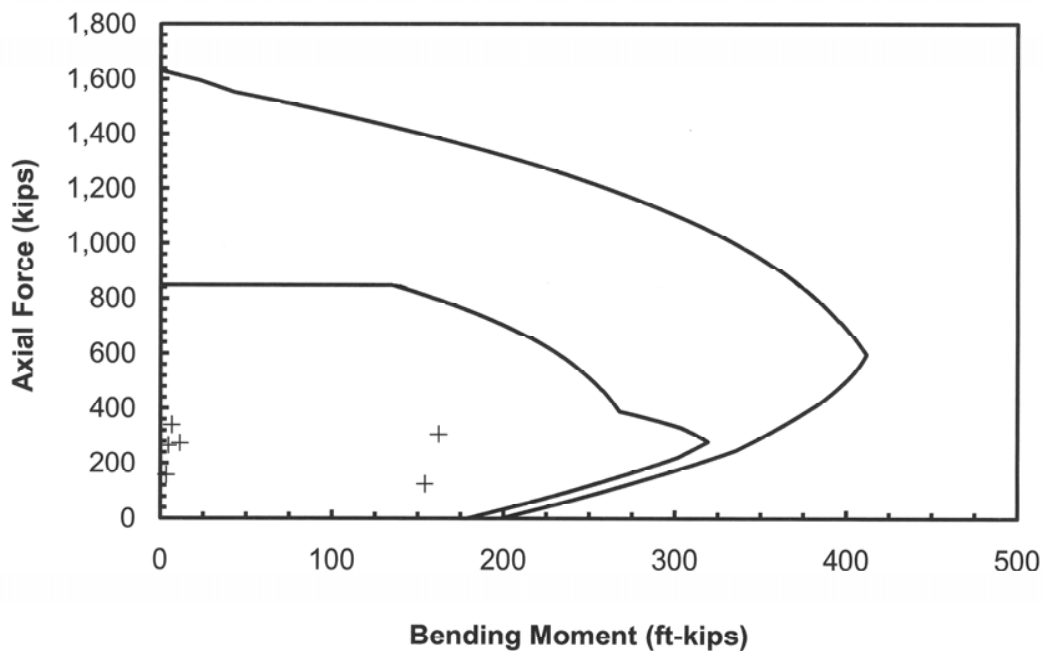

Figure 6.43 Design and Nominal Strength Interaction Diagrams for Column B3

Transverse reinforcement requirements and shear requirements for this column are the same as those for column A3.

Provide No. 4 ties and crossties at a 5.0 inches spacing over the full column length.

Lap splices of the longitudinal reinforcement for both columns must be Class B lap splices determined in accordance with ACI Chapter 12. These splices can occur just above the slab at each floor level.

In this example, it is evident that calculating the effects of the design displacements on the columns resulted in less stringent detailing requirements than those that would have been required if such effects were not determined.

Two-way Slab without Beams

Provisions for slab-column connections of two-way slabs without beams are given in ACI 21.13.6.

In lieu of providing shear reinforcement in accordance with ACI 21.13.6, check if either ACI 21.13.6(a) or 21.13.6(b) are satisfied.

ACI 21.13.6(a) requires calculation of shear stress due to the factored shear force and the moment induced by the design displacement $\delta_u = \delta_x$. Instead of calculating such shear stresses, check if the requirements of ACI 21.13.6(b) are satisfied for columns A3 and B3 for seismic forces in the north-south direction.

Column A3. The factored shear force, V_{ug} , on the slab critical section for two-way action due to gravity loads and the design shear strength, ϕV_c , are determined at the roof level and at the typical floor levels.

- Roof level

$$q_D = \left(\frac{9}{12} \times 150 \right) + 10 = 122.5 \text{ psf}$$

$$q_L = 20 \text{ psf}$$

$$q_u = (1.2 \times 122.5) + (0.5 \times 20) = 157 \text{ psf}$$

Critical section dimensions:

$$\text{Average } d = 9.0 - 1.25 = 7.75 \text{ in.}$$

$$b_1 = 20 + \frac{7.75}{2} = 23.875 \text{ in.}$$

$$b_2 = 20 + 7.75 = 27.75 \text{ in.}$$

$$V_{ug} = 0.157 \left[(18 \times 11.83) - \frac{23.875 \times 27.75}{144} \right] = 32.7 \text{ kips}$$

For square columns, ACI Equation (11-33) governs:

$$\phi V_c = \phi 4\lambda\sqrt{f'_c}b_o d = 0.75 \times 4.0\sqrt{4000} \times 75.5 \times 7.75/1000 = 111.0 \text{ kips}$$

Maximum story drift at roof level = 2.64 in. (see Table 6.12)

$$\text{Design story drift ratio} = \text{story drift/story height} = 2.64/(12 \times 12) = 0.0183$$

Limiting design story drift ratio:

$$0.035 - 0.05(V_{ug}/\phi V_c) = 0.035 - 0.05(32.7/111.0) = 0.0203 > 0.005$$

Since the design story drift ratio = 0.0183 < 0.0203, slab shear reinforcement satisfying the requirements of ACI 21.13.6 need not be provided.

- Typical floor levels

$$q_D = \left(\frac{9}{12} \times 150\right) + 30 = 142.5 \text{ psf}$$

$$q_L = 80 \text{ psf}$$

$$q_u = (1.2 \times 142.5) + (0.5 \times 80) = 211 \text{ psf}$$

$$V_{ug} = 0.211 \left[(18 \times 11.83) - \frac{23.875 \times 27.75}{144} \right] = 44.0 \text{ kips}$$

For square columns, ACI Equation (11-33) governs:

$$\phi V_c = \phi 4\lambda\sqrt{f'_c}b_o d = 0.75 \times 4.0\sqrt{4000} \times 75.5 \times 7.75/1000 = 111.0 \text{ kips}$$

Maximum story drift at level 2 = 3.58 in. (see Table 6.12)

$$\text{Design story drift ratio} = \text{story drift/story height} = 3.58/(12 \times 12) = 0.0249$$

Limiting design story drift ratio:

$$0.035 - 0.05(V_{ug}/\phi V_c) = 0.035 - 0.05(44.0/111.0) = 0.0152 > 0.005$$

Since the design story drift ratio = 0.0249 > 0.0152, slab shear reinforcement satisfying the requirements of ACI 21.13.6 must be provided.²⁰ Provide either stirrups in accordance with ACI 11.11.3 or headed shear stud reinforcement in accordance with ACI 11.11.5. In either case, the nominal shear strength of the shear reinforcement must be greater than or equal to $3.5\sqrt{f'_c}b_o d$ and the reinforcement must extend at least 4 times the slab thickness from the face of the column (see ACI

²⁰ In lieu of providing shear reinforcement, the provisions of ACI 21.13.6(a) can be checked. That check is not done in this example.

Figure R11.11.3(e) for arrangement of stirrup shear reinforcement at an edge column and ACI Figure R11.11.5 for arrangement of headed shear stud reinforcement at an edge column).

To illustrate the design of the required shear reinforcement, provide headed shear stud reinforcement around column A3. In order to satisfy the requirements of ACI 11.11.5.3 related to spacing between adjacent shear reinforcement elements, three lines of elements must be provided on each column face (provided spacing $\cong (20 - 1)/2 = 9.5 \text{ in.} < 2d = 15.5 \text{ in.}$).

Assuming $\frac{1}{2}$ -inch diameter studs ($A_{stud} = 0.196 \text{ in.}^2$), the required spacing is:

$$s = \frac{A_v f_{yt} d}{V_s} = \frac{(9 \times 0.196) \times 51,000 \times 7.75}{3.5 \sqrt{4000} \times 75.5 \times 7.75} = 5.3 \text{ in.}$$

where A_v is the cross-sectional area of all the shear reinforcement on one peripheral line that is approximately parallel to the perimeter of the column section and the minimum specified yield strength of the studs is 51,000 psi (see ACI R3.5.5).

Maximum spacing = $0.75d = 5.8 \text{ in.}$ (ACI 11.11.5.2)

Assuming a 5-inch spacing, check the requirement of ACI 11.11.5.1:

$$\frac{A_v f_{yt}}{b_o s} = \frac{(9 \times 0.196) \times 51,000}{75.5 \times 5} = 238.3 \text{ psi} > 2\sqrt{f'_c} = 126.5 \text{ psi} \quad \text{O.K.}$$

The studs must extend a distance of at least $4h = 36 \text{ in.}$ from the faces of the column (ACI 21.13.6) with the first peripheral line of shear reinforcement located no farther than $d/2 = 3.9 \text{ in.}$ from the column face.

No additional studs are required for shear stresses from gravity load effects.

Figure 6.44 illustrates the shear reinforcement detail for the joint at column A3.

Column B3. The factored shear force, V_{ug} , on the slab critical section for two-way action due to gravity loads and the design shear strength, ϕV_c , are determined at the roof level and at the typical floor levels.

- Roof level

$$q_D = \left(\frac{9}{12} \times 150 \right) + 10 = 122.5 \text{ psf}$$

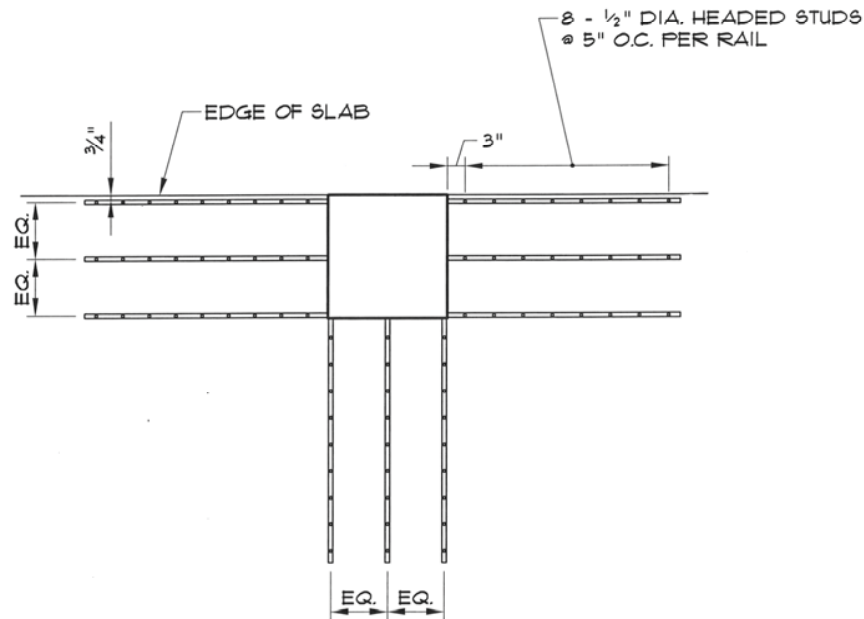

For SI: 1 inch = 25.4 mm.

Figure 6.44 Shear Stud Reinforcement Details for the Joint at Column A3 at Typical Floor Levels

$$q_L = 20 \text{ psf}$$

$$q_u = (1.2 \times 122.5) + (0.5 \times 20) = 157 \text{ psf}$$

Critical section dimensions:

$$\text{Average } d = 9.0 - 1.25 = 7.75 \text{ in.}$$

$$b_1 = b_2 = 20 + 7.75 = 27.75 \text{ in.}$$

$$V_{u.g} = 0.157 \left[(18 \times 22) - \frac{27.75^2}{144} \right] = 61.3 \text{ kips}$$

For square columns, ACI Equation (11-33) governs:

$$\phi V_c = \phi 4 \lambda \sqrt{f'_c} b_o d = 0.75 \times 4.0 \sqrt{4000} \times 111.0 \times 7.75 / 1000 = 163.2 \text{ kips}$$

Maximum story drift at roof level = 2.64 in. (see Table 6.12)

$$\text{Design story drift ratio} = \text{story drift} / \text{story height} = 2.64 / (12 \times 12) = 0.0183$$

Limiting design story drift ratio:

$$0.035 - 0.05(V_{u.g} / \phi V_c) = 0.035 - 0.05(61.3 / 163.2) = 0.0162 > 0.005$$

Since the design story drift ratio = 0.0183 > 0.0162, slab shear reinforcement satisfying the requirements of ACI 21.13.6 must be provided (see ACI Figure R11.11.3(d) for arrangement of stirrup shear reinforcement at an interior column and ACI Figure R11.11.5 for arrangement of headed shear stud reinforcement at an interior column).

Provide headed shear stud reinforcement around column B3. In order to satisfy the requirements of ACI 11.11.5.3 related to spacing between adjacent shear reinforcement elements, three lines of elements must be provided on each column face (provided spacing $\cong (20 - 1)/2 = 9.5$ in. < $2d = 15.5$ in.).

Assuming $\frac{1}{2}$ -inch diameter studs ($A_{stud} = 0.196$ in.²), the required spacing is:

$$s = \frac{A_v f_{yt} d}{V_s} = \frac{(12 \times 0.196) \times 51,000 \times 7.75}{3.5 \sqrt{4000} \times 111.0 \times 7.75} = 4.9 \text{ in.}$$

where A_v is the cross-sectional area of all the shear reinforcement on one peripheral line that is approximately parallel to the perimeter of the column section and the minimum specified yield strength of the studs is 51,000 psi (see ACI R3.5.5).

Maximum spacing = $0.75d = 5.8$ in. (ACI 11.11.5.2)

Assuming a 4.5-inch spacing, check the requirement of ACI 11.11.5.1:

$$\frac{A_v f_{yt}}{b_o s} = \frac{(12 \times 0.196) \times 51,000}{111.0 \times 4.5} = 240.1 \text{ psi} > 2\sqrt{f'_c} = 126.5 \text{ psi} \quad \text{O.K.}$$

As noted above, the studs must extend a distance of at least $4h = 36$ in. from the faces of the column (ACI 21.13.6) with the first peripheral line of shear reinforcement located no farther than $d/2 = 3.9$ in. from the column face.

No additional studs are required for shear stresses from gravity loads.

Figure 6.45 illustrates the shear reinforcement detail for the joint at column B3.

- Typical floor levels

$$q_D = \left(\frac{9}{12} \times 150 \right) + 30 = 142.5 \text{ psf}$$

$$q_L = 80 \text{ psf}$$

$$q_u = (1.2 \times 142.5) + (0.5 \times 80) = 211 \text{ psf}$$

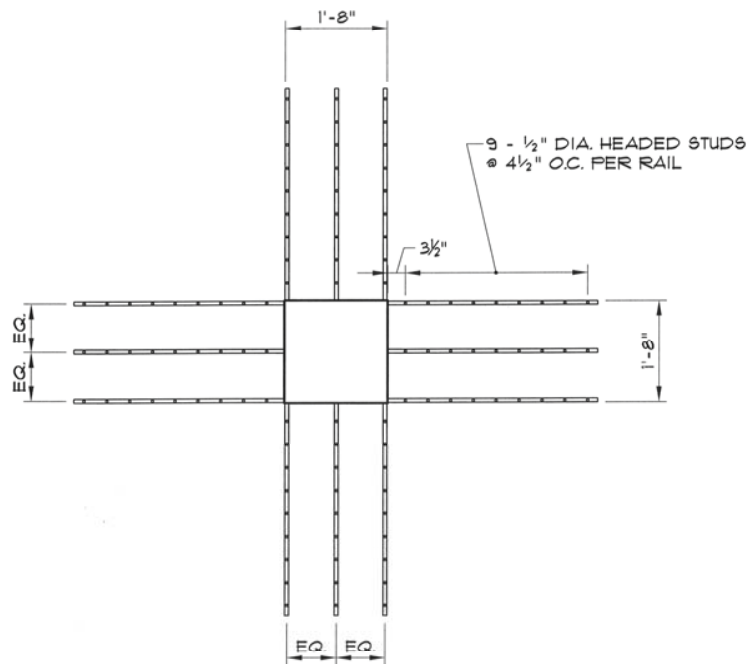

For SI: 1 inch = 25.4 mm.

Figure 6.45 Shear Stud Reinforcement Details for the Joint at Column B3

$$V_{ug} = 0.211 \left[(18 \times 22) - \frac{27.75^2}{144} \right] = 82.4 \text{ kips}$$

For square columns, ACI Equation (11-33) governs:

$$\phi V_c = \phi 4\lambda \sqrt{f'_c} b_o d = 0.75 \times 4.0 \sqrt{4000} \times 111.0 \times 7.75/1000 = 163.2 \text{ kips}$$

Maximum story drift at level 2 = 3.58 in. (see Table 6.12)

Design story drift ratio = story drift/story height = 3.58/(12 × 12) = 0.0249

Limiting design story drift ratio:

$$0.035 - 0.05(V_{ug}/\phi V_c) = 0.035 - 0.05(82.4/163.2) = 0.0098 > 0.005$$

Since the design story drift ratio = 0.0249 > 0.0098, slab shear reinforcement satisfying the requirements of ACI 21.13.6 must be provided [see ACI Figure R11.11.3(d) for arrangement of stirrup shear reinforcement at an interior column and ACI Figure R11.11.5 for arrangement of headed shear stud reinforcement at an interior column].

Provide the same shear stud reinforcement that is required at the roof level.

In addition to the required shear reinforcement due to the design displacement, flexural reinforcement must be provided in the slab, which is determined for the effects of the gravity loads. See Chapter 4 of this publication for design and detailing procedures for two-way slabs without beams.

Part 6: Design the diaphragm and the collector elements in the N-S and E-W directions

No significant openings occur in the roof diaphragm, and an 18-foot by 22-foot opening occurs in the diaphragms at levels 1 and 2. Check if there exists a Type 3 diaphragm discontinuity irregularity at levels 1 and 2 in accordance with ASCE/SEI Table 12.3-1:

$$\frac{\text{Area of diaphragm opening}}{\text{Gross enclosed diaphragm opening}} = \frac{18 \times 22}{72 \times 110} = 0.05 < 0.50$$

Also, since the area of the opening in diaphragms at levels 1 and 2 is only 5 percent of the gross area, the change in diaphragm stiffness from the roof to level 2 is less than 50 percent by inspection. Thus, a Type 3 diaphragm discontinuity irregularity does not exist, and the design forces need not be increased in accordance with the requirements in ASCE/SEI 12.3.3.4.

Diaphragm Design Forces

ASCE/SEI Equation (12.10-1) is used to determine the design seismic force, F_{px} , on the diaphragm.²¹

$$F_{px} = \left(\frac{\sum_{i=x}^n F_i}{\sum_{i=x}^n w_i} \right) w_{px}$$

$$\leq 0.4 S_{DS} I w_{px} = 0.4 w_{px}$$

$$\geq 0.2 S_{DS} I w_{px} = 0.2 w_{px}$$

where F_i = the seismic design force applied at level i

w_i = the weight tributary to level i

w_{px} = the weight tributary to the diaphragm at level x

Tables 6.16 and 6.17 contain diaphragm forces at each level of the building in the north-south and east-west directions, respectively.²²

²¹ The effects from wind forces do not govern in this example.

²² The base shear, V , for the special moment frame in the N-S direction is equal to 508 kips, and the base shear for the building frame system in the E-W is equal to 677 kips. The Equivalent Lateral Force Procedure of ASCE/SEI 12.8 was used to compute V in both cases using an approximate period equal to 0.40 sec in the N-S direction and 0.29 sec in the E-W direction.

Table 6.16 Design Seismic Diaphragm Forces in N-S Direction

Level	w_x (kips)	Σw_x (kips)	F_x (kips)	ΣF_x (kips)	$\Sigma F_x / \Sigma w_x$	w_{px} (kips)	F_{px} (kips)
3	1,167	1,167	227	227	0.200*	1,167	233
2	1,448	2,615	187	414	0.200*	1,448	290
1	1,448	4,063	94	508	0.200*	1,448	290

* Minimum value governs.

Table 6.17 Design Seismic Diaphragm Forces in E-W Direction

Level	w_x (kips)	Σw_x (kips)	F_x (kips)	ΣF_x (kips)	$\Sigma F_x / \Sigma w_x$	w_{px} (kips)	F_{px} (kips)
3	1,167	1,167	302	302	0.259	1,167	302
2	1,448	2,615	250	552	0.211	1,448	306
1	1,448	4,063	125	677	0.200*	1,448	290

* Minimum value governs.

According to ASCE/SEI 12.10.1.1, ρ shall equal to 1.0 where inertial forces are calculated in accordance with ASCE/SEI Equation (12.10-1), and for transfer forces, ρ shall be the same as that used for the structure.

Design of Roof Diaphragm in N-S Direction

Since the diaphragm is rigid, the 233-kip diaphragm force at the roof (level 3) is distributed to the frames in proportion to their relative stiffnesses. This force is applied at the location of the center of mass, which must be displaced from its actual location a distance of 5 percent of the dimension of the building perpendicular to the direction of the applied force = $0.05 \times 72 = 3.6$ ft (ASCE/SEI 12.8.4.2).

The center of mass is located essentially at the geometric center of the building. Due to symmetry in the stiffness and location of the elements of the seismic-force-resisting systems, the center of rigidity is located at the geometric center of the building as well.

The forces applied to each frame are determined by Equation 3.11 of this publication:²³

$$(V_i)_y = \frac{(k_i)_y}{\Sigma (k_i)_y} V_y + \frac{\bar{x}_i (k_i)_y}{\Sigma \bar{x}_i^2 (k_i)_y + \Sigma \bar{y}_i^2 (k_i)_x} V_y e_x$$

where \bar{x}_i = perpendicular distance from element i to the center of rigidity parallel to the x -axis

²³ The forces determined by this method are within 2 percent of those determined by a computer analysis assuming that the diaphragm is rigid.

\bar{y}_i = perpendicular distance from element i to the center of rigidity parallel to the y -axis

Equations 3.3 and 3.5 are used to determine the stiffnesses of the walls and frames, respectively, and the relative stiffnesses are

- Frames: 1.00
- Walls: 3.22

Assuming that the center of mass is displaced 3.6 feet to the east of its original location, the forces in the frames are as follows (see Equation 3.11):²⁴

Frame on column line 1:

$$V_1 = \frac{1.00 \times 233}{1.00 + 1.00} - \frac{36 \times 1.00 \times (233 \times 3.6)}{36^2(1 + 1) + 11^2(3.22 + 3.22)} = 116.5 - 9.0 = 107.5 \text{ kips}$$

Frame on column line 5:

$$V_5 = \frac{1.00 \times 233}{1.00 + 1.00} + \frac{36 \times 1.00 \times (233 \times 3.6)}{36^2(1 + 1) + 11^2(3.22 + 3.22)} = 116.5 + 9.0 = 125.5 \text{ kips}$$

The maximum shear force in the slab occurs along column line 5 and is equal to 125.5 kips, which is distributed over a length of 110 feet.

The shear strength of the slab is determined by ACI Equation (21-10) assuming that $\rho_t = 0$:

$$\begin{aligned} \phi V_c &= \phi A_{cv} 2\lambda \sqrt{f'_c} = 0.75 \times 9 \times (110 \times 12) \times 2 \times 1.0 \sqrt{4000} / 1000 \\ &= 1127.0 \text{ kips} > 125.5 \text{ kips} \quad \text{O.K.} \end{aligned}$$

$$< \phi 8 A_{cv} \sqrt{f'_c} = 4508.1 \text{ kips} \quad (\text{ACI 21.11.9.2})$$

where $\phi = 0.75$, which is the same ϕ used for the shear design of the columns in the special moment frame [ACI 9.3.4(b)].

In general, the diaphragm is assumed to act as a deep beam that spans between the vertical elements of the seismic-force-resisting system, which act as supports. The compressive or tensile chord force along the length of the diaphragm can be calculated by

²⁴ The values of V_1 and V_5 would be reversed if the center of mass were displaced 3.6 feet to the west of its original location.

dividing the bending moment in the diaphragm due to the seismic forces by the diaphragm dimension parallel to the direction of the load.²⁵

The concrete diaphragm in this example is modeled as a simply-supported beam with supports along column lines 1 and 2 for seismic forces in the north-south direction. The total reactions at these supports can be determined from the forces in the frames. It is assumed that the diaphragm force can be represented by a trapezoidal distributed load as illustrated in Figure 6.46. Since the reactions at the supports are known, the distributed loads, w_1 and w_2 , can be determined from statics. Once the distributed loads have been established, the maximum bending moment is computed and is used to determine the maximum chord force in the diaphragm.

For the center of mass located at 3.6 feet to the east of column line 3, the reactions are:

$$R_1 = V_1 = 107.5 \text{ kips}$$

$$R_5 = V_5 = 125.5 \text{ kips}$$

Summing forces in the north-south direction and summing moments about column line 5 results in the following two equations for the diaphragm at the roof level:

$$(w_1 \times 72) + \left[\frac{1}{2}(w_2 - w_1) \times 72 \right] = 233$$

$$\left(w_1 \times \frac{72^2}{2} \right) + \left[\frac{1}{2}(w_2 - w_1) \times 72 \times \left(\frac{1}{3} \times 72 \right) \right] = 107.5 \times 72$$

Solving these equations simultaneously results in $w_1 = 2.49$ kips/ft and $w_2 = 3.99$ kips/ft.

The shear and moment diagrams for this case are shown in Figure 6.47. The maximum bending moment in the diaphragm is equal to 2100.1 ft-kips.

The maximum chord force is equal to the following:

$$T_u = C_u = \frac{M_u}{D} = \frac{2100.1}{110} = 19.1 \text{ kips}$$

²⁵ Section 1602 of the IBC defines a diaphragm chord as a boundary element perpendicular to the applied lateral force that is assumed to resist the axial stresses due to the bending moments in the diaphragm.

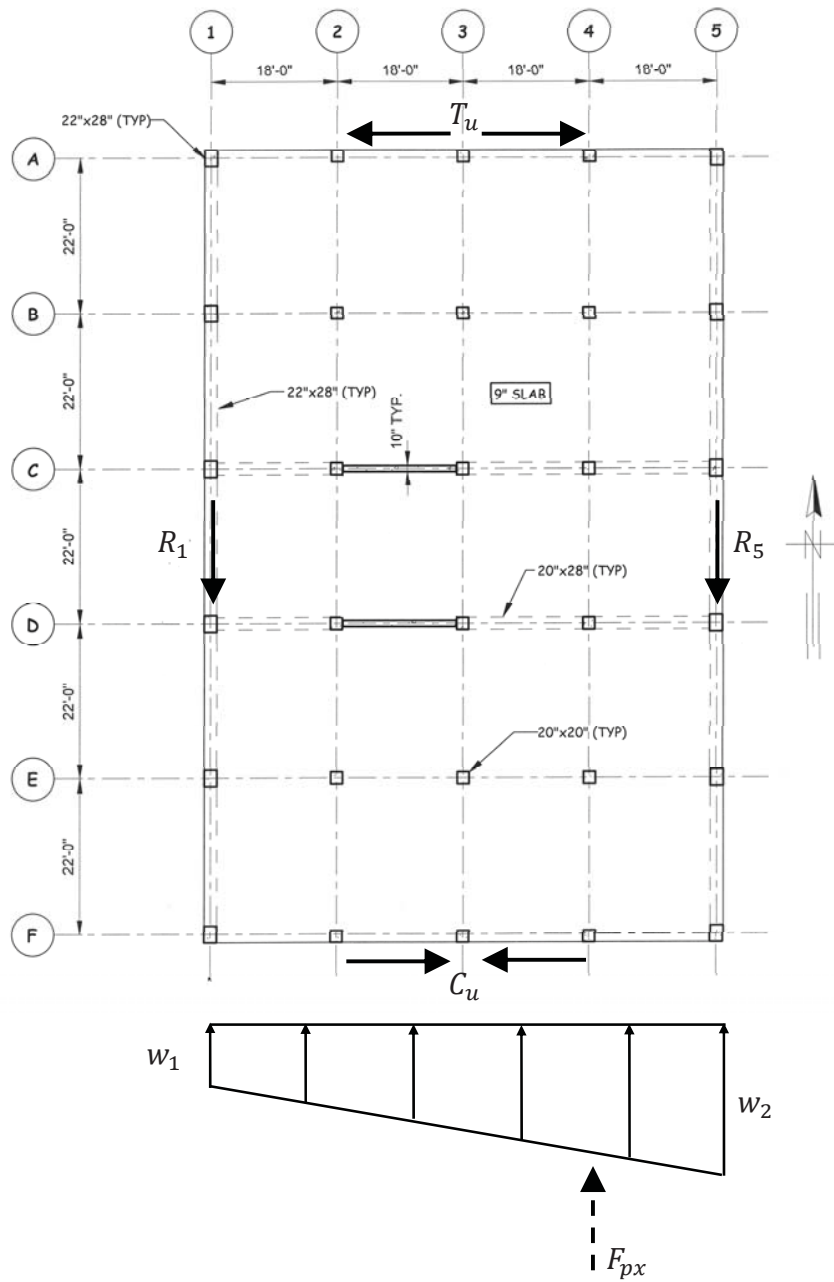

For SI: 1 inch = 25.4 mm; 1 foot = 304.8 mm.

Figure 6.46 Distributed Load on Roof Diaphragm for Seismic Forces in the North-South Direction

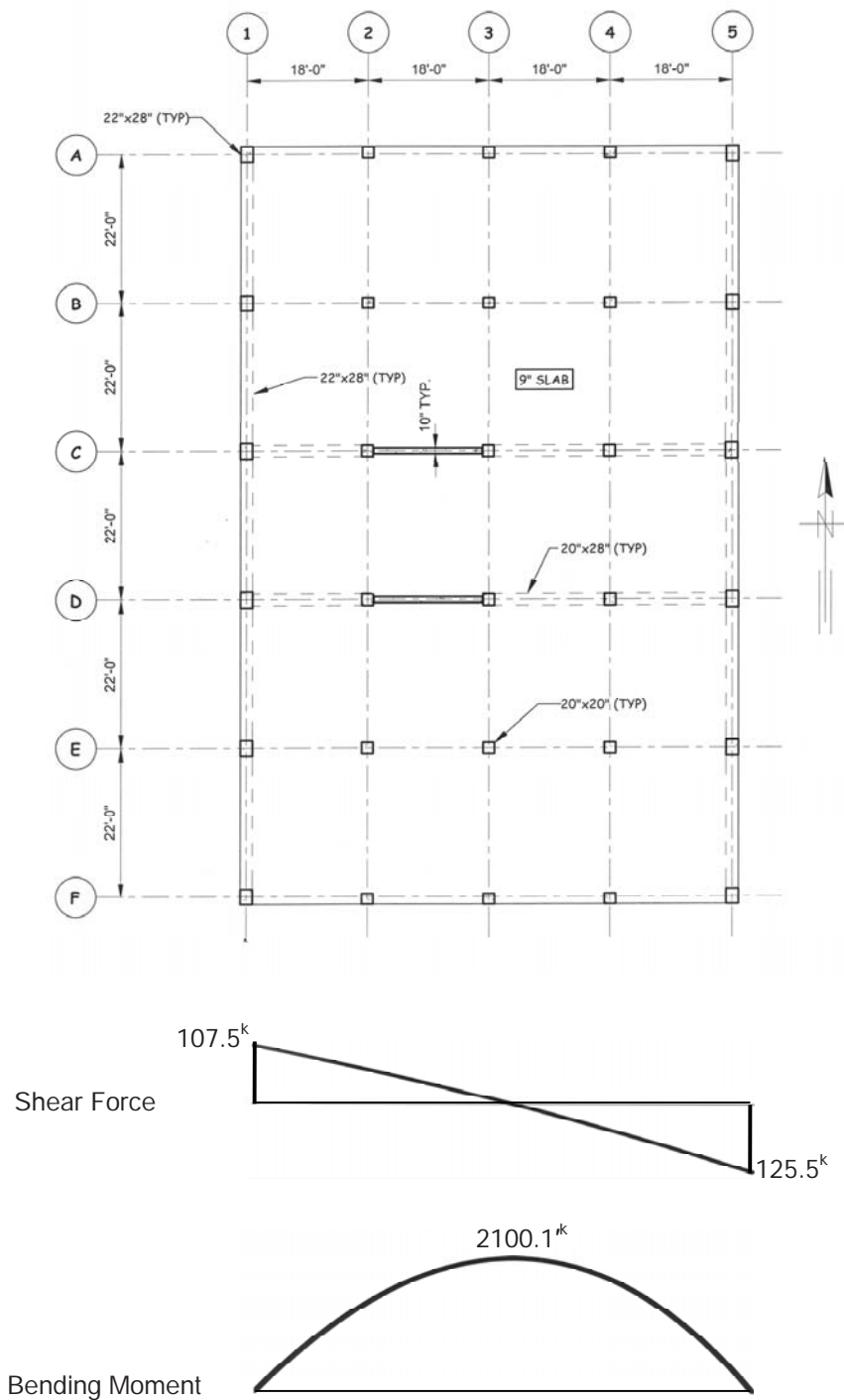

For SI: 1 inch = 25.4 mm; 1 foot = 304.8 mm.

Figure 6.47 Shear Force and Bending Moment Diagrams for the Roof Diaphragm for Seismic Forces in the North-South Direction

The required area of tension reinforcement is

$$A_s = \frac{T_u}{\phi f_y} = \frac{19.1}{0.9 \times 60} = 0.35 \text{ in.}^2$$

Therefore, provide two No. 4 chord bars along the slab edges on column lines A and F between lines 1 and 5.

Design of Roof Diaphragm in E-W Direction

Since the diaphragm is rigid, the 302-kip diaphragm force at the roof (level 3) is distributed to the walls in proportion to their relative stiffnesses. This force is applied at the location of the center of mass, which must be displaced from its actual location a distance of 5 percent of the dimension of the building perpendicular to the direction of the applied force = $0.05 \times 110 = 5.5 \text{ ft}$ (ASCE/SEI 12.8.4.2).

The forces applied to each frame are determined by Equation 3.12 of this publication:

$$(V_i)_x = \frac{(k_i)_x}{\sum (k_i)_x} V_x + \frac{\bar{y}_i (k_i)_x}{\sum \bar{x}_i^2 (k_i)_y + \sum \bar{y}_i^2 (k_i)_x} V_x e_y$$

where \bar{x}_i = perpendicular distance from element i to the center of rigidity parallel to the x -axis

\bar{y}_i = perpendicular distance from element i to the center of rigidity parallel to the y -axis

The relative stiffnesses, which were determined previously, are

- Frames: 1.00
- Walls: 3.22

Assuming that the center of mass is displaced 5.5 feet to the north of its original location, the forces in the frames are as follows (see Equation 3.11):²⁶

Wall on column line C:

$$V_C = \frac{3.22 \times 302}{3.22 + 3.22} + \frac{11 \times 3.22 \times (302 \times 5.5)}{36^2(1 + 1) + 11^2(3.22 + 3.22)} = 151.0 + 17.5 = 168.5 \text{ kips}$$

²⁶ The values of V_C and V_D would be reversed if the center of mass were displaced 5.5 feet to the south of its original location.

Wall on column line D:

$$V_D = \frac{3.22 \times 302}{3.22 + 3.22} - \frac{11 \times 3.22 \times (302 \times 5.5)}{36^2(1 + 1) + 11^2(3.22 + 3.22)} = 151.0 - 17.5 = 133.5 \text{ kips}$$

The concrete diaphragm in this example is modeled as a continuous beam with supports along column lines C and D for seismic forces in the east-west direction. The total reactions at these supports are equal to the forces in the walls.

It is assumed that the diaphragm force can be represented by a trapezoidal distributed load as illustrated in Figure 6.48. Since the reactions at the supports are known, the distributed loads, w_1 and w_2 , can be determined from statics. Once the distributed loads have been established, the maximum bending moment is computed and is used to determine the maximum chord force in the diaphragm.

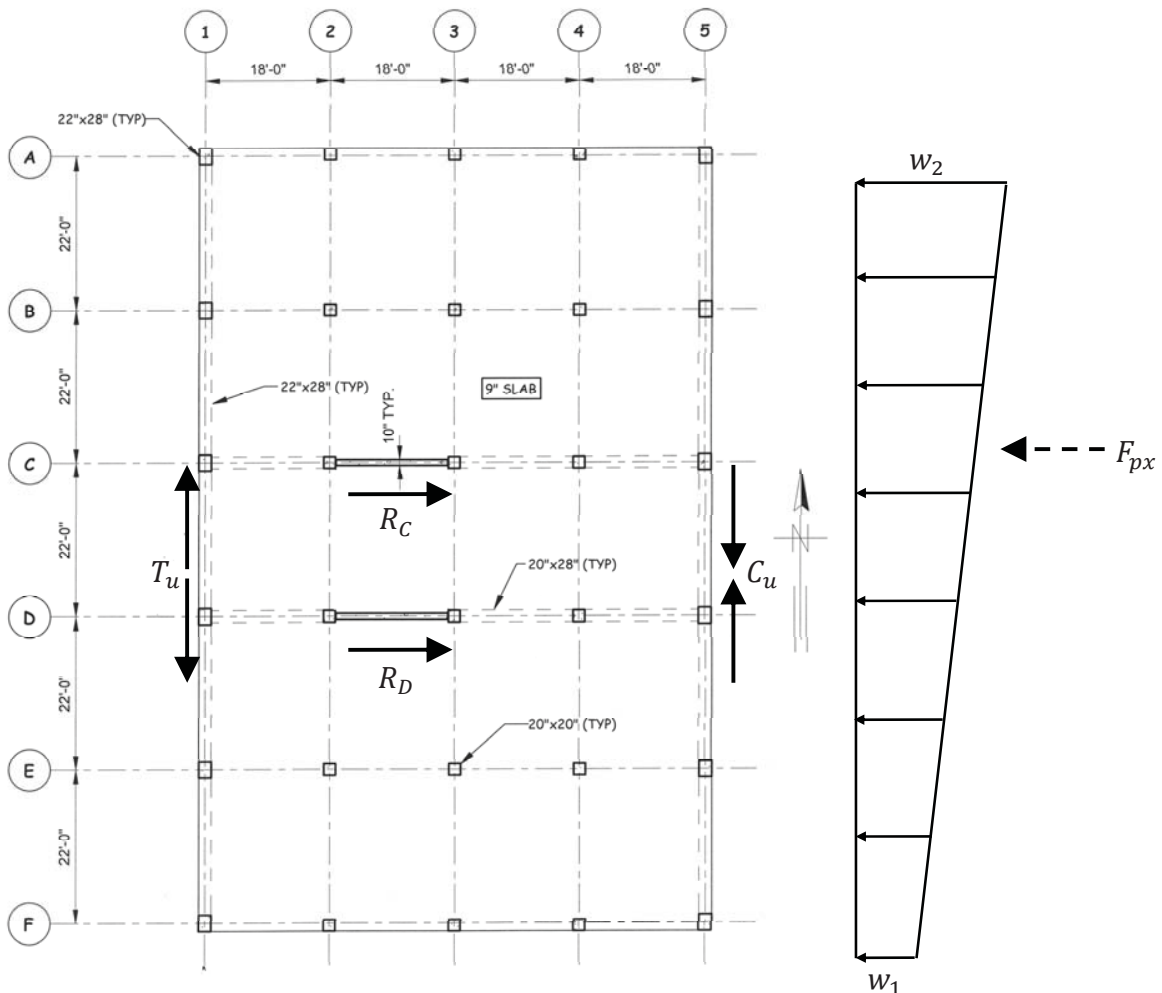

For SI: 1 inch = 25.4 mm; 1 foot = 304.8 mm.

Figure 6.48 Distributed Load on Roof Diaphragm for Seismic Forces in the East-West Direction

For the center of mass located at 5.5 feet to the north of its original location, the reactions are:

$$R_C = V_C = 168.5 \text{ kips}$$

$$R_D = V_D = 133.5 \text{ kips}$$

Summing forces in the east-west direction and summing moments about column line D results in the following two equations for the diaphragm at the roof level:

$$(w_1 \times 110) + \left[\frac{1}{2} (w_2 - w_1) \times 110 \right] = 302$$

$$(w_1 \times 110 \times 11) + \left\{ \frac{1}{2} (w_2 - w_1) \times 110 \times \left[\left(\frac{2}{3} \times 110 \right) - 44 \right] \right\} = 168.5 \times 22$$

Solving these equations simultaneously results in $w_1 = 2.56$ kips/ft and $w_2 = 2.94$ kips/ft. The shear and moment diagrams for this case are shown in Figure 6.49. The maximum bending moment in the diaphragm is equal to 2793.1 ft-kips.

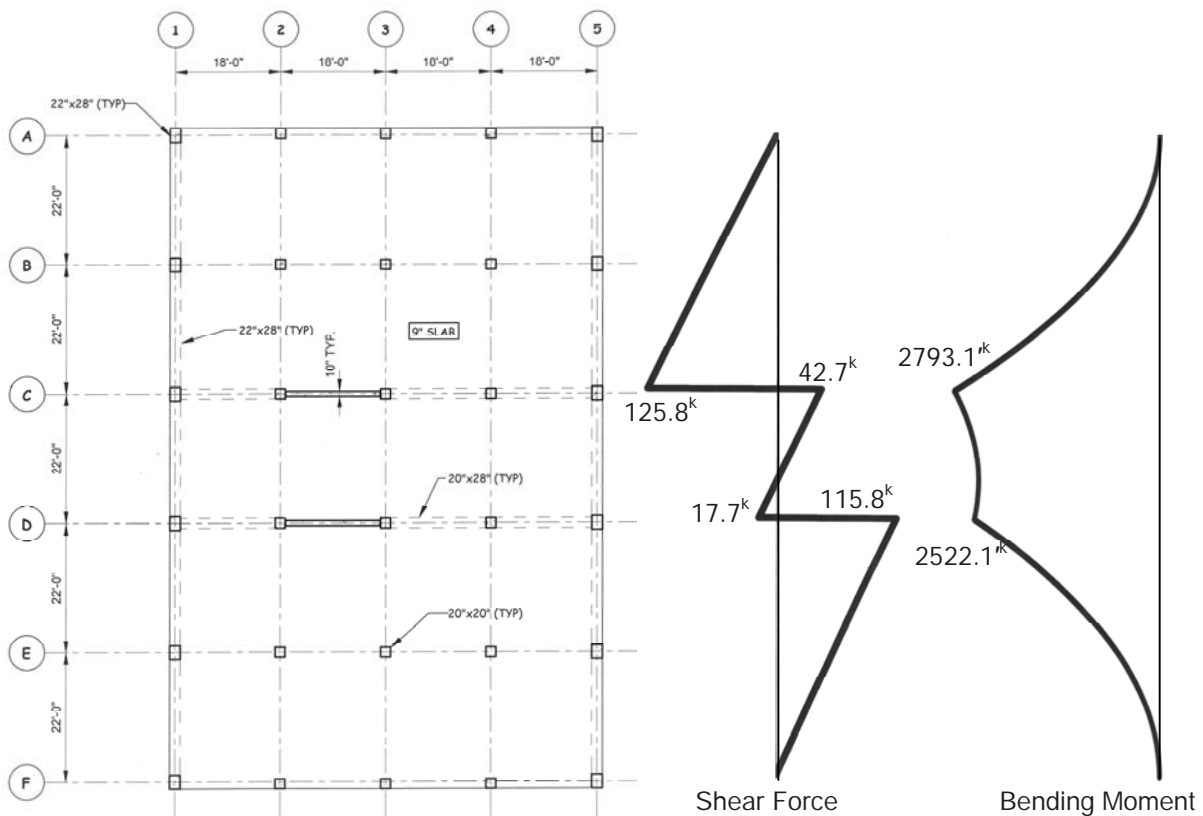

For SI: 1 inch = 25.4 mm; 1 foot = 304.8 mm.

Figure 6.49 Shear Force and Bending Moment Diagrams for the Roof Diaphragm for Seismic Forces in the East-West Direction

The maximum chord force is equal to the following:

$$T_u = C_u = \frac{M_u}{D} = \frac{2793.1}{72} = 38.8 \text{ kips}$$

The required area of tension reinforcement is

$$A_s = \frac{T_u}{\phi f_y} = \frac{38.8}{0.9 \times 60} = 0.72 \text{ in.}^2$$

Therefore, provide two No. 6 chord bars at mid-height of the beams along column lines 1 and 5. These bars are to be tied to the vertical legs of the transverse reinforcement.

The maximum shear force in the slab occurs along column line C and is equal to 128.5 kips, which is distributed over a length of 72 feet (see Figure 6.49).

The shear strength of the slab is determined by ACI Equation (21-10) assuming that $\rho_t = 0$:

$$\begin{aligned} \phi V_c &= \phi A_{cv} 2\lambda \sqrt{f'_c} = 0.60 \times 9 \times (72 \times 12) \times 2 \times 1.0 \sqrt{4000} / 1000 \\ &= 590.2 \text{ kips} > 125.8 \text{ kips} \quad \text{O.K.} \end{aligned}$$

$$< \phi 8 A_{cv} \sqrt{f'_c} = 2360.6 \text{ kips} \quad (\text{ACI 21.11.9.2})$$

where $\phi = 0.60$, which is the same ϕ used for the shear design of the walls in the building frame system [ACI 9.3.4(b)].

The beams along lines C and D are utilized as collectors that pull (or drag) the shear forces in the diaphragm into the walls along those lines.

It was determined above that the total diaphragm force along line C is equal to 168.5 kips. The total unit shear force in the diaphragm is equal to $168.5/72 = 2.34$ kips/ft. Similarly, the unit shear force for the wall is $168.5/18 = 9.36$ kips/ft.

The unit shear forces and net unit shear forces are depicted in Figure 6.50.

In general, the collector elements must be designed to resist the combined effects from gravity forces (bending moments and shear forces) and earthquake forces (axial compression and tension).

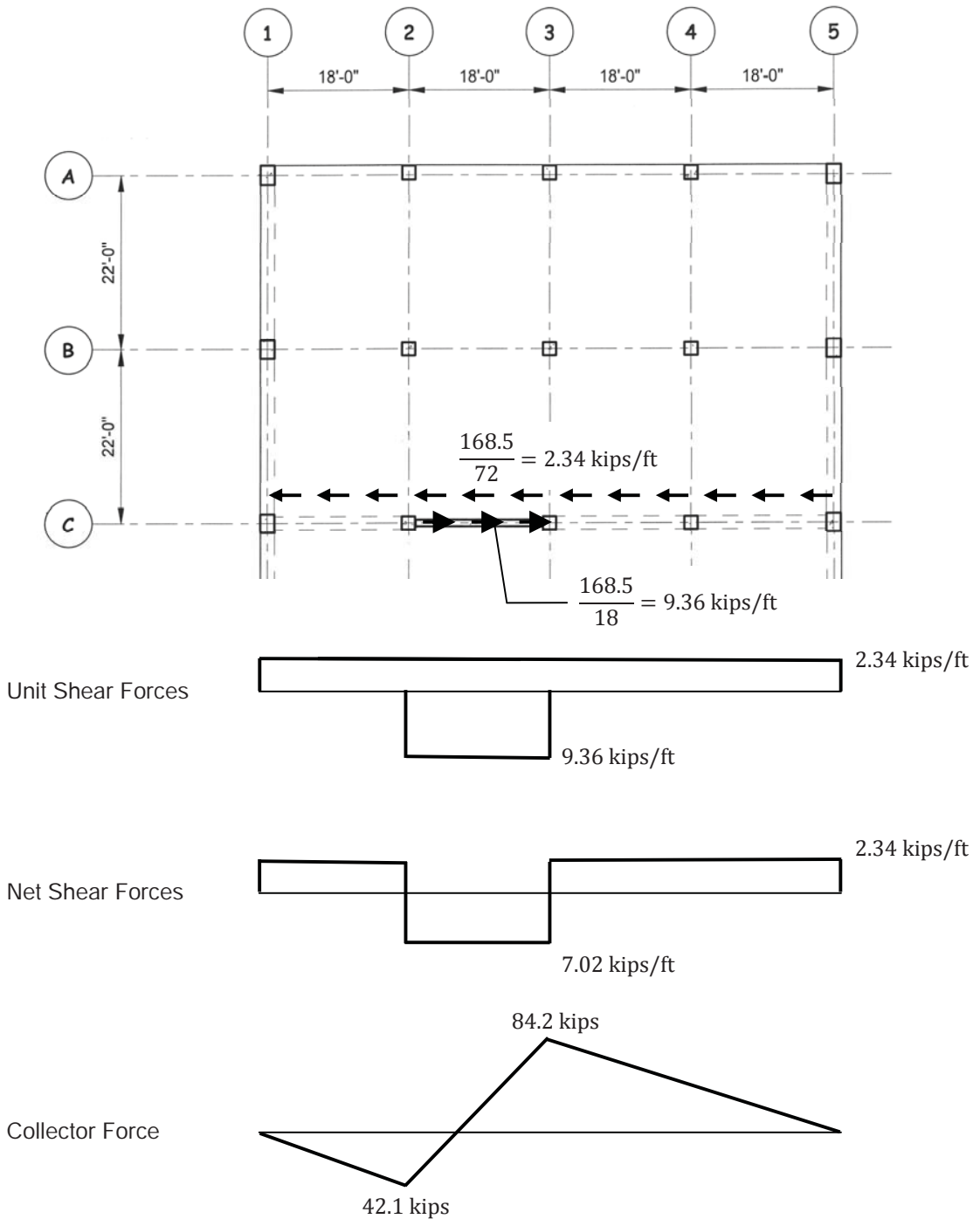

For SI: 1 inch = 25.4 mm; 1 foot = 304.8 mm.

Figure 6.50 Unit Shear Forces, Net Shear Forces and Collector Force Diagram on Column Line C at Roof Level

According to ASCE/SEI 12.10.2.1, collector elements, splices and their connections to the elements of the seismic-force-resisting system in structures assigned to SDC C, D, E or F must be designed to resist the load combinations with the overstrength factor, Ω_o , of ASCE/SEI 12.4.3.2. The overstrength factor, Ω_o , represents an upper bound lateral strength and is appropriate to use when estimating the maximum forces that can be developed in nonyielding elements of the seismic-force-resisting system during the design earthquake. The intent of this requirement is to ensure that collectors and their connections have adequate strength to transfer the seismic forces into the elements of the seismic-force-resisting system, which has been properly detailed to yield during the anticipated ground motion.

Therefore, the governing load combinations for the collector elements are:

- $1.4D$
- $1.2D + 1.6L_r$
- $(1.2 + 0.2S_{DS})D + 0.5L_r + \Omega_o Q_E = 1.4D + 0.5L_r + 2.5Q_E$
- $(0.9 - 0.2S_{DS})D + \Omega_o Q_E = 0.7D + 2.5Q_E$

where the system overstrength factor is equal to 2.5 for building frame systems with special structural walls (see ASCE/SEI Table 12.2-1).

Table 6.18 contains a summary of the axial forces ($Q_E = 84.2$ kips; see Figure 6.50), bending moments, and shear forces for the collector element along line C.

Table 6.18 Summary of Design Axial Forces, Bending Moments and Shear Forces for Collector Element on Line C at Roof Level

Load Case	Axial Force (kips)	Bending Moment (ft-kips)		Shear Force (kips)
		Negative	Positive	
Dead (D)	0	62.5	38.6	17.5
Roof live (L_r)	0	8.0	5.1	2.2
Seismic ($2.5Q_E$)	± 211	0	0	0
Load Combination				
$1.4D$	0	87.5	54.0	24.5
$1.2D + 1.6L_r$	0	87.8	54.5	24.5
$1.4D + 0.5L_r \pm 2.5Q_E$	± 211	91.5	56.6	25.6
$0.7D \pm 2.5Q_E$	± 211	43.8	27.0	12.3

Based on the load combinations in Table 6.18, a 20-inch by 28-inch collector element reinforced with three No 8 top bars, three No. 8 bottom bars, and two No. 8 side bars is

adequate ($A_{st} = 0.011A_g$).²⁷ The interaction diagram for this collector is shown in Figure 6.51.

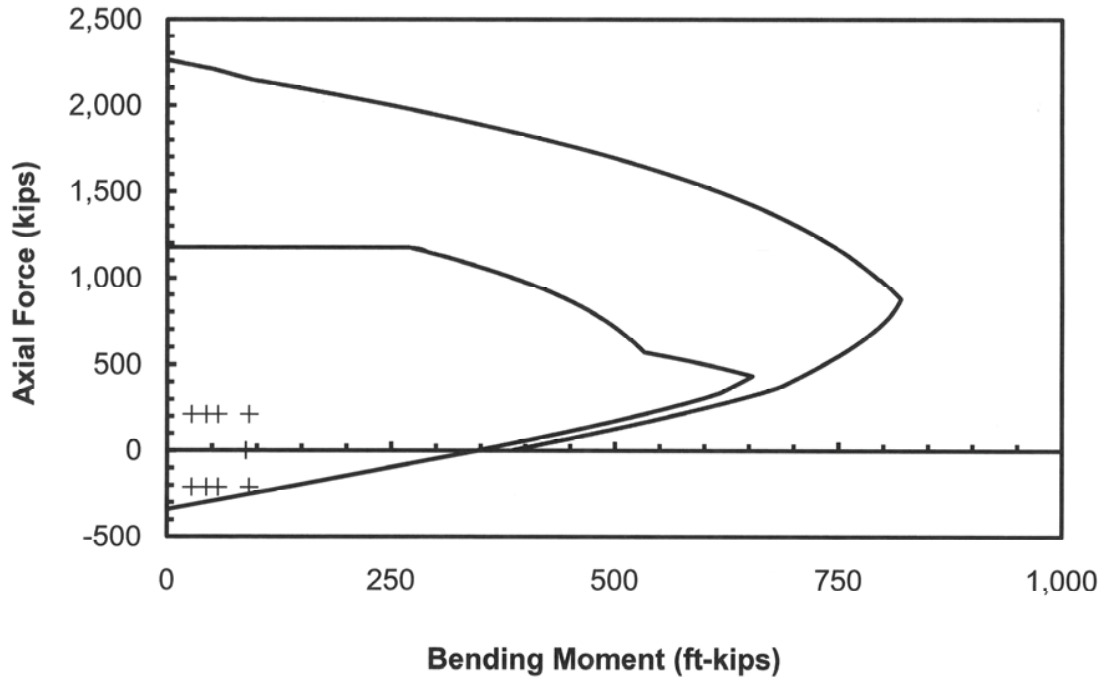

Figure 6.51 Design and Nominal Strength Interaction Diagrams for Collector Elements at Roof Level

Check if transverse reinforcement satisfying ACI 21.9.6.4(c) must be provided over the length of the collector elements (ACI 21.11.7.5):

$$\text{Compressive stress} = \frac{2.5Q_E}{A_g} = \frac{211}{20 \times 28} = 0.38 \text{ ksi} < 0.5f'_c = 2 \text{ ksi}^{28}$$

Therefore, transverse reinforcement satisfying ACI 21.9.6.4(c) need not be provided.

The maximum shear force, V_u , on the collector is 25.6 kips and the design shear strength of the concrete, ϕV_c , is set equal to zero since the collector is subjected to significant axial tension (ACI 11.2.1.3). Thus, assuming No. 3 ties, the required spacing is:

²⁷ The maximum axial force in the collector has been conservatively applied at all sections along the length of the collectors.

²⁸ The limit of $0.5f'_c$ is used since the axial force is amplified by the overstrength factor, Ω_o (ACI 21.11.7.5).

$$s = \frac{A_v f_{yt} d}{\frac{V_u}{\phi} - V_c} = \frac{(2 \times 0.11) \times 60 \times 25.5}{\frac{25.6}{0.75} - 0} = 9.9 \text{ in.} < \frac{d}{2} = 12.75 \text{ in.}$$

$$\leq \frac{A_v f_{yt}}{0.75 \sqrt{f'_c} b_w} = \frac{(2 \times 0.11) \times 60,000}{0.75 \sqrt{4000} \times 20} = 13.9 \text{ in.}$$

$$\leq \frac{A_v f_{yt}}{50 b_w} = \frac{(2 \times 0.11) \times 60,000}{50 \times 20} = 13.2 \text{ in.}$$

Provide No. 3 ties (two legs) spaced at 9.0 inches on center over the entire length of the collectors.

Reinforcement details for the collector elements are shown in Figure 6.52. Top, bottom and side longitudinal bars are continuous over the entire span and are spliced and anchored in accordance with one of the options in ACI 21.11.7.6.²⁹

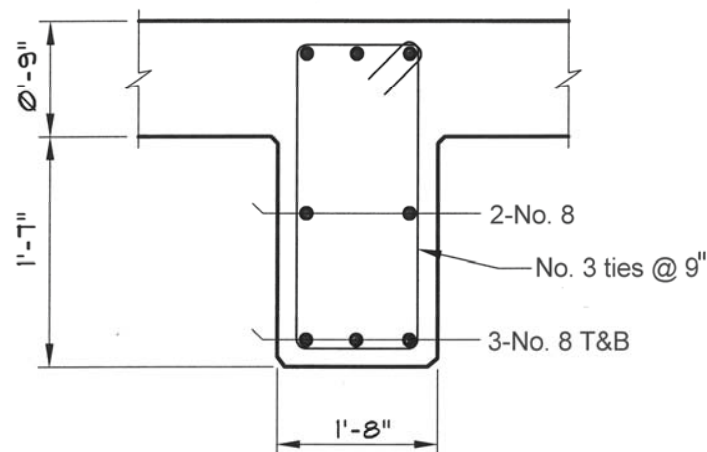

SLAB REINFORCEMENT NOT SHOWN FOR CLARITY

For SI: 1 inch = 25.4 mm; 1 foot = 304.8 mm.

Figure 6.52 Reinforcement Details for Collector Elements at Roof Level

²⁹ The No. 3 ties spaced at 9.0 inches provided along the span satisfies the requirements of ACI 21.11.7.6(b).

Design of Level 2 Floor Diaphragm in N-S Direction

Using Equation 3.11 of this publication, the 290-kip diaphragm force is distributed to the frames as follows, assuming that the center of mass is displaced 3.6 feet to the east of its original location:³⁰

Frame on column line 1:

$$V_1 = \frac{1.00 \times 290}{1.00 + 1.00} - \frac{36 \times 1.00 \times (290 \times 4.1)}{36^2(1 + 1) + 11^2(3.22 + 3.22)} = 145.0 - 12.7 = 132.3 \text{ kips}$$

Frame on column line 5:

$$V_5 = \frac{1.00 \times 290}{1.00 + 1.00} + \frac{36 \times 1.00 \times (290 \times 4.1)}{36^2(1 + 1) + 11^2(3.22 + 3.22)} = 145.0 + 12.7 = 157.7 \text{ kips}$$

A method of analysis similar to the one that was used for the roof diaphragm without an opening can be used for the level 2 diaphragm with an opening.

The concrete diaphragm in this example is modeled as a simply-supported beam with supports along column lines 1 and 2 for seismic forces in the north-south direction. The total reactions at these supports can be determined from the forces in the frames. It is assumed that the diaphragm force can be represented by a trapezoidal distributed load as illustrated in Figure 6.53. Since the reactions at the supports are known, the distributed loads, w_1 and w_2 , can be determined from statics.

For the center of mass located at 4.1 feet to the east of column line 3, the reactions are:

$$R_1 = V_1 = 132.3 \text{ kips}$$

$$R_5 = V_5 = 157.7 \text{ kips}$$

Summing forces in the north-south direction and summing moments about column line 5 results in the following two equations for the diaphragm at level 2:

$$(w_1 \times 72) + \left[\frac{1}{2}(w_2 - w_1) \times 72 \right] = 290$$

$$\left(w_1 \times \frac{72^2}{2} \right) + \left[\frac{1}{2}(w_2 - w_1) \times 72 \times \left(\frac{1}{3} \times 72 \right) \right] = 132.3 \times 72$$

Solving these equations simultaneously results in $w_1 = 2.97$ kips/ft and $w_2 = 5.09$ kips/ft.

³⁰ The center of mass is located 0.5 feet to the east of the center of rigidity due to the opening. Therefore, the total eccentricity = 0.5 + 3.6 = 4.1 ft.

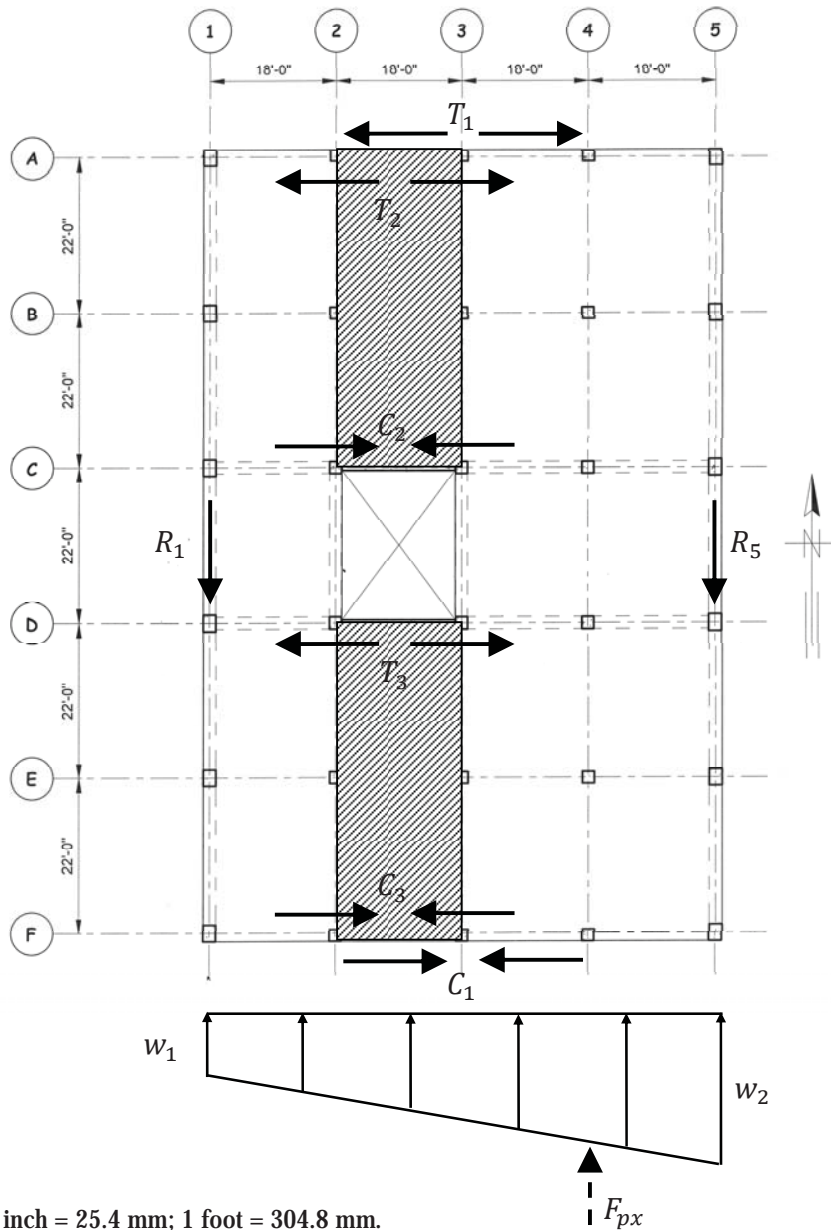

For SI: 1 inch = 25.4 mm; 1 foot = 304.8 mm.

Figure 6.53 Distributed Load on Level 2 Diaphragm for Seismic Forces in the North-South Direction

The shear and moment diagrams for this case are shown in Figure 6.54. The maximum shear force in the slab occurs along column line 5 and is equal to 157.7 kips, which is distributed over a length of 110 feet.

The shear strength of the slab is determined by ACI Equation (21-10) assuming that $\rho_t = 0$:

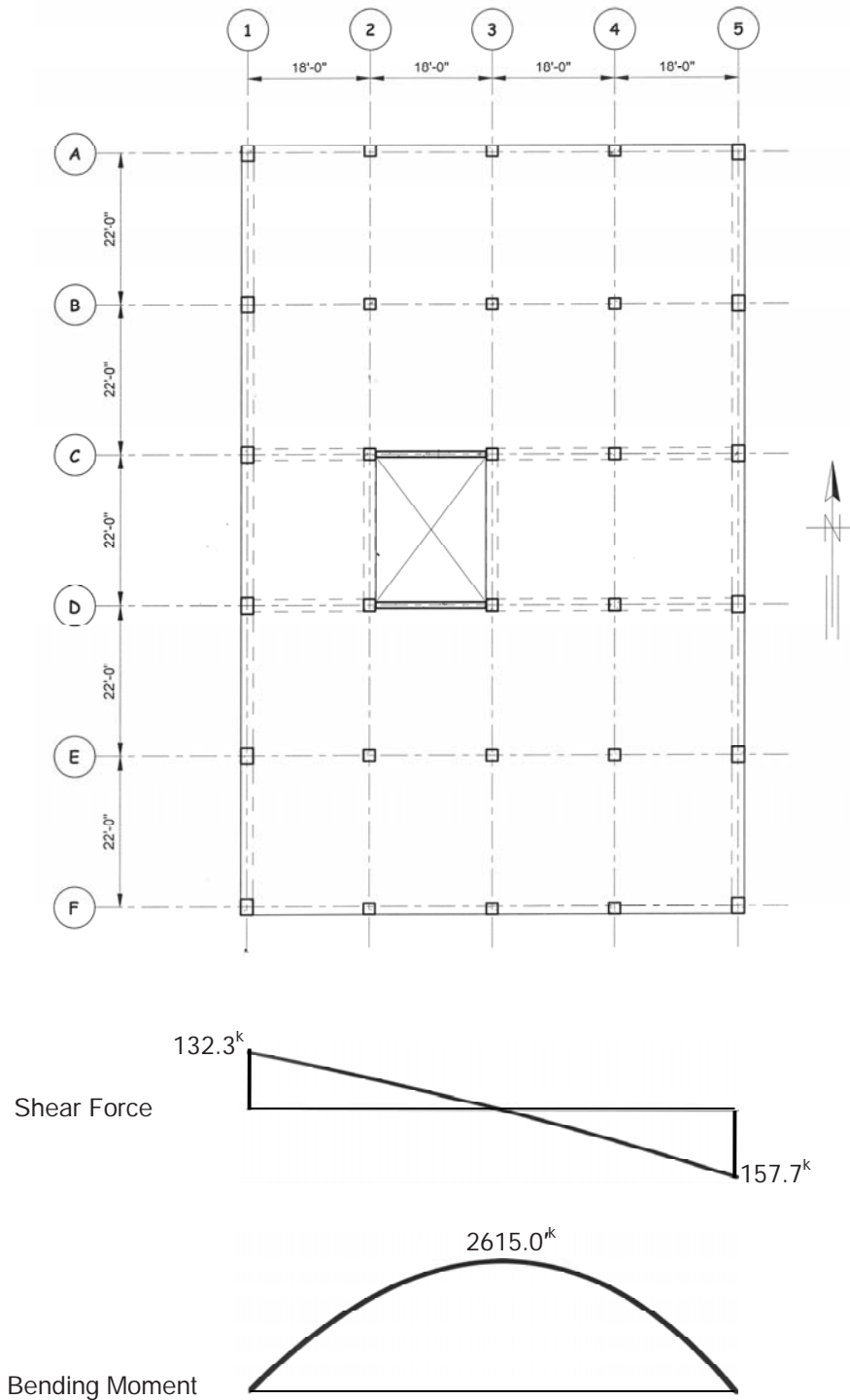

For SI: 1 inch = 25.4 mm; 1 foot = 304.8 mm.

Figure 6.54 Shear Force and Bending Moment Diagrams for the Level 2 Diaphragm for Seismic Forces in the North-South Direction

$$\phi V_c = \phi A_{cv} 2\lambda \sqrt{f'_c} = 0.75 \times 9 \times (110 \times 12) \times 2 \times 1.0 \sqrt{4000} / 1000$$

$$= 1127.0 \text{ kips} > 157.7 \text{ kips} \quad \text{O.K.}$$

$$< \phi 8A_{cv} \sqrt{f'_c} = 4508.1 \text{ kips} \quad (\text{ACI 21.11.9.2})$$

where $\phi = 0.75$, which is the same ϕ used for the shear design of the columns in the special moment frame [ACI 9.3.4(b)].

The shear force along column line 2 is equal to 74.1 kips, which is distributed over a length of 88 feet. The shear strength of the diaphragm is adequate at this location as well.

Primary chord forces (T_1, C_1) are calculated by dividing the maximum moment in the diaphragm by the total depth of the diaphragm perpendicular to the direction of loading.

The maximum primary chord force is equal to the following:

$$T_1 = C_1 = \frac{M_u}{D} = \frac{2615.0}{110} = 23.8 \text{ kips}$$

Secondary chord forces (T_2, C_2) and (T_3, C_3) occur due to local bending of the diaphragm segments on either side of the opening, which in this case are located to the north (segment bounded by lines AC23) and to the south (segment bounded by lines DF23) of the opening (see Figure 6.53). Typically, these diaphragm segments are idealized as beams that are fixed at the ends.³¹ The loading on these segments is based on the relative mass of the segments, and the secondary chord forces are calculated based on this loading and the length of the segment perpendicular to the direction of loading.

Referring to Figure 6.53, the value of the distributed load is equal to 3.50 kips/ft at column line 2 and is equal to 4.03 kips/ft at column line 3.³² Since the mass of the segments on either side of the opening are equal in the direction of analysis, one half of these loads are applied to each segment over the 18-foot length.

Depicted in Figure 6.55 is one of the segments of the diaphragm with the applied trapezoidal load and the corresponding moment diagram.

The secondary chord force near midspan is equal to the following:

$$T_2 = T_3 = C_2 = C_3 = \frac{M_u}{D} = \frac{25.5}{44} = 0.6 \text{ kips}$$

³¹ Actual beam end conditions are somewhere between a fixed and a pinned condition.

³² The distributed load along the length of the diaphragm is $w(x) = (5.09 - 2.97)x/72 + 2.97$ where x is measured from line 1. Thus, at $x = 18$ ft, $w = 3.50$ kips/ft and at $x = 36$ ft, $w = 4.03$ kips/ft.

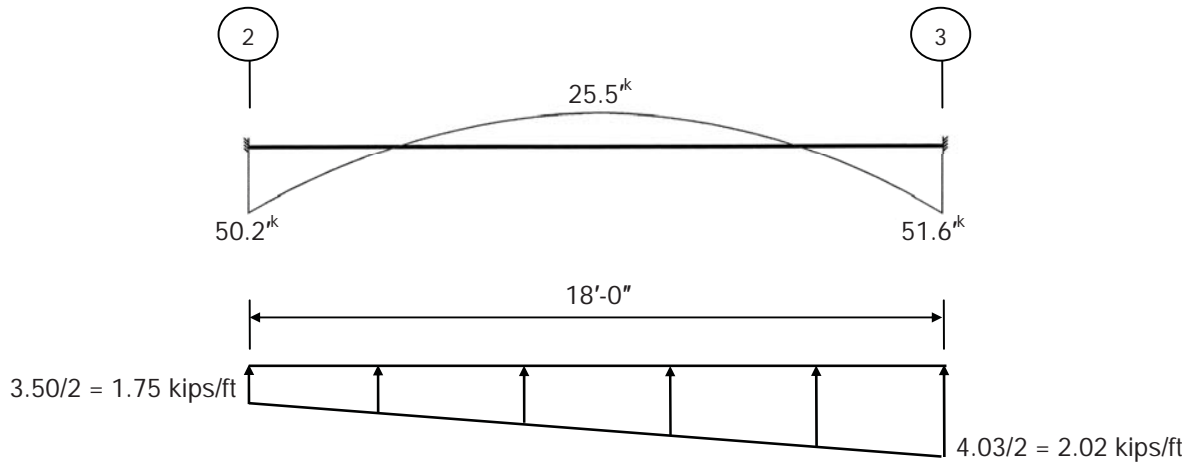

Figure 6.55 Loading and Bending Moment Diagrams for the Level 2 Floor Diaphragm Segment for Seismic Forces in the North-South Direction

Therefore, the total chord force near midspan is equal to $T_u = T_1 + T_2 = 23.8 + 0.6 = 24.4$ kips.

The required area of tension reinforcement along column lines A and F is

$$A_s = \frac{T_u}{\phi f_y} = \frac{24.4}{0.9 \times 60} = 0.45 \text{ in.}^2$$

Therefore, provide two No. 5 chord bars along the slab edges on column lines A and F between lines 1 and 5.

Tensile chord forces will also develop near the corners of the openings due to the negative moments at these locations (see Figure 6.55). The secondary chord force at the corner of the opening is:

$$T_2 = \frac{M_u}{D} = \frac{51.6}{44} = 1.2 \text{ kips}$$

The required area of tension reinforcement required for the negative moment adjacent to the opening at line 3 is

$$A_s = \frac{T_u}{\phi f_y} = \frac{1.2}{0.9 \times 60} = 0.02 \text{ in.}^2$$

Provide one No. 5 chord bar along the slab edges adjacent to the openings.

Design of Level 2 Diaphragm in E-W Direction

Using Equation 3.11 of this publication, the 306-kip diaphragm force is distributed to the frames as follows, assuming that the center of mass is displaced 5.5 feet to the north of its original location:

Wall on column line C:

$$V_C = \frac{3.22 \times 306}{3.22 + 3.22} + \frac{11 \times 3.22 \times (306 \times 5.5)}{36^2(1 + 1) + 11^2(3.22 + 3.22)} = 153.0 + 17.7 = 170.7 \text{ kips}$$

Wall on column line D:

$$V_D = \frac{3.22 \times 302}{3.22 + 3.22} - \frac{11 \times 3.22 \times (302 \times 5.5)}{36^2(1 + 1) + 11^2(3.22 + 3.22)} = 153.0 - 17.7 = 135.3 \text{ kips}$$

The concrete diaphragm in this example is modeled as a continuous beam with supports along column lines C and D for seismic forces in the east-west direction. The total reactions at these supports are equal to the forces in the structural walls.

It is assumed that the diaphragm force can be represented by a trapezoidal distributed load as illustrated in Figure 6.56. Since the reactions at the supports are known, the distributed loads, w_1 and w_2 , can be determined from statics.

For the center of mass located at 5.5 feet to the north of its original location, the reactions are:

$$R_C = V_C = 170.7 \text{ kips}$$

$$R_D = V_D = 135.3 \text{ kips}$$

Summing forces in the east-west direction and summing moments about column line D results in the following two equations for the diaphragm at level 2:

$$(w_1 \times 110) + \left[\frac{1}{2}(w_2 - w_1) \times 110 \right] = 306$$

$$(w_1 \times 110 \times 11) + \left\{ \frac{1}{2}(w_2 - w_1) \times 110 \times \left[\left(\frac{2}{3} \times 110 \right) - 44 \right] \right\} = 170.7 \times 22$$

Solving these equations simultaneously results in $w_1 = 2.59$ kips/ft and $w_2 = 2.97$ kips/ft.

The shear and moment diagrams for this case are shown in Figure 6.57. The maximum shear force in the slab occurs along column line C and is equal to 127.4 kips, which is distributed over a length of 72 feet.

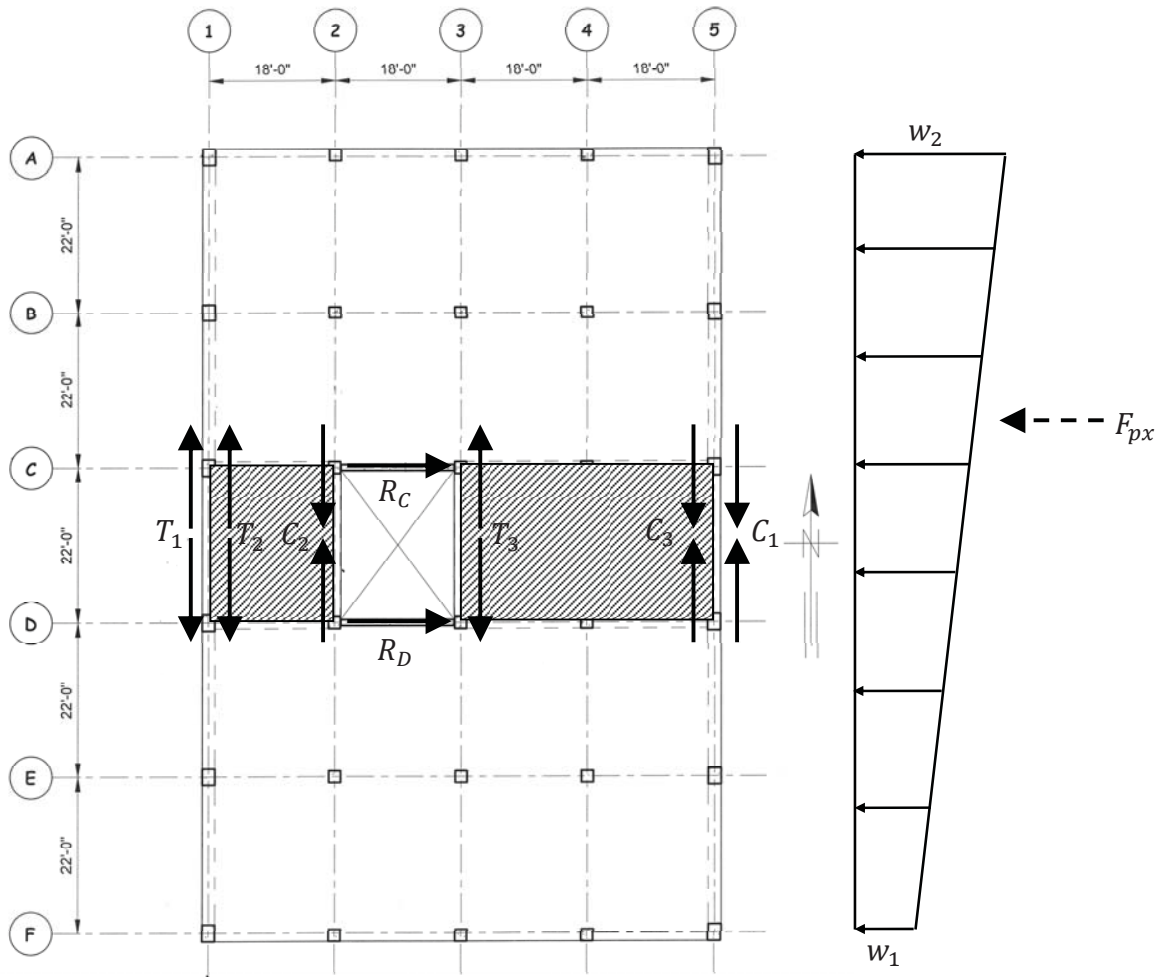

For SI: 1 inch = 25.4 mm; 1 foot = 304.8 mm.

Figure 6.56 Distributed Load on Level 2 Diaphragm for Seismic Forces in the East-West Direction

The shear strength of the slab is determined by ACI Equation (21-10) assuming that $\rho_t = 0$:

$$\begin{aligned}\phi V_c &= \phi A_{cv} 2\lambda \sqrt{f'_c} = 0.60 \times 9 \times (72 \times 12) \times 2 \times 1.0 \sqrt{4000}/1000 \\ &= 590.2 \text{ kips} > 127.4 \text{ kips} \quad \text{O.K.}\end{aligned}$$

$$< \phi 8 A_{cv} \sqrt{f'_c} = 2360.6 \text{ kips} \quad (\text{ACI } 21.11.9.2)$$

where $\phi = 0.60$, which is the same ϕ used for the shear design of the walls in the building frame system [ACI 9.3.4(b)].

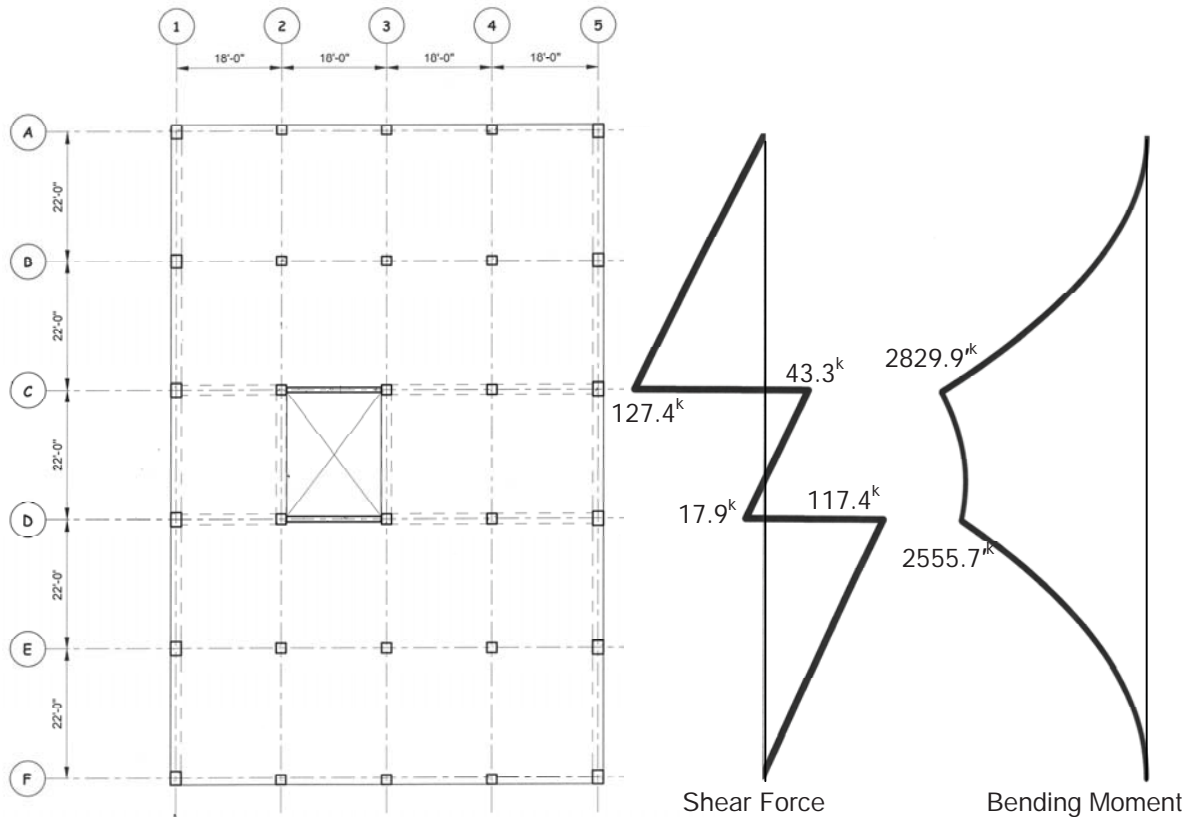

For SI: 1 inch = 25.4 mm; 1 foot = 304.8 mm.

Figure 6.57 Shear Force and Bending Moment Diagrams for the Level 2 Diaphragm for Seismic Forces in the East-West Direction

The shear force along column line C is equal to 43.3 kips just to the south of line C, which is distributed over a length of 54 feet. The shear strength of the diaphragm is adequate at this location as well.

Primary chord forces (T_1, C_1) are calculated by dividing the maximum moment in the diaphragm by the total depth of the diaphragm perpendicular to the direction of loading.

The maximum primary chord force is equal to the following:

$$T_1 = C_1 = \frac{M_u}{D} = \frac{2829.9}{72} = 39.3 \text{ kips}$$

Secondary chord forces (T_2, C_2) and (T_3, C_3) occur due to local bending of the diaphragm segments on either side of the opening, which in this case are located to the west (segment bounded by lines CD12) and to the east (segment bounded by lines CD35) of the opening (see Figure 6.56).

Referring to Figure 6.56, the value of the distributed load is equal to 2.82 kips/ft at column line C and is equal to 2.74 kips/ft at column line D.³³ Since the mass of the segment to the west of the opening is equal to one-half the mass to the right of the opening, it will resist one-third of the total diaphragm load over this segment and the segment to the east of the opening will resist two-thirds of the load.

Depicted in Figure 6.58 are the segments of the diaphragm with the applicable trapezoidal loads and the corresponding moment diagrams.

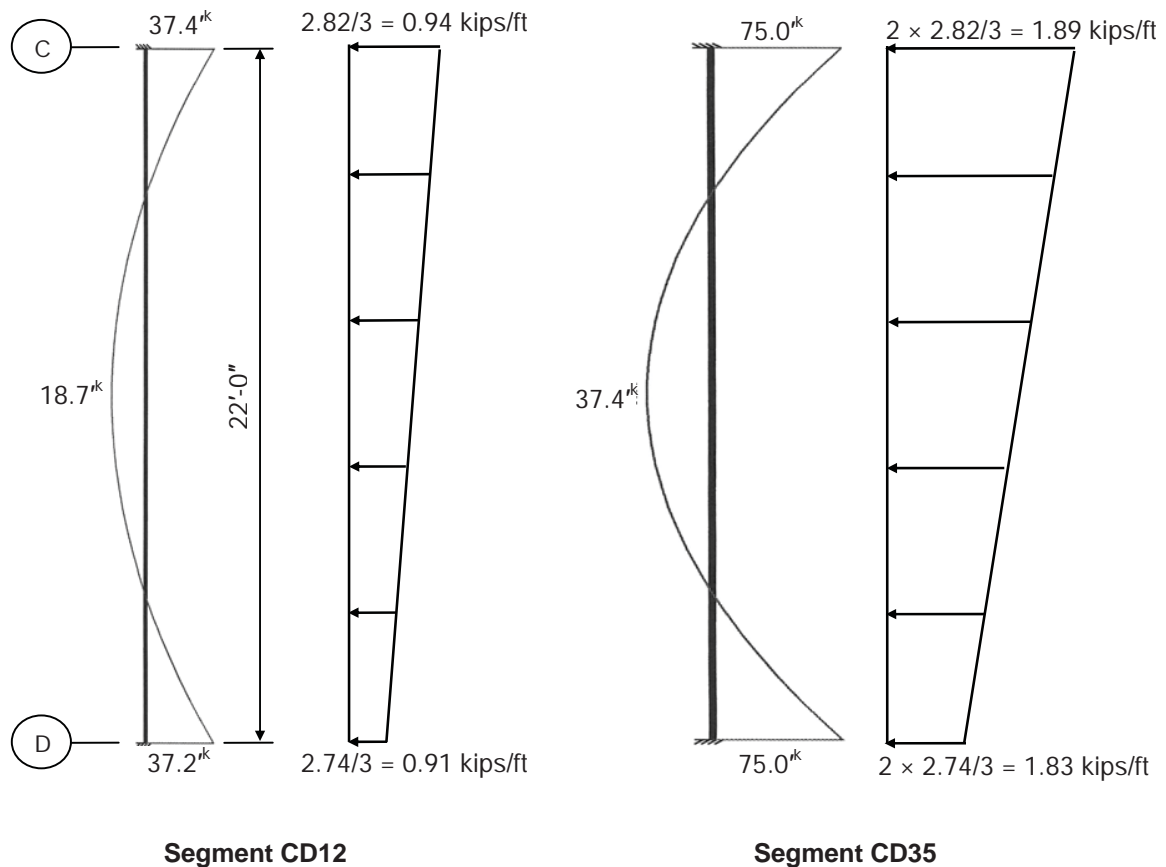

Figure 6.58 Loading and Bending Moment Diagrams in the Level 2 Diaphragm Segments for Seismic Forces in the East-West Direction

The secondary chord force near midspan for segment CD12 is equal to the following:

$$T_2 = C_2 = \frac{M_u}{D} = \frac{18.7}{18} = 1.1 \text{ kips}$$

³³ The distributed load along the length of the diaphragm is $w(x) = (2.59 - 2.97)x/110 + 2.97$ where x is measured from line A. Thus, at $x = 44$ ft, $w = 2.82$ kips/ft and at $x = 66$ ft, $w = 2.74$ kips/ft.

Therefore, the total chord force on line 1 near midspan is equal to $T_u = T_1 + T_2 = 39.3 + 1.1 = 40.4$ kips.

The required area of tension reinforcement along column line 1 is

$$A_s = \frac{T_u}{\phi f_y} = \frac{40.4}{0.9 \times 60} = 0.75 \text{ in.}^2$$

Therefore, provide two No. 6 chord bars at mid-height of the beams along column line 1. These bars are to be tied to the vertical legs of the transverse reinforcement.

Tensile chord forces will also develop near the corners of the openings due to the negative moments at these locations (see Figure 6.58). The secondary chord force is:

$$T_2 = \frac{M_u}{D} = \frac{37.4}{18} = 2.1 \text{ kips}$$

The required area of tension reinforcement required for the negative moment adjacent to the opening at line C is

$$A_s = \frac{T_u}{\phi f_y} = \frac{2.1}{0.9 \times 60} = 0.04 \text{ in.}^2$$

Provide one No. 5 chord bar along the slab edge adjacent to the opening on line 2.

The secondary chord force near midspan for segment CD35 is equal to the following:

$$T_3 = C_3 = \frac{M_u}{D} = \frac{37.4}{36} = 1.1 \text{ kips}$$

Therefore, the total chord force on line 1 near midspan is equal to $T_u = T_1 + T_3 = 39.3 + 1.1 = 40.4$ kips.

The required area of tension reinforcement along column line 5 is

$$A_s = \frac{T_u}{\phi f_y} = \frac{40.4}{0.9 \times 60} = 0.75 \text{ in.}^2$$

Therefore, provide two No. 6 chord bars at mid-height of the beams along column line 5. These bars are to be tied to the vertical legs of the transverse reinforcement.

Tensile chord forces will also develop near the corners of the openings due to the negative moments at these locations (see Figure 6.58). The secondary chord force is:

$$T_3 = \frac{M_u}{D} = \frac{75.0}{36} = 2.1 \text{ kips}$$

The required area of tension reinforcement required for the negative moment adjacent to the opening at line C is

$$A_s = \frac{T_u}{\phi f_y} = \frac{2.1}{0.9 \times 60} = 0.04 \text{ in.}^2$$

Provide one No. 5 chord bar along the slab edge adjacent to the opening on line 3.

The beams along lines C and D are utilized as collectors that pull (or drag) the shear forces in the diaphragm into the structural walls along those lines.

It was determined above that the diaphragm force to the north of line C is equal to 127.4 kips, and the unit shear force in the diaphragm is equal to $127.4/72 = 1.77$ kips/ft. Similarly, the diaphragm force to the south of line C is equal to 43.3 kips, and the unit shear force is equal to $43.3/54 = 0.80$ kips/ft. The unit shear force for the wall is $170.7/18 = 9.48$ kips/ft.

The unit shear forces and net unit shear forces are depicted in Figure 6.59.

In general, the collector elements must be designed to resist the combined effects from gravity forces (bending moments and shear forces) and earthquake forces (axial compression and tension).

The governing load combinations for the collector elements are:

- $1.4D$
- $1.2D + 1.6L$
- $(1.2 + 0.2S_{DS})D + 0.5L + \Omega_o Q_E = 1.4D + 0.5L + 2.5Q_E$
- $(0.9 - 0.2S_{DS})D + \Omega_o Q_E = 0.7D + 2.5Q_E$

where the system overstrength factor is equal to 2.5 for building frame systems with special structural walls (see ASCE/SEI Table 12.2-1).

Table 6.19 contains a summary of the axial forces ($Q_E = 92.5$ kips; see Figure 6.59), bending moments, and shear forces for the collector element along line C.

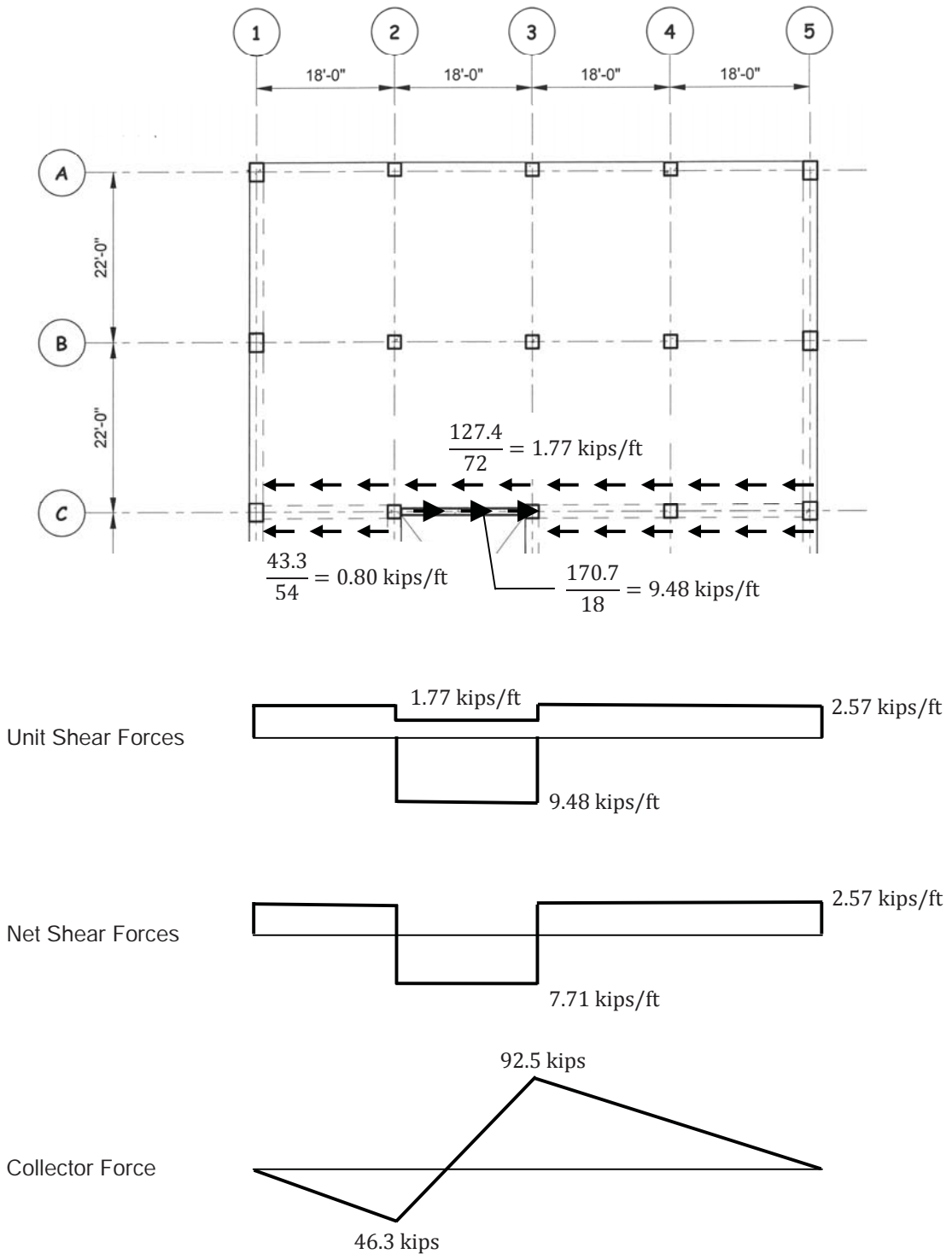

For SI: 1 inch = 25.4 mm; 1 foot = 304.8 mm.

Figure 6.59 Unit Shear Forces, Net Shear Forces and Collector Force Diagram on Column Line C at Level 2

Table 6.19 Summary of Design Axial Forces, Bending Moments and Shear Forces for Collector Element on Line C at Level 2

Load Case	Axial Force (kips)	Bending Moment (ft-kips)		Shear Force (kips)
		Negative	Positive	
Dead (D)	0	70.6	43.7	19.7
Live (L)	0	32.1	20.4	9.0
Seismic ($2.5Q_E$)	± 231	0	0	0
Load Combination				
$1.4D$	0	98.8	61.2	27.6
$1.2D + 1.6L$	0	136.1	85.1	38.0
$1.4D + 0.5L \pm 2.5Q_E$	± 231	114.9	71.4	32.1
$0.7D \pm 2.5Q_E$	± 231	49.4	30.6	13.8

Based on the load combinations in Table 6.19, a 20-inch by 28-inch collector element reinforced with three No 9 top bars, three No. 9 bottom bars, and two No. 9 side bars is adequate ($A_{st} = 0.014A_g$).³⁴ The interaction diagram for this collector is shown in Figure 6.60.

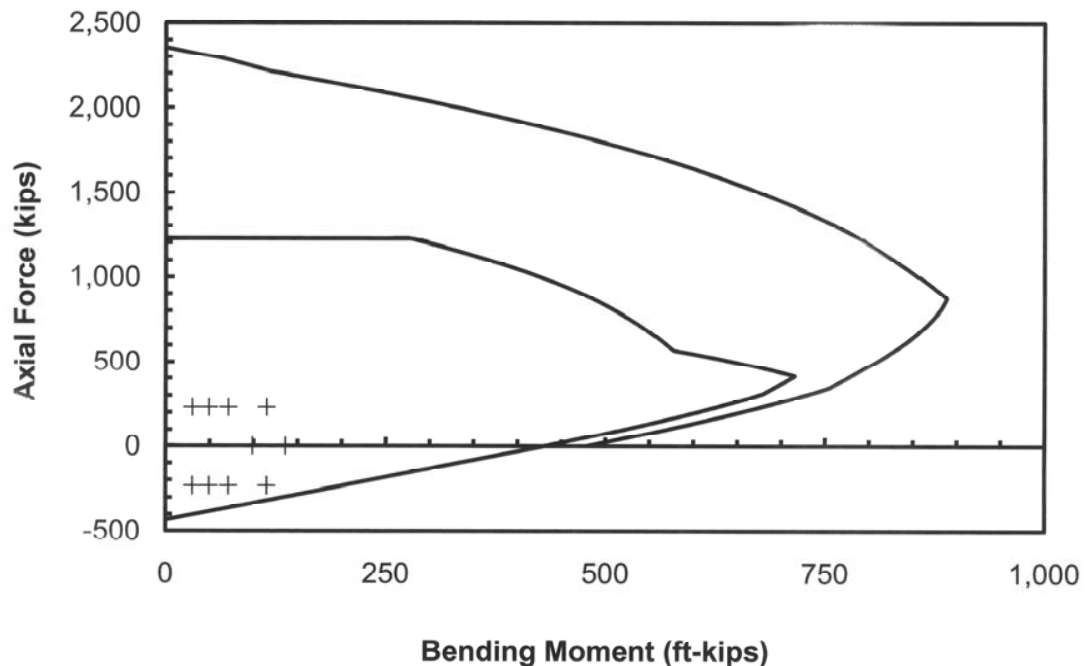

Figure 6.60 Design and Nominal Strength Interaction Diagrams for Collector Elements at Level 2

³⁴ The maximum axial force in the collector has been conservatively applied at all sections along the length of the collectors.

Check if transverse reinforcement satisfying ACI 21.9.6.4(c) must be provided over the length of the collector elements (ACI 21.11.7.5):

$$\text{Compressive stress} = \frac{2.5Q_E}{A_g} = \frac{231}{20 \times 28} = 0.41 \text{ ksi} < 0.5f'_c = 2 \text{ ksi}^{35}$$

Therefore, transverse reinforcement satisfying ACI 21.9.6.4(c) need not be provided.

The maximum shear force on the collector is 32.1 kips where the collector is subjected to significant axial tension. Therefore, the design shear strength of the concrete, ϕV_c , is set equal to zero (ACI 11.2.1.3). Assuming No. 4 ties, the required spacing is:

$$\begin{aligned} s &= \frac{A_v f_{yt} d}{\frac{V_u}{\phi} - V_c} = \frac{(2 \times 0.2) \times 60 \times 25.5}{\frac{32.1}{0.75} - 0} = 14.3 \text{ in.} > \frac{d}{2} = 12.75 \text{ in.} \\ &\leq \frac{A_v f_{yt}}{0.75 \sqrt{f'_c} b_w} = \frac{(2 \times 0.2) \times 60,000}{0.75 \sqrt{4000} \times 20} = 25.3 \text{ in.} \\ &\leq \frac{A_v f_{yt}}{50 b_w} = \frac{(2 \times 0.2) \times 60,000}{50 \times 20} = 24.0 \text{ in.} \end{aligned}$$

Provide No. 4 ties (two legs) spaced at 12.0 inches on center over the entire length of the collectors. This reinforcement is also adequate for the 38.0-kip shear force that is due to the factored gravity forces (see Table 6.19).

Reinforcement details for the collector elements are similar to those shown in Figure 6.52. Top, bottom, and side longitudinal bars are continuous over the entire span are spliced and anchored in accordance with one of the options in ACI 21.11.7.6.³⁶

The design of the diaphragm in the north-south direction at level 1 would be the same as that at level 2 since the diaphragm forces are the same (see Table 6.16). Even though the east-west diaphragm force at level 1 is smaller than that at level 2, use the same reinforcement for simplicity.

³⁵ The limit of $0.5f'_c$ is used since the axial force is amplified by the overstrength factor, Ω_o (ACI 21.11.7.5).

³⁶ The No. 4 ties spaced at 12.0 inches provided along the span satisfies the requirements of ACI 21.11.7.6(b).

About the Author

David A. Fanella, Ph.D., S.E., P.E., F.ASCE, is Associate Principal and Director of New Structures at Klein and Hoffman Inc., Chicago, IL. Dr. Fanella holds a Ph.D. in structural engineering from the University of Illinois at Chicago and is a licensed Structural Engineer in the State of Illinois and a licensed Professional Engineer in numerous states. He was formerly with the Portland Cement Association in Skokie, Illinois, where he was responsible for the buildings and special structures market. Dr. Fanella is an active member of a number of American Concrete Institute (ACI) Committees and is an Associate Member of the ASCE 7 Committee. He is currently President-Elect of the Structural Engineers Association of Illinois. Dr. Fanella has authored or co-authored many structural publications, including a series of articles on time-saving methods for reinforced concrete design.