

Alternative & Renewable Energy

The Choice of a New Generation



Ben Isaacson, MBA, CFA – (416) 945-5310

Utilities –
Alternative & Renewable Energy

For Reg AC Certification and important disclosures see Appendix A of this report

The Choice of a New Generation

Alternative and renewable energy is not a fad. Nor is it like the dot-com bubble of the early 2000s. It will not disappear if oil and natural gas prices suddenly drop, or if a long-awaited peace deal throughout the Middle East lessens the need for energy security and independence.

Rather, alternative and renewable energy is real. It is here to stay, forever. We believe there is no other option for energy-dependent societies and global economies to develop prosperously over the long term. Alternative and renewable energy has become big business, with billions of investment dollars pouring into the sector. In 2007, almost US\$150 billion was invested in the sector, and we expect the acceleration to continue, likely surpassing US\$175 billion this year alone.

In this report, **we focus specifically on renewable power generation** (and not renewable fuels such as ethanol, biodiesel, or clean syngas). We think it is critical that investors are aware of the drivers impacting the phenomenal growth we expect the renewable power space to realize. **We see these drivers of sector growth as strengthening, not weakening.** We present outlooks as well as reviews of the market, investment, and technology trends for various renewable power generation fuel sources, including wind, solar, geothermal, run-of-river hydro, biomass, wave, tidal, and ocean power.

The carbon challenge has arrived, even if federal, regional, and local carbon legislation has not been finalized. Many companies, including the five Canadian independent power producers on which we have transferred or initiated coverage, are attempting to provide profitable business solutions to this challenge. **Not all will succeed.** Globally, there are hundreds of emerging renewable power companies, both public and private. As an investor looking to play the theme, the thought of filtering through these companies can be daunting.

Since the start of 2008, stock prices within our coverage universe are down over 30%, on average. **In our opinion, these equities are mostly oversold, as investors have temporarily stepped back from high-growth/speculative names.** On a company-specific level, we believe little has happened to even partially justify such a sell-off. While several renewable project cost-overruns and time delays have occurred, this should be expected, and is a normal part of project development. On a macro level, the global credit crunch has clearly increased future costs of capital for renewable power projects, but, in our opinion, not enough to justify the steep sector sell-off. Were stock prices too high to begin with? Maybe a little, but it appears the euphoria over brag-a-watts is now over. Our coverage universe is, for the most part, unaffected by economic cycles, and **therein lies the current opportunity.**

In most industries, easily comparable financial metrics are both readily available as well as reliable. We find this not to be the case in the renewable power space, and understandably so. Many companies that we have observed in the sector are barely a few years old, typically with negative earnings for the next several years. Some companies won't even receive one dollar of revenue for at least two to three years out.

In this report, we offer clients both time-tested valuation methods as well as a more unique approach to valuing renewable power companies. In addition to providing our outlooks and specific stock recommendations, we trust this introductory report also presents the underlying knowledge, logic, and rationale to support our investment views.

Contents

The Choice of a New Generation	1
Launching Alternative & Renewable Energy Coverage	7
Investment Highlights	7
Short Term → Market Weight; Long Term → Overweight	8
Valuation Approach	9
Renewable Power Growth Drivers All Strengthening	10
Three Catalysts That Move IPP Stock Prices	10
Execution Is the Largest Risk Facing Independent Power Producers	11
Four “Must Knows” per Renewable Technology	11
Our Top Picks	13
Canadian Hydro Developers Inc. – 1-Sector Outperform, \$7 One-Year Target	13
Boralex Inc. – 1-Sector Outperform, \$18 One-Year Target	14
Our Top Sector Ideas – And How to Play Them	17
Get in on the BC Hydro Call for Power	17
The Alberta Merchant Power Market Is a Fairly Safe Bet	18
Two Small Hydro-Quebec Wind RFPs	18
Connecticut REC Prices Are Attractive	19
Pay for a Management Team’s Successful Track Record	19
Consider Geothermal Equity Exposure	20
Marine Technologies Are Still Speculative, For Now	20
Keep Solar Equity Exposure Upstream	20
Valuation Methodology	22
We Cannot Justify Using Current Multiples or Metrics to Value Our Coverage Universe	22
Our Approach to Valuing the Sector	22
Discounted Cash Flow (DCF) Analysis – Sum of the Projects	23
Net Asset Value (NAV) Calculation – Our Unique Approach	23
We Don’t Rely on Relative Valuation Metrics, But Here They Are	24
Renewable Energy Demand Drivers Suggest Industry Growth Acceleration Ahead	29
Equity Performance to Date	32
Cap-and-Trade or Carbon Tax?	35
Our Call on the B.C. Call	38
Follow Feed-In Tariff Legislation	42
We Are Bullish on Renewable Energy Certificates	43
Canadian Federal Incentives Support Renewable Growth	44

Provinces Also Encourage Renewable Power Investment	45
North American Initiatives Highlight Growing Acceptance of Climate Change Action	51
Europe Leads the World in Renewable Energy Targets	55
Global Investment Trends Support Our Bullish View	59
Boralex Inc. – A Lean, Green, Cash Flow Machine	67
Summary & Investment Recommendation	68
Capital Markets Profile	69
When Will Boralex Need New Equity?	70
We Like Boralex’s Geographic, Technology, and Seasonal Diversification	71
Production Profile & Outlook	73
Getting to 1,000 MW by 2012	77
We’re Bullish on Connecticut’s REC Market	78
A Small Hedge to High French Natural Gas Costs	81
ISO-NE’s Forward Capacity Markets	82
Key Investment Risks	83
French Wind Power Is Booming	85
Upcoming Stock Catalysts & Events	86
Cascades Likely Won’t Divest Its 34% Stake in Boralex	88
What About the Fund?	88
Valuation & Sensitivity Analysis	89
Financial Forecast	92
Management & Directors	99
Canadian Hydro Developers Inc. – The Best Bang for Your Renewable Buck	101
Summary & Investment Recommendation	102
Capital Markets Profile	103
When Will Canadian Hydro Developers Need New Equity?	104
Production Profile & Outlook	106
Alberta Spot Power Price Volatility Increasing...	108
...But KHD’s Proportionate Exposure Should Decline	108
Mixed Reactions on KHD’s Recent Acquisitions	109
Key Investment Risks	110
Upcoming Stock Catalysts & Events	112
Construction Projects & Development Prospects	113
The Value of KHD’s RECs	115
Warming Up to Dunvegan	116
Valuation & Sensitivity Analyses	117
Financial Forecast	120
Management & Directors	126

EarthFirst Canada Inc. – At Risk: Everything	127
Summary & Investment Recommendation	128
Capital Markets Profile	129
When Will EarthFirst Need More Equity?	130
Key Investment Risks	132
Upcoming Stock Catalysts & Events	135
EarthFirst’s Flagship 144 MW Dokie I Wind Farm	136
Grand Valley	140
EarthFirst’s Other Wind Projects	142
Valuation & Sensitivity Analyses	145
Financial Forecast	147
Management & Directors	152
Innergex Renewable Energy Inc. – PPAs in Hand – Now Execute!	155
Summary & Investment Recommendation	156
Capital Markets Profile	157
When Will Innergex Need New Equity?	158
Production Profile & Outlook	159
Innergex Power Income Fund	160
A Big Day for a Small Company	161
Overview of Projects	162
Key Investment Risks	166
Upcoming Stock Catalysts & Events	168
Our Best Guess on Innergex’s Future PPA Bids	169
Valuation & Sensitivity Analyses	170
Financial Forecast	172
Management & Directors	178
Plutonic Power Corporation – One Goal: Winning Its Next BC Hydro Bids	181
Summary & Investment Recommendation	182
Capital Markets Profile	184
When Will Plutonic Need More Equity?	187
Key Investment Risks	188
The Fall of Europa	189
Share Price Observations – A News-Driven Story	190
Upcoming Stock Catalysts & Events	192
Plutonic’s Flagship 196 MW Toba/Montrose Project	194
Plutonic’s Likely BC Hydro Clean Power Call Bids	196
Valuation & Sensitivity Analyses	198
Financial Forecast	201
Management & Directors	207
Wind Power – An Established & Mainstream Power Source	209
Overview	209
Investment Positives & Negatives	210
Wind Power Market Trends	210

Project Economics to Improve, in a Couple of Years	213
Modelling & Sensitivity Analyses of a Wind Project	213
Canada – A Review and Outlook	217
Catalysts for the Canadian Wind Power Market	220
The European Union Is Far More Advanced in Wind Power Development Than North America	221
Wind M&A Activity and Capital Markets Trends	223
Emerging Wind Technologies	226
Offshore Wind Capital Costs Have Not Peaked Yet	228
The Turbine Manufacturer Oligopoly	229
Select Canadian Wind Developer Equities	231
Solar Photovoltaic Power – Shining Bright Post-2013	236
Overview	236
What We Like About the Potential for Utility-Scale Solar PV	238
PV's Challenges: Cost Reductions Needed in Many Areas	239
Solar Equities: The Rise ...	240
... And Fall	240
Testing Ontario's Standard Offer Contract: Modelling & Sensitivity Analyses of a Solar Project	242
Canadian Content	245
Expect Solar PV Grid Parity in Five to Seven Years	246
Solar PV Trends & Observations	247
Solar Supply/Demand Outlook: Too Many (Silicon) Cooks Spoil the (Investment) Broth	248
Photovoltaics Science & Technology 101	249
Emerging Photovoltaic Technologies & Concepts	253
Select Canadian Solar Manufacturers	254
Run-of-River – Focus on B.C.	261
Overview	261
Terrific Outlook for B.C. Run-of-River Projects	262
Run-of-River Project Economics: Distinguishing the Good from the Not So Good	262
Run-of-River Equity Returns Are Quite Strong: Modelling & Sensitivity Analyses of a Run-of-River Project	263
Run-of-River Capital Costs per MWh Are Among the Least Expensive	266
Investment Positives	266
Investment Risks & Challenges	267
How Quickly a Great Project Can Fall Apart	268
Run-of-River Science & Technology 101	268
Run-of-River Capacity Development Process & Timeline	269
Select Canadian Run-of-River Developers	270
Geothermal Power – Mining for Heat	273
Overview	273
Canadian Geothermal Development Disappointing to Date	274
Project Equity Returns Are Reasonable: Modelling & Sensitivity Analyses of a Geothermal Power Project	275
Geothermal Capital Costs per MWh Are Materially Cheaper Than Wind	278
Investment Positives	279
Investment Risks & Challenges	279

Geothermal Power Science & Technology 101	280
Emerging Geothermal Technologies	282
Outlook	282
Strong Geothermal Showing at the 2008 PDAC	282
Select Canadian Geothermal Power Developers	283
Wood-Residue Biomass – Losing Value on High Fuel Costs	289
Overview	289
Consider Investing Biomass Dollars in REC Markets	289
Profiting from the Mountain Pine Beetle – The B.C. Bioenergy Call	290
Capital Costs Are Reasonable, But O&M Costs Are Soaring	291
Investment Positives	291
Investment Risks	291
Unexciting Equity Returns: Modelling & Sensitivity Analyses of a Wood-Residue Biomass Project	292
Wood-Residue Biomass Science & Technology 101	296
Coal-to-Wood Biomass Plant Conversion	296
Select Canadian Wood-Residue Biomass Projects	300
Tidal Power – The Next Renewable Play?	301
Overview	301
Tidal Power Potential in Canada Is Huge	301
Quality Equity Returns Likely 5+ Years Away: Modelling & Sensitivity Analyses of a Tidal Power Project	302
Tidal Power Science & Technology 101	305
Passing the Bay of Fundy Test	306
Select Global Tidal Power Projects	308
Wave Energy – Not the Wave of the Future, For Now	309
Overview	309
Limited Development in Canada, But the Potential Is Promising	310
Wave Power Science & Technology 101	311
Select Global Wave Power Projects	311
Ocean Thermal Energy Conversion – Using Earth’s Largest Solar Panel	315
Overview	315
OTEC Science & Technology 101	315
Appendix 1	317
Appendix 2	318
Appendix 3	319

Note: All prices are as at August 15, 2008.

Launching Alternative & Renewable Energy Coverage

We have initiated or transferred coverage on five Canadian equities within the Alternative & Renewable Energy space: Boralex Inc.; Canadian Hydro Developers Inc.; EarthFirst Canada Inc.; Innergex Renewable Energy Inc.; and Plutonic Power Corporation.

Our top stock picks, both rated 1-Sector Outperform, are Boralex and Canadian Hydro Developers.

Exhibit 1.1 highlights our one-year target prices, ratings, and implied relative valuation multiples; Exhibit 1.2 shows our alternative and renewable energy comparative valuation analysis.

INVESTMENT HIGHLIGHTS

Exhibit 1.1: Summary Table of Targets, Ratings, and Relative Valuation Metrics											
Company	Ticker	Last Price	SC Rating	1-Year Target	1-Year ROR	DCF	NAV	Market Cap	Enterprise Value to EBITDA		
									2008E	2009E	2010E
		8/15/2008						(\$M)	(x)	(x)	(x)
Boralex	BLX	\$14.80	1-SO	\$18.00	22%	\$18.33	\$17.03	\$560	9.9x	8.6x	7.6x
Canadian Hydro Developers	KHD	\$4.38	1-SO	\$7.00	60%	\$7.04	\$6.95	\$628	20.3x	9.9x	7.6x
Earthfirst Canada	EF	\$0.27	3-SU	\$0.40	48%	\$0.35	\$0.60	\$28	n.m.	-5.5x	-0.9x
Innergex Renewable Energy	INE	\$8.25	3-SU	\$9.50	15%	\$9.44	\$9.55	\$194	n.m.	18.4x	7.8x
Plutonic Power	PCC	\$7.04	2-SP	\$9.00	28%	\$9.03	\$8.75	\$297	n.m.	n.m.	n.m.
Average					35%			\$341	15.1x	7.8x	5.5x

Source: Bloomberg; Scotia Capital estimates.

While we anticipate sector volatility to continue over the short term due to shaky equity markets in general, we expect our top stock picks, Canadian Hydro Developers and Boralex, both rated 1-Sector Outperform, to perform exceptionally well over the next 12 months, as follows:

- **Canadian Hydro Developers oversold.** We believe the recent sell-off of Canadian Hydro Developers presents a compelling buying opportunity. Following several permitting-related project timing setbacks and associated cost overruns, we think KHD's current share price now reflects too much of an execution risk discount. **Our DCF and NAV analyses are supportive of a \$7/share price and a 50%+ ROR one year out.**
- **Boralex is a bargain, in our opinion, and is one of the few renewable power development companies that offers investors healthy cash flow generation, coupled with a well-funded and achievable growth plan.** Strong spot northeastern U.S. power prices coupled with easing diesel prices and our long-term bullish outlook for a tight Connecticut REC market are the basis for our positive thesis. **Our DCF and NAV support a price in the \$18/share area, suggesting a 20%+ one-year return.**

On balance, we have a positive outlook for all five of the companies that we have assumed coverage on, backed by our average one-year rate of return of 35%.

- **Plutonic Power – neutral on the name (2-Sector Perform; one-year target of \$9.00/share).** Plutonic is currently 100% dependent on the B.C. government choosing its renewable projects over others. We assume 1,047 MW of Plutonic projects get submitted into the current BC Hydro Clean Power Call. If no more of its projects are chosen, its stock price could drop to \$3 per share. If the company wins all 1,047 MW in the Call, and maintains a 40%+ economic interest in the projects, the stock could be worth close to \$15.

- **Innergex – a “show me” story (3-Sector Underperform; one-year target of \$9.50/share).** INE recently lost its bid in the 2,000 MW Hydro-Quebec wind request for proposal (RFP), while all other companies within our coverage universe that bid into the RFP won at least two projects. Innergex is sitting on over 290 MW of PPAs, spread over nine projects, most of which it has yet to execute. Execution and construction risk is high, and two of its three current construction projects have faced timing setbacks. We think investors should focus more on the successful commissioning of its PPA-signed projects than on winning new PPAs.

- **EarthFirst – highly speculative (3-Sector Underperform; one-year target of \$0.40/share).** Following \$35 million of cost overruns at its only construction project and a \$200+ million debt financing deal that expired prior to funding, EF is now uncertain whether it will remain a going concern. The company desperately needs \$50 million of equity/sub debt as well as a reworked debt financing agreement to complete construction of its 144 MW Dokie I project. We see one of four scenarios playing out over the short term: (1) bankruptcy; (2) a takeout; (3) financial partner; or (4) a successful refinancing. On August 21, the company announced that it had formally initiated a review of its strategic alternatives.

SHORT TERM → MARKET WEIGHT; LONG TERM → OVERWEIGHT

This year has been a rough year for most alternative and renewable energy equities. What makes it seem worse is the phenomenal year these equities had in 2007. Year-to-date, our universe of coverage is now down over 30% compared with the S&P/TSX Composite Index, which is down only 5.3% (note that all of our stocks have betas of less than one). The majority of these stocks are not (or should not be) materially impacted by economic downturns. On the top line, revenue (i.e., price x volume) is fairly predictable, as power prices are, for the most part, contractually locked in. On volume, Mother Nature certainly doesn't stop working during a recession. The wind still blows, the sun still shines, and rivers still flow. Operating and maintenance costs are also quite predictable, as are future project capital expenditures (albeit with some cost overrun and credit risks).

In our minds, nothing really has changed much over the past several months other than the market's sentiment towards renewable energy equities has turned somewhat sour. It is true that credit spreads have widened, increasing financing risks for future renewable projects. In our opinion, this increased risk is certainly not enough to warrant the massive sell-off we have seen. As a result, we are quite bullish on the sector as a whole (i.e., long-term overweight), although less so than some of our competitors. Our average one-year ROR is 35%, while the consensus average for our coverage universe is about 60%. **Our long-term bullish/overweight outlook comes with one short-term caution.**

Clearly, renewable energy stocks have temporarily fallen out of favour (-34% YTD), as investors steer clear of high-growth and somewhat speculative names during this down cycle in favour of info tech (+9.6% YTD) and blue-chip energy (+4.2% YTD) stocks. While we think there are currently excellent bargains within our coverage universe, **we suggest a cautious short-term trading approach until equity markets have reached trough levels.**

Exhibit 1.2: Alternative and Renewable Energy Comparative Valuation Analysis

Company		Boralex	Canadian Hydro Developers	EarthFirst Canada	Innergex Renewable Energy	Plutonic Power	Coverage Universe Average	Canadian IPP Average
Ticker		BLX	KHD	EF	INE	PCC		
Last Price (Aug 15, 2008)	(C\$)	\$14.80	\$4.38	\$0.27	\$8.25	\$7.04		
Rating ¹		1-SO	1-SO	3-SU	3-SU	2-SP		
1 Yr Target	(C\$)	\$18.00	\$7.00	\$0.40	\$9.50	\$9.00		
ROR (1 Yr)	(%)	21.6%	59.8%	48.1%	15.2%	27.8%	34.5%	
Dividend Yield	(%)	0.0%	0.0%	0.0%	0.0%	0.0%	0.0%	
Total Assets	(C\$M)	\$558	\$1,139	\$207	\$343	\$167		
Book Value per Share	(C\$)	\$7.79	\$3.45	\$1.65	\$9.71	\$1.40		
P/BV	(x)	1.9x	1.3x	0.2x	0.9x	5.0x	1.8x	3.0x
Market Data								
Shares O/S	(M)	37.8	143.5	103.3	23.5	42.2		
Market Cap.	(C\$M)	\$560	\$628	\$28	\$194	\$297	\$342	\$141
Ent. Value	(C\$M)	\$667	\$1,109	-\$24	\$263	\$291		
Beta		0.7	0.5	-	-	0.9	0.7	1.0
ROR 1m	(%)	4.9%	-12.4%	-73.0%	18.7%	17.3%	-8.9%	-10.7%
ROR 3m	(%)	-12.1%	-27.0%	-84.0%	-14.7%	-7.0%	-29.0%	-20.3%
ROR 6m	(%)	-6.6%	-22.2%	-86.5%	-27.0%	-7.1%	-29.9%	-24.1%
ROR YTD	(%)	-14.2%	-31.6%	-85.0%	-33.8%	-6.8%	-34.3%	-32.1%
52-Week Low	(C\$)	\$13.00	\$4.05	\$0.22	\$6.76	\$5.81		
52-Week High	(C\$)	\$19.39	\$8.01	\$2.60	\$14.00	\$9.29		
Debt Metrics								
LTD/(LTD + Equity)	(%)	38.5%	52.8%	n.m.	28.2%	39.4%	39.7%	35.5%
Debt/Assets	(%)	33.0%	48.7%	n.m.	26.1%	23.4%	32.8%	27.7%
Forecast								
Sales	(C\$M)	2008E	\$214.4	\$87.5	\$0.0	\$7.0	\$0.0	
		2009E	\$228.2	\$159.4	\$5.1	\$23.3	\$0.0	
		2010E	\$243.3	\$202.4	\$31.5	\$46.4	\$1.8	
EBITDA	(C\$M)	2008E	\$67.4	\$54.7	\$0.0	\$0.3	-\$14.5	
		2009E	\$77.9	\$112.3	\$4.3	\$14.3	-\$10.8	
		2010E	\$87.9	\$146.5	\$27.0	\$33.9	-\$8.4	
Earnings	(C\$/share)	2008E	\$0.51	\$0.08	-\$0.02	-\$0.19	-\$0.32	
		2009E	\$0.73	\$0.19	-\$0.04	\$0.03	-\$0.24	
		2010E	\$0.79	\$0.25	-\$0.03	\$0.32	-\$0.21	
Cash Flow	(C\$/share)	2008E	\$1.43	\$0.27	-\$0.03	-\$0.03	-\$0.16	
		2009E	\$1.69	\$0.49	-\$0.02	\$0.25	-\$0.16	
		2010E	\$1.93	\$0.67	\$0.05	\$0.81	-\$0.17	
Book Value	(C\$/share)	2008E	\$8.03	\$3.51	\$1.64	\$9.68	\$1.24	
		2009E	\$8.78	\$3.71	\$1.60	\$9.71	\$1.01	
		2010E	\$9.58	\$3.98	\$1.64	\$10.61	\$2.12	
Valuation								
NAV	(C\$/share)		\$17.03	\$6.95	\$0.60	\$9.55	\$8.75	
DCF ²	(C\$/share)		\$18.33	\$7.04	\$0.35	\$9.44	\$9.03	
P/NAV	(x)		0.9x	0.6x	0.4x	0.9x	0.8x	0.7x
P/DCF	(x)		0.8x	0.6x	0.8x	0.9x	0.8x	0.8x
Discount Rate	(%)		10.0%	9.5%	11.5%	11.0%	10.5%	10.7%
EV per Risked MW ³	(C\$000s per MW)		\$1,388	\$1,718	(\$113)	\$1,353	\$808	\$1,031
EV per Risked GWh/y ³	(C\$000s per GWh/y)		\$327	\$561	(\$47)	\$338	\$392	\$314
P/E	(x)	2008E	28.8x	54.6x	n.m.	n.m.	n.m.	41.7x
		2009E	20.2x	23.4x	n.m.	n.m.	n.m.	21.8x
		2010E	18.6x	17.3x	n.m.	25.5x	n.m.	20.5x
EV/EBITDA	(x)	2008E	9.9x	20.3x	n.m.	n.m.	n.m.	15.1x
		2009E	8.6x	9.9x	-5.5x	18.4x	n.m.	7.8x
		2010E	7.6x	7.6x	-0.9x	7.8x	n.m.	5.5x
P/S	(x)	2008E	2.6x	7.2x	n.m.	27.5x	n.m.	12.4x
		2009E	2.5x	3.9x	5.5x	8.3x	n.m.	5.1x
		2010E	2.3x	3.1x	0.9x	4.2x	n.m.	2.6x
P/CF	(x)	2008E	10.4x	16.0x	n.m.	n.m.	n.m.	13.2x
		2009E	8.7x	9.0x	n.m.	33.6x	n.m.	17.1x
		2010E	7.7x	6.6x	5.6x	10.2x	n.m.	7.5x
P/BV	(x)	2008E	1.8x	1.2x	0.2x	0.9x	5.7x	2.0x
		2009E	1.7x	1.2x	0.2x	0.8x	7.0x	2.2x
		2010E	1.5x	1.1x	0.2x	0.8x	3.3x	1.4x
Company Metrics								
Capacity (net)	(MW)	Operating	364 MW	364 MW	0 MW	8 MW	0 MW	147 MW
		Near Term ⁴	176 MW	359 MW	174 MW	103 MW	78 MW	178 MW
		Pipeline ⁵	160 MW	1,721 MW	2,476 MW	2,487 MW	1,637 MW	1,696 MW
Generation (net)	(GWh/y)	Operating	1,700 GWh/y	1,136 GWh/y	0 GWh/y	42 GWh/y	0 GWh/y	575 GWh/y
		Near Term	534 GWh/y	1,050 GWh/y	404 GWh/y	448 GWh/y	298 GWh/y	547 GWh/y
		Pipeline	434 GWh/y	5,254 GWh/y	6,118 GWh/y	8,016 GWh/y	3,399 GWh/y	4,644 GWh/y

1. SO - Sector Outperform, SP - Sector Perform, SU - Sector Underperform.
 2. DCF for EarthFirst is based on four equally-weighted scenarios: (1) refinancing; (2) bankruptcy; (3) takeover; and (4) financial partner.
 3. Capacity and generation are risk-adjusted as follows:
 (1) Operating - 100%; (2) Under Construction - 90%; (3) PPA & Permitted - 50%; (4) PPA or Permitted - 25%; (5) Some Development - 10%; and (6) Pipeline - 0%.
 4. Near Term: sum of (2) Under Construction; and (3) PPA & Permitted.
 5. Pipeline: sum of (4) PPA or Permitted; (5) Some Development; and (6) Pipeline.

Source: Reuters; Bloomberg; Company reports; Scotia Capital estimates.

VALUATION APPROACH

We are hesitant to give any weight to current trading multiples or other valuation metrics using current financial data, simply because the numbers are, in our opinion, somewhat meaningless. Why? Many companies in the sector that we have observed are barely a few years old, typically with negative earnings for the next several years. Some companies won't even receive one dollar of revenue for at least two to three years out. Our universe of coverage is primarily an event-driven basket of stocks.

We believe that a **prudent valuation approach** must take into account the following factors: (1) the unique characteristics and economics of each and every renewable power project; (2) corporate synergies/efficiencies from a multiple-project portfolio; (3) corporate level specifics; (4) rule-of-thumb metrics upon which some investors trade; and (5) forward relative valuation metrics.

We use a sum-of-the-projects discounted cash flow analysis, and a somewhat unique net asset value approach in setting our one-year targets. As a reality check, we calculate the implied forward EV multiples on 2009 through 2011 EBITDA estimates.

RENEWABLE POWER GROWTH DRIVERS ALL STRENGTHENING

We see three overall themes that have caused the phenomenal growth of renewable power generation. Our long-term overweight and bullish stance is predicated on each of these renewable power demand drivers strengthening.

1. Renewable portfolio standards. Regulatory policies that mandate the use of renewable energy is the number one key driver for the industry's growth. There are four primary reasons for accelerated growth in the number and the intensity of renewable portfolio standards around the world:

- rising energy prices;
- the increased need for energy security and independence;
- greater environmental awareness and fear of climate change; and
- compliance with the Kyoto Protocol or its successor.

2. The implementation of carbon emissions cap-and-trade programs or carbon taxes. Numerous proposals exist throughout the world to penalize industrial carbon emitters. Placing a price on carbon emissions increases the cost of fossil fuel power generation, making renewable energy options that much more attractive.

3. Renewable technology economics continue to improve. Real cost curves for most renewable energy technologies continue to decline. While there have been some setbacks, we view these as short term in nature.

THREE CATALYSTS THAT MOVE IPP STOCK PRICES

1. Bidding for and being awarded new long-term, fixed-price power purchase agreements;
2. Material progress or setback updates on a company's development pipeline, ranging from construction cost overruns to the announcement of new projects; and
3. The advancement of favourable renewable power policies, initiatives, or RFPs that support continued industry growth.

EXECUTION IS THE LARGEST RISK FACING INDEPENDENT POWER PRODUCERS

Poor project execution is the biggest threat to stock prices within our coverage universe. Timing setbacks and cost overruns can destroy equity IRRs. To mitigate this risk, some companies enter into 100% fixed-price EPC contracts, but typically at a higher overall cost, and therefore at a lower relative project return.

FOUR “MUST KNOWS” PER RENEWABLE TECHNOLOGY

Wind. (1) Wind power is now an established, mainstream power source in a rapidly growing number of countries, including Canada; (2) we think capital costs will continue to rise until the end of 2009, at which point a surge in Chinese turbine exports as well as growth of European manufacturer facilities in the United States will ease supply challenges; (3) by 2015, we could see up to 15,000 MW of wind capacity in Canada; and (4) our generic wind economic model returned an **equity IRR of 12.8%**.

Solar PV. (1) Grid-connected solar power is the fastest growing renewable power source on the planet, with capacity installations having increased about 50% per year since 2002; (2) the primary challenge facing the PV industry is the high cost to produce and install a PV system; (3) we see thin-film technologies quickly taking market share from traditional crystalline-based PV technologies, although solar PV could reach grid parity in about five years; and (4) our generic solar PV economic model returned an **equity IRR of 6.2%**.

Run-of-river. (1) BC Hydro estimates there are more than 8,200 commercially viable run-of-river hydro sites in British Columbia, of which about 121 would have levelized costs of less than \$100/MWh; (2) in our opinion, capital costs per MWh for run-of-river projects are among the least expensive for all renewable power technologies, and between 10% and 30% cheaper than wind; (3) we like the low technology risk of run-of-river assets as well as their 75+ year useful lives, if properly maintained; and (4) our generic run-of-river economic model returned a strong **equity IRR of 14.9%**.

Geothermal. (1) The global geothermal energy potential is enormous, and we see the cost of providing geothermal dropping over the long term; (2) the Canadian Geothermal Energy Association believes geothermal projects in British Columbia alone could amount to between 3,000 MW and 5,000 MW – currently there is nothing active; (3) project risk is high, and accordingly so are returns; and (4) we estimate an **18.8% average equity return** for utility-scale geothermal projects in the United States.

Biomass. (1) Wood-residue biomass power projects suffer from high operating costs, mainly feedstock and transportation-related diesel prices; (2) in our opinion, stronger returns can be found in coal-to-biomass plant conversion than in greenfield wood-residue project development; (3) we expect significant development of biomass power in British Columbia through the use of mountain pine beetle-infected wood; and (4) our generic open-loop wood-residue biomass economic model yielded an **equity IRR of 7.5%**.

Tidal/wave/ocean thermal. (1) In our view, marine technologies are at least several years behind wind, run-of-river, and even solar power development; (2) capital costs remain high; (3) we think tidal power will emerge as the first mainstream marine power technology; and (4) our generic tidal power economic model returned a **sub-5% equity IRR**.

Exhibit 1.3 summarizes our findings on the renewable power technology economics. In later sections, we provide our model assumptions and equity return sensitivity analyses on six of the eight renewable technologies. We found both wave and ocean thermal project economic models too speculative to derive meaningful results.

Exhibit 1.3: Summary Economics of Renewable Technologies

We see installed capital costs for wind farms peaking in late 2009 to early 2010, and then dropping slowly.

Levelized costs for solar PV power could hit grid parity in five to seven years.

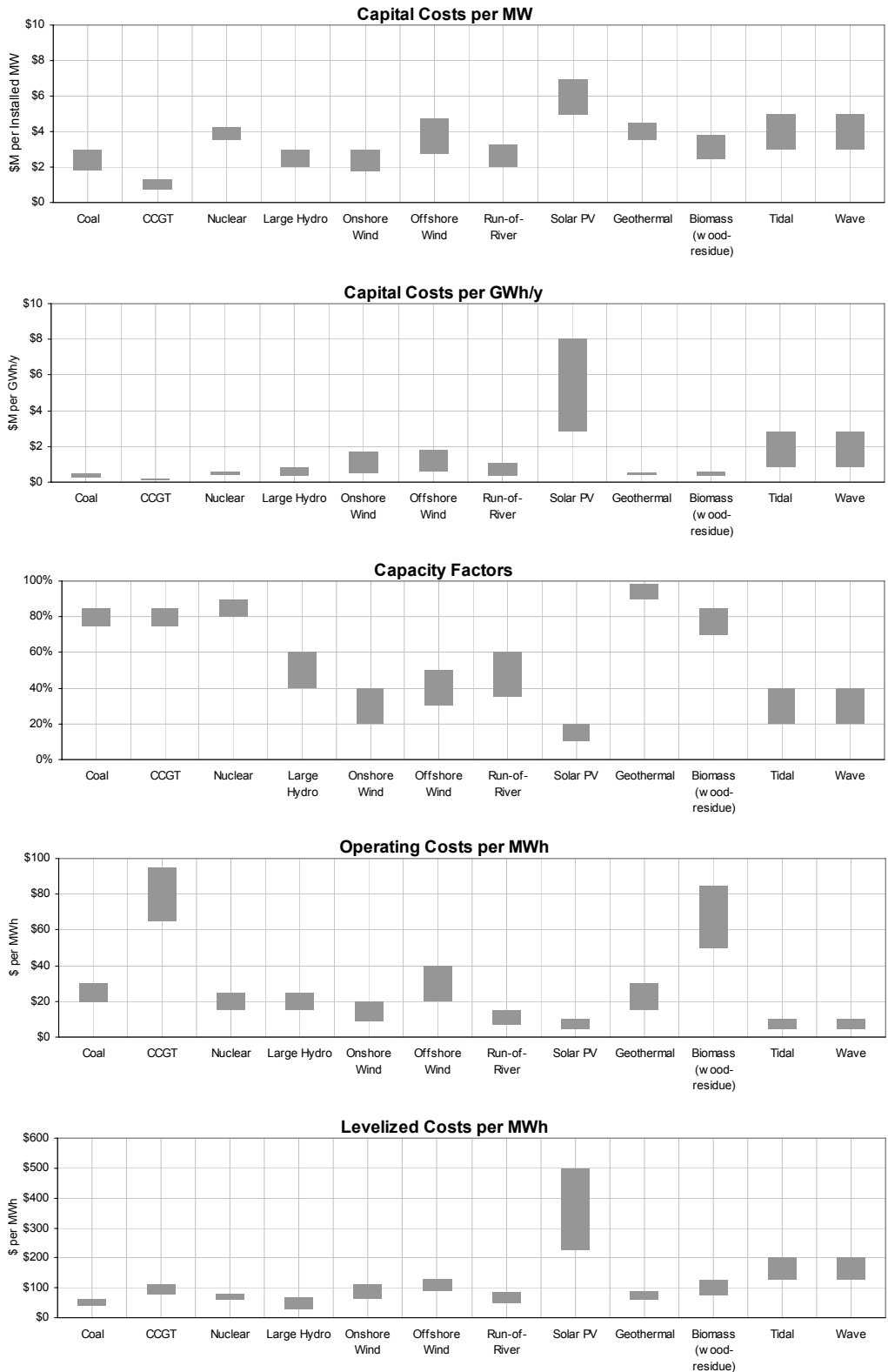

Source: Scotia Capital estimates.

Our Top Picks

CANADIAN HYDRO DEVELOPERS INC. – 1-SECTOR OUTPERFORM, \$7 ONE-YEAR TARGET

- Strong management track record.** With 19 years of experience, Canadian Hydro Developers’ (KHD) management has successfully executed on the development or acquisition of numerous projects within its portfolio.
- Production and EBITDA set to soar.** We anticipate the commissioning of over 400 MW (2.1x current capacity) of mostly contracted wind capacity over the next several years, which we believe will result in a 2011 EBITDA increase of 4x over 2007.
- Execution hiccups present an opportunity.** A few permitting holdups have forced the delay of several of KHD’s projects, resulting in slight cost overruns. However, we believe KHD’s current share price reflects too much of an execution risk discount, and is therefore undervalued.
- Stock catalysts over the coming 12 to 18 months are plentiful.** We expect to see near-perfect execution on the commissioning of several new KHD facilities in 2008 and 2009. We also look for KHD to bid up to 55 MW in the 2008 BC Hydro Clean Power Call and up to 70 MW in the Ontario RES III RFP. Dunvegan could be approved by Q1/09.
- Relative valuation attractive.** KHD is currently trading at 9.9x EV/2009E EBITDA and 7.6x EV/2010E EBITDA, quite low in our opinion. Our target EV/EBITDA multiples are 13.2x on 2009E EBITDA that drops to 10.1x on 2010E. We think these multiples are justified by the high growth we expect KHD to realize over the coming years. KHD is also trading at 0.6x our NAV, relative to our group average of 0.8x.

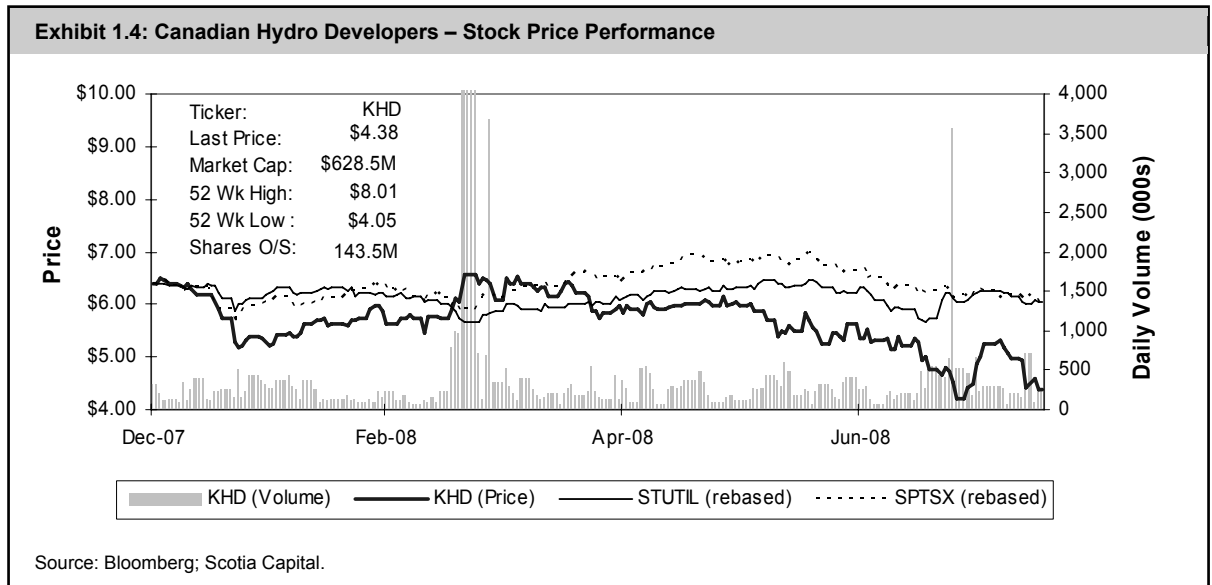

BORALEX INC. – 1-SECTOR OUTPERFORM, \$18 ONE-YEAR TARGET

- **1,000 MW by 2012 achievable.** In our minds, Boralex’s plan to nearly triple its capacity by 2012 from ~350 MW is not fully discounted in its share price. Its growth target is based on hydro growth in B.C., an entrance into the solar market, and new wind farm capacity in both Canada and Europe.
- **A New England call option on natural gas.** Boralex’s exposure to merchant power markets in the northeastern United States is high, as marginal power prices there are typically set by natural-gas-fired generators. We see natural gas prices rising over the long term.
- **Upside potential.** Strong spot northeastern U.S. power prices, our long-term outlook for a tight Connecticut REC market, and easing diesel prices coupled with improving burn rates at its wood-residue facilities are the basis for our positive outlook.
- **Stock catalysts.** We believe an extension of the U.S. Production Tax Credit will boost Boralex’s share price, as will higher Renewable Energy Certificate (REC) prices and Boralex being awarded power purchase agreements (PPAs) from several renewable request for proposals (RFPs). Reducing its relative commodity price exposure should occur naturally through the addition of free-fuel wind and hydro assets.
- **Relative valuation attractive.** While we don’t rely on relative valuation metrics to set our target prices, on a forward P/E, EV/EBITDA, P/S, and P/CF basis, Boralex is trading at a material discount to both its peer group and its closest comparable company, Canadian Hydro Developers. In our opinion, this discount is unwarranted and presents investors with an attractive entry point into the name.

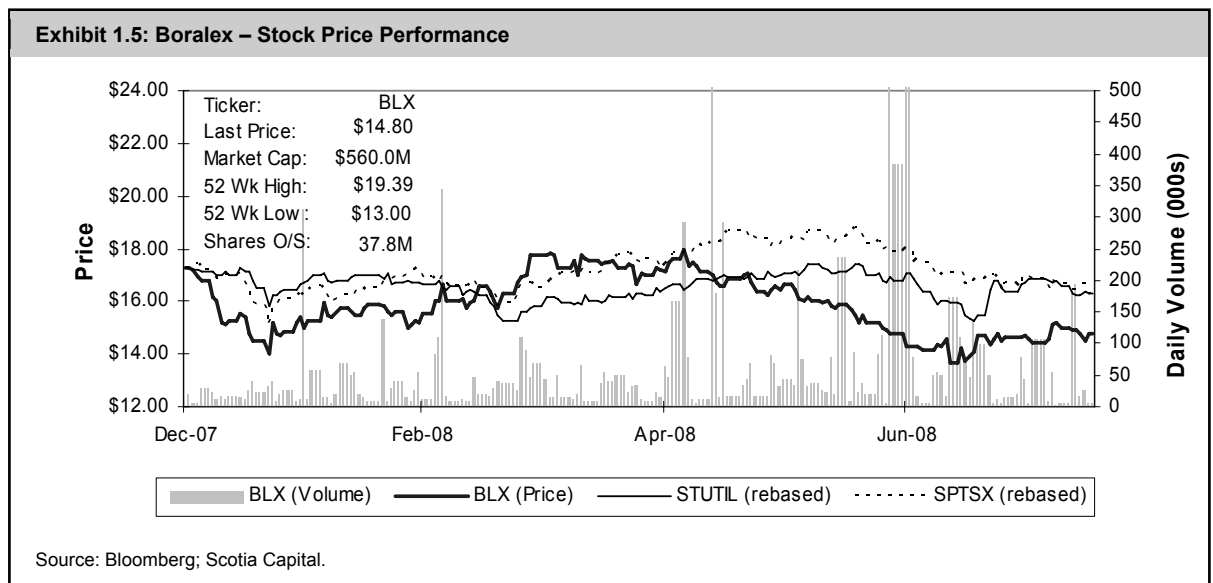

Exhibits 1.6 and 1.7 on the following pages show current capacity and generation status for our coverage universe.

Exhibit 1.6: Coverage Universe – Capacity Status

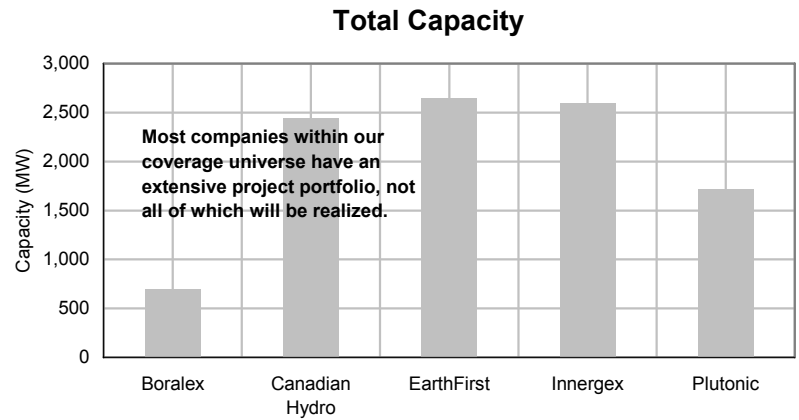
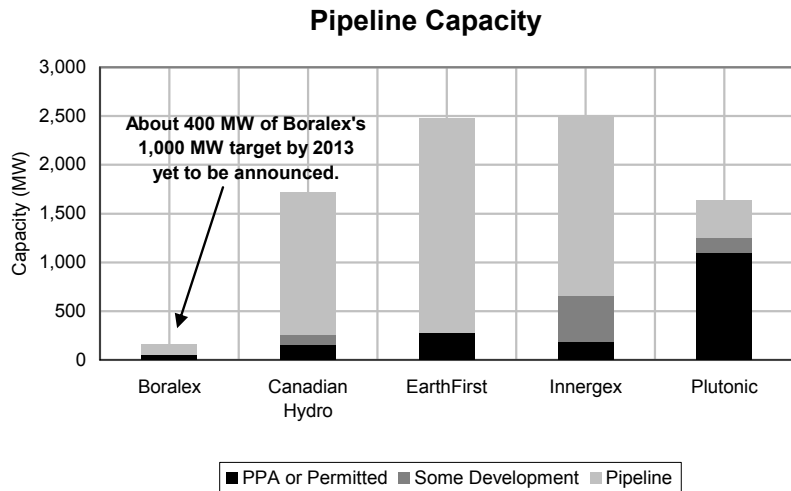
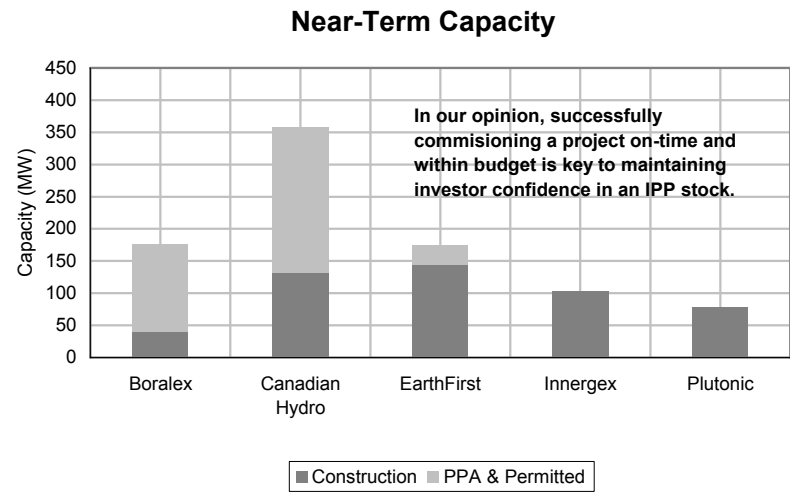

Source: Company reports; Scotia Capital estimates.

Exhibit 1.7: Coverage Universe – Generation Status

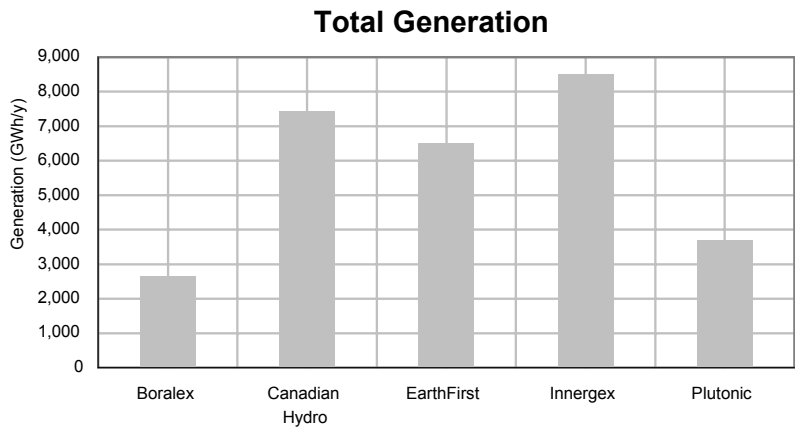
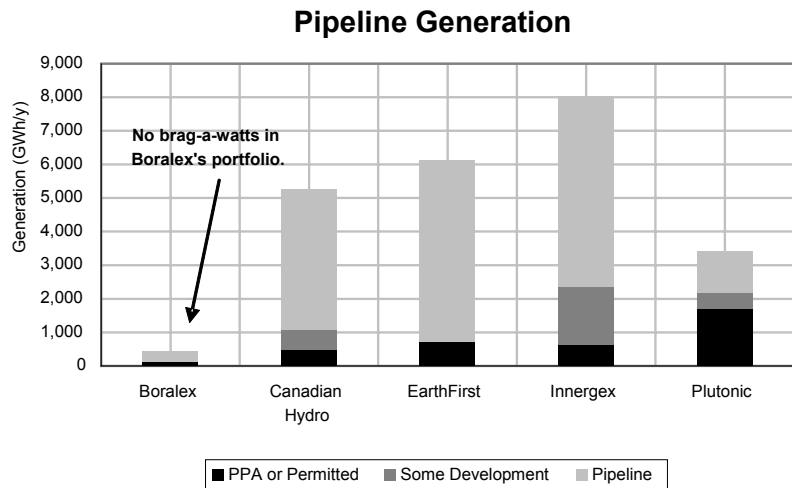
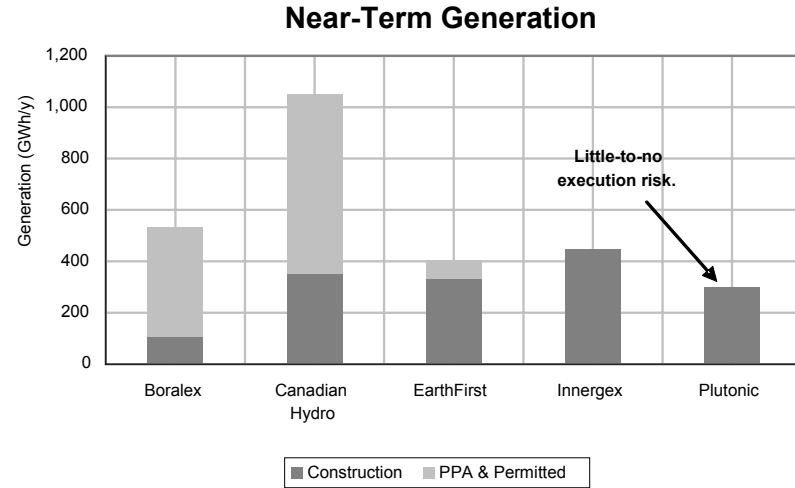
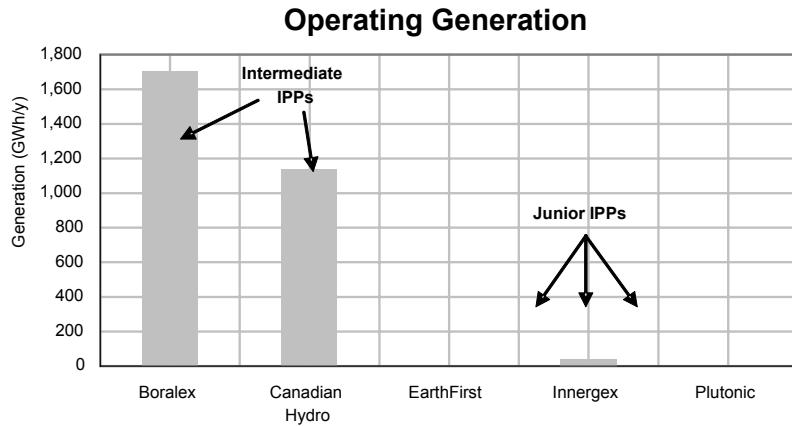

Source: Company reports; Scotia Capital estimates.

Our Top Sector Ideas – And How to Play Them

Sector Plays	Boralex	Canadian Hydro Developers	EarthFirst	Innergex	Plutonic Power	Other
B.C. Clean Power Call	◆	◆	◆	◆	◆	◆
Quebec 2 x 250 MW wind RFPs	◆			◆		?
Alberta merchant power		◆				◆
Connecticut RECs	◆					
Unrealized management value	◆	◆	?			
Geothermal						◆
Solar Power	n.m.	n.m.				◆
Marine Technologies						◆

Source: Scotia Capital.

GET IN ON THE BC HYDRO CALL FOR POWER

BC Hydro seeks 5,000 GWh/y of clean and renewable energy following the issuance of its Clean Power Call RFP earlier this year. The deadline for bid submissions is November 25, 2008, and we expect Electricity Purchase Agreements (EPAs or PPAs) to be awarded following the provincial government election in May 2009. Given a historical project attrition rate at about 50% and BC Hydro's RFP guideline changes to address this, we estimate that approximately 7,000 GWh/y of renewable power projects will be awarded.

How to Play

Plutonic Power has announced that it intends to submit its 133 MW Upper Toba Valley project (three sites) and all of its 914 MW Bute Inlet project (18 run-of-river sites) into the call. Plutonic was the overall winner in BC Hydro's 2006 Call for Power. If Plutonic's Bute Inlet project won EPAs, it would almost certainly lock the company in for top spot again. While this may not happen, Plutonic did take a giant leap forward recently by wrapping up financing arrangements for its bid, through a unit of GE, where GE would provide up to 100% of the equity. We believe Plutonic's current share price reflects about \$4/share for its Bute Inlet project.

EarthFirst currently has the only fully permitted wind power projects (we know of) that will be entered into the Clean Power Call. Fully permitted projects partially reduce the risk to BC Hydro of project attrition, although financing issues stand out as the primary reason for attrition. Financing risk for EarthFirst remains extremely high as uncertainty continues as to whether EarthFirst will remain a going concern. **We do not suggest using EarthFirst shares to play the Clean Power Call until there is more certainty regarding its future.**

Boralex, Canadian Hydro Developers, and Innergex will likely all submit something into the Clean Power Call as well. **Please refer to page 38 for our detailed analysis on the BC Hydro Clean Power Call.**

THE ALBERTA MERCHANT POWER MARKET IS A FAIRLY SAFE BET

Alberta power prices are forecast by most to keep rising in the short to mid-term, providing potential upside to those companies with Alberta merchant power exposure. We note that volatility has increased considerably over the past several years, doubling since 2002/03 (Exhibit 1.9).

How to Play

Canadian Hydro Developers has good merchant power exposure at about 20% to 25% of its portfolio (depending on the season). We believe **the best entry point to capitalize on KHD's merchant exposure is now**. Why? (1) We forecast that KHD will increase the contracted portion of its power portfolio to 88% by 2011, and to 92% by 2015, as 400 MW to 500 MW of new and fully contracted capacity should be online by then; and (2) In our opinion, KHD's share price is **deeply undervalued**. We estimate that a \$10/MWh increase in the Alberta spot price, sustained for a year, will increase KHD's annual earnings by 1.8¢ per share based on current production levels.

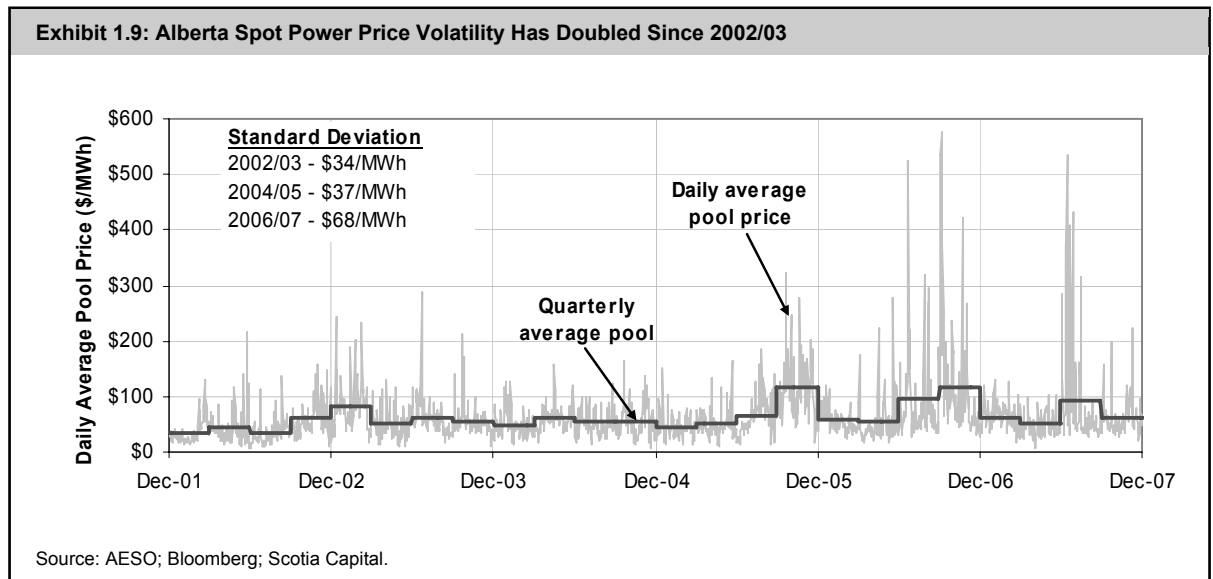

TWO SMALL HYDRO-QUEBEC WIND RFPs

Hydro-Quebec has announced, but not formally launched, two 250 MW Quebec wind RFPs. We expect the RFPs to be launched simultaneously in Q4/08. The PPA prices for the First Nations and Municipal wind RFPs have been set at \$95/MWh (\$2008).

How to Play

In our opinion, Innergex has the best shot at being awarded PPAs in the 250 MW Quebec Municipal wind RFP. Innergex's exclusive arrangement with Federation Quebecoise des Municipalites (FQM) essentially designates Innergex as the preferred partner for the development of all wind farm projects where municipalities choose to go through FQM.

CONNECTICUT REC PRICES ARE ATTRACTIVE

Renewable energy credit (REC) prices in Connecticut have dropped to the US\$30/MWh area recently from the US\$45/MWh to US\$50/MWh range. We believe that a main reason for the sell-off is due to an emergency motion for interim relief filed at FERC to immediately increase transfer capability at the New England–New Brunswick interface (Exhibit 1.10).

According to the *Integrated Resource Plan for Connecticut*, growing Connecticut renewable portfolio standards (RPS) requirements “will likely be met with high REC prices ... and substantial reliance on alternative compliance payments.” We agree. **We estimate that at least 800+ MW of new wind capacity would have to come online each year in the northeastern U.S. power markets just to keep REC prices from rising.**

How to Play

Borex offers the only Connecticut REC price exposure within our coverage universe, and is likely the largest REC seller in the Connecticut market. While we believe that Borex is finished REC-qualifying facilities for now (unless a new transmission line is constructed from northern Maine to NEPOOL), we estimate that about half of its EBITDA is generated through the sale of Connecticut Class I RECs. Currently, Borex has sold forward US\$45 million of RECs through 2012, or 34% of our forecast REC sales through 2012.

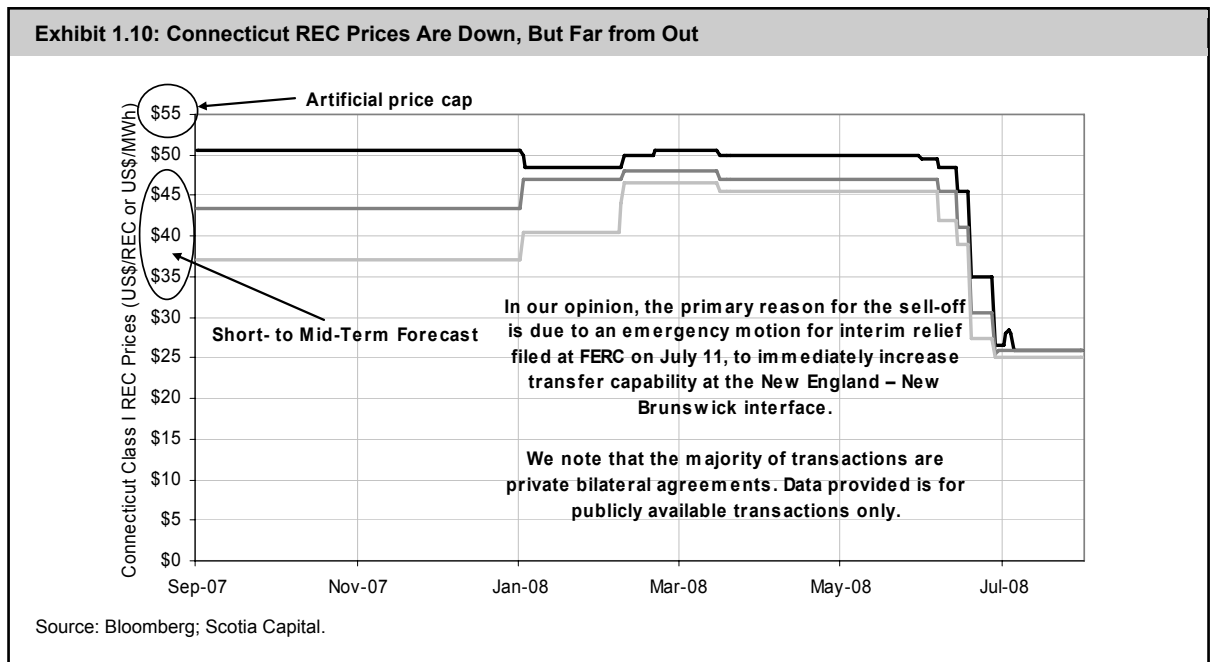

PAY FOR A MANAGEMENT TEAM’S SUCCESSFUL TRACK RECORD

How to Play

Most management teams bring to the table significant past project experience. In our opinion, the depth and quality of Borex’s and Canadian Hydro Developers’ management teams are not realized in their current share prices. For a possible management turnaround story, focus on EarthFirst (caution warranted) that recently brought Linda Chambers (an ex-TransAlta executive) on as its CEO. We do not envy her challenge at all – to bring EarthFirst away from the brink of bankruptcy.

CONSIDER GEOTHERMAL EQUITY EXPOSURE

Geothermal development projects offer investors the following: baseload power via high utilization rates (90% to 98%), strong equity IRRs in the high teens, falling capital and O&M costs over the next several years, low political risk as most projects are located in the western United States, long-term fixed price

power contracts, and government-supported financial incentives such as the U.S. PTC and RECs (Exhibit 1.11).

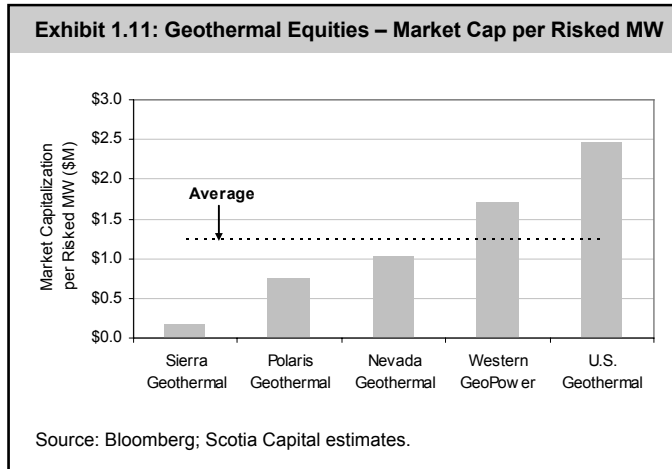

How to Play

There are five publicly traded geothermal power development companies in Canada: Sierra Geothermal, Polaris Geothermal, Nevada Geothermal Power, Western GeoPower, and U.S. Geothermal. We currently do not provide research coverage on any of these names, but offer company and project details at the end of the geothermal section of this report.

MARINE TECHNOLOGIES ARE STILL SPECULATIVE, FOR NOW

Tidal, wave, and ocean thermal power sources are slowly emerging as the next generation of renewable technologies. However, they are far from being deployed on a scale comparable to wind, run-of-river, or even solar power. Consensus has not been reached on which specific technologies will prevail and most of them remain in prototype or pilot phases. We see tidal power evolving the fastest of the three, followed by wave power and ocean thermal.

How to Play

The only Canadian equity that offers material exposure to marine technologies is Finavera Renewables (not research covered). In addition to Finavera's wind farm development projects, the company has three wave projects under development in North America, a signed PPA for a 2 MW wave farm to be located off the coast of northern California, and an early-stage wave project in South Africa.

KEEP SOLAR EQUITY EXPOSURE UPSTREAM

Solar-grade silicon suppliers currently enjoy the highest gross margins within the solar PV supply chain at 50% to 60%. Soaring demand for crystalline-based solar panels caused silicon prices to skyrocket to the US\$500/kg area from about US\$30/kg in 2004. Given the significant silicon capacity that we expect will be commissioned over the next 18 months, **in our opinion, current silicon prices are clearly not sustainable**. However, we believe that margin compression for silicon producers will be less than for other players within the solar value chain.

How to Play

We recommend focusing on silicon producers that are able to lock in long-term silicon supply contracts at these currently high and unsustainable prices. Solar equities, the darlings of Wall Street in 2007, have fallen out of favour since the start of the year, down about 20% on average, with many stocks down over 30%. We currently do not provide research coverage for any solar names but suggest reviewing our comps table within the solar PV section of this report for investment opportunities. We also provide brief descriptions of most publicly traded companies involved in the solar space, such as 5N Plus, Arise Technologies, ATS Automation, Carmanah Technologies, Day4 Energy, Opel International, and Timminco.

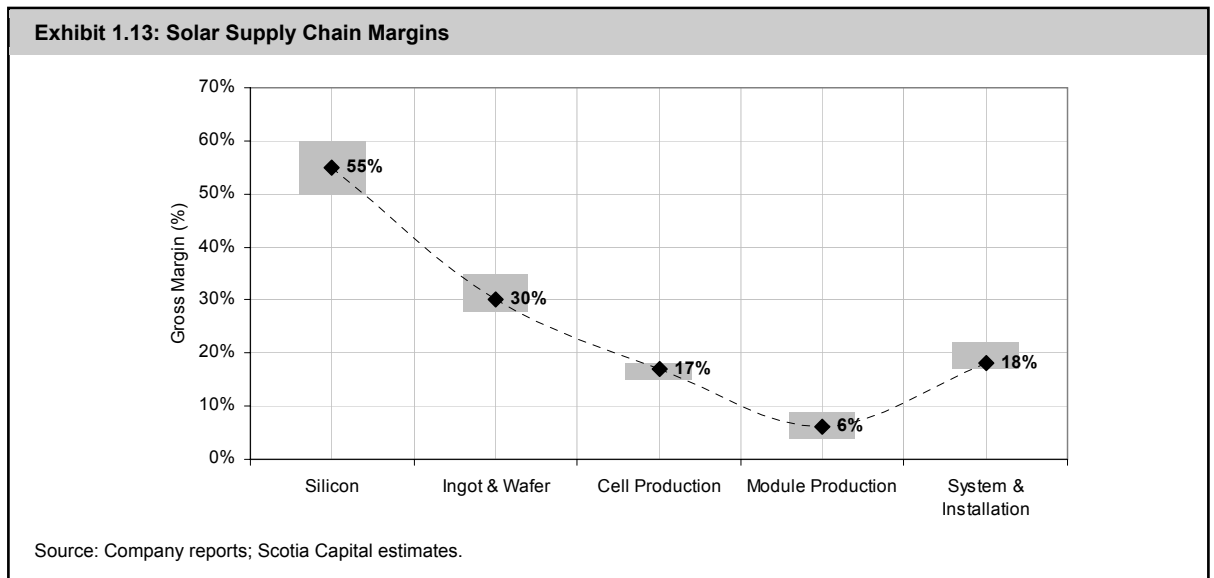
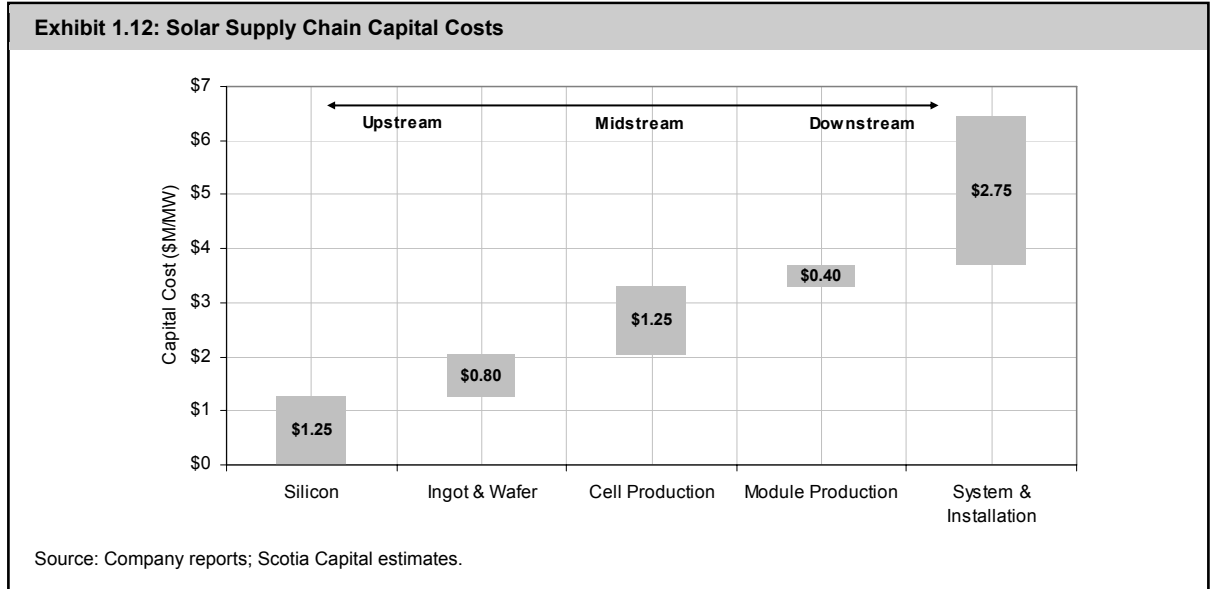

Valuation Methodology

WE CANNOT JUSTIFY USING CURRENT MULTIPLES OR METRICS TO VALUE OUR COVERAGE UNIVERSE

We are hesitant to give any weight to current trading multiples or other valuation metrics using current financial data, simply because the numbers are, in our opinion, near meaningless with little to no comparative value. Why: the companies within our coverage universe are mostly in their infancy – Plutonic Power and EarthFirst have no operating assets, and Innergex has 8 MW operating out of a 2,000+ MW pipeline. Boralex and Canadian Hydro Developers are the more mature companies in our universe, and are each no more than one-third built.

While **we don't focus on earnings for now**, future earnings power is critical. As these companies continue to mature, P/E and EV/EBITDA multiples will become more meaningful as a comparative tool.

Our universe of coverage is primarily an event-driven basket of stocks. These stocks seem to move based on project progress, new project announcements, changing federal and regional renewable power initiatives and incentives, and movement on carbon and emissions trading policies. On a macro level and over the long term, changes in various alternative and renewable energy indices have been directly related to changes in energy prices such as oil and gas.

OUR APPROACH TO VALUING THE SECTOR

We believe that a prudent valuation approach for companies within the renewable power space must take into account several factors:

- **The unique characteristics and economics of each and every renewable project**, on a stand-alone basis, including: type and quality of the renewable fuel source, contract terms and pricing (if any), capital costs and costs of capital, operating and maintenance costs, management experience in project development and operations, location of the project, ownership interest, estimated project cash flow, specific financial incentives from various government levels as well as the sustainability of these incentives, agreements with key stakeholders, permitting progress, equipment warranties, EPC construction contracts, and overall project status.
- **Corporate synergies/efficiencies from a multiple project portfolio**, including: regional, seasonal, and resource diversification, volatility of expected quarterly cash flows, tax regimes, and shared overhead and other fixed costs.
- **Corporate-level specifics** such as management quality, access to capital markets, credit ratings, quality of the company's project pipeline, and capital structure.
- **Rule-of-thumb metrics** that some investors use (and trade upon) as a back-of-the-envelope tool to identify good projects and/or power portfolios.
- **Forward relative valuation metrics** that enable the investor to more meaningfully compare the trading range of (more mature) companies relative to one another.

To accomplish our goal of considering each of these factors into our valuation approach, we chose three valuation approaches, two of which we use in setting our target prices and one as a comparative check. **We use discounted cash flow analysis (DCF) and net asset value (NAV) per share to set our one-year and two-year target prices and, as a reality check, we calculate implied forward EV multiples on both 2010E and 2011E EBITDA.** We explain our DCF and NAV methodologies next.

DISCOUNTED CASH FLOW (DCF) ANALYSIS – SUM OF THE PROJECTS

In our minds, and simply stated, a renewable power project should not be worth more than the present value of the expected future cash flows of that project, discounted at a rate that reflects the project’s riskiness.

Accordingly, our target prices are heavily influenced (i.e., 75% weighted) by a sum-of-the-projects DCF approach. Every project DCF takes into account each of the factors mentioned in the first bullet above, where quantitatively possible. Exhibit 1.14 summarizes renewable power project valuation drivers.

Exhibit 1.14: Renewable Power Project Valuation Drivers	
Value Drivers	Considerations
Project status	- operational, construction, development
Project cash flow	- contracted vs. merchant, taxes, incentives
Quality of resource	- P50, P75, P90, P95, P99
Contracts	- PPA, w warranties, EPC contract, permits, land leases
Financeability	
RECs	- sustainability
Location	
Ownership interest	- operating vs. non-operating, majority vs. minority, partner rights
Management	

Source: Scotia Capital.

We apply a firm-wide discount rate that reflects the cost of financing these assets, which we adjust slightly for qualitative factors such as management experience and non-project-specific corporate synergies. We also adjust our discount rate for various market-based risks (e.g., liquidity).

Most importantly, we then apply a probability of success to each project ranging from 100% for a fully commissioned, operating project to 0% for a “brag-a-watt.” In most cases, we give 90% credit for construction projects, 50% value for fully permitted projects with signed PPAs, 25% for projects with either a PPA in hand or permitting completion, and 10% credit for some material project progress. There are some exceptions to this. For example, a construction project with a 100% fixed-price construction contract deserves a higher probability of successful on-time and on-budget completion than a project that has not locked in its construction costs.

The sum of these projects plus other company-specific items such as investments are then added together to arrive at a one-year-out DCF value. **One of the benefits of this valuation approach is the ability to easily identify what the market should be willing to pay for various project-related events, such as the awarding of a specific project PPA.**

NET ASSET VALUE (NAV) CALCULATION – OUR UNIQUE APPROACH

We continuously see companies, consultants, investors, and other industry players discussing the “value” of a renewable project on a dollar per MW basis. While we find this approach to be almost too high level, we recognize and accept that it is relied upon by many market participants as a reality check for value, and therefore we should consider its use as a tool in determining what investors may be willing to pay for a stock (i.e., a compilation of projects).

In our opinion, there are several limitations to placing a value per MW on a project as timing and project-specific economics are completely ignored. Our sum-of-the projects DCF approach considers each project's specific economic characteristics, allowing us room to explore reality check value further.

Rather than assign a value per MW, **we chose to place a value per GWh, which eliminates differences in the quality of an asset's resource** (i.e., various capacity factors) and allows for a somewhat more meaningful comparison. We researched corporate and project transactions, as well as the average economics of the projects in our universe of coverage to determine rule-of-thumb values for different renewable technologies, and on a per GWh basis.

We assign a rule-of-thumb value of \$0.82 million per GWh for wind projects and a value of \$1 million per GWh for run-of-river projects. However, expected fixed and variable costs per GWh must also be considered, for which we have assigned \$0.65 million per GWh for wind and \$0.8 million per GWh for small hydro. Please refer to our wind and run-of-river sections of this report for further details. Assuming all else being equal, and that capacity utilization differences are irrelevant due to a production (GWh) consideration rather than a capacity (MW) consideration, the **primary difference** between wind and run-of-river assets is the length of the asset's expected life.

We finance every project using the company's stated or targeted project capital structure, issuing new equity (and increasing the share count) at our DCF price to avoid a circular reference. Identical to our sum-of-the-projects DCF approach, we identify each project's development stage, and multiply our standard NAV values by a probability of success (see above for details). Finally, we add and subtract (consistently across all companies) the value of unique items such as investments, management agreements, renewable energy certificates, and potential carbon credits.

We give a 25% weight to our NAV calculation in setting our target price.

WE DON'T RELY ON RELATIVE VALUATION METRICS, BUT HERE THEY ARE

Multiples reflect the valuation sentiment of the market, and therefore relative valuation multiples may be too high if the market is overvaluing comparable firms. In our opinion, the lower transparency of a relative valuation approach versus, say, a discounted cash flow approach is compounded for junior, volatile, and highly speculative firms that will have little to no operating assets over the coming two to three years, such as EarthFirst and Plutonic Power. For well-established IPPs with proven track records of successfully operating power assets, such as TransAlta, Boralex, and Canadian Hydro Developers, we find greater comfort in applying relative valuation techniques.

While we don't use forward EV/EBITDA and P/E multiples to set our one-year targets, we do consider them as a useful reality check. Exhibit 1.15 shows EV multiples on our 2009 and 2010 EBITDA estimates, as well as price multiples on our 2009 and 2010 earnings forecast. Exhibit 1.16 shows market capitalization and enterprise value per development stage of MW, while Exhibit 1.17 shows the same, but per development stage of expected generation (GWh/y). In Exhibit 1.18, we risk-adjusted capacities and production, which in our opinion, provides a much more meaningful comparison.

Exhibit 1.15: Forward Multiples

EV/EBITDA (2009E)

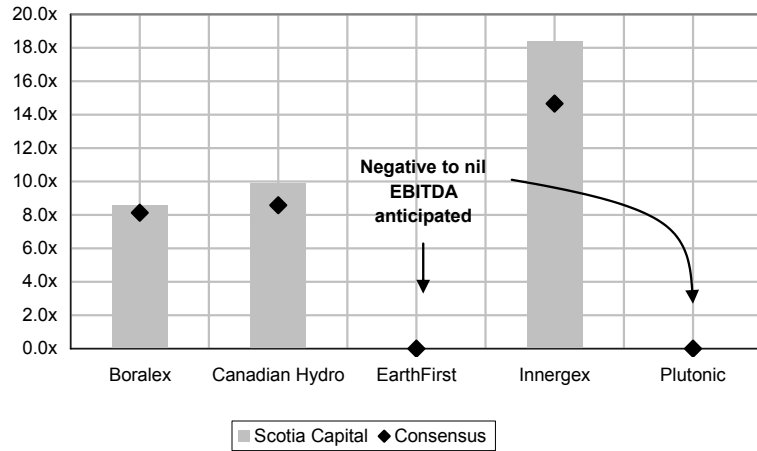

EV/EBITDA (2010E)

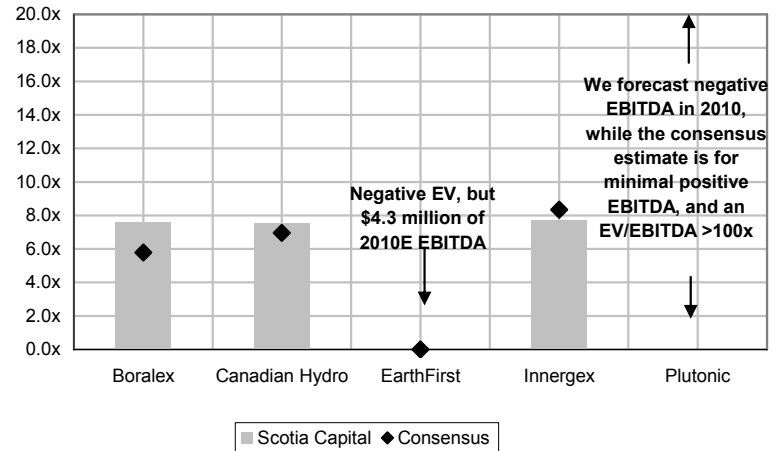

P/E (2009E)

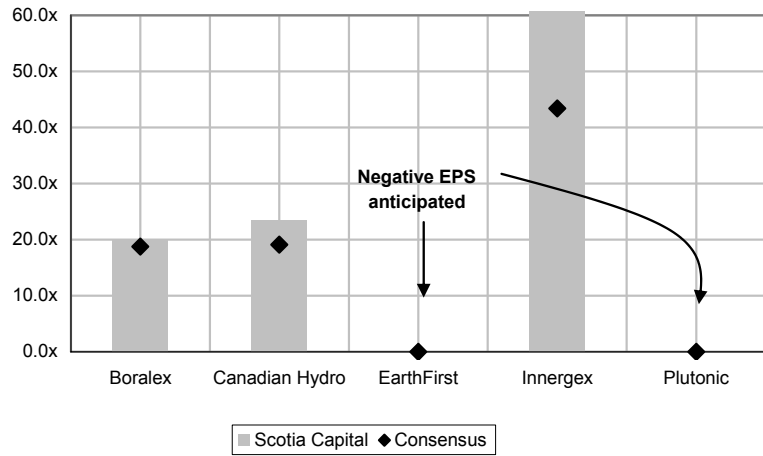

P/E (2010E)

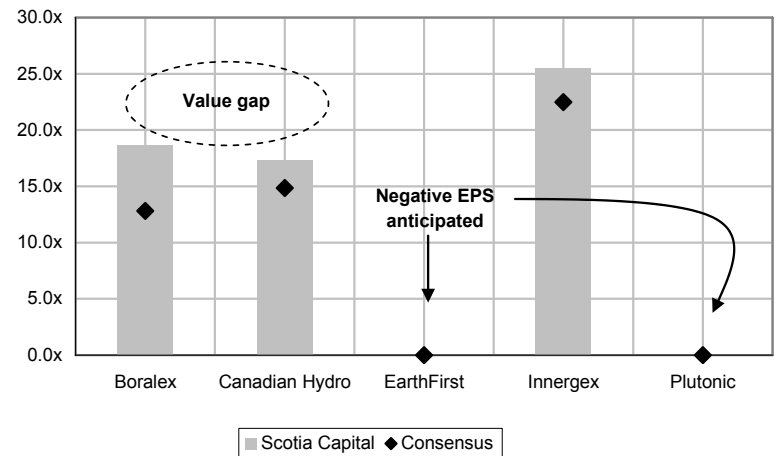

Source: Reuters; Scotia Capital estimates.

Exhibit 1.16: Market Capitalization and Enterprise Value per Capacity Status

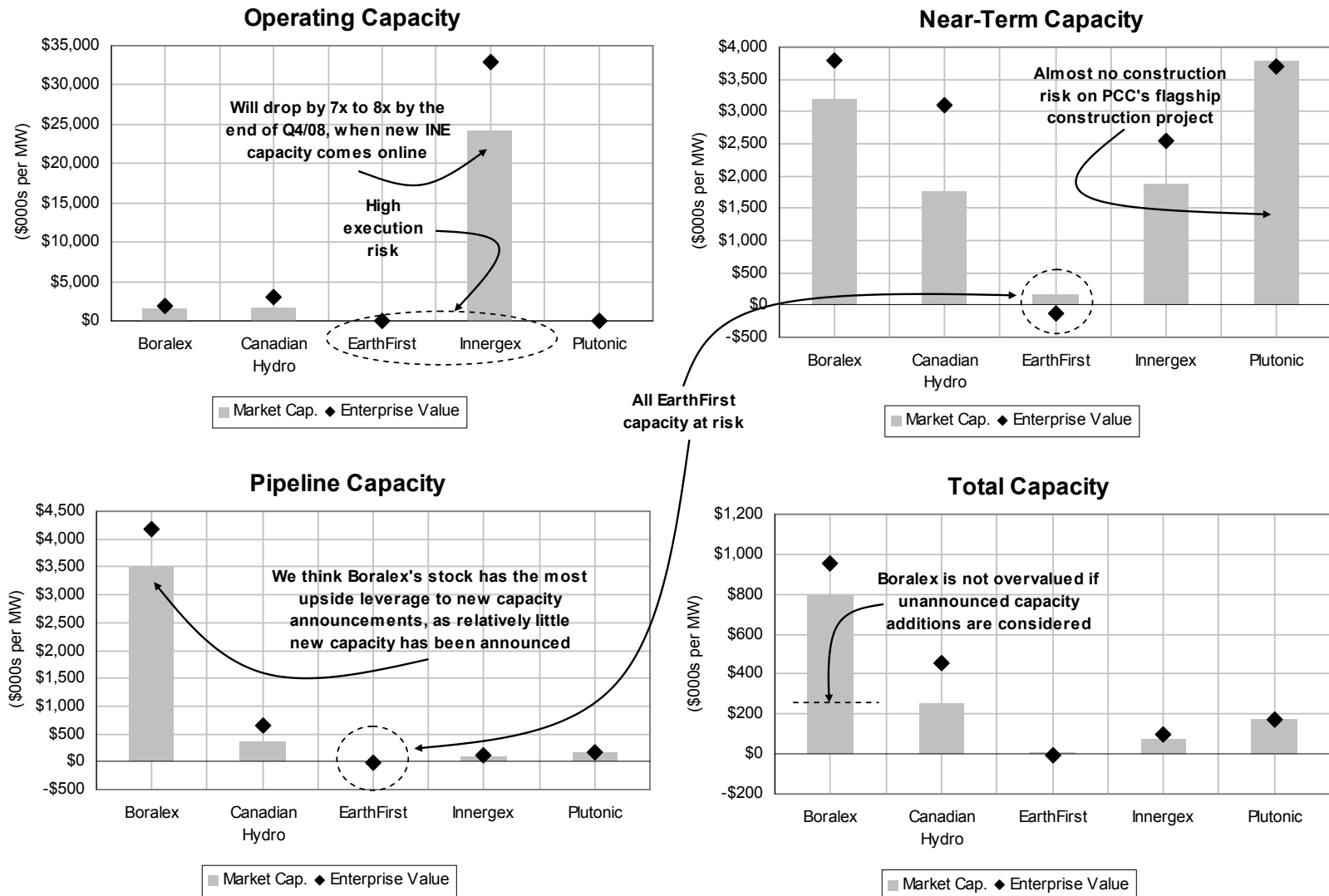

Source: Reuters; Scotia Capital estimates.

Exhibit 1.17: Market Capitalization and Enterprise Value per Generation Status

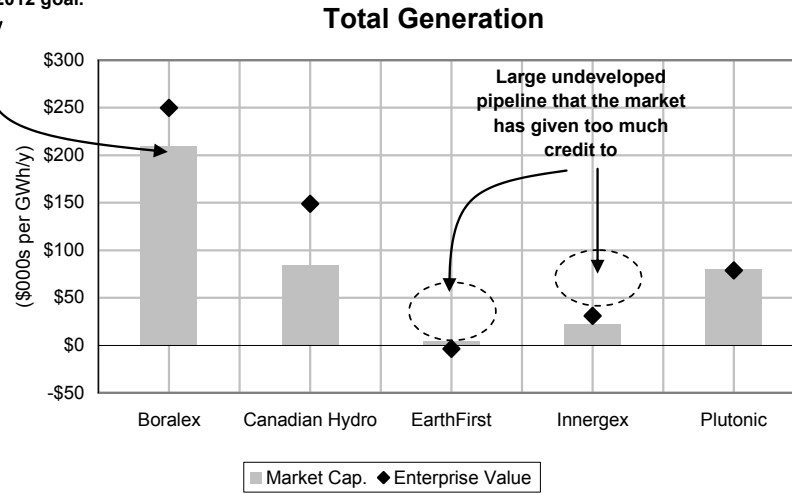
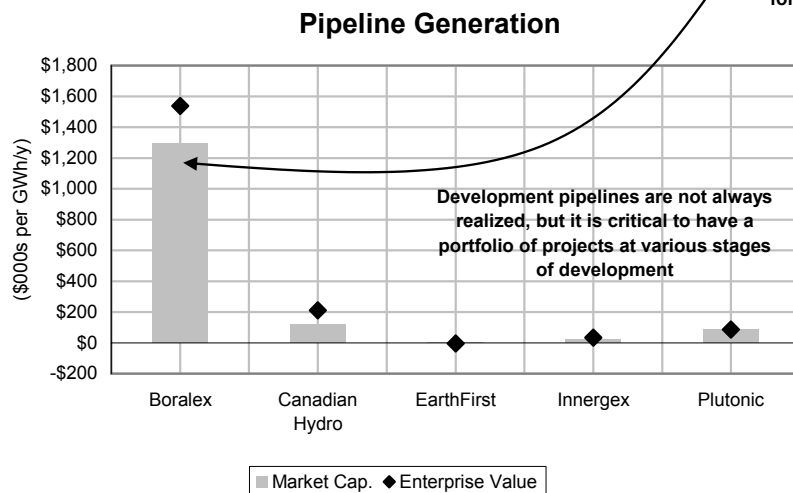
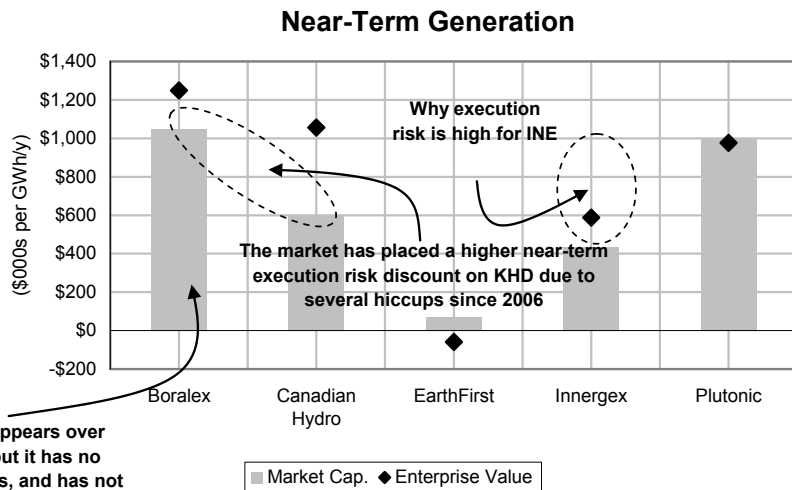
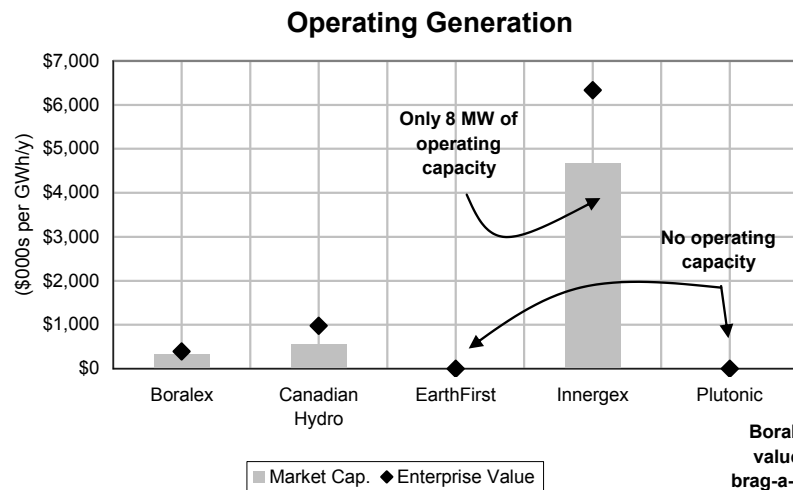

Source: Reuters; Scotia Capital estimates.

Exhibit 1.18: Other Comparable Metrics

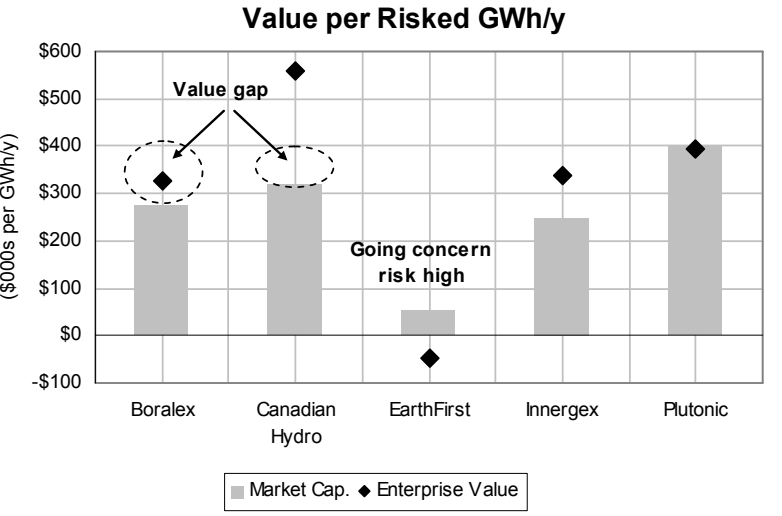
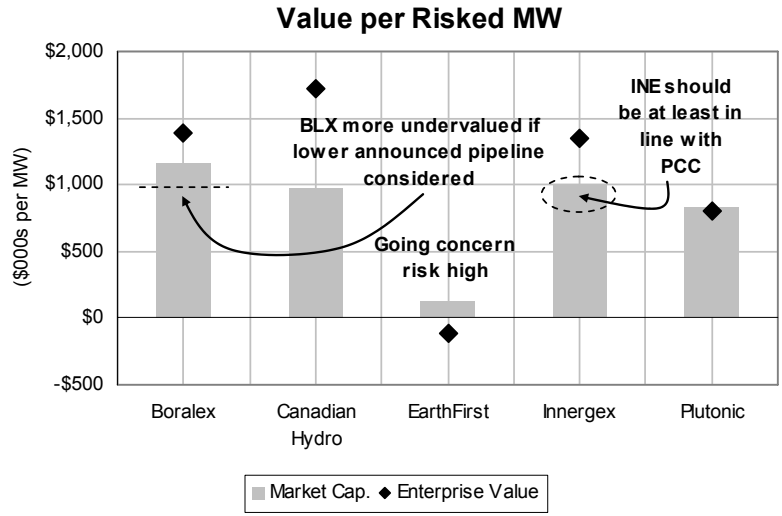
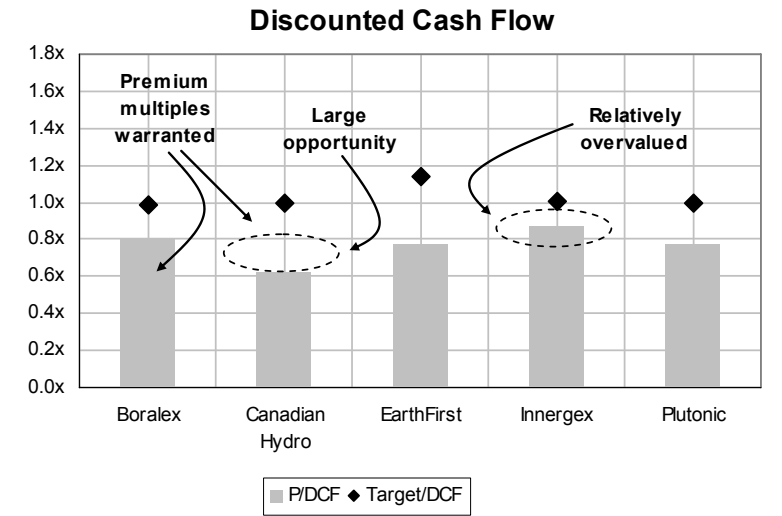
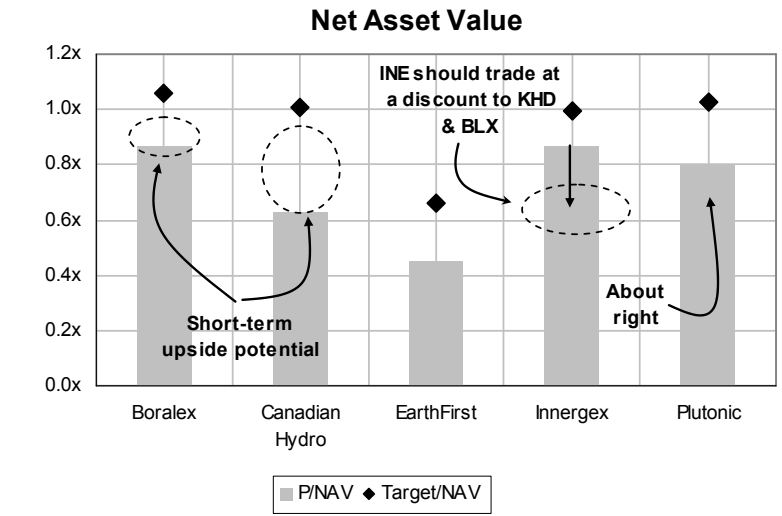

Source: Reuters; Scotia Capital estimates.

Renewable Energy Demand Drivers Suggest Industry Growth Acceleration Ahead

RENEWABLE PORTFOLIO STANDARDS

Regulatory policies that mandate the use of renewable energy is the number one key driver for the industry’s growth. Once implemented, renewable portfolio standards (RPS) obligate utilities to produce or purchase specific amounts of renewable power, including wind, solar, biomass, hydro, geothermal, and others. Typically RPS targets range between 5% and 25% to be achieved at some point in the future, generally between 2012 and 2020.

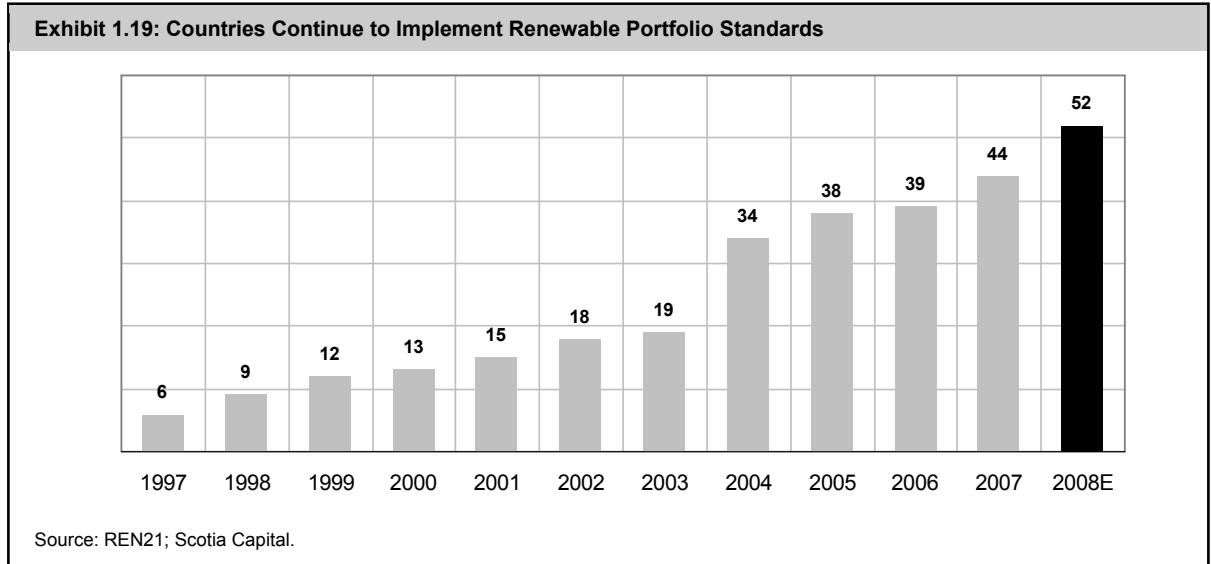

To achieve an RPS, financial support mechanisms must be adopted to ensure providers of renewable power earn reasonable economic returns, as the levelized cost of renewable power generation is typically higher than the levelized cost of traditional power generation sources such as coal. Later in this report, we outline and discuss the status of renewable portfolio standards and financial incentives in Canada, the U.S., and the rest of the world.

We believe there are four primary reasons for the growth in the number and the intensity of renewable portfolio standards around the world: (1) rising energy prices; (2) the increased need for energy security and independence; (3) greater environmental awareness and fear of climate change; and (4) the implementation of the Kyoto Protocol. We discuss each of these below.

1. Rising Energy Prices

Over the past four years, crude oil prices have increased by almost 200%, making non-fossil fuel power sources more attractive on a relative cost basis. Growth (population, GDP, real income per capita) in China, India, and other emerging economies is booming. The result: a surge in demand for fossil fuels, while supply has not been able to respond as quickly. Additionally, we believe that financial players such as hedge funds may have been pushing commodity prices higher through their speculative bets. Exhibit 1.20 shows a clear and strong correlation (>90%) between the change in prices of oil and the Wilderhill New Energy Global Innovation Index (NEX), a widely used tracking index for alternative & renewable energy stocks.

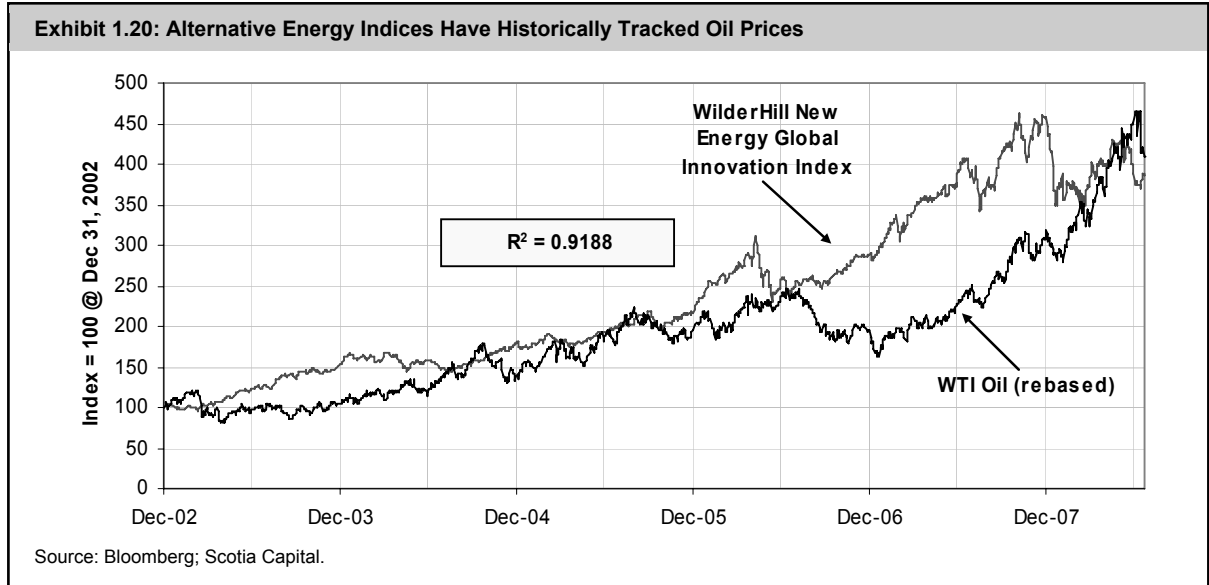

2. Need for Energy Security & Independence

The uneven distribution by country of fossil-fuel based energy supplies, coupled with the need for all nations to ensure their rising energy requirements are always fulfilled, have led to vulnerabilities. Threats to global energy security include: (1) political instability of energy-producing nations; (2) manipulation of energy supplies; (3) competition over energy sources; (4) attacks on supply infrastructure; and (5) accidents and natural disasters. **Renewable power can diversify energy portfolio mixes, reduce the need for energy imports, and introduce greater flexibility for deployment of fossil fuels.**

3. Greater Environmental Awareness and Fear of Climate Change

Two-thirds of Canadians rate climate change as a “very serious problem,” according to *Environment Monitor*. Around the world, people are sharing a similar concern. Exhibit 1.21 shows specifically what

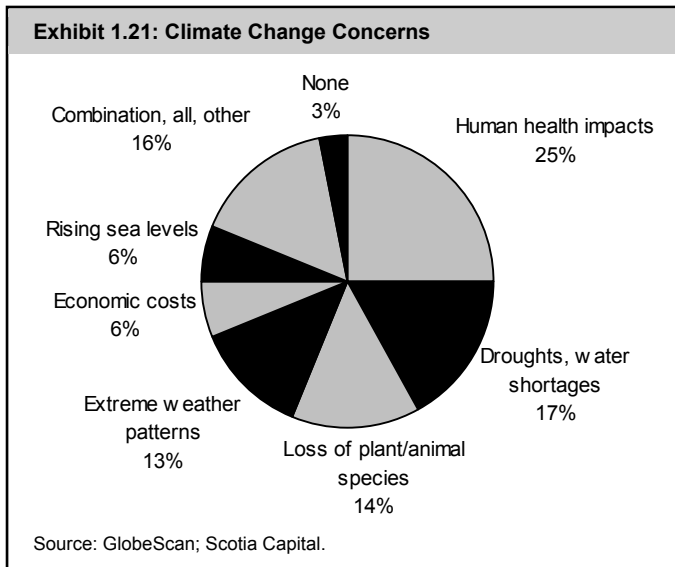

people fear most about climate change: the potential impact to human health, as well as possible water shortages.

The debate as to whether climate change is real; how much it has been accelerated by industrialization; and whether it can be controlled is well beyond the scope of this report. From an investment point of view, we believe **it is important to recognize that the awareness and fears of climate change are real**, and that politicians have picked up on this. These politicians are now taking steps to implement climate change-related policies that they believe will be viewed favourably by their constituents. **The result: renewable portfolio standards.**

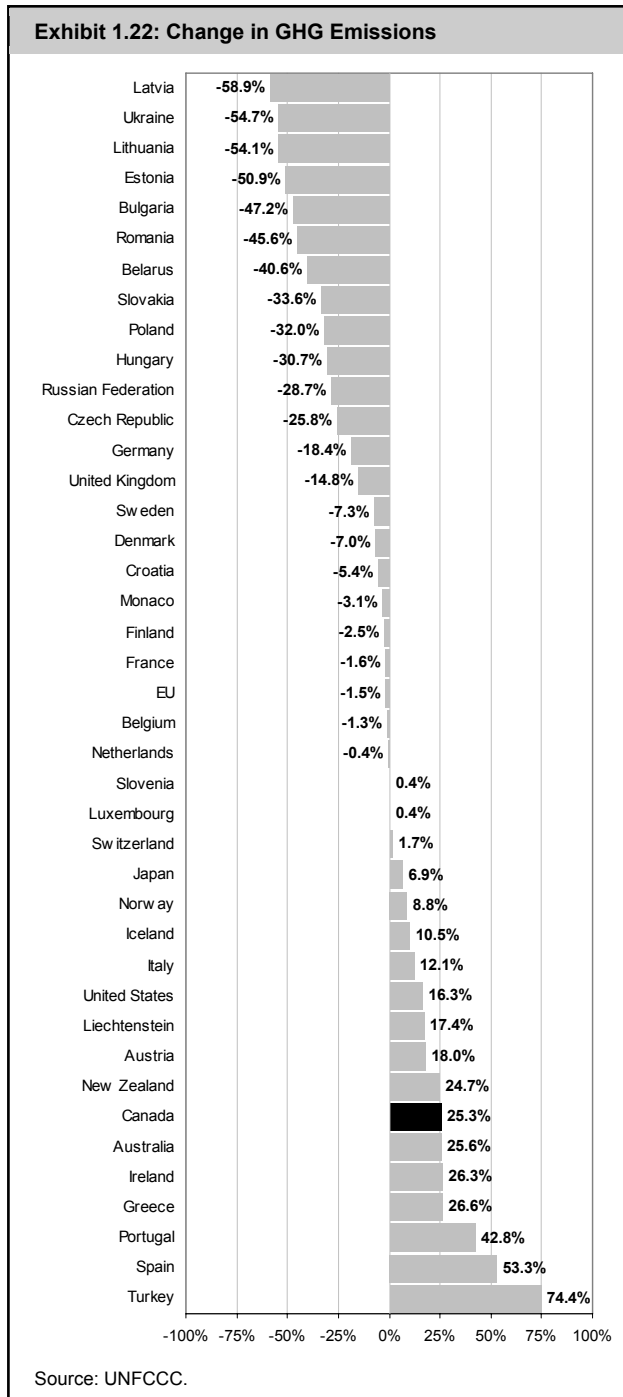

4. Kyoto Protocol

In 1997, the United Nations Framework Convention on Climate Change (UNFCCC) enacted the Kyoto Protocol, a protocol designed to reduce greenhouse gas (GHG) emissions for the purpose of preventing anthropogenic climate change. As of May 2008, 182 countries had ratified the Kyoto Protocol, including Canada. The United States has not ratified the treaty. **Between 2008 and 2012, Annex I countries (i.e., developed nations) must reduce their collective GHGs by 5.2% below a 1990 baseline level by 2012. Canada’s goal is for a 6% reduction.** Exhibit 1.22 shows the change in GHG emissions to date.

IMPLEMENTATION OF CAP-AND-TRADE PROGRAMS OR CARBON TAXES

Numerous proposals exist throughout the world to provide economic incentives to curb greenhouse gas emissions, the two most popular being a cap-and-trade system or a carbon tax, which are highlighted later in this report.

Regardless of the type of program implemented to achieve a reduction in carbon emissions, one thing is clear: **placing a price on carbon increases the cost per MWh to produce conventional fossil fuel-fired power plants**, making renewable energy options that much more attractive to governments, utilities, and consumers.

FALLING COSTS OF RENEWABLE POWER

On an absolute basis, the real cost curves for renewable energy technologies continue to decline. While there have been some setbacks such as a wind turbine component supply

bottleneck and a supply/demand imbalance for solar-grade silicon, we view these as short-term trends. Government and corporate R&D programs will continue to bring down the costs of new renewable power technologies.

On a relative basis, rising costs to build conventional power plants, such as the introduction of carbon costs, higher labour and material costs, and the sometimes arduous regulatory approval process (i.e., nuclear) have led to an increased demand for renewable power.

Equity Performance to Date

The WilderHill New Energy Global Innovation Index (NEX), our preferred tracking index for global alternative energy equities, increased almost 58% in 2007 (Exhibit 1.23). Why: (1) soaring energy prices; (2) solar stock euphoria; (3) numerous alternative energy funds and ETFs were launched; and (4) climate change fears increased. While wind-related equities rose sharply in 2007, up 65.8%, solar players were clearly preferred. On average, solar stocks increased by more than 150% as investors paid for exposure to soaring silicon prices. Despite record oil prices, ethanol and other biofuel companies went out of favour in 2007 (down 19.1%). Soaring corn prices led to almost zero ethanol cash margins, hurting U.S. ethanol producers, while soaring food-based biodiesel inputs did the same to biodiesel producers.

Alternative energy stocks fell 17.9% in Q1/08, led by solar equities that plummeted 31.6%. Solar equity investors learned their lessons from the dot-com bubble, and stopped chasing unreasonable expectations and valuations. Additionally, Q1/08 saw real (and an increased fear of further) tightening credit conditions that forced wind developers to sell off projects to finance others. The five worst performers in the NEX were all U.S.-based companies. The only gaining sector during Q1/08 in the NEX was power storage, up 10% in value. **Our coverage universe of Canadian junior and intermediate IPPs was down 0.1% on average.**

Q2/08 saw the NEX gain 6.2% compared to the S&P 500 and the MSCI World Index that were down 3.2% and 2.5%, respectively. Soaring oil prices seemed to keep renewable equities above water, while the credit crunch, coupled with fears of a global economic slowdown, weighed on the broader indices. Solar stocks bounced back, as did most other renewable power sectors. Biofuel-related stocks continued to fall, ending the quarter down another 1.3%. **Almost all equities in our coverage universe were hit hard in Q2/08, falling between 17% and 27%.** The **only** exception was Plutonic Power that slid a nominal 1.1% in the second quarter, likely due to positive press releases that included the addition of 11 projects to its development portfolio.

Canadian equities within the NEX include Boralex, Canadian Hydro Developers, 5N Plus, and Ballard Power. On the following page (Exhibit 1.24), we offer company-specific reasons for stock performance within our coverage universe during the first two quarters of the year. Exhibits 1.25, 1.26, and 1.27 show sub-sector performance of solar, wind, and geothermal equities over the past 18 months.

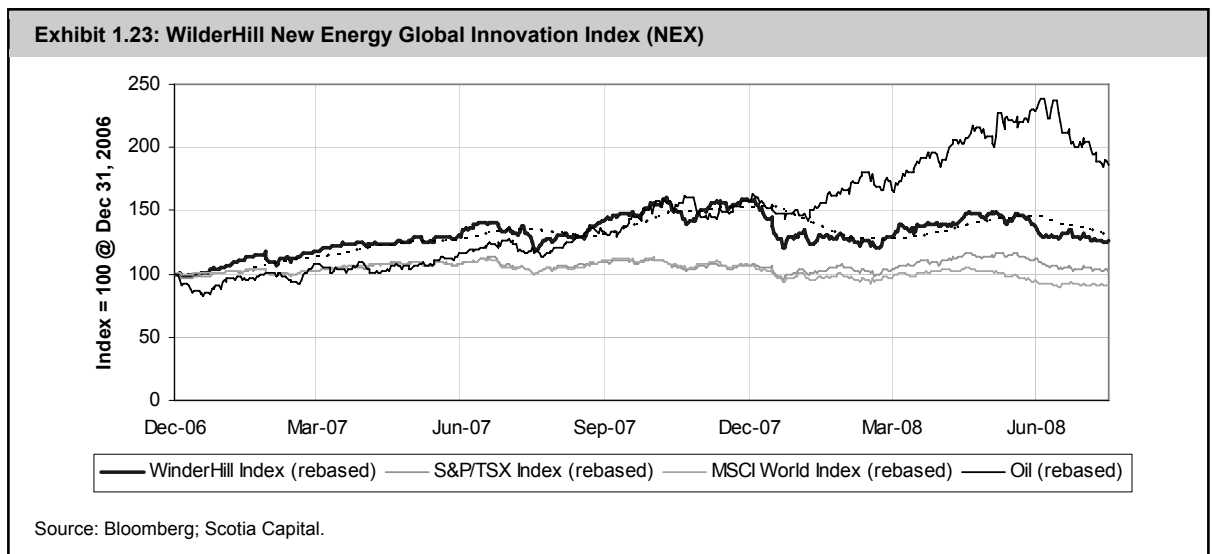

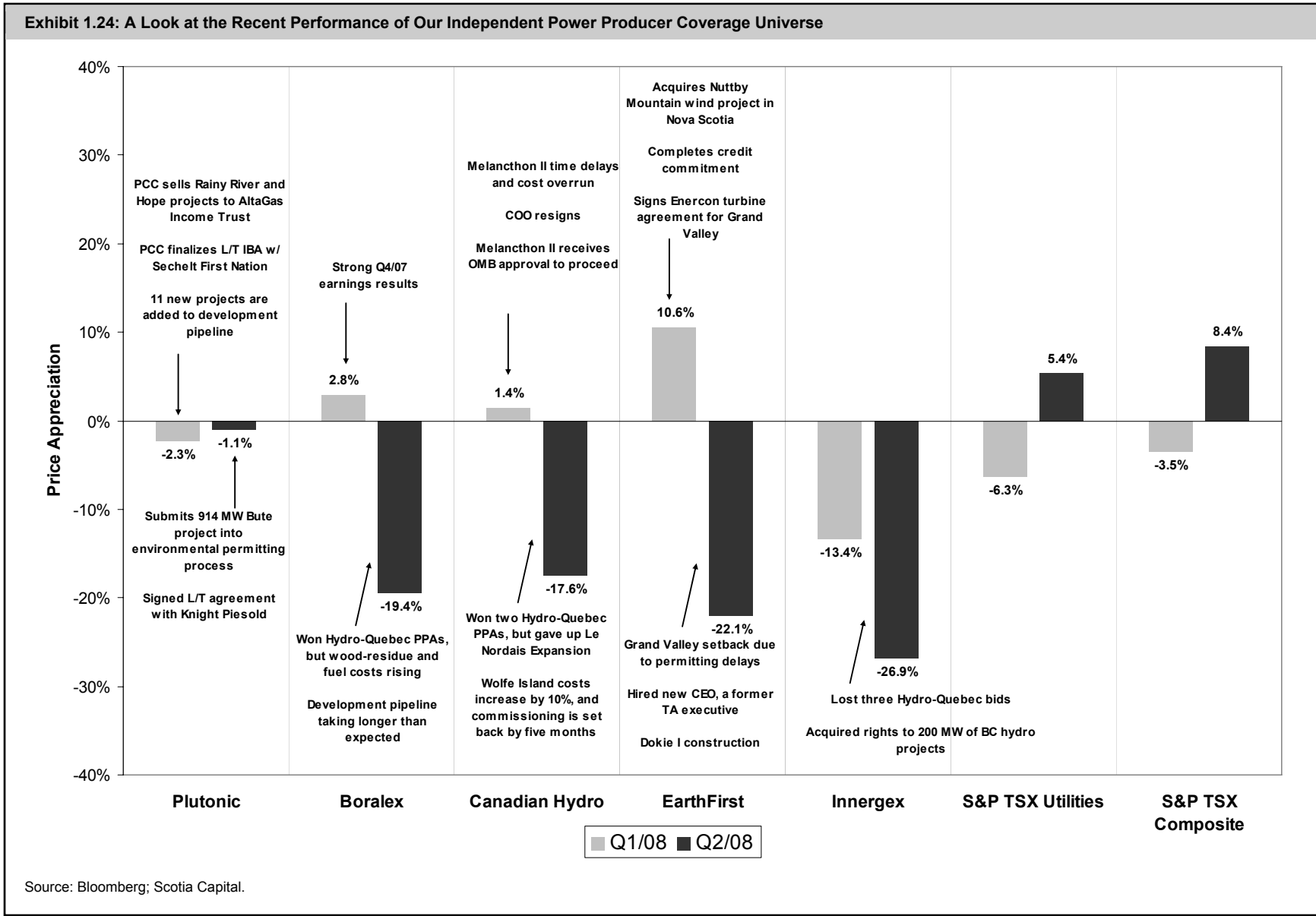
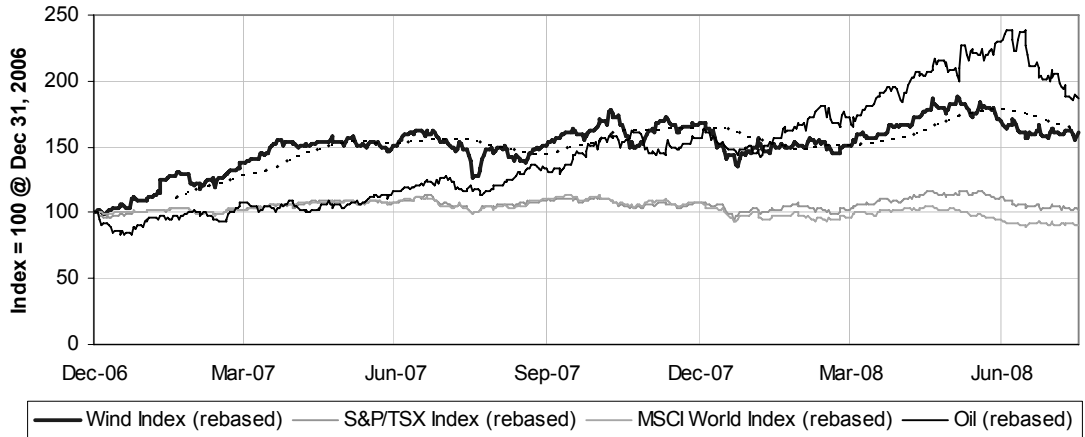
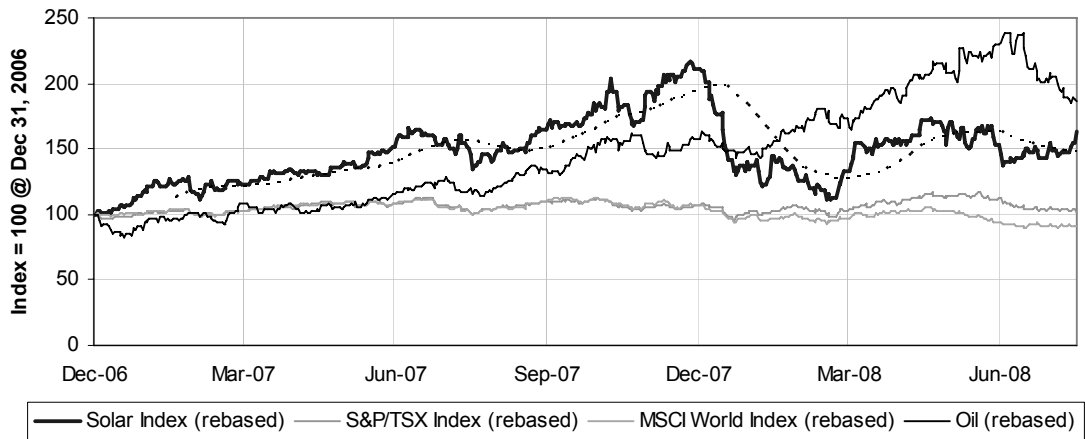

Exhibit 1.25: Wind Turbine Manufacturer Index Performance (Global)



Source: Bloomberg; Scotia Capital.

Exhibit 1.26: Solar Value Chain Index Performance (Global)



Source: Bloomberg; Scotia Capital.

Exhibit 1.27: Geothermal Index Performance (Canadian/U.S.)

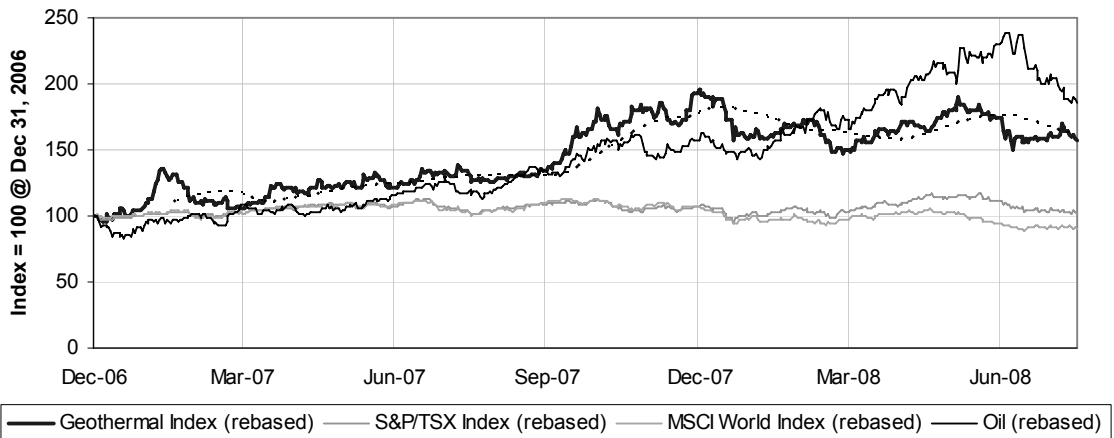

Source: Bloomberg; Scotia Capital.

Cap-and-Trade or Carbon Tax?

Canadians and others continue to debate whether a cap-and-trade or carbon tax is the most effective method to reduce emissions. As of early August, the Conservatives are formulating a national cap-and-trade program, while the Liberals have proposed a carbon tax. Both methods of penalizing carbon emissions have their merits. **We believe that a market-based system (i.e., cap-and-trade) is not only the better option, but will likely prevail in both Canada and the United States.**

Complicating matters are the provinces that have their own plans to achieve GHG emission reductions. Both B.C. and Quebec have implemented carbon taxes targeted at reducing emissions, while Ontario and Quebec are proposing a joint cap-and-trade system that could begin as early as 2010. Please refer to the section starting on p. 51 for a summary of regional climate change initiatives to date.

Under a cap-and-trade system, a regulatory body allocates CO_{2e} emission allowances to companies, typically by way of auction, but sometimes for no cost. Each allowance represents the right to emit one tonne of CO₂ or CO₂ equivalent GHG. The total allowances distributed to a company represent the total emissions that it can produce in any given year without penalty. Firms that emit less than their allowances permit, or can reduce emissions more cheaply than their peers, can either bank their surplus allowances for future years or can sell them to companies whose emissions exceed their own allowances. Distribution of allowances is typically reduced every year, creating a greater liability for those companies that have not lowered their emissions or their emission intensity. This market-based approach assures that emission reductions occur at the lowest possible cost.

A carbon tax simply charges producers of CO_{2e} a set price per tonne, which periodically increases to motivate emitting companies to produce fewer emissions. Unlike a cap-and-trade system, a carbon tax already has the supporting financial infrastructure and does not need a new financial market to exist.

UNDER EITHER CARBON PROPOSAL, CONSUMERS PAY MORE

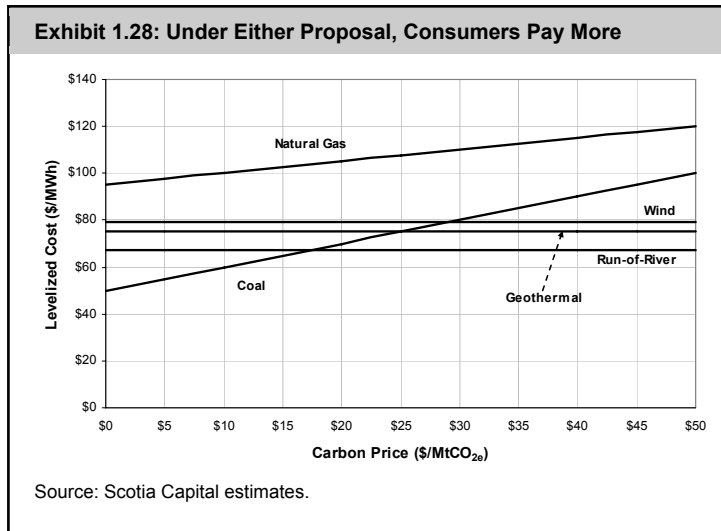

The cost of producing electricity will increase for fossil fuel power plants under either a tax or cap-and-trade system (Exhibit 1.28). In our view, utilities will pass on increasing costs to consumers regardless of which system is implemented, implying high generation costs for natural gas and coal plants. We believe that as commodity prices rise and the likelihood of a carbon trading system (or carbon tax) increases, investment in renewable power facilities should only accelerate as they become relatively cheaper alternatives. Exhibits 1.29 and 1.30 sensitize coal and natural gas levelized costs to changes in both carbon prices and fossil fuel prices.

Exhibit 1.29: Natural Gas Power Levelized Cost Sensitivity

		Carbon Price (US\$/MtCO _{2e})					
		\$0	\$10	\$20	\$30	\$40	\$50
Natural Gas Price (US\$/MMbtu)	\$6	\$68	\$73	\$78	\$83	\$88	\$93
	\$7	\$77	\$82	\$87	\$92	\$97	\$102
	\$8	\$86	\$91	\$96	\$101	\$106	\$111
	\$9	\$95	\$100	\$105	\$110	\$115	\$120
	\$10	\$104	\$109	\$114	\$119	\$124	\$129
	\$11	\$113	\$118	\$123	\$128	\$133	\$138
	\$12	\$122	\$127	\$132	\$137	\$142	\$147

Source: Scotia Capital estimates.

Exhibit 1.30: Coal Power Levelized Cost Sensitivity

		Carbon Price (US\$/MtCO _{2e})					
		\$0	\$10	\$20	\$30	\$40	\$50
Coal Price (US\$/st)	\$5	\$49	\$59	\$69	\$79	\$89	\$99
	\$6	\$49	\$59	\$69	\$79	\$89	\$99
	\$7	\$50	\$60	\$70	\$80	\$90	\$100
	\$8	\$50	\$60	\$70	\$80	\$90	\$100
	\$9	\$51	\$61	\$71	\$81	\$91	\$101
	\$10	\$51	\$61	\$71	\$81	\$91	\$101
	\$11	\$52	\$62	\$72	\$82	\$92	\$102

Source: Scotia Capital estimates.

In our view, a cap-and-trade system will likely prevail. Why: (1) generates innovation; (2) sets mandatory emissions reduction targets; (3) offers an equal playing field among competitors; (4) offers flexibility to firms deciding how to meet their obligations; (5) by selling allowances, governments can raise money for other programs – similar to carbon taxes; (6) allows the banking of allowances to deal with macroeconomic fluctuations. Additionally, in the United States, cap-and-trade systems have the most support (including both U.S. Presidential candidates); there are three regional initiatives in the United States supporting cap-and-trade, and the majority of environmentalists favour a system that places a hard limit on emissions.

A key challenge for a carbon tax proposal is the establishment of a fair price for carbon.

Additionally, a carbon tax does not set a limit on emissions. Under a carbon tax, no price discovery exists, and the price of carbon will always be a point of contention between business and government.

The Canadian government’s emissions reduction plan, details of which are to be released shortly, proposes to **reduce emissions to 20% below 2006 levels by 2020 through the implementation of a cap-and-trade system set to begin in 2010.** The plan will specifically be a baseline and credit program where entities that emit less than their targets will be given credits to be sold to those polluters that do not meet their targets. **The Canadian government has modelled a market-clearing carbon price that will rise from \$25/tonne CO_{2e} in 2010 to \$65/tonne CO_{2e} in 2020.** Exhibit 1.31 details GHG emissions reduction targets by the federal and provincial governments, while Exhibits 1.32 and 1.33 show the impact of the federal government’s *Turning the Corner* plan.

Exhibit 1.31: Federal and Provincial GHG Emissions Reduction Targets

Jurisdiction	Target	Announced
Federal	Reduce GHGs by 20% below 2006 levels by 2020	April, 2007
British Columbia	Reduce GHGs to 33% below 2007 levels by 2020	February 2007
Alberta	Reduce emissions by 50% relative to business-as-usual case by 2050 or 14% relative to 2005	January 2008
Saskatchewan	Reduce GHGs to 32% below 2004 levels by 2020	June 2007
Manitoba	Reduce GHGs to 6% below 1990 levels by 2012	October 2002
Ontario	Reduce GHGs to 15% below 1990 levels by 2020	June 2007
Quebec	Reduce GHGs to 6% below 1990 levels by 2012	June 2006
New Brunswick	Reduce GHGs to 10% below 1990 levels by 2020	June 2007
Nova Scotia	Reduce GHGs to 10% below 1990 levels by 2020	March 2007
Prince Edward Island	Reduce GHGs to 1990 levels by 2010, 10% below 1990 levels by 2020	August 2001
Newfoundland and Labrador	Reduce GHGs to 10% below 1990 levels by 2020	June 2007
Yukon	No explicit target	
Nunavut	No explicit target	
Northwest Territories	No explicit target	

Source: Government of Canada.

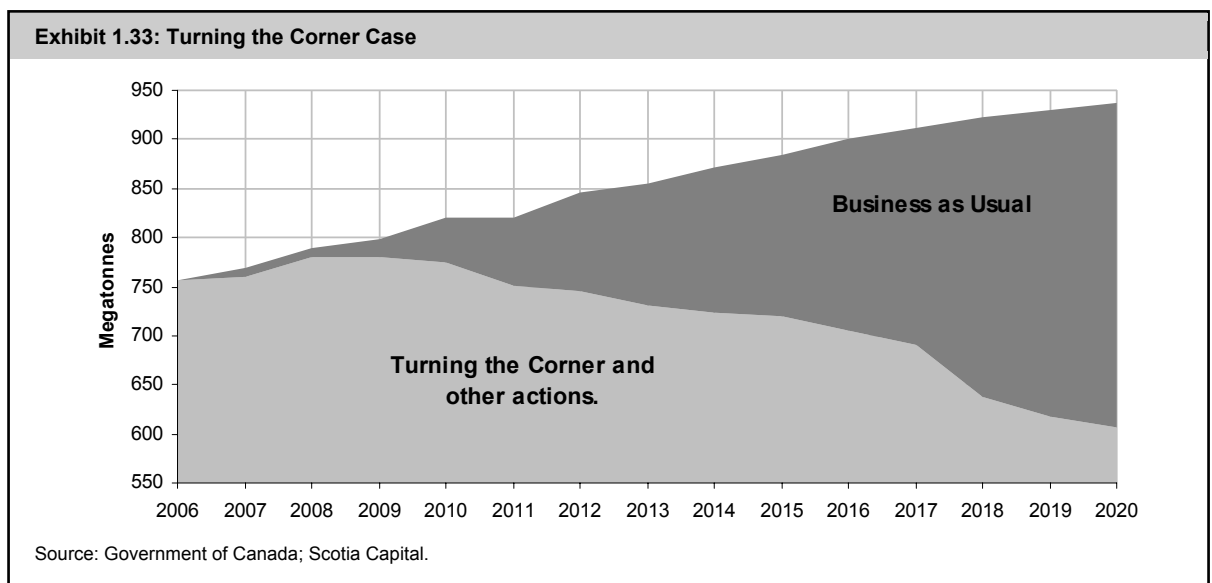
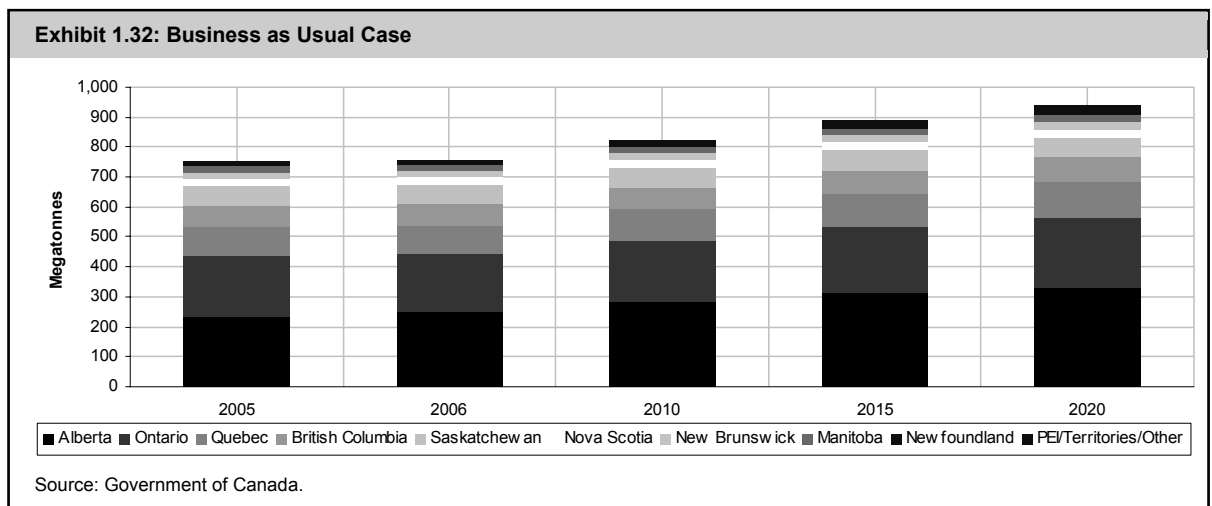

Our Call on the B.C. Call

On June 11, 2008, BC Hydro formally issued its Clean Power Call RFPs. Under the terms of the Call, **BC Hydro seeks 5,000 GWh/y of clean and renewable resources from projects using proven technologies.** In-service dates will range between 2010 and 2016. The RFP submission deadline is November 25, 2008. **We expect Electricity Purchase Agreements (EPAs or PPAs) to be awarded following the provincial government election in May 2009.**

Under BC Hydro’s 2006 Call for Power, **almost 50% more annual energy production was awarded than the Call had anticipated,** or 7,351 GWh/y, compared with 5,000 GWh/y that was requested.

In our opinion, EPAs awarded will average about \$120/MWh (\$2009).

Highlights of the 2008 BC Hydro Clean Power Call are as follows:

- **Wind integration adjustment:** Qualified wind power projects that are awarded EPAs will receive a \$10/MWh premium that will be added to the firm energy price.
- **More flexible commissioning period:** Unlike BC Hydro’s 2006 Call for Power, the Clean Power Call will allow for a six-year window for projects to be commissioned, from November 2010 through November 2016.
- **EPA length:** 15 to 40 years.
- **No environmental attributes:** All environmental attributes are to be assigned to BC Hydro. Winning developers will not be able to sell Emissions Reduction Credits, Renewable Energy Certificates, or any other types of carbon/renewable-related credits.

Based on the outcomes of several factors, we think anywhere from 1,000 MW (5,000 GWh/y) to 2,100 MW (7,500 GWh/y) of renewable power capacity could be awarded in the BC Clean Power Call. Our point estimate of awarded capacity is **1,776 MW (7,000 GWh/y),** or 200 MW more than what was awarded in the BC Hydro 2006 Call (Exhibit 1.34). Our point estimate is based on the following: (1) BC Hydro will award about 40% to 50% more expected annual generation than the announced 5,000 GWh/y, similar to its 2006 Call; and (2) more wind power capacity will be awarded than in the past Call, requiring more MW due to its typically lower capacity factor over run-of-river power.

Exhibit 1.34: Our Call on the B.C. Call

Potential BC Hydro Clean Power Call Award Scenarios (GWh per year)

	4,500	5,000	5,500	6,000	6,500	7,000	7,500	8,000
30%	1,712 MW	1,903 MW	2,093 MW	2,283 MW	2,473 MW	2,664 MW	2,854 MW	3,044 MW
35%	1,468 MW	1,631 MW	1,794 MW	1,957 MW	2,120 MW	2,283 MW	2,446 MW	2,609 MW
40%	1,284 MW	1,427 MW	1,570 MW	1,712 MW	1,855 MW	1,998 MW	2,140 MW	2,283 MW
45%	1,142 MW	1,268 MW	1,395 MW	1,522 MW	1,649 MW	1,776 MW	1,903 MW	2,029 MW
50%	1,027 MW	1,142 MW	1,256 MW	1,370 MW	1,484 MW	1,598 MW	1,712 MW	1,826 MW
55%	934 MW	1,038 MW	1,142 MW	1,245 MW	1,349 MW	1,453 MW	1,557 MW	1,660 MW
60%	856 MW	951 MW	1,046 MW	1,142 MW	1,237 MW	1,332 MW	1,427 MW	1,522 MW

SC Est. (low)
SC Est. (base)
2006 Call (actual)
SC Est. (high)

Source: Scotia Capital estimates.

EXPECT HUGE COMPETITION

By the end of November, we could see as much as **28,000 GWh/y of capacity bid into the B.C. Hydro Call**; assuming that no more than 7,000 GWh/y of renewable power production is awarded with EPAs, then there is an approximate 25% probability of a bid GWh being awarded a long-term power contract (see Exhibit 1.36 on the following page).

For our universe of coverage, we estimate that no more than 400 MW of wind capacity and 1,350 MW of hydro capacity could be bid. Excluding Plutonic Power’s 914 MW Bute Inlet project, which will almost certainly be bid, the likely hydro capacity bid drops to 300 MW. Please refer to our company-specific reports for further details.

MORE CLEAN POWER CALLS LIKELY POST B.C. ELECTION

The 2007 B.C. Energy Plan seeks energy self-sufficiency by 2016, 90% of its power production to be generated by renewable technologies, and a 33% reduction of CO_{2e} emissions by 2020 from current levels. To achieve energy independence today, we estimate that B.C. would need to add up to 8,000 GWh/y of generation capacity to eliminate the 10% to 15% of imports that the United States and Alberta supply. Consumption growth at 2% per year through 2016 would push B.C.’s new supply requirement to about 20,000 GWh/y. However, much of the supply needed has been addressed by various Calls already. **In our view, BC Hydro could issue one to three more ~5,000 GWh/y renewable power Calls to meet its 2016 goal of energy self-sufficiency** (Exhibit 1.35).

Exhibit 1.35: BC Hydro Could Issue Two More Clean Power Calls for a 2016 Start-Up	
	<u>2016E</u> (GWh)
Forecast consumption @ 2% growth per year	64,600
Insurance @ 2.5%	1,615
Est. 2007 B.C. supply (ex. Imports)	(44,750)
Actual 2006 Call for Power	(7,351)
Est. attrition @ 50%	3,676
Est. 2008 Clean Power Call	(7,000)
Est. attrition @ 30%	2,100
Est. 2008 Bioenergy Call - Phase I	(1,000)
Est. attrition @ 30%	300
Est. 2008 Bioenergy Call - Phase II	(500)
Est. attrition @ 30%	150
Est. Standing Offer Program	(1,000)
Est. attrition @ 30%	300
Scotia Capital est. (High)	11,140
	Two to three more Clean Power Calls?
Less: Peace River Site C	(4,600)
Less: Demand Side Management	(1,000)
Scotia Capital est. (Low)	5,540
	One to two more Clean Power Calls?

The Attrition rate in the 2003 Call for Power was 75%, and is expected to be at least 50% in the 2006 Call for Power. BC Hydro continues to design its Calls to reduce this rate. We assume it is somewhat successful.

Source: BC Hydro; Scotia Capital estimates.

Exhibit 1.36: Our Best Guess on What Companies May Bid in the B.C. Clean Power Call

Company	Wind		Run-of-River		Est. Total		Est. Total	
	MW (Low)	MW (High)	MW (Low)	MW (High)	MW (Low)	MW (High)	GWh/y (Low)	GWh/y (High)
Boralex	-	-	-	100	0	100	0	450
Canadian Hydro Developers	-	-	-	55	0	55	0	250
EarthFirst	-	227	-	-	0	227	0	650
Innergex	75	150	50	150	125	300	425	1,100
Plutonic Power	-	-	1,047	1,047	1,047	1,047	4,575	4,575
	75	377	1,097	1,352	1,172	1,729	5,000	7,025
Aeolis Wind Power	-	1,000	-	-	0	1,000	0	2,900
AXOR Group	-	-	-	125	0	125	0	550
Confederation Power	-	-	99	99	99	99	425	425
EPCOR Power	100	200	-	-	100	200	300	575
Finavera Renewables	300	300	-	-	300	300	875	875
Fred Olson Renewables	-	225	-	-	0	225	0	650
Kitamaat Renewable Energy	-	-	51	134	51	134	225	575
Kleana Power	-	-	280	800	280	800	1,225	3,500
NaiKun Wind	320	700	-	-	320	700	925	2,025
Nomis Power	100	200	-	-	100	200	300	575
NovaGoldPower	-	-	-	80	0	80	0	350
Primex	-	-	-	68	0	68	0	300
Pristine Power	-	-	308	808	308	808	1,350	3,550
Regional Power	-	-	100	145	100	145	450	625
Run of River Power	-	-	180	213	180	213	800	925
Schneider Power	-	-	-	-	0	0	0	0
Sea Breeze	-	100	28	28	28	128	125	400
Stlixwim Hydro	-	-	-	62	0	62	0	275
	820	2,725	1,046	2,562	1,866	5,287	7,000	19,075
Other/Utilities/Confidential	755	1,100	215	532	540	779	1,550	2,375
	1,650	4,202	2,358	4,446	3,578	7,794	13,550	28,475

Note: To estimate production, we assigned average capacity factors of 33% for wind, and 50% for hydro.

Source: Company reports; Scotia Capital estimates.

Exhibit 1.37 shows the anticipated schedule for the BC Hydro Clean Power Call. Key dates include the submission deadline of November 25 and the EPA awards, which we believe will occur after the May 2009 provincial election.

Exhibit 1.37: BC Hydro Clean Power Call RFP Schedule	
Event/Activity	Scheduled Date(s)
Submission of Registration Documents, and registration fee	August 12, 2008
BCTC Interconnection Workshop	September 15, 2008
Issue of Specimen EPA	September 22, 2008
Proponents Submit Request to BC Hydro (for Distribution System-connected Projects) for a Preliminary Interconnection Study	October 7, 2008
Proponents Submit Request to BCTC (for Transmission System-connected Projects) for a Feasibility Interconnection Study	October 17, 2008
Proponents' RFP Information Session	October 20, 2008
Filing of Preliminary Interconnection Study agreements with BC Hydro for Distribution System-connected Projects	November 7, 2008
Filing of Feasibility Interconnection Study agreements with BCTC for Transmission System-connected Projects	November 17, 2008
PROPOSAL SUBMISSION	November 25, 2008
Proponents with Projects in Fortis Service Area submit to BC Hydro a FortisBC interconnection study	December 1, 2008
Post-Proposal discussions	January through mid-April, 2009
Release of Feasibility Interconnection Study, Preliminary Interconnection Study, or special study (Fortis Service Area) as applicable	February 23, 2009
Final Evaluation and EPA awards	Mid-April through June, 2009

Source: BC Hydro.

Follow Feed-In Tariff Legislation

In our opinion, feed-in tariffs (FITs) have proven to be one of the world's most effective renewable energy policies. FIT legislation is currently in place in more than 40 countries, states, and provinces throughout the world. While FITs differ by region, the principles are essentially the same: (1) utilities provide grid access for developers producing renewable power; (2) utilities are required to purchase from the developer all of the renewable energy produced; (3) a pre-established price or price formula is set; and (4) the contract is for a set period of time, ranging between 10 and 40 years.

Germany introduced the first modern-day FIT in 1990, and is now the global leader in renewable energy technology and use. Germany has 1.3 million solar panels in place, over 22,000 MW of installed wind capacity, and has reached its target of producing 12.5% of its power from renewable sources three years ahead of schedule. Exhibit 1.38 shows the growth of feed-in tariff policies globally.

Ontario was the first to introduce feed-in tariffs to Canada, and now many provinces and states are following Ontario's lead. Michigan recently introduced the *Michigan Renewable Energy Sources Act* that offers 20-year contracts for all proven renewable energy technologies. Under the act, solar power could receive as much as US\$710/MWh (\$420/MWh in Ontario), and wind could receive up to US\$105/MWh (\$110/MWh in Ontario). **The catch:** any company that wants to participate in Michigan's program **must be connected to the grid within two months** of its application. Washington has a limited FIT program that offers solar producers US\$540/MWh for up to seven years.

Investors prefer feed-in tariffs. Why: Feed-in tariffs create a stable investment environment and provide long-term market certainty. As long as investment returns are reasonable, equity and debt investors have been eager to provide funds for renewable energy projects.

FITs are powerful, and they work: Twenty-five years ago, the United States had an 80% market share of the solar panel market. This has now been reduced to less than 25%, as Denmark, Germany, and Spain have taken over market share through the use of feed-in tariffs. Similarly, while the United States holds one of the strongest markets for wind turbine demand growth, the majority of mature turbine manufacturers are located in Europe, where feed-in tariffs are commonplace.

Exhibit 1.38: Global Growth of Feed-In Tariff Policies

Year	Cumulative	Countries/States/Provinces Added
1978	1	United States
1990	2	Germany
1991	3	Switzerland
1992	4	Italy
1993	6	Denmark, India
1994	8	Spain, Greece
1997	9	Sri Lanka
1998	10	Sweden
1999	13	Portugal, Norway, Slovenia
2001	15	France, Latvia
2002	21	Algeria, Austria, Brazil, Czech Republic, Indonesia, Lithuania
2003	28	Cyprus, Estonia, Hungary, South Korea, Slovak Republic, India
2004	34	Italy, Israel, Nicaragua, Prince Edward Island (Canada), India (2)
2005	41	Ecuador, Turkey, Washington (U.S.), Ireland, China, India (3)
2006	44	Ontario (Canada), Argentina, Thailand
2007	46	South Australia (Australia), Croatia

Source: REN21.

We Are Bullish on Renewable Energy Certificates

Renewable energy certificates (RECs) can represent a meaningful portion of a project’s economic return. Boralex’s wood-residue facilities in Maine are an excellent example of this, where the facilities there barely break even without the inclusion of renewable energy certificate (REC) sales. Depending on the price of the REC, earnings can be substantial, and **in Boralex’s case, REC earnings make up about 40% of its annual EBITDA.**

RECs are tradable environmental commodities that represent proof that 1 MWh of power was produced from a qualified renewable energy source. Owners of RECs can claim to have purchased renewable energy, which is essential for utilities and power marketers trying to meet state/provincial renewable portfolio standards. If a company does not hold RECs equivalent to the minimum RPS, it can be fined, typically between \$50/MWh and \$60/MWh. Thus, an artificial price cap is set on RECs, as companies will not pay more than the penalty.

Prices for RECs in the United States are typically in the US\$5/MWh to US\$10/MWh range.

However, in some states, such as Connecticut, which have high renewable portfolio standards coupled with power retailers that are falling short of their renewable mandates, **REC prices soared to around US\$50/MWh** (they have since eased to the US\$30/MWh area – see Exhibit 1.39). Typically, REC prices play a smaller role in the economics of renewable power projects, as federal incentives are more heavily relied upon and are government guaranteed.

Emera’s Nova Scotia Power is working with National Grid to develop a new high-voltage transmission line from northern Maine and Canada’s Maritime provinces to the New England market, or NEPOOL. The Northeast Energy Link would provide NEPOOL with substantial renewable energy. In particular, this could **severely impact the Connecticut REC market** that companies such as Boralex currently enjoy. CT Class I REC prices could drop to US\$5/MWh or lower from their recent range of US\$45/MWh to US\$50/MWh. Wind Power Monthly stated that the “U.S. Northeast is facing a supply gap of up to 10,000 MW in the next decade.”

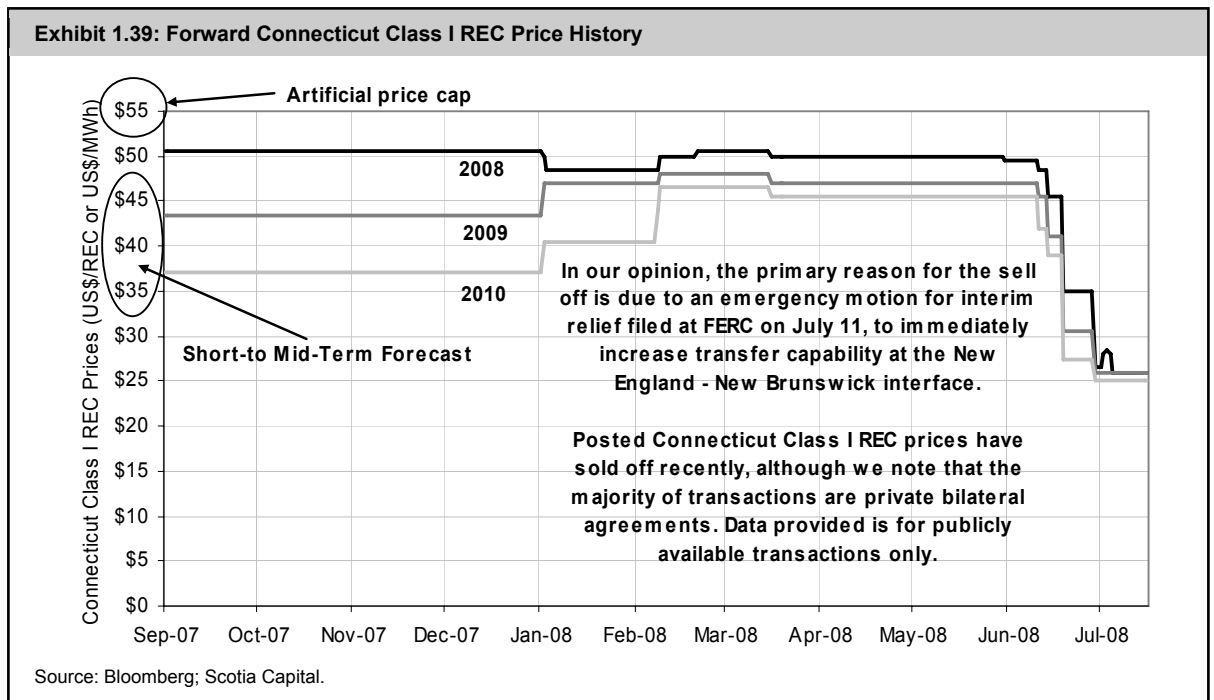

Canadian Federal Incentives Support Renewable Growth

Canadian federal incentive programs support the development of renewable power capacity. Past growth, at least for wind power, was driven by the federal Wind Power Production Incentive (WPPI) program and generous CCA tax treatment available to wind farm developers. In January 2007, the WPPI program was dropped by the Conservative government and was replaced by the \$1.5 billion ecoENERGY program, which provides a similar \$10/MWh incentive for renewable energy projects over 10 years. In addition, more favourable CCA treatment and other incentives discussed below have since emerged.

CAPITAL COST ALLOWANCE HAS IMPROVED FURTHER

CCA Class 43.2 was introduced in the 2006 federal budget and increased the Class 43.1 annual deduction rate to 50% from 30% per year, on a declining balance basis. CCA Class 43.1 of the federal *Income Tax Act* provides an accelerated rate of tax deductions for capital expenditures on equipment that is designed to generate energy from alternative renewable sources, such as wind power. Only equipment that is new and is acquired after February 2005 but before 2012 qualifies for the higher CCA deduction rate.

CANADIAN RENEWABLE AND CONSERVATION EXPENSES

The Canadian Renewable Conservation Expense (CRCE) gives qualifying companies the option of deducting certain project expenses, and either carrying them forward indefinitely or transferring these tax deductions to investors through flow-through shares. Expenses qualified under the CRCE become 100% deductible against income for income tax purposes. Eligible expenses include: (1) acquisition and installation costs associated with a test wind turbine; (2) costs of pre-feasibility and feasibility studies; (3) negotiation costs that are not property- or financing-related; and (4) site approval and preparation costs.

FEDERAL ECOENERGY INCENTIVE PLAN

The ecoENERGY plan provides \$1.48 billion to renewable energy projects to encourage the supply of 14.3 TWh/y. The program has enough funding to support approximately 4,000 MW of new renewable capacity, of which we expect about 3,000 MW to be allocated to wind energy and 1,000 MW to other renewable sources. Applications are considered on a first-constructed, first-served basis. **About 12,400 MW of applications have been filed.** Eligible projects must be commissioned between April 1, 2007, and March 31, 2011, and constructed no longer than one year after signing an agreement. Successful projects receive the incentive of \$10/MWh (not indexed to inflation) for up to 10 years, with a maximum project incentive of \$80 million and a maximum recipient incentive of \$256 million (Exhibit 1.40).

Exhibit 1.40: Optimizing Canada's ecoENERGY Renewable Production Incentive

Capacity Factor	Installed Capacity per Project									
	50 MW	100 MW	150 MW	200 MW	250 MW	300 MW	350 MW	400 MW	450 MW	500 MW
10%	\$4M	\$9M	\$13M	\$18M	\$22M	\$26M	\$31M	\$35M	\$39M	\$44M
20%	\$9M	\$18M	\$26M	\$35M	\$44M	\$53M	\$61M	\$70M	\$79M	\$80M
30%	\$13M	\$26M	\$39M	\$53M	\$66M	\$79M	\$80M	\$80M	\$80M	\$80M
40%	\$18M	\$35M	\$53M	\$70M	\$80M	\$80M	\$80M	\$80M	\$80M	\$80M
50%	\$22M	\$44M	\$66M	\$80M	\$80M	\$80M	\$80M	\$80M	\$80M	\$80M
60%	\$26M	\$53M	\$79M	\$80M	\$80M	\$80M	\$80M	\$80M	\$80M	\$80M
70%	\$31M	\$61M	\$80M	\$80M	\$80M	\$80M	\$80M	\$80M	\$80M	\$80M
80%	\$35M	\$70M	\$80M	\$80M	\$80M	\$80M	\$80M	\$80M	\$80M	\$80M
90%	\$39M	\$79M	\$80M	\$80M	\$80M	\$80M	\$80M	\$80M	\$80M	\$80M
100%	\$44M	\$80M	\$80M	\$80M	\$80M	\$80M	\$80M	\$80M	\$80M	\$80M

Source: Scotia Capital estimates.

Provinces Also Encourage Renewable Power Investment

BRITISH COLUMBIA

British Columbia has set a powerful renewables initiative that requires 90% of new generation to come from renewable sources. By 2016, B.C. wants to be energy self-sufficient. Additionally, the province wants to reduce emissions 33% from current levels by 2020. Based on B.C.'s progress to date, we view its renewable and emissions targets as achievable. **In our opinion, B.C. will remain a renewable power investment hotbed over the next three to five years.**

The current 2008 BC Hydro Clean Power Call that seeks 5,000 GWh/y of renewable power could award up to 7,500 GWh/y due to high expected attrition rates. In 2006, B.C. awarded over 1,500 MW (~7,500 GWh/y) of renewable capacity, or 50% more than what was originally requested by BC Hydro. Furthermore, the province is hosting a multi-phase bioenergy Call (1,000+ GWh/y), primarily as an environmentally and economically efficient way to deal with dead forests that stem from the mountain pine beetle infestation.

BC Hydro also offers a Standard Offer Program (BC SOP) for all renewable power facilities smaller than 10 MW. Long-term contract prices range from about \$70/MWh to \$84/MWh (2008 dollars) depending on several factors, including the region of the province. Prices escalate relative to changes in the Consumer Price Index (CPI).

In late 2007, British Columbia introduced the *Greenhouse Gas Reduction Act*, providing the framework necessary for the province to participate in the Western Climate Initiative. The act also supports the reduction of vehicle emissions, which may not directly impact the renewable energy industry but provides material support for the development of carbon policies in B.C.

As of July 2008, B.C. residents began paying North America's first revenue-neutral carbon tax of \$10/tonne CO_{2e} that equates to a 2.4¢ retail gasoline tax. The carbon tax will increase by \$5/tonne CO_{2e} each year to \$30/tonne CO_{2e} (7.2¢ per litre) in 2012. All revenue raised from the tax will be returned to individuals and businesses through reductions of other taxes.

ALBERTA

Alberta is Canada's leading province of installed wind power capacity, with over 524 MW operating today. Over 10,000 MW of wind power proposals remain in AESO's queue, of which over 3,500 MW is proposed wind capacity (Exhibit 1.42). Please refer to Exhibit 1.41 for a detailed list of all proposed Alberta power projects. Coal and natural-gas-fired plants currently make up over 90% of the province's power capacity, creating a significant opportunity for further renewable power investment.

Southwestern Alberta is considered to be one of the best regions in North America for wind resource quality.

Alberta's soaring demand for electricity, coupled with the Alberta Energy Minister's action to lift a 900 MW cap on wind power, has led to a massive queue for potential new wind capacity. Alberta is expected to require an additional 5,000 MW by 2017 and 11,500 MW of capacity by 2027. With peak load forecast to expand by over 3.5% per year (i.e., the highest rate in North America), **we see Alberta as another province for strong future renewable power investment activity over the long term.**

Exhibit 1.41: Proposed Power Projects in Alberta

Developer	Location	Capacity (MW)	Type	Status
AltaGas	Southern Alberta	14	Gas	2008
ATCO Valleyview #2	ValleyView	45	Gas	2008
CNRL Horizon Phase 1	Fort McMurray	101	Cogeneration	2008
Constellation Northern Prairie	County of Grande Prairie	85	Gas	2008
Earth Renew Organics	Strathmore	4	Biomass	2008
ECB Enviro North America	Lethbridge	3	Biomass	2008
Naturener Prairie Home Project Phase 1	County of Warner	9	Wind	2008
AltaGas	Stavely	7	Gas	2008
Verdant Energy	Westlock (DAPP)	10	Gas	2008
EPCOR Clover Bar	Edmonton	100	Gas	2008+
Naturer/Greenwind Power Yagos	Pincher Creek	100	Wind	2008+
Montana Alberta Tie Line	Lethbridge	300	Interconnection	2008+
NRGreen Power	Irma	8	Waste Heat	2009+
NRGreen Power	Morinville	8	Waste Heat	2009+
Alberta Wind Energy Oldman River Stage 2	Pincher Creek	46	Wind	2009+
ENMAX District Energy	Calgary	50	Cogeneration	2009+
ENMAX Crossfield	Crossfield	120	Gas	2009+
Finavera Ghost Pine	Three Hills	75	Wind	2009+
Kettles Hill Heritage	Pincher Creek	77	Wind	2009+
Maxim Deerland 1&2	Bruderheim	90	Gas	2009+
MEG Energy Corp.	Christina Lake	85	Cogeneration	2009+
Naturener Prairie Home Project Phase 2	County of Warner	80	Wind	2009+
Naturer/West WindEau Wild Rose	Cypress Hills	200	Wind	2009+
Suncor Firebag Stage 3	Fort McMurray	170	Cogeneration	2009+
TransAlta VisionQuest Blue Trail	Fort Macleod	66	Wind	2009+
TransAlta SD5 Upgrades	Wabamun	53	Coal	2009+
TransAlta/VisionQuest	Summerview Phase 2	63	Wind	2009+
Wind Power, Castle Rock Ridge I	Pincher Creek	112	Wind	2009+
Pteragen Peace Butte	Medicine Hat	120	Wind	2009+
City of Medicine Hat Replacement	Medicine Hat	42	Gas	2010+
EPCOR	Clover Bar	100	Gas	2010+
Greenwind Power Zoratti Flats	Pincher Creek	40	Wind	2010+
Legacy Ridge Energy	Pincher Creek	20	Wind	2010+
Naurener/Greenwind Southridge (Huck)	Pincher Creek	100	Wind	2010+
Sundance Forest Industries	Edson	10	Biomass	2010+
TransAlta VisionQuest Waterton Phase 1	Waterton	150	Wind	2010+
Wind Power, Castle Rock Ridge IIB	Pincher Creek	235	Wind	2010+
Wind Power, River View Project	Pincher Creek	115	Wind	2010+
Windrise Power	Fort Macleod	99	Wind	2010+
TransAlta VisionQuest Seven Persons	Medicine Hat	120	Wind	2010+
Petro-Canada MacKay River Expansion	Fort McMurray	190	Cogeneration	2010+
Greengate Black Spring Ridge	Lethbridge	300	Wind	2010+
Greengate Chigwell	Lacombe	150	Wind	2010+
Greengate Ponoka	Ponoka	150	Wind	2010+
Greengate Radar Hill	Red Deer	100	Wind	2010+
Greengate Wintering Hills	Drumheller	150	Wind	2010+
Greengate Halkirk	Stettler	150	Wind	2010+
TransCanada Sadlebrook Power Station	Okotoks	350	Cogeneration	2011+
Imperial Kearl Phase 1	Fort McMurray	85	Cogeneration	2011+
Canadian Hydro Developers	Cyr's Ridge	18	Wind	2011+
Finavera Lone Pine	Three Hills	75	Wind	2011+
Maxim Deerland 3&4	Bruderheim	90	Gas	2011+
Shell Canada Carmon Creek	Peace River	185	Cogeneration	2011+
TransAlta VisionQuest Waterton Phase 2	Waterton	150	Wind	2011+
Canadian Hydro Developers	Dunvegan	100	Hydro	2011+
Canadian Hydro Developers	Sennet	35	Wind	2011+
TransAlta/EPCOR Keephills #3	Keephills	450	Coal	2011+
Naturer West Raley Wind Energy	Cardston	120	Wind	2011+
Greengate Stirling	Lethbridge	100	Wind	2011+
Alberta Wind Energy Windy Point	Pincher Creek	90	Wind	2011+
Bow City Power	Brooks area	450	Coal	2012+
CNRL/ATCO	Primrose east	85	Cogeneration	2012+
ENMAX Phase 1	Southern Alberta	600	Gas	2012+
Shell Canada Jackpine	Fort McMurray	170	Cogeneration	2012+
Suncor Voyageur #1 & #2	Fort McMurray	160	Cogeneration	2012+
EPCOR Dodds Roundhill	Ryley	380	Coal/IGCC	2013+
Deer Creek Energy	Fort McMurray	85	Cogeneration	2013+
Petro-Canada/UTS Energy Fort Hills	Fort McMurray	170	Cogeneration	2013+
OPTI/Nexen Long Lake South	Fort McMurray	80	Cogeneration	2013+
Canadian Hydro Developers	St. Henry	72	Wind	2013+
TransAlta SD3 Upgrades	Wabamun	40	Coal	2013+
Total Deer Creek Joslyn North	Fort McMurray	85	Gas	2013+
Alberta Wind Energy Waterton Hutterite	Pincher Creek	200	Wind	2013+
CNRL Horizon Phase 3	Fort McMurray	85	Gas	2014+
Maxim Power Corp. HR Milner Expansion	Grande Cache	500	Coal	2014+
Synenco Northern Lights Mine	Fort McMurray	230	Cogeneration	2014+
Synenco Northern Lights Upgrader	Sturgeon County	40	Steam Turbine	2014+
ENMAX Phase 2	Southern Alberta	600	Gas	2015+
Suncor Firebag Step 4	Fort McMurray	160	Cogeneration	2015+
Total Proposed Generation		10,462		

Source: AESO.

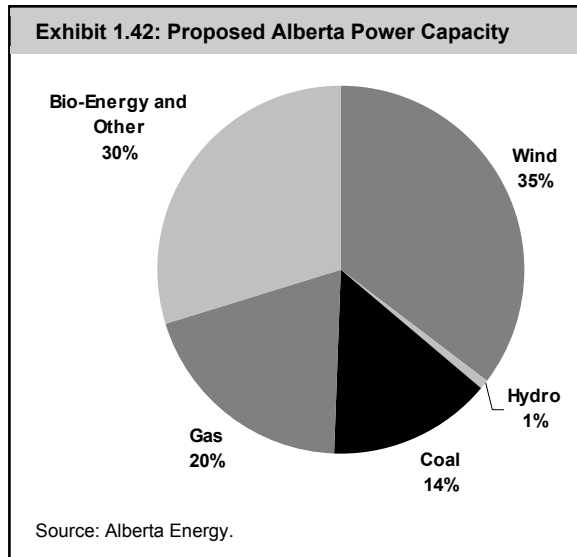

One big challenge remains for renewable power development in Alberta: the grid has not been updated in over two decades. Unless the system is expanded soon, the risk of blackouts occurring will rise, especially as the province has only 7% of excess capacity available for peak demand. In late 2007, AltaLink saw its proposal for a Calgary-Edmonton link fall through. **Bringing new transmission into operation can require as much as eight years to build,** potentially limiting massive wind power investment in Alberta, at least in the short term.

Alberta is Canada's leading greenhouse gas emitter and is the only province not a member of the Climate Registry. The province has put forward several plans to reduce its carbon footprint. In July 2008, the province announced that it will direct \$4

billion towards the reduction of GHG emissions, including the further development of carbon capture and storage technology, as well as energy-saving public transit. In 2007, Alberta introduced a provincial bill that charges large GHG emitters (i.e., >100,000 tonnes CO_{2e}/y) a \$15/tonne CO_{2e} fine for all emissions above a 12% reduction target over a three-year period. **Alberta's goal is to cut emissions 50% from current levels by 2050 primarily using carbon capture and storage technology.**

SASKATCHEWAN

Saskatchewan's Green Power Portfolio intends to meet all electricity demand requirements with renewable sources until 2010 and for 30% of all electricity to be generated by renewable power by 2020. The province's initiatives target 20 MW of biomass capacity by 2010, an additional 100 MW of wind by 2012, and 500 MW of wind by 2015.

Saskatchewan plans to issue a renewable baseload Request for Proposals (RFP) for between 200 MW and 400 MW in the near term. Similar to southern Alberta, Saskatchewan is home to some of the best wind resource sites in the country.

Saskatchewan has the most aggressive GHG reduction target in Canada, aiming for emissions to be reduced 32% from 2004 levels by 2020. Saskatchewan is also an observing member of the Western Climate Initiative.

MANITOBA

Manitoba does not have a renewable portfolio standard given its abundance of hydro power that provides over 98% of its power, but the province has set a goal of having 1,000 MW of wind capacity by 2014. After evaluating 10 short-listed proposals for 300 MW of wind power, it has selected a project near St. Joseph for further discussions with the developer. Manitoba Hydro has plans to hold further RFPs of 200 MW each in 2013-2014, 2015-2016, and 2017-2018. With the province currently having only 99 MW of wind facility and 300+ MW under various stages of development, we see further opportunity of up to 600 MW of wind investment.

The province seeks to reduce its GHG emissions level to 6% below 1990 levels by 2012 (i.e., Kyoto target). It is also an active participant in both the Western Climate Initiative and the Midwestern Regional GHG Reduction Accord.

ONTARIO

In 2004, the Ontario government set a renewable portfolio target of 10% by 2010, requiring the equivalent of about 2,700 MW of installed capacity. In the long term, the province is aiming for 15,700 MW of renewable supply by 2025. Currently, Ontario has less than 1,000 MW of installed renewable capacity, with the majority coming from wind and wood-waste at 518 MW and 224 MW, respectively.

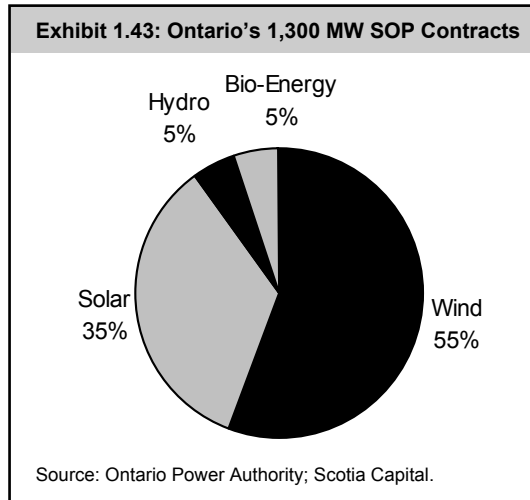

The Ontario Power Authority (OPA) has set an October 30 deadline for bids to be submitted under its Renewable Energy Standard (RES) III that seeks 500 MW of capacity. RES III is the first phase of the province's goal to build 2,000 MW of new renewable power capacity with plant sizes between 10 MW and 200 MW.

Ontario's Renewable Standard Offer Program (RESOP) provides small developers the opportunity to build wind, solar, biomass, and hydro projects less than 10 MW in size. RESOP has been too successful, handing out over 1,300 MW of contracted projects in its first year (Exhibit 1.43). When RESOP was launched in 2006, it was expected to develop 1,000 MW over 10 years.

Contract prices for RESOP projects are \$110/MWh

(\$420/MWh for solar) and are mostly 20 years in length. Given the success of the program and an application backlog, focus for the program has now shifted to development rather than awarding more contracts. To encourage broader participation in the program, a proponent will be limited to 50 MW per energy source of development capacity at any one time, and proponents will be restricted to a single 10 MW project per transformer station.

In January 2008, Ontario lifted its moratorium on offshore wind development, potentially opening the door to as much as 34,500 MW of offshore wind capacity. **The potential for offshore wind power in Ontario is positive, but the OPA has yet to include it in its current plans.**

In addition to Ontario's plan for a cap-and-trade program with Quebec (no details released yet), the province now holds member status with the Western Climate Initiative (announced July 17). Ontario is also an observer in the Regional Greenhouse Gas Initiative.

QUEBEC

Quebec is one of Canada's most aggressive provinces in pursuing renewable power, with a stated goal of having 4,000 MW of electricity derived from wind power by 2015. Hydro-Quebec, the province's utility and holder of North America's largest hydro portfolio, currently has 422 MW of installed and operating wind power capacity.

In mid-2008, Hydro-Quebec accepted 15 bids (2,004 MW) from its 2005 wind-only RFP. The average wind energy price awarded was \$87/MWh. Exhibit 1.44 outlines the successful bidders and the details of each bid.

We expect two 250 MW wind RFPs to be formally issued by Hydro-Quebec in Q4/08. Additionally, the province's rule-of-thumb ratio used for further wind power development is 100 MW for each 1,000 MW of new hydro installed.

Quebec also supports biomass, but on a much smaller scale, having recently announced (but not formally issued) a 100 MW biomass cogeneration RFP that seeks delivery of awarded projects no later than December 2011. In 2004, a proposal for a cogeneration RFP priced at \$100/MWh was rejected. We understand that this RFP will likely be priced between \$85/MWh and \$100/MWh.

Quebec has been proactive in attempting to reduce its carbon footprint by (1) signing a deal with Ontario for the two provinces to establish a cap-and-trade system by early 2010. Unlike national plans, **the partnership seeks real (i.e., absolute) reductions rather than intensity-based reductions**; (2) becoming a full member of the Western Climate Initiative; and (3) implementing a tax of 0.8¢ on every litre of gas and 0.9¢ on every litre of diesel sold in the province. Revenue from the tax, estimated to be about \$200 million per year, will be used to pay for energy-saving initiatives such as improvements to public transit.

Exhibit 1.44: Winning Bids in Hydro-Quebec's 2,000 MW Wind RFP

Winning Bidder	Project	Region	Expected Online	Turbine Manufacturer	Nameplate Capacity (MW)
Montérégie					
Kruger Énergie Inc	St-Rémi	Les Jardins-de-Napierville, Roussillon	2012	Enercon	100
Venterre (KHD)	St-Valentin	Le Haut-Richelieu	2012	Enercon	50
Centre-du-Québec					
Enerfin Sociedad	De l'Érable	L'Érable	2011	Enercon	100
Chaudières-Appalaches					
3Ci Inc.	Des Moulins	L'Amiante	2011	Enercon	156
St-Laurent Énergies	Massif du Sud	Les-Etchemins, Bellechasse	2012	REpower	150
Capitale nationale					
Boralex / Gaz Métro	Seigneurie de Beaupré #2	Côte-de-Beaupré	2013	Enercon	133
Boralex / Gaz Métro	Seigneurie de Beaupré #3	Côte-de-Beaupré	2013	Enercon	139
St-Laurent Énergies	Clermont	Charlevoix-Est	2015	REpower	74
Saguenay-Lac-St-Jean					
St-Laurent Énergies	Rivière du Moulin	Fjord-du-Saguenay Charlevoix	2014/2015	REpower	350
Bas Saint-Laurent					
Kruger Énergie Inc	Ste-Luce	La Mitis	2012	Enercon	68
St-Laurent Énergies	Lac Alfred	La Matapédia La Mitis	2012/2013	REpower	300
B&B VDK	Vents du Kempt	La Matapédia	2014	Enercon	100
Gaspésie-îles-de-la-Madeleine					
Invenergy Wind	Le Plateau	Avignon	2011	Enercon	138
Venterre (KHD)	New Richmond	Bonaventure	2012	Enercon	66
Minganie					
St-Laurent Énergies	Aguanish	Minganie	2011	REpower	80
					2,004

Source: Hydro-Quebec.

NEW BRUNSWICK

New Brunswick targets a renewable power portfolio of 10% by 2010 and for NB Power, the provincial utility, to purchase at least 400 MW of wind power by then. The province has yet to install any material wind power capacity, although over 300 MW is under construction, leaving about 100 MW of potential wind investments available by 2010.

NB Power's 2007 wind RFP sought 300 MW of projects, and was oversubscribed by more than 350%. Six wind capacity projects totalling 308 MW were selected.

New Brunswick has identified up to 90 MW of high-quality tidal power capacity potential.

New Brunswick holds observer status with the Regional Greenhouse Gas Initiative. Also, the province is a member of the New England Governors and Eastern Premiers that targets a reduction of GHG emissions to 1990 levels by 2010 and a further reduction of emissions to **10% below 1990 levels by 2020.**

NOVA SCOTIA

Nova Scotia targets 20% of its electricity to be generated from renewable sources by 2013. This equates to almost 600 MW of new capacity, with the majority of its renewable portfolio to likely come from wind power. Nova Scotia's coastal location offers excellent tidal (i.e., Bay of Fundy) and wind power (both onshore and offshore) resources.

In 2007, Nova Scotia issued a 130 MW renewable RFP and awarded 240 MW of capacity, of which the majority was wind power. **Currently, the province does not have any further RFPs scheduled that we are aware of; however, we believe this will likely change given the province is one of Canada's most intensive users of coal.** Coal power makes up roughly 80% of the province's power portfolio.

Nova Scotia operates one of the world's three commercial tidal facilities and offers the best location on the planet for potential tidal power at up to 2,700 MW.

PRINCE EDWARD ISLAND

Prince Edward Island has already met its initial goal of having 15% of all energy consumed to come from in-province renewable sources by 2010, but has since increased its target to 30%. The province is also exploring the possibility of having 100% of its required 1,170 GWh/y of power consumption supplied by renewable power sources.

NEWFOUNDLAND AND LABRADOR

Newfoundland currently has one small operating wind farm at 1 MW, and in our view, is one of the least attractive Canadian provinces for renewable investments. Despite Newfoundland having strong renewable power resources, the province seems to be solely focused on developing the massive 2,800 MW Lower Churchill Falls project. Over 5,000 MW of potential renewable capacity exists in Newfoundland, but we don't see rapid development of this occurring anytime soon.

Newfoundland held small wind power RFPs in both 2005 and 2006 that yielded about 25 MW per year of PPAs. The huge potential for wind power in Newfoundland is also limited by the current transmission system there, which could likely not handle more than 80 MW of wind power capacity.

We believe that Newfoundland will continue to see limited renewable investment given (1) no stated renewable portfolio target; (2) focus continues to be on the Lower Churchill Falls project; and (3) the transmission system is constrained for significant incremental wind power capacity.

North American Initiatives Highlight Growing Acceptance of Climate Change Action

The development of regional climate change initiatives in North America has come about as provinces and states continue to set their own emission reduction targets. In North America, there are three major climate initiatives that are expected to begin operating within the next several years: the Western Climate Initiative (WCI), the Midwestern Regional GHG Reduction Accord (Midwestern Accord), and the Regional Greenhouse Gas Initiative (RGGI). Each of these is expected to implement a market-based cap-and-trade program aimed at reducing GHGs.

The U.S. states participating in the initiatives make up nearly 30% of U.S. CO₂ emissions and represent over half the of the country’s population. Several of the major states and provinces not participating are leading emitters – Alberta, Texas, Ohio, and Florida.

To date, there has not been any formal announcement with respect to potential trading between the initiatives; however, as the market develops, we expect to see all three initiatives linked in a North-American-wide system.

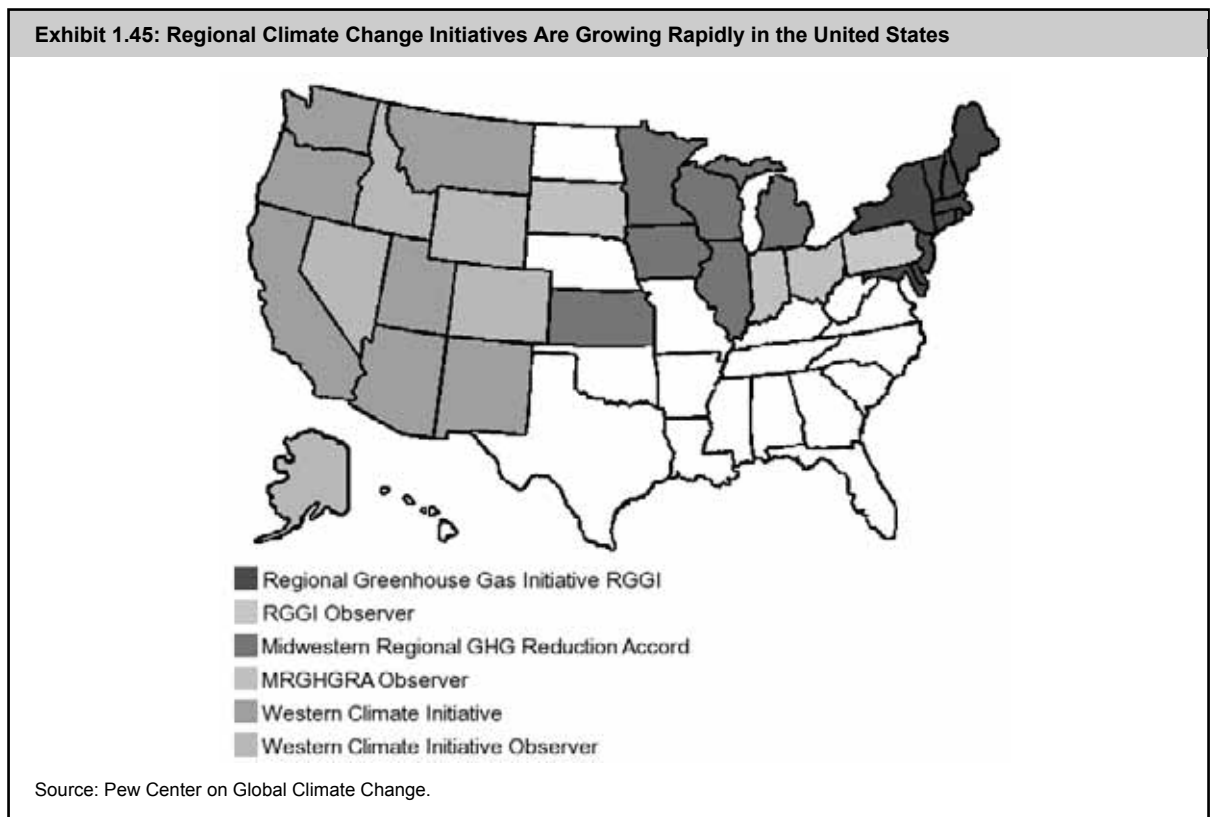

WESTERN CLIMATE INITIATIVE

The Western Climate Initiative targets emissions reduction of 15% below 2005 levels by 2020. The WCI is the broadest and most comprehensive of the North American initiatives, targeting all sectors and including all six GHGs, not just CO₂. British Columbia, Manitoba, Ontario, and Quebec are participating members, while Saskatchewan remains an observer.

Several of North America's major emitters, including Alberta and Texas, are not members of the WCI. Prior to becoming a member of WCI, candidate states/provinces must have:

- Adopted an economy-wide GHG reduction goal that reflects similar goals of the WCI;
- Developed a multi-sector climate action plan to achieve its goal;
- Committed to adopt GHG tailpipe standards for passenger vehicles; and
- Become a member of the Climate Registry.

The WCI's regional program covers less than 50% of the region's emissions as the transportation sector is not included. This has been one of the major criticisms of the WCI; however, the group plans to incorporate the transportation sector once further studies have been completed. The European Union's Emission Trading Scheme (EU ETS), which is universally accepted to be the most advanced emissions trading scheme in the world, also does not include the transportation sector in its plan.

To date, the WCI has recommended that each member auction between 25% and 75% of the allowances, with each region receiving the proceeds of the auction. **We expect the WCI to release its full cap-and-trade design guidelines in September** (a draft version was released in late July).

REGIONAL GREENHOUSE GAS INITIATIVE

The Regional Greenhouse Gas Initiative (RGGI) is scheduled to hold its first CO₂ emissions allowance auction in September 2008 and is targeting to reduce emissions 10% below 2003/2004 levels by 2018. The auction will consist of 188 million tonnes CO₂ (4% above the 2000 to 2004 average level) and beginning in 2014 will decline by 2.5% per year to 169 million tonnes CO₂. A reserve price of US\$1.86 has been set for the first auction. **Unlike the WCI and Midwestern Accord, the initiative is initially targeted at reducing only CO₂ emissions, specifically from electricity power plants.**

The RGGI is primarily targeting facilities greater than 25 MW. **Allowances are not sold or allocated to renewable facilities.** The RGGI should see the creation of a secondary market, as allowances are auctioned to both utilities and participating brokers who can purchase allowances to profit from later selling them.

MIDWESTERN REGIONAL GREENHOUSE GAS REDUCTION ACCORD

The Midwestern Accord has yet to set any firm emissions reduction targets, but is expected to be similar in scope to the WCI. Targets will be met through the implementation of both renewable portfolio standards and biofuels targets. **Manitoba is the only Canadian province to be a member of the Midwestern Accord, and Ontario is an observer for now.**

In late 2007, the Midwestern Governors Association held a climate-change-related summit that established a blueprint renewable portfolio objective as follows: 10% by 2015, 20% by 2020, 25% by 2025, and 30% by 2030. **To date, less than half of the Midwestern Accord member states have legislated these goals.**

The Midwestern Accord will cover all sectors and is expected to set goals for reductions by the end of 2008. We expect the accord to link with both the WCI and the RGGI, and will use the Climate Registry (see next page) as its emissions tracking system.

Exhibit 1.46: Summary of North American Regional Climate Change Initiatives

	Western Climate Initiative	Midwestern Accord	Regional GHG Initiative
Cap & Trade	Yes, ~2009	Yes, ~2009	Yes, Auction starts Sep. 2008; Cap & Trade in Jan. 2009
Target	15% below 2005 levels by 2020.	-	2000-2004 average through 2014, then 2.5% reduction per year through 2018.
GHGs	CO ₂ , CH ₄ , N ₂ O, HFCs, PFCs, SF ₆	CO ₂ , CH ₄ , N ₂ O, HFCs, PFCs, SF ₆	Start with CO ₂
Sectors	As many as possible. Start with electricity sector and large stationary combustion sources. Expand to industrial process, waste management, fossil fuel production, and other sectors.	Multi-sector, but not defined. Members may phase in programs to be consistent with WCI.	Fossil fuel-fired electric generators ≥ 25 MW.
Reporting	Develop GHG reporting rule based on each member's mandatory requirement. Reporting likely required before Cap & Trade program in place. Plans to use Climate Registry software.	Not defined. May develop a reporting program in addition to the Climate Registry.	Specific tracking registration system for tradable allowances will permit reporting of non-power plant emissions to the Climate Registry.

Source: Perkins Coie.

CLIMATE REGISTRY

The Climate Registry seeks to develop a GHG accounting system that tracks emissions from North American states, provinces, and companies. The majority of the U.S. states and all Canadian provinces with the exception of Alberta have signed on as members of the registry (Exhibit 1.47). The registry is currently working with the North American regional climate initiatives such as WCI and RGGI to ensure similar reporting standards, as well as to facilitate climate-change-related partnerships between the regions.

Exhibit 1.47: Alberta Is the Only Canadian Province That Is Not a Member of the Climate Registry



Source: www.theclimateregistry.org

Europe Leads the World in Renewable Energy Targets

Binding and non-binding targets for renewable energy have exploded in recent years as countries accept the reality of global warming and the need to reduce carbon emissions. Europe continues to lead the way in driving supportive renewable energy policy. Support in the United States is growing rapidly as well, with 33 U.S. states having renewable portfolio standards (RPSs). Furthermore, with both U.S. presidential candidates seeking a federal cap-and-trade system, we believe that a nationwide RPS may one day be in the cards.

EUROPEAN UNION RENEWABLE TARGETS ARE AGGRESSIVE AND ARE BEING MET

In 2001, the European Union set an initial target for its member states to have 21% of electricity come from renewable fuel sources. Since then, material progress has been made to achieve this target, as wind and solar capacity growth has exploded in several member countries. By the end of 2006, the EU had achieved two-thirds of its stated target, or 14%. However, the target has now changed to 20% by 2020 and includes total energy use rather than just electricity (Exhibit 1.48).

Exhibit 1.48: The EU Targets 20% Renewable Energy by 2020

Member State	Electricity		Energy	
	Share 2006	Target 2010	Share 2005	Target 2020
Austria	64.2%	78.1%	23.3%	34.0%
Belgium	2.8%	6.0%	2.2%	13.0%
Bulgaria	-	-	9.4%	16.0%
Cyprus	-	6.0%	2.9%	13.0%
Czech-Republic	4.2%	8.0%	6.1%	13.0%
Denmark	26.0%	29.0%	17.0%	30.0%
Estonia	1.6%	5.1%	18.0%	25.0%
Finland	24.0%	31.5%	28.5%	38.0%
France	10.9%	21.0%	10.3%	23.0%
Germany	12.0%	12.5%	5.8%	18.0%
Greece	13.0%	20.1%	6.9%	18.0%
Hungary	4.4%	3.6%	4.3%	13.0%
Ireland	10.0%	13.2%	3.1%	16.0%
Italy	16.0%	25.0%	5.2%	17.0%
Latvia	49.9%	49.3%	34.9%	42.0%
Lithuania	3.6%	7.0%	15.0%	23.0%
Luxembourg	6.9%	5.7%	0.9%	11.0%
Malta	-	5.0%	-	10.0%
The Netherlands	6.5%	9.0%	2.4%	14.0%
Poland	2.8%	7.5%	7.2%	15.0%
Portugal	35.7%	45.6%	20.5%	31.0%
Romania	-	-	17.8%	24.0%
Slovak Republic	16.1%	31.0%	6.7%	14.0%
Slovenia	24.4%	33.6%	16.0%	25.0%
Spain	19.0%	29.4%	8.7%	20.0%
Sweden	51.7%	60.0%	39.8%	49.0%
United Kingdom	4.1%	10.0%	1.3%	15.0%
EU	14.0%	21.0%	8.5%	20.0%

Source: International Energy Agency.

In Europe, high feed-in tariff rates are the key incentive that governments offer to renewable power producers to install new capacity. Germany and Spain, Europe’s leaders for renewable power, each have high tariffs for both wind and solar power. While it recently reduced its solar PV tariff (much less than expected) to motivate manufacturers to reduce costs quickly, Germany did raise its feed-in tariffs for both onshore and offshore wind to €92/MWh and €130/MWh, respectively. Spain also reduced its solar PV tariff, which was expected, but surprised all market observers by capping new solar build to 300 MW next year. **Many had expected a cap closer to 3,000 MW.**

SEVENTEEN U.S. STATES STILL DO NOT HAVE RPS GOALS

Unlike the European Union, **the United States does not have a nationwide RPS target, but has implemented multiple initiatives to help states achieve their goals.** These financial incentives are outlined in Exhibit 1.49 and include the U.S. Production Tax Credit, which is currently set to expire at the end of 2008.

Exhibit 1.49: U.S. Federal Renewable Energy Incentive Programs	
Production Tax Credit (PTC)	Wind, Geothermal, Closed-Loop Biomass, Solar: US\$20/MWh for first 10 years of operation. Small Hydro, Cogen, Waste-to-Energy, Open-Loop Biomass: US\$10/MWh for first 10 years of operation. Indexed to inflation and expires 12/31/2008.
Renewable Energy Production Incentive (REPI)	US\$1.5/MWh in 1993 current US\$ for first 10 years of operation. Subject to annual appropriations such that it may not be fully funded from year to year. Indexed to inflation and expires in 2026.
Corporate Investment tax Credit (ITC)	Credit against income tax as percent of investment. Reduces from 30% to 10% after 12/31/2008.
Personal Investment Tax Credit (ITC)	30% up to a maximum of US\$2,000 for solar electric and water heating. US\$500 per 0.5kW for fuel cells. Expires 12/31/2008.
Modified Accelerated Cost Recovery System (MACRS)	Eligible technologies are allowed 5 year versus 15 year depreciation.
Clean Renewable Energy Bonds (CREBs)	Bond instrument where holders earn returns through tax credits. US\$1.2 billion authorized through January 2009. Targeted at not-for-profit utilities.

Source: Database of State Incentives for Renewable Energy

Exhibit 1.50: U.S. State RPS Targets	
State	Target
Arizona	15% of electricity by 2025
California	20% of electricity by 2010
Colorado	20% of electricity by 2020
Connecticut	23% of electricity by 2020
District of Columbia	11% of electricity by 2022
Delaware	20% of electricity by 2019
Hawaii	20% of electricity by 2020
Iowa	105 MW
Illinois	25% of electricity by 2025
Massachusetts	4% of electricity by 2009
Maryland	20% of electricity by 2022
Maine	10% of new electricity by 2017
Minnesota	25% of electricity by 2025
Missouri	11% of electricity by 2020
Montana	15% of electricity by 2015
New Hampshire	23.8% of electricity by 2025
New Jersey	22.5% of electricity by 2021
New Mexico	20% of electricity by 2020
Nevada	20% of electricity by 2015
New York	24% of electricity by 2013
North Carolina	12.5% of electricity by 2021
North Dakota	10% of electricity by 2015
Ohio	25% of electricity by 2025
Oregon	25% of electricity by 2025
Pennsylvania	18% of electricity by 2020
Rhode Island	16% of electricity by 2020
South Dakota	10% of electricity by 2015
Texas	5,880 MW by 2015
Utah	20% of electricity by 2025
Vermont	20% of electricity by 2017
Virginia	12% of electricity by 2022
Washington	15% of electricity by 2020
Wisconsin	10% of electricity by 2015

Source: Database of State Incentives for Renewable Energy

Thirty-three U.S. states have now implemented RPS (hard) targets or (soft) goals. California (20% by 2010) and Texas (5,880 MW by 2015) have the most aggressive targets in the United States, which vary widely from as low as 4% to as high as 25%.

From an investment perspective, setting a high or a low RPS doesn't provide much insight into renewable power growth opportunities unless the RPS target is a material change from the state's current power portfolio mix. For example, if a state sets a target of 20% by 2010, the opportunities are likely limited if that state was already at 19% when the RPS was established. Conversely, a seemingly low RPS target (i.e., 5%) may offer more opportunity if: (1) that state consumes relatively more power than its peers; and (2) the original renewable proportion of its power portfolio was significantly lower than its RPS target.

For these U.S. states to achieve their RPS targets or goals, state-level financial incentives are typically offered to renewable power producers (and marketers) in addition to the federal ones listed in Exhibit 1.50. Exhibit 1.51 breaks down the types of financial incentives offered on a state-by-state basis.

Exhibit 1.51: U.S. State-Level Financial Incentives

State	Personal Tax	Corp. Tax	Sales Tax	Prop. Tax	Rebates	Grants	Loans	Industry Support	Bonds	Production Incentives
Alabama	1-S				3-U	1-S	1-S 1-U			1-U
Alaska							2-S			1-U
Arizona	3-S	1-S	1-S	2-S	6-U					
Arkansas										
California	1-S			1-S	5-S 34-U 1-L	1-L	2-S 1-U 1-L			1-S 2-U
Colorado			1-S 1-L	2-S	7-U 3-L	1-L 1-P	3-U 1-L	1-S		
Connecticut			1-S	1-S	2-S	4-S	2-S	2-S		1-P
Delaware					1-S	2-S				
Florida		2-S	1-S	1-S	1-S 7-U 2-L	2-S	4-U			1-U
Georgia	1-S	1-S	1-S		3-U		3-U			1-U
Hawaii	1-S	1-S			2-U		1-S 2-U 1-L	1-S	1-L	
Idaho	1-S		1-S	1-S	1-U	2-P	1-S		1-S	1-P
Illinois				2-S	1-S	3-S 1-P				
Indiana				1-S	1-S 25-U	1-S				
Iowa	1-S	1-S	1-S	3-S	6-U	1-S	2-S			
Kansas				1-S			1-S			
Kentucky	1-S	2-S	1-S		5-U		2-U 1-P			1-U
Louisiana	1-S	1-S		1-S			1-S			
Maine					1-S	1-S	1-S			
Maryland	2-S	2-S	2-S	4-S 3-L	3-S 1-L		2-S			
Massachusetts	2-S	3-S	1-S	1-S	2-S 2-U	3-S	1-S 1-U	2-S		1-P
Michigan				1-S	1-U	4-S		2-S		
Minnesota			2-S	1-S	2-S 9-U	3-U	5-S 1-U			1-S 1-U
Mississippi					4-U		1-S			1-U
Missouri		1-S			6-U		1-S 1-U			
Montana	3-S	1-S		3-S	2-U	1-U 2-P	1-S	2-S		1-P
Nebraska			1-S		2-U		1-S			
Nevada				3-S	1-S					
New Hampshire				1-S	3-U		1-S			
New Jersey			1-S		4-S 1-U		1-S 1-U			1-S
New Mexico	3-S	3-S	2-S					1-S	1-S	1-U
New York	2-S	1-S	1-S	2-S	5-S 3-U	1-S	2-S	3-S		1-S
North Carolina	1-S	1-S	1-S	1-S			1-S	1-S		1-U 1-P
North Dakota	1-S	1-S		2-S						
Ohio		1-S	1-S	1-S 1-L	6-U	2-S				1-S
Oklahoma		1-S					3-S	1-S		
Oregon	1-S	1-S		1-S	3-S 12-U	1-S 2-P	1-S 7-U	1-S		1-U 1-P
Pennsylvania				1-S		3-S 3-L	1-S 1-U 5-L			
Rhode Island	1-S	1-S	1-S	2-S	1-U	1-S		1-S		1-P
South Carolina	1-S	2-S	1-S		1-S 2-U	1-S	1-S 5-U			1-S
South Dakota				3-S	1-U		1-U			
Tennessee				1-S		1-S	1-S			1-U
Texas		1-S		1-S	11-U			1-S		
Utah	1-S	1-S	1-S		5-U					
Vermont		1-S	1-S	1-S	1-S	1-S 1-U	1-S			2-U
Virginia				1-S				1-S		1-U
Washington			1-S		11-U	1-L 2-P	9-U	1-S		1-S 3-U 1-P
West Virginia		1-S		1-S						
Wisconsin				1-S	2-S 2-U	1-S 1-U		1-S		4-U
Wyoming			1-S		1-S 1-U					
District of Columbia						1-S				
Palau										
Guam										
Puerto Rico	1-S		1-S	1-S						
Virgin Islands					1-S	1-S				
N. Mariana Islands										
American Samoa										
Totals	33	36	28	54	229	60	94	22	3	39

S = State/Territory L = Local U = Utility P = Private

Source: Database for State Renewable Energy Incentives

THE REST OF THE WORLD IS COMING AROUND

Outside of Canada, Europe, and the United States, **many developed and developing nations have set renewable energy portfolio targets or goals as well** (Exhibit 1.52). Most of these countries offer feed-in tariffs, investment tax credits, and tradable renewable energy certificates to achieve their goals.

Surprisingly, over the past two years, many developing countries have upgraded their previous RPS targets. Egypt recently revised its RPS to 20% by 2020 from 14%, while Argentina also increased its 2016 RPS target to 8%. Perhaps the most interesting country to watch achieve its RPS is China, which seeks 10% of total energy consumption by 2010 to come from alternative energy. **On average, China commissions one new coal-fired power plant per week.**

Exhibit 1.52: Select Country Renewable Energy Targets (ex. Canada, EU Members, and the U.S.)

Country	Share (2006)	Target
Argentina (ex. large hydro)	1.3%	8% of electricity by 2016
Australia	7.9%	9,500 GWh of electricity annually by 2010
Brazil (ex. large hydro)	5.0%	-
China	-	10% total energy by 2010; 15% by 2020
Egypt	15.0%	20% of electricity by 2020
India	4.0%	-
Israel	-	5% of electricity by 2016
Japan (ex. large hydro)	0.4%	1.63% of electricity by 2014
Korea	1.0%	7% of electricity by 2010
Malaysia	-	5% of electricity by 2025
Mexico	16.0%	4 GW of new renewables by 2014
Morocco	10.0%	20% of electricity by 2012, including 1 GW of wind power
New Zealand	65.0%	90% of electricity by 2025
Nigeria	-	7% by 2025
Norway	-	7 TWh from heat and wind by 2010
Pakistan	-	10% of electricity by 2015
Philippines	-	4.7 GW of new renewables by 2013
Singapore	-	50,000 m ² of solar thermal systems by 2012
South-Africa	-	10 TWh of renewables by 2013
Switzerland	52.0%	3.5 TWh from electricity and heat by 2010
Thailand	7.0%	-
Turkey	-	2% of electricity from wind by 2010
Uganda	-	100 MW small hydro and 45 GW geothermal by 2017

Source: IEA; REN21; Scotia Capital.

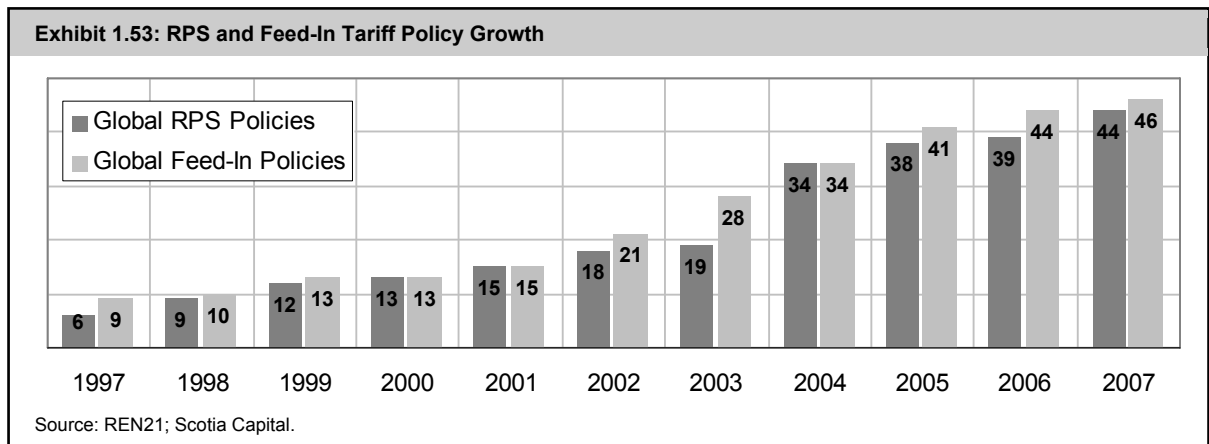

Global Investment Trends Support Our Bullish View

Annual investment in alternative & renewable energy could hit US\$450 billion by 2012.

The year 2007 was another record for investment into alternative and renewable energy, with US\$148.4 billion poured into the sector globally, up 60% from 2006 (Exhibit 1.54). On top of this, total M&A transactions in the space amounted to over US\$55 billion. Asset financing was the main driver for investment growth, up 68% year over year to US\$84.5 billion in 2007, mostly from wind power activity. According to New Energy Finance, annual investment in the space is expected to hit US\$450 billion by 2012 and US\$600 billion by 2020.

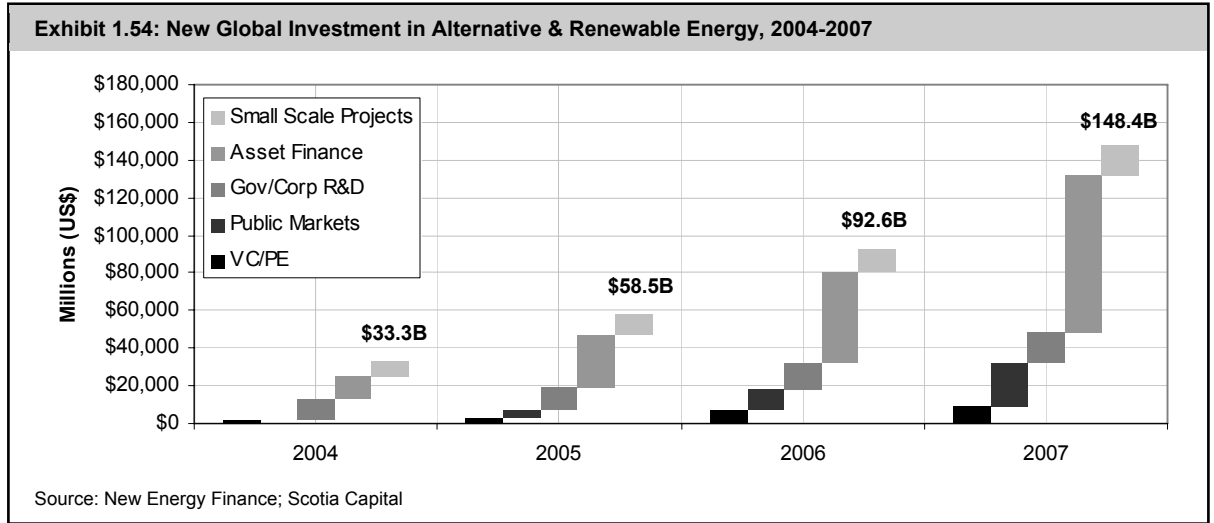

Assets under management in clean tech, environmental, and renewable power-related funds surged to over US\$65 billion by the end of last year (Exhibit 1.55). R&D spending on alternative and renewable energy in 2007 was US\$16.9 billion, split US\$9.8 billion from corporate R&D and US\$7.1 billion from government R&D programs.

Investment dollars are now flowing more towards developing nations than ever before. A large chunk of the money is being invested in Kyoto-related Clean Development Mechanism (CDM) projects in BRIC nations (i.e., Brazil, Russia, India, and China) as well as Mexico (Exhibit 1.56). Accordingly, at the end of this section, we focus our attention on the alternative energy investment trends of BRIC nations.

Exhibit 1.55: Clean Energy Funds, March 2008

Sector Focus	VC/PE (US\$M)	Public (US\$M)	Project (Equity) (US\$M)	Project (Debt) (US\$M)
Renewable Projects	\$1,579	\$0	\$7,831	\$1,448
Environmental & Climate Change	\$5,614	\$19,034	\$901	\$847
Clean Energy	\$6,326	\$22,864	\$682	\$96
Total	\$13,519	\$41,898	\$9,414	\$2,391

Source: New Energy Finance; Scotia Capital.

Exhibit 1.56: CDM Projects by Country, July 2008

Country	Registered	Pre-registered	Total
India	354	552+	906+
China	241	907+	1,148+
Brazil	142	137+	279+
Mexico	105	76+	181+
Avg.	211	418+	629+
Avg. for others	4	7	11

Source: New Energy Finance; United Nations; Scotia Capital.

PUBLIC MARKET INVESTMENT

Alternative and renewable energy companies raised US\$27 billion of equity in 2007, or a 114% improvement from 2006, which itself was a 125% increase from 2005 (Exhibit 1.57). About 60% of the money raised in public markets was for initial public offerings, followed by 20% for secondary offerings and 20% for convertible/other equity financings.

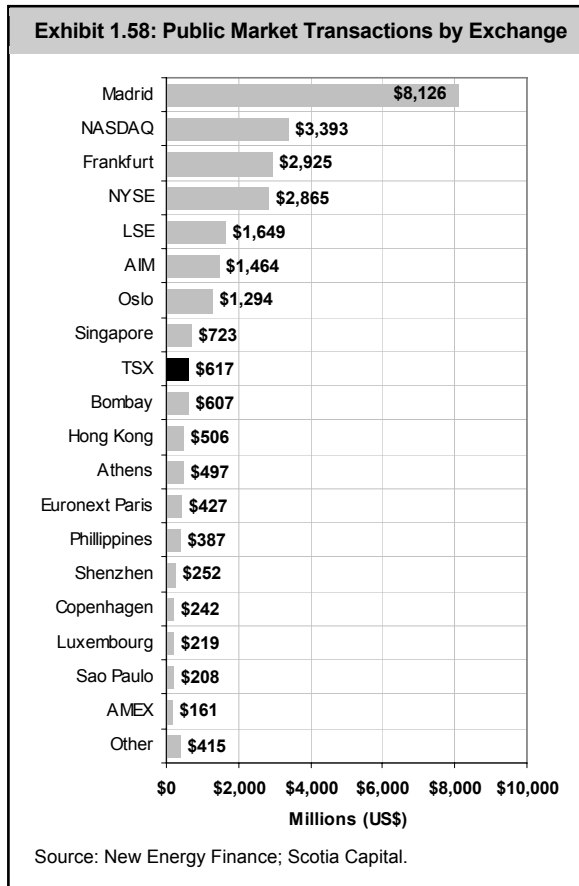
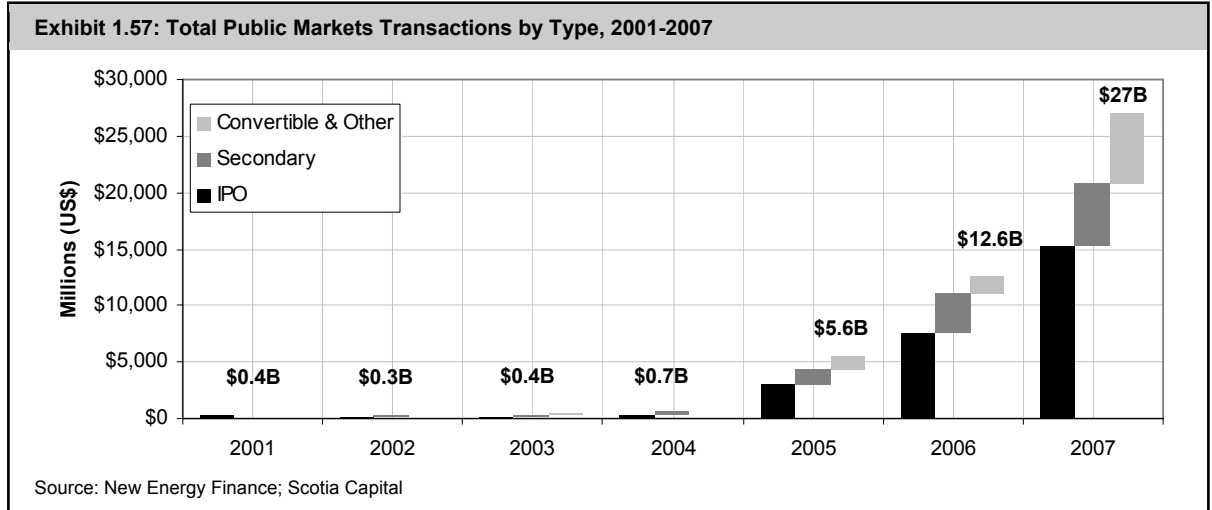

In 2007, Spain’s Iberdrola raised US\$7.2 billion from the IPO of its Iberdrola Energias Renovables (Ibernova), the largest renewable-related IPO to date. As a result, the Madrid Stock Exchange earned top spot for total public market investment in 2007, although only two IPOs and one secondary offering occurred there. There were 21 renewable-related IPOs and secondary offerings on Nasdaq for a combined value of US\$3.4 billion including convertibles (Exhibit 1.58).

The Alternative Investment Market (AIM) of London continues to attract alternative and renewable energy companies. Thirty-two transactions occurred on AIM last year, likely due to (1) its less stringent reporting requirements than U.S. markets; and (2) its access to the financial centre of Europe.

Solar companies raised over US\$9.4 billion last year, and more than double the US\$4.6 billion that was raised in 2006. Chinese cell and module manufacturers typically IPO’d in the United States. Also, German and U.S. solar players prepared themselves (via secondary offerings) for consolidation.

CORPORATE M&A ACTIVITY

Global M&A activity for alternative and renewable energy exploded in 2007 with 237 deals completed for US\$25.7 billion, up 52% from 2006 (Exhibit 1.59). Most of the increase occurred in the second half of 2007, when the credit crunch forced the start of market consolidation.

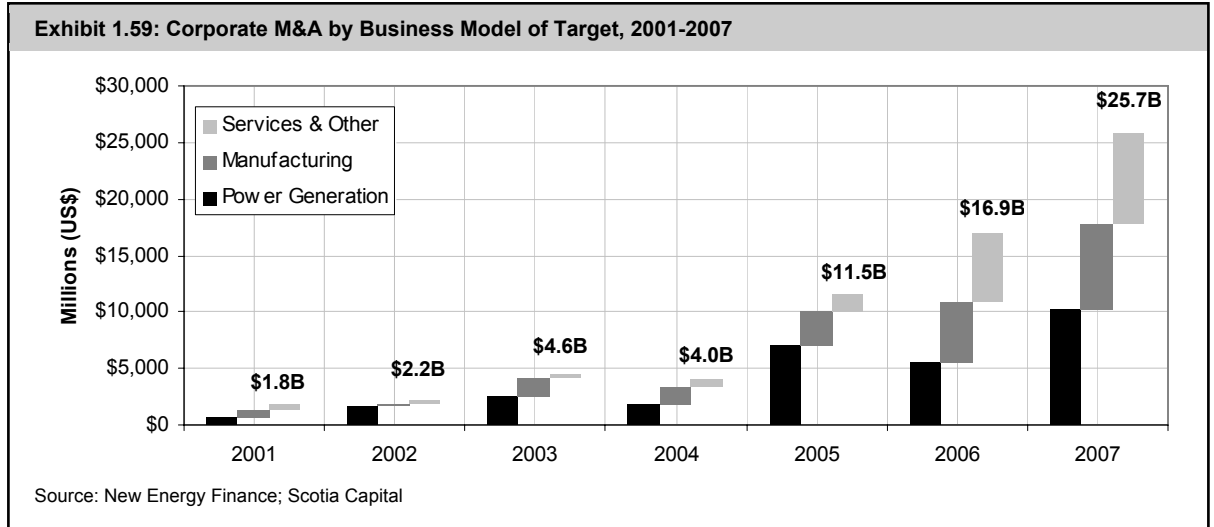

Driving M&A deals were utilities seeking to hedge against oil, coal, and gas price increases, and tougher market conditions that favour the investment-grade credit quality of utilities over IPPs. Also, the rising cost of building new plants partly increased M&A activity, as increases in steel

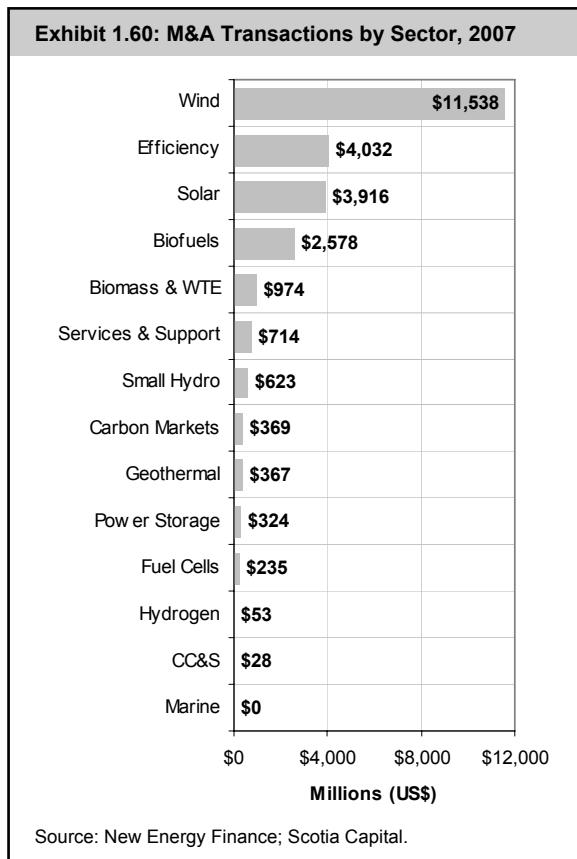

and nickel prices, as well as labour, made it cheaper to buy existing plants. The United States and Europe accounted for 84% of the value of deals completed in 2007.

Wind power led all M&A transactions in the space, with US\$11.5 billion of deals completed last year, dominated by three major deals (Exhibit 1.60): (1) Goldman Sachs' sale of Horizon Wind Energy to EDP for US\$2.7 billion; (2) Germany's E.ON purchase of the Iberian wind assets of Danish energy company Dong for US\$1 billion; and (3) E.ON's acquisition of Irish wind farm developer Airtricity's North American operations for US\$1.4 billion. In early 2008, the remaining assets of Airtricity were acquired by Scottish & Southern Energy for US\$2.2 billion.

ASSET FINANCING

US\$108 billion of alternative and renewable energy assets were financed in 2007, up 61% year over year from US\$67 billion in 2006 (Exhibit 1.61). US\$85 billion was spent on new capacity build, while US\$18 billion was used for acquisition, and almost US\$6 billion for refinancing.

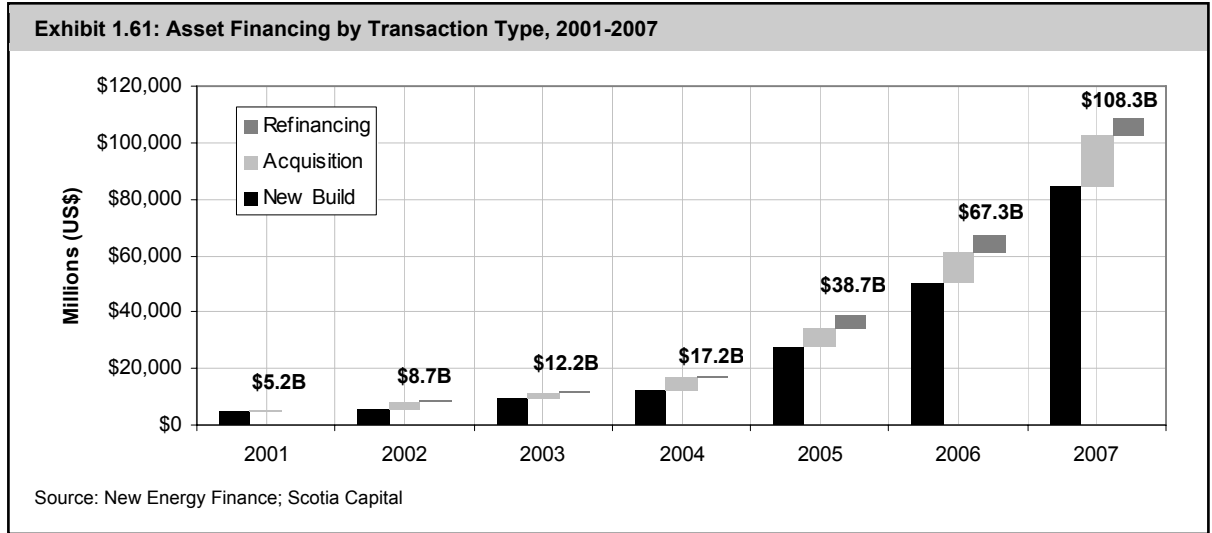

As expected, more money was spent on wind financing than any other type of renewable asset, at US\$38 billion, and up 68% year over year. According to New Energy Finance, 60% of these financed wind farms were located in three countries: China, Spain, and the United States.

Solar asset financing soared in 2007, up 250% to US\$17.7 billion. Fear of declining feed-in tariff rates as well as an increased global acceptance of solar PV as a future mainstream power source were the reasons for the growth. Biomass and waste-to-energy asset financing increased slightly in 2007 to US\$4.8 billion.

Regionally, asset financing in Europe doubled to US\$38.8 billion in 2007, while the United States saw no growth year over year at US\$16.3 billion (bioethanol financing fell). Funding more than doubled to US\$10.8 billion in China, while India’s asset financing market shot up by 250% to US\$2.3 billion.

Exhibit 1.62 details asset financing by sector.

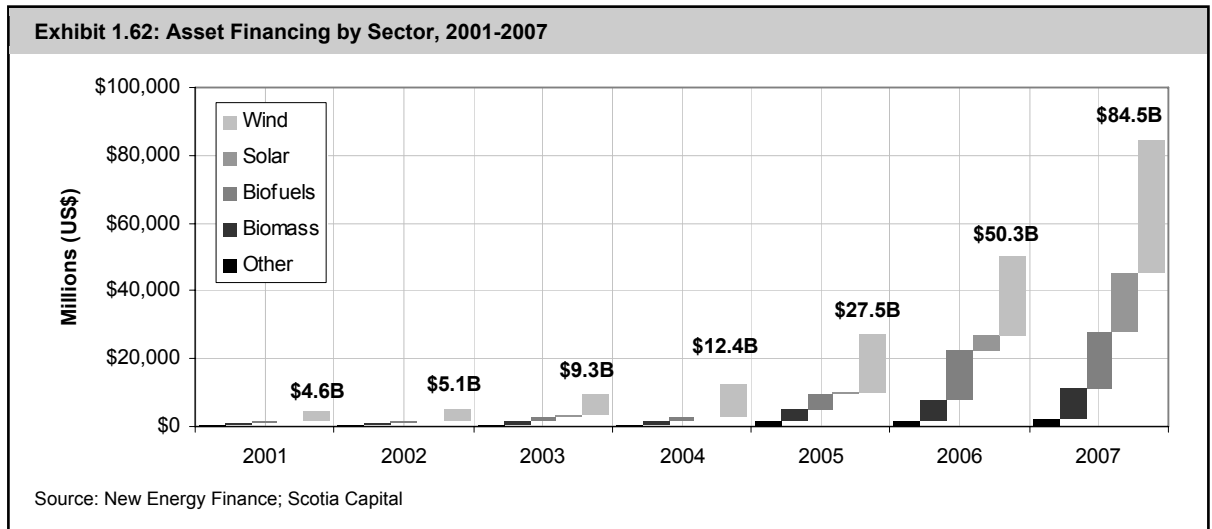

VENTURE CAPITAL AND PRIVATE EQUITY

US\$13.2 billion was invested into the alternative and renewable energy space by venture capital and private equity players in 2007, up 42% from 2006. The number of deals also increased in 2007 to 537 from 439 the previous year. Specifically, private equity investment of US\$7.2 billion mainly fell into two areas: (1) buyout deals that totalled US\$3.4 billion and (2) expansion funding of US\$3.8 billion; see Exhibit 1.63.

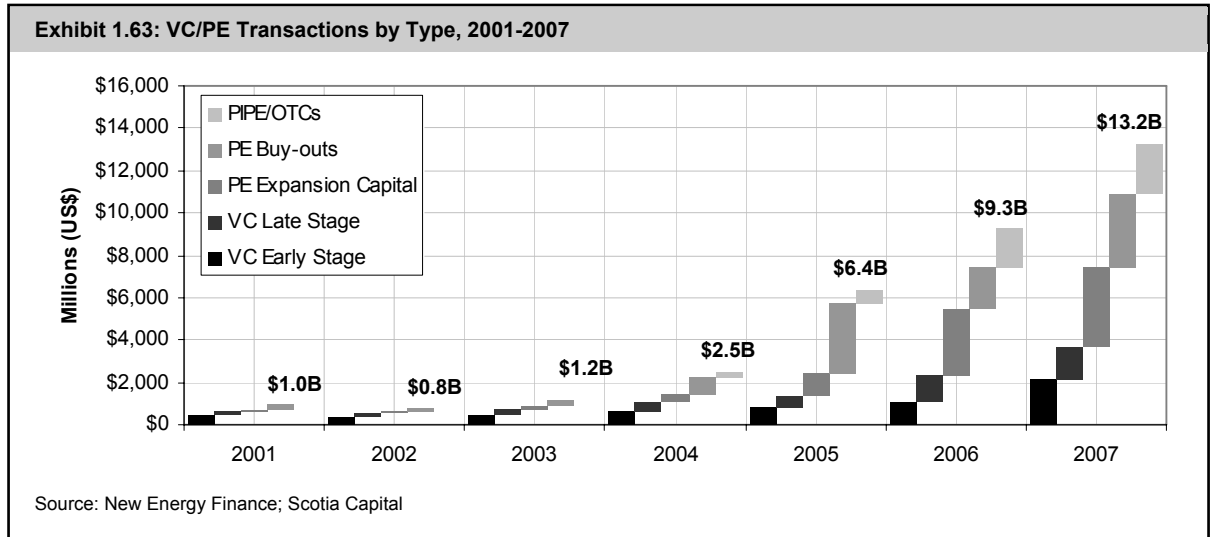

Solar companies dominated the venture capital market, attracting US\$3.7 billion last year, an 85% year-over-year increase. The majority of the 42 completed solar deals occurred in North America, and were mostly related to investment in thin-film technology.

Biomass and waste-to-energy VC/PE investment grew faster than any other sector, up 430% to US\$1.3 billion in 2007. Deals tripled to 37 from 11 in 2006.

Maturing renewable power technologies saw relatively little activity from the venture capital market. Wind investment increased by 20% to US\$1.8 billion from US\$1.5 billion in 2006, most of which was from the private equity market. Surprisingly, there was little interest in emerging marine-related technology investments such as tidal, wave, and ocean thermal power. Exhibit 1.64 details the market activity by sector.

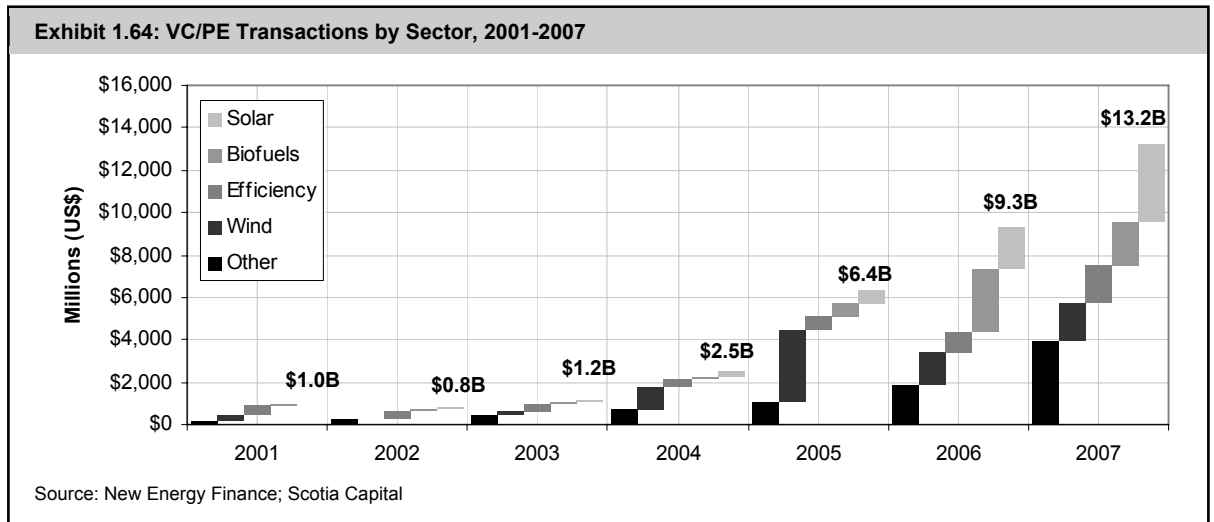

BRIC MARKETS

Renewable Investment in China Set to Soar

Installed capacity of renewable power generation in China is relatively small at only 9,000 MW, representing just over 1% of the country’s power requirements. Two-thirds of this capacity is wind power, 3,400 MW of which was added in 2007. In September 2007, China’s National Development and Reform Commission (NDRC) established new renewable targets, which if achieved, will require over

Exhibit 1.65: China’s Renewable Status & Targets

	2007 Capacity	2020 NDRC Target
Hydro	145,000 MW	300,000 MW (including 75,000 MW small hydro)
Wind	6,000 MW	30,000 MW
Solar PV	100 MW	1,800 MW
Biomass	3,000 MW	30,000 MW
Geothermal	32 MW (power)	12M tons of coal equivalent (power & thermal)
Tidal	-	100 MW

Source: New Energy Finance; NDRC; Scotia Capital.

US\$250 billion to be invested in the space, or more than US\$80 billion if large hydro is excluded (Exhibit 1.65).

While public market activity was strong in China in 2007 at US\$1.5 billion of alternative energy IPOs, US\$3.4 billion was raised by renewable power related Chinese companies on foreign exchanges, **mostly solar companies with IPOs in the U.S.** Asset financing in China nearly doubled year over year to US\$10.8 billion, while **M&A activity remained weak** at US\$386 million. Exhibit 1.66 shows the growth in alternative and renewable energy investment in China over the past four years.

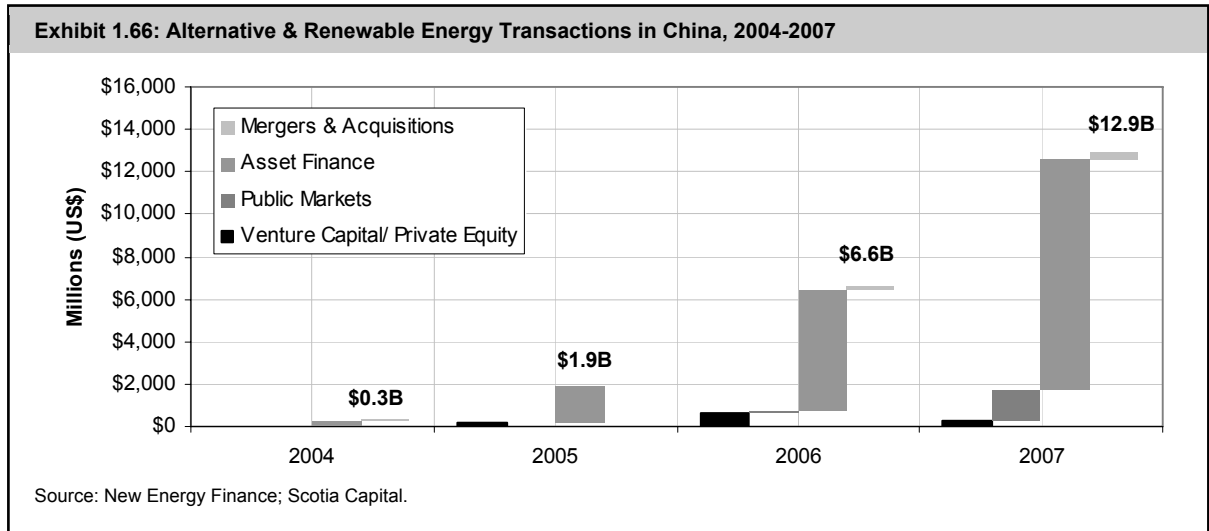

Excluding Wind, Investment Activity in India Is Quiet

Despite the Indian government setting a renewable energy target of 10% by 2032, wind power seems to be the only renewable fuel source that is attracting material investment attention. At the end of 2007, 11,400 MW of renewable capacity was online, most of which was wind power at 7,800 MW.

	2007 Capacity	2012 Target
Large Hydro	34,200 MW	-
Small Hydro	2,000 MW	3,400 MW
Wind	7,800 MW	18,300 MW
Solar PV	2.1 MW	52.1 MW
Biomass	~1,400 MW	~3,500 MW
Geothermal	-	-
Tidal	-	-

Source: New Energy Finance; MNRE; Scotia Capital.

Exhibit 1.67 shows India's official renewable targets from its most recent five-year plan (2007-2012).

In the capital markets, 2007 saw US\$628 million raised locally in new equity, compared to nothing raised in 2006. Similar to China, India-based renewable companies looked overseas for the majority of their funding requirements, raising US\$1.4 billion outside of India. Also notable was Suzlon raising US\$551 million via a secondary offering on the Bombay Stock Exchange to fund its acquisition of REpower. Exhibit 1.68 shows the growth in alternative and renewable energy investment in India over the past four years.

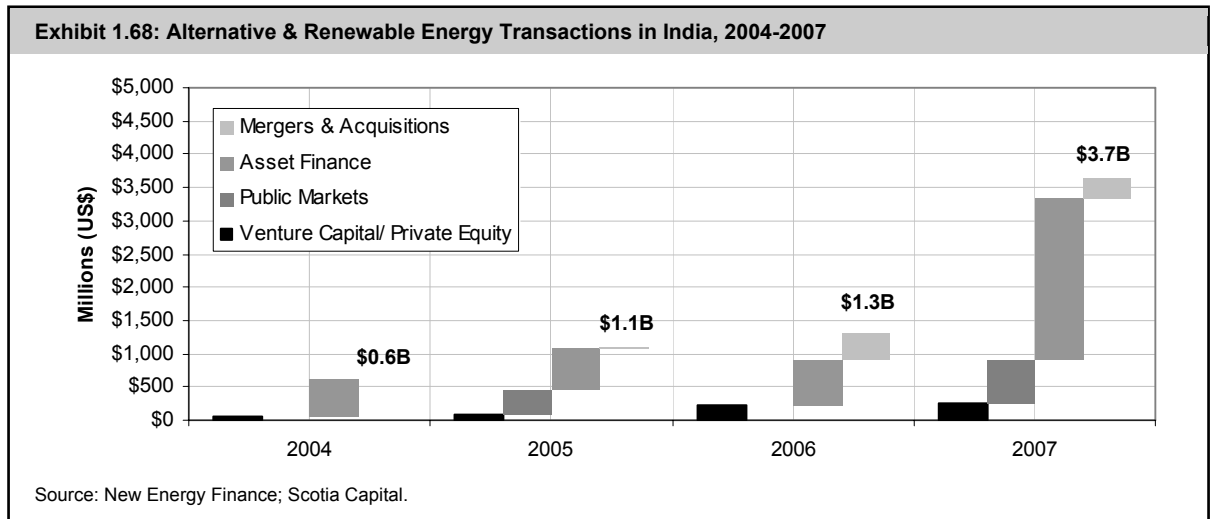

	2007 Capacity	2008 Target
Large Hydro	144,000 MW	-
Small Hydro	1,800 MW	2,900 MW
Wind	237 MW	1,637 MW
Solar PV	8.6 MW	-
Biomass	3,700 MW	4,600 MW
Geothermal	-	-
Tidal/Wave/OTEC	-	-

Source: Brazil Government; New Energy Finance; Scotia Capital.

Investment in Brazil Going Mainly to Large Hydro and Ethanol

Including large hydro, renewable fuel sources make up 84% of Brazil's power generation capacity, and 46% of its energy mix. However, despite Brazil's PROINFA program, which offers feed-in tariffs for wind, small hydro, and biomass, there seems to be a lack of investment interest in renewable power capacity other than large hydro. Exhibit 1.69 shows Brazil's 2008 renewable power targets.

US\$6.1 billion was spent on asset financing last year (up 40% year over year), mostly on biofuel plants with some towards small hydro. Only one wind financing deal took place in Brazil during 2007 for US\$69 million. Most venture capital and private equity dollars (US\$658 million) were directed towards ethanol expansion, as were M&A transactions. Australian wind developer Pacific Hydro acquired SES Ltda, for the only Brazilian wind deal of 2007. Exhibit 1.70 shows the growth in alternative and renewable energy investment in Brazil over the past four years.

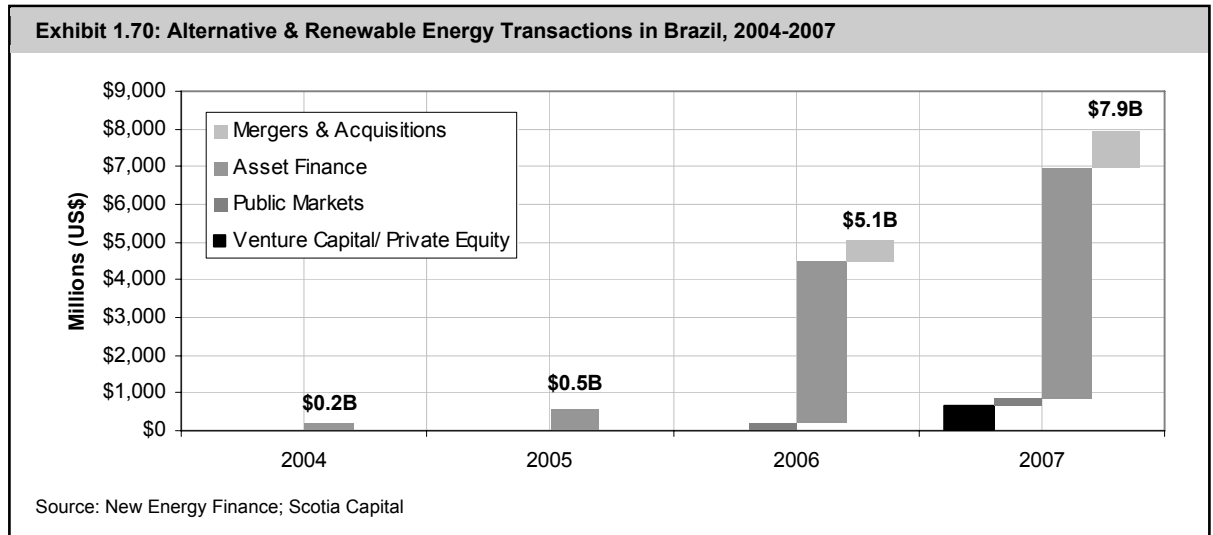

Russia Still Focused Heavily on Its Fossil Fuels

Russia's vast fossil fuel resources, coupled with its economy which has not grown as fast as its BRIC peers, has not yet forced the country to consider its alternative power generation options. Currently, there are 10 million Russians with no grid access. Russia's first wind project, the Kalmykia Wind Farm, recently completed construction of its first phase in early 2008. Dutch wind developer Windlife International plans to build a 200 MW facility near Murmansk by 2011.

Boralex Inc.

(BLX-T)

Aug 15, 2008:	\$14.80
Rating:	1-Sector Outperform
Risk:	High
IBES EPS 2008E	\$0.78
IBES EPS 2009E	\$0.89
Div. (Curr.):	\$0.00
Yield:	0.0%

1-Yr Target:	\$18.00
1-Yr ROR:	21.6%
2-Yr Target:	\$20.00
2-Yr ROR:	35.1%
Valuation:	75% DCF @ 10%; 25% NAV

Capitalization	
Shares O/S (M)	37.8
Total Value (\$M)	559.4
Float O/S (M)	19.1
Float Value (\$M)	282.1
TSX Weight	--

Qtly EPS (FD) (Next Release: Nov-08)

Y/E DECEMBER-31	Mar	Jun	Sep	Dec	Year	P/E
2007A	\$0.32A	\$0.15A	\$0.03A	\$0.15A	\$0.60	28.6x
2008E	\$0.24A	\$0.03A	\$0.08	\$0.16	\$0.51	28.8x
2009E	\$0.25	\$0.15	\$0.12	\$0.22	\$0.73	20.2x
2010E	\$0.27	\$0.18	\$0.10	\$0.24	\$0.79	18.6x

Industry Specific	2006A	2007A	2008	2009	2010
Production (GWh)	1,377	1,544	1,626	1,764	1,856

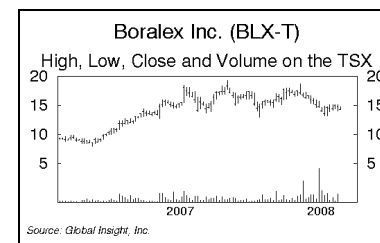

Note: Historical price multiple calculations use FYE price. Source: Reuters; company reports; Scotia Capital estimates.

A Lean, Green, Cash Flow Machine

INVESTMENT HIGHLIGHTS

- 1,000 MW by 2012 achievable.** In our minds, Boralex Inc.'s (Boralex) plan to nearly triple its capacity by 2012 from ~350 MW is not fully discounted in its share price. Its growth target is based on hydro growth in B.C., an entrance into the solar market, and new wind farm capacity in both Canada and Europe.
- A New England call option on natural gas.** Boralex's exposure to merchant power markets in the northeastern United States is high, as marginal power prices there are typically set by natural-gas-fired generators. We see natural gas prices rising over the long term.
- Upside potential.** Strong spot northeastern U.S. power prices, our long-term outlook for a tight Connecticut REC market, and easing diesel prices coupled with improving burn rates at its wood-residue facilities are the basis for our positive outlook.
- Stock catalysts.** We believe an extension of the U.S. Production Tax Credit will boost Boralex's share price, as will higher Renewable Energy Certificate (REC) prices and Boralex being awarded power purchase agreements (PPAs) from several renewable request for proposals (RFPs). Reducing its relative commodity price exposure should occur naturally through the addition of free-fuel wind and hydro assets.
- Relative valuation attractive.** While we don't rely on relative valuation metrics to set our target prices, on a forward P/E, EV/EBITDA, P/S, and P/CF basis, Boralex is trading at a material discount to both its peer group and its closest comparable company, Canadian Hydro Developers. In our opinion, this discount is unwarranted and presents investors with an attractive entry point into the name.
- We have transferred coverage of the common shares of Boralex Inc., raising our rating to 1-Sector Outperform.** We also increased our one-year target to \$18.00 per share, based on a 75%-weighted discounted cash flow approach, using a 10% discount rate, and a 25%-weighted net asset value calculation.

Summary & Investment Recommendation

Borex offers investors an opportunity to participate in one of the most well-diversified renewable power portfolios in North America. In addition to a strong capacity expansion plan expected over the next five years, we see material upside from several factors that we believe are not reflected in the current share price. Easing diesel costs, a reasonable likelihood of a U.S. Production Tax Credit renewal in 2009, coupled with our bullish long-term Connecticut REC market outlook, and northeastern U.S. power prices that should remain in the US\$90/MWh to US\$110/MWh range are several reasons why. Beyond that, we think that market uncertainty as to whether 34%-owner Cascades will need to sell Borex stock to avoid a potential cash crunch is for the most part unwarranted. Also, CO₂ allowance prices within the European Union's Emissions Trading Scheme remain 10% to 30% above our long-term forecast.

Major near-term stock catalysts for Borex include winning new renewable power PPAs in the Ontario RES III RFP, the BC Hydro Clean Power Call, two 250 MW Quebec wind RFPs, and the B.C. and Ontario standard offer programs. We also think the stock will move on announcements of new wind capacity development in France or Italy, a final decision to enter the solar power market in Spain or France, and the extension of the U.S. Production Tax Credit. While at least two to three years out, watch for a new transmission line announcement that would connect northern Maine into NEPOOL. If this were to occur, we think 68 MW of capacity could become REC-certified for the Connecticut market.

We have transferred coverage of the common shares of Borex. We rate the company a 1-Sector Outperform, with a High risk ranking and a one-year target of \$18 per share. Our target price is based on a 75% weighted discounted cash flow analysis at a 10% discount rate, and a 25% weighted net asset value per share.

FINANCIAL OUTLOOK

For 2008, we estimate EBITDA and fully diluted EPS of \$67.4 million and 51¢, respectively, slightly below consensus on both measures. Looking past 2008, we estimate EBITDA and fully diluted EPS of \$77.9 million and 73¢, respectively. Our 2009E production forecast increases by 8.5% year over year to 1,764.1 GWh. We estimate EBITDA per MWh will hit about \$44 in 2009, up from \$41 this year.

Exhibit 2.1: Borex Inc. – Relative Valuation Metrics											
Company	Ticker	Last Price 8/15/2008	SC Rating	1-Year Target	1-Year ROR	DCF	NAV	Market Cap (\$M)	Enterprise Value to EBITDA		
									2008E	2009E	2010E
Borex	BLX	\$14.80	1-SO	\$18.00	22%	\$18.33	\$17.03	\$560	9.9x	8.6x	7.6x
Canadian Hydro Developers	KHD	\$4.38	1-SO	\$7.00	60%	\$7.04	\$6.95	\$628	20.3x	9.9x	7.6x
Earthfirst Canada	EF	\$0.27	3-SU	\$0.40	48%	\$0.35	\$0.60	\$28	n.m.	-5.5x	-0.9x
Innergex Renewable Energy	INE	\$8.25	3-SU	\$9.50	15%	\$9.44	\$9.55	\$194	n.m.	18.4x	7.8x
Plutonic Power	PCC	\$7.04	2-SP	\$9.00	28%	\$9.03	\$8.75	\$297	n.m.	n.m.	n.m.
Average					35%			\$341	15.1x	7.8x	5.5x
Company	Ticker	Beta	Price to Earnings			Price to Sales			Price to Cash Flow		
			2008E	2009E	2010E	2008E	2009E	2010E	2008E	2009E	2010E
			(x)	(x)	(x)	(x)	(x)	(x)	(x)	(x)	(x)
Borex	BLX	0.7	28.8x	20.2x	18.6x	2.6x	2.5x	2.3x	10.4x	8.7x	7.7x
Canadian Hydro Developers	KHD	0.5	54.6x	23.4x	17.3x	7.2x	3.9x	3.1x	16.0x	9.0x	6.6x
Earthfirst Canada	EF	-	n.m.	n.m.	n.m.	n.m.	5.5x	0.9x	n.m.	n.m.	5.6x
Innergex Renewable Energy	INE	-	n.m.	n.m.	25.5x	27.5x	8.3x	4.2x	n.m.	33.6x	10.2x
Plutonic Power	PCC	0.9	n.m.	n.m.	n.m.	n.m.	n.m.	n.m.	n.m.	n.m.	n.m.
Average		0.7	41.7x	21.8x	20.5x	12.4x	5.1x	2.6x	13.2x	17.1x	7.5x

Source: Bloomberg; Scotia Capital estimates.

Capital Markets Profile

Since its 1982 incorporation, Boralex has grown into one of Canada’s pre-eminent independent power producers, with 350 MW (net) of renewable power capacity, as well as a 14 MW natural gas cogeneration facility. The company is well diversified, with hydro, wind, and wood-residue operations scattered throughout Quebec, New England, New York, and France. Boralex also manages various operating assets on behalf of Boralex Power Income Fund, of which it currently holds a 23% interest. In addition to traditional electricity sales, Boralex’s earnings are materially boosted by favourable renewable energy and climate change policies, such as the U.S. Production Tax Credit, and the sale of Renewable Energy Certificates. Please refer to Exhibit 2.41 at the end of this company section for a display of Boralex’s corporate structure.

Bernard Lemaire is the founder, visionary, and Executive Chairman of the board of Boralex. Mr. Lemaire’s son, Patrick, joined Boralex in 2006 as President and CEO. Prior to joining Boralex, Patrick Lemaire held the position of VP & COO at Containerboard of Norampac Inc. Mr. Jean-Francois Thibodeau, Boralex’s CFO since 2003, brings strong financial management experience to the team, having served as VP & Treasurer at CAE Inc. and as Treasurer for Transcontinental Group Ltd. Boralex’s management and directors collectively control 16.9% of the firm. Boralex employs over 300 people, with corporate offices in Kingsey Falls and Montreal, Quebec.

Cascades Inc. holds over 34% of Boralex; the Kernaghan family owns about 14%.

Boralex’s founder, Bernard Lemaire, is also co-founder and current Chairman of Cascades Inc., a Canadian-based paper and packaging company. Cascades currently owns 34.3% of Boralex, while Kernwood Ltd., a private investment company controlled by the Kernaghan family, owns 13.5% and Fidelity owns over 11%.

Boralex’s 37.8 million Class A shares trade on the Toronto Stock Exchange under the ticker symbol BLX. Exhibit 2.2 shows the stock’s historical trading range and volume. We believe the company’s policy of not paying dividends will continue and is in line with the firm’s strategy of funding future growth from earnings. Boralex’s institutional shareholder base is predominantly Canadian, with some holdings in both Europe and the United States. Boralex reports in Canadian dollars in accordance with Canadian Generally Accepted Accounting Principles (GAAP).

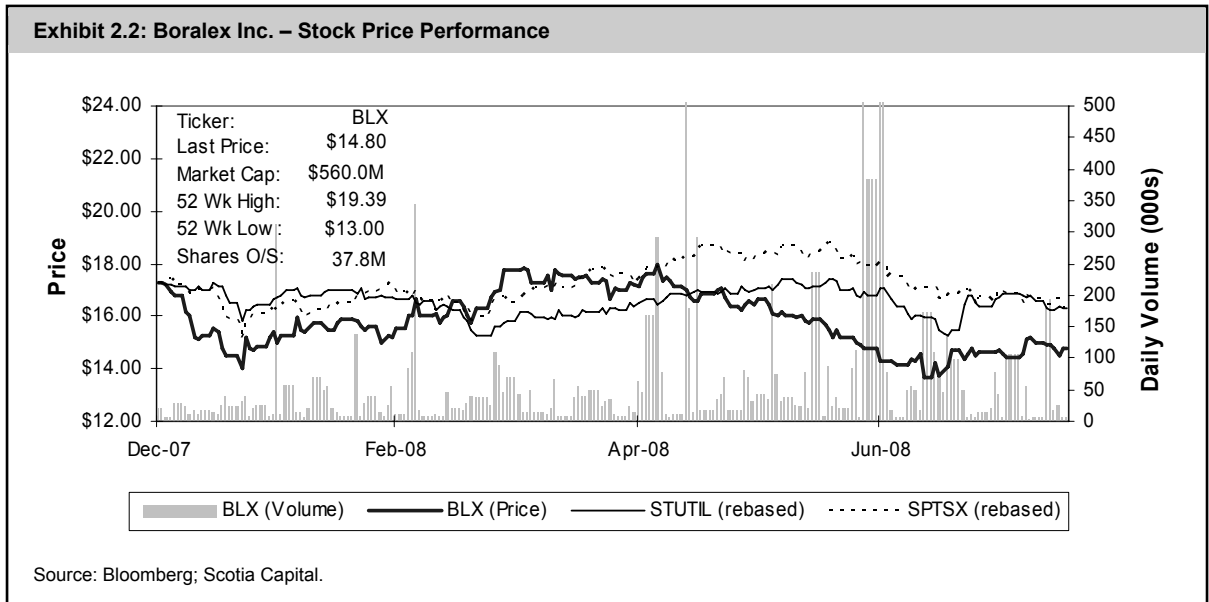

When Will Boralex Need New Equity?

Boralex could spend \$1.8 billion to \$2.1 billion on new capacity by 2012/13.

Unlike several companies within our coverage universe, **Boralex has a substantial operating asset base that generates strong annual free cash flow.** Its mid-term growth plan includes the installation of 600+ MW of new capacity, for a capital spend range between \$1.8 billion and \$2.1 billion. Typically, the company targets a debt to equity ratio of 80%/20% for its power projects, implying a **potential future equity need of up to \$400 million.**

For its current development plan, which includes Gengrowth (90 MW) and Seigneurie de Beupre (net 136 MW), Boralex will use its cash on hand as well as future free cash flow to finance the equity requirements. About 80% to 85% of cash expenditures for its Seigneurie de Beupre investment will not be spent before 2012 and 2013.

Beyond these two projects, we think that **Boralex could need \$90 million to \$110 million of new equity to complete its goal of 1,000 MW by 2012.** Exhibit 2.3 sensitizes our forecast Boralex future equity requirement to changes in (1) average cost per installed MW; and (2) total new installed capacity contracted by 2012, excluding its two development projects.

In mid-2007, Boralex closed a \$100 million bought deal that yielded \$105.6 million to the company, after a 10% overallotment was fully exercised and net of underwriter fees. The deal was priced at \$15 per share and was primarily used to reduce its revolving credit facility.

We think that Boralex could need \$90 million to \$110 million of new equity to complete its goal of 1,000 MW by 2012.

Exhibit 2.3: Boralex Could Require \$90M to \$110M of New Equity to Reach Its 1,000 MW Goal

		Weighted Average Capital Cost per Installed MW							
		\$2.70M	\$2.80M	\$2.90M	\$3.00M	\$3.10M	\$3.20M	\$3.30M	
New Installed Capacity	Excluding current development projects Gengrowth (90 MW) and Seigneurie de Beupre (136 MW).	150 MW	\$0M	\$0M	\$0M	\$0M	\$0M	\$0M	\$0M
		175 MW	\$0M	\$0M	\$0M	\$0M	\$0M	\$0M	\$0M
		200 MW	\$0M	\$0M	\$0M	\$0M	\$0M	\$0M	\$0M
		225 MW	\$0M	\$0M	\$0M	\$0M	\$0M	\$0M	\$0M
		250 MW	\$0M	\$0M	\$0M	\$0M	\$0M	\$5M	\$10M
		275 MW	\$0M	\$0M	\$5M	\$10M	\$16M	\$21M	\$27M
		300 MW	\$7M	\$13M	\$19M	\$25M	\$31M	\$37M	\$43M
		325 MW	\$20M	\$27M	\$34M	\$40M	\$47M	\$53M	\$60M
		350 MW	\$34M	\$41M	\$48M	\$55M	\$62M	\$69M	\$76M
		375 MW	\$47M	\$55M	\$63M	\$70M	\$78M	\$85M	\$93M
		400 MW	\$61M	\$69M	\$77M	\$85M	\$93M	\$101M	\$109M
		425 MW	\$75M	\$83M	\$92M	\$100M	\$109M	\$117M	\$126M
		450 MW	\$88M	\$97M	\$106M	\$115M	\$124M	\$133M	\$142M
		475 MW	\$102M	\$111M	\$121M	\$130M	\$140M	\$149M	\$159M
	500 MW	\$115M	\$125M	\$135M	\$145M	\$155M	\$165M	\$175M	
	525 MW	\$129M	\$139M	\$150M	\$160M	\$171M	\$181M	\$192M	
	550 MW	\$142M	\$153M	\$164M	\$175M	\$186M	\$197M	\$208M	

Source: Scotia Capital estimates.

We Like Boralex’s Geographic, Technology, and Seasonal Diversification

Unlike some of its peers, Boralex is well diversified by fuel source and geographic region.

Boralex is well diversified. Unlike some of its renewable peers such as Plutonic Power and EarthFirst that currently target one source of renewable power generation, **Boralex is active in three types of renewable electricity generation** – hydro, wind, and wood-residue. Boralex is also nicely spread among geographic regions such as Quebec, New England, New York, and France. Exhibit 2.4 shows Boralex’s 2007 capacity, generation, and EBITDA profile by fuel source, quarter, and region.

Power stations that are subject to long-term fixed price contracts are seasonally impacted by generation volume fluctuations only. Facilities that sell power on the open market are seasonally impacted by both

Exhibit 2.4: Boralex Is Well Diversified

	Technology Diversification			
	Hydro	Wind	Wood-residue	Co-gen
MW	7.4%	32.2%	56.1%	4.3%
MWh	6.9%	13.5%	77.1%	2.5%
EBITDA	8.5%	35.9%	52.0%	3.6%

	Seasonal Diversification			
	Q1	Q2	Q3	Q4
MWh	29.7%	21.2%	24.2%	24.9%
EBITDA	43.2%	10.4%	15.2%	31.2%

	Geographic Diversification		
	USA	Canada	France
MWh	83.1%	0.9%	16.0%
EBITDA ¹	62.0%	-3.3%	41.3%
Assets	35.2%	22.8%	42.0%

1. EBITDA in Canada of -3.3% includes corporate costs.

Source: Company reports.

volume and price fluctuations. **In the northeastern United States, electricity demand peaks in winter and summer periods**, typically resulting in higher NEPOOL open market prices in Q1 and Q3. This allows Boralex to increase its wood-residue generation during these periods and leave regular maintenance for Q2 and/or Q4. Conversely, hydrology conditions at its New York and Quebec hydro facilities are better in Q2 and Q4 as water flow tends to decrease in the summer and winter seasons. In France, wind conditions are much stronger in Q1 and Q4 that lead to stronger capacity factors over other quarters, although a higher risk exists of lower availability caused by unfavourable weather conditions such as icing.

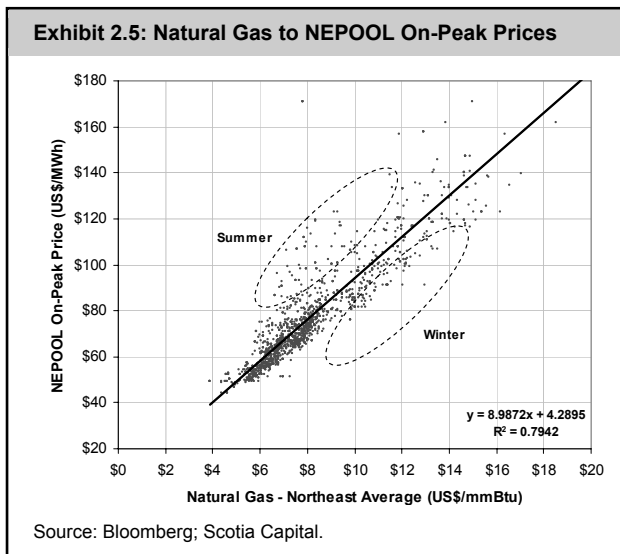

HIGHER CONTRACTED PRODUCTION = GREATER EARNINGS STABILITY

Boralex continues to increase its proportional share of long-term contracted production capacity versus merchant production. Currently, 15 facilities are under fixed-price contracts, while six facilities earn revenues from spot or day-ahead power markets. In our opinion, reduced volatility associated with stable, predictable, and certain power prices deserves a slight premium over spot and/or day-ahead power market unpredictability. Exhibit 2.5 shows the strong relationship between local natural gas and spot on-peak power prices, while Exhibit 2.6 forecasts future on-peak NEPOOL spot prices based on the current natural gas forward curve.

We think average NEPOOL and New York on-peak power prices will stay within a US\$90 to US\$110/MWh range through 2010.

Exhibit 2.6: On-Peak NEPOOL Power Prices Should Stay Around US\$100/MWh Through 2010

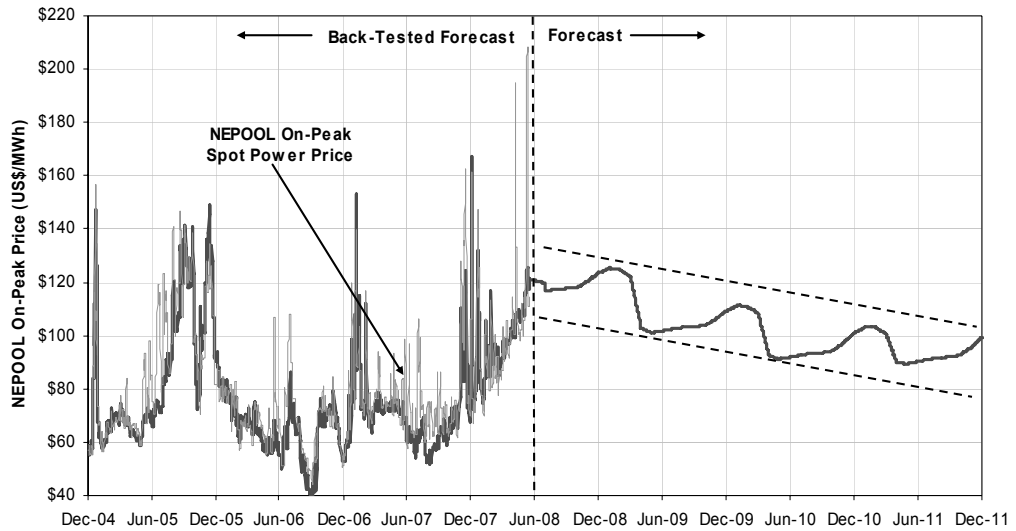

Source: Bloomberg; Scotia Capital.

BALANCE SHEET STRENGTH SUPPORTED BY RELATIVELY LOW DEBT

Boralex maintains a healthy balance sheet. In our opinion, liquidity is not a concern for Boralex due to (1) annual cash flow from operations generation of about \$50 million to \$60 million per year; (2) close to \$80 million of cash (and equivalents) on hand; (3) a current ratio of 2.4x; and (4) significant room in its debt facilities. Long-term debt continues to decline relative to total capital invested (now 33%), although we believe that the company’s debt to equity ratio will likely increase at a 4:1 ratio with the addition of new projects.

Undrawn debt facilities could support a further 125 MW of wind capacity in France.

In mid 2007, Boralex refinanced a €265 million (~\$380 million) master financing agreement for the development, until 2010, of wind power projects in France. **About €170 million remains undrawn, and could support a further 125 MW of capacity growth.** In our opinion, the master financing agreement could be extended beyond 2010 and beyond France to Italy if Boralex decides to develop wind farm projects there.

Production Profile & Outlook

HYDRO

Boralex owns and operates nine hydro facilities located in B.C., Quebec, France, and New York State, for a total installed capacity of 40.7 MW (net 39.1 MW including 14.5 MW for Ocean Falls), representing 9% of its production portfolio. Going forward, we forecast annual generation of about 116 GWh from these facilities, and 119.2 GWh for 2008 due to above-average water flow in Q1/08 (Exhibit 2.7). Boralex's

Hydro represents 9% of Boralex's production portfolio. Going forward, we forecast annual generation of about 116 GWh/y.

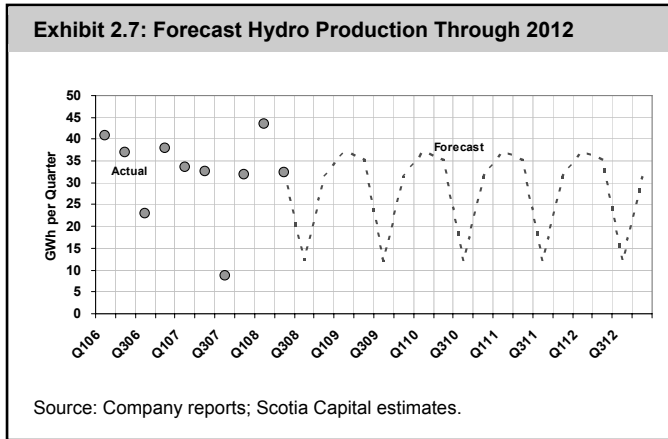

50%-owned, 1 MW La Rochette facility in France sells its electricity production under a 15-year contract with Electricite de France (EDF). In Quebec, two hydro facilities, East Angus (2.2 MW) and Huntingville (0.3 MW), produce a total of 16,000 MWh per year both under long-term (20-year and 25-year) contracts. The remaining five hydro facilities, all in New York State, sell power on the open market, with the exception of Middle Falls (2.3 MW), which supplies its electricity under a 40-year contract. Boralex's stated capacity factor for this segment is 50.5%.

On June 11, 2008, Boralex announced the purchase of a 14.5 MW hydro facility in B.C., marking the company's entrance into one of the most important renewable power markets in North America. The facility currently generates 1.5 MW of power that is sold to a local community, as the mill that originally required the facility's full power was shut down in the 1970s. We note that there is enough water flow to support an eventual expansion to about 37 MW. As part of the acquisition, Boralex also obtained the rights to two hydro development projects in B.C., with a combined potential capacity of 10 MW.

WIND

All 108 MW (net 106.8 MW) of Boralex's installed wind capacity is located in France under 15-year Electricite de France (EDF) contracts. This should change by 2H/09 when the 40 MW first phase of its 90 MW Gengrowth wind farm is commissioned in Ontario. The remaining 50 MW of the project are due online no later than the end of 2010, while its (operational) entrance into the Quebec wind market will not be until 2013. For 2008 and 2009, respectively, we forecast 243 GWh and 289.7 GWh of wind-based

We expect Boralex to receive an average contract price of €85/MWh at its French wind farms in 2009.

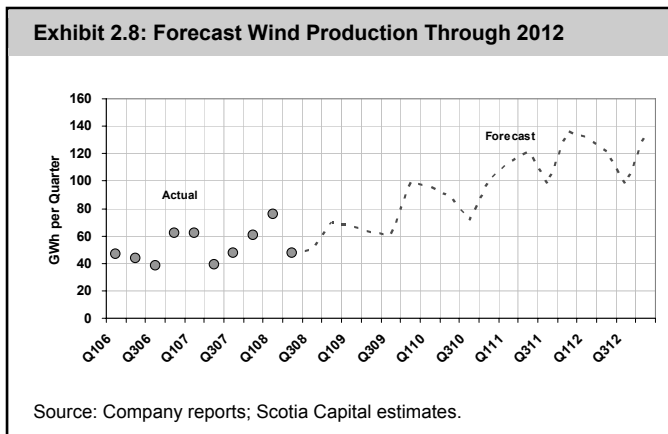

power production, or 15% and 17% of its annual production profile (Exhibit 2.8). We expect Boralex will receive an average 2009 contract price for its French wind farms of €85/MWh, increasing annually at 1.8%. We believe that Boralex will continue to focus much of its growth attention on this market, as contract prices are 10% greater than under Ontario's Standard Offer Program of \$110/MWh (plus \$5/MWh for 10 years under the \$10/MWh ecoENERGY program that is typically split 50:50 with the OPA program).

WOOD-RESIDUE

The core of Boralex's business is its northeastern U.S. wood-residue power stations, which have a total installed capacity of 204 MW and produce about 1,300 GWh/y, or at a 72.7% implied capacity factor. We forecast annual production of 1,224.7 GWh and 1,296 GWh in 2008 and 2009 due to the recent restart of its 18 MW Stacyville facility as well as better-than-expected production in Q1/08. Exhibit 2.9 shows our forecast seasonality chart for Boralex's wood-residue segment, which is much less seasonal than its other segments. As electricity consumption typically decreases in the spring and fall (and all else equal – spot power prices too), Boralex typically performs its routine maintenance during these periods of lower expected margins.

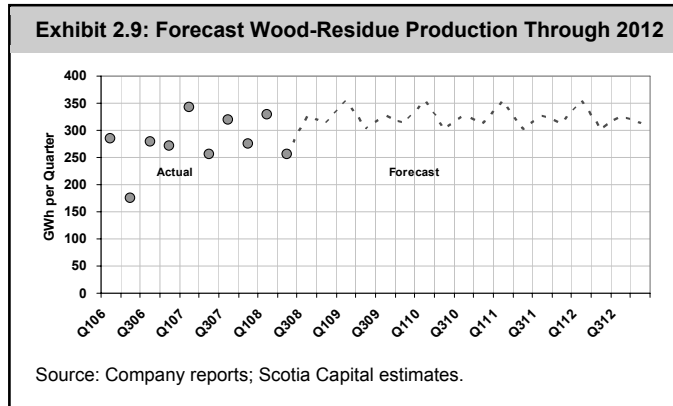

Wood-residue costs, the primary source of fuel for these plants, have risen significantly over the past few years due to higher transportation costs (mainly diesel) as well as Boralex's decision to use a better-quality wood-residue to ensure continued REC compliance. As a partial offset, Boralex has implemented various strategies that range from improving burn-rates at some facilities to the introduction of storage facilities in anticipation of seasonal spikes in wood-residue costs.

At a 35% humidity level, Boralex uses 1.65 tons of wood-residue per MWh. About 85% of Boralex's wood-residue supply is sourced from whole tree chips (30%-35% humidity), while most of the remainder comes from less expensive mill residue (25%-35% humidity). **Our operating cost per MWh assumes 25% fixed costs and 75% wood-residue costs.** Of the wood-residue costs, about 75% is attributable to transportation, while the remainder is the direct material cost. Depending on the season, Boralex keeps about 60 to 90 days of wood-residue inventory on hand. **Inventory typically peaks at the start of the year** when there is limited access to wood-residue due to local areas being covered by snow.

Boralex can earn up to US\$55 per REC (or MWh) in addition to the power price it receives.

On the back of soaring fuel costs, the historical saving grace for Boralex's wood-residue segment has been its ability to earn revenue in the Connecticut REC market. Boralex can earn up to the equivalent of US\$55/MWh from its REC-certified facilities. Historically, Boralex has sold about 75% of its expected RECs forward to hedge against new REC-qualified capacity that may come online in the region that would reduce REC prices. Additionally, its Chateaugay facility is qualified for the New York REC market, which has a 10-year agreement with the state that we believe is somewhat unique. The arrangement provides Boralex with a payment if open market power prices are not high enough to provide the facility with an ample return. Effectively, this program ensures a Chateaugay floor power price of about US\$75/MWh.

NATURAL GAS COGENERATION

Boralex operates a 14 MW natural-gas-based cogeneration plant in France with a material challenge: rising fuel costs with a cap on power prices during half of the year. Over the past several years, its Blendecques facility has shut down during April through October as its contract electricity prices are capped during this high-demand period, while the plant's natural gas costs are not capped and continue to rise. We believe that Boralex will likely continue this practice of operating only when it is profitable to

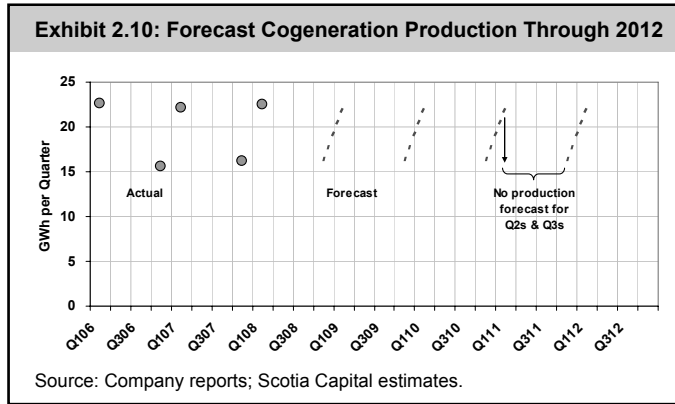

do so, and accordingly, we expect the facility to produce only 38.7 GWh of electricity per year, out of a 122 GWh/y of theoretical output. Exhibit 2.10 shows our forecast seasonality chart for Boralex's cogeneration facility. Steam is also produced at this plant, with an annual output of 528 million pounds per year. But, as the plant is shut down for more than half a year, Boralex is required to operate an auxiliary boiler from April through October to meet its customer contract requirements.

Boralex's Blendecques facility does not operate for seven months per year due to seasonally higher natural gas costs coupled with an electricity price cap during the summer.

Like a majority of European fossil fuel power producers, Boralex's Blendecques plant is allocated an annual allowance of CO₂ emissions permits under the EU Emissions Trading Scheme (ETS). As the facility does not run for about seven months per year, it is able to sell its excess permits for incremental EBITDA. At the start of 2008, and in accordance with the EU's Kyoto Protocol commitment, **CO₂ allowances were scaled back**, resulting in higher CO₂ prices to date due to lower supply and higher demand. However, for the Blendecques facility, lower sales volume will likely more than offset these higher prices.

In Exhibit 2.11, we have forecast EBITDA per MWh per business segment. Clearly, Boralex's EBITDA margin on its wind power business is far superior to its other segments. In our view, this is precisely why Boralex is seeking more new wind capacity than any other renewable power technology. **Our forecast below includes all incentives such as RECs, excess CO₂ quota sales, forward capacity premiums, the U.S. Production Tax Credit, and green credits.** Also, we use a par CAD/USD FX rate as well as a long-term CAD/EUR FX rate of \$1.50.

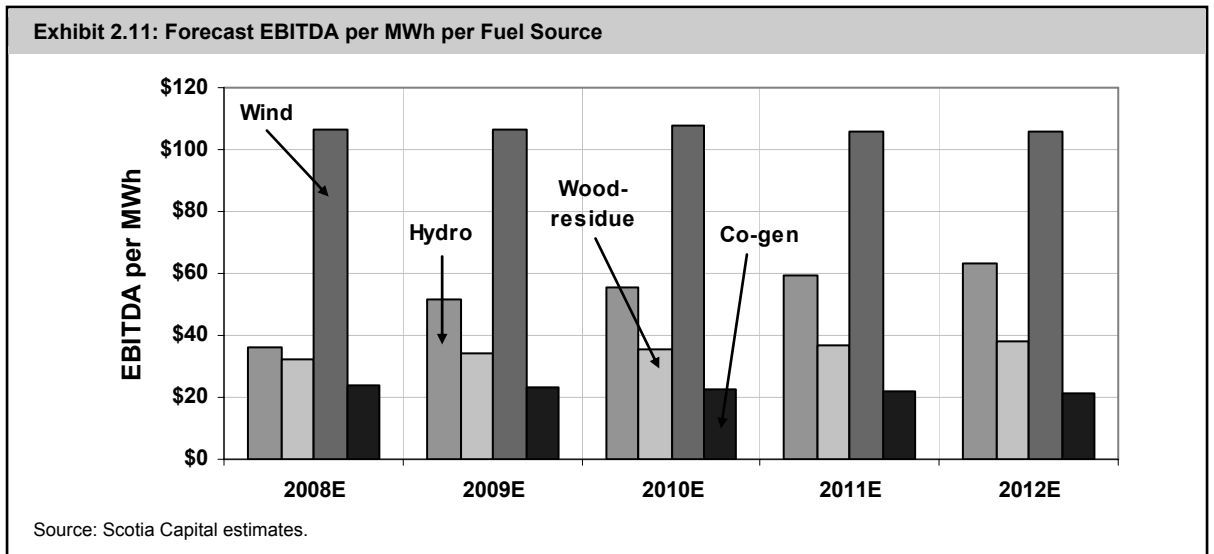

Exhibit 2.12 summarizes Boralex's operating facilities as well as its announced development projects.

Exhibit 2.12: Boralex's Portfolio of Assets and Development Prospects							
Project/Site	Location	Net Cap.	Est. Pdn	Capacity Factor	Power Purchaser	PPA Expiry	Status / Est. Cost
		(MW)	(GWh/y)	(%)			(\$M)
Hydro							
East Angus	Quebec	1.1	3.8	38.9%	Hydro-Quebec	2012	Online
Huntingville	Quebec	0.3	1.0	38.1%	Hydro-Quebec	2020	Online
La Rochette	France	0.5	1.5	34.2%	EDF	2013	Online
Fourth Branch	New York	3.1	14.0	51.6%	NYISO	-	Online
Middle Falls	New York	2.3	10.2	50.6%	Niagara	2027	Online
NY State Dam	New York	11.4	48.4	48.5%	NYISO	-	Online
Sissonville	New York	3.0	13.3	50.6%	NYISO	-	Online
Warrensburg	New York	2.9	10.9	42.9%	NYISO	-	Online
Ocean Falls	BC	14.5	13.0	10.2%	BC Hydro	-	Online
BC Prospects	BC	10.0	39.4	45.0%	-	-	\$30
		49.1	155.4				
Wood-Residue							
Ashland	Maine	40.0	251.0	71.6%	Integrlys	2009	Online
Chateaugay	New York	20.0	133.0	75.9%	NYISO	-	Online
Fort Fairfield	Maine	36.0	237.0	75.2%	Integrlys	2009	Online
Livermore Falls	Maine	40.0	220.0	62.8%	ISONE	-	Online
Stacyville	Maine	18.0	125.0	79.3%	ISONE	-	Online
Stratton	Maine	50.0	330.0	75.3%	ISONE	-	Online
		204.0	1,296.0				
Wind							
Avignonet-Lauragais I	France	8.0	18.4	26.3%	EDF	2016	Online
Avignonet-Lauragais II	France	5.0	11.5	26.3%	EDF	2023	Online
Chepy	France	3.4	6.0	20.0%	EDF	2017	Online
Nibas	France	11.4	20.9	20.9%	EDF	2018	Online
Ally-Mercoeur	France	39.0	78.1	22.9%	EDF	2019	Online
Cham de Cham Longe	France	18.0	59.9	38.0%	EDF	2019	Online
Plouguin	France	8.0	22.0	31.4%	EDF	2019	Online
La Citadelle	France	14.0	33.0	26.9%	EDF	2022	Online
Seigneurie de Beupre	Quebec	136.0	428.9	~36.0%	Hydro-Quebec	2032	\$400
Gengrowth I	Ontario	40.0	105.1	~30.0%	OPA	2029	\$100
Gengrowth II	Ontario	50.0	131.4	~30.0%	OPA	2030	\$125
Gengrowth III	Ontario	100.0	262.8	~30.0%	-	-	\$250
		432.8	1,178.0				
Cogeneration							
Blendecques	France	14.0	90.0	73.4%	EDF	2013	Online
		14.0	90.0				

Source: Company reports; Scotia Capital estimates.

Getting to 1,000 MW by 2012

Borex has targeted 1,000 MW of total contracted capacity by 2012, or a 30% annual capacity growth rate from its current 363.9 MW, which we believe is achievable. To reach this capacity, Borex is focused on the following growth initiatives (Exhibit 2.13):

We believe Borex will bid 50 MW to 100 MW of wind projects into Quebec's two 250 MW wind RFPs.

Exhibit 2.13: Getting to 1,000 MW by 2012

Fuel Source	Region	Target (net MW)	Notes
Installed		364	
Advanced Development			
Wind	Quebec	136	PPAs secured
Wind	Ontario (Gengrowth I & II)	90	Under construction
Our Best Guess			
Wind	Ontario (Gengrowth III)	100	Recently acquired
Wind	Quebec	100	Via two 250 MW RFPs
Wind	France	50	75 MW being studied
Wind	Italy	50	Being studied
Hydro	B.C.	150	
Solar	Spain or France	35	Being studied
		1,075	

Source: Scotia Capital estimates.

Wind (Quebec). In May 2008, Borex was awarded two (of three bid) Hydro-Quebec wind power PPAs for a total of 272 MW (net 136 MW). The 20-year PPAs offer an average price of \$87/MWh for wind energy plus an additional \$18/MWh for transmission and balancing. **We believe that Borex will bid 50 MW to 100 MW of wind projects (likely a reworked version of its Seigneurie de Beupre Phase I) into Quebec's two 250 MW wind RFPs** (i.e., Municipal and First Nations). PPAs for both these RFPs are offered at a fixed energy price of \$95/MWh (in 2008 dollars with an annual inflation adjustment).

Wind (France). Under its €265 million (~\$400 million) master financing agreement that was completed in June 2007, Borex could add a further 100 MW to 150 MW in France by 2012. **In our opinion, Borex will aim to install 50 MW of new wind capacity in France prior to the 2010 expiration of its Master Financing Agreement.**

In Italy, we see no more than 50 MW of installed wind capacity by Borex over the next five years. Social acceptance of wind turbines there is low.

Wind (Italy). Borex continues to investigate wind power opportunities in Italy where the aggregate price of power, green attributes, and government incentives could be in the €180/MWh area. Social acceptance of wind turbines in Italy is materially lower than in other European countries such as Spain and Germany. At best, we see no more than 50 MW (numerous small projects) of installed wind capacity by Borex in Italy over the next five years.

Gengrowth acquisition. In mid-2007, Borex acquired from Gengrowth the rights to 90 MW of wind farms to be located in the Windsor, Ontario, region. The acquisition of the nine 10 MW projects each included signed \$110/MWh Ontario Standard Offer Program contracts. **Borex expects 40 MW to be installed by Q2/09, with the remainder to be commissioned in 2009/10.** A further 100 MW of Ontario wind prospects were purchased by Borex from Gengrowth in July 2008, and will likely be entered into the 500 MW Ontario Power Authority RES III RFP.

B.C. run-of-river. Borex has targeted 100 MW to 150 MW of B.C. run-of-river power within the next several years. We believe that Borex will acquire the rights from local developers directly rather than invest the lengthy time required to conduct its own hydrology studies.

Spanish solar developer acquisition. In 2007, Borex paid \$1.5 million for the 50% acquisition of a local solar power developer in Spain. Spain currently offers a 25-year standard offer solar power PPA at €420/MWh (~\$630/MWh). While these contracts expire in September, new tariff rates will drop to the €250/MWh to €280/MWh range, in line with Ontario's \$420/MWh offer, or ~€280/MWh. **Borex aims to have about 35 MW of Spanish (or French) solar power generation in service within five years.** We expect an initial 5 MW to 10 MW of solar power to be contracted by the end of 2009.

We're Bullish on Connecticut's REC Market

In addition to its Stratton facility, Boralex recently qualified two wood-residue facilities into the Connecticut Class I REC market, which we believe will generate about US\$20 million to US\$22 million per year of EBITDA over the next several years, provided the REC market becomes tight again. Boralex is likely the largest provider of RECs into the Connecticut market.

Connecticut has one of the most demanding renewable portfolio standards in the United States, which, by 2020, requires a minimum of 20% of the state's electricity supply to come from traditional "Class I" renewable technologies. The state's RPS requirement currently calls for 5% traditional renewable generation that escalates by 1% to 1.5% (Exhibit 2.14). Class I renewable sources include solar, wind, biomass, landfill gas, fuel cells, ocean thermal power, wave or tidal power, and various conservation technologies/programs.

Exhibit 2.14: Connecticut Seeks 20% Renewable Power by 2020

Start Date	Class I	Class I or II	Class III	Total
01-Jan-06	2.0%	3.0%		5.0%
01-Jan-07	3.5%	3.0%	1.0%	7.5%
01-Jan-08	5.0%	3.0%	2.0%	10.0%
01-Jan-09	6.0%	3.0%	3.0%	12.0%
01-Jan-10	7.0%	3.0%	4.0%	14.0%
01-Jan-11	8.0%	3.0%	4.0%	15.0%
01-Jan-12	9.0%	3.0%	4.0%	16.0%
01-Jan-13	10.0%	3.0%	4.0%	17.0%
01-Jan-14	11.0%	3.0%	4.0%	18.0%
01-Jan-15	12.5%	3.0%	4.0%	19.5%
01-Jan-16	14.0%	3.0%	4.0%	21.0%
01-Jan-17	15.5%	3.0%	4.0%	22.5%
01-Jan-18	17.0%	3.0%	4.0%	24.0%
01-Jan-19	18.5%	3.0%	4.0%	25.5%
01-Jan-20	20.0%	3.0%	4.0%	27.0%

Class I: solar, wind, fuel cells, methane gas from landfills, biomass after 1998, ocean, wave or tidal power, run-of-river less than 5 MW beginning after July 1, 2003, low emission advanced renewable energy conversion technologies

Class II: trash-to-energy, run-of-river less than 5 MW and prior to July 1, 2003, and biomass before 1998.

Class III: combined heat and power systems with an operating efficiency greater than 50%

Source: Company reports; Scotia Capital estimates.

Power marketers may satisfy the state's requirements by either ensuring that the source of electricity meets the RPS requirements or by purchasing the green attributes (i.e., RECs) of renewable power. If the RPS is not satisfied, a non-compliance penalty of US\$55/MWh is charged for all power that falls short of the 5% RPS, effectively creating an artificial price cap for RECs at US\$55/MWh.

While there is no escalation rate to the US\$55/MWh penalty, the Connecticut Department for Utility Control (CT DPUB) reviews the Alternative Compliance Payment (ACP) every two years. Neighbouring REC markets that operate somewhat similar programs have penalty payments that are indexed to inflation, and are currently in the US\$57/MWh area. **We expect that CT DPUB will amend its ACP**

to include an annual inflation adjustment that results in near identical penalty prices. Why: In the long term, new wind power will likely be built to be REC-qualified in all northeastern U.S. states, allowing for a wind producer to sell its RECs in the highest-paying market at that moment, even if the difference is merely 1¢.

BORALEX IS LIKELY FINISHED REC-QUALIFYING FACILITIES, FOR NOW

We believe that Boralex will not qualify any additional capacity (i.e., Fort Fairfield or remaining Ashland capacity) into the CT Class I REC market unless a transmission line that Boralex can access is constructed from northern Maine into NEPOOL.

For those plants that are located in northern Maine and outside of NEPOOL, Boralex must wheel its power through New Brunswick and then into the NEPOOL market in order for those facilities to earn CT Class I RECs. **However, there's a catch.** The current agreement that Boralex has with New Brunswick allows for only 26 MW of power to be wheeled through the province and into the NEPOOL market. To increase its transmission capacity to 76 MW (i.e., Ashland + Fort Fairfield) would not provide an ample return to Boralex, as the wheeling cost is likely too high.

We believe that Boralex will not qualify any additional capacity into the Connecticut REC market for the next several years.

CONNECTICUT REC PRICES SHOULD REMAIN STRONG, BUT EXPECT VOLATILITY

By 2020, northeastern RPS demand for RECs could hit 30 million, or 6x higher than 2007 REC demand.

We believe that at least 800+ MW of new wind capacity (at a greater than 30% capacity factor) would have to come online each year in the northeastern U.S. power markets just to keep REC prices constant. By 2020, northeastern U.S. RPS annual demand for RECs could hit 30 million, or six times higher than 2007 REC demand of about 5 million (Exhibit 2.15). While there is not a lot of wind in New England, there are better wind power opportunities in New York, New Brunswick, and Quebec, or one wheel away. In addition to the possibility that state legislation can effectively change at any time, one small risk exists that about 100 MW of biomass (not owned by Boralex) could become REC-certified at any time, possibly putting temporary downward pressure on REC pricing.

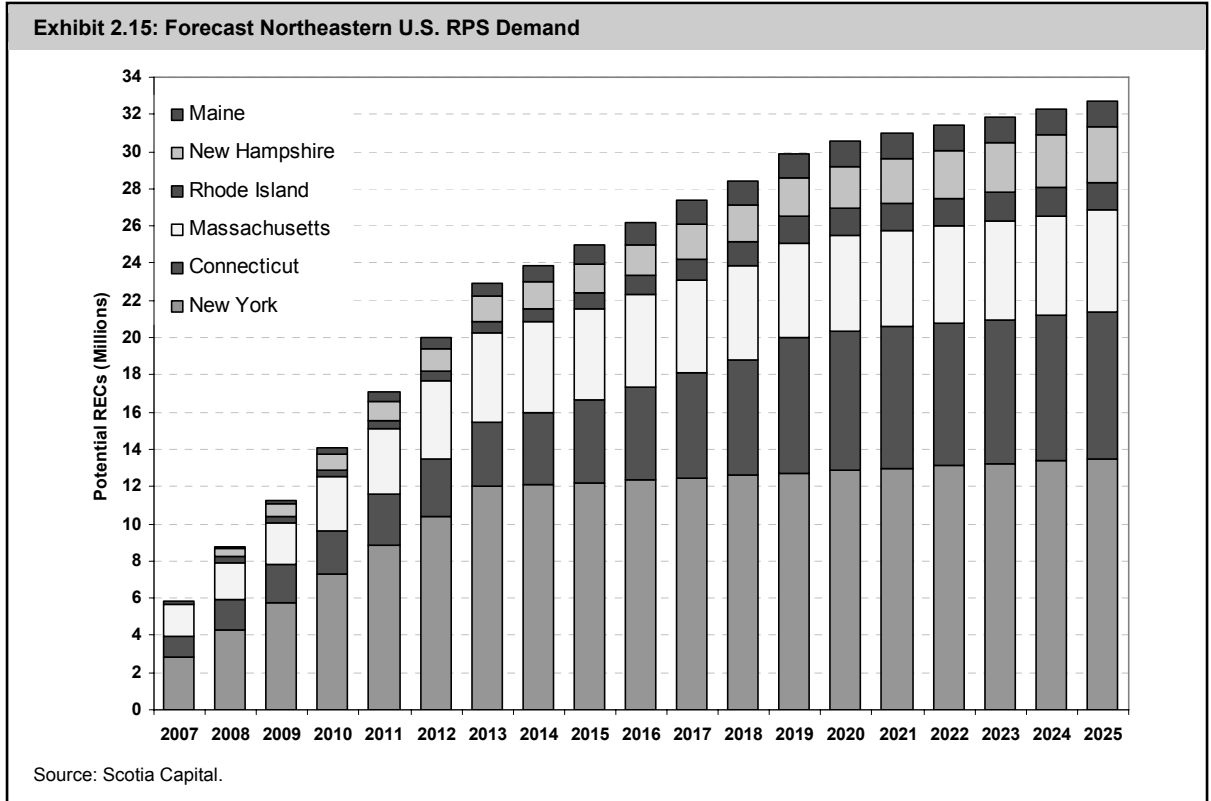

RECENT REC CERTIFICATION OF LIVERMORE FALLS IS WORTH \$1.35 PER SHARE

We believe the net present value of after-tax incremental REC-based earnings from Livermore Falls through to 2020 is worth \$1.35 per share. We do not consider potential REC value beyond 2020, as Connecticut’s current RPS expires by then. We assume a starting REC price of US\$48/MWh, in line with recent forward REC sales in the Connecticut market, and added US\$1/MWh per year through to 2020. Other assumptions include: (1) a par FX rate; (2) a 63% average capacity factor that is quite conservative compared to most wood-residue facilities; and (3) a 10% discount rate. Exhibit 2.16 outlines a sensitivity analysis of our REC value model.

Exhibit 2.16: Incremental BLX Value for New CT Class I REC Installed Capacity

	Discount Rate						
	13%	12%	11%	10%	9%	8%	7%
0	\$0.00	\$0.00	\$0.00	\$0.00	\$0.00	\$0.00	\$0.00
10	\$0.30	\$0.31	\$0.32	\$0.34	\$0.35	\$0.37	\$0.39
20	\$0.59	\$0.62	\$0.64	\$0.67	\$0.70	\$0.74	\$0.77
30	\$0.89	\$0.93	\$0.97	\$1.01	\$1.06	\$1.10	\$1.16
40	\$1.19	\$1.24	\$1.29	\$1.35	\$1.41	\$1.47	\$1.54
50	\$1.49	\$1.55	\$1.61	\$1.68	\$1.76	\$1.84	\$1.93
60	\$1.78	\$1.86	\$1.93	\$2.02	\$2.11	\$2.21	\$2.32
70	\$2.08	\$2.17	\$2.26	\$2.36	\$2.46	\$2.58	\$2.70
80	\$2.38	\$2.48	\$2.58	\$2.69	\$2.81	\$2.94	\$3.09
90	\$2.68	\$2.78	\$2.90	\$3.03	\$3.17	\$3.31	\$3.47
100	\$2.97	\$3.09	\$3.22	\$3.36	\$3.52	\$3.68	\$3.86

Source: Scotia Capital estimates.

NEW YORK REC ARRANGEMENT PROVIDES OPERATIONAL SECURITY

Boralex's 20 MW Chateaugay wood-residue facility qualified for the New York State REC market in early 2006. Boralex subsequently signed a 10-year contract to sell those RECs to the New York State government that will expire in mid-2016. The power station receives REC payments when open market power prices fall below a benchmark level, effectively guaranteeing a minimum return to the facility under a normal operating environment. In our opinion, Boralex's New York REC "hedge" locks in a minimum 2008 power price of US\$75/MWh for the Chateaugay facility.

A Small Hedge to High French Natural Gas Costs

Boralex’s 14 MW cogeneration plant in France typically shuts down during April to October as natural gas costs peak from high summer cooling demand, while its contract electricity prices are capped at a price that makes operating the facility uneconomical. Due to the plant being offline for about seven months per year, the Blendecques facility has significant excess carbon emission allowances that it can sell to those European CO₂ emitting companies that require them. **Excess CO₂ quota sales are free of operating costs, and go directly to EBITDA.**

EU ETS PHASE II (2008 – 2012) = REDUCED ALLOWANCES

Beginning January 2008, and as expected, the EU Emissions Trading Scheme (ETS) reduced its annual emissions cap to 1,859 million tonnes CO₂/y through 2012. This event resulted in two implications to the Blendecques facility’s ability to earn cost-free EBITDA from the sale of its excess CO₂

quota. First, the reduced volume of allowances will result in lower sales revenue to Boralex. Second, and partially offsetting, the reduced allowances available across the entire program have resulted in an average price increase of over 30%.

Assuming a long-term price of €20/tonne CO₂, and an unchanged annual operating cycle, we estimate that the sale of Blendecques’ CO₂ excess quota (EUA) will result in annual EBITDA of approximately \$1 million to \$1.3 million per year.

During the first phase of the EU ETS (i.e., the Trial Period), EUA prices crashed as some countries had emissions caps that were greater than what was actually emitted (Exhibit 2.17).

The second phase of the EU ETS (i.e., the Compliance Period) has an emission cap that is about 10% lower than under the first phase. In particular, France’s cap is 15% lower than it was under the Trial Period. As a result of the reduced cap, **we expect prices to remain above €20/tonne CO₂ through 2012** (Exhibit 2.18).

During the Trial Period, the EU ETS failed as some countries had emissions caps that were greater than what was actually emitted.

The Compliance Period of the EU ETS to date has been a success, with carbon emissions priced at about \$35/tonne CO₂.

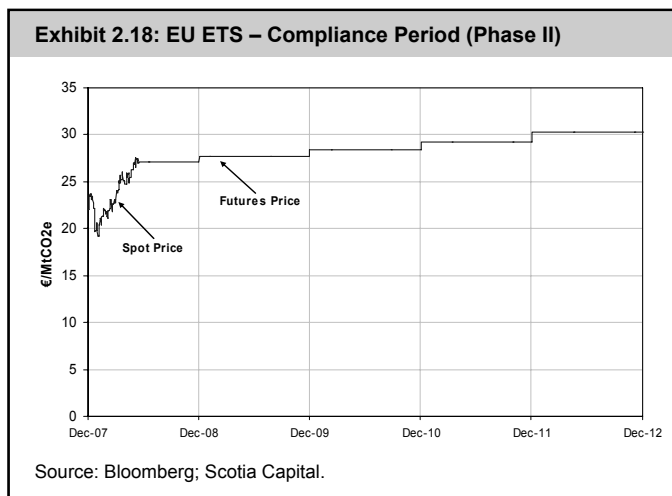
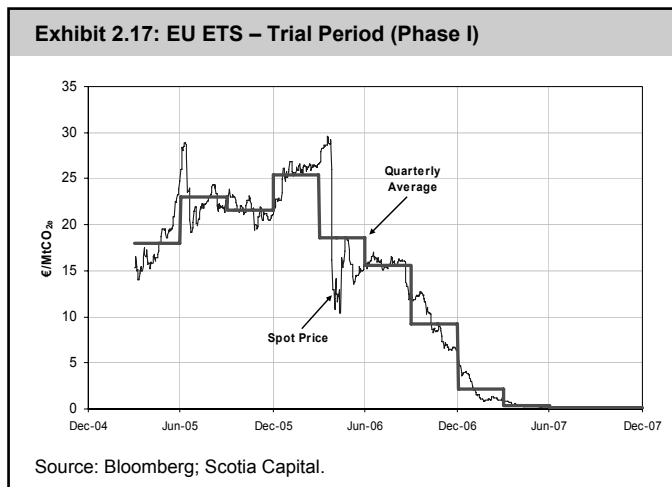

ISO-NE's Forward Capacity Markets

If a generator does not run, it typically does not get paid. As peaking generation may run for only a few hours per day, month, or year, **independent system operators (ISOs) need a way to motivate power producers to install new (non-baseload) generation capacity.** The problem is well illustrated by ISO New England's 2,700 MW increase in peak demand during 2005 that resulted in only 11 MW of new installed capacity. As a result, in 2006 ISO-NE introduced the Forward Capacity Premium (FCP), an incentive payment system to encourage investment in new capacity.

The ISO-NE Forward Capacity Premium could rise to between US\$5 and US\$6 per kW-Month beyond mid-2011.

Exhibit 2.19: ISO-NE's FCM Is Below Average FCMs

	Resource Clearing Price	
	2007/2008	2008/2009
Eastern MMAC	US\$6.01	US\$4.53
SW MAAC	US\$4.49	US\$6.39
RTO	US\$1.24	US\$3.40
Average	US\$3.92	US\$4.77
ISO NE	US\$3.05	US\$4.10
Discount		-22% → -14%

Catching up slowly. By end of 2010 ISO NE set prices will have changed to market clearing

Source: Scotia Capital.

FCM-qualified assets currently receive a US\$3.75/kW-Month capacity premium (about US\$3.7 million per year per 100 MW), **regardless of whether these facilities are online.** This will increase to US\$4.10/kW-Month by mid-2009 (Exhibit 2.19). Beyond this transition period of fixed payments, the Forward Capacity Premium will then switch to **a market clearing price mechanism effective June 1, 2010.** US\$4.25/kW-Month has already been set for June 1, 2010, through May 31, 2011. We believe that the FCP could then rise to between US\$5/kW-Month and US\$6/kW-Month, in line with ISO-NE's neighbouring regions that utilize similar market-based capacity incentive systems (Exhibit 2.20).

FCM-qualified resources include both traditional (oil, natural gas, coal, etc.) and renewable generation sources (wind, solar, biomass, etc.), as well as demand resources such as energy efficiency, load management, and distributed generation.

We expect Boralex to realize about \$3.9 million per year in 2008 EBITDA from the Forward Capacity Market, and about \$4.5 million the following year.

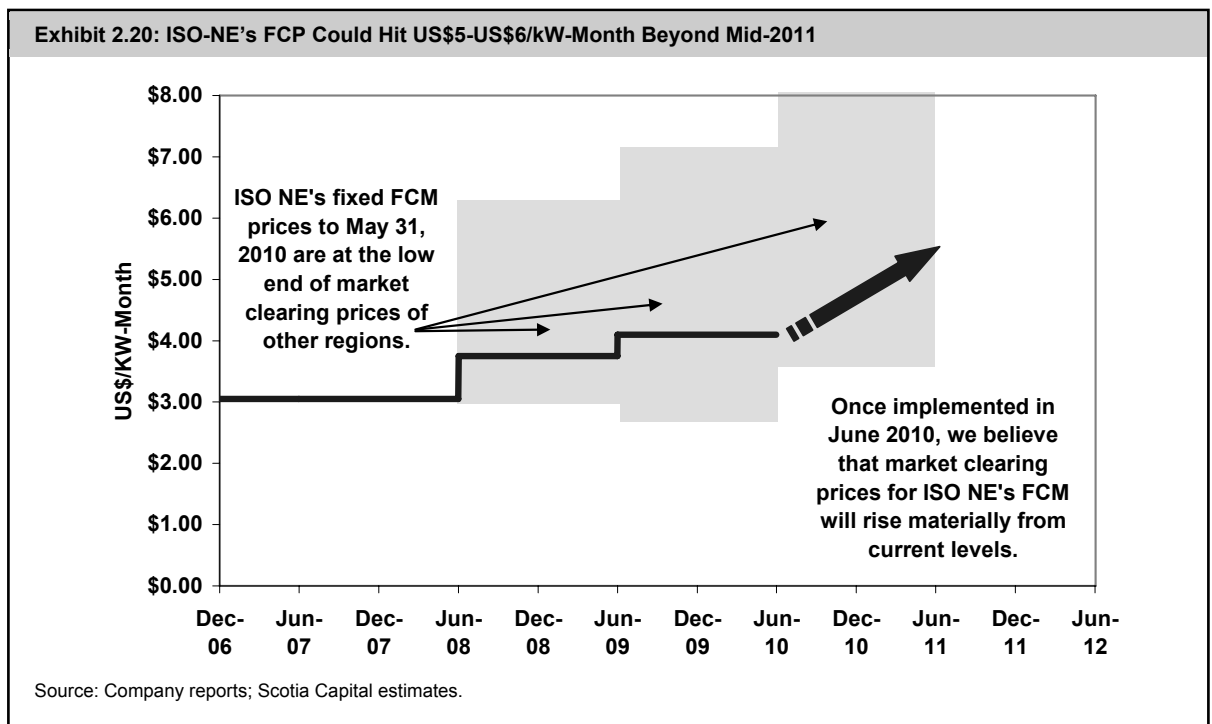

Key Investment Risks

At first glance, we find that Boralex has slightly more risks than its peer group within our universe of coverage, whose EBITDA profiles do not rely as much on open market prices and renewable incentives. However, many of the company's risks are somewhat mitigated through diversification and hedges.

Accordingly, we believe that Boralex has an overall average risk profile relative to its peers, but a high-risk profile within our Scotia Capital universe of coverage.

EXECUTION RISK

Obtaining all environmental and regulatory permits and licences, lease agreements, PPAs, local support, financing, and on-time/on-budget construction completion for Boralex's projects may not occur as planned. Boralex's stock price could face downward pressure from the unsuccessful completion of a project's development. However, we note that the company already has a substantial operating asset base from which it generates significant annual free cash flow, unlike some of its more junior peers in the Canadian renewable power space.

REGULATORY & POLITICAL ENVIRONMENT

A considerable amount of Boralex's annual revenue and/or EBITDA generation is based on it capitalizing on regulatory bodies' renewable power and climate change related policies. Within our universe of coverage, Boralex has the highest exposure to "green" financial incentives through its renewable energy certificates, the U.S. production tax credit, New England's forward capacity premium, and to a much lesser extent, excess CO₂ quota sales in France.

- While Boralex is likely the largest player in the Connecticut REC market, an increase in CT Class I REC-qualified capacity (likely) or a decline in that state's renewable portfolio standard (unlikely), could negatively impact the REC market there.
- EU ETS CO₂ allowance (EUAs) prices are capped by a non-compliance penalty of €100/MtCO₂. In 2006 and 2007, an over-allocation of EUAs by regulators caused a supply surplus that crashed local carbon emission prices to a near worthless amount. EUA prices are currently robust at about €23/tonne CO₂ (~\$35/tonne CO₂). Our long-term forecast of €20/tonne CO₂ (~\$30/tonne CO₂) gives us room for prices to drop 15%.
- The U.S. Production Tax Credit (PTC) is set to expire on December 31, 2008. The PTC accounts for a material portion of Boralex's EBITDA generation. **If the PTC is not renewed, we believe that annual EBITDA could drop by \$11 million to \$12 million per year, based on current qualified capacity.**
- The forward capacity premium that New England ISO introduced in 2006, and is currently US\$3.05/kW-Month for in-service capacity, could be rescinded if newly installed capacity surges over the coming two to three years. We believe that the forward capacity premium will remain in place and rise to US\$5/kW-Month to US\$6/kW-Month beyond mid-2011.

FOREIGN CURRENCY

Boralex reports in Canadian dollars and is exposed to both the U.S. dollar (net 226.7 MW) and the euro (net 107.3 MW). Please refer to our financial forecast for EBITDA sensitivities to FX changes.

If the U.S. PTC is not renewed, BLX's EBITDA could drop by \$11 to \$12 million per year.

MERCHANT POWER PRICE EXPOSURE

Boralex has over 200 MW of generation capacity that sells power into NEPOOL (108 MW), the NYISO day-ahead market (40.4 MW), or contracts that will expire within 12-18 months (76 MW). On-peak NEPOOL spot power prices are highly correlated to local natural gas prices, which can be both volatile and unpredictable.

OPERATIONAL

Unplanned and longer-than-planned plant outages for maintenance or repair will negatively impact Boralex's revenue and profitability, as (1) electricity deliveries could decline; and, (2) operating costs may increase. Many of the company's wind turbine contracts include warranty and service agreements that partially offset this risk.

COMMODITY PRICE EXPOSURE

Boralex's earnings from its wood-residue facilities are highly sensitive to changes in wood-residue costs. Rising diesel fuel costs that are tied to oil prices, as much of a facility's operational expenses are diesel-based fuel costs. Boralex has implemented various strategies to mitigate its wood-residue cost risk, including adopting storage strategies and seeking out alternatives to virgin residue as fuel. Additionally, the company continues to work on improving the burn-rates (i.e., lower humidity wood-residue) at its power stations for higher plant efficiency.

The company's cogeneration plant in France is exposed to volatile natural gas prices that have caused the shutdown of the facility for seven months per year in each of the past three years.

WEATHER & CLIMATE CHANGE

Boralex's wind farms (106.8 MW) and hydro assets (26.1 MW) are subject to uncertain weather and climate pattern changes. While **wind and hydrology conditions are fairly predictable over the long-term**, below forecast wind speeds and water flow would hinder Boralex's ability to produce electricity and therefore reduce the company's revenue and net income generation. Additionally, Boralex's co-generation facility has been forced to shut down from April through October over the past several years as the company is unable to pass on seasonally high natural gas costs to its power purchaser (EDF) as its electricity price is capped during these months.

FINANCING

Despite credit risk repricing that may increase Boralex's cost of capital, we don't believe the company will require significant new debt (ex. Quebec wind farms) or new equity in the near term. We believe Boralex has enough cash on hand as well as future free cash flow generation potential to complete the construction of its Gengrowth and Seigneurie de Beaupre projects. On debt, Boralex's wind farm growth in France is subject to a €265 million master credit agreement that was refinanced last year.

A large portion of Boralex's long-term debt has been issued at variable rates, which in a period of rising interest rates, could substantially reduce the company's profitability. As a partial mitigation to this risk, Boralex has entered into various interest rate swap agreements that effectively and materially reduce the company's variable interest rate exposure. Despite fair value appreciation on some of its swap arrangements, Boralex does not intend to monetize its swaps, but rather keep them as a risk reduction tool.

French Wind Power Is Booming

France seeks 25,000 MW of wind power by 2020, up from 2,455 MW in 2007.

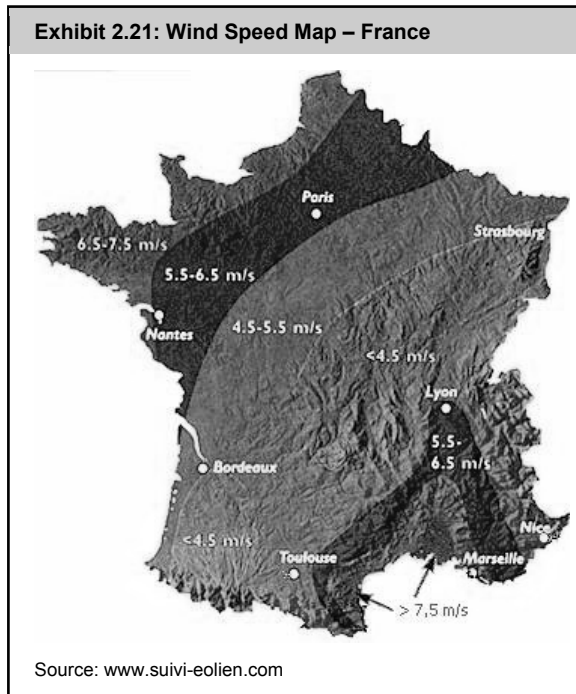

25,000 MW OF WIND POWER BY 2020

France has an ambitious renewable energy goal that currently seeks over 20% renewable power by 2020, up from 6.7% in 2004. New wind power capacity will play a significant role in reaching this target. Electricite de France (EDF), the world's largest electricity provider, estimates that wind power should reach 25,000 MW by 2020, and represent 10% of total power consumption. By the end of 2007, France had 2,455 MW of wind power capacity installed.

FROM NUCLEAR TO RENEWABLES

France derives over 75% of its electricity from nuclear generation and 15% from hydro, primarily due to a long-standing policy of energy security. As a result, France is highly energy independent and one of the lowest-cost providers of electricity in Europe.



While nuclear and utility-scale hydroelectricity will remain the dominant power source in France, much of the country's major waterways have been fully exploited, leaving wind, and to a lesser extent, run-of-river and biomass as emerging power generation technologies. Wind power in France is still a niche market, unlike its neighbours Germany and Spain, which are the two largest wind power users on the planet. Until 2005, wind farms in France had been capped at 12 MW, virtually eliminating cost advantages realized from economies of scale and the primary reason why it has historically been a niche market. Today, there is no limit as to the size of French wind farms.

BORALEX IN FRANCE

Boralex has operated wind farms in France since 2002, and currently boasts 106.8 net MW of French wind capacity spread over seven projects (Exhibit 2.22). Each of Boralex's wind farms is subject to

15-year fixed-price EDF contracts. We assume an €85/MWh 2009 contract price that escalates annually at 1.8%. We believe that Boralex will bring at least 50 MW of new French wind capacity online by 2010, financed 80% from its French master credit agreement and 20% from cash on hand and/or operations.

Boralex has operated wind farms in France since 2002, and currently boasts 106.8 MW (net) of French wind capacity.

Upcoming Stock Catalysts & Events

New PPAs and the extension of the U.S. Production Tax Credit are major Boralex stock catalysts.

We see many events over the next two years that could significantly move Boralex’s share price. In our view, awards of new PPAs (hydro in B.C., wind in Ontario, and solar in Spain), the commissioning of new capacity, and the extension of the U.S. Production Tax Credit will likely have the most material impacts on Boralex’s share price. Below, we have listed what we believe to be the more major short- to mid-term stock catalysts for Boralex.

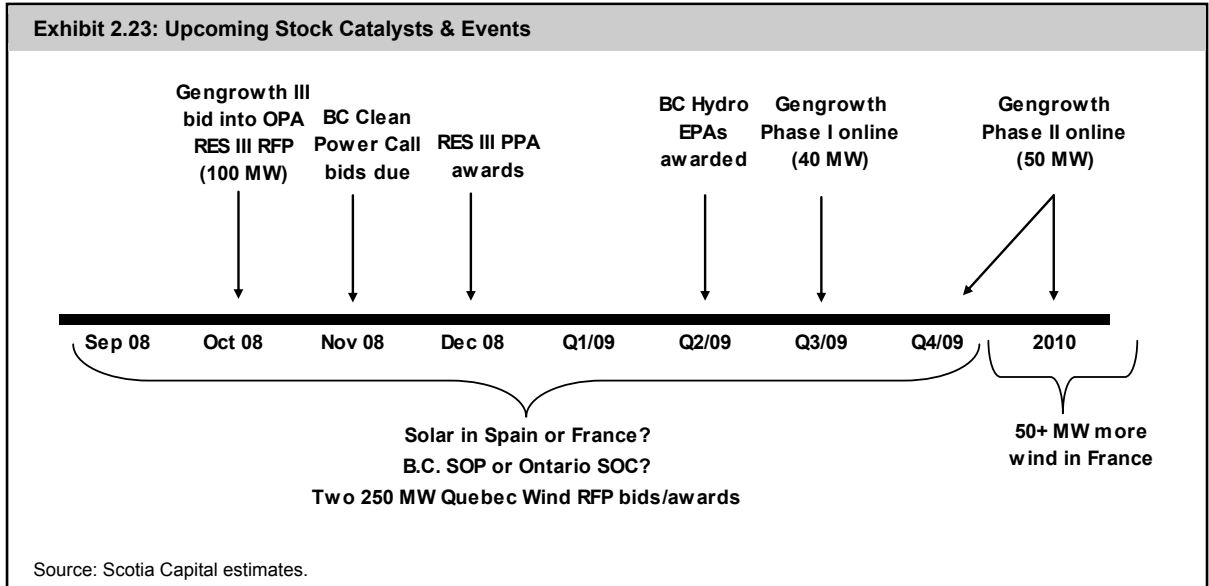

November 2008 – BC Hydro 2008 Clean Power Call bids due. Boralex may submit some hydro projects into this RFP, likely all acquired development projects.

Q4/08 – Ontario RES III. We expect Boralex to submit its 100 MW Gengrowth III wind project into the RFP.

2H/08 to 1H/09 – Entrance into B.C.’s Standing Offer Program. The initial goal for the program is to acquire 200 GWh of energy per year, although no official limits have been set. Qualified projects will be able to sell energy at fixed prices under standard contracts, as shown in Exhibit 2.24. **While we believe that these prices are too low to attract much attention,** it is possible that Boralex uses a Standing Offer Program to enter the B.C. power market.

Exhibit 2.24: B.C.’s Standing Offer Program ('07 dollars)

Region	Energy Price (\$/MWh)	Environmental Attribute Price (\$/MWh)	Total (\$/MWh)
Vancouver Island	79.00	3.05	82.05
Lower Mainland	78.00	3.05	81.05
Kelly Nicola	75.00	3.05	78.05
Central Interior	72.00	3.05	75.05
Peace Region	65.00	3.05	68.05
North Coast	66.00	3.05	69.05
South Interior	67.00	3.05	70.05
East Kootenay	71.00	3.05	74.05

Source: BC Hydro.

2H/08 to 1H/09 – Entrance into Ontario’s Standard Offer Program. Similar to B.C., the Ontario Power Authority (OPA) has a Standard Offer Program for renewable power generation that includes wind, solar (PV), biomass, biofuels, or waterpower. Under the terms of the SOP, renewable power producers must enter into a 20-year contract that will pay \$110/MWh (2007 dollars) for renewable power (\$420/MWh for solar). As the offer is materially more attractive than in B.C., we think that Boralex has a higher probability of seeking entrance into this program.

2H/08 to 1H/09 – Extension of U.S. Production Tax Credit? The expiration of the U.S. PTC is currently scheduled for December 31, 2008. **We believe the U.S. government will eventually extend the PTC, likely following the installation of a new U.S. president in early 2009.**

We think that the BC Hydro 2008 Clean Power Call awards will be announced after the May 2009 B.C. government election.

2009 – Solar power development in Spain. Subsequent to Boralex's \$1.5 million 2007 purchase of 50% of a Spanish solar power developer, we look for Boralex to announce either greenfield solar power projects or the acquisition of solar projects in Spain that total 5 MW to 10 MW, or 25 MW to 100 MW within five years.

Q2/09 – Commissioning of the first phase (40 MW) of the Gengrowth project (90 MW).

1H/09 – BC Hydro 2008 Clean Power Call awards expected, likely after the B.C. government election that is scheduled for May 2009.

2010 – Commissioning of the second phase (50 MW) of the Ontario-based Gengrowth project (90 MW).

Cascades Likely Won't Divest Its 34% Stake in Boralex

In our opinion, Cascades will not monetize its 34% ownership stake in Boralex within the next 12 to 24 months. Our Paper & Forest Products analyst believes (as we do) that the Lemaire family wants Cascades to hold on to its share of Boralex, as the Lemaire family likely believe that Boralex's potential is not reflected in its current share price. Under a scenario where Cascades' financial profile deteriorated, we believe that the company would first liquidate some of its non-core and low book value assets before considering its investment in Boralex.

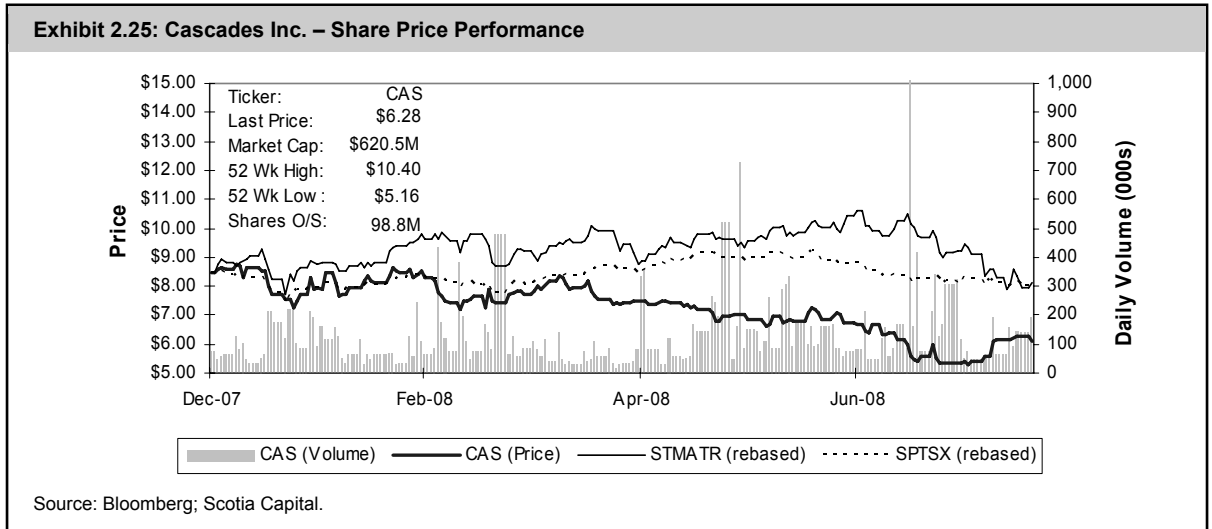

What About the Fund?

Boralex's 23% stake in BPT, as well as its management agreements, acts as an effective poison pill, which will likely result in a wind-up of BPT back into Boralex.

Boralex's 23% ownership stake in Boralex Power Income Fund (BPT) could be worth between \$80 million and \$85 million (gross) one year from now, according to our Power & Energy Infrastructure Trust analyst. Cash distributions to Boralex peaked at \$12 million in 2006 and then began to decline following the announcement of the Canadian government's Tax Fairness Plan of October 31, 2006. Our BPT analyst forecasts a constant 70¢ per unit cash distribution through 2009 that we use and assume will remain constant through 2011. This represents about \$9.6 million per year for Boralex. **Boralex continues to consider its options with respect to the fund.**

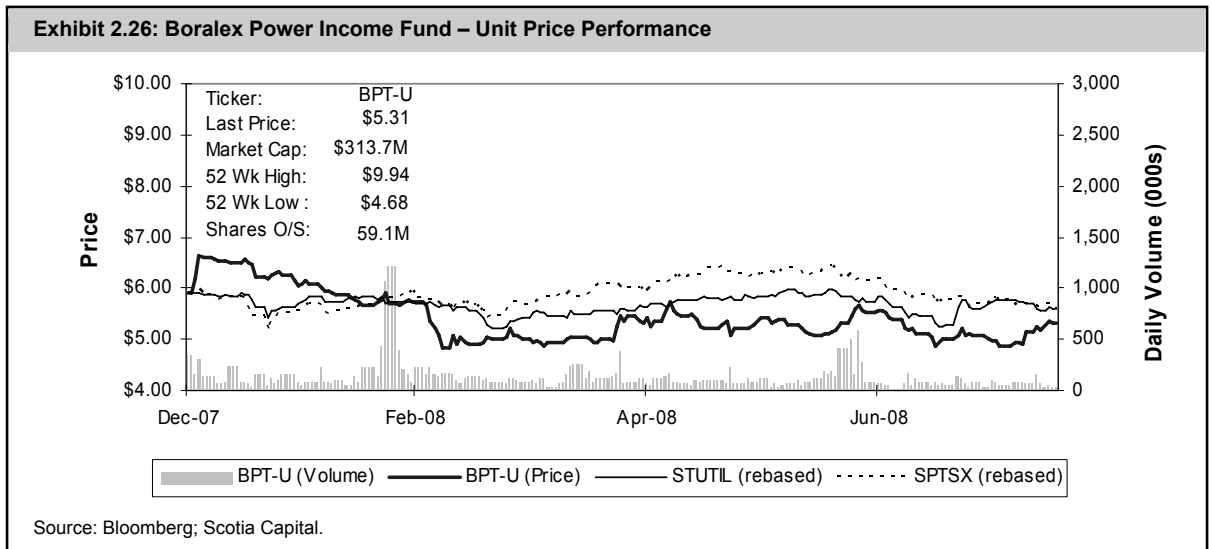

Valuation & Sensitivity Analysis

We value Boralex’s common shares using a blended approach as follows: a 75% weight to a project probability-weighted discounted cash flow (DCF) analysis, at a 10% discount rate, and a 25% weight to a net asset value calculation.

DISCOUNTED CASH FLOW ANALYSIS

Our project-probability-based DCF analysis suggests a one-year share price of \$18. For our DCF analysis, we use a discount rate of 10%, slightly above Canadian Hydro Developers’ 9.5% due to its higher commodity exposure. In our opinion, the discount rate selected appropriately captures Boralex’s risk/reward profile and outlook. Unlike Canadian Hydro Developers, which targets a 65% debt financed project capital structure, Boralex uses a greater degree of leverage for its projects, typically in the 75% to 80% range, but its high commodity price exposure offsets its heavily debt-weighted capital structure.

In our DCF model, we give full credit to Boralex’s operating facilities and then probability weight development projects based on progress. Specifically, we assign a 25% probability to the on-time and on-budget completion of its two Quebec wind farms, which were recently awarded PPAs by Hydro-Quebec.

Our DCF analysis suggests Boralex is fairly valued at \$18 per share one year out.

Exhibit 2.27: DCF Analysis of BLX Suggests \$18.33/share One Year Out

Project	Gross Capacity (MW)	Effective Capacity (MW)	Capacity Factor (%)	DCF (\$/share)	Prob. of Success (%)	Adjusted DCF (\$/share)	Comments
East Angus	2.2	1.1	39%	\$0.03	100%	\$0.03	
Huntingville	0.3	0.3	38%	\$0.01	100%	\$0.01	
La Rochette	1.0	0.5	34%	\$0.02	100%	\$0.02	
Fourth Branch	3.1	3.1	52%	\$0.10	100%	\$0.10	
Middle Falls	2.3	2.3	51%	\$0.10	100%	\$0.10	
NY State Dam	11.4	11.4	48%	\$0.33	100%	\$0.33	
Sissonville	3.0	3.0	51%	\$0.09	100%	\$0.09	
Warrensburg	2.9	2.9	43%	\$0.06	100%	\$0.06	
Ocean Falls	14.5	14.5	10%	\$0.12	100%	\$0.12	
BC Prospects	10.0	10.0	~45%	\$0.33	0%	\$0.00	
Ashland	40.0	40.0	72%	\$2.12	100%	\$2.12	
Chateaugay	20.0	20.0	76%	\$1.18	100%	\$1.18	
Fort Fairfield	36.0	36.0	75%	\$1.99	100%	\$1.99	
Livermore Falls	40.0	40.0	63%	\$1.62	100%	\$1.62	
Stacyville	18.0	18.0	79%	\$0.42	100%	\$0.42	
Stratton	50.0	50.0	75%	\$2.78	100%	\$2.78	
Avignonet-Lauragais I	8.0	8.0	26%	\$0.22	100%	\$0.22	
Avignonet-Lauragais II	5.0	5.0	26%	\$0.12	100%	\$0.12	
Chepy	4.0	3.4	20%	\$0.04	100%	\$0.04	
Nibas	12.0	11.4	21%	\$0.17	100%	\$0.17	
Ally-Mercoeur	39.0	39.0	23%	\$0.75	100%	\$0.75	
Cham de Cham Longe	18.0	18.0	38%	\$0.96	100%	\$0.96	
Plouguin	8.0	8.0	31%	\$0.31	100%	\$0.31	
La Citadelle	14.0	14.0	27%	\$0.40	100%	\$0.40	
Blendecques	14.0	14.0	73%	\$0.45	100%	\$0.45	
Seigneurie de Beupre	272.0	136.0	~36%	\$4.03	25%	\$1.01	Received Hydro-Quebec PPA in May/08.
Gengrowth I	40.0	40.0	~30%	\$1.06	50%	\$0.53	Commissioning expected in Q1/09
Gengrowth II	50.0	50.0	~30%	\$1.32	25%	\$0.33	Commissioning expected in 2010.
Gengrowth III	100.0	100.0	~30%	\$2.27	0%	\$0.00	
Interest in BPT				\$2.07	100%	\$2.07	Taken from NAV.
	738.7	599.9				\$18.33	

Note: All green attributes and other incentives are allocated on a project by project basis.
Source: Scotia Capital estimates.

NET ASSET VALUE CALCULATION

We calculate a NAV of \$17/share. Given recent transactions and using rule-of-thumb metrics, we give credit of \$0.82 million per GWh/y for wind capacity that is either operational or under construction with no construction risk. We probability-adjust these values lower for those projects that are less developed. For hydro assets, we give credit of \$1 million per GWh/y for operational capacity.

Unlike our DCF valuation, which includes project-specific green attributes, we have separated the value of Boralex's green attributes in our NAV calculation. We note that we give 1.5x value for Boralex's US\$45 million of RECs that have been sold forward, as we are fairly confident that a tight Connecticut REC market will re-emerge soon. While Connecticut's renewable portfolio standard will increase to 20% by 2020, we do not know how much extra REC-qualified capacity will come online that could negatively impact this market. There is significant upside potential here, but we will wait to see how this unfolds. Additionally, we use our Power & Energy Infrastructure Trust analyst's one-year Boralex Power Income Fund target price of \$6.00 per unit to arrive at a \$70 million net interest to Boralex, or slightly below \$2 per Boralex share. Exhibit 2.28 details our NAV calculation.

Our NAV calculation suggests Boralex is fairly valued at \$17 per share.

We believe there is significant upside potential to our NAV as we only give 1.5x booked RECs.

Exhibit 2.28: NAV Calculation Suggests \$17 per Share

Project	Financing Status	Generation	Unrisked Net Value	Asset Value (Risked)	NAV		NAVPS	
					(\$M)	(diluted)	(\$M)	(diluted)
Hydro Assets								
East Angus	1	1	4 GWh/y @	\$1.00M / GWh/y	\$3.8	\$0.10	0.6%	
Huntingville	1	1	1 GWh/y @	\$1.00M / GWh/y	\$1.0	\$0.03	0.2%	
La Rochette	1	1	2 GWh/y @	\$1.00M / GWh/y	\$1.5	\$0.04	0.2%	
Fourth Branch	1	1	14 GWh/y @	\$1.00M / GWh/y	\$14.0	\$0.36	2.1%	
Middle Falls	1	1	10 GWh/y @	\$1.00M / GWh/y	\$10.2	\$0.26	1.5%	
NY State Dam	1	1	48 GWh/y @	\$1.00M / GWh/y	\$48.4	\$1.25	7.3%	
Sissonville	1	1	13 GWh/y @	\$1.00M / GWh/y	\$13.3	\$0.34	2.0%	
Warrensburg	1	1	11 GWh/y @	\$1.00M / GWh/y	\$10.9	\$0.28	1.7%	
Ocean Falls	1	1	13 GWh/y @	\$1.00M / GWh/y	\$13.0	\$0.33	2.0%	
BC Prospects	6	4	39 GWh/y @	\$0.00M / GWh/y	\$0.0	\$0.00	0.0%	
155 GWh/y					\$116.0	\$3.00	17.6%	
Wood-Residue Assets								
Ashland	1	1	251 GWh/y @	\$0.15M / GWh/y	\$37.7	\$0.97	5.7%	
Chateaugay	1	1	133 GWh/y @	\$0.15M / GWh/y	\$20.0	\$0.52	3.0%	
Fort Fairfield	1	1	237 GWh/y @	\$0.15M / GWh/y	\$35.6	\$0.92	5.4%	
Livermore Falls	1	1	220 GWh/y @	\$0.15M / GWh/y	\$33.0	\$0.85	5.0%	
Stacyville	1	1	125 GWh/y @	\$0.15M / GWh/y	\$18.8	\$0.48	2.8%	
Stratton	1	1	330 GWh/y @	\$0.15M / GWh/y	\$49.5	\$1.28	7.5%	
1,296 GWh/y					\$194.4	\$5.02	29.5%	
Wind Assets								
Aignonet-Lauragais I	1	1	18 GWh/y @	\$0.82M / GWh/y	\$15.1	\$0.39	2.3%	
Aignonet-Lauragais II	1	1	12 GWh/y @	\$0.82M / GWh/y	\$9.4	\$0.24	1.4%	
Chepy	1	1	6 GWh/y @	\$0.82M / GWh/y	\$4.9	\$0.13	0.7%	
Nibas	1	1	21 GWh/y @	\$0.82M / GWh/y	\$17.1	\$0.44	2.6%	
Aily-Mercœur	1	1	78 GWh/y @	\$0.82M / GWh/y	\$64.0	\$1.65	9.7%	
Cham de Cham Longe	1	1	60 GWh/y @	\$0.82M / GWh/y	\$49.1	\$1.27	7.5%	
Plouguin	1	1	22 GWh/y @	\$0.82M / GWh/y	\$18.0	\$0.47	2.7%	
La Citadelle	1	1	33 GWh/y @	\$0.82M / GWh/y	\$27.1	\$0.70	4.1%	
Seigneurie de Beaupre	3	3	429 GWh/y @	\$0.41M / GWh/y	\$175.8	\$4.54	26.7%	
Gengrowth I	2	3	105 GWh/y @	\$0.74M / GWh/y	\$77.6	\$2.00	11.8%	
Gengrowth II	4	3	131 GWh/y @	\$0.21M / GWh/y	\$26.9	\$0.70	4.1%	
Gengrowth III	6	4	263 GWh/y @	\$0.00M / GWh/y	\$0.0	\$0.00	0.0%	
1,178 GWh/y					\$485.2	\$12.53	73.6%	
Cogen Assets								
Blendeccques	1	1	39 GWh/y @	\$0.15M / GWh/y	\$5.8	\$0.15	0.9%	
39 GWh/y					\$5.8	\$0.15	0.9%	
Investments								
BPT Ownership			13.8M units @	\$6.00 / unit	\$82.8	\$2.14	12.6%	
Less: capital gains tax					(\$12.8)	-\$0.33	-1.9%	
BPT Fees (net EBITDA)			\$1.25M @	8.0x	\$10.0	\$0.26	1.5%	
Solar (Spain)					\$2.0	\$0.05	0.3%	
					\$82.0	\$2.12	12.4%	

Green Attributes			
U.S. Production Tax Credit	\$11.5	\$0.30	1.7%
RECs (1.5x booked)	\$67.5	\$1.74	10.2%
CO ₂ Quota through 2012	\$12.0	\$0.31	1.8%
Forward Capacity Premiums	\$12.1	\$0.31	1.8%
	\$103.1	\$2.66	15.6%

Working Capital			
Current Assets (Q2/08A)	\$128.9	\$3.33	19.6%
Current Liabilities (Q2/08A)	(\$53.3)	(\$1.38)	-8.1%
	\$75.6	\$1.95	11.5%

Liabilities			
Est. Long-term debt post financing	(\$402.9)	(\$10.41)	-61.1%
	(\$402.9)	(\$10.41)	-61.1%

Net Asset Value			
	\$659.12	\$17.03	100%

Est. FD Shares O/S post any equity financing (M) **38.7**

L/F EIA Price	Multiple of Booked RECs			
	1.00x	1.25x	1.50x	2.00x
€ 8	\$16.21	\$16.50	\$16.79	\$17.08
€ 10	\$16.29	\$16.58	\$16.87	\$17.16
€ 20	\$16.45	\$16.74	\$17.03	\$17.61
€ 30	\$16.60	\$16.89	\$17.18	\$17.76
€ 40	\$16.76	\$17.05	\$17.34	\$17.92

Hydro Value (\$/GWh/y)	Wind Value (\$M/GWh/y)			
	\$0.6	\$0.7	\$0.8	\$0.9
\$0.8	\$13.37	\$14.90	\$16.43	\$17.96
\$0.9	\$13.67	\$15.20	\$16.73	\$18.26
\$1.0	\$13.97	\$15.50	\$17.03	\$18.56
\$1.1	\$14.27	\$15.80	\$17.33	\$18.85
\$1.2	\$14.57	\$16.10	\$17.63	\$19.15

Avg. Equity Issue Price	Capital Structure: Debt (%)				
	70%	75%	80%	85%	90%
\$15.33	\$17.73	\$17.38	\$17.03	\$16.67	\$16.32
\$16.33	\$17.73	\$17.38	\$17.03	\$16.67	\$16.32
\$17.33	\$17.73	\$17.38	\$17.03	\$16.67	\$16.32
\$18.33	\$17.73	\$17.38	\$17.03	\$16.67	\$16.32
\$19.33	\$17.73	\$17.38	\$17.03	\$16.67	\$16.32

Average equity issue price has no sensitivity impact for now as we believe that current development projects do not require the issuance of new equity.

1. We assume a stable capital structure of 80% debt & 20% equity.
 2. Project Probability Status: 1. Operating - 100%; 2. Construction - 90%; 3. Permitting & FPA - 50%; 4. Permitting or FPA - 25%; 5. Some Development - 10%; 6. Pipeline - 0%.
 3. Financing Status: (1) Full financing in place; (2) Debt drawn, equity required; (3) Equity in place, debt draw required; (4) Equity & debt draw required.

Source: Scotia Capital estimates.

TARGET PRICE, RATING, AND RISK RANKING

We have transferred coverage of Boralex with a 1-Sector Outperform rating. Our one-year share price target is \$18. Our one-year target comprises outcomes of the following valuation approaches: (1) 75% DCF at a 10% discount rate; and (2) 25% NAV.

Our risk ranking for Boralex is High, similar to Canadian Hydro Developers. The company's stated goal is to reach 1,000 MW of contracted capacity by 2012, or about triple what it currently has in place. We acknowledge that Boralex has a better track record than Canadian Hydro Developers with respect to commissioning projects on-time and within budget. However, Boralex is much more dependent on green attributes such as RECs where a monetary value is not guaranteed unless the certificates are sold forward.

EV/EBITDA CHECK

Our one-year target price of \$18 per share implies a forward EV/2010E EBITDA multiple of 9.25x

Our one-year target of \$18 per share implies an EV/EBITDA multiple of 9.25x on 2010E EBITDA of \$88 million. In our opinion, this multiple is reasonable due to (1) the significant growth Boralex aims to achieve over the next five years; (2) potential upside value in the Connecticut REC market, which we have not accounted for in our NAV calculation; and (3) strong seasonal, geographic, and fuel source diversification. Exhibit 2.29 provides a one-year price sensitivity analysis for changes in the EV/EBITDA multiple, as well as changes in 2010E EBITDA, while Exhibit 2.30 sensitizes our two-year target price.

Exhibit 2.29: \$18 per Share One-Year Target Implies 2010E EV/EBITDA Multiple of 9.25x								
		2010E EBITDA						
		-15%	-10%	-5%	Base	+5%	+10%	+15%
EV/EBITDA Multiple	7.25x	\$11.00	\$11.75	\$12.50	\$13.50	\$14.25	\$15.00	\$16.00
	7.75x	\$12.00	\$12.75	\$13.75	\$14.50	\$15.50	\$16.25	\$17.25
	8.25x	\$13.00	\$13.75	\$14.75	\$15.75	\$16.75	\$17.50	\$18.50
	8.75x	\$13.75	\$14.75	\$15.75	\$16.75	\$17.75	\$18.75	\$19.75
	9.25x	\$14.75	\$16.00	\$17.00	\$18.00	\$19.00	\$20.00	\$21.25
	9.75x	\$15.75	\$17.00	\$18.00	\$19.25	\$20.25	\$21.25	\$22.50
	10.25x	\$16.75	\$18.00	\$19.00	\$20.25	\$21.50	\$22.50	\$23.75
	10.75x	\$17.75	\$19.00	\$20.25	\$21.50	\$22.50	\$23.75	\$25.00
	11.25x	\$18.75	\$20.00	\$21.25	\$22.50	\$23.75	\$25.00	\$26.25

Source: Scotia Capital estimates.

Exhibit 2.30: \$20 per Share Two-Year Target Implies 2011E EV/EBITDA Multiple of 9.1x								
		2011E EBITDA						
		-15%	-10%	-5%	Base	+5%	+10%	+15%
EV/EBITDA Multiple	7.10x	\$12.25	\$13.25	\$14.00	\$15.00	\$16.00	\$16.75	\$17.75
	7.60x	\$13.50	\$14.25	\$15.25	\$16.25	\$17.25	\$18.25	\$19.25
	8.10x	\$14.50	\$15.50	\$16.50	\$17.50	\$18.50	\$19.50	\$20.75
	8.60x	\$15.50	\$16.75	\$17.75	\$18.75	\$20.00	\$21.00	\$22.00
	9.10x	\$16.75	\$17.75	\$19.00	\$20.00	\$21.25	\$22.50	\$23.50
	9.60x	\$17.75	\$19.00	\$20.25	\$21.50	\$22.50	\$23.75	\$25.00
	10.10x	\$18.75	\$20.00	\$21.25	\$22.75	\$24.00	\$25.25	\$26.50
	10.60x	\$20.00	\$21.25	\$22.50	\$24.00	\$25.25	\$26.50	\$28.00
	11.10x	\$21.00	\$22.25	\$23.75	\$25.25	\$26.50	\$28.00	\$29.50

Source: Scotia Capital estimates.

Financial Forecast

EUROPEAN AND B.C. CAPACITY GROWTH UPSIDE POTENTIAL

We think that Boralex's current installed capacity will generate over 1,500 GWh/y going forward.

We assume in our financial forecast that total **power generation from current operating plants will remain flat indefinitely at 1,575.5 GWh/y**. However, we do expect several production increases as a result of successful organic growth projects such as Seigneurie de Beaupre, and acquisitions such as Gengrowth. Our quarterly electricity production estimates do not include: (1) new wind power opportunities in France, Italy, or elsewhere; (2) solar power development in Spain or possibly Ontario; and (3) the awarding of any PPAs in the 2008 BC Hydro Clean Power Call, as well as the Ontario RES III Call. We will include these and other projects in our forecast as development progresses.

On a plant-by-plant basis, we have seasonally adjusted quarterly production to match the historical mean quarterly profiles. As we progress through a given quarter, we may adjust our production forecast up or down depending on material changes to various weather and climate related factors such as stronger-than-expected wind conditions or below-mean hydrology. Please refer to earlier Exhibits 2.7-2.10 for quarterly production forecasts by business segment through 2012.

While it is possible that Boralex may invest a minor amount of its annual capital expenditures toward increasing the availability at some of its facilities, we believe it is currently immaterial to explore further. Finally, **we believe that Boralex's 14 MW French cogeneration plant will continue to be shut between April and October (inclusive) for the remainder of the plant's contract life.**

Exhibits 2.31 and 2.32 show our estimated 2009 electricity generation mix by technology and by country, respectively.

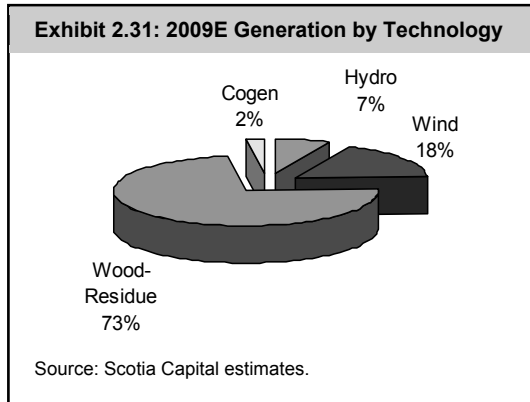

2008E TOTAL REVENUE UP 14% YEAR OVER YEAR

Our 14% year-over-year forecast revenue increase for 2008 is derived from electricity generation revenue of \$149.9 million, robust REC sales at \$34.9 million, and strong (non-REC) renewable incentives at \$14.2 million. We expect management fees associated with Boralex Power Income Fund will remain flat at \$5.6 million in 2008, while our forecast Boralex share in the Fund's earnings is pegged at \$8.8 million, a \$2 million increase over 2007.

2008E EBITDA PEGGED AT \$67 MILLION

We expect 2008 operating costs to jump by \$18.3 million year over year to \$129.6 million, while we think 2008 administration costs will rise slightly to \$13.4 million from \$13 million last year. Our 2008 EBITDA estimate of \$67 million represents a 15% increase year over year. While there are several factors associated with the jump in EBITDA, the primary reason is due to the increase in REC sales. On the surface, green attribute sales are generally considered cost-free, but for Boralex there are small but real additional capital and operating cost increases associated with keeping its wood-residue facilities REC-qualified.

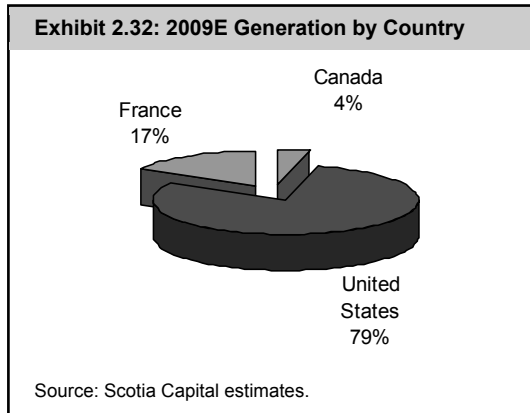

We are looking for 2008E EBITDA of about \$67 million.

We think total revenue per MWh will rise to \$110 by 2009, up from \$105/MWh in 2007.

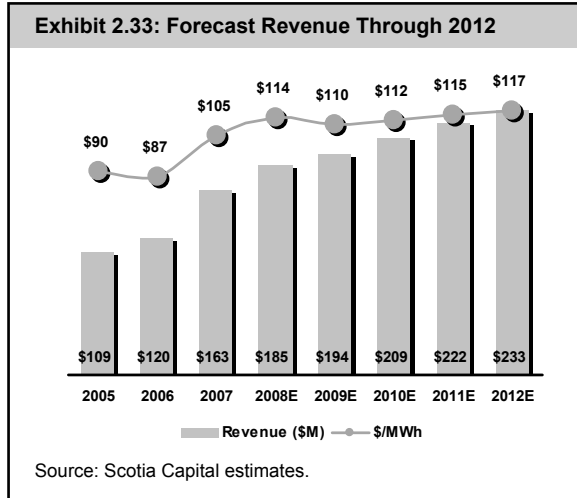

U.S. PTC WORTH ABOUT \$11.5 MILLION PER YEAR OF EBITDA

If the U.S. Production Tax Credit (PTC) is not renewed, **Boralex could face an \$11 million to \$12 million reduction in annual EBITDA generation.** While the U.S. PTC may not be extended throughout the remainder of our forecast period, we have assumed for now that it will be renewed at its current pricing level.

OUR EU ETS ESTIMATE OF €20/TONNE CO₂ COULD BE TOO LOW, BUT WE DON'T KNOW HOW THIS MARKET WILL PLAY OUT

EU Allowances (EUA) currently trade at €22.50/tonne CO₂ and should remain at least over €20/tonne CO₂ for the remainder of Phase II of the EU ETS (2008 to 2012). The average EUA exchange-traded price for much of Phase I of the program (2005 to 2007) did not reflect a reasonable carbon cost to producers due to more allowances being distributed than actual emissions produced. **We will keep our forecast price at €20/tonne CO₂ until we are able to review the first full year of Phase II (i.e., early 2009).** For Boralex, we estimate that about \$1 million per year of EUA sales will be recorded in both 2008 and 2009.

CONSTANT CDPU FOR BORALEX POWER INCOME FUND THROUGH 2011

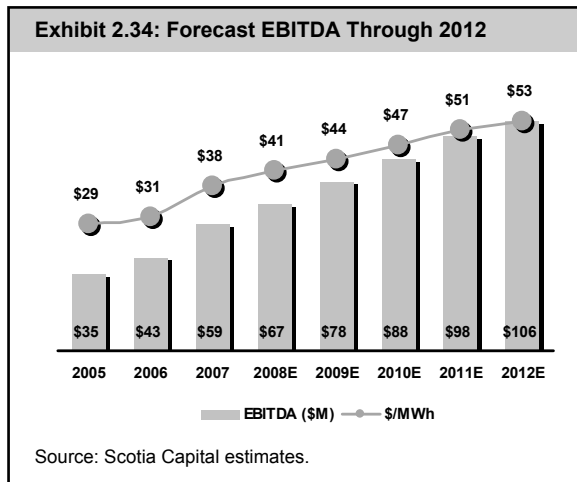

We believe that Boralex will maintain its 23% interest in BPT, for now. Our Power & Energy Infrastructure analyst currently forecasts a constant 70¢ annual CDPU through the end of 2009. In our financial forecast, we extend this through 2011.

2008E DILUTED EPS OF 51¢ THAT JUMPS TO 73¢ IN 2009E

We estimate 2008E fully diluted EPS will drop by 15% year over year to 51¢, as \$7.7 million of non-recurring gains and favourable tax adjustments were booked in 2007. On a recurring basis, we forecast a year-over-year EPS improvement due to a combination of increased REC sales and higher realized power prices.

Look for a 40%+ increase in 2009 EPS over 2008.

We expect 2009E EPS to jump to 73¢, or more than 40% year over year due to: (1) almost a full year of power production, sales/earnings from the first 40 MW of Boralex's Gengrowth wind farm; (2) proceeds from the federal government's \$10/MWh ecoENERGY incentive at Gengrowth (shared 50:50 with the Ontario Power Authority); (3) a US\$0.6 million increase in Forward Capacity Premium payments; and (4) a higher year-over-year weighted average power price received.

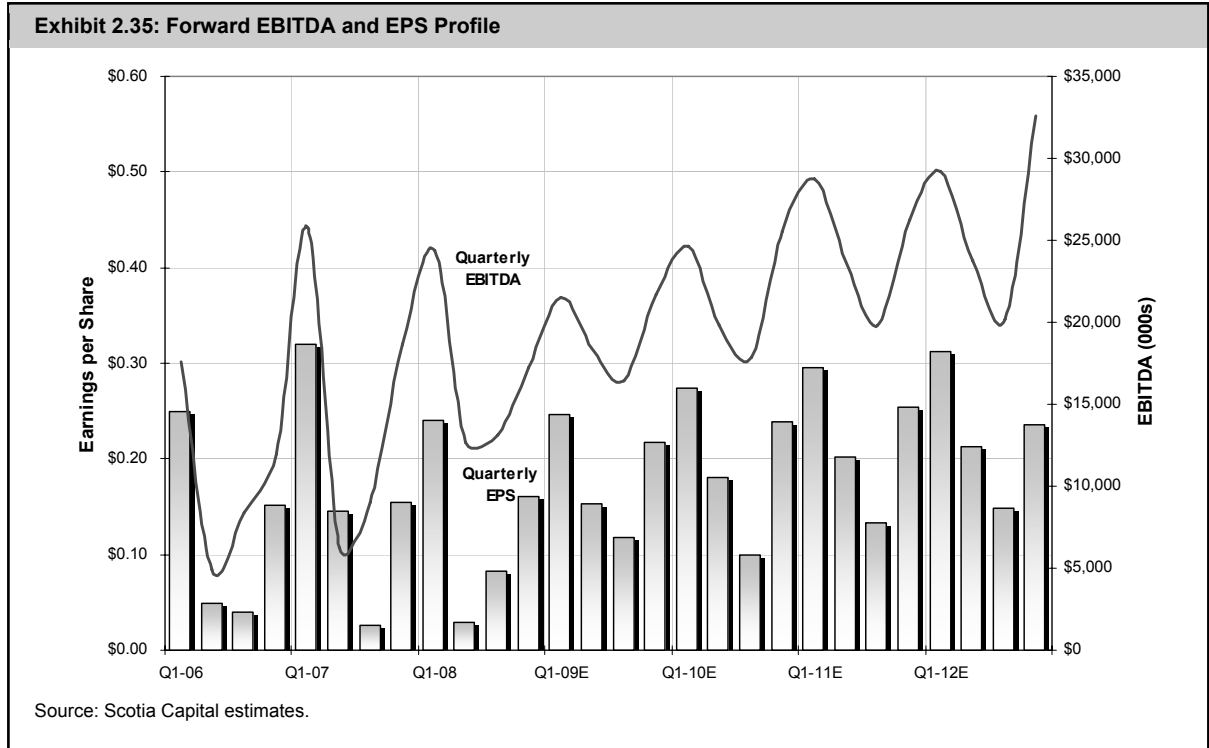

OTHER KEY ASSUMPTIONS & RATIONALE

New capacity. With the addition of new capacity, we do not speculate what specific day in a quarter new capacity will come online. Accordingly, and similar to the half-year CCA rule, we apply a 50% weight to generation produced from new capacity in its initial quarter.

Forward capacity market. ISO New England’s Forward Capacity Premium will increase from US\$3.05/kW-Month to US\$4.25/kW-Month by mid-2011, and to between US\$5/kW-Month to US\$6/kW-Month beyond mid-2011.

Project financing. Our financial forecast assumes that growth opportunities will be financed using Boralex’s targeted capital structure of 80% debt and 20% equity. Under its master credit agreement for its French wind farms, Boralex still has unused credit of about \$275 million that may be used through 2010.

Foreign exchange. We use a par CAD/USD FX rate, as well as a \$1.50 CAD/EUR FX rate.

Taxes. We forecast that Boralex’s French operations will not pay material cash taxes for seven to 12 years, and that its U.S. operations will not pay taxes for about five years. In the United States, Boralex still has approximately US\$18 million of unused Production Tax Credits, as well as \$20 million of unused tax losses. In Canada, distribution proceeds from the fund are approximately offset by head office expenses, which results in taxable income that is close to nil. For Boralex’s Canadian growth plans, we forecast no material cash taxes paid for seven to 12 years.

Most of Boralex’s operations will not pay cash taxes for at least five years.

We have not applied any free cash flow on the balance sheet for now, other than to finance Boralex's current Ontario and Quebec wind projects.

Free cash flow. We have not applied excess free cash flow on the balance sheet, for now, other than to finance those projects that we believe will be commissioned within our financial forecast. Cash on hand could be used to: (1) prepay outstanding principal balances on its debt; (2) implement (i) a regular dividend, (ii) a share buyback, and/or (iii) a one-time special dividend; (3) invest in other organic growth opportunities; and (4) enter into an acquisition, joint venture, or similar transaction.

Seasonality profile. We have used the unweighted average seasonality profiles of Boralex's current hydro and wind facilities as the basis for our future capacity production forecasts.

- Our hydro production profile assumes the following seasonality: Q1 → 32%; Q2 → 31%; Q3 → 10%; and Q4 → 27%.
- Our wood-residue production profile assumes the following seasonality: Q1 → 27%; Q2 → 23%; Q3 → 25%; and Q4 → 25%.
- Our wind production profile is as follows: Q1 → 30%; Q2 → 20%; Q3 → 20%; and Q4 → 30%.

SENSITIVITY ANALYSIS

Rising diesel costs remain a concern for Boralex's wood-residue operations.

Exhibit 2.36: Sensitivity Analysis					
	Item	Change	Period	Net Income	Comp. Income
Q1/08 Actual	Interest Rates	5%	Q1/08A	\$22,000	\$2,098,000
	Electricity Prices	5%	Q1/08A	\$371,000	\$1,032,000
	C\$ to both US\$ & €	\$0.05	Q1/08A	\$368,000	\$6,436,000
	Item	Change	Period	EBITDA	
2008E Estimated	Deisel Fuel	US\$0.10/gallon	2008E	\$600,000	
	CT Class I REC	US\$5/REC	2008E	\$3,200,000	

Source: Company reports; Scotia Capital estimates

Exhibits 2.37 through 2.39 display our forecast financial statements for Boralex.

Exhibit 2.37: Boralex Inc. – Income Statement

	2005	2006	2007	Q108	Q208	Q308E	Q408E	2008E	Q109E	Q209E	Q309E	Q409E	2009E	2010E	2011E
Generation Revenue	\$100,596	\$114,432	\$138,216	\$44,419	\$32,649	\$33,714	\$39,121	\$149,903	\$43,919	\$36,687	\$36,812	\$43,488	\$160,906	\$174,700	\$187,697
REC Revenue	\$8,100	\$5,600	\$24,600	\$10,600	\$7,800	\$8,379	\$8,167	\$34,946	\$8,882	\$7,972	\$8,457	\$8,243	\$33,555	\$33,869	\$34,186
Incentives	\$11,039	\$10,622	\$9,918	\$3,122	\$2,409	\$4,406	\$4,277	\$14,214	\$4,666	\$4,213	\$4,617	\$4,530	\$18,026	\$18,785	\$19,737
Operating Costs	\$87,851	\$94,572	\$111,281	\$34,460	\$29,310	\$32,179	\$33,621	\$129,571	\$36,092	\$29,680	\$32,298	\$33,942	\$132,012	\$135,900	\$139,732
	\$31,884	\$36,024	\$61,612	\$23,681	\$13,548	\$14,320	\$17,943	\$69,492	\$21,375	\$19,192	\$17,589	\$22,318	\$80,475	\$91,455	\$101,888
Share in Fund Earnings	\$8,873	\$10,023	\$6,830	\$3,248	\$1,790	\$1,425	\$2,300	\$8,763	\$3,375	\$1,775	\$1,425	\$2,300	\$8,875	\$8,875	\$8,875
Fund Management Revenue	\$5,357	\$5,457	\$5,602	\$1,341	\$1,352	\$1,463	\$1,428	\$5,584	\$1,375	\$1,386	\$1,499	\$1,464	\$5,723	\$5,866	\$6,013
CO ₂ Quota Revenue	\$1,000	\$3,200	\$300	\$0	\$0	\$432	\$132	\$564	\$0	\$475	\$475	\$158	\$1,109	\$1,210	\$1,304
Other Revenue	\$1,563	\$1,278	\$2,001	\$31	\$395	\$0	\$0	\$426	\$0	\$0	\$0	\$0	\$0	\$0	\$0
	\$48,677	\$56,010	\$76,186	\$28,301	\$17,085	\$17,640	\$21,803	\$84,829	\$26,125	\$22,828	\$20,988	\$26,240	\$96,182	\$107,405	\$118,080
Expenses															
Management & Operation of the Fund	\$4,054	\$4,249	\$4,510	\$938	\$1,039	\$1,039	\$1,039	\$4,055	\$1,064	\$1,064	\$1,064	\$1,064	\$4,258	\$4,471	\$4,694
Administration Costs	\$9,539	\$9,237	\$13,038	\$2,998	\$3,399	\$3,500	\$3,500	\$13,397	\$3,500	\$3,500	\$3,500	\$3,500	\$14,000	\$15,000	\$15,000
	\$13,593	\$13,486	\$17,548	\$3,936	\$4,438	\$4,539	\$4,539	\$17,452	\$4,564	\$4,564	\$4,564	\$4,564	\$18,258	\$19,471	\$19,694
EBITDA	\$35,084	\$42,524	\$58,638	\$24,365	\$12,647	\$13,101	\$17,264	\$67,377	\$21,561	\$18,263	\$16,424	\$21,676	\$77,924	\$87,935	\$98,386
Amortization	\$10,515	\$20,880	\$23,118	\$5,828	\$6,015	\$6,000	\$6,000	\$23,843	\$6,000	\$6,750	\$6,750	\$6,750	\$26,250	\$28,875	\$30,750
Financing Costs	\$4,421	\$12,528	\$11,886	\$3,465	\$2,991	\$2,698	\$2,723	\$11,877	\$2,452	\$3,393	\$3,368	\$3,359	\$12,572	\$16,782	\$20,485
Financial Instruments				\$319	\$785	\$0	\$0	\$1,104	\$0	\$0	\$0	\$0	\$0	\$0	\$0
Unusual Items	\$522	\$0	(\$5,875)	\$0	\$56	\$0	\$0	\$56	\$0	\$0	\$0	\$0	\$0	\$0	\$0
	\$15,458	\$33,408	\$29,129	\$9,612	\$9,847	\$8,698	\$8,723	\$36,880	\$8,452	\$10,143	\$10,118	\$10,109	\$38,822	\$45,657	\$51,235
Earnings from Continuing Operations before Taxes	\$19,626	\$9,116	\$29,509	\$14,753	\$2,800	\$4,403	\$8,541	\$30,497	\$13,109	\$8,121	\$6,306	\$11,567	\$39,102	\$42,278	\$47,151
Current Income Tax Expense	(\$2,646)	(\$563)	\$109	\$2	\$0	\$0	\$0	\$2	\$0	\$0	\$0	\$0	\$0	\$0	\$0
Future Income Tax Expense	\$86	(\$5,100)	\$8,348	\$5,436	\$1,642	\$1,233	\$2,392	\$10,702	\$3,670	\$2,274	\$1,766	\$3,239	\$10,949	\$11,838	\$13,202
	\$22,186	\$14,890	\$21,052	\$9,315	\$1,158	\$3,170	\$6,150	\$19,793	\$9,438	\$5,847	\$4,540	\$8,328	\$28,154	\$30,440	\$33,949
Non-Controlling Interests	(\$98)	(\$168)	\$70	(\$94)	(\$23)	\$0	\$0	(\$117)	\$0	\$0	\$0	\$0	\$0	\$0	\$0
Earnings from Continuing Operations	\$22,088	\$14,722	\$21,122	\$9,221	\$1,135	\$3,170	\$6,150	\$19,676	\$9,438	\$5,847	\$4,540	\$8,328	\$28,154	\$30,440	\$33,949
Loss from Discontinued Operations	\$0	\$0	\$0	\$0	\$0	\$0	\$0	\$0	\$0	\$0	\$0	\$0	\$0	\$0	\$0
Net Earnings	\$22,088	\$14,722	\$21,122	\$9,221	\$1,135	\$3,170	\$6,150	\$19,676	\$9,438	\$5,847	\$4,540	\$8,328	\$28,154	\$30,440	\$33,949
Basic shares - opening	29,986.7	29,989.4	30,049.6	37,454.6	37,784.4	37,836.1	37,836.1	37,454.6	37,836.1	37,836.1	37,836.1	37,836.1	37,836.1	37,836.1	37,836.1
Plus: Equity issued	2.7	60.2	7,405.0	329.8	0.0	0.0	0.0	329.8	0.0	0.0	0.0	0.0	0.0	0.0	0.0
Less: Share buyback	0.0	0.0	0.0	0.0	0.0	0.0	0.0	0.0	0.0	0.0	0.0	0.0	0.0	0.0	0.0
Basic shares - closing	29,989.4	30,049.6	37,454.6	37,784.4	37,836.1	37,836.1	37,836.1	37,836.1	37,836.1	37,836.1	37,836.1	37,836.1	37,836.1	37,836.1	37,836.1
Average Shares O/S - Basic (000s)	29,987.0	30,033.7	34,374.3	37,557.0	37,818.5	37,836.1	37,836.1	37,761.9	37,836.1	37,836.1	37,836.1	37,836.1	37,836.1	37,836.1	37,836.1
Average Dilution (000s)	253.6	404.6	658.9	926.4	517.8	517.8	517.8	619.9	517.8	517.8	517.8	517.8	517.8	517.8	517.8
Average Shares O/S - Diluted (000s)	30,240.6	30,438.3	35,033.2	38,307.0	38,336.3	38,353.9	38,353.9	38,337.8	38,353.9	38,353.9	38,353.9	38,353.9	38,353.9	38,353.9	38,353.9
EPS (Basic)	\$0.74	\$0.49	\$0.61	\$0.25	\$0.03	\$0.08	\$0.16	\$0.52	\$0.25	\$0.15	\$0.12	\$0.22	\$0.74	\$0.80	\$0.90
EPS (Diluted)	\$0.73	\$0.48	\$0.60	\$0.24	\$0.03	\$0.08	\$0.16	\$0.51	\$0.25	\$0.15	\$0.12	\$0.22	\$0.73	\$0.79	\$0.89

Source: Company reports; Scotia Capital estimates.

Exhibit 2.38: Boralex Inc. – Balance Sheet

	2005	2006	2007	Q108	Q208	Q308E	Q408E	2008E	Q109E	Q209E	Q309E	Q409E	2009E	2010E	2011E
Assets															
Current Assets															
Cash and cash equivalents	\$10,615	\$13,899	\$79,195	\$70,495	\$77,903	\$73,938	\$73,288	\$73,288	\$78,229	\$80,663	\$81,566	\$86,888	\$86,888	\$13,845	\$52,335
A/R	\$26,006	\$26,964	\$39,200	\$45,089	\$40,083	\$40,083	\$40,083	\$40,083	\$40,083	\$40,083	\$40,083	\$40,083	\$40,083	\$40,083	\$40,083
Inventory	\$5,232	\$5,342	\$8,002	\$6,582	\$6,944	\$6,944	\$6,944	\$6,944	\$6,944	\$6,944	\$6,944	\$6,944	\$6,944	\$6,944	\$6,944
Future Income Taxes	\$0	\$0	\$2,394	\$1,437	\$1,279	\$1,279	\$1,279	\$1,279	\$1,279	\$1,279	\$1,279	\$1,279	\$1,279	\$1,279	\$1,279
Prepays	\$1,955	\$2,776	\$2,171	\$2,824	\$2,699	\$2,699	\$2,699	\$2,699	\$2,699	\$2,699	\$2,699	\$2,699	\$2,699	\$2,699	\$2,699
	\$43,808	\$48,981	\$130,962	\$126,427	\$128,908	\$124,943	\$124,293	\$124,293	\$129,234	\$131,668	\$132,571	\$137,893	\$137,893	\$64,850	\$103,340
Investment	\$77,997	\$75,553	\$67,321	\$68,292	\$67,250	\$66,266	\$66,156	\$66,156	\$67,122	\$66,487	\$65,503	\$65,394	\$65,394	\$64,631	\$63,868
Property, plant and equipment	\$262,460	\$280,136	\$258,712	\$281,086	\$282,414	\$301,633	\$320,852	\$320,852	\$331,444	\$341,287	\$351,129	\$360,972	\$360,972	\$876,891	\$867,014
Electricity sales contracts	\$16,814	\$20,631	\$18,527	\$20,365	\$19,741	\$19,741	\$19,741	\$19,741	\$19,741	\$19,741	\$19,741	\$19,741	\$19,741	\$19,741	\$19,741
Future Income Taxes	\$7,979	\$6,249	\$0	\$0	\$0	\$0	\$0	\$0	\$0	\$0	\$0	\$0	\$0	\$0	\$0
Other Assets	\$20,457	\$44,480	\$39,209	\$56,416	\$60,088	\$60,088	\$60,088	\$60,088	\$60,088	\$60,088	\$60,088	\$60,088	\$60,088	\$60,088	\$60,088
Total Assets	\$429,515	\$476,030	\$514,731	\$552,586	\$558,401	\$572,670	\$591,129	\$591,129	\$607,629	\$619,271	\$629,032	\$644,087	\$644,087	\$1,086,201	\$1,114,051
Liabilities															
Current Liabilities															
Bank loans and advances	\$1,215	\$0	\$0	\$0	\$0	\$0	\$0	\$0	\$0	\$0	\$0	\$0	\$0	\$0	\$0
A/P and accrued liabilities	\$28,608	\$20,005	\$20,869	\$19,324	\$25,268	\$25,268	\$25,268	\$25,268	\$25,268	\$25,268	\$25,268	\$25,268	\$25,268	\$25,268	\$25,268
Income taxes	\$2,787	\$1,786	\$1,481	\$1,769	\$915	\$915	\$915	\$915	\$915	\$915	\$915	\$915	\$915	\$915	\$915
Current portion of long-term debt	\$37,802	\$41,835	\$26,786	\$27,573	\$27,142	\$36,000	\$36,000	\$36,000	\$36,000	\$36,000	\$36,000	\$36,000	\$36,000	\$36,000	\$36,000
	\$70,412	\$63,626	\$49,136	\$48,666	\$53,325	\$62,183	\$62,183	\$62,183	\$62,183	\$62,183	\$62,183	\$62,183	\$62,183	\$62,183	\$62,183
Long-Term Debt	\$164,832	\$192,493	\$148,747	\$160,143	\$156,942	\$159,259	\$170,434	\$170,434	\$174,708	\$178,982	\$183,256	\$187,530	\$187,530	\$587,365	\$568,064
Future Income taxes	\$28,026	\$20,780	\$23,430	\$28,759	\$24,265	\$25,498	\$27,890	\$27,890	\$31,560	\$33,834	\$35,600	\$38,838	\$38,838	\$50,676	\$63,879
Deferred Revenue	\$0	\$16,368	\$6,642	\$6,253	\$5,804	\$4,495	\$3,238	\$3,238	\$2,355	\$1,602	\$784	(\$2)	(\$2)	(\$2)	(\$2)
Fair value of derivatives	\$0	\$0	\$1,400	\$3,130	\$22,694	\$22,694	\$22,694	\$22,694	\$22,694	\$22,694	\$22,694	\$22,694	\$22,694	\$22,694	\$22,694
Non-controlling interest	\$1,034	\$730	\$607	\$714	\$737	\$737	\$737	\$737	\$737	\$737	\$737	\$737	\$737	\$737	\$737
Total Liabilities	\$264,304	\$293,997	\$229,962	\$247,665	\$263,767	\$274,866	\$287,176	\$287,176	\$294,237	\$300,032	\$305,253	\$311,980	\$311,980	\$723,653	\$717,554
Shareholders' Equity															
Capital Stock + Contributed Surplus	\$111,686	\$112,451	\$223,531	\$225,255	\$225,746	\$225,746	\$225,746	\$225,746	\$225,746	\$225,746	\$225,746	\$225,746	\$225,746	\$225,746	\$225,746
Retained Earnings	\$84,188	\$97,649	\$115,669	\$124,890	\$126,025	\$129,195	\$135,345	\$135,345	\$144,783	\$150,630	\$155,170	\$163,498	\$163,498	\$193,938	\$227,887
Acc. other comp. income	(\$30,663)	(\$28,067)	(\$54,431)	(\$45,224)	(\$57,137)	(\$57,137)	(\$57,137)	(\$57,137)	(\$57,137)	(\$57,137)	(\$57,137)	(\$57,137)	(\$57,137)	(\$57,137)	(\$57,137)
Total Shareholders Equity	\$165,211	\$182,033	\$284,769	\$304,921	\$294,634	\$297,804	\$303,954	\$303,954	\$313,392	\$319,239	\$323,779	\$332,107	\$332,107	\$362,547	\$396,496
Total Liabilities and Shareholders Equity	\$429,515	\$476,030	\$514,731	\$552,586	\$558,401	\$572,670	\$591,129	\$591,129	\$607,629	\$619,271	\$629,032	\$644,087	\$644,087	\$1,086,201	\$1,114,051

Source: Company reports; Scotia Capital estimates.

Exhibit 2.39: Boralex Inc. – Statement of Cash Flows

	2005	2006	2007	Q108	Q208	Q308E	Q408E	2008E	Q109E	Q209E	Q309E	Q409E	2009E	2010E	2011E
Operating Activities															
Earnings from continuing operations	\$21,088	\$14,721	\$21,545	\$9,221	\$1,135	\$3,170	\$6,150	\$19,676	\$9,438	\$5,847	\$4,540	\$8,328	\$28,154	\$30,440	\$33,949
Distributions received from the Fund	\$12,391	\$12,392	\$12,391	\$3,098	\$2,409	\$2,409	\$2,409	\$10,326	\$2,409	\$2,409	\$2,409	\$2,409	\$9,638	\$9,638	\$9,638
Items not affecting cash:															
Share in earnings of the Fund	(\$8,873)	(\$10,023)	(\$6,830)	(\$3,248)	(\$1,790)	(\$1,425)	(\$2,300)	(\$8,763)	(\$3,375)	(\$1,775)	(\$1,425)	(\$2,300)	(\$8,875)	(\$8,875)	(\$8,875)
Amortization	\$10,515	\$20,880	\$22,615	\$5,828	\$6,015	\$6,000	\$6,000	\$23,843	\$6,000	\$6,750	\$6,750	\$6,750	\$26,250	\$28,875	\$30,750
Amortization of deferred financing costs	\$477	\$475	\$1,807	\$708	\$724	\$500	\$500	\$2,432	\$500	\$500	\$500	\$500	\$2,000	\$2,000	\$2,000
Future income taxes	\$86	(\$5,100)	\$8,348	\$5,436	\$530	\$1,233	\$2,392	\$9,590	\$3,670	\$2,274	\$1,766	\$3,239	\$10,949	\$11,838	\$13,202
U.S Production Tax Credit	(\$11,039)	(\$9,870)	(\$4,460)	(\$1,093)	(\$395)	(\$1,309)	(\$1,257)	(\$4,054)	(\$883)	(\$753)	(\$818)	(\$786)	(\$3,240)	\$0	\$0
Unusual items	\$522	\$0	(\$5,875)	\$319	\$0	\$0	\$0	\$319	\$0	\$0	\$0	\$0	\$0	\$0	\$0
Other (incl. change in FV of energy swaps from 2005)	\$1,052	\$744	\$2,007	\$479	\$789	\$0	\$0	\$1,268	\$0	\$0	\$0	\$0	\$0	\$0	\$0
Cash flow from operations	\$26,219	\$24,219	\$51,548	\$20,748	\$9,417	\$10,578	\$13,894	\$54,637	\$17,760	\$15,252	\$13,722	\$18,140	\$64,875	\$73,916	\$80,664
Net change in non-cash working capital balances	(\$6,907)	(\$10,713)	(\$16,491)	(\$5,542)	\$9,140	\$0	\$0	\$3,598	\$0	\$0	\$0	\$0	\$0	\$0	\$0
	\$19,312	\$13,506	\$35,057	\$15,206	\$18,557	\$10,578	\$13,894	\$58,235	\$17,760	\$15,252	\$13,722	\$18,140	\$64,875	\$73,916	\$80,664
Investing Activities															
Business acquisitions	(\$18,642)	(\$6,749)	\$0	\$0	\$0	\$0	\$0	\$0	\$0	\$0	\$0	\$0	\$0	\$0	\$0
Purchases of property, plant and equipment	(\$135,753)	(\$19,201)	(\$21,859)	(\$3,997)	(\$9,231)	(\$25,219)	(\$25,219)	(\$63,666)	(\$16,593)	(\$16,593)	(\$16,593)	(\$16,593)	(\$66,370)	(\$544,794)	(\$20,873)
Proceeds on disposal of property, plant and equipment	\$400	\$0	\$0	\$0	\$0	\$0	\$0	\$0	\$0	\$0	\$0	\$0	\$0	\$0	\$0
Change in restricted funds held for the debt service	\$0	\$0	\$6,237	\$0	(\$25)	\$0	\$0	(\$25)	\$0	\$0	\$0	\$0	\$0	\$0	\$0
Reimbursement from lease financings	\$0	\$0	\$0	\$0	\$0	\$0	\$0	\$0	\$0	\$0	\$0	\$0	\$0	\$0	\$0
Development projects (and "Other")	(\$3,034)	(\$7,798)	(\$7,506)	(\$14,736)	(\$2,703)	\$0	\$0	(\$17,439)	\$0	\$0	\$0	\$0	\$0	\$0	\$0
	(\$157,029)	(\$33,748)	(\$23,128)	(\$18,733)	(\$11,959)	(\$25,219)	(\$25,219)	(\$81,130)	(\$16,593)	(\$16,593)	(\$16,593)	(\$16,593)	(\$66,370)	(\$544,794)	(\$20,873)
Financing Activities															
Bank loans and advances	\$19,637	(\$1,215)	\$0	\$0	\$0	\$0	\$0	\$0	\$0	\$0	\$0	\$0	\$0	\$0	\$0
Increase in long-term debt	\$136,108	\$69,629	\$151,437	\$0	\$0	\$20,175	\$20,175	\$40,350	\$13,274	\$13,274	\$13,274	\$13,274	\$53,096	\$435,835	\$16,699
Payments of long-term debt	(\$9,075)	(\$56,487)	(\$198,454)	(\$9,000)	(\$1,194)	(\$9,000)	(\$9,000)	(\$28,194)	(\$9,000)	(\$9,000)	(\$9,000)	(\$9,000)	(\$36,000)	(\$36,000)	(\$36,000)
Financing Costs	(\$2,547)	(\$1,167)	(\$2,011)	\$0	(\$151)	(\$500)	(\$500)	(\$1,151)	(\$500)	(\$500)	(\$500)	(\$500)	(\$2,000)	(\$2,000)	(\$2,000)
Net proceeds on issuance of shares (buyback)	\$12	\$273	\$105,307	\$1,466	\$238	\$0	\$0	\$1,704	\$0	\$0	\$0	\$0	\$0	\$0	\$0
Monetization program, net of related expenses	\$0	\$10,935	(\$593)	\$0	\$0	\$0	\$0	\$0	\$0	\$0	\$0	\$0	\$0	\$0	\$0
Other	(\$72)	\$0	(\$50)	\$0	\$4	\$0	\$0	\$4	\$0	\$0	\$0	\$0	\$0	\$0	\$0
	\$144,063	\$21,968	\$55,636	(\$7,534)	(\$1,103)	\$10,675	\$10,675	\$12,713	\$3,774	\$3,774	\$3,774	\$3,774	\$15,096	\$397,835	(\$21,301)
Translation adjustments on cash and cash equivalents	(\$1,173)	\$1,259	(\$2,269)	\$2,361	\$1,913	\$0	\$0	\$4,274	\$0	\$0	\$0	\$0	\$0	\$0	\$0
Net change in cash and cash equivalents from continuing ops	\$5,173	\$2,985	\$65,296	(\$8,700)	\$7,408	(\$3,966)	(\$650)	(\$5,907)	\$4,942	\$2,434	\$904	\$5,322	\$13,601	(\$73,043)	\$38,489
Net change in cash and cash equivalents from discontinued ops	\$0	\$0	\$0	\$0	\$0	\$0	\$0	\$0	\$0	\$0	\$0	\$0	\$0	\$0	\$0
Net change in cash and cash equivalents	\$5,173	\$2,985	\$65,296	(\$8,700)	\$7,408	(\$3,966)	(\$650)	(\$5,907)	\$4,942	\$2,434	\$904	\$5,322	\$13,601	(\$73,043)	\$38,489
Cash and cash equivalents - beginning of period	\$5,442	\$10,615	\$13,899	\$79,195	\$70,495	\$77,903	\$73,938	\$79,195	\$73,288	\$78,229	\$80,663	\$81,566	\$73,288	\$86,888	\$13,845
Cash and cash equivalents - end of period	\$10,615	\$13,600	\$79,195	\$70,495	\$77,903	\$73,938	\$73,288	\$73,288	\$78,229	\$80,663	\$81,566	\$86,888	\$86,888	\$13,845	\$52,335

Source: Company reports; Scotia Capital estimates.

Management & Directors

Borex's management strength runs deep. Bernard Lemaire is the founder, visionary, and Executive Chairman of the board of Borex. Mr. Lemaire's son, Patrick, joined Borex in 2006 as President and CEO. Mr. Jean-Francois Thibodeau, Borex's CFO since 2003, brings strong financial management experience to the team, having served as VP & Treasurer at CAE Inc. and as Treasurer for Transcontinental Group Ltd. In Exhibit 2.40, we present brief backgrounds of key management and directors of the corporation. In total, insiders and related entities control about 16.9% of Borex's fully diluted outstanding shares. Cascades Inc. owns slightly over 34%.

Exhibit 2.40: Management & Directors			
Name	Position	FD Shares Controlled Directly or Indirectly	Background
Patrick Lemaire	President and CEO	97,496	Mr. Lemaire has been CEO of Borex since September 2006 and a member of the board since June 2006. He is a member of the Environment, Health and Safety Committee. He was previously Vice-President and COO of Containerboard of Norampac Inc.
Jean-François Thibodeau	Vice-President and CFO	129,324	Mr. Thibodeau has been in his current position since October 6, 2003. Previously, Mr. Thibodeau was Vice-President and Treasurer of CAE Inc., since November 2001.
Sylvain Aird	General Counsel and Corporate Secretary	16,425	Mr. Aird has been in his current position since September 13, 2004. Previously, Mr. Aird was legal counsel for Abitibi-Consolidated Inc. from October 1996 to March 2004.
Bernard Lemaire	Board Chair	651,641	Mr. Lemaire has been Executive Chairman since 1995, was CEO from 2003 to September 2006 and is currently a member of the Administrative Committee. He has been a director of Cascades Inc. since 1964 and acts as chairman.
Germain Benoit	Director	70,000	Mr. Benoit is President of Capital Benoit Inc. He has been a director of Borex since 1995 and is a member of the Audit Committee and Corporate Governance Committee.
Allan Hogg	Director	1,650	Mr. Hogg is Director, Finance and Treasurer of Cascades Inc. He has been a member of Borex since 1996 and is a member of the Administrative Committee.
Edward H. Kernaghan	Director	5,235,400	Mr. Kernaghan is President of Principia Research Inc. and Executive Vice-President of Kernaghan Securities Inc. and Kernwood Ltd. He has been a director of Borex since June 2006 and is a member of the Corporate Governance Committee.
Richard Lemaire	Director	-	Mr. Lemaire is President of Séchoirs Kingsey Falls Inc. He has been a director of Borex since 1997 and is a member of the Environment, Health and Safety Committee.
Yves Rheault	Director	44,291	Mr. Rheault is a consultant and corporate director. Until October 2002, he was Vice-President, Business Development of Borex. He has been a member of the Board since 1997 and is a member of the Nominating and Compensation Committee.
Michelle Samson-Doel	Director	39,000	Ms. Samson-Doel is President of Groupe Samson-Doel Ltée and a corporate director. She has been a member of Borex since 2005 and is a member of the Audit Committee and the Nominating and Compensation Committee.
Pierre Seccareccia	Director	7,600	Mr. Seccareccia has been a director of Borex since 2003 and is a member of the Audit Committee, the Corporate Governance Committee, and the Nominating and Compensation Committee.
Gilles Shooner	Director	6,774	Mr. Shooner has been a director of Borex since 1996 and is a member of the Environment, Health and Safety Committee.
Other		258,072	
Total		6,557,673	
Fully Diluted Shares Outstanding		38,844,037	
% Insider Ownership (ex. Cascades Inc.)		16.9%	

Source: Company reports; SEDI; Scotia Capital.

Boralex's Corporate Structure

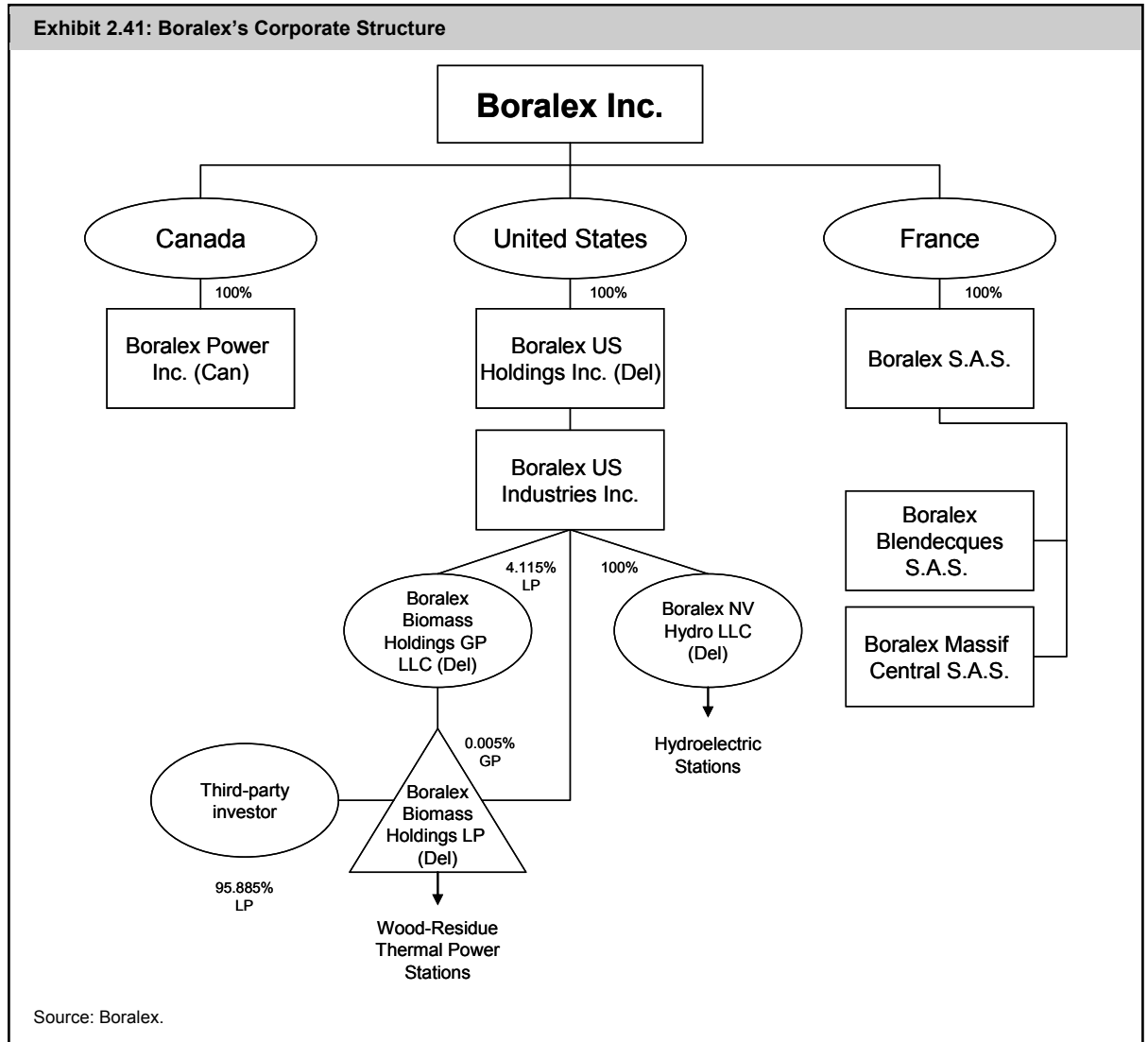

Canadian Hydro Developers Inc.

(KHD-T)

Aug 15, 2008:	\$4.38	1-Yr Target:	\$7.00	Capitalization	
Rating:	1-Sector Outperform	1-Yr ROR:	59.8%	Shares O/S (M)	143.5
Risk:	High	2-Yr Target:	\$7.50	Total Value (\$M)	628.5
IBES EPS 2008E	\$0.08	2-Yr ROR:	71.2%	Float O/S (M)	107.9
IBES EPS 2009E	\$0.23	Valuation:	75% DCF @ 9.5%; 25% NAV	Float Value (\$M)	472.5
Div. (Curr.):	\$0.00			TSX Weight	0.04%
Yield:	0.0%				

Qtly EPS (FD) (Next Release: Nov-08)

Y/E DECEMBER-31	Mar	Jun	Sep	Dec	Year	P/E
2007A	\$0.01A	\$0.01A	\$0.00A	\$0.04A	\$0.06	102.2x
2008E	\$0.01A	\$0.02A	\$0.00	\$0.04	\$0.08	54.6x
2009E	\$0.05	\$0.02	\$0.00	\$0.12	\$0.19	23.4x
2010E	\$0.07	\$0.05	\$0.01	\$0.12	\$0.25	17.3x

Industry Specific	2006A	2007A	2008	2009	2010
Production (GWh)	707	922	1,122	1,836	2,276

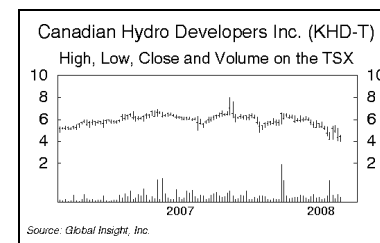

Note: Historical price multiple calculations use FYE price. Source: Reuters; company reports; Scotia Capital estimates.

The Best Bang for Your Renewable Buck

INVESTMENT HIGHLIGHTS

- Strong management track record.** With 19 years of experience under its belt, Canadian Hydro Developers (KHD) management has successfully executed on the development or acquisition of numerous projects within its portfolio.
- Production and EBITDA set to soar.** We anticipate the commissioning of over 400 MW (2.1x current capacity) of mostly contracted wind capacity over the next several years, which we believe will result in a 2011 EBITDA increase of about 300% over 2007.
- Execution hiccups present an opportunity.** A few permitting holdups have forced the delay of several KHD projects, resulting in slight cost overruns. However, KHD's current share price reflects too much of an execution risk discount and, therefore, we believe the company is undervalued.
- Stock catalysts over the coming 12 to 18 months are plentiful.** We expect to see near perfect execution on the commissioning of several new KHD facilities in 2008 and 2009. We look for KHD to bid up to 55 MW in the 2008 BC Hydro Clean Power Call and up to 70 MW in the Ontario RES III Request for Proposals (RFP). Dunvegan could be approved by Q1/09.
- Relative valuation attractive.** KHD is currently trading at 9.9x EV/2009E EBITDA and 7.6x EV/2010E EBITDA, quite low in our opinion. Our target EV/EBITDA multiple is 10.25x on 2010E EBITDA, which drops to 10.1x on 2011E. We think these multiples are justified by the high growth we expect KHD to realize over the coming years. KHD is also trading at 0.6x our NAV, relative to our group average of 0.8x.
- We have transferred coverage of the common shares of Canadian Hydro Developers, maintaining a 1-Sector Outperform rating and a one-year target price of \$7.00 per share.** Our valuation is based on a 75%-weighted discounted cash flow approach, using a 9.5% discount rate, and a 25% net asset value calculation.

Summary & Investment Recommendation

Canadian Hydro Developers' 364 MW of operating assets are well diversified, both regionally and by renewable technology. Its installed capacity is spread among B.C., Alberta, Ontario, and Quebec, and we believe that Manitoba could be added to its portfolio within the next several years. In the short to mid-term, we see over 400 MW of new capacity coming online, which KHD will need to execute near seamlessly. To further spread its wings, KHD may pierce the solar market, after having recently entered into a no-risk/no-cost 10 MW Ontario Standard Offer Contract. Lastly, we think a final decision on KHD's 100 MW Dunvegan hydro project in Alberta could come down before the year is out. If commissioned on-time and within budget, this project could add up to \$1.50 per share to KHD's stock price.

We have transferred coverage of the common shares of KHD, maintaining a 1-Sector Outperform rating and a one-year target price of \$7.00 per share. Our valuation is based on a 75%-weighted discounted cash flow approach, using a 9.5% discount rate, and a 25% net asset value calculation.

FINANCIAL OUTLOOK

We estimate 2008 EPS at 8¢, in line with consensus. Looking into 2009, we think EPS will grow to 19¢. We forecast \$54.7 million of EBITDA in 2008, which grows to \$112.3 million in 2009 and to \$146.5 million by 2010. Our financial forecast is predicated on the following capacity being commissioned: Melancthon II (Q4/08), Wolfe Island (Q2/09), Island Falls (Q4/09), and several B.C. run-of-river projects (Q4/09). On a per MWh basis, we think EBITDA will grow from \$41/MWh in 2007 to \$61/MWh in 2009, and to \$66/MWh by 2011.

RELATIVE VALUATION

KHD is currently trading at 9.9x EV/2009E EBITDA and 7.6x EV/2010E EBITDA, quite low in our opinion (Exhibit 3.1). Our target EV/EBITDA multiple is 10.25x on 2010E EBITDA, which drops to 10.1x on 2011E. We think these multiples are justified by the high growth we expect KHD to realize over the coming years. KHD is also trading at 0.6x our NAV, relative to our group average of 0.8x.

Exhibit 3.1: Canadian Hydro Developers Inc. – Relative Valuation Metrics											
Company	Ticker	Last Price	SC Rating	1-Year Target	1-Year ROR	DCF	NAV	Market Cap	Enterprise Value to EBITDA		
									2008E	2009E	2010E
		8/15/2008						(\$M)	(x)	(x)	(x)
Boralex	BLX	\$14.80	1-SO	\$18.00	22%	\$18.33	\$17.03	\$560	9.9x	8.6x	7.6x
Canadian Hydro Developers	KHD	\$4.38	1-SO	\$7.00	60%	\$7.04	\$6.95	\$628	20.3x	9.9x	7.6x
Earthfirst Canada	EF	\$0.27	3-SU	\$0.40	48%	\$0.35	\$0.60	\$28	n.m.	-5.5x	-0.9x
Innergex Renewable Energy	INE	\$8.25	3-SU	\$9.50	15%	\$9.44	\$9.55	\$194	n.m.	18.4x	7.8x
Plutonic Power	PCC	\$7.04	2-SP	\$9.00	28%	\$9.03	\$8.75	\$297	n.m.	n.m.	n.m.
Average					35%			\$341	15.1x	7.8x	5.5x
Company	Ticker	Beta	Price to Earnings			Price to Sales			Price to Cash Flow		
			2008E	2009E	2010E	2008E	2009E	2010E	2008E	2009E	2010E
			(x)	(x)	(x)	(x)	(x)	(x)	(x)	(x)	(x)
Boralex	BLX	0.7	28.8x	20.2x	18.6x	2.6x	2.5x	2.3x	10.4x	8.7x	7.7x
Canadian Hydro Developers	KHD	0.5	54.6x	23.4x	17.3x	7.2x	3.9x	3.1x	16.0x	9.0x	6.6x
Earthfirst Canada	EF	-	n.m.	n.m.	n.m.	n.m.	5.5x	0.9x	n.m.	n.m.	5.6x
Innergex Renewable Energy	INE	-	n.m.	n.m.	25.5x	27.5x	8.3x	4.2x	n.m.	33.6x	10.2x
Plutonic Power	PCC	0.9	n.m.	n.m.	n.m.	n.m.	n.m.	n.m.	n.m.	n.m.	n.m.
Average		0.7	41.7x	21.8x	20.5x	12.4x	5.1x	2.6x	13.2x	17.1x	7.5x

Source: Bloomberg; Scotia Capital estimates.

Capital Markets Profile

KHD operates 20 facilities with a net ownership capacity of 364 MW.

Over 75% of its generated electricity is sold under long-term power contracts to investment-grade counterparties.

Canadian Hydro Developers is a developer, builder, and operator of Canadian renewable power facilities. **The company currently operates 20 power generation facilities with a net ownership capacity of 364 MW**, broken down as 12 hydroelectric generating stations (net 86 MW), seven wind (253 MW), and one biomass plant (25 MW). **Over 75% of its generated electricity is sold under long-term power contracts** to investment-grade counterparties, with the remainder sold on the Alberta spot market. KHD is constructing two wind farms in Ontario that are due online in Q4/08 (Melancthon II – 132 MW) and in Q1/09 (Wolfe Island 197.8 MW). It also intends to commence construction shortly of another 150+ MW of fully contracted wind and hydro facilities in B.C., Ontario, and Quebec. Additionally, the company has over 1,600 MW of undeveloped renewable power prospects, including its 100 MW Dunvegan hydro project in Alberta.

In mid-1989, and two years after incorporating as Oilco Resources Ltd., the company acquired a private firm that was developing a hydroelectric opportunity. Following the acquisition and amalgamation of the private firm, KHD changed its strategy to focus solely on renewable power development, and as a result, Canadian Hydro Developers Inc. was born. With over 35 years of combined Canadian renewable power experience, the founding Keating brothers, John (CEO) and Ross (President), are backed by Kent Brown (EVP & CFO) who has been with KHD for seven years, Ann Hughes (Corporate Secretary) who joined KHD in the mid-1990s, and Keith O’Regan, KHD’s new COO. Executive management is well supported by the company’s board of directors, which includes former Alberta premier Ralph Klein.

With a market capitalization of over \$600 million, Canadian Hydro Developers’ shares trade on the Toronto Stock Exchange under the symbol KHD-T; they also trade on the Berlin Stock Exchange. Insiders control about 5% of outstanding KHD shares, and the company’s shareholder base is regionally split 40% Canada, 40% Europe, and 20% United States. KHD reports in Canadian dollars, using a December 31 year-end, and its financial statements are prepared in accordance with GAAP. Exhibit 3.2 shows KHD’s recent share price performance.

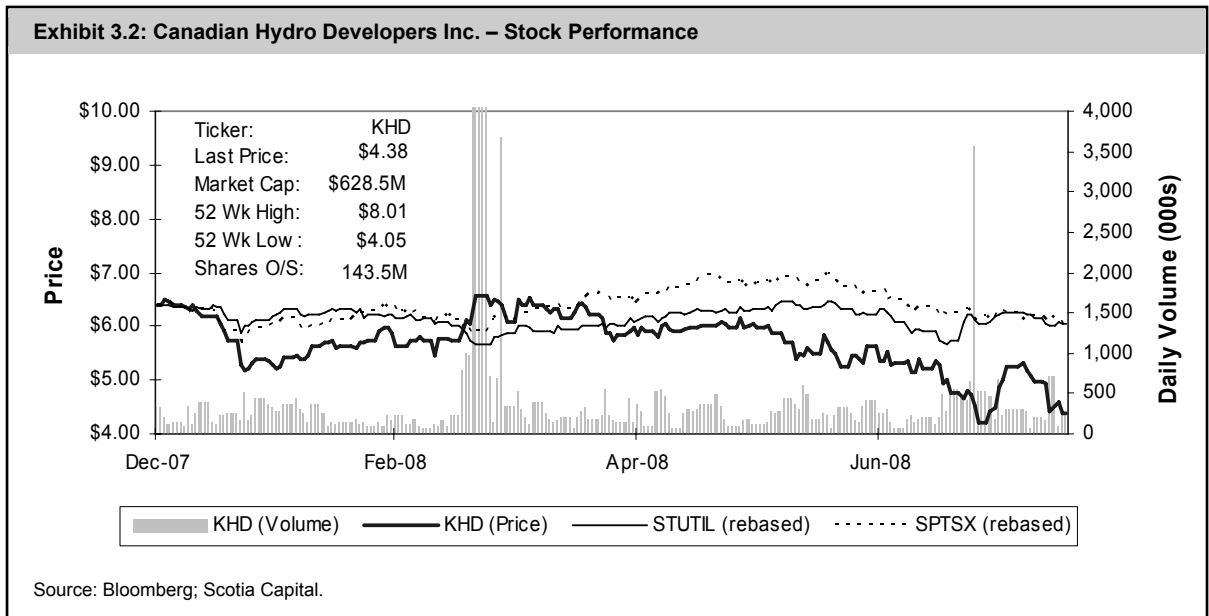

When Will Canadian Hydro Developers Need New Equity?

In its Q2/08 MD&A, KHD noted that it will likely not require new equity to finance its current capital expenditure plan through 2012, as its cash flow from operations should make up any shortfall of current and anticipated facilities. Its capex plan through 2012 includes the following projects: Melancthon II, Wolfe Island, Royal Road, Clemina Creek, Bone Creek, Serpentine Creek, English Creek, St. Valentin, and New Richmond (Exhibit 3.3).

We believe there are several scenarios under which KHD will require new equity to finance several power projects that are not included in its current capex plan.

Exhibit 3.3: No New Equity for KHD's Current Plan

Funding Sources		Funding Uses	
	(\$M)		(\$M)
Current construction facilities	412.5	Melancthon II	285.0
Anticipated construction facilities	302.7	Wolfe Island	450.0
Undrawn operating credit facility	5.4	Island Falls	35.5
Working capital surplus	37.0	Royal Road	40.0
Future cash flow from operations	60.4	English	10.0
		Serpentine	22.0
		Clemina	27.0
		Bone	49.0
		New Richmond	190.0
		St. Valentin	160.0
		Spent to date	(450.4)
	818.1		818.1

Source: Company reports; Scotia Capital estimates.

However, we believe there are several scenarios under which KHD will likely require new equity to finance several power projects that are not included in its current plan (Exhibit 3.4). Our table has been sensitized by an average installed cost per MW as well as the number of megawatts to be financed. Our primary assumption in Exhibit 3.4 is that KHD finances its future projects using its target capital structure of 65%/35% debt/equity. KHD could need \$100 million in new equity for Dunvegan and another \$100+ million for 125 MW of projects that we believe will be bid shortly. Exhibit 3.5 summarizes KHD's portfolio of both operating and development projects.

KHD could need about \$200 million in new equity if Dunvegan and another 125 MW of projects that are expected to be bid shortly are approved.

Exhibit 3.4: KHD Could Require \$200M of Equity for Dunvegan and 125 MW of Projects Soon to Be Bid

		Weighted Average Installed Cost per MW (\$M)								
		1.75	2.00	2.25	2.50	2.75	3.00	3.25	3.50	
Hydro in British Columbia	0	\$0M	\$0M	\$0M	\$0M	\$0M	\$0M	\$0M	\$0M	
	25	\$15M	\$18M	\$20M	\$22M	\$24M	\$26M	\$28M	\$31M	
	50	\$31M	\$35M	\$39M	\$44M	\$48M	\$53M	\$57M	\$61M	
	55	\$34M	\$39M	\$43M	\$48M	\$53M	\$58M	\$63M	\$67M	
	70	\$43M	\$49M	\$55M	\$61M	\$67M	\$74M	\$80M	\$86M	
	75	\$46M	\$53M	\$59M	\$66M	\$72M	\$79M	\$85M	\$92M	
	Dunvegan	100	\$61M	\$70M	\$79M	\$88M	\$96M	\$105M	\$114M	\$123M
		125	\$77M	\$88M	\$98M	\$109M	\$120M	\$131M	\$142M	\$153M
		150	\$92M	\$105M	\$118M	\$131M	\$144M	\$158M	\$171M	\$184M
		175	\$107M	\$123M	\$138M	\$153M	\$168M	\$184M	\$199M	\$214M
200		\$123M	\$140M	\$158M	\$175M	\$193M	\$210M	\$228M	\$245M	
All of the above	225	\$138M	\$158M	\$177M	\$197M	\$217M	\$236M	\$256M	\$276M	
	250	\$153M	\$175M	\$197M	\$219M	\$241M	\$263M	\$284M	\$306M	
	275	\$168M	\$193M	\$217M	\$241M	\$265M	\$289M	\$313M	\$337M	
	300	\$184M	\$210M	\$236M	\$263M	\$289M	\$315M	\$341M	\$368M	
	325	\$199M	\$228M	\$256M	\$284M	\$313M	\$341M	\$370M	\$398M	
	350	\$214M	\$245M	\$276M	\$306M	\$337M	\$368M	\$398M	\$429M	
	375	\$230M	\$263M	\$295M	\$328M	\$361M	\$394M	\$427M	\$459M	
	400	\$245M	\$280M	\$315M	\$350M	\$385M	\$420M	\$455M	\$490M	
	425	\$260M	\$298M	\$335M	\$372M	\$409M	\$446M	\$483M	\$521M	
	450	\$276M	\$315M	\$354M	\$394M	\$433M	\$473M	\$512M	\$551M	
475	\$291M	\$333M	\$374M	\$416M	\$457M	\$499M	\$540M	\$582M		
500	\$306M	\$350M	\$394M	\$438M	\$481M	\$525M	\$569M	\$613M		

Source: Scotia Capital estimates.

Exhibit 3.5: KHD's Portfolio of Assets and Development Prospects

Project/Site	Location	Net	Est.	Capacity	Power	PPA	Status/Est. Cost	
		Cap.	Pdn	Factor	Purchaser	Expiry	Low	High
		(MW)	(GWh/y)	(%)			(\$M)	(\$M)
Hydro								
Belly River	Alberta	3.0	12.0	45.7%	AB Pool	2011	Online	
Waterton	Alberta	2.8	12.4	50.6%	AB Pool	2012	Online	
St. Mary	Alberta	2.3	12.6	62.5%	AB Pool	2012	Online	
Taylor (hydro)	Alberta	6.5	22.1	38.8%	AB Spot	-	Online	
Akolkolex	B.C.	10.0	52.7	60.2%	BC Hydro	2015	Online	
Pingston	B.C.	22.5	89.0	45.2%	BC Hydro	2023	Online	
Upper Mamquam	B.C.	25.0	98.2	44.8%	BC Hydro	2025	Online	
Ragged Chute	Ontario	6.6	36.1	62.4%	Constellation	2011	Online	
Moose Rapids	Ontario	1.3	5.7	50.1%	Constellation	2011	Online	
Appleton	Ontario	1.4	6.6	53.8%	Constellation	2011	Online	
Galetta	Ontario	1.6	7.9	56.4%	Constellation	2011	Online	
Misema	Ontario	3.2	13.3	47.4%	OPA	2027	Online	
Bone Creek	B.C.	18.0	73.0	46.3%	BC Hydro	2029	49.0	53.9
Clemina Creek	B.C.	11.0	33.0	34.2%	BC Hydro	2049	27.0	29.7
Serpentine Creek	B.C.	9.6	34.0	40.4%	BC Hydro	2049	22.0	24.2
English Creek	B.C.	5.0	20.0	45.7%	BC Hydro	2049	10.0	11.0
Island Falls	Ontario	10.0	46.7	53.3%	OPA	2029	35.5	39.1
Dunvegan	Alberta	100.0	600.0	68.5%	-	-	300.0	330.0
(Hydro various)	B.C.	260.0	1,024.9	~45.0%	-	-	615.0	1,014.7
Wind								
Cowley Ridge	Alberta	21.4	55.0	29.3%	AB Pool	2013	Online	
Cowley North	Alberta	19.5	47.6	27.9%	AB Spot	-	Online	
Sinnot	Alberta	6.5	15.4	27.0%	AB Spot	-	Online	
Taylor (wind)	Alberta	3.4	6.6	22.2%	AB Spot	-	Online	
Soderglen	Alberta	35.3	119.8	38.8%	AB Spot	-	Online	
Melancthon I	Ontario	67.5	194.8	32.9%	OPA	2026	Online	
Le Nordais	Quebec	99.0	165.0	19.0%	Hydro-Quebec	2033	Online	
Melancthon II	Ontario	132.0	350.6	30.3%	OPA	2028	285.0	285.0
Wolfe Island	Ontario	197.8	593.5	34.3%	OPA	2028	450.0	450.0
Royal Road	Ontario	18.0	47.3	30.0%	OPA	2030	40.0	44.0
New Richmond	Quebec	66.0	178.7	30.9%	Hydro-Quebec	2032	190.0	209.0
St. Valentin	Quebec	50.0	143.9	32.9%	Hydro-Quebec	2032	160.0	176.0
(AB wind various)	Alberta	75.0	197.1	~30.0%	-	-	118.3	195.1
(MB wind various)	Manitoba	1,000.0	2,628.0	~30.0%	-	-	1,576.8	2,601.7
(ON wind various)	Ontario	127.0	333.8	~30.0%	-	-	200.3	330.4
Biomass								
Grande Prairie	Alberta	25.0	162.7	74.3%	Various	Various	Online	
Total		2,443.2	7,439.9					

Source: Company reports; Scotia Capital estimates.

Production Profile & Outlook

WIND — KHD'S BREAD & BUTTER

Wind power represents about 70% of KHD's portfolio of operating assets.

Canadian Hydro Developers owns 252.6 MW of operating wind power capacity, which represents slightly less than 70% of its portfolio of operating assets. About 86 MW of this capacity is situated in Alberta, almost all of which sells electricity into the local spot power market. Melancthon I (67.5 MW), KHD's only operating wind farm in Ontario, has a long-term contract with the Ontario Power Authority that expires in 2026. Similarly, its only Quebec facility, Le Nordais (99 MW), has a long-term contract with Hydro-Quebec that expires in 2033. The overall capacity factor for its operating wind farms is 27.3%.

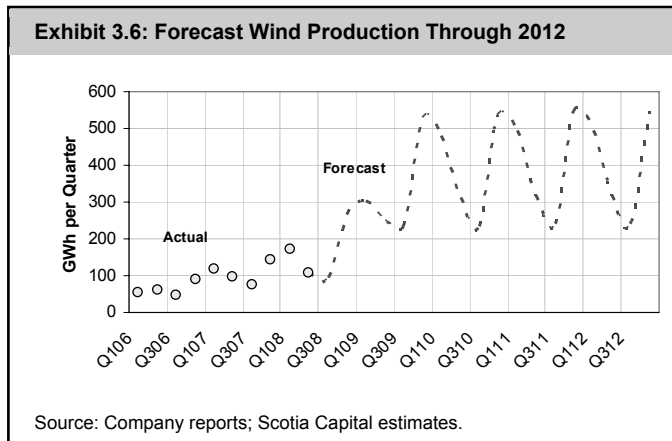

We expect 1,313 GWh generated from wind power in 2009, or 2x our 2008 forecast of 641 GWh and 3x actual 2007 wind generation of 431 GWh. Exhibit 3.6 shows our quarterly forecast for KHD's wind operations through 2012.

KHD continues to add new wind capacity to its portfolio, either through the construction of new projects or through the acquisition of existing ones. Two of its larger wind farms, Soderglen (35.25 MW) in Alberta, and Le Nordais (99 MW) in Quebec, were acquired by KHD in the past

two years. Both facilities have expansion potential, although in May 2008, KHD decided to shelve its 70 MW Le Nordais expansion project in favour of being awarded a 66 MW PPA by Hydro-Quebec. The company expects 132 MW (Melancthon II) of new wind capacity to be online by the end of 2008, 197.8 MW (Wolfe Island) in 1H/09, 18 MW (Royal Road) by the end of 2010, and 116 MW by the end of 2012 (New Richmond and St. Valentin). Additionally, KHD has 1,200+ MW of wind development prospects.

HYDRO – SLOW AND STEADY GROWTH

Almost all of KHD's hydro facilities operate under long-term contracts that expire between 2011 and 2027. The hydro facilities are geographically dispersed among British Columbia (57.5 MW), Alberta (14.6 MW), and Ontario (14.1 MW). As a result, production volatility due to seasonality is somewhat muted.

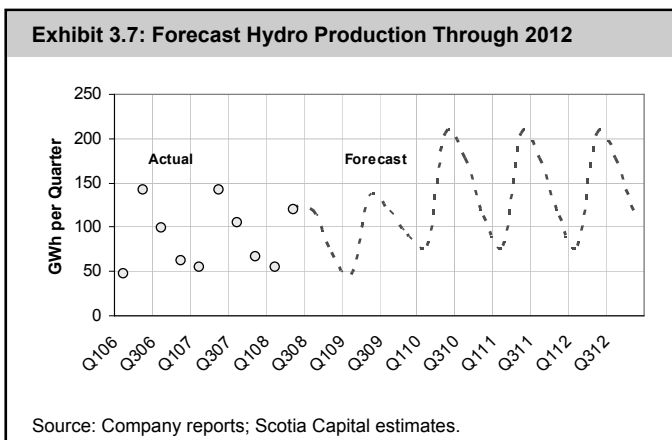

Five hydro projects, totalling 53.6 MW, are due to be constructed and commissioned before the end of 2009. Additionally, KHD is pursuing the development of multiple other hydro projects in B.C. (~260 MW) as well as its 100 MW Dunvegan facility in Alberta.

We expect 364 GWh and 390 GWh to be generated from KHD's hydro portfolio in 2008 and 2009, respectively, about flat with its 2007 hydro generation. Exhibit 3.7 shows our quarterly forecast for KHD's hydro operations through 2012.

Five hydro projects totalling 53.6 MW are due to be commissioned before the end of 2009.

BIOMASS – IMPROVEMENT EXPECTED OVER TIME

Production at KHD’s Grand Prairie EcoPower Centre has been disappointing to date, but we are optimistic that planned improvements will be implemented successfully.

KHD owns and operates a 25 MW wood-waste biomass facility in Alberta that is able to produce up to 162.7 GWh/y of energy and 300,000 GJ/y of steam. The \$65 million Grand Prairie EcoPower Centre (GPEC) consumes 220,000 tonnes of wood waste annually, and is CO₂ neutral. Ninety percent of power generation is sold through long-term contracts with Canfor (to 2019), the City of Grand Prairie (to 2019), and Alberta Infrastructure (to 2024). Power output in 2007 was 123.7 GWh (56.5%), up from 105.1 GWh

(48%) the previous year, but not close to its 162.7 GWh potential. We expect to see operational improvements at the facility soon. Q1/08 production at GPEC was a disappointment, having generated 21 GWh versus our estimated 40.2 GWh.

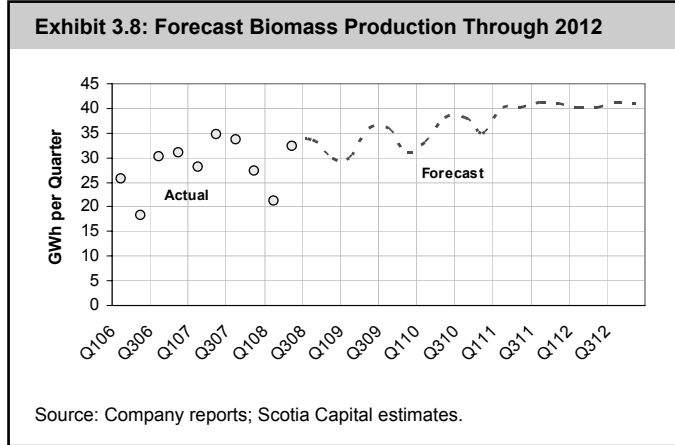

We expect production of 117 GWh will be generated from KHD’s biomass operations in 2008, which should improve to 133 GWh by 2009. Exhibit 3.8 shows our quarterly forecast for KHD’s biomass operations through 2012.

Alberta Spot Power Price Volatility Increasing...

The volatility of merchant power prices in the Alberta spot market has doubled since 2002/03.

A surge in Alberta power demand due in part to the oil sands boom, coupled with little new electricity capacity growth, has resulted in wildly volatile spot power prices there. During the past couple of years, daily average pool prices have, at several times, soared to over \$500/MWh. Our calculations show that **the volatility of power prices in the Alberta spot market has doubled since 2002/03**. We do not believe there are any direct or material valuation implications from this increased volatility. However, if KHD's merchant portion of its power portfolio increases in weight, then the stability of its earnings may decline.

...But KHD's Proportionate Exposure Should Decline

Rational investors **should** prefer more certainty over less certainty; therefore, a reduction in the company's proportionate exposure to unpredictable spot power prices should be viewed by the market as favourable. However, rising Alberta power prices represents significant upside for those companies that have fixed or no

fuel costs for their power production, including KHD. **We believe that Canadian Hydro will gradually reduce its earnings exposure to the Alberta spot power market to 12% by 2011, and to 8% by 2015** (Exhibit 3.9), as 400 MW to 500 MW of new and fully contracted capacity should be online by then.

We estimate that a \$10/MWh increase in the Alberta spot price, sustained for a year, will increase KHD's annual earnings by 1.8¢ per share, based on current production levels (Exhibit 3.10).

We think KHD's merchant power exposure will decline to 12% by 2011, from about 22% today.

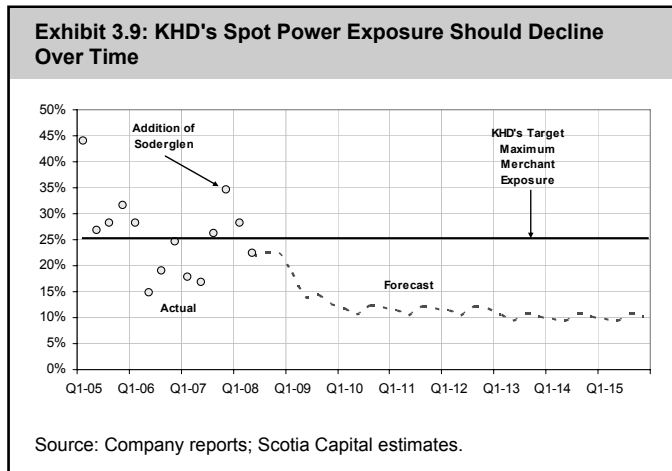

Exhibit 3.10: KHD's EPS Sensitivity to Alberta Merchant Price Changes

		Incremental Increase in Alberta Power Prices					
		\$1/MWh	\$2/MWh	\$5/MWh	\$10/MWh	\$20/MWh	\$50/MWh
Months	3	0.0¢	0.1¢	0.2¢	0.5¢	0.9¢	2.3¢
	6	0.1¢	0.2¢	0.5¢	0.9¢	1.8¢	4.5¢
	9	0.1¢	0.3¢	0.7¢	1.4¢	2.7¢	6.8¢
	12	0.2¢	0.4¢	0.9¢	1.8¢	3.6¢	9.0¢

Source: Scotia Capital estimates.

Mixed Reactions on KHD's Recent Acquisitions

Only some of KHD's acquisitions have been viewed favourably by the stock market.

Canadian Hydro Developers has completed numerous acquisitions to expand its portfolio of operating assets as well as its development pipeline. In our opinion, **only some of KHD's acquisitions have been viewed favourably by the market.** Below, we assess KHD's more recent transactions.

VECTOR WIND ENERGY INC.

Transaction highlights. December 2006 saw KHD purchase Vector Wind Energy for \$6.3 million. Vector offered KHD about 1,000 MW of wind energy prospects mainly in Manitoba, as well as the Royal Road project, and some development prospects in Eastern Canada. KHD's decision to purchase the Manitoba wind development prospects was premised on Manitoba Hydro's stated commitment to materially increase its installed wind capacity over the coming years by 900 MW to 1,000 MW.

The success of the transaction has been mixed to date. In December 2007, KHD announced that it had not been selected by Manitoba Hydro for 300 MW of wind power RFP negotiations. The company anticipates bidding in upcoming Manitoba Hydro wind RFPs over the coming years, likely totalling a further 600 MW. In mid-2007, KHD sold its 21 MW Fairfield Hill wind prospect located in New Brunswick to TransAlta for \$1.27 million. The 27 MW Fermeuse wind project in Newfoundland was also sold, for about \$0.5 million.

GW POWER CORPORATION

Transaction highlights. KHD announced the February 2007 acquisition of GW Power Corporation for \$87 million, or \$72.6 million after applying working capital deficiencies. The acquisition included (1) a 50% interest in Soderglen, a 70.5 MW wind farm in southern Alberta with a high 38.9% capacity factor; (2) 75 MW of wind prospects in Alberta; and (3) 70 MW of wind prospects in Ontario. In addition to selling Soderglen's power into the Alberta spot market, the facility qualified for a \$10/MWh federal Wind Power Production Incentive (WPPI).

After reducing the purchase price by \$14.4 million for working capital deficiencies, **\$2.06 million per installed MW seems reasonable for a wind farm that produces at a near 40% capacity factor.** Additionally, our research indicates that the Alberta and Ontario prospects of 145 MW are more than just "brag-a-watts." If we give \$0.1 million per prospective MW, the transaction price for Soderglen falls further to \$1.92 million. At this price, we view the acquisition as quite good, considering both the strength of the plant's ability to capture the wind resource, the WPPI incentive, and the upside potential of the spot market.

LE NORDAIS WIND PLANT

Transaction highlights: In November 2007, Canadian Hydro purchased the Quebec-based 99 MW Le Nordais Wind Plant for \$120.75 million (including debt and transaction costs). At the time, the facility had been in operation for eight years, with its power being sold to Hydro Quebec under a long-term PPA that expires at the end of 2033. The acquisition also includes a possible expansion at the site by up to 70 MW.

The transaction cost of about \$1.2 million per MW (excluding expansion opportunities) is quite inexpensive and impressive, although further investment will be required by KHD to raise the wind farm's capacity factor above its low 19%. We believe that over the next several years, KHD will work to increase the wind farm's availability, resulting in an overall capacity factor increase to between 21% and 22%. As part of the Quebec wind farm acquisition, KHD (negatively) surprised equity markets by also announcing a \$55 million bought deal (8.8 million shares @ \$6.25/share) to finance the transaction.

Key Investment Risks

In our opinion, execution risk is the largest threat to our target price for Canadian Hydro Developers. Similar to its IPP peers, KHD faces numerous other risks that could negatively impact its share price, all of which are not unique to the company. Below, we have highlighted the key investment risks to our one-year target price for KHD.

PERMITTING & EXECUTION RISK

On the one hand, Canadian Hydro Developers has been extremely successful over its 19-year history at successfully bringing numerous renewable power prospects into its portfolio of profitable operating assets. On the other hand, several delays and cost overruns over the past two years have likely hurt the company's share price. With approximately 1,135 GWh/y of annual electricity generation in operation and another 3,000 GWh/y at various stages of development, a significant portion of our target price is contingent upon management's successful execution of the company's prospects, not all of which will be realized.

At its worst, permitting delays can almost terminate a project, as we have seen with KHD's 100 MW Alberta-based hydro prospect Dunvegan. Permitting delays can result from as little as one person filing an objection to a project. This is different from a simple denial of a project permit due to, for example, fish habitat concerns. Even if permitting is finally approved for a renewable power prospect to move forward, the length of delays can sometimes materially alter the project's economics, calling into question the viability of the project.

COMMODITY & FUEL PRICE RISKS

Well over 200 GWh of KHD's annual power generation is exposed to the volatile Alberta wholesale spot power market (Exhibit 3.11). At times, this market can be highly unpredictable. We estimate that a \$10/MWh increase in the Alberta spot price, sustained for a year, will increase KHD's annual earnings by 1.8¢ per share, based on current production levels.

Execution risk is the largest threat to our target price for Canadian Hydro Developers.

We estimate that a \$10/MWh increase in the Alberta spot price, sustained for a year, will increase annual EPS by 1.8¢.

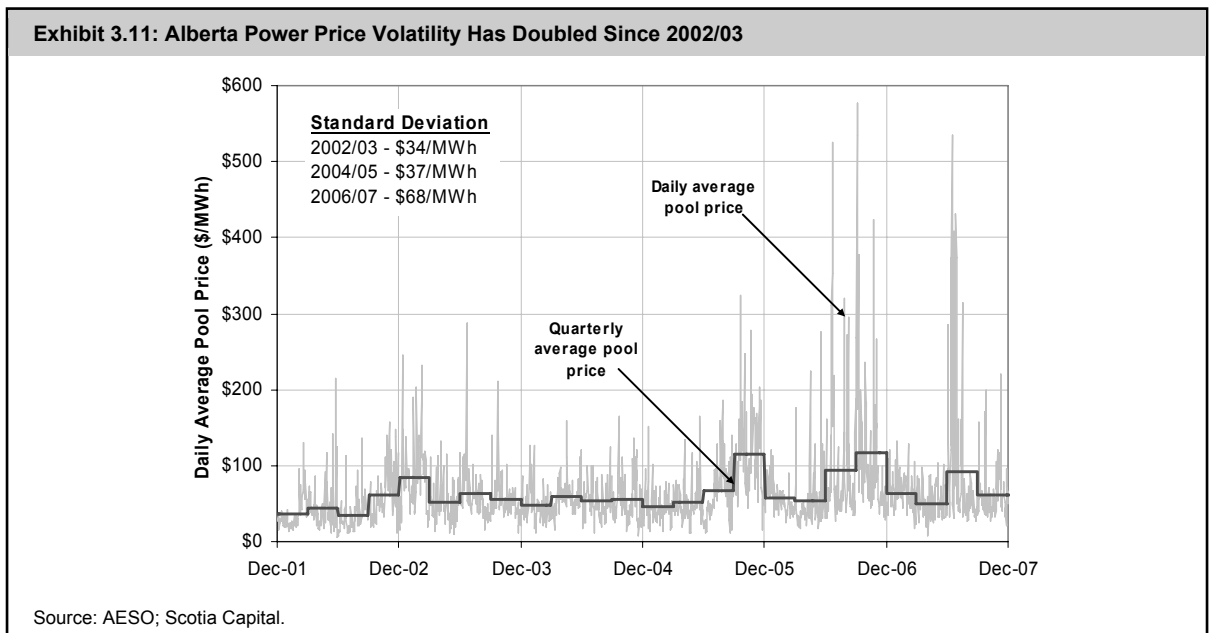

The company's 25 MW biomass facility in Alberta purchases up to 220,000 tonnes/y of wood waste annually from Canfor, one of the plant's power and steam output customers. Despite a long-term wood waste purchase agreement, the Canadian lumber industry continues to decline, and the viability of Canfor's lumber mill in Grand Prairie that supplies wood waste to GPEC could face closure risk. However, KHD is indemnified by Canfor should the mill close.

WEATHER & CLIMATE CHANGE

KHD's wind farms and hydro facilities are subject to unpredictable weather and climate patterns that may lead to material deviations from our quarterly production forecast.

KHD's wind farms and hydro facilities are subject to unpredictable weather and climate patterns that may lead to material deviations from our quarterly production forecast. As partial mitigation to this risk, KHD is diversified both regionally and by technology, which should somewhat "weather" the impact of large changes in expected production at any given facility.

REGULATORY & POLITICAL ENVIRONMENT

Transforming KHD's pipeline of prospects into operational assets depends heavily on the continuation of favourable federal and provincial initiatives that promote the development of renewable power as a viable alternative to traditional coal- and gas-fired power generation technologies. Our financial forecast assumes that current federal and provincial renewable power incentives, targets, and initiatives will continue.

FIRST NATIONS SUPPORT

Part of the Environmental Assessment process is a duty to consult with all stakeholders of a project, which may or may not include First Nations groups that once claimed a project's site as traditional land. Ultimately, the duty of First Nations relations rests with the Crown. However, without the support of local First Nations communities, KHD's projects could be delayed. As a result, **KHD has reached settlements with various First Nations bands that support the construction of projects on their traditional land.**

FINANCING

Given current credit market conditions and credit risk repricing, KHD's cost of capital may increase and its access to capital could be constrained going forward. Unlike some of its junior peers like EarthFirst and Plutonic Power, Canadian Hydro Developers already generates significant free cash flow and therefore its overall reliance on capital markets is of relatively less concern.

MANAGEMENT

Key management risk is normal at KHD.

Key management risk is normal at KHD. Canadian Hydro is heavily dependent on the founding Keating brothers as well as its EVP & CFO, Kent Brown, to promote the company and realize its future growth opportunities. On October 31, 2007, KHD announced the installation of a new COO that only lasted several months. Since then, a new COO has been hired, as well as a General Counsel. While we don't expect the Keating brothers to leave KHD within the next 12 months, we believe that KHD's succession planning to date has laid an appropriate foundation for a smooth transition. Please refer to Exhibit 3.29 for further details.

OPERATIONAL

We believe operational risk is medium for KHD due to its substantial geographic and technological diversification. The nature of multiple-turbine wind farms allow for one to several wind turbines to be offline at any given time without a major impact to the operation of the facility, not to mention the earnings of the overall company. With renewable power facilities sprouting up daily across Canada and around the world, forecasting O&M costs has become fairly effortless. High inflationary periods as well as repair costs for materially damaged or failed machinery are typically covered by insurance.

Upcoming Stock Catalysts & Events

Similar to most Canadian renewable power developers, we see many events over the next two years that could significantly move Canadian Hydro Developers' share price. In our view, awards of new capacity, the commissioning of new capacity, and movement on the delayed Dunvegan will likely have the most material impacts on KHD's share price. Below, we have listed what we believe to be the more major short- to mid-term stock catalysts for KHD.

In Q4/08, watch for a Dunvegan update, the commissioning of Melancthon II, and KHD's bid into the 2008 BC Hydro Clean Power Call (~55 MW).

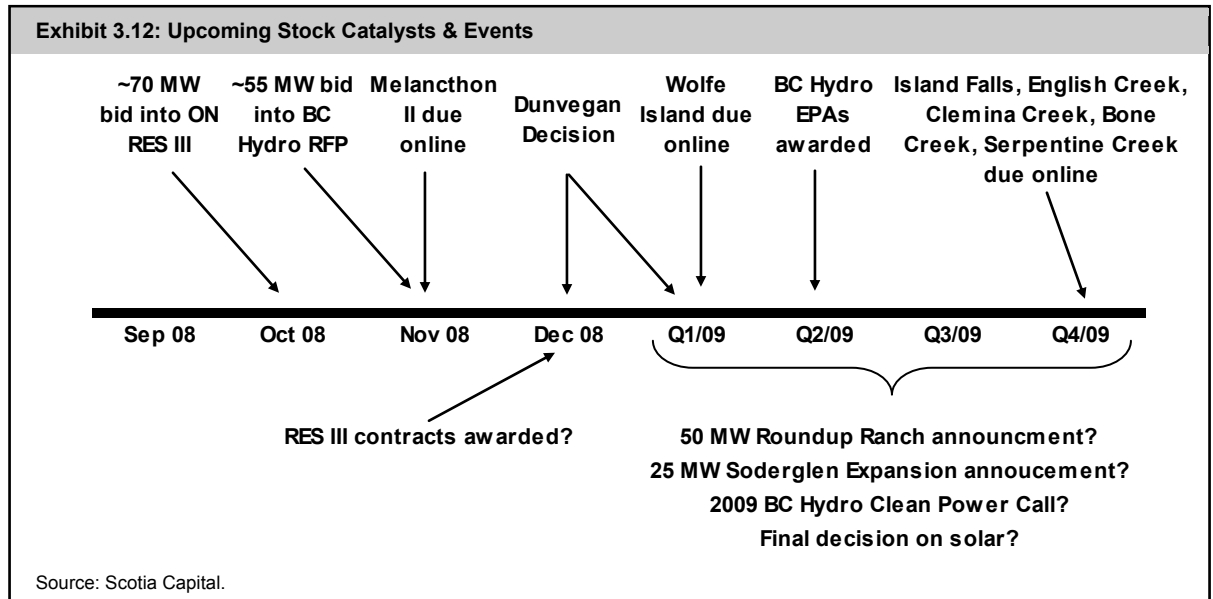

November 2008 – BC Hydro 2008 Clean Power Call bids due. We expect KHD will submit at least 55 MW of new hydro projects in this RFP.

Q4/08 – Commissioning of the 132 MW Melancthon II wind farm in Ontario.

2H/08 – Permitting movement on the 100 MW Dunvegan hydro project in Alberta or a decision to cancel the project altogether.

2H/08 – Decision to enter the Ontario solar market, through a 10 MW Standard Offer Contract.

2H/08 – Announcement that KHD has bid up to 70 MW of wind projects into the OPA's Renewable Energy Supply (RES) III.

1H/09 – Announcement of anticipated BC Hydro 2009 Clean Power Call. We believe, as do most industry observers, that BC Hydro will announce a 5,000 GWh renewable power RFP in early 2009.

Q1/09 – Commissioning of the 197.8 MW Wolfe Island wind farm in Ontario.

1H/09 – BC Hydro 2008 Clean Power Call awards expected, likely after the B.C. government election that is scheduled for May 2009.

Q4/09 – Commissioning of 20 MW (10 MW net to KHD) Island Falls hydro project in Ontario, and four hydro projects in B.C. that total 43.6 MW.

Commissioning of Wolfe Island was recently set back by five months to the end of Q1/09.

Construction Projects & Development Prospects

Canadian Hydro Developers has 401.4 MW of projects that are either under construction or are construction-ready, excluding two signed PPA wind farm projects in Quebec due online in 2012. Eighty-two percent of the capacity of these projects (or 79% of expected generation) are wind farms located in Ontario. The remaining 71.6 MW of capacity are small hydro projects located in Ontario (28 MW) and in B.C. (43.6 MW). We provide a brief summary of KHD's construction and construction-ready projects as well as a summary of its development pipeline.

MELANCTHON II

The 132 MW Melancthon II wind farm is under construction and is expected to be commissioned in November 2008. A longer-than-expected regulatory approvals process caused the anticipated project completion date to be moved back twice, first to June 2008 from Spring 2007, and then to November 2008. The \$285 million project, or \$2.16 million per MW, has an expected capacity factor of 30.3% on annual generation of 350 GWh. The wind farm has a RES contract with Ontario Power Authority that we estimate will pay KHD slightly less than \$100/MWh. Under the terms of the contract, the power price changes annually by a percentage equal to 15% of the annual change in Ontario CPI. We expect the project to receive the \$10/MWh ecoENERGY federal incentive payment on the first 10 years of its operation. KHD financed the project using 35% equity and 65% debt.

WOLFE ISLAND

Canadian Hydro's 197.8 MW Wolfe Island wind farm could be commissioned as early as March 2009, a five-month setback from KHD's previous estimate of October 2008. Annual power output is estimated at 593.5 GWh, representing a 34.3% capacity factor. The \$450 million project (was \$410 million before the setback announcement), or \$2.28 million per MW, will use 2.3 MW Siemens turbines. In our opinion, PPA terms are near identical to Melancthon II. We expect the project to receive the \$10/MWh ecoENERGY federal incentive payment on the first 10 years of its operation. KHD financed the project using 35% equity and 65% debt.

ROYAL ROAD

The 18 MW Royal Road wind project is expected to be operational in mid-2010, producing 47.3 GWh/y, or at a 30% capacity factor. The project received two Ontario 20-year Standard Offer Contracts (SOCs) that will pay KHD \$110/MWh as well as 50% of the \$10/MWh ecoENERGY federal incentive payment, should its application be approved. As Ontario SOC's require projects to be sub-10 MW in nature, Royal Road will be built in two 9 MW phases. The project will consist of twelve 1.5 MW GE turbines.

ISLAND FALLS

KHD's 50%-owned 20 MW Island Falls hydro project (10 MW net to KHD) is expected to be in service by October 2009, or one year later than originally planned. The delay stems from permitting setbacks and will not affect its PPA with Ontario Power Authority. The PPA is a 20-year RES II contract that we expect will be priced at close to \$100/MWh by October 2009. Annual escalation in the fixed-price contract is similar to the Melancthon II and Wolfe Island projects. With an estimated production of 93 GWh/y, the project's capacity factor is 53.3%. We expect the project to receive the \$10/MWh ecoENERGY federal incentive payment on the first 10 years of its operation. The capital cost for Island Falls is \$71 million, or \$3.55 million per MW.

KHD's Island Falls hydro project is expected to be in service by October 2009, or one year later than originally planned.

BONE CREEK

The 18 MW run-of-river Bone Creek project in B.C. is expected by KHD to be commissioned in the fall of 2009. At \$48.6 million, or \$2.7 million per MW, Bone Creek should generate 73 GWh/y of electricity, representing a capacity factor of 46.3%. The project has a 20-year BC Hydro PPA that we estimate will pay KHD about \$80/MWh in its first full year of operation. The power price is indexed to 50% of the change in annual CPI. Under the terms of the PPA, KHD will provide BC Hydro with all green attributes such as emissions credits and clean power allowances. However, KHD expects the project to be eligible for the \$10/MWh federal ecoENERGY incentive for its first 10 years of operation.

CLEMINA CREEK

KHD's 11 MW Clemina Creek hydroelectric project is capable of producing 33 GWh/y, or at a capacity factor of 34.2%. The \$27 million project, or \$2.45 million per MW, is expected online by the fall of 2009. BC Hydro has provided KHD with a 40-year PPA that we believe will be priced at \$74.50/MWh in the project's first full year of operation. Similar to KHD's Bone Creek project, all green attributes will be given to BC Hydro, with the exception of the possible federal ecoENERGY incentive payment.

SERPENTINE CREEK

The 9.6 MW Serpentine Creek run-of-river project is due online by the fall of 2009. At a capital cost of \$22 million, or \$2.3 million per MW, the facility is expected to generate 34 GWh/y of power, or at a 40.4% capacity factor. Similar to Clemina Creek, the project was awarded a 40-year BC Hydro PPA that we believe will be priced at about \$74.50/MWh in its first full year of operation. Again, all green attributes of the project have been forfeited by KHD, with the exception of the possible ecoENERGY incentive. The project will be 35% equity financed, in line with KHD's stated target.

ENGLISH CREEK

English Creek, a 5 MW run-of-river project in B.C., has an in-service date of fall 2009. The \$10 million project, or \$2 million per MW, is expected to generate 20 GWh/y, representing a capacity factor of 45.7%. We believe the project's 40-year PPA with BC Hydro will be priced identically to KHD's Serpentine Creek and Clemina Creek projects.

NEW RICHMOND & ST. VALENTIN

In May 2008, KHD was awarded two Hydro-Quebec wind PPAs for a total of 116 MW. The 66 MW New Richmond wind farm will consist of 33, 2 MW E82 Enercon turbines that are expected to generate 178.7 GWh/y, or at a capacity factor of 30.9%. The \$190 million project, or \$2.8 million per MW, has not received all regulatory approvals. St. Valentin will consist of 25, 2 MW E82 Enercon wind turbines that is expected to generate about 143.9 GWh/y, or at a capacity factor of 32.9%. The \$160 million project, or \$3.2 million per MW, has not received regulatory approvals as well. **KHD expects both projects to earn, on average, an 11% return, on a pre-tax, unlevered basis.**

DEVELOPMENT PROSPECTS

In addition to its 517 MW of projects that should be commissioned over the next five years, KHD has a further 1,632 MW of development prospects that may or may not move forward to commissioning. Two-thirds of this potential is in Manitoba, following KHD's 2006 acquisition of Vector Wind Energy. While the wind regime is strong in its Manitoba development regions, we don't see KHD commissioning a substantial amount of wind power capacity in the province over the next five years. Manitoba's target is to achieve 1,000 MW of wind capacity by 2015. **Of the remaining development prospects, we think the majority of its pipeline is viable.**

On an unlevered, pre-tax basis, KHD expects to earn 11% on its recent Hydro-Quebec PPA wins.

In addition to its 517 MW of projects that should be commissioned over the next five years, KHD has a further 1,632 MW of development prospects, two-thirds of which are in Manitoba.

The Value of KHD's RECs

Most of KHD's generated RECs are contracted for delivery via its PPAs, and are therefore not available for sale.

Exhibit 3.13: Potential 2013 REC Generation Could Be High

	Today	2013E
Alberta generation	466,200	466,200
50% of Le Nordais	82,500	85,000
Alberta prospects	0	197,100
Dunvegan	0	600,000
Contracted	(132,000)	(132,000)
Available for sale	416,700	1,216,300

Assumptions
 The capacity factor at Le Nordais is increased to 22% from 19% over five years.
 Dunvegan is commissioned by December 31, 2012.
 75 MW of new Alberta wind facilities are commissioned by December 31, 2012.
 Source: Scotia Capital estimates.

Renewable Energy Certificates (RECs) are no longer a “bonus” for companies generating alternative energy. Rather, many power developers now depend on the earnings contribution of RECs as a way to maintain a project's expected returns while providing greater flexibility in allowing companies to bid lower (and more competitive) long-term prices for renewable power RFPs.

KHD generates over one million RECs (or equivalents) per year, most of which are not available for sale. Under many of KHD's PPAs, the transfer of RECs to its PPA counterparty are required with the delivery of electricity. In Exhibit 3.13, we summarize the current flow of KHD's annual Alberta REC production (including Le Nordais in Quebec) as well as estimate KHD's 2013 annual REC production. If our 2013 forecast is accurate, and sustainable (with no more capacity increases), **we believe an additional \$0.75 to \$1.00 per share of upside value exists** (Exhibit 3.14).

KHD could one day sell up to 85,000 RECs from its Le Nordais facility into the Connecticut REC market.

Exhibit 3.14: REC Sales Could Be Worth \$0.75 to \$1/share

		Alberta RECs (\$/MWh)						
		\$0.00	\$2.50	\$5.00	\$7.50	\$10.00	\$12.50	\$15.00
CT Class I RECs (US\$/MWh)	\$0	0.00	0.19	0.39	0.58	0.78	0.97	1.17
	\$10	0.06	0.25	0.45	0.64	0.84	1.03	1.23
	\$20	0.12	0.31	0.51	0.70	0.89	1.09	1.28
	\$30	0.18	0.37	0.56	0.76	0.95	1.15	1.34
	\$40	0.23	0.43	0.62	0.82	1.01	1.21	1.40
	\$50	0.29	0.49	0.68	0.88	1.07	1.26	1.46

Source: Scotia Capital estimates.

For KHD's Quebec-generated RECs to be available for sale into NEPOOL, it must have its plants accredited to sell RECs into the region. Hydro-Quebec will likely have to help KHD in the accreditation process and would probably seek some of the upside from KHD's Quebec-generated RECs available for sale.

Warming Up to Dunvegan

Until recently, we had been disappointed with eight years of permitting delays at KHD’s Dunvegan hydro project with little to show for it. KHD has spent \$10.3 million on the development of what has grown to a 100 MW (~\$350 million or higher) project from a 40 MW project in 2000.

In its Q1/08 MD&A, KHD stated that in January 2008, it participated in a joint pre-hearing with the Alberta Utilities Commission and Natural Resources & Conservation Board. A hearing date has now been scheduled for mid-September, and is expected to last several days. KHD anticipates that a final decision on the project will be announced in late Q4/08 or early 2009.

Based on our discussions with management, we have warmed up to the idea that the project may receive a green light. All outstanding issues have been resolved for the project to receive regulatory approvals.

While installed capital costs have not been finalized, even at \$5 million per MW we believe that the long-term levelized cost for Dunvegan would be attractive and in range between \$60/MWh and \$70/MWh. Early indications are that two-thirds of the Dunvegan output (i.e., considered baseload) would likely be sold on five-year forward strip contracts, with the remainder sold into the Pool.

We believe that the Dunvegan project could be worth about \$1.50 per share (Exhibit 3.16).

We think that KHD’s Dunvegan project could be worth about \$1.50 per share. We currently give almost no value for the project.

Exhibit 3.15: Levelized Cost Curves for Dunvegan

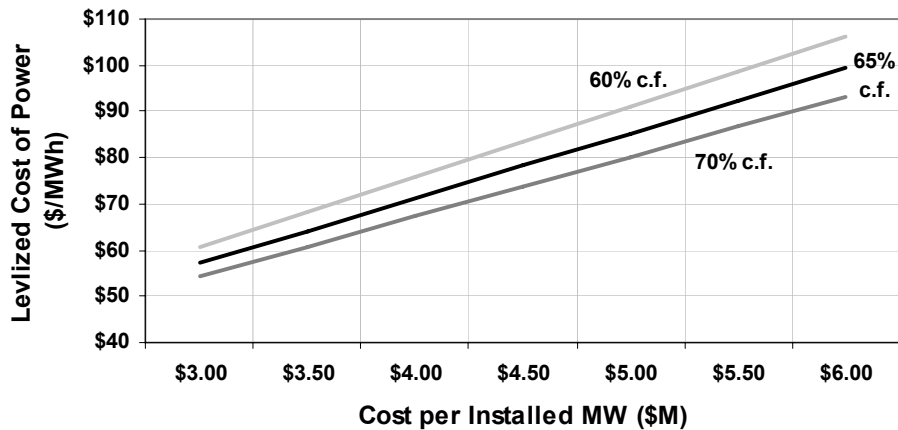

Source: Scotia Capital estimates.

Exhibit 3.16: Dunvegan Could Be Worth \$1.50 per Share

		Realized Dunvegan Power Price (2008\$/MWh)							
		\$55	\$60	\$65	\$70	\$75	\$80	\$85	\$90
Capacity Factor	44.5%	\$0.25	\$0.34	\$0.43	\$0.52	\$0.62	\$0.71	\$0.80	\$0.89
	48.5%	\$0.36	\$0.46	\$0.56	\$0.66	\$0.76	\$0.86	\$0.96	\$1.06
	52.5%	\$0.47	\$0.58	\$0.69	\$0.80	\$0.91	\$1.01	\$1.12	\$1.23
	56.5%	\$0.59	\$0.70	\$0.82	\$0.93	\$1.05	\$1.17	\$1.28	\$1.40
	60.5%	\$0.70	\$0.82	\$0.95	\$1.07	\$1.19	\$1.32	\$1.44	\$1.57
	64.5%	\$0.81	\$0.94	\$1.07	\$1.21	\$1.34	\$1.47	\$1.60	\$1.74
	68.5%	\$0.92	\$1.06	\$1.20	\$1.34	\$1.48	\$1.62	\$1.76	\$1.90
	72.5%	\$1.03	\$1.18	\$1.33	\$1.48	\$1.63	\$1.78	\$1.93	\$2.07

Source: Scotia Capital estimates.

Valuation & Sensitivity Analyses

We value Canadian Hydro Developers using a blended approach as follows: a 75% weight to a project probability-weighted discounted cash flow analysis (DCF), and a 25% weight to a net asset value calculation.

DISCOUNTED CASH FLOW ANALYSIS

Our project-probability DCF analysis suggests a one-year share price of \$7.04. We give no value for “brag-a-watts.”

Our project-probability based DCF analysis suggests a one-year share price of \$7.04. For our DCF analysis, we chose a discount rate of 9.5%, which we believe appropriately captures the sector’s standard risks as well as KHD’s unique ones. The discount rate reflects Canadian Hydro Developers’ slightly higher tolerance for construction and execution risks, as well as its targeted 65%/35% debt to equity capital structure. KHD’s discount rate of 9.5% is below that of its junior peers such as EarthFirst, Plutonic Power, and Innergex, and 0.5% lower than intermediate IPP Boralex due to KHD’s lower commodity exposure.

In our DCF model, we give full credit to KHD’s operating facilities and probability-weight development projects as follows: a 90% probability to those projects under (or ready for) construction, and a 25% to 75% probability range to projects that have completed various development stages such as permitting, financing, and receiving a PPA. We give no value for “brag-a-watts.” Exhibit 3.17 summarizes our DCF approach on a per project basis.

NET ASSET VALUE CALCULATION

We calculate a net asset value per share of \$6.95.

We calculate a NAV of \$6.95 per share. Given recent transactions and using rule-of-thumb metrics, we give credit of \$0.82 million per GWh/y for wind capacity that is either operational or under construction with no construction risk. For hydro assets, we give credit of \$1 million per GWh/y for operational capacity. We probability-adjust these values lower for those projects that are less developed. Projects that are under construction (and not 100% fixed-price) or are construction-ready receive about a 10% discount. Projects with signed PPAs or permitting completion are discounted further, as are projects with little to no development progress. Similar to our DCF valuation, we give no value for “brag-a-watts.” Our NAV calculation is laid out in Exhibit 3.18.

TARGET PRICE, RATING, AND RISK RANKING

We have transferred coverage of KHD with a 1-Sector Outperform rating. Our one-year share price target is \$7.00, which comprises outcomes of the following valuation approaches: (1) 75% DCF at \$7.04/share, using a 9.5% discount rate, and (2) 25% NAV at \$6.95/share.

Our risk ranking for Canadian Hydro Developers is High, the same as for Boralex. Much of the company has not been built yet, and a significant portion of our one-year target is based on the expectation that future projects are commissioned on time and on budget. This is partially offset by the company’s mostly long-term PPAs with investment-grade counterparties.

EV/EBITDA CHECK

Our one-year target of \$7.00 per share implies an EV/EBITDA multiple of 10.25x on 2010E EBITDA. In our view, this multiple is justified by the company’s terrific capacity growth prospects, as well as the upside potential for its uncontracted green credits. Exhibit 3.19 sensitizes this valuation approach to various EBITDA multiples as well as changes to our forecast 2010 EBITDA. We have also included our two-year target of \$7.50, which implies a 10.1x EV multiple on 2011E EBITDA.

Exhibit 3.17: DCF Analysis of KHD Suggests \$7.04/Share One Year Out

Project	Gross Capacity (MW)	Effective Capacity (MW)	Capacity Factor (%)	DCF (\$/share)	Prob. of Success (%)	Adjusted DCF (\$/share)	Comments
Belly River	3	3	46%	\$0.04	100%	\$0.04	
Waterton	3	3	51%	\$0.04	100%	\$0.04	
St. Mary	2	2	63%	\$0.04	100%	\$0.04	
Taylor (hydro)	13	7	39%	\$0.08	100%	\$0.08	
Akolkolex	10	10	60%	\$0.16	100%	\$0.16	
Pingston	45	23	45%	\$0.32	100%	\$0.32	
Upper Mamquam	25	25	45%	\$0.35	100%	\$0.35	
Ragged Chute	7	7	62%	\$0.11	100%	\$0.11	
Moose Rapids	1	1	50%	\$0.02	100%	\$0.02	
Appleton	1	1	54%	\$0.02	100%	\$0.02	
Galetta	2	2	56%	\$0.02	100%	\$0.02	
Misema	3	3	47%	\$0.05	100%	\$0.05	
Bone Creek	18	18	46%	\$0.18	90%	\$0.17	Construction risk remains.
Clemina Creek	11	11	34%	\$0.07	90%	\$0.06	Construction risk remains.
Serpentine Creek	10	10	40%	\$0.09	90%	\$0.08	Construction risk remains.
English Creek	5	5	46%	\$0.06	90%	\$0.05	Construction risk remains.
Island Falls	20	10	53%	\$0.13	50%	\$0.06	Permitting and financing incomplete.
Dunvegan	100	100	68%	\$1.34	10%	\$0.13	8 years of delays continue.
(Hydro various)	260	260	~45%	\$2.34	0%	\$0.00	Expect over 55 MW to be bid soon.
Cowley Ridge	21	21	29%	\$0.19	100%	\$0.19	
Cowley North	20	20	28%	\$0.17	100%	\$0.17	
Sinnot	7	7	27%	\$0.05	100%	\$0.05	
Taylor (wind)	3	3	22%	\$0.02	100%	\$0.02	
Soderglen	71	35	39%	\$0.55	100%	\$0.55	
Melancthon I	68	68	33%	\$0.99	100%	\$0.99	
Le Nordais	99	99	19%	\$0.75	100%	\$0.75	
Melancthon II	132	132	30%	\$0.83	90%	\$0.75	Expected online no later than November 2008.
Wolfe Island	198	198	34%	\$1.57	75%	\$1.18	Expected online no later than March 2009.
Royal Road	18	18	30%	\$0.16	50%	\$0.08	Permitting and financing incomplete.
New Richmond	66	66	31%	\$0.22	25%	\$0.06	PPA secured in Hydro-Quebec 2,000 MW RFP.
St. Valentin	50	50	33%	\$0.15	25%	\$0.04	PPA secured in Hydro-Quebec 2,000 MW RFP.
(AB wind various)	100	75	~30%	\$0.14	0%	\$0.00	Nothing announced.
(MB wind various)	1,000	1,000	~30%	\$4.75	0%	\$0.00	Nothing announced.
(ON wind various)	127	127	~30%	\$0.87	0%	\$0.00	Expect 70 MW to be bid soon.
Grande Prairie	25	25	74%	\$0.39	100%	\$0.39	
	2,542	2,443				\$7.04	

Source: Company reports; Scotia Capital estimates.

Exhibit 3.18: NAV Calculation Suggests \$6.95 per Share

	Project Status	Financing Status	Unrisked Net Capacity	Value	NAV			NAVPS		
					(\$M)	(diluted)	(%)	(\$M)	(diluted)	(%)
Hydro Assets										
Belly River	1	1	12 GWh/yr @	\$1.00M / GWh/yr	\$12.0	\$0.08	1.2%			
Waterton	1	1	12 GWh/yr @	\$1.00M / GWh/yr	\$12.4	\$0.08	1.2%			
St. Mary	1	1	13 GWh/yr @	\$1.00M / GWh/yr	\$12.6	\$0.09	1.2%			
Taylor (hydro)	1	1	22 GWh/yr @	\$1.00M / GWh/yr	\$22.1	\$0.15	2.2%			
Akolkolex	1	1	53 GWh/yr @	\$1.00M / GWh/yr	\$52.7	\$0.36	5.1%			
Pingson	1	1	89 GWh/yr @	\$1.00M / GWh/yr	\$89.0	\$0.60	8.7%			
Upper Mamquam	1	1	98 GWh/yr @	\$1.00M / GWh/yr	\$98.2	\$0.67	9.6%			
Ragged Chute	1	1	36 GWh/yr @	\$1.00M / GWh/yr	\$36.1	\$0.24	3.5%			
Moose Rapids	1	1	6 GWh/yr @	\$1.00M / GWh/yr	\$5.7	\$0.04	0.6%			
Appleton	1	1	7 GWh/yr @	\$1.00M / GWh/yr	\$6.6	\$0.04	0.6%			
Galetta	1	1	8 GWh/yr @	\$1.00M / GWh/yr	\$7.9	\$0.05	0.8%			
Misema	1	1	13 GWh/yr @	\$1.00M / GWh/yr	\$13.3	\$0.09	1.3%			
Bone Creek	3	3	73 GWh/yr @	\$0.50M / GWh/yr	\$36.5	\$0.25	3.6%			
Clemina Creek	3	3	33 GWh/yr @	\$0.50M / GWh/yr	\$16.5	\$0.11	1.6%			
Serpentine Creek	4	3	34 GWh/yr @	\$0.25M / GWh/yr	\$8.5	\$0.06	0.8%			
English Creek	4	3	20 GWh/yr @	\$0.25M / GWh/yr	\$5.0	\$0.03	0.5%			
Island Falls	4	3	47 GWh/yr @	\$0.25M / GWh/yr	\$11.7	\$0.08	1.1%			
Dunvegan	5	4	600 GWh/yr @	\$0.10M / GWh/yr	\$60.0	\$0.41	5.9%			
(Hydro various)	6	4	1,025 GWh/yr @	\$0.00M / GWh/yr	\$0.0	\$0.00	0.0%			
			2,200 GWh/yr		\$506.8	\$3.44	49.4%			
Biomass Assets										
Grande Prairie	1	1	163 GWh/yr @	\$0.08M / GWh/yr	\$12.2	\$0.08	1.2%			
			163 GWh/yr		\$12.2	\$0.08	1.2%			
Wind Assets										
Cowley Ridge	1	1	55 GWh/yr @	\$0.82M / GWh/yr	\$45.1	\$0.31	4.4%			
Cowley North	1	1	48 GWh/yr @	\$0.82M / GWh/yr	\$39.0	\$0.26	3.8%			
Sinnott	1	1	15 GWh/yr @	\$0.82M / GWh/yr	\$12.6	\$0.09	1.2%			
Taylor (wind)	1	1	7 GWh/yr @	\$0.82M / GWh/yr	\$5.4	\$0.04	0.5%			
Soderghen	1	1	120 GWh/yr @	\$0.82M / GWh/yr	\$98.2	\$0.67	9.6%			
Melanchon I	1	1	195 GWh/yr @	\$0.82M / GWh/yr	\$159.7	\$1.08	15.6%			
Le Nordais	1	1	165 GWh/yr @	\$0.82M / GWh/yr	\$135.3	\$0.92	13.2%			
Melanchon II	2	1	351 GWh/yr @	\$0.74M / GWh/yr	\$258.7	\$1.76	25.2%			
Wolfe Island	3	1	593 GWh/yr @	\$0.41M / GWh/yr	\$243.3	\$1.65	23.7%			
Royal Road	4	3	47 GWh/yr @	\$0.21M / GWh/yr	\$9.7	\$0.07	0.9%			
St. Valentin	4	3	144 GWh/yr @	\$0.21M / GWh/yr	\$29.5	\$0.20	2.9%			
New Richmond	4	3	179 GWh/yr @	\$0.21M / GWh/yr	\$36.6	\$0.25	3.6%			
(AB wind various)	6	4	197 GWh/yr @	\$0.00M / GWh/yr	\$0.0	\$0.00	0.0%			
(ON wind various)	6	4	334 GWh/yr @	\$0.00M / GWh/yr	\$0.0	\$0.00	0.0%			
(MB wind various)	6	4	2,628 GWh/yr @	\$0.00M / GWh/yr	\$0.0	\$0.00	0.0%			
			6,077 GWh/yr		\$1,073.3	\$7.28	104.7%			

	NAV (\$M)	NAVPS (diluted)	NAVPS (%)
Green Attributes			
Risk-adjusted NPV of RECs	\$63.0	\$0.43	6.1%
	\$63.0	\$0.43	6.1%
Working Capital			
Current Assets (Q2/08)	\$86.3	\$0.59	8.4%
Current Liabilities (Q2/08)	(\$50.1)	(\$0.34)	-4.9%
	\$36.2	\$0.25	3.5%
Liabilities			
Project status risk-adjusted LTD	(\$666.5)	(\$4.52)	-65.0%
	(\$666.5)	(\$4.52)	-65.0%
Net Asset Value	\$1,025.0	\$6.95	100%

	NAV (\$M)	NAVPS (diluted)	NAVPS (%)
Project-status risk-adjusted FD shares (M)		147.4	

Hydro Value (\$M/GWh/yr)	Wind Value (\$M/GWh/yr)				
	\$0.6	\$0.7	\$0.8	\$0.9	\$1.0
\$0.8	\$4.49	\$5.38	\$6.27	\$7.16	\$8.04
\$0.9	\$4.83	\$5.72	\$6.61	\$7.50	\$8.39
\$1.0	\$5.18	\$6.07	\$6.95	\$7.84	\$8.73
\$1.1	\$5.52	\$6.41	\$7.30	\$8.19	\$9.07
\$1.2	\$5.87	\$6.75	\$7.64	\$8.53	\$9.42

Financing Status	DUNVEGAN (100 MW)				
	5	4	3	2	1
4	\$6.95	\$7.08	\$7.27	\$7.54	\$7.61
3	\$7.07	\$7.37	\$7.86	\$8.66	\$8.86
2	\$7.17	\$7.59	\$8.26	\$9.23	\$9.45
1	\$7.28	\$7.91	\$8.94	\$10.59	\$11.01

CTI RECs (\$/MWh)	Alberta RECs (\$/MWh)				
	\$0.00	\$3.75	\$7.50	\$11.25	\$15.00
\$10	\$9M	\$27M	\$46M	\$65M	\$84M
\$20	\$17M	\$36M	\$55M	\$73M	\$92M
\$30	\$26M	\$44M	\$63M	\$82M	\$101M
\$40	\$34M	\$53M	\$72M	\$90M	\$109M
\$50	\$43M	\$61M	\$80M	\$99M	\$118M

1. We assume a stable capital structure of 65% debt & 35% equity. Equity issuance is assumed to be our DCF price of \$7.04/share.
 2. Project Probability Status: 1. Operating - 100%; 2. Construction - 90%; 3. Permitting & FPA - 50%; 4. Permitting or FPA - 25%; 5. Some Development - 10%; 6. Pipeline - 0%.
 3. Financing Status: (1) Full financing in place; (2) Debt draw n, equity required; (3) Equity in place, debt draw required; (4) Equity & debt draw required.

Source: Company reports; Scotia Capital estimates.

Exhibit 3.19: One- and Two-Year Targets Imply 2010E and 2011E EV/EBITDA Multiples of 10.25x and 10.1x

		2010E EBITDA						
		-15%	-10%	-5%	Base	+5%	+10%	+15%
EV/EBITDA Multiple	8.3x	\$3.75	\$4.25	\$4.75	\$5.00	\$5.50	\$6.00	\$6.25
	8.8x	\$4.25	\$4.75	\$5.00	\$5.50	\$6.00	\$6.50	\$7.00
	9.3x	\$4.75	\$5.25	\$5.50	\$6.00	\$6.50	\$7.00	\$7.50
	9.8x	\$5.00	\$5.50	\$6.00	\$6.50	\$7.00	\$7.50	\$8.00
	10.3x	\$5.50	\$6.00	\$6.50	\$7.00	\$7.50	\$8.25	\$8.75
	10.8x	\$6.00	\$6.50	\$7.00	\$7.50	\$8.25	\$8.75	\$9.25
	11.3x	\$6.50	\$7.00	\$7.50	\$8.00	\$8.75	\$9.25	\$9.75
	11.8x	\$6.75	\$7.50	\$8.00	\$8.50	\$9.25	\$9.75	\$10.50
12.3x	\$7.25	\$7.75	\$8.50	\$9.00	\$9.75	\$10.25	\$11.00	
		2011E EBITDA						
		-15%	-10%	-5%	Base	+5%	+10%	+15%
EV/EBITDA Multiple	8.1x	\$4.00	\$4.50	\$4.75	\$5.25	\$5.75	\$6.00	\$6.50
	8.6x	\$4.50	\$5.00	\$5.25	\$5.75	\$6.25	\$6.75	\$7.25
	9.1x	\$4.75	\$5.25	\$5.75	\$6.25	\$6.75	\$7.25	\$7.75
	9.6x	\$5.25	\$5.75	\$6.25	\$6.75	\$7.25	\$8.00	\$8.50
	10.1x	\$5.75	\$6.25	\$6.75	\$7.50	\$8.00	\$8.50	\$9.00
	10.6x	\$6.25	\$6.75	\$7.25	\$8.00	\$8.50	\$9.00	\$9.50
	11.1x	\$6.75	\$7.25	\$7.75	\$8.50	\$9.00	\$9.75	\$10.25
	11.6x	\$7.25	\$7.75	\$8.25	\$9.00	\$9.50	\$10.25	\$10.75
	12.1x	\$7.50	\$8.25	\$8.75	\$9.50	\$10.25	\$10.75	\$11.50

Source: Scotia Capital estimates.

Financial Forecast

850+ MW OF CAPACITY ONLINE BY 2012

We expect at least 550 MW of new installed capacity to be commissioned by the end of 2012.

Our financial forecast does not include any wind power development in Manitoba, for now.

We expect 2009E revenue to soar by 80% to \$159.4 million.

We expect close to 550 MW of new installed capacity to be commissioned by the end of 2012.

Specifically, we believe 53.6 MW of hydro facilities will be installed in B.C. (43.6 MW) and Ontario (10 MW) by the end of next year, and possibly an additional 55 MW of future B.C. projects further down the road (~20% of its B.C. pipeline). We also estimate 330 MW of new wind power capacity to come online by mid-2009 (i.e., Melancthon II in Q4/08 and Wolfe Island in Q1/09). We forecast the 18 MW Royal Road project (2010) and up to another 127 MW of wind capacity (2011/12) to be online in Ontario, 75 MW in Alberta (2012), and 116 MW in Quebec (2012). **Our financial forecast does not include any wind power development in Manitoba, for now.** While we don't expect to see any further biomass projects in the short- to mid-term, there is a possibility that KHD may venture into solar power development, although we have not accounted for this in our financial forecast. **As a result of these increases to KHD's operating portfolio over the next several years, we expect annual electricity generation to increase by 1,200+ GWh/y to 2,333 GWh/y by 2012.**

In our view, 2009E revenue will soar to \$159.4 million from our \$87.5 million forecast for 2008 due to over 325 MW of newly installed wind capacity in Ontario, as well as 53.6 MW of new hydro capacity in B.C. and Ontario. We think that KHD's 2009 revenue mix will be 72% from wind power, 21% from hydro, and 7% from biomass (Exhibit 3.21). We believe the average power price earned by KHD in 2008 will range between \$78/MWh and \$80/MWh.

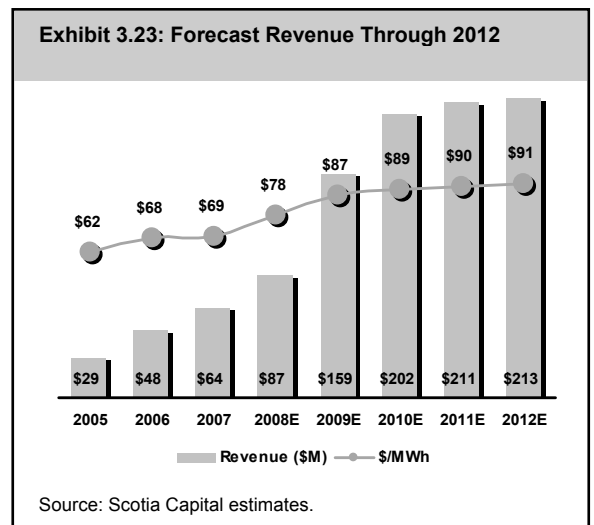
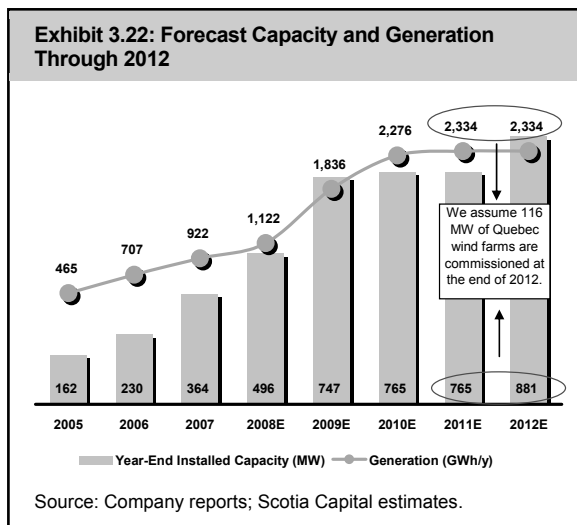
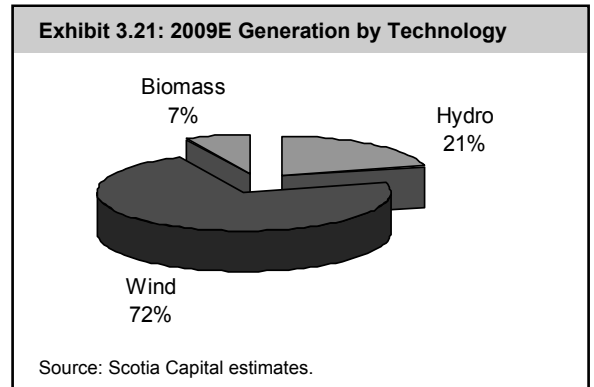
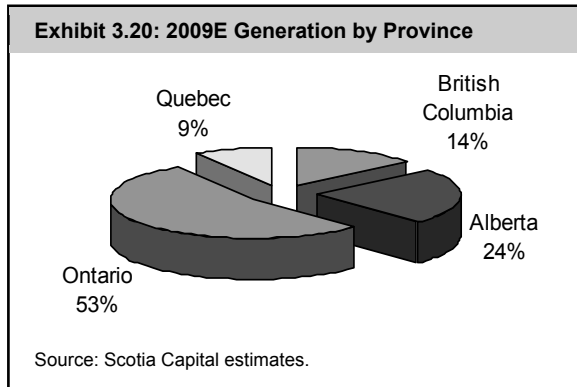

Look for 8¢ of 2008E EPS followed by a jump to 19¢ in 2009E.

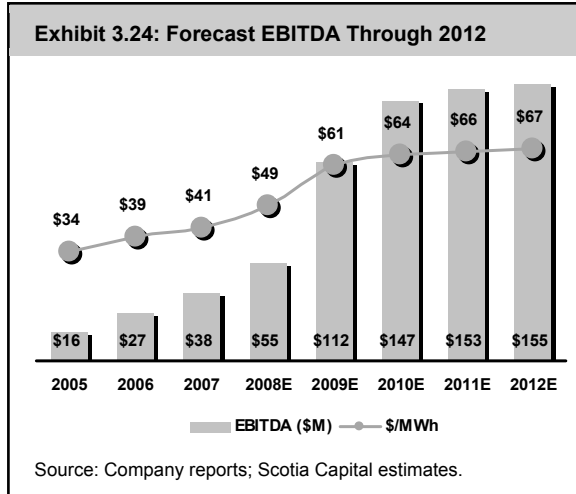

Our 2009 financial forecast estimates EBITDA at \$112.3 million, or about double our forecast 2008 EBITDA of \$54.7 million. On a per MWh basis, we believe operating costs will ease slightly to \$20/MWh in 2009 from our estimate in 2008 of \$22/MWh. In 2007, operating costs were \$20.85/MWh.

We expect 2009 net income to increase to \$0.19 per share, or by 135% year over year. The surge in our forecast net income is primarily due to added power generation, and somewhat due to higher power prices received.

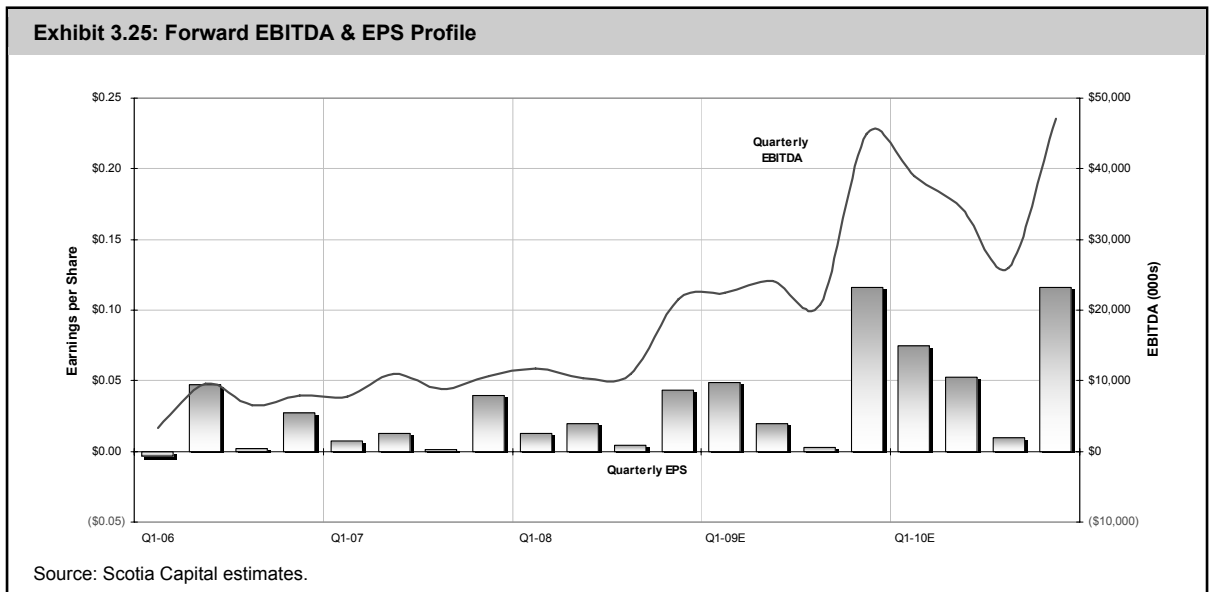

KEY FINANCIAL FORECAST ASSUMPTIONS

New capacity: With the addition of new capacity, we do not speculate what specific day in a quarter new capacity will come online. Accordingly, and similar to the half-year CCA rule, we apply a 50% weight to generation produced from new capacity in its initial quarter.

Capital costs. For the most part, KHD has stated its expected capital costs for its development projects. For those (unannounced) projects that we assume are commissioned within our financial forecast, we have estimated capital costs for wind projects that range between \$1.75 million to \$2.75 million, and for hydro projects, between \$2.65 million to \$3 million (excluding Dunvegan).

Project financing. Our financial forecast assumes that growth opportunities will be financed using Canadian Hydro Developers’ targeted capital structure of 65% debt and 35% equity.

KHD’s targeted capital structure is 65% debt and 35% equity.

Seasonality profile. We have used the unweighted average seasonality profiles of KHD's current hydro and wind facilities as the basis for our production forecasts.

- Our hydro production profile assumes the following seasonality: Q1 → 16%; Q2 → 35%; Q3 → 28%; and Q4 → 21%.
- Our wind production profile is as follows:
Q1 → 30%; Q2 → 20%; Q3 → 16%; and Q4 → 34%.

We have not applied excess free cash flow on the balance sheet, for now.

Free cash flow. We have not applied excess free cash flow on the balance sheet, for now, other than to finance those projects that we believe will be commissioned within our financial forecast. Cash on hand could be used to: (1) prepay outstanding principal balances on its debt; (2) implement (i) a regular dividend, (ii) a share buyback, and/or (iii) a one-time special dividend; (3) invest in other organic growth opportunities; and (4) enter into an acquisition, joint venture, or similar transaction.

Exhibit 3.26: Canadian Hydro Developers – Income Statement

(\$000s)	2006A	2007A	Q108	Q208	Q308E	Q408E	2008E	Q109E	Q209E	Q309E	Q409E	2009E	2010E	2011E
Energy Sales	\$47,653	\$63,195	\$19,275	\$19,538	\$18,201	\$29,841	\$86,856	\$33,017	\$35,170	\$32,460	\$58,118	\$158,765	\$201,766	\$210,050
Revenue Rebate	\$535	\$562	\$186	\$123	\$103	\$191	\$604	\$176	\$130	\$108	\$200	\$614	\$641	\$670
Total Revenue	\$48,188	\$63,757	\$19,461	\$19,661	\$18,305	\$30,033	\$87,460	\$33,193	\$35,300	\$32,568	\$58,318	\$159,379	\$202,407	\$210,720
Operating Costs	\$16,662	\$19,213	\$5,150	\$7,483	\$5,461	\$6,555	\$24,649	\$8,253	\$8,579	\$9,186	\$10,828	\$36,845	\$45,690	\$47,763
Amortization	\$11,503	\$15,508	\$5,029	\$5,100	\$5,436	\$5,581	\$21,147	\$5,375	\$9,133	\$9,133	\$10,030	\$33,671	\$47,458	\$48,471
Admin. (incl. stock comp)	\$4,270	\$6,395	\$2,535	\$1,819	\$1,902	\$1,902	\$8,158	\$2,565	\$2,565	\$2,565	\$2,565	\$10,260	\$10,192	\$9,934
Interest on LTD	\$13,056	\$14,847	\$4,424	\$4,743	\$5,438	\$7,869	\$22,474	\$7,869	\$11,717	\$11,717	\$12,941	\$44,244	\$54,592	\$55,678
Interest income	(\$7,047)	(\$1,451)	(\$205)	(\$175)	(\$733)	(\$321)	(\$1,434)	(\$346)	(\$437)	(\$515)	(\$586)	(\$1,884)	(\$4,529)	(\$7,674)
Write-off (gain) of asset/prospect sales	\$573	\$442	\$0	\$188	\$0	\$0	\$188	\$0	\$0	\$0	\$0	\$0	\$0	\$0
FX loss (gain)	(\$788)	\$1,585	(\$201)	(\$5,081)	\$0	\$0	(\$5,282)	\$0	\$0	\$0	\$0	\$0	\$0	\$0
Loss (gain) on derivatives	\$73	(\$363)	\$0	\$0	\$0	\$0	\$0	\$0	\$0	\$0	\$0	\$0	\$0	\$0
Other	(\$142)	\$1,664	(\$201)	(\$4,893)	\$0	\$0	(\$5,094)	\$0	\$0	\$0	\$0	\$0	\$0	\$0
Total expenses	\$38,302	\$56,176	\$16,732	\$14,077	\$17,504	\$21,586	\$69,900	\$23,716	\$31,557	\$32,086	\$35,778	\$123,136	\$153,403	\$154,172
Earnings before tax expense	\$9,886	\$7,581	\$2,729	\$5,584	\$800	\$8,446	\$17,560	\$9,477	\$3,743	\$483	\$22,540	\$36,243	\$49,004	\$56,548
Current tax	\$822	\$1,964	\$138	\$1,097	\$30	\$317	\$1,582	\$355	\$140	\$18	\$845	\$1,359	\$1,838	\$2,121
Future tax	\$168	(\$2,726)	\$782	\$1,604	\$170	\$1,795	\$4,351	\$2,014	\$795	\$103	\$4,790	\$7,702	\$10,413	\$12,016
Net income	\$8,896	\$8,343	\$1,809	\$2,883	\$600	\$6,335	\$11,627	\$7,108	\$2,807	\$362	\$16,905	\$27,182	\$36,753	\$42,411
Basic shares - opening	118,223.9	119,652.0	141,835.0	143,378.7	143,488.7	143,488.7	141,835.0	143,488.7	143,488.7	143,488.7	143,488.7	143,488.7	143,488.7	143,488.7
Plus: Equity issued/warrant conversion	1,428.1	22,183.0	1,543.8	0.0	0.0	0.0	1,543.8	0.0	0.0	0.0	0.0	0.0	0.0	0.0
Less: Share buyback	0.0	0.0	0.0	0.0	0.0	0.0	0.0	0.0	0.0	0.0	0.0	0.0	0.0	0.0
Basic shares - closing	119,652.0	141,835.0	143,378.7	143,488.7	143,488.7	143,488.7	143,488.7	143,488.7	143,488.7	143,488.7	143,488.7	143,488.7	143,488.7	143,488.7
Average Shares O/S - Basic (000s)	119,297.7	130,648.0	142,001.3	143,413.2	143,488.7	143,488.7	143,098.0	143,488.7	143,488.7	143,488.7	143,488.7	143,488.7	143,488.7	143,488.7
Average Dilution (000s)	2,689.5	2,667.7	2,048.3	1,712.5	1,712.5	1,712.5	1,796.5	1,712.5	1,712.5	1,712.5	1,712.5	1,712.5	1,712.5	1,712.5
Average Shares O/S - Diluted (000s)	121,987.2	133,315.7	144,049.6	145,125.7	145,201.2	145,201.2	144,894.4	145,201.2	145,201.2	145,201.2	145,201.2	145,201.2	145,201.2	145,201.2
EPS (Basic)	\$0.07	\$0.06	\$0.01	\$0.02	\$0.00	\$0.04	\$0.08	\$0.05	\$0.02	\$0.00	\$0.12	\$0.19	\$0.26	\$0.30
EPS (Diluted)	\$0.07	\$0.06	\$0.01	\$0.02	\$0.00	\$0.04	\$0.08	\$0.05	\$0.02	\$0.00	\$0.12	\$0.19	\$0.25	\$0.29
EBITDA	\$27,256	\$38,149	\$11,776	\$10,359	\$10,941	\$21,576	\$54,652	\$22,375	\$24,156	\$20,817	\$44,925	\$112,273	\$146,525	\$153,022
EBITDA/MWh	\$39	\$41	\$47	\$40	\$45	\$59	\$49	\$59	\$57	\$54	\$69	\$61	\$64	\$66

Source: Company reports; Scotia Capital estimates.

Exhibit 3.27: Canadian Hydro Developers – Balance Sheet

(\$000s)	2006A	2007A	Q108	Q208	Q308E	Q408E	2008E	Q109E	Q209E	Q309E	Q409E	2009E	2010E	2011E
Assets														
Current Assets														
Cash and cash equivalents	\$61,669	\$22,785	\$22,791	\$73,311	\$32,108	\$34,628	\$34,628	\$43,671	\$51,511	\$58,608	\$87,833	\$87,833	\$164,459	\$242,855
Accounts receivable	\$13,530	\$11,897	\$12,238	\$10,442	\$10,442	\$10,442	\$10,442	\$10,442	\$10,442	\$10,442	\$10,442	\$10,442	\$10,442	\$10,442
Revenue rebate	\$594	\$0	\$0	\$0	\$0	\$0	\$0	\$0	\$0	\$0	\$0	\$0	\$0	\$0
Prepaid expenses	\$535	\$568	\$929	\$1,597	\$1,597	\$1,597	\$1,597	\$1,597	\$1,597	\$1,597	\$1,597	\$1,597	\$1,597	\$1,597
Taxes receivable	\$0	\$0	\$0	\$0	\$0	\$0	\$0	\$0	\$0	\$0	\$0	\$0	\$0	\$0
Derivative financial instruments	\$0	\$0	\$3,502	\$931	\$931	\$931	\$931	\$931	\$931	\$931	\$931	\$931	\$931	\$931
	\$76,328	\$35,250	\$39,460	\$86,281	\$45,078	\$47,598	\$47,598	\$56,641	\$64,481	\$71,578	\$100,803	\$100,803	\$177,429	\$255,825
Deferred financing costs	\$2,628	\$0	\$0	\$0	\$0	\$0	\$0	\$0	\$0	\$0	\$0	\$0	\$0	\$0
Capital assets	\$547,797	\$797,387	\$796,379	\$1,018,600	\$1,310,313	\$1,388,243	\$1,388,243	\$1,414,603	\$1,440,625	\$1,451,267	\$1,448,756	\$1,448,756	\$1,431,288	\$1,435,329
Development costs	\$60,289	\$117,277	\$126,260	\$34,360	\$34,360	\$34,360	\$34,360	\$34,360	\$34,360	\$34,360	\$34,360	\$34,360	\$34,360	\$34,360
Total Assets	\$687,042	\$949,914	\$962,099	\$1,139,241	\$1,389,751	\$1,470,201	\$1,470,201	\$1,505,604	\$1,539,466	\$1,557,206	\$1,583,919	\$1,583,919	\$1,643,078	\$1,725,515
Liabilities														
Current Liabilities														
Revolver	\$0	\$0	\$0	\$0	\$0	\$0	\$0	\$0	\$0	\$0	\$0	\$0	\$0	\$0
A/P and accrued liabilities	\$9,587	\$12,084	\$12,112	\$45,164	\$45,164	\$45,164	\$45,164	\$45,164	\$45,164	\$45,164	\$45,164	\$45,164	\$45,164	\$45,164
CP LTD	\$1,996	\$2,825	\$2,853	\$2,191	\$11,500	\$12,000	\$12,000	\$12,500	\$13,000	\$13,500	\$14,000	\$14,000	\$16,000	\$18,000
Deferred credit	\$85	\$0	\$0	\$0	\$0	\$0	\$0	\$0	\$0	\$0	\$0	\$0	\$0	\$0
Derivative liability	\$0	\$1,703	\$1,104	\$1,763	\$1,763	\$1,763	\$1,763	\$1,763	\$1,763	\$1,763	\$1,763	\$1,763	\$1,763	\$1,763
Other liabilities (incl. bridge for now)	\$0	\$72,300	\$72,300	\$0	\$0	\$0	\$0	\$0	\$0	\$0	\$0	\$0	\$0	\$0
Taxes payable	\$100	\$304	\$0	\$973	\$973	\$973	\$973	\$973	\$973	\$973	\$973	\$973	\$973	\$973
	\$11,768	\$89,216	\$88,369	\$50,091	\$59,400	\$59,900	\$59,900	\$60,400	\$60,900	\$61,400	\$61,900	\$61,900	\$63,900	\$65,900
Long-Term Debt	\$314,331	\$339,631	\$339,164	\$552,530	\$792,461	\$863,781	\$863,781	\$889,062	\$918,322	\$934,597	\$938,616	\$938,616	\$946,608	\$970,618
Future income taxes	\$22,017	\$39,091	\$39,805	\$41,408	\$41,578	\$43,373	\$43,373	\$45,387	\$46,182	\$46,285	\$51,074	\$51,074	\$61,488	\$73,504
Total Liabilities	\$348,116	\$467,938	\$467,338	\$644,029	\$893,439	\$967,054	\$967,054	\$994,849	\$1,025,404	\$1,042,282	\$1,051,590	\$1,051,590	\$1,071,996	\$1,110,022
Shareholders' Equity														
Share capital	\$313,852	\$448,031	\$454,365	\$454,703	\$454,703	\$454,703	\$454,703	\$454,703	\$454,703	\$454,703	\$454,703	\$454,703	\$454,703	\$454,703
Contributed surplus	\$2,186	\$4,299	\$4,840	\$5,299	\$5,299	\$5,299	\$5,299	\$5,299	\$5,299	\$5,299	\$5,299	\$5,299	\$5,299	\$5,299
Retained earnings	\$22,888	\$31,349	\$33,158	\$36,041	\$36,641	\$42,976	\$42,976	\$50,084	\$52,891	\$53,253	\$70,158	\$70,158	\$106,911	\$149,322
Accumulated comprehensive income (loss)	\$0	(\$1,703)	\$2,398	(\$831)	(\$331)	\$169	\$169	\$689	\$1,169	\$1,669	\$2,169	\$2,169	\$4,169	\$6,169
Total Shareholders Equity	\$338,926	\$481,976	\$494,761	\$495,212	\$496,312	\$503,147	\$503,147	\$510,755	\$514,062	\$514,924	\$532,329	\$532,329	\$571,082	\$615,493
Total Liabilities and Shareholders Equity	\$687,042	\$949,914	\$962,099	\$1,139,241	\$1,389,751	\$1,470,201	\$1,470,201	\$1,505,604	\$1,539,466	\$1,557,206	\$1,583,919	\$1,583,919	\$1,643,078	\$1,725,515

Source: Company reports; Scotia Capital estimates.

Exhibit 3.28: Canadian Hydro Developers – Cash Flow Statement

(\$000s)	2006A	2007A	Q108	Q208	Q308E	Q408E	2008E	Q109E	Q209E	Q309E	Q409E	2009E	2010E	2011E
Operating Activities														
Net (loss) earnings	\$8,896	\$8,343	\$1,809	\$2,883	\$600	\$6,335	\$11,627	\$7,108	\$2,807	\$362	\$16,905	\$27,182	\$36,753	\$42,411
Adjustments for:														
Amortization	\$11,503	\$15,508	\$5,029	\$5,100	\$5,436	\$5,581	\$21,147	\$5,375	\$9,133	\$9,133	\$10,030	\$33,671	\$47,458	\$48,471
(Gain) loss on derivative financial instruments	\$229	(\$100)	\$0	\$0	\$0	\$0	\$0	\$0	\$0	\$0	\$0	\$0	\$0	\$0
Stock compensation expense	\$1,439	\$2,288	\$722	\$584	\$500	\$500	\$2,306	\$500	\$500	\$500	\$500	\$2,000	\$2,000	\$2,000
(Gain) loss on sale of capital assets &/or development prospects	\$573	\$442	\$0	\$188	\$0	\$0	\$188	\$0	\$0	\$0	\$0	\$0	\$0	\$0
Future income tax (recovery) expense	\$168	(\$2,726)	\$782	\$1,604	\$170	\$1,795	\$4,351	\$2,014	\$795	\$103	\$4,790	\$7,702	\$10,413	\$12,016
Cash flow from operations	\$22,808	\$23,755	\$8,342	\$10,359	\$6,706	\$14,211	\$39,618	\$14,997	\$13,236	\$10,098	\$32,225	\$70,555	\$96,624	\$104,898
Net change in non-cash working capital balances	(\$9,544)	\$2,133	\$2,610	\$35,153	\$0	\$0	\$37,763	\$0	\$0	\$0	\$0	\$0	\$0	\$0
	\$13,264	\$25,888	\$10,952	\$45,512	\$6,706	\$14,211	\$77,381	\$14,997	\$13,236	\$10,098	\$32,225	\$70,555	\$96,624	\$104,898
Financing Activities														
Net issue (buyback) of common shares	\$2,012	\$53,901	\$6,084	\$213	\$0	\$0	\$6,297	\$0	\$0	\$0	\$0	\$0	\$0	\$0
Long-term debt advances	\$148,000	\$10,000	\$0	\$214,400	\$251,740	\$74,321	\$540,460	\$28,781	\$32,760	\$19,775	\$7,519	\$88,835	\$23,992	\$42,010
Long-term debt repayments	(\$1,838)	(\$1,475)	(\$439)	(\$1,696)	(\$2,500)	(\$2,500)	(\$7,135)	(\$3,000)	(\$3,000)	(\$3,000)	(\$3,000)	(\$12,000)	(\$14,000)	(\$16,000)
Credit facilities advances (repayments)	(\$56,600)	\$87,970	\$0	(\$72,300)	\$0	\$0	(\$72,300)	\$0	\$0	\$0	\$0	\$0	\$0	\$0
Deferred financing costs	(\$887)	(\$85)	\$0	\$0	\$0	\$0	\$0	\$0	\$0	\$0	\$0	\$0	\$0	\$0
Other	\$0	\$0	\$0	\$0	\$0	\$0	\$0	\$0	\$0	\$0	\$0	\$0	\$0	\$0
	\$90,687	\$150,311	\$5,645	\$140,617	\$249,240	\$71,821	\$467,322	\$25,781	\$29,760	\$16,775	\$4,519	\$76,835	\$9,992	\$26,010
Investing Activities														
Capital asset additions, bus or prospect acquisitions	(\$193,141)	(\$145,923)	(\$4,441)	(\$130,222)	(\$297,149)	(\$83,512)	(\$515,324)	(\$31,734)	(\$35,156)	(\$19,775)	(\$7,519)	(\$94,184)	(\$29,990)	(\$52,512)
Development costs	(\$28,942)	(\$55,737)	(\$12,150)	(\$5,387)	\$0	\$0	(\$17,537)	\$0	\$0	\$0	\$0	\$0	\$0	\$0
Working capital acquired on acquisition	\$0	(\$13,423)	\$0	\$0	\$0	\$0	\$0	\$0	\$0	\$0	\$0	\$0	\$0	\$0
Proceeds on sale of capital assets &/or prospects	\$0	\$0	\$0	\$0	\$0	\$0	\$0	\$0	\$0	\$0	\$0	\$0	\$0	\$0
Other	\$0	\$0	\$0	\$0	\$0	\$0	\$0	\$0	\$0	\$0	\$0	\$0	\$0	\$0
	(\$222,083)	(\$215,083)	(\$16,591)	(\$135,609)	(\$297,149)	(\$83,512)	(\$532,861)	(\$31,734)	(\$35,156)	(\$19,775)	(\$7,519)	(\$94,184)	(\$29,990)	(\$52,512)
Net change in cash and cash equivalents	(\$118,132)	(\$38,884)	\$6	\$50,520	(\$41,203)	\$2,520	\$11,843	\$9,043	\$7,839	\$7,098	\$29,225	\$53,205	\$76,626	\$78,396
Cash and cash equivalents - beginning of period	\$179,801	\$61,669	\$22,785	\$22,791	\$73,311	\$32,108	\$22,785	\$34,628	\$43,671	\$51,511	\$58,608	\$34,628	\$87,833	\$164,459
Cash and cash equivalents - end of period	\$61,669	\$22,785	\$22,791	\$73,311	\$32,108	\$34,628	\$34,628	\$43,671	\$51,511	\$58,608	\$87,833	\$87,833	\$164,459	\$242,855

Source: Company reports; Scotia Capital estimates.

Management & Directors

There are few (if any) renewable power developers in Canada that have as much quality management experience as Canadian Hydro's founding Keating brothers. We have seen only one management-related hiccup at KHD, which resulted in a new COO being announced on October 31, 2007, who then resigned several months later. A new COO has since been installed, which adds to KHD's bench-strength. Additionally, KHD recently added the position of Executive Vice President to Kent Brown's continued role as CFO. Ed Ma was recently hired as General Counsel, and Kathy Boutin was promoted to VP Finance. Canadian Hydro Developers has a solid board of directors, including former Alberta Premier Ralph Klein. The company's management and directors control about 5% of KHD's shares on a fully diluted basis (Exhibit 3.29).

Exhibit 3.29: Management & Directors			
Name	Position	FD Shares Controlled Directly or Indirectly	Background
John Keating	CEO	2,432,315	A Chartered Accountant with more than 20 years financial experience. Mr. Keating is also the founding director of the Independent Power Producers Society of Alberta (IPPSA) and is an active participant in the Clean Air Renewable Energy Coalition.
Ross Keating	President, Operations & Development	2,479,500	Mr. Keating brings 20 years experience in hydroelectric design and construction. He is also a founding shareholder.
M. Ann Hughes	Corporate Secretary	365,650	Ms. Hughes has been a member of KHD's executive team since 1991. She was admitted to the Bar of Manitoba in 1977 and the Bar of Alberta in 1980.
Kent Brown	EVP & CFO	405,500	Prior to 2001, Mr. Brown previously served as CFO and VP Finance at another publicly listed Canadian corporation.
Dennis Erker	Board Chair	944,500	Director and Managing Partner with Fairley Erker Advisory Group, a private estate planning and insurance consultant. In addition to having served as the Board Chair for at least the past five years, Mr. Erker is also a director of Corus Entertainment Inc.
Ralph Klein	Director	100,000	Premier of Alberta from 1992 through 2006. Since then, Mr. Klein acts as a senior business advisor to Canadian law firm Borden, Ladner, Gervais LLP. Additionally, Mr. Klein serves as director of numerous other organizations.
Douglas Patriquin	Director	100,000	Head of Institutional Development at CPCS Transcom Ltd. Mr. Patriquin also serves as President of DPC Consultants, an international strategy and finance consulting firm. Prior to these roles, Mr. Patriquin was EVP, President and Chair of the Canadian Commercial Corporation, a federal Crown corporation.
David Stenason	Director	302,500	Mr. Stenason is a partner and director of MacDougall Investment Counsel Inc., a private investment counselling company. He is also a director of Whitemud Resources Inc.
John Thomson	Director	150,000	Mr. Thomson has over 25 years experience in the Canadian energy industry as an officer of three different oil and gas companies, and more recently as a director of Compton Petroleum and Crew Energy
Kathy Boutin	VP Finance	87,500	Ms. Boutin was promoted to VP Finance in May 2008, after having served as Manager, Finance since 2005. Previously, she was a Senior Accountant with Deloitte & Touche LLP.
Keith O'Regan	EVP & COO	300,000	Prior to joining KHD in July 2008, Mr. O'Regan served as regional VP Operations at Maple Leaf Foods and as Director of Operations for JDS Uniphase, Canada.
Edwin Ma	General Counsel	151,000	Mr. Ma has served as General and/or Legal Counsel for several companies including SMART Technologies ULC, SAP Canada Inc., and Aspen Technology Inc.
Total		7,818,465	
Fully Diluted Shares Outstanding		153,905,873	
% Insider Ownership		5.1%	

Source: SEDI, Company reports; Scotia Capital.

EarthFirst Canada Inc.

(EF-T)

Aug 15, 2008:	\$0.27
Rating:	3-Sector Underperform
Risk:	Caution Warranted
IBES EPS 2008E	\$-0.04
IBES EPS 2009E	\$-0.06
Div. (Curr.):	\$0.00
Yield:	0.0%

1-Yr Target:	\$0.40
1-Yr ROR:	48.1%
2-Yr Target:	\$0.40
2-Yr ROR:	48.1%
Valuation:	75% DCF @ 11.5%; 25% NAV

Capitalization	
Shares O/S (M)	103.3
Total Value (\$M)	27.9
Float O/S (M)	87.4
Float Value (\$M)	23.6
TSX Weight	--

Qtly EPS (FD) (Next Release: Nov-08)

Y/E DECEMBER-31	Mar	Jun	Sep	Dec	Year	P/E
2008E	\$-0.01A	\$-0.00A	\$-0.00	\$-0.00	\$-0.02	n.a.
2009E	\$-0.01	\$-0.01	\$-0.01	\$-0.01	\$-0.04	n.a.
2010E	\$-0.02	\$-0.01	\$-0.01	\$0.01	\$-0.03	n.a.
2011E	\$-0.00	\$-0.01	\$0.00	\$0.02	\$0.01	19.3x

Industry Specific	2007A	2008	2009	2010	2011
Production (GWh)		0	48	294	498

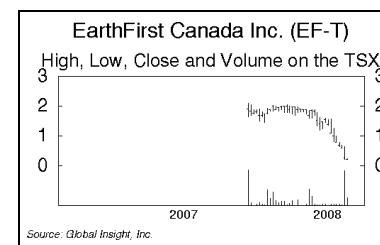

Note: Historical price multiple calculations use FYE price. Source: Reuters; company reports; Scotia Capital estimates.

At Risk: Everything

INVESTMENT HIGHLIGHTS

- **The not so good.** EarthFirst's (EarthFirst Canada) only construction project, its 144 MW Dokie I wind farm in B.C., has been hurt by cost overruns (up 10.8%), and a reduced wind resource estimate (down 2.3%).
- **The bad.** On August 5, the company's \$215.7 million debt financing commitment expired as some of the conditions precedent had not been met. Additionally, about \$50 million of sub debt and/or equity is likely needed to fund the cost overruns.
- **The ugly.** EarthFirst is now uncertain whether it will remain a going concern.
- **What's next.** We see one of four scenarios unfolding for EarthFirst over the next several months, each of which could substantially move its share price: (1) bankruptcy; (2) a financial partnership; (3) the company is acquired; or (4) refinancing.
- **We have transferred coverage of the common shares of EarthFirst Canada Inc., maintaining a 3-Sector Underperform rating and a one-year target price of \$0.40 per share.**
- **Extremely high-risk profile.** Despite our probability-weighted one-year target price of \$0.40 per share, we suggest investors switch out of this name in favour of relatively lower-risk intermediate independent power producers that generate strong cash flow, such as Canadian Hydro Developers and/or Boralex.

Summary & Investment Recommendation

We have transferred coverage on the common shares of EarthFirst Canada, maintaining a 3-Sector Underperform rating and a one-year target price of \$0.40 per share. In light of the company's recent developments, we now consider four equally weighted scenarios, one of which will likely play out over the next several months. We call this our "New DCF," and when coupled with a net asset value calculation of 60¢, we arrive at a one-year target price of 40¢ (Exhibit 4.1).

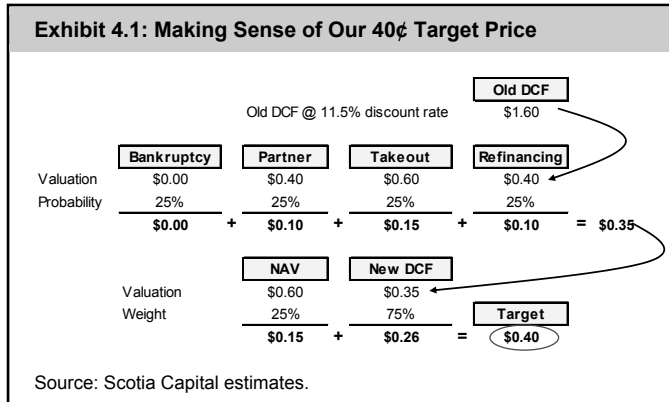

We believe that risk-averse investors would be better served by avoiding this stock until reasonable certainty has been established with respect to the company's ability to remain a going concern.

We recommend investors consider switching into intermediate, established, and cash flow generating renewable power companies such as Canadian Hydro Developers and Boralex, our two top picks.

FINANCIAL FORECAST

In our opinion, EarthFirst's earnings over the next couple of years are not too important until (1) its financing challenge is straightened out; and (2) its first project is fully commissioned in Q4/09. We look for EarthFirst to turn EPS-positive by 2011. We estimate that EarthFirst will generate 2009 EBITDA of \$4.3 million, increasing to \$27 million in 2010 and to \$48.1 million by 2011. Our forecast is based on a 2010 commissioning of its 45 MW Nuttby wind farm in Nova Scotia as well as its 30 MW Grand Valley wind project in Ontario.

Exhibit 4.2: EarthFirst Canada Inc. – Relative Valuation Metrics

Company	Ticker	Last Price	SC Rating	1-Year Target	1-Year ROR	DCF	NAV	Market Cap	Enterprise Value to EBITDA		
									2008E	2009E	2010E
8/15/2008											
Boralex	BLX	\$14.80	1-SO	\$18.00	22%	\$18.33	\$17.03	\$560	9.9x	8.6x	7.6x
Canadian Hydro Developers	KHD	\$4.38	1-SO	\$7.00	60%	\$7.04	\$6.95	\$628	20.3x	9.9x	7.6x
Earthfirst Canada	EF	\$0.27	3-SU	\$0.40	48%	\$0.35	\$0.60	\$28	n.m.	-5.5x	-0.9x
Innergex Renew able Energy	INE	\$8.25	3-SU	\$9.50	15%	\$9.44	\$9.55	\$194	n.m.	18.4x	7.8x
Plutonic Power	PCC	\$7.04	2-SP	\$9.00	28%	\$9.03	\$8.75	\$297	n.m.	n.m.	n.m.
Average					35%			\$341	15.1x	7.8x	5.5x

Company	Ticker	Beta	Price to Earnings			Price to Sales			Price to Cash Flow		
			2008E	2009E	2010E	2008E	2009E	2010E	2008E	2009E	2010E
(x) (x) (x) (x) (x) (x) (x) (x) (x) (x) (x)											
Boralex	BLX	0.7	28.8x	20.2x	18.6x	2.6x	2.5x	2.3x	10.4x	8.7x	7.7x
Canadian Hydro Developers	KHD	0.5	54.6x	23.4x	17.3x	7.2x	3.9x	3.1x	16.0x	9.0x	6.6x
Earthfirst Canada	EF	-	n.m.	n.m.	n.m.	n.m.	5.5x	0.9x	n.m.	n.m.	5.6x
Innergex Renew able Energy	INE	-	n.m.	n.m.	25.5x	27.5x	8.3x	4.2x	n.m.	33.6x	10.2x
Plutonic Power	PCC	0.9	n.m.	n.m.	n.m.	n.m.	n.m.	n.m.	n.m.	n.m.	n.m.
Average		0.7	41.7x	21.8x	20.5x	12.4x	5.1x	2.6x	13.2x	17.1x	7.5x

Source: Bloomberg; Scotia Capital estimates.

Capital Markets Profile

Over 80% of EarthFirst's development capacity is located in B.C., a province that seeks 90% of its new power from renewable sources.

Management experience includes raising \$0.5 billion of capital and the installation of almost 150 MW of wind capacity.

EarthFirst is a Canadian pure-play wind power developer, with over 2,600 MW of potential generation capacity, including 144 MW of under construction capacity, 226.5 MW of fully permitted projects, and a 45 MW project that has a signed PPA that is yet to be fully permitted. Over 80% of its planned wind power capacity is in British Columbia, with the remainder scattered throughout other Canadian provinces. EarthFirst intends to install its first wind turbines in B.C. by the end of 2008 and tender its two fully permitted projects into the 2008 BC Hydro Clean Power Call.

EarthFirst, established as a partnership between Creststreet Capital Corporation and Earth First Energy Inc., was awarded its first B.C. PPA in mid-2006 – a 20-year fixed-price contract with BC Hydro for the 144 MW Dokie I wind project. **In December 2007, EarthFirst completed its initial public offering, raising \$140 million to partially finance its \$360 million Dokie I project.** It did so through the issuance of 50.2 million units at \$2.25 per unit and 10.4 million flow-through shares at \$2.60 per share. Each unit consists of one common share (\$2.10) and one-half warrant (\$0.15), with each warrant granting the purchase of one common share at \$2.60 per share prior to December 11, 2009.

EarthFirst's management team is solid. Robert J. Toole, one of EarthFirst's founders, is a chartered accountant and is also the founder of Creststreet. Earth First Energy's Ron Percival, holds the title of Vice-Chairman, and has been the Chair of the Independent Power Producers of British Columbia (IPPBC) Wind Committee for the past three years. In June 2008, EarthFirst announced that Linda Chambers, a former executive of TransAlta, joined the company as its President and CEO. Ms. Chambers was recently President of TransAlta's U.S. operations as well as Executive Vice-President of Generation Technology.

With a market capitalization of less than \$30 million, EarthFirst's common shares trade on the Toronto Stock Exchange under the ticker symbol EF. Insiders and related parties control about 15.5% of the fully diluted outstanding company shares, and Pala Investment Holdings Ltd., a private long-term investment company with US\$1 billion under management, owns over 14% of the company. EarthFirst reports in Canadian dollars and its financial statements are prepared in accordance with Canadian GAAP.

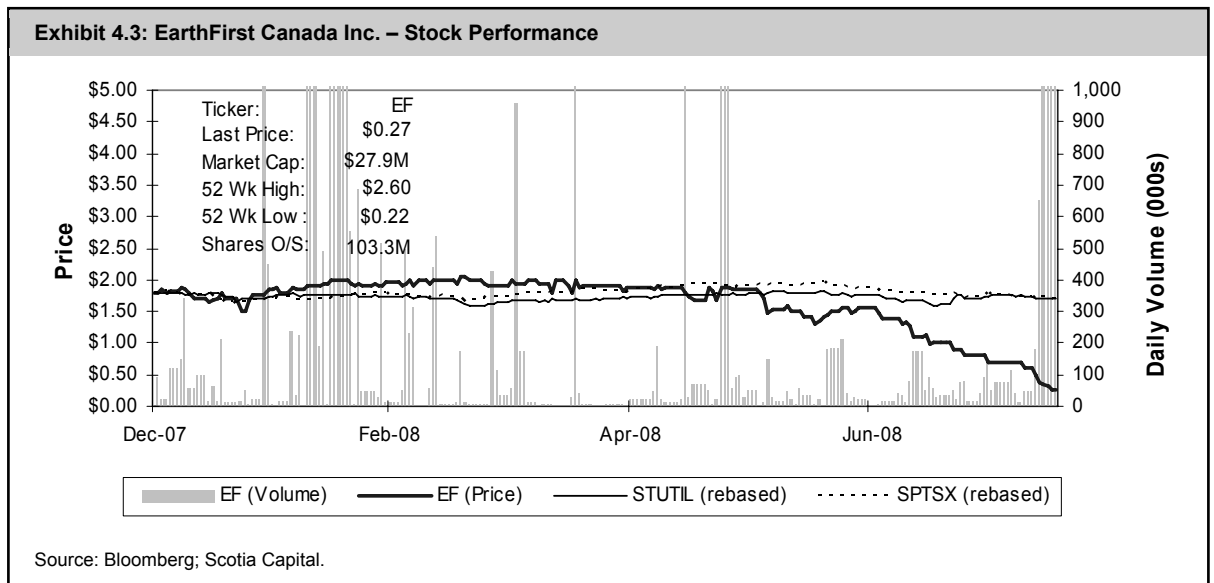

When Will EarthFirst Need More Equity?

With neither operating assets nor free cash flow generation for the near term, **we believe EarthFirst will need to access both equity and debt capital markets again in order to complete its Dokie I project.** Following its debt financing commitment from WestLB that expired on August 5 due to some funding conditions that were not met, **EarthFirst is now \$235 million short to complete construction of its first project.**

In our opinion, about \$50 million now needs to be raised as either equity or subordinated debt, with the remaining \$200+ million raised as part of a refinanced debt package.

On top of that, more equity will likely be required to continue developing its project pipeline. We assume project financing will occur at a 60%/40% debt/equity split, in line with the company's stated target and other Canadian renewable power projects.

If its two fully permitted projects receive PPAs in the 2008 BC Hydro Clean Power Call, EarthFirst could require about \$200 million of new equity.

It is not unreasonable to assume that both EarthFirst's 156 MW Dokie Expansion and its 70.5 MW Wartenbe projects receive PPAs in the 2008 BC Hydro Clean Power Call and begin construction in 1H/10. Within our financial forecast, we assume the successful on-time and on-budget completion of these two fully permitted projects. Using an installed capital cost of \$2.3 million per MW, EarthFirst could require about \$200 million of new equity within the next 12 to 18 months (over and above any equity raised to complete Dokie I). Exhibit 4.4 shows a table of potential new equity requirements by 2010 that we have sensitized to changes in new capacity additions, as well as various installed capital costs per MW.

Exhibit 4.4: EarthFirst Could Require \$200M in Equity Financing by 2010 Over and Above Dokie I Requirements

		Weighted Average Capital Cost per Installed MW								
		\$2.00M	\$2.10M	\$2.20M	\$2.30M	\$2.40M	\$2.50M	\$2.60M		
New Installed Capacity	Wartenbe	25 MW	\$20M	\$21M	\$22M	\$23M	\$24M	\$25M	\$26M	
		50 MW	\$40M	\$42M	\$44M	\$46M	\$48M	\$50M	\$52M	
		70.5 MW	\$56M	\$59M	\$62M	\$65M	\$68M	\$71M	\$73M	
		100 MW	\$80M	\$84M	\$88M	\$92M	\$96M	\$100M	\$104M	
		125 MW	\$100M	\$105M	\$110M	\$115M	\$120M	\$125M	\$130M	
	Dokie Exp.	156.0 MW	\$125M	\$131M	\$137M	\$144M	\$150M	\$156M	\$162M	
		175 MW	\$140M	\$147M	\$154M	\$161M	\$168M	\$175M	\$182M	
		200 MW	\$160M	\$168M	\$176M	\$184M	\$192M	\$200M	\$208M	
		Both	226.5 MW	\$181M	\$190M	\$199M	\$208M	\$217M	\$227M	\$236M
			250 MW	\$200M	\$210M	\$220M	\$230M	\$240M	\$250M	\$260M
		275 MW	\$220M	\$231M	\$242M	\$253M	\$264M	\$275M	\$286M	
		300 MW	\$240M	\$252M	\$264M	\$276M	\$288M	\$300M	\$312M	
		325 MW	\$260M	\$273M	\$286M	\$299M	\$312M	\$325M	\$338M	
		350 MW	\$280M	\$294M	\$308M	\$322M	\$336M	\$350M	\$364M	
		375 MW	\$300M	\$315M	\$330M	\$345M	\$360M	\$375M	\$390M	
		400 MW	\$320M	\$336M	\$352M	\$368M	\$384M	\$400M	\$416M	
425 MW		\$340M	\$357M	\$374M	\$391M	\$408M	\$425M	\$442M		

Source: Scotia Capital estimates.

UPSIDE VALUE IN EMISSIONS SALES & TRADING

North American carbon emissions markets will continue to develop in the near term.

In our opinion, EarthFirst’s share price could realize up to \$0.20 of upside (pre-refinancing) value from reasonable growth in carbon prices coupled with a moderate expansion of its generation asset portfolio. To arrive at this estimate, we assume a US\$5.00/CO_{2e} tonne starting price for emissions reductions (Exhibit 4.5), which is above the most recent price available on the Chicago Climate Exchange (CCX). We chose this price rather than using CCX pricing because: (1) **carbon prices have consistently been trending higher on the CCX**; and (2) prices and volumes on the CCX are likely lower than can be realized in bilateral voluntary markets in Canada and the United States. As a comparison, 2009 EU ETS prices are currently hovering around €24/CO_{2e} tonne (\$36/CO_{2e} tonne or about \$24/MWh), while Alberta charges \$15/CO_{2e} tonne (~\$10/MWh) as a non-compliance penalty for its largest industrial emitters. B.C. recently introduced a \$10/CO_{2e} tonne cost that will rise to \$30/CO_{2e} tonne over the next several years.

In our opinion, EarthFirst’s Dokie I green credits could become eligible for sale on the Chicago Climate Exchange (CCX) as an offset provider. This is contingent on the following assumptions: (1) production occurs prior to the end of 2010; (2) projects remain wholly owned by EarthFirst; (3) electricity sold to BC Hydro is “non-green,” meaning the green attributes of the project’s production will be retained by EarthFirst; and (4) EarthFirst does not sell its green credits to BC Hydro or any other counterparty.

In addition to the possibility of registering as an offset provider, **we believe EarthFirst may consider forward-selling its green credits**, similar to what some of its peers have done.

EarthFirst intends to retain its green credits for sales to carbon markets, or directly to third parties seeking to comply with emissions reduction targets.

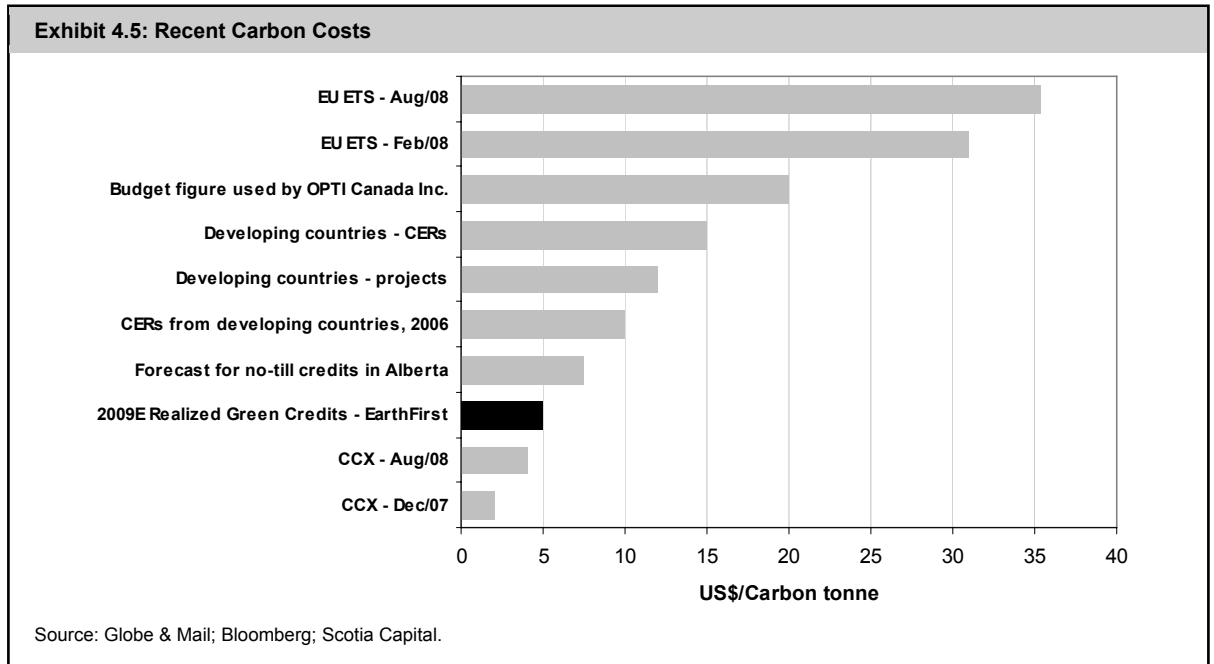

Key Investment Risks

EarthFirst's investment risks are typical of many junior Canadian renewable power companies that we follow (i.e., high). Similar to Plutonic Power, with only one project under construction, single plant production volatility will have a greater EPS impact than for companies such as Canadian Hydro Developers and Boralex, which have multiple operating facilities in multiple regions. First Nations support, financing risk, turbine supply constraints, operational risk, and a rapidly evolving renewable regulatory environment are all fairly standard for EarthFirst. Unlike Plutonic Power, which has a full fixed-price contract for its flagship project, EarthFirst has limited protection from cost overruns and time delays.

FINANCING

Given recent cost overruns as well as a debt financing package that has now expired, leaving EarthFirst \$235 million short for completion of its Dokie I project, EarthFirst's cost of capital will almost certainly increase and its access to capital may be constrained going forward. Additionally, as the company does not yet generate free cash flow, its IRR-based project selection criteria, which targets 9%-15%, could be significantly impaired by higher project financing costs. EarthFirst intends to finance its future projects using 60% debt and 40% equity.

WIND RESOURCE VARIABILITY

Wind as a resource is variable and intermittent. The amount of power generated by wind farms is dependent on the quality and consistency of wind flow. Below-forecast wind conditions would hinder EarthFirst's ability to produce electricity and therefore reduce the company's revenue and net income. As wind farms do not have power storage capability, there is no offset to wind resource variability risk, other than regional diversification of facility sites. A production volatility range of $\pm 15\%$ annually is typical for wind farms.

Annual volatility of wind power generation at a particular site of $\pm 15\%$ is not uncommon.

LIMITED CUSTOMERS

EarthFirst's growth is highly dependent on its development projects being awarded long-term, fixed-price contracts from a small group of provinces. BC Hydro, expected to be the company's main customer for its portfolio of projects, has delayed Calls for Power in past years. Prior to the 2006 CFP, BC Hydro's last two CFPs were held in 2002 and 1989. A 2004 CFP was planned but was delayed by two years. BC Hydro has delayed the submission deadline for 2008 Clean Power Call bids to November 25, 2008. **Future government delays in renewable power RFP bidding could significantly lower our future free cash flow expectations for EarthFirst.**

FIRST NATIONS SUPPORT

Lack of agreements or unfavourable outcomes to negotiations with First Nations groups that claim the land base on which EarthFirst's projects lie could adversely affect the company's profitability. Without the support of local First Nations communities, EarthFirst's projects could be delayed or even terminated. The company has reached settlements with three of four First Nations bands that support the construction and operation of EarthFirst's wind farm projects on their land.

MANAGEMENT

Key management risk is high for EarthFirst, as the company has only 17 full-time employees. EarthFirst is heavily dependent on current management to develop, promote, and realize its future growth opportunities. If a key member of EarthFirst's management were to leave the company, operations could be significantly impaired.

Key management risk at EarthFirst is high, as the company has only 17 full-time employees.

COST & TIMING OVERRUNS

There is no certainty that future development and construction cost spending will be within budget or on time. Upon being awarded a government-backed PPA, companies typically set a date to commence power generation. If that date is not met, bid winners could lose expected revenue and may be exposed to financial penalties from either the PPA provider or via debt covenants. **On July 4, 2008, EarthFirst announced a 10.8% capital cost increase to \$360 million for its 144 MW Dokie I project.**

REGULATORY ENVIRONMENT

EarthFirst's expected EBITDA is based solely on it capitalizing on various Canadian regulatory bodies' desires to boost their own renewable portfolios. Federal and provincial government policy changes could alter renewable power-related initiatives and incentives that EarthFirst depends upon. Our financial forecast assumes the continuation of current federal and provincial renewable power targets and policies.

EarthFirst's share price is vulnerable if it does not receive environmental and regulatory permits as expected.

GREEN CREDIT MARKETS ARE ILLIQUID AND UNDEVELOPED

Part of EarthFirst's corporate strategy includes, where possible, retaining its earned green credits for sales and/or trading on various emissions markets, climate exchanges, or directly to third parties. **These markets in Canada and the United States are highly illiquid, mostly voluntary, and undeveloped.** Government policies impacting emissions markets are evolving rapidly. While we believe the long-term implications to EarthFirst as a renewable power provider are positive, a high level of uncertainty remains with respect to these green credit markets.

STANDARD OPERATIONAL RISK

Unplanned and longer-than-planned outages for maintenance and repair will negatively impact EarthFirst's revenue and profitability, as (1) electricity delivery will decline; and (2) operating costs will likely increase. Unlike a conventional power plant (i.e., coal, natural gas, or nuclear) where an outage could impact the entire facility's operations, an outage of one wind turbine typically has a minor impact on the generation output of a wind farm. Outage materiality depends on the number of turbines on a wind farm.

WIND TURBINE SUPPLY

With the current supply-constrained market for turbines, EarthFirst may face longer-than-expected lead times for its turbine orders. As a result of soaring wind turbine demand in Europe and North America, as well as a lack of U.S.-based turbine manufacturers, we expect the current supply/demand imbalance for wind turbines to continue over the near term. Many North American wind farm projects now wait up to two years to receive turbines once an order has been placed.

EARLY-STAGE PROJECTS

Obtaining all environmental and regulatory permits and licences, lease agreements, PPAs, local support, and favourable wind data for all projects may not occur as planned. Project implications from unsuccessful completion of a project's development and construction process could have major share price implications. Exhibit 4.6 shows a summary of EarthFirst's current development pipeline.

Exhibit 4.6: EarthFirst's Development Pipeline Summary										
		Wind Data		Environmental		Interconnection		Long-Term		Turbines
		(MW)	Months	Initiated	Completed	Initiated	Completed	Leases	EPA	Acquired
Under Construction										
Dokie I	B.C.	144	54	X	X	X	X	X	X	X
Advanced Stage										
Grand Valley	ON	30	29	X		X		X	X	X
Nutby Mountain	NS	45	23	X		X		X	X	
Dokie Expansion	B.C.	156	54	X	X	X	X	X		
Wartenbe	B.C.	70	69	X	X	X	X	X		
Bonavista	NL	45	45	X		X				
Development Stage										
Grand Valley	ON	10	29	X		X				
Windrise	AB	99	57	X	X	X		X		
Benchlands	SK	70	21	X		X		X		
N.E.	B.C.	630	17	X						
Interior/Kelly Lake	B.C.	500		X						
Interior/Nicola	B.C.	200								
Buffalo Atlee	AB	200	33			X		X		
Islands	B.C.	450	26							

Source: EarthFirst Canada Inc.

Upcoming Stock Catalysts & Events

Below, we have outlined upcoming events that we believe could affect EarthFirst's stock, as follows:

In our minds, in addition to a refinancing plan announcement, the 2008 BC Hydro Clean Power Call award date is the largest foreseeable stock catalyst for EarthFirst.

Next two to three months – Announcement of a refinancing package.

November 2008 – BC Hydro 2008 Clean Power Call bids due. In our opinion, EarthFirst's current share price reflects a high expectation that the company will bid its Dokie I Expansion (156 MW) and Wartenbe (70.5 MW) projects into BC Hydro's current call for power.

Q4/08 – Commissioning of Dokie I CRCE Turbine Phase (24 MW).

2H/08-1H/09 – Future project turbine supply agreements. The lack of available wind turbines in the market is no longer a minor issue. Projects are being delayed and economic returns reduced due to the long lead time required to secure turbine supply. If the U.S. production tax credit (PTC) is not renewed beyond the end of 2008, we expect several U.S. wind farm projects to be delayed, likely resulting in a short-term phenomenon of excess wind turbines available for Canadian projects.

1H/09 – Financing of Grand Valley. Completion of debt financing at favourable rates for EarthFirst's 30 MW Grand Valley project will increase the probability of successful project completion.

1H/09 – BC Hydro 2008 Clean Power Call awards expected, likely after the B.C. government election that is scheduled for May 2009.

Q4/09 – Commissioning of Dokie I Infill Phase (120 MW).

Ongoing – New project announcements and other growth initiatives. EarthFirst intends to grow its asset base by (1) bringing construction-ready and advanced-stage projects under PPAs into production; (2) seeking additional PPAs for other advanced-stage projects; (3) moving the remainder of its portfolio through the development pipeline; and (4) acquiring construction-ready and development-stage projects or operating assets that are accretive to shareholders.

Ongoing – Permitting progress on future projects. Specifically, we look for 2008 permitting progress on EarthFirst's recent acquisition of the 45 MW Nuttby wind farm in Nova Scotia. EarthFirst acquired the project with a signed PPA and interconnection agreement with Nova Scotia Power Inc.

Ongoing – Other provincial RFP announcements or possible forward sales of green credits.

EarthFirst's Flagship 144 MW Dokie I Wind Farm

We expect the first full year of Dokie I operations will be in 2010.

Located about 150 kilometres south of Fort St. John, the 144 MW Dokie I wind farm project is adjacent to the 500 kV and 230 kV transmission lines originating from the Bennet Dam. Access to Dokie Ridge is available through the use of existing provincial roads, logging roads, and rail corridors. Exhibit 4.7 shows the company's Dokie I project timeline.

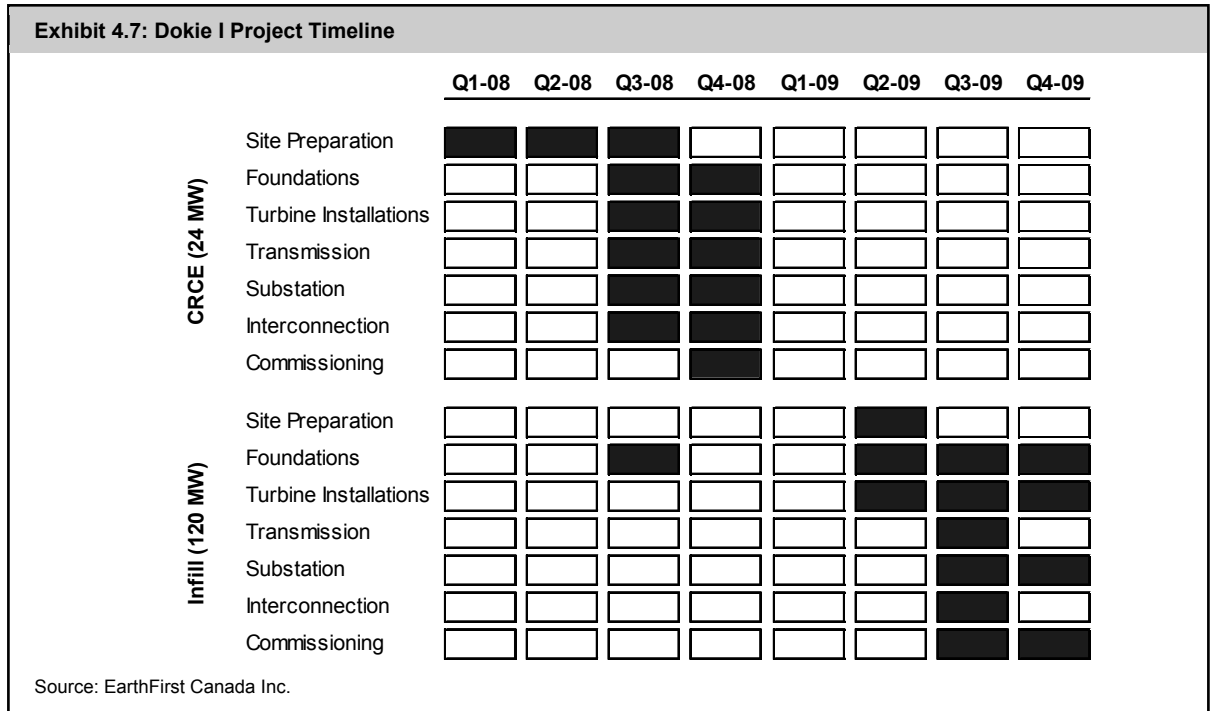

POWER PURCHASE AGREEMENTS

We expect Dokie I to realize a weighted average PPA price of \$85/MWh in its first full year of operations, or mostly a firm energy delivery price of \$81/MWh that we have adjusted by 50% of our expected annual consumer price index changes. In August 2006, the Dokie I wind farm project was awarded a 20-year PPA from BC Hydro for 144 MW. The PPA is effective on the commercial operating date (COD), which cannot be before November 1, 2009, unless consent is given by BC Hydro. PPA prices are subject to slight hourly and monthly delivery price adjustments. Additionally, the contract enables Dokie I to increase or decrease its monthly firm energy delivery commitment by up to 10%, subject to various conditions.

EarthFirst could benefit from pre-COD sales at prices equivalent to a discount to the Mid-Columbia power market.

We expect pre-COD sales to occur on the installation of the project's 24 MW CRCE Turbine Phase. Should pre-COD sales take place, EarthFirst must sell its power to third parties. Management believes that realized power prices to third parties could be equivalent to a discount of mid-Columbia prices (Exhibit 4.8). The average on-peak price from March 2007 to March 2008 was US\$61.62/MWh, while the off-peak average during that time was US\$47.80/MWh. Using a par FX rate, **we use a \$45/MWh average power price for EarthFirst's pre-COD sales.**

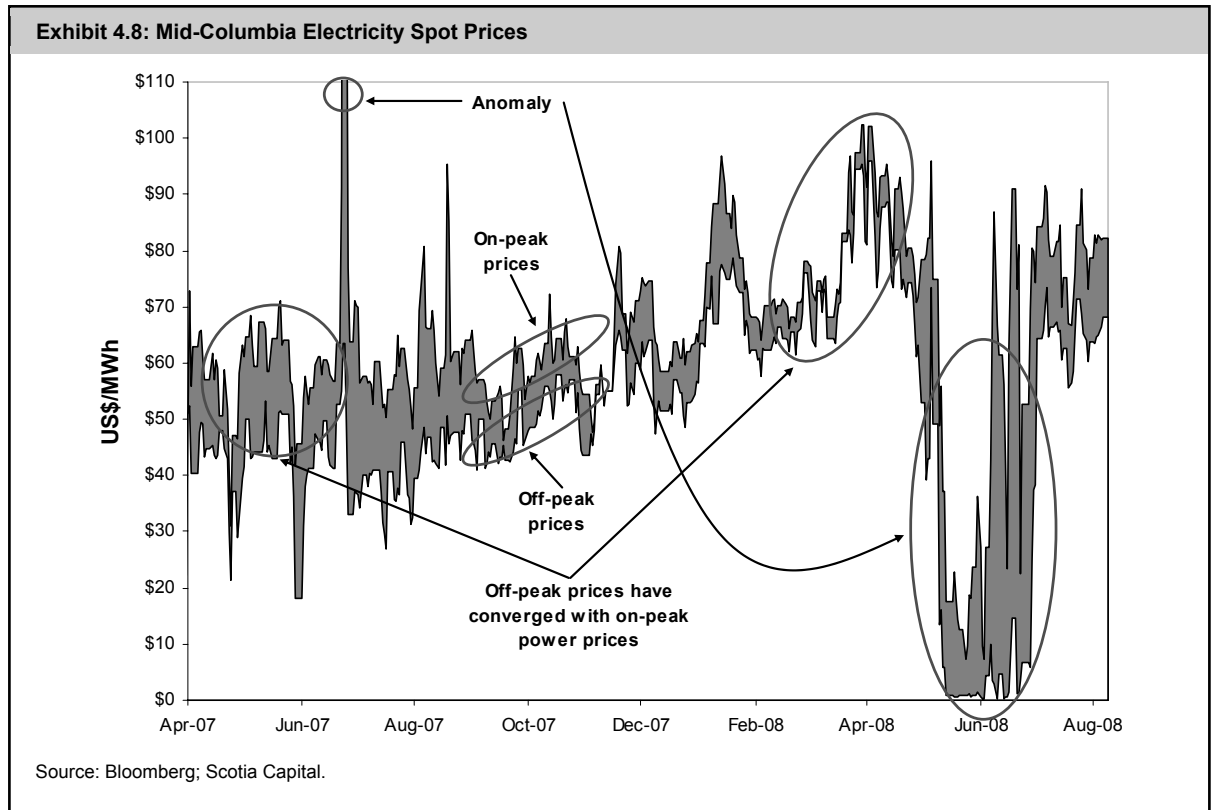

PERMITS AND APPROVALS

EarthFirst has successfully received approvals on all Dokie I permitting to date. Management anticipates that permitting requirements during construction will be met on time as well. Dokie I was originally awarded a B.C. Environmental Assessment Certificate in August 2006 for a project up to 300 MW, a permit required for all B.C. projects over 50 MW. The project also received a Licence of Occupation tenure, permitting the construction of the project.

EarthFirst will connect its wind farm to the BC Hydro 230 kV transmission system running adjacent to the project site. A British Columbia Transmission Corporation (BCTC) Preliminary Interconnection Study Report confirmed that the B.C. transmission system will accommodate electricity generated by Dokie I.

Submission for the ecoENERGY Renewable Power Incentive program (eRPI) is complete.

Qualifying projects commissioned between April 1, 2007, and March 31, 2011, will receive \$10/MWh over 10 years up to a maximum of \$80 million per project and \$256 million per company. The incentive is awarded on a first-constructed, first-served basis. **We believe Dokie I will qualify for the full incentive.**

Three of four First Nations groups have signed MOUs that enable benefit sharing. EarthFirst has engaged relevant First Nations groups in its environmental work, road work, and clearing work to date.

Our forecast capacity factor for Dokie I is 0.9% below the company's estimation of 27.1%.

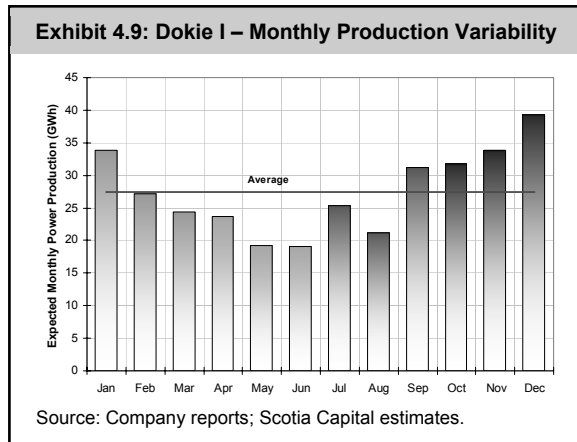

WIND RESOURCE

Garrad Hassan, a leading wind energy resource consultant, estimates a mean wind energy production level of 341.5 GWh/y. Furthermore, over a 10-year period, there is a 90% probability of exceeding 297.5 GWh. These estimates are based on wind readings from 11 separate locations at the Dokie I and Dokie Expansion project sites. Based on two recent presentations by Garrad Hassan that examined actual results to their estimations, our forecast capacity factor is 26.2%, or 0.9% below the Garrad Hassan forecast (Exhibit 4.9).

TURBINE SUPPLY AND WARRANTY/SERVICE AGREEMENTS

Vestas will supply Vestas V90 wind turbines for the project, with the first turbines used for the CRCE (Canadian Renewable Conservation Expense) phase and the remainder used for the infill construction phase. Delivery of the first turbines occurred in July 2008, with the remainder expected in 2H/09. EarthFirst, through its subcontractor Canadian Projects Limited, is responsible for unloading, erecting, assembling, installing, and ensuring grid connection for the turbines.

We believe EarthFirst's five-year warranty and service agreement with Vestas is of low quality and reflects a growing trend of poor warranty and service agreements offered by international turbine suppliers. The warranty and service agreements require Vestas to conduct (1) scheduled maintenance, (2) unscheduled maintenance, (3) repair and replacement where necessary, (4) regular status meetings with Dokie I Project representatives, and (5) preparation of regular service reports. Because wind turbine suppliers continue to have the upper hand in a supply-controlled market, strong warranty and service agreements are no longer required by manufacturers to differentiate themselves from their competition and to ensure maximum sales targets are achieved.

CONSTRUCTION

EarthFirst has arranged a construction contract with Canadian Projects Limited, a consulting engineering firm specializing in renewable energy development. The company has 100 years of combined experience constructing power projects across Canada. It has worked on wind farm projects ranging in size from 1 MW to 200 MW.

Management forecasts the capital cost for the CRCE turbine phase, consisting of eight turbines, to be \$100 million. EarthFirst intends to fund this amount through a combination of IPO proceeds and debt financing. The high price for the installation of only a few turbines is due to the anticipated completion of infrastructure spending for both phases of the project. We expect the first 24 MW of Dokie I to be online by the end of Q4/08. We use a 50% rule in our financial forecast and assume that 12 MW is online for all of Q1/09, as we do not know when specifically during the quarter operations will commence.

Given a satisfactory level of production for the CRCE turbine phase, EarthFirst will install 40 additional turbines during its infill phase. Commencement of this phase is expected to be four months after electricity production of the test turbines from the above phase. Full electricity production from the additional 40 turbines is expected to start sometime during Q4/09. The anticipated cost of \$237 million for this phase will likely be financed primarily through debt facilities.

EarthFirst plans to have 24 MW operating by the end of Q4/08.

Exhibit 4.10: EarthFirst Was a Big Winner in the 2006 BC Hydro Call for Power

Bidder Name	Project Name	Nearby City	Energy Source	Capacity (MW)	Energy (GWh/yr)
Plutonic Power Corporation	East Toba and Montrose Hydroelectric Project	Powell River	Water	196	702
AESWapiti Energy Corporation	AESWapiti Energy Corporation	Tumbler Ridge	Coal / Biomass	184	1,612
Dokie Wind Energy Inc.	Dokie Wind Project	Chetwynd	Wind	180	536
Bear Mountain Wind Limited Partnership	Bear Mountain Wind Park	Dawson Creek	Wind	120	371
3986314 Canada Inc.	Canada - Glacier / Howser / East - Project	Nelson	Water	91	341
Green Island Energy Ltd.	Gold River Power Project	Gold River	Biomass	90	745
Kwalsa Energy Limited Partnership	Kwalsa Energy Project	Mission	Water	86	384
Anyox Hydro Electric Corp.	Anyox and Kilsault River Hydroelectric Projects	Alice Arm	Water	57	242
Compliance Power Corporation	Princeton Power Project	Princeton	Coal / Biomass	56	421
Upper Slave Energy Limited Partnership	Upper Slave Energy Project	Mission	Water	55	264
Mackenzie Green Energy Inc.	Mackenzie Green Energy Centre	Mackenzie	Biomass / Other	50	441
Kwoiek Creek Resources Limited Partnership	Kwoiek Creek Hydroelectric Project	Lytton	Water	50	147
Mount Hays Wind Farm Limited Partnership	Mount Hays Wind Farm	Prince Rupert	Wind	25	72
Canadian Hydro Developers, Inc.	Bone Creek Hydro Project	Kamloops	Water	20	81
Songhees Creek Hydro Inc.	Songhees Creek Hydro Project	Port Hardy	Water	15	61
Plutonic Power Corporation	Rainy River Hydroelectric Project	Gibson	Water	15	51
Hydromax Energy Ltd.	Lower Clowhom	Sechelt	Water	10	48
Hydromax Energy Ltd.	Upper Clowhom	Sechelt	Water	10	45
Global Cogenix Industrial Corporation	Kookipi Creek Hydroelectric Project	Boston Bar	Water	10	39
Cogenix Power Corporation	Log Creek Hydroelectric Project	Boston Bar	Water	10	38
Canadian Hydro Developers, Inc.	Clemina Creek Hydro Project	Kamloops	Water	10	31
KMC Energy Corp.	Tamih Creek Hydro Project	Chilliwack	Water	10	52
Valisa Energy Incorporated	Serpentine Creek Hydro Project	Blue River	Water	10	29
Synex Energy Resources Ltd.	Victoria Lake Hydroelectric Project	Port Alice	Water	10	39
Second Reality Effects Inc.	Fries Creek Project	Squamish	Water	9	41
Renewable Power Corp.	Tyson Creek Hydro Project	Sechelt	Water	8	48
Hupacasath First Nation	Franklin River Hydro Project	Port Albemi	Water	7	19
Axiom Power Inc.	Clint Creek Hydro Project	Woss	Water	6	27
EnPower Green Energy Generation Inc.	Savona ERG Project	Savona	Waste Heat	6	41
EnPower Green Energy Generation Inc.	150 Mile House ERG Project	150 Mile House	Waste Heat	6	34
Maroon Creek Hydro Partnership	Maroon Creek Hydro Project	Terrace	Water	5	25
Spuzzum Creek Power Corp.	Sakwi Creek Run of River Project	Agassiz	Water	5	21
Canadian Hydro Developers, Inc.	English Creek Hydro Project	Revelstoke	Water	5	19
Synex Energy Resources Ltd.	Barr Creek Hydroelectric Project	Tahsis	Water	4	15
Raging River Power & Mining Inc.	Raging River 2	Port Alice	Water	4	13
Synex Energy Resources Ltd.	McKelvie Creek Hydroelectric Project	Tahsis	Water	3	14
Advanced Energy Systems Ltd.	Cranberry Creek Power Project	Revelstoke	Water	3	11
District of Lake Country	Eldorado Reservoir	Kelowna	Water	1	4
Subtotal				1,439	7,125
Brilliant Expansion Power Corporation	Brilliant Expansion Project (2)	Castlegar	Water	120	226
Total				1,559	7,351

Reduced to 144 MW due to the requirements to meet the turbine manufacturer's site suitability criteria

Source: BC Hydro; Scotia Capital.

Grand Valley

The 30 MW Grand Valley wind farm project is located 15 kilometres west of Orangeville, Ontario. This project has a potential installed capacity of 40 MW. It received three Standard Offer Contracts (SOCs) from the Ontario Power Authority in January 2007 for a total of 30 MW. The site location has adequate access to transmission and roads. **In its Q1/08 MD&A, EarthFirst stated “it appears unlikely that the necessary permits will be received in time to commence construction in 2009.”**

ONTARIO STANDARD OFFER CONTRACTS

Ontario Standard Offer Contracts require EarthFirst to relinquish control of its earned green credits.

EarthFirst was awarded three 10 MW, 20-year term SOCs by the Ontario Power Authority in early 2007. Power generation will occur at facilities in Grand Valley and Shelburne, Ontario. All electricity generated at the facilities will be sold to the OPA at \$110/MWh. Twenty percent of this base rate will be adjusted for inflation on an annual basis, using the Ontario Consumer Price Index (OCPI). If the OCPI is negative, there will be no change in payment (i.e., rates will not decline).

EarthFirst is obligated to transfer any green credits earned at its Grand Valley wind farms to the OPA during the terms of the contracts, unlike its PPA with BC Hydro.

PERMITS AND APPROVALS

We think that the OPA will not terminate its Grand Valley SOCs and will extend or renew the contracts.

EarthFirst expects environmental permitting will not be complete by mid-2008, as originally planned for. The OPA's Standard Offer Contracts (SOCs) for the Grand Valley project each require a commissioning date of January 27, 2010. If this date is not achieved, the OPA has an option to terminate the SOCs. **We think that the OPA will not terminate its Grand Valley SOCs and will either extend or renew the contracts.** Reasons why include: (1) 30 MW is a relatively small amount of capacity; (2) the permitting delays are out of EarthFirst's control; and (3) the proposed power is renewable, non-dispatchable, and non base-load (i.e., it is not heavily relied upon). Following permitting completion, EarthFirst will reassess the economic viability of its Grand Valley project.

Screening studies are under way to satisfy eRPI application requirements. Should the eRPI be granted, EarthFirst is contractually obligated to share the proceeds equally with the OPA, or **net \$5/MWh** to EarthFirst.

WIND DATA

Wind data has been collected for over 29 months from two towers. No results have been released yet. Grand Valley's consultant, Garrad Hassan Canada Inc., will complete a wind data study once wind tower locations are confirmed to be in accordance with environmental assessment and manufacturer requirements.

LEASE RIGHTS

The Grand Valley project will be constructed on privately owned land, requiring annual royalties up to 3% of expected revenue. Grand Valley has 19 options to lease agreements with individual landowners that would allow for the installation of wind turbines, the electrical collection system, and the construction of a road network between Grand Valley's infrastructure.

PROJECT CONSTRUCTION & FINANCING

We expect the \$73 million project to begin generating power by Q4/10, or one year later than planned. Financing arrangements have not been disclosed, and we believe that terms will be announced as permitting completion and construction decisions progress.

TURBINE SUPPLY AND WARRANTY/SERVICE AGREEMENTS

The Grand Valley project will use 15 Enercon E82 2.0 MW wind turbines that are expected to be delivered in mid-2009. Under the terms of the warranty agreement, EarthFirst will pay Enercon an annual fee per turbine of €9,000 plus \$12,500 per annum for the first five years, and €18,000 per turbine plus \$25,000 per annum for the following seven years.

If the project does not move forward, we believe that EarthFirst will have the option to allocate the turbines onto another site that is acceptable to Enercon, and which is not further than 300 km from one of Enercon's wind farm service stations. Alternatively, Enercon has an option to extend the contract in its current form by one year.

Enercon was recently rated the top turbine manufacturer-based service provider.

Enercon was rated the top turbine manufacturer-based service provider in 2007, according to a recent survey of over 2,000 turbine operators. The study was conducted by the German Wind Energy Association and included Enercon (#1), REpower Systems (#2), Nordex (#3), Siemens (#4), Vestas (#5), and GE Energy (#6).

EarthFirst's Other Wind Projects

We expect EarthFirst to submit 226.5 MW of fully permitted wind projects into the 2008 BC Hydro Clean Power Call. EarthFirst's 2,600 MW portfolio of construction-ready and development-stage wind projects spans from B.C. to Newfoundland. We highlight each of its projects below. Exhibit 4.11 shows a map of EarthFirst's project locations in Canada.

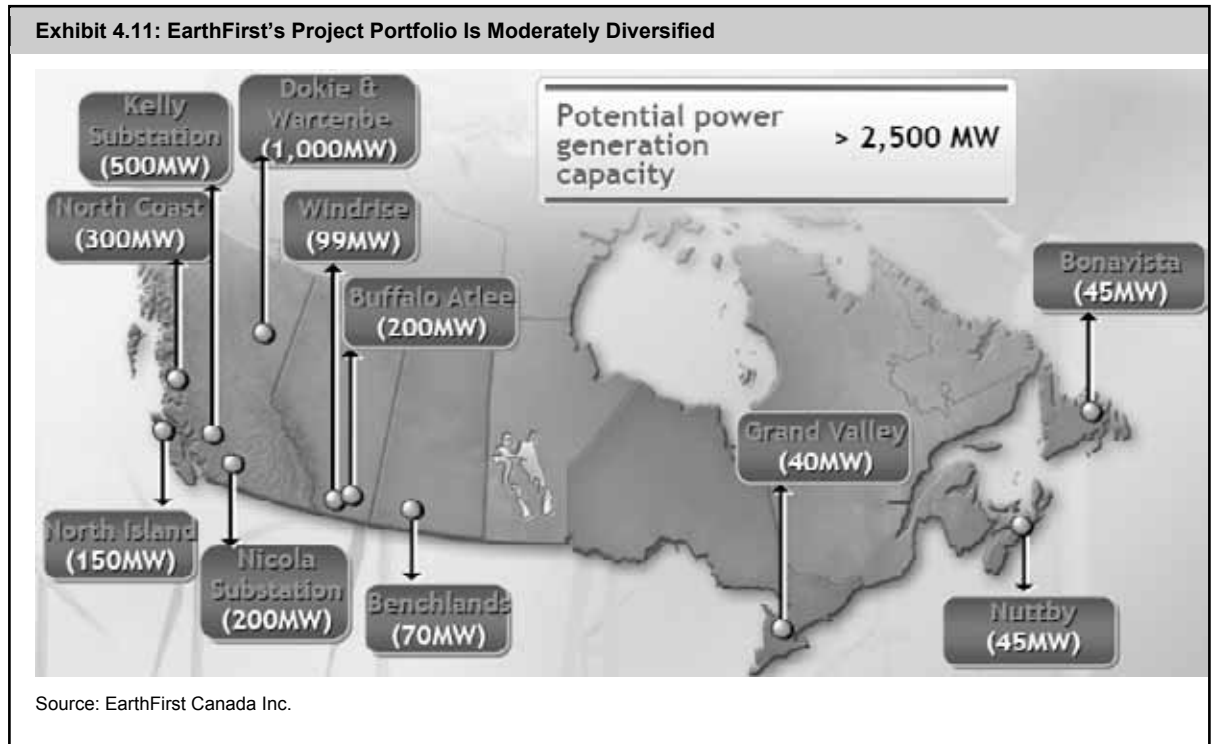

DEVELOPMENT PROJECTS WITHIN BRITISH COLUMBIA

Wartenbe

We believe that EarthFirst will submit its fully permitted 70.5 MW Wartenbe project into the 2008 BC Hydro Clean Power Call. A provincial Environmental Assessment Certificate for the project was awarded in late 2006 and requires construction to begin prior to October 2011. As the company intends to build the wind farm on Crown lands, a five-year Interim Licence of Occupation has been signed that allows the project a five-year window to complete construction. Once the wind farm is operational, a 30-year land lease with the Crown will commence.

Dokie Expansion

EarthFirst should submit its fully permitted 156 MW Dokie Expansion project into the 2008 BC Hydro Clean Power Call. The project site is located next to Dokie I and represents the remainder of 300 MW of capacity that received a B.C. Environmental Assessment Certificate in mid-2006. Should a PPA be granted, management expects the realization of operational synergies from infrastructure and interconnection sharing with Dokie I.

Peace Region

EarthFirst holds numerous permits within B.C.'s Peace Region. These permits enable the company to investigate potential development properties that **currently total 630 MW**. Within this portfolio is a group of projects (about 300 MW), known as the Hasler Group, which EarthFirst intends to submit into a future BC Hydro Clean Power Call. In late 2007, the Hasler Group of wind farm development properties applied for environmental permitting.

Other B.C. Projects

The Kelly Lake wind power projects represent up to 500 MW of capacity and are in close proximity to the Kelly Lake Substation. **EarthFirst has exclusive investigative rights to these wind resources.** Environmental assessment application submissions are planned for 2008. **We believe the Kelly Lake projects will likely be submitted into a future BC Hydro Power Call.**

The Monte Nicola project is composed of three sites located near the Nicola Substation transmission line in the B.C. interior. These projects represent a potential wind power capacity of 200 MW, and may also be tendered into a future BC Hydro Power Call. Similar to its Kelly Lake development prospects, EarthFirst holds exclusive investigative rights to these resources.

EarthFirst also holds comparable rights for several projects on Vancouver Island and Trutch Island that represent a potential wind capacity of 450 MW.

DEVELOPMENT PROJECTS OUTSIDE OF BRITISH COLUMBIA

Windrise

If constructed, we believe EarthFirst's 99 MW Windrise project will be one of two EarthFirst projects that do not have long-term power price contracts. The development site is located adjacent to Nexen and Canadian Hydro Developers' Soderglen wind power facility. The majority of the environmental, wind, and engineering studies are complete. The project location is transmission-constrained and will likely not proceed until construction of a new transmission line is complete.

Buffalo Atlee

The early-stage 200 MW Buffalo Atlee project is located near Brooks, Alberta. **It is the second possible site for merchant power generation by EarthFirst.** Unlike its Windrise project, EarthFirst has not begun the majority of the required environmental and engineering studies. EarthFirst holds a four-year exploratory Crown land permit.

Benchlands

EarthFirst's 70 MW Benchlands project did not receive a SaskPower PPA in late 2005 due to a bidding price that was likely too high. The project received a 5 MW PPA in early 2006 that EarthFirst terminated given its small size and high interconnection costs. The wind farm is located near Tompkins, Saskatchewan. It is believed by management to have a potential capacity of 70 MW. **We believe EarthFirst will bid this project into the next SaskPower RFP, which may occur in 2009.**

Nuttby

In March 2008, EarthFirst acquired the 45 MW Nuttby wind farm from Atlantic Wind Power Corporation. The acquisition price was paid for with about 192,000 EarthFirst common shares, a share of the gross revenue generated from the project over the 23-year life of the PPA with Nova Scotia Power Inc., as well as a \$75,000 cash payment. An interconnection agreement has been reached between EarthFirst and Emera subsidiary Nova Scotia Power. Turbine negotiations are under way for a 2009 delivery, and the Environmental Assessment process is expected to be fully complete by the end of the year. In July, EarthFirst announced that it had received an environmental approval by the Government of Nova Scotia.

Bonavista

The 45 MW Bonavista project, located in Newfoundland, has had two PPA bids rejected by Newfoundland & Labrador Hydro, both in 2006, likely due to bid prices that were too high. While PPAs have been granted at lower prices to other bidders, the only project that has begun construction there is Skypower's 27 MW Fermeuse wind farm. EarthFirst expects the project to be bid into Newfoundland's next RFP, which may be announced shortly.

Valuation & Sensitivity Analyses

FULL VALUE FOR PROJECTS UNDER CONSTRUCTION; NONE FOR BRAG-A-WATTS

We value EarthFirst using a blended approach as follows: a probability-weighted discounted cash flow analysis, and a probability-weighted net asset value (NAV) per share.

Our DCF analysis, prior to the recent development that EarthFirst may not continue as a going concern, supported a one-year target price of \$1.60 per share (Exhibit 4.12). At that time, we used an 11.5% discount rate. Since then, we have introduced four equally weighted scenarios that may play out over the short term, which suggests a risk-adjusted DCF valuation of \$0.35 per share (Exhibit 4.13).

Exhibit 4.12: Our Old DCF Analysis of EF Supported \$1.60 per Share One Year Out

Project	Gross Capacity (MW)	Effective Capacity (MW)	Capacity Factor (%)	DCF (\$/share)	Prob. of Success (%)	Adjusted DCF (\$/share)	Comments
Dokie I CRCE	24	24	26%	\$0.10	100%	\$0.10	Expected online Q4/08
Dokie I Infill	120	120	26%	\$0.86	100%	\$0.86	Expected online Q4/09
Grand Valley I	30	30	28%	\$0.22	25%	\$0.05	Lower probability due to permitting delays, f/x exposure
Nuttby	45	45	30%	\$0.43	25%	\$0.11	
Dokie Expansion	156	156	30%	\$1.36	25%	\$0.34	Expect the project to enter the BC Hydro Clean Power Call
Wartenbe	71	71	30%	\$0.59	25%	\$0.15	Expect the project to enter the BC Hydro Clean Power Call
Grand Valley II	10	10	28%	\$0.08	0%	\$0.00	
Bonavista	45	45	28%	\$0.35	0%	\$0.00	
Windrise	99	99	28%	\$0.76	0%	\$0.00	
Benchlands	70	70	28%	\$0.54	0%	\$0.00	
N.E.	630	630	28%	\$4.83	0%	\$0.00	
Interior/Kelly Lake	500	500	28%	\$3.84	0%	\$0.00	
Interior/Nicola	200	200	28%	\$1.53	0%	\$0.00	
Buffalo Atlee	200	200	28%	\$1.53	0%	\$0.00	
Islands	450	450	28%	\$3.45	0%	\$0.00	
	2,650	2,650				\$1.60	

Source: Scotia Capital estimates.

We do not include any potential non-permitted renewable power projects in our DCF. We assign 25% weights to EarthFirst’s fully permitted projects, Dokie Expansion (156 MW), and Wartenbe (70.5 MW), which we believe will be submitted into the 2008 BC Hydro Clean Power Call. We also assign a

Exhibit 4.13: Making Sense of Our 40¢ Target Price

Old DCF @ 11.5% discount rate				Old DCF	\$1.60
Valuation	Bankruptcy	Partner	Takeout	Refinancing	
	\$0.00	\$0.40	\$0.60	\$0.40	
Probability	25%	25%	25%	25%	
	\$0.00	\$0.10	\$0.15	\$0.10	= \$0.35
Valuation	NAV	New DCF			
	\$0.60	\$0.35			
Weight	25%	75%		Target	\$0.40
	\$0.15	\$0.26			

Source: Scotia Capital estimates.

25% weight to the PPA-signed 45 MW Nuttby wind project in Nova Scotia. Finally, we reduced our probability of success on EarthFirst’s Grand Valley project to 25% from 100% previously due to its announcement that it will not complete permitting on time for a Q1/10 commissioning date.

We calculate a NAV of \$0.60 per share. Given recent transactions and using rule-of-thumb metrics, we give credit of \$0.82 million per GWh/y for capacity that is either operating or under mostly fixed-price contract construction. We reduce this amount according to various stages of project progress. We assign no value for the rest of its wind project portfolio (Exhibit 4.14).

EarthFirst's targeted debt/equity split is 60%/40%, and its counterparties are investment-grade crown corporations that offer long-term fixed-price contracts.

Exhibit 4.14: Net Asset Value Suggests \$0.60 per Share

	Project Status	Financing Status	Unrisked Net Generation	Risk-Adjusted Asset Value	NAV (\$M)	NAVPS (diluted)	NAVPS (%)
Projects							
Dokie I CRCE	2	2	55.0 GWh/y @	\$0.74M / GWh/y	\$40.6	\$0.16	26.0%
Dokie I Infill	2	2	275.0 GWh/y @	\$0.74M / GWh/y	\$203.0	\$0.79	130.2%
Grand Valley I	3	4	73.5 GWh/y @	\$0.41M / GWh/y	\$30.1	\$0.12	19.3%
Nuttby	4	4	118.3 GWh/y @	\$0.21M / GWh/y	\$24.2	\$0.09	15.6%
Dokie Expansion	4	4	410.0 GWh/y @	\$0.21M / GWh/y	\$84.0	\$0.33	53.9%
Wartenbe	4	4	184.0 GWh/y @	\$0.21M / GWh/y	\$37.7	\$0.15	24.2%
Grand Valley II	6	4	24.5 GWh/y @	\$0.00M / GWh/y	\$0.0	\$0.00	0.0%
Bonavista	6	4	110.4 GWh/y @	\$0.00M / GWh/y	\$0.0	\$0.00	0.0%
Windrise	6	4	242.8 GWh/y @	\$0.00M / GWh/y	\$0.0	\$0.00	0.0%
Benchlands	6	4	171.7 GWh/y @	\$0.00M / GWh/y	\$0.0	\$0.00	0.0%
N.E.	6	4	1,545.3 GWh/y @	\$0.00M / GWh/y	\$0.0	\$0.00	0.0%
Interior/Kelly Lake	6	4	1,226.4 GWh/y @	\$0.00M / GWh/y	\$0.0	\$0.00	0.0%
Interior/Nicola	6	4	490.6 GWh/y @	\$0.00M / GWh/y	\$0.0	\$0.00	0.0%
Buffalo Atlee	6	4	490.6 GWh/y @	\$0.00M / GWh/y	\$0.0	\$0.00	0.0%
Islands	6	4	1,103.8 GWh/y @	\$0.00M / GWh/y	\$0.0	\$0.00	0.0%
			6,521.7 GWh/y		\$419.7	\$1.63	269.2%
Green Attributes							
Carbon Offsets					\$32.0	\$0.12	20.5%
					\$32.0	\$0.12	20.5%
Working Capital							
Current Assets (uncommitted)					n.m.	\$0.00	0.0%
Current Liabilities (uncommitted)					n.m.	\$0.00	0.0%
					\$0.00	0.0%	
Liabilities							
Est. Probability-adjusted LTD post future debt financing					(\$295.8)	(\$1.15)	-189.7%
					(\$295.8)	(\$1.15)	-189.7%
Est. Probability-adjusted FD Shares O/S post future equity financing						258.2	
Net Asset Value					\$155.9	\$0.60	100%

Financing Status	Project Status				
	5	4	3	2	1
4	\$0.58	\$0.60	\$0.64	\$0.70	\$0.71
3	\$0.59	\$0.62	\$0.67	\$0.75	\$0.77
2	\$0.60	\$0.65	\$0.73	\$0.85	\$0.88
1	\$0.60	\$0.66	\$0.76	\$0.91	\$0.95

Financing Status	Project Status				
	5	4	3	2	1
4	\$0.52	\$0.60	\$0.73	\$0.90	\$0.94
3	\$0.54	\$0.65	\$0.83	\$1.12	\$1.19
2	\$0.59	\$0.76	\$1.02	\$1.37	\$1.45
1	\$0.60	\$0.81	\$1.16	\$1.72	\$1.86

Financing Status	Project Status				
	5	4	3	2	1
4	\$0.57	\$0.60	\$0.66	\$0.75	\$0.77
3	\$0.57	\$0.62	\$0.70	\$0.83	\$0.86
2	\$0.60	\$0.67	\$0.80	\$0.98	\$1.02
1	\$0.60	\$0.69	\$0.84	\$1.08	\$1.14

1. We assume a stable capital structure of 60% debt & 40% equity. Equity issuance is assumed to be our DCF price of \$1.6/share.
 2. Project Probability Status: 1. Operating - 100%; 2. Construction - 90%; 3. Permitting & PPA - 50%; 4. Permitting or PPA - 25%; 5. Some Development - 10%; 6. Pipeline - 0%.
 3. Financing Status: (1) Full financing in place; (2) Debt draw n, equity required; (3) Equity in place, debt draw required; (4) Equity & debt draw required.

Source: Scotia Capital estimates.

TARGET PRICE, RATING, AND RISK RANKING

We have transferred coverage of EarthFirst with a 3-Sector Underperform rating. Our one-year share price target is \$0.40. Embedded in our one-year target are a 25% probability that fully permitted projects Dokie Expansion (156 MW) and Wartenbe (70.5 MW) successfully receive PPAs in the 2008 BC Hydro Clean Power Call, debt and/or equity financing, fixed-price construction contracts, and a two-year wait period for turbine supply.

Our risk ranking for EarthFirst is Caution Warranted, as it is for Plutonic Power and for Innergex Renewable Energy. We believe this is justified by the early stage of the company's life, the speculative nature of its future projects being successful, the company's volatile stock price, and stock illiquidity.

Financial Forecast

WE EXPECT DOKIE I TO START ON TIME AND ON (THE REVISED) BUDGET

We assume that the capital cost for Dokie I (144 MW) does not deviate from \$360 million, which was recently revised upwards following higher-than-expected labour and commodity-related costs.

Our experience with actual versus expected wind power generation led us to shave our Dokie I forecast capacity factor down to 26.2% (330,000 MWh per year), or 0.9% lower than EarthFirst's expected 27.1%. For the Grand Valley project, we assume a net capacity factor of 28%.

We expect 24 MW of effective capacity to be online by the end of Q4/08, but our financial model only gives credit for 50% of this in the first quarter following commissioning, as speculation of the exact day in a quarter that new capacity comes online is useless. Similar to the half-year CCA rule, we apply a 50% weight to generation produced from new capacity in its initial quarter. Exhibit 4.15 shows our effective forecast generating capacity over the next three years.

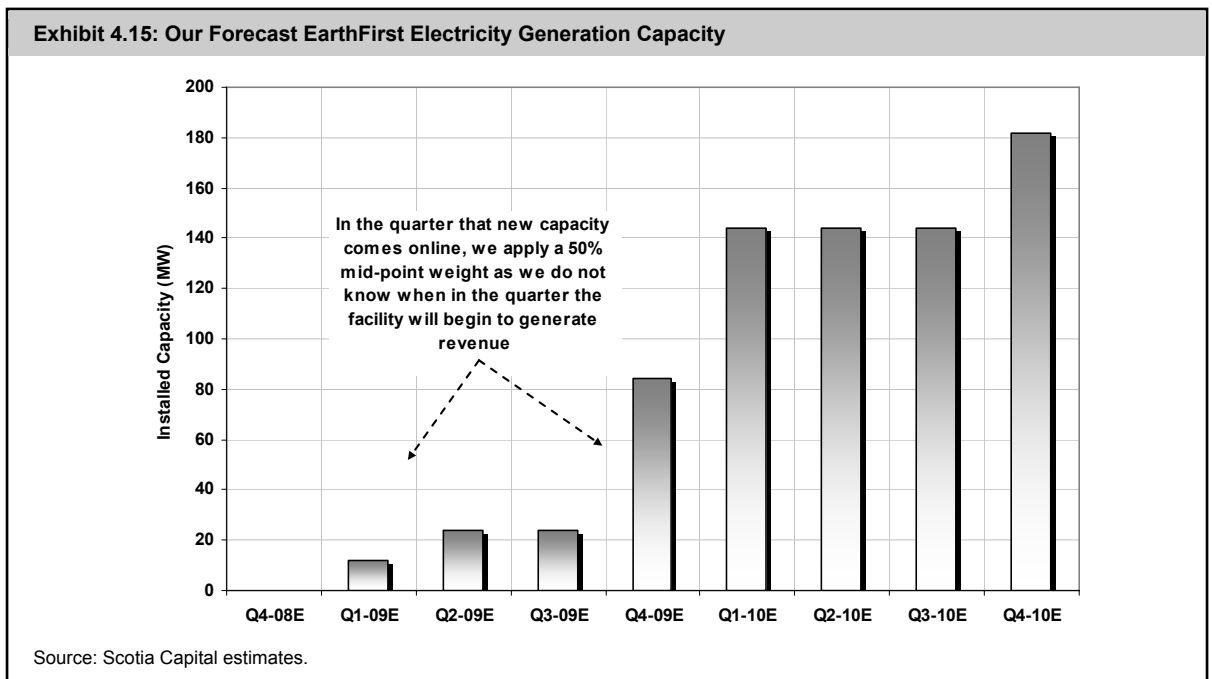

Our financial forecast excludes those projects that have not achieved at least some of the following milestones: (1) awarded PPAs; (2) project financing; (3) permitting; (4) fixed-price construction contracts; and (5) construction progress. As we expect Dokie I to begin operating on time, we project 2009 generation revenue of \$5.1 million, climbing to \$31.5 million in 2010 and to \$55.5 million the following year.

We believe EarthFirst will retain and sell all of its green credits from its Dokie I wind farm. The company's stated strategy is to maximize its exposure to the emerging markets for green credits. We have assumed US\$5/CO₂ tonne is received by EarthFirst on emissions markets such as the Chicago Climate Exchange, or about \$3.33/MWh using a par FX rate. Under Ontario's Standard Offer Contract, all green credits earned are the property of the Ontario Power Authority. EarthFirst's Nuttby project in Nova Scotia will also not earn any green credits.

We have not applied our (forecast) excess cash on the balance sheet, for now.

Our financial forecast shows healthy growth in EBITDA through 2011, at which point annual generation is constant and EBITDA growth is limited to rising power prices based on various CPI indexation formulas. We believe annual EBITDA will likely exceed \$4.3 million in 2009 and \$27 million in 2010. We expect **EarthFirst will pay an immaterial amount of cash taxes over the next several years** due to its ability to use the accelerated Class 43.2 CCA rate of 50%, as well as the availability of tax loss carry-forwards. Exhibit 4.16 charts our quarterly EBITDA and earnings forecasts through 2015, giving full credit to Dokie I, Grand Valley, and Nuttby. **Material upside exists in our financial forecast and one-year price target should Dokie Expansion and Wartenbe be awarded EPAs.**

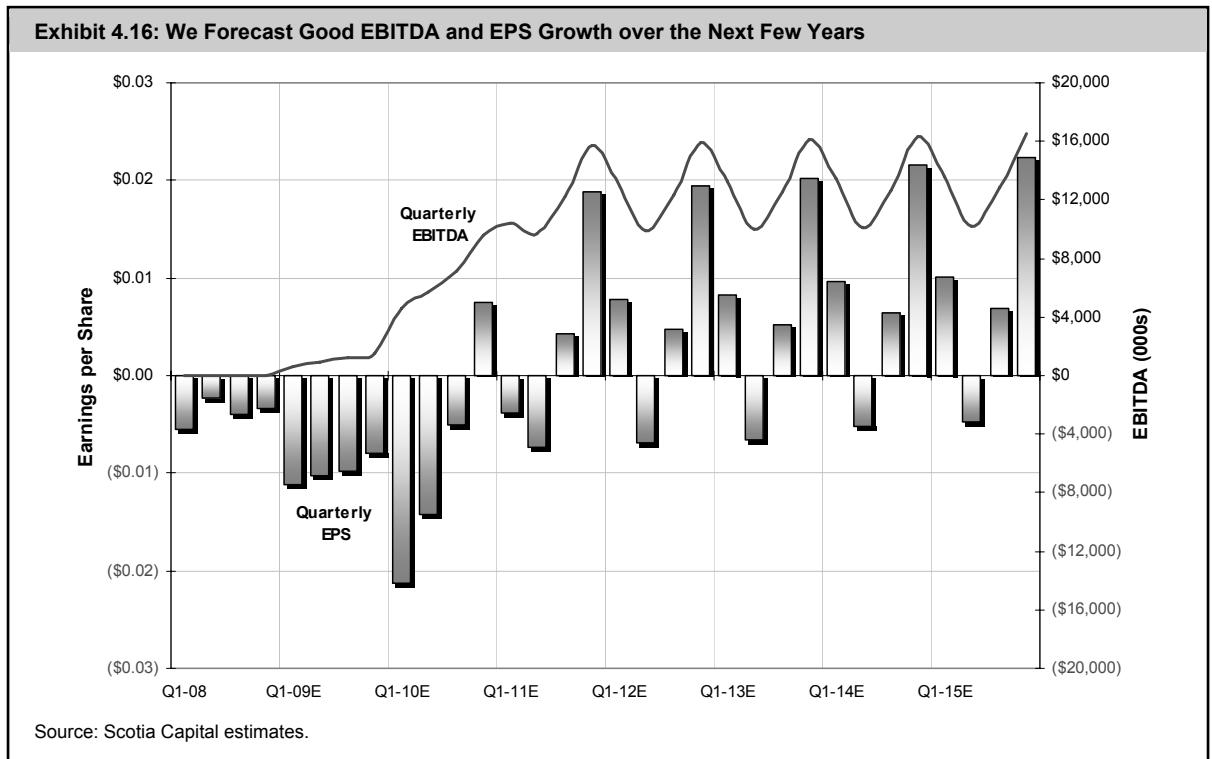

OTHER KEY ASSUMPTIONS

New capacity. With the addition of new capacity, we do not speculate what specific day in a quarter new capacity will come online. Accordingly, and similar to the half-year CCA rule, we apply a 50% weight to generation produced from new capacity in its initial quarter.

Free cash flow. We have not applied free cash on the balance sheet, for now. Cash on hand could be used to: (1) prepay outstanding principal balances on its debt; (2) implement (i) a regular dividend – unlikely, (ii) a share buyback – unlikely, and/or (iii) a one-time special dividend – unlikely; (3) invest in other organic growth opportunities; and (4) enter into an acquisition, joint venture, or similar transaction.

Future capital costs. Going forward, we assume that installed capital costs per MW in 2008 dollars ranges between \$2.25 million and \$2.75 million, or slightly above management guidance.

Equity financing. Unlike Plutonic Power's GE financing deal for its East Toba and Montrose Creek run-of-river projects, we assume that EarthFirst equity is issued at the corporate level.

Exhibits 4.17 through 4.19 display our forecast financial statements for EarthFirst Canada Inc.

Exhibit 4.17: EarthFirst Canada Inc. – Income Statement

(\$000s)	Q108	Q208	Q308E	Q408E	2008E	Q109E	Q209E	Q309E	Q409E	2009E	2010E	2011E	2012E	2013E	2014E	2015E
Generation Revenue	\$0	\$0	\$0	\$0	\$0	\$647	\$940	\$1,180	\$1,585	\$4,352	\$27,027	\$48,550	\$51,626	\$52,141	\$52,663	\$53,190
Incentive Revenue	\$0	\$0	\$0	\$0	\$0	\$71	\$103	\$130	\$174	\$478	\$2,944	\$4,655	\$4,849	\$4,849	\$4,849	\$4,849
Green Credits	\$0	\$0	\$0	\$0	\$0	\$33	\$48	\$61	\$82	\$225	\$1,479	\$2,323	\$2,553	\$2,703	\$2,853	\$3,003
	\$0	\$0	\$0	\$0	\$0	\$751	\$1,091	\$1,371	\$1,841	\$5,055	\$31,450	\$55,528	\$59,028	\$59,693	\$60,365	\$61,042
Operating Costs	\$0	\$0	\$0	\$0	\$0	\$107	\$155	\$195	\$262	\$718	\$4,416	\$7,467	\$7,826	\$7,826	\$7,826	\$7,826
General & Admin	\$1,099	\$1,354	\$1,000	\$1,000	\$4,453	\$1,050	\$1,050	\$1,050	\$1,050	\$4,200	\$4,400	\$4,600	\$4,800	\$5,000	\$5,200	\$5,400
Capital Amortization	\$0	\$0	\$27	\$28	\$55	\$638	\$639	\$640	\$641	\$2,556	\$10,424	\$15,359	\$15,375	\$15,391	\$15,407	\$15,423
Pre-Op Amortization	\$17	\$23	\$20	\$20	\$80	\$200	\$200	\$200	\$200	\$800	\$800	\$800	\$800	\$800	\$0	\$0
Interest on LTD	\$0	\$0	\$0	\$0	\$0	\$959	\$959	\$959	\$959	\$3,834	\$16,201	\$23,948	\$23,948	\$23,949	\$23,949	\$23,949
Interest income	\$0	\$0	(\$407)	(\$518)	(\$925)	(\$431)	(\$269)	(\$108)	\$0	(\$808)	\$0	\$0	\$0	\$0	\$0	(\$8)
Other	\$25	\$1	\$0	\$0	\$0	\$0	\$0	\$0	\$0	\$0	\$0	\$0	\$0	\$0	\$0	\$0
Total expenses	\$1,141	\$1,378	\$640	\$531	\$3,690	\$2,522	\$2,733	\$2,935	\$3,111	\$11,301	\$36,240	\$52,174	\$52,749	\$52,966	\$52,382	\$52,591
Earnings before tax expense	(\$1,141)	(\$1,378)	(\$640)	(\$531)	(\$3,690)	(\$1,771)	(\$1,642)	(\$1,564)	(\$1,270)	(\$6,247)	(\$4,790)	\$3,355	\$6,278	\$6,727	\$7,983	\$8,452
Current Income Taxes	\$0	\$0	\$0	\$0	\$0	\$0	\$0	\$0	\$0	\$0	\$0	\$0	\$0	\$0	\$0	\$0
Future Income Taxes	(\$417)	(\$1,135)	(\$224)	(\$186)	(\$1,962)	(\$620)	(\$575)	(\$547)	(\$444)	(\$2,186)	(\$1,676)	\$1,174	\$2,197	\$2,355	\$2,794	\$2,958
Earnings from continuing operations	(\$724)	(\$243)	(\$416)	(\$345)	(\$1,728)	(\$1,151)	(\$1,067)	(\$1,017)	(\$825)	(\$4,060)	(\$3,113)	\$2,181	\$4,081	\$4,373	\$5,189	\$5,494
Gain (loss) on sale of assets/prospects	\$0	\$0	\$0	\$0	\$0	\$0	\$0	\$0	\$0	\$0	\$0	\$0	\$0	\$0	\$0	\$0
Net Income	(\$724)	(\$243)	(\$416)	(\$345)	(\$1,728)	(\$1,151)	(\$1,067)	(\$1,017)	(\$825)	(\$4,060)	(\$3,113)	\$2,181	\$4,081	\$4,373	\$5,189	\$5,494
Basic shares - opening	103,300.0	103,300.0	103,300.0	103,300.0	103,300.0	103,300.0	103,300.0	103,300.0	103,300.0	103,300.0	103,300.0	128,300.0	128,300.0	128,300.0	128,300.0	128,300.0
Plus: Equity issued	0.0	0.0	0.0	0.0	0.0	0.0	0.0	0.0	0.0	0.0	25,000.0	0.0	0.0	0.0	0.0	0.0
Less: Share buyback	0.0	0.0	0.0	0.0	0.0	0.0	0.0	0.0	0.0	0.0	0.0	0.0	0.0	0.0	0.0	0.0
Basic shares - closing	103,300.0	103,300.0	103,300.0	103,300.0	103,300.0	103,300.0	103,300.0	103,300.0	103,300.0	103,300.0	128,300.0	128,300.0	128,300.0	128,300.0	128,300.0	128,300.0
Average Shares O/S - Basic (000s)	103,300.0	103,300.0	103,300.0	103,300.0	103,300.0	103,300.0	103,300.0	103,300.0	103,300.0	103,300.0	106,425.0	128,300.0	128,300.0	128,300.0	128,300.0	128,300.0
Average Dilution (000s)	26,907.5	26,907.5	26,907.5	26,907.5	26,907.5	26,907.5	26,907.5	26,907.5	26,907.5	26,907.5	26,907.5	26,907.5	26,907.5	26,907.5	26,907.5	26,907.5
Average Shares O/S - Diluted (000s)	130,207.5	130,207.5	130,207.5	130,207.5	130,207.5	130,207.5	130,207.5	130,207.5	130,207.5	130,207.5	133,332.5	155,207.5	155,207.5	155,207.5	155,207.5	155,207.5
EPS (Basic)	(\$0.01)	(\$0.00)	(\$0.00)	(\$0.00)	(\$0.02)	(\$0.01)	(\$0.01)	(\$0.01)	(\$0.01)	(\$0.04)	(\$0.03)	\$0.02	\$0.03	\$0.03	\$0.04	\$0.04
EPS (Diluted)	(\$0.01)	(\$0.00)	(\$0.00)	(\$0.00)	(\$0.02)	(\$0.01)	(\$0.01)	(\$0.01)	(\$0.01)	(\$0.04)	(\$0.03)	\$0.01	\$0.03	\$0.03	\$0.03	\$0.04

Source: Scotia Capital estimates.

Exhibit 4.18: EarthFirst Canada Inc. – Balance Sheet

(\$000s)	Q108	Q208	Q308E	Q408E	2008E	Q109E	Q209E	Q309E	Q409E	2009E	2010E	2011E	2012E	2013E	2014E	2015E
Assets																
Current Assets																
Cash (incl. Res. & Escrow)	\$81,526	\$65,127	\$82,803	\$68,912	\$68,912	\$43,029	\$17,276	\$0	\$0	\$0	\$0	\$0	\$0	\$0	\$0	\$7,892
A/R	\$3,748	\$1,573	\$1,573	\$1,573	\$1,573	\$1,573	\$1,573	\$1,573	\$1,573	\$1,573	\$1,573	\$1,573	\$1,573	\$1,573	\$1,573	\$1,573
Due from Related	\$1,240	\$965	\$965	\$965	\$965	\$965	\$965	\$965	\$965	\$965	\$965	\$965	\$965	\$965	\$965	\$965
Prepaid Expenses	\$2,537	\$5,170	\$5,170	\$5,170	\$5,170	\$5,170	\$5,170	\$5,170	\$5,170	\$5,170	\$5,170	\$5,170	\$5,170	\$5,170	\$5,170	\$5,170
Deferred Financing Charges	\$0	\$0	\$0	\$0	\$0	\$0	\$0	\$0	\$0	\$0	\$0	\$0	\$0	\$0	\$0	\$0
	\$89,051	\$72,835	\$90,511	\$76,620	\$76,620	\$50,737	\$24,984	\$7,708	\$7,708	\$7,708	\$7,708	\$7,708	\$7,708	\$7,708	\$7,708	\$15,600
Development Costs	\$87,655	\$121,400	\$121,400	\$121,400	\$121,400	\$121,400	\$121,400	\$121,400	\$121,400	\$121,400	\$121,400	\$121,400	\$121,400	\$121,400	\$121,400	\$121,400
Pre-Operating Costs	\$0	\$0	\$980	\$1,960	\$1,960	\$1,760	\$1,560	\$1,360	\$1,160	\$1,160	\$360	(\$440)	(\$1,240)	(\$2,040)	(\$2,040)	(\$2,040)
Performance Deposits	\$12,193	\$12,241	\$12,241	\$12,241	\$12,241	\$12,241	\$12,241	\$12,241	\$12,241	\$12,241	\$12,241	\$12,241	\$12,241	\$12,241	\$12,241	\$12,241
Future Income Tax Asset	\$0	\$0	\$0	\$0	\$0	\$0	\$0	\$0	\$0	\$0	\$0	\$0	\$0	\$0	\$0	\$0
Capital Assets	\$273	\$397	\$31,390	\$62,382	\$62,382	\$117,870	\$173,356	\$228,842	\$284,326	\$284,326	\$397,808	\$400,188	\$399,712	\$390,060	\$374,654	\$359,231
Other	\$0	\$0	\$0	\$0	\$0	\$0	\$0	\$0	\$0	\$0	\$0	\$0	\$0	\$0	\$0	\$0
Total Assets	\$189,172	\$206,873	\$256,522	\$274,603	\$274,603	\$304,008	\$333,541	\$371,551	\$426,835	\$426,835	\$539,517	\$541,097	\$539,821	\$529,369	\$513,963	\$506,432
Liabilities																
Current Liabilities																
Revolver	\$0	\$0	\$0	\$0	\$0	\$0	\$0	\$8,399	\$33,778	\$33,778	\$38,906	\$36,488	\$29,995	\$19,372	\$5,982	\$0
A/P, accruals, turbine loan	\$1,957	\$20,994	\$20,994	\$20,994	\$20,994	\$20,994	\$20,994	\$20,994	\$20,994	\$20,994	\$20,994	\$20,994	\$20,994	\$20,994	\$20,994	\$20,994
CP LTD	\$0	\$0	\$7,500	\$10,000	\$10,000	\$10,000	\$10,000	\$10,000	\$10,000	\$10,000	\$10,000	\$10,000	\$10,000	\$10,000	\$10,000	\$10,000
Due to related	\$135	\$66	\$66	\$66	\$66	\$66	\$66	\$66	\$66	\$66	\$66	\$66	\$66	\$66	\$66	\$66
	\$2,092	\$21,060	\$28,560	\$31,060	\$31,060	\$31,060	\$31,060	\$39,459	\$64,838	\$64,838	\$69,966	\$67,548	\$61,055	\$50,432	\$37,042	\$31,060
Long-Term Debt	\$0	\$0	\$11,112	\$27,224	\$27,224	\$58,399	\$89,574	\$120,749	\$151,924	\$151,924	\$216,268	\$216,911	\$215,850	\$209,293	\$199,293	\$189,293
Preferred Shares	\$0	\$0	\$0	\$0	\$0	\$0	\$0	\$0	\$0	\$0	\$0	\$0	\$0	\$0	\$0	\$0
Future Income Tax Liability	\$16,459	\$15,323	\$46,776	\$46,590	\$46,590	\$45,971	\$45,396	\$44,848	\$44,404	\$44,404	\$42,728	\$43,902	\$46,099	\$48,454	\$51,248	\$54,206
Other	\$0	\$0	\$0	\$0	\$0	\$0	\$0	\$0	\$0	\$0	\$0	\$0	\$0	\$0	\$0	\$0
Total Liabilities	\$18,551	\$36,383	\$86,448	\$104,874	\$104,874	\$135,430	\$166,030	\$205,056	\$261,166	\$261,166	\$328,962	\$328,361	\$323,004	\$308,180	\$287,584	\$274,559
Shareholders' Equity																
Share capital (&CS)	\$239,864	\$239,976	\$239,976	\$239,976	\$239,976	\$239,976	\$239,976	\$239,976	\$239,976	\$239,976	\$287,976	\$287,976	\$287,976	\$287,976	\$287,976	\$287,976
Retained earnings	(\$69,243)	(\$69,486)	(\$69,902)	(\$70,247)	(\$70,247)	(\$71,398)	(\$72,465)	(\$73,482)	(\$74,307)	(\$74,307)	(\$77,421)	(\$75,240)	(\$71,159)	(\$66,786)	(\$61,597)	(\$56,103)
Total Shareholders Equity	\$170,621	\$170,490	\$170,074	\$169,729	\$169,729	\$168,578	\$167,511	\$166,494	\$165,669	\$165,669	\$210,555	\$212,736	\$216,817	\$221,190	\$226,379	\$231,873
Total Liabilities & SE	\$189,172	\$206,873	\$256,522	\$274,603	\$274,603	\$304,008	\$333,541	\$371,551	\$426,835	\$426,835	\$539,517	\$541,097	\$539,821	\$529,369	\$513,963	\$506,432

Source: Scotia Capital estimates.

Exhibit 4.19: EarthFirst Canada Inc. – Cash Flow Statement

(\$000s)	Q108	Q208	Q308E	Q408E	2008E	Q109E	Q209E	Q309E	Q409E	2009E	2010E	2011E	2012E	2013E	2014E	2015E
Operating Activities																
Net (loss) earnings	(\$724)	(\$243)	(\$416)	(\$345)	(\$1,728)	(\$1,151)	(\$1,067)	(\$1,017)	(\$825)	(\$4,060)	(\$3,113)	\$2,181	\$4,081	\$4,373	\$5,189	\$5,494
Adjustments for:																
Capital Amortization	\$0	\$0	\$27	\$28	\$55	\$638	\$639	\$640	\$641	\$2,556	\$10,424	\$15,359	\$15,375	\$15,391	\$15,407	\$15,423
Pre-Op Amortization	\$17	\$23	\$20	\$20	\$80	\$200	\$200	\$200	\$200	\$800	\$800	\$800	\$800	\$800	\$0	\$0
(Gain) loss on sale of assets/prospects	\$0	\$0	\$0	\$0	\$0	\$0	\$0	\$0	\$0	\$0	\$0	\$0	\$0	\$0	\$0	\$0
Future income tax (recovery) expense	(\$417)	(\$1,135)	(\$224)	(\$186)	(\$1,962)	(\$620)	(\$575)	(\$547)	(\$444)	(\$2,186)	(\$1,676)	\$1,174	\$2,197	\$2,355	\$2,794	\$2,958
Other (incl. stock comp. exp.)	\$141	\$114	\$0	\$0	\$255	\$0	\$0	\$0	\$0	\$0	\$0	\$0	\$0	\$0	\$0	\$0
Cash flow from operations	(\$983)	(\$1,241)	(\$593)	(\$483)	(\$3,300)	(\$933)	(\$803)	(\$724)	(\$429)	(\$2,890)	\$6,434	\$19,513	\$22,453	\$22,918	\$23,390	\$23,874
Net change in non-cash WC	(\$2,340)	\$2,319	\$0	\$0	(\$21)	\$0	\$0	\$0	\$0	\$0	\$0	\$0	\$0	\$0	\$0	\$0
	(\$3,323)	\$1,078	(\$593)	(\$483)	(\$3,321)	(\$933)	(\$803)	(\$724)	(\$429)	(\$2,890)	\$6,434	\$19,513	\$22,453	\$22,918	\$23,390	\$23,874
Financing Activities																
Net issue (buyback) of common shares	\$3,454	\$0	\$0	\$0	\$3,454	\$0	\$0	\$0	\$0	\$0	\$48,000	\$0	\$0	\$0	\$0	\$0
Debt advances	\$0	\$13,210	\$18,612	\$18,612	\$50,434	\$33,675	\$33,675	\$33,675	\$33,675	\$134,700	\$74,343	\$10,643	\$8,939	\$3,443	\$0	\$0
Long-term debt repayments	\$0	\$0	\$0	\$0	\$0	(\$2,500)	(\$2,500)	(\$2,500)	(\$2,500)	(\$10,000)	(\$10,000)	(\$10,000)	(\$10,000)	(\$10,000)	(\$10,000)	(\$10,000)
	\$3,454	\$13,210	\$18,612	\$18,612	\$53,888	\$31,175	\$31,175	\$31,175	\$31,175	\$124,700	\$112,343	\$643	(\$1,061)	(\$6,557)	(\$10,000)	(\$10,000)
Investing Activities																
Capital asset additions/business acquisitions	(\$46)	(\$148)	(\$31,020)	(\$31,020)	(\$62,234)	(\$56,125)	(\$56,125)	(\$56,125)	(\$56,125)	(\$224,501)	(\$123,906)	(\$17,739)	(\$14,899)	(\$5,739)	\$0	\$0
Prospect development costs	(\$23,599)	(\$28,108)	\$0	\$0	(\$51,707)	\$0	\$0	\$0	\$0	\$0	\$0	\$0	\$0	\$0	\$0	\$0
Pre-Operation Costs	\$0	(\$2,381)	(\$1,000)	(\$1,000)	(\$4,381)	\$0	\$0	\$0	\$0	\$0	\$0	\$0	\$0	\$0	\$0	\$0
Restricted cash returned (paid)	(\$461)	\$31,627	\$0	\$0	\$31,166	\$0	\$0	\$0	\$0	\$0	\$0	\$0	\$0	\$0	\$0	\$0
Proceeds on sale of assets/prospects	\$0	\$0	\$0	\$0	\$0	\$0	\$0	\$0	\$0	\$0	\$0	\$0	\$0	\$0	\$0	\$0
	(\$24,106)	\$990	(\$32,020)	(\$32,020)	(\$87,156)	(\$56,125)	(\$56,125)	(\$56,125)	(\$56,125)	(\$224,501)	(\$123,906)	(\$17,739)	(\$14,899)	(\$5,739)	\$0	\$0
Net change in cash and cash equivalents + CHANGE in Res. & Escrow Cash	(\$23,975)	\$15,278	(\$14,001)	(\$13,891)	(\$36,589)	(\$25,883)	(\$25,753)	(\$25,674)	(\$25,379)	(\$102,691)	(\$5,128)	\$2,418	\$6,494	\$10,623	\$13,390	\$13,874
Cash & Equivalents - Beginning	\$105,501	\$81,526	\$96,804	\$82,803	\$105,501	\$68,912	\$43,029	\$17,276	(\$8,399)	\$68,912	(\$33,778)	(\$38,906)	(\$36,488)	(\$29,995)	(\$19,372)	(\$5,982)
Cash & Equivalents - End	\$81,526	\$96,804	\$82,803	\$68,912	\$68,912	\$43,029	\$17,276	(\$8,399)	(\$33,778)	(\$33,778)	(\$38,906)	(\$36,488)	(\$29,995)	(\$19,372)	(\$5,982)	\$7,892

Source: Scotia Capital estimates.

Management & Directors

EarthFirst has a strong management team with a broad range of industry experience specifically related to wind power development companies. Through predecessor companies that include various wind power entities related to Creststreet Capital Corporation and EarthFirst Energy Inc., EarthFirst's management team has been involved in developing, financing, constructing, and operating wind power projects with an aggregate capacity of 148 MW. Specific past projects include the Pubnico project in Nova Scotia (30 MW), Mount Copper in Quebec (54 MW), and Kettles Hill (63 MW).

The management team has also raised \$435 million in capital for Canadian wind power projects above and beyond equity and debt financing raised for EarthFirst. In Exhibit 4.20, we present brief backgrounds of key management and directors of the corporation. In total, **insiders and related entities control about 15.5% of EarthFirst fully diluted outstanding shares.**

Exhibit 4.20: Management & Directors					
Name	Position	FD Shares Held Personally	Partial to Fully Controlled Shares	Options/Warrants	Background
Linda Chambers	President & CEO	-	-	500,000	Ms. Chambers spent 11 years at TransAlta, including President of TransAlta's U.S. operations and Executive Vice President of Generation Technology. She has a strong background of hydro, wind, geothermal, coal, and gas-fired power generation.
David Erskine	Chairman & Director	27,500	-	50,000	Mr. Erskine is an independent businessman who has held the position of President and Chief Executive Officer at two companies for ten years. From 1999 to 2006 Mr. Erskine was President and CEO at CSS industries Inc. and from 1996 to 1999 he held these positions at Scott Paper Limited.
Robert Toole	Vice Chairman	-	15,026,230	192,000	Mr. Toole is the founder and Managing Director of Creststreet. He was recognized by CanWEA for Exceptional Achievement and Individual Leadership in the Canadian wind industry. Mr. Toole graduated from Queen's University with a Bachelor of Commerce, is a Chartered Accountant, and is a registered portfolio manager in Ontario.
Ron Percival	Vice Chairman	417,110	3,604,685	225,125	Mr. Percival is the founder of Earth First Energy Inc. He holds the position as a Director of the Independent Power Producers of British Columbia (IPPBC) and has served as the Chair of the IPPBC Wind Committee for the last three years. He is a member of the B.C. and Federal Caucus of CanWEA, and serves on various other committees.
Gary Patterson	Director	20,000	-	50,000	Mr. Patterson is the President and CEO of GAP Financial Ltd. Mr. Patterson was Executive Vice-President and CFO of Invest Investments Ltd. and was also Executive Vice President and CFO of Future Shop Ltd. Mr. Patterson received a Bachelor of Commerce from Mount Allison University, New Brunswick, and is a Fellow of the Institute of Chartered Accountants.
Gordon Barefoot	Director	14,358	-	53,333	Prior to spending three years as the President of Cabgor Management Inc., Mr. Barefoot served as the Senior VP of Finance and CFO of Terasen Inc. Mr. Barefoot worked for Ernst & Young for 19 years, 13 of which he was a partner, and currently sits on the board of directors and is the chairman of the audit committee for both Nventa Biopharmaceuticals Corporation and Auto Canada Income Fund. Mr. Barefoot is a Certified Director and member of the Institute of Corporate Directors and is a Chartered Accountant.
John Budreski	Director	100,000	-	100,000	A director and independent businessman, Mr. Budreski was the CEO of Orion Securities Inc. and Orion Financial Inc. from March 2005 to November 2007. Prior to March 2005, Mr. Budreski was a Managing Director of the Canadian Capital Structuring Group of Scotia Capital Inc. and has held various roles in the firm since 1998.
Paul Bradley	Director	10,000	-	55,000	Mr. Bradley currently serves as the Managing Director of PJB Energy Solutions Inc., and from 2005 to 2007 held the position as VP of Electricity Resources for the OPA. From 1997 to 2003, Mr. Barefoot was an Executive Director for the investment banking Power and Utilities team at a leading Canadian financial institution. Prior to 1997, Mr. Bradley held various management roles at Duke Energy Corporation and was a Senior Accountant at Arthur Anderson & Co.
Dennis Nelson	Senior VP, Project Development, Chief Operating Officer, Director	129,070	3,604,685	199,973	Mr. Nelson has been involved in the forestry industry for more than 30 years. He has been involved in the development and implementation of new timber harvesting methods within the forestry resource sector.
Derren Newell	VP Finance, Chief Financial Officer	50,000	-	222,000	Prior to joining Creststreet, Mr. Newell was VP Finance at Superior Plus Income Fund and later assumed the role of Business Process and Compliance. Mr. Newell holds a Bachelor of Commerce from the University of Alberta and is a Chartered Accountant.
Erich Ossowski	VP, Windpower Development, Director	-	-	222,000	Prior to leading sales and business development at GE Wind Energy in Canada, Mr. Ossowski worked for three years at ABB Power Generation as a design engineer. He holds an MBA from the Richard Ivey School of Business and a Bachelor of Applied Science in Mechanical Engineering from the University of Waterloo.
Total		740,538	22,235,599	1,319,431	
Fully Diluted Shares Outstanding		152,112,000			
% Insider Ownership		15.5%			

Source: SEDI; Bloomberg; company reports; Scotia Capital.

THIS PAGE LEFT INTENTIONALLY BLANK

Innergex Renewable Energy Inc.

(INE-T)

Aug 15, 2008:	\$8.25
Rating:	3-Sector Underperform
Risk:	Caution Warranted
IBES EPS 2008E	\$-0.17
IBES EPS 2009E	\$0.19
Div. (Curr.):	\$0.00
Yield:	0.0%

1-Yr Target:	\$9.50
1-Yr ROR:	15.2%
2-Yr Target:	\$10.50
2-Yr ROR:	27.3%
Valuation:	75% DCF @ 11%; 25% NAV

Capitalization	
Shares O/S (M)	23.5
Total Value (\$M)	193.9
Float O/S (M)	14.3
Float Value (\$M)	117.6
TSX Weight	--

Qtly EPS (FD) (Next Release: Nov-08)

Y/E DECEMBER-31	Mar	Jun	Sep	Dec	Year	P/E
2008E	\$-0.23A	\$0.06A	\$-0.01	\$-0.02	\$-0.19	n.a.
2009E	\$-0.02	\$0.02	\$0.01	\$0.02	\$0.03	n.a.
2010E	\$0.06	\$0.11	\$0.07	\$0.07	\$0.32	25.5x
2011E	\$0.08	\$0.15	\$0.10	\$0.10	\$0.43	19.4x

Industry Specific	2007A	2008	2009	2010	2011
Production (GWh)	42	42	237	570	748

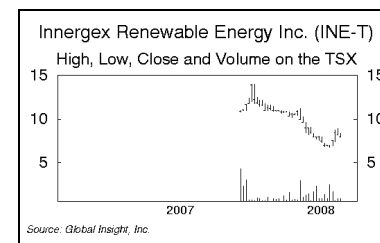

Note: Historical price multiple calculations use FYE price. Source: Reuters; company reports; Scotia Capital estimates.

PPAs in Hand – Now Execute!

INVESTMENT HIGHLIGHTS

- **Seamless execution critical.** Innergex is sitting on over 290 MW of PPAs spread over nine projects. Commissioning of these hydro and wind projects on time and within budget is key to Innergex's success.
- **Above-average risk profile.** We believe that Innergex carries an above-average risk profile due its acceptance of high execution and construction risk in return for higher IRRs. To date, two of its three current construction projects have experienced significant delays.
- **Rich relative valuation.** Based on our 2009 and 2010 forecast, we believe Innergex's share price is fairly rich. INE is trading above our peer group average on the following forward metrics: P/E, P/S, P/CF, and EV/EBITDA.
- **Turning the story around.** In our minds, the company's exclusive relationship with Federation Quebecoise des Municipalites (FQM) puts it ahead of all other bidders in the anticipated Quebec Municipal 250 MW wind RFP.
- **Stock catalysts.** While winning future PPA bids is important, such as those that we expect INE to enter into the BC Hydro Clean Power Call, we believe the market will place more focus on the successful commissioning of its construction and construction-ready projects.
- **We have initiated coverage on the common shares of Innergex Renewable Energy with a 3-Sector Underperform rating and a one-year target price of \$9.50 per share.** Our valuation is based on a 75%-weighted discounted cash flow approach, using an 11% discount rate, and a 25%-weighted net asset value calculation.

Summary & Investment Recommendation

Innergex owns and operates an 8 MW hydro facility in Ontario, and has **signed PPAs for 293 MW** (net to INE) of hydro and wind projects that are under construction, construction-ready, or completing permitting. In addition to its 16.1% equity interest in Innergex Power Income Fund, the company has **2,300 MW** of prospective projects in its development pipeline. **Innergex intends to commission its current PPA-signed projects by the end of 2012.**

We have initiated coverage on the common shares of Innergex Renewable Energy with a 3-Sector Underperform rating and a one-year target price of \$9.50 per share. In our opinion, Innergex's above-average risk profile, coupled with a somewhat rich relative valuation, justifies our rating. After losing its Hydro-Quebec wind farm bids in May, and announcing timing setbacks to two of its three construction projects, we believe investors are now focused on the successful execution of its PPAs in hand.

There is upside to Innergex's share price should a substantial portion of its pipeline be commissioned as planned. In our view, by early 2009, Innergex's operating assets, fund management fees, and investment in the fund will set a floor price of \$6.90 per share, implying about \$2.60 per share for its development pipeline, based on our one-year target price.

We like Innergex's strategic agreement with Federation Quebecoise des Municipalites that essentially designates Innergex as the preferred partner for the development of wind farm projects under the anticipated 250 MW Quebec Municipal Wind RFP (Q4/08).

FINANCIAL OUTLOOK

Innergex's revenue stream is diverse and comparable to a young Boralex. Our financial forecast suggests the company will become EPS-positive (on a recurring basis) in Q2/09. We estimate 2009 revenue and EBITDA of \$23.3 million and \$14.3 million, respectively. With the addition of new wind and hydro capacity expected to be commissioned over the next 12 to 24 months, our 2010 revenue and EBITDA estimates soar to \$46.4 million and \$33.9 million, respectively.

Exhibit 5.1: Innergex Renewable Energy Inc. – Relative Valuation Metrics											
Company	Ticker	Last Price	SC Rating	1-Year Target	1-Year ROR	DCF	NAV	Market Cap	Enterprise Value to EBITDA		
									2008E	2009E	2010E
		8/15/2008						(\$M)	(x)	(x)	(x)
Boralex	BLX	\$14.80	1-SO	\$18.00	22%	\$18.33	\$17.03	\$560	9.9x	8.6x	7.6x
Canadian Hydro Developers	KHD	\$4.38	1-SO	\$7.00	60%	\$7.04	\$6.95	\$628	20.3x	9.9x	7.6x
Earthfirst Canada	EF	\$0.27	3-SU	\$0.40	48%	\$0.35	\$0.60	\$28	n.m.	-5.5x	-0.9x
Innergex Renewable Energy	INE	\$8.25	3-SU	\$9.50	15%	\$9.44	\$9.55	\$194	n.m.	18.4x	7.8x
Plutonic Power	PCC	\$7.04	2-SP	\$9.00	28%	\$9.03	\$8.75	\$297	n.m.	n.m.	n.m.
Average					35%			\$341	15.1x	7.8x	5.5x
Company	Ticker	Beta	Price to Earnings			Price to Sales			Price to Cash Flow		
			2008E	2009E	2010E	2008E	2009E	2010E	2008E	2009E	2010E
			(x)	(x)	(x)	(x)	(x)	(x)	(x)	(x)	(x)
Boralex	BLX	0.7	28.8x	20.2x	18.6x	2.6x	2.5x	2.3x	10.4x	8.7x	7.7x
Canadian Hydro Developers	KHD	0.5	54.6x	23.4x	17.3x	7.2x	3.9x	3.1x	16.0x	9.0x	6.6x
Earthfirst Canada	EF	-	n.m.	n.m.	n.m.	n.m.	5.5x	0.9x	n.m.	n.m.	5.6x
Innergex Renewable Energy	INE	-	n.m.	n.m.	25.5x	27.5x	8.3x	4.2x	n.m.	33.6x	10.2x
Plutonic Power	PCC	0.9	n.m.	n.m.	n.m.	n.m.	n.m.	n.m.	n.m.	n.m.	n.m.
Average		0.7	41.7x	21.8x	20.5x	12.4x	5.1x	2.6x	13.2x	17.1x	7.5x

Source: Bloomberg; Scotia Capital estimates.

Capital Markets Profile

We expect Innergex to have 60 MW of operating capacity by the end of 2008.

Innergex's IPO was completed in December 2007, raising \$115 million.

Innergex is a developer and operator of Canadian hydro and wind power facilities. It owns and operates an 8 MW hydro facility in Ontario, and has **signed PPAs for 293 MW** (net to INE) of hydro and wind projects that are under construction, construction-ready, or completing permitting. INE also has a 16.1% equity interest in Innergex Power Income Fund (the "Fund"). The Fund, which has an ownership interest in 210 MW of renewable power capacity (33.8 MW net to INE), is operated by Innergex for which Innergex charges a management fee. Additionally, Innergex has **2,300 MW** of prospective projects in its development pipeline. **Innergex intends to commission its current PPA-signed projects by the end of 2012.**

In December 2007, Innergex completed its initial public offering, raising \$115 million (\$120.2 million after exercise of over-allotment) to fund a large portion of the equity requirements for its signed PPA renewable power projects. Around the same time, and by way of a private placement, an additional \$122 million was raised by Innergex to purchase the outstanding portion it did not own at the time of Innergex II, the company that held all of the operating and development assets. Additionally, Innergex II sold its 38% interest in two Cartier portfolio wind farms to the Fund for an effective 16.1% interest in the Fund.

The management team at Innergex is solid and is led by Michel Letellier, who was appointed President and CEO near the time of INE's 2007 IPO. Mr. Letellier spent seven years with Boralex before joining Innergex as CFO in 1997. The founder of Innergex, Mr. Gilles Lefrancois, is the company's Executive Chairman of the board of directors, and still provides the strategic vision for the company. Mr. Letellier is backed by a large management team that has many years of energy development experience.

With a market capitalization of slightly under \$200 million, Innergex's common shares trade on the Toronto Stock Exchange under the symbol INE. Insiders and related parties control (directly or indirectly) about 12.7% of outstanding INE shares, and the company's shareholder base is located mostly in North America. Innergex reports in Canadian dollars, using a December 31 year-end, and its financial statements are prepared in accordance with GAAP. Exhibit 5.2 shows the recent share price performance of INE.

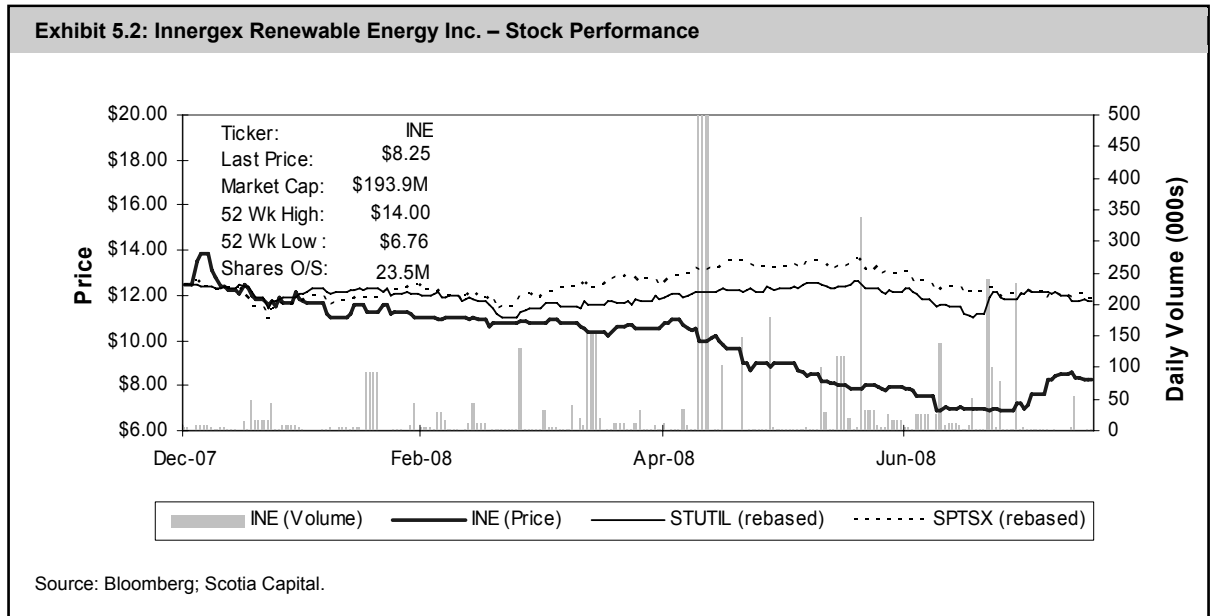

When Will Innergex Need New Equity?

We don't think Innergex will require new equity to commission its nine signed-PPA projects.

Innergex has stated that it should not require new equity financing to fund its nine power projects that already have PPAs, totalling 293 MW (net). Using some of the proceeds from its December 2007 IPO, as well as cash generated from its three distinct revenue sources (energy-based revenue, CDPU from the Fund, and fund management fees), Innergex should be able to satisfy the equity requirements of its current advanced stage projects.

However, we do think that new equity will be required to finance any additional projects that Innergex develops over the next several years. We see Innergex bidding up to 200 MW of projects into the BC Hydro Clean Power Call in addition to bidding up to 150 MW of wind projects into the two upcoming Hydro-Quebec RFPs.

If Innergex is successful in its bids, we think that the company could require up to \$200 million of new equity over the coming four or five years. Exhibit 5.3 summarizes possible equity financing scenarios that we have sensitized by (1) average installed cost per MW; and (2) the number of megawatts to be financed.

Exhibit 5.3: Innergex Could Require \$170M to \$200M in Equity Financing by 2011/12

		Weighted Average Capital Cost per Installed MW						
		\$2.4M	\$2.5M	\$2.6M	\$2.7M	\$2.8M	\$2.9M	\$3.0M
New Installed Capacity	25.0 MW	\$15M	\$16M	\$16M	\$17M	\$18M	\$18M	\$19M
	50.0 MW	\$30M	\$31M	\$33M	\$34M	\$35M	\$36M	\$38M
	B.C. - Wind (low) 75.0 MW	\$45M	\$47M	\$49M	\$51M	\$53M	\$54M	\$56M
	Ledcor - Hydro 100.0 MW	\$60M	\$63M	\$65M	\$68M	\$70M	\$73M	\$75M
	B.C. - Wind (high) 125.0 MW	\$75M	\$78M	\$81M	\$84M	\$88M	\$91M	\$94M
	Quebec Municipal 150.0 MW	\$90M	\$94M	\$98M	\$101M	\$105M	\$109M	\$113M
	175.0 MW	\$105M	\$109M	\$114M	\$118M	\$123M	\$127M	\$131M
	200.0 MW	\$120M	\$125M	\$130M	\$135M	\$140M	\$145M	\$150M
	225.0 MW	\$135M	\$141M	\$146M	\$152M	\$158M	\$163M	\$169M
	Total (low) 250.0 MW	\$150M	\$156M	\$163M	\$169M	\$175M	\$181M	\$188M
	275.0 MW	\$165M	\$172M	\$179M	\$186M	\$193M	\$199M	\$206M
	Total (high) 300.0 MW	\$180M	\$188M	\$195M	\$203M	\$210M	\$218M	\$225M
	325.0 MW	\$195M	\$203M	\$211M	\$219M	\$228M	\$236M	\$244M
	350.0 MW	\$210M	\$219M	\$228M	\$236M	\$245M	\$254M	\$263M
	375.0 MW	\$225M	\$234M	\$244M	\$253M	\$263M	\$272M	\$281M
400.0 MW	\$240M	\$250M	\$260M	\$270M	\$280M	\$290M	\$300M	

Source: Scotia Capital estimates.

Production Profile & Outlook

HYDRO

Innergex's 8 MW Glen Miller hydroelectric plant is the company's only operating asset (excluding those assets indirectly owned through its 16.1% interest in the Fund), producing 41.5 GWh/y, or at a capacity factor of 59.2%. In our opinion, the facility generates about \$2.7 million in energy sales per year, under a 20-year PPA with the Ontario Power Authority. The Ontario-based plant was commissioned in December 2005.

We estimate Innergex will have almost 150 MW of operating hydro capacity by 2011.

Looking ahead, we estimate 148.8 MW (net to INE) of new hydro capacity will come online by the end of 2011, adding a further 644 GWh/y of hydro-based generation. Specifically, we expect the 49%-owned 23 MW Umbata Falls to be in service in 2008, generating 53.5 GWh of power net to Innergex. By the end of 2009, the fully-owned 49.9 MW Ashlu Creek, located in B.C., should be commissioned, providing 265 GWh/y of incremental output to Innergex's portfolio. One year later, the remaining 326 GWh/y of hydro-

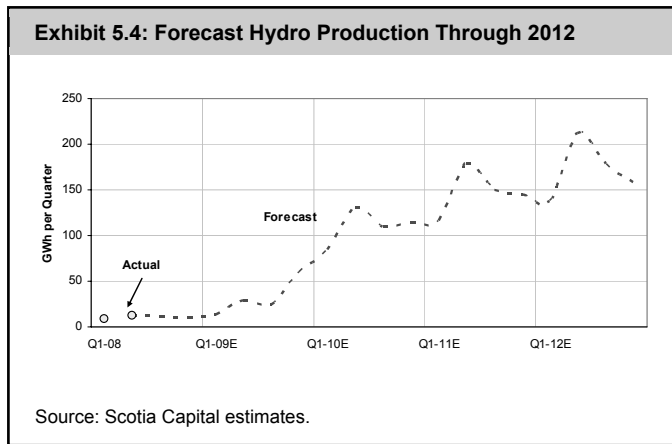

based power generation could be operational as the Quebec-based Matawin project (15 MW) and B.C.-based Mkw'Alts (47.7 MW) and Kwoiek Creek (25 MW net to INE) projects come online.

We estimate Innergex's installed capital costs to bring on **148.8 MW of new hydro capacity to be \$404 million, or about \$2.72 million per MW. Under a best-case scenario**, where all expected new capacity is commissioned on time and on budget, with no operational issues, **we forecast 2011E hydro-based revenue of \$36.6 million.**

WIND

Innergex has no installed wind capacity, for now. However, through its 38%-owned JV with TransCanada, 109.5 MW of wind capacity should be commissioned by the end of 2008. The JV is developing the Cartier portfolio of wind projects, which includes multiple Quebec-based wind farms. We estimate that the Carleton wind farm, due online in Q4/08, should provide 129.4 GWh/y of output net to Innergex, or over \$9 million of revenue in its first full year of operation.

Innergex's first wind farms should be online by the end of 2008.

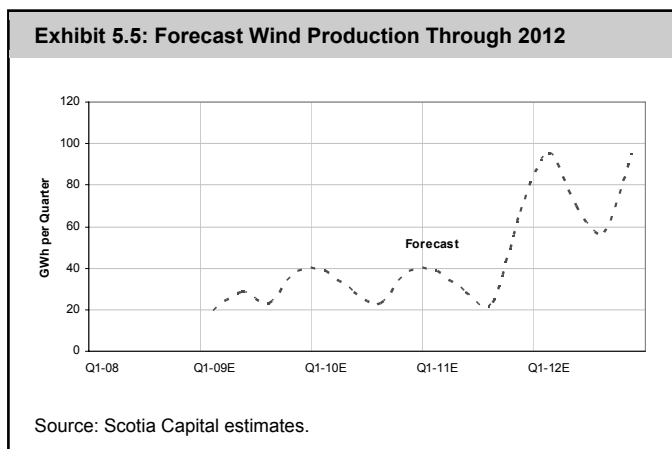

Beyond 2009, Innergex is working toward an additional 270 MW from its Cartier JV (102.6 MW net to INE) with estimated in-service dates before the end of 2012, as well as another 900+ MW of Quebec-based prospective wind projects. Additionally, 475 MW of B.C.-based wind capacity has been targeted by the company for future development, of which we think that 75 MW to 125 MW will be bid into the BC Hydro Clean Power Call.

Innergex Power Income Fund

Innergex Power Income Fund (IEF.u-T) operates seven run-of-river facilities in Quebec, one in Ontario, one in B.C., and one south of the border, in Idaho. As well, the Fund has a 38% interest in two Quebec-based wind farms with its 62% partner, TransCanada Corp. Exhibit 5.6 summarizes the Fund's operational assets. Total installed capacity net to Innergex is 33.8 MW at a weighted average capacity factor of 45.4%.

Exhibit 5.6: Innergex Power Income Fund's Operating Assets								
Facility	Location	Power Purchaser	Remaining PPA Term (years)	Gross Capacity (MW)	IEF.u Interest (%)	INE Interest (%)	Gross Generation (GWh/y)	INE Interest (GWh/y)
Hydro								
St. Paulin	Quebec	Hydro-Qubec	6	8.0	100%	16.1%	41.1	6.6
Portneuf-1	Quebec	Hydro-Qubec	13	8.0	100%	16.1%	40.8	6.6
Portneuf-2	Quebec	Hydro-Qubec	13	9.9	100%	16.1%	68.5	11.0
Portneuf-3	Quebec	Hydro-Qubec	13	8.0	100%	16.1%	42.4	6.8
Chaudiere	Quebec	Hydro-Qubec	11	24.0	100%	16.1%	116.7	18.8
Montmagny	Quebec	Hydro-Qubec	13	2.1	100%	16.1%	8.0	1.3
Windsor	Quebec	Hydro-Qubec	8	5.5	100%	16.1%	31.0	5.0
Batawa	Ontario	Ontario Power Authority	21	5.0	100%	16.1%	32.9	5.3
Rutherford Creek	B.C.	BC Hydro	16	49.9	100%	16.1%	180.0	29.0
Horseshoe Bend	Idaho	Idaho Power	22	9.5	100%	16.1%	46.8	7.5
Wind								
Baie-des-Sables	Quebec	Hydro-Qubec	18	109.5	38%	6.1%	298.3	18.3
Anse-a-Valleau	Quebec	Hydro-Qubec	19	100.5	38%	6.1%	298.0	18.2
				340 MW	210 MW	34 MW	1,204.5	134.4

Source: Company reports; Scotia Capital.

Innergex has a long-term management agreement with the Fund that expires in 2030, and also owns 16.1% of the Fund.

Innergex owns 16.1% of IEF.u, currently worth about \$60.6 million, or 1.7% below Innergex's \$61.7 million investment into the Fund. Concurrently with its initial public offering, Innergex sold its 38% interests in the 109.5 MW Baie-des-Sables and the 100.5 MW Anse-a-Valleau wind farms to the Fund. Payment to Innergex by the Fund was made through the issuance of 4.7 million trust units that was valued at \$61.7 million on the date of the transaction.

The Fund currently distributes 8.33¢ per unit per month, or \$1.00 per annum, or \$4.7 million to Innergex per year. **We believe that this rate of distributable cash per unit (DCPU) will be maintained throughout at least 2008 and 2009.**

Exhibit 5.7: Innergex's Management Fees from the Fund		
Contract	2008E	2009E
	(\$M)	(\$M)
Management Agreement	0.91	0.93
Incentive Fee	0.74	0.74
Administration Agreement	0.11	0.11
Services Agreement*	0.00	0.00
	1.76	1.79

* Out-of-pocket expenses covered

Source: Scotia Capital estimates.

In addition to its 16.1%-ownership interest in the Fund, **Innergex earns various fees related to management of the Fund, which we expect to be approximately \$1.76 million in 2008 and \$1.79 million in 2009,** as per Exhibit 5.7. Innergex's management agreements with the Fund have a current expiry date of 2030, which will automatically be renewed for five-year periods unless notice of non-renewal is given by either party.

A Big Day for a Small Company

On December 6, 2007, Innergex completed its initial public offering of \$115 million, and its shares began trading on the Toronto Stock Exchange under the ticker symbol INE-T. Concurrent to its IPO, Innergex completed a variety of transactions that set the foundation of today's company. Those transactions, detailed below, included a private placement, the sale of interests in certain operating facilities, and the purchase from equity partners of Innergex II.

INITIAL PUBLIC OFFERING

Priced at \$11 per share, Innergex raised gross proceeds of \$115 million on the 10.455 million shares it issued under its IPO. Underwriters' fees totalled \$6.04 million, while other expenses totalled \$6 million, for net proceeds to the company of about \$103 million. Prior to the final IPO price of \$11 per share, the deal had been marked down twice from an original range of \$14 to \$16.

Institutional shareholders and management control over 50% of the company.

Institutional Investor	FD Ownership (%)
CDPQ	10.2%
Regime de rentes du Mouvement Desjardins	10.2%
Kruger Inc. Master Trust	10.2%
TD Capital Ltd.	10.2%
Sun Life	3.7%

Source: Innergex; Scotia Capital.

PRIVATE PLACEMENT

Innergex issued 5.34 million shares at \$11 per share to various institutional investors for proceeds of \$58.77 million. The group that purchased the shares included: TD Capital, Desjardins, CDPQ, Sun Life, and Kruger Inc. (Exhibit 5.8).

PURCHASE OF INNERGEX II

Innergex purchased the outstanding equity interests in Innergex II for \$63.4 million. For payment, Innergex issued the equity partners a total of 5.76 million shares @ \$11 per share.

Innergex repaid and purchased all of the outstanding Innergex II debt owed to the equity partners for \$123.9 million.

INNERGEX II SELLS TWO WIND FARM INTERESTS

Innergex II sold its 38% interests in two wind farms to Innergex Power Income Fund for \$61.7 million. Payment to Innergex II by the Fund was satisfied by the issuance of 4.7 million fund units, resulting in a 16.1% equity interest in the Fund by Innergex. The 109.5 MW Baie-des-Sables wind farm and the 100.5 MW Anse-a-Valleau wind farm are both Cartier projects that are 62% owned by TransCanada. Through its partial ownership of the Fund, Innergex effectively owns a 6.1% interest in each of the two wind farms.

Sources	(\$M)	Uses	(\$M)
IPO proceeds	115.0	Acquisition of Innergex II	63.4
Private placement	58.8	Repayment of Innergex II debt	123.9
Sale of two Innergex II wind farms	61.7	Underwriters fees	6.0
		Other IPO expenses	6.0
		Special dividend	3.8
		Construction of new capacity	30.0
		General corporate purposes	2.4
	<u>\$235.5</u>		<u>\$235.5</u>

Source: Company reports; Scotia Capital estimates.

Overview of Projects

GLEN MILLER: INNERGEX'S ONLY OPERATING FACILITY

Located near Trenton, Ontario, Innergex's 8 MW Glen Miller hydroelectric plant is the company's only 100%-owned operating power generation facility. With an average annual production of 41.5 GWh/y, the plant's capacity factor is 59.2%. On a per MW basis, the construction cost of the facility was \$2.81 million (2004 dollars), for a total cost of \$22.5 million. The hydro project has a 20-year PPA with the Ontario Power Authority that expires in 2025. The initial PPA price per MWh in 2006 was a little above \$66, and is indexed annually to 15% of the change in Canada's CPI.

Innergex finances its projects using 70% to 85% debt.

UMBATA FALLS: UNDER CONSTRUCTION

Innergex's 49%-owned 23 MW Umbata Falls hydro project is currently under construction with an expected commissioning date of Q4/08. The facility is expected by management to operate at a 54.2% capacity factor, and generate about 109 GWh/y. The \$60 million project, or \$2.61 million per MW, is 85% debt financed with the \$9 million equity portion partially financed by the company's IPO proceeds as well as its free cash flow. The plant has a 20-year signed PPA with the Ontario Power Authority that we believe will expire near the end of 2028. In our opinion, the Umbata Falls project will receive a 2008 power price of about \$73.50/MWh, which is indexed annually to 15% of the change in CPI. Additionally, we expect the project to receive a \$10/MWh federal ecoENERGY incentive payment for the first 10 years of operations.

ASHLU CREEK: UNDER CONSTRUCTION

The 49.9 MW Ashlu Creek project, located near the Squamish River in B.C., is forecast to generate 265 GWh/y, representing a solid 60.6% capacity factor. Construction has been underway for two years with commercial operations due in 2009. The \$132 million price tag for the facility, or \$2.65 million per MW, will be 83% debt financed with the 17% equity portion coming from Innergex's IPO proceeds. The project has a 30-year PPA with BC Hydro with an initial power price of \$56.36/MWh that is adjusted by 50% of the annual change in CPI. We believe the project will receive a \$10/MWh federal ecoENERGY incentive payment for the first 10 years of operations. In addition to a revenue-based royalty scheme provided to the Squamish First Nation, and for a nominal price, Innergex will transfer all of the assets of the project to the Squamish First Nation 40 years after commercial operations have commenced.

Many of Innergex's PPAs are at below-market prices.

MATAWIN: PPA COULD BE FINALIZED BY NOVEMBER

The 15 MW Matawin run-of-river project boasts a 49.9% capacity factor and is expected by Innergex to be commissioned sometime in 2010.

Located near the Saint-Maurice River in Quebec, the project has not finalized its 25-year PPA with Hydro-Quebec, although the project was selected by a Quebec RFP in 2002. Innergex is confident that it will finalize its Matawin PPA shortly as the initial power price to be received in the facility's first year of operation is a very low at \$39.40/MWh, and therefore quite favourable to Hydro-Quebec. The power price is expected to increase each contract year by 0.6%.

We suspect the introduction of the \$10/MWh federal ecoENERGY incentive payment is the only reason why the project was not dropped by Innergex. The installed capital cost for Matawin is forecast by the company at \$24.6 million, or \$1.64 million per MW. The facility will be 73% debt financed with the equity portion provided by Innergex's IPO proceeds as well as cash flow from operations. Under the terms of the RFP, ownership of the Matawin facility will be transferred to Hydro-Quebec when the 25-year PPA expires.

KWOIEK CREEK: WHERE'S THE WATER LICENCE?

Despite having a 40-year PPA from BC Hydro, Innergex's 50%-owned 49.9 MW Kwoiek run-of-river hydro project does not have an approved water licence, which was first applied for in 1990. The \$152 million project, or \$3.05 million per MW, is expected to generate power at a 49.2% capacity factor, or 215 GWh/y. Innergex appears certain that it will receive its water licence as it intends to commence construction in late 2008 with an in-service date sometime in 2010. The project is 50% owned by the Kanaka Bar Indian Band, which will receive royalty payments as well as the transfer of the project's assets for a nominal price after 40 years. The initial 2006 PPA price was set at \$81.68/MWh, which is adjusted annually by 30% of the change in CPI.

Innergex intends to transfer many projects' assets to local First Nations bands at the expiration of the associated PPAs.

MKW'ALTS: EXPIRED PPA TO BE RENEGOTIATED

Under the terms of a 20-year BC Hydro PPA, the 47.7 MW Mkw'Alts hydro project had a deadline to begin commercial operations by September 2007. Almost one year later, construction has not begun. Innergex expects to renegotiate with BC Hydro for an extension to December 2010, as well as an increase in the PPA length to 30 years from 20 years. The rationale behind Innergex's confidence that BC Hydro will approve this is due to the favourable PPA power price that BC Hydro will pay the project. The 2004 awarded power price is \$57.26/MWh, which will be adjusted annually by 50% of the change in CPI. Should the project move forward, we believe that it will receive the \$10/MWh federal ecoENERGY incentive payment for the first 10 years of its operations. Despite the project being located on public lands (near Mount Currie, B.C.), Innergex intends to negotiate with the Mount Currie Indian Band for a royalty payment to the Band to ensure their support of the project. The installed capital cost for Mkw'Alts is \$87.3 million, or \$1.83 million per MW.

CARLETON: DUE ONLINE IN Q4/08

The 109.5 MW Carleton wind farm is part of the larger Cartier portfolio of wind power projects, a JV between TransCanada (62%) and Innergex (38%). Currently under construction, commissioning of the \$181.2 million facility is expected in Q4/08, with a forecast annual electricity generation of 340.5 GWh/y, or a **high capacity factor of 35.5%**. Seventy-three GE 1.5 MW turbines will be used at the wind farm that have a GE-guaranteed 96% availability and are under a five-year warranty. At **\$1.65 million per MW installed**, we find the project quite inexpensive, especially given its high-quality turbines. The project has a 20-year PPA with Hydro-Quebec at a 2004 starting power price of \$73.32/MWh, which changes annually according to a formula that includes CPI changes. While we believe the project will qualify for and receive the \$10/MWh ecoENERGY federal incentive payment for its first 10 years of operations, the PPA states that Hydro-Quebec is entitled to 75% of the incentive. Accordingly, our financial forecast uses a \$2.50/MWh net to Innergex federal incentive for its 38% share of the project.

Despite a minority equity interest in its Cartier JV, Innergex shares decision making equally with its JV partner, TransCanada Corporation.

MONTAGNE-SECHE: PPA, BUT REGULATORY APPROVALS FAR AWAY

Located near Cloridorme, Quebec, the 58.5 MW Montagne-Seche wind farm project is estimated to yield a strong 35.7% capacity factor, assuming annual electricity output of 182.7 GWh/y. With an installed capital cost of \$103 million, or \$1.76 million per MW, the 38% Innergex-owned project (i.e., part of the Cartier portfolio) is expected to come online in 2011. A 20-year PPA has been signed with Hydro-Quebec with a 2004 power price of \$68.80/MWh that changes annually according to a formula that includes CPI changes. We believe the project will qualify for and receive the \$10/MWh ecoENERGY federal incentive payment, or \$2.50/MWh net to Innergex's 38% ownership of the project.

GROS MORNE PHASES I & II: PPA, REGULATORY PROCESS UNDERWAY

Also part of the Cartier portfolio are the Gros Morne wind power projects, which consist of two phases, representing a combined 211.5 MW of capacity and 657.7 GWh/y of electricity output, or a 35.5% capacity factor. Phase I (100.5 MW) is expected by Innergex to commence commercial operations in 2011, while Phase II (111 MW) could come online one year later. Similar to the Carleton project, GE 1.5 MW turbines will be used for both phases of the project. Both phases of the project have 21-year signed PPAs with Hydro-Quebec at a 2004 initial price of \$65.58/MWh that increases annually according to a formula that includes CPI changes.

Exhibit 5.10: Innergex's Portfolio of Assets and Development Prospects (Excluding Interest in the Fund)								
Project/Site	Location	Net	Est.	Capacity	Power	PPA	Status/Est. Cost	
		Cap.	Pdn	Factor	Purchaser	Expiry	Low	High
		(MW)	(GWh/y)	(%)			(\$M)	(\$M)
Wind								
Carleton	Quebec	41.6	129.4	35.5%	Hydro-Quebec	2028	68.9	93.6
Montagne Seche	Quebec	22.2	69.4	35.7%	Hydro-Quebec	2031	39.1	50.0
Gros Morne I	Quebec	38.2	118.8	35.5%	Hydro-Quebec	2032	62.9	85.9
Gros Morne II	Quebec	42.2	131.2	35.5%	Hydro-Quebec	2032	69.5	94.9
Roussillon	Quebec	108.0	312.5	33.0%	-	-	189.0	243.0
Kamouraska	Quebec	124.5	363.0	33.3%	-	-	217.9	280.1
Saint-Constant	Quebec	70.0	220.0	35.9%	-	-	122.5	157.5
Club des Hauteurs	Quebec	195.5	600.0	35.0%	-	-	342.1	439.9
Haute-Cote-Nord Est	Quebec	170.0	530.0	35.6%	-	-	297.5	382.5
Haute-Cote-Nord Ouest	Quebec	168.0	540.0	36.7%	-	-	294.0	378.0
Riviere-aux-Renards	Quebec	12.5	37.0	33.8%	-	-	21.9	28.1
Les Mechins	Quebec	57.0	150.2	30.1%	-	-	99.8	128.3
(9 Various)	B.C.	1,217.5	3,732.9	~35.0%	-	-	2,130.6	2,739.4
		2,267.2	6,934.3	34.9%			3,955.7	5,101.2
Hydro								
Glen Miller	Ontario	8.0	41.5	59.2%	OPA	2025	Online	
Umbata Falls	Ontario	11.3	53.5	54.2%	OPA	2028	29.4	32.3
Ashlu Creek	B.C.	49.9	265.0	60.6%	BC Hydro	2039	132.2	149.7
Matawin	Quebec	15.0	62.5	47.6%	Hydro-Quebec	2034	24.6	28.0
Kwoiek Creek	B.C.	25.0	107.5	49.2%	BC Hydro	2050	76.0	84.0
Mkw'Alts	B.C.	47.7	156.0	37.3%	BC Hydro	2030	87.3	96.2
Kaipit	B.C.	9.9	31.0	35.7%	-	-	26.2	29.7
Kokish	B.C.	9.9	38.4	44.3%	-	-	26.2	29.7
Kipawa	Quebec	20.2	115.2	65.2%	-	-	53.4	60.5
(Ledcor 18)	B.C.	133.3	700.8	~60.0%	-	-	353.3	400.0
		330.1	1,571.4	54.3%			853.1	964.9
Total		2,597.3	8,505.7	37.4%				

Source: Company reports; Scotia Capital estimates.

PROSPECTIVE PROJECTS

Innergex has about 2,300 MW of prospects in its development pipeline as seen in Exhibit 5.11.

Innergex has 2,300 MW of wind and hydro prospects in its development pipeline.

Exhibit 5.11: Innergex Has a 2,300 MW Development Pipeline										
Project Name	Fuel Type	Site Location	Gross Capacity (MW)	Output (GWh/y)	Capacity Factor (%)	Est. Online	Incentive Payment (\$/MWh)	Incentive (Years)	Net Ownership (%)	
Carp Forest	Wind	B.C.	125.0	-	-	-	-	-	100%	
Club des Hauteurs	Wind	Quebec	195.5	600.0	35.0%	-	-	-	100%	
Crater Mountain	Wind	B.C.	45.0	-	-	-	-	-	100%	
Haute-Cote-Nord Est	Wind	Quebec	170.0	530.0	35.6%	-	-	-	100%	
Haute-Cote-Nord Ouest	Wind	Quebec	168.0	540.0	36.7%	-	-	-	100%	
Hixon	Wind	B.C.	100.0	-	-	-	-	-	100%	
Kaipit	Hydro	B.C.	9.9	31.0	35.7%	-	3.05	-	100%	
Kamouraska	Wind	Quebec	124.5	363.0	33.3%	2012	2.50	10	100%	
Kipawa	Hydro	B.C.	42.0	240.0	65.2%	-	-	-	48%	
Kokish	Hydro	B.C.	9.9	38.4	44.3%	-	3.05	-	100%	
Ledcor 18	Hydro	B.C.	200.0	~1,000.0	57.1%	-	-	-	67%	
Les Mechins ^{1,2}	Wind	Quebec	150.0	395.3	30.1%	-	-	-	38%	
Nulki Hills	Wind	B.C.	60.0	-	-	-	-	-	100%	
Poplar Hills ³	Wind	B.C.	475.0	-	-	-	-	-	100%	
Riviere-au-Renard	Wind	Quebec	25.0	74.0	33.8%	-	-	-	50%	
Roussillon	Wind	Quebec	108.0	312.5	33.0%	2011	2.50	10	100%	
Saint-Constant	Wind	Quebec	70.0	220.0	35.9%	-	-	-	100%	
Saxton Lake	Wind	B.C.	125.0	-	-	-	-	-	100%	
Tatuk Lake	Wind	B.C.	175.0	-	-	-	-	-	100%	
Trachyte Hills	Wind	B.C.	52.5	-	-	-	-	-	100%	
Vancouver Island Range	Wind	B.C.	60.0	-	-	-	-	-	100%	
			2,490.3							
Net MW to Innergex									2,296.3	

1 A Cartier portfolio project, 62%-owned by TransCanada
 2 Les Mechins received a 20-year PPA but was unable to meet land rights requirements by February 2008. Innergex has not received a notice of default from Hydro-Quebec. The 2004 PPA price was \$71.81 per MWh.
 3 While the potential capacity is 475 MW, the current transmission line in the region can only support a capacity of about 150 MW.

Source: Company reports; Scotia Capital estimates.

Key Investment Risks

In our opinion, execution risk is the largest threat to our one-year target price for Innergex Renewable Energy as the company has installed less than 1% of its planned capacity. Similar to its IPP peers, the company faces numerous other risks that could negatively impact its share price, all of which are not unique to the company. Below, we have highlighted the key investment risks to our one-year target price for Innergex.

EXECUTION RISK

Innergex has well over 2,300 MW of hydro and wind renewable power capacity that it seeks to install and operate over the next decade. Less than 15% of this capacity has received long-term power purchase agreements, leaving a substantial risk that PPAs for its prospective projects may not be received. For several of its projects with PPAs, **Innergex does not hold all of the required approvals, licences, and permits needed to proceed to construction and eventual commissioning.**

Permitting holdups may lead to time delays, project cost overruns, and possible financial penalties for failure to deliver electricity as contractually required. However, we note that **Innergex has a track record of commissioning power plants both on time and within budget.**

WEATHER & CLIMATE CHANGE

Innergex's operating and planned wind farms and hydro facilities are subject to unpredictable weather and climate patterns that may lead to material deviations from our quarterly production forecast. The relative risk of resource variability to quarterly earnings will undoubtedly lower as more capacity is brought online. Similar to Boralex, Innergex's stable quarterly management fee and ownership interest in the Fund acts as a partial risk mitigant to resource variability.

COMPETING BIDS

Some of Innergex's prospective projects include lands that are covered by PPA bids made by competing independent power producers. Accordingly, if a PPA is awarded to another power producer, the prospective project would either be reduced in size or abandoned altogether.

REGULATORY & POLITICAL ENVIRONMENT

Transforming Innergex's pipeline of prospects into operational assets depends heavily on the continuation of favourable federal and provincial initiatives that promote the development of renewable power as a viable alternative to traditional coal- and gas-fired power generation technologies.

Our financial forecast assumes that current federal and provincial renewable power incentives, targets, and initiatives will continue indefinitely.

FIRST NATIONS SUPPORT

Lack of agreements or unfavourable outcomes to negotiations with First Nations groups that claim the land base on which Innergex's projects lie could adversely affect the company's profitability. Without the support of local First Nations communities, INE's projects could be delayed or even terminated. The company has reached settlements with many First Nations bands that support the construction and operation of its projects on their land.

Execution risk is the largest threat to our one-year target price of \$9.50 per share.

Innergex's 150 MW Les Mechains wind farm is technically in default of its PPA terms with Hydro-Quebec.

FINANCING

Innergex's cost of capital may increase and its access to capital could be constrained going forward. Unlike some of its peers like EarthFirst and Plutonic Power, Innergex already generates free cash flow from its fund management fees and distributions, as well as from its only operating facility, the 8 MW Glen Miller hydro plant. **As more than 85% of the company is yet to be funded, we view financing risk as high for Innergex.**

Innergex depends on distributable cash receipts from the Fund to pay its interest and other operating expenses. For 2008 and 2009, we forecast \$4.7 million per year of cash received by Innergex from the Fund.

MANAGEMENT

We believe key management risk is high at Innergex as the company only has several people in full-time senior management positions. Overall, there are 59 employees at Innergex, which includes 14 employees of the Fund. Innergex is heavily dependent on its President and CEO, as well as the founder and Executive Chairman of the Innergex to promote the company and realize its future growth opportunities. If a key member of Innergex's management team were to leave the company, operations and earnings could be significantly impaired.

Key management risk at Innergex is high.

OPERATIONAL

In our view, operational risk is high for Innergex due to its limited operating capacity. While the nature of multiple-turbine wind farms allow for one to several wind turbines to be offline at any given time without a major impact to the operation of the facility, not to mention the earnings of the overall company, Innergex does not have this benefit, for now. Additionally, equipment failures at hydro facilities typically result in a temporary shutdown of the entire project.

WIND TURBINE SUPPLY

With the current supply-constrained market for wind turbines, Innergex may face longer-than-expected lead times for its turbine orders. As a result of soaring wind turbine demand in Europe and North America, as well as limited U.S.-based turbine manufacturers, the current supply/demand imbalance for wind turbines will likely continue over the next several years. Many North American wind farm projects now wait up to two years to receive turbines once an order has been placed.

We note that all wind turbines for Innergex's Cartier JV with TransCanada have been secured. The Cartier project includes the following sites: Baie-des-Sables (commissioned), Anse-a-Valleau (commissioned), Carleton (109.5 MW), Les Mechins (150 MW), Montagne-Seche (58.5 MW), and Gros-Morne I and II (211.5 MW).

Upcoming Stock Catalysts & Events

Similar to most Canadian renewable power developers, we see several events over the next two years that could significantly move Innergex Renewable Energy’s share price. In our view, awards of new capacity and the commissioning of capacity under construction will likely have the most material impacts on INE’s share price. Below, we have listed what we believe to be major short- to mid-term stock catalysts for Innergex (Exhibit 5.12).

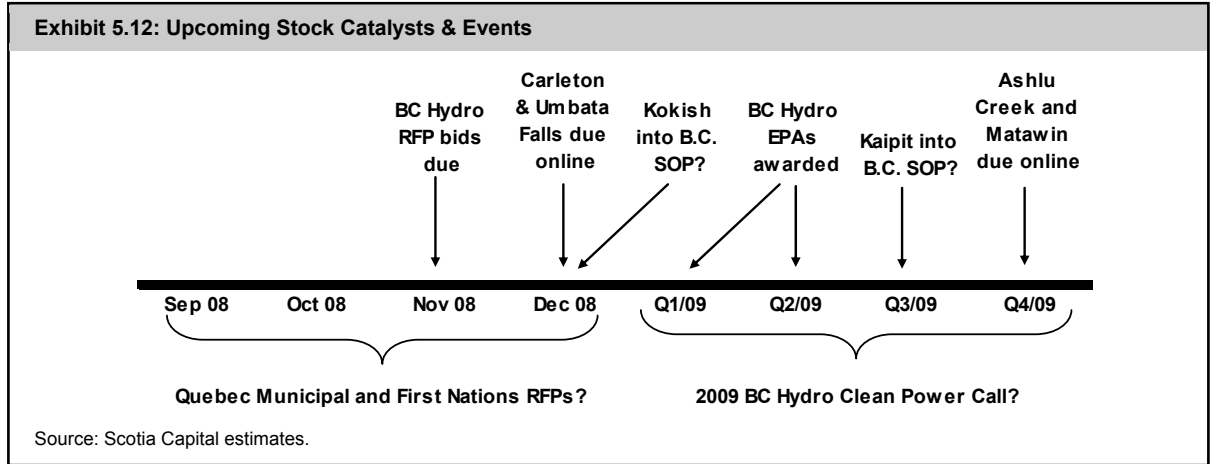

November 2008 – BC Hydro 2008 Clean Power Call bids due. We expect Innergex will submit up to 125 MW of wind projects and up to 100 MW of (Ledcor) hydro projects into this RFP.

We expect Umbata Falls and Carleton to be commissioned before the end of 2008.

Q4/08 – Commissioning of the 23 MW Umbata Falls hydro project in Ontario (11.3 MW net).

Q4/08 – Commissioning of the 109.5 Carleton wind farm in Quebec (41.6 MW net).

1H/09 – BC Hydro 2008 Clean Power Call awards expected, likely after the B.C. government election that is scheduled for May 2009.

Q4/09 – Commissioning of the 49.9 MW Ashlu Creek hydro project in B.C.

Q4/09 – Commissioning of the 15 MW Matawin hydro project in Quebec.

Unknown – Bids/awards of the two 250 MW Quebec wind RFPs (i.e., Municipal and First Nations).

Ongoing – Announcement of significant new greenfield or acquisition-based development prospects, projects, or operating assets.

Ongoing – Announcement of bids/awards into the B.C. Standard Offer Program.

We anticipate Hydro-Quebec announcing two 250 MW wind RFPs in late 2008.

Our Best Guess on Innergex's Future PPA Bids

In our view, Innergex has over 1,600 MW of bid-ready projects, but will likely bid about 350 MW over the next year.

We think that Innergex could bid up to 350 MW into various RFPs over the next year, from a pool of bid-ready projects that total over 1,600 MW. We believe that the company will only bid on projects located in Quebec and B.C. In Exhibit 5.13, we have outlined Innergex's bid-ready projects, and which RFP(s) we think each project will be bid into.

For the Quebec Municipal and First Nations RFPs, the terms of the RFPs have not been released yet (likely Q4/08), but the PPA price is set at \$95/MWh and projects are limited in size to 25 MW. We expect those bid-ready projects that are greater than 25 MW to be broken down into smaller projects for bidding purposes.

Innergex has an exclusive agreement with the Federation Quebecoise des Municipalities (FQM) that represents about 75% of Quebec's municipalities. Under the terms of the agreement, should any municipality decide to pursue PPA negotiations of the Quebec Municipal wind RFP through FQM, Innergex has the right of first refusal to negotiate. Alternatively, municipalities may elect not to use FQM, and to negotiate PPA terms with other wind developers/bidders. **We think this agreement gives Innergex an excellent advantage over its peers and potential upside to our target price.**

Exhibit 5.13: Innergex's Likely Bid-Ready Projects

Quebec Municipal and/or First Nations	Technology	Ownership (%)	Gross Capacity (MW)	Net to INE Capacity (MW)	Capacity Factor (%)
Kamouraska	Wind	100%	124.5	124.5	33.3%
Riviere-au-Renard	Wind	50%	25.0	12.5	33.8%
Roussillon	Wind	100%	108.0	108.0	33.0%
Saint-Constant	Wind	100%	70.0	70.0	35.9%
Others	Wind	100%	~50.0	~50.0	-
				365.0	

We expect about 150 MW bid in Quebec

BC Hydro Clean Power Call	Technology	Ownership (%)	Gross Capacity (MW)	Net to INE Capacity (MW)	Capacity Factor (%)
Carp Forest	Wind	100%	125.0	125.0	-
Crater Mountain	Wind	100%	45.0	45.0	-
Hixon	Wind	100%	100.0	100.0	-
Nulki Hills	Wind	100%	60.0	60.0	-
Poplar Hills	Wind	100%	475.0	475.0	-
Saxton Lake	Wind	100%	125.0	125.0	-
Tatuk Lake	Wind	100%	175.0	175.0	-
Trachyte Hills	Wind	100%	52.5	52.5	-
Vancouver Island Range	Wind	100%	60.0	60.0	-
Some of the Ledcor 18?	Hydro	67%	60.0	40.0	-
				1,257.5	

We expect about 200 MW bid in B.C.

BC Hydro SOP	Technology	Ownership (%)	Gross Capacity (MW)	Net to INE Capacity (MW)	Capacity Factor (%)
Kaipit	Hydro	100%	9.9	9.9	35.8%
Kokish	Hydro	100%	9.9	9.9	44.3%
Some of the Ledcor 18?	Hydro	67%	8.0	5.3	-
				25.1	
				1,647.6	

Source: Scotia Capital estimates.

Valuation & Sensitivity Analyses

We value Innergex Renewable Energy using a blended approach as follows: a probability-weighted discounted cash flow (DCF) analysis, and probability weighted net asset value (NAV) per share.

DISCOUNTED CASH FLOW ANALYSIS

Our DCF analysis results in a one-year target price of \$9.44 per share. For our DCF analysis, we chose a discount rate of 11%, which we believe appropriately captures the sector's standard risks as well as Innergex's unique ones. The discount rate reflects Innergex's start-up operation, tolerance for construction and execution risks, as well as its targeted 75%/25% debt to equity capital structure. Innergex's discount rate of 11% is below that of EarthFirst as Innergex has a somewhat diverse cash flow stream, as well as a broader portfolio of projects by region and by fuel source.

Our DCF analysis suggests a one-year share price of \$9.44.

We give full value to Innergex's 8 MW operating hydro facility, Glen Miller, and adjust our project-success probabilities lower based on project milestones achieved to date. Specifically, we assign 90% probabilities to Umbata Falls and Carleton, both of which are due online by the end of 2008. Also under construction is Ashlu Creek, but some setbacks have pushed our estimated commissioning date back to Q4/09, and accordingly, we reduced our project probability to 75%. Exhibit 5.14 details our DCF approach.

Exhibit 5.14: DCF Suggests \$9.44 per Share							
Project	Gross Capacity (MW)	Effective Capacity (MW)	Capacity Factor (%)	DCF (\$/share)	Prob. of Success (%)	Adjusted DCF (\$/share)	Comments
Glen Miller	8.0	8.0	59%	\$0.26	100%	\$0.26	Operating.
Umbata Falls	23.0	11.3	54%	\$0.69	90%	\$0.62	Completion expected Q4/08
Ashlu Creek	49.9	49.9	61%	\$3.08	75%	\$2.31	Completion expected late fall 2009.
Matawin	15.0	15.0	48%	\$0.43	25%	\$0.11	
Kwoiek Creek	49.9	25.0	49%	\$1.74	25%	\$0.44	
MkwAlts	47.7	47.7	37%	\$1.48	25%	\$0.37	
Kaipit	9.9	9.9	36%	\$0.57	0%	\$0.00	
Kokish	9.9	9.9	44%	\$0.63	0%	\$0.00	
Kipawa	42.0	20.2	65%	\$2.31	0%	\$0.00	
(Ledcor 18)	200.0	133.3	~60%	\$11.66	0%	\$0.00	
Carleton	109.5	41.6	36%	\$1.68	90%	\$1.51	Completion expected Q4/08
Montagne Seche	58.5	22.2	36%	\$0.54	50%	\$0.27	
Gros Mome I	100.5	38.2	35%	\$0.95	50%	\$0.47	
Gros Mome II	111.0	42.2	35%	\$1.29	50%	\$0.65	
Roussillon	108.0	108.0	33%	\$3.78	0%	\$0.00	Recently lost FPA bid in Hydro-Quebec 2,000 MW Wind RFP.
Kamouraska	124.5	124.5	33%	\$4.42	0%	\$0.00	Recently lost FPA bid in Hydro-Quebec 2,000 MW Wind RFP.
Saint-Constant	70.0	70.0	36%	\$2.87	0%	\$0.00	
Club des Hauteurs	195.5	195.5	35%	\$7.66	0%	\$0.00	
Haute-Cote-Nord Est	170.0	170.0	36%	\$6.86	0%	\$0.00	
Haute-Cote-Nord Ouest	168.0	168.0	37%	\$7.17	0%	\$0.00	
Riviere-aux-Renards	25.0	12.5	34%	\$0.46	0%	\$0.00	
Les Mechins	150.0	57.0	30%	\$1.64	0%	\$0.00	
(9 Various)	1,217.5	1,217.5	~35%	\$57.00	0%	\$0.00	
Interest in IEF				\$2.43	100%	\$2.43	
	3,063	2,597				\$9.44	

Source: Scotia Capital estimates.

NET ASSET VALUE CALCULATION

We calculate a risk-adjusted NAV of \$9.55/share. Given recent transactions and using rule-of-thumb metrics for wind and hydro power facilities, we give credit of \$0.82 million to \$1 million per GWh/y for capacity that is either operational or under construction with no construction risk, such as Plutonic’s Toba/Montrose project. We probability-adjust this value lower for those projects that are less developed. Our NAV per share is broken down by project in Exhibit 5.15. We have also sensitized various projects for potential future upside value.

Our risk-adjusted NAV suggests \$9.55/share.

Exhibit 5.15: Net Asset Value Suggests \$9.55 per Share

Project	Financing Status	Unrisked Net Capacity	Value	NAV		
				(\$M)	(diluted)	(%)
Hydro Assets						
Glen Miller	1	1	42 GWhly @ \$1.00M / GWhly	\$41.5	\$1.12	11.7%
Umbata Falls	2	4	53 GWhly @ \$0.90M / GWhly	\$48.1	\$1.30	13.6%
Ashlu Creek	2	4	265 GWhly @ \$0.90M / GWhly	\$238.5	\$6.43	67.3%
Matawin	4	4	63 GWhly @ \$0.25M / GWhly	\$15.6	\$0.42	4.4%
Kwoiek Creek	4	4	108 GWhly @ \$0.25M / GWhly	\$26.9	\$0.72	7.6%
MkwAlts	4	4	156 GWhly @ \$0.25M / GWhly	\$39.0	\$1.05	11.0%
Kaipit	5	4	31 GWhly @ \$0.10M / GWhly	\$3.1	\$0.08	0.9%
Kokish	5	4	38 GWhly @ \$0.10M / GWhly	\$3.8	\$0.10	1.1%
Kipawa	5	4	115 GWhly @ \$0.10M / GWhly	\$11.5	\$0.31	3.3%
(Ledcor 18)	5	4	701 GWhly @ \$0.10M / GWhly	\$70.1	\$1.89	19.8%
			1,571 GWhly	\$498.2	\$13.43	140.7%
Wind Assets						
Carleton	2	1	129 GWhly @ \$0.74M / GWhly	\$95.5	\$2.58	27.0%
Montagne Seche	4	1	69 GWhly @ \$0.21M / GWhly	\$14.2	\$0.38	4.0%
Gros Morne I	4	4	119 GWhly @ \$0.21M / GWhly	\$24.3	\$0.66	6.9%
Gros Morne II	4	4	131 GWhly @ \$0.21M / GWhly	\$26.9	\$0.73	7.6%
Roussillon	5	4	313 GWhly @ \$0.08M / GWhly	\$25.6	\$0.69	7.2%
Kamouraska	5	4	363 GWhly @ \$0.08M / GWhly	\$29.8	\$0.80	8.4%
Saint-Constant	6	4	220 GWhly @ \$0.00M / GWhly	\$0.0	\$0.00	0.0%
Club des Hauteurs	6	4	600 GWhly @ \$0.00M / GWhly	\$0.0	\$0.00	0.0%
Haute-Cote-Nord Est	6	4	530 GWhly @ \$0.00M / GWhly	\$0.0	\$0.00	0.0%
Haute-Cote-Nord Ouest	6	4	540 GWhly @ \$0.00M / GWhly	\$0.0	\$0.00	0.0%
Riviere-aux-Renards	6	4	37 GWhly @ \$0.00M / GWhly	\$0.0	\$0.00	0.0%
Les Mechins	5	4	150 GWhly @ \$0.08M / GWhly	\$12.3	\$0.33	3.5%
(9 Various)	6	4	3,733 GWhly @ \$0.00M / GWhly	\$0.0	\$0.00	0.0%
			6,934 GWhly	\$228.7	\$6.17	64.6%
Working Capital						
Est. Current Assets (uncommitted)				n.m.	\$0.00	0.0%
Est. Current Liabilities (uncommitted)				n.m.	\$0.00	0.0%
					\$0.00	0.0%
Liabilities						
Est. risk-adjusted LTD post future debt financing				(\$434.2)	(\$11.71)	-122.6%
				(\$434.2)	(\$11.71)	-122.6%

		NAV (\$M)	NAVPS (diluted)	NAVPS (%)
Green Attributes				
Emission Reduction Credits		\$0.0	\$0.00	0.0%
		\$0.0	\$0.00	0.0%
Investments				
IEF.u Ownership	4.7M @	\$12.25	\$57.9	\$1.56 16.3%
Less: capital gains tax	4.7M @	(\$1.90)	(\$9.0)	(\$0.24) -2.5%
IEF.u Fees (net EBITDA)	~\$2.0M/y @	6.0x	\$12.0	\$0.32 3.4%
		\$60.9	\$1.64	17.2%
Net Asset Value		\$353.50	\$9.55	100%
Est. risk-adjusted FD Shares O/S post financing			37.1	

Financing Status	Project Status				
	6	5	4	3	2
4	\$9.45	\$9.55	\$9.60	\$9.75	\$10.00
3	\$9.45	\$9.60	\$9.80	\$10.10	\$10.60
2	\$9.45	\$9.70	\$10.10	\$10.70	\$11.60
1	\$9.45	\$9.80	\$10.25	\$11.05	\$12.60

Kipawa

Financing Status	Project Status				
	6	5	4	3	2
4	\$9.30	\$9.40	\$9.55	\$9.75	\$10.05
3	\$9.30	\$9.50	\$9.75	\$10.20	\$10.85
2	\$9.30	\$9.65	\$10.15	\$10.95	\$12.20
1	\$9.30	\$9.75	\$10.40	\$11.45	\$13.20

MkwAlts

Financing Status	Project Status				
	6	5	4	3	2
4	\$9.40	\$9.45	\$9.55	\$9.65	\$9.90
3	\$9.40	\$9.50	\$9.70	\$10.00	\$10.45
2	\$9.40	\$9.60	\$9.95	\$10.55	\$11.40
1	\$9.40	\$9.70	\$10.10	\$10.85	\$12.05

Kwoiek Creek

1. We assume a stable capital structure of 75% debt & 25% equity. Equity issuance is assumed to be our DCF price of \$9.44017089673835/share.
 2. Project Probability Status: 1. Operating - 100%; 2. Construction - 90%; 3. Permitting & PPA - 50%; 4. Permitting or PPA - 25%; 5. Some Development - 10%; 6. Pipeline - 0%.
 3. Financing Status: (1) Full financing in place, (2) Debt draw n, equity required, (3) Equity in place, debt draw required, (4) Equity & debt draw required.

Source: Scotia Capital estimates.

TARGET PRICE, RATING, AND RISK RANKING

We have initiated coverage of Innergex Renewable Energy with a 3-Sector Underperform rating. Our one-year share price target is \$9.50.

Our risk ranking for Innergex Renewable Energy is Caution Warranted, similar to EarthFirst and Plutonic Power. Despite its diverse revenue stream (like Boralex), almost all of the company has not been built yet, and a significant portion of our one-year target is based on the expectation that future projects are commissioned on time and on budget. Additionally, the early stage of the company’s life coupled with the speculative nature of its future projects being successful, as well as stock illiquidity, supports our view of a Caution Warranted risk ranking.

Financial Forecast

We are looking for 237 GWh of production in 2009, rising to 570 GWh the following year.

We assume in our financial forecast that total **power generation ramps up from our estimated 41.5 GWh of production in 2008 to 237.3 GWh in 2009 and to 569.8 GWh in 2010**. Our quarterly electricity production estimates through 2010 only include those projects that already have PPAs and are expected to be commissioned before 2011. Specifically, we include Glen Miller (operating), Umbata Falls (Q4/08), Carleton (Q4/08), Ashlu Creek (Q4/09), Matawin (2H/09), and Mkw'Alts (2H/10).

On a plant-by-plant, basis we have seasonally adjusted quarterly production to match mean quarterly profiles. As we progress through a given quarter, we may adjust our production forecast up or down depending on material changes to various weather and climate-related factors such as stronger-than-expected wind conditions or below-mean hydrology. Please refer to earlier Exhibits 5.4 and 5.5 for quarterly production forecasts by business segment through 2012.

Exhibits 5.16 and 5.17 show our estimated 2011 electricity generation mix by province and by fuel source, respectively.

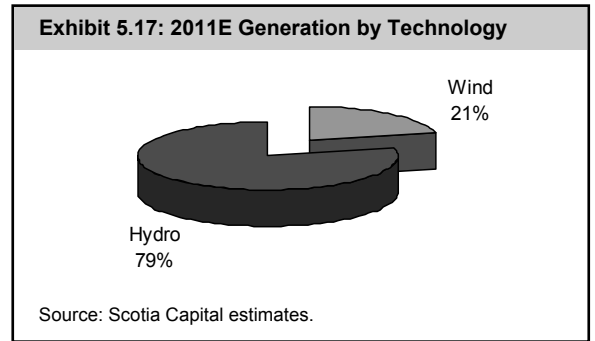
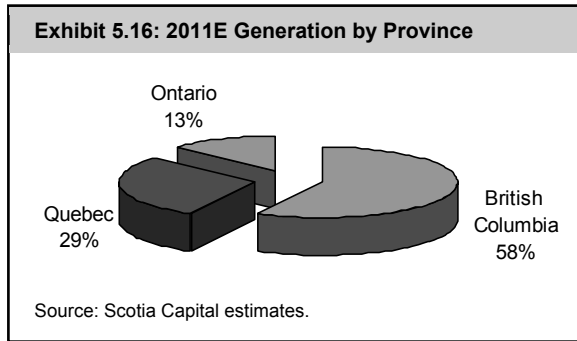

2011E TOTAL REVENUE UP 8.5X OVER 2008E

We think 2011 revenue could grow 8.5x over 2008.

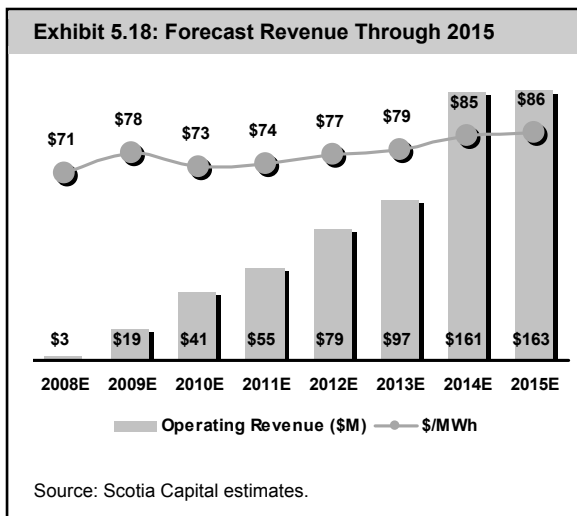

Almost all of our forecast revenue growth for Innergex is driven by annual increases in installed capacity, with a minor amount attributable to growth in fund-related earnings. In 2009, our forecast revenue per MWh rises to \$78/MWh from our estimated \$71/MWh in 2008, but then **drops** to \$73/MWh the following year. The decrease in revenue per MWh in 2010 is attributable to the commissioning of Ashlu Creek and Matawin, both expected to earn less than \$60/MWh in their first full year of operations. **By 2011, we forecast total revenue of \$60.8 million, or about 8.5x our 2008 estimate of \$7 million.** Exhibit 5.18 shows our forecast energy-based revenue growth through 2015, on both an absolute basis as well as on a per MWh basis.

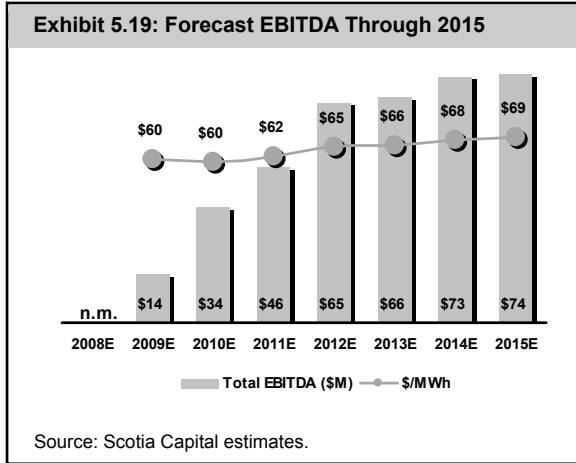

2011E EBITDA PEGGED AT \$46.1 MILLION

As new capacity ramps up over the next several years, we expect operating margins and EBITDA to be somewhat choppy. By 2011, we anticipate EBITDA of \$46.1 million, up from our 2010 EBITDA estimate of \$33.9 million, and our \$14.3 million 2009 forecast. To arrive at our 2011 estimate, we think that operating expenses will come in at \$8.7 million, and will typically range between 15% and 20% of revenue. For now, we have assumed flat SG&A of \$6 million per year, or in line with where Innergex is currently tracking.

POSITIVE EPS IN 2009

Innergex should have positive and sustainable EPS by Q2/09.

We estimate that Innergex's 2008 loss per share will settle at 19¢ and will improve to positive 3¢ in 2009E, followed by EPS of 32¢ in 2010E.

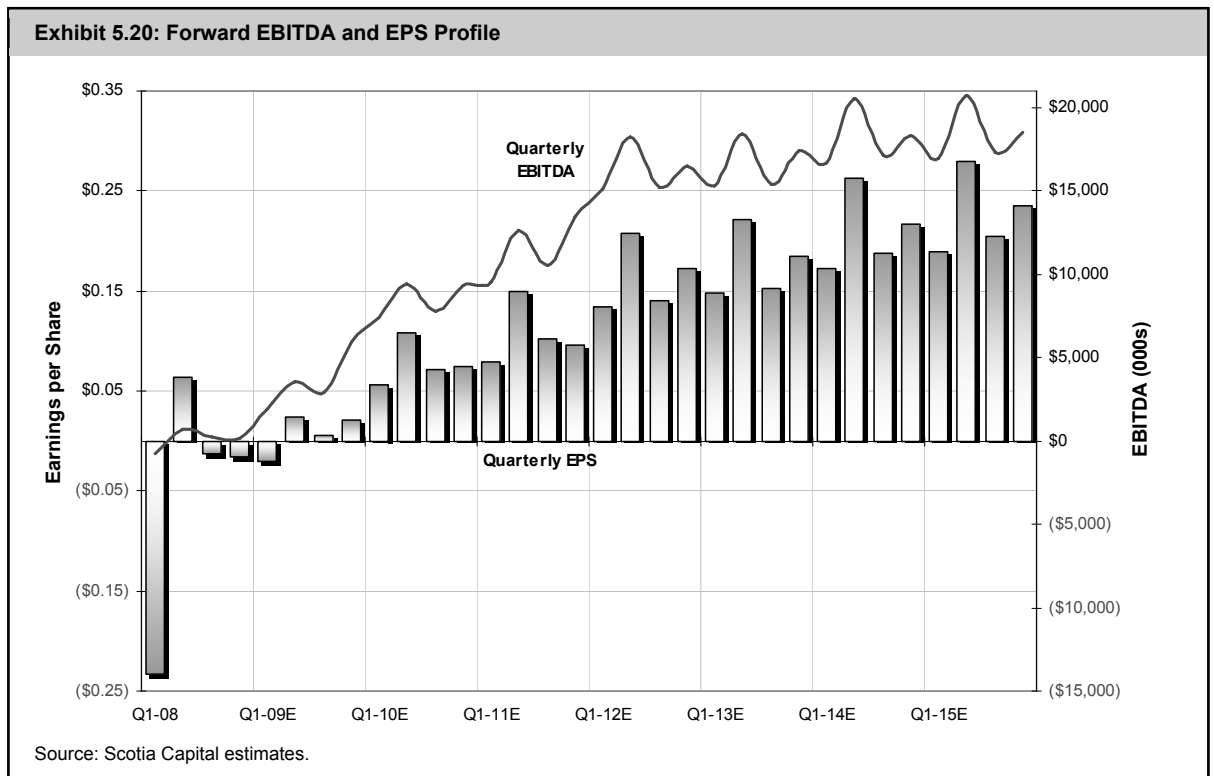

CONSTANT CDPU FOR INNERGEX POWER INCOME FUND THROUGH 2011

We believe that Innergex will maintain its 16.1% interest in IEF, for now. We have also held the Fund's CDPU constant at \$1/unit per year through 2011.

OTHER KEY ASSUMPTIONS AND RATIONALE

New capacity. With the addition of new capacity, we do not speculate what specific day in a quarter the new facility will come online. Accordingly, and similar to the half-year CCA rule, we apply a 50% weight to generation produced from new capacity in its initial quarter.

Capital costs. For the most part, Innergex has disclosed its project cost estimates for those facilities that have PPAs. For hydro, costs range from \$1.64 million to \$3.05 million per MW. We use \$2.65 million per MW (2008) for those hydro projects with no capital cost disclosure. For wind, costs range from \$1.65 million to \$1.75 million per MW. We conservatively use \$2.25 million per MW to \$2.75 million per MW for those wind projects with no capital cost disclosure.

Project financing. Our financial forecast assumes that growth opportunities will be financed using Innergex's targeted capital structure of 75% debt and 25% equity. Additionally, we have assumed that its current projects with signed PPAs will not require the issuance of new equity to commission the facilities.

We don't see Innergex paying material cash taxes for several years.

Taxes. We forecast that Innergex's operations will not pay material cash taxes for several years. Also, distribution proceeds and management fees from the Fund are somewhat offset by head office expenses that result in minimal taxable income.

Free cash flow. We have not applied excess free cash flow on the balance sheet, for now, other than to finance those projects that we believe will be commissioned within our financial forecast. Cash on hand could be used to: (1) prepay outstanding principal balances on its debt; (2) implement (i) a regular dividend, (ii) a share buyback, and/or (iii) a one-time special dividend; (3) invest in other organic growth opportunities; and (4) enter into an acquisition, joint venture, or similar transaction. **We estimate that if no new projects are financed (highly unlikely), Innergex's cash on hand could exceed \$2.50 per share by the end of 2010.**

Seasonality profile. For many of Innergex's future hydro and wind projects that do not have monthly or quarterly generation forecasts disclosed, we have used the following seasonality profiles as the basis for our future capacity production estimates.

- Our hydro production profile assumes the following seasonality: Q1 → 20%; Q2 → 31%; Q3 → 26%; and Q4 → 23%.
- Our wind production profile is as follows: Q1 → 30%; Q2 → 22%; Q3 → 18%; and Q4 → 30%.
- Exhibits 5.21 through 5.23 display our forecast financial statements for Innergex.

Exhibit 5.21: Innergex Renewable Energy Inc. – Income Statement																
	(\$000s)															
	Q108	Q208	Q308E	Q408E	2008E	Q109E	Q209E	Q309E	Q409E	2009E	2010E	2011E	2012E	2013E	2014E	2015E
Operating	\$712	\$883	\$720	\$637	\$2,952	\$2,639	\$4,649	\$3,849	\$7,422	\$18,559	\$41,370	\$55,455	\$77,715	\$79,135	\$86,064	\$86,748
Management Fees	\$594	\$547	\$516	\$516	\$2,174	\$525	\$525	\$525	\$525	\$2,101	\$2,137	\$2,174	\$2,211	\$2,249	\$2,288	\$2,328
Share of Fund Earnings	(\$335)	\$994	\$624	\$637	\$1,920	\$649	\$662	\$676	\$689	\$2,677	\$2,897	\$3,136	\$3,395	\$3,675	\$3,978	\$4,305
Total Revenue	\$971	\$2,424	\$1,860	\$1,790	\$7,045	\$3,814	\$5,836	\$5,050	\$8,636	\$23,337	\$46,404	\$60,765	\$83,321	\$85,059	\$92,330	\$93,381
Operating Expenses	\$277	(\$15)	\$126	\$111	\$499	\$444	\$772	\$639	\$1,194	\$3,050	\$6,485	\$8,674	\$12,333	\$12,568	\$13,673	\$13,793
General & Administrative	\$1,499	\$1,755	\$1,500	\$1,500	\$6,255	\$1,500	\$1,500	\$1,500	\$1,500	\$6,000	\$6,000	\$6,000	\$6,000	\$6,000	\$6,000	\$6,000
	\$1,776	\$1,740	\$1,626	\$1,611	\$6,754	\$1,944	\$2,272	\$2,139	\$2,694	\$9,050	\$12,485	\$14,674	\$18,333	\$18,568	\$19,673	\$19,793
EBITDA	(\$806)	\$684	\$234	\$178	\$291	\$1,870	\$3,564	\$2,911	\$5,942	\$14,287	\$33,919	\$46,091	\$64,988	\$66,491	\$72,657	\$73,589
Depreciation & Amortization	\$373	\$368	\$377	\$378	\$1,496	\$1,251	\$1,252	\$1,253	\$2,233	\$5,990	\$9,488	\$12,636	\$17,140	\$17,433	\$18,281	\$18,297
Interest	\$255	\$209	\$295	\$367	\$1,127	\$1,368	\$1,421	\$1,421	\$2,889	\$7,100	\$11,186	\$14,948	\$19,310	\$18,172	\$17,650	\$15,530
(Gain)/Loss on Sale/Writedown of Assets/Prospects	\$50	\$1,554	\$0	\$0	\$1,603	\$0	\$0	\$0	\$0	\$0	\$0	\$0	\$0	\$0	\$0	\$0
(Gain)/Loss on Derivatives	\$6,072	(\$3,436)	\$0	\$0	\$2,636	\$0	\$0	\$0	\$0	\$0	\$0	\$0	\$0	\$0	\$0	\$0
Misc.	(\$281)	(\$190)	\$0	\$0	(\$471)	\$0	\$0	\$0	\$0	\$0	\$0	\$0	\$0	\$0	\$0	\$0
Other	\$5,841	(\$2,073)	\$0	\$0	\$3,768	\$0	\$0	\$0	\$0	\$0	\$0	\$0	\$0	\$0	\$0	\$0
EBT	(\$7,275)	\$2,180	(\$437)	(\$567)	(\$6,099)	(\$750)	\$891	\$237	\$820	\$1,197	\$13,246	\$18,506	\$28,538	\$30,886	\$36,727	\$39,762
Current tax	\$1	\$1	\$0	\$0	\$2	\$0	\$0	\$0	\$0	\$0	\$0	\$0	\$0	\$0	\$0	\$0
Future tax	(\$1,802)	\$605	(\$153)	(\$198)	(\$1,548)	(\$262)	\$312	\$83	\$287	\$419	\$4,636	\$6,477	\$9,988	\$10,810	\$12,854	\$13,917
Net income	(\$5,474)	\$1,573	(\$284)	(\$369)	(\$4,554)	(\$487)	\$579	\$154	\$533	\$778	\$8,610	\$12,029	\$18,550	\$20,076	\$23,872	\$25,845
Basic shares - opening	23,500.0	23,500.0	23,500.0	23,500.0	23,500.0	23,500.0	23,500.0	23,500.0	23,500.0	23,500.0	23,500.0	26,833.3	26,833.3	26,833.3	26,833.3	26,833.3
Plus: Equity issued/warrant conversion	0.0	0.0	0.0	0.0	0.0	0.0	0.0	0.0	0.0	0.0	3,333.3	0.0	0.0	0.0	0.0	0.0
Less: Share buyback	0.0	0.0	0.0	0.0	0.0	0.0	0.0	0.0	0.0	0.0	0.0	0.0	0.0	0.0	0.0	0.0
Basic shares - closing	23,500.0	23,500.0	23,500.0	23,500.0	23,500.0	23,500.0	23,500.0	23,500.0	23,500.0	23,500.0	26,833.3	26,833.3	26,833.3	26,833.3	26,833.3	26,833.3
Average Shares O/S - Basic (000s)	23,500.0	23,500.0	23,500.0	23,500.0	23,500.0	23,500.0	23,500.0	23,500.0	23,500.0	23,500.0	25,166.7	26,833.3	26,833.3	26,833.3	26,833.3	26,833.3
Average Dilution (000s)	44.4	1,410.0	1,410.0	1,410.0	1,068.6	1,410.0	1,410.0	1,410.0	1,410.0	1,410.0	1,410.0	1,410.0	1,410.0	1,410.0	1,410.0	1,410.0
Average Shares O/S - Diluted (000s)	23,544.4	24,910.0	24,910.0	24,910.0	24,568.6	24,910.0	24,910.0	24,910.0	24,910.0	24,910.0	26,576.7	28,243.3	28,243.3	28,243.3	28,243.3	28,243.3
EPS (Basic)	(\$0.23)	\$0.07	(\$0.01)	(\$0.02)	(\$0.19)	(\$0.02)	\$0.02	\$0.01	\$0.02	\$0.03	\$0.34	\$0.45	\$0.69	\$0.75	\$0.89	\$0.96
EPS (Diluted)	(\$0.23)	\$0.06	(\$0.01)	(\$0.02)	(\$0.19)	(\$0.02)	\$0.02	\$0.01	\$0.02	\$0.03	\$0.32	\$0.43	\$0.66	\$0.71	\$0.85	\$0.92

Source: Company reports; Scotia Capital estimates.

Exhibit 5.22: Innergex Renewable Energy Inc. – Balance Sheet																
(\$000s)	Q108	Q208	Q308E	Q408E	2008E	Q109E	Q209E	Q309E	Q409E	2009E	2010E	2011E	2012E	2013E	2014E	2015E
Assets																
Current Assets																
Cash & Cash Equivalents	\$23,626	\$20,528	\$13,264	\$5,277	\$5,277	\$0	\$0	\$0	\$0	\$0	\$38,516	\$40,811	\$79,298	\$119,038	\$170,707	\$225,950
A/R	\$19,027	\$6,927	\$6,927	\$6,927	\$6,927	\$6,927	\$6,927	\$6,927	\$6,927	\$6,927	\$6,927	\$6,927	\$6,927	\$6,927	\$6,927	\$6,927
Prepaid & Other	\$361	\$474	\$474	\$474	\$474	\$474	\$474	\$474	\$474	\$474	\$474	\$474	\$474	\$474	\$474	\$474
	\$43,014	\$27,930	\$20,666	\$12,678	\$12,678	\$7,402	\$7,402	\$7,402	\$7,402	\$7,402	\$45,917	\$48,213	\$86,700	\$126,440	\$178,109	\$233,352
Investment (Fund)	\$61,629	\$61,442	\$60,885	\$60,340	\$60,340	\$60,045	\$59,763	\$59,493	\$59,238	\$59,238	\$59,300	\$60,547	\$62,052	\$63,837	\$65,925	\$68,341
PP&E	\$120,264	\$136,316	\$166,922	\$199,856	\$199,856	\$223,224	\$247,280	\$260,646	\$273,032	\$273,032	\$366,782	\$464,308	\$469,671	\$479,176	\$465,658	\$448,721
Intangibles	\$40,746	\$40,688	\$40,348	\$40,008	\$40,008	\$39,668	\$39,328	\$38,988	\$38,648	\$38,648	\$37,288	\$35,928	\$34,568	\$33,208	\$31,848	\$30,488
Project Development Costs	\$38,368	\$38,315	\$38,315	\$38,315	\$38,315	\$38,315	\$38,315	\$38,315	\$38,315	\$38,315	\$38,315	\$38,315	\$38,315	\$38,315	\$38,315	\$38,315
Future Income Taxes	\$4,801	\$4,295	\$4,448	\$4,647	\$4,647	\$4,909	\$4,909	\$4,909	\$4,909	\$4,909	\$4,909	\$4,909	\$4,909	\$4,909	\$4,909	\$4,909
Goodwill	\$30,553	\$31,874	\$31,874	\$31,874	\$31,874	\$31,874	\$31,874	\$31,874	\$31,874	\$31,874	\$31,874	\$31,874	\$31,874	\$31,874	\$31,874	\$31,874
Other	\$2,308	\$2,581	\$2,181	\$1,781	\$1,781	\$1,381	\$981	\$581	\$181	\$181	(\$1,419)	(\$3,019)	(\$4,619)	(\$6,219)	(\$7,819)	(\$9,419)
Total Assets	\$341,683	\$343,442	\$365,639	\$389,500	\$389,500	\$406,818	\$429,852	\$442,209	\$453,599	\$453,599	\$582,967	\$681,076	\$723,471	\$771,541	\$808,819	\$846,581
Liabilities																
Current Liabilities																
Revolver	\$0	\$0	\$0	\$0	\$0	\$96	\$4,013	\$5,924	\$6,286	\$6,286	\$0	\$0	\$0	\$0	\$0	\$0
A/P and Accrued Liabilities	\$8,028	\$6,965	\$6,965	\$6,965	\$6,965	\$6,965	\$6,965	\$6,965	\$6,965	\$6,965	\$6,965	\$6,965	\$6,965	\$6,965	\$6,965	\$6,965
CP LTD	\$0	\$0	\$2,000	\$2,000	\$2,000	\$2,000	\$2,000	\$2,000	\$2,000	\$2,000	\$2,000	\$2,000	\$2,000	\$2,000	\$2,000	\$0
Derivatives	\$8,438	\$7,643	\$7,643	\$7,643	\$7,643	\$7,643	\$7,643	\$7,643	\$7,643	\$7,643	\$7,643	\$7,643	\$7,643	\$7,643	\$7,643	\$7,643
	\$16,466	\$14,608	\$16,608	\$16,608	\$16,608	\$16,704	\$20,621	\$22,532	\$22,894	\$22,894	\$16,608	\$16,608	\$16,608	\$16,608	\$16,608	\$14,608
Construction Holdbacks	\$2,420	\$3,046	\$3,046	\$3,046	\$3,046	\$3,046	\$3,046	\$3,046	\$3,046	\$3,046	\$3,046	\$3,046	\$3,046	\$3,046	\$3,046	\$3,046
Derivatives	\$2,616	\$0	\$0	\$0	\$0	\$0	\$0	\$0	\$0	\$0	\$0	\$0	\$0	\$0	\$0	\$0
Long-Term Debt	\$87,125	\$89,526	\$110,008	\$134,237	\$134,237	\$151,946	\$170,173	\$180,382	\$190,592	\$190,592	\$264,999	\$344,602	\$358,459	\$375,643	\$376,194	\$376,194
Future Income Taxes	\$7,601	\$8,180	\$8,180	\$8,180	\$8,180	\$8,180	\$8,491	\$8,574	\$8,861	\$8,861	\$13,497	\$19,974	\$29,963	\$40,773	\$53,627	\$67,544
Minority Interest	\$5	\$5	\$5	\$5	\$5	\$5	\$5	\$5	\$5	\$5	\$5	\$5	\$5	\$5	\$5	\$5
	\$116,234	\$115,364	\$137,846	\$162,075	\$162,075	\$179,881	\$202,337	\$214,539	\$225,397	\$225,397	\$298,155	\$384,235	\$408,080	\$436,074	\$449,480	\$461,397
Shareholders' Equity																
Share capital	\$228,808	\$229,472	\$229,472	\$229,472	\$229,472	\$229,472	\$229,472	\$229,472	\$229,472	\$229,472	\$277,472	\$277,472	\$277,472	\$277,472	\$277,472	\$277,472
Contributed surplus	\$521	\$912	\$912	\$912	\$912	\$912	\$912	\$912	\$912	\$912	\$912	\$912	\$912	\$912	\$912	\$912
Retained earnings	(\$3,881)	(\$2,307)	(\$2,592)	(\$2,960)	(\$2,960)	(\$3,448)	(\$2,869)	(\$2,715)	(\$2,182)	(\$2,182)	\$6,427	\$18,457	\$37,006	\$57,082	\$80,954	\$106,800
Total Shareholders Equity	\$225,448	\$228,077	\$227,793	\$227,424	\$227,424	\$226,937	\$227,516	\$227,669	\$228,202	\$228,202	\$284,812	\$296,841	\$315,391	\$335,467	\$359,339	\$385,184
Total Liabilities and Shareholders Equity	\$341,683	\$343,442	\$365,639	\$389,500	\$389,500	\$406,818	\$429,852	\$442,209	\$453,599	\$453,599	\$582,967	\$681,076	\$723,471	\$771,541	\$808,819	\$846,581

Source: Company reports; Scotia Capital estimates.

Exhibit 5.23: Innergex Renewable Energy Inc. – Cash Flow Statement

(\$000s)	Q108	Q208	Q308E	Q408E	2008E	Q109E	Q209E	Q309E	Q409E	2009E	2010E	2011E	2012E	2013E	2014E	2015E
Operating Activities																
Net (loss) earnings	(\$5,474)	\$1,573	(\$284)	(\$369)	(\$4,554)	(\$487)	\$579	\$154	\$533	\$778	\$8,610	\$12,029	\$18,550	\$20,076	\$23,872	\$25,845
Adjustments for:																
Depreciation & Amortization	\$373	\$368	\$377	\$378	\$1,496	\$1,251	\$1,252	\$1,253	\$2,233	\$5,990	\$9,488	\$12,636	\$17,140	\$17,433	\$18,281	\$18,297
Share of Fund Earnings	\$335	(\$994)	(\$624)	(\$637)	(\$1,920)	(\$649)	(\$662)	(\$676)	(\$689)	(\$2,677)	(\$2,897)	(\$3,136)	(\$3,395)	(\$3,675)	(\$3,978)	(\$4,305)
Stock-based Compensation	\$391	\$391	\$400	\$400	\$1,582	\$400	\$400	\$400	\$400	\$1,600	\$1,600	\$1,600	\$1,600	\$1,600	\$1,600	\$1,600
Gain/(Loss) on Sale of Assets/Prospects	\$49	\$1,554	\$0	\$0	\$1,603	\$0	\$0	\$0	\$0	\$0	\$0	\$0	\$0	\$0	\$0	\$0
Unrealized (Gain)/Loss on Derivatives	\$6,072	(\$3,436)	\$0	\$0	\$2,636	\$0	\$0	\$0	\$0	\$0	\$0	\$0	\$0	\$0	\$0	\$0
Future Income Taxes	(\$1,802)	\$605	(\$153)	(\$198)	(\$1,548)	(\$262)	\$312	\$83	\$287	\$419	\$4,636	\$6,477	\$9,988	\$10,810	\$12,854	\$13,917
Cash flow from operations	(\$55)	\$61	(\$285)	(\$426)	(\$704)	\$252	\$1,880	\$1,214	\$2,763	\$6,110	\$21,436	\$29,606	\$43,883	\$46,245	\$52,630	\$55,353
Net change in non-cash working capital balances	(\$5,491)	\$12,164	\$0	\$0	\$6,672	\$0	\$0	\$0	\$0	\$0	\$0	\$0	\$0	\$0	\$0	\$0
	(\$5,547)	\$12,225	(\$285)	(\$426)	\$5,968	\$252	\$1,880	\$1,214	\$2,763	\$6,110	\$21,436	\$29,606	\$43,883	\$46,245	\$52,630	\$55,353
Financing Activities																
Net issue (buyback) of common shares	\$0	\$0	\$0	\$0	\$0	\$0	\$0	\$0	\$0	\$0	\$48,000	\$0	\$0	\$0	\$0	\$0
Long-term debt advances	\$5,990	\$2,401	\$22,982	\$24,729	\$56,102	\$18,209	\$18,727	\$10,709	\$10,709	\$58,355	\$76,408	\$81,602	\$15,857	\$19,184	\$2,552	\$0
Long-term debt repayments	(\$2,000)	\$0	(\$500)	(\$500)	(\$3,000)	(\$500)	(\$500)	(\$500)	(\$500)	(\$2,000)	(\$2,000)	(\$2,000)	(\$2,000)	(\$2,000)	(\$2,000)	(\$2,000)
Dividends	\$0	\$0	\$0	\$0	\$0	\$0	\$0	\$0	\$0	\$0	\$0	\$0	\$0	\$0	\$0	\$0
Other	\$431	\$625	\$0	\$0	\$1,056	\$0	\$0	\$0	\$0	\$0	\$0	\$0	\$0	\$0	\$0	\$0
	\$4,421	\$3,026	\$22,482	\$24,229	\$54,158	\$17,709	\$18,227	\$10,209	\$10,209	\$56,355	\$122,408	\$79,602	\$13,857	\$17,184	\$552	(\$2,000)
Investing Activities																
Capital asset additions, bus or prospect acquisitions	(\$9,680)	(\$17,944)	(\$30,642)	(\$32,972)	(\$91,239)	(\$24,279)	(\$24,969)	(\$14,279)	(\$14,279)	(\$77,806)	(\$101,877)	(\$108,803)	(\$21,143)	(\$25,578)	(\$3,402)	\$0
Proceeds on sale of capital assets &/or prospects	\$0	\$0	\$0	\$0	\$0	\$0	\$0	\$0	\$0	\$0	\$0	\$0	\$0	\$0	\$0	\$0
New project development costs	(\$1,439)	(\$1,586)	\$0	\$0	(\$3,025)	\$0	\$0	\$0	\$0	\$0	\$0	\$0	\$0	\$0	\$0	\$0
Distributions from Fund	\$1,181	\$1,181	\$1,181	\$1,181	\$4,723	\$945	\$945	\$945	\$945	\$3,780	\$2,835	\$1,890	\$1,890	\$1,890	\$1,890	\$1,890
Other	\$0	\$0	\$0	\$0	\$0	\$0	\$0	\$0	\$0	\$0	\$0	\$0	\$0	\$0	\$0	\$0
	(\$9,939)	(\$18,349)	(\$29,461)	(\$31,791)	(\$89,540)	(\$23,334)	(\$24,024)	(\$13,334)	(\$13,334)	(\$74,027)	(\$99,042)	(\$106,913)	(\$19,253)	(\$23,689)	(\$1,513)	\$1,890
Net change in cash and cash equivalents	(\$11,064)	(\$3,098)	(\$7,264)	(\$7,988)	(\$29,414)	(\$5,373)	(\$3,917)	(\$1,911)	(\$362)	(\$11,562)	\$44,801	\$2,295	\$38,487	\$39,740	\$51,669	\$55,243
Cash and cash equivalents - beginning of period	\$34,691	\$23,626	\$20,528	\$13,264	\$34,691	\$5,277	(\$96)	(\$4,013)	(\$5,924)	\$5,277	(\$6,286)	\$38,516	\$40,811	\$79,298	\$119,038	\$170,707
Cash and cash equivalents - end of period	\$23,626	\$20,528	\$13,264	\$5,277	\$5,277	(\$96)	(\$4,013)	(\$5,924)	(\$6,286)	(\$6,286)	\$38,516	\$40,811	\$79,298	\$119,038	\$170,707	\$225,950

Source: Company reports; Scotia Capital estimates.

Management & Directors

In our opinion, Innergex's management team and board of directors appear exceptionally experienced, with several members having crossed paths with Boralex and Canadian Hydro Developers. As Executive Chairman, Mr. Lefrancois, the founder of Innergex, still plays an active role in the vision and strategy of the company, while Mr. Letellier, a former Boralex employee and former CFO of Innergex, took over as Innergex's President and CEO at the end of 2007. The company's management and directors directly and indirectly control approximately 12.7% of INE's shares on a fully diluted basis (Exhibit 5.24).

Exhibit 5.24: Management & Directors			
Name	Position	FD Shares Controlled Directly or Indirectly	Background
Gilles Lefrancois	Chairman of the Board of Directors	864,769	From 2003 to 2007, Mr. Lefrancois was President and CEO of Innergex, at which time he was appointed Chairman. He founded Innergex in 1990 and is a founding member of <i>Association quebecoise de la production d'énergie renouvelable</i> . Mr. Lefrancois, a Chartered Accountant, previously worked at Innocan Inc. as well as a publicly traded transportation company.
Michel Letellier	President, CEO, and Director	283,617	A director of the company since 2003, Mr. Letellier was appointed President & CEO in 2007. Prior to his appointment, he had been CFO since 1997. From 1990 to 1997, Mr. Letellier was employed by Boralex.
Raymond Laurin	Director	600	Over the past 27 years, Mr. Laurin has held various positions at Desjardins and is currently Executive Director of the <i>Régime de rentes du Mouvement Desjardins</i> . He was appointed director of Innergex in 2007.
Pierre Brodeur	Director	2,000	Mr. Brodeur brings 25 years of experience to Innergex's board, having previously served as President of Sico Inc., Boulangeries Weston, Quebec Ltd., and Videotron International. He is a director of Industrial Alliance as well as Van Houtte. Mr. Brodeur became a director of Innergex in 2007.
Susan M. Smith	Director	1,000	Since 1997, Ms. Smith has acted as President and CEO of RBC Technology Ventures Inc., a subsidiary of Royal Bank of Canada. She is also a director on numerous technology fund boards and has served on the Prime Minister's Advisory Council on Science and Technology. She became a director of the corporation in 2007.
Jean Perron	VP & CFO	195,633	As a Chartered Accountant, Mr. Perron spent 13 years with KPMG before joining Innergex in 2003. He was appointed VP & CFO in 2007.
Jean Trudel	VP Finance & IR	194,000	Mr. Trudel has been VP Finance & Investor Relations since 2003. Previously, Mr. Trudel worked for Sun Life as a director in its Investment Project Finance group. From 1996 to 1999, he was employed by the Bank of Nova Scotia's Corporate Banking group.
Michele Beauchamp	VP Legal	193,288	Ms. Beauchamp has held a role as VP Legal Affairs and Corporate Secretary since mid-2004. Prior to that, she was legal counsel to Cascades, and was a law partner at Desjardins Ducharme.
Francois Hebert	VP Operations	288,176	Mr. Hebert has been VP Operations since 2003 and acted in a similar capacity for Innergex GP since 1999. Previously, he spent 12 years with Alstom Inc.
Normand Bouchard	VP Wind Energy	171,622	Since 2001, Mr. Bouchard has been VP Wind Energy at Innergex. He previously spent 10 years at Kruger as a project engineer, and prior to that, 10 years with a cogeneration developer as a designer of power plants.
Guy Dufort	VP Public Affairs	172,622	Mr. Dufort has been VP Public Affairs since 2003, and was a consultant to Innergex GP from 1994 to 2003. He previously spent 10 years in a similar role at Alcan.
Renaud de Batz	VP Hydro - East	162,010	Prior to joining Innergex in 2002, Mr. de Batz spent 12 years with RSW, an energy-related engineering firm.
Peter Grover	VP Project Management	163,460	Since 2004, Mr. Grover has been responsible for development projects with PPAs and for prospective projects. He previously worked at Alstom as well as spent 20 years in project management for various companies.
Richard Blanchet	VP Hydro - West	288,176	Mr. Blanchet has appointed to his position in 2004, and was previously with Innergex GP. Prior to 2001, Mr. Blanchet spent 13 years with RSW.
Total		2,980,973	
Diluted Shares Outstanding (Q2/08)		23,500,000	
% Insider Ownership		12.7%	

Source: SEDI, Company reports; Scotia Capital.

Innergex's Corporate Structure

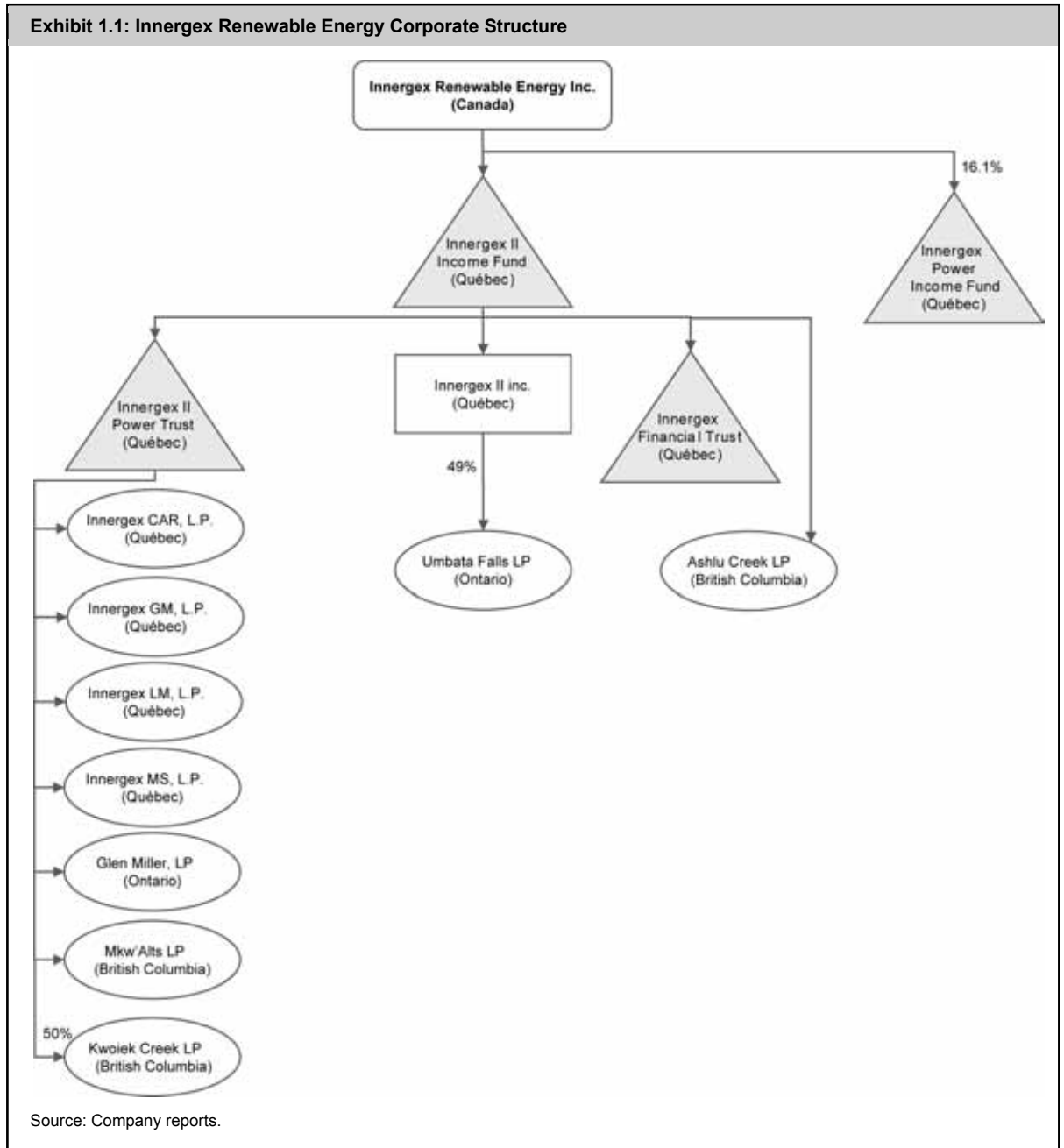

THIS PAGE LEFT INTENTIONALLY BLANK.

Plutonic Power Corporation

(PCC-T)

Aug 15, 2008:	\$7.04
Rating:	2-Sector Perform
Risk:	Caution Warranted
IBES EPS 2008E	\$-0.24
IBES EPS 2009E	n.a.
Div. (Curr.):	\$0.00
Yield:	0.0%

1-Yr Target:	\$9.00
1-Yr ROR:	27.8%
2-Yr Target:	\$10.00
2-Yr ROR:	42.0%
Valuation:	75% DCF @ 10.5%; 25% NAV

Capitalization	
Shares O/S (M)	42.2
Total Value (\$M)	297.3
Float O/S (M)	35.5
Float Value (\$M)	250.1
TSX Weight	--

Qtly EPS (FD) (Next Release: Nov-08)

Y/E DECEMBER-31	Mar	Jun	Sep	Dec	Year	P/E
2008E	\$-0.07A	\$-0.09A	\$-0.08	\$-0.08	\$-0.32	n.a.
2009E	\$-0.06	\$-0.06	\$-0.06	\$-0.06	\$-0.24	n.a.
2010E	\$-0.05	\$-0.04	\$-0.04	\$-0.07	\$-0.21	n.a.
2011E	\$-0.08	\$0.02	\$0.08	\$-0.05	\$-0.02	n.a.

Industry Specific	2007A	2008	2009	2010	2011
Production (GWh)	0	0	0	18	298

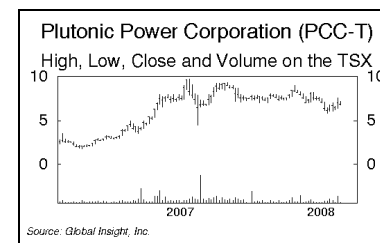

Note: Historical price multiple calculations use FYE price. Source: Reuters; company reports; Scotia Capital estimates.

One Goal: Winning Its Next BC Hydro Bids

INVESTMENT HIGHLIGHTS

- Strong growth plan.** Plutonic's \$660 million (196 MW) first pair of B.C. run-of-river projects is now under construction, which we believe is worth about \$3 per share. The company has 38 additional projects for about 1,700 MW (\$6+ billion) under development, which we estimate is worth an additional \$6 per share on a risk-adjusted basis.
- High government risk.** Plutonic is currently 100% dependent on the B.C. government choosing its renewable projects over others. A possible 2009 government change could risk future growth prospects for British Columbia's independent power producers.
- Focused on the Call:** We assume 1,047 MW of Plutonic projects get submitted into the current BC Hydro Clean Power Call. We estimate the market has placed a 25% probability of success on its bids being awarded long-term power purchase contracts.
- Neutral on the name, for now.** If no more of Plutonic's projects are chosen, its stock price could drop to \$3 per share. If the company wins all 1,047 MW in the BC Hydro Clean Power Call, the stock could be worth about \$15.
- We have transferred coverage of the common shares of Plutonic Power, maintaining a 2-Sector Perform rating and our one-year target price of \$9.00 per share.** Our valuation is based on a 75%-weighted discounted cash flow approach, using a 10.5% discount rate, and a 25%-weighted net asset value calculation.

Summary & Investment Recommendation

Plutonic Power Corporation (Plutonic) is one of Canada's fastest-growing suppliers of green run-of-river hydro power. Its first two projects are now under construction (196 MW) in southwest British Columbia, near Powell River. A further 38 potential run-of-river projects are at various stages of development and could add about 1,700 MW of capacity. **The key to Plutonic's future success is the receipt of long-term electricity purchase agreements (EPAs) to be awarded in BC Hydro's Clean Power Call. We estimate Plutonic will submit 1,047 MW into the Call.**

In our minds, while Plutonic is well positioned within the B.C. power industry to secure future BC Hydro Clean Power Call bids, **we remain cautious as to whether BC Hydro will award 60% of its Clean Power Call to one project** (i.e., ~3,000 GWh/y out of 5,000 GWh/y)

In addition to giving full credit of \$3/share for Plutonic's 196 MW Toba/Montrose project under construction, our DCF valuation gives a 35% probability of success to both its 133 MW Upper Toba and its 914 MW Bute Inlet projects. We have also assumed that Plutonic's financial arrangement with GE to provide 100% of the total equity requirements for a 41.3% (net to Plutonic) economic interest in the combined projects does not change.

We see no value for Plutonic's green attributes. Plutonic relinquished control of its initial CO_{2e} Emission Reduction Credits (ERCs) to BC Hydro in a \$3/MWh bid credit for its East Toba and Montrose Creek projects. In the current BC Hydro Clean Power Call, project bidders are required to surrender their green attributes.

We have transferred coverage of the common shares of Plutonic Power, maintaining a 2-Sector Perform rating and our one-year target price of \$9.00 per share. Our valuation is based on a 75%-weighted discounted cash flow approach, using a 10.5% discount rate, and a 25%-weighted net asset value calculation.

FINANCIAL FORECAST

We do not expect Plutonic to become EPS-positive until at least 2011. However, we do expect its flagship 196 MW East Toba and Montrose Creek sites to be fully commissioned by the end of 2010. In 2011, we estimate revenue of \$30.2 million, followed by \$32.9 million in 2012. Our 2008E and 2009E EPS forecast is for a loss of 32¢ and 24¢ per share, respectively.

Exhibit 6.1: Plutonic Power – Relative Valuation Metrics											
Company	Ticker	Last Price	SC Rating	1-Year Target	1-Year ROR	DCF	NAV	Market Cap	Enterprise Value to EBITDA		
									2008E	2009E	2010E
		8/15/2008						(\$M)	(x)	(x)	(x)
Boralex	BLX	\$14.80	1-SO	\$18.00	22%	\$18.33	\$17.03	\$560	9.9x	8.6x	7.6x
Canadian Hydro Developers	KHD	\$4.38	1-SO	\$7.00	60%	\$7.04	\$6.95	\$628	20.3x	9.9x	7.6x
Earthfirst Canada	EF	\$0.27	3-SU	\$0.40	48%	\$0.35	\$0.60	\$28	n.m.	-5.5x	-0.9x
Innergex Renewable Energy	INE	\$8.25	3-SU	\$9.50	15%	\$9.44	\$9.55	\$194	n.m.	18.4x	7.8x
Plutonic Power	PCC	\$7.04	2-SP	\$9.00	28%	\$9.03	\$8.75	\$297	n.m.	n.m.	n.m.
Average					35%			\$341	15.1x	7.8x	5.5x
Company	Ticker	Beta	Price to Earnings			Price to Sales			Price to Cash Flow		
			2008E	2009E	2010E	2008E	2009E	2010E	2008E	2009E	2010E
			(x)	(x)	(x)	(x)	(x)	(x)	(x)	(x)	(x)
Boralex	BLX	0.7	28.8x	20.2x	18.6x	2.6x	2.5x	2.3x	10.4x	8.7x	7.7x
Canadian Hydro Developers	KHD	0.5	54.6x	23.4x	17.3x	7.2x	3.9x	3.1x	16.0x	9.0x	6.6x
Earthfirst Canada	EF	-	n.m.	n.m.	n.m.	n.m.	5.5x	0.9x	n.m.	n.m.	5.6x
Innergex Renewable Energy	INE	-	n.m.	n.m.	25.5x	27.5x	8.3x	4.2x	n.m.	33.6x	10.2x
Plutonic Power	PCC	0.9	n.m.	n.m.	n.m.	n.m.	n.m.	n.m.	n.m.	n.m.	n.m.
Average		0.7	41.7x	21.8x	20.5x	12.4x	5.1x	2.6x	13.2x	17.1x	7.5x

Source: Bloomberg; Scotia Capital estimates.

Exhibit 6.2: Plutonic Power Was the Big Winner in BC Hydro's 2006 Call for Power

Bidder Name	Project Name	Nearby City	Energy Source	Capacity (MW)	Energy (GWh/yr)
Plutonic Power Corporation	East Toba and Montrose Hydroelectric Project	Powell River	Water	196	702*
AESWapiti Energy Corporation	AESWapiti Energy Corporation	Tumbler Ridge	Coal / Biomass	184	1,612
Dokie Wind Energy Inc.	Dokie Wind Project	Chetwynd	Wind	180	536
Bear Mountain Wind Limited Partnership	Bear Mountain Wind Park	Dawson Creek	Wind	120	371
3986314 Canada Inc.	Canada - Glacier / Howser / East - Project	Nelson	Water	91	341
Green Island Energy Ltd.	Gold River Power Project	Gold River	Biomass	90	745
Kwalsa Energy Limited Partnership	Kwalsa Energy Project	Mission	Water	86	384
Anyox Hydro Electric Corp.	Anyox and Kitsault River Hydroelectric Projects	Alice Arm	Water	57	242
Compliance Power Corporation	Princeton Power Project	Princeton	Coal / Biomass	56	421
Upper Stave Energy Limited Partnership	Upper Stave Energy Project	Mission	Water	55	264
Mackenzie Green Energy Inc.	Mackenzie Green Energy Centre	Mackenzie	Biomass / Other	50	441
Kw-oiek Creek Resources Limited Partnership	Kw-oiek Creek Hydroelectric Project	Lytton	Water	50	147
Mount Hays Wind Farm Limited Partnership	Mount Hays Wind Farm	Prince Rupert	Wind	25	72
Canadian Hydro Developers, Inc.	Bone Creek Hydro Project	Kamloops	Water	20	81
Songhees Creek Hydro Inc.	Songhees Creek Hydro Project	Port Hardy	Water	15	61
Plutonic Power Corporation	Rainy River Hydroelectric Project	Gibson	Water	15	51*
Hydromax Energy Ltd.	Lower Clowhom	Sechelt	Water	10	48
Hydromax Energy Ltd.	Upper Clowhom	Sechelt	Water	10	45
Global Cogenix Industrial Corporation	Kookipi Creek Hydroelectric Project	Boston Bar	Water	10	39
Cogenix Power Corporation	Log Creek Hydroelectric Project	Boston Bar	Water	10	38
Canadian Hydro Developers, Inc.	Clemina Creek Hydro Project	Kamloops	Water	10	31
KMC Energy Corp.	Tamhi Creek Hydro Project	Chilliwack	Water	10	52
Valisa Energy Incorporated	Serpentine Creek Hydro Project	Blue River	Water	10	29
Synex Energy Resources Ltd.	Victoria Lake Hydroelectric Project	Port Alice	Water	10	39
Second Reality Effects Inc.	Fries Creek Project	Squamish	Water	9	41
Renewable Power Corp.	Tyson Creek Hydro Project	Sechelt	Water	8	48
Hupacasath First Nation	Franklin River Hydro Project	Port Alberni	Water	7	19
Axiom Power Inc.	Clint Creek Hydro Project	Woss	Water	6	27
EnPower Green Energy Generation Inc.	Savona ERG Project	Savona	Waste Heat	6	41
EnPower Green Energy Generation Inc.	150 Mile House ERG Project	150 Mile House	Waste Heat	6	34
Maroon Creek Hydro Partnership	Maroon Creek Hydro Project	Terrace	Water	5	25
Spuzzum Creek Power Corp.	Sakwi Creek Run of River Project	Agassiz	Water	5	21
Canadian Hydro Developers, Inc.	English Creek Hydro Project	Revelstoke	Water	5	19
Synex Energy Resources Ltd.	Barr Creek Hydroelectric Project	Tahsis	Water	4	15
Raging River Power & Mining Inc.	Raging River 2	Port Alice	Water	4	13
Synex Energy Resources Ltd.	McKelvie Creek Hydroelectric Project	Tahsis	Water	3	14
Advanced Energy Systems Ltd.	Cranberry Creek Power Project	Revelstoke	Water	3	11
District of Lake Country	Eldorado Reservoir	Kelowna	Water	1	4
Subtotal				1,439	7,125
Brilliant Expansion Power Corporation	Brilliant Expansion Project (2)	Castlegar	Water	120	226
Total				1,559	7,351

* Engineering optimization increased expected GWh/yr to 745 for East Toba and Montrose Creek project and 53 for Rainy River project.

Source: BC Hydro; Scotia Capital.

Exhibit 6.3: 2006 Average Residential Electricity Prices (¢/kWh – in CAD)

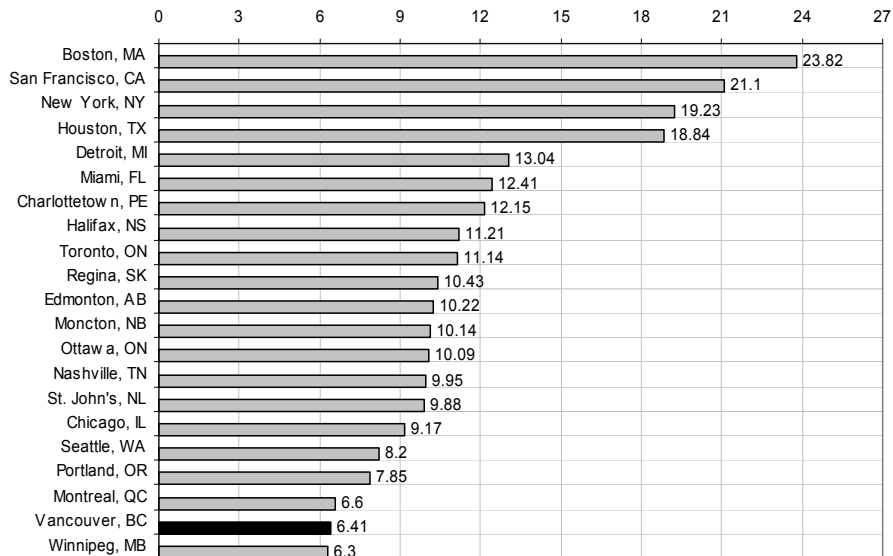

Source: BC Hydro; Scotia Capital.

Capital Markets Profile

Plutonic has two construction projects and 38 development projects that total almost 1,900 MW.

Plutonic Power Corporation is a British Columbia-based independent power producer that focuses on the identification, development, construction, and operation of non-storage hydroelectric projects, or run-of-river projects. Plutonic currently has 38 B.C. run-of-river projects at various stages of development in addition to two under construction, totalling almost 1,900 MW. Production from these projects could be about 6,200 GWh/y. **The company believes this could provide over 25% of the incremental generation that British Columbia is forecasting the province will require by 2016.**

Incorporated in 1999 as Plutonic Capital under the Capital Pool Company (CPC) program, the company initially engaged in various businesses that included software solutions for the call centre industry, diamond drilling, and mineral exploration. **The company went public on November 25, 1999, at \$0.20 per share via a \$0.26 million initial public offering.**

On October 27, 2003, Plutonic entered into a transaction for the purchase of a private British Columbia-based independent power company (Power Co.) founded by engineering firm Knight Piésold in exchange for 20% of Plutonic’s stock. At the time of Plutonic’s acquisition, Power Co. had B.C. water licence applications to generate power for nine drainage basins in Bute Inlet (Bute Inlet projects), three drainage basins in the Toba Inlet district (Toba Inlet projects), and three drainage basins in the vicinity of Knight Inlet (Knight Inlet projects), among others. **On May 17, 2004, the transaction to create Plutonic Power Corporation closed.**

Donald McInnes, the company’s founder, has equipped himself with a strong executive management team.

Plutonic Power’s management team has a successful history of starting up companies, as well as raising capital. Donald McInnes, the company’s founder, CEO, and Vice Chairman, has equipped himself with a strong executive management team, which collectively have an appropriate mix of engineering, finance, electricity, and business talents.

Plutonic currently has a market capitalization of about \$300 million, and its common shares trade on the Toronto Stock Exchange under the ticker symbol PCC. Insiders and related parties control about 16.2% of the fully diluted outstanding company shares. Fidelity Investments owns approximately 15.5% of the company. Plutonic Power reports in Canadian dollars and its financial statements are prepared in accordance with GAAP.

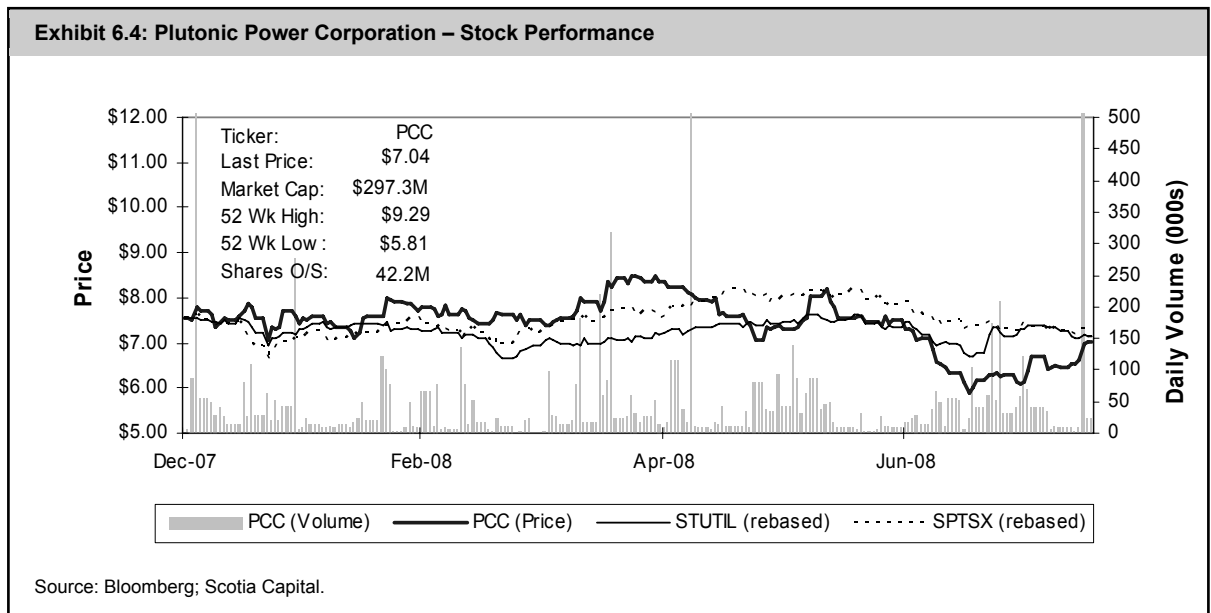

In the 2006 BC Hydro CFP, Plutonic was awarded more new capacity than any other company.

In the 2006 BC Hydro Call for Power (CFP), Plutonic was awarded 211 MW of capacity backed by 35-year EPAs that totalled about 15% of BC Hydro’s awards. **Plutonic received more new capacity than any other company in the 2006 BC Hydro CFP awards.** Plutonic was awarded three of its four project submissions – namely, East Toba (123 MW), Montrose Creek (73 MW), and Rainy River (15 MW).

In July 2007, Plutonic **dropped its Rainy River project** due to fish habitat concerns, and subsequently sold the project, among others, to AltaGas Income Trust. Construction of the East Toba and Montrose Creek projects is underway as of early July 2007, with expected completion dates in 2H/10.

We believe that Plutonic will bid on 1,047 MW of new capacity proposals in the current BC Hydro Clean Power Call.

We think that Plutonic will submit over 1,000 MW of bids into the 2008 BC Hydro Clean Power Call.

Exhibit 6.5: Plutonic’s Project Pipeline

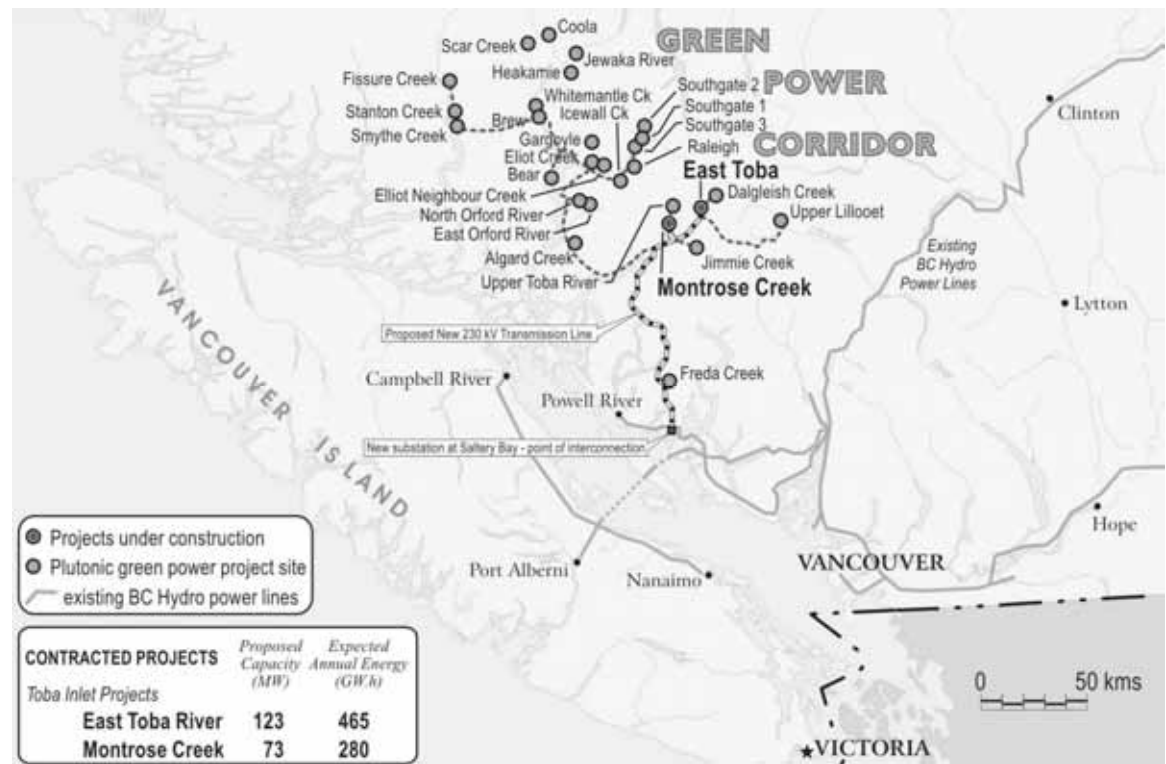

Source: Plutonic Power.

Exhibit 6.6: Plutonic's Portfolio of Assets and Development Projects

Project/Site	Loc.	Est.	Est.	Est. Cap.	Exp. Power Purchaser	Capital Cost	
		Cap.	Pdn	Factor		Low	High
		(MW)	(GWh/y)	(%)		(\$M)	(\$M)
Toba/Montrose							
East Toba	B.C.	123	465	43.2%	BC Hydro	660	660
Montrose Creek	B.C.	73	280	43.8%	BC Hydro		
Upper Toba							
Dagleish Creek	B.C.	30	103	39.2%	BC Hydro	68	80
Jimmie Creek	B.C.	56	200	40.8%	BC Hydro	126	148
Upper Toba River	B.C.	47	163	39.6%	BC Hydro	106	125
Bute Inlet							
Algard Creek	B.C.	21	70	38.1%	BC Hydro	80	89
Bear River	B.C.	38	115	34.5%	BC Hydro	145	162
Brew Creek	B.C.	81	281	39.8%	BC Hydro	308	342
Coola Creek	B.C.	27	79	33.3%	BC Hydro	103	115
East Orford River	B.C.	35	108	35.1%	BC Hydro	134	149
Elliot Creek	B.C.	56	187	38.0%	BC Hydro	214	238
Elliot Neighbour	B.C.	34	114	38.3%	BC Hydro	130	145
Gargoyle Creek	B.C.	28	88	35.7%	BC Hydro	107	119
Heakamie River	B.C.	47	140	33.9%	BC Hydro	180	200
Icewall Creek	B.C.	56	204	41.6%	BC Hydro	214	238
Jewakwa River	B.C.	96	283	33.7%	BC Hydro	367	408
North Orford River	B.C.	22	68	35.3%	BC Hydro	84	94
Raleigh Creek	B.C.	39	112	32.8%	BC Hydro	149	166
Scar Creek	B.C.	58	182	35.8%	BC Hydro	222	247
Southgate River 1	B.C.	131	453	39.6%	BC Hydro	499	555
Southgate River 2	B.C.	39	134	39.2%	BC Hydro	149	166
Southgate River 3	B.C.	39	134	39.2%	BC Hydro	149	166
Whitemantle Creek	B.C.	68	231	38.8%	BC Hydro	260	289
Knight Inlet							
Fissue Creek	B.C.	56	165	33.6%	BC Hydro	214	238
Smythe Creek	B.C.	31	89	32.8%	BC Hydro	118	132
Stanton Creek	B.C.	65	197	34.6%	BC Hydro	248	276
Europa Creek							
	B.C.	81	280	39.5%	BC Hydro	309	344
Freeda Creek							
	B.C.	35	119	38.8%	BC Hydro	134	149
Other							
Chusan Creek	B.C.	22	70	36.3%	BC Hydro	84	94
Crevice Creek	B.C.	22	72	37.4%	BC Hydro	84	94
Hoodo Creek	B.C.	32	104	37.1%	BC Hydro	122	136
Mellersh Creek	B.C.	22	72	37.4%	BC Hydro	84	94
Mill Creek & Woodfibre Creek	B.C.	30	100	38.1%	BC Hydro	115	128
Paradise River	B.C.	27	95	40.2%	BC Hydro	103	115
Racoon Creek	B.C.	18	57	36.1%	BC Hydro	69	77
Sirenia Mountain	B.C.	32	101	36.0%	BC Hydro	122	136
Tahumming River	B.C.	28	88	35.9%	BC Hydro	107	119
Tumult Creek	B.C.	41	122	34.0%	BC Hydro	157	174
Upper Lillooet River	B.C.	81	257	36.2%	BC Hydro	309	344
Zoltan Creek	B.C.	29	91	35.8%	BC Hydro	111	123
TOTAL		1,895	6,270	37.8%		6,942	7,668

Source: Company reports; Scotia Capital estimates.

When Will Plutonic Need More Equity?

Plutonic has arranged for a financial partner to provide the entire equity financing requirements for its Bute and Upper Toba projects, should they be awarded PPAs.

With neither operating assets nor free cash flow generation for the near term, **we believe Plutonic Power may need to access the equity markets within the next 12 months in order to further develop its portfolio of projects.**

On August 14, Plutonic announced that it had signed a memorandum of understanding (MOU) with GE Energy Financial Services (GE), a unit of GE, to partner on a bid to develop the Upper Toba (133 MW) and the Bute Inlet (914 MW) projects. If the two bids are awarded PPAs, GE will make a \$70 million equity contribution for a 50% interest in the Upper Toba project, and a \$650 million equity contribution for a 60% interest in the Bute project.

In total, GE **would provide 100% of the equity requirements for the projects**, leaving Plutonic with no need to raise equity other than possibly for the following: (1) to fund itself until its Toba/Montrose project begins to generate cash; (2) Plutonic could exercise an option to repurchase a 10% interest in the Bute Inlet project for \$100 million; and (3) to further develop its remaining projects and/or acquisitions.

Please refer to Exhibit 6.7 for a summary of Plutonic Power's equity financing history.

Exhibit 6.7: Plutonic's Equity Financing History				
Date	Method of Sale	Price per Security	Number of Securities	Net Proceeds
18-Apr-2007	Private Placement	\$4.55	7,100,000	\$30,467,059
2007	Exercise of options and warrants	\$0.20 to \$2.00	1,996,639	\$2,122,290
9-Nov-2006	Private Placement	\$2.00	10,000,000	\$18,608,478
28-Mar-2006	Private Placement	\$0.80	3,100,000	\$2,480,000
2006	Exercise of options and warrants	\$0.20 to \$2.00	4,670,020	\$2,894,200
2005	Exercise of options and warrants	\$0.20 to \$0.32	226,250	\$58,750
23-Dec-2004	Private Placement	\$0.70 to \$0.80	3,259,169	\$2,173,865
17-May-2004	Private Placement	\$0.25	2,270,000	\$538,171
2004	Exercise of options and warrants	\$0.20 to \$0.25	1,205,000	\$300,500
8-Aug-2003	Private Placement	\$0.20	2,500,000	\$480,873
2003	Exercise of options and warrants	\$0.25	60,000	\$15,000
Prior to 30-Apr-2002	Escrow shares and IPO	\$0.20 to \$0.40	1,150,000	\$3,004,593
				\$63,143,779
Securities Issued for Considerations Other than Cash				
2003 - 2007		\$0.20 to \$4.65	2,264,563	\$1,800,000 (est. value)

Source: Toronto Stock Exchange; Plutonic Power; Scotia Capital.

Key Investment Risks

HYDROLOGY

Plutonic’s hydrology volatility risk is unavoidable and cannot be hedged without storage capability. The amount of energy generated by run-of-river hydro plants is dependent on water flow. Below-forecast water flow could hinder Plutonic’s ability to produce electricity and therefore reduce the company’s ability to generate revenue and net income. As run-of-river facilities do not have the ability to store water, there is no offset to hydrology risk, other than regional diversification of facility sites. An annual volatility range of +/-12% to 15%% annually is likely.

Expect annual water flow volatility of +/-12% to 15% per project.

SINGLE CUSTOMER

Plutonic’s growth is 100% dependent on it being selected by its sole customer, BC Hydro. Plutonic relies completely on winning future power purchase agreements and is constrained by the timing of BC Hydro’s CFPs. Prior to the 2006 CFP, there was a 2002/03 Green Power Generation RFP, as well as a 2000/01 Call. A 2004 CFP was planned but delayed by two years. Future government delays in renewables bidding could **significantly lower our future free cash flow expectations** for Plutonic. In our view, the anticipated 2009 BC Hydro Clean Power Call has likely been pushed back by up to 12 months.

Plutonic’s growth strategy is 100% dependent on its sole customer, BC Hydro.

FIRST NATIONS SUPPORT

Lack of agreements or unfavourable outcomes to negotiations with First Nations groups that claim the land base on which Plutonic’s projects lie could adversely affect the company’s profitability. Run-of-river hydro facility sites are located in unique rugged landscapes that are essential to generating run-of-river power. Without the support of local First Nations communities, Plutonic’s projects could be delayed or even terminated. Plutonic has reached settlements with three First Nations bands that support the construction and operation of its first two run-of-river projects on their land. The outcome of future negotiations with First Nations is a risk to the company’s prospects.

Plutonic has excellent relationships with local First Nations bands.

Exhibit 6.8: Status of Plutonic’s Impact Benefits Agreements

First Nations Bands	Project	Achieved	In Progress	Notes
Sliammon First Nations	Toba/Montrose Transmission Line	√		Framework for future agreements set.
Klahoose First Nations	Toba/Montrose Project	√		Framework for future agreements set.
	Upper Toba Projects		√	Consultation underway.
Sechelt First Nations	Toba/Montrose Transmission Line	√		Accommodation to be provided by Plutonic Power.
Homalco First Nations	Bute Inlet Projects		√	Target before Q3/08
Da'naxda'xw First Nations	Knight Inlet Projects		√	Consultation underway.

Source: Plutonic Power.

MANAGEMENT

Key management risk is significant for Plutonic, as the company has only 35 full-time employees. Plutonic is heavily dependent on current management to promote and realize its future growth opportunities. If a key member of Plutonic’s management were to leave the company, operations could be significantly impaired.

COST/TIMING OVERRUNS

There is no certainty that Plutonic's future run-of-river projects and/or construction contracts will mitigate construction delay risks/overruns. Upon being awarded a PPA with BC Hydro, COD dates are typically agreed upon with the utility for a facility's power generation to commence. If that date is not met, bid winners could lose expected revenue and may be exposed to penalties from debt covenants or from BC Hydro. For Plutonic, this risk is mostly mitigated as it has transferred the initial financial penalty risk on its first two projects to its engineering, procurement, and construction (EPC) contractor, Peter Kiewit Sons Co. (Kiewit).

FINANCING

Plutonic's future financing risk is fairly low, following its recently announced deal with GE.

However, should the arrangement with GE fall through (unlikely), we believe that Plutonic will need to raise 100% of its future project financing from either capital markets or from financial partners. Given current credit market conditions and credit risk repricing, Plutonic's cost of capital may be somewhat higher and its access to capital may be somewhat constrained going forward. On debt financing, Plutonic typically seeks to fix the interest rate on its long-term project loans.

REGULATORY ENVIRONMENT

Growth in the company's operating assets is based exclusively on the B.C. government's desire to maintain or increase the proportion of the province's power portfolio that is generated by independent power producers. Our financial forecast assumes the continuation of current federal and provincial renewable power targets and policies.

STANDARD OPERATIONAL RISK

Unplanned and longer-than-planned outages for maintenance and repair will negatively impact Plutonic's revenue and profitability, as (1) electricity delivery will decline; and (2) operating costs will likely increase. Run-of-river outages that affect an entire power plant are generally more material than outages of wind farms, as an equipment failure of one wind turbine typically has an insignificant impact on the production output of an entire facility.

EXECUTION RISK

Obtaining all environmental and regulatory permits and licences, lease agreements, PPAs, local support, and favourable resource data for all projects may not occur as planned. Project implications from unsuccessful completion of a project's development and construction process could have major share price implications.

The Fall of Europa

Plutonic's 81 MW Europa project will likely be abandoned.

Plutonic's 81 MW Europa Creek project, located about 80 km southeast of Kitimat, may be permanently shelved. In May 2008, the B.C. government introduced legislation to finalize conservation area boundaries in the central and north coast areas of the province. Part of the introduced legislation precludes any type of power production within the specified boundaries, which includes the site for the \$250 million run-of-river facility. Plutonic Power continues to seek B.C. government clarification on its new legislation. **In our opinion, Plutonic's Europa Creek project will likely be abandoned, and therefore we currently give no value to this project in our one-year target price.** If the project is commissioned on time and within budget, we estimate the facility **could be worth up to \$3.50 per share.**

Share Price Observations – A News-Driven Story

To date, Plutonic has showered the market with numerous news releases, which overall, have had positive stock price reactions (Exhibit 6.9). The story has, as expected, been much quieter in the first half of 2008 as the market waits to see what projects Plutonic will be awarded in the upcoming BC Hydro Clean Power Call. In mid-2009, the anticipated time frame that BC Hydro will announce winning bids, we expect the stock to rise/fall by the net present value of the difference in value of the actual megawatts awarded to the number of megawatts the market anticipates will be awarded. We believe that Plutonic will bid 1,047 MW, or its 914 MW Bute Inlet project (18 sites) as well as its 133 MW Upper Toba project (three sites). **Within our DCF, we currently assign a 35% probability of success to both the Upper Toba project and to the Bute Inlet project.**

Exhibit 6.9: Plutonic's Press Releases

Date	Headline	Value	PCC Changes
August 14, 2008	Plutonic Power, GE Energy Financial Services Lay Foundation for Largest Canadian Private Sector Hydroelectric Generation Investment	XXX	+6.1%
May 15, 2008	Plutonic Power announces resolution results from AGM	X	-5.4% over surrounding days
May 14, 2008	Plutonic Power and Knight Piesold extend agreement of partnership for identification and evaluation of run-of-river sites through 2014.	X	
April 22, 2008	Plutonic Power submits 914 MW Bute Inlet project into Environmental Permitting Process	XX	+10.3% during next week
April 14, 2008	Plutonic Power announces project development activities to advance the Green Power Corridor	-	-2.5%
March 31, 2008	Plutonic Power announces the addition of 11 new run-of-river sites to the Green Power Corridor	XXX	+7% during the next two weeks
March 3, 2008	Plutonic Power finalizes Long-Term Impact Benefit Agreement with Sechelt First Nation	-	-2% the next day
February 13, 2008	Plutonic Power sells Rainy River and Hope Projects to AltaGas Income Trust	XX	+4.5% during the week
February 11, 2008	Plutonic Power energizes executive team through addition of Senior Vice President, Legal Affairs and Corporate Secretary	X	
January 24, 2008	Plutonic Power lauds historic and innovative partnership between Klahoose First Nation, Peter Kiewit Sons Co. and Powell River School District	X	+5% the next day
November 8, 2007	Plutonic and GE Close \$470 Million Credit Facility; Financing of 196 MW Run-of-River Hydroelectric Project Completed	XX	-3.5% since commencing on October 30
October 30, 2007	Plutonic and GE commence funding for Toba Montrose General Partnership	-	Flat the next day
October 16, 2007	Plutonic Power announces transformation of its executive management team	X	+4.5% the next day
October 4, 2007	BC's Largest Private Run-Of-River Project Unites First Nations and Business Community	XX	+7% the next day
September 20, 2007	Plutonic Power and GE Energy Financial Services execute \$500 million fixed-price contract for BC's largest renewable energy project	XX	+17% during next week
August 13, 2007	Plutonic Power Successfully Applies for Three New Run-Of-River Hydroelectric Projects	XX	+3%
August 03, 2007	Plutonic Power exits electricity purchase agreement with BC Hydro for Rainy River project due to environmental permitting complexities	XXX	-9% during next week

Source: Company reports; Bloomberg; Scotia Capital.

Exhibit 6.9 : Plutonic's Press Releases (cont'd)

Date	Headline	Value	PCC Changes
July 31, 2007	Plutonic Power Submits 120 MW Upper Toba Valley Run-of-River Project into the Environmental Permitting Process	X	+2%
July 17, 2007	Plutonic Breaks Ground On \$660 Million East Toba/Montrose Green Energy Project	XXX	+9% over next three days
July 11, 2007	Plutonic Adds Power To Its Management Team	X	+12%
July 09, 2007	Plutonic Power Successfully Applies for Two New Run-Of-River Hydroelectric Projects	XX	+17% over next three days
June 27, 2007	Plutonic Power Graduates To The TSX	X	+3%
May 29, 2007	Plutonic Power Successfully Applies For Four New Run-of-River Hydroelectric Projects	XX	+5% the previous day
May 24, 2007	GE Unit To Invest In 196-Megawatt Hydroelectric Project In British Columbia, Its First Equity Investment In Canada -- Plutonic Lays Financing Groundwork For Additional 300 MW	XXX	+8% during the week
May 22, 2007	Federal level screening successfully completed for East Toba and Montrose Run of River Project	X	
April 30, 2007	Plutonic Power Terminates Consulting Agreement	-	+10% during the week
April 25, 2007	Plutonic Power Awarded Environmental Assessment Certificate	XX	+6% next day
April 19, 2007	Plutonic Power Finalizes Impact Benefits Agreement with Sliammon First Nation	-	Flat during the week
April 18, 2007	Plutonic Power Closes \$32.3 Million Bought Deal Private Placement	-	
April 17, 2007	Plutonic Power Successfully Applies For Three New Run-Of-River Green Energy Hydropower Projects	XX	
March 29, 2007	Plutonic Power Corporation Announces \$32 Million Bought Deal Private Placement Financing	XXX	+18% during the week
March 28, 2007	Plutonic Power Corporation Grants Stock Options	-	
March 27, 2007	Plutonic Power Corporation Appoints Bruce Ripley Executive Vice-President, Operations	X	
March 06, 2007	Plutonic Power Signs Term Sheet With Sliammon First Nation For Run-of-River Hydroelectric Project	X	+5%
February 20, 2007	Plutonic Power Finalizes Impact Benefits Agreement With Klahoose First Nation	X	+16% during the week leading up to announcement

Source: Company reports; Bloomberg; Scotia Capital.

Upcoming Stock Catalysts & Events

In our opinion, Plutonic's current share price of about \$7.00 likely reflects the following: a 100% probability of its Toba/Montrose project being commissioned on time and on budget, and a 20% to 25% probability of both its Bute Inlet and Upper Toba projects being selected in the BC Hydro Clean Power Call, as well as being financed and constructed on time and on budget (Exhibit 6.10).

Exhibit 6.10: What the Market Is Likely Thinking							
Project	Gross Capacity (MW)	Effective Capacity (MW)	Capacity Factor (%)	DCF (\$/share)	Prob. of Success (%)	Adjusted DCF (\$/share)	Comments
East Toba & Montrose	196	78	43%	\$2.98	100%	\$2.98	Fixed-price EPC increased probability to 100% from 90%
Upper Toba	133	67	40%	\$3.32	25%	\$0.83	Assumes 50% economic interest
Bute Inlet	914	366	37%	\$13.97	25%	\$3.49	Assumes 40% economic interest
Knight Inlet	156	156	34%	\$5.01	0%	\$0.00	
Europa Creek	81	81	39%	\$3.51	0%	\$0.00	At risk of being shelved
Freda Creek	35	35	39%	\$0.98	0%	\$0.00	
Other (12)	384	384	37%	\$12.84	0%	\$0.00	
	1,899	1,167				\$7.30	

Note: We have assumed the federal government ecoEnergy incentive payment is extended beyond 2011.

Source: Scotia Capital estimates.

Below, we have identified upcoming events that we believe could move Plutonic's stock price:

November 25, 2008, could be the next major stock catalyst for Plutonic, which is when BC Hydro RFP bids are due.

November 2008 – BC Hydro 2008 Clean Power Call bids due. In our opinion, Plutonic will submit its 133 MW Upper Toba and its 914 MW Bute Inlet projects into BC Hydro's current Call for Power.

1H/09 – BC Hydro 2008 Clean Power Call awards expected, likely after the B.C. government election that is scheduled for May 2009.

Ongoing – Permitting progress on future projects. Specifically, we look for 2008 permitting progress on Plutonic's Upper Toba, Bute Inlet, Freda Creek, and Knight Inlet projects. We also expect hydrology study progress on many of its other projects.

Ongoing – New project announcements and other growth initiatives.

PLUTONIC AS A POSSIBLE TAKEOVER TARGET

We don't think Plutonic has a high probability of being acquired.

Plutonic could be a future acquisition target for energy utility and pipeline companies and/or other large IPPs that wish to enhance the renewable portion of their energy portfolios. Emissions reduction requirements for power companies with coal- and natural-gas-fired power plants could make Plutonic attractive, as 100% of Plutonic's planned generation will be emissions-free. Possible Canadian suitors for its renewable power portfolio include TransCanada Pipelines Ltd., TransAlta Corporation, and ATCO Ltd., which have about 87%, 86%, and 99% of their portfolios in either coal, nuclear (TransCanada only), or oil- or natural-gas-fired power plants, respectively. Possible international suitors include GE itself, Suez (recently acquired Ventus), AEP (largest coal-fired emitter in North America), or other U.S. entities if/when future GHG emission rules are established for both the United States and Canada on a consistent basis.

We believe that Canadian Hydro Developers and Boralex are not likely suitors for Plutonic as any deal for Plutonic would appear too dilutive for too many years. These two companies already have renewable generation at 100% and 96% of total installed MW capacity, respectively. We believe that synergies with Plutonic, besides some SG&A saving, would be minimal.

In our opinion, only a major publicly traded company could consider Plutonic due to likely EPS dilution effects in the near term. Potential private equity bidders would likely focus more on future free cash flows than EPS and may be willing to pay more once Plutonic's construction and financing risks are over.

Plutonic's Flagship 196 MW Toba/Montrose Project

Exhibit 6.11: Satellite Image of Toba/Montrose Sites

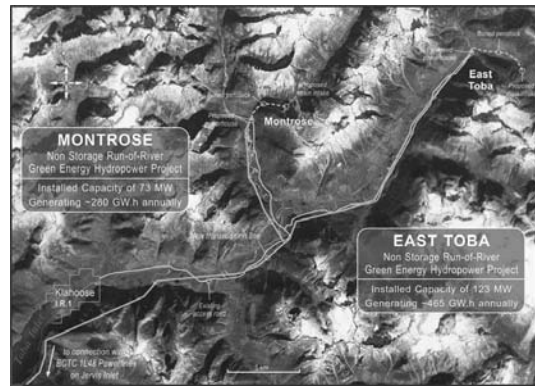

Source: Plutonic Power.

Located near the Toba Inlet (Exhibit 6.11), approximately 130 km northeast of Powell River, B.C., **the 196 MW Toba/Montrose project is expected to generate 745 GWh/y, or at a capacity factor of 43.4%**. Commissioning date for the East Toba site is July 2010, and for the Montrose Creek site is November 2010.

The two sites will require construction of a new 150 km, 230 kV transmission line (~\$100 million) that will be interconnected to BC Transmission Corporation's (BCTC) grid. **All permitting and environmental assessments for the project are complete.**

Construction of the projects began in Q3/07 and is now 31% complete. The general contractor, Kiewit, is one of North America's largest construction and

engineering organizations. For 12 consecutive years, Kiewit was ranked by *Engineering News-Record* as one of the top 10 general contractors in North America. In addition to giving Plutonic a fixed-price contract, **all construction-delay-related financial penalties imposed by BC Hydro will flow through Plutonic to Kiewit's account.** Additionally, Kiewit will also pay damages if the project does not perform to an agreed benchmark.

POWER PURCHASE AGREEMENTS

Both project sites, East Toba (123 MW) and Montrose Creek (73 MW), were awarded 35-year Electricity Purchase Agreements (EPAs or PPAs) in BC Hydro's 2006 Call for Power. We estimate that the weighted-average power price awarded in 2006 dollars is \$87/MWh. The Toba/Montrose project is eligible to receive three types of power prices, as follows:

- 1. Firm energy price.** The initial price that was established when the projects were awarded contracts, applicable to a pre-specified amount of generation per month ("firm energy");
- 2. Tier 1 non-firm energy price.** Equal to the firm energy price, less an \$8/MWh discount. Tier 1 energy may not exceed 100% of firm energy, calculated on a monthly basis; and
- 3. Tier 2 non-firm energy price.** The lesser of (a) Tier 1 non-firm energy price and (b) 70% of the average non-firm Mid-C Off-Peak Index price. Tier 2 energy is all delivered energy in excess of firm energy and Tier 1 energy.

FEDERAL ECOENERGY INCENTIVE

Plutonic has applied for the \$10/MWh federal ecoENERGY incentive payment, and **we assume that the full incentive is awarded to both project sites.** If the incentive is awarded to the project, Plutonic will receive incremental revenue of \$10/MWh for the first 10 years of Toba/Montrose power production, to a maximum \$80 million. **The incentive is awarded on a first-constructed, first-served basis.**

All construction-delay-related financial penalties imposed by BC Hydro will flow through Plutonic to its general contractor's account.

The Toba/Montrose cost per MW is \$2.85 million, excluding a \$100 million transmission line.

GE has the right of first refusal to negotiate participation in up to 200 MW of future B.C. run-of-river projects.

PROJECT ECONOMICS

The total cost for Toba/Montrose is about \$660 million, which we break down in Exhibit 6.12. At first glance, a cost per installed MW of \$3.4 million seems high, but after subtracting \$100 million for the construction of a new transmission line that will serve other potential projects, **we estimate a comparable cost of \$2.85 million per MW.**

To finance the \$660 million project, Plutonic made the following arrangements with GE Energy Financial Services (GE):

- GE will invest \$100 million equity in the Toba/Montrose project.
- GE will co-lead an approximate \$470 million senior secured debt offering to finance the project.
- **GE will receive a 60% economic interest and 49% ownership interest in the project** during the 35-year EPA, at which point the economic interest will revert to 51% to Plutonic and 49% to GE. Additionally, Plutonic granted GE 375,000 two-year common share purchase warrants with an exercise price of \$2.50 per share, as well as a further 650,000 two-year common share purchase warrants with an exercise price of \$9.03 per share.
- GE will establish a \$28 million credit facility as a standby contingency facility.
- GE will establish a \$100 million three-year credit facility that will be repaid with the proceeds of its equity investment once commercial operations begin.
- Plutonic will provide \$30 million in direct equity prior to the completion of construction, for which GE has provided Plutonic a \$30 million line of credit in support of this funding requirement.
- Plutonic will grant GE the right of first refusal to negotiate its participation in up to 200 MW of other run-of-river power projects in that Plutonic tenders into the 2008 BC Hydro Clean Power Call.

Sources		Uses	
GE Equity	\$100M	EPC Contract	\$498M
Plutonic Equity	\$30M	Financing Expense	\$87M
GE Guarantee - Contingency	\$28M	Contingencies and Debt Service Reserve	\$29M
GE Guarantee - Performance Bond	\$12M	Working Capital and Start-Up Costs	\$16M
Pre-COD Revenue	\$20M	EPA Performance Security	\$12M
Senior Loan	\$470M	Land Lease Insurance Property Taxes	\$7M
		Development Costs and First Nations Payment	\$11M
	\$660M		\$660M

Source: Plutonic Power; Scotia Capital estimates.

Plutonic's Likely BC Hydro Clean Power Call Bids

Our DCF valuation has significant upside room should Plutonic's Bute Inlet and Upper Toba projects be awarded BC Hydro PPAs.

We anticipate that Plutonic Power will submit 1,047 MW of potential installed capacity into BC Hydro's Clean Power Call – its 914 MW Bute Inlet project and its 133 MW Upper Toba project. We describe these two projects below. While the outcome of the project bids are binary in nature, we have probability-adjusted our estimated success rates of each project in our discounted cash flow valuation. Our valuation therefore has significant upside room should both projects be awarded long-term PPAs.

Exhibit 6.13: Upper Toba Hydrology

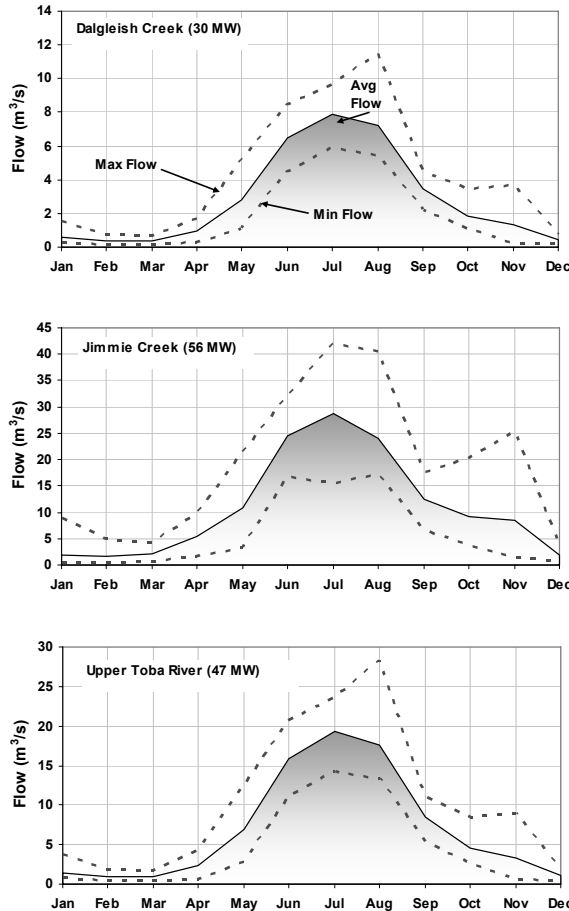

Source: Plutonic Power; Scotia Capital.

UPPER TOBA

Three run-of-river sites make up the 133 MW Upper Toba Valley project, which are all located in an area approximately 50 km northeast of the head of the Toba Inlet. **Plutonic estimates the project will be able to achieve an aggregate 466 GWh/y of power production, or an implied capacity factor of 40.0%.** Site specifics are as follows: (1) Dalglish Creek @ 30 MW, producing up to 103 GWh/y; (2) Jimmie Creek @ 56 MW, producing up to 200 GWh/y; and (3) Upper Toba River @ 47 MW, producing up to 163 GWh/y. Plutonic anticipates that the project would use the transmission line currently being built for its Toba/Montrose project. **If the project is awarded a PPA, we estimate a 2012 commissioning date.** We expect the project's seasonal production profile to be similar to the Toba/Montrose project. Exhibit 6.13 shows the hydrology of the three sites.

Under the terms of its MOU with GE, **Plutonic would provide a 50% economic interest in the project in return for GE providing the entire equity requirement of about \$70 million, as well as the right to arrange debt financing.** We estimate the total capital cost of the project will range between \$300 million and \$350 million. Using an 80% debt and 20% equity project capital structure, and assuming no free cash flow is used to support the project as there isn't any, **Plutonic should not need to issue any equity to develop the project.**

We estimate the price tag for Plutonic's Bute Inlet project at about \$3.5 billion.

Exhibit 6.14: Map of Bute Inlet Project

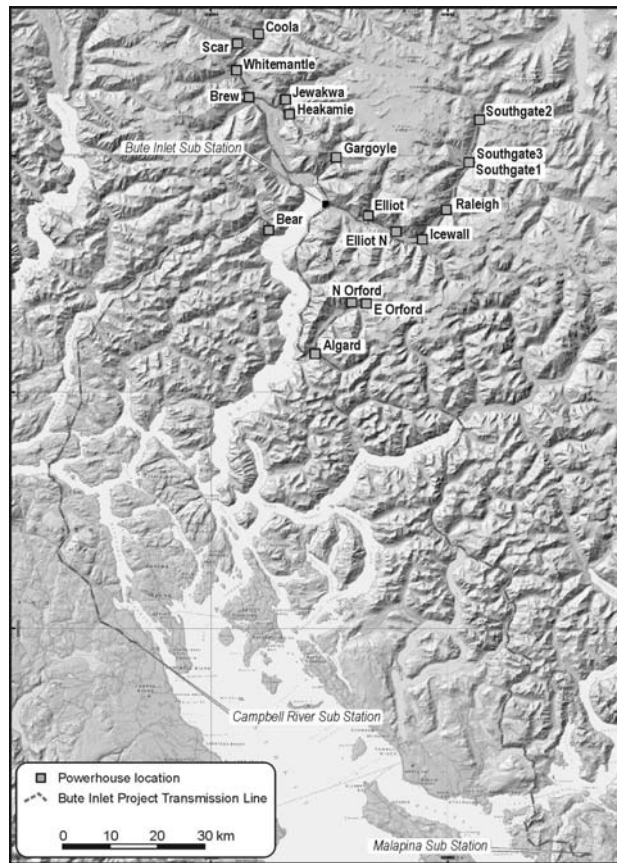

Source: Plutonic Power.

BUTE INLET

Plutonic's colossal 914 MW Bute Inlet project consists of 18 sites that are estimated by the company to generate up to 2,980 GWh/y of electricity, or an implied capacity factor of 37.2%. The project sites are located within a 50 km radius of the head of Bute Inlet, which is located about 150 km north of Power River, B.C. (Exhibit 6.14). COD for the 18 Bute sites will likely be staged from 2014 to 2016. **We estimate the price tag for the project at \$3.5 billion**, and accordingly, we believe Plutonic made a smart move by having GE provide the entire equity financing requirement in return for a 60% economic interest. Plutonic has completed Stages 1 and 2 of the process of securing water licences and Crown land from the B.C. government.

OTHER PROJECTS

Plutonic has numerous other sites that, for the most part, are likely too early in the development process to be submitted into the current BC Hydro Clean Power Call. Exhibit 6.6 (earlier) details all of the company's project sites.

RAINY RIVER AND HOPE PROJECTS SOLD

On February 13, 2008, Plutonic announced that it had sold its 14 MW Rainy River and 37 MW Hope projects to AltaGas Income Trust in an effort to focus on the development of its Green Power Corridor along the southwest coast of B.C. Plutonic received a payment of \$4.5 million for the projects, in the form of 180,433 special warrants for AltaGas trust units valued at \$24.94 per special warrant. The special warrants convert to AltaGas units on a one-for-one basis on January 1, 2010. **On a per MW basis, AltaGas paid \$90,000, in line with similar transactions we have seen in the renewable space.**

In mid-2006, Plutonic was awarded a 35-year EPA for the Rainy River project by BC Hydro. However, following receipt of the EPA, **on August 3, 2007, further development of the project was temporarily abandoned.** Plutonic cited "unexpected complexities in the environmental permitting process caused by the discovery of a number of fish species in the area."

Plutonic received about \$90,000 per MW for its Rainy River and Hope projects, in line with similar transactions we have seen.

Valuation & Sensitivity Analyses

FULL VALUE FOR TOBA/MONTROSE; SOME VALUE FOR BID-READY PROJECTS; NONE FOR BRAG-A-WATTS

Our DCF analysis results in a one-year target price of \$9.03 per share. We use a WACC of 10.5%.

We value Plutonic Power using a blended approach as follows: a probability-weighted discounted cash flow (DCF) analysis and a probability-weighted net asset value (NAV) per share.

Our DCF analysis results in a one-year target price of \$9.03 per share (Exhibit 6.15). For our DCF analysis, we use a discount rate of 10.5%. In our view, the discount rate selected reasonably reflects the company’s risk profile, as follows: (1) we chose not to include any project in our financial forecast that wasn’t (i) under construction; or (ii) bid-ready with material permitting progress made; (2) Plutonic mitigates cost and timing overrun risks by entering into fixed-price contracts with its contractor (although there is no guarantee this will continue); (3) Plutonic’s only customer (BC Hydro) is an investment-grade crown corporation that offers long-term fixed-price contracts to its PPA holders; and (4) the company uses a project capital structure that is 80% debt-weighted. The cost of debt for Toba/Montrose debt facilities is effectively locked in at a pre-tax rate of less than 6.5%.

Exhibit 6.15: DCF Valuation Suggests Plutonic Is Fairly Valued at \$9.03/Share One Year Out

Project	Gross Capacity (MW)	Effective Capacity (MW)	Capacity Factor (%)	DCF (\$/share)	Prob. of Success (%)	Adjusted DCF (\$/share)	Comments
East Toba & Montrose	196	78	43%	\$2.98	100%	\$2.98	Fixed-price EPC increased probability to 100% from 90%
Upper Toba	133	67	40%	\$3.32	35%	\$1.16	Assumes 50% economic interest
Bute Inlet	914	366	37%	\$13.97	35%	\$4.89	Assumes 40% economic interest
Knight Inlet	156	156	34%	\$5.01	0%	\$0.00	
Europa Creek	81	81	39%	\$3.51	0%	\$0.00	At risk of being shelved
Freda Creek	35	35	39%	\$0.98	0%	\$0.00	
Other (12)	384	384	37%	\$12.84	0%	\$0.00	
	1,899	1,167				\$9.03	

Note: We have assumed the federal government ecoEnergy incentive payment is extended beyond 2011.
Source: Scotia Capital estimates.

- **We give full value (i.e., 100% probability) for the Toba/Montrose project** being constructed on time and on budget, as financial penalties imposed on Plutonic as a result of a delayed COD will be passed on to Plutonic’s general contractor.
- **We assign a 35% probability of success to Plutonic’s 133 MW Upper Toba project** being (1) bid into the BC Hydro Clean Power Call; (2) awarded a long-term PPA; (3) constructed on time and within budget. We also assume that Plutonic’s net interest in the project is reduced to 50% in return for 100% of the equity funding requirements provided by GE.
- **We assign a 35% probability of success to Plutonic’s 914 MW Bute Inlet project** being (1) bid into the BC Hydro Clean Power Call; (2) awarded a long-term PPA; (3) constructed on time and within budget. We also assume that Plutonic’s net interest in the project is reduced to 40% in return for 100% of the equity funding requirements provided by GE.
- Simply put, if the full Bute Inlet project did win its bid submission, it would lock in Plutonic Power as the overall BC Hydro Call for Power winner for a **second straight time**. It is possible that BC Hydro may not allow this to happen for the following reasons: (1) the project makes up 60% of the 5,000 GWh/y Clean Power Call – too many eggs in one basket; (2) there could be a backlash by independent power producers; and (3) the implications of possible public criticism could be costly in a B.C. government election year (~May 2009).

We calculate a risk-adjusted NAV of \$8.75 per share. Given recent transactions and using rule-of-thumb metrics for run-of-river facilities, we give power generation credit of \$1 million per GWh/y for capacity that is either operational or under construction with no construction risk, such as Plutonic's Toba/Montrose project. Note that for this project, and for all other projects, we use Plutonic's net effective interest in the project (i.e., 78.4 MW for Toba/Montrose). We probability-adjust this value lower for those projects that are less developed. Our NAV per share is broken down by project in Exhibit 6.16.

TARGET PRICE, RATING, AND RISK RANKING

We have transferred coverage of Plutonic Power with a 2-Sector Perform rating. Our one-year share price target is \$9.00. Embedded in our one-year target are a 35% probability that Upper Toba (133 MW) successfully receives a PPA in the 2008 BC Hydro Clean Power Call, and a 35% probability that Bute Inlet (914 MW) receives the same.

Our risk ranking for Plutonic Power is Caution Warranted, as it is for EarthFirst and for Innergex. We believe this is justified by the early stage of the company's life, the speculative nature of its future projects being successful, and stock illiquidity.

Exhibit 6.16: Net Asset Value Suggests \$8.75 per Share																																																	
Project Status	Financing Status	Unrisked Net Generation	Asset Value (Risked)	Risked Asset Value (\$M)	Risked AVPS (diluted)		Sensitivity Tables																																										
Hydro Projects																																																	
East Toba & Montrose	2	1	298 GWh/y @ \$1.00M / GWh/y	\$298.0	\$5.29	60.4%	<table border="1"> <thead> <tr> <th colspan="6">Capital Structure: Debt (%)</th> </tr> <tr> <th></th> <th>70%</th> <th>75%</th> <th>80%</th> <th>85%</th> <th>90%</th> </tr> </thead> <tbody> <tr> <td>Avg. Equity Issue Price \$6.03</td> <td>\$7.99</td> <td>\$8.08</td> <td>\$8.18</td> <td>\$8.29</td> <td>\$8.42</td> </tr> <tr> <td>\$7.53</td> <td>\$8.44</td> <td>\$8.48</td> <td>\$8.52</td> <td>\$8.56</td> <td>\$8.60</td> </tr> <tr> <td>\$9.03</td> <td>\$8.77</td> <td>\$8.76</td> <td>\$8.75</td> <td>\$8.74</td> <td>\$8.73</td> </tr> <tr> <td>\$10.53</td> <td>\$9.02</td> <td>\$8.98</td> <td>\$8.93</td> <td>\$8.88</td> <td>\$8.83</td> </tr> <tr> <td>\$12.03</td> <td>\$9.22</td> <td>\$9.15</td> <td>\$9.07</td> <td>\$8.98</td> <td>\$8.90</td> </tr> </tbody> </table>	Capital Structure: Debt (%)							70%	75%	80%	85%	90%	Avg. Equity Issue Price \$6.03	\$7.99	\$8.08	\$8.18	\$8.29	\$8.42	\$7.53	\$8.44	\$8.48	\$8.52	\$8.56	\$8.60	\$9.03	\$8.77	\$8.76	\$8.75	\$8.74	\$8.73	\$10.53	\$9.02	\$8.98	\$8.93	\$8.88	\$8.83	\$12.03	\$9.22	\$9.15	\$9.07	\$8.98	\$8.90
Capital Structure: Debt (%)																																																	
	70%	75%	80%	85%	90%																																												
Avg. Equity Issue Price \$6.03	\$7.99	\$8.08	\$8.18	\$8.29	\$8.42																																												
\$7.53	\$8.44	\$8.48	\$8.52	\$8.56	\$8.60																																												
\$9.03	\$8.77	\$8.76	\$8.75	\$8.74	\$8.73																																												
\$10.53	\$9.02	\$8.98	\$8.93	\$8.88	\$8.83																																												
\$12.03	\$9.22	\$9.15	\$9.07	\$8.98	\$8.90																																												
Upper Toba	4	4	117 GWh/y @ \$0.25M / GWh/y	\$29.1	\$0.52	5.9%																																											
Bute Inlet	4	4	1,192 GWh/y @ \$0.25M / GWh/y	\$298.0	\$5.29	60.4%																																											
Knight Inlet	5	4	463 GWh/y @ \$0.10M / GWh/y	\$46.3	\$0.82	9.4%																																											
Europa Creek	4	4	280 GWh/y @ \$0.25M / GWh/y	\$70.0	\$1.24	14.2%																																											
Freda Creek	4	4	119 GWh/y @ \$0.25M / GWh/y	\$29.8	\$0.53	6.0%																																											
Other (12)	6	4	1,229 GWh/y @ \$0.00M / GWh/y	\$0.0	\$0.00	0.0%																																											
				\$771.2	\$13.69	156.4%																																											
Green Attributes																																																	
Emissions Reduction Credits				\$0.0	\$0.00	0.0%																																											
				\$0.0	\$0.00	0.0%																																											
Investments																																																	
AltaGas Income Trust				\$4.5	\$0.08	0.9%																																											
				\$4.5	\$0.08	0.9%																																											
Working Capital																																																	
Current Assets (Q2/08)				\$65.2	\$1.16	13.2%																																											
Current Liabilities (Q2/08)				(\$24.9)	(\$0.44)	-5.0%																																											
				\$40.3	\$0.72	8.2%																																											
Liabilities																																																	
Est. Long-term debt post future debt financing				(\$322.9)	(\$5.73)	-65.5%																																											
				(\$322.9)	(\$5.73)	-65.5%																																											
Est. Shares O/S post future equity financing (M)						56.3																																											
Net Asset Value				\$493.1	\$8.75	100%																																											

1. We assume a stable capital structure of 80% debt & 20% equity. Equity issuance is assumed to be our DCF price of \$9.03/share.
 2. Project Probability Status: 1. Operating - 100%; 2. Construction - 90%; 3. Permitting & PPA - 50%; 4. Permitting or PPA - 25%; 5. Some Development - 10%; 6. Pipeline - 0%.
 3. Financing Status: (1) Full financing in place; (2) Debt draw n, equity required; (3) Equity in place, debt required; (4) Equity & debt required.
 4. We give full credit of \$1 million per GWh/y for the East Toba & Montrose Creek project due to the fixed-price nature of its EPC contracts.

Source: Scotia Capital estimates.

Financial Forecast

We expect Plutonic’s East Toba and Montrose Creek sites will be up and running by Q3/10 and Q4/10, respectively (Exhibit 6.17). We are not too concerned with construction cost overruns, as Plutonic has passed on the liability for higher-than-budgeted costs to its general contractor through the use of a fixed-price contract. If the Upper Toba and Bute Inlet projects receive PPAs in the current BC Hydro Clean Power Call, and assuming successful completion of permitting, financing, and construction, we think those projects could be online in 2012 and between 2014 and 2016 (staged), respectively.

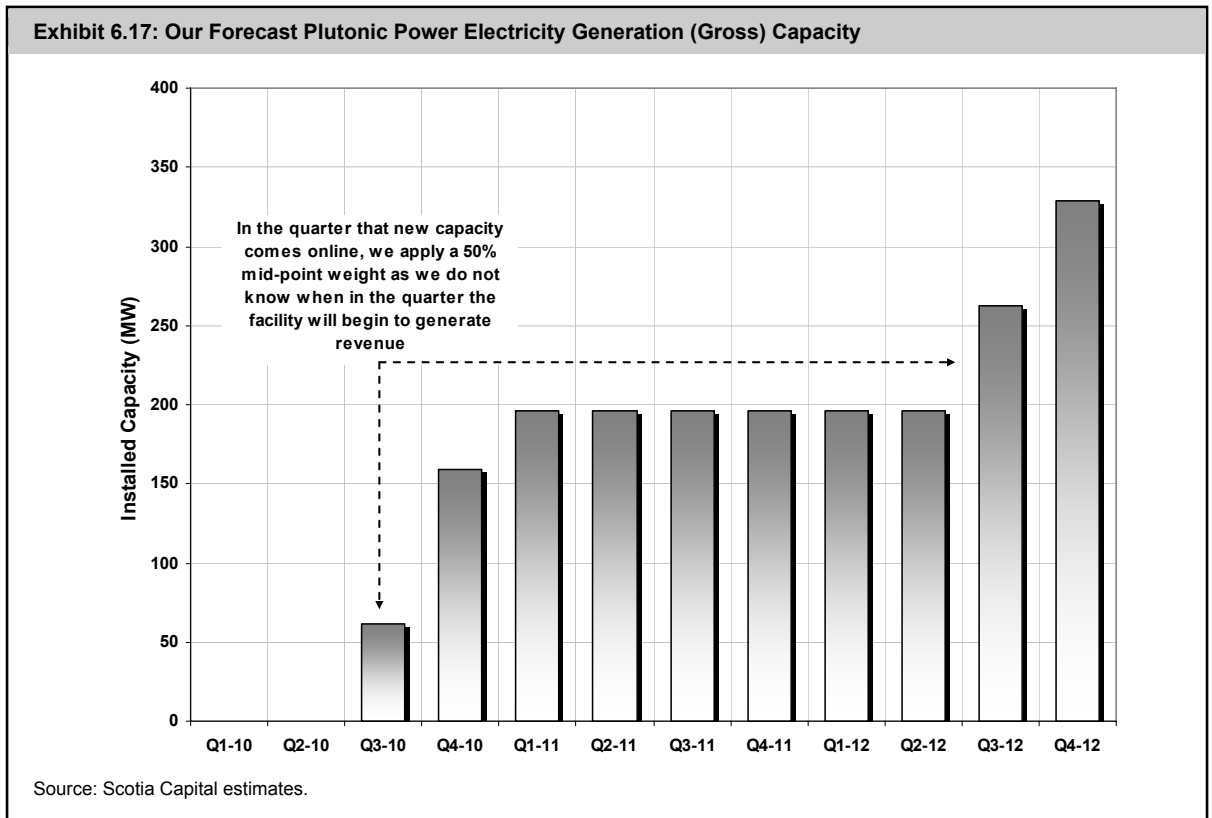

For now, our financial forecast includes earnings associated with the Bute Inlet and Upper Toba Valley projects, as well as Plutonic’s flagship Toba/Montrose project.

STANDARD BC HYDRO EPA PRICING PLUS ECOENERGY INCENTIVES

We estimate that the Toba/Montrose project will receive a weighted-average power price of \$91.44/MWh in 2011, or the project’s first full year of operation. We also expect the project will qualify for and receive the federal government’s ecoENERGY incentive payment of \$10/MWh for the power plant’s first 10 operating years, to a maximum of \$80 million. While the current federal government ecoENERGY incentive program is closed for new projects coming online after 2011, we believe the program will be extended for a further three to five years.

Exhibit 6.18: Toba/Montrose Seasonality

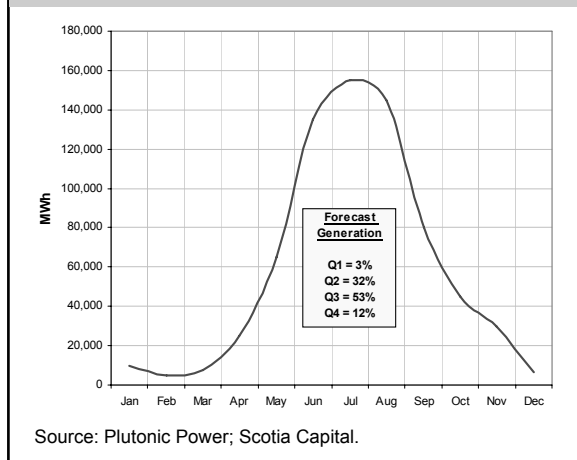

For Upper Toba, we use a 2013 weighted-average power price of \$126.12/MWh. For Bute Inlet, we adjusted the Upper Toba power price by 50% of annual CPI to arrive at a 2017 full-year, weighted-average price of \$131.24/MWh, or \$141.24/MWh including the ecoENERGY incentive payment. We used the same pricing formula for both of these projects as Plutonic intends to submit them into the same RFP.

PLUTONIC WILL HAVE NO GREEN ATTRIBUTES AVAILABLE FOR SALE

In the 2006 BC Hydro Call for Power, Plutonic elected to surrender its Toba/Montrose green attributes for a \$3/MWh bid credit (i.e., not an

Plutonic will have no green attributes available for sale.

additional \$3/MWh of revenue). While Plutonic would like to keep the Emission Reduction Credits earned from future projects, **BC Hydro requires bidders to tender all green attributes.**

QUARTERLY REVENUE & EARNINGS VOLATILITY WILL BE SEVERE DUE TO SEASONALITY OF WATER FLOW

We forecast 2011 revenue of about \$30.2 million.

We expect energy-based revenue from Plutonic’s interest in the Toba/Montrose project to be \$27.2 million in 2011 with an additional \$3 million of incentive revenue that year. If the Upper Toba project comes online in 2012, then total **2013 energy-based revenue could hit \$57.2 million**, assuming Plutonic maintains a 50% economic interest in the facility. We forecast an additional \$5.3 million in total 2013 incentives.

Due to the seasonality of B.C. water flow, we expect quarterly earnings will be volatile for at least the next five years (Exhibit 6.19).

Exhibit 6.19: Expect Seasonally Volatile Quarterly EBITDA and EPS

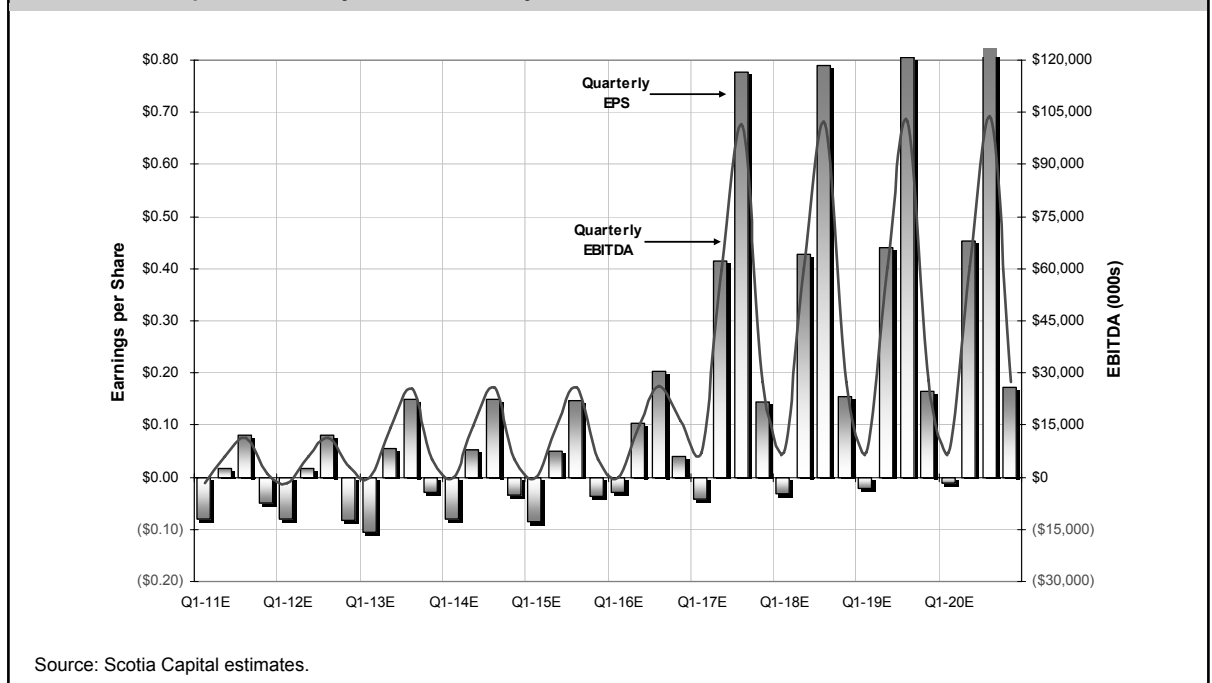

We have not applied any excess free cash on the balance sheet beyond 2020, for now. Post-2020 cash on hand could be used to: (1) prepay outstanding principal balances on its debt; (2) implement (i) a regular dividend; (ii) a share buyback; and/or (iii) a one-time special dividend; (3) invest in other organic growth opportunities; and (4) enter into an acquisition, joint venture, or similar transaction.

KEY FINANCIAL FORECAST ASSUMPTIONS

Capital costs. We assume an installed capital cost per GWh/y of \$0.8 million. This excludes major infrastructure costs such as transmission lines/upgrades. On capital costs, we assume the following: (1) three years prior to commissioning requires a 20% cash outlay; (2) two years prior requires 35%; (3) one year prior requires 30%; and (4) the year a facility is commissioned requires a 15% capital cost cash outlay, using a half-year rule of thumb.

Incentives. In our opinion, the federal government's ecoENERGY incentive program for renewable power producers will be extended for a further several years. As a result, we expect all of Plutonic's run-of-river projects to qualify and receive the \$10/MWh incentive, subject to a project cap of \$80 million and a company cap of \$256 million.

Taxes. We forecast that most of Plutonic's projects will not pay material cash taxes for the first seven to 12 years of operation.

Future financing. Unlike Plutonic's financing deal with GE, we assume that all future projects are 100% owned and self-financed, with the exception of the company's 914 MW Bute Inlet project and its 133 MW Upper Toba project.

In the first quarter that a run-of-river facility is commissioned, we use a half-year rule for capacity utilization, as it is impractical to speculate exactly when a facility will come online.

Our First Nations payment assumption of 1.75% of gross revenue is higher than others.

We have adjusted our revenue according to company seasonality guidance, with much heavier weights in Q2 and Q3. We forecast expenses with a significantly flatter structure, in general.

Royalties. For First Nations payments/royalties, we assume 1.75% of gross revenue, the middle of Plutonic's 1.5% to 2.0% guidance range.

Line losses. We assume a 2.7% transmission line loss rate for all projects in the Green Power Corridor.

Exhibit 6.20: Plutonic Power Corporation – Income Statement

(\$000s)	Q108	Q208	Q308E	Q408E	2008E	Q109E	Q209E	Q309E	Q409E	2009E	2010E	2011E	2012E	2013E	2014E	2015E
Generation Revenue	\$0	\$0	\$0	\$0	\$0	\$0	\$0	\$0	\$0	\$0	\$1,619	\$27,249	\$29,704	\$57,183	\$57,755	\$58,333
Incentive Revenue	\$0	\$0	\$0	\$0	\$0	\$0	\$0	\$0	\$0	\$0	\$179	\$2,980	\$3,154	\$5,310	\$5,310	\$5,310
Green Credits	\$0	\$0	\$0	\$0	\$0	\$0	\$0	\$0	\$0	\$0	\$0	\$0	\$0	\$0	\$0	\$0
Total Revenue	\$0	\$0	\$0	\$0	\$0	\$0	\$0	\$0	\$0	\$0	\$1,798	\$30,229	\$32,858	\$62,493	\$63,065	\$63,643
Operating & Maintenance Costs	\$0	\$0	\$0	\$0	\$0	\$0	\$0	\$0	\$0	\$0	\$253	\$4,301	\$4,644	\$7,973	\$8,133	\$8,295
General & Admin	\$1,458	\$2,013	\$2,150	\$2,150	\$7,771	\$2,193	\$2,193	\$2,193	\$2,193	\$8,772	\$8,947	\$9,126	\$9,309	\$9,495	\$9,685	\$9,879
Depreciation & Amortization	\$8	\$9	\$10	\$10	\$37	\$10	\$10	\$10	\$10	\$40	\$1,690	\$6,640	\$8,228	\$12,991	\$12,991	\$12,991
Interest on LTD	\$0	\$0	\$0	\$0	\$0	\$0	\$0	\$0	\$0	\$0	\$3,168	\$12,672	\$15,720	\$24,865	\$24,865	\$24,865
Interest income	(\$426)	(\$300)	(\$245)	(\$191)	(\$1,161)	(\$149)	(\$253)	(\$192)	(\$135)	(\$729)	(\$1,187)	(\$898)	(\$640)	(\$3,794)	(\$3,947)	(\$2,464)
Stock-based compensation	\$992	\$1,046	\$1,000	\$1,000	\$4,038	\$500	\$500	\$500	\$500	\$2,000	\$1,000	\$0	\$0	\$0	\$0	\$0
Other	\$728	\$918	\$500	\$500	\$2,646	\$0	\$0	\$0	\$0	\$0	\$0	\$0	\$0	\$0	\$0	\$0
Total expenses	\$2,760	\$3,686	\$3,415	\$3,469	\$13,331	\$2,554	\$2,450	\$2,511	\$2,568	\$10,083	\$13,871	\$31,842	\$37,261	\$51,530	\$51,727	\$53,566
Earnings before tax expense	(\$2,760)	(\$3,686)	(\$3,415)	(\$3,469)	(\$13,331)	(\$2,554)	(\$2,450)	(\$2,511)	(\$2,568)	(\$10,083)	(\$12,073)	(\$1,613)	(\$4,403)	\$10,963	\$11,338	\$10,077
Current Income Taxes	\$0	\$0	\$0	\$0	\$0	\$0	\$0	\$0	\$0	\$0	\$0	\$0	\$0	\$0	\$0	\$0
Future Income Taxes	\$0	\$0	\$0	\$0	\$0	\$0	\$0	\$0	\$0	\$0	(\$1,908)	(\$564)	(\$1,541)	\$3,837	\$3,968	\$3,527
Earnings from continuing operations	(\$2,760)	(\$3,686)	(\$3,415)	(\$3,469)	(\$13,331)	(\$2,554)	(\$2,450)	(\$2,511)	(\$2,568)	(\$10,083)	(\$10,166)	(\$1,048)	(\$2,862)	\$7,126	\$7,370	\$6,550
Gain (loss) on sale of assets/prospects	\$0	\$0	\$0	\$0	\$0	\$0	\$0	\$0	\$0	\$0	\$0	\$0	\$0	\$0	\$0	\$0
Net Income	(\$2,760)	(\$3,686)	(\$3,415)	(\$3,469)	(\$13,331)	(\$2,554)	(\$2,450)	(\$2,511)	(\$2,568)	(\$10,083)	(\$10,166)	(\$1,048)	(\$2,862)	\$7,126	\$7,370	\$6,550
Basic shares - opening	40,414.0	41,953.2	42,734.6	42,734.6	40,414.0	42,734.6	42,734.6	42,734.6	42,734.6	42,734.6	42,734.6	49,552.8	49,552.8	49,552.8	68,783.6	68,783.6
Plus: Issued	1,539.2	781.4	0.0	0.0	2,320.6	0.0	0.0	0.0	0.0	0.0	6,818.2	0.0	0.0	19,230.8	0.0	0.0
Less: Buyback	0.0	0.0	0.0	0.0	0.0	0.0	0.0	0.0	0.0	0.0	0.0	0.0	0.0	0.0	0.0	0.0
Basic shares - closing	41,953.2	42,734.6	42,734.6	42,734.6	42,734.6	42,734.6	42,734.6	42,734.6	42,734.6	42,734.6	49,552.8	49,552.8	49,552.8	68,783.6	68,783.6	68,783.6
Average Shares O/S - Basic (000s)	41,399.3	42,155.9	42,734.6	42,734.6	42,256.1	42,734.6	42,734.6	42,734.6	42,734.6	42,734.6	48,700.5	49,552.8	49,552.8	66,379.7	68,783.6	68,783.6
Average Dilution (000s)	1,000.0	6,325.7	6,325.7	6,325.7	4,994.3	6,325.7	6,325.7	6,325.7	6,325.7	6,325.7	6,325.7	6,325.7	6,325.7	6,325.7	6,325.7	6,325.7
Average Shares O/S - Diluted (000s)	42,399.3	48,481.7	49,060.4	49,060.4	47,250.4	49,060.4	49,060.4	49,060.4	49,060.4	49,060.4	55,026.3	55,878.5	55,878.5	72,705.5	75,109.3	75,109.3
EPS (Basic)	(\$0.07)	(\$0.09)	(\$0.08)	(\$0.08)	(\$0.32)	(\$0.06)	(\$0.06)	(\$0.06)	(\$0.06)	(\$0.24)	(\$0.21)	(\$0.02)	(\$0.06)	\$0.11	\$0.11	\$0.10
EPS (Diluted)	(\$0.07)	(\$0.09)	(\$0.08)	(\$0.08)	(\$0.32)	(\$0.06)	(\$0.06)	(\$0.06)	(\$0.06)	(\$0.24)	(\$0.21)	(\$0.02)	(\$0.06)	\$0.10	\$0.10	\$0.09

Source: Company reports; Scotia Capital estimates.

Exhibit 6.21: Plutonic Power Corporation – Balance Sheet

(\$000s)	Q108	Q208	Q308E	Q408E	2008E	Q109E	Q209E	Q309E	Q409E	2009E	2010E	2011E	2012E	2013E	2014E	2015E
Assets																
Current Assets																
Cash & Equivalents	\$41,787	\$48,926	\$38,115	\$29,783	\$29,783	\$50,592	\$38,397	\$27,062	\$18,664	\$18,664	\$50,256	\$34,641	\$25,445	\$228,135	\$149,302	\$83,174
Receivables	\$487	\$1,112	\$1,112	\$1,112	\$1,112	\$1,112	\$1,112	\$1,112	\$1,112	\$1,112	\$1,112	\$1,112	\$1,112	\$1,112	\$1,112	\$1,112
Prepaid Expenses	\$426	\$320	\$320	\$320	\$320	\$320	\$320	\$320	\$320	\$320	\$320	\$320	\$320	\$320	\$320	\$320
Other	\$0	\$0	\$0	\$0	\$0	\$0	\$0	\$0	\$0	\$0	\$0	\$0	\$0	\$0	\$0	\$0
	\$42,700	\$50,358	\$39,547	\$31,215	\$31,215	\$52,024	\$39,829	\$28,494	\$20,096	\$20,096	\$51,688	\$36,073	\$26,877	\$229,567	\$150,734	\$84,606
Development Costs	\$9,457	\$14,533	\$14,533	\$14,533	\$14,533	\$14,533	\$14,533	\$14,533	\$14,533	\$14,533	\$14,533	\$14,533	\$14,533	\$14,533	\$14,533	\$14,533
Perf. Deposits & Res. Cash	\$20,681	\$19,205	\$19,205	\$19,205	\$19,205	\$19,205	\$19,205	\$19,205	\$19,205	\$19,205	\$19,205	\$19,205	\$19,205	\$19,205	\$19,205	\$19,205
Future Income Tax Asset	\$0	\$0	\$0	\$0	\$0	\$0	\$0	\$0	\$0	\$0	\$1,908	\$2,472	\$4,013	\$176	\$0	\$0
PP&E	\$45,262	\$73,153	\$102,343	\$122,733	\$122,733	\$151,424	\$190,916	\$227,207	\$253,099	\$253,099	\$386,319	\$455,888	\$485,765	\$752,093	\$1,227,909	\$1,633,896
Intangibles	\$5,223	\$5,198	\$5,198	\$5,198	\$5,198	\$5,198	\$5,198	\$5,198	\$5,198	\$5,198	\$5,198	\$5,198	\$5,198	\$5,198	\$5,198	\$5,198
Investments & Other	\$4,793	\$4,645	\$4,645	\$4,645	\$4,645	\$4,645	\$4,645	\$4,645	\$4,645	\$4,645	\$4,645	\$4,645	\$4,645	\$4,645	\$4,645	\$4,645
Total Assets	\$128,115	\$167,093	\$185,472	\$197,530	\$197,530	\$247,031	\$274,327	\$299,283	\$316,777	\$316,777	\$483,497	\$538,016	\$560,238	\$1,025,418	\$1,422,225	\$1,762,085
Liabilities																
Current Liabilities																
Revolver	\$0	\$0	\$0	\$0	\$0	\$0	\$0	\$0	\$0	\$0	\$0	\$0	\$0	\$0	\$0	\$0
Payables & accruals	\$7,789	\$24,855	\$24,855	\$24,855	\$24,855	\$24,855	\$24,855	\$24,855	\$24,855	\$24,855	\$24,855	\$24,855	\$24,855	\$24,855	\$24,855	\$24,855
CP LTD	\$0	\$0	\$0	\$0	\$0	\$0	\$0	\$0	\$0	\$0	\$5,400	\$5,400	\$5,400	\$5,400	\$5,400	\$5,400
Due to related	\$0	\$0	\$0	\$0	\$0	\$0	\$0	\$0	\$0	\$0	\$0	\$0	\$0	\$0	\$0	\$0
	\$7,789	\$24,855	\$24,855	\$24,855	\$24,855	\$24,855	\$24,855	\$24,855	\$24,855	\$24,855	\$30,255	\$30,255	\$30,255	\$30,255	\$30,255	\$30,255
Long-Term Debt	\$18,811	\$39,034	\$59,828	\$74,355	\$74,355	\$95,910	\$125,156	\$152,124	\$171,685	\$171,685	\$270,171	\$325,738	\$350,822	\$568,876	\$954,522	\$1,284,304
Holdback Payable	\$3,745	\$6,417	\$6,417	\$6,417	\$6,417	\$6,417	\$6,417	\$6,417	\$6,417	\$6,417	\$6,417	\$6,417	\$6,417	\$6,417	\$6,417	\$6,417
Future Income Tax Liability	\$0	\$0	\$0	\$0	\$0	\$0	\$0	\$0	\$0	\$0	\$0	\$0	\$0	\$0	\$3,792	\$7,319
Swap Contracts	\$3,603	\$4,499	\$4,499	\$4,499	\$4,499	\$4,499	\$4,499	\$4,499	\$4,499	\$4,499	\$4,499	\$4,499	\$4,499	\$4,499	\$4,499	\$4,499
Non controlling interest	\$17,178	\$16,826	\$16,826	\$16,826	\$16,826	\$16,826	\$16,826	\$16,826	\$16,826	\$16,826	\$16,826	\$16,826	\$16,826	\$16,826	\$16,826	\$16,826
Other	\$15,495	\$15,495	\$15,495	\$17,495	\$17,495	\$47,995	\$48,495	\$48,995	\$49,495	\$49,495	\$50,495	\$50,495	\$50,495	\$50,495	\$50,495	\$50,495
Total Liabilities	\$66,622	\$107,125	\$128,919	\$144,446	\$144,446	\$196,501	\$226,247	\$253,715	\$273,776	\$273,776	\$378,662	\$434,229	\$459,313	\$677,367	\$1,066,805	\$1,400,114
Shareholders' Equity																
Share capital (&CS)	\$77,898	\$80,060	\$80,060	\$80,060	\$80,060	\$80,060	\$80,060	\$80,060	\$80,060	\$80,060	\$152,060	\$152,060	\$152,060	\$392,060	\$392,060	\$392,060
Retained earnings	(\$16,405)	(\$20,091)	(\$23,507)	(\$26,976)	(\$26,976)	(\$29,530)	(\$31,980)	(\$34,491)	(\$37,059)	(\$37,059)	(\$47,225)	(\$48,273)	(\$51,135)	(\$44,009)	(\$36,639)	(\$30,089)
Total Shareholders Equity	\$61,493	\$59,968	\$56,553	\$53,084	\$53,084	\$50,529	\$48,079	\$45,568	\$43,001	\$43,001	\$104,835	\$103,787	\$100,925	\$348,051	\$355,420	\$361,970
Total Liabilities & SE	\$128,115	\$167,093	\$185,472	\$197,530	\$197,530	\$247,031	\$274,327	\$299,283	\$316,777	\$316,777	\$483,497	\$538,016	\$560,238	\$1,025,418	\$1,422,225	\$1,762,085

Source: Company reports; Scotia Capital estimates.

Exhibit 6.22: Plutonic Power Corporation – Cash Flow Statement

(\$000s)	Q108	Q208	Q308E	Q408E	2008E	Q109E	Q209E	Q309E	Q409E	2009E	2010E	2011E	2012E	2013E	2014E	2015E
Operating Activities																
Net (loss) earnings	(\$2,760)	(\$3,686)	(\$3,415)	(\$3,469)	(\$13,331)	(\$2,554)	(\$2,450)	(\$2,511)	(\$2,568)	(\$10,083)	(\$10,166)	(\$1,048)	(\$2,862)	\$7,126	\$7,370	\$6,550
Adjustments for:																
Depreciation & amortization	\$8	\$9	\$10	\$10	\$37	\$10	\$10	\$10	\$10	\$40	\$1,690	\$6,640	\$8,228	\$12,991	\$12,991	\$12,991
(Gain) loss on sale of assets/prospects	\$0	\$0	\$0	\$0	\$0	\$0	\$0	\$0	\$0	\$0	\$0	\$0	\$0	\$0	\$0	\$0
Stock-based compensation	\$992	\$1,046	\$1,000	\$1,000	\$4,038	\$500	\$500	\$500	\$500	\$2,000	\$1,000	\$0	\$0	\$0	\$0	\$0
Future income tax (recovery) expense	\$0	\$0	\$0	\$0	\$0	\$0	\$0	\$0	\$0	\$0	(\$1,908)	(\$564)	(\$1,541)	\$3,837	\$3,968	\$3,527
Other	\$870	\$1,042	\$0	\$0	\$1,912	\$0	\$0	\$0	\$0	\$0	\$0	\$0	\$0	\$0	\$0	\$0
Cash flow from operations	(\$890)	(\$1,589)	(\$2,405)	(\$2,459)	(\$7,344)	(\$2,044)	(\$1,940)	(\$2,001)	(\$2,058)	(\$8,043)	(\$9,383)	\$5,027	\$3,825	\$23,954	\$24,328	\$23,068
Net change in non-cash WC	\$193	(\$50)	\$0	\$0	\$143	\$0	\$0	\$0	\$0	\$0	\$0	\$0	\$0	\$0	\$0	\$0
	(\$697)	(\$1,639)	(\$2,405)	(\$2,459)	(\$7,202)	(\$2,044)	(\$1,940)	(\$2,001)	(\$2,058)	(\$8,043)	(\$9,383)	\$5,027	\$3,825	\$23,954	\$24,328	\$23,068
Financing Activities																
Net issue (buyback) of common shares	\$1,064	\$578	\$0	\$0	\$1,642	\$0	\$0	\$0	\$0	\$0	\$72,000	\$0	\$0	\$240,000	\$0	\$0
Other financing	(\$7,491)	\$1,690	\$0	\$0	(\$5,801)	\$30,000	\$0	\$0	\$0	\$30,000	\$0	\$0	\$0	\$0	\$0	\$0
Long-term debt advances	\$10,749	\$20,223	\$20,794	\$14,527	\$66,293	\$21,555	\$29,246	\$26,967	\$19,561	\$97,330	\$103,886	\$60,967	\$30,484	\$223,455	\$391,046	\$335,182
Long-term debt repayments	\$0	\$0	\$0	\$0	\$0	\$0	\$0	\$0	\$0	\$0	\$0	(\$5,400)	(\$5,400)	(\$5,400)	(\$5,400)	(\$5,400)
	\$4,323	\$22,490	\$20,794	\$14,527	\$62,134	\$51,555	\$29,246	\$26,967	\$19,561	\$127,330	\$175,886	\$55,567	\$25,084	\$458,055	\$385,646	\$329,782
Investing Activities																
Capital asset additions/business acquisitions	(\$3,500)	(\$11,897)	(\$29,200)	(\$20,400)	(\$64,996)	(\$28,702)	(\$39,502)	(\$36,302)	(\$25,902)	(\$130,406)	(\$134,911)	(\$76,209)	(\$38,105)	(\$279,318)	(\$488,807)	(\$418,978)
Prospect development costs	(\$1,794)	(\$3,917)	\$0	\$0	(\$5,711)	\$0	\$0	\$0	\$0	\$0	\$0	\$0	\$0	\$0	\$0	\$0
Performance Deposits (Paid) Returned	\$55	\$2,102	\$0	\$0	\$2,157	\$0	\$0	\$0	\$0	\$0	\$0	\$0	\$0	\$0	\$0	\$0
Proceeds on sale of assets/prospects	\$0	\$0	\$0	\$0	\$0	\$0	\$0	\$0	\$0	\$0	\$0	\$0	\$0	\$0	\$0	\$0
	(\$5,239)	(\$13,711)	(\$29,200)	(\$20,400)	(\$68,550)	(\$28,702)	(\$39,502)	(\$36,302)	(\$25,902)	(\$130,406)	(\$134,911)	(\$76,209)	(\$38,105)	(\$279,318)	(\$488,807)	(\$418,978)
Net change in cash and cash equivalents	(\$1,613)	\$7,140	(\$10,811)	(\$8,332)	(\$13,618)	\$20,810	(\$12,195)	(\$11,335)	(\$8,398)	(\$11,119)	\$31,592	(\$15,614)	(\$9,196)	\$202,690	(\$78,833)	(\$66,128)
Cash & Equivalents - Beginning	\$43,400	\$41,787	\$48,926	\$38,115	\$43,400	\$29,783	\$50,592	\$38,397	\$27,062	\$29,783	\$18,664	\$50,256	\$34,641	\$25,445	\$228,135	\$149,302
Cash & Equivalents - End	\$41,787	\$48,926	\$38,115	\$29,783	\$29,783	\$50,592	\$38,397	\$27,062	\$18,664	\$18,664	\$50,256	\$34,641	\$25,445	\$228,135	\$149,302	\$83,174

Source: Company reports; Scotia Capital estimates.

Management & Directors

Plutonic's senior management has a successful history of starting up companies. The company's management and directors control approximately 16.2% of Plutonic's outstanding shares on a fully diluted basis (Exhibit 6.23).

Exhibit 6.23: Management & Directors				
Name	Position	Shares Held	Options & Warrants	Employment History
R. Stuart Angus	Director	988,749	127,500	Independent business advisor and director of several other publicly listed companies. Prior thereto, Managing Director, Mergers and Acquisitions, Endeavor Financial Corp. from 2003 to 2005 and lawyer with Fasken Martineau DuMoulin before 2003.
Grigor E. Cook	President of the Toba Montrose General Partnership	131,875	410,000	Mr. Cook has over 30 years of experience in the Canadian engineering and construction industry. Prior to joining Plutonic, he was President and Senior Operating Officer for Commonwealth Construction Canada Ltd and worked in operational positions across Canada with Barnett-McQueen.
Peter Flynn	Director	60,000	187,500	Mr. Flynn has over 30 years of experience in the Canadian energy and engineering industry and currently holds director positions for the Electricity Balancing Pool for the Province of Alberta. A former founding director of Edmonton Power, now EPCOR, Mr. Flynn holds the Poole Chair in Management of Engineers at the University of Alberta where he is also a professor for the Faculty of Engineering.
William Lindqvist	Director	368,500	76,500	Business consultant. Prior thereto, VP Exploration of Barrick Gold Co. from 2001 to 2002 and VP Exploration of Homestake Mining Co. from 1995 to 2001. Mr. Lindqvist is also a director of Gallant Minerals Ltd. and consultant to Uruguay Minerals Exploration Inc.
Donald McInnes	Vice-Chairman and CEO	1,672,926	450,000	Mr. McInnes formed Plutonic Power in 2003. His background is in funding natural resource development through Canadian capital markets including the founding of Blackstone Ventures and Western Keltic Mines. In the last 18 months these companies have raised over \$750 million in debt and equity. From 1996 to 2002, he was a Director of the Association for Mineral Exploration British Columbia. He has served on a variety of industry boards and committees including the Prospector and Developers Association of British Columbia as well as IFFBC.
Bruce Ripley	President and COO		350,000	Mr. Ripley has over 25 years of engineering experience in the hydroelectric industry including 16 years with BC Hydro where he was Vice-President, Engineering, from 2004 through 2006. In this role, he was responsible for delivery of engineering and construction projects for the generation, transmission, and distribution systems with annual value of greater than \$400 million.
Walter T. Segsworth	Chairman of the Board, Director	1,044,000	150,000	A self-employed businessman and engineer, Mr. Segsworth was formerly the President, COO, and Director of Homestake Mining Co. from 1998 until a merger with Barrick in early 2002. Mr. Segsworth is currently a director at five other junior companies, all of which are in the mining sector.
Paul Sweeney	EVP, Business Development	467,500	237,500	Mr. Sweeney most recently served as CFO of Canico Resource Corp. Prior to this, he was Vice-President and Chief Financial Officer for Sutton Resource Corp. He has directly been involved in several billion dollars of project financing.
Michael Volker	Director	318,874	110,500	Michael Volker is a high-tech entrepreneur and investor involved in the development of technology-based businesses. He is Director of Simon Fraser University's Industry Liaison Office, President of the Western Universities Technology Innovation Fund (WUTIF) and manages the Vancouver Technology Angel network. Mr. Volker currently serves on many non-profit boards such as Telus New Ventures BC and the Canadian Listed Companies Association as well as several public and private corporate boards. Recently, he was Chairman of the Vancouver Enterprise Forum and the B.C. Advanced Systems Institute.
Peter Wong	CFO	400,000	105,000	From 1989 to 1992, Mr. Wong articulated with the accounting firm of Deloitte and Touche in Vancouver and obtained his Chartered Accountant designation in 1992. He has held a number of progressive senior financial management positions with a number of mineral exploration stage, development stage and producing companies. Most recently, Mr. Wong served as a treasurer of the Huckleberry mine and was CFO of Rubicon Minerals Corporation.
Other		53,500	255,000	
Total		5,505,924	2,459,500	
Fully Diluted Shares Outstanding (Aug 14, 2008)		49,060,003		
% Insider Ownership (FD)		16.2%		

Source: SEDI; Bloomberg; company reports.

THIS PAGE LEFT INTENTIONALLY BLANK.

Wind Power – An Established & Mainstream Power Source

OVERVIEW

Wind power is now an established, mainstream power source in a rapidly growing number of countries, including Canada. In our minds, threats of global climate change and high fossil-fuel based energy prices will continue to promote the rapid expansion of the wind power industry well into the next decade. Wind power economics should eventually improve soon to a point where government incentives are no longer required to assure profitability.

Globally, cumulative installed wind power capacity has surpassed 100,000 MW, growing at an annual rate of 27% since 2000.

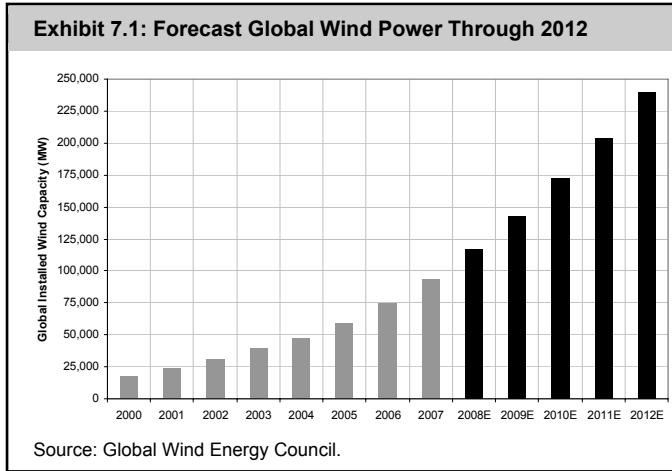

Globally, cumulative installed wind power capacity has surpassed 100,000 MW, growing at an annual rate of 27% since 2000. The Global Wind Energy Council (GWEC) forecasts 240,000 MW of installed capacity by the end of 2012, representing a reduction in the annual growth rate to about 15%, as the industry begins to mature (Exhibit 7.1). GWEC also estimates that 30% of this growth will come from North America, 30% from Europe, and 30% from Asia. Exhibit 7.2 shows the total installed capacity of the top 10 wind power developers.

In 2007, over 20,000 MW of new wind projects were commissioned, with the U.S., China, and Spain leading the way. Canada only installed 310 MW in 2007, but has hundreds of megawatts either under construction or with signed PPAs, and thousands of megawatts in development.

In the U.S., at least 80% of the wind capacity needed to achieve 20% of U.S. power demand (~300 GW) is already in various interconnection queues. Wind power contributed 35% (~5,300 MW) of all new generating capacity in the U.S. in 2007, and was the second largest resource added for the third straight year.

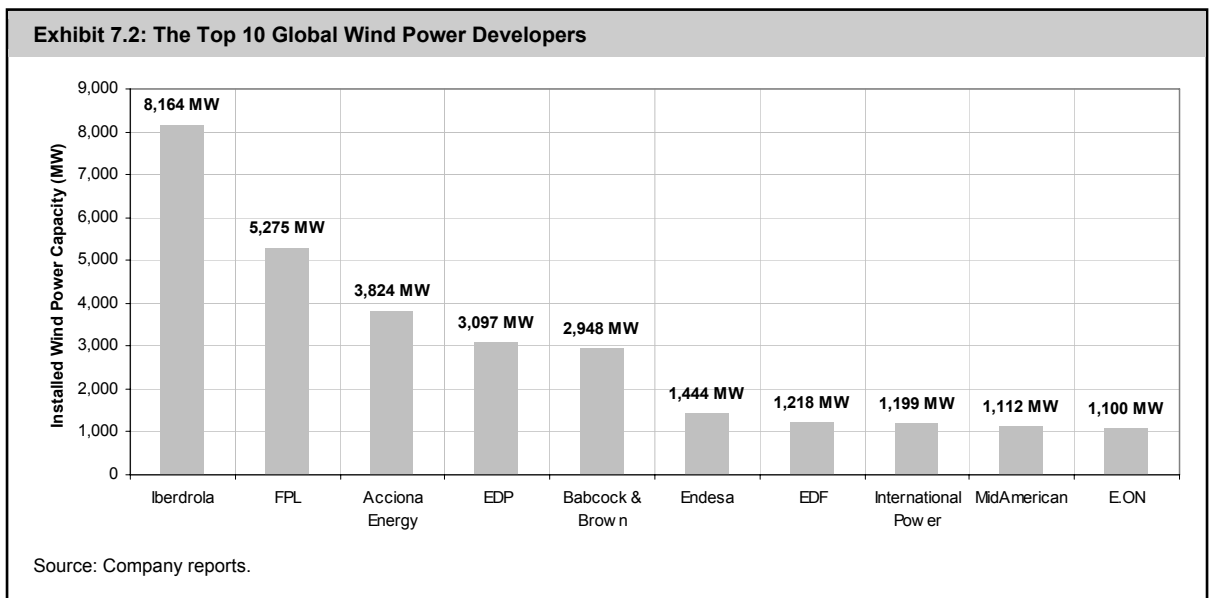

INVESTMENT POSITIVES & NEGATIVES

What we like about wind power: (1) the fuel is free, plentiful, renewable, and clean; (2) all the good wind sites aren't gone, especially in Canada; (3) can behave like a notional call option on natural gas prices, where natural gas sets the marginal cost of power; (4) turbine efficiency is improving; (5) favourable government legislation continues; (6) failure of one wind turbine will typically have a minimal impact on revenue and earnings, as all other wind farm turbines continue to operate; and (7) surplus power and carbon credits can serve as an incremental revenue source.

What we don't like about wind power: (1) an intermittent power source that cannot be relied upon for base-load generation; (2) it is non-dispatchable, and therefore it cannot be turned on at will to meet increased power demand or to receive above-average power prices; (3) dependent on favourable government legislation that can change at any time; (4) challenging grid integration – wind farms are typically located further away from urban load centres relative to competing power generation technologies, resulting in higher transmission capital costs; (5) turbine supply is currently constrained by various component part bottlenecks; and (6) we see installed capital costs rising over the next two years. Other (non-investment) concerns that society has placed on wind farms are: visual impact, flickering, turbine noise, and the impact on birds/bats.

WIND POWER MARKET TRENDS

Turbine size is growing. The average turbine size installed in 2007, at 1.65 MW, is much more powerful than the average wind turbine installed in 1999 at less than 0.8 MW (Exhibit 7.3). The largest wind turbines being installed today are generally 3 MW, although we have seen plans for turbines in the 5 MW to 7.5 MW range.

Project size is growing. The average wind project 10 years ago used to be under 40 MW. Today a newly installed wind farm in North America averages 120 MW in size (Exhibit 7.4). South of the border, there are at least three gigawatt sized wind projects that have been proposed, one in California and two in Texas. In our opinion, the growth in project size is evidence of the strong interest in wind power investments, will drive investment in transmission, and will reduce operating costs per MWh due to economies of scale.

Turbine efficiency is improving. Each new generation of wind turbines that is added to a manufacturer's portfolio typically results in a 3% to 5% decline in wind power production costs.

Each new generation of wind turbines that is added to a manufacturer's portfolio typically results in a 3% to 5% decline in wind power production costs.

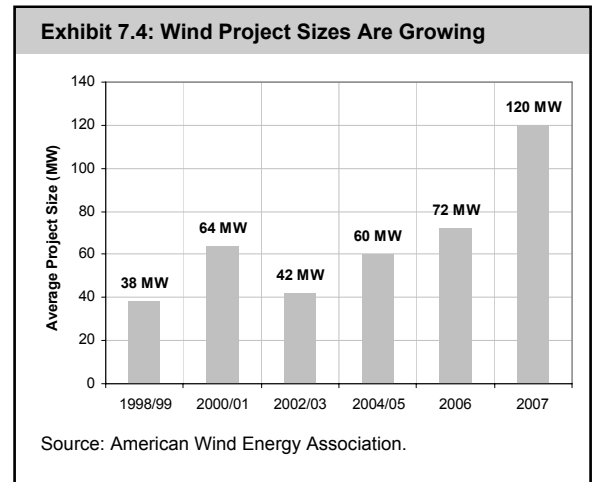
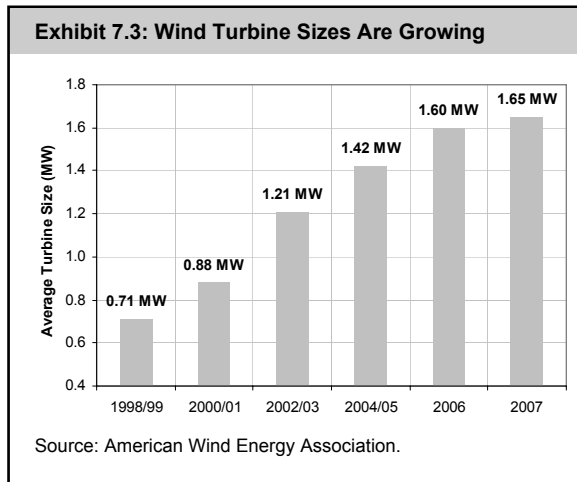

Capital costs still rising. Globally, consumption of raw materials and other factors are driving up capital costs for all power generation technologies, including wind turbines. We estimate that the cost of wind turbines account for about 80% of a project's installed capital cost. The European Wind Energy Association (EWEA) believes that installed capital costs for traditional and offshore wind projects have peaked (Exhibit 7.5). We think this is optimistic, as turbine component bottlenecks still exist.

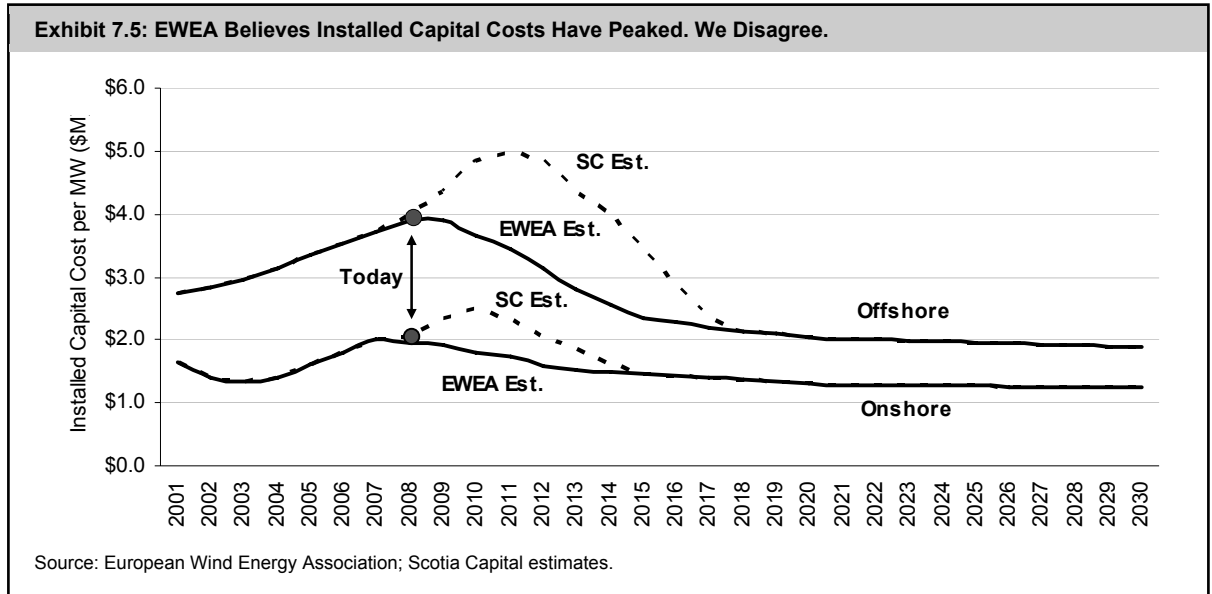

Supply chain challenges remain... Wind turbine components such as ball bearings and blades are in shortage, as turbine demand continues to increase in Canada and worldwide. Overcoming these bottlenecks is not as easy as just ramping up production of turbine components. Large investment decisions must be made based on a long-term view of the industry's growth potential. **The problem:** the growth potential of the industry is heavily dependent on federal and provincial/state legislation being passed, which would provide the financial incentives for wind power developers to continue investing in the sector. This will remain unchanged until: (1) long-term incentives are offered; or (2) wind power project economics become more cost competitive.

...But easing slightly in the U.S. Finding, developing, and building new manufacturing capacity has proven to be a challenge for suppliers, until recently. Despite the U.S. federal government's inability to extend its Production Tax Credit for a long period of time, explosive U.S. demand for wind turbines has started to lure global turbine manufacturers to set up shop there (Exhibit 7.6).

It's a suppliers' market. With global turbine shortages that can result in two-year delivery wait times, suppliers are offering **shorter warranty periods**, and demanding **standard terms of sale**, as well as **larger down payments**. **Buyers are beginning to take on more turbine-related risks than in the past.**

Transmission constraints limiting growth. Canada's transmission is **not** built for distributed generation that includes wind and other renewable power technologies. Jurisdiction for new transmission capacity rests with provincial governments and not in Ottawa, making a national transmission strategy challenging. We like what Texas has done, which is to legislate five Competitive Renewable Energy Zones (CREZs) in order to facilitate a build-out of new transmission that is dedicated to renewable power. If approved, these CREZs could facilitate 23,000 MW of new wind capacity in Texas. In May 2008, BC Hydro announced that it plans to spend more than \$1 billion to connect new renewable generation resources, including the interconnection of its first wind power projects.

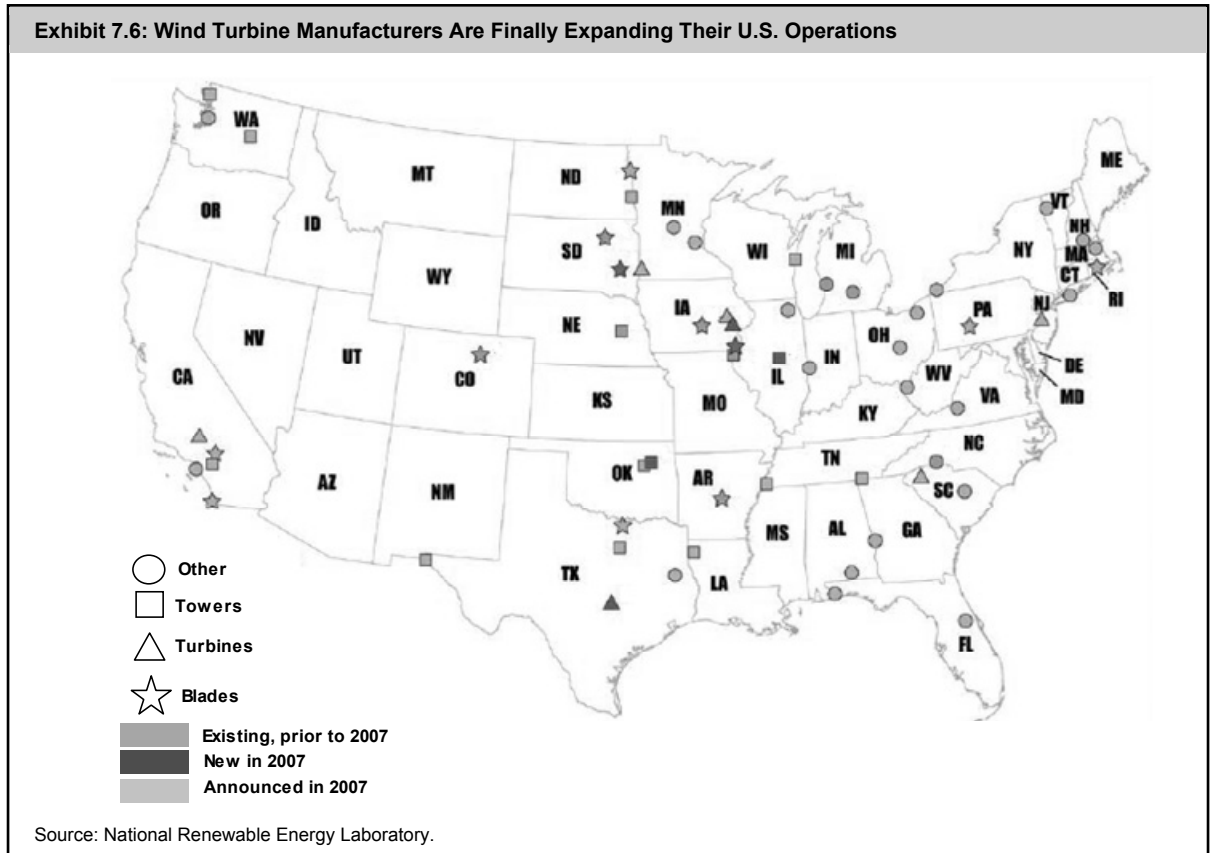

Merchant over contracted power. IPPs in the U.S. and to some extent in Canada are beginning to turn to deregulated wholesale power markets rather than accept long-term PPAs. To satisfy lenders that want to minimize their investment risks, developers typically enter into various hedge contracts that protect against price volatility. Why: (1) forward prices can be higher in wholesale markets; (2) the developer can retain the green attributes of its renewable power such as RECs; and (3) it allows the developer greater flexibility with respect to turbine supply. **As peak marginal power is typically produced using natural gas-fired power plants, merchant wind power production creates a notional call option on natural gas prices as well as RECs.**

Chinese turbine exports picking up speed. Chinese turbine manufacturers have begun to enter the North American market, primarily to take advantage of the supply backlog their European counterparts face. Ming Yang Wind Power Technology currently has 2,000 MW of turbine orders, **50% of which are destined for the U.S.** Other China-based companies are following. **There are now over 60 wind turbine manufacturers in China making turbines greater than 1.5 MW. Beyond China, we think South Korea will emerge as the next dominant wind turbine exporter.**

Cost competitiveness. Wind energy is the most cost competitive source of renewable power that exists (excluding large hydro). While **we expect installed capital costs for wind projects to rise in the short term**, over the mid- and long term, we think wind power will eventually become cost competitive with base-load power generation sources such as coal, natural gas, and nuclear power.

PROJECT ECONOMICS TO IMPROVE, IN A COUPLE OF YEARS

The investment economics of a typical wind power project in Canada has certainly been appealing to date: long-term contracts backed by creditworthy counterparties, fixed power prices that are partially hedged against inflation, potential incremental earnings from the sale of emissions reduction credits, and of course, government subsidization programs as well as various tax-treatment benefits. **But, after a long period of decline, installed wind power project costs are on the rise, averaging \$2 million to \$2.25 million per MW in the first half of 2008.**

By 2005, installed project costs had dropped more than 70% from the early 1980s. However, over the last several years, rising materials (oil up over 2.5x, steel up almost 2x, copper up 2x) and labour (up ~10%) costs coupled with multiple turbine component shortages have reversed this trend. Project cost changes are a function of wind turbine prices, which typically represent 70% to 80% of an installed project's cost. **We expect further increases of turbine prices and therefore to installed project costs through 2010.**

The good news, at least for project operators and their investors, is that **operating and maintenance (O&M) costs continue to fall.** According to the U.S. Department of Energy, the capacity-weighted average 2000 to 2007 O&M costs for projects built in the 1980s was US\$30/MWh, dropping to US\$20/MWh for projects built in the 1990s, and to **US\$9/MWh for projects built in the 2000s.** Logically, O&M costs decrease for more recently constructed projects, and increase with project age. Also, smaller projects have higher O&M costs on a per MWh basis due to fewer MWhs to spread over a project's fixed costs. As a rule of thumb, O&M expenses are fairly low for the first two or three years at 2% to 3% of total investment costs, but increase with turbine age, typically up to 5% to 6% in later years.

Wind power economics are driven primarily by: (1) wind turbine capital costs; (2) electricity production, or average wind speed; (3) expected power prices; (4) government incentives; (5) operation and maintenance costs; (6) the cost of capital; and (7) various auxiliary costs.

MODELLING & SENSITIVITY ANALYSES OF A WIND PROJECT

Our financial modelling and analysis of Canadian wind power projects indicates that equity IRRs typically range from 9% to 15%. We modelled numerous scenarios and sensitized for variations in (1) installed capital cost per MW; (2) PPA prices and escalations rates; (3) capital costs and costs of capital; (3) the federal ecoENERGY incentive payment; (4) operating & maintenance costs; (5) capacity factors; (6) tax rates; and (7) carbon credits/offsets/RECs. **Our average, generic project yielded a 12.8% equity IRR.** To arrive at this, we made the following assumptions:

- **35% capacity factor.** Using a capacity factor of 35% may be a little bit generous, but we note that **turbines are becoming more efficient each year**, capacity factors are rising, and wind resource estimation and site selection has become much more of a science than an art. Turning to our companies under coverage for guidance, the unweighted average capacity factor for all projects that are either operational or have at least two years of wind data is slightly under 35%.
- **\$2.25 million per MW installed cost.** We picked the upper end of the installed capital cost range we have seen over the past year, as costs are rising. We note that this base case does not include any infrastructure costs such as transmission.
- **Starting PPA @ \$95/MWh + 1.5% p.a.** We have seen lower and higher PPA prices, but took a midpoint. As a point of reference, Hydro-Quebec's two 250 MW wind RFPs that we anticipate will be formally announced shortly, are both priced at starting PPA prices of \$95/MWh.

- **Starting O&M @ \$14/MWh + 1.5% p.a.** Operating and maintenance costs, on a per MWh basis, generally range between \$9/MWh and \$20/MWh. As wind turbine and project sizes increase, O&M costs per MWh continue to fall.
- **Federal ecoENERGY incentive @ \$2.50/MWh.** In Canada, we have seen qualified projects receive none, some, or all of the \$10/MWh federal ecoENERGY incentive payment, as PPA providers may demand the incentive payment to partially offset the higher-than-normal power prices being offered to developers. To be somewhat conservative, we chose to locate our generic wind project in Quebec, where the provincial utility there takes 75% of the incentive, leaving \$2.50/MWh for the developer.
- **No carbon credits.** Similar to the federal government's ecoENERGY incentive payment, many PPA providers demand that all green attributes be forfeited to the provincial utility. In Quebec, these carbon credits are effectively trapped, as there is no real method to effectively monetize them.
- **Debt to equity split 75%/25%.** We have seen project debt as a percentage of total capital invested, range between 65% and 85%. We chose the median and the midpoint for our project capital structure, and assume that the debt is non-recourse (project specific). **Equity investors in wind projects have historically required an average return of 12%.** However, we note that equity returns have fallen recently to the 9%-10% area.
- **Other.** For wind projects, PPA terms in Canada typically range between 15 and 25 years. We chose 25 years. We also matched the term of debt financing to this 25-year PPA term, and assumed **no merchant tail**.

Equity investors in wind projects have historically required an average return of 12%.

In Exhibit 7.7 on the following page, we provide our equity investment IRR sensitivity analyses to changes in the factors listed above.

Exhibit 7.7: Generic Wind Project IRR Sensitivity Charts

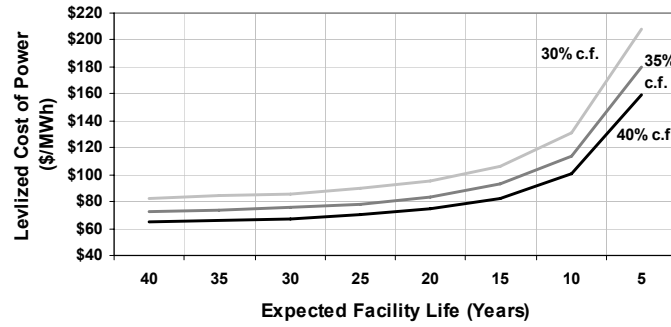
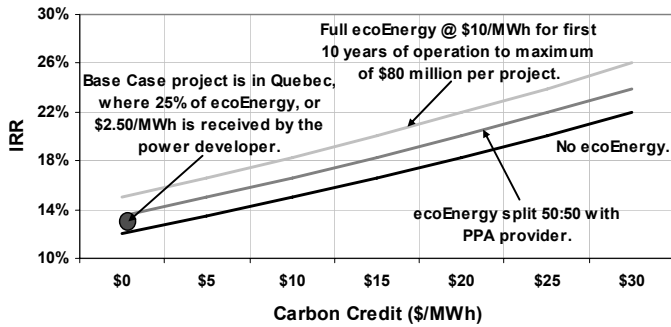
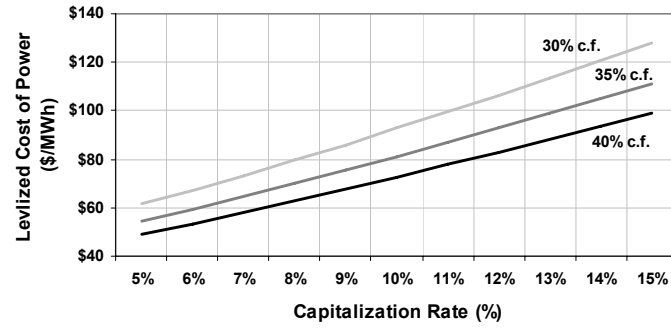
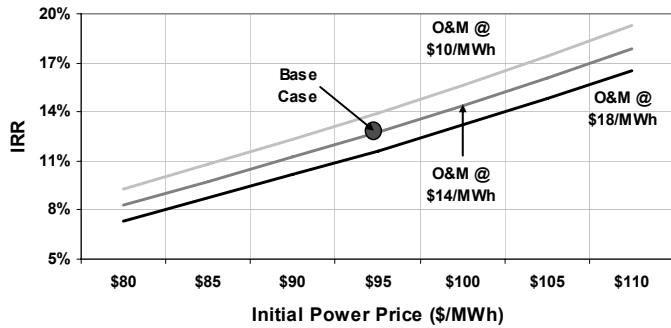
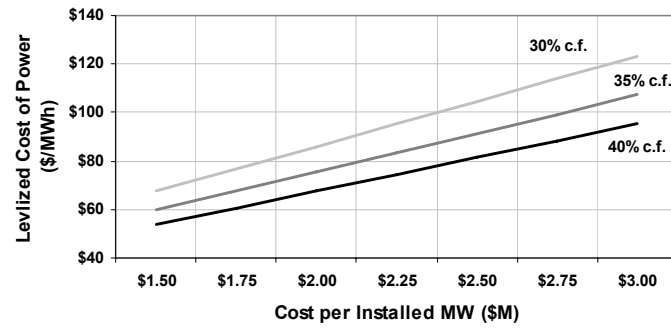
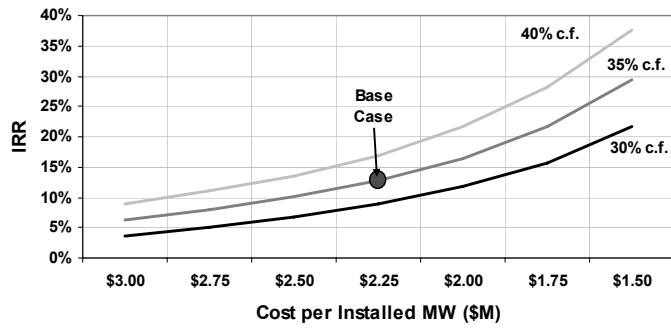

Source: Scotia Capital estimates.

Exhibit 7.8: Generic Wind Project IRR Sensitivity Tables

		Starting PPA Price (\$/MWh)						
		\$80	\$85	\$90	\$95	\$100	\$105	\$110
Starting O&M Cost (\$/MWh)	\$22	6.4%	7.8%	9.1%	10.6%	12.1%	13.6%	15.3%
	\$20	6.9%	8.2%	9.6%	11.1%	12.6%	14.2%	15.9%
	\$18	7.3%	8.7%	10.1%	11.6%	13.2%	14.8%	16.5%
	\$16	7.8%	9.2%	10.7%	12.2%	13.8%	15.5%	17.2%
	\$14	8.3%	9.7%	11.2%	12.8%	14.4%	16.1%	17.9%
	\$12	8.8%	10.3%	11.8%	13.3%	15.0%	16.7%	18.6%
	\$10	9.3%	10.8%	12.3%	13.9%	15.6%	17.4%	19.3%

		Installed Capital Cost (\$/MW)						
		\$3.00	\$2.75	\$2.50	\$2.25	\$2.00	\$1.75	\$1.50
Capacity Factor (%)	29%	3.2%	4.5%	6.2%	8.2%	10.9%	14.6%	20.2%
	31%	4.2%	5.7%	7.4%	9.7%	12.7%	16.8%	23.1%
	33%	5.2%	6.8%	8.7%	11.2%	14.5%	19.2%	26.2%
	35%	6.3%	8.0%	10.1%	12.8%	16.4%	21.6%	29.3%
	37%	7.3%	9.2%	11.4%	14.4%	18.4%	24.2%	32.6%
	39%	8.4%	10.4%	12.8%	16.1%	20.5%	26.8%	36.0%
	41%	9.5%	11.6%	14.3%	17.9%	22.7%	29.6%	39.4%

		Cost of Debt (%)						
		8.25%	7.75%	7.25%	6.75%	6.25%	5.75%	5.25%
Effective Cash Tax Rate (%)	30%	6.3%	7.2%	8.2%	9.3%	10.4%	11.6%	12.9%
	25%	6.9%	7.9%	8.9%	10.0%	11.2%	12.4%	13.8%
	20%	7.5%	8.5%	9.6%	10.7%	12.0%	13.3%	14.6%
	15%	8.1%	9.1%	10.2%	11.4%	12.7%	14.1%	15.5%
	10%	8.6%	9.7%	10.9%	12.1%	13.4%	14.9%	16.4%
	5%	9.2%	10.3%	11.5%	12.8%	14.1%	15.6%	17.2%
	0%	9.7%	10.8%	12.1%	13.4%	14.9%	16.4%	18.0%

		Carbon price (\$/REC or \$/ERC or \$/MWh)						
		\$0	\$5	\$10	\$15	\$20	\$25	\$30
ecoEnergy (\$/MWh)	\$0.0	12.1%	13.5%	15.0%	16.6%	18.3%	20.1%	22.0%
	\$2.5	12.8%	14.2%	15.8%	17.4%	19.2%	21.0%	22.9%
	\$5.0	13.5%	15.0%	16.6%	18.3%	20.1%	22.0%	23.9%
	\$7.5	14.2%	15.8%	17.4%	19.2%	21.0%	22.9%	25.0%
	\$10.0	15.0%	16.6%	18.3%	20.1%	22.0%	23.9%	26.0%

Source: Scotia Capital estimates.

CANADA – A REVIEW AND OUTLOOK

Installed wind capacity in Canada has grown nearly 3x to 1,876 MW from 2005 to 2008 to date (Exhibit 7.9). We believe that another 300 MW to 400 MW of wind capacity will be commissioned in 2008. **By 2015, we could see up to 15,000 MW of wind power operating in Canada.**

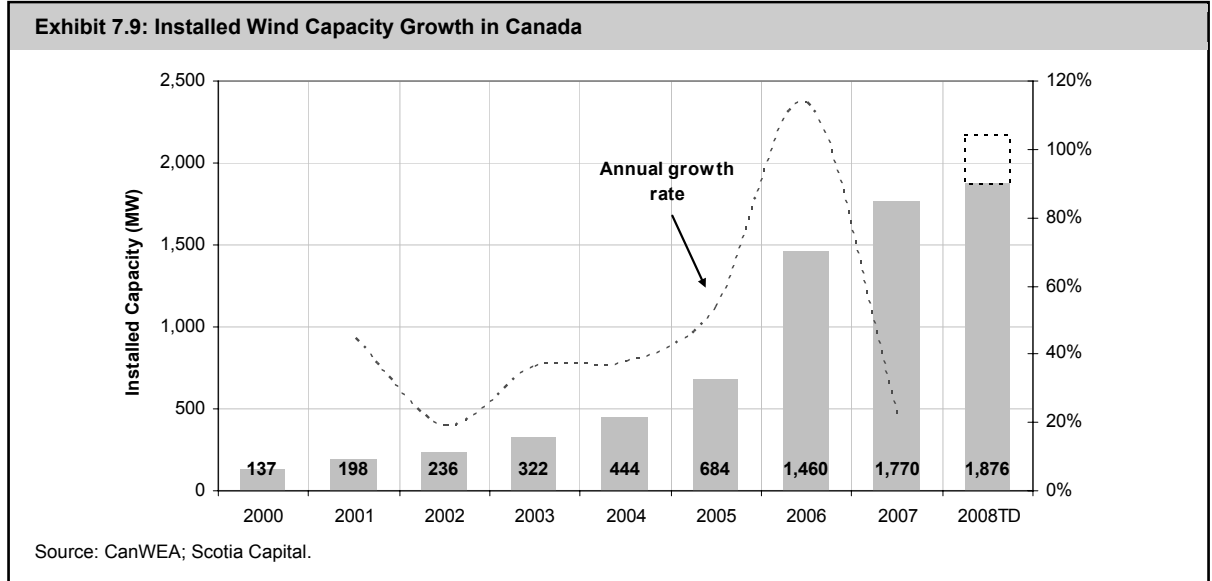

Contracts have already been signed for an additional 5,500 MW of wind energy projects that are to be constructed between 2009 and 2015. Please refer to Exhibit 7.11 for a list of current wind farms installed in Canada, and to Exhibit 7.12 for a list of advanced stage wind development projects (i.e., signed PPAs or under construction). **Overall, wind power in Canada is still relatively small, representing only 1% of Canada’s power supply.**

Canadian wind power growth is fuelled by federal and provincial subsidies, as well as renewable targets set by provincial utilities. Many provincial governments have directed their government-owned utilities to purchase renewable wind or other renewable power from IPPs through: (1) competitive requests for proposals; (2) the implementation of renewable portfolio standards; and (3) standard offer contracts that are typically less than 10 MW in size. In Exhibit 7.10, we present our province-by-province wind industry outlook in which we estimate a potential of 7,500+ MW still up for grabs to reach 15,000 MW by 2015.

Exhibit 7.10: We Could See Up to 15,000 MW of Canadian Wind Capacity by 2015

Province	Initiative	2015E Wind Capacity (MW)	July 2008 Installed Capacity (MW)	July 2008 Capacity Under Development (MW)	Current Opportunity (MW)
British Columbia	90% of new capacity from clean renewables	3,940	0	269	3,671
Alberta	900 MW wind capacity cap removed, transmission upgrades could accommodate 3,000 MW	2,000	524	156	1,320
Saskatchewan	5% electricity demand from wind energy by 2015	200	171	25	4
Manitoba	1,000 MW of wind by 2015	1,000	104	0	896
Ontario	10% renewables by 2010, of which 80% likely wind capacity	2,300	501	1,489	309
Quebec	4,000 MW of wind capacity by 2015	4,000	422	2,999	579
New Brunswick	400 MW of wind capacity by 2016	400	0	309	91
Nova Scotia	20% renewables by 2013, of which 80% likely wind capacity	600	59	124	417
Prince Edward Island	~60 MW by 2010, 100% by 2015	410	72	79	258
Newfoundland	150 MW of wind capacity (no timeline)	150	0	51	99
		15,000	1,855	5,501	7,644

Source: CanWEA; Company reports; Scotia Capital estimates.

Exhibit 7.11: Operating Wind Farms in Canada

Project Name	Capacity	Commissioned	Turbines	Project Owner
Aeolus Wind Farm	3.0	2003	1x Vestas V90	Aeolus PEI Wind
Baie-des-Sables	109.5	2006	73x GE 1.5 MW	Carlier Energy
Brookfield	0.6	2005	1x Turbowinds T-600	Renewable Energy Services Limited
Castle River Wind Farm	9.9	2000	15x Vestas V47 660kW	TransAlta Wind
Castle River Wind Farm	29.0	2001	44x Vestas V47 660kW	TransAlta Wind
Castle River Wind Farms	0.6	1997	1x Vestas V44-600 (600 kW)	TransAlta Wind
Centennial Wind Power Facility	149.4	2006	83x Vestas 1.8 MW (90 MW On-line in 2005/12)	SaskPower International
Chin Chute Wind Farm	30.0	2006	20x 1.5 MW GE	Suncor / Acciona / Enbridge
Cowley Ridge North Wind Farm	19.5	2001	15x Nordex 1,300 kW	Canadian Hydro Developers, Inc.
Cypress Wind Power Facility	5.9	2001	9x Vestas V47 (660 kW)	SaskPower International
Cypress Wind Power Facility	4.6	2003	7x Vestas V47 660 kW	SaskPower International
Digby Limited	0.8	2006	1x Enercom E48 800 kW	Renewable Energy Services Limited
Dunville Wind Turbine	0.6	2006	1x Fuhrlander 600 kW	Rosa Flora Limited
Eastern Kings Wind Farm	30.0	2007	10x Vestas V90 3 MW	PEI Energy Corporation
Erie Shores Wind Farm	99.0	2006	66x GE 1.5 MW	Clean Power Income Fund
Ex Place Turbine	0.8	2003	1 Lagerway 750 kW	
Ex Place Turbine	0.8	2003	1 Lagerway 750 kW	Toronto Hydro/Windshare
Ferndale Wind Farm	5.1	2002	1x Vestas 1.8 MW, 2x Vestas 1.65 MW	Sky Generation
Fitzpatrick Mountain	0.8	2006	1x Enercom E48 800 kW	Renewable Energy Services Limited
Fitzpatrick Mountain	0.8	2006	1x Enercom E48 800 kW	Renewable Energy Services Limited
Glance Bay & Donkin	1.6	2005	2x Enercon 800 kW	Cape Breton Power
Goodwood	0.6	2005	1x Turbowinds 600 kW	Renewable Energy Services Limited
Grand Etang	0.7	2002	1x Vestas V47-660 (660 kW)	Nova Scotia Power
Haeckel Hill 1	0.2	1993	1x bonus 150 kW	Yukon Energy Corporation
Haeckel Hill 1	0.7	2000	1x Vestas V47 660 kW	Yukon Energy Corporation
Higgins Mountain Riverhurst	3.6	2006	3x Vensys 1.2 MW	Vector Wind Energy/Spring Hill
Huron Wind	9.0	2002	5x Vestas 1.8 MW	Huron Wind
Kettles Hill Phase I	9.0	2006	5x Vestas 1.8 MW	Kettles Hill Wind Energy Company
Kettles Hill Phase II	54.0	2007	30x Vestas V80 1.8 MW	Kettles Hill Wind Energy Inc.
Kingsbridge 1 Wind Power Project	39.6	2006	22x Vestas 1.8 MW	EPCOR
Le Nordais (Phase 1 - Cap Chat)	57.0	1999	76x NEG-Micon NM750/48 (750 kW)	Axor
Le Nordais (Phase 2 - Matane)	42.8	1999	57x NEG-Micon NM750/48 (750 kW)	Axor
Lingan	10.0	2007	5x Enercon 2 MW	Cape Breton Power
Lingan	0.6	2002	2x Enercon 2 MW	Nova Scotia Power
Little Brook	0.6	2002	1x Turbowinds T600	Nova Scotia Power
Lundbreck	0.6	2001	1x Enercon E40 600kW	Lundbreck Developments Joint Venture A
Magrath	30.0	2004	20x 1.5 MW GE Wind	Suncor, Enbridge, EHN
Marshallville Limited	0.8	2006	1x Enercom E49 800 kW	Renewable Energy Services
Matane	2.3	1998	3x NEG-Micon 750/44 (750 kW)	Hydro-Québec
McBride Lake	75.2	2003	114x Vestas 660 kW	ENMAX, TransAlta Wind
McBride Lake East	0.7	2001	1x Vestas V47 660 kW	TransAlta Wind
Melancton 1 Wind Plant	67.5	2006	45x 1.5 MW GE	Canadian Hydro Developers, Inc.
Mont Miller Project	54.0	2005	30x Vestas V80 1.8 MW	Northland Power Income Fund
Mount Copper Project	9.0	2004	5x V80 1.8 MW	3Ci and Creststreet Asset Management Ltd
Mount Copper Project (Phase 2)	45.0	2005	25x Vestas V80 1.8 MW	3Ci and Creststreet Asset Management Ltd
North Cape Wind Farm	5.3	2004	8x Vestas V47-660 (660 kW)	Prince Edward Island Energy Corporation
North Cape Wind Farm	5.3	2001	8x Vestas V47-660 (660 kW)	Prince Edward Island Energy Corporation
Norway Wind Park	9.0	2007	3 X Vestas V90 3 MW	Ventus Energy
Old Man River Project	3.6	2007	2x Vestas V80 1.8 MW	Alberta Wind Energy Corp.
Parc éolien du Renard	2.3	2003	3x Jeumont 750 kW J48c	Groupement éolien Québécois
Pickering Turbine	1.8	2001	1x Vestas V80 1,800 kW	Ontario Power Generation
Point Tupper	0.8	2006	1x Enercon E48 800 kW	Renewable Energy Services Limited
Port Albert Wind Turbine	0.7	2001	1x Vestas V47 (660 kW)	Private
Prince Wind farm	189.0	2006	126x GE 1.5 MW	Brookfield Power
Pubnico Point - Phase 1	3.6	2004	2x Vestas 1.8 MW	Atlantic Wind Power
Pubnico Point - Phase 2	27.0	2005	15x Vestas 1.8 MW	Atlantic Wind Power
Ramea	0.4	2004	6x 65 kW Windmatic WM15S	Frontier Power Systems Inc.
Ravenswood Wind Farm	9.9	2008	6x Vestas 1.65 Mw	Sky Generation
Sinnott Wind Farm	6.5	2001	5x Nordex 1,300 kW	Canadian Hydro Developers, Inc.
Soderglen Wind Farm	70.5	2006	47x GE 1.5 MW	Nexen / GW Power
Spring Bay Wind farm	1.6	2007	2x Enercon E48 800 kW	Schneider Power
Springhill Project	1.2	2005	1x Vensys 1.2 MW	Vector Wind Energy
Springhill Riverhurst	0.9	2006	1x Americas Wind Energy	Vector Wind Energy/Springhill
St. Leon Project	19.8	2005	12x Vestas NM82 1.65 MW	Airsource Power Fund 1 LP
St. Leon Project - Phase 2	84.2	2006	51x Vestas NM82 1.65 MW	Airsource Power Fund 1 LP
Summerview Wind Farm	1.8	2002	1x 1.8MW	TransAlta Wind
Summerview Wind Farm	68.4	2004	38x Vestas 1.8 MW	TransAlta Wind
Sunbridge	11.2	2001	17x Vestas V47-660 (660 kW)	Suncor & Enbridge
Taber Wind Farm	81.4	2007	37x Enercon E70 2.2 MW	ENMAX
Tallon Energy Project	0.8	2004	1x Lagerway 750 kW	Tallon Energy
Taylor Project	3.4	2004	9x Kenetech 375 kW	Canadian Hydro Developers, Inc.
Tiverton Riverhurst	0.9	2006	1x Americas Wind Energy	Vector Wind Energy/Springhill
Tiverton Wind Turbine	0.6	1995	1x Tacke TW-600	Ontario Power Generation
Vestas Prototype	3.0	2004	1x Vestas V90 3 MW	TransAlta Wind and Vestas
Waterton Wind Turbines	3.8	1998	6x Vestas 600kW	TransAlta Wind
Weather Dancer 1	0.9	2001	1x NEG-Micon 900 kW	Epcor/Peigan Nation Reserve
West Cape Wind Farm	19.8	2007	11x Vestas V80 1.8 MW	West Cape Wind Energy Inc.

Source: CanWEA.

Exhibit 7.12: Advanced Stage Wind Farm Development Projects in Canada

Province	Project	Capacity	Developer	Completion
Alberta	Blue Trail	66.0	TransAlta	2009
Alberta	Prairie Home Phase 1	9.0	Naturener	2008
Alberta	Prairie Home Phase 2	81.0	Naturener	2009
B.C.	Dokie Wind Project	144.0	Dokie Wind Energy Inc.	2009
B.C.	Bear Mountain Wind Park	100.0	Bear Mountain Wind LP	2009
B.C.	Mount Hays Wind Farm	25.2	Katabatic Power	2008
Saskatchewan	Red Lily Wind Farm	24.8	Gaia, Algonquin	-
Ontario	Wolfe Island	197.8	Canadian Hydro	2008
Ontario	Melancthon II	132.0	Canadian Hydro	2008
Ontario	Kingsbridge II	158.7	EPCOR	-
Ontario	Ontario Wind Power	181.5	Enbridge	2008
Ontario	Port Alma	101.2	Kruger Energy	2008
Ontario	Standard Offer	718.0	Various	-
Quebec	Terrawinds	160.5	SkyPower	-
Quebec	Carleton	109.5	Cartier Wind Energy	2008
Quebec	Les Méchins	150.0	Cartier Wind Energy	2009
Quebec	Montagne-Sèche	58.5	Cartier Wind Energy	2011
Quebec	Gros-Morne Phase 1	100.5	Cartier Wind Energy	2011
Quebec	Gros-Morne Phase 2	111.0	Cartier Wind Energy	2012
Quebec	St. Ulric/ St. Léandre	150.0	Northland	2009
Quebec	Mont-Louis	100.5	Northland	2010
Quebec	Murdochville Wind Farm	54.0	3Ci	-
Quebec	Le Plateau	138.6	Invenergy Wind Canada ULC	2011
Quebec	New Richmond	66.0	Venterre	2011
Quebec	De l'Érable	100.0	Enerfin Sociedad de Energia	2011
Quebec	Des Moulins	156.0	3Ci	2011
Quebec	St-Rémi	100.0	Kruger Énergie Inc	2012
Quebec	Ste-Luce	68.0	Kruger Énergie Inc	2012
Quebec	St-Valentin	50.0	Venterre	2012
Quebec	Seigneurie de Beaupré #2	132.6	Boralex/Gaz Métro	2013
Quebec	Seigneurie de Beaupré #3	139.3	Boralex/Gaz Métro	2013
Quebec	Vents du Kempt	100.0	B&B VDK Holdings	2014
Quebec	Aguanish	80.0	St-Laurent Énergies	2011
Quebec	Massif du Sud	150.0	St-Laurent Énergies	2012
Quebec	Lac Alfred	300.0	St-Laurent Énergies	2012/13
Quebec	Rivière du Moulin	350.0	St-Laurent Énergies	2014/15
Quebec	Clermont	74.0	St-Laurent Énergies	2015
New Brunswick	Lamèque Island project	49.5	Acciona Energy	2009
New Brunswick	Kent Hills	96.0	Transalta	2008
New Brunswick	Aulac project	64.5	Acciona Energy	2009
New Brunswick	Caribou Mountain	99.0	SUEZ Energy	2009
Newfoundland and Labrador	Fermeuse	24.0	SkyPower	2008
Newfoundland and Labrador	St. Lawrence	27.0	NeWind Group	2008
Nova Scotia	Dalhousie Mountain	51.0	RMSenergy	2009
Nova Scotia	Maryvale	6.0	RMSenergy	2009
Nova Scotia	Nuttby Mountain	45.0	Earthfirst Canada	2009
Nova Scotia	Statia Terminals	22.0	RESL	2009
P.E.I.	West Cape Phase 2	79.2	Ventus Energy	2008

Source: CanWEA.

CATALYSTS FOR THE CANADIAN WIND POWER MARKET

Positive → A downturn in the U.S. market will likely lead to increased activity in Canada, as well as increased turbine availability. The most likely event that would cause a downturn in the U.S. wind power market is a non-renewal of the U.S. Production Tax Credit by the U.S. federal government.

Positive → Federal legislation on mandatory carbon emissions reductions will give the Canadian wind power market a positive boost. Whether a carbon tax, a cap-and-trade program, or something else, more renewable power will be required, and wind power will likely continue to lead the pack.

Positive → Growth of turbine suppliers establishing manufacturing facilities in the U.S. (or Canada).

Negative → Caps or ceilings on future wind power development. Alberta recently eliminated its 900 MW cap on wind energy capacity in the province (a positive), and it is now designing transmission upgrades that could connect up to 3,000 MW of wind capacity in the southern part of the province. Caps will likely be implemented when provincial utilities cannot provide or build transmission to support further wind power development.

Negative → Better project economics from competing renewable technologies such as solar power will likely reduce activity in Canadian wind power development.

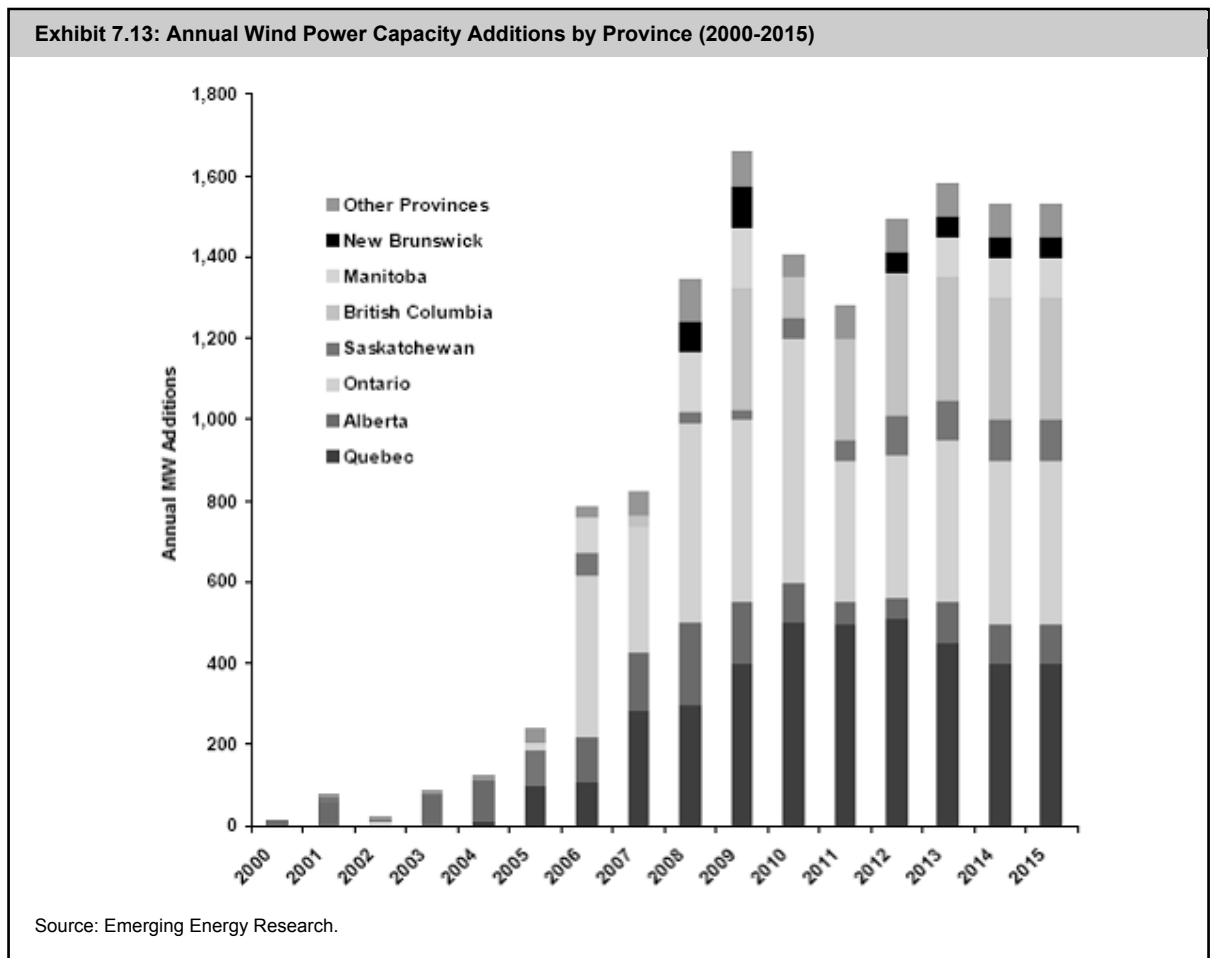

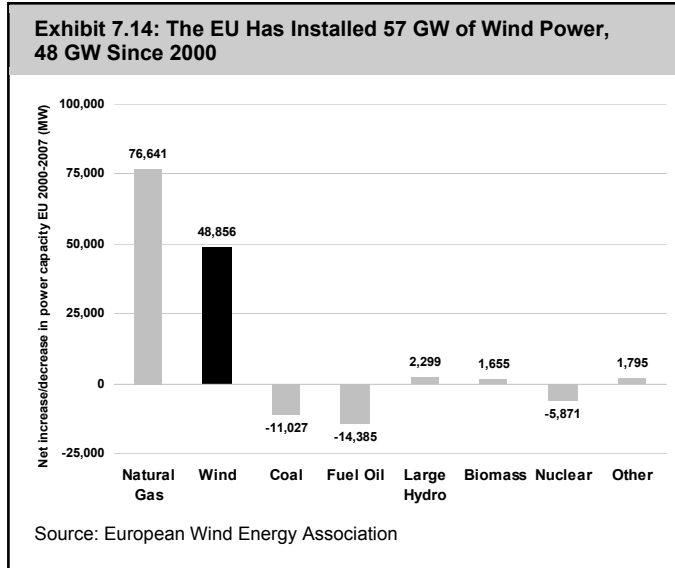

THE EUROPEAN UNION IS FAR MORE ADVANCED IN WIND POWER DEVELOPMENT THAN NORTH AMERICA

Europe continues to lead the market in wind power, although the U.S. and China are catching up quickly. Between 2000 and 2007, total EU power capacity increased by 200 GW to 775 GW. The most notable change in the mix of capacity is the near doubling of natural gas capacity to 164 GW. Wind energy more than quadrupled from 9 GW to 57 GW (Exhibit 7.14).

Wind power is working to reduce GHG emissions in Europe. By 2007, Spain, Denmark, and Portugal had all reduced their CO_{2e} emissions by more than 5% below 1990 levels due solely to the installation of wind power capacity. Overall, Europe's 2007 emissions were 2.1% below the 1990 level from wind energy (Exhibit 7.15).

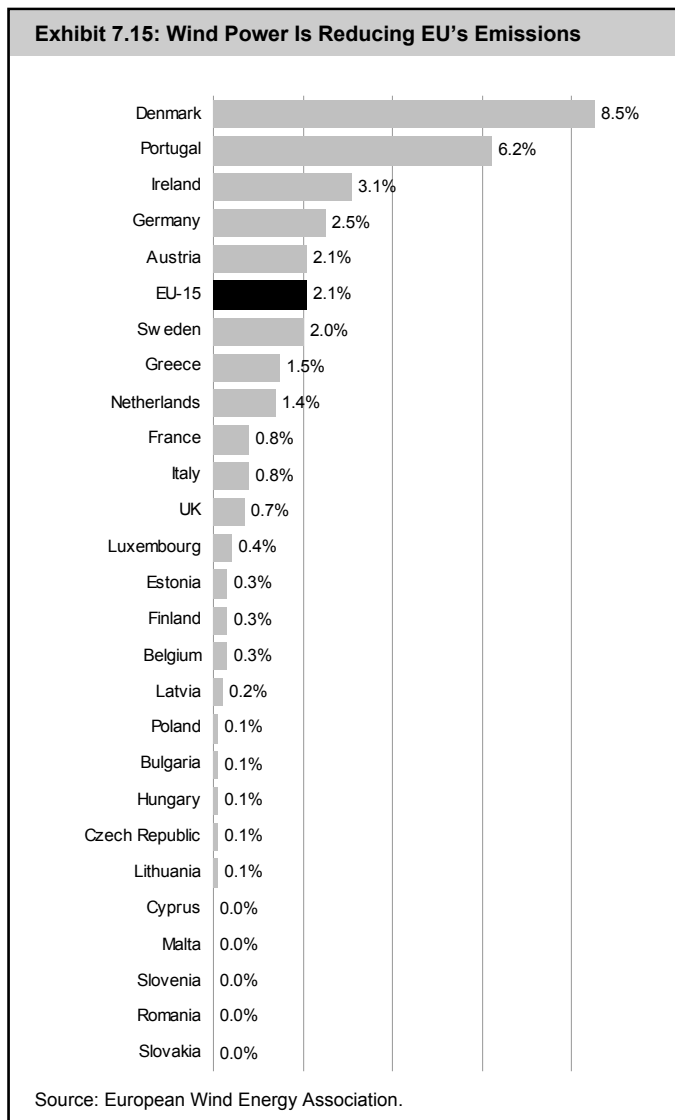
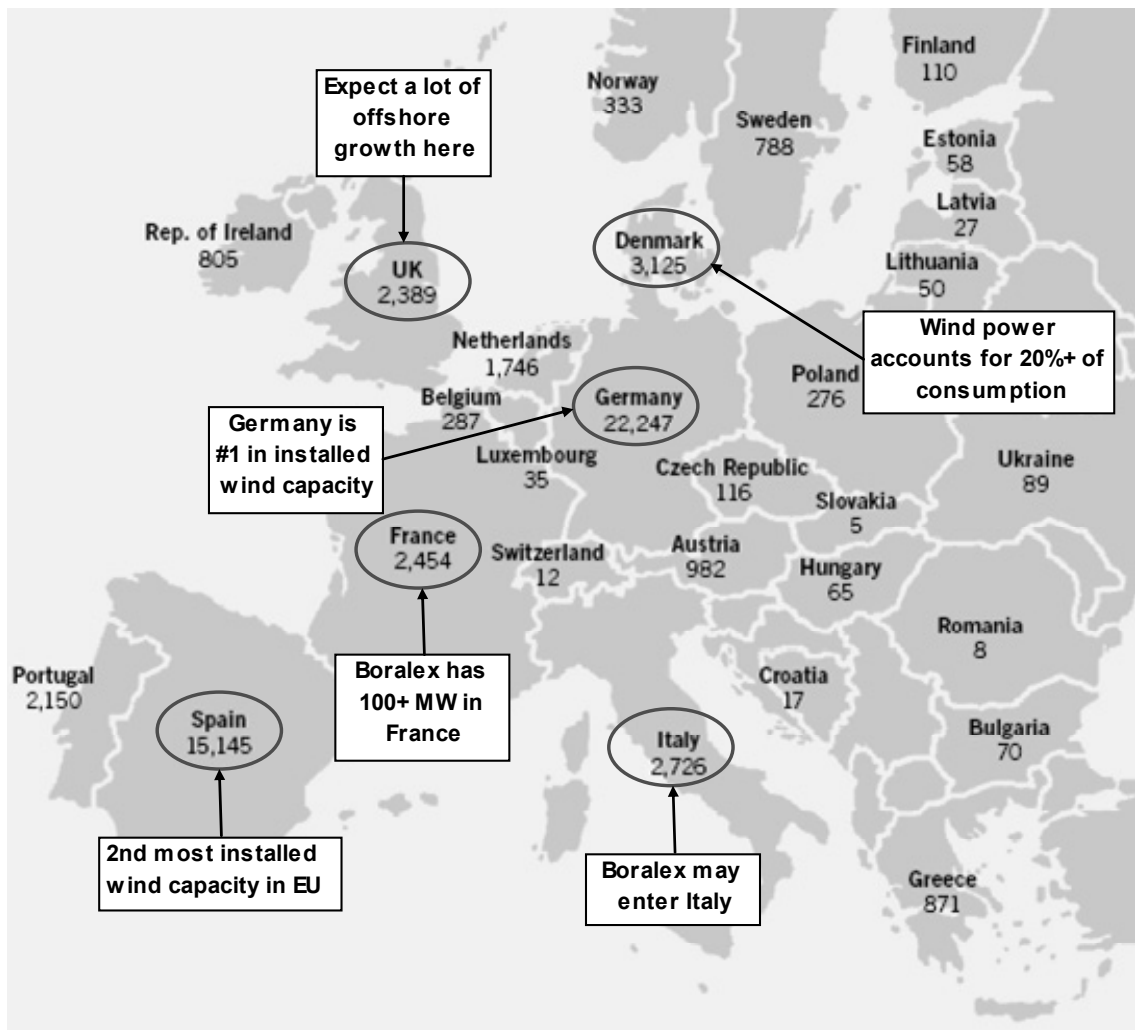

Exhibit 7.16, on the following page, shows a map of Europe's installed wind capacity. Perhaps more interesting is Exhibit 7.17, which shows the impact that wind power investments will have on avoided fuel costs @ US\$120/bbl oil and avoided carbon costs @ €40/tonne CO_{2e}.

Exhibit 7.16: Map of Europe's Installed Wind Power Capacity



Source: European Wind Energy Association; Scotia Capital.

Exhibit 7.17: Forecast EU Wind Investments Compared with Lifetime Avoided Fuel and CO_{2e} Costs

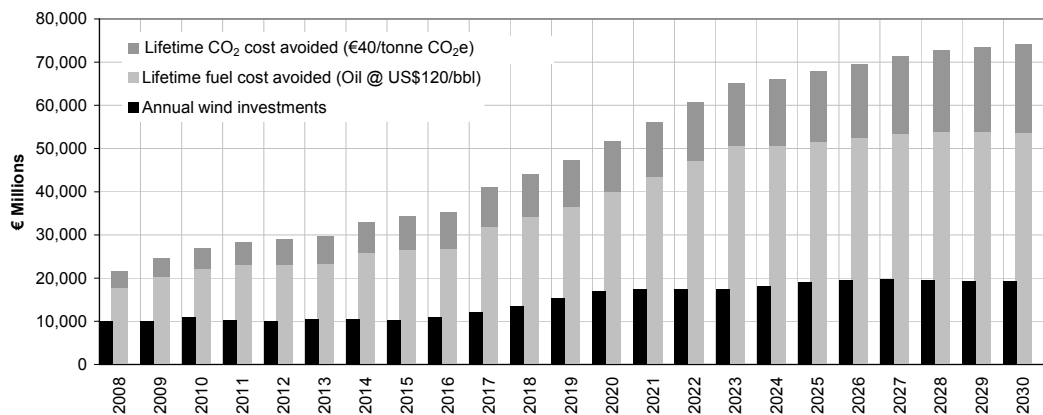

Source: European Wind Energy Association; Scotia Capital.

WIND M&A ACTIVITY AND CAPITAL MARKETS TRENDS

The global credit crunch has caused lenders and equity investors to become more cautious about their investments. Finance costs are increasing for wind power projects, reducing equity returns, and potentially lowering developer appeal.

Exhibit 7.18: The 500+ MW M&A Club

Acquiror	Target	Date
E.ON	Airtricity North America	Oct-07
Wind Energy America	Boreal	Oct-07
Babcock & Brown	Bluewater Wind	Sep-07
Acciona	EcoEnergy	Jun-07
Duke Energy	Tierra Energy	May-07
Iberdrola	CPV Wind	Apr-07
Energias de Portugal	Horizon	Mar-07
Naturener	Great Plains Wind & Energy	Feb-07
Iberdrola	PPM (Scottish Power)	Dec-06
BP	Orion Energy	Dec-06
Iberdrola	Midwest Renewable Energy Corp.	Oct-06
BP	Greenlight	Aug-06
Babcock & Brown	Superior	Aug-06
CPV Wind	Disgen	Jul-06
NRG	Padoma	Jun-06
Iberdrola	Community Energy Inc.	Apr-06
Babcock & Brown	G3 Energy	Jan-06
Airtricity	Renewable Generation Inc.	Dec-05
Diamond Castle	Catamount	Oct-05
Goldman Sachs	Zilkha (Power)	Mar-05
AES	SeaWest	Jan-05

Source: Berkeley Lab.

Consolidation Continues

2007 was another strong year for wind developer corporate transactions, with eight announced acquisitions for target companies that had 500 MW or more of wind capacity in development (Exhibit 7.18).

Europeans Entering North American Markets

One emerging trend over the past two years is the increase of large **European energy companies entering the North American wind market**, typically through acquisitions, rather than greenfield development. Increased globalization of the wind sector, as well as the very early stages of a maturing European wind power market, are the reasons why.

European wind power development companies are attracted to the Canadian market due to its provincial RFPs and/or standard offer contracts, as well as the potential upside in future federal, regional, or provincial carbon markets. But, as in all industries, foreign companies lack the people on the ground as well as the cultural experience to effectively compete against greenfield developers.

Equity Returns Falling

Equity returns in large portfolio deals where there is risk diversification among turbine types and region have dropped to below 7% in the U.S. For most American projects, however, equity returns typically range between 7% to 8%, but can go as high as 10%. The impact of low returns: **large equity players unhappy with a poor risk/reward profile are now turning to solar and geothermal projects.**

Junior Banks More Aggressive

According to Garrad Hassan Canada Inc., equity investors are more interested in P50 or P75 wind resource estimates, while experienced lenders continue to demand more conservative estimates of P90, P95, or even P99. Junior banks typically seek out new business more aggressively, and tend to offer better rates to developers than large financial institutions that have experienced wind power development financing problems.

Equity players unhappy with a poor risk/reward profile in wind power are now turning to solar and geothermal projects.

The Debt to Equity Switch

Historically, we have seen wind farm project financing occur at a capital structure of two-thirds debt and one-third equity. In 2006 and 2007, this financing structure **reversed** to two-thirds equity and one-third debt, although **we don't expect this to continue**. On the debt side, about 99% consisted of senior debt, while on the equity side, we have seen 90% of equity requirements funded from the balance sheet, 4% from CRCE flow through shares, 3% from IPO proceeds, and 2% from private equity. **We see an increased interest by private equity players in the wind power development space.**

Wind Power Transactions Suggest \$0.82 Million Paid per Operating GWh/y

We analyzed 90+ global wind power transactions since 2005 that led us to an average transaction price paid per operating MW of \$2.16 million, and per operating GWh/y of \$0.82 million.

Accordingly, our net asset value calculations for operating wind farms assign a value of \$0.82 million per GWh/y. The breakdown of the types of deals we looked at is shown in Exhibit 7.19.

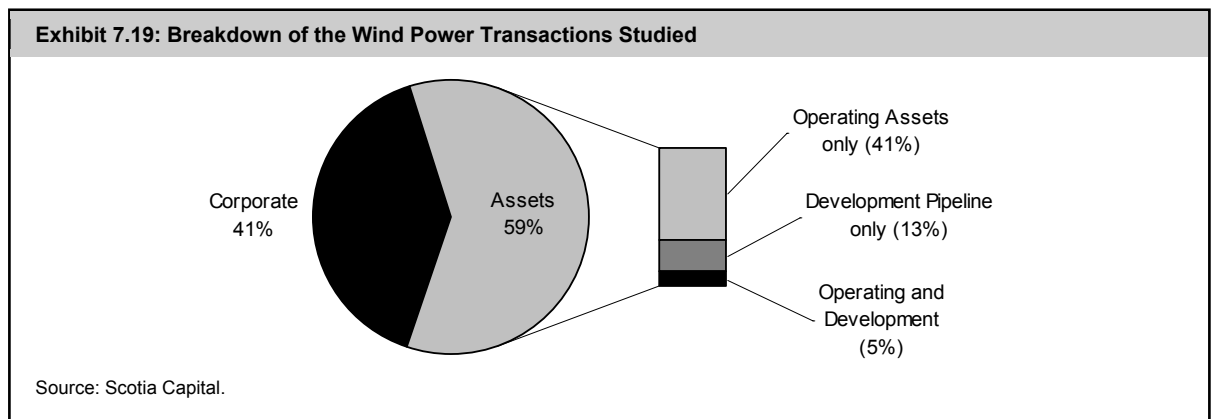

On average, development capacity for wind projects traded for slightly above \$0.4 million per MW, but by no means should this be used as a rule-of-thumb. Depending on the progress of a project, these transaction prices ranged between ~\$0 (almost free) and ~\$2 million (almost operational) per MW.

Exhibit 7.20 lists the transactions we looked at.

Exhibit 7.20: Select Wind Power Transactions Since 2005

Date	Acquirer	Target	Transaction Type	Target Location	Operating Capacity (MW)	Estimated Production (GWh/yr)	Development Pipeline (MW)	Transaction Price (Local \$M)	Transaction Price (CSM)	Adjusted Transaction Price (CSM)	Adjusted Operating Price (CSM/MW)	Adjusted Operating Price (CSM/GWh/yr)
Jul 08	E.ONDong	London Array	Assets	Europe	-	-	330	-	-	-	-	-
Jul 08	GreenHunter Energy	Wheatland Wind Project	Assets	United States	-	-	390	-	-	-	-	-
Jul 08	Boralex	Gengrow th III	Assets	Canada	-	-	100	-	-	-	-	-
Jun 08	Duke Energy	Catacunt Energy	Corporate	United States	300	788	1,750	320	324	-	-	-
Jun 08	Multiple Acquirers	Allico Finance	Assets	United States	-	-	-	325	331	331	-	-
Apr 08	Energias de Portugal	Wind Farms in France	Assets	France	35	83	560	95	150	-	-	-
Apr 08	NTR	Wind Capital Group	Assets	United States	-	-	-	150	152	152	-	-
Apr 08	FPL Energy	Mount Copper and Pubnico Point	Corporate	Canada	85	269	-	122	122	122	1.43	0.45
Mar 08	Ventus Energy	West Cape Wind Energy	Corporate	Canada	-	-	-	21	21	-	-	-
Mar 08	Enmax Energy Corporation	Kettles Hill	Corporate	Canada	63	166	77	163	163	131	2.07	0.79
Feb 08	Wind Energy America	Boreal	Corporate	United States	-	-	1,200	-	-	-	-	-
Feb 08	Gaz de France	Nass & Wind	Corporate	Europe	34	89	150	-	-	-	-	-
Feb 08	Scottish & Southern Energy	Airtricity	Corporate	Europe	310	815	2,000	1,455	2,155	1,307	4.22	1.60
Feb 08	Iberdrola	Rights to 1,600 MW in Romania	Assets	Europe	-	-	1,600	363	364	-	-	-
Jan 08	Acciona	Corporación Eólica CESA	Corporate	Europe	37	97	9	114	114	110	3.00	1.14
Dec 07	GE Energy	Four Wind Farms in US	Assets	United States	-	-	600	600	599	346	-	-
Dec 07	Babcock & Brown	Wind Farms From Gamesa	Assets	Spain	-	-	150	-	-	-	-	-
Dec 07	Electrabel	1 Wind Farm in Portugal	Assets	Portugal	38	77	-	50	71	71	1.88	0.93
Dec 07	Sorgenia	La Française d'EolienNES	Assets	Europe	115	302	-	496	497	497	4.32	1.64
Dec 07	Nuevas Energías del Occidente	Relax Wind Parks	Assets	Europe	-	-	1,022	54	-	-	-	-
Dec 07	Gaz de France	EolienNES	Corporate	Europe	38	99	-	-	-	-	-	-
Dec 07	Canadian Hydro Developers	99 MW Le Nordais Wind Plant	Assets	Canada	99	165	-	121	121	121	1.20	0.70
Dec 07	Marififer Renewables	Two Wind Farms in Germany	Assets	Europe	53	140	-	132	134	134	2.52	0.96
Dec 07	Babcock & Brown	Three Wind Farms in US	Assets	United States	315	937	-	309	313	313	-	0.33
Dec 07	Innervex Power Income Fund	Two Wind Farms in Quebec	Assets	Canada	80	210	-	154	154	154	1.93	0.73
Dec 07	Iberdrola	Two Wind Parks in Almeria	Assets	Europe	50	131	-	66	97	97	1.95	0.74
Nov 07	Electrabel	Wind Farms in Mourisca and Fafe II	Assets	Europe	64	168	-	137	133	133	2.07	0.79
Nov 07	Electrabel	La Compagnie du Vent S.A.	Corporate	Europe	-	-	-	468	449	449	-	-
Oct 07	EnerTAD	Five Wind Farms	Assets	France	55	126	-	82	112	112	2.03	0.89
Oct 07	E.ON	Airtricity, Inc., North American Operations	Corporate	United States	650	1,708	5,000	1,400	1,320	-	-	-
Oct 07	Iberdrola	Four Hungarian Wind Farms	Assets	Europe	-	-	108	155	213	168	-	-
Oct 07	Iberdrola	Eólicas de Euskadi	Corporate	Europe	-	-	-	164	161	161	-	-
Oct 07	Gaz de France	Erelagroupe	Corporate	France	70	184	300	-	-	-	-	-
Sep 07	SUEZ Energy North America	Ventus Energy	Corporate	United States	29	76	379	119	119	-	-	-
Sep 07	Babcock & Brown	Bluewater Wind	Corporate	United States	-	-	450	-	-	-	-	-
Sep 07	Vardar Eurus	Tooma Tuulepark	Corporate	Europe	24	63	-	35	49	49	2.06	0.78
Sep 07	Babcock & Brown	EnerSis Wind Farms (50% Interest)	Assets	Portugal	262	648	69	487	694	665	2.53	1.03
Sep 07	M&G Investment Management	Zephyr Investments	Corporate	Europe	129	339	-	289	301	301	2.33	0.89
Aug 07	International Power	Wind Farms in Italy and Germany	Assets	Europe	581	1,527	-	1,196	1,263	1,263	2.17	0.83
Aug 07	Renewable Energy Holdings	Wind Farm	Assets	Germany	8	21	-	11	15	15	1.89	0.72
Aug 07	Iberdrola	Three Wind Farms in Germany	Assets	Europe	-	-	-	30	43	43	-	-
Aug 07	Finavera Renewables	Wind Farm	Assets	Germany	20	39	-	-	-	-	-	-
Aug 07	E.ON	ENERGI E2 Renovables Ibéricas	Corporate	Europe	260	683	560	994	1,048	1,048	3.12	1.19
Aug 07	Babcock & Brown	The Valdeconejonos Wind Farm	Assets	Spain	32	85	-	51	74	74	2.30	0.87
Jul 07	Boralex	Gengrow th II	Assets	Canada	-	-	90	-	-	-	-	-
Jul 07	TransAlta	Fairfield Hill Prospect	Corporate	Canada	21	55	-	-	-	-	-	-
Jul 07	Babcock & Brown	Conjuro Wind Farm (70% Interest)	Assets	Spain	12	22	-	30	27	27	2.30	1.25
Jul 07	Energias de Portugal	Horizon Wind Energy	Corporate	Canada	559	1,469	9,000	2,700	2,866	-	-	-
Jul 07	Theolia	165 Megawatt Wind Farms	Assets	Europe	165	434	-	132	140	140	-	-
Jun 07	Acciona	Wind Assets in Illinois	Corporate	United States	-	-	1,300	1,300	1,852	1,303	-	-
Jun 07	Babcock & Brown	Two Wind Farms in Spain	Assets	Spain	64	185	-	180	163	163	2.55	0.88
Jun 07	Electrabel	1 Wind Farm in Portugal	Assets	Portugal	32	107	-	55	78	78	2.45	0.74
May 07	AES	Two Wind Farms	Assets	United States	186	489	-	-	-	-	-	-
May 07	Duke Energy	Tierra Energy Wind Business	Corporate	United States	-	-	1,000	-	-	-	-	-
Apr 07	Iberdrola	CPV Wind	Corporate	United States	-	-	3,500	55	84	-	-	-
Apr 07	Finavera Renewables	3 Hills Wind Power Project	Assets	Canada	-	-	225	3	3	-	-	-
Mar 07	Babcock & Brown	Wattle Point Wind Farm	Assets	United States	91	312	-	225	260	260	2.85	0.83
Mar 07	Allico Finance	German Wind Assets	Assets	Europe	112	294	-	200	235	235	2.10	0.80
Mar 07	Canadian Hydro Developers	GW Power Corporation	Corporate	Canada	35	145	-	87	87	73	2.06	0.60
Feb 07	Naturener	Great Plains Wind & Energy	Corporate	United States	-	-	300	-	-	-	-	-
Feb 07	Endesa	Seven Wind Farms in Italy	Assets	Europe	240	631	-	401	466	466	1.94	0.74
Feb 07	GE Energy	Wind Farm	Assets	United States	287	754	-	212	247	247	-	-
Jan 07	Babcock & Brown	Six Wind Farms	Assets	United States	410	1,167	-	387	454	454	-	-
Jan 07	Babcock & Brown	Kaarst Wind Farm	Assets	Germany	12	23	-	30	28	28	2.30	1.19
Dec 06	Theolia	Natenco	Corporate	Europe	25	66	810	133	154	-	-	-
Dec 06	Shear Wind	Wind Resources	Corporate	Canada	-	-	100	1	1	-	-	-
Dec 06	BP Alternative Energy	Orion Energy	Corporate	United States	-	-	6,000	-	-	-	-	-
Dec 06	Novas Energias do Ocidente	Agrupación Eólica	Corporate	France/Spain	155	475	1,044	348	531	91	0.59	0.19
Nov 06	Babcock & Brown	Four U.S. Wind Farms	Assets	United States	232	610	-	345	394	394	1.70	0.65
Nov 06	International Power	Levanto Onshore Wind Farm Portfolio	Assets	Europe	436	1,146	-	721	817	817	1.87	0.71
Oct 06	Iberdrola	Midwest Renewable Energy	Corporate	United States	-	-	400	30	43	-	-	-
Oct 06	Iberdrola	Wind Farms from Gamesa	Assets	Europe	-	-	1,000	1,000	1,122	700	-	-
Sep 06	Enbridge Income Fund	Wind Farm	Assets	Canada	25	66	-	42	42	42	1.66	0.63
Sep 06	Iberdrola	Wind Farms in UK	Assets	Europe	21	54	-	-	-	-	-	-
Aug 06	Babcock & Brown	Superior Renewable Energy	Corporate	United States	125	329	500	-	-	-	-	-
Aug 06	BP Alternative Energy	Greenlight Energy	Corporate	United States	-	-	6,500	98	110	-	-	-
Jul 06	Babcock & Brown	Two Wind Farms (Class B Ownership)	Assets	United States	118	427	-	72	81	81	-	-
Jul 06	NRG Energy	Padoma Wind Power	Corporate	United States	-	-	1,000	-	-	-	-	-
Jul 06	CPV Wind	Distributed Generation's Wind Portfolio	Assets	United States	-	-	1,000	-	-	-	-	-
Jul 06	Iberdrola	Perfect Wind	Corporate	Europe	-	-	600	52	74	-	-	-
Jul 06	Babcock & Brown	Crescent Ridge (Class B Ownership)	Assets	United States	54	172	-	50	56	56	-	-
May 06	Iberdrola	Community Energy	Corporate	United States	-	-	200	30	33	-	-	-
May 06	Iberdrola	Community Energy	Corporate	United States	-	-	-	30	33	-	-	-
Mar 06	Babcock & Brown	Three Wind Farms in France	Assets	Europe	22	50	-	30	42	42	1.92	0.85
Feb 06	Babcock & Brown	Eifel Wind Farm	Assets	Europe	23	46	13	9	13	7	-	-
Jan 06	Babcock & Brown	G3 Energy	Corporate	United States	-	-	500	-	-	-	-	-
Jan 06	Acciona	Corporación Eólica CESA	Corporate	Europe	499	1,312	129	1,658	1,908	1,853	3.71	1.41
Jan 06	Iberdrola	Naturener Eolica	Corporate	Europe	-	-	280	26	37	-	-	-
Dec 05	Airtricity	Renewable Generation	Corporate	United States	-	-	1,000	-	-	-	-	-
Dec 05	Boralex	La Citadelle	Assets	France	12	28	-	21	21	21	1.75	0.75
Dec 05	Babcock & Brown	Wind Farms in Texas, Oklahoma and Oregon	Assets	United States	98	257	-	-	-	-	-	-
Nov 05	Electrabel	Fafe Wind farm	Assets	Europe	80	210	-	123	146	146	1.82	0.69
Oct 05	Iberdrola	Wind Farms in Spain and Italy	Assets	Europe	700	1,840	-	900	1,279	1,279	1.83	0.70
Sep 05	Energias de Portugal	Five Wind Farms in Portugal	Assets	Portugal	48	127	72	72	84	84	1.12	0.42
Aug 05	Endesa	FINERCE - Gestión de Proyectos Energéticos, S.A.	Corporate	Europe	60	158	280	214	259	149	2.49	0.95
Jul 05	Iberdrola	Wind Farms in Greece	Assets	Europe	58	147	-	78	115	115	2.06	0.78
Jul 05	Iberdrola	Wind Farms in Germany and France	Assets	Europe	-	-	201	-	-	-	-	-
Mar 05	Goldman Sachs	Zilkha Renewable Energy	Corporate	United States	-	-	350	-	-	-	-	-
Feb 05	Energias de Portugal	Wind Farms in Spain	Assets	Europe	-	-	-	21	34	34	-	-
Jan 05	AES	SeaWest Holdings	Corporate	United States	-	-	500	60	72	-	-	-

Source: Scotia Capital.

For a detailed review of wind power science & technology 101, please refer to our May 2007 report, *Seizing the Wind Power Opportunity*.

EMERGING WIND TECHNOLOGIES

Not just bigger and better. While it is true that turbines have been growing in size and improving in efficiency, we now see several companies developing unique methods of capturing wind energy. With respect to traditional turbine size growth, Clipper Windpower out of the U.K. may be leading the pack as it has already pre-sold some 7.5 MW deep water Britannia turbines. To put this in perspective, imagine a turbine nearly twice the height of London's famous Big Ben clock tower. Below, we summarize three unique wind turbine emerging technologies that we have come across.

Exhibit 7.21: Magenn's Air Rotor System (MARS)

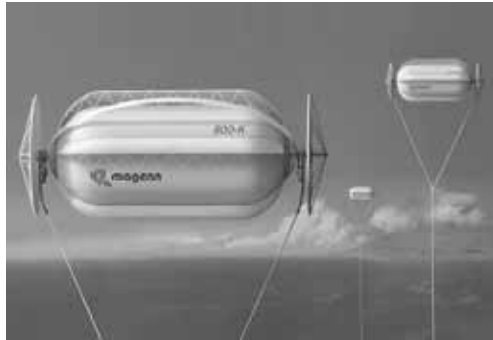

Source: Magenn.

Exhibit 7.22: MagLev Wind Turbine



Source: www.magturbine.com.

Exhibit 7.23: Flying Electric Generator



Source: Sky Wind Power.

Canadian-based Magenn Power has developed a lighter-than-air tethered device that rotates about a horizontal axis in response to wind (Exhibit 7.21).

According to the company, the technology generates electricity "at a lower cost than all competing systems," primarily due to no structural capital costs such as a tower that requires the use of an expensive crane. Helium provides the closed air rotor with lift as well as the ability to ascend to optimal altitudes. The company also claims that its technology has a potential capacity factor of 40% to 50%, unlike traditional wind turbines with capacity factors in a 25% to 35% range. The higher capacity factor is due to MARS' ability to climb to 1,000 feet above ground in search of stronger and optimal wind speeds. Other advantages of the technology include: (1) the floating wind farms can be placed closer to demand centres; (2) the Magenn Air Rotors are mobile and can easily be moved to different locations; and (3) the system can operate at wind speeds as low as 1 m/s, compared with traditional wind turbines that begin operating at 3 m/s.

At the 2007 Wind Power Asia exhibition in Beijing, **MagLev Wind Turbine Technologies introduced a magnetic levitation wind power technology that could revolutionize the industry** (Exhibit 7.22). Vertically oriented blades are suspended in the air using neodymium magnets, replacing the need for ball bearings. Potential advantages of the frictionless technology include: (1) starting speeds as low as 1.5 m/s and as high as 40 m/s; (2) 20% higher than capacity factors than conventional wind turbines; (3) 50% lower operating costs; and (4) a 500-year potential lifespan. MagLev and Zhongke Hengyuan Energy Technology are developing a 1 GW Maglev wind turbine, enough electricity to power 750,000 homes, and would require only 100 acres of land. This compares with 1,000 standard wind turbines that can power 500,000 homes and require about 64,000 acres of land. The company claims that it will generate power for less than US\$10/MWh.

Sky Wind Power recently demonstrated a 0.2 MW Flying Electric Generator (FEG) at high altitudes (Exhibit 7.23). Similar to Magenn Power, the flying power generators would use a tether to bring the electricity to the ground. The California-based company believes that **FEGs could reach 20 MW each, with capacity factors as high as 80%**.

Surplus Wind to Hydrogen

The 240-resident town of Utsira, Norway, recently won the Platts Global Energy Award for the world's best site in renewable energy. Two Enercon wind turbines provide energy to 10 households when the wind is blowing. Surplus energy at Utsira is converted to hydrogen, using an electrolyzer, and stored. When there is no wind, the stored hydrogen is used to run a fuel cell and a motor that produces electricity. The hydrogen plant is built to provide up to **two days of power with no wind**.

Compressed Air Wind Energy Storage

Iowa Stored Energy Park is currently building a system where wind power is stored underground as compressed air during off peak hours and used to generate energy during peak times (Exhibit 7.24). Wind turbines power air compressors during off peak hours and store the energy underground and then during peak hours, using a natural gas catalyst, the compressed air is used to power turbines allowing the company to sell the electricity at on-peak prices.

Only two compressed air energy storage plants are currently operating, one in the U.S. and one in Germany. The project in Iowa is expected to come online in 2011. The technology, while not 100% renewable, opens the door to capacity factors well above 35%.

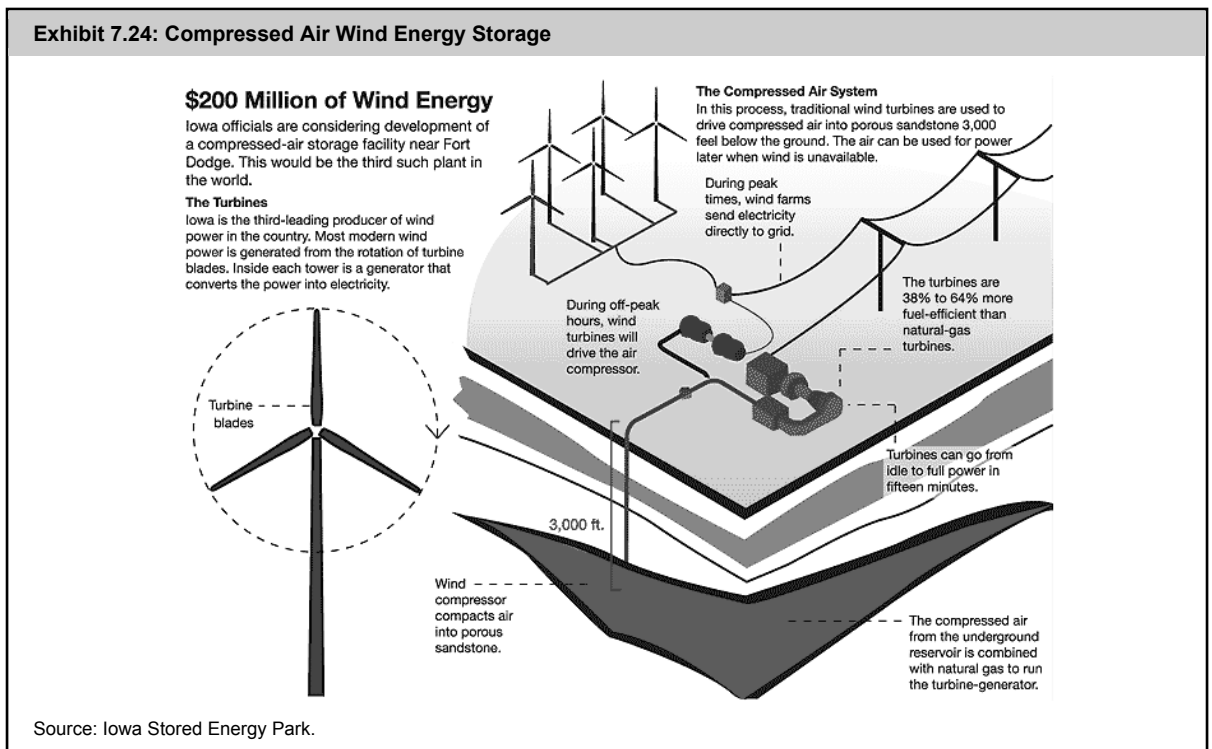

OFFSHORE WIND CAPITAL COSTS HAVE NOT PEAKED YET

Offshore wind energy is growing faster than onshore wind. At least, it is outside of North America. Canada and the U.S. are off to a slow start to install offshore wind farms. In fact, they haven't started at all. So far, all operating offshore wind energy projects have been constructed in Europe, which totalled about 1,100 MW at the end of 2007 (200 MW installed in 2007). In Europe, offshore wind farms are seen as essential to meeting its renewable power targets.

The lag in North American offshore wind power development is mainly due to its much higher capital costs per installed MW than compared with onshore wind farms. For offshore wind projects, there are higher costs for civil engineering, electrical connection costs (i.e., undersea cable installation), and the requirement for non-corrosive materials to be used. Also, offshore wind developers have to compete with oil and gas companies for the specialized vessels needed to install turbines and other heavy equipment at sea.

To make matters worse, we expect capital costs to increase by a further 10% to 20% over the next two to three years, before peaking. Today, the average cost of an offshore wind project is US\$4.8 million per MW, which could jump to US\$6 million per MW by 2011. The higher capital costs are **partially offset** by higher capacity factors due to less surface turbulence, as well as an average availability rate of 98%. A rule-of-thumb cost comparison that we have come across several times, and which is somewhat accurate, is as follows: **Onshore wind project costs → 25% infrastructure and 75% turbines; Offshore wind project costs → 75% infrastructure and 25% turbines.**

Canada is likely three to five years away from having any utility-scale offshore wind farms commissioned. Why: Canada still has lots of potential for traditional and less expensive land-based wind farms. We have only come across two Canadian offshore wind project proposals to date.

1. Naikun Wind Development Inc. wants to build a massive 1,750 MW wind farm in the Hecate Strait, off the coast of British Columbia. We expect Naikun to submit its first phase of the project, about 350 MW, into the BC Hydro Clean Power Call, due November 25, 2008.

2. Trillium Power Wind Corp. is developing a 710 MW project that would be sited 20 kilometres offshore in Lake Ontario. **Helimax Energy** suggests that **the Great Lakes could generate up to 47,000 MW of electricity per year**, or close to double Ontario's existing capacity.

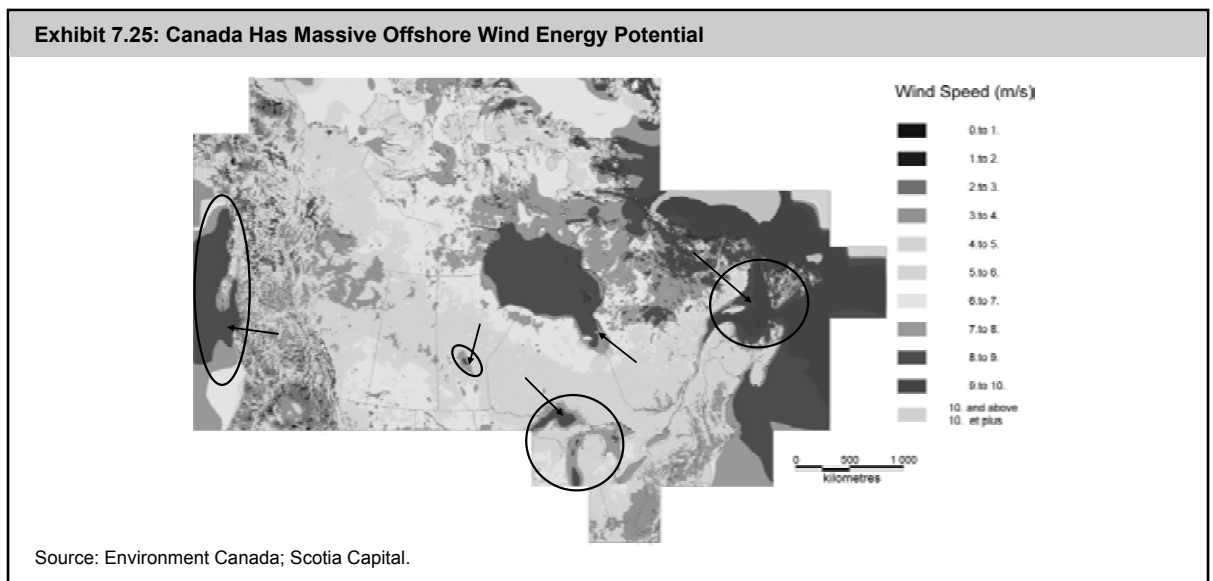

Exhibit 7.26: 1,000+ GW of U.S. Offshore Wind Potential

Region	Offshore Wind Resource (MW) by Depth (m)				Total
	0 - 30	30 - 60	60 - 900	> 900	
New England	10,300	43,500	130,600	0	184,400
Mid-Atlantic	64,300	126,200	45,300	30,000	265,800
Great Lakes	15,500	11,600	193,600	0	220,700
California	0	300	47,800	168,000	216,100
Pacific Northwest	0	1,600	100,400	68,200	170,200
Total (MW)	90,100	183,200	517,700	266,200	1,057,200

Source: National Renewable Energy Laboratory.

In late January 2008, the Ontario government lifted its 14-month moratorium on offshore wind projects in the Great Lakes. The moratorium on offshore wind power development was put in place so the government could study the potential impact of offshore wind projects on aquatic species, bird migration routes, and recreational boating and fishing.

Exhibit 7.27: Interest for U.S. Offshore Wind Is Active

U.S. State	Proposed Offshore Wind Capacity
Massachusetts	783 MW
Delaware	450 MW
New Jersey	350 MW
New York	160 MW
Texas	150 MW
Ohio	20 MW
Georgia	10 MW

Source: U.S. Department of Energy.

The U.S. is still waiting for the final rules and regulations for offshore wind energy development. However, five areas in coastal waters have been approved by the Minerals Management Service for renewable energy research, including New Jersey, Delaware, Georgia, and California. The Cape Wind project off of New England is the most advanced U.S. offshore wind project and will likely be the first to be commissioned, although no green light has been given to date. Exhibit 7.26 shows the potential size of the U.S. offshore wind farm market.

Regulatory delays, turbine supply shortages, high and uncertain project costs, and public acceptance concerns continue to weigh down progress in the North American offshore wind space. According to the U.S. Department of Energy, 2007 saw the cancellation of a 500 MW Texas project, and has put a 150 MW New York project and a 450 MW Delaware project in jeopardy (Exhibit 7.27).

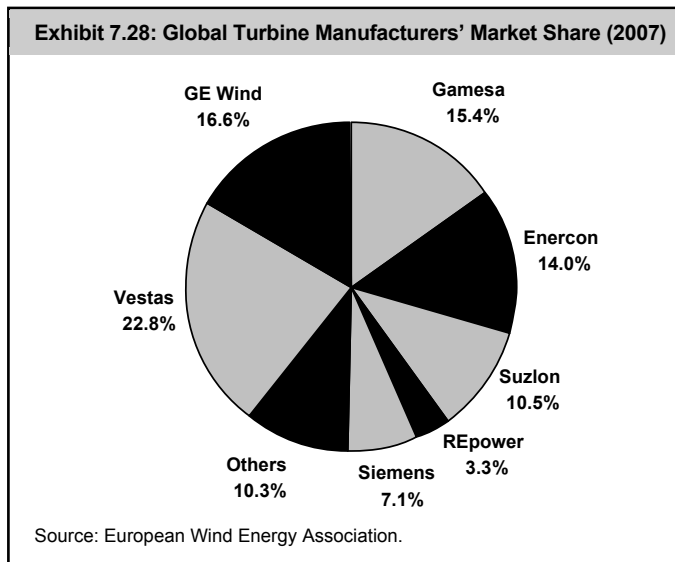

THE TURBINE MANUFACTURER OLIGOPOLY

Six manufacturers control 85% of the global market for wind turbines. With a 23% market share, Vestas leads the pack, followed by GE Wind, and Gamesa (Exhibit 7.28). However, smaller players – particularly in China and India – are growing rapidly, but we expect will primarily serve their domestic markets rather than expanding globally. Stock prices of the pure-play wind turbine manufacturers have soared over the last two and half years, up almost five times over the S&P/TSX Composite Index and the S&P 500 Index (Exhibit 7.29).

In the Canadian market, Danish manufacturer Vestas is the lead turbine supplier to date, followed by GE and Siemens.

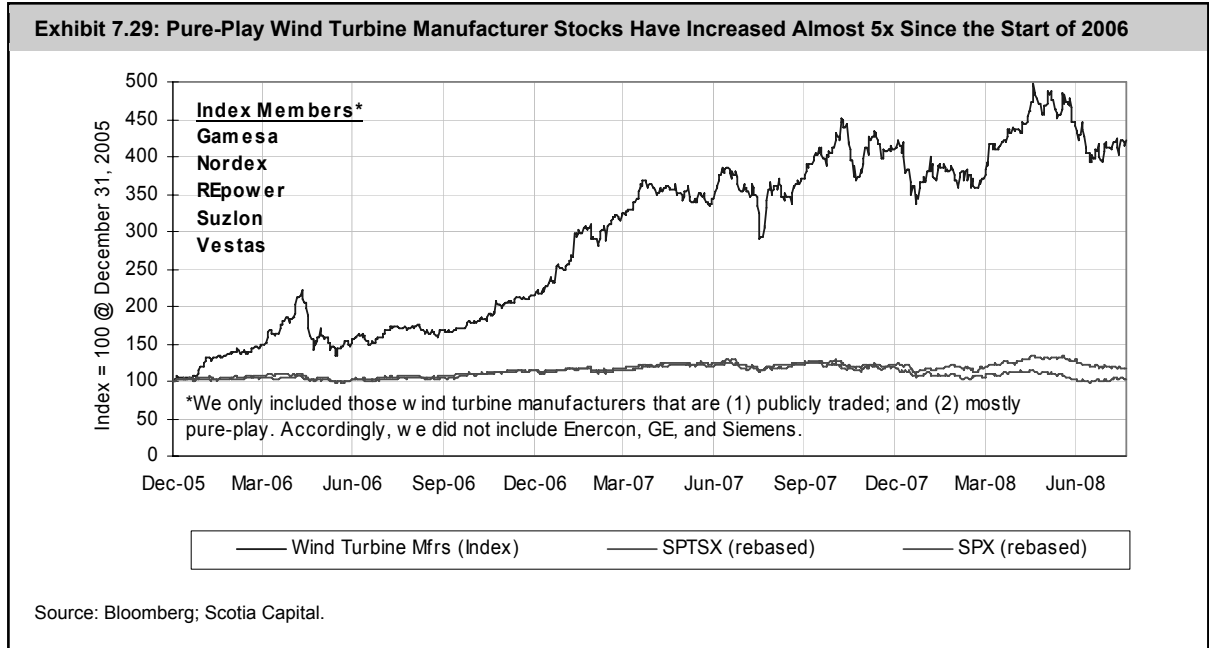

Entrance into the U.S. market by major European turbine manufacturers has been limited, due primarily to the short-term nature of the U.S. Production Tax Credit. Exhibit 7.30 clearly shows why foreign manufacturers have historically been reluctant to set up shop in the U.S.

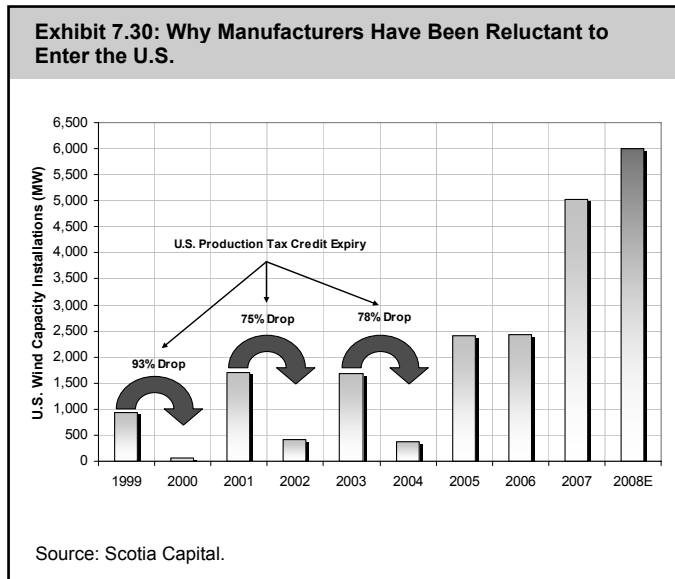

We see several reasons why global turbine manufacturer investment in new U.S. capacity is accelerating: (1) a weak U.S. dollar; (2) many U.S. states now have a Renewable Portfolio Standard (RPS); (3) the United States has one of the largest wind power market potentials; and (4) there is a clear focus on clean power generation technologies. **Evidence in 2008 can be seen through U.S. investment by most global turbine manufacturers**, including Siemens (new blade plant in Iowa); Suzlon (new nose cone plant in Minnesota); Vestas (new blade plant in Colorado); Acciona (new production plant in Iowa); Moventas (doubles gear production); REpower (new turbine plant); and GE Energy (doubling annual production in the U.S.).

In Canada, following Hydro-Quebec’s awarding of 2,000 MW of wind PPAs in May 2008, REpower and Enercon were indirectly selected as the winning turbine suppliers. Both of these companies must incur at least 60% of their project-related costs in Quebec.

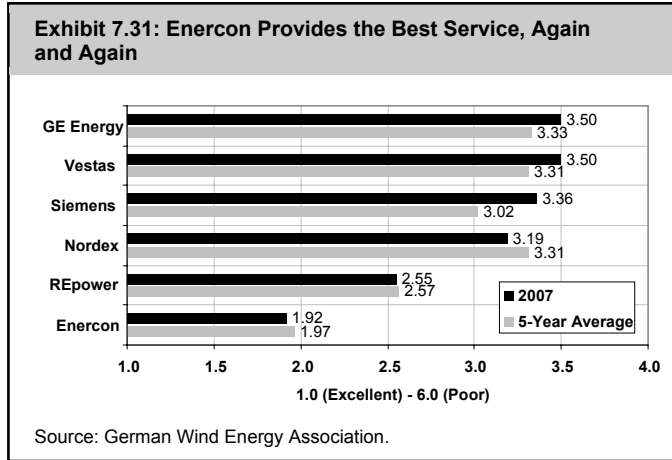

Multibrid, an offshore turbine manufacturer that is majority-owned by French nuclear giant Areva, intends to open its first North American manufacturing plant in southern Ontario. Trillium Power Wind Corp.'s Lake Ontario project, together with another project being developed by Fisherman's Energy of New Jersey, represent potential orders for more than 300 offshore wind turbines.

Enercon Still Number One in Service

For the fifth year in a row, the German Wind Energy Association's (BWE) annual survey on service reveals that Enercon needs little repair. Siemens and Vestas received lower service rankings in 2007 over 2006, (Exhibit 7.31). Perhaps a more telling story is shown in Exhibit 7.32, where over 50% of operators of GE wind turbines want to switch to a different service company in the future, compared with 1.1% for Enercon.

Exhibit 7.32 Operators That Want to Switch

Turbine Manufacturer	Turbine Age			Total
	Under Warranty	< 6 Years	> 6 Years	
Enercon	0.0%	1.1%	1.3%	1.1%
REpower	0.0%	0.0%	33.3%	6.9%
Nordex	20.0%	56.3%	17.4%	26.9%
Siemens	0.0%	14.3%	36.6%	29.3%
Vestas	30.8%	18.9%	22.3%	22.0%
GE Energy	62.5%	62.5%	42.6%	52.6%

Source: German Wind Energy Association.

FINAVERA RENEWABLES INC.

Finavera Renewables (FVR-V) is developing wind projects in B.C., Alberta, and in Ireland. The Peace Region project (seven sites), which targets 366 MW of wind capacity to be commissioned between 2011 and 2013, has now received land permit approvals. The Cascades Region of projects (nine sites) is further behind, having only received Investigative Use Permits for three of its sites. In Alberta, the company purchased a two-phase project (Three Hills) with a total expected capacity between 155 MW and 165 MW. While FVR has targeted a 2008 construction start date for Ghost Pine, the first phase of Three Hills, **we believe that FVR may be looking to sell the project in order to fund further development.** FVR also has 175 MW of wind power development opportunities in Ireland at two different sites. **In Ireland, wind farm projects can receive up to 100% debt financing.**

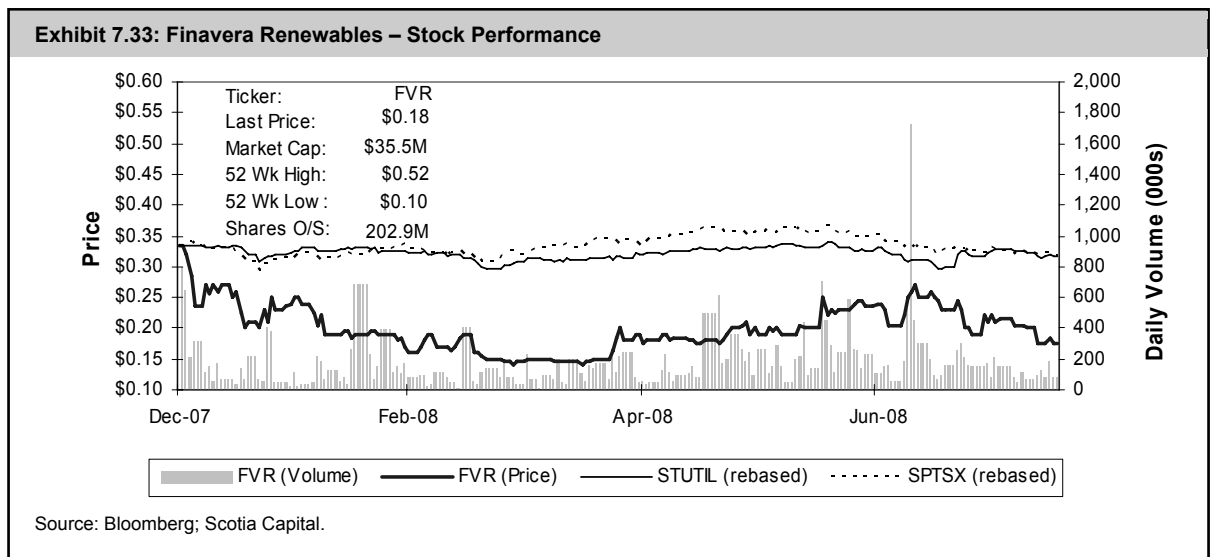

KEEWATIN WINDPOWER CORP.

Keewatin Windpower (KWPW-OTCBB) is a development stage company, which recently acquired Sky Harvest Wind Power, a company that owns a wind farm site located in southern Saskatchewan. Keewatin has secured land lease agreements for the site and expects to develop 150 MW of wind power capacity there. In total, Keewatin anticipates the development of about 300 MW in southern Saskatchewan.

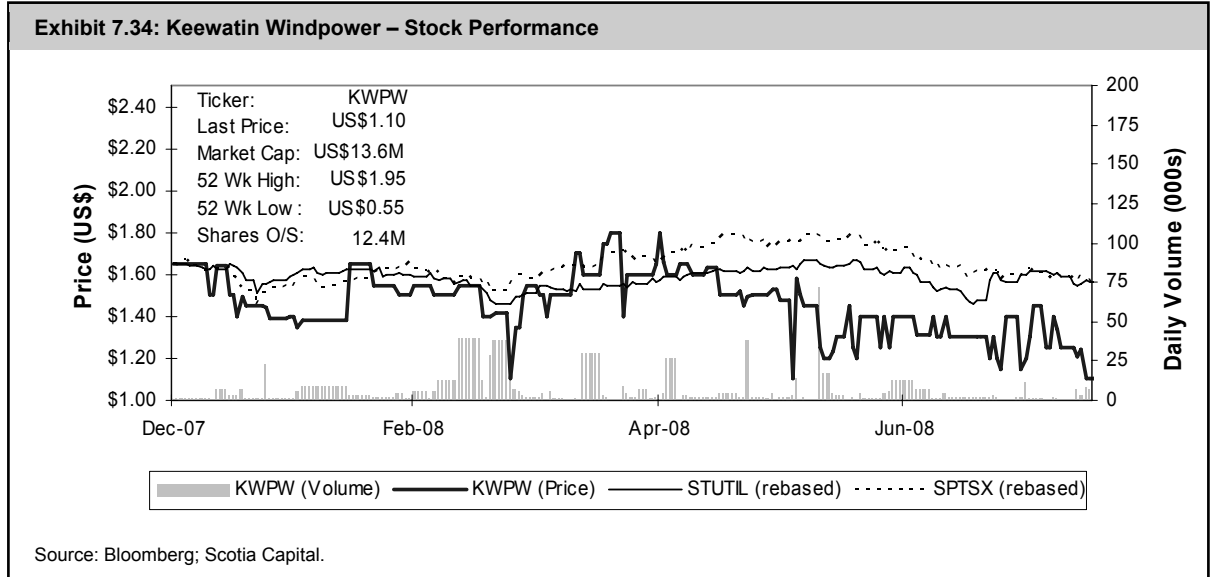

SEA BREEZE POWER CORP.

Sea Breeze (SBX-V) is a British Columbia-based energy development company with one wind project in development, a number of wind farm prospects, and plans to develop two underwater transmission lines. SBX’s Knob Hill project is a 99 MW wind farm to be located on the northern tip of Vancouver Island. The project has been approved by the B.C. Environmental Assessment Office (EAO) and is now preparing for a bid submission into the BC Hydro Clean Power Call. There are 700+ MW of wind power prospects for Sea Breeze, all of which are in B.C.

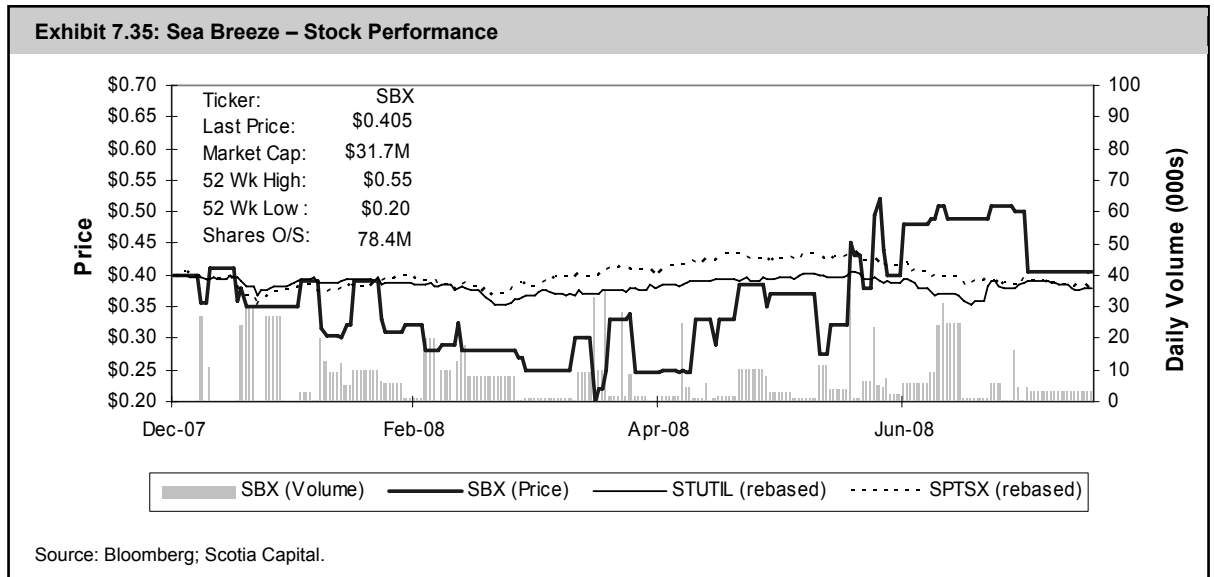

NAIKUN WIND ENERGY GROUP INC.

NaiKun (NKW-V) is developing an offshore wind farm in B.C. near Prince Rupert. The company has the rights to a 550 km² offshore wind site in the Hecate Strait Energy Field, **which is known as one of the world's 10 best locations for offshore wind energy due to its high and consistent wind speeds.** NKW proposes to develop the site in five phases, with a final anticipated capacity of 1,750 MW. Construction of the 320 MW Phase I is expected to begin in 2009. With the BC Hydro Clean Power Call looking for larger projects, NKW hopes to bid for and win a BC Hydro PPA over the next year.

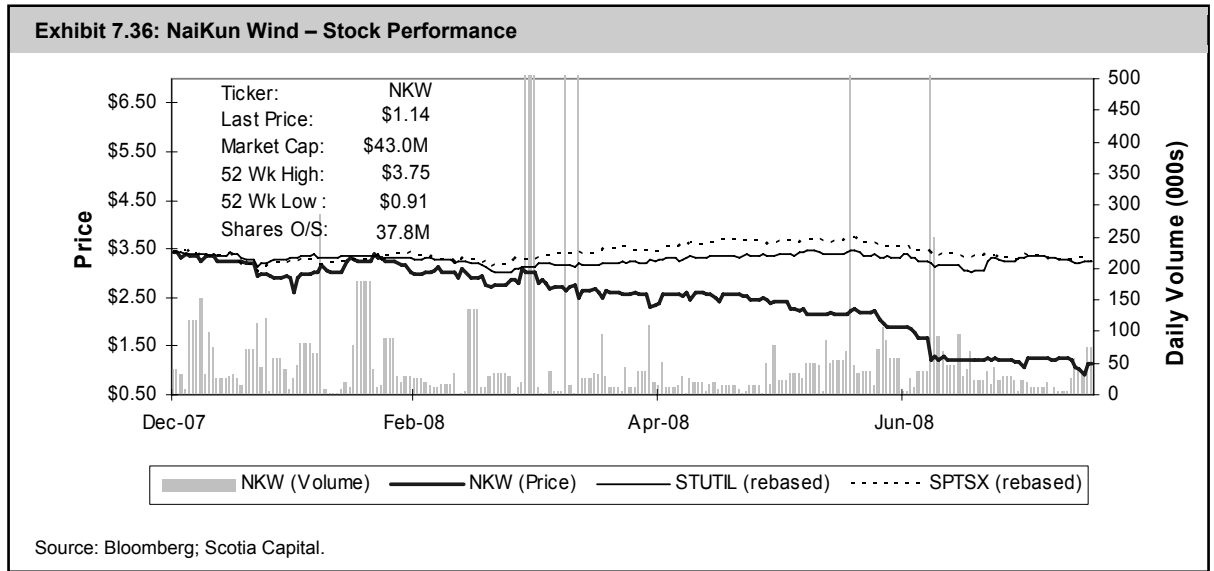

SHEAR WIND INC.

Shear Wind (SWX-V) is developing seven wind projects in Nova Scotia, New Brunswick, Saskatchewan, and Alberta. Shear's projects have a potential total capacity of 1,500+ MW with two projects of 160 MW expected to begin construction in 2009. SWX's 60 MW Glen Dhu Wind Park in Nova Scotia is expected to consist of thirty 2 MW turbines at a total cost of \$150 million, or an installed capital cost of \$2.5 million per MW. Shear has secured a 20-year PPA with Nova Scotia Power and expects the site to be commissioned by 2011. The company believes the site can support an additional 170 MW. In June, Shear secured a 100 MW build-out position on the Alberta electrical grid for its Glenridge Phase I project.

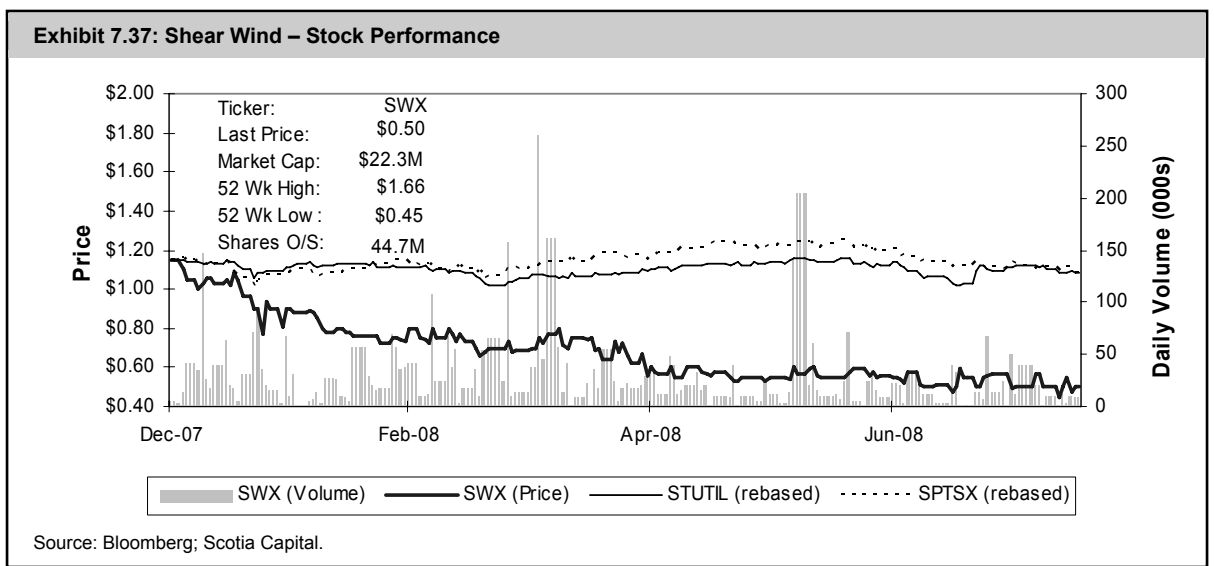

WESTERN WIND ENERGY CORP.

Western Wind (WND-V) operates 35 MW of wind capacity and is pursuing three U.S. wind projects. The Mesa Wind Generating facility, located near Palm Springs, California, has a capacity of 30 MW as well as signed PPAs through 2011. The company’s smaller 4.5 MW Windridge facility also has a PPA, which expires in 2014. In 2005, WND was awarded a 120 MW PPA for its Windstar I project, to supply California with renewable power over a 20-year period. Installation of the turbines is expected by 2H/09. Once completed, WND’s 15 MW Steel Park project, located in Arizona and which can be expanded by a further 200 MW, would be the first utility-scale wind energy project in the state.

Western Wind also has a 100 MW wind and solar energy site near Barstow, California, which is currently completing environmental permitting. WND is 100% debt free and owns 3,700 acres of land that are zoned and permitted for wind power development.

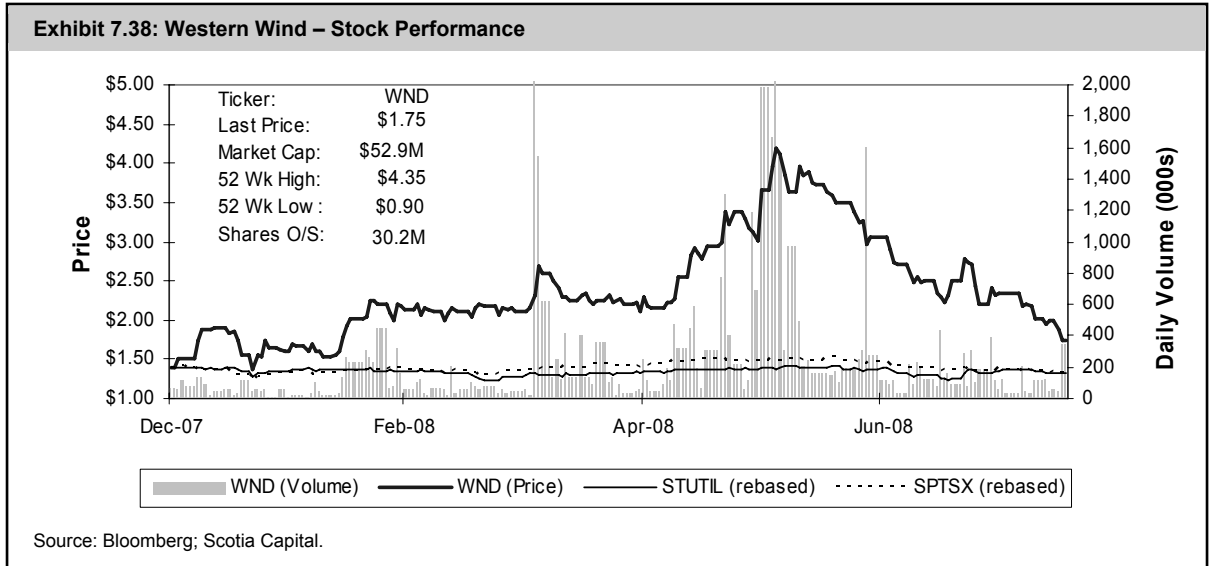

Exhibit 7.39: Wind Turbine Manufacturer Valuation Metrics

Company Name	Ticker	Last Price	52-Wk Low	52-Wk High	Shares O/S	Market Cap	Debt/Equity	Debt/Assets	Debt/EBITDA	1-Month ROR	3-Month ROR	1-Year ROR
		(8/15/2008)			(M)	(C\$M)	(%)	(%)	(x)	(%)	(%)	(%)
AAER	AAE	\$0.21	\$0.21	\$2.10	85.5	\$18	-	-	n.m.	-7%	-50%	-41%
Americas Wind Energy	AWNE	US\$0.30	US\$0.27	US\$0.79	31.3	\$10	-	-	-	-5%	-20%	-56%
Cleanfield Alternative Energy	AIR	\$1.10	\$0.52	\$2.85	23.7	\$26	-	-	n.m.	6%	22%	-52%
Gamesa Corp Tecnologica	GAM	€29.63	€21.30	€36.44	243.3	\$11,227	47%	14%	1.2x	-6%	-8%	10%
General Electric	GE	US\$29.80	US\$25.60	US\$42.15	9,948.0	\$314,105	470%	66%	15.7x	6%	-7%	-22%
Nordex	NDX1	€22.32	€17.50	€39.60	66.8	\$2,324	6%	2%	0.3x	17%	-29%	-6%
REpower Systems	RPW	€201.96	€93.31	€243.54	9.0	\$2,829	3%	1%	-	-1%	-8%	98%
Siemens	SIE	€76.32	€64.89	€109.96	914.2	\$108,658	48%	16%	1.6x	7%	0%	-13%
Suzlon Energy	SUEL	Rp241.10	Rp174.50	Rp460.00	1,498.3	\$8,828	123%	37%	5.1x	23%	-22%	3%
Vergnet	ALVER	€10.38	€8.96	€18.29	6.4	\$103	-	-	-	-1%	-13%	-38%
Vestas Wind Systems	VWS	DKK629	DKK285	DKK700	185.2	\$24,324	6%	2%	-	3%	5%	107%
Average						\$42,950	100%	20%	4.8x	4%	-12%	-1%

Company Name	Enterprise Value to EBITDA			Price to Earnings			Price to Sales			Price to Cash Flow		
	2008E	2009E	2010E	2008E	2009E	2010E	2008E	2009E	2010E	2008E	2009E	2010E
	(x)	(x)	(x)	(x)	(x)	(x)	(x)	(x)	(x)	(x)	(x)	(x)
AAER	-	1.8x	-	-	6.0x	-	0.4x	0.1x	-	-	-	-
Americas Wind Energy	-	-	-	-	-	-	-	-	-	-	-	-
Cleanfield Alternative Energy	-	-	-	-	-	-	-	-	-	-	-	-
Gamesa Corp Tecnologica	13.4x	10.9x	8.9x	26.7x	20.4x	16.6x	2.0x	1.7x	1.5x	16.3x	14.1x	11.0x
General Electric	19.7x	18.5x	17.2x	13.5x	12.8x	11.6x	1.6x	1.5x	1.4x	8.7x	8.1x	7.3x
Nordex	15.3x	10.5x	6.7x	31.0x	20.8x	13.9x	1.4x	1.0x	0.7x	20.1x	15.8x	12.4x
REpower Systems	22.6x	12.7x	7.8x	43.9x	31.7x	21.7x	1.8x	1.4x	0.9x	-	-	-
Siemens	8.7x	7.1x	6.1x	17.2x	11.4x	9.4x	0.9x	0.9x	0.8x	9.4x	8.0x	6.6x
Suzlon Energy	14.6x	10.4x	7.7x	21.3x	14.3x	10.1x	1.8x	1.3x	1.0x	16.0x	11.7x	5.4x
Vergnet	-	7.2x	2.7x	-	n.m.	12.5x	1.6x	1.0x	0.6x	n.m.	13.8x	4.9x
Vestas Wind Systems	18.4x	13.8x	11.1x	32.9x	24.4x	19.0x	2.6x	2.1x	1.8x	25.4x	18.7x	14.7x
Average	16.1x	10.3x	8.5x	26.6x	17.7x	14.4x	1.6x	1.2x	1.1x	16.0x	12.9x	8.9x

Source: Bloomberg; Scotia Capital.

Solar Photovoltaic Power – Shining Bright Post-2013

OVERVIEW

Grid-connected solar photovoltaic (PV) technology is the fastest-growing renewable power source on the planet.

Grid-connected solar photovoltaic (PV) technology is the fastest-growing renewable power source on the planet, with capacity installations having increased about 50% per year since 2002. Investor interest in the solar space continues to soar; over US\$25 billion was invested in the space in 2007. **Many believe, as we do, that solar power, whether PV or thermal, will become a mainstream energy source within a decade.** Currently, solar power supplies less than 0.1% of global energy requirements.

To date, over 9,000 MW of solar PV power has been commissioned globally (Exhibit 7.40), mostly in Germany, Japan, and Spain (Exhibit 7.41 shows 2007 solar PV installations). On an installed watt per capita basis, Japan replaces Spain as one of the top three (Exhibit 7.42). While the German and Japanese markets may begin to mature over the next couple of years, **we see growth opportunities in Australia, China, the U.S., and Greece ramping up quickly over the next several years.**

The primary challenge facing the PV industry is the relatively high cost to produce and install a PV system, which currently ranges between \$5 million and \$7 million per MW depending on the specific technology employed. Over the past 15 years, costs have fallen substantially, from an average of \$16 million per installed MW in the early 1990s. **We expect costs to decline further over the mid-term, although several bottlenecks could limit cost reductions through mid-2009.**

Competition among solar PV technologies is fierce. Traditional crystalline-based solar cells are beginning to lose market share to second-generation solar technologies such as thin-film. Some third-generation solar technologies being developed such as nanoparticle ink or solar polymers will undoubtedly also compete for market share in the next decade.

In our opinion, solar PV will not reach grid parity for at least the next five years.

In our opinion, solar PV will not reach grid parity for at least the next five years (possibly more), so demand growth will continue to depend primarily on high government feed-in tariffs, as well as other incentives and subsidies. **Feed-in tariffs for solar PV systems are substantial, and can exceed \$700/MWh in some countries.** In Canada, the Ontario Power Authority offers \$420/MWh under its Standard Offer Program, compared with \$110/MWh for all other renewable power technologies in Ontario.

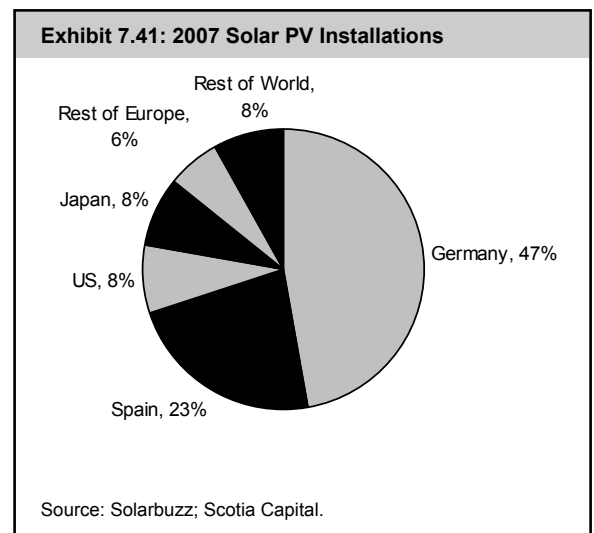
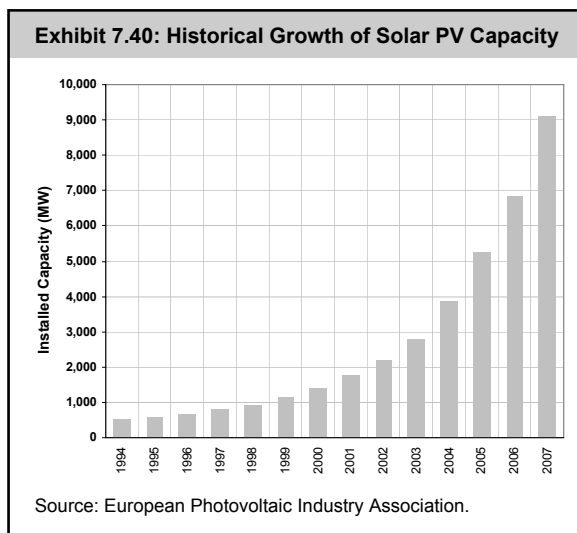

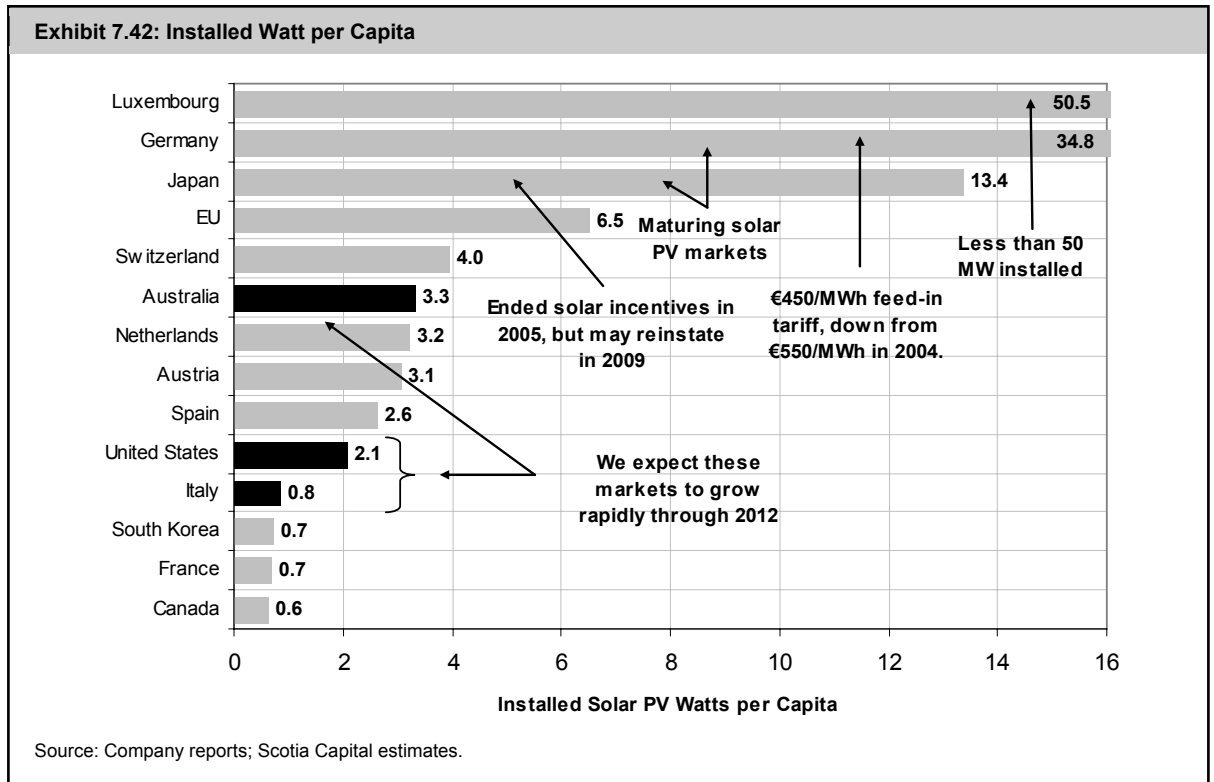

We see both costs and selling prices for installed crystalline and thin-film solar systems falling over the next several years, as shown in Exhibits 7.43 and 7.44. Our view is based on the following beliefs:

- **Economies of scale** in solar manufacturing processes are increasing. Solar modules are quickly becoming commodities, despite slight variations in each manufacturer’s solar PV system.
- **The supply shortage of solar-grade silicon will be over imminently** with a surge of new production capacity expected to come online by 2010.
- **Technological advancements** are accelerating.
- **Feed-in tariff rates are declining**, forcing cost reductions for margin preservation.

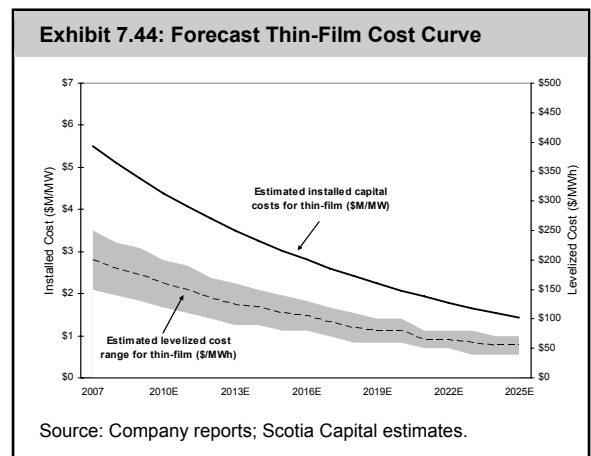
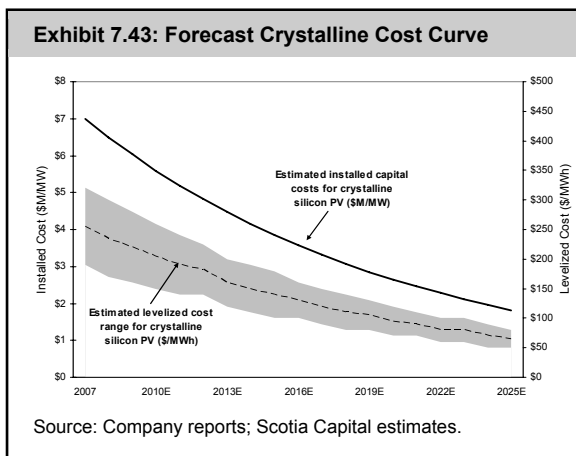

WHAT WE LIKE ABOUT THE POTENTIAL FOR UTILITY-SCALE SOLAR PV

- Solar power acts as a **hedge** against volatile and increasing costs for fossil-fuel resources such as natural gas and coal.
- Provided government support continues, **solar power will eventually become cost-competitive** as a peak-generation resource. Unlike wind power, the output of PV systems correlates highly with electricity demand, especially in hot regions where air conditioning use is high throughout the day. Today, solar power can compete in regions that offer high power prices and offer various financial incentives such as tax credits or subsidies.
- **No fuel costs and very low operating and maintenance costs** (there are typically no moving parts), unlike other renewable technologies such as wind power.
- **Carbon credits can be earned and sold as an incremental revenue source** for power developers, similar to other renewables.
- Utilities can use solar power to meet their **renewable portfolio standards**.
- **Scalability**. Solar systems range in size from less than 0.1 MW to 500+ MW for a utility-scale system.
- **Efficiency improvements are inevitable**. Commercial solar PV equipment efficiency is about half the efficiency of lab-tested equipment, and far below theoretical limits. From 1990 through 2006, the mean efficiency value for solar plants with crystalline cell modules increased to 12.9% from 11.6%. Exhibit 7.45 summarizes PV efficiency improvements since 1975.

Unlike wind power, the output of PV systems correlates highly with electricity demand.

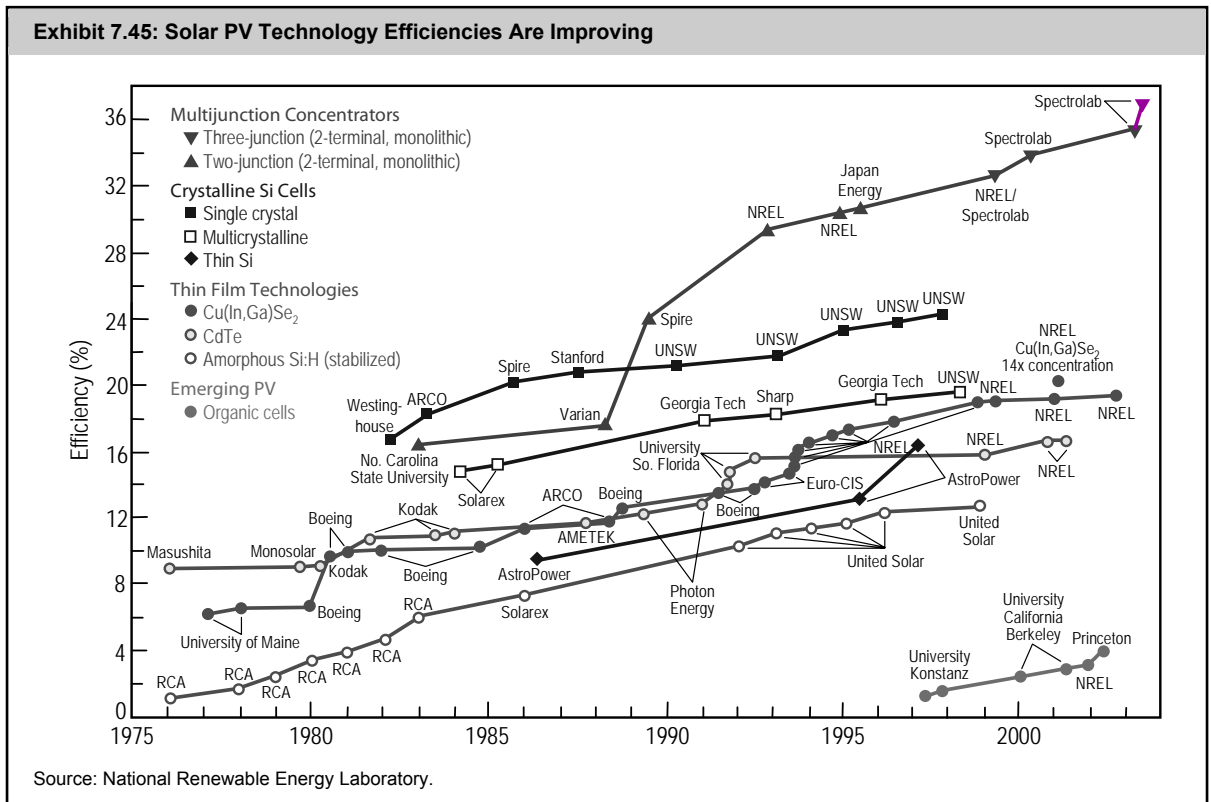

On August 14, PG&E placed an order for 800 MW of solar PV capacity, which is due to be commissioned between 2010 and 2011. The project is dependent on an extension of the U.S. Production Tax Credit.

PV'S CHALLENGES: COST REDUCTIONS NEEDED IN MANY AREAS

Silicon, the primary material used to develop most solar PV systems, has been in short supply over the past several years, as it competes with demand from semiconductor chip manufacturers. In 2007, and for the first time, the solar industry used more silicon than the semiconductor industry. As a result of tight silicon supply, **the decline of the solar PV module cost curve decline has stalled for now.** On the bright side, solar-grade silicon suppliers have begun to respond to the supply/demand imbalance. New factories are coming online, which in our opinion, will ease the solar-grade silicon supply shortage by 2010. However, many solar panel producers have locked in fixed-price contracts with silicon suppliers at prices well above the spot market. **In our view, until these fixed-price supply contracts expire, panel manufacturer margins will suffer at the expense of silicon suppliers. Other challenges to solar PV include the following:**

- Some solar systems become less efficient over their lifetime;
- Efficiency (i.e., capacity factor) is poorer than other renewable technologies;
- Sunlight is an intermittent fuel source, similar to wind;
- Production of PV cells are energy intensive; and
- PV systems require a (costly) power conditioning system (i.e., DC → AC).

SunPower provides a good example of how industry-wide solar PV cost reductions may occur. **The company anticipates a 60% cost reduction by 2012, or to about \$3.5 to \$4 per installed watt** (Exhibit 7.46). Specifically, SunPower aims to reduce wafer thickness to 145 um from 250 um currently, increase its production scale to 250 MW, and open more dealers in the U.S. (150+).

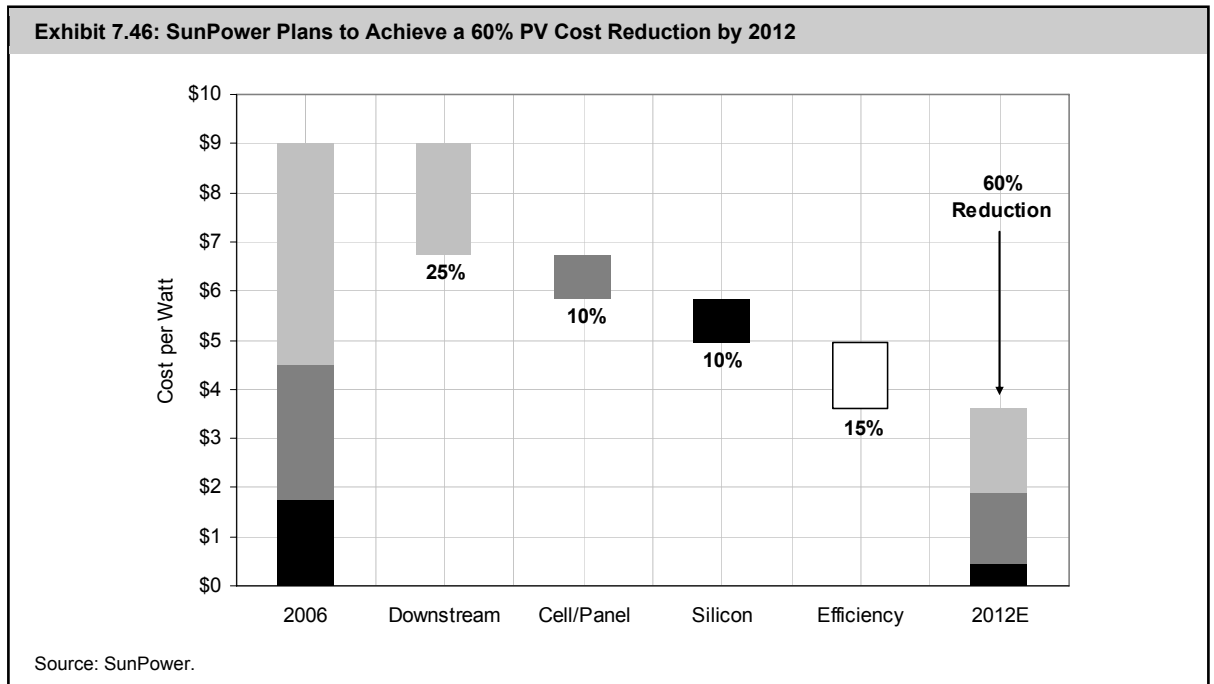

SOLAR EQUITIES: THE RISE ...

As energy prices soared throughout 2007, so did the value of most public companies that offer alternatives to fossil fuel-based power, and global solar equities were no exception. Government, media, and investor interest peaked in 2007. Solar index performance charts closely resembled those during the dot-com bubble ... before it burst. Wall Street darlings First Solar and SunPower Corporation rose about 800% and 250% in 2007, respectively. We see the following reasons for the success of solar-based public companies in 2007:

- Global solar panel **demand in 2007 far exceeded manufacturing capacity.**
- **Solar public market investment globally** hit US\$9.4 billion in 2007, over 2x and 4x the levels achieved in 2006 and 2005, respectively. Many of the solar IPOs in 2007 came from China where inexpensive labour and manufacturing subsidies are offered.
- **Government support** for solar power continued throughout 2006 and 2007, primarily with renewable portfolio standard carve-outs for solar (e.g., the Ontario Power Authority's \$420/MWh Standard Offer Contract that started in 2006).
- Talk (and hype) continued about **the grid-potential of solar power**, which if and/or when occurs on a material and near-incentive/subsidy-free basis, will cause solar PV demand to skyrocket.
- U.S. presidential candidate **Barack Obama** continued to speak out that solar power is the primary way that the U.S. can reduce its reliance on foreign oil. A poll conducted by Kelton Research in mid-2008 suggested that 94% of Americans feel "it is important for the U.S. to develop and use solar energy."

... AND FALL

Solar stocks are down 24% on average since the start of the year, despite fossil-fuel prices continuing to rise. The S&P/TSX Composite Index, Dow Jones Industrial Average, S&P 500, and Nasdaq are down 5.3%, 12.1%, 11.6%, and 7.5%, respectively. We see several reasons why these stocks are down, as follows:

- **Some institutional investors rotated out of the first wave of solar stocks and into IPOs** of the second and third waves of solar stocks, primarily to capture 2007 gains, and to take advantage of new opportunities.
- **Emerging industries tend to be volatile** until markets "figure out" reasonable multiples they are willing to pay on forward earnings.
- **Fears of global recessions and credit tightening** likely postponed many consumers' decisions to invest in solar installations, despite the soaring costs of energy.
- Margins at most stages of the solar value chain are trending or are forecast to trend downward as solar products begin the early stages of commoditization.
- **Thin-film solar market share is increasing**, at the expense of crystalline silicon-based solar manufacturers. Average thin-film efficiency levels are now in the 11% area, compared with 8.5% at the end of 2006.
- Spain has proposed reduced feed-in tariffs of €330/MWh for roof-top solar installations and €290/MWh for ground-based installations. To make matters worse, the Secretary General for Energy also proposed a 300 MW solar cap for 2009, broken down as 200 MW for roof-top capacity and 100 MW for ground capacity. **Some industry observers thought a 3,000 MW cap on the solar space in Spain for 2009 would be a negative.**

- In our opinion, **investment in the solar sector carries more political risk (i.e., unpredictable) than other renewable technologies**, simply because it is the least cost-effective technology, as well as the furthest away from grid-parity.
- There are rumours swirling that some regulatory bodies may not be “on board” with the use of Cadmium Telluride (CdTe) to produce thin-film solar. Cadmium is an extremely toxic metal, even in low concentrations.
- Although it was recently reversed, the U.S. Bureau of Land Management implemented a 22-month moratorium on new applications for solar energy development on public lands in six western states.
- The 30% U.S. investment tax credit on residential solar technologies is set to expire at the end of 2008. Perhaps more importantly, the U.S. Production Tax Credit (US\$20/MWh for solar) is also set to expire at the end of the year.

Solar PV (levelized) costs are driven by (1) the amount of sunlight available at a site; (2) the efficiency of the PV system to convert the sunlight into electricity (i.e., capacity factor); (3) the cost of panels/modules and other parts of the system (i.e., mounting, installation, etc.); (4) the cost of money; (5) operating and parts replacement costs; and (6) the costs of development (i.e., permitting, land leases, etc.). Capital costs for traditional solar PV systems (i.e., crystalline) range from \$5 million to \$7 million per MW. Exhibit 7.47 breaks down the approximate capital costs for a typical installed system, while Exhibit 7.48 shows the range of gross margins achieved in 2007 by players in the solar space.

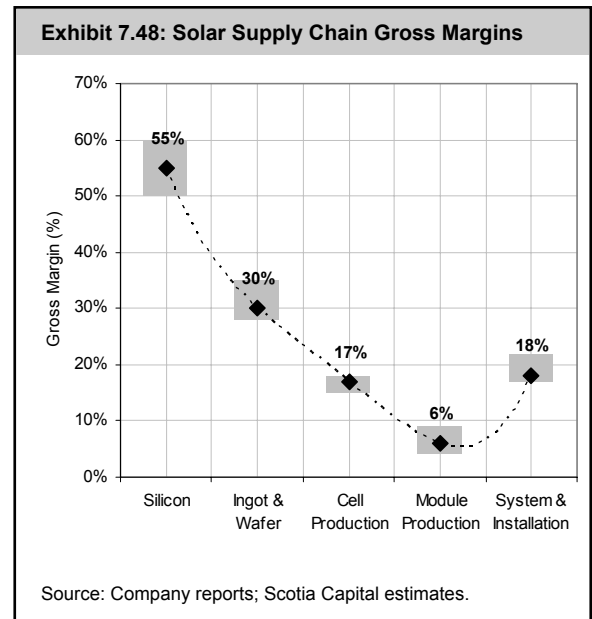
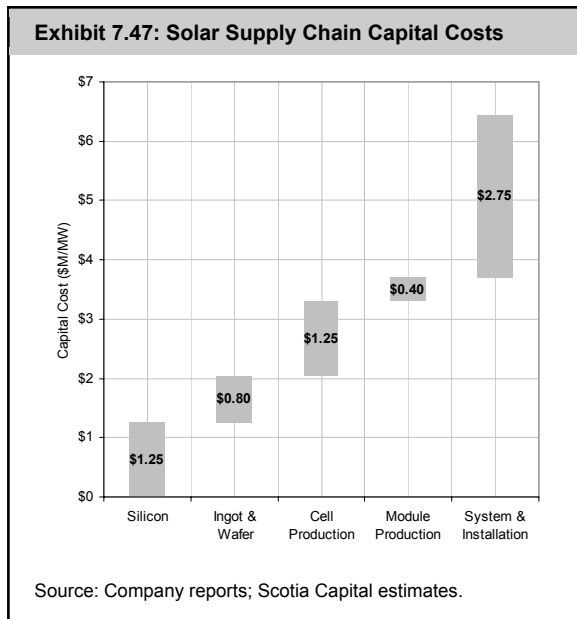

Our solar comps table is shown in Exhibit 7.70.

TESTING ONTARIO'S STANDARD OFFER CONTRACT: MODELLING & SENSITIVITY ANALYSES OF A SOLAR PROJECT

Our generic Ontario-based solar PV project yielded a 6.2% equity IRR.

Our financial modelling and analysis of generic Ontario-based solar PV power projects indicates that equity IRRs typically are fairly low, as expected. We modelled numerous scenarios and sensitized for variations in (1) installed capital cost per MW; (2) PPA prices and escalations rates; (3) capital costs and costs of capital; (3) the federal ecoENERGY incentive payment; (4) operating & maintenance costs; (5) cell efficiencies factors; (6) tax rates; and (7) carbon credits/offsets/RECs. **Our average generic solar project yielded a 6.2% equity IRR.** To arrive at this, we made the following assumptions:

- **15% gross cell efficiency.** There are many variations of solar PV cell technologies and cell efficiencies are improving quickly. We chose a 15% gross cell efficiency as our base case. We then assumed a 95% power conditioning efficiency, a 90% system efficiency, and a 90% temperature correction.
- **\$6 million per MW installed cost.** We picked the average of the most recent installed costs we have seen throughout 2008 to date.
- **Insolation of 2.4 kWh/m² per day,** based on an insolation map of Ontario (Rupprecht & Pataschnick Co., Inc.).
- **Starting PPA @ \$420/MWh.** This is the only solar-specific Standard Offer Contract in Canada. The PPA price is not eligible for inflation increases or peak-performance pricing.
- **Starting O&M @ \$5.50/MWh + 1.5% p.a.** Operating and maintenance costs, on a per MWh basis, generally range between \$5/MWh and \$8/MWh. We found that on average, a good approximation for annual solar PV O&M is 0.12% of installed capital cost.
- **Federal ecoENERGY Incentive @ \$5/MWh.** In Canada, we have seen qualified projects receive none, some, or all of the \$10/MWh federal ecoENERGY incentive payment, as PPA providers may demand the incentive payment to partially offset the higher-than-normal power prices being offered to developers. In Ontario, the ecoENERGY incentive payment of \$10/MWh is shared equally between the IPP and the Ontario Power Authority.
- **Debt to equity split 75%/25%.** We have seen project debt as a percentage of total capital invested, range between 65% and 85%. We chose the midpoint for our project capital structure, and assume that the debt is non-recourse (project specific).
- **Other.** For solar projects, PPA terms in Ontario are for 20 years. We also matched the term of debt financing to this 20-year PPA term, and assumed no merchant tail.

In Exhibit 7.49 on the following page, we provide our equity investment IRR sensitivity analyses to changes in the factors listed above.

Exhibit 7.49: Solar Project Equity IRRs Are Improving

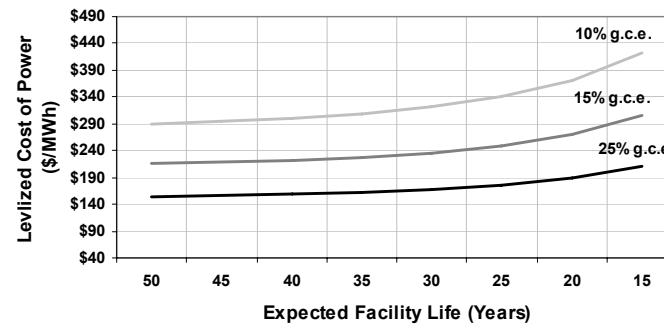
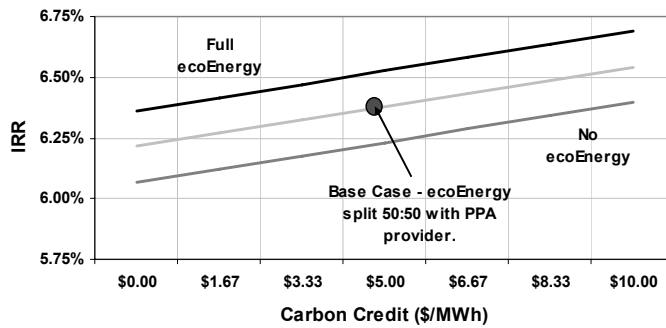
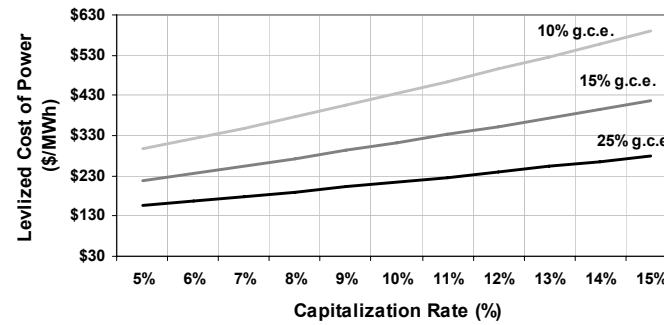
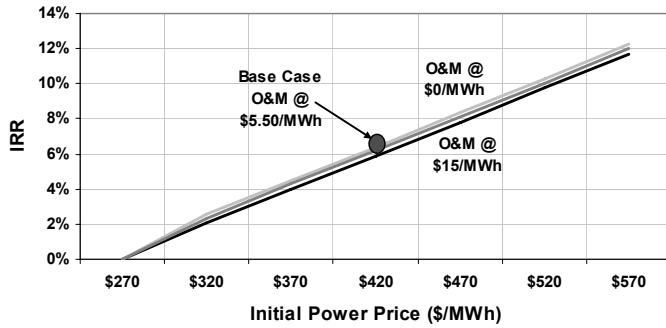
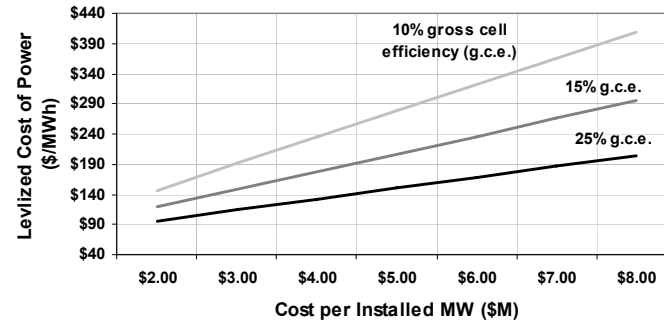
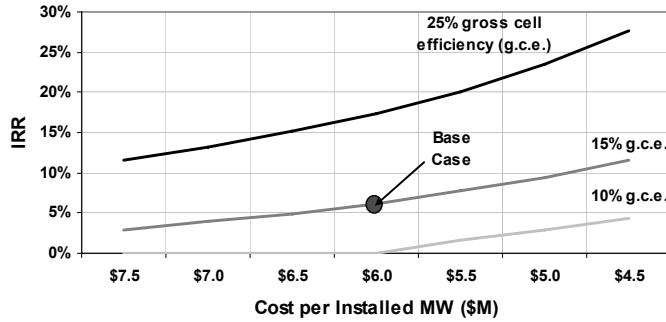

Source: Scotia Capital estimates.

Exhibit 7.50: Solar Project Equity IRRs Are Improving

		Starting PPA Price (\$/MWh)						
		\$270	\$320	\$370	\$420	\$470	\$520	\$570
Starting O&M Cost (\$/MWh)	\$15	-	2.0%	4.0%	5.9%	7.8%	9.7%	11.7%
	\$12	-	2.1%	4.1%	6.0%	7.9%	9.8%	11.8%
	\$9	-	2.2%	4.2%	6.1%	8.0%	9.9%	11.9%
	\$6	-	2.3%	4.3%	6.2%	8.1%	10.1%	12.0%
	\$5	-	2.4%	4.3%	6.2%	8.2%	10.1%	12.0%
	\$4	-	2.4%	4.4%	6.3%	8.2%	10.1%	12.1%
	\$0	-	2.5%	4.5%	6.4%	8.3%	10.3%	12.2%

		Installed Capital Cost (\$/MW)						
		\$7.5	\$7.0	\$6.5	\$6.0	\$5.5	\$5.0	\$4.5
Gross Cell Efficiency (%)	5%	-	-	-	-	-	-	-
	10%	-	-	-	-	1.7%	2.9%	4.4%
	15%	2.9%	3.9%	5.0%	6.2%	7.7%	9.5%	11.6%
	20%	7.3%	8.5%	10.0%	11.6%	13.7%	16.2%	19.4%
	25%	11.6%	13.2%	15.1%	17.4%	20.1%	23.5%	27.7%
	30%	16.2%	18.2%	20.6%	23.5%	26.9%	31.2%	36.5%
	35%	21.0%	23.5%	26.4%	29.9%	34.1%	39.2%	45.5%

		Cost of Debt (%)						
		8.00%	7.50%	7.00%	6.50%	6.00%	5.50%	5.00%
Effective Cash Tax Rate (%)	35%	2.8%	3.5%	4.1%	4.8%	5.5%	6.3%	7.0%
	30%	3.3%	3.9%	4.6%	5.3%	6.0%	6.8%	7.6%
	25%	3.7%	4.4%	5.1%	5.8%	6.5%	7.3%	8.1%
	20%	4.1%	4.8%	5.5%	6.2%	7.0%	7.8%	8.6%
	15%	4.5%	5.2%	5.9%	6.6%	7.4%	8.2%	9.1%
	10%	4.8%	5.5%	6.3%	7.0%	7.8%	8.7%	9.5%
	5%	5.2%	5.9%	6.6%	7.4%	8.3%	9.1%	10.0%

		Carbon price (\$/REC or \$/ERC or \$/MWh)						
		\$0.00	\$1.67	\$3.33	\$5.00	\$6.67	\$8.33	\$10.00
ecoEnergy (\$/MWh)	\$0.0	6.1%	6.1%	6.2%	6.2%	6.3%	6.3%	6.4%
	\$2.5	6.1%	6.2%	6.3%	6.3%	6.4%	6.4%	6.5%
	\$5.0	6.2%	6.3%	6.3%	6.4%	6.4%	6.5%	6.5%
	\$7.5	6.3%	6.3%	6.4%	6.5%	6.5%	6.6%	6.6%
	\$10.0	6.4%	6.4%	6.5%	6.5%	6.6%	6.6%	6.7%

Source: Scotia Capital estimates.

CANADIAN CONTENT

Installed grid-connected PV systems in Canada have grown an average of 25% per year since 1995. While the growth rate is half that of the global average, the Canadian market seems to be more interested in off-grid PV applications, which represents over 90% of the total installed PV capacity in Canada (Exhibit 7.51).

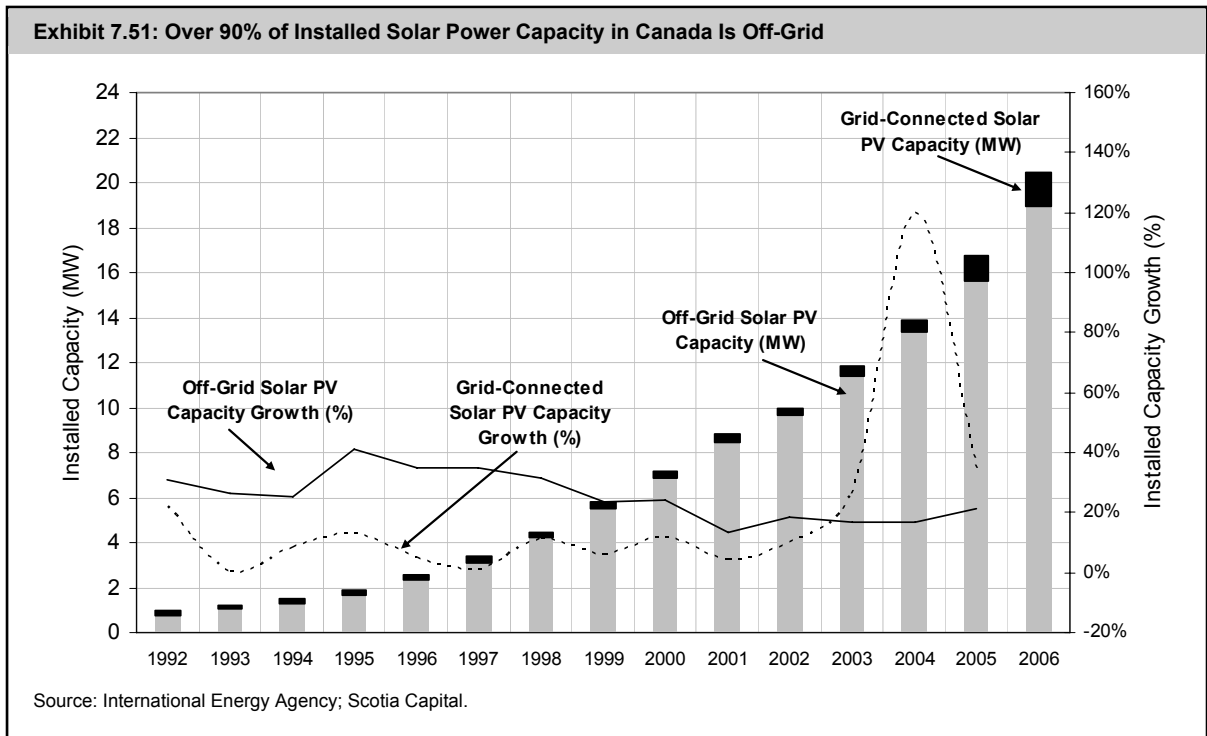

Canada has been slow to adopt grid-connected solar power, primarily due to two reasons:

1. The federal and provincial governments of Canada have not offered solar-specific feed-in tariff rates to attract substantial investment in the sector. Ontario is the exception, having offered \$420/MWh for solar power since 2006, through its Renewable Energy Standard Offer Program.
2. On average, the levelized cost to produce a MWh of solar PV power in Canada is higher than in southern U.S. states. Why: insolation is lower in Canada than in much of the U.S., requiring more modules to produce an equivalent amount of electricity (Exhibit 7.53).

There are about 200 Ontario Power Authority SOCs issued for solar projects, totalling 470 MW.

As at May 31, 2008, there were 198 Ontario Power Authority SOCs issued for solar projects, totalling 470 MW. In Canada, solar projects are considered easier than wind farms to grind through the approvals process as they do not require an environmental assessment. While municipality approval is needed, solar farms are currently allowed to be placed on agricultural- or industrial-zoned land.

In April 2008, **SkyPower** and **SunEdison Canada** announced the official groundbreaking of First Light, a 19 MW Ontario-based solar farm that will be one of the largest solar PV parks in North America. With an anticipated commissioning date of Q4/09, First Light will sell its power under an OPA 20-year standard offer contract at \$420/MWh.

Exhibit 7.52: Insolation Map – North America

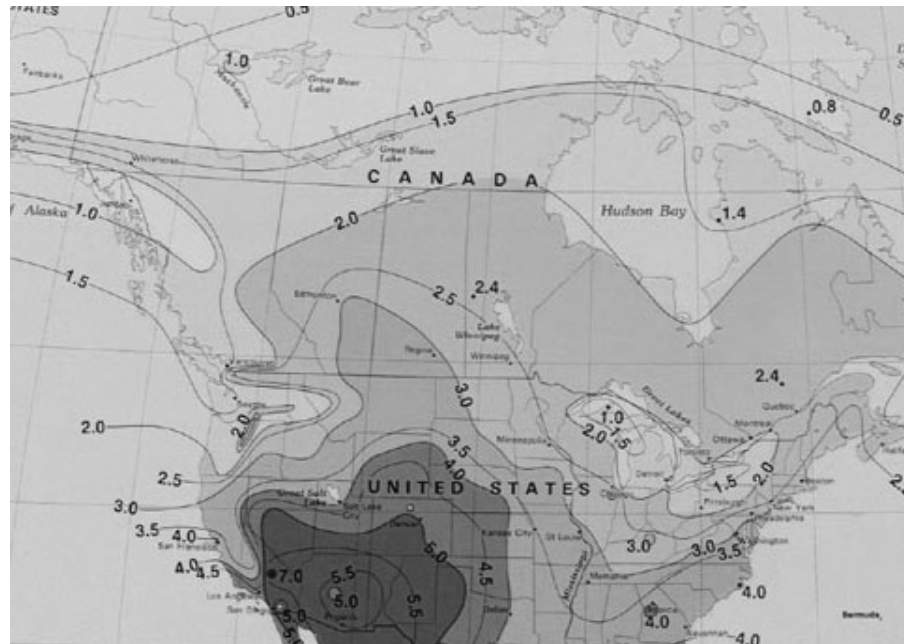

Source: Rupprecht & Patashnick Co., Inc.

OptiSolar Canada is developing three Ontario-based solar projects with a combined capacity of 90 MW. Each of the three solar farms (Petrolia @ 20 MW, Sarnia @ 50 MW, and Tillbury @ 20 MW) are expected to be operational in 2010. OptiSolar has an additional 60 MW of signed OPA contracts, although no project announcements have been made to date for these contracts.

Pod Generating Group is developing several Ontario solar projects with a total capacity of 60 MW, primarily near Sault Ste. Marie. The expected installed capital cost of the project is \$360 million, or \$6 million per MW.

On the supply side, we have provided brief summaries at the end of this section on public Canadian companies involved in the solar supply chain.

EXPECT SOLAR PV GRID PARITY IN FIVE TO SEVEN YEARS

We see solar PV prices declining quickly over the next decade, while capital costs for fossil fuel-fired and nuclear power plants continue to escalate. Grid parity, the point where the cost of producing PV power becomes equivalent to the cost to produce power from conventional sources, could be achieved by 2013 to 2015. Logically, grid parity will first be achieved in those markets with higher-than-average power prices. Exhibits 7.53 and 7.54 show U.S. locations that may achieve solar PV power grid parity first, assuming that solar costs decline as expected, and that power prices there rise close to 2% per year.

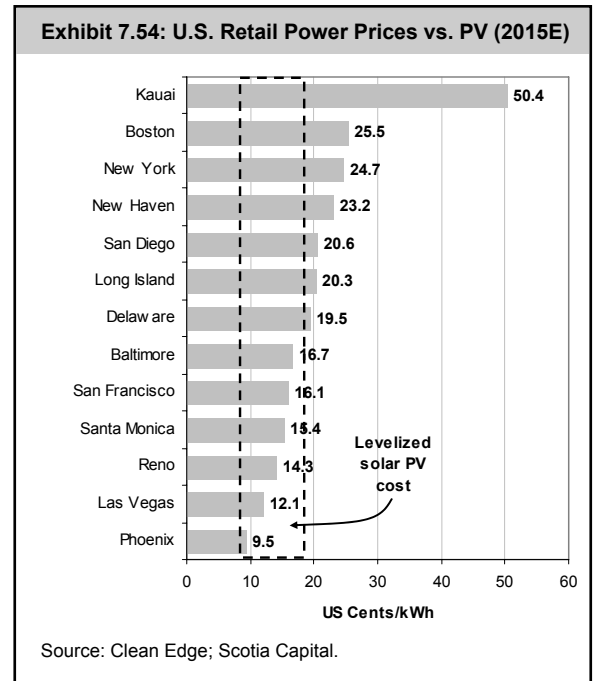
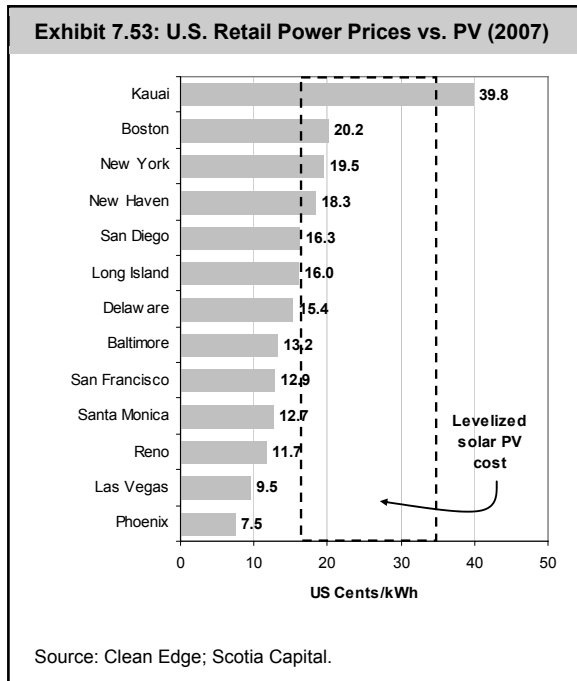

SOLAR PV TRENDS & OBSERVATIONS

PV companies are moving to thinner silicon wafers and solar cells with higher efficiencies, primarily to reduce silicon costs per kW.

Thin-film solar technologies are regaining market share on crystalline-based technologies.

Thin-film solar technologies are regaining market share on crystalline-based technologies, and we expect this trend to continue through the mid-term. Exhibit 7.55 shows the average change over time in solar technology market share based on various consultant and trade association forecasts. **If all announced thin-film production capacity increases are realized, almost 6,000 MW of thin-film production could be reached by 2010.**

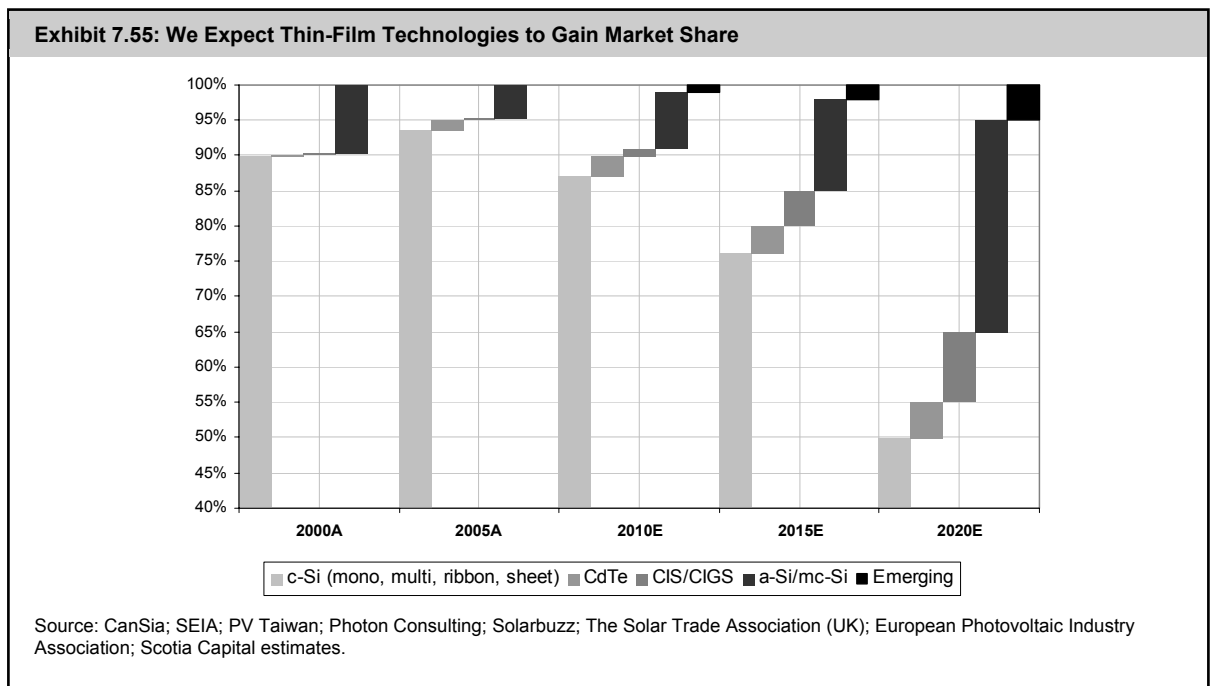

Solar PV feed-in tariff rates are declining to force cost reductions for margin preservation.

Solar PV feed-in tariff rates are declining to force cost reductions for margin preservation. As solar power has not reached grid parity, the market for PV-based electricity is to a large extent dependent on the political framework of a given country.

Some solar PV optimists believe that a massive switch from fossil fuel and nuclear plants to solar power plants could supply over 65% of the U.S.'s electricity and over 35% of its total energy (including transportation) requirements by 2050. Highlights: (1) massive amounts of desert land in the U.S. southwest would be covered with PV panels and solar heating troughs, replacing 300 coal-fired plants and 300 natural gas plants; (2) a direct-current (DC) transmission system would be required to send the energy across the nation; (3) the federal government would need to spend \$400 billion to \$500 billion over the next 40 years; and (4) cadmium telluride efficiency would need to rise to 14% and installed capital costs to decline to \$1.2 million per MW. These modules currently have an efficiency rate of 10% (up 1% over the past year) and have an average installed capital cost of \$4 million per MW. Ohio-based First Solar managed to increase the efficiency of the technology to 10% from 6% since 2005. Their goal is to achieve an 11.5% efficiency rate by 2010.

SOLAR SUPPLY/DEMAND OUTLOOK: TOO MANY (SILICON) COOKS SPOIL THE (INVESTMENT) BROTH

In our view, the supply/demand imbalance surrounding the tight silicon market of the past several years will likely come to end next year, with a surplus position emerging in 2010. Capacity addition announcements from many suppliers have been driven primarily by a surge in the spot price for solar-grade polysilicon. In 2008, spot prices for polysilicon soared past US\$500/kg, and over 16x the US\$30/kg level seen in 2004.

The top five polysilicon producers have announced production capacity expansions of over 54,000 tonnes, or more than double current capacity. Additionally, we see at least a further 40,000 tonnes of potential new capacity coming from new entrants and companies that have proposed blended polysilicon solutions.

On the demand side, feed-in tariff price decreases in Germany and Spain, coupled with a 300 MW solar cap in Spain for 2009, will likely stabilize to lower demand growth next year. In 2007, Spain and Germany were the two hottest markets for installed solar PV capacity installations.

In addition to capacity ramp-ups from existing players, new entrant capacity is expected to come online as well, over the next several years. Elkem in Norway, Dow Corning in Brazil, and Timminco are all expected to increase production by blending metals with virgin polysilicon. At a blended rate of 30%, Timminco's plans alone will account for over 14,000 tonnes of solar grade silicon.

Exhibit 7.56 shows our supply/demand outlook over the next several years.

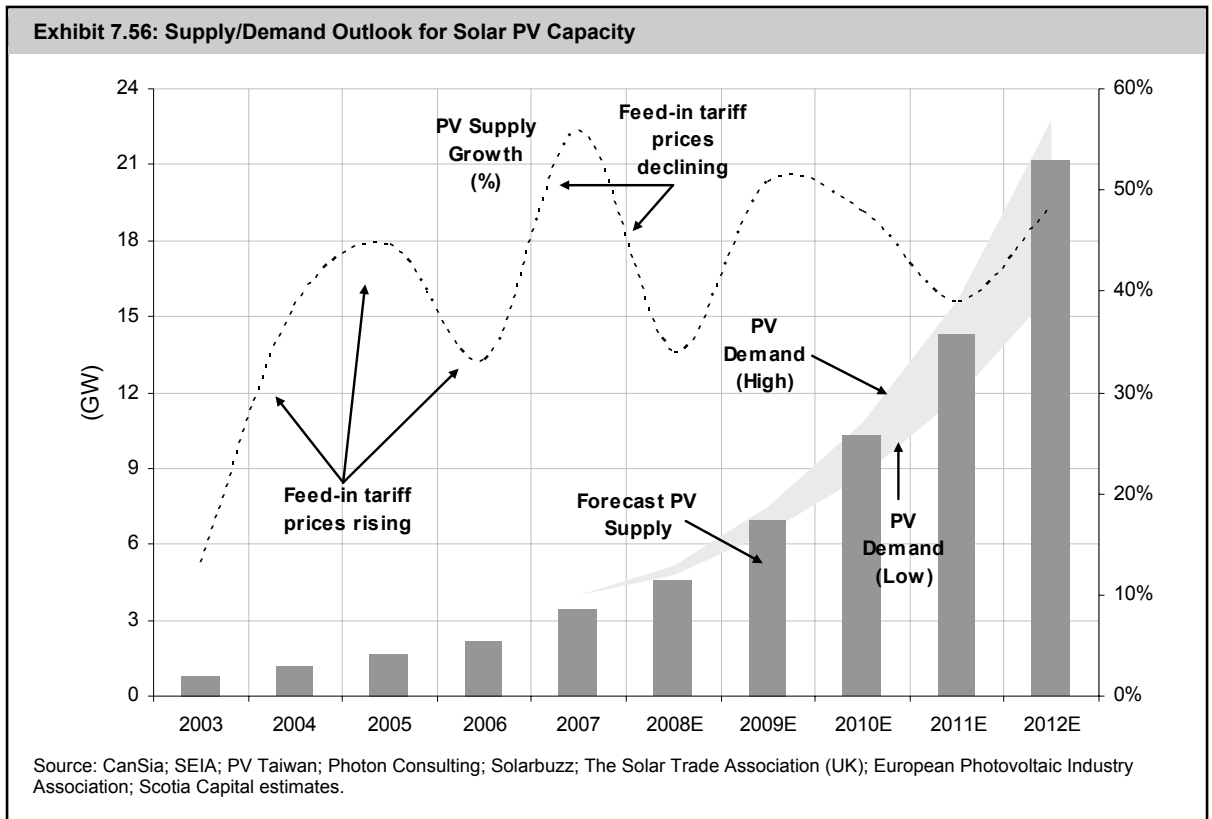

PHOTOVOLTAICS SCIENCE & TECHNOLOGY 101

Simply put, **photovoltaic technology converts the sun's energy into electricity**, unlike a solar thermal system that generates electricity from hot water. Solar panels, which can be seen on rooftops, the sides of highways, or in solar parks, are packages of interconnected devices known as solar cells. Within a solar cell lies a semiconductor material, traditionally silicon-based, which when hit by photons from the sun, knocks loose electrons that flow through the cell to create electricity.

The solar photovoltaic value chain consists of seven parts: (1) production of a solar-grade **semiconductor** material such as silicon; (2) casting of **ingots**; (3) cutting/slicing of ingots into **wafers**; (4) production of a **solar cell**; (5) the interconnection of numerous cells to form a **module**; (6) the packaging or casing of a module, which becomes a **solar array**; and (7) the **installation, testing, and commissioning** of the solar PV system. While the above list is representative of a typical solar PV value chain, there are numerous variations to this. Exhibit 7.58 shows a typical production process of a crystalline-based solar system.

Crystalline

Until the turn of the century, the majority of solar cells were made from pure monocrystalline silicon (c-Si), having virtually no defects or impurities. Using the Czochralski process, c-Si is grown from a small crystal that is slowly pulled out of a molten mass (Exhibit 7.57). Polycrystalline silicon (poly-Si), which contains randomly packed grains of c-Si, is produced by slowly cooling a container filled with molten silicon. Cube-shaped ingots are then cut using fine wire saws into thin square wafers. **Poly-Si PV cells are easier and less expensive to manufacture than c-Si cells, but are also less efficient.**

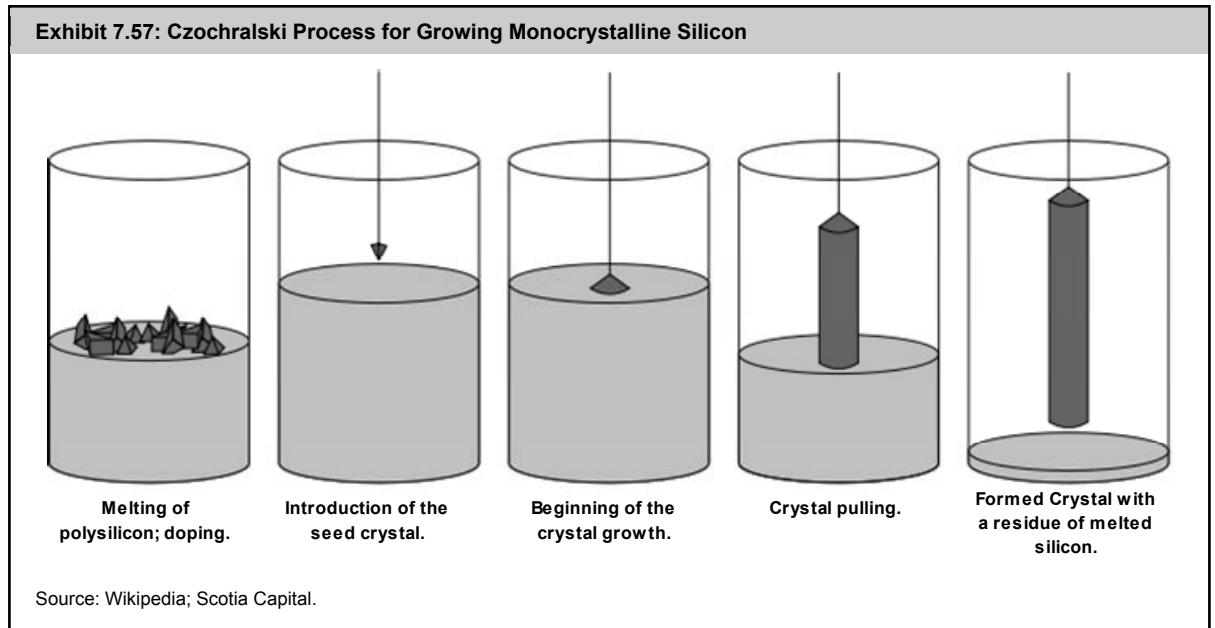

Edge-defined, film-fed growth (EFG) involves drawing thin ribbons or sheets of multicrystalline silicon (mc-Si). Thin, hollow polygonal tubes of mc-Si are slowly pulled through a die from a “melt” of pure silicon, then cut by laser into individual cells. As the sawing requirements for c-Si, poly-Si, and multi-Si are eliminated, material use/waste is reduced, lowering costs.

Exhibit 7.58: Typical Solar PV Panel Production Process

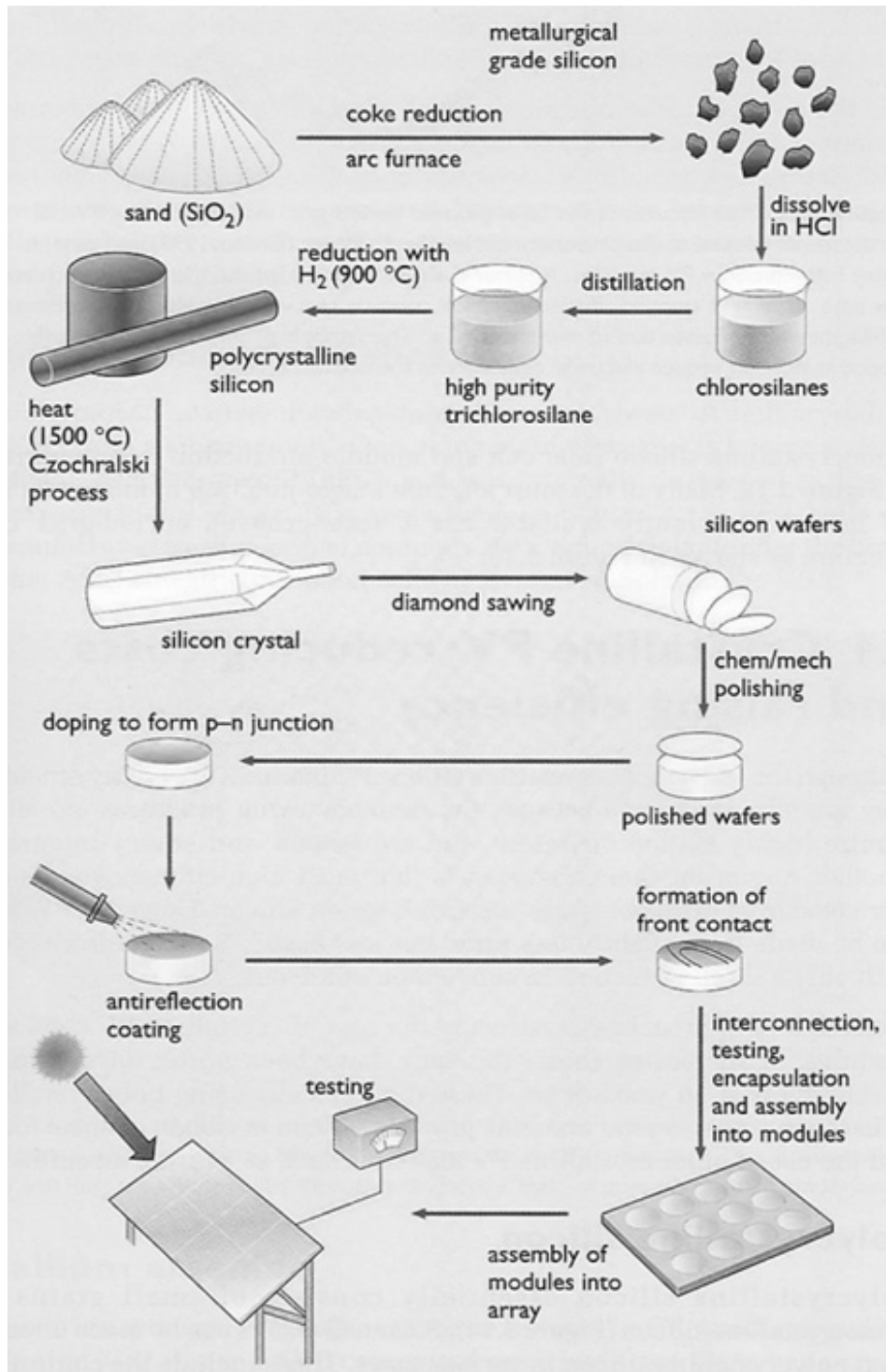

Source: Renewable Energy: Power for a Sustainable Future; Second Edition.

Thin-Films

Solar thin-film modules, which typically use one-micron-thick films of materials, are cheaper to manufacture relative to crystalline-based modules. Why: (1) thin-films can generally be much more efficient at absorbing sunlight than “thick” wafers; (2) relatively less PV material is needed, greatly reducing costs; and (3) the production techniques of thin-films are well suited for mass production.

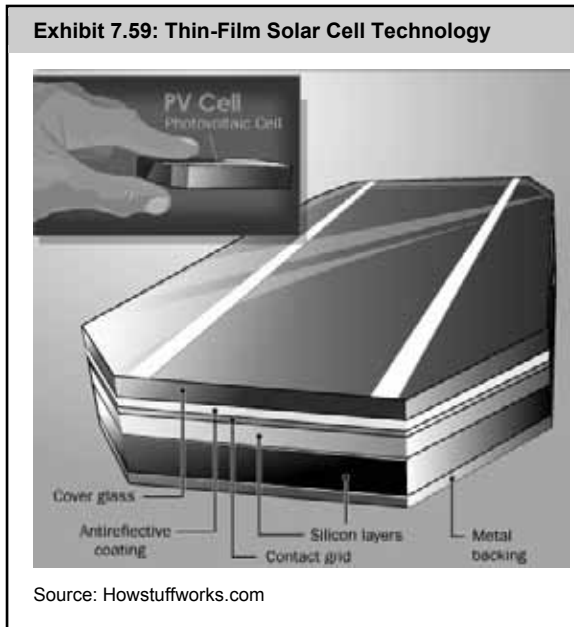

While amorphous silicon (a-Si) has received the most attention to date, performance typically degrades during the first year of operation, stabilizing between 4% and 8%. Some of the most promising thin-film technologies are those based on compound materials such as copper indium diselenide (CIS), copper indium gallium diselenide (CIGS), and cadmium telluride (CdTe). In early 2008, Global Solar Inc. claimed it had achieved a 10% average efficiency rate on a CIGS-based thin-film module. Exhibit 7.59 shows a schematic of typical thin-film solar technology.

Solar Concentrator Systems

Solar concentrator systems likely hold the most promise for utility-scale, grid-connected photovoltaic systems. Why: (1) concentrators reduce the amount of solar cells required to generate an equivalent amount of output; (2) capital

costs are less expensive on a per watt basis; (3) solar concentrators can use a much larger part of the light spectrum than standard solar cells; and (4) the potential exists for relatively larger module sizes than traditional solar PV modules.

In 2007, over 70 MW of new CSP systems were installed globally, and hundreds of CSP-based megawatts are currently being developed. According to the Solar Industries Association (SEIA), more than 4,000 MW of CSP plants are in the pipeline with signed PPAs, half of which are in Europe.

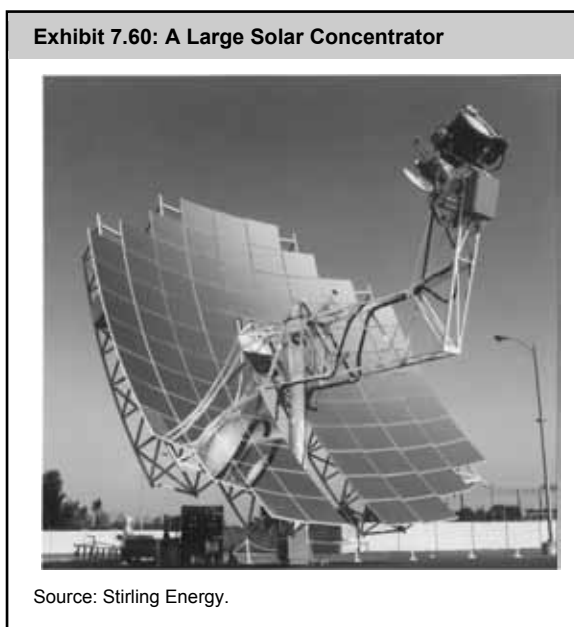

Concentrator systems use mirrors or lenses to focus incoming solar radiation onto solar cells. Concentration ratios can vary from two to several hundred to 2,500x that of a solar cell. However, in concentrating PV systems, the cells need to be cooled to prevent overheating. High-ratio concentrators use motors that allow the device to track the sun on two axes, ensuring that the cells always receive the maximum amount of solar radiation. One shortfall of concentrator systems is that direct sunlight is required to utilize the system, unlike crystalline technologies. In countries such as Canada, Germany, and the U.K., where a large part of solar radiation is diffuse, solar concentrators may be impractical.

EMERGING PHOTOVOLTAIC TECHNOLOGIES & CONCEPTS

Most solar technology R&D is primarily focused on reducing production costs while also increasing energy efficiency levels. The majority of the R&D work that we have seen is chemical based, with new and less expensive materials beginning to replace polysilicon. Here we summarize select emerging solar PV technologies.

Nanoparticle Ink

Nanoparticle ink provides material advantages over both thin-film and crystalline technologies as it reduces material waste, allows production economies of scale, and does not require capital intensive clean-room technology. **NanoSolar**, a private U.S.-based company, has reportedly achieved 1 GW of production using its proprietary nanoparticle ink that the company says can achieve **efficiencies of 14%**. It uses a printing press-like technology and deploys ink at over 100 feet per minute.

Solar Paints/Polymers

The **New Jersey Institute of Technology** has developed a solar cell that can be **painted or printed** on flexible plastic sheets. The technology is not directed towards large utilities for grid-connection, but the commercialization potential of this low-cost process appears strong. Carbon nanotubes that are combined with technology developed by **Konarka Technologies** have demonstrated the ability to manufacture solar cells by **inkjet printing**. Konarka's technology uses roll-to-roll methods similar to that used by the newspaper industry to print newspapers, which are then printed onto flexible ribbon materials.

Exhibit 7.61: EnviroMission's Solar Tower

Source: EnviroMission.

Organic Solar Cells

Organic solar cell R&D is booming. However, **we do not expect the flexible technology to compete with classic silicon cells as they are not nearly as efficient**, for now.

Other Solar Concepts

EnviroMission, an Australia-based public company, is in the process of developing a kilometre-high solar tower that could generate up to 200 MW by using solar thermal energy to turn 34 turbines (Exhibit 7.61). **The expected cost of the project has been estimated at \$1 billion.**

Exhibit 7.62: CSEM's Solar Island Prototype

Source: Solarislands.com; Cleantechnica.com.

The **Swiss Center for Electronics (CSEM)** has proposed a solar-island concept, designed to improve the performance of CPV technologies. The island would be up to 5 km wide and supported by a floatation device similar to a very large air mattress. To improve on the limitations of current tracking technology, the entire island would rotate to track the sun. A prototype is currently being developed in the United Arab Emirates and is expected to be completed in Q4/08 (Exhibit 7.62).

5N PLUS INC.

5N Plus (VNP-T) is a manufacturer of refined metals for use in several applications (primarily solar panels) and is the key supplier of cadmium telluride (CdTe) to one of the leading producers of thin-film technologies, First Solar. In addition to supplying cadmium and telluride, VNP also produces zinc, antimony, and bismuth. **VNP has secured long-term supply agreements with several customers, which over the next three years are expected by the company to comprise about 50% of its revenue.** One of the key risks of 5N Plus remains its dependence on First Solar, which accounts for over 50% of its current revenue base. VNP’s agreements with First Solar represent the potential to earn up to \$37 million per year, depending on volume supplied and other services provided (e.g., recycling). On July 29, VNP announced the opening of its new German facility that will begin shipping cadmium telluride and other products.

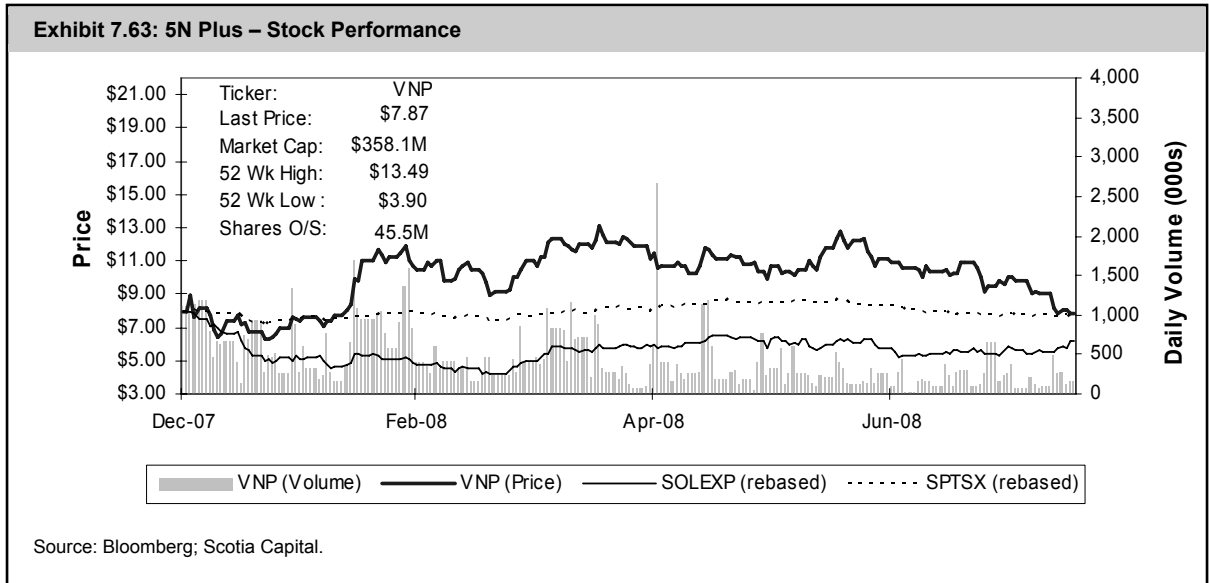

ARISE TECHNOLOGIES CORPORATION

Arise Technologies (APV-T) operates three business units in the solar value chain: (1) PV Cell Technology; (2) PV Silicon Technology; and (3) PV System Solutions. APV has proprietary technologies in both the cell and silicon divisions and aims to achieve thin-film cell efficiencies between 15% and 20%.

Its proprietary manufacturing process removes several steps from the typical (Siemens) process, which it claims reduces capital and operating costs by more than 50%. Its silicon manufacturing division is not expected to reach 10,400 tonnes per year of capacity until at least 2011. The capital cost of its planned 10,000 tonne per year plant is estimated by the company to range between \$0.5 billion to \$0.7 billion. In its cell division, Arise anticipates achieving capacity of 560 MW by 2012.

APV’s PV System Solutions unit is focused on Ontario’s Standard Offer Program. The firm intends to implement a vertical integration strategy and use its position at the back end of the solar chain to take advantage of what it sees as a major supply demand imbalance between electricity prices and solar operating costs by 2011/12.

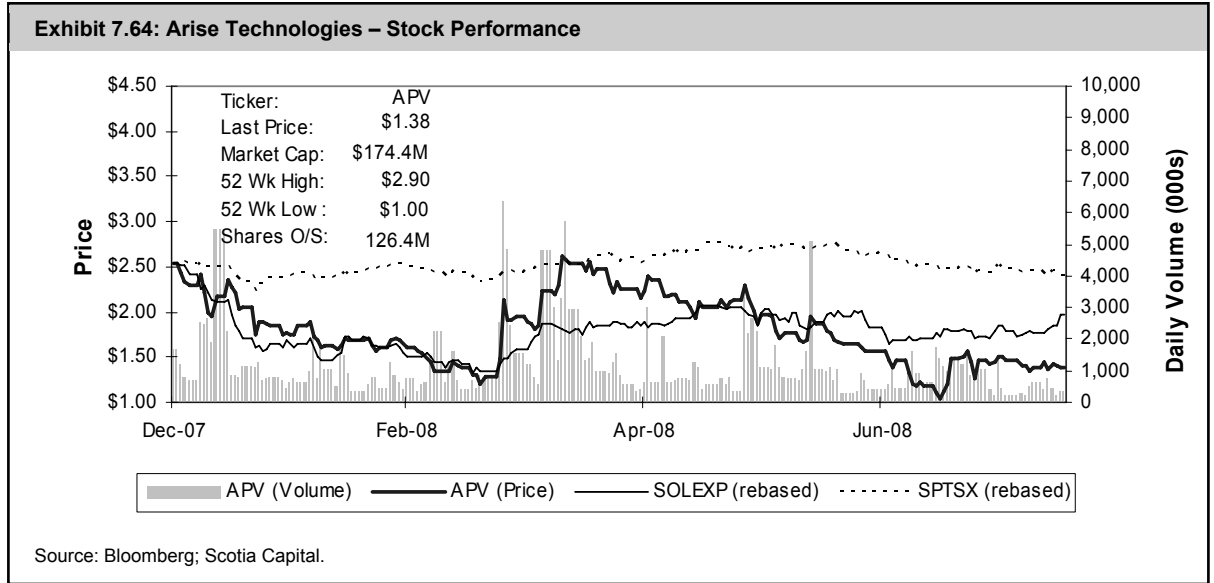

ATS AUTOMATION TOOLING SYSTEM INC.

ATS Automation (ATA-T), through its fully owned subsidiary Photowatt Technologies, manufactures ingots, wafers, cells, and solar modules for the crystalline solar market. The company’s solar division currently operates 60 MW and has capacity expansion plans over the coming years. Higher cell efficiency and lower manufacturing costs returned Photowatt to profitability in its most recent quarter. Additionally, PV Alliance, a JV between Photowatt and a subsidiary of Electricite de France, was formed to increase cell efficiency by a further 2%.

ATS intends to separate its solar division into a stand-alone company upon the implementation of the following initiatives: (1) fix operations in the existing facility in France (i.e., cell efficiency, yield, and profitability); (2) secure silicon feedstock; and (3) prepare for increased scale. **Our analyst that covers ATA believes it is difficult to assess the timing of this separation/divesture.**

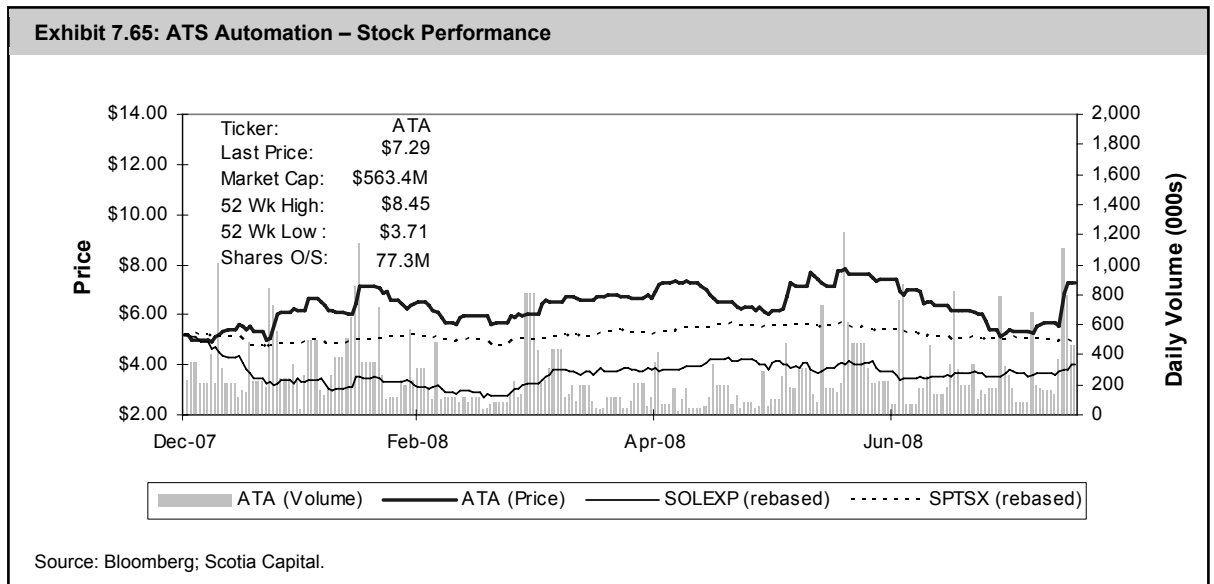

CARMANAH TECHNOLOGIES CORPORATION

Carmanah Technologies (CMH-T) is primarily a solar integrator, delivering stand-alone solar lighting and solar power systems for industrial applications. The company underwent explosive growth from 2001 to 2006, with sales increasing by 20x to \$60 million over the five-year period. Since then, CMH has restructured its business, and has divested certain product lines. Part of this restructuring also included the hiring of a new management team as well as the installation of a new board of directors. Going forward, the company plans to focus on: (1) solar LED lighting – used in the marine, aviation, industrial, and traffic markets; and (2) solar power systems, for the oil and gas, telecom, and security markets. Twenty of the top 25 grid-tie solar installations in Canada were completed by Carmanah.

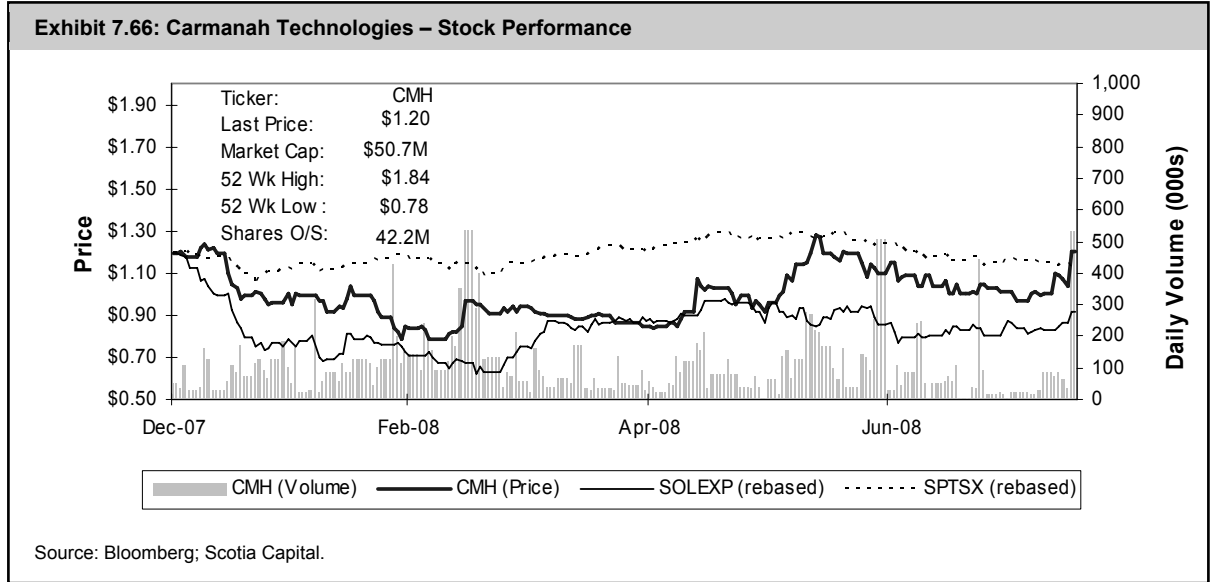

DAY4 ENERGY INC.

Day4 Energy (DFE-T) manufactures multicrystalline silicon-based solar PV modules. The company also engages in R&D in support of its Day4 proprietary technology that increases the efficiency of solar modules by reducing the resistance of normal solar panels. **Day4 Energy’s cell design has demonstrated 18.5% efficiency, compared with the industry average of 16%.**

Since Q3/07, Day4 has operated at full capacity (12 MW), and has a backlog of 153 MW. The backlog is split as follows: 32 MW due in 2008, 55 MW in 2009, and 66 MW in 2010. To meet the surge in demand for its products, Day4 expects to reach 90 MW of capacity by the end of the year. On July 15, DFE announced that it had increased its production capacity by almost 300% to 47 MW, well on its way to meeting its 90 MW target by the end of 2008. DFE has entered into multiple panel supply agreements to meet most of its contracted sales for 2008 and 2009.

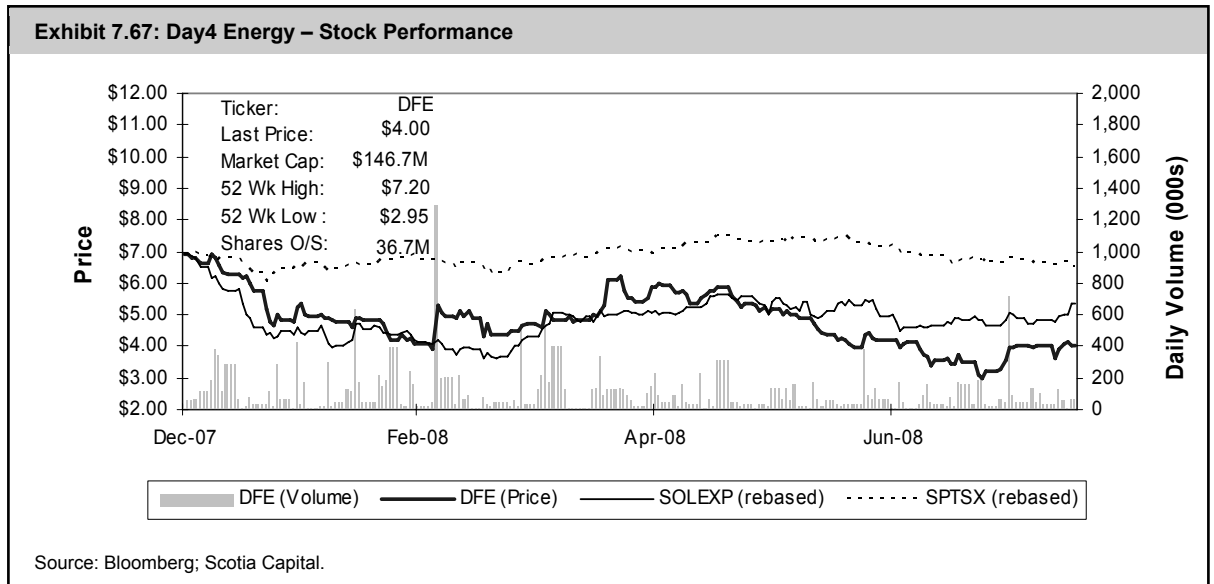

OPEL INTERNATIONAL INC.

Opel International (OPL-V) is a developer of solar concentrating systems and infrared sensor products used in military and industrial applications. OPL’s CPV systems generate up to 40% more kWh than conventional fixed solar panels. Additionally, OPL is developing gallium arsenide processes and semi-conductor microchip products.

The company is still in its infancy, with less than \$1 million of revenue in 2007 and no profits to date. However, OPL expects to transition to profitability in 2008. OPL has entered into a long-term supply contract with Boeing-Spectrolab for volume supply of its triple-junction high efficiency solar cells. Additionally, the company recently shipped its first trial installations of its high-density concentrator systems to customers in California and the Czech Republic.

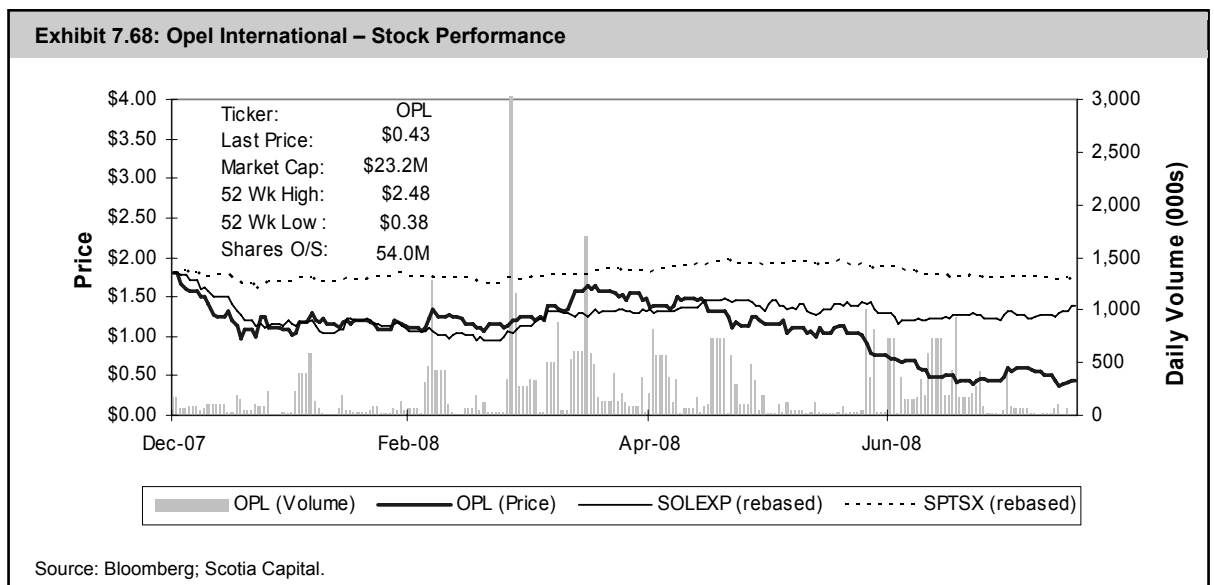

TIMMINCO LIMITED

Timminco (TIM-T) is a light metals producer with magnesium and silicon operations in Canada, the U.S., Australia, Mexico and Norway. Historically, TIM focused on only magnesium production, but in 2004 entered the solar market with the acquisition of Becancour Silicon. The company has a patented technology that produces a **somewhat impure** silicon metal that materially reduces the cost of producing solar grade silicon when blended with polysilicon. **Timminco is positioning its magnesium business and aluminum wheels investment for divestures as it wants to focus entirely on the solar market.**

The Becancour plant, located 125 km southwest of Quebec City, is one of North America's largest silicon production plants. The company's patented Silbec process produces silicon at substantially lower cost than typical plants, with an expected nominal cost of \$10 to \$15/kg. **TIM has a backlog for all of 2008 production and aims to expand its production capacity to over 14,000 tonnes per year by Q3/09.**

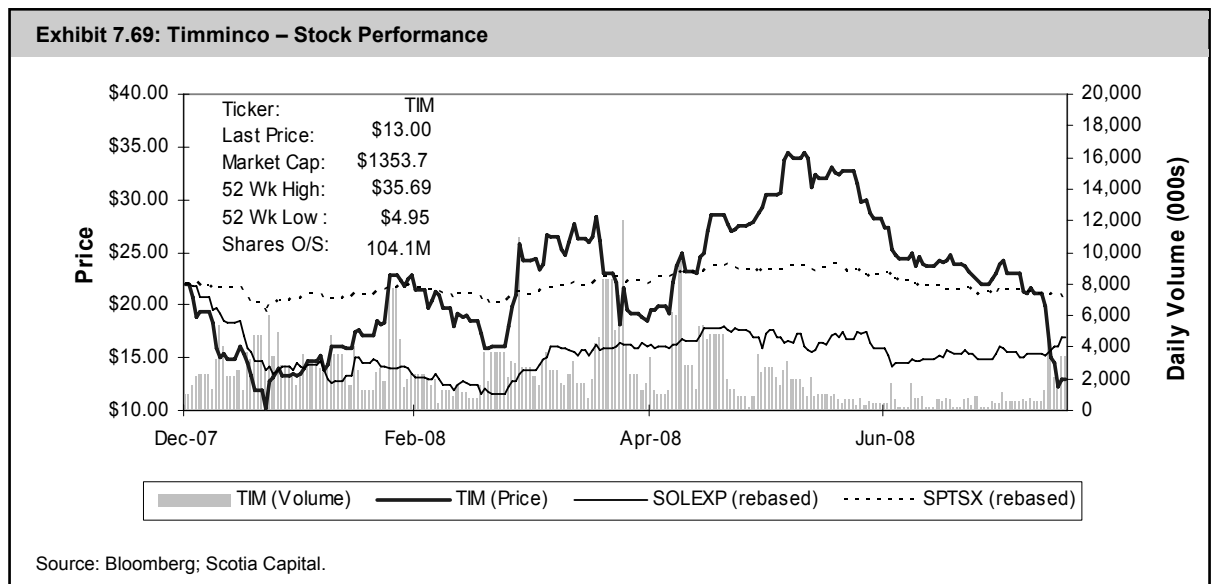

Exhibit 7.70: Solar PV Chain Valuation Metrics

Sub Sector	Company Name	Ticker	Last Price (8/15/2008)	52-Wk Low	52-Wk High	Shares O/S (M)	Market Cap (C\$M)	Debt/Equity (%)	Debt/Assets (%)	Debt/EBITDA (x)	1-Month ROR (%)	3-Month ROR (%)	1-Year ROR (%)
Silicon	5N Plus	VNP	\$7.87	\$3.00	\$13.49	45.5	\$358	3%	2%	-	-23%	-30%	-
Silicon	Timminco	TIM	\$13.00	\$4.95	\$35.69	104.1	\$1,354	6%	4%	n.m.	-47%	-54%	139%
Silicon	Wacker Chemie	WCH	€118.73	€110.48	€199.07	52.2	\$9,643	12%	5%	0.2x	-4%	-29%	-14%
Wafers	AXT	AXTI	US\$3.49	US\$3.37	US\$7.20	30.4	\$113	7%	5%	0.7x	-22%	-28%	-25%
Wafers	LDK Solar	LDK	US\$42.80	US\$19.64	US\$76.75	106.0	\$4,809	125%	36%	5.4x	21%	15%	4%
Wafers	MEMC	WFR	US\$49.86	US\$41.58	US\$96.08	225.9	\$11,934	1%	1%	0.0x	-7%	-32%	-8%
Wafers	PV Crystalox	PVCS	£1.63	£1.03	£2.02	416.7	\$1,343	-	-	-	-2%	-2%	55%
Upstream	Canadian Solar	CSIQ	US\$28.26	US\$7.08	US\$51.80	35.6	\$1,067	56%	29%	-	-10%	-37%	289%
Upstream	Renewable Energy Corp.	REC	NOK152.75	NOK108.25	NOK306.50	494.3	\$14,762	24%	15%	0.9x	6%	-13%	-21%
Cells	China Sunergy	CSUN	US\$9.05	US\$4.83	US\$19.23	39.6	\$379	64%	37%	7.2x	22%	-37%	26%
Cells	E-Ton	3452	NT\$275.00	NT\$137.52	NT\$294.50	100.9	\$938	190%	63%	14.2x	5%	4%	28%
Cells	JA Solar	JASO	US\$16.50	US\$9.66	US\$27.00	154.4	\$2,699	39%	25%	-	3%	-34%	62%
Cells	Q-Cells	QCE	€60.03	€44.59	€102.85	112.6	\$10,527	23%	16%	1.6x	0%	-22%	2%
Midstream	Daystar Technologies	DSTI	US\$3.27	US\$2.35	US\$7.71	33.4	\$116	-	-	n.m.	4%	-30%	-17%
Midstream	Energy Conversion Devices	ENR	US\$70.07	US\$20.47	US\$83.33	45.1	\$3,345	5%	4%	4.3x	3%	23%	132%
Midstream	Evergreen Solar	ESLR	US\$9.58	US\$7.52	US\$18.85	164.7	\$1,672	18%	13%	n.m.	-7%	1%	8%
Midstream	Motech	6244	NT\$171.00	NT\$139.63	NT\$333.02	249.5	\$1,441	21%	16%	1.0x	-5%	-26%	-21%
Midstream	Solarfun Power	SOLF	US\$15.17	US\$8.95	US\$40.19	53.8	\$865	120%	48%	-	2%	-34%	49%
Midstream	Suntech Power	STP	US\$37.38	US\$28.19	US\$90.00	153.1	\$6,065	159%	56%	-	2%	-19%	8%
Midstream	Sunways	SWW	€6.70	€5.90	€10.49	11.4	\$119	21%	10%	1.1x	-6%	-1%	-15%
Midstream	Trina Solar	TSL	US\$30.98	US\$25.33	US\$68.26	25.6	\$841	68%	37%	-	1%	-37%	-32%
Modules	Carmanah Technologies	CMH	\$1.20	\$0.78	\$1.84	42.2	\$51	-	-	n.m.	14%	17%	-25%
Modules	Day4 Energy	DFE	\$4.00	\$2.95	\$7.25	36.7	\$147	1%	1%	-	8%	-32%	-
Modules	First Solar	FSLR	US\$264.92	US\$79.23	US\$317.00	80.0	\$22,468	11%	8%	0.4x	-5%	-15%	211%
Modules	XSunX	XSNX	US\$0.38	US\$0.29	US\$0.74	182.3	\$72	-	-	n.m.	-4%	-6%	25%
Downstream	Conergy	CGY	€9.63	€7.85	€69.91	35.1	\$526	n.m.	62%	n.m.	-9%	-24%	-82%
Downstream	OPEL International	OPL	\$0.43	\$0.38	\$2.48	54.0	\$23	-	-	n.m.	2%	-67%	-57%
Downstream	Solar Fabrik	SFX	€8.95	€8.17	€19.98	11.7	\$163	12%	8%	2.3x	1%	-17%	-47%
Downstream	Solon	SOO1	€41.83	€35.00	€94.45	12.5	\$816	73%	35%	4.9x	-1%	-13%	-11%
Downstream	SunPower	SPWR	US\$92.52	US\$53.18	US\$164.49	85.1	\$8,340	44%	23%	3.1x	23%	-1%	42%
Integrated	ARISE Technologies	APV	\$1.38	\$0.60	\$3.30	126.4	\$174	34%	20%	n.m.	15%	-33%	126%
Integrated	ATS Automation	ATA	\$7.29	\$3.71	\$8.45	77.3	\$563	6%	4%	0.8x	18%	12%	26%
Integrated	Ersol Solar Energy	ES6	€101.23	€38.79	€105.00	10.7	\$1,691	45%	22%	3.0x	1%	57%	64%
Integrated	Solarworld	SWW	€30.25	€21.00	€48.81	111.7	\$5,263	90%	37%	2.5x	7%	-14%	-7%
Integrated	Yingli Green Energy	YGE	US\$15.64	US\$13.11	US\$41.50	126.9	\$2,103	63%	33%	3.2x	-6%	-37%	8%
Silicon Average							\$3,785	7%	4%	0.2x	-25%	-38%	62%
Wafers Average							\$4,550	45%	14%	2.1x	-3%	-12%	6%
Upstream Average							\$7,915	40%	22%	0.9x	-2%	-25%	134%
Cells Average							\$3,636	79%	35%	7.7x	7%	-22%	30%
Midstream Average							\$1,808	59%	26%	2.1x	-1%	-15%	14%
Modules Average							\$5,685	6%	4%	0.4x	3%	-9%	70%
Downstream Average							\$1,974	43%	32%	3.5x	3%	-24%	-31%
Integrated Average							\$1,959	48%	23%	2.4x	7%	-3%	43%
Total Average							\$3,337	46%	23%	3.0x	0%	-17%	28%

Source: Bloomberg; Scotia Capital.

Exhibit 7.70 (cont'd): Solar PV Chain Valuation Metrics

Sub Sector	Company Name	Enterprise Value to EBITDA			Price to Earnings			Price to Sales			Price to Cash Flow		
		2008E	2009E	2010E	2008E	2009E	2010E	2008E	2009E	2010E	2008E	2009E	2010E
		(x)	(x)	(x)	(x)	(x)	(x)	(x)	(x)	(x)	(x)	(x)	(x)
Silicon	5N Plus	31.3x	14.6x	10.6x	60.2x	24.6x	17.8x	12.0x	6.4x	4.7x	n.m.	n.m.	n.m.
Silicon	Timminco	27.2x	4.1x	2.6x	60.5x	7.8x	4.8x	5.4x	2.2x	1.6x	35.1x	5.7x	3.8x
Silicon	Wacker Chemie	5.2x	4.9x	4.3x	11.6x	11.1x	8.8x	1.4x	1.3x	1.2x	6.5x	6.3x	5.4x
Wafers	AXT	-	-	-	18.4x	12.7x	-	1.3x	1.1x	-	-	-	-
Wafers	LDK Solar	16.5x	7.9x	5.5x	16.6x	9.9x	5.5x	2.9x	1.9x	1.4x	24.6x	13.5x	9.0x
Wafers	MEMC	8.4x	6.7x	6.4x	12.1x	9.7x	8.7x	4.9x	3.9x	3.6x	10.9x	9.3x	8.2x
Wafers	PV Crystalox	7.5x	5.7x	4.9x	15.2x	13.3x	11.5x	3.4x	2.7x	2.3x	n.m.	17.2x	14.8x
Upstream	Canadian Solar	10.1x	6.6x	-	10.4x	7.5x	6.0x	1.0x	0.6x	0.5x	n.m.	20.8x	-
Upstream	Renewable Energy Corp.	21.2x	10.6x	6.6x	41.1x	19.9x	12.3x	8.8x	5.1x	3.5x	28.5x	14.6x	9.1x
Cells	China Sunergy	45.4x	11.4x	-	n.m.	13.7x	-	0.9x	0.6x	-	-	-	-
Cells	E-Ton	22.5x	15.2x	12.2x	18.5x	12.4x	9.2x	2.2x	1.5x	1.2x	13.5x	9.5x	8.1x
Cells	JA Solar	13.0x	8.1x	7.4x	17.2x	10.1x	10.9x	2.4x	1.3x	1.2x	14.7x	8.8x	-
Cells	Q-Cells	21.6x	14.3x	10.0x	31.1x	18.7x	13.6x	5.2x	3.2x	2.4x	26.5x	16.6x	11.4x
Midstream	Daystar Technologies	-	-	-	-	-	-	-	8.7x	3.0x	-	-	-
Midstream	Energy Conversion Devices	n.m.	32.3x	20.9x	n.m.	46.0x	26.9x	12.6x	7.1x	5.1x	n.m.	35.1x	21.6x
Midstream	Evergreen Solar	-	16.6x	7.9x	-	22.2x	9.2x	13.7x	2.7x	2.2x	n.m.	10.3x	7.5x
Midstream	Motech	10.7x	7.5x	6.3x	15.0x	10.3x	9.1x	1.8x	1.4x	1.1x	16.7x	8.7x	6.5x
Midstream	Solarfun Power	14.1x	10.3x	7.0x	16.3x	12.5x	9.0x	1.1x	0.8x	0.6x	-	-	-
Midstream	Suntech Power	18.0x	10.8x	7.6x	23.4x	14.2x	10.8x	2.7x	1.9x	1.4x	21.5x	15.6x	8.0x
Midstream	Sunways	5.9x	3.0x	1.9x	16.9x	6.4x	4.3x	0.3x	0.2x	0.2x	12.2x	4.0x	-
Midstream	Trina Solar	8.0x	4.9x	3.5x	10.0x	7.3x	3.9x	1.0x	0.6x	0.5x	7.0x	6.6x	7.1x
Modules	Carmanah Technologies	22.5x	9.3x	7.5x	n.m.	15.0x	10.3x	0.9x	0.8x	0.7x	8.3x	10.0x	10.9x
Modules	Day4 Energy	-	3.0x	1.6x	-	14.7x	4.5x	1.1x	0.4x	0.3x	n.m.	13.8x	17.4x
Modules	First Solar	45.8x	24.0x	16.7x	71.3x	38.5x	26.7x	17.4x	9.7x	7.2x	57.8x	30.6x	24.4x
Modules	XSunX	-	-	-	-	-	-	-	-	-	-	-	-
Downstream	Conergy	-	10.6x	6.5x	-	41.0x	10.2x	0.3x	0.3x	0.2x	n.m.	8.4x	5.6x
Downstream	OPEL International	n.m.	n.m.	n.m.	31.2x	3.7x	2.4x	0.8x	0.3x	0.2x	n.m.	5.8x	2.9x
Downstream	Solar Fabrik	6.3x	3.8x	2.9x	10.1x	9.4x	6.1x	0.4x	0.3x	0.3x	8.1x	6.1x	2.5x
Downstream	Solon	9.4x	7.3x	6.0x	14.0x	10.6x	8.5x	0.6x	0.4x	0.4x	9.0x	8.1x	9.0x
Downstream	SunPower	29.5x	18.0x	13.5x	41.1x	26.4x	19.9x	5.5x	3.8x	2.8x	80.3x	34.9x	19.0x
Integrated	ARISE Technologies	-	32.0x	2.9x	-	-	4.7x	3.9x	0.7x	0.4x	n.m.	n.m.	4.6x
Integrated	ATS Automation	7.9x	6.1x	-	17.0x	12.4x	-	0.7x	0.6x	-	11.8x	8.3x	-
Integrated	Ersol Solar Energy	12.2x	9.3x	7.3x	25.9x	21.1x	17.7x	3.5x	2.6x	1.9x	16.7x	12.1x	12.4x
Integrated	Solarworld	10.5x	8.0x	6.2x	21.9x	16.6x	12.8x	3.8x	2.7x	2.1x	15.8x	12.5x	9.8x
Integrated	Yingli Green Energy	10.7x	6.1x	5.0x	15.8x	9.4x	7.4x	1.8x	1.1x	1.1x	14.5x	8.5x	6.4x
Silicon Average		21.2x	7.9x	5.8x	44.1x	14.5x	10.5x	6.3x	3.3x	2.5x	20.8x	6.0x	4.6x
Wafers Average		10.8x	6.8x	5.6x	15.6x	11.4x	8.6x	3.1x	2.4x	2.4x	17.7x	13.3x	10.7x
Upstream Average		15.6x	8.6x	6.6x	25.7x	13.7x	9.2x	4.9x	2.9x	2.0x	28.5x	17.7x	9.1x
Cells Average		25.6x	12.2x	9.9x	22.3x	13.7x	11.2x	2.7x	1.7x	1.6x	18.3x	11.6x	9.7x
Midstream Average		11.3x	12.2x	7.9x	16.3x	17.0x	10.5x	4.8x	3.1x	1.8x	14.3x	13.4x	10.1x
Modules Average		34.1x	12.1x	8.6x	71.3x	22.7x	13.8x	6.4x	3.6x	2.7x	33.1x	18.1x	17.6x
Downstream Average		15.1x	9.9x	7.2x	24.1x	18.2x	9.4x	1.5x	1.0x	0.8x	32.5x	12.7x	7.8x
Integrated Average		10.3x	12.3x	5.3x	20.2x	14.9x	10.6x	2.7x	1.6x	1.4x	14.7x	10.3x	8.3x
Total Average		17.0x	10.7x	7.2x	24.7x	15.9x	10.4x	3.8x	2.4x	1.8x	21.0x	12.9x	9.8x

Source: Bloomberg; Scotia Capital.

Run-of-River – Focus on B.C.

OVERVIEW

BC Hydro estimates there are more than 8,200 commercially viable run-of-river sites in British Columbia with a potential installed capacity of over 12,000 MW, which could generate nearly 50,000 GWh of power per year. However, according to the study commissioned by BC Hydro and the BC Transmission Corporation (BCTC), **only 121 of those potential sites would cost less than \$100/MWh.** About 450 sites would cost between \$100/MWh to \$150/MWh, while the remaining 7,650+ would produce power at a cost greater than \$150/MWh. The development of new transmission lines and road infrastructure could greatly improve the cost effectiveness of many of these projects.

Currently, there are 34 operating run-of-river projects in B.C. (~3,700 GWh/y), 119 granted licences, and 546 licence applications under review at the B.C. Integrated Land Management Bureau (Exhibit 7.71). **We estimate that 95% of ILMB waterpower applications are approved.**

Exhibit 7.71: Map of Water Power Licences in British Columbia

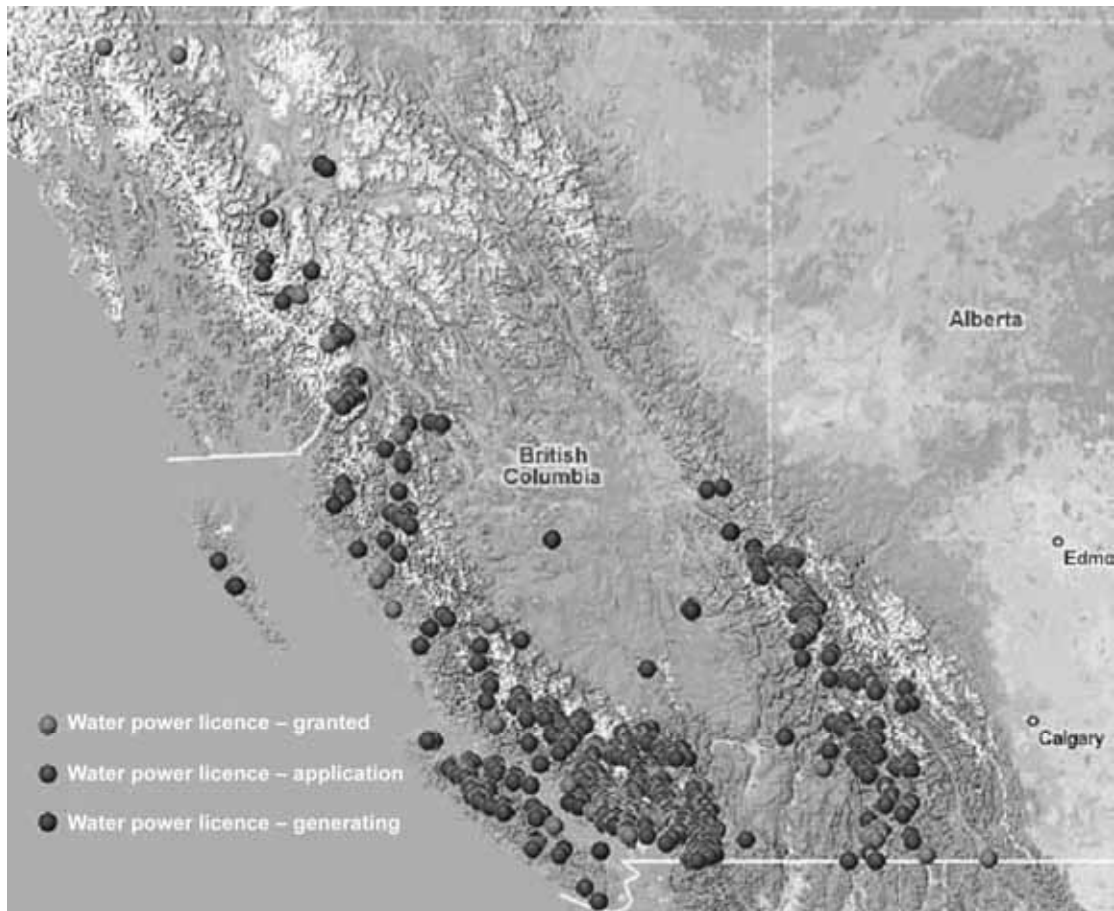

Source: www.ippwatch.com

In 2006, 29 of 38 awarded power purchase contracts in B.C. went to run-of-river hydro.

In the 2006 BC Hydro Call for Tender, the utility awarded 38 electricity purchase agreements (EPAs or PPAs) totalling an estimated 7,350 GWh/y, or **170% more than its initial request. Twenty-nine of the 38 PPAs went to run-of-river projects.** Details of the 2006 BC Hydro CFT can be reviewed in Appendix 3.

TERRIFIC OUTLOOK FOR B.C. RUN-OF-RIVER PROJECTS

In the 2007 B.C. Energy Plan, several policy action items stood out as favourable for the growth of renewable power in the province: (1) electricity self-sufficiency by 2016, plus “insurance” power to supply unexpected demand thereafter; (2) ensure clean or renewable generation continues to represent at least 90% of total generation; (3) no nuclear power; (4) establish a standing offer contract for sub-10 MW clean energy projects; and (5) all new electricity generating facilities constructed in B.C. will be required to achieve net zero green house gas emissions.

As a result of the 2007 B.C. Energy Plan, the following initiatives are either under way, or we believe will be announced within the next 12 months:

- **2008 BC Hydro Clean Power Call → 5,000 GWh/y**
- **2009/10 BC Hydro Clean Power Call → 5,000 GWh/y?**
- **Standing Offer Program → No limit and no expiry date.** The need for total or annual volume caps will be reviewed after the first two years of the program. Additionally, BC Hydro will provide a one-year notice to developers prior to the program being cancelled.
- **BC Hydro Bioenergy Call for Power → 1,000 GWh/y for Phase I, and an undetermined amount for Phase II.** While this call is not directly applicable to run-of-river, it is important to note that bioenergy-based IPPs that might have otherwise bid against run-of-river projects in Clean Power Calls or the Standing Offer Program have essentially been removed as direct run-of-river project competition.

RUN-OF-RIVER PROJECT ECONOMICS: DISTINGUISHING THE GOOD FROM THE NOT SO GOOD

Excluding soft costs such as insurance, transmission, and financing, the average capital cost of building a run-of-river generating facility in B.C. is approximately **\$2.65 million per MW**. Installed capital costs can come in as high as \$3.3 million or as low as \$2 million per MW. Plutonic Power has set an early estimate for its two bids into the Clean Power Call at about \$4 billion for 1,047 MW, or **\$3.82 million per MW, which includes all infrastructure and soft costs.**

A good run-of-river project will cost about \$0.6 to \$0.8 million per GWh/y.

While capital cost per installed MW is an industry standard metric widely used for evaluating back-of-the-envelope project economics, we believe that a more accurate metric is installed capital costs per GWh per year, as projects have wide-ranging capacity factors. According to Plutonic Power, **a good run-of-river project will cost in the \$0.6 million area per GWh/y, while a project costing \$1 million per GWh/y is considered expensive.**

Operating costs, including water rental, property taxes, insurance, etc., but excluding First Nations royalty payments, average about \$11,500/GWh, in a range from \$7,000 to \$16,000/GWh. First Nations payment structures are company-specific or even project-specific and vary substantially.

Exhibit 7.72: Run-of-River Cost Breakdown

Cost	Metric	Low	Average	High
Construction	per MW	\$2.00M	\$2.65M	\$3.30M
"	per GWh/y	\$0.60M	\$0.80M	\$1.00M
Operating	per GWh	\$7,000	\$11,500	\$16,000
Maintenance	per GWh	\$800	\$2,100	\$3,400
Levelized	per MWh	\$65	\$98	\$130

Source: Scotia Capital estimates.

While maintenance costs vary throughout the year, \$2,100/GWh is a reasonable point estimate. On the low end, maintenance costs can drop to \$800/GWh. Conversely, these costs can reach as high as \$3,400/GWh.

On an “all-in” basis, the average levelized cost per MWh for a run-of-river project is just under \$100/MWh. Excluding outliers, the lower and upper bounds of levelized costs for run-of-river projects range between \$65/MWh and \$130/MWh (Exhibit 7.72). This compares quite favourably with other sources of renewable power generation.

RUN-OF-RIVER EQUITY RETURNS ARE QUITE STRONG: MODELLING & SENSITIVITY ANALYSES OF A RUN-OF-RIVER PROJECT

In our opinion, run-of-river power projects offer equity investors IRRs slightly below that of geothermal power projects, but in line with its lower technology risk. We modelled a generic run-of-river project, and sensitized for variations in (1) PPA prices and escalation rates; (2) capital costs and costs of capital; (3) emission reduction credits or offsets; (4) the federal ecoENERGY incentive payment; (5) operating & maintenance costs; (6) capacity factor; and (7) tax rates. **Our average generic run-of-river project yielded a 14.9% equity IRR.** To arrive at this, we made the following assumptions:

- **50% capacity factor.** Our research results revealed a wide run-of-river capacity factor range of 35% to 65%, much lower than geothermal’s 90% to 95% average capacity, but almost double the average capacity factor of wind power in Canada. While our 50% assumption is higher than Plutonic Power’s weighted average forecast capacity of just under 40%, we chose to use the midpoint of the range.
- **\$4 million per MW installed cost.** In our \$4 million estimate, we have included costs associated with transmission access as well as other soft costs. Capital costs generally range from \$2 million per MW to \$3.3 million per MW, although we expect these costs to rise slightly over time. For now, we have used Plutonic’s early estimate of \$4 billion for its ~1,000 MW of run-of-river projects it intends to submit into the Clean Power Call.
- **Starting PPA @ \$120/MWh + 1.25% p.a.** For PPAs issued in the BC Hydro 2008 Clean Power Call, we estimate the average inflation-adjusted starting power price in a project’s first full year of operations will range between \$110/MWh and \$120/MWh (\$2009E). We chose the upper end of the range.
- **Starting O&M @ \$12/MWh + 1.25% p.a.** Operating and maintenance cost estimates (and actuals) have ranged between \$7/MWh to \$20/MWh. We used a weighted average cost of \$12/MWh.
- **Federal ecoENERGY incentive.** We applied a \$10/MWh ecoENERGY federal incentive payment on our generic project’s first 10 years of operation, with no adjustments for inflation, and to a maximum of \$80 million.
- **Emission reduction credits @ \$0/MWh.** In the BC Clean Power, all green attributes (i.e., ERCs) will go to BC Hydro, with no credit going to the IPP.
- **Debt to equity split 75%/25%.** This is in line with most current and proposed run-of-river project capital structures that we have seen. We assume the debt is non-recourse (project specific). **Equity investors in renewable projects (excluding geothermal) have historically required 10% annual returns,** with most falling in the 8% to 12% range. We use 10%.
- **Other.** We matched the term of debt financing to a 30-year PPA term.

In Exhibit 7.73, we provide our equity investment IRR sensitivity analyses to changes in the factors listed above.

Exhibit 7.73: Run-of-River Equity Returns Are Quite Strong

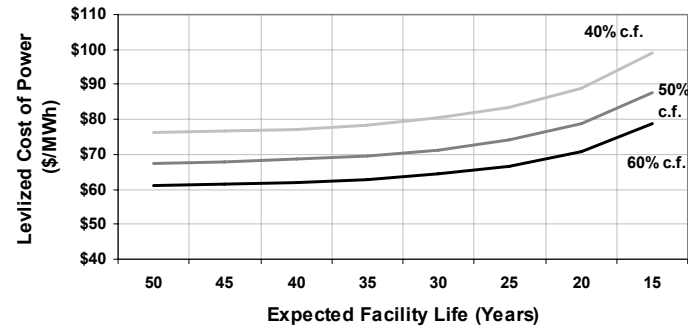
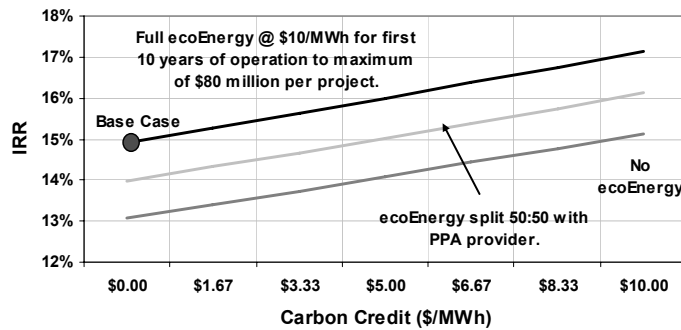
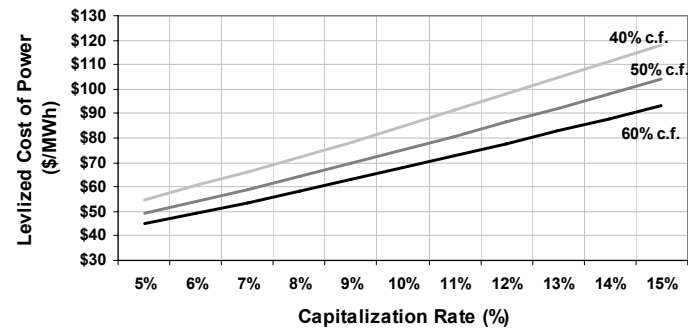
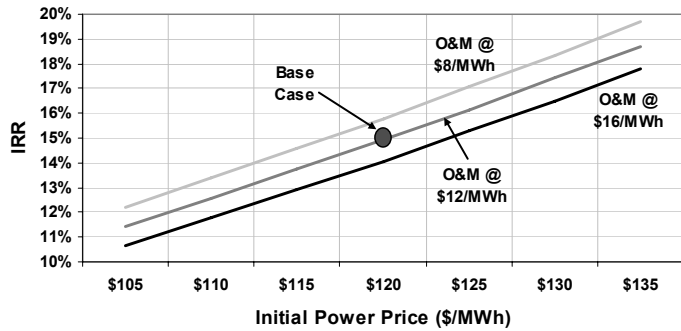
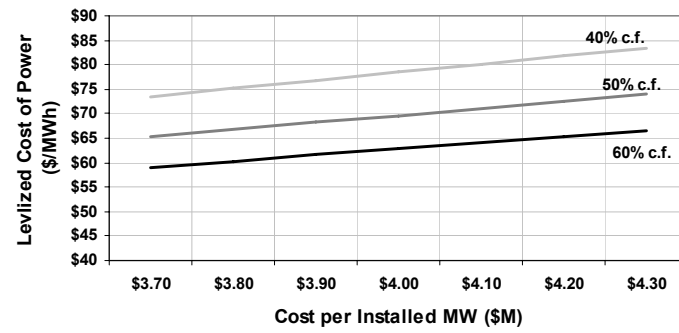
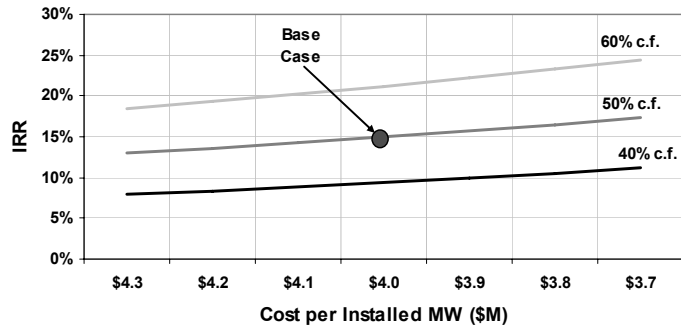

Source: Scotia Capital estimates.

Exhibit 7.74: Run-of-River Equity Returns Are Quite Strong

		Starting PPA Price (\$/MWh)						
		\$105	\$110	\$115	\$120	\$125	\$130	\$135
Starting O&M Cost (\$/MWh)	\$18	10.3%	11.4%	12.5%	13.7%	14.8%	16.1%	17.3%
	\$16	10.7%	11.8%	12.9%	14.1%	15.3%	16.5%	17.8%
	\$14	11.0%	12.2%	13.3%	14.5%	15.7%	17.0%	18.2%
	\$12	11.4%	12.6%	13.7%	14.9%	16.2%	17.4%	18.7%
	\$10	11.8%	13.0%	14.1%	15.4%	16.6%	17.9%	19.2%
	\$8	12.2%	13.4%	14.6%	15.8%	17.1%	18.4%	19.7%
	\$6	12.6%	13.8%	15.0%	16.2%	17.5%	18.8%	20.2%
		Installed Capital Cost (\$/MW)						
		\$4.3	\$4.2	\$4.1	\$4.0	\$3.9	\$3.8	\$3.7
Capacity Factor (%)	35%	5.6%	6.0%	6.4%	6.8%	7.3%	7.8%	8.3%
	40%	7.9%	8.4%	8.9%	9.4%	9.9%	10.5%	11.1%
	45%	10.4%	10.9%	11.5%	12.1%	12.7%	13.4%	14.1%
	50%	12.9%	13.5%	14.2%	14.9%	15.7%	16.5%	17.3%
	55%	15.6%	16.3%	17.1%	17.9%	18.8%	19.8%	20.8%
	60%	18.4%	19.3%	20.2%	21.1%	22.2%	23.2%	24.4%
	65%	21.4%	22.4%	23.4%	24.5%	25.7%	26.9%	28.2%
		Cost of Debt (%)						
		8.00%	7.50%	7.00%	6.50%	6.00%	5.50%	5.00%
Effective Cash Tax Rate (%)	35%	8.8%	9.8%	10.9%	12.1%	13.3%	14.6%	15.9%
	30%	9.6%	10.7%	11.8%	13.0%	14.3%	15.7%	17.1%
	25%	10.4%	11.5%	12.7%	14.0%	15.3%	16.8%	18.2%
	20%	11.2%	12.3%	13.6%	14.9%	16.3%	17.8%	19.4%
	15%	11.9%	13.1%	14.4%	15.8%	17.3%	18.9%	20.5%
	10%	12.6%	13.9%	15.3%	16.7%	18.3%	19.9%	21.7%
	5%	13.3%	14.7%	16.1%	17.7%	19.3%	21.0%	22.8%
		Carbon price (\$/REC or \$/ERC or \$/MWh)						
		\$0.00	\$1.67	\$3.33	\$5.00	\$6.67	\$8.33	\$10.00
ecoEnergy (\$/MWh)	\$0.0	13.1%	13.4%	13.7%	14.1%	14.4%	14.8%	15.1%
	\$2.5	13.5%	13.9%	14.2%	14.5%	14.9%	15.3%	15.6%
	\$5.0	14.0%	14.3%	14.7%	15.0%	15.4%	15.7%	16.1%
	\$7.5	14.4%	14.8%	15.2%	15.5%	15.9%	16.2%	16.6%
	\$10.0	14.9%	15.3%	15.6%	16.0%	16.4%	16.8%	17.1%

Source: Scotia Capital estimates.

RUN-OF-RIVER CAPITAL COSTS PER MWH ARE AMONG THE LEAST EXPENSIVE

Run-of-river capital costs generally range between \$2.5 million to \$3 million per MW, depending on project size, transmission requirements, site accessibility, and infrastructure costs. We have seen outliers as high as \$3.5 million per installed MW, and as low as \$2 million per installed MW. Increasing labour, commodity, and material costs will likely put pressure on installed capital costs in the near term. Plutonic estimates its project could cost about \$4 million per MW.

Run-of-river installed capital costs per GWh/y are 10% to 30% less expensive than that of wind power.

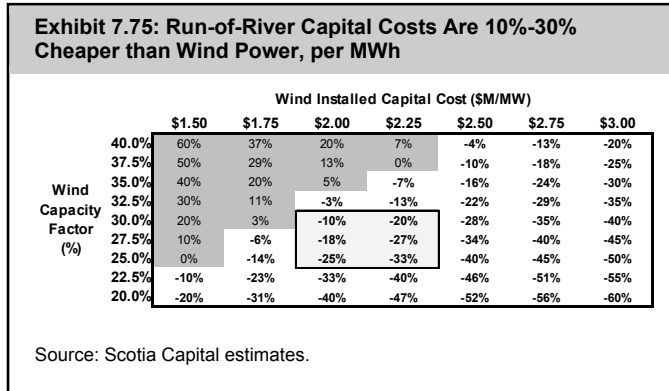

In our opinion, run-of-river installed capital costs (including transmission access) are 10% to 30% less expensive than wind power, when comparing expected annual generation per technology. Exhibit 7.75 sensitizes the run-of-river discount relative to wind power that has a materially lower capacity factor. Using a mid-point installed capital cost of \$2.125 million per MW and a 27.5% average capacity factor, we see that run-of-river is 22% less expensive than wind, on a per GWh/y basis.

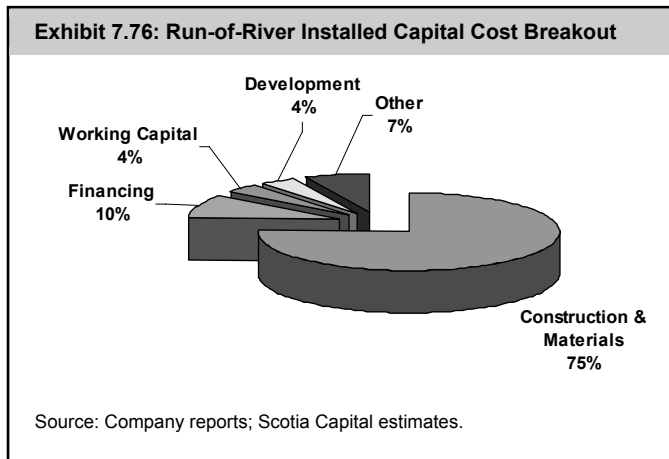

We estimate that up to 80% of run-of-river installed capital costs go towards equipment, construction, and infrastructure (including transmission access). The remainder is spread among financing costs, working capital requirements, as well as contingencies, property taxes, royalty payments, land lease, and insurance costs (Exhibit 7.76).

The levelized cost for run-of-river power production ranges from as low as \$30/MWh to as high as \$130/MWh, averaging over \$70/MWh, although we expect this to increase in the near term.

INVESTMENT POSITIVES

- **Reliability.** Unplanned outage rates for run-of-river hydro plants are among the lowest in the electricity generating industry. Typical small hydro equipment has very few moving parts, resulting in a long asset life with low maintenance requirements when compared with other technologies.
- **Low and predictable operating costs with no fuel risk.** With no fuel costs, the cost structure of run-of-river facilities are significantly different and less expensive (on a per MWh basis) than fossil-fueled power plants. Additionally, most facilities can be operated remotely from a control centre.
- **Higher capacity factor than wind power.** Run-of-river capacity factors generally range between 40% and 60%, while wind power capacity factors range between 25% and 35%. Wind power capacity factors are rising with the emergence of more efficient technologies, while run-of-river capacity factors are flat.
- **Low environmental impact.** Small hydro generation produces almost no greenhouse gas emissions that can have harmful effects on the environment. Also, as run-of-river facilities typically do not have significant storage capacity, there is no risk of upstream flooding or the possibility that the seasonality of water flow within a given area may change.

If properly maintained, run-of-river assets can last 80+ years.

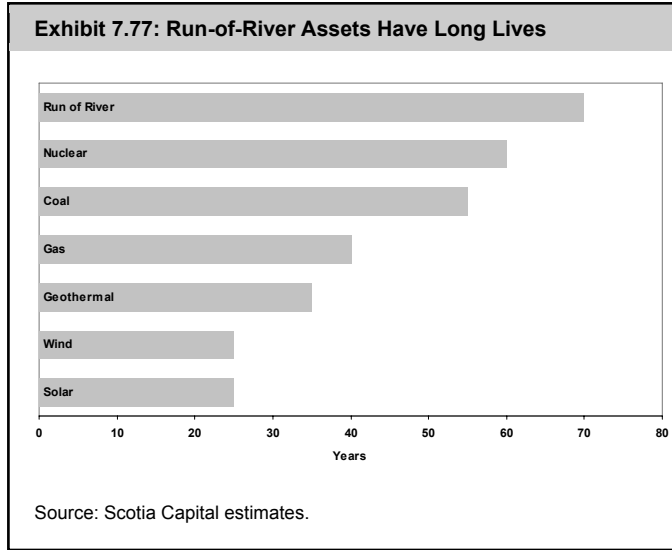

- **No technology risk.** Run-of-river technology is simple, proven, and highly efficient.
- **Long-life assets.** Unlike wind turbines that typically last 20 to 30 years, small hydro plants, if properly maintained, can last 80+ years (Exhibit 7.77).
- **Ability to earn and sell emission reduction credits.** Run-of-river projects can earn CO_{2e} emissions reductions credits due to the GHG emissions that are displaced relative to non-green power generators such as coal, natural gas, and other fossil fuel-based generation plants.

INVESTMENT RISKS & CHALLENGES

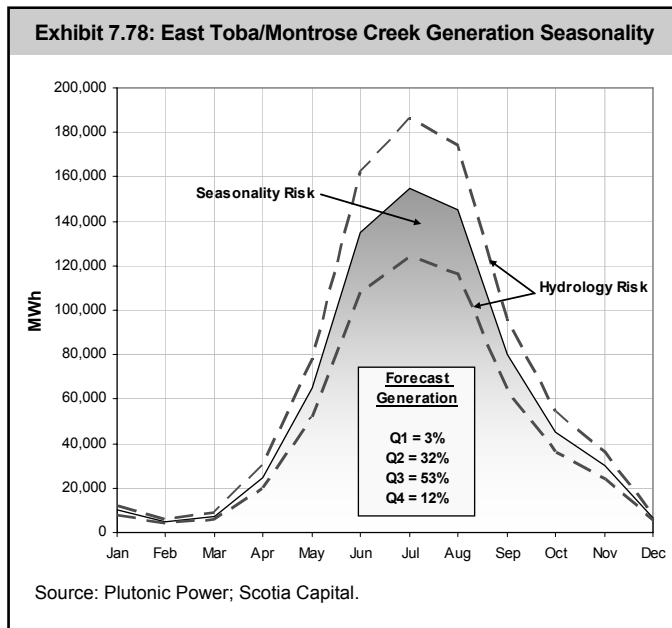

- **Seasonal.** Power generation can be cyclical, as winter snow reduces water flow while spring/summer melting produces seasonally larger water flow. A good example of this can be seen in Exhibit 7.78, where we have shown the power generation seasonality profile of Plutonic Power’s East Toba/Montrose Creek project.
- **Hydrology risk.** Without storage capability, hydrology volatility risk is unavoidable and cannot be hedged away. Below-forecast water flow could hinder a run-of-river project’s ability to produce electricity and therefore reduce a company’s ability to generate revenue and net income. We have found that a hydrology volatility range of +/-15% annually is likely.

- **Little to no water storage capacity.** Run-of-river projects possess little to no capacity for water storage so the consistency of timing of generation to meet fluctuations in consumer demand is poor.
- **Higher installed capital costs per MW than wind power.** Upfront installed capital costs could be as much as \$1.5 million per MW more than for wind power. In return for higher costs, the asset has a lifespan that is typically 2x to 3x greater than wind turbines, as well as generates almost double the power than an equivalent wind farm.

HOW QUICKLY A GREAT PROJECT CAN FALL APART

Run-of-River Power's 180 MW Pitt River project was effectively terminated earlier this year due to B.C. Minister Barry Penner's decision not to issue a park boundary adjustment that was required for the project to proceed. ROR's CEO previously stated that the project would not proceed without a park boundary adjustment, as there was no other feasible (i.e., economic) alternative. Additionally, while the project is still awaiting an environmental approval certificate, the Outdoor Recreation Council recently named the Upper Pitt the most endangered river in B.C. in 2008 due to threat to the local fish habitat. We note that project itself was not rejected, just the power line route through a provincial park, which environmentalists strongly opposed. If the project is ever reshaped and proceeds, the seven sites of the project are expected by the company to generate 557 GWh/y. **Following the announcement by the B.C. Minister, ROR's stock fell by 60%+ from its previous 2008 high of 58¢ per share.**

RUN-OF-RIVER SCIENCE & TECHNOLOGY 101

Simply put, a run-of-river power facility diverts some of a river's flow to power-producing turbines, returning the water back to the river, downstream of the turbines (Exhibit 7.79). Most run-of-river hydro projects include the following:

- **Headpond.** A small dam that floods a sufficient area to ensure that the intake to the penstock is under water. Headponds typically do not store water.
- **Penstock.** A buried pipe system that delivers water from the headpond to the lower-elevation turbines. Penstocks can range from two kilometres to 10 kilometres long, but are generally three to four kilometres.
- **Powerhouse.** A building that contains one or more turbines. The moving water turns the turbine blades that spin electromagnets inside a collar of conductors, which generates power.
- **Tailrace.** A channel that returns the diverted water back to the river system.

Unlike large-scale hydro, **run-of-river technology is flexible enough that it can be constructed around difficult terrain**, rather than the other way around.

Exhibit 7.79: Schematic of a Typical Run-of-River Facility



Source: Plutonic Power.

Constructing a run-of-river project into a cash generating operational asset typically takes two dry seasons.

RUN-OF-RIVER CAPACITY DEVELOPMENT PROCESS & TIMELINE

Constructing a run-of-river project into a cash generating operational asset typically takes two dry seasons, but varies on the size of the project as well as infrastructure requirements. Before construction of a run-of-river facility can commence, a PPA is required, as well as over 50 permits and approvals from multiple government agencies. These permits, approvals, and reviews can include water and land licences, environmental evaluations such as the impact on local fish habitat, and conflicts with wildlife. The entire process is complex. As an example, we have outlined in Appendix 2 the 10 steps required by Land and Water British Columbia (LWBC) to develop a run-of-river power project. Additionally, Appendix 1 shows the environmental assessment process. Generally, the sequence of steps are as follows:

- 1. Site selection.** When selecting a site for run-of-river power project development, the following factors are favoured: (1) a large and divertible water stream; (2) a high head that results in less flow required; (3) close proximity to transmission lines; and (4) site accessibility. Determining the feasibility of developing a site consists of reviewing topographic maps, conducting detailed hydrology studies and stream flow measurements, determining water quality, and in-stream fish flow requirements.
- 2. Costs.** Costs for developing a run-of-river project generally fall into three categories: (1) development; (2) construction; and (3) annual. Initial development costs typically include feasibility studies, and application fees and related expenses. Construction costs include engineering, equipment, infrastructure, owner's costs, and contingency costs (about 10%). Annual costs include financing, land leases, property taxes, water rental, insurance premiums, transmission line maintenance, and general administration costs.
- 3. Permitting process.** Permitting and licensing requirements can involve a wide variety of issues such as legal, compliance, public safety, environmental concerns, and First Nations consultation. Permitting can take a year or longer, depending on the project's complexity and location. Before a run-of-river hydro project can be built, it typically requires over 50 permits, licences, reviews, and approvals, from up to 14 regulatory bodies, including federal, provincial, local, and aboriginal.
- 4. Grid interconnection.** Interconnection refers to the connection of a generation source to a transmission network. All IPPs must have an interconnection agreement, which provides the technical and legal requirements of physical connection. Essentially, the utility is attempting to ensure that connections to its system are made in a manner that: (1) provides adequate protection from electrical faults; (2) ensures the quality of power provided meets industry standards; (3) follows established notification protocols; and (4) meets its requirements in terms of power quantity.
- 5. Energy sales.** To sell power in most provinces, an IPP must enter into a power purchase agreement with either a provincial utility or another energy purchaser, such as TransAlta. Contracting for the sale of energy output is typically focused on price, quantity, and duration. An IPP can find a buyer for its electricity in two ways: (1) an unsolicited proposal; or (2) a response to a request for proposal (RFP).
- 6. Construction.** The construction phase of a project is usually completed under a fixed-price contract and can average between two to three years, depending on the size of the project and infrastructure requirements.
- 7. Operation and maintenance.** Ongoing operation, maintenance, and surveillance are required to keep a plant running smoothly.

On the following pages, we have summarized pure-play, or mostly pure-play, run-of-river public and private companies that are currently not under Scotia Capital research coverage.

RUN OF RIVER POWER INC. (ROR-V)

In 2005, Run of River Power Inc. (ROR) began operating its first B.C.-based run-of-river project, the 7.6 MW Brandywine Creek project. Producing over 40 GWh/y of electricity, the project’s capacity factor is about 60%, and produces over \$2 million in annual revenue. Additionally, Brandywine Creek displaces over 12,000 tonnes of CO_{2e} annually. The company has a current market capitalization of about \$14 million. ROR hopes to build its portfolio to almost 700 MW of installed renewable capacity in B.C.

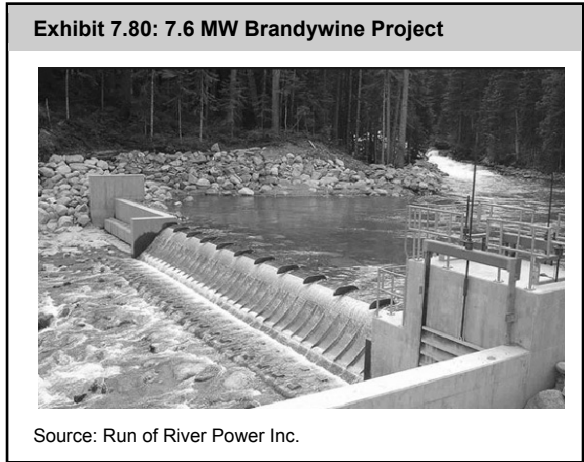

Projects Worth Watching

First, the company is developing a three-project cluster, known as the Mamquam Projects, located about 70 km from Vancouver, that could total 40 MW of installed capacity. Second, Run of River Power could bid its Pitt River Project into BC Hydro’s Clean Power Call, with an estimated potential installed capacity of 180 MW. Third, and further down the pipeline, is the 6 MW Dewdney Creek prospect, estimated to generate 28 GWh/y, as well as the 10 MW Gott Creek project, forecast by Run of River Power to produce up to 53 GWh/y.

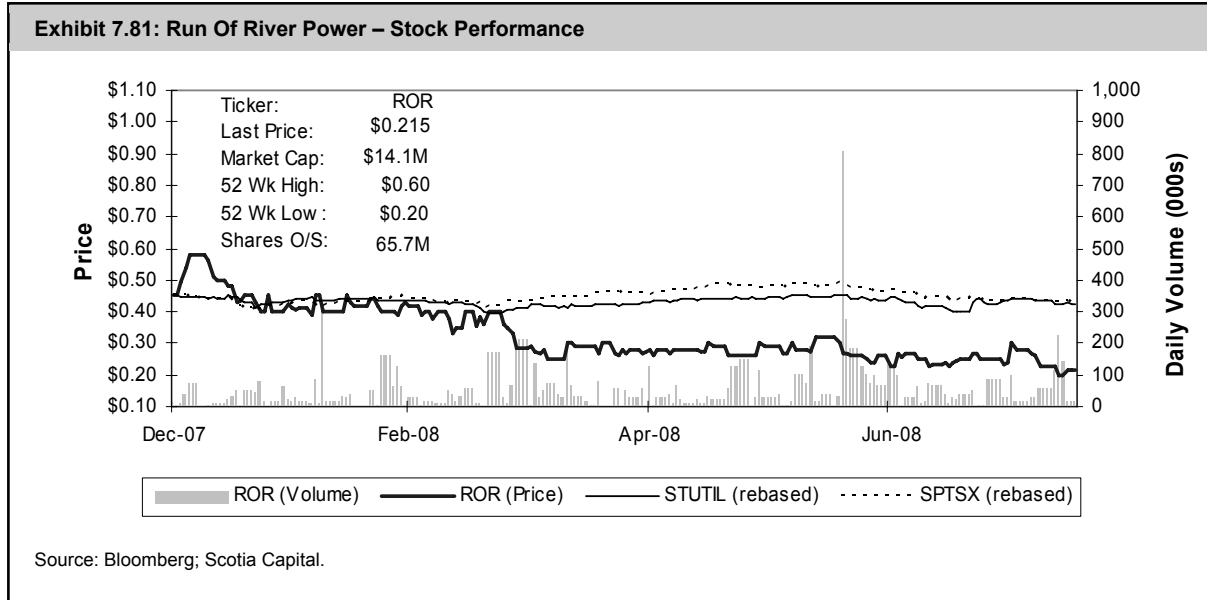

SYNEX INTERNATIONAL INC. (SXI-T)

Synex Energy, a wholly owned subsidiary of Synex International, has been developing energy projects for 25 years. It currently owns and operates a 3.8 MW run-of-river facility at Mears Creek that was constructed in 2003 for less than \$7 million, or about \$1.8 million per installed MW. Also, Synex holds a 12.5% interest in the 6.5 MW China Creek power plant, and owns the recently completed Kyuquot regulated utility, which is a mixed overhead/submarine cable connecting the Kyuquot region to the BC Hydro integrated grid. Over the past few years, Synex has also developed and sold several projects in both Canada and the U.S.

Projects Worth Watching

Construction is under way on the 100% owned, 2.8 MW Cypress Creek project, located near Gold River on Vancouver Island. Synex also received two BC Hydro 2006 CFP EPAs for its 4 MW Barr Creek hydro project and for its 10 MW Victoria Lake project. Commercial operation dates for these projects range between 2009 to 2010. Additionally, the company intends on submitting various developments such as its 5 MW McKelvie Creek hydro project into BC Hydro’s Standing Offer Program for sub-10 MW projects. Exhibit 7.82 shows a map of the company’s present and future operations.

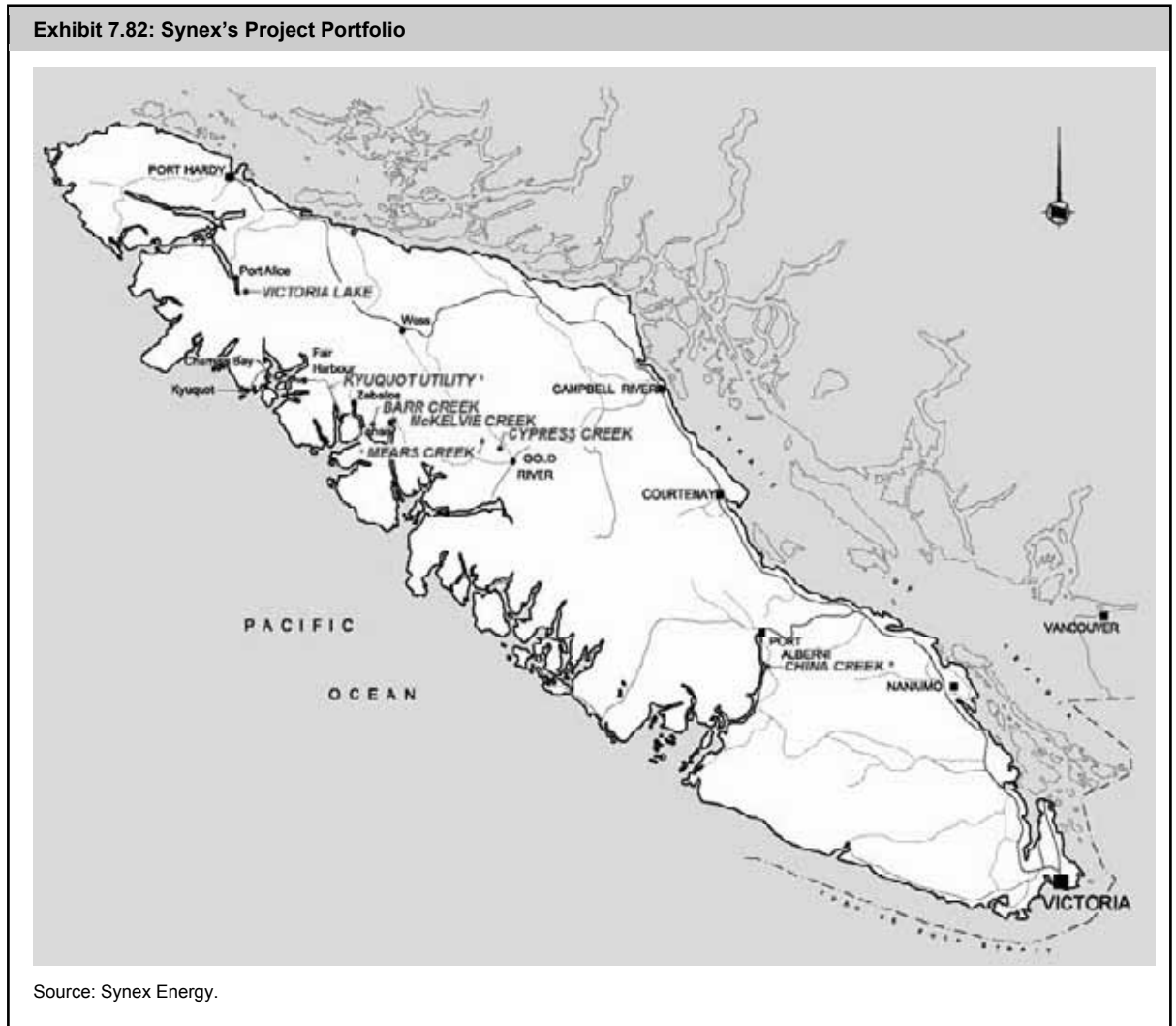

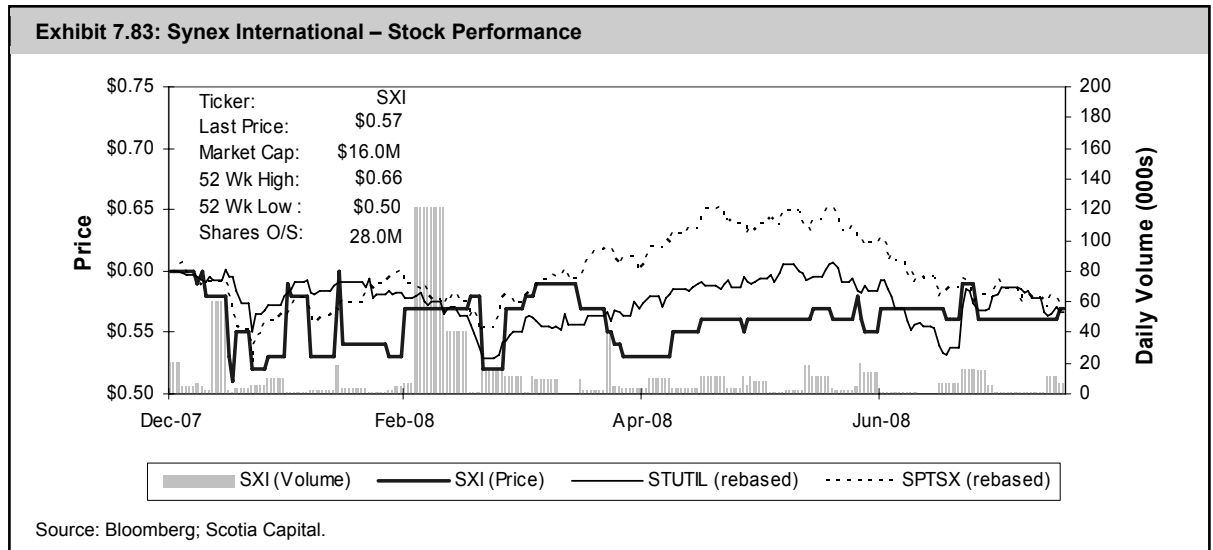

CLOUDWORKS ENERGY INC.

Formed in 1999, Cloudworks Energy is a private, Vancouver-based company engaged in the development, ownership, and operation of run-of-river energy projects. In July 2006, Cloudworks was awarded EPAs for six projects in the 2006 BC Hydro Call for Power. The awarded projects, grouped under the name Harrison Hydro LP, are all run-of-river facilities that are forecast by management to produce up to 530 GWh/y of electricity. Additionally, the company has numerous water licence applications for other B.C. run-of-river projects. Completion of the Harrison Hydro portfolio is slated for late 2010.

HYDROMAX ENERGY LTD.

Hydromax is a wholly owned subsidiary of ENMAX Corporation that develops potential run-of-river hydro projects. In the 2006 BC Hydro CFP, Hydromax was awarded long-term EPAs for its 10 MW Lower Clowhom and 10 MW Upper Clowhom projects. Total generation is expected to be 93 GWh/y, representing a 53% capacity factor. Commissioning of the projects is expected to occur in late 2009.

NOVAGREENPOWER INC.

In August 2006, NovaGold acquired Coast Mountain Power, a run-of-river developer with 335 MW of projects under development. The company's largest asset is the Forrest Kerr run-of-river project, designed to generate and transmit up to 115 MW (600 GWh/y) of power onto the grid. In addition to a 15-year BC Hydro EPA, the project has received all approvals and permits required for construction. In mid-2008, NovaGreenPower determined that its Forrest Kerr project capacity could be increased to 195 MW. As a result, the company intends to submit up to 80 MW in the BC Hydro Clean Power Call.

On July 31, AltaGas Income Trust acquired 100% of NovaGreen Power Inc. for approximately \$40 million.

REGIONAL POWER INC.

Regional Power, a subsidiary of Manulife Financial, has been developing, building, refurbishing, and operating hydro power plants for over 20 years. Currently, Regional operates six hydro plants with a total capacity of 36 MW. The company also has six projects with PPAs that total over 120 MW (three in B.C., two in Ontario, and one in Quebec). Additionally, Regional has the rights to five other sites with an aggregate capacity of 207 MW.

Geothermal Power – Mining for Heat

OVERVIEW

The global geothermal energy potential is enormous, and represents about 35 billion times the world's annual energy consumption. However, current economics limit geothermal exploitation to a maximum depth of 6 km below the surface of the earth, which corresponds to a much smaller amount of recoverable energy. Exhibit 7.84 shows the primary regions of the world where total heat flow and the concentration of geothermal energy are highest.

Geothermal development in the U.S. is accelerating while development in Canada has been disappointing to date.

Exhibit 7.84: World Geothermal Regions

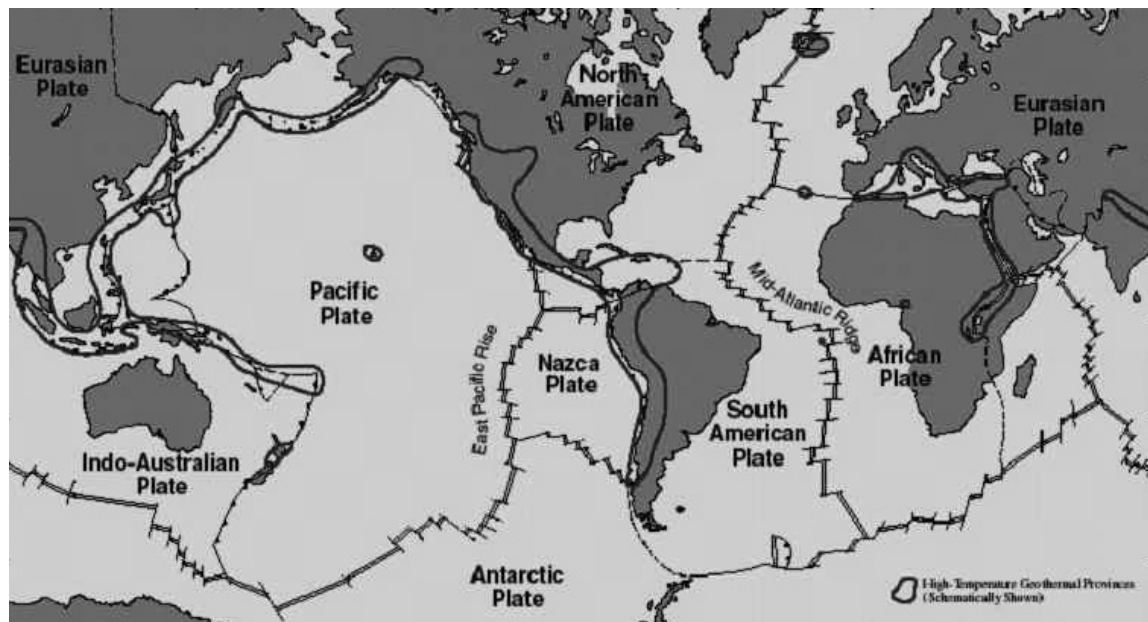

Source: U.S. Geological Survey.

Western U.S. states boast about 3,000 MW of installed geothermal capacity, or about one-third of global capacity. Of this amount, California has over 2,500 MW of capacity, meeting 5% of the state's electricity generation requirements. **There are 13,000 MW of known and exploitable geothermal resources in western U.S. states, 5,600 MW of which are located in California and Nevada.**

The cost of geothermal energy is dropping fast. Since 1980, geothermal generation facility capital costs have declined by 50%, or at a much faster rate than that of coal-fired plants. The U.S. Energy Information Administration (EIA) places geothermal energy at a lower levelized cost than natural gas, wind, biomass, nuclear, and solar (both thermal and photovoltaic).

Geothermal power development is accelerating. We see over 3,300 MW of U.S. geothermal generation capacity at various development stages. Of this amount, 251 MW of capacity is under construction, and another 20 to 30 projects totalling between 700 MW and 1,000 MW are in the process of either securing PPAs or under final drilling and facility construction.

CANADIAN GEOTHERMAL DEVELOPMENT DISAPPOINTING TO DATE

Canada remains the only country in the Ring of Fire not to exploit geothermal-based power generation (Exhibit 7.85). Only a couple of companies have geothermal exploration rights in Canada, but

no clear date remains as to when these projects will become commercial. Over the past several decades, federal and provincial governments, B.C. in particular, did not bother with geothermal power development due to a readily available and inexpensive power supply. **Today B.C. is a net importer of electricity.**

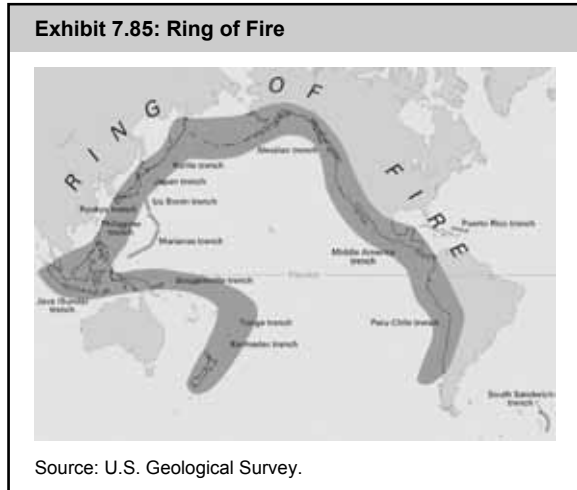

The Meager Mountain area in B.C. is the most significant geothermal energy discovery in Canada.

The Meager Mountain area in B.C. is the most significant geothermal energy discovery in Canada. In addition to Western GeoPower’s South Meager project, which could result in 30 MW to 35 MW of installed capacity, Gaea Energy, a privately held geothermal development company, holds three exploration permits near Pebble Creek, B.C., which were acquired in 2002 to 2004.

The Canadian Geothermal Energy Association (CanGEA) believes geothermal projects in B.C. alone could amount to between 3,000 MW to 5,000 MW. Additionally, Alberta, Yukon, and the Northwest Territories have a further 1,000 MW to 2,500 MW of economic geothermal capacity available for potential exploitation (Exhibit 7.86). **We think this is optimistic.**

Geothermal power qualifies for the federal ecoENERGY incentive of \$10/MWh. However, the incentive is not indexed to inflation, and falls short of similar programs such as the US\$20/MWh PTC that are indexed to inflation.

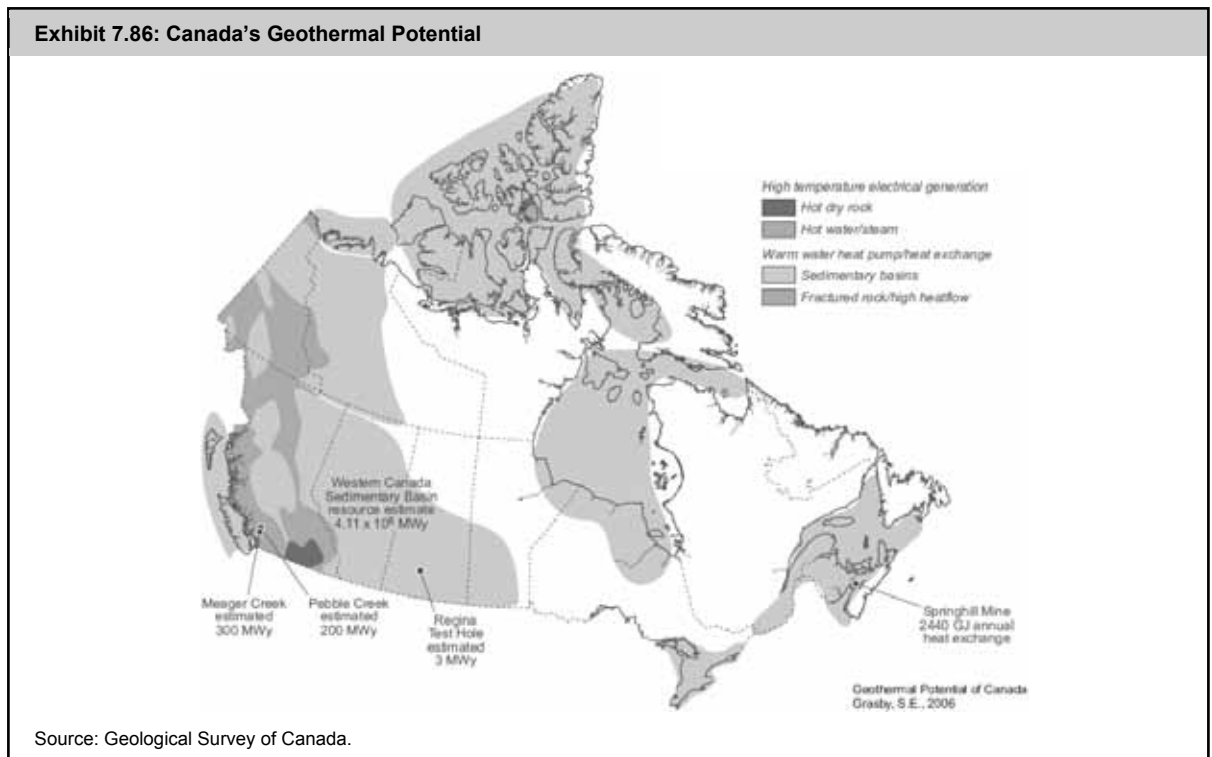

In our opinion, the success of future geothermal energy development in Canada depends more on sustained government policies and initiatives, as well as adequate funding sources, than on geological factors.

PROJECT EQUITY RETURNS ARE REASONABLE: MODELLING & SENSITIVITY ANALYSES OF A GEOTHERMAL POWER PROJECT

Our financial modelling and analysis of geothermal power projects indicates that equity investors will be reasonably satisfied with investment returns. We modelled numerous scenarios and sensitized for variations in (1) PPA prices and escalations rates; (2) capital costs and costs of capital; (3) RECs, U.S. PTCs, and other renewable incentives; (4) operating & maintenance costs; (5) capacity factor; and (6) tax rates. **Our generic geothermal project yielded an 18.8% equity IRR.** To arrive at this, we made the following assumptions:

- **93% capacity factor.** Our research revealed a geothermal capacity factor range of 90% to 95%, the highest among all power technologies that we have seen, including renewables, fossil fuels, and other alternatives such as nuclear. Several geothermal development companies we looked at stated capacity factor expectations that ranged from 96% to 98%. We chose 93%.
- **US\$4 million per MW installed cost.** The majority of our research led us to assume an installed capital cost of US\$4 million per MW, although several developers have forecast installed costs as low as US\$3.5 million per MW.
- **Starting PPA @ US\$83/MWh + 1.5% p.a.** We took the average U.S. PPA price of several states that ranged from the mid-US\$60s/MWh (Nevada) to US\$98/MWh (California). We tacked on an annual escalation rate of 1.5% per year.
- **Starting O&M @ US\$24/MWh + 1.5% p.a.** Operating and maintenance cost estimates (and actuals) have ranged between US\$15/MWh to US\$30/MWh. We used a median cost of US\$24/MWh.
- **U.S. PTC intact.** We applied an initial U.S. production tax credit at US\$20/MWh, adjusted annually for inflation. We also assumed the PTC is extended throughout the life of the project.
- **Starting RECs @ US\$5/REC.** This is our most speculative model assumption, as we do not know how RECs will trade among Western Climate Initiative member states and provinces. We added US\$0.50/REC per year to US\$20/REC by the end of the plant's 30-year life. We note that global REC prices vary widely, from US\$4/MtCO_{2e} on the Chicago Climate Exchange to ~US\$35/tonne CO_{2e} on the EU ETS.
- **Debt to equity split 80%/20%.** This is in line with most current and proposed geothermal project capital structures that we have seen. We assume the debt is non-recourse (project specific) and at the current U.S. Treasury bond rate plus 3%. **Equity investors in geothermal projects have historically required 17% annual returns,** with most falling in the 16% to 20% range. We use 17%.
- **Other.** Most geothermal PPAs in California and Nevada are for a 20-year term. We matched the term of debt financing to this 20-year PPA term. We then assumed that the PPA would roll over for a further 10 years to match a 30-year plant life.

In Exhibit 7.87 on the following page, we provide our equity investment IRR sensitivity analyses to changes in the factors listed above.

Exhibit 7.87: Geothermal Project Equity IRRs Seem Reasonable

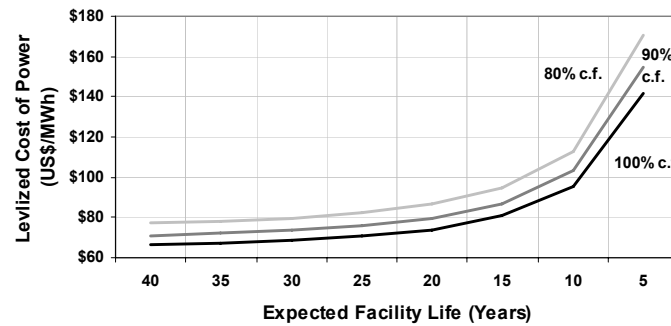
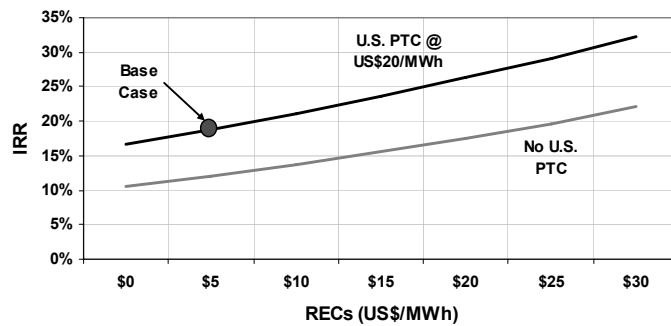
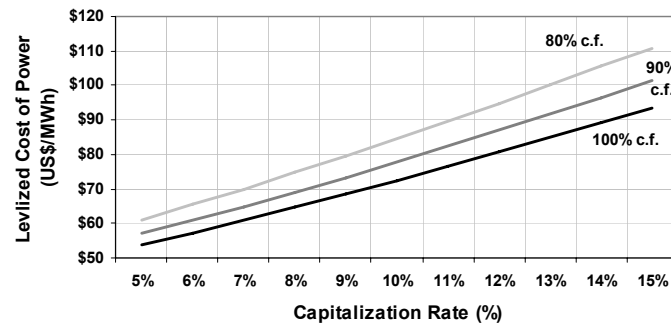
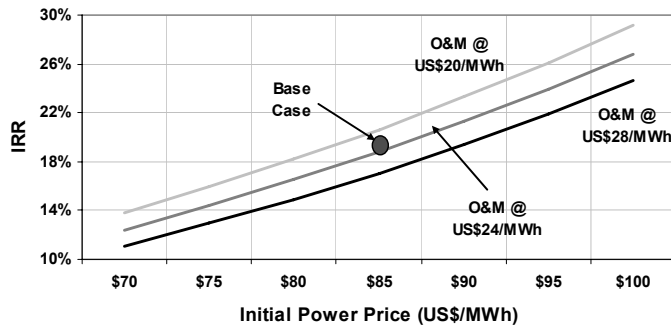
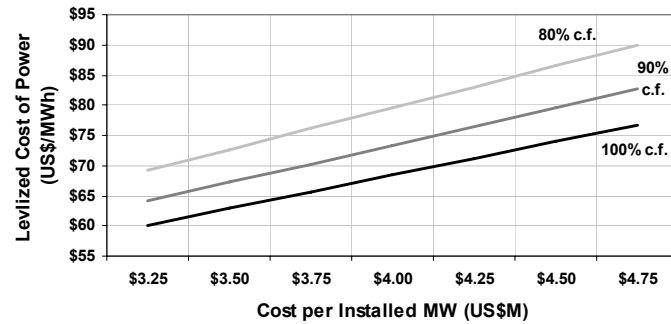
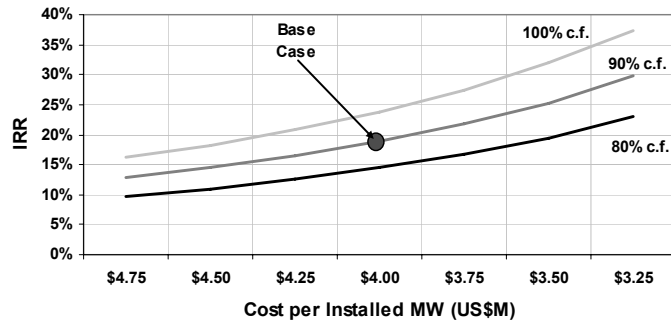

Source: Scotia Capital estimates.

Exhibit 7.88: Geothermal Project Equity IRRs Seem Reasonable

		Starting PPA Price (US\$/MWh)						
		\$70	\$75	\$80	\$85	\$90	\$95	\$100
Starting O&M Cost (US\$/MWh)	\$30	10.4%	12.2%	14.2%	16.2%	18.5%	20.9%	23.6%
	\$28	11.1%	12.9%	14.9%	17.1%	19.4%	21.9%	24.6%
	\$26	11.7%	13.6%	15.7%	17.9%	20.3%	22.9%	25.7%
	\$24	12.4%	14.4%	16.5%	18.8%	21.3%	23.9%	26.8%
	\$22	13.1%	15.1%	17.3%	19.7%	22.3%	25.0%	27.9%
	\$20	13.8%	15.9%	18.2%	20.6%	23.3%	26.1%	29.1%
	\$18	14.6%	16.7%	19.1%	21.6%	24.3%	27.2%	30.3%

		Installed Capital Cost (US\$/MWh)						
		\$4.75	\$4.50	\$4.25	\$4.00	\$3.75	\$3.50	\$3.25
Capacity Factor (%)	70%	6.9%	7.9%	9.2%	10.6%	12.3%	14.4%	17.0%
	75%	8.2%	9.4%	10.8%	12.5%	14.4%	16.8%	19.9%
	80%	9.7%	11.0%	12.6%	14.4%	16.7%	19.5%	23.0%
	85%	11.2%	12.7%	14.4%	16.5%	19.1%	22.3%	26.3%
	90%	12.8%	14.4%	16.4%	18.8%	21.7%	25.3%	29.8%
	95%	14.4%	16.3%	18.5%	21.2%	24.5%	28.5%	33.5%
	100%	16.2%	18.3%	20.8%	23.8%	27.4%	31.9%	37.4%

		Cost of Debt (%)						
		9.50%	9.00%	8.50%	8.00%	7.50%	7.00%	6.50%
Effective Cash Tax Rate (%)	35%	11.5%	12.7%	13.9%	15.2%	16.6%	18.1%	19.7%
	30%	12.5%	13.7%	15.0%	16.4%	17.9%	19.5%	21.2%
	25%	13.5%	14.7%	16.1%	17.6%	19.2%	20.9%	22.7%
	20%	14.4%	15.8%	17.2%	18.8%	20.5%	22.3%	24.2%
	15%	15.4%	16.8%	18.3%	20.0%	21.8%	23.7%	25.8%
	10%	16.3%	17.8%	19.4%	21.2%	23.1%	25.1%	27.3%
	5%	17.2%	18.8%	20.5%	22.4%	24.4%	26.5%	28.8%

		Carbon price (US\$/REC or US\$/ERC or US\$/MWh)						
		\$0	\$5	\$10	\$15	\$20	\$25	\$30
Initial PTC (US\$/MWh)	\$0	10.5%	12.0%	13.7%	15.5%	17.5%	19.7%	22.1%
	\$20	16.7%	18.8%	21.1%	23.6%	26.3%	29.2%	32.2%

Source: Scotia Capital estimates.

GEOHERMAL CAPITAL COSTS PER MWH ARE MATERIALLY CHEAPER THAN WIND

We continue to see geothermal capital costs at about \$4 million per MW, which on the surface, appears higher than run-of-river and wind power installed capacity costs at \$2 million to \$3 million per MW. However, run-of-river and wind power capacity factors range between 40%-60% and 20%-35%, respectively. Average geothermal capacity factors range between 90%-98%. We believe it is more prudent to compare capital costs on a per MWh basis.

In our opinion, geothermal capital costs are actually 30% to 50% cheaper than run-of-river and wind power, when comparing expected production output by technology. Exhibit 7.89 sensitizes the materiality of geothermal’s capital cost discount relative to wind power. Using a mid-point capital cost of \$2.5 million per MW and a 35% average capacity factor (good for wind and poor for hydro), we see that geothermal capital costs per MWh are quite cheaper than its peers, and we have conservatively assumed a 90% geothermal capacity factor.

Exhibit 7.89: Geothermal Capital Costs Are 30%-50% Cheaper than Wind Power, per MWh

		Wind Installed Capital Cost (\$M/MW)						
		\$1.50	\$1.75	\$2.00	\$2.25	\$2.50	\$2.75	\$3.00
Wind Capacity Factor (%)	40.0%	19%	2%	-11%	-21%	-29%	-35%	-41%
	37.5%	11%	-5%	-17%	-26%	-33%	-39%	-44%
	35.0%	4%	-11%	-22%	-31%	-38%	-43%	-48%
	32.5%	-4%	-17%	-28%	-36%	-42%	-47%	-52%
	30.0%	-11%	-24%	-33%	-41%	-47%	-52%	-56%
	27.5%	-19%	-30%	-39%	-46%	-51%	-56%	-59%
	25.0%	-26%	-37%	-44%	-51%	-56%	-60%	-63%
	22.5%	-33%	-43%	-50%	-56%	-60%	-64%	-67%
	20.0%	-41%	-49%	-56%	-60%	-64%	-68%	-70%

Source: Scotia Capital estimates.

We believe that geothermal installed capital costs will remain fairly flat over the next several years.

While capital costs of geothermal projects are site and resource specific, we believe that installed capital costs will remain relatively flat over the next several years, averaging \$4 million per MW. Lower turbine costs as a result of increasing supplier economies of scale, should mostly offset rising labour and non-turbine material costs.

Drilling expenses can consume 30% of geothermal capital costs. During exploration and field development, drilling costs are large and highly variable. Additionally, drilling-related infrastructure costs that include access roads, well sites, and water supplies can consume another 30% of costs. Construction of the actual gathering system and plant generally account for 30% to 50% of the total capital costs, depending on the geothermal technology employed. A study by the Electric Power Research Institute estimated that capital reimbursement and associated interest makes up about 65% of the total levelized cost of geothermal power production.

The levelized cost for geothermal power production ranges from US\$50/MWh to US\$70/MWh until the project has paid back capital costs (15 to 20 years), and then drops by up to 50% for the remaining 10 to 15 years the facility operates. Western GeoPower’s South Meager project will likely cost \$59/MWh, compared with BC Hydro’s long-run marginal cost of \$55/MWh. We believe operations & maintenance costs range between \$15/MWh and \$30/MWh, with a median cost of \$24/MWh.

INVESTMENT POSITIVES

• **Demanding renewable portfolio standards support geothermal growth.** California requires 20% of its energy to come from renewable sources by 2010, while Nevada (20% by 2015), Oregon (25% by 2015), and Washington (15% by 2020) also have tall standards. We believe that incremental geothermal generation capacity will play a significant role to help these particular states achieve their targets. Idaho and Utah currently do not have renewable portfolio standards, although geothermal energy exploration and development is occurring in these states as well.

Unlike almost all other renewable power technologies, geothermal production is unaffected by changing weather conditions.

- **High reliability = baseload power.** Geothermal energy is the only continuously available renewable energy source, and is commonly used as baseload power due to its high predictability over a 24-hour period. Unlike almost all other renewable power technologies, **geothermal production is unaffected by changing weather conditions.**
- **Incentives, incentives, incentives.** Similar to other renewable power producers, geothermal energy developers somewhat rely on economic incentives to yield reasonable investment returns. In the U.S., the production tax credit of US\$20/MWh, coupled with an unknown value for emission reduction credits, support prospective geothermal developers in their investment decisions. Canada's ecoENERGY incentive of \$10/MWh that is not indexed to inflation is a start, but not enough to attract material attention by geothermal developers to date.
- **Capital costs could fall further.** Technological advances have reduced geothermal generation costs by over 25% during the past decade. **Many consultants forecast that generation costs could fall an additional 20% by 2020 (over 2000 levels), while operation and maintenance costs could decline by up to 30% by 2020.**
- **Price stabilizer.** With zero fuel costs, geothermal energy acts as a power price stabilizer that partly offsets dependence on the highly volatile fossil fuel-based power market.
- **Minimal environmental impact.** While geothermal energy production is considered a clean form of electricity generation, some geothermal plants produce small amounts of CO₂, or about 1,000x to 2,000x less than an average fossil fuel plant. Additionally, geothermal power stations have a very low land area requirement.

INVESTMENT RISKS & CHALLENGES

- **Renewable...at a cost.** While a geothermal reservoir can be depleted of water or grow too cool, this can take decades to centuries to occur, if at all. Typically, a natural rejuvenation period exists that will return a geothermal field to economically exploitable levels. Also, many current technologies re-inject geothermal fluids back into the reservoir, which can extend reservoir life almost indefinitely, although further capital costs are required for re-injection equipment. The best example of this is at the world's first geothermal power plant (Larderello, Italy) that began operating a 0.25 MW facility in 1913. Today the geothermal boasts a 700 MW capacity that is expected to rise to 1,200 MW over the next several years.
- **Turbine supply delays.** Similar to the wind power industry, demand growth for geothermal turbines has caused a two-year backlog for delivery of most types of turbines. Fuji, Mitsubishi, and Toshiba are the primary turbine suppliers. Italian utility company Enel recently placed a five- to six-turbine order with Toshiba, adding to the backlog for North American geothermal-focused IPPs. One company we spoke with recently bucked this trend by securing a 16-month delivery timeframe for a turbine.

- **Seasonality still a concern.** Unlike wind, solar, and run-of-river power, geothermal energy generation is unaffected by changing weather conditions. However, air-cooled binary power plants located in desert terrain such as California and Nevada, have material power output variations both on a daily basis, and seasonally, which can meaningfully change the project's earnings profile. Maximum power delivery typically occurs during the coolest hours of the day while lower power production happens during the hottest hours of day. Exhibit 7.90 presents an example of seasonal output variation for a 20 MW air-cooled binary power plant.

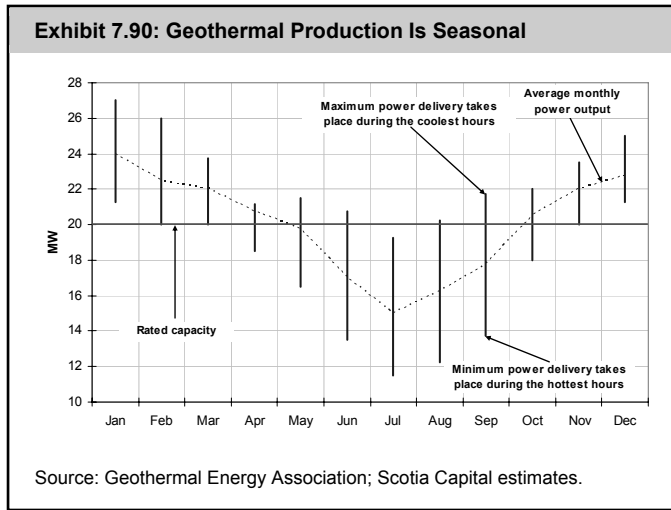

Maximum power delivery typically occurs during the coolest hours of the day while lower power production happens during the hottest hours of day. Exhibit 7.90 presents an example of seasonal output variation for a 20 MW air-cooled binary power plant.

- **Subsidence.** While the risk is small, the potential for geothermal-based subsidence or hydrothermal eruptions exists, which if it occurs, could materially impair a project's expected future cash flow.

GEOTHERMAL POWER SCIENCE & TECHNOLOGY 101

Geothermal energy is the only source of renewable power that is independent of the sun. For the most part, geothermal power producers attempt to capture and use heat energy created under the Earth's crust. Similar to oil & gas exploration, boreholes are drilled into a reservoir, so that hot geothermal fluid either flows or is pumped to the surface. This fluid is then employed by conventional steam turbines for electric power generation.

Enthalpy is critical to assessing the quality of geothermal resources, and is defined as heat content per unit of mass, which is a function of pressure and volume as well as temperature. High enthalpy is classified as temperatures above 180°C-200°C, with medium enthalpy at 100°C-180°C, and low enthalpy at less than 100°C. High enthalpy resources, including all those currently exploited for geothermal electric power production, are confined to volcanically active plate margins or localized hot spots such as the Hawaiian Islands.

Traditional geothermal power production technologies depend not only on fluid temperature and pressure, but also on the nature of the resource, including its salinity and content of other gases. Therefore, we believe that a majority of western U.S. geothermal development projects will utilize binary cycle power plants for power production. The main advantage of binary cycle technology is that lower-temperature resources can be developed where single flash systems have proven unsatisfactory. Additionally, the surface loop is closed, which results in zero emissions into the environment.

The primary challenge for geothermal power production is the turbine's consumption of 30% of the overall power output that is lost to keeping geothermal fluid under pressure as well as re-pressurizing secondary working fluids (i.e., pentane or butane). There are three main types of geothermal electrical production technologies that we review in Exhibit 7.91.

Exhibit 7.91: First Generation Geothermal Technologies

	Dry Steam	Flash Steam	Binary Cycle
Process	Steam goes directly to a turbine, which drives a generator that produces electricity. Low exhaust steam is vented directly to the atmosphere.	High enthalpy fluids can be used in flash plants to generate power. The fluid is sprayed into a tank held at a much lower pressure than the fluid, causing some of the fluid to rapidly vaporize, or "flash". The vapour then drives a turbine, which drives a generator. If any liquid remains in the tank, it can be flashed again in a second tank to extract even more energy.	Binary cycle plants use a secondary working fluid with a lower boiling point than water, such as pentane or butane, which is then vaporized to drive a turbine.
Positives	Ideal for vapour-dominated resources where steam production is not contaminated with liquid. Modern dry steam plants can achieve 6.5 kg of steam per kWh, down from 15 kg per kWh in the 1960s.	Geothermal fluid reaching the surface may be either steam or hot water at a high pressure.	Lower temperature resources can be exploited where flash-based systems have proven unsatisfactory. The surface loop is closed and no emissions to the environment occur.
Negatives	While the units are simple, they are very inefficient. As a result, their main use is as temporary transportable units during the development of a new geothermal field. The plants emit minor amounts of non-condensable gases such as carbon dioxide and hydrogen sulphide.	Plant typically requires more steam than a dry steam plant, around 8 kg per kWh. Additionally, the bulk of the fluid, often up to 80%, may remain as unflashed brine that is then re-injected.	Keeping the geothermal fluid under pressure and re-pressurizing the secondary fluid can consume up to 30% of the overall power output of the system.

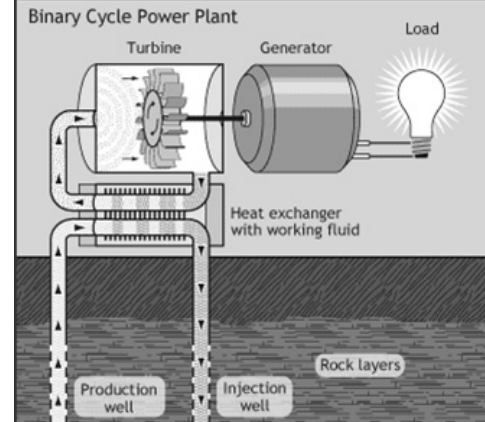
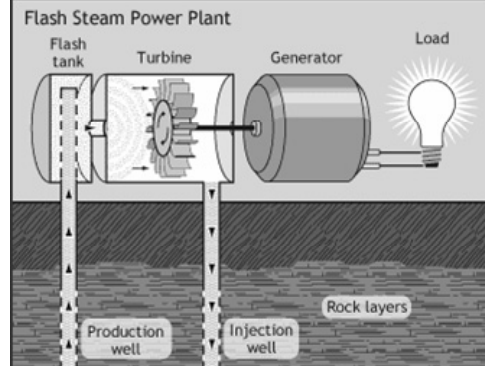
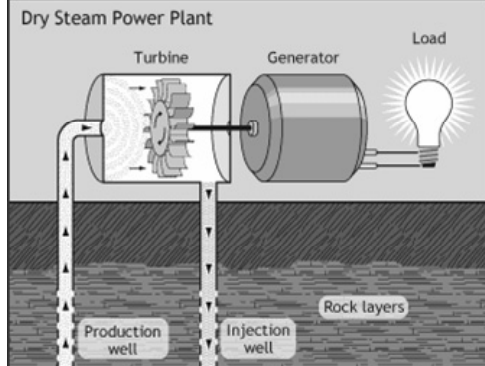

Source: U.S. Department of Energy; Scotia Capital.

EMERGING GEOTHERMAL TECHNOLOGIES

Enhanced Geothermal Systems (EGS) are fundamentally different from traditional systems, as EGS attempts to capture heat directly from hot rocks rather than relying on water circulation around those hot rocks. To accomplish this, chemically treated water is pumped into rock fractures (hydraulic fracturing – used widely in the oil and gas industry) to open, extend, and interconnect areas of low permeability. The fluid is then forced out of a borehole and converted into electricity using traditional plant technologies. A 2006 MIT study estimated **100,000 MW of resources are available for EGS exploitation over the coming decades within the U.S.** Ormat Technologies, an Israeli company that is considered the world leader in geothermal power development, has begun work on the first application of enhanced geothermal systems in the U.S.

There is also a growing interest in producing electricity from geothermal fluid flowing out of oil and gas wells. In general, medium-grade heat from a conventional well could run a 250 kW micro turbine. There are hundreds of thousands of wells in Alberta and B.C.

The **Kalina Cycle**, which utilizes an ammonia-water working fluid with a varying composition throughout the production cycle, is expected to **increase net generating efficiency by 20% to 40%** over a binary cycle power plant. Additionally, capital costs are forecast by consultants to be materially lower than Organic Ranking Cycle (binary) plants.

OUTLOOK

In our opinion, the outlook for geothermal development in western U.S. states is very positive.

In our opinion, the outlook for geothermal energy development in western U.S. states over the next several years is very positive. The incorporation of (1) tough U.S. renewable portfolio standards; (2) incentives at federal and state levels; (3) significant untapped economical geothermal fields; (4) increasingly efficient turbine and exploration technologies, and (5) a successful operational track record as a base load provider, will benefit geothermal developers with U.S. projects.

Some geothermal experts at the University of British Columbia estimate **3,000 MW of high-temperature geothermal power will be established in B.C.** “within the next 10 to 15 years.” While possible, we think this is highly optimistic due to moderate federal and provincial government support. Additionally, strong U.S. incentives have attracted all Canadian geothermal producers to develop geothermal projects in California, Nevada, and various Pacific Northwest states rather than in their home country. Western GeoPower is a partial exception, as it enters its sixth year of exploring the feasibility of its South Meager project.

STRONG GEOTHERMAL SHOWING AT THE 2008 PDAC

We attended presentations by five TSX-listed geothermal power developers at the 2008 Prospectors & Developers Association of Canada (PDAC) conference. On the following pages, we highlight these companies and provide brief summaries of the status of their main projects.

SIERRA GEOTHERMAL POWER CORPORATION

Sierra Geothermal (SRA-V) is focused on North American geothermal exploration and development using binary plant technology. The company currently has an interest in 16 geothermal projects in Nevada and one project in California, which cover a combined 88,000 acres. **Sierra aims to commission 50 MW per year of installed capacity to its portfolio beginning in 2013.** With a market capitalization of \$27 million, it is one of the smallest among the five Canadian listed geothermal companies.

Projects Worth Watching

Sierra’s 100%-owned Reese River project has a production target of 2011 with a nameplate capacity range between 26 MW (P90) and 58 MW (P50). Capital costs are estimated at US\$100 million to US\$230 million, or US\$4 million per MW, and in line with other U.S.-based geothermal projects. We believe the PPA contract is for a 20-year period and in a range between US\$60/MWh and US\$70/MWh that escalates at about 1% per year. In 2009, Sierra intends to finalize an EPC contract for the construction of the geothermal plant.

Pumpnickel, a 20 MW (P90) to 30 MW (P50) project that is 50% owned by SRA, is also slated to be commissioned in 2011, although its progress is further behind the Reese River project. Sierra and its partner plan to begin production drilling, and financing the US\$80 million to US\$120 million project in 2009. SRA acquired the 50% interest in Pumpnickel in mid-2005. Phase II permitting is in progress for three shallow gradient holds to locate its first production assessment well. Exhibit 7.92 shows a list of Sierra’s five Tier-I geothermal projects as well as several of its 11 other Tier II potential development properties.

Exhibit 7.92: Select Sierra Geothermal Projects

Project Name	Land Size	Net Capacity		Capital Cost		Production Target	Ownership Interest	Tier
		Low (P90)	High (P50)	Low	High			
Reese River	25 km ²	26 MW	58 MW	US\$104M	US\$232M	2011	100%	I
Pumpnickel	27 km ²	10 MW	15 MW	US\$40M	US\$60M	2011	50%	I
Silver Peak	29 km ²	15 MW	30 MW	US\$60M	US\$120M	2012	100%	I
Wilson	23 km ²	55 MW	117 MW	US\$220M	US\$468M	2013	100%	I
Alum	29 km ²	40 MW	90 MW	US\$160M	US\$360M	2013	100%	I
Salt Wells	34 km ²	10 MW	20 MW	US\$40M	US\$80M	-	-	II
Hawthorne	12 km ²	10 MW	15 MW	US\$40M	US\$60M	-	-	II
Gerlach	7 km ²	5 MW	10 MW	US\$20M	US\$40M	-	-	II
Soda Lake	4 km ²	-	-	-	-	-	-	II

Source: Company reports.

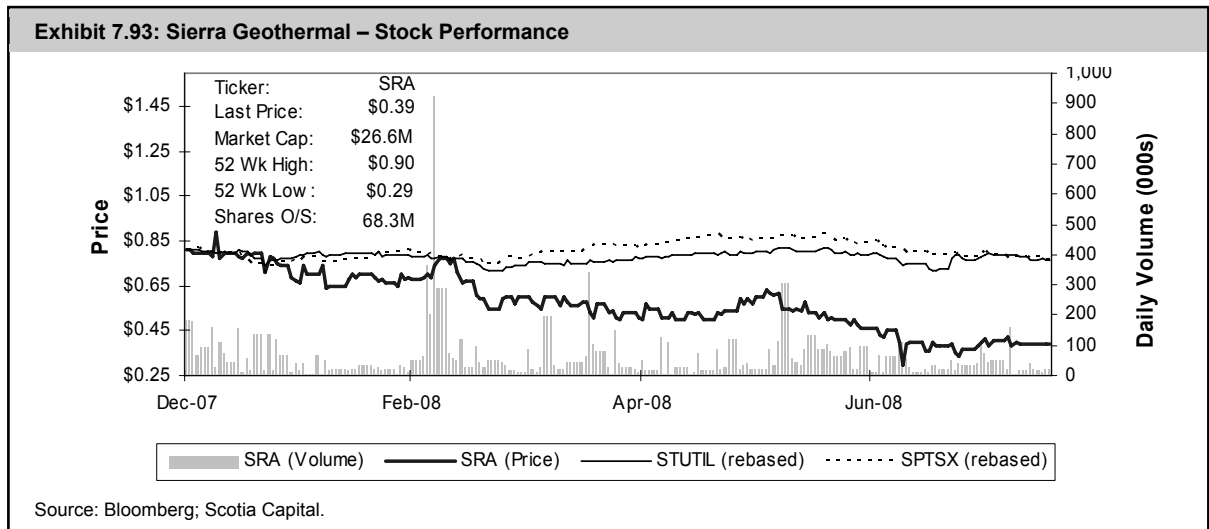

POLARIS GEOTHERMAL INC.

Unlike many of its peers, which focus their geothermal exploration and development efforts in Nevada, Polaris Geothermal (GEO-T) is attempting to build a 72 MW facility in **Nicaragua**. The company was founded in June 2004 and has since completed construction of a 10 MW facility at its site.

Projects Worth Watching

The 40 km² San Jacinto-Tizate geothermal concession is located 90 km northwest Managua, and has a resource base confirmed at 203 MW (P90), with a 50% probability of exceeding 270 MW. Polaris signed a 20-year “take-or-pay” PPA with Union Fenosa, a Spanish utility that is committed to purchasing 66 MW of power from the facility at an initial price of US\$60.10/MWh, and which will escalate at about 1% per year. The PPA is backed and guaranteed by the Government of Nicaragua and enables Polaris to sell its excess power to the grid. By early 2010, an 18-month delay, Polaris hopes to have completed the first phase of the project, the installation of one 24 MW modular condensing turbine (MCT). Phase II, to be completed by 2H/10, will add two more 24 MW MCTs upon successful drilling of production and injection wells to bring total capacity to 72 MW. Phase III will consist of the additional installation of two 60 MW condensing turbines. Polaris intends to retain and sell Emission Reduction Credits from the project.

GEO’s other key project includes a 137 MW (P90) geothermal concession located at Casita, Nicaragua. The San Jacinto–Tizate and Casita concessions are both 87.6% owned by Polaris, with the remaining ownership held by a Daimler Chrysler subsidiary, debis Industriehandel GmbH (10%), and Consorcio Electrico de Centroamericano S.A. de C.V. (2.4%).

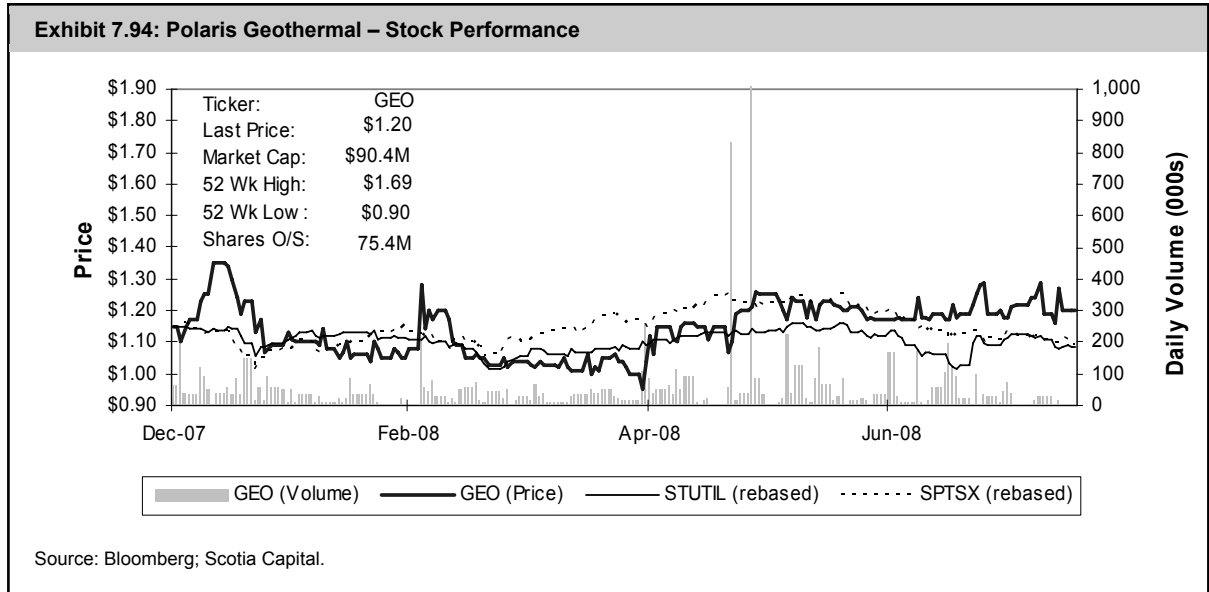

NEVADA GEOTHERMAL POWER INC.

Nevada Geothermal (NGP-V) is developing three geothermal properties in Nevada, and one in Oregon. In addition to seeking PPAs for its projects, NGP is also negotiating with mining companies for the direct sale of its power.

Projects Worth Watching

NGP’s primary undertaking is the development of Blue Mountain, a 100%-owned 49.5 MW geothermal project. The project has a net 31.25 MW 20-year PPA with Nevada Power Company and is projected to generate power by Q4/09. The PPA will pay NGP between US\$60/MWh to US\$70/MWh with a fixed annual escalator. Additionally, the project is expected to earn incremental EBITDA from the U.S. PTC as well as from the sale of RECs. GeothermEx, a large global geothermal energy consulting firm, stated that the inferred resource of the Blue Mountain project is 110 MW. As a result, Nevada Geothermal recently submitted a second Blue Mountain PPA bid for an additional 30 MW. An interconnection agreement (20-mile transmission line required) and environmental permitting have been approved. Just recently, the

company entered into an EPC with Ormat for the construction of the Blue Mountain Faulkner I project. Construction is anticipated to begin by late 2008.

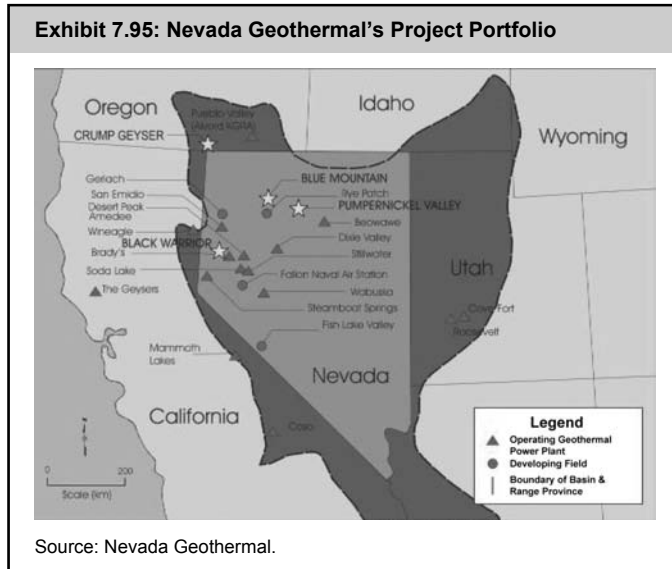

Other notable projects include: (1) Crump Geysers, a 40 MW (P90) to 60 MW (P50) project located in Oregon; (2) Pumpernickel, a 50:50 JV project with Sierra Geothermal for 20 MW (P90) to 30 MW (P50); and (4) Black Warrior, a 37 MW (P90) to 50 MW (P50) project over 21 km² located in western Nevada that would likely deliver power to California. Exhibit 7.95 shows the location of the company’s project portfolio relative to other development fields and current geothermal operating plants.

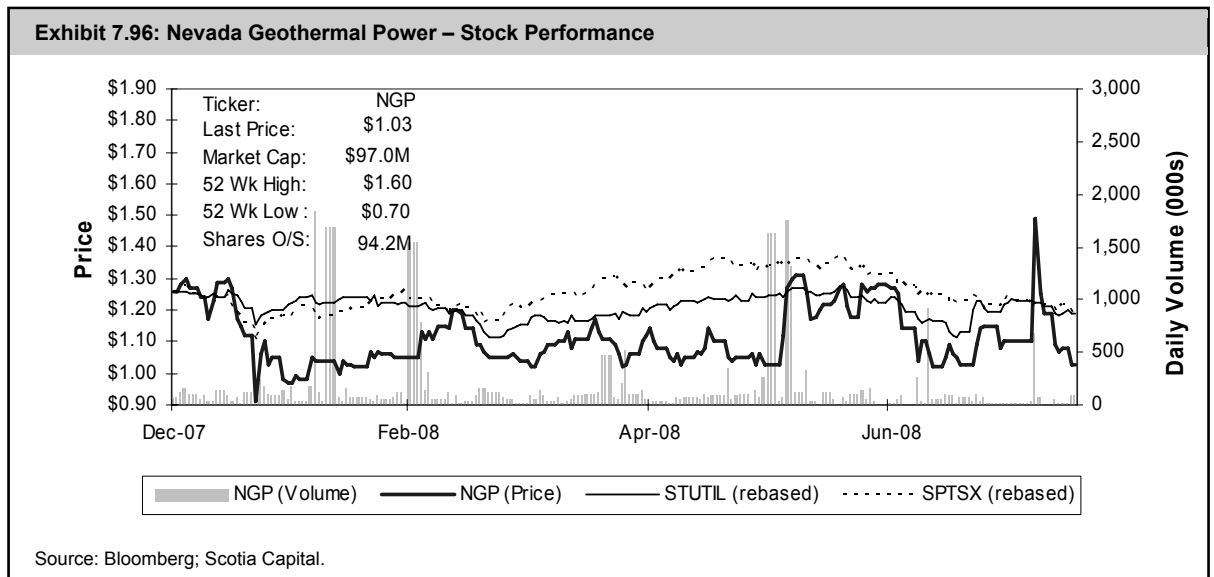

WESTERN GEOWPOWER CORP.

Western GeoPower Corp. (WGP-V) is focused on the development of two geothermal projects in North America. **The company has the only geothermal lease in Canada for the commercial production of geothermal energy.**

Projects Worth Watching

WGP is developing a 35 MW geothermal plant at Geysers Field in northern California, with a planned start-up of early 2010. The Geysers is the largest geothermal field on the planet and has been in operation since 1960, with a current installed capacity of 900 MW. Capital costs for the project are estimated by WGP at US\$4 million per MW. The project’s drilling program is expected to continue until December 2009. A signed PPA agreement with Pacific Gas & Electric (PG&E) in mid-2007 was terminated by WGP in February 2008 as California Public Utilities Commission approval was not received within the stipulated time-frame. WGP’s CEO stated that the termination of the PPA “will not affect the projected start of commercial operations in early 2010.” In May 2008 the company signed a PPA for 265,000 MWh/y with the Northern California Power Agency. The PPA is for 20 years at a price of US\$98/MWh and is not subject to further approvals.

Western GeoPower is in the early stages of testing commercial viability at its South Meager, B.C., geothermal project. Preliminary test drilling was initiated in 2004, and GeothermEx has since classified the project as having between 100 MW and 200 MW of capacity. If development of the project continues on time, WGP estimates commercial production will commence in 2012. The site location is 83 km from the grid and 170 km from Vancouver.

WGP is also exploring geothermal opportunities in Chile and launched operations there in April 2008.

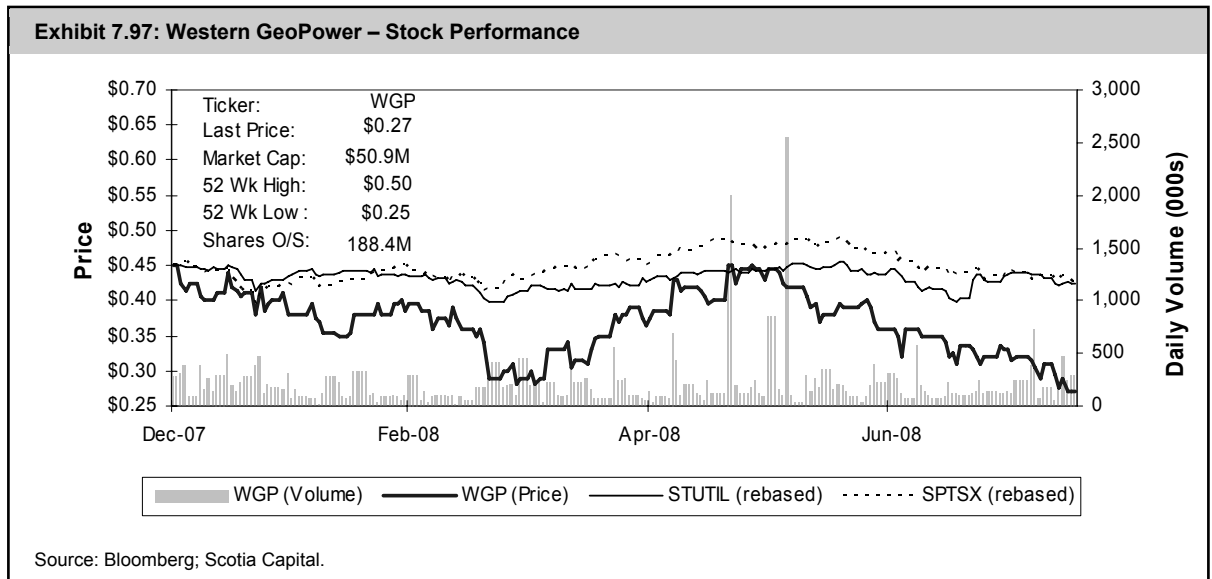

U.S. GEOTHERMAL INC.

U.S. Geothermal (GTH-T) is developing its geothermal assets in Idaho, Oregon, and Nevada. The company began trading on the TSX in September 2007, and currently has a market capitalization of \$147 million. PPAs for 65 MW have either been completed or are in an advanced stage of negotiation.

Projects Worth Watching

GTH's 15.6 MW (P50) Raft River project is located about 200 miles southeast of Boise, Idaho, at the site of a former U.S. Department of Energy geothermal installation. Based on estimates provided by GeothermEx, the site may be capable of producing up to 110 MW. The project was acquired by U.S. Geothermal in 2002 and power plant construction began in mid-2006, with commercial production achieved in January 2008. Power production will be sold to Idaho Power Company under a 13 MW, 25-year PPA. Additionally, the company signed a 25-year PPA for 16 MW of capacity with the Eugene Water and Electric Board. A total of 36 MW of transmission has been reserved on a 138 kV transmission line that is located adjacent to the project that ensures accessibility to western power markets.

The Neal Hot Springs development project, located in Oregon, about 90 miles northwest of Boise, Idaho, anticipates 26 MW of power production. The project has already been selected by Idaho Power Company for the negotiation of a PURPA contract. In early 2008, a drilling permit was issued to GTH followed by the commencement of drilling in May. The expected commercial operation date for the project is Q3/11.

The San Emidio project, acquired in April of 2008, has a net capacity of 3.6 MW and is located in Washoe County, Nevada. GTH recently received drilling permits for the project and is currently in the process of adding 27 MW with commercial operations expected by the end of 2010. The project has the potential for up to 44 MW (P90) and has a PPA in place for current production that continues until 2017.

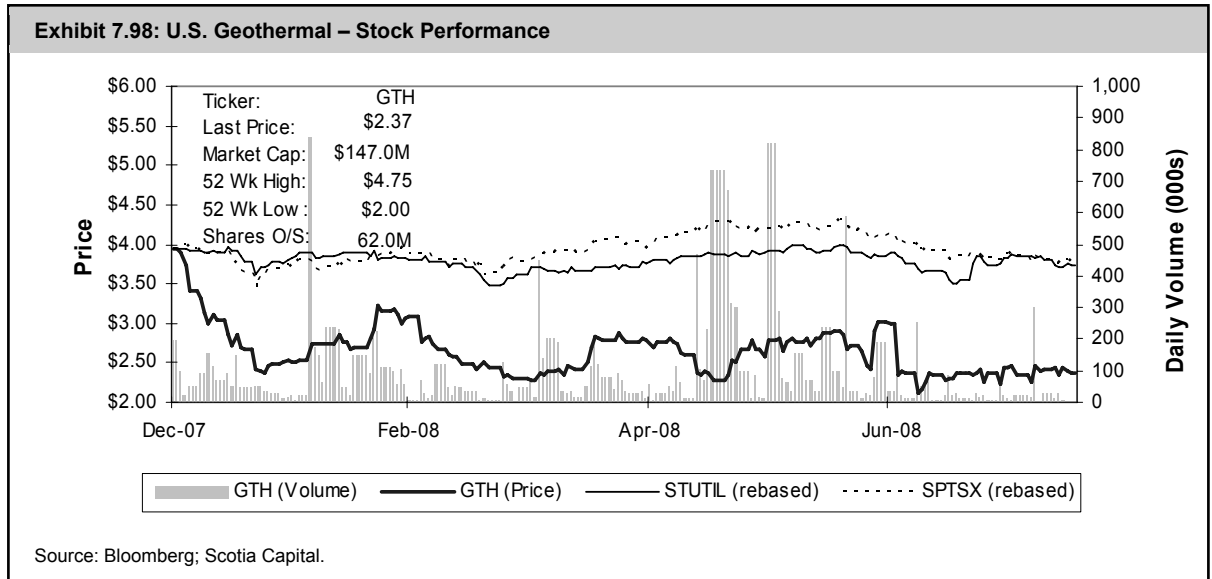

Exhibit 7.99: Geothermal Comps

Company Name	Ticker	Last Price (8/15/2008)	52-Wk Low	52-Wk High	Shares O/S (M)	Market Cap (C\$M)	Debt/Equity (%)	Debt/Assets (%)	Debt/EBITDA (x)	1-Month ROR (%)	3-Month ROR (%)	1-Year ROR (%)
Nevada Geothermal Power	NGP	\$1.03	\$0.68	\$1.60	94.2	\$97	45%	24%	n.m.	-2%	-6%	43%
Polaris Geothermal	GEO	\$1.20	\$0.90	\$1.69	75.4	\$90	15%	11%	n.m.	2%	4%	4%
Sierra Geothermal Power	SRA	\$0.39	\$0.29	\$0.90	68.3	\$27	-	-	-	3%	-22%	-22%
US Geothermal	GTH	\$2.37	\$2.00	\$4.75	62.0	\$147	-	-	n.m.	0%	4%	1%
Western GeoPower	WGP	\$0.27	\$0.25	\$0.50	188.4	\$51	2%	2%	-	-13%	-33%	4%
Average						\$82	20%	12%	-	-2%	-11%	6%

Company Name	Enterprise Value to EBITDA			Price to Earnings			Price to Sales			Price to Cash Flow		
	2008E (x)	2009E (x)	2010E (x)	2008E (x)	2009E (x)	2010E (x)	2008E (x)	2009E (x)	2010E (x)	2008E (x)	2009E (x)	2010E (x)
Nevada Geothermal Power	-	-	-	-	-	20.6x	-	-	13.3x	n.m.	n.m.	-
Polaris Geothermal	-	-	-	-	-	-	-	-	-	-	-	-
Sierra Geothermal Power	-	-	-	-	-	-	-	-	-	-	-	-
US Geothermal	n.m.	9.9x	3.7x	-	74.4x	14.0x	39.9x	15.5x	8.9x	n.m.	-	-
Western GeoPower	-	-	-	-	-	-	-	-	-	-	-	-
Average	-	9.9x	3.7x	-	74.4x	17.3x	39.9x	15.5x	11.1x	-	-	-

Source: Bloomberg; Scotia Capital.

Wood-Residue Biomass– Losing Value on High Fuel Costs

OVERVIEW

Our overall long-term view on wood-residue biomass is that renewable power investment dollars could be better spent elsewhere.

In our view, the outlook for wood-residue biomass capacity investment in Canada remains lukewarm. B.C. appears to be the only materially active province developing its substantial biomass resource, through BC Hydro’s 1,000 GWh/y Bioenergy Call for Power. Ontario has seen minimal capacity additions from wood-residue plants since 2003. **Why:** Wood-residue power facilities typically require (1) a partnership with a mill (poor outlook) to procure cheap wood; and/or (2) diesel-intensive logging and transportation (costs soaring).

Despite accelerated growth of renewable energy projects across Canada and the world, wood-residue capacity has remained fairly flat since 2002. Only a handful of greenfield wood-residue plants have been constructed in North America since then with the majority of “bio-dollars” going towards biodiesel and biomass-to-ethanol plants. In our opinion, and when compared to a **free and renewable** fuel source such as wind, wood-residue based power generation (**renewable, but not free fuel**) has typically not been able to earn quality economic returns. Further exacerbating the situation, at least in the U.S., is the Production Tax Credit that offers open-loop biomass developers **only 50%** of the incentive that wind developers are offered. As a result, wood-residue biomass power capacity growth has suffered over the past five years, partially at the expense of an explosion of wind power capacity growth (Exhibit 7.100).

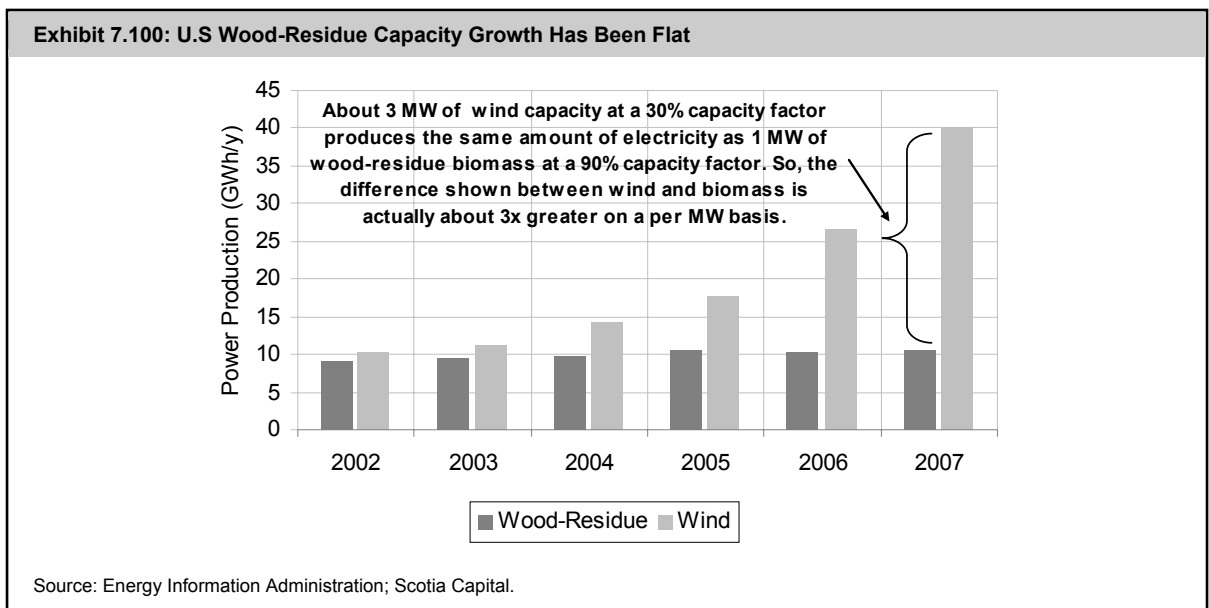

At current commodity prices, the cost of obtaining wood-residue is such that project returns (excluding renewable energy incentives) are fairly unattractive.

CONSIDER INVESTING BIOMASS DOLLARS IN REC MARKETS

In our opinion, the most lucrative wood-residue biomass investment is one where an idle biomass or coal plant is purchased by an IPP for a fraction of its original cost, retrofitted to meet local renewable portfolio standard requirements, and commissioned primarily to collect and sell Renewable Energy Certificates (RECs), as well as the U.S. Production Tax Credit. Connecticut and Massachusetts are among the best U.S. states to do this, as those states’ RECs are currently priced in the US\$30/MWh to US\$50/MWh range, with a strong short- to mid-term outlook. **Our long-term view on wood-residue biomass is that renewable power investment dollars could be better spent elsewhere.**

PROFITING FROM THE MOUNTAIN PINE BEETLE – THE B.C. BIOENERGY CALL

In early 2008, BC Hydro issued a two-phase Bioenergy Call for Power (BioCFP) that seeks to utilize wood infected by the mountain pine beetle as well as other wood fibre fuel sources for power production. In addition to attracting existing and new IPPs, the BioCFP has drawn interest from forestry

companies as well as First Nations groups. EPAs could be awarded anytime through mid-October 2008.

Phase I of the BioCFP seeks a total of 1,000 GWh/y of projects that are immediately viable, using proven technologies. We anticipate Phase II of the BioCFP to be announced shortly. Potential biomass resources in British Columbia could be up to 32.3 million dry tonnes per year for the next 20 years (Exhibit 7.101).

In the BC Hydro 2006 Call for Power, 24% of capacity and 44% of anticipated annual power generation were awarded to biomass-related power projects, but much of this since has been shelved (Exhibit 7.102).

Potential biomass resources in B.C. could be up to 32.3 million dry tonnes per year for the next 20 years.

Biomass Feedstock	Resource Size (Dry t/y)	Bioenergy Potential (PJ/y)	% of Potential (%)	% of Total Fossil Energy (%)
Municipal Solid Waste	948,450	15.2	2.9%	1.6%
Sustainable Agriculture				
Crop residues	143,901	2.3	0.4%	0.3%
Livestock manure	388,426	6.1	1.2%	0.7%
Biomass Crops on summer fallow land	147,060	2.4	0.5%	0.3%
Biomass Crops on new/ converted land	2,587,118	41.4	8.0%	4.5%
	3,266,505	52.1	10.1%	5.7%
Sustainable Forestry				
Forest residues	11,940,429	191.0	36.9%	20.8%
Silviculture for traditional forest products	1,194,043	19.1	3.7%	2.1%
Silviculture for bioenergy plantations	3,980,143	63.7	12.3%	6.9%
	17,114,615	273.8	52.9%	29.8%
Mountain Pine Beetle (MPB)				
Residue from increased AAC	2,353,882	37.7	7.3%	4.1%
Whole tree harvest of non-recoverable pine	8,660,736	138.6	26.8%	15.1%
	11,014,618	176.2	34.1%	19.2%
Total Potential	32,344,188	517.4	100.0%	56.2%

Source: BioCap Canada; ENVIT Consulting; Scotia Capital.

Bidder	Project	Plant Capacity (MW)	Expected Production (GWh/y)	Status (July 2008)
AESWapiti Energy Corporation	AESWapiti Energy Corporation	184	1,612	Shelved
Green Island Energy Ltd.	Gold River Power Project	90	745	On track
Compliance Power Corporation	Princeton Power Project	56	421	Shelved
Mackenzie Green Energy Inc.	Mackenzie Green Energy Centre	50	441	One-year delay
		380	3,219	

Source: BC Hydro; Scotia Capital estimates.

Challenges that potential bidders may face in the BioCFP are: (1) forecasting project fuel availability over the long term; (2) fuel make-up and cost will likely change over time; and (3) existing forest tenures may not match the duration of a power contract.

CAPITAL COSTS ARE REASONABLE, BUT O&M COSTS ARE SOARING

The average installed capital cost for greenfield wood-residue plants, at about **US\$3 million per MW**, is **in line with other renewable** energy technologies, and **slightly less expensive than its peers on a per GWh/y basis**. However, wood-residue facilities are materially **more expensive to operate than wind, solar, hydro, or geothermal as the cost of fuel is not free**.

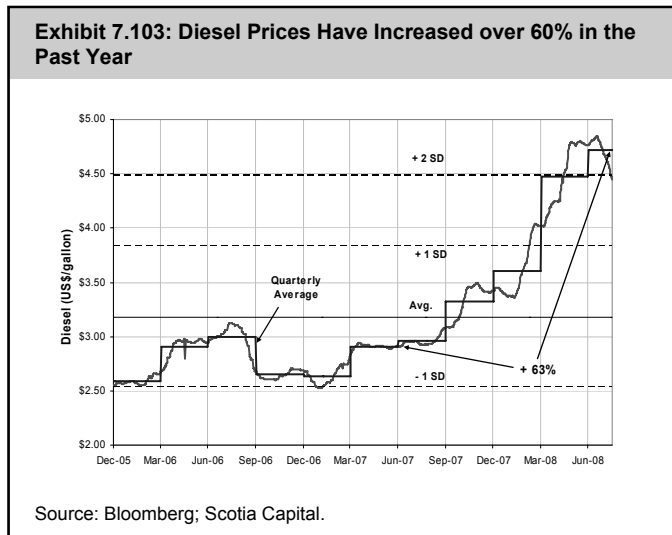

Up to 50% of wood-residue operating costs are associated with wood transportation. The U.S. average diesel price over the past year has increased by over 60%, crushing operating margins for many wood-residue biomass operators (Exhibit 7.103). As an example, Boralex's operating cost per MWh has increased about 30% per year since mid-2006, or by half the growth of U.S. diesel prices (Exhibit 7.104).

With most analysts forecasting oil prices to remain above US\$100/bbl through 2012, we continue to see wood-residue biomass facility operating costs as a major challenge for further capacity growth.

INVESTMENT POSITIVES

Proven, simple technology. Wood is one of the oldest fuel sources for energy generation and requires one of the least complex conversion technologies to produce power. Wood-residue biomass facilities are similar to coal-fired plants and require only a boiler and a steam turbine as primary capital equipment investments.

Reliable. Provided that an ample supply of wood-residue inventory is available, these facilities are not impacted by seasonality, as are wind farms and hydro facilities, nor are biomass plants an intermittent power source. However, procuring wood during winter months from snow-covered areas can materially impact the cost of fuel.

High capacity factor. Biomass plant capacity factors are materially higher than for wind, solar, and run-of-river due to a constant fuel supply. A typical wood-residue facility will operate at a capacity factor of 75%.

Ability to earn incentives. While provincial, state, and federal laws/regulations vary, wood-residue biomass power plants typically qualify for renewable power financial incentives such as the U.S. Production Tax Credit or the ecoENERGY program in Canada. Additionally, some form of carbon credits such as Renewable Energy Certificates can usually be earned and sold, which in some cases can materially change the economics of a project. Boralex is one the best examples of this that we have seen.

INVESTMENT RISKS

High commodity risk. Whether purchasing wood residue from third parties or obtaining wood in house, the wood-residue must be transported via truck, making costs heavily dependent on the price of diesel and indirectly the price of oil. Depending on a plant's proximity to its wood supply, **diesel-related costs can exceed 25% of total operating costs.**

High operating & maintenance costs. Wood-residue biomass plants require an operational team to constantly source, procure, prepare, and store wood, as well as supply the fuel to the facility. In contrast, wind and run-of-river projects require minimal on-site involvement and can easily be run remotely.

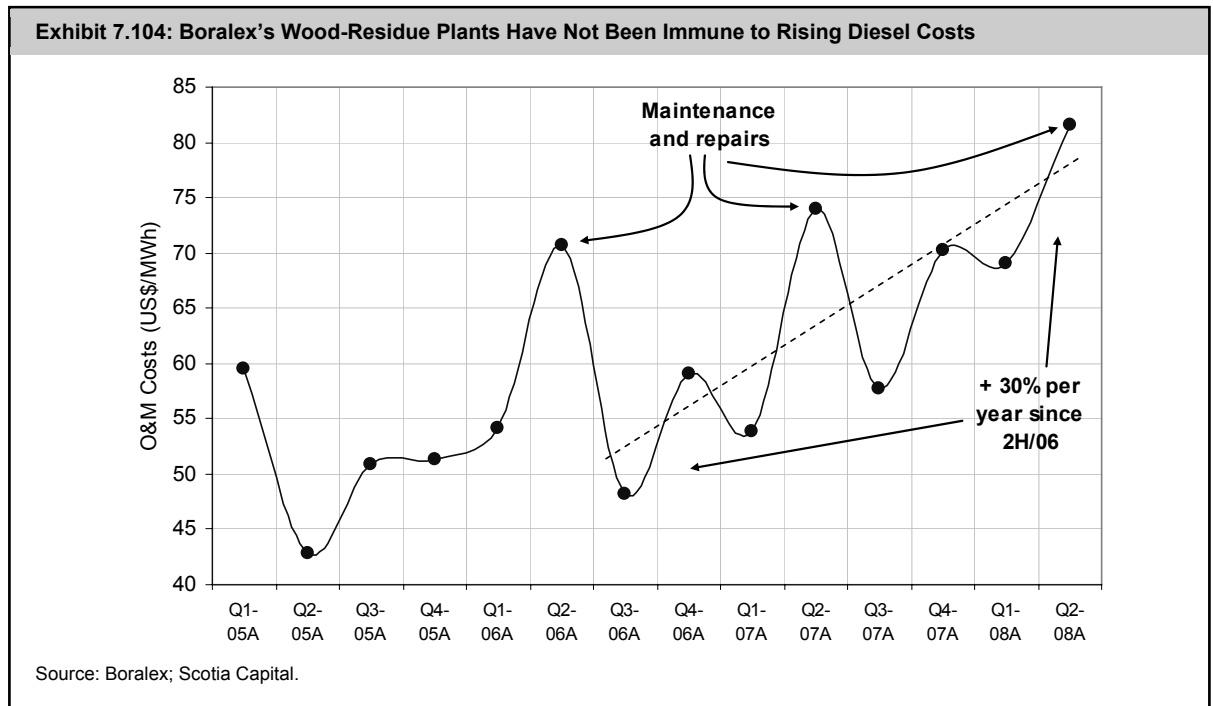

UNEXCITING EQUITY RETURNS: MODELLING & SENSITIVITY ANALYSES OF A WOOD RESIDUE BIOMASS PROJECT

On a stand-alone basis (i.e., excluding financial incentives), **wood-residue projects offer investors one of the least attractive returns compared to other renewable technologies.** We modelled several generic wood-residue project scenarios and sensitized for variations in (1) PPA prices and escalation rates; (2) capital costs and costs of capital; (3) various financial incentives, including Renewable Energy Certificates (RECs), the U.S. Production Tax Credit (PTC), and the ecoENERGY incentive payment, among others; (4) operating and maintenance costs; (5) capacity factors; and (6) tax rates. **Our generic open-loop wood-residue biomass project yielded a 7.5% IRR.** To arrive at this, we made the following assumptions:

- **75% capacity factor.** Capacity factors for wood-residue power plants vary widely, from as low as 35% to as high as 95%. Typically, well maintained plants range from 70% to 85%. **We chose 75%.**
- **US\$3 million per MW installed cost.** The installed capital cost for an average greenfield wood-residue biomass facility in North American is US\$3 million. We have seen installed capital costs range between US\$2.5 million and US\$3.8 million.
- **Starting PPA @ US\$90/MWh + 1.5% p.a.** We took the weighted-average U.S. renewable PPA price of several states that ranged from the mid-US\$60s/MWh to US\$98/MWh. We tacked on an annual escalation rate of 1.5% per year.
- **Starting O&M @ US\$65/MWh + 1.5% p.a.** Operating and maintenance cost estimates (and actuals) have ranged widely between US\$45/MWh and US\$75/MWh. We used a cost of US\$65/MWh to reflect rising wood-residue and transportation (diesel) costs.

- **U.S. PTC @ US\$10/MWh.** We placed our generic wood-residue biomass facility in the U.S., which as an open-loop facility, qualifies for a U.S Production Tax Credit of \$10/MWh. Note that closed-loop facilities receive twice this amount (i.e., the same as qualified wind farms).
- **No REC sales.** While some U.S. states such as Connecticut and Massachusetts have REC prices in the US\$30/MWh to US\$50/MWh range, many states have REC values worth less than US\$1/MWh, and over half of the U.S states don't offer RECs.
- **Debt to equity split 75%/25%.** This is in line with most current and proposed wood-residue project capital structures that we have seen.
- **Other.** Most wood residue plants operate for 30 years or more. We assume a project life of 40 years given the reliability of the technology.

In Exhibits 7.105 and 7.106 on the following pages, we provide sensitivity analyses to changes in the factors listed above.

Exhibit 7.105: Wood-Residue Biomass Equity Returns Are Fairly Unattractive

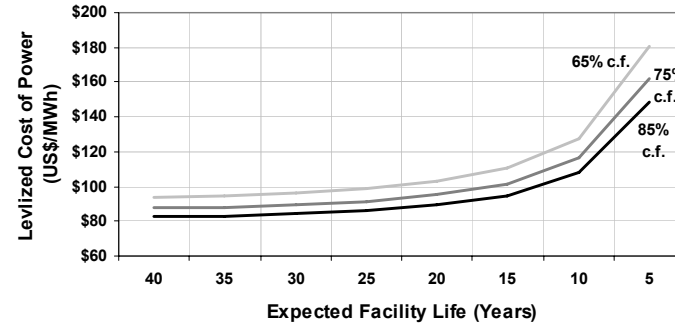
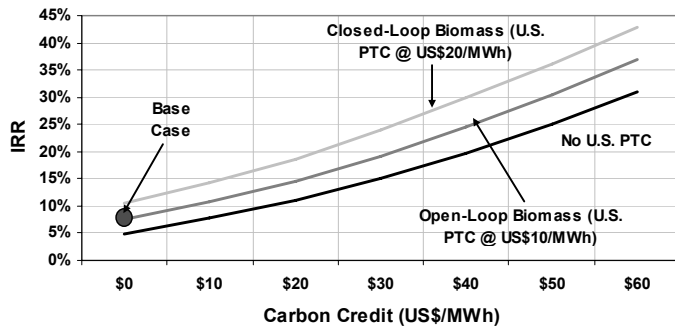
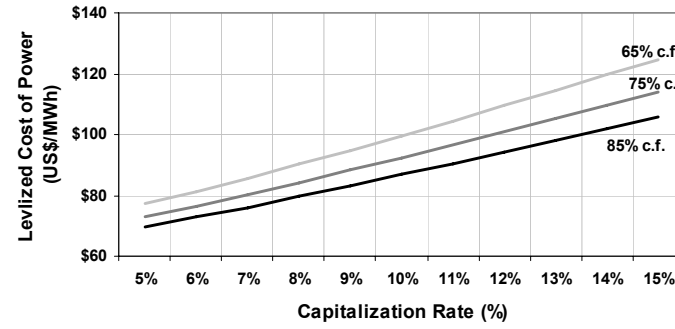
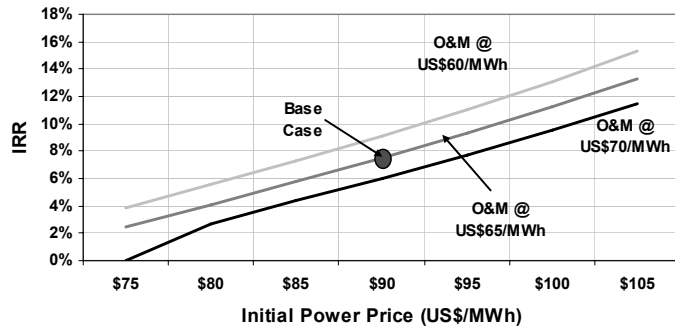
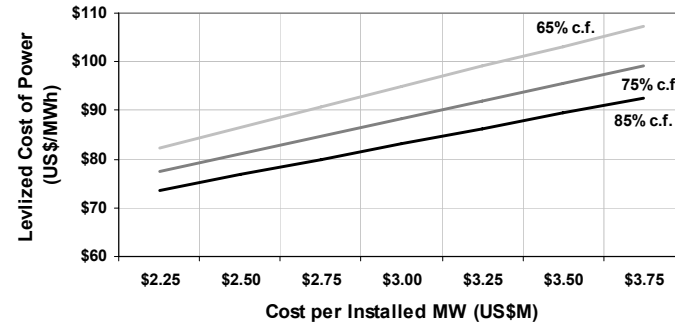
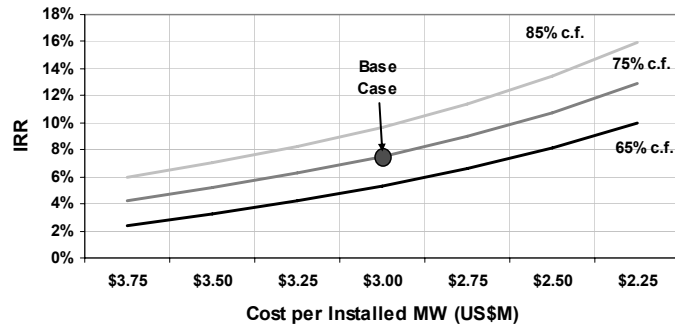

Source: Scotia Capital estimates.

Exhibit 7.106: Wood-Residue Biomass Equity Returns Are Fairly Unattractive

		Starting PPA Price (US\$/MWh)						
		\$75	\$80	\$85	\$90	\$95	\$100	\$105
Starting O&M Cost (US\$/MWh)	\$70.0	-	2.7%	4.3%	6.0%	7.7%	9.5%	11.5%
	\$67.5	-	3.4%	5.1%	6.8%	8.5%	10.4%	12.4%
	\$65.0	2.4%	4.1%	5.8%	7.5%	9.3%	11.3%	13.3%
	\$62.5	3.1%	4.8%	6.5%	8.3%	10.2%	12.2%	14.3%
	\$60.0	3.8%	5.5%	7.3%	9.1%	11.1%	13.1%	15.3%
	\$57.5	4.6%	6.3%	8.1%	10.0%	12.0%	14.1%	16.4%
	\$55.0	5.3%	7.1%	8.9%	10.9%	12.9%	15.1%	17.5%

		Installed Capital Cost (US\$/MWh)						
		\$3.75	\$3.50	\$3.25	\$3.00	\$2.75	\$2.50	\$2.25
Capacity Factor (%)	60.0%	-	2.3%	3.2%	4.3%	5.5%	6.9%	8.6%
	65.0%	2.4%	3.3%	4.3%	5.4%	6.6%	8.2%	10.0%
	70.0%	3.4%	4.3%	5.3%	6.4%	7.8%	9.5%	11.5%
	75.0%	4.3%	5.2%	6.3%	7.5%	9.0%	10.8%	13.0%
	80.0%	5.1%	6.1%	7.3%	8.6%	10.2%	12.1%	14.5%
	85.0%	6.0%	7.1%	8.3%	9.7%	11.3%	13.4%	16.0%
	90.0%	6.9%	8.0%	9.3%	10.8%	12.5%	14.8%	17.6%

		Cost of Debt (%)						
		8.00%	7.50%	7.00%	6.50%	6.00%	5.50%	5.00%
Effective Cash Tax Rate (%)	30%	4.0%	4.7%	5.4%	6.2%	7.0%	7.9%	8.8%
	25%	4.4%	5.1%	5.9%	6.7%	7.5%	8.4%	9.4%
	20%	4.8%	5.5%	6.3%	7.1%	8.0%	8.9%	9.9%
	15%	5.2%	5.9%	6.7%	7.5%	8.4%	9.4%	10.4%
	10%	5.5%	6.3%	7.1%	7.9%	8.8%	9.8%	10.8%
	5%	5.8%	6.6%	7.4%	8.3%	9.2%	10.2%	11.3%
	0%	6.1%	6.9%	7.8%	8.7%	9.6%	10.6%	11.7%

		Carbon price (US\$/REC or US\$/ERC or US\$/MWh)						
		\$0	\$10	\$20	\$30	\$40	\$50	\$60
U.S. PTC (US\$/MWh)	\$0.0	4.9%	7.8%	11.2%	15.1%	19.7%	25.0%	31.0%
	\$10.0	7.5%	10.8%	14.6%	19.2%	24.5%	30.4%	36.8%
	\$20.0	10.5%	14.2%	18.7%	23.9%	29.8%	36.2%	42.9%

Source: Scotia Capital estimates.

WOOD-RESIDUE BIOMASS SCIENCE & TECHNOLOGY 101

Wood-residue plants are similar in concept to coal-fired plants where the fuel is burned in a boiler to create steam that turns a turbine to generate electricity (Exhibit 7.107). Wood-based fuels can take the form of raw wood waste logged from forests or processed wood in the form of chips. Moisture content is one of the most important factors in determining the burn-rate of the wood (i.e., energy conversion efficiency). Exhibit 7.108 shows the average energy content of most biomass fuel sources relative to the major fossil fuels. Unlike fossil fuels, plant matter often has a high water content, which adds to mass but contributes no energy. **In general, each 10% increase in moisture content reduces the low heat value (i.e., the heat value per kilogram) of the fuel by about 11%.**

The combustion of wood releases the same amount of CO₂ as had the wood decomposed naturally. Whether or not wood residue plants are truly carbon neutral remains a debatable topic as **burning wood accelerates the carbon cycle and also requires transportation operations that are CO₂ and GHG intensive.** To meet local emissions standards and qualify to earn Renewable Energy Certificates (RECs), standard burners are typically retrofitted with a bubbling fluidized bed, which provides a cleaner burn by injecting oxygen into the floor of the boiler.

The permitting and building of a wood residue plant typically takes 24 to 28 months, but varies by size and location of the proposed facility. Studies must be conducted to ensure that enough wood fuel exists to support the plant over its lifetime, typically 20 to 40 years. Site selection must consider road access given the significant transportation demands required to supply fuel to the plant.

COAL-TO-WOOD BIOMASS PLANT CONVERSION

U.S. Renewables Group (USRG), a California-based private equity fund, recently acquired the Niagara Generating Facility from WPS Resources for US\$31 million. USRG is now spending an additional US\$25 million to **convert the facility from burning coal to burning wood biomass.** Once converted, the total capital cost for the 45 MW project will come in at less than US\$1.5 million per MW, or **at least 50% less than a greenfield wood-residue biomass project.** USRG has targeted Pennsylvania for further coal-to-biomass conversion projects.

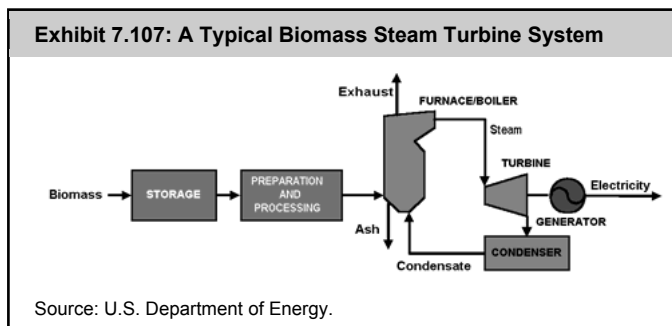

in at less than US\$1.5 million per MW, or **at least 50% less than a greenfield wood-residue biomass project.** USRG has targeted Pennsylvania for further coal-to-biomass conversion projects.

Exhibits 7.109 and 7.110 show prominent biomass fuel source regions in both Canada and the U.S.

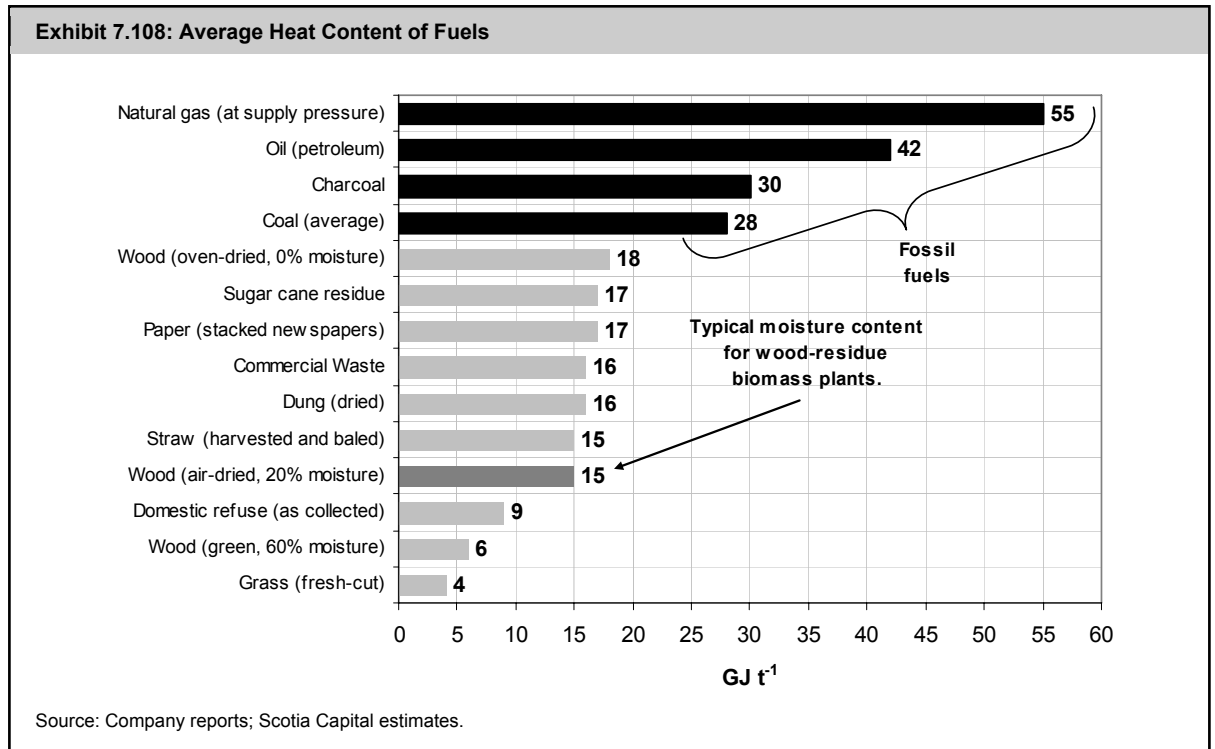
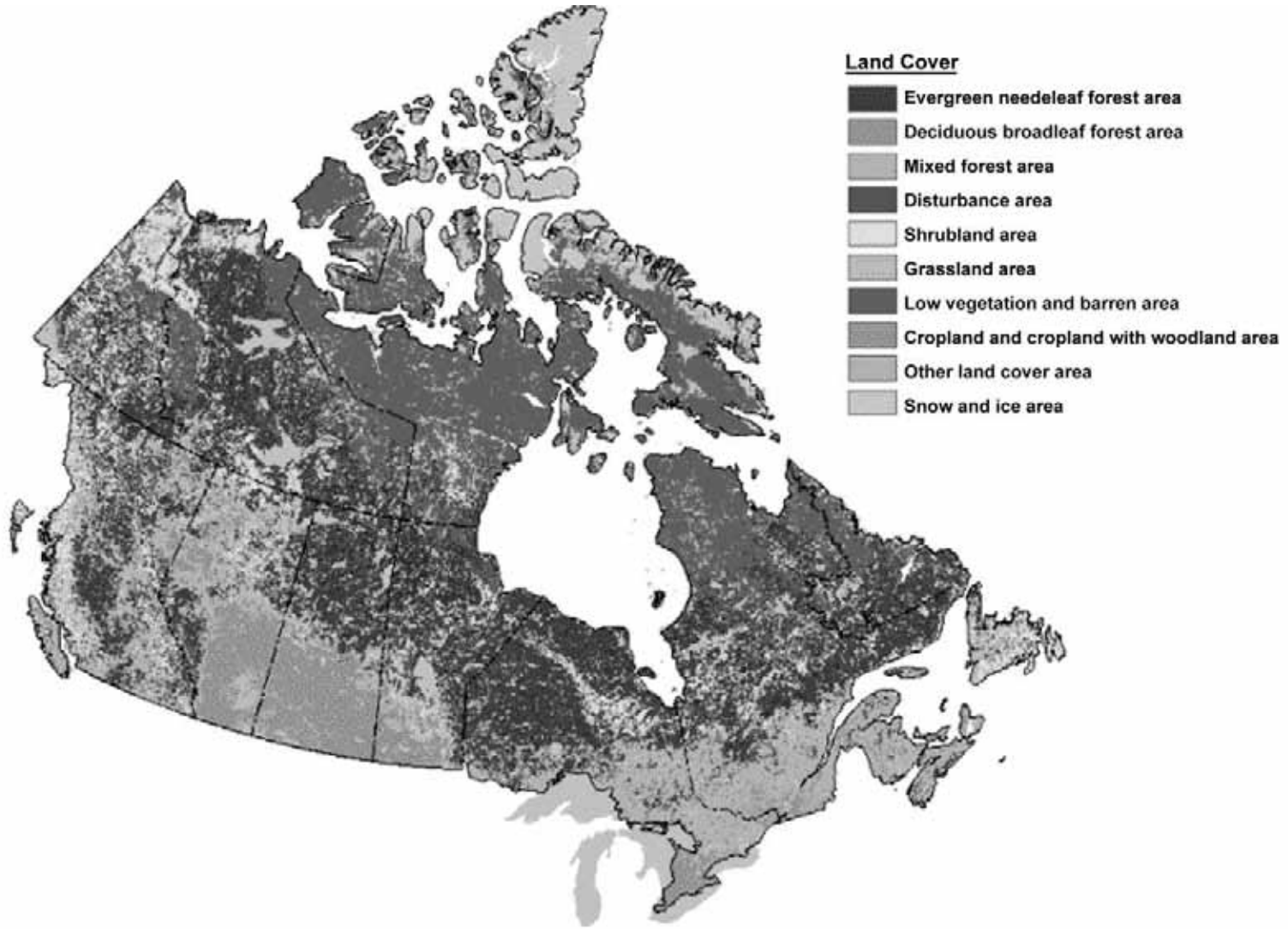
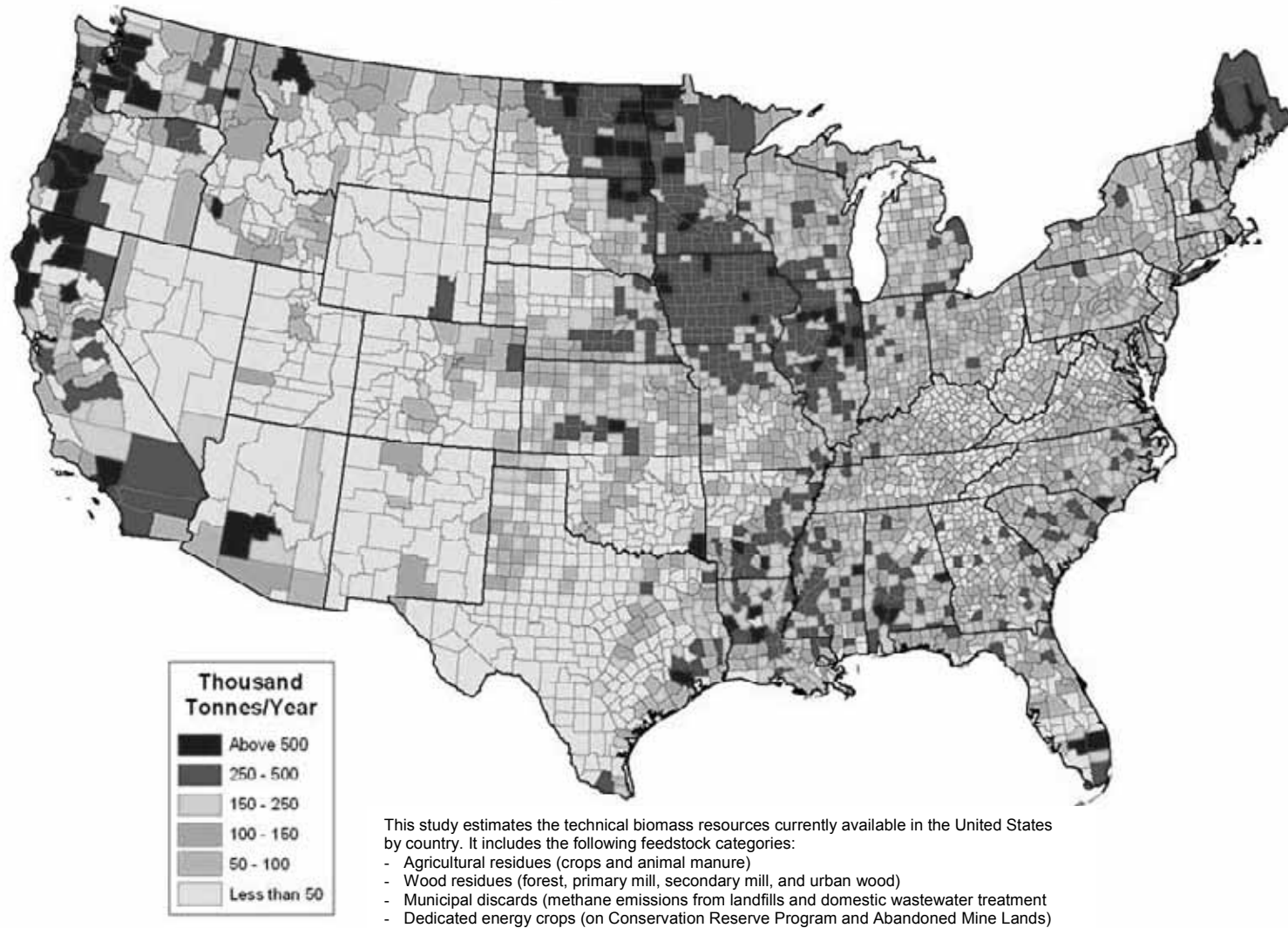

Exhibit 7.109: Land Cover in Canada



Source: Statistics Canada.

Exhibit 7.110: Biomass Resources in the U.S.

Source: National Renewable Energy Laboratory.

PRISTINE POWER INC.

Pristine Power (PPX-T) is an independent power producer with planned power generation facilities in Ontario, Alberta, and British Columbia. Pristine has wood-residue, run-of-river, and cogeneration projects under development. In addition to its Mackenzie Green Energy Centre biomass project summarized below, Pristine has a 25% interest in Fort Chicago's 84 MW East Windsor Cogeneration facility, as well as a 25% stake in 10 MW of waste-heat projects with ENMAX. **We believe that Pristine Power, with various financial partners, could bid up to 70 MW (gross) of new B.C. biomass capacity in the second phase of the BioCFP.**

Projects Worth Watching

The Mackenzie Green Energy Centre, a 65 MW biomass project in B.C., was awarded a 25-year, 50 MW EPA from BC Hydro in its 2006 Call for Power. Pristine Power has a 35% (to be reduced to 17.5% post-commissioning) stake in the project, which is expected to be commissioned by the second half of 2011 (i.e., one year late). The project's site is located adjacent to the now bankrupt Pope & Talbot pulp mill, where it was to receive almost cost-free wood-residue. We spoke with one of the project's co-owners that told us all potential acquirers of the mill would likely keep the supply agreement between the mill and the biomass project unchanged. As an alternative, the project is seeking substitute fuel sources such as mountain pine beetle infected wood.

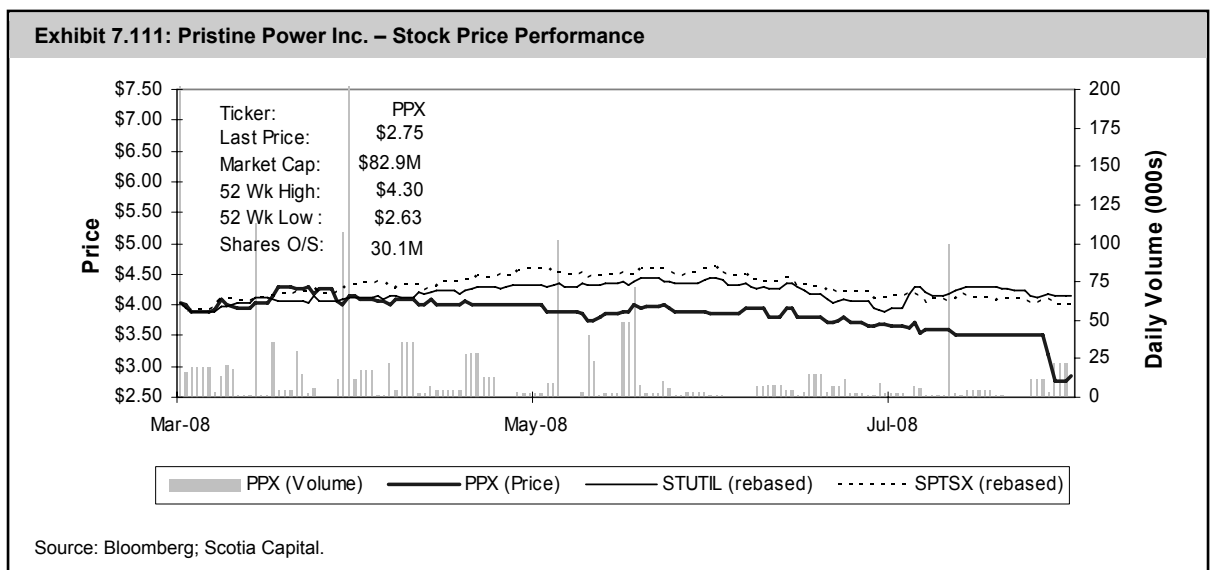
**OTHER SELECT CANADIAN WOOD-RESIDUE BIOMASS PROJECTS**

EPCOR Utilities Inc. and West Fraser Timber Co. Ltd (WFT-T) recently began working together to explore the possibility of a wood-fuelled 50 MW to 70MW power plant in Houston, B.C. A plant of this size would be one of North America's largest and would likely be submitted to Phase II of BC Hydro's BioCFP. The proposed plant would use wood waste from the province's mountain pine beetle infestation.

In addition to its hydro development portfolio, **Run of River Power Inc. (ROR-V)** acquired 80% of the outstanding shares of Pacific Northwest Biomass Corp. (PNBC). PNBC has proposed a 30 MW (\$140 million) biomass plant located near Hazelton, B.C., which could generate up to \$30 million in annual revenue for ROR. Run of River Power Inc. has another biomass initiative under way known as the Tsilhqot'in Bio-energy Project. The 60 MW, \$225 million 50:50 JV with the Tsilhqot'in National Government would utilize mountain pine beetle damaged timber as feedstock. In mid-2008, BC Hydro informed ROR that its two biomass projects had met the first-phase requirements for the 2008 BC Hydro Bioenergy Call for Power.

Tidal Power – The Next Renewable Play?

OVERVIEW

There may be over 100,000 MW of commercially viable tidal power.

While few countries have completed tidal resource assessments, industry observers believe there are over 100,000 MW of commercially viable tidal power on the planet, representing a \$300 billion to \$400 billion market. Tidal power growth has mostly been limited to pilot projects in the past due to relatively inexpensive fossil fuel prices.

We believe that tidal power growth will skyrocket over the next decade, similar to the growth in installed wind power capacity over the past 10 years. A subsidiary of Russia's Unified Energy Systems is developing two massive tidal-power projects with a total installed capacity of 11,800 MW, due online by 2020. Numerous other projects and pilot projects are popping up all over the map, all much smaller in scale than the colossal undertaking in Russia. We describe some of the key projects below.

Globally, only one utility-scale tidal-power generating station is in use, located at the mouth of the La Rance River along France's northern coast. Built in 1966, the 240 MW power plant generates 600 GWh/y, or at a capacity factor of 28.5%. The plant's costs have been fully recovered, and electricity production costs are lower than for nuclear power generation, at under \$20/MWh.

Capital costs are high, currently averaging \$4.5 million per installed MW.

Tidal power generation is predictable, as the ocean's currents flow constantly. We believe that operating and maintenance costs are quite low, averaging about 0.5% per year of a project's installed capital cost. But, capital costs are high, currently averaging \$4.5 million per MW, although we think this will fall as technologies improve and economies of scale emerge.

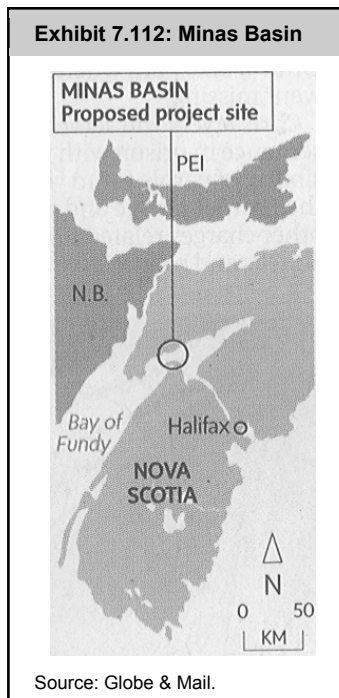

TIDAL POWER POTENTIAL IN CANADA IS HUGE

With its massive coastline, Canada's tidal power potential is about 42,000 MW, according to National Research Council, which includes 30,000 MW in Nunavut, 2,500 MW in B.C., and 2,700 MW at Nova Scotia's Bay of Fundy. Nunavut's large tidal resources exist as tidal ranges are greater the further an ocean shore is from the equator. No plans have been made to exploit these resources since climate conditions do not favour current infrastructure.

In early 2008, Nova Scotia's government became the first provincial government in Canada to approve the commercial development of tidal energy. Three companies were selected to install turbines near the entrance to the Minas Basin (Exhibit 7.112). We anticipate production will commence in 2010.

B.C. is now exploring the possibility of tidal power sites around Vancouver Island.

QUALITY EQUITY LIKELY 5+ YEARS AWAY: MODELLING & SENSITIVITY ANALYSES OF A TIDAL PROJECT

Our financial modelling and analysis of tidal power projects indicates that equity investors will be somewhat disappointed with investment returns, as expected. We modelled numerous scenarios and sensitized for variations in (1) PPA prices and escalations rates; (2) capital costs and costs of capital; (3) renewable power incentives; (4) operating & maintenance costs; (5) capacity factor; and (6) tax rates. **Our average generic project yielded a sub-5% equity IRR.** To arrive at this, we made the following assumptions:

- **30% capacity factor.** Our research revealed that tidal capacity factors are quite similar to wind, possibly a little higher. **We used 30% to be conservative.**
- **\$4 million per MW installed cost.** For the most part, pilot project costs per installed MW varied widely from about \$3 million to \$6 million per MW. We took the midpoint of \$4.5 million and then **rounded down** to \$4 million per MW as we assume economies of scale and technological advances will prevail soon.
- **Starting PPA @ \$95/MWh.** We chose to use a starting PPA price below Ontario's Standard Offer Contract price of \$110/MWh as we rounded down our installed capital cost to \$4 million per MW.
- **Starting O&M @ \$8/MWh.** Various project plans we reviewed indicated that annual O&M costs would average about 0.5% of installed capital costs. Using a \$4 million per MW installed capital cost, coupled with a 30% capacity factor, we rounded up to \$8/MWh.
- **Federal ecoENERGY incentive @ \$10/MWh.** We applied a \$10/MWh ecoENERGY federal incentive payment on our generic project's first 10 years of operation, with no adjustments for inflation, and to a maximum of \$80 million for the project.
- **Emission reduction credits @ \$5/MWh.** This is a highly speculative model assumption, as we do not know how ERCs will trade in the future. We decided to be conservative and keep our ERC price of \$5/MWh flat for the life of the project.
- **Debt to equity split 60%/40%.** We chose to use a lower debt to equity ratio at 60%/40% as technologies are still unproven. Wind and run-of-river power projects can be 75% to 85% debt financed. **Equity investors in renewable projects (excluding geothermal) have historically required 10% annual returns,** with most falling in the 8% to 12% range. We use 14%, slightly less than geothermal projects, but more than run-of-river and onshore wind power projects.
- **Other.** We matched the term of debt financing to a 30-year PPA term.

Exhibit 7.113: Quality Tidal Power Equity Returns Are 5+ Years Away

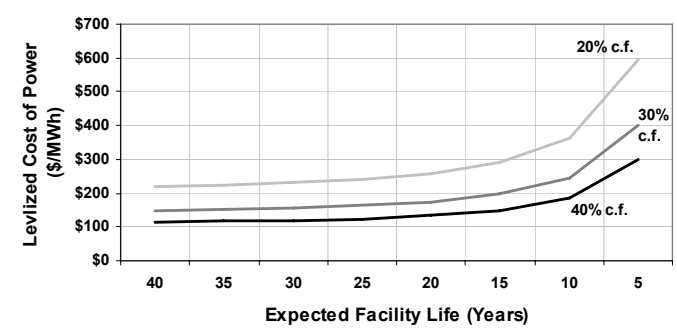
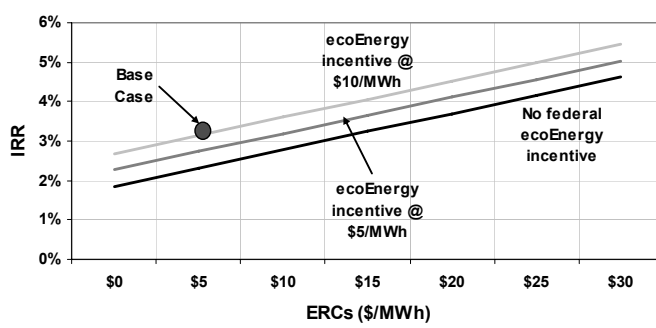
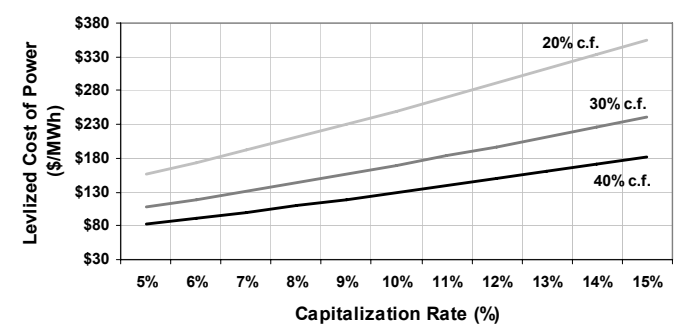
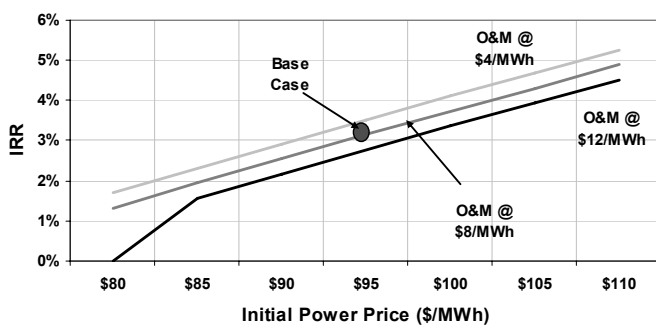
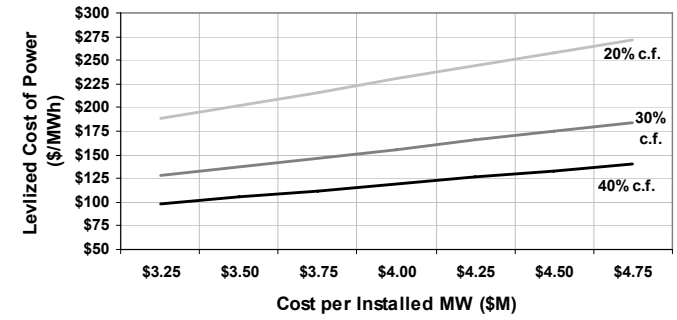
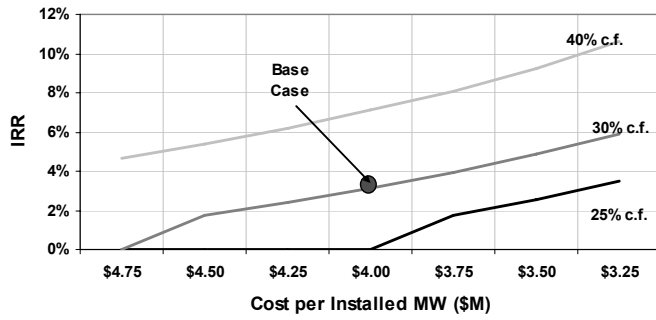

Source: Scotia Capital estimates.

Exhibit 7.114: Quality Tidal Power Equity Returns Are 5+ Years Away

		Starting PPA Price (\$/MWh)						
		\$80	\$85	\$90	\$95	\$100	\$105	\$110
Starting O&M Cost (\$/MWh)	\$14	-	1.4%	2.0%	2.6%	3.2%	3.8%	4.3%
	\$12	-	1.6%	2.2%	2.8%	3.4%	3.9%	4.5%
	\$10	-	1.7%	2.4%	3.0%	3.5%	4.1%	4.7%
	\$8	1.3%	1.9%	2.5%	3.1%	3.7%	4.3%	4.9%
	\$6	1.5%	2.1%	2.7%	3.3%	3.9%	4.5%	5.1%
	\$4	1.7%	2.3%	2.9%	3.5%	4.1%	4.7%	5.2%
	\$2	1.9%	2.5%	3.1%	3.7%	4.3%	4.9%	5.4%

		Installed Capital Cost (\$/MW)						
		\$4.75	\$4.50	\$4.25	\$4.00	\$3.75	\$3.50	\$3.25
Capacity Factor (%)	15%	-	-	-	-	-	-	-
	20%	-	-	-	-	-	0.0%	-
	25%	-	-	-	-	1.7%	2.5%	3.5%
	30%	-	1.7%	2.4%	3.1%	4.0%	4.9%	5.9%
	35%	2.9%	3.6%	4.3%	5.2%	6.1%	7.1%	8.3%
	40%	4.6%	5.4%	6.2%	7.1%	8.1%	9.3%	10.6%
	45%	6.3%	7.1%	8.0%	9.0%	10.1%	11.4%	12.9%

		Cost of Debt (%)						
		8.00%	7.50%	7.00%	6.50%	6.00%	5.50%	5.00%
Effective Cash Tax Rate (%)	35%	-	-	1.5%	2.0%	2.7%	3.3%	3.9%
	30%	-	1.3%	1.8%	2.4%	3.1%	3.7%	4.3%
	25%	-	1.6%	2.2%	2.8%	3.4%	4.1%	4.7%
	20%	-	1.9%	2.5%	3.1%	3.8%	4.4%	5.1%
	15%	1.7%	2.2%	2.8%	3.5%	4.1%	4.8%	5.5%
	10%	1.9%	2.5%	3.1%	3.8%	4.4%	5.1%	5.8%
	5%	2.2%	2.8%	3.4%	4.1%	4.7%	5.4%	6.1%

		Carbon price (\$/REC or \$/ERC or \$/MWh)						
		\$0	\$5	\$10	\$15	\$20	\$25	\$30
ecoEnergy Incentive (\$/MWh)	\$0	1.9%	2.3%	2.8%	3.2%	3.7%	4.2%	4.6%
	\$5	2.3%	2.7%	3.2%	3.6%	4.1%	4.6%	5.0%
	\$10	2.7%	3.1%	3.6%	4.1%	4.5%	5.0%	5.4%

Source: Scotia Capital estimates.

TIDAL POWER SCIENCE & TECHNOLOGY 101

Tidal power generating systems typically operate 10 hours a day, during the time the tides are in motion. Unlike wind patterns, **tidal patterns are extremely predictable**, therefore reducing the implications of intermittency.

Exploitable tidal sites require a mean tidal range exceeding three metres.

Exploitable sites require a mean **tidal range exceeding three metres**, a requirement that can be met by only **20 to 40 site locations globally**.

Two methods exist to generate electricity through tidal resources: one is through a barrage tidal system, and the other is a tidal stream power system, both explained below.

Barrage Tidal Power

Only about 20 locations worldwide have sufficient resources to construct a tidal barrage. Tidal barrages are built across estuaries and are designed to capture energy through the rise and fall of tides. Provided there is a large enough difference in the water levels on either side of the barrage, water is allowed to flow through the turbines. As the tide comes in, water passes through the barrage and is held in an estuary or basin. Once the tide wanes, the barrage’s sluice gates open, driving turbines and generating electrical power. **Currently, a minimum difference of five metres between high and low tide is required to economically implement a tidal barrage.** Exhibit 7.115 lists select regions where the mean tidal range is greater than 5 metres, while Exhibit 7.116 shows a tidal barrage schematic.

Exhibit 7.115: Select Areas with Mean Tidal Range >5 Metres

Country	Location	Mean Tidal Range (m)	Area of Basin (km ²)	Potential Capacity (MW)
Argentina	San Jose	5.9	-	6,800
Australia	Secure Bay	10.9	-	-
Canada	Cobequid	12.4	240	5,338
	Cumberland	10.9	90	1,400
	Shepody	10.0	115	1,800
	Passamaquoddy	5.5	-	-
India	Kutch	5.3	170	900
	Cambay	6.8	1,970	7,000
Mexico	Rio Colorado	6.5	-	-
United Kingdom	Severn	7.8	450	8,640
	Mersey	6.5	61	700
	Conwy	5.2	6	33
United States	Passamaquoddy Bay, Maine	5.5	-	-
	Knik Arm, Alaska	7.5	-	2,900
	Turnagain Arm, Alaska	7.5	-	6,501
Russia	Mezen	9.1	2,300	19,200
	Penzhinskaya Bay	6.0	20,500	87,000

Source: Company reports; Scotia Capital.

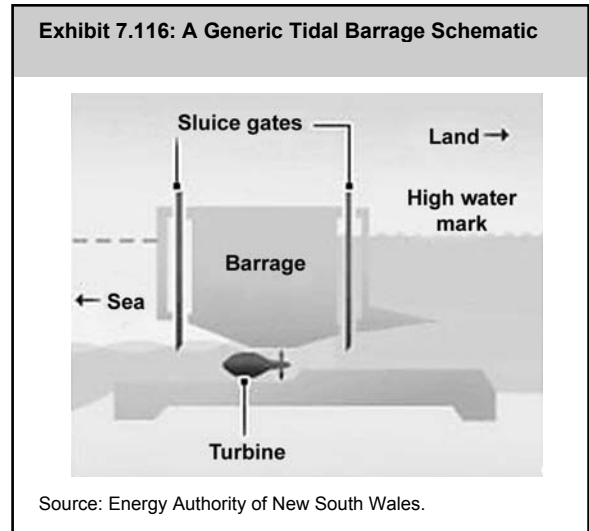

Tidal Stream Power

Tidal power investment is gaining in popularity.

A second method to capturing tidal energy is through tidal streams, which is **quickly gaining in popularity**. This approach captures energy through turbines, similar to wind turbines, the primary difference being that the turbines are submerged underneath the water (Exhibit 7.117). Unlike barrages, these turbines are relatively simple to construct and are fairly inexpensive.

Nova Scotia's Bay of Fundy has the world's highest tides.

Exhibit 7.117: A Tidal Stream Power System



Source: Aviation Enterprises Ltd.

PASSING THE BAY OF FUNDY TEST

In the world of tidal power, if an underwater tidal stream facility can successfully operate in Nova Scotia's fierce Bay of Fundy, it will almost certainly function in any other tidal stream on the planet. The Bay of Fundy has the world's highest tides, with a peak tidal range of 16 metres (Exhibit 7.118).

In January 2008, the government of Nova Scotia picked three firms to establish tidal stream demonstration projects in the Bay of Fundy that will cost \$40 million in total. The three companies selected were Clean Current Power Systems, Emera's Nova Scotia Power (NSPI), and Minas Basin Pulp and Paper. Minas Basin Pulp and Paper will also construct the infrastructure required to connect all of the projects to the province's electric grid.

Exhibit 7.118: The Bay of Fundy Has the Highest Tides in the World



Source: Hopewell Rocks.

Exhibit 7.119: Clean Current's Mark III



Source: Clean Current Power Systems.

Clean Current Power Systems

Based in Vancouver, Clean Current Power Systems is one of three companies selected by the Nova Scotia government to install pilot project tidal turbines at the Bay of Fundy. The company's 2.2 MW Mark III turbines have only one moving part and no drive shaft or gearbox (Exhibit 7.119). The model is designed for tidal currents peaking at 4.5 m/s, and will deliver about 4 GWh of electricity per year, representing a capacity factor of 20.8%. This turbine model successfully tested near Race Rock, B.C. for three months in 2006, and is expected to have a service life of 25 to 30 years, similar to wind turbines. **The project will cost \$4 million per MW, split 75% for the turbines and 25% for installation.**

Exhibit 7.120: NSPI Will Use OpenHydro's Turbine

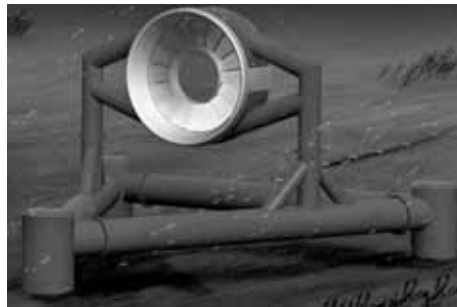

Source: Open Hydro.

Nova Scotia Power Inc.

Emera's NSPI already owns and operates the 20 MW Annapolis tidal power facility, which generates about 30 GWh/y, using tidal barrage technology. In its tidal stream pilot project, NSPI selected OpenHydro's turbine technology, which is fairly similar to Clean Current Power System's Mark III turbine (Exhibit 7.120). **In early 2008, NSPI purchased a 7% interest in OpenHydro for \$15 million.**

Minas Basin Pulp & Paper

Exhibit 7.121: UEK's Turbine for Minas Basin Pulp & Paper's Pilot Project



Source: UEK.

Minas Basin Pulp and Paper plans to install UEK's hydrokinetic buoyant turbine with a **cost estimate of \$5 million to \$7 million**. The 0.5 MW turbine is unique in that, instead of being secured to the ocean floor, it will function similar to a kite by floating to the point with the greatest current; refer to Exhibit 7.121.

SELECT GLOBAL TIDAL POWER PROJECTS

The United Kingdom appears to be the world leader in tidal power development with about as many pilot projects as the rest of the world combined. The reason for this is simple: government incentives. In the U.K., and beginning in 2009, twice as many Renewable Obligation Certificates (ROCs) per MWh will be granted to tidal stream power projects than for onshore wind projects. Additionally, **the 2008 U.K. Energy Bill awarded tidal projects the greatest level of financial support among all renewable technologies.** Below, we have summarized some key tidal power project developments over the past year.

- 1. China.** Chinese officials from Liaoning province are building a 300 MW tidal power project based on artificial tidal lagoons, known as the Yalu project. Tidal Electric Ltd. of the United Kingdom will supply the turbines and construct the project. According to Modern Power Systems, since the 2004 agreement was signed, little has happened. **With a stated cost of US\$600 million, or US\$2 million per MW, we believe the estimate is for the turbines only.**
- 2. India.** The West Bengal Renewable Energy Development Agency is developing a 4 MW tidal power project that is expected to cost US\$12.6 million, or US\$3.15 million per installed MW. 100% of the funding is from the central (90%) and the state governments (10%). The project is scheduled online in 2010.
- 3. Scotland.** In mid-2007, Scottish Power (owned by Iberdrola – the world’s largest wind farm developer) formed a JV with Norway’s Statoil to test tidal stream technology off the coast of Britain. A project manager stated if the pilot is commercialized, **the cost to produce power will range between US\$80/MWh to US\$130/MWh.** Project commissioning is expected in 2009.
- 4. South Korea.** Daewoo Engineering & Construction recently ordered tidal barrage equipment rated at 260 MW from an Austrian manufacturer, to construct its Lake Sihwa project, expected to be the world’s largest tidal power plant. Daewoo has a turnkey contract for the plant at US\$250 million, with an estimated commissioning date of 1H/09.
- 5. United Kingdom.** The British government has launched a study into building a massive tidal barrage across the Severn Estuary between England and Wales. The potential capacity of the project at 8,600 MW is astounding, and could provide 5% of the U.K.’s power requirements, as well as help the nation reach its goal of cutting its CO₂ emissions 20% below 1990 levels by 2020. The estuary has the second highest tidal range in the world at 14 metres. The cost is £15 billion, or approximately **US\$3.5 million per MW.**
- 6. United Kingdom.** Marine Current Turbines and Npower Renewables have established a JV to develop a 10.5 MW commercial tidal power stream project off the coast of North Wales. Seven turbines, rated 1.5 MW each, are expected to be commissioned by 2012. If operationally successful, the project would be one of the world’s largest tidal stream power facilities. Financing for the project remains incomplete. The total installed cost is estimated at **US\$3.8 million to US\$5.7 million per MW.**
- 7. United Kingdom.** A subsidiary of German utility E.ON AG, along with JV partner Lunar Energy, intends to construct an 8 MW tidal stream power plant off the coast of Wales. If approved, the facility would be operational by 2011 at the latest.
- 8. United States.** The Roosevelt Island Tidal Energy project is installing six tidal turbines in New York’s East River to demonstrate the potential of tidal stream power. The US\$8 million pilot project will be operational for 18 months. Verdant Power (Canada), the project developer, hopes that a successful project will result in a 10 MW commercial tidal farm at a cost of US\$2.5 million to US\$3 million per MW.

Wave Energy – Not the Wave of the Future, For Now

OVERVIEW

Despite a seemingly unlimited amount of wave energy available, wave power is one of the least developed renewable technologies. While the total wave power resource has been estimated by the World Energy Council to exceed 10 TW, we believe that commercially viable wave power production globally is likely in the 140 TWh/y to 2,000 TWh/y range, still remarkably high for a virtually untapped resource. Exhibit 7.122 highlights areas of wave power strength around the globe.

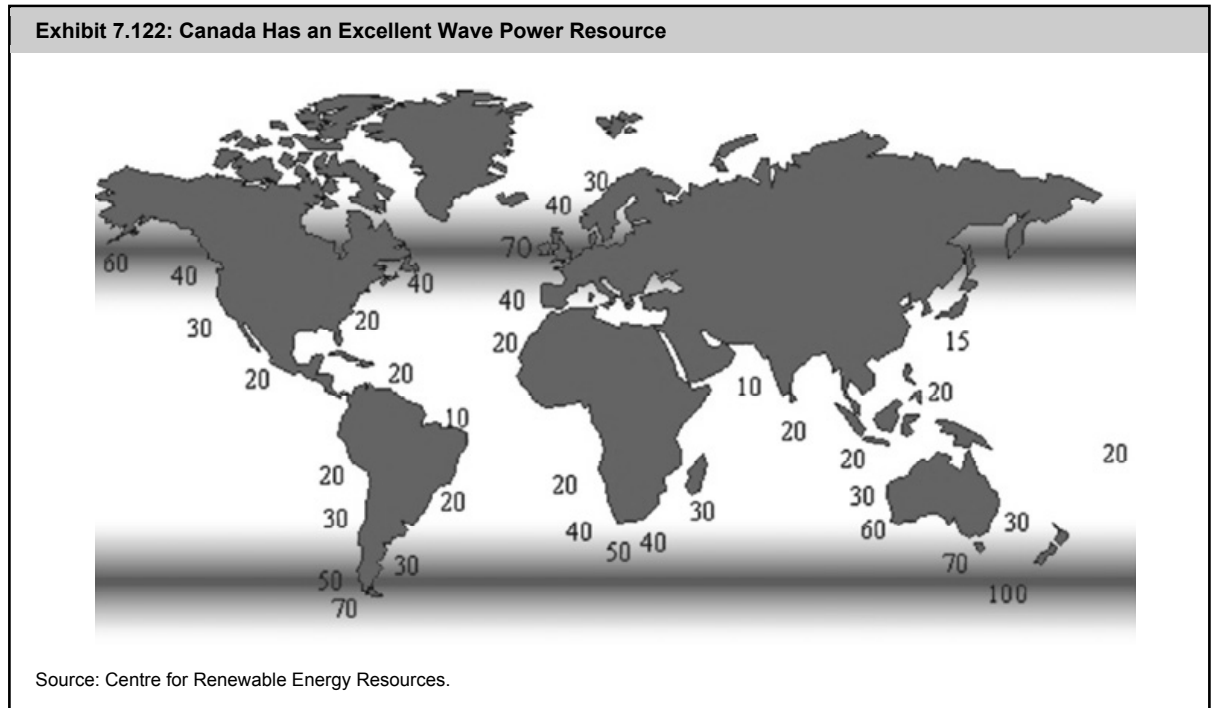

There are currently no active utility-scale wave power projects, due to wide differences in technology development, poor economics, and material investment opportunities in other renewable technologies. In our opinion, until mainstream renewable markets for solar and wind power mature, wave power capacity will likely not develop beyond commercial-scale pilot projects and possibly a few scattered wave farms. Wave energy development likely requires technology convergence and considerable R&D to produce economies of scale, as well as to deal with challenges arising from operating in harsh marine environments. We don't see wave energy becoming a major contributor to the world's energy supply for at least 10 years.

In addition to the fuel source being free, waves offer energy densities far greater than both wind and solar. Also, the majority of the best potential wave power sites are conveniently located near the globe's largest power consumers such as the west coast of North America and Western Europe.

High operating and maintenance costs pose a significant barrier to wave energy development. The most effective wave power sites are located at relatively deep sea levels, making service both difficult and expensive. Additionally, the devices must be controlled remotely, and unlike wind and solar cannot be easily accessed for simple monitoring and upkeep. While many cite that wave power has lower costs than wind power did at this stage of development, we do not think that a similar cost curve decline will occur.

High operating and maintenance costs pose a significant barrier to commercial wave energy development.

Wave energy is highly seasonal, and wave power flux during winter months can measure 9x more than during summer months (Exhibit 7.123). The seasonal variation of wave power generation makes grid integration difficult, and limits operators to selling the majority of their power in winter months. However, on a daily basis, wave power is less variable than both solar and wind power.

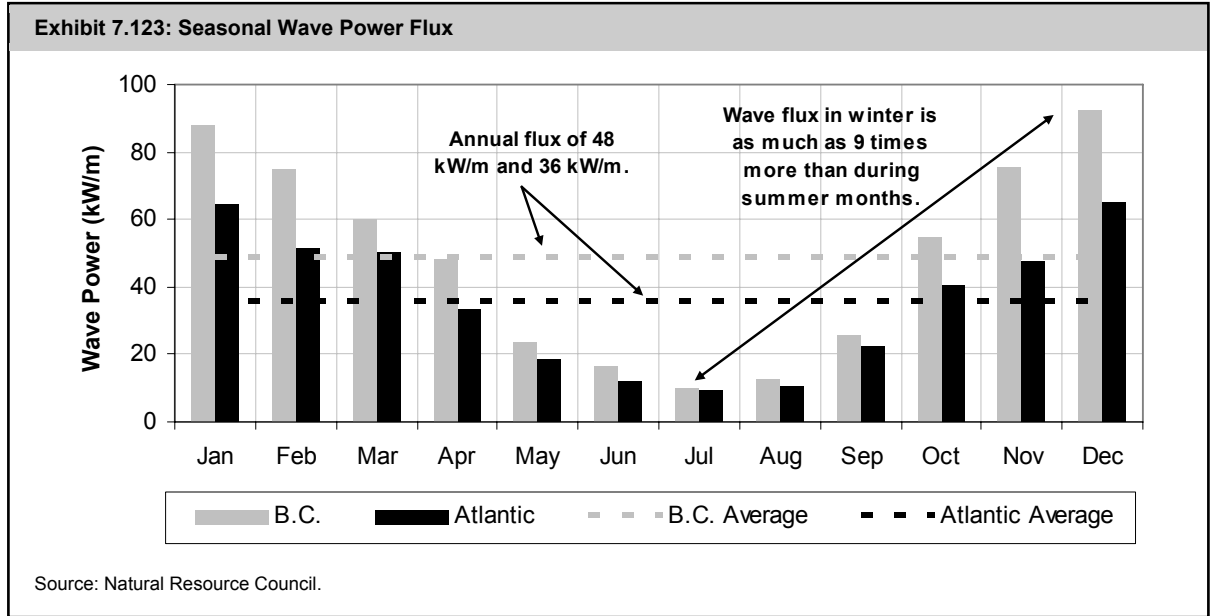

In our view, wave energy development is likely 10 to 15 years behind wind power and will not make up a significant part of the world’s energy supply until at least 2030.

LIMITED DEVELOPMENT IN CANADA, BUT THE POTENTIAL IS PROMISING

B.C. has over 37,000 MW of potential wave power. Wave flux on some of B.C.’s coastline has been measured as high as 54 kW/m, making this region one of the most abundant wave power sources in the world (Exhibit 7.124). Despite mild climates, the strong wave energy off the B.C. coast is attributable to significant ocean exposure and to favourable bathymetry (sea-bed shape). While wave fluxes greater than 70 kW/m do exist in Europe, the resource is located much further away from the coast than compared to B.C.

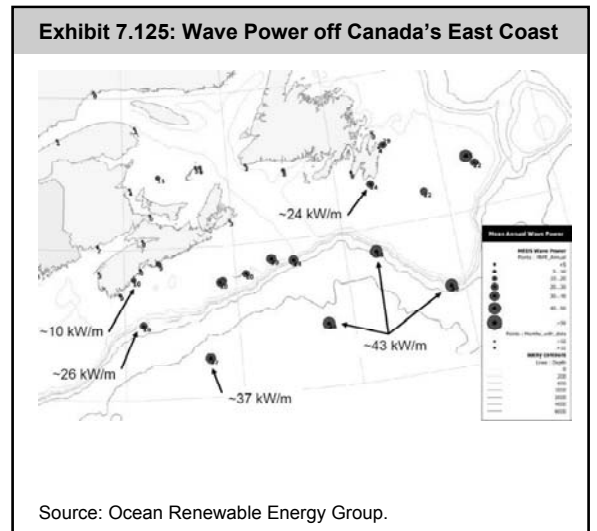
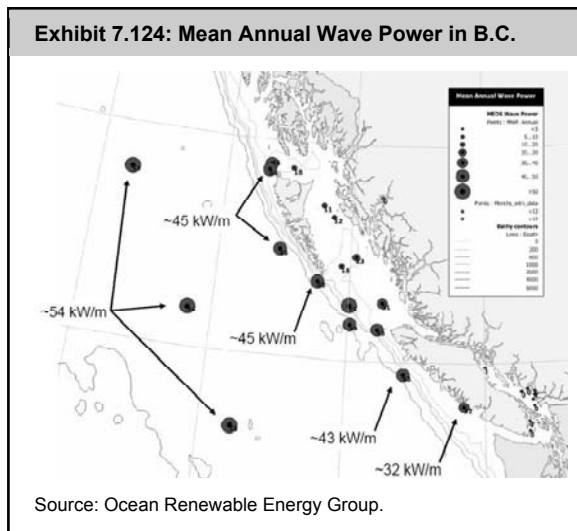

WAVE POWER SCIENCE & TECHNOLOGY 101

Wave energy is a concentrated form of solar energy, generated when wind passes over water, transferring energy to the water in the form of waves. Wave energy is mainly a function of wind speed, as well as the distance over which the wind blows. **Wave-based power is substantially reduced as it approaches shore**, primarily due to the friction that develops between the wave and the sea bed. Ideal sea beds are those with material depth close to shore.

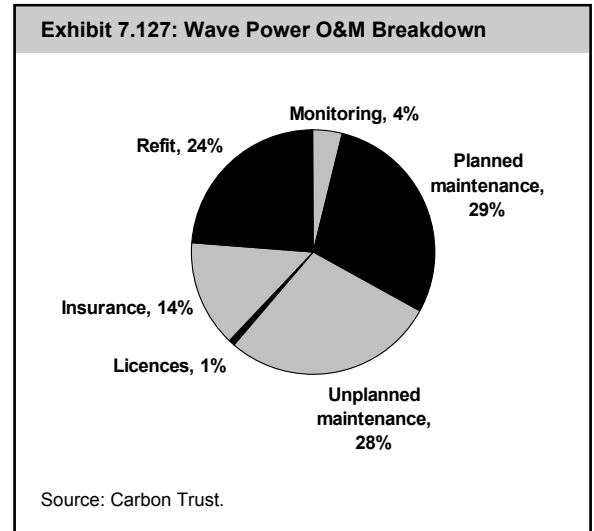
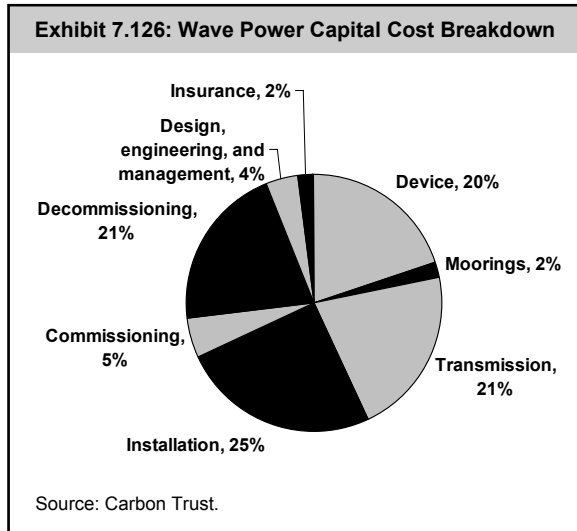

We believe that future wave power development is likely to gravitate towards deepwater installations.

A variety of wave power technologies are in development, and have been so for almost 20 years. Exhibit 7.130 (on page 318) compares four of the most common technologies that we have seen. We believe that future wave power development is likely to gravitate towards **deep water installations** to take advantage of the higher wave power away from shore.

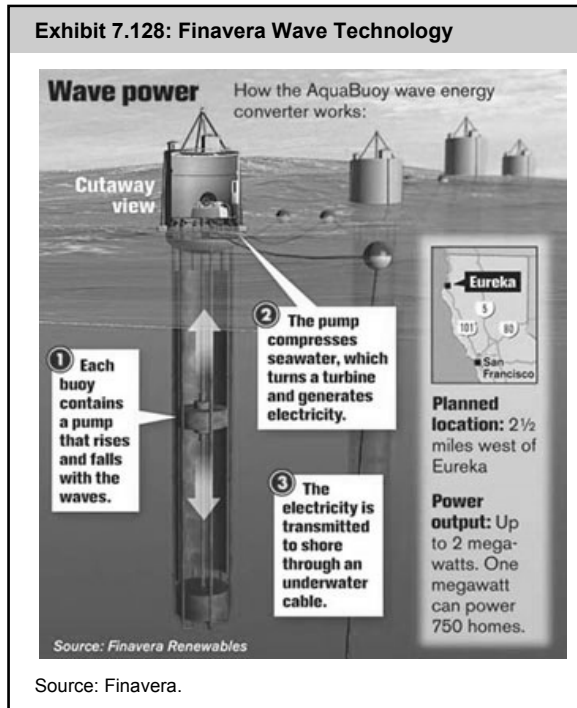

FINAVERA – CANADA’S WAVE POWER LEADER

Finavera (FVR-V), a Canadian renewable energy company with both wind and wave energy projects, is the only Canadian company that offers investors exposure to wave energy. While FVR is slowly advancing its wave projects, the company’s short- to mid-term stock performance is heavily dependent on its wind power progress. **FVR has three wave projects under development in North America, a PPA signed for a future project in California, and an early-stage project in South Africa.**

Trinidad, California Project

Pacific Gas and Electric issued FVR a PPA for a 2 MW wave farm to be located off the shore of northern California. The project is set to begin delivering power in 2012 and has the potential to expand its capacity by up to 100 MW. The expected capacity factor of the project is 22%, on the lower end of the 20% to 45% range that we have seen.

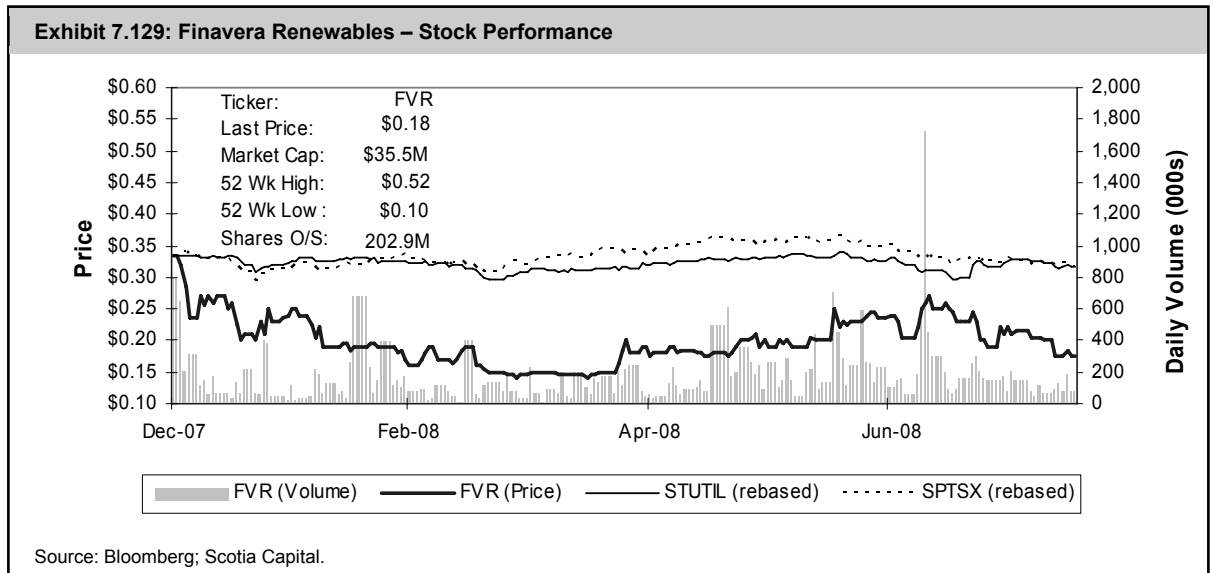
**Makah Bay, Ucluelet, and Coos Projects**

FVR's Makah Bay project is located off the coast of Neah Bay, Washington, and is a 1 MW demonstration project with an expected capacity factor of 17% (i.e., ~1,500 MWh/y). Off the coast of Ucluelet, B.C., FVR is planning a 5 MW project, and a preliminary permit has been granted for a 100 MW wave farm near Coos Bay, Oregon.

SELECT GLOBAL WAVE POWER PROJECTS

Similar to tidal power, the U.K. is also a leader in wave power development, accounting for many of the world's wave projects. Government incentives for wave power development there are identical to tidal power, at two ROCs per MWh. Below we summarize select wave power project development.

1. United Kingdom. The Wave Hub, a demonstration project that will include four different wave power conversion technologies, was recently delayed until 2010, or one year later than expected. Within the Wave Hub will be a 5 MW installation using Pelamis technology, and three other technologies contributed by Fred Olsen, Ocean Power Technologies, and Oceanlinx.

2. Ireland. In April 2007, Wave Dragon submitted its environmental impact statement for a 70 MW wave power plant in the Celtic Sea. The project will begin with the deployment of a 7 MW pre-commercial demonstrator.

3. Scotland. In September 2007, ScottishPower was granted permission for a 3 MW wave facility using four Pelamis devices off the west coast of the Orkney mainland, Scotland. The project is expected to be operating by the end of 2008, as underwater cabling, licensing, and funding is complete. The installed capital cost is estimated at \$6.7 million per MW.

4. Hawaii. In February 2008, Oceanlinx signed an MoU with Renewable Hawaii, where three of Oceanlinx's wave energy converters will be installed providing 2.7 MW of power. Oceanlinx's technology is a floating oscillating water column device. The company already has a 450 kW PPA signed in Port Kembla, Australia, and is obtaining the necessary environmental permits for a 27 MW wave project, made up of 18 1.5 MW units, located near Victoria, Australia.

5. Portugal. Enersis, a Spanish company, will use Pelamis Wave Power technology to launch one of the world's first commercial wave farms. The project will begin with three "sea snakes," which if successful, could eventually increase to hundreds, producing enough electricity to power about 350,000 homes. Portugal aims to one day supply 20% of its electricity needs by wave power.

Exhibit 7.130: Select Wave Power Technologies

	Point Absorption	Attenuator	Oscillating Water Column	Overtopping
Process	Point absorbers are floating structures where the vertical motion of the waves is converted to energy. The relative motion is used to drive water up a vertical shaft into a buoy, which then turns a turbine. Individual devices range from 100 kW to 750 kW.	The 140m long device is made up of several sections, which ride the waves transferring energy through the use of hydraulic motors in between the articulating sections.	OWC devices use water to compress air in a closed chamber, which then turns a bi-directional Wells turbine. Challenges with OWC systems include low turbine efficiencies and the inability for the device to self start. OWC devices can be installed either onshore or offshore.	This system uses a wave reflector to drive water towards a ramp and onto reservoir that is above the normal sea level. The raised water is then dropped over turbines to create electricity.
Positives	The technology is scalable, and due to its small size, the buoy can ride out violent storms. The buoys can also absorb wave energy regardless of the direction of the waves.	Scalable, and does not need to be grounded to the ocean floor. One of the most developed wave power technologies that operates at capacity factors between 25-40%.	All of the moving parts operate above water with the compression chamber being the only component operating below water. The technology is mechanically simple. The onshore location for some devices eliminates the challenge of offshore maintenance.	Can be located offshore as the device must only be slack-moored to ocean bed. Given the large physical size the device can undergo maintenance while at sea.
Negatives	The small size of the device requires onshore maintenance.	At extremely long wavelengths the system can become unstable, making use in large storms difficult. The device must always be oriented perpendicular to the wave front in order to operate, and must also be moored to the seabed.	Onshore devices capture smaller amounts of the potential wave power that is available offshore. Given the reduced wave power, operating costs per MWh are estimated to be higher than other wave technologies.	Given its large size, the devices do not scale well into a wave farm.

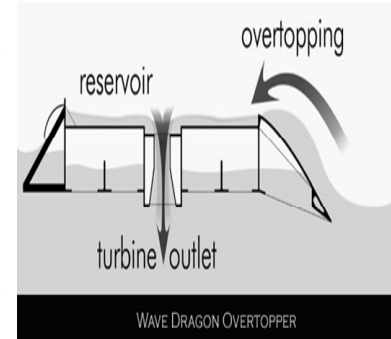
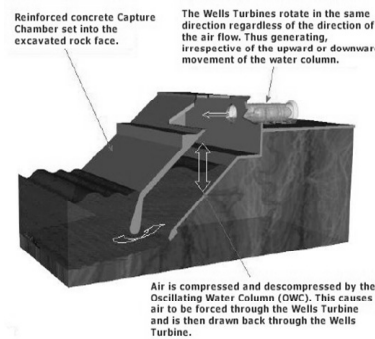
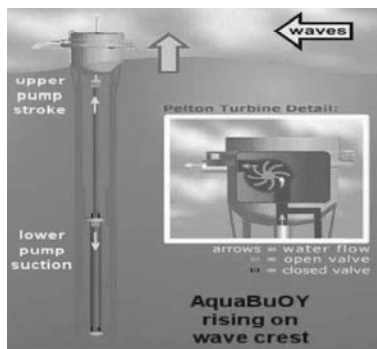

Source: Company reports.

Ocean Thermal Energy Conversion – Using Earth’s Largest Solar Panel

OVERVIEW

The ocean surface, effectively a massive solar panel, has several times more potential power than either wave or tidal power. The majority of the resource is focused around the equator where water temperature gradients are the greatest (Exhibit 7.131). Despite the size and availability of the resource, Ocean Thermal Energy Conversion (OTEC) is mostly still in the R&D phase, with only a handful of projects having been demonstrated over the last 50 years.

In our view, Canada and the U.S. will not see significant OTEC development, given the lack of access to favourable ocean temperature differentials.

The ocean’s surface temperature is fairly stable over a 24-hour period, providing the potential for base load power.

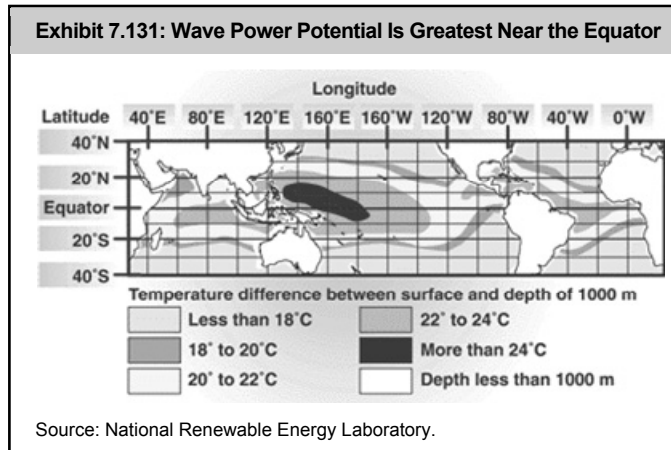

In our view, Canada and many of the States will not see significant OTEC development given the lack of access to favourable ocean temperature differentials. According to the National Renewable Energy Laboratory, only four markets will likely support OTEC over the next 10 years, three of which are located near the central or southern Pacific Ocean. The fourth is an obscure concept for a floating energy island that would support not only OTEC power, but also other renewables such as wind and solar.

Major positives for OTEC beyond its resource size include the ability for the technology to operate all day without suffering from major power fluctuations or variability, and that the process can generate useful byproducts such as fresh water. The ocean’s surface temperature is fairly stable within a few degrees over a 24-hour period, providing the potential for base load power. Further, a standard open-cycle OTEC process brings up cool water that can be used for air conditioning, and that also produces fresh water.

A lack of working projects, high capital costs, and limited government incentives will likely keep OTEC on the backburner for up to 20 years. Only recently have some demonstration project proposals gained enough momentum to become funded. The U.S. government has proposed a 13 MW facility near Diego Garcia while the U.S. Army wants a facility in the Marshall Islands. We note that these areas and Hawaii, the centre for OTEC research, are minor consumers of electricity and are fairly isolated, resulting in high power prices that could make OTEC power economical there before most other places.

OTEC facilities require substantial capital costs, not only for the pipe material to bring water up from 1,000+ metres below the surface, but also for a strong pump to bring water to the surface.

OTEC SCIENCE & TECHNOLOGY 101

OTEC is an indirect form of solar power that extracts thermal energy from water based on ocean temperature differences between sun-heated surface waters and cool subsurface waters. The hot surface water is used to turn a turbine, while the cool water piped up from 1 km below the ocean’s surface is used for condensing the steam. The process normally requires a temperature difference of 20°C.

Closed-Cycle OTEC

A closed-cycle system relies on vapour created by the hot surface water to drive a turbine. Surface water is pumped through a heat exchanger where it heats a liquid with a low boiling point such as ammonia. Cool subsurface waters then pass through a second heat exchanger to condense the vapour back into liquid form. A visual representation of a closed-cycle system is in Exhibit 7.132.

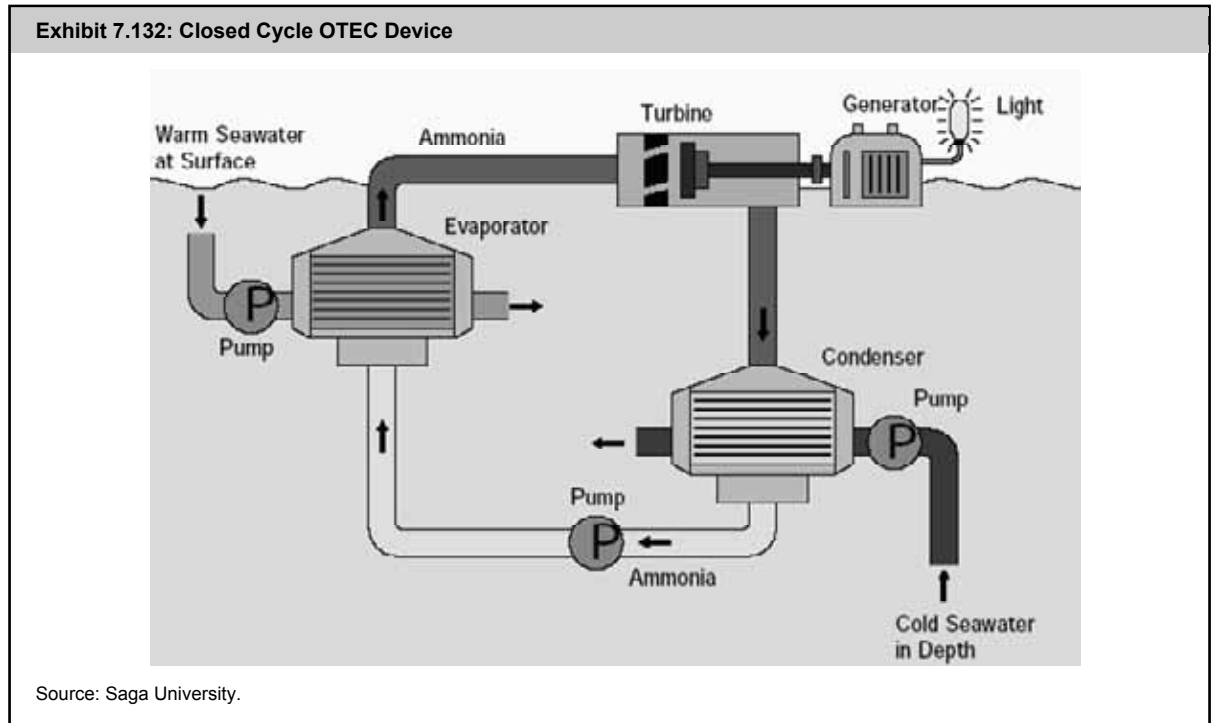
**Open-Cycle OTEC**

In an open-cycle process, which is very similar to a closed cycle process, the cycle uses ocean water instead of ammonia to create a vapour. **This process produces fresh water as a byproduct** when the steam is condensed by the cooler sub-sea water.

Appendix 2

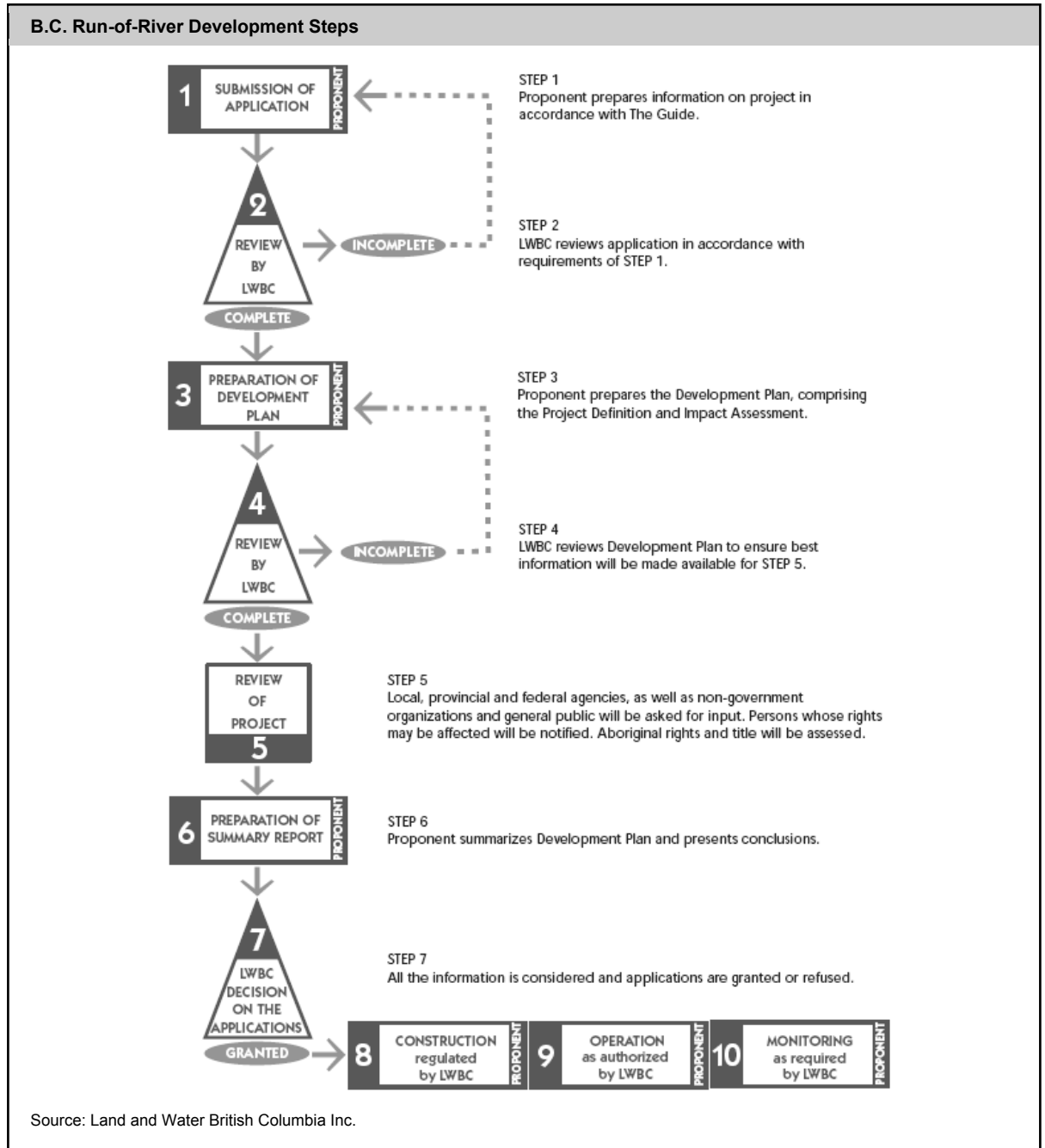

Appendix 3

- Winning bids and details of BC Hydro's 2006 Call for Tender are summarized as follows:
- Sixteen large stream projects for 5,700 GWh/y of Firm Energy and 750 GWh/y of Non-Firm Energy. These projects were awarded at an average bid price of \$74/MWh;
- Twenty-two small stream projects at an average starting power price of \$70/MWh for an estimated 650 GWh/y of energy;
- A 230 GWh/y contract to Brilliant Expansion Power Corporation, an affiliate of the Columbia Power Corporation; and
- An average EPA term of 30 years, with an average completion date set between 2010 and 2011.
- Clean energy represented 73% of the capacity awarded in the 2006 BC Hydro CFP. This included 29 hydro, three wind, two biomass, and two waste heat projects.

BC Hydro 2006 Results Call for Power					
Bidder Name	Project Name	Nearby City	Energy Source	Capacity (MW)	Energy (GWh/yr)
Plutonic Power Corporation	East Toba and Montrose Hydroelectric Project	Powell River	Water	196	702*
AESWapiti Energy Corporation	AESWapiti Energy Corporation	Tumbler Ridge	Coal / Biomass	184	1,612
Dokie Wind Energy Inc.	Dokie Wind Project	Chetwynd	Wind	180	536
Bear Mountain Wind Limited Partnership	Bear Mountain Wind Park	Dawson Creek	Wind	120	371
3986314 Canada Inc.	Canada - Glacier / Howser / East - Project	Nelson	Water	91	341
Green Island Energy Ltd.	Gold River Power Project	Gold River	Biomass	90	745
Kwalsa Energy Limited Partnership	Kwalsa Energy Project	Mission	Water	86	384
Anyox Hydro Electric Corp.	Anyox and Kitsault River Hydroelectric Projects	Alice Arm	Water	57	242
Compliance Power Corporation	Princeton Power Project	Princeton	Coal / Biomass	56	421
Upper Stave Energy Limited Partnership	Upper Stave Energy Project	Mission	Water	55	264
Mackenzie Green Energy Inc.	Mackenzie Green Energy Centre	Mackenzie	Biomass / Other	50	441
Kwoiek Creek Resources Limited Partnership	Kwoiek Creek Hydroelectric Project	Lytton	Water	50	147
Mount Hays Wind Farm Limited Partnership	Mount Hays Wind Farm	Prince Rupert	Wind	25	72
Canadian Hydro Developers, Inc.	Bone Creek Hydro Project	Kamloops	Water	20	81
Songhees Creek Hydro Inc.	Songhees Creek Hydro Project	Port Hardy	Water	15	61
Plutonic Power Corporation	Rainy River Hydroelectric Project	Gibson	Water	15	51*
Hydromax Energy Ltd.	Lower Clowhom	Sechelt	Water	10	48
Hydromax Energy Ltd.	Upper Clowhom	Sechelt	Water	10	45
Global Cogenix Industrial Corporation	Kookipi Creek Hydroelectric Project	Boston Bar	Water	10	39
Cogenix Power Corporation	Log Creek Hydroelectric Project	Boston Bar	Water	10	38
Canadian Hydro Developers, Inc.	Clemina Creek Hydro Project	Kamloops	Water	10	31
KMC Energy Corp.	Tamih Creek Hydro Project	Chilliwack	Water	10	52
Valisa Energy Incorporated	Serpentine Creek Hydro Project	Blue River	Water	10	29
Synex Energy Resources Ltd.	Victoria Lake Hydroelectric Project	Port Alice	Water	10	39
Second Reality Effects Inc.	Fries Creek Project	Squamish	Water	9	41
Renewable Power Corp.	Tyson Creek Hydro Project	Sechelt	Water	8	48
Hupacasath First Nation	Franklin River Hydro Project	Port Alberni	Water	7	19
Axiom Power Inc.	Clint Creek Hydro Project	Woss	Water	6	27
EnPower Green Energy Generation Inc.	Savona ERG Project	Savona	Waste Heat	6	41
EnPower Green Energy Generation Inc.	150 Mile House ERG Project	150 Mile House	Waste Heat	6	34
Maroon Creek Hydro Partnership	Maroon Creek Hydro Project	Terrace	Water	5	25
Spuzzum Creek Power Corp.	Sakwi Creek Run of River Project	Agassiz	Water	5	21
Canadian Hydro Developers, Inc.	English Creek Hydro Project	Revelstoke	Water	5	19
Synex Energy Resources Ltd.	Barr Creek Hydroelectric Project	Tahsis	Water	4	15
Raging River Power & Mining Inc.	Raging River 2	Port Alice	Water	4	13
Synex Energy Resources Ltd.	McKelvie Creek Hydroelectric Project	Tahsis	Water	3	14
Advanced Energy Systems Ltd.	Cranberry Creek Power Project	Revelstoke	Water	3	11
District of Lake Country	Eldorado Reservoir	Kelowna	Water	1	4
Subtotal				1,439	7,125
Brilliant Expansion Power Corporation	Brilliant Expansion Project (2)	Castlegar	Water	120	226
Total				1,559	7,351

* Engineering optimization later increased the expected output to 745 GWh/y for the Toba/Montrose Creek project and to 53 GWh/y for the Rainy River project.

Source: BC Hydro; Scotia Capital.

Appendix A: Important Disclosures

Company	Ticker	Disclosures*
ATS Automation Tooling Systems Inc.	ATA	P, U, U8
Boralex Inc.	BLX	T
Canadian Hydro Developers Inc.	KHD	U
Cascades Inc.	CAS	B2
EarthFirst Canada Inc.	EF	U

The following analysts certify that (1) the views expressed in this report in connection with securities or issuers they analyze accurately reflect their personal views and (2) no part of their compensation was, is, or will be directly or indirectly, related to the specific recommendations or views expressed by them in this report: Ben Isaacson, Tony Courtright, Benoit Laprade, and David Tyerman.

The Research Analyst's compensation is based on various performance and market criteria and is charged as an expense to certain departments of Scotia Capital Inc., including investment banking.

Scotia Capital Inc. and/or its affiliates: expects to receive or intends to seek compensation for investment banking services from issuers covered in this report within the next three months; and has or seeks a business relationship with the issuers referred to herein which involves providing services, other than securities underwriting or advisory services, for which compensation is or may be received. These may include services relating to lending, cash management, foreign exchange, securities trading, derivatives, structured finance or precious metals.

For Scotia Capital Research analyst standards and disclosure policies, please visit <http://www.scotiacapital.com/disclosures>

* *Legend*

- B2** The Executive Vice-Chairman of Cascades Inc. is a director of The Bank of Nova Scotia.
- P** This issuer paid a portion of the travel-related expenses incurred by the Fundamental Research Analyst/Associate to visit material operations of this issuer.
- U** Within the last 12 months, Scotia Capital Inc. and/or its affiliates have undertaken an underwriting liability with respect to equity or debt securities of, or have provided advice for a fee with respect to, this issuer.
- U8** Scotia Capital Inc has been retained by ATS Automation Tooling Systems Inc. to assist in identifying and evaluating strategic alternatives available for its PCG operations, including divestiture.
- T** The Fundamental Research Analyst/Associate has visited material operations of this issuer.

Definition of Scotia Capital Equity Research Ratings & Risk Rankings

We have a three-tiered rating system, with ratings of 1-Sector Outperform, 2-Sector Perform, and 3-Sector Underperform. Each analyst assigns a rating that is relative to his or her coverage universe.

Our risk ranking system provides transparency as to the underlying financial and operational risk of each stock covered. Statistical and judgmental factors considered are: historical financial results, share price volatility, liquidity of the shares, credit ratings, analyst forecasts, consistency and predictability of earnings, EPS growth, dividends, cash flow from operations, and strength of balance sheet. The Director of Research and the Supervisory Analyst jointly make the final determination of all risk rankings.

Ratings

1-Sector Outperform

The stock is expected to outperform the average total return of the analyst's coverage universe by sector over the next 12 months.

2-Sector Perform

The stock is expected to perform approximately in line with the average total return of the analyst's coverage universe by sector over the next 12 months.

3-Sector Underperform

The stock is expected to underperform the average total return of the analyst's coverage universe by sector over the next 12 months.

Other Ratings

Tender – Investors are guided to tender to the terms of the takeover offer.

Under Review – The rating has been temporarily placed under review, until sufficient information has been received and assessed by the analyst.

Risk Rankings

Low

Low financial and operational risk, high predictability of financial results, low stock volatility.

Medium

Moderate financial and operational risk, moderate predictability of financial results, moderate stock volatility.

High

High financial and/or operational risk, low predictability of financial results, high stock volatility.

Caution Warranted

Exceptionally high financial and/or operational risk, exceptionally low predictability of financial results, exceptionally high stock volatility. For risk-tolerant investors only.

Venture

Risk and return consistent with Venture Capital. For risk-tolerant investors only.

Scotia Capital Equity Research Ratings Distribution*

Distribution by Ratings and Equity and Equity-Related Financings*

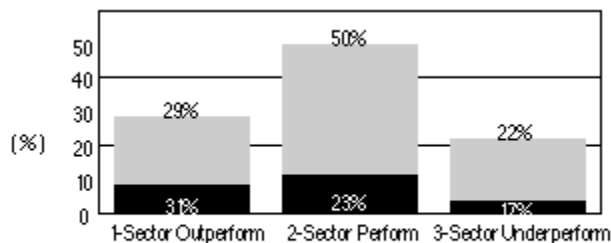

* As at July 31, 2008.

Source: Scotia Capital.

For the purposes of the ratings distribution disclosure the NASD requires members who use a ratings system with terms different than "buy," "hold/neutral" and "sell," to equate their own ratings into these categories. Our 1-Sector Outperform, 2-Sector Perform, and 3-Sector Underperform ratings are based on the criteria above, but for this purpose could be equated to buy, neutral and sell ratings, respectively.

Scotia Capital Equity Research Team

HEAD OF EQUITY RESEARCH

Greg Pardy, CFA (416) 945-7393
greg_pardy@scotiacapital.com

SUPERVISORY ANALYST

Claude King, CFA (416) 863-7985
claud_king@scotiacapital.com

DIRECTOR OF ADMINISTRATION

Erika Osmond (416) 945-4529
erika_osmond@scotiacapital.com

CHINA STRATEGY

Na Liu, CFA (416) 945-4235
na_liu@scotiacapital.com

CONSUMER DISCRETIONARY

Autos & Components

David Tyerman (416) 863-7108
david_tyerman@scotiacapital.com

Cable

John Henderson, P.Eng (416) 863-7780
john_henderson@scotiacapital.com

Hotels, Restaurants & Leisure

Turan Quettawala, CFA (416) 863-7065
turan_quettawala@scotiacapital.com

Media

Paul Steep (416) 945-4310
paul_steep@scotiacapital.com

CONSUMER STAPLES

Food Products

Cherilyn Radbourne, CA, CFA (416) 863-2899
cherilyn_radbourne@scotiacapital.com

Retailing

Ryan Balgopal, CFA (416) 863-7902
ryan_balgopal@scotiacapital.com

ENERGY

Energy Equipment & Services

Peter Doig, CFA (403) 213-7331
peter_doig@scotiacapital.com

Oil & Gas – Integrated and E&P

Mark Polak, CFA (403) 213-7349
mark_polak@scotiacapital.com

Oil & Gas – International

Gavin Wylie (403) 213-7333
gavin_wylie@scotiacapital.com

Oil & Gas – Junior E&P

Peter Doig, CFA (403) 213-7331
peter_doig@scotiacapital.com

George Toriola, P.Eng (403) 213-7345
george_toriola@scotiacapital.com

FINANCIALS

Banks & Diversified Financials

Kevin Choquette, CFA, CMA (416) 863-2874
kevin_choquette@scotiacapital.com

Diversified Financials – Small Cap

Phil Hardie, CFA, P.Eng (416) 863-7430
phil_hardie@scotiacapital.com

Insurance

Tom MacKinnon, FSA, FCIA, MAAA (416) 863-7299
tom_mackinnon@scotiacapital.com

HEALTH CARE

John Maletic, BSc Pharm, CFA (416) 863-7708
john_maletic@scotiacapital.com

INCOME TRUSTS

Diversified Business Trusts

Navdeep Malik (416) 863-7499
navdeep_malik@scotiacapital.com

Turan Quettawala, CFA (416) 863-7065
turan_quettawala@scotiacapital.com

Power & Energy Infrastructure Trusts

Tony Courtright, CA (416) 945-4536
tony_courtright@scotiacapital.com

REITs

Mario Saric, CA, CFA (416) 863-7824
mario_saric@scotiacapital.com

Pammi Bir, CA, CFA (416) 863-7218
pammi_bir@scotiacapital.com

INDUSTRIALS

Transportation & Aerospace

David Tyerman (416) 863-7108
david_tyerman@scotiacapital.com

Cherilyn Radbourne, CA, CFA (416) 863-2899
cherilyn_radbourne@scotiacapital.com

INFORMATION TECHNOLOGY

Hardware & Equipment

Gus Papageorgiou, CFA (416) 863-7552
gus_papageorgiou@scotiacapital.com

Software & Services

Paul Steep (416) 945-4310
paul_steep@scotiacapital.com

MATERIALS

Chemicals

Sam Kanes, CA, CFA (416) 863-7798
sam_kanes@scotiacapital.com

Gold & Precious Minerals

Trevor Turnbull, MSc (416) 863-7427
trevor_turnbull@scotiacapital.com

David Christie, P. Geo (416) 863-7141
david_christie@scotiacapital.com

Metals & Mining

Lawrence Smith, CFA (416) 945-4526
lawrence_smith@scotiacapital.com

Paper & Forest Products

Benoit Laprade, CA, CFA (514) 287-3627
benoit_laprade@scotiacapital.com

PORTFOLIO STRATEGY

Vincent Delisle, CFA (514) 287-3628
vincent_delisle@scotiacapital.com

QUANTITATIVE STRATEGY

Darwin McGrath, CFA (416) 863-7293
darwin_mcgrath@scotiacapital.com

REAL ESTATE

Mario Saric, CA, CFA (416) 863-7824
mario_saric@scotiacapital.com

Pammi Bir, CA, CFA (416) 863-7218
pammi_bir@scotiacapital.com

SPECIAL SITUATIONS

Anthony Zicha (514) 350-7748
anthony_zicha@scotiacapital.com

Cherilyn Radbourne, CA, CFA (416) 863-2899
cherilyn_radbourne@scotiacapital.com

David Tyerman (416) 863-7108
david_tyerman@scotiacapital.com

TELECOMMUNICATION SERVICES

John Henderson, P.Eng (416) 863-7780
john_henderson@scotiacapital.com

UTILITIES

Pipelines, Energy Utilities & IPPs

Sam Kanes, CA, CFA (416) 863-7798
sam_kanes@scotiacapital.com

Alternative & Renewable Energy

Ben Isaacson, CFA (416) 945-5310
ben_isaacson@scotiacapital.com

ECONOMICS

Warren Jestin (416) 866-6136

Aron Gampel (416) 866-6259

Mary Webb (416) 866-4202

Derek Holt (416) 863-7707

PORTFOLIO ADVISORY GROUP (SCOTIAMCLEOD)

Managing Director:

Stewart Hunt (416) 863-2855

Trading

Elliott Fishman (416) 863-7860

Angelo Rizzo (416) 863-7521

Dave Stephens (416) 862-3115

Portfolio Manager:

Stephen Uzielli (416) 863-7939

Equity Advisory

Paul Danesi (416) 863-7735

Gareth Watson, CFA (416) 863-7604

Katie Tabesh, CA (416) 945-5332

Institutional Equity Sales & Trading

Toronto (416) 863-2885
1-888-251-4484

Montreal (514) 287-4513

Vancouver (604) 661-7411

1-888-926-2288

New York (212) 225-6605/04

1-800-262-4060

Boston (617) 330-1477

London, U.K. 011-44-207-826-5919



Products. Industry Knowledge. **Relationships.**

www.scotiacapital.com

TM Trademark of The Bank of Nova Scotia. The Scotia Capital trademark represents the corporate and investment banking businesses of The Bank of Nova Scotia, Scotiabank Europe plc, Scotia Capital Inc. and Scotia Capital (USA) Inc. - all members of the Scotiabank Group and authorized users of the mark. Scotia Capital Inc. is a member of CIPF.

Equity research reports published by Scotia Capital are available electronically via: Bloomberg, Thomson Financial/First Call - Research Direct, Reuters, Capital IQ, and FactSet. Institutional clients with questions regarding distribution of equity research should contact us at 1-800-208-7666.

This report has been prepared by SCOTIA CAPITAL INC. (SCI), a subsidiary of the Bank of Nova Scotia. Opinions, estimates and projections contained herein are our own as of the date hereof and are subject to change without notice. The information and opinions contained herein have been compiled or arrived at from sources believed reliable but no representation or warranty, express or implied, is made as to their accuracy or completeness. Neither SCI nor its affiliates accepts any liability whatsoever for any loss arising from any use of this report or its contents. This report is not, and is not to be construed as, an offer to sell or solicitation of an offer to buy any securities and/or commodity futures contracts. The securities mentioned in this report may not be suitable for all investors nor eligible for sale in some jurisdictions. This research and all the information, opinions, and conclusions contained in it are protected by copyright. This report may not be reproduced in whole or in part, or referred to in any manner whatsoever, nor may the information, opinions, and conclusions contained in it be referred to without the prior express consent of SCI. SCI is authorized and regulated by The Financial Services Authority. U.S. Residents: Scotia Capital (USA) Inc., a wholly owned subsidiary of SCI, accepts responsibility for the contents herein, subject to the terms and limitations set out above. Any U.S. person wishing further information or to effect transactions in any security discussed herein should contact Scotia Capital (USA) Inc. at 212-225-6500.