

Methods in Molecular Biology™

VOLUME 178

Antibody Phage Display

Methods and Protocols

Edited by

Philippa M. O'Brien

Robert Aitken

 HUMANA PRESS

Antibody Phage Display



guoxingzhong and huangzhiman

www.dnathink.org

2003.2.26

METHODS IN MOLECULAR BIOLOGY™

John M. Walker, SERIES EDITOR

204. **Molecular Cytogenetics: Methods and Protocols**, edited by Yao-Shan Fan, 2002
203. **In Situ Detection of DNA Damage: Methods and Protocols**, edited by Vladimir V. Didenko, 2002
202. **Thyroid Hormone Receptors: Methods and Protocols**, edited by Aria Baniahmad, 2002
201. **Combinatorial Library Methods and Protocols**, edited by Lisa B. English, 2002
200. **DNA Methylation Protocols**, edited by Ken I. Mills and Bernie H. Ramsahoye, 2002
199. **Liposome Methods and Protocols**, edited by Subhash C. Basu and Manju Basu, 2002
198. **Neural Stem Cells: Methods and Protocols**, edited by Tanja Zigova, Juan R. Sanchez-Ramos, and Paul R. Sanberg, 2002
197. **Mitochondrial DNA: Methods and Protocols**, edited by William C. Copeland, 2002
196. **Oxidants and Antioxidants: Ultrastructural and Molecular Biology Protocols**, edited by Donald Armstrong, 2002
195. **Quantitative Trait Loci: Methods and Protocols**, edited by Nicola J. Camp and Angela Cox, 2002
194. **Post-translational Modification Reactions**, edited by Christoph Kannicht, 2002
193. **RT-PCR Protocols**, edited by Joseph O'Connell, 2002
192. **PCR Cloning Protocols, 2nd ed.**, edited by Bing-Yuan Chen and Harry W. Janes, 2002
191. **Telomeres and Telomerase: Methods and Protocols**, edited by John A. Double and Michael J. Thompson, 2002
190. **High Throughput Screening: Methods and Protocols**, edited by William P. Janzen, 2002
189. **GTPase Protocols: The RAS Superfamily**, edited by Edward J. Manser and Thomas Leung, 2002
188. **Epithelial Cell Culture Protocols**, edited by Clare Wise, 2002
187. **PCR Mutation Detection Protocols**, edited by Bimal D. M. Theophilus and Ralph Rapley, 2002
186. **Oxidative Stress and Antioxidant Protocols**, edited by Donald Armstrong, 2002
185. **Embryonic Stem Cells: Methods and Protocols**, edited by Kursad Turksen, 2002
184. **Biostatistical Methods**, edited by Stephen W. Looney, 2002
183. **Green Fluorescent Protein: Applications and Protocols**, edited by Barry W. Hicks, 2002
182. **In Vitro Mutagenesis Protocols, 2nd ed.**, edited by Jeff Braman, 2002
181. **Genomic Imprinting: Methods and Protocols**, edited by Andrew Ward, 2002
180. **Transgenesis Techniques, 2nd ed.: Principles and Protocols**, edited by Alan R. Clarke, 2002
179. **Gene Probes: Principles and Protocols**, edited by Marilena Aquino de Muro and Ralph Rapley, 2002
178. **Antibody Phage Display: Methods and Protocols**, edited by Philippa M. O'Brien and Robert Aitken, 2002
177. **Two-Hybrid Systems: Methods and Protocols**, edited by Paul N. MacDonald, 2001
176. **Steroid Receptor Methods: Protocols and Assays**, edited by Benjamin A. Lieberman, 2001
175. **Genomics Protocols**, edited by Michael P. Starkey and Ramnath Elasarapu, 2001
174. **Epstein-Barr Virus Protocols**, edited by Joanna B. Wilson and Gerhard H. W. May, 2001
173. **Calcium-Binding Protein Protocols, Volume 2: Methods and Techniques**, edited by Hans J. Vogel, 2001
172. **Calcium-Binding Protein Protocols, Volume 1: Reviews and Case Histories**, edited by Hans J. Vogel, 2001
171. **Proteoglycan Protocols**, edited by Renato V. Iozzo, 2001
170. **DNA Arrays: Methods and Protocols**, edited by Jang B. Rampal, 2001
169. **Neurotrophin Protocols**, edited by Robert A. Rush, 2001
168. **Protein Structure, Stability, and Folding**, edited by Kenneth P. Murphy, 2001
167. **DNA Sequencing Protocols, Second Edition**, edited by Colin A. Graham and Alison J. M. Hill, 2001
166. **Immunotoxin Methods and Protocols**, edited by Walter A. Hall, 2001
165. **SV40 Protocols**, edited by Leda Raptis, 2001
164. **Kinesin Protocols**, edited by Isabelle Vernos, 2001
163. **Capillary Electrophoresis of Nucleic Acids, Volume 2: Practical Applications of Capillary Electrophoresis**, edited by Keith R. Mitchelson and Jing Cheng, 2001
162. **Capillary Electrophoresis of Nucleic Acids, Volume 1: Introduction to the Capillary Electrophoresis of Nucleic Acids**, edited by Keith R. Mitchelson and Jing Cheng, 2001
161. **Cytoskeleton Methods and Protocols**, edited by Ray H. Gavin, 2001
160. **Nuclease Methods and Protocols**, edited by Catherine H. Schein, 2001
159. **Amino Acid Analysis Protocols**, edited by Catherine Cooper, Nicole Packer, and Keith Williams, 2001
158. **Gene Knockout Protocols**, edited by Martin J. Tymms and Ismail Kola, 2001
157. **Mycotoxin Protocols**, edited by Mary W. Trucksess and Albert E. Pohland, 2001
156. **Antigen Processing and Presentation Protocols**, edited by Joyce C. Solheim, 2001
155. **Adipose Tissue Protocols**, edited by Gérard Ailhaud, 2000
154. **Connexin Methods and Protocols**, edited by Roberto Bruzzone and Christian Giaume, 2001
153. **Neuropeptide Y Protocols**, edited by Ambikaipakan Balasubramaniam, 2000
152. **DNA Repair Protocols: Prokaryotic Systems**, edited by Patrick Vaughan, 2000
151. **Matrix Metalloproteinase Protocols**, edited by Ian M. Clark, 2001
150. **Complement Methods and Protocols**, edited by B. Paul Morgan, 2000
149. **The ELISA Guidebook**, edited by John R. Crowther, 2000
148. **DNA-Protein Interactions: Principles and Protocols (2nd ed.)**, edited by Tom Moss, 2001
147. **Affinity Chromatography: Methods and Protocols**, edited by Pascal Bailon, George K. Ehrlich, Wen-Jian Fung, and Wolfgang Berthold, 2000
146. **Mass Spectrometry of Proteins and Peptides**, edited by John R. Chapman, 2000

METHODS IN MOLECULAR BIOLOGY™

Antibody Phage Display

Methods and Protocols

Edited by

Philippa M. O'Brien

and

Robert Aitken

University of Glasgow, Glasgow, Scotland, UK

Humana Press  **Totowa, New Jersey**

©2002 Humana Press Inc.
999 Riverview Drive, Suite 208
Totowa, New Jersey 07512

www.humanapress.com

All rights reserved. No part of this book may be reproduced, stored in a retrieval system, or transmitted in any form or by any means, electronic, mechanical, photocopying, microfilming, recording, or otherwise without written permission from the Publisher. *Methods in Molecular Biology*[™] is a trademark of The Humana Press Inc.

The content and opinions expressed in this book are the sole work of the authors and editors, who have warranted due diligence in the creation and issuance of their work. The publisher, editors, and authors are not responsible for errors or omissions or for any consequences arising from the information or opinions presented in this book and make no warranty, express or implied, with respect to its contents.

This publication is printed on acid-free paper. 
ANSI Z39.48-1984 (American Standards Institute) Permanence of Paper for Printed Library Materials.

Cover illustration: Fig. 2 from Chapter 20, "Subtractive Isolation of Single-Chain Antibodies Using Tissue Fragments," by Katarina Radošević and Willem van Ewijk.

Production Editor: Jessica Jannicelli.
Cover Design by Patricia F. Cleary.

For additional copies, pricing for bulk purchases, and/or information about other Humana titles, contact Humana at the above address or at any of the following numbers: Tel.: 973-256-1699; Fax: 973-256-8341; E-mail: humana@humanapr.com or visit our Website: humanapress.com

Photocopy Authorization Policy:

Authorization to photocopy items for internal or personal use, or the internal or personal use of specific clients, is granted by Humana Press Inc., provided that the base fee of US \$10.00 per copy, plus US \$00.25 per page, is paid directly to the Copyright Clearance Center at 222 Rosewood Drive, Danvers, MA 01923. For those organizations that have been granted a photocopy license from the CCC, a separate system of payment has been arranged and is acceptable to Humana Press Inc. The fee code for users of the Transactional Reporting Service is: [0-89603-906-4/02 \$10.00 + \$00.25].

Printed in the United States of America. 10 9 8 7 6 5 4 3 2 1

Library of Congress Cataloging in Publication Data

Antibody phage display : methods and protocols / edited by Philippa M. O'Brien and Robert Aitken.

p. cm. -- (Methods in molecular biology ; v. 178)

Includes bibliographical references and index.

ISBN 0-89603-906-4 (alk. paper) (hardcover) ISBN 0-89603-711-8 (comb)

1. Monoclonal antibodies--Research--Methodology. 2. Bacteriophages. I. O'Brien, Philippa M. II. Aitken, Robert, 1960- III. *Methods in molecular biology* (Clifton, N.J.) ; v. 178.

QR186.85 .A585 2002
616.07'98--dc21

2001039568

Preface

The closing years of the 19th century and the start of the 20th century witnessed the emergence of microbiology and immunology as discrete scientific disciplines, and in the work of Roux and Yersin, perhaps the first benefits of their synergy—immunotherapy against bacterial infection. As we advance into the new millennium, microbiology and immunology again offer a conceptual leap forward as antibody phage display gains increasing acceptance as the definitive technology for monoclonal production and unleashes new opportunities in immunotherapy, drug discovery, and functional genomics.

In assembling *Antibody Phage Display: Methods and Protocols*, we have aimed to produce a resource of real value for scientists who have followed the development of phage display technology over the past decade. The founding principles of phage display have always held an elegant simplicity. We hope that readers will find similar clarity in the technical guidance offered by the book's contributors. In meeting our objectives, we have tried to cover the broad scope of the technology and the key areas of library construction, screening, antibody modification, and expression. Of course, the technology continues to advance apace, but we trust that readers will be able to gage the potential of phage display from our coverage, that some of its subtleties will emerge, and that our selection of methods will prove appealing.

We are indebted to all the contributing authors for sharing their expertise with the wider scientific community. We also thank the Beatson Institute for Cancer Research, the Association for International Cancer Research (PO'B), the Caledonian Research Foundation, and the Scottish Hospitals Endowment Research Trust for their funding during the preparation of this book. Finally, we are grateful to our friend and colleague Professor M. Saveria Campo who has encouraged and supported our ventures into phage display.

Philippa M. O'Brien
Robert Aitken

Contents

Preface	v
Contributors	xi
1 Overview of Antibody Phage-Display Technology and Its Applications Hennie R. Hoogenboom	1
2 Standard Protocols for the Construction of Fab Libraries Michelle A. Clark	39
3 Standard Protocols for the Construction of scFv Libraries Simon Lennard	59
4 Broadening the Impact of Antibody Phage Display Technology: <i>Amplification of Immunoglobulin Sequences from Species Other than Humans or Mice</i> Philippa M. O'Brien and Robert Aitken	73
5 Construction of Large Naïve Fab Libraries Hans J. W. de Haard	87
6 Construction of Polyclonal Antibody Libraries Using Phage Display Jacqueline Sharon, Seshi R. Sompuram, Chiou-Ying Yang, Brent R. Williams, and Stefanie Sarantopoulos	101
7 Antigen-Driven Stimulation of B-Lymphocytes In Vitro Zhiwei Hu	113
8 The Recovery of Immunoglobulin Sequences from Single Human B Cells by Clonal Expansion Ruud M. T. de Wildt and René M. A. Hoet	121
9 Panning of Antibody Phage-Display Libraries: <i>Standard Protocols</i> David W. J. Coomber	133
10 Selection of Antibodies Against Biotinylated Antigens Patrick Chames, Hennie R. Hoogenboom, and Paula Henderikx	147
11 Isolation of Anti-Hapten Specific Antibody Fragments from Combinatorial Libraries Keith A. Charlton and Andrew J. Porter	159
12 Blocking Immunodominant Epitopes by Competitive Deselection Roberto Burioni	173

13	Rescue of a Broader Range of Antibody Specificities Using an Epitope-Masking Strategy Henrik J. Ditzel	179
14	Screening of Phage-Expressed Antibody Libraries by Capture Lift Jeffry D. Watkins	187
15	Antibody-Guided Selection Using Capture-Sandwich ELISA Kunihiko Itoh and Toshio Suzuki	195
16	Proximity-Guided (ProxiMol) Antibody Selection Jane K. Osbourn	201
17	Isolation of Human Monoclonal Antibodies Using Guided Selection with Mouse Monoclonal Antibodies Mariangela Figini and Silvana Canevari	207
18	Selecting Antibodies to Cell-Surface Antigens Using Magnetic Sorting Techniques Don L. Siegel	219
19	Isolation of Human Tumor-Associated Cell Surface Antigen-Binding scFvs Elvyra J. Noronha, Xinhui Wang, and Soldano Ferrone	227
20	Subtractive Isolation of Single-Chain Antibodies Using Tissue Fragments Katarina Radosevic and Willem van Ewijk	235
21	Selection of Antibodies Based on Antibody Kinetic Binding Properties Ann-Christin Malmberg, Nina Nilsson, and Mats Ohlin	245
22	Selection of Functional Antibodies on the Basis of Valency Manuela Zaccolo	255
23	Two-Step Strategy for Alteration of Immunoglobulin Specificity by In Vitro Mutagenesis Yoshitaka Iba, Chie Miyazaki, and Yoshikazu Kurosawa	259
24	Targeting Random Mutations to Hotspots in Antibody Variable Domains for Affinity Improvement Partha S. Chowdhury	269
25	Error-Prone Polymerase Chain Reaction for Modification of scFvs Pierre Martineau	287
26	Use of <i>Escherichia coli</i> Mutator Cells to Mature Antibodies Robert A. Irving, Gregory Coia, Anna Raicevic, and Peter J. Hudson	295
27	Chain Shuffling to Modify Properties of Recombinant Immunoglobulins Johan Lantto, Pernilla Jirholt, Yvelise Barrios, and Mats Ohlin	303

28	Generation of Bispecific and Tandem Diabodies Sergey M. Kipriyanov	317
29	High-Level Periplasmic Expression and Purification of scFvs Sergey M. Kipriyanov	333
30	Periplasmic Expression and Purification of Recombinant Fabs Robert L. Raffai	343
31	Expression of Antibody Fragments in <i>Pichia pastoris</i> Philipp Holliger	349
32	Expression of V _{HH} Antibody Fragments in <i>Saccharomyces cerevisiae</i> J. Marcel van der Vaart	359
33	Intrabodies: Targeting scFv Expression to Eukaryotic Intracellular Compartments Pascale A. Cohen	367
34	Expression of scFvs and scFv Fusion Proteins in Eukaryotic Cells Michelle de Graaf, Ida H. van der Meulen-Muileman, Herbert M. Pinedo, and Hidde J. Haisma	379
35	Expression of Antibody Fab Fragments and Whole Immunoglobulin in Mammalian Cells Pietro P. Sanna	389
	Index	397

Contributors

- ROBERT AITKEN • *University of Glasgow, Glasgow, Scotland, UK*
YVELISE BARRIOS • *Department of Immunotechnology, Lund University, Lund, Sweden*
- ROBERTO BURIONI • *Istituto di Microbiologia, Facoltà di Medicina, Università di Ancona, Ancona, Italy*
- SILVANA CANEVARI • *Istituto Nazionale per lo Studio e la Cura dei Tumori, Department of Experimental Oncology, Unit of Molecular Therapies, Milano, Italy*
- PATRICK CHAMES • *Department of Pathology, Maastricht University and University Hospital, Maastricht, The Netherlands*
- KEITH A. CHARLTON • *Remedios Ltd., Aberdeen, Scotland, UK*
- PARTHA S. CHOWDHURY • *Human Genome Sciences, Rockville, MD*
- MICHELLE A. CLARK • *St. Vincent's Hospital, Sydney, Australia*
- PASCAL A. COHEN • *Faculté de Pharmacie, Université Montpellier I, Montpellier, France*
- GREGORY COIA • *CRC for Diagnostic Technologies at CSIRO Health Sciences and Nutrition, Parkville, Victoria, Australia*
- DAVID W. J. COOMBER • *Department of Surgery and Molecular Oncology, Ninewells Hospital and Medical School, University of Dundee, Scotland, UK*
- MICHELLE DE GRAAF • *Division of Gene Therapy, Department of Medical Oncology, Vrije University, Amsterdam, The Netherlands*
- HANS J. W. DE HAARD • *Department of Functional Biomolecules, Unilever Research Laboratorium Vlaardingen, Vlaardingen, The Netherlands*
- RUUD M. T. DE WILDT • *MRC Laboratory of Molecular Biology, Cambridge, UK*
- HENRIK J. DITZEL • *Department of Immunology, The Scripps Research Institute, La Jolla, CA*
- SOLDANO FERRONE • *Department of Immunology, Roswell Park Cancer Institute, Buffalo, NY*
- MARIANGELA FIGINI • *Istituto Nazionale per lo Studio e la Cura dei Tumori, Department of Experimental Oncology, Unit of Molecular Therapies, Milano, Italy*
- HIDDE J. HAISMA • *Department of Medical Oncology, Division of Gene Therapy, Vrije University, Amsterdam, The Netherlands*
- PAULA HENDERIKX • *Dyax sa, Liège, Belgium*

- RENÉ M. A. HOET • *Dyax sa, Liège, Belgium*
- PHILIPP HOLLIGER • *MRC Laboratory of Molecular Biology, Cambridge, UK*
- HENNIE R. HOOGENBOOM • *Dyax sa, Liège, Belgium*
- ZHIWEI HU • *Cancer Research Institute, Hunan Medical University, Changsha, Hunan, China; Current address: Department of Molecular Biophysics and Biochemistry, Yale University, New Haven, CT*
- PETER J. HUDSON • *CRC for Diagnostic Technologies at CSIRO Health Sciences and Nutrition, Parkville, Victoria, Australia*
- YOSHITAKA IBA • *Institute for Comprehensive Medical Science, Fujita Health University, Toyoake, Japan*
- ROBERT A. IRVING • *CRC for Diagnostic Technologies at CSIRO Health Sciences and Nutrition, Parkville, Victoria, Australia*
- KUNIHICO ITOH • *Department of Pharmaceutical Science, Akita University Hospital, Akita, Japan*
- PERNILLA JIRHOLT • *Department of Immunotechnology, Lund University, Lund, Sweden*
- SERGEY M. KIPRIYANOV • *Affimed Therapeutics AG, Ladenburg, Germany*
- YOSHIKAZU KUROSAWA • *Institute for Comprehensive Medical Science, Fujita Health University, Toyoake, Japan*
- JOHAN LANTTO • *Department of Immunotechnology, Lund University, Lund, Sweden*
- SIMON LENNARD • *Cambridge Antibody Technology, The Science Park, Melbourn, Cambridgeshire, UK*
- ANN-CHRISTIN MALMBORG • *Department of Immunotechnology, Lund University, Lund, Sweden*
- PIERRE MARTINEAU • *CNRS, Faculté de Pharmacie, Montpellier, France*
- CHIE MIYAZAKI • *Toyota Central R&D Laboratories, Nagakute, Japan*
- NINA NILSSON • *Department of Immunotechnology, Lund University, Lund, Sweden*
- ELVYRA J. NORONHA • *Department of Microbiology, Hammer Health Science Center, Columbia University, New York, NY*
- PHILIPPA M. O'BRIEN • *University of Glasgow, Glasgow, Scotland, UK*
- MATS OHLIN • *Department of Immunotechnology, Lund University, Lund, Sweden*
- JANE K. OSBOURN • *Cambridge Antibody Technology, The Science Park, Melbourn, Cambridgeshire, UK*
- HERBERT M. PINEDO • *Division of Gene Therapy, Department of Medical Oncology, Vrije Universiteit, Amsterdam, The Netherlands*
- ANDREW J. PORTER • *Department of Molecular and Cell Biology, Institute of Medical Science, University of Aberdeen, Aberdeen, Scotland, UK*
- KATARINA RADOŠEVIĆ • *Department of Immunology, Erasmus University Rotterdam/University Hospital Rotterdam-Dijkzigt, Rotterdam, The Netherlands*

- ROBERT L. RAFFAI • *Gladstone Institute of Cardiovascular Disease and Cardiovascular Research Institute, University of California, San Francisco, CA*
- ANNA RAICEVIC • *CRC for Diagnostic Technologies at CSIRO Health Sciences and Nutrition, Parkville, Victoria, Australia*
- PIETRO P. SANNA • *Department of Neuropharmacology, The Scripps Research Institute, La Jolla, CA*
- STEFANIE SARANTOPOULOS • *Boston Medical Center, Boston, MA*
- JACQUELINE SHARON • *Boston University School of Medicine, Boston, MA*
- DON L. SIEGEL • *Department of Pathology and Laboratory Medicine, University of Pennsylvania Medical Center, Philadelphia, PA*
- SESHI R. SOMPURAM • *CytoLogix Corporation, Cambridge, MA*
- TOSHIO SUZUKI • *Department of Pharmaceutical Science, Akita University Hospital, Akita, Japan*
- IDA H. VAN DER MEULEN-MUILEMAN • *Division of Gene Therapy, Department of Medical Oncology, Vrije University, Amsterdam, The Netherlands*
- J. MARCEL VAN DER VAART • *Unilever Research Vlaardingen, Vlaardingen, The Netherlands*
- WILLEM VAN EWIK • *Department of Immunology, Erasmus University Rotterdam/University Hospital Rotterdam-Dijkzigt, Rotterdam, The Netherlands*
- XINHUI WANG • *Department of Immunology, Roswell Park Cancer Institute, Buffalo, NY*
- JEFFRY D. WATKINS • *Applied Molecular Evolution, Inc., San Diego, CA*
- BRENT R. WILLIAMS • *Boston University School of Medicine, Boston, MA*
- CHIOU-YING YANG • *Institute of Molecular Biology, National Chung Hsing University, Taichung, Taiwan*
- MANUELA ZACCOLO • *Dipartimento di Scienze Biomediche Sperimentali, Università di Padova, Padova, Italy*

Overview of Antibody Phage-Display Technology and Its Applications

Hennie R. Hoogenboom

1. Introduction

The generation of new drugs has long involved the screening of hundreds of thousands of components with well defined *in vitro* tests, seeking compounds to mimic as closely as possible the desired *in vivo* activity of the new drug. New library methodologies offer many alternative routes that are at least as powerful as traditional approaches by combining the generation of billions of components with a fast screening or selection procedure to identify the most interesting lead candidates. One of the most widely used library methodologies is based on the use of filamentous phage (**1**), a virus that lives on *Escherichia coli*. Phage display has proven to be a powerful technique for the interrogation of libraries containing millions or even billions of different peptides or proteins. One of the most successful applications of phage display has been the isolation of monoclonal antibodies using large phage antibody libraries (**2,3**). This chapter reviews the progress made in this rapidly developing field and discusses a broad range of applications, including the use of large phage Ab libraries to discover novel therapeutic targets and methods for selection of biologically active ligands. Finally, it addresses the potential of combining phage display with complementary methods to increase the scope and range of applications of this technology.

2. Antibody Phage Display

2.1. The Phage-Display Principle

The power of the phage-display system is illustrated in **Fig. 1**. DNA encoding millions of variants of certain ligands (e.g., peptides, proteins, or fragments

From: *Methods in Molecular Biology*, vol. 178: *Antibody Phage Display: Methods and Protocols*
Edited by: P. M. O'Brien and R. Aitken © Humana Press Inc., Totowa, NJ

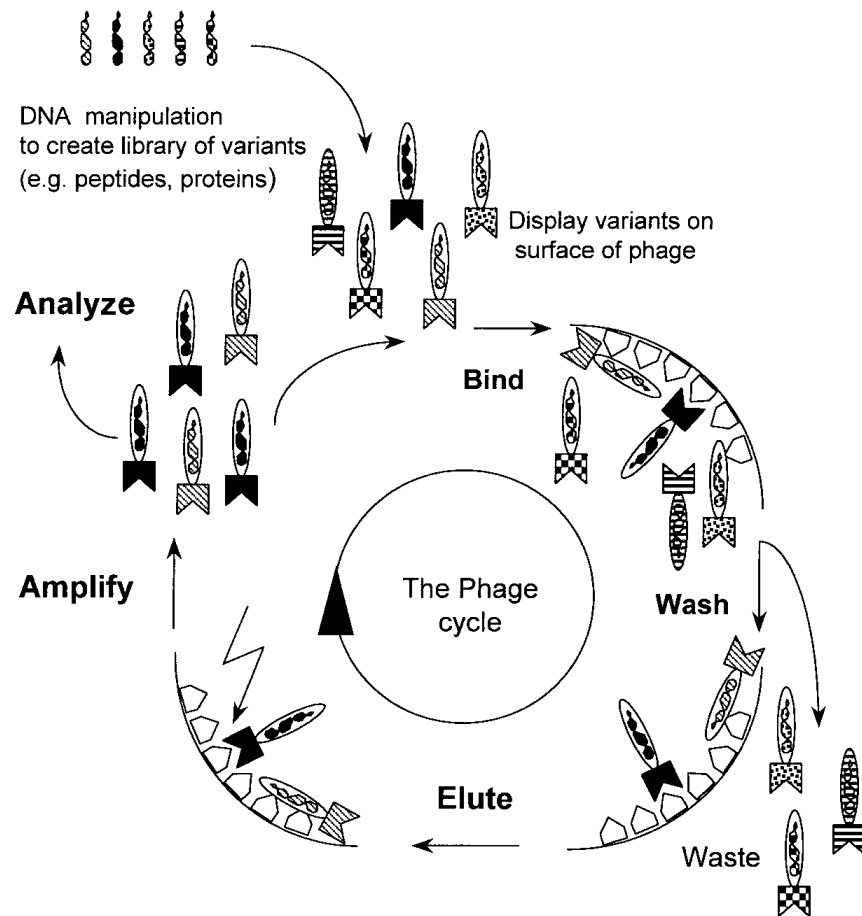

Fig. 1. Phage-display cycle. DNA encoding for millions of variants of certain ligands (e.g., peptides, proteins, or fragments thereof) is batch-cloned into the phage genome as part of one of the phage coat proteins (pIII, pVI, or pVIII). Large libraries containing millions of different ligands can be obtained by force-cloning in *E. coli*. From these repertoires, phage carrying specific-binding ligands can be isolated by a series of recursive cycles of selection on Ag, each of which involves binding, washing, elution, and amplification.

thereof) is batch-cloned into the phage genome as a fusion to the gene encoding one of the phage coat proteins (pIII, pVI, or pVIII). Upon expression, the coat protein fusion will be incorporated into new phage particles that are assembled in the bacterium. Expression of the fusion product and its subsequent incorporation into the mature phage coat results in the ligand being presented on the phage surface; its genetic material resides within the phage particle. This connection between ligand genotype and phenotype allows the enrichment of specific phage, e.g., using selection on an immobilized target. Phage that

display a relevant ligand will be retained, but nonadherent phage will be washed away. Bound phage can be recovered from the surface, infected into bacteria, replicated to enrich for those clones recovered from the library, and eventually subjected to more detailed analysis. The success of ligand phage display hinges on the synthesis of large combinatorial repertoires on phage and the combination of display and enrichment.

2.2. Filamentous Phage Biology and Display

Although other display systems have been described (*see Subheading 3.4.*), the most popular vehicle for display remains the filamentous bacteriophage. The nonlytic filamentous phage, fd, or M13, infects strains of *E. coli* containing the F conjugative plasmid. Phage particles attach to the tip of the F pilus encoded by genes on the plasmid and the phage genome, a circular single-stranded DNA molecule, is translocated into the cytoplasm. The genome is replicated involving both phage- and host-derived proteins and packaged by the infected cell into a rod-shaped particle, which is released into the media. All virion proteins will undergo transport to the cell periplasm prior to assembly and extrusion. Several filamentous phage coat proteins have been used for display of ligands (*4,5*), but the most extensively used is the pIII phage protein, which is involved in bacterial infection and is present in 3–5 copies/phage particle.

2.3. Basic Display Methodology

Antibodies (Abs) were the first proteins to be displayed successfully on the surface of phage (*6*). This was achieved by fusing the coding sequence of the antibody variable (V) regions encoding a single-chain Fv (scFv) to the N-terminus of the phage minor coat protein pIII using a phage vector based on the genome of fdtet (*7*). The scFv sequence was cloned in frame with gene III and downstream of the gene III signal sequence, which normally directs export of the adsorption protein. In the periplasmic environment, the V_H and V_L domains fold correctly (both stabilized by an intramolecular disulphide-bridge) and pair to form a functional scFv (*8,9*). Initially, phage vectors that carried all the genetic information required for the phage life cycle were used (*6–10*), but phagemids have since become the most popular vector system for display.

Phagemids are small plasmid vectors that have high transformation efficiencies and are therefore ideally suited for generating large repertoires. They carry gene III with appropriate cloning sites (*11–13*) so that the scFv or other ligand may be fused at the N-terminus of the mature gene III protein (*6,12*) or at the N-terminus of a truncated pIII lacking the first two N-terminal domains (*11,14*). They may also be formatted for direct secretion of the unfused Ab fragment without subcloning (*12*). Many phagemids utilize the *lacZ* promoter to drive expression of the antibody-pIII fusion (*12,14,15*), but whenever

expression-mediated toxicity is an issue (which is the case for some, mostly hybridoma-derived, antibody fragments [16]), regulating expression more tightly may be required. This can be achieved through catabolite repression by including glucose in the culture medium by addition of an extra transcriptional terminator (17) or use of the phage shock promoter (18). For display of the Ab-pIII product, limited expression must be triggered, and the fusion must be incorporated into phage carrying the phagemid sequence. The former can be achieved by relieving catabolite repression, the latter by using the phage packaging signal also carried on the phagemid and a helper phage, such as M13KO7 or VCSM13, which supplies all structural proteins. Since the helper-phage genome encodes wild-type pIII, typically over 90% of rescued phage display have no Ab at all, and the vast majority of the rescued phage particles that do display the fusion product will only contain a single copy. Ideally, more efficient, even multivalent display would therefore be preferable when selecting large Ab libraries to guarantee selection with a limited number of phage particles/clone. Monovalent display, on the other hand, may be essential when selecting Abs of higher affinity. Therefore, the use of inducible promoters (19) or the use of a helper phage with gene III deleted (20,21), which may be efficiently produced in cells containing *gIII* under control of the phage shock promoter (18), may in the future allow modulation of the valency of displayed Abs.

2.4. Formats for Ab Display

Effective display formats for Abs are scFv (6,10,22), Fabs (11,12,14,23,24), immunoglobulin variable fragments (Fvs) with an engineered intermolecular disulphide bond to stabilize the V_H-V_L pair (25) and diabody fragments (26,27). The smaller size of the scFv format makes these libraries genetically more stable than Fab libraries. However, many scFvs can form higher molecular weight species, including dimers and trimers, which can complicate selection and characterization (26). Fabs lack this tendency, which facilitates assays to screen the kinetics of binding for example (*see Subheading 5.2.*). To display Fabs on phage, either the light or heavy (Fd) chain is fused via its C-terminus to pIII, and the partner chain is expressed and secreted into the periplasmic space where chain association forms an intact Fab (Fig. 2). Because light chains can form dimers, the preferred option is to anchor the heavy chain to the phage coat protein. A similar method is used to express bispecific diabodies (27). Such bispecific dimers of scFvs can be displayed on phage by expression from a bicistronic cassette containing two V_H-V_L fusion products, one of which is fused to *gIII*. The advantage of the diabody format is that either bivalent Abs may be isolated, a feature that could be used for functional screening (*see*

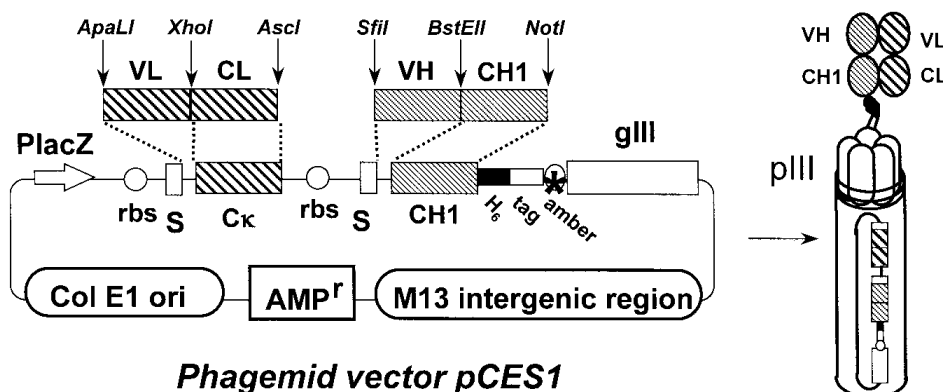

Fig. 2. Display of Fabs on filamentous phage. Fabs may be displayed on phage using phagemids (pCES1 is shown as an example) that express the heavy chain (Fd) fragment containing the variable domain and the first constant domain fused to a coat protein gene, gene III, of filamentous phage, fd, in combination with separate expression of the partner (light) chain. Bacteria harboring this phagemid vector are superinfected with helper phage, driving production of phage particles carrying the Fab as a fusion product with the phage coat protein, pIII, on the surface. DNA encoding the immunoglobulins is packaged within the particle. Ribosome-binding site (rbs); ampicillin resistance (AMP^r) H_6 and tag, histidine stretch and peptide tag, respectively, for purification and detection purposes; amber codon (TAG) that allows expression of soluble Ab fragment in nonsuppressor strains; *gIII*, gene III for phage, fd; S, signal sequence directing the expressed protein to the bacterial periplasm.

Subheading 5.4.), or large panels of bispecific molecules may be generated, avoiding extensive recloning after selection (27).

3. The Construction of Ab Libraries

A direct application of phage technology is to clone the Ab genes from hybridomas or cloned B cells (described in Chapter 8), or stimulated B-cell cultures (in Chapter 7), thereby giving rapid access to expressed V genes. One of the broadest areas of application for phage display has been the isolation of monoclonal Abs (MAbs) from large random combinatorial phage Ab libraries (Fig. 3). Such libraries have been built in scFv and Fab format, exemplified by the contributions of Lennard (Chapter 3) and Clark (Chapter 2). This chapter discusses the three types of such phage antibody libraries (immune, naïve, and synthetic antibody) in more detail.

3.1. Ab Libraries from Immunized Animals or Immune Donors

Repertoires may be created from the IgG genes of spleen B cells of mice immunized with antigen (Ag) (10) or from immune donors. An immune phage

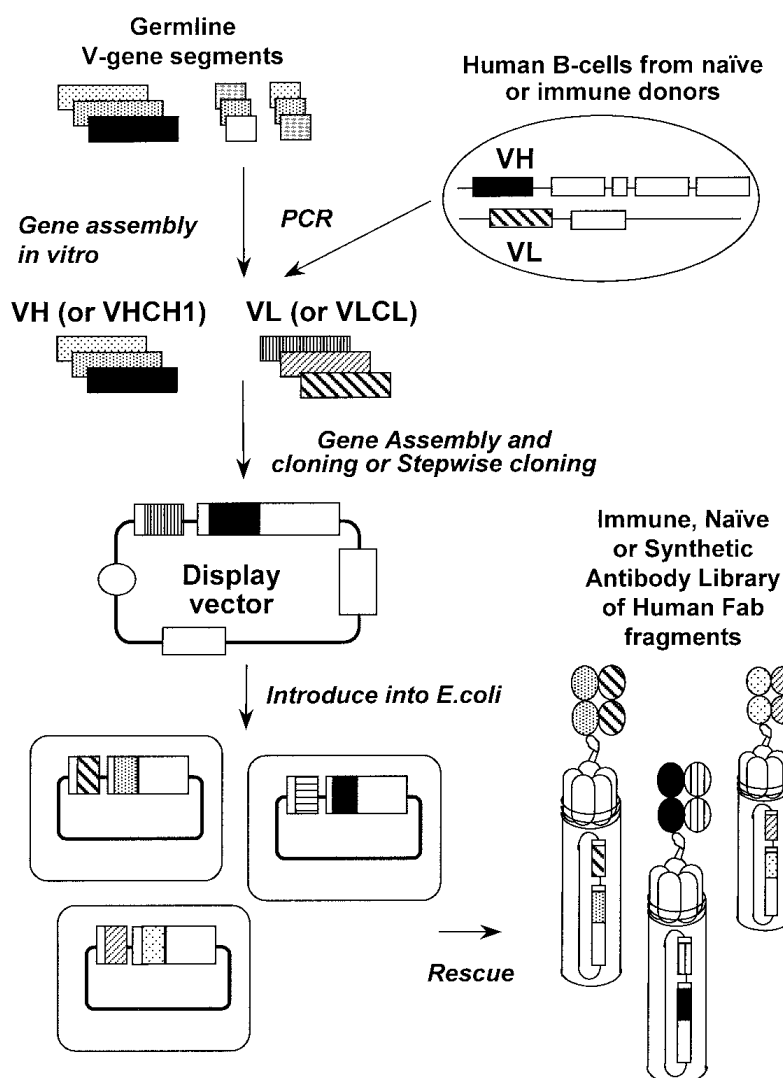

Fig. 3. Construction of a human Ab library displayed on phage. cDNA encoding for the heavy and the light variable regions of Abs (V_H , V_L) are amplified from human B cells by PCR and assembled. The assembled genes are inserted into a phagemid vector in frame with the gene encoding the CP pIII. The vector is introduced into *E. coli*. After rescue with helper phage, the random combinatorial library of Abs is displayed on phage and selection can be performed.

Ab repertoire will be enriched in Ag-specific Abs, some of which will have been affinity-matured by the immune system (10,28). This method sometimes yields Abs with higher affinity than obtained from hybridomas, as was reported for an anti-carcinoembryonic antigen (CEA) Ab (29). Other advantages of this procedure are that, compared to hybridoma technology, many more Abs may

be accessed from the material of a single immunized donor, and selected Abs can be rapidly produced or manipulated further. The construction of immune libraries from a variety of species has been reported, including mouse (10,29,30), human (31,32), chicken (33,34), rabbit (35), and camel (36). Chapter 4 specifically addresses the construction of immune libraries from livestock species.

Provided that suitable sources of Ab-producing B cells or plasma cells are available, immune-phage libraries are useful in analyzing natural humoral responses, for example, in patients with autoimmune disease (37–39), viral infection (40), neoplastic diseases (32,41,42), or to study in vitro immunization procedures (43). In addition, when studying specific (e.g., mucosal) humoral responses, mRNA coding for specific Ig isotypes (e.g., IgA) may be selectively used for library synthesis (44). Active immunization, however, is not always possible because of ethical constraints, nor always effective because of tolerance mechanisms toward, or toxicity of, the Ag involved. Tolerance mechanisms may be put to use in some cases, e.g., to deplete Abs to certain Ags in vivo through tolerization, followed by immunization with target Ag and in vitro selection of the derived phage library (32).

3.2. Single-Pot Repertoires

From immune libraries, Abs can be obtained only against the set of Ags to which an immune response was induced, which necessitates repeated immunization and library construction. Ideally, universal Ag-unbiased libraries would be available from which high-affinity Abs to any chosen Ag may directly be selected, independent of the donor's immunological history. At present, several such single-pot libraries have been described (2,45). They are particularly useful for the selection of human Abs, which are difficult to establish with more traditional techniques. The distinction between naïve and synthetic Ab libraries depends on the source of immunoglobulin genes. For most applications, the availability of large premade collections of nonimmune repertoires has thus superseded the use of immune repertoires.

3.2.1. Ab Libraries from Nonimmunized Donors

The primary (unselected) Ab repertoire contains a large array of IgM Abs that recognize a variety of Ags. This array can be cloned as a naïve repertoire of rearranged genes by harvesting the V genes from the IgM mRNA of B cells of unimmunized human donors isolated from peripheral blood lymphocytes (22), spleen (46), bone marrow or tonsil B cells (47), or from similar animal sources (48). In theory, the use of Ag-biased IgG and V genes that may potentially carry mutations should be avoided. However, a repertoire with excellent performance has been synthesized using random priming to include

mRNA of all Ig isotypes (47). Libraries could also be made from the naïve pool of IgD mRNA.

V genes are amplified from B-cell cDNA using V-gene-family based oligonucleotides (49), and heavy and light chains are randomly combined and cloned to generate a combinatorial library of scFv or Fab Ab fragments. This procedure provides access to Abs derived from B cells that have not yet encountered Ag, although the frequency of truly naïve Abs will depend heavily on the source of B cells (50). A single naïve library, if sufficiently large and diverse, can indeed be used to generate Abs to a large panel of Ags, including self, nonimmunogenic, and toxic Ags (20,22,47).

The affinity of Abs selected from a naïve library is proportional to the size of the library, ranging from $10^{6-7} M^{-1}$ for a small library of 3×10^7 clones (20,22) to $10^{8-10} M^{-1}$ for a large repertoire of 10^{10} clones made by brute-force cloning (47). This finding is in line with theoretical considerations (51). Other large naïve human scFv libraries (6.7×10^9 clones) (52) and a very large Fab library (3.7×10^{10} clones) (46), made via an efficient two-step restriction fragment-cloning procedure described by de Haard (Chapter 5), also seem to perform well.

3.2.2. Synthetic Ab Libraries

In the second type of single-pot repertoire, Abs are built artificially by in vitro assembly of V-gene segments and D/J segments. V genes may be assembled by introducing a predetermined level of randomization into complementary determining regions (CDR) (and possibly also of bordering framework regions) into germline V-gene segments (53) or rearranged V genes (54). The regions and degree of diversity may be chosen to correspond to areas in which the Ab repertoire is naturally most diverse. Most natural structural and sequence diversity is found in the loop most central to the Ag-combining site, the CDR3 of the heavy chain; the five other CDRs have limited variation (55). CDR3 has therefore been the target for introduction of diversity in the first synthetic libraries.

In the first synthetic Ab library constructed according to these principles (53), a set of 49 human V_H segments was assembled via polymerase chain reaction (PCR) with a short CDR3 region (encoding either five or eight amino acids) and a J region and cloned for display as a scFv with a human λ light chain. From this repertoire, many Abs to haptens and one against a protein Ag were isolated (53). Subsequently, the CDR3 regions were enlarged (ranging from 4 to 12 residues) to supply more length diversity in this loop (56). Other original designs have used only one (cloned) rearranged V gene with a single-size randomized CDR3 region in the heavy chain (54) or have used complete randomization of all three CDR loops in one Ab V domain (57,58). Some of

these libraries have yielded Abs against many different Ags, including haptens (53,54), proteins (56), and cell-surface markers (59), but their affinities are typically in the micromolar range.

Abs with nanomolar affinity were eventually isolated from a synthetic Ab library that combined *in vivo* recombination (a novel method for synthesis of combinatorial libraries) and a strategy to maximally mimic natural Ab diversity (i.e., to optimally use sequence space). In the largest synthetic library made in the period up to 1994 (60), the 49 human heavy chain segments that were used earlier (53) were combined with a collection of 47 human κ and λ light chain segments with partially randomized CDR3 regions. The heavy and light chain V-gene repertoires were combined on a phage vector in bacteria using the Cre-*lox* site-specific recombination system to create a repertoire of Fabs displayed on phage comprising 6.5×10^{10} clones. The library yielded Abs against numerous Ags, some with nanomolar affinities (37,60). This phage library proved to be difficult to repropagate without significant loss of diversity. However, a more stable scFv phagemid library (1.2×10^9 clones) made by standard methods and using the same synthetic V genes was recently shown to be equally effective (Griffin, personal communication).

It seems desirable to synthesize even larger collections of Abs. However, there are physical limits to the enrichment that may be achieved in the selection procedure, which places an upper limit on accessible genetic diversity. Enrichment factors for a single selection round have never been reported in excess of 10^5 /round, and, typically, 10^6 phage clones are eluted in the first critical round of selection. The total genetic diversity accessed by the selection procedure would thus be 10^{11} clones at the most. If selection conditions are so stringent that few phage particles are recovered in the first round (typical for example, when panning on cells, followed by sorting via flow cytometry [59]), chances are that different subsets of Abs will be selected every time the selection is repeated. It therefore appears crucial to optimize the quality of the displayed Abs regarding display and expression level and the selection procedure itself, in which synthetic Ab libraries will have a major advantage over naïve libraries that use naturally rearranged V genes. For example, the choice of V-gene segments for the construction of synthetic Ab repertoires may be guided by factors that will increase the overall performance of the library, such as good expression and folding and low toxicity in *E. coli*. This will increase the functional library size. Large differences in V gene usage, both *in vivo* and in phage repertoires (60), also suggest that some scaffolds may be better suited to form Ag-binders than others. Such a second-generation synthetic Ab library was built by MorphoSys using V-gene segments based on master frameworks representing each of the Kabat subclasses to incorporate, in principle, only well-expressed scaffolds (61). To avoid the introduction of stop codons,

which would decrease the functional library size, V genes were assembled with oligonucleotides made from trinucleotides instead of from single bases (61,62).

Further thoughtful design may continue to improve the performance of these libraries. For example, preselection of amplified and displayed synthetic V domains on Ig-domain binding proteins (Protein A for V_H, Protein L for V_K, and so on [63]) would remove clones with stop codons and frameshifts, as well as select for functional expression (Tomlinson, unpublished). Finally, an exciting idea is to combine the complementary diversity of the primary (germline) and secondary (somatic hypermutation) Ab libraries in one single phage Ab library. This may be feasible since only a few residues are known to be hotspots for the hypermutation machinery, as exemplified also by a library design by Neri's team (64). These developments may eventually establish a super library containing Abs of a superior affinity to those offered by lymphocytes (45,65). When combined with novel methods for further library diversification (66) and appropriate affinity selection (*see Subheading 3.3.*), such libraries are likely to become the preferred source of Abs for any application.

3.3. Secondary Phage Libraries for Affinity Maturation

Although the Abs selected from many of the immune and even the large single-pot, repertoires may be useful for the scientist, their affinity is often not sufficiently high for applications such as immunotherapy, viral neutralization, or sensitive diagnosis. Sufficient gain in apparent affinity may be achieved by simply constructing multivalent molecules (67,68), but situations will arise in which *in vitro* affinity maturation of the selected Abs is required.

The process essentially involves three steps: introduction of diversity in the V genes chosen for maturation, creating a secondary library; selection of variants of higher affinity; and screening to discriminate between Ab variants with differences in affinity or kinetics of binding. Diversity in the Ab genes may be introduced using a variety of methods described in this volume: mutator strains of bacteria (69,70), error-prone PCR (71), chain shuffling (10,72), and DNA shuffling (73), or codon-based mutagenesis, oligonucleotide-directed mutagenesis, and PCR techniques directed at defining residues or regions of the V genes (62,74,75). The nondirected approaches have been used to mature some Abs with low starting affinity (69,72,76,77).

Once Abs with nanomolar affinities are used as starting leads, it appears that CDR-directed approaches are more successful. For example, residues that modulate affinity may be randomized (ideally, 4–6 residues at a time) to allow efficient sampling of the sequence space. Such residues that contact the Ag or that influence other residues contacting the Ag may be defined experimentally by chain shuffling (16), alanine-scanning of the CDR regions

(78), parsimonious mutagenesis (79,80), or modeling (78). Targeting CDRs in parallel has been carried out (75), but additive effects of mutants are frequently unpredictable. The most successful approaches report improvements of affinity to below 100 pM by saturation mutagenesis and affinity selection of CDR3 of HC and LC (75,76). A detailed study of the sequence diversity of human Abs created in the primary and secondary immune responses also suggests other key residues for targeting in affinity maturation studies (65,81).

3.4. Beyond Phage-Display Libraries

Before discussing selection and screening procedures in detail, a recent development should be noted, which may allow even larger repertoires of biomolecules to be made, as well as facilitate Ab affinity maturation. An *in vitro* display method has been described in which proteins are translated, displayed, and selected on ribosomes (82,83). The polysome complex containing the encoding mRNA and translated amino acid sequence is utilized for selection with a ligand. The mRNA from selected polysomes is converted into cDNA and used for the next transcription, translation, and selection round. Ab fragments, particularly scFvs, may form functional molecules in several cell-free translation systems (83,84). This ribosome display approach has therefore recently been used for the display (83,85) and evolution of a scFv Ab *in vitro* (83). This system has the major advantage that the diversity of any repertoire of proteins will not be limited by the host cell/phage life cycle. The size of repertoire that can be sampled is potentially unlimited, and its generation would be very fast and greatly simplified. Other methods essentially similar to this *in vitro* procedure have been developed, e.g., the “Profusion” technology, in which covalent RNA–peptide fusions are created (86), yet it remains to be seen whether these *in vitro* methods will compete with the robust and technically amenable *in vivo* display technologies.

4. Phage Ab Selection Procedures and Applications

4.1. Diversity in Selection Methods

Phage Ab selections involve the sequential enrichment of specific binding phage from an excess of nonbinding clones, which is achieved by multiple rounds of phage binding to the target, washing to remove nonspecific phage, and elution to retrieve specific binding phage. A schematic outline is depicted in **Fig. 1**. Any method that separates clones that bind from those that do not can be used for selection, and, as such, many different selection methods have been used. In **Fig. 4** (top panel), the most popular procedures are listed, including biopanning on immobilized Ag coated onto solid supports, columns,

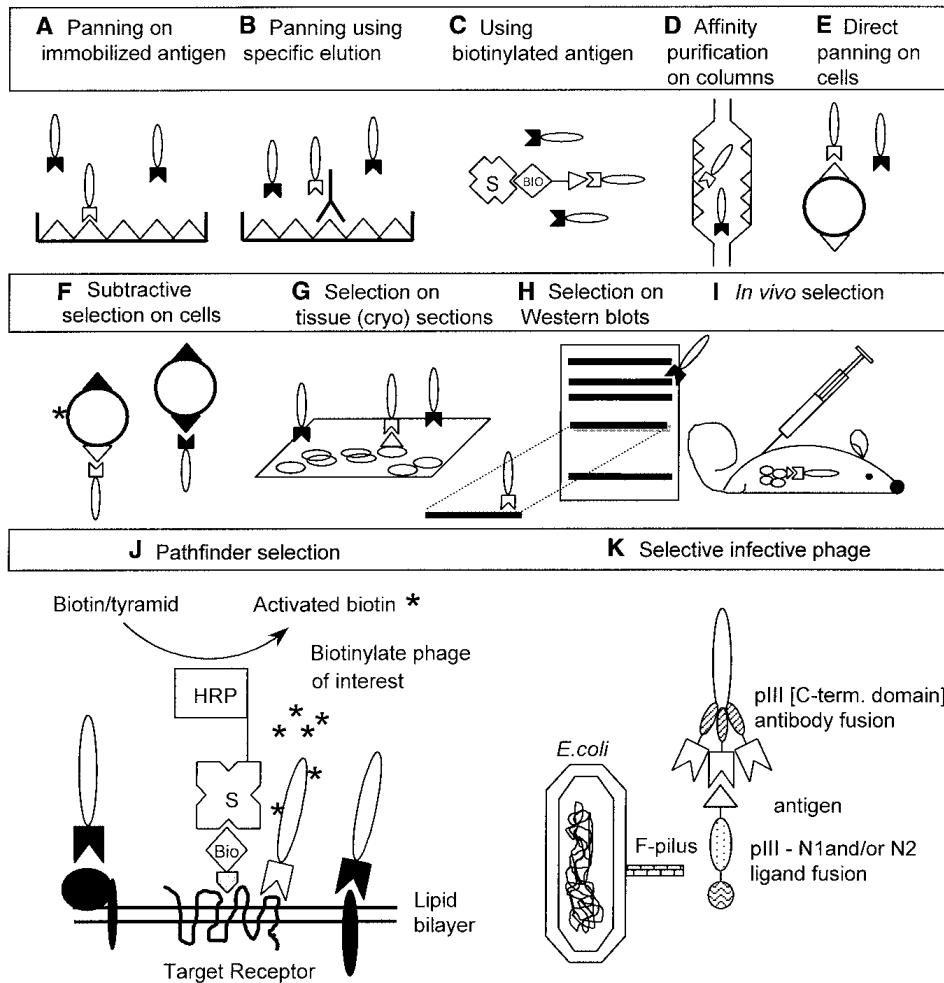

Fig. 4. Selection strategies for obtaining specific phage ligands. Affinity selection of phage Ab libraries by panning on Ag adsorbed onto a solid support (A). After washing, specific phage are eluted with acidic or basic solutions. Alternatively, elution with Ab or an excess of the Ag is possible (B). To avoid conformational changes during coating, selection of specific Abs to biotinylated Ag in solution is more favored (C). Bound and unbound phage Abs are separated using streptavidin-coated magnetic beads. Ag can be immobilized onto a column for affinity selection (D). Selection is also possible on cells by panning directly on cell monolayers or cells in suspension (E). Subtraction via fluorescence-activated cell sorting: the cells of interest are fluorescently labeled and separated from the others by cell sorting (F). Tissue- and organ-specific phage Abs can be obtained by selection on tissue slides (G). Nonpurifiable or unknown Ags may be separated on sodium dodecyl sulfate-polyacrylamide gel electrophoresis and blotted onto membranes for selection (H). Selection *in vivo* can also be considered (I). Finally, outlines are shown of Pathfinder selection (J) and infection-mediated selection (K). In the cartoons, specific phage are shown with a white ligand and irrelevant phage bear a black ligand.

or BIAcore sensor chips (10,22,60,87), selection using biotinylated Ag (71), panning on fixed prokaryotic cells (88) and on mammalian cells (32), subtractive selection using sorting procedures (59), enrichment on tissue sections or pieces of tissue (89), selection on paramagnetic liposomes (90), and, in principle, selection using living animals, as reported for peptide phage libraries (91). The selection methods described in **Fig. 4** (panels A–F) have been reviewed elsewhere (2,45,92); many are the subject of protocols in this book.

Phage Abs bound to Ag can be eluted in different ways: with (one step or gradients of) acidic solutions such as HCl or glycine buffers (93,94); with basic solutions such as triethylamine (22); with chaotropic agents; with dithiothreitol when biotin is linked to Ag by a disulphide bridge (20); by enzymatic cleavage of a protease site engineered between the Ab and gene III (95); or by competition with excess Ag (10) or Abs to the Ag (96).

The background binding of phage to the matrix or Ag itself inevitably necessitates the repetition of the selection procedure. Background problems may diminish when repeated selections of phage libraries are carried out without amplification, reusing the eluted and neutralized polyclonal phage directly for selection, as reported for protease inhibitors (97). Alternatively, the use of a protease-sensitive helper phage may reduce background (described briefly in Chapter 11) (98). If reamplification *in vivo* could be bypassed, it might be possible to fully automate the isolation of Ab fragments from large libraries. During affinity maturation studies, direct selection without reamplification may speed up the procedure and reduce selection of clones with a growth, but no affinity, advantage (7,71).

The relative robustness of the phage Ab particle has allowed a wide range of selection procedures to be developed. By choosing the most appropriate protocol (e.g., the use of competing Abs or ligands, depletion of irrelevant phage Abs, and so on), Abs with exquisite binding features can be selected. Examples include Abs to unique epitopes on highly related glycoproteins (46), Abs to epitopes exposed upon activation of the protein (99), or Abs to unique major histocompatibility–peptide complexes (100). A significant part of this book is therefore given over to selection procedures. Basic protocols include the selection on Ags adsorbed onto plastic surfaces (Chapter 9) or the use of biotinylated Ag (Chapter 10). If the Ag cannot be labeled or immobilized without loss of integrity or modification of its structure, selection can be performed with the Ag captured to an Ab-coated surface (Chapter 15). In order to prevent the selection of Abs directed against immunodominant determinants, such epitopes may be blocked during the selection (Chapter 13), or these Abs given a competitive disadvantage in the selection (Chapter 12). Some of the more advanced selection methods will be discussed in more detail.

4.2. Selection for Affinity

Chapter 21 describes the selection of Abs for binding kinetics. Analogous to events *in vivo* during B-cell selection, phage Abs with higher affinity may be enriched during successive rounds of selection by decreasing the concentration of Ag. The selection may be chosen to favor affinity or kinetic parameters, such as off-rate (**101**); this hinges on the use of limited and decreasing amounts of Ag and on performing the selections in solution, rather than by avidity-prone panning on coated Ag (**71**). When selecting from a secondary phage library (*see Subheading 3.3.*), the Ag concentration is typically reduced below the K_d of the parent clone to allow preferential selection of higher-affinity mutants (**71**). In one of the most thorough studies on Ab-affinity maturation carried out to date (**78**), it was necessary to determine empirically the Ag concentration to be used for selection, as well as the elution condition for phage retrieval using BIAcore (**102**).

4.3. Selection on Complex Ags

Most successful selections have used purified Ag. Selections on impure Ags are significantly more difficult because of the limited amount of target Ag present in the mixture and the enrichment of phage Abs specific for nonrelevant antigens. Examples of complex, difficult Ags are those that cannot easily be purified from contaminants with similar properties or cell surface receptors that are only functionally retained in lipid bilayers. Depletion and/or subtraction methods, competitive elution with an Ab or the Ag itself (**96**), or selection by alternating between different sources of Ag (**103**) may be used. Theoretical and experimental studies may help to understand the extent to which different parameters govern the outcome of subtractive selection processes (**5,104,105**). The enrichment of phage Abs specific for the target Ag is also influenced by the background binding of nonspecific phage particles, which necessitates reiteration of the selection procedure. Background binding of phage has also been a major obstacle to carrying out selection on Ags blotted onto nitrocellulose or other membranes. Such a procedure could be applied to batch-select phage Abs to large collections of (denatured) Ags and possibly to isolate Abs to small quantities of partially purified proteins.

4.4. Selection on Cells

Cell-surface Ags present a special case. Direct panning on cell surfaces may be carried out on adherent cells grown in monolayers or on intact cells in suspension (**Fig. 4E; 32,106,107**). This may fortuitously select for Ag-specific phage Abs, particularly when using immune libraries in which the frequency

of irrelevant phage Abs will be lower (**32,106**). Depletion and/or subtraction methods, cell sorting (**Fig. 4F**) using flow cytometry (**59**) or magnetic bead systems (**108**), competitive elution with an Ag-specific ligand, or selection by alternating between different cell types, all carrying the Ag, are possible, at least in theory. Selection of Abs on cells using magnetic-activated beads is discussed in detail in Chapter 18. Similarly, subtractive selections using cell panning or tissue fragments are addressed in Chapters 19 and 20, respectively.

When a human phage Ab to the Ag of interest cannot be isolated by direct or subtractive cell selection, and a murine Ab to the Ag exists, a procedure termed “guided selection” (**109**) can be used. In this method, the murine Ab-variable genes are sequentially shuffled with human V genes, driving selection toward the Ag on the cell surface. This can be applied to cases in which the Ag is a cell surface receptor (**110**) and is not readily available as a well-behaved, purified Ag (Chapter 17), or when a particular epitope on the Ag needs to be targeted.

In many cases, Ags will be present at low densities on the cell surface, and Ag concentrations during selection will reach values much lower than the K_d of any Ab in the library. The avidity of the phage in combination with the spacial flexibility of the Ags on the cell surface may help to drive the selection of Abs with affinities much lower than those that should be theoretically possible. It should be considered that in some instances the cell surface Ag may be inaccessible through steric hindrance caused by the presence of other proteins or glycosylation, preventing the selection of Abs specific for the target Ag. This is illustrated by the example of a naïve library selection (**47**), which the author’s research group carried out on cell transfectants expressing high levels (1–200,000 copies/cell) of 1 of 2 different membrane Ags. Different results were obtained depending on the structure and nature of the transmembrane protein. Selections on CHO cells expressing one of the seven-transmembrane (7-TM) receptors for somatostatin were unsuccessful, despite extensive preabsorption of phage with receptor-negative cells (**111**). On the other hand, direct panning (without depletion) on cells carrying the transmembrane glycoprotein CD36, at similar surface density, generated a large collection of Ag-specific Abs to a selection-dominant epitope on the Ag (**112**). It is therefore difficult to assess the value of subtractive methods, i.e., cell sorting by flow cytometry (**113**) or magnetic-activated cell separation (**108**), without a direct comparison with cell panning. For most applications, it is likely that such refined subtraction methods will be required to home in on the desired Ag-specific phage Abs. In many instances, the purification of the membrane-anchored Ag could be considered, for example, after genetic tagging and Ab affinity purification; the Ags may be reconstituted on proteoliposomes before selection (**90**).

Table 1
Enrichment Factors and Phage Recovery After Single Round
of Selection on Different Complex Ags^a

Ag source	Mode of selection	Enrichment	Recovery of specific phage (% input)
Colon cancer cell line	Panning on cells in suspension	10,000	2–5
Tissue cryosection	Panning on glass slide-mounted cryosections	80	0.02
In vivo grown tumor	Injection of phage into tumor interstitium	10	0.005
In vivo grown tumor	Injection of phage into the tail vein	none	0.001

^aMixtures of an excess of control phage compared to specific (anti-epithelial glycoprotein-2) phage were selected on a number of different target materials. Since Ag-specific and control phage confer a different antibiotic resistance to the bacterial host upon infection (ampicillin [AMP] and tetracycline [TET], respectively), enrichment and recovery of binding phage can easily be determined by titration and parallel selection on both antibiotics. Recovery of specific phage was calculated as the percentage of AMP-resistant colonies colony-forming units (CFU) recovered after one round of selection. Enrichment factors were calculated as the product of ratios of AMP- and TET-resistant colonies before and after selection, according to the formula (in = input titer; out = output titer):

$$\text{Enrichment factor} = [(\text{inCFU}_{\text{tet}} / \text{inCFU}_{\text{amp}}) * (\text{outCFU}_{\text{amp}} / \text{outCFU}_{\text{tet}})].$$

The feasibility of selecting Abs to difficult complex Ags, particularly to cell surface molecules, would expand the utility of phage libraries tremendously. In these cases, it is important to determine the selection conditions (pretreatment of the samples, incubation conditions, washing procedure, and phage retrieval) empirically to ensure maximal sampling of the phage Ab repertoire. The authors have developed several models (**III4**) that can compare and determine the relative efficacies of various enrichment procedures on cells and other sources of mixed Ags. In the first model designed for cancer cell selection, phage carrying a scFv specific for the tumor-associated Ag, epithelial glycoprotein-2, were mixed with an excess of irrelevant phage, and the enrichment factor and recovery of specific phage were determined after a single round of selection. As Ag source, a tumor cell line was used, a tissue cryosection of primary colon carcinoma, and (subcutaneous) in-vivo-grown solid tumors in mice (**Fig. 4E,G,I**).

Results summarized in **Table 1** show major differences regarding selection efficacy; however, Ab-displaying phage were enriched in all but one selection

method. The efficacy of the procedure depends on the Ag amount and concentration (**Table 1**; estimated to decline from top to bottom) and on Ag accessibility. The most efficient procedure (selection of phage using panning on cells in suspension [with 2–5% recovery of the input phage]) reaches an enrichment factor similar to that reported for purified Ags (**5**). For the *in vivo* selection, Ab-displaying phage are enriched compared to nonbinding phage only when phage are directly injected into the tumor interstitium, but not when injected intravenously. Efficient *in vivo* selection may thus be suited only for Ags that are in direct contact with the bloodstream, i.e., endothelial cell Ags (**115**). In the second model, similar methods were applied to develop a selection procedure for the enrichment of phage Ab libraries on endothelial cells using cell panning or a more gentle, magnetic-activated cell-sorting-based system (**114**). Such model selections help to define the optimal experimental parameters for selections on complex antigens.

4.5. Finding New Ags with Phage Ab Libraries

Selection from phage Ab libraries provides a new tool for the isolation of novel self Ags, such as those associated with disease (e.g., tumor-associated Ags). Both naïve and synthetic Ab libraries (but particularly the latter) are not constrained by the immune system and thus avoid bias caused by *in vivo* tolerance mechanisms. Therefore, Abs to unique self epitopes can be isolated provided powerful cell depletion or subtraction methods are available.

Many attempts to identify novel target Ags have been described. One of the best illustrations is the Ab-assisted cloning of CD55 as an overexpressed cell-surface target on lung carcinoma cells (**116**). We have recently generated panels of anti-epithelial cell Abs by panning a large naïve Ab library on colorectal tumor cell lines, yielding epithelial-cell-specific Abs with a different fine specificity than found for the most frequently encountered tumor-associated Ags (EpCAM, CEA). This procedure has also been successful using libraries derived from the B-cells of a tumor-draining lymph node of a patient with colorectal cancer (**117**) (Roovers et al., submitted). Similarly, libraries have been made and screened by cell selection using material from patients immunized with autologous tumor cells (**32,118**). These approaches advance the study of the natural humoral immune response of cancer patients to the autologous tumor and may identify alternative targets for active or passive immunotherapy.

A recently described method called “Pathfinder” or “ProxyMol” selection may be suitable for overcoming several difficulties associated with phage Ab selections, i.e., the use of complex Ags like cell surfaces for selection and the preferential selection of Abs to dominant epitopes on a given Ag (**119**); the procedure is schematically depicted in **Fig. 4K**. The method uses a peroxidase-

conjugated ligand (lead) to deposit biotin-tyramid free radicals in a local area around the binding site of the lead. If phage are bound within this radius (approx 25 nm), they will be biotinylated and therefore retrievable on streptavidin-coated beads. The target Ag in this procedure can be anything from a purified protein to a receptor on a cell surface or an Ag fixed on tissue sections. The procedure was exemplified by selecting Abs to TGF- β_1 , CEA, and a cell-surface receptor, CC-CKR5. The method may provide a means to select phage Abs to rare cell surface receptors of orphan ligands. This elegant procedure is discussed in Chapter 16.

4.6. Selection for Ab Stability and Folding

The display methodology can also be useful in screening other characteristics of Abs, such as intrinsic stability, resistance to proteases, or production levels. The thermodynamic stability of a displayed protein is often linked to protease resistance and expression yield and can be assessed by a variety of selection procedures, including temperature stress (*120*) and proteolytic digestion (*98*). This approach provides a means of selection for folded and stable proteins and may prove important in constructing well-behaved synthetic Ab libraries and in optimizing these characteristics of selected Ab fragments.

5. Phage Ab Screening Procedures and Applications

5.1. Basic Screening Assays

The outcome of any selection procedure is a mixture of binding ligands with differing properties. It may be necessary to screen large numbers of Abs to identify those variants with optimal characteristics. The best screening assays are fast, robust, amenable to automation (e.g., 96-well format), and use nonpurified phage Abs or the soluble Ab fragments from the bacterial supernatant. The bacterial periplasm is an alternative to the culture supernatant, and offers a more concentrated source of Ab (discussed in Chapters 29 and 30). Expression levels of selected phage Ab fragments may be increased by recloning into appropriate high-level expression vectors, possibly aided by co-expression of chaperonins. The screening assay should also be linked as closely as possible to the ultimate (functional) requirements of the ligand. Binding of poly- or monoclonal phage Abs to the Ag has been tested with diverse assays, ranging from a simple ELISA with coated Ag (*22*) to bioassays that screen for direct neutralization upon binding (*121*), and whole-cell ELISA or flow cytometry. For a first screen, ELISA-based assays are typically used in combination with restriction fingerprinting of the Ab-encoding DNA to identify different clones (*22*). Further, specificity of Abs may be tested using immunoprecipitation (*37*) or immunocyto- or histochemistry (*89,122*).

To speed up screening procedures, dual purpose phagemid vectors have been developed that allow both monovalent display of Ab fragments and the production of soluble Ab fragments for screening without the necessity to subclone the Ab V genes. In such systems, an amber codon is positioned between the Ab and pIII genes (12). A variety of tags have been described that can be appended to the Ab fragment for detection, including the myc-derived tag recognized by the Ab 9E10 (22) and the FLAG sequence (123,124). This setup will allow the use of unpurified phage Abs or Ab fragments present in crude supernatant or periplasmic extracts for screening assays. Finally, it is possible to fuse a histidine-encoding tag, for example, between the Ab and *gIII*, for purification of soluble Abs using immobilized metal-affinity chromatography (125,126), described in contributions by Kipriyanov (Chapter 29) and others.

5.2. Screening for Affinity or Kinetics of Binding

After selection of Abs with high affinity for the target, the screening assay will need to differentiate between variants that differ in affinity or the kinetics of binding. ELISA-based methods have been described, as well as screening using BIAcore (75,78), which has been extensively described elsewhere (92,127). Affinity and dissociation rate screening on the BIAcore is particularly straightforward when using Ab Fabs. These lack the multimerization behavior inherent to many scFv formats (67), which complicates measurement of Ag-binding kinetics of unpurified scFvs. We have developed on- and off-rate screening assays for panels of unpurified Fabs using periplasmic extracts (46); an example of an off-rate screen is shown in Fig. 5A. BIAcore-based methods are able to determine the amount of Fab in these crude preparations, which is necessary for accurate determination of the association rate constants (128); they may also determine the affinity of large panels of Abs. A routine, reliable determination of affinity constants is important in deciding which molecules to use in further analysis and affinity maturation steps. It will be necessary to test biological potency, crossreactivity, and expression level to further assess the potential of the affinity-matured candidates because these parameters may change with changing affinity (129,130). Multimerization (131) may be a required feature for some applications, e.g., to screen receptor-crosslinking Abs (121,132) or to increasing the avidity and therefore sensitivity of binding of the selected Abs. Contributions by Kipriyanov (Chapter 28) to this volume address how multivalent and multispecific forms of scFvs can be made.

5.3. Recloning Selected Phage Abs for Expression in Other Hosts

One drawback for analysis after the first screen is that Ab expression levels in *E. coli* are dependent on the primary sequence of the individual Ab and can

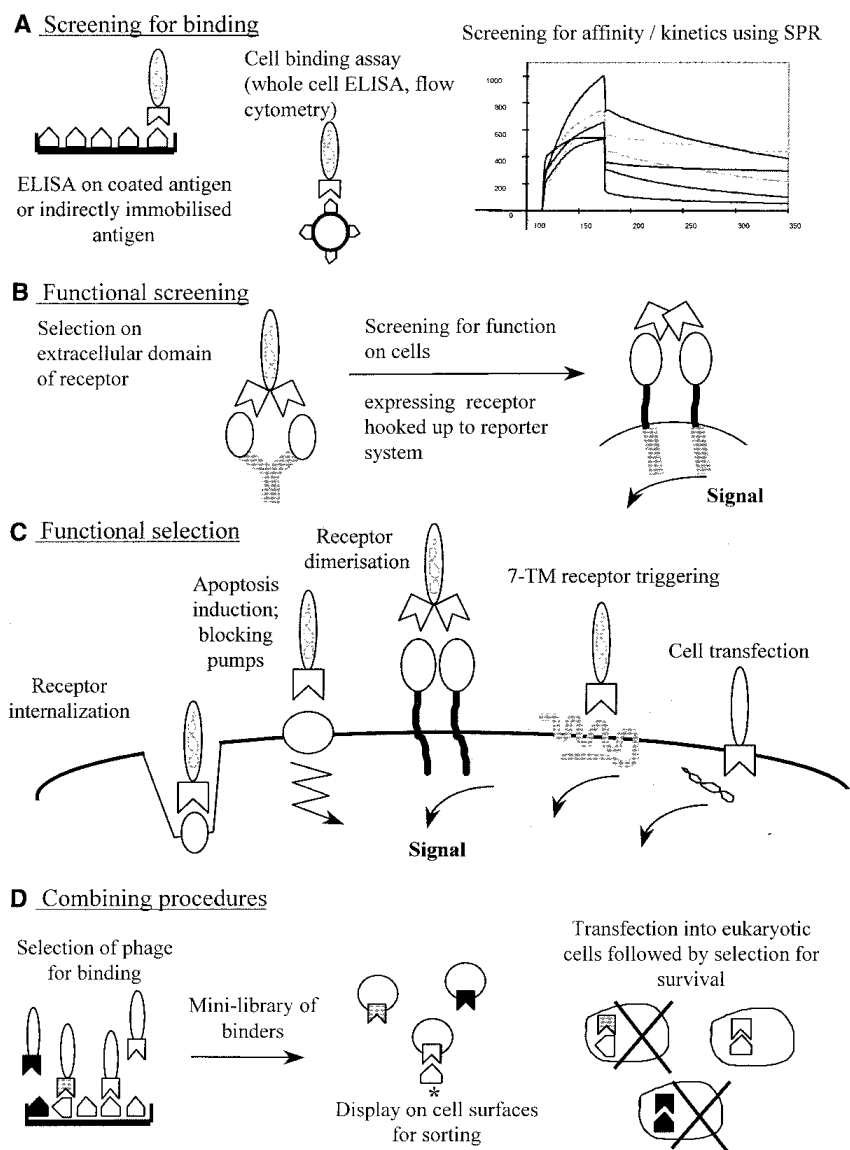

Fig. 5. Multiple strategies for selecting and screening phage ligands. Primary screens of selected phage ligands frequently involve tests to measure binding, including ELISA, cell-binding methods, and BIAcore screening (A). Alternatively, selected phage ligands may be tested for bioactivity, e.g., by selecting on a receptor-immunoadhesin and screening for receptor triggering on cells (B). Direct selection of phage ligands for a particular function may be envisaged by using a variety of methods. Depicted here are cell-related methods only (C). Combined procedures are also possible involving selection of Ag-binding phage ligands and secondary selection in an alternative system (i.e., using a prokaryotic or eukaryotic cell system), either for affinity sorting or for selection based on cell survival (*see text for details*) (D).

be variable (from 10 μg to 100 mg/L). Unless expression is at sufficiently high levels, consideration should be given to reclone the Ab into another expression system (for review, *see* **ref. 67**). Chapters in this book address the use of *Pichia pastoris* for the production of Ab fragments, particularly diabodies (Chapter 31), or of mammalian cells for the production of scFvs (Chapter 34), Fabs or whole IgG (Chapter 35).

To reformat the many Abs that typically arise from a selection, fast recloning methods are needed. Eukaryotic expression vectors have been described that may be used for one-step recloning of V genes derived from any phage repertoire, and cloned for expression as Fabs or whole Ab of different isotypes, or for targeting to different intracellular compartments (**133–135**). This permits facile and rapid one-step cloning of Ab genes for either transient or stable expression in mammalian cells. By carefully choosing restriction sites that are rare in human V genes, the immunoglobulin genes of selected populations may be batch-cloned into these expression vectors. All the important elements in the vectors (promoter, leader sequence, constant domains, and selectable markers) are flanked by unique restriction sites, allowing simple substitution of elements and further engineering. Fast batch recloning procedures, taking into account the maintenance of the heavy and light chain pairing of selected phage Abs have been described recently (**36**): using an elegant cloning route, whole populations of selected, polyclonal Fab populations can be converted into whole IgG molecules, as described here by Sharon et al. (Chapter 6).

By design of the correct promoter cassette, ribosome binding site, consensus signal sequences, and by using intron space appropriately, it should be possible to make vectors that mediate both phage display of Ab fragments in prokaryotic hosts, as well as expression of Ab fragments or whole Abs from eukaryotic hosts (A. Bradbury and H. Hoogenboom, unpublished). Such shuttle vectors would be suitable for linking selection of panels of binding Abs with a screening assay based on a particular format of the Ab. They would also allow the combination of different methods of display or combinatorial library screening. For example, a preselection for binding from a large phage display library followed by a fine-tuned affinity selection by means of flow cytometry of the medium-sized library using yeast or bacterial surface display (**Fig. 5D**), can be envisaged. In a milestone study that is further discussed in **Subheading 6.2.**, Gargano and Cattaneo (**137**) demonstrate the power of such combined methods for retrieving biologically active antiviral agents.

5.4. Bioactivity Assays with Phage Abs and Peptides

Fast read-out is particularly important for screening methods in which the influence of affinity or kinetic behavior is unclear or less important than the

functional result of binding (e.g., virus or cytokine neutralization and receptor blocking or triggering). Methods have been reported to quickly test phage-derived Fabs or scFvs for their blocking or enhancing effect on the activity of a growth factor (*121*), or for their direct receptor-triggering effects based on receptor dimerization (*138*). In the latter case, high-affinity Abs against muscle-specific receptor tyrosine kinase (MuSK) were selected from a large naïve Ab library by selection on an MuSK–Fc immunoadhesin, and scFv-agonists were identified by screening on cells expressing a chimeric MuSK–Mpl receptor (**Fig. 5B**). An elegant study with epidermal growth factor displayed on phage demonstrates that phage particles themselves may also induce receptor triggering (*139*).

In the well-studied example of MuSK, receptor dimerization is required for signal transduction; thus, the ligand needs to be dimeric either by multivalent display on phage or via the dimerization behavior noted for scFvs (*138*). The use of repertoires of bivalent ligands, such as diabody libraries (*27*) or phage-based, rather than phagemid-based libraries, would be preferable for these applications. Phage-mediated receptor triggering is also feasible for receptors that do not require dimerization for activation. This is particularly the case for phage that recognize G-protein-coupled receptors with multiple membrane spanning regions, which are normally triggered directly via ligand interaction. Such receptors have a wide range of activities and have therefore been used as targets for ligand screening using chemical, peptide, and other libraries. We have recently obtained evidence that peptide ligand-displaying phage themselves act as receptor agonists (*140*), a feature that will dramatically simplify screening for phage-based ligands in search of antagonistic lead compounds.

Phage carrying somatostatin, a 14-mer cyclic peptide, were shown to be enriched via panning on cells expressing one of its receptors and also scored positive in flow cytometry, whole-cell ELISA, and ELISA using anti-ligand sera. Upon cell binding, this phage lowered intracellular cyclic adenosine monophosphate concentration, and reduced adenylyl cyclase activity, providing evidence for specific triggering of this G-protein-coupled 7-TM receptor. One other early study (*141*) has addressed phage-mediated triggering of 7-TM receptors: in that study, the melanocortin receptor was triggered by using one of the receptor's natural ligands displayed on phage. It should thus be feasible to isolate receptor-specific ligands from phage libraries using panning on cells that overexpress the target receptor and to screen the selected phage directly for activity. After selection for binding, individual phage clones may be screened for receptor-triggering effects to differentiate agonists from antagonists from irrelevant binders.

6. New Avenues for Phage Libraries

6.1. Selection for Function

With large libraries at hand, one may go beyond the *in vitro* binding interaction itself and select for a particular function. For example, provided that reporter systems with sufficient sensitivity are used, it may eventually be possible to sort cells that have been triggered by a phage particle displaying an antagonistic ligand. Such sorting procedures could allow the direct selection of phage particles with agonist or antagonist activity for a given receptor directly from the phage library. With new reporter genes and sensitive fluorescent read-out methods under development (for review, *see ref. 142*), we envisage that such functional selection schemes will be useful tools for drug discovery. Such methods may be used to identify peptide ligands for orphan receptors (such as the many related opioid receptors), for which a function, but not a natural ligand, is known. In this book, Zaccolo (Chapter 22) describes the selection of Abs that dimerize receptors. One interesting and documented procedure is the selection for phage-mediated gene transfer originally described by LaRocca (*143*) and for internalization of the Ab (*143a*), a potential route to phenotypic knockouts. Other, as yet underexplored, avenues are selection for cell survival or killing (e.g., the induction of apoptosis) upon ligand binding, specific inhibition of certain cell surface molecules such as drug pumps, the inhibition of viral entry, Ab catalysis (*144*), and, finally, G-protein-coupled receptor triggering. The list of these novel applications, some of which are depicted in **Fig. 5C**, will keep growing as access to the technology widens.

6.2. Combining Phage Display with Other Procedures

After preselection of Ag-specific phage Abs, functional selection may also be carried out, using schemes in other cellular systems. In **Fig. 5D**, two such possible procedures are outlined. The first hypothetical application is to display the selected library on the surface of particles that are large enough to allow affinity sorting (bacteria, yeast, or mammalian cells) (*145,146*). This could provide a rapid method for Ab affinity maturation. The other application involves a selection step for bioactivity, accessing a subset of phage-library-derived ligands from a mini-library, which interact with the target Ag. An elegant example of this using intracellular selection was described by Gargano and Cattaneo (*137*), who developed a model system showing that Ab fragments expressed in the cytoplasm, inhibiting reverse transcriptase, could block integration of a retrovirus containing the herpes simplex thymidine kinase gene. This resulted in the selective survival of transfected cells through protection

against the cytotoxic action of gancyclovir. Using pools of Ab fragments cloned into vectors mediating cytosolic expression, it was possible to select for reverse-transcription-neutralizing activity from a polyclonal population of Abs that bound, but failed to block, reverse transcription. Thus, selection of pools of Ag-specific phage from large libraries can be combined with selection using a mammalian host cell (137) or other cell systems (147). This combination of technologies may optimally utilize the advantages of each system and also bypass some of the disadvantages of individual methods.

6.3. High-Throughput Selection and Screening

Because phage display selection is amenable to automation, high-throughput screening of selected populations has become possible. With appropriate equipment, Abs can be selected simultaneously against hundreds of different Ags, appropriately tagged for detection, immobilization, or purification. This has clear applications in functional genomics and proteomics research, not least to obtain binding sites specific for the many gene and protein products that need to be characterized in this field (148). Further, the availability of large collections of recombinant Abs will aid the development of Ab-based chips and arrays (149,150), opening many new applications for display-derived binding-site libraries.

7. Beyond Abs

Ideas on functional selection and screening procedures may be expanded to the use of alternative proteins or protein domains for constructing binding molecules (151). Scaffolds different from Abs have been reported to form suitable binding ligands for many types of molecules. There are many examples of host scaffolds able to accommodate a reasonable numbers of substitutions that may be used to generate a library of localized variability. Alternative scaffolds reported to date include β -sheet proteins (152,153), α -helical bundle proteins (154–158), combinations of the two (159,160), a separate group of highly constrained protease inhibitors (97,161,162), proteins based on a single immunoglobulin fold (163–165) or on the eight-strand β -barrel of the lipocalins (166) or green fluorescent protein (167). Since secreted, as well as cytoplasmic and nuclear, proteins have been displayed on phage (151), display on phage is often the first strategy to define permissive sites for randomization and to generate ligand-binding variants (168). Alternatively, the use of λ (169), bacterial (146), or eukaryotic cell display methods has been reported. Regarding functional selection methods, choosing other types of molecules besides Abs is validated by the fact that Ab expression and folding may be impaired in the subcellular location, where the desired functional activity is required. It would

be advantageous to engineer the Ab for intracellular expression, for example, by building stable disulphide-free Abs (**170**) or to use libraries of scaffolds that are naturally produced in the targeted cell organelle, provided that effective and sufficient structural diversity may be obtained. The use of such intrabodies is discussed by Cohen (Chapter 33).

8. Conclusions

This review highlights the advantages and possible applications of phage display for the development of Abs. With this technology, Ab engineering may be used for the first time to design an Ab from scratch with an option to choose its component parts, affinity (up to the picomolar range), format (size and valency), and effector function (natural [IgG] or novel [enzymes and so on]) (**171**). Tailor-made reagents may thus be generated for in vitro or in vivo diagnosis and for therapy. We expect that the number and quality of naïve and synthetic phage Ab libraries will increase over the next few years. The use of phage Ab libraries in academic research will benefit from the virtually unrestricted availability of such large and stable phage libraries. The libraries may be used to search for new drug targets, cell receptors and their ligands, interfacing with the human genome project and functional genomics. Combining the design and generation of millions to billions of different ligands with a function-based selection procedure, rather than mere selection for binding, will open even more challenging applications of this inspiring technology and provide a powerful tool for drug and target discovery well into the next decade.

Acknowledgment

Text and figures are reprinted from **ref. 172** with permission from Elsevier Science.

References

1. Smith, G. P. (1985) Filamentous fusion phage: novel expression vectors that display cloned antigens on the virion surface. *Science* **228**, 1315–1317.
2. Winter, G., Griffiths, A. D., Hawkins, R. E., and Hoogenboom, H. R. (1994) Making antibody by phage display technology. *Ann. Rev. Immunol.* **12**, 433–455.
3. Hoogenboom, H. R. and Chames, P. (2000) Natural and designer binding sites made by phage display technology. *Immunol. Today* **21**, 371–378.
4. Abelson, J. N. and Simon, M. (eds). (1996) *Combinatorial Chemistry*, vol. 267, in *Methods in Enzymology*. Academic, San Diego.
5. Kay, B., Winter, L., and McCafferty, J. (eds.) (1996) *Phage Display of Peptides and Proteins*, Academic Press, San Diego.

6. McCafferty, J., Griffiths, A. D., Winter, G., and Chiswell, D. J. (1990) Phage antibodies: filamentous phage displaying antibody variable domains. *Nature* **348**, 552–554.
7. Zacher, A. N., Stock, C. A., Golden, J. W., and Smith, G. P. (1980) New filamentous phage cloning vector: fd-tet. *Gene* **9**, 127–140.
8. Skerra, A. and Pluckthun, A. (1988) Assembly of a functional immunoglobulin Fv fragment in *Escherichia coli*. *Science* **240**, 1038–1041.
9. Better, M., Chang, C. P., Robinson, R. R., and Horwitz, A. H. (1988) *Escherichia coli* secretion of an active chimeric antibody fragment. *Science* **240**, 1041–1043.
10. Clackson, T., Hoogenboom, H. R., Griffiths, A. D., and Winter, G. (1991) Making antibody fragments using phage display libraries. *Nature* **352**, 624–628.
11. Garrard, L. J., Yang, M., O’Connell, M. P., Kelley, R. F., and Henner, D. J. (1991) Fab assembly and enrichment in a monovalent phage display system. *Biotechnology* **9**, 1373–1377.
12. Hoogenboom, H. R., Griffiths, A. D., Johnson, K. S., Chiswell, D. J., Hudson, P., and Winter, G. (1991) Multi-subunit proteins on the surface of filamentous phage: methodologies for displaying antibody (Fab) heavy and light chains. *Nucleic Acids Res.* **19**, 4133–4137.
13. Bass, S., Greene, R., and Wells, J. A. (1990) Hormone phage: an enrichment method for variant proteins with altered binding properties. *Proteins* **8**, 309–314.
14. Barbas, C., Kang, A. S., Lerner, R. A., and Benkovic, S. J. (1991) Assembly of combinatorial antibody libraries on phage surfaces: the gene III site. *Proc. Natl. Acad. Sci. USA* **88**, 7978–7982.
15. Breitling, S. D., Seehaus, T., Klewinghaus, I., and Little, M. (1991) A surface expression vector for antibody screening. *Gene* **104**, 147–153.
16. Thompson, J., Pope, T., Tung, J. S., Chan, C., Hollis, G., Mark, G., and Johnson, K. S. (1996) Affinity maturation of a high-affinity human monoclonal antibody against the third hypervariable loop of human immunodeficiency virus: use of phage display to improve affinity and broaden strain reactivity. *J. Mol. Biol.* **256**, 77–88.
17. Krebber, A., Burmester, J., and Pluckthun, A. (1996) Inclusion of an upstream transcriptional terminator in phage display vectors abolishes background expression of toxic fusions with coat protein g3p. *Gene* **178**, 71–74.
18. Rakonjac, J., Jovanovic, G., and Model, P. (1997) Filamentous phage infection-mediated gene expression: construction and propagation of the gIII deletion mutant helper phage R408d3. *Gene* **198**, 99–103.
19. Lutz, R. and Bujard, H. (1997) Independent and tight regulation of transcriptional units in *Escherichia coli* via the LacR/O, the TetR/O and AraC/I1-I2 regulatory elements. *Nucleic Acids Res.* **25**, 1203–1210.
20. Griffiths, A. D., Malmqvist, M., Marks, J. D., Bye, J. M., Embleton, M. J., McCafferty, J., et al. (1993) Human anti-self antibodies with high specificity from phage display libraries. *EMBO J.* **12**, 725–734.
21. Duenas, M. and Borrebaeck, C. A. (1995) Novel helper phage design: intergenic region affects the assembly of bacteriophages and the size of antibody libraries. *FEMS Microbiol. Lett.* **125**, 317–321.

22. Marks, J. D., Hoogenboom, H. R., Bonnert, T. P., McCafferty, J., Griffiths, A. D., and Winter, G. (1991) By-passing immunization: human antibodies from V-gene libraries displayed on phage. *J. Mol. Biol.* **222**, 581–597.
23. Chang, C. N., Landolfi, N. F., and Queen, C. (1991) Expression of antibody Fab domains on bacteriophage surfaces. *J. Immunology* **147**, 3610–3614.
24. Orum, H., Andersen, P. S., Oster, A., Johansen, L. K., Riise, E., Bjornvad, M., Svendsen, I., and Engberg, J. (1993) Efficient method for constructing comprehensive murine Fab antibody libraries displayed on phage. *Nucleic Acids Res.* **21**, 4491–4498.
25. Brinkmann, U., Chowdhury, P. S., Roscoe, D. M., and Pastan, I. (1995) Phage display of disulfide-stabilized Fv fragments. *J. Immunol. Methods* **182**, 41–50.
26. Holliger, P., Prospero, T., and Winter, G. (1993) “Diabodies”: small bivalent and bispecific antibody fragments. *Proc. Natl. Acad. Sci. USA* **90**, 6444–6448.
27. McGuinness, B. T., Walter, G., FitzGerald, K., Schuler, P., Mahoney, W., Duncan, A. R., and Hoogenboom, H. R. (1996) Phage diabody repertoires for selection of large numbers of bispecific antibody fragments. *Nature Biotechnol.* **14**, 1149–1154.
28. Burton, D. R., Barbas, C. F., Persson, M. A. A., Koenig, S., Chanock, R. M., and Lerner, R. A. (1991) A large array of human monoclonal antibodies to type 1 human immunodeficiency virus from combinatorial libraries of asymptomatic individuals. *Proc. Natl. Acad. Sci. USA* **88**, 10,134–10,137.
29. Chester, K. A., Begent, R. H., Robson, L., Keep, P., Pedley, R. B., Boden, J. A., et al. (1994) Phage libraries for generation of clinically useful antibodies. *Lancet* **343**, 455–456.
30. Kettleborough, C. A., Ansell, K. H., Allen, R. W., Rosell-Vives, E., Gussow, D. H., and Bendig, M. M. (1994) Isolation of tumor cell-specific single-chain Fv from immunized mice using phage-antibody libraries and the re-construction of whole antibodies from these antibody fragments. *Eur. J. Immunol.* **24**, 952–958.
31. Barbas, C. F., Collet, T. A., Amberg, W., Roben, P., Binley, J. M., Hoekstra, D., et al. (1993) Molecular profile of an antibody response to HIV-1 as probed by combinatorial libraries. *J. Mol. Biol.* **230**, 812–823.
32. Cai, X. H. and Garen, A. (1995) Anti-melanoma antibodies from melanoma patients immunised with genetically modified autologous tumor cells: selection of specific antibodies from single-chain Fv fusion phage libraries. *Proc. Natl. Acad. Sci. USA* **92**, 6537–6541.
33. Davies, E. L., Smith, J. S., Birkett, C. R., Manser, J. M., Anderson, D. D., and Young, J. R. (1995) Selection of specific phage-display antibodies using libraries derived from chicken immunoglobulin genes. *J. Immunol. Methods* **186**, 125–135.
34. Yamanaka, H. I., Inoue, T., and Ikeda, T. O. (1996) Chicken monoclonal antibody isolated by a phage display system. *J. Immunol.* **157**, 1156–1162.
35. Lang, I. M., Barbas, C. F., and Schleef, R. R. (1996) Recombinant rabbit Fab with binding activity to type-1 plasminogen activator inhibitor derived from a phage-display library against human alpha-granules. *Gene* **172**, 295–298.

36. Arbabi Ghahroudi, M., Desmyter, A., Wyns, L., Hamers, R., and Muyldermans, S. (1997) Selection and identification of single domain antibody fragments from camel heavy-chain antibodies. *FEBS Lett.* **414**, 521–526.
37. de Wildt, R. M., Finnern, R., Ouwehand, W. H., Griffiths, A. D., van Venrooij, W. J., and Hoet, R. M. (1996) Characterization of human variable domain antibody fragments against the U1 RNA-associated A protein, selected from a synthetic and patient-derived combinatorial V gene library. *Eur. J. Immunol.* **26**, 629–639.
38. Finnern, R., Pedrollo, E., Fisch, I., Wieslander, J., Marks, J. D., Lockwood, C. M., and Ouwehand, W. H. (1997) Human autoimmune anti-proteinase 3 scFv from a phage display library. *Clin. Exp. Immunol.* **107**, 269–281.
39. Graus, Y. F., de Baets, M. H., Parren, P. W., Berrih-Aknin, S., Wokke, J., van Breda Vriesman, P. J., and Burton, D. R. (1997) Human anti-nicotinic acetylcholine receptor recombinant Fab fragments isolated from thymus-derived phage display libraries from myasthenia gravis patients reflect predominant specificities in serum and block the action of pathogenic serum antibodies. *J. Immunol.* **158**, 1919–1929.
40. Barbas, C. F. and Burton, D. R. (1996) Selection and evolution of high-affinity human antiviral antibodies. *Trends Biotechnol.* **14**, 230–234.
41. Pereira, S., van Belle, P., Elder, D., Maruyama, H., Jacob, L., Sivanandham, M., Wallack, M., Siegel, D., and Herlyn, D. (1997) Combinatorial antibodies against human malignant melanoma. *Hybridoma* **16**, 11–16.
42. Clark, M. A., Hawkins, N. J., Papaioannou, A., Fiddes, R. J., and Ward, R. L. (1997) Isolation of human anti-c-erbB-2 Fabs from a lymph node-derived phage display library. *Clin. Exp. Immunol.* **109**, 166–174.
43. Duenas, M., Chin, L. T., Malmborg, A. C., Casavilla, R., Ohlin, M., and Borrebaeck, C. A. (1996) In vitro immunization of naive human B cells yields high affinity immunoglobulin G antibodies as illustrated by phage display. *Immunology* **89**, 1–7.
44. Moreno de Alboran, I., Martinez-Alonso, C., Barbas, C. F., Burton, D. R., and Ditzel, H. J. (1995) Human monoclonal Fab fragments specific for viral antigens from combinatorial IgA libraries. *Immunotechnology* **1**, 21–28.
45. Hoogenboom, H. R. (1997) Designing and optimizing library selection strategies for generating high-affinity antibodies. *Trends Biotechnol.* **15**, 62–70.
46. de Haard, H. J., van Neer, N., Reurs, A., Hufton, S. E., Roovers, R. C., Henderikx, P., et al. (1999) A large non-immunized human Fab fragment phage library that permits rapid isolation and kinetic analysis of high affinity antibodies. *J. Biol. Chem.* **274**, 18,218–18,230.
47. Vaughan, T. J., Williams, A. J., Pritchard, K., Osbourn, J. K., Pope, A. R., Earnshaw, J. C., et al. (1996) Human antibodies with sub-nanomolar affinities isolated from a large non-immunized phage display library. *Nature Biotechnol.* **14**, 309–314.
48. Gram, H., Marconi, L., Barbas, C. F., Collet, T. A., Lerner, R. A., and Kang, A. S. (1992) In vitro selection and affinity maturation of antibodies from a naive combinatorial immunoglobulin library. *Proc. Natl. Acad. Sci. USA* **89**, 3576–3580.

49. Marks, J. D., Tristem, M., Karpas, A., and Winter, G. (1991) Oligonucleotide primers for polymerase chain reaction amplification of human immunoglobulin variable genes and design of family-specific oligonucleotide probes. *Eur. J. Immunol.* **21**, 985–991.
50. Klein, U., Kuppers, R., and Rajewsky, K. (1997) Evidence for a large compartment of IgM-expressing memory B cells in humans. *Blood* **89**, 1288–1298.
51. Perelson, A. S. and Oster, G. F. (1979) Theoretical studies of clonal selection: minimal antibody repertoire size and reliability of self-non-self discrimination. *J. Theor. Biol.* **81**, 645–670.
52. Sheets, M. D., Amersdorfer, P., Finnern, R., Sargent, P., Lindquist, E., Schier, R., et al. (1998) Efficient construction of a large nonimmune phage antibody library: the production of high-affinity human single-chain antibodies to protein antigens. *Proc. Natl. Acad. Sci. USA* **95**, 6157–6162.
53. Hoogenboom, H. R. and Winter, G. (1992) By-passing immunisation. Human antibodies from synthetic repertoires of germline VH gene segments rearranged in vitro. *J. Mol. Biol.* **227**, 381–388.
54. Barbas, C. F., Bain, J. D., Hoekstra, D. M., and Lerner, R. (1992) Semisynthetic combinatorial libraries: a chemical solution to the diversity problem. *Proc. Natl. Acad. Sci. USA* **89**, 4457–4461.
55. Chothia, C., Lesk, A. M., Tramontano, A., Levitt, M., Smith-Gill, S. J., Air, G., et al. (1989) Conformations of immunoglobulin hypervariable regions. *Nature* **342**, 877–883.
56. Nissim, A., Hoogenboom, H. R., Tomlinson, I. M., Flynn, G., Midgley, C., Lane, D., and Winter, G. (1994) Antibody fragments from a ‘single pot’ phage display library as immunochemical reagents. *EMBO J.* **13**, 692–698.
57. Garrard, L. J. and Henner, D. J. (1993) Selection of an anti-IGF-1 Fab from a Fab phage library created by mutagenesis of multiple CDR loops. *Gene* **128**, 103–109.
58. Soderlind, E., Vergeles, M., and Borrebaeck, C. A. K. (1995) Domain libraries: synthetic diversity for de novo design of antibody V regions. *Gene* **160**, 269–272.
59. de Kruijff, J., Terstappen, L., Boel, E., and Logtenberg, T. (1995) Rapid selection of cell subpopulation-specific human monoclonal antibodies from a synthetic phage antibody library. *Proc. Natl. Acad. Sci. USA* **92**, 3938–3942.
60. Griffiths, A. D., Williams, S. C., Hartley, O., Tomlinson, I. M., Waterhouse, P., Crosby, W. L., et al. (1994) Isolation of high affinity human antibodies directly from large synthetic repertoires. *EMBO J.* **13**, 3245–3260.
61. Knappik, A., Ge, L., Honegger, A., Pack, P., Fischer, M., Wellnhofer, G., et al. (2000) Fully synthetic human combinatorial antibody libraries (HuCAL) based on modular consensus frameworks and CDRs randomized with trinucleotides. *J. Mol. Biol.* **296**, 57–86.
62. Virnekas, B., Ge, L., Pluckthun, A., Schneider, K. C., Wellnhofer, G., and Moroney, S. E. (1994) Trinucleotide phosphoramidites: ideal reagents for the synthesis of mixed oligonucleotides for random mutagenesis. *Nucleic Acids Res.* **22**, 5600–5607.

63. Akerstrom, B., Nilson, B. H., Hoogenboom, H. R., and Bjorck, L. (1994) On the interaction between single-chain Fv antibodies and bacterial immunoglobulin-binding proteins. *J. Immunol. Methods* **177**, 151–163.
64. Pini, A., Viti, F., Santucci, A., Carnemolla, B., Zardi, L., Neri, P., and Neri, D. (1998) Design and use of a phage display library. Human antibodies with subnanomolar affinity against a marker of angiogenesis eluted from a two-dimensional gel. *J. Biol. Chem.* **273**, 21,769–21,776.
65. Tomlinson, I. M., Walter, G., Jones, P. T., Dear, P. H., Sonnhammer, E. L. L., and Winter, G. (1996) The imprint of somatic hypermutation on the repertoire of human germline V genes. *J. Mol. Biol.* **256**, 813–817.
66. Sblattero, D. and Bradbury, A. (2000) Exploiting recombination in single bacteria to make large phage antibody libraries. *Nature Biotechnol.* **18**, 75–80.
67. Pluckthun, A. and Pack, P. (1997) New protein engineering approaches to multivalent and bispecific antibody fragments. *Immunotechnology* **3**, 83–105.
68. Hoogenboom, H. R. (1997) Mix and match: building manifold binding sites. *Nature Biotechnol.* **15**, 125–126.
69. Low, N. M., Holliger, P. H., and Winter, G. (1996) Mimicking somatic hypermutation: affinity maturation of antibodies displayed on bacteriophage using a bacterial mutator strain. *J. Mol. Biol.* **260**, 359–368.
70. Irving, R. A., Kortt, A. A., and Hudson, P. J. (1996) Affinity maturation of recombinant antibodies using *E. coli* mutator cells. *Immunotechnology* **2**, 127–143.
71. Hawkins, R. E., Russell, S. J., and Winter, G. (1992) Selection of phage antibodies by binding affinity. Mimicking affinity maturation. *J. Mol. Biol.* **226**, 889–896.
72. Marks, J. D., Griffiths, A. D., Malmqvist, M., Clackson, T. P., Bye, J. M., and Winter, G. (1992) By-passing immunization: building high affinity human antibodies by chain shuffling. *Biotechnology* **10**, 779–783.
73. Stemmer (1996) Construction and evolution of antibody-phage libraries by DNA shuffling. *Nature Med.* **2**, 100–102.
74. Glaser, S. M., Yelton, D. E., and Huse, W. D. (1992) Antibody engineering by codon-based mutagenesis in a filamentous phage vector system. *J. Immunol.* **149**, 3903–3913.
75. Yang, W. P., Green, K., Pinz, S. S., Briones, A. T., Burton, D. R., and Barbas, C. F. (1995) CDR walking mutagenesis for the affinity maturation of a potent human anti-HIV-1 antibody into the picomolar range. *J. Mol. Biol.* **254**, 392–403.
76. Schier, R., Bye, J., Apell, G., McCall, A., Adams, G. P., Malmqvist, M., Weiner, L. M., and Marks, J. D. (1996) Isolation of high-affinity monomeric human anti-c-erbB-2 single chain Fv using affinity-driven selection. *J. Mol. Biol.* **255**, 28–43.
77. Deng, S. J., MacKenzie, C. R., Sadowska, J., Michniewicz, J., Young, N. M., Bundle, D. R., and Narang, S. A. (1994) Selection of antibody single-chain variable fragments with improved carbohydrate binding by phage display. *J. Biol. Chem.* **269**, 9533–9538.
78. Schier, R., McCall, A., Adams, G. P., Marshall, K. W., Merritt, H., Yim, M., et al. (1996) Isolation of picomolar affinity anti-c-erbB-2 single-chain Fv by molecular

- evolution of the complementarity determining regions in the center of the antibody binding site. *J. Mol. Biol.* **263**, 551–567.
79. Balint, R. F. and Larrick, J. W. (1993) Antibody engineering by parsimonious mutagenesis. *Gene* **137**, 109–118.
 80. Schier, R., Balint, R. F., Larrick, J. W., et al. (1996) Identification of functional and structural amino-acid residues by parsimonious mutagenesis. *Gene* **169**, 147–155.
 81. Ignatovich, O., Tomlinson, I. M., Jones, P. T., and Winter, G. (1997) The creation of diversity in the human immunoglobulin V(lambda) repertoire. *J. Mol. Biol.* **268**, 69–77.
 82. Mattheakis, L. C., Bhatt, R. R., and Dower, W. J. (1994) An in vitro polysome display system for identifying ligands from very large peptide libraries. *Proc. Natl. Acad. Sci. USA* **91**, 9022–9026.
 83. Hanes, J. and Pluckthun, A. (1997) In vitro selection and evolution of functional proteins by using ribosome display. *Proc. Natl. Acad. Sci. USA* **94**, 4937–4942.
 84. Nicholls, P. J., Johnson, V. G., Andrew, S. M., Hoogenboom, H. R., Raus, J. C., and Youle, R. J. (1993) Characterization of single-chain antibody (sFv)-toxin fusion proteins produced in rabbit reticulocyte lysate. *J. Biol. Chem.* **268**, 5302–5308.
 85. He, M. and Taussig, M. J. (1997) Antibody-ribosome-mRNA (ARM) complexes as efficient selection particles for in vitro display and evolution of antibody combining sites. *Nucleic Acids Res.* **25**, 5132–5134.
 86. Roberts, R. and Szostak, J. (1997) RNA-peptide fusions for the in vitro selection of peptides and proteins. *Proc. Natl. Acad. Sci. USA* **94**, 12,297–12,302.
 87. Malmberg, A. C., Duenas, M., Ohlin, M., Soderlind, E., and Borrebaeck, C. A. (1996) Selection of binders from phage displayed antibody libraries using the BIAcore biosensor. *J. Immunol. Methods* **198**, 51–57.
 88. Bradbury, A., Persic, L., Werge, T., and Cattaneo, A. (1993) Use of living columns to select specific phage antibodies. *Biotechnology* **11**, 1565–1569.
 89. van Ewijk, W., de Kruif, J., Germeraad, W. T., Berendes, P., Ropke, C., Platenburg, P. P., and Logtenberg, T. (1997) Subtractive isolation of phage-displayed single-chain antibodies to thymic stromal cells by using intact thymic fragments. *Proc. Natl. Acad. Sci. USA* **94**, 3903–3908.
 90. Mirzabekov, T., Kontos, H., Farzan, M., Marasco, W., and Sodroski, J. (2000) Paramagnetic proteoliposomes containing a pure, native, and oriented seven-transmembrane segment protein, CCR5. *Nature Biotechnol.* **18**, 649–654.
 91. Pasqualini, R. and Ruoslahti, E. (1996) Organ targeting *in vivo* using phage display peptide libraries. *Nature* **380**, 364–366.
 92. McCafferty, J., Hoogenboom, H. R., and Chiswell, D. J. (eds.) (1996) *Antibody Engineering: A Practical Approach*. IRL, Oxford, UK.
 93. Roberts, B. L. (1992) Protease inhibitor display M13 phage: selection of high-affinity neutrophil elastase inhibitors. *Gene* **121**, 9–15.
 94. Kang, A. S., Barbas, C. F., Janda, K. D., Benkovic, S. J., and Lerner, R. A. (1991) Linkage of recognition and replication functions by assembling combinatorial antibody Fab libraries along phage surfaces. *Proc. Natl. Acad. Sci. USA* **88**, 4363–4366.

95. Ward, R. L., Clark, M. A., Lees, J., and Hawkins, N. J. (1996) Retrieval of human antibodies from phage-display libraries using enzymatic cleavage. *J. Immunol. Methods* **189**, 73–82.
96. Meulemans, E. V., Slobbe, R., Wasterval, P., Ramaekers, F. C. S., and van Eys, G. J. J. M. (1994) Selection of phage-displayed antibodies specific for a cytoskeletal antigen by competitive elution with a monoclonal antibody. *J. Mol. Biol.* **244**, 353–360.
97. Markland, W., Ley, A. C., Lee, S. W., and Ladner, R. C. (1996) Iterative optimization of high-affinity proteases inhibitors using phage display. 1. Plasmin. *Biochemistry* **35**, 8045–8057.
98. Kristensen, P. and Winter, G. (1998) Proteolytic selection for protein folding using filamentous bacteriophages. *Folding Design* **3**, 321–328.
99. Horn, I. R., Wittinghofer, A., de Bruine, A. P., and Hoogenboom, H. R. (1999) Selection of phage-displayed Fab antibodies on the active conformation of Ras yields a high affinity conformation-specific antibody preventing the binding of c-Raf kinase to Ras. *FEBS Lett.* **463**, 115–120.
100. Chames, P., Hufton, S. E., Coulie, P. G., Uchanska-Ziegler, B., and Hoogenboom, H. R. (2000) Direct selection of a human antibody fragment directed against the tumor T-cell epitope HLA-A1-MAGE-A1 from a nonimmunized phage-Fab library. *Proc. Natl. Acad. Sci. USA* **97**, 7969–7974.
101. Duenas, M., Malmborg, A. C., Casavilla, R., Ohlin, M., and Borrebaeck, C. A. K. (1996) Selection of phage displayed antibodies based on kinetic constants. *Mol. Immunol.* **33**, 279–285.
102. Schier, R. and Marks, J. D. (1996) Efficient in vitro affinity maturation of phage antibodies using BIAcore guided selections. *Hum. Antibodies Hybridomas* **7**, 97–105.
103. Andersen, P. S., Stryhn, A., Hansen, B. E., Fugger, L., Engberg, J., and Buus, S. (1996) A recombinant antibody with the antigen-specific, major histocompatibility complex-restricted specificity of T cells. *Proc. Natl. Acad. Sci. USA* **93**, 1820–1824.
104. Mandeck, W., Chien, Y. C., and Grihalde, N. (1995) A mathematical model for biopanning (affinity selection) using peptide libraries on filamentous phage. *J. Theor. Biol.* **176**, 523–530.
105. Stausbol-Gron, B., Wind, T., Kjaer, S., Kahns, L., Hansen, N. J., Kristensen, P., and Clark, B. F. (1996) A model phage display subtraction method with potential for analysis of differential gene expression. *FEBS Lett.* **391**, 71–75.
106. Marks, J. D., Ouwehand, W. H., Bye, J. M., Finnern, R., Gorick, B. D., Voak, D., et al. (1993) Human antibody fragments specific for human blood group antigens from a phage display library. *Biotechnology* **11**, 1145–1149.
107. Palmer, D. B., George, A. J., and Ritter, M. A. (1997) Selection of antibodies to cell surface determinants on mouse thymic epithelial cells using a phage display library. *Immunology* **91**, 473–478.
108. Siegel, D. L., Chang, T. Y., Russell, S. L., and Bunya, V. Y. (1997) Isolation of cell surface-specific human monoclonal antibodies using phage display

- and magnetically-activated cell sorting: applications in immunohematology. *J. Immunol. Methods* **206**, 73–85.
109. Jespers, L. S., Roberts, A., Mahler, S. M., Winter, G., and Hoogenboom, H. R. (1994) Guiding the selection of human antibodies from phage display repertoires to a single epitope of an antigen. *Biotechnology* **12**, 899–903.
 110. Figini, M., Obici, L., Mezzanzanica, D., Griffiths, A., Colnaghi, M. I., Winter, G., and Canevari, S. (1998) Panning phage antibody libraries on cells: isolation of human Fab fragments against ovarian carcinoma using guided selection. *Cancer Res.* **58**, 991–996.
 111. Hoogenboom, H. R., Lutgerink, J. T., Pelsers, M. M., Rousch, M. J., Coote, J., van Neer, N., de Bruine, A., et al. (1999) Selection-dominant and nonaccessible epitopes on cell-surface receptors revealed by cell-panning with a large phage antibody library. *Eur. J. Biochem.* **260**, 774–784.
 112. Pelsers, M., Lutgerink, J. T., Nieuwenhoven, F. A. V., Tandon, N. N., Vusse, G., Arends, J. W., Hoogenboom, H. R., and Glatz, J. F. C. (1999) A sensitive immunoassay for rat fatty acid translocase (CD36) using phage antibodies selected on cell transfectants: abundant presence of fatty acid translocase/CD36 in cardiac and red skeletal muscle and up-regulation in diabetes. *Biochem. J.* **337**, 407–414.
 113. de Kruif, J. and Logtenberg, T. (1996) Leucine zipper dimerized bivalent and bispecific scFv antibodies from a semi-synthetic antibody phage display library. *J. Biol. Chem.* **271**, 7630–7634.
 114. Mutuberria, R., Hoogenboom, H. R., van der Linden, E., de Bruine, A. P., and Roovers, R. C. (1999) Model systems to study the parameters determining the success of phage antibody selections on complex antigens. *J. Immunol. Methods* **231**, 65–81.
 115. Pasqualini, R., Koivunen, E., and Ruoslahti, E. (1997) Alpha v integrins as receptors for tumor targeting by circulating ligands. *Nature Biotechnol.* **15**, 542–546.
 116. Ridgway, J. B., Ng, E., Kern, J. A., Lee, J., Brush, J., Goddard, A., and Carter, P. (1999) Identification of a human anti-CD55 single-chain Fv by subtractive panning of a phage library using tumor and nontumor cell lines. *Cancer Res.* **59**, 2718–2723.
 117. Topping, K. P., Hough, V. C., Monson, J. R., and Greenman, J. (2000) Isolation of human colorectal tumour reactive antibodies using phage display technology. *Int. J. Oncol.* **16**, 187–195.
 118. Hall, B. L., Boroughs, J., and Kobrin, B. J. (1998) A novel tumor-specific human single-chain Fv selected from an active specific immunotherapy phage display library. *Immunotechnology* **4**, 127–140.
 119. Osbourn, J. K., Derbyshire, E. J., Vaughan, T. J., Field, A. W., and Johnson, K. S. (1998) Pathfinder selection: in situ isolation of novel antibodies. *Immunotechnology* **3**, 293–302.
 120. Jung, S., Honegger, A., and Pluckthun, A. (1999) Selection for improved protein stability by phage display. *J. Mol. Biol.* **294**, 163–180.
 121. Zaccolo, M., Griffiths, A. P., Prospero, T. D., Winter, G., and Gherardi, E. (1997) Dimerization of Fab fragments enables ready screening of phage antibodies

- that affect hepatocyte growth factor/scatter factor activity on target cells. *Eur. J. Immunol.* **27**, 618–623.
122. Carnemolla, B., Neri, N., Castellani, P., Veirana, N., Neri, G., Pini, A., Winter, G., and Zardi, L. (1996) High-affinity human recombinant antibodies to the oncofetal angiogenesis marker fibronectin ED-B domain. *Int. J. Cancer* **68**, 397–405.
 123. Lah, M., Goldstraw, A., White, J. F., Dolezal, O., Malby, R., and Hudson, P. J. (1994) Phage surface presentation and secretion of antibody fragments using an adaptable phagemid vector. *Hum. Antibodies Hybridomas* **5**, 48–56.
 124. Lindner, P., Bauer, K., Krebber, A., Nieba, L., Kremmer, E., Krebber, C., et al. (1997) Specific detection of his-tagged proteins with recombinant anti-his tag scFv-phosphatase or scFv-phage fusions. *Biotechniques* **22**, 140–149.
 125. Hochuli, E., Bannwarth, W., Döbeli, H., Gentz, R., and Stüber, D. (1988) Genetic approach to facilitate purification of recombinant proteins with a novel metal chelate adsorbent. *Biotechnology* **6**, 1321–1325.
 126. McCafferty, J., Fitzgerald, K. J., Earnshaw, J., Chiswell, D. J., Link, J., Smith, R., and Kenten, J. (1994) Selection and rapid purification of murine antibody fragments that bind a transition-state analog by phage display. *Appl. Biochem. Biotechnol.* **47**, 157–171.
 127. Goldberg, M. E. and Djavadi, O. L. (1993) Methods for measurement of antibody/antigen affinity based on ELISA and RIA. *Curr. Opin. Immunol.* **5**, 278–281.
 128. Kazemier, B., de Haard, H., Boender, P., van Gemen, B., and Hoogenboom, H. R. (1996) Determination of active single chain antibody concentrations in crude periplasmic fractions. *J. Immunol. Methods* **194**, 201–209.
 129. Ohlin, M., Owman, H., Mach, M., and Borrebaeck, C. A. (1996) Light chain shuffling of a high affinity antibody results in a drift in epitope recognition. *Mol. Immunol.* **33**, 47–56.
 130. Casson, L. P. and Manser, T. (1995) Random mutagenesis of two complementarity determining region amino acids yields an unexpectedly high frequency of antibodies with increased affinity for both cognate antigen and autoantigen. *J. Exp. Med.* **182**, 743–750.
 131. Hudson, P. J. and Kortt, A. A. (1999) High avidity scFv multimers; diabodies and triabodies. *J. Immunol. Methods* **231**, 177–189.
 132. Souriau, C., Gracy, J., Chiche, L., and Weill, M. (1999) Direct selection of EGF mutants displayed on filamentous phage using cells overexpressing EGF receptor. *Biol. Chem.* **380**, 451–458.
 133. Persic, L., Roberts, A., Wilton, J., Cattaneo, A., Bradbury, A., and Hoogenboom, H. R. (1997) An integrated vector system for the eukaryotic expression of antibodies or their fragments after selection from phage display libraries. *Gene* **187**, 9–18.
 134. Persic, L., Righi, M., Roberts, A., Hoogenboom, H. R., Cattaneo, A., and Bradbury, A. (1997) Targeting vectors for intracellular immunisation. *Gene* **187**, 1–8.
 135. Boel, E., Verlaan, S., Poppelier, M. J., Westerdaal, N. A., van Strijp, J. A., and Logtenberg, T. (2000) Functional human monoclonal antibodies of all isotypes constructed from phage display library-derived single-chain Fv antibody fragments. *J. Immunol. Methods* **239**, 153–166.

136. Den, W., Sompuram, S. R., Sarantopoulos, S. C., and Sharon, J. (1999) A bidirectional phage display vector for the selection and mass transfer of polyclonal antibody libraries. *J. Immunol. Methods* **222**, 45–57.
137. Gargano, N. and Cattaneo, A. (1997) Rescue of a neutralizing anti-viral antibody fragment from an intracellular polyclonal repertoire expressed in mammalian cells. *FEBS Lett.* **414**, 537–540.
138. Xie, M. H., Yuan, J., Adams, C., and Gurney, A. (1997) Direct demonstration of MuSK involvement in acetylcholine receptor clustering through identification of agonist scFv. *Nature Biotechnol.* **15**, 768–771.
139. Souriau, C., Fort, P., Roux, P., Hartley, O., Lefranc, M. P., and Weill, M. (1997) A simple luciferase assay for signal transduction activity detection of epidermal growth factor displayed on phage. *Nucleic Acids Res.* **25**, 1585–1590.
140. Rousch, M., Lutgerink, J. T., Coote, J., de Bruine, A., Arends, J. W., and Hoogenboom, H. R. (1998) Somatostatin displayed on filamentous phage as a receptor-specific agonist. *Br. J. Pharmacol.* **125**, 5–16.
141. Szardenings, M., Tornroth, S., Mutulis, F., Muceniece, R., Keinanen, K., Kuusinen, A., and Wikberg, J. E. (1997) Phage display selection on whole cells yields a peptide specific for melanocortin receptor 1. *J. Biol. Chem.* **272**, 27,943–27,948.
142. Broach, J. R. and Thorner, J. (1996) High-throughput screening for drug discovery. *Nature* **384**, 14–16.
143. Larocca, D., Kassner, P. D., Witte, A., Ladner, R. C., Pierce, G. F., and Baird, A. (1999) Gene transfer to mammalian cells using genetically targeted filamentous bacteriophage. *FASEB J.* **13**, 727–734.
- 143a. Poul, M. A., Becerril, B., Nielsen, U. B., Morrison, P. and Marks, J. D. (2000) Selection of tumor-specific internalizing human antibodies from phage libraries. *J. Mol. Biol.* **301**, 1149–1161.
144. Janda, K. D., Lo, C. H., Li, T., Barbas, C. F., Wirsching, P., and Lerner, R. A. (1994) Direct selection for a catalytic mechanism from combinatorial antibody libraries. *Proc. Natl. Acad. Sci. USA* **91**, 2532–2536.
145. Fuchs, P., Weichel, W., Dubel, S., Breitling, F., and Little, M. (1996) Separation of *E. coli* expressing functional cell-wall bound antibody fragments by FACS. *Immunotechnology* **2**, 97–102.
146. Georgiou, G., Stathopoulos, C., Daugherty, P. S., Nayak, A. R., Iverson, B., and Curtiss, R. (1997) Display of heterologous proteins on the surface of microorganisms: from the screening of combinatorial libraries to live recombinant vaccines. *Nature Biotechnol.* **15**, 29–34.
147. Pausch, M. H. (1997) G-protein-coupled receptors in *Saccharomyces cerevisiae*: high-throughput screening assays for drug discovery. *Trends Biotechnol.* **15**, 487–494.
148. Lueking, A., Horn, M., Eickhoff, H., Bussow, K., Lehrach, H., and Walter, G. (1999) Protein microarrays for gene expression and antibody screening. *Anal. Biochem.* **270**, 103–111.
149. Abbott, A. (1999) A post-genomics challenge: learning to read patterns of protein expression. *Nature* **402**, 715–720.

150. de Wildt, R. M. E., Mundy, C. R., Gorick, B. D., and Tomlinson, I. M. (2000) Antibody arrays for high-throughput screening of antibody-antigen interactions. *Nature Biotechnology* **18**, 989–994.
151. Nygren, P. A. and Uhlen, M. (1997) Scaffolds for engineering novel binding sites in proteins. *Curr. Opin. Struct. Biol.* **7**, 463–469.
152. Tramontano, A., Bianchi, E., Venturini, S., Martin, F., Pessi, A., and Sollazzo, M. (1994) The making of the minibody: an engineered beta-protein for the display of conformationally constrained peptides. *J. Mol. Recognit.* **7**, 9–24.
153. McConnell, S. J. and Hoess, R. H. (1995) Tendamistat as a scaffold for conformationally constrained phage peptide libraries. *J. Mol. Biol.* **250**, 460–470.
154. Nord, K., Nilsson, J., Nilsson, B., Uhlen, M., and Nygren, P. A. (1995) A combinatorial library of an alpha-helical bacterial receptor domain. *Protein Eng.* **8**, 601–608.
155. Ku, J. and Schultz, P. G. (1995) Alternate protein frameworks for molecular recognition. *Proc. Natl. Acad. Sci. USA* **92**, 6552–6556.
156. Houston, M. E., Jr., Wallace, A., Bianchi, E., Pessi, A., and Hodges, R. S. (1996) Use of a conformationally restricted secondary structural element to display peptide libraries: a two-stranded alpha-helical coiled-coil stabilized by lactam bridges. *J. Mol. Biol.* **262**, 270–282.
157. Miceli, R., Myszka, D., Mao, J., Sathe, G., and Chaiken, I. (1996) The coiled coil stem loop miniprotein as a presentation scaffold. *Drug Des. Discov.* **13**, 95–105.
158. Perez-Paya, E., Forood, B., Houghten, R. A., and Blondelle, S. E. (1996) Structural characterization and 5'-mononucleotide binding of polyalanine beta-sheet complexes. *J. Mol. Recognit.* **9**, 488–493.
159. Choo, Y., Castellanos, A., Garcia-Hernandez, B., Sanchez-Garcia, I., and Klug, A. (1997) Promoter-specific activation of gene expression directed by bacteriophage-selected zinc fingers. *J. Mol. Biol.* **273**, 525–532.
160. Vita, C., Roumestand, C., Toma, F., and Menez, A. (1995) Scorpion toxins as natural scaffolds for protein engineering. *Proc. Natl. Acad. Sci. USA* **92**, 6404–6408.
161. Rottgen, P. and Collins, J. (1995) A human pancreatic secretory trypsin inhibitor presenting a hypervariable highly constrained epitope via monovalent phagemid display. *Gene* **164**, 243–250.
162. Wang, C. I., Yang, Q., and Craik, C. S. (1995) Isolation of a high affinity inhibitor of urokinase-type plasminogen activator by phage display of ecotin. *J. Biol. Chem.* **270**, 12,250–12,256.
163. Nuttall, S. D., Rousch, M. J., Irving, R. A., Hufton, S. E., Hoogenboom, H. R., and Hudson, P. J. (1999) Design and expression of soluble CTLA-4 variable domain as a scaffold for the display of functional polypeptides. *Proteins* **36**, 217–227.
164. Hufton, S. E., van Neer, N., van den Beucken, T., Desmet, J., Sablon, E., and Hoogenboom, H. R. (2000) Development and application of cytotoxic T lymphocyte-associated antigen 4 as a protein scaffold for the generation of novel binding ligands. *FEBS Lett.* **475**, 225–231.

165. Koide, A., Bailey, C. W., Huang, X., and Koide, S. (1998) The fibronectin type III domain as a scaffold for novel binding proteins. *J. Mol. Biol.* **284**, 1141–1151.
166. Beste, G., Schmidt, F., Stibora, T., and Skerra, A. (1999) Small antibody-like proteins with prescribed ligand specificities derived from the lipocalin fold. *Proc. Natl. Acad. Sci. USA* **96**, 1898–1903.
167. Abedi, M. R., Caponigro, G., and Kamb, A. (1998) Green fluorescent protein as a scaffold for intracellular presentation of peptides. *Nucleic Acids Res.* **26**, 623–630.
168. Nord, K., Gunneriusson, E., Ringdahl, J., Stahl, S., Uhlen, M., and Nygren, P. A. (1997) Binding proteins selected from combinatorial libraries of an alpha-helical bacterial receptor domain. *Nature Biotechnol.* **15**, 772–777.
169. Mikara, Y. G., Maruyama, I. N., and Brenner, S. (1996) Surface display of proteins on bacteriophage lambda heads. *J. Mol. Biol.* **262**, 21–30.
170. Proba, K., Honegger, A., and Pluckthun, A. (1997) A natural antibody missing a cysteine in VH: consequences for thermodynamic stability and folding. *J. Mol. Biol.* **265**, 161–72.
171. Winter, G. (1989) Antibody engineering. *Phil. Trans. R. Soc. Lond. B* **324**, 537–547.
172. Hoogenboom, H. R., de Bruine, A. P., Hufton, S. E., Hoet, R. M., Arends, J. W., and Roovers, R. C. (1998) Antibody phage display technology and its applications. *Immunotechnology* **4**, 1–20.

Standard Protocols for the Construction of Fab Libraries

Michelle A. Clark

1. Introduction

Fab libraries, in which light-chain (LC) and heavy-chain (HC) variable-region genes are cloned into a phagemid vector and subsequently displayed on the surface of the filamentous phage particle, have been widely used for the isolation of antibodies (Abs) with specificity for haptens, foreign antigens (Ags), and self Ags. Immune Fab libraries, in which lymphoid tissue from individuals who, perhaps because of disease, have mounted an immune response to particular Ags, have been used in the recovery of Fabs with binding specificity for a number of clinically relevant Ags including *c-erbB-2* (1) and p53 (2). Fab libraries are thus valuable as a means whereby the genes for Abs of interest can be immortalized and propagated. This enables information to be gathered regarding the Ab, including structural features, V-gene usage, and the nature of the immune response in the individual. Additionally, the isolated Abs can be used to evaluate immunogenic epitope(s) of the Ag. Furthermore, the Abs themselves provide potentially useful diagnostic or therapeutic agents (2). The isolation of Fabs from combinatorial libraries is thus valuable in contributing to the understanding of Ab–Ag interactions, as well as the nature of the *in vivo* immune response.

Technically, the construction of Fab libraries has the advantage of simplicity, compared to the construction of other Ab fragment libraries. The methods described here cover the construction of mouse and human Fab libraries in the phagemid vector, MCO3 (3). This vector has several features, such as different leader sequences for the light and heavy chains, a stop codon that allows easy shuttling between appropriate host strains for the preparation of phage or the

expression of soluble Fab, a *myc* tag for analysis and purification of protein, and a subtilisin cleavage site useful for recovery of bound phage during library screening. Methods included in this chapter are outlined below.

1. RNA is extracted from the tissue of interest (e.g., mouse spleen, human lymph node), and RNA quality is assessed by agarose gel electrophoresis and spectrophotometry (*see Subheading 3.1.*). If DNA is present in the RNA sample, then the sample is digested with DNase I.
2. Reverse transcription (RT) of total RNA is done using immunoglobulin chain specific primers (*see Subheading 3.2.*).
3. The cDNA so generated is used immediately in the polymerase chain reaction (PCR) amplification of immunoglobulin genes using appropriate primers for V-gene families (κ , λ LCs, and γ HCs). PCR reactions are assessed by standard agarose gel electrophoresis. The PCR products from each Ab chain are pooled and precipitated with ethanol. The pooled PCR products are run on a two-concentration agarose gel system to isolate specific product, and are purified using commercial gel purification columns (*see Subheading 3.3.*).
4. Purified PCR products are digested sequentially with *SacI/XbaI* (LC) or *SpeI/XhoI* (HC). Any differences in digestion conditions and subsequent methods are noted (*see Subheadings 3.4.–3.7.*).
5. Phagemid vector, MCO3 (or the LC library in MCO3), is double-cut in preparation for cloning digested PCR products. Vector is cut for insertion of LC (or HC), purified on a two-concentration gel system and double-cut DNA is isolated from the gel using commercial columns. LC or HC PCR product is cloned into the vector and trial ligations done to determine approximate library size and the calculation of vector background (*see Subheadings 3.8. and 3.10.*).
6. Large-scale ligation of double-digested LC PCR product with vector is followed by electroporation into *Escherichia coli* XL1-Blue. DNA carrying the LC libraries is prepared and digested for insertion of HC PCR product. Cloning of digested HC PCR product is done via trial ligation, then large-scale ligation, as for construction of LC library (*see Subheading 3.11.*).
7. Newly constructed Fab libraries are verified by digestion of miniprep DNA with cloning enzymes, PCR analysis from single colonies, and *BstNI* analysis of diversity and sequencing, and are stored as DNA, bacterial glycerol stocks and phage (*see Subheadings 3.15., 3.17., and 3.18.*).

2. Materials

2.1. RNA Extraction and Analysis

1. Fresh lymphoid tissue or preparation of lymphocytes for library construction.
2. RNase decontamination spray.
3. Autoclaved, precooled (-80°C) mortar and pestle.
4. Guanidine stock solution: 4 M guanidine thiocyanate, 25 mM Na citrate, pH 7.0, 0.5% Sarkosyl. Filter-sterilize through a 0.2- μm filter (*see ref. 4*).

5. Solution D: 54 μL β -mercaptoethanol mixed with 7 mL guanidine stock solution.
6. 2 M Na acetate, pH 4.1.
7. Buffered, saturated phenol, pH 4.3 (for RNA extraction only).
8. Chloroform:isoamyl alcohol (24:1).
9. Isopropanol.
10. Absolute and 70% (v/v) ethanol.
11. 1% (w/v) Sodium dodecyl sulfate (SDS).
12. RNA sample buffer: 10% (w/v) sucrose, 90% (v/v) formamide, 0.05% (w/v) bromophenol blue.
13. 10 mg/mL Ethidium bromide in H_2O .
14. DNase I (RNase-free) and manufacturer's 10X buffer.
15. Phenol:chloroform:isoamyl alcohol (25:24:1).

2.2. RT and PCR Reactions

1. 10X PCR reaction buffer (commercial).
2. 25 mM MgCl_2 .
3. 10 mM Deoxyribonucleoside triphosphate (dNTP) mix (deoxyadenosine triphosphate, deoxycytidine triphosphate, deoxyguanosine triphosphate, deoxythymine triphosphate).
4. Immunoglobulin 3' primers at 20 μM (see **Tables 1–4**).
5. Murine leukemia virus RTase (20 U/ μL).
6. RNasin.
7. *Tth* polymerase (5.5 U/ μL).
8. LC or HC oligonucleotide primers at 20 μM (see **Tables 1–4**).

2.3. Digestion and Cloning of PCR Products

1. Appropriate restriction enzymes for cloning PCR products into chosen phage display vector (e.g., *SacI* (100 U/ μL), *XbaI* (100 U/ μL), *SpeI* (50 U/ μL), *XhoI* (40 U/ μL), and associated 10X buffers).
2. Bovine serum albumin (BSA) (1 mg/mL).
3. 100 mM Tris base.
4. 100 mM Tris-HCl.
5. 350 mM β -mercaptoethanol.
6. 100 mM MgCl_2 .
7. Commercial kits for the isolation of DNA from agarose gels and from solution.
8. Appropriate phagemid vector (e.g., MC03) (**Fig. 1**).
9. Low-melting-temperature agarose.
10. Long-wave, hand-held UV lamp.
11. UV-transparent shrink-wrap film.
12. Scalpel blades.
13. Ethidium bromide stock (1 mg/mL).
14. Solution of DNA of known concentration (100 $\mu\text{g/mL}$).
15. T4 DNA ligase (400 U/ μL) and commercial buffer.

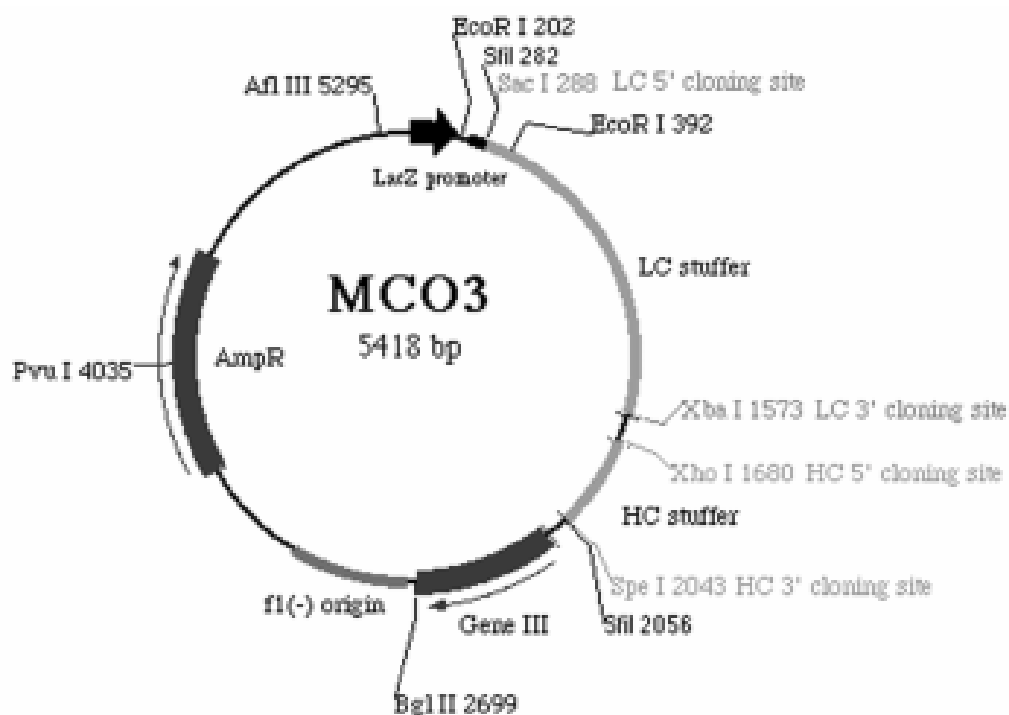

Fig. 1.

Table 1
Murine LC Primer Sequences

	Gene family	Primer sequence 5' to 3'
3' LC primer	C _κ 1	CATGTCTAGAACTCATTCTGTTGAAGCTCTTG
5' LC primers	V _κ A	CATGGAGCTCGATGTTTTGATGACCCAACTCCA
	V _κ B	GATCGAGCTCGACATTGTGCTCACCCAATCTCC
	V _κ C	CATGGAGCTCGACATTGTGCTRACCCAGTCTTCCA
	V _κ D	CATGGAGCTCGACATCCAGATGACNCAGTCTCAA
	V _κ E	CATGGAGCTCCAAATTGTTCTCACCCAGTCTCCA
	V _κ F	CATGGAGCTCGAAAATGTGCTTCACCCAGTCTCCA

R = A or G; N = A, G, C or T.

Restriction sites are in bold (*Sac*I GAGCTC, *Xba*I TCTAGA).

Table 2
Murine HC Primer Sequences

	Gene family	Primer sequence 5' to 3'
3' HC primers	Ig γ 1	AGGCTT ACTAGT TATGCAAGGCTTACAACC
	Ig γ 2A	AGGCTT ACTAGT TACAGGGCTTGATTGTGGGCC
	Ig γ 2B	AGGCTT ACTAGT TACAGGGGTTTCAGTGTGAAATGG
5' HC primers	IA	TGGAGGCTT CTCGAGG AKGTGCAGCTTCAGGAGTC
	IB	TGGAGGCTT CTCGAGC AGGTGCAGCTGAAGSAGTC
	IIA	TGGAGGCTT CTCGAGS AGGTCCAGCTGCARCAGTC
	IIB	TGGAGGCTT CTCGAGC AGGTCCARCTGCAGCAGYTTGG
	IIC	TGGAGGCTT CTCGAGG AGGTTTCAGCTGCAGCAGTC
	IIIA	TGGAGGCTT CTCGAGG ARGTGAAGCTGGTGGARTCTGG
	IIIB	TGGAGGCTT CTCGAGG AGGTGAAGCTTCTGGAGTCTGG
	IIIC	TGGAGGCTT CTCGAGG AAAGTGAAGCTTGAGGAGWCTGG
	IIIDA	TGGAGGCTT CTCGAGG AAAGTGCAGCTGGTGGAGTCTGG
	IIIDB	TGGAGGCTT CTCGAGG AAAGTGATGCTGGTGGAGTCTGG
	VA	TGGAGGCTT CTCGAGG AGGTYCAGCTKCAGCAG
C _H 1	GCCAAAACGACACCCCA	

R = A or G; Y = C or T; S = C or G; W = A or T; K = G or T.
Restriction sites are in bold (*Xho*I CTCGAG, *Spe*I ACTAGT).

2.4. Preparation of Electrocompetent Cells and Transformation

1. *E. coli* XL-1 Blue. Cells prepared for electroporation can be obtained commercially or prepared in the laboratory (see **Subheading 3.12.**).
2. Luria-Bertani medium (LB). Composition/L: 10 g Bacto-tryptone, 5 g Bacto-yeast extract, 5 g NaCl, pH 7.0. Autoclave.
3. LB agar plates. Composition as for LB, but containing 15 g/L agar.
4. LB-TET50. LB plates containing 50 μ g/mL tetracycline, taken from a stock of the antibiotic at 10 mg/mL in 70% ethanol.
5. 2TY. Composition/L: 16 g Bacto-tryptone, 10 g Bacto-yeast extract, 5 g NaCl, pH 7.0. Autoclave.
6. 2TY-TET10. 2TY containing 10 μ g/mL tetracycline.
7. Cold, autoclaved 10% glycerol in H₂O.
8. 20% Glucose, filter-sterilized.
9. Appropriate centrifuge rotor and tubes (e.g., Beckman JA14).
10. Cryotubes.
11. Liquid nitrogen.
12. Electroporation cuvetts (0.2 cm gap).
13. SOC. Composition/L: 20 g Bacto-tryptone, 5 g Bacto-yeast extract, 0.5 g NaCl, pH 7.5. Sterilize by autoclaving. Just before use, add 20 mL sterile 1 M MgSO₄ and glucose to a final concentration of 0.4%.

Table 3
Human LC Primer Sequences

	Gene family	Primer name	Primer sequence 5' to 3'
3' LC (κ) primer	C_{κ}	$C_{\kappa}1z$	GCGCCGTCTAGAAATTAACACTCTCCCCTGT TGAAGCT CTTTGTGACGGGCGAACTCAG
5' LC (κ) primers	1	$V_{\kappa}1a$	GACATCGAGCTCACCCAGTCTCCA
		$V_{\kappa}2a$	GATATTGAGCTCACTCAGTCTCCA
		$V_{\kappa}3a$	GAAATTGAGCTCACGCAGTCTCCA
		κ Constant	CON_{κ}
3' LC (λ) primer	C_{λ}	$C_{\lambda}2$	CGCCGTCTAGAACTATGAACATTCAGG
5' LC (λ) primers	1,2	$V_{\lambda}1,2$	CAGTCTGAGCTCACTCAGCCRCCC
		$V_{\lambda}3$	CAGCCTGAGCTCACTCAG
	4,5,9	$V_{\lambda}4,5,9$	TCTGTGGAGCTCCAGCCGCCCTCAGTG
	6	$V_{\lambda}6$	AATTTTGAGCTCACTCAGCCC
	7	$V_{\lambda}7$	CAGGCTGAGCTCACTCAGGAG
	8	$V_{\lambda}8$	CAGACTGAGCTCACCCAGGAG
	10	$V_{\lambda}10$	CAGGCAGAGCTCACTCAGCCA
	λ Constant	$CON_{\lambda}2$	AAGGCTGCCCCCACGGTCACTCTG

R = A or G.

Restriction sites are in bold (*Sac*I GAGCTC, *Xba*I TCTAGA).

14. LB-CARB50. LB plates containing 50 μ g/mL carbenicillin, taken from a stock of the antibiotic at 10 mg/mL in H₂O.

2.5. Library Preparation and Analysis

1. Large (14 cm) 2TY agar plates (*see Subheading 2.4., item 5* containing 15 g/L agar), supplemented with glucose to 2% and carbenicillin to 50 μ g/mL (2TY-GLU-CARB).
2. 2TY (*see Subheading 2.4., item 5*).
3. Sterile glycerol.
4. 2TY-GLU. 2TY supplemented with glucose to 2%.
5. Carbenicillin at 10 mg/mL in H₂O.
6. Commercial kit for the isolation of plasmid DNA (maxi/mega-scale).
7. 2TY-GLU-TET-CARB. 2TY supplement with glucose to 2%, tetracycline (5 μ g/mL) and carbenicillin (20 μ g/mL).
8. VCS-M13 helper phage.
9. Tetracycline (10 μ g/mL in 70% ethanol).
10. 2TY-TET-CARB-KAN. 2TY containing tetracycline (10 μ g/mL), carbenicillin (50 μ g/mL), and kanamycin (70 μ g/mL).

Table 4
Human HC Primer Sequences

	Primer name	Gene family	Primer sequence 5' to 3'
3' HC primers	C _γ 1z	γ1	GCATG TA CTAGTTTTGTCACAAGATTTGGG
	C _γ 2z	γ2	CGGTGG ACTAGT GACACAACATTTGCC
	C _γ 3z	γ3	TGGGCA ACTAGT GTCATGTGTGAGTTGTG
	C _γ 4z	γ4	TGGGCA ACTAGT GTCATGGGGGACCATATTTGGA
	CON _γ a	γ1,2,3,4	TCCACCAAGGGCCCATCG
5' HC primers	V _H 1a	1 and 4	CAGGTGCAGCT CGAG CAGTCTGGG
	V _H 1f	1 and 4	CAGGTGCAGCT GCTCGAGT CTGG
	V _H 2fN	2	CAGATCAC CTCGAGG AGTCTGGT
	V _H 3a	3	GAGGTGCAGCT CGAGG AGTCTGGG
	V _H 3f	3	GAGGTGCAGCT GCTCGAGT CTGGG
	V _H 5f	5	GAGGTGCAGCT CGAGC AGTCTGGA
	V _H 6f	6	CAGGTACAGCT GCTCGAGT CAGGTCCA
	V _H 7f	7	CAGGTCCAGCT CGAGCA ATCTGG

Restriction sites are in bold (*Xho*I CTCGAG, *Spe*I ACTAGT).

11. 2.5 M NaCl, 20% polyethylene glycol (PEG) 6000 in H₂O.
12. Phosphate-buffered saline containing 1% BSA and Na azide at 0.02%.
13. 2TY–TET10.
14. Kanamycin stock (10 mg/mL in H₂O).
15. Dimethylsulfide.
16. Cryotubes.
17. LB agar plates (*see Subheading 2.4., item 3*).
18. Top agar. Prepare LB liquid medium and add agarose to 0.6%. Autoclave.
19. LB liquid medium (*see Subheading 2.4., item 2*).
20. Commercial kits for the isolation of plasmid DNA (miniprep scale).
21. Cracking buffer. 10 mM Tris-HCl, pH 7.0, 1 mM ethylene diamine tetraacetic acid, 50 μg/mL Proteinase K.
22. *Tth* or other thermostable DNA polymerase, commercial buffer, and stock MgCl₂ solution (25 mM).
23. Oligonucleotide primers flanking the sites of insertion of LC and HC in the chosen phage-display vector.
24. Sequencing primers (5' to 3'; redissolve to 20 μM). Before synthesis, check that the suggested sequences will hybridize to the phage display vector selected for library construction.
 - ompA* forward: AAAGACAGCTATCGCGATT
 - pelB* reverse: CAGCGAGTAATAACAATCCA

pelB forward: CTACGGCAGCCGCTGGATTG
gene III: CATCGGCATTTTCGGTCATA

25. *Bst*NI and 10X buffer.

3. Methods

3.1. Preparation of RNA

3.1.1. RNA Extraction from Tissue (see Note 1)

1. Wipe down hood, all pipets, and other equipment with 70% ethanol or RNase decontamination spray. Treat an autoclaved mortar and pestle with RNase decontamination spray for 5 min, wipe out with a Kimwipe and keep cold (see Note 2).
2. With liquid nitrogen in the mortar, add the tissue and tap with the pestle until the tissue has broken up into small pieces. Let the liquid nitrogen evaporate then grind the tissue into a fine powder. Scrape the powder from the mortar and pestle with a sterile blade and add to fresh solution D. It is best to add approx 1 mL solution D/0.1 g tissue in a 2 mL microcentrifuge tube (see Notes 2 and 3).
3. Push the solution through a fine-gauge needle until no lumps are left.
4. Add 66 μ L 2 M Na acetate, pH 4.1, 660 μ L buffered phenol (pH 4.3), and 130 μ L chloroform–isoamyl alcohol (24:1). Mix well after each addition then vortex for 30 s and incubate on ice for 15 min. The solution should be cloudy at this stage (see Note 3).
5. Centrifuge for 30 min at 4°C in a microcentrifuge. If the interface between the aqueous (upper) phase and the organic (lower) phase is not well-defined, then extra chloroform should be added until the two phases have separated.
6. Transfer the top, aqueous layer to a fresh tube (avoid the interface because it contains DNA) and back-extract if there was only a small amount of tissue to begin with. To back-extract, add an equal volume of fresh solution D to the organic phase and repeat incubation on ice and centrifugation steps. Pool both aqueous phases.
7. Add an equal volume of isopropanol, mix, and incubate overnight at –20°C.
8. Centrifuge at full speed in a microcentrifuge for 30 min at 4°C to precipitate RNA.
9. Discard supernatant, drain pellet and resuspend RNA in solution D to a total volume of 500 μ L. Pool RNA if there was more than one tube. RNA should be clearly visible as a clean, white pellet at the bottom of the tube.
10. Adjust pH by adding one-tenth vol of 2 M Na acetate, pH 4.1. Add 2 vol of cold 100% ethanol and incubate RNA for 2 h at –20°C. Centrifuge as in step 8.
11. Discard supernatant and rinse the pellet with 500 μ L of cold 70% ethanol, followed by 100 μ L of cold 100% ethanol.
12. Air-dry RNA for 15 min. Do not overdry or the RNA will be difficult to resuspend.
13. Resuspend RNA in 20 μ L of sterile H₂O/0.1 g original tissue. Leave on ice, or at 4°C to dissolve. For this and subsequent steps, use the highest quality sterile H₂O available, preferably a commercial batch to reduce the risk of contamination with RNases.

14. Read A_{260}/A_{280} of 1 : 100 dilution of the RNA (*see Note 4*).
15. Aliquot and store RNA at -70°C (*see Note 5*).

3.1.2. RNA Analysis

1. RNA can be assessed quickly and easily, using a minigel apparatus. Use a new minigel apparatus or, if this is not possible, treat the gel rig, spacers, and comb with 3–4 washes with 1% SDS. Rinse all apparatus with sterile H_2O . Rinse a spatula with 1% SDS, followed by sterile H_2O , and prepare a standard 1% agarose gel in TBE.
2. Add 0.5–2.0 μg RNA to RNA sample buffer. RNA should be in a volume <50% of the total, which should be <20 μL . Add 1–2 μL 0.1 mg/mL ethidium bromide. Mix well then heat the sample at $60\text{--}65^{\circ}\text{C}$ for 3 min, cool to room temperature, and load onto the gel. Run the gel for about 2 h, room temperature, 50 V.
3. High-quality RNA shows two discrete bands on the gel, representing the 28S and 18S rRNA species. The intensity of the 28S (upper) band is usually twice that of the 18S (lower) band. Any smearing below either of these bands indicates degradation (slight trailing under the bands may be visible if the gel is overloaded). High molecular weight material in the well of the gel is DNA, which needs to be removed by digestion with DNase I.

3.1.3. DNase Treatment of RNA Sample

1. If the RNA is in a volume less than 200 μL , treat as follows, otherwise scale-up to appropriate volume: μL RNA sample, 20 μL 10X DNase digestion buffer, 5 μL DNase I (RNase-free), and sterile H_2O to 200 μL .
2. Incubate for 1 h at 37°C .
3. Add an equal volume of phenol:chloroform:isoamyl alcohol (25:24:1) and mix well (*see Note 3*).
4. Spin 15 min in a microcentrifuge at 4°C . Remove aqueous (upper) layer to a fresh tube.
5. Adjust pH with one-tenth vol 2 M Na acetate, pH 4.1, then precipitate RNA with 2 vol 100% ethanol for 2 h at -80°C .
6. Centrifuge 30 min at 4°C , wash pellet with 200 μL 70% ethanol, then 200 μL 100% ethanol. Air-dry for 15 min.
7. Resuspend the RNA pellet in 40 μL sterile H_2O /0.1 g tissue.
8. Check concentration of RNA (usually about 1 $\mu\text{g}/\mu\text{L}$) and integrity on 1% agarose gel (*see Subheading 3.1.2.*).
9. Aliquot RNA and store at -80°C (*see Note 5*).

3.2. Reverse Transcription of Light Chain (LC) and Heavy Chain (HC) Genes

1. Prepare a reverse transcription (RT) reaction of sufficient volume to supply 1.5 μL reaction mix for each 50 μL PCR reaction at **Subheading 3.3., step 2**. The number of PCR reactions, and hence the volume of the RT mix, will depend on the number of primer combinations required to recover the immunoglobulin

repertoires from the species under study. The RT reaction comprises 5–10 μg RNA in 1X PCR buffer containing 5 mM MgCl_2 , 1 mM dNTP mix, and 1.2 μM 3' LC primer or 3' HC primers (see **Tables 1–4**). A single bulk RT reaction for the LC repertoire and a single bulk RT reaction for the HC repertoire, each RT mix containing all relevant 3' primers is satisfactory.

2. Incubate at 65°C for 5 min, then on ice for 5 min.
3. Add murine leukemia RTase to a final concentration of 1 U/ μL , 1/20 vol RNasin, and incubate at 37°C for 60 min, 95°C for 5 min, then ice for 5 min. cDNA should be used as soon as possible in the PCR.

3.3. PCR of LC and HC Genes

1. Prepare reaction mix sufficient for all combinations of 3' and 5' primers (murine, human, or other species as appropriate), with final concentrations as follows: 1X PCR reaction buffer, 2 mM MgCl_2 , 0.2 mM dNTP mix, 0.03 U/ μL *Tth* polymerase (see **Note 6**).
2. On ice, add 45.5 μL reaction mix/tube, 1.5 μL each 3' and 5' primer (see **Tables 1–4**) from stock concentrations of 20 μM and 1.5 μL RT reaction. Separate reactions should be prepared for each 5' primer with the selected 3' primer. Omit RT reaction from the negative controls. Mix all reactions gently and keep on ice (see **Note 7**).
3. Commence LC PCR with denaturation at 94°C for 4 min, followed by 35 cycles as follows: 94°C for 15 s, 52°C for 50 s, and 72°C for 90 s. Commence HC PCR with denaturation at 94°C for 4 min, then apply touchdown cycling for a total of 35 cycles as in **Table 5** (see **Note 8**):
4. End PCRs with extension at 72°C for 10 min. The samples can be stored at 4°C overnight or frozen if necessary.
5. Run 5 μL of each PCR reaction on standard 1% agarose gels to check the size and yield of the products (see **Subheading 3.9**).
6. Clean up PCR product on two-agarose-gel system as described (see **Subheading 3.8**, steps 2–9).

3.4. Digestion of LC PCR Product with *SacI* for Cloning into MCO3

The LC PCR products (1–3 μg) are digested with *SacI* (50 U/ μg DNA) in a dedicated buffer containing 10 mM Tris base: Tris-HCl (1:3.5, pH 7.3), 0.1 mg/mL BSA, 7 mM β -mercaptoethanol, 20 mM NaCl, 7 mM MgCl_2 , total vol 50 μL . Digest DNA for 2–3 h at 37°C, then heat deactivate *SacI* at 65°C for 15 min.

3.5. Digestion of LC PCR Product with *XbaI*

1. Clean-up of the *SacI* cut DNA prior to digestion with *XbaI* is not necessary (see **Note 9**). Increase the volume to 100 μL with a dedicated buffer containing

Table 5
Touchdown Conditions for HC PCR

Denaturation	Annealing	Extension	Cycles
94°C, 30 s	65°C, 1 min	72°C, 90 s	2
94°C, 30 s	64°C, 1 min	72°C, 90 s	2
94°C, 30 s	63°C, 1 min	72°C, 90 s	2
94°C, 30 s	62°C, 1 min	72°C, 90 s	2
94°C, 30 s	61°C, 1 min	72°C, 90 s	2
94°C, 30 s	60°C, 1 min	72°C, 90 s	2
94°C, 30 s	59°C, 1 min	72°C, 90 s	2
94°C, 30 s	58°C, 1 min	72°C, 90 s	2
94°C, 30 s	57°C, 1 min	72°C, 90 s	2
94°C, 30 s	56°C, 1 min	72°C, 90 s	2
94°C, 30 s	55°C, 1 min	72°C, 90 s	15

100 mM NaCl, 10 mM Tris base: Tris-HCl (5:1, pH 7.9), 0.1 mg/mL BSA, 7 mM β -mercaptoethanol, 7 mM MgCl₂ and 50 U/ μ g DNA *Xba*I. Digest for 2–3 h at 37°C, then heat-deactivate at 65°C for 15 min.

2. Clean up *Sac*I/*Xba*I digested LC DNA with commercial DNA purification columns. We have found Qiagen columns to be quick and reliable, but phenol extraction (pH 8.0) followed by ethanol precipitation will work just as well. Resuspend DNA in H₂O and calculate concentration of DNA as described below (see **Subheading 3.9.**) or by reading A₂₆₀.

3.6. Digestion of HC PCR Product with *Spe*I

The HC PCR products (1–3 μ g) are digested with *Spe*I (25 U/ μ g DNA) in buffer containing 10 mM Tris base: Tris-HCl (1:4.5, pH 7.3), 0.1 mg/mL BSA, 7 mM β -mercaptoethanol, 80 mM NaCl, 7 mM MgCl₂ in a total volume of 50 μ L. Digest DNA for 2–3 h at 37°C, then heat-deactivate at 65°C for 15 min.

3.7. Digestion of HC PCR Product with *Xho*I

1. As in **Subheading 3.5.**, *Spe*I-cut DNA can be digested with *Xho*I without prior cleanup by adapting the buffer composition (see **Notes 9** and **10**). Add a dedicated buffer containing 100 mM NaCl, 10 mM Tris base: Tris-HCl (5:1), 0.1 mg/mL BSA, 7 mM β -mercaptoethanol, 100 mM NaCl, 7 mM MgCl₂, and *Xho*I to 20 U/ μ g DNA, raising the total volume of the reaction mix to 100 μ L. Incubate for 2–3 h at 37°C, then heat-deactivate at 65°C for 15 min.
2. Clean up *Spe*I/*Xho*I digested HC DNA and determine concentration of DNA as described (see **Subheading 3.9.**).

3.8. Preparation of Double-Cut MCO3 for Cloning of Digested LC and HC PCR Products, and Cleanup of PCR Products (see Note 11)

1. MCO3 vector (20–40 μg) (**Fig. 1**) is digested in a commercial buffer with *SacI* (50 U/ μL) and *XbaI* (50 U/ μL) for 2–3 h at 37°C. For cloning of digested HC PCR product, the LC library in MCO3 is similarly digested with *SpeI* (25 U/ μL) and *XhoI* (20 U/ μL). Double-digestion of vector DNA is efficient because of the length of intervening sequence between the restriction sites (compare digestion of PCR products).
2. Pour a thick 0.8% agarose gel in TBE containing 0.5 $\mu\text{g}/\text{mL}$ ethidium bromide and load the wells with <5 μg DNA/well. A thick-spaced well-former in a minigel apparatus is suitable.
3. Run the gel at 20–25 V overnight at room temperature so that there is good separation of vector (4.1 kb for MCO3) from the LC stuffer fragment (1.3 kb) and uncut and single cut vector (5.4 kb). When LC products have been cloned into the vector, double-digestion should give a vector fragment of 4.4 kb plus a 0.3-kb stuffer fragment; single-cut vector yields a band of 4.7 kb. Electrophoresis of PCR product (660 bp) need only be for a few hours.
4. Under long-wave UV, cut away the agarose around the vector or PCR products with a clean scalpel. Long-wave UV is used so that nicking of DNA is minimized because it can affect subsequent cloning steps.
5. Prepare low-melting-temperature agarose at a concentration of 0.4–0.6% in TBE buffer and pour around the agarose gel containing the double-cut vector. Allow this to set at 4°C.
6. Run the gel at 4°C until the double-cut vector band (or PCR product) has run into the low-melting-temperature agarose, typically a further 2 h at 50 V.
7. Under long-wave UV, excise the band from the low-melting-temperature gel and purify the DNA using a commercial DNA purification kit.
8. Estimate the DNA concentration by DNA spotting (*see Subheading 3.9.*; *see Note 12*) and/or measurement of the A_{260} .
9. Digested vector DNA should be purified again on the two-gel system as described in **steps 2–6** to ensure a low background of contaminating single-cut vector. Specific PCR product may only need one purification in this manner unless a large number of non-specific products are present.

3.9. Determination of DNA Concentration by Spot Testing (see Note 12)

1. Stretch a piece of UV transparent plastic wrap over a UV transilluminator.
2. Spot several aliquots of 1–5 μL of ethidium bromide (2 $\mu\text{g}/\text{mL}$). There should be enough for the series of standards and the unknown DNA samples.
3. Add an equal volume (1–5 μL) of unknown DNA sample and standard DNA solutions (0, 1, 2.5, 5, 10, and 20 $\mu\text{g}/\text{mL}$) onto the wrap. Mix with spotted ethidium bromide by carefully pipeting up and down.

4. Photograph the spots under short-wave UV and estimate the concentration of the unknown by comparing with the intensity of fluorescence in the standards.

3.10. Small-Scale Ligation of PCR Product into MCO3 Vector

1. Prepare the ligation reaction as follows: double-digested MCO3 vector (for LC insertion) or LC library in MCO3 (for HC insertion) (50–100 ng), double-digested, purified LC or HC PCR products (16–32 ng; 1:2 or 1:5, vector:insert), T4 DNA ligase (0.15 U/ μ L) in 1X ligase buffer. Ligation controls should be set up to include only the vector to check for presence of single-cut DNA and vector only with no ligase to check for the presence of uncut DNA. A control insert (such as Fab LC or HC DNA cut out of a vector with *SacI/XbaI* or *SpeI/XhoI*, respectively) can be used also to check the efficiency of ligation of PCR product.
2. Incubate the ligation reactions at 15°C overnight or 1–3 h at room temperature.
3. Ligation reactions can be used without further purification for electroporation into XL1-Blue cells (*see Subheadings 3.12., 3.13.*) to check vector background and library size (*see Notes 13 and 16*).

3.11. Large-Scale Ligation of PCR Product with Vector

1. Prepare ligation reaction as follows: double-digested, purified MCO3 vector (for LC insertion) or LC library in MCO3 (for HC insertion) (2–3 μ g), double-digested, purified LC or HC PCR products (1 μ g; 1:2, vector:insert), T4 ligase (20 U/ μ L) in 1X ligase buffer.
2. Incubate reactions at 15°C overnight (*see Note 14*).
3. Clean up either by using a commercial DNA cleanup kit or by phenol extraction and ethanol precipitation (*see Note 3*).
4. Elute or resuspend the DNA in 50 μ L H₂O.
5. Electroporate the ligated material into *E. coli* XL1 Blue (*see Subheadings 3.12. and 3.13.*) to calculate the size of the library (*see Note 17*).

3.12. Preparation of Electrocompetent Cells (*see Note 15*)

1. Sample XL1 Blue cells from a fresh culture on LB–TET50 plates and grow an overnight starter culture in 2TY–TET10.
2. Prepare 1 L 10% glycerol, sterilize, and chill to 4°C overnight.
3. Add 10 mL overnight culture to 1 L 2TY and divide between four large (e.g., 1-L) flasks. Add to each flask 25 mL 20% D-glucose and tetracycline to a final concentration of 10 μ g/mL.
4. Chill a high-speed rotor and centrifuge tubes to 4°C.
5. Grow cultures at 37°C until OD₆₀₀ reaches 0.8–1.0 (typically about 4.5 h).
6. Transfer the contents of the flasks into four 250-mL chilled, centrifuge bottles and allow to stand on ice until cold (typically about 30 min).
7. Centrifuge at 1200g, 15 min, 4°C.
8. Resuspend the pellets with a 10-mL pipet in cold 10% glycerol to a total volume of 500 mL. Transfer to two centrifuge bottles. Keep cells on ice while resuspending.

9. Centrifuge at 1200g, 15 min, 4°C.
10. Resuspend the pellets with a 10-mL pipet in cold 10% glycerol to a total volume of 250 mL and transfer to one centrifuge bottle. Keep cells on ice while resuspending.
11. Centrifuge at 1200g, 15 min, 4°C.
12. Remove supernatant with a pipet. Be careful because the pellet is soft here. Resuspend the pellet with a 10-mL pipet in 10% glycerol to a total volume of 50 mL. Keep cells on ice while resuspending.
13. Centrifuge at 1200g, 15 min, 4°C.
14. Remove supernatant with a pipet. Be careful because the pellet is very soft here. Resuspend the pellet with a 10-mL pipet in residual glycerol. Keep cells on ice while resuspending. The final volume should be 5–10 mL/L original culture.
15. Aliquot 200 μ L/cryotube and quick-freeze in liquid nitrogen (wear safety glasses when doing this). Store cells at -80°C .
16. Transformation efficiency of cells should be determined by electroporating 100 pg control (uncut) vector DNA and plating onto appropriate selective medium (*see Subheading 3.13.*). Cells should yield 10^9 transformants/ μ g DNA.

3.13. Electroporation into E. coli XL1 Blue

1. Use new cuvetts for each library. The cuvetts should be kept at -20°C .
2. For small-scale ligation, add 50 μ L electrocompetent XL1 Blue to each cuvet and 1 μ L ligation mixture (*see Subheading 3.10., step 3*). Use one cuvet for each ligation reaction. For large-scale library construction, add 100 μ L competent XL1 Blue to each cuvet and 3 μ L ligation products dissolved in H_2O (*see Subheading 3.11., step 5*). Between 15 and 20 cuvetts will be needed for each large-scale ligation. Electroporation conditions are according to manufacturer's recommendations.
3. After electroporation, rescue cells by quickly adding to each cuvet 1 mL SOC. Transfer to a 5-mL tube and incubate at 37°C for 60 min (*see Note 15*). After rescue, preparation of a large-scale library should yield a total volume of cells of 15–20 mL.
4. Plate out 100 and 10 μ L from each transformation onto LB–CARB50 plates and incubate overnight at 37°C . For large-scale library, pool remaining transformations after rescue and proceed to **Subheading 3.14.**
5. From the number of colonies that appear on the plates, calculate the library size (*see Notes 16 and 17*).

3.14. Large-Scale Preparation of LC Library DNA and Bacterial Glycerol Stock

1. The library pool should comprise 15–20 mL in SOC after transformation (*see Subheading 3.13., step 3*). Divide ~ 5 mL from this between 10 large 2TY–GLU–CARB plates, spread, and incubate overnight at 30°C .

2. Scrape cells off plate into 2TY, add glycerol to a final concentration of 25%, and store the LC library at -70°C as a bacterial glycerol stock.
3. Make up the volume of the remaining pool to 100 mL with 2TY–GLU and incubate 60 min, 37°C .
4. Add carbenicillin to 20 $\mu\text{g}/\text{mL}$ and incubate a further 60 min at 37°C .
5. Increase volume to 500 mL with 2TY–GLU, increase carbenicillin to 50 $\mu\text{g}/\text{mL}$, and incubate overnight at 37°C .
6. Recover cells by centrifugation and prepare DNA by CsCl gradient or other reliable method (*see Note 18*).
7. Analyze library to confirm insert size and diversity (*see Subheading 3.17.; see Note 19*).

3.15. Preparation of HC Library DNA, Bacterial Glycerol Stock, and Library Phage

1. After ligation of HC genes into the LC library and electroporation into XL1 Blue, prepare the glycerol stock of the final Fab library (*see Subheading 3.14., steps 1 and 2*).
2. Make up the volume of the remaining pool of cells to 100 mL with 2TY–GLU–TET–CARB and incubate 60 min, 37°C .
3. Add 2.5×10^{12} VCSM13 helper phage (*see Subheading 3.16.; see Note 20*) to each 100 mL culture. Increase the concentration of tetracycline to 10 $\mu\text{g}/\text{mL}$ and carbenicillin to 50 $\mu\text{g}/\text{mL}$. Incubate with shaking for 2 h, 37°C .
4. Centrifuge the cells at 1500g, 10 min. Resuspend the pellet in 500 mL 2TY–TET–CARB–KAN and incubate overnight at 30°C with shaking.
5. Centrifuge to collect bacteria (**step 4**) and collect the supernatant. Precipitate phage from the supernatant by adding 1/5 vol 2.5 M NaCl, 20% PEG, and incubating on ice for 60 min.
6. Pellet the phage by centrifuging at 6200g, 4°C , 20 min. The phage should appear as a large white pellet. Resuspend the pellet in 1 mL PBS–1% BSA–Na azide. Spin the phage for 1 min in a microcentrifuge to remove bacterial debris. Recover the clarified supernatant to a fresh microcentrifuge tube and reprecipitate phage by adding 1/5 vol 2.5 M NaCl–20% PEG. Spin again (the phage will precipitate immediately) and resuspend in 1 mL fresh PBS–1% BSA–Na azide. The phage can be stored at 4°C for up to 12 mo.
7. If required, DNA can be prepared using standard procedures from the bacterial pellet (**step 5**).

3.16. Preparation of Helper Phage (see Note 20)

1. Inoculate an overnight plate culture of XL1-Blue (*see Subheading 3.12., step 1*) into 2TY–TET10. Grow overnight at 37°C .
2. Prepare two flasks, each containing 100 mL 2TY–TET10, and inoculate with 2 mL of overnight culture. Incubate 2 h, 37°C with shaking.

3. Add 2×10^{11} pfu VCSM13 helper phage from a commercial source to each 100 mL culture.
4. Incubate 1 h, 37°C with shaking.
5. Add kanamycin to 70 µg/mL and incubate further 3–4 h, 37°C with shaking.
6. Centrifuge the culture at 2500g for 15 min. Transfer the supernatant to a fresh container. Discard the pellet.
7. Add dimethylsulfoxide to supernatant to 7% final concentration and aliquot helper phage in 1–2-mL lots. Store the tubes at –70°C.
8. Titer the phage by inoculating XL1 Blue into 10 mL 2TY–TET 10, and growing until the A_{600} reaches a value of 1 (late log phase). Prewarm fresh, dry LB plates to 37°C (*see Note 21*), melt a stock of top agar, and maintain it at 50°C until required. Prepare serial dilutions of helper phage (10^{-6} , 10^{-8} , 10^{-10} , 10^{-12}) in LB and add 1 µL of each dilution to 100 µL of log-phase XL1 Blue cells. Add the mixture to 3-mL aliquots of top agar that has been cooled to about 42°C (*see Note 21*). Pour quickly to a prewarmed LB plate and swirl to distribute the mixture evenly over the surface. Incubate overnight at 37°C and count plaques the following day. Calculate titer of phage as pfu/mL.

3.17. Analysis of Library Clones

1. After construction of the phage library containing LC (*see Note 19*) and HC, prepare plasmid DNA from individual colonies on a miniprep scale. Plates used for titrating the LC and the complete libraries are a convenient source of clones. The analysis aims to verify the presence of LC and HC inserts, which is done by simply digesting plasmid DNA with the enzymes used for cloning (*SacI/XbaI* for the LC and *SpeI/XhoI* for the HC). LC and HC inserts should be 660 bp in size and at least 90% of the clones should contain a full-length insert.
2. An alternative to digestion of miniprep DNA with cloning enzymes is to amplify the DNA directly from bacterial colonies (*see Subheading 3.18.*), then digest with the enzyme, *BstNI*, to provide a fingerprint of the LC and HC inserts. This can be used to assess the diversity of LC and HC sequences. DNA prepared in this way can also be used in sequencing reactions.
3. The ultimate test of the library is the sequencing of random clones. This should be done on DNA from 10–20 clones to verify that the inserts are immunoglobulin, that they are derived from the species of interest, and to confirm that they are full-length with no widespread cloning errors, such as deletion of restriction sites. Sequencing is not covered in this protocol but is amply described in many general methods books and contract sequencing services are widely available. Sequencing primers are suggested (*see Subheading 2.5., item 24*).

3.18. Crack PCR and *BstNI* Digestion

1. Transfer a single colony to a 1.5-mL microcentrifuge tube containing 20 µL cracking buffer (*see Note 22*).
2. Incubate for 15 min at 55°C, 15 min at 80°C, then in ice for 1 min.

3. Centrifuge for 3 min in a microcentrifuge and transfer the supernatant to a fresh tube.
4. Prepare a PCR mix containing 2 mM MgCl₂, 2 U/μL *Tth* polymerase, and 25 pmol of each flanking primer in 1X PCR buffer. Prepare sufficient for 48 μL for each PCR reaction to be carried out (see **Notes 6** and **7**). Add 2 μL of each colony supernatant.
5. Commence PCR at 94°C for 3 min, then carry out 30 cycles as follows: 50°C for 30 s, 72°C for 60 s, 95°C for 30 s. Finish by incubating at 72°C for 10 min.
6. Confirm that the reactions have been successful by analyzing 5 μL on standard 1% agarose gels before sampling 10 μL of each PCR product for digestion with *Bst*NI at 50°C for 3 h.
7. Analyze the profiles of restriction fragments on 8 and 12% polyacrylamide gels in TBE buffer (see **Note 22**). Details for preparing these gels are not covered here but are amply described in many general protocol books.

4. Notes

1. The RNA method described takes 2 d and gives high-quality RNA. It is suitable for the purification of RNA from small quantities of tissue (>0.05 g) in 2 mL microcentrifuge tubes. For the construction of human libraries, we have found lymph nodes to be a source of RNA superior to peripheral blood lymphocytes (**5**).
2. Aseptic technique should be used throughout the procedure and gloves should be worn and changed frequently to minimize RNase contamination. It is best to use disposable plasticware and fresh, sterile solutions. For details on how to treat glassware and nonsterile solutions to prevent contamination with RNases, consult a general laboratory manual.
3. Grinding of sample tissue should be done in a class II Biohazard tissue culture hood. Phenol/chloroform extractions should be performed in a fume hood.
4. A₂₆₀ of 1 is equivalent to 40 μg/mL RNA. Good-quality RNA yields A₂₆₀/A₂₈₀ of 1.8–2.0.
5. RNA is best stored long-term at –70°C in 100% ethanol. However, we have successfully stored RNA at –80°C for more than 5 yr in sterile H₂O without apparent degradation.
6. cDNA product can be stored short term in a dedicated box at –80°C, although the preparation of fresh reactions is recommended. Reagents for cDNA synthesis and PCR should be dispensed into small aliquots and stored at –20°C. Discard unused portions after use.
7. Precautions should be taken when doing PCR to minimize contamination from external sources of template DNA. These are listed as follows: keep cDNA reagents separate from PCR product; PCR reactions are to be set up in a hood or designated bench space; use only PCR-dedicated pipets for setup; wipe down pipets with 0.1 M NaOH, followed by 70% ethanol before use; always use plugged tips and sterile technique so as not to create aerosols that could contaminate other reactions; use sterile disposable plasticware for preparation of reagents and solutions and for PCR reactions; keep caps tightly closed on all

tubes not in immediate use; the cDNA should be the last component added to the PCR reaction; pipet PCR product separately, away from reaction assembly area; store PCR products in a dedicated box at -20°C ; negative controls in PCRs are imperative and all primer combinations should be covered. If there are many combinations, then it is advisable to pool a few 5' primers with a single 3' primer.

8. Touchdown PCR has been found to give the best yield of specific product in the PCR of murine HC genes.
9. The efficiency of ligation of the LC or HC genes into MCO3 is substantially reduced when incomplete digestion has occurred. To increase the efficiency of digestion of the PCR product with both restriction enzymes, a two-step buffer system was developed. In order to achieve the optimal conditions for digestion of DNA with *XbaI*, the pH and the salt concentration have to be increased. To do this, the volume of the reaction is doubled as it is for the digestion with *XhoI/SpeI* of the HC.
10. Note that in some murine HCs, there is an internal *XhoI* site, which results in additional, smaller products. These need to be gel-purified away from the full-length HC amplicon prior to ligation so that only complete HC genes are cloned into the library.
11. Extensive purification of the vector after digestion with *SacI/XbaI* (for cloning of LC PCR product) or *SpeI/XhoI* (for cloning of HC PCR product into the LC library) is carried out to minimize contamination of the preparation with uncut vector, single-cut vector, or stuffer fragments. We have found it to be important that contaminating material (i.e., any form of the vector or insert that is not desirable in the final library) be removed so that only full-length PCR products are cloned into appropriately cleaved vector, thus ensuring that the final library size is correctly estimated and the library will only express full length Fab. Approximately 5 μg double-cut vector is recovered from every 20 μg MCO3 digested. For ligation of LC PCR product, 2–3 μg double-digested, purified vector is required. Similar amounts are required for ligation of the HC PCR product into the LC library.
12. The method of determining DNA concentration by spotting onto a transilluminator is used when there is insufficient DNA ($<250\text{ ng/mL}$) to assay spectrophotometrically, or there are other substances present that will interfere with UV quantification. It gives adequate concentration estimates for subsequent double digestions and ligations. Standards should contain a single species of DNA, about the same size as the expected size of the unknown DNA. DNA standards are stable for several months at -20°C .
13. A trial ligation of double-digested vector with double-digested LC or HC DNA will determine the optimal vector:insert ratio (molar ratio) for large-scale ligation of vector with insert to create the library. An optimal vector:insert ratio greater than 2:1 is generally an indication that only partial digestion of the PCR product has occurred.

14. For the large-scale ligation, incubation overnight works best rather than a few hours at room temperature. Cleanup of the large-scale ligation is essential to remove buffer, to have the ligation reaction in a smaller volume and for the DNA to be in H₂O for the electroporation.
15. A high transformation efficiency of XL1-Blue is required for the construction of Fab libraries. In order to obtain highly electrocompetent cells, work as quickly as possible during resuspension of cells, and do not leave cells on ice any longer than necessary. Cells made competent by chemical means are not of sufficiently high quality for library construction. If electrocompetent cells are not available in-house, a commercial source can be used, although the cost of these can be high.
16. An indication of library size can be obtained from the small-scale ligation by calculating colony-forming units (cfu)/μg DNA, which should be >10⁷. The value for ligation of the vector alone should be <1 × 10⁴ cfu/μg, which indicates a low proportion of single-cut vector. This is essential to ensure a good library size in the large-scale ligation.
17. Library size is calculated from the test plates after large-scale ligation of LC products and after ligation of HC products into LC library as cfu/μL, then multiplied by the total volume (15–20 mL) of the library after electroporation and rescue. Libraries of 2–8 × 10⁷ LC and HC are standard.
18. Generally, the LC library is stored as DNA at –20°C and as a bacterial glycerol stock from which phage can be prepared if required. The LC DNA library is then subjected to digestion, cleanup (*see Subheading 3.8.*), trial ligation (*see Subheading 3.10.*), large-scale ligation with HC (*see Subheading 3.11.*) and electroporation (*see Subheading 3.13.*) to create the final Fab library.
19. It is best to proceed with the LC library by electroporating into *E. coli*, preparing DNA, verifying that the library size is adequate, and that the inserts are full-length (*see Subheading 3.17.*) prior to cloning of the HC. Once these analyses have been carried out, the HC can be cloned into the LC library for completion of the Fab library.
20. Initial stocks of helper phage may need to be purchased, but, afterwards, stocks made in-house (*see Subheading 3.16.*) are generally of high quality and can be stored for several years at –70°C without loss of infectivity. Helper phage are stable for a few months at 4°C.
21. When titrating helper phage, it is critical that the plates be warm and dry because the top agar sets quickly. It is also important to cool the molten top agar a little after removing from the water bath because the *E. coli* will be killed if the temperature is too high.
22. For crack PCR, colonies need to be fresh (no more than 1 wk old). Do not use excess (>30 μL) cracking buffer as the ethylene diamine tetraacetic acid will inhibit the PCR. Analysis of 10 clones is usually enough to get an estimate of the quality of the library. *Bst*NI digestion provides a fingerprint of the clones, which gives an estimate of the diversity of the library. A range of banding patterns is

seen, if the clones are different. Similarity, or otherwise, of banding patterns should be scored (e.g., 3/10 same, 7/10 different profiles).

References

1. Clark, M. A., Papaioannou, A., Hawkins, N. J., Fiddes, R. J., and Ward, R. L. (1997). Isolation of human anti-c-erbB-2 Fabs from a lymph node-derived phage display library. *Clin. Exp. Immunol.* **109**, 166–174.
2. Coomber, D. W. J., Clark, M. A., Hawkins, N. J., and Ward, R. L. (1999) Generation of anti-p53 Fab fragments from individuals with colorectal cancer using phage display. *J. Immunol.* **163**, 2276–2283.
3. Ward, R. L., Clark, M. A., Lees, J., and Hawkins, N. J. (1996) Retrieval of human antibodies from phage-display libraries using enzymatic cleavage. *J. Immunol. Meth.* **189**, 73–82.
4. Chomczynski, P. and Sacchi, N. (1987) Single-step method of RNA isolation by acid guanidinium thiocyanate-phenol-chloroform extraction. *Anal. Biochem.* **162**, 156–159.
5. Yip, Y. L., Hawkins, N. J., Clark, M. A., and Ward, R. L. (1997) Evaluation of different lymphoid tissue sources for the construction of human immunoglobulin gene libraries. *Immunotechnology* **3**, 195–203.

Standard Protocols for the Construction of scFv Libraries

Simon Lennard

1. Introduction

Since the generation of the first human antibodies (Abs) by phage display (1,2), technology has evolved to allow the creation of large, nonimmunized fully human scFv repertoires that yield Abs with comparable affinities to those obtained using hybridoma technology (3,4). Using a variety of selection and screening strategies, the same single-pot library can be used to simultaneously derive many high-affinity Abs with different specificities in only a few weeks. Abs isolated from such large, fully human scFv repertoires have a multitude of applications, from immunological reagents for enzyme-linked immunosorbant assay, immunocytochemistry, Western blotting, or epitope mapping, to therapy. The first fully human therapeutic monoclonal Abs isolated from a phage-displayed library for the treatment of rheumatoid arthritis and ocular scarring are currently progressing through late-stage clinical trials (5).

Construction of such scFv libraries from naturally rearranged V genes in a phagemid vector ensures natural diversity in the length of the V_H CDR3, a higher number of functional scFvs, and soluble scFv expression without the need for subcloning (3). Furthermore, phage-display technology also provides a means by which a selected Ab can, if necessary, be affinity-matured for improved neutralization potency or binding kinetics. Maximum diversity is generated by amplifying V genes from peripheral blood lymphocytes (PBL) or lymphoid tissue isolated from several nonimmunized donors using polymerase chain reaction (PCR) primers that correspond to all known V_H, V_K, and V_λ gene sequences. These are principally based on those published previously (6) with further information on the most recent V_H sequences obtained from the

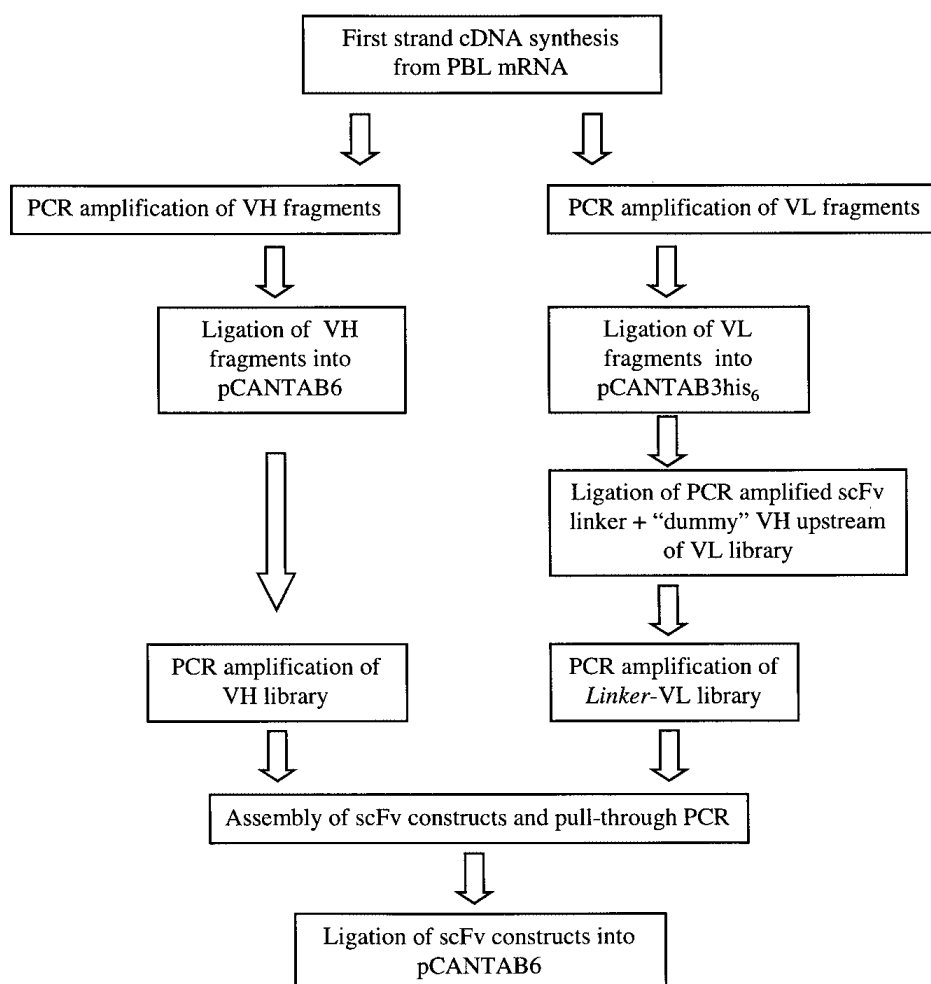

Fig. 1. Protocol flow chart.

V-BASE directory (Tomlinson et al., MRC Centre for Protein Engineering). To ensure that all five Ab classes are likely to be represented and increase the overall size of the final library, random hexamers are employed in the primary first-strand cDNA synthesis from PBL mRNA. Component V_H and V_L gene segments are amplified in separate PCR reactions, and initially cloned into two different vectors, pCANTAB6 and pCANTAB3his₆ (see Fig. 1). The latter is used for cloning the V_L repertoire because it has the appropriate polylinker cloning sites for the digested V_L fragments; the V_H repertoire is cloned into pCANTAB6. A short linker from an existing scFv is cloned (together with

an irrelevant or “dummy” V_H) into the V_L repertoire, upstream of the V_L fragments. The V_H and linker- V_L repertoires are then amplified from their vectors, and the scFv construct is prepared using a simple two-fragment PCR assembly procedure. This construct is then cloned into pCANTAB6 to create the large naïve scFv library (3).

2. Materials

1. Fresh source of lymphoid tissue from which mRNA can be isolated.
2. Kit for the preparation of mRNA (e.g., an oligo(dT)-purification system, such as the Quickprep mRNA Kit; Amersham Pharmacia Biotech).
3. Kit for the synthesis of cDNA (e.g., “First-strand cDNA synthesis kit”; Amersham Pharmacia Biotech).
4. PCR reagents: *Taq* DNA polymerase with 10X *Taq* DNA polymerase buffer (Boehringer Mannheim), a stock of deoxyribonucleoside triphosphates (dNTPs) (5 mM each) (Pharmacia), PCR H_2O [ACS] reagent; Aldrich cat. no. 32, 007-2).
5. Oligonucleotide primers at 10 μM . **Tables 1–4** show primer sets currently used in the author’s laboratory for the construction of human scFv libraries.
6. Buffer-saturated phenol *UltraPure*[™] (Gibco-BRL).
7. Chloroform.
8. Absolute ethanol ($-20^\circ C$); 70% (v/v) ethanol ($-20^\circ C$).
9. Kit for the isolation of DNA from gels (e.g., GeneClean, Bio101).
10. H_2O (ACS reagent grade).
11. Phage display vector(s) and appropriate restriction enzymes for cloning. In the example described, the vectors, pCANTAB6 and pCANTAB3*his*₆, are used with the enzymes *Sfi*I, *Not*I, *Xho*I, *Hind*III, *Apa*LI, although the principles of library construction are not limited to these vectors or restriction enzymes. Samples of pCANTAB6 and pCANTAB3*his*₆ can be obtained from Cambridge Antibody Technology under a standard materials transfer agreement.
12. Kit for medium-scale isolation of plasmid DNA (e.g., Qiagen midipreps).
13. Ligation kit (e.g., “Rapid ligation kit,” Amersham Pharmacia Biotech, cat. no. RPN 1507), 5X ligation buffer (500 mM Tris-HCl, 25 mM $MgCl_2$, pH7.4).
14. Electrocompetent *Escherichia coli* TG1.
15. Bio-Rad Gene Pulser[™] and suitable electroporation cuvetts.
16. 2TY as liquid and solid media (refer to index or **ref. 8** for composition).
17. Glucose 20% (w/v) sterile-filtered.
18. Ampicillin (100 mg/mL stock) and kanamycin (50 mg/mL stock), both filter-sterilized.
19. Kit for the purification of PCR products (e.g., Wizard PCR preps, Promega).
20. 20% (w/v) Polyethylene glycol (PEG) 8000, 2.5 M NaCl.
21. TE buffer (10 mM Tris-HCl, 1 mM ethylene diamine tetraacetic acid, pH 8.0).
22. Ultrapure cesium chloride (CsCl).

(Text continued on page 65)

Table 1
Primers for Amplification of Human V_H Sequences

Human V_H Back*Sfi*I primers

V_H1b/7a Back *Sfi*I

5'-GTC CTC GCA ACT GCG GCC CAG CCG GCC ATG GCC CAG (AG)TG
 CAG CTG GTG CA(AG) GG-3'

V_HLC Back*Sfi*I

5'-GTC CTC GCA ACT GCG GCC CAG CCG GCC ATG GCC (GC)AG GTC
 CAG CTG GT(AG) CAG TCT GG-3'

V_H2b Back*Sfi*I

5'-GTC CTC GCA ACT GCG GCC CAG CCG GCC ATG GCC CAG (AG)TC
 ACC TTG AAG GAG TCT GG-3'

V_H3b Back*Sfi*I

5'-GTC CTC GCA ACT GCG GCC CAG CCG GCC ATG GCC (GC)AG GTG
 CAG CTG GTG GAG TCT GG-3'

V_H3c back*Sfi*I

5'-GTC CTC GCA ACT GCG GCC CAG CCG GCC ATG GCC GAG GTG CAG
 CTG GTG GAG (AT)C(TC) GG-3'

V_H4b Back*Sfi*I

5'-GTC CTC GCA ACT GCG GCC CAG CCG GCC ATG GCC CAG GTG CAG
 CTA CAG CAG TGG GG-3'

V_H4c Back*Sfi*I

5'-GTC CTC GCA ACT GCG GCC CAG CCG GCC ATG GCC CAG (GC)TG
 CAG CTG CAG GAG TC(GC) GG-3'

V_H5b Back*Sfi*I

5'-GTC CTC GCA ACT GCG GCC CAG CCG GCC ATG GCC GA(AG) GTG
 CAG CTG GTG CAG TCT GG-3'

V_H6a Back*Sfi*I

5'-GTC CTC GCA ACT GCG GCC CAG CCG GCC ATG GCC CAG GTA CAG
 CTG CAG CAG TCA GG-3'

Human J_H for *Xho*I primers

HuJ_HFor1-2*Xho*I

5'-ACC GCC TCC ACC ACT CGA GAC GGT GAC CAG GGT GCC
 (TC)(TC)(GT) GCC CCA-3'

HuJ_HFor3*Xho*I

5'-ACC GCC TCC ACC ACT CGA GAC GGT GAC CAT TGT CCC
 (TC)(TC)(GT) GCC CCA-3'

HuJ_HFor4-5*Xho*I

5'-ACC GCC TCC ACC ACT CGA GAC GGT GAC CAG GGT TCC
 (TC)(TC)(TG) GCC CCA-3'

HuJ_HFor6*Xho*I

5'-ACC GCC TCC ACC ACT CGA GAC GGT GAC CGT GGT CCC
 (TC)(TC)(TG) CCC CCA-3'

Table 2
Oligonucleotide Primers for Amplification of Human V_L Sequences

Human V_λ BackApaLI Primers

Huλ1a BackApaLI

5'-ACC GCC TCC ACC AGT GCA CAG TCT GTG CTG ACT CAG CCA CC-3'

Huλ1b BackApaLI

5'-ACC GCC TCC ACC AGT GCA CAG TCT GTG (TC)TG ACG CAG CCG
 CC-3'

Huλ1c BackApaLI

5'-ACC GCC TCC ACC AGT GCA CAG TCT GTC GTG ACG CAG CCG CC-3'

Huλ2 BackApaLI

5'-ACC GCC TCC ACC AGT GCA CA(AG) TCT GCC CTG ACT CAG CCT-3'

Huλ3a BackApaLI

5'-ACC GCC TCC ACC AGT GCA CTT TCC TAT G(AT)G CTG ACT CAG
 CCA CC-3'

Huλ3b BackApaLI

5'-ACC GCC TCC ACC AGT GCA CTT TCT TCT GAG CTG ACT CAG GAC
 CC-3'

Huλ4 BackApaLI

5'-ACC GCC TCC ACC AGT GCA CAC GTT ATA CTG ACT CAA CCG CC-3'

Huλ5 BackApaLI

5'-ACC GCC TCC ACC AGT GCA CAG GCT GTG CTG ACT CAG CCG TC-3'

Huλ6 BackApaLI

5'-ACC GCC TCC ACC AGT GCA CTT AAT TTT ATG CTG ACT CAG CCC
 CA-3'

Huλ7/8 BackApaLI

5'-ACC GCC TCC ACC AGT GCA CAG (AG)CT GTG GTG AC(TC) CAG GAG
 CC-3'

Huλ9 BackApaLI

5'-ACC GCC TCC ACC AGT GCA C(AT)G CCT GTG CTG ACT CAG CC(AC)
 CC-3'

Human V_κ BackApaLI Primers

Huκ1b BackApaLI

5'-ACC GCC TCC ACC AGT GCA CTT GAC ATC CAG (AT)TG ACC CAG
 TCT CC-3'

Huκ2 BackApaLI

5'-ACC GCC TCC ACC AGT GCA CTT GAT GTT GTG ATG ACT CAG TCT
 CC-3'

Huκ3b BackApaLI

5'-ACC GCC TCC ACC AGT GCA CTT GAA ATT GTG (AT)TG AC(AG) CAG
 TCT CC-3'

(continued)

Table 2 (Continued)

Huk4b BackApaLI
5'-ACC GCC TCC ACC AGT GCA CTT GAT ATT GTG ATG ACC CAC ACT CC-3'
Huk5 BackApaLI
5'-ACC GCC TCC ACC AGT GCA CTT GAA ACG ACA CTC ACG CAG TCT CC-3'
Huk6 BackApaLI
5'-ACC GCC TCC ACC AGT GCA CTT GAA ATT GTG CTG ACT CAG TCT CC-3'
Human J _λ ForNotI Primers
HuJ _λ 1 ForNotI
5'-GAG TCA TTC TCG ACT TGC GGC CGC ACC TAG GAC GGT GAC CTT GGT CCC-3'
HuJ _λ 2-3 ForNotI
5'-GAG TCA TTC TCG ACT TGC GGC CGC ACC TAG GAC GGT CAG CTT GGT CCC-3'
HuJ _λ 4-5 ForNotI
5'-GAG TCA TTC TCG ACT TGC GGC CGC ACT TAA AAC GGT GAG CTG GGT CCC-3'
Human J _κ ForNotI Primers
HuJ _κ ForNotI
5'-GAG TCA TTC TCG ACT TGC GGC CGC ACG TTT GAT TTC CAC CTT GGT CCC-3'
HuJ _κ 2 ForNotI
5'-GAG TCA TTC TCG ACT TGC GGC CGC ACG TTT GAT CTC CAG CTT GGT CCC-3'
HuJ _κ 3 ForNotI
5'-GAG TCA TTC TCG ACT TGC GGC CGC ACG TTT GAT ATC CAC TTT GGT CCC-3'
HuJ _κ 4 ForNotI
5'-GAG TCA TTC TCG ACT TGC GGC CGC ACG TTT GAT CTC CAC CTT GGT CCC-3'
HuJ _κ 5 ForNotI
5'-GAG TCA TTC TCG ACT TGC GGC CGC ACG TTT AAT CTC CAG TCG TGT CCC-3'

Table 3
Oligonucleotide Primers for Recovery of V_H and Linker Sequence

pUC19 Rev Primer
 5'-AGC GGA TAA CAA TTT CAC ACA GG-3'

fdtseq Primer
 5'-GTC GTC TTT CCA GAC GTT AGT-3'

Table 4
Oligonucleotide Primers for Pull-Through PCR

J_H for Primers
 HuJ_H1-2For
 5'-TGA GGA GAC GGT GAC CAG GGT GCC-3'

HuJ_H3For
 5'-TGA AGA GAC GGT GAC CAT TGT CCC-3'

HuJ_H4-5For
 5'-TGA GGA GAC GGT GAC CAG GGT TCC-3'

HuJ_H6For
 5'-TGA GGA GAC GGT GAC CGT GGT CCC-3'

Rev J_H Primers
 RHuJ_H1-2
 5'-GCA CCC TGG TCA CCG TCT CCT CAG GTG G-3'

RHuJ_H3
 5'-GGA CAA TGG TCA CCG TCT CTT CAG GTG G-3'

RHuJ_H4-5
 5'-GAA CCC TGG TCA CCG TCT CCT CAG GTG G-3'

RHuJ_H6
 5'-GGA CCA CGG TCA CCG TCT CCT CAG GTG C-3'

3. Methods

3.1. Synthesis of Primary cDNA Template (see Note 1)

1. Isolate approx 1×10^7 cells peripheral blood lymphocytes from 50 mL whole blood (6) (see Note 2).
2. Immediately isolate the mRNA from the cell pellet (7) using an oligo(dT)-purification system, following the manufacturer's instructions.
3. Synthesize first-strand cDNA from the mRNA template with random hexamers using a kit. Follow the manufacturer's instructions (3).

3.2. V_H Repertoire Construction

1. Perform separate 50 μ L PCR reactions for each V_H Back primer using the following cycling parameters: 94°C 1 min, 55°C 1 min, 72°C 2 min for 30

cycles; final extension at 72°C for 10 min (*see Note 3*). Each reaction comprises 5.0 µL 10X *Taq* buffer, 2.5 µL 5 mM dNTP stock, 2.5 µL individual V_H Back*Sfi*I primer at 10 µM, 2.5 µL equimolar mix of J_H1-6For*Xho*I primers at 10 µM total, 5.0 µL first-strand cDNA mix (typically 0.5 ng cDNA), 31.5 µL PCR H₂O, and 1.0 µL *Taq* polymerase (5 U).

2. Pool the PCR reactions and concentrate the DNA by phenol/chloroform extraction, followed by ethanol precipitation (8). Resuspend the DNA pellet in ACS reagent-grade H₂O.
3. Digest the DNA with *Sfi*I using the reaction buffer provided by the distributor, noting that the optimal temperature for this enzyme is 50°C. Extract with phenol/chloroform and concentrate the DNA by ethanol precipitation.
4. Digest the products with *Xho*I. After digestion, heat-inactivate the enzyme at 65°C for 20 min.
5. Run the products on a TAE agarose gel, and check that the V_H segments are approx 350 bp in size.
6. Excise the band and purify the V_H fragments using a commercial kit, following the manufacturer's recommended protocol. Estimate the concentration of the V_H product by comparison with a DNA marker (typically λ DNA digested with *Hind*III) of known concentration on a 1% (w/v) TAE agarose gel.
7. Digest and concentrate the pCANTAB6 vector (*see Note 4*) with *Sfi*I and *Xho*I restriction enzymes (steps 2 and 3 above). Estimate the concentration of recovered DNA by comparison with known DNA markers (step 5).
8. Set up a series of trial ligations covering a range of molar ratios of insert:vector (e.g., 1:1, 2:1, 4:1, 1:2) and a fixed concentration of pCANTAB6 within the range specified by the manufacturer of the ligation kit (typically, 50–500 ng vector DNA) (*see Note 5*). Carry out the ligation reaction according to the manufacturer's instructions.
9. Precipitate the DNA with ethanol (8), redissolve in the smallest-possible volume of ACS reagent-grade H₂O, and electroporate into *E. coli* TG1 (2.5 V, 200 Ω) (*see Note 5*). Add 2TY containing 2% glucose (2TYG) and allow the cells to recover for 1 h with shaking at 200 rpm in a 37°C incubator.
10. Plate aliquots from each transformation to 2YTG plates containing ampicillin (100 µg/mL; 2TYAG) and incubate overnight at 30°C. Confirm that background levels of vector self-ligation are minimal and which ligation ratio yields the highest numbers of transformants.
11. From the planned size of the V_H library (*see Note 6*) and the recovery of transformants from the optimal ligation, calculate the number of ligation reactions required for library construction. Set up ligations and precipitate the products as before (steps 6 and 7).
12. Perform at least 40 electroporations with electrocompetent *E. coli* TG1 cells (step 7), and let the cells recover for 1 h in 2TYG with shaking at 200 rpm at 37°C. Pool the cells from all electroporations, and take a small aliquot for

plating at 10-fold serial dilutions onto 2TYAG plates to determine the size of the library.

13. Centrifuge the rest of the cells at 1200g for 10 min, remove the supernatant, and resuspend in 1–2 mL 2TY. Plate out the total library on four large 243 × 243 mm 2TYAG plates.
14. Incubate all plates overnight at 30°C. Determine the size of the library from the titer plates: this should be in the region of 1×10^7 to 1×10^8 individual recombinants. Scrape cells from the large plates and prepare glycerol stocks for storage at –70°C (see **Subheading 3.4., step 7**).

3.3. V_L Repertoire Construction (see Note 7)

1. Perform 50 μ L PCR reactions using the same cycling parameters as outlined for recovery of V_H products (see **Subheading 3.2.**). Use 5 μ L first-strand cDNA mix as the template with the following primer combinations: V_λ BackApaLI + J_λ 1–5ForNotI primer mix and V_κ BackApaLI + J_κ 1–5ForNotI primer mix.
2. Pool and concentrate the PCR products as described previously (see **Subheading 3.2.**), and digest with ApaLI. Extract with phenol/chloroform, precipitate the DNA, then digest with NotI. Heat-inactivate at 65°C for 20 min and gel-purify the V_L fragments. Estimate the concentration of purified insert as described previously (see **Subheading 3.2.**). The size of the resulting V_L fragments will be 350 bp.
3. Digest the pCANTAB3his₆ vector sequentially with ApaLI and NotI restriction enzymes (**step 2**) and concentrate the cut vector by performing a phenol/chloroform extraction, followed by ethanol precipitation. Estimate the concentration of DNA recovered by comparison with markers.
4. Perform ligation reactions and subsequent electroporations as described for the V_H repertoire (see **Subheading 3.2.**). The size of the V_κ and V_λ repertoires should be between 1×10^5 and 1×10^6 individual recombinants.
5. To introduce the (Gly₄Ser)₃ scFv-linker into the finished V_L repertoire, PCR-amplify the linker from an existing scFv, together with an irrelevant (dummy) V_H fragment. First, pick a single colony of an irrelevant clone that possesses the required scFv linker and PCR-amplify with primers pUC19rev and fdtetseq primers (see **Table 3**) using the cycling parameters described previously (see **Subheading 3.2.**).
6. Assuming that gel analysis shows a single product, isolate the amplicon using a commercial kit and digest with ApaLI. Phenol/chloroform extract, ethanol-precipitate, and digest with HindIII to generate a product of ~450 bp. Heat-inactivate (65°C for 20 min), purify the DNA from a 1% TAE agarose gel, and estimate its concentration by comparison with DNA markers.
7. Prepare the pCANTAB3his₆ vector containing the V_L repertoire on midiprep scale and sequentially digest 10 μ g with ApaLI and HindIII restriction enzymes (**step 6**).

8. Concentrate the digested V_L repertoire by phenol/chloroform extraction, followed by ethanol precipitation. Gel-purify the large DNA fragment and estimate its concentration by comparison with markers.
9. Perform sufficient ligation reactions to ligate approx 0.4 μg dummy V_H -linker DNA fragment into a 1- μg pool of the V_K and V_λ libraries.
10. Electroporate into *E. coli* TG1 cells, and plate out as described previously (see **Subheading 3.2.**). Aim to generate between 1×10^6 and 1×10^7 recombinants, carrying V_L inserts with upstream scFv linker and dummy V_H .

3.4. Construction of the scFv Library (see Notes 8 and 9)

1. Amplify the V_H and linker- V_L DNA fragments separately from each of the cloned repertoires. Perform 50 μL PCR reactions using the cycling parameters described previously (see **Subheading 3.2.**), amplifying the V_H repertoire with pUC19rev and J_H For primers and the V_L repertoire with reverse J_H and fdtetseq primers. Purify the products from 1% TAE agarose gels and estimate DNA concentrations by comparison with markers.
2. Combine equal amounts of the V_H and linker- V_L PCR products (5–20 ng each), increase the total volume to 100 μL with ACS, reagent-grade H_2O prior to recovery of the DNA by ethanol precipitation. Resuspend the DNA pellet in 25 μL H_2O .
3. To perform the assembly reaction, add the following reagents to the pooled V_H and linker- V_L products, and perform 25 cycles of 94°C for 1 min, followed by 65°C for 4 min: 3.0 μL 10X *Taq* buffer, 1.5 μL 5 mM dNTP stock, and 0.5 μL *Taq* polymerase (2.5 U).
4. Prepare 50 μL pull-through PCR reactions, pairing each V_H Back*Sfi*I primer with either the J_K1 -5For*Not*I primer mix or the $J_\lambda1$ -5For*Not*I primer mix. Replicates of each reaction are advisable, to maximize the diversity of the final library. Using 5.0 μL assembly DNA/reaction, amplify with cycling parameters described previously (see **Subheading 3.2.**). The correct size of the assembled construct is around 700 bp.
5. Pool and concentrate the PCR products by phenol/chloroform extraction, followed by ethanol precipitation. Sequentially digest with *Sfi*I and *Not*I restriction endonucleases as described previously (see **Subheadings 3.2.** and **3.3.**).
6. Gel-purify the digested scFv assembly construct and ligate with *Sfi*I/*Not*I digested pCANTAB6 after determining the optimum insert:vector ratio as described previously (see **Subheading 3.2.**). Perform at least 100 electroporations, pool into batches, and plate out each batch on large 243 \times 243 mm 2TYAG plates. Determine the total size of the library by taking aliquots from each batch and plating out serial dilutions on 2TYAG. The final library should contain in the region of 1×10^8 to 1×10^9 individual recombinants. Clones picked from these plates can be used to characterize the library (see **Note 9**).
7. Scrape the large plates, using 5 mL 2TY/plate, and pool the cells in 50-mL Falcon tubes. Add 0.5 vol 50% (v/v) glycerol to each tube, and ensure homogeneous

resuspension of the cells by mixing on a rotating wheel for 30 min. Determine cell density by optical density measurement at 600 nm. Store the library in aliquots at -70°C .

3.5. Preparation of Library Phage (see Note 10)

1. Inoculate 500 mL 2TYG with 10^{10} cells from the library glycerol stock and incubate at 37°C with shaking at 250 rpm until the optical density at 600 nm reaches 0.5–1.0.
2. Add M13KO7 helper phage to a final concentration of 5×10^9 pfu/mL, and incubate for 30 min at 37°C without shaking, then for 30 min with gentle shaking (200 rpm), to allow phage infection.
3. Recover the cells by centrifugation at 2200g for 15 min and resuspend the pellet in the same volume of 2TYAK (2TY containing 100 $\mu\text{g}/\text{mL}$ ampicillin, 50 $\mu\text{g}/\text{mL}$ kanamycin). Incubate overnight at 30°C with rapid shaking (300 rpm).
4. Pellet the cells by centrifugation at 7000g for 15 min at 4°C and recover the supernatant containing the phage into prechilled 1-L bottles.
5. Add 0.3 vol of PEG/NaCl. Mix gently and allow the phage to precipitate for 1 h on ice.
6. Pellet the phage by twice centrifuging at 7000g for 15 min in the same bottle at 4°C . Remove as much of the supernatant as possible and resuspend the pellet in 8 mL TE buffer.
7. Recentrifuge the phage in smaller tubes at 12,000g for 10 min and recover the supernatant, which will now contain the phage. Ensure that any bacterial pellet that appears is left undisturbed.
8. Add 3.6 g of caesium chloride to the phage suspension and raise the total volume to 9 mL with TE buffer. Using an ultracentrifuge, spin the samples at 110,000g, 23°C , for at least 24 h.
9. After ultracentrifugation, the phage should be visible as a tight band, which can be recovered by puncturing the tube with a 19-gage needle plus syringe and careful extraction.
10. Dialyze the phage against two changes of 1 L TE at 4°C for 24 h.
11. Finally, titer phage stocks by infecting TG1 cells with dilutions of phage stock, plating to 2TYAG, incubation, and enumeration of the numbers of ampicillin-resistant colonies that appear. The phage can then be stored in aliquots at 4°C for long periods (see Note 10), ready for screening (see Note 11).

4. Notes

1. Rapid processing of fresh tissue samples is essential if the full diversity of the Ab repertoire is to be recovered. If some loss of diversity is acceptable (perhaps when preparing libraries from infected or immunized individuals, rather than in developing a comprehensive naïve library) tissue, mRNA, or cDNA product can be stored at -70°C .

2. RNA isolation (7) from Ficoll-isolated leukocytes, as described by Marks et al. (6), is the method of choice. 50 mL of blood should yield approx 1×10^7 cells, which in turn yield about 10 μg total RNA, of which 1–5% is mRNA. It is important to ensure that there is enough cDNA for all the V_H and V_L PCR reactions planned, each of which requires 0.5 ng cDNA.
3. The PCR primers employed are based on those published by Marks et al. (6), and/or gene sequences in the V-BASE directory. The 5' and 3' V_H primers include *SfiI* and *XhoI* restriction sites, respectively, to allow for cloning (see **Table 1**). Include “no template” controls and check all PCR products on 1–2% (w/v) TAE agarose gels to ensure that a clean product of the expected size has been generated.
4. Plasmid DNA (pCANTAB6 or pCANTAB3his₆) is prepared either by the alkali lysis method (and subsequently caesium-banded as detailed in Sambrook et al. [8]), or by using a commercial kit (medium-scale). Approximately 20 μg Cs-banded vector will yield ~5–10 μg purified cut vector. Efficient digestion with both enzymes is crucial to avoid self-ligation of the vector and high backgrounds at transformation.
5. A “vector only” ligation control should be included to determine the background caused by nonrecombinants. Protocols for the preparation of electrocompetent *E. coli* TG1 cells and subsequent electroporations are described in Sambrook et al. (8) and by other contributors to this volume.
6. In most cases, a repertoire of $\sim 1 \times 10^7$ – 1×10^8 recombinants can be generated if 0.5 μg digested V_H segments are ligated with 1.5 μg digested vector.
7. V_L κ and V_L λ gene fragments are amplified separately using each back primer in combination with the appropriate equimolar mixture of the J_κ or J_λ Forward primers (see **Table 2**). After recovery of the combined V_L repertoire, the next stage is to clone in the (Gly₄Ser)₃ scFv linker from an existing scFv, together with a dummy V_H , recovered by PCR from an irrelevant clone. Primer sequences are shown in **Table 3**.
8. Final scFv library construction involves the amplification of V_H and linker- V_L DNA fragments from each cloned repertoire (V_H in pCANTAB6 and linker- V_L in pCANTAB3his₆), followed by assembly on the J_H region and amplification by pull-through PCR (see **Table 3** for pull-through PCR primers). The resulting scFv constructs (V_H -linker- V_L) are digested with *SfiI* and *NotI* and ligated into *SfiI/NotI* digested pCANTAB6.
9. Quality control analysis of the library is routinely performed by two methods to determine the percentage of recombinant clones and the level of library diversity. For both methods, the first stage is to PCR-amplify the scFv insert from 50 randomly picked clones/repertoire, using the vector primers, pUC19 reverse and fdtetseq, as described in **Subheading 3.2**. Digestion of the PCR products with *BstNI* restriction endonuclease and agarose gel electrophoresis can then be used to visualize the restriction profile for each clone. The low cost and technical simplicity of this approach are its main strengths, but, as a means to assess the diversity of a library, it is limited by the resolving power of the agarose gel.

Greater resolution and sensitivity can be achieved with polyacrylamide gels and silver staining (8), but sequence analysis with fluorescent dideoxy chain terminators directly from the PCR products is clearly a better method, since it is sensitive to single-base differences between clones beyond the *Bst*NI recognition sequence. Each clone picked should carry a unique combination of V_H and V_L sequences.

10. The resultant phage are purified by PEG precipitation and caesium-banding, and, as a result, are stable at 4°C for 2 yr. Phage prepared by PEG precipitation alone should only be stored at 4°C for 1–2 wk.
11. The affinities of Abs directly isolated from scFv repertoires constructed in this manner without further engineering can be in the subnanomolar range and tend to have slower off-rates than those derived from rodent immune responses, smaller scFv repertoires, or large synthetic Fab libraries (3).

References

1. McCafferty, J., Griffiths, A. D., Winter, G., and Chiswell, D. (1990) Phage antibodies: filamentous phage displaying antibody variable domains. *Nature* **348**, 552–554.
2. Winter, G., Griffiths, A. D., Hawkins, R. E., and Hoogenboom, H. R. (1994) Making antibodies by phage display technology. *Annu. Rev. Immunol.* **12**, 433–455.
3. Vaughan, T. J., Williams, A. J., Pritchard, K., Osbourn, J. K., Pope, A. R., Earnshaw, J. C., et al. (1996) Human antibodies with sub-nanomolar affinities isolated from a large non-immunized phage display library. *Nature Biotechnol.* **14**, 309–314.
4. Xie, M.-H., Yuan, J., Adams, C., and Gurney, A. (1997) Direct demonstration of MuSK involvement in acetylcholine receptor clustering through identification of agonist scFv. *Nature Biotechnol.* **15**, 768–771.
5. Glover, D. R. (1999) Fully human antibodies come to fruition. *SCRIPS* (May), 16–19.
6. Marks, J. D., Hoogenboom, H. R., Bonnert, T. P., McCafferty, J., Griffiths, A. D., and Winter, G. (1991) By-passing immunization: human antibodies from V-gene libraries displayed on phage. *J. Mol. Biol.* **222**, 581–597.
7. Cathala, G., Savouret, J., Mendez, B., West, B. L., Karin, M., Martial, J. A., and Baxter, J. D. (1983) Method for isolation of intact, transcriptionally active ribonucleic acid. *DNA* **2**, 329–335.
8. Sambrook, J., Fritsch, E. F., and Maniatis, T. (1990) *Molecular Cloning: A Laboratory Manual*. Cold Spring Harbor Laboratory, Cold Spring Harbor, NY.

Broadening the Impact of Antibody Phage Display Technology

Amplification of Immunoglobulin Sequences from Species Other than Humans or Mice

Philippa M. O'Brien and Robert Aitken

1. Introduction

The production of monoclonal antibodies (MAb) through the immortalization of B lymphocytes has generally had little impact beyond human and murine immunology. This can be explained by the lack of appropriate myeloma lines or transforming viruses for species outside this select group and the instability of heterohybridoma cell lines generated with, for example, murine myeloma lines (*I*). The advent of Ab phage-display technology offers a solution to this problem: success pivots upon the ability to recover the immunoglobulin (Ig) repertoire from a source of B-lymphocyte mRNA and to construct representative display libraries from the encoded proteins for screening. In many species, understanding of the basis to Ig formation is now sufficiently detailed for the application of these methods to MAb isolation.

We anticipate that the availability of MAb via phage display from a broad range of species will benefit several areas:

1. To take livestock as an example, phage-display technology will obviate the modeling of viral, bacterial, or parasitic infections in rodent systems simply to obtain MAbs. This should eliminate potential artifacts arising from the limited ability of many veterinary pathogens to colonize laboratory animals or differences in antigenic recognition between natural and laboratory hosts.

2. In several important cases, human pathogens fail to establish in rodents, but relevant infection models are available in other animal species. Similarly, there are many human diseases with close parallels in veterinary medicine. The availability of MAbs from a wider range of species should increase the appeal of animals other than rodents for the study of human disease. The outbred characteristics of many of these mammals increases their value as models for human disease.
3. If they are derived from the animal under investigation, passive transfer of MAbs should not provoke the antispecies responses triggered by delivery of murine monoclonals. This may enable rapid evaluation of in vitro observations in relevant animal infection models.
4. The application of phage display should speed the development of MAb-based therapies for species of veterinary and economic importance and provide, through transgenesis (2) or other novel methods of immunoprophylaxis (3), a rational basis for enhanced disease resistance. Other applications include passive immunomodulation of a range of physiological processes and Ig-targeted drug or vaccine delivery (4).

To date, MAbs derived by phage display have been generated from rabbits (5–7), chickens (8–10), sheep (11,12), cattle (13), camels (14), and primates (15–20). The Abs have been produced as scFv and Fab constructs, utilizing vectors originally devised for human/murine immunology or expression systems optimized for the species under investigation. Excluding rabbits and primates, it is generally less complicated to amplify Ig-variable region sequences from veterinary species than from mice or humans. Many domesticated species (e.g., cattle) predominantly express Ig λ light chains (LCs) compared to κ -chains, and, despite the apparent complexity of many LC loci, often the LC repertoire is dominated by expression of a single or small numbers of families of V_{λ} segments. In addition, the expressed heavy-chain (HC) repertoire may be founded on single Ig HC gene families (e.g., cattle) or the rearrangement, diversification, and expression of single HC or LC V segments (e.g., chickens). Overall this means that, in comparison to humans or mice, far fewer oligonucleotide primers are required to recover the Ig repertoire by polymerase chain reaction (PCR) from many of the species highlighted here.

This chapter presents a general protocol for the PCR amplification of expressed variable region sequences from a lymphoid RNA source and details oligonucleotide primers required for repertoire recovery from a selection of species other than mice and humans.

2. Materials

1. Purified total RNA (peripheral blood, B-lymphocyte, lymphocyte-infiltrated tissue, and so on) stored at -70°C .
2. Sterile diethylpyrocarbonate-treated deionized H_2O .

3. Maloney murine leukemia virus reverse transcriptase (MMLV-RT) and commercially supplied buffer(s).
4. 10 mM Deoxyribonucleoside triphosphates (dNTPs), oligo(dT) primer, RNase inhibitor.
5. *Taq* polymerase and buffer (*see Note 1*).
6. Oligonucleotides for amplification of species-specific Ig cDNA (*see Tables 1–6* and *Note 2*).
7. Spin columns for cleanup of PCR reactions.
8. 10 mM Tris-HCl, 1 mM ethylene diamine tetraacetic acid, pH 7.4 (TE).
9. Ethidium bromide solution (2 mg/mL).
10. Stock of double-stranded DNA of defined concentration (e.g., determined by spectrophotometry) and 0.5–1 kb in size. This can be generated by PCR or isolation of a restriction fragment from a plasmid.

3. Methods

1. Aliquot 16 μM oligo (dT), 30 μg RNA, and the appropriate volume of diethylpyrocarbonate- H_2O to make a final reaction volume of 100 μL (including the reagents in **step 2**) into an RNase-free sterile microcentrifuge tube. Heat at 70°C for 10 min, then chill on ice.
2. Add 200 U RNase inhibitor, buffer(s) to 1X final concentration, 2 mM dNTPs, and 500 U MMLV-RT. Leave at room temperature for 10 min, then incubate at 37°C for 1 h (*see Note 3*).
3. PCR-amplify V_H and V_L sequences in a 100 μL reaction using 5 μL cDNA, 1X *Taq* polymerase buffer, 1.25–2.5 U *Taq* polymerase, 0.2 mM dNTPs, and 0.5 mM of each oligonucleotide primer (*see Note 4*). PCR conditions are 95°C for 5–15 min (*see Notes 1* and *3*), followed by 35 cycles at 95°C for 30 s, 52°C for 50 s, and 72°C for 1.5 min, followed by a final incubation at 72°C for 10 min. A separate PCR reaction should be performed for each primer combination.
4. Check the amplification of each Ig variable region by running a small aliquot of the reaction on a 1% agarose gel.
5. Combine PCR reactions for each Ig class/isotype (V_H , V_λ , V_κ) and clean up the reactions using spin columns.
6. Gel-purify products on 1.5% agarose gels (*see Note 5*) and extract using spin columns. Check the purity of the PCR products by running on a second 1.5% agarose gel.
7. Estimate the concentration of the products. Prepare a series of dilutions of the isolated products in TE buffer. Spot 5 μL to UV-transparent food wrap (e.g., plastic wrap) and set up a series of spots of a standardized DNA preparation. Add equal volumes of ethidium bromide solution to each, and, by comparison of fluorescence intensities under UV illumination, calculate the concentrations of the PCR products.

(Text continues on page 83)

Table 1
Primers for Recovery of Rabbit Ig Repertoire

V _κ Primers			Targeted to framework region 4 of V _κ domain	
	Targeted to framework region 1 of V _κ domain			
	L			
	V M T Q T P			(L)(I)(E)(L)(E)(T)(G)
V _κ 1	GTGMTGACCCAGACTCCA		V _κ 4	TAGGATCTCCAGCTCGGTCCC
	L			(K)(I)(E)(V)(N)(T)(G)
	D M T Q T P			TTTGATTTCCACATTGGTGCC
V _κ 2	GATMTGACCCAGACTCCA		V _κ 5	(K)(V)(V)(V)(E)(T)(G)
			V _κ 6	TTTGACSACCACCTCGGTCCC
	I			
	L D			Targeted against κ constant region to native stop codon
	A P E L			(*)(C)(D)(G)(R)(N)(F)
	D T V M T Q T P			C _κ 1 TTAACAGTCACCCCTATTGAAGC
V _κ 2a	GMCMYYGWKMTGACCCAGACTCC			(*)(C)(N)(K)(R)(S)(F)
	V M T Q T E			C _κ 2 TTAACAGTTCTTCCTACTGAAGC
V _κ 3	GTGATGACCCAGACTGAA			
	A Q V L T Q T			
V _κ 3a	GCTCAAGTGCTGACCCAGAC			
V _λ Primers			Targeted to framework region 4 of V _λ and first residues of C _λ	
	Targeted to framework region 1 of the V _λ domain			
	V L T Q S P S			(G)(T)(V)(T)(L)(Q)(T)(G)
V _λ 1	GTGCTGACTCAGTCGCCCTC		V _λ 2	CCTGTGACGGTCAGCTGGGTCCC
	Q P V L T Q S			(G)(T)(V)(T)(L)(Q)(T)
V _λ 1a	CAGCCTGTGCTGACTCAGTCG		V _λ 2a	ACCTGTGACGGTCAGCTGGGTCC

V_H Primers

Targeted to framework region 1 of V_H domain

V_H1 Q S V E E S G
 CAGTCGGTGGAGGAGTCCRGG
 V_H2 Q S V K E S E
 CAGTCGGTGAAGGAGTCCGAG
 V_H3 Q S L E E S G
 CAGTCGYTGGAGGAGTCCGGG
 V_H3a Q S L E E S G G
 CAGTCGCTGGAGGAGTCCGGGGGT
 Q M
 E M
 Q V
 V_H4 Q E Q L V E S G
 CAGSAGCAGCTGRTGGAGTCCGG

Targeted to framework region 4 of V_H

(P)(T)(V)(T)(L)(Q)(T)(G)
 V_H5 CCTGTGACGGTCAGCTGGGTCCC

Targeted to the N-terminal region of IgG constant domain 1

(V)(S)(P)(A)(K)(P)(Q)
 C_Hγ1 CTGACTGAYGGAGCCTTAGGTTGC

Targeted to hinge region of IgG constant domain

(K)(S)(C)(T)(S)(P)
 C_Hγ2 CTTGCTGCATGTCGAGGG
 (T)(P)(K)(S)(C)(T)(S)(P)
 C_Hγ2a CGTGGGCTTGCTGCATGTCGAGGG

77

See Note 2 for details. Data compiled from refs. 5-7.

Table 2
Primers for Recovery of Chicken Ig Repertoire

V_λ Primers		Targeted to framework region 4 and λ constant domain	
	Targeted to framework region 1 of V_λ domain		
	A L T Q P		(L)(V)(T)(L)(T)
$V_\lambda 1$	GCGCTGACTCAGCC	$V_\lambda 2$	AAGGACGGTCAGGGTT
	L T Q P S S V S		(Q)(G)(L)(V)(T)(L)
$V_\lambda 1a$	CTGACTCAGCCGTCCTCGGTGTC	$V_\lambda 2a$	CTGACCTAGGACGGTCAGG
	T Q P S S V S		(I)(T)(P)(A)(V)(K)(P)(Q)
$V_\lambda 1b$	GACTCAGCCGTCCTCGGTGTCAG	$V_\lambda 3$	TGATGGTGGGGCCACATTGGGCTG
V_H Primers		Targeted to framework region 4 of V_H	
	Targeted to C-terminal region of leader and framework region 1 of V_H domain		(S)(S)(L)(I)(V)(E)(T)
	L M A A V T L	$V_H 2$	CGGAGGAGACGATGACTTCGGTCC
$V_H 1$	CTGATGGCGGCCGTGACGTT		
	L M A A V T L D		
$V_H 1a$	CTGATGGCGGCCGTGACGTTGGAC		
	A V T L D E		
$V_H 1b$	GCCGTGACGTTGGACGAG		

See **Note 2** for details. Data compiled from **refs. 8–10**.

Table 3
Primers for Recovery of Sheep Ig Repertoire

V_κ Primers			
	Targeted to framework region 1 of V _κ domain		Targeted to framework region 4 of V _κ and first residue of C _κ
	L		
	D I Q V T Q S P		(R) (K) (I) (E) (V) (N) (T)
V _κ 1	GACATCCAGSTGACCCAGTCTCCA	V _κ 2	CCGTTTGATTTCCACGTTGGTCC
			Targeted to N-terminal regions of constant domain
			(P) (K) (F) (L) (S) (V) (S) (P) (Q) (A)
		C _κ 1	GATGGTTTGAAGAGGGAGACGGATGGCTGAGC
V_λ Primers			
	Targeted to framework region 1 of V _λ domain		Targeted to framework region 4 of the V _λ domain
	Q A V L T Q P		(G) (L) (V) (T) (L) (R) (T)
V _λ 1	CAGGCTGTGCTGACTCAGCCG	V _λ 6	ACCCAGGACGGTCAGCCTGGTCC
	L		(R) (S)
	Q A V L T Q P		(G) (L) (V) (T) (L) (S) (T)
V _λ 2	CARGCTGTGCTGACYCARCYG	V _λ 7	ACCAGGACGGTCAGYCKRGWCC
	L L		
	Q A V V T Q P		Targeted to N-terminal regions of γ constant region
V _λ 3	CAGGCYSTGSTGACTCAGCCR		(L) (T) (V) (S) (P) (A) (S) (K)
	K	C _γ 1	ACAGGGTGACCGAGGGTGCGGACTTGG
	Q M L		
	R V V R T Q P		
V _λ 4	MRGGTCRTGCKGACTCARCCG		
	A A		
	Q S V L T Q P		
V _λ 5	CAGKCTGYSCTGACTCAGCCK		
V_H Primers			
	Targeted to framework region 1 of V _H domain		Targeted to framework region 4 of V _H
	Q E		
	V R L Q G S G		(S) (S) (V) (T) (V) (L) (L) (G)
V _H 1	AGGTKCRRCTGCAGGRGTCGGG	V _H 3	TGAGGAGACGGTGACCAGGAGTCC
	F		(A) (S) (I)
	V Q L Q E S G		(S) (S) (V) (T) (V) (L) (L) (G)
V _H 2	AGGTKCAGYTKCAGGAGTCGGG	V _H 4	TGAGGAGRCGGWGAYYAGKAGTCC

See Note 2 for details. Data compiled from refs. 11 and 12.

Table 4
Primers for Recovery of Bovine Ig Repertoire

V_{λ} Primers		
Targeted to framework region 1 of V_{λ} domain		Targeted to N-terminal regions of λ constant region
	N	
	S	
	T	
	S V S V Y L G	(T)(V)(S)(P)(P)(S)(K)(P)
$V_{\lambda}1$	TCCGTGTCGGTSMYCTGGG	$C_{\lambda}1$ GGTCACCGAAGGTGGGGACTTGGG
V_H Primers		
Targeted to framework region 1 of V_H domain		Targeted to central region of C_H1
	G P S L V K P S Q T	(V)(A)(K)(D)(V)(K)(T)
V_H1	CGGACCGAGCCTGGTGAAGCCCTCACAGACC	$C_H\gamma1$ AACAGCCTTGTCCACCTTGGTGC

See Note 2 for details. Data compiled from ref. 13.

80

Table 5
Primers for Recovery of Camel Ig Repertoire

V_H Primers		
Targeted to V_H leader sequence		Targeted to C_H2 sequences in all IgG isotypes
	V L A A L L Q G	(Y)(T)(S)(N)(F)(Q)(E)
V_H1	GTCCTGGCTGCTCTTCTACAAGG	$C_H\gamma1$ GGTACGTGCTGTTGAACTGTTCC
Targeted to framework 1 sequences in V_H		Targeted to framework 4 sequences in V_H
	D	
	E	
	H	(L)
	M A Q V Q L V E S G	(S)(S)(V)(T)(V)(Q)
V_H2	CATGGCTSAKGTGCAGCTGGTGGAGTCTGG	V_H3 TGAGGAGACRGTGACCWG

See Notes 2 and 7 for details. Data provided by Dr. S. Muyldermans (personal communication).

Table 6
Primers for Recovery of Primate Ig Repertoires

Macaques

V_k Primers

Targeted to framework region 1 of V_k domain

V_k1 D I E L T Q S P
 GACATCGAGCTCACCCAGTCTCCA

V_k2 D I E L T Q S P
 GACATCGAGCTCACCCAGTCTCC

V_k3 D I E L T Q S P
 GATATTGAGCTCACTCAGTCTCCA

V_k4 E I E L S Q S P
 GAAATTGAGCTCAGCCAGTCTCCA

V_k5 E I E L T Q S P
 GAAATTGAGCTCACRCAGTCTCCA

V_k6 E P H E P E L Q M T Q S P
 GAGCCGCACGAGCCCGAGCTCCAGATGACCCAGTCTCC

V_k7 E P H E P E L Q M T Q S P
 GAGCCGCACGAGCCCGAGCTCGTGWTGACRCAGTCTCC

V_H Primers

Targeted to framework region 1 of V_H domain

V_H1 Q V Q L E Q S G
 CAGGTGCAGCTCGAGCAGTCTGGG

V_H2 Q V Q L L E S G
 CAGGTGCAGCTGCTCGAGTCTGGG

Targeted to the C-terminal region of macaque C_k

C_k1 (C)(E)(G)(R)(N)(F)(S)(K)(T)(V)(P)(S)(S)(L)
 ACACTCTCCCCTGTTGAAGCTCTTTGTGACGGGCGAACTCAG

Targeted to hinge region of macaque IgG

C_Hγ1 (P)(K)(S)(T)(G)(G)(C)(T)(K)(I)(E)
 AGGTTTACTAGTACCACCACATGTTTTGATCTC

81

(continued)

Table 6
Primers for Recovery of Primate Ig Repertoires (*Continued*)

	Q V Q L L E S G
V _H 3	CAGGTGCAGCTACTCGAGTCGGG
	E V Q L E E S G
V _H 4	GAGGTGCAGCTCGAGGAGTCGGGG
	E V Q L L E S G
V _H 5	GAGGTGCAGCTGCTCGAGTCTGGG
	Q V Q L E Q S G
V _H 6	CAGGTACAGCTCGAGCAGTCAGG
	V Q L L Q S G
V _H 7	AGGTGCAGCTGCTCGAGTCTGG
	Q V Q L L Q S G
V _H 8	CAGGTGCAGCTGCTCGAGTCGGG
	Q V Q L L Q W G
V _H 9	CAGGTGCAGCTACTCGAGTGGGG

82

Chimpanzees

V_H Primer

Targeted to hinge region of chimpanzee IgG

(C)(T)(H)(T)(T)(D)(C)(S)(K)(P)

C_Hγ1 GCATGTACTAGTTGTGTCACAAGATTTGGG

See **Notes 2** and **8** for details. Data compiled from **refs. 17** and **19**.

8. The amplified products are now ready for restriction digestion or other modifications for insertion into the appropriate vector for expression as scFv or Fab (*see Note 6*).

4. Notes

1. In order to avoid nonspecific amplification during PCR, it is best to use an amplification protocol that incorporates a “hot start.” It is not advisable to use a polymerase that needs to be added to the tubes after denaturation of the template, because this increases the chance of contamination between samples. There are many commercial options for enzymes that would be suitable: we find that Hot Star *Taq* polymerase (Qiagen, Germany) works well. This enzyme requires a 15-min incubation at 95°C to become active.
2. Oligonucleotide primers should be purified before use in PCR to avoid nonspecific amplification and the recovery of truncated products. Data in the tables are derived from the cited literature, but, for clarity and flexibility, sequences encoding restriction sites, linker sequences, and so on, have been omitted. Therefore, when designing primers, additional sequence should be added at the 5' terminus of each primer to enable cloning of products into the phage-display vector selected for library construction, taking note of the reading frame(s) of coding regions flanking the cloning site (e.g., bacterial leaders, purification/detection tags, and so on) and adding standard linker sequences if scFvs are to be constructed by overlap extension prior to cloning. All primers are shown 5' to 3' with standard codes for degeneracy. The Ig reading frame and encoded amino acids are shown along with the region targeted by each primer. Amino acids in brackets are encoded by the reverse complement of the primer sequence presented.
3. Inactivation of RT is not necessary if a hot-start step is incorporated into the PCR method.
4. The number of reactions required for recovery of the Ig repertoire will depend on the number of variable region families for the species of interest (*see Tables 1–6*).
5. Do not overload the gels when purifying PCR products because contaminating PCR bands may be carried over, which can result in truncated products being incorporated preferentially into the expression vector.
6. Some expression vectors have been modified to express species-specific amino acid sequences around the V_L and/or V_H cloning sites (e.g., pComBov for expression of bovine Fab [13]). If a general-purpose phage-display vector is to be used, check its sequence and the amino acids encoded by restriction sites for the potential incorporation of nonnative residues at the termini of the mature Ig fragment. For example, if the vector adds murine sequences that differ from the residues commonly in the species under investigation, this may compromise the use of purified MAbs in the host species at a later date.
7. Specific Ig classes from camels (21) and llamas (22) are unusual, in that they lack Ig LCs. These Ig carry a single variable domain with amino substitutions

at positions that would typically contact the LC-promoting interaction with the solvent (23,24). They also lack the first constant region domain. Although this sequence is present in the genome, it is spliced out during RNA processing (25,26). Expression of these Ig in *Saccharomyces cerevisiae* is described in Chapter 32.

8. In several cases (15–20), libraries of primate Ig have been successfully constructed with primers designed for recovery of the human repertoire. For macaques, **Table 6** shows primers used by Glamann et al. (17) as an example of this approach. For chimpanzees, **Table 6** shows only the species-specific primer targeted to the HC hinge region (27), which was used with human primers by Schofield et al. (19).

References

1. Suter, M. (1992) The potential of molecular biology for the production of monoclonal antibodies derived from outbred veterinary animals. *Vet. Immunol. Immunopathol.* **33**, 285–300.
2. Sola, I., Castilla, J., Pintado, B., Sanchez Morgado, J. M., Whitelaw, C. B. A., Clark, A. J. and Enjuanes, L. (1998) Transgenic mice secreting coronavirus neutralizing antibodies into the milk. *J. Virol.* **72**, 3762–3772.
3. Lorenzen, N., Cupit, P. M., Einer-Jensen, K., Lorenzen, E., Ahrens, P., Secombes, C. J., and Cunningham, C. (2000) Immunoprophylaxis in fish by injection of mouse antibody genes. *Nature Biotechnol.* **18**, 1177–1180.
4. Wang, H., Griffiths, M. N., Burton, D. R., and Ghazal, R. (2000) Rapid antibody responses by low-dose, single-step, dendritic cell-targeted immunization. *J. Immunol.* **96**, 847–852.
5. Ridder, R., Schmitz, R., Legay, F., and Gram, H. (1995) Generation of rabbit monoclonal antibody fragments from a combinatorial phage display library and their production in the yeast *Pichia pastoris*. *Biotechnology* **13**, 255–260.
6. Foti, M., Granucci, F., Ricciardi-Castagnoli, P., Spreafico, A., Ackermann, M., and Suter, M. (1998) Rabbit monoclonal Fab derived from a phage display library. *J. Immunol. Meth.* **213**, 201–212.
7. Li, Y., Cockburn, W., Kilpatrick, J. B., and Whitlam, G. C. (2000) High affinity scFvs from a single rabbit immunized with multiple haptens. *Biochem. Biophys. Res. Commun.* **268**, 398–404.
8. Davies, E. L., Smith, J. S., Birkett, C. R., Manser, J. M., Anderson-Dear, D. V., and Young, J. R. (1995) Selection of specific phage-display antibodies using libraries derived from chicken immunoglobulin genes. *J. Immunol. Methods* **186**, 125–135.
9. Yamanaka, H. I., Inoue, R., and Ikeda-Tanaka, O. (1996) Chicken monoclonal antibody isolated by a phage display system. *J. Immunol.* **157**, 1156–1162.
10. Cary, S. P., Lee, J., Wagenknecht, R., and Silverman, G. J. (2000) Characterization of superantigen-induced clonal deletion with a novel clan III-restricted avian monoclonal antibody: exploiting evolutionary distance to create antibodies specific for a conserved V_H region surface. *J. Immunol.* **164**, 4730–4741.

11. Charlton, K. A., Moyle, S., Porter, A. J. R., and Harris, W. J. (2000) Analysis of the diversity of a sheep antibody repertoire as revealed from a bacteriophage display library. *J. Immunol.* **164**, 6221–6229.
12. Li, Y., Kilpatrick, J., and Whitelam, G. C. (2000) Sheep monoclonal antibody fragments generated using a phage display system. *J. Immunol. Methods* **236**, 133–146.
13. O'Brien, P. M., Aitken, R., O'Neil, B. W., and Campo, M. S. (1999) Generation of native bovine MAbs by phage display. *Proc. Natl. Acad. Sci. USA* **96**, 640–645.
14. Arbabi Ghahroudi, M., Desmyter, A., Wyns, L., Hamers, R., and Muyldermans, S. (1997) Selection and identification of single domain antibody fragments from camel heavy-chain antibodies. *FEBS Lett.* **414**, 521–526.
15. Samuelsson, A., Chiodi, F., Öhman, P., Putkonen, P., Norby, E., and Persson, M. A. A. (1995) Chimeric macaque/human Fab molecules neutralize simian immunodeficiency virus. *Virology* **207**, 495–502.
16. Tordsson, J., Abrahmsén, L., Kalland, T., Ljung, C., Ingvar, C., and Brodin, T. (1997) Efficient selection of scFv antibody phage by absorption to *in situ* expressed antigens in tissue sections. *J. Immunol. Methods* **210**, 11–23.
17. Glamann, J., Burton, D. R., Parren, P. W. H. I., et al. (1998) Simian immunodeficiency virus (SIV) envelope-specific Fabs with high-level homologous neutralizing activity: recovery from a long-term-nonprogressor SIV-infected macaque. *J. Virol.* **72**, 585–592.
18. Siegel, D. L., Reid, M. E., Lee, H., and Blancher, A. (1999) Production of large repertoires of macaque MAbs to human RBCs using phage display. *Transfusion* **39**, 92S.
19. Schofield, D. J., Glamann, J., Emerson, S. U., and Purcell, R. H. (2000) Identification by phage display and characterization of two neutralizing chimpanzee monoclonal antibodies to the hepatitis E virus capsid protein. *J. Virol.* **74**, 5548–5555.
20. Tordsson, J. M., Ohlsson, L. G., Abrahmsen, L. B., Karlstrom, P. J., Lando, P. A., and Brodin, T. N. (2000) Phage-selected primate antibodies fused to superantigens for immunotherapy of malignant melanoma. *Cancer Immunol. Immunother.* **46**, 691–702.
21. Hamers-Casterman, C., Atarhouch, T., Muyldermans, S., et al. (1983) Naturally-occurring antibodies devoid of light chains. *Nature* **363**, 446–448.
22. Vu, K. B., Ghahroudi, M. A., Wyns, L., and Muyldermans, S. (1997) Comparison of llama V-H sequences from conventional and heavy chain antibodies. *Mol. Immunol.* **34**, 1121–1131.
23. Desmyter, A., Transue, T. R., Ghahroudi, M. A., et al. (1996) Crystal structure of a camel single-domain V_H antibody fragment in complex with lysozyme. *Nature Struct. Biol.* **3**, 803–811.
24. Spinelli, S., Frenken, L., Bourgeois, D., de Ron, L., Bos, W., Verrips, T., et al. (1996) The crystal structure of a llama heavy chain variable domain. *Nature Struct. Biol.* **3**, 752–757.

25. Nguyen, V. K., Muyldermans, S., and Hamers, R. (1998) The specific variable domain of camel heavy-chain antibodies is encoded in the germline. *J. Mol. Biol.* **275**, 413–418.
26. Woolven, B. P., Frenken, L. G. J., van der Logt, P., and Nicholls, P. J. (1999) The structure of the llama heavy chain constant genes reveals a mechanism for heavy-chain antibody formation. *Immunogenet.* **50**, 98–101.
27. Ehrlich, P. H., Moustafa, Z. A., and Ostberg, L. (1991) Nucleotide sequence of chimpanzee Fc and hinge regions. *Mol. Immunol.* **28**, 319–322.

Construction of Large Naïve Fab Libraries

Hans J. W. de Haard

1. Introduction

In recent years, a number of single-pot antibody (Ab) libraries have been described, which permit the rapid isolation of high-affinity Abs against large panels of antigens (Ags). Naïve libraries have been generated by tapping the natural primary (unselected) immune repertoire via cloning of Abs that recognize a variety of Ags (1,2). The rearranged V genes were amplified with the polymerase chain reaction (PCR) from B-cell mRNAs encoding immunoglobulin M (IgM) taken from nonimmunized donors. By using this procedure, Abs were recovered prior to encounter with Ag and unscreened for tolerance by the immune system. Indeed, a naïve library represents a good source of Abs against self, nonimmunogenic, and toxic Ags if the library is sufficiently large and diverse.

Library size is a major determinant in successful selection against a large set of Ags and it also correlates with the affinity of the isolated Abs (3). Only Abs with moderate affinities were selected from the first small libraries, but, by increasing the repertoire size in the construction of later libraries, Abs with better affinities have since been obtained. It has also been established (3,4) that larger libraries deliver greater numbers of different Abs against target Ags of interest (3,4).

Given the importance of library size, over the past few years more efficient techniques have been developed for the construction of large Ab libraries. These include *in vivo* Cre-*lox* recombination (3) or brute-force cloning procedures (4). Technical difficulties associated with the construction of the libraries, the loss of diversity upon library amplification, and the correct interpretation of the outcome of the selection process have limited the general application and

acceptance of single-pot libraries for the generation of Abs. Therefore, this chapter focuses on the construction and handling of large Ab libraries.

Recently, an efficient two-step cloning strategy has been reported for the construction of phage libraries displaying human Fabs based on the isolation of restriction fragments from plasmid vectors instead of PCR products (5). When digesting PCR products with restriction sites defined by the oligonucleotide primer, efficiency is dependent on the number of extra nucleotides appended to the primer, but it is always low compared to the digestion of plasmid DNA. In the first step of the procedure described, primary repertoires are prepared from PCR products encoding the V_H , V_K , and V_λ domains, yielding typical medium-sized libraries (1–100 million clones). In the second step, V_H fragments are isolated by digestion of plasmid DNA purified from the primary repertoires, and cloned into the acceptor phagemid vector containing the light-chain (LC) repertoires. This innovation increases the size of the libraries dramatically (10–100 billion clones).

A range of lymphoid tissues can be used as a source of Ab-producing B cells for RNA isolation. The peripheral blood lymphocytes of adults are easily accessible and more than 60% of the B cells are unmutated IgM⁺/IgD⁺ naïve cells (6). Other sources are spleen, bone marrow, and tonsils, which contain higher proportions of plasma cells. This type of lymphocyte produces 10,000-fold more mRNA than nonactivated B cells, and encodes somatically mutated immunoglobulin (Ig) genes. Considering the large differences in levels of Ig transcript, it is important to amplify the naïve V_H genes with an IgM-derived oligonucleotide primer, avoiding primer combinations that preferentially yield IgG-derived V_H fragments. Finally, the only meaningful measure of quality is whether the generated repertoire can deliver specific and high-affinity Abs after selection with a panel of Ags.

2. Materials

1. Ficoll-Paque (research grade) (Amersham Pharmacia Biotech, Uppsala, Sweden).
2. Buffer A: 4 M guanidine isothiocyanate, 25 mM citric acid, 0.5% (w/v) *N*-lauroyl sarcosine, 1% (v/v) 2-mercaptoethanol, pH 7.0.
3. Ultra-turrax T25 (Janke & Kunkel, Steufen, Germany).
4. 2 M Sodium acetate (NaAC), pH 4.0.
5. H₂O-saturated phenol.
6. Chloroform isoamyl alcohol (24:1).
7. Absolute ethanol.
8. Random hexamer primers (Amersham Pharmacia Biotech).
9. Deoxyribonucleoside triphosphates (dNTP) (deoxynucleotides, sequencing-grade solutions) (Amersham Pharmacia Biotech).
10. Dithiothreitol (100 mM).

11. RNasin Ribonuclease Inhibitor (Promega, Madison, WI).
12. Moloney murine leukemia virus reverse transcriptase (MMLV-RT) and reaction buffer (Life Technologies, Grand Island, NY).
13. AmpliTaq Gold (Perkin-Elmer/Roche, Branchburg, NJ).
14. QIAex-II extraction kit (Qiagen, Hilden, Germany).
15. *Sfi*I, *Bst*EII, *Not*I, *Apa*LI, *Asc*I (New England Biolabs, Beverly, MA).
16. Microcon-50 (Amicon/Millipore, Bedford, MA).
17. Qiagen Plasmid Mega kit (Qiagen) or Nucleobond AX-500 and AX-2000 plasmid purification kit (Clontech, Palo Alto, CA).
18. T4 DNA ligase (Promega).
19. Gene pulser and pulse controller; electroporation cuvettes (0.2-cm gap) (Bio-Rad, Hercules, CA).
20. Luria Bertani (LB) solid and liquid media. Refer to index for composition.
21. Autoclave a solution of 16 g/L Bacto-tryptone, 10 g/L yeast extract, 5 g/L NaCl, pH 7.0. After cooling, add filter-sterilized glucose (GLU) solution to a final concentration of 2% (2TY–GLU). For 2TY, omit the glucose. For solid media, add agar at 15 g/L prior to autoclaving.
22. Kanamycin.
23. Phage precipitant: 20% polyethylene 6000, 2.5 M NaCl in H₂O.

3. Methods

3.1. RNA Isolation (see Note 1)

1. Peripheral blood lymphocytes purified by centrifugation on Ficoll-Paque gradients can form one source of starting material (*see Note 2*). Recover the layers containing lymphocytes, pellet the cells, and wash with phosphate-buffered saline (PBS) (*see Note 3*). Lymphocytes residing in bone can be obtained by flushing a segment with PBS using a syringe. Dissolve the cell pellets from 1 L blood in 30 mL buffer A. Shear chromosomal DNA by passing the suspension several times through a syringe fitted with a narrow needle.
2. Solid tissues, such as spleen or lymph nodes, are alternative starting materials (*see Note 2*). Cut 0.5–1.0 g of the sample into small pieces. After addition of 30 mL buffer A, homogenize the tissue rapidly with an Ultra-turrax homogenizer and a potter. Remove debris by centrifugation (10 min at 5000g) and pass the supernatant through a narrow syringe to shear chromosomal DNA.
3. After adding 0.1 vol 2 M NaAC, pH 4.0, extract the mixture with an equal volume of H₂O-saturated phenol and 1/2 vol chloroform–isoamyl alcohol (24:1). Incubate the mixture on ice for 15 min to improve phase separation. Following centrifugation (10 min at 5000g), transfer the H₂O phase to a new tube and re-extract with phenol and chloroform.
4. Precipitate the RNA with 0.75 vol ethanol during 16 h at –20°C. Pellet the nucleic acids (30 min at 13,000g), dissolve in 0.1 vol autoclaved H₂O, and precipitate again by adding 0.01 vol 2 M NaAC, pH 4.0 and 0.25 vol ethanol. Store the RNA under ethanol at –20 or –80°C until required.

5. Quantify the RNA by measuring the optical density at 260 nm. Typically, $1.0\text{--}1.5 \times 10^9$ peripheral blood lymphocytes (with approx 10–20% B cells) can be isolated from 1 L blood, which yields 1.2–2.5 mg total RNA, when using the method described. One-half gram spleen yields 1.2 mg and 0.5 g lymph node yields 1.5 mg total RNA (*see Note 4*).

3.2. Amplification of Variable-Region Genes

1. Prepare random primed cDNA from 250 μg total RNA. Centrifuge an appropriate volume of ethanol mixture (10 min at 13,000g), and, after dissolving in autoclaved H_2O , heat-denature the RNA for 5 min at 65°C in the presence of 20 μg random primers in a total vol of 50–100 μL (*see Note 5*).
2. Place the reaction vessel on ice and add RT buffer, dithiothreitol (to 10 mM), dNTP (to 250 μM), RNasin (800 U) and MMLV-RT (2000 U), yielding a total volume of 500 μL . Incubate for 2 h at 42°C, then terminate the reaction by a phenol–chloroform extraction (*see Note 6*). Precipitate the cDNA from the aqueous layer by adding 0.1 vol NaAC and 2 vol ethanol, and centrifuge (10 min at 13,000g). Wash the pellet (70% ethanol), centrifuge, and dissolve the dried pellet in 85 μL H_2O . Use the cDNA solution immediately, or store at -20°C .
3. Amplify the human variable-region genes by PCR with the oligonucleotides described in **Table 1** (*see Note 7*). IgM-derived heavy-chain (HC) variable regions are obtained by a primary PCR, with an IgM constant-region primer combined with separate V_H -family-specific Back primers, which anneal to the 5' end of the V regions. κ and λ LC-derived variable regions are amplified with a set of C_κ -For and C_λ -For primers annealing to the 3' end of the constant domain and separate V_κ - and V_λ -family-specific Back primers. Perform PCR in a volume of 50 μL using *AmpliTaq* Gold polymerase using the supplier's buffer, 0.2 mM dNTPs, 500 nM of each primer, and 2.5 μL cDNA as template. After activation of the polymerase by heating at 94°C for 11 min, carry out 28 cycles of amplification (30 s denaturation at 94°C, 30 s annealing at 55°C, and 2.5 min elongation at 72°C) (*see Note 8*). Nine separate reactions generate the different V_H -family-derived amplicons; for the LC families, six separate $\text{V}_\kappa\text{C}_\kappa$ products and 11 $\text{V}_\lambda\text{C}_\lambda$ products ($\text{C}_\lambda 2$ and $\text{C}_\lambda 7$ primers combined in one reaction) are generated.
4. Purify the PCR products from 1.5% agarose gel with a QIAex-II extraction kit, and elute in 40 μL H_2O (*see Note 9*). The V_H regions are reamplified from individual HC-derived amplicons using the corresponding *Sfi*I-tagged V_H -Back and a set of J_H -For primers, which contain a *Bst*EII site (*see Notes 10 and 12*). The complete $\text{V}_\kappa\text{C}_\kappa$ and $\text{V}_\lambda\text{C}_\lambda$ products are reamplified with *Apa*LI- and *Asc*I-tagged primers. As input to these reactions, use 100–200 ng purified product in 100 μL PCR reactions (*see Note 8*). Sufficient DNA for cloning should be obtained from 25 cycles (*see Subheading 3.2, step 3*).

Table 1
Oligonucleotide Primers for Construction of Human Fab Libraries

Primary amplification									
IgM C_H1 region									
HuIgMFor	5'-TGG	AAG	AGG	CAC	GTT	CTT	TTC	TTT	-3'
κ Chain constant region									
HuC _κ For	5'-ACA	CTC	TCC	CCT	GTT	GAA	GCT	CTT	-3'
λ Chain constant region									
HuC _λ 2-For	5'-TGA	ACA	TTC	TGT	AGG	GGC	CAC	TG	-3'
HuC _λ 7-For	5'-AGA	GCA	TTC	TGC	AGG	GGC	CAC	TG	-3'
V_H Back									
HuV _H 1B/7A-Back	5'-CAG	RTG	CAG	CTG	GTG	CAR	TCT	GG	-3'
HuV _H 1C-Back	5'-SAG	GTC	CAG	CTG	GTR	CAG	TCT	GG	-3'
HuV _H 2B-Back	5'-CAG	RTC	ACC	TTG	AAG	GAG	TCT	GG	-3'
HuV _H 3B-Back	5'-SAG	GTG	CAG	CTG	GTG	GAG	TCT	GG	-3'
HuV _H 3C-Back	5'-GAG	GTG	CAG	CTG	GTG	GAG	WCY	GG	-3'
HuV _H 4B-Back	5'-CAG	GTG	CAG	CTA	CAG	CAG	TGG	GG	-3'
HuV _H 4C-Back	5'-CAG	STG	CAG	CTG	CAG	GAG	TCS	GG	-3'
HuV _H 5B-Back	5'-GAR	GTG	CAG	CTG	GTG	CAG	TCT	GG	-3'
HuV _H 6A-Back	5'-CAG	GTA	CAG	CTG	CAG	CAG	TCA	GG	-3'
V_κ Back									
HuV _κ 1B-Back	5'-GAC	ATC	CAG	WTG	ACC	CAG	TCT	CC	-3'
HuV _κ 2-Back	5'-GAT	GTT	GTG	ATG	ACT	CAG	TCT	CC	-3'
HuV _κ 3B-Back	5'-GAA	ATT	GTG	WTG	ACR	CAG	TCT	CC	-3'
HuV _κ 4B-Back	5'-GAT	ATT	GTG	ATG	ACC	CAC	ACT	CC	-3'
HuV _κ 5-Back	5'-GAA	ACG	ACA	CTC	ACG	CAG	TCT	CC	-3'
HuV _κ 6-Back	5'-GAA	ATT	GTG	CTG	ACT	CAG	TCT	CC	-3'
V_λ Back									
HuV _λ 1A-Back	5'-CAG	TCT	GTG	CTG	ACT	CAG	CCA	CC	-3'
HuV _λ 1B-Back	5'-CAG	TCT	GTG	YTG	ACG	CAG	CCG	CC	-3'
HuV _λ 1C-Back	5'-CAG	TCT	GTC	GTG	ACG	CAG	CCG	CC	-3'
HuV _λ 2-Back	5'-CAR	TCT	GCC	CTG	ACT	CAG	CCT	-3'	
HuV _λ 3A-Back	5'-TCC	TAT	GWG	CTG	ACT	CAG	CCA	CC	-3'
HuV _λ 3B-Back	5'-TCT	TCT	GAG	CTG	ACT	CAG	GAC	CC	-3'
HuV _λ 4-Back	5'-CAC	GTT	ATA	CTG	ACT	CAA	CCG	CC	-3'
HuV _λ 5-Back	5'-CAG	GCT	GTG	CTG	ACT	CAG	CCG	TC	-3'
HuV _λ 6-Back	5'-AAT	TTT	ATG	CTG	ACT	CAG	CCC	CA	-3'
HuV _λ 7/8-Back	5'-CAG	RCT	GTG	GTG	ACY	CAG	GAG	CC	-3'
HuV _λ 9-Back	5'-CWG	CCT	GTG	CTG	ACT	CAG	CCM	CC	-3'

(continued)

Table 1 (Continued)

Secondary amplification

κ Chain constant region

HuC_κ-For-ASC 5'-ACC GCC TCC ACC GGG CGC GCC TTA TTA ACA
CTC TCC CCT GTT GAA GCT CTT-3'

λ Chain constant region

HuC_λ2-For-ASC 5'-ACC GCC TCC ACC GGG CGC GCC TTA TTA TGA
ACA TTC TGT AGG GGC CAC TG-3'

HuC_λ7-For-ASC 5'-ACC GCC TCC ACC GGG CGC GCC TTA TTA AGA
GCA TTC TGC AGG GGC CAC TG-3'

V_H Back

HuV_H1B/7A-Back-SFI 5'-GTC CTC GCA ACT GCG GCC CAG CCG GCC ATG
GCC CAG RTG CAG CTG GTG CAR TCT GG-3'

HuV_H1C-Back-SFI 5'-GTC CTC GCA ACT GCG GCC CAG CCG GCC ATG
GCC SAG GTC CAG CTG GTR CAG TCT GG-3'

HuV_H2B-Back-SFI 5'-GTC CTC GCA ACT GCG GCC CAG CCG GCC ATG
GCC CAG RTC ACC TTG AAG GAG TCT GG-3'

HuV_H3B-Back-SFI 5'-GTC CTC GCA ACT GCG GCC CAG CCG GCC ATG
GCC SAG GTG CAG CTG GTG GAG TCT GG-3'

HuV_H3C-Back-SFI 5'-GTC CTC GCA ACT GCG GCC CAG CCG GCC ATG
GCC GAG GTG CAG CTG GTG GAG WCY GG-3'

HuV_H4B-Back-SFI 5'-GTC CTC GCA ACT GCG GCC CAG CCG GCC ATG
GCC CAG GTG CAG CTA CAG CAG TGG GG-3'

HuV_H4C-Back-SFI 5'-GTC CTC GCA ACT GCG GCC CAG CCG GCC ATG
GCC CAG STG CAG CTG CAG GAG TCS GG-3'

HuV_H5B-Back-SFI 5'-GTC CTC GCA ACT GCG GCC CAG CCG GCC ATG
GCC GAR GTG CAG CTG GTG CAG TCT GG-3'

HuV_H6A-Back-SFI 5'-GTC CTC GCA ACT GCG GCC CAG CCG GCC ATG
GCC CAG GTA CAG CTG CAG CAG TCA GG-3'

V_H Forward

HuJ_H1/2-For 5'-TGA GGA GAC GGT GAC CAG GGT GCC-3'

HuJ_H3-For 5'-TGA AGA GAC GGT GAC CAT TGT CCC-3'

HuJ_H4/5-For 5'-TGA GGA GAC GGT GAC CAG GGT TCC-3'

HuJ_H6-For 5'-TGA GGA GAC GGT GAC CGT GGT CCC-3'

V_κ Back

HuV_κ1B-Back-APA 5'-ACC GCC TCC ACC AGT GCA CTT GAC ATC CAG
WTG ACC CAG TCT CC-3'

HuV_κ2-Back-APA 5'-ACC GCC TCC ACC AGT GCA CTT GAT GTT GTG
ATG ACT CAG TCT CC-3'

HuV_κ3B-Back-APA 5'-ACC GCC TCC ACC AGT GCA CTT GAA ATT GTG
WTG ACR CAG TCT CC-3'

HuV _κ 4B-Back-APA	5'-ACC GCC TCC ACC AGT GCA CTT GAT ATT GTG ATG ACC CAC ACT CC-3'
HuV _κ 5-Back-APA	5'-ACC GCC TCC ACC AGT GCA CTT GAA ACG ACA CTC ACG CAG TCT CC-3'
HuV _κ 6-Back-APA	5'-ACC GCC TCC ACC AGT GCA CTT GAA ATT GTG CTG ACT CAG TCT CC-3'
V_λ Back	
HuV _λ 1A-Back-APA	5'-ACC GCC TCC ACC AGT GCA CAG TCT GTG CTG ACT CAG CCA CC-3'
HuV _λ 1B-Back-APA	5'-ACC GCC TCC ACC AGT GCA CAG TCT GTG YTG ACG CAG CCG CC-3'
HuV _λ 1C-Back-APA	5'-ACC GCC TCC ACC AGT GCA CAG TCT GTC GTG ACG CAG CCG CC-3'
HuV _λ 2-Back-APA	5'-ACC GCC TCC ACC AGT GCA CAR TCT GCC CTG ACT CAG CCT-3'
HuV _λ 3A-Back-APA	5'-ACC GCC TCC ACC AGT GCA CTT TCC TAT GWG CTG ACT CAG CCA CC-3'
HuV _λ 3B-Back-APA	5'-ACC GCC TCC ACC AGT GCA CTT TCT TCT GAG CTG ACT CAG GAC CC-3'
HuV _λ 4-Back-APA	5'-ACC GCC TCC ACC AGT GCA CAC GTT ATA CTG ACT CAA CCG CC-3'
HuV _λ 5-Back-APA	5'-ACC GCC TCC ACC AGT GCA CAG GCT GTG CTG ACT CAG CCG TC-3'
HuV _λ 6-Back-APA	5'-ACC GCC TCC ACC AGT GCA CTT AAT TTT ATG CTG ACT CAG CCC CA-3'
HuV _λ 7/8-Back-APA	5'-ACC GCC TCC ACC AGT GCA CAG RCT GTG GTG ACY CAG GAG CC-3'
HuV _λ 9-Back-APA	5'-ACC GCC TCC ACC AGT GCA CWG CCT GTG CTG ACT CAG CCM CC-3'

3.3. Construction of Primary V_H, V_κ, and V_λ Libraries

1. Purify the PCR products appended with restriction sites from 1.5% agarose gels (*see Note 9*).
2. Pool equal amounts of DNA from the different V_H families and digest with *Sfi*I and *Bst*EII at 50°C. Similarly, V_κC_κ and V_λC_λ fragments (family-derived PCR products pooled, but κ and λ LCs kept separately) are digested with *Apa*LI and *Asc*I at 37°C. Run all digests for 16 h with 50–100-fold excess of enzyme (U vs μg DNA) (*see Note 10*).
3. Remove restriction enzymes and salts by spin-dialysis against H₂O using a Microcon-50 unit. Determine the amount of DNA recovered on an agarose gel.

4. Purify the phagemid vector (e.g., pCES1: map and sequence shown in **Fig. 1**) from 1 L cultures using Nucleobond AX-500 or AX-2000 kits or a Qiagen plasmid mega kit. Digest approx 400 μg DNA with *Sfi*I and *Bst*EII or with *Apa*LI and *Asc*I and purify from 1% agarose gel, using the QIAex-II kit (*see Notes 11 and 12*).
5. Determine the optimal ratio of vector:fragment with test ligations. Ligate 25 ng vector with three different amounts of fragment, varying from 2 to 25 ng, in a volume of 20 μL using 1 U T4 DNA ligase and the buffer supplied by the manufacturer. After incubation for 15–60 min at room temperature, use 3 μL ligation reaction for transformation of 40 μL electrocompetent TG1 cells (*see Note 13*) with 0.2-cm cuvetts (2.5 kV pulse at 25 μF and 200 Ω). Immediately after electroporation, add 1 mL 2TY–GLU, and plate 100 and 1 μL onto LB plates containing 100 $\mu\text{g}/\text{mL}$ ampicillin and 2% glucose LB medium (LB–AMP–GLU). Compare the number of transformants with those found on the control (ligation of vector alone) to reveal which ratio is to be used (*see Notes 11 and 12*).
6. For the library construction, ligate 1–5 μg vector with the optimal amount of fragment (varying from 0.1 to 1.5 μg) for 16 h at room temperature in a total volume of 100–200 μL using 9 U T4 DNA ligase. Desalt the reaction mixture by spin-dialysis against H_2O with a Microcon-50 unit.
7. Divide the ligation mixture into 20–40- μL aliquots and separately electroporate with 100–150 μL freshly prepared TG1 cells (*see Notes 13 and 14*). Immediately after transformation, transfer the cells in 1 mL 2TY–GLU medium to a tube. Pool the remaining fractions belonging to the same ligation and rinse the cuvetts with 1 mL medium. To establish the library size, prepare a dilution series (10^{-3} , 10^{-4} , 10^{-5} , and 10^{-6}) in medium and plate 100 μL onto small (9 cm diameter) LB–AMP–GLU plates. Plate the rest of the transformation mixture on large LB–AMP–GLU plates (24 \times 24 cm) to allow outgrowth of individual clones (approx 10^8 – 10^9 clones/plate) (*see Notes 15 and 16*). Incubate overnight at 37°C.
8. Scrape plates with 2TY–AMP–GLU medium to get suspensions with an OD_{600} of 50 to 100. Add glycerol to a final concentration of 20%, measure the OD_{600} and store in aliquots at -80°C as individual primary library stocks (*see Note 17*).

3.4. Combining V_H , V_K , and V_λ into Fab Single-Pot Library

1. Thaw glycerol stocks from the individual primary libraries and inoculate a sample containing at least 10-fold more cells than the library size to 1 L LB–AMP–GLU liquid medium. After 8–16 h of growth, purify plasmid DNA using the previously mentioned kits (*see Subheading 3.3., step 4*).
2. Digest plasmid DNA (approx 500 μg) from the LC and HC repertoires with *Sfi*I and *Bst*EII (or *Not*I) (*see Note 12*). Purify vector from the LC repertoires from 1% agarose gel, and V_H fragments from the HC repertoires using 1.5% agarose gels (*see Subheading 3.2., step 4*).
3. Perform test ligations and electroporations to establish the optimal ratios of vector:fragment (*see Subheading 3.3., step 5*).

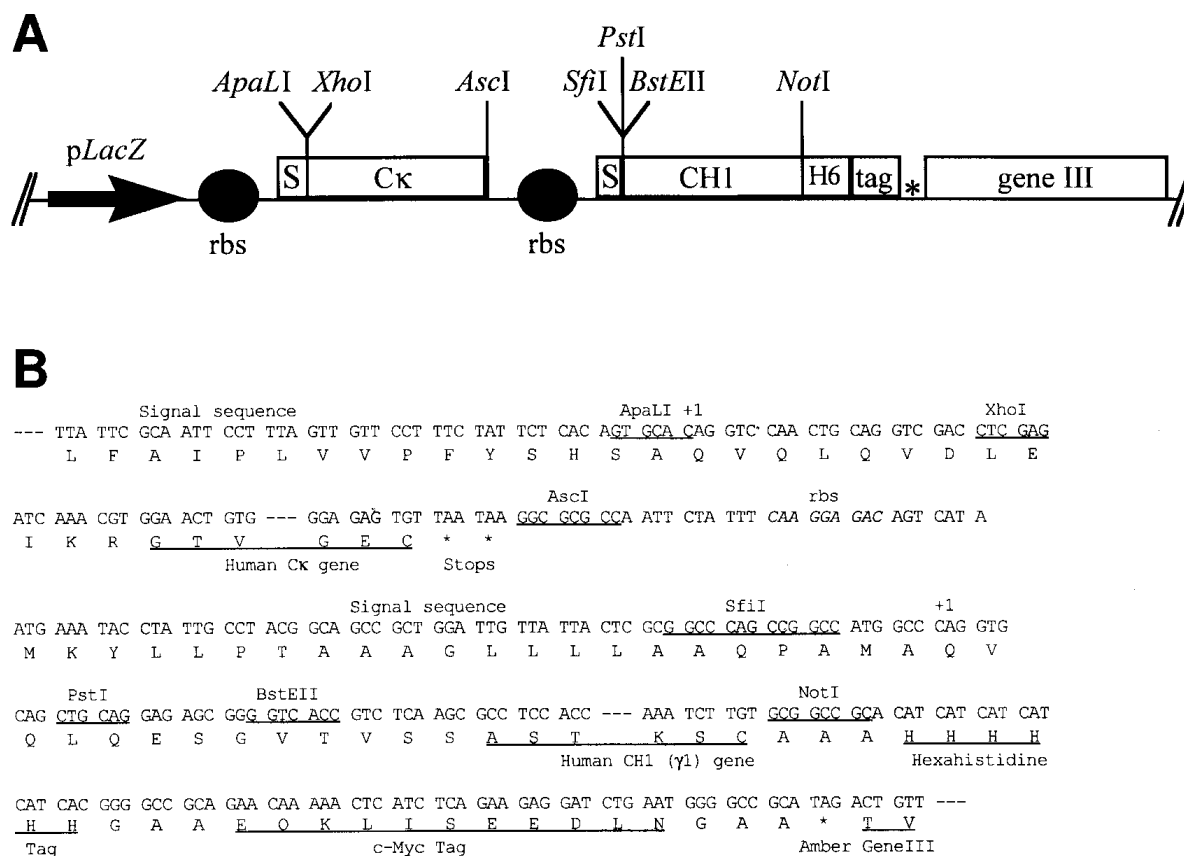

Fig. 1. Organization (A) and sequences (B) of the phage display vector pCES1.

4. Upscale the ligation reactions and electroporation of freshly prepared TG1 cells to yield the final library (*see Subheading 3.3., steps 6 and 7, and Notes 13–15*). Store individual combinations of κ and λ LC-derived libraries with the V_H fragments separately as glycerol stocks (*see Subheading 3.3., step 8, and Notes 16 and 17*).

3.5. Preparation of Phage

1. Prepare helper phage by infecting log-phase TG1 bacteria with M13K07 or VCSM13 phage at different dilutions for 30 min at 37°C and plating out in top agar onto 2TY plates.
2. Take phage from a small plaque, and resuspend in 3 mL liquid 2TY medium. Add 30 μ L overnight culture of TG1 and grow for 2 h at 37°C.
3. Dilute the culture in 1 L 2TY medium and grow for 1 h. Add kanamycin to 50 μ g/mL and grow for 16 h at 37°C.
4. Remove cells by centrifugation (10 min at 5000g) and precipitate phage from the supernatant by addition of 0.25 vol of phage precipitant. After 30 min incubation on ice, collect the phage particles by centrifugation during 10 min at 5000g. Resuspend the pellet in 5 mL PBS and sterilize through a 0.22- μ m filter.
5. Titrate the helper phage by determining the number of plaque-forming units (pfu) on 2TY plates with top-agar layers containing 100 μ L TG1 (saturated culture) and dilutions of phage. Dilute the phage stock solution to 1×10^{13} pfu/mL and store in small aliquots at -20°C .
6. Before preparation of phage from the Fab library, prepare a master stock solution from the individual glycerol stocks by combining appropriate volumes (according to the size of each library) into a single mixture. Using a sample large enough to ensure the presence of at least 10 bacteria from each clone present in the final library, inoculate an appropriate volume of 2TY–AMP–GLU medium to obtain a log phase culture (*see Note 18*).
7. Grow for a few hours at 37°C until the culture reaches an OD_{600} of 0.5–0.9. Take a sample containing at least that number of bacteria at least 10-fold the size of the library. Add helper phage at a multiplicity of infection of 10–20 (i.e., the number of phage particles/host cell). Infect cells by incubating the suspension during 30 min at 37°C without shaking and an additional period of 30 min with shaking. Collect infected cells by centrifugation (10 min at 5000g) and resuspend in 2TY medium containing 100 μ g/mL ampicillin and 25 μ g/mL kanamycin. Grow the culture during 16 h at 30°C (*see Note 15*).
8. Precipitate phage particles from the supernatant as described before (**step 4**). Resuspend the phage pellet in 0.05 vol (i.e., 50 mL/L culture) of PBS and remove cellular debris by centrifugation (10 min at 5000g). To remove Ab fragments not associated to phage particles, carry out a second polyethylene glycol precipitation. Resuspend the phage pellet in 0.005 vol of PBS, clarify again by centrifugation, and pass through a 0.45- μ m filter. Add an equal volume of glycerol and store the phage suspension at -80°C .

9. Titrate the phage as the number of transducing units by infecting TG1 cells and counting the clones after plating on LB–AMP–GLU plates. Adjust the phage stock solution with 50% glycerol/PBS, to a final titer of 10^{13} transducing U/mL. Divide the phage solution into 1-mL aliquots and store at -80°C . For each selection, thaw one tube. Remove glycerol by polyethylene glycol precipitation and resuspend the phage pellet in 1 mL buffer solution compatible with the desired selection procedure (*see Note 19*).

4. Notes

1. The method for RNA isolation (7) is robust and relies on the inactivation of RNases by the combined action of the chaotropic agent, guanidine isothiocyanate and 2-mercaptoethanol. Wear gloves during the isolation and use freshly autoclaved H_2O and disposables.
2. Process tissues and blood samples as soon as these are taken from the donor, since prolonged storage on ice or at 4°C results in the isolation of degraded RNA. Freezing tissues rapidly in liquid nitrogen and storage at -80°C will also yield RNA of poor quality.
3. The total number of peripheral blood lymphocytes can be determined by counting a sample of cells diluted in Turks solution on a Bürker-Turk cell.
4. The quality of the RNA preparation should be checked on an appropriate gel (for instance, on systems using glyoxal- or formaldehyde-denatured RNA) (*see Fig. 2*), before starting cDNA synthesis. This analysis is more useful than determining the ratio between OD_{260} and OD_{280} , which reveals the presence of protein; however, this will not interfere with cDNA synthesis.
5. Instead of total RNA, poly A⁺-containing transcripts purified with oligo(dT) beads can be used for synthesis of random primed cDNA. Random primers are preferred, instead of Ig-derived oligonucleotide primers, to generate cDNA, because the latter will yield nonspecific bands during PCR. Abundant amounts of total RNA in cDNA preparations can affect the efficiency of amplification. This can be solved by hydrolysis of RNA with NaOH after cDNA synthesis.
6. It is not strictly necessary to phenol-extract and precipitate cDNA. Samples from the RT mixture can be used directly as template for PCR.
7. All primary PCRs should be carried out with separate Back primers to amplify even rarely occurring V genes.
8. Large amounts of cDNA and a limited number of cycles are used during PCR to obtain maximal diversity and to prevent the overamplification of just a few V regions. As a control, 1- μL 50-fold-diluted cDNA solution can be added as template in separate reactions, which should yield products, using the described PCR protocol. For the same reason, a large input of gel-purified product is used during reamplification with the tagged primers. Yields can be checked by analysis of 4 μL unamplified PCR mixture on a gel.
9. Efficient QIAex purification of the pooled V_{H} , V_{κ^-} , and V_{λ} -derived amplicons or fragments digested from library-derived plasmid DNA is achieved by dissolving

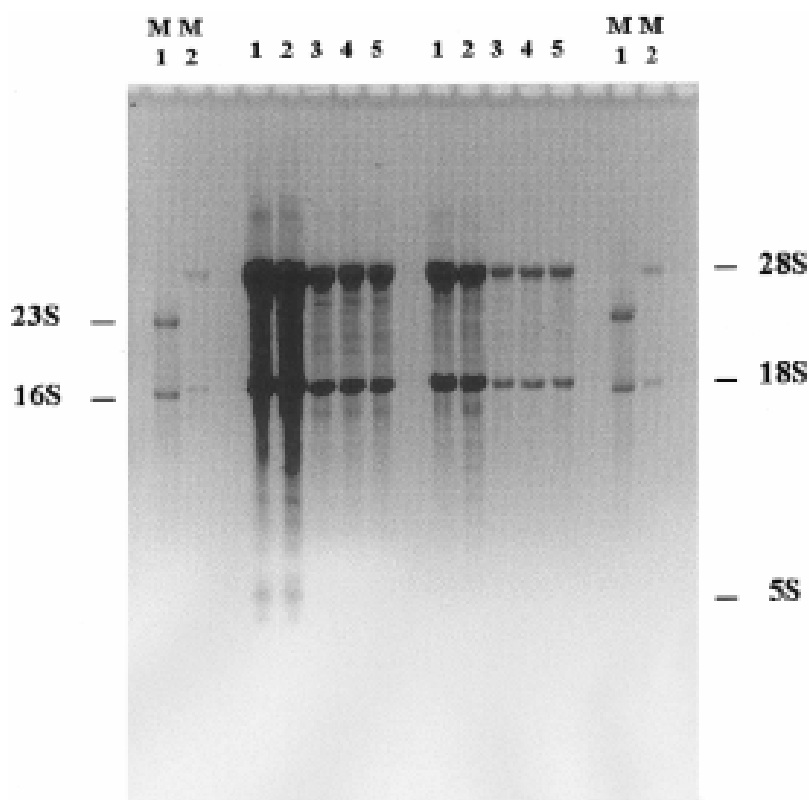

Fig. 2. Analysis of RNA (samples coded 1–5 and loaded in two different amounts on the left and right in the figure) isolated from peripheral blood lymphocytes on 1% agarose gel. As ribosomal markers, mould-derived rRNA (M1) and human rRNA (M2) were included.

the gel slices in large volumes of QX1-buffer (up to 0.5 g gel in 30 mL buffer) using 50-mL Falcon tubes. A large quantity of adsorption mixture (100 μ L for 5 μ g PCR product) is added before incubation at 50°C. After the gel has completely dissolved, pellet the glass particles (10 min at 5000g) and resuspend in 2.5 mL QX1-buffer. Divide the suspension among five microcentrifuge tubes and process according to the instruction of the supplier.

10. High quantities of restriction enzymes and prolonged incubation times, as well as extended oligonucleotide primers, improve the efficiency of digestion of PCR products.
11. The quality and the quantity of the acceptor vector used during ligation will determine the size of the library. Digestion with an additional restriction enzyme cutting within the stuffer fragment (such as *Pst*I) will reduce the background considerably (W. Bos, personal communication). Screen a limited number of clones from each (test) ligation with PCR to confirm the presence of a high fraction (>80%) of clones containing insert.

12. The use of a smaller plasmid vector for the generation of the primary libraries, such as pUC119-CES1 (lacking the pIII gene), increases the cloning efficiency considerably. Also, the cloning of a small fragment (V_H instead of $V_{\kappa}C_{\kappa}$ or $V_{\lambda}C_{\lambda}$) is more efficient during the combining of HC and LC repertoires. The *BstEII* site occurs in one of the human J_{λ} regions. For this reason, *NotI* is used during the recloning of the $V_H C_H1$ -derived fragments into the V_{λ} repertoires.
13. To prepare electrocompetent cells, inoculate 1 L 2TY medium with 10 mL overnight culture of *Escherichia coli* TG1 cells. When an OD_{600} of 0.5–0.9 is reached (after approx 100–110 min shaking at 37°C), transfer the culture to centrifuge bottles, and cool on ice for at least 30 min. Pellet the cells (10 min at 5000g and 4°C) and gently resuspend in 1 vol (1 L) of ice-cold H_2O . Incubate the suspension for at least 30 min on ice and centrifuge as before. Resuspend the pellet in one-half vol (0.5 L) H_2O and again incubate on ice for at least 30 min. After centrifugation, take the cells up in 0.03 vol (30 mL) 10% glycerol solution and keep on ice for at least 30 min. Following the last centrifugation, add 1 mL 10% glycerol to the cells and gently resuspend. Following an incubation of at least 30 min on ice, use the cells for electroporation. Remaining cells can be divided into 400 μ L aliquots and stored at $-80^{\circ}C$.
14. To obtain high cloning efficiencies, it is important to prepare fresh competent cells, which will always give better results than frozen or commercially acquired cells. Because competence may vary, it is advised that the ligation mixture is divided and electroporated into two batches of cells made on different days. Extended periods of incubation on ice (longer than 30 min) during washing with H_2O and 10% glycerol will improve the quality of the cells.
15. During all manipulations of the cells, the expression of Ab fragments should be prevented, since this might enhance selective growth. For this reason, glucose is always included in media except during the propagation of phage particles when surface-expressed Ab fragments are required for affinity selection. To get improved folding into functional Ab domains, decrease culture temperatures ($30^{\circ}C$) during phage propagation.
16. It is preferable to grow transformed cells on plates, since this will allow a noncompetitive outgrowth of all clones.
17. The storage of individual glycerol stocks enables the identification of libraries containing polyreactive Ab clones and exclusion of the relevant sublibrary from the master stock, should this problem arise.
18. When preparing phage particles from huge repertoires, large volumes of culture are used to enable the growth of log-phase cells from inoculations that contain high numbers of cells. These high numbers may be used to maintain the original diversity of the library.
19. High numbers of phage prepared from the large single-pot repertoires must be used during selection. It has been estimated that only 1–10% of all rescued phage particles display a functional Ab fragment (8). Thus, in a repertoire of 10^{11} , only 1–10 functional copies of each clone may be present among 10^{13} phage particles.

References

1. Marks, J. D., Hoogenboom, H. R., Bonnert, T. P., McCafferty, J., Griffiths, A. D., and Winter, G. (1991) By-passing immunization: human antibodies from V-gene libraries displayed on phage. *J. Mol. Biol.* **222**, 581–597.
2. Sheets, M. D., Amersdorfer, P., Finnern, R., Sargent, P., Lindqvist, E., Schier, R., et al. (1998) Efficient construction of a large nonimmune phage antibody library: the production of high-affinity human single-chain antibodies to protein antigens. *Proc. Natl. Acad. Sci. USA* **95**, 6157–6162.
3. Griffiths, A. D., Malmqvist, M., Marks, J. D., Bye, J. M., Embleton, M. J., McCafferty, J., et al. (1993) Human anti-self antibodies with high specificity from phage display libraries. *EMBO J.* **12**, 725–734.
4. Vaughan, T. P., Williams, A. W., Pritchard, K., Osbourn, J. K., Pope, A. R., Earnshaw, J. C., et al. (1996) Human antibody with sub-nanomolar affinities isolated from a large non-immunized phage display library. *Nature Biotechnol.* **14**, 309–314.
5. de Haard, H. J., van Neer, N., Reurs, A., Hufton, S. E., Roovers, R. C., Henderikx, P., et al. (1999) A large non-immunized human Fab fragment phage library that permits rapid isolation and kinetic analysis of high affinity antibodies. *J. Biol. Chem.* **274**, 18,218–18,230.
6. Klein, U., Rajewsky, K., and Kuppers, R. (1998) Human immunoglobulin (Ig)M+IgD+ peripheral blood B cells expressing the CD27 cell surface antigen carry somatically mutated variable region genes: CD27 as a general marker for somatically mutated (memory) B cells. *J. Exp. Med.* **188**, 1679–1689.
7. Chomczynski, P. and Sacchi, N. (1987) Single-step method of RNA isolation by acid guanidinium thiocyanate-phenol-chloroform extraction. *Anal. Biochem.* **162**, 156–159.
8. McCafferty, J. (1996) Phage display: factors affecting panning efficiency, in *Phage Display of Peptides and Proteins* (Kay, B., Winter, L., and McCafferty, J., eds.), Academic, San Diego, pp. 261–276.

Construction of Polyclonal Antibody Libraries Using Phage Display

Jacqueline Sharon, Seshi R. Sompuram, Chiou-Ying Yang, Brent R. Williams, and Stefanie Sarantopoulos

1. Introduction

Polyclonal antibody libraries (PCALs) are standardized mixtures of antibodies (Abs) specific for an antigen (Ag) or multi-Ag target (a poly-Ag). As the immunoglobulin (Ig) genes are cloned, the mixtures can be perpetuated, amplified, and modified as desired. Poly-Ags of special interest are microbes and tumor cells, with potential for both therapeutic and diagnostic applications. PCALs combine the advantages of serum-derived polyclonal Abs with the perpetuity of monoclonal antibodies (MAbs). Like serum-derived polyclonal Abs, PCALs target multiple epitopes on poly-Ags, resulting in high-avidity binding, low likelihood of Ag “escape variants” emerging, and efficient triggering of effector functions (*1*). A PCAL is not merely a collection of Ag-specific MAbs: the PCAL is selected in mass for binding to a target poly-Ag, and is, thereafter, perpetuated without isolation or characterization of individual library members. Thus, a PCAL contains Abs specific for the target poly-Ag, and Abs that crossreact with other poly-Ags (e.g., normal cells). However, the Ag profile of the target poly-Ag differs qualitatively and quantitatively from the Ag profile of any other poly-Ag, enabling the PCAL to recognize the target poly-Ag with a high signal:noise ratio. This concept is illustrated schematically in **Fig. 1**. Because effector functions are inefficient at low Ab density, low-level crossreactivity with normal tissue will probably be tolerated in therapeutic applications.

PCAL generation usually involves the recovery of V_L and V_H repertoires, and their random pairing as Fabs into a phage-display vector. The library is posi-

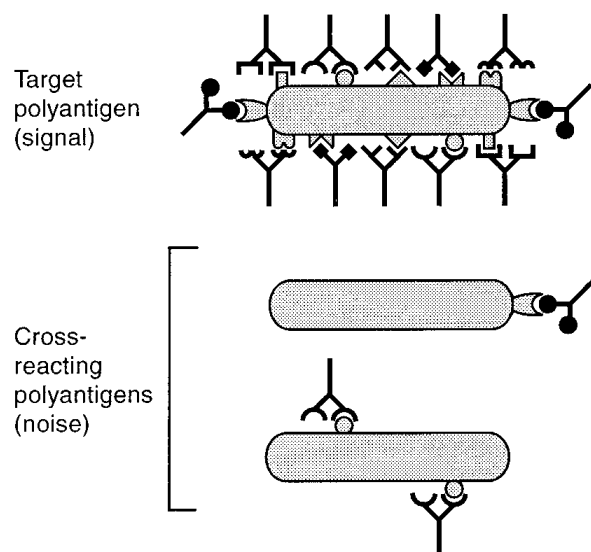

Fig. 1. Schematic representation of target recognition with high signal : noise ratio.

tively and negatively selected. Selected V_L - V_H gene pairs are then transferred in mass to a mammalian expression vector, which has been engineered to maintain the V_L - V_H combinations. In our system, this is facilitated by the bidirectional orientation of the V_L and V_H transcription units. The constructs are then transfected into a mammalian cell line for expression.

Mammalian vectors may contain constant-region genes of any isotype or species (or fragments or modifications thereof). Hence, the same selected V_L - V_H library can be used to produce libraries of full-length, glycosylated Abs of any isotype, or from any species (2-6). The flow chart for PCAL generation is shown in **Fig. 2**. Any manipulation that can be done with monoclonals derived from hybridomas or from phage-display systems, can also be done with PCALs. The difference is that, with PCALs, the individual Abs are not isolated, but are handled in mass.

2. Materials

1. Total RNA obtained from any B-cell-containing tissue in mice or humans.
2. C-region cDNA primers.
3. Forward and reverse polymerase chain reaction (PCR) primers.
4. Reverse transcriptase (RT) and buffer.
5. *Taq* DNA polymerase and buffer.
6. DNA thermal cycler.
7. Agarose gels and electrophoresis equipment.
8. TA cloning kit (Invitrogen, Carlsbad, CA) for cloning of PCR products.

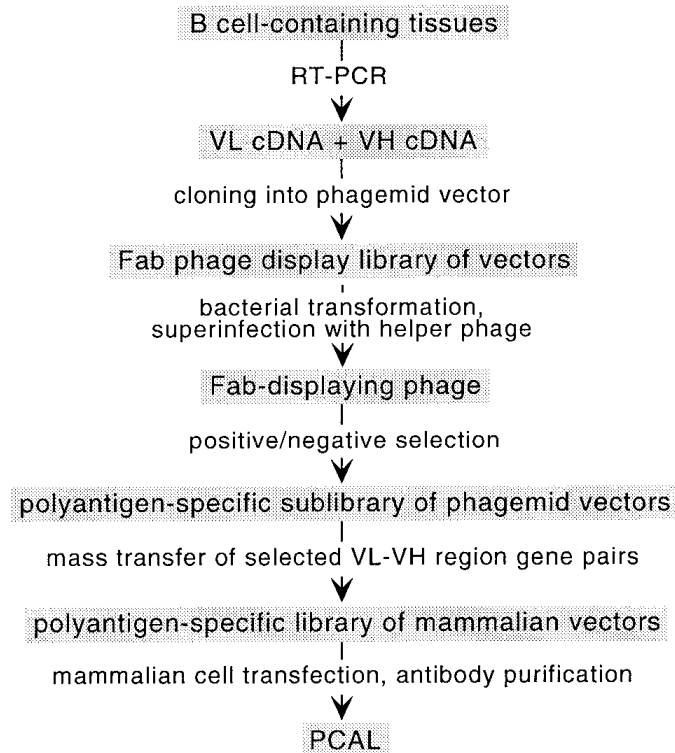

Fig. 2. Flow chart for PCAL generation.

9. Systems (or kits) for purification of plasmids, PCR products, and DNA fragments.
10. T4 DNA ligase, restriction enzymes (*EcoRI*, *HindIII*, *XhoI*, *SacI*) and their corresponding buffers.
11. Phagemid vector for Fab display.
12. Luria Bertani (LB) agar and liquid medium. Stock solutions of carbenicillin, glucose, tetracycline, and glycerol.
13. System for positive and negative selection of Fab phage-display libraries.
14. Mammalian expression vectors for expression of whole Abs.
15. VCSM13 helper phage.
16. Supercompetent *Escherichia coli* XL1-Blue and HB101 cells.
17. Mammalian cell lines for expression of whole Abs, e.g., mouse myeloma Sp2/0 or Chinese hamster ovary (CHO).
18. Iscove's modified Dulbecco's medium (IMDM), fetal bovine serum (FBS), hybridoma enhancing supplement (HES) (Sigma, St. Louis, MO), and stock solutions of gentamicin, and of hypoxanthine, mycophenolic acid, xanthine (HMX; 1X HMX = 15 μg hypoxanthine/mL, 6 μg mycophenolic acid/mL, 250 μg xanthine/mL).

19. Electroporator for bacterial transformation and mammalian cell transfection.
20. Dulbecco's Modified Eagle's Medium (DMEM) supplemented with 10% sucrose and 10 mM MgCl₂, 50% (w/v) hybridoma-grade polyethylene glycol (PEG).

3. Methods

1. Produce heavy chain (HC) first strand cDNA for each desired Ig class or isotype from each tissue, using 3 μg total RNA/reaction, RT, and HC RT primers (*see Fig. 3* for an example of murine cDNA primers; and **Note 1**). Set up one reaction for each Ab class or isotype, for example, μ, γ, and α (*see Fig. 4* for RT-PCR scheme). Produce light chain (LC) first-strand cDNA from each tissue, using RT and LC RT primers, one tube/LC isotype, e.g., κ. *See* index for detailed protocols for the isolation of RNA and RT reactions.
2. Amplify the HC cDNA from each tissue in a low-stringency PCR, using three V_H (forward) primers for each nested (reverse) C primer (expected sizes 375–520 bp). Amplify the LC cDNA from each tissue in a low-stringency PCR, using two V_L (forward) primers for each nested (reverse) C primer (expected size 400 bp) (*see Fig. 4* and **Note 2**). PCR conditions: 1–2 μL cDNA, 1.5 U *Taq* DNA polymerase, 1.5 mM MgCl₂, 0.2 mM dNTPs, 20 pmol of each primer in a total volume of 50 μL. Cycle conditions: 94°C hot start; 94°C, 1 min; 37°C, 0.5 min; 72°C 2.5 min for 30 cycles; 72°C, 5 min. Gel-purify the products from a 0.8% TAE agarose gel, resuspending in a final volume of 30 μL.
3. Amplify each gel-purified product of the first HC PCR in a second reaction with each J_H primer (reverse primer, nested) and the same forward V_H primer (expected size, 360 bp). Amplify each LC product of the first PCR in a second reaction with each J_L primer (reverse primer, nested) and the corresponding forward V_L(2) primer (expected size 330 bp) (*see Fig. 4*). PCR conditions: 1–2 μL gel-purified first PCR product, 1.5 U *Taq* DNA polymerase, 1.5 mM MgCl₂, 0.2 mM dNTPs, 20 pmol of each primer in a total volume of 50 μL. Cycle conditions: 94°C hot start; 94°C, 0.5 min; 58°C, 1 min; 72°C, 5 min for 15–30 cycles; 72°C, 5 min (*see Note 3*). Run samples of the second PCR reactions (5 μL each) on a 1% TBE agarose gel to check size and yield. Immediately clone samples of representative second PCR products (e.g., one PCR product for the V_H region and one PCR product for the V_L region) into a TA vector for nucleotide sequencing to ensure diversity following the manufacturer's recommendations.
4. Combine all second PCR products for V_H, purify using purification kit for PCR products, digest with *Eco*RI and *Xho*I, and gel-purify from a 0.8% TAE gel. Combine and purify all second PCR products for V_L, digest with *Sac*I and *Hind*III, and gel-purify from a 0.8% TAE gel.
5. Ligate the purified *Eco*RI/*Xho*I-cut V_H product with *Eco*RI/*Xho*I-cut backbone (5.9 kb) from phagemid vector no. C134 phh3-stuffer (*see Fig. 5* and **Note 4**). Set up a 20-μL ligation reaction containing 200 U T4 DNA ligase, 320 ng vector no. C134 phh3-stuffer, and V_H products at a 1:3 molar ratio vector:insert. Incubate overnight at 16°C.

First strand cDNA (RT) primers (as)

Heavy Chain

166 157
 CH1- μ -RT GAT GAC TTC AGT GTT GTT CTG GTA GTT CC
 196 188
 CH1- γ -RT GCT GGA GGG TAC AGT CAC TGA GCT GCT
 157 147
 CH1- α -RT CCA GGT CAC ATT CAT CGT GCC GAA AGG GAA G

Light Chain

149 139
 CL-k-RT TT CCA CTT GAC ATT GAT GTC TTT GGG GTA G

C primers (as, reverse) for first PCR

Heavy Chain

139 129
 CH1- μ -LS GGC CAC CAG ATT CTT ATC AGA CAG GGG GCT
 174 165
 CH1- γ -LS TGG GAA TGT GTG CAC ACC GCT GGA CAG GG
 125 116
 CH1- α -LS TGT CAG TGG GTA GAT GGT GGG ATT TCT CGC

Light Chain

136 126
 CL-k-LS A GAA GCA CAC GAC TGA GGC ACC TCC AGA TG

V primers (sn, forward) for first & second PCR

Heavy Chain

1 *XhoI* 11 15
 VH1 GAG GTG CAG CTT CTC GAG TCA GGA CCT GGC CT
 VH2 GAG GTG CAG CTT CTC GAG TCT GGG GCT GAG CTT GTG AGG CTT GG
 VH3 GAA GTG AAG CTT CTC GAG TCT GGG GGA GGC TT

Light Chain - first PCR

1 *SacI* 13 14
 VL1 GAG CTC GTG ATG ACA CAG ACT CCA TCC TCC CTG CCT G
 VL2 GAG CTC GTT CTC ACC CAA TCT CCA GCA TCA ATG TCT GTG TCT

Light Chain - second PCR

1 *SacI* 10
 VL1(2) AT ATA GAG CTC GTG ATG ACA CAG ACT CCA TCC TCC
 VL2(2) AT ATA GAG CTC GTT CTC ACC CAA TCT CCA GCA TC

J primers (as) for second PCR

Heavy Chain

EcoRI 113 104
 JH-1 CTT AGA ATT CGC TGA GGA GAC GGT GAC CGT GGT CCC TGC GC
 JH-2 TC GGA ATT CGC TGA GGA GAC TGT GAG AGT GGT GCC
 JH-3 CTT AGA ATT CGC TGC AGA GAC AGT GAC CAG AGT CCC TTG GC
 JH-4 CTT AGA ATT CGC TGA GGA GAC GGT GAC TGA GGT TCC TTG AC

Light Chain

110 108 *HindIII* 99 97
 JL-k1 CG TTT GAT TTC AAG CTT GGT GCC TCC ACC
 JL-k2 TTT TAT TTC AAG CTT GGT CCC CCC TCC GAA CGT
 JL-k4 ATC AGC CCG TTT TAT TTC AAG CTT TGT CCC CGA GCC GAA CGT
 JL-k5 TTT CAG CTC AAG CTT GGT CCC AGC ACC GAA CGT

Fig. 3. Oligonucleotide primers used for library construction. The antisense and sense strands are denoted by "as" and "sn," respectively. Restriction sites are underlined. Corresponding amino acid numbers in the Kabat system (9) are shown above the sequences.

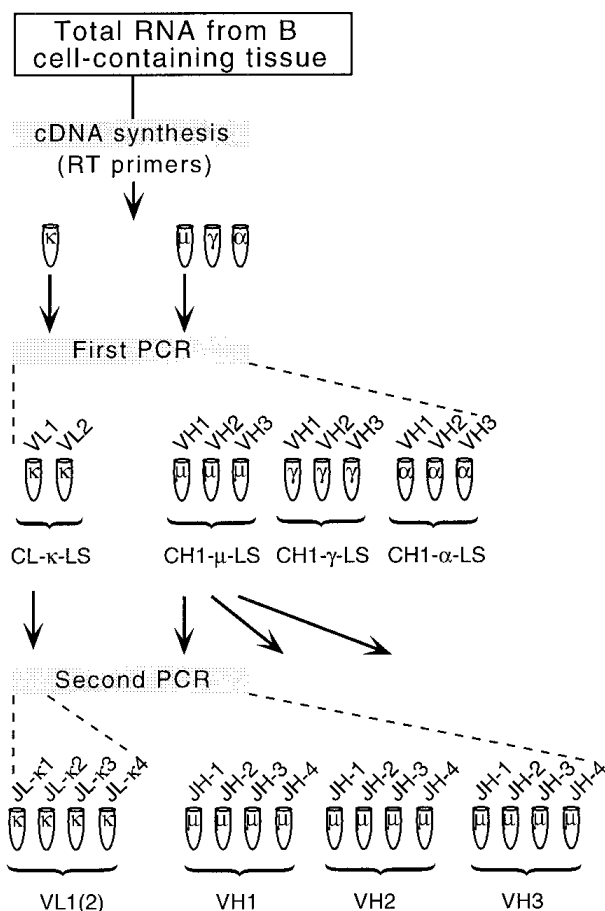

Fig. 4. Scheme for RT-PCR (see Fig. 3 for primers).

- Precipitate the ligation products with ethanol and resuspend the dried DNA in 4 μ L molecular-biology-grade H₂O. Use 2 μ L of this to transform supercompetent XL1-Blue bacteria according to the supplier's instructions. To build a V_H library of 1×10^6 members, 1–2 transformations must be performed.
- Plate the transformation mixture on plates of Luria-Bertani (LB) medium supplemented with 50 μ g/mL carbenicillin and 1% glucose (LB-CARB-GLU) in serial dilutions, to determine the library size of phh3-V_H-lib (see Fig. 5 and Note 5) and to ascertain that $\geq 90\%$ of library members have the correct size insert (as determined by diagnostic restriction enzyme digestion of selected clones) and at high density to recover the library.
- Scrape the phh3-V_H-lib bacterial colonies from the dense plates with a rubber policeman into LB-CARB-GLU-15% glycerol and store in aliquots at -80°C as the original V_H library stock. Grow an aliquot of the V_H library ($\geq 1 \times 10^8$ bacteria for a library of 1×10^6 members) in LB-CARB-GLU, and prepare DNA.

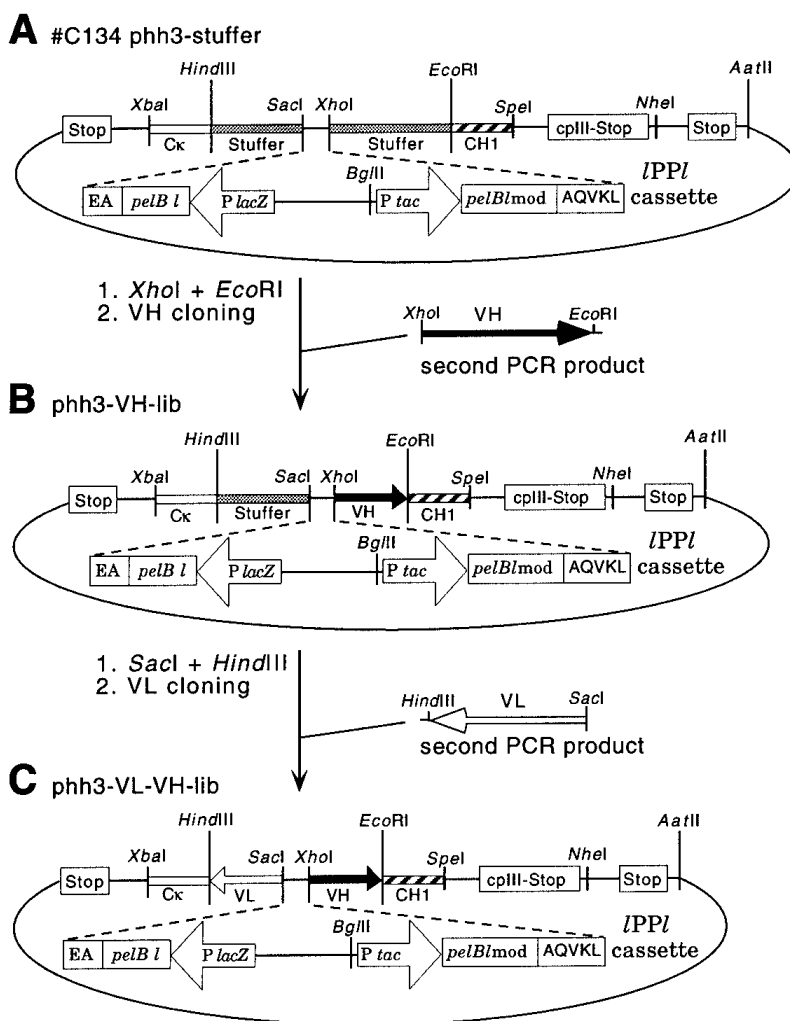

Fig. 5. Scheme for construction of Fab phage-display libraries (partial maps and not to scale). The phagemid vector no. C134 phh3-stuffer (JS no. 620 as well as an analogous, but smaller vector, no. 622 stuff2-phh3), has been modified from the pComb3 vector (10). The direction of transcription is indicated by arrows and by arrowheads on promoters and variable-region genes. Note that the order of ligation of the V_H and V_L second PCR products can be reversed. P, promoter; l, leader sequence; lmod, leader sequence with modified nucleotide sequence; Stop, translation termination. Amino acids encoded by the vectors are shown in one-letter code.

9. Digest the phh3-V_H-lib DNA with *SacI/HindIII*, and gel-purify the 4.6-kb backbone (see Note 4). Ligate the backbone with *SacI/HindIII*-cut V_L product to obtain phh3-V_L-V_H-lib using ligation conditions as in step 5. Multiple ligations will be necessary to obtain a library of the intended size. Transform the ligation mix into supercompetent XL1-Blue bacteria (see Note 5).

10. Repeat **steps 7 and 8** for phh3-V_L-V_H-lib (see **Fig. 5**) and store in aliquots at -80°C as the original V_L-V_H library stock.
11. Plate an aliquot of the V_L-V_H library (1 × 10⁹ bacteria for a library of 1 × 10⁷ members) at high density on LB-CARB-GLU plates. Scrape the bacterial colonies and grow in LB-CARB-GLU containing 10 µg/mL tetracycline (LB-CARB-GLU-TET) to an OD₆₀₀ of 0.5. Superinfect with VCSM13 helper phage at a 20:1 ratio of phage:bacteria and prepare phage as indexed elsewhere in this volume. Also determine the cfu/pfu ratio by plating serial dilutions of the phage on LB-CARB plates for phagemid colonies and on B plates (per L: 10 g Bacto-tryptone, 8 g NaCl, 15 g agar) for plaques (a cfu/pfu ratio ≥ 1 is desirable).
12. Carry out positive/negative selection on the phage following appropriate methods. See index for details.
13. After positive/negative selection, infect XL1-Blue supercompetent bacteria with the selected phage. Plate the infected cells on LB-CARB-GLU plates in serial dilutions to determine the size of the selected library and at high density to recover the library. Scrape the bacterial colonies and superinfect a portion of the culture with VCSM13 helper phage to produce phage for immunoassay (e.g., enzyme-linked immunosorbant assay against the poly-Ag target). Store the remainder of the selected library culture in aliquots in LB-CARB-GLU-15% glycerol at -80°C.
14. Prepare dsDNA from the selected library and digest with *SacI* and *XhoI*. Gel-purify the 5-kb backbone (see **Note 4**). Also isolate the 1.8-kb *SacI/XhoI* fragment from vector no. 578 pIPEHPI(+) (see **Fig. 6**), the bidirectional mammalian IPPI cassette, which carries the mammalian promoter and leader sequences and the mouse Ig µ enhancer. Ligation of these fragments will generate phh3-V_L-m-V_H-lib.
15. Transform phh3-V_L-m-V_H-lib into supercompetent HB101 cells and plate on LB-CARB plates in serial dilutions to determine the size of the selected library and to ascertain that ≥90% of library members have the correct-size insert (as determined by diagnostic restriction enzyme digestion of selected clones) and at high density to recover the library.
16. Prepare DNA from the recovered phh3-V_L-m-V_H-lib and digest with *EcoRI* and *HindIII*. Gel-purify the 2.3-kb fragment containing the V_L-V_H pairs and the mammalian IPPI cassette, and ligate with the 15.2-kb *EcoRI/HindIII* backbone from the mammalian vector no. 577 pMDV-IgG2b. This will generate pM-DV-IgG2b-lib (see **Fig. 6**).
17. Repeat **step 15** for pMDV-IgG2b-lib (see **Note 6**).
18. Prepare DNA from the recovered pMDV-IgG2b-lib and transfect into Sp2/0 mammalian cells (see **Note 7**).
19. Plate transfected cells in 96-well microtiter plates (0.1 mL/well) in IMDM/10% FBS and 50 µg/mL gentamicin, in serial dilutions, to determine the size of the transfected library (see **Note 8**), and at high density, to obtain multiple clones/well (see **Note 9**). After overnight incubation, add 0.1 mL/well medium

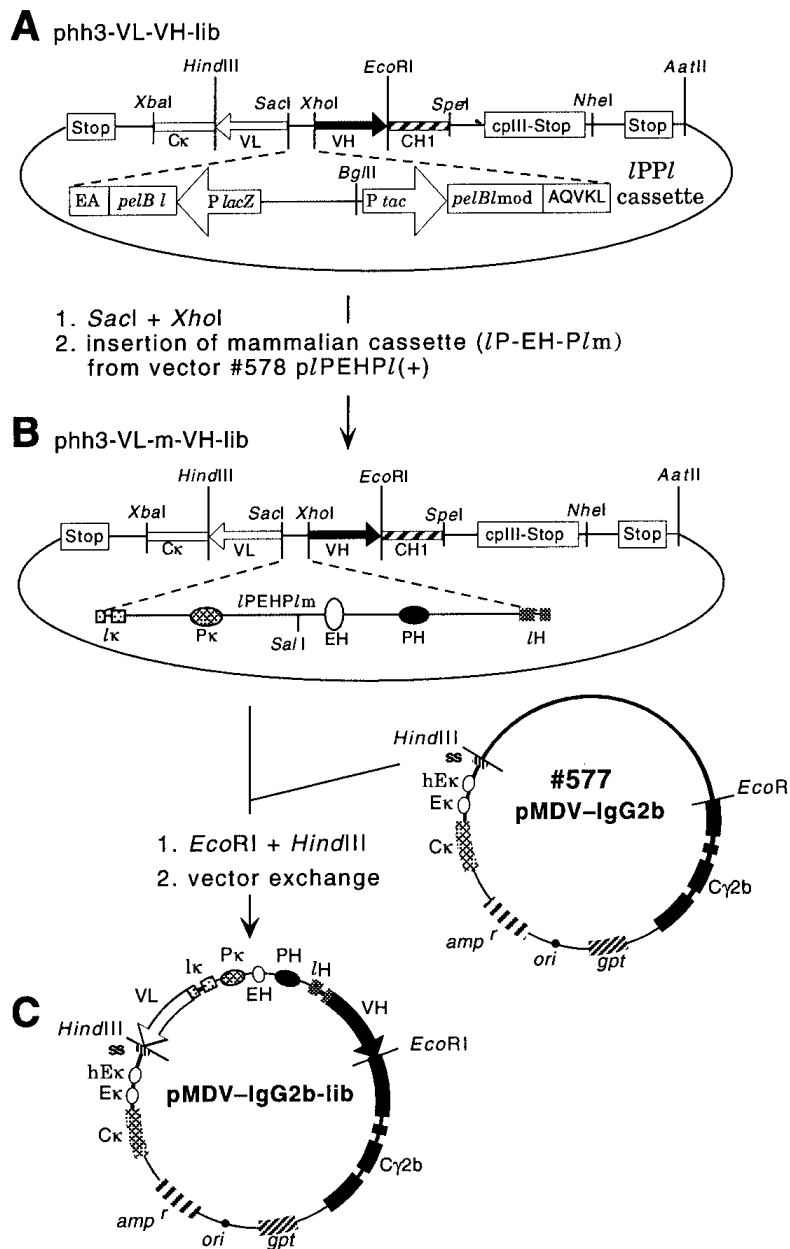

Fig. 6. Transfer of V-region gene pairs between bidirectional phage-display and mammalian expression vectors (partial maps and not to scale). Prokaryotic elements are as in Fig. 5. Mammalian regulatory elements are oval shaped. *amp^r*, ampicillin resistance; *ori*, prokaryotic origin of DNA replication; P, promoter; E, enhancer; *l*, leader sequence; *ss*, splice site; *h*, human (all other mammalian regulatory elements are murine).

(IMDM, 20% FBS, 50 $\mu\text{g}/\text{mL}$ gentamicin) containing 1/30X HMX. Two days later, aspirate one-half the medium from each well and replace with 0.1 mL/well medium containing 1/5X HMX and 10% (v/v) HES. Feed by replacement with medium containing 1X HMX when the cell supernatants in the plates turn orange-yellow about 1 wk later.

20. When clones appear in the dense plates, transfer entire library of transfectomas to a flask. Use one-half the cells for cryopreservation in several freezing vials. Grow the other half of the cells as desired, and purify the Ab library for immunoassay and further biological characterization (*see Note 10*). This is the PCAL.

4. Notes

1. Primers for cDNA synthesis and subsequent PCR steps must be designed for every species.
2. The low-stringency first PCR (37°C) ensures amplification of a large repertoire of V-region genes using a limited primer set; nesting of reverse primers in the first PCR, compared to the cDNA reaction, and in the second PCR, compared to the first PCR, minimizes amplification of non-V-region sequences. Examples of primer sequences for the mouse are shown in **Fig. 3**. The principles of design can be adapted with ease to other species of interest.
3. The optimal number of cycles is the minimum number that will yield the maximum amount of V-region gene PCR product. To determine this, sample small volumes from a test PCR after 10, 15, 20, 25, and so on, cycles for gel analysis, and use the lowest cycle number yielding a strong-staining band (15 cycles in this lab).
4. For backbone preparation, the vector is linearized by cutting with the first (less-efficient) enzyme, gel-purified and the recovered DNA fragment is then cut with the second enzyme and gel-purified. This procedure minimizes the amount of uncut vector in the backbone sample.
5. A library size $\geq 1 \times 10^6$ members is desirable for phh3-V_H-lib. A library size $\geq 1 \times 10^8$ members is desirable for phh3-V_L-V_H-lib, although at the time of writing, our largest library has comprised 2×10^7 clones.
6. A library size $\geq 10\times$ the size of the poly-Ag-selected library is desirable, to ensure good representation of every member of the selected library.
7. Transfection into Sp2/0 cells can be done by electroporation (7) of 2×10^7 Sp2/0 cells in 0.8 mL PBS/cuvet with 10 μg DNA, linearized by prior digestion with *SaI*I, followed by gel purification. Electroporation conditions are 960 μF and 240 V. Alternatively, transfection can be achieved by spheroplast fusion (8). Prepare spheroplasts from about two OD₅₅₀ of chloramphenicol-treated bacterial culture, and add 13 mL DMEM/sucrose/MgCl₂ to a DMEM-washed monolayer of Sp2/0 cells in a 10-cm tissue culture dish. Centrifuge 5 min at 1200g in appropriate plate carriers, and aspirate the medium. Add 4 mL 50% PEG, and 70 s later, dilute the PEG, and gently wash with DMEM. Resuspend in complete medium and incubate for 4 h at 37°C, then harvest the cells by scraping. To

avoid expression of more than one pair of HC and LC per transfected cell, electroporation should be done at a limiting DNA concentration that favors integration and expression of a single plasmid molecule. Spheroplast fusion should be done at limiting spheroplast number that favors fusion of a single spheroplast; this may contain up to 1000 copies of the same plasmid per mammalian cell.

8. A transfected library size $\geq 10\times$ the size of the poly-Ag-selected library is desirable to ensure good representation of every member of the selected library.
9. The library of transfected cells is initially plated in 96-well microtiter plates, to allow development of clones in an immobile crossfeeding environment.
10. The library can be regenerated by growth from cryopreserved aliquots of the transfection mixture or by retransfection of pMDV-IgG2b-lib.

Acknowledgments

We thank Liyan Chen for discussion and Steven Pageau for computer graphics and manuscript preparation. This work was supported by grant no. AI23909 from the National Institutes of Health to J. Sharon. Seshi Sompuram and Chiou-Ying Yang have contributed equally to establishment of this method. Chiou-Ying Yang was formerly known as Chiou-Ying Y. Kao.

References

1. Sharon, J. (1998) *Basic Immunology*. Williams & Wilkins, Baltimore, MD.
2. Sarantopoulos, S., Kao, C. Y., Den, W., and Sharon, J. (1994) A method for linking VL and VH region genes that allows bulk transfer between vectors for use in generating polyclonal IgG libraries. *J. Immunol.* **152**, 5344–5351.
3. Den, W., Sompuram, S. R., Sarantopoulos, S., and Sharon, J. (1999) A bidirectional phage display vector for the selection and mass transfer of polyclonal antibody libraries. *J. Immunol. Methods* **222**, 45–57.
4. Baecher-Allan, C. M., Santora, K., Sarantopoulos, S., Den, W., Sompuram, S. R., Cevallos, A. M., et al. (1999) Generation of a polyclonal Fab phage display library to the protozoan parasite *Cryptosporidium parvum*. *Combinatorial Chem. High Throughput Screening* **2**, 299–305.
5. Santora, K. E., Sarantopoulos, S., Den, W., Petersen-Mahrt, S., Sompuram, S. R., and Sharon, J. (2000) Generation of a polyclonal fab phage display library to the human breast carcinoma cell line BT-20. *Combinatorial Chem. High Throughput Screening* **3**, 51–57.
6. Sharon, J., Sarantopoulos, S., Den, W., Kao, C.-Y., Baecher-Allan, C. M., Santora, K. E., et al. (2000) Recombinant polyclonal antibody libraries. *Combinatorial Chem. High Throughput Screening* **3**, 185–196.
7. Sharon, J., Gefter, M. L., Wysocki, L. J., and Margolies, M. N. (1989) Recurrent somatic mutations in mouse antibodies to p-azophenylarsonate increase affinity for hapten. *J. Immunol.* **142**, 596–601.

8. Sharon, J., Gefter, M. L., Manser, T., and Ptashne, M. (1986) Site-directed mutagenesis of an invariant amino acid residue at the variable-diversity segments junction of an antibody. *Proc. Natl. Acad. Sci. USA* **83**, 2628–2631.
9. Kabat, E. A., Wu, T. T., Perry, H. M., Gottesman, K. S., and Foeller, C. (1991) *Sequences of Proteins of Immunological Interest*. U.S. Department of Health and Human Services, Bethesda, MD.
10. Barbas, C. F. I., Kang, A. S., Lerner, R. A., and Benkovic, S. J. (1991) Assembly of combinatorial antibody libraries on phage surfaces: the gene III site. *Proc. Natl. Acad. Sci. USA* **88**, 7978–7982.

Antigen-Driven Stimulation of B-Lymphocytes In Vitro

Zhiwei Hu

1. Introduction

When attempting to establish libraries of immunoglobulins (Igs) from human subjects during the course of infection or other illness, a number of basic problems present themselves. First, the only source of lymphocytes that can be easily sampled is the peripheral blood in which the representation of antibodies (Abs) against the chosen target is likely to be low. Since direct immunization to increase representation is unethical, alternative means must be devised to drive the proliferation of the clones of interest in vitro. In our own studies of the colorectal cancer (CRC)-associated antigen (Ag) CA-Hb3, a 50-kDa protein that is recognized by monoclonal antibody (MAb), Hb3 (*I*), procedures were developed to drive the proliferation of specific B cells from the blood of patients, through exposure to Ag in vitro. This has enabled generation, through phage display, of recombinant human Abs against CA-Hb3.

2. Materials

1. Affinity-purified Ag in phosphate-buffered saline (PBS) or crude Ag (*see* **Notes 1** and **2**).
2. Recombinant human interleukin-2 (rhIL-2).
3. Pokeweed mitogen (PWM).
4. Lymphocyte separation solution.
5. Dulbecco's modified Eagle's medium (DMEM) culture medium.
6. Fetal bovine serum (FBS) heat-inactivated at 56°C for 30 min.
7. Hank's balanced salt solution (HBSS).
8. Heparin diluted in PBS or heparinized tubes.

From: *Methods in Molecular Biology*, vol. 178: *Antibody Phage Display: Methods and Protocols*
Edited by: P. M. O'Brien and R. Aitken © Humana Press Inc., Totowa, NJ

9. Glutaraldehyde (1%).
10. Butanol-1.
11. 50 mM Carbonate buffer, pH 9.6.
12. 1% Bovine serum albumin (BSA) in PBS.
13. Antihuman IgG and IgM horseradish peroxidase conjugates.
14. *O*-phenylenediamine (OPD).
15. Hydrogen peroxide (30%).
16. 2 M Sulfuric acid.
17. Ampicillin and streptomycin.
18. Trizol reagent.
19. Standard reagents for polymerase chain reaction (PCR) (*Taq* polymerase, buffer, deoxyribonucleoside triphosphates [dNTPs], primers, and so on).

3. Methods

3.1. Screening for Seropositive Donors

1. In order to drive a secondary immune reaction during *in vitro* stimulation, enzyme-linked immunosorbent assay (ELISA) assay should be used to select patients with Abs against the given Ag and/or the Ag itself, if possible. If samples are negative for Ag and/or Ab, it may still be worthwhile to go ahead with *in vitro* stimulation (*see Subheading 3.2.*).
2. To test for Abs in serum (plasma, if heparin has been used) against CA-Hb3, the Ag of interest here, culture the cancer cells overnight at 10^4 cells/well in 100 μ L medium in 96-well plates at 37°C and 5% CO₂, then fix cells with 0.24% glutaraldehyde at room temperature for 10 min. Alternatively, coat microtiter wells with 100 μ L of 10 μ g/mL crude butanol extraction (CBE) Ag at 37°C for 2 h then 4°C overnight. The Ag is extracted from cells with 2.5% 1-butanol (2) and diluted in 0.05 M bicarbonate buffer, pH 9.6 (coating buffer).
3. Wash the plates 3 \times 3 min with PBS.
4. Block wells with 200 μ L of 1% BSA in PBS at room temperature for 30 min.
5. Incubate each well with 100 μ L of serially diluted plasma at 37°C for 2 h.
6. Wash 3 \times 3 min with PBS.
7. Incubate each well with 100 μ L of 1:2000 diluted anti-human IgG + IgM HRP conjugate in 1% BSA at 37°C for 1 h.
8. Wash 3 \times 3 min with PBS.
9. Incubate each well with 100 μ L OPD (1 mg OPD powder in 2 mL PBS containing 1 μ L 30% H₂O₂) as HRP substrate at room temperature for 15 min.
10. Add 50 μ L 2 M sulfuric acid to each well to stop reaction and read absorbance at 490 nm in a ELISA reader.

3.2. Screening for Ag in Patient Sera

1. To test for Ag in blood samples, sandwich or indirect ELISA procedures can be used if MAbs or polyclonal Abs are available.

2. To conduct a sandwich ELISA, dilute a mAb against the Ag of interest to 10 $\mu\text{g}/\text{mL}$ in carbonate buffer and add to a 96-well plate for 37°C for 2 h, then 4°C overnight.
3. Follow the procedure above (*see Subheading 3.1.*), except use an HRP labeled MAb against the Ag of interest in place of the anti-IgG + IgM HRP conjugate.
4. To conduct an indirect ELISA, coat serially diluted plasma to a 96-well plate at 37°C for 2 h, then 4°C overnight.
5. Wash and incubate wells with 10 $\mu\text{g}/\text{mL}$ of a MAb or polyclonal Ab against the Ag of interest at 37°C for 1 h.
6. After washing, incubate wells with HRP-labeled second Ab conjugate at 37°C for 1 h.
7. After washing, incubate wells with OPD, then read A_{490} nm, as described (*see Subheading 3.1., step 10*).
8. Control blood sample should come from the peripheral blood of a healthy volunteer and should be diluted identically.
9. Phage libraries are best constructed from patients who are positive for both Ab and Ag (*see Note 3*).

3.3. Recovery and Culture of Lymphocytes

1. Sterile plastic tubes and flasks are used throughout. All solutions and reagents are filtered through 0.22- μm filter.
2. Take 10-mL blood samples from either a cancer patient or a patient with another disease of interest. Blood should be collected into a tube containing heparin (up to 50 U/mL blood) or a heparinized tube.
3. Dilute the blood sample with 10 mL HBSS.
4. Add 6 mL diluted blood sample to the top of 6 mL lymphocyte separation solution in a wide transparent centrifuge tube with a cap.
5. Centrifuge at 4°C or room temperature for 15 min at 250g.
6. Carefully pipet out the white layer containing peripheral blood lymphocytes (PBL) into a fresh 50-mL centrifuge tube.
7. Resuspend PBL with 20 mL HBSS and centrifuge at room temperature at 100g for 3 min.
8. Gently resuspend PBL pellet again in 20 mL HBSS.
9. Count PBL numbers and viable cells using 0.4% trypan blue exclusion assay (*see Note 5*), then centrifuge at 100g for 3 min.
10. Gently resuspend PBL with appropriate volume of DMEM supplemented with 50 U/mL ampicillin and 50 $\mu\text{g}/\text{mL}$ streptomycin and 15% heat-inactivated FBS to adjust cell density to 10^6 cells/mL in a flask.
11. For in vitro stimulation, add affinity-purified Ag to a final concentration of 10 μM (10 μM is equal to 0.5 $\mu\text{g}/\text{mL}$ CA-Hb3) or CBE Ag (*see Notes 1 and 2; 2*). Then add rhIL-2 (*see Note 6; 3*) to a final concentration of 20 U/mL and PWM to 10 $\mu\text{g}/\text{mL}$ into the PBL culture.

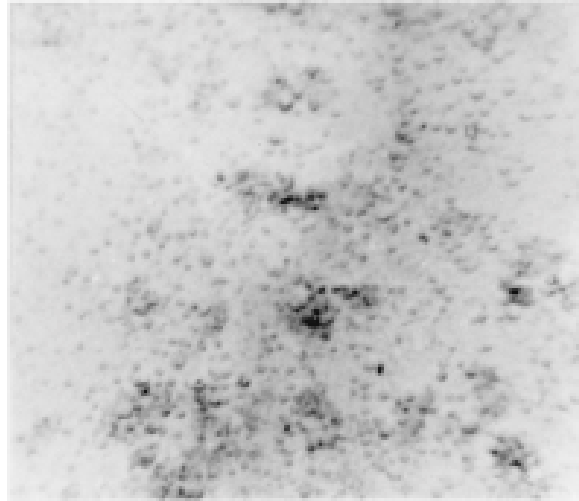

Fig. 1. Typical cellular morphology of PBL from colon cancer patient no. 1 from **Table 1** at d 7 after in vitro stimulation with a colorectal cancer-associated CA-Hb3 Ag.

12. Incubate the PBL at 37°C and 5% CO₂ for 5 d. Do not change the DMEM–15% FBS supplemented with Ag, rhIL-2, and PWM during these 5 d.
13. At d 5, remove and keep old medium and add 10 mL fresh DMEM–15% heat-inactivated FBS, Ag, rhIL-2, PWM, and antibiotics in the same concentrations as above (*see Subheading 3.3., steps 10 and 11*) and culture the PBL for 2 d more or until cell colonies and lymphoblast cells form (*see Fig. 1 and Notes 3 and 7*).
14. Collect the PBL, using a cell scraper for extraction of total RNA and/or further purification of mRNA. Total RNA samples can be used to assay Ig transcript levels (*see Subheading 3.4.*) or for making phage Ab libraries (*see Note 4*).

3.4. Assay of Ig Transcript Levels by Reverse Transcriptase (RT)-PCR

1. Collect in vitro stimulated PBL from tissue culture flasks by scraping with a cell scraper and spin briefly to remove culture medium.
2. Resuspend the PBL in 10 mL PBS and count cell numbers using trypan blue exclusion assay (*see Note 5*).
3. Extract total RNA of the PBL with Trizol reagent or other total RNA extraction reagent according to the manufacturer's instructions. In vitro stimulation procedure should increase total RNA content of the PBL and the abundance of Ig mRNA. For example, 10 µg total RNA was extracted from 10 mL peripheral blood from a colon cancer patient without in vitro stimulation, but 25 µg total RNA was extracted from 10 mL peripheral blood from the same patient (number 1 in **Table 1**) after in vitro stimulation.

Table 1
Numbers of Total Peripheral Blood Lymphocytes Counted by Trypan Blue Exclusion Assay in 10 mL Peripheral Blood from Four Colorectal Cancer Patients, Before and after In Vitro Stimulation Driven by a Colorectal Cancer-Associated CA-Hb3 Ag

CRC patient	Total cell no. before stimulation	Total cell no. after stimulation
1	1.00×10^7	0.98×10^7
2	1.52×10^7	0.85×10^7
3	0.75×10^7	0.68×10^7
4	1.20×10^7	0.48×10^7

- To synthesize complementary DNA (cDNA) from total RNAs from the stimulated and unstimulated PBLs, add 1 μg total RNA to 0.2 μg oligo(dT), 10 U RNase inhibitor, 5 mM dNTPs, 1X RT buffer and 5 U avian myeloblastosis virus RT in a reaction volume of 20 μL . Incubate the reaction tubes at 42°C for 60 min.
- To amplify $V_{\text{H}}\text{-C}_{\text{H}}1$ (λ) and $V_{\text{L}}\text{-C}_{\text{L}}$ (κ), a touchdown PCR procedure was used (4). The 5' primer for amplification of $V_{\text{H}}\text{-C}_{\text{H}}1$ is 5'-GAGGTGCAGCTGKTGSAGTCTGS-3', 3' primer is 5'-GTCCACCTTGGTGTGCTGGGCTT-3'. For amplification of $V_{\text{L}}\text{-C}_{\text{L}}$, 5' primer is 5'-GAWRTTGTGMTGACKCAGTCTCC-3' and 3' primer is 5'-AGACTCTCCCCTGTTGAAGCTCTT-3', where R is A or G, W is A or T, S is C or G, K is T or G. β -actin can be used as an internal control (5'-primer is 5'-CTTCTACAATGAGCTGCGTG-3', and 3' primer 5'-TCATGAGGTAGTCAGTCAGG-3'). Set up 50- μL PCR reactions containing 2 μL cDNA from stimulated or unstimulated PBL, 1X PCR buffer, 200 μM of dNTPs, 20 pmol of each 5'-primer or 3'-primer, and 2.5 U *Taq* DNA polymerase.
- Amplify with a modified touchdown procedure consisting of three cycles each of denaturation at 94°C for 30 s, annealing at 55°C for 1 min, and elongation at 74°C for 1.5 min. Repeat for annealing temperatures reduced in steps of 1°C, from 55° to 46°C. Follow the touchdown cycles with 10 cycles using an annealing temperature of 45°C and a 10-min extension at 74°C.
- Analyze one-tenth of the PCR reaction by electrophoresis on 1% agarose gels. In our experience, $V_{\text{H}}\text{-C}_{\text{H}}1$ and $V_{\text{L}}\text{-C}_{\text{L}}$ amplification yields from stimulated PBL were 0.3 \times greater than from the unstimulated PBL (Fig. 2).

4. Notes

- The use of an affinity-purified Ag is important since it determines the specificity of the phage Abs. To make an affinity column, if the MAbs is available, it could

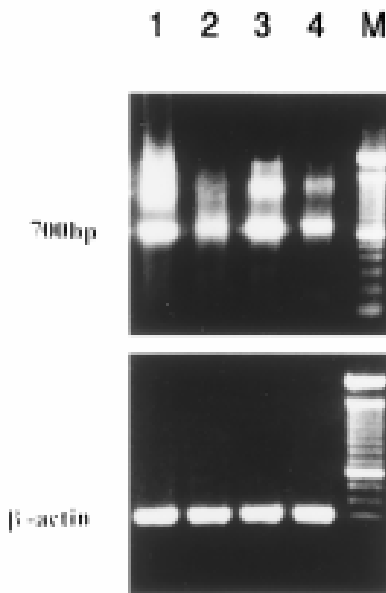

Fig. 2. Assay of Ig transcript levels by RT-PCR. The amounts of Ig from the stimulated PBL (V_H-C_H1 in lane 1 and V_L-C_L in lane 3) were $0.3\times$ more than those from the unstimulated PBL (V_H-C_H1 in lane 2 and V_L-C_L in lane 4) estimated by band brightness. β -actin is the internal control. The marker (M) was 100 bp DNA ladder (Life Technologies).

- be conjugated with cyanogen bromide-activated Sepharose 4B according to manufacturer's instructions.
2. If there is no existing MAb against the Ag of interest, crude Ag or recombinant sources of protein or synthetic peptides can be used. Because 2.5% 1-butanol in PBS extracts tumor-specific transplantation Ag from cancer cell membranes, CBE Ag extracted in this way from tumor cell lines can be used at a final concentration of 10 $\mu\text{g}/\text{mL}$ for in vitro stimulation (2).
 3. Successful in vitro stimulation can be judged from the following: morphology changes to cells in culture reflecting a secondary immune response, specifically, the size of PBL and colony formation; the appearance of specific Ab against the Ag of interest in culture supernatant over the 7 d of culture (this can be assessed by ELISA) (*see Subheading 3.1.*); the amounts of total RNA from PBL before and after in vitro stimulation; the yields of PCR products from Ig RT-PCR (*see Subheading 3.3., step 7*).
 4. For screening of phage Ab libraries, progressive decreases in the concentration of binding Ag are suggested, i.e., use 1 $\mu\text{g}/\text{mL}$ affinity-purified Ag or recombinant protein or synthetic peptide for the first panning, 0.1 $\mu\text{g}/\text{mL}$ for the second panning, then 0.01 $\mu\text{g}/\text{mL}$ for the third panning step. If pure Ag is not available, but a MAb can be obtained, a sandwich procedure can be used for screening. To

carry this out, 1–5 $\mu\text{g/mL}$ MAb is coated onto a Petri dish. After washing 3×3 min with PBS and blocking with 1% BSA, 50 $\mu\text{g/mL}$ crude Ag (e.g., CBE Ag) is added to the dish for 1 h at 37°C . After washing 3×3 min with PBS, the dish is ready for the first panning; for the second or third screening, concentrations of the crude Ag can be reduced to 5 or 0.5 $\mu\text{g/mL}$, respectively. If the MAb is not available, crude Ag (50, 5, and 0.5 $\mu\text{g/mL}$ for the first, second, and third screening, respectively) could still be used for screening of phage Ab libraries. The step-by-step decreases in Ag concentration may increase the chances of recovering phage clones of high affinity.

5. In my experiments, PBL numbers from 10 mL peripheral blood from a typical colon cancer patient were 1×10^7 before in vitro stimulation and the numbers were 0.98×10^7 7 d later after in vitro stimulation. The cell numbers were counted with trypan blue exclusion assay and a hemocytometer, viable cells comprising more than 95% before and after in vitro stimulation. After in vitro stimulation, the total numbers of PBLs from 10 mL peripheral blood per patient from four colorectal cancer patients fell to 40–98% of their original numbers (**Table 1**).
6. It should be noted that IL-2 alone will induce apoptosis of T-lymphocytes (**3**). Therefore, IL-2 and pokeweed mitogen should be added after or simultaneously with Ag.
7. After in vitro stimulation, PBLs become rounder and bigger and the classical morphology of a secondary immune response appears. In detail, lymphocytes at d 0 are small and round, lymphoblast-like cells appear at d 3, some colonies form and lymphoblast cells can be observed at d 5, and at d 7, colonies are more numerous, bigger, and lymphoblast-like cells can still be seen (**Fig. 1**).

References

1. Sun, Q. B., Ho, J. I. L., and Kim, Y. S. (1986) Human colonic cancer associated antigens detected by three monoclonal antibodies. *Chin. Med. J.* **99**, 63–74.
2. Coggin, J. H., Gillis, L. D., and Payne, W. J., Jr. (1984) Differential extraction of tumor-transplantation antigen and embryonic antigen from simian virus 40- and adenovirus 7-induced sarcoma cells of hamsters with 1-butanol and 3 M potassium chloride. *J. Natl. Cancer Inst.* **72**, 853–862
3. Lenardo, M. J. (1991) Interleukin-2 programs mouse $\alpha\beta$ T lymphocytes for apoptosis. *Nature* **353**, 858–861.
4. Cai, X. and Garen, A. (1995) Anti-melanoma antibodies from melanoma patients immunized with genetically modified autologous tumor cells: Selection of specific antibodies from single-chain Fv fusion phage libraries. *Proc. Natl. Acad. Sci. USA* **92**, 6537–6541.

The Recovery of Immunoglobulin Sequences from Single Human B Cells by Clonal Expansion

Ruud M. T. de Wildt and René M. A. Hoet

1. Introduction

The development of phage-display technology and the construction of huge libraries of antibody (Ab) fragments have provided an unlimited source of binders to virtually any antigen (Ag) (**1**). However, it is unlikely that the heavy (V_H) and light (V_L) chains of the Abs obtained from these libraries resemble original *in vivo* pairings. In certain autoimmune diseases and immunological processes, such as B-cell tolerance, these V_H and V_L combinations can be of crucial importance. To be able to determine the original V_H and V_L combinations of Abs, we have set up a single B-cell culture system. This comprises the sorting of individual lymphocytes into culture wells using flow cytometry, a culture system to expand these cells (**2**) and polymerase chain reaction (PCR) amplification of their variable-region genes, thereby immortalizing the V_H and V_L regions from individual human B cells. The method relies on the clonal expansion of single B cells in which cell–cell interactions (CD40–CD40L), as well as soluble factors, have been shown to be essential. One advantage beyond conventional hybridoma technology is that this method circumvents laborious plating and screening; the advantage compared to phage-display technology is that original V_H and V_L pairings can be isolated. This system has been used to analyze V_H and V_L pairings of human immunoglobulin G⁺ (IgG⁺) B cells of unknown specificity (**3**) and, combined with a selection on the Ag U1A, a frequent autoantigenic protein target in patients with systemic lupus erythematosus, to analyze pairings in Ag-specific B cells (**4**). The efficiency of the system makes it possible to analyze large numbers of B cells and should therefore allow rare B-cell activities to be studied.

Other technologies that retain original V_H/V_L pairings involve PCR assembly of V_H and V_L within a single cell (5), which has been achieved with hybridomas but has yet to be routinely applied to populations of B cells because of technical problems. Others have isolated single Ag-specific lymphocytes using micromanipulation of lymphocytes bound to Ag-coated erythrocytes (6) or Ag-coated beads (7). The V_H and V_L genes from these single cells are amplified using reverse transcriptase (RT)-PCR, and cloned as functional Ab fragments. However, these techniques involve laborious manipulation of every cell of interest and hence suffer low throughput.

2. Materials

2.1. Preparation of Lymphocytes

1. Heparinized blood from a patient group of interest.
2. Phosphate-buffered saline (PBS) with and without 0.3% Na citrate.
3. Ficoll-Paque (Pharmacia Biotech).
4. Dulbecco's modified Eagle's medium (DMEM)–HAM's F12 (1:1) (Gibco product code 21331).
5. Supplemented calf serum (CS) (Hyclone product code A 2151L).
6. Dimethyl sulfoxide.
7. Fetal calf serum (Gibco).
8. Fluorescein isothiocyanate (FITC)-conjugated anti-human IgG (Kallestadt, Amiter, TA).
9. Phycoerythrin-conjugated anti-CD19 (Dako).
10. Coulter Epics Elite flow cytometer equipped with an automatic deposit unit (Coulter, Hialeah, FL).
11. Target Ag of interest (e.g., U1A).
12. 6-Well culture plates (Greiner).
13. 0.1 M NaHCO_3 , pH 9.6.
14. Tissue culture incubator with associated gas supply.
15. Trypsin (Gibco).
16. Ethylenediamine tetraacetic acid (EDTA).
17. FITC-conjugated anti-CD19 and anti-CD20 monoclonal antibodies (MAbs) (Dako).

2.2. Culture of B Cells

1. 96-Well round-bottomed plates (Costar).
2. Phytohemagglutinin (Murex).
3. β -Phorbol-12-myristate-13-acetate (PMA) (Sigma).
4. Freshly cultured EL4-B5 thymoma cells obtainable from R. Zubler (*see Note 4*).

2.3. Enzyme-Linked Immunosorbant Assay (ELISA)-Testing of Culture Supernatant

1. 96-Well plates (Nunc, Maxisorp).
2. 0.1 M NaHCO₃, pH 9.2 or pH 9.6, depending on application (*see Subheading 3.3., step 1*).
3. Anti-human IgG, IgM, and total Ig (Dako).
4. 2% Skimmed milk powder in PBS (PBSM).
5. Tween-20 in PBS (PBST).
6. Horseradish-peroxidase conjugated anti-human IgG, IgM, and total Ig (Dako).
7. PBSM containing 2% CS.
8. Substrate solution: 100 mM sodium acetate (NaAc), pH 6.0, containing 100 µg/mL 3'3'5'5'-tetramethylbenzidine and 0.5 µL/mL 30% hydrogen peroxide solution. Add the hydrogen peroxide solution immediately before use of the substrate solution.
9. 1 M Sulphuric acid.

2.4. Cloning of V_H/V_L Regions from B-Cell Clones

1. RNazol (Cinna/Biotech Laboratories).
2. Chloroform.
3. 20 mg/mL Glycogen (Boehringer Mannheim) dissolved in Millipore filtered H₂O.
4. Ethanol-NaAc mix: combine 96 mL absolute ethanol with 4 mL 3 M NaAc, pH 5.0.
5. 70% Ethanol.
6. RNasin (Promega).
7. 10 pmol/µL 15-mer Oligo(dT) primer (Boehringer Mannheim).
8. RT buffer: 250 mM Tris-HCl, pH 8.3, 375 mM KCl, 15 mM MgCl₂.
9. 0.1 M Dithiothreitol.
10. SuperScript II RT (100 U/µL; Gibco).
11. Deoxyribonucleoside triphosphate (dNTP) mix (10 mM each nucleotide).
12. *Taq* DNA polymerase and 10X reaction buffer.
13. QIAquick PCR purification kit (Qiagen, CA).
14. Phage-display or expression vector (e.g., pHENIX).
15. Mouse MAb P5D4 (Boehringer Mannheim).
16. Electrocompetent *Escherichia coli* TG1 and electroporation apparatus.
17. TYE agar plates: 15 g Bacto-agar, 8 g Na chloride, 10 g tryptone, 5 g yeast extract in 1 L.
18. Ampicillin.
19. 20% Glucose.
20. 2TY: 16 g tryptone, 10 g yeast extract, and 5 g Na chloride in 1 L.

21. Isopropyl thiogalactopyranoside (IPTG).
22. Extraction buffer: 200 mM Na borate, pH 8.0, 160 mM NaCl, 1 mM EDTA.
23. Rabbit anti-mouse Ig horseradish peroxidase conjugate (Dako).

2.5. Sequencing of V_H/V_L Regions

1. ABI PRISM Big Dye Terminator Cycle Sequencing Kit (Perkin Elmer, Foster City, CA).
2. Automated sequencer (Applied Biosystems 373A, Perkin-Elmer).

3. Methods

3.1. Preparation of Lymphocytes

1. Dilute heparinized blood with an equal amount of PBS–0.3% Na citrate. Carefully layer 20–30 mL diluted blood onto 15 mL Ficoll-Paque. Centrifuge at 500g for 30 min at room temperature.
2. Remove the layer containing the peripheral blood mononuclear cells (PBMC), transfer to another tube and add at least 3 vol DMEM–HAM's F12 containing 10% CS.
3. Centrifuge the cells for 10 min at 200g, resuspend in DMEM–HAM's F12–10% CS, centrifuge, and resuspend in the same medium.
4. At this stage, PBMC are either used directly or frozen in culture medium containing 10% dimethylsulfoxide and 50% fetal calf serum.
5. When no Ag selection is preferred, PBMC can be used directly to sort single IgG- or IgM-positive B cells (*see Note 8*). Label the cells with FITC-conjugated anti-human IgG and phycoerythrin-conjugated anti-CD19 for 10 min at room temperature at a concentration of 1 $\mu\text{g}/10^6$ cells. Centrifuge the cells for 5 min at 200g and resuspend in 0.5 mL PBS. Viable, single IgG⁺, CD19⁺ lymphocytes are then sorted into 96-well plates using a Coulter Epics Elite flow cytometer equipped with an automatic cell deposit unit. Continue from **Subheading 3.2**.
6. When Ag selection is preferred, first remove monocytes from the PBMC by incubating the cells for 1–2 h at 1–2 $\times 10^6$ cells/mL in DMEM–HAM's F12–10% CS at 37°C, >98% humidity, and 5% CO₂. Recover nonadherent cells for further selection (*see Note 1*).
7. Coat 6-well culture plates with of the target Ag (e.g., recombinant U1A) at a concentration of 5 $\mu\text{g}/\text{mL}$ in 0.1 M NaHCO₃, pH 9.6, overnight at 4°C.
8. Wash the coated plates 3 \times with PBS and add 1–5 $\times 10^6$ monocyte-depleted PBMC in 4 mL DMEM–HAM's F12–10% CS. Incubate for 1–2 h at 37°C (*see Note 2*).
9. Remove unbound cells by washing 6 \times with PBS. Collect those cells that have adhered to the target Ag using 300 μL PBS containing 0.05% trypsin, 1.1 mM EDTA. Terminate trypsin treatment after 5 min at 37°C by adding 5 mL DMEM–HAM's F12–10% CS.

10. Harvest the cells and label with a mixture of anti-CD19 and anti-CD20 MAbs conjugated to FITC for 10 min at room temperature at a concentration of 1 $\mu\text{g}/10^6$ cells. Centrifuge the cells for 5 min at 200g and resuspend in 0.5 mL PBS.
11. Sort viable, single CD19⁺/CD20⁺ cells into 96-well plates using the flow cytometer.

3.2. Culture of B Cells

1. First, human T-cell–macrophage supernatant (TSN) is prepared from freshly isolated PBMC (buffycoat) using Ficoll-Paque density centrifugation as described (*see Subheading 3.1., step 1*).
2. Wash the cells 3 \times with DMEM–HAM's F12–10% CS and culture in the presence of 5 $\mu\text{g}/\text{mL}$ phytohemagglutinin and 10 ng/mL PMA, at a concentration of 1.5×10^6 cells/mL.
3. After 48 h, centrifuge the cell suspension for 10 min at 1000g. Harvest the cell supernatant (TSN) and store in aliquots at -70°C (*see Note 3*).
4. Single, sorted B cells (*see Subheading 3.1., step 5* or *Subheading 3.1., step 11*) are deposited in 96-well plates containing 200 $\mu\text{L}/\text{well}$ DMEM–HAM's F12–10–15% TSN–10% CS and 20,000 irradiated (2500 rad) EL4-B5 thymoma cells/well (*see Notes 3–5*).
5. Remove 100 μL from each well at d 3 and 6 and replace with DMEM–HAM's F12–10% TSN–10% CS.
6. Test culture supernatants from the B-cell cultures for (Ag-specific) Ab production (*see Subheading 3.3.*) at d 10 or 11 (*see Notes 6–9*).

3.3. ELISA-Testing of Culture Supernatant

1. To detect the production and Ag-specific Ig, coat 96-well plates with 100 $\mu\text{L}/\text{well}$ of an Ag solution at 1 $\mu\text{g}/\text{mL}$ Ag (e.g., recombinant U1A) in 0.1 M NaHCO_3 , pH 9.6. Incubate overnight at 4°C . To detect the production of IgG, IgM, or total Ig (*see Note 3*), coat plates with the same volume of 1 $\mu\text{g}/\text{mL}$ anti-human IgG, IgM, or total Ig in 0.1 M NaHCO_3 , pH 9.2.
2. Block the plates with 200 $\mu\text{L}/\text{well}$ PBSM for 2 h at room temperature, then wash 3 \times with PBS.
3. Mix 40 μL culture supernatant with an equal volume of PBSM, add to the coated plates, and incubate for 1 h at room temperature.
4. Wash the plates 3 \times with PBST and 3 \times with PBS.
5. Detect the binding of IgG, IgM, or total Ig by adding 100 $\mu\text{L}/\text{well}$ of the corresponding horseradish peroxidase conjugated anti-human Ab, diluted 1:5000 in PBSM containing 2% CS. Dilute the conjugates 1:1000 for detection of Ag-specific Ab production.
6. Wash the plates 3 \times with PBST and 3 \times with PBS.

7. Add 100 μL /well substrate solution. Stop the reactions when the color has developed by adding 50 μL /well 1 M sulphuric acid. Measure the $\text{OD}_{650}-\text{OD}_{450}$ (see Notes 3 and 6)

3.4. Cloning and Expression of V_H/V_L Regions from B-Cell Clones (see Note 10)

1. Using a Pasteur pipet, remove the medium carefully from wells containing IgG^+ or Ag-specific Ab-producing cells. Resuspend all cells in 200 μL RNazol and transfer to 1.5-mL microcentrifuge tubes. Add 20 μL chloroform, mix the tube contents, and incubate 5 min at 4°C. Centrifuge the samples in a microcentrifuge for 15 min and collect the aqueous phase.
2. Add 2 μL glycogen solution and precipitate the RNA by adding 2 vol ethanol–NaAc. Mix and incubate for 45 min at 4°C. Spin the tubes for 15 min, 15,000g at 4°C. Carefully remove the ethanol–NaAc mix without disturbing the RNA pellet. Add 0.5 mL 70% ethanol and spin again for 5 min at 4°C. Air-dry the RNA and dissolve in 100 μL Millipore-filtered H_2O containing 20 U RNasin. Precipitate the RNA again using ethanol/NaAc and store at -70°C until further use (see Note 10).
3. Recover, wash, and air-dry the RNA as above (see Subheading 3.4., step 2). Dissolve in 20 μL Millipore-filtered H_2O containing 20 U RNasin. Use half of the RNA for first-strand cDNA synthesis and store the remainder at -70°C .
4. Add 2 μL of 10 pmol/ μL oligo(dT) primer and briefly centrifuge. Heat the mixture to 70°C for 5–10 min, then chill on ice to anneal the primer. Add 4 μL RT buffer, 2 μL 0.1 M dithiothreitol, 1 μL (100 U) SuperScript II RT and 2 μL dNTP mix. Mix and incubate for 1 h at 42°C. Inactivate the RT reaction by heating for 2 min at 80°C.
5. Use 5- μL aliquots of these cDNAs in separate PCRs to amplify V_H , V_K , and V_L genes using family-specific 5' primers and 3' constant-region primers (Table 1; see Note 11).
6. To carry out PCRs, add 20 pmol of each primer in 1X *Taq* reaction buffer containing 1.5 mM MgCl_2 , 250 μM dNTPs, and 2.5 U *Taq* polymerase. Carry out 25 cycles of 94°C, 1 min; 55°C, 1 min; and 72°C, 1.5 min (see Note 12).
7. Purify the PCR products using a QIAquick PCR purification kit, following the manufacturer's protocol.
8. At this stage, PCR products can be used for direct sequencing (see Subheading 3.5.), or for cloning as scFv.
9. In a 3'-nested second PCR, use 1 μL of the first PCR product under the same conditions as described above (see Subheading 3.4., steps 5 and 6) with primers containing appropriate restriction sites for cloning. As 5' primers, the same primers as in Table 1 can be used, extended with *SfiI/NcoI* restriction sites for V_H primers (8) and *ApaL1* restriction sites for V_K and V_L primers (9). As 3' primers for the heavy chains (HC), J_H forward primers with a *SalI* site (10) are used, and for the light chains (LC), J_K or J_L primers containing a *NotI* site (8) are used.

Table 1
Primers for Amplifying Rearranged Ab V Genes

V _H 1Back:	CAG (AG)T(CGT) CAG CTG GTG CAG TCT GG
V _H 2Back:	CAG (AG)TC ACC TTG AAG GAG TCT GG
V _H 3Back:	GAG GTG CAG CTG GTG GAG TCT GG
V _H 4Back:	CAG GTG CAG CTG CAG GAG T(CG)(CG) GG
V _H 5Back:	GAG GTG CAG CTG GTG CAG TCT GG
V _H 6Back:	CAG GTA CAG CTG CAG CAG TCA GG
V _κ 1Back:	G(AC)C ATC C(AG)G ATG ACC CAG TCT CC
V _κ 2Back:	GAT GTT GTG ATG ACT CAG TCT CC
V _κ 3Back:	GAA ATT GTG (AT)TG AC(AG) CAG TCT CC
V _κ 4Back:	GAC ATC GTG ATG ACC CAG TCT CC
V _κ 5Back:	GAA ACG ACA CTC ACG CAG TCT CC
V _κ 6Back:	GAA ATT GTG CTG ACT CAG TCT CC
V _λ 1Back:	CAG TCT GTG (CT)TG AC(GT) CAG CC
V _λ 2Back:	CAG TCT GCC CTG ACT CAG CCT GC
V _λ 3aBack:	TCC TAT GAG CTG AC(AT) CAG CC
V _λ 3bBack:	TCT TCT GAG CTG ACT CAG GAC CC
V _λ 4Back:	CAG C(CT)T GTG CTG ACT CAA TC
V _λ 5Back:	CAG (CG)CT GTG CTG ACT CAG CC
V _λ 6Back:	AAT TTT ATG CTG ACT CAG CCC CA
V _λ 7/8Back:	CAG (AG)CT GTG GTG AC(CT) CAG GAG
V _λ 9/10Back:	CAG (CG)C(TA) G(GT)G CTG ACT CAG CCA
IgG1-4C _H 1For	GTC CAC CTT GGT GTT GCT GGG CTT
C _κ For	AGA CTC TCC CCT GTT GAA GCT CTT
C _λ For	TGA AGA TTC TGT AGG GGC CAC TGT CTT
Sequencing primers	
C _H 1.lib.seq primer	GGT GCT CTT GGA GGA GGG TGC
C _κ .lib.seq	CAA CTG CTC ATC AGA TGG CG
C _L .seq	AGT GTG GCC TTG TTG GCT TG
fdseq1	GAA TTT TCT GTA TGA GG
forlinkseq	GCC ACC TCC GCC TGA ACC

10. Clone HCs and LCs sequentially into a phagemid vector, such as pHENIX (**11**), in which a peptide epitope of the vesicular stomatitis virus glycoprotein is fused at the C-terminus as a tag for detection using mouse MAb, P5D4.
11. Electroporate the ligated vector into electrocompetent TG1 and plate onto TYE plates containing 100 µg/mL ampicillin and 1% glucose.
12. To determine whether isolated clones are reactive with the Ag of interest in ELISA, pick single colonies into 2TY containing 100 µg/mL ampicillin and 1% glucose and grow overnight at 37°C.

13. Inoculate 2TY containing 100 $\mu\text{g}/\text{mL}$ ampicillin and 0.1% glucose with 0.01 vol from the overnight culture. Grow with shaking at 37°C until the OD_{600} is approx 0.9. Add IPTG to a final concentration of 1 mM and shake the cultures at 30°C for 3 h (for periplasmic fractions) or overnight (expression in supernatant).
14. For the isolation of periplasmic fractions, centrifuge the bacteria at 4000g at 4°C for 10 min. Resuspend the pellet in 20 mL/L culture cold-extraction buffer. Centrifuge the fractions at 8000g at 4°C for 10 min and filter-sterilize.
15. Test soluble scFv in periplasmic fractions, or in the culture supernatant, for binding to the Ag (recombinant auto-Ag U1A) in ELISA, which is performed as described (*see Subheading 3.3.*), except that scFv are detected with mouse MAb P5D4 at a dilution of 1:1000 and rabbit anti-mouse Ig HRP conjugate (1:1000 in PBSM) (*see Note 13*).

3.5. Sequencing of V_H/V_L Regions (*see Note 14*)

1. PCR products can be directly sequenced from amplified rearranged human variable–constant region genes using C_{H1} .lib.seq primer for the HCs. C_{κ} .lib.seq for the κ LCs and C_L .seq for the λ LCs (**Table 1**). These primers anneal ~50 nucleotides from the 5' end of the constant-region genes.
2. For sequencing cloned scFv fragments, fdseq1 and forlinkseq are used. We use Big Dye reagents and analyze on an Applied Biosystems 373A machine.
3. Nucleotide sequences are aligned to their germline counterparts using the V-BASE Sequence Directory (**12**) (<http://www.mrc-cpe.cam.ac.uk/imt-doc/index.html>).

4. Notes

1. Removal of monocytes by plastic adherence, the enrichment for Ag-specific B cells, and subsequent culturing are performed essentially as has been described in **ref. 13**.
2. As described, Ag selection is performed on Ag-coated plates. Immobilization of Ag on superparamagnetic minibeads (Mylteni Biotech, Germany) has also been effective. A major advantage of these magnetically sorted cells is that they can be used directly for flow cytometry analyses in contrast to Dynabeads (Dyna, Norway), from which the cells must be detached before use on the flow cytometer.
3. TSN may contain a small amount of human Ig, which may interfere with ELISA testing for Ig production. This can be depleted from the TSN using Protein G Sepharose, although we have found that positive signals in ELISA can be clearly distinguished from background. The optimum amount of TSN for efficient outgrowth of B cells can be established by titration (**13**), but we found that 10% TSN routinely gave good results.
4. EL4-B5 thymoma cells are routinely cultured in DMEM–HAM's F12 (1:1)–10% CS between 1×10^4 and 1×10^6 cells/mL. EL4-B5 cells can be obtained with permission from Dr. R. Zubler (Hopital Cantonal Universitaire de Geneve,

Centre de Transfusion Sanguine, Division d'Hematologie, CH 1211 Geneva 14, Switzerland) or from R. D. W.

5. Hyclone-supplemented CS batches gave best results with B-cell outgrowth and no stimulation of the irradiated EL4-B5 cells was observed.
6. Typical percentages of Ig-positive cultures determined by ELISA after 10–11 d culture varies between 50 and 70%. The frequency of U1A-specific B-cell clones varies between 1 and 2.5% as a percentage of Ig-positive wells. As a control, cells from a healthy donor were used and subjected to the same procedure. No U1A-specific Ab production could be detected in these cultures; the percentage of Ig-producing wells was similar to those found with the systemic lupus erythematosus patient B cells. Distributions of IgG, IgM, and IgG–IgM double-positive isotypes in Ig-producing single B-cell cultures were 3:3:1.
7. Assuming that the frequency of Ag-specific B cells in the periphery varies between 10^{-4} and 10^{-5} (**14**), a frequency of 1–2.5% of Ag-specific B cells indicates an enrichment factor of 100–1000. Other groups have also succeeded in the isolation of Ag-specific B cells from peripheral blood using an expansion B-cell culture system using virally infected donors (**15**) or donors vaccinated with bacterial Ags (**7**). The frequency of specific cells to those Ags in the periphery is most likely much higher compared to the auto-Ag-specific B cells analyzed in our studies.
8. We have sorted single IgG⁺ B cells of unknown specificity and used this system to analyze V_H and V_L pairings (**3,16**) and to compare V_H and V_L pairings between healthy and autoimmune disorders (**17**).
9. After culture in the EL4-B5 system, the B cells obtained a plasmablast-like phenotype expressing CD38^{HIGH} and syndecan-1^{MODERATE}, a plasma cell marker stained with MAbs B-B4 (**18**). One B cell generates about 400 cytoplasmic Ig positive cells after 8–10 d in culture (**2**), but, because of the large number of EL4-B5 cells present (~20,000 cells/well), these B-cell clones are not easily distinguishable under the microscope.
10. The expansion step results in an increase of mRNA levels derived from one clone, which avoids the risk of contamination in downstream procedures and makes it more convenient to analyze single peripheral B cells, which are mostly resting cells with low mRNA levels. One major consideration in studying peripheral B cells often is the lack of other available patient materials.
11. PCR products amplified with a mixture of V_H family-specific primers and a constant-region primer should give rise to a product of ~750 (for V_H) or 700 nucleotides (for V_L). With the LCs, V_κ and V_λ should never be found together in the same clone, indicating clonality. As a control for the PCR, cDNA isolated from a well in which no B cell was used. Such control reactions should never result in a PCR product.
12. With the current set of primers, almost all functional V genes should be amplified. Indeed, using these primers, we detected the majority of expressed V genes: 86% V_H, 80% V_λ, and 58% of the functional V_κ segments (**3**). Recently, other primer sets has been published, which theoretically should be able to amplify

all functional V genes (**12,19**), although mixes of these primers have never been used to amplify V regions from single B-cell clones.

13. We were able to detect five U1A-specific B-cell clones. Two of these (B5 and C9) were cloned into a phagemid vector for scFv expression. Soluble scFvs present in bacterial supernatant or periplasmic fractions were tested for binding in ELISA on a number of auto-Ags. Indeed, this showed that these clones specifically recognized the U1A protein (**4**).
14. For a more detailed description of the analysis of human Ab sequences, see ref. **20**.

References

1. Winter, G., Griffiths, A. D., Hawkins, R. E., and Hoogenboom, H. R. (1994) Making antibodies by phage display technology. *Annu. Rev. Immunol.* **12**, 433–455.
2. Zubler, R. H., Erard, F., Lees, R. K., Van Laer, M., Mingari, C., Moretta, L., and MacDonald, H. R. (1985) Mutant EL-4 thymoma cells polyclonally activate murine and human B cells via direct cell interaction. *J. Immunol.* **134**, 3662–3668.
3. de Wildt, R. M. T., Hoet, R. M. A., van Venrooij, W. J., Tomlinson, I. M., and Winter, G. (1999) Analysis of heavy and light chain pairings indicates that receptor editing shapes the human antibody repertoire. *J. Mol. Biol.* **285**, 895–901.
4. de Wildt, R. M. T., Steenbakkens, P. G., Pennings, A. H. M., van den Hoogen, F. H. J., van Venrooij, W. J., and Hoet, R. M. A. (1997) A new method for the analysis and production of monoclonal antibody fragments originating from single human B cells. *J. Immunol. Methods* **207**, 61–67.
5. Embleton, M. J., Gorochoy, G., Jones, P. T., and Winter, G. (1992) In-cell PCR from mRNA: amplifying and linking the rearranged immunoglobulin heavy and light chain V-genes within single cells. *Nucleic Acids Res.* **20**, 3831–3837.
6. Babcook, J. S., Leslie, K. B., Olsen, O. A., Salmon, R. A., and Schrader, J. W. (1996) A novel strategy for generating monoclonal antibodies from single, isolated lymphocytes producing antibodies of defined specificities. *Proc. Natl. Acad. Sci. USA* **93**, 7843–7848.
7. Lagerkvist, A. C. S., Furebring, C., and Borrebaeck, C. A. K. (1995) Single, antigen-specific B cells used to generate Fab fragments using CD40-mediated amplification or direct PCR cloning. *Biotechniques* **18**, 862–869.
8. Marks, J. D., Hoogenboom, H. R., Bonnert, T. P., McCafferty, J., Griffiths, A. D., and Winter, G. (1991) By-passing immunization. Human antibodies from V-gene libraries displayed on phage. *J. Mol. Biol.* **222**, 581–597.
9. Jespers, L. S., Roberts, A., Mahler, S. M., Winter, G., and Hoogenboom, H. R. (1994) Guiding the selection of human antibodies from phage display repertoires to a single epitope of an antigen. *Biotechnology* **12**, 899–903.
10. Figini, M., Marks, J. D., Winter, G., and Griffiths, A. D. (1994) In vitro assembly of repertoires of antibody chains on the surface of phage by renaturation. *J. Mol. Biol.* **239**, 68–78.

11. Finnern, R., Pedrollo, E., Fisch, I., Wieslander, J., Marks, J. D., Lockwood, C. M., and Ouwehand, W. H. (1997) Human autoimmune anti-proteinase 3 scFv from a phage display library. *Clin. Exp. Immunol.* **107**, 269–281.
12. Tomlinson, I. M., Williams, S. C., Ignatovich, O., Corbett, S. J., and Winter, G. (1999) V Base Sequence Directory, MRC Centre for Protein Engineering, Cambridge, UK.
13. Steenbakkers, P. G., Hubers, H. A., and Rijnders, A. W. (1994) Efficient generation of monoclonal antibodies from preselected antigen-specific B cells. Efficient immortalization of preselected B cells. *Mol. Biol. Rep.* **19**, 125–134.
14. Zubler, R. H., Perrin, L. H., Doucet, A., Zhang, X., Huang, Y. P., and Miescher, P. A. (1992) Frequencies of HIV-reactive B cells in seropositive and seronegative individuals. *Clin. Exp. Immunol.* **87**, 31–36.
15. Steenbakkers, P. G., van Wezenbeek, P. M., and Olijve, W. (1993) Immortalization of antigen selected B cells. *J. Immunol. Methods* **163**, 33–40.
16. de Wildt, R. M., van Venrooij, W. J., Winter, G., Hoet, R. M., and Tomlinson, I. M. (1999) Somatic insertions and deletions shape the human antibody repertoire. *J. Mol. Biol.* **294**, 701–710.
17. de Wildt, R. M., Tomlinson, I. M., van Venrooij, W. J., Winter, G., and Hoet, R. M. (2000) Comparable heavy and light chain pairings in normal and systemic lupus erythematosus IgG(+) B cells. *Eur. J. Immunol.* **30**, 254–261.
18. Wijdenes, J., Vooijs, W. C., Clement, C., Post, J., Morard, F., Vita, N., et al. (1996) A plasmocyte selective monoclonal antibody (B-B4) recognizes syndecan-1. *Br. J. Haematol.* **94**, 318–323.
19. Sblattero, D. and Bradbury, A. (1998) A definitive set of oligonucleotide primers for amplifying human V regions. *Immunotechnology* **3**, 271–278.
20. Walter, G. and Tomlinson, I. (1996) Analysis of human antibody sequences, in *Antibody Engineering* (McCafferty, J., Hoogenboom, H., and Chiswell, D., eds.), Oxford University Press, Oxford, pp. 119–145.

Panning of Antibody Phage-Display Libraries

Standard Protocols

David W. J. Coomber

1. Introduction

Recombinant antibody (Ab) libraries have been constructed from a wide range of B-lymphocyte sources using a number of different approaches. Sizes of the libraries that have been produced vary considerably, from small libraries of 10^6 up to large libraries $>10^{10}$. Often an Ab with the desired specificity exists at low frequencies in the recombinant Ab repertoire. It is therefore necessary to have an effective technique for the enrichment and identification of a desired Ab from a heterogenous repertoire.

The process for the selection of specific Abs is referred to as “panning,” and, in principle, involves the selection of Abs on the basis of their affinity. The isolation of a desired Ab generally involves repeated rounds of panning, with each successive round resulting in the enrichment of the desired Ab. Each round of Ab selection can be divided into panning, removal of nonspecific phage, and the elution and amplification of phage Abs for the next round (**Fig. 1**). In this way, it has been shown that antigen (Ag)-specific Ab that occur at low frequencies in a library can be enriched by over a million-fold (**1**).

The methods for the selection of Ab from phage-display Ab libraries are many and varied, of which some appear later in this chapter. One of the more frequently used methods is panning against purified Ag coated on a well of a microtiter plate or in an immunotube. Using this approach, the methods presented below have been successfully used to isolate Ag-specific Abs (*see Fig. 2*).

There are several points that should be noted about the protocols that are presented below. First, the libraries used for panning are constructed in the

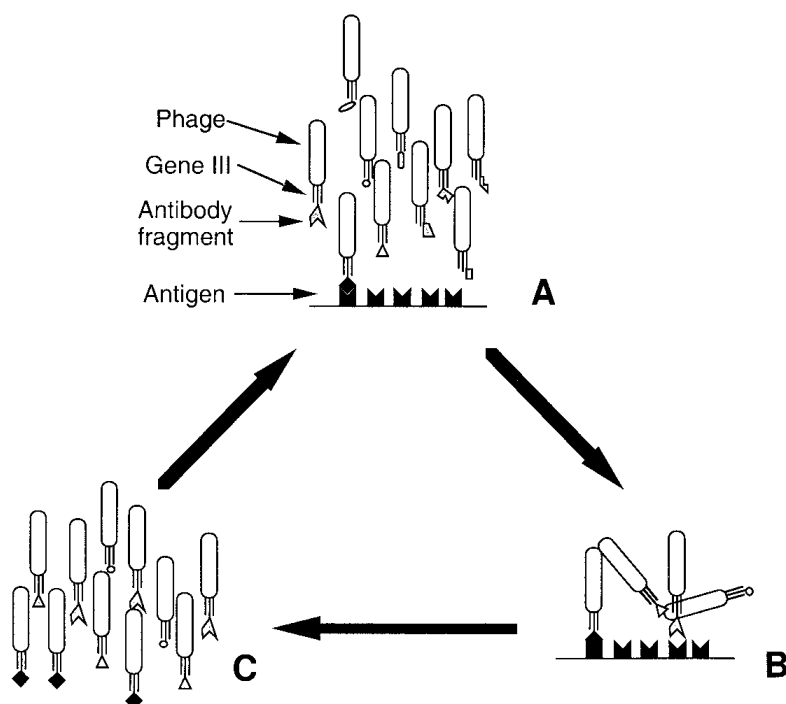

Fig. 1. Schematic diagram of the panning process. **(A)** Library of phage Abs with a range of Ab specificities is applied to an Ag bound to a solid phase. **(B)** Surface is washed to remove nonbinding phage Abs, which are then eluted from the surface. **(C)** Eluted phage are used to infect *E. coli* for the production of fresh phage Abs, which will be used in the next round of panning. Repeated rounds of panning lead to the enrichment of those phage Abs that are specific to the Ag.

MCO phage-display vector system (2), which is derived from pComb3 (3), and was specifically designed for the production, selection, and screening of Fab phage. These protocols are therefore also suitable for Fab libraries produced in other pComb3-based vectors. In addition, the MCO vector contains an amber codon between the heavy chain (HC) gene-cloning site and gene III, which enables the expression of soluble Fab in nonsuppressor strains of *Escherichia coli*. This feature has also been included in some other derivatives of pComb3. Second, protocols for the panning of scFv phage libraries, although similar, vary slightly from these protocols because of the use of different expression vectors: These protocols have been extensively detailed elsewhere (4). However, the basic principles of the panning process are the same. Therefore, these protocols can be modified according to the expression vector and Ab system of choice.

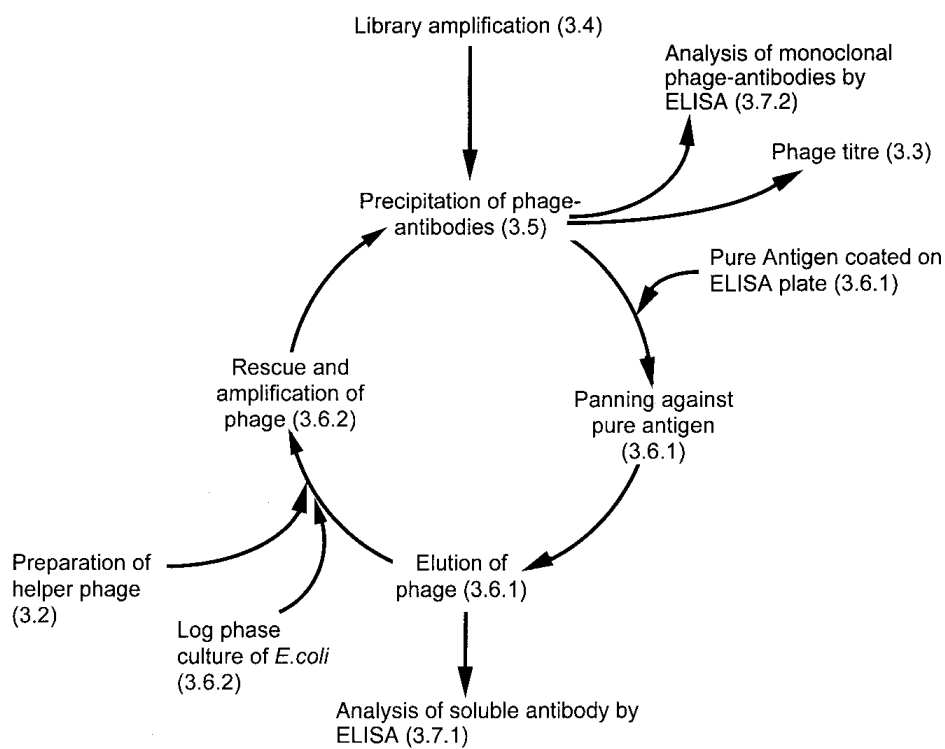

Fig. 2. Flow diagram linking the methods of the standard panning protocol. The identifying number of each method as it is found in the text is in brackets.

2. Materials

1. Luria Broth Agar (LA) (for agar plates): 10 g/L tryptone, 5 g/L yeast extract, 5 g/L NaCl, 15 g/L Bacto-agar, made up to 1 L in deionized H₂O, and adjusted to pH 7.0 with 1 M NaOH. Autoclave and cool to 50°C. Add 10 µg/mL tetracycline for LA-TET plates; 50 µg/mL carbenicillin and 2% (w/v) glucose for LA-CARB-GLU plates.
2. Top agar: as for LA medium, but use 7 g/L Bacto-agar. Before use, melt and cool to 50°C.
3. 2TY medium: 16 g/L tryptone, 10 g/L yeast extract, 5 g/L NaCl, made up to 1 L in deionized H₂O, and adjusted to pH 7.0 with 1 M NaOH. Autoclave.
4. 2TY-TET: 2TY with 10 µg/mL tetracycline.
5. 2TY growth medium: 2TY with 50 µg/mL carbenicillin, 10 µg/mL tetracycline, and 2% (w/v) glucose.
6. 2TY phage medium: 2TY with 50 µg/mL carbenicillin, 10 µg/mL tetracycline, 70 µg/mL kanamycin.

7. 2TY microtiter growth medium: 2TY with 50 $\mu\text{g}/\text{mL}$ carbenicillin and 0.1% (w/v) glucose.
8. 2TY induction medium: 2TY with 50 $\mu\text{g}/\text{mL}$ carbenicillin, 2 μM isopropyl- β -D-thiogalactopyranoside.
9. Bacterial strains: XL1 Blue: *recA1*, *endA1*, *gyrA* 46, *thi-1*, *hsdR* 17, *supE* 44, *relA1*, *lac*⁻, (F' *proA*⁺*B*⁺, *lacI*^q, *lacZ* Δ M15 Tn10[Tet^r]); HB2151: K12, *ara*, Δ (*lac-pro*), *thi*/F'(*proA*⁺*B*⁺, *lacI*^q Δ M15).
10. VCSM13 helper phage (Stratagene).
11. Dimethyl sulfoxide (DMSO).
12. Phage Ab (Fab) library, constructed in pComb3 or similar vectors.
13. Ag of interest, purified and diluted in PBS or carbonate Ag coating buffer.
14. Phosphate-buffered saline (PBS)–1% bovine serum albumin (BSA); PBS–2% (w/v) skim milk powder (PBSM); PBS–0.1% (v/v) Tween-20 (PBST).
15. Elution buffer: 0.1 M HCl, adjusted to pH 2.2 with glycine. Store at room temperature.
16. 1 M Tris-HCl, pH 8.0.
17. PEG–NaCl solution: 20% (w/v) polyethylene glycol (PEG) 6000, 2.5 M NaCl. Store at room temperature.
18. Abs: For detection of soluble Fab: anti-species immunoglobulin (F(ab)₂-specific or anti-immunoaffinity tag (e.g., 9E10 anti-myc) mouse MAb; appropriate horseradish peroxidase (HRP)-conjugated anti-mouse IgG. For detection of phage Ab: anti-M13-biotin Ab and HRP–streptavidin conjugate (e.g., Pharmacia/Amersham or Sigma).
19. HRP substrate for development of enzyme-linked immunosorbant assay (ELISAs) e.g., tetramethyl benzidine (TMB) substrate.
20. Plasticware: Polysorb flat-bottomed microtiter plates and/or immunotubes (Nunc) for panning; round-bottomed 96-well plates for microtiter growth cultures.

3. Methods

3.1. Maintenance of Bacterial Strains and Viruses (see Notes 1–3)

1. XL1 Blue: The F' episome contains the tetracycline resistance gene. Maintenance of this stain on LA–TET agar plates maintains the F' episome for the production of the bacterial pili that are essential for M13 phage infection. This strain is also a suppressor strain of *E. coli* (mutant SupE44), and therefore reads an amber stop codon (TAG) as a glutamine residue.
2. HB2151: This strain is maintained on minimal media plates to retain the F' episome. It is a nonsuppressor strain of *E. coli*, and therefore reads the amber codon as a stop codon.
3. VCSM13: This helper phage carries the kanamycin resistance gene for antibiotic selection. Stocks of the phage can be stored at -80°C in 7% (v/v) DMSO indefinitely, or for up to 6 mo at 4°C .
4. Phage-Ab libraries can be stored indefinitely at 4°C (in PBS–1% BSA–0.01% [w/v] Na azide). Libraries should be freshly amplified before panning. Keep

plasmid DNA stocks of the primary library and/or glycerol stocks of bacteria containing the phagemid library.

3.2. Preparation of Helper Phage VCSM13

1. Inoculate a single colony from a freshly streaked LA–TET plate of XL1 Blue into 10 mL 2TY–TET and grow overnight at 37°C.
2. Inoculate 100 mL 2TY–TET with 1 mL of the overnight culture and grow until an optical density 600 nm (OD_{600}) of 0.6–0.8 is reached (exponential growth or log phase).
3. Add 5×10^{12} plaque-forming units (pfu) of VCSM13 helper phage to the 100 mL culture, and grow for 1 h, with shaking, at 37°C.
4. Add kanamycin to 70 $\mu\text{g}/\text{mL}$ and incubate for a further 6 h at 37°C.
5. Centrifuge the culture at 2500g for 15 min at room temperature.
6. Remove the supernatant to a clean tube and incubate for 15 min at 65°C, then recentrifuge at 8000g for 10 min at 4°C.
7. Add 7% (v/v) DMSO to the supernatant and store the phage stock in 1–2 mL aliquots at –80°C.
8. To titer the helper phage, make dilutions of the phage preparation at 10^{-6} , 10^{-8} , and 10^{-10} in PBS or 2TY medium.
9. Add 1 μL of each dilution to 100 μL freshly grown log-phase XL1 Blue and incubate at 37°C for 30 min (no shaking). Add 3 mL top agar (cooled slightly to 42°C) and pour quickly and evenly onto LA plates (no antibiotics).
10. Incubate overnight at 37°C and count the number of plaques the following day. Calculate the titer of VCSM13 as pfu/mL.

3.3. Calculating Recombinant Ab-Phage Titer (Input)

1. Grow an overnight culture of XL1 Blue in 2TY–TET at 37°C.
2. Inoculate 10 mL of 2TY–TET with 100 μL of the overnight culture of XL1 Blue and grow until OD_{600} reaches 0.6–0.8.
3. Dilute the phage preparation to be titered (library phage or input phage for panning) 10^{-4} , 10^{-6} , 10^{-8} , and 10^{-10} in PBS or 2TY medium.
4. Add 1 μL of each dilution to 100 μL log-phase culture and incubate for 30 min at 37°C (no shaking).
5. Spread each aliquot of infected cells onto LA–CARB–GLU plates and incubate overnight at 37°C.
6. Count the colonies on the plate, which has between 100 and 1000 colonies and calculate the titer of the phage preparation (colony-forming units [cfu]/mL).

3.4. Amplification of Phage Libraries for Panning (see Notes 4 and 5)

1. Pick a single XL1 Blue colony from a LA–TET agar plate and grow overnight in 2TY–TET at 37°C.
2. Inoculate 50 mL 2TY–TET with 0.5 mL of the overnight culture and grow to an OD_{600} of 0.6–0.8, which will take approx 3 h.

3. Add 10^9 – 10^{10} cfu library phage Ab to 5 mL log-phase XL1 Blue culture and incubate at 37°C for 30 min (no shaking).
4. Plate out 0.1-, 1-, and 10- μ L aliquots of this culture onto LA–CARB–GLU plates and incubate overnight at 37°C. The number of colonies that grow on these plates is used to determine the total number of phage (cfu) that have infected the *E. coli*. For amplification of a library, the total number of transfected bacteria should exceed the library size of the library being amplified (*see Note 6*).
5. Continue growing the remaining culture at 37°C for a further 1 h without the addition of antibiotics. This allows the newly infected bacteria time to express the antibiotic resistance gene contained on the phagemid.
6. Add 90 mL 2TY growth medium to the culture and grow for a further 1 h at 37°C.
7. Add 10^{12} pfu VCSM13 helper phage and grow at 37°C for 2 h.
8. Centrifuge the culture at 5000g for 10 min at room temperature. Resuspend the pellet in 100 mL 2TY phage medium and incubate with shaking overnight at 30°C.
9. Precipitate the phage as described below.

3.5. Precipitation of Phage

1. Pellet the bacterial cells by centrifugation at 6000g for 10 min and remove the culture supernatant to a clean tube.
2. Add one-fifth vol PEG–NaCl, mix well, then incubate on ice for at least 1 h.
3. Centrifuge at 10,000g for 25 min at 4°C. Discard the supernatant and drain the phage pellet by inverting the tube upside down on paper tissue for several minutes.
4. Resuspend the white phage pellet in 2 mL PBS–1% BSA (per 100 mL supernatant).
5. Centrifuge for 5 min at 12,000g to remove any remaining bacterial debris.
6. Reprecipitate the phage by adding 400 μ L PEG–NaCl solution. Incubate on ice for 10 min.
7. Centrifuge at 12,000g for 2 min, discard the supernatant, and resuspend the phage pellet in 1–4 mL PBS–1% BSA.
8. Titer the phage as described in **Subheading 3.3**.

3.6. Selection of Ag-Specific Phage Abs (see Note 7)

The method for panning that uses the wells of a microtiter plate is essentially the same as the protocol for panning in immunotubes. The chief difference between the two approaches is the final surface area that is coated with Ag. The panning protocol below describes the panning for microtiter plates with the scaled-up volumes and directions for immunotubes contained in parentheses. Generally, panning and amplification is repeated 3–5 \times before proceeding with the postpanning analysis.

3.6.1. Panning

1. Coat a well of a polysorb microtiter plate in a 100- μ L vol with the desired Ag under optimal coating conditions (*see* **Notes 8** and **9**) (1 mL for an immunotube with end-over-end mixing).
2. Discard the Ag solution and wash the well 3 \times with 200 μ L PBS (fill the immunotube and tap out the excess buffer).
3. Block the well with 200 μ L PBSM (fill the immunotube) for 2 h at 37°C.
4. Add 100 μ L (2 mL with slow rotation) of freshly prepared phage (input phage; $\sim 10^{11}$ – 10^{12} cfu) to each well and incubate for 2 h at room temperature (*see* **Notes 10** and **11**).
5. Wash the wells 8 \times with 200 μ L PBST, followed by two washes with PBS (fill tube and tap out excess) (*see* **Note 12**).
6. Elute the phage (output phage) with 100 μ L elution buffer for 10 min at room temperature (1 mL with end-over-end mixing). Adjust the pH of the eluate to pH 7.5 by adding 10 μ L (100 μ L) of 1 M Tris-HCl, pH 8.0 (*see* **Note 13**).

3.6.2. Rescue and Amplification of Phage

1. Grow an overnight culture of XL1 Blue in 2TY–TET at 37°C.
2. Inoculate 20 mL 2TY–TET with 200 μ L of the overnight culture of XL1 Blue and grow until an OD₆₀₀ of 0.6–0.8 is reached.
3. Add 100 μ L (1 mL) of the output phage to 5 mL of the log-phase XL1 Blue and incubate for 30 min at 37°C (no shaking). Leave a small amount of each output (10 μ L) to be used for postpanning analysis.
4. Remove 10-, 1-, and 0.1- μ L aliquots from the infected culture and plate each onto an LA–CARB–GLU plates to determine the number of *E. coli* that have been transfected (i.e., to titrate the number of phage in the output). At the same time, titer the input phage according to **Subheading 3.3**. (*see* **Note 14**).
5. To the remaining culture, add carbenicillin to a concentration of 20 μ g/mL and grow with shaking at 37°C for 1 h.
6. Add the 5 mL (6 mL) culture to 20 mL 2TY growth medium containing 2×10^{10} VCSM13 helper phage. Incubate with slow shaking (~ 200 rpm/min) for 2 h at 37°C.
7. Centrifuge the culture at 5000g for 10 min at room temperature, discard the supernatant, and resuspend the bacterial pellet in 50 mL 2TY phage medium. Incubate this culture with shaking overnight at 30°C.
8. Precipitate the phage as described above (**Subheading 3.5**) to proceed with the next round of panning.

3.7. Postpanning Analysis of Ab Specificity

Two protocols are described for the identification of Ag-specific clones. The production of soluble recombinant Ab in **Subheading 3.7.1**. is dependent on the library expression vector containing an amber stop codon between the *gIII*

and the HC insertion site. Alternative approaches for the expression of soluble Ab fragments in vector systems without an amber codon are discussed in **Note 15**. If the production of soluble Ab fragments is not an option, then the analysis of phage Ab specificity (*see Subheading 3.7.2.*) can be used as an alternative.

3.7.1. Analysis of Soluble Ab by ELISA

3.7.1.1. PRODUCTION OF SOLUBLE AB IN 96-WELL PLATES

1. Pick a single colony of HB2151 from a LA plate and grow overnight at 37°C in 2TY.
2. Add 100 μ L HB2151 culture to 50 mL 2TY and grow at 37°C (with shaking) to an OD₆₀₀ of 0.6–0.8.
3. Inoculate 1 μ L from the phage outputs remaining from each round of panning into 200- μ L aliquots of the log-phase HB2151 culture. Incubate for 30 min at 37°C (no shaking).
4. Take a 100-, 10-, and 1- μ L aliquot from each of the transfected cultures and plate them onto LA–CARB–GLU plates and incubate overnight at 37°C.
5. Aliquot 200 μ L 2TY growth medium into the wells of a 96-well microtiter culture plate (round-bottomed). Inoculate a single colony into each well and grow overnight at 37°C (with gentle shaking).
6. Using a multichannel pipeting device fitted with sterile tips, take a 10- μ L aliquot from each well and transfer to the corresponding well of a fresh microtiter culture plate containing 100 μ L 2TY microtiter growth medium/well. Grow the cultures at 37°C until OD₆₀₀ is approx 0.6.
7. Add 100 μ L 2TY induction medium to each well and grow overnight at 30°C.
8. Centrifuge the microtiter plates at 3500g for 10 min. Use the resulting supernatants in a Fab ELISA to detect Ag-specific Ab.

3.7.1.2. SOLUBLE FAB ELISA

1. Coat the wells of an ELISA plate with the desired Ag (100 μ L) using optimal coating conditions.
2. Wash the wells 3 \times with 200 μ L PBS.
3. Block the wells with 200 μ L PBSM for 2 h at room temperature.
4. Discard the block solution and add 100 μ L culture supernatant containing the expressed Ab. Incubate for 2 h at room temperature.
5. Wash the wells 3 \times with 200 μ L PBST.
6. Add 100 μ L of an anti-Fab-specific Ab (~0.05 μ g/mL diluted in PBSM) to each well and incubate for 1 h at room temperature (*see Note 16*).
7. Wash the wells 3 \times with 200 μ L PBST, then add 100 μ L appropriate HRP-conjugated detection Ab (~0.05 μ g/mL in PBSM) for 1 h at room temperature.
8. Wash the wells 3 \times with 200 μ L PBST.
9. Develop the HRP reaction using an appropriate substrate and read optical density at the appropriate wavelength.

10. The primary screen should be repeated for those clones that are positive to confirm their reactivity (*see Note 17*).

3.7.2. Analysis of Monoclonal Phage-Abs by ELISA

3.7.2.1. PRODUCTION OF MONOCLONAL PHAGE IN A MICROTITER PLATE

1. Inoculate single colonies from the plates used to titer output phage into a 96-well round-bottomed microtiter plate containing 100 μ L 2TY growth medium. Grow overnight at 37°C (with gentle shaking).
2. Using a multichannel pipet, transfer 5–10 μ L of each overnight culture into the corresponding well of a new microtiter plate containing 90 μ L 2TY growth medium and grow at 37°C for 1 h.
3. Add 25 μ L VCSM13 (10^9 cfu/mL in 2TY growth medium) to each well.
4. Incubate for 30 min at 37°C (no shaking), then shake the plate for 1 h at 37°C.
5. Centrifuge the plate at 4000g for 10 min, carefully remove the supernatant from each well and resuspend the cells in 200 μ L 2TY phage medium. Grow the cells at 30°C overnight.
6. Centrifuge the plate at 4000g for 10 min and use the supernatant in a phage ELISA.

3.7.2.2. PHAGE ELISA

1. Coat the wells of a microtiter ELISA plate with 100 μ L/well of Ag using optimal coating conditions.
2. Wash the wells 3 \times with 200 μ L PBS.
3. Block the wells with 200 μ L PBSM for 2 h at 37°C.
4. Discard the blocking solution, then add 100 μ L phage supernatant to each well, and incubate for 2 h at room temperature.
5. Wash the wells 3 \times with 200 μ L PBST.
6. Add 100 μ L of biotin-linked anti-M13 Ab (diluted to the manufacturer's recommendations in PBSM) to each well and incubate for 1 h at room temperature.
7. Wash the wells 4 \times with PBST.
8. Add 100 μ L of streptavidin–HRP to each well (diluted to the manufacturer's recommendations in PBSM) and incubate for 30 min at room temperature.
9. Wash the wells 3 \times with 200 μ L/well PBST.
10. Add 100 μ L of an appropriate HRP substrate to each well and read the optical density at the appropriate wavelength.

4. Notes

1. Filamentous phage, either helper phage or library phage, are robust and can remain viable on glassware or other surfaces for extended periods of time or after autoclaving; therefore, whenever possible, use disposable tubes and pipets to avoid phage contamination. If the use of glassware is unavoidable, then the most effective method for the removal of phage is treatment with 2% (v/v) hypochlorite solution.

2. The F' episome contains the gene for the production of the bacterial pili, which is essential for phage infection. It is important to prepare fresh plates of bacteria under the appropriate selection conditions for the retention of the F' episome. The use of old plates and cultures throughout panning and screening can result in reduced infectivity.
3. If, when growing a log-phase culture of *E. coli*, it takes longer than usual to reach the desired OD, discard the culture and prepare a fresh overnight culture. Slow growth can be an indication of infection with spurious phage or loss of the F', which can lead to problems when using the culture for infection with phage.
4. The stability of Fab and scFv on the surface of the phage is reduced over time. Use freshly prepared phage Abs for panning to maximize the number of phage that bind during panning: this applies to the use of both library phage and phage amplified during panning.
5. Each successive round of library amplification can result in a reduction of diversity in the recombinant Ab repertoire because of an outgrowth of fast-growing clones or clones with deletions of the HC or light chain (LC). Amplify phage for panning from the primary phage library or from phage that have undergone a single round of amplification. Libraries that have undergone several rounds of amplification should be reassessed for full-length HC and LC inserts. A simple diagnostic polymerase chain reaction (PCR) to amplify the HC and/or LC genes can be used to confirm the frequency of clones with deletions. In addition, *Bst*NI digestion of those PCR products with full-length HC and LC inserts can be used to assess the diversity of the library (5).
6. Ensure that the titer of the infected cells exceeds the total library size. The protocol for the amplification of library phage routinely results in the infection of 10^8 – 10^9 cells and is therefore adequate for the amplification of phage libraries of a moderate size (10^7 – 10^8 cfu). Libraries of a larger size would require a larger volume of log-phase *E. coli* (proportional to the library size and volumes given), perhaps up to 500 mL.
7. Simple variations in the standard panning protocol, such as changing the constituents of buffers, the washing conditions, and Ag concentration can reduce the levels of nonspecific phage binding and/or the degree of specific phage Ab binding. Some variations in the panning protocol that could be useful are described below.
8. The optimal coating concentration for each Ag (coating buffer, concentration, and temperature) should be determined prior to panning, using an appropriate ELISA. The panning protocol described suggests a single optimal coating concentration be used over all rounds of panning (dependent on the Ag being used). Not all approaches to panning maintain a single concentration. Mathematical models of the panning process have demonstrated that the concentration of Ag can influence the selection of Abs (6). For example, high concentrations of Ag increase the possibility of enriching for low-affinity Abs or Abs that exist at low frequencies in the library. With this in mind, panning strategies using high, low, or varying

concentrations of Ag could be used to isolate Abs found at a particular frequency in the library or with a specific affinity.

9. Although the best Ag-coating strategy will ultimately depend on the library being panned and the Ag used, the following approach has been provided as a practical example. On the first day of panning a high Ag-coating concentration of 50–100 $\mu\text{g}/\text{mL}$ might be used, followed by a 10-fold reduction in coating concentration with each successive day of panning over five rounds. The strategy here is that the higher concentrations of Ag used in the early rounds of panning would facilitate the selection of Abs that exist at low frequencies in the library and the low Ag concentrations in the final rounds would enrich for high-affinity binders.
10. The number of phage produced after amplification is generally $\sim 10^{13}$ cfu/mL, although it can fluctuate in different rounds of Ab selection. Because the phage titer is not determined until the next day, an unknown amount of phage (input) is added to the microtiter plate. Generally, 50–500 μL fresh phage preparation is diluted into 1 mL of PBSM, of which 100 μL (2 mL) is added to the Ag-coated surface.
11. Although most phage Ab-binding to Ag occurs at room temperature, it is possible to vary the temperature from 4 to 37°C to increase the chance of a desired phage Ab binding. The use of temperature in this way depends on the kinetics of the Ab being isolated, and, as such, may not be applicable to all situations.
12. The washing of a well or tube after phage-Ab binding is the principle means by which nonspecific phage Abs are removed. To this end, detergents such as Tween-20 are often included in panning buffers to reduce nonspecific binding of phage. If there is excessive binding of nonspecific phage to the Ag, then it may help to increase the concentration of Tween-20, e.g., up to 0.5% (v/v). Alternatively, the length and/or number of the washes can be increased or decreased to minimize nonspecific interactions or maximize retrieval of specific binders.
13. An alternative to elution at low pH is the elution with triethylamine at high pH, which may lead to the retrieval of phage Abs with a higher affinity. In this method, freshly diluted 100 mM triethylamine, pH 10.0 is incubated with the bound phage for 10 min. The pH of the eluted phage is then adjusted immediately with one-half vol 1 M Tris-HCl, pH 7.4. The phage can then be used to infect XL1 Blue as normal. Care must be taken with this method because elution for longer than 10 min can damage the phage and affect infection. If there is still difficulty in eluting Ag-specific phage using this method, then it is possible to add the log-phase XL1 Blue directly to the well (100 μL) or immunotube (2 mL with slow rotation) and incubating for 30 min at 37°C. Amplification can then proceed as normal.
14. The number of phage eluted following panning (output phage) can be used as an indication of panning success. The data can be expressed either as total phage number or as a percentage of input phage/output phage. Theoretically, if the panning is successful, increasing numbers of phage should remain bound to the

Ag-coated surface after each round of panning, resulting in higher output titers. An increase in phage output of between 10- and 1000-fold over 4–5 rounds of panning can indicate panning success. However, this increase in output titer is not always seen even in a successful panning because of other limiting factors, including binding affinity and efficiency of phage production.

15. Many expression vectors for phage Ab libraries are constructed so that the HC variable region is fused to gene III with an in frame amber stop codon between the two genes (and often also including an affinity tag for immunodetection, such as *myc* or His₆). The expression of Ab in suppressor strains of *E. coli*, such as XL1 Blue, leads to the amber codon being recognized as a glutamine and therefore, the production of Ab is fused to *gIII*. In contrast, expression in a nonsuppressor strain, such as HB2151, leads to the amber codon being read as a stop codon, resulting in the expression of soluble (unfused) Ab. The protocol for the expression of soluble Ab (*see Subheading 3.7.1.*) assumes the use of an expression vector that contains an amber codon between the HC cloning site and *gIII*, such as the MCO vector for Fab expression (2) or the pHEN vector for scFv expression (5). If the vector system being used does not contain an amber codon, then there are several alternative approaches that can be used for the production of soluble Ab. The first is the excision of gene III from the construct/s of interest. An example of this has been described using the pComb3 and its derivatives, in which gene III is removed by *NheI* and *SpeI* digestion (3). Another option is to subclone the Ab genes of interest into a vector that permits expression of soluble Ab, such as MCO or pHEN. If neither of these is practical, then the investigator may be restricted to using the phage ELISA as a method of detecting binding clones.
16. The Ab used to detect expression of recombinant Ab will depend on the vector system being used. This protocol describes the use of a polyclonal Ab specific for the relevant Fab to detect expression. In addition, many vector systems incorporate an immunoaffinity tag, such as *myc*, into the expressed recombinant Ab sequence (7). In this way, the Ab can be detected in a wide range of assays with an Ab against the tag.
17. Both the assays described for the detection of binding clones after panning (*see Subheadings 3.7.1.* and *3.7.2.*) can result in clones with a false-positive signal. Often these clones can be eliminated from further analysis by assessing whether there is a full-length HC or LC gene present (by PCR) or if a full-length Ab fragment is being expressed (by immunoblotting). If the clone is still positive after this analysis, a second round of screening should be carried out against a range of Ags to confirm the Ab specificity.

References

1. McCafferty, J., Griffiths, A. D., Winter, G., and Chiswell, D. J. (1990) Phage antibodies: filamentous phage displaying antibody variable domains. *Nature* **348**, 552–554.

2. Ward, R. L., Clark, M. A., Lees, J., and Hawkins, N. J. (1996) Retrieval of human antibodies from phage-display libraries using enzymatic cleavage. *J. Immunol. Methods* **189**, 73–82.
3. Barbas, C. F., Kang, A. S., Lerner, R. A., and Benkovic, S. J. (1991) Assembly of combinatorial antibody libraries on phage surfaces: the gene III site. *Proc. Nat. Acad. Sci. USA* **88**, 7978–7982.
4. Harrison, J., Williams, S., Winter, G., and Nissim, A. (1996) Screening of phage antibody libraries. *Methods Enzymol.* **267**, 83–109.
5. Marks, J. D., Hoogenboom, H. R., Bonnert, T. P., McCafferty, J., Griffiths, A. D., and Winter, G. (1991) By-passing immunization: human antibodies from V-gene libraries displayed on phage. *J. Mol. Biol.* **222**, 581–597.
6. Levitan, B. (1998) Stochastic modeling and optimization of phage display. *J. Mol. Biol.* **277**, 893–916.
7. Ward, E. S., Gussow, D., Griffiths, A. D., Jones, P. T., and Winter, G. (1989) Binding activities of a repertoire of single immunoglobulin variable domains secreted from *Escherichia coli*. *Nature* **341**, 544–546.

Selection of Antibodies Against Biotinylated Antigens

Patrick Chames, Hennie R. Hoogenboom, and Paula Henderikx

1. Introduction

Phage antibody (Ab) library selections on peptides or proteins are usually carried out using antigens (Ags) directly coated onto a plastic surface (e.g., Petri dishes, microtiter plate wells, and immunotubes). This straightforward method is easy to perform and has been shown to be successful for a diverse set of Ags (for review, *see ref. 1*). However, phage Ab selections on some proteins and especially on peptides are not always successful, which is often caused by immobilization-associated features. The main problem observed for selection on peptides is the poor coating efficiency of some peptides and the altered availability of epitopes on plastic-coated peptides. The direct coating of proteins on plastic is usually more efficient, but may also be problematic because the passive adsorption on plastic at pH 9.6 is a mechanism of protein denaturation. Under these conditions, 95% of adsorbed proteins are nonfunctional (2,3). This problem is not important for a classical enzyme-linked immunosorbant assay (ELISA) mostly because a small fraction of proteins having a native conformation are still detectable. However, this phenomenon can be troublesome for phage Ab library selections because phage Abs binding to epitopes, only present in denatured molecules may be selected.

Several methods have been developed to increase peptide coating, including coupling to bigger proteins (4) to amino acid linkers binding plastic (5,6) or use of the multiple antigen peptide system (7). The most successful method has been the indirect coating of biotinylated Ags via streptavidin: biotinylation of the peptide and immobilization via streptavidin improves the sensitivity in ELISA (8) and allows more efficient selection of anti-peptide phage Abs (9,10).

In the case of phage library selection against proteins, the indirect coating via streptavidin results in higher-density coating, more uniform distribution of Ags on the well surface, and, above all, 60–70% of active molecules (2,3). The use of biotinylated peptide or protein also allows the use of paramagnetic streptavidin-coated microbeads to capture the biotinylated Ags with the phage bound to them. The interaction between the phage particle and the Ag therefore takes place in solution; Ag-bound phage are retrieved via a short incubation with the beads. This technique allows precise control of the Ag concentration and the time of exposure of the Ag to the phage Ab library, two parameters that are useful in affinity selection, e.g., during affinity maturation protocols (11,12). This interaction between Ag and phage Ab in solution leaves a maximum of epitopes available for binding and avoids the selection of scFvs with low affinity, but a high tendency to form dimers (13). The latter will be preferentially selected on Ag-coated surfaces because of their avid binding.

This chapter outlines a protocol for the chemical biotinylation of Ag, followed by the Ab phage library selection against biotinylated Ag in solution. Briefly, the selection procedure is as follows: once specific phage are bound to the Ag, paramagnetic beads, coupled to streptavidin, are added into the solution. The biotinylated Ags with bound phages are captured and the whole complex is drawn out from the suspension by applying a magnet on the side of the tube. The beads are washed several times and specific phages are eluted from the beads (see Fig. 1). A sensitive ELISA procedure to monitor selection using the same biotinylated Ag as used during the selection step is also included. In this protocol, the indirect coating of the Ag via streptavidin ensures maintenance of the native structure of the Ag and precoating of the plastic panning surface with biotinylated bovine serum albumin (BSA) is used to circumvent the low adsorption properties of streptavidin (Fig. 2).

2. Materials

2.1. Biotinylation of Ag and Selection of Phage Ab

1. Protein/peptide of interest.
2. NHS-SS-Biotin (cat. no. 21331, Pierce, IL) (see Notes 1–3).
3. Dialysis tubing or ultrafiltration centrifugation devices (e.g., Centricon 30 or Centricon 10, Amicon, Beverly, MA).
4. 50 mM NaHCO₃, pH 8.5; 1 M Tris-HCl, pH 7.5.
5. Streptavidin Dynabeads (M280, Dynal, Oslo, Norway) and magnetic separation device.
6. Phosphate-buffered saline (PBS) containing 0.1% Tween-20 (PBST).
7. Apparatus and buffers for sodium dodecyl sulfate polyacrylamide gel electrophoresis (SDS-PAGE).

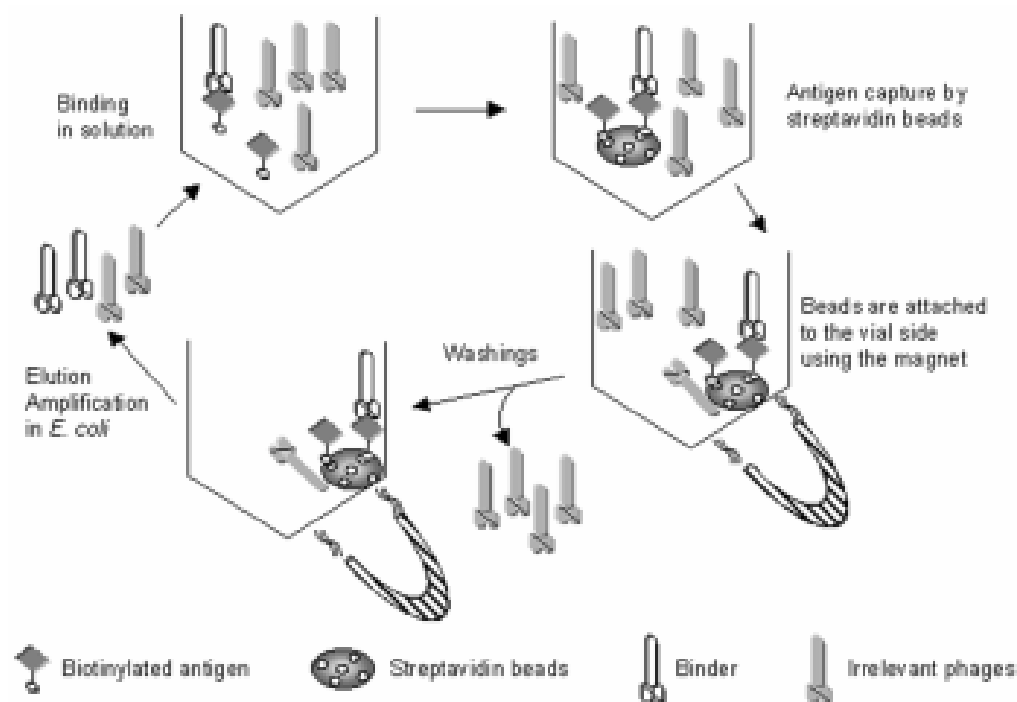

Fig. 1. Principle of phage antibody selection on paramagnetic beads.

8. Ab-phage display library, freshly amplified and titered (colony-forming U/mL).
9. 2% (w/v) and 4% Dried skimmed milk powder (e.g., Marvel) in PBS (PBSM).
10. PBS containing 5% dimethyl sulfoxide (DMSO) (*see Note 4*).
11. 2% Marvel, 2% Tween-20 in PBS (PBSMT).
12. 10 mM Dithiothreitol (DTT).
13. *Escherichia coli* TG1 and medium, helper phage, and so on, required for amplification of phage-Ab.

2.2. ELISA

1. Biotinylated Ag at a concentration of 1–5 $\mu\text{g/mL}$ in PBSM–5% DMSO (*see Note 4*). For inhibition ELISA (IE), the concentration of biotinylated Ag should be 1 $\mu\text{g/mL}$. IE also requires nonbiotinylated Ag at 1 mg/mL in 2% PBSM.
2. Selected phage-Ab clones, expressed as (*myc*-tagged) soluble Ab fragments.
3. 0.1% (v/v) Tween-20 in PBS (PBST).
4. Biotinylated BSA stock solution: 2 mg/mL in PBS. Working solution per microtiter plate: add 10 μL stock solution to 10 mL PBS.
5. Streptavidin solution: 1 mg/mL H_2O . Working solution per microtiter plate: add 100 μL stock solution to 10 mL PBS–0.5% gelatin.

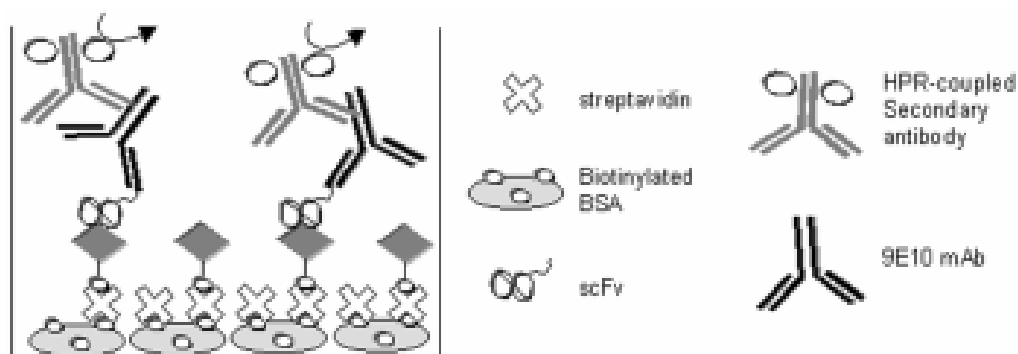

Fig. 2. ELISA using biotinylated antigen and soluble antibody fragments.

6. Anti-tag monoclonal Ab (e.g., 9E10 for *myc*-tagged Abs). Dilute in 2% PBSM according to the supplier's recommendations.
7. Rabbit anti-mouse peroxidase (RAMPO). Dilute in 2% PBSM at a concentration recommended by the supplier.
8. 10X Tetramethylbenzidine buffer (TMB). Dissolve 37.4 g Na acetate-3H₂O in 230 mL of H₂O. Adjust the pH with saturated citric acid (92.5 g citric acid-50 mL H₂O) and adjust the volume to 250 mL.
9. TMB stock. Dissolve 10 mg TMB in 1 mL DMSO.
10. TMB staining solution. Mix 1 mL 10X TMB buffer with 9 mL H₂O/microtiter plate. Add 100 μ L TMB and 1 μ L 30% hydrogen peroxidase. Make this solution fresh and keep it in the dark.
11. 96-Well, flat-bottomed ELISA microtiter plates (2 plates to screen 96 colonies).
12. For IE: microtiter plates with low coating efficiency (2/96 colonies).
13. Microtiter plate reader (for optical density 450 nm [OD₄₅₀] measurements).

3. Methods

3.1. Biotinylation of Ag

This method describes chemical biotinylation, which is the most common way to obtain a biotinylated Ag. For other alternatives, *see* **Notes 1–3**.

3.1.1. Chemical Biotinylation of Ag

1. Dissolve the peptide/protein of interest at a concentration of 1–10 mg/mL in 50 mM NaHCO₃, pH 8.5. If the peptide/protein is in another solvent, dialyze for at least 4 h against 1 L 50 mM NaHCO₃, changing the buffer 2–3 \times .
2. Calculate the amount of NHS-SS-Biotin required using a molar ratio of biotin:protein between 5 and 20:1 (*see* **Note 5**).
3. Dissolve the required amount of NHS-SS-Biotin in dH₂O (*see* **Note 6**) and immediately add to the protein sample, or, alternatively, when using larger amounts of protein, add NHS-SS-Biotin directly to the protein solution.

4. Incubate for 30 min at room temperature or for 2 h on ice if the protein is temperature-sensitive.
5. Add 1 M Tris-HCl, pH 7.5, to a final concentration of 50 mM and incubate for 1 h on ice to block any free NHS-SS-Biotin.
6. To remove the free NHS-SS-Biotin, dialyze for at least 4 h (to overnight) at 4°C against PBS, changing the buffer. Alternatively, follow **steps 7–9** below. For small peptides (<20 amino acids), alternative separation protocols (e.g., affinity chromatography, high-performance liquid chromatography) should be followed.
7. Alternative to **step 6**: spin the solution at 1000–5000g in an ultrafiltration device (e.g., Centricon 10 or 30) to concentrate the sample in 100 µL.
8. Dilute the sample in PBS to dilute out free NHS-SS-Biotin left after concentration.
9. Repeat **steps 6** and **7** twice more.
10. Add Na azide to a final concentration of 0.1%.
11. Store in small aliquots at –20°C or at 4°C. Storage conditions should be tested for individual proteins.

3.1.2. Determination of Biotinylation Efficiency

It is important to determine the percentage of protein that has actually been biotinylated. If the Ag has to be used for selection in solution, the nonbiotinylated part of the preparation will be detrimental to selection, blocking specific phages, and impairing their binding to the biotinylated fraction. Hence, this nonbiotinylated fraction must represent less than 10–15%. This protocol is also used to determine the amount of biotinylated peptide captured by a certain amount of magnetic beads. Extrapolation of the results can be used for determining the concentration of Ag and amount of beads to be used during phage library selection.

1. Resuspend the streptavidin Dynabeads with gentle shaking.
2. Make five dilutions of the biotinylated protein/peptide between 5 and 50 nM in 200 µL PBS.
3. Transfer 50 µL beads into a tube that fits into the magnetic separator and add an excess of PBS; shake gently to mix.
4. Put the tube into the magnetic separation device for 2 min and pipet off the PBS.
5. Add 0.5 mL PBST and incubate for 60 min.
6. Remove the PBST as in **step 4** and resuspend the beads in 50 µL of PBST.
7. Aliquot 10 µL of the beads into 5 tubes and add 100 µL diluted peptide/protein to each tube. Seal the tubes and incubate for 30 min at room temperature in an end-over-end rotator. The remaining 100 µL of each dilution (fraction 0) will be used to evaluate the percentage of biotinylation.
8. Place the tubes into the magnet for 2 min, remove, and store 100 µL of the supernatants (fraction 1).

9. Resuspend the Dynabeads in 1 mL PBST, place the tubes into the magnet, and discard the supernatant. Repeat 4×.
10. If the protein measurements are to be performed by SDS-PAGE, resuspend the beads in 110 μL 1X reducing SDS-PAGE sample buffer and incubate for 10 min (fraction 2a; eluted protein). Alternatively, the protein concentration can be measured by UV 280 nm. In this case, resuspend the beads in PBS containing 10 mM DTT (fraction 2b).
11. For SDS-PAGE measurements, add 10 μL 10X reducing loading buffer to fractions 0 and 1, and load samples (e.g., 10 μL and 50 μL) of fractions 0, 1, and 2a to a gel of suitable acrylamide percentage for the protein of interest. Perform SDS-PAGE, stain gel with Coomassie blue, and destain.
12. Alternatively, dilute fractions 0, 1, and 2b in an amount of PBS suitable for the quartz cuvet. Measure UV_{280} absorption.
13. The percentage of protein found in fraction 2 is the percentage of biotinylation. The proteins in fraction 1 are not biotinylated.
14. If the biotinylation was efficient, check the maximum amount of biotinylated protein able to bind 10 μL streptavidin dynabeads (the highest concentration for which there is almost no protein in fraction 1). Extrapolate this amount to phage-selection conditions (e.g., a maximum of 30 nM can be bound at >85% to 10 μL beads: therefore, for 500 mM Ag used during the selections, 166 μL of magnetic beads should be used).

3.2. Selection of Abs by Means of Phage Display

1. Mix equal volumes of the phage library and 4% PBSM in a total volume of 0.5 mL. During the first selection, the number of phage particles should be at least 100× higher than the library size (e.g., 10^{12} cfu for a library of 10^{10} clones). Diversity drops to 10^6 after the first round and is thus not limiting in the next rounds.
2. Incubate on a rotator at room temperature for 60 min.
3. While preincubating the phage, wash 100–200 μL streptavidin Dynabeads/Ag sample in a tube with 1 mL PBST using the magnetic separation device as described in **Subheading 3.1.2**. The minimal amount of beads for selection can be calculated as described in **Subheading 3.1.2**.
4. Resuspend the beads in 1 mL 2% PBSM.
5. Equilibrate the beads at room temperature for 1–2 h using a rotator.
6. Add the biotinylated Ag (100–500 nM) diluted in 0.5 mL PBS (+ 5% DMSO if the Ag solubility is an issue, e.g. for certain peptides) directly into the equilibrated phage mix. Incubate on a rotator at room temperature for 30 min–1 h.
7. Using the magnet, draw the equilibrated beads to one side of the tube and remove the PBSM.
8. Resuspend the Dynabeads in the phage–Ag mix and incubate on a rotator at room temperature for 15 min (*see Note 7*).

9. Place the tubes in the magnetic separator and wait until all the beads are bound to the magnetic site (1 min).
10. Tip the rack upside down and back again with the caps closed, which will wash down the beads from the cap. Leave the tubes in the rack for 2 min, then aspirate the tubes carefully, leaving the beads on the side of the tube.
11. Using the magnet, wash the beads carefully 6× with 1 mL PBSMT.
12. Transfer beads to a new Eppendorf tube and wash the beads 6× with 1 mL PBSMT.
13. Transfer the beads to a new Eppendorf tube and wash the beads 2× with 1 mL PBS.
14. Transfer the beads to a new tube and elute the phage from the beads by adding 200 μ L 10 mM DTT and rotate the tube for 5 min at room temperature (*see Note 8*). Place the tubes in the magnetic separator and transfer the supernatant containing the phages to a new tube.
15. Infect a fresh exponentially growing culture of *Escherichia coli* TG1 with the eluted phage and amplify according to standard protocols (*see Chapter 9*) to perform further rounds of selection (*see Notes 9 and 10*). Store any remaining phage eluate at 4°C.
16. Express soluble Ab fragments from the selected phage clones using standard protocols for the particular expression system.

3.3. Inhibition ELISA

The purpose of this ELISA is to identify binders among phages retrieved after each selection round. The setup of this ELISA is similar to the setup used for selection. It uses the same biotinylated Ag and an indirect coating via streptavidin, to ensure maintenance of the native structure of the Ag and precoating of the plastic panning surface with biotinylated BSA is used to circumvent the low adsorption properties of streptavidin. This ELISA uses an anti-tag (*myc*) Ab to detect soluble Ab bound to biotinylated Ag. The use of other Ab expression systems will necessitate the use of a different detection Ab.

An optional competition step (IE) allows one to ensure that the Ag is also recognized in solution by the binders. These extra steps are in parentheses at the end of some of the following steps.

1. Add 100 μ L biotinylated BSA to each well of the microtiter plate. For screening colonies in 96-well plates, coat two plates (negative control and positive plates). Incubate for 1 h at 37°C or overnight at 4°C.
2. Discard the coating solution and wash the plates 3× in PBST for 5 min by submerging the plate into the wash buffer and removing the air bubbles by rubbing the plate. Following the final wash, remove any remaining wash solution from the wells by tapping on paper towels.

3. Add 100 μL /well of streptavidin to both plates. Incubate for 1 h at room temperature while shaking gently.
4. Wash the plates as described in **step 2**.
5. Add 100 μL biotinylated Ag diluted in PBS (1–10 $\mu\text{g}/\text{mL}$) to each well of the positive plate and add 100 μL of 2% PBSM to the wells of the negative control plate. Incubate for 1 h at room temperature. (For IE only: add the biotinylated Ag to both plates.)
6. Wash the plates 3 \times with PBST (+ DMSO) (*see Note 4*) as described in **step 2**.
7. Block the plates with 200 μL /well 2% PBSM–DMSO and incubate for at least 30 min at room temperature.
8. Discard the blocking solution and add 50 μL /well 4% PBSM–DMSO to all the wells of both plates. (For IE only: this step must be done in two other noncoated plates with low coating efficiency. It will be used to incubate the Abs and the nonlabeled Ag).
9. Add 50 μL /well culture supernatant containing soluble Ab fragment and mix by pipeting. (For IE: add also 10 μL /well PBSM to one of the plates from **step 8** [positive] and add 10 μL /well nonbiotinylated Ag to the other plate from **step 8** [negative]. Mix by pipeting and incubate for 30 min. Discard the blocking agent of plates from **step 7**. Add 100 μL positive mix to one plate and 100 μL negative mix to the other.)
10. Incubate for 1.5 h at room temperature with gentle shaking.
11. Wash 3 \times with PBST as described in **step 2**.
12. Add 100 μL /well diluted detection Ab (e.g., 9E10) to all of the wells and incubate for 1 h at room temperature with gentle shaking.
13. Wash as in **step 2**.
14. Add 100 μL /well RAMPO solution to all of the wells and incubate for 1 h at room temperature with gentle shaking.
15. Wash as in **step 2**.
16. Develop the ELISA by adding 100 μL /well TMB substrate solution. Incubate for 10–30 min in the dark until sufficient color has developed. Stop the reaction by adding 50 μL /well 2 M H_2SO_4 .
17. Measure the optical density at 450 nm. If the optical density of a clone on the positive plate is higher than 2 \times the optical density of the same clone on the negative plate, it can be considered positive and should be tested further.

4. Notes

1. There are many commercially available reagents that can be used for biotinylation using a variety of chemistries. For most biotinylations, we prefer to use the chemical reagent NHS-SS-Biotin (sulfo-succinimidyl-2-[biotinamido]ethyl-1,3-dithiopropionate, mol wt 606.70). This molecule is a unique biotin analog with an extended spacer arm of approx 24.3 Å in length, capable of reacting with primary amine groups (lysines and NH_2 termini). The long chain reduces

steric hindrances associated with binding of biotinylated molecules to avidin or streptavidin and should not interfere with the structure of the protein/peptide involved.

2. It is also possible to efficiently biotinylate proteins using an enzymatic reaction. *E. coli* possesses a cytoplasmic enzyme, BirA, which is capable of specifically recognizing a sequence of 13 amino acids, and adding a biotin on a unique lysine present on this sequence (**14**). If this sequence is fused as a tag to the N- or C-terminal part of a protein, the resulting fusion will also be biotinylated. The chief advantage of this system is that the protein remains fully intact. Conversely, chemical biotinylation randomly modifies any accessible lysine. Overbiotinylation often leads to inactivation of the protein of interest, especially if a lysine is present in the active site of the protein. The use of a low ratio of biotin:protein may reduce this problem, but this may lead to poor yield of biotinylation. The enzymatic biotinylation avoids this drawback, leading to a 100% active protein, but also to a high yield of biotinylation (typically 85–95%). The “tagged” enzymatic method of biotinylating Ag has another important advantage: it allows an ideal orientation of the protein during the selection or the ELISA analysis. In both instances, the tag will be bound to streptavidin and will thus be directed toward the solid surface (beads or plastic); the rest of the molecule is perfectly oriented, available for interaction with the phage-Ab. This allows a uniform presentation of the Ag, whereas chemical biotinylation will lead to a number of Ags having the epitope of interest directed toward streptavidin and thus not available for phage-Ab binding.
3. It is also possible to perform enzymatic biotinylation in vivo if the Ag is produced in the cytoplasm of *E. coli*. In this case, the only requirement is to overexpress *birA* and add free biotin to the culture medium. The biotinylation is also efficient on intracellularly expressed proteins that form inclusion bodies. However, if the Ag has to be produced in the periplasm of *E. coli*, the biotinylation yield is poor (0.1–1%) (Chames et al., unpublished). In this case, and when the Ag is produced in another expression system, the biotinylation of the tag can still be performed in vitro on the purified protein using purified commercially available BirA. The main drawbacks of the enzymatic methods are that they cannot be applied on nonrecombinant proteins, and that the link between biotin and the Ag cannot be broken using DTT. In addition, failure to obtain good yields of biotinylation may occur because of degradation of the biotinylation tag caused by the presence of proteases co-purified with the protein of interest. Therefore, protease inhibitors must be included.
4. Check whether the Ag is water-soluble in the buffers used. If the Ag (peptide) is too hydrophobic, one must find alternative buffer conditions in which it remains in solution and use these conditions for the selection. We have, for example, successfully used 5% DMSO in all solutions.
5. Although the amount of NHS-SS-Biotin required depends on the number of lysines present within the protein, a ratio of 5:1 protein:biotin usually works

well. When enough protein is available, it is advised to test different ratios of protein:biotin. Overbiotinylation often results in nonfunctional protein (aggregation, and so on), therefore, the best molar ratio of biotin:protein must be determined empirically. Ideally, 1–2 biotinylated residues should be present per molecule. To determine the number of biotin molecules per protein/peptide, the HABA method can be used (*see* www.piercenet.com) (NHS-SS-Biotin, mol wt 606.70; NHS-LC-Biotin, mol wt 556.58).

6. Avoid buffers containing amines (such as Tris-HCl or glycine) since these compete with peptide/protein during the biotinylation reaction. In addition, reducing agents should not be included in the conjugation step to prevent cleavage of the disulfide bond within NHS-SS-Biotin.
7. If a significant proportion of the peptide/protein is not labeled, one can incubate the Ag first with the streptavidin beads, taking into account the molarity of the biotinylated peptide/protein and wash away the nonbiotinylated peptide. The beads are then used directly for the selection.
8. The presence of the S-S linker in NHS-S-S-Biotin enables the use of a reducing agent (DTT, DTE, β -mercaptoethanol) to separate the Ag and all phage-Abs bound to it from the beads. This feature allows a more specific elution, which is useful when unwanted streptavidin binders are preferentially selected from a phage-Ab repertoire. For other biotinylation chemistries, elute the bound phage with 1 mL 100 mM triethylamine, then transfer the solution to an Eppendorf tube containing 0.1 mL 1 M Tris-HCl, pH 7.4, and mix by inversion. It is necessary to neutralize the phage eluate immediately after elution.
9. For the selection of high-affinity Abs, it is advisable to perform further rounds of selection with a decreasing Ag concentration. For example, use 100 nM biotinylated Ag for the first round, 20 nM for the second round, 5 nM for the third round, and 1 nM for the fourth round.
10. The use of 10 mM DTT as elution buffer should avoid the preferential selection of streptavidin phage binders. However, if this still occurs (which may be the case when using nonimmunized or synthetic Ab libraries), deplete the library by incubating for 1 h (from round 2 on, and later) with 100 μ L streptavidin-Dynabeads before adding the biotinylated Ag to the depleted library.

References

1. Winter, G., Griffiths, A. D., Hawkins, R. E., and Hoogenboom, H. R. (1994) Making antibodies by phage display technology. *Ann. Rev. Immunol.* **12**, 433–455.
2. Davies, J., Dawkes, A. C., Haymes, A. G., Roberts, C. J., Sunderland, R. F., Wilkins, M. J., et al. (1994) Scanning tunnelling microscopy comparison of passive antibody adsorption and biotinylated antibody linkage to streptavidin on microtiter wells. *J. Immunol. Methods* **167**, 263–269.
3. Butler, J., Ni, L., Nessler, R., Joshi, K. S., Suter, M., Rosenberg, B., et al. (1992) The physical and functional behaviour of capture antibodies adsorbed on polystyrene. *J. Immunol. Methods* **150**, 77–90.

4. Oshima, M. and Atassi, M. Z. (1989) Comparison of peptide-coating conditions in solid phase plate assays for detection of anti-peptide antibodies. *Immunol. Invest.* **18**, 841–851.
5. Pyun, J. C., Cheong, M. Y., Park, S. H., Kim, H. Y., and Park, J. S. (1997) Modification of short peptides using epsilon-aminocaproic acid for improved coating efficiency in indirect enzyme-linked immunosorbent assays (ELISA). *J. Immunol. Methods* **208**, 141–149.
6. Loomans, E. E., Gribnau, T. C., Bloemers, H. P., and Schielen, W. J. (1998) Adsorption studies of tritium-labeled peptides on polystyrene surfaces. *J. Immunol. Methods* **221**, 131–139.
7. Tam, J. P. and Zavala, F. (1989) Multiple antigen peptide: a novel approach to increase detection sensitivity of synthetic peptides in solid-phase immunoassays. *J. Immunol. Methods* **124**, 53–61.
8. Ivanov, V. S., Suvorova, Z. K., Tchikin, L. D., Kozhich, A. T., and Ivanov, V. T. (1992) Effective method for synthetic peptide immobilization that increases the sensitivity and specificity of ELISA procedures. *J. Immunol. Methods* **153**, 229–233.
9. Henderikx, P., Kandilogiannaki, M., Petrarca, C., von Mensdorff-Pouilly, S., Hilgers, J. H., Krambovitis, E., Arends, J. W., and Hoogenboom, H. R. (1998) Human single-chain Fv antibodies to MUC1 core peptide selected from phage display libraries recognize unique epitopes and predominantly bind adenocarcinoma. *Cancer Res.* **58**, 4324–4332.
10. de Haard, H. J., van Neer, N., Reurs, A., Hufton, S. E., Roovers, R. C., Henderikx, P., et al. (1999) A large nonimmunized human Fab fragments phage library that permits rapid isolation and kinetic analysis of high affinity antibodies. *J. Biol. Chem.* **274**, 18,218–18,230.
11. Hawkins, R. E., Russell, S. J., and Winter, G. (1992) Selection of phage antibodies by binding affinity. Mimicking affinity maturation. *J. Mol. Biol.* **226**, 889–896.
12. Schier R. and Marks, J. D. (1996) Efficient in vitro affinity maturation of phage antibodies using BIAcore guided selections. *Hum. Antibodies Hybridomas* **7**, 97–105.
13. Schier, R., Bye, J., Apell, G., McCall, A., Adams, G. P., Malmqvist, M., Weiner, L. M., and Marks, J. D. (1996) Isolation of high-affinity monomeric human anti-c-erbB-2 single chain Fv using affinity-driven selection. *J. Mol. Biol.* **255**, 28–43.
14. Schatz, P. J. (1993) Use of peptide libraries to map the substrate specificity of a peptide-modifying enzyme: a 13 residue consensus peptide specifies biotinylation in *Escherichia coli*. *Biotechnology* **11**, 1138–1143.

Isolation of Anti-Hapten Specific Antibody Fragments from Combinatorial Libraries

Keith A. Charlton and Andrew J. Porter

1. Introduction

The generation of high-affinity antibodies (Abs) against hapten targets (molecular weight below 1000 Dalton) presents particular problems not encountered with larger antigens (Ags). By their nature, haptens are invisible to the host immune system unless presented as an epitope conjugated to a suitable immunogenic carrier protein, such as bovine thyroglobulin. The principal interest in anti-hapten Abs is as detection molecules for use in diagnostic assays. These typically use dipstick (qualitative) or, more commonly, enzyme-linked immunosorbant assay (ELISA) formats, for the quantification and/or detection of targets such as environmental pollutants or for monitoring the presence of drugs in clinical samples. There are also applications related to biological functions, e.g., Abs directed against signal molecules enhance the study of cell signaling pathways and have potential as candidate therapeutic agents.

When designing methodologies to select or generate Abs against a hapten, it is necessary to consider how the Ag will be presented at the binding site on the Ab. Specifically, it is important to estimate which atoms or groups will be significant in Ab-Ag interactions and therefore how to conjugate the Ag to the carrier protein (*1-3*). Halogens and other strongly electronegative atoms, charged groups, and groups capable of forming H-bonds are all good candidates for enhancing Ab binding and so should not be used for conjugation where alternative sites exist. Many hapten Ags belong to groups of structurally related compounds and Abs may be required that are either specific for one particular compound or are able to bind to all members of the family. In the former case, those regions that distinguish the compound of interest should

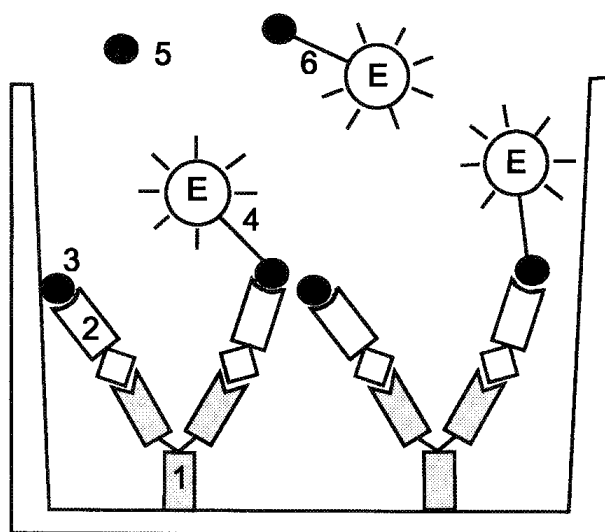

Fig. 1. Schematic representation of a direct competition ELISA. (1) Anti-affinity tag polyclonal antibody; (2) scFv with affinity tag; (3) haptens; (4) alkaline-phosphatase [E] labeled haptens; (5) and (6) unbound free and labeled haptens removed by washing.

be exposed when conjugated, and, in the latter, it is the conserved structural elements that are more important.

Most applications of anti-haptens Abs involve their use in competitive-inhibition ELISA using either of two formats. With direct-competition assays, native and enzyme-labeled Ag in solution compete for the Ab-binding site (**Fig. 1**). The Ab is captured by an immobilized secondary Ab directed against a suitable affinity tag, for example, the *c-myc* and FLAG tags. Residual enzyme activity is then measured across a range of native Ag concentrations. With indirect competition assays, native Ag in solution competes with immobilized Ag conjugate and with residual immobilized anti-haptens Ab detected using a labeled secondary Ab (**Fig. 2**). In both cases, increasing the concentration of native haptens results in a signal reduction, allowing a calibration curve to be constructed (**Fig. 3**).

In order to be effective, Abs are required that bind to conjugate with sufficient affinity to generate a usable signal in ELISA, but which also bind preferentially to free haptens. A high affinity for the conjugate is generally undesirable because such Abs do not dissociate readily and reduce the sensitivity of the assay. Care must also be taken to avoid selection of interface binders (**3**). These Abs recognize the haptens Ag in the context of the conjugate and bind to some extent to the linker used in conjugation and perhaps to the carrier protein itself in the vicinity of the point of conjugation. As a result, they show higher affinity for conjugate than for free haptens and so are unsuitable (**Fig. 3**).

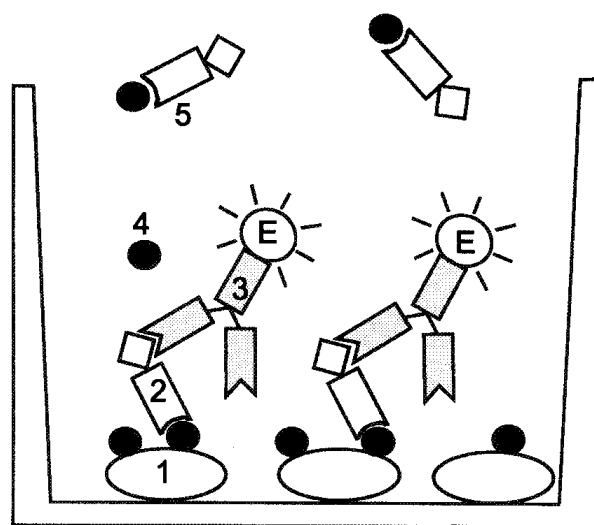

Fig. 2. Schematic representation of an indirect competition ELISA. (1) Immobilized hapten conjugate; (2) scFv; (3) horse radish peroxidase [E]-labeled anti-affinity tag polyclonal antibody; (4) free and (5) scFv-bound soluble hapten removed by washing.

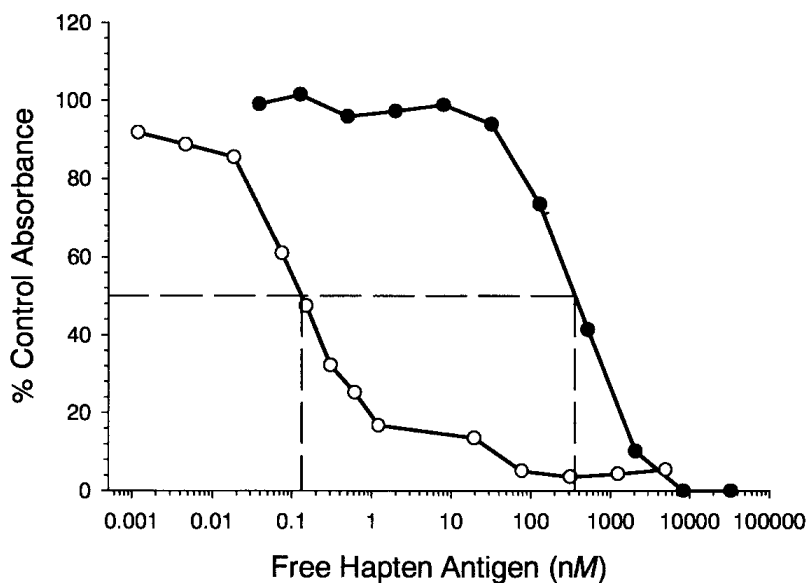

Fig. 3. Indirect competition ELISA data of two antibodies selected from the same immune library against the hapten antigen atrazine. (•) Selected against atrazine-BSA and eluted with triethylamine (*see Subheading 3.2.*); (o) selected against atrazine-BSA and eluted with free atrazine (round 3 onwards). Broken vertical lines indicate IC_{50} values.

This chapter describes protocols for the isolation of anti-hapten Abs from Ab phage-display libraries. The method utilizes two different hapten conjugates for alternative rounds of selection, therefore avoiding the selection of phage to the carrier protein and also uses different phage elution methods for each step of the selection, which aid in the isolation of high-affinity anti-hapten Abs. The technique may be performed using any of the available types of phage Ab libraries, e.g., those constructed from naïve repertoires (whether native, semisynthetic, or fully synthetic) or a custom-made library produced from an animal immunized against the hapten conjugate in the same way as for generating hybridomas. Such immune libraries offer the advantage of being biased in favor of Abs recognizing the hapten of interest, although they require time to construct and separate libraries are usually required for each target of interest. However, it is possible to immunize an animal with several Ags simultaneously and to isolate phage Abs specific for each target (4). A single suitable naïve library can also be used to select Abs to any number of targets with an equal chance of success. However, in order to yield Abs with affinities comparable to those from an immune library, large ($>10^{10}$) naïve libraries are normally required. For anti-hapten diagnostic Abs, the typical limits of sensitivity achievable (IC_{50}) are <1 nM (immune library) vs >100 nM (naïve library).

2. Materials

1. Phage Ab library, freshly amplified and titered (*see Note 1*).
2. Hapten conjugate 1 and hapten conjugate 2, purified (*see Note 2*).
3. Free Ag (hapten).
4. Phosphate-buffered saline (PBS).
5. PBS containing 2% (w/v) and 4% skim milk powder (PBSM) (make fresh as required).
6. PBS containing 0.1% (v/v) Tween-20 (PBST).
7. Elution buffers. 100 mM TEA: 70 μ L triethylamine (7.18 M) in 5 mL H_2O (dilute on day of use). For KM13 helper phage: trypsin stock solution at 10 mg/mL. Dilute 50 μ L stock solution in 450 μ L PBS for use.
8. 1 M Tris-HCl, pH 7.4.
9. *Escherichia coli* TG1 (Stratagene).
10. Helper phage VCSM13 (Stratagene) or KM13 (MRC Laboratory, Cambridge, UK) (*see Note 3*).
11. 2TY medium. 2TY containing 15% (v/v) glycerol. Antibiotic stock solutions: 100 mg/mL ampicillin in H_2O ; 50 mg/mL kanamycin in H_2O ; both filter-sterilized (0.2 μ m).
12. TYE agar plates containing 100 μ g/mL ampicillin and 1% glucose (TYE-AMP-GLU), in standard and large-size diameter Petri dishes.
13. PEG-NaCl: 20% (w/v) polyethylene glycol 6000, 2.5 M NaCl.

14. 4 mL Nunc Maxisorb immunotubes (Gibco-BRL); Immulon-4 96-well flat-bottomed ELISA plates (Dyrex Technologies); 96-well flat-bottomed tissue culture plates.
15. Peroxidase-conjugated anti-M13 Ab (Pharmacia).
16. Tetramethyl benzidine (TMB) microwell peroxidase substrate (Dyrex Technologies); tetramethyl benzidine (TMB) tablets (Sigma).
17. 1 M H₂SO₄.

3. Methods

3.1. Selection on Immunotubes

3.1.1. Round 1

1. Coat an immunotube with 4 mL 10–100 µg/mL hapten conjugate 1 in PBS overnight at 4°C (*see Note 4*).
2. Discard the contents of the tube, and wash 3× with PBS (pour in and immediately pour out).
3. Block the tube with 4 mL 2% PBBSM at room temperature for 1–2 h.
4. Wash as in **step 2**.
5. Add approx 10¹² cfu phage library (*see Note 5*) in 4 mL 2% PBBSM and incubate at room temperature by tumbling on an over-under turntable for 30 min, followed by 90 min without tumbling (*see Note 6*).
6. Discard the phage solution (*see Note 7*) and wash the tube 10× with PBST, followed by 10× with PBS as in **step 2**. Shake out any remaining wash buffer. (For subsequent rounds, wash at least 20× with each of PBST and PBS).
7. Elute the bound phage (*see Subheading 3.2.*).

3.1.2. Further Rounds of Selection

1. For the second round, repeat **Subheading 3.1.1.** with the following modification: at **step 1**, coat the immunotube with hapten conjugate 2 at 10 µg/mL.
2. For subsequent rounds, revert to coating with hapten conjugate 1 at 1 µg/mL (*see Note 8*).

3.2. Elution of Bound Phage

The panning strategy employed and the elution steps, in particular, are critical to the isolation of Abs with high affinity for hapten Ags. The approaches used vary with the different stages of selection and are covered under separate subheadings.

3.2.1. Elution with Triethylamine (Rounds 1 and 2)

1. From a fresh overnight culture of *E. coli* TG1 cells in 2TY broth (no antibiotics or glucose), make a 1:100 dilution in fresh media and grow, shaking at 37°C, to optical density 600 nm (OD₆₀₀) 0.4–0.5 (1–2 h) (*see Note 9*).

2. Add 1 mL 100 mM TEA to the immunotube and incubate with tumbling for 10 min (*see Note 10*).
3. Immediately pour the contents of the immunotube into 500 μ L of 1 M Tris-HCl (pH 7.4) to neutralize the pH.
4. Add one-half (0.75 mL) of the eluted phage to 5.25 mL log-phase TG1 cells (from **step 1**). Add a further 4 mL log-phase TG1 cells to the immunotube. Incubate both for 30 min without shaking in a 37°C water bath.
5. Pool the cells, and prepare 4–5 serial 10-fold dilutions (100 μ L in 900 μ L 2TY). Plate 100 μ L of each dilution on TYE–AMP–GLU plates and incubate overnight at 30°C to titer the number of infective phage eluted (*see Note 11*).
6. Centrifuge the remaining cells at 3000g for 10 min at 4°C, resuspend in 1 mL fresh media, then spread over a large-diameter TYE–AMP–GLU plate, and incubate at 30°C overnight.
7. Rescue the phage for use in round 2 as detailed in **Subheading 3.3**.

3.2.2. Elution with Trypsin (Rounds 1 and 2 if Using KM13 Helper Phage)

1. To the washed immunotube (*see Subheading 3.1.1., step 6*) add 500 μ L trypsin–PBS, and rotate on an over-under turntable for 10 min at room temperature (*see Note 12*).
2. Add 250 μ L eluted phage to 9.75 mL log-phase TG1 cells (store the remaining 250 μ L at 4°C). Incubate for 30 min at 37°C in a water bath.
3. Use 100 μ L infected cells to prepare 4–5 serial 10-fold dilutions. Spread these on TYE–AMP–GLU plates and incubate overnight at 30°C, to titer the eluted phage.
4. Centrifuge the remaining cells at 3000g for 10 min at 4°C, then resuspend in 1 mL fresh media, spread over a large-diameter TYE–AMP–GLU plate, and incubate at 30°C overnight.
5. Rescue the phage as detailed in **Subheading 3.3**.

3.2.3. Elution with Free Ag (Round 3 Onwards)

1. Add 4 mL 10 μ M solution (*see Note 13*) of free Ag (hapten) in PBS to the immunotube and incubate on an over–under turntable for 1 h (*see Note 14*).
2. Pour out the contents of the immunotube (DO NOT DISCARD) (*see Note 15*). Add one-half of the eluted phage to 8 mL log-phase TG1 cells (the remaining 2 mL should be stored at 4°C) and incubate without shaking in a 37°C water bath for 30 min.
3. Prepare serial 10-fold dilutions (100 μ L in 900 μ L 2TY). Plate 100 μ L of each dilution on TYE–AMP–GLU plates and incubate overnight at 30°C to titer the number of infective phage eluted.
4. Centrifuge the remaining cells at 3000g for 10 min at 4°C, resuspend in 1 mL of media, then spread over a large-diameter TYE–AMP–GLU plate, and incubate at 30°C overnight.

5. Rescue phage as detailed in **Subheading 3.3**.
6. For subsequent rounds, reduce the concentration of free Ag used to elute the phage by 100–1000-fold for each successive round (*see* **Notes 16** and **17**).

3.3. Rescue of Enriched Phage Abs

1. Add 2–3 mL 2TY–15% glycerol to the agar plate and scrape off the cells with a glass spreader. Inoculate 50–100 μ L cell suspension into 100 mL 2TY–100 μ g/mL ampicillin/1% glucose (2TY–AMP–GLU) and check that OD₆₀₀ nm is \leq 0.1. Incubate at 37°C with shaking until the OD₆₀₀ reaches 0.4–0.5. Store the remaining glycerol stock in aliquots at –70°C.
2. To 10 mL culture, add a 20-fold excess of helper phage (*see* **Note 18**) and incubate without shaking in a 37°C water bath for 30 min.
3. Spin the infected cells at 3000g for 10 min and resuspend the cell pellet in 50 mL 2TY–100 μ g/mL ampicillin/50 μ g/mL kanamycin (2TY–AMP–KAN). Incubate at 30°C with shaking overnight.
4. Spin the cells at 10,000g for 10 min (or 3000g for 30 min).
5. Add one-fifth vol (10 mL) PEG–NaCl to the supernatant, briefly mix by vortexing, and leave on ice for at least 1 h.
6. Spin at 10,000g for 10 min and pour off the supernatant. Respin briefly and remove any remaining supernatant by pipeting or aspiration.
7. Resuspend the pellet in 2 mL PBS and spin at maximum speed for 10 min, to remove any remaining bacterial debris. Use 1 mL phage suspension for the next round of selection. Add glycerol (15%) to the remaining aliquot and store at –70°C.

3.4. Screening Phage Abs by ELISA

3.4.1. Polyclonal Phage ELISA

1. Coat duplicate wells of a 96-well ELISA plate with 100 μ L hapten conjugate 1 and with each hapten carrier protein alone at 1 μ g/mL in the same buffer as used for panning. Incubate the plates overnight at 4°C (*see* **Note 19**).
2. Wash the plate 3 \times with PBS by filling the wells using a multichannel pipet or squeeze bottle, inverting the plate, and shaking. Residual wash buffer can be removed by patting the plate onto paper towels.
3. Block the wells with 200 μ L/well 2% PBSM at 37°C for 1–2 h, then wash 3 \times with PBS as in **step 3**.
4. Dilute 10 μ L PEG-precipitated phage from the end of each round of selection and from the initial library rescue in 100 μ L 2% PBSM and incubate for 1 h at room temperature. Include wells that contains PBSM only.
5. Discard the phage solution (*see* **Note 7**) and wash the plate 3 \times with PBST.
6. Add 100 μ L/well 1:5000 dilution of horseradish peroxidase (HRP)–anti-M13 Ab in 2% PBSM and incubate for 1 h at room temperature.
7. Wash the wells 3 \times with PBST, then 3 \times with PBS.

8. Add 100 μL /well TMB solution (*see Note 20*) and incubate at room temperature until a blue color develops (2–20 min or until color appears in the control [no phage] wells).
9. Stop the reaction by adding 50 μL 1 M H_2SO_4 (the blue color will turn yellow). Using a plate reader, measure the OD at 450 nm and 650 nm. Subtract OD_{650} from OD_{450} , to determine the reading for each well.

3.4.2. Monoclonal Phage ELISA

1. Inoculate individual colonies from the plates generated by the titration of eluted phage (*see Subheading 3.2.*) into 100 μL 2TY–AMP–GLU in 96-well tissue culture plates and incubate with shaking (250 rpm) at 37°C overnight (*see Note 21*).
2. Using a multichannel (96-well) pipeting device, inoculate a second replicate 96-well plate containing 175 μL /well 2TY–AMP–GLU with 25 μL overnight culture, then touch the pipet tips to the surface of a large-diameter TYE–AMP–GLU agar plate (*see Note 22*). Incubate the 96-well plate at 37°C with shaking (250 rpm) for 2 h, then proceed to **step 3**. Incubate the agar plate at 30°C overnight. Add glycerol to the first 96-well plate (overnight culture) to a final concentration of 15% and store at –70°C.
3. Add 25 μL 2TY–AMP–GLU containing 10^9 helper phage to each well and incubate for 30 min at 37°C without shaking followed by 30 min with shaking (250 rpm).
4. Spin at 1800g for 15 min, then aspirate off the supernatant and discard.
5. Resuspend the pellet in 200 μL 2TY–AMP–KAN and incubate with shaking (250 rpm) overnight at 30°C.
6. Coat three 96-well ELISA plates overnight at 4°C with 100 μL /well Ag as follows: plates 1 and 2, hapten conjugate 1; plate 3, carrier protein 1. Wash and block the plates as in **Subheading 3.4.1., steps 2 and 3**.
7. Add 50 μL /well 4% PBSM to plates 1 and 3 and 50 μL 4% PBSM containing 1–10 μM free hapten to plate 2. Spin the plates from **step 5** at 1800g for 15 min. Add 50 μL /well of the phage supernatant to each plate and incubate for 1 h at room temperature.
8. Continue the ELISA as detailed in **Subheading 3.4.1., steps 5–9**.
9. Select those clones for further analysis that bind to plate 1, do not bind to plate 3, and do not bind or give reduced signals to plate 2 (*see Note 23*).

3.5. Competitive Inhibition ELISA

Competition ELISA is best performed with soluble Ab fragments (*see Notes 24 and 25*).

3.5.1. Indirect Competition ELISA

1. Coat a 96-well ELISA plate with 100 μL /well of hapten conjugate 1 at 1 $\mu\text{g}/\text{mL}$.
2. Wash the plate 3 \times with PBS.

3. Block the wells with 200 μL /well 2% PBSM at 37°C for 1–2 h (*see Note 26*) and wash 3 \times with PBS.
4. Prepare serial (2- or 4-fold) dilutions of free Ag (hapten) in PBS in microcentrifuge tubes, including a tube with PBS only. Add an equal volume of the Ab fragment to a final subsaturating concentration (*see Note 27*) and incubate at 4°C for 1 h.
5. Apply 100 μL of the Ab–Ag solution to replicate wells of the blocked plate and incubate at room temperature for 1 h. Wash the plate 3 \times with PBST.
6. Continue the ELISA as before (**Subheading 3.4.1., steps 6–9**) using a suitable labeled secondary reagent diluted in PBST (*see Note 28*).
7. Plot the signal generated for each concentration of free Ag as a percentage of that obtained without free Ag against free Ag concentration and determine the concentration that reduces the signal by 50% (IC_{50}) (*see Fig. 3*).

3.5.2. Direct Competition ELISA

1. Coat a 96-well ELISA plate with 100 μL /well anti-affinity tag Ab (Protein A or Protein L can be used as a alternative).
2. Wash the wells 3 \times with PBS, block with PBSM, then wash 3 \times with PBS, as mentioned previously.
3. Prepare serial (2- or 4-fold) dilutions of free Ag in PBS. Include a tube without free Ag. Add each dilution to tubes containing a constant concentration of enzyme labeled (usually alkaline phosphatase) Ag (*see Note 29*).
4. Add an equal volume of soluble Ab fragment to the predetermined final subsaturating concentration and incubate at 4°C for 1 h.
5. Add 100 μL of the Ab–Ag solution to replicate wells of the blocked plate and incubate at room temperature for 1 h.
6. Develop the ELISA with pNPP substrate according to the manufacturer's instructions and measure the optical density at 405 nm and 650 nm. Subtract the OD_{650} from OD_{405} to determine the reading for each well.
7. Plot a curve as in **Subheading 3.5.1., step 7** (*see Fig. 3*).

4. Notes

1. For the isolation of hapten-specific Abs, a library based on a phagemid system is preferable to one using an entire functional phage genome. Phagemid vectors allow expression of a single Ab fragment per virus particle and so avoid problems associated with avidity effects, which are encountered with multivalent display. The protocols in this chapter are based on a phagemid expression system that encodes ampicillin resistance.
2. Prepare two hapten conjugates for panning (hapten conjugate 1, hapten conjugate 2) using two different carrier proteins, which, where applicable, differ from that used for immunization, e.g., bovine serum albumin, keyhole limpet hemocyanin (KLH), and bovine thyroglobulin. These should be purified if possible, for example, by high-performance liquid chromatography to avoid the selection of Ab against protein contaminants common to both preparations.

3. There are several strains of helper phage available, e.g., VCSM13 (Stratagene), M13KO7 (Pharmacia), and KM13 (MRC, Cambridge, UK). KM13 differs in that it includes a trypsin-cleavage site within the minor coat protein (*gIII*). Therefore, bound phage Abs can be eluted by incubation with 500 μ L trypsin solution (1 mg/mL in PBS) for 10 min at room temperature. Only those phage that include a displayed Ab fragment fused to the noncleavable product of *gIII*, will be infective, so reducing the background of nonspecific binders carried through to subsequent rounds. All of the helper phage above encode a selectable kanamycin resistance gene.
4. It is important to recover as many different clones as possible that recognize the target Ag from the library in the first round of selection so a high concentration of coating Ag is used. The incubation temperature and buffering solution may need to be altered for different carrier proteins. The conditions given are suitable for BSA and KLH conjugates.
5. The number of phage applied to the immunotube is particularly important during the first round of selection. Aim to include $\sim 10^3$ – 10^4 copies of each clone represented (10^3 – $10^4 \times$ library size); however, consideration should be given to the size of the library and the number of hapten molecules conjugated to the carrier protein. An excessive number of phage from a library of limited diversity and a low coating Ag density may lead to exclusion of all but those clones with a high affinity for the hapten conjugate.
6. In order to reduce the number of phage selected against the carrier proteins, each protein used can be added to the immunotube during the phage-binding step at final concentrations of 1 mg/mL. If using an immune library, the immunizing carrier protein can also be included.
7. Dispose of solutions containing unwanted phage directly into a viracidal solution, such as Virkon to prevent accidental infection of TG1 cells during later stages.
8. Alternation of the carrier protein during the initial rounds of selection is necessary to remove phage that bind to the carrier. It is not necessary to continue alternating beyond round 3.
9. Efficient infection of *E. coli* cells by phage is dependant on cells being in log phase (OD_{600} 0.4–0.5). Cells can be kept on ice for up to 30 min before infection, if necessary, but procedures should be timed to avoid this if possible.
10. TEA is destructive to phage and incubation should not exceed 10 min.
11. The number of phage recovered will vary with the stage of the selection process and the library used. When using a library of good size, i.e., $>10^8$ clones, and particularly when using an immune library, expect to get at least 10^4 phage back after the first round of panning. Naïve libraries and those of smaller size will yield less. The first round of selection is the most important and errors made here will be amplified during later rounds. If less than 1000 phage are recovered, repeat the infection and rescue (*see Subheading 3.2.1., steps 4–7*) using the remaining 0.75 mL eluted phage. If a similar recovery is seen, check that the Ag is coating efficiently under the conditions used and alter conditions if necessary. Store titration plates containing colonies for later monoclonal analysis.

12. By reducing the carry-through of nonspecific phage, the use of trypsin as a means of eluting bound phage increases the rate of enrichment of Ag-specific clones (5).
13. For the first round of free Ag elution, a high concentration of free Ag is used in order to recover as many different phage Abs as possible from the immobilized population, which are able to recognize soluble Ag. The concentration used may be restricted by the solubility of the Ag in aqueous solution. If the Ag is particularly insoluble in H₂O, then methanol up to 10% (v/v) can be used without any significant effect on Ab binding.
14. The incubation time with free Ag can be varied and consideration should be given to the effects of this. The Ab–Ag interaction is a dynamic process with ligand and analyte continually dissociating and reassociating. In the absence of free Ag, a large number of phage Abs will be found in the liquid phase at any time. Excessive incubation times will increase the number of clones displaying Abs with high affinities for the hapten conjugate, which are carried through to the next round. Shorter times may help to select clones with a rapid dissociation rate from the hapten conjugate, but incubations of less than 30 min are not recommended.
15. If using the KM13 helper phage, then nondisplaying background phage can be reduced at this stage by adding 50 μ L trypsin stock to the eluted phage and incubating at room temperature for 10 min prior to infection.
16. Reducing the concentration of free Ag used to elute bound phage with successive rounds can help to select those Abs with the highest affinities for the native Ag. Care should be taken not to use too low a concentration.
17. The number of phage recovered from each round by elution with free Ag may only increase slowly (if at all) when the concentration of free Ag is progressively reduced. If numbers fall significantly, rescue the remaining stored eluted phage or repeat the round of selection.
18. An OD₆₀₀ of 1.0 = approx 8×10^8 *E. coli*/mL.
19. All Ag-coating and blocking steps can be carried out at 37°C for 1–2 h or overnight at 4°C.
20. If not available, TMB tablets are available from Sigma. 30% H₂O₂ and citric phosphate buffer will be required. Dissolve 2.55 g citric acid and 3.545 g NaH₂PO₄ in 400 mL of H₂O. Adjust the pH to 5.0 with 5 M NaOH, add H₂O to 500 mL, and autoclave. This substrate is generally slower to develop color and gives lower OD₄₅₀ readings, but is otherwise suitable.
21. Place the plate into a suitable container and surround with damp paper towels to prevent evaporation.
22. It is convenient to inoculate an agar plate with phage clones for further analysis to prevent repeated thawing of the glycerol stock.
23. The signal generated from plate 1 results from a combination of the binding kinetics of the Ab and the expression level of the phage–Ab clone. High signals do not necessarily indicate the best diagnostic clone. Similarly, a low % reduction of signal on plate 2, relative to plate 1, may result from the presence of a saturating

concentration of phage regarding the coating Ag. Select several clones displaying a range of apparent free Ag binding for more detailed analysis.

24. Most commonly used phagemid vectors, e.g., pHEN and pCANTAB, allow for the expression of soluble Ab fragments by including a *lac* promoter and an amber (TAG) stop codon between the Ab genes and the *gIII* minor coat protein gene. Infection of phage Abs into a nonsuppressor strain of *E. coli*, such as HB2151, permits the induction of Ab expression with 1 mM isopropyl- β -thiogalactopyranoside (IPTG). When using a synthetic or semisynthetic library, ensure that the coding variability does not allow for the inclusion of TAG codons within the variable region genes. When this is the case, TG1 cells can also be induced with IPTG. However, the amber codon between the scFv and *gIII* will also be suppressed, leading to expression of both scFv and scFv-pIII fusions. Ideally scFv genes should be cloned into a dedicated soluble expression vector, e.g., pIMS147 (6). Amber codons, where present, can be altered to GAG (glutamate) by site-directed mutagenesis.
25. Soluble Ab fragments should be purified for use in ELISAs, for example, by Protein-A or Protein-L affinity column or by immobilized metal affinity chromatography if the construct includes a histidine tag. Crude culture supernatants or periplasmic extracts can be used, but it is possible that contaminating proteins may influence the results.
26. For assays using soluble Ab fragments, 3% BSA in PBS can be used as an alternative blocking agent when high-background binding of enzyme-labeled secondary Ab is experienced.
27. Prepare a binding profile of a range of serial dilutions of soluble Ab fragment to 1 μ g/mL hapten-conjugate coating concentration. Select a concentration of Ab fragment that lies on the linear portion of the sigmoidal curve and gives a suitable ELISA signal, i.e., >0.5 absorbance.
28. Most phagemid/soluble expression vectors include a tag 3' of the Ab fragment for purification/detection purposes. Suitable detection reagents include an HRP-labeled Ab to the affinity tag or either Protein A-HRP or Protein L-HRP, if this is not available. Weak signals can be amplified by using an unlabeled anti-affinity tag secondary Ab in a sandwich ELISA format and detecting with an enzyme-labeled anti-species Ab.
29. Empirically determine the optimum concentrations of Ab fragment and enzyme-labeled Ag. Ab fragment should be subsaturating regarding the immobilized capture Ab (*see Subheading 3.5.2., step 1*) and labeled Ag (just) subsaturating regarding the captured Ab fragment.

Acknowledgments

Data included in this manuscript is drawn from research funded by the Biotechnology and Biological Sciences Research Council, UK.

References

1. Goodrow, M. H., Harrison, R. O., and Hammock, B. D. (1990) Hapten synthesis, antibody development, and competitive inhibition enzyme immunoassay for s-triazine herbicides. *J. Agric. Food Chem.* **38**, 990–996.
2. Karu, A. E., Goodrow, M. H., Schmidt, D. J., Hammock, B. D., and Bigelow, M. W. (1994) Synthesis of haptens and derivation of monoclonal antibodies for immunoassay of the phenylurea herbicide diuron. *J. Agric. Food Chem.* **42**, 301–309.
3. Tuomola, M., Harpio, R., Mikola, H., Knuuttila, P., Lindström, M., Mukkala, V.-M., Matikainen, M.-T., and Lövgren, T. (2000) Production and characterization of monoclonal antibodies against a very small hapten, 3-methylindole. *J. Immunol. Meth.* **240**, 111–124.
4. Li, Y., Cockburn, W., Kilpatrick, J. B., and Whitelam, G. C. (2000) High affinity ScFvs from a single rabbit immunized with multiple haptens. *Biochem. Biophys. Res. Commun.* **268**, 398–404.
5. Kristensen, P. and Winter, G. (1998) Proteolytic selection for protein folding using filamentous bacteriophages. *Folding Design* **3**, 321–328.
6. Hayhurst, A. and Harris, W. J. (1999) *Escherichia coli* Skp chaperone co-expression improves solubility and phage display of single chain antibody fragments. *Protein Exp. Purif.* **15**, 336–343.

Blocking Immunodominant Epitopes by Competitive Deselection

Roberto Burioni

1. Introduction

The development of combinatorial antibody (Ab) libraries displayed on the surface of phage has led to the production of a wide range of human monoclonal antibodies (MAbs) against a plethora of viral antigens (Ag) (1–5). However, sometimes the isolation of a given Ab can be particularly difficult because of the predominance of some epitopes, and, in the case of impure Ags, because the protein or compound of interest is present in a low amount. Many techniques have been developed for overcoming this problem, including epitope-masking (6) or sandwich-capture (7) procedures. These approaches require a MAb against the Ab or epitope of interest, which is not always available. In this chapter, a new procedure of preadsorption panning is described, which facilitates the molecular cloning of MAb fragments against nonimmunodominant Ag determinants using phage-display immunoselection. The procedure, called competitive deselection, is easy, fast, inexpensive, and can be coupled with other described panning techniques; however, its chief advantage is in the isolation of Abs against less-represented Ag determinants.

The procedure described in this chapter also increases the efficiency of cloning Abs of rare specificities. In our hands we have successfully isolated human recombinant Fabs from phage display libraries able to distinguish herpes simplex virus type 1 from type 2 in immunofluorescence assays (8). We have also been able to increase the efficiency of selection of anti-idiotypic mouse monoclonal Fabs bearing the internal image of the template Ag (Burioni, R., in press).

The protocol is a modification of a standard panning protocol, except that the phage library is first preabsorbed on the Ag of interest to remove phage that react with the immunodominant epitope. The unbound phage are then incubated a second time with Ag and eluted and amplified according to normal protocols. One caveat that must be kept in mind when using this approach is that, as shown clearly by our results (8), the subtraction of unwanted clones is only partial and should be considered as a negative enrichment rather than a complete subtraction. Subtracted clones are always present at the end of the panning procedure, but their frequency is lower than that obtained with an unmodified panning procedure, which appears to leave room for rare clones to be selected and analyzed. Therefore, this limitation does not appear to affect the success of the technique.

2. Materials

1. Ab phage library, freshly amplified according to standard protocols, resuspended in phosphate-buffered saline (PBS)–1% (w/v) bovine serum albumin (BSA), and titered (colony-forming units [cfu]/mL) (*see* **Notes 1** and **2**).
2. PBS or 0.1 M carbonate buffer, pH 8.6: for 1 L, dissolve 8.4 g NaHCO₃ in H₂O, adjust the pH to 8.6, then filter, and store at 4°C.
3. Ag of interest, diluted in PBS or 0.1 M carbonate buffer (*see* **Note 3**).
4. PBS–1% BSA; PBS–0.5% (v/v) Tween-20.
5. Elution buffer: for 200 mL, add 1.6 mL 12 M HCl to H₂O and adjust to pH 2.2 with solid glycine. Autoclave and store at room temperature.
6. 2 M Tris-HCl base.
7. *Escherichia coli* strain XL1 Blue; VCSM13 helper phage (Stratagene).
8. Superbroth medium (SB), variably containing antibiotics at the following final concentrations: tetracycline (10 µg/mL); carbenicillin (20 µg/mL in low-carbenicillin SB; 50 µg/mL in high-carbenicillin SB); kanamycin (70 µg/mL).
9. Luria-Bertani agar plates containing 100 µg/mL carbenicillin.
10. Polyethylene glycol (PEG)–NaCl: 20% (w/v) PEG-8000, 2.5 M NaCl. Autoclave and store at room temperature.
11. Enzyme-linked immunosorbant assay (ELISA) plates (half area, high-affinity binding: Costar cat. no. 3690); Oak Ridge centrifuge tubes (Sigma, St. Louis, MO).

3. Methods

1. Coat ELISA plate wells with the appropriate amount of Ag in each well (*see* **Note 4**). Coat both the adsorption and panning plate at the same time. For the adsorption plate, coat at least 10 wells for each phage selection. For the first round of panning, coat four wells; for the following rounds, coat two wells/phage selection.
2. Incubate the sealed plate at 4°C overnight.

3. Wash both plates 5× with dH₂O (100 μL/well), then blot dry on paper towel. Block both plates with 150 μL/well PBS–1% BSA for 2 h at 37°C. Do not let the plates dry out (*see Note 5*).
4. Inoculate a single fresh colony of *Escherichia coli* XL1 Blue into 15 mL SB–tetracycline in a 50-mL tube. Grow at 37°C in a rotatory shaker. Start the culture in time to have a exponential growth culture (OD₆₀₀ = 0.6) for infection at **step 9** (*see Note 6*).
5. Remove the block solution from the wells of the adsorption plate with a pipet and add 20 μL (>10¹⁰ cfu) of freshly amplified library phage to each of the 10 wells (*see Note 7*). Seal the plate and incubate at 37°C for 2 h (*see Note 8*).
6. Carefully remove 15 μL phage from each well of the adsorption plate and combine in a 0.5-mL microcentrifuge tube and keep on ice. Remove the blocking solution from the panning plate and immediately add 25–35 μL combined adsorbed phage to each well for the first round of panning (using four wells) or 50–70 μL phage for subsequent panning rounds (two panning wells). Seal the plate and incubate for an further 2 h at 37°C.
7. Wash the wells 10× with PBS–0.5% Tween-20 by adding 100 μL/well incubating for 5 min, then discarding (*see Note 9*). Use barrier tips to avoid contamination.
8. Elute the phages bearing specific Abs by adding 50 μL elution buffer/well and incubating at room temperature for 3 min. Remove the elution buffer into a microcentrifuge tube and neutralize immediately by adding 3 μL 2 M Tris-HCl per 50 μL elution buffer.
9. Add the eluted phage to 2 mL exponential growth-phase *E. coli* XL1 Blue and incubate for 15 min at 37°C.
10. Add 10 mL prewarmed SB–low carbenicillin + tetracycline to the 2 mL infected cells. Plate 10-, 1-, and 0.1-μL aliquots of the infected cell suspension on Luria-Bertani–CARB plates and incubate overnight at 37°C. Calculate the approximate number of eluted phages from the number of colonies. Incubate the remaining cell suspension for 1 h at 37°C in a shaker.
11. Add 100 mL prewarmed SB (high carbenicillin + tetracycline) and incubate for 1 h at 37°C in a shaker.
12. Add 10¹² pfu helper phage VCSM13. Incubate at 37°C in a shaker for a further 2 h.
13. Add kanamycin to a final concentration of 70 μg/mL and incubate the culture overnight at 30°C in a shaker.
14. Centrifuge the cultures at 2000g for 10 min at room temperature.
15. Precipitate the phage from the resulting supernatant by adding 7 mL PEG–NaCl solution to 30 mL supernatant in Oak Ridge tubes. Incubate on ice for 30 min.
16. Centrifuge at 15,000g for 20 min at 4°C and discard the supernatant. Let the tubes dry upside down on paper towel for 2–4 min.
17. Carefully resuspend the phage pellet in 1 mL PBS–1% BSA per tube. Be careful to also resuspend the pellet that usually forms on the wall of the tube. Transfer

the suspension to a microcentrifuge tube and mix the tube by inverting several times (do not vortex).

18. Centrifuge at 10,000g for 15 min at 4°C, then transfer the supernatant into a clean microcentrifuge tube.
19. Use this phage suspension to perform further rounds of panning (*see Note 10*), or once several rounds have been completed, for the infection of *E. coli* for the subsequent production of soluble Fab (**9**).

4. Notes

1. This protocol uses a Fab library constructed in pComb3 or its derivatives. The use of alternative expression systems may require a modification to the antibiotic selection used in the amplification of eluted phage.
2. The phage library, or subsequently selected phage, need to be freshly amplified for each panning cycle. Although phage molecules themselves are stable and can be stored for years at -70°C without losing infectivity, displayed Ab molecules on the surface are not stable. Panning of a stored phage preparation can yield unpredictable results.
3. Optimal conditions for binding, including temperature of binding and coating buffer, need to be determined experimentally for each individual Ag. Most proteins bind well in PBS or in 0.1 M carbonate buffer. Do not reuse the plates. Use a fresh plate for each round of panning and a (fresh) different one for adsorption each time. The best results are obtained using plates freshly coated with Ag.
4. As a rule, dilute the Ag to a concentration 5× greater than that used in ELISA for detection of Abs. If this ELISA concentration is not known, use 500 ng/well Ag for panning and 100 ng/well for ELISA. This concentration is usually suitable for the isolation of Ab-bearing phages. The volume in which the Ag is added can range from 25 to 50 µL.
5. Proper blocking of the wells is crucial. The procedure must be performed simultaneously for both the adsorption and panning plate. Do not let the wells dry out at any stage.
6. Infection of bacteria is a critical step. It is important that the OD of the *E. coli* culture is approximately that indicated (i.e., exponential growth) in order to obtain maximal infection. Do not dilute the bacterial culture to obtain the correct OD, but schedule the time of inoculation of the culture appropriately.
7. The amount of starting phage is critical. A low phage titer (<10¹¹ cfu/mL) usually results in an unsuccessful subtraction experiment. The first round of panning is crucial for a successful selection.
8. Subtraction is not as efficient as selection. For this reason, it is necessary to use a higher number of wells (10) for adsorption than used for panning (four in the first round, two in subsequent rounds). In the case of an over-representation of dominant clones, the number of adsorption wells can be doubled, while trying to keep to a minimum the total volume of phage. An alternative or additional procedure is to increase the adsorption time. If this is shown to be required,

subtract for 5 h at 4°C using the same procedure. Do not incubate more than overnight at 4°C (although this is rarely needed).

9. Check that the washing conditions used in panning do not detach bound Ag from the surface of the plate. To exclude this possibility, coat an ELISA plate with Ag, wash using the same conditions used for panning, then use the plate for an ELISA using an Ab known to react with Ag.
10. Do not perform more than five rounds of panning. After this point, a dominant (and often unwanted) clone will emerge. Usually, the fourth and fifth rounds are the best source for clonal diversity.

References

1. Burton, D. R., Barbas, C. F., Persson, M. A., Koenig, S., Chanock, R. M., and Lerner, R. A. (1991) A large array of human monoclonal antibodies to type 1 human immunodeficiency virus from combinatorial libraries of asymptomatic seropositive individuals. *Proc. Natl. Acad. Sci. USA* **88**, 10,134–10,137.
2. Burioni, R., Plaisant, P., Manzin, A., Rosa, D., Delli Carri, V., Bugli, F., et al. (1998) Dissection of human humoral immune response against hepatitis C virus E2 glycoprotein by repertoire cloning and generation of recombinant Fab fragments. *Hepatology* **28**, 810–814.
3. Burioni, R., Williamson, R. A., Sanna, P. P., Bloom, F. E., and Burton, D. R. (1994) Recombinant human Fab to glycoprotein D neutralizes infectivity and prevents cell-to-cell transmission of herpes simplex viruses 1 and 2 in vitro. *Proc. Natl. Acad. Sci. USA* **91**, 355–359.
4. Plaisant, P., Burioni, R., Manzin, A., Solforosi, L., Candela, M., Gabrielli, A., Fadda, G., and Clementi, M. (1997) Human monoclonal recombinant Fabs specific for HCV antigens obtained by repertoire cloning in phage display combinatorial vectors. *Res. Virol.* **148**, 165–169.
5. Williamson, R. A., Burioni, R., Sanna, P. P., Partridge, L. J., Barbas, C. F., and Burton, D. R. (1993) Human monoclonal antibodies against a plethora of viral pathogens from single combinatorial libraries. *Proc. Natl. Acad. Sci. USA* **90**, 4141–4145.
6. Ditzel, H. J., Binley, J. M., Moore, J. P., Sodroski, J., Sullivan, N., Sawyer, L. S., et al. (1995) Neutralizing recombinant human antibodies to a conformational V2- and CD4-binding site-sensitive epitope of HIV-1 gp120 isolated by using an epitope-masking procedure. *J. Immunol.* **154**, 893–906.
7. Sanna, P. P., Williamson, R. A., De Logu, A., Bloom F. E., and Burton D. R. (1995) Directed selection of recombinant human monoclonal antibodies to herpes simplex virus glycoproteins from phage display libraries. *Proc. Natl. Acad. Sci. USA* **92**, 6439–6443.
8. Burioni, R., Plaisant, P., Bugli, F., Solforosi, L., Delli Carri, V., Varaldo, P. E., and Fadda, G. (1998) A new subtraction technique for molecular cloning of rare antiviral antibody specificities from phage display libraries. *Res. Virol.* **149**, 327–330.
9. Burioni, R., Plaisant, P., Bugli, F., Delli Carri, V., Clementi, M., and Fadda, G. (1998) A vector for the expression of recombinant monoclonal Fab fragments in bacteria. *J. Immunol. Meth.* **217**, 195–199.

Rescue of a Broader Range of Antibody Specificities Using an Epitope-Masking Strategy

Henrik J. Ditzel

1. Introduction

The use of combinatorial libraries displayed on the surface of filamentous bacteriophage offers an efficient route to obtain a diverse set of monoclonal antibodies (MAbs) with desired specificity (1,2). However, following selection of such libraries, certain epitope specificities may dominate the cloned Abs because, for example, the epitope is immunodominant or because Abs to that epitope have a selective advantage in the panning process arising from a higher affinity. Although these attributes may be desirable, other selection conditions are required to recover Abs with different characteristics. In this chapter, an epitope-masking strategy is described by which Abs to an extended range of epitopes can be retrieved from phage-display libraries. The strategy uses antigen (Ag)-specific Fabs or single-chain Abs retrieved by an initial selection of the phage libraries to block the corresponding immunodominant epitope. Reselection of the phage library on the masked Ag refocuses the selection against other epitopes on the Ag (*see Fig. 1*).

One advantage of the epitope-masking approach compared to alternative selection strategies is that it is a self-progressing process that does not require predetermined knowledge about the antigenic sites on the Ag and can be used cumulatively to retrieve Abs recognizing noncompeting epitopes from the same library. On the other hand, prior knowledge of epitopes to be avoided allows use of already existing intact Abs or other proteins that recognize this epitope as masking reagents, thereby avoiding the initial direct selection of the library on the unmasked Ag. Although the focus of this book is Ab phage display, the described epitope-masking approach should be generally applicable to

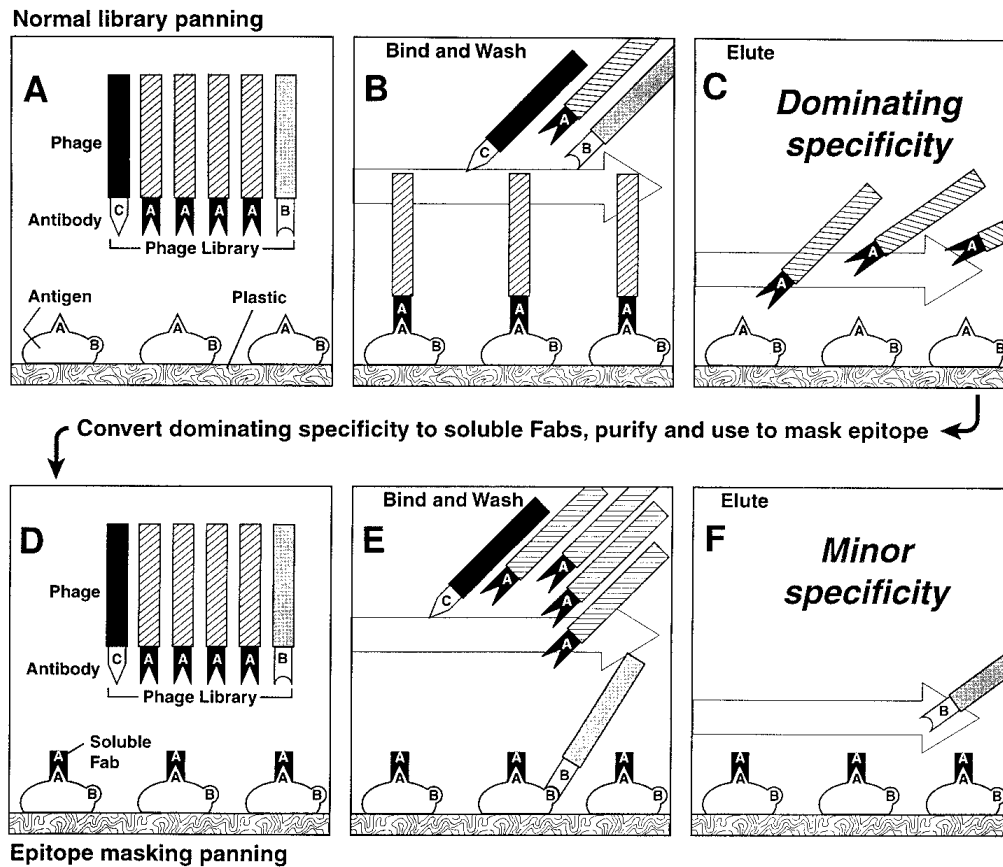

Fig. 1. Library selection using an epitope-masking strategy. The phage-display library is applied to immobilized Ag (A). Following incubation, unbound phage are washed away (B), after which the Ag-specific phage are eluted and amplified (C). If individual clones are present in a high proportion in the library, or particular epitopes on the Ag are more exposed, certain Abs may dominate the selected phage Ab clones. These clones are converted to soluble Ab (Fab) and are used to mask the corresponding epitope(s) on the Ag before the phage-display library is applied to the Ag (D). Since the dominating epitopes are blocked, phage recognizing this site will not bind and are washed away (E). Instead, minor phage specificities may bind to their epitope on the Ag (E). Phage Ab against these minor specificities are then eluted and amplified (F).

selection of diverse sets of specificities from small protein or peptide libraries as well.

The strategy was initially used to successfully clone novel, neutralizing human Ab Fabs directed to a previously undefined conformational epitope on the gp120 surface molecule of human immunodeficiency virus type 1 (HIV-1)

(3). Initial affinity selection of an Ab library, constructed from asymptomatic, long-term HIV-1 seropositive donors against recombinant HIV-1 gp120 (strain LAI), resulted in isolation of a panel of Ab Fabs directed against the CD4 binding site (CD4bs) of gp120 (4,5). Two factors probably contributed to this selection result: first, the immune response in HIV-1-infected patients is strongly directed to this epitope (6), and second, the retrieved Abs were not selected by gp120 from the infecting strain, but rather by that of the divergent strain, LAI. This tends to focus Ab selection onto the CD4bs, but even in hypervariable regions, such as the V2 and V3 loops, some conserved features are found (7,8).

To retrieve Abs against such minor strain-crossreactive specificities from the library, we purified the anti-CD4bs Fabs initially retrieved and added them to the microtiter plate wells coated with HIV-1 gp120, thereby masking their epitopes. After incubation of the two Fabs for 1 h, the Ab library was added to the well and panning was performed. Analysis of the gp120-binding clones, obtained following four rounds of panning (each round with the CD4bs Fabs included for masking), revealed four new unique Ab clones and none of the initial set of Ab Fabs, indicating that the epitope masking was complete.

Three of the four new Fabs recognized a previously undescribed epitope influenced by both the V2 region and the CD4bs of gp120 molecule on HIV-1. Cross-competition experiments revealed that this epitope was distinct from the CD4bs. The last of the four new Fabs was directed against the CD4bs and competed with the masking Abs (3). The reason for the isolation of this Fab was determined by analysis of the affinity of the anti-gp120 clones by plasmon resonance using BIAcore. The anti-CD4bs Fabs, isolated following the epitope-masking, had a 10-fold higher affinity than the blocking Ab. Presumably, the high-affinity Fab was rare in the library or had a growth disadvantage that overrode its selection based on affinity. This represents a novel application of the epitope-masking strategy in that masking a particular site on an Ag led to selection of higher-affinity clones against the epitope-masked epitope. We subsequently used this strategy to improve the affinity of an existing recombinant Ab by mutagenesis (P. W. I. Parren and D. R. Burton, personal communication).

Following an initial report, epitope-masking has been applied with various modifications by us and others (9–13). In the area of Ab phage-display libraries, the strategy was used to retrieve extended panels of mouse Ab Fabs against the prion protein (11,12) and human Abs against respiratory syncytial virus (RSV) (10). In the latter paper, Ping et al. used one of a panel of non-neutralizing anti-RSV human Fabs, obtained from initial direct selection on RSV to mask its corresponding epitope. Subsequent selection was refocused against a second

epitope on RSV, resulting in isolation of a neutralizing anti-RSV Fab (**10**). As an example of the use of the epitope-masking strategy for selection of small-molecule phage libraries, Martin et al. retrieved a minibody with improved antagonistic potency and greater specificity for interleukin-6, following epitope-masking by a MAb with known specificity (**13**).

Cross-contamination between phage-display libraries can complicate retrieval of Abs against a given Ag from libraries constructed from different immune sources. In situations in which such cross-contamination occurs, epitope-masking may be a useful strategy for avoiding retrieval of known contaminating phage/Ab specificities from a new library.

Other approaches have been employed to increase the utility of phage biopanning. For example, Ames et al. (**14**) reported the isolation of Fabs specific for human C5a vs C5, from an immunized mouse library by a combined subtractive and competitive panning scheme. The Ab library was first incubated with immobilized C5 to deplete C5-reactive Fabs. The C5 nonadherent phage were then incubated with immobilized recombinant C5a in the presence of soluble C5 (**14**). Lowman et al. (**15**) described affinity selection of human growth hormone variants by inclusion of these proteins in the elution step, and Meulemans et al. (**16**) reported the isolation of a murine Fab recognizing an epitope cross-competitive with a selected MAb by inclusion of that MAb in the elution buffer.

In summary, the epitope-masking procedure described is a valuable approach by which Abs, small proteins, or peptides reactive against minor epitopes from phage libraries can be accessed. The strategy of masking highly immunogenic epitopes with Abs to rescue a broader range of specific Abs from combinatorial libraries should be widely applicable.

The procedure described below is for the screening of phage Ab libraries in the Fab format, based on phagemid-expression libraries constructed in pComb3 or its derivatives.

2. Materials

1. ELISA plates (Costar 96 wells, flat-bottomed, high-binding polystyrene EIA/RIA plates [cat. no. 3690] Corning, Corning NY) for coating of Ag.
2. 0.1 M Bicarbonate buffer, pH 8.6, or phosphate-buffered saline (PBS).
3. Purified Ag at a coating concentration of 0.5–5 $\mu\text{g}/\text{mL}$ in PBS.
4. Blocking solution: 3 mg/mL bovine serum albumin (BSA) in PBS; or 5 mg/mL nonfat dry milk in PBS; or 0.2% (w/v) gelatin in PBS (type A from porcine skin, Sigma).
5. Affinity-purified masking Ab diluted to 40 $\mu\text{g}/\text{mL}$ in PBS (*see Note 1*).
6. Ab-phage library in PBS–1% BSA, freshly amplified and titered (10^{11} colony-forming units (cfu)/well).

7. PBS–1% (w/v) BSA; PBS–0.05% (v/v) Tween-20.
8. Elution buffer: 0.1 M glycine, pH 2.2, or 0.1 M triethylamine (Sigma), freshly diluted in H₂O.
9. Neutralization buffer: 1 M Tris-HCl, pH 9.0, or 1 M Tris-HCl, pH 7.4.
10. *Escherichia coli* XLI Blue and VCSM13 helper phage (10¹² pfu, Stratagene); 2YT medium and antibiotics for amplification of eluted phage Abs.

3. Methods

1. Coat four microtiter wells overnight at 4°C with 50 µL (0.5 µg/well) Ag in 0.1 M bicarbonate buffer, pH 8.6, or in PBS, pH 7.4.
2. Between 8 and 24 h later, wash the wells by completely filling 3× with PBS and discard. Block the wells by completely filling with block solution (PBS containing 5% dry milk, 3% BSA, or gelatin) for 1 h at 37°C.
3. Discard the block solution and add 50 µL masking Ab Fab to the wells for 1 h at 37°C (see Notes 2–4).
4. Add 50 µL phage library to each well (~10¹¹ cfu/well) and incubate for 2 h. **Do not discard the masking Ab.**
5. Remove the unbound phage by vigorous washing. The wells are completely filled with PBS–0.05% Tween-20 and the solution vigorously pipeted up and down 10×. The washing procedure is repeated 10×.
6. Elute the bound phage with 50 µL of either acid (0.1 M glycine-HCl, pH 2.2) or base (0.1 M triethylamine) for 10 min at room temperature, then pipet the solution up and down, transfer to a tube, and neutralize with 1 M Tris-HCl, pH 9.0, or 1 M Tris-HCl, pH 7.4, respectively (see Note 5).
7. Infect the eluted phage into a freshly exponential growth culture of *E. coli* XL1 Blue and amplify the recombinant phage using VCSM13, according to standard protocols.
8. Repeat the panning procedure, including the masking Ab, 4× before analyzing the binding specificity of phage-bound or soluble Fabs (see Notes 6 and 7).

4. Notes

1. Fabs for epitope masking need to be purified from bacterial supernatants by affinity chromatography (3). Briefly, as an example, 1 L cultures of a recombinant Fab clone in the pComb3 vector and electroporated into *E. coli* XL1 Blue are grown at 37°C in Superbroth containing carbenicillin (50 µg/mL), tetracycline (10 µg/mL) and MgCl₂ (20 mM) with shaking for 6 h. Protein expression in the pComb3 vector (*lacZ* promoter) is then induced with 1 mM isopropyl β-D-thiogalactopyranoside and the cells grown at 30°C overnight. The bacteria are sedimented by centrifugation and the pellet resuspended in PBS–0.2% phenylmethylsulfonyl fluoride and lysed by freeze-thawing 4×, followed by centrifugation for 30 min at 21,000g at 4°C. The bacterial supernatant is applied to an affinity chromatography column consisting of a rabbit anti-human Fab Ab or a rabbit anti-mouse Fab Ab coupled to Protein A Sepharose Fast Flow matrix

(Amersham Pharmacia Biotech, Piscataway, NJ). The column is washed with PBS and the Ab eluted in 0.2 M glycine-HCl buffer, pH 2.2, and immediately brought to neutral pH with 1 M Tris-HCl, pH 9.0.

2. The concentration of the masking Ab depends on the affinity and size of the Ab (Fab vs intact Ab). To be certain that the masking Abs are in excess, we use a concentration of 40 $\mu\text{g}/\text{mL}$ Fab. If an intact mouse MAb is used for masking, the bivalency will increase the avidity of the molecule. However, the molecular size is also 3 \times as large. Therefore, the concentration of the Ab needs to be adjusted accordingly.
3. If the masking is incomplete, meaning that Fabs with the same heavy and light chain sequences as the blocking Ab are retrieved following the masking-panning, the concentration of the masking Ab is too low and should be increased by a factor of approx 5.
4. An alternative approach to the masking strategy is to initially coat the masking Ab onto the ELISA wells, then follow with Ag after an appropriate blocking step. Using this approach, epitope-masking is ensured by the nature of the coating, and, furthermore, nonpurified Ag may be used (9,17). One disadvantage of this "capture" approach is that all the Ags will be oriented in the same manner, which may limit the epitopes exposed to Ab phage particles. The capture approach is described in more detail in Chapter 15 of this book.
5. These are the most commonly used methods for elution of phage and generally give good results, although the optimal elution procedure may vary from Ag to Ag. Some alternative phage-elution procedures have been used, including:
 - a. Washing the bound phage 2 \times with 50 mM Tris-HCl, pH 7.6, 1 M NaCl for 5 min, followed by 2 \times with PBS, pH 7.6. Bound phage are eluted with 0.1 M triethylamine for 15 min and neutralized with 1 M Tris-HCl, pH 7.4.
 - b. Washing for 5 \times 5 min with PBS-0.05% Tween, pH 7.4. Bound phage are eluted with high salt, either Na acetate, pH 2.8, containing 500 mM NaCl or 2.6 M MgCl₂.
 - c. Washing 2 \times for 5 min in Genenase buffer, pH 8.0 (1 M NaCl, 10 mM Tris-HCl, 6 mM CaCl₂, 1 mM EDTA). Bound phage are eluted with 30 $\mu\text{g}/\text{mL}$ Genenase (Genentech, Palo Alto, CA, subtilisin BNPI mutated S24C/H64A/E156S/G169A/Y217L) for 30 min.
 - d. Washing for 2 \times 5 min in Factor Xa buffer, pH 8.0 (100 mM NaCl, 50 mM Tris-HCl, 1 mM CaCl₂). Bound phage are eluted with 100 $\mu\text{g}/\text{mL}$ Factor Xa (New England Biolabs, Beverly, MA) for 2 h.

While the first two alternative elution procedures can be used with any Fab/scFv plasmids vectors system, the latter two require particular vector systems.

6. After four rounds of the panning procedure with the masking Ab, soluble Ab (Fab or scFv) should be obtained for screening of Ab specificity. The manner in which soluble Ab is obtained will depend on the expression vector used.
7. To determine whether the Abs isolated following epitope-masking are directed against novel epitopes on the selection Ag, the Fabs can be labeled with alkaline

phosphatase using the two-step maleimide method or with biotin, and cross-competition experiments performed between the directly labeled and nonlabeled human Fabs for binding to immobilized Ag. For example, in our experiments, a fixed concentration of labeled Fab was used which, in earlier titration experiments, had been determined to give 75% of maximum binding and incubated this with gp120 and unlabeled Fab in twofold dilution steps (0.01–100 µg/mL) in PBS for 2 h. The wells were then washed and bound AP-labeled Fab was detected with NPP substrate.

References

1. Burton, D. R. and Barbas, C.F. (1994) Human antibodies from combinatorial libraries. *Adv. Immunol.* **57**, 191–280.
2. Ditzel, H. J. (1997) Combinatorial libraries: an approach for generating human monoclonal antibodies, in *Immunotechnology* (Gosling, J. P. and Reen, D. J., eds.), Portland, London, UK, pp. 27–38.
3. Ditzel, H. J., Binley, J. M., Moore, J. P., Sodroski, J., Sullivan, N., Sawyer, L. S. W., et al. (1995) Neutralizing recombinant human antibodies to a conformational V2- and CD4-binding site-sensitive epitope of HIV-1 gp120 isolated by using an epitope-masking procedure. *J. Immunol.* **154**, 893–906.
4. Burton, D. R., Barbas, C. F., Persson, M. A. A., Koenig, S., Chanock, R. M., and Lerner, R. A. (1991) A large array of human monoclonal antibodies to type 1 human immunodeficiency virus from combinatorial libraries of asymptomatic seropositive individuals. *Proc. Natl Acad. Sci. USA* **88**, 10,134–10,137.
5. Barbas, C. F., Collet, T. A., Amberg, W., Roben, P., Binley, J. M., Hoekstra, D., et al. (1993) Molecular profile of an antibody response to HIV-1 as probed by combinatorial libraries. *J. Mol. Biol.* **230**, 812–823.
6. Moore, J. P. and Ho, D. D. (1993) Antibodies to discontinuous or conformationally sensitive epitopes on the gp120 glycoprotein of human immunodeficiency virus type 1 are highly prevalent in sera of infected humans. *J. Virol.* **67**, 863–875.
7. LaRosa, C. J., Davide, J. P., Weinhold, K., Waterbury, J. A., Profy, A. T., Lewis, J. A., et al. (1990) Conserved sequence and structural elements in HIV-1 principal neutralizing determinant. *Science* **249**, 932–935.
8. Lamers, S. L., Sleasman, J. W., and Goodenow, M. M. (1996) A model for alignment of Env V1 and V2 hypervariable domains from human and simian immunodeficiency viruses. *AIDS Res. Hum. Retroviruses* **12**, 1169–1178.
9. Ditzel, H. J., Parren, P. W. H. I., Binley, J. M., Sodroski, J., Moore, J. P., Barbas, C. F., and Burton, D. R. (1997) Mapping the protein surface of human immunodeficiency virus type 1 gp120 using human monoclonal antibodies from phage display libraries. *J. Mol. Biol.* **267**, 684–695.
10. Ping, T., Tornetta, M. A., Ames, R. S., Bankosky, B. C., Griego, S., Silverman, C., et al. (1996) Isolation of a neutralizing human RSV antibody from a dominant, non-neutralizing immune repertoire by epitope-blocked planning. *J. Immunol.* **157**, 772–780.

11. Williamson, R. A., Peretz, D., Smorodinsky, N., Bastidas, R., Serban, A., Mehlhorn, I., et al. (1996) Circumventing tolerance in order to generate autologous monoclonal antibodies to the prion protein. *Proc. Natl. Acad. Sci. USA* **93**, 7279–7282.
12. Williamson, R. A., Peretz, D., Pinilla, C., Ball, H., Bastidas, R. B., Rozenshteyn, R., et al. (1998) Mapping the prion protein using recombinant antibodies. *J. Virol.* **72**, 9413–9418.
13. Martin, F., Toniatti, C., Salvati, A. L., Ciliberto, G., Cortese, R., and Sollazzo, M. (1996) Coupling protein design and in vitro selection strategies: improving specificity and affinity of a designed beta-protein IL-6 antagonist. *Mol. Biol.* **255**, 86–97.
14. Ames, R. S., Tornetta, M. A., Jones, C. S., and Tsui, P. (1994) Isolation of neutralizing anti-C5a monoclonal antibodies from a filamentous phage monovalent Fab display library. *J. Immunol.* **152**, 4572–4581.
15. Lowman, H. B., Bass, S. H., Simpson, N., and Wells, J. A. (1991) Selecting high-affinity binding proteins by monovalent phage display. *Am. Chem. Soc.* **30**, 10,832–10,838.
16. Meulemans, E. V., Slobbe, R., Wasterval, P., Ramaekers, F. C. S., and van Eys, G. J. J. M. (1994) Selection of phage-displayed antibodies specific for a cytoskeletal antigen by competitive elution with a monoclonal antibody. *J. Mol. Biol.* **244**, 353–360.
17. Sanna, P. P., Williamson, A., De Logu, A., Bloom, F. E., and Burton, D. R. (1995) Directed selection of recombinant human monoclonal antibodies to HSV glycoproteins from phage display libraries. *Proc. Natl Acad. Sci. USA* **92**, 6439–6443.

Screening of Phage-Expressed Antibody Libraries by Capture Lift

Jeffry D. Watkins

1. Introduction

Cloning and expression of functional antibody fragments (Fabs) in bacteria and on the surface of filamentous phage has revolutionized the processes by which antibodies (Abs) are discovered and engineered. Cloning, expression, and screening efficiencies of phage systems permit the characterization of large numbers of Abs ($>10^6$). For example, using immobilized antigen (Ag), specific Abs can be rapidly enriched from large populations of Fabs displayed on the surface of filamentous phage (*I*). However, the selection methods are typically biased toward the enrichment of the highest affinity Fabs displaying the slowest dissociation rates because of prolonged incubation times and multiple washing steps. Thus, a significant number of unique clones displaying low or intermediate affinities to diverse epitopes may be lost while enriching higher-affinity clones to potentially less interesting dominant epitopes. An optimal screening system would permit the rapid characterization of all clones present in the library.

Phage-expressed libraries of Fabs can be screened by filter lifts probed with Ag without using prior enrichment or selection steps. Screening by filter lift permits the rapid characterization of all clones present in large libraries of Abs ($\sim 10^7$), while allowing the characterization of Ab specificity through the probing of replica lifts with different Ags. Unfortunately, as in enrichment methods, the discovery of lower-affinity Abs that recognize unique epitopes, or of novel Abs to rare Ags present in complex mixtures, requires an assay with greater sensitivity than conventional filter-lift approaches. Moreover, the signal generated by filter-lift screening reflects both the affinity of the

Ab and its expression level, thereby limiting its utility as a screening assay for Ab engineering.

The sensitivity of conventional filter-lift assays is limited, in part, by the binding capacity of the filter. Secreted bacterial proteins compete with Fab expressed in the periplasmic space for binding to the nitrocellulose filters. In a modified form of the filter-lift assay, termed “capture lift,” phage-expressed soluble Fabs are selectively captured on the nitrocellulose, significantly enhancing the signal of the assay (2,3). Briefly, the nitrocellulose filters are coated with an Ab capture reagent, such as a polyclonal anti- κ -chain Ab (for human Fabs) and the remaining protein-binding sites are blocked prior to performing the plaque lift (Fig. 1). The selective binding of phage-expressed Fab, coupled with the reduced binding of unrelated bacterial proteins, enhances the sensitivity of the assay (Fig. 2).

In addition to increasing the sensitivity of the filter-lift assay, the filters can be coated with saturable quantities of capture reagent, resulting in the binding of comparable amounts of different phage-expressed Fabs, regardless of clonal variations in the expression levels. Consequently, subsequent probing of the filter with Ag generates an assay signal that reflects the relative affinity of each Fab, mostly independent of expression levels. Moreover, the capture-lift screen can be used for the rapid one-step identification of higher-affinity Abs present in complex Fab libraries (4,5) by probing the filters with Ag at concentrations below the K_d of the Ab–Ag interaction.

The increased sensitivity and normalization of the amount of Fab bound on the nitrocellulose in the capture-lift assay increases the utility of filter-lift screening, permitting broader applications in both the discovery and engineering of phage-expressed Fabs.

2. Materials

1. Nitrocellulose filters (82 mm, 0.45 μ m pore size).
2. 100-mm plastic Petri dishes.
3. Capture reagent: affinity-purified anti-immunoglobulin (Ig) reactive with the phage-expressed Abs. Dilute to 10 μ g/mL in phosphate-buffered saline (PBS) (see Note 1).
4. Crystalline bovine serum albumin (BSA). Prepare a solution of BSA at 10 mg/mL in PBS (PBS–1% BSA).
5. Ab phage (Fab) library, freshly amplified and titered (plaque-forming units [pfu]/mL).
6. Exponential growth culture of *Escherichia coli* XL1 Blue (Stratagene), grown in 2YT medium containing 10 μ g/mL tetracycline.
7. Luria-Bertani agar plates: 1.5% Bacto-agar in Luria broth.

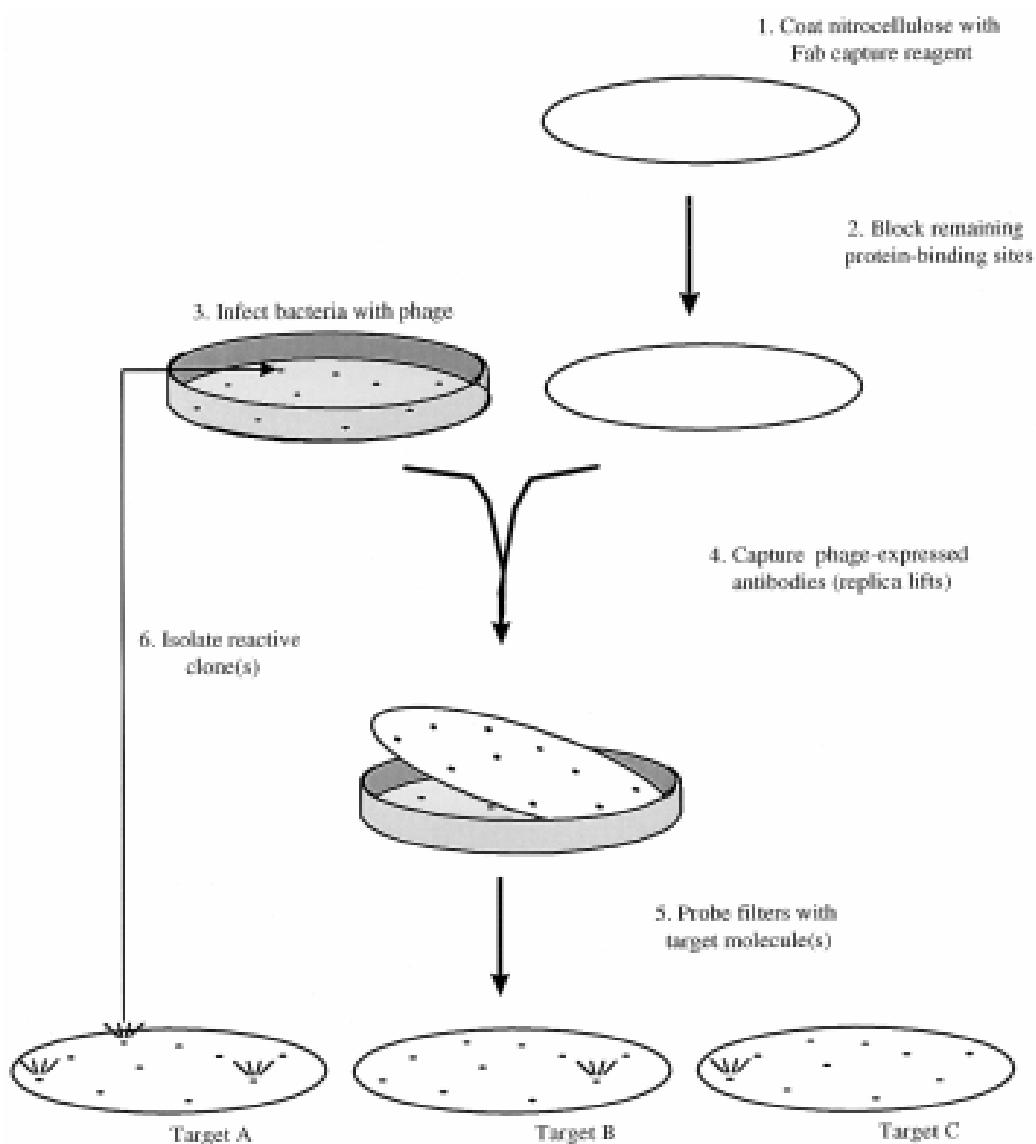

Fig. 1. Flow chart of the capture-lift screening procedure. Nitrocellulose filters are incubated with a capture reagent (1), then the remaining nonspecific binding sites on the filter are blocked (2). A bacterial lawn is infected with the Ab-phage library (3) and is overlaid with the pretreated nitrocellulose filter for 12–14 h (4). The filter is removed and probed with labeled Ag(s) and the appropriate detection reagent (5). In the example in this figure, three distinct Fabs are reactive with target A, but two are crossreactive with targets B and C. The developed filter is aligned with the agar plate to isolate the clone(s) of interest specifically reactive with target A (6).

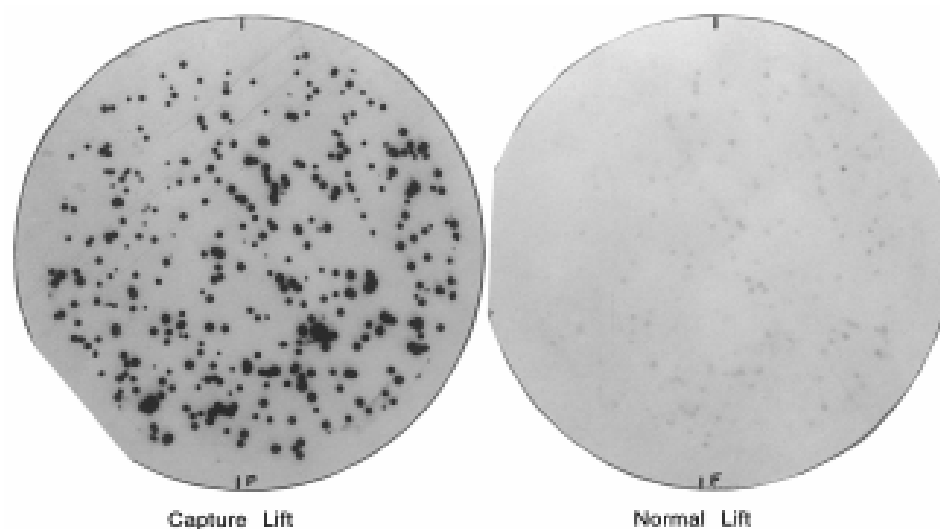

Fig. 2. Enhanced sensitivity of capture lifts. Phage-expressed Lewis Y-reactive Ab was captured on replica lifts using untreated nitrocellulose (normal lift) or nitrocellulose coated with anti-Ig and blocked with BSA (capture lift). Subsequently, the lifts were probed with Lewis Y–horseradish peroxidase conjugate and developed in parallel.

8. 0.7% Bacto-agar in Luria broth. Melt and cool to 50°C, then add 1 mM isopropyl- β -D-thiogalactopyranoside (IPTG).
9. PBS–0.1% (v/v) Tween-20 (PBS-T).
10. Ag of interest, biotinylated (*see Note 2*) and diluted to 1–2 μ g/mL in PBS-T (*see Note 3*).
11. Detection reagent: streptavidin–alkaline phosphatase (AP) conjugate diluted 1:1000 in 1% PBS–BSA for the detection of biotinylated Ags. Alternatively, a streptavidin–horseradish peroxidase conjugate may be used.
12. AP substrate, e.g., combine 0.4 mM 2,2'-di-*p*-nitrophenyl-5,5',-diphenyl-3,3'-[3,3'-dimethoxy-4,4'-diphenylene] ditetrazolium chloride and 0.38 mM 5-bromo-4-chloro-3-indoxyl phosphate mono-(*p*-toluidinium) salt in 0.1 M Tris-HCl, pH 9.5, immediately prior to use (JBL, Northridge, CA).
13. Elution buffer: 10 mM Tris-HCl, pH 7.5, 1 mM ethylene diamine tetraacetic acid, 100 mM NaCl.

3. Methods

3.1. Preparation of Capture Filters

1. Prepare the capture filter just prior to use. Label the nitrocellulose filter on one side.

2. Overlay the filter, labeled-side-up, on 10 mL Ig capture reagent in a plastic dish for 2–3 h at 25°C (*see Note 4*). At the completion of the coating step, submerge the filter for 20 min.
3. Remove the filter, lightly blotting the excess buffer, and place it (capture-side-up) on plastic wrap until dry (approx 30 min).
4. Block the remaining protein binding sites on the filter by submerging it in 10 mL 1% PBS–BSA for 2 h at 25°C (*see Note 5*).
5. Remove the filter, lightly blotting the excess blocking solution, and place it (capture-side-up) on plastic wrap until dry (approx 30 min).

3.2. Phage Infection of Bacterial Lawns

1. Add the phage Ab (500–100,000 pfu) (*see Note 6*) to 300 µL freshly grown log-phase *E. coli* XL1 Blue, then add 3 mL 0.7% agar–1 mM IPTG. Immediately overlay the mixture onto a Luria Bertani agar plate.
2. Incubate the plates at 37°C for 12–16 h.

3.3. Capture of Phage-Expressed Abs

1. Apply the Ig capture-coated side of the dried filter to the phage-infected bacterial lawn and incubate at 22°C for 14 h.
2. Use a needle to place at least three asymmetric holes through the filter into the agar to facilitate the alignment of the filter with the plate after the identification of positive plaques, following the development of the filter.
3. Remove the filter from the plate and rinse briefly 3× with PBS. If desired, a second filter can be applied immediately without further incubation of the plate.
4. Dilute the biotinylated Ag to 1–2 µg/mL in an appropriate buffer (*see Note 3*). Incubate the filter in the Ag solution and incubate for 2 h at 25°C.
5. Wash the filter 4–6× with PBS-T (*see Note 7*).
6. Place the filter in 7 mL diluted streptavidin–AP conjugate and incubate for 30 min at 25°C with constant slow agitation.
7. Wash the filter 4–6× with PBS-T.
8. Rinse the filters once with 0.1 M Tris-HCl, pH 9.5, to remove the excess phosphate buffer and detergent. Develop the filters by placing in 7 mL freshly prepared AP substrate solution.
9. When the plaques have developed sufficient color, rinse the filters with PBS and air-dry.

3.4. Isolation of Ab-Expressing Clones

1. Align the filter with the original agar plate using the asymmetric holes.
2. Isolate the plaque(s) of interest using a wide-bore pipet tip to core the agar (*see Note 6*) and elute the phage by incubating at 4°C for 16 h in 200 µL elution buffer.

3. Transfer an aliquot of the eluted Ab-phage clone to 2YT medium containing the appropriate antibiotics and amplify according to standard protocols. Isolate the amplified phage for further selection procedures or soluble Fab for further characterization of Ag specificity.

4. Notes

1. Polyclonal anti-Ig Ab is one of the most efficient and broadly applicable capture reagents identified to date, presumably because of the variability between different clones in the Ab library. Unlabeled polyclonal goat anti-human κ Ab (mouse-adsorbed; Southern Biotechnology Associates) is a general capture reagent that has been used successfully on multiple occasions for libraries of human Abs expressing a κ light chain. Monoclonal Abs to affinity tags may also be used when appropriate.
2. Labeling of the Ag with biotin permits the rapid subsequent detection of complexes using streptavidin enzyme conjugates. Commercially available biotin labeling reagents with a wide range of reactive chemistries should be tested to identify an Ag-labeling protocol that does not disrupt the epitope(s) of interest and/or interfere with binding. In these instances, a biotinylated second Ab that reacts with a distinct epitope on the Ag can be used for detection.
3. The selection of dilution buffer is predominantly Ag-dependent and should be determined experimentally. Inclusion of nonionic detergents is generally useful for reducing background in the assay, regardless of the properties of the Ag. For example, for the discovery of Abs to cell surface Ags, some of which are integral membrane proteins, we have used a diluent consisting of PBS–1% BSA, 1% Triton X-100, and 0.145% sodium dodecyl sulfate, containing 0.1% Na azide (3).
4. The filter is floated on the capture solution in order to minimize the quantity of capture reagent used.
5. The blocking of excess nonspecific protein-binding sites on nitrocellulose is typically accomplished by incubating the filter in a buffered solution of unrelated protein, such as BSA, hemoglobin, gelatin, or milk. The appropriate blocking reagent must bind the extra sites, while not interfering with the subsequent interaction and detection steps and is best determined empirically with control Ab and Ag.
6. A low phage titer (500 pfu/100-mm dish) will form distinct plaques (clones) that can be isolated without requiring further purification. Higher-phage titers (100,000 pfu/100-mm dish) can be used for the initial screening of larger libraries, but reactive clones will require subsequent replating at lower titers, to isolate the specific clone of interest. Because 100,000 distinct clones (plaques) can be screened using a single 100-mm filter, libraries containing millions of clones can be routinely analyzed.
7. Typically, the filters are washed 4–6 \times for 5 min each with constant agitation in ~10 mL PBS-T filter. However, rapid washes using a squirt bottle and a vacuum filtration device are better for the detection of lower-affinity interactions.

References

1. McCafferty, J., Griffiths, A. D., Winter, G., and Chiswell, D. J. (1990) Phage antibodies: filamentous phage displaying antibody variable domains. *Nature* **348**, 552–554.
2. Skerra, A., Dreher, M. L., and Winter, G. (1991) Filter screening of antibody Fab fragments secreted from individual bacterial colonies: specific detection of antigen binding with a two membrane system. *Anal. Biochem.* **196**, 151–155.
3. Watkins, J. D., Beuerlein, G., Wu, H., McFadden, P. R., Pancook, J. D., and Huse, W. D. (1998) Discovery of human antibodies to cell surface antigens by capture lift screening of phage-expressed antibody libraries. *Anal. Biochem.* **256**, 169–177.
4. Wu, H. R., Beuerlein, G., Nie, Y., Smith, H., Lee, B. A., Hensler, M., Huse, W. D., and Watkins, J. D. (1998) Stepwise in vitro affinity maturation of Vitaxin, an $\alpha v\beta 3$ -specific humanized mAb. *Proc. Natl. Acad. Sci. USA* **95**, 6037–6042.
5. Wu, H., Nie, Y., Huse, W. D., and Watkins, J. D. (1999) Humanization of a murine monoclonal antibody by simultaneous optimization of framework and CDR residues. *J. Mol. Biol.* **294**, 151–162.

Antibody-Guided Selection Using Capture-Sandwich ELISA

Kunihiko Itoh and Toshio Suzuki

1. Introduction

Antibody (Ab) phage display is a recently developed recombinant DNA technology for making human monoclonal antibodies (MAbs) from immune sources, such as bone marrow, lymph node, or peripheral blood lymphocytes from patients with various diseases, or from healthy individuals (1,2). Many human MAb Fabs or scFvs specific for viral pathogens, self antigens (Ags), or nonself Ags have been isolated by phage display system. This technology is expected to provide more powerful diagnostic, prophylactic, and therapeutic tools of human origin than do currently used polyclonal Abs or MAbs derived from other species.

Although it is not necessary to immunize the donor with the Ag of interest to isolate human MAbs, purification of the Ag is normally required for panning or screening of human libraries. Ags (e.g., membrane proteins, cytosolic proteins, nuclear proteins, recombinant proteins, nucleic acids, and so on) have been purified by column chromatography or affinity chromatography techniques from various sources (e.g., eukaryotic cells, insect cells, bacterial cells, their culture supernatants, and so on). However, the purification of Ag can be laborious and time-consuming, especially if the Ag is a minor component of the starting material.

In this chapter, a panning procedure to isolate Ag specific MAb using a modified capture sandwich enzyme-linked immunosorbant assay (ELISA) are described (Fig. 1). Sandwich ELISA uses two separate Abs for capture and detection of Ags and is widely used for specific detection of target Ags from crude preparations. A similar premise can be applied to a panning procedure, in

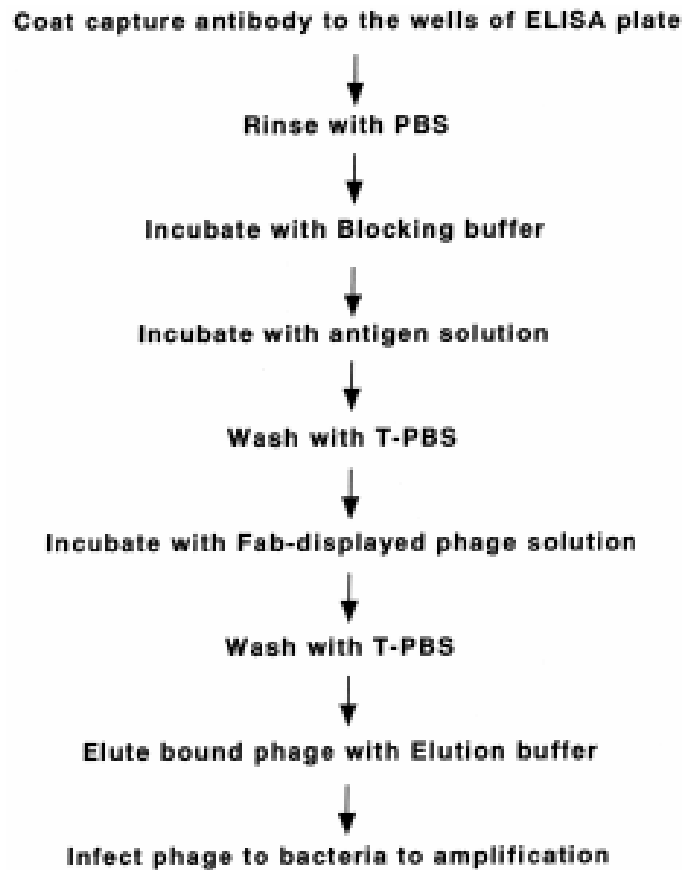

Fig. 1. Outline of the panning procedure for enrichment of Ag-specific phage Ab by Ab-guided selection using a capture sandwich ELISA

which a crude Ag preparation can be used, if an appropriate Ab with a defined specificity against the Ag of interest is available. In this case, the Ab-displayed phage library replaces the second detection Ab.

The advantages of this system are as follows:

1. Purification of target Ag(s) is not necessary.
2. Abs against conformation-sensitive Ags can be selected because Ag denaturation for direct coating to a plastic surface is not required.
3. By using capture Abs with varying specificities, MAbs against a variety of Ag epitopes can be isolated from a single library. For instance, Abs specific for functional determinants, e.g., neutralization, adhesion, and so on, can be selected by using a capture Ab against nonfunctional determinants. Alternatively, MAbs reactive with less immunogenic epitopes can be selected by using a capture Ab against an immunodominant epitope. For example, the selection of human Fabs

against herpes simplex virus glycoproteins by utilizing MAbs with different specificities, has been reported (3).

- Both MAbs and polyclonal Abs can be used as capture Abs. Since polyclonal Abs will recognize several epitopes on the Ag, polyclonal Ab-captured Ag theoretically should present a variety of Ag epitopes accessible for panning, depending on their abundance. We have isolated human Ab Fabs specific for rotavirus VP6 protein using culture supernatants of virus-infected Vero cells as an Ag and polyclonal Ab against human rotavirus Wa as a capture Ab (4).

2. Materials

- ELISA plates: 96-well half-area plates (well vol 190 μ L) (no. 3690, Costar, Cambridge, MA). Regular area size ELISA plates or 60-mm plastic dishes can also be used (*see Note 1*).
- Capture Ab: either MAb or polyclonal Ab with defined Ag specificity, diluted to 5–10 μ g/mL in phosphate-buffered saline (PBS) (*see Note 2*).
- 3% (w/v) and 1% (w/v) Bovine serum albumin (BSA) in PBS (PBS-BSA).
- Ag: crude or partially purified extract or purified Ags from any source, e.g., culture supernatants, bacterial cell lysates, or tissue culture cell extracts are all applicable. Ag should be diluted in PBS–1% BSA to a predetermined optimal concentration (*see Note 3*).
- Washing buffer: 0.05% (v/v) Tween-20 in PBS (PBS-T).
- Ab phage library, constructed from bone marrow, lymph node, or peripheral blood lymphocytes from patients or healthy individuals with high serum titer to the Ag of interest. The library should be freshly amplified and titered and diluted to the appropriate concentration in PBS–1% BSA.
- Elution buffer: 0.1 M glycine–HCl (pH 2.2).
- Neutralization buffer: 2 M Tris-HCl.
- Escherichia coli* XL1-Blue or other suitable strain for amplification.

3. Methods

- Add 50 μ L capture Ab into each well (*see Note 4*). Cover the plate with plastic wrap or adhesive tape to prevent evaporation of the solution. Incubate overnight at 4°C.
- Discard the Ab solution and rinse the wells once with 150 μ L of PBS. Fill the wells with 150 μ L PBS–3% BSA and incubate for 1 h at 37°C.
- Discard the blocking solution and remove any residual solution by tapping the plate onto a paper towel. Add 50 μ L Ag solution into each well and incubate for 1 h at 37°C.
- Discard the unbound Ag solution and wash the wells 5 \times with PBS-T (*see Note 5*).
- Add 50 μ L phage Ab library (typically containing 10^{11} cfu) into each well and incubate for 2 h at 37°C.
- Discard the phage solution and wash the wells with PBS-T by pipeting vigorously up and down (*see Note 6*).

7. Add 50 μL of elution buffer to each well. Wait for 1 min, then pipet vigorously up and down. Transfer the solution into an Eppendorf tube containing 3 μL neutralization solution (*see Note 7*).
8. Infect the eluted phage into to a mid-log-phase bacterial culture (e.g., XL1-Blue) and amplify overnight according to standard protocols.
9. Repeat the panning process for a further 3–4 rounds to enrich the Ag-specific Ab phage population.

4. Notes

1. Half-area ELISA plates are used to minimize the amount of capture Ab and Ag used. If using regular-size ELISA plates or 60-mm size Petri dishes, increase the amount of capture Ab and Ag accordingly, corresponding to their surface area.
2. Affinity-purified or Protein A/G-purified Ab with no or minimal contamination, should be used as the capture Ab. The optimal concentration of the capture Ab should be predetermined by a direct ELISA. Briefly aliquot the serial dilutions of the capture Ab (twofold dilutions from 20 to 0.1 $\mu\text{g}/\text{mL}$) into the wells and incubate overnight at 4°C. Detect binding of the coated Ab by using an appropriate enzyme-labeled secondary Ab. Choose the capture Ab concentration that correlates to approx 70% of total Ab binding as the optimal concentration for plate coating.
3. The optimal concentration of Ag for plate coating, particularly for crude Ags, should be predetermined by a sandwich ELISA using the optimized capture Ab concentration as outlined in **Note 2**. If more than one Ab against the Ag is available, e.g., from different species, detection of Ag-bound Ab with a secondary Ab may be possible.
4. As the output of eluted phage increases with each panning round, the number of wells used for each successive round of panning can be decreased. For example, coat four wells with capture Ab for the first three rounds of panning. Only two panning wells would be required for a fourth and any subsequent panning round (*see Table 1*).
5. Each wash consists of following four steps:
 - a. Add 150 μL PBS-T into the wells.
 - b. Pipet vigorously up and down 10 \times .
 - c. Leave for 1 min.
 - d. Discard the solution.Remove the residual solution completely after the final wash by tapping the plate onto a paper towel.
6. Increase the number of washes with successive panning rounds, because the Ag-specific Ab phage increase in frequency to become the majority of phage Ab in later rounds (*see Table 1*). A recommended procedure is as follows: wash once in round 1, 5 \times in rounds 2 and 3, and 10 \times in round 4 and any further rounds.
7. Confirm that the eluted phage has effectively neutralized using a pH paper to avoid loss of phage infectivity.

Table 1
Enrichment of Fab-Displayed Phage Library During Panning Against Polyclonal Ab-Captured Ag (see ref. 4)

Round of panning	Cap. Ab coating (wells)	Eluted phage titer (cfu/mL)		Washing (times)
		Library O	Library N	
1	4	2.9×10^5 (1)	7.2×10^6 (–)	1
2	4	3.9×10^5 (1.3)	3.8×10^5 (1)	5
3	4	7.6×10^5 (2.6)	8.9×10^5 (2.3)	5
4	2	5.7×10^6 (19.7)	1.1×10^6 (2.9)	10
5	2	8.9×10^6 (30.7)	1.1×10^7 (28.9)	10

Number in parentheses shows the enrichment of the Ag-specific Fab phage population in the library.

References

1. Burton, D. R. and Barbas, C. F. (1994) Human antibodies from combinatorial libraries. *Adv. Immunol.* **57**, 191–280.
2. Winter, G., Griffiths, A. D., Hawkins, R. E., and Hoogenboom, H. R. (1994) Making antibodies by phage display technology. *Ann. Rev. Immunol.* **12**, 433–455.
3. Sanna, P. P., Williamson, R. A., De Logu, A., Bloom, F. E., and Burton, D. R. (1995) Directed selection of recombinant human monoclonal antibodies to herpes simplex virus glycoproteins from phage display libraries. *Proc. Natl. Acad. Sci. USA* **92**, 6439–6443.
4. Itoh, K., Nakagomi, O., Suzuki, K., Inoue, K., Tada, H., and Suzuki, T. (1999) Recombinant human monoclonal Fab fragments against rotavirus from phage display combinatorial libraries. *J. Biochem.* **125**, 123–129.

Proximity-Guided (ProxiMol) Antibody Selection

Jane K. Osbourn

1. Introduction

Cell surfaces provide a rich source of potential antigen (Ag) targets for therapeutic and research reagent antibodies (Abs). However, in some circumstances, access to these targets may be difficult since it is technically challenging to purify individual Ags while retaining their native configuration. One way to circumvent the need for purification is to use whole cells or cell membranes as the basis for Ab selection. This has, in a number of cases, been successful, but necessitates the need for large-scale screening processes because the selection process will also generate many Abs that are not specific for the target of interest, but which bind to other proteins on the cell surface. Proximity (ProxiMol) selection is a method of selection that enriches the selected population for Abs that bind at or around sites on the cell surface of the target Ag and so reduce the need for labor-intensive screening processes.

The selection process involves the use of catalyzed reporter enzyme deposition (CARD), which is a method of signal amplification previously used in enzyme-linked immunosorbant assay, immunocytochemistry, blotting, and flow cytometry formats (1–5). CARD uses horseradish peroxidase (HRP)-conjugated targeting reagents, such as Abs together with biotin tyramine. In the presence of H₂O₂ (the natural substrate of HRP), HRP catalyzes the formation of biotin tyramine free radicals, which are highly reactive species capable of covalently binding to proteins in the vicinity of the HRP. This reaction can form the basis of a signal amplification system by the addition of streptavidin–HRP, which increases the number of enzyme moieties at the target site. This results in signal enhancement when the enzyme is detected colorimetrically with no detectable loss of resolution.

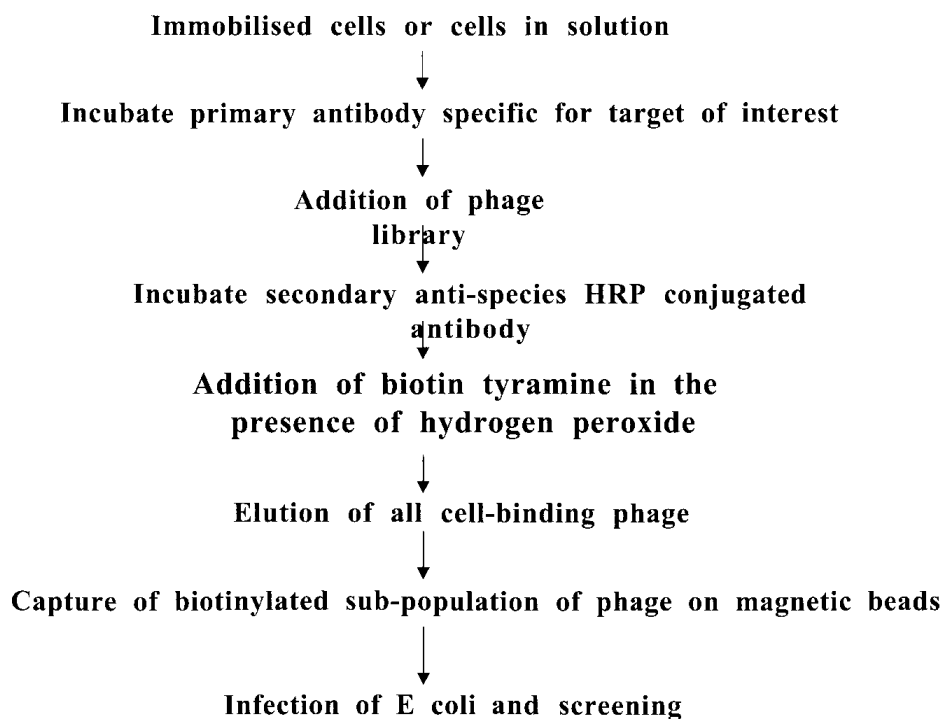

Fig. 1. Flow chart for isolation of Abs against cell surface Ags by ProxiMol selection.

This signal-enhancement procedure can be modified for Ab phage display, in which HRP and biotin tyramine are used to biotinylate phage particles that bind around the site of the HRP activity. HRP can be targeted to specific sites on the cell surface using Abs, natural ligands (such as growth factors or chemokines), or any other molecule that is known to bind specifically to a target Ag. Only phage that bind at, or close to, the site of enzyme activity are biotinylated and these phage can be recovered on streptavidin-coated magnetic beads.

This chapter describes the use of ProxiMol selection to isolate phage Ab against cell surface markers (**Fig. 1**). However, proximity selections need not be restricted to cell surfaces: purified Ags, cell extracts, or membrane preparations may also be used. Selection of Abs that bind to a number of different target Ags has been demonstrated using this technique, using either Abs or natural ligands as guide molecules (6,7).

2. Materials

1. 16-Well chamber slides (Nunc).
2. Cell line for selection. Cells should be grown under normal culture conditions on chamber slides to approx 80% confluence (1×10^5 – 1×10^6 cells/chamber).

3. Cell fixative, e.g., 0.1% glutaraldehyde in phosphate-buffered saline (PBS) (or other appropriate fixative).
4. Phage Ab library, freshly amplified and titered (colony-forming units [cfu]/mL).
5. PBS–3% (w/v) skim milk powder (PBSM) (*see Note 1*).
6. PBS–0.1% (v/v) Tween-20.
7. Primary Ab to be used as a guide molecule, diluted as appropriate in PBSM (*see Note 2*).
8. Secondary anti-species–HRP conjugate at an appropriate dilution (normally 1 : 1000–1 : 5000) in PBSM.
9. Biotin tyramine, stock concentration ~1 mg/mL (available as part of the Renaissance TSA kit) (NEN, Perkin Elmer Life Sciences, Boston, MA).
10. 50 mM Tris-HCl, pH 7.4, containing 0.03% H₂O₂ (freshly made).
11. 1 M Tris-HCl, pH 7.4.
12. 100 mM Triethylamine, freshly diluted in H₂O on day of use.
13. Streptavidin-coated magnetic beads with magnetic rack (Dynal).
14. *Escherichia coli* strain TG1, freshly grown exponential phase culture.
15. 2TY agar plates (243 × 243 mm) containing 100 µg/mL ampicillin and 2% (w/v) glucose (or other appropriate antibiotics for recombinant Ab phage selection).

3. Methods

1. Using a pipet tip, remove the culture media from the chamber slides and wash with 100 µL PBS.
2. Fix the cells with 100 µL 0.1% glutaraldehyde for 15 min at room temperature (*see Notes 3 and 4*). Wash with 100 µL PBS as above.
3. Block the cells with 100 µL PBSM for 1–2 h at room temperature.
4. Gently wash the cells 3× by adding 100 µL PBS, then discarding.
5. Add 100 µL of the primary guide molecule and incubate for 1 h at room temperature (*see Note 5*).
6. Wash the cells as in **step 4**.
7. Add 1×10^{12} cfu Ab phage in 100 µL PBSM and incubate for 1–2 h at room temperature.
8. Wash the cells as in **step 4**.
9. Add 100 µL secondary anti-species–HRP conjugate and incubate for 1 h at room temperature.
10. Wash the cells as in **step 4**.
11. For each well, dilute 0.4 µL biotin tyramine stock solution in 100 µL 50 mM Tris-HCl, pH 7.4–0.03% H₂O₂. Add to the wells and incubate at room temperature for 10 min.
12. Wash the cells as in **step 4**.
13. Elute the bound phage Ab by adding 100 µL 100 mM triethylamine and incubate at room temperature for 20 min.
14. Transfer the eluted phage to a 1.5 mL Eppendorf tube and neutralize immediately with 50 µL 1 M Tris-HCl, pH 7.4.

15. Take a 20- μ L aliquot of the streptavidin-coated magnetic beads and remove from the solution using the magnetic rack. Preblock the beads by resuspending them in 50 μ L PBSM.
16. Add the blocked beads to the eluted phage and incubate the suspension for 15 min at room temperature on a rotating platform.
17. Using the magnetic rack, remove the beads from the suspension and wash them 3 \times in 1 mL PBS–0.1% Tween-20, followed by another three washes in 1 mL PBS.
18. Resuspend the beads in 100 μ L PBS and use 50 μ L of this suspension to infect 5 mL exponentially growing culture of *E. coli* TG1. Incubate at 37°C for 30 min (no shaking), followed by a further incubation at 37°C for 30 min with slow shaking (150 rpm).
19. Spin the bacteria at 2500g for 10 min and plate on 2TY agar–ampicillin–glucose plates and incubate overnight at 30°C.
20. Use the resulting colonies to generate soluble Ab according to standard protocols and screen for binding specificity or activity in an appropriate assay (see **Note 6**).

4. Notes

1. It is advisable to remove large particulates from the PBSM solution by a 10 s pulse in a microcentrifuge. If preferred, it is also possible to use PBS containing 0.5% BSA as a blocking reagent.
2. The primary guide Ab can be directly conjugated to HRP to avoid the use of an anti-species HRP conjugate. HRP conjugation can be achieved using maleimide-activated HRP, which is available in kit form from Pierce and Warriner (Chester, UK). If a direct guide molecule–HRP conjugate is used, proceed directly to **step 10**, following incubation of the phage Ab library.
3. It is possible to use unfixed cells in a proximity selection, although some loss of cells may occur from the chamber slides after washing. If unfixed cells are used, washing steps must be carried out with the utmost care and all stages of the selection process should be carried out at 4°C to reduce possible internalization of target Ags.
4. Cells in solution can also be used for proximity selections. In this case, the protocol should be modified to include pelleting of the cells after each washing step. If selections are to be carried out in solution, use approx 1×10^5 cells in a volume of 200–500 μ L PBS block solution.
5. Abs are just one example of the type of molecule that can be used as a guide molecule. Any ligand that is known to specifically bind to the target Ag, and which can be tagged in some way to allow HRP localization, can be used. Alternatives include natural ligands. Biotinylated ligands can be used in combination with streptavidin–HRP as long as a specific staining profile is retained.
6. Any Abs selected using a ProxiMol selection will not bind to the epitope on the target molecule to which the guide molecule binds since this particular epitope will be blocked. It is possible, however, to carry out a second round of ProxiMol selection, using the output from a first as a guide population. In this way, Abs that

bind to the original guide-molecule binding site can be isolated. As an example of this, Abs that block the binding of the chemokine macrophage inhibitory protein 1- α (MIP-1 α) have been isolated using MIP-1 α as the original guide molecule (7). The second round of selection was performed using the captured biotinylated phage population output from the first round as a guide population. The phage were added to a fresh batch of cells without MIP-1 α present and HRP localization to the phage particles was achieved using streptavidin–HRP. The output of this selection (referred to as a “step-back selection”) included clones that blocked MIP-1 α binding to the cells, along with other clones that bound to the CD4⁺ cells, but which did not inhibit binding. This general principle may be applicable to many other selection targets.

References

1. Bobrow, M. N., Harris, T. D., Shaughnessy, K. J., and Litt, G. J. (1989) Catalyzed reporter deposition, a novel method of signal amplification. *J. Immunol. Methods* **125**, 279–285.
2. Bobrow, M. N., Litt, G. J., Shaughnessy, K. J., Mayer, P. C., and Colon, J. (1992) The use of catalyzed reporter deposition as a means of signal amplification in a variety of formats. *J. Immunol. Methods* **150**, 145–149.
3. Merz, H., Malisius, R., Mannweiler, S., Zhou, R., Hartmann, W., Orscheschek, K., Moubayed, P., and Feller, A. C. (1995) A maximised immunohistochemical method for the retrieval and enhancement of hidden antigens. *Lab. Invest.* **73**, 149–156.
4. Adams, J. C. (1992) Biotin amplification of biotin and horseradish. *J. Histochem. Cytochem.* **40**, 1457–1463.
5. Earnshaw, J. C. and Osbourn, J. K. (1999) Signal amplification in flow cytometry using biotin tyramine. *Cytometry* **35**, 176–179.
6. Osbourn, J. K., Derbyshire, E. J., Vaughan, T. J., Field, A. W., and Johnson, K. S. (1998) Pathfinder selection: *in situ* isolation of novel antibodies. *Immunotechnology* **3**, 293–302.
7. Osbourn, J. K., Earnshaw, J. C., Johnson, K. S., Parmentier, M., Timmermans, V., and McCafferty, J. (1998) Directed selection of MIP-1 α neutralizing CCR5 antibodies from a phage display human antibody library. *Nature Biotechnol.* **16**, 778–781.

Isolation of Human Monoclonal Antibodies Using Guided Selection with Mouse Monoclonal Antibodies

Mariangela Figini and Silvana Canevari

1. Introduction

Repertoires of antibody (Ab) V genes derived from nonimmunized human donors (1) or made synthetically (2,3) have been cloned for display on filamentous bacteriophage as either scFvs or Fabs fused to the minor phage coat protein (pIII) (4). Phage Ab repertoires can be subjected to multiple rounds of panning on individual immobilized antigens (Ags) in order to isolate individual Ag-binding clones. This approach has been successfully applied to numerous purified soluble molecules, yielding high-affinity Abs (5). Selection against almost any soluble Ag is now theoretically feasible.

Although conventional biochemistry and advanced biotechnological approaches have led to the availability of a large variety of molecules in purified and/or recombinant form, such molecules often do not maintain the correct conformation in soluble form and are easily disrupted by biochemical manipulation. Thus, the use of whole living cells as a direct source of target Ag is desirable to retain the physiological status of the molecule as much as possible. Selection of Abs against unpurified cell surface markers by panning on whole cells is also desirable. Of particular interest is the generation of human Abs against the surface Ags of human tumor cells since these reagents have a potential application in immunotherapy. Unfortunately, panning on whole cells has proven difficult because of the enormous number of different Ags and the low abundance of many of them on the cell surface.

Thus, a general methodology was developed that is tailored to specific needs, such as raising an Ab against a predefined epitope or a cell surface Ag not

available in purified form. The procedure, originally called “epitope imprinting selection,” and now defined as “guided selection” (6,7) uses one of the variable chains of an available mouse monoclonal antibody (MAb) directed against the target Ag to drive selection of a human Ab of corresponding-specificity from a preassembled repertoire of genes encoding the variable domains of human Ab heavy chains (HCs) and light chains (LCs).

The combination of shuffling of V genes and selection on cells provides a powerful tool for isolating human MAb reagents with potential clinical application, including when the corresponding murine MAb is already in clinical use. For example, guided selection using the murine complementarity determining region 3 and panning on purified recombinant Ag identified a high-affinity human Ab against epithelial glycoprotein 2, a transmembrane protein abundantly expressed on a variety of human carcinomas (8). This technique also provides an additional approach for isolating human MAbs against Ags present on human tumor cells (9). By combining guided selection and panning on whole cells, we have selected human Fabs against the folate receptor, a cell surface Ag overexpressed in many human carcinomas from phage Ab libraries (6). Selection for other tumor-associated Ags is in progress.

In this chapter we outline our strategy to isolate Abs against a cell-associated Ag not available in purified form. To produce and characterize such reagents, the following procedures are carried out sequentially (**Fig. 1**):

1. Cloning of murine MAb $V_L C_L$ gene.
2. Production of murine–human hybrid Ab library.
3. First selection by panning on cell monolayers.
4. First screening of selected Ab.
5. Production of fully human Fab library.
6. Second selection by panning on cell monolayers.
7. Second screening of selected Ab.
8. Characterization of Fab binders.

In the authors’ published procedure, the LC of a murine MAb was used to guide HC pairings from a repertoire of human HCs (6), but either HC or LC can be used. When soluble Ag is available for selection, the panning (**steps 3 and 6**) is performed on immobilized or biotinylated Ag (*see* Chapters 9 and 10).

2. Materials

1. Libraries (*see Note 1*).
 - a. Library 1: Human HC repertoire ($V_H C_H1$) in a fd filamentous phage vector, e.g., fdDOG (4) in *Escherichia coli* TG1, freshly amplified and titered (colony-forming units [cfu]/mL) (*see Note 2*).

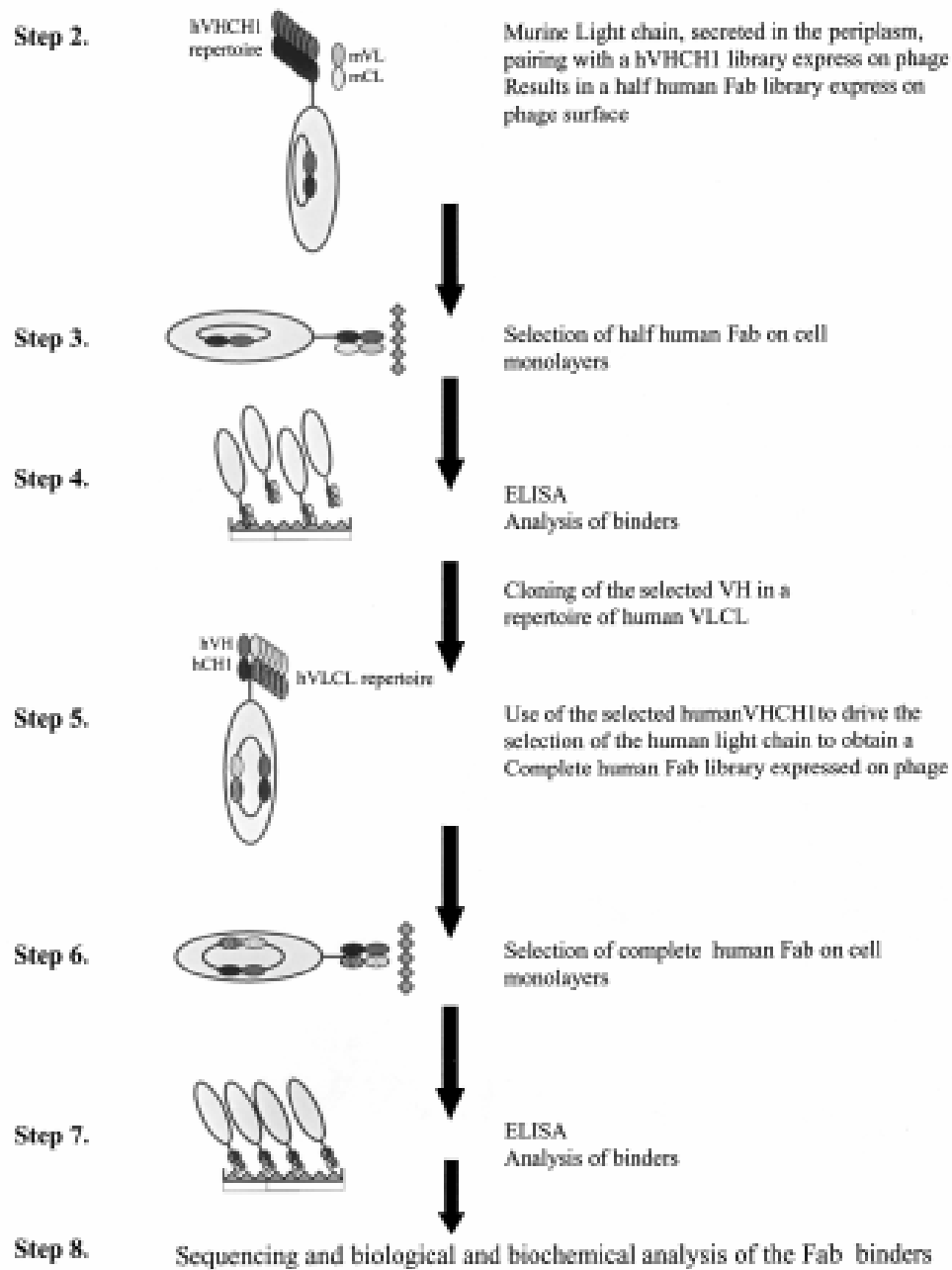

Fig. 1. Schematic diagram of antibody-guided selection on cells (steps 2–8).

- b. Library 2: Human LC repertoire ($V_L C_L$), expressed as an equimolar mixture of phagemid expressing κ -chain and λ -chain as fusion proteins with the pIII protein, e.g., pHEN (6) in *E. coli* TG1.
2. Total RNA extracted from the hybridoma cell line expressing a MAb against the Ag of interest.
3. Cell line(s) expressing the surface Ag of interest.
4. Reagents for reverse transcriptase-polymerase chain reaction (PCR) e.g., GeneAmp RNA PCR Kit (Perkin-Elmer); appropriate restriction enzymes and T4 DNA ligase for cloning.
5. Oligonucleotides (Table 1; see Note 3).
6. Periplasmic expression vector for cloned $V_L C_L$ e.g., pUC19SNMyc (6).
7. 8% Glutaraldehyde stock solution. Dilute to 0.2% in phosphate-buffered saline (PBS) for fixation.
8. PBS: PBS containing 2% (w/v) and 10% nonfat dry milk powder (PBSM); PBS–0.1% (v/v) Tween-20; PBS–0.75% glycine–0.001% phenol red; PBS–1% bovine serum albumin (BSA).
9. Freshly grown exponential culture of *E. coli* TG1.
10. 2TY medium: 2TY containing 100 $\mu\text{g}/\text{mL}$ ampicillin (AMP); 2TY–AMP containing 10 $\mu\text{g}/\text{mL}$ tetracycline (TET).
11. TYE agar plates: Add 15 g agar to 1 L 2TY medium, autoclave, when cool, add glucose to 1% (w/v) and AMP and TET (as done previously).
12. Electrocompetent *E. coli* TG1 cells; Gene Pulser (e.g., Bio-Rad).
13. Reagents for amplification of libraries (antibiotics, helper phage VCSM13, 20% polyethylene glycol (PEG)–2.5 M NaCl solution).
14. Anti-M13 horseradish peroxidase-conjugated Ab (Pharmacia Biotech cat. no. 27-9411-01); fluorescein-isothiocyanate-conjugated anti-sheep Ab; anti-M13 Ab (Pharmacia Biotech cat. no. 27-9410-01).
15. Tetramethyl-benzidine dihydrochloride (TMB) solution (Sigma, T8665); 1 M H_2SO_4 .
16. Petri dishes and 96-well flat-bottomed plates for cell culture; enzyme-linked immunosorbent assay (ELISA) plates; large, square plastic Petri dishes (243 \times 243 mm).

3. Methods

All of the following methods are based on the expression vectors and bacterial strains that are used in our system. Variations may require modification to antibiotics and restriction enzymes used.

3.1. Cloning of Murine MAb $V_L C_L$ Gene

This step allows cloning of the murine LC variable region (V_L) gene, together with the constant region (C_L), into a plasmid vector that enables secretion of the entire murine LC into the bacterial periplasm. This protocol

Table 1
Oligonucleotide Primers for PCR

Primer	Sequence
G3LASC GTGBack	GTCCTCGCAACTGGCGGCCACAATTCACAGTAAGG AGGTTTAACTTGTGAAAAAATTATTATTCGCAATT
MOCKForNot	CCAGCATTCTGCGGCCGCTCATTCTGTGGAAGCTC TTGAC
VKBackSfi	CATGACCACGCGGCCAGCCGGCCATGGCCGACATTG AGCTCACCCAGTCT
FdSEQ1	GAATTTTCTGTATGAGG

describes a method for cloning into pUC19SNMyc, but can be adapted for other suitable vectors.

1. Perform a cDNA reaction according to standard protocols using 1–2 μg hybridoma RNA and 20 pmol VKBackSfi primer (**Table 1**).
2. Set up a 50 μL PCR reaction according to standard protocols using 50 ng cDNA and 10 pM each of the VKBackSfi and MOCKForNot primers (**Table 1**).
3. Amplify by PCR using 30 cycles at 94°C for 1 min, 55°C for 1 min, and 72°C for 2 min, followed by incubation at 72°C for 10 min.
4. Purify the PCR product (~600 bp) on an agarose gel and extract from the agarose using standard protocols. Digest the PCR product and the expression vector using the appropriate restriction enzymes (*Sfi*I and *Not*I for pUC19SNMyc). Inactivate the enzymes and/or clean up the reaction as appropriate.
5. Ligate the PCR product into the plasmid vector using standard protocols (*see* Chapters 2 and 3).
6. Transform the ligated DNA into *E. coli* TG1 by electroporation and plate out the transformants on TYE–AMP plates. Incubate overnight at 37°C.
7. Using standard molecular biology methods, determine those clones with the correct size insert and sequence (*see* **Note 4**).

3.2. Production of a Murine–Human Hybrid Ab Library

Bacteria bearing the plasmid with the LC are infected with recombinant phage expressing the human $V_{\text{H}}C_{\text{H}}1$ repertoire. Phage particles produced by these infected bacteria display hybrid Fabs (human $V_{\text{H}}C_{\text{H}}$ –murine $V_{\text{L}}C_{\text{L}}$) on their surface: the human HCs fused at their C-terminus to the phage pIII and their murine LC partners associate spontaneously in the periplasmic space (2).

1. Grow a 10 mL culture from a fresh colony of the $V_{\text{L}}C_{\text{L}}$ clone in TG1 in 2TY containing the appropriate antibiotic selection (AMP for pUC19SNMyc) at 37°C until optical density 600 nm reaches 0.5.

2. Mix the 10 mL log-phase culture of the $V_L C_L$ clone with 10^{12} cfu freshly amplified phage from the $V_H C_H$ library and incubate for 30 min at 37°C without shaking.
3. Take out a 0.5 mL aliquot and use to calculate the library titer (cfu/mL) by infecting diluted aliquots in log-phase *E. coli* TG1 and plating on TYE-AMP-TET plates.
4. Centrifuge the remaining 9.5 mL at 3300g for 10 min and resuspend the pellet in 0.6 mL 2TY.
5. Plate the resuspended pellet on a TYE-AMP-TET large, square plate (243 × 243 mm) and grow overnight at 30°C.
6. Harvest the cells by flooding the plate with 2–10 mL 2TY and detaching the cells with a sterile scraper. Transfer the cells to a sterile polypropylene tube and disperse clumps using a vortex.
7. Inoculate a 500 mL culture of 2TY-AMP-TET with an aliquot of this suspension containing the number of bacteria that corresponds to at least 10× the library size (where optical density of 1 at 600 nm is approx 8×10^8 bacteria/mL). Amplify and isolate the recombinant phage by PEG precipitation according to standard protocols (*see Note 2*).

3.3. First Selection by Panning on Cell Monolayers

The hybrid murine–human Fab phage repertoire is selected by panning on a monolayer of cells overexpressing the target Ag. Phage that bind are used to directly infect bacterial cells containing the LC and the bacteria are grown to produce more Fab phage. The repertoire must be subjected to repeated rounds of selection and infection to enrich the population for Ag binders. The first panning round is the most critical since selection for any abnormalities or mistakes at this point will be amplified during further panning. Usually, the selection and reinfection must be carried out 2–3× in order to obtain a positive signal in polyclonal ELISA (*see Note 5*).

1. Recover the cell line for panning (*see Note 6*) by detachment with trypsin–ethylenediamine tetraacetic acid or by centrifugation, depending on their growth characteristics (*see Note 7*).
2. Seed the cells in 100 mm cell culture Petri dishes at a concentration of 4×10^5 /mL in 20 mL standard growth medium and grow at 37°C until 80% confluent (1–2 d, depending on the duplication time of the cell line).
3. If necessary (i.e., when the attachment of cells to plastic is not strong enough), and, if it is possible (i.e., Ag does not change conformation during the fixation), fix the cells with glutaraldehyde by adding 4 mL 0.2% glutaraldehyde in PBS and leave for 5 min only (NOT MORE).
4. Wash the cells 5–6× by adding 10 mL PBS briefly swirling the plate, then discarding.
5. Add 4 mL PBS–0.75% glycine–0.001% phenol red and leave for 5 min.

6. Wash 5–6× with PBS.
7. Add 20 mL 2% PBSM and incubate for 2 h at 37°C to block any remaining unsaturated binding sites on the plastic.
8. Discard the block solution and add $\sim 10^{12}$ cfu freshly amplified phage library displaying the hybrid Fabs in 10 mL 2% PBSM. Shake slowly at room temperature for 1 h (*see Note 8*).
9. Wash the dish 5× with 10 mL PBS–0.1% Tween-20, then 10× with 10 mL PBS alone. In each washing step, gently add the buffer, briefly swirl in the plate, and immediately remove (*see Note 9*).
10. Add 10 mL log-phase *E. coli* TG1 bearing the $V_L C_L$ plasmid (*see Subheading 3.1.*) directly to the Petri dish (*see Note 10*). Incubate for 30 min at 37°C without shaking.
11. Collect the bacterial suspension from the dish, take out a 0.5 mL aliquot, and use to calculate the rescue titer (cfu/mL) by plate-diluted aliquots on TYE–AMP–TET glucose plates.
12. Centrifuge the remaining 9.5 mL at 3300g for 10 min and resuspend the pellet in 0.6 mL 2TY.
13. Plate the resuspended pellet on a TYE–AMP–TET large, square plate (243 × 243 mm) and grow overnight at 30°C.
14. Harvest the cells by flooding the plate with 2–10 mL 2TY and detaching the cells with a sterile scraper. Transfer the cells to a sterile polypropylene tube and disperse clumps using a vortex.
15. Inoculate a 500 mL culture of 2TY–AMP–TET with an aliquot of this suspension, corresponding to at least 10× the library size (*see Subheading 3.2., step 7*). Amplify and isolate the recombinant phage by PEG precipitation according to standard protocols (*see Note 2*).
16. Check the phage-binding specificity by phage ELISA or fluorescence-activated cell sorting (FACS) analysis using the total amplified selected phage (polyclonal) or single clones (monoclonal).
17. Repeat the selection and infection 2–3×. After every round of infection, check the titer of the phage to monitor the extent of enrichment and check the cell binding by ELISA. Repeat the panning until a positive signal against Ag is detected.

3.4. Screening of Selected Phage Clones

Single clones (monoclonal) or the bulk amplified (polyclonal) phage are tested for binding both in ELISA and in FACS analysis on cells overexpressing the Ag of interest and on Ag-negative cells.

3.4.1. Monoclonal Phage ELISA

1. Seed the target cells in 96-well flat-bottomed plates at a concentration of $1-3 \times 10^5$ cells/mL in 200 μ L and grow until they reach confluence (1–2 d depending on the duplication time of cells).

2. Pick individual colonies from the last round of panning using a sterile toothpick into wells of a 96-well sterile ELISA plate containing 200 μ L 2TY–AMP–TET. Grow with shaking (300 rpm) at 30°C for 16–20 h (*see Note 11*).
3. Centrifuge the bacterial plate at 3300g for 10 min.
4. Wash the plate containing the cell monolayer 3 \times by gently adding 200 μ L of PBS and aspirating off. Block the unsaturated binding sites on the plastic by adding 200 μ L 2% PBSM to each well and incubate at 37°C for 2 h.
5. Aspirate off the 2% PBSM and add 25 μ L 10% PBSM to each well.
6. Using a multichannel pipet, transfer 80 μ L bacterial culture supernatant from **step 3** above to the ELISA plate, mix, and incubate at room temperature for 1 h.
7. Wash the wells 3 \times with PBS–0.1% Tween-20, then 3 \times with PBS.
8. Add 100 μ L 1:5000 dilution of the anti-M13–horseradish peroxidase conjugate Ab in 2% PBSM to each well. Incubate for 1 h at room temperature.
9. Wash the wells as in **step 7**.
10. Add 50 μ L TMB substrate to each well and leave at room temperature for 10–20 min or until a clear signal is seen.
11. Stop the reaction by adding 50 μ L 1 M H₂SO₄ to each well and read the absorbance at 450 nm in an ELISA multichannel reader.

3.4.2. FACS Analysis Using Polyclonal Phage

1. Detach the adherent cell line expressing the Ag of interest from the flask as described in **Subheading 3.3., step 1**. Wash the cells by adding 1 mL PBS and centrifuging at 350g for 5 min, then count the cells. For each FACS sample, aliquot 3 \times 10⁵ cells into a centrifuge tube and pellet by centrifugation described previously.
2. Resuspend the cell pellet with \sim 5 \times 10⁹ polyclonal phage particles in 100 μ L PBS–1% BSA and incubate at room temperature for 1 h.
3. Wash the cells 3 \times with PBS, as in **Subheading 3.4.1., step 7**.
4. Add 100 μ L anti-M13 Ab (1:1000 dilution in PBS–1% BSA) to each tube and incubate on ice for 30 min.
5. Wash the cells 3 \times with PBS.
6. Add 100 μ L fluorescein-isothiocyanate-conjugated anti-sheep Ab (1:1000 dilution in PBS–1% BSA) and incubate on ice for 30 min.
7. Wash the cells 3 \times with PBS.
8. Immediately analyze the cells using a FACScan. Alternatively, fix the cells in PBS–1% formaldehyde and store at 4°C (the cells will retain their fluorescence for about 2 wk).

At the end of 3–6 rounds of positive selection and screening, at least one human V_HC_H1-bearing clone should be identifiable, which, in combination with the original murine LC used as the guide probe, can bind to the target Ag.

3.5. Selection of the Human LC

After screening and identification of the best human V_H , the second shuffle can be performed. To obtain a completely human Fab, the selected $V_H C_H1$ is amplified and inserted into the phagemid library containing precloned repertoires of human κ and human λ LC genes. The resulting human Fab phagemid repertoire is rescued by infection with helper phage and the phagemid particles are selected on cell monolayers as previously mentioned.

1. Pick a fresh colony of the selected clone(s) into 10 mL 2TY–TET and grow overnight at 37°C.
2. Extract the plasmid DNA using standard miniprep procedures.
3. Amplify the $V_H C_H1$ insert, using a 50- μ L PCR reaction containing 100 ng $V_H C_H1$ plasmid DNA and 10 pM each of the Fdseq1 primer and G3LASC GTGBack primers (**Table 1**) and perform 30 cycles at 94°C for 1 min, 55°C for 1 min, 72°C for 2 min, followed by incubation at 72°C for 10 min.
4. Run out the reaction on a 1.5% agarose gel and purify the fragment using standard protocols.
5. Digest 5 μ g $V_H C_H1$ fragment and 6 μ g plasmid containing the human $V_L C_L$ library DNA with *AscI* and *NotI*. Inactivate the enzymes and/or clean up the reaction as appropriate.
6. Using standard protocols, construct the fully human library by ligation. Amplify the library using helper phage, VCSM13, and isolate recombinant phage using PEG precipitation.
7. Perform a further 3–4 rounds of panning on the cell line as in **Subheading 3.3.** and analyze the selected phage by phage ELISA (**Fig. 1**; see **steps 6** and **7**).
8. Characterize the selected fully human Fab clones, e.g., by sequencing and by biological/biochemical analysis (**Fig. 1**; see **step 8**; **ref. 10**).

4. Notes

1. These libraries may be prepared using the protocol described in **ref. 6**, or may be available in other laboratories. To obtain an update of the primers used in amplification of the immunoglobulin variable genes, consult the website <http://www.mrc-cpe.cam.ac.uk/imt-doc/restricted/PRIMERS.html>. A critical step in determining the success of the guided selection procedure is that these libraries should be as large as possible, with a high number of functional inserts. Since the aim of guided selection is to recapitulate all the properties of binding specificity and affinity of the mouse Ab in its human equivalent, maximization of library sizes during chain shuffling ensures that as many permutations as possible of HC/LC pairings are available for Ag selection. The ease with which a high-affinity Ab can be isolated by phage display correlates with the size of the starting repertoire (**1,5**).

2. The fdDOG vector is a phage, therefore, helper phage is not required for packaging of this library. pHEN is a phagemid, and requires helper phage (VCSM13) for amplification. The fdDOG vector carries a tetracycline-resistance marker.
3. **Table 1** lists the sequences of the universal primers, MOCKForNot and VKBackSfi, which can be used to amplify the majority of murine VKCK. If these primers fail to amplify the LC, try the primers designed by Pharmacia (cat. no. 27-1583-01). Also check that the LC is not from a rare murine family.
4. Many hybridomas also express nonfunctional mRNAs that encode abortive immunoglobulin variable regions and that can be amplified during PCR. It is therefore advisable to construct scFvs from the hybridoma, before proceeding to ensure the identification of functional V_L . Furthermore, for some Abs, the V_H alone is sufficient to determine the binding specificity to the target Ag (**II**). Therefore, it is advisable to control for this possibility before proceeding to guided selection with the LC.
5. Starting with 10^{12} phage, the first round of selection should yield at least 10^4 phage. Initial rounds of selection should be carried out under low stringency (using cells with high Ag density and minimizing the number and duration of washes), so as not to lose rare binders, then use more stringent conditions in later rounds. Stringency conditions should be fine-tuned by the operator according to the topobiology of the target Ag. All rescues should be checked for the presence of insert (by PCR) and the number of positive clones should be scored. If no enrichment is obtained after 4–6 panning, check the length of the insert, change the conditions of panning (temperature, incubation time, fixation of cells), use an alternative cell line, if possible, and/or carry out a new selection from the beginning.
6. Maintain the cells expressing the target Ag in complete culture medium in a humidified 5% CO_2 atmosphere at 37°C . Routinely confirm cell surface expression of the Ag by FACS analysis or ELISA.
7. These procedures pertain to adherent cells. Similar procedures can be applied to cells growing in suspension, using centrifugation for each wash step. The major risk with using cells in suspension is their loss and consequently that of the bound phage during centrifugation. Thus, a centrifugation speed must be selected that is appropriate to the size and sensitivity of the cells, balancing the risk of cell loss caused by flotation (low speed) and centrifugation damage (squashing) (high-speed). Alternatively, the cells can be attached to the plastic substrate, using polylysine.
8. Culture plates are treated to ensure cell adhesion even in presence of excess protein; therefore, shaking is necessary to reduce nonspecific phage adherence to plates.
9. If the cells are detergent-sensitive, wash with PBS alone, or, alternatively, use fixed cells.
10. Infection of bound phages by direct addition of the *E. coli* strain containing the $V_L C_L$ to the cells generally leads to an increased number of rescued phage without an increase in background. Alternatively, bound phages can be eluted

from the plate with 100 mM triethylamine or 50 mM glycine-HCl, pH 2.7, 150 mM NaCl.

11. At this stage, the culture is saturated, and should yield 10^{10} cfu/mL. Aeration is important at this stage of growth; aeration and yields can be increased by placing the 96-well plate into a box without a lid.

References

1. Marks, J. D., Hoogenboom, H. R., Bonnert, T. P., McCafferty, J., Griffiths, A. D., and Winter, G. (1991) By-passing immunization: human antibodies from V-gene libraries displayed on phage. *J. Mol. Biol.* **222**, 581–197.
2. Hoogenboom, H. R. and Winter, G. (1992) Bypassing immunization: human antibodies from synthetic repertoires of germ line VH-gene segments rearranged in vitro. *J. Mol. Biol.* **227**, 381–388.
3. Nissim, A., Hoogenboom, H. R., Tomlinson, I. M., Flynn, G., Midgley, C., Lane, D., and Winter, G. (1994) Antibody fragments from a ‘single pot’ phage display library as immunochemical reagents. *EMBO J.* **13**, 692–698.
4. Hoogenboom, H. R., Griffiths, A. D., Johnson, K. S., Chiswell, D. J., Hudson, P., and Winter, G. (1991) Multi-subunit proteins on the surface of filamentous phage: methodologies for displaying antibody (Fab) heavy and light chains. *Nucleic Acids Res.* **19**, 4133–4137.
5. Griffiths, A. D., Williams, S. C., and Hartley, O. (1994) Isolation of high affinity human antibodies directly from large synthetic repertoires. *EMBO J.* **13**, 3245–3260.
6. Figini, M., Marks, J. D., Winter, G., and Griffiths, A. D. (1994) In vitro assembly of repertoires of antibody chains on the surface of phage by renaturation. *J. Mol. Biol.* **239**, 68–78.
7. Jespers, L. S., Roberts, A., Mahler, S. M., Winter, G., and Hoogenboom, H. R. (1994) Guiding the selection of human antibodies from phage display repertoires to a single epitope of an antigen. *Biotechnology* **12**, 899–903.
8. Beiboer, S. H. W., Reurs, A., Roovers, R. C., Arends, J. W., Whitelegg, N. R., Rees, A. R., and Hoogenboom, H. R. (2000) Guided selection of a pan carcinoma specific antibody reveals similar binding characteristics yet structural divergence between the original murine antibody and its human equivalent. *J. Mol. Biol.* **296**, 833–849.
9. Kupsch, J. M., Tidman, N. H., Kang, N. V., Truman, H., Hamilton, S., Patel, N., et al. (1999) Isolation of human tumor-specific antibodies by selection of an antibody phage library on melanoma cells. *Clin. Cancer Res.* **5**, 925–931.
10. Figini, M., Obici, L., Mezzanzanica, D., Griffiths, A. D., Colnaghi, M. I., Winter, G., and Canevari, S. (1998) Panning phage antibody libraries on cells: isolation of human Fab fragments against ovarian carcinoma using guided selection. *Cancer Res.* **58**, 991–996.
11. Ward, E. S., Gussow, D. H., Griffiths, A. D., Jones, P. T., and Winter, G. (1989) Binding activities of a repertoire of single immunoglobulin variable domains secreted for *Escherichia coli*. *Nature* **341**, 544–546.

Selecting Antibodies to Cell-Surface Antigens Using Magnetic Sorting Techniques

Don L. Siegel

1. Introduction

As described in other chapters, the selection of phage-displayed immunoglobulin (Ig) fragments with desired specificity can be accomplished through successive rounds of panning on purified antigen (Ag). However, for many applications, the target Ag may not be able to be purified because its identity is unknown (e.g., a putative stem cell or tumor-specific marker) or because the process of purification destroys its native conformation (e.g., in the case of some integral membrane proteins). In such experimental systems, methods that select phage-displayed Ig directly on intact cell surfaces are required.

Compared to panning on purified Ag, cell-surface selection must overcome a number of technical hurdles, most notably the nonspecific adsorption of phage by irrelevant protein, carbohydrate, or lipid structures expressed by the cell. In some cases, several rounds of negative selection on Ag-negative cells can be performed prior to positive selection on cells bearing the target molecules. This strategy may be inefficient because only a small fraction of nonspecific phage can be removed during each cycle of negative selection and one runs the risk of losing the desired phage particles (initially present at low levels) through nonspecific interactions with the Ag-negative cells.

More efficient methods for cell-surface panning utilize simultaneous positive and negative selection. In this chapter, such a competitive cell-panning approach is presented, in which target cells are precoated with magnetic beads and mixed with an excess of unmodified Ag-negative cells (*I*). Following incubation of the cell mixture with a phage-display library, the target cells bearing Ag-specific phage are rapidly separated on a magnetic column and

washed, and the desired phage-displayed Igs are eluted from the cell surface for subsequent amplification. This approach has been used for the isolation of human auto- and alloantibodies, particularly for the selection of large arrays of anti-red blood cell (RBC) antibodies from human immune libraries (2). In the protocols and notes that follow, representative sample data from these studies are provided for reference.

2. Materials

1. Phage-display library, freshly amplified and titered (typically at a concentration of $\sim 10^{13}$ colony-forming units [cfu]/mL in phosphate-buffered saline [PBS]).
2. Ag-positive (target) cells and Ag-negative (absorber) cells. For RBCs, 3–4% (v/v) suspensions of phenotyped cells are available from Gamma Biologicals, Houston, TX. Approximately 10^8 target and absorber RBCs are needed per experiment. For other cell types, *see Note 1*.
3. Sulfo-NHS-LC-biotin (Pierce, Rockford, IL). Prepare a 1 mg/mL solution (*see Note 2*) in room temperature (RT) PBS immediately prior to use.
4. Streptavidin-coated paramagnetic beads; minicolumns for magnetically activated cell sorting (MACS); magnet separation unit (MiniMACS) (Miltenyi Biotec, Sunnyvale, CA).
5. 30-gauge \times 1/2-in. hypodermic needle (Becton-Dickinson, Franklin Lakes, NJ).
6. 5 \times PBSM: 10% (w/v) nonfat dry milk in PBS, pH 7.4; PBSM: 5 \times PBSM diluted to 1 \times with PBS and degassed before use.
7. PBS-BSA: bovine serum albumin (BSA) prepared as a 3% (w/v) solution in PBS, pH 7.4.
8. Acidic phage elution buffer (76 mM citric acid, pH 2.4) and phage elution neutralization solution (untitrated 2 M Tris-HCl base) (*see Note 3*).
9. Materials for phage amplification (*see Note 4*).
10. Materials for assaying the binding of panned libraries and isolated phage clones (*see Note 5*).

3. Methods

1. To prepare the target cells for surface biotinylation, wash the cells 5 \times with RT PBS and resuspend to a final volume that yields a 20% (v/v) cell suspension (*see Fig. 1* and *Note 6*). For experiments utilizing RBCs, 10^8 RBCs will provide enough target cells for ~ 10 selection procedures (*see Note 1*).
2. Add an equal amount of freshly prepared biotin reagent solution to the cell suspension, mix thoroughly by drawing up and down with a micropipetor, and incubate for 40 min at RT on a laboratory rotator to maintain the cells in suspension.
3. Wash the cells 5 \times with 400 μ L RT PBS to remove the unreacted biotin reagent. For RBC, pulse centrifugation for approx 4 s in a microcentrifuge set at full speed is sufficient to pellet the cells. After the final wash, resuspend the cells in PBS to their prebiotinylated volume as in **step 1**.

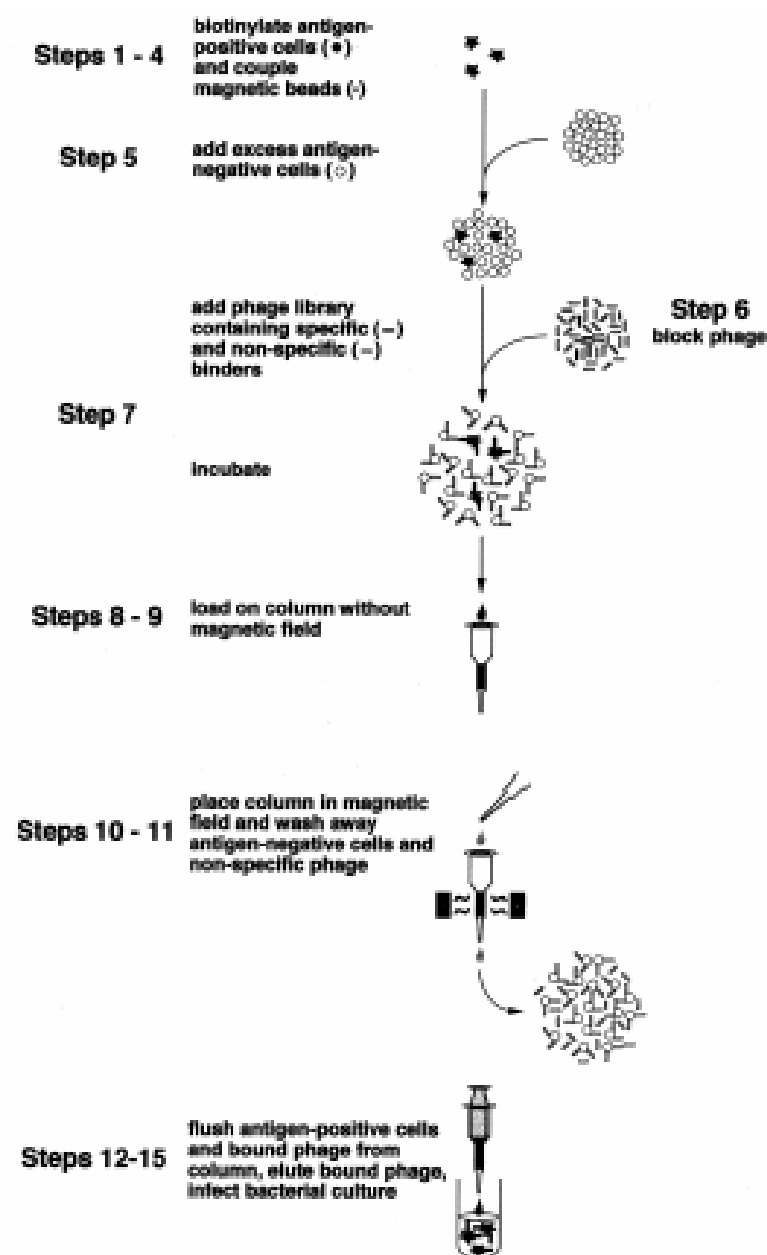

Fig. 1. Protocol flow sheet for cell-surface panning using magnetically activated cell sorting. Adapted with permission from **ref. 1**.

- Aliquot 8×10^6 biotinylated target RBCs (for other cell types, *see Note 1*) in a microcentrifuge tube and adjust the volume to 90 μL with RT PBS. Add 10 μL streptavidin-coated microbeads and incubate for at least 20 min on a rotator. Wash once in PBS and resuspend the magnetic bead-coated cells in 100 μL of RT PBS-BSA.

5. Place a 10-fold excess of absorber (Ag-negative) cells (e.g., 8×10^7 , in the case of RBCs) in a microcentrifuge tube, pellet as above, then resuspend in 100 μ L PBS-BSA. Pellet the magnetically labeled target cells (from **step 4**) and resuspend them with the suspension of absorber cells. Block the cell mixture in the BSA-containing solution at RT for 15 min (*see Note 7*).
6. Mix an excess amount of phage library ($\sim 10^{12}$ cfu, e.g., 100 μ L 10^{13} cfu/mL preparation) with one-fourth vol 5 \times PBSM in a microcentrifuge tube to achieve a final concentration of 2% PBSM. Block the phage for 60 min at RT (*see Note 8*).
7. Pellet the cell mixture and resuspend in 33 μ L blocked phage library. Incubate for 2 h at 37°C on a rotator to keep the cells in suspension (*see Note 9*).
8. During the cell–phage incubation, equilibrate a magnetic column with ice-cold PBSM as follows: run 500 μ L PBS through the column to remove the wetting agent, followed by 3 mL PBSM (*see Note 10*). Attach the 30-gauge needle to the column outlet, fill the column reservoir with PBSM, place the column in a cold room, and allow the column matrix to block until needed. With the out-flow needle in place, the PBSM should flow through the column at a rate of ~ 10 μ L/min.
9. When the cell–phage incubation is complete, allow the remaining column reservoir PBSM to flow through (surface tension will prevent the column from running dry), then load the cell–phage mix (~ 40 μ L) directly on top of the column matrix and allow it to seep in (*see Note 11*).
10. After the cell–phage incubation mix has completely entered the column, place the column within the MiniMACS separation unit. Allow 2 min for the labeled cells to adhere to the magnetically charged column matrix.
11. Wash the column with 500 μ L volumes of ice-cold PBSM (*see Note 12*), followed by a final wash with 500 μ L ice-cold PBS (to wash away the milk protein).
12. After the last column wash, remove the column from the magnet and flush off the target cells with bound phage using the plunger supplied with the column and two 500- μ L aliquots of ice-cold PBS. Immediately pellet the cells by centrifugation and discard the supernatant.
13. Resuspend the cell pellet in 200 μ L RT acid elution buffer (*see Note 3*) and incubate for 10 min with periodic vortex mixing.
14. Transfer the eluted phage and cellular debris to a tube containing 18 μ L Tris-HCl neutralization buffer (*see Note 3*).
15. Infect F' pilus-expressing *Escherichia coli* (e.g., XL1 Blue) with the phage eluate and amplify phage for additional rounds of cell-surface selection, according to standard protocols (*see Notes 4 and 13*).

4. Notes

1. The absolute number of target cells and the target cell:absorber cell ratio are determined by considering several factors, including cell size and Ag copy number/cell, as well as certain physical constraints imposed by the magnetic selection process. The single most important factor that determines the efficient

capture of specific, compared to irrelevant, phage particles is the effective Ag concentration in the incubation mix (**Subheading 3., step 7**). In theory, to capture >50% of Ag-specific phage present in an aliquot of library, the concentration of Ag must be greater than the K_d of the desired binders. For in-solution panning against soluble purified Ag, achieving an Ag concentration of, e.g., 10^{-8} M is not difficult (20 ng 50-kDa protein in 40 μ L is 10^{-8} M). However, for an Ag expressed at 10,000 copies/cell, $\sim 2 \times 10^7$ cells/40- μ L incubation volume would be required. Depending on the particular cell volume, it might not be possible to fit that many target cells in 40 μ L, along with an excess number of absorber cells and phage.

With this in mind, efforts should be made to perform cell–phage incubations with as high a target-cell concentration as is practically possible and by choosing target cells that express the highest copy number of Ags/cell. As a rough guide, the manufacturer of the magnetic columns recommends the application of no more than 2–10 μ L of magnetically labeled material (roughly equivalent to $\sim 10^7$ lymphocytes). For target cells that are considerably smaller (e.g., platelets), as many as 2×10^8 target cells have been applied to a column yielding excellent phage selection results (**3**). Once the number of target cells is chosen, the maximum ratio of target cell:absorber cell can be determined empirically by performing a series of mock panning experiments, in which aliquots of magnetically labeled target cells are mixed with increasing amounts of Ag-negative cells at ratios of 1:5, 1:10, 1:20, and so on. The cell mixtures are applied to magnetic columns, washed, and eluted, and the quality of separation of the two cell populations is assessed as a function of ratio. In the case of RBCs, when 8×10^6 magnetically labeled target cells were mixed with a 10-fold excess of Ag-negative cells (8×10^7 cells) in a 40 μ L volume, then separated on the MiniMACS column, <0.6% of the applied absorber cell population contaminated the final Ag-positive cell preparation (**1**).

2. When used as directed (**Subheading 3., step 2**), a 1 mg/mL solution of biotin reagent yields a final concentration of 500 μ g/mL, which has been shown to be suitable for the cell-surface biotinylation of most cell types. However, it may be necessary to conduct a series of pilot experiments to determine the optimal concentration of biotin to use. Target cells should be sufficiently biotinylated, so that an adequate number of streptavidin-coated paramagnetic beads bind to the cells and cause their retention by the magnetic column. However, overbiotinylation is to be avoided, because the binding properties of the target Ag could become altered or destroyed. Therefore, aliquots of target cells may be biotinylated over a range of final biotin reagent concentrations of 100 μ g/mL–2 mg/mL, and tested for quantitative retention by the columns. That the biotinylation process has not affected the target Ag can be assessed by performing an appropriate binding assay (e.g., flow cytometry) with antisera to the particular Ag. In the case in which the Ag is unknown (e.g., the putative tumor cell marker), the level of biotin reagent to use may have to be determined empirically.

3. The use of a low (or high) pH elution buffer works well for nonnucleated cells, such as RBCs and platelets. For other cell types, it may be necessary to use harsher conditions, such as urea, to strip bound phage from the cell surface. Alternatively, competitive elution methods with MAbs or the use of proteases, such as trypsin, to cleave the infectious phage particle from the displayed Ig fragment, may be more appropriate.
4. These are described elsewhere in this volume (*see* Chapters 2 and 9), but would include, at a minimum, a bacterial strain expressing the F' pilus (e.g., XL1 Blue, TG1, ER2738 strains of *E. coli*), bacterial media and plates, appropriate selection materials (i.e., antibiotics), helper phage, and polyethylene glycol for phage-particle precipitation.
5. Such assays are used for monitoring the enrichment for Ag binders following each round of selection and may utilize flow cytometry, immunofluorescence microscopy, immunohistochemistry, and so on. To detect the binding of Ig fragments while displayed on phage, enzyme- or fluorescently conjugated anti-M13 Ab can be used. To detect the binding of soluble Ig fragments, anti-Fab Abs or Abs to fusion peptides (e.g., hemagglutinin decapeptide, *c-myc* tag, and so on) may be required. For RBCs, indirect agglutination assays with anti-M13 Ab can be performed (*I*).
6. As an alternative to biotinylation and the use of streptavidin beads, target cells may be labeled with Ab directed to an unrelated Ag present on only the target cells, followed by the addition of magnetic beads bearing the appropriate secondary Ab. This method, analogous to the fluorescence-activated cell sorting-based method of de Kruif et al. (*4*), is useful when the isolation of purified populations of target cells for biotinylation is difficult. However, it does require the availability of a target cell-specific Ab. This alternative approach may be problematical for certain applications, e.g., if tumor cells are the target and the discovery of tumor-specific Abs is the goal.
7. In this protocol, cells that are to be subsequently centrifuged are blocked in BSA, not milk, because milk solids with adherent phage tend to sediment with the cells. Note that, after the milk-blocked phage is mixed with cells, the use of the magnetic column for washing obviates the need for centrifuging milk-containing cell suspensions.
8. In most investigators' hands, the use of nonfat dry milk appears to be the ideal blocking agent to reduce nonspecific adsorption of phage particles. However, it should be appreciated that milk contains numerous carbohydrate substances (including some soluble blood-group Ags), which could conceivably inhibit the specific binding of phage-displayed Ig to a particular target Ag. Therefore, it may be prudent to first check that other Abs to the target Ag (if any are available) are not inhibited by milk before carrying out a series of panning experiments. If one is working with a phage library constructed from an immunized subject, control experiments of this sort may be carried out with immune sera.
9. Incubation at 37°C for 2 h may not be appropriate for all applications. Incubations on ice may be necessary if the target Ag "caps," endocytoses, or is otherwise altered at elevated temperatures for extended periods of time.

Table 1
Isolating Anti-Rh ABs from Human Fab/Phage Library by Cell-Surface Panning on Intact RBCs

Panning round ^a	Phage input (cfu) ^b	Phage output (cfu) ^c	% Bound ^d ($\times 10^{-4}$)	Enrichment ^e	Agglut Titer ^f	Binders/ Total (%) ^g
$\gamma_1\kappa$ Fab/phage library panning results						
0					0	0/24 (0)
1	2.94×10^{11}	6.04×10^5	2.1		1/16	0/16 (0)
2	2.15×10^{11}	1.68×10^7	78.3	38.0 \times	1/2048	15/15 (100)
3	1.72×10^{11}	1.44×10^8	840.0	10.7 \times	1/2048	12/12 (100)
$\gamma_1\lambda$ Fab/phage library panning results						
0					0	0/20 (0)
1	2.28×10^{11}	3.48×10^5	1.5		0	
2	5.51×10^{11}	1.34×10^6	2.4	1.6 \times	1/128	32/36 (89)
3	3.93×10^{11}	3.86×10^8	980.0	404.0 \times	1/512	24/24 (100)
4	2.87×10^{11}	3.08×10^8	1100.0	1.1 \times	1/1024	

^a“0” represents the initial, unpanned Fab/phage library; ^btotal number of phage incubated with Rh-positive/-negative RBC admixture; ^ctotal number of phage contained in target cell (Rh-positive cell) eluate; ^d(phage output/phage input) $\times 100$; ^e-fold increase in % bound, compared to previous round of panning; ^fagglutination titer against Rh-positive RBCs, using anti-M13 Ab in an indirect agglutination assay (**I**); ^gnumber of individual Rh-binding Fab/phage clones per total number of individual clones screened from panning round. Adapted with permission from **ref. 1**.

10. If the column has been used before, it is essential that it be properly rewetted before use, otherwise, only a small fraction of its ~60 μL excluded volume will be available for the attachment of cells. Push the supplied plunger into the reservoir of the column. Place the tip of the column in a small beaker containing several milliliters 100% ethanol and vigorously push and pull the plunger in and out using the ethanol to purge all of the trapped air from within the column matrix. End this procedure with a final aspiration of ethanol into the column as the plunger is pulled out. Allow the ethanol remaining in the reservoir to flow through the column. Before the last 100–200 μL enters the column, fill the reservoir with PBS and let it wash out the ethanol. Before the PBS completely flows through, fill the reservoir with PBSM, and proceed with **step 8**.
11. For this step, the column is loaded in the absence of a magnetic field, so that the cells will distribute throughout the length of the column, yet not run off, because the 40 μL load volume is less than the column's excluded volume of ~ 60 μL .
12. Perform a total of three washes for panning rounds 1 and 2 and a total of six washes for all subsequent pannings. For the first wash of each panning round, the column outlet needle is used; for subsequent washes, it should be removed. Do not pull off the needle unless wash buffer is in the reservoir; otherwise, air

will clog the column. After the needle is removed, the column flow rate should increase to $\sim 200 \mu\text{L}/\text{min}$.

13. To monitor the enrichment process, it is useful to tabulate the phage input to each round of panning and the phage output (i.e., number of phage in the target-cell eluate), then calculate a % bound for each round. **Table 1** illustrates a set of typical results obtained using cell-surface panning and magnetic cell sorting (**I**). In this study, separate $\gamma_1\kappa$ and $\gamma_1\lambda$ Fab-display libraries were panned independently for human anti-Rh alloantibodies on magnetically labeled Rh-positive RBCs in the presence of a 10-fold excess of unmodified Rh-negative RBCs. As shown in the table, significant enrichment for binders occurred over the series of pannings, as reflected by increases in % phage bound, increases in the agglutination titer of the phage libraries against Rh-positive cells and the increased prevalence of Rh-Ag binders among individual clones randomly picked after each round of selection.

References

1. Siegel, D. L., Chang, T. Y., Russell, S. L., and Bunya, V. Y. (1997) Isolation of cell surface-specific human monoclonal antibodies using phage display and magnetically-activated cell sorting: applications in immunohematology. *J. Immunol. Methods* **206**, 73–85.
2. Chang, T. Y. and Siegel, D. L. (1998) Genetic and immunological properties of phage-displayed human anti-Rh(D) antibodies: implications for Rh(D) epitope topology. *Blood* **91**, 3066–3078.
3. Roark, J. H., Chang, T. Y., Caton, M., and Siegel, D. L. (1998) Isolation of human IgG platelet autoantibodies using phage display. *Transfusion* **38**, 1S (Abstr).
4. de Kruif, J., Terstappen, L., Boel, E., and Logtenberg, T. (1995) Rapid selection of cell subpopulation-specific human monoclonal antibodies from a synthetic phage antibody library. *Proc. Natl. Acad. Sci. USA* **92**, 3938–3942.

Isolation of Human Tumor-Associated Cell Surface Antigen-Binding scFvs

Elvyra J. Noronha, Xinhui Wang, and Soldano Ferrone

1. Introduction

Several approaches have been used to identify antibody (Ab)-defined human tumor-associated antigens (TAA) that can be used for passive and/or active specific immunotherapy of malignant diseases. For example, hybridoma technology has been successfully used to identify TAA recognized by mouse monoclonal Abs (for review, *see ref. 1*). The SEREX methodology, i.e., serological analysis of recombinant cDNA expression libraries prepared from malignant cells, has also been successfully used to identify TAA recognized by Abs present in sera from patients with malignant diseases (2). A number of novel TAA have been identified with the SEREX methodology, but most of them are intracellular (3), and are therefore not likely to be useful targets for Ab-based immunotherapy of malignant diseases. More recently, TAA have been identified by utilizing phage-display Ab libraries, which are a diverse collection of Abs displayed as Fabs (4,5) or scFvs (6) on the surface of filamentous phages (for review, *see ref. 7*). Phage libraries have been constructed using a collection of cloned V_H and/or V_L fragments that have been assembled in vitro with random complementarity-determining region 3 (CDR3) (synthetic libraries) (6). Alternatively, phage libraries have been constructed using lymphocytes from either unimmunized (naïve libraries) (4) or immunized (immune libraries) (5,8) individuals.

Panning on intact cells, either in suspension (5,9–11) or grown as a monolayer (8,12), of synthetic (9,10), naïve (11), and immune (5,8) phage Ab libraries has resulted in the isolation of Ab fragments recognizing TAA expressed on the surface of human tumor cells, including melanoma (5,8,9), colorectal

carcinoma (**10**), and lung adenocarcinoma (**11**) cell lines. Furthermore, panning with live cells has been successfully used to isolate Ab fragments reacting with blood group antigens (Ags) (**13**) and with antigens expressed on different subpopulations of peripheral blood lymphocytes (**14**).

This chapter describes a protocol for panning a phage Ab library with live tumor cell lines, followed by absorption of the amplified phage with a second cell line to remove phage-Ab recognizing common epitopes. The method, which has been adapted from that utilized to isolate Ab fragments specific for blood group Ags (**13**), was used to isolate human melanoma associated Ag-binding scFvs (**9**) from a synthetic phage scFv library (**6**). Although the protocol described here is for panning with melanoma cells, it can be used with appropriate modifications to isolate Abs to any cell surface Ag. In addition, the method can also be adapted for screening of any type of phage Ab library.

2. Materials

The following details the phage library and cell lines we have used to isolate scFvs against human melanoma surface Ags. These will need to be modified accordingly to suit the individual system. All buffers, media, and reagents should be prepared in phage-free bottles (*see Note 1*), autoclaved and stored at room temperature unless otherwise indicated.

1. Phage scFv library, freshly amplified and titered (*see Note 2*).
2. Human tumor cell lines for selection and absorption, e.g., melanoma cell line, SK-MEL-28, and B-lymphoid cell line, LG-2. Cell lines should be maintained according to specific growth requirements (e.g., in Dulbecco's modified Eagle's medium supplemented with 10% fetal bovine serum at 37°C in a 5% CO₂ atmosphere).
3. Phosphate-buffered saline (PBS); PBS + 4% dry milk powder (PBSM).
4. Elution buffer: 76 mM citric acid–PBS, pH 2.8.
5. Neutralization buffer: 1 M Tris-HCl, pH 7.4.
6. Polyethylene glycol (PEG)–NaCl: 20% PEG 8000, 2.5 M NaCl.
7. *Escherichia coli* TG1; VCSM13 helper phage.
8. 2XTY medium.
9. Ampicillin (100 mg/mL stock solution, filter-sterilize, and store at –20°C); kanamycin (25 mg/mL stock solution, filter-sterilize, and store at –20°C); glucose (GLU) (50% stock solution, filter-sterilize, and store at room temperature).
10. 80% Sterile glycerol solution.
11. TYE agar containing 100 µg/mL ampicillin and 1% glucose (TYE–AMP–GLU) in large BioAssay dishes (Nunc A/S, Roskilde, Denmark) and in 100-mm Petri dishes. Store at 4°C.
12. Centrifuge bottles and Oak Ridge centrifuge tubes (Nalgene, Nalge Nunc, Rochester, NY).
13. Hanks' balanced salt solution (HBSS).
14. 96-Well tissue culture plates.

3. Methods

All procedures should be carried out using sterile/aseptic techniques.

3.1. Panning of Phage scFv Library with Cultured Human Melanoma Cells, SK-MEL-28 (9)

1. Suspend 1×10^7 melanoma cells in 2 mL PBSM (*see* **Notes 3** and **4**) in a 15-mL polypropylene culture tube.
2. Add $\sim 10^{13}$ tu freshly amplified phage scFv library in 2 mL PBS to the cell suspension (*see* **Note 5**).
3. Incubate the cell suspension for 90 min at room temperature on a rotating wheel, then allow the tube to stand at room temperature for 30 min (*see* **Note 6**).
4. Centrifuge the cell suspension at 1000g for 5 min at room temperature.
5. Wash the cells 6 \times by resuspending in 8 mL of PBS and centrifuging as in **step 4**.
6. Resuspend the cells in 1 mL PBS and transfer the cell suspension to a 1.5-mL microcentrifuge tube.
7. Centrifuge the cell suspension at 1000g for 5 min at room temperature and discard the supernatant.
8. Elute the bound phages by adding 200 μ L elution buffer (**13**; *see* **Note 7**) to the cell pellet and incubating the cell suspension on a rotating wheel for 5 min at room temperature.
9. Centrifuge the cell suspension at 7000g for 1 min at room temperature and transfer the supernatant containing eluted phages to a microcentrifuge tube containing 200 μ L neutralization buffer.
10. Grow *E. coli* TG1 cells (from frozen stock or overnight culture) in 2XTY medium, to an optical density 600 nm (OD_{600}) of 0.5 (*see* **Note 8**).
11. Infect 10 mL *E. coli* TG1 cells with 180 μ L eluted phages in a 15-mL polypropylene tube. Incubate the cell suspension in a 37°C water bath for 30 min (without shaking).
12. Remove a 100- μ L aliquot of the infected bacteria for determining the titer of eluted phages (*see* **Subheading 3.4** and **Note 9**). Centrifuge the remaining culture at 3000g for 10 min at room temperature.
13. Add 0.5 mL 2XTY medium to the bacterial pellet and plate the bacteria on TYE-AMP-GLU medium in a large BioAssay dish.
14. Incubate the BioAssay dish overnight at 37°C.

3.2. Rescue of Phagemid After Selection (15)

1. Add 2–5 mL 2XTY medium to the BioAssay dish containing the infected bacteria, and loosen cells with a sterile glass spreader.
2. Inoculate 50 μ L cell suspension into 50 mL 2XTY medium supplemented with ampicillin (100 μ g/mL) and 1% glucose. Resuspend the remaining bacteria in 15% glycerol, aliquot into 1.5-mL microcentrifuge tubes, and store at -70°C .
3. Grow infected cells on an orbital shaker at 37°C to an OD_{600} of 0.5.

4. Add VCSM13 helper phage to 10 mL of this culture. The ratio of bacterial cells:helper phage particles should be 1:20 (1 OD₆₀₀ bacteria represents 8×10^8 bacteria/mL) (15).
5. Incubate the cell culture without shaking in a 37°C water bath for 30 min.
6. Centrifuge the infected cells at 3000g for 10 min at room temperature.
7. Discard the supernatant and resuspend the infected cells in 300 mL prewarmed 2XTY medium containing ampicillin (100 µg/mL) and kanamycin (25 µg/mL).
8. Grow cells in an orbital shaker–water bath at 30°C for 18 h.

3.3 Purification of Phages (15)

1. Centrifuge the bacterial culture in phage-free plastic bottles at 8000g for 10 min at 4°C.
2. Transfer the phage supernatant into fresh bottles and add PEG–NaCl equivalent to one-fifth supernatant volume. Mix well and leave for 1 h at 4°C.
3. Centrifuge the bottles at 8000g for 30 min at 4°C and discard the supernatant. Make sure the bottles are completely free of PEG solution.
4. Resuspend the phage pellet in 40 mL deionized H₂O and transfer the suspension to Oak Ridge tubes.
5. Add 8 mL PEG–NaCl. Mix well and incubate the phage suspension for 30 min at 4°C.
6. Centrifuge the tubes at 8000g for 20 min at 4°C and discard the supernatant.
7. Recentrifuge briefly and aspirate off any remaining PEG–NaCl.
8. Resuspend the phage pellet in 2.5 mL deionized H₂O and centrifuge at 8000g for 10 min at room temperature to remove any cell debris.
9. Remove the supernatant to a clean tube. Phages can be stored at 4°C until further use.

Use these phages for the second round of panning. Follow the same protocol of selection, rescue, and purification of phages for further rounds of panning (see Note 10).

3.4 Titer of Eluted Phages (15)

1. Take 100 µL infected bacteria suspension (see Subheading 3.1., step 12, and make a series of 10-fold dilutions (10^{-1} to 10^{-7}) in 2XTY medium.
2. Plate 100 µL of each dilution on TYE–AMP–GLU plates and incubate the plates overnight at 37°C.
3. Count the resulting colonies and calculate the phage titer.

3.5 Absorption of Selected Phages with Human B-Lymphoid Cells, LG-2 (see Note 11)

After four rounds of panning, the eluted phages are absorbed against human B-lymphoid cells, LG-2, to remove phages binding to Ags shared by human melanoma and lymphoid cells (9,16).

1. Add 2 μL eluted phage suspension to 48 μL HBSS and mix with 1×10^6 LG-2 cells for 2 h at room temperature in a 96-well tissue culture plate.
2. Centrifuge the cell suspension at 1500g for 10 min at 4°C.
3. Harvest the supernatant and repeat the absorption step 5–7 \times .
4. Infect *E. coli* TG1 cells with the final supernatant and grow on TYE–AMP–GLU plates as described previously (see **Subheading 3.1., step 11** and **Subheading 3.4., steps 1** and **2**).
5. Test phage-displayed or soluble scFvs produced from individual colonies for reactivity with melanoma cells in an enzyme-linked immunosorbent assay (**9,16**; see **Note 12**).

4. Notes

1. All nondisposable glassware and plasticware should be made phage-free by rinsing once with 0.1 M NaOH, once with 1% sodium dodecyl sulfate, 3 \times with deionized H₂O, once with ethanol, and finally washed 3 \times with deionized H₂O. Following the completion of rinsing, all items are autoclaved. Autoclaving alone is not sufficient to remove phage contamination. Precautions should be taken to avoid carryover of phage. Wherever possible, disposable plasticware should be used (**15**).
2. The synthetic phage scFv library #1 (**6**) was a gift from Dr. Greg Winter (Medical Research Council Center for Protein Engineering, Cambridge, UK). This library consists of more than 1×10^8 clones of distinct specificities. It was generated by rearranging 50 human germline V_H gene segments in vitro and ligating to a random, synthetic, 4–12-residue-long CDR3, followed by cloning into the phagemid vector, pHEN1, carrying a rearranged human anti-bovine serum albumin V _{λ} 3 light chain. *E. coli* TG1, harboring the library, was grown and phagemid were rescued with helper phage VCSM13 (Stratagene, La Jolla, CA), followed by PEG precipitation of phage particles, to obtain a titer of 1×10^{13} tu/mL (**15**).
3. Cells used for panning should be at least 90% viable. Adherent cells should be harvested using 1 mM ethylenediamine tetraacetic acid–PBS. Trypsinization may cause loss and/or alteration of cell surface molecules (**11**).
4. Use of dry milk during the panning procedure is necessary to minimize nonspecific binding of phages to cell surfaces.
5. Usually, 10^{12} – 10^{13} phage particles are used for each round of selection (**15**). The number of cells used for panning has ranged from 5×10^6 to 1×10^7 /mL (**9–11,14,17**). Cells grown as a monolayer in 24-cm² flasks (**8**) or 100-mm Petri dishes (**12**) can also be used.
6. Incubation of phages with cells has been carried out at room temperature (**8–11,18**), 4°C (**13,14**), or at 37°C (**17**). Incubation times have ranged from 30 min (**13**) to overnight (**14**).
7. Besides citric acid–PBS, other acidic buffers, such as 0.1 M glycine-HCl, pH 2.2 (**8**) and 0.5 M glycine-HCl, pH 2.3 (**18**), have been used to elute bound phages.

8. *E. coli* TG1 cells should always be monitored for spontaneous ampicillin resistant mutants by growing an aliquot in 2XTY supplemented with ampicillin (100 µg/mL).
9. Titration of the eluted phages after each round of selection helps determine the success of the panning procedure. At least a 10-fold increase in titer can be expected after each round of panning. The authors obtained a 10³–10⁵-fold enrichment after four rounds of panning with melanoma cells (9).
10. Generally, 3–4 rounds of panning should result in isolation of cell-surface-specific Abs. However, as many as eight rounds of panning have been reported (18).
11. Absorption of phages with cells lacking the Ag of interest in order to eliminate Abs reacting with cell surface Ags not of interest may be performed before panning (5,13), after each round of panning (10,11), or at the end of all rounds of panning (8,9,16). Alternatively, panning with cells positive for the Ag of interest has been carried out in the presence of an excess of cells that are negative for that Ag (14,17).
12. The specificity of the Abs isolated depends on the density of the various Ags on the surface of the cells used for selection. In our study, panning with melanoma cells, SK-MEL-28 and S5, resulted in the isolation of scFvs, all of which reacted with the human high molecular weight melanoma associated Ag (1). These results probably reflect its in vitro immunodominance (9).

References

1. Reisfeld, R. A. and Cheresch, D. A. (1987) Human tumor antigens. *Adv. Immunol.* **40**, 323–377.
2. Sahin, U., Tureci, O., Schmitt, H., Cochlovius, B., Johannes, T., Schmits, R., et al. (1995) Human neoplasms elicit multiple specific immune responses in the autologous host. *Proc. Natl. Acad. Sci. USA* **92**, 11,810–11,813.
3. Tureci, O., Sahin, U., Schobert, I., Koslowski, M., Schmitt, H., Schild, H. J., et al. (1996) The *SSX-2* gene, which is involved in the t(X;18) translocation of synovial sarcomas, codes for the human tumor antigen HOM-MEL-40. *Cancer Res.* **56**, 4766–4772.
4. Williamson, R. A., Burioni, R., Sanna, P. P., Partridge, L. J., Barbas, C. F., and Burton, D. R. (1993) Human monoclonal antibodies against a plethora of viral pathogens from single combinatorial libraries *Proc. Natl. Acad. Sci. USA* **90**, 4141–4145 [published erratum appears in *Proc. Natl. Acad. Sci. USA* **91**, 1193].
5. Pereira, S., Van-Belle, P., Elder, D., Maruyama, H., Jacob, L., Sivanandham, M., et al. (1997) Combinatorial antibodies against human malignant melanoma. *Hybridoma* **16**, 11–16.
6. Nissim, A., Hoogenboom, H. R., Tomlinson, I. M., Flynn, G., Midgley, C., Lane, D., and Winter, G. (1994) Antibody fragments from a ‘single pot’ phage display library as immunochemical reagents. *EMBO J.* **13**, 692–698.
7. Winter, G., Griffiths, A. D., Hawkins, R. E., and Hoogenboom, H. R. (1994) Making antibodies by phage display technology. *Annu. Rev. Immunol.* **12**, 433–455.

8. Cai, X. and Garen, A. (1995) Anti-melanoma antibodies from melanoma patients immunized with genetically modified autologous tumor cells: selection of specific antibodies from single-chain Fv fusion phage libraries. *Proc. Natl. Acad. Sci. USA* **92**, 6537–6541.
9. Noronha, E. J., Wang, X., Desai, S. A., Kageshita, T., and Ferrone, S. (1998) Limited diversity of human scFv fragments isolated by panning a synthetic phage-display scFv library with cultured human melanoma cells. *J. Immunol.* **161**, 2968–2976.
10. Topping, K. P., Hough, V. C., Monson, J. R., and Greenman, J. (2000) Isolation of human colorectal tumour reactive antibodies using phage display technology. *Int. J. Oncol.* **16**, 187–195.
11. Ridgway, J. B., Ng, E., Kern, J. A., Lee, J., Brush, J., Goddard, A., and Carter, P. (1999) Identification of a human anti-CD55 single-chain Fv by subtractive panning of a phage library using tumor and nontumor cell lines. *Cancer Res.* **59**, 2718–2723.
12. Figini, M., Obici, L., Mezzanzanica, D., Griffiths, A., Colnaghi, M. I., Winter, G., and Canevari, S. (1998) Panning phage antibody libraries on cells: isolation of human Fab fragments against ovarian carcinoma using guided selection. *Cancer Res.* **58**, 991–996.
13. Marks, J. D., Ouwehand, W. H., Bye, J. M., Finner, R., Gorick, B. D., Voak, D., et al. (1993) Human antibody fragments specific for human blood group antigens from a phage display library. *Biotechnology* **11**, 1145–1149.
14. de Kruif, J., Terstappen, L., Boel, E., and Logtenberg, T. (1995) Rapid selection of cell subpopulation-specific human monoclonal antibodies from a synthetic phage antibody library. *Proc. Natl. Acad. Sci. USA* **92**, 3938–3942.
15. Harrison, J. L., Williams, S. C., Winter, G., and Nissim, A. (1996) Screening of phage antibody libraries. *Methods Enzymol.* **267**, 83–109.
16. Desai, S. A., Wang, X., Noronha, E. J., Kageshita, T., and Ferrone, S. (1998) Characterization of human anti-high molecular weight-melanoma-associated antigen single-chain Fv fragments isolated from a phage display antibody library. *Cancer Res.* **58**, 2417–2425.
17. Siegel, D. L., Chang, T. Y., Russell, S. L., and Bunya, V. Y. (1997) Isolation of cell surface-specific human monoclonal antibodies using phage display and magnetically-activated cell sorting: applications in immunohematology. *J. Immunol. Methods* **206**, 73–85.
18. Pereira, S., Maruyama, H., Siegel, D., Van-Belle, P., Elder, D., Curtis, P., and Herlyn, D. (1997) A model system for detection and isolation of a tumor cell surface antigen using antibody phage display. *J. Immunol. Methods* **203**, 11–24.

Subtractive Isolation of Single-Chain Antibodies Using Tissue Fragments

Katarina Radošević and Willem van Ewijk

1. Introduction

Cell and/or tissue-specific phage antibodies (Abs) are usually generated using single-cell suspensions as a starting material for selection. However, isolation of Abs specific for certain cells and/or tissue components may be hampered because the natural architecture of the tissue (and thereby related structures), as well as certain types of cells, are lost or inefficiently recovered during the preparation of single-cell suspensions as the result of tissue digestion and (extensive) isolation protocols. This is a particularly important issue when the function of a cell, as well as its immunophenotypic make-up, is dependent on the organization within the organ. One example of such a sensitive three-dimensional organization is the thymus, a primary lymphoid organ where T lymphocytes are generated (1). The interaction between developing T cells and the thymic stromal microenvironment is reciprocal in nature and is therefore termed “thymic crosstalk” (2). Thus, the composition and organization of the stromal thymic microenvironment determines the differentiation of T cells, but, on the other hand, developing T cells influence the architecture of the stromal compartment (3).

With the aim of generating (phage) Abs that recognize molecules expressed on stromal cells in their native configuration (and that eventually might be used in functional studies), we have developed a protocol for the subtractive selection of phage Ab libraries on intact thymic fragments (4). The selection was performed using a human semisynthetic phage scFv display library (5), generously provided by T. Logtenberg. Prior to selection on thymic fragments (selector tissue), the library was preabsorbed with mildly fixed thymocytes and

splenocytes (absorber cells), in order to remove phage of undesired specificities. The thymic tissue was fixed using total body perfusion fixation (6), then minced into small fragments and nonadherent thymocytes were removed by vigorous shaking. The selection of the preabsorbed library on the thymic fragments was performed overnight at 4°C in the presence of a fresh batch of fixed absorber cells. After extensive washing, the bound phages were eluted and amplified before being used for the next selection round (Fig. 1). Following three and four rounds of selection, we analyzed scFv Abs from individual phage clones for reactivity against thymus and various lymphoid and nonlymphoid organs using immunohistochemistry. Using this subtractive selection protocol, we were able to isolate scFv Abs that bind to murine thymic stromal cells (selector tissue); Abs reactive with lymphoid cells (absorber cells) were not detected. Furthermore, some of the isolated clones crossreacted with human thymic stromal cells, indicating that Abs recognizing evolutionarily conserved epitopes were recovered (Fig. 2).

The subtractive selection of phage Ab libraries on tissue fragments should be adaptable for use against tissues other than the thymus with the aim of generating Abs against tissue-specific antigens. The choice of selector tissue and absorber cells/tissue, as well as incubation conditions, will depend on the individual research question and desired application. In general, this approach could be applied in the studies of all disease processes that involve qualitative changes in the histology of the affected tissue. One possible application is in tumor biology, in which tumor-cell-specific markers might easily be lost during the preparation of single-cell suspensions because of the isolation procedure. Furthermore, abnormalities related to a tumor may not only be located on the tumor cells, but also in the extracellular matrix. Therefore, using this approach with tumor tissue as the selector and normal healthy tissue of the same type as the absorber tissue, it may be possible to isolate Ab clones that identify cellular and histological abnormalities of a tumor.

2. Materials

1. Mice as a source of selector tissue and absorber cells (*see Note 1*).
2. For total body perfusion fixation: phosphate-buffered saline (PBS)–70 mg/mL Nembutal; PBS–0.1% procaine–HCl.
3. PBS–0.05% glutaraldehyde: freshly prepared monomeric-distilled glutaraldehyde (e.g., Polysciences) in PBS, adjusted to pH 7.4.
4. PBS; PBS–1% fetal calf serum (FCS), filter-sterilized; PBS–4% skim milk powder (block solution); PBS–0.05% Tween-20.
5. Nylon sieve with 100 µm pores.
6. Phage-Ab library, freshly amplified and titered.
7. Elution buffer: 76 mM citric acid, pH 2.5.

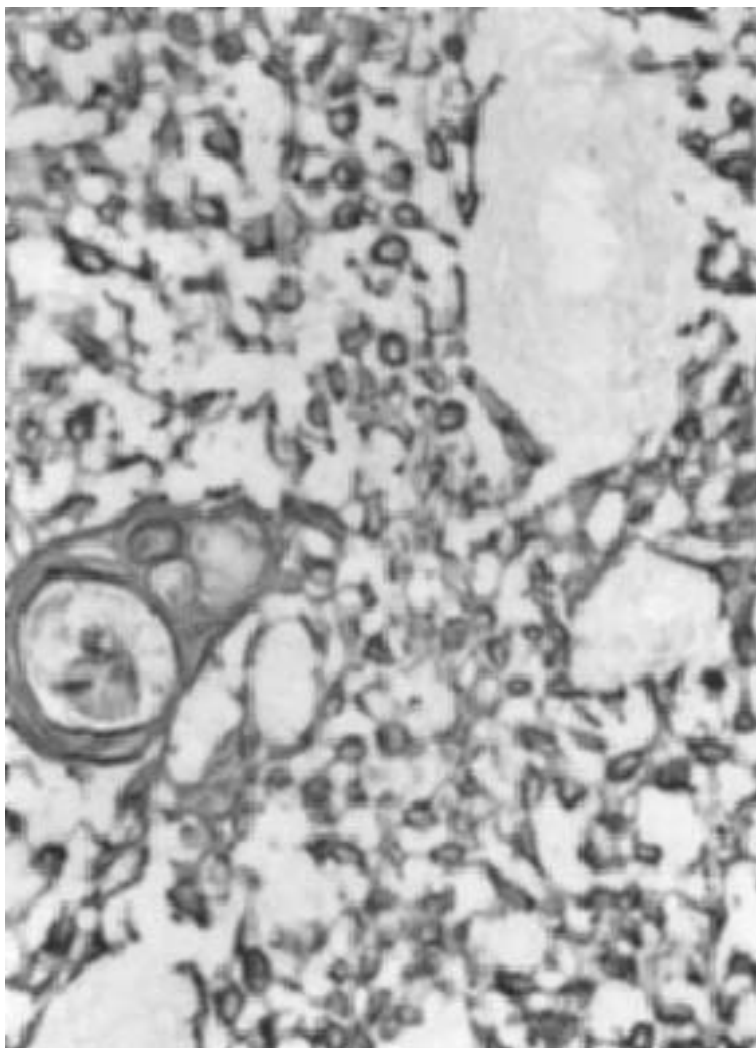

Fig. 2. Immunohistological identification of epithelial cells in the human thymus using TB4-20 scFv Ab (objective: $\times 40$).

8. 1 M Tris-HCl, pH 7.4.
9. XL1 Blue *Escherichia coli*.
10. 2TY medium: containing 12 $\mu\text{g}/\text{mL}$ tetracycline, 100 $\mu\text{g}/\text{mL}$ ampicillin, and 5% (w/v) glucose (TAG medium); large 2TY agar plates containing 12 $\mu\text{g}/\text{mL}$ tetracycline, 100 $\mu\text{g}/\text{mL}$ ampicillin, and 5% (w/v) glucose (TAG plates).
11. 5-mL polystyrene round-bottomed centrifuge tubes; 50-mL conical-bottomed centrifuge tubes.

3. Methods

The method described here uses thymic tissue as selector tissue, splenocytes as absorber cells, and a scFv phage Ab library. These protocols should be adapted accordingly for each individual system. The individual steps below (**steps 1–19**) are schematically presented in **Fig. 1**.

1. Fix the thymic tissue by total body perfusion fixation (*see Notes 2–4; 6*).
2. Isolate the thymus, mince with scissors or a razor blade, and transfer into a 50 mL tube filled with PBS.
3. Remove the nonadherent cells (thymocytes) by vigorously vortexing the thymic fragment suspension for 15 min.
4. Let the fragments sediment by standing the tube at room temperature for 5–10 min, then pipet off the PBS containing the nonadherent cells, and transfer to a clean tube. Centrifuge the nonadherent cells at 200g for 5 min and resuspend them either in 5 mL PBS–1% FCS to store (*see Note 5*) or in block solution (at concentration of 10^8 /mL) for selection (these are the thymocyte absorber cells). Resuspend the thymic fragments either in 5 mL PBS–1% FCS to store (*see Note 5*) or in 1 mL block solution for selection.
5. Prepare the splenocyte absorber cells: mince a (nonfixed) spleen through a nylon sieve (100- μ m pores) into 50 mL PBS. Centrifuge the cells at 200g for 5 min and resuspend them in 10 mL PBS–0.05% glutaraldehyde. Incubate for 15 min at room temperature. Wash the cells once with 50 mL PBS, then resuspend either in 5 mL PBS–1% FCS to store (*see Note 5*) or in block solution (at a concentration of 10^8 /mL) for selection (*see Note 6*).
6. Preabsorb, and preblock the library: mix 0.5 mL freshly amplified phage library (approx 10^{13} phages/mL) with 1 mL thymocyte absorber cells and 1 mL of splenocyte absorber cells in a 5 mL tube. Incubate the tube on an end-over-end rotator for 1 h at room temperature. Centrifuge the tube at 200g for 5 min and collect the supernatant. This represents the preabsorbed/preblocked library.
7. Preblock the fixed-tissue fragments (from **step 4**): incubate the fragments in block solution for 1 h at room temperature.
8. Add the preabsorbed/preblocked library (2.5 mL) and a fresh batch of fixed absorber cells (a mix of 10^8 thymocyte and 10^8 splenocyte absorber cells in 0.5 mL block solution) to the tissue fragments. This represents the selection mixture (*see Note 7*).
9. Incubate the suspension overnight at 4° on an end-over-end rotator with slow rotation.
10. Let the fragments sediment, then pipet off the supernatant and discard.
11. Wash the fragments thoroughly using a total volume of 1–2 L PBS–0.05% Tween-20 in order to remove unbound phages (*see Note 8*).
12. To elute the bound phages, resuspend the fragments after the final wash in 450 μ L 76 mM citric acid (pH 2.5) and incubate for 5 min at room temperature. Add 900 μ L 1 M Tris-HCl, pH 7.4, to neutralize the pH and mix gently.

13. Allow the fragments to sediment and pipet off the supernatant (containing the eluted phages) into a fresh tube (*see Note 9*).
14. Add 3 mL 2TY medium and 3 mL fresh log-phase culture of *E. coli* XL1 Blue (optical density 590 nm = 0.5) to the eluted phages and infect for 30 min at 37°C.
15. Centrifuge the bacterial culture at 2000g for 15 min and resuspend the bacterial pellet in 0.5 mL 2TY. Spread the bacteria on a TAG plate and incubate overnight at 37°C.
16. Add 3 mL 2TY medium to the plate and loosen the colonies with a sterile spreader. Collect the bacterial suspension into a clean tube.
17. Inoculate 100 µL bacteria into 50 mL TAG medium and amplify and precipitate the phage, according to standard protocols. Make a 15% (v/v) glycerol stock from the remaining bacterial suspension and freeze in aliquots at -70°C.
18. Repeat the selection for the desired number of rounds (usually 3–4).
19. Using standard protocols, isolate soluble scFv Ab from randomly selected individual clones and check the specificity of binding to thymus and lymphoid and nonlymphoid tissue (or other appropriate tissue) using immunohistochemistry and/or fluorescence-activated cell sorting (FACS) analysis (*see Notes 10 and 11*).

4. Notes

1. In order to avoid isolation of phages directed to major histocompatibility complex (MHC) antigens, mouse strains of different MHC haplotypes should be used as a source of cells/tissue for individual selection rounds (i.e., change the strain each round).
2. Total body perfusion fixation is performed as follows (6): anesthetize a mouse by intraperitoneal injection of 200 µL PBS–70 mg/mL Nembutal. Incise the thorax to expose the heart. Insert a cannula in the tip of the left ventricle. Incise the right atrium and start the total body perfusion with a prewashing solution of PBS–0.1% procaine-HCl for 2 min (procaine is used for the dilatation of blood vessels, it may be omitted). Keep the flow rate at 0.5 mL/s at a pressure of 40 mm Hg. After prewashing, switch the perfusion to PBS–0.05% glutaraldehyde for 10 min.
3. Instead of fixation by total body perfusion, the tissue can also be fixed by immersion fixation as follows: using scissors, mince the thymic tissue on a nylon sieve above a glass beaker. Rinse thoroughly to remove the nonadherent cells (thymocytes) by pipeting 50 mL PBS onto the tissue fragments. Transfer the fragments to a tube, fix with 10 mL PBS–0.05% glutaraldehyde for 15 min at room temperature. Let the fragments sediment, pipet off the fixative, and resuspend in 50 mL PBS. Let the fragments sediment, pipet off the supernatant, and resuspend either in 5 mL PBS–1% FCS to store or in 1 mL block solution, for selection (selector tissue). Collect the nonadherent cells that were rinsed out of the tissue (thymocyte absorber cells) and fix them as described for the splenocyte absorber cells in **Subheading 3., step 5**. Proceed with **step 5** in **Subheading 3**.

4. The mild fixation used might be advantageous for the selection protocol for several reasons. The epitopes remain well-preserved during overnight incubation (no internalization or proteolytic cleavage) and the tissue fragments can be shaken vigorously in order to efficiently remove nonadherent cells (thymocytes), thus exposing the thymic stromal cells for selection.
5. Fixed tissue fragments and absorber cells can be stored in PBS–1% FCS at 4°C for 1–4 wk.
6. It is also possible to use appropriate tissue fragments, instead of a single-cell suspension as an absorber population. The absorber tissue fragments should be prepared as described previously for the selector tissue fragments.
7. If using tissue fragments, instead of a single-cell suspension as the absorber, only the preabsorbed/preblocked library is added to the selector tissue fragments.
8. Transfer the fragments to a 50 mL tube, and wash at least 20×. Each washing step is performed as follows: add 50 mL PBS–0.05% Tween-20, vortex, incubate for 5–10 min at room temperature, then remove and discard the supernatant using a capillary pipet.
9. An alternative is to allow the fragments to sediment during the elution, then to pipet off the supernatant (containing the eluted phages) into a tube containing 1 M Tris-HCl, pH 7.4, in order to prevent the possible rebinding of phages to the tissue upon neutralization.
10. In general, for preliminary screenings of scFv Abs we prepare periplasmic (TES) extracts from the output (selected) clones in strain XL1 Blue. Although this is a suppressor *E. coli* strain, the suppression is not complete, resulting in the production of a mixture of scFv and fusion-scFv (scFv coupled to the pIII protein). In addition, we recently used mini-scFv preparations for immunohistochemistry and FACS screenings. Mini-scFv preparations are supernatants of individual clones (either in suppressor or nonsuppressor *E. coli* strains) grown in 96-well plates and induced with isopropyl thiogalactopyranoside. The volume obtained from one well is sufficient for a single immunostaining. The signals obtained using these preparations are usually weaker than from the periplasmic preparations, but they do enable high-throughput preliminary screenings. A limiting factor in the number of clones that can be screened in one experiment is the number of sections or FACS samples that can be handled at one time. For further screenings, we transform a nonsuppressor strain of *E. coli* (e.g., SF110) with the scFv DNA and prepare periplasmic extracts for binding analysis. A flow diagram of our current screening strategy is shown in **Fig. 3**.
11. To date, we have isolated a limited repertoire of thymus-reactive clones following three and four rounds of selection. The reasons for this are as yet unclear, but may partly result from the vigorous washing step following incubation with the phage library, in which only the clones with the highest affinity would remain bound to epitopes on the stromal cells. It is also possible that clones with other specificities were recovered in the first and second selection rounds, but that they

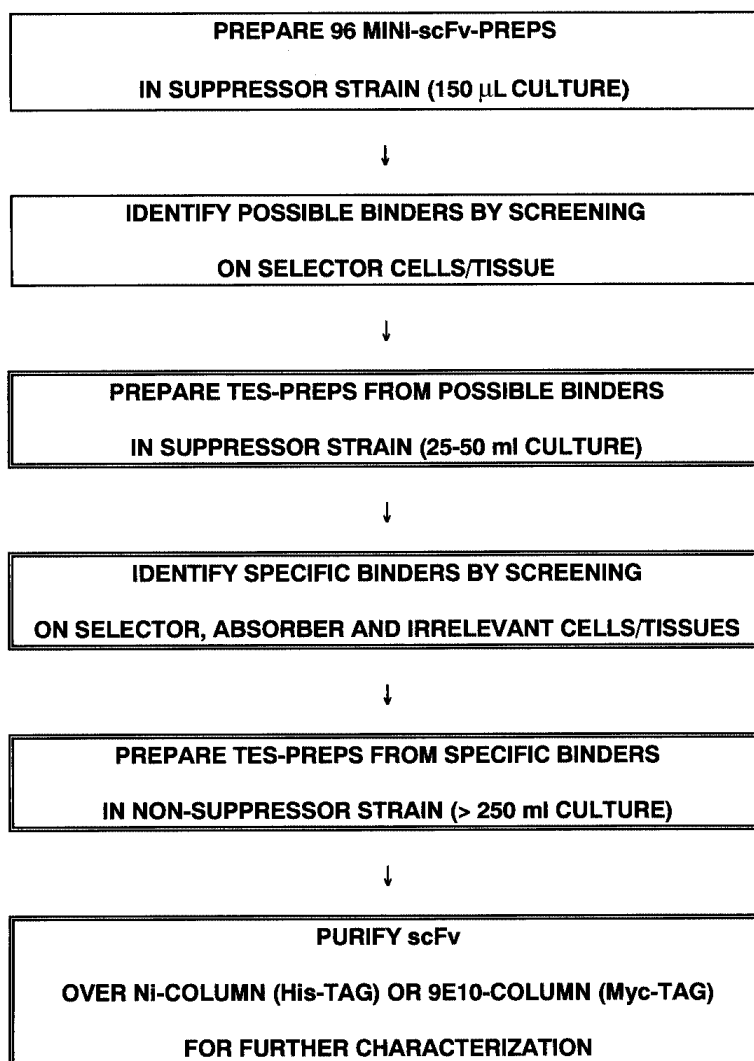

Fig. 3. Screening strategy for postpanning analysis of isolated scFv Abs using immunohistochemistry and FACS (see Note 10).

were lost (overselected) during further selection rounds because of the growth advantage of dominant clones.

References

1. van Ewijk, W. (1991) T-cell differentiation is influenced by thymic microenvironments. *Annu. Rev. Immunol.* **9**, 591–615.
2. van Ewijk, W., Shores, E. W., and Singer, A. (1994) Crosstalk in the mouse thymus. *Immunol. Today* **15**, 214–217.

3. van Ewijk, W., Wang, B., Hollander, G., Kawamoto, H., Spanopoulou, E., Itoi, M., et al. (1999) Thymic microenvironments, 3-D versus 2-D? *Semin. Immunol.* **11**, 57–64.
4. van Ewijk, W., de Kruif, J., Germeraad, W. T. V., Berendes, P., Röpke, C., Platenburg, P. P., and Logtenberg, T. (1997) Subtractive isolation of phage-displayed single-chain antibodies to thymic stromal cells using intact thymic fragments. *Proc. Natl. Acad. Sci. USA* **94**, 3903–3908.
5. de Kruif, J., Boel, E., and Logtenberg, T. (1995) Selection and application of human single chain Fv antibody fragments from a semi-synthetic phage antibody display library with designed CDR3 regions. *J. Mol. Biol.* **248**, 97–105.
6. van Ewijk, W., Brons, N. H. C., and Rozing, J. (1975) Scanning electron microscopy of homing and recirculating lymphocyte populations. *Cell Immunol.* **19**, 245–261.

Selection of Antibodies Based on Antibody Kinetic Binding Properties

Ann-Christin Malmberg, Nina Nilsson, and Mats Ohlin

1. Introduction

Molecular evolution approaches to developing molecules with characteristics particularly suited for specific applications have become important tools in biomedicine and biotechnology. Not only is it possible to identify molecules with specificities that cannot easily be obtained by other means, but it is also possible to fine-tune in an efficient manner the properties for, in principle, any specified application. Attention has particularly been put into identifying molecules with specific reaction-rate and affinity properties. Depending on the intended application, the binding of a molecule to its target is desired to be long-lived or short-lived. In biosensors, it will generally be appropriate for the association between the ligand and its receptor to be rapid. However, the dissociation of the complex should also be fast to ensure a rapid response of the sensor to a changing environment, particularly in on-line systems. In contrast, stable, nondissociating interactions are favored when, for example, an antibody (Ab) is used for tumor imaging or tumor therapy. In conventional immunoassays, high affinity (and specificity) is often sought to ensure a high sensitivity of the assay. However, under conditions in which a high throughput rather than a highly sensitive format is necessary, it may be more important to have a rapid association rate and a rapid establishment of equilibrium of the assay system than simply to have an assay based on high affinity alone.

Mostly independent of the requirements of the system to be developed, tools are now available to identify molecules with kinetic and affinity properties that are appropriate for the specific application being developed. It is now possible to devise systems based on display of libraries that select for molecular

variants with such specific properties. These systems may be developed using a variety of display technologies, but the following discussion focuses on the identification of receptors displayed on the surface of filamentous phage. Although the examples are limited to display of Ab fragments, many of the principles could be applicable to any receptor–ligand pair.

Most conventional selection systems based on interaction of phage-displayed molecules with soluble ligands, followed by a step through which the complexes are caught onto a solid matrix, tend to select for a slow dissociation rate of the complex. These systems usually depend on using low concentrations of the ligand in a monomeric, soluble format. Binders that, because of their reaction rate and affinity properties, are able to bind the ligand under the conditions employed, will subsequently be retrieved. Theoretical considerations, describing how such selections should be carried out, have been put forward (1). In all of these systems, specific attention must be paid to problems associated with avidity effects that will result from multivalent display of binders on the surface of the protein-displaying particle (see **Note 1**). Furthermore, it is not easy to fine-tune the selection to achieve specific reaction-rate properties. However, the kinetic parameters for antigen (Ag)–Ab interactions, rather than the affinity alone, have been shown to correlate with biological or technological performance, as outlined above, which points at the importance of being able to efficiently select for and evaluate kinetic parameters of conventional and recombinant Abs. Approaches to specifically identify and retrieve clones, based on their reaction rate kinetics, have also been established (2–4). This chapter describes procedures for isolating Abs from phage libraries by employing the Biacore technology to select for displayed molecular variants, which is primarily based on a reduced dissociation rate, and the specific amplification of phages (SAP) approach (see **Note 2**) to identify molecules dependent on either their association rate constant (k_{ass}) or dissociation rate constant k_{diss} (see **Fig. 1**).

2. Materials

1. BIACORE biosensor (Biacore, Uppsala, Sweden) equipped with an elution device, i.e., BIACORE®2000 and BIACORE®3000. Older models may be upgraded for this purpose.
2. Phage-Ab library constructed in an appropriate phagemid vector, which encodes the C-terminal domain of the bacteriophage, *gene III* protein (gIIIp) (6).
3. Ag of interest, purified. For SAP experiments, fusion proteins consisting of the N1 and N2 domain of gIIIp fused to the Ag of interest should be prepared according to Nilsson et al. (7) and Krebber et al. (8).
4. Relevant *Escherichia coli* strain of male origin (e.g., Top10F'). This strain is used as indicator bacteria and to harbor and propagate phagemids and phage.

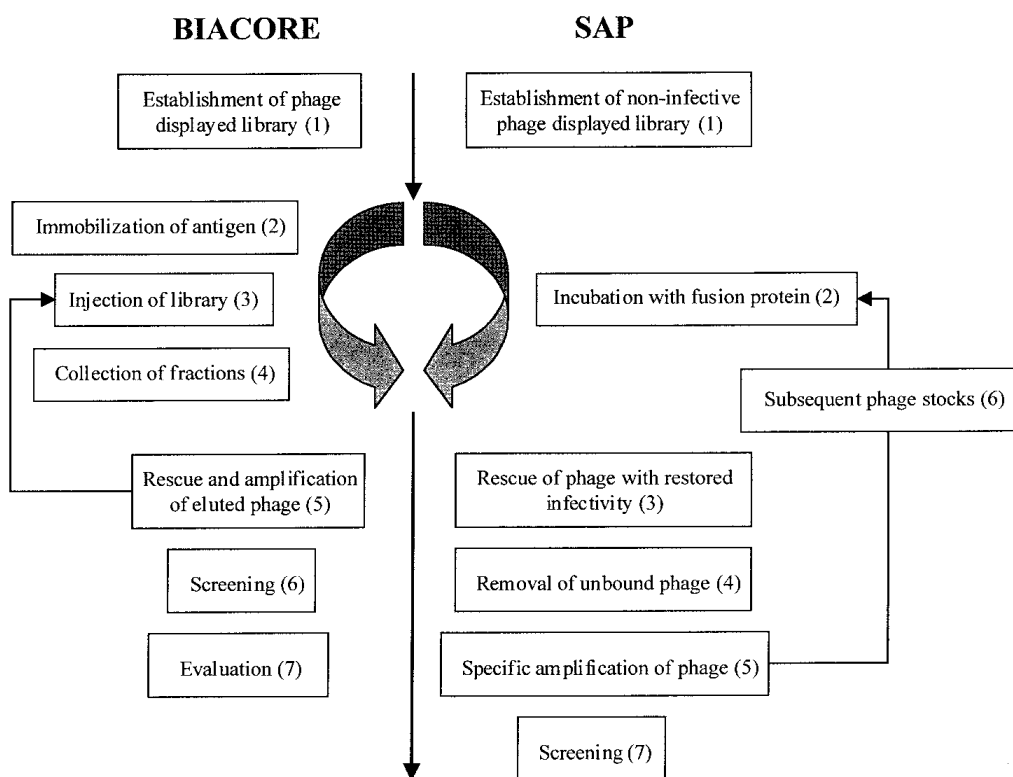

Fig. 1. Summary of procedures followed in Biacore-based and SAP-based procedures to enrich for clones displaying diverse affinity and reaction rate characteristics. Numbers in parenthesis refer to steps in **Subheading 3**.

5. For Biacore, conventional helper phage (e.g., VCSM13). A *gIII*-deleted helper phage, e.g., R408d3 (5), is required for SAP.
6. Liquid media (e.g., 2TY), antibiotics, and agar plates for selection, according to the requirements of the specific phage Ab library expression system.

3. Methods

3.1. Selections Using the BIACORE Biosensor

1. Amplify the phage library using helper phage, VCSM13, according to standard protocols and determine the titer (cfu/mL).
2. Immobilize the Ag according to appropriate coupling routines to the sensor chip, preferably a Pioneer Chip C1 (*see Note 3*). The amount of Ag immobilized to the chip should be optimized, according to specific requirements (*see Note 4*).
3. Inject the phage library at 1 $\mu\text{L}/\text{min}$ (*see Notes 5 and 6*) undiluted or diluted in the running buffer provided by the manufacturer or in any other buffer known to be compatible with Ab recognition of the Ag of interest. The injected volume

will determine the association time, i.e., injection of 10 μL at the specified flow rate will give an association time of 10 min.

4. Collect 10 μL fractions of the eluate at the desired time-points (*see Note 7*). The longer the dissociation time, the more likely it is to find an Ab fragment of slower k_{diss} (*see Notes 8–10*).
5. Infect a freshly grown log-phase culture of *E. coli* (optical density 600 nm = 0.4–0.6) with dilutions of the eluate by adding 10 μL of each phage dilution to 100 μL bacteria. Incubate at room temperature for 30 min and plate on agar plates with the appropriate antibiotics for selection. Incubate at 37°C overnight.
6. Screen the individual colonies by monoclonal phage enzyme-linked immunosorbent assay to determine Ag specificity. Repeat the selection process if necessary.
7. Evaluation of the ranking of k_{diss} of positive clones can be performed directly on the monoclonal phage stocks using Biacore (*see Note 11*). For determination of absolute k_{diss} and k_{ass} and therefore affinity constants for the selected Abs, it is advisable to express the Abs as soluble fragments.

3.2. SAP Selections

This protocol is designed to select specific phage binders of ranging affinity from a library of noninfectious Ab-displaying, phagemid-containing phage particles, i.e., SAP phage particles.

1. Amplify the phage Ab library using standard protocols using *gIII*-deleted helper phage at a multiplicity of infection (MOI) of 10–100. Grow the SAP phage particles for 6–16 h at 37°C (*see Note 12*), then precipitate the phage particles using polyethylene glycol and resuspend the pellet in phosphate-buffered saline.
2. Incubate the phage (normally 10^7 – 10^{10} phage/selection) with the N1/N2-domain fused Ag, using a series of increasing Ag concentrations (*see Notes 13 and 14*) in a total volume of 100–150 μL of PBS. Depending on the desired affinity, use fusion protein concentrations ranging from 10^{-6} to 10^{-11} M (*see Notes 15–17*). Incubate at room temperature for 3 h with moderate shaking (in order to avoid precipitation of the phage and to increase the mobility of the interacting pairs).
3. Add 100–500 μL freshly grown log-phase *E. coli* and infect for 30 min at 37°C (no shaking).
4. Remove the unbound-input phage particles by centrifugation for 10 min at 2000g. It is important to remove unbound-input phage since these phage might give rise to nonspecific interactions, which will compromise the specificity of the selection and the amplification.
5. Resuspend the bacterial pellet in 100–500 μL growth medium and plate onto agar plates supplemented with selective antibiotics and grow overnight at 30°C.
6. Using a small amount of 2TY, scrape the bacterial cells from the plates and amplify according to standard protocols using *gIII*-deleted helper phage at a MOI of 10–100 to generate secondary stocks of SAP phage particles.
7. The selection is repeated until satisfactory results (e.g., as evaluated by standard immunoassay procedures) are obtained. It is advisable to analyze the material

after each round of selection using standard polymerase chain reaction procedures with Ab gene-specific primers because a large accumulation of clones lacking an Ab gene insert suggests that the selection process does not operate properly.

4. Notes

1. Avidity effects have been shown to be a particular problem when displaying single-chain Ab fragments (scFvs) because many of them tend to dimerize under conditions in which for example, the linker causes hindrance to formation of the V_H - V_L interaction within the same scFv molecule. Similarly, high levels of display may also, in the absence of dimerization, cause some phage particles to carry multiple copies of the displayed protein. Unless appropriate selection conditions are used, avidity effects, rather than reaction rate properties of the displayed protein, will come to dominate the selection process. However, the use of monovalent Ag and stringent conditions under which phage carrying specific binders are caught (9) have mostly eliminated the problems associated with avidity-based, rather than affinity-based, selection conditions, allowing retrieval of high-affinity clones recognizing essentially any ligand.
2. The SAP procedure is performed in solution and is therefore based on affinity, rather than avidity, which is often the case in standard selection procedures involving selection against immobilized Ag. Consequently, despite multivalent display of the Ab fragment (all gIIIp C-terminal domains display the Ab fragment) on SAP phage particles, high-affinity binders are preferentially selected. In addition, it is possible to select lower-affinity binders and binders displaying specific reaction rate properties under certain circumstances (*see Note 16*).
3. The properties of the sensor chip used for the analysis can influence the size of the signal. A conventional CM sensor chip consists of a three-dimensional dextran matrix, which allows the Ag to be immobilized not only on the surface of the dextran layer, but also within the matrix. However, because of the size of the phage, only the Ag on the surface of the dextran is accessible to the bulky phage, thus giving a lower-than-expected signal. For this reason, Biacore has developed two new types of sensor chips, especially suitable for analysis of phage-displayed molecules. These are the Sensor Chip C1, with a flat carboxy-methylated surface, and the Sensorchip F1, with a short carboxy-methylated dextran matrix. Both have proven to be more efficient when working with phage-displayed molecules, probably as a combination of altered charge and reduction of steric effects. More efficient, in this context, means that lower titers of phage are needed to observe the binding and binding of phages displaying low-affinity Abs can be analyzed.
4. Optimization of the density of immobilized Ag is important to obtain true kinetic properties. An increased Ag density gives rise to an apparent slower dissociation rate, because a surface with a high surface density of Ag increases the probability for a dissociated Ab to rebind to the surface before it reaches the bulk buffer flow. Consequently, this applies not only to di/multivalent Abs, but also to monovalent binders, which may be influenced by the Ag density.

5. The signals obtained from phage libraries in Biacore are low, considering the size of the phage itself, which may result from steric hindrance occurring when the large phage particles are to find their immobilized target antigens. A titer of $\sim 1 \times 10^9$ cfu/mL is usually necessary for observing any signal. However, selections may be performed even if no signal is visible.
6. There may be a problem with the rebinding of dissociated phages (as discussed in **Note 4**), which reduces the efficiency by which phage-displaying Ab fragments of low k_{diss} are enriched. One way to overcome this problem is to increase the flow rate. A higher flow rate gives rise to a faster dissociation, probably because of more efficient removal of dissociated phages. This is probably an effect of a reduced thickness of the stationary liquid layer above the surface, and consequently, the residence time of molecules in this layer, i.e. mass transport limitations are minimized at high flow rates. However, bulky molecules such as phage may be diffusion-limited at high flow rates in the small channels of the IFC. For this reason, the flow should be kept as low as possible.
7. Another approach to minimizing the effect of rebinding of dissociating phages and Ab fragments, resulting in an inefficient enrichment of phage displaying slowly dissociating Ab fragments, would be to add a competing soluble Ag in the flow buffer during the dissociation phase. This would increase the apparent k_{diss} .
8. After a long period, the remaining fraction of bound phage may display multiple copies of the Ab fragment. Collect the eluate before such phages come to dominate the eluted fraction. A suitable time-point can only be determined by experience, and it will differ between different experimental systems. Some guidance might be obtained by assessing the theoretical rate by which binders displaying different dissociation rates ought to dissociate. The theoretical dissociation of complexes follows the relationship

$$m(t) = m(0) \times e^{(-k_{\text{diss}} \times t)}$$

in which $m(0)$ is the amount of complexes at time-point 0, $m(t)$ is the amount of complexes at time-point t , t is the time of dissociation (s), and k_{diss} is the dissociation rate constant (s^{-1}).

9. In order to retrieve the binders with the highest affinity, fractions can be collected during a regeneration step. However, a regeneration step is a general washing step, and the number of nonbinders and Abs of lower affinity is often higher than expected. Furthermore, regeneration is usually performed at either reduced or elevated pH, meaning that an immediate neutralization step is essential for the survival of the phage.
10. The BIAcore can be used to evaluate conditions for elutions in conventional selection systems, e.g., panning or magnetic beads. These so-called BIA-guided selections were evaluated by Schier and Marks (**10**), who determined optimal conditions for elution of a phage-displayed Ab library, to ensure selection based on increased affinity, and not on irrelevant parameters, such as decreased toxicity or increased expression levels. This was evaluated based on the percentage

eluted phage derived from a polyclonal library bound to an Ag immobilized to the sensor chip surface using different eluants. Furthermore, they determined the concentration of competing Ag for each round of the panning by testing in Biacore in a similar manner.

11. Direct determination of the k_{ass} from sensorgrams using phage-displayed molecules is not advisable since the signal is limited by mass transport, and thus determination of the k_{diss} may also be difficult. However, a relative ranking of molecules could be obtained by comparing their dissociation curves.
12. When using the SAP selection system to select specific phage binders, whether peptides, Ab fragments (e.g., scFv, Fab), or any other protein, it is of utmost importance that the phage particles do not display wild-type gIIIp. The SAP phage particles need to be checked thoroughly for their display content, which can be performed by an anti-gIIIp Western blot analysis. The presence of wild-type gIIIp will destroy the selectivity of the selection, thereby making it difficult to select low abundant binders. R408-generated *gIII*-deleted helper-phage stocks have proven to be more stable than VCSM13- and M13KO7-derived helper-phage stocks. The former phage shows considerably lower frequency of reverting to wild-type genotype than other deleted helper phages (5).
13. To be able to accomplish efficient and highly specific SAP experiments, it is crucial to determine the exact and preferably functional, active concentration of the respective parts of the selection, i.e., phage particles and fusion proteins. This can be achieved through conventional protein concentration assays (such as bicinchoninic acid protein assay kit) (7). Ab-displaying phage particles to be used in SAP selections can be stored at 4°C for several weeks if polyethylene-glycol-precipitated and appropriate protease inhibitors are added, but freshly produced phage stocks perform better.
14. Even though the generated SAP phage particles are free of wild-type gIIIp, they can infect bacterial cells by a pilus-independent mechanism. The receptor, if one exists, for this kind of infection is currently not known. Furthermore, if a library of Ab fragments is displayed on the surface of the phage, there is a high probability for antibacterial Abs to be present in the large pool of Abs. Phage displaying such antibacterial Abs will hamper the specificity and thereby the efficiency of the system. It is therefore necessary to evaluate the phage particles to be used in selection for nonspecific binding to bacterial cells or to irrelevant Ag.
15. Important parameters when selecting for specific binders using the SAP procedure, is the time of interaction and the concentration of fusion protein (4). Through modulation of these two parameters, it is possible to select specific binders with different affinity properties. Shorter incubation times will favor the selection of high-affinity binders; longer incubation times, exceeding 3–4 h at room temperature and with moderate shaking will decrease the amount of specific binders because of decreased stability of the fusion protein–phage complex (4). Furthermore, to select high-affinity binders, it is advisable to keep the fusion protein concentration low (the molarity of the fusion protein should

be below the desired affinity constant), since high amounts of fusion protein will lead to increased levels of nonspecific background infections.

16. The k_{ass} between the interacting pairs most influences the SAP event (4). SAP experiments with shorter incubation times and low concentration of fusion protein will favor the selection of binders with fast k_{ass} , and particularly those binders showing a fast k_{diss} . To obtain binders with slower k_{diss} values, competing free Ag (i.e., without the N1 and N2 domains) can be added during the selection, to capture the fast dissociating binders.
17. The SAP procedure favors the selection of high-affinity binders, and the number of selected clones of Ab-displaying phage increases with the affinity of the interacting Ag–Ab complex (7). To select low-affinity binders, it is necessary to increase the concentration of the fusion protein, thereby increasing the number of nonspecific binders. To circumvent this problem, it is possible to perform a subtractive preselection step, and, in doing so, deleting the high-affinity binders. The preselection is achieved in the presence of a low concentration of fusion protein selecting high-affinity Abs. The nonbinders remain in the supernatant, and are used for a second selection experiment with high amounts of fusion protein, favoring the retrieval of low-affinity Abs.

References

1. Levitan, B. (1998) Stochastic modeling and optimization of phage display. *J. Mol. Biol.* **277**, 893–916.
2. Hawkins, R. E., Russell, S. J., and Winter, G. (1992) Selection of phage antibodies by binding affinity. Mimicking affinity maturation. *J. Mol. Biol.* **226**, 889–896.
3. Malmborg, A.-C., Dueñas, M., Ohlin, M., Söderlind, E., and Borrebaeck, C. A. K. (1996) Selection of binders from phage displayed antibody libraries using BIACORE™ biosensor. *J. Immunol. Methods* **198**, 51–57.
4. Duenas, M., Malmborg, A.-C., Casalvilla, R., Ohlin, M., and Borrebaeck, C. A. K. (1996) Selection of phage displayed antibodies based on kinetic constants. *Mol. Immunol.* **33**, 279–285.
5. Rakonjac, J., Jovanovic, G., and Model, P. (1997) Filamentous phage infection-mediated gene expression: construction and propagation of the gIII deletion mutant helper phage R408d3. *Gene* **198**, 99–103.
6. Johansen, L. K., Albrechtsen, B., Andersen, H. W., and Engberg, J. (1995) pFab60: a new, efficient vector for expression of antibody Fab fragments displayed on phage. *Protein Eng.* **8**, 1063–1067.
7. Nilsson, N., Karlsson, F., Rakonjac, J., and Borrebaeck, C. A. K. (2000) Dissecting selective infection of *E. coli* based on specific protein-ligand interactions, in press.
8. Krebber, C., Spada, S., Desplancq, D., Krebber, A., Ge, L., and Pluckthun, A. (1997) Selectively-infective phage (SIP): a mechanistic dissection of a novel in vivo selection for protein-ligand interactions. *J. Mol. Biol.* **268**, 607–618.

9. Schier, R., Bye, J., Apell, G., McCall, A., Adams, G. P., Malmqvist, M., Weiner, L. M., and Marks, J. D. (1996) Isolation of high-affinity monomeric human anti-c-erbB-2 single chain Fv using affinity-driven selection. *J. Mol. Biol.* **255**, 28–43.
10. Schier, R. and Marks, J. D. (1996) Efficient in vitro affinity maturation of phage antibodies using BIACore guided selections. *Hum. Antibodies Hybridomas* **7**, 97–105.

Selection of Functional Antibodies on the Basis of Valency

Manuela Zacco

1. Introduction

Antibodies (Abs) displaying an agonist or antagonist activity are powerful tools for mimicking or blocking physiological functions in the cell. A number of applications of Abs in diagnosis and therapy require multivalent reagents, either because biological activity depends on the polymeric nature of the antigen (Ag), or because biological activity depends on an effect on the formation of homodimeric species. Often dimerization is a prerequisite for activation of a number of surface receptors by their natural ligands and divalent Abs are typically required for mimicking or blocking the activity of such ligands.

Ab fragments can be generated by using phage-display technology, but these are normally monomeric fragments (Fvs, scFvs, and Fabs) (1). Strategies for engineering multivalent fragments have been described (2–4), but they are laborious and inappropriate for mass screening. The methodology presented here allows for the selection from phage-display libraries of Ab fragments capable of modulating cell surface receptor functions when in a divalent format (5). This approach combines the advantage of easy selection offered by phage display of monovalent Ab fragments with an approach to isolating Abs whose function depends on divalency. A two-step selection protocol is used: the first step consists of the selection of monovalent recombinant Ab fragments from phage-display libraries using standard protocols. Selection at this stage is based on the specificity of binding to the Ag of interest and the only requirement for the next step is that the recombinant Ab fragment is tagged with an epitope recognized by a specific anti-tag Ab (e.g., a Myc tag). The selected Ab fragment

is then expressed in *Escherichia coli* and purified before testing its ability to interfere with a specific cellular function.

The second step consists of the identification of those Ab fragments that show biological activity when in a dimeric format. To this end, the Ab fragments are dimerized using the anti-tag Ab as a dimerization domain: two identical Ab fragments bind via their tag to each of the two binding sites of a divalent (immunoglobulin G) anti-tag Ab, thus generating a divalent binding site for the Ag of interest. Cells can subsequently be challenged with the anti-tag–Ab-fragment complexes and inhibition or enhancement of specific cellular functions can be evaluated.

This approach is versatile and allows for conditional selection of monomeric or dimeric Abs and is readily suited to mass-screening for activity. Abs that prove to be active as dimers can be further engineered for multivalency (e.g., as complete immunoglobulin G expressed in mammalian cells).

This chapter contains the detailed protocol for the selection of Ab fragments (Fab) capable of interfering with the cell-proliferation signal induced by binding of a growth factor (hepatocyte growth factor/scatter factor [HGF/SF]) to its transmembrane receptor (Met). In this specific case, the selection procedure relies on a DNA–thymidine incorporation assay to evaluate cell proliferation as an indication of function. For other applications, the assay of choice for the isolation of functionally active Ab fragments will necessarily depend on the specific system and on the particular function the Ab is expected to mimic or inhibit.

2. Materials

This method is based on dimerization using Myc-tagged recombinant Ab fragments.

1. Recombinant Ag-specific Ab (in this case, anti-HGF/SF), expressed as an affinity-tagged fusion protein (e.g., Myc) and purified using affinity chromatography (*see Note 1*).
2. Mouse keratinocyte cell line expressing the HGF/SF receptor on cell surface.
3. Serum-free medium (SFM) basal medium (Gibco LRT, 041-17005 M); purified epidermal growth factor (Gibco LRT cat. no. 13029-012); bovine pituitary extract (Gibco LRT, cat. no. 13028-014).
4. 96-Well flat-bottomed tissue culture plates.
5. Purified anti-Myc tag monoclonal Ab (e.g., 9E10, which is commercially available).
6. ³H-methylthymidine (Amersham, TRA 120, 1 mCi/mL and 5 Ci/mmol): 25X stock solution at 10 μ Ci/mL in SFM.
7. Purified recombinant HGF/SF.
8. 0.2 M NaOH.

9. Phosphate-buffered saline (PBS).
10. Ecolume liquid scintillation solution, 5 mL scintillation vials, and liquid scintillation β analyzer.

3. Methods

1. Plate the mouse keratinocytes in a 96-well plate at 5×10^3 cells/well in 200 μ L keratinocyte SFM basal medium supplemented with 5 ng/mL epidermal growth factor and 50 μ g/mL bovine pituitary extract. Incubate at 37°C in a 5% CO₂ humidified atmosphere until confluent (approx 2–3 d).
2. Once confluent, wash the cells once by adding 200 μ L warm sterile PBS/well, then aspirating off.
3. Add 200 μ L SFM basal medium (no additives) to each well, and incubate for 20–24 h, to growth-arrest the cells.
4. When the cells are ready for the experiment, preincubate 10^{-7} M of Ab fragments (final concentration) (see **Note 2**) with 0.5×10^{-7} M of anti-tag Ab (e.g., 9E10) in a total volume of 100 μ L PBS for 1 h at 37°C (see **Note 3**). As a control, set up the same experiment omitting the anti-tag Ab.
5. Aspirate the media from the cells and replace it with 200 μ L (total volume) of SFM basal medium containing the 100 μ L preincubated Ab mix and 30 pmol/mL HGF/SF (see **Note 4**).
6. Add 20 μ L ³H-methylthymidine in SFM basal medium to give a final concentration of 2 μ Ci/well. Incubate the plate for 24 h at 37°C.
7. Wash the cells twice with 200 μ L ice-cold PBS. Keep the cells on ice throughout the washing procedure.
8. Remove the plate from the ice and add 200 μ L of 0.2 M NaOH to each well and incubate for 30 min at 37°C.
9. Transfer the 200 μ L medium from each well to a 5 mL scintillation vial. Wash the wells with an additional 200 μ L 0.2 M NaOH and also add to the scintillation vial.
10. Add 5 mL scintillation fluid/vial, mix thoroughly, and count on a liquid scintillation analyzer for 1 min.
11. Compare the counts from the wells with dimerized Ab fragments to the counts from control wells (no anti-tag Ab). Abs with agonist or antagonist activity will generate an increase or reduction in counts, respectively, compared to the control wells.

4. Notes

1. If the available Ab clone does not express a tag, this can be easily rectified by subcloning into an appropriate expression vector. In the specific example described in **Subheading 3.**, the Abs against HGF/SF were first selected as Fabs displayed on phage, then were subcloned into pUC119His₆MycXba vector (**6**), which includes two different tags: a His₆ tag for purification of Ab fragments and a Myc tag for dimerization. The Abs were then purified via the His tag using

immobilized metal affinity chromatography on Ni-agarose resin. However, it is not necessary to use two different tags for purification and dimerization and there are other phage display and/or recombinant protein expression plasmids that would also be appropriate.

2. This corresponds to 5 $\mu\text{g/mL}$ if purified Fabs are used. For different Ab fragments, the amount must be calculated according to the molecular weight of the fragment.
3. A twofold molar excess of Ab fragment to anti-tag Ab ensures that most binding sites are in a divalent conformation.
4. A growth-response curve was determined empirically by evaluating the cell growth rate (as measured by ^3H -thymidine incorporation) using increasing amounts of HGF/SF. The resulting curve is a sigmoid and 30 pmol/mL is the amount of HGF/SF that gives half-maximal stimulation of DNA synthesis in mouse keratinocyte cells. This is the optimal concentration of growth factor to use, because small changes in ligand concentration result in maximal effect on growth rate.

References

1. Winter, G., Griffiths, A. D., Hawkins, R. E., and Hoogenboom, H. R. (1994) Making antibodies by phage display technology. *Ann. Rev. Immunol.* **123**, 443–455.
2. Pack, P. and Pluckthun A. (1992) Miniantibodies: use of amphipathic helices to produce functional, flexibly linked dimeric Fv fragments with high avidity in *Escherichia coli*. *Biochemistry* **31**, 1579–1584.
3. Ito, W. and Kurosawa, Y. (1993) Development of an artificial antibody system with multiple valency using an Fv fragment fused to a fragment of Protein A. *J. Biol. Chem.* **268**, 20668–20675.
4. Kipriyanov, S. M., Little, M., Kropshofer, H., Bretling, F., Gotter, S., and Dubel, S. (1996) Affinity enhancement of a recombinant antibody: formation of complexes with multiple valency by a single-chain Fv fragment-core streptavidin fusion. *Protein Eng.* **9**, 203–211.
5. Zaccolo, M., Griffiths, A. D., Prospero, T. D., Winter, G., and Gherardi, E. (1997) Dimerization of Fab fragments enables ready screening of phage antibodies that affect hepatocyte growth factor/scatter factor activity on target cells. *Eur. J. Immunol.* **27**, 618–623.
6. Griffiths, A., Williams, S. C., Hartley, O., Tomlinson, I. M., Waterhouse, P., Crosby, W. L., et al. (1994) Isolation of high affinity human antibodies directly from large synthetic repertoires. *EMBO J.* **13**, 3245–3260.

Two-Step Strategy for Alteration of Immunoglobulin Specificity by In Vitro Mutagenesis

Yoshitaka Iba, Chie Miyazaki, and Yoshikazu Kurosawa

1. Introduction

A two-step strategy for changing the specificity of antibodies (Abs) is presented, which we have used to change the specificity of an Ab from 11-deoxycortisol (11-DOC) to cortisol (CS). Two kinds of in vitro mutagenesis are utilized in this protocol: first, mutations are introduced at restricted positions in the complementarity-determining regions (CDRs) by site-directed mutagenesis; second, mutations are introduced into the entire V-coding regions by random mutagenesis.

Prior to manipulation, the genes encoding the Fab form of the original Ab were isolated and inserted into a phage-display expression vector. Based on computer modeling of the antigen (Ag)–Ab complex, several residues thought to be directly involved in forming the Ag-binding pocket were selected as targets for mutation. A library of Abs was constructed in which mutations were introduced by polymerase chain reaction (PCR) with degenerate oligonucleotide primers. Using this procedure, several clones can usually be isolated, which have gained a new Ag specificity. In many cases, however, the isolated Abs retain the ability to bind to the original Ag. Therefore, a second library was constructed, in which mutations were introduced at random by error-prone PCR. Clones were then selected for altered Ag specificity.

These strategies generated mutants with different characteristics. In the case of site-directed mutagenesis, the constructed library carried a large number of different sequences, but the mutants appeared to have some limitations, in terms of fine-tuning and/or fitting to the Ag. On the other hand, random mutagenesis may generate too many clones to be entirely represented in the

constructed library, and many of the Abs that have acquired random mutations may be unable to fold properly (*I*). Nevertheless, this approach generated a better resource for the isolation of anti-CS Abs when coupled with a competitive selection strategy. In order to change the specificity of Abs, we recommend the two-step strategy described here.

2. Materials

1. A hybridoma line secreting an monoclonal Ab specific for a relevant Ag or recombinant Ab clone. In the example described, the monoclonal Ab, SCET, which is specific for 11-DOC, was used as a starting material (*2*).
2. A phage-display vector for expression of Fab–cp3 fusions, mutagenesis, and selection. Our methods describe the use of vector, pAALFab (*3*), which permits the simultaneous introduction of highly diverged sequences into six CDRs of an Ab by PCR with degenerate oligonucleotide primers (*3*). Helper phage (e.g., M13KO7) will be required for the production of phage stocks from *Escherichia coli*-carrying phagemids.
3. Ags for screening. In the case described here, cortisol conjugated with ovalbumin (CS-OVA) was used as an Ag to screen for alteration in Ab specificity following mutagenesis. Free 11-DOC, the cognate Ag for Fab, SCET, was used as a competitor in panning.
4. Tubes, buffers, and immunochemicals for screening. Immunotubes and enzyme-linked immunosorbant assay (ELISA) plates for Ag immobilization. Phosphate-buffered saline (PBS), PBS supplemented with 2% skimmed milk (PBSM), 0.1% Tween-20 (PBST), or both additives (PBSMT). 100 mM triethylamine; 1 M Tris-HCl, pH 6.8; anti-M13 Ab, Ab–enzyme conjugate, and substrate solution for phage ELISA.
5. An appropriate *E. coli* host (e.g., DH12S) and microbial growth media (2TY liquid and solid media), antibiotics, glucose supplements.
6. Reagents for conventional and error-prone PCR. 10X buffer for conventional PCR: 100 mM Tris-HCl (pH 8.3), 500 mM KCl, 1 mg/mL gelatine and 25 mM MgCl₂. 10X buffer for error-prone PCR: 100 mM Tris-HCl (pH 9.0), 500 mM KCl, 75 mM MgCl₂, 5 mM MnCl₂, 1% Triton X-100. Separate nucleotide solutions, to enable preparation of deoxyribonucleoside triphosphate stocks of different concentration and composition. *Taq* DNA polymerase. Oligonucleotide primers.

3. Methods

3.1. Construction of Plasmid DNA Encoding Fab Form of Ab Fused with Truncated cp3 (see Note 1)

1. Amplify DNA fragments encoding the V_HDJ_H and V_LJ_L genes of the starting Ab by PCR from either cloned DNA or mRNA using back and forward primers carrying restriction sites, which change minimally the original amino acid sequence.

2. Digest the amplified DNA fragments and the chosen phage-display vector with appropriate restriction enzymes. Several unique restriction sites are used in this protocol. If these sites also exist in the V-coding regions, they should be eliminated by site-directed mutagenesis (4). Note that the SCET V_H template used here for mutagenesis to specificity to CS carried an *NdeI* site in CDR2 (Fig. 1).
3. Clone the PCR products into the phage-display vector. Methods for these steps can be found in Chapter 2.

3.2. Structural Modeling of Ag-Binding Pocket

The three-dimensional structure formed by the main chains of V domains can be predicted from their amino acid sequences (5). It will be difficult, however, to predict the three-dimensional (3D) structure of the Ag–Ab complex without prior knowledge from X-ray crystallographic analysis. Since the 3D structure of a complex between progesterone and a progesterone-specific monoclonal Ab had been reported, we were able to construct structural models of the Ag-binding pocket (6,7). From these models, target residues for mutagenesis were identified (see Note 2).

3.3. Introduction of Mutations at Restricted Positions by PCR with Degenerate Oligonucleotide Primers

1. In the case described here, it was predicted that the CDRs of the V_L domain would form the binding pocket for the A ring of the steroid (6–8). In an attempt to alter the specificity of the Ab, mutations were introduced into the V_H gene only. In many other cases, it would prove necessary to apply the protocol that follows to both the V_H and the V_L sequences.
2. After identifying the regions to be targeted and the kinds of amino acids to be introduced, introduce mutations by PCR with degenerate primers as shown in Fig. 1 (5,6,9,10; see Notes 2 and 3). Primer sequences used to diversify the CDRs of the SCET Fab are shown in Fig. 1B. Perform the PCR in 100 μL 1X standard PCR buffer: 1 μM of each of the primers; 10 ng/mL of plasmid DNA, 0.2 mM each of dATP, dCTP, dGTP, and dTTP; and 2.5 U *Taq* DNA polymerase.
3. Cycle the mixture 25× through 94°C for 1 min, 55°C for 2 min, and 72°C for 1.5 min.
4. In the example shown in Fig. 1, the SCET template was initially amplified with HI-B (in addition to diversifying CDR1, this oligonucleotide carries a *SnaI* site) and HI-F (encodes a *PstI* site) and separately with HII-B (diversifies CDR2, eliminating the *NdeI* site present in the template) and HII-F (diversifies CDR3 and carries a *BstPI* site).
5. Mix the products of the primary reactions and reamplify with flanking primers, to create products diversified in all three CDRs by overlap extension. In the example, reamplification with HIII-B and F-I retained *SnaI* and *BstPI* sites at the termini of the amplicons.

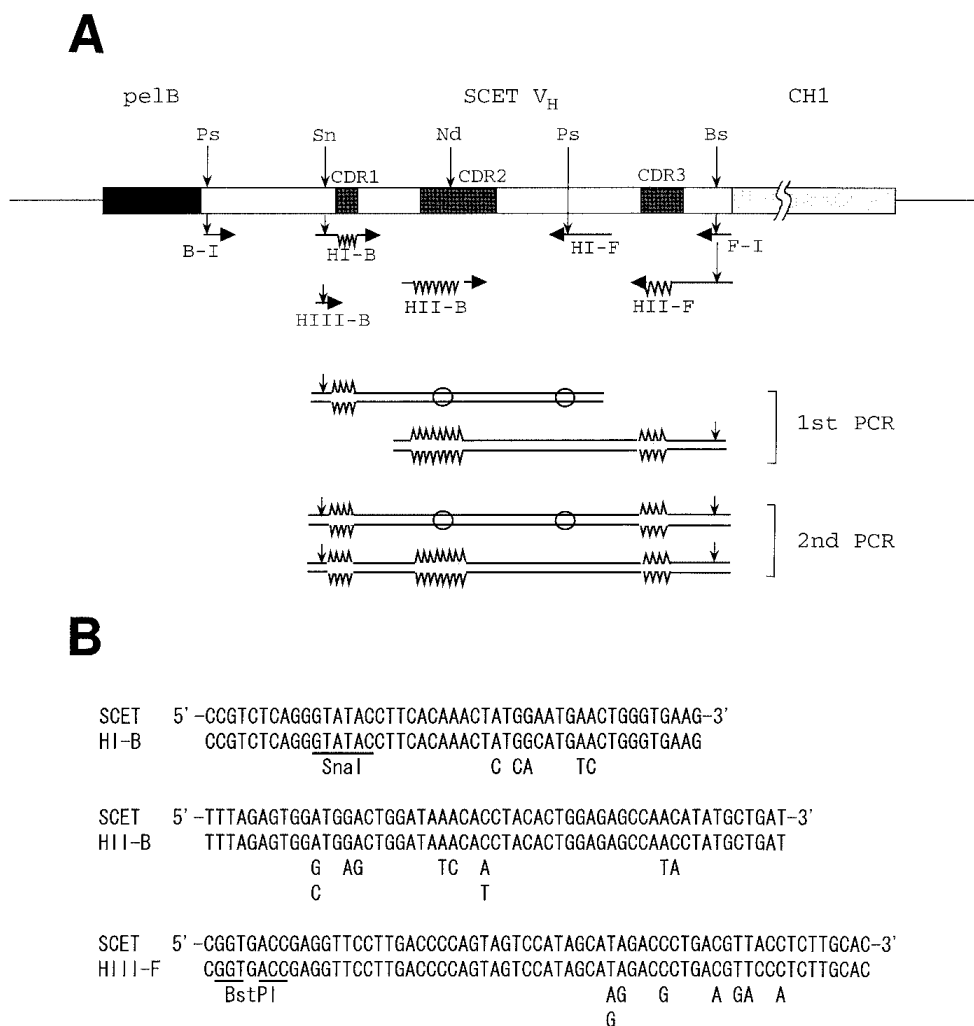

Fig. 1 (A) Method used for introduction of mutations into three CDRs of the V_H gene. Plasmid DNA encoding the original monoclonal Ab was used as the template. Fortuitously, an *NdeI* site was present in the SCET V_H sequence (indicated by a circle). PCR reactions were performed with primers HI-B plus HI-F and HIII-B plus HII-F. Wavy portions of respective primers indicate the presence of degenerate codons (see 1B). A *PstI* site was introduced on the HI-F primer (indicated by a circle). The products of the first PCRs were combined and reamplified with primers HIII-B and F-I. The resulting amplicons were digested with *NdeI* and *PstI* to eliminate those fragments in which diversification of CDR2 had not occurred, but, as a general principle, digestion with two restriction enzymes is not obligatory. Primers B-I and F-I were used in error-prone PCR. Ps, *PstI*; Sn, *SnaI*; Nd, *NdeI*; Bs, *BstPI*. Other unique restriction sites could be used. (B) Sequences of degenerate primers aligned with the SCET sequence.

6. After reamplification, eliminate any products that have escaped thorough diversification. In the example, inefficiently diversified products retained *NdeI* and *PstI* restriction sites, so digestion with these nucleases could be used to select appropriate amplicons for library construction.
7. Isolate the diversified products by electrophoresis and clone into the original phage-display vector. For the diversified SCET derivatives, DNA was run through a 10% acrylamide gel after further digestion with *SnaI* and *BstPI*.
8. Transform an appropriate strain of *E. coli* and determine the size of the final library by plating aliquots of the transformation mixture. With SCET, we estimated that diversification to the planned extent would generate 5×10^7 unique sequences. The number of clones independently generated in the resulting library was estimated to be 1×10^8 .

3.4. Screening of Library by Panning

1. Coat the surface of an immunotube with a solution of Ag at 5 $\mu\text{g}/\text{mL}$ in an appropriate buffer for binding. In the example presented, CS-OVA was diluted into PBS and added to the tubes for 2 h at room temperature.
2. Block remaining protein-binding sites on the coated surface by adding PBSM for 30–60 min and wash off the excess blocker with PBS.
3. Add a suspension of phage (10^{13} colony-forming units) in PBSMT to the Ag-coated immunotube and incubate at room temperature for 2 h (see **Note 4**).
4. Wash the tube 10 \times with PBST, then 10 \times with PBS (see **Note 5**).
5. Elute those phage adhering to the tube with 100 mM triethylamine for 15 min.
6. Recover, and immediately neutralize the eluate with 1 M Tris-HCl, pH 6.8.
7. Add the solution of phage to *E. coli* DH12S in 2 \times YT medium and incubate the cells at 37°C for 1 h.
8. The recovery of phage can be measured by transduction of the bacterial host with the antibiotic marker carried on the phagemid vector.
9. Amplify the recovered phage by standard methods and repeat the panning cycle up to 5 \times (**3,6,7**).
10. Monitor the recovery of phage with altered Ag specificity by the binding of pools of eluted phage to the new target Ag (e.g., CS) after each round of elution/amplification using immunochemical reagents against the viral coat in a phage ELISA. In the example presented, microtiter plates were coated with CS-OVA. A pool of phage, recovered after the fifth round of panning, showed positive evidence for CS-binding activity.
11. After the final panning, isolate phagemid DNA from individual clones for characterization. With the vector used in our studies, digestion with *SalI* and self-ligation converts the phage-display Abs into Fabs fused to two Fc-binding domains of Protein A (Fab-PP) (**3,11**). The recircularized DNA was transformed into *E. coli* DH12S and 20 colonies were picked for sequencing and ELISA of the Fab-PP proteins against CS. One of the 20 clones isolated had high CS-binding activity (see **Notes 4 and 5**).

3.5. Introduction of Random Mutations into Entire V-Coding Regions by Error-Prone PCR (see Note 6)

1. Set up a reaction mix for error-prone PCR containing 1X reaction buffer with 0.2 mM dATP, 0.2 mM dGTP, 1.0 mM dCTP, 1.0 mM dTTP, 0.3 μ M primers (B-I and F-I in the example described), 100 ng template DNA, and 2.5 U *Taq* DNA polymerase, in a total volume of 100 μ L.
2. Cycle the reaction 30 \times through 94°C for 1 min, 50°C for 1 min, and 72°C for 4 min.
3. Isolate the product, digest with appropriate restriction enzymes, and clone into a phage-display vector (7).
4. Transform into an *E. coli* host and determine the size of the library by the number of antibiotic-resistant colonies resulting. The SCET-derived library generated by error-prone PCR was estimated to comprise 5×10^6 clones. Phage displaying the mutated Fab constructs were produced by standard methods, and the library was screened by competition panning (see **Subheading 3.6.**) to select clones with an increased affinity for CS and little or no 11-DOC-binding activity.

3.6 Screening of Library Competition Panning

The conditions for the competition panning are the same as those for the panning described above (see **Subheading 3.4.**), except for the presence of competitors.

1. Mix the phage library with various amounts of the competitor molecules (see **Note 7**) in PBSMT and incubate the mixtures at room temperature for 30 min (**Fig. 2**).
2. Transfer each mixture to an immunotube coated with 5 μ g/mL target Ag (CS-OVA in this instance) (7) and incubate for 2 h.
3. Wash, elute, neutralize, and amplify as described (see **Subheading 3.4**). Repeat for up to four rounds of selection.
4. Monitor the progress of selection by phage ELISA and characterize individual clones from the final round by sequencing and ELISA of the encoded Fab products. Of 24 SCET-derived mutants generated by error-prone PCR and competitive selection, two were unmutated and two showed no enhanced reaction with CS. The other 20 clones could be classified into three groups based on their relative affinities for CS.

4. Notes

1. Fabs are recommended in this protocol. Although scFvs have been most commonly used in phage-display Ab systems, they may differ from the original Ab in terms of specificity and affinity.
2. The following principles were adopted in choosing CDR residues for targeted mutagenesis and the kinds of substitutions to be introduced (7).

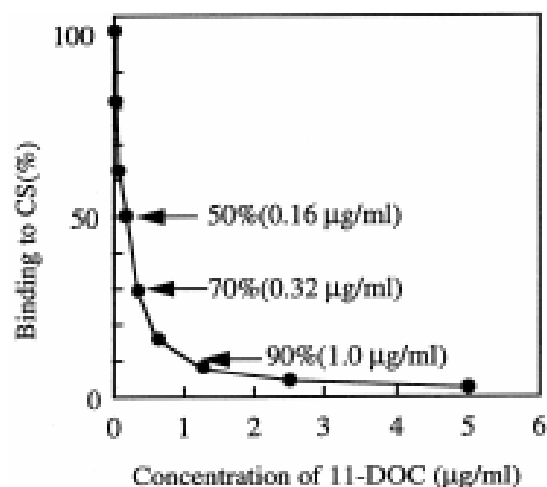

Fig. 2. Competition ELISA of phage Abs. 1.9×10^{10} phage from the library constructed by error-prone PCR were mixed with various concentrations of 11-DOC in 100 μ L PBS and allowed to stand at room temperature for 30 min. The mixtures were added to ELISA wells coated with CS-OVA. Phage that bound to the wells were detected with rabbit Abs against M13, alkaline phosphatase-conjugated Abs against rabbit immunoglobulin G and *p*-nitrophenylphosphate.

- a. On models of the Ag–Ab complex, possible contact residues in the CDRs were selected as candidate targets for mutation.
 - b. Since aromatic amino acids at the fiftieth and one hundredth positions, appeared to play a key role in sandwiching a steroid ring, tyrosine, phenylalanine, and tryptophan were assigned to these positions (6–8).
 - c. Since amino acids at some positions are perfectly conserved among a number of steroid-specific Abs, these residues were not altered.
 - d. Where, in the CDRs of different Abs, variable amino acids can be observed, each of these residues was included.
 - e. The amino acids able to form hydrogen bonds and which are less bulky were preferred.
3. Diversification at some specific positions can be achieved by PCR, using degenerate oligonucleotide primers (9,12). When one codon in the primer sequence contains (A/T)(G/A)G, the products of PCR will carry AGG (arginine), AAG (lysine), TGG (tryptophan), and TAG (stop) codons. To avoid a termination codon, codons for lysine and tryptophan cannot coexist at the same position in one primer. When codons for lysine (AA(A/G)) and aspartic acid (GA(C/T)) are required to be co-located at the same position, the possible sequence (A/G)A(A/G/C/T) necessarily includes codons for asparagine (AA(C/T)) and glutamic acid (GA(A/G)).

4. When Ag is bound to the surface of a tube, and Ab is in solution during the panning procedure, the interactions can be considered to proceed to an equilibrium state. Since the concentration of Ag is likely to be much higher than that of Ab, the following relationship holds:

$$[\text{Ag}\cdot\text{Ab}]/[\text{Ab}] = K_A[\text{Ag}]_0$$

Although it is difficult to estimate $[\text{Ag}]_0$ on the surface of a tube, the ratio $[\text{Ag}\cdot\text{Ab}]/[\text{Ab}]$ indicates the ratio of bound phage: free phage. Even if there exist clones with the desired specificity in the library, they may not be recovered under the conditions in which the value of $K_A[\text{Ag}]_0$ is low. Moreover, if numbers of clones with Ag-binding capability, but with undesired specificity, are much larger than that of the target clones, the majority of the isolated clones may be irrelevant.

5. Recovery of clones with the desired properties from panning may be strongly effected by their affinity for the intended target, their representation in the library, and their replication in *E. coli*. Hawkins et al. (11) have described a selection method based on affinity.
6. Since the presence of Mn^{2+} ions and limiting amounts of dATP and dGTP enhance the frequency of incorporation of mismatched nucleotides in PCR by *Taq* DNA polymerase, mutations can be introduced at random into the region sandwiched by primers. The frequency of mutations can be regulated by the number of PCR cycles. Under the conditions described (see **Subheading 3.5.**), the frequency of mutation was 3.1/312 base pairs. In general, more mutations might provide more opportunities to generate clones with the desired affinity, but they would simultaneously increase the likelihood of destruction of the authentic Ag-binding activity. The number of mutations introduced into each clone should correspond to Poisson's distribution. Poisson law states that

$$P_\gamma = \frac{\chi^\gamma e^{-\chi}}{\gamma!}$$

Where P_γ is the fraction of a large number of clones that contain γ mutations each, if an average χ of mutations/clone is distributed at random over the entire ensemble of clones. When the frequency of mutations introduced by error-prone PCR is estimated to be 3.1, i.e., χ is 3.1, P_0 is 4.5%. This means that the percentage of clones with no mutations should be 4.5%; one mutation, 14.0%; two mutations, 21.6%; three mutations, 22.4%; four mutations, 17.3%; five mutations, 10.7%; six mutations, 5.6%, and so on. The total number of clones with multiple mutations appears to be large; however, the original clone carries no mutations, and therefore remains the sequence most frequently represented in the mixture. Therefore, steps will be required to exclude the original clone from the screening process. Competition panning worked efficiently, in our experience, to enrich for clones with the desired specificity.

7. To determine the optimal concentration of competitors, various concentrations

of 11-DOC were examined, as shown in **Fig. 2**. Although 50, 70, and 90% inhibition was observed in the presence of 11-DOC at 0.16, 0.32, and 1 $\mu\text{g/mL}$, respectively, the best results, in terms of enrichment, were obtained under the conditions of 70% inhibition (**6**).

References

1. Casson, L. P. and Manser, T. (1995) Evaluation of loss and change of specificity resulting from random mutagenesis of an antibody V_H region. *J. Immunol.* **155**, 5647–5654.
2. Sawada, J., Mizusawa, S., Terao, T., Naito, M., and Kurosawa, Y. (1991) Molecular characterization of monoclonal anti-steroid antibodies. Primary structures of the variable regions of seven antibodies specific for 17 alpha-hydroxyprogesterone or 11-deoxycortisol and their pH reactivity profiles. *Mol. Immunol.* **28**, 1063–1072.
3. Iba, Y., Ito, W., and Kurosawa, Y. (1997) Expression vectors for the introduction of highly diverged sequences into the six complementarity-determining regions of an antibody. *Gene* **194**, 35–46.
4. Ito, W., Ishiguro, H., and Kurosawa, Y. (1991) General method for introduction a series of mutations in a cloned DNA using the polymerase chain reaction. *Gene* **102**, 67–70.
5. Chothia, C. and Lesk, A. M. (1987) Canonical structures for the hypervariable regions of immunoglobulins. *J. Mol. Biol.* **196**, 901–917.
6. Iba, Y., Hayashi, N., Sawada, J., Titani, K., and Kurosawa, Y. (1998) Changes in the specificity of antibodies against steroid antigens by introduction of mutations into complementarity-determining regions of the V_H domain. *Protein Engineer.* **11**, 361–370.
7. Miyazaki, C., Iba, Y., Yamada, Y., Takahashi, H., Sawada, J., and Kurosawa, Y. (1999) Changes in the specificity of antibodies by site-specific mutagenesis followed by random mutagenesis. *Protein Eng.* **12**, 407–415.
8. Arevalo, J. H., Taussig, M. J., and Wilson, J. A. (1993) Molecular basis of crossreactivity and the limits of antibody-antigen complementarity. *Nature* **365**, 859–863.
9. Ito, W. and Kurosawa, Y. (1994) Construction and application of libraries of artificial antibodies, in *Monoclonal Antibodies: The Second Generation* (Zola, H., ed.), BIOS Scientific, Oxford, UK, pp. 141–164.
10. Iba, Y. and Kurosawa, Y. (1997) Comparison of strategies for the construction of libraries of artificial antibodies. *Immunol. Cell Biol.* **75**, 217–221.
11. Ito, W. and Kurosawa, Y. (1993) Development of an artificial antibody system with multiple valency using an Fv fragment fused to a fragment of Protein A. *J. Biol. Chem.* **268**, 20,668–20,675.
12. Ito, W., Iba, Y., and Kurosawa, Y. (1993) Effects of substitution of closely related amino acids at the contact surface in an antigen-antibody complex on thermodynamic parameters. *J. Biol. Chem.* **268**, 16,639–16,647.
13. Hawkins, R. E., Russel, S. J., and Winter, G. (1992) Selection of phage antibodies by binding affinity. Mimicking affinity maturation. *J. Mol. Biol.* **226**, 889–896.

Targeting Random Mutations to Hotspots in Antibody Variable Domains for Affinity Improvement

Partha S. Chowdhury

1. Introduction

The potential of Fvs as magic bullets for targeting therapeutic drugs or imaging agents is well-documented. However, the conversion of whole antibodies (Abs) into Fvs (scFvs or dsFvs) is often associated with a drastic reduction in antigen (Ag)-binding affinity. For efficient use of Fvs as targeting agents, this property must be improved.

Until recently, there were two different approaches to improve binding affinity of Abs (whole immunoglobulin Gs, Fabs, and Fvs). One approach utilized the high-resolution crystal structure of the Ab–Ag complex to engineer key contact residues in the Fv portion to enhance the interaction. Although this approach is logical, it is not widely applicable. The other approach was to randomly or semirandomly mutate the complementarity-determining regions (CDRs), and create large expression libraries (e.g., scFv or Fab phage-display libraries), which served as a source of high-affinity variants. Although this approach has been used with success in several instances, it entails the construction, maintenance, and handling of large and/or multiple phage-display libraries, which requires technical expertise and can be time-consuming and expensive.

The method described herein is a new approach that also uses scFv phage Ab-display technology, but aims at creating small libraries that can be a rich source of higher-affinity variants. The essence of the approach is to mimic *in vitro* the natural somatic hypermutation process that underlies affinity maturation.

tion of Abs in vivo. It is based on results published by the groups of Milstein and Neuberger (1–3), which indicate that during somatic hypermutation mutations in genes encoding the Ab variable domains are not randomly distributed, but are preferentially focused in certain regions termed “hotspots.” Although the exact features of hotspots are yet to be understood, they can be defined by consensus nucleotide sequences and certain codons. The consensus sequence is the tetranucleotide, RGYW (in which R can be A or G, Y can be C or T, and W can be A or T). The AGY serine codons (these may or may not be part of an RGYW consensus) also seem to constitute hotspots. The existence of hotspots is not restricted to mammals: they have also been identified in birds, but it is not known if they exist in lower vertebrates.

Hotspots in Ab variable-region genes can be considered nature’s way of efficiently improving the affinities of Abs by localizing mutations to certain regions, for directed evolution of better binding variants. Although the existing literature (1–3) shows that affinity maturation of Abs *de novo* is associated with mutation in hotspots, these have not always been found to be associated with improvement in affinity of an Ab.

The nucleotide sequence of V_H and V_L of any Ab reveals many potential hotspots localized to almost all the framework regions (FRs) and CDRs. How does one decide which hotspot should be manipulated in vitro in order to improve the affinity of a given Fv? Certain basic principles of the Fv region should be borne in mind: conserved residues in variable regions play important structural roles; CDRs contribute mostly to Ag binding; buried residues in CDRs are not likely to interact with the Ag; and junctional residues undergo selection in vivo, a consideration that is important when the Fv has been obtained from an immunized individual.

The current method couples the concept of affinity maturation, via mutation at hotspots, to the existing knowledge of Fv structures, which enables one to eliminate a large number of hotspots that code for residues within FRs, and also those CDR residues that are conserved, buried, or occupy junctional positions between FR3 and CDR3 and/or CDR3 and FR4. Small phage-display libraries are then generated by random mutagenesis at those hotspots that have been shortlisted. The libraries are panned on the relevant Ag to enrich for binders and clones picked at random for more detailed study to identify those that bind better to the target Ag than the parental type. Since analysis of binding may be effected by the number of scFvs on the phage surface, monomeric scFvs or monomeric scFv-fusion proteins are purified to make a final assessment of the affinity of the Fv for its Ag. The method described here has been found to work in several systems (4,5).

2. Materials

2.1. Bacterial Strains and Bacteriophages

1. *Escherichia coli* TG1: K12 $\Delta(lac-pro)$, *supE*, *thi*, *hsd* Δ 5/*F'*[*traD36*, *proAB*, *lacI^q*, *lacZ* Δ M15].
2. *E. coli* CJ236: *F' cat* (= pCJ105; M13[°]Cm^r)/*dut ung 1*, *thi-1 relA1*, *spoT1 mcrA* (available from Bio-Rad).
3. Helper phage, M13KO7 (available from Bio-Rad and other suppliers) and R408 (available from Stratagene) (*see Note 5*).

2.2. Growth Media and Supplements

1. Luria agar and liquid media.
2. 2 \times YT liquid medium.
3. Antibiotics for selection of the bacterial host (chloramphenicol for CJ236), phagemid, plasmid which has the *lacI^q* gene and helper phage.
4. Filter-sterilized glucose (20%).
5. Filter-sterilized uridine (50 μ g/mL).

2.3. Recombinant DNA

1. A phagemid with the scFv of interest fused in frame with the *gene III* (*gIII*) of M13 or a related filamentous phage (e.g., pCANTAB5E from Pharmacia). It is important to know the antibiotic resistance marker, the *E. coli* origin of replication, and the direction of the phage origin of replication (*see Note 2*).
2. A plasmid that has the *lacI^q* gene and a different antibiotic resistance marker and a different origin of replication to the phagemid (*see Note 2* and **ref. 6**).

2.4. Reagents

2.4.1. Enzymes

1. T7 DNA polymerase.
2. T4 DNA ligase.
3. Polynucleotide kinase (3' phosphatase-free).
4. A high-fidelity thermostable DNA polymerase (e.g., *Pwo*, *Pfu*, or *Vent*).
5. Restriction enzymes for sites flanking the scFv-coding region in the phagemid and enzymes for two other unique and mutually incompatible restriction sites, which lie outside the scFv–gIIIp-coding region. These enzymes will vary depending on the phage-display vector being used.

2.4.2. Buffers and Chemicals

1. 10X Buffers for all enzymes (usually provided with the enzymes).
2. 10X Annealing buffer: 200 mM Tris-HCl, pH 7.4 (at 37°C), 20 mM MgCl₂, 500 mM NaCl.

3. 10X Synthesis buffer: 5 mM, each of deoxyadenosine triphosphate, deoxycytidine triphosphate, deoxyguanosine triphosphate, deoxythymidine triphosphate, 10 mM adenosine triphosphate, 100 mM Tris-HCl, pH 7.4 (at 37°C), 50 mM MgCl₂, 20 mM dithiothreitol.
4. T7 DNA polymerase dilution buffer: 20 mM potassium phosphate, pH 7.4, 1 mM dithiothreitol, 0.1 mM ethylenediamine tetraacetic acid (EDTA), 50% glycerol.
5. 20% Polyethylene glycol (PEG) 8000–2.5 M NaCl. Store at 4°C after autoclaving.
6. 1X NET: 100 mM NaCl, 1 mM EDTA, 10 mM Tris-HCl, pH 7.5.
7. Agarose for analytical gels and low-melting-point agarose for preparative gels.
8. Buffer-saturated phenol. Store at 4°C in amber bottle.
9. Phenol:chloroform:isoamyl alcohol, 25:24:1. Store at 4°C in amber bottle.
10. Chloroform.
11. Chilled ethanol.
12. 8 M Lithium chloride.
13. 10 mM Tris-HCl, pH 7.4.

2.4.3. Oligonucleotides for Mutagenesis and Polymerase Chain Reaction (PCR)

These should be high-quality oligos purified, preferably by high-performance liquid chromatography or at least through a reverse-phase cartridge.

2.4.4. Abs, Ab–Enzyme Conjugates, and Accessories

1. Anti-tag Ab. The tag is a peptide between the scFv and the gIIIp, which can vary, depending on the phage-display vector used.
2. Anti-M13 gVIIIp monoclonal Ab or polyclonal Ab.
3. Secondary Ab against the anti-tag Ab and anti-gVIIIp Ab coupled to alkaline phosphatase or horseradish peroxidase (HRP).
4. Substrate for the enzyme attached to the secondary Ab (e.g., DAB for HRP).

2.5. Special Apparatus and Accessories

1. Dot blot apparatus.
2. Enzyme-linked immunosorbant assay (ELISA) reader.
3. Densitometric scanner (optional).
4. Nitrocellulose or PVDF membranes.
5. Nonfat dry milk.
6. Tween-20.

3. Methods

The methods for randomizing hotspots for in vitro affinity improvement of scFvs consist of several steps, which are as follows: identification of hotspots

- Step 1: Remove hotspots from FRs.
- Step 2: Remove hotspots that code for conserved and buried residues in CDRs.
- Step 3: Keep aside CDR1 and CDR2 hotspots (low priority).
- Step 4: Segregate V_H and V_L CDR3 hotspots.

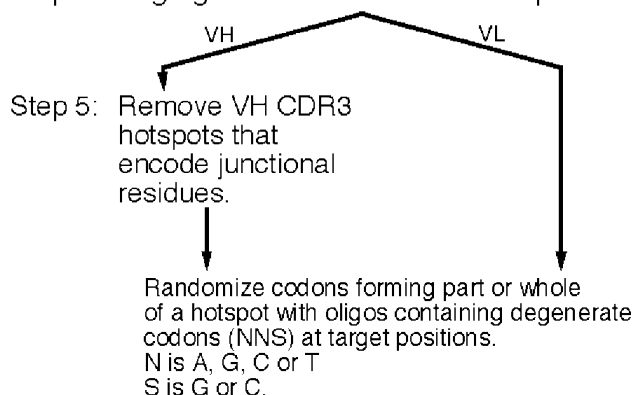

Fig. 1. Steps involved in the selection of hotspots in Ab V genes for targeting random mutations for in vitro affinity improvement.

in the V_H and V_L; rational selection of hotspots for mutations; random mutation of the residues covered by the selected hotspots; construction and panning phage-display library/libraries; and analysis of selected clones.

3.1. Identification of Hotspots in V_H and V_L and Rational Selection for Mutation

- Hotspots in the Ab variable region can be identified either manually or with the help of a computer. Record the location of RGYW and AGY serine codons. Typically, many hotspots will be spread over a V_H and V_L. Many of the AGY serine codons will also form part of the tetranucleotide hotspots.
- A limited number of hotspots should be selected for random mutagenesis. To do this, existing knowledge about Ab structure must be used. A scheme for selection is shown schematically in **Fig. 1** and consists essentially of the following steps.
- Ignore hotspots that are located in FRs.
- Eliminate hotspots that code for conserved and buried amino acids in CDRs. To determine if a particular residue(s) is (are) conserved and/or buried, check the variability and exposure state of that particular amino acid at the Kabat database (maintained by Johnson and Wu. Website <http://immuno.bme.nwu.edu>), and by consulting **Fig. 1A,B** in **ref. 7** and **Tables 1 and 2** in **ref. 8**.

5. For most Abs the following generally holds true. Residues 25, 29, and 33 in V_L CDR1 are buried. Similarly, residue 51 in V_L CDR2, and 89, 90, and 97 in V_L CDR3 can be excluded. In the V_H , residues 32 and 34 in CDR1 and residues 51, 52, and 63 in CDR2 are buried. V_H CDR3 usually does not have any buried residues.
6. For example, if there is a hotspot covering residues 89 and 90 in V_L , then reference to the Kabat database will show that position 90 has a conserved glutamine, and as mentioned in **step 5**, is buried. Therefore, this hotspot should not be targeted for random mutations.
7. For the first experiment, keep aside hotspots that fall into CDRs 1 and 2, because it is usually CDR3 that contributes most to Ag binding. If it later proves necessary, residues in CDRs 1 and 2 can be targeted for engineering.
8. One should be left with hotspots coding only for exposed residues in the CDR3 of V_H and V_L . The exposed residues for V_L CDR3 are good candidates for mutations.
9. Eliminate CDR3 hotspots in V_H , if they have been formed by N addition in B-cells from an immunized animal. By comparing the V_H CDR3 sequence with germline D and J minigenes available in the Kabat database, one can make out whether the junctional residues were formed by N addition. If they are found to be formed by N addition, then these residues should not be changed because they have gone through a natural selection process in the immunized animal.

3.2. Random Mutagenesis of Codons Falling Within Selected Hotspots

This subheading describes steps for randomizing codons that fall within one or more hotspots. A problem that is frequently faced when using one clone as a template for a randomized library is the overrepresentation of the parental sequence, because of carryover of the template. A good way to overcome this problem is to first insert in the parental clone a stop codon in the region targeted for randomization, then use this as a template to make the library (*see Note 1*). This eliminates background contamination by the parental clone. The procedure to do this is described below.

3.2.1. Preparation of Template for Introduction of Stop Codon by Kunkel's Mutagenesis

1. Begin by transforming CJ236 cells with 5 ng phagemid encoding the scFv-gIIIp and 5 ng *lacI^q*-encoding plasmid (*see Note 2*).
2. Plate 25–100 μ L transformation mix onto LB plates containing 2% glucose (*see Note 3*) and appropriate antibiotics for selection of the host, phagemid, and the *lacI^q*-encoding plasmid. Incubate overnight at 37°C.
3. Inoculate transformants to an initial optical density 600 nm (OD_{600}) of ~ 0.1 in 150 mL LB containing 15 μ g/mL chloramphenicol, 2% glucose and 50 μ g/mL uridine. Use a 2 L baffle flask (*see Note 4*).

4. Incubate at 37°C with shaking at 250 rpm. Check OD₆₀₀ every 30 min.
5. When OD₆₀₀ reaches ~0.3, add helper phage to a multiplicity of infection (MOI) of 3–5 (*see Note 5*).
6. Incubate at 37°C with shaking at 100 rpm for 1 h, then increase to 300 rpm for 6 h (*see Note 6*).
7. Four hours into the experiment, start fresh 10–15 mL cultures of CJ236 and TG1. Incubate at 37°C, with shaking at 250 rpm, until OD₆₀₀ is ~0.3–0.4. Keep ready plates containing LB agar with 2% glucose (*see Note 3*) and the antibiotic for the selection of the scFv–gIIIp-encoding phagemid. These plates will be needed for titration (*see Subheading 3.2.2.*).
8. Chill the 150 mL cultures and pellet the cells by centrifuging the chilled culture at 3000g for 15 min at 4°C.
9. Centrifuge the supernatant from **step 8** at 17,000g for 15 min at 4°C and collect the supernatant (*see Note 7*). Save 1 mL in a labeled, sterile microcentrifuge tube for titration (*see Subheading 3.2.2.*).
10. Measure the volume of the remaining supernatant and add one-fifth volume cold 20% PEG–2.5 M NaCl. Mix thoroughly and store overnight at 4°C.
11. Centrifuge the precipitated culture supernatant at 27,000g for 30 min at 4°C. Check for the pellet. Discard the supernatant.
12. Invert the centrifuge bottle and allow traces of solution adhering to the centrifuge tube or bottle to drain out.
13. Add 10 mL NET buffer to the pellet. Allow it to stand for 10–15 min at room temperature. The pellet will become loose. Resuspend the pellet by pipeting repeatedly but gently. Transfer the pellet to a clear polycarbonate centrifuge tube, and centrifuge at 3000g for 15 min at 4°C (*see Note 8*).
14. Collect the supernatant carefully and add 2 mL of PEG–NaCl solution. Mix and keep in ice for 20 min.
15. Centrifuge at 27,000g for 30 min at 4°C. Check for the pellet. Discard the supernatant and invert the centrifuge bottle to allow traces of solution adhering to the centrifuge tube or bottle to drain out.
16. Add 10 mL NET buffer to the pellet. Let it stand for 10–15 min at room temperature. Resuspend pellet by pipeting repeatedly but gently. Transfer the pellet to a clear polycarbonate centrifuge tube. Centrifuge at 3000g for 15 min at 4°C. Carefully collect the supernatant into an opaque polypropylene centrifuge tube.
17. Add an equal volume of buffer-saturated phenol (make sure the phenol is colorless). Vortex for 1 min, then shake at room temperature for 20 min.
18. Centrifuge at 27,000g for 15 min at 4°C. Collect the upper aqueous layer into another polypropylene tube, and add an equal volume of phenol:chloroform:isoamyl alcohol mixture. Vortex for 1 min, then shake at room temperature for 15 min.
19. Centrifuge at 27,000g for 15 min at 4°C. Collect the upper aqueous layer into another polypropylene tube and add an equal volume of chloroform. Vortex for 1 min and shake at room temperature for 15 min.

20. Centrifuge at 27,000g for 15 min at 4°C. Collect the upper aqueous layer into a clear polycarbonate tube and measure the volume.
21. Add one-tenth volume sterile 8 M lithium chloride and 3 volume chilled ethanol. Mix thoroughly. Keep in dry ice for 20 min.
22. Centrifuge at 27,000g for 20 min at 4°C. The pellet will be very light and off-white in color. Carefully decant the supernatant. Invert the tube to drain out the remaining solution and air-dry the sample.
23. Dissolve the pellet in 100–200 μL 10 mM Tris-HCl, pH 7.4. Run a 1.2% agarose gel with 1- and 2- μL aliquots of the DNA. The samples should show a distinct and clean band. Although the ssuDNA will be half the size of the scFv-gIIIp-encoding phagemid in the gel it may run anomalously because of secondary structure formation.

3.2.2. Titration of Phage in TG1 and CJ236 Cells

1. Label eight 1.5-mL microcentrifuge tubes and add 450 μL 2 \times YT or LB medium to each.
2. Add 50 μL of the culture supernatant (*see Subheading 3.2.1., step 9*) to tube 1 (10-fold dilution). Vortex to mix thoroughly.
3. Take 50 μL from this tube and add to the next (tube 2, 100-fold dilution) and continue likewise to the eighth tube.
4. Mark nine autoclaved 1.8-mL microcentrifuge tubes as follows: TG1-10⁻¹, TG1-10⁻², TG1-10⁻³, TG1-10⁻⁴, CJ236-10⁻⁴, CJ236-10⁻⁵, CJ236-10⁻⁶, CJ236-10⁻⁷, and CJ236-10⁻⁸. Into each, pipet 300 μL fresh cultures of TG1 or CJ236 (OD₆₀₀ ~0.3) (*see Subheading 3.2.1., step 7*).
5. Sample 100 μL from the dilution series and add to the correspondingly labeled tube containing TG1 or CJ236. Mix by tapping and incubate at 37°C for 30 min. After 15 min, mix by tapping the contents of the tube again.
6. At the end of the incubation, plate 40 μL onto LB plates containing 2% glucose (*see Note 3*) and the appropriate antibiotic for selection of the scFv-gIIIp-encoding phagemid. Incubate overnight at 37°C. Count the colonies on each plate, and thereby determine the phage titer.
7. The phage titer should typically be between 10,000- and 100,000-fold higher in CJ236 cells than in TG1.

3.2.3. Design of Oligonucleotide for Insertion of Stop Codon

The strategy employed here is to introduce a TAA stop codon into the targeted hotspot, which will later be replaced in random mutagenesis (*see Subheading 3.2.5.*). The consequence of this change is that the ssuDNA, which constitutes the template for mutagenesis, cannot lead to phage bearing scFv-gIIIp at their surface and will thus fail to be selected during panning of the library (*see Subheading 3.3.*). This effectively suppresses any carryover of the parental clone.

Table 1
Annealing of Oligo to Template

	Experimental (μL)	Control (μL)
H ₂ O	7	8
10X Annealing buffer	1	1
Template (diluted in H ₂ O)	1	1
Phosphorylated oligonucleotide	1	0
Total	10	10

The design of the oligonucleotide for Kunkel's mutagenesis depends on the orientation of the gene of interest and the direction of the F' origin of replication. Use the following guidelines:

1. If the gene of interest and the F' origin are in a clockwise direction, then the oligonucleotide should be made complementary to the coding strand of the gene.
2. If the gene of interest is in the clockwise direction and the F' ori in the anticlockwise direction, then the oligonucleotide should be complementary to the noncoding strand of the gene.
3. If the gene of interest is in the anticlockwise direction and the F' ori is in the clockwise direction, then the oligonucleotide should be complementary to the noncoding strand.
4. If the gene of interest and the F' ori are both in the anticlockwise direction, then oligonucleotide should be complementary to the coding strand of the gene.
5. The oligonucleotide should be designed in such a way that it introduces a TAA stop codon at or near the site where random mutations will be targeted. Design should include 12–15 nucleotides on either flank of the mismatch, which will anneal perfectly with the ssuDNA.

3.2.4. Introduction of Stop Codon

1. Set up the following reaction mix to phosphorylate the oligonucleotide: 25 μL H₂O, 3 μL 10X ligase buffer, 1 μL oligonucleotide (250 pmol/ μL), 1 μL polynucleotide kinase (10 U/ μL) for a total of 30 μL .
2. Mix by tapping, gently vortex, and spin briefly in a microcentrifuge.
3. Incubate at 37°C for 30 min, then heat to 65°C for 10 min. Keep on ice before use. For long-term storage, move to -20°C.
4. In annealing the oligonucleotide to the template, the amount of phosphorylated oligonucleotide is typically kept between 8 and 10 pmol. The amount of template to be used depends on the type of experiment. For an experiment such as the introduction of a TAA stop codon for which a single clone is sufficient, use 5–10 pg ssuDNA. Prepare tubes as in **Table 1**.

Table 2
Synthesis of the Mutagenic Strand

	Experimental (μL)	Control (μL)
10X Synthesis buffer	1.3	1.3
T4 DNA ligase (3 U/ μL)	1.0	1.0
T7 DNA polymerase (1U/ μL diluted 1 : 1 in T7 polymerase buffer)	1.0	1.0
Total	13.3	13.3

5. Mix by tapping, vortex, then spin briefly in a microcentrifuge.
6. Incubate the tubes at 72°C for 2 min, then cool over a period of 60 min to less than 30°C. Store the tubes in ice or at 4°C.
7. Add reagents to the annealing reactions as in **Table 2**.
8. Mix by tapping, vortex, then spin briefly in a microcentrifuge.
9. Incubate in ice for 10 min, then at room temperature for 10 min, and finally at 37°C for 2 hours. Store in ice.
10. Transform 50 μL competent TG1 cells with 1 μL reaction mix, and plate 10, 25, 50, and 100 μL onto LB agar plates containing 2% glucose and the appropriate antibiotic for selecting the scFv–gIIIp-encoding phagemid. Incubate overnight at 37°C. Pick, and analyze clones for introduction of the TAA mutation.

3.2.5. Introduction of Random Mutations at Selected Hotspots

Construction of the randomized library can also be done by Kunkel's mutagenesis (*see Note 9*) using as template the scFv–gIIIp-encoding phagemid with introduced TAA stop codon (*see Note 10*). Preparation of ssuDNA has been described (*see Subheading 3.2.1.*).

1. The basic rules for designing oligonucleotides are as described in **Subheading 3.2.3.**, but, in the present case, one must keep in mind the following points: Codons falling into the hotspot regions have to be randomized; the region to be randomized must encompass the TAA stop codon introduced in **Subheading 3.2.4.**; if the TAA stop codon was inserted outside the hotspot region, then it must be changed to the original codon, or one encoding the wild-type amino acid, by adding an additional oligonucleotide to the annealing mix (*see Subheading 3.2.4., steps 1–6*). The oligonucleotides to be used for randomization should have degenerate codons, such as NNS (N is A, G, C, or T; S is G or C), which codes for all the amino acids, but not the TAA and TGA stop codons. Although NNS codes for the TAG stop codon, this is not a serious drawback, since *E. coli* TG1 is a *supE* strain and can read through this codon. All the codons falling wholly or partly within the targeted hotspot should be substituted with NNS or alternative degenerate sequences.

2. Mutagenesis is essentially as described (*see Subheading 3.2.4.*). One should be particularly careful about the amount of template to be used. From the titration experiment (*see Subheading 3.2.2.*), one should know how many phage particles were used for extracting ssuDNA. For example, one may have a total volume of 200 μL ssuDNA obtained from 10^{11} phage particles. If one tries to randomize four codons, the minimum library size would be 20^4 or 1.6×10^5 . To get complete representation of all clones, one would have to make a library of about 1.6×10^6 . To achieve this, one should typically take ssuDNA that comes from $\sim 10^7$ – 10^8 phage particles, i.e., between 0.02 and 0.2 μL stock solution of ssuDNA (*see Note 11*).
3. After the extension and ligation reactions (*see Subheading 3.2.4., step 9*), improved transformation efficiencies will result from ethanol precipitation of the DNA and resuspension in 5–10 μL H_2O . Unless the intended size of the library is small (less than 8000 clones), transform 4–5 μL aliquots of the DNA into 100- μL samples of competent *E. coli* TG1.
4. The numbers of bacteria successfully transformed with the randomized constructs should be determined by titration, and compared with the intended size of the library (*see Subheading 3.2.5., step 2*) to ensure comprehensive diversification of the targeted hotspot.
5. If the size of the library is judged satisfactory, phage can be prepared for panning by growing the bacteria in selective liquid medium, superinfecting with helper phage M13K07 at an M.O.I. of 10–20 for 12–14 h, and harvesting the supernatant (*see Subheading 3.2.1., steps 1–12*, noting that, for preparation of a phage library from TG1 cells, chloramphenicol and uridine additions [*steps 2 and 3*] will be unnecessary). Rescue of phage particles from the library is described elsewhere in the book.

3.3. Panning of Phage Library

This is described in Chapter 9, and therefore is not discussed in detail. However, during panning, one should be able to see enrichment of binders (*see Note 11*). Typically, for libraries made by targeting random mutations to hotspots, an enrichment of about 200-fold occurs by the end of round two. This becomes about 2000 by round three, then levels off (*see Note 12*). However, these values may vary.

3.4. Analysis of Binders

Analysis of binders following panning is also discussed in Chapter 9. However, after analysis, one should be able to see a number of phage clones that will have better binding characteristics than the parental clone. A prototypical ELISA result is shown in **Fig. 2** (*see Note 13*). A drawback of the phage system for affinity maturation of scFvs (and also for isolating binders from an immunized or naïve library) is that it is not free from interference, because of

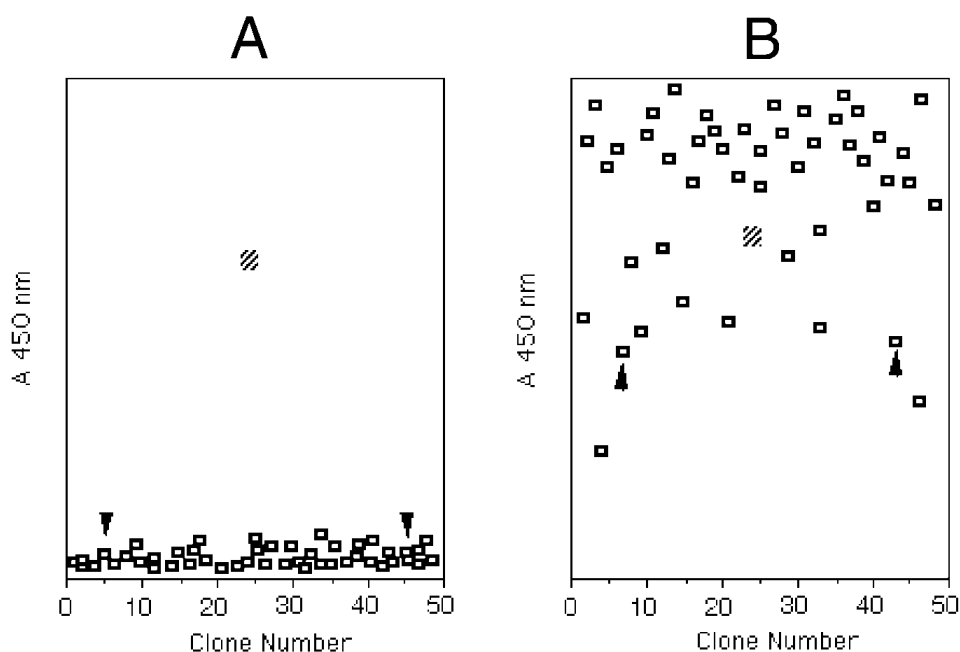

Fig. 2. Prototypical illustration of what one is likely to see in ELISA assay of culture supernatants containing phage particles recovered from clones obtained from panning a hotspot-randomized library. Each square symbol represents phage particles from one single clone. (A) ELISA of the phage clones on an irrelevant Ag (e.g., bovine serum albumin); (B) ELISA on the target Ag. The phage particles should only bind specifically to the Ag on which they were selected. Occasionally, one may come across clones (hatched square) that bind to both Ags. These represent nonspecific binders. During these assays, it is important to include the wild-type parental clone during phage rescue and ELISA to compare the difference in Ag-binding between the mutated clones and the parental clone. The parental clone is shown twice, represented by open square and marked with an arrow. From a hotspot-randomized library, one would see a number of clones that show better binding than the parental clone, and few that could have lower or comparable binding. The titers of phage in few randomly picked sample should be determined, to ensure that they are comparable.

avidity effects. In other words, analysis of phage binding can be misleading because some phage clones may have more copies of the scFv displayed per particle than others, or some clones may have a greater percentage of particles displaying the scFv than other clones. Therefore, before choosing any particular phage clone for further development, compare the relative levels of scFv molecules displayed on the chosen mutants and the parental type. This can be done in a dot blot format (*see Note 13*). This experiment is dependent

on the presence of a peptide tag, which is often incorporated into phage-display vectors between the scFv and the gIIIp. The protocol for this method is described below.

1. Purify recombinant phage particles (wild-type and mutants) by PEG–NaCl precipitation, and titrate them.
2. On two separate nitrocellulose or PVDF membranes, spot equivalent numbers of phage of each type, ranging from 10^8 to 10^{11} or more. Include M13KO7 helper phage as a control.
3. Probe one membrane with anti-gVIIIp Ab and the other with the anti-tag Ab. Since the scFv–gIIIp is expressed in low amounts, the anti-tag Ab should be used at low dilution (1:500–1:1,000), and, since gVIIIp is expressed at high amount, the anti-gVIIIp Ab should be used at higher dilution (1:5,000–1:10,000). Experimental details are not included here: the method for spotting the sample would depend on the apparatus used, but treatment of the membranes will be like a typical Western blot experiment.
4. **Figure 3** is a hypothetical figure provided to help explain what one should expect to see in this type of dot blot experiment. One should see in the membrane probed with anti-gVIIIp a similar degree of staining intensity for each dilution for all samples including M13KO7. This intensity should decrease with decrease in number of the phage particles applied to the membrane. On the membrane probed with anti-tag Ab, the intensity of staining may vary across a given dilution for different samples and this would indicate the relative expression of the scFv on the surface of the phage particles. Typically, one should focus on those mutants that give the same signal or less, compared to the wild-type clone for a given dilution (for example, Mut 2 in **Fig. 3**). In this blot, one should not see any signal for M13KO7.
5. Based on the results of the dot-blot experiment, the scFvs from promising clones should be purified, and the affinity of the purified sample should be compared to the wild-type scFv. Details for this are described in Chapter 21. Alternatively, one can make fusion proteins with the wild type and the selected mutant scFvs, and compare their affinity and other biological activity. Examples of this type of study can be found in **refs. 4** and **5**.

4. Notes

1. The introduction of the stop codon is a crucial step. Although TGA is known to be an effective stop codon, it can be leaky under some circumstances, and therefore may not eliminate the background of wild-type phage in a library. TAA is the stop codon of choice.
2. CJ236 does not have a *lacI^q* gene, and because leaky expression of the scFv–gIIIp fusion protein might affect bacterial growth, a plasmid-carrying *lacI^q* must be transformed into the strain. The phagemid encoding the scFv–gIIIp and the plasmid-carrying *lacI^q* must have different *E. coli* origins of replication in order

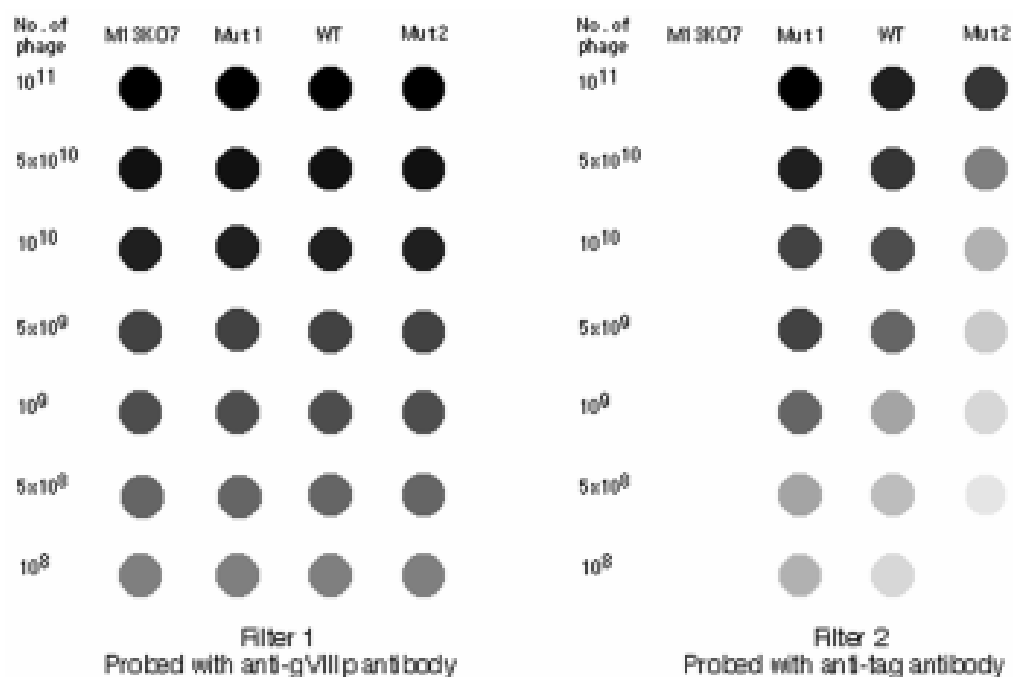

Fig. 3. Illustration of how one can make an estimate of the relative level of scFv expression on the surface of phage particles from different clones. M13KO7 should be used as a control. Mut 1 and 2 represent two mutant clones with greater Ag-binding by ELISA in a preliminary screening assay. Different numbers of purified phage particles are spotted onto two different nitrocellulose or PVDF membranes. One (A) should be developed with anti-gVIIIp Ab; the other (B) should be developed with an anti-tag Ab. The relative intensity of the spots with respect to each other and to the parental clone in blot B give an indication of the expression of the scFv on each clone. If the intensities are the same or lower and ELISA signals are different, then the one with lower intensity in the dot blot, but comparable or higher signal in ELISA, is likely to have greater affinity and vice versa.

to co-exist stably. Also, the plasmids chosen and the helper phage need to have different selection markers. In the studies described here, a construct based on pACYC177 was used (6).

3. Instead of taking plates containing glucose, one can take plates containing the appropriate antibiotics, then spread 0.5 mL 20% glucose, and let it dry in the hood. Although this does not give an exact final concentration of 2% for glucose it is good enough to suppress leaky expression of proteins. Use of 0.5 mL 20% glucose is based on the assumption that each plate contains between 25 and 30 mL LB agar, but volumes can be adjusted if this is not the case.
4. For Kunkel's mutagenesis, one can scale-up or -down the volume of culture for preparing phage for ssuDNA.

5. Helper phage, R408, is useful, since it is packaging-deficient, and therefore is not produced efficiently in the presence of phagemids carrying a normal phage origin of replication. To calculate the MOI, one may note that 1 OD₆₀₀ unit of CJ236 contains $\sim 5 \times 10^8$ bacteria. Do not use helper phage at a MOI greater than 3–5.
6. When recovering the phage for making ssuDNA, do not let the culture age for more than 7 h after addition of the helper phage.
7. When harvesting the ssuDNA-containing phage, two rounds of centrifugation are required to remove any bacteria remaining in suspension.
8. When the phage particles are PEG-purified, additional centrifugation steps, between PEG precipitations, help to remove traces of bacterial contamination.
9. The quality of the ssuDNA should be good for successful mutagenesis by Kunkel's method. Any nucleic acid from the bacterial chromosome, helper phage, or small fragments of DNA or RNA fragments that run with the bromophenol blue in an agarose gel, may be deleterious.
10. Libraries can also be made using "splicing-by-overlap-extension" (SOE) PCR, as illustrated in **Fig. 4**. A protocol for SOE PCR appears elsewhere in this volume (*see* Chapters 23 and 27), but the following considerations are offered from the author's experience with the technique. Use a thermostable DNA polymerase of high fidelity, to minimize the introduction of inadvertent mutations during library construction. Purify fragments at each step—although commercial PCR purification kits are good, many of them do not completely eliminate excess primers as successfully as gel purification. Recovery of the fragment from agarose gels can be done by electroelution or by using gel purification kits, of which there are several available on the market that perform well. Some of these kits involve an isopropanol washing step. The author has found that this reduces the recovery of DNA, without any improvement in quality of the recovered fragment. Bypassing the isopropanol wash increases the recovery.
11. A good library in the context of this protocol will be one that is small in size and a rich source of mutants with affinities higher than the wild-type Ab. Construction of such a library depends on intelligent selection of the most appropriate hotspot for random mutagenesis and successful reduction of the background level of the parental wild-type phage.
12. Rescued phage and phage eluted after panning should be treated like proteins. Unless otherwise required in the experiment, these samples should always be kept at 4°C.
13. Successful analysis depends on accurate titration of the phage samples and identification of false-positive signals. Like most other screening systems, false-positives are common with phage display. In this context, a phage clone may show good Ag-binding properties, but the scFv on its surface may have a much lower affinity than initial indications might suggest. Therefore, preliminary screening should be done on the target Ag and on a negative-control Ag. Dot blotting provides a further check for false-positives.

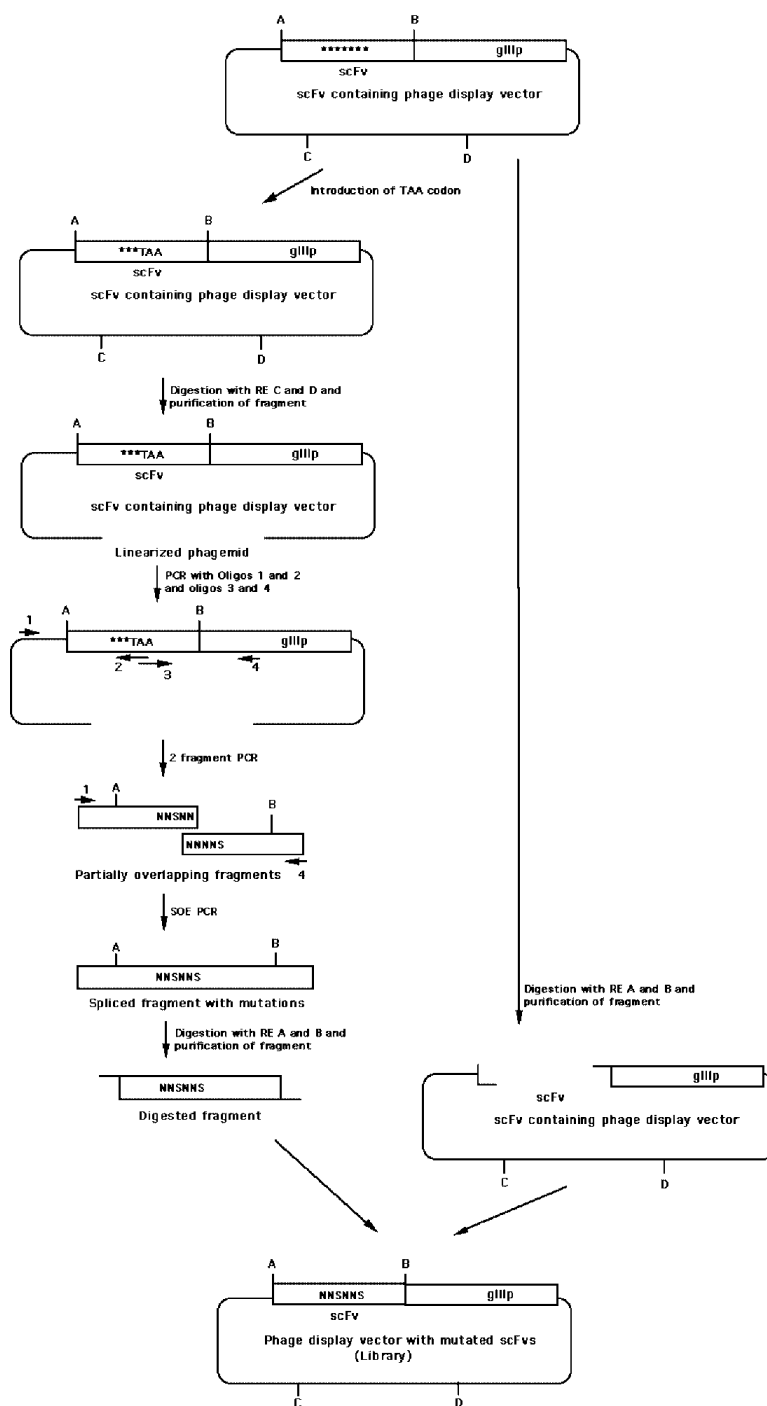

Fig. 4. Flow diagram to illustrate the steps involved in PCR-mediated construction of a randomized library starting from a single template. Introduction of a TAA stop codon and linearizing the phagemid eliminates template carryover and background

References

1. Betz, A. G., Neuberger, M. S., and Milstein, C. (1993) Discriminating intrinsic and antigen-selected mutational hotspots in immunoglobulin V genes. *Immunol. Today* **14**, 405–411.
2. Neuberger, M. S. and Milstein, C. (1995) Somatic hypermutation. *Curr. Opin. Immunol.* **7**, 248–254.
3. Jolly, C. J., Wagner, S. D., Rada, C., Klix, N., Milstein, C., and Neuberger, M. S. (1996) Targeting of somatic hypermutation. *Semin. Immunol.* **8**, 159–168.
4. Chowdhury, P. S. and Pastan, I. (1999) Improving antibody affinity by mimicking somatic hypermutation in vitro. *Nature Biotechnol.* **17**, 568–572.
5. Beers, R., Chowdhury, P. Bigner, D., and Pastan, I. (2000) Immunotoxins with increased activity against epidermal growth factor receptor vIII-expressing cell lines produced by antibody phage display. *Clin. Can. Res.* **6**, 2835–2843.
6. Brinkmann, U., Mattes, R. E., and Buckel, P. (1989) High-level expression of recombinant genes in *Escherichia coli* is dependent upon the availability of the *dnaY* gene product. *Gene* **85**, 109–114.
7. Chowdhury, P. S., Vasmatzis, G., Beers, R., Lee, B.-K., and Pastan, I. (1998) Improved stability and yields of a Fv-toxin fusion protein by computer design and protein engineering of the Fv. *J. Mol. Biol.* **281**, 917–928.
8. Chowdhury, P. S., et al. (2000) Engineering of recombinant antibodies for greater stability. To appear in *Recombinant Antibody Technology for Cancer Therapy*, Methods in Molecular Medicine (Welschof, M. and Krauss, J., eds.), Humana, Totowa, NJ.

Fig. 4. (*continued*) contamination of the library by the wild-type clone. Restriction enzymes A and B represent the cloning sites for the scFv. Restriction enzymes C and D are unique sites in the phagemid, and are incompatible with each other. * Represents the hotspots to be randomized. Primers 1 and 4 anneal to sites ~50–100 nucleotides away from the scFv, which creates a fragment that can be efficiently cleaved by enzymes A and B. Primers 2 and 3 are degenerate mutagenic primers, which have complementary 5' ends that help to splice the fragments they generate in a SOE PCR. Digestion of the spliced fragment is followed by ligation into the parental phagemid backbone.

Error-Prone Polymerase Chain Reaction for Modification of scFvs

Pierre Martineau

1. Introduction

The use of antibody (Ab) molecules and their fragments in research, diagnosis, and therapy has prompted the development of methods to improve their affinity and stability to increase their expression levels and to change or improve their specificity. This is easier to carry out on Ab fragments (scFvs or Fabs) expressed in *Escherichia coli* than on a complete Ab molecule expressed in B cells. Several methods can be used in *E. coli* to generate mutations: chemical mutagenesis, use of mutagenic strains of bacteria, incorporation of degenerate oligonucleotides, DNA shuffling, or error-prone polymerase chain reaction (PCR).

The chief advantages of PCR-based methods are that mutations are precisely targeted to the amplified fragment, the error rate is easy to control (*see below*) and the method is quick and easy to set up and does not use hazardous chemicals.

It is well known that the *Taq* DNA polymerase duplicates DNA with low fidelity, substantially because of the absence of 3' to 5' proofreading activity. The mutagenic rate has been measured to be about 10^{-4} errors/duplication (**I**). The type of mutation introduced is mostly T to C (and thus TA to CG transitions), but most mismatches may also be obtained (**I**).

The high error rate of *Taq* DNA polymerase is usually seen as a major problem in PCR, since it may result in the cloning of a mutated fragment. However, it becomes an advantage when the goal of the experiment is to introduce mutations into the amplified region. By choosing the right PCR conditions, it is easy to control the *Taq* DNA polymerase error rate and the

mismatches that are generated. The main parameters that can be adjusted to manipulate the enzyme's fidelity are the concentration of divalent cations, the concentration of deoxyribonucleoside triphosphates (dNTPs), and the number of PCR cycles.

1. Effect of divalent cations. Divalent cations, such as Mg^{2+} (2) and Mn^{2+} (3) are known to increase the misincorporation rate of the *Taq* DNA polymerase. Mn^{2+} is usually used at a final concentration of 0.5 mM and increases the error rate about fivefold without affecting the efficiency of amplification. In the case of Mg^{2+} , increasing its concentration not only results in a higher error rate (2–3-fold), but also in a reduction in efficiency of the PCR.
2. Concentration of dNTPs. Under normal PCR conditions (0.2 mM dNTPs, no Mn^{2+} , 1.5 mM Mg^{2+}), the most frequently formed mismatch is T:G, resulting in a T to C mutation (1). However, by using a high concentration of one nucleotide, one can force this nucleotide to be used in a mismatch. For instance, an excess of deoxyadenosine triphosphate (dATP) compared to the three other nucleotides will result in accumulation of N to T mutations caused by mismatched N:A pairs (4). Fromant et al. (4) have determined the probability of misincorporation for each nucleotide. Using their data, it is possible to predict the rate of each mutagenic event for each dNTP concentration. **Table 1** gives the probabilities of bp substitutions for various sets of nucleotides. This table is used in the protocol described in **Subheading 3**.
3. Number of PCR cycles. The probability of misincorporation depends on the number of duplications during the PCR. When the mutation rate is low (i.e., the probability of reversion of a previously introduced mutation is negligible), this probability is proportional to the number of duplications. For instance, if, during the PCR, the fragment is amplified 1000-fold (2^{10}), the mutagenic rate will be 10-fold the mutagenic rate obtained with one duplication.

The method presented below shows how these three parameters might be chosen in order to obtain the desired rate of mutagenesis and the intended spectrum of misincorporation. The detailed protocols show the following: how to measure the number of duplications (*see Subheading 3.1.*), how to obtain scFv gene mutants at a rate of 0.2% with the same probability of obtaining substitutions on AT and GC pairs, and an equal probability of AT to GC and AT to TA substitutions (*see Subheading 3.2.*). A 0.2% mutagenic rate has been chosen, since it gives a high rate of point (33%) (*see Note 1*) and double (25%) mutations and limits the number of genes without any mutation (22%). The protocols indicate those conditions that may be changed in order to get other mutagenic patterns and/or rates (*see Note 2*).

2. Materials

1. 1 M $MgCl_2$ and 1 M $MnCl_2$ diluted to 12.5 and 2.5 mM, respectively. Aliquot and store frozen (*see Note 3*).

Table 1
Probabilities of bp Substitutions (%) for Various Sets of Nt Concentrations (mM)

dATP	dCTP	dGTP	dTTP	<i>p</i>	$P_{AT \rightarrow GC}$	$P_{AT \rightarrow GC}$	$P_{AT \rightarrow TA}$	$P_{GC \rightarrow AT}$	$P_{GC \rightarrow TA}$	$P_{GC \rightarrow CG}$
Low MgCl ₂										
0.56	0.90	0.20	1.40	1.5	0.7	0.1	0.7	1.1	0.4	<0.1
0.35	0.40	0.20	1.35	2	1.0	<0.1	1.0	1.6	0.4	<0.1
0.20	0.20	0.18	1.26	3	1.5	<0.1	1.5	2.6	0.4	<0.1
0.22	0.20	0.27	1.82	4	2.0	<0.1	2.0	3.6	0.4	<0.1
0.22	0.20	0.34	2.36	5	2.5	<0.1	2.5	4.6	0.4	<0.1
0.23	0.20	0.42	2.90	6	3.0	<0.1	3.0	5.5	0.4	0.1
0.23	0.20	0.57	4.00	8	4.0	<0.1	4.0	7.5	0.4	0.1
0.12	0.10	0.36	2.50	10	5.0	<0.1	5.0	9.4	0.4	0.2
0.12	0.10	0.55	3.85	15	7.5	<0.1	7.5	14.3	0.4	0.3
High MgCl ₂										
0.51	0.20	1.15	3.76	15	7.5	<0.1	7.5	13.2	0.9	0.9
0.39	0.15	1.17	3.85	20	10.0	<0.1	10.0	17.9	0.9	1.2
0.26	0.10	1.20	3.94	30	15.0	<0.1	15.0	27.3	0.9	1.8

Sets of nucleotides were chosen to ensure substitutions of AT and GC with the same probability ($P_{AT \rightarrow GC} + P_{AT \rightarrow CG} + P_{AT \rightarrow TA} = P_{GC \rightarrow AT} + P_{GC \rightarrow TA} + P_{GC \rightarrow CG}$) and equiprobability of AT→GC and AT→TA substitutions ($P_{AT \rightarrow GC} = P_{AT \rightarrow TA}$). *p* is the probability of mutation on a given bp ($p = P_{AT \rightarrow GC} + P_{AT \rightarrow CG} + P_{AT \rightarrow TA} = P_{GC \rightarrow AT} + P_{GC \rightarrow TA} + P_{GC \rightarrow CG}$). The data are for a concentration of 0.5 mM MnCl₂ and either a low MgCl₂ concentration ([MgCl₂] + [MnCl₂] = [dNTP] + 0.7 mM) or a high MgCl₂ ([MgCl₂] + [MnCl₂] = [dNTP] + 6 mM) concentration. The substitution probabilities are for 10 duplications. For *n* duplications, the probabilities must be multiplied by *n*/10. This table is reproduced with permission from **ref. 4**.

2. 5 U/μL Recombinant *Taq* DNA polymerase (see **Note 4**).
3. dNTP solutions may be obtained from any supplier and must be kept frozen. Dilutions and 5X mix are prepared in 10 mM Tris-HCl, pH 7.0, buffer. 5X mix must be prepared according to **Table 1** or to the data presented by Fromant et al. (**4**). For the protocol below, the 5X dNTP mix is: 1.75 mM dATP, 2 mM deoxycytidine triphosphate (dCTP), 1 mM deoxyguanosine triphosphate (dGTP), 6.75 mM deoxythymidine triphosphate (dTTP) (see **Note 5**).
4. A PCR thermocycler for 0.2 mL tubes (see **Note 6**).
5. Large, square Petri dishes (245 × 245 mm) (Nunc, Corning, or another supplier).

3. Methods

The goal of the two protocols is to obtain an average of two mutations/1000 bp. The first protocol (see **Subheading 3.1.**) determines the number of cycles necessary to obtain 10 duplications (see **Note 7**). These cycling conditions then are used in the second protocol (see **Subheading 3.2.**), which is the error-

prone PCR, followed by cloning of the mutated fragment in order to get a library of scFv mutants.

3.1. Setup of PCR Conditions

1. Perform a first PCR under standard conditions to get the amplified band (*see Note 8*). The amplified band is called PCR1 below and serves as a standard.
2. Prepare a reaction mix comprising 5 μL template (PCR1 diluted 1×200 in H_2O), 20 pmol each of the chosen forward and backward oligonucleotides (p1 and p2, respectively) (**Fig. 1**), 5 μL 5X dNTP mix (*see Note 9*), 2.5 μL 10X *Taq* DNA polymerase buffer without Mg^{2+} (*see Note 10*), 5 μL 12.5 mM MgCl_2 (*see Notes 1 and 11*), and H_2O to 19.6 μL . Then add 5 μL 2.5 mM MnCl_2 (*see Notes 1 and 12*) and 0.4 μL *Taq* DNA polymerase (5 U/ μL). Overlay with mineral oil or use a thermocycler with a hot lid.
3. Run the PCR for 1 min at 94°C, then cycle 15 \times at 94°C for 30 s, 55°C for 30 s, and 3 min at 72°C (*see Note 13*). Finish with 3 min at 72°C. The result of this PCR will be called PCR2.
4. Analyze 1, 2, and 4 μL of PCR1 and PCR2 on a 1% agarose gel. Visual comparison is sufficient to estimate the amplification yield (*see Note 14*). Obtain an amplification of 1000-fold (2^{10}), and thus the intensity of PCR2 should be comparable to PCR1. If this is not the case, reperform **steps 2–4**, but decrease or increase the number of cycles.

3.2. Error-Prone PCR

1. Prepare a reaction mix containing 15 nmol of the chosen target plasmid (50 ng 5000 bp plasmid), 20 pmol each of the chosen forward and backward oligonucleotides (p1 and p2, respectively, in **Fig. 1**), 5 μL 5X dNTP mix (*see Note 9*), 2.5 μL 10X *Taq* DNA polymerase buffer without Mg^{2+} (*see Note 10*), 5 μL 12.5 mM MgCl_2 (*see Notes 1 and 11*), and H_2O to 19.6 μL . Then add 5 μL 2.5 mM MnCl_2 (*see Notes 1 and 12*) and 0.4 μL *Taq* DNA polymerase (5 U/ μL).
2. Run the PCR under the conditions determined in the first protocol (*see Subheading 3.1.*), i.e., 1 min at 94°C, 15 or that number of cycles determined empirically (*see Subheading 3.1., step 4*) at 94°C for 30 s, 55°C for 30 s, and 3 min at 72°C (*see Note 13*). Finish with 3 min at 72°C.
3. Analyze an 5 μL aliquot from the PCR reaction on an agarose gel (*see Note 15*).
4. Purify the amplified product using a favorite protocol (*see Note 16*).
5. Digest the band with *NcoI* and *NotI* enzymes or whichever enzymes are required for cloning into the phage-display vector in use (*see Note 17*). Typical conditions are 50 μL purified PCR product, 1 μL *NcoI* (10 U), 1 μL *NotI* (10 U), 6 μL 10X buffer (*see Note 18*), and 2 μL H_2O . Incubate for 20 h at 37°C. Digest also 1 μg recipient plasmid with the same enzymes.
6. Purify the digested PCR and the recipient plasmid on an agarose gel (*see Note 16*) using a favorite protocol.

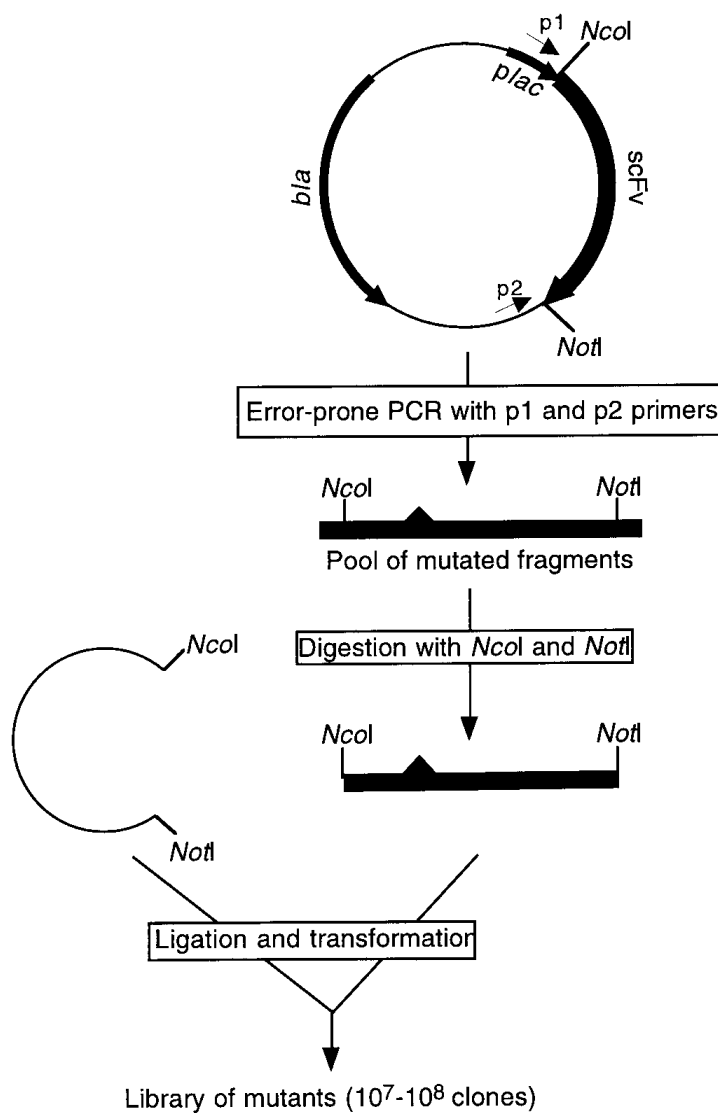

Fig. 1. Outline of strategy for creation of scFv mutants by error-prone PCR.

7. Set up a ligation mix containing 45 μL digested and purified PCR fragment (the whole PCR reaction), 45 μL digested and purified recipient plasmid (1 μg), 10 μL 10X T4 DNA ligase buffer containing ATP, and 1 μL T4 DNA ligase (400 Biolabs U). Incubate for 16 h at 16°C.
8. Inactivate the T4 DNA ligase by heating for 10 min at 65°C.
9. Clean the DNA ligation with a favorite protocol (e.g., phenol extraction, followed by ethanol precipitation, silica-based columns, ultrafiltration, or other procedure). Resuspend in 10–50 μL of H₂O.

10. Transform competent *E. coli* cells (see **Note 19**) and plate onto a 245 × 245 mm Petri dish containing Luria agar, 100 µg/mL ampicillin, and 1% glucose to repress the expression of the scFv gene (see **Note 20**). Incubate at 30°C for 16–24 h.
11. Add 5–10 mL 2TY medium containing 10% sterile glycerol to the plate and resuspend the cells with a scraper. Measure the optical density at 600 nm, aliquot, and freeze at –80°C (see **Note 21**).

4. Notes

1. The probability of getting m mutations among n bp is

$$C_n^m \times p^m \times (1 - p)^{(n - m)}$$

where p is the probability of mutation/bp (0.2%). For an scFv fragment, n is close to 750 bp.

2. In addition to the concentration of the dNTP, the number of duplications, and the concentration of divalent cations, the spectrum and the efficacy of mutagenesis may be adjusted by carrying out successive error-prone PCRs using different conditions. For example, it is possible to perform a first PCR with a high dATP concentration to force N to T mutations, followed by a second PCR with a high excess of dGTP. Possible variations of the protocol are only limited by one's imagination.
3. Because MgCl₂ and MnCl₂ powders are hygroscopic, it is not possible to prepare 1 M solutions by weighing. It is easier and safer to order commercially prepared titrated solutions. We use solutions from Sigma (nos. M1028 and M1787), but any other commercial source is suitable. Depending on the supplier, an MgCl₂ solution may be distributed with the *Taq* DNA polymerase enzyme.
4. Any good-quality *Taq* DNA polymerase is adequate. We however always use recombinant *Taq* overexpressed in *E. coli* for its high reproducibility from batch to batch.
5. It is easier and safer to order dNTP directly in solution (usually 100 mM). The mix must be aliquoted and may be stored for several months at –20°C.
6. Any thermocycler may be used. The efficiency of the PCR will, however, depend on the thermocycler used and the conditions used with one machine cannot be transferred to another without adaptation.
7. The number of duplications may be increased or decreased in order to respectively increase or decrease the mutagenic rate, without changing the spectrum of the induced mutations (see **Subheading 1.**).
8. We use 30 cycles in *Taq* buffer with 1.5 mM Mg²⁺ and 0.2 mM of each dNTP.
9. The dNTP mix used here results in the same probability of obtaining substitutions on AT and GC pairs, and in an equiprobability of AT to GC and AT to TA substitutions (**Table 1**). This may be changed in order to get another spectrum of mutations (**4**).
10. If the *Taq* buffer contains Mg²⁺ (usually 1.5 mM final), the Mg²⁺ concentration must be adjusted in order to obtain the correct final Mg²⁺ concentration (2.5 mM).

11. The final Mg^{2+} concentration is 2.5 mM. It must be noted that, because dNTPs bind stoichiometrically divalent cations, the free concentration of Mg^{2+} and Mn^{2+} is the total Mg^{2+} and Mn^{2+} concentration minus the total dNTP concentration ($[\text{Mg}^{2+}] + [\text{Mn}^{2+}] = [\text{dNTP}] + [\text{Mg}^{2+}]_{\text{free}} + [\text{Mn}^{2+}]_{\text{free}}$). In **Table 1**, the low Mg^{2+} concentration corresponds to a free cation concentration of 0.7 mM ($[\text{Mg}^{2+}]_{\text{free}} + [\text{Mn}^{2+}]_{\text{free}} = 0.7$ mM), as in a classic PCR ($[\text{Mg}^{2+}] = 1.5$ mM, $[\text{Mn}^{2+}] = 0$, $[\text{dNTP}]_{\text{total}} = 0.8$ mM). For short fragments (<400 bp), this concentration of free Mg^{2+} may be increased to 6 mM in order to increase the mutagenic rate (see **Table 1**).
12. The MnCl_2 must be added at the end just before the enzyme to avoid precipitation.
13. Fifteen cycles are usually suitable to give about 10 duplications. If the goal is to obtain n duplications, one must start with $15n/10$ cycles and adjust the template (PCR1) dilution to $5/2^n$. In addition, the hybridization temperature (55°C) should be chosen in accordance with the melting temperature of the primers.
14. The mutagenesis efficiency is directly proportional to the number of duplications. A visual examination of the gel is good enough to evaluate the efficiency of amplification, since an error of a factor 2 on the estimation of the DNA amount on 10 duplications (9–11 duplications, i.e., a 500- to 2000-fold amplification) will result in an error of only 10% on the mutagenesis efficiency ($9/10$ – $11/10 \times$ [efficiency for 10 duplications], i.e., $0.2 \pm 0.02\%$).
15. If the PCR fails to amplify, attempt the following modifications. Verify that under standard conditions the target is amplified; if the high Mg^{2+} concentration was used, try using the low Mg^{2+} concentration (**Table 1**). Use a new aliquot of *Taq* buffer, dNTP mix, MgCl_2 , and MnCl_2 .
16. To purify the PCR product, and to extract the band from the agarose gel after digestion, good results are obtained with silica-based methods, e.g., Qiaprep (Qiagen) or Nucleospin (Macherey-Nagel) columns.
17. It may be tricky to digest restriction sites at the extremity of a PCR fragment. As a guideline when designing oligonucleotides, use the data in the Reference Appendix of the New England Biolabs catalog data (“Cleavage close to the end of DNA fragments”). Information is also available at the company website (http://www.neb.com/neb/tech/tech_resource/restriction/properties/cleave_vector.html and http://www.neb.com/neb/tech/tech_resource/restriction/properties/cleave_oligo.html).
18. For *NcoI* and *NotI*, it is easy to find a buffer compatible with both enzymes (e.g., NEB3 buffer from New England Biolabs). If the enzymes are not compatible, digest with one enzyme for 4–20 h, then, after changing the buffer, with the second enzyme.
19. The transformation method used depends on the library size needed. The author usually uses electrocompetent *E. coli* cells (10^{10} transformants/ μg of DNA) to get $\sim 10^8$ clones, but a chemical method may be sufficient. For electroporation, the author uses TG1 cells [*F' traD36 lacI^q Δ(lacZ)M15 proA+B+*] *supE Δ(hsdM-mcrB)5 thi Δ(lac-proAB)*, prepared as follows. Grow the cells up to an optical density 600 nm of 0.7 in 2TY medium, cool them down on ice and pellet at

4000g. After resuspension in 1 vol cold buffer (1 mM HEPES, pH 7.0), spin down the cells again (4000g) and resuspend in one-half vol cold buffer. Repeat the centrifugation and resuspend in one twentieth vol cold buffer. After a final centrifugation step, resuspend the cells in one-hundredth vol cold buffer. Make 10 electroporations with 50–100 μ L of competent cells and one-tenth vol ligation mixture. For transformation, it is better to use a bacteria of high transformation efficiency than to prepare the DNA as a pool for transformation into the recipient strain.

20. Because scFv can be toxic for *E. coli*, conditions must be used that repress as much as possible, their expression. In common with many other systems, we express scFv sequences from the *lac* promoter, which can be repressed by addition of glucose to the medium. If expression in the vector selected is from a different promoter, other compounds may be necessary (e.g. tryptophan for the *trp* promoter, [5]).
21. Depending on downstream applications, the library may be used either directly in the recipient cell (TG1), or, if the plasmid targeted for mutagenesis is a phagemid after rescue with a helper phage and infection into another strain. Alternatively, display of mutated scFvs at the phage surface enables selection, or a pool of plasmids prepared from the scraped cells may be transformed into a suitable bacterial host for other purposes. Some clones may be sequenced to verify the efficacy and specificity of the error-prone PCR, but most of the time this is not needed, since we have found excellent correlation between the theoretical values predicted by Fromant et al. (4) and the experimental mutations obtained (5).

References

1. Tindall, K. R. and Kunkel, T. A. (1988) Fidelity of DNA synthesis by the *Thermus aquaticus* DNA polymerase. *Biochemistry* **27**, 6008–6013.
2. Eckert, K. A. and Kunkel, T. A. (1990) High fidelity DNA synthesis by the *Thermus aquaticus* DNA polymerase. *Nucleic Acids Res.* **18**, 3739–3744.
3. Leung, D. W., Chen, E., and Goeddel, D. V. (1989) A method for random mutagenesis of a DNA segment using a modified polymerase chain reaction. *Technique* **1**, 11–15.
4. Fromant, M., Blanquet, S., and Plateau, P. (1995) Direct random mutagenesis of gene-sized DNA fragments using polymerase chain reaction. *Anal. Biochem.* **224**, 347–353.
5. Martineau, P., Jones, P., and Winter, G. (1998) Expression of an antibody fragment at high levels in the bacterial cytoplasm. *J. Mol. Biol.* **280**, 117–127.

Use of *Escherichia coli* Mutator Cells to Mature Antibodies

Robert A. Irving, Gregory Coia, Anna Raicevic,
and Peter J. Hudson

1. Introduction

Despite the power of antibody (Ab) phage-display technology, a problem which can be commonly encountered is the recovery of Abs of low affinity for the antigen (Ag) of interest. Two general strategies can be applied to increase affinity: mutations can be scattered randomly throughout the genes; substitutions can be introduced in a directed manner to specific regions, such as the complementarity-determining loops. In order to select those changes that improve on the starting affinity for the target Ag, phage display can be utilized, the power of this approach lying in the display of Abs at the viral surface coupled with carriage of the encoding sequences within the phage particle. Repeated rounds of mutation and increasingly stringent selection (**Fig. 1**) enable recovery of Abs of substantially elevated affinity for the target. In general, the greatest improvements in affinity are observed when low-affinity Abs ($K_d < 10^{-6} M$) are used as the starting point. Although high-affinity Abs ($K_d > 10^{-8} M$) are less readily improved, there have been isolated successes.

The use of *Escherichia coli* mutator strains (**1,2**) is just one of several mutation strategies to introduce random mutations, and thereby modify the affinity and expression of recombinant Ab fragments. There are several mutator strains of *E. coli* available. *E. coli* mutD5-FIT introduces random, predominantly point mutations to DNA, a function of a defective *dnaQ* gene, which results in proofreading errors (**3–5**). The rate and specificity of mutation is governed by the growth conditions: mutation in rich media is increased by up to 5× compared to the rate in minimal media; the ratio of transitions:transversions

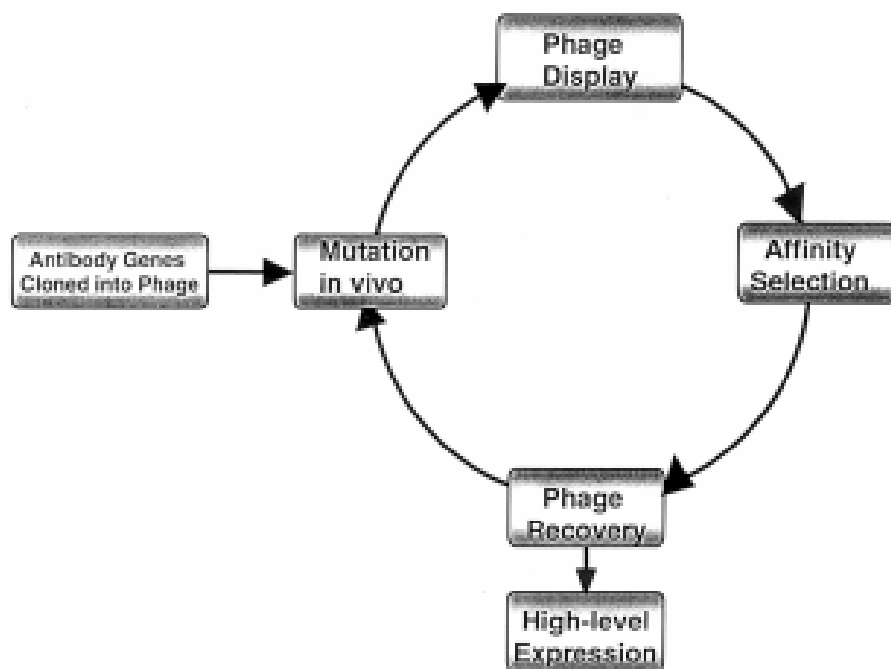

Fig. 1. Affinity maturation cycle. Ab genes (scFvs or Fabs) are cloned into bacteriophage-display vectors, Abs are mutated and displayed on the surface of phage. Affinity selection leads to phage recovery of the highest-affinity phage–Abs. The recovered phage are then taken through further cycles of mutation, display, and selection. After the final affinity maturation cycle, the scFv or Fab genes are subcloned into vectors designed for high-level expression.

is also affected; the mutation rate is highest when the cells are in exponential growth and decreases as the cells approach stationary phase. Alternative *E. coli* mutator strains, such as XL1-RED (*mutD*, *mutL*, and *mutS* mutations) and XLmutS Kan^r (*mutS* mutation), are commercially available (Stratagene). However, these strains do not carry the F' episome and cannot be infected directly with phage to introduce immunoglobulin sequences. Because the affinity maturation process is iterative, requiring several cycles of mutation, affinity selection, and amplification (Fig. 1), there is an advantage in utilizing mutator cells, such as mutD5-FIT, which express the F pilus and can thus be directly infected, rather than transformed with the genes to be mutated.

When these mutator cells are transformed with a plasmid or phagemid carrying sequences for a recombinant Ab or infected with phage, mutations are incorporated into the replicating DNA. An additional method is required for screening the mutations so-created for function: rescue and display of the molecular library at the surface of bacteriophage enables selection of Abs with

affinity for an immobilized Ag or cognate-binding partner. Usually, between 4 and 10 cycles of mutation are required for the majority of Ab genes to acquire at least one mutation, and, until a high-affinity Ab is displayed, each round is followed by rescue, selection, and amplification of phage. Finally, expression of the affinity-matured Ab is achieved by either subcloning to an expression vector or a further switch of *E. coli* host. In appropriate phagemid vectors, the linkage of Ab and viral *gene III* can be prevented by changing from an amber-suppressing strain (e.g. mutD5-FIT or TG1) to a nonsuppressing strain (e.g., HB2151).

2. Materials

2.1. E. coli Strains and Phage

1. The amber suppressor strain, TG1 (K12, $\Delta[lac-pro]$, *supE*, *thi*, *hsdD5*, *F'*[*traD36*, *proAB*⁺, *lacI*^q, *lacZ* Δ *M15*]) is used for amplification of phage after mutation and selection.
2. The nonsuppressing strain, HB2151 (K12, $\Delta[lac-proAB]$, *araD*, *nal*^r, *thi*, *F'*[*proAB*⁺, *lacI*^q, *lacZ* Δ *M15*]) is used for expression of Abs as free, recombinant proteins.
3. *E. coli* mutD5-FIT (*ara*, *thi*, *supE*, *rif*, *metB*, *argE*^(am), Δ (*pro lac*), *F'* [*pro lac*, *mutD5*-Tn10 (Tet^r)]) is the mutating bacterial strain described here for affinity maturation. Stocks of mutD5-FIT are maintained on M9 minimal medium supplemented with casamino acids and tetracycline (*see Note 1*). The strain can be obtained from the authors.
4. Phage stock encoding the recombinant Ab that is to be matured. Typically, $\sim 5 \times 10^9$ transducing units (tu)/mL.
5. VCSM13 helper phage (Stratagene). This is usually stored as a stock at 10^{13} tu/mL.

2.2. Growth Media

1. M9–GLU–THI–CAS–TET: Prepare M9 salts in 1 L H₂O, add Bacto-agar to 15 g/L, and sterilize by autoclaving. Before pouring plates, add the following supplements: glucose to 0.4% (w/v), thiamine-HCl to 5 mg/mL, casamino acids to 0.67–2% (w/v) (*see Note 1*), and tetracycline to 10 μ g/ml.
2. Tetracycline stock at 5 mg/mL (w/v) in ethanol.
3. 2 mM Thymidine stock. Use at 20 μ M final concentration only during the mutation phase of growth.
4. TY: 8 g/L bacto-tryptone, 5 g/L Bacto-yeast extract, 5 g/L NaCl, pH 7.0. Sterilize by autoclaving. 2TY is simply double-strength TY.
5. TYAG: Prepare and sterilize TY by autoclaving. When cooled to 65°C, add ampicillin (or antibiotic appropriate to the vector in use) to 100 μ g/mL and glucose to 1%. For solid TYAG, bacto-agar is added to TY at 15 g/L before autoclaving.

6. TYAG–THY–TET: TYAG medium supplemented with 20 μ M thymidine and 100 μ g/mL tetracycline.
7. Kanamycin stock at 25 (w/v) mg/mL.
8. Phage precipitation solution: 20% polyethylene glycol 6000–2.5 M NaCl.
9. Phosphate-buffered saline (PBS).

2.3. Selection

1. For bead capture methods, M280 streptavidin-coated magnetic beads and MPC-E magnetic separator (Dynal).
2. A stock of biotinylated Ag, to which the recombinant Ab (*see Subheading 2.1., item 4*) is reactive.
3. Blocking buffer: 3% (w/v) bovine serum albumin in PBS.
4. Binding buffer: blocking buffer containing 0.05% (v/v) Tween-20.
5. 1 M triethylamine.
6. 1 M Tris-HCl, pH 7.4.

3. Methods

3.1. Infection of *E. coli* Mutator Cells

1. Plate *E. coli* mutD5-FIT mutator cells onto M9–GLU–THI–CAS–TET plates, and grow at 37°C (*see Note 1*). Inoculate 10 mL 2TY broth, supplemented with 10 μ g/mL tetracycline and 1% (w/v) glucose (plus/minus 2% [w/v] casamino acids) with a colony of *E. coli* mutD5-FIT mutator cells and incubate overnight at 37°C with shaking (200 rpm).
2. In a 10 mL tube, mix together 20 μ L recombinant phage (approx 10^8 tu) and 0.6 mL overnight culture of mutD5-FIT cells. Typically, a clonal stock of phage is used for initial infection (*see Subheading 2.1., item 4* and *Note 2*). Typically, phage in later rounds of mutagenesis will have been generated through mutagenesis, phage rescue, amplification, and Ag selection and thus will comprise mixed populations of phage for which titration and characterization (*see Subheading 3.1., steps 5–7*) will be required.
3. Incubate at 30°C for 1 h without shaking followed by a further 30 min at 37°C with gentle shaking (200 rpm).
4. Centrifuge at 2440g for 10 min to collect cells.
5. Resuspend the cells in 1 mL TYAG broth.
6. Spread 100 μ L aliquots of the cell suspension onto TYAG plate media and incubate overnight at 37°C.
7. Count the resulting colonies to establish maximum potential library size. Pick 30, and check for the presence of the intended inserts by colony polymerase chain reaction and restriction digestion.

3.2. Mutation with *E. coli* Mutator Cells in Liquid Culture

1. To perform the first round of mutation, inoculate 10 μ L phage infected mutD5-FIT mutator cells (*see Subheading 3.1., step 5*) in 2 mL TYAG–THY–TET (*see*

- Note 1**) and incubate at 30°C with shaking (200 rpm) until the optical density 600 nm reaches 0.2.
2. Dilute the culture to a final volume of 20 mL with fresh TYAG–THY–TET broth, and incubate at 30°C for 4–6 h, with shaking (200 rpm). The progressive increase in culture volume improves growth rate.
 3. Dilute the culture to a final volume of 1 L with fresh TYAG–THY–TET broth.
 4. Incubate overnight at 30°C, with shaking (200 rpm).
 5. This is the stock mutation library. For further rounds of mutagenesis without selection, remove 20 mL mutagenized culture, and repeat mutation steps up to 4×.
 6. Generally, the stock mutation library is rescued, amplified (*see Subheading 3.3.* and **Note 3**), and selected on Ag (*see Subheading 3.4.*), after successive rounds of mutation. This results in a higher mutation rate with over 80% of Ab genes having at least one mutation after four cycles.
 7. To concentrate the stock mutation library for rescue and subsequent steps, centrifuge at 2440g for 10 min and resuspend the pellet in 10 mL TYAG broth.

3.3. Rescue and Amplification of Mutated Phage Library

1. Inoculate 10 µL of the concentrated stock library into 10 mL TYAG broth, and incubate the cells with shaking (200 rpm) at 37°C until optical density at 600 nm reaches 0.4–0.5 (~2 h).
2. Add VCSM13 helper phage to the culture at a phage:*E. coli* ratio of approx 20:1 and incubate the mixture for 30 min in 37°C water bath without shaking (*see Notes 3* and **4**).
3. Continue incubation of cell–helper-phage mixture for 30 min in 37°C water bath with shaking at 200 rpm.
4. Add 90 mL fresh TYAG broth, supplemented with 25 µg/mL (w/v) kanamycin, and incubate overnight at 37°C, with shaking (200 rpm) (*see Note 3*).
5. Pellet the cells by centrifugation at 10,000g for 15 min and keep the supernatant, which contains phage.
6. Precipitate the phage particles by adding one-fifth volume phage precipitation solution to the supernatant fraction and incubate mixture on ice for a minimum of 1 h.
7. Centrifuge at 10,000g for 40 min to collect the precipitated phage. Remove and discard all supernatant.
8. Resuspend the pellet in 30 mL H₂O and reprecipitate the phage by adding one-fifth vol phage precipitation solution. Incubate on ice for 1 h.
9. Centrifuge at 2440g for 40 min to collect precipitated phage. With a fine-tipped pipet, remove all supernatant.
10. Resuspend the phage in 1 mL PBS. Yield is about 2×10^{13} tu (*see Note 4*).
11. Filter through 0.2-µm filter attached to a syringe to remove cell debris and aggregated phage. The yield of phage can be assessed by infection of *E. coli* TG1 with dilutions of the stock (*see Subheading 3.1.*). Store the filtrate at 4°C (*see Note 5*).

3.4. Selection of Mutation Library (see Note 6)

1. There is a wide range of affinity supports to which Ag can be bound for selection (see Note 7). Described here is a protocol based on the binding of biotinylated Ag to streptavidin-coated dynabeads in suspension (see Note 8). Begin by pretreating 100 μ L M280 streptavidin-coated magnetic beads in 1 mL blocking buffer for 2 h at room temperature to eliminate adhesive sites.
2. Add 1 μ L phage library at suitable titer (typically, about 10^{11} /mL in binding buffer) (see Note 4) to 200 μ L biotinylated Ag (see Note 9). Dilute to a final volume of 1 mL with PBS and allow equilibrium to be reached (typically, 1 h at room temperature).
3. Mix 100 μ L of blocked beads with the Ag-phage solution (1 mL) and incubate for 30 min at room temperature (see Note 10).
4. Separate the magnetic particles on an MPC-E magnetic separator for 5 min at room temperature. Carefully remove the supernatant, being careful not to disturb the beads.
5. Wash the beads with five cycles, each comprising one wash with 1 mL blocking buffer, followed by two washes with 1 mL PBS. Flick tube to resuspend the beads in the tube.
6. Elute the bound phage by adding 0.5 mL 100 mM triethylamine to the washed beads (see Note 11).
7. Quickly separate the beads with an MPC-E magnetic separator, which takes \sim 30 s.
8. Transfer the supernatant (phage stock) to a new tube and immediately neutralize with 0.2 mL 1 M Tris-HCl, pH 7.4 to prevent damage to the eluted phage.
9. Titrate the phage stock by infection of samples of an overnight culture of *E. coli* TG1 (see Subheading 3.1.). Monitor the recovery of specific phage Abs by phage enzyme-linked immunosorbant assay (ELISA) or soluble ELISA (see Note 12).
10. The phage can then be amplified in TG1 cells (see Subheading 3.1., steps 1–5, then Subheading 3.2.) and reinfected into mutD5-FIT for further rounds of mutation (see Subheadings 3.1. and 3.2.), rescue (see Subheading 3.3.), and selection (see Subheading 3.4.).

4. Notes

1. The mutD5-FIT strain is maintained on M9 medium supplemented with 0.67% (w/v) casamino acids and 10 μ g/mL tetracycline. The concentration of casamino acids can be increased to 2% (w/v) to increase growth rate. Although growth on this medium limits mutation of chromosomal DNA and loss of F', growth rates are slow. For mutation of DNA, the cells are grown in rich media, such as TYAG broth supplemented with thymidine which, at 20 μ M, increases the mutation rate on overnight incubation at 37°C by fivefold.
2. Phagemid DNA is introduced into the *E. coli* cell by infection. The mutator cells may be transformed by any of the standard methods (CaCl₂ and heat shock, or

electroporation). When possible, phage infection is the method of choice, since it produces larger libraries and there is less chance of loss of diversity.

3. Rescue is essential because the phagemid vector does not encode the proteins required for assembly of viable phage particles. A helper phage, such as VCSM13, can be used to superinfect *E. coli* mutD5-FIT or TG1 cells harboring the phagemid, thereby supplying functions required for assembly. Kanamycin selection eliminates those bacteria that fail to become superinfected. The helper phage themselves have decreased packaging efficiency compared with the phagemid.
4. **Caution:** Because of high phage titers, caution must be taken to avoid any carryover of phage contamination from flasks and plasticware. This can be achieved by thoroughly washing all labware in 2% hypochlorite solution, followed by autoclaving.
5. Since there are proteases present in the phage preparations, proteins displayed on the surface may be degraded following isolation. Phage preparations should be used within 24 h in selection experiments. Libraries can be stored as phage stock, for up to 1 wk at 4°C, or at -20°C in 50% glycerol for longer term or as an *E. coli* library stock at -80°C. Phage will retain infectivity when Ab is proteolytically cleaved from the *gene III* protein. Therefore, frozen phage stocks should be reamplified via infection into new host *E. coli* cells and rescued before undertaking selection.
6. Phage selection is the most crucial step in the recovery of high-affinity clones. The process is inefficient, usually yielding only a 10²–10³-fold enrichment of the higher-affinity phage particles. Therefore, selection from a library requires several rounds, each comprising binding to Ag, elution, amplification of phage, and monitoring of phage selection.
7. A variety of supporting matrices can be coated with Ag. These range between ordinary tissue culture dishes (35 × 10 mm Falcon 3001 tissue culture dish), ELISA trays (for small-scale selections), or Nunc Immuntubes (Polysorb or Maxisorb). All of these surfaces vary in their hydrophobic properties, hence, each protein Ag will have varying affinity to each surface. The density of coated Ag can be tested by ELISA against Ag-specific Ab.
8. There are several alternative matrices that can be used as affinity supports in selection, along the lines described (e.g., tosylated dynabeads [Dynal] or Gammabind beads [Pharmacia]). Alternatively, phage can first be bound to biotinylated Ag in solution. Aliquots containing the complex of phage and biotinylated Ag are diluted into excess nonbiotinylated Ag to initiate dissociation. Those phage retaining the biotinylated Ag are then captured by streptavidin-conjugated magnetic beads.
9. The concentration of Ag should be similar to the expected affinity of the selected Ab (e.g., if the Ab is expected to have a K_d of 100 nM, then a final Ag concentration of 50–100 nM should be used).
10. Competitive selection can be applied by adding excess unlabeled Ag (approx 10-fold greater than expected K_d , after this 30 min incubation).

11. The bound phage can be eluted with either alkali (e.g., 100 mM triethylamine), acid (e.g., glycine), soluble Ag or soluble competing Ab. Alternatively, live *E. coli* cells can be added to the immobilized phage after the washing step, usually resulting in efficient phage infection. The first selection round is the most critical step, since this is when most of the specific phage can be lost, if the conditions are not finely tuned.
12. The aim is to determine the number of Ag-specific phage Abs within the selected population. Two types of ELISA test are commonly used to ascertain whether the Ab fragments expressed by single clones are correctly folded, and can bind the target Ag. Phage stocks prepared from selected clones can be applied to Ag-coated surfaces and detected by immunochemistry against the viral coat (phage ELISA). Alternatively, selected phage clones are infected into a nonsuppressor *E. coli* host and the soluble Ab, which are then expressed are tested in ELISA (soluble ELISA). Soluble ELISA has less background, and is more accurate than phage ELISA.

References

1. Irving, R. A., Kortt, A. A., and Hudson, P. J. (1996) Affinity maturation of recombinant antibodies using *E. coli* mutator cells. *Immunotechnology* **2**, 127–143.
2. Coia, G., Ayres, A., Lilley, G. G., Hudson, P. J., Irving, R. A. (1997) Use of mutator cells as a means for increasing production levels of a recombinant antibody directed against Hepatitis B. *Gene* **201**, 203–209.
3. Schaaper, R. M. (1988) Mechanisms of mutagenesis in the *Escherichia coli* mutator mutD5: role of DNA mismatch repair. *Proc. Natl. Acad. Sci USA* **85**, 8126–8130.
4. Schaaper, R. M. (1989) *Escherichia coli* mutator mutD5 is defective in the *mutHLS* pathway of DNA mismatch repair. *Genetics* **121**, 205–212.
5. Schaaper, R. M. and Radman, M. (1989) Extreme mutator effect of *Escherichia coli* mutD5 results from saturation of mismatch repair by excessive DNA replication errors. *EMBO J.* **8**, 3511–3516.

Chain Shuffling to Modify Properties of Recombinant Immunoglobulins

Johan Lantto, Pernilla Jirholt, Yvelise Barrios, and Mats Ohlin

1. Introduction

Combinatorial libraries and selection of variants from such libraries have proven to be a successful approach for identifying molecules with novel or improved properties. The importance of antibody (Ab) molecules in basic and applied research, as well as the extensive knowledge of how they interact with their antigen (Ag) targets, have made them favorite targets for modification by this approach. The binding site of Abs can be described as a set of modules that together make up the Ag-binding site. These modules may be defined either as the heavy-chain (HC) and light-chain (LC) variable domains (V_H and V_L , respectively) or as the six individual complementarity-determining regions (CDRs) or hypervariable loops, which act together to form this structure. The variable CDRs reside in a relatively fixed framework region (FR) that makes up the basic structure and fold of the protein.

The fundamental structural similarities of different Abs and the inherent ability of this structure to carry variability in the hypervariable loops, make them good targets for strategies that will incorporate variability into the loops, while retaining the overall structure. Nature has devised a number of different strategies, e.g., recombination of gene segments, somatic mutation, and gene conversion, as well as intricate systems of selection of appropriate members from a large, diverse population, to initially create and subsequently introduce modifications into these proteins. Together, they allow the individual to create molecular variants able to carry out diverse functions. A number of principles have been devised that will allow one to, by similar means, introduce diversity into these molecules in the laboratory.

From: *Methods in Molecular Biology*, vol. 178: *Antibody Phage Display: Methods and Protocols*
Edited by: P. M. O'Brien and R. Aitken © Humana Press Inc., Totowa, NJ

After selection of Ab fragments from a naïve library (or identification of a suitable hybridoma-derived monoclonal Ab), it is often necessary to modify their characteristics to obtain variants with more appropriate properties. Important properties that need to be modified may include the affinity constant, reaction rate, or fine specificity. Similarly, it may be necessary to evolve an existing murine Ab into one employing a human protein sequence (*see Note 1*). Approaches such as chain shuffling, CDR walking, DNA or CDR shuffling, and random mutagenesis (*see Note 2 and Fig. 1*) have been used to introduce diversity into an existing Ab gene. Subsequent selection of molecular variants using phage display has been used efficiently to identify the most desirable molecular variants.

Described here is a method for recombining an Ag-specific HC and/or LC sequence with sequence variants of the other chain. It is based on overlap-extension polymerase chain reaction (PCR) between the two fragments encoding the HCs and LCs of the Ab, followed by insertion of the complete scFv gene into a phage-display vector by conventional enzymatic restriction and ligation. The benefits of this technique are that the entire cloning procedure requires only two rare-cutting restriction endonucleases (*see Note 3*) and that it can easily be utilized for other shuffling approaches, such as CDR shuffling (*1*).

2. Materials

2.1. Preparation of Gene Fragments

1. Parent phagemid containing the Ab gene of interest (*see Note 4*).
2. cDNA from peripheral blood lymphocytes, splenocytes, tonsil-derived lymphocytes, or another source encoding Ab genes (e.g., a previously selected Ab library).
3. Reaction components for PCR. Thermostable DNA polymerase (e.g., *AmpliTaq*, PE Applied Biosystems, Foster City, CA), PCR buffer, and deoxynucleotide triphosphates (dNTPs).
4. Oligonucleotide primers for amplification of Ab HCs and LCs (*see Note 5*).
5. Oligonucleotide primers for final amplification of the assembly product (*see Note 6*).
6. Low-melting agarose.
7. Gel extraction kit (e.g., QIAquick Gel Extraction Kit, Qiagen, Hilden, Germany).
8. PCR purification kit (e.g., Wizard PCR Preps, Promega, Madison, WI).

2.2. Cloning of Gene Fragments

1. PCR products encoding the Ab fragment variants, as produced in **Subheading 3.1**.
2. The parent phagemid without any inserted Ab fragment-encoding gene (*see Note 4*).

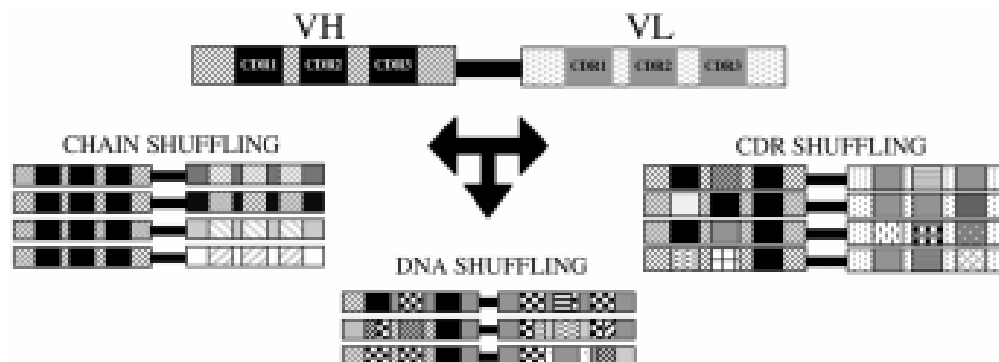

Fig. 1. The basic principle of some methodologies, chain, CDR, and DNA shuffling, used to introduce variability into Ab fragment encoding genes.

3. Appropriate restriction enzymes and accompanying buffers. For example, *NheI* and *NotI* (e.g., New England Biolabs, Beverly, MA), in the case of cloning scFv in the pFabIT vector (*see Note 7*).
4. Low-melting agarose and a gel extraction kit (*see Subheading 2.1., item 7*).
5. T4 DNA ligase and accompanying buffer, as provided by the manufacturer (e.g., New England Biolabs).
6. 10 mM Tris-HCl buffer, pH 8.5.
7. 3 M Sodium acetate.
8. Absolute and 70% ethanol.

2.3. Transformation of DNA into *Escherichia coli*

1. *E. coli* TOP10F' cells (F'⁺[*lacI*^q, Tn10{*Tet*^R}] *mcrA* Δ[*mrr-hsdRMS-mcrBC*] φ80 *lacZ*ΔM15 Δ*lacX*74 *deoR* *recA1* *araD*139 Δ[*ara-leu*]7697 *galU* *galK* *rpsL*[*Str*^R] *endA1* *nupG*), as provided by Invitrogen (Groningen, The Netherlands) (*see Note 8*).
2. Standard liquid culture medium. 2TY broth: 10 g Bacto-tryptone/L, 10 g yeast extract/L, 5 g NaCl/L, pH 7.0. Luria-Bertani broth: 10 g Bacto-tryptone/L, 5 g yeast extract/L, 10 g NaCl/L, pH 7.0. Tryptone and yeast extract are obtained from Difco (Detroit, MI), or from Merck KKaA (Darmstadt, Germany).
3. BTX electro cell manipulator (ECM) 600 (BTX/Genetronics, San Diego, CA).
4. Electroporation Cuvettes PlusTM (model number 610, 1-mm gap) (BTX/Genetronics).
5. Sterile 10% glycerol in H₂O.
6. SOC medium. To 950 mL deionized H₂O, add 20 g Bacto-tryptone, 5 g yeast extract, 0.5 g NaCl. Shake until the components have dissolved and adjust the pH to 7.0. Sterilize by autoclaving, allow to cool, and add 20 mL sterile 1 M solution of glucose. Adjust the volume to 1000 mL with sterile H₂O.
7. Large standard Petri dishes (150 mm diameter) or square plates (245 × 245 mm) (Nunc, Roskilde, Denmark) containing TY agar culture medium (1.5% Bacto-

agar [Difco] in 2TY broth), supplemented with 100 µg/mL ampicillin, 10 µg/mL tetracycline and 1% glucose.

8. Standard Petri dishes containing TY agar culture medium, supplemented with 100 µg/mL ampicillin, 10 µg/mL tetracycline, and 1% glucose.

3. Methods

The method described below focuses on chain shuffling of single-chain Ab fragments (scFv), but it can be easily modified for chain shuffling on Ab in Fab format. This protocol summarized in **Figs. 2** and **3** assumes that the parent scFv-encoding gene has already been cloned into the same vector that is to be used to construct the library.

3.1. Preparation of Gene Fragments

This method for preparation of the Ab (scFv) genes consists of three PCR amplification steps (**Fig. 3**): amplification of the variable region genes, assembly of the scFv genes, and amplification of the complete scFv genes.

1. Using a phagemid harboring the gene for the parent Ab fragment, PCR-amplify the Ab variable-region gene that is to remain constant. Similarly, PCR the variable-region gene that is to be partnered from a suitable source of DNA. Set up 50 µL reactions (*see Note 9*) using the following cycle profile: 94°C for 5 min, (94°C for 1 min, 55°C for 1 min, 72°C for 3 min) × 25, 72°C for 7 min.
2. Purify the PCR products by standard agarose gel electrophoresis, followed by gel extraction (*see Note 10*).
3. Assemble the scFv genes by overlap-extension PCR in a 25 µL reaction using the following cycle profile: 94°C for 5 min (94°C for 1 min, 55°C for 1 min, 72°C for 3 min) × 6, 72°C for 7 min (*see Notes 9, 11, and 12*).
4. PCR-amplify the assembled scFv genes with the flanking (outside) primers by using 5 µL assembly reaction as template in a 100 µL reaction using the following cycle profile: 94°C for 5 min (94°C for 1 min, 55°C for 1 min, 72°C for 3 min) × 25, 72°C for 7 min (*see Notes 9 and 13*).
5. Analyze the reactions by agarose gel electrophoresis and purify the PCR products by the method of choice (*see Note 13*).

3.2. Cloning of Gene Fragments

The assembled PCR product is digested sequentially with *NheI* and *NotI* and cloned into digested pFabIT.

1. For 5 µg of both assembled product and pFabIT, perform the first digestion (in 80 µL reactions) using 25 U enzyme in a mixture containing the DNA, 8 µL 10X buffer (NEB2) and 0.8 µL bovine serum albumin (10 mg/mL). Incubate at 37°C for 8 h. Inactivate the enzyme by heating at 65°C for 30 min. Add *NotI*

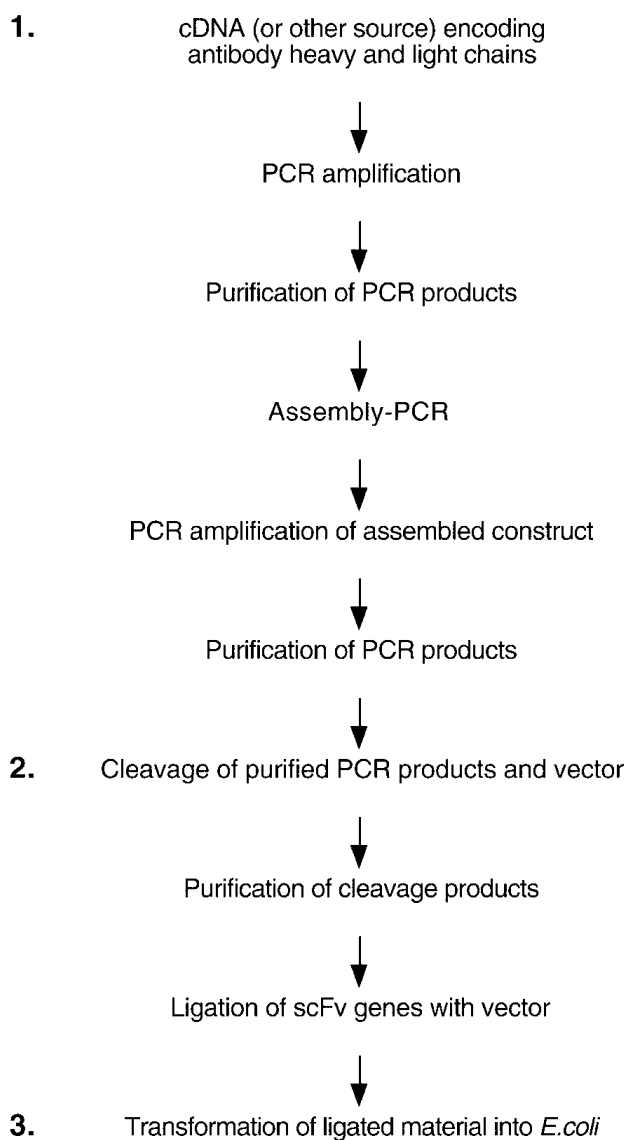

Fig. 2. Flow chart of the chain-shuffling procedure.

(25 U) to the first restriction digestion, 10 μ L 10X buffer (NEB3), 1 μ L bovine serum albumin (10 mg/mL), and H₂O to a final total volume of 100 μ L. Incubate for 8 h at 37°C and inactivate the enzyme by heating at 65°C for 30 min (*see Note 7*).

2. Gel-purify the genes to eliminate the fragments that have been cleaved off. Elute the purified fragments in 10 mM Tris-HCl buffer, pH 8.5. Determine the DNA concentration after the purification step by the method of choice.

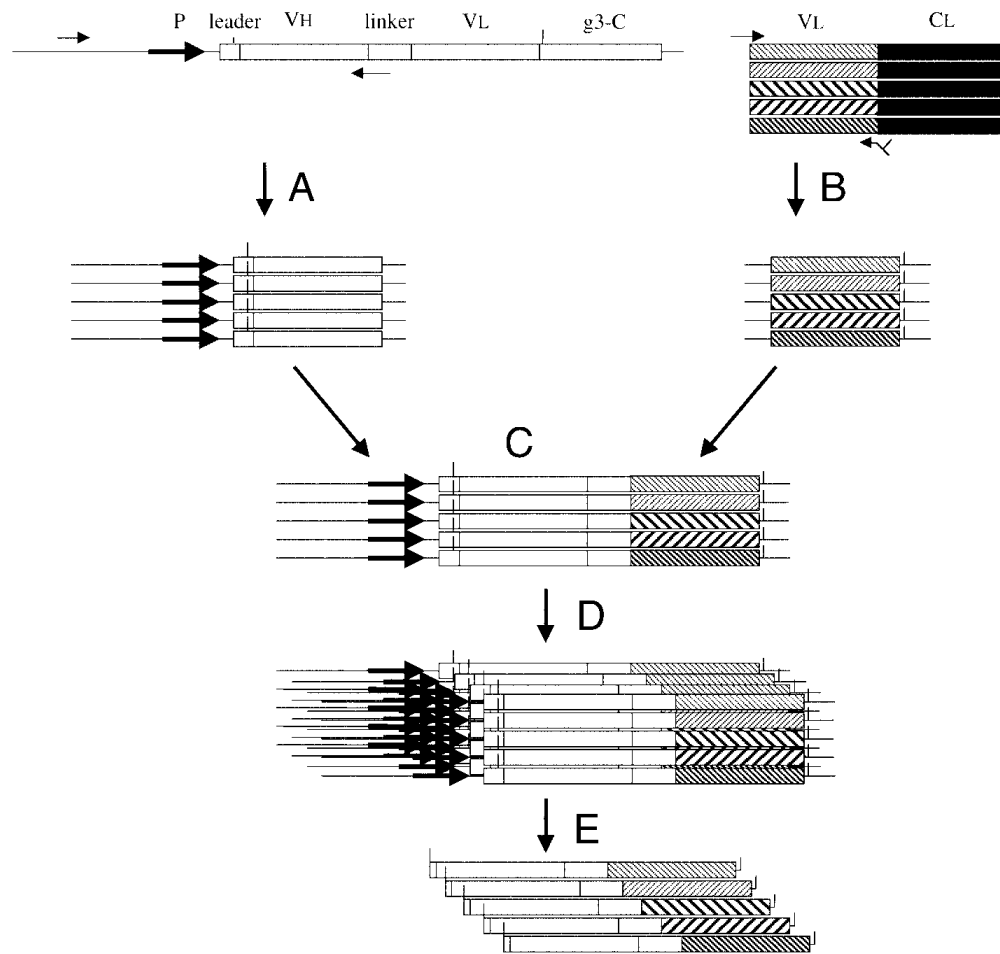

Fig. 3. Principle of PCR amplification and assembly process used to construct the scFv library. The part of the Ab gene that is not to be modified is amplified (A) from the parent phagemid vector into which it has been cloned. This is accomplished by using one primer annealing to the vector far away (>100 bp) from the restriction enzyme site (vertical line), and another annealing within the linker sequence. The product may, as shown in this example, come to include the transcription promoter region (P), as well as the leader sequence. Alternatively, a downstream amplification primer may be located inside the gene encoding the C-terminal part of protein 3 (gIII-C) when amplifying the V_L -encoding gene when that part of the gene is to be kept without modification in the library. A set of variable-region genes is amplified, e.g., from cDNA obtained from polyclonal B cells (B). One primer incorporates part of the linker sequence and the other incorporates a vector-specific restriction enzyme site. The fragments are purified and assembled into a complete scFv-encoding gene (C). The assembled sequence is reamplified (D) using flanking primers located outside of the restriction enzyme sites. Finally, the product is cleaved with appropriate restriction enzymes (E) and purified after separation of the fragments on an agarose gel.

3. For the ligation of the library, set up the following reaction at a 5:1 insert:vector molar ratio (*see Note 14*). In a tube containing the ligase buffer, mix 1.25 μg insert with 1.6 μg cut vector and T4 DNA ligase (6 Weiss units), and incubate at 15°C overnight. Precipitate the reaction by adding 0.1 vol 3 M Na acetate and 2.5 vol of ethanol. Vortex and leave on ice for 1–8 h, centrifuge in a tabletop centrifuge at maximum speed for 20 min and wash once with 70% cold ethanol. Let the pellet air-dry and dissolve it in 50 μL sterile H₂O.

3.3. Transformation of DNA into *E. coli*

High efficiency of electroporation is important for producing large libraries (*see Note 15*). This protocol ensures that highly competent *E. coli* can be prepared and efficiently electroporated to produce Ab gene libraries.

1. For preparation of electrocompetent cells, inoculate 3 mL overnight culture of TOP10F' cells in 380 mL LB medium, supplemented with tetracycline (10 $\mu\text{g}/\text{mL}$ final concentration). Shake at 37°C, 300 rpm until optical density 600 nm reaches 0.8.
2. Chill the cells in an ice-water bath for 5 min. Transfer the cells to six 250 mL ice-cold sterile centrifuge bottles and pellet the cells for 6 min at 3100g (e.g., using a Beckman JA-14 rotor). Decant the supernatant and resuspend each cell pellet gently in 5 mL 10% glycerol. Add 10% glycerol to a final volume of 150 mL/bottle and mix gently. Repeat the centrifugation step and reduce the number of centrifuge bottles to three. Repeat this process 3 \times . Resuspend the final pellets in 5 mL 10% glycerol, transfer to a 40-mL centrifuge tube, add 10% glycerol up to 40 mL, and centrifuge the cells at 2500g for 6 min (e.g., in a Beckman JA-20 rotor). Resuspend the final pellet in 1.25 mL 10% glycerol. Use the cells immediately or prepare aliquots of cells in chilled microcentrifuge tubes, snap-freeze, and store at -70°C .
3. To electroporate the library into *E. coli*, mix 25 μL TOP10F'-competent cells (*see Note 16*) with 25 μL ice-cold H₂O and add 2 μL ligation reaction. Transfer the mixture into a prechilled 0.1 cm cuvet and pulse with the following settings on the BTX ECM600: $T = 2.5$ kV/resistance, $R = 129$ Ω , and $S = 2.0$ kV.
4. After the pulse, immediately add 1 mL SOC (prewarmed to 37°C), transfer the cells to a tube, and incubate for 1 h at 37°C with shaking. After that recovery phase, plate the cells onto agar plates containing tetracycline and ampicillin. Also include 1% glucose in the solid medium to reduce any leaky expression from the *lac* promoter because the gene of interest is controlled by this regulatory element. The plating is usually performed on large plates at an expected density of 1–10 $\times 10^6$ colony forming units/plate. Also plate appropriate dilutions of the transformation reaction to determine the size of the library. Invert plates, and incubate at 37°C overnight. To recover the cells, add liquid culture medium onto the plates and scrape them using a sterile spreader. Add glycerol to the cell suspension to a final concentration of 20%, and snap-freeze aliquots, which are stored at -70°C .

4. Notes

1. It has been shown possible to evolve a mouse Ab into a human counterpart by sequentially exchanging using chain shuffling both murine variable domains into functional human counterparts. A first library is made, carrying the existing murine V_H sequence and a library of human V_L sequences. Based on initially selected human V_L sequences, a second-generation library is constructed carrying a large array of human V_H sequences. From this second-generation library, a fully human Ab fragment, retaining essentially the original specificity, can be obtained. One should be aware that major differences in the key elements of the binding site may be observed when transforming a murine Ab into a human counterpart by using this approach (2).
2. Variability may be introduced into an existing Ab sequence by a variety of means, several of which are described in detail elsewhere in this volume. The basis for the methodologies can be summarized as follows:
 - a. By exchanging either the V_H or the V_L sequence, so-called “chain shuffling,” useful libraries have been developed in a number of cases. This approach is the main focus of this presentation. As described in this chapter, the preparation of libraries in scFv format is often accomplished by a PCR-based assembly of one unmodified variable gene (V_H or V_L) fragment and a library of gene fragments (V_L or V_H , respectively) obtained from a large B-cell population. When preparing Fab-based libraries, the modified V-region gene can often be cloned directly into the plasmid, already carrying the V region that is initially fixed. In some cases, scFv-based systems carry restriction sites in the linker separating V_H and V_L , allowing cloning of each of these fragments independent of the other, thus eliminating the need for a PCR overlap-extension assembly reaction.
 - b. PCR primers incorporating variability into selected CDRs have been used to direct synthetic variability into one or several hypervariable loops simultaneously (3), while maintaining the original framework of the Ab (see Chapter 23).
 - c. An approach to incorporate natural CDR sequences (derived from normal, polyclonal B cells) into the existing framework of the Ab that is to be affinity-matured or evolved in other ways (so-called “CDR shuffling”) has been used successfully to develop highly functional libraries. This methodology generally involves assembly of several PCR fragments by the use of overlap-extension PCR (1,4), in a manner similar to the one used for the construction of chain-shuffled scFv libraries. As an alternative to this approach, there are certain vector systems that allow for direct exchange of individual CDR, using restriction enzyme sites located at the extreme ends of each CDR (5).
 - d. The use of error-prone PCR (see Chapter 25 and ref. 6), or mutator strains of *E. coli* harboring scFv- or Fab-encoding plasmids for some time (see Chapter 26 and ref. 7), has proven efficient in introducing random substitutions in pre-existing variable-domain sequences. After transfer of the plasmids into a

normal *E. coli* strain, mutations that enhance the properties of the original Ab can be isolated using phage-display selection.

- e. DNA shuffling (8) is an iterative process by which Ab gene fragments, in contrast to chain and CDR shuffling, can be recombined at random sites, to create the variability from which optimal variants may be selected using phage-display technology.
3. The frequencies of many restriction enzyme sites in human and mouse Ab variable-region genes have been determined. *NotI*, *NheI*, and *SfiI* are among those enzymes that rarely cut in such genes.
4. There are a number of vector systems, such as pCANTAB, pHEN, and pFab60, that can be utilized for this kind of Ab modification and the following phage display. This chapter describes chain shuffling using pFabIT, a modified version of pFab60 (9), as parent vector. This phagemid carries *NheI* and *NotI* restriction sites for cloning of scFv genes. Similar approaches may be followed when cloning Ab specificities/variants in the Fab format. For example, when using the pFab60 vector system, the gene fragment that is not to be modified is initially cloned, and libraries of V_L-C_L , V_H , Fd gene fragments are introduced using *NheI/AscI*, *SfiI/SpeI* or *SfiI/NotI* restriction sites, respectively, without PCR assembly of any gene fragment (10).
5. The design of the primers is of great importance when performing chain (or CDR) shuffling, and there are a number of issues to consider. Primers that only amplify a small set of variable gene sequences (e.g., a family) may be used, if the intention is to introduce restricted variability. If more variability is sought, degenerate primers and/or a cocktail of primers that match several variable gene families, may be used. Primer sets suitable for the amplification of human and mouse V_H , V_κ , and V_λ have been published and are widely used (10–14). The primers must also be designed to incorporate the 5'-overhangs necessary for overlap-extension PCR and cloning into the vector. The exact design depends on the orientation of the scFv construct (V_H-V_L or V_L-V_H), but one of the primers used for the amplification of the gene fragment that is to be modified should incorporate part of the scFv linker. The other primer should incorporate the restriction site used for cloning of the final construct. A few examples of this primer design are given in **Table 1**.

One of the primers used for amplification of the variable region that is to remain unaltered should also incorporate part of the scFv linker. The other primer should anneal to a vector sequence far (preferably, >100 bases) beyond the restriction site to be used for cloning of the final product to ensure efficient digestion and removal of any uncleaved product.

For successful assembly of the scFv genes, overlap of the products of the initial PCR should be approx 18 bp. Thorough evaluation of the overlapping sequences is required, if erroneous amplification products are obtained (15).

The choice of polymerase may also affect the primer design. *Taq* polymerase has a nontemplate-dependent activity that adds a single deoxyadenosine (A) to the 3' ends of PCR products. One must either avoid the addition of these overhangs

Table 1
Examples of Primer Design for Chain Shuffling of scFv Genes

Primer	Sequence
1. V _H -FR1 (<i>Nhe</i> I) (murine)	5'-GTCGACCTGCAGACAGAGTTAGCTAGCTGCCCAACCAGCGATGGCC SAGGTKCAGCTKMAGCAGTCWG
2. V _H -FR1 (<i>Nhe</i> I)	5'-GTCCTCGCAACTGCCCATGCTAGCTGCCCAACCAGCGATGGCC GAGGTGCAGCTGGTGCAGTCTGG
3. V _H -FR4	5'-CCGCCGGATCCACCTCCGCCTGAACCGCCTCCACCTGAGGAGACGGTGAC
4. V _κ -FR1 no. 1	5'-GGAGGCGGTTTCAGGCGGAGGTGGATCCGGCGGTGGCGGATCG GAAATTGTGTTGACGCAGTCTCC
5. V _κ -FR1 no. 2	5'-GGAGGCGGTTTCAGGCGGAGGTGGATCCGGCGGTGGCGGATCG GACATCCAGATGACCCAGTCTCC
6. V _λ -FR1	5'-GGAGGCGGTTTCAGGCGGAGGTGGATCCGGCGGTGGCGGATCG CAGTCGGTGTTGACGCAGCCGCC
7. V _κ -FR4 (<i>Not</i> I)	5'-GAGTCATTCTCGACTGCTATGCGGCCGCTTTATCATCATCATCTTTATAATCACG TTTGATCTCCACCTTGGT
8. V _λ -FR4 (<i>Not</i> I)	5'-GAGTCATTCTCGACTGCTATGCGGCCGCTTTATCATCATCATCTTTATAATCTAG GACGGTCAGCTTGGTCCC

The incorporated restriction sites (doubly underlined) and the sequences amplified with each primer are indicated in the primer name. Nucleotides encoding the scFv linker are bold. Underlined sequences correspond to bases encoding FR1- and FR4-related structures. Sequences outside of the restriction enzyme sites can be used as targets for primers in the final amplification step. Primer 1 is an example of the use of sequence degeneracy in a primer, which in this case is to be used for amplification of murine V_H genes. Primers 2 and 3 are examples of a primer pair suitable for amplification of certain human V_H genes; primers 4 or 5 and 7, and 6 and 8 are examples of primer pairs suitable for amplification of certain human V_κ and V_λ genes, respectively. Primers 4 and 5 are shown as examples of primers preferentially annealing to different variable-region gene families. Primer sets can similarly be constructed to fit the majority of other human and murine Abs variable-domain-encoding genes (10–14).

or take them into account when designing the primers for the amplification of the HC and LC fragments (or CDR). Failure to do so may lead to mismatches in assembly. These overhangs can be avoided by the use of polymerases with 3' to 5' exonuclease activity, such as *Vent* and *Pfu*. It is also thought that untemplated additions at the 3' end of amplicons can be reduced by avoiding long PCR extension times (e.g., by not using a final extension period in the PCR amplification protocol). Extended incubation of the PCR reaction even at 4°C before removal of the *Taq* polymerase should also be avoided. This general problem can best be avoided by designing primers for the overlap that anneal to the template immediately 3' to a deoxythymidine. This will ensure that addition of a nontemplated deoxyadenosine will be complementary to the native template sequence.

6. The final amplification of the scFv genes is performed with flanking or outer primers approx 20 nucleotides in length, which anneal to the outmost parts of the constructs. The vector-based primer used for the amplification of the unaltered variable region (*see Note 5*) is usually well-suited for this purpose.
7. As mentioned in **Note 4**, there are a number of different phage and phagemid vector systems that have been utilized for display of Ab fragments. These systems use a range of sets of rare restriction enzyme sites (*see Note 3*) for direct gene cloning. Evaluate the different options available with the chosen vector system, then proceed with the digestion of purified PCR fragments and vector DNA, using the appropriate enzymes with the recommended buffers, according to the manufacturer's recommendations. Although a detailed description of each vector system is beyond the scope of this chapter, some general principles do exist. Digestion at restriction sites near the ends of fragments is often more difficult than digestion at internal sites. Consequently, overdigestion of the scFv PCR fragment (calculate 10× more enzyme than required for digestion of plasmids, and prolong the incubation time) with restriction enzymes should be performed, in order to increase the efficiency of the reaction. This protocol introduces substantial distances between the ends of the PCR product and the restriction enzyme site (**Fig. 3**), whenever possible to facilitate the enzymatic reaction. Large amounts of scFv fragment and vector are usually required. Our protocol recommends 5 µg starting material of both the insert and the vector in order to obtain at least 1 µg ligated product at the end of the cloning procedure.
8. A variety of other strains are used in phage-display protocols. Commonly used strains are TG1, JM110, JS5, DH5αF', MC1061, XL1-Blue, and SURE.
9. Standard PCR conditions will usually amplify most target sequences. The following may act as a guideline for a 25-µL reaction: 4 µL dNTPs (1.25 mM each), 2.5 µL 10X PCR buffer, 1.25 µL of each primer (20 µM each), 0.125 µL *AmpliTaq* polymerase (5 U/µL), template (when the parent plasmid is used as template, 10 pg is a suitable amount; for amplification of variable chains from cDNA, 10 ng is a suitable amount) and H₂O to 25 µL.

For other reaction volumes, simply use multiples of these volumes, and add H₂O to the desired final volume. We recommend using only small quantities of the plasmid when amplifying the gene fragment that is to remain unmodified

in the construct, because this facilitates the removal of the template in the subsequent gel-purification step (*see Note 10*).

10. Purification of the product from an agarose gel is necessary for removing the parent Ab gene, which would otherwise contaminate the chain-shuffled library. The method for extraction of the PCR fragments from the gel is not of importance, although it is desirable that the yield is as high as possible. Several commercially available kits, including QIAquick Gel Extraction Kit (Qiagen), usually work satisfactory.
11. 50 fmol of each fragment is usually sufficient to give a product of good quality. The optimal number of cycles may have to be determined empirically, but should in any case be kept low (not more than 10 cycles). A larger number of PCR cycles may lead to erroneous products caused by mismatch priming. In some cases, it may be necessary to increase the annealing temperature (e.g., to 60°C) to eliminate the mismatches that produce erroneous PCR products.
12. Although the present protocol refers to assembly of V_H and V_L fragments, it is also suitable for simultaneous assembly of a larger number of fragments. This approach can be used for the assembly of several fragments encoding individual framework and CDRs that together will make up a complete gene (so-called “CDR shuffling” [Fig. 1]).
13. In this final amplification step, it is important to determine the optimal number of PCR cycles. A large number of PCR cycles may increase the amount of nonspecific products, thereby decreasing product yield and may necessitate purification of the correct product from an agarose gel. With the optimal number of cycles (usually 20–30), the correct assembly product will dominate the product mix and can easily be purified using a PCR purification kit. The number of amplification reactions needed to produce sufficient DNA for cloning depends heavily on the size of the library being made (each assembly reaction contains 50 fmol DNA, which is equivalent to approx 3×10^{10} molecules), but it is advisable to start with at least 2–3 reactions. The number of assembly reactions that has to be made will also depend on the intended size of the final library. It must be kept in mind that the number of sequence variants may be lower than the actual number of gene fragments and that the assembly reaction may not go to completion, thus reducing the actual diversity of the library.
14. In order to optimize the ligation conditions, different vector:insert ratios should be tried, keeping the amount of vector constant, while varying the amount of the insert in the ligation reaction. The ligation should be tested on a small scale prior to library construction. Purification and desalting of the ligation mixture must be performed in order to avoid arcing during electroporation. Set up a separate ligation reaction containing only the cleaved and purified vector to assess the background of religated vector. Also set up a negative control without any DNA to check that the cells or the reaction mixtures are not contaminated with plasmid DNA.
15. All glassware used for preparation of electrocompetent cells must be washed, washed again without detergent and finally thoroughly rinsed with deionized

H₂O, to ensure that it does not contain any remaining detergent. Better yield in competence could be achieved if fresh medium is used and if a new overnight culture of cells is prepared the day before. Because everything (cells, buffers, plastic, and glass equipment) should be kept ice-cold, working in a cold room during the procedure is recommended. Using this protocol, efficiencies of approx 10¹⁰ cfu/μg supercoiled pUC19 test DNA could be expected with TOP10F'.

16. Maximum efficiency is obtained using freshly prepared cells. If frozen electrocompetent cells are used, they should be thawed gently and maintained on ice until transferred into the cold electroporation cuvet. For other *E. coli* strains, electroporation conditions should be optimized by varying field strength and cell density. The optimal field strength is, for most strains, between 16 and 19 kV/cm, but exact conditions have to be determined for each bacterial strain. The optimal amount of DNA gives a time constant when using the BTX ECM 600 between 4.5 and 5.0 ms. Optimal conditions when using other gene pulsers available on the market may be different and they have to be established empirically, or can be obtained from the manufacturer. Transformation of chemically competent cells could be used, but will give much lower yields of transformants. It may, however, still be an option for smaller-size libraries.

References

1. Ohlin, M., Jirholt, P., Thorsteinsdottir, H. B., and Borrebaeck, C. A. K. (2000) Understanding human immunoglobulin repertoires *in vivo* and evolving specificities *in vitro*, in *The Antibodies*, vol. 6 (Zanetti, M. and Capra, J. D., eds.), Harwood, Amsterdam, pp. 81–104.
2. Beiboer, S. H., Reurs, A., Roovers, R. C., Arends, J. W., Whitelegg, N. R., Rees, A. R., and Hoogenboom, H. R. (2000) Guided selection of a pan carcinoma specific antibody reveals similar binding characteristics yet structural divergence between the original murine antibody and its human equivalent. *J. Mol. Biol.* **296**, 833–849.
3. Barbas, C. F., 3rd, Hu, D., Dunlop, N., Sawyer, L., Cababa, D., Hendry, R. M., Nara, P. L., and Burton, D. R. (1994) In vitro evolution of a neutralizing human antibody to human immunodeficiency virus type 1 to enhance affinity and broaden strain cross-reactivity. *Proc. Natl. Acad. Sci. USA* **91**, 3809–3813.
4. Jirholt, P., Ohlin, M., Borrebaeck, C. A. K., and Söderlind, E. (1998) Exploiting sequence space: shuffling *in vivo* rearranged CDR into a master framework. *Gene* **215**, 471–476.
5. Knappik, A., Ge, L., Honegger, A., Pack, P., Fischer, M., Wellenhofer, G., et al. (2000) Fully synthetic human combinatorial antibody libraries (HuCAL) based on modular consensus frameworks and CDRs randomized with trinucleotides. *J. Mol. Biol.* **296**, 57–86.
6. Cadwell, R. C. and Joyce, G. F. (1994) Mutagenic PCR. *PCR Methods Appl.* **3**, S136–140.
7. Low, N. M., Holliger, P. H., and Winter, G. (1996) Mimicking somatic hypermutation: affinity maturation of antibodies displayed on bacteriophage using a bacterial mutator strain. *J. Mol. Biol.* **260**, 359–368.

8. Cramer, A., Cwirla, S., and Stemmer, W. P. (1996) Construction and evolution of antibody-phage libraries by DNA shuffling. *Nature Med.* **2**, 100–102.
9. Johansen, L. K., Albrechtsen, B., Andersen, H. W., and Engberg, J. (1995) pFab60: a new, efficient vector for expression of antibody Fab fragments displayed on phage. *Protein Eng.* **8**, 1063–1067.
10. Engberg, J., Andersen, P. S., Nielsen, L. K., Dziegiel, M., Johansen, L. K., and Albrechtsen, B. (1996) Phage-display libraries of murine and human antibody Fab fragments. *Mol. Biotechnol.* **6**, 287–310.
11. Sblattero, D. and Bradbury, A. (1998) A definitive set of oligonucleotide primers for amplifying human V regions. *Immunotechnology* **3**, 271–278.
12. de Boer, M., Chang, S. Y., Eichinger, G., and Wong, H. C. (1994) Design and analysis of PCR primers for the amplification and cloning of human immunoglobulin Fab fragments. *Hum. Antibodies Hybridomas* **5**, 57–64.
13. Ørum, H., Andersen, P. S., Øster, A., Johansen, L. K., Riise, E., Bjørnvad, M., Svendsen, I., and Engberg, J. (1993) Efficient method for constructing comprehensive murine Fab antibody libraries displayed on phage. *Nucleic Acids Res.* **21**, 4491–4498.
14. Marks, J. D., Tristem, M., Karpas, A., and Winter, G. (1991) Oligonucleotide primers for polymerase chain reaction amplification of human immunoglobulin variable genes and design of family-specific oligonucleotide probes. *Eur. J. Immunol.* **21**, 985–991.
15. Kobayashi, N., Söderlind, E., and Borrebaeck, C. A. K. (1997) Analysis of assembly of synthetic antibody fragments: expression of functional scFv with pre-defined specificity. *Biotechniques* **23**, 500–503.

Generation of Bispecific and Tandem Diabodies

Sergey M. Kipriyanov

1. Introduction

A major goal of antibody (Ab)-based tumor targeting has been to specifically deliver a variety of agents, such as radioisotopes, drugs, toxins, lymphokines, and enzymes for imaging and therapy. Intact immunoglobulin G molecules are large (150 kDa) glycoproteins that exhibit a slow systemic clearance, often leading to poor tumor-targeting specificity (**Fig. 1**). Smaller Ab-derived molecules include enzymatically produced 50-kDa Fabs and engineered 25-kDa single-chain Fvs (scFvs) consisting of heavy- and light-chain variable regions (V_H and V_L) connected by a flexible peptide linker of 14–24 residues (**1,2; Fig. 1**). Compared to immunoglobulin G molecules, Fabs and scFvs exhibit significantly improved tumor specificity and intratumoral penetration (**3–5**). However, the rapid blood clearance and monovalent nature of these small molecules result in considerably lower quantitative tumor retention (**3,6**).

Recently, attention has focused on the generation of scFv-based molecules with molecular weight in the range of the renal threshold for first-pass clearance. Construction of such molecules can be achieved by shortening the linker between the V_H and V_L domains in scFvs. Reduction of the linker length, to shorter than 12 residues, disfavors the formation of monomeric scFv molecules, and promotes intermolecular V_H – V_L pairings into 50-kDa noncovalent scFv dimer diabodies (**7,8; Fig. 2A**). The prolonged tumor retention *in vivo* and higher tumor: blood ratios reported for diabodies compared to scFv monomers, result from both their reduced kidney clearance and higher avidity (**9,10**). The diabody format can also be used for generation of recombinant bispecific antibodies (BsAb), which are obtained by the noncovalent association of two single-chain fusion products consisting of the V_H domain from one Ab

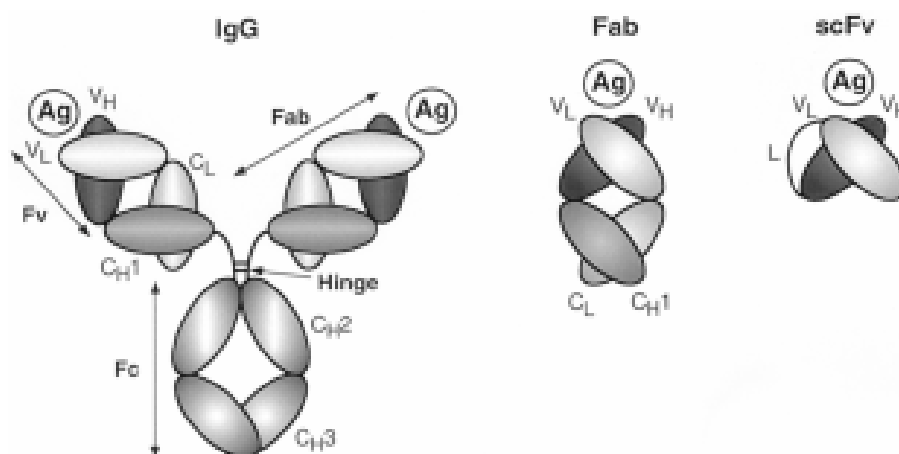

Fig. 1. Schematic representation of the domain structure of immunoglobulin G, Fab, and scFv molecules. The scFv linker and Ag-binding sites are indicated (L and Ag, respectively).

connected by a short linker to the V_L domain of another Ab (7,11,12; Fig. 2B). The two antigen (Ag)-binding domains have been shown by crystallographic analysis to be on opposite sides of the diabody molecule so that they are able to crosslink two cells (13; Fig. 2C). Diabodies are potentially less immunogenic than quadroma-derived BsAb and can be easily produced in bacteria in high yields (14).

Bispecific diabodies appeared to be more effective than quadroma-derived BsAb in mediating T-cell (11,12) and NK-cell (15) cytotoxicity in vitro against tumor cells. In vivo, the antitumor activity of diabodies was similar to that of the parental BsAbs, which have longer blood retention because of their much larger size (15,16). However, the co-secretion of two hybrid scFvs may give rise to two types of dimer: active heterodimers and inactive homodimers. A second problem is that the two chains of diabodies are held together by noncovalent associations of the V_H and V_L domains and can diffuse away from one another. Moreover, to ensure the assembly of a functional diabody, both hybrid scFvs must be expressed in the same cell in similar amounts. This latter requirement is difficult to uphold in eukaryotic expression systems, such as yeast, which are often preferred because high yields of enriched product can be obtained (17,18). In contrast to native Abs, diabodies have only one binding domain for each specificity. However, bivalent binding is an important means of increasing the functional affinity and possibly the selectivity for particular cell types carrying densely clustered Ags.

To circumvent the drawbacks of diabodies and to increase the valence, stability, and therapeutic potential of recombinant BsAbs, we have recently

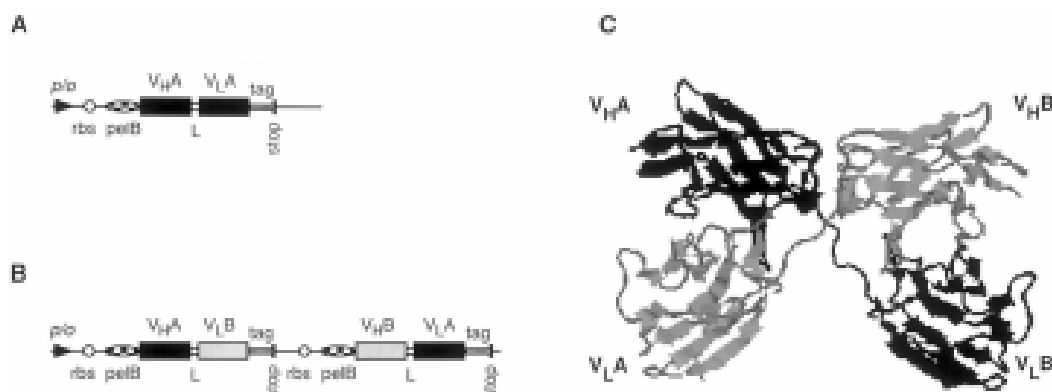

Fig. 2. Schematic representation of bacterial operons coding for monospecific (**A**) and bispecific (**B**) diabody. The locations of promoter/operator (*p/o*), ribosome-binding site (*rbs*), *pelB* leader sequence (*pelB*), V_H and V_L domains of two different specificities (“A” and “B”), linker (L), peptide tag for immunodetection and/or purification (tag), and stop codon (stop) are indicated. (**C**) The diabody protein organization based on its crystal structure (**13**).

constructed single-chain molecules comprising four Ab-variable domains (V_H and V_L) of two different specificities, in an orientation preventing Fv formation (**19**). They can either form bivalent BsAbs by diabody-like folding (sc-diabodies) or dimerize with the formation of tetravalent BsAbs with M_r 115 kDa (tandem diabodies [Tandab]) (**Fig. 3**). The efficacy of Tandab formation is dependent on the length of the linker between two halves of the molecule. The Tandabs are both bispecific and have higher avidity, resulting from the bivalency for each specificity. For example, CD3 \times CD19 Tandabs were more potent than the diabody for inducing human T-cell proliferation in the presence of irradiated CD19⁺ B cells. In cytotoxic assays, Tandabs were able to retarget human T lymphocytes to malignant B cells. The efficacy of Tandab-mediated cell lysis also compared favorably to that obtained with a diabody of the same dual specificity (**19**). In vivo studies demonstrated that tetravalent Tandabs were more stable and were retained longer in the blood of normal mice, compared to scFv and diabodies. Treatment of severe combined immunodeficient mice bearing established Burkitt’s lymphoma (5 mm in diameter) with human peripheral blood lymphocytes, Tandab, and anti-CD28 monoclonal Ab resulted in the complete elimination of tumors in all animals within 10 d. In contrast, mice receiving human peripheral blood lymphocytes in combination with either the diabody alone or diabody plus anti-CD28 monoclonal Ab, showed only partial tumor regression (**20**). This BsAb format could therefore prove to be particularly advantageous for cancer immunotherapy.

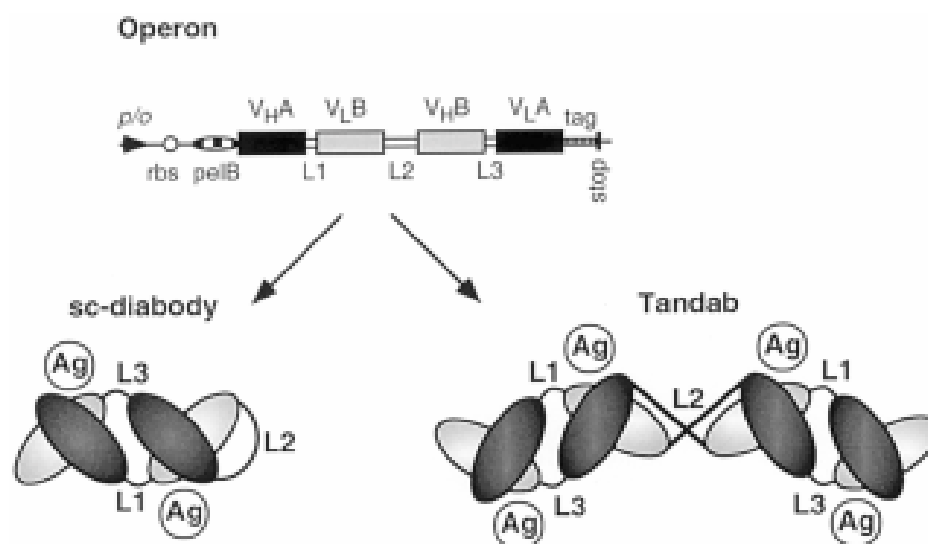

Fig. 3. Schematic representation of single-chain four-domain gene constructs for the production of dimeric or tetrameric bispecific molecules. Depending on the linker length, a single-chain diabody (sc-diabody) or tetravalent tandem diabody can be formed. Ab-variable domains (V_H , V_L), peptide linkers (L), and antigen-binding sites (Ag) of Fv modules are indicated. The Tandab orientation is shown according to a molecular model of the CD3 \times CD19 tandem diabody (19).

This chapter describes the generation of genetic constructs coding for bispecific diabody and Tandab, as well as protocols for bacterial expression and purification of active bispecific molecules. The generation of plasmids for high-level expression of bispecific diabody and Tandab in *Escherichia coli* includes the following steps:

1. Construction of genes encoding hybrid scFvs consisting of the V_H domain from one Ab (V_{HA}) connected by a 5–10 amino acid linker to the V_L domain of another Ab (V_{LB}).
2. Construction of a dicistronic operon for co-expression and co-secretion of two hybrid scFvs, V_{HA} – V_{LB} and V_{HB} – V_{LA} , with the formation of functional heterodimer (diabody) in the bacterial periplasm (Fig. 2B).
3. Joining the two dimerizing parts, V_{HA} – V_{LB} and V_{HB} – V_{LA} , with a peptide linker of 10–20 amino acids in length.

As an example, the primers used for the generation of genetic constructs coding for a CD3 \times CD19 diabody (12) and Tandab (19) are listed in Table 1.

9. 1X Tris-acetate electrophoresis buffer (1X TAE buffer): Prepare a stock solution of 50X TAE, and dilute it 1:50 with H₂O before use.
10. 50X TAE buffer: Dissolve 242 g Trizma base (Sigma-Aldrich, Steinheim, Germany) in dH₂O. Add 57.1 mL glacial acetic acid, 100 mL 0.5 M ethylenediamine tetraacetic acid (EDTA), and H₂O to a total volume of 1 L.
11. 0.5 M EDTA.
12. Ethidium bromide (10 mg/mL) (Merck, Darmstadt, Germany).

2.2. Cloning into Expression Vector

1. Tabletop microcentrifuge.
2. QIAquick Gel Extraction Kit (Qiagen, Hilden, Germany).
3. QIAquick-spin PCR Purification Kit (Qiagen).
4. *Afl*III, *Bgl*III, *Eco*RI, *Eco*RV, *Hind*III, *Nco*I, *Nde*I, *Pvu*II, and *Xba*I restriction endonucleases (New England Biolabs).
5. 10X Restriction enzyme buffers (New England Biolabs).
6. Calf intestinal alkaline phosphatase (CIP) (New England Biolabs).
7. T4 DNA ligase (Stratagene, La Jolla, CA).
8. 10X T4 DNA-ligase buffer (Stratagene).
9. 3 M Sodium acetate, pH 4.8.
10. Glycogen from mussels, molecular-biology grade (20 µg/mL) (Boehringer).
11. Absolute ethanol.
12. 80% (v/v) Ethanol.

2.3. Preparation of Bacterial Culture

1. 85-mm Petri dishes (Greiner, Frickenhausen, Germany).
2. Sterile glass Erlenmeyer flasks, 100, 1000, and 5000 mL.
3. Thermostatic shaker (Infors, Einsbach, Germany).
4. Sorvall centrifuge with a set of fixed-angle rotors (Kendro, Hanau, Germany).
5. Either *E. coli* K12 XL1-Blue (Stratagene) or RV308 (Δ *lac* χ 74*gal*ISII::OP308*strA*) (21) competent cells (see Note 1).
6. 2YT medium: 1 L contains 16 g Bacto-tryptone, 10 g Bacto-yeast extract, 5 g NaCl, pH 7.5 (see Note 2).
7. 2YTGA: 2YT medium containing 0.1 g/L ampicillin and 2% (w/v) glucose.
8. 2YTGA agar plates. Media and agar plates are prepared according to standard protocols, as described (22).
9. 2YTSA: 2YT medium containing 0.1 g/L ampicillin and 0.4 M sucrose (see Note 3).
10. YTBS: 2YT medium containing 0.1 g/L ampicillin, 1 M sorbitol, and 2.5 mM glycine betaine.
11. 100 mM Solution of isopropyl- β -D-thiogalactopyranoside (IPTG). Store at -20°C.

2.4. Isolation of Recombinant Product from Soluble Periplasmic Fraction and Culture Medium

1. Ammonium sulfate powder.
2. Magnetic stirrer.
3. Dialysis tubing with a 12–14 kDa cutoff (Spectrum, Rancho Dominguez, CA).
4. 50 mM Tris-HCl, 20% sucrose, 1 mM EDTA, pH 8.0.
5. 50 mM Tris-HCl, 1 M NaCl, pH 7.0.
6. 50 mM Tris-HCl, 1 M NaCl, 50 mM imidazole, pH 7.0.
7. 50 mM Tris-HCl, 1 M NaCl, 250 mM imidazole, pH 7.0.
8. C16/20 column (Amersham Pharmacia Biotech, Freiburg, Germany).
9. Chelating Sepharose Fast Flow (Amersham Pharmacia Biotech).
10. 0.1 M CuSO₄.

2.5. Purification of BsAb Fragments and Analysis of Molecular Forms

1. Mono S HR5/5 column (Amersham Pharmacia Biotech).
2. Mono Q HR5/5 column (Amersham Pharmacia Biotech).
3. Superdex 200 HR10/30 column (Amersham Pharmacia Biotech).
4. 50 mM Imidazole-HCl, pH 6.4. Filter (0.2 μm) and store at 4°C.
5. 50 mM Imidazole-HCl, 1 M NaCl, pH 6.4. Filter (0.2 μm) and store at 4°C.
6. 20 mM Tris-HCl, pH 8.0. Filter (0.2 μm) and store at 4°C.
7. 20 mM Tris-HCl, 1 M NaCl, pH 8.0. Filter (0.2 μm) and store at 4°C.
8. Phosphate-buffered saline (PBS): 15 mM Na phosphate, 0.15 M NaCl, pH 7.4. Filter (0.2 μm) and store at 4°C.
9. PBSI: PBS containing 50 mM imidazole, pH 7.4. Filter (0.2 μm) and store at 4°C.
10. Biomax-10 Ultrafree-15 centrifugal filter device (Millipore, Eschborn, Germany).
11. PD-10 prepacked disposable columns containing Sephadex G-25 (Amersham Pharmacia Biotech).
12. High- and low-molecular weight gel-filtration calibration kits (Amersham Pharmacia Biotech).
13. Bio-Rad protein assay kit (Bio-Rad, Munich, Germany).
14. 20% Human serum albumin (Immuno, Heidelberg, Germany).

3. Methods

3.1. Generation of Plasmids for Expression of BsAbs

3.1.1. PCR Amplification

1. Perform the PCR amplification of DNA fragments in a total volume of 50 μL containing 50 ng plasmid DNA, 25 pmol of each primer, 300 μM dNTPs, 5 μL 10X PCR buffer, 5 μg BSA, and 1 U *Vent* DNA polymerase.

2. Run 15–20 PCR cycles on a thermocycler. The thermal cycle is 95°C for 1 min (denaturation), 57°C for 2 min (annealing), and 75°C for 2 min (extension). At the beginning of the first cycle, incubate for 3 min at 95°C, and, at the end of the last cycle, incubate for 5 min at 75°C.
3. The author et al's published (**12,16**) construction of a CD3 × CD19 diabody serves as an example of the general approach. Primers DP1 and DP2 (**Table 1**) were used to amplify the V_H domain from pHOG-αCD19, which encodes an scFv reactive with human CD19 (**12**; shown schematically in **Fig. 2A**). The primers introduce *EcoRI* and *BglIII* sites upstream of the ribosome-binding site and a short linker downstream from V_H19 to *HindIII* and *EcoRV* sites. Amplification from the same template with DP3 and DP4 (**Table 1**) recovered the V_L domain and detection/purification tags, fitting the product with a linker sequence and restriction sites (*HindIII/EcoRV* [upstream] and *BglIII/XbaI* [downstream]).
4. For Tandab construction (**19**), the hybrid scFv 3-19 gene encoded by pHOG3-19 (see **Subheading 3.1.2., step 6**) was amplified with primers, Bi3sk and Li-2 (**Table 1**). This introduces a short rigid linker downstream of the V_L19 domain and restriction sites (*NcoI* upstream of V_H3, *PvuII* downstream of the linker).
5. Analyze the amplified DNA fragments by electrophoresis on a 1.5% agarose gel prestained with ethidium bromide.

3.1.2. Cloning into Expression Vector (see **Note 4**)

1. Digest 10 μg appropriate vector with suitable restriction endonuclease, in presence of alkaline phosphatase (CIP). Incubate at least 2 h at temperature recommended by the supplier.
2. Purify the PCR fragments and the linearized vector by agarose gel electrophoresis, followed by extraction using a QIAquick gel extraction kit.
3. Digest isolated PCR fragments with restriction endonucleases suitable for cloning into the vector of choice.
4. Remove stuffer fragments, and purify the digested PCR products using the QIAquick-spin PCR purification kit.
5. Ligate the vector and insert using a molar ratio between 1:1 and 1:3. The reaction mixture consists of 50 ng DNA, 1 U T4 ligase, ligation buffer, and H₂O to a final volume of 10–20 μL. Incubate overnight at 16°C.
6. In our construction of the CD3 × CD19 diabody, the DP1/DP2 amplicon (see **Subheading 3.1.1., step 3**), was cut *EcoRI/EcoRV* and ligated into pHOG-dmOKT3, a plasmid carrying an anti-CD3 scFv, after digestion of the vector with the same endonucleases. This substituted the V_H3 domain with V_H19, fusing it to V_L3 through the linker encoded on primer DP2. The construct was designated pHOG19-3. The DP3/DP4 product was cut *HindIII/XbaI* and ligated into pHOG-dmOKT3, thereby fusing V_L19 to V_H3 through the linker encoded on DP3, creating pHOG3-19. The BsAb was finally generated by excising the

V_H19-V_L3 scFv cassette from pHOG19-3 and ligating it into pHOG3-19 (**12**). This construct is shown schematically in **Fig. 2B**.

7. The CD3 × CD19 Tandab was generated by cutting the Bi3sk/Li-2 product *NcoI/PvuII* and ligation into pHOG19-3, shown schematically in **Fig. 3**.
8. Precipitate the DNA by adding one-tenth volume 3 M Na acetate, 20 μg glycogen, and 2.5 volume absolute ethanol. Incubate for at least 3 h at −20°C. Recover the precipitate by centrifugation for 15 min at 10,000g (minicentrifuge). Wash the pellet 4 × with 500 μL 80% ethanol, followed by centrifugation for 10 min at 10,000g. Allow the pellet to dry at room temperature. Dissolve the dry pellet in 5 μL H₂O.
9. Use the products of one ligation reaction for the electroporation of 40 μL electrocompetent *E. coli* cells (*see Note 1*), according to the supplier's protocol. Plate the bacteria on 2YT agar plates containing 0.1 g/L ampicillin and 2% (w/v) glucose. Incubate overnight at 37°C.
10. Test individual colonies for the presence of the desired insert by plasmid minipreps (*see Note 5*).

3.2. Preparation of Bacterial Culture

1. Inoculate a few milliliters of 2YTGA (*see Note 2*) with an individual bacterial colony, and let it grow overnight at 37°C when using *E. coli* XL1-Blue or at 26°C when using RV308.
2. Dilute an overnight bacterial culture 40 × with fresh 2YTGA, and incubate at 37°C (XL1-Blue) or at 26°C (RV308) with vigorous shaking (180–220 rpm), until optical density 600 nm reaches 0.8–0.9.
3. Harvest bacteria by centrifugation at 1500g for 10 min at 20°C.
4. Resuspend the pelleted bacteria in the same volume of either fresh 2YTSA or YTBS medium (*see Note 6*). Add IPTG to a final concentration of 0.2 mM (*see Note 7*) and incubate the bacterial culture for 14–16 h with shaking at room temperature (22–24°C).
5. Collect the cells by centrifugation at 6200g for 20 min and either discard the culture supernatant (RV308) or retain it and keep on ice (XL1-Blue) (*see Note 8*).

3.3. Isolation of Recombinant Product from Soluble Periplasmic Fraction and Culture Medium (*see Note 4*)

1. Resuspend the pelleted bacteria in 5% of the initial volume of ice-cold 50 mM Tris-HCl, 20% sucrose, 1 mM EDTA, pH 8.0, and incubate on ice for 1 h with occasional stirring.
2. Centrifuge the cell suspension at 30,000g for 40 min at 4°C and carefully collect the supernatant (soluble periplasmic extract). When using RV308, go to **step 5**. When using XL1-Blue, combine the culture supernatant and the soluble periplasmic extract.

3. Concentrate the bispecific recombinant product by ammonium sulfate precipitation (*see Note 9*). Place the beaker with the culture supernatant and the soluble periplasmic extract on a magnetic stirrer. Slowly add ammonium sulfate powder to a final concentration 70% saturation (472 g/1 L solution). Continue stirring for at least another 2 h at 4°C.
4. Collect the protein precipitate by centrifugation (30,000g, 4°C, 30 min) and dissolve it in one-tenth the initial volume of 50 mM Tris-HCl, 1 M NaCl, pH 7.0.
5. Thoroughly dialyze the concentrated protein against 50 mM Tris-HCl, 1 M NaCl, pH 7.0, at 4°C. Clarify the dialyzed material by centrifugation (30,000g, 4°C, 60 min).
6. For immobilized metal-affinity chromatography (IMAC), prepare a column of Chelating Sepharose (1–2 mL resin/1 L flask culture), and wash with 5 bed volume H₂O. Charge the column with Cu²⁺ by loading 0.7 bed volume of 0.1 M CuSO₄ (*see Note 10*), wash the excess of ions with 10 bed volume H₂O; equilibrate with 3 volume 50 mM Tris-HCl, 1 M NaCl, pH 7.0 (*see Note 11*).
7. Pass the soluble periplasmic proteins over a Chelating Sepharose column, either by gravity-flow or using a peristaltic pump. Wash the column with 10 bed volume start buffer (50 mM Tris-HCl, 1 M NaCl, pH 7.0), followed by start buffer containing 50 mM imidazole (*see Note 12*) until the absorbance (280 nm) of the effluent is minimal (20–30 column volume). Perform all chromatography steps at 4°C.
8. Elute bound Ab fragments with a start buffer containing 250 mM imidazole (*see Note 13*).
9. Analyze the purity of eluted material by sodium dodecyl sulfate-polyacrylamide gel electrophoresis (SDS-PAGE) (23).

3.4. Final Purification of BsAb Fragments and Analysis of Molecular Forms

1. If the IMAC yields homogeneous BsAb preparation according to reducing SDS-PAGE, go to **step 6** (*see Note 14*). Otherwise, calculate the isoelectric point (pI) of the bispecific product on the basis of amino acid composition of Ab fragment (*see Note 15*).
2. Subject the protein material eluted from the IMAC column to buffer exchange, either for 50 mM imidazole-HCl, pH 6.0–7.0, or 20 mM Tris-HCl, pH 8.0–8.5, using prepacked PD-10 columns (*see Note 16*). Remove the turbidity of protein solution by centrifugation (30,000g, 4°C, 30 min).
3. Load the protein solution, either on a Mono Q or Mono S column, equilibrated either with 20 mM Tris-HCl (pH 8.0–8.5) or 50 mM imidazole-HCl (pH 6.0–7.0), respectively. Wash the column with a least 10 vol start buffer.
4. Elute the bound material using a linear 0–1 M NaCl gradient in the start buffer and collect 0.5 mL fractions.
5. Perform the SDS-PAGE analysis of eluted fractions.

6. Pool the fractions containing pure recombinant Abs. Determine the protein concentration (*see Note 17*).
7. Perform a buffer exchange for PBSI, pH 7.0–7.4 (*see Note 18*) and concentrate the purified Ab preparations up to 1.0–2.0 mg/mL using Ultrafree-15 centrifugal filter units.
8. Equilibrate a Superdex 200 column with PBSI buffer and calibrate the column using high- and low-molecular weight gel-filtration calibration kits.
9. For analytical size-exclusion chromatography, apply 50 μ L concentrated preparation of bispecific product to a Superdex HR10/30 column. Perform gel filtration at 4°C, monitor the UV-absorption of effluent at 280 nm, and, if necessary, collect 0.5-mL fractions.
10. For long-term storage, stabilize purified Ab fragments by adding human serum albumin to a final concentration of 10 mg/mL. Store the sample at –80°C (*see Note 19*).

4. Notes

1. Both XL1-Blue and RV308 are suitable hosts for expression of BsAb fragments in shake-flask bacterial cultures. XL1-Blue has the following advantages: electrocompetent bacterial cells are commercially available (Stratagene) and standard DNA isolation protocols yield pure DNA preparations for restriction digests and sequencing. However, RV308 is a more robust, fast-growing strain, suitable for high-cell-density fermentation (**24**). Moreover, unlike XL1-Blue, no leakage of Ab fragments into the culture medium was observed for RV308.
2. LB (Luria-Bertani) broth can also be used. However, we observed that the simple substitution of LB for richer 2YT medium gave an essential increase in the yield of soluble bispecific molecules.
3. 2YTSA medium is prepared directly before use by dissolving 137 g sucrose powder in 1 L sterile 2YT medium containing 0.1 g/L ampicillin.
4. The protocols were established for vectors, pHOG21 (**25**) and pSKK (**19**), which were designed for periplasmic expression of single recombinant products, and for their derivatives, pKID (**12**) and pSKID2 (**16**), respectively, which allowed co-expression of two hybrid scFvs. Note that these vectors add to the expressed inserts C-terminal histidine repeats for IMAC isolation of recombinant proteins (*see Subheading 3.3.*). Alternative methods of purification must be sought for those vector systems that do not confer this property.
5. All DNA manipulations and transformation experiments are performed according to standard cloning protocols (**22**).
6. The change of medium and induction of protein synthesis in bacteria under osmotic stress significantly increases the yield of BsAb fragments, since these conditions favor domain-swapping and promote the formation of dimers (**19**).
7. This concentration of IPTG was found to be optimal for vectors containing scFv gene under the control of wild-type *lac* promoter/operator, such as pHOG21 (**25**)

or pSKK (**19**). Nevertheless, performing small-scale experiments to optimize the induction conditions is recommended for each vector.

8. For XL1-Blue, a significant portion of Ab fragments is found in the culture medium, either because of the leakiness of the bacterial outer membrane or because of partial cell lysis. Therefore, supernatant should also be used as a starting material for isolation of recombinant protein.
9. Ammonium sulfate precipitation is especially recommended for concentrating bispecific diabodies. This procedure was shown to be ineffective for precipitating monospecific scFvs (**12**).
10. IMAC can be also performed on Ni²⁺-charged Chelating Sepharose or Ni-NTA-Superflow resin (Qiagen). However, the use of Cu²⁺, instead of Ni²⁺, is recommended for isolation of Ab fragments for clinical applications (**26**).
11. Tris-HCl buffer is usually not recommended for IMAC because of the presence of amines interacting with immobilized metal ions. However, we have found that such conditions do not influence the absorption of strong binders containing six histidines, while preventing nonspecific interactions of some *E. coli* proteins with the Chelating Sepharose.
12. Unlike Chelating Sepharose, the Ni-NTA columns should not be washed with buffers containing imidazole at concentrations higher than 20 mM.
13. To avoid the unnecessary dilution of eluted scFvs, collect 0.5–1.0 mL fractions and monitor the UV absorbance at 280.
14. The purity of the Ab fragments eluted from the IMAC column depends on the expression level of particular recombinant protein. As a rule, the yield and purity of bispecific diabody are higher than those of Tandab.
15. Isoelectric point of the protein can be calculated using a number of computer programs, e.g., DNAid+1.8 Sequence Editor for Macintosh (F. Dardel and P. Bensoussan, Laboratoire de Biochimie, Ecole Polytechnique, Palaiseau, France). The calculated *pI* value hints at what ion exchange matrix and buffer system should be used.
16. For bispecific molecules with *pI* values below 7.0, the author recommends using an anion exchanger, such as a Mono Q with a linear 0–1 M NaCl gradient in 20 mM Tris-HCl, pH 8.0. For proteins with *pI* values higher than 7.0, cation exchange chromatography on a Mono S column with linear 0–1 M NaCl gradient in 50 mM imidazole-HCl buffer (pH 6.0–7.0) can be recommended. Moreover, the author found that, by exchanging the buffer, after IMAC, for 50 mM imidazole-HCl, pH 6.4–6.7, most of the contaminating bacterial proteins precipitate while the recombinant Ab fragments remain soluble (**19**).
17. For determination of protein concentrations, the author recommends using a Bradford dye-binding assay because it is easy to use, sensitive, and fast (**27**).
18. The author recommends PBSI buffer because PBS alone appears to destabilize some Ab fragments. It was determined empirically that PBS with 50 mM imidazole, pH 7.0–7.5, is a suitable buffer for various Ab fragments kept at high concentrations (2–3 mg/mL). Moreover, this buffer does not interfere with Ag

binding, and does not show any toxic effects after incubation with cultured cells or after injection into mice (intravenous injection of 200 μ L) (19).

19. Alternatively, recombinant protein can be stabilized by adding bovine serum albumin or fetal calf serum. Human serum albumin is recommended for Ab fragments developed for clinical applications. The recombinant Abs stabilized by albumin can be stored at -80°C for years, without loss of activity. These preparations may be used for a number of biological assays, such as enzyme-linked immunosorbent assay, fluorescence-activated cell sorting analysis, and analyses of antitumor activity both *in vitro* and *in vivo*.

References

1. Bird, R. E., Hardman, K. D., Jacobson, J. W., Johnson, S., Kaufman, B. M., Lee, S. M., et al. (1988) Single-chain antigen-binding proteins. *Science* **242**, 423–426.
2. Huston, J. S., Levinson, D., Mudgett Hunter, M., Tai, M. S., Novotny, J., Margolies, M. N., et al. (1988) Protein engineering of antibody binding sites: recovery of specific activity in an antidigoxin single-chain Fv analogue produced in *Escherichia coli*. *Proc. Natl. Acad. Sci. USA* **85**, 5879–5883.
3. Milenic, D. E., Yokota, T., Filpula, D. R., Finkelman, M. A., Dodd, S. W., Wood, J. F., et al. (1991) Construction, binding properties, metabolism, and tumor targeting of a single-chain Fv derived from the pancarcinoma monoclonal antibody CC49. *Cancer Res.* **51**, 6363–6371.
4. Yokota, T., Milenic, D. E., Whitlow, M., and Schlom, J. (1992) Rapid tumor penetration of a single-chain Fv and comparison with other immunoglobulin forms. *Cancer Res.* **52**, 3402–3408.
5. Yokota, T., Milenic, D. E., Whitlow, M., Wood, J. F., Hubert, S. L., and Schlom, J. (1993) Microautoradiographic analysis of the normal organ distribution of radioiodinated single-chain Fv and other immunoglobulin forms. *Cancer Res.* **53**, 3776–3783.
6. Adams, G. P., McCartney, J. E., Tai, M. S., Oppermann, H., Huston, J. S., Stafford, W. F., et al. (1993) Highly specific *in vivo* tumor targeting by monovalent and divalent forms of 741F8 anti-c-erbB-2 single-chain Fv. *Cancer Res.* **53**, 4026–4034.
7. Holliger, P., Prospero, T., and Winter, G. (1993) “Diabodies”: small bivalent and bispecific antibody fragments. *Proc. Natl. Acad. Sci. USA* **90**, 6444–6448.
8. Kortt, A. A., Lah, M., Oddie, G. W., Gruen, C. L., Burns, J. E., Pearce, L. A., et al. (1997) Single-chain Fv fragments of anti-neuraminidase antibody NC10 containing five- and ten-residue linkers form dimers and with zero-residue linker a trimer. *Protein Eng.* **10**, 423–433.
9. Wu, A. M., Chen, W., Raubitschek, A., Williams, L. E., Neumaier, M., Fischer, R., et al. (1996) Tumor localization of anti-CEA single-chain Fvs: improved targeting by non-covalent dimers. *Immunotechnology* **2**, 21–36.
10. Adams, G. P., Schier, R., McCall, A. M., Crawford, R. S., Wolf, E. J., Weiner, L. M., and Marks, J. D. (1998) Prolonged *in vivo* tumour retention of a human

- diabody targeting the extracellular domain of human HER2/neu. *Br. J. Cancer* **77**, 1405–1412.
11. Holliger, P., Brissinck, J., Williams, R. L., Thielemans, K., and Winter, G. (1996) Specific killing of lymphoma cells by cytotoxic T-cells mediated by a bispecific diabody. *Protein Eng.* **9**, 299–305.
 12. Kipriyanov, S. M., Moldenhauer, G., Strauss, G., and Little, M. (1998) Bispecific CD3 × CD19 diabody for T cell-mediated lysis of malignant human B cells. *Int. J. Cancer* **77**, 763–772.
 13. Perisic, O., Webb, P. A., Holliger, P., Winter, G., and Williams, R. L. (1994) Crystal structure of a diabody, a bivalent antibody fragment. *Structure* **2**, 1217–1226.
 14. Zhu, Z., Zapata, G., Shalaby, R., Snedecor, B., Chen, H., and Carter, P. (1996) High level secretion of a humanized bispecific diabody from *Escherichia coli*. *Biotechnology* **14**, 192–196.
 15. Arndt, M. A., Krauss, J., Kipriyanov, S. M., Pfreundschuh, M., and Little, M. (1999) Bispecific diabody that mediates natural killer cell cytotoxicity against xenotransplanted human Hodgkin's tumors. *Blood* **94**, 2562–2568.
 16. Cochlovius, B., Kipriyanov, S. M., Stassar, M. J. J. G., Christ, O., Schuhmacher, J., Strauss, G., Moldenhauer, G., and Little, M. (2000) Treatment of human B cell lymphoma xenografts with a CD3 × CD19 diabody and T cells. *J. Immunol.* **165**, 888–895.
 17. Ridder, R., Schmitz, R., Legay, F., and Gram, H. (1995) Generation of rabbit monoclonal antibody fragments from a combinatorial phage display library and their production in the yeast *Pichia pastoris*. *Biotechnology* **13**, 255–260.
 18. Shusta, E. V., Raines, R. T., Plückthun, A., and Wittrup, K. D. (1998) Increasing the secretory capacity of *Saccharomyces cerevisiae* for production of single-chain antibody fragments. *Nature Biotechnol.* **16**, 773–777.
 19. Kipriyanov, S. M., Moldenhauer, G., Schuhmacher, J., Cochlovius, B., Von der Lieth, C. W., Matys, E. R., and Little, M. (1999) Bispecific tandem diabody for tumor therapy with improved antigen binding and pharmacokinetics. *J. Mol. Biol.* **293**, 41–56.
 20. Cochlovius, B., Kipriyanov, S. M., Stassar, M. J. J. G., Schuhmacher, J., Benner, A., Moldenhauer, G., and Little, M. (2000) Cure of Burkitt's lymphoma in SCID mice by T cells, tetravalent CD3 × CD19 tandem diabody and CD28 costimulation. *Cancer Res.* **60**, 4336–4341.
 21. Maurer, R., Meyer, B., and Ptashne, M. (1980) Gene regulation at the right operator (O_R) bacteriophage λ . I. O_{R3} and autogenous negative control by repressor. *J. Mol. Biol.* **139**, 147–161.
 22. Sambrook, J., Fritsch, E. F., and Maniatis, T. (1989) *Molecular Cloning: A Laboratory Manual*. Cold Spring Harbor Laboratory, Cold Spring Harbor, NY.
 23. Laemmli, U. K. (1970) Cleavage of structural proteins during the assembly of the head of bacteriophage T4. *Nature* **227**, 680–685.
 24. Horn, U., Strittmatter, W., Krebber, A., Knupfer, U., Kujau, M., Wenderoth, R., et al. (1996) High volumetric yields of functional dimeric miniantibodies

- in *Escherichia coli*, using an optimized expression vector and high-cell-density fermentation under non-limited growth conditions. *Appl. Microbiol. Biotechnol.* **46**, 524–532.
25. Kipriyanov, S. M., Moldenhauer, G., and Little, M. (1997) High level production of soluble single chain antibodies in small-scale *Escherichia coli* cultures. *J. Immunol. Methods* **200**, 69–77.
 26. Casey, J. L., Keep, P. A., Chester, K. A., Robson, L., Hawkins, R. E., and Begent, R. H. (1995) Purification of bacterially expressed single chain Fv antibodies for clinical applications using metal chelate chromatography. *J. Immunol. Methods* **179**, 105–116.
 27. Bradford, M. M. (1976) A rapid and sensitive method for the quantitation of microgram quantities of protein utilizing the principle of protein-dye binding. *Anal. Biochem.* **72**, 248–254.

High-Level Periplasmic Expression and Purification of scFvs

Sergey M. Kipriyanov

1. Introduction

In the past few years, some of the limitations of monoclonal antibodies (MAbs) as therapeutic agents have been addressed by genetic engineering. Such an approach is particularly suitable because of the domain structure of the Ab molecule, where functional domains carrying antigen (Ag)-binding activities (Fabs or Fvs) or effector functions (Fcs) can be exchanged between Abs. Furthermore, genetically truncated versions of Ab can be produced, ranging in size from the smallest Ag-binding unit or Fv, to Fab' and F(ab')₂s. To stabilize the association of recombinant V_H and V_L domains, they have been joined in scFv constructs with a short peptide linker (1,2). These small scFvs are particularly interesting for clinical applications (3). They are only one half the size of Fabs and thus have lower retention times in nontarget tissues, more rapid blood clearance, and better tumor penetration. They are also less immunogenic and are amenable to fusions with proteins and peptides.

Unlike glycosylated whole Abs, scFvs can be easily produced in bacterial cells as functional Ag-binding molecules. There are two basic strategies for obtaining recombinant Ab fragments from *Escherichia coli*. The first is to produce Ab proteins as cytoplasmic inclusion bodies, followed by refolding in vitro. In this case, the protein is expressed without a signal sequence under a strong promoter. The inclusion bodies contain the recombinant protein in a nonnative and nonactive conformation. To obtain functional Ab, the recombinant polypeptide chains have to be dissolved and folded into the right shape by using a laborious and time-consuming refolding procedure (4).

The second approach for obtaining functional Ab fragments is to imitate the situation in the eukaryotic cell for secreting a correctly folded Ab. Rapid growth in the field of Ab engineering occurred after it was shown that functional Ab fragments could be secreted into the periplasmic space and even into the medium of *E. coli* by fusing a bacterial signal peptide to the Ab N-terminus (5,6). The scFvs are usually correctly processed in the periplasm; they contain intramolecular disulfide bonds and are soluble. However, the high-level expression of a recombinant protein with a bacterial signal peptide in *E. coli* often results in the accumulation of insoluble Ab fragments after transport to the periplasm (7,8).

It is now recognized that aggregation *in vivo* is not a function of the solubility and stability of the native state of the protein, but of those of its folding intermediates in their particular environment (9,10). The degree of successful folding in the periplasm appears to depend to a large extent on the primary sequence of the variable domains (11). Nevertheless, modifying the bacteria growth and induction conditions can increase the proportion of correctly folded soluble scFvs. For example, lowering the bacterial growth temperature has been shown to decrease periplasmic aggregation and to increase the yield of soluble Ab protein (9,12).

Alternatively, the aggregation of recombinant Ab fragments in the *E. coli* periplasm can be reduced by growing the induced cells under osmotic stress in the presence of certain nonmetabolized additives, such as sucrose (13) or sorbitol and glycine betaine (14). For example, addition of 0.4 M sucrose to the growth medium gives a 15–25-fold increase in the yield of soluble scFvs for bacterial shake-tube cultures and an 80–150-fold increase for shake-flask cultures (13). Moreover, inducing synthesis of recombinant Ab fragments in bacteria under osmotic stress promotes the formation of domain-swapped scFv dimers, or so-called “diabodies” (14). In this chapter, protocols for growing and inducing bacterial cells with or without nonmetabolized additives, as well as for the purification of active scFvs from soluble periplasmic extracts are described.

The purification scheme includes immobilized metal-affinity chromatography (IMAC) as the main step for separating recombinant Abs from bacterial proteins. In contrast to methods based on Ag-affinity chromatography, it does not depend on the specificity of the particular scFv (15). Our procedure is useful for any scFv Ab fragment that is secreted into the periplasm and which has six histidine (His) residues as a C-terminal tag. If the His-tagged protein is highly overexpressed in *E. coli*, a one-step IMAC purification can result in sufficiently pure material for most applications (16,17). However, if the protein of interest is present only as a small fraction, several contaminating bacterial

proteins can bind to the IMAC column under the purification conditions and co-elute (for list of His-rich *E. coli* proteins, see ref. 18). For further purification of Ab fragments from IMAC-eluted material, Ag-affinity chromatography (8), thiophilic adsorption chromatography (19,20), or immunoaffinity purification using immobilized anti-His-tag-MAbs (18), have been used. Here is found a description of a simple alternative procedure based on the separation of proteins by ion-exchange chromatography. This purification technique has been tested for a number of scFvs and seems to be generally applicable.

2. Materials

2.1. Preparation of scFv Expression Cultures

1. Either *E. coli* XL1 Blue (Stratagene) or RV308 ($\Delta lac\chi 74galISII::OP308strA$) (21) competent cells (see Note 1).
2. scFv Ab in an appropriate vector for His-tagged periplasmic expression.
3. 2YT medium: 1 L contains 16 g Bacto-tryptone, 10 g Bacto-yeast extract, 5 g NaCl, pH 7.5 (see Note 2).
4. 2YTGA: 2YT medium containing 0.1 g/L ampicillin and 2% (w/v) glucose; 2YTGA agar plates.
5. 2YTSA: 2YT medium containing 0.1 g/L ampicillin and 0.4 M sucrose (see Note 3).
6. YTBS: 2YT medium containing 0.1 g/L ampicillin, 1 M sorbitol, and 2.5 mM glycine betaine.
7. 100 mM solution of isopropyl- β -D-thiogalactopyranoside (IPTG). Store at -20°C .

2.2. Isolation of scFvs

1. 50 mM Tris-HCl, 20% sucrose, 1 mM ethylene diamine tetraacetic acid (EDTA), pH 8.0.
2. All-glass bacteria filter of pore size 10–16 μm (porosity 4) (Schott Glaswerke, Mainz, Germany); Membrex TF filters of pore size 0.2 μm (MembraPure, Lörzweiler, Germany).
3. Amicon High Performance Stirred Ultrafiltration Cell (Millipore, Eschborn, Germany).
4. Amicon YM10 membranes with a 10 kDa cutoff (Millipore).
5. 50 mM Tris-HCl, 1 M NaCl, pH 7.0.
6. Chelating Sepharose Fast Flow (Amersham Pharmacia Biotech, Freiburg, Germany).
7. C16/20 column (Amersham Pharmacia Biotech).
8. 0.1 M CuSO_4 .
9. 50 mM Tris-HCl, 1 M NaCl, 50 mM imidazole, pH 7.0.
10. 50 mM Tris-HCl, 1 M NaCl, 250 mM imidazole, pH 7.0.

2.3. Purification of scFvs and Analysis of Molecular Forms

1. PD-10 prepacked disposable columns containing Sephadex G-25 (Amersham Pharmacia Biotech).
2. 20 mM Tris-HCl, pH 8.0; or 50 mM imidazole-HCl, pH 6.4. Filter (0.2 μ m) and store at 4°C.
3. Mono Q HR5/5 column or Mono S HR5/5 column (Amersham Pharmacia Biotech).
4. 20 mM Tris-HCl, 1 M NaCl, pH 8.0; or 50 mM imidazole-HCl, 1 M NaCl, pH 6.4. Filter (0.2 μ m) and store at 4°C.
5. PBSI: Phosphate-buffered saline (PBS) containing 50 mM imidazole, pH 7.4. Filter (0.2 μ m) and store at 4°C.
6. Biomax-10 Ultrafree-15 Centrifugal Filter Device (Millipore).
7. Superdex 75 or Superdex 200 HR10/30 column (Amersham Pharmacia Biotech).
8. High- and low-molecular weight gel-filtration calibration kits (Amersham Pharmacia Biotech).
9. Bio-Rad protein assay kit (Bio-Rad, Munich, Germany).
10. 20% Human serum albumin (Immuno, Heidelberg, Germany).

3. Methods

3.1. Expression of scFvs

1. Inoculate 10 mL 2YTGA with an single freshly plated colony of the scFv expression clone on 2YTGA plates and grow overnight at 37°C (*E. coli* XL1 Blue) or at 26°C (RV308).
2. Dilute the overnight bacterial culture 1:40 \times in fresh 2YTGA, and incubate at 37°C (XL1 Blue) or at 26°C (RV308) with vigorous shaking (180–220 rpm) until optical density 600 nm = 0.8–0.9.
3. Either induce the expression of the scFvs by adding IPTG to a final concentration of 0.2 mM (*see Note 4*) or harvest the bacteria by centrifugation at 1500g for 10 min at 20°C (*see Note 5*). Resuspend the pelleted bacteria in the same volume of either fresh 2YTSA or YTBS medium and add IPTG to a final concentration of 0.2 mM.
4. Incubate the culture for 14–16 h with shaking at room temperature (22–24°C).
5. Collect the cells by centrifugation at 6200g for 20 min and retain the bacterial cell pellets. If using RV308, discard the culture supernatant, or, for XL1 Blue, retain the supernatant and keep it on ice (*see Note 6*).

3.2. Isolation of Soluble Secreted scFvs

1. Resuspend the pelleted bacteria in 5% of the initial volume of ice-cold 50 mM Tris-HCl, 20% sucrose, 1 mM EDTA, pH 8.0, and incubate on ice for 1 h with occasional stirring.

2. Centrifuge the cell suspension at 30,000g for 40 min at 4°C, then carefully collect the supernatant (soluble periplasmic extract). If using RV308, go directly to **step 4**.
3. If using XL1 Blue, combine the culture supernatant and the soluble periplasmic extract and clarify by an additional centrifugation (30,000g, 4°C, 1 h). Pass through a glass filter of pore size 10–16 µm, then through a filter of pore size of 0.2 µm. Reduce the volume by 10× by concentrating the solution using an Amicon ultrafiltration cell and YM 10 membrane (*see Note 7*).
4. Thoroughly dialyze the extracts against 50 mM Tris-HCl, 1 M NaCl, pH 7.0, at 4°C. Clarify the dialyzed extracts by centrifugation (30,000g, 4°C, 1 h).
5. For IMAC, prepare a column of Chelating Sepharose (1–2 mL resin/1 L flask culture) and wash with 5 bed volume H₂O.
6. Charge the column with Cu²⁺ by loading 0.7 vol 0.1 M CuSO₄ (*see Note 8*), then remove the excess ions by washing the column with 10 vol H₂O. Finally, equilibrate the column with 3 vol 50 mM Tris-HCl, 1 M NaCl, pH 7.0 (*see Note 9*).
7. Pass the soluble periplasmic proteins over the column, either by gravity flow or by using a peristaltic pump. Wash the column with 10 bed volume of starting buffer (50 mM Tris-HCl, 1 M NaCl, pH 7.0), followed by starting buffer containing 50 mM imidazole (*see Note 10*) until the absorbance (280 nm) of the effluent is minimal (20–30 column volume). Perform all chromatography steps at 4°C.
8. Elute the bound scFvs with starting buffer containing 250 mM imidazole (*see Note 11*).
9. Analyze the purity of the eluted material by reducing sodium dodecyl sulfate-polyacrylamide gel electrophoresis (SDS-PAGE).

3.3. Final Purification of scFv and Analysis of Molecular Forms

1. If the IMAC procedure yields a homogeneous scFv preparation, go directly to **step 6** (*see Note 12*). Otherwise, calculate the isoelectric point (pI) of the scFv on the basis of the amino acid composition of the Ab fragment (*see Note 13*).
2. Subject the protein material eluted from the IMAC column to buffer exchange, either with 20 mM Tris-HCl, pH 8.0–8.5, or 50 mM imidazole-HCl, pH 6.0–7.0 using prepacked PD-10 columns (*see Note 14*). Remove the turbidity of protein solution by centrifugation (30,000g, 4°C, 30 min).
3. Load the protein solution on either a Mono Q or Mono S column, equilibrated either with 20 mM Tris-HCl, pH 8.0–8.5, or 50 mM imidazole-HCl, pH 6.0–7.0, respectively. Wash the column with at least 10 vol starting buffer.
4. Elute the bound material using a linear 0–1 M NaCl gradient in the starting buffer, collecting 0.5 mL fractions.
5. Perform an SDS-PAGE analysis of the eluted fractions.
6. Pool the fractions containing pure scFvs and determine the protein concentration (*see Note 15*).

7. Perform a buffer exchange in PBSI, pH 7.0–7.4 (*see Note 16*), then concentrate the purified Ab preparation to 1.0–2.0 mg/mL using Ultrafree-15 centrifugal filter units.
8. Equilibrate a Superdex column with PBSI buffer and calibrate the column, using high-molecular weight (HMW) and low-molecular weight (LMW) gel-filtration calibration kits (*see Note 17*).
9. For analytical size-exclusion chromatography, apply 50 μ L concentrated scFv preparation to a Superdex HR10/30 column. Perform the gel filtration at 4°C, monitoring the UV absorption of effluent at 280 nm, and, if necessary, collect 0.5-mL fractions.
10. For long-term storage, stabilize the purified scFv by adding human serum albumin to a final concentration of 10 mg/mL. Store the sample at –80°C (*see Note 18*).

4. Notes

1. Both XL1 Blue and RV308 are suitable hosts for expression of Ab fragments in flask cultures of *E. coli*. XL1 Blue has the following advantages: electrocompetent bacterial cells are commercially available (Stratagene) and standard DNA isolation protocols yield pure DNA preparations for restriction digests and sequencing. However, RV308 is a more robust, fast-growing strain suitable for high-cell-density fermentation (*21*). Moreover, unlike XL1 Blue, no leakage of Ab fragments into the culture medium has been observed for RV308.
2. Luria-Bertani broth can also be used for the culture of the bacteria. However, we have observed that the simple substitution of Luria-Bertani broth for the somewhat richer 2YT medium gives a fourfold increase in the yield of soluble scFvs.
3. 2YTSA medium is prepared directly before use by dissolving 137 g sucrose powder in 1 L sterile 2YT medium containing 0.1 g/L ampicillin.
4. This concentration of IPTG was found to be optimal for vectors containing scFv gene under the control of wild-type *lac* promoter/operator systems, such as pHOG21 (*13*) or pSKK (*14*). Nevertheless, performing small-scale experiments to optimize the induction conditions is recommended for each vector.
5. Direct induction without medium change is recommended for production of scFv in predominantly monomeric form. However, the change of medium and induction of scFv synthesis in bacteria under osmotic stress significantly increases the yield of Ab fragments, although these conditions promote the formation of domain-swapped dimers (*14*).
6. For XL1 Blue, because of the leakiness of the outer membrane or a partial cell lysis, a significant fraction of Ab fragments is found in culture medium. Therefore, supernatant should also be used as a starting material for the isolation of scFv.
7. Other devices suitable for concentrating protein solutions with a cut-off of 10–12 kDa may also be used.
8. IMAC can be also performed on Ni²⁺-charged Chelating Sepharose or Ni-NTA-Superflow resin (Qiagen, Germany). However, the use of Cu²⁺, instead of Ni²⁺, is recommended for isolation of Ab fragments for clinical applications (*16*).

9. Tris buffers are usually not recommended for IMAC, because of the presence of amines interacting with immobilized metal ions. However, the author has found that such conditions do not influence the absorption of strong binders containing six His, and prevent nonspecific interactions of some *E. coli* proteins with the Chelating Sepharose.
10. Unlike Chelating Sepharose, the Ni-NTA columns should not be washed with buffers containing imidazole at concentrations higher than 20 mM.
11. To avoid the unnecessary dilution of eluted scFvs, collect 0.5–1.0 mL fractions and monitor the UV absorbance at 280 nm.
12. The purity of the scFvs eluted from the IMAC column depends on the expression level of a particular Ab fragment.
13. The *pI* of a protein can be calculated using a number of computer programs, e.g., DNAid+1.8 Sequence Editor for Macintosh (F. Dardel and P. Bensoussan, Laboratoire de Biochimie, Ecole Polytechnique, Palaiseau, France). The calculated *pI* value gives an estimate of which ion exchange matrix and buffer system should be used.
14. For scFvs with *pI* values below 7.0, we recommend using an anion exchanger, such as a Mono Q with a linear 0–1 M NaCl gradient in 20 mM Tris-HCl, pH 8.0. For proteins with *pI* values higher than 7.0, cation exchange chromatography on a Mono S column with a linear 0–1 M NaCl gradient in 50 mM imidazole-HCl buffer, pH 6.0–7.0, is recommended. Moreover, we have found that by exchanging the buffer after IMAC for 50 mM imidazole-HCl, pH 6.4–6.7, most of the contaminating bacterial proteins precipitated, but the recombinant Ab fragments remained soluble (**14**).
15. For determination of protein concentrations, we recommend using a Bradford dye-binding assay because it is easy to use, sensitive, and fast (**22**).
16. We recommend using PBSI buffer because PBS alone appears to be unfavorable for the stability of some Ab fragments. Therefore, the presence of imidazole stabilizes the scFvs. PBS with 50 mM imidazole, pH 7.0–7.5, was determined empirically to be a suitable buffer for a variety of Ab fragments kept at high concentrations (2–3 mg/mL). Moreover, this buffer does not interfere with Ag binding and does not show any toxic effects after incubation with cultured cells or after injection into mice (intravenous injection of 200 μ L) (**14**).
17. Size-exclusion chromatography on Superdex 75 separates scFv monomers ($M_r = 25$ –30 kDa) from dimers (diabody, $M_r = 50$ –60 kDa) (**8**). HMW forms will be eluted from this column in a void volume. In contrast, Superdex 200 determines whether the Ab preparation contains trimers (triabody, $M_r = 90$ kDa) and tetramers (tetraabody, $M_r = 120$ kDa) (**23**). Accordingly, Superdex 200 should be calibrated with both the HMW and LMW gel-filtration calibration kits. In contrast, the LMW gel-filtration calibration kit is sufficient for calibrating the Superdex 75 column.
18. Alternatively, scFvs can be stabilized by adding bovine serum albumin or fetal calf serum. Human serum albumin is recommended for Ab fragments developed for clinical applications. The recombinant Abs stabilized by albumin can be

stored at -80°C for years without loss of activity. These preparations may be used for a number of biological assays, such as enzyme-linked immunosorbent assay, fluorescence-activated cell sorting analysis, and analyses of antitumor activity both *in vitro* and *in vivo*.

References

1. Bird, R. E., Hardman, K. D., Jacobson, J. W., Johnson, S., Kaufman, B. M., Lee, S. M., et al. (1988) Single-chain antigen-binding proteins. *Science* **242**, 423–426.
2. Huston, J. S., Levinson, D., Mudgett-Hunter, M., Tai, M. S., Novotny, J., Margolies, M. N., et al. (1988) Protein engineering of antibody binding sites: recovery of specific activity in an anti-digoxin single-chain Fv analogue produced in *Escherichia coli*. *Proc. Natl Acad. Sci. USA* **85**, 5879–5883.
3. Huston, J. S., McCartney, J., Tai, M. S., Mottola-Hartshorn, C., Jin, D., Warren, R., Keck, P., and Oppermann, H. (1993) Medical applications of single-chain antibodies. *Int. Rev. Immunol.* **10**, 195–217.
4. Kipriyanov, S. M. and Little, M. (1999) Generation of recombinant antibodies. *Mol. Biotechnol.* **12**, 173–201.
5. Better, M., Chang, C. P., Robinson, R. R., and Horwitz, A. H. (1988) *Escherichia coli* secretion of an active chimeric antibody fragment. *Science* **240**, 1041–1043.
6. Skerra, A. and Plückthun, A. (1988) Assembly of a functional immunoglobulin Fv fragment in *Escherichia coli*. *Science* **240**, 1038–1041.
7. Whitlow, M. and Filpula, D. (1991) Single-chain Fv proteins and their fusion proteins. *Methods: Companion Methods Enzymol.* **2**, 97–105.
8. Kipriyanov, S. M., Dübel, S., Breitling, F., Kontermann, R. E., and Little, M. (1994) Recombinant single-chain Fv fragments carrying C-terminal cysteine residues: production of bivalent and biotinylated miniantibodies. *Mol. Immunol.* **31**, 1047–1058.
9. Plückthun, A. (1994) Antibodies from *Escherichia coli*, in *Handbook of Experimental Pharmacology*, vol. 113: *The Pharmacology of Monoclonal Antibodies* (Rosenberg, M. and Moore, G. P., eds.) Springer-Verlag, Berlin, Heidelberg, pp. 269–315.
10. Hockney, R. C. (1994) Recent developments in heterologous protein production in *Escherichia coli*. *Trends Biotechnol.* **12**, 456–463.
11. Knappik, A. and Plückthun, A. (1995) Engineered turns of a recombinant antibody improve its *in vivo* folding. *Protein Eng.* **8**, 81–89.
12. Skerra, A. and Plückthun, A. (1991) Secretion and *in vivo* folding of the Fab fragment of the antibody McPC603 in *Escherichia coli*: influence of disulphides and cis-prolines. *Protein Eng.* **4**, 971–979.
13. Kipriyanov, S. M., Moldenhauer, G., and Little, M. (1997) High level production of soluble single chain antibodies in small-scale *Escherichia coli* cultures. *J. Immunol. Methods* **200**, 69–77.
14. Kipriyanov, S. M., Moldenhauer, G., Schuhmacher, J., Cochlovius, B., von der Lieth, C. W., Matys, E. R. and Little, M. (1999) Bispecific tandem diabody for

- tumor therapy with improved antigen binding and pharmacokinetics. *J. Mol. Biol.* **293**, 41–56.
15. Skerra, A., Pfitzinger, I., and Plückthun, A. (1991) The functional expression of antibody Fv fragments in *Escherichia coli*: improved vectors and a generally applicable purification technique. *Biotechnology* **9**, 273–278.
 16. Casey, J. L., Keep, P. A., Chester, K. A., Robson, L., Hawkins, R. E., and Begent, R. H. (1995) Purification of bacterially expressed single chain Fv antibodies for clinical applications using metal chelate chromatography. *J. Immunol. Methods* **179**, 105–116.
 17. Kipriyanov, S. M., Moldenhauer, G., Strauss, G., and Little, M. (1998) Bispecific CD3 x CD19 diabody for T cell-mediated lysis of malignant human B cells. *Int. J. Cancer* **77**, 763–772.
 18. Müller, K. M., Arndt, K. M., Bauer, K., and Plückthun, A. (1998) Tandem immobilized metal-ion affinity chromatography/immunoaffinity purification of His-tagged proteins: evaluation of two anti-His-tag monoclonal antibodies. *Anal. Biochem.* **259**, 54–61.
 19. Schulze, R. A., Kontermann, R. E., Queitsch, I., Dübel, S., and Bautz, E. K. (1994) Thiophilic adsorption chromatography of recombinant single-chain antibody fragments. *Anal. Biochem.* **220**, 212–214.
 20. Müller, K. M., Arndt, K. M., and Plückthun, A. (1998) A dimeric bispecific miniantibody combines two specificities with avidity. *FEBS Let.* **432**, 45–49.
 21. Horn, U., Strittmatter, W., Krebber, A., Knupfer, U., Kujau, M., Wenderoth, R., et al. (1996) High volumetric yields of functional dimeric miniantibodies in *Escherichia coli*, using an optimized expression vector and high-cell-density fermentation under non-limited growth conditions. *Appl. Microbiol. Biotechnol.* **46**, 524–532.
 22. Bradford, M. M. (1976) A rapid and sensitive method for the quantitation of microgram quantities of protein utilizing the principle of protein-dye binding. *Anal. Biochem.* **72**, 248–254.
 23. Le Gall, F., Kipriyanov, S. M., Moldenhauer, G., and Little, M. (1999) Di-, tri- and tetrameric single chain Fv antibody fragments against human CD19: effect of valency on cell binding. *FEBS Let.* **453**, 164–168.

Periplasmic Expression and Purification of Recombinant Fabs

Robert L. Raffai

1. Introduction

The ability to refine the affinity, specificity, and immunogenicity of recombinant antibodies (Abs) offers distinct advantages for the preparation of *in vivo* diagnostic and therapeutic immunoreagents. The bacterial expression vector pComb3 allows production of recombinant Ab Fabs (rFab) (**1**). Light-chain (LC) and heavy-chain (HC) Ab cDNA fragments are inserted separately into this vector, which produces heterodimeric rFab Abs that are isolated in a native form. Fabs generated with the pComb3 expression vector are documented to bind Ag with affinities similar to that of the parental hybridoma-generated Fab (**2**). In the plasmid, both chains are independently controlled by isopropyl-1- β -D-thiogalactopyranoside (IPTG)-inducible *lac* expression. The original pComb3 vector allows for the display of rFabs on the surface of M13 filamentous phage and can be converted to produce rFabs in a soluble form. We have modified this vector to allow the expression and purification of soluble Fab Ab fragments using immobilized metal-affinity chromatography via a pentahistidine (His) tag fused to the HC constant region 1 (**Fig. 1; 2**). A similar modification to pComb3 (pComb3x) designed exclusively for the expression of soluble rFabs has been performed by Barbas at the Scripps Research Institute (*see Note 1*).

Upon induction with IPTG, both Ab chains are expressed with the N-terminal *pelB* bacterial leader sequence that targets the chains to the periplasm, where the *pelB* sequence is subsequently cleaved by the enzyme signal peptidase. Within the periplasm, appropriate oxidizing conditions allow the Ab chains

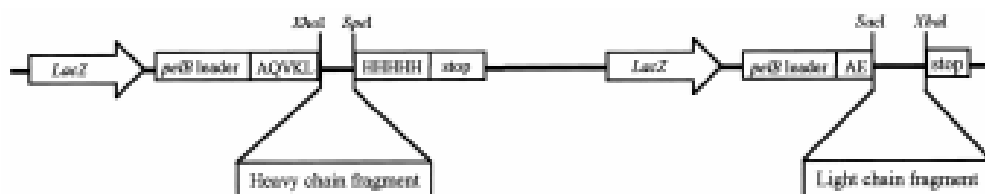

Fig. 1. Modified pComb3 expression vector for the expression of rFabs. The vector allows the co-expression of both the LC and the Fd portion of the HC of an Ab molecule. Both chains are independently synthesized with the *pelB* bacterial leader sequence that directs the polypeptides to the periplasm, where they can assemble as heterodimers. The Fd portion of the HC includes a C-terminal extension of five His residues to facilitate purification of the rFabs.

to correctly fold and assemble as heterodimeric proteins. Soluble rFabs are obtained from the bacteria by a mild osmotic shock, which selectively releases periplasmic proteins. The crude rFab preparation is first purified by metal chelate chromatography and is further purified by size-exclusion chromatography. Its final concentration can be adjusted by ultrafiltration.

2. Materials

1. rFab clone in pComb3-His-tagged expression vector (*see Note 1*), or any Fab expression vector encoding a His tag fused to the Fd region of the HC. If required, the Ab of choice can be cloned into a pComb3 vector (*see Notes 2 and 3*).
2. *Escherichia coli* bacterial strains XL1 Blue or TG1 (Stratagene, San Diego, CA).
3. 2 L Erlenmeyer flasks.
4. LBA: Luria-Bertani broth (LB) supplemented with 100 $\mu\text{g}/\text{mL}$ ampicillin.
5. SBA: Super broth (SB) supplemented with 100 $\mu\text{g}/\text{mL}$ ampicillin.
6. 1 M IPTG stock solution.
7. STE buffer: 20% sucrose, 10 mM Tris-HCl, pH 8.0, 5 mM ethylenediamine tetraacetic acid (EDTA).
8. TE buffer: 10 mM Tris-HCl, pH 8.0, 5 mM EDTA.
9. Histidine-binding (His-bind) column buffer: 500 mM NaCl, 10 mM HEPES, pH 7.0.
10. Dialysis tubing; glass wool; 30 mL disposable syringes.
11. 2X Nonreducing sodium dodecyl sulfate-polyacrylamide gel electrophoresis (SDS-PAGE) loading buffer; 12% SDS-PAGE gels and running apparatus; blot transfer apparatus and nitrocellulose membrane (e.g., Hybond ECL); Coomassie blue staining solution.
12. Horseradish peroxidase (HRP)-conjugated anti-mouse or anti-human Fab Ab or HRP-conjugated Ni-NTA (Qiagen).
13. Phosphate-buffered saline (PBS); 1% bovine serum albumin.
14. ECL chemiluminescent reagents (Amersham/Pharmacia); X-ray film.

15. His-bind Fast Flow resin (Amersham/Pharmacia).
16. His-bind wash buffer: 100 mM Na₂PO₄, 100 mM Na citrate, at pH 7.0, 6.5, 6.0, and 5.0.
17. 2 M Tris-HCl.
18. Ultrafiltration protein concentrators (molecular weight cutoff, 50 kDa) (e.g., Pall Filtron, Northborough, MA).
19. Fast protein liquid chromatography (FPLC) system with a Superdex-75 size-exclusion chromatography column (Amersham/Pharmacia).

3. Methods

3.1. Expression and Isolation of Soluble rFabs

1. Inoculate a single colony of XL1 Blue or TG1 *E. coli*, transformed with the appropriate rFab plasmid into a culture tube containing 5 mL LBA culture medium (*see Note 4*).
2. Grow the culture at room temperature (25°C) overnight, with constant agitation.
3. Transfer the culture to a 2 L Erlenmeyer flask containing 1 L SBA (*see Note 5*) and grow at room temperature with agitation until an absorbance (600 nm) of 0.6 is reached.
4. Add IPTG to a final concentration of 1 or 0.1 mM (*see Note 6*) and grow the culture for a further 24 h at room temperature (*see Note 7*).
5. Collect the cells by centrifugation in a 1 L centrifuge bottle at 3000g for 30 min.
6. Discard the culture supernatant (*see Note 8*), invert the centrifuge bottle, and remove any remaining growth buffer by blotting with tissue paper.
7. Resuspend the bacterial pellet in 200 mL of ice-cold STE and transfer to a 250 mL centrifuge bottle (*see Note 9*). Incubate for 45 min on ice with occasional inversion (*see Note 10*).
8. Centrifuge the cells at 8000g for 30 min and discard the supernatant (*see Note 11*).
9. Resuspend the bacterial pellet in 40 mL ice-cold TE and incubate on ice for 15 min.
10. Pellet the bacteria by centrifugation at 8000g for 10 min and transfer the supernatant (i.e., periplasmic extract) to a clean tube.
11. Dialyze the periplasmic extract overnight at 4°C in 4 L His-bind column buffer.

3.2. Identification of rFabs in Bacterial Periplasmic Extract

The presence of rFabs in the isolated bacterial periplasm is determined by Western blot analysis.

1. Dilute 20 µL periplasmic extract in 2X SDS loading buffer at 95°C for 5 min.
2. Run on a 12% SDS-PAGE and transfer to nitrocellulose membrane, according to standard protocols.
3. Block nonspecific binding sites by incubating the nitrocellulose blot in PBS-bovine serum albumin for 1 h at room temperature.

4. Discard the block solution and add the appropriate HRP–anti-species Fab Ab or the HRP–Ni-NTA for 1 h at room temperature.
5. Wash the blot 3× in PBS for 20 min.
6. Develop the blot using ECL reagents according to the manufacturer’s instructions, and expose to X-ray film.

3.3. Purification of rFabs

Recombinant Fab Abs are purified from the periplasmic extract by metal-chelate affinity chromatography with commercially available His-bind resins.

1. Assemble a disposable column by pipeting 1 mL resin slurry into a 30-mL syringe that has been plugged with glass wool.
2. Wash the column twice by adding 10 mL ice-cold His-bind column buffer.
3. Slowly transfer the periplasmic extract into the syringe and collect the flow-through eluent.
4. Wash the resin with 50 mL ice-cold His-bind column buffer to remove unbound rFabs.
5. Elute the bound rFabs by sequentially adding 10 mL ice-cold His-bind wash buffer, beginning with pH 7.0, followed by pH 6.5, 6.2, 6.0, and 5.0. Collect each eluate into 15-mL tubes containing 200 μ L 2 M Tris-HCl.
6. Run a 20 μ L sample of each eluate on a 12% SDS-PAGE gel and visualize the eluted rFabs by staining the gel with Coomassie blue. An intense rFab band, corresponding to 50 kDa, is usually observed in the pH 6.2 and 6.0 eluates (*see Note 12*).
7. Pool the eluates containing rFab and dialyze overnight at 4°C into PBS.
8. If required, increase the Ab concentrations by ultrafiltration in microconcentrators centrifuged at 6000g in a fixed-angle rotor.

3.4. Isolation of rFab Monomers by Size-Exclusion Chromatography (*see Note 13*)

1. Prepare a Superdex-75 FPLC column at a flow rate of 0.5 mL/min in PBS.
2. Inject a 250 μ L aliquot of rFab solution onto the column and monitor the elution profile by absorbance at 280 nm to collect the rFab peak.
3. Determine the Ab concentration spectrophotometrically by absorbance at 280 nm with a 1% extinction coefficient of 13.6 or by standard Lowry assay.

4. Notes

1. We modified the original pComb3 expression vector to encode a penta-His tag fused to the HC by PCR mutagenesis (2). The addition of a His tail to the HC allows the use of metal chelate chromatography, which greatly facilitates the isolation of rFabs. Also, the mild elution conditions required to elute the rFabs from the His-bind column probably help preserve functional binding activity. A similar version of pComb3, pComb3x, which encodes a His tag onto the HC, can

now be obtained from Dr. Carlos Barbas at the Scripps Research Institutes, San Diego, CA (e-mail: carlos@hermes.scripps.edu). This vector is recommended if one wishes to express rFabs in a soluble form only.

2. If required, the desired Ab genes can be cloned into pComb3 by amplifying the LC and HC cDNA fragments by PCR with appropriate sense and antisense oligonucleotide primers. The 5' and 3' region primers should be based on previously compiled Ab sequences for murine LCs and HCs (3). LC primers should encode *SacI* and *XbaI* restriction sites; HC primers should encode *XhoI* and *SpeI* sites to allow the subsequent cloning of the PCR amplification products into pComb3 (see Fig. 1).
3. Cloning of the HC and LC cDNAs into the pComb3 vector may result in the replacement of several of the N-terminal residues in both chains, as shown in Fig. 1. Since the N-terminal portion of both chains is often in close proximity to the Ab paratope in solved Ab crystal structures, it may be wise to design 5' PCR oligonucleotide primers to incorporate as much of the correct Ab sequence of each chain as possible. Additional site-directed mutagenesis may be performed on the fully assembled expression vector to faithfully encode the original Ab sequence.
4. In our laboratory, we consistently observe substantial differences in the amount of rFabs expressed in different *E. coli* strains. For example, yields may be 5–10× higher in the TG1 strain than in the XL1 Blue strain (2). The reasons for higher levels of rFab expression in the TG1 strain are not clear. Although the transformed TG1 always grows faster than the XL1 Blue, the higher expression of Fabs by the TG1 strain is not solely the result of a higher density of bacteria in the cultures because the strain differences are also apparent when yields are expressed in terms of wet bacterial pellet mass.
5. The addition of 0.4 M sucrose to the culture medium reduces rFab production, in contrast to what has been reported for the bacterial expression of scFv Ab fragments (5).
6. Increasing the amount of IPTG used for induction beyond 0.1 mM has little effect on the production rate of rFabs (2). This fact should be considered in view of the high cost of IPTG.
7. Overexpression of rFabs can pose a strain on the bacteria that can lead to cell lysis. This problem can be circumvented by incubating the induced culture at room temperature rather than at 37°C, a condition now recommended by many experts in the field (4).
8. We have found small amounts of rFab expressed in the culture medium (6). However, when starting to work with a new rFab, one should routinely test for the presence of rFabs in the culture medium and in the hypertonic STE because some rFabs have been reported to localize to all three compartments of an induced culture. Moreover, variants of a given rFab may localize differently than the original Fab (7).
9. The best method for resuspending bacterial pellets is to use a disposable 25 mL sterile plastic pipet powered by a hand-held pipet pump.

10. The STE solution used to render the bacterial periplasm hypertonic typically contains little rFab after the bacteria are pelleted. However, rFab leakage may occur if the bacteria are incubated in STE for more than 1 h. Therefore, do not incubate the bacteria in STE for more than 45 min on ice.
11. After centrifugation, care should be taken not to pour the cells out of the bottle because the pellet is loose after incubation in STE. It may be necessary to respin the bottles to form appropriate conditions for good pellet formation.
12. By comparing Western blotting results of crude rFab periplasmic extracts, we observed that the total amount of rFab reactive to anti-mouse Fab Ab was not always detected by the Ni-NTA conjugate. This suggests that the His tag fused to the HC can be proteolytically cleaved within the bacterial periplasm. Therefore, the successful purification of rFabs should be checked after metal chelate chromatography and before further purification. The addition of protease inhibitors to the periplasmic extract may help reduce proteolysis.
13. Concentrated rFab preparations may be subjected to size-exclusion chromatography to remove residual impurities, such as aggregated rFabs and contaminating *E. coli* proteins, which can co-elute from the His-bind column. This may increase the avidity of the rFab preparation.

References

1. Barbas, C. F., Kang, A. S., Lerner, R. A., and Benkovic, S. J. (1991) Assembly of combinatorial antibody libraries on phage surfaces: the gene III site. *Proc. Natl. Acad. Sci. USA* **88**, 7978–7982.
2. Raffai, R., Vukmirica, J., Weisgraber, K. H., Rassart, E., Innerarity, T. I., and Milne, R. (1999) Bacterial expression and purification of the Fab fragment of a monoclonal antibody specific for the low density lipoprotein receptor-binding site of human apolipoprotein E. *Protein Exp. Purif.* **16**, 84–90.
3. Huse, W. D., Sastry, L., Iverson, S. A., Kang, A. S., Alting-Mees, M., Burton, D. R., Benkovic, S. J., and Lerner, R. A. (1989) Generation of a large combinatorial library of the immunoglobulin repertoire in phage lambda. *Science* **246**, 1275–1281.
4. Bothmann, H. and Plückthun, A. (1998) Selection for a periplasmic factor improving phage display and functional periplasmic expression. *Nature Biotechnol.* **16**, 376–380.
5. Kipriyanov, S. M., Moldenhauer, G., and Little, M. (1997) High level production of soluble single chain antibodies in small-scale *Escherichia coli* cultures. *J. Immunol. Methods* **200**, 69–77.
6. Raffai, R., Weisgraber, K. H., MacKenzie, R., Rupp, B., Rassart, E., Hiramata, T., Innerarity, T. L., and Milne, R. (2000) Binding of an antibody mimetic of the human low density lipoprotein receptor to apolipoprotein E is governed through electrostatic forces. *J. Biol. Chem.* **275**, 7109–7116.
7. Forsberg, G., Forsgren, M., Jaki, M., Norin, M., Sterky, C., Enhörning, Å., et al. (1997) Identification of framework residues in a secreted recombinant antibody fragment that control production level and localization in *Escherichia coli*. *J. Biol. Chem.* **272**, 12,430–12,436

Expression of Antibody Fragments in *Pichia pastoris*

Philipp Holliger

1. Introduction

Since the advent of hybridoma technology 25 years ago, monoclonal antibodies (Abs) have revolutionized many aspects of biological research and health care. After some initial setbacks, Abs are also beginning to make an impact as therapeutic agents in the clinic (**1**). In the last decade, novel selection technologies, such as phage display and ribosome display, have emerged, allowing the isolation of Abs directly from diverse repertoires of V genes (**2**). Phage display, in particular, has become a mature technology, allowing Abs with nanomolar (or even subnanomolar) affinities to be made to order against virtually any Ag, including self Ags (**3**; *see Note 1*). Furthermore, using high-throughput technologies, such as robotics and array screening, a multitude of Abs against a given Ag (or mixtures thereof) can now be isolated simultaneously, greatly increasing the options for assay or drug development (*see Note 2*).

Regardless of the method of isolation, Abs have to be expressed in recombinant form for screening, characterization, and application. Although both whole Abs and Ab fragments (Fabs [**4**], Fvs [**5**], scFvs [**6**], and diabodies [**7**]) can be expressed in eukaryotic cells (e.g., mammalian yeast, plant, and insect cells [**8**]), it is time-consuming and cost-intensive. Expression in bacteria, particularly secretion to the bacterial periplasm (*see Note 3*), is a quick and cheap alternative and is best-suited for the screening and characterization of a large number of Ab variants. Some phagemid vectors (**9**) even offer a built-in switch between phage display and soluble expression, allowing direct screening of Ab fragments isolated by phage selection without the need for

recloning. However, because of the lack of glycosylation, only Ab fragments and not whole Abs (*see* above) can be produced in a functional form in bacteria.

Expression yields in bacteria can vary widely between different Ab fragments, but yields of 1–10 mg/L are typical for shaker-flask cultures. Using fermentation technology, expression levels of up to 1 g/L can be reached (**10**). Generally, expression yields are a function of the Ab fragment sequence and format (e.g., Fv vs Fab), rather than the expression system. Fvs (5–50 mg/L) often give the highest expression yields (but are sometimes unstable), followed by scFvs, then diabodies, with Fabs usually giving the lowest expression yields (0.1–1 mg/L). As a rule of thumb, Ab fragments derived from phage libraries tend to give higher yields than those recloned from hybridomas. However, some Ab fragments are generally difficult to express in *Escherichia coli*. Although yields of difficult fragments can sometimes be improved through protein engineering (**11,12**) or selection (**12**), no general rules have emerged.

A pragmatic alternative to time-intensive optimization of bacterial expression is the use of a eukaryotic expression host. The methylotrophic yeast, *Pichia pastoris*, combines some of the advantages of eukaryotic expression systems, e.g., more efficient folding of multidomain and cys-rich proteins, with the speed and cost efficiency approaching that of prokaryotic systems (**13**). Optimal expression in *Pichia* is dependent on a range of factors, including codon usage (**14**), aeration, temperature control (at 28–30°C: *Pichia* is temperature-sensitive) and methanol (MeOH) concentration (when using the alcohol oxidase 1 [AOX1] promoter). Protease-sensitive proteins are usually not well expressed, because *Pichia* secretes a number of proteases. Nevertheless, *Pichia* has become a popular host for heterologous protein expression (**13**), and a range of Ab fragments, including scFvs and diabodies, have been successfully expressed in *Pichia*, with yields up to 200 mg/L (**15**) in shaker flasks and >1 g/L in fermentor cultures.

This chapter focuses on the expression of functional Ab fragments by the yeast, *P. pastoris* (**3**). Using appropriate expression vectors, the Abs are secreted into the yeast culture supernatant, and purified using affinity chromatography. The Ag specificity and binding affinity of the Abs can be determined using BIAcore technology or other suitable methods.

2. Materials

1. *P. pastoris* strain, GS115 (Invitrogen) (*see* **Note 4**).
2. YP medium: 1% (w/v) yeast extract, 2% peptone.
3. YPD medium: 1% yeast extract, 2% peptone, 2% glucose.
4. YPDS medium: 1% yeast extract, 2% peptone, 2% glucose, 1 M sorbitol. For YPDS plates, add 2% (w/v) agar.

5. Sterile Millipore H₂O.
6. 1 M sorbitol (SORB).
7. *Pichia* expression vectors: pPIC (AOX promoter) or pGAPZ (Invitrogen) (see **Note 4**). Both vectors have a C-terminal c-myc epitope tag for convenient immunodetection with an anti-myc Ab (9E10) (Invitrogen), as well as a C-terminal hexahistidine tag for immobilized metal-affinity chromatography (IMAC) purification.
8. Ab clone. Because bicistronic expression works only poorly in *Pichia* (unlike *Escherichia coli*), it is preferable to use single-chain Ab formats (e.g., scFv, diabody). Two-chain Ab formats (e.g., Fvs, Fabs, bispecific diabodies) require that the two chains be cloned and transformed separately.
9. Appropriate restriction enzymes and DNA purification and other reagents for molecular cloning of Ab sequences.
10. *E. coli* strain for propagation of plasmid vectors, e.g., TG1.
11. Zeocin (Invitrogen): stock solution 100 mg/mL. Store at -20°C (in the dark).
12. 2TY medium, supplemented with 0.1–5% (w/v) glucose. Autoclave for sterilization, then supplement with sterile-filtered (0.2 µm) glucose (20%).
13. TYE agar (for plates), supplemented with 0.1–5% (w/v) glucose. Autoclave, then supplement with sterile-filtered glucose (20%).
14. TE: 10 mM Tris-HCl, 1 mM ethylenediamine tetraacetic acid (EDTA), pH 8.0. Filter-sterilize.
15. Electroporator, e.g., Bio-Rad Genepulser.
16. Methanol.
17. 1 M Phosphate buffer: 132 mL 1 M KH₂HPO₄, 868 mL 1 M KH₂PO₄. Adjust pH to 6.0 with KOH. Filter-sterilize.
18. 10X YNB: 134 g yeast nitrogen base (with NH₄SO₄)/L MilliQ H₂O. Autoclave.
19. 500X B: 20 mg biotin/100 mL MilliQ H₂O. Filter-sterilize.
20. 10X GY: 10% glycerol (v/v) in MilliQ H₂O. Filter-sterilize.
21. BMGY: 100 mL 1 M phosphate buffer, pH 6.0, 100 mL 10X YNB, 2 mL 500X B, 100 mL 10X GY in 1 L of YP medium. Filter-sterilize.
22. BMMY: as BMGY, but replace the 10X GY with 100 mL 5% MeOH (v/v) in H₂O. Filter-sterilize.
23. BIAcore machine and software, CM5 BIAcore chip.
24. N-ethyl-Ni-(diaminopropyl) carbodimide (EDC); (*N*-hydroxysuccinimide (NHS)).
25. Ag of interest, purified.
26. 100 mM Na acetate, pH 6.0–4.0; 1 M ethanolamine.
27. Phosphate buffered saline (PBS).
28. Ni-NTA resin (Qiagen).
29. IMAC phosphate buffer: 29.82 g NaH₂PO₄, 5.52 g NaH₂PO₄•H₂O, 147 g NaCl/L. Adjust the pH to 7.5 with 1 M NaOH.
30. Imidazole (Sigma).
31. IMAC Loading buffer: 50 mM IMAC phosphate buffer, pH 7.5, 0.5 M NaCl, 20 mM imidazole. Dilute IMAC phosphate buffer fivefold in H₂O, then add imidazole powder to give a final concentration of 20 mM. Store at 4°C.

3. Methods

3.1. Preparation of Electrocompetent *Pichia* GS115

1. Inoculate a single colony of *Pichia* GS115 into 5 mL YPD medium and grow overnight at 30°C.
2. Dilute the overnight culture 1:1000 into fresh YPD medium (e.g., add 1 mL overnight culture into 1 L) and grow overnight at 30°C.
3. Pellet the cells at 1500g for 20 min at 4°C, then resuspend in an equal volume of ice-cold sterile Millipore H₂O.
4. Pellet the cells, then resuspend in 0.5 vol ice-cold Millipore H₂O.
5. Pellet the cells, then resuspend in 0.2 vol ice-cold sterile 1 M SORB.
6. Pellet the cells, then resuspend in 0.005 vol ice-cold sterile 1 M SORB.
7. Use the cells for transformation, or store in 0.1 mL aliquots by flash-freezing on dry ice and store at -70°C (see Note 5).

3.2. Cloning of Ab Fragments for Expression in *P. pastoris*

1. Clone the selected Ab fragment(s) into the appropriate *Pichia* expression vector in *E. coli* using standard cloning procedures (see Notes 6 and 7).
2. Prepare plasmid DNA from the resulting clones by miniprep procedures, then linearize with *AvrII* (pGAPZ α) or *BstXI* (pPICZ). Extract the digests with phenol:chloroform (1:1) once, and precipitate the DNA with ethanol. Resuspend the precipitated pellet in 5 μ L TE.
3. Add 2.5 μ L DNA to 50 μ L electrocompetent *Pichia* cells and electroporate at 1.5 kV, 25 μ F, and 200 Ω . Resuspend the cells in 1 mL 1 M SORB and incubate for 2 h at 30°C.
4. Plate the transformed cells on YPDS plates containing 50 μ g/mL zeocin and incubate at 30°C. Colonies (10–1000) will appear in 3–4 d.

3.3. Expression of Ab Fragments in *Pichia* (see Note 8)

3.3.1. Expression in pPIC (MeOH Induction) (see Note 9)

1. Inoculate a colony expressing a pPIC/Ab clone into 1 mL YPD medium containing 0.1mg/mL zeocin and grow overnight at 30°C.
2. Dilute the overnight culture 1:100 into fresh YP medium (e.g., dilute 0.1 mL into 10 mL) and grow for 24 h at 30°C. Add MeOH to a final concentration of 0.5% (v/v) and grow for a further 24 h. Repeat the MeOH addition every 24 h until the culture is harvested after 1–4 d (see Note 10).

Alternatively, dilute the overnight culture 1:100 into fresh BMGY medium (e.g., dilute 0.1 mL into 10 mL) and grow at 30°C to an optical density 600 nm of 4.0. Pellet the cells by centrifugation at 1500g for 20 min, then resuspend in an equal volume of BMMY medium and grow for 24 h at 30°C. Add MeOH (0.5% [v/v] final concentration) and grow for a further 24 h. Repeat the MeOH addition every 24 h until the culture is harvested (after 1–4 d).

3. Spin the culture at 10,000g for 30 min at 4°C and collect the supernatant (see Note 11). The supernatant can be used directly for analysis of Ab expression

(e.g. by enzyme-linked immunosorbant assay [ELISA] or BIAcore) or can be stored and/or purified before use (*see* **Notes 12** and **13**).

3.3.2. Expression in pGAPZ (Constitutive Expression)

1. Inoculate a colony expressing a pGAPZ α /Ab clone into 1 mL YPD medium containing 0.1 mg/mL zeocin and grow overnight at 30°C.
2. Dilute the overnight culture 1:100 (e.g., dilute 0.1 mL into 10 mL) into fresh YPD medium (without zeocin) (*see* **Note 14**). Grow the culture at 30°C for 1–4 d (*see* **Note 11**).
3. Harvest the culture supernatant and store or purify the Ab as described in **Subheading 3.3.1**.

3.4. Analysis of Ab Binding by BIAcore (*see* **Note 15**)

This procedure can be used to quickly investigate Ab specificity using crude extracts of yeast culture supernatant as an alternative to ELISA (*see* **Note 16**). If purified material is used, the method can also be used to determine affinity. More information about the BIAcore instrument and the method can be found at the BIAcore website: <http://www.biacore.com>.

1. Dock a research-grade CM5 chip (BIAcore) in the BIAcore machine, according to the manufacturer's instructions.
2. Amine-couple 500–5000 resonance units (RU) of the desired Ag, according to the manufacturer's instructions (the amount of Ag this corresponds to depends on its molecular weight, because the BIAcore signal [RU] is mass-dependent). Briefly, activate the chip surface with EDC–NHS (typical injection is 30 μ L at 10 μ L/min flow rate). Inject the Ag (typically, 100 μ g/mL in 100 mM Na acetate, pH 6.0–4.0) (*see* **Note 17**). Stop the coupling reaction by injecting 1.0 M ethanolamine, which blocks the remaining activated sites.
3. Filter the recombinant Ab samples through a 0.2 μ m filter before injection.
4. Pass the Ab solution over the chip surface (typical injection times range from 1 to 10 min at flow rates of 5–50 μ L/min). An increase in RU indicates binding.
5. Plot a graph of RU vs time. Analyze the binding affinity and/or kinetics using the BIAcore software.

3.5. Purification of Recombinant Ab Fragments by IMAC

Like Ab fragments expressed from polyhistidine-tagged *E. coli* expression vectors, Abs expressed in *P. pastoris* using the pPIC or pGAPZ plasmids can be purified by IMAC. The Ab-containing culture supernatants must first be dialyzed against PBS before purification to remove chelating compounds present in the growth media (*see* **Note 18**).

1. Dialyze the culture supernatant against two changes of PBS (ideally at 4°C). For smaller volumes, dialysis tubing with a 10 kDa cutoff is suitable. For large

- volumes, dialysis is best performed using tangential flow filtration using repeated addition of PBS during the concentration process (*see Note 12*).
2. Add the appropriate amount of Ni-NTA resin to an appropriate column and equilibrate the resin with 10 column volume loading buffer (e.g., for 5 mL resin, use 50 mL buffer). 1 mL Ni-NTA resin is usually sufficient to purify 2–3 mg Ab fragment (*see Note 19*).
 3. Load the dialyzed Ab preparation onto the column (either by gravity flow or using a peristaltic pump) and collect the unbound fraction.
 4. Wash the column with at least 10 column volume loading buffer. If the washing process can be observed using an UV-flowcell, washing should continue until a stable baseline is reached.
 5. Elute the Ab fragments using an imidazole gradient from 35 to 200 mM in loading buffer (*see Note 20*). Elution peak fractions should ideally be detected using an UV-flowcell. The elution of Ab should be confirmed by ELISA or BCA protein assay (Pierce).
 6. Dialyze the Ab fractions into the desired buffer (e.g., PBS) to remove the imidazole, then concentrate the Ab by ultrafiltration using a stirred cell device with an appropriate cutoff (10 kDa for scFvs, 30 kDa for Fabs, and diabodies).
 7. Aliquot the Ab preparations for storage. Concentrated Ab preparations (>0.5 mg/mL) in PBS are suitable for freezing. As a rule, preparations should always be flash-frozen in dry ice or liquid nitrogen and never in a –20°C freezer. Once frozen, a –20°C freezer is suitable for short- to medium-term storage.

4. Notes

1. Protocols for the selection of Ab specificities from phage libraries have been published (*16*) and several libraries are available to researchers (<http://www.mrc-cpe.cam.ac.uk/phage/index.html>).
2. An alternative method for isolating human Abs is transgenic “human” mice with partial human heavy- and light-chain loci inserted into their genomes (*17*). A possible advantage of this approach may be the ability to use the isolated hybridomas directly for production of whole Abs with no need for further genetic manipulation.
3. Ab fragments can be expressed both intra- and extracellularly, i.e., secreted. Intracellular expression of Ab fragments in *E. coli* usually gives rise to insoluble aggregates (inclusion bodies) that have to be refolded. Secretion from bacteria (to the periplasm) or yeast mimics the natural expression and folding pathway of Abs and often provides a more direct route to functional Ab fragments.
4. *P. pastoris* strains and expression vectors are commercially available from Invitrogen. *Pichia* protocols are available to download from the Invitrogen website (<http://www.invitrogen.com/manuals.html>).
5. Freezing reduces competence. In order to obtain the highest possible transformation efficiencies, it is advisable to use freshly prepared cells. However, frozen competent cells are perfectly adequate for standard transformations. Before

use, thawed frozen cells should be washed once in 0.5 mL ice-cold sterile 1 M sorbitol.

6. Ab fragments can be cloned using PCR directly from hybridomas using standard methodology (a kit comprising mouse V-gene-specific primers is available from Pharmacia) or isolated from phage selected from libraries using panning procedures.
7. When using zeocin selection in combination with high-salt media (TYE, 2TY), it is advisable to use a final concentration of 100 $\mu\text{g/mL}$ zeocin for selection. Transformed *E. coli* cells should be incubated for 1–2 h in 2TY, 1% glucose at 37°C, before plating on zeocin plates because zeocin resistance is expressed slowly.
8. There are two types of promoter systems available in *Pichia*; the MeOH-inducible AOX1 promoter and the constitutive glyceraldehyde-phosphate dehydrogenase (GAPDH) promoter. Expression of some proteins can be higher under control of the GAPDH promoter (using glucose as a carbon source) than by MeOH induction of the AOX1 promoter. Both promoters should be tried because expression yields can differ dramatically. Furthermore, expression levels usually vary a great deal among different *Pichia* clones. It is advisable to screen a number of colonies for expression in order to identify high-expressing “jackpot” clones. *Pichia* expression can also depend on good aeration so expression cultures should be grown with vigorous shaking (350 rpm).
9. For optimal protein yields with MeOH induction, the alternative may be more effective than the primary methods.
10. Protein expression takes place over 1–4 d at 30°C. Maximum yields usually are obtained by harvesting on d 2 or 3.
11. Respin the culture if the supernatant is not clear.
12. The cleared supernatant can be used directly in ELISA or BIAcore analysis, or can be stored at -20°C prior to purification. For large-scale preparations (>1 L), it may be advantageous to concentrate the supernatant before purification. Various concentration methods are available (e.g., ammonium sulphate precipitation), but ultrafiltration is preferable. Filter the supernatant through a 16 μm tangential-flow filter (Flowgen Minisette system) with the use of a peristaltic pump to remove small debris. Concentrate the supernatant using the Minisette system, using a tangential-flow filter minisette with an appropriate cutoff (e.g., 10 kDa for scFvs and Fvs, or 30 kDa cutoff for Fabs and diabodies). The concentrate (typically, 0.3–0.5 L) can be stored at -20°C prior to purification.
13. Ab fragments produced in *Pichia* often have nonhomogenous N-termini because of incomplete processing of the leader peptide, giving rise to fuzzy bands on sodium dodecyl sulfate-polyacrylamide gel electrophoresis gels. These N-terminal extensions can be shaved off using 5 $\mu\text{g/mL}$ trypsin digestion for 5 min (immobilized TPCK trypsin [Pierce]). The reaction is stopped by addition of Pefabloc trypsin inhibitor (at 5 $\mu\text{g/mL}$) and removal of the enzyme gel by centrifugation. Because trypsin may also cleave off polyhistidine tags, it is advisable to carry out the digestion after purification.

14. Zeocin selection during expression is unnecessary and can reduce the yield of expressed protein.
15. These methods are not limited to Ab expressed in *Pichia* and can also be used for determining Ag specificity (crude periplasmic extracts) and binding affinity (purified Ab) of Ab expressed in *E. coli*.
16. Either ELISA or BIAcore can be used to determine affinity constants of purified Ab fragments. In my opinion, BIAcore is superior to ELISA-based methods, provided attention is paid to the oligomerization state of the Ab fragment. Multimeric fragments (e.g., some scFvs, bivalent diabodies) bind to solid-phase Ags with much-increased affinity (avidity). Failure to take this into account can lead to an overestimation of affinity by several orders of magnitude. On the other hand, multimerization can be helpful in increasing the sensitivity of Ag-binding assays, particularly for Ab fragments with modest affinities for Ag. For methods relating to Ab multimerization (and expression), see ref. 18. BIAcore can also be used to measure Ag-binding kinetics.
17. For optimal coupling efficiencies, the pH should be determined by experimental analysis (knowledge of the isoelectric point value of the Ag is not sufficient). Coupling should be spontaneous. For slow-reacting Ags, it may be appropriate to slow down the flow rate.
18. Purification by IMAC has advantages beyond other purification methods because of its versatility and mild elution conditions. The commonly used rich medium for *Pichia* (YP) expression (and for *E. coli* [2TY or Luria-Bertani broth]) contain metal-chelating compounds, which strip the metal from the IMAC column (the same also applies for periplasmic preparations from *E. coli*-containing EDTA). Metal loss from the IMAC column is easy to spot because the column loses its blue-green color (in the case of Ni²⁺) and turns white.
19. Ab fragments can give widely differing expression yields, ranging from 1 to 100 mg/L of induced *Pichia* culture. It is thus advisable to determine approximate expression levels before embarking on purification.
20. Most Ab fragments elute between 50 and 100 mM imidazole. Diabodies and triabodies, which have two and three hexahistidine tags, respectively, usually elute at higher concentrations (50–200 mM imidazole).

References

1. Milstein, C. and Waldmann, H. (1999) Optimism after much pessimism: what next? *Curr. Opin. Immunol.* **11**, 589–591.
2. Winter, G., Griffiths, A. D., Hawkins, R. E., and Hoogenboom, H. R. (1994) Making antibodies by phage display technology. *Ann. Rev. Immunol.* **12**, 433–455.
3. Griffiths, A. D. and Duncan, A. R. (1998) Strategies for selection of antibodies by phage display. *Curr. Opin. Biotechnol.* **9**, 102–108.
4. Better, M., Chang, C. P., Robinson, R. R., and Horwitz, A. H. (1988) *Escherichia coli* secretion of an active chimeric antibody fragment. *Science* **240**, 1041–1043.
5. Skerra, A. and Pluckthun, A. (1988) Assembly of a functional immunoglobulin Fv fragment in *Escherichia coli*. *Science* **240**, 1038–1041.

6. Huston, J. S., Levinson, D., Mudgett, H. M., Tai, M. S., Novotny, J., Margolies, M. N., et al. (1988) Protein engineering of antibody binding sites: recovery of specific activity in an anti-digoxin single-chain Fv analogue produced in *Escherichia coli*. *Proc. Natl Acad. Sci. USA* **85**, 5879–5883.
7. Holliger, P., Prospero, T., and Winter, G. (1993) “Diabodies”: small bivalent and bispecific antibody fragments. *Proc. Natl Acad. Sci. USA* **90**, 6444–6448.
8. Verma, R., Boleti, E., and George, A. J. (1998) Antibody engineering: comparison of bacterial, yeast, insect and mammalian expression systems. *J. Immunol. Methods* **216**, 165–181.
9. Hoogenboom, H. R., Griffiths, A. D., Johnson, K. S., Chiswell, D. J., Hudson, P., and Winter, G. (1991) Multi-subunit proteins on the surface of filamentous phage: methodologies for displaying antibody (Fab) heavy and light chains. *Nucleic Acids Res.* **19**, 4133–4137.
10. Carter, P., Kelley, R. F., Rodrigues, M. L., Snedecor, B., Covarrubias, M., Velligan, M. D., et al. (1992) High level *Escherichia coli* expression and production of a bivalent humanized antibody fragment. *Biotechnology* **10**, 163–167.
11. Knappik, A. and Pluckthun, A. (1995) Engineered turns of a recombinant antibody improve its in vivo folding. *Protein Engineering* **8**, 81–89.
12. Coia, G., Ayres, A., Lilley, G. G., Hudson, P. J., and Irving, R. A. (1997) Use of mutator cells as a means for increasing production levels of a recombinant antibody directed against hepatitis B. *Gene* **201**, 203–209.
13. Hollenberg, C. P. and Gelissen, G. (1997) Production of recombinant proteins by methylotrophic yeasts. *Curr. Opin. Biotechnol.* **8**, 554–560.
14. Sreekrishna, K., Brankamp, R. G., Kropp, K. E., Blankenship, D. T., Tsay, J. T., Smith, P. L., et al. (1997) Strategies for optimal synthesis and secretion of heterologous proteins in the methylotrophic yeast *Pichia pastoris*. *Gene* **190**, 55–62.
15. Luo, D., Mah, N., Krantz, M., Wishart, D., Jacobs, F., and Martin, L. (1997) High-level secretion of single-chain antibody in *Pichia* expression system. *Biotechnol. Tech.* **11**, 759–761.
16. Harrison, J. L., Williams, S. C., Winter, G., and Nissim, A. (1996) Screening of phage antibody libraries. *Methods Enzymol.* **267**, 83–109.
17. Bruggeman, M. and Taussig, M. J. (1997) Production of human antibody repertoires in transgenic mice. *Curr. Opin. Biotechnol.* **8**, 503–508.
18. Tomlinson, I. and Holliger, P. (2000) Methods for generating multivalent and bispecific antibody fragments. *Methods Enzymol.* **326**, 461–479.

Expression of V_{HH} Antibody Fragments in *Saccharomyces cerevisiae*

J. Marcel van der Vaart

1. Introduction

The use of *Saccharomyces cerevisiae* as a production host for heterologous proteins has several advantages compared to the use of a bacterial host. First, *S. cerevisiae* has proven to be a productive host capable of expressing many heterologous proteins at high levels. Second, because *S. cerevisiae* does not secrete many homologous proteins during growth, an efficiently produced heterologous protein will be the major component of the growth medium. This, and the fact that *S. cerevisiae* does not produce any toxins and is generally regarded as safe, simplifies the processes of downstream processing. Third, *S. cerevisiae* contains a secretion machinery comparable to the mammalian system, including an endoplasmic reticulum and Golgi. These organelles ensure the efficient formation of intramolecular disulphide bonds, as well as the glycosylation of the produced heterologous proteins.

S. cerevisiae has also been tested for the production of antibodies (Abs) and Ab fragments. Horwitz et al. (1) have reported the production of complete immunoglobulin G molecules, as well as Fabs, but production levels were only in the range of micrograms per litre. Ab fragments of the scFv format were also tested for production in *S. cerevisiae*. The best yields for this format were obtained by Shusta et al. (2), combined the expression of scFvs with the overexpression of two chaperones in the secretion route, resulting in production levels of up to 20 mg/L. However, for a yeast expression system, these production levels are still relatively low.

Several years ago, it was discovered (3) that a nonconventional type of Immunoglobulin G-like molecule was present in the serum of camelids.

These immunoglobulin G molecules are composed of heavy-chain dimers and are devoid of light chains. Furthermore, these molecules lack the C_H1 domain. Expression of the binding domain (V_{HH}) of these heavy chain Abs in *S. cerevisiae* resulted in the efficient secretion of this molecule and production levels of 250 mg/L were obtained in shake-flask experiments (4). We have shown that the level of V_{HH} expression is dramatically higher than that seen when the same Ab fragment is expressed in *Escherichia coli* (Fig. 1).

This chapter describes protocols for the expression of heavy chain Ab fragments (V_{HH}) in *S. cerevisiae* using an episomal yeast expression plasmid (pUR4548) under control of the GAL7 promoter. The recombinant plasmid is transformed into yeast by lithium acetate transformation or electroporation and the expressed Ab fragments are extracted from the yeast growth medium. More detailed information on yeast expression systems can be found in Romanos et al. (5).

2. Materials

1. Yeast strain for expression. A typical yeast strain used in this laboratory is SU51 (*can1, his4, 519, leu2, 3, 112, cir⁺*; 6). This strain grows in the presence of histidine, leucine, and a proper carbon source (see **Subheading 2.7.** for selective minimal medium, and **Subheading 2.8.** for rich, nonselective medium for this strain).
2. Plasmid vector suitable for Ab expression in yeast. The plasmid used in the laboratory, pUR4548 (4), contains the LEU2 selection marker, the SUC2 signal sequence for protein secretion, and the galactose-inducible GAL7 promoter (see **Notes 1–2**).
3. Distilled H₂O used for the preparation of buffers and growth media should be double-autoclaved. Used glassware should be free of any contaminants (an overnight incubation with 100 mM HCl, followed by washing and autoclaving, is sufficient).
4. SD broth: 10X stock solution: 6.7 g yeast nitrogen base (without amino acids) dissolved in 100 mL H₂O; filter-sterilize through a 0.22 μm filter.
5. 20% Glucose 10X stock solution, sterilized by autoclaving (20 min at 120°C/1.4 bar).
6. Amino acid stock solutions: 100X stocks are prepared in distilled water then filter-sterilized through 0.22 μm filters. Final concentrations for the most commonly used amino acids are: L-adenine, 0.4 mg/mL; L-valine, 1.5 mg/mL; L-histidine, 0.2 mg/mL; uracil, 0.2 mg/mL; L-leucine, 0.6 mg/mL.
7. YEPD broth: 1% (w/v) yeast extract and 2% (w/v) peptone. Autoclave, then add 2% (v/v) glucose.
8. 1.0 M LiAC: 1.02 g in 10 mL distilled water; filter-sterilize through a 0.22 μm filter.
9. 50% (w/v) Polyethylene glycol (PEG) 4000 in distilled water. Autoclave.

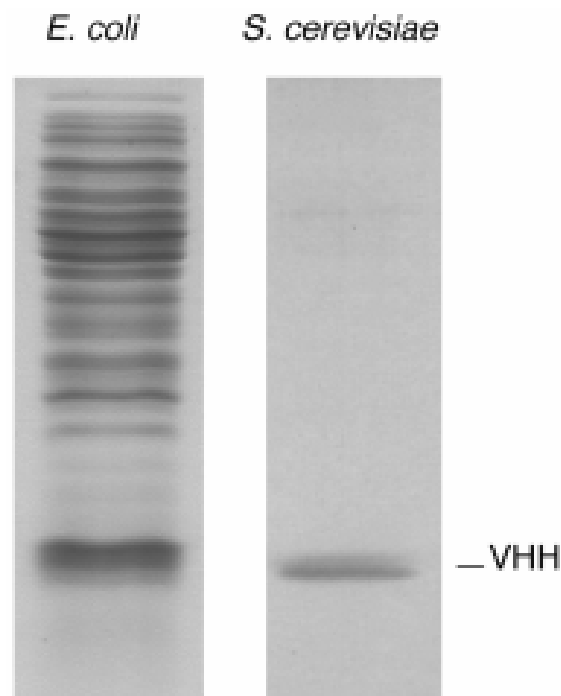

Fig. 1. Comparison of llama Ab fragment (V_{HH}) production in *E. coli* and *S. cerevisiae*. The periplasmic fraction of *E. coli* and growth medium of an *S. cerevisiae* strain expressing an identical llama Ab fragment were separated on a 14% SDS-PAGE gel. After separation, the protein bands were visualized by Coomassie blue staining. The molecular weight of the V_{HH} protein band is approx 13 kDa.

10. TE buffer: 10 mM Tris-HCl, pH 7.5, 1 mM ethylene diamine tetraacetic acid, pH 8.0. Autoclave.
11. Salmon testes carrier DNA (Sigma D1626): 2 mg/mL TE buffer. Mix vigorously on a magnetic stirrer for 2–3 h or until fully dissolved. If convenient, leave the covered solution mixing overnight in a cold room. Aliquot the DNA into 1 mL vol and store at -20°C . Before use, boil for 5 min and chill quickly on ice (*see Note 3*).
12. SD agar (for use if an auxotrophic marker is complemented in the yeast strain): Dissolve 15 g Bacto-agar in 790 mL distilled water and autoclave. Cool to 60°C and add 100 mL 10X stock of yeast nitrogen base without amino acids, 100 mL 10X glucose stock, and 10 mL 100X stock(s) of amino acids as appropriate (*see above*).
13. YEPD agar (for use if a dominant marker has been introduced into the yeast strain): 1.5% (w/v) Bacto-agar, 1% (w/v) yeast extract, and 2% (w/v) peptone. Autoclave. Depending on the dominant selection marker used, antibiotics and carbon sources may need to be added.

14. HEPES–dithiothreitol buffer: 20 mM HEPES, 25 mM dithiothreitol in YEP containing 2% (w/v) glucose. Filter-sterilize through a 0.22- μ m filter. Prepare freshly before use.
15. 1 M Sorbitol. Autoclave.
16. Electroporation cuvetts, 2 mm gap, precooled on ice.
17. 40% Glycerol stock solution. Autoclave. Dilute to 10% in distilled-water for use.
18. Phosphate-buffered saline (PBS).
19. Glass beads, 425–600- μ m diameter, acid-washed.
20. Lysis buffer: 4% (w/v) sodium dodecyl sulfate (SDS), 20% (v/v) glycerol, 0.005% (w/v) bromophenol blue, 0.1 M Tris-HCl, pH 6.8, 280 mM β -mercaptoethanol. Dissolve 2 g SDS, 10 g glycerol, and 0.0025 g bromophenol blue in 25 mL 0.5 M Tris-HCl, pH 6.8. Adjust the volume to 50 mL. Just before use, add 20 μ L β -mercaptoethanol to 1 mL of lysis buffer.
21. 14% SDS-polyacrylamide gel electrophoresis (PAGE) gel and apparatus; Coomassie blue staining solution.

3. Method

3.1. Transformation of Yeast Strains

Yeast strains can be transformed by electroporation (7) or LiAC (8). Electroporation is preferable because it gives higher transformation efficiencies.

3.1.1. Transformation of Yeast by LiAC Method

1. Inoculate a colony of the yeast strain of choice (e.g., SU51) into 5 mL selective SD broth (SD broth supplemented with glucose, leucine, and histidine for SU51), and grow with agitation overnight at 30°C.
2. Inoculate 50 mL YEPD broth with approx 50 μ L (see Note 4) of the overnight culture and grow with agitation overnight at 30°C.
3. Harvest the yeast cells when the culture reaches an optical density 660 nm (OD_{660}) of 1.0–2.0. Centrifuge the culture for 5 min at 4000g.
4. Pour off the growth medium, and discard. Resuspend the cell pellet in 25 mL sterile H₂O and centrifuge as above.
5. Pour off the distilled water and discard. Resuspend the cells in 1.0 mL 100 mM LiAc and transfer the suspension to a 1.5 mL sterile microtube.
6. Centrifuge the suspension at 14,000g (top speed in a microcentrifuge) for 15 s, then remove the LiAc with a micropipet.
7. Resuspend the cell pellet in 100 mM LiAc to a final volume of 300 μ L (approx 2×10^9 cells/mL).
8. Pipet 50 μ L samples of the cells into labeled microtubes. Centrifuge at 14,000g for 15 s and remove the LiAc.
9. Add 240 μ L PEG solution to each cell pellet. Resuspend carefully, but thoroughly (see Note 5).
10. Add 36 μ L 1.0 M LiAc to each suspension and mix thoroughly.
11. Add 25 μ L boiled ssDNA (2.0 mg/mL) to each suspension and mix thoroughly.

12. Add 50 μ L sterile H₂O containing plasmid DNA (0.1–10 μ g) and mix thoroughly.
13. Incubate the microtubes for 30 min at 30°C.
14. Heat-shock the yeast cells by incubating in a water bath at 42°C for 20–25 min (*see Note 6*).
15. Centrifuge the microtubes at 6000–8000g for 15 s and discard the supernatant.
16. Pipet 250 μ L sterile H₂O into each microtube and resuspend the pellet gently.
17. Plate the cell suspension on the appropriate SD or YEPD agar plates (for the SU51 strain transformed with a plasmid containing the *LEU2* marker gene, SD plates, supplemented with GLU and histidine, are used).
18. Incubate the agar plates for 2–4 d at 30°C to recover transformants.

3.1.2. Transformation of Yeast by Electroporation

For the generation of yeast cells with a high transformation efficiency, it is essential to use precooled buffers, and to keep the yeast cells on ice throughout this protocol (except where stated otherwise).

1. Grow the yeast strain as described in **Subheading 3.1.1.**, except inoculate 150 mL YEPD broth.
2. Harvest the culture when it reaches an OD₆₆₀ of 1.0–2.0 by centrifugation at 4000g for 5 min.
3. Discard the growth medium and resuspend the cell pellet in 2.0 mL HEPES/dithiothreitol buffer and transfer the suspension to two sterile microtubes.
4. Incubate both microtubes in a water bath at 30°C for 10 min (*see Note 7*).
5. Centrifuge the suspensions at 14,000g for 15 s and remove the supernatant.
6. Resuspend each cell pellet in 1 mL ice-cold distilled water and incubate on ice for 2–3 min.
7. Centrifuge as in **step 5** and remove the supernatant.
8. Repeat **steps 6** and **7**.
9. Resuspend each cell pellet in 1 mL ice-cold 10% glycerol and incubate on ice for 2–3 min.
10. Centrifuge as in **step 5** and remove the supernatant.
11. Repeat **steps 9** and **10**.
12. Resuspend the cells in ice cold 10% glycerol, according to the following equation:

$$\text{Final volume (mL)} = \text{OD}_{660} \text{ of the initial culture} / 1.46$$

The final volume should be approx 1–1.5 mL/microtube.

13. Keep the cells on ice for at least 1 h before electroporation.
14. Mix 50 μ L aliquots of the competent cells with the appropriate amount of DNA (3–5 μ g of an 8 kb plasmid) (*see Note 8*).
15. Transfer the mixture to a precooled electrocuvet and electroporate at 800 Ω , 25 μ F and at the following voltages: 0.9, 1.0, 1.1, and 1.2 kV. Time constants should be 10–16 ms (*see Note 9*).

16. Quickly add 0.8 mL prewarmed YEPD broth (30°C) to the electroporated cells and incubate at 30°C for 1 h without shaking.
17. Plate the cells on plates and incubate as described in **Subheading 3.1.1.** (*see Note 10*).

3.2. Growth and Induction of Yeast Transformants

1. Pick several yeast transformants, and strike them out on selective SD plates.
2. Pick a single colony and grow overnight with agitation in 3 mL selective SD broth at 30°C.
3. Inoculate a 1 : 100 dilution of the culture in 10 mL YEPD induction medium (*see Note 11*), and grow overnight at 30°C (*see Note 12*). The remaining culture is used to prepare glycerol stocks: mix 0.8 mL culture with 0.8 mL 40% sterile glycerol, and store at –80°C (*see Note 13*).
4. Transfer 1 mL culture to a microtube and centrifuge at 14,000g for 15 s.
5. Place the supernatant in fresh microtube (i.e., medium fraction).
6. Resuspend the cell pellet in 1 mL PBS and centrifuge at 14,000g for 15 s.
7. Discard the supernatant and resuspend the cell pellet in 0.5 mL PBS.
8. Add 1 g glassbeads to the cell suspension.
9. Lyse the yeast cells by vortexing 4× for 30 s. Keep the cell suspension on ice between vortexing.
10. Add 0.5 mL PBS and transfer the supernatant fraction to a fresh microtube.
11. Centrifuge the suspension for 15 min at 14,000g at 4°C.
12. Transfer the supernatant (i.e., soluble cell fraction) into a fresh microtube.
13. Resuspend the pellet in 500 µL PBS (i.e., insoluble cell fraction).
14. Add 15 µL lysis buffer to 15 µL of each fraction (**steps 5, 12, and 13**) and boil for 5 min.
15. Electrophorese the samples on a 14% SDS-PAGE gel to separate the proteins. Visualize the protein bands by Coomassie blue staining or by Western blot analysis with appropriate Abs.
16. The fractions can then be analyzed by enzyme-linked immunosorbant assay or other appropriate assay to analyze the Ab fragment specificity and/or functionality.
17. Samples can be stored at –20°C. Further purification of Ab fragments can be performed by ion exchange chromatography or by Protein A purification (the latter is only applicable if the Ab fragment binds to Protein A).

4. Notes

1. Auxotrophic or dominant markers can be used as selection markers on plasmids. Auxotrophic markers complement a deficiency (e.g., *LEU2*, complementing leucine deficiency, or *HIS4*, complementing histidine deficiency). Dominant markers introduce resistance against a harmful compound (e.g., resistance against geneticin or chloramphenicol). To establish secretion of an Ab fragment expressed in yeast, a signal sequence needs to be included at the N-terminus of

the Ab fragment coding sequence. For secretion of llama V_{HH} , we use either the signal sequence of the *SUC2* gene (encoded in plasmid pUR4548) or the signal sequence of the mating factor α gene.

2. Plasmid pUR4548 can also be used for the expression of scFvs, but the yield is much lower than that of V_{HH} (heavy chain only).
3. It is not necessary or desirable to boil the carrier DNA every time. After boiling, it is best to keep a small aliquot in a freezer box and boil again only after 3–4 freeze-thaws.
4. Yeast strains differ in growth rate. This rate determines the dilution by which yeast strains are inoculated in YEPD before transformation. On average, yeast strains used in laboratories will need between 15 and 20 h after inoculation to reach this OD.
5. The resuspension of yeast cells in PEG should be performed gently, but thoroughly. Cells that are not dissolved properly are not shielded from the detrimental effects of the high concentration of LiAC.
6. The optimum time for heat shock may vary for different yeast strains and may need to be tested to obtain a high efficiency.
7. During this step the yeast cells are producing CO_2 . Make sure that the lids of the microtubes do not snap open because of build-up of pressure during the incubation by securing the lids, e.g., with a weight. Release the pressure before the centrifugation step, by opening the microtubes.
8. The amount of DNA that is added to the yeast cells is dependent on the size of the plasmid that has to be transformed. For smaller plasmids, less DNA will be necessary for an efficient transformation.
9. Depending on the yeast strain used, the optimal voltage for the most efficient transformation efficiency has to be determined. For subsequent transformations, only the most optimal voltage is used (for SU51, this is 1.0 kV).
10. When generation of the transformants is on minimal medium plates, a wash in 1 M sorbitol is recommended (centrifuge the electroporated cells at 14,000g for 15 s, remove the supernatant, add 1 mL 1 M sorbitol, then resuspend the cells carefully). If washing is omitted, a slightly more intensive background of nontransformed cells is visible.
11. The type of induction medium that is used for production of an Ab fragment in yeast is dependent on the promoter that is placed in front of the Ab fragment gene. If a constitutive promoter is used (e.g., *PGK*), no additives are needed for promoter activation (just a carbon source for yeast growth is sufficient). In case of an inducible promoter, a compound must be added to the growth medium for promoter activation. In case of *GAL7*, 2.5% w/v galactose is added (the addition of glucose will repress this promoter).
12. Optionally, the cultures can be grown in induction medium for an additional 24 h. Depending on the yeast strain and the expression system used, this can result in higher protein yields (for SU51 transformed with pUR4548, 24 h induction is sufficient).

13. Transformants can be recovered from glycerol stocks by striking them out on selective SD plates, and growing as described in **Subheading 3.2**. The stability of the yeast transformants is not decreased during storage.

References

1. Horwitz, A. H., Chang, C. P., Better, M., Hellstrom, K. E., and Robinson, R. R. (1988) Secretion of functional antibody and Fab fragment from yeast-cells. *Proc. Natl Acad. Sci. USA* **85**, 8678–8682.
2. Shusta, E. V., Raines, R. T., Pluckthun, A., and Wittrup, K. D. (1998) Increasing the secretory capacity of *Saccharomyces cerevisiae* for production of single-chain antibody fragments. *Nature Biotechnol.* **16**, 773–777.
3. Hamers-Casterman, C., Atarhouch, T., Muyldermans, S., Robinson, G., Hamers, C., Songa, E. B., Bendahman, N., and Hamers, R. (1993) Naturally-occurring antibodies devoid of light-chains. *Nature* **363**, 446–448.
4. Frenken, L. G. J., van der Linden, R. H. J., Hermans, P. W. J. J., Bos, J. W., Ruuls, R. C., de Geus, B., and Verrips, C. T. (2000) Isolation of antigen specific llama VHH antibody fragments and their high level secretion by *Saccharomyces cerevisiae*. *J. Biotech.* **78**, 11–21.
5. Romanos, M. A., Scorer, C. A., and Clare, J. J. (1992) Foreign gene expression in yeast: a review. *Yeast* **8**, 423–488.
6. Van der Vaart, J. M., de Biesebeke, R., Chapman, J. W., Toschka, H. Y., Klis, F. M., and Verrips, C. T. (1997) Comparison of cell wall proteins of *Saccharomyces cerevisiae* as anchors for cell surface expression of heterologous proteins. *Appl. Env. Microb.* **63**, 615–620.
7. Weaver, J. C., Harrison, G. I., Bliss, J. G., Mourant, J. R., and Powell, K. T. (1988) Electroporation: high-frequency of occurrence of a transient high-permeability state in erythrocytes and intact yeast. *FEBS Lett.* **229**, 30–34.
8. Ito, H., Fukuda, Y., Murata, K., and Kimura, A. (1983) Transformation of intact yeast-cells treated with alkali cations. *J. Bacteriol.* **153**, 163–168.

Intrabodies

Targeting scFv Expression to Eukaryotic Intracellular Compartments

Pascale A. Cohen

1. Introduction

Molecular techniques for inhibiting the expression of specific genes represent a highly refined approach to the analysis and manipulation of microbial and cellular pathways. The specific and high affinity binding properties of antibodies (Abs), combined with their ability to be stably expressed in precise intracellular locations inside mammalian cells, have provided a powerful new family of molecules for gene therapy. These intracellular Abs are called “intrabodies.” A key factor contributing to the success of this approach has been the use of single-chain Abs (scFvs) in which the heavy- and light-chain variable domains (V_H and V_L , respectively) are synthesized as a single polypeptide, and are separated by a flexible linker peptide, generally $(GGGS)_3$. The result is a small molecule of approx 28 kDa. Examples of Fab intrabodies have also been reported, but only where an internal ribosomal entry site has been used to allow stoichiometric amounts of heavy- and light-chain fragments to be expressed simultaneously (1,2).

Intrabodies can be directed to cellular compartments such as the cytoplasm, endoplasmic reticulum (ER), nucleus, or mitochondria, by modification with N-terminal or C-terminal extensions that encode classic intracellular-trafficking signals. Once the targeted compartment is reached, intrabodies can modulate cellular physiology and metabolism by a wide variety of mechanisms. They may block or stabilize macromolecular interactions, such as protein–protein or protein–DNA interactions; they may modulate enzyme function by

occluding an active site, sequestering substrate, or fixing the enzyme in an active or inactive conformation; they may divert proteins from their usual cellular compartment, for example, by sequestering transcription factors in the cytosol or by retention in the ER of proteins that are destined for the cell surface or secretion pathways (hormones, cytokines, or surface molecules). Intracellular Ab efficacy has been demonstrated in studies on human immunodeficiency virus 1 (HIV-1) infection (3,4), and on oncogene or tumor suppressor protein functions (5–7), showing their potential value in gene therapy.

Intrabodies intended for localization in the ER are generally fitted with a leader peptide and the ER retention signal, KDEL, at their carboxy-termini. This peptide sequence corresponds to the carboxy-terminus of the BiP protein (8). A KDEL-tagged scFv intrabody has been used to downregulate the α -subunit of the receptor for human interleukin (IL2) and to immunomodulate interleukin receptor-dependent tumor cell growth (9). Moreover, ER-targeted scFv intrabodies have been shown to decrease markedly the cell surface expression of human and rhesus CCR5-dependent HIV-1 and simian immunodeficiency virus envelope glycoprotein, preventing CCR5-dependent HIV-1 infection (4).

Although scFvs are small enough to pass through nuclear pores, the addition of a nuclear localization signal (NLS) increases their transport efficiency. The most common NLS used for nuclear targeting of intrabodies is PPKKKRKY from the large T antigen of SV40. As an example, a PPKKKRKY-scFv has been designed to modulate HIV-1 Tat-mediated LTR transactivation (10). Directing scFv to mitochondria has also been described (11), and can be achieved by ligation of the N-terminal presequence of subunit VIII of human cytochrome *c* oxidase (COX8.21) in frame with the scFv.

Intrabody expression in the cytosol has generally been accomplished by simple removal of the immunoglobulin (Ig) leader sequences. However, folding and stability problems often occur, resulting in low expression levels, limited half-life, and formation of insoluble aggregates (12). This is probably caused by the reducing environment of the cell cytoplasm, which hinders the formation of the intrachain disulfide bond of the V_H and V_L domains, important for the stability of the folded protein. Because many residues in the frameworks contribute to the folding stability of Ab domains (13), different scFvs will have different overall stability. Therefore, those scFvs that are intrinsically more stable will tolerate the loss of the intrachain disulfide bonds and remain folded, but others will not. Different studies (5,10) have pointed out that fusing a κ -chain constant domain (C_κ) at the carboxy-terminus of the scFv cassette (scFv- C_κ) may increase the stability of scFvs expressed in the cytosol possibly by a dimerization event. Recently, different groups have applied methods of

evolutionary engineering to the generation of functional intrabodies. One group (**13**) has used random mutagenesis and screening; others (**14**) have engineered stabilizing mutations predicted from a consensus sequence analysis or used a two-hybrid in vivo system to select functional intracellular Abs (**15**). Unfortunately, the general application of these methods does not appear to be straightforward.

Targeting Ig expression to eukaryotic intracellular compartments comprises the following steps:

1. Cloning the V_H and V_L domains of interest and engineering the corresponding scFv. Insertion into a prokaryotic vector and expression in *Escherichia coli* to investigate the scFv's functionality, in terms of folding and binding to the antigen. Most of the described scFvs arise from well-characterized murine hybridomas.
2. Addition of N- or C-terminal extensions that encode classical intracellular-trafficking signals to target the recombinant Ab to the intended cellular compartment.
3. Insertion of the modified scFv into a eukaryotic expression vector, then transfection of mammalian cells. Investigation by in vitro studies of stability, localization, and binding of the expressed scFv to the antigen of interest.

In this chapter, we focus on the construction of both nuclear- and cytosol-targeted scFvs, on the assumption that construction and prokaryotic expression have already been achieved. We also describe transfection of eukaryotic cells with these constructs and immunofluorescence detection in the intracellular environment.

2. Materials

1. An scFv cloned into an appropriate prokaryotic expression vector. This protocol describes the anti-p53 scFv DO-1 cloned into the pCANTAB5E phagemid (Pharmacia Biotech, Uppsala, Sweden).
2. Ultrapure-grade H_2O (MilliQ or equivalent). Autoclave.
3. Stock solution of 100 mM deoxyribonucleoside triphosphates (dNTPs). Keep at $-20^\circ C$. Make a 2 mM solution by dilution with sterile H_2O .
4. AmpliTaq DNA Polymerase 5 U/ μL (Perkin-Elmer, Gaithersburg, MD). Store at $-20^\circ C$ in a constant-temperature freezer. The enzyme is provided with a 25 mM $MgCl_2$ solution and a 10X PCR buffer II (100 mM Tris-HCl, pH 8.3, 500 mM KCl).
5. Oligonucleotide primers: these can be ordered from any oligonucleotide synthesis company. Store at $-20^\circ C$.
6. Thermocycler (Perkin-Elmer, Gene Amp PCR system).
7. Kit for the isolation of polymerase chain reaction (PCR) products (e.g., Wizard PCR preps system, Promega, Madison, WI). Keep at room temperature.

8. pcDNA3 vector (Invitrogen, Leek, The Netherlands). This plasmid allows eukaryotic expression under the control of a cytomegalovirus promoter.
9. *Eco*RI restriction enzyme (20 U/ μ L) and *Xba*I restriction enzyme (20 U/ μ L) with bovine serum albumin (BSA) 100X and NEBuffer 2 10X (500 mM NaCl, 100 mM Tris-HCl, 100 mM MgCl₂, 10 mM dithiothreitol, pH 7.9) (New England Biolabs, Beverly, MA). Keep at -20°C .
10. DNA Mass Ladder (Gibco-BRL, Gaithersburg, MD).
11. T4 DNA ligase (5 U/ μ L) and 5X DNA ligase reaction buffer (250 mM Tris-HCl (pH 7.6), 50 mM MgCl₂, 5 mM adenosine triphosphate, 5 mM dithiothreitol, 25% polyethylene glycol-8000). Keep at -20°C .
12. DH5 α *E. coli* cells. Can be directly ordered as competent cells (subcloning efficiency DH5 α^{TM} competent cells, Gibco-BRL). Keep at -70°C .
13. Kit for the small-scale (e.g., Wizard Minipreps DNA purification system, Promega) and large-scale preparation of plasmid DNA (e.g., Qiagen Plasmid Maxi Kit, Qiagen, Valencia, CA).
14. Dulbecco's modified eagles' medium (DMEM), supplemented with 10% fetal calf serum (FCS) (Gibco-BRL). Keep at 4°C .
15. Polystyrene tissue culture dish (8.8 cm², Nunclon Dishes) and 24-well tissue culture plate (Nunclon MultiDishes) (Nunc, Roskilde, Denmark).
16. 2 M CaCl₂: Dissolve 10.8 g CaCl₂ 6H₂O in 20 mL H₂O. Sterilize by filtration through a 0.22 μm filter. Store at -20°C .
17. 2X HeBs buffer: 1.6 g NaCl; 0.074 g KCl; 0.027 g Na₂HPO₄, 2H₂O; 0.2 g dextrose; 1 g HEPES (free acid); sterile H₂O qsp 90 mL. Adjust to pH 7.1 with 0.5 N NaOH. Complete to 100 mL with sterile H₂O. Sterilize by filtration through a 0.22 μm filter. Keep at 4°C for 1 mo.
18. Sterile Dulbecco's phosphate-buffered saline (PBS) (with calcium and magnesium) (Gibco/BRL).
19. 50% Acetone–50% methanol. Prepare just before use.
20. Glycerol mounting medium.
21. Mouse anti-ETag monoclonal antibody (MAb) (Pharmacia Biotech) or other Ab appropriate for detection of the scFv under investigation.
22. Fluorescein isothiocyanate (FITC)-conjugated anti-mouse IgG serum.

3. Methods

In this protocol, it is assumed that the scFv of interest is already cloned into a prokaryotic expression vector. As a model, the DO-1 anti-human p53 MAb is described (5). This recombinant Ab was cloned into the pCANTAB5E phagemid, in frame with a short sequence called ETag (Fig. 1A), which facilitates detection with a murine anti-ETag MAb. The pCANTAB5E phagemid permits the bacterial expression of DO-1 scFv, either at the surface of the filamentous M13 phage or as soluble protein in the periplasmic fraction. The DO-1 scFv–pCANTAB5E will be used in PCRs with primers introducing a start codon at the 5' end of the cassette, the appropriate extensions to target the

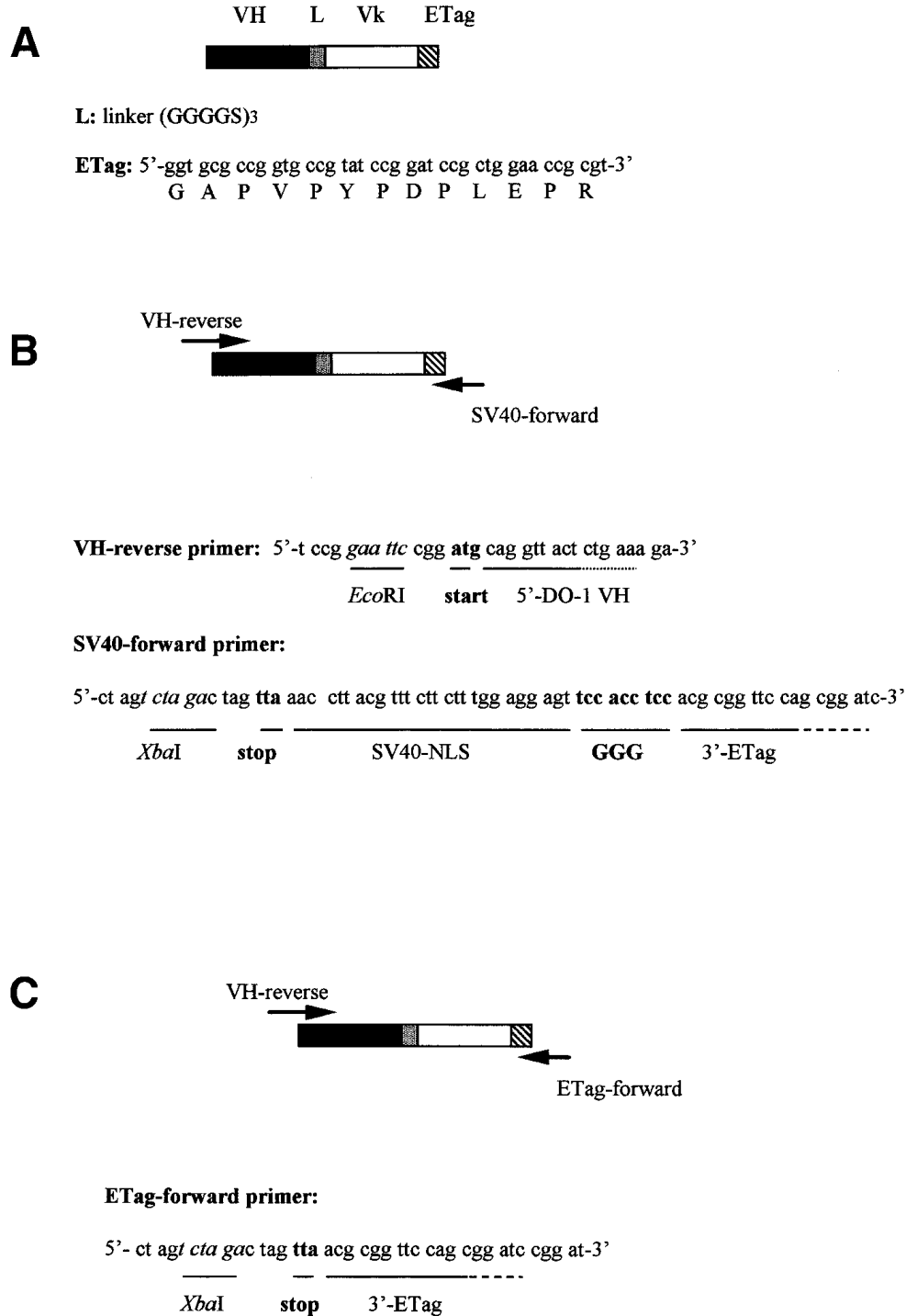

Fig. 1. Different scFv constructs (A) scFv: single-chain variable region fragment comprising the V_H and V_K Ig chains linked together by the (GGGGS)₃ sequence linker (L) and fused in frame with the ETag peptide to allow immunodetection. (B) Nucleus-targeted scFv: same as (A), but with addition of a C-terminal SV40 nuclear localization signal PPKKKRKV for specific expression in nuclear compartment of the cell after cloning into the pcDNA3 vector. (C) Same as (A), but specifically targeted for cytoplasmic expression, after cloning into the pcDNA3 vector.

scFv to the nucleus or cytosol, a stop codon, and unique restriction sites for cloning into the eukaryotic expression pcDNA3 plasmid.

3.1. Engineering of scFv Constructs

3.1.1. Nucleus-Targeted scFvs

1. The V_H-reverse primer encodes an *EcoRI* site and an atg start codon at the 5' end of the V_H domain. The SV40-forward primer contains the *XbaI* restriction site, a stop codon, and the NLS (PPKKKRKV) separated from the 3' end of the ETag sequence by a GGG coding sequence (**Fig. 1B**; *see Notes 1 and 2*).
2. Set up the PCR reaction as follows: x μ L DO-1 scFv-pCANTAB5E (40 ng), 5 μ L 10X PCR buffer II, 3 μ L MgCl₂ (25 mM), 5 μ L deoxyribonucleoside triphosphates (dNTPs) (2 mM), 2.5 μ L V_H-reverse primer (10 mM), 2.5 μ L SV40-forward primer (10 μ M), 0.3 μ L *AmpliTaq* DNA polymerase (5 U/ μ L) and qsp 50 μ L with sterile MilliQ H₂O. A master mix of reagents (H₂O, buffer, dNTPs, enzyme, primers) for all samples can be prepared first, then aliquoted to individual PCR tubes. MgCl₂ and template DNA are then added. A PCR control tube is prepared by replacing the template DNA with H₂O (*see Note 3*).
3. Carry out the reaction under the following conditions: 3 min, 94°C; 30 cycles (1 min, 94°C; 1 min, 60°C; 2 min, 72°C); 10 min, 72°C (*see Note 4*).

3.1.2. Cytosol-Targeted scFvs

In the absence of any signal, the recombinant Ab is directed to the cytosol. Set up a 50 μ L PCR reaction as described above (*see Subheading 3.1.1.*), using the V_H-reverse primer (10 μ M) and the ETag-forward primer (10 μ M) (**Fig. 1C**). The latter introduces a stop codon and the *XbaI* restriction site at the 3' end of the scFv-ETag cassette (*see Note 5*).

3.2. Purification of PCR Products

1. After amplification, mix 7 μ L of each reaction with 5 μ L gel loading buffer, and run with a molecular weight marker on a 1% (w/v) agarose ethidium bromide gel in 1X TBE.
2. Check the size of the amplified single band by exposure to ultraviolet light (~820 bp for the nucleus-targeted scFv DO-1 construct, and 780 bp for the cytosol-targeted scFv DO-1 construct).
3. Purify the amplification products with Wizard PCR preps or equivalent (according to the manufacturer's recommendations) to remove contaminants (DNA polymerase, excess of primers, salts). Elute with 50 μ L sterile MilliQ H₂O and store at -20°C.

3.3. Restriction Enzyme Digestion

1. Digest the purified PCR products and the pcDNA3 vector with *XbaI* and *EcoRI* enzymes in the following reaction (*see Note 6*): x μ L DNA (pcDNA3 or purified scFv construct) (100 ng–1 μ g), 1.5 μ L NEBuffer 2 10X, 0.15 μ L BSA 100X,

- 1 μL *Xba*I (20 U/ μL), and qsp 15 μL with sterile MilliQ H₂O. Incubate overnight at 37°C. Then add 1 μL NEBuffer 2 10X, 0.1 μL BSA 100X, 1 μL *Eco*RI (20 U/ μL), qsp 25 μL with sterile MilliQ H₂O. Incubate for 4 h at 37°C.
- Run the entire mixture of digested PCR products and the plasmid on a 1% low-melting-point agarose gel in 1X TBE. Excise the desired DNA bands using a clean, sterile razor blade or scalpel. Transfer the agarose slices (~300 μL) to a 1.5-mL tube, incubate at 70°C until the agarose is totally melted, then add a commercial preparation of resin intended for DNA isolation, following the manufacturer's recommendations.
 - Wash the resin and elute the DNA with 50 μL of sterile MilliQ H₂O (see **Note 7**).
 - Analyze 2 μL purified products on a 1% agarose gel and quantify by comparison with a DNA mass ladder (see **Note 8**).

3.4. Ligation

Perform a ligation with a plasmid:scFv molar ratio of 1:3 (~25 ng plasmid and 12.5 ng scFv construct). As a control, ligate the *Eco*RI/*Xba*I-digested plasmid only. Prepare the reaction as follows:

	Reaction	Control
Purified <i>Eco</i> RI/ <i>Xba</i> I-digested pcDNA3 (25 ng)	x μL	x μL
Purified <i>Eco</i> RI/ <i>Xba</i> I-digested scFv construct (12.5 ng)	y μL	–
5X DNA Ligase reaction buffer	4 μL	4 μL
T4 DNA Ligase (5 U/ μL)	1 μL	1 μL
Sterile MilliQ H ₂ O	qsp 20 μL	qsp 20 μL

Incubate 16°C overnight.

3.5. Preparation of scFv–pcDNA3 Plasmids for Eukaryotic Expression

- Transform DH5 α *E. coli*-competent cells with the scFv–pcDNA3 DNA construct and the ligation-control DNA. For each sample, thaw 50 μL competent *E. coli* cells on ice, mix with 5 μL of the 20 μL ligation reaction, and follow the transformation protocol provided by the supplier of the competent cells.
- Spread 100 μL transformation mixture on LB agar plates containing 50 $\mu\text{g}/\text{mL}$ ampicillin and incubate overnight at 37°C.
- Pick ampicillin-resistant colonies to 4 mL LB medium containing 50 $\mu\text{g}/\text{mL}$ ampicillin and grow overnight at 37°C with shaking.
- Prepare plasmid DNA (miniprep scale), and analyze by digestion with *Xba*I and *Eco*RI (see **Subheading 3.3**). Analyze on a 1% agarose gel to identify positive clones harboring an insert of the right size (see **Note 9**).
- Grow positive bacterial clones overnight at 37°C with shaking, in 500 mL LB medium supplemented with 50 $\mu\text{g}/\text{mL}$ ampicillin.
- Isolate plasmid DNA (large scale prep) and adjust the concentration to 1 $\mu\text{g}/\text{mL}$ with sterile H₂O (1 OD_{260 nm} = 50 $\mu\text{g}/\text{mL}$). The nucleus-targeted and cytosol-targeted scFv–pcDNA3 constructs are then ready for transfection into eukaryotic cells.

3.6. Transient Transfections for Immunofluorescence Staining of Eukaryotic-Expressed scFv Constructs

3.6.1. Cell Culture

Human breast tumor (p53^{+/+}) MCF7 cells and p53-null human lung carcinoma H1299 cells are maintained in DMEM–10% FCS at 37°C, 5% CO₂. Cells are seeded 24 h before transfection at 70–80% confluence in a 8.8-cm² polystyrene tissue culture dish in 3 mL DMEM–FCS medium.

3.6.2. Calcium Phosphate-Mediated Transfections (see Note 10)

1. Replace cell culture medium with 3 mL fresh DMEM–FCS 4 h before transfection.
2. For each purified plasmid (scFv–pcDNA3 plasmids or pcDNA3 control vector), prepare 3 µL sample, then add 106.8 µL sterile MilliQ H₂O and 15.2 µL 2 M CaCl₂. Mix well.
3. Add this mixture, dropwise, to 125 µL 2X HeBs buffer in a 24-well culture plate. Incubate the precipitates for 10–20 min at room temperature. Add them to the cell culture and gently rock to spread the precipitates over the whole surface. Incubate at 37°C, 5% CO₂.
4. Sixteen hours post-transfection, wash the cells with sterile PBS, then add fresh DMEM–FCS. Incubate the cells for 24 h at 37°C and 5% CO₂.

3.6.3. Immunolocalization of the Nucleus- and Cytosol-Targeted scFvs

1. Thirty-six hours post-transfection, wash the cells gently, once with cold PBS, then fix on the plastic plate with 50% acetone–50% methanol, for 2 min (*see Note 11*). Take care not to disturb the cell monolayer.
2. Wash the cells again briefly with PBS, then incubate with the mouse anti-ETag MAb or alternative detecting Ab (1 µg/mL in DMEM–FCS) for 2 h at room temperature in a humid atmosphere.
3. Wash 3× quickly with PBS, then twice for 5 min with gentle rocking.
4. Incubate the cells with an FITC-conjugated anti-mouse IgG serum (one-fiftieth in DMEM–FCS) for 1 h at room temperature. Wash twice quickly with PBS, then once for 5 min with gentle rocking.
5. Cover the cells with mounting medium and overlay with a coverslip. Examine the labeled cells under a fluorescent microscope (*see Notes 12 and 13*). A diffuse distribution of fluorescence in the right intracellular compartment is typical of soluble scFv proteins (**Fig. 2**).

4. Notes

1. The GGG sequence is introduced in the SV40-forward primer to separate the nuclear localization signal from the rest of the coded protein by a flexible GGG arm, which should prevent interference with scFv folding.

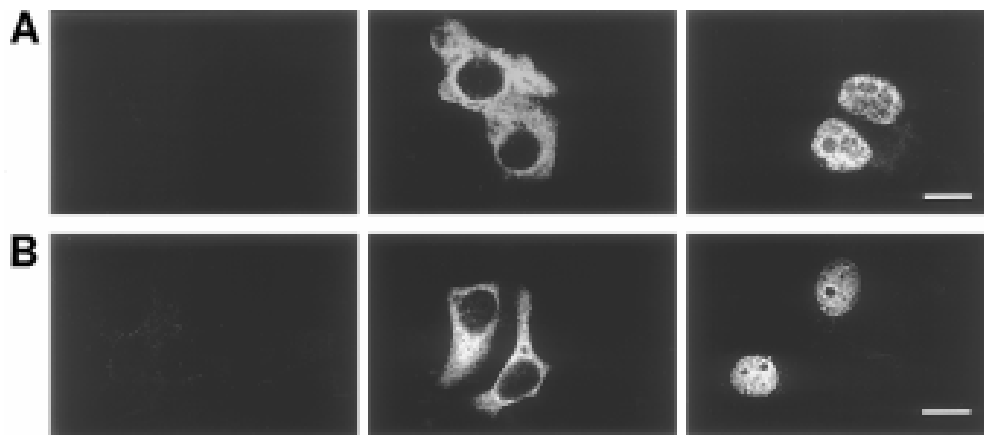

Fig. 2. Expression of DO-1 scFv proteins in eukaryotic cells (5). (A) Immunofluorescent staining with the anti-ETag Ab of transiently transfected H1299 cells ($p53^{-/-}$). (B) Immunofluorescent staining with the anti-ETag MAb of transiently transfected MCF7 cells ($p53^{+/+}$). Left panels: transfection with pcDNA3 vector. Middle panels: transfection with the cytoplasmic-targeted scFv construct. Right panels: transfection with the nucleus-targeted scFv construct. The calibration bar in (A) and (B) indicates 30 μm .

2. The SV40-forward primer is a long primer (71 nucleotides), which must be extensively purified after synthesis.
3. The PCR is performed in a designated area to avoid DNA cross-contamination. The use of specific or disposable glassware and solutions will also minimize contamination. Use of sterile siliconized PCR tubes and pipet tips is preferable.
4. The thermocycler used must perform temperature transitions as fast as possible. By using a machine with a heated lid, the use of mineral oil can be avoided.
5. Some reports indicate that the scFv may be stabilized in the cytosol by linking its 3' end to a C_{κ} domain (3,5). If such a construct is desired, different strategies are possible. For example, by modifying the primers to recover the V_H domain and the full-length murine κ light chain, the scFv- C_{κ} can be constructed by an overlapping PCR reaction, which splices them through the $(GGGGS)_3$ linker sequence. An alternative strategy is to fuse the human C_{κ} domain in frame to the 3' end of the murine scFv cassette by an overlapping PCR. The human C_{κ} domain may be obtained by PCR from a human plasmocytoma cell line producing human IgG1, κ (ARH77 cell line, available from the American Type Culture Collection).
6. If it proves difficult to digest the PCR products directly, they can be cloned into a vector designed to accept *Taq*-derived amplicons (e.g., pGEM-T Easy Vector System, Promega), exploiting the addition of a single deoxyadenosine residues to the 3' ends of the amplified fragments. Aside from facilitating digestion by *Xba*I

and *EcoRI*, the presence of other restriction sites in the vector's polylinker may allow flexibility when cloning into different eukaryotic vectors.

7. DNA fragments longer than 3 kb (e.g., the pcDNA3 vector) require elution at an elevated temperature (65–80°C). For this purpose, preheat the H₂O before elution.
8. If the purified products are not sufficiently concentrated for ligation, precipitate them by adding one-tenth vol 3 M Na acetate, pH 5.2, and 2 vol ice-cold absolute ethanol. Precipitate overnight at –20°C. Centrifuge 15 min at 12,000g. Wash with 70% ethanol. Resuspend in an appropriate volume of sterile H₂O.
9. Before transfection, it is recommended that selected plasmids are sequenced to confirm the constructs.
10. Alternative methods of transfection of eukaryotic cells (electroporation, diethylaminoethyl-dextran, Lipofectin transfection kit [BRL], Lipofectamine) may be used.
11. Alternatively, fix the cells with 4% paraformaldehyde in PBS for 10 min at room temperature. Wash once with PBS and add 1% NP40 in PBS for 10 min at room temperature.
12. If cellular-expressed scFvs, particularly cytosol-expressed intrabodies, are unstable, they can be visualized as granular structures whose number, shape, and size vary. Higher expression levels obtained with optimized promoters do not necessarily increase the yield of soluble Ab.
13. Instead of using the ETag/anti-ETag MAb system, other detection systems have been described such as a rabbit polyclonal anti-scFv serum (**16**) or the mycTag/9E10 anti-mycTag MAb system (**6**).
14. Expression of scFvs in eukaryotic cells can also be achieved with retroviral (**17**) or adenoviral delivery systems (**7**).
15. The addition of an N-terminal leader and a C-terminal KDEL sequence allows scFv expression and trapping in the ER. Constructs of this sort can be engineered by designing appropriate primers. For example, the reverse primer would introduce an *EcoRI* restriction site, a start codon, a hydrophobic leader sequence (e.g., the murine leader sequence, NFGLSFIFLVLILKGVEC); the forward primer would introduce the KDEL signal sequence, a stop codon, and the *XbaI* site at the C-terminus of the scFv–ETag cassette.
16. Directing scFvs to mitochondria could be achieved by fusing the presequence of the subunit VIII of human cytochrome-c oxidase (MSVLTPLLLRGLTGSAR-RLPVPRAK) and the first 10 amino acids of the mature human cytochrome c oxidase (IHSLPPEGKL) to the N-terminus of the V_H sequence. The mitochondrial presequence is removed once the protein is translocated through the mitochondrial membrane.

Acknowledgments

We are grateful to Dr. S. L. Salhi for critical reading of the manuscript.

References

1. Chen, S. Y., Khouri, Y., Bagley, J., and Marasco, W. A. (1994) Combined intra- and extracellular immunization against human immunodeficiency virus type 1 infection with a human anti-gp120 antibody. *Proc. Natl. Acad. Sci. USA* **91**, 5932–5936.
2. Chen, J. D., Yang, Q., Yang, A. G., Marasco, W. A., and Chen, S. Y. (1996) Intra- and extracellular immunization against HIV-1 infection with lymphocytes transduced with an AAV vector expressing a human anti-gp120 antibody. *Hum. Gene Ther.* **7**, 1515–1525.
3. Marasco, W. A., LaVecchio, J., and Winkler, A. (1999) Human anti-HIV-1 tat scFv intrabodies for gene therapy of advanced HIV-1-infections and AIDS. *J. Immunol. Methods* **231**, 223–238.
4. Steinberger, P., Andris-Widhopf, J., Buhler, B., Torbett, B. E., and Barbas, C. F., 3rd (2000) Functional deletion of the CCR5 receptor by intracellular immunization produces cells that are refractory to CCR5-dependent HIV-1 infection and cell fusion. *Proc. Natl. Acad. Sci. USA* **97**, 805–810.
5. Cohen, P. A., Mani, J. C., and Lane, D. P. (1998) Characterization of a new intrabody directed against the N-terminal region of human p53. *Oncogene* **17**, 2445–2456.
6. Cochet, O., Gruel, N., Fridman, W. H., and Teillaud, J. L. (1999) Ras and p53 intracellular targeting with recombinant single-chain Fv (scFv) fragments: a novel approach for cancer therapy? *Cancer Detect. Prev.* **23**, 506–510.
7. Alvarez, R. D., Barnes, M. N., Gomez-Navarro, J., Wang, M., Strong, T. V., Arafat, W., et al. (2000) Cancer gene therapy approach using an anti-erbB-2 single-chain antibody-encoding adenovirus (AD21): a phase I trial. *Clin. Cancer Res.* **6**, 3081–3087.
8. Munro, S. and Pelham, H. R. (1987) A C terminal signal prevents secretion of luminal ER proteins. *Cell* **48**, 899–907.
9. Richardson, J. H., Sodroski, J. G., Waldmann, T. A., and Marasco, W. A. (1995) Phenotypic knock-out of the high-affinity human interleukin 2 receptor by intracellular single-chain antibodies against the alpha subunit of the receptor. *Proc. Natl. Acad. Sci. USA* **92**, 3137–3141.
10. Mhashilkar, M., Bagley, J., Chen, S. Y., Szilvay, A. M., Helland, D. G., and Marasco, W. A. (1995) Inhibition of HIV-1 tat-mediated LTR transactivation and HIV-1 infection by anti-tat single chain intrabodies. *EMBO J.* **14**, 1542–1551.
11. Stuart, R. A., Cyr, D. M., Graig, E., and Neupert, W. (1994) Mitochondrial molecular chaperones: their role in protein translocation. *Trends Biochem. Sci.* **19**, 87–92.
12. Cattaneo, A. and Biocca, S. (1999) The selection of intracellular antibodies. *Trends Biotechnol.* **17**, 115–121.
13. Proba, K., Worn, A., Honegger, A., and Pluckthun, A. (1998) Antibody scFv fragments without disulfide bonds made by molecular evolution. *J. Mol. Biol.* **275**, 245–253.

14. Ohage, E. C., Wirtz, P., Barnikow, J., and Steipe, B. (1999) Intrabody construction and expression II. A synthetic catalytic Fv fragment. *J. Mol. Biol.* **291**, 1129–1134.
15. Visintin, M., Tse, E., Axelson, H., Rabbitts, T. H., and Cattaneo, A. (1999) Selection of antibodies for intracellular function using a two-hybrid in vivo system. *Proc. Natl. Acad. Sci. USA* **96**, 11,723–11,728.
16. Cochet, O., Kenigsberg, M., Delumeau, I., Virone-Oddos, A., Multon, M. C., Fridman, W. H., et al. (1998) Intracellular expression of an antibody fragment-neutralizing p21 ras promotes tumor regression. *Cancer Res.* **58**, 1170–1176.
17. Jannot, C. B., Beerli, R. R., Mason, S., Gullik, W. J., and Hynes, N. E. (1996) Intracellular expression of a single-chain antibody directed to the EGFR leads to growth inhibition of tumor cells. *Oncogene* **13**, 275–282.

Expression of scFvs and scFv Fusion Proteins in Eukaryotic Cells

Michelle de Graaf, Ida H. van der Meulen-Muileman,
Herbert M. Pinedo, and Hidde J. Haisma

1. Introduction

scFvs have considerable therapeutic potential against antigens (Ags) involved in disease processes (1,2), either as proteins synthesized *ex vivo* for passive administration, or introduced by gene therapy for *in vivo* expression. Their small size confers many pharmacological advantages, compared to whole antibodies (Abs). However, they lack intrinsic biological activity because they lack the Fc (effector) portion of native (whole) Abs. Biological activity can be imparted to scFvs by generating bifunctional molecules, in which the scFv that specifically recognizes an Ag on the target cells is genetically fused to an effector molecule. Examples include cytokines (3,4) or prodrug-converting enzymes (1,5,6). Alternatively, the effector molecule can be a second scFv that retargets the molecules toward a cell population, e.g., for activation of cytotoxic T cells (7) or for gene therapy, e.g., targeting recombinant adenoviruses carrying therapeutic genes (8).

Expression of scFv in mammalian cells may be desirable in order to ensure the production of biologically functional protein because of factors such as the presence of native leader sequences that ensure successful secretion of the protein, the presence of appropriate folding factors and the capacity for posttranslational modifications. In addition, the expression of bifunctional scFv in mammalian cells is essential for use in gene therapy studies.

Described here is an expression vector, pLead-mycHis, for the rapid construction and evaluation of bispecific scFvs and scFv–enzyme fusion proteins in eukaryotic cells (Fig. 1). DNA sequences encoding scFvs can be directly



Fig. 1. Schematic representation of the expression cassette of the eukaryotic vector pLead-mycHis. The structural elements include the CMV promoter, immunoglobulin κ leader (secretion) sequence, C-terminal myc and 6His tags, and a MCS. The MCS contains unique *SfiI*, *NotI*, and *ApaI* sites for insertion of scFvs selected by established phage-display technology or other molecules.

recloned into the multiple cloning site (MCS) of this vector, from plasmids commonly used in the establishment of scFv phage libraries. If desired, a second sequence encoding another scFv or a biological effector function can be cloned downstream of the inserted scFv in-frame with the myc and six histidine (His) immunoaffinity tag sequences for easy detection of expression and purification, respectively. In addition to the transient transfection of mammalian cell lines (COS-7) to assess the activity of the expressed fusion proteins, stable cell lines can be obtained by transfection of CHO cells and appropriate selection (zeocin).

We have used this vector to construct bispecific scFvs for the retargeting of recombinant adenovirus to tumor cells. The first construct consists of a neutralizing anti-adenovirus fiber scFv Ab (s11) fused to a second scFv Ab (425) directed against epidermal growth factor receptor (EGFR). The second fusion protein combines the scFv 425 and the enzyme-cytosine deaminase (CD), designed to activate the relatively nontoxic prodrug, 5-fluorocytosine, into the anticancer drug, 5-fluorouracil, at the site of tumors that are EGFR-positive. These constructs were transfected into COS-7 cells, which were subsequently stained with an anti-myc monoclonal Ab to detect expression of the fusion proteins. In addition, culture supernatants of the infected cells were screened by Western blot (**Fig. 2**). We have also performed an enzyme-linked immunosorbant assay (ELISA) assay to assess binding of the bispecific scFv s11-425 construct to the adenovirus fiber knob protein using transfection culture medium (**Fig. 3**) and an enzyme assay to determine the integrity of the CD activity by measuring the percentage of cytosine conversion to uracil (**9**; see **Fig. 4**). These results show that the fusion proteins are successfully secreted in mammalian cells and retain their binding (scFv) and biological (CD) activity when expressed in this vector.

This chapter describes methods for the construction of bifunctional scFv fragments in the pLead-mycHis vector, the transient and stable expression of

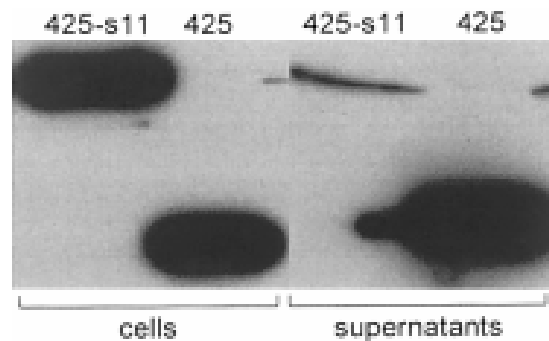

Fig. 2. Western blot analysis comparing secretion of the bispecific scFv 425-s11 to scFv 425 alone. COS-7 cells were transfected with 425-s11 or 425 and cell lysates and supernatants collected after 2 d. Protein bands were detected using an Ab against the C-terminal myc tag. Proteins of the correct molecular weight were detected in both the cell lysates and culture medium (supernatants) of both bands (425-s11, 60 kDa; 425, 30 kDa). Both proteins were secreted, but the scFv 425 was more efficiently secreted (supernatant) than the fusion protein, 425-s11.

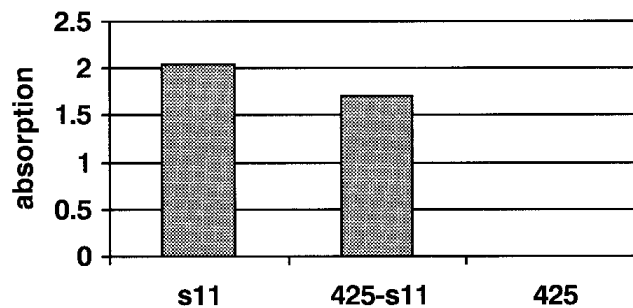

Fig. 3. ELISA analysis of binding of the scFv to the recombinant adenovirus fiber knob protein. Plates were coated with recombinant fiber knob, incubated with culture supernatants of transfected COS-7 cells, and bound fusion protein detected via the myc tag. Absorption was measured at 490 nm. A comparable level of binding was detected using scFv s11 and the bispecific fusion protein, but was not detected by using scFv 425.

the fusion proteins in mammalian cells, and techniques for determining the expression of the fusion proteins.

2. Materials

1. pLead-mycHis plasmid (*see Note 1*).
2. Appropriate restriction enzymes, DNA extraction kits, *Escherichia coli* for propagation of plasmids, growth media, and so on, for the subcloning of scFv and/or effector DNA sequences.

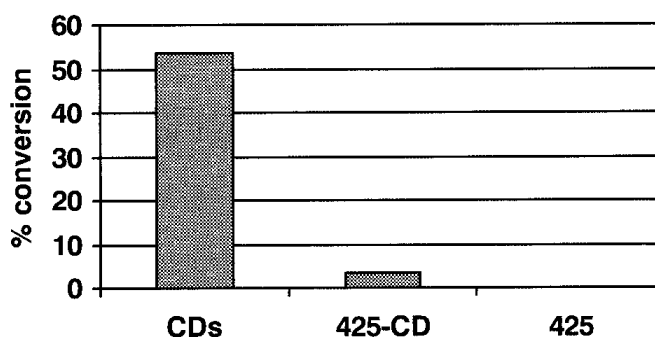

Fig. 4. CD activity in the culture medium (supernatants) of COS-7 cells transfected with scFv. CD activity was detectable in cells transfected with the bispecific fusion protein, 425-CD, but was only approx 10% of the enzymatic activity detected in supernatants of cells transfected with CD alone. Supernatant containing the scFv 425 served as a negative control for enzyme activity.

3. COS-7 cells grown in Dulbecco's modified Eagle's medium (DMEM) supplemented with 5% heat-inactivated fetal calf serum (FCS) and antibiotics; trypsin and solutions for routine passaging of cells.
4. Lipofectamine Plus (Gibco-BRL) or other appropriate mammalian cell transfection reagent.
5. 100 mM Tris-HCl, pH 7.8.
6. Methanol-acetone (1 : 1) fixative.
7. Phosphate-buffered saline (PBS) containing 0.1% (w/v) bovine serum albumin (BSA).
8. Abs: anti-myc 9E10 (**10**) (supernatant from the hybridoma cell line [American Type Culture Collection]), horseradish peroxidase-conjugated rabbit anti-mouse immunoglobulin G (Dako); fluorescein isothiocyanate (FITC)-conjugated rabbit anti-mouse immunoglobulin G (Dako).
9. AEC horseradish peroxidase substrate (Dako).
10. Buffers, apparatus, sodium dodecyl sulfate-polyacrylamide gel electrophoresis (SDS-PAGE) gels (7.5–10%), and nitrocellulose membrane for Western blotting analysis.
11. Tris-buffered saline (TBS) containing 0.1% (v/v) Tween-20 and 5% (w/v) nonfat milk powder.
12. Chemiluminescent detection reagents, e.g., Lumi-Light Plus (Boehringer Mannheim).
13. PBS containing 1% (w/v) formaldehyde.
14. Target cell line expressing Ag on cell surface against which scFv is directed.
15. CHO cells grown in DMEM supplemented with 5% FCS and antibiotics.
16. DMEM containing 5% FCS and 800 $\mu\text{g}/\text{mL}$ zeocin (Invitrogen).
17. 6-, 24-, and 96-Well sterile tissue culture plates; fluorescence-activated cell-sorting (FACS) tubes (Greiner).

3. Methods

3.1. Subcloning of scFv into pLead-mycHis

1. Isolate the scFv DNA from the phage-display expression vector using *Sfi*I and *Not*I, and subclone into the pLead-mycHis vector using standard molecular biology techniques (*see Note 2*).
2. If constructing a bispecific scFv molecule, clone the second scFv or effector protein DNA into the *Not*I site using standard molecular biology techniques (*see Note 1*). If necessary, perform a polymerase chain reaction to replace the *Sfi*I site at the 5' end of the scFv in a phage display expression vector with a *Not*I site.
3. Prepare a large-scale DNA preparation (maxiprep) of the construct, e.g., using Qiagen columns or cesium chloride gradients. Resuspend the DNA in 10 mM Tris-HCl, pH 8.0. Calculate the concentration of the DNA by measuring optical density 260 nm.

3.2. Transient Transfection of COS-7 Cells

Each plasmid construct is transfected into two wells of the plate. One well is used for direct immunodetection of the myc-tagged fusion protein, to rapidly check for in-frame expression. The culture medium and cell lysates are collected from the other well and are used for Western blotting and FACS analysis. Although not described here, other types of assays can also be performed using these samples, e.g., ELISA and specific functional assays, to check secretion levels of the fusion protein.

1. Using standard techniques, detach the COS-7 cells from the culture flask with trypsin, wash, and resuspend in DMEM–5% FCS. Count the cells and aliquot 2×10^4 cells/well (in 1 mL) in a 24-well plate (2 wells/construct). Incubate overnight at 37°C–5% CO₂ in a humidified atmosphere.
2. Check that the cells are approx 60–80% confluent. Wash and transfect the cells according to the transfection reagent manufacturer's instructions (for Lipofectamine Plus, use 0.4 µg DNA/well in 250 µL transfection medium) (*see Note 3*). Transfect each construct in two wells. Incubate for 3 h as above.
3. Aspirate the transfection medium and replace with 250 µL DMEM–5% FCS/well (*see Note 4*) and incubate the cells for 2 d (*see Note 5*).
4. Collect the culture medium and store at –20°C.
5. Well 1: For direct detection of expressed fusion protein in the transfected cells, proceed directly to **Subheading 3.3.1**.
6. Well 2: Wash the wells with 0.5 mL PBS, then trypsinize the cells to remove from the plastic surface and wash in PBS.
7. Resuspend the cells in 25 µL 100 mM Tris-HCl, pH 7.8, and freeze-thaw 5× in an ethanol/dry ice bath.
8. Store at –20°C.

3.3. Detection of Expression of Fusion Protein

3.3.1. Direct myc-Staining of Transiently Transfected Cells

1. Aspirate the culture medium.
2. Fix the cells by adding 250 μ L ice-cold 50% methanol/acetone for 10 min.
3. Discard the fixative and wash the wells 3 \times with PBS as done previously.
4. Add 250 μ L 1 : 10 dilution of the anti-myc hybridoma supernatant in PBS–0.1% BSA (approx 1 μ g/mL) to each well and incubate for 1 h at 37°C.
5. Wash the wells 3 \times with PBS.
6. Add 250 μ L 1 : 100 dilution of horseradish peroxidase-conjugated rabbit anti-mouse Ab in PBS–0.1% BSA to each well and incubate for 1 h at room temperature.
7. Wash the wells 3 \times with PBS.
8. Add three drops of AEC substrate to each well. Cells expressing myc-tagged protein will become red (within 5 min). Wash the cells with PBS to stop the reaction.

3.3.2. Detection of Expression Using Quantitative Western Blotting

1. Separate 1 μ L of the cell lysates and 10 μ L culture medium by reducing SDS-PAGE and transfer the proteins to nitrocellulose membrane using standard techniques (*see Note 6*).
2. Block the membrane in TBS–0.1% Tween–5% milk powder for 1 h at room temperature (with shaking).
3. Discard the block solution and incubate the membrane in a 1 : 10 dilution of anti-myc Ab in TBS–0.1% Tween for 1 h at room temperature or overnight at 4°C (with shaking).
4. Wash the membrane with TBS–0.1% Tween by rinsing briefly 3 \times , followed by one wash for 15 min, then a further two washes for 5 min (with shaking).
5. Incubate the membrane in a 1 : 3000 dilution of horseradish peroxidase-conjugated rabbit anti-mouse Ab in TBS–0.1% Tween for 1 h at room temperature (with shaking).
6. Wash as in **step 4**.
7. Develop the blots using chemiluminescent detection, according to the manufacturer's instructions.

3.3.3. Targeting of Fusion Proteins (FACS Analysis)

To check functionality of the scFv in the fusion protein, FACS analysis can be performed.

1. Wash and detach the target cell line from the culture flask, according to standard protocols. Count the cells and aliquot 5×10^5 cells into FACS tubes.
2. Centrifuge at 250g for 4 min. Add 1 mL PBS and respin, then discard the supernatant.
3. Add 50 μ L transfection culture medium and incubate on ice for 1 h.
4. Wash the cells 3 \times with PBS as in **Subheading 3.3.1., step 7**.

5. Add 50 μL of a 1:10 dilution of anti-myc Ab in PBS–0.1% BSA and incubate on ice for 1 h.
6. Wash 3 \times with PBS.
7. Add 50 μL 1:100 dilution of FITC-conjugated rabbit anti-mouse Ab in PBS–0.1% BSA and incubate on ice for 1 h in the dark.
8. Wash 3 \times with PBS.
9. Resuspend the cells in 500 μL PBS/1% formaldehyde (*see Note 7*).
10. Evaluate binding of the scFv–fusion protein to the target cells using flow cytometry.

3.4. Isolation of Stably Transfected Mammalian Cells

1. Using standard techniques, detach the CHO cells from the culture flask with trypsin, wash, and resuspend in DMEM–5% FCS. Count the cells and aliquot 2.5×10^5 cells/well (in 2 mL) in a 6-well plate. Incubate overnight at 37°C–5% CO₂ in a humidified atmosphere.
2. Check that the cells are approx 60–80% confluent. Wash and transfect the cells using Lipofectamine Plus as follows: use 1 μg DNA/well and 6 μL Plus reagent and 4 μL Lipofectamine in 1 mL transfection medium (*see Subheading 3.2*). Incubate for 3 h, then replace the medium with nonselective medium and incubate for a further 48 h.
3. Trypsinize the cells, wash in PBS, then resuspend in DMEM–5% FCS–800 $\mu\text{g}/\text{mL}$ zeocin. Plate out 300, 30, and 3 cells/well into 96-well plates (in a total volume of 100 μL) and incubate at 37°C–5% CO₂ in a humidified atmosphere. Change the medium every 3–4 d.
4. After 1–2 wk, examine the wells for the growth of clones. Select those clones resulting from the smallest aliquot of transferred cells for analysis, expansion, and purification (*see Notes 8 and 9*). Screen the culture medium for fusion protein secretion using the protocols above.

4. Notes

1. pLead-mycHis was adapted from the eukaryotic expression vector pSec Tag (Invitrogen). Expression of the fusion protein is driven by a cytomegalovirus promoter upstream of an immunoglobulin κ (light) chain leader sequence at the 5' end of the MCS, which directs the expressed protein into the secretory pathway of the cells. The first scFv sequence is inserted using the *SfiI/NotI* restriction sites. A second scFv can be inserted into the *NotI* site, resulting in a bispecific scFv in which the two scFvs are separated by a short alanine linker, encoded by the *NotI* site. If desired, especially for scFv–enzyme constructs, a long, flexible linker sequence (Gly₄Ser)₂ can be inserted into the *NotI* and *ApaI* sites of the MCS, which then is expressed between the two inserted protein-coding sequences and should aid in correct folding of the two protein moieties. This linker sequence can be constructed by annealing the 5'-phosphorylated oligonucleotide primers, shown in **Table 1**. This results in a double-stranded DNA fragment with a 5' *NotI* site and a 3' *ApaI* site. Upon ligation into the vector,

Table 1
Primers for Introduction of (Gly₄Ser)₂ Linker

	Sequence (5'→3')
Forward primer	ggccggaggtggaggctccggaggtggaggctctgcggccgccgggcc
Reverse primer	cggcggccgcagagcctccacctccggagcctccacctcc

the *NotI* site at the 5' end of the linker is lost. A second *NotI* site is encoded at the 3' end of the linker sequence, which allows insertion of the second scFv or the biological effector function downstream of the (Gly₄Ser)₂ linker. This second sequence is then expressed in frame with the myc and His tags (and transcriptional stop codon). The pLead-mycHis plasmid is available for use from this laboratory.

- The unique *SfiI* and *NotI* restriction enzyme sites in the MCS of this vector can be used for direct insertion of scFvs selected from established phage-display systems, such as pHEN (*II*) and pCANTAB5E (Pharmacia Biotech), without the need for intermediate cloning steps. Because of the design of the vector, a single scFv inserted in this way can be expressed in mammalian cells without the addition of a second coding sequence. However, if a bispecific molecule is desired, following propagation of the plasmid encoding the scFv, the *NotI* site can be used to insert a sequence encoding a second scFv or a biological effector function.
- We use liposome-mediated transfection of COS-7 and CHO cells. However, alternative methods of transfection can also be used, e.g., calcium phosphate or DEAE-dextran. A transfection efficiency of about 20% is sufficient for screening.
- When more than 250 μL medium is used, the secreted fusion protein will be diluted, and, therefore, more difficult to detect.
- Screening for transient expression and secretion of fusion proteins is normally performed using cell lysates and culture medium collected 2 d after transfection. This time can be prolonged for up to 5 d to increase the sensitivity of the chosen assay (yield of secreted protein). However, culture medium collected after 3 d may contain fusion protein that has leaked from the transfected cells or has been released by dying cells, rather than genuinely secreted protein. A control transfection with a vector encoding a nonsecreted protein (such as LacZ) should be included as a negative control.
- Using equivalent transfection (culture) volumes of cell lysates and culture medium allows the determination of the percentage of secreted protein compared to intracellular protein. In our experience, secretion levels of scFv fusion proteins are ~20% of the levels obtained when the two proteins of the fusion are expressed separately.
- At this point, the cells may be stored at 4°C before FACS analysis.

8. The fusion proteins can be purified from the culture medium of the stable CHO cell lines by immobilized metal-affinity chromatography using the His tag.
9. To obtain higher concentrations of fusion protein in the culture medium, the stable CHO lines can be cultured using the Integra Celline system (Micronic). This system is based on membrane technology, which makes it possible to grow cells to high densities. The protein concentration in the supernatants can also be increased by centrifugation over molecular weight exclusion membrane filters (e.g., Millipore, Centricon).

References

1. Haisma, H. J., Sernee, M. F., Hooijberg, E., Brakenhoff, R. H., Meulen-Muileman, I. H., Pinedo, H. M., and Boven, E. (1998) Construction and characterization of a fusion protein of single-chain anti-CD20 antibody and human beta-glucuronidase for antibody-directed enzyme prodrug therapy. *Blood* **92**, 184–190.
2. Yokota, R., Milenic, D. E., Whitlow, M., and Schlom, J. (1992) Rapid tumor penetration of a single-chain Fv and comparison with other immunoglobulin forms. *Cancer Res.* **52**, 3402–3408.
3. Savage, P., So, A., Spooner, R. A., and Epenetos, A. A. (1993) A recombinant single chain antibody interleukin-2 fusion protein. *Br. J. Cancer* **67**, 304–310.
4. Whittington, H. A., Ashworth, L. J., and Hawkins, R. E. (1998) Recombinant adenoviral delivery for in vivo expression of scFv antibody fusion proteins. *Gene Ther.* **5**, 770–777.
5. Haisma, H. J., Brakenhoff, R. H., van der Meulen-Muileman, I., Pinedo, H. M., and Boven, E. (1998) Construction and characterization of a fusion protein of single-chain anti-carcinoma antibody 323/A3 and human beta-glucuronidase. *Cancer Immunol. Immunother.* **45**, 266–272.
6. Helfrich, W., Haisma, H. J., Magdolen, V., Luther, T., Bom, V. J., Westra, J., et al. (2000) A rapid and versatile method for harnessing scFv antibody fragments with various biological effector functions. *J. Immunol. Methods* **237**, 131–145.
7. Holliger, P. and Winter, G. (1993) Engineering bispecific antibodies. *Curr. Opin. Biotechnol.* **4**, 446–449.
8. Haisma, H. J., Grill, J., Curiel, D. T., Hoogeland, S., van Beusechem, V. W., Pinedo, H. M., and Gerritsen, W. R. (2000) Targeting of adenoviral vectors through a bispecific single-chain antibody. *Cancer Gene Ther.* **7**, 901–904.
9. Mullen, C. A., Kilstrup, M., and Blaese, R. M. (1992) Transfer of the bacterial gene for cytosine deaminase to mammalian cells confers lethal sensitivity to 5-fluorocytosine: a negative selection system. *Proc. Natl Acad. Sci. USA* **89**, 33–37.
10. Chan, S., Gabra, H., Hill, F., Evan, G., and Sikora, K. (1987) Novel tumour marker related to the c-myc oncogene product. *Mol. Cell Probes* **1**, 73–82.
11. Hoogenboom, H. R., Griffiths, A. D., Johnson, K. S., Chiswell, D. J., Hudson, P. J., and Winter G. (1991) Multi-subunit proteins on the surface of filamentous phage: methodologies for displaying antibody (Fab) heavy and light chains. *Nucleic Acids Res.* **19**, 4133–4137.

Expression of Antibody Fab Fragments and Whole Immunoglobulin in Mammalian Cells

Pietro P. Sanna

1. Introduction

The technologies described in this volume enable the isolation of recombinant antibodies (Abs) from libraries of variable regions (Fvs) or Fabs displayed on the surface of filamentous phage by fusion to a structural protein (1–7). Production of selected Abs in sufficient quantity for further evaluation often requires the transfer of their coding sequences to vectors specifically designed for expression in eukaryotic cells. For Fab and/or immunoglobulin G (IgG) expression, these systems either employ separate plasmids for the heavy-chain (HC) and light-chain (LC) sequences or a single plasmid in which both HC and LC cassettes are expressed.

We have developed a single-vector system, pFab–CMV, which allows the expression of either Fabs or whole IgG in eukaryotic cells (Fig. 1). pFab–CMV has been designed for use with the pComb3 phagemid and its related vectors (1). The restriction sites utilized in pComb3 for insertion of the HC (*Xho*I and *Spe*I) and LC (*Sac*I and *Xba*I) are used in pFab–CMV to allow rapid subcloning and expression in eukaryotic cells, which eliminates the need to modify restriction sites by polymerase chain reaction in order to transfer HC or LC sequences to noncompatible expression vectors. The property also facilitates the rapid removal and replacement of either the LC or HC in chain shuffling or other engineering experiments.

A further feature of pFab–CMV is its modular design, allowing the expression of either Fabs or whole IgG in eukaryotic cells. The complete vector encodes the HC hinge, C_H2 and C_H3 of a human Ig γ 1, and thus expression in pFab–CMV will produce IgG1 Abs. Simple removal of the cassette encoding

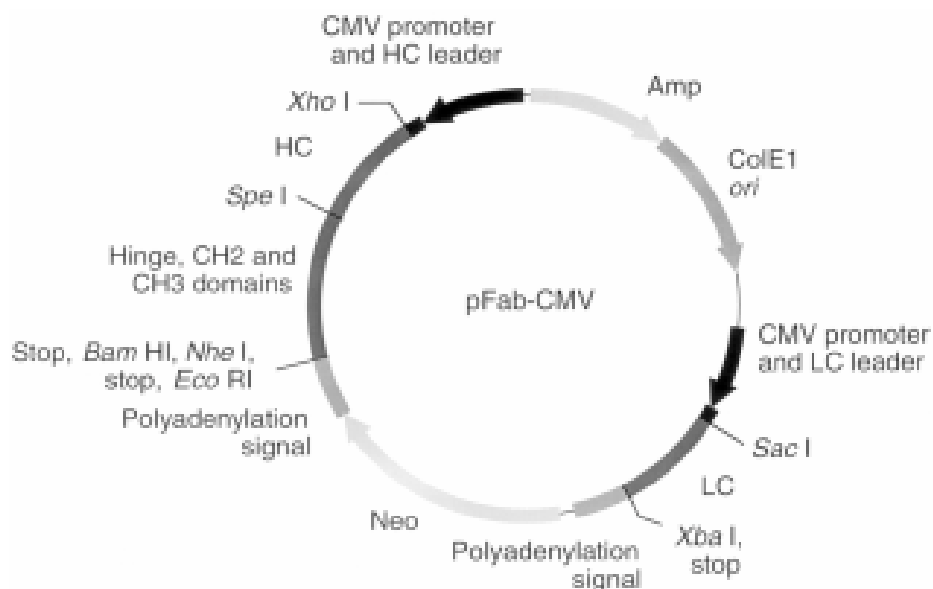

Fig. 1. Map of the expression vector pFab–CMV showing functional regions and unique restriction sites for cloning of HC and LC and excision of Ig γ 1 constant-region sequences.

these HC constant regions by digestion with *NheI* and *SpeI*, brings a second stop codon, located after the *NheI* site into frame with the Fd region, terminating expression and yielding Fab products.

Expression of the HC and LC cassettes is driven by identical CMV IE promoters to ensure high yields of stoichiometrically equal amounts of the two chains. This eliminates the risk of either generating Bence-Jones-like protein from the overexpression of LCs or the toxicity sometimes associated with overexpression of HCs.

The neomycin phosphotransferase gene (*NEO*) is also encoded in pFab–CMV for selection of transfected eukaryotic cells. Unlike two-vector systems, pFab–CMV does not require co-transfection of two separate plasmids. This reduces the risk of plasmid loss over time, and simplifies the selection and maintenance of Ab-expressing cell lines.

Described here are protocols for the subcloning of selected Fab recombinant Abs into pFab–CMV, the transfection and selection of stable CHO cell lines, and the large-scale production of Ab in suspension cultures.

2. Materials

1. pFab–CMV plasmid DNA (*see Note 1*).
2. Plasmid DNA of a selected Fab clone in pComb3 vector or one of its derivatives.

3. Restriction and modifying enzymes and buffers: *XhoI*, *SacI*, *SpeI*, *XbaI*, *NheI*; T4 DNA ligase.
4. Competent *Escherichia coli* cells.
5. Bacterial media and supplements for selection: Luria-Bertani (LB) liquid and solid media; sterile ampicillin stock solution (25 mg/mL in H₂O); LB-agar plates containing 100 µg/mL ampicillin (LBA).
6. Purification kits for small- and large-scale extraction of plasmid DNA (e.g., Qiagen).
7. CHO cells, maintained in Dulbecco's modified Eagle's medium containing 5% fetal calf serum (DMEM-FCS), at -37°C-5% CO₂, in a humidified atmosphere (see **Note 2**).
8. Phosphate-buffered saline.
9. 1X Trypsin-ethylenediamine tetraacetic acid solution (Life Technologies).
10. Lipofectamine 2000 (Life Technologies) or an alternative lipid-based transfection reagent.
11. Serum-free medium (SFM), e.g., Opti-MEM (Life Technologies) or serum-free DMEM. These solutions should be free of antibiotics.
12. Tissue culture flasks; 6-well tissue culture dishes.
13. G418 (Life Technologies): stock solution 250 mg/mL in sterile pyrogen-free H₂O. Store at -20°C.

3. Methods

Eukaryotic expression vectors, compatible with any of the common phage-display systems, could be constructed using the principles outlined for design of pFab-CMV (see **Subheading 1.**). The protocol that follows assumes that an Ig clone of interest has been isolated from a library constructed in pComb3 or one of its derivatives.

3.1. Subcloning of Recombinant Fab Fragments in pFab-CMV

1. Using standard molecular biology techniques, digest the selected Fab clone and pFab-CMV with *XhoI* and *SpeI*. Isolate the large pFab-CMV fragment (7.4 kb) and the HC (660 bp) to be cloned on an agarose gel and extract using standard procedures. Ligate the HC fragment into the pFab-CMV vector and transform into *E. coli*, selecting on LBA plates overnight at 37°C.
2. Pick a single colony and inoculate into 10 mL LB containing 100 µg/mL ampicillin, and grow overnight at 37°C with shaking. Using standard small-scale procedures, isolate the plasmid DNA and check by restriction analysis that the HC has been correctly inserted.
3. Digest the pFab-CMV construct, carrying the HC and the selected Fab clone, with *XbaI* and *SacI*. Isolate the pFab-CMV vector (7.4 kb) and the LC fragment (660 bp) to be cloned; ligate and transform into *E. coli*, selecting on LBA plates overnight at 37°C.

4. Repeat **step 2**, digesting the DNA to check for correct insertion of the LC fragment.
5. If Fab expression is desired (*see Note 3*), remove the HC constant regions by digestion with *SpeI* and *NheI* (*see Note 4*). Gel-purify the vector fragment, and ligate the compatible termini. Transform, select and check that the fragment has been removed by restriction digestion as above.
6. Perform a large-scale (maxiprep) DNA extraction of the selected clone(s).

3.2. Transfection of pFab–CMV into CHO Cells

1. Prepare CHO cells, and, using standard techniques, detach them from the culture flask with trypsin. Wash the cells and resuspend in culture medium. Count the cells, then dispense 7×10^5 /well in 1.5 mL DMEM–FCS (no antibiotics) into each of 6-well (35-mm) tissue culture plates. Incubate overnight at 37°C–5% CO₂.
2. Check that the cells are approx 90–95% confluent in each well (*see Note 5*).
3. For each well, dilute 2–2.5 µg DNA of each construct (*see Note 6*) into 150 µL SFM. This can be prepared in bulk for multiple wells.
4. For each well, dilute 6–8 µL Lipofectamine 2000 in 150 µL SFM. Include wild-type pFab–CMV as a negative control. Incubate for 5–30 min at room temperature (*see Note 7*). This can be prepared in bulk for multiple wells.
5. Combine the diluted DNA and Lipofectamine and incubate for 20 min at room temperature to allow complexes to form.
6. Add 300 µL DNA–Lipofectamine complex to each well, rocking the plate gently to cover the cells, and incubate for 4–6 h at 37°C–5% CO₂.
7. Aspirate the transfection medium and replace with 1–2 mL DMEM–FCS/well (*see Note 8*) and incubate the cells for 24–48 h (*see Note 9*).
8. Collect the medium and analyze the production of specific Ab by enzyme-linked immunosorbant assay using plates coated with the Ag of interest. Successful transfection can be confirmed by polymerase chain reaction with cell lysates or Western blotting using anti-human conjugates to detect the presence of secreted Ab (*10*).

3.3. Selection of Stable Cell Lines Expressing Recombinant Ab

1. Follow **Subheading 3.2.** up to and including **step 6**. Incubate the transfected cells for 24 h at 37°C–5% CO₂, retaining the transfection medium.
2. Trypsinize the cells, wash, and seed the transfected cells, at a 1:10 dilution, into new 6-well plates in 1–2 mL DMEM–FCS. Incubate for 24 h at 37°C–5% CO₂.
3. Replace the medium with 1–2 mL fresh DMEM–FCS containing 500 µg/mL G418 and continue to incubate until the cells reach 80–90% confluence, replacing the selective medium every 2 d.
4. Expand the transfected cell line into tissue culture flasks, maintaining the G418 selection. Keep the passage density low (1:10–1:20).

5. Use the culture supernatant as a source of Ab. If desired, the Ab can be produced in larger-scale cultures (*see* **Note 10**) and/or purified (*see* **Note 11**).

4. Notes

1. pFab–CMV is available from this laboratory by request.
2. Other eukaryotic cell lines are also suitable for expression, e.g., COS cells. The transfection conditions may need to be adjusted to suit other cell lines (*see* www.lifetech.com [Life Technologies] for suggestions for suitable transfection reagents).
3. Fabs are better-suited to certain applications than whole IgGs, e.g., they have better penetration into samples or tissue *in vivo*, and they are preferable for the surface-labeling of cells expressing Fc receptors.
4. Alternative expression cassettes can be inserted in-frame into the *NheI/SpeI* sites, following removal of the HC constant-region cassette to create fusion proteins, e.g., Ab Fd regions, or a 6His-coding sequence to allow for purification of the expressed Fabs using immobilized metal-affinity chromatography (IMAC). The author et al. (**9**) have generated a cassette that allows for the conversion of Fabs into Protein A fusion proteins. Such chimeric constructs bind to IgG Fcs, allowing for their rapid purification on IgG columns, and other applications, such as the testing of Fabs as bispecific Abs (**9**).
5. Transfection efficiency with different liposome-based transfection reagents is effected to a variable degree by culture confluence. Some reagents may be more effective when cultures are at low density (20–40% confluence). With Lipofectamine 2000 (Life Technologies), efficiency is highest when the CHO cells are at a high density (90–95%).
6. Transient or stable transfection of different cell lines can be used for Fab or IgG expression. We typically establish stable Ab-secreting CHO cell lines. For stable transfection, pFab–CMV is linearized by digesting with *ScaI* at a unique restriction site in the AMP open reading frame. Linearization with this enzyme reduces the likelihood of integration via those cassettes necessary for Ab expression and selection (HC, LC, and *NEO*). Although we often produce Abs in suspension cultures (*see* below), we use adherent cells because high transfection efficiencies can be achieved and because it is less laborious to work with these cells. If large-scale Ab production in suspension cells is then carried out, cells are adapted to suspension culture conditions after successful transfection (*see* **Note 10**).
7. The Lipofectamine reagent can be incubated for up to 30 min at room temperature, following dilution, before being combined with the DNA. Longer incubation times may result in decreased activity. If serum-free DMEM is used as a diluent for the Lipofectamine reagent, mix with the diluted DNA within 5 min.
8. It is not necessary to remove the transfection medium at this step: the cells can be incubated for up to 24 h in the DNA–Lipofectamine complex after which expression of the transgene (Ab) can be detected. However, if desired, it can be

replaced with fresh culture medium. It is best to keep the volume of medium low in order not to dilute the amount of secreted fusion protein, which can lead to difficulties in detection.

9. Screening for transient expression and secretion of fusion proteins is normally performed using cell lysates and culture medium collected 2 d after transfection. This time can be prolonged for up to 5 d to increase the sensitivity of the chosen assay as yields of secreted protein build-up. Note that culture medium collected after 3 d may contain fusion protein that has leaked from the transfected cells or has been released by dying cells, rather than genuinely secreted protein.
10. Large-scale production of recombinant Fabs or IgG can be carried out in suspension cultures. Following selection, CHO cells or other cell lines can be adapted to suspension culture for higher-density growth and better Ab production yields. Cells are typically seeded at a density of $1\text{--}5 \times 10^5/\text{mL}$ and maintained $\sim 10^6/\text{mL}$. Growth to $10^6/\text{mL}$ typically takes about 7 d, after which cell density can be maintained by replacement of the medium. In order to expand cultures, cells that have adapted to growth in suspension can be seeded to fresh culture vessels at $1\text{--}5 \times 10^5/\text{mL}$, grown on, and maintained. We use CHO suspension medium (Life Technologies or Irvine Scientific) with G418 selection. Suspension culture vessels (1–3-L capacity) are used with a magnetic stirrer designed for use in tissue culture incubators and set at 90 rpm. The adaptation of cells to suspension culturing conditions may be difficult in some cases: the cells may fail to grow. To facilitate adaptation, cells can be initially subcultured in a 50:50 ratio of their original serum-containing medium and the serum-free cell suspension medium, before seeding in 100% SFM.
11. Purification of the recombinant Fabs or IgG is carried by affinity purification, using standard procedures (**10**), e.g., using immobilized anti-Fab or anti-IgG Abs, or, alternatively, using Protein A or G columns if the Abs are expressed in SFM. If Fab is carried out by IMAC using an incorporated His6 tag (*see Note 4*), the tissue culture supernatants must be dialyzed before purification.

References

1. Barbas, C. F., Kang, A. S., Lerner, R. A., and Benkovic, S. J. (1991) Assembly of combinatorial antibody libraries on phage surfaces: the gene III site. *Proc. Natl. Acad. Sci. USA* **88**, 7978–7982.
2. Burioni, R., Williamson, R. A., Sanna, P. P., Bloom, F. E., and Burton, D. R. (1994) Recombinant human Fab to glycoprotein D neutralizes infectivity and prevents cell-to-cell transmission of herpes simplex viruses 1 and 2 in vitro. *Proc. Natl. Acad. Sci. USA* **91**, 355–359.
3. Chanock, R. M., Crowe, J. J., Murphy, B. R., and Burton, D. R. (1993) Human monoclonal antibody Fab fragments cloned from combinatorial libraries: potential usefulness in prevention and/or treatment of major human viral diseases. *Infect. Agents Dis.* **2**, 118–131.
4. Lerner, R. A., Kang, A. S., Bain, J. D., Burton, D. R., and Barbas, C. F. (1992) Antibodies without immunization. *Science* **258**, 1313–1314.

5. Sanna, P. P., Williamson, R. A., De Logu, A., Bloom, R. E., and Burton, D. R. (1995) Directed selection of recombinant human monoclonal antibodies to herpes simplex glycoproteins from phage display libraries. *Proc. Natl. Acad. Sci. USA* **92**, 6439–6443.
6. Williamson, R. A., Burioni, R., Sanna, P. P., Partridge, L. J., Barbas, C. F., and Burton, D. R. (1993) Human monoclonal antibodies against a plethora of viral pathogens from single combinatorial libraries. *Proc. Natl. Acad. Sci. USA* **90**, 4141–4145.
7. Winter, G., Griffiths, A. D., Hawkins, R. E., and Hoogenboom, H. R. (1994) Making antibodies by phage display technology. *Ann. Rev. Immunol.* **12**, 433–455.
8. Sanna, P. P., Samson, M. E., Moon, J. S., Rozenshteyn, R., De Logu, A., Williamson, R. A., and Burton, D. R. (1999) pFab-CMV, a single vector system for the rapid conversion of recombinant Fabs into whole IgG1 antibodies. *Immunotechnology* **4**, 185–188.
9. Sanna, P. P., De Logu, A., Williamson, R. A., Samson, M. E., Altieri, D. C., Bloom, R. E., and Burton, D. R. (1995) Rapid assay of phage-derived recombinant human fabs as bispecific antibodies. *Biotechnology* **13**, 1221–1224.
10. Harlow, E. and Lane, D. (1988) *Antibodies: a Laboratory Manual*. Cold Spring Harbor Press, Cold Spring Harbor, NY.

Index

A

Adenovirus, 380
Affinity determination, 247, 249, 353, 355
Alternative display molecules, 24
Ammonium sulphate precipitation, 326
Anti-idiotypic antibodies, 173

B

Bacteriophage, *see* Helper phage or Phage
Bacterial culture, *see* Media
Biotinylation,
 biotinylation in vivo, 155
 chemical methods, 150
Biacore, 247, 249, 353, 355
birA, 155
Blocking proteins, 224
Buffers,
 PBS, 323
 TAE, 322
 TE, 61, 75, 344, 361
Burkitt's lymphoma, 319

C

CA-Hb3, 113
Capping of cell surface antigens, 224
Carcinoembryonic antigen, 6, 17, 18
CC-CKR5, 18
CCR5, 368
CD3, 319
CD19, 319
CD28, 319
CD36, 15
CD40, 121
CD55, 17
cDNA,
 storage, 55

 synthesis, 47, 65, 75, 83, 90, 97, 117,
 126, 211

c-erbB-2, 39

Chromatography,
 immobilized metal affinity (IMAC),
 326, 328, 334, 337–339, 346,
 353, 354, 356
 ion exchange, 326, 328, 337
 size exclusion, 327, 338, 339, 346

Colorectal cancer, 227

Complement factors, 182

Competent cells, *see* Electrocompetent
 cells

Cortisol, 259

Cytosine deaminase, 380

D

11-deoxycortisol, 259

Decontamination from phage, 141, 168,
231, 301

Denaturation of antigens, 147

DNA,

 isolation of fragments, 50

 isolation of plasmid DNA, 70

 isolation of single-stranded DNA, 274

 ligation, *see* Ligation

 quantitation, 50, 56, 66, 75

E

EGF, 22

Electroporation,

 methods, 52, 66, 94, 293, 309, 314,
 352, 363, 365

 preparation of cells, 51, 99, 293, 309,
 352, 354, 363

ELISA,

 antigen capture, 115, 195, 198

- antigen in serum, 115
- antigen-specific antibody, 114, 125, 140, 165
- biotinylated antigen, 153
- common epitopes, 184
- inhibition ELISA, 153, 166, 167
- monoclonal phage ELISA, 166, 213
- overview, 18
- phage ELISA, 141, 165, 166
- streptavidin capture of antigen, 153
- total immunoglobulin, 125
- Endoplasmic reticulum retention, 376
- Epidermal growth factor receptor, 380
- Epithelial glycoprotein 2, 16, 208
- Expression,
 - bacterial strains, 347
 - diabodies, 325, 328
 - inclusion bodies, 333, 334, 354
 - Fab,
 - expression in bacteria, 140, 183, 345
 - expression in eukaryotic cells, 392
 - osmotic stress, 334
 - overview, 3, 18, 21
 - rank order of yields, 350, 355, 359
 - scFv,
 - expression in bacteria, 128, 336
 - expression in eukaryotic cells, 383
 - Pichia pastoris*, 352, 355
 - Saccharomyces cerevisiae*, 364, 365
 - toxicity, 4
- F**
- FACS analysis of polyclonal phage, 214
- Filter-lift assay, 190
- Folate receptor, 208
- G**
- gp120, 180
- H**
- Helper phage,
 - biology, 4
 - function, 4
 - KM13, 162, 168
 - preparation, 53, 96, 137
 - protease sensitivity, 162, 168
 - quantitation, 54, 57
 - R408, 271, 283
 - R408d3, 247, 251
 - storage, 136
- Hepatocyte growth factor, 256
- Herpes simplex, 173, 197
- HIV-1, 180, 368
- Hotspots, 273
- Hybridomas and potential artefacts, 216
- I**
- Inclusion bodies, 333, 354
- Integral membrane proteins, 15, 192, 219, 224
- Interleukin-2, 368
- Interleukin-6, 182
- Internalization, 23
- Isoelectric point determination, 328, 339
- K**
- Kunkel mutagenesis, 274
- L**
- Lewis Y antigen, 190
- Libraries,
 - definition of types
 - immune, 5
 - nonimmune, 7
 - secondary, 10
 - single-pot, 7
 - synthetic, 8
 - storage, 53, 54, 69, 71, 94, 97, 108, 136, 142, 165, 176, 229, 301, 309
- Ligation, 51, 56, 66, 70, 94, 291, 309, 314, 324, 373
- Linker sequences, 317, 320
- Lung carcinoma, 228
- Lymphocytes,
 - markers,
 - general, 228
 - specific, *see* individual CD markers
 - naïve, 88

- isolation,
 - antigen-specific lymphocytes, 124
 - peripheral blood lymphocytes, 115, 124
 - plasma cells, 88
 - separation from monocytes, 124
- M**
- Macrophage inhibitory protein 1- α , 205
 - Media,
 - 2TY, 43, 89, 123, 135, 238, 305, 335
 - 2YT, 332, 335, *see also* 2TY
 - 2XYT, *see* 2TY
 - 2XYT, *see* 2TY
 - B agar, 108
 - LB, 43, 135, 305
 - Luria agar or broth, *see* LB
 - SOC, 43, 305
 - Top agar, 135
 - TY (or YT), 297
 - TYE, 123
 - Melanocortin receptor, 22
 - Melanoma-associated antigens, 228
 - Membrane proteins, 15, 192, 219, 224
 - Milk proteins, 224
 - Mitochondrial import, 376
 - Morphosys, 9
 - Muscle-specific tyrosine kinase, 22
 - Mutagenesis, *see* Kunkel mutagenesis, PCR, and Primers
- N**
- Nuclear localization signal, 371
- O**
- Oligonucleotides, *see* Primers
 - Osmotic stress, 334
 - Overviews,
 - libraries,
 - immune, 5
 - nonimmune, 7
 - secondary, 10
 - single-pot, 7
 - synthetic, 8
 - phage display, 2, 3
 - ribosome display, 11
- P**
- p53, 39, 368
 - Pathfinder technology, 17
 - PCR,
 - contamination, 55, 375
 - controls, 70, 97
 - degenerate primers, 261
 - error-prone, 264, 290
 - general method, 306, 313, 324, 372
 - heavy chain recovery, 215
 - hot start polymerase, 83
 - hybridoma recovery, 211, 216
 - overlap PCR, 68, 261, 306, 311, primers, *see* Primers
 - product digestion, 313, 372, 373, 375
 - product isolation, 50, 66, 67, 90, 97, 98, 372
 - pull-through PCR, 68
 - repertoire recovery, 48, 65, 75, 90, 126
 - single colony, 54, 70
 - site-directed mutagenesis, 261
 - strand overlap extension (SOE), *see* overlap PCR
 - touchdown, 49, 117
 - variable stringency, 104
 - Phage,
 - biology, 3
 - decontamination, 141, 168, 231, 301
 - preparation of display libraries, 54, 69, 96
 - purification, 69
 - removal, *see* Phage decontamination
 - storage, 54, 69, 71, 76, 97, 108, 165, 176, 230, 251, 301
 - titration, 54, 57, 69, 97, 276
 - Plasmid compatibility, 281
 - Plasmid DNA,
 - isolation, 70
 - Primers,
 - applications and modifications, extension reaction, 277, 278

- primer directed mutagenesis, 276
 - phosphorylation, 277
- β actin, 117
- chain shuffling, 312
- diabody assembly, 321
- Fab construction,
 - cattle, 80
 - camel, 80
 - chimpanzee, 82
 - human, 44, 45, 91–93
 - macaque, 81
 - mouse, 42, 43
 - rabbit, 76, 77
- genIII* primer, 46
- nuclear localization signal, 371
- ompA* primer, 45
- pelB* primers, 45, 46
- scFv construction,
 - chicken, 78
 - human, 62–64, 127
 - linker length, 317, 320
 - rabbit, 76, 77
 - sheep, 79
- Prion protein, 181
- Profusion technology, 11
- Progesterone, 261
- Protein storage, 327, 328
- ProxyMol technology, 17, 201, 203
- R**
- Restriction digests,
 - analysis, 54, 55
 - conditions, 48, 49, 66, 67, 93, 94, 110, 313, 372, 373, 375
- Reporter enzyme deposition, 201
- Respiratory syncytial virus, 181
- Restriction fragments,
 - isolation, 50
- Reverse transcription, *see* cDNA synthesis
- Rhesus alloantibodies, 225, 226
- Ribosome display, 11
- RNA,
 - analysis, 47
 - isolation, 46, 89, 97, 126
- precautions, 55
- quality, 47, 55, 97
- quantitation, 90
- removal of DNA, 47
- storage, 55, 97
- Rotavirus, 197
- S**
- Scaffolds, *see* Alternative display molecules
- Scatter factor, 256
- Screening,
 - bacteria,
 - antibody capture, 190
 - dimerisation-dependent activity, 257
 - dot blots, 279
 - ELISA, *see* ELISA
 - false-positives, 283
 - overviews,
 - affinity, 19
 - bioactivity, 21
 - ELISA, 18
 - kinetics, 19
 - sandwich, 118
- Selection,
 - phage,
 - antibody capture, 197, 198
 - antibody guiding, 208, 210
 - Biacore, 247, 249
 - biotinylated antigen, 152
 - blocking reagents, 224
 - cell surface antigens, 229, 239
 - competitive deselection, 174
 - competitive elution,
 - using antigen, 164, 182
 - using antibody, 182
 - counter-selection,
 - antigen, 264
 - carriers, 162, 168
 - cell surfaces, 222, 230
 - direct selection, 139, 263
 - epitope masking, 183
 - hapten targets, 163
 - limitations, 9

- magnetic separation, 221, 300
- overviews and objectives,
 - affinity, 14
 - antigen discovery, 17
 - cell surfaces, 14
 - folding, 18
 - function, 23
 - in vivo, 13,16
 - internalization, 23
 - novel antigens, 17
 - stability, 18
- ProxiMol methods, 203
- solution methods, 152
- specific amplification of phage,
 - 247–249
- step-back selection, 205
- temperature considerations, 204,
 - 224, 231
- tissue fragments, 239
- transfected cell lines,
 - eukaryotic cells, 385, 392, 393
 - Sp2/0 cells, 110
- Shuffling,
 - antibody chains, 303, 310
 - CDR, 305, 310
 - DNA, 305, 311
- Site-directed mutagenesis, *see* PCR and Primers
- Somatostatin receptor, 15, 22
- Superinfection, 53, 69
- Systemic lupus erythematosus, 121
- T**
- Thymic crosstalk, 235
- Tissue, sources for repertoire recovery,
 - 69, 70, 88
- TGF- β_1 , 18
- Total body perfusion fixation, 236, 240
- Touchdown PCR, 49
- Toxicity of expressed product, 4
- Transfection,
 - eukaryotic cells, 374, 383, 392
 - Sp2/0 cells, 110
- Transformation,
 - E. coli*, 52, 66, 94, 293, 309
 - Pichia*, 352
 - yeast, 362, 363, 365
- U**
- U1A, 121
- V**
- Vectors,
 - 577 pMDV-IgG2b, 109
 - 578 p/PEHP/+, 109
 - 622 stuff2-phh3, 107
 - C134 phh3-stuffer, 107
 - fdDOG, 208, 216
 - MCO, 134
 - MCO3, 39, 42
 - pACYC177, 282
 - pAALFab, 260
 - pCANTAB, 170, 311
 - pCANTAB3 his_6 , 60, 61
 - pCANTAB5E, 271, 369, 370, 386
 - pCANTAB6, 60, 61
 - pCES1, 5, 95
 - pcDNA3, 370
 - pComb3, 107, 134, 344, 389
 - pComBov, 83
 - pCombx, 343, 346
 - pFab60, 311
 - pFab-CMV, 389
 - pFabIT, 311
 - pGAPZ, 351
 - pHEN, 170, 210, 216, 311, 386
 - pHENIX, 127
 - pHOG21, 327
 - pIMS147, 170
 - pLead-mycHis, 379
 - pPIC, 351
 - pSecTag, 385
 - pSKK, 327
 - pUC19SNMyc, 210, 211
 - pUC113-CES1, 99
 - pUC119His $_6$ MycXba, 257
 - pUR4548, 360

Antibody Phage Display

Methods and Protocols

Edited by

Philippa M. O'Brien and Robert Aitken*University of Glasgow, Glasgow, Scotland, UK*

Antibody phage display, the definitive technology for monoclonal production, has now advanced to a stage where it can be performed in nonspecialized research laboratories. In *Antibody Phage Display: Methods and Protocols*, Philippa M. O'Brien and Robert Aitken combine in one volume a comprehensive collection of established antibody phage display protocols, each accompanied by authoritative guidance that will enable the nonspecialist to carry them out successfully. Coverage spans the construction of antibody libraries, the selection of antibody clones with the desired properties, and their modification, expression, and purification. Each readily reproducible method is described by a hands-on expert in step-by-step detail and includes a wealth of practical advice not found in the scientific literature. Extensive notes discuss pitfalls to avoid and offer many possible alternative methods to suit special research situations. An overview by one of the world's leading experts in antibody phage display, Dr. Hennie R. Hoogenboom, surveys the current status of the field and the future of the technology.

Comprehensive and highly practical, *Antibody Phage Display: Methods and Protocols* provides biochemists, molecular biologists, and immunologists with a gold-standard reference guide to the successful isolation, modification, and expression of recombinant antibodies using today's powerful phage display technology.

FEATURES

- Reproducible techniques for producing monoclonal antibodies using phage display technology
- Step-by-step instructions that ensure experimental success

CONTENTS

Overview of Antibody Phage-Display Technology and Its Applications. Standard Protocols for the Construction of Fab Libraries. Standard Protocols for the Construction of scFv Libraries. Broadening the Impact of Antibody Phage Display Technology: *Amplification of Immunoglobulin Sequences from Species Other than Humans or Mice*. Construction of Large Naïve Fab Libraries. Construction of Polyclonal Antibody Libraries Using Phage Display. Antigen-Driven Stimulation of B-Lymphocytes In Vitro. The Recovery of Immunoglobulin Sequences from Single Human B Cells by Clonal Expansion. Panning of Antibody Phage-Display Libraries: *Standard Protocols*. Selection of Antibodies Against Biotinylated Antigens. Isolation of Anti-Hapten Specific Antibody Fragments from Combinatorial Libraries. Blocking Immunodominant Epitopes by Competitive Deselection. Rescue of a Broader Range of Antibody Specificities Using an Epitope-Masking Strategy. Screening of Phage-Expressed Antibody Libraries by Capture Lift. Antibody-Guided Selection Using Capture-Sandwich ELISA. Proximity-Guided (ProxiMol) Antibody Selection. Isolation of Human Monoclonal Antibodies Using Guided Selection with Mouse Monoclonal Antibodies. Selecting Antibodies to Cell-Surface Antigens Using Magnetic Sorting Techniques. Isolation of Human Tumor-Associated Cell Surface Antigen-Binding scFvs. Subtractive Isolation of Single-Chain Antibodies

Using Tissue Fragments. Selection of Antibodies Based on Antibody Kinetic Binding Properties. Selection of Functional Antibodies on the Basis of Valency. Two-Step Strategy for Alteration of Immunoglobulin Specificity by In Vitro Mutagenesis. Targeting Random Mutations to Hotspots in Antibody Variable Domains for Affinity Improvement. Error-Prone Polymerase Chain Reaction for Modification of scFvs. Use of *Escherichia coli* Mutator Cells to Mature Antibodies. Chain Shuffling to Modify Properties of Recombinant Immunoglobulins. Generation of Bispecific and Tandem Diabodies. High-Level Periplasmic Expression and Purification of scFvs. Periplasmic Expression and Purification of Recombinant Fabs. Expression of Antibody Fragments in *Pichia pastoris*. Expression of V_H Antibody Fragments in *Saccharomyces cerevisiae*. Intrabodies: *Targeting scFv Expression to Eukaryotic Intracellular Compartments*. Expression of scFvs and scFv Fusion Proteins in Eukaryotic Cells. Expression of Antibody Fab Fragments and Whole Immunoglobulin in Mammalian Cells. Index.

Methods in Molecular Biology™ • 178
ANTIBODY PHAGE DISPLAY: METHODS AND PROTOCOLS
 ISBN: 0-89603-906-4
humanapress.com

ISBN 0-89603-906-4



9 780896 039063

9 0 0 0 0