



DESIGN

Bernhard E. Bürdek

History,
theory
and
practice
of
product
design

Birkhäuser

DESIGN

DESIGN

Bernhard E. Bürdek

History,
Theory
and
Practice
of
Product
Design

Edition form
Birkhäuser – Publishers for Architecture

Basel • Boston • Berlin

Translation: Meredith Dale, Susan Richter, Nina Hausmann

Drawings: pict/gestaltung analoger und digitaler medien,
Arnsburger Straße 41, D-60385 Frankfurt, www.pict.de

Graphic Concept: Muriel Comby

Graphic Design: Micha Lotrovsky

This book is also available in a German language edition.
(ISBN 3-7643-7028-9)

A CIP catalogue record for this book is available from the Library of
Congress, Washington D.C., USA.

Bibliographic information published by Die Deutsche Bibliothek
Die Deutsche Bibliothek lists this publication in the Deutsche
Nationalbibliografie; detailed bibliographic data is available in the
internet at <http://dnb.ddb.de>.

This work is subject to copyright. All rights are reserved, whether the
whole or part of the material is concerned, specifically the rights of
translation, reprinting, re-use of illustrations, recitation, broadcasting,
reproduction on microfilms or in other ways, and storage in data
bases. For any kind of use, permission of the copyright owner must
be obtained.

© 2005 Publishers for Architecture, P.O. Box 133, CH-4010 Basel,
Switzerland.
Part of Springer Science+Buisness Media

Printed on acid-free paper produced from chlorine-free pulp. TCF[∞]

Printed in Germany

ISBN 3-7643-7029-7

9 8 7 6 5 4 3 2 1

<http://www.birkhauser.ch>

CONTENTS

Preface	7
Design as a Concept	13
Design and History	17
The Bauhaus	28
The Ulm School of Design	41
The Example of Braun	55
From Good Design to the Art of Design	59
Design and Globalization	71
Great Britain	73
Germany (Federal Republic)	84
German Democratic Republic	103
Austria	107
Switzerland	111
Italy	120
Spain	145
France	149
The Netherlands	156
Scandinavia	163
Denmark	163
Finland	165
Norway	167
Sweden	167
Russia	172
North America	177
United States	177
Canada	192
South America	195
Brazil	196
Asia	198
China	202
Hong Kong	206

Japan	209
Korea	219
Singapore	221
Taiwan	223
Design and Methodology	225
Epistemological Methods in Design	227
Semiotics and Design	230
Phenomenology and Design	239
Hermeneutics and Design	244
Developments in Design Methodology	251
Design and Theory	273
Aspects of a Disciplinary Design Theory	280
On the Communicative Function of Design	293
The Formal Aesthetic Functions	297
The Marking Functions	312
The Symbolic Functions	322
From Product Language to Product Semantics	333
Design and Its Contexts	343
From Corporate Design to Service Design	343
From Design Management to Strategic Design	358
Architecture and Design	367
Utopias, Visions, Concepts, and Trends	385
Microelectronics and Design	401
From the Digital to the Biological Age	425
Appendix	433
Bibliography	433
Quotation References	455
List of Illustrations	461
Index of Names	465
Subject Index	471

PREFACE

Since the early 1980s design has been experiencing a global boom. Propelled to dizzy new heights worldwide by the rise of the postmodernist movement starting at the end of the 1970s, and especially by the Memphis group of the early 1980s, design will continue to soar well into the twenty-first century. Corporations and institutions across the world recognize the strategic value of design, and are busy cultivating it to a high degree of perfection. These days, design is the talk of the town.

Today there is an endless flow of publications (periodicals, books, and catalogs), media reports, product presentations at trade fairs, exhibitions, and galleries, and even whole museums dedicated to the discipline of design. For example, the Neue Sammlung in Munich – opened in 2002 as a major component of the Pinakothek der Moderne – contains over 70,000 objects, making it one of the world’s largest design museums. And the relentless global outpouring of new commodities means there are always more new products just waiting to be honored in such a museum. So what is it that makes design so important?

First of all, we should note that the traditional concept of the “product” is in the process of being transformed. Today designers concern themselves not only with the hardware (the object itself), but also with the software, in the form of operator interfaces and user environments. The example of the telecommunications industry shows clearly how the focus is increasingly shifting from products to services, which have to be designed to win the acceptance of potential users (who are expected to pay not inconsiderable charges for the privilege). The concept of event design is even more far-reaching. At today’s trade fairs and exhibitions, product presentations are spectacles and celebrations; new automobiles are launched at enormous expense. In 2002 DaimlerChrysler shipped the resurrected Maybach by luxury liner to New York, where it was exclusively shown to a select audience at one of the city’s most exclusive hotels. Other corporations even

Since its societal institution-
alization in the 1950s,
design has become ubiquitous.
Since then there have
been no more doubts about
the necessity of design;
economic policy, media pre-
sence, cultural journalism
and design theory have
made it an acceptable sub-
ject of discourse.

— GERT SELLE, 1997



PINAKOTHEK DER MODERNE

view of the continuous elevator
"Perpetuum Mobile der Gegenwart"
("Perpetual motion machine of
the present")

© and ownership: Die Neue Samm-
lung, Munich



PRODUCT DISPLAYS IN
A DEPARTMENT STORE
laptop computers, digital
cameras, washing machines



THE TRANSPARENT FACTORY in Dresden,
Volkswagen AG

create entire “car worlds” of their own. Volkswagen AG has a Car City (Autostadt) in Wolfsburg, and a transparent factory in Dresden, where the Phaeton is assembled and delivered to customers on the spot. In Dresden they will also arrange a visitor program (for example a visit to the Semper Opera), to make delivery of the new car into a memorable personal event. In this situation, design and art work hand in hand, culturally speaking.

Today, most people’s lives would be unimaginable without design. It accompanies us from dawn till after dusk: at home, at work, in our leisure time, in education, in health services, in sports, in the transport of people and goods, in the public sphere, everything is designed, intentionally or not. Design can be very close (fashion) or far, far away (space travel). These days, design determines not only existence, but also self; through products we communicate with other people, define ourselves in social groups, and thus mark out our individual place in society. In other words, design is a sign of the times.

So after more than a decade it was time for this book to be fully revised, updated and, of course, expanded. After its first publication in German in 1991, translations into Italian (1992), Spanish (1994), Dutch (1996), and also Chinese (1996) soon followed. Now the English translation is appearing at the same time as the new German edition, which will doubtlessly prove beneficial to the global design discourse. The considerable language barriers have meant that, to date, very few German-language books on design have made any international impact at all.

The students in the Department of Product Design are deserving of mention once again for their contributions in various seminars, essays, dissertations, and projects. Bianca Beutel and Stephanie Dietmann assisted me with the picture research, scrutinizing today’s world of artifacts with eyes that are considerably fresher than mine, and making important suggestions for new products. Florian Jäger provided me with significant help in digital processing.

Christa Scheld, the librarian at the Offenbach School of Design, is always an enormous help in the search for information, as is Helge Aszmoneit, librarian at the German Design Council in Frankfurt am Main. My special thanks to both of them.

The drawings, which are of great help in understanding the texts, were prepared by pict in Frankfurt. My gratitude also extends to the graduates of the Offenbach School of Design.

Obertshausen, March 2004

Design is communication. It waits patiently until it is read, and it understands this. In view of its and our understanding, it is a kind of communication that assumes communication even where there is none, namely between the two sides of an interface.

— DIRK BAECKER, 2002

DESIGN AS A CONCEPT

The manifold currents and tendencies of design are reflected in the very use of the concept of “design,” up to and including sometimes rather diffuse definitions of the word. A number of these interpretations will be introduced at the outset of this essay.

From a historical perspective, it is popular to regard Leonardo da Vinci as the first designer. In addition to his scientific studies on anatomy, optics, and mechanics, he performed pioneering work in the elementary science of mechanical engineering, producing a “Book of Patterns of Machine Elements.” The concept of design da Vinci applied to practical objects, machines, and apparatus was thus more technically than creatively oriented. Nevertheless, it decisively influenced the idea of design: the designer as an inventor.

The sixteenth-century painter, master builder, and literary author Giorgio Vasari was one of the first to plead in his writings for the autonomous character of works of art. He designated the principle to which art owes its existence as *disegno*, which translates directly into “drawing” or “sketch.” At that time, *disegno* referred to the artistic idea. Accordingly, even back then, people differentiated between the *disegno interno*, the concept for an emerging work of art (the sketch, the draft, or the plan), and the *disegno esterno*, the completed work of art (such as a drawing, painting, or sculpture). Vasari himself pronounced drawing, or *disegno*, to be the father of the three arts: painting, sculpture, and architecture (for more information, see Bürdek 1996).

According to the Oxford Dictionary the concept of “design” was used in 1588 for the first time. Its definition reads:

- a plan or scheme devised by a person for something that is to be realized,

The word “design” has Latin roots. The verb “designare” is translated as “determine,” but its literal meaning is more like “showing from on high”. That which has been determined is definite. Design transforms vagueness into definiteness by continual differentiation. Thus design (*designatio*), in its general and abstract conception, is above all determination through representation, the science of design as it corresponds to the science of determination.

— HOLGER VAN DEN BOOM, 1994



MIMO 32: TREMO SUBWOOFER SATELLITE SYSTEM
ARTICO HIGH-FIDELITY SOUND SYSTEM
design: Phoenix, Fa. Loewe

- a first graphic draft of a work of art, or
- an object of the applied arts, which is to be binding for the execution of a work.

Later, Sigfried Giedion (first edition 1948, see also 1987) significantly described how the industrial designer appeared in the twentieth century: "He fashioned the housing, saw to it that the visible machinery (of the washing machines) disappeared, and gave the whole, in short, a streamlined shape like the train and the automobile." In the U.S., this clear separation of technical work from artistic work on the product led to the discipline's increasing orientation toward styling, and thus to pure fashioning.

The concept of "industrial design" can be traced back to Mart Stam, who supposedly used the term for the first time in 1948 (Hirdina, 1988). For Stam, an industrial designer was someone who drafted, sketched, and planned. In his opinion designers should be employed in every area of industry, especially in the production of new kinds of materials.

The definition of design has long been a matter of intense concern, above all in the former German Democratic Republic. This regime always understood design to be a component of social, economic, and cultural policy. Horst Oehlke (1978), in particular, pointed out that shaping affects more than the sensually perceptible side of objects. On the contrary, the designer must be concerned with satisfying the needs of societal and individual life.

A broad and therefore quite useful definition of design was worked out by the Internationales Design Zentrum Berlin in 1979 in the context of an exhibition:

- Good design may not be a mere envelopment technique. It must express the individuality of the product in question through appropriate fashioning.
- It must make the function of the product, its application, plainly visible so that it can be understood clearly by the user.
- Good design must allow the latest state of technical development to become transparent.
- Design must not be restricted just to the product itself; it must also take into consideration issues of ecology, energy conservation, recyclability, durability, and ergonomics.
- Good design must take the relationship between humans and objects as the point of departure for the shapes it uses, especially

taking into account aspects of occupational medicine and perception.

This complex definition clearly takes into consideration not only the functional aspects (practical functions), but also the product language and the ever more important ecological aspects of design. In the same sense, but in a quite compressed form, Michael Erlhoff undertook a clear and current delimitation of design on the occasion of the *documenta 8* in Kassel (1987): "Design, which – unlike art – requires practical justification, finds this chiefly in four assertions: being societal and functional and meaningful and concrete."

There was no problem with such an open description of design well into the 1980s. However, the age in which a uniform – and thus ideologically cemented – concept of design could predominate now appears to be over once and for all. The reflections of the postmodern age have promoted the dissolution of totality in a variety of disciplines. Anyone who continues to regard this as a loss is thus, in the Lyotardian sense, stuck in the "discussion condition" of a modern age which has since become history (Welsch 1987).

The diversity of concepts and descriptions is not a sign of post-modern arbitrariness, however, but rather a necessary and justifiable pluralism. In the transition from the twentieth to the twenty-first century I have therefore proposed, instead of yet another definition or description, listing a number of the tasks design is supposed to fulfill (Bürdek 1999). Thus, for instance, design should:

- visualize technological progress,
- simplify or make possible the use and operation of products (hardware or software),
- make transparent the connections between production, consumption, and recycling,
- promote and communicate services, but also – pursued energetically enough – help to prevent products that are senseless.

He then calls the result of such considerations "Grand Design." He (Joschka Fischer) relates with great passion that everything in a "Grand Design" is connected with everything else: the global economy and the trade cycle, demographic developments and pensions, German unity and Europe.

— DER SPIEGEL, 6/2003

DESIGN AND HISTORY

RETROSPECTIVE

This chapter can in no way substitute for a comprehensive history of design. Instead, it outlines the developments that have shaped the history of industrial design in a number of countries, briefly covering the products, companies, and designers that mark the significant events and their repercussions. Readers seeking greater depth and detail are encouraged to turn to the many standard works on the history of design. These include, for example, John Heskett (1980), Guy Julier (2000), Penny Sparke (1986), Gert Selle (1978, 1987, 1994), John A. Walker (1992), and Jonathan M. Woodham (1997).

Ultimately, wasn't the history of design even more fantastic and adventurous than pure and free art?

— EDUARD BEAUCAMP, 2002

The Beginnings of Design

The origins of functionally optimized product design can be traced all the way back to classical antiquity. The writings of the Roman artist, architect, and military engineer Vitruvius (ca. 80–10 B.C.) are among the oldest surviving architectural documents. His comprehensive *De architectura libri decem* (*Ten Books on Architecture*) comprised the first handbook of planning and design. In his book, Vitruvius describes the close relationship between theory and practice, saying that an architect has to be interested in art and science, as well as being versed in rhetoric and having a good knowledge of history and philosophy. In chapter three of his first book, Vitruvius names a guiding principle that has found its place in design history: “all buildings must satisfy three criteria: strength (*firmitas*), functionality (*utilitas*), and beauty (*venustas*)” (Bürdek 1997). It could be said that Vitruvius laid out the basic tenets for the concept of functionalism, whose time did not come until the twentieth century, when it was to define modernism in design across the world.

It is actually only since the mid-nineteenth century, the age of the Industrial Revolution, that we can speak of industrial design in the

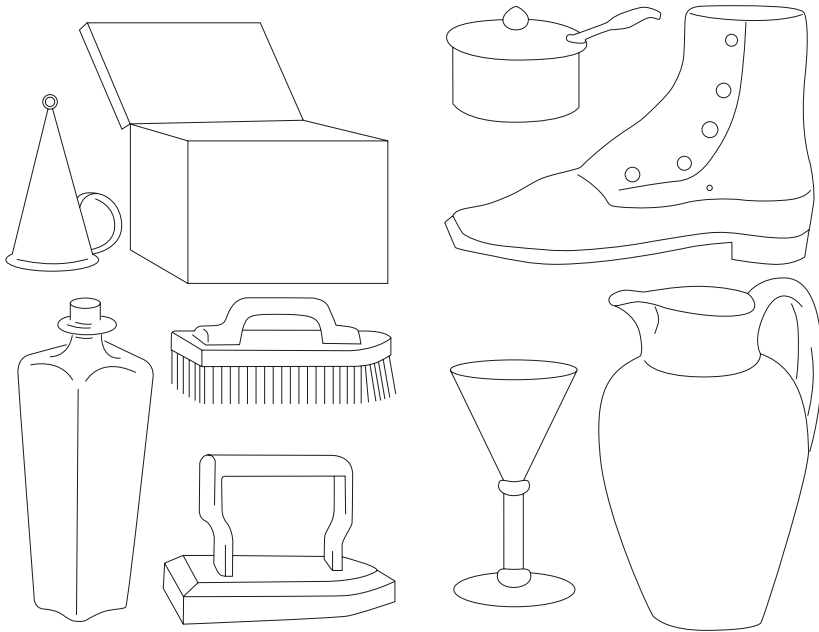

modern sense. Increasing divisions of labor meant that the design and manufacture of a product were no longer carried out by one and the same person, as had previously been the case. Over time, this process of specialization has progressed to such an extent that today a designer in a large company is only responsible for one specific part of a product. In the 1970s a reaction to this division of labor led younger designers in particular to attempt to undertake design, production, and marketing as a unified whole.

In the mid-nineteenth century a number of English designers rebelled against the grandiloquent interiors of the Regency style. In Europe the room itself had been steadily losing importance since the Middle Ages, whereas the furniture in the room increasingly became the center of attention. Sigfried Giedion (1987) has vividly described how a medieval room always appeared furnished; it never seemed bare, even when empty of furniture, as it came alive through its proportions, materials, and forms. A trend that treated the furniture as if it were the room itself reached its zenith in the Regency period (approx. 1811–1830). The declining significance of the room as a space was only recognized in the twentieth century, by the architects and designers of the Bauhaus. They responded by designing very simple, reductionist furniture in order to direct attention back to the meaning of the room.

In England, Henry Cole aspired to influence applied design educationally through his modest and short-lived publication, the *Journal of Design*, which appeared from 1849 to 1852. Cole's work focused on the practical and functional aspects of design, to which he felt the representative and decorative elements should be secondary. Cole also proposed holding a Great Exhibition in London, where all nations would be given the opportunity to present their manifold products. At the heart of his thought was the idea of "learning to see, seeing by comparing," which was taken up by the German Werkbund in the twentieth century.

Joseph Paxton won the commission to design the building for the 1851 Great Exhibition in London. His Crystal Palace, which Friemert (1984) refers to as a "glass ark," was prototypical of the industrialized construction methods of the nineteenth century. The structure was built in just four and a half months, all the parts being manufactured elsewhere and assembled at the site. Furthermore, the building was dismantled several years later and re-erected at a different location (Sembach 1971).

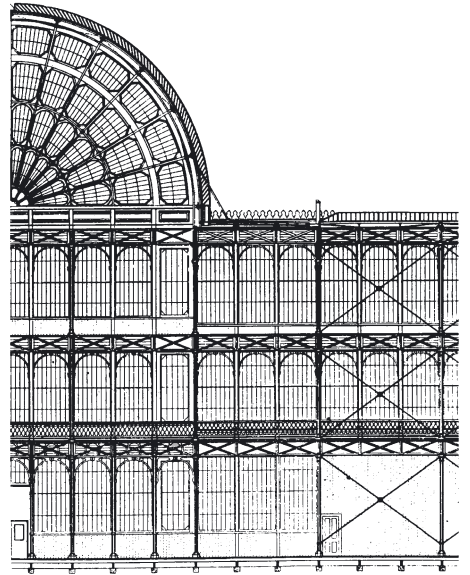
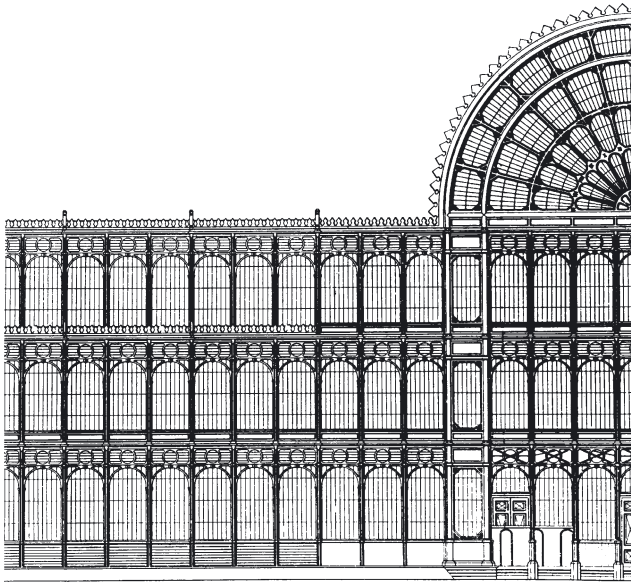

JOSEPH PAXTON, London's Crystal Palace
(1851)

The first World's Fairs – among them 1873 in Vienna, 1876 in Philadelphia, and 1889 in Paris (with Gustave Eiffel's tower) – were gigantic collections of products and expositions of design, where the technical and cultural developments of the age were put on show.

It was an era of new materials and technologies: cast iron, steel, and cement were no longer processed in small-scale workshops, as mechanized industrial enterprises replaced older modes of production. Automated looms, steam engines, industrial carpentry, and prefabricated construction methods utterly transformed the conditions of life and work. The social consequences of industrialization were plain to see. A large part of the population fell into poverty and became the proletariat, while the environment was transformed by the advent of mass accommodations and extensive industrial zones. The real fathers of design were contemporaries of this Industrial Revolution: Gottfried Semper, John Ruskin, and William Morris. They, like Henry Cole, reacted against the superficial embellishment of the new industrial products. This reform movement was strongly influenced by John Stuart Mill's philosophy of utilitarianism, which stated that the moral quality of human acts depended solely on their usefulness (or harmfulness) to society. This criterion, incidentally, can be traced right through to the present as a determining category in design. Wend Fischer (1971) even saw it as the foundation of rational design: "In considering the nineteenth century we have also learned something about our own century. We recognize ourselves in the efforts of reason to establish the idea of functional design against the arbitrariness of historical formalism, in order for the world of people, their houses, rooms, and utensils to be given a characterful form in which the expression of life can be found."

German architect Gottfried Semper emigrated in 1849 to seek political asylum in England, where he pushed for the reform of industrial design activities, advocating that the form should be appropriate to the function, the material, and the manufacturing process. Semper worked together with Cole on the Great Exhibition of 1851 and taught at the newly founded drawing school in London. At the turn of the twentieth century Semper's ideas exerted a strong influence on the German Arts and Crafts movement, which also placed the pure function of the object in the foreground.

John Ruskin, art historian and philosopher, attempted to revitalize medieval production methods in a countermovement to the Industrial Revolution. Craft production, he believed, would make better living

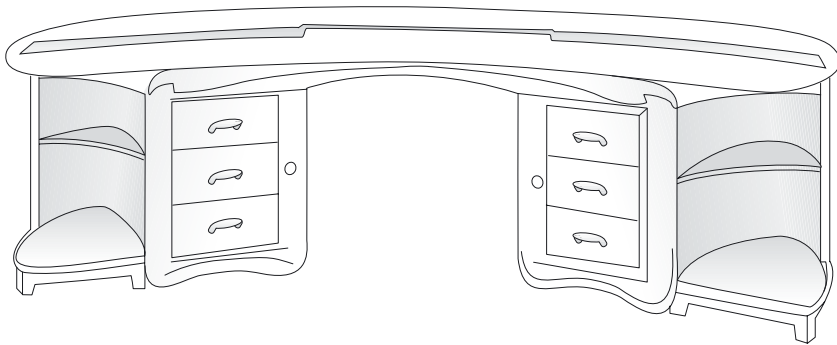
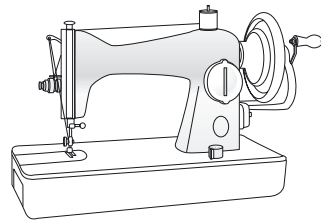
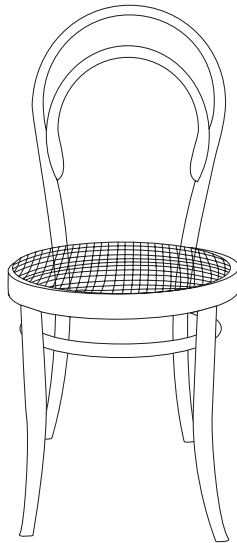

THONET CHAIR NO. 14 (1859)

SINGER SEWING MACHINE (around 1900)

DESK, design: Henry van de Velde (1899)

conditions possible for the workers and represent a counterweight to the aesthetically impoverished world of machines.

William Morris founded Morris, Marshall, Faulkner & Company in 1861 with the aim of reinvigorating the arts and crafts. The British Arts and Crafts movement that formed around Morris worked for social reform and to rejuvenate style. Revoking the division of labor and reuniting design with production, the Arts and Crafts revival movement directed its energies especially against the aesthetic of the machine, but was thwarted by the tumultuous industrial developments of the second half of the nineteenth century.

One typical example from this early phase of design is the Singer sewing machine, whose annual production volume had already surpassed 400,000 by 1879.

This period also saw the development of the bentwood chair by the Thonet brothers, first in Germany, then in Austria. Their method of steaming wood to make it pliable was patented in Vienna, and became the basis for worldwide success. These chairs were already on display at the Great Exhibition of 1851 in London. The principles of standardization (using only a small range of identical components) and mass production meant that a reduced language of form had to be used. The Thonets' chairs thus embody an important keynote of design – high production volume with reductionist aesthetic – that was to remain ascendant in that form until the 1970s. It is said that fifty million units of Chair No. 14 had been made by 1930, and it is still in production today.

New movements emerged in Europe toward the end of the nineteenth century: Art Nouveau in France, Jugendstil in Germany, the Modern Style in England, and the Secession Style in Austria. What they all shared was an artistic *joie de vivre*, which was reflected especially in the visual appearance of everyday products.

The leading proponent of this movement, the Belgian Henry van de Velde, designed furniture, implements, and interiors, but the ideas of social reform formulated by William Morris were forgotten. All that the two had in common was the arts and crafts renaissance. Van de Velde was an elitist and an individualist; a combination we shall meet again in the early 1980s in the Memphis movement and “new design.”

In Austria Josef Hoffmann, Josef Olbrich, and Otto Wagner joined together to form the Vienna Secession, establishing a group of artists whose work prominently featured geometric ornaments and a reduced

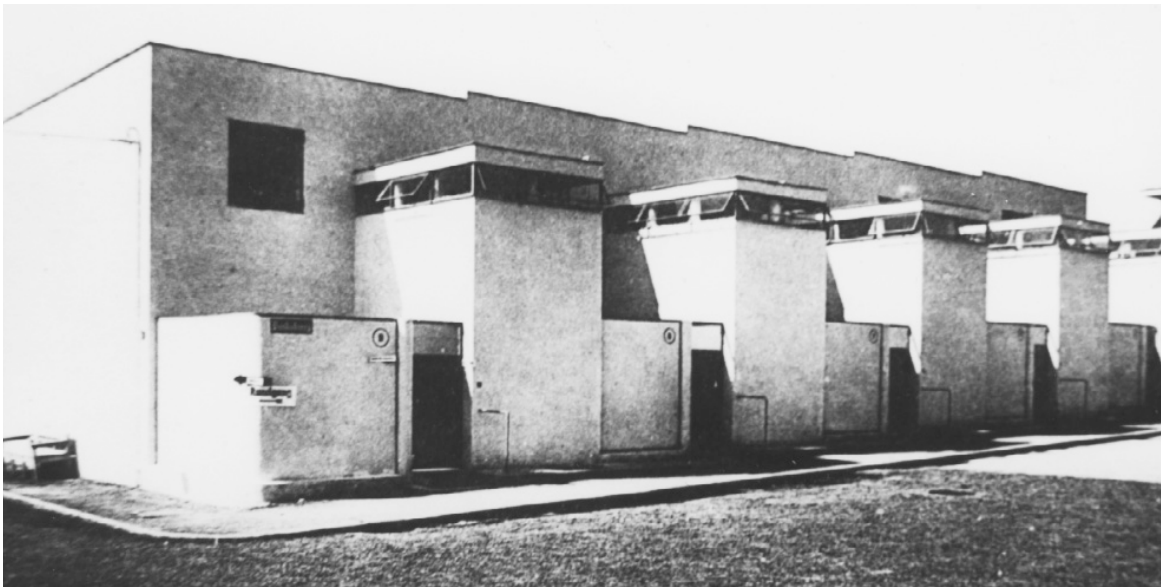

THE WEISSENHOF SIEDLUNG ESTATE IN STUTT GART
(1927)

living space in a house
residential houses
design: Jacobus J. P. Oud

language of form. In the Vienna Workshops, which were set up at this time, craftsmen designed furniture for the upper middle classes.

From Werkbund to Bauhaus

The German Werkbund was founded in Munich in 1907. It was a society of artists, craftsmen, industrialists, and journalists, who set themselves the goal of improving mass-produced goods through cooperation between industry, the arts, and the craft trades, and by means of education and publicity work. Leading members of the Werkbund at the turn of the twentieth century included Peter Behrens, Theodor Fischer, Herman Muthesius, Bruno Paul, Richard Riemerschmid, and Henry van de Velde. Both leading currents of the time were represented in the Werkbund: industrial and product standardization on the one hand, expression of artistic individuality à la van de Velde on the other. These were, in fact, to be the two decisive tendencies in twentieth-century design.

Werkbund organizations sharing the same central tenets were set up in other countries, too: the Austrian Werkbund in 1910, the Swiss Werkbund in 1913, the Swedish Slöjdföreningen (1910–1917), and the English Design and Industries Association in 1915. The goal they all shared was to popularize a holistic good taste among manufacturers and consumers of products, working educationally in the tradition of Henry Cole.

The high point of the German Werkbund's work after World War I was an exposition held in 1927 in Stuttgart: the Weissenhof project. Under the leadership of Mies van der Rohe, more than a dozen of the most famous architects of the time – including Le Corbusier, Hans Scharoun, Walter Gropius, Max Taut, Jacobus Johannes Pieter Oud, Hans Poelzig, Peter Behrens, and Mart Stam – were invited to put their new ideas about architecture and design into practice in houses and apartment buildings.

The application of new construction materials made the design of new housing concepts possible, and the intention was to restore significance to the room itself, as mentioned earlier. The Weissenhof project represented an attempt to subject everything – from the house itself right down to the coffee cup – to a fundamental design concept. The apartment as a total work of art was intended on the one hand to propagate new aesthetic models (reduction to the elementary functions, utilitarianism), and on the other to offer affordable furnishings to a broad section of the population. Giedion credits the Dutch architect

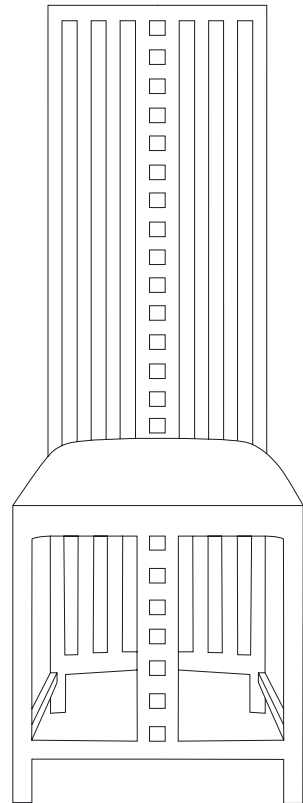
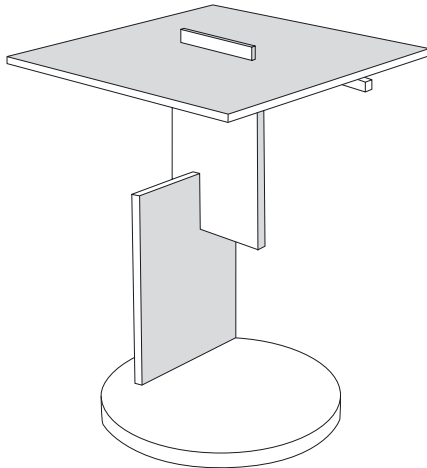
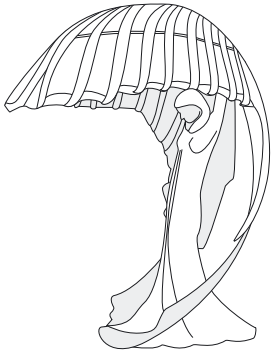
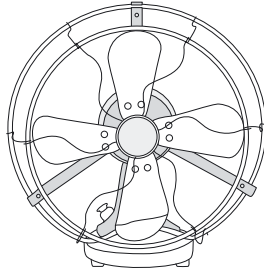

TABLE FAN, design: Peter Behrens (before 1912), AEG

JUGENDSTIL TABLE LAMP, design: Peter Behrens (1902)

HIGH-BACKED CHAIR, design: Charles Rennie Macintosh (1904/05)

SIDE TABLE, design: Gerrit T. Rietveld (1922/23)

Oud with being the first to treat the working-class apartment as an artistic challenge. The holistic ideas expressed in the Weissenhof exposition corresponded to the basic ideas of the Bauhaus (see p. 28f.).

In hindsight, Weissenhof represented the first visible expression of the so-called International Style in architecture. But in contrast to the superficial formal manifestations we know, for example, from the satellite towns built round the major conurbations since the 1960s, Weissenhof embodied a well-thought-out, meaningful unity of social conditions using new materials and forms (Kirsch 1987).

In Scotland a group centered on Charles Rennie Mackintosh formed in opposition to Jugendstil. His purist utilitarian forms stood in the tradition of medieval Scottish furniture, as well as demonstrating a severity that was to resurface in constructivism.

Peter Behrens was one of the key pioneers of modern design. Behrens, a German architect and advertising expert, was appointed as artistic adviser to AEG (Allgemeine Elektrizitäts Gesellschaft) in 1906–1907. His responsibilities there included designing buildings and electrical domestic appliances. Because he designed mass products for general consumption, he is regarded as one of the very first industrial designers. The rationale of industrialized manufacturing led him to turn his back on Jugendstil and concentrate on products that were economical to manufacture, simple to operate, and easy to service.

The De Stijl group in the Netherlands formed in 1917. Its most important representatives were Theo van Doesburg, Piet Mondrian, and Gerrit T. Rietveld, all of whom put forward aesthetic and social utopias that were futuristic rather than backward-looking like those of Ruskin and Morris. Doesburg rejected the crafts in favor of the machine, and spent time in Weimar in 1921–1922. His concept of “mechanical aesthetics” was identical to the technical aesthetics of the Russian constructivists.

The reductionist aesthetic of De Stijl was characterized on the two-dimensional plane by simple geometric elements such as circles, squares, and triangles, and in the three-dimensional world by spheres, cubes, and pyramids. This specific use of formal elements created enduring design categories, some of which are still valid today. The Bauhaus and its successors, such as the Ulm School of Design and the New Bauhaus in Chicago, looked to this tradition, especially in their foundation courses. The geometric principles of De Stijl are also reflected in the sparing use of design elements found in Swiss graphic art, and the oft-quoted catch phrase of Dieter Rams, Braun’s long-

serving head designer, that “less design is more design” can also be traced back to the same origins.

In Russia a group known as the constructivists formed after the October Revolution of 1917; the most famous of them were El Lissitzky, Kazimir Malevich, and Vladimir Tatlin. They made social aesthetics their top priority; satisfying the basic needs of the general population was the primary goal of their work. The basic principles of constructivism developed by Tatlin were based on the real material conditions of production: technology, materials, and processes. Style was to be replaced by technology. Malevich drew up guiding principles for the VKhuTeMas, which was a kind of Russian Bauhaus (see p. 172).

The ideas of this group, too, can be followed through to the present. Design in the 1960s and 1970s, especially, was characterized by themes of social relevance, and, because of the crippling lack of basic consumer goods, the rigid concentration of technology continues to govern design in most countries of the Third World today.

THE BAUHAUS

In 1902 Henry van de Velde established an arts and crafts seminar in Weimar, which was expanded to form the School of Arts and Crafts under his directorship in 1906. The School merged with the Academy of Arts in 1919 to form the Staatliches Bauhaus Weimar, with Walter Gropius as its director. The Bauhaus was to become the flagship for the subsequent development of design (Wingler 1962).

With the exception of sculptor Gerhard Marcks, Gropius appointed only representatives of abstract and cubist painting to teaching posts at the Bauhaus. These included Wassily Kandinsky, Paul Klee, Lyonel Feininger, Oskar Schlemmer, Johannes Itten, Georg Muche, and László Moholy-Nagy.

The unity of design and execution that had existed in the craft trades had been torn asunder by the advance of industrial modes of production during the nineteenth century. Gropius was guided by the idea that the Bauhaus should bring together art and technology to form a new, modern unity. Technology might not need art, but art certainly needed technology, was the motto. This idea was associated with a fundamental social objective, namely to anchor art in society.

The Bauhaus drew on the ideas of the life reform movement of the turn of the twentieth century, which had taken a particular interest in

housing issues. The fustiness of the nineteenth century with its dark furniture in dark rooms was to be blown away, supplanted by new forms of accommodations. The idea was that the modern twentieth-century individual, housed in clear bright rooms, would develop new ways of living (Becher 1990).

THE FOUNDATION COURSE

The foundation course at the Bauhaus represented the heart of the program of basic polytechnical artistic education. Introduced in 1919–1920 by Johannes Itten, it was a significant component of the curriculum and was obligatory for all students. The twin purposes of the course were to encourage students to experiment and to explore their own creative talents, and to teach fundamental design skills through an understanding of an objective science of design.

The foundation course was conducted first by László Moholy-Nagy and later by Josef Albers, whose goals were “inventive building and observational discovery.” Methodologically Albers, like Itten, took an inductive approach to design, allowing the students to investigate, explore, and experiment. In this manner, cognitive skills were fostered indirectly. Theory did not lead the way; instead the conclusions drawn from analysis and discussion of experiments were progressively distilled into a generalized “theory of design.”

In 1925 the Bauhaus moved from Weimar to a new building in Dessau designed by Gropius, where it stayed for seven years before being forced to close under pressure from the Nazis. A small group of Bauhaus teachers and students kept the school going in 1932–1933 in Berlin under extremely difficult conditions as a private school, which van der Rohe finally closed down in summer 1933.

DEVELOPMENT PHASES

According to Rainer Wick (1982) the Bauhaus period can be divided into three developmental phases:

The Founding Phase 1919–1923

The most important educational element was the foundation course described above. Students who had completed it then chose from a

Today it is impossible to resist the impression that for several years, the industrial spirit of the world blew through Bauhaus. Not only because of the resulting images of newly invented spaces and things, but also because of the self-confidence in the ideal subject of modernity trained there, which is at the same time the object of modernity. — GERT SELLE, 1997

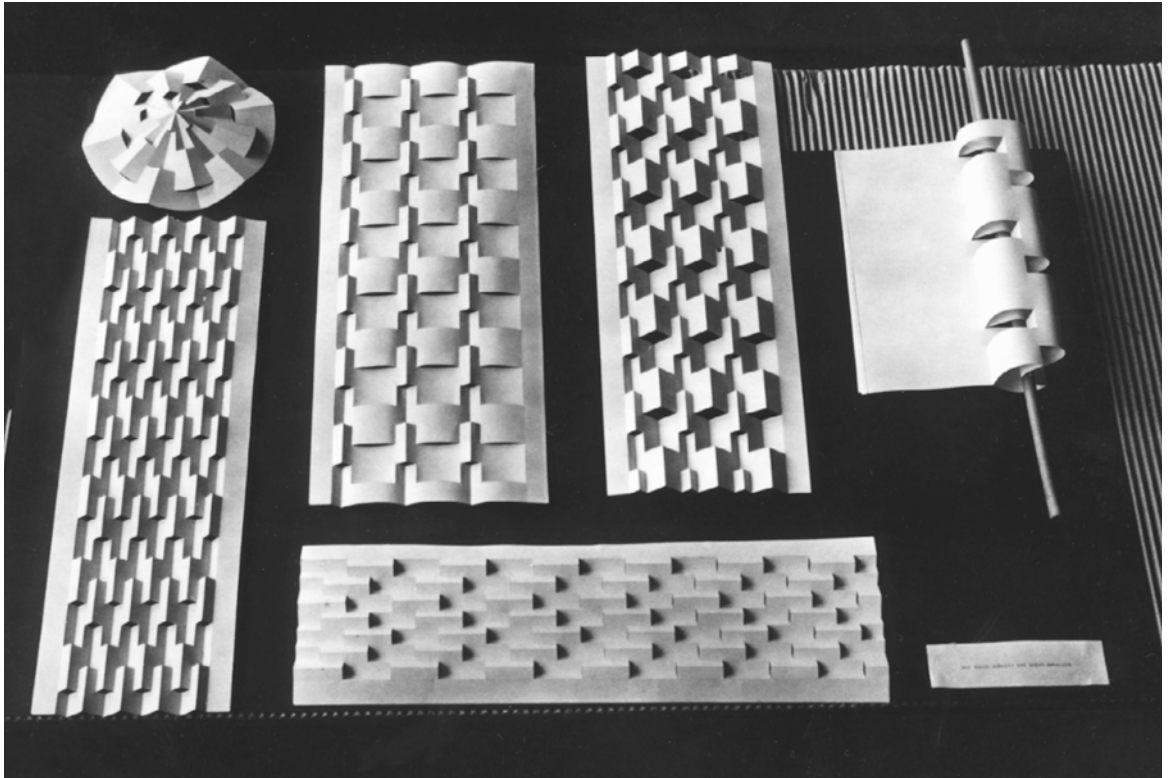
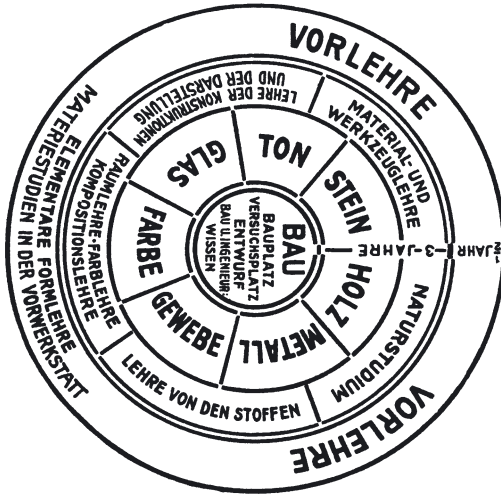

WALTER GROPIUS, diagram of the structure of instruction at the Bauhaus school, 1922

PRELIMINARY COURSE WITH JOSEF ALBERS, plastic materials exercise with paper, paper folding, around 1927

number of specialist workshops: printing, pottery, metalwork, mural painting, stained glass, carpentry, stagecraft, weaving, bookbinding, and woodcarving.

Each workshop had two supervisors: a master of form (an artist) and a master craftsman. The intent of this dualism was to promote the students' manual and artistic skills equally, but in practice it soon became clear that the craftsmen were subordinate to the artists. Pervasive social tensions arose, because in the end the autonomous artist was the center of attention, even at the Bauhaus. In the field of design mostly unique items were produced during this phase, representing the first moves toward a product aesthetic.

The Consolidation Phase 1923–1928

The Bauhaus increasingly became a teaching and production facility for industrial prototypes, which aimed to meet both the realities of industrial manufacturing and the social needs of the general population. From our perspective today, the most successful Bauhaus workshop, apart from metalworking, was carpentry. Marcel Breuer, who had studied at the Bauhaus since 1920, took over the carpentry workshop as “young master” in 1925. In developing his tubular steel furniture, Breuer achieved a breakthrough: functional furniture capable of exploiting the opportunities offered by mass production. Probably inspired by the curved form of his bicycle handlebars, Breuer made a mental leap to the Thonet chairs. Combining the strength and stability of steel tubing with lightweight coverings (wickerwork, fabric, leather), he succeeded in creating a completely new category of seating furniture (Giedion 1948); the same principles were soon being applied to tables, cabinets, shelves, desks, beds, and combination furniture.

The aim of the design activities at the Bauhaus was to develop affordable products for the populace, while maintaining a high degree of functionality. During this second phase much theoretical and practical work was conducted on the concept of function, which always involved a social perspective in its aim to “govern the circumstances of life and labor” (Moholy-Nagy) and take “questions of mass demand” seriously. Function always meant a combination of two factors in design, marrying the conditions of industrial manufacturing (technology, construction methods, materials) with the social conditions, in the service of the needs of the broader population and the requirements of social planning.



THE BAUHAUS BUILDING in Dessau

Accordingly, during this second phase of the Bauhaus, undirected artistic experimentation retreated in favor of applied design tasks. To some extent as a result of assignments that gave rise to industrial commissions, the Bauhaus became a “university of design.” Standardization, series manufacturing, and mass production became the backbone of all Bauhaus activities. The principal force behind these developments was Swiss architect Hannes Meyer, who became head of the Department of Architecture in 1927 and set up a systematic, scientifically grounded architecture program.

The Phase of Disintegration 1928-1933

Hannes Meyer was appointed director of the Bauhaus in 1928. On his watch new subjects and workshops were introduced, including photography, sculpture, psychology, and several others. Meyer energetically promoted a social purpose for architecture and design. The designer should serve the people, he said, which meant providing adequate products to satisfy their basic needs, for example, in the field of housing. This meant giving up for good the original concept of an art academy. Many artists left the Bauhaus, among them Schlemmer, Klee, Moholy-Nagy. In 1930 Meyer, too, left the Bauhaus, emigrating to Moscow with twelve students to escape the political pressure in Germany.

Mies van der Rohe was named the new director, but in 1932 the Nazis closed the Bauhaus in Dessau. Mies attempted to keep it going as an independent institute in Berlin, but the Bauhaus disbanded just a few months after Adolf Hitler seized power in Berlin, on 20 July 1933 (Hahn 1985).

THE GOALS OF THE BAUHAUS

The Bauhaus had two central aims:

- to achieve a new aesthetic synthesis by integrating all the artistic genres and craft trades under the primacy of architecture, and
- to achieve a social synthesis by aligning aesthetic production with the needs of the general population.

Both of these aspects became central categories of design activity over the course of the subsequent decades. Aside from its purely educational contributions, the Bauhaus was also a “school of life,” where

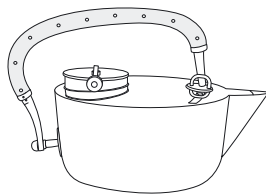
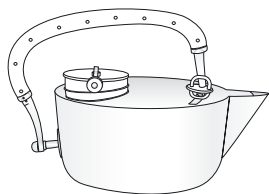
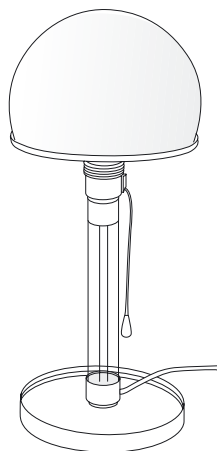
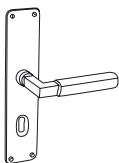
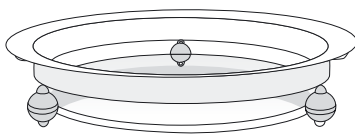
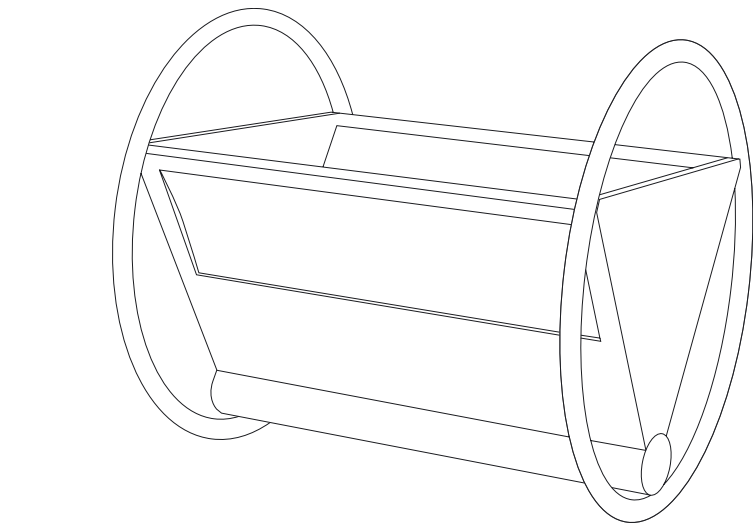
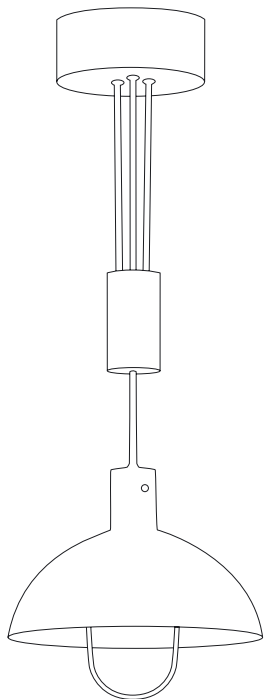

- CRADLE, design: Peter Kehler (1922)
 ME 105 CEILING LAMP, design: Marianne Brandt/Hans Przyrembel (1926)
 FRUIT BOWL, design: Josef Albers (1923)
 TABLE LAMP, design: Carl Jacob Jucker/
 Wilhelm Wagenfeld (1923/24)
 DOOR HANDLE for the Bauhaus Building in
 Dessau, design: Walter Gropius (1929)
 TEA MACHINE, design: Marianne Brandt
 (1928/30)

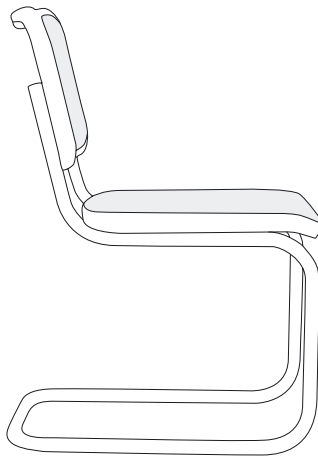
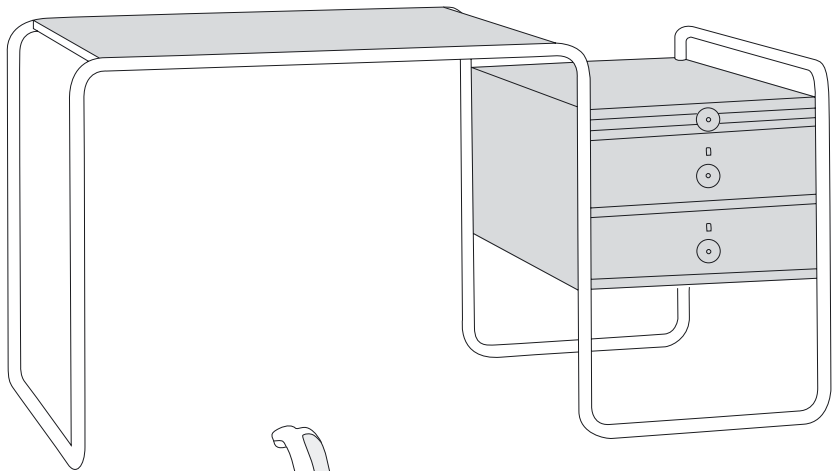
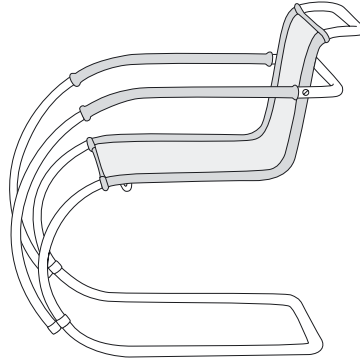

CHAIR WITH ARMRESTS, design: Mies van der Rohe (1927)

B 65 DESK, design: Marcel Breuer (1929/30)

TUBULAR STEEL CHAIR, design: Mart Stam (1928)

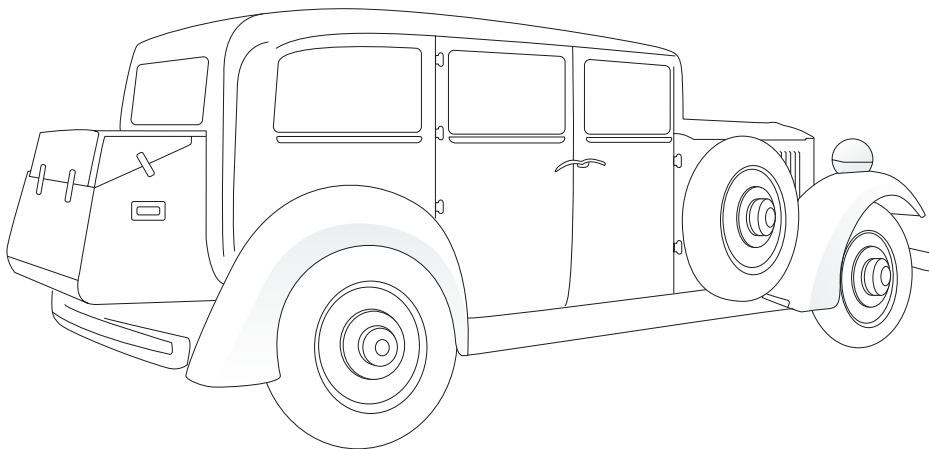
 Design Center Stuttgart

INVITATION to the "Wilhelm Wagenfeld"
exhibition, Design Center Stuttgart, 1988
LIMOUSINE, design: Walter Gropius (1929/33),
Adler-Automobilwerke

teachers and students practiced a shared constructivist philosophy of life (Wünsche 1989), and which, during the Weimar phase at least, resembled a “closed community,” as Moholy-Nagy put it. This common identity was certainly crucial in building the almost missionary zeal with which the Bauhaus idea was transported all over the world. Similar phenomena can also be found after World War II at the Ulm School of Design. The voluminous work by Fiedler and Feierabend (1999), quickly established as the second major standard work after the “Wingler,” does justice to these previously largely disregarded facets of the Bauhaus.

THE INFLUENCE OF THE BAUHAUS ON PRODUCT DESIGN CULTURE

Walter Gropius’s postulate, “art and technology – a new unity,” was aimed at producing new experts in industry who would be competent both in modern technology and in the corresponding language of form. Gropius thus laid the groundwork for the transformation in vocational practice that turned the traditional artisan craftsman into the modern industrial designer.

The methods of eidetic inquiry, functional analysis, and a nascent science of form were to be used to elucidate the objective conditions for design. In 1926 Gropius formulated this as follows: “A thing is determined by its nature. In order to design it so that it functions properly, whether it be a vessel, a chair, or a house, its nature must first be investigated, because it should serve its purpose perfectly, meaning that it fulfills its functions practically, is long-lasting, inexpensive, and attractive” (Eckstein 1985). The concept of “eidetic marks” (Fischer and Mikosch 1983) also stands in this tradition, denoting as it does that every product has typical marks, or visualizations of practical functions, that point to the specifics of a product class.

This social stance is particularly apparent in the work of Bauhaus student Wilhelm Wagenfeld, who was adamant that mass-produced goods should be both cheap and excellently designed and made. His designs for the Lausitz Glassworks and WMF (Württembergische Metallwarenfabrik) have become so widespread that they occupy an almost anonymous position in everyday culture, because Wagenfeld as a designer gave prominence to his products rather than his person (for his lifework see Manske and Scholz 1987).

It should, however, be pointed out that the Bauhaus designs had no influence on the mass culture of the 1930s. Purchasers of Bauhaus products came from intellectual circles, which were open to new design concepts. Nonetheless, looking back from today's perspective, we can certainly speak of a "Bauhaus style" that was a formative influence in twentieth-century design (Bittner 2003).

BAUHAUS AND FURNITURE DESIGN

Design at the Bauhaus was largely shaped by a generation of young architects whose main interest was the functions of products and the surroundings of those who lived in buildings. In a radical break with the nineteenth century (the period that gave us the plush decor of the upper-middle-class home), designers turned their attention to technological questions. Fascination with new construction methods led to functionally reconceived "type furniture." At this early stage the allure of technology was already giving rise to a symbolism of its own. Steel tubing in the apartment became a trademark of the intellectual avant-garde. However, the market potential of such furniture was not exploited properly until the 1960s, for example, by Cassina and other Italian furniture manufacturers.

THE INFLUENCE OF THE BAUHAUS ON DESIGN TRAINING

When political developments forced many Bauhaus students and teachers into emigration, the pioneering Bauhaus concepts were carried across the world and developed further in research, teaching, and practical application:

- 1926: Johannes Itten founds a private art school in Berlin.
- 1928: the "Budapest Bauhaus" (Mühely) is set up in Hungary with Sandor Bortnik as its head.
- 1933: Josef Albers goes to Black Mountain College in North Carolina, where he teaches until 1949.
- 1937: The New Bauhaus with Moholy-Nagy as its head is founded in Chicago.
- also in 1937: Walter Gropius is appointed head of the Department of Architecture at the Harvard Graduate School of Design. Marcel Breuer also teaches there until 1946.

In fact, our actions did not proceed from art, but rather from things and thus actually from people. Thus we equated artistic design with technical realization, albeit from another perspective.

— WILHELM WAGENFELD, 1948



CARPETING BY "FRAUEN AM BAUHAUS" (women
at Bauhaus)

CLASSIC, design: Gertrud Arndt,
Vorwerk Teppichwerke



- 1938: Mies van der Rohe is appointed head of the Department of Architecture at the Armour Institute of Technology in Chicago, which joins with other institutes in 1940 to form the influential Illinois Institute of Technology.
- 1939: Moholy-Nagy founds the School of Design in Chicago, re-named the Institute of Design, with college status, in 1944.
- 1949: under Moholy-Nagy's successor, Serge Chermayeff, the Institute of Design merges into the Illinois Institute of Technology and gains university status. Under Chermayeff special departments are set up for visual design, product design, architecture, and photography. Many design schools across the world subsequently adopt this same structure.
- 1950–1959: Albers teaches at Yale University in New Haven, Connecticut, where he prepares his famous investigation of color, *Interaction of Colour* (Albers 1963, 1977), which is still used in color courses, especially in foundation courses for designers.

THE ULM SCHOOL OF DESIGN

The most significant new institution to be founded after World War II was the Ulm School of Design. Just as the Bauhaus put its decisive stamp on the architecture, design, and art of the 1920s, the Ulm School of Design also exerted such manifold influences on the theory, practice, and teaching of design and visual communication that a direct comparison of the two institutions would seem legitimate. The Swiss Max Bill, who himself studied at the Bauhaus from 1927 to 1929, was involved in setting up the Ulm School of Design and was its rector until 1956. Former Bauhaus staff who taught as visiting lecturers in Ulm included Albers, Itten, and Walter Peterhans. The School's curriculum, too, initially adhered closely to the Dessau Bauhaus model.

Continuity is also apparent in Walter Gropius's inaugural speech of 1955. He spoke of the significant role of the artist in an advanced democracy, and rejected the charge that the Bauhaus had promoted a one-sided rationalism. In his work, Gropius said, he was searching for a new equilibrium between the practical and the aesthetic, psychological demands of the age. Gropius understood functionalism in

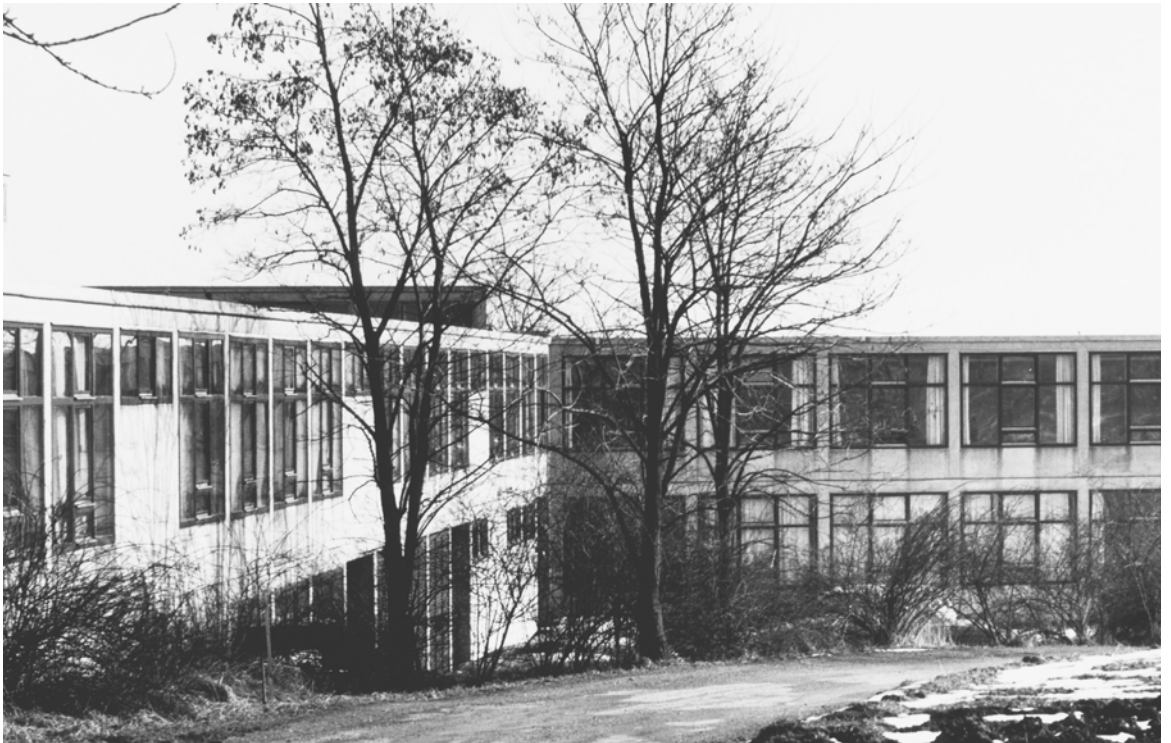
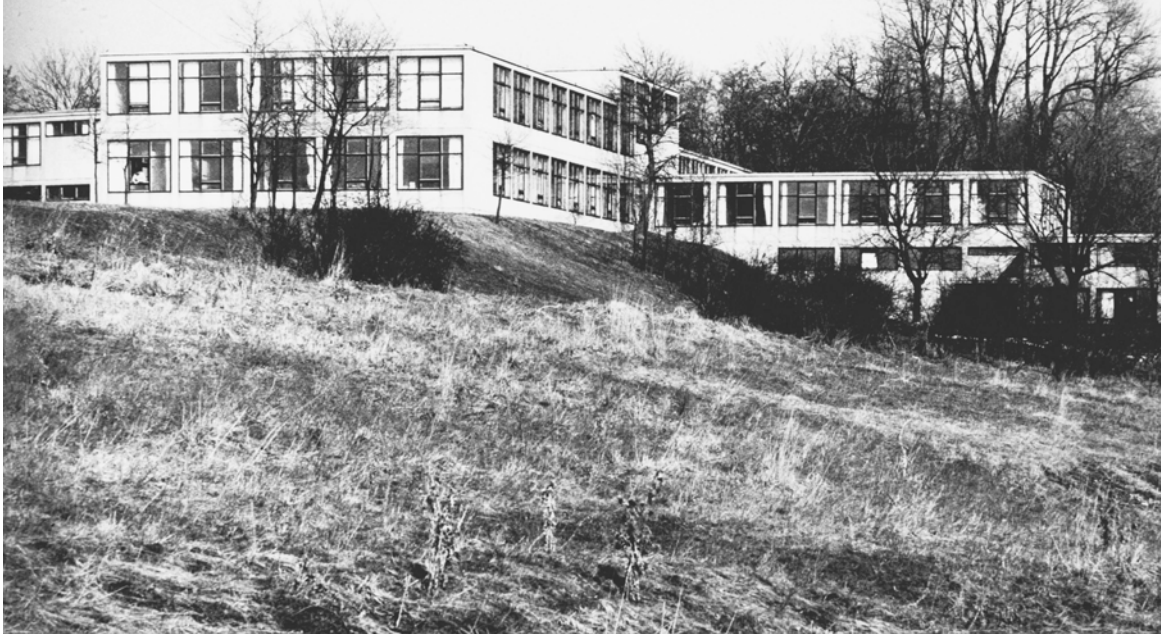

ULM SCHOOL OF DESIGN BUILDING (1967)

(Photos: Bürdek archive)

design to mean providing the products to satisfy the physical and psychological needs of the population. Gropius saw questions about the beauty of form, especially, as being psychological in nature. He believed that the task of a college was not only to educate the intellect by teaching the acquisition of knowledge, but also to educate the senses.

In the wake of a growing interest in its history, the Ulm School of Design has been the subject of increased attention since the 1980s. In 1982 the HfG-Synopse working party illustrated the events and developments at the School by means of documents arranged in a synchronous visual presentation (Roericht 1982, 1985). This presentation was used as the basis for an exhibition about the Ulm School of Design (for the documentation published at the same time, see Lindinger 1987). Several dissertations have been written from an art history perspective, including a quite controversial one by Hartmut Seeling (1985), one by Eva von Seckendorff (1989), and an extremely meticulous one by René Spitz (2001), who dealt in particular with the institutional processes and political and social context of the Ulm School of Design. Since autumn 2003 a traveling exhibition and an associated catalog entitled *ulm models – models after ulm* (Ulmer Museum and HfG-Archiv 2003) have been presented.

Today the hfg could be interpreted as something that for a few years constituted the realization of the old dream of a technical-humanistic institution of higher education, with goals that represented an alternative to the technical institutions of higher education.

— RENÉ SPITZ, 2001

THE SIX DEVELOPMENT PHASES

We can identify six distinct phases in the history of the Ulm School of Design:

1947–1953

To commemorate her brother and sister, Hans and Sophie Scholl, who had been executed by the Nazis, Inge Scholl proposed setting up a foundation with the objective of starting a college where vocational skills and cultural creativity would be allied with political responsibility. On the initiative of John McCloy, the American High Commissioner for Germany, the Geschwister Scholl Foundation was set up as the institution responsible for the Ulm School of Design.

Inge Scholl, Otl Aicher, Max Bill, and Walter Zeischegg led the development work on the concept for the school, and in 1953 construction of the building, designed by Bill, began.



D00R HANDLES at the Ulm School of Design,
design: Max Bill/Ernst Moeckl
(hfg ulm homage 2003)
(Photos: Bürdek archive)

1953-1956

The first students at Ulm were taught in temporary accommodation by former Bauhaus teachers Helene Nonné-Schmidt, Walter Peterhans, Josef Albers, and Johannes Itten. The teaching represented a direct continuation of the Bauhaus tradition, although there were no painting or sculpture classes; in fact, there was no free or applied art at all. The first newly appointed lecturers had an artistic educational background, but the Ulm School of Design actually only had an instrumental interest in the knowledge of art, for instance, in its application in foundation course projects.

In 1954 Max Bill was appointed the first rector of the Ulm School of Design, and the official opening of the new building on the slopes of the Kuhberg followed on 1 and 2 October 1955. In his opening speech Bill set out the institution's lofty ambitions: "Our goal is clear. All activities at the School are directed to participation in building a new culture, with the aim of creating a way of life concomitant with the technical age we live in. . . . Our culture today has been too deeply shaken for us to start building again, so to speak, at the top of the pyramid. We have to begin at the bottom by examining the foundations" (Spitz 2001).

Otl Aicher, Hans Gugelot, and Tomás Maldonado were appointed as the School's first lecturers.

1956-1958

This phase was characterized by the inclusion of new scientific disciplines in the curriculum. The lecturers, Aicher, Maldonado, Gugelot, and Zeischegg in particular, pointed out the close relationships between design, science, and technology. Max Bill left the School in 1957 because he no longer agreed with the direction it was taking. This phase was also marked by the preparation of an educational model for the School, which Maldonado countersigned in 1958 with a clear statement: "As you can see we have spared no effort to put the work of the School on a precise footing" (Spitz 2001).

1958-1962

Disciplines such as ergonomics, mathematical techniques, economics, physics, politics, psychology, semiotics, sociology, and theory of science grew in importance in the curriculum. The Ulm School of Design thus stood clearly in the tradition of German rationalism, trying as it

did to demonstrate “scientific character,” in particular through the application of mathematical methods. At the same time, the selection of disciplines to be included in the curriculum was also heavily influenced by the choice of visiting lecturers willing to come at a particular time, and was therefore rarely characterized by continuity. Despite upholding its avant-garde, intellectual claims, the School ultimately proved unsuccessful in rigorous theoretical work. Hence, Michael Erlhoff’s claim that the last well-founded design concept was developed at the School, appears problematic to me, because what was discussed in Ulm – and was integrated into teaching and research – was a series of rather random theoretical fragments and chance discoveries (Bürdek 2003).

Walter Zeischegg, Horst Rittel, Herbert Lindinger, and Gui Bonsiepe were appointed as lecturers in the Product Design Department. During this time particular emphasis was placed on developing design methods; modular design and system design came to the fore in design projects.

1962–1966

During this phase equilibrium was achieved between theoretical and practical disciplines in the curriculum. Teaching itself was very strongly formalized and became a reference model for many other design schools throughout the world.

Increasingly, projects for industrial clients were handled by independent development groups (institutes), while at the same time industry’s interest in exploiting design for its own ends became ever clearer. German corporations were quick to recognize that the principles applied at the Ulm School of Design could be used to realize rational manufacturing concepts that were particularly well suited to the technologies of the time. From outside, the Ulm School of Design itself was no longer regarded as a university-level institution in terms of research and development, and as a result, using the justification of “no research, no funding,” the German government stopped financing the School (Spitz 2001).

1967–1968

During the final two years, attempts to preserve the School’s autonomy sparked a search for new ideas and institutional structures, which, however, never came to fruition. The demands of the state parliament of Baden-Württemberg for new concepts were not met,

The attempt to integrate science in design can be regarded as a failure. Science is oriented toward the production of new knowledge; design is intervention in practice.

— GUI BONSIPE, 2002

not least because of internal disagreements among the staff and students, and as a result the School of Design closed its doors at the end of 1968 (Spitz 2001).

Quite apart from all the often-cited political reasons, the School also failed because after the mid-1960s it was unable to generate modern concepts and ideas. The critique of functionalism that arose at that time and the debate over ecological questions that took off a little later fell on deaf ears at the School. The institutes, in particular, had become so strongly commercialized through industrial projects that many lecturers could no longer be said to possess independence and critical detachment. Once the Ulm style had finally been established, it proved impossible to resist the temptation to reap the rewards in industry. These entanglements made it impossible to find solutions that would have satisfied the massive demands made by students at the same time: demands for work to be socially relevant and for colleges and universities to maintain academic independence.

The Institute for Environmental Planning

In 1969 Stuttgart University opened an Institute for Environmental Planning in the buildings of the Ulm School of Design. The intention was to continue the former School's work while opening up its narrow definition of design. The Institute increasingly dedicated itself to social and political issues, which the students' movement of 1967–1968 had brought to the awareness of designers (Klar 1968; Kuby 1969). Losing the autonomous status of an independent university meant that the Institute was heavily dependent on Stuttgart University, which shut it down in 1972. It should be mentioned, however, that a working party at the Institute in this period sketched out the groundwork for a reorientation of design theory (see p. 276).

THE DEPARTMENTS OF THE ULM SCHOOL OF DESIGN

A brief examination of the School's individual departments also shows where its work was focused.

Foundation Course

As at the Bauhaus, the foundation course was taken very seriously at Ulm. Its goal was to teach the general fundamentals of design, theoretical and scientific knowledge, and to introduce students to the



STUDENT ASSEMBLY at the Ulm
School of Design
(Photos: Bürdek archive)

practical work of design (including model-making and techniques of representation). Here, too, the teaching method aimed to sensitize the faculties of perception through experimentation with the elementary tools of design (colors, forms, Gestalt laws, materials, surfaces). Initially strongly influenced by Bauhaus, over time the foundation course moved in the direction of a visual methodology with a precise mathematical and geometrical basis (Lindinger 1987).

The ultimate intention of the foundation course at Ulm, however, was to achieve intellectual discipline by training students in manual precision. Cartesian thought dominated scientific theory. Thinking was governed by the wish for rationality, for strict form and construction. Only the "exact" natural sciences were truly accepted as reference disciplines. Mathematical disciplines, especially, were investigated with respect to possible applications in design (Maldonado and Bonsiepe 1964), including:

- combinatorial analysis (for modular systems and problems of dimensional coordination),
- group theory (in the form of a theory of symmetry for constructing networks and grids),
- curve theory (for mathematical treatment of transitions and transformations),
- polyhedral geometry (for constructing bodies), and
- topology (for problems of order, continuity, and neighborhood).

Students were trained to carry out conscious, controlled design, and taught a way of thinking that mirrored the task definitions that they would later have to work through in the fields of product design, industrialized construction, or communication (Rübenach 1958-1959, 1987).

Architecture

The Department of Architecture concentrated on prefabricated construction methods, with training focusing on construction elements, connection techniques, production management, and modular design. These methods were to be applied primarily in order to create affordable accommodation for a large section of the population. In its approach to design, the Ulm School took up the ideas of Hannes Meyer at the Bauhaus, which also fitted seamlessly with the trend for prefabricated design in the construction industry at that time.

One recognizes how ingenious a thing can be – and how banal art.

—ANGELIKA BAUER, 2004

Film

A separate Film Department was set up in 1961. As well as learning the required practical and technical skills, students also developed new experimental forms of film. The lecturers were Edgar Reitz, Alexander Kluge, and Christian Straub. The Film Department set itself up as the independent Institute of Film Design in October 1967.

Information Studies

The aim of this department was to train students for new professions in the press, film, radio, and television. The three most influential lecturers were Max Bense, Abraham A. Moles, and Gerd Kalow. The Information Studies Department also attempted to apply information theory to other areas of design.

Product Design

This department's interests were centered on developing and designing industrially mass-produced products to be used in everyday contexts, offices, and factories. Special emphasis was placed on a design method that takes into consideration all the factors that determine a product: functional, cultural, technological, and economic.

Design projects focused less on individual products than on questions of product systems, through which a unified image could be achieved: for example, a corporate design for a business. Appliances, machines, and instruments were the main product sectors. Objects that possessed an artistic or craft character were more or less taboo, nor was the design of prestige and luxury items part of the task definition of the Product Design Department.

Visual Communication

The problems of mass communication were the main interest of this department. Design projects here covered the whole spectrum from typography, photography, packaging systems, and exhibition systems right through to technical communications, designing displays, and developing sign systems.

THE EDUCATIONAL IMPACT OF THE ULM SCHOOL OF DESIGN

Like the Bauhaus, the Ulm School of Design continued to be exceptionally influential after its closure, despite its relatively short existence of just fifteen years. The School's graduates also benefited from a fortunate circumstance. Public-sector employers (for instance in Germany) prefer job applicants to hold a university degree. Until well into the 1960s only graduates from Ulm were able to meet this condition in the field of design. With their internalized rigid Cartesian thought they guaranteed that "deviating tendencies" were nipped in the bud or prevented from germinating in the first place. This also explains the very clear demarcation between design on the one hand, and arts and crafts on the other, during that period. In the end this provoked the postmodernist countercurrent of the 1980s, which attracted a great deal of attention to design but remained ultimately counterproductive, because little progress was made in the fundamental science of the discipline. In fact, today, at those universities where both free and applied arts are taught, we find that the much-trumpeted interdisciplinary dialog of the subjects fails in the face of an insistence on status by the supposedly "free" and apparently "independent" artists, among whom ways of thinking that date right back to the independent art academies of the nineteenth century are still very widespread. So it appears that design schools are especially successful when they demonstrate active, broad involvement in cultural contexts, which does not necessarily mean only the free arts, but can also include architecture, stage design, production and event design, film, photography, literature, fashion, music, pop culture, urban and regional planning, and theater.

The field of design methodology, in particular, would be unimaginable without the work of the Ulm School of Design. Dealing systematically with problems, using methods of analysis and synthesis, and justifying and selecting design alternatives, are today all part of the common repertoire of the design profession. Ulm was the first school of design to place itself absolutely and intentionally in the intellectual tradition of modernism.

Just as the members of the Bauhaus saw themselves not only as artists, architects, or designers, but also as a residential and intellectual community (Fiedler and Feierabend 1999), the "Ulmer" also saw themselves as a group with a similar character. Although a total of

During the heyday of the hfg ulm, the design discourse was about as well developed as scientific chemistry in the age of alchemy.

— GUI BONSIPEPE, 2002

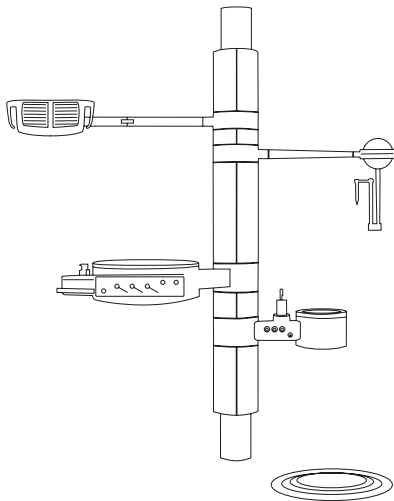
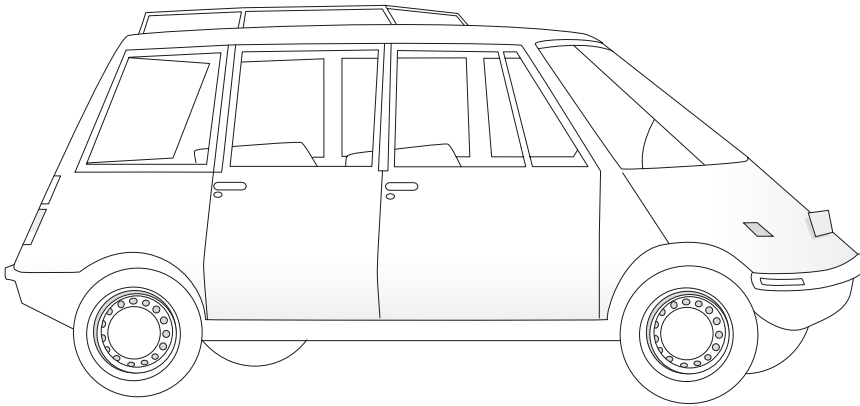
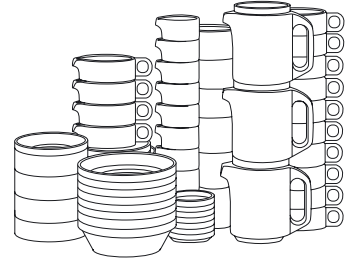
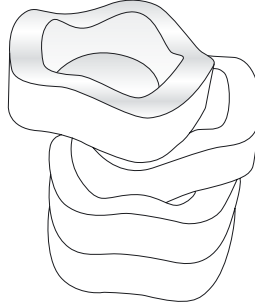
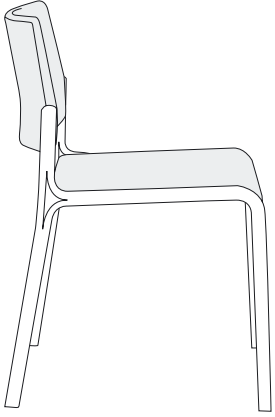

PLYWOOD CHAIR, design: Wilhelm Ritz (1958/59),

Wilkhahn

STACKABLE ASHTRAYS, design: Walter Zeischegg (1967),

Helit

TC 100 STACKABLE DISHES, design: Hans Roericht (1958/59), Thomas/Rosenthal

AUTONOVA FAM, design: Fritz B. Busch, Michael Conrad, Pio Manzù (1965)

DENTAL UNIT, design: Peter Beck, Peter Emmer, Dieter Reich (1961/62)

ANIMAL BUILDING BLOCKS, design: Hans von Klier (1958)

CAROUSEL 5 SLIDE PROJECTOR, design: Hans Gugelot (1963), Kodak

STREETLAMP, design: Peter Hofmeister, Thomas Mentzel, Werner Zemp (1965/66)

ELEVATED TRAIN in Hamburg, design: Hans Gugelot, Herbert Lindinger, Helmut Müller-Kühn (1961/62)

ULMER STools, design: Max Bill, Hans Gugelot, Paul Hildinger (1954)

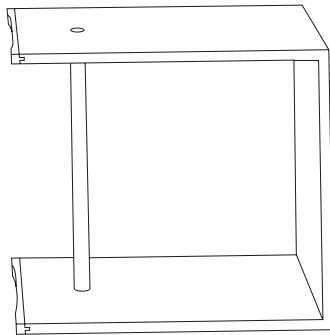
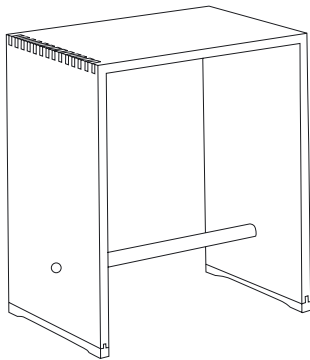
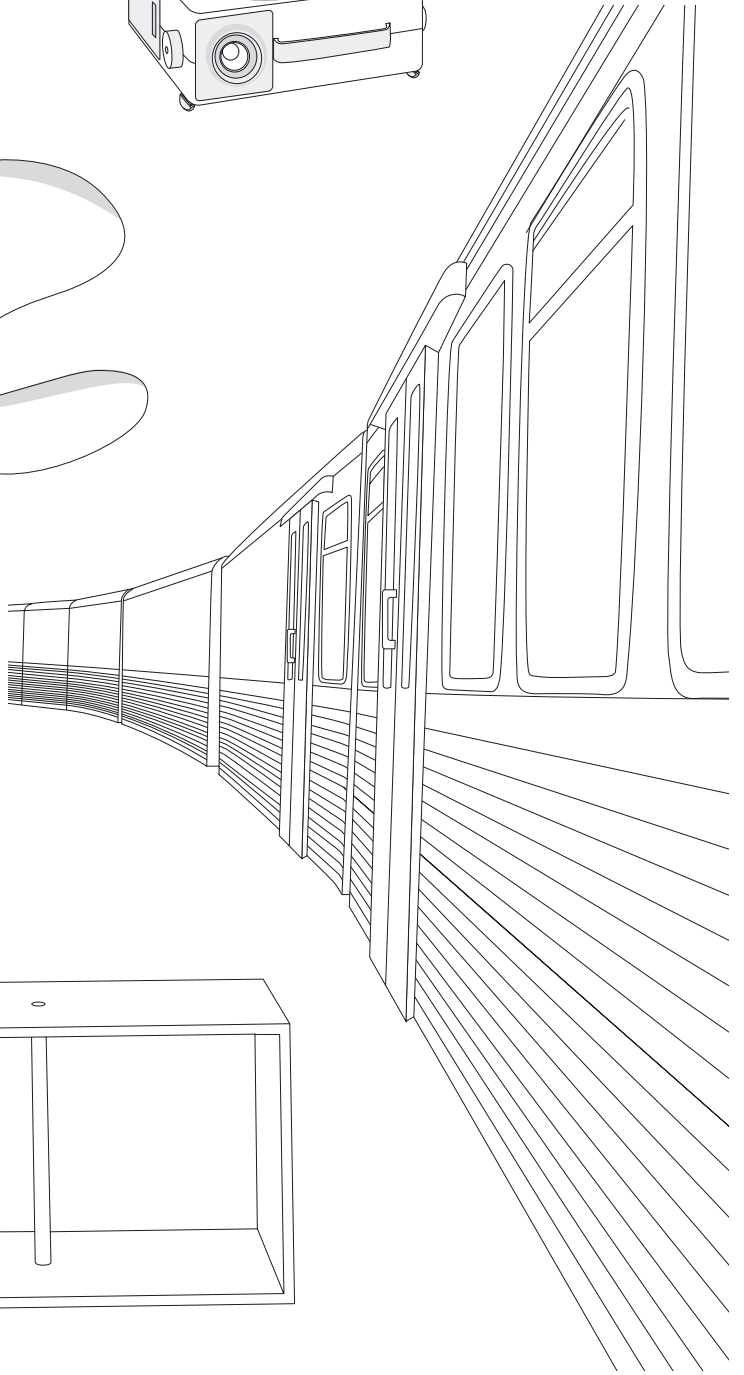
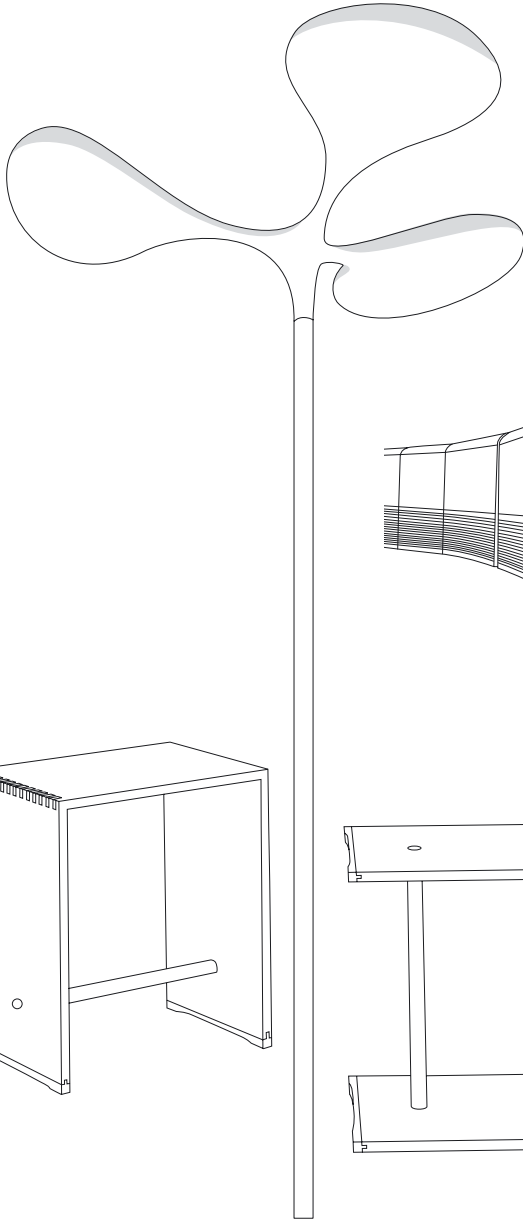
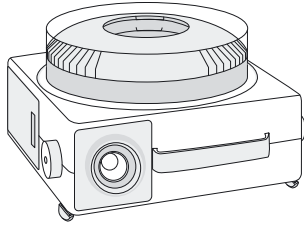
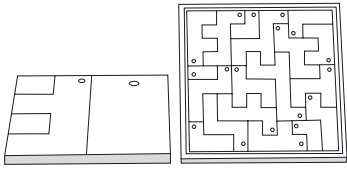

640 students studied there, only 215 left the School with a degree, so it is certainly correct to speak of a “Mayflower effect” (Bürdek 1980).

Today, having studied at Ulm has taken on the same kind of importance for a designer as being able to trace one’s ancestry back to the Mayflower does for Americans.

A rough overview shows that about half the Ulm graduates work in design agencies or corporate design departments. Many product designers went to Italy, while the architects generally settled in Switzerland. The other half work, or have worked, in higher education. It is down to this second group and their participation in the curriculum reform of the 1970s (which produced new university regulations and examination rules) that the Ulm ideas have been incorporated into the respective curricula.

It is, above all, abroad that the Ulm School of Design has made its ideas felt. In a migration that echoes the Bauhaus exodus after 1933 – although the reasons are very different, of course – many lecturers and students from Ulm went out across the world in search of new challenges:

- In the 1960s designers from Ulm played a crucial role in setting up the Escola Superior de Desenho (ESDI) in Rio de Janeiro.
- At the beginning of the 1970s an Institute of Environmental Design was founded in Paris, although it only existed for a few years.
- At the same time in Chile attempts were made to develop products for basic needs. The design concepts were very strongly influenced by Ulm (Bonsiepe 1974).
- The influence of Ulm is apparent in India at both the National Institute of Design in Ahmedabad and the Industrial Design Center in Bombay.
- The same applies to the Oficina Nacional de Diseño Industrial (ONDI) in Cuba, the postgraduate course for designers at the Universidad Autónoma Metropolitana (UAM) in Mexico City, and the former Laboratorio Asociado in Florianopolis, Brazil.

The flaw in reasoning upon which the hfg was founded was a utopia, and it does honor to its creators that they took it upon themselves to make this utopia reality: that was what constituted the experiment hfg. That which I have designated in my analysis to be a flaw in reasoning, as the reason for the failure of the hfg, is the forbidden mingling of design and social-policy ideas and demands. For when the quality of design is at issue, equal rights for tolerance and participation in decision-making are inappropriate.

— RENE SPITZ, 2001

THE INFLUENCE OF THE ULM SCHOOL OF DESIGN ON PRODUCT CULTURE

The Ulm design principles were applied quickly in an exemplary industrial context in the 1960s through the School’s cooperation with

the Braun brothers. Braun became the fulcrum of a movement that gained worldwide attention as “good design,” which ideally matched the manufacturing possibilities of industry while also gaining rapid market acceptance when it was applied to consumer and capital goods. Over a span of two decades, good design, el buen diseño, bel design, and gute Form have become more or less international trademarks of German design. The concept met its first serious challenge in the 1970s (critique of functionalism), and an even stronger one in the early 1980s (postmodernism). Nonetheless, many German businesses have applied its principles with considerable success.

THE EXAMPLE OF BRAUN

No other company has had such a decisive influence on the development of design in Germany as Braun in Kronberg near Frankfurt. An unbroken tradition of modernism guides Braun’s business and design policies to this day. For many decades Braun was a model for many other companies, and not only in Germany.

THE BEGINNINGS

After World War II Max Braun started rebuilding his company, in which his sons Erwin and Artur Braun took on commercial and technical responsibilities in 1950. Initially the company produced electric razors, radios, kitchen appliances, and electronic flash equipment.

At the beginning of the 1950s Fritz Eichler, who was responsible for the company’s design policies, initiated a collaboration with the Ulm School of Design to develop a new product line. Hans Gugelot, then a lecturer at the Ulm School, had a decisive part in this work. In 1955 Dieter Rams – who incidentally studied not only at Ulm but also at the School of Arts and Crafts in Wiesbaden – started work as an architect and interior designer at Braun, where he was already taking on his first product design tasks by 1956 (Burkhardt and Frankson 1980). Hans Gugelot and Herbert Hirche worked with Rams to create the first substantive basis for Braun’s corporate image.



HIGH-FIDELITY SOUND SYSTEM, t+a akustik
606 SHELVES, design: Dieter Rams, sd+

THE PRINCIPLES

The implementation of functionalist principles is extremely clear in Braun's products (Industry Forum Design Hannover 1990). Their characteristic features include:

- high fitness for use,
- fulfillment of ergonomic and physiological requirements,
- high functional order of individual products,
- painstaking design down to the smallest detail,
- harmonious design, achieved with simple means,
- intelligent design, based on innovative technology and the needs and behavior of the user.

Firmly in the tradition of classical modernism, Dieter Rams describes his work as a designer as "Less design is more design," a direct reference to the "Less is more" of Mies van der Rohe, whose affirmation of the International Style was so influential for architecture after World War II. Although Robert Venturi had already aptly parodied Mies with "Less is bore" in 1966, that discussion had almost no influence on Rams.

In the example of Braun, it is clear how the unity of technological concept, controlled product design, and strictly ordered means of communication (as in letterheads, brochures, catalogs) produces an overall visual appearance for the company, one that is exemplary in its stringency. This kind of coordination of all design elements is known as a business's corporate design.

BRAUN AFTER DIETER RAMS

The ramifications of the postmodernist design of the 1980s were not felt in Braun's product culture until the second half of the 1990s. The great success of firms like Alessi, Authentics, Koziol, and Philips, who flooded department stores and boutiques with product lines adorned with the style elements of a new pop culture, did not go unnoticed at a corporation like Braun. As head of the Design Department until 1997, Dieter Rams had been one of the most tenacious advocates of German functionalism (Klatt and Jatzke-Wigand 2002), so when he left in 1997 his decisive – but also rigid – influence on Braun's product designs came to an end. The growing influence of marketing strate-

I think the company was happy that I had reached retirement age, for some of them just couldn't hear "less but better" any more.
— DIETER RAMS, 2001

gies increasingly based on global design led to a loss of uniqueness in many product sectors too (Braun Design 2002).

FROM GOOD DESIGN TO THE ART OF DESIGN

IT ALL BEGAN WITH SULLIVAN

For a long time the commonly used definition of function was based on a glaring misunderstanding of the theses of American architect Louis H. Sullivan (1856–1924), who was actually interested not only in the practical function of buildings, but also in the semiotic dimensions of the objects: “All things in nature have a shape, that is to say, a form, an outward semblance, that tells us what they are, that distinguishes them from ourselves and from each other.” (Sullivan 1896). What Sullivan wanted was for life and form to correspond and harmonize completely but that has hardly been reflected in “good design” as practiced in the twentieth century.

Adolf Loos, author of *Ornament und Verbrechen (Ornament and Crime, 1908)*, initiated the development of rational design in Europe, which spread largely through the rapid expansion of industrial methods of production. Loos failed, however, to recognize that the everyday needs of the population were complex and generally shaped by traditional aesthetic models. Even before the work of the Bauhaus, Ernst Bloch attempted dialectically to at least keep the rigid dictum of ornamentlessness a little open.

Loos’s ideas had their first heyday during the Bauhaus period. The design approach and methodology developed there was understood as overcoming styles, although in fact, their strict application gave rise to a new style, which became the symbol of a small intellectual and progressive stratum of the population, who demonstrated it in their houses and apartments through tubular steel furniture and spartan bookcases.

Functionalism’s real boom came after World War II in the Federal Republic of Germany, and a few years later in East Germany, too. As mass production started up again, it was seen as a suitable tool for standardizing and rationalizing manufacturing. That applied to both design and architecture. This concept was developed systematically and refined – in theory and practice – during the 1960s, especially at the Ulm School of Design.

Obstetric forceps have to be smooth, sugar tongs not at all.

— ERNST BLOCH, 1918



KITCHEN STOVE, Dessauer
POCKET BINOCULARS, Minox
MP VIEWFINDER CAMERA, Leica

THE RADICAL SIXTIES

The first signs of crisis appeared in certain European countries in the mid-1960s. The lengthy economic upturn that had followed World War II was almost at an end. The long Vietnam War gave rise to student protest movements in the United States, which were soon taken up in Europe in the Prague Spring, the May uprising in Paris, and demonstrations in Berlin and Frankfurt am Main. Their shared foundation was their critique of society, which is subsumed under the term "New Left" in Western Europe. In Germany this movement took its fundamental arguments from the theoretical works of the Frankfurt School: Theodor W. Adorno, Max Horkheimer, Herbert Marcuse, Jürgen Habermas, and others.

The work of Wolfgang Fritz Haug proved to be particularly important for design. His *Critique of Commodity Aesthetics* investigated, from a marxist perspective, the dual nature of commodities (products), which can be defined by their use value and exchange value. In several examples, Haug demonstrated how design functions as a means of increasing exchange value or, in other words, how aesthetic design cannot increase the use value of objects (see p. 276).

The critique of functionalism had a particularly incendiary effect on architecture and urban planning. The International Style, which had been demonstrated very clearly in the Stuttgart Weissenhof project (Hitchcock and Johnson 1966), reappeared in a perverted form in the satellite towns around many conurbations. In Germany these included Märkisches Viertel in Berlin, Nordweststadt in Frankfurt, Neu-Perlach near Munich, and the Marzahn district of East Berlin. Later, this type of mass-produced environment was even accused of representing repression and violation of the human psyche (Gorsen, 1979).

The work of Alexander Mitscherlich (1965), Theodor W. Adorno's 1965 lecture "Functionalism Today," and the contributions of Heide Berndt, Alfred Lorenzer, and Klaus Horn (1968) were especially important milestones in the scientific criticism of functionalism.

Criticism of functionalism was much slower to surface within design. Abraham A. Moles (1968) saw instead the problems of an affluent society rearing their heads, and drew from the crisis of functionalism the conclusion that functionalism had to be interpreted even more rigidly. His *Magna Carta of functionalism* produced an outlook on life based on frugality and the rational use of existing means for clearly defined purposes.

Architect Werner Nehls responded with polemical irony, shocking the design scene with his opinion that the rational and functionalist understanding of design was completely outdated. Designers were producing wrong design, Nehls said, to exactly the extent that they were trapped in the ideas of the Bauhaus and the Ulm School of Design. Right angles, straight lines, geometric or objective forms, open forms, lack of contrast, and colorlessness all had to go. "Furthermore, the planar-optical approach to design must be done away with, the cube, the design of the masculine. Today's design comes from a feminine stance, the emotional is emphasized. Feminine, irrational design prefers organic forms, contrasting colors, random attributes." (Nehls 1968) This understanding of design was practiced to excess by Luigi Colani (Dunas 1993). He, in particular, exploited in exemplary fashion the freedoms offered by inexpensive new plastics and expressed them in design.

Distinguishing between the functionalism of the Bauhaus and of the Ulm School of Design, Gerda Müller-Krauspe (1969) advocated an "expanded functionalism," defined as an interpretation of design whose proponents attempt to discover as many product-determining factors as possible and include them in the design process. The role of the designer as coordinator was already featured in theory and practice at the Ulm School of Design.

THE FIRST ECOLOGICAL APPROACHES

At the beginning of the 1970s *The Limits to Growth* burst into public consciousness in the form of a report for the Club of Rome on the state of humanity (Meadows 1972). The authors stated clearly that continued exponential growth would cause industrialized nations to lose the basis of their existence within the foreseeable future. Rapid depletion of natural resources, rising population densities, and increasing pollution would lead to destabilization or a complete collapse of industrialized societies. Ecological demands were made for design, too, but they were largely disregarded.

Responding to such considerations, a working party entitled des-in at the Offenbach School of Design developed the first attempts at "recycling design" in 1974 for a competition run by the Internationales Design Zentrum Berlin (IDZ). This early model, which involved the

group designing, producing, and marketing its own products, was doomed to failure by the group's lack of business acumen. Nonetheless, des-in was probably the first group in the field of design to attempt to connect new theoretical concepts with an alternative design practice.

THE ECLECTICIST COUNTERMOVEMENT

In design, however, a movement in the opposite direction was to gain the upper hand. The influence of the eclecticist movement of post-modernism (or neomodernism), which had formed principally in Italy in the Memphis group (see p. 137), became increasingly noticeable in Germany. By 1983 Rolf-Peter Baacke, Uta Brandes, and Michael Erlhoff were already proclaiming the "new shine of things," in a book which gave a huge boost to design's change of course – in the sense of overcoming the doctrine of functionalism. Not only in Italy, and especially in Germany, there were a large number of designers who worked outside the framework of functionalist design ideology.

The architect, sculptor, and designer Stefan Wewerka designed mutated chairs that could not be sat on (Fischer, Gleininger, and Wewerka 1998). His one-legged cantilever chair takes up the tradition of the Bauhaus classics and pokes fun at them at the same time. In fact, Tecta, itself a manufacturer of furniture classics, saw Wewerka's chair as an important addition to its product range (Wewerka 1983).

In 1982, the Hamburg Museum of Arts and Crafts showed the first cross-section of new German design. Progressive furniture shops and galleries (for example, Möbel Perdu and Form und Funktion in Hamburg, Strand in Munich, and Quartett in Hannover) offered the designers – who caused a furor like the Neue Wilden of 1980s painting – a platform on which to present their objects (Hauffe 1994).

The young designers worked in groups like Bellefast in Berlin, Kunstflug in Düsseldorf, and Pentagon in Cologne. Solo designers such as Jan Roth, Stefan Blum, Michael Feith, Wolfgang Flatz, Jörg Ratzlaff, Stiletto, and Thomas Wendtland experimented with materials, forms, and colors, which they combined apparently at random. Discarded items found in refuse were mixed together with industrial, half-finished (or semi-manufactured) products (Albus and Borngräber 1992).

In the process, designers intentionally adopted artistic working methods, but they were interested in discovering new qualities and

No other designation sounds more obscene in the academy classes of painters and sculptors, no slander is more painful there, than the invective "designer."

— WALTER GRASSKAMP, 1991

expression in things rather than in founding some kind of elevated do-it-yourself movement. The separation of art and kitsch was dissolved too, and shops, boutiques, and galleries were created, as well as interiors for cafés and restaurants. The climax and swan song of the new German design came in the summer of 1986 in the Düsseldorf exhibition *Gefühlscollagen – Wohnen von Sinnen (Feeling Collages – Living Madness)* (Albus et al. 1986).

DESIGN ON THE THRONE OF ART

After design had finally thrown off its functional shackles in the apparent radicalism of the 1980s, it was only a matter of time before it would finally metamorphose into apparently pure art. The parallels here are obvious. During the 1980s art had largely subscribed to Jean Baudrillard's theory of simulation (1985), presenting itself as the art of spectacle and façade. This was demonstrated impressively in the summer of 1987 at the *documenta 8* in Kassel. There, design was practically seated on art's throne, where, as Michael Erlhoff (1987) insisted, it neither belonged nor wanted to be.

As well as a number of architects, the design section of *documenta 8* had invited about fifteen designers to present objects and environments, including the Spaniards Javier Mariscal and Oscar Tusquet Blanca, the Italians Lapo Binazzi, Paolo Deganello, Guglielmo Renzi, Denis Santachiara, and Ettore Sottsass, London-based Ron Arad, the Germans Andreas Brandolini, Florian Borkenhagen, and the Pentagon group. The displayed objects were largely unica and were suited to be neither prototypes nor models for any kind of series production whatsoever. Whether modernism, postmodernism, or post-postmodernism modernism, the displayed designs fitted perfectly into the new obscurity of the 1980s.

FROM DESIGN TO ART AND BACK AGAIN?

It would therefore be an obvious step to take a closer look at the transitions from art to design and vice versa. For more than a century the separations of art from craft, and design from art and craft, were clearly defined. However, just as designers had entered the territory of art in the 1980s, so had many artists long beforehand dedicated

Design clings to art like a child to its mother; a sixty-year-old child that does not want to accept that it has long come of age.

— WALTER GRASSKAMP, 1991

The true artists of our time are the industrial designers.

— GAETANO PESCE, 1988



DESIGNWERKSTATT BERLIN (1988)

MEDIA COMPONENTS STAND, design: Joachim B.

Stanitzek

COMPUTER DESK FOR WAITING AREAS, design:

Gabriel Kornreich

(Photos: Idris Kolodziej)



GEFÜHLSCOLLAGEN – WOHNEN VON SINNEN
EXHIBITION ("Feeling Collages – Living Madness"), Düsseldorf 1986
(Photo: Bürdek archive)

themselves to working on utility objects. Furniture and household objects were particularly popular objects for artistic reflection and production: Gerrit T. Rietveld's chairs, Constantin Brancusi's *Table of Silence*, Marcel Duchamps's ready-mades, René Magritte's surrealist objects, Salvador Dalí's *Mae West sofa*, Meret Oppenheim's *Table with Bird's Feet*, Allen Jones's *Green Table*, the installations of Kienholz and Segal. Claes Oldenburg and David Hockney, Timm Ulrichs, Wolf Vostell, Günther Uecker, Daniel Spoerri, Joseph Beuys, Richard Artschwager, Mario Merz, Franz Erhard Walther, Donald Judd, and, currently, Tobias Rehberger, as well as many others, have worked on utility objects. However, they were not interested in reconciling with design, but rather in alienating the products, calling the objects into question in paradoxical transformations, paraphrases, breaks, and fragments. "Furniture by artists contains the possibility of use, but that is not its primary intention. Its quality depends not on the degree of comfort, the space offered by shelves, or the ergonomics of the form" (Bochynek 1989). Franz Erhard Walther, one of the afore-mentioned artists, who also works in the field of objects, was once asked what he could learn from design. His simple reply was: "Nothing."

Here, however, a sea change took place during the 1990s. Design became a cultural flagship discipline that operated holistically, and now has more influence on art than vice versa. In fact, transdisciplinary concepts like the Prada Shop in New York (design: Rem Koolhaas) or the one in Tokyo (design: Herzog & de Meuron), often appear to be style-formative (Prada Aoyama Tokyo 2003).

The far-sighted sentence by Lucius Burckhardt, "Design is invisible," formulated as the title of an exhibition back in the 1970s, even today is countered much too often with the stupid line: "Design is art that makes itself useful" – an insult to both art and design.

— UTA BRANDES, 1998

Art and design are fundamentally different worlds of discourse. The former is directed toward individual self-realization; the latter toward solving societal problems.

— GUI BONSIPE, 2002



WEANER BLUT CHANDELIER, design:
Volker Albus (1987)

KUNSTFLUG COUNTRY CHAIR, design:
Harald Hullmann (1983)

SOLID CHAIR, design: Heinz H. Landes (1986)



CHAIR/CHAIR, design: Richard Artschwager,
Vitra Edition (Photo: Vitra)

INTERIOR DESIGN of the optician's shop of
Markus Nicolai, Frankfurt am Main, design:
Tobias Rehberger
general view/detail



VW'S NEW BEETLE

DESIGN AND GLOBALIZATION

During the 1990s design, too, was swept up by globalization as it took rapid hold on the Asia–Europe–America axis. Asian corporations from Japan and Taiwan recognized very early on the importance of design for their intensive marketing efforts. The degree of the socio-cultural differences between users means that assessments conducted from afar cannot produce adequate conclusions for product policy and design. Consequently, corporations and institutions opened contact offices in Europe, which functioned as probes in their respective markets. This is verified by various examples where agencies in Europe and the United States are commissioned by Asian corporations to develop products that are then marketed in those regions. Some major design agencies such as Design Continuum, frogdesign, and IDEO opened their own branches in Asia in order to cooperate more directly with clients there by having staff on the spot. Global networking allowed the design and development projects themselves to be handled in the European and American offices. European corporations, too, particularly in the electronics and automotive industries, opened offices abroad (especially in California) in order to follow current lifestyle trends more closely and to integrate the results of foreign studies more quickly into product development at home. The Audi TT was born on the drawing boards of a Californian agency and enjoyed equally spectacular success in America and Europe.

Another form of globalization involves utilizing differences in manufacturing conditions. Design is conducted centrally, while production is decentralized. In one example, Braun, based in the German town of Kronberg, has some of its electric shavers assembled in Shanghai. The motors are actually Chinese, while the rechargeable batteries come from Japan, and the heads for the high-quality blades are from Germany (Köhler 2002). It is then an obvious step to use these manufacturing structures to design products for the Chinese market in Europe, to be produced and sold in China.

In truth: Globalization is nothing new; Europeans have been globalizing staunchly for 500 years. My work proceeds along the same lines, showing that terrestrial globalization and the flight from its effects are equally old – namely a whole half-millennium, assuming that we interpret Columbus' first voyage in 1492 to have launched the age of globalization as it actually takes place.

— PETER SLOTERDIJK, 1999



AUDI TT
detail/general view

The current situation and future position of design in the tug-of-war between national and global remain important open questions for the discipline (Aldersey-Williams 1992). Might the new technologies, for example, allow us to do one thing without neglecting the other? These questions will be examined in the following chapters, taking as examples a selection of countries, in some of which design has been established for a long time, while others have seen design spring up only very recently. The résumé makes no pretense of totality, and is not intended to pronounce judgment.

GREAT BRITAIN

Great Britain is often called the home of design because it was there, in the eighteenth century, that industrialization began – certainly the most important single precondition for the development of industrial design. The invention of an efficient steam engine by the Scotsman James Watt marked the beginning of the long era of the industrial revolution. Used to power textile machines, the steam engine conquered the field of transport (locomotives, shipbuilding, land vehicles), as well as successively influencing the production of paper, glass, porcelain, and metal, to name but a few. New inventions left deep impressions as they spread out from Britain – initially to Europe and the United States – and dramatic changes were also felt in the socio-economic conditions of the population, in work life and home life, and in housing and urban planning. Never before in history had the world been transformed so radically and quickly as in the nineteenth century, a process in which Britain was to play a dominant global role until well into the twentieth century.

The history of the technical civilization that was made in Britain can be followed in two voluminous works, both of which are among the indispensable standard works about design. In his extremely knowledgeable and detailed *Mechanization Takes Command*, the Swiss Sigfried Giedion (1948) traces the early history of product development and design through the examples of numerous inventions, while the American Lewis Mumford's two-volume opus *The Myth of the Machine* (1964, 1966) describes how the process of developing and continuously refining machines has influenced technology, culture, sociology, and economics – the very framework of civilization.



VACUUM CLEANER, design: James Dyson,
Dyson

The Arts and Crafts movement that formed in Britain toward the end of the nineteenth century represented the first serious opposition to the myths of progress promoted by industrialization. This movement, in turn, is regarded as one of the most important sources for design. In one of the first comprehensive accounts of the early history of design, Nikolaus Pevsner (1957) drew particular attention to the major figures of British design: John Ruskin, William Morris, Christopher Dresser, Charles Rennie Mackintosh, Walter Crane, and C. R. Ashbee, whose practical and theoretical work had a decisive effect on the design of the twentieth century. The founding of the English Design and Industries Association (1915) was modeled on the German Werkbund, the primary intention being to promote high-quality design at the expense of Victorian kitsch, especially in industry.

After World War I most designers adhered to the national craft traditions, designing furniture, glass, ceramics, and textiles that sold very well in the still-flourishing empire. Wedgwood stands as a good example of the British ceramics, porcelain, and glass industries. Founded during the eighteenth century, Wedgwood has become the world's largest company in its field, taking over its German competitor Rosenthal in 1997. Today Wedgwood has become a leading lifestyle business operating in a wide range of market segments.

Douglas Scott gained his reputation as one of the pioneers of modern industrial design through his work for London Transport (Glancey 1988). Scott, a trained silversmith and graduate of the Central School of Arts and Crafts, worked from 1936 to 1939 in Raymond Loewy's London office. His many designs included the legendary Routemaster double-decker bus (1946), various other buses and coaches, as well as construction machinery, electrical devices, and household appliances.

After World War II it was the car companies – Aston Martin, Bentley, Jaguar, MG, Mini Cooper, Lotus, Rover (Land Rover), Triumph – that led the way in establishing the image of British design, where creative traditions harmonized with technological innovation. An important role was played by the London-based Council of Industrial Design, which is a particularly vigorous promoter of British companies and design agencies.

Since the 1960s British pop culture has been a key influence in design, advertising, art, music, photography, fashion, applied art, and



SCHOOL CHAIR, design: Ron Arad, Vitra Edition
(Photo: Vitra)

WELL-TEMPERED CHAIR, design: Ron Arad, Vitra
Edition (Photo: Vitra)

WAIT CHAIR, design: Matthew Hilton,
Authentics (Photo: Christian Stoll/
Markus Richter)

interior design. Bands like the Beatles, the Rolling Stones, Pink Floyd, and others epitomized the lifestyle of a young generation rebelling against conservatism. Thanks to intense media coverage, beat, pop, and rock music spread out from Britain to become global socio-cultural and aesthetic phenomena. In the sphere of architecture, the Archigram group has played a major role as an avant-garde movement since that time.

One of the outstanding figures in industrial design was Sir Misha Black, who made a major contribution to shaping design training, in particular, through his long service at the Royal College of Art. Black represented his country in many international organizations and was involved in setting up the Design Research Unit, which is still in operation today.

Sir Terence Conran injected new energy into the tradition of British home furnishings. The Habitat retail chain that he founded in 1964 brought a modernism rooted in the design paradigms of the twentieth century to a mass audience. Conran's many publications also promote a thoroughly progressive understanding of design.

James Dyson (2001) is one of the most exceptional personalities of British design. He became a successful businessman (Muranka and Rootes 1996) as the inventor of a new type of vacuum cleaner that works without a dust bag (the Dual Cyclone). He designs, manufactures and markets his own products, whose originality of design is distinguished by a postmodern formal language.

Some of the best-known British designers include Israeli-born Ron Arad, Nigel Coates, Tunisian-born Tom Dixon, Roy Fleetwood, Matthew Hilton, James Irvine, Danny Lane (born in the United States), Ross Lovegrove (Lovegrove and Antonelli 2004), Jasper Morrison (2002), who is regarded as the quintessence of "new simplicity" in design, Argentine-born Daniel Weil (a member of Pentagram), and Sebastian Bergne, whose special interest in product manufacturing processes generates surprising, innovative designs.

The origins and/or head offices of many international design agencies can be found in London: for example, Fitch, IDEO (founded by Bill Moggridge in London in 1969 as ID One), Pentagram, and Seymour & Powell, who have made a name for themselves especially through their spectacular vehicle designs.

During the 1980s British institutions recognized that training would be a particularly important factor in the long term, and sustained investment was made in this sector. Merging the arts and



PICENO SIDE TABLE, Cappellini
PICENO BENCH, Cappellini
(Photos: Volker Fischer archive)

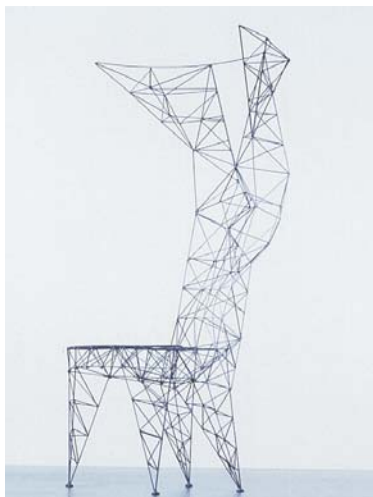

PRODUCTS BY TOM DIXON

S-CHAIR, Cappellini

PYLON CHAIR

FAT CHAIR

BIRD CHAIR



FLAG PASSENGER INFORMATION SYSTEM, design:
Jasper Morrison, Mabeg
CITY BUS, design: James Irvine, üstra,
Hannoversche Verkehrsbetriebe,
manufacturer: EvoBus Gesellschaft
Mercedes-Benz

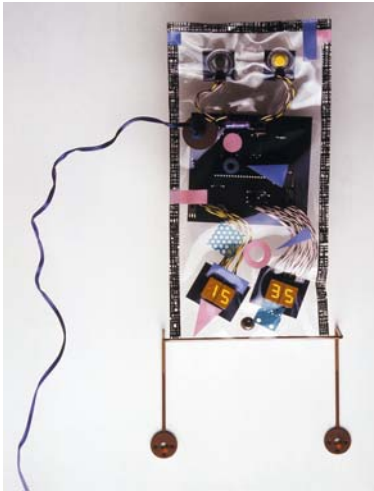

DIGITAL CLOCK, design: Daniel Weil

STACK ORGANIZER, design: Sebastian Bergne,
Authentic

PRODUCTS OF THE INFLATE GROUP

(Photos: Volker Fischer archive)

ATM ADVANCED TABLE MODULE FOR VITRA

(Photo: Hans Hansen)

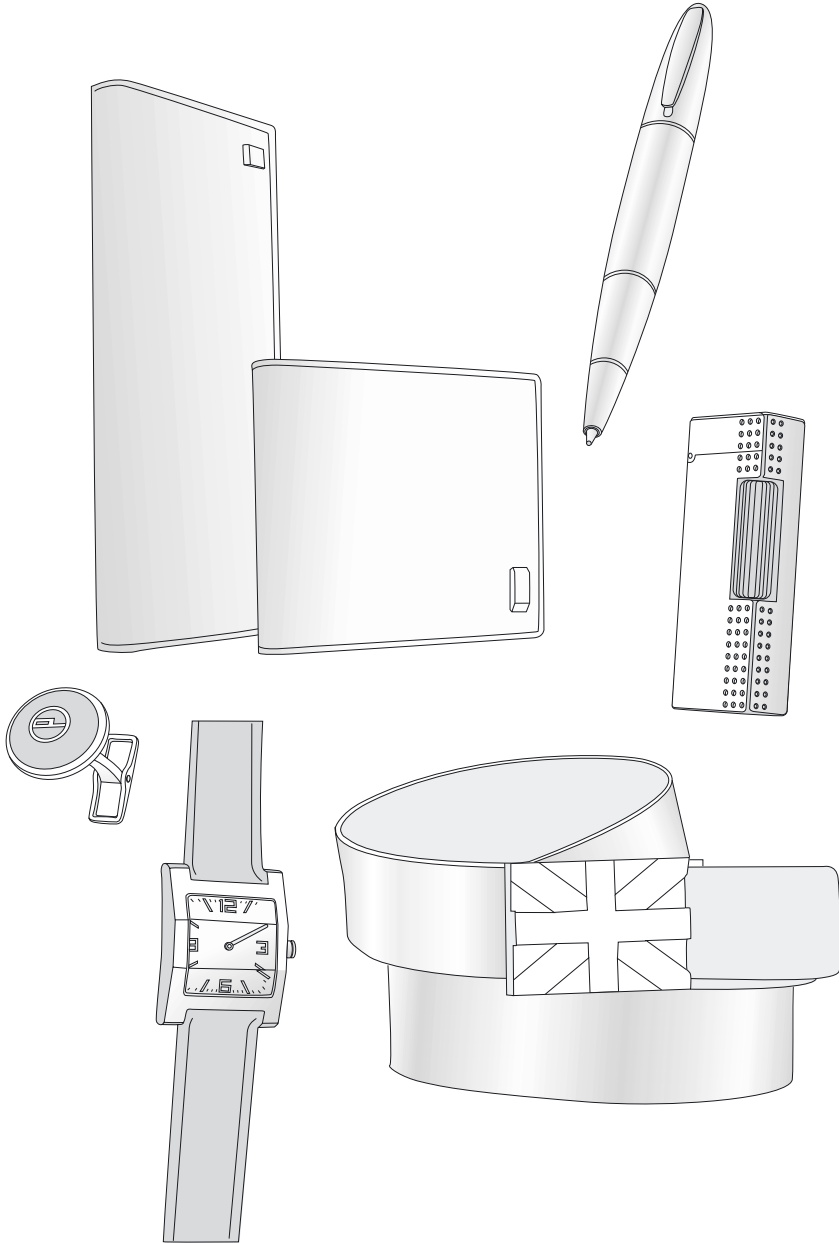
**DUNHILL PRODUCTS**

CREDIT CARD CASE AND WALLET

TORPEDO BALLPOINT PEN

DOTS CIGARETTE LIGHTER

WHEEL CUFFLINK

FACET WATCHBAND

UNION JACK BELT

crafts schools into the respective regional universities was a particularly difficult step (because their cultures were so different) but it brought about a significant improvement in the quality of design training and led to a boom in enrollment, especially from foreign students.

During the 1990s a radical new design scene took shape – ironic, spectacular and drawn from the pop and beat culture of the 1960s (British Council/Barley 1999). In their study, *The Secret Life of Electronic Objects*, Anthony Dunne and Fiona Raby (2001) use the term “design noir” to describe designs that engage the interface between hardware and software, the abolition of products altogether, and also fictitious narrative scenarios dealing with digital objects, in the sense of concept design.

The Inflate group, founded in 1995 by designers Nick Crosbie and Michael and Marc Sodeau, designs inexpensive inflatable objects, meant to be understood in the context of pop culture.

Alongside industrial design, British fashion design is an important factor, represented internationally by Laura Ashley, Ralph Lauren, and Vivienne Westwood – not to mention the 1960s creator of the mini-skirt, Mary Quant. In a wider sense, too, British clothing is an important element in the idea of “Britishness”: tweed jackets and Burberry coats, Barbour jackets and Kangol hats, worn by those who drive the legendary car makes mentioned above. Always very high quality, hard-wearing, and a little conservative – an image that the British like to export and the world loves to adopt.

F. K. K. Henrion and Wolf Olins are regarded as important pioneers of corporate design, while since his time as art director of *The Face* during the 1980s, Neville Brody has enjoyed a reputation as one of the world’s leading avant-garde visual designers. That epithet can also be applied to groups like the graphic designers Why Not and Tomato, whose experimentation congruously juggles free and applied design to generate an avant-garde crossover of image, language, and music. This interplay of influences has played a major role in blurring the dividing line between two-dimensional and three-dimensional design. Great Britain – especially the metropolis London – has developed a top-notch design-specific culture, which draws in designers from all over the world. Experts estimate that in the London region, at the beginning of the twenty-first century, about 10 percent of the gross national product is generated by design-related products and services.

GERMANY (FEDERAL REPUBLIC)

In Germany the formative influences of the Bauhaus, Ulm School of Design, and also Braun's products of the 1960s and 1970s on product culture promoted a formal language of design that quickly became a widespread standard: "German design" (Erlhoff 1990). Everywhere in the world "German design" prompted the same associations – functional, practical, sensible, economical, unpretentious, neutral.

This stylistic functionalism became the touchstone for large sectors of German industry. Institutions such as Die Neue Sammlung in Munich, the Design Center in Stuttgart, Design Zentrum Nordrhein-Westfalen in Essen, and Industrieform (now called International Forum Design) played a decisive long-term role in disseminating the idea of "good design" to the point where it was able to become the standard for 1960s and 1970s mass culture.

The "Ten Commandments" (Lindinger 1983) laid down the creed of "good industrial design," stating that a well-designed product or product system was characterized by a number of specific features:

1. High degree of practical usefulness,
2. Adequate safety,
3. Long service life and validity,
4. Ergonomic adaptability,
5. Technical and formal autonomy,
6. Relationship to surroundings,
7. Environmental soundness,
8. Use of visualization,
9. High quality of design,
10. Intellectual and sensory stimulation.

"Depending on the object and the branch, additional product-specific criteria may also be relevant. The significance and weighting of the criteria will also depend on the function of the objects. For example, those for a wine glass will be different than [those for] setting up an intensive-care ward. Furthermore, it should be emphasized that these standards are subject to slow but steady change. Industrial products are created under the sometimes conflicting influences of technical progress, social change, economic realities, and developments in architecture, design, and the arts (Lindinger 1983)."

Until the 1980s design in Germany was dominated by the credo of functionalism: "form follows function." The task was to design

solutions possessing maximum functionality based on an analysis of the needs of society. This approach, however, built on a very narrow concept of function that only covered the practical or technical function of the products (handling, ergonomics, design, manufacture), while denying the communicative dimension of the products.

A whole series of major companies adopted the functionalist interpretation of design as the guiding principle of their product policies.

TYPICAL COMPANIES

AEG

AEG (Allgemeine Elektrizitäts-Gesellschaft), founded in 1883 in Berlin, took on a pioneering role at the beginning of the twentieth century when it appointed the architect Peter Behrens (who was strongly influenced by William Morris) as its artistic adviser – the first ever corporate designer. From 1907 to 1914 he designed buildings, products, and graphic artwork for AEG, setting trailblazing standards for the design of the twentieth century (Buddensieg 1979). During the 1960s and 1970s AEG design was strongly influenced by the intellectual concepts of the Ulm School of Design, and the company developed products that shared a similar formal language (in competition with Braun). AEG was taken over by Electrolux of Sweden during the 1990s (Strunk 1999).

Bega

The lighting company Bega has followed strict functionalist design principles since the 1960s. Its lamps for public spaces, in particular, are formally reduced to such an extent that they can be used in an enormous range of situations.

Bree

The leather goods manufacturer Bree believes that its products should be reduced to the functional essentials, and that this should be expressed in the design.

Bulthaup

By the 1960s kitchen manufacturer Bulthaup had already started applying the principles of system design as developed at the Ulm School of Design to its product range. Product development – in particular,

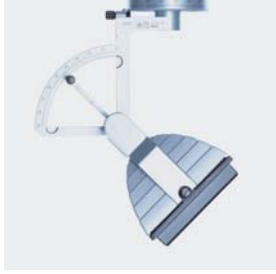

LIGHTING PROGRAM, ERCO
KITCHEN FURNITURE, Bulthaup

through the fundamental contribution of Otl Aicher (1982) – led to independent product language concepts adhering to the principles of classical functional modernism.

Deutsche Lufthansa

During the 1960s this company, too, cooperated with a development group from the Ulm School of Design led by Otl Aicher. Guidelines (corporate design manuals) were produced for the design of all two-dimensional and three-dimensional manifestations (symbols, fonts, colors, exhibition systems, airline dishes, right through to interfaces) (Steguweit 1994). System design was the guiding principle.

ERCO

Today, ERCO is one of the world's leading lighting manufacturers. The company's design image – again heavily influenced by Otl Aicher – is apparent in its architecture, products, and visual image (ERCO 1990). The company expresses the functional modernism of the twentieth century in a perfected form that has been exploited by leading architects such as Norman Foster (see p. 374), Frank O. Gehry (p. 374), Hans Hollein (p. 375), and I. M. Pei for their museum buildings.

Festo

Festo produces automation components, pneumatic systems, and teaching materials, and is regarded as an important proponent of system design. At the beginning of the 1990s the company set up a Corporate Design department headed by Axel Thallemer, which drew up spectacular ideas for visualizing and communicating the company's hallmark product: air. This very quickly brought about a major shift in the company's image – from an anonymous tool manufacturer to a cutting-edge, design-savvy business.

FSB

Since the 1980s the metal fittings manufacturer Franz Schneider Brakel (see p. 350) has worked together with Otl Aicher to establish a leading global position with its corporate design, and especially design in its business culture.

Gardena

During the 1960s Gardena, a manufacturer of gardening products and tools, worked with a development group from the Ulm School of Design. The result was the introduction of a consistent system design

that characterizes the company's products and visual image to this day.

Gira

This manufacturer of electric installations, switches, and controllers has a reputation as an important representative of the functional approach to design. Its products are designed according to modular principles, allowing them to be applied universally.

Grohe und Hansgrohe

These two medium-sized sanitary appliance manufacturers both stand by the tradition of modernism and follow functional design policies in their taps and bathroom fittings. While Grohe sees itself as the "Mercedes of sanitary fitting manufacturers" and concentrates on innovation, marketing, and design, Hansgrohe puts its faith in long-term cooperation, formerly with Hartmut Esslinger (see p. 185) and, since the 1980s, with the Phoenix design agency (see p. 14).

Hewi

Hewi manufactures architectural hardware and sanitary products. The company started out in the 1960s with an uncompromising product range based on simple geometrical elements. The systematic concept behind these products is regarded as the prototypical functional design in this product area (Kümmel 1998).

Interlübke

This furniture maker has followed functional modernist product policies since the 1960s. For example, its fitted cupboards are devised according to a rigorous system design.

Krups

Until the 1990s this household appliance manufacturer followed the functionalist design principles of modernism, formally placing it very close to Braun. Krups now belongs to the French SEB group.

Lamy

Lamy, a manufacturer of writing instruments, is one of the most consistent of companies, with an international reputation gained through the integrated, functional appearance of its products, architecture, and graphic design (Lamy 1986). Lamy practices a reduced formal



BATHROOM ACCESSORIES, Hewi
CUBE RANGE OF FURNITURE, design:
Werner Aislinger, Interlübke



LAMY BUILDING
WRITING IMPLEMENTS, design: Richard Sapper,
Lamy

language – the influence of Braun again – that manifests in technical perfection and a perfect synthesis of form and technology.

Leitner and Burkhardt Leitner konstruktiv

Both Leitner exhibition and display businesses practice consistent system design; their products dazzle through their clear, formal principles and their visual design represents the best of classical modernism.

Miele

Household appliance manufacturer Miele jealously guards its reputation for the high technical quality of its products (washing machines, dryers, dishwashers, refrigerators, freezers, fitted kitchens), which are realized in a clear, functional product language.

Niessing

Jewelry manufacturer Niessing adopted the principles of functionalist design in the early 1970s, utilizing a limited repertoire of formal design elements to give its product range an overall unpretentious appearance.

Pott

Cutlery manufacturer Pott has been following the design principles of Werkbund and Bauhaus since the 1920s. The company gained its status as a leading proponent of modernism through numerous simple, unornamented cutlery sets created by famous designers.

Rimowa

This luggage manufacturer started making products out of aluminum in the 1930s, and made the first suitcase of aircraft aluminum in 1950. The typical grooved structure of the aluminum also functions as a clear pointer to its origins: Junkers aircraft. The material became the dominating element of the company's corporate design, appearing on everything from visiting cards to company architecture. The products themselves combine minimum weight with high stability, and are regarded as prototypical classics of functional design.

Rowenta

For a long time household appliance manufacturer Rowenta followed Braun's design principles. Clear, rational product design defined its pro-

duct range (irons, coffee machines, toasters, etc.). Like Krups, Rowenta is now part of the French SEB group.

SSS Siedle

SSS Siedle produces communications equipment (telephones, intercoms) and has, since the 1960s, followed rigorous design policies expressed through a functional product language. The company sees itself in the Bauhaus tradition and boasts an impressive all-encompassing corporate design, implemented in the best sense of modernism (Siedle 2000).

Siemens

The electrical engineering and electronics giant Siemens dates back to the nineteenth century. For many decades its products have embodied a modern, functional approach that has made the company into one of the major classics of modern design. The company's consistent image – the principles of which are documented in comprehensive corporate design manuals – sets standards worldwide. The company's medical equipment products, in particular, are regarded as prototypical examples of functional product design (Feldenkirchen 1997).

Tecta

Furniture-maker Tecta originally produced only Bauhaus-era design classics by Jean Prouvé and Franco Albino (Smithson and Unglaub, 1990). In producing designs by Stefan Wewerka, it continued the tradition of modernism, while subjecting it to a quite critical and ironic reinterpretation (Wewerka 1983).

Viessmann

During the 1960s Viessmann, a manufacturer of heating systems, contracted with the office of Hans Gugelot formerly a lecturer at the Ulm School of Design, and as a result the principles of system design were introduced. The all-encompassing corporate design that was created – based on the orange company color introduced by graphic artist Anton Stankowski – ensures a high degree of market recognition.

Wilkhahn

This supplier of office furniture stands openly in the tradition of Bauhaus and the Ulm School of Design. A holistic company philosophy guides the modern architecture, product design, graphic image, and especially the sustainable ecological orientation of all its business activities (Schwarz 2000). The Picto office chair stands as an emblematic product of the early 1990s.

This selection represents just a few of those companies that could be described as being in the functionalist line of German design. After World War II numerous design agencies following this tradition of modernism achieved success in Germany: Busse Design, Egon Eiermann, Hartmut Esslinger and frogdesign, Rolf Garnich, Herbert Hirche, Herbert Lindinger, Moll Design, Alexander Neumeister, Phoenix Product Design, Hans Roericht, Schultes & Schlagheck (now Schlagheck Design), Peter Schmidt Studios, Sieger Design, Erich Slany (today Teams Design), Via 4, Arno Votteler, Otto Zapf, and Walter Zeischegg.

Luigi Colani (born 1928) has played an outsider role since the 1960s. After studying aerodynamics in Paris, he began applying organic-dynamic design principles to a wide range of product categories, including furniture, cars, and technical products. He sees himself as a rebel against functional German design who only gained real recognition abroad (in Asia) (Dunas 1993, Bangert 2004).

German interpretations of design were so dogmatic that it is no surprise that a vehement critique of functionalism found fertile ground in Asia at the end of the 1960s and later. During the 1980s a radical new German design sprang up. It was not made to last, however, and the media attention it attracted bore absolutely no relation to its product-cultural and economic significance.

At the beginning of the 1990s German carmakers launched a veritable design offensive. They realized that as vehicle concepts became technically ever more similar, the strategic importance of design would grow. Corporate design initiatives came with increasingly detailed analyses of consumer habits and wishes. But cars are also projection screens for visions and desires, and the myth of speed and mobility is cultivated from cradle to grave – “Mama, Dada, Car.” Fortunately, however, a number of absolutely sensible vehicle concepts also emerged (for example, the Smart). On the other hand, German manufacturers, in particular, poured enormous resources into new or

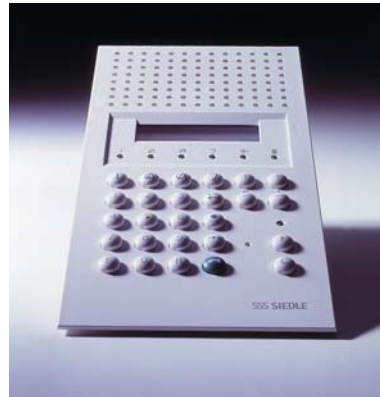

LUGGAGE, Rimowa

HOUSE AND TELECOMMUNICATIONS APPLIANCES

intercom/house phone, SSS Siedle

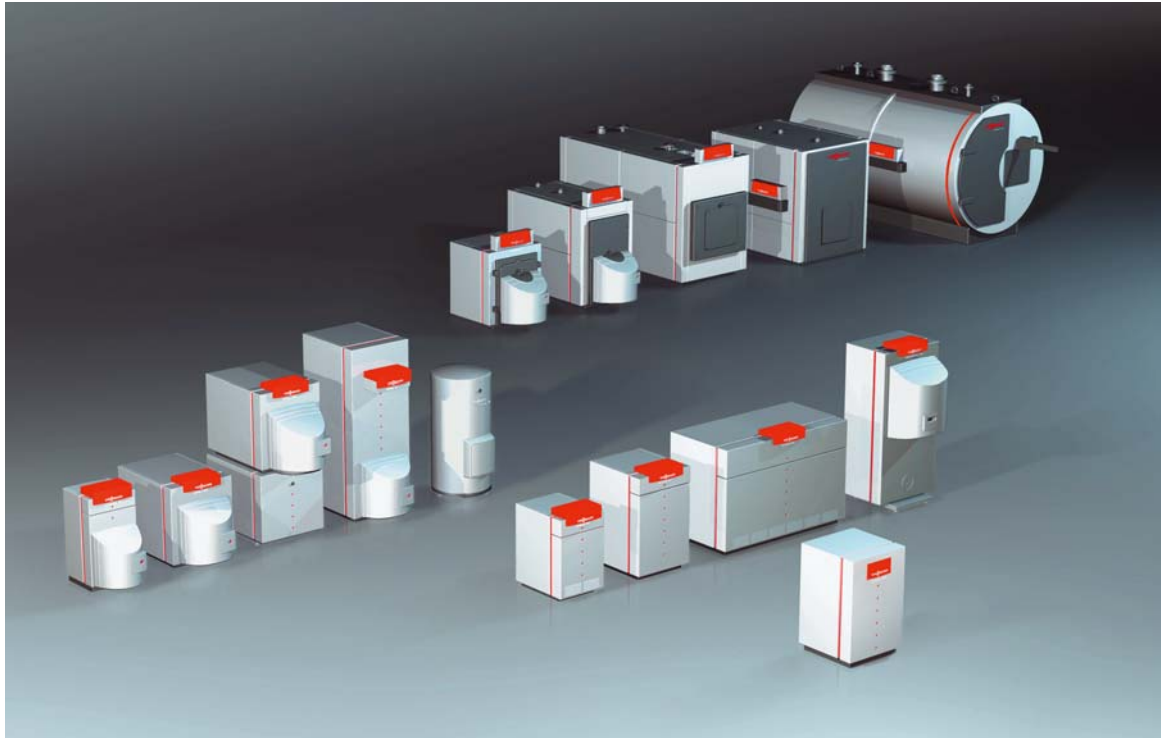

VITOTEX HEATING SYSTEM, design: Phoenix,
Viessmann
CONFERENCE FURNITURE, Wilkhahn

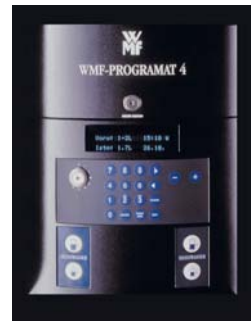

PROGRAMAT COFFEE MACHINE, design: Sieger
Design, WMF

revived luxury makes (Bentley, Maybach, Phaeton, Rolls-Royce). The recession that began at the start of the twenty-first century – not only in Germany – shook this strategy, whereas the car industry in France, for example, had concentrated extremely innovatively on the mass markets.

Audi

Audi has been part of the Volkswagen group since the 1960s. For twenty years it operated under the motto “*Vorsprung durch Technik*,” (“Leading through technology”) which clearly distinguished it from the parent company. The A4, A6, and A8 product groups competed with Audi’s Bavarian rival BMW in its home market segments. In the 1990s the TT Coupé and TT Roadster followed in the company’s sports car tradition of the 1930s. The A2 has an all-aluminum body and is seen as a representative of a new generation of vehicles, reacting to increasingly crowded traffic conditions.

DaimlerChrysler

This most typically German car company underwent a clear change of image during the 1990s. The A-class of 1997 introduced a new vehicle concept – compact, clearly organized, and intelligently adaptable inside – to open up new demographics for the company, and indeed, the A-class is driven by pensioners as well as young families. Additions such as a four-wheel drive version and a compact sport tourer have turned the A class into a full-fledged product family of its own. Cooperation with the Swiss SMH Group resulted, in the 1990s, in the founding of MCC (Micro Compact Car), whose Smart put an exceptionally successful, exceptionally city-savvy car on the market. Since 2002, at the other end of the spectrum, the Maybach has been reviving the legendary traditions of the 1930s when luxury automobiles became status symbols. Considerable design resources were devoted to creating an appropriate modern interpretation.

Opel

Opel, a subsidiary of the American General Motors group since 1931, has regularly caused astonishment with its imaginative and superbly designed cars – at the end of the 1960s, the GT sports car; in the early 1990s, the Tigra; and in 1999, the Zafira, whose great variability means that it can be used for a wide range of different purposes.

**PRODUCTS BY LUIGI COLANI**

STUDY OF AN AIRPLANE with a Wankel engine
and double propeller

PATIO FURNITURE, Westeifel Werke

TELEVISION SET, TechniSat

CAROLINEN MINERAL WATER BOTTLE, Wüllner
GmbH+Co. KG

Porsche

This, the most prestigious sports carmaker, is an example of how consistent product and design policies can be pursued successfully over many decades. Ferdinand Alexander Porsche designed the legendary 911 at the beginning of the 1960s before going on to open his own design agency, Porsche Design, in Zell am See, Austria, in 1974.

The Cayenne took Porsche into a new market segment, as SUVs (Sports Utility Vehicles) became an important market segment during the 1990s.

Volkswagen

No other vehicle has left such deep impressions on product culture as the VW Beetle. More than twenty-one million were sold and it became a symbol of the German car industry. The attempted revival with the New Beetle in 1996 succeeded only in the United States, where the Beetle had long held cult status. The VW Golf, itself in production for more than twenty years now, dominated the compact class all the way up to the high-performance Golf GTI, a teenager's dream machine. Along with the Phaeton VW, it is also aiming to gain a foothold at the very top, in order to cover the complete product spectrum from compact to luxury.

A whole number of smaller companies have also gained international renown for their product design. In 1987 sculptor Hansjerg Maier-Aichen founded Authentics, which gained a reputation for its wide range of innovative products made of high-grade plastic and its employment of internationally famous designers like Sebastian Bergne, Konstantin Grcic, and Matthew Hilton. In particular, the use of semi-transparent materials, such as polypropylene and polyethylene, created a new and autonomous world of plastic products. Following insolvency in 2002, Authentics was taken over by the furniture-maker Flötotto.

During the 1960s graphic artist Ingo Maurer set up a production company for lamps, and today he and his team are among the most creative designers and manufacturers in the lighting field. Ingo Maurer – also known as the twentieth-century poet of light – has drawn hitherto almost unknown attention to light through a complete creative reinterpretation.

During the early 1980s Nils Holger Moormann founded a marketing company for furniture and accessories. Shortly thereafter he began to

SPIEGEL: "Mr. Wiedeking, who really needs a Porsche?"

Wiedeking: "Nobody really needs a Porsche. But everyone who enjoys life, enjoys performance, and enjoys driving feels wonderful in a Porsche. Our automobiles may not have high utility, but their emotional value is very high."

— DER SPIEGEL, 21/2002



LAMP BY INGO MAURER

PLUS SHELVES, design: Werner Aislinger, Magis

KANT DESK, design: Marcus Frey/Patrick Boge,
Nils Holger Moormann

MAXI SQUARE WASTEPAPER BASKETS, design:

Konstantin Grcic, Authentics

(Photo: Markus Richter)

have products designed and manufactured, which he would then market himself. Numerous designers were commissioned for his ambitious plans: Axel Kufus (FNP shelving system), Wolfgang Laubersheimer (tensioned bookcase), Benjamin Thut, Burkhardt Leitner, Konstantin Grcic, and many others helped Moormann to gain his position as one of the most progressive German manufacturers in the field of furniture design.

During the 1990s a series of young designers attracted attention with innovative products. Werner Aisslinger experimented with new materials, especially plastics, which he used to create functionally and aesthetically innovative product concepts. Konstantin Grcic is one of the most successful furniture and object designers. He uses a minimalist formal language and often designs products that are especially innovative and versatile. As a neofunctionalist he has had a great influence on German design. Oliver Vogt and Hermann Weizenegger work at the interface between experimental and conceptual design; their projects include the d-light lamp series, household articles for Authentics, and an imaginary workshop for the Berlin Institute for the Blind, comprising the typical products, such as brushes and brooms.

At the turn of the twenty-first century, Germany finally shook off the weighty heritage of functionalism and set itself on the road to genuinely pluralistic interpretation of design.



COMBINE HARVESTER, design: Gunter Schober,
Rüdiger Laleike, Erhard Noack,
VEB Erntemaschinen Singwitz
UB 1233 HYDRAULIC EXCAVATOR, design: Georg
Böttcher, Gerhard Bieber, Peter Prusseit,
VEB NOBAS Nordhausen

GERMAN DEMOCRATIC REPUBLIC

Design in the German Democratic Republic (GDR, or East Germany) was characterized by three main features:

- intensive state patronage, beginning right after World War II,
- clear long-term social policy objectives, and
- intensive theoretical consideration of questions of functionalism and product semantics, starting in the early 1980s.

Developments in East Germany were based on completely different social conditions than in West Germany. During the first phase, design was oriented primarily toward tasks in the public sphere. Work, transport, residential, and leisure facilities were the most important fields of work for designers. Originally a largely agricultural economy, East Germany put great effort into building up heavy industry, principally to produce capital goods. It was not until the mid-1960s that the emphasis began to shift to consumer goods.

A serious historical assessment of the consumer goods design sector did not even begin until many years after reunification. Günter Höhne, who had been an editor on the journal *form + zweck* during the 1980s, collected and meticulously documented all the objects that made up East German product culture, and his search for the design classics produced astonishing insights (Höhne 2001). For example, many of the products were in fact absent from everyday life in eastern Germany, having been manufactured exclusively for major mail-order firms in West Germany. Their design was consequently modeled directly on the American, Italian, and Scandinavian products that filled the catalogs in the West. Thus Penti (compact viewfinder camera), Erika (mechanical typewriter), and Bebo Sher (electric razor) take their rightful – if relatively modest – place in the ranks of significant product designs from the former East Germany.

State promotion of design was upgraded considerably in 1972 through the establishment of the Office of Industrial Design (AIF). It reported directly to the East German Council of Ministers – its head held the rank of undersecretary – and possessed far-reaching powers in all branches of the economy. It drew up directives, decrees, and legislation that laid down the law for product design across the country and applied to exports as well as to the domestic market. With more than two hundred staff, the AIF was one of the world's largest state-run design institutions at the time.

The relationship between design and art was important, and apparently largely unproblematic. For example, from 1958–1959 on, the major Dresden art exhibitions had a design section where machines and appliances, vehicles and interiors, and designs for textiles and glass were presented alongside painting, sculpture, and free graphic art. The state “Good Design” award for “superbly designed products” was presented at the international trade fairs in Leipzig, which were economically extremely important events for East Germany.

One important characteristic of East German design was the “open principle” (Hirdina 1988). Clauss Dietel, who became president of the East German Association of Visual Artists in fall 1988, is regarded as the founder of the “open principle.” He called for the objective and spatial environment to be treated with responsibility, saying that the repertoire of design should be continuously improved, but not thrown overboard for the sake of short-lived fashions (such as postmodernism, for example). “Openness” referred both to changes resulting from scientific and technical progress and to the changing needs and requirements of users. People, in particular, should be allowed to develop freely, and the design of things should assist them. “Openness” also applied (at least in theory) to internationalization, but at that time it was almost impossible to put into practice.

Clauss Dietel and Lutz Rudolph were two of the best-known East German designers (Kassner 2002); their work often swam counter to the currents of the ruling ideology and aimed to put people at the center of design. By influencing the outer form of objects through design they wished to change the inner state of society as well, hoping that their products would enable their users to interact democratically. East Germany was a particularly good example of how the power of form becomes a form of power, or in other words: how the powerlessness of design can be a special (political) form of power.

At the beginning of the 1950s functional design was more or less banned; designers were to follow the traditional petty-bourgeois values of the years preceding World War II. For a long time the traditions of the Bauhaus – geographically within East Germany – were almost taboo. Not until the end of the 1960s did East Germany declare itself the only legitimate heir to the Bauhaus tradition and seize on the principles of functionalist design as a national resource for its manufacturing sector.

The only area in which we were actually able to develop a higher degree of self-sufficiency was the sector of investment goods.

— MARTIN KELM, 1991

The International Bauhaus Colloquiums were initiated in 1976 in Weimar, and continued in 1979, 1983, and 1986. The papers for these colloquiums dealt with the historical, social, educational, and international repercussions of Bauhaus, and were published in the academic journal of the College of Architecture and Construction.

This openness to theoretical questions of design became particularly clear at a seminar on functionalism held in 1982 at the Office of Industrial Design (AIF) in Berlin (for more on this see the series of articles in *form + zweck*, 1982–83). Functionalism was declared to be the design principle that most closely corresponded to the living conditions of a socialist society. Functionalism, in this case, was understood not as a category of style (gray, angular, stackable), but as a “method of work” (Blank 1988).

In a series of lectures on “Postmodernism and Functionalism,” Bruno Flierl (1985) pointed out that the functionalist program – theory and practice – often lacked unity of material and ideal functionality. Criticism of functionalism – for example, in West Germany and Italy – he said, quickly turned into blind antifunctionalism, and was thus antisocial and reactionary.

Heinz Hirdina (1985) said that postmodernist design was reactionary because the designed object was merely inflated – styled – and subjected to the same mechanisms that applied in advertising and packaging. Hirdina believed that the crucial factor was not that postmodernist design abandoned the use–value discourse, but that it was obviously integrated into the capitalist principles of commodity aesthetics – manipulation by means of commodities that quickly go out of fashion.

Horst Oehlke (1982) made important contributions to design theory. His profound study of the semantics of design objects – the language of objects under conditions of socialism – was a decisive influence behind the reorientation of design in East Germany (see p. 341).

While the products documented by Heinz Hirdina (1988) – in hitherto unknown detail – largely fall into the traditional functionalist design categories, his short chapter on “Exploration and Experimentation in the 1980s” reveals new tendencies, as documented, for example, by a writing stand by Herbert Pohl that was shown in the *Design in East Germany* exhibition held in 1988 at the Stuttgart Design Center (see p. 340).

The strong export orientation led, on the other hand, to autonomous design for products for the domestic market, whose exotic



UPDATE DISHES, design: Barbara Schmidt,

Kahla

JB 12 BINOCULARS, Jenoptik (Photo: Wolfgang
Seibt)

character was documented in summer 1989 in an exhibition (*SED – Stunning Eastern Design*). Just a few months before the fall of the Berlin wall, this show revealed a concentration of products whose particular product-semantic significance lay in their rigid simplicity: “An independent identity arose, partly deliberately, partly unplanned, whose meagerness is a permanent irritation. One could almost say that the commodities suffer from a lack of fetish” (Bertsch and Hedler 1990).

As late as summer 1989 Clauss Dietel was making the case that it was high time for East Germany to do more for its “image” and get itself a new corporate identity (Zimmermann 1989). Nothing, however, was to come of this, because the loss of a separate identity progressed more quickly than anyone had imagined. In a little more than a year, East Germany had ceased to exist. The mechanisms of the market spread through the eastern part of Germany just as quickly as they had in the western half since the 1960s.

One of the few companies that continues to exist with its own product identity is the porcelain manufacturer Kahla. Targeting younger consumers and purchasers of hotel china, Kahla succeeded in establishing a new image and succeeded in the market economy. The company’s definitive breakthrough came in 1998 with the Update combination service, which comprises just a few pieces but offers a wide range of patterns.

AUSTRIA

The origins of industrial design in Austria can be dated to the first works by the Thonet brothers in Vienna, which marked the beginning of the standardization of household articles in the course of mass production. The design concept that originated here spread out across the world and was taken up not least by the Bauhaus, where it produced the famous tubular steel furniture. Fittingly, it was Thonet-Mundus in Vienna that took Marcel Breuer’s tubular steel furniture into series production at the end of the 1930s.

The Vienna Workshops were founded in 1903 by Josef Hoffmann and others. Fostering first-class craftsmanship – especially as required for furniture-making – was at the top of their agenda, which called for purpose and form (as espoused by the Werkbund) to be blended into a harmonizing whole. The furniture designed by Robert

M. Stieg and Herbert Hammerschmied at the end of the 1970s represented an attempt to pick up the tradition of the Vienna Workshops. In line with the spirit of the times, they attempted to integrate the interests of users, designers, and producers (joiners and upholsterers).

The architect and author Adolf Loos was regarded as the pioneer of the “new architecture” in Vienna. In his *Ornament und Verbrechen* (*Ornament and Crime*) – often misquoted, intentionally or not, as “Ornament is Crime” – he formulated the fundamental tenets of functionalism: removing the ornamentation from utility articles and separating product design from art. Taking the art out of architecture and interior design was an important goal of his work.

The repercussions of the Linz *Forum Design* in the summer of 1980 were felt far beyond the borders of Austria, and it can be called the central event of the decade. It represented an attempt to examine the most important influences in architecture and design for the coming decade in a major exhibition, conference, and wide-ranging documentation (Gsöllpointner, Hareiter, and Ortner 1981). The architects Haus-Rucker-Co. (Laurids Ortner, Klaus Pinter, and Günter Zamp Kelp) developed an exhibition building that alluded cleverly to Joseph Paxton’s Crystal Palace, made for the Great Exhibition of 1851. In 1980 the Austrian architect Christopher Alexander added the Linz-Café, a timber construction demonstrating the use of basic craft skills.

The exhibition halls themselves were on view in Linz for just three months, after which they were sold cheaply to a composting business in a small place in Upper Austria. They are now used to contain waste while organic processes transform it back into valuable humus. As Laurids Ortner (1983) noted ironically, the purpose of the halls has changed only marginally – in Linz they were containers for cultural substrates, whereas now they perform the same function for a natural substrate.

Two crucial events for architecture and design were held in 1980: the *Architecture Biennial* in Venice, where a broad spectrum of post-modernist architects were represented for the first time, and the Linz *Forum Design*. Although works by architects – Michael Graves, Charles Moore, Robert A. M. Stern, and Robert Venturi – were shown in Linz, the focus there was on design and its interface with art. The Spaniards Oscar Tusquets and Lluís Clotet, the Alchimia group with Alessandro Mendini, Barbara Radice with a project on “space design,” and the first major presentation of furniture objects by Ettore

Sottsass, formed the focus of the Linz exhibition. Under the motto of a "new iconography," Sottsass attempted, to a degree, to distance his work from radical design and counterdesign. He saw this as an attempt to break out of his previous dependence on designing for industry, and to develop a new formal language capable of expressing different cultural experiences. Sottsass's hopes that these furniture objects would take him into the realm of "non-culture" or "no-man's culture" actually represented the beginnings of the Memphis movement, whereby these aspects were quickly disseminated and commercialized. Clever public relations work by his then partner, Barbara Radice, transformed Sottsass's individual experience and resignation and formulated a new movement. Memphis, which was quickly taken up by designers almost all over the world, brought forth a range of different national expressions (e.g., new German design).

At the beginning of the 1980s the postmodernist or neomodernist movement pushed the Austrian architect Hans Hollein into the public eye. His previous works (shop fittings, façade conversions, interior designs in Vienna) were known only to a few specialists, but the Abteiberg Museum in Mönchengladbach – designed by him and opened in 1982 – turned out to be a *Gesamtkunstwerk* of the first order. In this work Hollein achieved his decisive breakthrough – from the architectonic shell through to the interior design and the individual furniture objects. The architect's penchant for designing furniture also led to objects of his being included in the Memphis collection, while his work on micro-architecture opened the doors of the Italian firm of Alessi to him.

During the 1990s Austrian designers increasingly returned to the great paragons of the twentieth century: personalities such as Carl Auböck and Marianne Menzel, who founded the tradition of Austrian modernism. The documentation compiled by Thomas Redl and Andreas Thaler (2001) showed a very lively selection of works by agencies and individual designers, all of whom enjoy international reputations and all of whom largely abstained from the postmodernist trends of the 1980s. They included Hermann Czech, who works as an architect and designer; Gerhard Heuffler (1987) and Kristian Fenzl (1987), two industrial designers of exceptional repute; and Gerald Kiska, known for his spectacular motorcycle designs for KTM and for his work for Porsche Design. Founded by Ferdinand Alexander Porsche (who designed the legendary 911 in the early 1960s), Porsche Design in Zell am See has a consistent track record



COMPOST TURNING MACHINE, design:

Gerhard Heufler

FIRE TRUCK, design: Kristian Fenzl, Rosenbauer

for designing and developing classical, functional and, thus, timeless products (glasses, leather goods, etc.) for the Porsche marketing company in Salzburg, but also works for international companies such as Grundig, Samsung, Sharp, and Yamaha.

Today, alongside Thonet, firms such as sports equipment makers Head and Tyrolia are setting international standards, as does Kufstein-based Riedel, which produces some of the classics of modernism in crystal. Another glassmaker, Swarovski, whose products have attained cult status for collectors across the world, has successfully applied its experience to binoculars, putting them firmly in the tradition of rational functional design as well. The furniture-maker Wittmann, which produced the designs of Josef Hoffmann at the beginning of the twentieth century, has cooperated with international designers such as Joe Colombo, Jørgen Kastholm, and Hans Hollein since the 1960s. Today, the Italians Paolo Piva and Matteo Thun, the Germans Martin Ballendat and Burkhard Vogtherr, and the Swiss Hannes Wettstein are responsible for the company's design. Last but not least, it should not be forgotten that capital goods manufacturers like Doppelmayr (cable car systems) and Rosenbauer (fire engines) also represent classic Austrian product design across the world.

SWITZERLAND

The influence of the Werkbund in the early twentieth century fell on especially fertile ground in Switzerland: great attention to detail, sophisticated technology, and a certain rigor characterize most Swiss products. "Swiss Made" stands for quality and durability, with the Swiss Army knife as the emblematic product. However, during the twentieth century, Swiss commercial art and typography have also gained high recognition for their sparing application of design elements, and are regarded as models of visual modernism.

The origins of Swiss design can be found in the work of Sigfried Giedion who, in the 1930s in Zurich, joined with others to found Wohnbedarf AG to manufacture and sell socially and functionally oriented products. At the time, however, the venture struggled to survive economically. Instead, the intellectual horizons of the Bauhaus came into view more prominently in the architecture of Le Corbusier (Charles Edouard Jeanneret), whose contributions to the Weissenhof project in Stuttgart, the "machine for living" in Marseilles, and the



DRINKING GLASSES, Riedel

GLOBAL KNIFE SERIES, design: Porsche Design
 ALCHIMIA T-SHIRT for Forum Design Linz,
 (1980)

church in Ronchamp have gone down in architectural history. The Modular measuring system designed by Le Corbusier became an important design tool in architecture. The pieces of tubular steel furniture he designed with Charlotte Perriand in the 1930s are still regarded as modern classics of furniture design.

Le Corbusier was also the initiator of the Charter of Athens, a resolution by architects and urban planners that was passed in 1933 at a meeting of CIAM (International Congress for Modern Architecture) and called for strict separation of urban functions such as accommodation, leisure, work, and transport. This postulate was accepted as the basis for urban planning through to the 1970s, and led to satellite towns being built beside many big cities. The social problems that have arisen there are due in no small part to the lack of the infrastructure facilities that would be present in an urban environment. Sunshine, green areas, and generous open spaces simply cannot replace the social relationships that exist in established neighborhoods.

For the Swiss National Exhibition of 1938, Hans Coray – who saw himself as an artist and designer – designed an aluminum chair, the Landi chair, which caused an international sensation. There are forty-nine holes in the back of the chair and forty-two holes in the single-piece seat, causing the chair to produce dramatic shadows under particular lighting conditions, and thus enhancing the product's potentialities. The Landi chair is regarded as prototypical for outdoor furniture.

The importance of the two Swiss, Max Bill and Hans Gugelot, for the development of design has already been discussed in the chapter on the Ulm School of Design. Willy Guhl is another pioneer of Swiss design. He designed Packet Furniture (1948), and a dining chair (1959) that bears his name was produced in enormous numbers and became an emblem of the country's product culture (Guhl himself says the chair was an all-embracing, space-dominating design), along with various pieces of outdoor furniture made of Eternit. Guhl also had a great influence on design training in Switzerland.

Andreas Christen's work in the "good design" tradition is also important. In the early 1960s he developed a stackable polyester bed, which typified reductionist design and maximum economy of production, and can be seen as the prototype for series production in plastic. His thirty-year cooperation with Lehn AG (Schmidt-Lorenz 1995) resulted in furniture designs that number among the most notable phenomena of Swiss design.

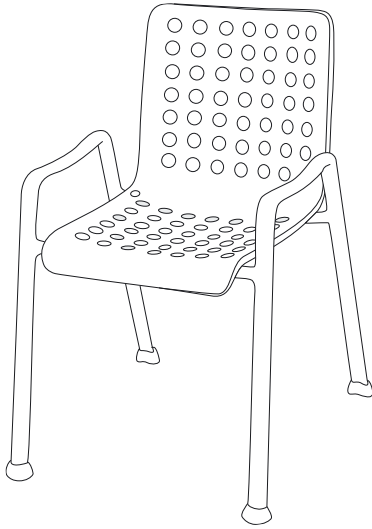

- LANDI CHAIR, design: Hans Coray (1938)
 GARDEN PUMP, design: Franco Clivio, Gardena
 LAWN SPRINKLER, design: Franco Clivio, Gardena
 WALL CLOCK, design: Max Bill (1957), Junghans
 PORTABLE TAPE RECORDER, design: Ludwig Walser Design AG, Sondor

The USM modular furniture system by Fritz Haller and Paul Schärer (1964) is one of the design classics of the twentieth century (Klemp 1997). This system furniture, made up of spherical joints, tubes, and panels, represents a concept that is extremely flexible yet nonetheless reduced to the max, and functions equally well in living and working environments.

The work of architect Mario Botta stems from a similar intellectual stance. His architecture is characterized by the use of elementary geometrical forms in a strictly orthogonal and additive style that, while standing formally in the tradition of modernism, operates with playfulness, fun, and irony. Mario Botta's design work also taps into an understanding that architecture should not only design the outer shell of a building, but create the interior, too. Sparing utilization of forms and materials characterize his furniture designs, while his design work features delicate elegance and clear material contrasts (sprung perforated sheet metal for the seat and cylindrical polyurethane foam elements for the back rest), and draws on the tubular steel furniture of Bauhaus tradition.

Trix and Robert Haussmann have followed a very different trajectory since the 1970s. Originally architects, their work now spans urban planning, interior design, and furniture design, right through to art objects. Using a broad spectrum of materials, forms, and colors, they break the accepted conventions of seeing and are regarded as prominent representatives of postmodernist design.

In the mid-1980s Beat Frank and Andreas Lehmann founded the Vorsprung studio in Berne, and have designed a great number of furniture objects in the interim. They stand in the tradition of modernism and utilize simple technologies to create new design concepts that are highly communicative and also mystical. Their furniture does very well without artificial expression, without painted emotion, and without affixed symbolism. Echoing the architecture of Mies van der Rohe, their means of expression is the constructive element.

During the 1990s a whole series of designers and firms gained international reputations, their high standards of design and great inventiveness representing a modernism of design with a breadth and totality unique to Switzerland (Lueg and Gantenbein 2001). The best known include Franco Clivio (technical products), Francesco Milani (medical equipment), Ludwig Walser (capital goods), Werner Zemp (technical products), Les Ateliers du Nord in Lausanne (consumer goods), and Hannes Wettstein, who designs technical products,



DOUBLE YOU OFFICE FURNITURE, design: Hannes
Wettstein, Bulo
general view/details

furniture, lighting, and carpets, as well as practicing interior design. His work is especially concerned with connecting technical craft precision with emotional needs. Wettstein sees many of his objects as symbols against meaninglessness (Müller 1990), making him a designer who explicitly emphasizes the product-semantic character of his work.

Walter and Benjamin Thut are both designers and producers. Originally joiners, they design highly conceptualized modern furniture, firmly in the tradition of twentieth-century modernism (Schmidt-Lorenz 1995). Since the end of the 1980s Carmen Greutmann-Bolzern and Urs Greutmann have worked as a team on technical products and furniture, wholeheartedly following an ecologically enlightened modernism that links technological innovation with purity of design. Alfredo Häberli and Christophe Marchand in Zurich also see themselves in the tradition of Swiss modernism, but imbue their furniture designs (e.g., for Röthlisberger, Thonet, and Zanotta) with humor and irony. In the process they succeed in producing a thoroughly creative evolution of the Swiss design tradition (for more detail on Swiss furniture design, see Rüegg 2002).

In 1991 Ruedi Alexander Müller, August Müller, and Christian Habeke left the renowned corporate identity agency Zintzmeyer & Lux AG to found NOSE AG in Zurich. NOSE AG works in design, in visual communication, and increasingly also in digital media (Rogalski 1998). Well-known examples of its work include projects for Deutsche Telekom, Hilti AG, and the interior design of the Transrapid.

Many other firms have also made names for themselves with and by design during the 1990s. They include, for example, ASCOM (telecommunications), Belux (lighting), deSede (leather furniture), Röthlisberger (a furniture company that cooperates with many international designers), and Vitra (office furniture) (see p. 350).

Intense competition from Asia drove the venerable Swiss clock industry into an existential crisis during the 1970s. Nicolas Hayek, a Swiss engineer, management consultant, and founder of SMH, struck back with the Swatch (Swatch & Swatch 1981). Every year two new Swatch collections are brought out, with ever-changing designs but the same underlying components (mechanism, case, strap). This principle has even entered the discourse of design theory in the term "Swatchization," which Milan designer Matteo Thun used to designate the design of short-lived consumer goods that convey the





PICK UP, design: Alfredo Häberli, Asplund
DAS BETT FÜR MOBILE MENSCHEN ("The Bed for
People on the Move"), design: Atelier Oi, Wogg
EXPANDER COAT RACK, design: Benjamin Thut,
Moormann
COUCH AND OTTOMAN, design: Christophe
Marchand, Edra
SWATCH WATCHES, Canton models
FREITAG BAG

experience of being “in,” that is, participating in the group dynamic (Keine Garantie für gut abgehangene Klassiker 1987). Hayek’s firm was also responsible for the Smart car, which applied these design principles to the automotive sector.

The designer brothers Markus and Dani Freitag created a more exotic line of products with their Freitag bags (shoulder bags made from recycled truck tarpaulins). The used look and authentic smell of the products made them veritable cult products in the 1990s. These fashionable accessories are sold at moderate prices in urban boutiques all over the world – more than 6,000 to date (Müller 2001).

ITALY

No country has had as much written about its design as Italy. Since World War II, Italian designers, businesses, and media have been very good at occupying a domain for which they seemed more or less predestined by tradition. The civilizational and cultural tradition founded by the Roman Empire received a classical updating during the Renaissance by the architect Andrea Palladio with his many and varied buildings, and continues into the present in the work of Aldo Rossi (see p. 381) with, for example, his neoclassical architecture such as the Centro Torri shopping mall in Parma. The consistently high value placed on architecture, design, art, literature, fashion, and music in Italian cultural life, the exceptional openness of even small businesses to these subjects, and widespread enthusiasm for creative experimentation have all contributed to the worldwide dominance of Italian design, which only began to decline at the end of the 1980s under the impact of a massive design offensive coming out of Asia.

Numerous exhibits, catalogs, illustrated books, magazines, and films have communicated Italian lifestyle and design, including the following examples:

- the catalog *Italy — The New Domestic Landscape*, edited by Emilio Ambasz (1972) for the exhibit at the Museum of Modern Art in New York,
- the exhibit catalog *Design als Postulat am Beispiel Italiens* (IDZ Berlin 1973), which was conceived as a first response to the New York exhibit,

In principle it is true: Design increases the legibility of the world. But this can no longer be achieved through “objective” attempts to read forms from functions. It was Nicholas Hayek’s genius that brought a purely emotional product to the market, the cult object Swatch, just as quartz technology was making old standards of objectivity and functionalism obsolete.

— NORBERT BOLZ/
DAVID BOSSHART, 1995

- *Atlante del Design Italiano 1940/1980*, edited by Alfonso Grassi and Anty Pansera (1980), which was largely dedicated to Italian bel design,
- *Il disegno del prodotto industriale: Italia 1860–1980*, by Vittorio Gregotti (1982), probably the most comprehensive history of Italian design,
- the catalog *Italien: Design 1945 bis heute*, edited by Hans Wichmann (1988), then head of the Neue Sammlung in Munich,
- Penny Sparkes's *Italian Design* (1988),
- Volker Albus's spectacular exhibit in the Bundeskunsthalle in Bonn, *4:3 50 Jahre italienisches & deutsches Design*, and its voluminous catalog (Erlhoff, 2000),
- a collection of essays titled *Italy – Contemporary Domestic Landscapes 1945–2000*, edited by Giampiero Bosoni, which expertly took up where the New York exhibition of 1972 left off, in a sense representing its "update."

Our intention here is not to make yet another coffee-table volume on Italian design, but rather to investigate its intellectual roots, given Italian design's exemplary character for the discipline as a whole.

Design as part of a cultural *Gesamtkunstwerk* could only have arisen in Italy. Paola Antonelli (2001) very pertinently characterizes the difference between interpretations of design in northern Europe (for example, Germany, Great Britain, and Scandinavia) and those in Italy. While designers in the former – in the tradition of the Werkbund or Bauhaus – always sought the "existential minimum," Italian designers were oriented to the "existential maximum," crossing traditional boundaries between graphic, media, and industrial design, between free art and applied design – to where the room as a whole is the subject matter. Fashion plays a significant role as well. Armani (2001), Benetton, Brioni, Cerruti, Dolce & Gabbana, Gucci, Missoni, Prada (2001), Versace, Ermenegildo Zegna, and others, all mix two-dimensional with three-dimensional design, and their presentations at shows and exhibitions are often rich in spectacle – life by design. Over the course of the 1980s the "American way of life," which had become increasingly trivial and populist, was largely superseded by a (fine) Italian lifestyle, one that is today savored not only in Europe, but in America and Asia, too. Whether we are looking at fashion, furniture, vehicles, or food and drink, the global cultural paradigms are essentially Italian (Schümer 2002).

Italy itself contains huge economic disparities between the highly industrialized north and the agricultural south. The big cities of Milan, Turin, and Genoa are home to major industries producing vehicles (Fiat, Ferrari, Lancia, Lamborghini, Maserati, Piaggio), machines, and domestic and office appliances (Olivetti), as well as a vibrant craft-oriented small and medium-sized business sector. The latter is particularly well-known for glass (e.g., Murano), ceramics, lamps, and furniture, (especially in the region surrounding Milan) (see also Vann 2003).

The Italian designers' association ADI (Associazione per il Disegno Industriale) plays a major role in promoting design. This body, founded in 1956, is by its very tradition no narrow-minded society of designers interested only in professional matters like taxes, laws, and contracts, but a circle of committed architects, artists, producers, writers, and designers who play an active role in cultural events. ADI also awards one of the world's most prestigious design prizes, the Compasso d'Oro, offered by the Milan department store La Rinascente.

One significant factor is the strong political commitment of Italian designers. The countercurrents that sprang up during the 1960s should be understood as reactions against consumerism (consumismo), which also found expression in new product concepts. By contrast, at the same time in West Germany, for example, a critical position on design (as formulated by the *Critique of Commodity Aesthetics*) led to a design nihilism that was especially apparent in the design schools at the beginning of the 1970s.

The influence of Italian design theorists is also especially worthy of mention. During the 1960s Tomás Maldonado – born in Argentina but resident in Italy since the 1950s – initiated an intense exchange of ideas between the Ulm School of Design and the Milan design scene. Maldonado, for example, facilitated Rodolfo Bonetto's appointment as visiting lecturer in Ulm. Hans von Klier arrived at Olivetti from Ulm via Ettore Sottsass's Milan office, while Pio Manzù commuted industriously between the two cities. The cooperation between Sottsass and Maldonado at the Ulm School of Design (*Rassegna* 19/3, 1984) could never have been more than an episode, as is very clear in their interview with Andrea Branzi (1985). Other prominent promoters and critics of Italian design include Gillo Dorfles, Giulio Carlo Argan, Alessandro Mendini, and Vittorio Gregotti.

In the twentieth century, the "plastic and graphic arts" transcended all boundaries. They opened up and threw off so much excess baggage that they relinquished central areas of their traditional expression to competing, often new types of culture: their "realistic" possibilities to photography, their narrative possibilities to film, their plastic and graphic potentials to design, the fabulous to popular culture, and their potentials for self-portrayal and staging to the theater.

— EDUARD BEAUCAMP, 1994

A whole series of periodicals play important roles in connection with the development of design, among them *Abitare*, *Casabella*, *Domus*, *Interni*, *Modo*, *Ottagono*, and *Rassegna*. They are multipliers, conveying the diversity of design to a broad public, and should definitely not be seen as just specialist journals for insiders.

The Triennals held in Milan starting after World War II concentrated explicitly on design topics, and were much more than mere product shows (Neumann 1999). In 1947 the theme was “L’abitazione” (Home and Furnishings), while the first design projects – light sculptures by Lucio Fontana – were presented at the ninth Triennial in 1951, “Unity of the Arts.” In the following years the Castiglioni brothers, for example, were represented (1954 and 1960) and in 1964 Vittorio Gregotti created an entrance area on the theme of “Leisure.” Sottsass, Mendini, Adolfo Natalini, and others presented their work under the motto “Related by Choice” in Milan in 1985. The theme of the nineteenth Triennial in 1994 was “Identità e differenze” (Identity and Differences). As can be seen in these examples, the broad Italian definition of culture makes it easy to integrate design and art in shared exhibitions.

THE EXAMPLE OF OLIVETTI

In 1908 Camillo Olivetti, an engineer, founded a business in Ivrea in northern Italy that was to become a twentieth-century paradigm of modern design. Olivetti started off producing typewriters. In 1933 his son, Adriano Olivetti, took over the business, and two years later Marcello Nizzoli started working for Olivetti as a graphic artist and designer. Nizzoli’s Summa calculating machine of 1940 marked the starting point of an unparalleled design development story.

It is noteworthy that Olivetti applied deliberate design not just to products, but to an entire two-dimensional image (Kicherer 1990). Hans von Klier headed Olivetti’s studio for corporate design in Milan, where the legendary Red Books were drafted. These design manuals described all the graphic elements used within the company and externally. The design guidelines cover letterheads, calling cards, catalogs, brochures, packaging, lettering on vehicles, and so on.

Taken together, the graphic presentation and the products by different designers form the “Stile Olivetti.” Unlike the German firm of Braun, which aims to operate with a minimum of design elements,

Art comes from skill, design from intention. Art is laid back, design cramped. Art is style; design is stylized. Design is the unhealthy mean between art and kitsch, it is not this and that, but rather everything and nothing. Design has overrun us everywhere. Everywhere nothing but design. Nothingness as design.

— GÜNTHERR NENNING, 1996

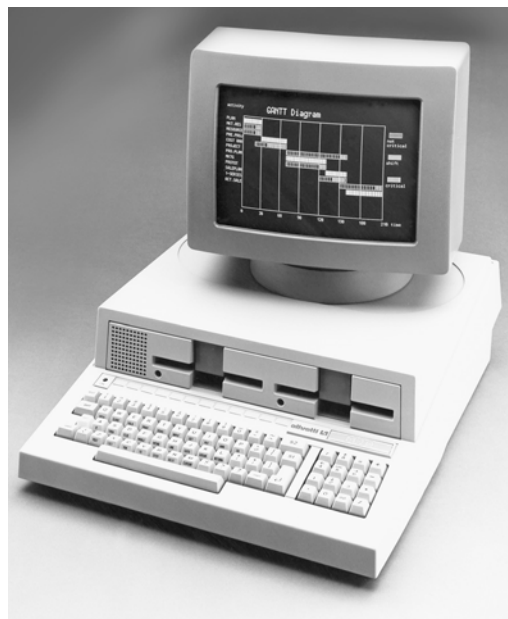

PRODUCTS BY OLIVETTI

INSPECTOR MIDI MACHINE TOOL, design: Rodolfo Bonetto (1975)

LOGOS 42A ADDING MACHINE, design: Mario Bellini (1977) (Photo: Ezio Frea)

STUDIO 42 TYPEWRITER, design: Alberto Magnelli (1935)

M 20 PERSONAL COMPUTER, design: Ettore Sottsass (1981)

the Olivetti style is to develop a new unity – the corporate design – from a wide spectrum of selected elements (see also: *Design Process Olivetti 1908–1983* and *Olivetti Corporate Identity Design*, 1986).

In addition to Hans von Klier, such artists as Walter Ballmer, Alexander Calder, Clino Castelli, Milton Glaser, and Roy Lichtenstein contributed to the Olivetti image. Their widely differing styles and approaches fit seamlessly into Olivetti's corporate design – and also evidence the firm's cultural openness.

Olivetti's workforce facilities – childcare, sport facilities, leisure centers, and apartments – typify the company's business culture and showcase important elements of the company philosophy. From 1934 on, Olivetti ran a huge construction program involving world-class architects such as Le Corbusier, Louis I. Kahn, Kenzo Tange, Egon Eiermann, Hans Hollein, Richard Meier, and James Stirling.

ITALIAN BEL DESIGN

The massive industrialization of northern Italy after World War II brought forth a design style that built on the cultural tradition of artistic craftsmanship and established itself as the dominant global movement for several decades. Mario Bellini (1984) correctly observed that Italy broke the dominance of Scandinavian design at the beginning of the 1960s, after the Scandinavians had failed to transform craft concepts into modern interpretations of industrial culture. Companies like Braun of Germany deliberately built on these ascetic Nordic traditions and were absolutely immune to the ideas from Italy.

The mid-1960s marked the beginning of the golden age of experimentation with new materials (for example, plastics) by Italian designers and architects. Free of the dominating heritage of functionalism, they proceeded almost playfully. Rapid technological progress was a major factor in shaping an Italian design methodology that was guided less by rational (functionalist) considerations than by the new product's expected acceptance in international markets (Munari 1980). Cultural diversity is reflected in the variety of forms that fill the breadth of Italian design.

Italian bel design is primarily characterized by technical and design innovations, which have had quasi-standardizing effects on particular product categories. The Plia folding chair designed by Giancarlo Piretti stood out for its brilliantly simple swivel-joint, manufactured



CORPORATE DESIGN MANUALS (1971–1978),
Olivetti
OLIVETTI CORPORATE DESIGN
shipping packages

by die-cast molding. The chair's lightness and mobility are emphasized by the use of Plexiglas. Well over three million of these chairs have been produced since 1969.

Achille Castiglioni's Cumano folding table is another successful example of mobility. The option of hanging it on the wall by the hole in the tabletop points to the product's object/image character over and above its practicality. The portable television set Algol 11, with the screen tilted toward the viewer; the filigree lamp Parentesi, adjustable in all directions; and the similarly adaptable lamp Tizio, have all become more or less classics of the *Anzeichenfunktionen*, as have Richard Sapper's espresso machine for Alessi – a tabletop steam machine par excellence – and Achille and Pier Castiglioni's stool Mezzadro, where the great comfort of a large saddle or tractor seat is ingeniously combined with the elasticity of a leaf spring. When asked how they came up with the idea, the Castiglioni brothers replied that it had already existed, and they had not designed anything (Koenig 1983).

These associative methods of design (e.g., change of situation, modification of use) are typical for Italian products. The almost playful treatment of form, material, and color are absolutely decisive in shaping their image. Concurring absolutely with Sigfried Giedion, we can speak of "typical" Italian products that have shaped their respective product classes. Furthermore, many designers possess an acute awareness of product-semantic statements, such as visualized use functions and symbolic connotations, which are implemented in many of their products.

ITALIAN COUNTERCURRENTS

The second important element of Italian design, alongside designers' aforementioned integration in cultural developments, is their involvement in political movements. The formation of different groups produced working methods with perspectives that extended considerably further than the restricted horizons of narrow professionalism. Furthermore, communicative interaction is particularly intense in such groups and it is relatively easy to interest the media in spectacular group formations – factors that were also exploited during the 1980s by a number of designers from the new German design movement, including Kunstflug, Bellefast, Pentagon, and Berliner Zimmer (see

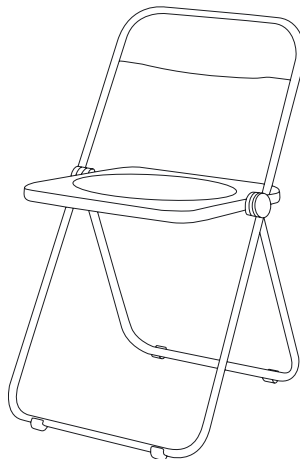
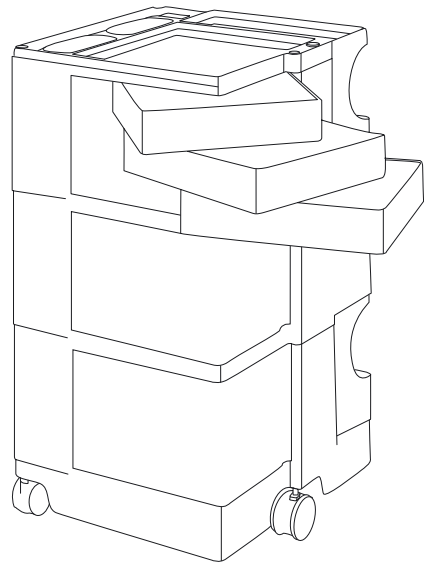
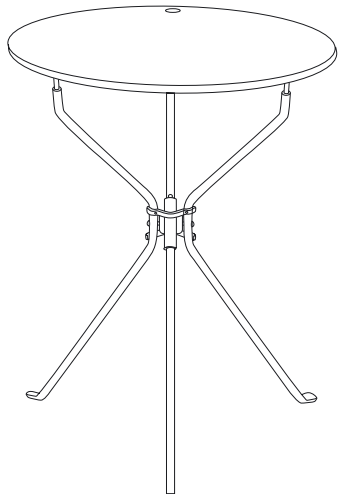
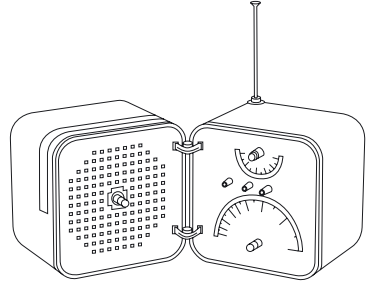
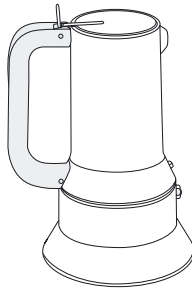
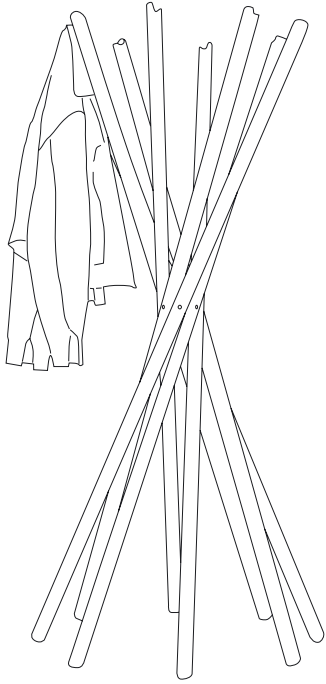

ITALIAN BEL DESIGN

SCIANGAI COAT RACK, design: de Pas/Urbino/
Lomazzi, Zanotta

CAFFETIERA 909 ESPRESSO MACHINE, design:
Richard Sapper (1979), Alessi

TS 502 RADIO, design: Marco Zanuso/Richard
Sapper (1965), redesign (1978), Brionvega

BOBO 3 CONTAINER WITH FIXED WHEELS, design:
Joe Colombo (1970), Bieffeplast

CUMANO FOLDING TABLE, design: Achille
Castiglioni (1979), Zanotta

PLIA FOLDING CHAIR, design: Giancarlo Piretti
(1969), Castelli

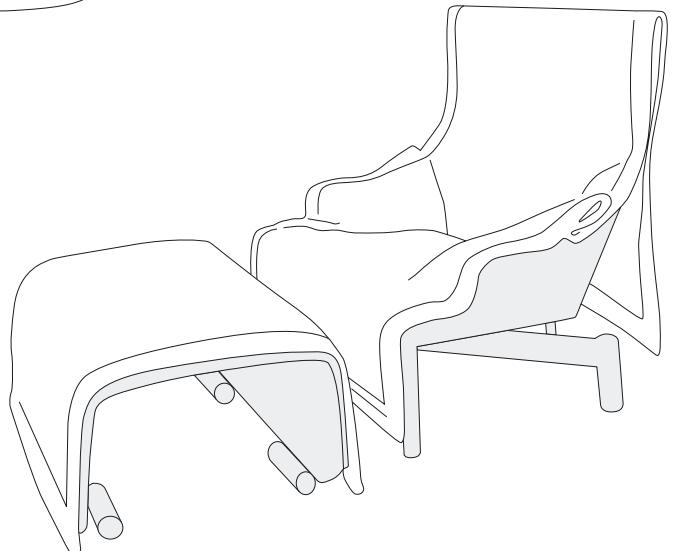
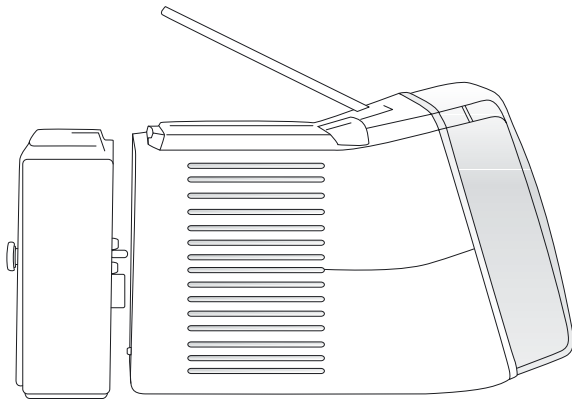
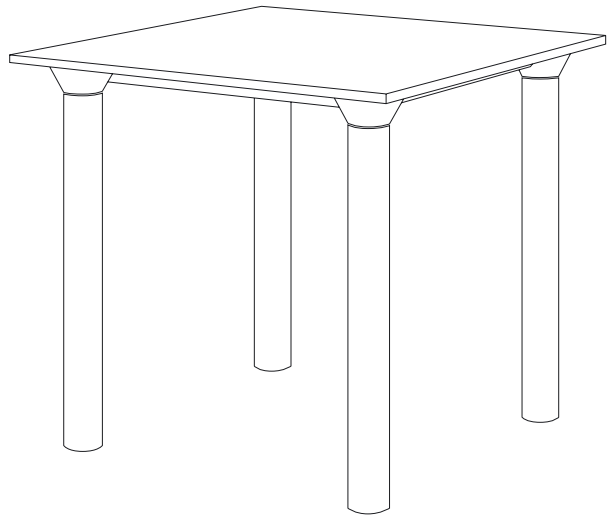
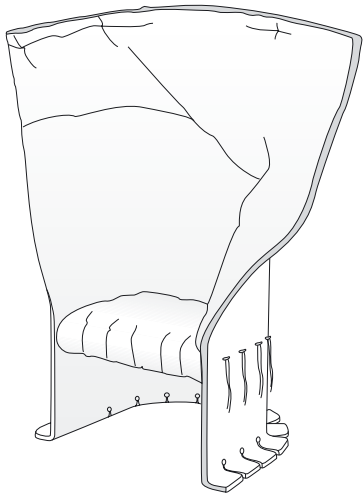

FELTRI ARMCHAIR, design: Gaetano Pesce
(1987), Cassina

4300 TABLE, design: Anna Castelli Ferrieri
(1982), Kartell

ALGOL TELEVISION SET, design: Marco Zanuso,
Richard Sapper (1964), Brionvega

SINDBAD ARMCHAIR, design: Vico Magistretti
(1981), Cassina

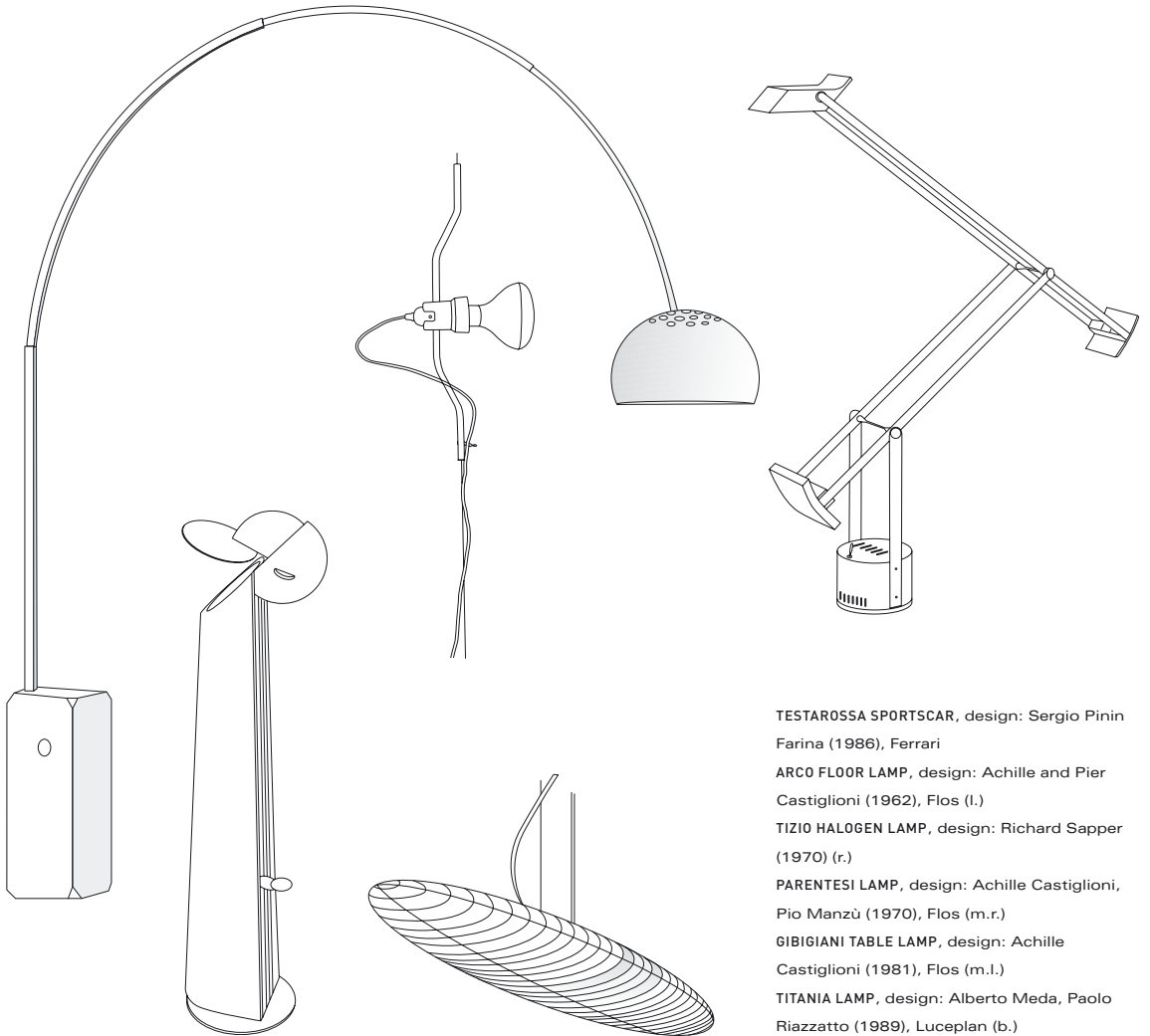
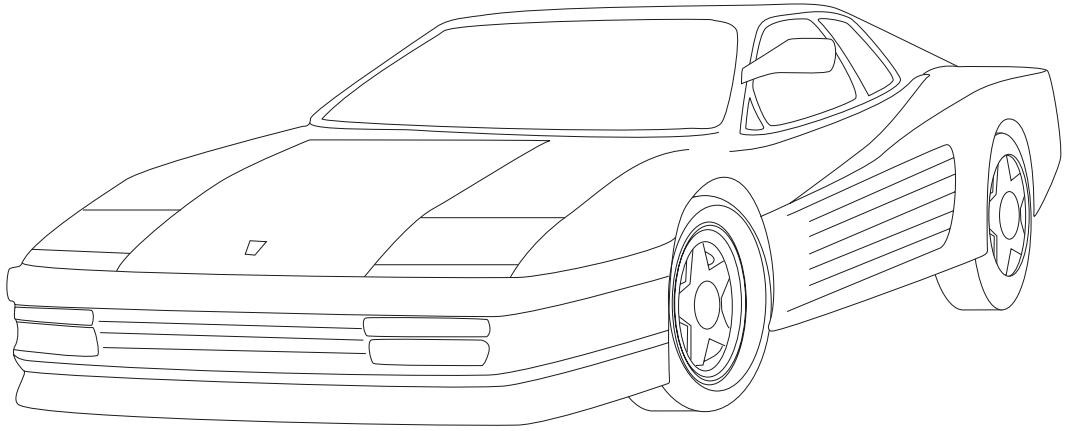

TESTAROSSA SPORTSCAR, design: Sergio Pinin Farina (1986), Ferrari

ARCO FLOOR LAMP, design: Achille and Pier Castiglioni (1962), Flos (I.)

TIZIO HALOGEN LAMP, design: Richard Sapper (1970) (r.)

PARENTESI LAMP, design: Achille Castiglioni, Pio Manzù (1970), Flos (m.r.)

GIGIGIANI TABLE LAMP, design: Achille Castiglioni (1981), Flos (m.I.)

TITANIA LAMP, design: Alberto Meda, Paolo Rizzatto (1989), Luceplan (b.)

p. 64). Ettore Sottsass, a promoter of socially critical design for many decades, gained important inspiration for new design trends through his contacts in American counterculture.

A number of groups that formed during the 1960s, especially in Florence and Milan, produced conceptual projects that exercised a decisive influence on design and laid the groundwork for the postmodernism of the 1980s, which led in turn to the end of the monolithic functionalist design interpretations dating from the 1920s.

The period when the first groups formed in Italy coincided with the American hippie movement of the mid-1960s, whose growing dissatisfaction with “more and more civilization” was also articulated in artistic and design circles. Influenced by, among others, the critical writings of Sigmund Freud and Herbert Marcuse, they called for open communities free of repression and attempted to live out the theory as an example to others. This was all going on in times that were shaken by student protest movements in the major European cities – Berlin, Frankfurt, Milan, and Paris – which quickly shifted their focus from purely student issues to much broader social questions.

The emblematic product of that period was the Sacco, a beanbag chair that gave the user the freedom to adopt any sitting position. Its perfect, informal way of interpreting young people’s sitting postures led it to be seen as a forerunner of “antidesign” (Koenig 1984). However, in the long run, the apparent absolute freedom of posture actually turned out to be extremely strenuous. For a time, the product-semantic expression of lifestyle protest outweighed the real ergonomic requirements of seating comfort.

Superstudio

Superstudio started work in December 1966 in Florence. The group, whose intellectual mentor was Adolfo Natalini, was set up to carry out theoretical research on the creative process in architecture and design. Unlike the English group Archigram, which used technological means to design concrete utopias, Superstudio saw itself more as a socially critical instance creating “negative utopias” (Vittorio Magnago Lampugnani). In a 1969 document titled “Design as Invention — Design as Evasion,” Superstudio described their work as an alternative to classic product design (bel design). Poetry and the irrational were the methods of “design as evasion,” representing an

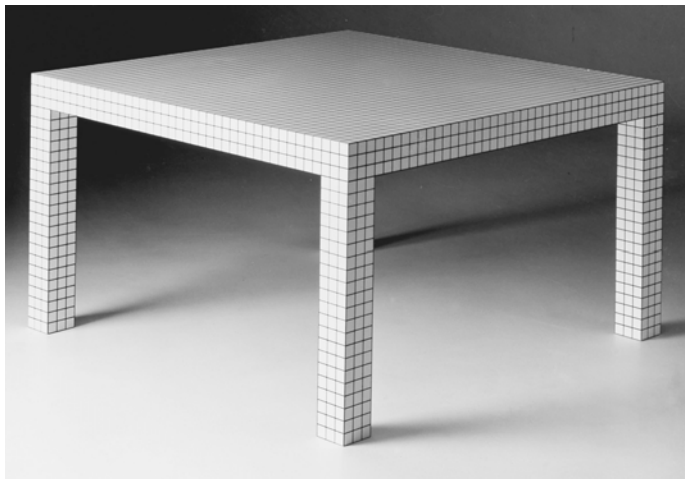

QUADERNA TABLE, design: Superstudio, Zanotta
(Photo: Aldo Ballo)

CHAISE LONGUE, design: Alberto Meda, Alias
SACCO, design: Piano Gatti, Cesare Paolini,
Franco Teodoro (1968), Zanotta

attempt to escape the horror of the mundane. As well as having a practical function, every thing was also an object of contemplation. This, the group said, was the end of the myth of rationalism that had governed design for almost a hundred years.

Archizoom Associati

Archizoom, regarded as the founder of antidesign, was also founded in 1966 in Florence. Andrea Branzi and Paolo Deganello were among the group's founding members. In 1968 – the year the European protest movement reached a climax in the May uprising in Paris – they presented a project titled “Eclecticistic Conspiracy” at the Triennial in Milan. The goal of their design activities was to destroy the fetish character of the objects. The group opposed expressions of status through design, consumerism, and chicness in fashion, design, and architecture. Although Archizoom disbanded in 1974, its influence on the later foundings of Alchimia and Memphis is unmistakable.

Group 9999

9999 was a didactic organization in Florence that ran a private school for conceptual architecture in cooperation with Superstudio. The group was especially interested in the role of theater as a location for architecture and art. Here, too, the interconnections are obvious. The 1972 study *Learning from Las Vegas* by Robert Venturi and others was informed by the idea that “decorated shacks” or the façades of gigantic skyscrapers really can make an enriching contribution to the cityscape. About the same time, the American architect Charles Moore took up the idea of the city as stage-set with biting irony in his Piazza d'Italia in New Orleans (1975/1978), the façades of which echoed Italian palaces.

Strum

This Turin-based group was another of the late-1960s intellectual circles of radical design. It called itself a group for instrumental architecture and attempted to use architecture as a means to communicate political propaganda. However, Strum also produced furniture designs blending flexibility of utilization with naive natural associations; their use of polyurethane foam, then a new material, led to the creation of sculptural objects for use in the home environment.



COVER OF EXHIBITION CATALOG for "Italy: The New Domestic Landscape,"
Museum of Modern Art, New York (1972)
(Photo: Wolfgang Seibt)

Italy – The New Domestic Landscape

In 1972 Emilio Ambasz staged what was probably the most spectacular exhibit of Italian design ever held, in New York's Museum of Modern Art. This broad presentation of the diversity of its creativity generated worldwide admiration for Italian design. The exhibit showed projects by proponents of *bel design*, such as Mario Bellini, Joe Colombo, Richard Sapper, and Marco Zanuso, as well as by advocates of the counterdesign currents, like Archizoom, Superstudio, Strum, and 9999. The spectrum of works ranged from those of great socio-cultural significance, for example, Ettore Sottsass's monumental cabinets, or the tractor seat by the Castiglioni brothers, through to artistic room installations. The whole spectrum of trends and opinions in Italian design was put on show, including historical overviews by Leonardo Benevolo and Vittorio Gregotti, through to critical contributions by Giulio Carlo Argan and Alessandro Mendini.

Concept design

The work of Superstudio, Archizoom, and other groups in the 1960s introduced a new category of design: concept design. This was the time when concept art developed in visual art, putting the artist's ideas at center stage as purely intellectual concepts. Divorced from material conditions, these works only achieved existence through associative thought processes in the viewer's imagination (Brockhaus Enzyklopädie 1987).

On the one hand, Italian concept design expressed the political hope that a revolutionary transformation of society would make new socially meaningful work possible. On the other hand, it was also concerned with changes in individual behavior, which the sketched suggestions were supposed to make possible. In one example, idealized representations such as those of Superstudio were supposed to transcend the limitations of spaceship earth.

Global Tools

Global Tools was founded on 12 January 1973 in the offices of the periodical *Casabella*. It was an alliance of various groups (including Archizoom, 9999, and Superstudio), individual designers (such as Gaetano Pesce, Ugo La Pietra, and Ettore Sottsass), and the magazines *Casabella* and *Rassegna*, who aimed to set up a network of workshops in Florence to promote the use of natural materials and

corresponding technical applications (Burkhardt 1987). The idea was to promote the free development of individual creativity, and the participating periodicals were to report regularly on the results.

Banal Design and Re-Design

Alessandro Mendini began experimenting with everyday objects in 1978, turning the conventional categories of good design and kitsch on their heads and styling trivial culture as the real high culture. Mendini himself believed that planning the banal was a revolutionary idea in design (Burkhardt 1984). He thought that the middle classes of society could re-appropriate this art of the banal, but his hopes were not to be fulfilled. In any case, one should not overrate the earnestness of banal design, just as re-design never actually progressed beyond an intellectual gimcrackery, yet still built bridges from design to art.

The driving force in this process, Alessandro Mendini, started out reinterpreting design classics by transforming them with artistic applications (painting, decoration, little flags, balls). This “alchemical transformation” (the attempt to turn base substances into gold) became the program of an entire group.

Alchimia

The Alchimia studio in Milan, set up in 1976 by Alessandro Guerriero, started off producing and selling artistic craft products. In 1979 the studio began offering designers exhibition opportunities for experimental works created without regard for issues concerned with production. The first exhibitors included Ettore Sottsass, Alessandro Mendini, Andrea Branzi, Michele de Lucchi, and others (Sato 1988).

One of the very first Alchimia projects in 1979 was called *Bauhaus I and Bauhaus II*. It largely comprised an ironic intellectual banalization of the Bauhaus tradition through drawings that transformed classic furniture designs.

In 1980 Alessandro Mendini and Alchimia participated in designing the *Forum Design* exhibition in Linz. The central event of the exhibition was a presentation of furniture objects by Ettore Sottsass, to which he himself gave a semiotic art historical interpretation according to a “new iconography.” This term had already been used by Robert Venturi, Denise Scott Brown, and Steven Izenour (1972) in *Learning from Las Vegas*, their description and interpretation of the symbolism of the architecture of American business and entertain-

ment cities. Reception of the semiotic theories of Roland Barthes, Jean Baudrillard, and Umberto Eco, which also make use of iconographic descriptive categories, exerted a great influence on new tendencies in design. For Sottsass the furniture represented a provisional end point on his personal development path, which he had trodden alone or with friends in the radical design (counterdesign) movement. His aim was to create a kind of iconography – a study in pictures – designing objects and images for a culture that was neither in the usual, nor oriented on use and usefulness. In so doing, Sottsass wanted to penetrate the realm of non-culture, of no man's culture. He saw his objects as monuments that should stand just for themselves: "They can't create style" (Sottsass 1980). The fact that the Memphis style was born just a year later is not an irony, but rather the consequence of savvy marketing.

Memphis

In the first December days of 1980 Barbara Radice, Michele de Lucchi, Matteo Thun, and a few others met in Ettore Sottsass's Milan apartment to enjoy an evening of Italian wine and American music. Bob Dylan's song "Stuck Inside of Mobile with the Memphis Blues Again" was the cue for a storm of creativity in which they planned to involve friends and acquaintances from other countries, too. The idea was to design a completely new collection of furniture, lamps, glass, and ceramic products and have them produced by small Milan craft workshops. The results were presented in Milan on 18 September 1981: thirty-one furniture objects, three clocks, ten lamps, and eleven ceramic objects were euphorically acclaimed by 2,500 visitors. This first collection featured products by the initiators, Sottsass, de Lucchi, and Thun, as well as by an illustrious group of architects and designers including Andrea Branzi, Michael Graves, Hans Hollein, Arata Isozaki, Shiro Kuramata, Javier Mariscal, Alessandro Mendini, Studio Alchimia, and Masanori Umeda (Radice 1988).

Memphis represented the final rejection of the Italian radical design and antidesign tendencies of the 1970s. Memphis neither formulated utopias nor postulated a critical stance with respect to social conditions or objects; instead it strove to derive individual profit – at long last – from the new ideas of the 1970s. The fashion world was especially enthusiastic: Karl Lagerfeld furnished his entire apartment in Monte Carlo with Memphis pieces, Elio Fiorucci said that a new aesthetic had been created, and Isa Vercelloni, editor of the magazine



ALCHIMIA POSTER (1983) (Photo: Wolfgang Seibt)

PROUST ARMCHAIR, design: Alessandro Mendini, Cappellini

COVER OF EXHIBITION CATALOG for "Memphis: The New International Style," Milan (1981)

RING TAWARAYA, design: Masanori Umeda, Memphis (Photo: Volker Fischer archive)

Casa Vogue, said the Memphis style represented a new way of seeing and feeling.

That is just what the Memphis designers – first and foremost Ettore Sottsass – wanted: design that took inspiration from different cultural contexts, supercharged it aesthetically, and transplanted it into objects. Aiming to create a new sensuality, capable in its arbitrariness of being represented on all continents, they also called Memphis the “New International Style.” This ironic reference to the International Style of the 1930s was one of the main reasons why the New International Style was disseminated so quickly by the media all over the world. The meaning within the objects was intended to provoke communication, but the question of which “messages” were to be disseminated remained open. The Memphis designers’ rejection of the traditionally interrelated categories of form, function, and material can hardly be designated a Copernican Revolution (Fischer 1988a), because this development had been observed continuously since the 1960s – especially in Italy – and Memphis represented the end of a process rather than a new beginning. Instead, Memphis launched a phase of absolute arbitrariness, the “new obscurity” (Habermas 1984). The actual effect of Memphis was merely that new interpretations of design were able to gain recognition quickly alongside the official functionalist doctrine that “form follows function.” The age of heresy had been overcome for design. In that sense, Memphis stands as a synonym for design liberated from regimentation (Burkhardt 1984). The new ideas were quickly adopted in Germany, leading to the development of a new design movement that found its climax and swan song in 1986 in the Düsseldorf exhibition *Gefühlscollagen – Wohnen von Sinnen* (Feeling Collages – Living Madness).

STAGNATION IN THE 1990S

Thereafter, very few relevant trends developed in Italy. The demise of Olivetti in the face of international competition during the 1990s left Italian designers and manufacturers largely fixated on designing furniture, celebrating themselves at the annual Milan furniture fair and in the city’s downtown showrooms. By investing heavily in design, Alessi succeeded in becoming a global lifestyle business, whereas investigation of and experimentation with digitalization, for example, remained mostly theoretical (Anceschi 1992; Maldonado 1997). One

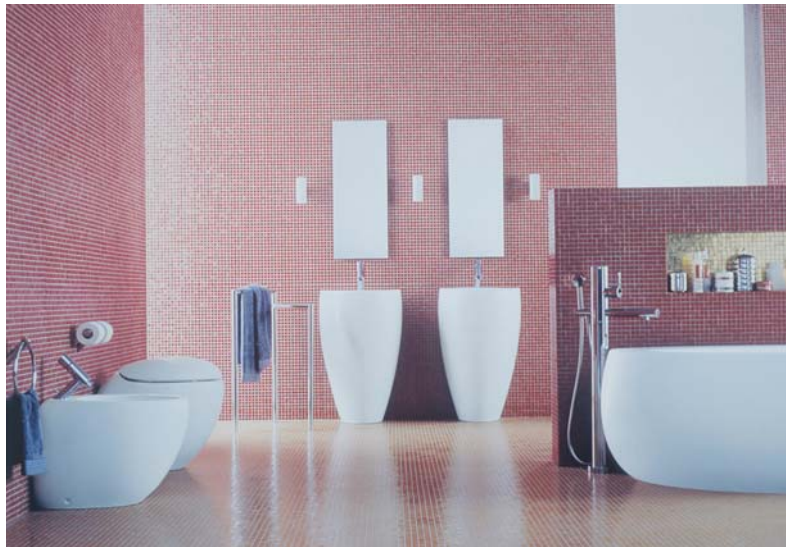

THE SISTERS CHAIR, design: Denis Santachiara,
Vitra Edition (Photo: Vitra)

IL BAGNO ALESSI, design: Stefano Giovannoni,
Alessi

CARLTON SHELVES, design: Ettore Sottsass
(1981), Memphis

of the few designers who proved able – and willing – to make the transition from counterdesign (via progressive furniture design for firms like Cassina, Friade, Poltronova, Vitra Edition, and Zanotta) to digital design was Paolo Deganello (2002). As the digital age eclipsed the mechanical age the task profiles for design had to change, too, but in Italy – of all places – this went almost unnoticed. So the new centers for advanced design are no longer in Milan and environs, but are more likely to be found in Barcelona or in the big Asian cities of Seoul, Shanghai, Taipei, and Tokyo.



DR. NO ARMCHAIR and DR. NA TABLE, design:
Philippe Starck, Kartell



EXERCISES IN STYLE, design: Paolo Deganello,
ICE in the Ace Gallery, New York (2000)
and in Park Tower Hall, Tokyo (2001)
ZOE WASHING MACHINE, Zanussi



GUGGENHEIM MUSEUM BILBAO
design: Frank O. Gehry
(Photo: Bürdek archive)

SPAIN

After the fall of the forty-year Franco regime (1975), Spain witnessed remarkable cultural developments across a wide range of fields. There was much catching up to do and a plethora of activities resulted in the rapid growth of literature, fashion, film, theater, music – and also of design. The traditional rivalry between the two centers of Madrid and Barcelona flourished in an explosion of culture, but the regions around Valencia and Bilbao also demonstrated their enthusiasm for design (furthered in Bilbao by the energetic DZ Centro de Diseño and Frank O. Gehry's spectacular Guggenheim Museum, which opened in 1997). An additional contributing factor was Spain's economic structure, which resembles that of northern Italy: numerous craft businesses and artisan workshops are today recalling their traditional qualifications and opening up to new cultural and design-oriented trends.

At the turn of the twentieth century the architect Antonio Gaudí was already designing expressive buildings, interiors, and furniture, which drew their special meaning from these traditional values. Gaudí pursued the idea of a *Gesamtkunstwerk*, designing the building's architecture, furniture, and decoration in a single "language," so that these elements would complete and complement one another (Giralt-Miracle/Capella/Larren 1988). By the 1930s the Gatpac company was already producing tubular steel furniture, and working with the German architect Mies van der Rohe.

Industrial design in Spain began with the founding of the designers' association (ADIFAD) in 1960. One of those involved in setting up the organization was André Ricard (2000), the grand seigneur of Spanish design. Ricard met Raymond Loewy in the United States in 1956 – a detail rarely omitted from his biography – and represented the tradition of Spanish bel design over many decades in the same way as Sottsass did in Italy.

The founding of the Barcelona Centro de Diseño (BCD) in 1967 brought about increasing acceptance of industrial design in the Spanish economy. Until the end of the 1970s industrial design was largely governed by the principles of "good design." For a long time system design as practiced by the Ulm School of Design or Braun determined the outward appearance of product design in Spain.

At the beginning of the 1980s the strong cultural influence of Italy led to the emergence of a "vanguardia movement," exhibiting strong neomodernist traits, which were plain for all to see at the great art



CANOLA/RAPSEED OIL FILLING STATIONS, design:
Sir Norman Foster, ERCO

and design exhibition Arteder, in Bilbao. Large-scale production of designer furniture ensued, with the results being shown for the first time in a group show at the Cologne Furniture Fair in 1987. Since then, Spanish manufacturers have bolstered their already massive presence at the Milan Furniture Fair, aiming to gain a foothold in the European market with sophisticated marketing strategies and the latest technology.

The 1992 Olympics caused a veritable design boom in Barcelona. The large number of new buildings, public design initiatives, shops and restaurants, and graphic works, turned the city into probably the most vibrant design center in Europe.

The Gustavo Gili publishing house's voluminous book production in the fields of art, architecture, and design exerts a special influence in Spanish-speaking countries, including Latin America. As in Italy, new Spanish design is propagated by a number of magazines, including *de diseño*, *Experimenta*, and *On*, which see themselves as interdisciplinary platforms for graphic and product design, interior design, architecture, art, and fashion.

The best-known Spanish designers include Ramón Benedito, Pepe Cortés, Javier Mariscal, Jorge Pensi, Oscar Tusquet, and Lluís Clotet (*El Diseño en España* 1985, BCD 1987). Tusquet and Clotet were at the Linz *Forum Design* of 1980 but went largely unnoticed there. It was not until they participated in the *documenta 8* (1987 in Kassel) that they drew attention to the potential of Spanish design, through, for example, Tusquet's lamp that provides illumination in the form of a book.

The younger generation of Spanish designers numbers in its ranks Martín Azúa, Anna Bujons, Emili Padrós Curro Claret, Martí Guixé (2003), known in particular for his conceptual work, Ana Mir, and Torres & Torres (furniture and interior design). The biennial *Primavera del diseño* in Barcelona has become an international forum for design. Relatively few Spanish companies have made a name for themselves through active design initiatives. The exceptions include Amat, B. D. Ediciones de Diseño, Disform, Santa Ilole, and Puig (all furniture manufacturers); with the assistance of international designers, the ceramics business Roca has also become a global operator.

The most important overview of design in Spain to date was probably the 1998 exhibition *Diseño Industrial en España* in Madrid, with its comprehensive catalog (Giralt-Miracle, Capella, and Larrea 1998).

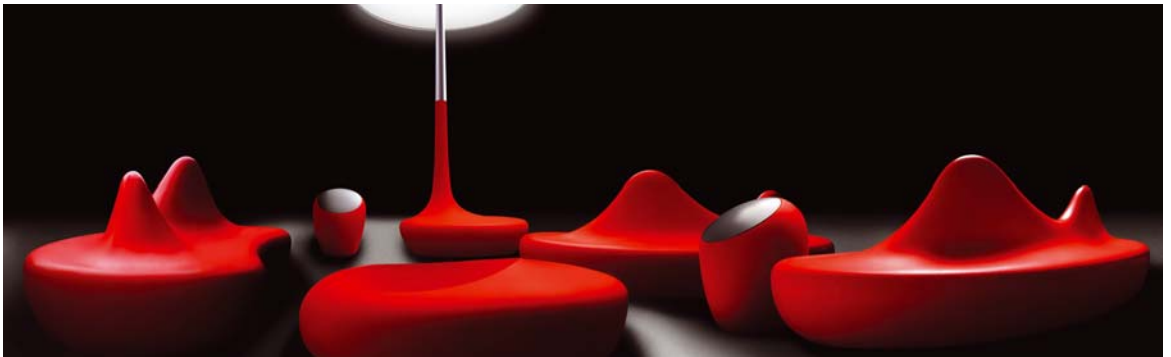
**TRANSIT FURNITURE CONCEPT**

design: Ross Lovegrove, B.D. Ediciones de Diseño

FRANCE

For a long time France's huge impact on the fine arts (painting, sculpture, literature, music, theater) and fashion – not to mention philosophy and the natural sciences – had little effect on design. The decorative arts of French craftsmen and architects did not experience their first apogee until the 1930s, the age of art deco. The interiors of apartments, public buildings, and even ocean liners became a field of experimentation for French *dessinateurs*, and the heritage of these *arts décoratifs* runs through French design to this day; representatives include designers like Philippe Starck and Garouste and Bonetti. Starck recurrently emphasizes elegance, proportionality, and playfulness, all of which characterize his work; alongside hundreds of products this includes, in particular, interior designs (for hotels, cafés, and bars, for example), as well as complete buildings.

Raymond Loewy – who had emigrated to the United States in 1919 and found success there – opened a design office in Paris in 1956; his work in France concentrated on graphics. Jacques Viénot founded the Technes design agency in 1952, also in Paris; this agency undertook projects in the fields of graphics and industrial design. Lucien Lepoix opened his office, F.T.I. (Formes Techniques Internationales), in Paris in 1956.

Roger Tallon gained an international reputation through his many designs for furniture, lamps (e.g., ERCO), clocks, and, in particular, through his work on the image of modern mass-transit systems – for example, the Mexico City subway (1969) and the high-speed TGV Atlantique for the French state railways (Tallon 1993).

Unlike other European nations, the French did not really start dealing seriously with questions of industrial design until the early 1960s. When they did, an important role was played by the C.C.I. (Centre de Création Industrielle), which was founded in 1969 and moved to the Centre Pompidou in 1976, where the exhibition *Design français 1960–1990* (A.P.C.I./C.C.I. 1988) gave a first representative overview of design in France.

Design developments from Italy reached France at the beginning of the 1990s. Groups of young designers such as Nemo, Totem, Olivier and Pascal Morgue (now operating worldwide), and Philippe Starck (the best-known internationally) stand as examples of new French design. Under the influence of postmodernist philosophers like Jean François Lyotard and Jean Baudrillard, France produced a broad

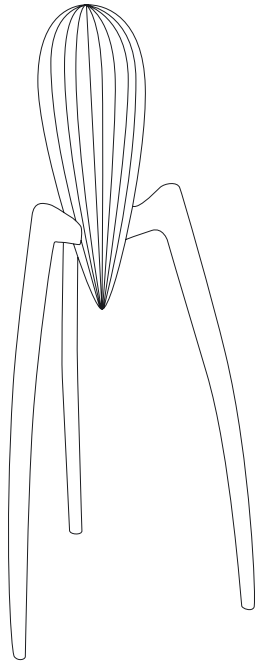

THE BATHROOM, design: Philippe Starck, Duravit
JUICY SALIF CITRUS PRESS, design: Philippe
Starck (1987), Alessi

spectrum of designs throwing together the most diverse of materials: concrete and plastic, glass and iron, exquisite and banal.

This new design was particularly apparent in shop fittings, boutiques, and bars. The most famous examples are the furnishings for Café Costes (1981) and the interiors in the Elysée Palace in Paris, designed in 1982 by Philippe Starck at the behest of then President Mitterand.

Starck became one of the world's most famous and significant designers in the 1980s. Unlike the Italian avant-garde movement (such as Alchimia and Memphis), Starck must be duly credited for maintaining democratic pretensions in his furniture, ensuring that it is manufactured and marketed at affordable prices. For example, during the late 1980s some of his furniture was marketed through the French mail-order company Trois Suisse. In his work for the Italian company Alessi – especially the Juicy Salif citrus press (1987) – he placed communicative functions before practical ones. Starck is regarded as one of the most important proponents of semantic (product-semantic) design. With hundreds of products, as well as buildings and interiors, he became one of the main standard-bearers of design in the late twentieth century.

A major role in promoting new design in France is played by VIA (Valorisation de l'Innovation dans l'Ameublement). This institution fosters new developments in furniture design by organizing competitions, exhibitions, and promotional work, and brings designers together with potential manufacturers (Kluge 1989). Representatives of the Ministry of Industry also attend regular meetings to discuss designs and assess their market potential. Prototypes of the selected works are produced in order to investigate expected production volumes and manufacturing processes. In just a few years this procedure led to hundreds of furniture objects being developed and put on the market.

When discussing the decorative tradition in French design, mention must be made of the designer Andrée Putmann, whose work includes the interiors of the Franco-British supersonic airliner, Concorde, and the Quai d'Orsay Museum in Paris, and also the interior design duo Elizabeth Garouste and Mattia Bonetti, who number among the exponents of an exuberant neobaroque design style and whose dazzling designs find their clientele in the postmodern conurbations. The internationally renowned architect Jean Nouvel, by contrast, adheres to classical modernism in his furniture designs. A number of young de-

Starck changes and exchanges the roles and the rules according to which products are designed and used. For him, the relationship between form and function is not a functionalistic system of rules to be followed by the letter, but rather a cosmos of possible surprises in which one can design with passion without ever giving up the premises of utility.

— VOLKER ALBUS/
VOLKER FISCHER, 1995



AÉROLITE 2 DESK LAMP, design: Éric Hourdeaux

PARADOX LAMP, design: Guillaume Bardet

BULLE NIGHT LIGHT, design: Sandra Ancelot,
Thomas Bleicher

VERY NICE CHAIR, design: François Azambourg

CECI EST UNE LAMPE LAMP, design: Flavien
Théry

CARRÉS DE JARDIN, design: Séverine Szymanski

signers caused a stir in the 1990s, almost all of them working with interiors and thus continuing the decorative line in French design. They included, for example, the Bouroullec brothers (2003), Erwan and Ronan, who create utensils and furniture for Cappellini and Vitra as well as experimenting with conceptual design. The office furniture system they unveiled in 2002, Joyn, breaks with all conventions and represents a spectacular contribution to a new, highly flexible, modularized product culture – completely redefining the world of work and the home environment.

Companies also made reputations by design during the 1990s: Thomson Multimedia (hi-fi, entertainment electronics) became known especially for its avant-garde home entertainment systems, or the domestic appliances group SEB (Arno, Moulinex, Calor, Rowenta, Krups, Tefal), whose Moulinex subsidiary displays a particular awareness of design. A real design boom broke out in the French car industry. The PSA group (Peugeot and Citroën) made waves with especially innovative and affordable vehicles. The C3 Pluriel is becoming the new cult vehicle of a young clientele, because it will be available as a pick-up, roadster, targa, and sedan. With it Citroën takes up the tradition of the legendary 2CV, which wrote design and lifestyle history in the second half of the twentieth century.

Under Patrick le Quément, Renault succeeded in setting completely new standards in product culture (Mason 2000). The Espace became the model for the European vans of the 1990s and the Twingo (1992) was a graceful compact that particularly attracted young and female target groups, while the Avantime, the Vel Satis, and the Scénic are examples of automobiles whose expressive forms repositioned French car design.

We used to use the Esperanto design, one language for all. Now we have found new, convincing concepts and a language of our own.

— PATRICK LE QUÉMENT, 2003



JOYN OFFICE FURNITURE SYSTEM, design:
Bouroullec brothers, Vitra (photo: Miro
Zagnoli)

PORCELAIN RADIO, Thomson

NEW KIND OF SLED, design: Benoit Vignot



CITROËN C3 PLURIEL
RENAULT SCÉNIC II

THE NETHERLANDS

In the geography of design, the Netherlands occupies something of a special position as the model for public design activities. Everywhere – in the two-dimensional plane of banknotes, stamps, forms, street signs, and in the three-dimensional world of buses and trains, post office and government agencies, cities, streets, squares – one is confronted with a modern visual language that beggars comparison.

At the beginning of the twentieth century the design initiatives of the Werkbund were also felt in the Netherlands, and improvements in the quality of industrial production went hand in hand with a rational, functional design language. Gerrit T. Rietveld's furniture designs – such as the *Red and Blue Chair* (1918), his *Schröder I table* (1923), and the *Zig-Zag chair* (1934) – stand as emblematic examples of that approach.

In the period between 1910 and 1930 the De Stijl group was already receiving commissions from public bodies to design urban planning projects as well as products and services (Lueg 1994). Mart Stam worked at the Bauhaus in Dessau for a time during the 1920s, where he developed the legendary tubular steel furniture.

Wim Rietveld (son of Gerrit T.) was one of the first industrial designers. He created many pieces of furniture, as well as vehicles (such as the Amsterdam subway), agricultural machines, and electrical appliances (Hinte 1996). Another follower of the functionalist tradition in design was Friso Kramer, who designed many items of office furniture for the Ahrend group and for the German manufacturer Wilkhahn.

Many internationally renowned design agencies operate from the Netherlands, the most prominent of them probably being n/p/k (Ninaber, Peters, and Krouwel 2002), who made their reputation mostly in the field of public design. Other agencies practicing functional technical design specifically for international clients are Brandes en Meurs in Utrecht, Flex in Delft, Landmark in Rotterdam, and Well Design in Utrecht. Firms that are particularly active in corporate design include Studio Dumbar in The Hague (communication and public design) and Total Design in Amsterdam, Brussels, The Hague, Maastricht, and Cologne (communication, identity, exhibition design, and design strategies).

The Droog group began with an eclectic collection of products by different designers, selected by Renny Ramakers and Gijs Bakker,

which was presented under the name of Droog Design by Andrea Branzi at the 1992 furniture fair in Kortrijk, Belgium, and the 1993 International Furniture Fair in Milan. What the designers had in common was a creative – and often very unusual – treatment of materials and product functions (Zijl 1997). Concrete commissions followed very quickly, from Rosenthal in Germany, glassmaker Salviati in Venice, and Bang & Olufsen in Denmark (Ramakers, Bakker, and Gijs 1998; Ramakers 2002). Hella Jongerius became known for her work for Droog, which radically redefined everyday objects. The “Jongerinslab” group she founded in Rotterdam in 2000 has already made a name for itself internationally (Jongerius and Schonwenberg 2003).

The Philips company began in 1891 in Eindhoven as a light bulb manufacturer; radio receivers (with Bakelite cases) followed in 1924, and television sets in 1950. Today Philips is a global player, a position due in no small part to its design activities. Philips set up a corporate design center in the 1980s headed by American Robert Blaich (Blaich 1993), which grew to become one of the largest in the world under Blaich’s successor, Stefano Marzano. More than five hundred designers work at the headquarters in Eindhoven and at twenty branch offices across the world. Philips is one of the leading manufacturers of medical equipment, but also collaborates on products with firms like Alessi and Capellini. A whole series of important publications on design were also published under Marzano’s auspices – for example, Manzini and Susani (1995), Mendini, Branzi, and Marzano (1995), Philips (1996), Marzano (1998), and Philips (1998) – all of which helped to establish the Philips Corporate Design Center as a think-tank.

Carmaker DAF launched its daf 600, a minicar with a fully automatic transmission, in 1958, but was taken over in 1974–1975 by Volvo of Sweden (itself since taken over by Ford). Océ in Venlo is a renowned manufacturer of reproduction machines, which made a name for itself in the 1990s with its outstanding interface concepts.

Delft Technical University plays an important role in Dutch design through its Faculty of Industrial Design Engineering, which was set up in 1969 and is today one of the world’s leading design training institutions. Most of the designers working in the Netherlands are recruited from this Design Department. The Design Academy in Eindhoven, based in the same building as the Philips Corporate Design Center, sees itself largely as a place for young designers to experiment in.

A vivid example of a new way to establish a brand in the future is furnished by the Dutch electronics concern Philips. It developed an on-line product for children, soon to go on the market in Europe. The first thing Philips did was send industrial designers, developmental psychologists, anthropologists and sociologists to their customers.

In specially equipped mobile homes, they drove to communities in Italy, France and the Netherlands, where they asked adults and children to help them look for ideas for new electronic products that might better do justice to customers’ changing needs.

— REGIS MCKENNA, 1996



LABORATORY EQUIPMENT, design: nlpk industrial design, Vital Scientific

MAILBOX for the Nederlands Post, design: nlpk industrial design

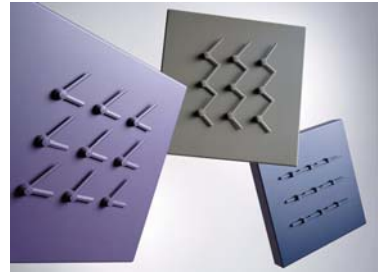

PRODUCTS BY FLEX

CABLE REEL

CABLE DRUM

NINE O'CLOCK WALL CLOCK

CHILDREN'S CHAIRS, design: Droog

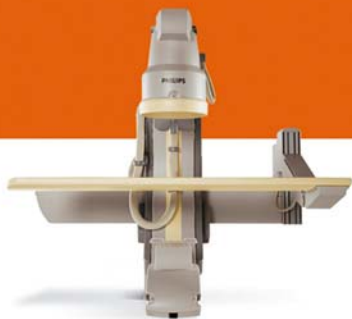
**PRODUCTS BY PHILIPS**

ELECTRIC KETTLE

DIGITAL AUDIO PLAYER

LCD MONITOR

DESIGN FOR LIFE



V-MAIL CAMERA (USB desktop webcam)

RADIO/CD PLAYER

MIXER (Philips Alessi line)



MONTANA FURNITURE INSTALLATION, Potsdamer
Platz subway station, Berlin

PRODUCTS BY KNUD HOLSCHER

LAMP

STAIRWAY RAILING

COAT RACK

SCANDINAVIA

Furniture, lamps, wallpaper, glass, porcelain, and ceramics are the products usually spontaneously associated with “Scandinavian design,” which is also characterized by a consistently high standard of product culture and an absence of the prominent single pieces found in Italy. The development of Scandinavian design has been associated with an uninterrupted tradition of quality craftsmanship. For many years applied arts and domestic appliances dominated design activities. Only recently have product designers turned to the fields of steel and plastics, office equipment, apparatus engineering, the automobile industry, medical and rehabilitation equipment, and, most recently, telecommunications (Ericsson and Nokia).

The solidly functionalist formal language of Scandinavian design and its economical use of materials and colors certainly made it a model for German post-war design. The origins of Braun’s products (e.g., radios) can also be interpreted in this context.

As Hans Wichmann (1988) described in his retrospective, the dominance of Scandinavian product design was not broken until the 1960s, when Italian designers proved better able to adapt their designs and materials to the altered technological and product-cultural conditions of the second half of the twentieth century.

DENMARK

Craft traditions are the decisive factor in Danish design, too: glass, ceramics, household items, and furniture are typical, joined more recently by hi-fi equipment. The most important Danish designer was probably the architect Arne Jacobsen, who designed chairs, lamps, glasses, and cutlery, as well as numerous buildings. His collection of sanitary fittings is regarded as the quintessence of reductional functionalist aesthetics. Nanna Ditzel (furniture), Poul Kjaerholm (lamps), Erik Magnussen (metal goods), Jørgen Møller (household goods and furniture), and Hans J. Wegener (furniture) are also major internationally known figures in Danish design. Verner Panton, probably the least Danish of the Danes, created furniture, lamps, and textiles. His stackable plastic chair – designed in 1960 and manufactured from 1967 to 1975 by Herman Miller – was felt to be the essence of the new freedom of form brought by plastics. At the beginning of the 1970s he



CHAIRS, design: Arne Jacobsen, Fritz Hansen
BANG & OLUFSEN HIGH-FIDELITY SOUND SYSTEMS
Avant DVD system

created visionary living environments – veritable orgies of color and form – that were presented at the International Furniture Fairs in Cologne. The interior design of *Der Spiegel* magazine's Hamburg offices survives to this day as evidence of this understanding of design.

Architect and designer Knud Holscher is one of the major proponents of a functionalist interpretation of design, operating with minimal means to generate optimal simplicity of design (Skriver 2000). Bang & Olufsen also hails from the same tradition, following a consistent course of classical modernism in the hi-fi sector (Bang 2000). The furniture manufacturer Fritz Hansen combines craft traditions with the creative concepts of international designers, while global player Lego (toys) plays a major role in developing modular principles and its products exert a significant influence on psycho-social child development.

FINLAND

Finland also boasts a long and excellent artistic craft tradition, principally in the fields of glass and ceramics. The huge expansion of telecommunications manufacturer Nokia during the 1990s, however, changed Finland's image to that of a high-tech nation. The UIAH (University of Art and Design) in Helsinki was a significant factor, having been transformed during the 1990s by massive state investment into one of the world's leading design universities.

In the 1930s architect and designer Alvar Aalto started experimenting with plywood, which had previously only been used for skis (on account of its elasticity). Aalto took the constructional ideas of the Bauhaus tubular steel furniture and applied them to wood. Tapio Wirkkala became best-known for his glass and ceramic designs for the German firm of Rosenthal. Today firms such as Arabia (ceramics), Artek and Askö (furniture), Fiskas (tools), Hackmann (homeware), and Woodnotes (floor coverings) are the primary representatives of Finnish design. The younger generation of designers includes Harri Koskinen, who stands in the tradition of Finnish modernism and works for international companies in the fields of glass, tableware, kitchen appliances, furniture, and lighting, and also Stefan Lindfors, who works as an architect, designer, artist, and textile designer, and designs glass and household items for companies such as Arabia, Hackmann, and Iittala (Design Forum Finland 1998).



GLASSES AND VASES, design: Alvar Alto, Iittala
 7600 UMTS MOBILE PHONE, Nokia
 VOICE-CONTROLLED WATCH for the elderly,
 ist (international security technology)

Originally a manufacturer of rubber boots and car tires, Nokia branched out to become one of the world's leading manufacturers of telecommunications systems and equipment. Nokia operates highly diversified product policies, combining state-of-the-art technology with up-to-date contemporary trends, and has become one of the world's leading cell phone manufacturers.

NORWAY

Norway is the Scandinavian country where design is least developed. The almost complete absence of manufacturing industry lent added weight to arts and crafts activities, which have only recently progressed into product design for series production. Scandinavian design is understood as a way of life: reduced formal language, simple manufacturing processes, and high reliability are important characteristics for product design in Norway, too. However, designers tend to refer back to early European modernism rather than explicitly following a Scandinavian tradition of their own.

Two different approaches arose during the 1970s. "Unika" involved designers producing one-off creations for clients in their studios, while a second attitude was to aim for industrial mass production (often abroad). The third way, followed today, involves a very earnest, ethical, and ecological working method (Butenschøn 1998), which is followed by, to name but a few, Olav Eldøy (furniture), Eirik Lund Nielsen (for the German sporting goods gear manufacturer adidas among others), Camilla Songe-Møller (furniture), Sari Syvaluoma (textiles), Johan Verde (furniture), Herman Tandberg (stoves), and 360 Grader Produktdesign in Oslo (technical products).

SWEDEN

The first serious reform initiatives in Swedish architecture came at the beginning of the twentieth century. Gunnar Asplund's combined kitchen and living room of 1917 aimed to exploit the opportunities offered by industrial mass production to present simple robust furniture, made of Scandinavia's ubiquitous pinewood; this formed the starting point for subsequent developments. An exhibition in Stockholm in 1930 showed functional furniture that can be seen as an expression



SWEDISH FURNITURE, Swedese Möbler AB

(Photo: Gösta Reiland)

PEBBLES COUCHES, design: Claesson Koivisto
Rune Arkitektkontor, Cappellini

of the age: simplicity and functionality were the dominating principles. As in Germany, there was intense experimentation with steel tubing for seating. The New York World's Fair of 1939 helped "Swedish modernism" to make a breakthrough as an international design concept (Sparke 1986).

During the 1940s the Swedish Werkbund worked to improve the home environment, concentrating particularly on apartments suitable for children. During the subsequent decade new ways of living together were developed. Lena Larsson was one of the architects who created multi-purpose rooms for living, cooking, playing, and working, presenting her work at the 1955 Werkbund exhibition in Helsingborg.

After World War II Sweden turned itself into the model welfare state, one element of which was an enormous house-building program. In the new complexes, community facilities such as schools, libraries, youth clubs, cinemas, and shops were planned, constructed, and furnished. However, the worldwide economic crisis of the 1970s was enough to put an end to this development even in Sweden, although a high standard of living remained. Not until the 1990s did the Swedes say farewell to a welfare state concept that had become practically unaffordable.

During the 1960s and 1970s a number of major furniture chains were founded in Sweden which were to shape the product-cultural image of Swedish furniture design. The best-known is IKEA, which now runs more than 150 stores in thirty countries on all five continents. About seventy thousand employees generate an annual turnover of more than ten billion euros, and more than 11,500 items are on sale in each store. IKEA presents its products in an annual catalog that now enjoys worldwide distribution. Customers can read and shop in peace and quiet at home, order by mail, or pick up the products from one of the stores. For reasons of rationalization, most of the furniture is packed in pieces for the customer to assemble (Brenner and Johannsen 1998). By choosing their own color combinations, some of the products can be customized by the purchaser. IKEA's product range primarily attracts consumers aged between twenty and forty, buying furniture for themselves and their children. The products are consequently inexpensive, and have come to shape the home furnishing ideas of whole generations. The Billy bookcase is a design classic that sells more than two million units every year.

Systematically combining a cliché of Sweden – based on Carl Larsson's residential idyll – with the complete design of every aspect of everyday life – as had once been propagated by Bauhaus and the Werkbund – was directed to a nation of consumers that loves everything Nordic, holds the comforts of home to be sacred and indulges in a propensity for totality.

____ KRISTINA MAIDT-ZINKE,
1999



ELECTROLUX VACUUM CLEANER ROBOT
P800 MOBILE PHONE, SonyEricsson

IKEA's manufacturing is by no means restricted to Sweden – low-wage countries also work to the designs and production methods of international designers and engineers. At the beginning of the 1980s IKEA started an image transfer to expand its markets. The elk – originally a symbol of the Scandinavian pine tradition – was driven out. Along with a new product line – IKEA Office – the product range was expanded to encompass an international modernism influenced by Italian furniture design (Bomann 1988). Lightweight design concepts – sometimes very fashionable – were added to the catalog to help entice younger customers (fed up with the pine look favored by their flower-power-generation parents) to join the big “IKEA community.” The Danish-based designer Nils Gammelgaard and his agency, Pelikan Design, made a great contribution to IKEA's new product culture.

The David Design agency markets its own designs, as well as products by renowned international designers. Its Stockholm location was joined in 2002 by another new showroom in Tokyo. Young businesses offering design and production are becoming increasingly established; examples are Materia, David Design, and cbi – all of which belong to the avant-garde of Swedish design.

In the field of social design, the Ergonomi Design Gruppen agency enjoys a high international standing on the basis of its many products that are excellently designed in medical, ergonomic, social, and aesthetic terms.

In 1996 Stefan Ytterborn founded Ytterborn & Fuentes, which operates in the fields of corporate identity and strategic design. He is regarded as an important figure in the renewal of the Scandinavian design scene, working for international companies and coordinating design projects for Arabia, Ericsson, Hackmann, IKEA, Iittala, McDonald's, Saab, and others. On top of all that, he curates exhibitions and helps organize design competitions. In fact, he is interested less in the design of individual products than in which designers can give the best visual expression to companies' strategies and ambitions (Frenzl 2003).

Companies like Electrolux (domestic appliances), Hasselblad (photographic equipment), Sandvik (tools), and Saab and Volvo (cars) have made a major contribution to Sweden's reputation for high-quality technical products that are very long-lasting and almost immune to the vagaries of fashion. During the 1990s telecommunications company Ericsson turned itself into a leading manufacturer of cell phones and the associated infrastructure.

For a long time the market was dominated by designer names, but this development is at an end. Selecting designers is a strategic matter: the point is not who makes something beautiful, but which designer can best visualize a corporation's strategies and ambitions.

— STEFAN YTTERBORN, 2003

RUSSIA

The origins of design in the former Soviet Union can be traced back to the Russian avant-garde art movement of the early twentieth century (Wolter and Schwenk 1992). Two very different lines of development shaped this movement: on the one hand, an emotional, intuitive oneness with the world, and on the other, a rational, constructivist analysis of context. The latter lent its name to the period, although that perspective is actually too narrow. This dialectic of subjective and objective approaches to solving problems and developing products formed the basis of early design work in Russia.

Kazimir Malevich and Vladimir Tatlin were among the early avant-gardists who developed a new realism in painting. Their fundamental investigations (of shape, color, plane, etc.) also indirectly laid important foundations for later basic course. Today, we can even see a synthesis of nature and technology in Tatlin's work. His monument to the Third International, the Dynamo Tower, designed in Moscow in 1919–1920, is regarded as an emblematic work of Russian revolutionary art, and, indeed, an icon of twentieth-century modernism.

Tatlin also designed models for clothing, tableware, stoves, and many other things, and taught at the Higher Artistic-Technical Studios (VKhuTeMas, 1920–1930, from 1927 on VKhuTeIn), which followed educational principles similar to those of the Bauhaus in Weimar and Dessau. Tatlin strongly believed that the free arts should provide models for the applied design of technical objects, and attempts were also made to formulate standardized laws of design. The artistic and intellectual avant-garde enjoyed great scope for airing their theoretical reflections, as witnessed by their many manifestos and pamphlets.

During this period the State Porcelain Factory turned out many products that were closely linked to the Soviet government's propaganda efforts: plates with hammer and sickle décor, and slogans such as "Science must serve the people" and "If a man will not work, he shall not eat" (Adamowitsch 1921). Many textile designs also expressed calls for a new communist social order, and architecture, too, placed itself at the service of the revolution.

The principles of industrial design were first applied in manufacturing during the 1930s. Designers worked on products such as locomotives, motor vehicles, telephone sets, appliances, as well as the Moscow subway construction projects. During the 1940s and 1950s

industrial design groups were formed in factories, design offices, and research institutes. They worked in the fields of aircraft construction, carmaking, shipbuilding, and machine-tool manufacture.

The initiatives of the 1960s to develop industrial design as an integral system attempted to connect with these longstanding traditions (VNITE 1976). Following a decision by the Council of Ministers of the Soviet Union, work began in 1962 to set up a unified system the activities of which were to be based on scientific methodology and closely meshed with the manufacturing industry. To this end the All-Union Research Institute for Technical Aesthetics was established in Moscow. With its ten regional branches, it conducted pure research and coordinated manufacturing activities. During the 1970s there were more than 1500 design departments and teams operating in the participating companies. The "technical aesthetic" that was introduced at this time represented an attempt, similar to bionics, to reconcile nature, technology, and design (Borisowski 1969).

Yuri Soloviev was the long-serving director of VNITE, president of the Society of Soviet Designers, and a member of the executive board of the ICSID. He worked to promote a "national design," whose results were seen primarily in the design of capital goods. The close relationship between fundamental ergonomic research and production conditions in industry led to rigidly functional technical design, a phenomenon that was also typical for many other socialist states, such as East Germany. The goal was not to produce commodities for consumption, but rather to create satisfactory conditions for the working population. As it turned out, the humanist goals of design came into their own in a situation of shortages, where the social usefulness of production concurred with the interests of the individual.

By the early 1980s design had matured. During the preceding development stages it had accumulated theoretical, methodological, and practical experience while solving great historical problems (Design in der USSR 1987). This was seen in a plethora of products, such as machine tools and aggregates, whose whole appearance was transformed by the introduction of microelectronics. Here it is worth noting that a strong orientation toward Western cultural product standards became apparent. The Oka automobile was similar to the Fiat Panda, optical devices were modeled on Hasselblad and Rollei, and the Phobos radio cassette recorder echoed products from Philips.



LOMO CAMERA (Photo: Wolfgang Gastager,
Lomographische Gesellschaft Vienna)
LADA NIVA (1977)

Mikhail Gorbachev's inauguration as general secretary of the Communist Party of the Soviet Union (CPSU) in 1985 ushered in the process of perestroika, which involved transforming the social and economic structures of the Soviet Union. The economic reforms of 1990 were designed to introduce a "regulated market economy." As the Soviet Union collapsed, the newly independent Baltic republics (Estonia, Latvia, Lithuania) began to revive their traditional ties with Scandinavia and started to cultivate design activities of their own. However, the massive economic restructuring also led to significant discontinuities in design policy, and a process of renewal got under way, which showed similarities to the post-1917 renewal in Russia (Lavrentiev and Nasarow 1995). The dissolution of COMECON (the Council for Mutual Economic Assistance) in 1991 brought forth completely new trading structures, which today expose Russian design to conditions of real market competition. Working conditions and opportunities in the Russian Federation have, however, tended to deteriorate rather than improve as a result.

The most important independent design agency is probably the one run by Dmitrii Askiran in Moscow (domestic appliances, vehicles, technical products, office furniture). Tatjana Samojlowa runs a studio in St. Petersburg that straddles the divide between free and applied design (clocks, electric razors, everyday products). Andrei Meshchaninov, who worked with Samojlowa for many years in the St. Petersburg branch of VNITE, runs a design office that creates medical equipment, underwater equipment, and corporate identities, as well as designing new high-speed trains for the Moscow–St. Petersburg line.

With Italian assistance from Fiat, a car plant was established during the 1970s at Togliatti on the Volga, where the internationally successful Lada is still manufactured. Originally a Fiat 124 produced under license, the car was progressively developed into an independent model. It stands for the practical, functional interpretation that has characterized Russian design since World War II. The Lada Niva off-roader was more or less a precursor of the SUV category (Sports Utility Vehicle) that is currently so fashionable that every car-maker keeps churning out one new model after another.

The Lomo camera, named after a special lens by Radino Lomo, has become a cult product in Western countries. Its frugal reductionist design is complemented by superlative technical performance (e.g., allowing long exposures of up to sixty seconds).



The transformation of the Coca-Cola bottle over history (Photo: Coca-Cola GmbH Deutschland)

NORTH AMERICA

Since the eighteenth century immigrants of many nationalities have come to North America, bringing with them a diversity of cultural, technical, and economic influences that brought forth an exceptionally vibrant blend of design-related disciplines in the twentieth century. Architecture, graphic art, industrial design, the free arts, music, and literature, all found a highly receptive and tolerant audience that encouraged diversity of media and styles. Puritanism and pop culture, inventive spirit and economic obsession, hegemonic behavior and respect for regional cultures – these are just some of the factors that have played a role in shaping and forming North American design.

The United States, in particular, has turned out to be an exceptional promoter of a success-oriented style of design that both prompted admiration and provoked aggressive rejection of what was criticized as superficial “styling.” The product-cultural dominance of American design, in particular, as felt in Asian and European countries, gave rise to enormous resistance. Where there is also far-reaching economic dependency, as is the case in many Latin American countries, those at the receiving end turn to other models. Thus, in the case of Latin America, European design interpretations dominated for a long time. Other countries, such as Japan, Korea, and Taiwan, long stood under massive American design influence, which they had shaken off completely by the end of the 1990s.

UNITED STATES

THE BEGINNINGS

In the United States the origins of product design are often identified in the second half of the eighteenth century, when the Shakers – a religious community of English and French origin – settled in North America. With Protestant severity and the most spartan of means, they began to develop craft-based utilitarian objects to meet their own needs (Andrews and Andrews 1964). The Shakers’ ideas about life and design only became more widely relevant at the turn of the twentieth century when there was a move to overthrow the principles of a historicism that had become bombastic and ornamentally and formally overloaded. The simplicity and functionality of Shaker

The Origin of Design in the Name of God.

The Shakers were inventive, humble, creative and conscientious. All of their efforts were directed toward realizing products of the highest quality.

— ANON., 2000

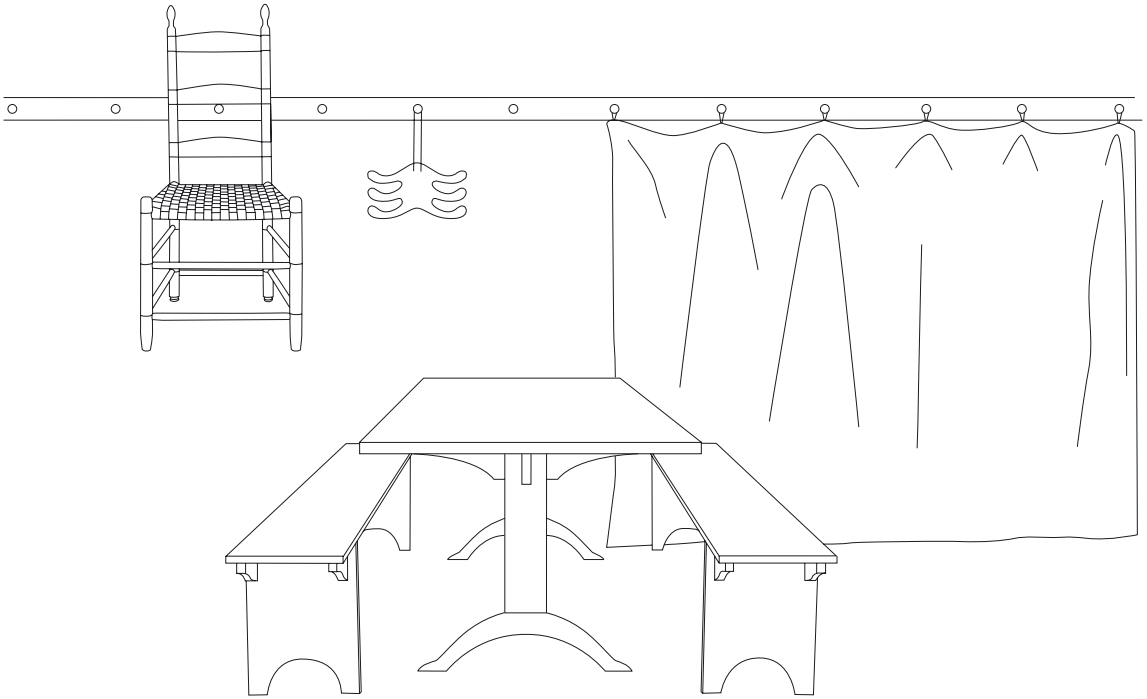
**SHAKER OBJECTS**

SHAKER CHAIR

CLOTHES HANGER

SHAKER MOLDING WITH WALL CLOTH

SHAKER TABLE WITH BENCHES

furniture and implements grew out of principles of spiritual provenance. The link between form and way of life was intact, whereas the widely propagated Bauhaus-based functionalist ideas degenerated into a lifestyle in the 1960s and 1970s – and today even the products of the Shakers are marketed as “lifestyle products” (Donaldson 2001), a fate they share with a good many other historical movements.

For the development of design it was of no small importance that several of the most prominent Bauhaus teachers, including Herbert Bayer, Walter Gropius, and Ludwig Mies van der Rohe, emigrated to the United States, where they encountered exceptionally open-minded institutions and clients and were able to complete their lifework successfully.

During the second half of the nineteenth century the United States had already experienced an exceptionally productive phase of inventive intelligence on the part of engineers described by Sigfried Giedion (1948) as the “patent furniture movement.” For example, fundamental investigations of an ergonomic nature were conducted as the basis for seating furniture that was adaptable to every posture of the human body. Chairs, beds, and cabinets that were convertible, space-saving, and easy to transport laid the groundwork for an American tradition of functional and democratic product culture that lasted until the early twentieth century, when society increasingly differentiated into a two-class system.

THE STREAMLINED DECADE

The mass production that took hold in the twentieth century was driven forward – especially in the United States – largely by mechanization and automation. In contrast to the tendency to view product development and design primarily from the perspective of function (which was steadily gaining ground in Europe at that time, on the back of the tradition of rationalism), Americans quickly recognized the marketing potential of a pleasing design.

The age of art deco in Europe, the 1920s, was “the streamlined decade” in the United States (Lichtenstein and Engler 1992). This was the era when streamlined product design was applied to everything from car bodywork, radio sets, household appliances, and office equipment to complete interiors. One archetypal product for American

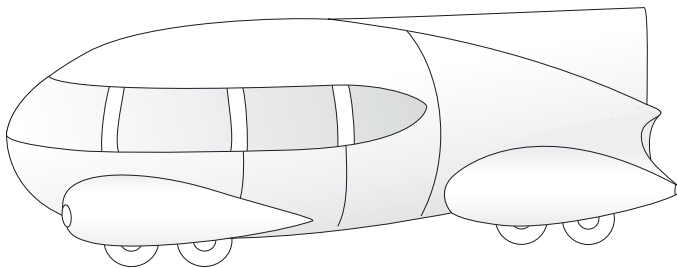
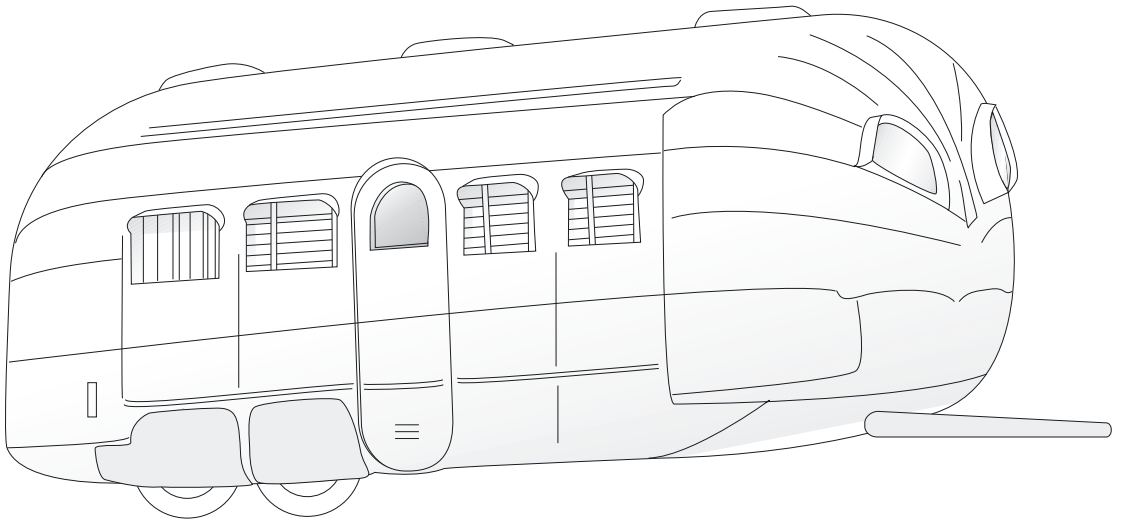
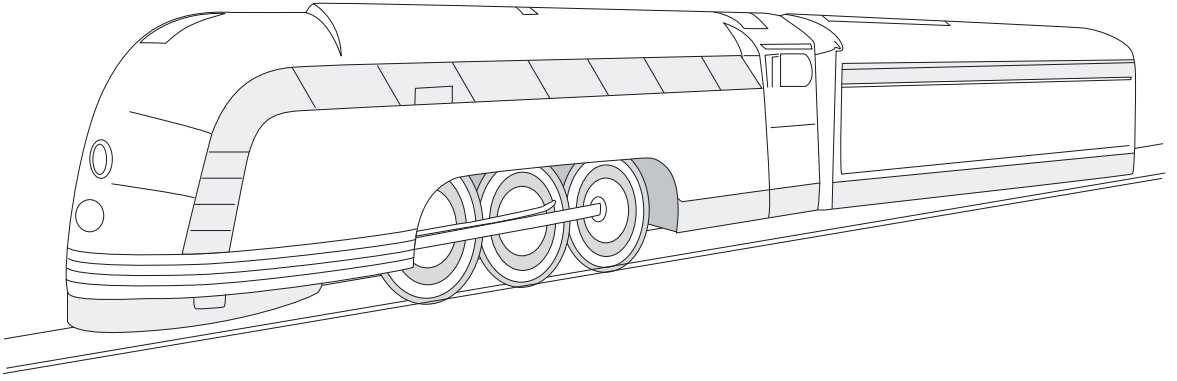

MERCURY LOCOMOTIVE, design: Henry Dreyfuss
(1936), New York Central

CLIPPER MOBILE HOME (1936), Airstream

MOTOR CAR NUMBER 9, design: Norman
Bel Geddes (1932)

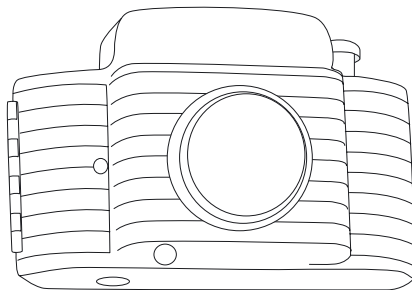
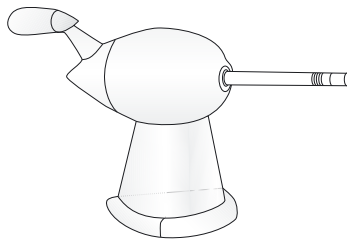
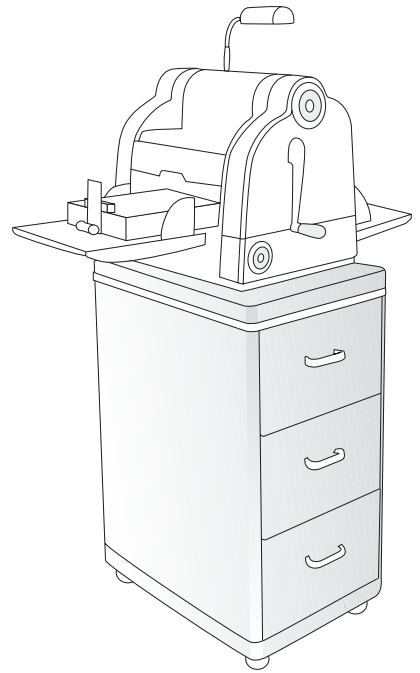
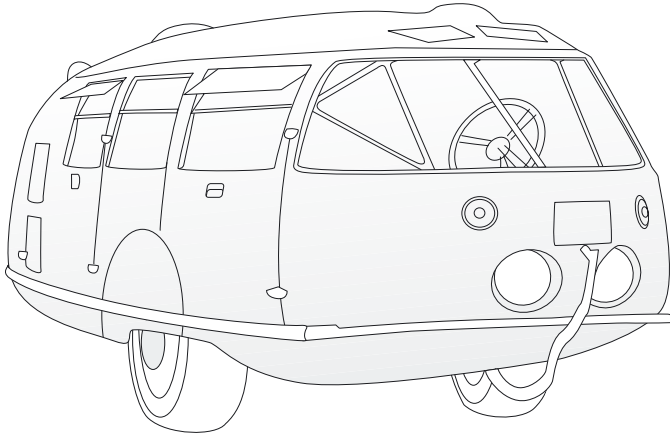

DYMAXION CAR, design: Richard Buckminster Fuller (1933)

MIMEOGRAPH MACHINE, design: Raymond Loewy (1951), Gestetner

PENCIL SHARPENER, design: Raymond Loewy (1934)

BANTAM SPECIAL CAMERA, design: Walter Dorwin Teague (1936), Kodak

mass culture is the Airstream caravan, which has been around since the 1930s. The aluminum technology developed in aircraft construction was transferred to vehicle manufacture and the products themselves were aerodynamically shaped. The caravans thus became an expression of the ever-mobile American society.

Developed from natural forms – the drop was regarded as the most ideal form – streamlining became a symbol of modernity, progress, and the expectation of a better future. Designers understood that their job was to make the products “irresistible” – in other words, they strove to motivate consumers to purchase goods by projecting their subliminal hopes and desires onto the objects. Divorced from technical problem-solving, the designer’s job was restricted to styling. During this period, Giedion (1987) compares the influence of the industrial designer on the formation of taste with the role of cinema.

One congenial exception of the twentieth century was Richard Buckminster Fuller, the architect, engineer, and designer who coined the term “dymaxion” for the combination of “dynamic” and “maximum efficiency.” Following this principle, he designed architectural structures, such as the geodesic domes, with which he hoped to cover districts of cities. He also worked at the micro level, designing a rowboat and automobiles (like the three-wheeled Dymaxion Car), which were regarded as precursors of the streamlined decade.

One important figure in the development of design was the Frenchman Raymond Loewy, who immigrated to the United States in 1919, where he succeeded very quickly in publicizing design as a marketing tool. His breathtaking rise began with his redesign of a duplicator for Gestetner; refrigerators, domestic appliances, vehicles, department store interiors, and the packaging for Lucky Strike cigarettes are just a few of the projects that were to follow. “Never Leave Well Enough Alone,” was his motto and the title of his autobiographical book (Loewy 1949), and it became the catchphrase for a whole generation of designers, not only in the United States. The origins of design as styling, as superficial variations in the form of an existing product, can be found in this ideology. Raymond Loewy’s lifework (Loewy 1979) wonderfully documents how a discipline can place itself fully at the service of business interests (Schönberger 1990). The vehement criticism of commodity aesthetics in the 1960s was directed at precisely these superficial mechanisms, to which design is largely subjugated in the capitalist countries.

Norman Bel Geddes, Henry Dreyfuss, and Walter Dorwin Teague were regarded as the main figures of the streamlined decade. They founded long and successful careers through their pioneering designs for ocean liners, automobiles, buses, trains, furnishings, and many other products.

DESIGNERS AND CORPORATIONS

Furniture designs by people like Eero Saarinen, Harry Bertoia, Charles Eames, or George Nelson, on the other hand, were much more strongly connected to the European design tradition. These designers were primarily interested in investigating new materials such as plywood and plastics and applying them experimentally in designs. They blended aspects of functionality with a new sculptural interpretation of design that established a continuity with the organic approach of the American streamlined era.

Car designer Harley Earl headed the design studio at General Motors (GM) for more than thirty years, starting in 1927, and made decisive contributions to the designs of many vehicles. He played a major role in shaping a new American product category: the street cruiser. This was the car for a nation with a well-developed road network, affordable gas prices, and an excessive propensity for mobility. The street cruiser was subject to an annual model change (Bayley 1983, 1991), which gave rise to the concept of "styling": short-lived fashion-related alterations to products. At that time styling definitely held positive connotations for Harley Earl – in the sense of being modern and up-to-date.

Eliot Noyes was one of the first American designers to specialize in designing technical products. Following his appointment as IBM's design director in 1956, he exerted considerable influence on the company's visual identity. During his long term as director of the Institute of Design at IIT (Illinois Institute of Technology) in Chicago, Jay Doblin promoted an interdisciplinary approach to design, which lives on in the design consulting business, Doblin Group.

The clear commitment of American design to styling was not seriously challenged until the late 1960s. As socially critical movements grew and their influence on music, painting, and architecture became apparent, new tendencies in design began to appear, too. Alternative models for living and working were practiced, especially in California.

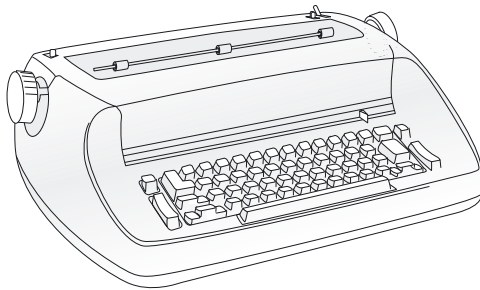
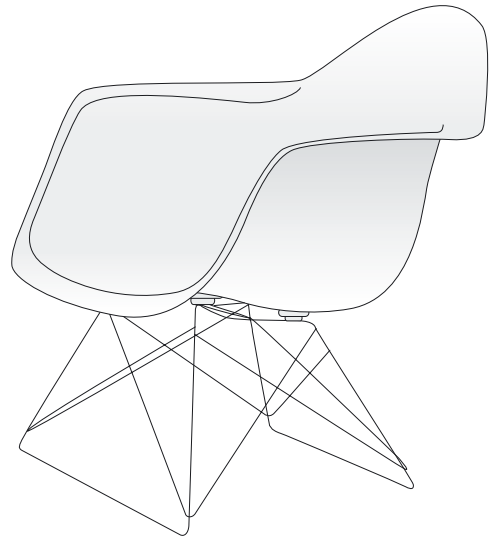
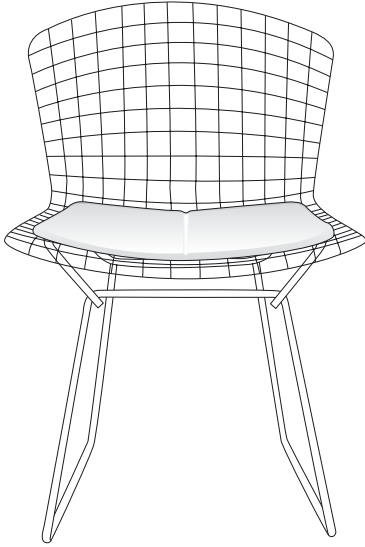

ARMCHAIR model No. 420 C, design: Harry Bertoia (1953), Knoll

ARMCHAIR, design: Charles and Ray Eames (1949)

SELECTRIC 72 TYPEWRITER, design: Eliot Noyes (1961), IBM

It is against this background that the work of Victor Papanek must be considered. Papanek, an Austrian who spent a long time in the United States, called for mass series production to be abandoned. However, his design proposals for Third World products never progressed much beyond amateurish naiveté (Papanek 1972, 1977).

Since the 1980s large corporations, in particular, have made the United States a global player not only in economic terms, but also with respect to its significance for design. Traditionally vehicle manufacturers top the list, with the big carmakers Ford and General Motors, Harley-Davidson (Stark 1999), and Boeing (aircraft), but we also find furniture manufacturers like Haworth, Knoll International, Herman Miller, and Steelcase; electronics corporations such as Apple Computers, Hewlett Packard, IBM, Microsoft, Motorola, Palo Alto Products International (Palm pilot digital assistant and Rocket eBook), Sun (computer hardware and software), and Xerox (photocopier systems). Corporations like Black & Decker (power tools), Bose (hi-fi), John Deere (agricultural machinery), Kodak (photographic products), Nike (sports gear), Oxo (household appliances), Ray Ban (sunglasses), Samsonite (luggage), Sunbeam, (domestic appliances), Thomson Consumer Electronics, and Tupperware (homeware) are also significant for design.

SILICON VALLEY

During the early 1980s the so-called Silicon Valley in California became the epicenter of a new design boom. The computer firms that sprang up generated a high demand for design. Englishman Bill Moggridge foresaw the tumultuous growth very early, in 1976, and set up a second office there – ID TWO – to complement his London base. Steven P. Jobs, one of the two founders of Apple Computers, was thrilled by Hartmut Esslinger's Walkman for Sony, and engaged Esslinger's agency, frogdesign, to work for Apple. In 1982 frogdesign, based in Altensteig, Germany, consequently set up a branch in Campbell, California. During this period Ettore Sottsass also attempted to gain a foothold in California, having as he did years of experience in related fields through his work for Olivetti. The California boom led to the founding of numerous new American design agencies, such as David Kelley Design (which merged with ID two in 1991 to form IDEO), Lunar Design, Matrix Product Design, and GVO (which ceased



HARLEY-DAVIDSON VRSVA V-R0D motorcycle
RESOLVE OFFICE FURNITURE SYSTEM, Herman
Miller



APPLE COMPUTER

IPOD MP3 PLAYER

G5 COMPUTER

AIRPORT EXTREME

POWERBOOK



CAMERA, design: Design Continuum, Polaroid
HUMAN TRANSPORTER, concept: Dean Kamen,
Segway
FASTSKIN SWIMMING SUIT, Speedo

operations in 2001) in Palo Alto; Interform in Menlo Park; Designworks in Los Angeles (this firm was taken over in the 1990s by German carmaker BMW and now maintains an office in Munich); Design Continuum in Boston, Milan, and Seoul; Fitch and Montgomery Pfeiffer in San Francisco; Design Central in Columbus, Ohio; RichardsonSmith in Worthington, Ohio, and Boston; Design Logic in Chicago (wound up in the mid-1990s); Smart Design and Ecco Design in New York; and Ziba Design in Portland, Oregon, and Munich. All of these made major contributions to a new identity for American design, one where creative handling of microelectronic products is a decisive factor. Seeing themselves as important partners in corporate marketing strategies, they also develop complete two- and three-dimensional corporate designs and corporate identities.

A carefree lifestyle, cutting-edge technological and cultural innovation, and not least the climate ("It never rains in Southern California") all helped to predestinate the westernmost continental American state for a role in design and product development. The design departments of European and Asian corporations, in particular, opened offices there in the 1980s, in order to stay in close touch with the latest trends. Products of Californian provenance include the mountain bike and the Rollerblade inline-skate, as well as the concepts for cars such as the Nissan Pulsar, Mazda MX-5, and Audi TT.

Robert I. Blaich became internationally famous as a designer and design manager after he moved from Herman Miller to Philips in Eindhoven, where he headed the Corporate Design Center from 1980 to 1992 (Blaich 1993). His work gave Philips a high profile as one of the world's most important design-oriented corporations. Tucker Viemeister, who has worked for Smart Design, frogdesign, and multimedia firm Razorfish in New York, calls himself "the world's last industrial designer." He made the transition from hardware to software seamlessly and with great success. Donald Chadwick and William Stumpf designed one of the most distinctive American products: the Aeron office chair (1992) for Herman Miller, which offers congenially ergonomic seating comfort combined with absolutely clear – vividly visualized – use and representation of technological progress. Richard Holbrook and Jack Kelley, whose clients also include Miller, are two of the best-known American designers of the second half of the twentieth century.

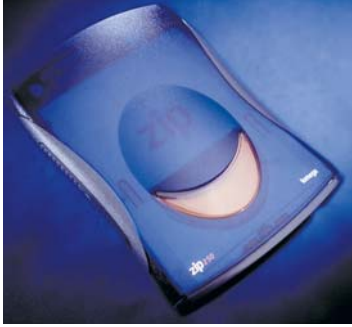

ZIP DRIVE 250, design: Fitch, Iomega

V70 MOBILE PHONE, design: Joseph Forakis, Motorola

TABLET PC, Hewlett Packard

LEAP OFFICE CHAIR, design: Ideo, Steelcase

WAVE RADIO with CD player, Bose

COBALT QUBE 3 COMPUTER, Sun

CRANBROOK ACADEMY

An important role in the development of American design was played by the Cranbrook Academy of Fine Arts in Bloomfield Hills near Detroit (Aldersey-Williams 1988). Back in the 1930s and 1940s designers like Eliel Saarinen, Harry Bertoia, and Charles Eames taught there, while the Academy experienced a veritable boom in the 1970s and 1980s through Katherine and Michael McCoy's commitment to applying product semantics in graphic and product design (Aldersey-Williams 1990) (see also p. 337).

THE AMERICAN WAY OF LIFE

Mention should also be made of a number of American architects who worked as designers, generally in connection with the buildings they designed. These include David Friedman, Frank O. Gehry (see p. 374), Michael Graves, Richard Meier (see p. 377), Stanley Tigerman, and Robert Venturi and Denise Scott Brown. Paul Rand, Tibor Kalman, April Greiman, and David Carson helped American graphic design gain an international reputation, always in close interaction with product design.

The new American design idol at the turn of the millennium is Karim Rashid, who was born in Egypt, grew up and studied in Canada, and now lives in New York. In just a few years he has designed hundreds of products, including furniture, interiors, retail store fixtures, fashion accessories, packaging, light fixtures, and fashion for Tommy Hilfiger, Issey Miyake, Prada, and Sony, among others. His treatment of color, form, and material is playful and extremely creative. He follows no particular style, preferring to experiment on all levels of design ("Design is the whole experience of living"), in which he demonstrates a certain similarity to Raymond Loewy, who also produced designs in quick succession and, somewhat naively, measured success in exclusively economic terms. Rashid's mercurial rise and success are rooted in the accuracy of his sense of zeitgeist. In his book, *I Want to Change the World* (Rashid 2001), he nails his flag to the mast of high-frequency consumerism and nourishes our hopes that he will design many more thousands of products. Karim's brother, Hani Rashid, is a cofounder of Asymptote Architecture in New York (Couture and Rashid 2002),

"The faster you work, the better the design will be," says Karim Rashid.

— BERND POLSTER, 2002

and his designs include the trailblazing A3 office furniture system for Knoll.

The close interrelationship between the disciplines that shape our environment and culture – architecture, design, and art – is particularly apparent in the United States (Inside Design Now 2003). Major fashion designers such as Tommy Hilfiger, Donna Karan, Calvin Klein, and Ralph Lauren also play a major role in exporting the “American way of life” all across the world (Polster 1995).

CANADA

British immigrants brought the ideas of the Arts and Crafts movement with them to Canada at the end of the nineteenth century, but – just like the principles of Scandinavian design that were imported later – these were only taken up very gradually. Traditional ways of life and housing models governed the product culture of this huge but thinly populated country until well into the twentieth century. Industrial manufacturing in the big cities was largely geared to exporting products to the United States.

Gotlieb and Golden (2002) describe how a craft revival began around 1930, especially in the areas of furniture, textiles, ceramics, and lamps. On Canada’s west coast the influence of Charles Eames was felt, and the local aircraft industry, although still in its infancy, fostered the use of plywood. After World War II independent plastics and aluminum industries started to become established, and with them came a demand for product innovations of their own. However, it is not until the 1960s that we can speak of autonomous design developments; pop culture brought forth a “space-age styling” based on the nation’s dreams of space travel.

One of the most important pioneers of Canadian design was Julien Hébert, who achieved nationwide recognition through his work for *Expo '67* in Montreal. *Expo '67* also generated wider interest in “public design” and urban planning. Hébert was a philosopher and a sculptor, and it was this synthesis that led to his interest in questions of design. He worked as a designer and architect, designing various chairs and receiving numerous design awards. His understanding of design was rooted in the interrelationship between nature and culture (Racine 2002).



KARIM RASHID, The "Techno-organic House,"
International Furniture Fair Cologne (2003)
(Photo: C. Meyer, Cologne + I. Kurth, Frankfurt a.M.)

Robin Bush was another major figure in Canadian furniture design, while the most renowned office was probably KAN Industrial Design, which operated from 1963 until 1996 in Toronto, developing furniture, public design objects, lamps, and exhibition concepts.

Canadian design is characterized less by the designs of supposed star designers (who are almost unknown there), than by a wide variety of technological principles and design solutions. The Canadian cult product is the kettle, at which almost all designers try their hand at least once; the number of different versions on offer is considerable.

The rise of the consumer electronics industry in the 1960s brought with it an increased demand for design. One emblematic design was the G3 stereo designed by Hugh Spencer for Clairtone Sound in Toronto.

The younger generation of designers includes Michael Steward, Keith Muller, and Thomas Lamb, while Helen Kerr gained a national standing with her agency Kerr and Company in Toronto, which practices strategic product development, design, and marketing in the furniture and consumer goods sectors. Diane Bisson conducts theoretical and practical work on new materials and ecological problems in product design, and has designed a very successful range of furniture (Delacretaz 2002).

Karim Rashid was born in Egypt, grew up in Canada, studied design at Carleton University, and gained his first professional experience at KAN Industrial Design. Although he opened his office in New York in 1992 and is regarded as one of the world's most successful designers (having already designed more than eight hundred products), he is still often labeled a "Canadian designer." His design for the Garbo and Garbino wastepaper baskets (1996), for the Canadian company Umbra, is regarded as a typical example of cutting-edge, lifestyle-oriented design style.

Also worthy of mention is the media scientist Marshall McLuhan, who taught and researched in Toronto, and back in the 1960s and 1970s was already predicting the long-term development of the electronic media, using television as his example. Today the McLuhan Program in Culture and Technology continues his work and applies his insights to current questions (de Kerckhove 2002). Today, Montreal-based Softimage produces high-tech computer animation software that is used all over the world in architecture, design, and the movie industry.

Thanks to digitally-based shaping and styling, design is becoming a fashion and lifestyle phenomenon characteristic of the style of the new century, the zeros.

— KARIM RASHID, 2003

SOUTH AMERICA

The differences in development between North and South America could hardly be greater. As Constantin von Barloewen (2002) pointed out in his detailed study, the differences (especially philosophical and historical/cultural) and the resulting extreme contrasts in the speed of industrialization are unmistakable. These factors are also very relevant to design in the region.

In the wake of European immigration – whose goal for several centuries was America – an unbridled belief in progress developed in North America, which was further heightened in the twentieth century by the concept of modernity. The pragmatic ideas of William James (1842–1910) and John Dewey (1859–1952) built on the assumption that humans are responsible for their own fate and can always act to improve their situation. South American culture, by contrast, is to this day deeply rooted in theocentrism (i.e., one's destiny is determined by the supernatural, the divine). While in North America the application of scientific methods blended with a Calvinist value system, "the sacred realm of the pacha mama and her magical universality" continues to dominate in South America (Barloewen 2002). The outcome is two completely contrary attitudes to nature: in the North exploitation, in the South respect.

The rather cautious progress of industrialization in Latin America must also be seen in this light. It was mostly North American corporations, such as the United Fruit Company and manufacturers of cars or household articles, that exploited low production costs in the countries of Latin America. This led to people becoming alienated from their own original cultures, as well as to considerable resentment against North America.

Since manufacturing was oriented exclusively to the United States, there was very little space for autonomous or national product development, and still less for design. It was not until after World War II that industrial design gradually began to become established in Latin America. The Argentine Tomás Maldonado was part of the artistic avant-garde in 1950s Buenos Aires. After moving to Europe he taught at the Ulm School of Design until 1967 and also exercised a great influence on the countries of Latin America, especially through his contributions to design theory. Design, he said, should develop within the intellectual framework of modernism rather than looking to the continent's arts and crafts traditions. However, the

practical absence of a national industrial base industry left little scope for anything but adapting locally manufactured products for local markets.

Gui Bonsiepe studied and later lectured at the Ulm School of Design, and after it closed in 1968, he moved to Chile where he worked at the Technological Research Institute in Santiago de Chile under the Popular Unity government of Salvador Allende. The primary aim of product development there was to advance the country's technological standing, and the creative aspects of the products developed during that period were less pronounced. At the same time, they were so exemplary that they gained model status in many countries of Latin America. Furthermore, the theoretical discourses on design were heavily influenced by issues such as metropolis/periphery, technological underdevelopment and dependency, innovation, and mass culture (Bonsiepe 1983).

Even so, it is not difficult to understand the shock experienced by Latin American countries in the 1980s, when design exhibitions presented a European postmodernism that had absolutely nothing in common with the conceptual life-worlds of the population.

However, in the subsequent period, there were no serious attempts to combine the continent's superb arts and crafts traditions with modern design, despite the manifold opportunities offered by new technologies. As a result, many Latin American design initiatives remain peripheral.

BRAZIL

In the course of its ongoing industrialization – in certain regions at least – Brazil has seen a number of design-related developments. When the ESDI (Escola Superior de Desenho Industrial) in Rio de Janeiro was set up at the beginning of the 1960s, one of its main points of reference was the tradition of the Ulm School of Design. Karl Heinz Bergmiller, a graduate of the Ulm School, was long responsible for the curriculum at ESDI, as well as practicing successfully himself as a furniture designer. Today, more than fifty design schools exist, putting design in Brazil on a sound footing.

An important role in national design development is played by the CNPq (Conselho Nacional de Desenvolvimento Científico e Tecnológico), which employed designers like Gui Bonsiepe and thus promoted



**FURNITURE BY HUMBERTO AND
FERNANDO CAMPANA**
FAVELA ARMCHAIR, Edra
VERMELHA ARMCHAIR, Edra

a strongly technological thrust for Brazilian design. The “Programa brasileiro de design” was established in 1995 to promote awareness of design among businesses. Design activities concentrate on the furniture industry (with a strong export sector) and, since the 1980s, the computer and telecommunications industries (Design: método e industrialismo 1998).

Prominent designers include José Carlos Mário Bornancini, who has been working together with Nelson Ivan Petzold since the 1960s, primarily in the field of household articles; Sergio Rodriguez, an architect who specialized in furniture design and from 1955 to 1968 ran the firm of OCA Furniture, for which many designers have worked; Freddy van Camp, one of ESDI’s first graduates and now a lecturer there, who works in the fields of furniture design, electronic products, and interior design; Newton Gama, head of the Design Department at Multibrás (part of the Whirlpool corporation); Oswaldo Mellone, another furniture designer, who also works on electronic products; Fernando and Humberto Campana, who work in furniture and object design and can probably claim to be presently Brazil’s most famous international designers (Campana 2003); Giorgi Giorgi Jr. and Fabio Falange, who developed a lighting system that is manufactured in Brazil under license from Artemide; and Guto Índio da Costa, who operates in the areas of street furniture and domestic appliances. Angela Carvalho runs NCS Design in Rio de Janeiro together with the German designer Alexander Neumeister.

ASIA

In a string of Asian countries including Hong Kong, Japan, South Korea, Singapore, and Taiwan, the 1980s marked the beginning of a design boom that has since reached unprecedented dimensions. Major corporations, particularly in Japan, South Korea, Singapore, and Taiwan, have wagered heavily on the strategic importance of design. By the mid-1990s some of the design departments established there had already accumulated truly imposing workforces: Matsushita had around 100 staff at the Corporate Design Center in Osaka and another 250 in various factories across the country; Hitachi had around 180 at the Corporate Design Center; Sony employed about 300; NEC about 100; and Sharp had more than 300 designers on staff (Bürdek 1997a). The Digital Design Center set up in the late 1990s in Seoul by the Ko-

rean firm LG Electronics (formerly Goldstar) already employs more than 200 designers, the Samsung group around 500 designers.

However, at the turn of the twenty-first century, ever more Asian businesses are transferring their manufacturing activities to China in order to cut costs. As a consequence, design agencies are also moving there, hoping to profit from the expected boom. The new centers are Shanghai and the Pearl River Delta in Hong Kong's hinterland.

Kristof and WuDunn (2000) predict that by the mid-twenty-first century more than two thirds of the world's population will be living in Asia. Three countries deserve particularly close attention: India (for its especially fast population growth), Japan (for its high-tech industries), and China (as the biggest market of all). It should also be remembered – not least for reasons of design strategy – that the distinct economic region that is developing there operates independently of Europe and the United States. While the United States' share of world trade is shrinking fast, China's share is growing rapidly. By the end of the twenty-first century the world will be a very different place economically, politically, and in terms of design.

The rapid success of Asian businesses is based in no small part on a series of strategic considerations. Since the 1970s they have generally concentrated on specific markets in order to justify large-scale mass production and to gain a competitive edge through steadily falling prices. This phenomenon can be observed for typewriters, photographic products, hi-fi and entertainment electronics, wristwatches, computers and office electronics, telecommunications devices, and cars.

The invasion of the mass markets was followed in the 1980s by a reorientation to high-tech products, which became a domain of Asian manufacturers through the application of electronics and digitalization. Involving the homegrown microchip industry ensured significant technological advantages, which are often visualized and communicated through modern design. For example, in 2002, the German corporation Siemens decided to move its production of simple cell phones to China, because they have much more in-depth experience there than Europe in marketing and designing these products.

There are no barriers to alliances between market rivals when an opportunity appears for achieving strategic goals (Kölling 2002). Such alliances are forged not only nationally, as between Matsushita and NEC or Toshiba and Mitsubishi in Japan, but also at the global level.

Yes, over in Asia there still exists the consciousness, oppressed to the point of disappearance in this country, that basic research has as much to do with art as with design - and that these cannot always be implemented analogously, but rather require multifarious transformations and thus both time and fantasy.

— MICHAEL ERLHOFF, 1997



MICROELECTRONICS AS GROCERIES
computer shop in Taipei/Taiwan
(Photo: Bürdek archive)

Examples of the latter include the cooperation between Fujitsu (Japan) and Siemens (Germany) for manufacturing personal computers; the joint venture set up by Sony (Japan) and Ericsson (Sweden) for manufacturing and marketing cell phones; and the integration of Nokia software (Finland) in Samsung cell phones (South Korea). These examples demonstrate how macroeconomic developments have turned design, too, into a global instrument.

These developments have also given rise to a vocal opposition. Canadian Naomi Klein caused a stir in 2000 with her book *No Logo*, which attacked the global operations of the big corporations. Attac is an organization that combats economic imperialism and represents a worldwide umbrella movement of critics of globalization.

The speed at which global developments are progressing is evident in the way Chinese investors, for example, are particularly interested in businesses that have run into difficulties in Europe. The Asian investors are only interested in the brand names, as the products themselves are to be manufactured in their home countries. Hong Kong-based Hutchison Whampoa is one such example: a conglomerate and global investor that has also put considerable funds into telecommunications businesses (UMTS).

An important role has also been played by "Asian values," such as the subordination of the individual to the group, as opposed to individualism, which is regarded as a trait confined to Western cultures (Yintai 1999). A common Japanese figure of speech speaks of a nail that sticks out and has to be hammered down. This phenomenon encompasses, on the one hand, thorough consensus-finding processes (especially concerning new products and their design), but also the tendency towards large-scale mass production. There are signs, however, that this cultural edifice is starting to crumble.

The skills of imitation are also highly valued in Asian cultures. Whether in the free or the applied arts, achieving the standard of quality of the original is an important virtue, which is practiced intensively in the respective training systems. The value of the copied product is measured against the perfection of the original in a tradition that is diametrically opposed to the Western value system. In this context it is also significant that during the 1980s Asian institutions and corporations started engaging Western design partners in order to learn from their experience. The involvement of American and European designers, in particular, played an important role in shaping autochthonous design activities.

Another important step was the establishment of contact offices in the United States and Europe, in order to be even closer to the respective markets. These offices organize market research and trend studies (for example at trade fairs and exhibitions), as well as maintaining contact with institutions and design agencies. In addition there are a number of technology and design centers where Asian businesses conduct research and development: Toyota in Brussels (development) and Nice (design), Honda and Mazda in the Rhine–Main region around Frankfurt, Canon in the Cologne area, Minolta in Hamburg, and Sony in Cologne and Berlin, to name but a few. Western businesses do not focus on Asian markets with anything approaching the same intensity.

Other factors felt in Asian countries include an unbridled enthusiasm for progress and an unbending faith in innovation. After European dominance in the nineteenth century and American in the twentieth, the twenty-first century will undoubtedly be the Asian century (Naisbitt 1995), in other words, the new “cultural imperialists” will be Asian.

CHINA

One cannot speak of independent design development in China until the early 1980s. Previously there had been various arts and crafts schools, such as the college in Nanjing that was founded in 1902 and taught drawing, painting, materials, and the like. Subsequently, colleges modeled on Nanjing sprang up all across the country, focusing on textiles, ceramics, and graphic design (Jun 2001). However, it must be taken into consideration that the country’s political history, along with its specific socio-economic framework, were factors of significant influence.

China remained largely isolated until well into the twentieth century. Only a small number of companies manufactured products based on foreign originals, for example, in the 1930s, bicycles modeled on the British Raleigh of 1903, sewing machines in the style of the American firm Singer, or fountain pens based on American designs. Some of these products remained largely unaltered through to the 1980s, because meeting the population’s enormous pent-up demand for basic products took absolute priority over innovation and creative variation in design. Additionally, there was almost no competition between manufacturers.

After the People's Republic of China was founded in 1949, a program was initiated to build up heavy industry (iron and steel), the transportation system, and engineering. Massive assistance was provided by the Soviet Union, which also supplied the product-cultural models. The planned economy of the 1950s involved centralizing the development and production of all commodities. There was not even a term for design at that time; instead the creative work involved in planning products was referred to as "applied art" or even "handicrafts." The first such departments for graphic art, textiles, ceramics, and architecture were established when the Academy of Arts and Crafts in Beijing was founded in 1956; other colleges in the provinces soon followed. During the Cultural Revolution (1966–1976), however, these activities were closed down again.

In his detailed analysis of these developments, Shou Zhi Wang (1995) showed that the Chinese modernization process – led by premier Deng Xiaoping after the Cultural Revolution had come to an end – concentrated on four areas: agriculture, industry, science, and defense. These would appear to have little immediate bearing on design. We cannot speak of systematic design activity until the 1979 founding of the CAIA (China Association of Industrial Art), which was officially renamed CAID (China Association of Industrial Design) in 1987. During the 1980s more than twenty design training institutions were set up, international design experts were invited to China, and student exchanges were started. The first independent design agencies arose in the mid-1980s, and that is also when design was recognized as an instrument of competition, both national and international. Many companies in the fields of household articles, motorcycles, furniture, and electronics set up their own design departments. Today, China has more than two hundred training facilities where design is taught, every year turning out about four thousand graduates ready to try their hand in the field.

The China Industrial Design Council has been a major factor in national development since it was founded in 1987. Structured in ten sectors (e.g., electronic products, furniture, glass, ceramics, medical products, and exhibition design), it concentrates on managing decentralized support for industrial development in the respective sectors, as well as maintaining contact with the colleges, and organizing exhibitions and publications, all with the aim of promoting design on the national level. By 1988 the CIDC reportedly already had more than 6,500 members.

In the next 20 years China could overtake even the U.S. to become the greatest economy in the world.
— WIRTSCHAFTSWOCHE,
4/2002

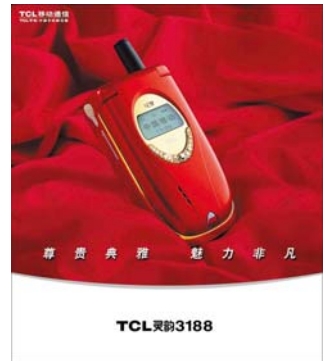

REFRIGERATOR, Haier

GAS STOVE, design: System Design Studio,
Vantage

WASHING MACHINE, Haier

MOBILE PHONE, TCL

AVANTIA PC, Lenova

In the 1980s China started importing large quantities of high-tech products from Asia, Europe, and the United States to speed up the development of the economy. One consequence was that the country was flooded with product-cultural models whose adoption was largely divorced from any context of tradition.

The foreign corporations that began setting up branches in China in the 1990s were following two aims. Firstly, they wanted to exploit the significantly lower labor costs, but secondly, they were also preparing for the future, because the Chinese domestic market (with a population exceeding one billion) is thought to be the most promising sales prospect for the twenty-first century. In the process, China quickly became the “workbench of the world.”

The corporations involved include Canon, General Motors, Hitachi, Jeep, Kodak, NEC, Peugeot, Sony, Toyota, Yamaha, and the German Volkswagen group, whose plant in Shanghai produces versions of its vehicles adapted for the Chinese market.

The development as a whole can be categorized in the following phases (Jun 2001):

- early 1980s: import of products,
- 1980s: imitation of products,
- early 1990s: adaptation of product lines,
- late 1990s: creative development work,
- since 2000: Chinese innovations – technologies, design, marketing.

At the end of the 1990s the first companies began to recognize the importance of corporate identity and gain an awareness of industrial design (June 2000). Since it was set up in 1989, the Haier Group (domestic appliances) has grown into a major corporation operating at home and abroad. It already runs eight design centers and operates thirteen factories outside China. In fact, Haier has become the world’s second-largest manufacturer of refrigerators, exporting to the United States in particular and even manufacturing products there. Haier’s export achievements have already been compared with those of Sony in the 1950s and Samsung in the 1980s (Sprague 2002). The Lenovo Company is a major manufacturer of microelectronic products, which made an early start in adapting to the differing needs of increasingly differentiated purchaser groups. Design plays a strategic role in the company’s success. Objectively it is clear that more and more Chinese corporations will develop their own brands with which

they will operate as global players (as Haier already does). China probably holds the greatest design potential for the twenty-first century.

Companies and design agencies from Taiwan play a special role in this process, because the process of industrialization in China is similar to the developments in Taiwan following World War II, though on a much larger scale. The shared language and culture naturally make it easy to move from Taiwan to the People's Republic, and Taiwanese design agencies are increasingly opening branch offices there. But Taiwanese and Japanese industrial corporations are also moving their manufacturing operations to China, in some cases completely (e.g., Acer of Taiwan). China itself, meanwhile, is energetically expanding its pure research programs for advanced technologies, so we can expect that it will soon be producing its own innovative technologies (and design with them).

This process also involves a rapid socio-cultural transformation. The Asian principle of conformity – the almost complete absence of expressions of individuality (for example, through fashion or products) – is in a process of dissolution. China is on the threshold of explosive changes in the way of life for large parts of the population, just as happened in Japan. Therein lies a great opportunity for design to continue flourishing and expanding in China.

"China's rise is changing the world just as much as the industrialization of the U.S. did – and perhaps even much more." (Andy Xie, Morgan Stanley Dean Witter Bank, Hong Kong)
 — WIRTSCHAFTSWOCHEN, 46/2002

HONG KONG

The story of design in Hong Kong began with the onset of industrialization in the Pearl River Delta in the nineteenth century (Turner 1988). Initially handicraft products were made there and exported in large volumes: glassware, ceramics, porcelain, metalware, textiles, wooden and rattan furniture, leather goods, and many others.

Hong Kong was a British colony from the nineteenth century until it was handed back to China on 1 January 1997, when the lease expired. At the beginning of the twentieth century the range of products expanded considerably, while in the 1930s the possibilities offered by plastics brought yet more new products, initially made of Bakelite, and later of other plastics as well. Completely new industries grew up, producing gift articles, electrical gadgets, household items, clocks, and toys, to name but a few. Additionally, steel furniture, means of transport such as bicycles, trucks, and public transport vehicles, and

military products were manufactured in close cooperation with British corporations.

The colony's low production costs led to an explosive growth of manufacturing following World War II, but it possessed little in the way of independent local character. Trade with primarily Western export markets demanded that design strategies be oriented to those markets. The products themselves were either specified by the Western companies as OEM (Original Equipment Manufacture), or emulated the product-cultural models. The term "design" was first used in the 1940s, initially in the fields of furniture, interior, and exhibition design.

Due to the orientation toward export markets – as well as generally risk-averse and conventionally hierarchical business structures – Hong Kong never managed to produce an independent product-cultural identity of its own. The broad principle of "adaptive design" meant that the respective Eastern or Western models dominate and persist in Hong Kong's own product culture, which sometimes results in direct copies of the respective models.

A special standing was attained in the field of graphic design, where it is particularly easy to generate adaptations of diverse styles. Here, there was a good deal more experimentation, which succeeded in using images and characters to tap the Western fascination for Asian cultures. Packaging, posters, and brochures blended Western and Eastern stylistic elements, echoing the development of Hong Kong's social structures as a British crown colony.

Since the mid-1990s, however, a stronger awareness of design has grown up, fostered and developed not least by a number of institutions, among them the School of Design at Hong Kong Polytechnic University, which has become an international center for teaching and research. By organizing design exhibitions, prizes, and publications, professional bodies like the Hong Kong Designers Association and the Chartered Society of Designers also help to establish a stable awareness of design in the spheres of politics, industry, and public opinion.

In reaction to the aforementioned generally conventional, hierarchical structures of industrial companies, several Hong Kong designers have founded "manufacturing companies" of their own, where they can supervise design, production, and marketing themselves. Agencies like Longford Industrial, Gear Atelier, and Alan Yip Design exemplify this phenomenon. They cooperate closely with marketing specialists for the respective export markets. Some individual firms



SUSHI CALCULATOR (the former FlexiCal),
design: Alan Yip (Photo: Alan Yip)

such as Sun Hing/E'zech and Vtech have also made reputations with independent design for Western export markets.

As production in Hong Kong became increasingly expensive, manufacturers started moving production to mainland China even before control of the colony was returned to the People's Republic. In Hong Kong, a service industry is emerging to supply and manage design and engineering. Currently there are about 1,700 design service companies with about 5,500 staff, while the number employed in design as a whole is estimated at 20,000.

Reunification with China has led to changes in corporate market orientation, while also considerably expanding the product range. In Hong Kong, people are at last beginning to take increasing interest in the cultural identity of design.

JAPAN

Japan's isolation from the rest of the world – which ended only gradually around the end of the nineteenth century – produced a stable, centuries-old culture and traditional social structures that persist to this day. After 1945 the United States exerted a decisive influence on the Japanese economy as it expanded rapidly to make Japan one of the leading industrialized nations. Like Germany, Japan had been largely destroyed in World War II, and as in Europe, the economic, political, and social effects of American occupation (1945–1952) left deep impressions on the culture. For example, Japanese designers long regarded American styling as the model for their work. Industry initially looked to North America for its main markets, and lack of raw materials forced Japan to export technical products in huge volumes in order to finance its own imports.

An interesting historical/cultural question is how modern technology – and with it design – affects a country whose culture is thousands of years old. After World War II, religion, aesthetics, and everyday life in Japan all came under enormous pressure. Rapid industrialization and opening the country to the world market caused the traditional ways of life to be lost. There is often talk of an ongoing deterioration of discipline, working morale, and social behavior in Japan. Western cultural imports have also contributed to a transformation of the Japanese way of life. Intensive utilization of digital media in the mid-1980s, such as entertainment electronics and

Japan is the most semio-tized society, everything is signs, everything is surface and interface.

— VOLKER GRASSMUCK, 1994

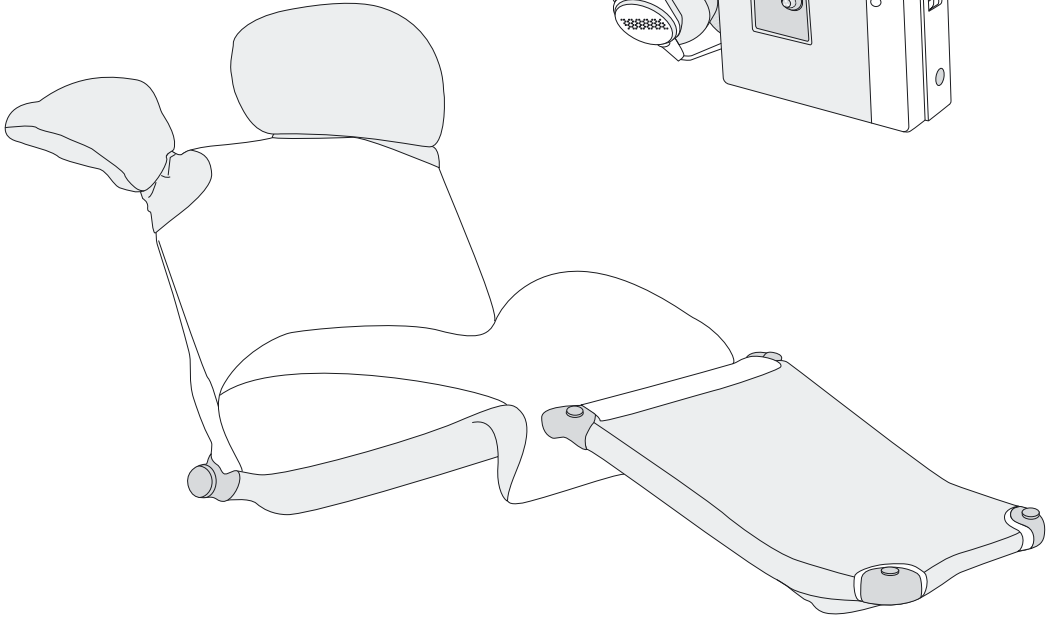
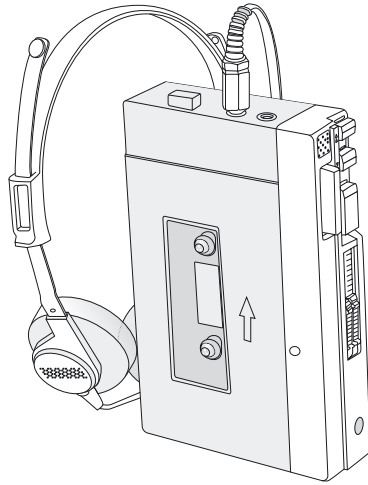
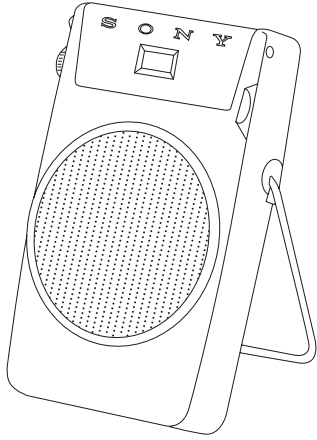

TRANSISTOR RADIO, Sony (1958)

WALKMAN, Sony (1978)

WINK CHAISE LONGUE, design: Toshiyuki Kita
(1980), Cassina

telecommunications, led to an unprecedented boom in rapidly changing electronic devices, which resulted in complete flooding of whole product sectors in Japan and abroad.

High population density and housing shortages (with three or four people living in a small two-room apartment) produced a strong ethic of social conformity associated, on the one hand, with collective leisure pursuits, and on the other, with individual bastions of seclusion, such as "love hotels" for couples. Western individualism has always been utterly foreign to the Japanese, but today it is becoming increasingly attractive and provoking social conflict.

Thinking strategically, Japanese industry concentrated on a small number of product sectors where it was able to achieve technological excellence extremely quickly. These included precision mechanics (especially clocks), optics, electrical and electronic devices (hi-fi, television, and video), vehicles, and, more recently microelectronic products (computers, monitors, peripherals), and office communication products. The marketing strategies of Japanese corporations require that the products offer high technical quality, good value for money, and up-to-date design. A spokesman for Sony Germany, responding to a comment about "Japanese cultural imperialism," once said that there was often a gulf between research and industry in Europe and the United States, and what the Japanese sometimes did better was to take innovations and make them marketable: "Let's take the example of the transistor. An American won the Nobel Prize for inventing it, but the Americans did not know what to do with it. They thought it might be good for hearing aids. And anyway, Japanese predominance is limited to certain sectors, such as electronics" (Wagner 1990).

Today, Japanese engineers and designers place particular emphasis on miniaturization. In response to the spatial restrictions of their own surroundings, they try to make technical objects as small as possible and, in the process, maximize availability wherever possible. By 1958 Sony had already succeeded in introducing a pocket-sized transistor radio (Sparke 1988). In Japan, the headlong development of microelectronics was taken as a challenge to shrink products and add ever-growing numbers of functions: for example, the wristwatch with integrated calculator (requiring a special stylus to use it), the dashboard television set, the radio integrated into headphones, and so on.

The aforementioned spatial constrictions of Japanese accommodation gave rise to a tendency to arrange hi-fi components not next to each other (as was the case, for example, with Braun's products of

the 1960s), but as vertical configurations inspired by control centers and consoles. These audio towers – in their mini and maxi versions – remain the product-cultural standard to this day.

The Walkman – symbol of a dynamic, permanently mobile young generation – was invented in Japan during the late 1970s, after the technological preconditions had been met. One glance at similar electronic products shows that they bear absolutely no relation to the Japan of tradition, although, in this export-oriented country, that was not the intention anyway. The cultural roots of the old Japan are more likely to be found in post-war architecture, which offers a number of major buildings that succeed in bridging the divide between past and present.

Architect Kenzo Tange was the first to progress from an interest in European modernism to an attempt to combine the formal language of traditional timber construction methods with the new pre-stressed concrete techniques (for example his stadium design for the 1964 Tokyo Olympics). Kisho Kurokawa was one of the authors of the “Metabolism” manifesto (1960), which combined Buddhist traditions with European individualism. Architect and designer Arata Isozaki succeeds in uniting traditional and postmodernist elements very attractively in his buildings and furniture (for example in his design for the Museum of Contemporary Art in Los Angeles). His buildings and interiors are supposed to promise maximum pleasure of living through the principle of asceticism (Krüger 1987). Isamu Noguchi worked as a sculptor and designer, and his lamps and furniture (for example, for Knoll International) embody a sculptural understanding of design that has met with international acclaim, especially since the 1940s.

A young generation of Japanese architects view the mega-machines of urban construction with the utmost of skepticism, and have lost faith in the idea of progress through technology. Their response to general chaos is to “let one hundred flowers bloom.” In other words, in place of an ideology of design, there is freedom for everyone to design and build as they deem appropriate for the respective construction task. In this respect, the renaissance of the contemplative interior is an important element of the creative work of architects and designers. They deliberately deploy the traditional categories of meditation and retreat into the self to counteract the frantic public nature of the Japanese life-world (Lebenswelt), creating in the process impressive examples of contemporary interior design.



PAPER MOON LAMP, design: Shigeru Uchida,
(Photo: Kazumi Kanda)

HOW HIGH THE MOON ARMCHAIR, design: Shiro
Kuramata, Vitra Edition, (Photo: Vitra)

GETSUEN ARMCHAIR, design: Masanori Umeda,
Edra

ORCHID ARMCHAIR, design: Masanori Umeda,
Edra



PORTABLE MD PLAYER STUDY, Sharp,

© AXIS magazine

CD WALKMAN, design: Noriaki Takagi, Sony

DIMAGE X DIGITAL CAMERA, Minolta (front and back views)

ELECTRONIC MUSIC INSTRUMENT, Yamaha

These tendencies have been much less apparent in design. The waning dominance of American markets and the associated decline in their influence on styling led Japanese designers at the end of the 1970s to increasingly orient their styles to the varied approaches of Italian designers. For example, Toshiyuki Kita's Wink chair (manufactured by Cassina) is a happy synthesis of ironic pop culture and an inspired interpretation of functional design. German designer Luigi Colani – developer of the organic, aerodynamic formal language (see p. 304) – first visited Japan in 1973, and lived there from 1982 to 1986, working for various corporations including Canon, Sony, and Yamaha. His influence on the product language of Japanese products of the 1980s and 1990s is said – at least by some authorities – to be considerable (La collection de design 2001).

Masanori Umeda's living accessoires and lighting fixtures were included in the 1981 Memphis Collection in Milan, while Shiro Kuramata's furniture objects demonstrate a successful synthesis of Japanese household tradition and Western modernism. In line with a value system that stresses the group, only a few Japanese designers have become internationally famous figures, and independent agencies are fairly thin on the ground, too. Water Studio has been working for companies like Nissan, Olympus, Sharp, and Suzuki since 1973. Today, the top rank of Japanese design agencies includes GK Design Group (cofounded by Kenji Ekuan (2003)), which gained its reputation through its motorcycle designs for Yamaha, as well as the design for a soy sauce bottle for Kikkoman, and Hirano Design in Tokyo and Chicago (integrated marketing and design, medical products, and interaction design).

Overall, though, the image of Japanese design is defined by the big corporations: electronics manufacturers Canon, Hitachi, Honda, Matsushita, NEC, Sharp, Sony, and Toshiba; makers of optical products Minolta and Olympus; and vehicle manufacturers Honda, Mazda, Nissan, Suzuki, Toyota, and Yamaha.

One peculiarity – for design, too – is the Akihabara district of Tokyo, where a large number of shops showcase the very latest products from the electronics and domestic appliances industries. Many are only intended for the Japanese market, and are often only sold in small numbers. Akihabara is, therefore, a huge test market where corporations can try out their innovations and design concepts on real consumers.



THE ELECTRIC CITY in Tokyo's Akihabara district
(Photo: Bürdek archive)



MUJI PRODUCTS

(Photo: Wolfgang Seibt)

Sony has succeeded in establishing itself as a global player: today, "It's a Sony" (see p. 362) is synonymous with high-tech, state-of-the-art design, and the ultimate in modern lifestyle. At the turn of the twenty-first century the company backed up this concept by setting up Sony Style Shops where the company's latest, most innovative products are presented in a cutting-edge interior design, with interactive presentations and computerized ordering options for the customer.

Japanese fashion designers represent another important communication factor linking modern and traditional ways of life. They include, for example, the exceptionally imaginative Kenzo Takada, normally referred to by only his first name, which is also the name of his company. Kenzo withdrew from actively running the business in 1999, but his company remains a global operator. In an example of image transfer, Kenzo presented a special metallic version of the Nokia 8210 cell phone at the launch of his 1999 fashion collection. Issey Miyake, whose label has gained the status of one of the global cult brands, certainly makes a contribution to redefining the meaning of clothing when he styles body and surroundings at the same time, congenially combining traditional and modern materials in the process. Yohji Yamamoto is a radical designer who follows particularly purist working methods; he always aspires to undertake a fresh, fundamental investigation into the nature of each item of clothing. His work includes stage set designs for William Forsythe, the British director of the ballet in Frankfurt am Main. German filmmaker Wim Wenders made a film about Yamamoto in 1991, called *Notebook on Cities and Clothes* (Hiesinger and Fischer 1994).

The firm of Muji, founded in 1980, took a very different tack. Today, it operates 260 shops in Japan, twenty-one in Europe (five in France and sixteen in England), and two in Hong Kong, selling a product range based on the traditional craftsmanship of Japanese products, but combining it with the design ideas of twentieth-century modernism. Furniture, household articles, office items, all kinds of travel accessories, and selected items of clothing form a product range that is largely manufactured from recycled materials (Schmitt 1996). Muji means "unbranded quality goods" and embodies the lifestyle concept of a young, environmentally-aware clientele that values longevity, functionality, and simplicity of the products more highly than hectic seasonal product change.

KOREA

Design in Korea can now look back on almost a century of history, leaving in its wake exemplary products with typical Korean designs (g/df 2001). The early handicrafts products embody a philosophy of usefulness and aesthetic pleasure. Examples include the *gat*, a horse-hair hat from the time of the Chosun dynasty; a woven straw egg-holder that has inspired modern packaging designs; the *dadumi* percussion instrument; the plain *maksabal* clay bowls; and the room dividers of *changhoji* paper.

The importance of training and promotion in this field was recognized at the beginning of the twentieth century, which led to Korean products being presented – and winning awards – at international fairs and exhibitions. The Japanese occupation from 1910 to 1945 generated a great rivalry between the nations, and led to Korea setting itself the goal of overtaking Japan.

After World War II great efforts went into design, which had been recognized as an important factor for the country's economic development. KIA was already manufacturing bicycles and cars by the 1950s, while Daewon was exceptionally successful with rice cookers. Goldstar (now called LG Electronics) designed, manufactured, and exported domestic appliances and radios, setting up its own design department in 1977, which now has several hundred staff.

The electronics and automotive industries are very strongly design-oriented. All the companies maintain their own substantial design departments, whose task is to follow the various trends and developments in their respective markets (Asia, America, and Europe) and implement their findings in new product concepts. Samsung, for example, currently employs around five hundred designers, as well as working with external and international design agencies, (such as Design Continuum, Fitch, frogdesign, IDEO, and Porsche Design). In its design, Samsung is increasingly focusing on an organic formal language and leaning strongly on the product-semantic canon of Asian (especially Japanese) companies, whereas LG Electronics sees itself more in the European tradition of modernism, although the boundaries are fluid in both cases. Other well-known companies are Daewoong Electric Industry (domestic appliances), Rinnai Korea (ovens), and Mutech (hi-fi electronics).

In the automobile industry, Hyundai Motors, KIA, and Daewoo are nationally and internationally successful corporations with a broad

"Design is the key to competition in the 21st century."

(Lee Bong-ju, Chairman of Samsung)

— WIRTSCHAFTSWOCHEN
45/2002



SGH-T100 GSM MOBILE PHONE, Samsung

MOBILE PHONES, LG Electronics

SR-N759 CSC REFRIGERATOR with Internet port
and LCD monitor, Samsung

CABLE CLAMPS, design: Marcus Ting, Sumajin
Design

range of products. Hankook's car tire design responds to customers' increased interest in tire profiles, and the company markets highly designed products that can be interpreted as an expression of the company's technological strength.

At the turn of the twenty-first century Korea has taken a dominant position in global design. With around eighty thousand designers working in all fields of design, one can speak of a virtual design offensive.

At present there are more than twenty thousand product designers in the country, and a large number of independent agencies and studios, the best known of which include Clip Design, Creation & Creation, Dadam Design Associates, Eye's Design, Inno Design, Jupiter Project, M.I. Design, Moto Design, Nuos, Seoul Design, and Tandem Design Associates, most of which are based in Seoul.

An important role is also played by the design colleges – of which there are now more than thirty – and institutions that work to promote design, such as the Korea Society of Industrial Designers and the KAID (Korean Association of Industrial Designers). The country gained important international recognition for its design activities when it hosted the ICSID world congress in October 2001 in Seoul.

SINGAPORE

The history of design in Singapore is fairly short. The microelectronics boom of the 1980s brought many companies to Singapore whose products generated an increasing demand for design. The Asian strategy of emulating successful models, whether from the East or the West, means keeping a close eye on the clients' target markets. An additional factor is that the city state of Singapore is a melting pot for a wide variety of cultures, so its design comprises truly global dimensions, making the question of a design identity of its own seem almost irrelevant.

Design is regarded as a significant economic factor, and it receives corresponding state support. Since 1984 the Singapore Trade Development Board (TDB) has been promoting a wide range of activities: a design agency, joint venture programs, and various forums, trade fairs, seminars, and so on. Since 1988 the International Design Forum (IDF) has provided an important platform for international exhibitions and conferences. Since it was inaugurated in 1990, the Singapore



LCD MONITOR, design: Via 4 Thomas Gerlach,
ADI
TELEVISION SET, design: Via 4 Thomas Gerlach,
ADI

Design Award has become an international event with a high reputation that extends well beyond Asia.

Many design agencies and consultants working for both regional and international business clients are based in Singapore. They include, for example, Designexchange Pte. Ltd., Inovasia Design Pte. Ltd., Orcadesign Consultants, Oval Design Ltd., and Sumajin Industrial Design Services. Fashion designers Song & Kelly develop complete virtual rooms where future forms of communication can be demonstrated (Singapore Design Award 2000).

TAIWAN

Over the relatively short period of four decades, Taiwan has transformed itself from a rural agricultural nation into a high-quality, high-tech economy through the state's extremely active promotion of design.

In the 1960s the Taiwan Handicrafts Promotion Center and the China Productivity Centers began strongly promoting their design activities, especially in the international markets. Industrial design was seen as important for social development and as a significant building block for the country's economic growth. By the early 1960s German and Japanese experts were being invited to advise on the planned design activities of local industries. The founding of the China External Trade Development Council (CETRA) in 1970 and the Design Promotion Centers (DPCs) in 1979 represented important preconditions for bringing about far-reaching improvements in the quality, image, and competitiveness of Taiwanese products. Numerous design programs were also set up at various universities. In an effort to globalize, Taipei Design Centers were established in Germany (Düsseldorf), Italy (Milan), Japan (Osaka), and the United States (San Francisco), in order to keep better and closer track of socio-cultural and technological developments and trends in those countries, as well as to assist Taiwanese businesses in their export efforts.

Following this example, design departments were founded by many companies, including Tatung Co. (hi-fi products, domestic appliances), Sampo Corporation (electrical domestic appliances) and Sampo Technologies (entertainment electronics), Giant (bicycles), and Acer Computer, although the latter moved its manufacturing operations to the People's Republic of China in 2001 to cut costs (and now only

operates as a service company in Taiwan). The People's Republic of China offers the same language and a 90 percent saving on wage costs, giving Taiwanese industries a significant incentive to move their manufacturing there (Bremer 2001). The result is a structural transformation that is already very important for designers working there, and will become more so in future.

Since the 1980s many design offices – working for a wide range of clients – have been founded in Taiwan. The most important of them include I-U, U2id, Nova, Conner, Xcellent, Er, NDD, Duck, Quinte Design, and Wen's Design. In response to growing design activities in China, several design firms have already opened branches in the Shanghai area and the Pearl River Delta.

"People buy design."

— HO HENG-CHUN, 2003

DESIGN AND METHODOLOGY

Design is an activity associated with creativity and creative fantasy, the spirits of invention and technical innovation. The design process is often seen as a sort of act of creation.

It is certainly a creative process. However, design does not take place in a vacuum, with a completely free choice of colors, shapes, and materials. Each design object is the result of a development process influenced by various – not only artistic – conditions and decisions. Socio-economic, technological, and cultural developments, in particular, along with the historical background and the conditions of production technology, play just as important a role here as ergonomic and ecological demands, economic and political interests, and artistic-experimental aspirations. Dealing with design therefore also always entails reflecting on the conditions under which it emerged and visualizing their effect on the products.

The theory and methodology of design like to lay claim to a certain objectivity, because ultimately their efforts are directed toward optimizing the methods, rules, and criteria to be used in order to investigate, evaluate, and even improve design. Upon closer observation, however, it becomes apparent that the development of theory and methods is itself also shaped by cultural, historical, and social conditions. Thus the first step in dealing with design theory is to turn one's attention to epistemology. This focus then leads to recognizability, which, in the sense of Ernst Bloch (1980), also means that the world can be changed on the basis of this recognition, and on the basis of the difficult path which humanity has had to travel and which it is far from completing.

Just as in every other discipline, the theory and methodology of design develop on the basis of certain basic assumptions and requirements, most of which are self-evident and remain subconscious. Dealing with design theory therefore must also involve

confronting the ideas underlying the methodological approaches and creative concepts. This ultimately leads to the study of philosophy.

After World War II, a major economic upswing began in the industrialized countries of Europe, and in those countries characterized by a market economy, competition quickly intensified to become the international business rivalry known today as globalization. In this situation, design, too, had to adapt to the changed conditions. It was not possible to continue practicing the subjective and emotional methods of design which originated in the tradition of the *Werkkunst* arts and crafts while industry was rationalizing design, construction, and production. It was thus an obvious step for designers to try to integrate scientific methods into the design process so that they could be accepted as serious partners in the sphere of industry. The Ulm School of Design played a pioneering role in this process.

It was not until this intensive confrontation with methodology that design became in any way teachable, learnable, and thus communicable. Today, the continuing importance of design methodology for instruction lies in its special contribution to training designers in logical and systematic thinking. As a result, methodology has more the character of didactic meaning than of a patented recipe – although the latter misunderstanding has proven persistent.

The world is always becoming more complicated; it is no longer possible for any single designer to comprehend all of its facets. For this reason, systems theory was recognized as an important discipline that could be helpful for design. This approach is growing even more relevant today as theorists of design proceed from Niklas Luhmann's considerations and attempt to proclaim systemic – holistic, networked – thinking for design. Increasingly, questions of meaning are shifting into the foreground of design: thus, from the methodological perspective, the question is not so much *how* to design products as it is *which* products should be designed at all.

From the scientific and theoretical perspective, methodology – the science of method – covers significantly more territory than the concept of design methodology, as it is usually too narrowly applied. The Polish philosopher Józef Maria Bocheński (1954) proposed a scientific derivation of methodology, which serves as a reasonable framework for the above observations. Based on his description, it can be said that traditional design methodology was nearly exclusively concerned with the methods of physical behavior, which have certainly been documented sufficiently (Bürdek 1971, 1977),

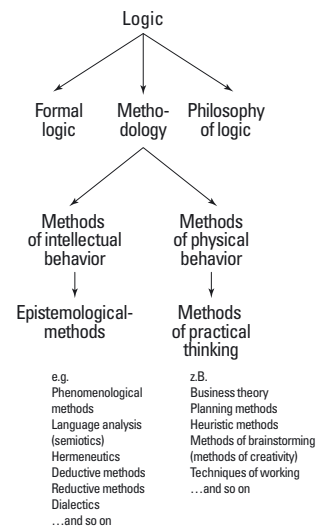

Derivation of Methodology

whereas methods of intellectual behavior in design have rarely been thematized. On the basis of this imbalance, the former will be outlined only briefly, whereas the latter will be discussed in greater detail. This appears all the more important as ever more semiotic (emblematic), hermeneutic, and phenomenological methods are being applied in discussions about new tendencies in design.

This view of design from the perspective of the humanities was enhanced by a number of crucial concepts in the 1990s. The focus on design management even lent design a sort of strategic importance. Of course, the broad discussions about brands or trademarks are, at their core, semiotic processes as well. On the other hand, an increasing demand in practice was to check before production to see whether the new product concepts would find any resonance among potential users: empiricism had entered the methodology of design.

He who believes in meaning
will perish by meaning, even
if it is well wrapped in the
irony of appearance.

— JEAN BAUDRILLARD, 1989

EPISTEMOLOGICAL METHODS IN DESIGN

The humanities take on a special role in the development of the methodology and theory of design. The discipline's constant crisis of meaning is in fact an expression of its increased need for theory and reflection – that is, for philosophy. For this reason, the next section will discuss which aspects of design theory, or design methodology, have their origins in European philosophy.

A FEW ASPECTS OF GREEK PHILOSOPHY

Socrates (470–399 B.C.) can be designated as the first real theorist of epistemology who developed and practiced a theory of method. Never concerned with the collection or conveyance of the content of knowledge or finished systems, his interest was always directed toward the essence of a thing and the question of how genuine and certain knowledge could be obtained at all.

Plato (427–347 B.C.) formulated a dialectic to enable investigation of the connections between different concepts through reflection. A generic concept was broken down into all its different types until indivisible concepts were obtained. This method is called dieresis (division of ideas), and is the first known example of rules of definition.

Today, a related method is applied to the structuring of complex facts.

Aristotle (384–322 B.C.) was the first to apply systematic analysis to the essence and methods of science, and subdivided philosophy into logic, physics, and ethics. In his formal logic he showed that thinking always uses three simple basic elements, which even today are still the most important elements of logic: concept, judgment, and conclusion. His main achievement in logic was developing the methods of deduction (inference from the general to the particular) and induction (inference from the particular to the general).

Archimedes (circa 285–212 B.C.) was a mathematician and physicist. In his *On the Methods of Mechanical Theorems*, he described how, by means of mechanical ideas – what we would call models today – he found certain assumptions and solutions to mathematical problems, for which he was later able to provide exact proofs. The science of heuristics is named after his cry of “Eureka!” (I found it!). This method of problem-solving presents a counterpart to the procedures of logic, as it seeks solutions using such tools as analogies and hypotheses.

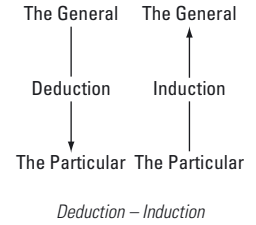

FROM ANTIQUITY TO MODERNITY

In antiquity (and for a long time thereafter), there were no significant new approaches of a philosophical or methodological nature after Aristotle, merely extensions or modifications. The modern natural sciences were not founded until the time of *Galileo Galilei* (1564–1642). He criticized Aristotle’s assertion that the deductive method was scientific and his consequent exclusion of, for instance, the study of processes and their dynamics. Galileo’s own investigations were based on induction, but he did not hold this alone to be sufficient either. It had to be accompanied by the experiment as a method and the objective of deriving and formulating laws on this basis.

René Descartes (1596–1650) is considered to be the father of modern philosophy. His goal was to develop a new, comprehensive, and exact science of nature. His search for a fixed foundation of human cognition has its basis in the method of doubt. Proceeding from his famous statement “*Cogito, ergo sum*” (“I think,

therefore I am”), he attributed all human knowledge to the intellectual mind.

Descartes helped to establish mathematics as a general method. He held the opinion that – just as in his analytical geometry – everything in the world was synthetically constructed of the simplest rationally conceivable basic elements: numbers. Through analysis, intuition, and deduction all complex facts could be fathomed and understood by breaking them down into their basic components. Descartes’ mathematical understanding of knowledge, combined with his firm belief in the rational obviousness of all existence, made him the forefather of rationalism. The entire history of the development of design was characterized by Cartesian thinking well into the 1970s.

Gottfried Wilhelm Leibniz (1646–1716) attempted to synthesize mathematical and logical processes in order to create a general science (*scientia generalis*) in which all truths can be depicted in their natural logical context. His catholic character, comparable to that of Aristotle, directed his interests to the entire spectrum of the sciences. Leibniz said that scientific thinking should always be placed in an interrelation between finding and proving, whereby finding was always understood to be researching, (i.e., finding out new things). For this he developed his own method, called the “art of inventing.”

Immanuel Kant (1724–1804), the theorist of the modern concept of science, attempted to answer the question of what human cognition actually is. He criticized both rationalism (e.g., Leibniz) and empiricism (e.g., Locke) for basing their explanations for the possibility of knowledge on pure thought alone, or on pure perception, respectively. With his famous declaration: “Thoughts without content are empty, intuitions without concepts are blind,” he attempted to develop a synthesis of both, and concluded that, while science may offer general and necessary principles, sensory experience must also be consulted.

Of particular importance in design is the Kantian concept of reason. Wilfried Fiebig (1986), a philosopher in Frankfurt, proceeded from this concept to conclude that the source of human ideas resides in sensory perception and rational conception, both of which enter into his concept of the unity of reason. Although this concept of reason dissolves the external separation (dualism) between perception and reason, in and of themselves, they remain

Descartes also proposed a method for the observation of more complex problems: they must be reduced to smaller units that can be explained. This is known as Cartesian reductionism. One of its consequences was that it also made superfluous any considerations about the complexity of the relationships between the parts that make up a whole.

— MIHAI NADIN, 2003

Everything that is generated according to a draft is design. Kant said: We only understand what we generate according to our own draft.

— HÖLGER VAN DEN BOOM, 1994

dialectically present. Since the differences between these concepts can only be determined through their separation, a shared concept of reason is presumed in the unity of languages. In other words, reason is based on the appearance of language. The objective of design must therefore be to develop rational (“reasonable”) solutions.

Georg Wilhelm Friedrich Hegel (1770–1831) was the first to portray nature, history, and thought as processes; here he proceeded from a permanent movement, change, and development of the natural, historical, and spiritual world and attempted to prove the connections in this movement and development.

Friedrich Engels (1820–1895) went beyond Hegel’s findings about natural philosophy and developed dialectic materialism. In particular, he protested against the separation of method from object. As he conceived it, the dialectical method is always the method of an object, the thing itself, for instance, nature, history, art, and justice. For Engels, understanding a thing as it really is meant knowing the conditions necessary for its emergence, its history, and its transition into something else.

For Engels, however, the three steps of thesis, antithesis, and synthesis were not merely a method, but simultaneously the history of ideas. Since everything in life is in flux, and because he subscribed to Hegel’s opinion that everything which is supposedly static is merely a moment of this eternal and open motion, he considered the concepts themselves to be dynamic rather than static.

In the twentieth century the individual sciences became even more specialized. Three branches of the humanities took on particular importance for the field of design: semiotics, phenomenology, and hermeneutics.

SEMIOTICS AND DESIGN

The discipline of design not only generates material reality; it also fulfills communicative functions (Bürdek 1997b). Yet for a long time this aspect received little attention: designers always focused on the practical functions of products (i.e., their functional and technical performance) and the social functions of products (i.e., questions of operability and meeting users’ needs).

Philosophy is not one of the human sciences, Heinrich once said, and Gadamer nodded. One may be certain that he did not want to signalize any approval of the fashionable project of re-inventing the humanities as “cultural sciences.” On the contrary, philosophy is not a human science because it is not a science. For philosophy is after truth, and science is erected on methods.

— PATRICK BAHNERS, 1993

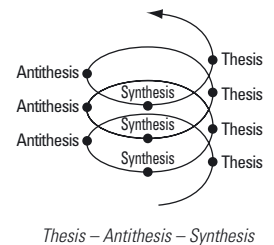

Even at the dawn of the twentieth century, there were products known as “talking furniture.” In Nancy, the French designer Emile Gallé designed and produced furniture that supposedly spoke a lively language endowed with the “sentiment of the soul.” His furniture sought to portray what he perceived as the soul of plants – artistic expression in delicately proportioned stands, wilting leaves, or fine woods. In day-to-day contact these were then supposed to exert a soothing and conciliatory influence on people, who were already plagued by technology and industry in this period (Bangert 1980).

Chairs provide a vivid example of how product designs must do more than satisfy ergonomic, constructive, manufacturing, economic, and ecological demands. Besides the question of what kind of sitting is concerned – for instance, sitting in the workplace, at home, in public areas, in school, in vehicles, short-term or long-term sitting, sitting by children or older people – design always has to deal with the connotations (that is, additional emotional or expressive meanings) the word sitting can also contain.

Using the example of a chair as a throne, Umberto Eco (1972) explained that in this case sitting down is only one function among many, and one that is often fulfilled quite poorly. What is more important is that the throne project majestic dignity, might, and inspire awe. Such patterns of interpretation can also be transferred to other chairs. An office chair, for instance, should meet ergonomic demands to the highest standard, while also demonstrating the user’s position in the workplace hierarchy.

Such observations can be made for all products. Automobiles, for instance, are not only a means of transport, but also highly symbolic everyday or cult objects. His analysis of clothing occasioned Roland Barthes (1967) to state that fashion, too, has two meanings: practical utilization and rhetorical statement (“for cocktails, the little black dress”). The things of nature speak to us; those that are artificially constructed must be given a voice, too: they should say how they originated, which technologies were used, and from which cultural contexts they arose. They should also tell us something about the users and their ways of life, about real or supposed memberships in social groups, about their values. First, the designer must understand these languages; then, he must be able to teach the objects to speak. Once we understand this, we can recognize the respective shapes of lives in the shapes of objects (Bauer-Wabnegg 1997).

Objects can be subdivided into two broad classes according to their semiotic specificity (Eco, 1975): household utensils and symbolic objects. Off the cuff I would like to designate as symbolic objects those things that serve explicitly and primarily to mean something, like signs and flags, but also pictures and figures as well as aesthetic objects. Objects designated as household utensils are those that primarily fulfill a practical task, and are thus both things that can be manipulated and objects of utility that can be applied instrumentally.

— TILMANN HABERMAS, 1996

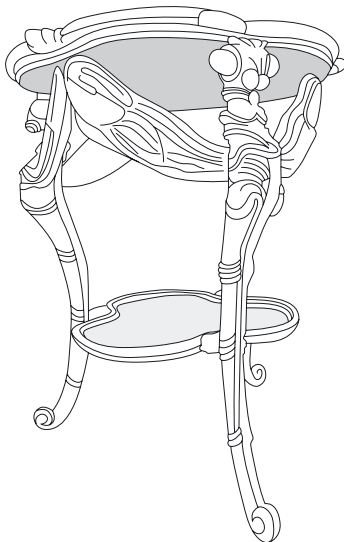

KING ARMCHAIR, design: Enthoven Associates,
Belgo Chrom

GUÉRIDON AUX TROIS LIBELLULES TABLE, design:
Emile Gallé (1900)

A SHORT HISTORY OF SEMIOTICS

Semiotics itself goes back to antiquity. This concept was used in ancient Greece in the field of medicine. There, it designated the branch in which the diagnosis and prognosis of diseases was performed through signs. In antiquity a urine sample to be analyzed was called a *signum* – a sign.

Plato presented a number of semiotic discourses, and the distinctions between the following words can be traced back to him:

- sign (*semeion*),
- meaning of the sign (*semainómenon*), and
- object.

He was concerned with establishing the relationships between the sign, its meaning, and the thing it designated. This threefold relation was largely forgotten until Charles Sanders Peirce picked it up again in the nineteenth century.

Aristotle used various semiotic concepts, such as the science of signs, theory of signs, art of signs (*semeiotiké*), sign (*sema* or *semeion*), and many others. He proceeded from Plato's discourses and developed a theory of phonetic and written signs, whose essence resided in the fact that with signs "something stands for something else" (*aliquid stat pro aliquo*).

In the nineteenth century semiotics underwent further development at the medical faculties of European universities. Following up on the ancient Greeks, a medical science of signs (Reimers 1983) was developed. It pursued a holistic approach, evaluating a past lifetime according to anamnestic signs (anamnesis = recall to memory, prehistory of an acute illness), observing the present condition according to diagnostic signs (diagnosis = discern), and putting forward prognostic signs (prognosis = prediction) for the expected course of illness or recovery. All of these signs were then connected with each other. Explaining these connections consists in the recognition and interpretation of signs (i.e., semiotics).

In today's form of semiotics, as it is applied in design, two directions have had predominant influence: semiology, which emerged from linguistics, and semiotics in the current sense, whose origins can be found in American pragmatism.

Let us call the totality of the learning and skills that enable one to make the signs speak and to discover their meaning, hermeneutics; let us call the totality of the learning and skills that enable one to distinguish the location of the signs, to define what constitutes them as signs, and to know how and by what laws they are linked, semiology.

— MICHEL FOUCAULT, 1997

Charles Sanders Peirce (1839–1914)

is considered the actual father of semiotics. He was the founder of the school of pragmatism and was regarded as the last representative of universal scholarship: universality in his case was oriented toward the unity of knowledge, which he saw fulfilled in the logic of semiotics. In 1867 Peirce began with the publication of his semiotic studies. He is credited with rediscovering the central concept of semiotics: the triadic relation. He emphasized the relative character of signs, that is, that they exist only as they relate to an object and an interpreter. This relation he called a three-way, or triadic relation. Peirce uses the concept of representation, meaning that something stands for something else, or is treated mentally as if it were the other thing. In this sense signs are representatives for something else.

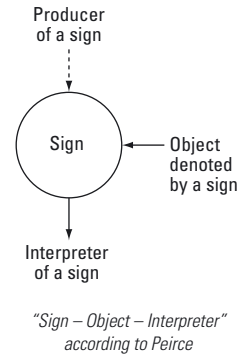

Ferdinand de Saussure (1857–1913)

lectured at the university in Geneva from 1906 until 1911. The work *Cours de Linguistique générale* (1916) was compiled and published from his students' notes. Saussure is considered the founder of structuralist linguistics and structuralist thought in general. Thanks to his work, linguistics was able to establish itself as an independent discipline.

Saussure spoke of the referential character of language, meaning that people use language to refer to things that lie beyond language: real existing objects and facts. Linguistic signs are not only physical sounds, but also psychological impressions. He called the whole complex the unity of idea and articulation. The idea of a chair thus has no natural connection to the sequence of its sounds. This connection is established only through collective agreement (i.e., convention).

Jan Mukařovský (1891–1975)

This Czech linguist belonged to a literary circle in Prague in the 1930s that discussed the foundations of the theoretical concept of structuralism and reviewed the works of Ferdinand de Saussure at quite an early date. He analyzed the aesthetic functions of works of art, which in his opinion had to be classified as social phenomena. Mukařovský referred in his works to both the triadic concept of signs by Charles William Morris and to Saussure's key concepts of *langue* (the language system of a community) and *parole* (the speech act of the individual).

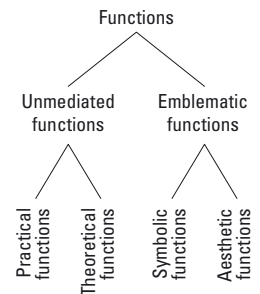

Typology of functions according to Mukařovský

The central point of his semiotic approach in aesthetics is the replacement of the concept of the beautiful through the concept of function. Through deduction Mukařovský developed a typology of functions (1942) that made express reference to structuralism, in which he conceived of the hierarchy of the respective functions as a constantly dynamic process.

Charles William Morris (1901–1979)

picked up on the studies by Peirce and John Dewey (1910) to formulate a behavioristic approach to semiotics. He discerned the behavior of signs through the three categories of characteristic, evaluation, and prescription (or command). In his programmatic work, *Foundations of the Theory of Signs* (1938), he distinguished three semiotic dimensions:

- the syntactic dimension, that is, the formal relations of the signs among each other and their relations to other signs,
- the semantic dimension, that is, the relation of the signs to the objects or their meanings, and
- the pragmatic dimension, that is, the relation between the signs and the users of signs, the interpreters.

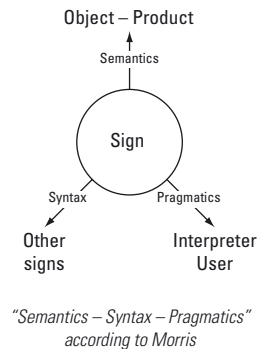

Max Bense (1910–1990)

Through his work on semiotics Bense probably exerted the most enduring influence on the creative disciplines in the second half of the twentieth century (Walther 2002). He was among the first to study the work of Peirce and Morris, and attempted to apply their conceptualizations to issues of aesthetics. Through his parallel teaching positions at the University of Stuttgart and the Ulm School of Design, he also initiated semiotic studies in the areas of information, product design, and visual communication at these institutions. Bense published a great number of works on semiotics (Bense 1954–1960/1967/1969/1971), which left their enduring imprint on discourses of design.

Jean Baudrillard (born 1929)

can be regarded as the actual founder of a semiotically grounded theory of design, because he applied semiotic-structuralist methods to the analysis of the everyday. He studied the language of objects (1991), by which he meant, for example, objects in the home, the automobile, technical appliances, and so on. If the things with which

humans surround themselves can speak, then they can report about the owners, about their values, desires, and hopes. Baudrillard's analysis of objects amounts to a political-economic exposé: commodities exist not in order to "be taken possession of and used, but to be produced and purchased. In other words, they structure themselves neither according to our needs, nor in the sense of a traditional order of the world, but exclusively for the purpose of an order of production and ideological standardization" (Baudrillard 1974).

Umberto Eco (born 1932)

concerned himself in numerous works with issues of the semiotics of literature, aesthetics, epistemology, semiotics, and the structuralist method. He utilizes the concept of the semiotic field, in which various different semiotic approaches are realized. For Eco, any semiotic study must presume that communication functions as the transmission of messages on the basis of codes.

Eco proceeds from Peircean considerations to investigate processes of communication. All cultural processes can be analyzed by means of semiotics. The codes are rules of transformation, through which certain signs are encrypted so that their meaning can be recognized when they are decoded. He continues to use the concepts of denotation and connotation that are so central to design.

With denotation Eco means the unmediated effect that an expression (a sign) triggers in the recipient of a message (in a particular culture). In the case of a chair, therefore: this is seating. With connotation, by contrast, he means everything that can occur to an individual (within a particular culture) as regards the meaning of a sign. Using the chair example, this may be a throne, a work of art, a judge's chair, or many other things. The connotation can thus be understood as the sum of associations evoked by a certain sign in a specific society.

In his *Introduction to Semiotics*, Eco (1972) dedicated a detailed chapter to the topic of semiotics and architecture, and he claims that this topic includes design and city planning. Using vivid examples, he demonstrates that the tenet of functionalism, of form following function, remains mystical if the code of the respective product has not been learned or imparted by society. How can an elevator be operated if no one can decipher the various buttons and arrows? From the perspective of communications technology, the form must denote the function so clearly that the operation of a product is not

only possible, but also desirable, that is, leads to the movements which are best suited to fulfilling the functions. The form designates function only on the basis of a system of acquired expectations and habits (i.e., on the basis of codes).

SEMIOTICS AND ARCHITECTURE

Semiotic studies on the subject of architecture were particularly popular. In the 1960s Robert Venturi pursued this approach explicitly in a fundamental study entitled *Complexity and Contradiction in Architecture* (Venturi 1966), in which he advocated meaningful buildings, which should clearly reject the International Style. In the circle of the Bense School in Stuttgart, the first works positing a connection between semiotics and architecture emerged in the 1960s (Kiemle 1967). Georg R. Kiefer (1970) investigated architecture as a system of non-verbal communication and established a “semiotization of the environment,” meaning that the environment conducts a conversation with humanity through signs.

It was not until the work of Charles Jencks (1978) that the analogies between architecture and language were introduced to a wider public: according to Jencks one can speak of architectural words, sentences, syntax, and semantics. His writings opened the doors for postmodern architecture – that is, an architecture of diversity – to attain importance worldwide; for this reason, Jencks can certainly be regarded as the most influential promoter of postmodernism.

Every attempt to solve the problem of cognition uses language as the instrument of representation, of impartation or of analysis. We use language to plead or attack views, to support or contradict statements. Language is the common element of every attempt at explanation.

— HUBERTO R. MATORANA,
1987

SEMIOTICS AT THE ULM SCHOOL OF DESIGN

Interest in semiotics in Germany in the field of design can be traced back to the 1950s. Tomás Maldonado published a seminal article about semiotics in 1959, which was followed by an early *Terminology of Semiotics* in 1961. Gui Bonsiepe (1963) emphasized the importance of semiotics for design with the words: “The hypothesis that the world of objects and the world of signs are structured identically can indeed be quite fruitful. Moreover, the communicative aspects – and these are based on sign processes – of the relationship between the user and the utensil are probably the most important part of a theory of industrial design.”

Under the motto of "Design as Sign," Hans Gugelot had already referred to the identity of sign and design in a lecture in 1962: "Any product with correct information content is a sign. That is why I stand by my decision to unify the concepts of design and sign. (. . .) For our perspective it is a matter of course to presume that man understands the language of things. To a certain extent, this can even be presupposed within a closed cultural circle."

The Ulm School of Design was the first institution to attempt to exploit semiotics for design, in part at the instigation of Max Bense.

SEMIOTICS AND COMMUNICATION

Early models of communication that were applied in design and based on telecommunications (Meyer-Eppler 1959; Maser 1971), proceeded from the assumption that these were what were known as transmitter/receiver models. The scientific foundations for this are found in cybernetics, which enjoyed particularly high esteem at the Ulm School of Design and in its methodology. That such technical models cannot be applied to interactions between biological, cognitive systems (Rusch 1994) did not actually become apparent until the paradigmatic works of radical constructivism. The works by Humberto Maturana and Francisco J. Varela, Heinz von Foerster, Ernst von Glasersfeld and Gerhard Roth, and especially the two comprehensive volumes by Siegfried J. Schmidt (1987, 1992), led to thoroughly new ways of regarding communication. This new concept designates a reciprocal process of exchange between actors, for whom the objective is what are known as adaptation outputs, for only then can communication be truly successful. The basic thesis here is that perception (of signs or products) is always interpretation, that is, the attribution of meaning occurs in the human brain. In this case, it resorts to previous experiences or even conventions (Schmidt 1986).

A decisive feature of communication is that information is not transmitted (as in telecommunications), but constructed: "Here every kind of situational, socio-cultural, and personal factors that has an influence on this process of construction is taken into consideration. But all aspects of communication are described plausibly in the coherent model of the functioning of operationally closed autopoietic systems" (Schmidt 1987). A common criticism of the product

language approach was that the products themselves do not actually speak at all. Certainly they do not, nor are they signals or messages (as presumed in the earlier models); nevertheless, during the process of communication (between the manufacturer, the vendor, and the user) they are ultimately assigned language (and thus meaning). The parties to such communication processes agree in a sense upon the meaning warranted by certain products (expensive, professional, technical, ecological, innovative, etc.).

The sociologist Niklas Luhmann (1984) once said in this context that “communication is contingent on communication.” For the parties to such communication processes it is therefore necessary to produce what is known as connectability, for only then can communication be successful. From this it follows that designers do not – as presumed in the traditional models – transmit messages to the world that are subsequently understood by potential recipients. Rather, in such communicative processes, the point is that interactions emerge (i.e., reciprocal relationships). From the analysis of product culture contexts, ways of life, and modes of behavior, it is necessary to offer communications that are understood, classified, and valued by potential users. From this perspective, design must formulate and generate identification that can be effective on the most varied of levels. The products themselves function in such processes as vehicles of social interaction; they offer a wide variety of potential connections (Bürdek 2001a).

Different authors have used similar concepts to describe the communicative functions of objects or products. Jean Baudrillard (1968) spoke of the primary and secondary functions of an object. Umberto Eco (1968) illuminated the “absent structure” of objects and subdivided these into the first and second functions. Of course, for him, this order is not a value judgment, as if one function were more important than the other; on the contrary, the second functions (the connotations) are based on the first (the denotations, i.e., the objective meanings). For Eco the entire world is constructed of signs, and the condition of a culture can be read from its signs.

Connecting means making meaning possible. Meaning originates when connections are available that make it possible to continue the game in the future. And the more connections I have in my relationships – naturally functioning, not constantly interrupted, and thus well-designed connections – the more options or possibilities of choice I have for the future.

— BERNHARD VON MUTIUS, 2000

PHENOMENOLOGY AND DESIGN

Phenomenology, a method with a rich tradition in the humanities, has found only cautious application in design. It is understood to

be the system of phenomena that can be described by forgoing theoretical analysis (especially reduction). The first phenomenological approaches emerged in the eighteenth century. Kant, for instance, formulated a *phaenomenologia generalis*, a science held to be one of the precursors of metaphysics, but not until the nineteenth century was this philosophical orientation elaborated more intensively.

Edmund Husserl (1859–1938)

It was Husserl who shaped phenomenology into its current form. He is regarded as the founder of a phenomenological philosophy, which was made public in its early form in his *Logical Studies* (1900–1901). His objective was to advance “to the things themselves” (i.e., to the original logical forms of thought).

The history of phenomenology is closely intertwined with that of hermeneutics (see p. 244). With his *Ideas on a Pure Phenomenology* and *Phenomenological Philosophy* (1913), Husserl established himself as the representative of a transcendental subjectivism. In this theory, every object is studied from the perspective of its manifestation, in which the object may be:

- a phenomenon in the external world of the senses,
- a visual quality in the sphere of experience, or
- the symbolic manifestation of intellectual structures or processes.

Husserl introduced the concept of life-world to emphasize that the analysis of objects must always reflect a particular world (and time). Accordingly, a phenomenological method is a procedure that attempts to understand the life-world of man directly and as a whole, while taking everyday life and its environment into account. Only by delving into these life-worlds is it possible to grasp the meanings of everyday objects. These are then subjected to hermeneutic interpretation, an approach from the humanities. Moreover, any phenomenological statement can claim validity only within the context of a certain spatially and temporally restricted historical horizon. When applied to design, therefore, phenomenology aspires to nothing less than a comprehensive investigation and characterization of the entire horizon of a product.

Herzog & de Meuron conceive of their approach as phenomenological – which holds that understanding of the location and openness in the specifications of the project are decisive points of departure for shaping the design and selecting the materials.

— KARIN SCHULZE, 2004

EXAMPLES OF PHENOMENOLOGICAL STUDIES

The work of philosopher Martin Heidegger (1889–1976) exhibits strong connections to phenomenology, for example, in his works on art (1968). Heidegger succeeded Husserl at the University of Freiburg and published phenomenological studies on concrete objects. Three of his essays count among the classics of the field: “Das Ding” (What is a Thing), “Die Frage nach der Technik” (The Question Concerning Technology), and “Bauen Wohnen Denken” (Building Dwelling Thinking) (1967), all of which are certainly within the context of designing. The Swiss architect Peter Zumthor, for instance, refers explicitly to these philosophical positions (see p. 384).

Not until the 1980s did the phenomenological approach re-enter the discourse. Two phenomenological studies were dedicated to the Walkman, by now a legendary product. Invented in Japan and brought onto the market by Sony in 1980, it was the origin of a categorically new and soon omnipresent product group – the playback of music possible under all circumstances. Shuhei Hosokawa (1987) directed his essay not to the original product, but to its effects on the urban environment: “the Walkman as an urban strategy, as an urban sound/music device.” Here he applies Baudrillard’s categories (1972) of primary (practical) and secondary (non-material) functions. Hosokawa is less concerned with the object in and of itself than with the object in use: what it means for the user, how it is perceived by the world around it, and what image of urbanity is behind it. He displays these life-worlds in their entirety.

A significantly more comprehensive phenomenological study on the Walkman was published by Rainer Schönhammer (1988). Proceeding from the tradition of applied phenomenological research (Waldenfels 1980, 1985), Schönhammer describes how the Walkman decisively influences the life-world of its users today. He also calls his study a snapshot of the cultural history of sensory experience: “The possibility of using the device to secure a kind of musical shelter in exposed situations creates a corresponding valence of the object: the Walkman becomes a symbol of a life beyond the separation between subject and world, a symbol for the permanent possibility of experiencing fusion” (Schönhammer 1988). In this way “the separation from what is happening acoustically in the space surrounding the headphones in itself will give occasion to an experience of alienation. The separation can be used to subject oneself to a

Had Heidegger been asked in what way or with which vehicle this departure should begin, he might have been obliged to reconsider his entire speech more precisely. But as it was, history passed this question on to Ferdinand Porsche, who was to answer it in his way with the invention of the Volkswagen. Heidegger provided only the philosophical accompaniment for this dream of a people’s automobile. This car was to become Heidegger’s “Fahr-Zeug” (driving equipment), in the sense of his theory of “equipment” that serves the realization of human existence.

— MANFRED RUSSO, 2000



LOVE GETTIES (Photo: Museum für Angewandte Kunst Frankfurt, donated by Bürdek)

musical event of particular forcefulness. Shutting out the acoustic environment can be both a (secondary) objective of its use and an undesired condition, which the user seeks to escape by adjusting the volume accordingly. The provocation of others is taken into consideration in a variety of ways" (ibid.).

In his study on the remote control, Schönhammer (1997) pursued the question of how these "magic implements for the household" have become established and propagated. The effect that they exert from afar, namely enabling the user to operate products without touching them, changes the way we handle these products on the most elementary level. Be it for television, stereo, CD player, video, or garage door, the remote control has become an "intervening technology of culture" with which we may think we determine our media behavior autonomously, but which ultimately only further cements our dependency on electronic media.

At the end of the 1990s, two thoroughly design-oriented publications set out to build on the tradition of philosophers like Husserl and Heidegger and brought the tradition of phenomenology to bear in the present. Jens Soentgen made his reputation as a modern phenomenologist by dedicating himself to *Materials, Things, and Fractal Creations* (1997), thereby consciously establishing references to current design. Soentgen makes clear that the staunchly semiotic orientation of product language can indeed be expanded by a phenomenological dimension, for "semiotics is a theoretical option which may have many advantages, but also [has] the disadvantage that it must always conceive of everything as signs and ignores anything that cannot be reinterpreted as a sign" (Soentgen 1997). He also points out the critical difference between these two human-science methods: "describing phenomenologically means describing something as it appears without considering previous knowledge, without considering hypotheses, without any consideration for anything which does not belong directly to the perceptible sensory existence of the thing itself. Signs, on the other hand, are always mediated, be it through experience or through convention; semiotics thus concerns itself with the mediated or with that which can be thought of as mediated, and phenomenology with the unmediated, the direct."

In another collection of essays, Soentgen (1998) vividly discussed a variety of phenomena that determine our everyday life, including "Kitsch," "Marble, Stone and Isopropyl Alcohol," "Patina," "Shining

Objects do not stand for themselves, but in "horizons," as phenomenology tells us. Horizons are not concretely present, but are drafts of the space of an object, which extend what is concretely given and circumscribe it more or less incisively from a field of alternatives.

— KRAFT WETZEL, 1995

Chrome,” and many more. All of these also serve as instructive and illuminating examples of how a humanities orientation can be applied to design.

Volker Fischer (2001) subtitled an essay “A Phenomenology of Electronic ‘Devices’” as a means of designating all of those useful and useless digital helpers (like mobile CD players, minidisk recorders, cell phones, Walkmans, cameras, GameBoys, tamagotchis, and Love Getties) (see p. 327). Fischer not only discussed these gadgets as individual examples of product design, but put them forward as the basis for exemplifying all of the life-worlds that have an enduring influence, especially on children and teenagers in the way they deal with contemporary “digital devices.” That the changes in users’ behavior have significantly greater consequences here than product design (which in many of these cases can be considered fairly banal) is only one of the insights we owe to phenomenological analyses.

HERMENEUTICS AND DESIGN

Hermeneutics in the strict sense is the art of interpreting, explaining, and translating texts. Interpretation is the key to understanding. This can be applied to nearly all contexts of life, including actions and gestures, works of science, literature and art, and historical events. As a theory, hermeneutics explains reflections on the conditions and norms of understanding and expresses them in language.

A SHORT HISTORY OF HERMENEUTICS

Hermeneutics has two ancient historical roots: on the one hand, Greek philosophy – Plato, for instance, used the concept of *techné hermeneutiké*, which means the art of interpreting and explaining texts – and on the other hand, the exegesis of the Bible in Judaism.

Modern hermeneutics emerged in the nineteenth century, at the time when scientists were changing their Cartesian conception of the world as a machine. This was also the period during which the Englishman John Stuart Mill distinguished the natural sciences from humanities: the latter he designated the “moral sciences.”

This subdivision was scrutinized by Charles Percy Snow (1959) in his book *The Two Cultures*. He saw the separation of literary from natural science research as a consequence of the industrialization of Europe. Today's discussions about the impact of technology, especially the problems in dealing with microelectronics (Weil and Dorsen 1997; Bürdek 2001) are examples of how the progress of natural science is challenged by studying advances in terms of the humanities (i.e., by inquiring as to their meaning).

Friedrich Daniel Ernst Schleiermacher (1768-1834)

is considered the first representative of modern hermeneutics. Although he did not write any independent works on hermeneutics, his Bible interpretations, which he put forward in lectures and talks, are classic hermeneutic works. Schleiermacher developed general rules of exposition that can also be applied to non-theological objects of interpretation. He proceeded from the universality of language: language and thinking constitute an inseparable unity. Just as in the Kantian concept of reason – the unity of sensory perception and intellectual conception – here, too, we find an important prerequisite for the scientific interpretation of design.

Johann Gustav Droysen (1808-1884)

founded historiography as a hermeneutic science. He defined the essential methods in the humanities as recognizing, explaining, and understanding. The three basic theoretical questions of the historical sciences are attributed to Droysen:

- the question of their object,
- the question of their methods, and
- the question of their objectives.

Wilhelm Dilthey (1833-1911)

is considered the actual founder of the humanities and the father of the hermeneutic, scientific philosophy of life. Using the example of psychology, Dilthey demonstrated the difference between explanatory (natural) and descriptive humanities. This subdivision is based on his statement (which remains pertinent even today): "We explain nature, but we understand the workings of the mind."

At this juncture an analogy to design theory can be established as products also always have this dual nature, consisting of a material reality and a non-material reality (i.e., the meanings they convey).

I do not believe that even the applying of the greatest effort to hermeneutical research can unearth the true concepts of our thinking ancestors.

— ERNST VON GLASERSFELD,
1996

Otto Friedrich Bollnow (1903–1990)

was strongly influenced by Dilthey's life philosophy; he has often been designated the hermeneutist of "small understanding" or of "small forms." His work *Understanding* (1949) attained particular importance. It picks up on a thought of Schleiermacher's that the idea is to "understand a writer better than he understood himself." This sentence neatly summarizes the actual objective of hermeneutics, namely to understand by reconstructing how an idea was produced (Gadamer 1960).

Hans-Georg Gadamer (1900–2002)

was probably the most important hermeneutist in the twentieth century; among his teachers was Martin Heidegger. His primary work, *Truth and Method* (1960), deals with the central question of truth's inaccessibility to any consciously scientific method. What was important for Gadamer was that the object being interpreted and the person who interprets it are involved in a kind of exchange with one another. Interpretation thus always also means influencing what is understood. Hermeneutics is, in and of itself, not a mechanical procedure, but rather an art.

Gadamer (1988) also grappled with the Snovian problematic of two cultures, according to which human knowledge is grasped in two kinds of languages: instrumental language (formulas, calculations, mathematical symbols, scientific experiments) and the language of philosophy.

Historical developments are portrayed in language. Human experience is set out in language; language is the means of understanding the world. Hence, Gadamer firmly embraced the theory that language, located at the center of philosophy, should be regarded as the core problem of the humanities, and the same, obviously, also holds true for design.

SOME BASIC HERMENEUTIC CONCEPTS

Hermeneutics has developed a number of concepts that prove useful in design.

The Hermeneutic Triangle

consisting of a work, a worker (the producer of the work), and a recipient, describes in other words the relationship between the designer, the design object, and the user.

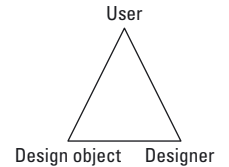
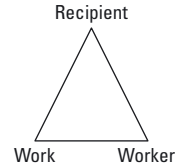

Hermeneutic Triangles

Previous Understanding and the Fusion of Horizons

are important basic concepts in hermeneutics. The first is understood to mean that each recipient already has knowledge about, and a consciousness of, the object to be interpreted, for only then is actual interpretation possible.

Fusion of horizons means that “wanting to understand” proceeds from the assumption that the recipient’s previous knowledge can be unified with the horizon (and thus intentions) of the artist (or designer) and vice versa (i.e., that they meld together).

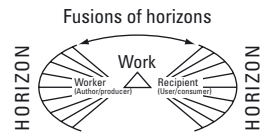

The Hermeneutic Circle

serves as the basic pattern of intersubjective understanding. A circle has no beginning and no end; analogously, the “circular structure of understanding” means that a logical circle (vicious circle) exists when what is to be proven is given as a premise. One of the uses of this phenomenon, also known as a “philosophical circle,” is in Hegel’s idealism: In order to recognize something, I must know what recognition means, which means I must have recognized something already.

Interpretation of a Work

According to Rudi Keller (1986), the process of interpretation consists of the following steps:

- perceiving a sign,
- interpreting its reference, and
- understanding its sense.

Interpretation thus basically means explanation, exposition, and signification. It is usually understood to mean the interpretation of works of art. Interpretation is thus not emotional, superficial talk, but instead, as a method of the human sciences, has a trans-

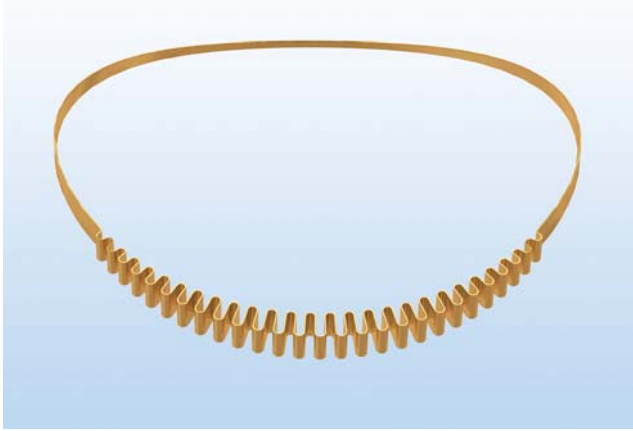
**BODYSIGN COLLECTION**

Biegel Schmuckdesign

ELIZABETH, design: Shin and Tomoko Azumi

MOLECULAR, design: Uwe Fischer

FRAME, design: Hannes Wettstein

CLOUD, design: Ronan and Erwan Bouroullec

LOOP, design: Axel Kufus

subjective character: just as with the “unity of reason”, the concern here is the dialectic of rational and subjective aspects.

Sense and Reference

The concept of reference (or denotation) used here is largely identical with the concept of semantics used in semiotics. It is, however, important to distinguish reference from the concept of sense (or meaning). Keller (1986) used the example of language to explain the difference: Either one knows the reference of a word or one does not know it. One knows it whenever one knows how an expression is used (in accordance with an agreement or convention). “Understanding the sense” thus means grasping the intention, which is analogous to being able to classify a move as part of strategy in a game of chess. This example makes it clear that it is not until interpretation – in this case through familiarization with the rules – that the sense (of a chess move) can be concluded from the reference (of a chess piece).

There is no cultural or social science of design, no research on questions of aesthetic ecology, on the anthropology of handling or the psychology of usage. The foundations of the effects of design remain unknown, a hermeneutics of industrial culture is not desired.

— GERT SELLE, 1990

ON APPLYING HERMENEUTICS

Linguistic and textual critique is concluded with the steps of perception, interpretation, and understanding the sense. However, if one wishes to transcend the descriptive level, a further step must follow: application. Gadamer (1960) recalled that in the tradition of the eighteenth century the hermeneutic process was already organized as follows:

- *subtilitas intelligendi* (understanding),
- *subtilitas explicandi* (exposition),
- *subtilitas applicandi* (application).

These three elements must interact with each other to make up comprehension.

CRITIQUE OF HERMENEUTICS

Despite all of the altogether positive assessments hermeneutics has experienced in the field of design in the past, it should not be overlooked that, since Gadamer’s *Truth and Method* (1960) came out,

However, always just generating symbols instead of working on something meaningful may mean merely playing around at designing the gravestones of our culture.

— JOSÉ R. MÉNDEZ-SALGUEIRO, 1998

this approach has developed an unnerving claim to universality that moved Jochen Hörisch to discuss the issue in *The Frenzy of Understanding* (1988).

What hermeneutics is criticized for is its universal urge to generate uniform interpretations. Its reduction of doubt or plurality holds a promise of unity that, ultimately, cannot be fulfilled: "Fusing horizons means that in the place of many perspectives only a single one remains. Raising a claim to universality at the least integrates, and usually subsumes, alternative claims. For someone who speaks hermeneutically on the metalevel, obscure relationships present themselves as quite comprehensible" (Hörisch 1988).

Critical Theory and the social sciences of the Frankfurt School had already voiced significant reservations about traditional hermeneutics in the 1970s. Jürgen Habermas (1968), in particular, diagnosed its missing critical distance; furthermore, he believed that recognition is always driven by interests. In his *Universal Pragmatics*, he described the principles of universal conditions of human understanding, but not until his *Theory of Communicative Action* (1981) did Habermas develop a system that built on language to make interpersonal understanding possible at all. With recourse to the "linguistic turn," it raises an interesting parallel to the development of design theory.

A thoroughly different critique of the methods used in the humanities (and also in hermeneutics and phenomenology) is formulated in design practice. Uli Skrypalle, vice president of the exhibition services firm designafairs in Munich, spoke of the necessity to move from phenomenology to empiricism in practice (Bürdek 2002), saying that the product development process today was not determined merely by the subjective feelings of individuals (designers, market specialists or developers); instead, the process required that the concepts be continuously revised by the relevant target groups.

ON EMPIRICAL HERMENEUTICS

The Frankfurt School produced an important further development in hermeneutics. Thomas Leithäuser and Birgit Volmerg (1979) outlined first reflections on an "empirical hermeneutics." They said that it was necessary to lead a metahermeneutic discourse in order to avoid the subjective misinterpretations that often occur in

hermeneutic circles. The psychoanalytical approach behind this idea is based on empirical investigations of everyday consciousness. Methodologically, empirical hermeneutics has its roots in linguistic philosophy ("the linguistic turn"), and thus also demonstrates an interesting affinity to the communicative discourses in design.

The methodologically decisive step of empirical hermeneutics thus is to take the given, real socio-cultural conditions as the point of departure in any attempts to interpret, and to reflect on these permanently to prevent speculative explanations. This opens up important potential junctures for the practice of design.

DEVELOPMENTS IN DESIGN METHODOLOGY

The roots of design methodology can be traced back to the 1960s, when it was the subject of particularly intensive work at the Ulm School of Design. The emergence of methodology as a field was a consequence of the great number, and completely new nature, of tasks assigned to industrial designers at this time. Christopher Alexander (1964), one of the fathers of design methodology, listed four reasons why the design process needed its own methodology:

- design problems had become too complex to treat them purely intuitively,
- the amount of data required to solve design problems had increased so rapidly that one designer working alone could not collect, let alone process, them all,
- the number of design problems had increased rapidly, and
- totally new design problems were emerging at a faster rate than previously, so ever fewer design problems could be resolved by referring back to long-established practice.

Often it was incorrectly presumed that the objective of methodological research was to develop a uniform and stringent method for designing. This view overlooked the fact that different tasks require different kinds of methods, and that the first step in any design process is to decide which method should be used for which problems. The methodological effort involved in redesigning a simple household utensil is significantly lower than in developing complex public transport systems. Design methodology was guided by the principle that it was important to understand what the task was

before beginning with any changes or new designs. In retrospect, this early phase can be designated as the analytical paradigm of architecture and of design, as well (Tzonis 1990).

THE SYSTEM RESEARCH OF THE FIRST GENERATION

Important works on design methodology emerged in the 1960s, initially from the United Kingdom and North America. They were strongly influenced by space research, where complex problems had to be solved. Horst Rittel (1973) called these early approaches "system research of the first generation," whose basic assumption was that it must be possible to dissect the design process into discrete steps:

1. Understand and define the mission (formulation of the task).
This must be done very conscientiously and is the necessary prerequisite for everything that follows.
2. Collect data. In this phase one informs oneself about the current condition, the technical possibilities, and the like.
3. Analyze the data obtained. Draw conclusions from the information by comparing it with the mission (the target condition).
4. Develop alternative solutions. Frustration is frequent in this phase, but so are occasional creative leaps. In any case this phase should end with the development of at least one solution and the demonstration of its feasibility.
5. Assess the pros and cons of the alternatives and decide on one or more solutions. This phase may be accompanied by all kinds of complicated processes, such as simulations, which should provide the system researcher with an idea of the quality of solutions.
6. Test and implement the solutions. After testing, present the solutions to the decision makers. On the basis of this presentation they will choose between the alternatives offered and order the implementation of their choice.

Many authors developed similar models, replete with various detailed procedures. For instance, Morris Asimov (1962) developed what he called a morphology of design; Bruce Archer (1963–1964) published voluminous checklists, which sought to determine every step in the

process of design, but were so highly formalized that they could hardly be used. John R. M. Alger and Carl V. Hays (1964) directed their intensive efforts to a procedure for evaluating design alternatives, and Christopher J. Jones (1969) made essential contributions to methodology on the international level. I published detailed overviews of these at the conclusion of my studies in Ulm (Bürdek 1971a, b). In the 1970s Nigel Cross (1984, 1989) continued in this tradition, which was sometimes overdone, especially in the area of industrial design engineering at the Technical University of Delft (Roozenburg and Eekels 1995).

Christopher Alexander’s Method

The work of Christopher Alexander (1964) played a special role in the development of design methodology, as he focused specifically on the problems of form and context. Alexander consistently advocated introducing rationalism to design, as derived from the formal sciences of mathematics and logic. Alexander’s primary concern was to break down complex design problems into their components as a means of finding concrete solutions.

If the form is the solution of the design problem, and the context defines the form (as it comprises the requirements that the form must fulfill), then discussion about design is not about form alone, but about the unity of form and context (see p. 258).

Alexander developed a method for structuring a design problem (defining the context) and then using the resulting hierarchical composition to develop the form.

To put it in its context in the history of science, Alexander’s method integrates the Cartesian dissection of a problem with the deductive method. In the 1970s this strict methodological approach, involving first the decomposition and then the composition of design processes, was adapted and implemented in data processing systems. However, the euphoria for processing problem structures by means of computers evaporated quickly, not least because of the significant cost at the time. What remains is Alexander’s basic approach of using deduction to dissect complex problems into sub-problems and making the search for alternative solutions to these subsidiary issues the first step in the design process.

This method proved quite effective in the practice of industrial design, but its limits became clear in the 1990s when the relationship

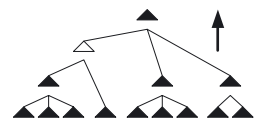

Program, consisting of sets

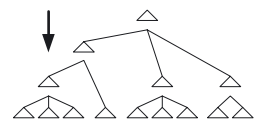

Realization, consisting of diagrams

Decomposition und Composition according to Christopher Alexander, 1964

between form and context experienced a crucial shift. As functionalism was replaced by postmodernism, the increased focus on the communicative function of design, including the new non-material subjects it presented (like interaction and interface design), required completely new approaches and methods (see p. 407). For this reason Mihai Nadin (2002) made a radical break with “Cartesian reductionism,” which prohibits the application of non-deterministic (i.e., dynamic) models of change. Using even those networking potentials available today, as insufficient as they may be (see the section on mind mapping on p. 259), would require throwing Cartesian thinking overboard.

On the Methodology of the Ulm School of Design

A first retrospective on the phase where design was transformed from an art to a science was completed by Tomás Maldonado and Gui Bonsiepe in 1964. At this time the Ulm School of Design had distanced itself quite clearly from design as taught at the German schools in the arts and crafts (*Werkkunst*) tradition, most of which offered little more than a slightly modified version of the basics of Bauhaus, and all of which had a hard time making a successful transition from handicrafts design to industrial design. Because the Ulm School of Design articulated a strong interest in the relationship between science and design, numerous scientific disciplines and methods were studied in terms of their applicability to the design process.

Extensive discussion was dedicated to methods and to methodology itself: The latter consists in a systematic classification of all methods involved in the design of products. However, it would be incorrect to conclude that there is any such thing as a single generally valid methodology of product design. On the contrary, there is merely a collection of methods, among which a number of mathematical ones have achieved special standing (Maldonado and Bonsiepe 1964).

This mathematic approach shows particularly clearly that the intention of the “Ulm methodology” was to apply a methodology to the actual design process, that is, to the aesthetic character of the products. In the 1960s the aspect of rationalization was promoted intensively by the new technological capabilities of industry, while the language of form rapidly took on the standing of a new style principle: “Ulm functionalism.”

Trans-Classical Science

Probably the most important contribution to explaining and re-orienting the scientific theory of design came from Siegfried Maser (1972), who distinguished the following kinds of science:

- real sciences,
- formal sciences, and
- humanities or human sciences.

Maser applied the criteria of objective, progress, principle, path, consequence, and critique to determine which sciences might serve as the basis of an autonomous body of design theory. Because each of these criteria contains components of the classical sciences, he conceived of design theory as a trans-classical science along the lines of control sciences such as cybernetics. In this case, practice is the sphere of action and theory the sphere of argumentation. The role of theory is to provide reasons for action or to question, justify, or criticize it.

Changes in real conditions are at the center of a trans-classical or control approach (Maser 1972): "Using the terminology of cybernetics, this can also be formulated as follows:

1. Existing (ontic) conditions initially should be described as precisely and comprehensively as language allows (classical!).
2. From this knowledge a target condition should be determined, accompanied by at least one plan for converting the existing condition into the target condition.
3. The actual change to reality is based on the plan provided."

These steps represent the most basic form of the design process.

Models of the Design Process

The fact that there are no elementary tools of methodology was attributed to a practice-oriented model of the design process in the *Introduction to Design Methodology* (Bürdek 1975). A number of simple methods and techniques were listed there.

The model emphasizes the design process as an information processing system and is characterized by numerous feedback loops, which illustrate how far the design process is removed from linear problem solving. Allowances are made for a design practice in which such factors as objections, missing or updated data, technological

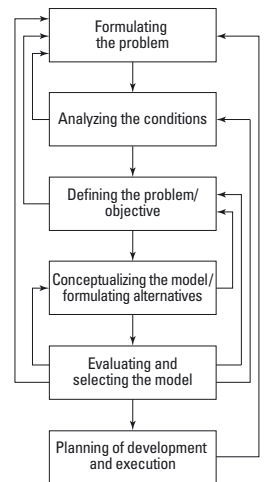

Model of the design process

advances, and legal restrictions can make a development process protracted and redundant. So much input from so many different sources does not serve to make the process more transparent, but rather less so.

Introduction to Design Methodology also introduced a basic canon of methods that had proven effective in practice and suggested that they be taught as part of design training. These included: preparing analyses (market, function, and information analyses), compiling a list of requirements and specifications, creativity and problem-solving methods, methods of rendering (two-dimensional and three-dimensional), evaluation procedures, and test procedures.

As I compiled this canon it became clear that the repertoire of methods to be applied depends on the complexity of the problems posed (on a scale ranging from a coffee cup to public transportation); this point was overlooked all too easily in discussions about whether or not methodology made sense. Part of training in design methods entails explaining to the pupil which repertoire should be implemented in which case, and this very aspect requires maintaining a critical distance from methodology.

THE PARADIGM SHIFT IN METHODOLOGY

The reorientation in methodology that began in the late 1970s amounted to nothing less than a paradigm shift. This concept was propagated by Thomas S. Kuhn (1967), who understood a paradigm to be those components of a scientific discipline that are held to be generally valid by the majority of researchers in the given discipline. The concept of a paradigm shift expresses the view that science does not progress at a steady pace, gradually accumulating knowledge, but rather experiences occasional revolutionary breaks, which entail more or less radical changes in the dominant ways of thinking (Seiffert 1983).

The work of Paul Feyerabend (1976) was particularly influential for methodology. He objected to the idea that only one fixed method (e.g., the Cartesian) should be accepted as generally valid: "A unified opinion may be the right thing for a church, for the intimidated or greedy victims of a (traditional or new) myth, or for the weak and complaisant subjects of a tyrant." Objective knowledge required

many different ideas, he asserted, adding that only a method that encourages diversity can be reconciled with a humanistic standpoint.

This conception did not actually become important in design until the early 1980s, when new design tendencies were fostered by postmodernism. A paradigm shift occurred in design methodology as well. Until well into the 1970s, most of the methods applied had been deductively oriented, with work proceeding from a general problem and oriented toward a special solution (from the outside in). What became known as the “new design” increasingly used an inductive approach, asking first for whom (which target group) a special design was intended and to whom it could be marketed (from the inside out).

Christopher Alexander’s Pattern Language

In methodology itself, it was a major publication by Christopher Alexander that marked what was probably the decisive paradigm shift. In 1977, together with his colleagues at the Center for Environmental Structure in Berkeley, California, he published what is probably the most important work on issues of planning and architecture: *A Pattern Language*. This book and its successor, *The Timeless Way of Building* (1979), represent a decisive step in the development of methodology.

The design method known as Pattern Language elucidates and reveals the social and functional issues of design discourse and how they can be implemented in the three-dimensional world. Its central section comprised a plan to provide the residents of cities and houses with the means necessary to shape their environment themselves. The core of this plan was that the residents understand that everything surrounding them – structures, buildings, and objects – possesses its own language. In no less than 253 individual examples he describes the individual words (pattern) of this language, which can be used to create an infinite number of combinations (e.g., essays and speeches). Such patterns then constitute regions and cities, neighborhoods, buildings, spaces and niches, all the way down to details like the atmosphere of the dining room, the bedrooms, seating, colors and lighting. Each individual pattern is connected to the others; none is an isolated unit. All are hypotheses and thus provisional; they can be developed further on the basis of new experiences and observations.

Both the graphic arts and architecture experienced an intensified interest in context. “Context” here means: prosaicness, forms of social behavior, but also the conditions that lead to the emergence of art and architecture and their ideological backdrops.

— BARBARA STEINER, 1994

On the Ambiguity of Form and Context

If form represents the solution for the problem of design and context defines the form, then discussions about design are not only about form, but about the unity of form and context. This statement by Alexander (1964) opened a discourse which became relevant again in the 1990s.

Up until the 1980s context was generally understood to mean only those practical demands (such as ergonomic conditions, construction specifications, and manufacturing options) that designers had to take into consideration in their designs. In reality, however, the design is often dominated by an entirely different set of conditions. Today, the contexts are the actual topic of designs: first the relevant lifestyle must be formulated and designed as a backdrop that determines which products can endure. A telling example is provided by the automobile manufacturer Volkswagen AG, whose Autostadt Wolfsburg (Wolfsburg Car City) and Gläserne Manufaktur (Transparent Factory) in Dresden are examples of how context can become more important than the products themselves. This showcasing of “the car” is supposed to culminate in a total experience and thus ultimately reinforce the purchasers’ brand loyalty.

Design problems are therefore no longer questions of form alone; instead, it is becoming increasingly important to design contexts, to set the stage for contexts, or at least to provide contexts as models of interpretation for a design. The question today is not: “How are these things made?” but “What do these things mean for us?”

Things exist in the context of societal usage, in lived cultures. As soon as this context no longer exists and things can be isolated in the sterile space of the museum, they are already clinically dead.

— GERT SELLE, 1997

NEW DESIGN METHODS

Although the transition from the natural science paradigm to the humanities paradigm started rather hesitantly in the design of the 1980s, the increasingly predominant process of digitalization in the 1990s necessitated a fundamental reorientation. New methods were also needed for design practice, as design concepts for hardware and software required empirical testing.

Thus it came as no surprise that Christopher Alexander’s Pattern Language took on new relevance in the context of software development; after all, that is where the linearity of design processes

(problem – analysis – solution) was abandoned and the focus shifted to the stratified nature of users' needs and interests. Patterns began to exert increasing influence on the development processes (Borchers 2001).

These patterns reveal a crucial problem for mass culture and society: how to deal with electronics. Donald A. Norman (1989) stated that a significant portion of the design process should be concerned with how the objects to be designed will be employed and operated. In the design of digital products (hardware and software), the emphasis shifts away from the external form toward the user interface.

Mind Mapping

Probably the most radical departure from the problem-solving methods – be they linear or characterized by diverse feedback mechanisms – are what are known as mind mapping models. These models have been marketed under the catchword of “visualizing knowledge” since the mid-1990s in the form of interactive software. Developed by Tony Buzan in the 1970s (Buzan 1991, 2002), mind mapping methods are designed to assist in structuring problems, product development, and process planning. These models are conceived in the tradition of the *Ars Memoria*, techniques of remembering that date back to antiquity.

When linear thinking is abandoned, intuitive leaps and innovative ideas and products often result. The simple reason for this is that problems (in design, too) are becoming so complex that traditional methods (like trees, quasi-groups) can no longer be used to outline them, let alone to solve them.

The mind mapping programs associated with the field of knowledge management allow problems to be presented using a multimedia approach (texts, pictures, films, and music) that can suggest to the users completely new ways of structuring problems. The interactive nature of this method provides for extremely versatile problem descriptions and thus holds great potential for innovation. Mind maps are available in different versions offered under product names like Hyperbolic Tree, MindManager, Mind Map, The Brain, and Think Map. The compilations of mapping examples by Matt Woolman (2002), Roger Fawcett-Tang, and William Owen (2002) illustrate the great versatility of this method of structuring and visualizing problems.

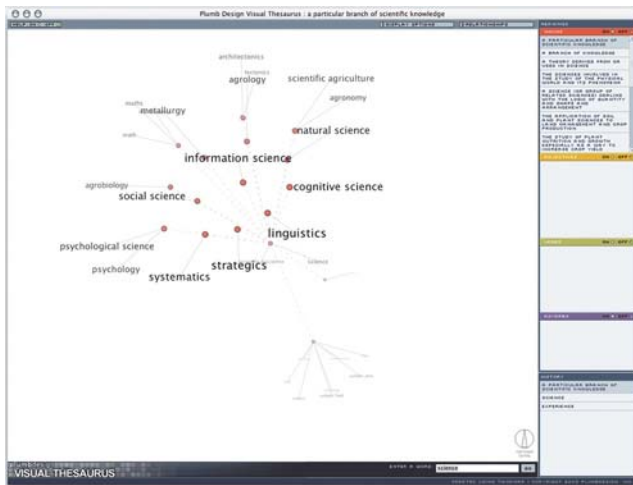
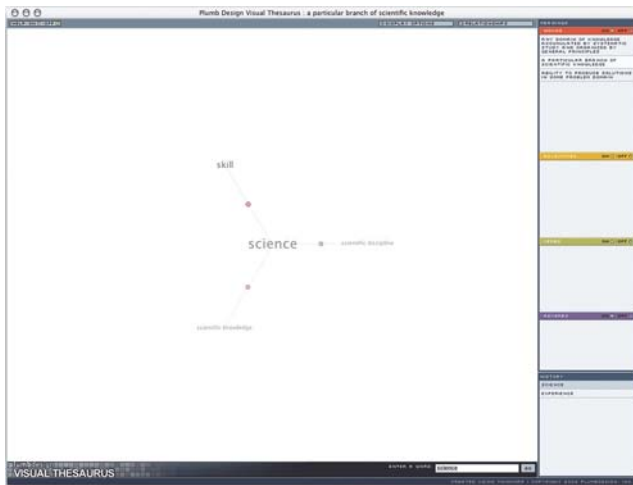
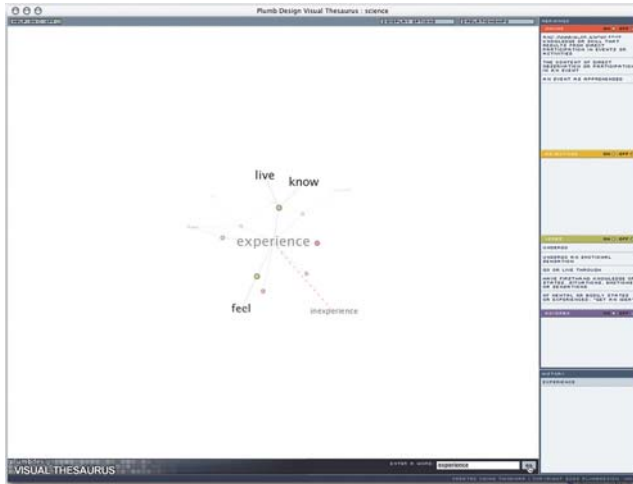

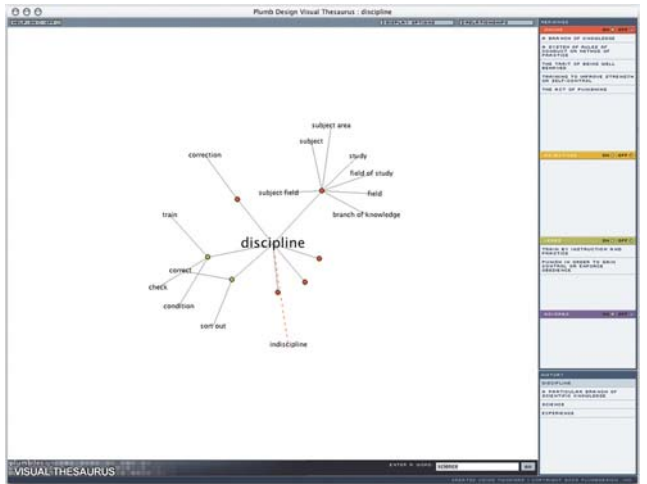
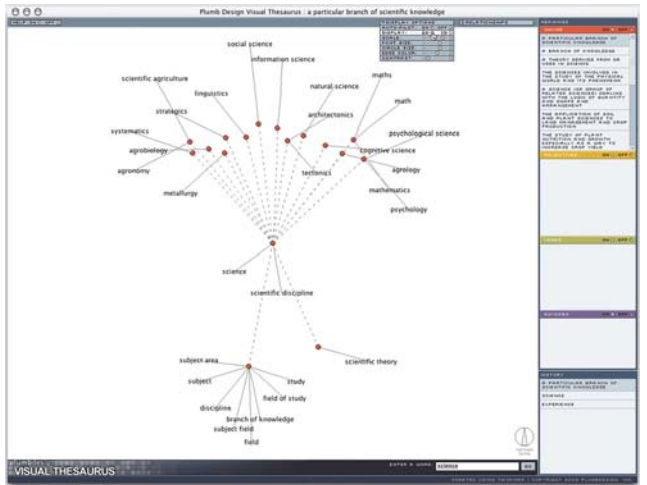
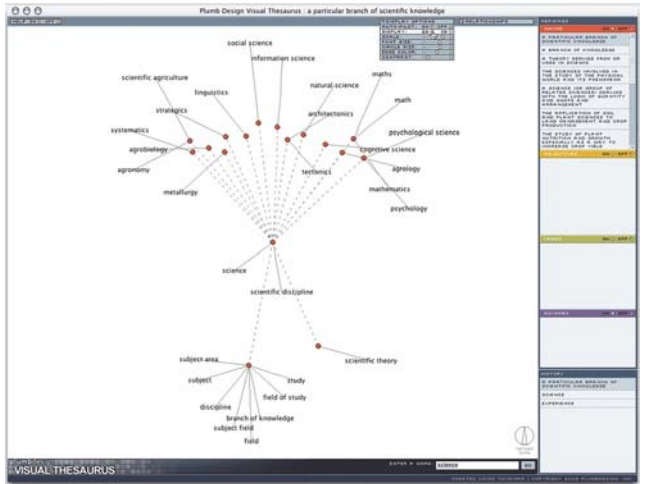

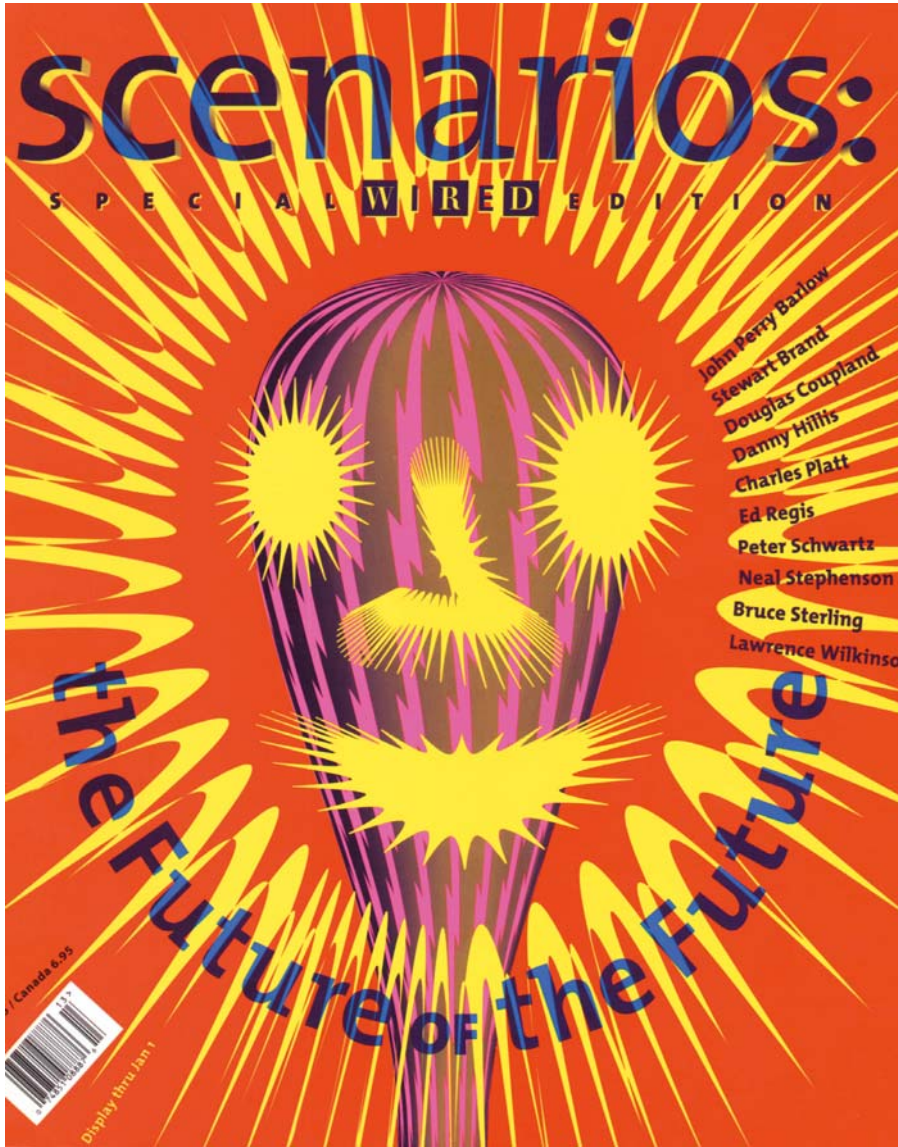

COVER OF SCENARIOS, special edition of *Wired*, (1996)

The Scenario Technique

The concept of scenario was derived from the Greek term “scene,” which designates the smallest unit of a play (drama, film, or opera). Today, it can mean a draft (of a film, for example), or, in the field of project and product planning, the hypothetical sequence of events constructed to take into account causal connections. In product development such scenarios are implemented as important methods in two different areas.

Scenarios as Prognostic Instruments

In the 1960s Hermann Kahn, an American performing research on developments of the future, invented a procedure for depicting possible future developments in the sciences, in politics, and in society as a whole, to facilitate the derivation of alternative action plans. This approach armed users with the tools necessary to assess extreme possibilities in the given spheres of action (from the best case to the worst). Kahn himself introduced these methods in a number of books (Kahn 1977, 1980), but many of his prognoses appear rather improbable.

The method of scenarios was also adopted by a number of other authors and has proven its worth as a relevant instrument. Alvin Toffler applied it in three important works (Toffler 1970, 1980, 1990), whereby his supposedly sensational prognoses apparently also opened the floodgates for the speculative works that followed.

Subsequent publications based on this approach were even less scientifically grounded than Kahn’s. Increasingly, authors dedicated themselves to known trends, which they propagated as a kind of scenario. Particularly successful in this endeavor was John Naisbitt (1984, 1995, 1999). A scenario portrayal oriented toward product development was published by the Japanese scientist Michio Kaku (1998); it is especially concerned with future generations of computers, biotechnology, and medical technology.

The scenario technique has become established in design practice and has consistently proven its worth as a reliable instrument. Under the direction of Eckard P. Minx (Minx 2001), DaimlerChrysler AG, for instance, retains an interdisciplinary study group divided between Berlin, Cape Town, Palo Alto, and Tokyo. The participating scholars are trained as both disciplinary specialists and interdisciplinary team

partners. For DaimlerChrysler and other clients they pursue questions like the following:

- How will people live in the future?
- Which products will be needed for the future way of life?
- How and where will these be produced?
- How will the sale of these products be changed (by new technologies)?

The consistent scenarios developed by the study group provide a base line that organizations or companies can use to plan feasible action alternatives. Among the works documenting how much these alternatives differ from the speculative prognoses mentioned above are two scenarios on the topic of *City, Mobility and Communication in the Year 2020* (Minx et al. 1994).

In the 1990s the Philips Corporate Design Center in Eindhoven (directed by Stefano Marzano) (see p. 395) and the Domus Academy in Milan conducted a broad-based study on the future of digital media, which vividly formulated scenarios and visualized them using design concepts (Manzini and Susani 1995). The study was important for the company's internal dialog regarding questions of future product development, but even more so for the competition, as it clearly signaled Philips' ambition to lead the avant-garde of the industry through design.

Scenarios in Software Development

Scenarios are applied in a similar manner in the field of software development, primarily in the design of interaction and interfaces. Here they are used to save time (and thus costs) in the design, development, and programming of new applications, where hardly any feedback is received as to their potential acceptance by users. Scenarios for software development include short operating procedures, simulated with prototypes of a new hardware or software product. These allow relatively fast and economical empirical testing of user acceptance, comprehensibility of operating routines, and even the aesthetic characteristics of user interfaces.

Virtual prototypes for hardware simulation were introduced at the beginning of the 1990s (Bürdek and Schupbach 1992) and have proven to be a useful tool. By means of what are known as "author systems," they generate interactive visual renderings of products, which can be operated by the potential users (VDI 4500).

Mood Charts

Working with visualization methods is gradually becoming a necessity in product development and design. Verbal descriptions of objectives, concepts, and solutions are no longer sufficient, especially for designs developed for the global market. The semantic differences between concepts result in misunderstandings, even among designers, technicians, and marketing directors collaborating in the same development team. Obviously, the problem is even more complex and more misleading in national and global contexts.

In keeping with the view that context determines form, starting in the 1980s collage principles from the artistic sphere were applied to design. At the beginning of the twentieth century Georges Braque and Pablo Picasso began creating “*papiers collés*” – montages of pictorial elements and texts comprised of paper, fabrics, wood and other materials. Such montages were produced in the futurist, Dadaist, and surrealist schools; text montages were created in the field of literature, and the same creative principle was used in the music of the 1960s.

In design, such collages (charts) are produced in order to visualize and portray the life-worlds of users (their mood), the market fields in which companies are active, or entire product fields (contexts) (Küthe and Thun 1995). Detailed studies of the relevant life-worlds are completed and visual horizons developed based on them. The most consistent visual horizon that can be achieved then serves as the context for the work of design. A visual horizon can also be used to test design variants in a later phase. Its coherence with given product environments therefore does not have to be described laboriously in words, but can be checked by comparing images. Here the limits of this method become clear, however: while it facilitates communication about the objectives and results of a design, it neither encourages innovation nor generates new product-cultural models. Technological innovations often have far-reaching effects on our modes of behavior (take the example of cell phones), and the development of new models is a highly complex socio-psychological process that cannot be portrayed on the level of pictures alone. Nevertheless, there is no dispute about the application of mood charts in product development, as they have proven quite useful for internal communication between the various disciplines involved in developing a product.

Empirical Methods

At the close of the 1980s (as postmodernism began to decline), it became clear that the practice of design could not rely on creative or clever designs. One consequence of the increasing costs of product development (for instance, today it is not possible to launch a completely new automobile model for less than one billion euros) is that companies wanted (and had) to be certain long before launching new products that these would find acceptance among potential customers. The processes developed for this purpose are finding increasing application for both products (hardware) and software (interfaces).

Target Group Determination through Milieus

No methodological expense is spared to determine the potential user groups of new products. Traditional socio-demographic characteristics (age, education, gender, income, and place of residence) have become largely irrelevant, so now the point is to determine and categorize the habits of the target groups (which indeed run along different lines than classical characteristics). In his work of cultural sociology, *Erlebniswelten* (Worlds of Experience), Gerhard Schulze (1992) combined such life-worlds into what he called "milieus."

Sinus Sociovision has performed broad-based social science research on our contemporary life-world since the early 1980s. Since then the *Sinus Milieus* have been published at regular intervals, presenting not only the fundamental value orientations of our society, but also our attitudes toward work, family, leisure time, money, and consumption. These more general observations are bolstered by qualitative assertions, making reliable data available to users in product development, marketing, and design as to which values are shared by the respective milieus (i.e., the potential target groups for new products). Of particular interest here are the qualitative changes over the course of time. Milieu research has become increasingly international in recent years: today milieu data are available for numerous countries in Europe, but also for the United States (since 1997) and Russia (since 1999).

Design, especially product design, plays a special role in this development. The centrality of design itself is becoming increasingly important for the strategic orientation of corporations. Design not only creates clear and unmistakable guidelines for the entire "aesthetic

output" of a company – brand design, product design and all of the multifarious tasks involved in constructing a corporate identity and image; it also provides a basis for the strategic orientation of the company as a whole.

Example:

*Let us look at the "residence typology" of the Gruner & Jahr publishing house, depicted in *Leben und Wohnen 5*. This study takes stock of the housing conditions of all individuals from the ages of 18 to 64 in Germany (around 48 million people) living in private households. It indicates housing conditions and attitudes toward the home, the kitchen, and lifestyle as well as matters of taste in the residential sphere.*

This residence typology was investigated in combination with Sinus's milieu structure. The figure shows that typologies specific to consumers and milieus alone are not sufficient to achieve meaningful strategic segmentation for the suppliers of interior products. For instance, the target group Gruner & Jahr's typology calls "demanding" transverses the upper Sinus milieus. Not until this group is split up into different lifestyles (illustrated here through three examples) does a clearly recognizable strategic orientation emerge that offers concrete approaches for suppliers in this sphere.

Source: hm+p Herrmann, Moeller + Partner, Frankfurt am Main

Product Clinics

The objective of this method is to present new products to a series of test subjects (potential buyers) and to question them from various perspectives. This can be done using sketches or renderings, preliminary or final models, computer-simulated models, or even prototypes. The questions asked must be designed scientifically so that the results can be verified and compared. Product clinics can produce reliable results using even relatively small random samples (of five to eight subjects), as long as they are carefully pre-selected. The financial benefits of such an economical method are obvious.

Different batteries of questions can be developed for specific clinics to provide the information required at the given development stage of the project. Such questions may concern the market prospects of a product, what distinguishes it from competing products,

Design empiricism and everyday life: In design to date there has been far too little systematic and, above all, qualitative research on the effects it evokes in the different areas of society, and on the consequences it has on the everyday life of women and men. In other words: This concerns using design and dealing with it empirically. Overall, there is a yawning gap here, especially as regards research on the potential differences in the way men and women use and interpret the practical value of things.

— UTA BRANDES, 1998

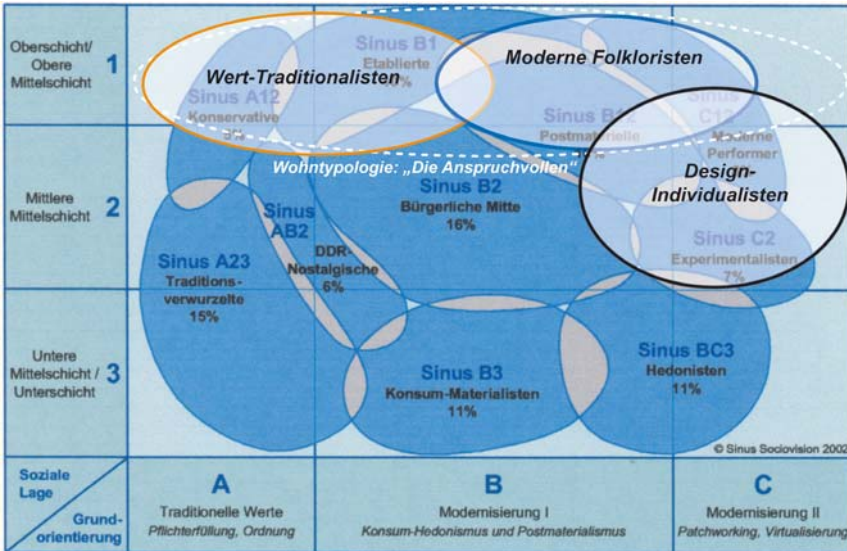

SINUS MILIEUS with three segment areas selected, Sinus 2002, hm+p, Gruner & Jahr "Wohnen+Leben5"
 (Figure: hm+p Hermann, Moeller + Partner, Corporate Consulting)

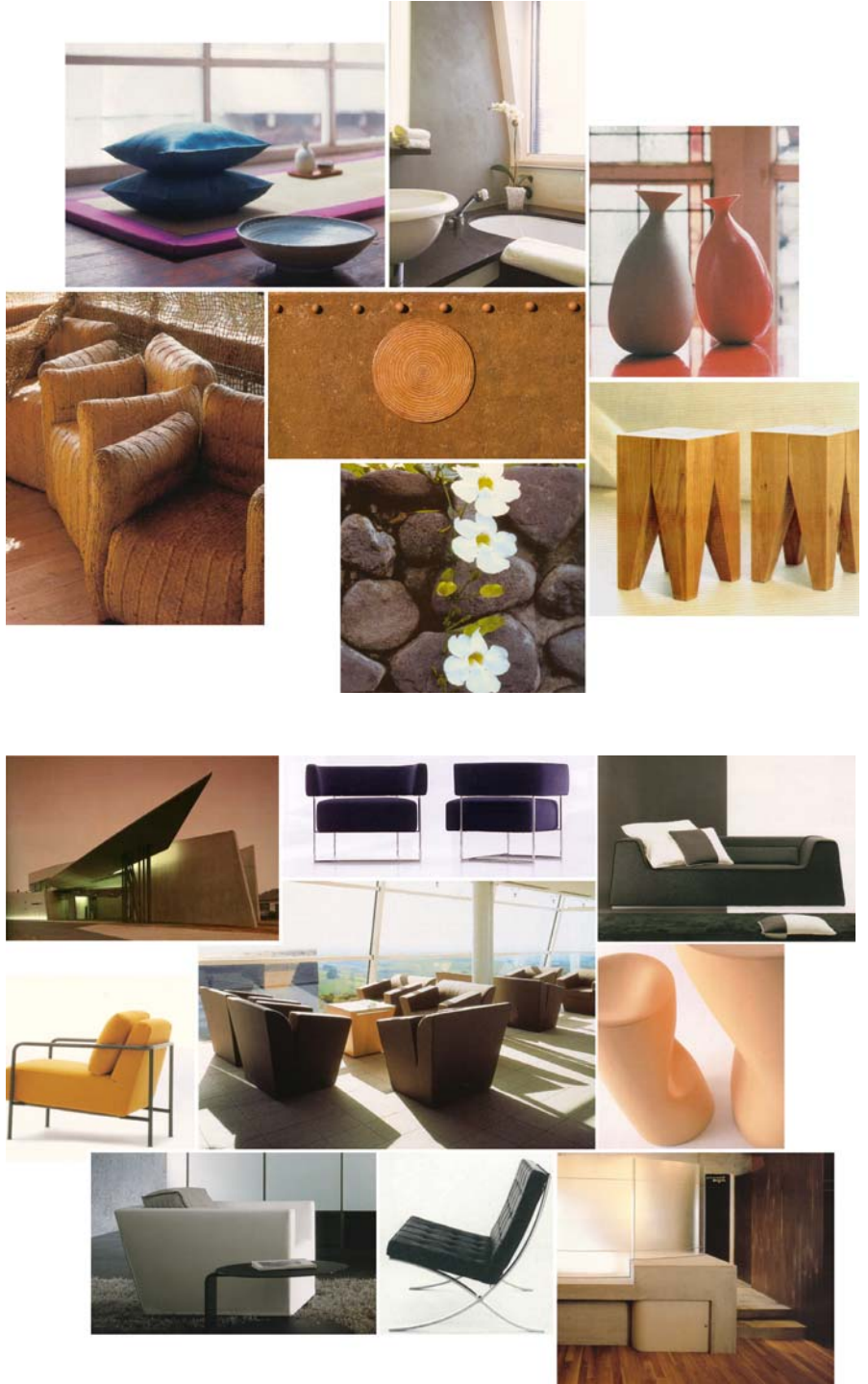

"STYLE WORLDS" COLLAGES
value traditionalists (left)
modern folklorists (above)
design individualists (right)

(Figures: hm+p Hermann, Moeller + Partner,
Corporate Consulting)

**NON-INTENTIONAL DESIGN**

CLOTHESPIN as a package fastener

PLASTIC BAG as waterproof seat protector

CHAIR as hanger/coat rack

BALANCER/STABILIZER for wobbly table legs

(Photos: Uta Brandes)

and how well it fits into the subject's sphere of life. Indirect associations evoked by a design, expected image transfers, and any analogies to other products that occur to the subject are all integrated into the evaluation of a design. Subjective reactions, impressions of material and surface qualities, smells, and other impressions rendered by test subjects are of great importance for the further development of the product (Heß 1997).

An important element of product clinics, especially for design, is that the designs must be judged in their respective (future) contexts. These should be generated as a part of the design process in order to obtain adequate statements from the test subjects.

Usability

Another set of comprehensive test procedures developed to test software concepts before their market launch is subsumed under the concept of usability. Here, too, even with relatively small groups of test subjects, fast and reliable findings can be obtained about the reactions to the interfaces through which users interact with and navigate through software, about the understandability of the specific solutions, and about the software's potential for intuitive operation (look and feel). The ISO standard 9241-11 sets the benchmark for the most important aspects of usability on an international level.

Recently, two new topics that escape strictly scientific evaluation methods have taken on new importance. First is the issue of the usefulness of applications, that is, how much learning and training are needed to use the software, and how high the effective benefit of its use is in comparison. The second addresses the "joy of use," the emotional side of interface design: today software also has to be fun.

Recourse to empirical methods has increased the relevance and promise of design for industrial applications. Decisions about new concepts no longer come from "gut feelings," but can be grounded in the natural and human sciences. As a consequence, today design can hold its own against other scientific disciplines.

NID Non-Intentional Design

The Cologne-based design professor Uta Brandes (1999, 2000) pursues a completely different kind of empiricism, investigating the question of how products are actually used after they have been

purchased. She has established that things do not actually receive their real meaning until they are used. Just as stones were used in prehistoric times to make fire, and also as cutting implements and spearheads, today private possessions spill over into the office: potted plants decorate window sills, and products themselves (like the computer) serve as bulletin boards and storage space (Brandes 2001). Discarded objects take on new meanings in new contexts, and in many cases it is no longer clear what they were originally designed to do. The unintentional supplants the intention.

DESIGN AND THEORY

Parallel to the development of design methodology, various attempts were made to develop and formulate a theory of design with binding force for the discipline. While design methodology always had the declared goal of explaining the process of design itself and providing the necessary tools to optimize that process, the objective of design theory is more vague. Certainly one important task would be to use hypotheses or experiences to obtain the knowledge on which to base the discipline's general framework – knowledge that would address the questions of what design can do, what it should do, and what it wants to do.

Due to the multiplicity of interactions involved in design, creating a theory of design with aesthetics at its core would certainly not have been sufficient. Methodologists focused instead on technological, socio-economic, ecological, and even political categories as they attempted to ground the discipline and provide it with academic legitimacy.

The first German attempt to take stock of design theory was undertaken at a congress of the Internationales Design-Zentrum (International Design Center), the IDZ-Forum, in Berlin. At the congress, Gerda Müller-Krauspe (1978) gave an account of the four trends in design theory she was able to discern:

- efforts to make the design process transparent and to arrive at operable design methods (design methodology),
- a focus on mastering the quantification of visual phenomena (information aesthetics),
- critical design theory (politically and economically based), as well as
- discussions about functionalism, which ultimately yielded the approach of expanded functionalism.

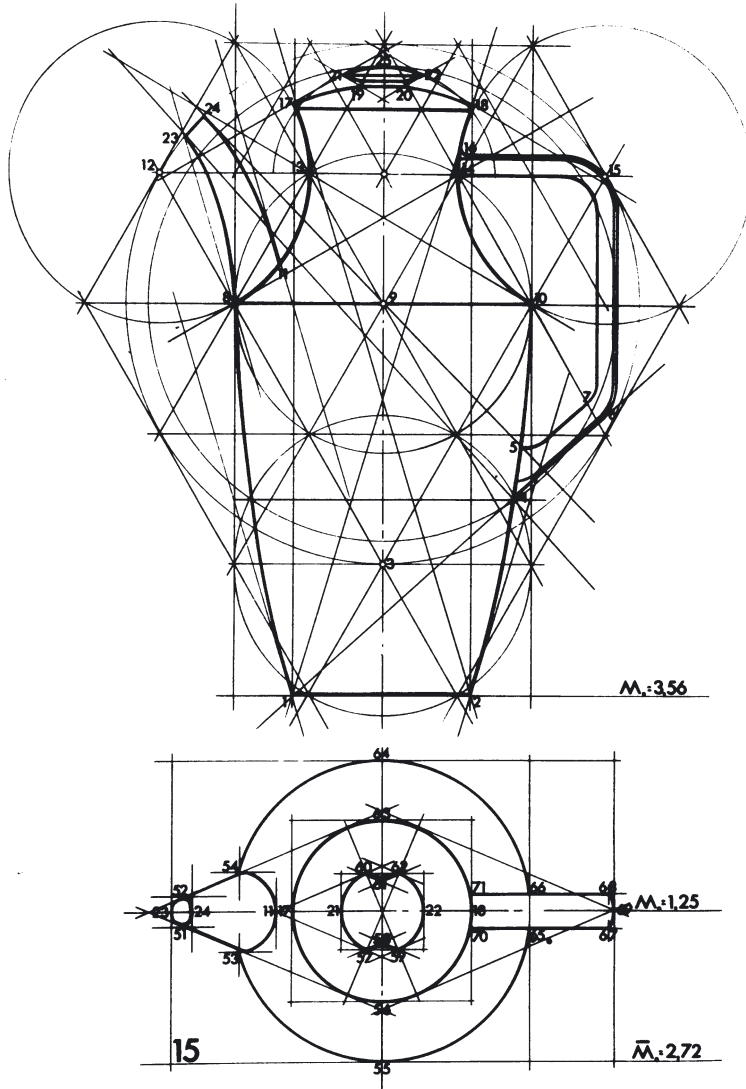

CALCULATIONS of the aesthetic dimensions of a coffee pot, Rolf Garnich (1968)

THE INFORMATION AESTHETICS APPROACH

At the Ulm School of Design, ideas from information theory were applied to design practice. The works of Max Bense and Abraham A. Moles (1965) exerted a particular fascination, as they appeared to show possibilities for making aesthetics measurable.

Rolf Garnich (1968) subtitled his dissertation published during this period "A General Mathematical Method for the Objective Description of Aesthetic Conditions in the Analytical Process and for Generative Design in the Synthetic Process of Design Objects." Today, this work's attempt to pin down the aesthetic dimension of coffee pots seems rather exotic.

In architecture, too, the information theory approach enjoyed great resonance. Looking at aesthetic problems from this perspective was the object of a far-reaching work by Manfred Kiemle (1967). It remained up to Siegfried Maser (1970) from the Bense School in Stuttgart to publish what was probably the conclusive work on this topic, *Numerische Ästhetik* (Numerical Aesthetics).

Nevertheless it took a long time for methodologists to dismiss the idea of applying information theory to design. The idea that aesthetic matters could be judged with Cartesian rigor simply proved too seductive. A full ten years after this movement peaked, the former design college instructor Herbert Ohl, who had since been appointed Technical Director of the Rat für Formgebung (Council for Design) stated triumphantly that, "design has become measurable" (1977). By then, however, the critique of functionalism and the discussion about ecology had advanced to the point where such a statement could be regarded as little more than a relic from design's frivolous youth.

THE INFLUENCE OF CRITICAL THEORY

In the wake of the student movement and socially critical works, primarily from the Frankfurt School, design, too, came under attack at the end of the 1960s. As the profession was not yet firmly established, it was an easy target for pithy slogans: "There are professions which do more damage than that of the designer. But not very many. Actually, only one profession is even more questionable: that of the advertiser. Convincing people to buy

superfluous things with money they do not have, only to impress others, is probably the shabbiest way to make a living these days" (Papanek 1972).

Under the influence of the works of Theodor W. Adorno, Max Horkheimer, and Herbert Marcuse, designers, too, published works on the social function of their discipline. The diploma theses at the Ulm School of Design by Michael Klar in 1968 and by Thomas Kuby in 1969 can be regarded as the first works that originated in the context of a far-reaching critique of the aesthetics of commodities (Haug 1971).

A major event for design was the founding of the IDZ Berlin (Internationales Design-Zentrum), which opened with the publication of *design? Umwelt wird in Frage gestellt* (design? Questioning the Environment) (Berlin 1970). Containing over forty papers by various authors, this volume discussed the role of design in society as a whole and thus the context for its critique. Here Haug characterized design as follows: "In a capitalist environment, design takes on a function comparable to that of the Red Cross in times of war. It attends to a few – never the worst – wounds inflicted by capitalism. It works cosmetically in a few places and keeps up spirits, thus lengthening capitalism as the Red Cross lengthens war" (Haug 1970).

Thanks to positions like those advocated by Haug (1970, 1971, 1972, 1986), design eventually succumbed to paralysis. Design nihilism was the consequence, especially at the design schools, and has perpetuated the deep rift that remains between design theory and practice in the minds of many to this day (Bürdek 2002). This point of departure also precluded any emancipative approach. The only alternative remaining was the illusion that producing analyses of society would help the working class prepare for class struggle.

ON THE ROAD TO DISCIPLINARY DESIGN THEORY

Integrating discussions about design theory into the general social discourse, however, encouraged new approaches as well. These were initiated in particular at the Ulm Institute for Environmental Planning. Under the title *The Dialectics of Design*, Jochen Gros (1971) published a number of theses advocating a reorientation

away from the traditional principle of purity of form (functionalism) toward a principle of primacy of form (expanded functionalism). His integration of psychological aspects into the concept of design had a profound impact on the way design was regarded.

Nevertheless, the idea that design theory should acquire and advance the specific technical knowledge required for the discipline took shape only gradually. While the superstructure, that is, the conditions of society, must be investigated in an interdisciplinary manner, design theory must contribute something specific, perhaps a precise technical language with which to describe the knowledge of the discipline. Specialized disciplinary expertise is essential to interdisciplinary collaboration.

Siegfried Maser played an important role in this, creating for the first time the necessary prerequisites for scientific theory (1972, 1976). To illustrate his approach to science theory he coined the concepts of “knowers” and “doers.” Knowers of a field are those capable of putting together as much knowledge as possible to work toward a concrete solution to a problem. Thus, a knower must have as much knowledge as possible about as many areas as possible. The doer, on the other hand, is a specialist in the classic sense. He knows his own discipline (physics, chemistry, technology, marketing or design) as completely as possible and is consulted to solve actual problems during the development process.

This distinction can become essential in design practice. While the designer is the doer responsible for all creative, communicative aspects of products, he is a knower in questions of ergonomics, manufacturing, and calculation, areas in which there are numerous other specialists.

The doer–knower idea was developed further starting in the mid-1970s, especially at the Offenbach School of Design. In the 1980s several publications appeared on the subject (Fischer and Mikosch 1984; Gros 1983, 1987), which long remained isolated in the field of design, but nevertheless received a lively reception among those involved in product development (design, economics, ecology, technology), especially in the business sphere.

Nevertheless, designers and design institutions still like to – or at least claim to – regard themselves as “do-gooders,” and miss no opportunity to demonstrate this at international congresses like those of the ICSID (International Council of Society of Industrial

Everything that deals with design in a conscious, cognizant and reasoning manner is understood in the following ways to be design theory: Questions as to the essence and the cause of design; as to judging design; as to the validity of and ability to substantiate such judgements; as to the emergence of design; as to its history, present and future; as to the self-understanding of the designer as a craftsman, artist or scientist; as to the objectives and ideals of design; as to the connections with other fields of knowledge and activity; and much more.

— SIEGFRIED MASER, 1993

ICSID 2001 SEOUL INDUSTRIAL DESIGNERS' DECLARATION

Challenge

- *Industrial design will no longer be a term defining design for industry in the limited sense used hitherto.*
- *Industrial design will no longer solely direct its attention toward the method of industrial production.*
- *Industrial design will no longer regard the environment as a separate entity.*
- *Industrial design will no longer aspire only to material well-being.*

Mission

- *Industrial design shall seek for proactive communication between people and their artificial environment by prioritizing the question "why?" over that of reaching conclusive answers to the premature question "how?".*
- *Industrial design shall strive to arrange mutual, equal and holistic relationships between people; people and objects; people and nature; and the mind and body by searching for the place of harmony between subject and object.*
- *Industrial design shall encourage people to experience the depth and diversity of life by linking the visible and invisible.*
- *Industrial design shall be an open concept, answering the demands of both present and future societies flexibly.*

Renewed Calling

- *We, as ethical industrial designers, shall cultivate human autonomy and confer human dignity by providing the opportunities in which individuals can correlate to artifacts creatively.*
- *We, as global industrial designers, shall pursue the path of sustainable development by coordinating the different aspects influencing its attainment such as politics, economy, culture, technology and environment.*
- *We, as enlightened industrial designers, shall promote a life blessed by the rediscovery of the deeper values and meanings concealed in everyday existence, instead of provoking endless human desires.*
- *We, as humane industrial designers, shall contribute to the coexistence of cultures by promoting dialogue between them, while respecting their diversity.*
- *And, most of all, as responsible industrial designers, we must be aware that making today's design decision is an act that will influence the course of tomorrow.*

Designers). Looking more closely at the practice often reveals yawning gaps between claims and reality, however: in the great majority of cases, designers work only on objects – and not on the whole world.

As the concept of core competency became accepted in the management schools of the 1990s (Prahalad and Hamel 1992; Boos and Jarmai 1994), design theory, too, hesitantly sought a new orientation. The hymn of interdisciplinary, transdisciplinary, and multidisciplinary design was still sung with enthusiasm, but increasingly it became accepted that its words were little more than rhetoric. For instance, the English definition of the prefix “inter-” is “between or among; mutually or together.” This “between” is thus a space, emptiness, something that definitely should not be determined by design: “The point is rather to bring specific qualifications into such projects – in this case, emphasizing the procedural alone is truly not sufficient” (Bürdek 1997b).

In the second half of the 1990s a broad discourse began debating whether design had become established enough as a discipline to permit doctoral students to write dissertations on topics in the field of design. A discussion ensued about the “scholarliness” of design.

At international conferences scholars of design took stock of the state of the art, while at the same time encouraging the areas of research and development to create global networks. Voluminous proceedings reflected a quite representative picture of current design theory and research. Specifically, these included:

- *Doctoral Education in Design*, Ohio State University, Columbus, Ohio, 1998
- *Design plus Research*, Politecnico di Milano, Italy, 2000
- *Doctoral Education in Design: foundations for the future*. La Clusaz, France, 2000
- *International Symposium on Design Science*. Fifth Asian Design Conference, Seoul, Korea, 2001
- *Integration of Knowledge, Kansei and Industrial Power*. Sixth Asian Design Conference and *Third Doctoral Education in Design*, Tsukuba, Japan 2003

In Seoul, the English design methodologist Nigel Cross drew an interesting conclusion that aptly characterizes the development of

design. He claimed that, in hindsight, paradigmatic changes can be detected in forty-year cycles:

- In the 1920s scientific findings were integrated into design training for the first time (Bauhaus).
- The 1960s were the heyday of design methodology (England, Ulm School of Design, United States), and were also designated as the era of scientific design.
- In the 2000s the emphasis has been on enhancing design's profile as an independent discipline (Cross 2001).

Cross's speech was the culmination of an international debate, not least about design's standing in academia as compared with other (scientific) disciplines. It was thought that attaining the same status as other disciplines would liberate design from the taint of charlatanism and ensure its acceptance by the scientific community. The only way it can establish itself there is to become a self-reliant discipline that develops independent knowledge and is capable of communicating with other disciplines. The requisite body of knowledge is just starting to emerge: "Design as a discipline, rather than design as a science. This discipline seeks to develop domain-independent approaches to theory and research in design. The underlying axiom of this discipline is that there are forms of knowledge peculiar to the awareness and ability of a designer, independent of the different professional domains of design practice" (Cross 2001).

In future it will become increasingly important to develop and communicate design knowledge both vertically (within the discipline) and horizontally (between disciplines). At the first Doctoral Design Conference in Columbus, Ohio in 1998, Alain Findeli (University of Montreal, Canada) pointed out that design knowledge is already being transferred to other disciplines such as engineering sciences, marketing, communication sciences, and education. The next logical step is then to lay down precisely what constitutes design knowledge.

ASPECTS OF A DISCIPLINARY DESIGN THEORY

The discourse about the need to develop design theory puts forward various views about how this theory should be constructed: as an

interdisciplinary, a multidisciplinary, or even as a transdisciplinary theory. Rarely does anyone mention that a design theory could also be disciplinary. Perhaps the apologists of design theory have so little faith in their own contributions that they must always lean on other disciplines. Moreover, interdisciplinarity (i.e., collaboration between various disciplines) is all the rage these days, not least because of the increasing complexity of problem-solving in which design plays a role.

Design has always had a hard time developing a specific basis from which to reach out to other disciplines. There is no conceivable reason for this, as the much lauded interdisciplinarity cannot come into its own unless individual disciplines work together. Thus, an interesting statement by Lutz Göbel (1992) is relevant for design as well. He indicated that companies increasingly need neither specialists (people who know a lot about a little), nor generalists (people who know a little about a lot) but rather integralists (people who have a good overview of various disciplines with deeper knowledge in at least one area). These people must be especially capable of thinking about and acting on issues in their entirety.

As doctoral design programs were developed and design became increasingly established in the upper echelons of private industry (keyword: design management), it became necessary to identify expertise in the field and to provide for a massive increase in personnel. Carnegie Mellon University succeeded in putting through an initiative to orient its doctoral program so that the graduates carried the title of “stewards of the disciplines” (see next page) (Golde and Walker 2001).

All of this appears to be fairly new for design, although in the early 1970s, for instance, at the Offenbach School of Design, work with the concept of “sensual functions” was to launch a disciplinary discourse on design (Gros 1976). The double coding of the word “sensual,” meaning “perceptible (by the senses)” and, at the same time, “sensuous” (thus similar to the Kantian concept of the “unity of reason”) was, however, either not understood correctly or even deliberately misunderstood. It was too tempting to follow the direct path from “sensuality” to sensual-erotic design, which certainly had its charm after the long predominant rigidity of morose German functionalism, but the mere fact that these concepts cannot be readily translated into all other languages condemned it to failure.

Today the critique of design is thus located on a level that is actually quite intellectual on occasion, but this is not at all true for design theory itself, the theoretical foundation of design, which is often supplied in passing by the critics. So far the design theory that has originated from people professionally active in design is, soberly appraised according to conventional scientific criteria, quite often mere scrap.

— HÖLGER VAN DEN BOOM,
1994

“Steward of a discipline”

We believe that the purpose of Ph.D. training should be the creation of “stewards of the discipline.” The degree should signal a high level of accomplishment in three facets of the discipline: Generation, Conservation and Transformation. The Ph.D. holder should be capable of generating new knowledge and defending knowledge claims against challenges and criticism; of conserving the most important ideas and findings that are a legacy of past and current work; and of transforming knowledge that has been generated and conserved into powerful pedagogies of engagement, understanding and application. Moreover, stewards should understand how the discipline fits into the intellectual landscape, have a respectful understanding of the questions and paradigms of other disciplines, and understand how their discipline can speak to important questions.

The formulation of stewardship is discipline-specific. What it means to be a steward of chemistry may in some measure be different than in English or mathematics. Similarly, the process for creating stewards may differ by discipline. We are committed to locating this initiative in the context of each discipline, recognizing that there will be discipline-specific lessons as well as cross-disciplinary insights to be gained.

Therefore at the beginning of the 1980s the concept of sensual functions was replaced by that of product language. The new reflection on semiotics which took place at this time – perhaps inspired by Charles Jencks’s *The Language of Postmodern Architecture* (1977) – constituted an interesting parallel.

The above shows clearly that, on the one hand, a scientific design theory must be founded in the humanities. On the other hand, the disciplinary nature of such a theory must be emphasized. Design, too, must define its specific competence, its own body of knowledge – and thus its own theory.

Responding to the question of how a science is actually characterized, Siegfried Maser (1972) listed three important categories: goal, object, and method. Although in the past design had not claimed to be a science in and of itself, these categories are certainly quite suitable as guides in sketching a disciplinary design theory.

The Goal

is to develop a technical language; that is, concepts and propositions are to be formulated so that they have general validity for the entire discipline.

The Object

is what is special to a discipline. In design this means questions of form and context or form and meaning, which can be described by the concept of communicative function.

The Method

is located in the sphere of the humanities, as neither the methods of natural science nor those of other formal sciences allow the essence of communication to be described in terms specific to design.

Language – or communicative action – was once designated by Jürgen Habermas (1985) as the “key to constructing theory,” which better allowed us to deal with the capricious structures of the life-world. Reality is imparted and explained through language, and this also holds true for design. A further analogy is significant here: language is not uniform; there are different languages and within them more dialects and figures of speech exist. Language is a many-layered entity that can describe complicated and complex facts. At the same time, each language has rules of usage. Moreover, over the course of its development, each language becomes increasingly differentiated, providing even more possibilities to describe phenomena and thus contributing to their distinction. This is just as true for the language of products. Communication develops through a continuous process of exchange, which is based in turn on perpetually new “agreements” (conventions). The products do not speak in and of themselves, but they come to speak through language.

The following several examples will illustrate how this disciplinary approach to design theory has proven to be valid globally – and particularly successful, even in practice.

Not only the language of words has something to tell us; things also talk to those who know how to use their senses. The world is full of figures, full of facial expressions, full of faces; from every direction signals are issued to our senses from shapes, colors, atmospheres.

— PETER SLOTERDIJK, 1983

THE INFORMATION FUNCTION OF THE PRODUCT

Wilhelm Vershofen’s statement (1939) that products have both basic and supplementary uses set the general course for the science of



ART COLLECTOR'S ROOM in Milan
design: Masanori Umeda

business administration from a very early date. This orientation also proved sound for design. The industrial engineer Theodor Ellinger (1966) proceeded in this direction to develop the concept of product information, which was defined as a product's ability to communicate information about itself actively in the market: "The product can possess a multi-layered, perhaps even symbolic language, which is far more comprehensive than normal verbal language." To describe this, Ellinger also introduces the concept of product language, which he describes as follows: "Product language includes very heterogeneous forms of expression such as dimension, form, structure of the physical surface, movement, quality of material, means of fulfilling function, colors, and the graphic design of the surface, sounds and tones, taste, smell, temperature, packaging, and resistance to external influences. All of this information has a strong effect – positive or negative – on the potential buyer."

This was indeed quite a broad description, when one considers that aspects such as sound design (Langenmaier 1993), the olfactory characteristics of products, or even "haptic design" (Strassmann 2003) have become serious topics only in recent years. The automobile industry, in particular, invests significant sums to research and develop these areas, as they represent important characteristics for the branding of the company. The door of a Daimler-Chrysler vehicle must close quite differently than one from BMW, and even the motors must be clearly distinct from each other. As a result, "semantic added value" is granted the utmost attention, especially in the automotive industry. Thus, DaimlerChrysler has opened a research center in Berlin that concerns itself exclusively with the emotional sensations of the vehicle's occupants: their sensory perception while clicking switches, the textures of the materials used in the interior, the influence of telematic (location) systems – the emotional worlds of the users are investigated empirically (HTR 2003), and the findings obtained from this study flow into the next new model.

In general, Ellinger's thoughts appear quite up-to-date, for instance on the triangular relationship between the poles of manufacturer, product sold, and potential buyer, or the differentiation of product information into existential, origination, and quality information, because they do in fact describe much of what is dealt with in today's debates about branding. Collectively, these debates are about corporate identity, which is also generated and imparted through design.

DESIGN AS AN EVERYDAY LANGUAGE

The German design historian Gert Selle stated in 1973 that design had become an everyday language. Here his comments proceeded explicitly from Ellinger's considerations: "One can speak of a product language to the extent that the design objects are not only carriers of function, but always carriers of information as well." Here Selle was referring, in particular, to the societal function that increasingly falls to products. Signals are emitted through products, signals about the users (e.g., their status), and also about the producers of these objects. He regarded product-language codification as an important future task of design and advocated that it be researched scientifically: "For language is a means of interpreting reality, and product language provides the consumer opportunities to identify with the product and its linguistically proposed level of reality, which often appears irrational and dreamlike." However, for Selle, it is also quite apparent that such a product language approach is not affirmative, but to be pursued critically; the point is to reveal the knowledge interests located behind the "design of certain product languages" and to communicate them, too. In this light, he subsumed design under the phenomenon of mass communication, which was quite a farsighted position at the time.

THE MEANING OF THINGS

In the 1970s two economists in the United States performed empirical studies about the home, analyzing the relations between residents and their objects in particular. This study (Csikszentmihalyi and Rochberg-Halton 1989) was practically ignored in the field of design, although its authors picked up not only on the studies of the psychosocial meanings of things performed by the French anthropologists (Claude Lévi-Strauss) and structuralists (Roland Barthes), but also by semiotics and social ecology. In contrast to socialization (the process of an individual taking his or her place in society), they coined the concept of "cultivation," which designates the process of a person confronting things (products) and appropriating them: "The self is enriched and expanded through the symbolic acceptance of material reality, indeed, it has no identity at all until this happens. The subsequent feedback of the external signs is imperative both for

the development of the self and for the constitution of society” (Lang 1989).

Csikszentmihalyi and Rochberg-Halton designate things as units of information that are perceived and represented in a person’s consciousness. From the semiotic perspective, these are signs, whose triadic relation has already been discussed in greater detail. They also state that the objects surrounding us are not merely tools, but in fact constitute the frame of reference for our experiences, thus making an essential contribution to the way we structure ourselves. The communication science concept of “connectivity” is also suitable in this context: experiences (conventions) also shape the way we deal with products. The helplessness that often befalls us at ticket machines for public transport systems in strange cities, for instance, has to do with lack of experience, which makes us even more confused. It is hardly necessary to emphasize again that cultural differences are relevant in such cases. The field of “cultural studies” attempts to compensate for these very deficits, but has yet to be extended effectively to design.

With reference to the home, it is apparent that the things with which people surround themselves may at least potentially reflect their inner lives. The home becomes the mirror of the personality. In the 1980s, at the latest, the home became a status symbol, replacing the automobile for large sectors of the population. The interior takes on the role of contributing to the stabilization of the social order through hierarchical differentiation. Furniture designs illustrate this vividly: be it IKEA, Bauhaus classics, Italian bel design, new German design, or the avantgarde of the present, objects are loaded with so much semantic baggage that for the most part their only remaining function is to serve as orientation aids in the context of the larger society.

What is overlooked here is that functions are nothing more than linguistic distinctions made by an observer. Functions do not lie hidden in products, but in language. By this means the defining character of design – it is this way because I make it so – is confirmed.

— GUI BONSIPEPE, 1991

THE MUNICH SCHOOL OF EUGEN LEITHERER

While teaching at the University of Munich, Eugen Leitherer investigated industrial design as a scientific object (1991). Methodologically speaking, he performed this study on the level of sensory perception. On the definition of design he writes, “Industrial design thus shapes particularly perceptible qualities of products which can be subjected to evaluation,” an observation that is certainly specific

and perhaps even disciplinary, but also draws attention to critical issues: "Giving form to industrial products as designers do – that is, concretely determining their groups of qualities and especially their external appearance, their aesthetic-cultural quality – is an extremely risky matter."

In order to specify what is disciplinary in design, Leitherer refers to the developments of linguistic philosophy (Ferdinand de Saussure, Karl Bühler, and others) and utilizes the concept of product language in the classic semiotic sense:

- on the syntactic level, as the language of the signals or their relations among each other,
- on the semantic level, as the meaning of the signs for their recipients, and
- on the pragmatic level, as the language of the sign users and their intentions.

"Design's task is to group these elements such that they 'express,' impart messages, or more precisely: 'talk'." Leitherer attempted to produce at least an initial sketch of the basics for a "linguistic work of product language" that built on the foundations of Gestalt theory.

Also worth mentioning here are the dissertations of his students H. J. Escherle (1986), and especially Sybille Kicherer (1987), who commented extensively on the product language approach, but also presented important arguments about how product design could become effective in the company strategies of corporate design or design management. She described the communication between product, user, and company as the disciplinary core of design.

THE COLOGNE SCHOOL OF UDO KOPPELMANN

An eminent economics professor at the University of Cologne, Udo Koppelman has been concerned with the interactions between design and business management since the 1970s. He links back up with Vershofen's concepts of the basic and supplementary uses of products and derives from those concepts the more up-to-date distinction between "services in kind" and "expected services" (Koppelman 1978).

In a fundamental discourse, Koppelman's approaches were compared with the product language approach in terms of

terminology, semantics, and content (Bürdek and Gros, 1978). Here the parallels are quite clear between services in kind and expected services on the one hand, and between practical and semiotic (product language) functions on the other. Koppelman focused his remarks especially on what were known as the “means of design,” which he differentiated into elementary means like fabrics, materials, shapes, colors, and signs, and complex means like principles of function and construction, historical principles of problem solving, and product parts. Building on this theoretical foundation, a series of dissertations originated in the “Koppelman School” over a period of around twenty years, all of which concerned issues of design and thus must be counted as part of the disciplinary body of knowledge of design. Worth mentioning here are the works by Volkhard Dörner (1976), A. Friedrich-Liebenberg (1976), Heinz Schmitz-Maibauer (1976), Holger Hase (1989), and Jana-Maria Lehnhardt (1996), as well as Patrick Reinmöller’s work *Product Language: The Comprehensibility of Dealing with Products through Product Design* (1995). At the time this was probably the most painstaking contribution to the construction of a disciplinary theory in design. Structured in no less than 1492 remarks, Reinmöller mapped the terrain of product language in nearly perfect form; however, the actual progression of knowledge ultimately received short shrift.

PRODUCTS AS MESSAGES

The Austrian psychologist Helene Karmasin published a far-reaching work on the topic of *Products as Messages* (1993), linking aspects of psychology (cognitive and linguistic), sociology, cultural studies, and communication sciences (semiotics) to develop a quite remarkable and highly original work. Her central thesis is the statement that what makes products and services “interesting and distinguishable on the market, ‘unique,’ is actually their meaning, their ‘semantic added value’.” For Karmasin, this meaning is imparted by signs and sign systems. From this she derived the prognosis that the success of new products would lie increasingly in the area of “sign management.” The scientific theory upon which this is based can be found in semiotics.

Communication can be performed with products, and the combination of various single products results in a communication mix that can be regarded as a construct of meaning (connotation), and which can be understood (denoted) by different social groups. This describes precisely the current approach in design, aside from its omission of the important principle of connectivity.

In a further paper Karmasin (1998) made clear which methods can be used to describe cultures adequately, referring back to the cultural theory developed by Mary Douglas (1973, 1992). Here it becomes clear that products should be seen not only in terms of satisfying needs and maximizing individual utility, but predominantly as means of communication. In other words, she draws another analogy to the communicative function of design. Karmasin describes a number of cultures – the hierarchical, the individual, the egalitarian, and the fatalistic – and derives from them different design concepts (for a detailed description of her methodology, see Karmasin 1997).

THREE SCANDINAVIAN CONTRIBUTIONS

Carl Eric Linn, a Swedish corporate consultant who worked both in product development and in marketing, published an extremely illuminating book (1992), which unfortunately was scarcely reviewed in the field of design. Linn proceeded from the assumption that products possess both material and non-material characteristics. He used the concept of the metaproduct to cover the entire range of non-material aspects like image, reputation, market niche, product positioning, and the distinctions between products, using a fitting metaphor: "The product in your hand is never the same as the product in your imagination." Also interesting in this case is that he shows how such factors as experiencing a product positively can annul the conventional price-demand relation. In other words: when the added value imparted by design is high enough, then a product will be bought for its own sake and not because of its practical functionality. The luxury automobiles that came on the market in the first decade of the twenty-first century, like the Maybach (Daimler-Chrysler), Bentley and Phaeton (Volkswagen), and Rolls-Royce (BMW) are vivid examples of how principles of image transfer are brought to bear. For Linn, too, the language of objects is a central

impetus with which such mechanisms can be described and initiated: "An imperative demand on the functions of the product is that they be communicable. It must be possible to describe the product such that the listener understands what is meant." The task of design is brought down to the lowest common denominator: it must inform, communicate, and symbolize.

The Swede Rune Monö published a work called *Design for Product Understanding* (1997), whose subtitle designated it explicitly as a semiotic approach to product aesthetics. Monö refers to the works of such semioticians as Umberto Eco (1972), who had declared semiotics to be a universal cultural technique. Monö picks up on Linn's concept of the metaproduct, which he defines as the context behind the physical entity, including, for example, prejudices, status, nostalgia, and group belonging. His recourse to Gestalt theory (see p. 298) refers to the shared foundation for a design theory and practice based on perception and language. Monö advocates a holistic approach; that is, he studies the effect of signs in acoustic, visual, sensory, olfactory, and tactile perspective in order to encompass all the various levels of product design. He, too, refers to Karl Bühler's linguistic theory as an important building block in a design theory and practice influenced by product language. His remarks on product semantics also connect directly to the works of Butter and Krippendorff (McCoy 1996).

With her dissertation *Products as Representations* (1995), Susann Vihma, an instructor at the UIAH in Helsinki, published an especially well-grounded study that must be regarded as one of the key contributions to the design theory of the 1990s. She proceeds from a semiotic basis (Barthes, Eco, Peirce) and discusses which signal-type effects emanate from products. In her first approach, Vihma also describes the syntactic, pragmatic, and semantic dimensions. On the basis of numerous "precedents," like irons, electric shavers, and telephone booths, she discusses their emblematic effects at great length. Her considerations, too, flow into a model in which design is understood as communication.

TWO DUTCH CONTRIBUTIONS

Dutchman Andries van Onck studied at the Ulm School of Design at the beginning of the 1960s and then relocated to Italy; there he

worked for Kartell, Olivetti, Zanussi and a number of other companies. His deliberations, set down in *Design il senso delle forme dei prodotti* (1994), result from theoretical studies and reflection on product examples; they are an excellent example of practice-based research in design. Van Onck dedicated a long chapter to the subject of “Una semiotica del design” (with reference to Eco, Barthes, R. Jacobsen, Lévi-Strauss, and Maldonado) and formulated a non-verbal product language. On the basis of manifold precedents from the history of twentieth-century design (including a number of his own designs) he presents a broad and practice-related spectrum. His considerations flowed into what he called an “attribution of meaning through products,” which addresses what is probably the latest facet of the design theory discourse. Humans as symbol-generating beings employ their products today in an increasing variety of ways; rites and myths are determined through the respective product languages.

Finally, Wim Muller, an instructor at Delft Technical University, published *Order and Meaning in Design* (2001), a standard work on the aspects of design discussed here. Influenced by a strong methodological background, which he developed over a period of many years at Delft, he concentrated on the creative aspects of designing. Beyond the material functions that all products possess, he is interested in the social and cultural values of design. Art theorist Ernst Gombrich’s statement (1979) that form engenders order and meaning is an important point of departure. Muller, however, also picks up on the debate of the “form follows function” movement – which was presumed to be the disciplinary element of design well into the 1990s – or, in other words, the relationship between the form of the product, its function, and its use. He also confronts the debate about “sensual functions” at the Offenbach School of Design with the semiotic discourses of Umberto Eco, claiming that for some time now form has not followed function, but rather convention. What is required is no longer design knowledge about technology, but knowledge about the basics of behavioral sciences, the influences on user-product interaction. Muller therefore strongly advocates empirical research about the use of products in order to avoid conceptual errors in product development.

There was and is form. That we also know in design and in architecture. I believe that form is increasingly becoming In-Form-ation. In art, the art of form was always simultaneously an art of de-functionalizing everything in the surroundings that was not art. That was the function of art. Outside of art the rule was to combine form and function.

— JOCHEN GERZ, 1996

NO CONCLUSION

All of the examples discussed here – which are by no means exhaustive – illustrate that in numerous countries a disciplinary design theory has indeed emerged, proceeding from similar theoretical points of departure to reach quite consistent results. Toward the end of the twentieth century, design took shape as an independent discipline with a respectable and disciplinary body of knowledge.

ON THE COMMUNICATIVE FUNCTION OF DESIGN

The concept of product language in the 1980s implied that design is concerned chiefly with human–object relations. This means that design knowledge focuses on the relationships between users and objects (and thus products and product systems, vehicles, interior designs, public design, technical products, etc.). Of particular importance here are the functions imparted by perception (i.e., those which are perceived through the human senses). Important progress has been made using semiotics as an explanatory model.

The essence of design is communication. Designers learned to give objects language, and they will not be speechless in the future either: even if it becomes increasingly less important in the future to design hardware – that is, genuine, concrete objects – and the focus shifts increasingly to the design of software, that is, of more complex ideas and concepts.

— THOMAS REMPEN, 1994

SEVERAL PRECURSORS

Among the pioneers of this approach was the American philosopher Susanne Langer. Along with Charles W. Morris, she was considered the most important representative of what was known as the semantic school of American aesthetics. In her work she picked up on the symbol theory of Ernst Cassirer, conceiving of art as a semiotic, or emblematic process. Langer described cultural expressions, language, rituals, and music as symbolic life expressions.

In her work *Philosophy in a New Key*, published in 1942, she distinguished between the basic concepts of “mark” and “symbol,” which have become especially important for design. Marks in this sense are direct or unmediated signs, whereas symbols are indirect or mediated signs. Marks show the (past, present, or future) existence of a thing, an event, or a state of affairs. In her discussion, Susanne Langer distinguished further between natural and artificial marks. Wet streets are marks indicating that it has rained; the smell of smoke indicates the presence of fire; a scar is a mark for a pre-



vious wound. A whistle at the train station means that the train is about to depart; mourning dress means that someone has died. Between a mark and its object there is a logical relation, and an unambiguous relation. The mark is thus something that prompts an action, or even an agent that demands an action.

Symbols are a different case entirely. Langer regards them as instruments of thinking, which stand for something other than the object itself and refer to something beyond it. As Ernst Cassirer put it, they have “representative” character. Into this concept of symbol flow aspects like experience, intuition, values held, and cultural norms. It is important that symbols are not given by nature, but rather emerge from convention, through relevant social agreements and traditions. Another major contribution to design knowledge, which also led to the creation of new disciplinary instruments, came from Alfred Lorenzer’s work on symbolic interactions (1970, 1974), which built on Sigmund Freud’s psychology of the subconscious.

In his analysis of the aesthetic function, the linguist Jan Mukařovský proceeded from the assumption that aesthetics could be categorized among the social phenomena (Mukařovský 1970). Based on the linguistic (semiotic) approach, he postulated that the “concept of the beautiful,” which had been the subject of aesthetics for millennia, must be replaced by the concept of function. He then proceeded from the phenomenological perspective to develop a general model of the typology of this concept: “According to our assumption, this is the typology of functions: two groups, namely the unmediated and the emblematic functions, which can be distinguished further; the unmediated into the practical functions and the theoretical function, the emblematic into the symbolic and the aesthetic function. We speak of the practical functions in the plural, but of the theoretical, symbolic, or aesthetic in the singular” (Mukařovský 1970).

A MODEL OF PRODUCT FUNCTIONS

Mukařovský understood the interactions among the individual functions as a dynamic process based on the principles of structuralism, whereas the model Gros (1983) subsequently developed eventually proved to be rather too restrictive. Critiques of Mukařovský’s model

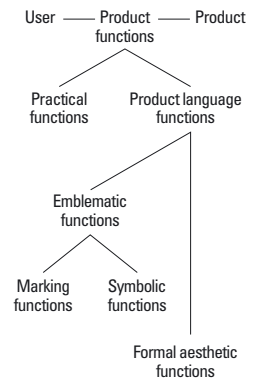

Product functions, 1983

focused either on its rigid separation of formal aesthetics from mark function and symbol function (known as the “Offenbach trinity” because of its propagation at the Offenbach School of Design), which makes no sense in practice, or on the model’s autopoietic character, which fails to address the problematic relationship between form and context. The rapid emergence of new media and new fields of activity like strategic design, service design, and information design are opening up topics which require that the concepts be reinterpreted and developed further.

ON THE NEW RELEVANCE OF GIVING FORM

Many of the attempts at enlisting design to explain the world – not to mention the frequent, ambitious attempts to change the world through design – neglect a decisive influence on the discipline since it originated: giving form.

Although perception theory and Gestalt theory may have created important foundations, the concept of giving form is defined and used more broadly today. A discipline of design oriented on the postulate of form and context has focused significantly more strongly on studying the contexts than the forms. Indeed, one could almost believe that designers no longer need concern themselves with anything so trivial as giving form.

The philosopher and corporate consultant Bernhard von Mutius (2002, 2004) sees this quite differently. In a discussion with *form* magazine he outlined a new concept of design and the far-reaching perspectives it entails for design in the twenty-first century. First he advocated that material and non-material objects be put on an equal footing, so that hardware, software, and services all receive their due emphasis in the field of design. The central factor here is that the invisible (the abstract) can be made concrete (visible) through design. Mutius is also concerned with improving what Niklas Luhmann calls the “connectability” of our communicative interactions. On the one hand, he refers to my thesis that design is also the “visualization of innovations” (Bürdek 1999), but on the other hand, he sees the necessity of getting “from the raw materials to the information,” and thus to the subject of “knowledge designs.”

Competency in design therefore means significantly more than giving things form. Mutius defines it as an entire spectrum of new

Let us work together to ensure that “design” is interpreted to cover more than just product design. Perhaps we will manage one day [to make it so] that “design” also includes verbal forms of communication, and that only the uneducated public can misunderstand names to be nothing more than “noise and smoke.”

— JÜRGEN HÄUSSER, 2001

“It is our great opportunity to take on the task of designing the entire decade.”

— GERHARD SCHRÖDER, 2002

topics like communication, creativity, second-order solutions, cooperation, net product, transformation, progress, globalization, polarity, synergy. For all of this, the point is to develop new languages of form that can do justice to the respective topics. In this case, design expertise could become a key competency for creatively resolving many technological, economic, and social problems of the present and future.

Generating pictures or images is indisputably a domain of design, and this is what comprises the new area of “imagineering” (see p. 419). This area aims to conceptualize possible futures, possible interactions, and also possible new products long before they are realized.

Bernhard von Mutius also uses Luhmann’s concept of connectibility as a basis for assessing the qualities of non-material processes. As traditional frames – such as three-dimensional product design – are of little use today, it is time to ask how the new “qualities of design” should be defined and determined. A promising approach to answering this question is to pick up on the design discourses from the beginning of the twentieth century.

Art and architecture currently do not avail themselves of their function to guide culture; design takes on this task instead.

— HERBERT H. SCHULTES, 2003

THE FORMAL AESTHETIC FUNCTIONS

The conceptual pair of shape and content has been used for many centuries to conduct discourses about the artistic (aesthetic) value and the material nature of a work. The twentieth century was characterized by a strong preoccupation with the way and manner in which artistic works emerge, and less with their values. The loss of meaning this entails was manifested similarly in architecture, in design, and in art. Aesthetic formalism (or “the aesthetics of form,” in this scientific parlance) is clearly distinguished from “the aesthetics of content.” The latter refers exclusively to the experience of the formal elements of sensory impressions. Rhythm, proportions, and harmony are important elements of artistic or creative works.

The formal aesthetic functions of products are those aspects that can be observed independent of their meaning. In semiotic terms, the issue here is the distinction between syntax and semantics. On the one hand, every language has rules and regulations about how signs (words and sentences) can be created and described. Applied

to design, this means a grammar of design, with a syntax completely void of meaning. Not until they refer to practical functions (sign functions) or social contexts (symbolic functions) do signs take on their respective meanings in design. Formalism, by contrast, is when formal devices (signs) are used indiscriminately and arbitrarily without any consideration of their meaning.

EARLY PERCEPTION RESEARCH

The foundations of formal aesthetics were laid in perception research, which enjoys a long-established tradition. Strictly speaking, here, too, the origins can be traced back to Aristotle, who designated the five senses as the foundation of perception.

In the eighteenth century the English philosopher George Berkeley (1685–1753) developed an independent theory of perception, in which he studied the human sense of sight and the individual components that condition it.

Decisive progress was not achieved until the nineteenth century, when Hermann Helmholtz investigated the foundations of visual perception. For him perception was a two-step process: the basis is sensations, whose quality and intensity are inborn and conditioned by the specific characteristics of the sensory organs. These sensations are signs that take on meaning only through associations (experiences) over the course of human development.

A further important foundation for the theory of perception was research on geometric optical illusions, the first of which were published around the middle of the nineteenth century.

PIONEERS OF GESTALT PSYCHOLOGY

Wilhelm Wundt (1832–1920) is considered the founder of modern psychology, as he granted the discipline an autonomous object and method, and structured it according to the scientific model. He defined psychology as the science of inner and direct experience, which should be based on experiment and observation.

Objections to the application of scientific methods in psychology were raised by Theodor Lipps (1851–1914). He designated psychology the science of mental life, and argued that knowledge is

founded on the principle of inner human experience. Lipps' work is closely connected to that of Wilhelm Dilthey, who also conceived of art and literature as expressions of life and sought to understand them in their essence. Especially important for Lipps were the formal characteristics of works of art and objects. He believed that forms evoke feelings, a view that certainly runs counter to the tenets of Gestalt psychology. Lipps' principle of "unity in multiplicity" (Schneider 1996) denotes the oppositions and common interests effective in aesthetic objects and responsible for their complexity. Generating tension or even dissonance, along with the seemingly contradictory search for the harmonic principle, are standard practice in works of art – and this is equally true for forms and colors. Lipps' concept of empathy addresses a general communicative process and even serves as the basis for his own symbol theory: "for only through empathy in sensory phenomena or life expressions can something become symbolic" (Schneider 1996).

Wundt's ideas were also opposed by the Austrian school of psychology, founded at the end of the nineteenth century, whose prominent members included not only Lipps, but also Alexius Meinong and Christian von Ehrenfels.

Alexius Meinong (1853–1920) was one of the pioneers of Gestalt psychology. He demonstrated that psychological phenomena are more complex than the sum of their individual elements. In his object theory for the science of perception (1907), he concluded that each of the basic kinds of psychological experience (imagining, thinking, feeling, wanting) conceives of itself as its own object.

THE SPECIAL INFLUENCE OF CHRISTIAN VON EHRENFELS

Christian von Ehrenfels (1859–1932), one of Meinong's students, is regarded as the actual founder of Gestalt psychology. In 1890 he published a short tract that made him famous: "About Gestalt Qualities." In this work he argued that one factor effective in perception is independent of sensations: what he calls Gestalt quality. A triangle is a triangle regardless of its color or size. The Gestalt psychology thesis, "The whole is greater than the sum of its parts" can also be traced back to Ehrenfels. In other words, a melody consists of many individual notes, but its effect arises from the combination of the individual notes. Ehrenfels thus rejected elemental psychology

Recognizing or perceiving is first of all reducing complexity, searching for compressed algorithms or for constancy. Recognizing means suppressing, overlooking, neglecting, omitting, abridging, deleting, compromising information.

— FLORIAN RÖTZER, 1998

and its deconstructive approach, exerting a strong influence on the Gestalt psychologists David Katz, Wolfgang Köhler, and Max Wertheimer.

In 1916 Ehrenfels published a treatise about the “The Value and Purity of Form,” which took on central importance for design at a much later date. He stated that there is a degree of formation, that each form demonstrates a certain value of formation. Greater forms are distinguished from lesser through a greater degree of unity and multiplicity (purity of form and value of form). The concept of unity can also be paraphrased with order; the concept of multiplicity with complexity. Thus the value of form can be calculated as the product of order (O) and complexity (C).

In the 1960s Max Bense proceeded from such approaches to develop the concept of an “exact aesthetics” under the motto “design is the creation of order.” This view was closely connected to the functionalist approach, which aimed to develop design concepts based on simple geometric elements and solids (the square, triangle, circle, cube, pyramid, and cone). This approach followed up on just one side of Ehrenfels’s dual concept, emphasizing only the concept of purity of form or, as Dieter Rams liked to say, “Less design is more design.” The conflicting influences of order and complexity are always the background for developments in design, thus the “measure of design” (M) is a function (f) of order (O) *and* complexity (C).

THE GREAT GESTALT PSYCHOLOGISTS

A number of the individuals who performed important theoretical research in this area in the first half of the twentieth century and their approaches deserve special mention. The physician and psychologist Karl Bühler (1879–1963) is considered the founder of semantic language research (what is known as “language theory”) and researched psychological processes in the holistic tradition.

The most important contributions to perception and imagination were made in the “Berlin School” during the 1930s. Among the scholars there were Max Wertheimer (1880–1943), Wolfgang Köhler (1887–1967), and Kurt Koffka (1886–1941). They believed that any processes of experience and behavior had to be researched as a

Thus Gestalt psychologists such as Wolfgang Metzger and Wolfgang Köhler were able to show as early as the 1930s that we operate using constant differentiations, whose most important differentiation is that between figure and ground.

— SIEGFRIED J. SCHMIDT/
GUIDO ZURSTIEGE, 2000

whole. After World War II these approaches were pursued further, especially by Wolfgang Metzger (1899–1979) and Rudolf Arnheim (born 1904).

Wertheimer demonstrated how perception, through a series of organizational principles (known as the Gestalt laws) is subject to a spontaneous tendency toward structuring in formal terms. With these rules he illustrated how objects are grouped and experienced spatially and temporally.

Köhler published treatises on the problem of the assumption of constancy, on figural after-effects, on the psychology of learning and memory, and on the Gestalt theory of brain physiology.

In 1935 Koffka published his *Principles of Gestalt Psychology*, at the time the most comprehensive attempt to present a broad overview of Gestalt psychology research. In his theory of learning he demonstrated that memory strives toward what he called “perfect form” (regularity, precision).

David Katz (1979) focused in particular on the perception of color and formulated a number of Gestalt laws. He followed closely in the footsteps of Wertheimer, Köhler, and Koffka.

Wolfgang Metzger was the leading Gestalt psychologist of the Berlin School. Köhler was his doctoral adviser, and his first assistantship was with Wertheimer. His research concentrated on the psychology of perception and imagination and the psychology of learning. His studies about the sense of sight and its laws were published in 1935 and even today are considered to be the standard works on the psychology of perception and Gestalt psychology; as they have been out of print for some time, I also refer to Metzger’s collection of essays from the years 1950 through 1982 (Stadler and Crabus 1999).

Over one hundred Gestalt laws are described in the writings of the psychologists of perception and Gestalt psychologists. Each of these laws shows how perception constructs what are known as totalities. The Gestalt laws constitute important foundations for designing and creating holistic sensory impressions even today. In design they are applied to fulfill the formal aesthetic functions and marking functions.

Gestalt laws can be demonstrated more or less effectively for just about any two- or three-dimensional design object. However, as purely syntactical instruments (and thus without a specific meaning), they do not give any indication of the overall impression of a design

Since Gestalt psychology, psychology has worked out various basic laws that were of great use for designers in visual shaping. As we know, we see not with the eyes, but with the brain.
 — FELICIDAD ROMERO-TEJEDOR, 2003

object. Without the semantic dimension, in and of themselves, they can not proceed beyond the level of formalism.

PERCEIVING AND IMAGINING

Gestalt theory approaches have been reviewed and reworked repeatedly over the course of their development. One particular new approach was formulated by Rudolf Arnheim (1972), who attempted to demonstrate that perceiving and imagining can not be separated from each other. He advocated constructing a concept based on the conceptions of perception.

Concepts do not become clear until they are processed by means of the imagination. For Arnheim, the foundation of thinking is the human capacity for abstraction. He differentiates further between two kinds of vivid thinking: intellectual and intuitive thinking. The latter is based on productive (i.e., creative) thinking in the sciences, the arts, and also in design.

ON THE ASPECTS OF ORDER AND COMPLEXITY

In connection with the investigation of Gestalt laws at the Offenbach School of Design in the 1970s, a number of formal aesthetic dichotomies were derived from Ehrenfels's categories of order and complexity, which are quite practicable for the work of designing. Among these are, for instance: simple/complicated, regular/irregular, closed/open, homogeneous/heterogeneous, symmetrical/asymmetrical, clear/unclear, in the frame/out of the frame, in equilibrium/out of balance, familiar/new, and order of experience/complexity of novelty.

The higher-order features of order and complexity, however, do not imply any valuation. In each concrete design project it must be decided anew whether a solution in the direction of greater order or higher complexity appears more appropriate to the task at hand. Of course, the formal complexity discussed here has nothing to do with the (semantic) complexity of a product's content. Even products that are simple in form can turn out to be thoroughly complex in their functionality or operation.

The currently unrivaled cognitive theory of radical constructivism tells us that all perception is already a kind of interpretation, and that every system must construct its information itself. We never have knowledge of an objective reality, only of the way our experience is organized.

— NORBERT BOLZ/DAVID
BOSSHARD, 1995

The long tradition of functionalism was based primarily on the formal aim of order. Attractiveness, in terms of the psychology of perception, suffered accordingly, and visual monotony resulted in such areas as architecture, urban planning, visual communication, and design.

The objective of complexity can be achieved by various creative means, for instance, with materials, surfaces, textures, structures, colors, and product graphics. But functional complexity, too, especially as it is often applied to electronic products (keyword: “featuritis”), is also applied in product development and design. Each of these criteria has to be discussed on the basis of a concrete design example.

ON THE ECOLOGICAL APPROACH TO VISUAL PERCEPTION

A fundamentally new approach in the science of perception was developed by the American psychologist James J. Gibson (1973, 1982). Surmounting the atomistic theory of perception, he formulated a contrasting holistic, ecological approach to visual perception. In this case, perception is studied under the natural conditions of the environment. Gibson distinguishes three main characters of the environment: the medium (atmosphere), the substance (materials and gases), and the surface (defined as the border between medium and substance, that serves as a point of orientation for sentient beings). Thus colors, the arrangement of surfaces (forms), and the given illumination become important elements in perception. Gibson defines the environment on an ecological level, comprising surroundings, objects, events and also other living beings, which are perceived in their interactions. Perception itself is defined as an activity oriented toward developing one’s own consciousness about the environment and developing one’s self within it.

PRINCIPLES OF FORMAL DESIGN

A more precise description of the formal principles of design was offered by Dieter Mankau at the Offenbach School of Design as part of his studies of formal aesthetics:

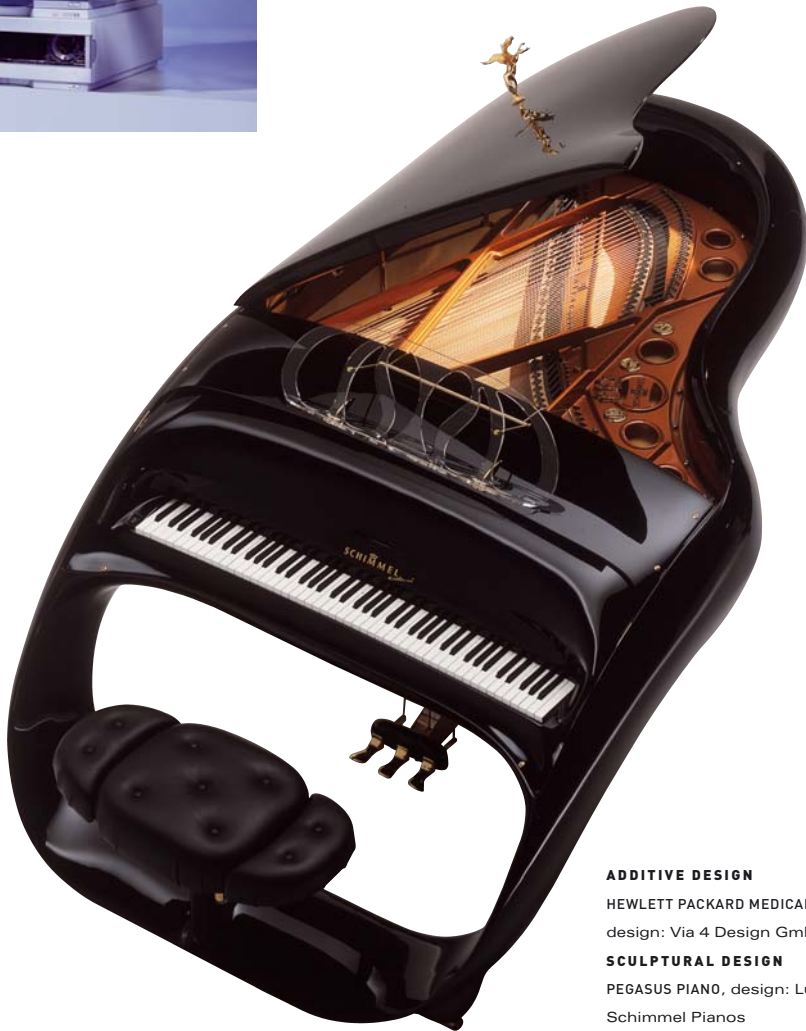
**ADDITIVE DESIGN**

HEWLETT PACKARD MEDICAL TECHNOLOGY,
design: Via 4 Design GmbH

SCULPTURAL DESIGN

PEGASUS PIANO, design: Luigi Colani,
Schimmel Pianos

Additive Design

One speaks of additive design when, in the perception of a product or a form, the technical or practical functions characteristic to a product are arranged so that they largely maintain their visual independence.

Integrative Design

Here the creative instruments that are employed lead to a holistic perception of the product. Visual irritations that emerge primarily through multiple or different technical and practical functions, and through the materials used for these, can be considerably reduced by formal means, including uninterrupted lines, continuity, and uniformity of materials and colors.

Integral Design

What dominates here is the basic form, which is generally mathematically geometric and whose multiplicity of forms is limited to a few elementary basic shapes, including spheres, cylinders, squares, and pyramids. Cognitive and cultural imprinting make these geometric solids extremely stable in terms of the psychology of perception; they remain visually stable in our mental conceptualization even when their form is violated, for instance, through notches or clear reductions or additions to the form.

Sculptural Design

This variant does not merely conform to the pure, practical, and functional requirements of the products, but rather interprets the functions individually or even artistically, generating highly symbolic expressive power.

Organic Design

This method refers to biological principles (bionics); it also allows nature-like associations. The resulting sentiments not only build on a visual perception, but also integrate our spectrum of perception as a whole. Such perceptions as smells, sensations of cold and hot, tactile experience, and hearing as a spatial phenomenon are elementary experiences with only minimal differences in meaning for different cultures.

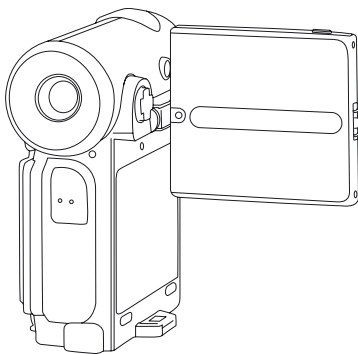
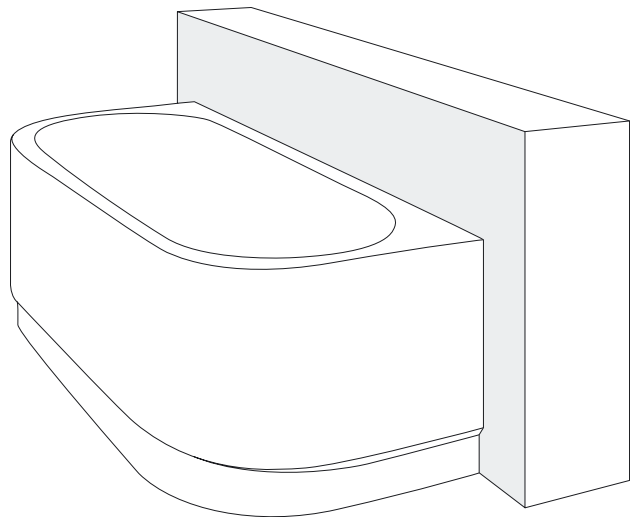
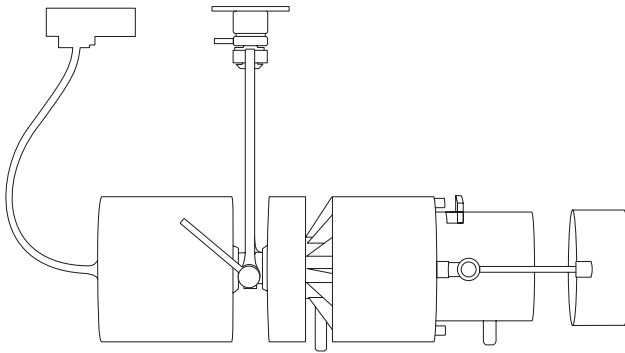
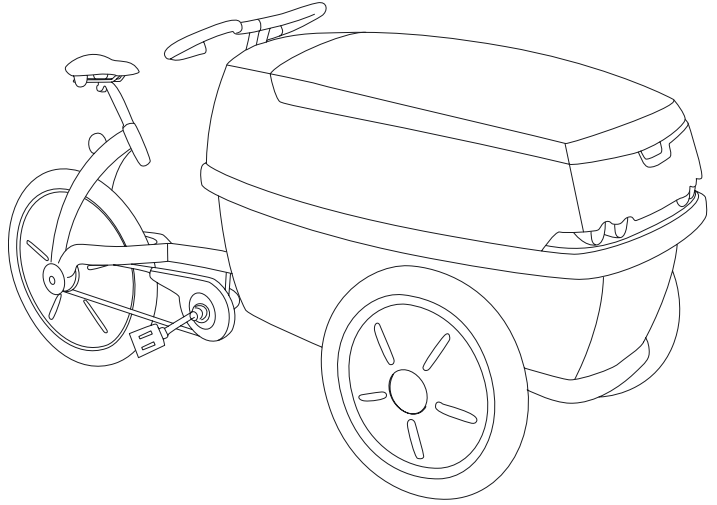
**ADDITIVE DESIGN**

MAIL WAGON

GUZZINI DIRECTIONAL SPOTLIGHT

BATHTUB

VIDEO CAMERA

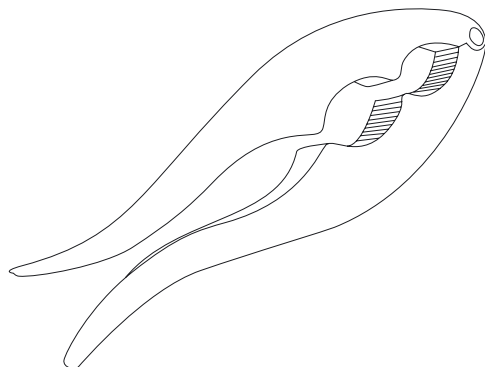
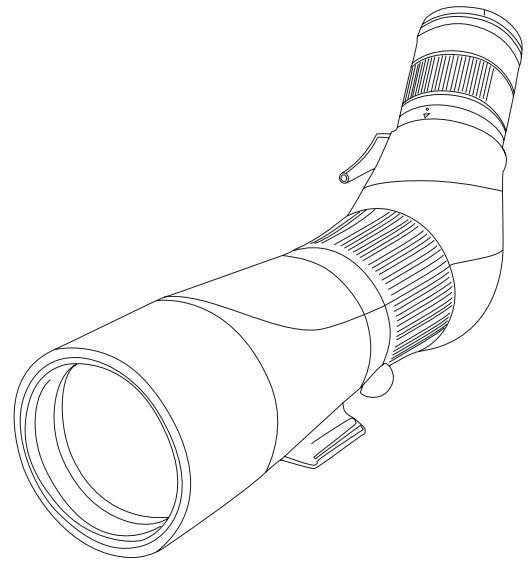
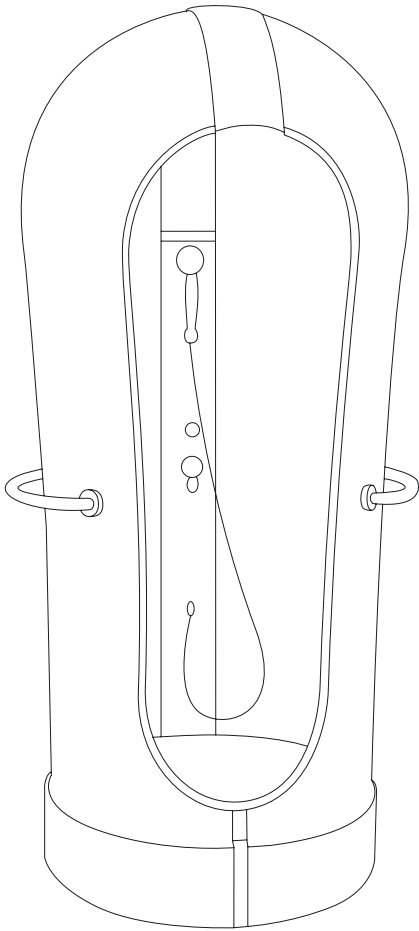

INTEGRATIVE DESIGN

SHOWER STALL

CYCLING HELMET

CAMERA LENS

NUTCRACKER

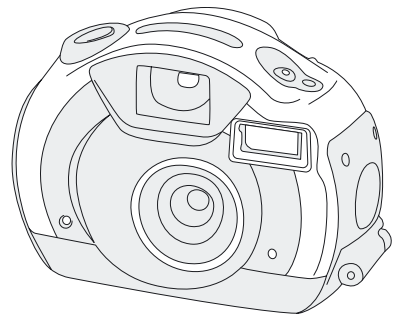
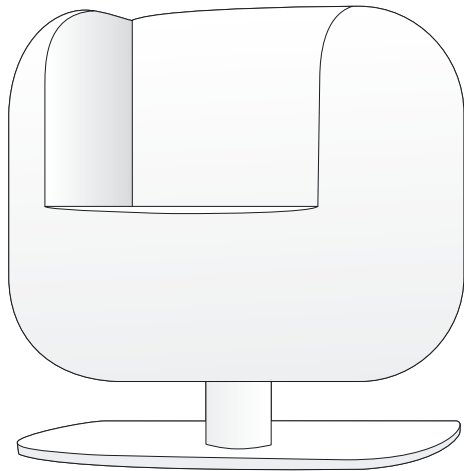
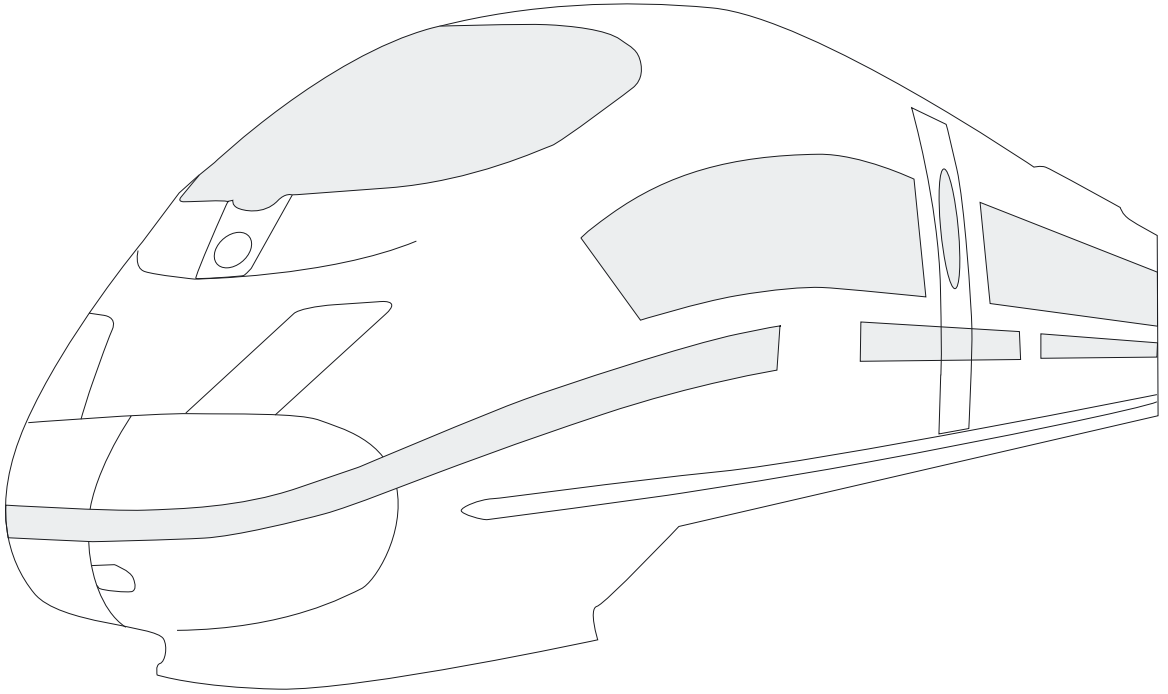
**INTEGRAL DESIGN**

POWER HEAD OF THE ICE TRAIN

CUBE ARMCHAIR

CAMERA HOUSING

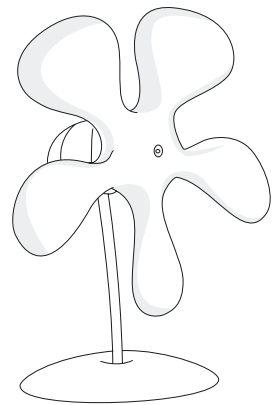
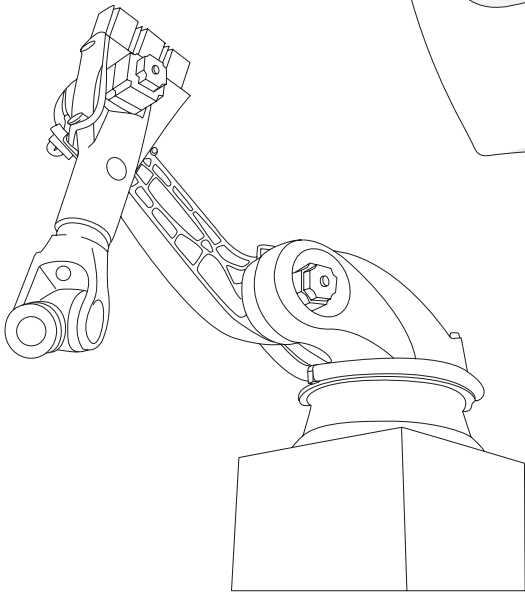
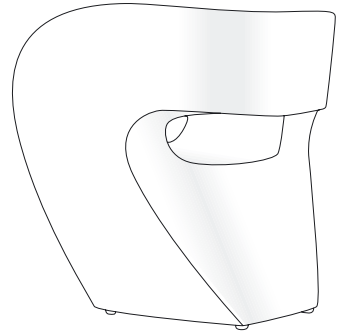
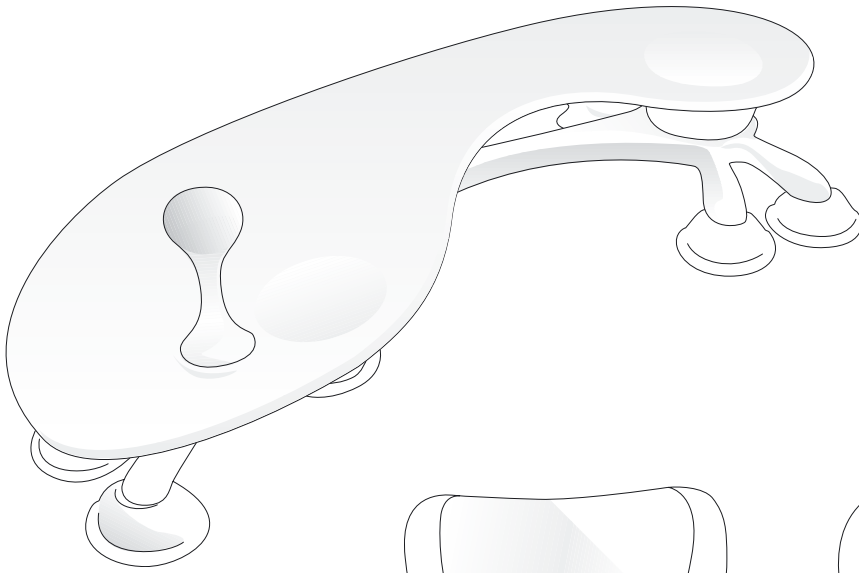

SCULPTURAL DESIGN

TABLE

ARMCHAIR

INDUSTRIAL ROBOT

FAN

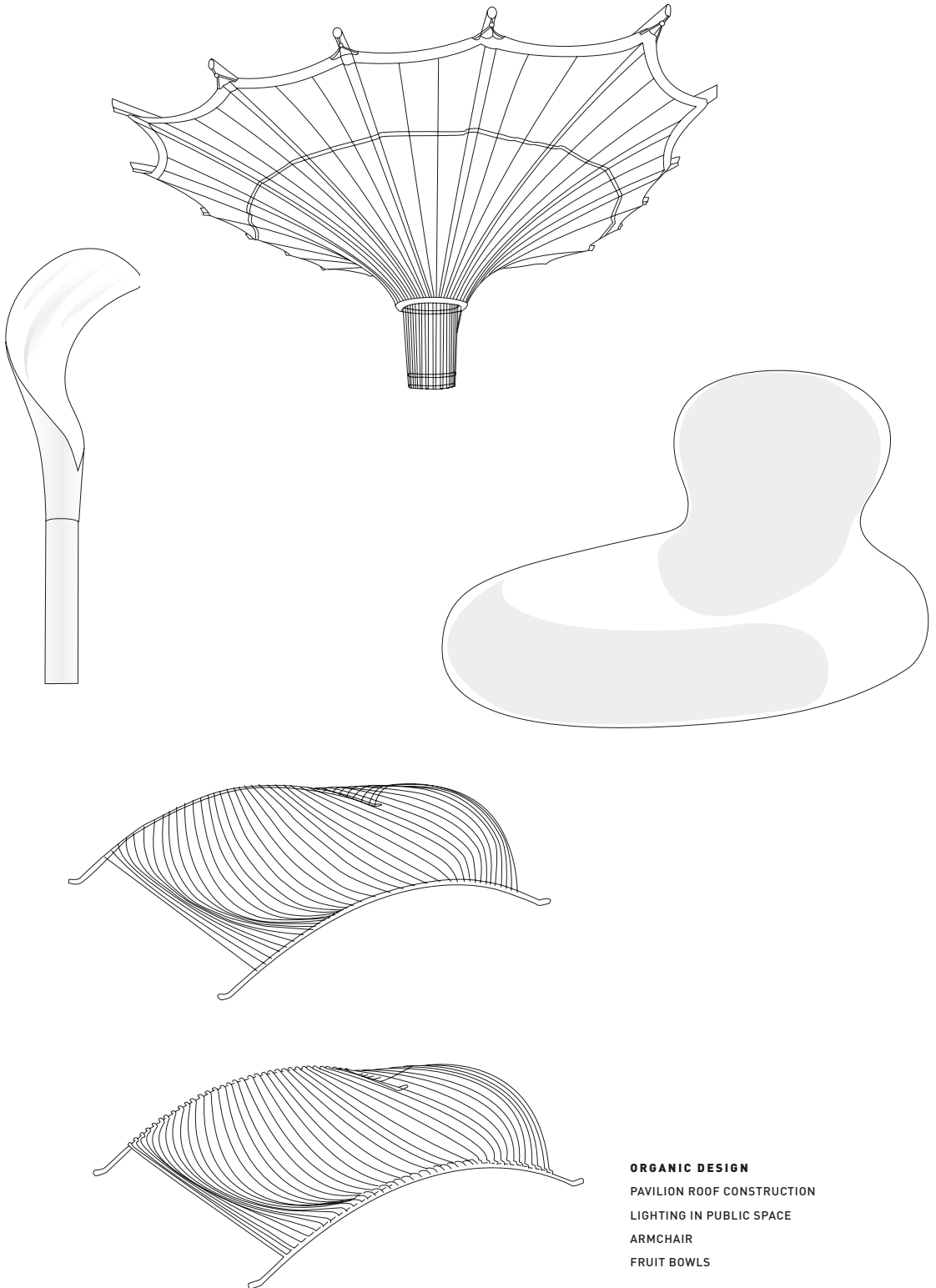
**ORGANIC DESIGN**

PAVILION ROOF CONSTRUCTION

LIGHTING IN PUBLIC SPACE

ARMCHAIR

FRUIT BOWLS



TOLEMEO LAMP, design: Michele de Lucchi,
Artemide (Photos: Wolfgang Seibt)

These examples show that formal aesthetic functions extend far beyond the purely syntactical sphere. The given forms are always imparted socio-culturally and therefore have different meanings in their given contexts. From the design of objects it is thus possible to read the mental, technological, or social stance from which a product was designed.

An Example

The “Tolomeo” lamp (designed by Michele de Lucchi for Artemide) picks up both on familiar creative technical principles and on the classic Swedish desk lamp “Luxo” by Jacob Jacobsen. The high-gloss, anodized aluminum frame contrasts with the matte reflector, which appears ready to “fly away.” Tightrope (association: suspension architecture), concealed springs, and screws generate a heightened functionality that is accompanied by a multiplicity of complex creative details. The black dots are not pivots, which is incorrect under the marking aspect, but the lamp is extremely simple to handle. The association with lightweight construction techniques from aircraft construction makes the Tolomeo a modern high-tech product so neutral that it can be used in a wide range of application areas; for this reason it rapidly became a product-cultural model of the 1990s.

THE MARKING FUNCTIONS

As discussed above, markings always refer to the practical functions of products. They visualize a product’s technical functions, explaining how it is to be handled or operated. Markings show users how they should deal with a product. Since the design of markings is directly connected to the function of a product, this is the area of design which allows the least individual interpretation and personal statement. Nevertheless, the design of markings requires coming to terms with the users and their contexts and experiences.

VISUALIZING PRACTICAL FUNCTIONS

The design of markings is part of the “classic” repertoire of design, as it was portrayed by such designers as Hans Gugelot at the Ulm School of Design in the early 1960s. Strictly speaking, however,

Plato had dealt with this topic already; he recognized in every thing a “peculiar ability,” and believed that the essence of an object must be comprehended directly in order to be able to identify its special significance. The tradition of “good design” is inconceivable without the design of markings, although these have not always been consciously used or perceived.

Systematic work on the marking functions was begun at the Offenbach School of Design in the 1970s using the cognitive methods of the humanities, particularly the groundbreaking works of Richard Fischer (1978). These were developed further and depicted comprehensively in 1984 by Richard Fischer and Gerda Mikosch, as well as Dagmar Steffen (et al.) (2000).

Sven Hesselgreen (1980) published a study in which he reached similar findings for the fields of architecture and design. This topic was the subject of intensive study, especially in the former East Germany. In a historical discussion on the topic of signs and markings, Günther Feuerstein (1981) demonstrated the development of an “apparative semiotics,” in which what was substantial about products (i.e., their meaning) makes up the pre-eminent principle of design: “We defend ourselves against the apparatus not by storming it or destroying it, but rather by interpreting it as an aesthetic object: a process of ‘interpretative aesthetics’.”

The close linkage of design in East Germany to the tradition of functionalism was also evident in a paper by Horst Oehlke (1982), in which he describes the visualization of a product’s uses as a task of the functional method of design. Oehlke held the dialectics of product function and product appearance to be the central topic of design in the 1980s (see p. 341).

Work on the theory of product language soon showed that the transition from formal aesthetic functions to marking functions is often quite fluid. Here, it was also evident how new meanings can be generated systematically by applying Gestalt laws, as these exist independent of specific meanings.

On the one hand the context of the “Offenbach approach,” starting in the seventies, was to structure the way in which design works and classify it into operationalized factors. This model of design theory, the only one that was consistent in itself, has been practiced and developed further up to today.

— ALEX BUCK, 2003

DISCUSSION OF PRECEDENTS

In a collection of precedents from design praxis, a number of categories of markings were identified as general points of orientation



HANDLING

MAGNAT M.ONE DVD PLAYER, Magnat

STRUKTURA POCKET KNIFE, Richartz

GRIP 2001 PENCIL, design: Heinrich

Stuchenkemper, Faber-Castell

BINOCULARS, design: B/F Industrial Design,

Eschenbach

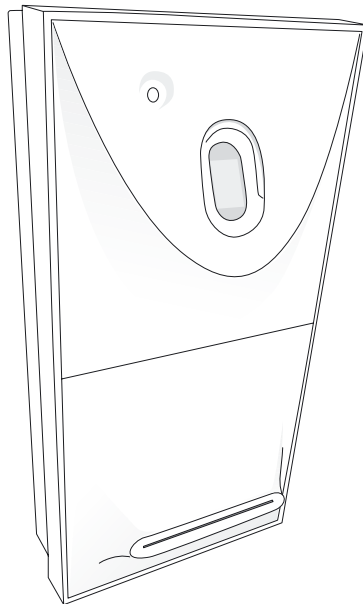
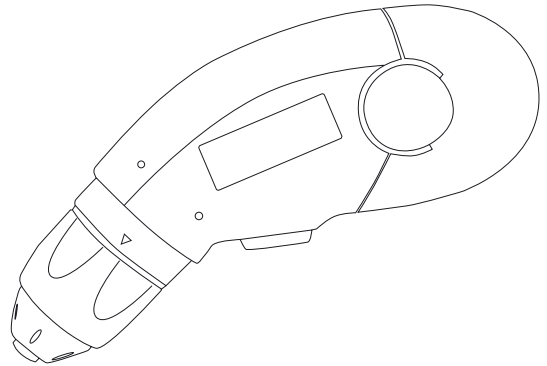
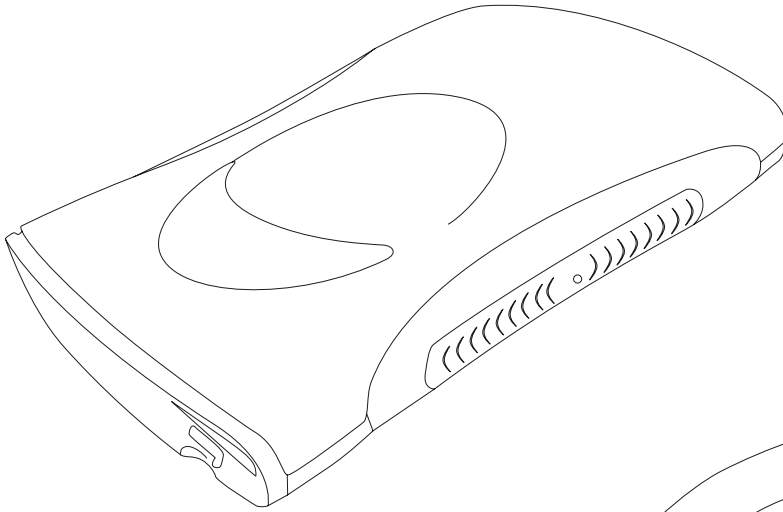

ORIENTATION

ZIP DRIVE

POWER SCREWDRIVER

INTERCOM

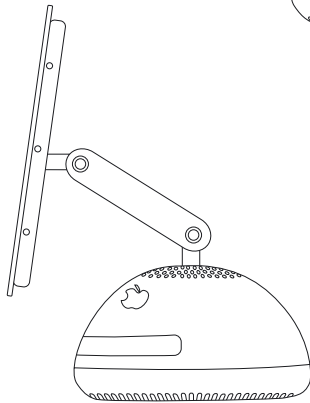
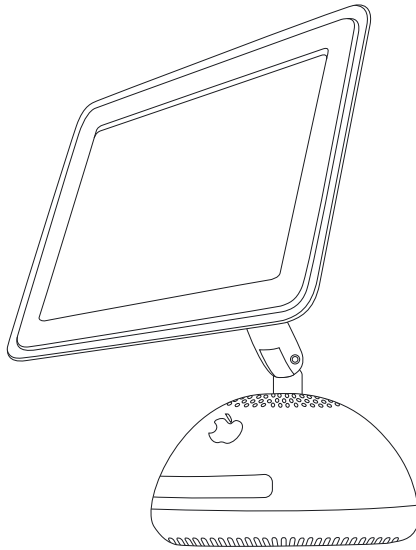
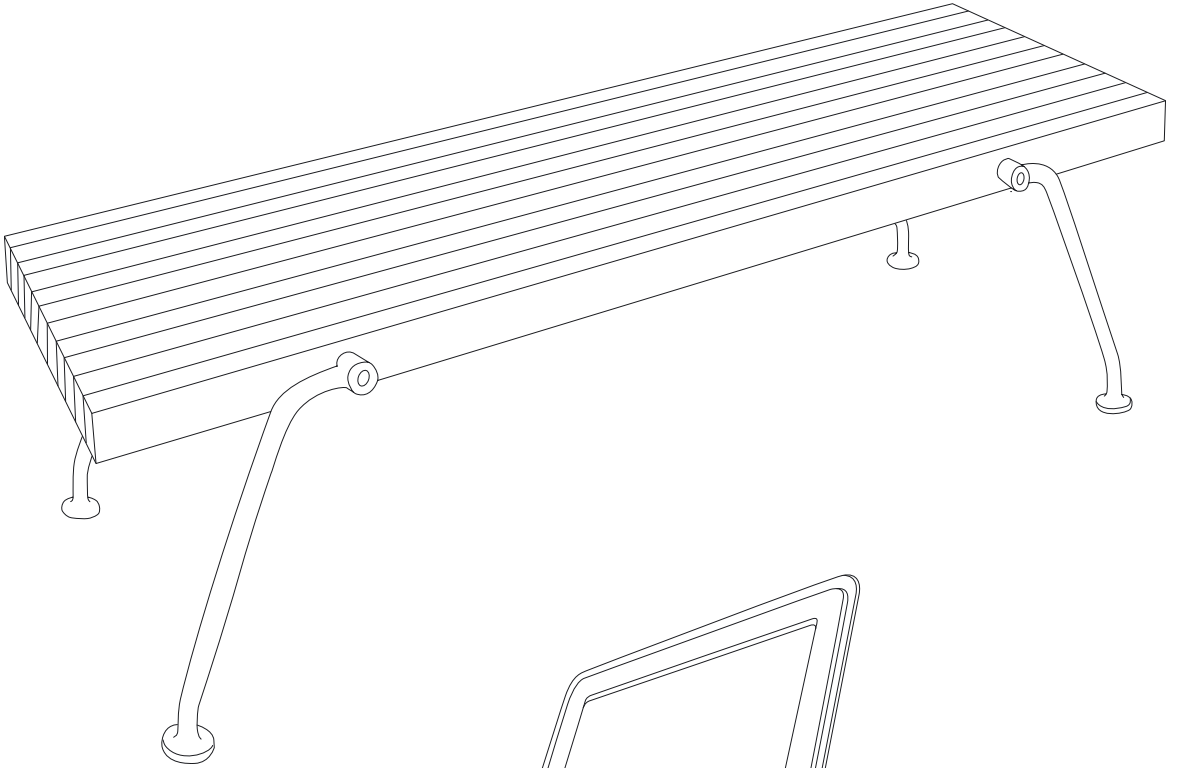

IDLE FUNCTION
GARDEN BENCH
IMAC COMPUTER

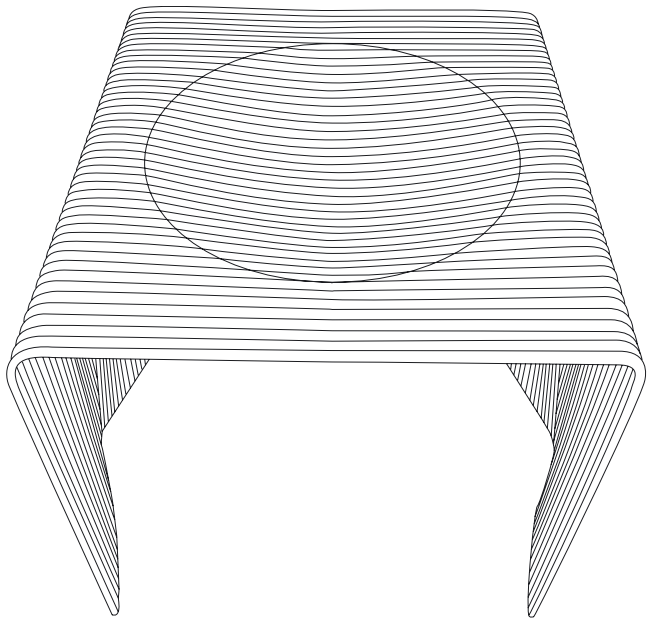
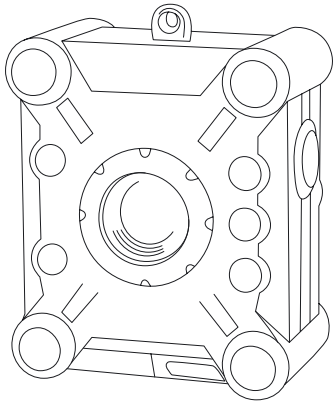
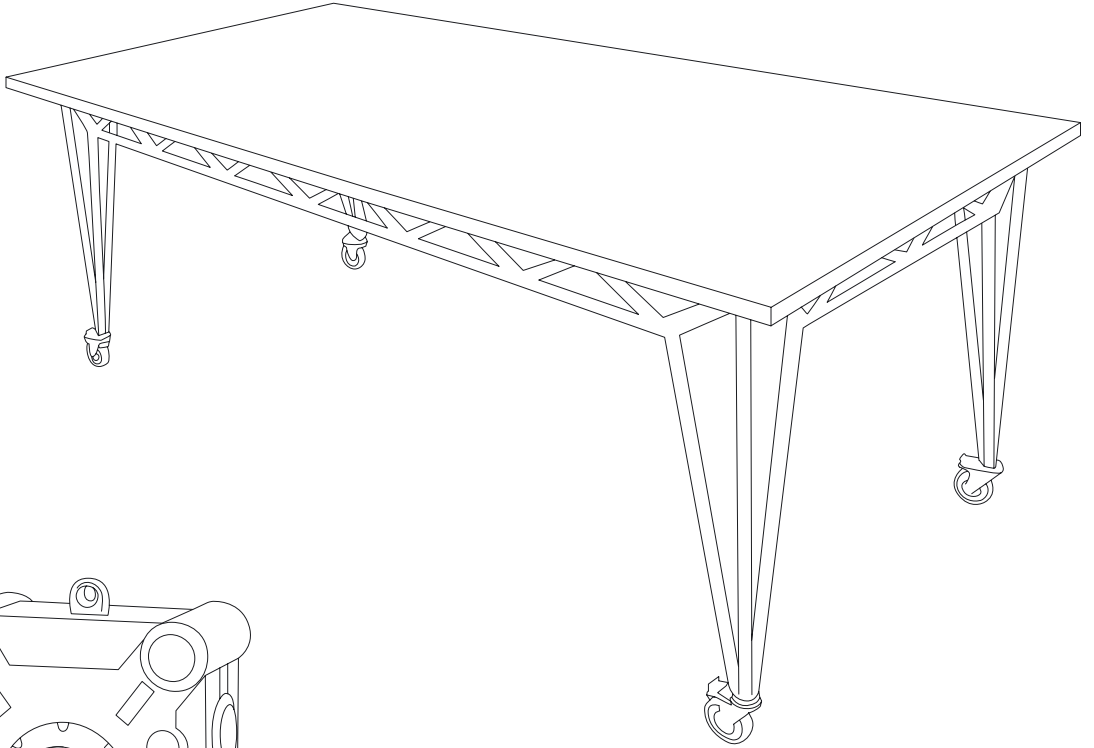

STABILITY
TABLE
CAMERA HOUSING
STOOL

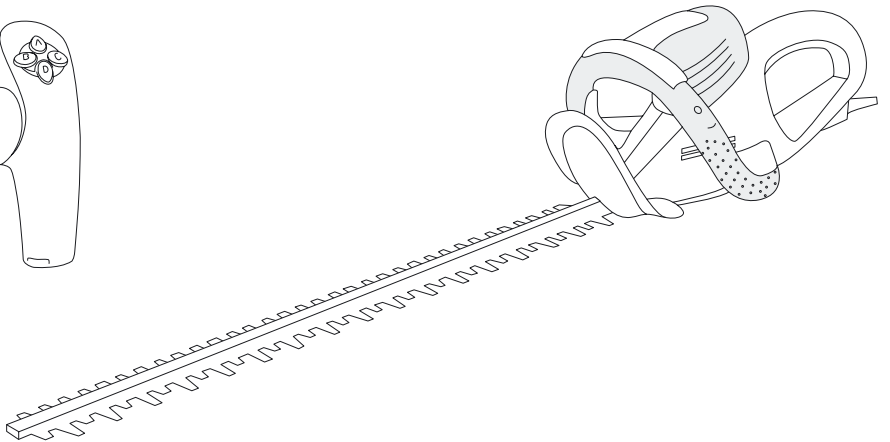
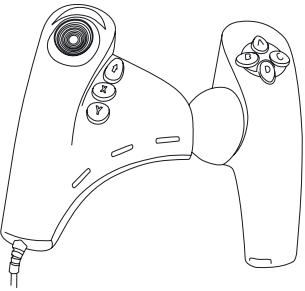
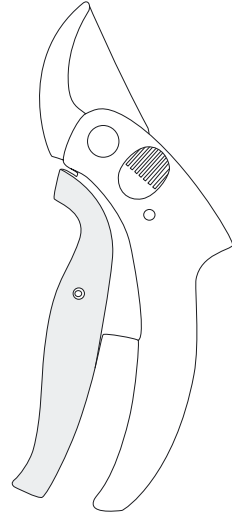
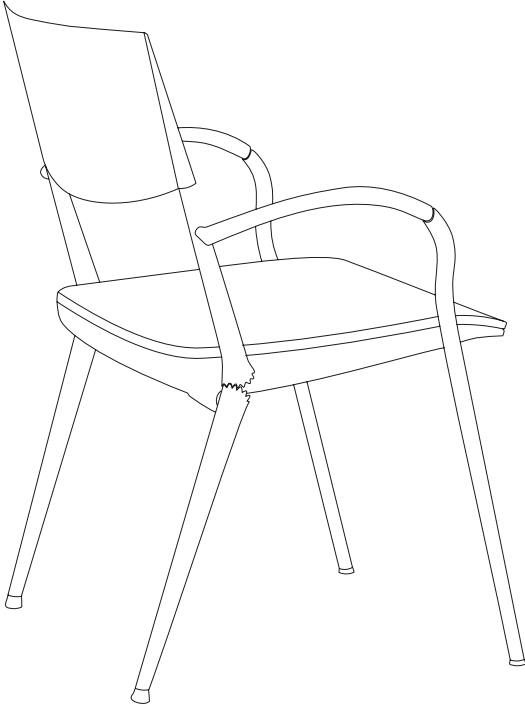

CHANGEABILITY AND CONFIGURABILITY

CHAIR WITH ARMRESTS

GARDEN SHEARS

OPERATION

REMOTE CONTROL FOR VIDEO GAMES

ELECTRIC HEDGE CLIPPERS

ELECTRIC TOOTHBRUSH

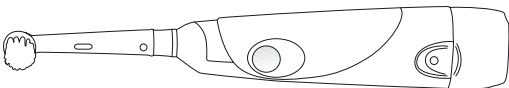

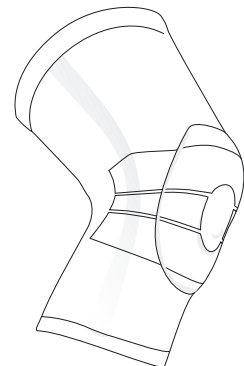
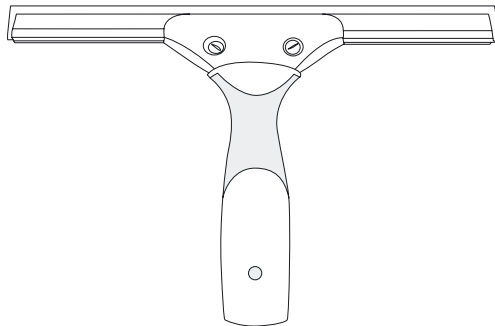
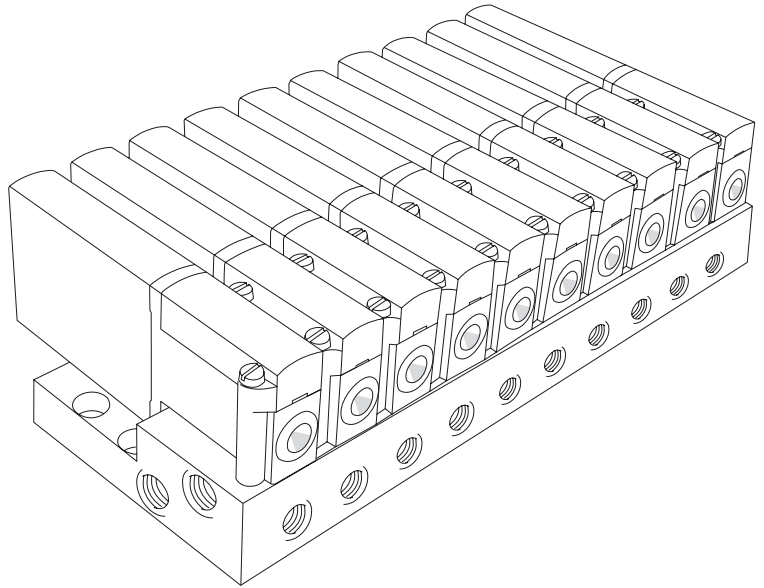
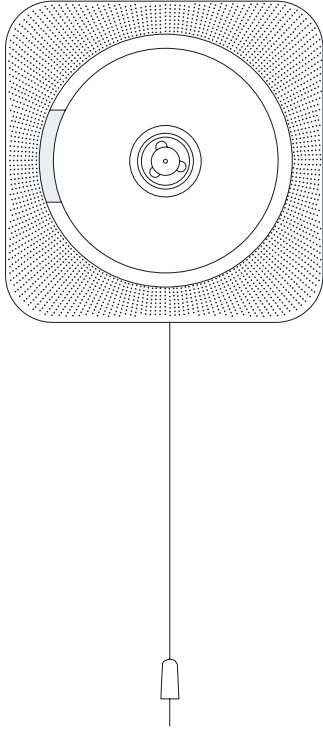

PRECISION

CD-PLAYER

PNEUMATIC SWITCH

REFERENCE TO THE HUMAN BODY

SQUEEGEE FOR WINDOW CLEANING

SUPPORT BANDAGE

(Fischer and Mikosch 1984), and remain valid even today. This work quite correctly pointed out that a holistic observation of all product language (communicative) functions must always be the first step in designing new products.

Such examples are oriented primarily toward a product world characterized by the transition from the mechanical to the electric, or even electronic world. However, they ultimately can serve as examples only for the relationship between language and its formal aesthetic visualization (portrayal, specification), as understanding always depends on the context, the cultural background, and the experiences of the users. To a somewhat lesser degree, such product categories and corresponding markings continue to exist, including:

- *orientation*

such as the orientation toward the users

- *idle function*

through which, for instance, visual information about how to use the product can be provided

- *stability*

may concern the representation of technical and physical laws

- *changeability and configurability*

markings serve to visualize ways in which the product may be adapted

- *operation*

controls should communicate to the user the details about how a device is to be used. Individual elements should be designed to make their application immediately obvious (for instance, push, turn, slide, firmly or gently)

- *precision*

concerns the visualization of how precisely certain products can be manipulated or how they can be adjusted. The precision of a device always has functional reasons: the level of precision needed on a measuring device, a camera, or a medical device is high, whereas such signs on a stereo have more of a symbolic character

- *reference to the human body*

concerns not only the direct adaptation of the product to anthropometric conditions, but also associative indications of this adaptation

These examples again make it evident that a clear delimitation of individual communicative functions is often impossible and rarely makes sense. In each individual case of design, the point is to carefully consider which emblematic categories will receive special emphasis.

Thus ticket machines for mass transportation systems require a clear operating design (“on the fly”), whereas it is quite legitimate to design a stereo system that only the owner understands how to operate.

These examples show that product language is not an end in itself, but merely a basis for discussion in the process of product development. Here designers and design managers have to present their specialized expertise to the sales and marketing experts and developers involved. From this perspective, product language can become a strategic tool which can have a major influence on the expressiveness of a product and its relation to, or acceptance by, the user.

In the past, this recognition of a communicative product function in design was accompanied by the successive surmounting of a strictly functionalistic notion of design.

— STEFFEN KLEIN, 2001

CHANGES THROUGH MICROELECTRONICS

The 1980s saw the mass influx of microelectronics into the world of artifacts, which fundamentally changed marking functions. The obvious markings, originating from the mechanical world, gradually disappeared and were replaced by the “interfaces” used to operate digital products. This paradigmatic change meant a developmental leap for design after the postmodern obscurity of the 1980s (Bürdek, 1990a, 2001b).

CAD (Computer Aided Design) is a particularly vivid example of this process. The conceptual worlds of developers and builders were transferred almost directly to the new tools emerging at that time (CAD software).

Problems – if not a public menace – arose when these worlds of imagination entered into the development of devices for broad groups of users. In most cases, rather cryptic user interfaces resulted. As a consequence, interfaces, and also the increasingly imperative user’s manuals, began to receive more attention (Bürdek and Schupbach 1993).

Against a completely different background – namely, that of cognitive psychology – the American scientist Donald A. Norman (1989)

obtained quite convincing findings about the real environment, which can be subsumed directly under the concept of marking functions. A multiplicity of mistakes and errors in dealing with products can be traced back not to human incompetence, but to inadequate design.

Norman referred in particular to “creeping featurism” – the tendency to raise to absurdity the number of functions a device can perform. This phenomenon – also called “featuritis” or “function overload” (Fischer 2001) – is increasingly evident in products equipped with microprocessors. In such cases, the costs of realizing ever more functions in a product are negligible, although the user cannot comprehend most of them, let alone apply them sensibly.

User Interface Design

This results in the design of user interfaces, which is becoming an ever more decisive criterion for purchasing (and is especially evident with cell phones and for software in general). Beyond the actual hardware, the emphasis is on the design of the virtual level behind it (i.e., the design of user instructions – also called interaction design – and thus access to a device’s spectrum of features).

Designers of user interfaces have learned to account for differences in users’ experiences and cultural backgrounds. Hardware design is difficult to adapt to the individual needs of users, though opportunities for individual adaptation abound with interfaces, signs and symbols, visibility, and sizes. In the words of Peter Eckart of the Offenbach School of Design, this means that products can even become a bit more democratic, less restrictive, and ultimately, more usable.

THE SYMBOLIC FUNCTIONS

The concept of the symbol has taken on different meanings at various stages of its history. Generally speaking, it means a (distinguishing) sign that receives intercultural meaning through convention. It has the function of a sign or emblem because symbols serve as representatives for something that is not perceptible. Such symbols exist in religions, in art and literature, but also in the natural sciences, in logic and linguistic philosophy, and in countless variants in

everyday life. The meanings of symbols often develop by association, and cannot be determined unambiguously: interpretation always depends on the respective context.

Susanne Langer's distinction between marks and symbols (1965) established this concept of symbol in the process of developing a disciplinary design theory.

SYMBOLS AND CONTEXTS

To all appearances, symbolism did not exist at all in the functionalist tradition of the twentieth century – after all, the emphasis there was on realizing the practical functions of a product to maximize creative order in keeping with the motto “form follows function.” Marking functions were dealt with more or less intuitively, primarily to facilitate the optimal operation of a product by the user.

But how exactly was the practical function of a product indicated? Designers had always taken pains to analyze and interpret the respective functions. However, the answers were often more ideological than functionalistic. Thus the early functionalism of the 1920s, in fact, became an “unacknowledged symbolism,” because it was applied as a sign of technological progress (Venturi, Scott Brown, and Izenour 1972).

Functionalism itself was regarded as a way of overcoming style: supposedly value-free design was considered significant for mass culture, or even as a revolutionary milestone in the social history of architecture and design. However, in retrospect, it appears that the functionalism of the Bauhaus period between 1920 and 1930 was the symbol of an intellectual and progressive minority. After 1945, functionalism became the foundation of mass production and was considered the symbol of the industrial development of Western Europe. This consensus held until the rise of postmodernism in the 1980s.

Dealing with symbolic functions in the practical work of design is complicated by the fact that there is no “dictionary of meanings” for products: symbolic meanings can be interpreted only from their given socio-cultural contexts. While marking functions are oriented primarily on the product itself (indicating its use), symbolic functions serve as background reports, representing the different contexts of each given product.



SYMBOLIC LANGUAGE, Erich Fromm (Figure: Bürdek archive)
(Translation: The language of symbols seems to me the only foreign language everyone should learn.)



ADIDAS SPORT STYLE COLLECTION

Design: Yohji Yamamoto

TENNIS SHOE

SKI JUMPING SHOE

OUTDOOR SHOE

SPRINTING SHOE

NIKE PRODUCTS

LEISURE JACKET

SUNGLASSES with interchangeable lenses

WATCH with sports functions

Furniture designs from the Bauhaus period had shown that the original intentions of the designers to design affordable mass furnishings for broad sectors of the population could be turned around to the opposite effect. Today, designers like Philippe Starck try to ensure their products' direct influence on mass culture by distributing their furniture designs through mail-order catalogs, and even by taking over distribution themselves.

It is impossible to arrive at generally valid propositions about the symbolic functions of products. For this reason a scientific theory of design grounded in the humanities must also allow different interpretations of one and the same object.

SEMIOTIC METHODS OF INVESTIGATION

Semiotics, conceptualized as a method for studying all cultural processes (Eco 1972), is also a suitable instrument for investigating symbolism. Since one of the objectives of the process of design is to provide "accesses" between the symbolic worlds of the respective users (or groups of users) and the producers of the symbols (companies), a thorough understanding of the respective sign worlds is imperative. This form of communication can also be designated as a process of coding and decoding information. Particularly important for design are those codes that are supported by agreements, cultural traditions and conventions, and by group-specific socialization processes. From this perspective, as long as products remain within a socially compulsory sign system – a product language – it is possible to decode their lexical content (Selle 1978).

Dealing with symbolic functions means dealing intensively with the multifarious communicative functions of design. In the design process it is often necessary to produce one product version for the national market and another for the global market to ensure that each can be decoded under the conditions of the given socio-cultural context.

Our critique of hermeneutics thus can be applied analogously to symbolism: further empirical studies are required to protect the interpretations of products from the consequences of speculation.

The studies by Csikszentmihalyi and Rochberg-Halton (1989) mentioned above were a major step in this direction, analyzing three generations of American households (with 315 subjects). They

This is the way things were seen even sixty years ago. And I believe: what was still speculation and metaphor at that time has become tangible today. The market has long since recognized that it is no longer possible to sell products that speak for themselves to the most important – that is, the young – groups of consumers. They are no longer concerned with the practical value of goods, but with their value as a spectacle. What is in demand are topical worlds, lifestyles, images of the world – which have to be set in scene by means of cult-like rituals.

— NORBERT BOLZ, 1997

showed that even the instrumental utilization of products in the household is located in the symbolic domains of the given culture: "The development of symbols – signs whose relation to an object is based on a convention rather than on qualitative or physical similarities – in the context of a cultural tradition enables people to compare their modes of behavior with those of their ancestors in order to predict new experiences" (Csikszentmihalyi and Rochberg-Halton 1989). Furthermore, by pointing out that the symbolic dimensions of objects have been researched by ethnologists, Csikszentmihalyi and Rochberg-Halton are able to relate their findings back to the anthropological and semiotic approaches of French structuralism: "Indeed, ethnologists have compiled an abundance of unbelievably detailed descriptions of the symbolic uses of objects from a multiplicity of different cultures" (Csikszentmihalyi and Rochberg-Halton 1989).

In addition to their function as status symbols, objects take on another role in social integration. This is especially evident among children and teenagers, for whom the use of identical products or brands is tantamount to group membership. Sporting goods manufacturers like adidas, Nike, and Puma (see p. 362) are particularly adept at exploiting this phenomenon in their product development and design. The implicit inverse is also true: not using these brands (for whatever reason) results in social exclusion: wearing shoes with two stripes guarantees complete ostracism. Decisive here is not the missing third stripe, but rather the mere fact that the cult brand – adidas – is missing.

One of the best works on the symbolic functions of products was published by Tilmann Habermas (1999), who bases his methodology on both the sociological tradition of Emile Durkheim (1912) and the linguistic tradition of Ferdinand de Saussure. In this it is also reminiscent of the exemplary analysis by Roland Barthes (1985), who defined articles of clothing (fashion) as technological (pattern, textile structure), iconic (emblematic), and verbal (descriptive) systems. The codes which Barthes described have both a denotative and a connotative character. Tilmann Habermas also picks up on Eco's categories of objects of utility and symbolic objects, defining symbolic objects as things "whose explicit and primary use is to mean something," as opposed to objects of utility, which "primarily fulfill a practical task, including both *manipulanda* and *utilitanda* to be applied instrumentally."

Tilman Habermas's approach thus dovetails neatly with the previous discussions and derivations of a design theory based on communication. He also offers an updated discussion of how to apply this theory to non-material products, as Donald A. Norman (1989) proposed.

With reference to Mary Douglas (1988), Tilman Habermas mentions yet another significant contribution to the disciplinary design research adopted and extended by Helene Karmasin. He identifies the process that enables social groups to take part in culture by consuming goods, suggesting that these goods (products) can even be regarded as means of communication. "The more stable the society, the more clearly objects and goods function as indicators of social position."

Hardly any such traditional systems are intact in industrialized countries today, but they are still cultivated in primitive societies. Today, the relations that products have to the social positions of their respective users are only implicit. For this reason the use of symbols is actually more similar to Baudrillard's "proliferation of signs," which, however, can also result in the loss of users' social identities.

A FEW EXAMPLES

This deficit can certainly be regarded as psychological; many retreat into their domestic environments (keyword: cocooning) and load the objects accumulated there with symbolic meaning. An individual's own apartment, house, or room (in the case of children and teenagers) becomes a place that "symbolizes social identity." The body takes on this task all the more: clothing, shoes, jewelry, glasses, hairstyles, tattoos, are all unmediated fields of action for the construction of personal symbols. Indirect fields of action are those related to the body, such as foods, beverages, and personal accessories (pens, purses, backpacks), and also means of transport like skateboards, rollerblades, and scooters. And last but not least, all of the electronic "devices" needed to play and communicate (Fischer 2001). The worldwide cult associated with cell phones also has its source in these teenage symbolization rituals (see p. 348).

Products developed just for this demographic group include the Japanese "Love Getties," the small electronic devices (in mother-of-pearl for females and light blue for males) that can be programmed

Selling stories surrounding the product becomes ever more important in this context. Convincing someone to buy a new bathtub takes more than just the product description, even if the tub is much more ergonomically designed or uses space more efficiently than previous models. Today a bathtub must be sold as a "fun bath," which lets couples bathe together, or God only knows what else. The semantic aspect plays a much greater role than the pure efficiency of the concrete product.

—UDO KOPPELMANN, 1998



SONY STYLE STORE BERLIN
(Photo: Sony Deutschland)

with customized preferences to help teens make contact with the opposite sex. Here individual preferences blend with the collective in a seamless fashion.

On the whole, individualization appears to function only through intense collective experiences. When all members of a group of teenagers have the same sneakers (or at least the same brands), backpacks, and cell phones, every member is equal – the perfect form of social individuality. One remarkably well-founded and illuminating study on teen culture (SPoKK 1997) demonstrated the multifarious spectrum of such communities of identification: the techno scene, ravers, punks, skinheads, head-bangers, hip hop, inline skaters, street basketball players, acid house fans, boy groups and girl groups and their fans, snowboarders, beach volleyball players, and many, many more. What they all share is the use of identical sign systems, rituals, and clothing.

Tilman Habermas also picked up on Bourdieu (1979), claiming that membership in subcultures (with their respective value and life orientations) can be portrayed and described not with individual symbols, but only with entire systems of symbols. In the 1990s the “lifestyle discussion” this initiated became a leitmotif of both design theory and design practice.

A post-doctoral dissertation at the philosophy department of the University of Cologne provided evidence for the validity of the lifestyle approach. Friedrich W. Heubach’s psychological analysis of the everyday (1987) proceeded from the different connotations possessed by, for instance, household utensils. Every culture in the world has attributed to these objects symbolic meanings – often, these have become more important than their original meanings. Without alluding directly to design – Uta Brandes (1988) was the first to chart that territory with a profound review that greatly enhanced the impact of Heubach’s work – Heubach established a direct link to semiotic models of cognition, speaking of the “double objectivity of things,” which is equivalent to Eco’s conceptualization of first and second functions.

However, sociological research is concerned with similar questions. Paul Nolte (2001) claimed that private consumption (especially based on the purchase of brand products) has great importance for an individual’s “self-styling;” that is, the social determination of the individual today no longer occurs through prescribed patterns as when “belonging to a certain class was part of individual identity; it offered

**BMW X3**

general view/detail of interior
(Photos: BMW Munich)

VOLVO XC90

general view/detail of interior
(Photos: Volvo Cologne)

a community that granted social security." These mechanisms emerged in the nineteenth century and have definitely hit retirement age. The social definition of the individual takes place through the acquisition and possession of products. "Tell me what you buy, and I'll tell you who you are" runs the new creed. Individuals no longer define their social role through the world of work, but rather through everyday life, and especially through consumption. Whether you shop at the discount supermarket or the specialized delicatessen expresses more than the traditional sociographic features used in market research: age, gender, education, profession, and income.

Consumption and the respective lifestyle thus take on a new role, not leveling social differences, but making them particularly evident. Consumption, therefore, also yields new class societies, formed and simultaneously differentiated by social behavior, sports, vacation habits, and fashionable restaurants. From this perspective, consumption also constitutes a broad field for the study of design.

One of the most successful new categories of automobiles is the SUV (sports utility vehicle), which secured a considerable market share in the second half of the 1990s. In 2002 over three million were sold in the United States alone. The practical functions of these products (four-wheel drive, step-down gears, differential lock) can actually be used by very few owners (farmers, foresters, residents of mountainous areas). However, the symbolic effect of SUVs is unmistakable: their owners clearly set themselves apart from the drivers of other mass-produced vehicles; they increase the individuality of the driver. The driver sits high, looking down, not only on traffic, but on the world in general. The elevated seating position also imparts security, which is particularly valued by female drivers (Reinking 2002).

Proceeding from the classics of this market segment (Land Rover Defender, Range Rover, Mercedes G, Jeep Wrangler, Lada Niva), a number of new vehicles emerged (BMW X5 and X3, Mercedes M Class, and the Volvo XC 90), all of which were developed and designed to meet the buyers' symbolic needs. Porsche and Volkswagen brought two new vehicles onto the market in 2002, which, based on a similar platform, led to different creative interpretations. The Porsche Cayenne is an all-terrain race car (with 340 or 450 horsepower, and a maximum speed of 242 or 266 km/h), while the VW Touareg caters to the need for luxury, for a clientele that connects cross-country mobility with a fine interior and comfort: a SUV-vehicle

What would Jesus drive?
By now Lutz, the head of GM's development division, has an answer ready:
"Jesus would drive a Hummer." The military all-terrain vehicle, tried and tested in the first Gulf War, is an obvious choice because the Messiah spent most of his time in desert areas.
____DER SPIEGEL, 3/2003



OUTDOOR PRODUCTS by Globetrotter

BRAKE

SCREW CARABINER

FIGURE EIGHT

KNIFE WITH SAW-TOOTHED EDGE

TOURING BACKPACK

for cruising in the metropolis, or for field trips away from the office towers of the working world in and everyday life in suburbia.

Thanks to symbolic supercharging, the manufacturers of outdoor clothes and equipment have experienced a similar boom since the 1980s. As a consequence of increasing global travel to the most remote regions of the world (Andes, Himalayas, Antarctica), demand has grown for practical, high-quality equipment. Designers have successively integrated the experiences of professional mountaineers (in the Alps, for instance) to market products to a broader clientele. In Germany, for instance, a great number of specialized stores emerged to provide selected products for globetrotting travelers. The names are symbols in themselves: Outdoor, SINE (from "sinecure" = without care), Supertramp, and many more.

These stores carry clothing and shoes, backpacks and tents, sleeping bags and mountain climbing equipment, equipment for winter sports and water sports, knives and tools, outdoor kitchens, maps and books – everything required for expeditions, safaris, survival vacations, and trekking. An autonomous, functional world of products, which stands out for its symbolic compactness and consistency. This is where professionals buy their equipment: only high-tech materials are used and quality is guaranteed. All of the salespeople have outdoor experience themselves; they know what they are talking about and can give advice accordingly – which is truly necessary, for selling an item like a flashlight for about EUR 400 (approx. US \$900) requires a user's expert knowledge. But even people who spend time in open country only sporadically and are unlikely to be exposed to danger can appreciate the qualities of high-tech equipment: the image transfer and symbol transfer works flawlessly (Ronke 2002).

Symbolic worlds such as these are what determine current design discourses and therefore describe anew the close interactions between products and their contexts (see Kohl 2003).

The "Swiss knife" thus feels good as a haptic object in your hand, even when there is nothing to cut and you're just playing with it in your pocket.

— GERT SELLE, 1997

FROM PRODUCT LANGUAGE TO PRODUCT SEMANTICS

The Kantian category of reason outlined a cognitive horizon that can serve as the foundation for a consistent and logical disciplinary theory of design. In complete opposition to the beginnings of theory

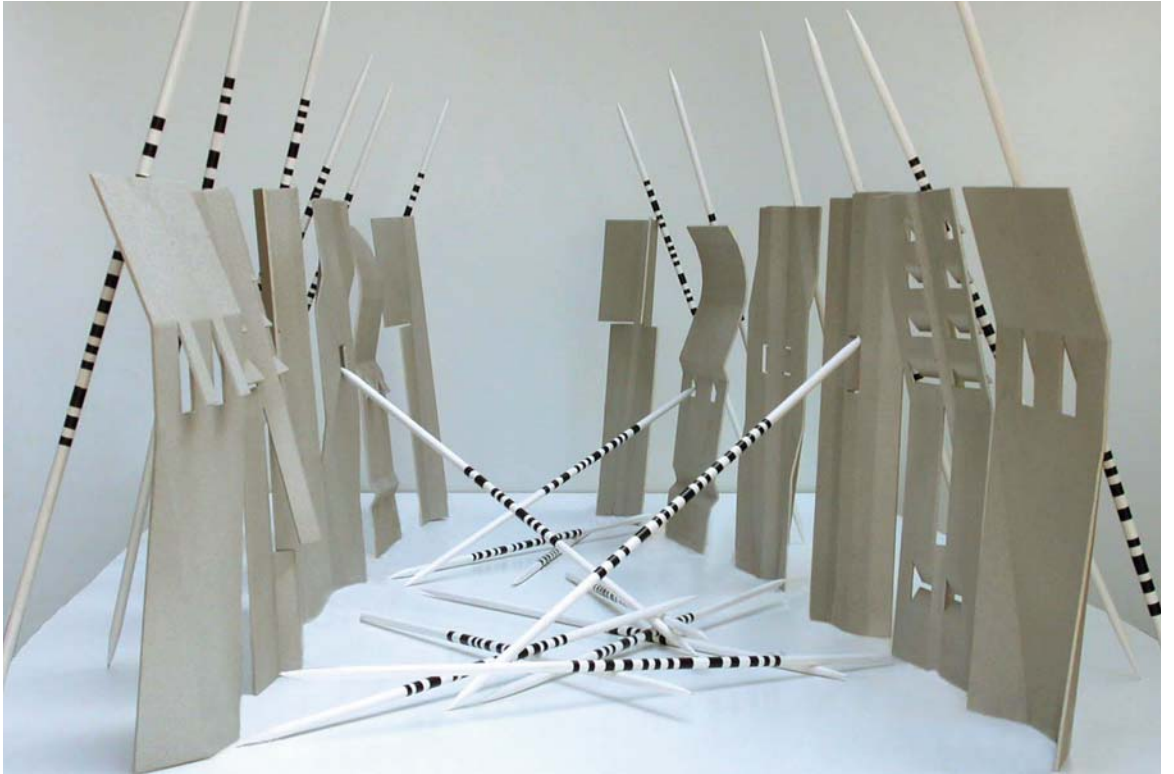
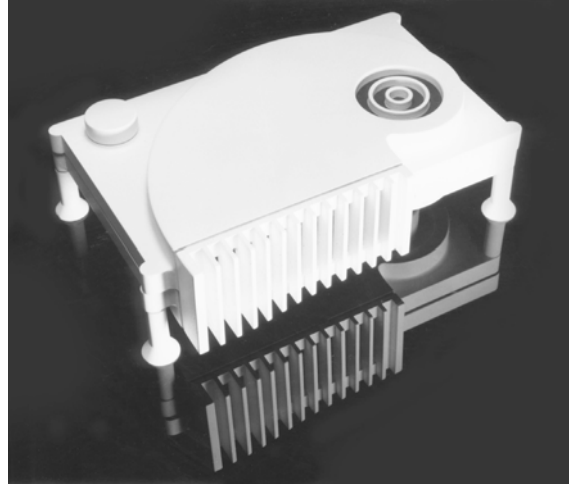
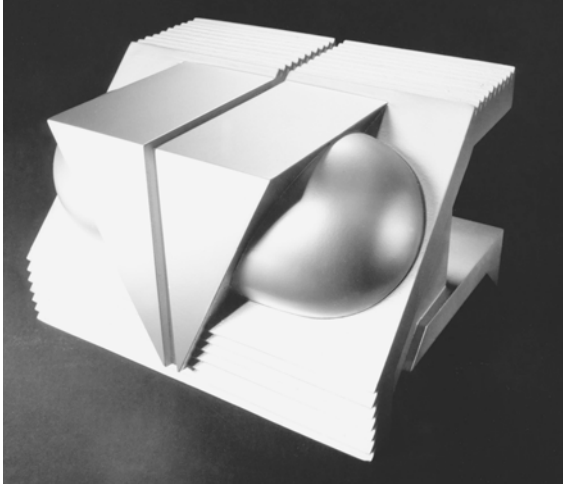

PRELIMINARY MODEL OF AN ESPRESSO MACHINE

design: Uri Friedländer

FAN HEATER, design: Winfried Scheuer

KAMPFSTÄTTE ("BATTLEFIELD"), design: Helga
Lannoch

construction at the Ulm School of Design – the contingencies of which were discussed in a previous section – a decisive instrument has existed since the 1970s that can be applied to design for description and generation. Description here designates the processes of defining, analyzing, and criticizing design using the expedient and evident methods of the humanities. Generation means the actual process of designing, for which this instrument has proven its worth over a wide spectrum of tasks.

THE FORERUNNERS

Uri Friedländer (1981/82) stated at the beginning of the 1980s that the epoch of timeless design was over, that weariness prevailed in the face of “good design.” In contrast to the postmodern tendency of groups like Alchimia and Memphis (who concerned themselves exclusively with interior design) prevalent at the time, Friedländer – and separately, but in parallel, Winfried Scheuer – attempted to apply new design tendencies to technical devices. They did not intend for products to become the carriers of practical functions; instead, symbolic functions would attain even more importance.

Friedländer’s approach involved an extensive use of what he called “metaphors” and defined in relation to three bases of comparison:

- the historical metaphor, which reminds us of earlier objects,
- the technical metaphor, which contains elements from science and technology, and
- the natural metaphor, in which shapes, movements, and incidents from nature appear.

The first results of these attempts were designated as sensual-expressionistic or metaphorical designs.

In the 1970s Helga and Hans-Jürgen Lannoch (1983, 1984, 1987) responded with irony to Wolfgang Fritz Haug’s exposé of the dual character of the commodity by designing erotic product sculptures, which they called meta-realistic sculptures (Lannoch, 1977). While mechanical products had been designed from the interior to the exterior (form followed function), today’s electronic products consist almost exclusively of an exterior directed toward the user. Now the user and his/her physical and psychological characteristics are determining form. Using the example of semantic space, the Lannochs



ROLLER RADIO, design: Philips Corporate Design

BOOK COMPUTER, design: D.M. Gresham with Hel Rinkleib, Cranbrook Academy

STEREO RECEIVER, design: Robert Nakata, Cranbrook Academy

demonstrated that relationships between people can be described spatially to the extent that they are mediated by objects. They called the method thus derived “semantic transfer” and developed creative exercises that transpose words into shapes and interpret them from the perspective of the given period. Accordingly, once again semiotic and hermeneutic elements are included in this approach.

Through language every human is subjected to super-individual, comprehensive structures. This is also true for the architect/artist. He is not an independent author, but rather determined by discourses.

— BARBARA STEINER, 1994

INFLUENCES FROM LINGUISTICS

Design theory based on linguistics was of particular importance in the United States. In 1984 Reinhart Butter, together with the Industrial Designers Society of America, initiated a special issue of the journal *innovation* on “The Semantics of Form.” With papers by Klaus Krippendorff and Butter himself, Jochen Gros, Michael McCoy, Uri Friedländer, Hans-Jürgen Lannoch, and others, this journal paved the way for a new conception of design in the United States. Butter succeeded in enlisting the enthusiastic support of American designer Robert I. Blaich, who was design director at Philips in Eindhoven from 1980 until 1992. From this point on, product semantics was propagated throughout Europe through seminars, publications, and new product lines. Philips had great success with its “design strategy of expressive forms” (Kicherer, 1987). For instance, over 500,000 units of the “roller radio” were sold shortly after its market launch.

A close relationship is evident between American product semantics and the semiotic approach of the Ulm School of Design, as Krippendorff (1984, 1985) indicates. For him, the meaning of an object constitutes the aggregate of all contexts in which the object can occur. Everything that one knows about it and can state – history, manufacturing process, users, logic of its functions, economic value – is mediated through language.

Krippendorff describes three models of product semantics. First, a linguistic model that studies the meaning of concepts, and thus language within the language. Here he makes reference to Wittgensteinian discourse analysis. Second, a communicative model in which the designer functions as the transmitter, but affects this by evoking associations in the recipient (What do consumers buy? How do they deal with a product? What impression do they want to make on others by using the product?). And third, a cultural model in which systems of symbols are analyzed, that is, the inner structure,

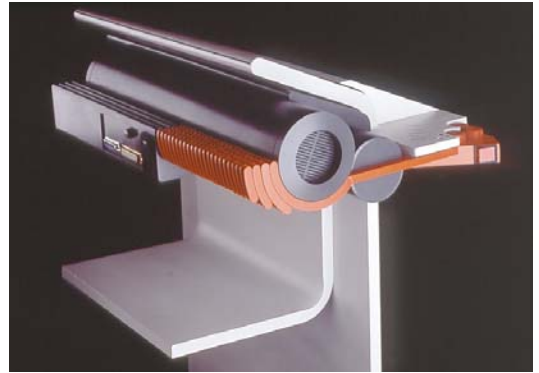

ELAINE PRINTER, design: Technology Design
general view/detail

PHONEBOOK, design: Lisa Krohn, Forma
Finlandia

(Photo: Pekka Haraste/Studio Fotoni)

the elements of form, the inherent dynamics, and their representative functions. Further developments in product semantics were reported in the journal *Design Issues* (V:2, Spring 1989), and in publications on the occasion of a conference at the UIAH in Helsinki in summer 1989 (Vihma 1990); a comprehensive documentation is under preparation by Krippendorff.

THE MCCOYS AND CRANBROOK

One of the first American institutions to pick up on the concept of product semantics for training was the renowned Cranbrook Academy near Detroit. Eliel Saarinen and Charles Eames had taught there in the 1930s and 1940s; graduates included Harry Bertoia and Florence Knoll. The designer couple Michael and Katherine McCoy consciously emphasized these historical roots in their instruction: Harry Bertoia developed his chairs from pictures of cellular structures, and Eero Saarinen used associations of flight for his design of the Dulles Airport building. The principle of metaphors plays a major role even today: visual analogies in design improve the practical functions of the respective products (McCoy 1984).

In a very short time the McCoy's succeeded in developing with their students a number of exemplary designs based on product semantics. In a paper about design in the information age (1988) they, too, picked up on the semiotic approaches of the French structuralists (especially of Ferdinand de Saussure), by portraying the designer as the interpreter of the product's meaning for the user, the mediator between people and the information that surrounds them. The McCoy's also recalled Le Corbusier's claim that some objects function as background, whereas others come into the foreground with great expressive power. In the 1920s it had been Le Corbusier's tables, cabinets, and tables that receded into the background.

Product semantics experienced its actual breakthrough when Cranbrook student Lisa Krohn won first prize in the Forma Finlandia design competition, demonstrating the kind of design potential the concept would release, especially for electronic products. Lisa Krohn's design was true to the traditional way of dealing with books – leafing. Each page of her electronic notebook contains a user's manual, and the interplay between hardware and software makes it easy for even a computer novice to use.

It is high time to stop and take serious stock of the linguistic shift in the human sciences. If anything, one might hit on the fact that the favored activity of flogging the dead horse of the emblematicness of everything and anything is an expression of pseudo-enlightenment. The popular vulgar semiotics cultivates a class of free riders who have "seen the light." It simply does not get us anywhere to keep on emphasizing that signs are only determined by other signs and not through their correspondence with the world.

— JÜRGEN LAU, 1998

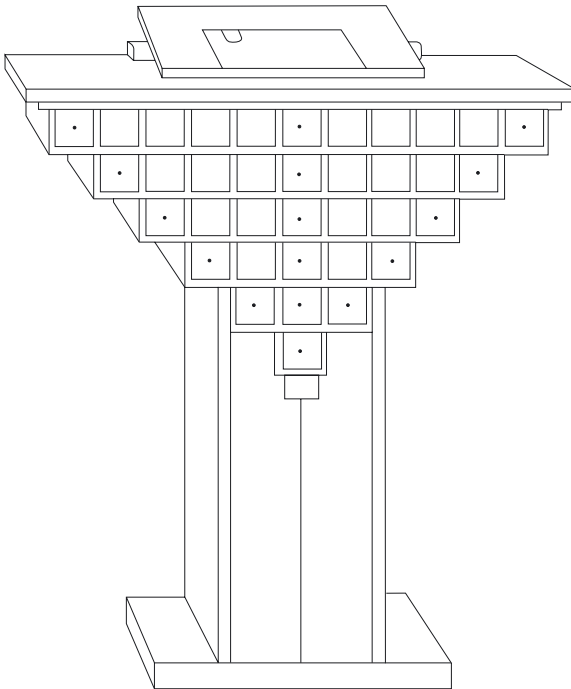
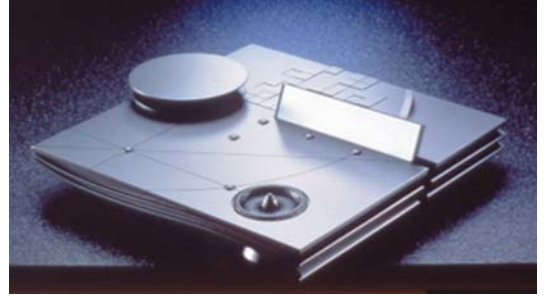
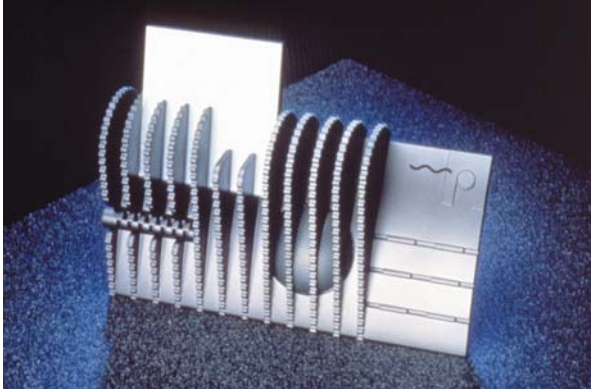

DIGITAL ANSWERING MACHINES, design: Design
Logic

ASPIRANT STANDING DESK, design: Herbert Pohl
(1986)

This is why product semantics received special attention in a far-reaching publication about American design by Hugh Aldersey-Williams (1988). This publication even propagated the impression that product semantics was the topic of American design in the 1980s. Although it had been characterized by more pragmatic approaches in the past, here explicit reference was made to the ideas of the French semioticians Roland Barthes and Jean Baudrillard.

On the other hand, product semantics demonstrated a continuity with the great designers of the styling period, who were explicitly concerned with shaping their products (i.e., the aesthetic questions of design). Aldersey-Williams pointed out that since social, cultural, and even mythical aspects flow into design today, design had to do justice to all of them.

When the McCoys left Cranbrook Academy in 1995 (after teaching for over twenty-four years), it meant the end of product semantics at this design school. In a kind of retrospective, Michael McCoy (1996) designated this phase as one of "interpretive design," which at its core is even closer to product language. He compared the linguistic turn, which came into force in structuralism and post-structuralism, with examples from the architecture of the 1970s and 1980s – which he indicates were the conscious point of departure for his work at Cranbrook. He said he believes semiotics to be too tightly restricted to the production and reception of signs and therefore prefers the concept of interpretive design, which covers the broader field of cultural production. His idea of good design is any design suitable for the given use and context.

PRODUCT SEMANTICS IN EAST GERMANY

Product semantics was reviewed and underwent further development not only in the United States, but also in former East Germany, where its extension constituted an interesting parallel to the product language approach. From 1977 to 1996, Horst Oehlke directed the department of theory and methodology at the former Hochschule für industrielle Formgestaltung Halle, Burg Giebichenstein (Academy for Industrial Design in Halle, Burg Giebichenstein). The foundations for a new direction in design theory were laid in the regular colloquia held there (Oehlke 1977, 1978). At a seminar on functionalism, held in February 1982 by the Office for Industrial Design in Berlin, Oehlke outlined

the topic of visualization, which he identified as the central task of functional design. His definition of visualization was making the respective utility values of a product visible to the user so that the user could easily comprehend its nature. Here Oehlke followed up on Gropius's eidetic inquiry. Probably the most concrete contribution to this field was Oehlke's dissertation, submitted in 1982 and published in 1986, on the topic of "Produkterscheinung / Produktbild / Produktleitbild – ein Beitrag zur Bestimmung des Gegenstandes von industriellem Design" (Product Appearance/Product Image/Product Model: A Contribution to the Determination of the Object of Industrial Design). In further publications, especially in the journal *form + zweck*, he presented intermediate findings, follow-up studies, and the like.

DESIGN AND ITS CONTEXTS

FROM CORPORATE DESIGN TO SERVICE DESIGN

Companies and organizations worldwide have increasingly come to recognize the importance of the design factor. Going beyond the design of individual products to include product systems, hardware and software, and service design means entering a sphere that is gaining more and more significance in design: corporate identity and corporate design.

HOW IT ALL BEGAN

The Shakers mentioned previously in the context of the development of design in the United States may be considered as the first to have taken an all-encompassing approach to living and designing. The furniture and domestic utensils they developed in the eighteenth century manifest a shared system of ideas, values, and norms. This early brand of functionalism, which did not begin to take shape elsewhere until the nineteenth century, can be counted as an example of identity in that the functional, aesthetic, and social quality of the products was understood to express religious culture. A characteristic feature of Shaker products was the principle of equality apparent in them. Aesthetic distinctions were not used to mark any hierarchies of use, nor did the products reflect contemporary design fashions.

Early in the twentieth century, from 1907 to 1914, the German architect Peter Behrens was responsible for redesigning the products, factory buildings, showrooms, graphic materials (catalogs, price lists, etc.), and even the trademark of the German electrical corporation AEG (Allgemeine Elektrizitäts-Gesellschaft). He also designed exhibition stalls, sales outlets, and apartments for the

Even if Shaker aesthetics are quite cool, their functionalism was by no means merely materialistic, but determined in essence through their social ethics, without which there can be no design that completely satisfies human needs. The perfect serviceability that these aesthetics demanded of the practical object also includes non-material qualities. They knew this well, even if they only recognized the beauty integrated into the expedience. As rigorous and well suited to their Puritan life as their functionalism was, it still set standards for the design of serviceable objects.

— HANS ECKSTEIN, 1985

workers. It is to him that we owe the notion of industrial culture that goes beyond the recording of objects and emphasizes the knowledge of historical contexts and living conditions (Glaser 1982). Peter Behrens, in the usage of his day, would have been called the artistic adviser of an industrial company; today, however, he would bear the title of corporate designer or even design manager.

The Italian company Olivetti introduced corporate design and corporate identity as commercial strategies and expanded corporate culture to include, in particular, social services provided by the company for its employees.

Meanwhile, in Germany, after World War II, Braun was the first company to seek to unify the visible aspects of its activities in areas ranging from product design to visual communication and architecture. "Good design" is an established term for such efforts to bring unity to the visible aspects of a corporation's activities and institute a consistent identity in the two- and three-dimensional areas of its output. The German graphic designer Otl Aicher gave design an important impetus here when he created the visual image for the Olympic Games in Munich in 1972, but he also developed corporate design programs for Deutsche Lufthansa, the kitchen furnisher Bulthaupt, Dresdner Bank, ERCO, FSB, the television station ZDF (Zweites Deutsches Fernsehen), and Westdeutsche Landesbank. Other companies that adhere to this modernist tradition and orient their image on its principles are IBM, the writing instruments manufacturer Lamy, Siemens AG, the heating technology supplier Viessmann, and the office furniture company Wilkhahn.

that is what actually makes the question of the corporate image a philosophical and moral phenomenon. it raises the issues of clothing, of fashion, of appearance, but not first and foremost. it raises the question of existence. who am i? that is the decisive question of self-portrayal.

— OTL AICHER, 1990

DEFINING TERMINOLOGY

So what exactly do companies mean when they talk about strategic design? The most common terms are corporate behavior, corporate communication, corporate culture, corporate design, corporate identity, corporate strategy, and corporate wording. In this context, "corporate" means unified, joint, overall. The fusion of different elements, images, and strategies is therefore the key to these important instruments of management policy.

DEFINING IDENTITY

The notion of identity plays an important role in this context.

Martin Heidegger discussed problems of identity and difference in two lectures (1957). Both terms today resurface at the center of the debate on questions of corporate identity or corporate design.

In Heidegger's words: "According to a common formula the axiom of identity reads: $A = A$. The axiom applies as the supreme rule of thinking. In the German language the identical is also called the same (*das Selbe*). And for something to be the same, one thing is sufficient, while equivalence requires two. Hence this concept is based on a mediation, a combination, a synthesis: uniting into a unity" (Heidegger 1957).

Hence "identity" refers to the complete unity or correspondence of things or persons, to an essential consubstantiality. With regard to "identity," the question therefore is one of uniting or creating a synthesis of two different elements. Applied to the activities of corporations, organizations, or municipalities, this means that a company's internal performance profile, its specific know-how, expertise, and attitude is brought in line with its external performance profile (e.g., product design, communication, or the brand image). The degree of correspondence then represents the respective company identity. "Corporate identity" in this sense is an exact term for the unity of content, communication, and behavior of a company or organization (Bürdek 1987). The aim of all CI activities therefore must be to express the identity of a company's internal and external essence (Rieger 1989) or, to put it simply: "Be what you are."

A good way of finding out what that is, is by developing the personality of a company or institution. Defining the basic principles for implementing corporate identity in practice, Peter G. C. Lux (1998) explicitly pointed out that identity has to be shaped from within, and can never be imposed from the outside. To this end, Lux suggests emphasizing the respective "personality" (of the company or institution):

- Its needs are a central concern in this context, while
- expertise refers to particular skills and abilities, and
- attitude stands for a company's philosophy and policy;
- the constitution encompasses the physical, structural, organizational, and legal framework of activities;

- temperament describes how results are achieved (i.e., the company's strengths, intensities, speed, and emotional state); while
- origins refers current features back to the past, placing special emphasis on the principle of continuity; and
- interests include the concrete mid- to long-term objectives and goals set for the future.

These, then, are the features that corporate identity experts outline, discuss, and decide. The next step is to work them into a code of conduct that is binding for all concerned and so provide the basis for design activities.

THE ROLE OF PRODUCT DESIGN

Product design itself increasingly represents the central concern of all corporate measures. First impressions are the most lasting, and design determines the first impression that (potential) users have of the product. In 1980 Wolfgang Sarasin pointed out that, in many cases, forceful corporate identities emerged with the development of distinctive product identities. Since a company's identity-building process is primarily seen from the outside, he says, particular care has to go into aspects related to product design.

This is also an important background for the design campaigns of the 1990s. Numerous European companies noticeably increased their design activities, even promoting them to the status of strategic instruments, as is especially evident in the automobile industry. In some Asian countries, such as Japan, Korea, or Taiwan, design has been recognized as the crucial instrument for achieving success on a global scale, and is deployed accordingly.

CORPORATE STRATEGY

The activities of numerous corporations and institutions illustrate the strategies employed, individually or in combination, to shape a company's image. The following areas are especially relevant in the context of design:

- communication
- behavior
- product design
- interface design
- interior design and architecture

CORPORATE COMMUNICATION

This is the area in which corporate design measures have been implemented most frequently. Following the outline mentioned above, all the elements of a company’s graphic image are planned and realized on the basis of “design bibles,” the design manuals that specify standards for the logotype, lettering, colors, printed materials, vehicle lettering, and similar material.

The Italian company Olivetti is both a classic and a pioneer in this field. In the early 1970s its Servizio di Corporate Identity section, headed by Hans von Klier, produced the legendary Red Books, laying down a design framework within which Olivetti’s national subsidiaries could develop initiatives and variations of their own (Bachinger and Steguweit 1986). In the meantime, numerous other companies have developed similar graphic manuals, taking what is certainly an important step toward a corporate design (Schmidt 1994, 1995). From an international point of view, the design manual of the Xerox corporation is an outstanding example. Assembled in the 1980s, it sets up binding guidelines on product forms, communication materials, interfaces, and so on.

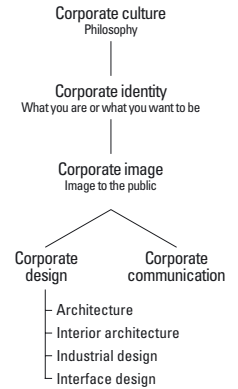

CORPORATE BEHAVIOUR

Behavior – both inside the company and toward the outside – is an important factor in companies and institutions. It includes components like interaction between employees, but also their behavior toward people outside the company. A further aspect is behavior toward the media and the public. How are innovations, change, accidents, or other matters best communicated? Public-relations work in itself has become a key element of the behavior used by the public to gauge the credibility of a company or institution. The “image” essentially deriving from a company’s behavior strongly



influences the way it is perceived and judged by the public. Though companies have realized that the challenge is to shape and design this image, product design has been slow to react; nonetheless, it is one of the non-material aspects of design.

CORPORATE DESIGN

This includes all measures aimed at shaping a company's image at the material level (i.e., its two- and three-dimensional manifestations from logo to company headquarters). This classic field of corporate activity is characterized by fixed design constants and variables that guarantee the desired unity in the visual appearance of companies and institutions. That includes binding instruments like the corporate design manuals mentioned above.

Corporate design as systemic thinking and acting drives the interaction of all elements of a corporation; that means its products, its services, its facilities.

— FLORIAN FISCHER, 1996

EXCELLENCE IN CORPORATE DESIGN

Siemens

Founded in Berlin in the nineteenth century, Siemens today is one of the leading manufacturers of electrical and electronic products worldwide. Over the decades its product design has always been oriented on modernism (i.e., the company aims to communicate the technical efficiency of its products through a corresponding design idiom). Short-lived, fashionable, or trendy frills are strictly banned in this high-tech enterprise. It is only in the area of cell phones, a branch that has been gaining economic importance since the mid-1990s, that an increase of lifestyle elements can be observed, constituting, as they do, an indispensable feature of this product area.

To keep up a uniform standard in the company's numerous operations, in the 1980s Siemens began developing a corporate design manual and created one of the most comprehensive and exemplary manuals in existence. Approximately twenty individual booklets define uniform standards for areas ranging from business documents to printed materials, trade fairs, packaging, company vehicles, dress code, and architecture. The manual describes the constants of design (trademark, colors and surfaces, artwork) to be applied in all products. However, it also addresses the products, stipulating that they be up-to-date and adequate to their contexts and target

groups. As the dematerialization of products progresses, the company has also devoted a separate booklet to the subject of user interfaces.

Vitra

The German-Swiss company Vitra is generally considered one of the most distinctive examples of a pluralist corporate design that manifests itself in a variety of different activities. From all over the world, visitors interested in design and architecture today flock to the factory in Weil am Rhein in southern Germany.

The owner of the company, Rolf Fehlbaum, is one of the foremost collectors of chairs from all over the world and from all periods. This extensive collection provides the essential basis for the great creativity that characterizes Vitra's product development. In 1987 Fehlbaum launched the Vitra Edition, which he sees as his contribution to research (Bürdek 1996c). Experimental designs by artists such as Ron Arad, Paolo Deganello, Frank O. Gehry, Jasper Morrison, Gaetano Pesce, Bořek Šípek, and many others, composed a product line marketed side by side with the traditional collection.

Vitra's most daring enterprise, however, took the form of architecture. Proposals for new factories and a design museum were drawn up and realized on the basis of a master plan devised in the early 1980s by British architect Nicholas Grimshaw. Variety was once more the guiding principle; each building was designed by a different architect. Tadao Ando's conference pavilion was his first building in Europe. Alvaro Siza created a manufacturing hall, Zaha Hadid the fire station, Frank O. Gehry the design museum. This architectural ensemble vividly illustrates how targeted design activities can transform a medium-sized company into a veritable global player of corporate culture. That the outstanding architecture also has an influence on the everyday operations of the company, the owner only mentions in passing: "Its presence on the company site, the daily confrontation with the best that the history of design has to offer, does have a noticeable internal effect. The stimulating surroundings have become a crucial motivating factor for all employees" (Fehlbaum 1997).

FSB (Franz Schneider Brakel)

In the early 1980s Jürgen W. Braun, who had originally trained as a lawyer, was appointed managing director of the medium-sized

Good design has another point of departure. It derives from an attitude, and is thus a mixture of ethics (the designer's and the manufacturer's) and aesthetics. It emerges over the course of what is usually a protracted problem-solving process, during which many experiments are performed until a balanced result is achieved.

— ROLF FEHLBAUM, 1998



VITRA DESIGN MUSEUM in Weil am Rhein,
design: Frank O. Gehry (Photo: Thomas Dix)

**FSB DOOR HANDLES**

design: Christoph Ingenhoven

design: Hartmut Weise

design: Rahe+Rahe

design: Hans Kohlhoff

design: Tom Haas

company FSB, based in Brakel in Westphalia. At this time the manufacturer of metal fittings and door and window handles was an unknown quantity as far as design was concerned, and the products were marketed more or less anonymously in hardware stores. During preparatory work for a new product catalog, ERCO's Klaus J. Maack put FSB in touch with Otl Aicher, who told Braun to pause and consider the sense and purpose of FSB as an enterprise. The result was a book (Aicher and Kuhn 1987) bringing to light important insights on "the art of holding and gripping," while at the same time representing the first in a truly unique series of books (see bibliography: FSB).

In 1986 FSB invited a number of architects and designers to a workshop on door handles in Brakel. The outcome was a string of new designs, some of which went into series production. Clear identification linked each product to its designer (e.g., Hans Hollein (see p. 375), Mario Botta (see p. 371), Alessandro Mendini (see p. 379), Dieter Rams). Press reports on this event were so extensive that they triggered a public-relations effect that would otherwise have required the advertising budget of a large corporation. But the door handle workshop in Brakel also had the additional effect of making architects aware of FSB as an open-minded partner for the creation of unusual fittings for new buildings. Corporate image becomes manifest even in such seemingly banal architectural details, moving away from standardized mass products to customized solutions (Kleefisch-Jobst and Flagge 2002).

Alessi

The example of the Italian metal goods manufacturer Alessi illustrates how a small workshop and foundry, working with brass and nickel silver sheet (founded in Crusinallo in 1921), turned into a global player that ideally represents the great variety of Italian design while giving perfect expression to a postmodern lifestyle. In the 1920s and 1930s the workshop produced household articles such as pots and pans, trays, tea and coffee services, and cutlery, all ornamented in the style of the time. Carlo Alessi, who had trained as an industrial designer, created most of the company's post-war products, and since 1955 the company has also worked with freelance designers whose product proposals contributed to the development of the Italian *bel design*. In the 1970s Alberto Alessi began to outline a company philosophy centered around the



PRODUCTS BY ALESSI

TRAY, design: Josef Hoffmann

PRESSURE COOKER, design: Stefano Giovannoni

UNICCI SOAP DISH, design: Francesca Amfitheatrof

FLATWARE, design: Marc Newson

VEGETABLE CHOPPER, design: Stefano Giovannoni



SITGES PLATE SERIES, design: Lluís Clotet

GINEVRA GLASSWARE, design: Ettore Sottsass

FISH PLATTER, design: Jasper Morrison

FRUIT PLATTER, design: Stefano Giovannoni

idea of mass-producing affordable articles that would meet artistic standards.

In 1972 Ettore Sottsass joined the company and opened up meta-theoretical discourses on design and the world for Alessi. In the following years Richard Sapper, Achille Castiglioni, Alessandro Mendini, Aldo Rossi, Michael Graves, Philippe Starck, Enzo Mari, and many others worked with Alessi. The company had turned into the spiritual home of Italian design.

The Tea and Coffee Piazza project illustrates this particularly well. In 1979, on the suggestion of Alessandro Mendini, the company began commissioning eleven different architects and designers to create tea and coffee services. Production was limited to ninety-nine services of each design, most of which went to international museums, galleries, and private collectors.

In the 1990s collaboration between Alessi and the Dutch company Philips resulted in a product line of emblematic character. The articles were so emotionally charged that they could be filled with personal meaning as home companions. Their actual functionality was relegated so far into the background that it was basically negligible.

Alessi successfully used its strategic and comprehensive design activities (e.g., the Museo Alessi opened in Crusinallo in 1998) to stay on the cutting edge of creativity. Individual products such as the espresso machine *9090* (1979), the kettle with the bird-shaped whistle by Michael Graves (1985), the corkscrew *Anna G.* (1994), the kettle *Hot Bertaa*, and the lemon squeezer *Juicy Salif* (both 1990) by Philippe Starck, the *King-Kong* manikins and other ornamental articles by Stefano Giovannoni and Guido Venturini, turned into veritable cult products and are represented in galleries and department stores in Europe, Asia, and the United States. In Alessi the postmodern lifestyle finds congenial expression in perfect products endowed with an ironic sense of humor (Alessi 1998).

CORPORATE INTERFACE DESIGN

The increasing digitalization of many product areas has caused traditional corporate measures to be extended to non-material products (software, display screens on products, websites). The activities of computer scientists and programmers were in pursuit

of objectives totally different from those the designers sought to reach. Efficiency and speed, the overall performance of an application, optimized use of the screen, orientation on standards (e.g., Windows) were important criteria in the development of software user interfaces. It was common practice for every division of a company to develop its own applications and bring them to the market or to the users. The result was a general visual chaos; deep chasms opened up in company identities as well-designed brochures, products, and company buildings contrasted with desolate arbitrariness on-screen.

The product designers were the first to take note of these shortcomings. They began to translate insights from their experience in the three-dimensional world of hardware design into the two-dimensional idioms of software design (Bürdek 1990b, 1993). One of the first companies to recognize the problem and take appropriate action was the former Siemens Nixdorf AG (an amalgamation of the Paderborn-based computer company Nixdorf with Siemens in Munich). A design manual for the creation of user interfaces for consumer software applications (Siemens Nixdorf 1993) was assembled to define and specify the framework for software: brand, colors, fonts, screen layout, graphic symbols (icons), menus and displays, layout grids, codes, and so on. The manual provided developers and programmers with important aids – including model applications – to help them realize their projects in accordance with the Siemens corporate design.

In 1998 the Swiss insurance group Winterthur had a corporate design manual developed that went beyond printed materials to include the company's Internet presence. For this purpose the company's basic visual standards for the logo, fonts, colors, symbols, and layout grid were brought to bear on model web pages.

Looking at the numerous institutional and corporate websites that seem to have not the slightest relation to their owner's corporate design, we understand the fundamental importance of such measures. Websites are all too frequently used as playgrounds for design experiments, an approach that is problematic insofar as the Internet is often the medium by which the first contact with potential clients or customers is established. Corporate communication and corporate behavior play an important role in this context. If, for example, a query submitted by e-mail goes unanswered for a long period, communication opportunities are simply being wasted.

This consideration already takes us beyond the field of corporate interface design and toward customer relations management or CRM. It soon becomes clear that in the age of increasing digitalization, the interface has a much wider scope than previously assumed, as the point where company meets consumer. The challenge is to think in terms of what consumers want. Hadwiger and Robert (2002) have found an apposite formula for branding and usability as important factors in a holistic approach: "Product equals communication."

FROM DESIGN MANAGEMENT TO STRATEGIC DESIGN

DESIGN MANAGEMENT

As design methodology emerged during the 1960s, currents sprang up, principally in the United Kingdom and North America, that were to contribute toward a positive re-evaluation of design in the context of corporate activities. Design management was the new battle cry.

Peter Behrens is once again the obvious figure to mention. His seminal work for AEG at the beginning of the twentieth century has been cited as the first contribution to design management. The corporate design activities that Olivetti initiated during the 1930s also belong in this context. But it was only in 1966 that the Briton Michael Farr combined fundamental principles from systems theory and project management to derive a framework for handling design at the corporate level (Bürdek 1989).

These currents had a strong impact on approaches developed in Germany – which drew on British and American sources as well as methodological work done at the Ulm School of Design – especially on business economics. The main focus was on two issues:

- the development of strategic planning
- the problems related to systematic information management.

These early considerations centered on how companies can appropriately process the information and methodically pursue the kind of product development that successful corporate development relies on (beyond blithe trial-and-error approaches) (Geyer and Bürdek

The supply of information is the actual basis of the brand's and the provider's credibility and thus serves as a pillar of corporate identity. This also includes – as always – corporate design. Interactive consulting and service offers that appear in the Internet in the form of standardized user interfaces usually prove to be a crude break in corporate image, because they convey the image of the system developer rather than that of the actual provider or the purchased brand. With the increasing spread and importance of computer-based media, especially with the diversity of products on offer, there is a growing need for each provider to differentiate itself from the competition and to present a multi-media corporate image of its own.

— WALTER BAUER-WABNEGG,
1997

1970). For this purpose, comprehensive checklists were compiled to aid companies in guiding processes and making decisions on a systematic and transparent basis. AW design was one of the first consulting agencies to develop corresponding instruments and implement them in the operations of a large number of companies (Geyer et al. 1970, 1972).

In the mid-1970s the DMI (Design Management Institute) was founded in Boston, Massachusetts. One of its aims was to prepare and distribute product case studies according to the method used at American business schools, investigating specific product developments to illustrate the possibilities of success and failure. The TRIAD design project, initiated together with the Harvard Business School, gained international acclaim. Fifteen case studies were outlined in a publication and a touring exhibition to draw attention to the importance of design management. Contributors included companies as diverse as the Swedish machine-tool company Bahco, the Dutch producer of ultrasound scanners Philips, as well as Braun (coffeemakers) and ERCO (gantry lighting systems) from Germany. The Design Management Institute regularly hosts seminars and conferences and also publishes the quarterly *Design Management Journal*.

In the 1980s the subject of design management received noticeable impetus once a small group of business economists realized that design had not only aesthetic effects, but also highly relevant economic impacts. A series of doctoral theses (e.g., Sybille Kicherer (1987), Heinrich Spieß (1993), Carlo Rummel (1995), and Hans Jörg Meier-Kortwig (1997)) exhaustively discussed related issues. Design gradually emancipated itself from its roots in the traditions of craftsmanship and gained its place as a full-fledged research discipline. In the 1970s economic considerations also largely defeated efforts to shift the emphasis in design to environmental concerns. The postmodern caprices of the 1980s (such as Memphis or the new design), however, were equally soon forgotten, and it is only in furniture design that designers still flirt with the zeitgeist and flaunt lifestyle rather than adopting a creative attitude.

However, it is this attitude (you could also call it an ethic) that moves companies to embrace design management. Their insecurity and ignorance of how to make design a success turned out to be a relevant gap that up-and-coming consultancy agencies in the 1990s

Although we usually interpret the concept of design in the sense of product design, of industrial design, there is no doubt that it includes far more, that design management indeed primarily refers to corporate design management. Today this increasingly means communication management, because the hardware, that is, the product, is largely comparable and interchangeable. Communicating the brand replaces communicating the product.

— NORBERT HAMMER, 1994

filled by offering know-how in both design and industry, in packages covering the entire process of product development, from market analysis to the conceptual and project phase, to communication and market launch (Buck and Vogt 1996). A comprehensive approach was in order here, and companies also learned that it is possible to fill design with meaning and use it to position products in the market. This became especially evident in the European automobile industry, which garnered great success with a large number of new and differentiated vehicle types. What also became apparent was that beyond individual projects, images and brands – or the process today known as branding – play an increasingly important role.

BRANDING

The term branding originally referred to the marking of cattle on the North American plains. A branding iron burned their owner's name into the cattle's hides for identification. The process works just the same for today's product flows, where individual products are only identifiable (and recognizable to potential buyers) if they stand out from the surrounding variety, if they are conspicuous, and gain attention: labels such as Made by Sony, Made by DaimlerChrysler, or simply adidas, Apple, IBM, Levi's, Microsoft, Nike, Nokia, Palm, Puma, Siemens, Swatch, Vitra, and so forth. The name of a company has to have the same connotation worldwide, and product design is an important factor in economic globalization.

In more and more areas, technical performance is largely identical, with products even being assembled from the same components (e.g., chips mass-produced by Asian manufacturers). So while design plays an important role for differentiation, branding (i.e., the trademark image) gains significance as the factor that, in the end, decides the purchase. The German automobile association ADAC, for example, publishes a quarterly car brand index according to which factors like the brand (trademark image), market power, and brand trends account for approximately 50 percent of the potential consumer's awareness. Vehicle performance (as based on breakdown statistics) or technical trends (innovations introduced by companies) take a distant second place. Brands, therefore, have

Today design management as an autonomous category is being replaced by a comprehensive concept, innovation management, which also integrates the dimension of design.

— GUI BONSIÈPE, 1996

a growing influence on value creation in companies, a development that confirms what has been seen in a different context, that non-material qualities are rated far higher than material ones. Products increasingly convey messages rather than fulfilling practical functions. Brand value has become a central concern for companies. At an estimated \$80 billion, Coca-Cola heads the world ranking in brand value, followed by Microsoft with approximately \$56 billion, and IBM at approximately \$44 billion.

NEW METHODS IN DESIGN MANAGEMENT

Just as design methodology developed a marked innovative thrust in the 1990s, numerous studies compiled around the same time, concentrating on questions related to design management, have a methodological orientation. Remarkably, the focus of analysis was less on the business side than on the communicative function of products: "The theory of product communication makes a comparatively strict distinction between practical and symbolic functions, and among the latter, between aesthetic form and symbolic function. But, in the end, it is their combined effect that allows a coherent product line to be created. The product-effect model overcomes these shortcomings by elaborating the basic principle of the theory of product communication to encompass issues related to innovation" (Buck, Herrmann, and Lubkowitz 1998).

In spite of its strong economic orientation, this holistic approach obviously draws on the communicative approach, while making it clear that the management of symbolic and communicative product functions can be seen as a corporate task.

Methods such as screening (examinations of real product worlds), trend analysis, style mapping (visualization of socio-aesthetic models), or the style configurations of existing and planned products were employed in this context. Different consumer milieus are also investigated and the results brought to bear on the respective aesthetic models. The potentials of this very consistent method of design management lie in its emphasis on visualization, which generates significant advantages in communicating design. The effectual target group are industrial managers who, with a

What makes products/ services on the market interesting and distinguishable, "unique," is actually their meaning, their "semantic added value". One way of imparting meaning is through signs and codes. I assert that success in future markets will depend not only on skillful production and marketing, but also, and perhaps even primarily, on efficiency in the sphere of sign management.

—HELENE KARMASIN, 1993



PUMA BLACK STATION 96 HOURS

BUSINESS COLLECTION

(Photo: Nicole Weber Communications)

MY FIRST SONY

background in marketing or technologies, rarely have much understanding or instinct for questions of design.

These methods, however, are just as useful in a global perspective, where, for example, appropriate visualizations do a much better job of convincing Asian managers of the merits the product proposals of European or American designers and design practices than do dry marketing briefs. In this respect, design management in the 1990s certainly developed into an intercultural skill.

Another publication uses six case studies to show how this approach to design theory and design management proves itself in practice (Buck 2003). The studies rely on some of the methods already mentioned here (e.g., social milieu modeling as developed by Gerhard Schulze and visualized trademark models representing the product-cultural contexts of existing brands, or brands ready for positioning). The concise slogan "Design visualizes everything!" (Buck 2003) once more emphasizes that the communicative approach has become a vital element when design is employed in an industrial context and handled successfully.

STRATEGIC DESIGN

These developments show how, during the 1990s, design became a central concern in product development, with designers taking on an increasing number of communicative tasks for companies, ranging from corporate design to corporate culture, corporate communication, and so forth. The challenge for designers results from their position at the interface of design and business concerns, which also requires a secure sense of context: for example, the contexts of corporate cultures or target groups. The specific role of design here is to illustrate concepts and product strategies in convincing images, communicating at a non-verbal level. "Imagining" (see p. 417) is the apposite term coined to describe this approach.

Design today plays a major role in most companies. "Design or die" is no longer an ironic quip as it was in the 1980s; design today is a serious topic discussed at the management level, and strategic company decisions nearly always include design decisions.

Two examples

In the 1960s British carmaker Morris Motor Company launched the Mini Cooper, a vehicle whose compact dimensions soon made it the most successful city car of London's Swinging Sixties (Woodham 2000). Of course it was just the right car for Mary Quant, inventor of the legendary miniskirt. The car's considerable racing successes and appearance in numerous movies (some starring the comedian Mr. Bean), combined with its prototypical character as a minimalist vehicle, both spawned a cult and made the Mini an ideal everyday vehicle. In this sense it was the British answer to the German Volkswagen, though its technological development had skidded to a halt by the end of the twentieth century.

After taking over the Morris Mini brand, BMW launched a fiercely design-oriented strategic repositioning of this automobile. While drawing on the cult of the previous make, a fresh infusion of meaning directed it toward a new target group: young, successful, urban professionals with high incomes who, when living together, are known as "dinks" (double income no kids), and can and are willing to do some serious spending on a car that is fun, stands for success, and is ideally suited to an urban environment. These creative young consumers appreciate the emotional appeal of the design and the driving fun, and they indulge in a wealth of accessories including sun roofs, five-star alloy wheels, sound systems, and air conditioning (Gorgs 2003). The new Mini fits in well with the sporty image of the BMW trademark and represents a successful strategic extension of the product range.

The Smart was originally conceived of as a vehicle also targeting a young urban audience, which, however, played hard to get at first. For one thing, the list price was too high, and for another, the playfully organic interior design made for a slightly childish impression that was at odds with the intelligent vehicle concept. As a result, it is mostly older drivers who buy the Smart and use it, so to speak, as a shopping cart for the city. Volker Albus, a lecturer at the Karlsruhe School of Design, observed that a designer would probably not take the Smart on a visit to a client, unless, perhaps, he had a daughter and could claim to be using her car. But this unsophisticated image did not stick. Today the German railway Deutsche Bahn offers Smart car-sharing arrangements at about thirty railway stations that provide rail passengers with a Smart (or a bicycle) for urban transport, incidentally accomplishing the orig-

So what can strategic design planning really contribute? The majority of authors proceed from the assumption that our society (and the individuals assembled in it) explains and structures itself to an increasing degree through signs. In the foreseeable future, this emblematic dimension of objects, in opposition to previous functional or even directly practical dimensions of use, will become the wheel that drives society and with it the production of goods as well. Providing a sufficient quantity of sufficiently differentiated signs, which can thus react to all of the demands placed on them, will thus become the task of design.

— ALEX BUCK, 1998



THE NEW MINI
general view/detail

**SMART**

SMART ROADSTER

SMART FOR FOUR

SMART CITY-COUPÉ

CARSHARING with the Smart (Photo: DB AG/
Mann)

inal purpose of the vehicle. The high-speed ICE train linking Germany's big cities and the Smart car certainly represent a meaningful symbiosis.

The Smart Roadster (launched in 2003) addresses a similar target group to that for the Mini: young, active, dynamic, and moneyed consumers who will not let anyone spoil their enjoyment of driving. On the contrary, they consciously use the vehicle to communicate that life is fun.

It only makes sense, therefore, that Smart is planning to launch a "real" car next (i.e., one with four seats), in order to offer a wider range of vehicles that express this user group's attitude to life.

Both examples, Mini and Smart, illustrate the extent to which strategic product decisions are based on design as a major factor in consumer perception. Technical features are taken for granted these days, and no longer convey any sufficient mark of differentiation.

Today we buy cars as if they were toys: a new Volkswagen Beetle for nostalgia, a Smart Car for fun, and a Humvee for attention.

Nicholas G. Hayek, founder and CEO of the Swatch Group and coproducer of the playful, original Smart Car, told us: "If you combine powerful technology with the fantasy of a six-year-old kid, you can create miracles."

— JOHN NAISBITT, 1999

ARCHITECTURE AND DESIGN

The history, theory, and practice of design are closely linked to developments in architecture. From the famous Vitruvian treatise on architecture (Bürdek 1997b) to the present, architectural theory has referred not only to function, but also to aesthetic effect and design, particularly to the meaning of buildings. But what is a matter of course in architecture is not nearly as well established in the theory of design.

Architecture, often referred to as the oldest of the arts and therefore the "mother of all arts," gained a highly important role for design at the beginning of the twentieth century. Many early designers, not least Peter Behrens, Walter Gropius, Mart Stam, Le Corbusier, and Mies van der Rohe, were architects. Walter Gropius, in the 1919 Bauhaus manifesto, called building the ultimate goal of all design activities, and all classes and workshops, were geared toward it. The impacts of architecture and urban planning that triggered a critique of functionalism have already been pointed out. Building activities after World War II, especially in Europe, were so intense that they prevented a discussion of what it was that architects did. Occasional individual statements could hardly aspire to the status of architectural theory. It was only after the building boom declined in the 1970s that architects

once more began to feel the need for theoretical foundations (Kruft 1985).

Important impetus came from American architects. On the occasion of an exhibition at the New York Museum of Modern Art in 1932, Philip Johnson, together with Henry-Russell Hitchcock, published *The International Style*, giving this term worldwide currency. During the 1950s, however, Johnson shed the influence of Mies van der Rohe, and turned his interest toward postmodern architecture.

Architects also had a strong influence on the emergence of Italian design. Mario Bellini, Rodolfo Bonetto, Achille and Pier Castiglioni, Paolo Deganello, Alessandro Mendini, Ettore Sottsass, and Marco Zanuso shaped, one could even say invented, Italian bel design and determined its features through several decades.

In the United States the impact of French structuralism was especially strong in the field of linguistics. Though Tom Wolfe (1986) saw its roots in a kind of late-Marxist duff, its effect on the young Robert Venturi was positive and momentous. His book *Complexity and Contradiction in Architecture*, published in 1966 in the United States, is rooted in a pluralistic attitude (hence the title) and can be seen as the first argued challenge to the predominant International Style. Venturi pointed out that architectural thought in the 1960s turned exclusively on function and form, and that hardly any architects took account of the symbolism of architecture. He used the terms ambiguity, double-functioning, and plurality, and drew on Gestalt psychology to talk about frame of reference. In architecture, the frame of reference can be employed to extend the reference of a sign to include a meaning beyond its immediate signification. This was the first mention of the symbolism of architecture, which was given much greater scope in the study published in 1972 by Robert Venturi, Denise Scott Brown and Steven Izenour called *Learning from Las Vegas*. The authors focused on semiotics as an explanatory model for architectural phenomena. Looking back in 2002, Robert Venturi and Denise Scott-Brown said: "We feel that it is an obsolete approach to make architecture ever more abstract, to reduce it ever farther. That was an important development, but the challenge today is to open architecture to meaning and endow it with a new symbolism." With regard to the language of architecture they refer to early church buildings which, they say, did not just stand around meaninglessly,

but had much to tell people, be it by their imposing shape, the rituals celebrated inside, or the sermons and interpretations proclaimed from the pulpit.

The debate on postmodernist literature that began in the United States in the late 1960s came to Europe by two channels, through the works of Jean-François Lyotard (1982, 1985) and through actual implementation in architecture: "Architecture may not be the first, but it is certainly the most prominent manifestation of the postmodern. It was through architecture and the related debate that people learned that today there is a postmodernist agenda, and that it is not just an idea but a reality" (Welsch 1987).

The worldwide breakthrough of postmodern architecture came in 1978 when Charles Jencks published his book *The Language of Post-Modern Architecture*. The author proclaimed the death of modernity, dating its demise to 15 July 1972 at precisely 3:32 p.m. in St. Louis, Missouri. To him, the end of the International Style in architecture had come with the demolition of the dilapidated Pruitt-Igoe housing estate. The mention of language in the book's title clearly indicates the frame of reference, a renunciation of the monotony and univalence of the International Style. Post-modernism developed from semiotics, which, as a branch of linguistics and hence one of the humanities, allows very different interpretations.

In 1987 Charles Jencks described eleven emergent rules of post-modern classicism in a list that included the terms cultural pluralism, eclecticism, double coding, multivalence, and tradition reinterpreted, and illustrated them with examples of existing buildings. This underlines how much importance architecture today attaches to semiotic debate. Wolfgang Iser even defines post-modernism as the recourse to semiotics, and Hanno Walter Krufft identified the symbolism of architecture as the common denominator in contemporary architectural theories. Obviously, it was no accident that in a parallel development the emphasis in design also shifted to the communicative function of objects. Architecture and design both moved from working with the notion of function to exploring the meaning of buildings or objects in order to arrive at an encompassing language of objects.

Due to the postmodern movement, architecture at the end of the twentieth century experienced a new boom that found expression in a wide variety of concepts, styles, and manifestations.

Many architects engage in theoretical discourse on their buildings, relating them to their respective historical, philosophical, or cultural contexts. This dimension is almost entirely lacking with designers. Their widespread speechlessness ultimately attests to the discipline's lack of maturity, which, however, is hardly surprising. After all, documents of architectural theory go back more than 2,000 years, while the history of design is barely 150 years long.

The various museum buildings erected in many countries are especially illuminating, providing a broad field for experiments with a linguistic angle, while at the same time adding important traits to the identity of a city or region that contribute toward image transfer.

Volker Fischer (1988b) once referred to this kind of boundary crossing between architecture and design as professional piracy of a decidedly one-sided nature. For while numerous architects quite naturally move into the professional field of design by producing, incidentally it seems, furniture, lighting fixtures, door handles, accessories, and so forth, designers rarely reverse the process. On the other hands, in 1994, Philippe Starck designed a wooden house near Paris for his own use and marketed the building kit through the mail-order firm *Trois Suisses*; and in 1999, Matteo Thun developed the low-energy house *sole mio* for a German manufacturer, but its success was rather limited.

ARCHITECTS AS DESIGNERS

The work of a number of architects illustrates the interactions between architecture and design.

Tadao Ando

In projects that reflect the logic and stringency of European philosophers like Heidegger and Wittgenstein, Japanese architect Tadao Ando has been strikingly successful in using contemporary materials to reinterpret traditional conceptions of space. The seminar and conference center he built for Vitra in Weil am Rhein, for example, expresses a high degree of concentration and contemplation in untreated concrete walls and austere furnishings. It is the users who bring these spaces to life.

In my view, architecture is hardly a discipline that suffers from the inability to scrutinize its structures and foundations; indeed, I would actually assert that it is the field that will undergo the greatest innovation in the next century.

— BERNARD TSCHUMI, 1991

Alfredo Arribas

Alfredo Arribas is an important representative of new Spanish design (Bertsch 1993). The restaurants, bars, and shops he created in Barcelona, Frankfurt am Main, Fukuoka, Madrid, Sapporo, and Tokyo express contemporary metropolitan lifestyles in a vivid architectural idiom, and his buildings were soon adopted as in-places by a young, trendy, and well-to-do group of customers.

Asymptote

This American group of architects and designers works at the interface of traditional architecture, urban design, multi-media installations, and computer-generated environments. For Knoll they designed the A3 office system, an environment representing a congenial combination of micro- and macro-architecture. The A3 project is a characteristic example of the way architecture, product design, and media increasingly merge into each other.

Mario Botta

Based in Swiss Tessin, Botta is an important representative of an approach to design that emphasizes the regional and topographical context of a project. His furniture, living accessories, and door handle designs for FSB rely on reduced forms characterized by geometric simplicity. The objects are icons of equal status to his buildings and represent a highly topical reinterpretation of modernism in addressing design and its relevance to all aspects of living spaces.

Santiago Calatrava

Spanish architect Santiago Calatrava is one of the representatives of a structural approach to design oriented on organic models that stand out spectacularly, like icons, in their locations. His focus is on bridges and public buildings, but he also designs furniture. Important buildings he has created include a train station in Lisbon for EXPO 1998 and another for the TGV high-speed train in Lyon, the airport terminal in Bilbao, and various buildings in the Ciutat de les Arts i les Ciències in Valencia. In the latter he paid homage to an explicit symbolism and created a huge eyeball to house the vast Imax cinema L'Hemisfèric, which is also known as the "eye of wisdom" because of the movies it screens. The central building of the complex, the science museum Museu de les Ciències Príncipe Felipe, however, reveals the problems inherent in such expressive



A3 OFFICE FURNITURE SYSTEM, design:

Asymptote, Knoll

A 900 PROGRAM OFFICE CHAIR, design: Foster
and Partners, Thonet

architecture. The dominant curtain walls do not allow much in the way of an independent interior design, and the arrangements of scientific exhibits are squeezed into the building awkwardly. In what could be called a form of architectural branding, the artistic quality of his buildings makes them immediately recognizable as genuine Calatrava creations. Clients are happy to draw on the image transfer related to this effect.

Coop Himmelblau

This Austrian group was founded in Vienna in 1968 by Wolf D. Prix, Helmut Swiczinsky, and Rainer Michael Holzer. Under the influence of the experimental creations of Hans Hollein and the group Haus-Rucker-Co., they concentrated mostly on pneumatic structures, discussed alternative urban structures, and actively promoted a deconstructivist approach to design. Their “burning” projects (Reiss Bar, Flammenflügel, Hot Flat, and others) express opposition to postmodernism, which they see as a new Biedermeier period. Their emblematic kitchen design *Mahlzeit* (1990) redefined the preparation of meals as the central activity of living. Using materials like stainless steel, they staged the kitchen as a professional workplace at home and anticipated the kitchen boom that was to unfold in the 1990s. Their UFA multiplex cinema in Dresden (1998) is probably one of the most idiosyncratic deconstructivist buildings ever realized.

Egon Eiermann

The German Eiermann was also a well-known designer who embraced a holistic principle of design. Important buildings include the Kaiser Wilhelm Memorial Church in Berlin, offices for Olivetti in Frankfurt am Main, the German embassy in Washington, and an office building for IBM in Stuttgart. His numerous designs for furniture sought to relate the interior and exterior of buildings and to achieve a uniformity of spaces (*Egon Eiermann – Die Möbel* 1999). Apart from numerous chairs of molded plywood or wickerwork, he designed base frames for drawing tables originally intended for his own studio. Characterized by high flexibility and variability, they can support different types of worktops and became an emblematic product of the twentieth century. Legibility was an important feature of his designs, with visible construction details revealing how the pieces of furniture worked.

Norman Foster

Early in his career the Briton Norman Foster (honored with a life peerage in 1999) worked with Richard Rogers, and together they developed a high-tech architecture that explored the possibilities of cutting-edge technologies. One example of their approach is the Sainsbury Centre for Visual Arts at the University of East Anglia, near Norwich, England. Foster Associates achieved its international breakthrough with the Hong Kong headquarters of the Hong Kong and Shanghai Bank. Apart from numerous public buildings, Foster also designed airport terminals (e.g., in Hong Kong), train stations, a metro system in Bilbao (for which the German graphic designer Otl Aicher created the visual image), bridges, service stations, high-rises, and many others (Jenkins 2000). Foster is a star on the international architecture scene, and his various studios employ more than six hundred staff. The wide-ranging creative complexity of his work serves a principle of unity that seeks to reconcile the needs of people, technology, economics, and ecology. The mutual interdependence of exterior and interior is another of Foster's themes. For the Hong Kong and Shanghai Bank, his practice created the office furniture system Nomos, which uses the same technological vocabulary as the building itself, and thus defines furnishings as architecture in miniature. Be it a tray designed for Alessi, a bathroom series for Duravit and Hoesch, lamps for ERCO, door handle designs for FSB, desktop accessories for Helit, or office furniture for Thonet, all Foster's designs are characterized by the same rigor and dedication to quality as the buildings. No doubt the manufacturers of these products also benefit from the image transfer linked to designs by Norman Foster.

Frank O. Gehry

Gehry, a Canadian-born American, started out with deconstructivist buildings (e.g., a private home in Santa Monica, California) and is today considered one of the world's most important and idiosyncratic designers. His proposal for the Vitra Design Museum in Weil am Rhein made an essential contribution to the company's overall corporate identity. With the Guggenheim Museum in Bilbao, he created one of the most spectacular museums of the twentieth century. In its wake the city itself changed profoundly from a dismal industrial port to a cultural center in northern Spain as masses of visitors attracted high-class galleries and shops. It is a develop-

ment that has altered the character of the entire region. The boundaries between art, design, and architecture have begun to shift, and Gehry's congenial crossings stand for highly topical approaches that are landmarks on today's cultural map.

Zaha Hadid

Born in Iraq and today based in London, Zaha Hadid is considered the architect pursuing the most expressive, but also the most deconstructivist approach of all her contemporaries. Her international breakthrough came in 1983 when her spectacular drawings won the competition for the Peak project in Hong Kong. Her large-format drawings of urban situations and buildings seek to illustrate what new, visionary concepts of construction could look like. In her work Hadid pursues a radical rediscovery and reinterpretation of modernism. Her philosophy of velocity, buoyancy, and contemporaneity is brilliantly expressed in the fire station of the Vitra company in Weil am Rhein (her first building to be completed, in 1993). Today, it houses a collection of eighty-three chairs, all of them classics of twentieth-century design. Other important works by Hadid include the Contemporary Arts Center in Cincinnati, a pavilion for the international gardening show (Landesgartenschau) in Weil am Rhein, the Mind Zone in London's Millennium Dome, the central building of the new BMW plant in Leipzig, the Center for Contemporary Arts in Rome, and the ferry terminal in Salerno. Her most recent project, the ski jump at Bergisel mountain near Innsbruck, was inaugurated in 2002.

Her designs for furniture are consistent with her approach to architecture. Manufactured since 1988, they embody the transition from spaces to objects. For the company Sawaya & Moroni she designed the z.scape furniture line of expressive tables and lounge furniture. The sofa glacier (2001) is shaped like an iceberg, made of CNC-machined wood, and weighs about 600 kilograms (1,300 lb).

Hans Hollein

The Austrian Hollein is considered one of the most important representatives of postmodernism. The transition from object to space to make a total work of art is a characteristic feature of his creative work. Even his earliest commissions – a candle shop and a jewelry store in Vienna, and the partly state-owned tourist office based in



MORAINE COUCHES AND LOUNGES, design:
Zaha Hadid, Sawaya & Moroni
LITTLE BEAVER ARMCHAIR, design: Frank O.
Gehry, Vitra Edition

the same city – were marked by an idiomatic expressiveness. His international breakthrough came with the Abteiberg Museum in the German city of Mönchengladbach. The works of art presented there enter into harmonious relationships with the museum's interiors and architecture. The MMK Museum of Modern Art erected in Frankfurt am Main is considered one of the highlights of post-modern architecture. The objects Hollein designed for the Memphis collection in the early 1980s are among the few examples of post-modern furniture design. Apart from various pieces of jewelry and watches, he designed tiles and sunglasses, a grand piano for Bösendorf, a crystal phial for Swarovski, and also a door handle for the German company FSB, all of which unfold complex meanings in a tradition of narrative design.

Design is a method of communication; however, even communication methods are an object of design. The body itself is a medium of announcement. These methods range from the mere encoding of language (through letters like in semaphore), to gestures assigned certain meanings (which, however, can vary in different cultures) all the way to behavior expressing meaning, be it consciously or unconsciously.

— HANS HOLLEIN, 1989

Toyo Ito

The Japanese architect Ito addresses the continuous change of interrelations between human beings, nature, and technology. Ito is one of the architects who use new technologies extensively while at the same time emphasizing the effect and experience of space on and for users. His exploration of the topic of wind led Ito to the roots of Japanese living, with sliding walls and sparse furnishings, defining rooms characterized by a high flexibility.

Rem Koolhaas

In 1975 the Dutch architect Koolhaas founded the OMA (Office for Metropolitan Architecture), which started out with artistic and experimental design projects. His design for the flagship store of Italian fashion giant Prada in New York congenially crossed the boundaries between architecture, design, and fashion (Koolhaas/OMA/AMO 2001). In extensive explorations that, among other things, yielded a voluminous book on shopping, he and his collaborators investigated the phenomenon of shopping around the world (Koolhaas/OMA/AMO 2002). The shop itself is staged like a play. The premises include platforms, follow a dramaturgy, and are enlivened by changes of scenery, from daytime shop to nighttime concert hall, theater, or discotheque.

Richard Meier

The American Meier gives the tradition of classical modernism a contemporaneous twist. White interior and exterior surfaces endow



PRADA SHOP in New York
design: OMA Rem Koolhaas

his freestanding buildings with a brilliance that can be said to reflect back on the architect himself. Meier translates the same reduced idiom of shapes, focused on simple geometric forms, to furniture designs mostly created for the buildings he designed. His output includes designs for Alessi (tea services), Knoll International (object furniture), and Swid Powell (silver bowls). To him, design is as important an area of creative productivity as architecture (Fischer 2003).

Alessandro Mendini

The Italian architect, designer, and critic Mendini is one of the leading minds in design in the second half of the twentieth century. He co-initiated the Memphis movement at the beginning of the 1980s, founded the Alchimia studio in Milan, and designed numerous artifacts. Moving easily between architecture, design, fine art, literature, and music, Mendini is the prototypical boundary-crossing artist, and his work can undoubtedly be called a *Gesamtkunstwerk*.

Jean Nouvel

The Frenchman Nouvel is probably one of the most intellectual architects of the present day. Strongly influenced by the philosophical and sociological currents of his country (e.g., Jean Baudrillard, Jacques Derrida, and Paul Virillo), he developed a symbolic architecture, always using the latest in high-tech materials. He aims to test the principles of statics and to disrupt sensory experience. His minimalist aesthetics juxtapose simple exteriors with often highly complex interior structures in his buildings (Nouvel 2001).

The Institut du Monde Arabe in Paris (1987) united these aspects to a high degree and added a topical reinterpretation of Arabic ornament in façade elements that change depending on the incidence of light. Nouvel's design for the Fondation Cartier in Paris (1995) addressed the question of materiality and non-materiality, which, with the coming of the new digital media, has also been discussed in the field of design since the late 1980s. A curtain of glass panes renders the building both visible and invisible by affecting to adhere to the existing line of buildings, while the real building, also fronted in glass, is markedly set back in a park. Nouvel is revealed as an expert player in the game of

"There is no style," said France's architecture guru Jean Nouvel at a discussion event attended by over a thousand people. "There is only an attitude." What is important, he continued, is not to do the same thing twice, to accept inspiration from one's surroundings, and to give the object to be shaped an identity in space.
 — HENNING KLÜVER, 2002



FURNITURE DESIGNS, design: Richard Meier,

Knoll

MARACATU SOFA, design: Alessandro Mendini,

Edition Vitra (Photo: Vitra)

reality and unreality. For this building Nouvel designed the office system *Less*, which is manufactured and marketed by the Italian company Unifor. The desktops resemble two-dimensional disks; made from aluminum, their necessary third dimension is only revealed at second glance, their volume only perceptible from below. All technical features, cables, and so on remain invisible, seemingly non-material.

Aldo Rossi

The Italian Rossi was one of the most important representatives of the rational architecture that had its roots in the 1920s (Adolf Loos, Le Corbusier, Mies van der Rohe). Attention to ratio was recommended by Vitruvius (Bürdek 1997b) and today finds a place in the concepts of the rationalist branch of the postmodernist movement. Rossi also published a number of theoretical essays on issues of architecture and urban planning (1966, 1975). His work was represented at the 1980 Venice biennale, which was devoted to milestones in the incipient postmodern architecture movement. His contribution, the floating *Teatro del Mondo*, proved him a master of allusion to a historical vocabulary. It is only consistent that the skills he perfected in manufacturing stage sets point back to his experience as a stage designer for the opera.

His project for the *Bonnefanten Museum* (1995) in Maastricht (Netherlands) proposed a museum that resembles an austere, functional industrial building of the early twentieth century. A number of details give perfect expression to Rossi's delight in asceticism and his penchant for simple geometric forms: A seemingly endless flight of stairs refers to Mediterranean streets with glaring light at the end. The building's domes are clad in zinc sheets to evoke the style of industrial buildings, which the deliberate color scheme inside the building caricatures in an ironic twist. The entire building plays with shape and color in ubiquitous allusions to architecture past and present.

The distinctive independence of his buildings is reflected in the micro-architectures of the products designed by Rossi, ranging from coffee pots for Alessi, to seating furniture for Molteni, and the office system *Parigi* for the Italian company Unifor. His designs for the Maastricht museum provided the basis for the *Cartesio* bookcase, which mirrors the geometric austerity of Rossi's rationalist style of design.



MOMENTO WATCH, design: Aldo Rossi, Alessi
SWISS PAVILION, Expo 2000, design: Peter
Zumthor

James Stirling

The Briton Stirling began his career with a critical examination of the late works of Le Corbusier, such as the church at Ronchamp (1957) in France, which turned his interest to brutalism, a style of design conspicuous for its use of exposed concrete (in French, *béton brut*). Up until the 1970s he designed numerous buildings in this style, including the Leicester University Engineering Building, the Olivetti Training School in Haslemere, buildings for Siemens AG, and the Derby Civic Centre.

At the end of the 1970s Stirling consciously embraced postmodernism and became the spokesman for a narrative approach to design that was not without ironic overtones. His method relied on the quotation of individual phenomena from the history of architecture (such as Schinkel's domed halls, the stoa of antiquity, or Palladian neoclassicism), but in contexts that yielded new meanings, "teaching architecture to dance" (Pehnt 1992).

The Neue Staatsgalerie in Stuttgart (1984), for example, recalls the forms of an Italian palazzo. But at its center is a classical rotunda, the trapezoid pylon follows the Egyptian style, and the access ramps are designed to be imposing. The interior is also characterized by deliberate inconsistencies that juxtapose a bright green high-tech elevator with massive mushroom-headed pillars in the exhibition rooms. All the same, the interior provides a contemplative atmosphere that contrasts clearly with the spectacular exterior, and the museum as a total work of art is in harmony with the works of art it houses.

With his 1992 design of factory buildings for the German medical technology company B. Braun, based in Melsungen, Stirling made an important contribution to the industrial architecture of the late twentieth century. Starting out as a functional and rational workplace, the building mutated into a postmodern ensemble that gives employees a sense of belonging and identity.

Oswald Matthias Ungers

Early in the 1980s the German architect Ungers began to explore the square as a basic geometric form that was to become a characteristic feature of his design style. Ungers' designs extend to the interiors of his buildings, so it is only consistent that the chairs he created for the DAM (Deutsches Architektur Museum) in Frankfurt am Main should translate the formal overall concept to a smaller

scale. The result is a black wooden frame with square, white leather upholstery. The building's austerity has been communicated directly to the furniture.

Peter Zumthor

Swiss architect Zumthor is one of the most rigorous representatives of his field, putting stringency, passion, and perfectionism into buildings that completely redefine the concept of space. Training as a carpenter in his father's workshop, he learned early on what flawless craftsmanship means, and his ten-year experience in conservation gave him an intimate knowledge of buildings. Zumthor almost exclusively uses natural materials (wood, stone, metal, or concrete) openly exposed to the eye. He uses harsh and geometric forms, and from the outside the buildings resemble solitaires. The interiors, in contrast, feel warm and comfortable. His intellectual point of reference is the philosopher Heidegger (1967), whose "longing for the primeval, for a sense of belonging, of being at home" he can well understand (Zumthor 2001). But beyond all questions of philosophy or design, he is not only interested in ideas or images, but in the things themselves, and their value as such. Their vividness is what fascinates Zumthor. Hence, the rock pool built from gray-green natural stone in the Swiss spa of Bad Vals (1997) is a powerful symbol of nature, water, repose, and profound contemplation. Zumthor's art house in Bregenz in Austria is a translucent cube that after nightfall shines out luminously across the waters of Lake Constance.

Zumthor also designed the Swiss pavilion for EXPO 2000 in Hannover. For this temporary event he used 3,000 square meters (9,800 sq. ft.) of fir beams connected without screws, nails, or plugs. Steel braces provided the building's only supporting structure, leaving the individual beams undamaged for later reuse. The open pavilion, designed as an acoustic body, expressed an intense sense of space through the scent of the wood, its untreated surfaces, and the pattern formed by the beams. Nature itself became an open room, a metaphor that seems highly appropriate for the country represented, Switzerland.

DIE ZEIT: "Your buildings are structures of resistance?"

Zumthor: "Yes, they offer resistance to the increasing division of labor in construction. I do not want to be just a designer, or, ideally, a philosopher, and therefore my buildings also herald that our world is determined not only by pictures and ideas. There are also still things, and these have a value in themselves."

— DIE ZEIT, 45/2001

UTOPIAS, VISIONS, CONCEPTS, AND TRENDS

The previous chapter has shown that far from revolving solely around its more immediate products – from individual buildings to the built environment – architecture tends to look beyond the everyday business of designing. Architects discuss the tasks of architecture in intellectual debates that go much deeper than any undertaken in the field of design. Moreover, the utopias and visions outlined in architecture provide room for analyzing, formulating, outlining, and simulating new concepts of living and designing. In contrast to design, architecture has taken these dimensions into account throughout its history.

The origins of utopian thought go back to antiquity and Plato's writings on the *politeia*, but the subject only began to draw wider attention when, in 1516, Thomas More published *Utopia*. Francis Bacon picked up the theme in *Nove Atlantis* (1626), and utopian, foresighted, and conceptual approaches to design have a long tradition in architecture (Kruft 1985). Some examples will serve to illustrate this. In the eighteenth century French architect Etienne-Louis Boullée created designs not intended for realization, but for display in an imaginary museum of architecture. His compatriot and contemporary Claude-Nicolas Ledoux, an adherent of the French revolution, designed buildings whose most important aspect was their symbolic meaning.

Italian futurism as it emerged at the beginning of the twentieth century was regarded as a prime example of a boundless idealization of technology, and the Russian artist Kazimir Malevich even attempted to design architecture that would articulate the tenets of a communist society.

The Japanese metabolists and Richard Buckminster Fuller are among the best-known utopians of the twentieth century, both in the field of architecture and in design. In the late 1960s Hans Hollein, among others, explored futuristic architectures, and the English group Archigram (including Peter Cook) developed projects expressive of a positivist technology cult.

Since the 1970s Leon Krier, the Site group, Haus-Rucker-Co., Coop Himmelblau, Superstudio, Peter Eisenman, Rem Koolhaas, Bernhard Tschumi, Daniel Libeskind, and, since the early 1980s, Zaha Hadid, in particular, have explored the future of space and time in drawings and designs (McQuaid 2003).

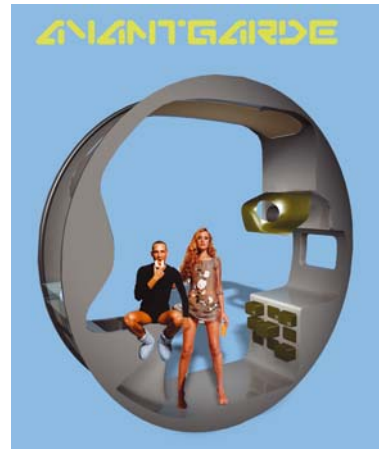

DIE WOHNROLLE ("THE HOUSING ROLL"), design:
AllesWirdGut (Photos: AllesWirdGut)
DUTCH PAVILION, Expo 2000, design: MVRDV
(Photo: Bürdek archive)

In the 1990s the Dutch MVRDV group continued the long tradition of utopian and visionary architecture. The Netherlands pavilion that MVRDV designed for EXPO 2000 in Hannover, for example, was among the most spectacular structures exhibited there: the very smallness of the country spawned the idea of carving its traits onto several thematic levels and presenting them as a stacked landscape in a horizontal building.

EARLY DESIGN UTOPIAS

Jürgen Zänker (1981) sees the work of William Morris (1890) in the tradition of Thomas More's novel. Morris is regarded as one of the fathers of design and at the same time one of the last "utopian socialists," for to him, the two functions embodied in the artist and the social revolutionary were basically one and the same.

Both Bauhaus and the Ulm School of Design took up this socially oriented understanding of the utopia. The Bauhaus approach was based on a radical vision: to develop new design concepts that would overcome the petit-bourgeois fustiness of the nineteenth century.

The social vision in the Bauhaus approach, however, was also evident in the belief that new design concepts could bring about democratic change in society. Investigations into the objective, scientific conditions of design were seen as a basis for this.

The German designer Luigi Colani, who in the 1960s and 1970s was a proponent of an approach to design characterized by organic and erotic forms (Dunas 1993), gained fame with futuristic visions including a spherical kitchen, a secretary's workplace, and a container truck for the year 2001. Many of his drawings of cars and airplanes were greeted with acclaim by sensationalist marketing people who presented the designs at trade shows to create an aura of progressiveness for their companies. However, few of Colani's designs were ever actually produced.

The 1960s ushered in the age of space travel both in the USSR and in the United States, and the impact was felt in the field of design. The designs Verner Panton made for Bayer AG were not quite as abstruse as Colani's. The annual Visiona exhibition staged orgies of color and material that reflected the brave new world of synthetics of the late 1960s. These futuristic homes had more to do



VISIONA 2, design: Verner Panton, Bayer AG
TRUCK ON A DAF CHASSIS, design: Luigi Colani

with the world of science fiction than with real human needs, and accordingly contributed little to meeting them. At that time, the Italian designer Joe Colombo also designed futuristic habitats.

One nuance of meaning worth noting is that the idea of utopia always implies an element of social change, whereas visions are no more than projections of possible – or fanciful – future buildings, spatial concepts, and products. Heinrich Klotz (1987) introduced the related concept of fiction into this context, saying that not only function, but also fiction is a crucial factor in the formula for post-modernist architecture.

The prospects in design are altogether different, but also in need of redefinition. For a long time now design has concerned more than the design of individual things or product groups. Design structures information, communication and their interfaces, is a concept and process much more than an object; it imparts and links economy and ecology, technology, media and services, culture and sociality.

— UTA BRANDES, 1998

FROM CONCEPTUAL ART TO CONCEPTUAL DESIGN

Sol LeWitt's claim that "ideas alone can be works of art" (first published in the May 1969 edition of *Art-Language*) marked the point of departure for a direction in art that became known as conceptual art. Its basis is a dematerialization of the art object, meaning, the fundamental abstention from physical manifestation that is so indispensable to classic forms of art (Felix 1972). If conceptual art is about stimulating creative thought processes in the viewer, it refers to categories that, deriving directly from philosophy, can be translated to the field of design.

Leaving behind the visionary synthetic euphorias of the likes of Luigi Colani and Verner Panton, the Italian design and architecture scene since the 1960s has produced a wide range of concepts and visions mainly developed by groups of designers whose work was rooted in social criticism or even political radicalism. Italian cultural developments of the 1960s brought forth countercultures that made reputations as "radical design," "counterdesign," or "antidesign." In contrast to English formations like Archigram, these groups consciously sought to develop negative utopias (dystopias) by drawing attention to the devastating impacts of industrialization. Important representatives of Italian conceptual design were Gaetano Pesce, Andrea Branzi, and the Alchimia group of Alessandro Mendini.

In Germany, meanwhile, the group Kunstflug, founded in 1982, saw itself in the tradition of Italian designer and architect groups like Archizoom, Superstudio, or Strum, but its influence did not outlive the comparatively short flowering of the new German

design in the 1980s. The point of departure for their work was a rigorous critique of the ossified forms of good design. In a provocative response they designed ironical objects that consciously alluded to the artistic traditions of Dada, ready-mades, and objet-trouvé art. Kunstflug started out by combining industrial semi-manufactured products (laminations, connectors, cables, lamps, transformers) with natural materials (timber). The Geröll-radio ("scree radio" 1986) stands for their insight that the future of the avant-garde would lie in electronics. Their concept for a new ticket and service machine (Kunstflug 1988) pointed to the declining importance of machines and devices (hardware design) against the increasing importance of user interfaces (software design).

Operating under the colors of GINBANDE since 1985, the two Frankfurt-based designers Uwe Fischer and Achim Heine followed the intellectual tradition of classical modernism through to its logical conclusion as they developed what they called creative mental leaps (Lenz 1988). Folding furniture, for example, has been a popular theme with architects and designers for centuries (Blaser 1982, Spalt 1987). GINBANDE used floor surfaces to fold away chairs, tables, or lamps in an interior that stands less for functional thinking than for thinking beyond function. In their folded state, these pieces of furniture come into their own as floor ornaments that use the floor to define interior space in the best Japanese sense. The Tabula Rasa project presented in 1987 at the exhibition *Un posto a tavola* (A place at the table) attracted international attention. The well-established, simple scissor principle was ingeniously applied to an extendable table measuring from 0.5 up to 5 meters (1.6 to 16 ft.). From an intimate tête-à-tête at a small bistro table to an opulent dinner at a vast board, Tabula Rasa provides hosts and guests with the space they need, whatever the occasion.

The London-based Ron Arad focused on concepts such as a hi-fi system set into broken pieces of concrete. By doing so he destroyed archetypal signifiers of high-quality technology to combine them with the ruins of modern civilization. The concept, however, also made sense technically, as concrete has excellent vibration absorption characteristics.

In the mid-1990s the Spaniard Martí Guixé began work on conceptual projects that explore the interactions between product and



TABULA RASA, design: GINBANDE,
Vitra Management AG

consumer. He playfully crosses the boundaries between design, typography, anthropology, humanities, and natural science as he outlines concepts and stages performances and happenings (Ed van Hinte 2002). His motto is, "Form follows destruction," for he intends his works to subvert traditional habits of handling and using products.

Martí Guixé had a strong influence on the German Zirkeltraining group founded by Volker Klag and Max Wolf, not least because Klag worked at Guixé's studio in Barcelona for a year. Parallel to their work in product and media design, Zirkeltraining developed design concepts, objects, and ideas. Their output includes designs for public spaces, furniture, jewelry, and fashion, but also electronic devices and photographic works. The Re-Braun system designed by Markus Bader and Max Wolf as part of the Bootleg Objects series, for example, takes up the creative attitude that Dieter Rams embraced in the 1960s and translates it to a design concept for an up-to-date Internet terminal. "Re-contextualization" is an apposite term for Zirkeltraining's creative work.

THE DAWNING OF THE AGE OF MICROELECTRONICS

The industrial index fossil of the waning twentieth century (Bürdek 1988), the microchip, has its obvious place in the computer. Yet this constantly accelerating machine has, in manifold different guises, gradually wormed its way into nearly every domain of our lives, and how it has done so is the subject of numerous design studies and concepts.

The Knowledge Navigator study that Adam Grosser and Gavin Ivester created for Apple in 1988 showed what a computer with a visionary design could look like: a computer for the year 2006. The portable device incorporated a video camera for scanning pictures that doubled as a videophone; it featured speech recognition and a touchscreen; and it worked with optical disc technology. The study, however, went beyond hardware design to present a simulated software concept that anticipated software agents (Henseler 2001).

The integration of the most diverse technological possibilities stands at the center of numerous research projects, particularly in the United States. The Media Laboratory at the Massachusetts

Institute of Technology in Cambridge/Boston has achieved outstanding results in this area (Brand 1987; Negroponte 1995). Since the 1980s its researchers have been exploring and presenting concepts for integrating television, computers, and telecommunications. Substantial funds supplied by international corporations go into developing the product concepts of the future. For some years, for example, “things that think” were the overriding concern (Gershenfeld 1999), and numerous “intelligent products” were developed. Apart from devices known as “wearables” (Richard 2001), this also includes programmable or remote-controlled coffeemakers, smart telephones, and sneakers with integrated chips that remind you to do the shopping when you pass a supermarket.

In the late 1990s Media Lab opened a branch in Dublin that also works on a multitude of new digital products. After British product designer James Auger joined their team, he caught the public imagination with a design for an audio tooth implant that effectively struck out to the realms of human design. Today, research at Media Lab is concerned less with visions of a digital future than with developing related added functions that will make products attractive to potential buyers.

Anthony Dunne, a graduate of the London Royal College of Art who now teaches there, follows the tradition of conceptual design. His *Hertzian Tales* (Dunne 1999) publicized a fantastic array of novel electronic products, aesthetic experiments, and design criticism. Dunne describes how designers and artists build bridges between virtual digital worlds and the material culture of objects. In addition to a searching history of digital technologies, he presents a number of concepts of his own, such as “electroclimate” (an abstract radio), “tuneable cities” (mapping the overlap of electromagnetic, urban, and natural environments), and the “Faraday chair” (offering contemplative shelter in a radio-opaque zero field space).

Together with Fiona Raby, Dunne presented concepts addressing the unexploited narrative potential of electronic products (Dunne and Raby 2001). The Sony Walkman (1980), they say, was far more than a device for listening to music; it dramatically affected social relationships as well as perception. Their “design noir” is a method fundamentally aimed at changing and expanding the psychological dimension of electronic products.

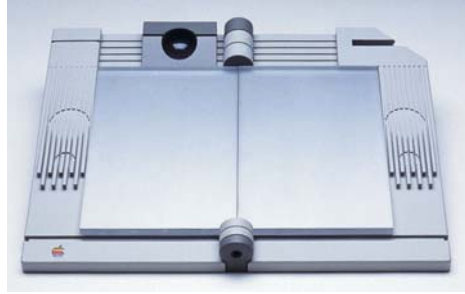

THE KNOWLEDGE NAVIGATOR, computer study by Adam Grosser and Garvin Ivester, Apple Computer (Photos: Rick English)

REBRAUN BOOTLEG OBJECT, design: Markus Bader, Max Wolf

E:PEN CONCEPT STUDY, design: Cambridge Consultants

HOW CORPORATIONS THINK ABOUT THE FUTURE

Utopias, visions, concepts – corporations are under massive pressure to feed the market with innovative products launched at regular intervals. Some examples will serve to illustrate the strategies design departments employ to meet this demand.

Philips

The Eindhoven-based Corporate Design Center of Dutch electronics giant Philips has caused a stir since the Italian Stefano Marzano took over as its head in the early 1990s. Looking far beyond the horizons of immediate marketing, the Philips “Vision of the Future” project (1996) turned into one of the most spectacular events in the design landscape of the 1990s. Information technologies, Stefano Marzano says in his foreword, play a vital role in advancing the arrival of the New Modernity. To investigate their effect on design, Philips set up multidisciplinary teams (consisting of cultural anthropologists, ergonomists, sociologists, engineers, product designers, interaction designers, exhibition designers, graphic designers, and video and film experts) commissioned to discover which product fields and concepts would be relevant to a corporation like Philips in the future. In a multi-layered process, the resulting scenarios were distilled down to sixty well-defined concept descriptions representing the four domains of everyday life: personal, domestic, public, and mobile. The combination of socio-cultural trends with new materials and technologies as well as creative visions produced a large number of spectacular product concepts, which were then presented to a group of experts (consisting of futurologists and trend analysts) for evaluation.

A similar project on “Television at the Crossroads” (Mendini, Branzi, and Marzano 1995) developed and presented various product studies on the topic of television. Along with “The Solid Side” (Manzini and Susani 1995), these three projects and publications probably represent the most important contributions to the development of corporate visions in the area of design at the turn of the twenty-first century.

LG Electronics

The Korean LG Electronics (formerly Goldstar) is one of the world’s most important electronics companies. It pursues a fairly

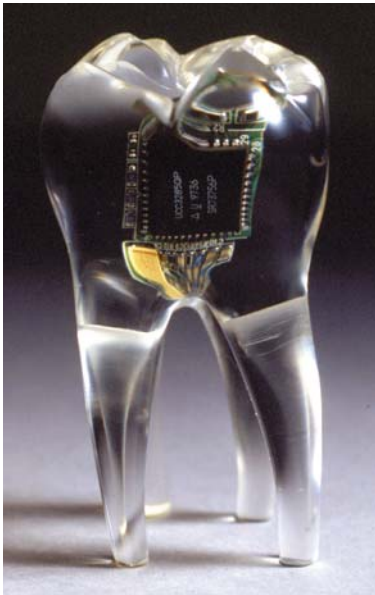

VISION OF THE FUTURE, design: Philips
 Corporate Design
BEDSIDE UNIT
BIKO GAMES
ARM-MOUNTED-DISPLAY
MOBILE HOSPITAL
MOBILE PHONE IN TOOTH CONCEPT STUDY,
 design: James Auger

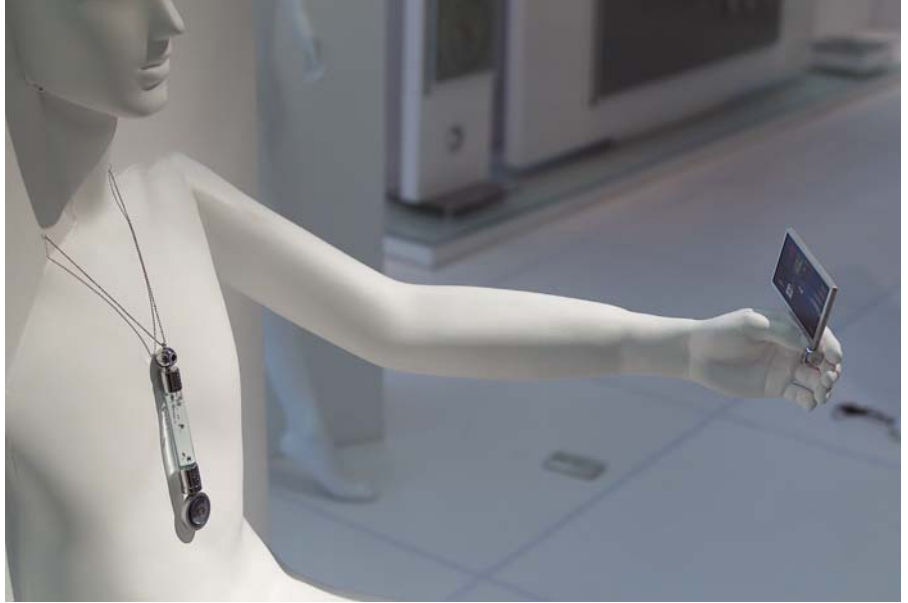

GOOD MORNING - GOOD EVENING STUDY,
LG Electronics

independent design policy that is to a certain extent oriented on the principles of European modernism. In the fall of 2001 the LG Electronics Digital Design Center presented the study “Good Morning, Good Evening” at an exhibition in Seoul. The theme was a Home Network System integrating and digitally linking all of a person’s activities (from morning to night). Scenarios illustrate the processes of change that will affect our lives as digital technologies advance further.

The Automobile Industry and Its Concept Cars

Since the 1990s the automobile industry could be regarded as the most innovative branch of industry. The growing influence of electronics is changing vehicles in many ways. Numerous computer-based systems are deployed to control and regulate driving safety, engines, transmissions, steering mechanisms, and so on. The microchips that actually do the work are invisible to the user, who only experiences the ever-growing convenience of many vehicles. But the change affects drivers in other ways, too, as the increasing presence of electronic aids changes the way they handle, perceive, and control vehicles (Bürdek 1998, 1999).

At regular intervals (generally at the big automobile shows in Detroit, Frankfurt, Geneva, Paris, and Tokyo), the automobile industry presents what are known as concept cars, which invariably express part of the respective manufacturer’s vision. The main purpose is to test the audience’s reactions, to discuss feasibility with a multitude of subcontractors, to outdo the competition, and last but not least, to garner media coverage for the new concepts. And the media are happy to oblige with what is basically free advertising – an important factor in company calculations.

TREND RESEARCH AND ITS LIMITS

The boom in future research (also known as futurology) in the 1960s and ’70s was followed by the triumph of a new discipline in the 1990s: trend research. But its mission is no longer to assemble long-term or medium-term forecasts. Instead, trend research makes short-term diagnoses of how consumer lifestyles and ways of life will change, which models consumers will orient their behavior on, enabling companies to draw up-to-date conclusions for the

If we do not manage to obtain this strategic key quickly and soon, things will get worse for all of us. We will rush through product cycles, generate ever more arbitrary and interchangeable design and lose identity, both as designers and for our clients, the corporations. Not until strategies and the technical variables of mastering the process are recognized will we again be more successful and generate more outstanding design. Strategies implement the visions and values of companies and create something original instead of merely complaisant, good design.

— CHRISTOPH BÖNINGER, 1998

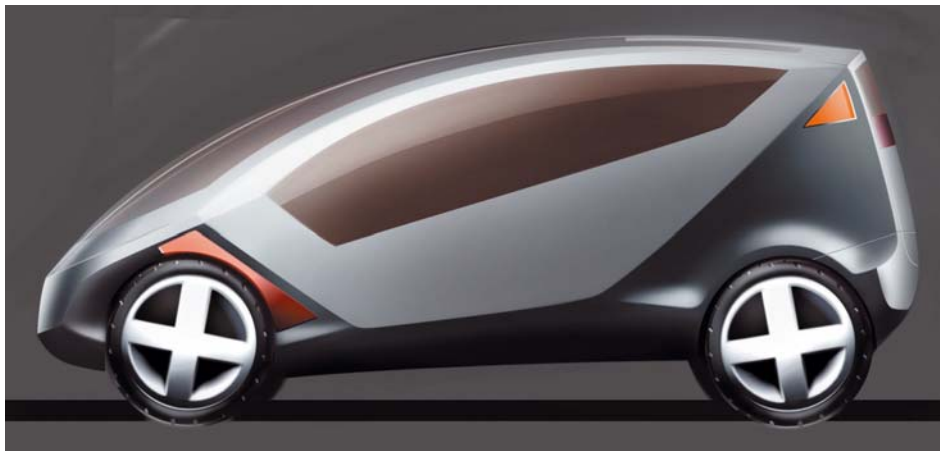

CINEMA 7D SHOW CAR, Edag
interior/exterior

products and their design. Trends can manifest themselves in colors and surfaces, in materials and their combinations, but “trends” can also spawn whole new market segments, as the example of SUVs (Sports Utility Vehicles) illustrates.

A host of trend gurus soon conquered this field, offering expensive seminars, selling publications, and surfacing personally in the media in bursts of PR activity. An army of trend scouts scour the world’s metropolises to spy out products and behaviors that might indicate new trends. No matter whether they hail from the United States or from Germany, the likes of Douglas Coupland, Faith Popcorn, Suzi Chauvel, Gerd Gerken, Gertrud Höhler, Matthias Horx, and Peter Wippermann all share a penchant for the breathless marketing of trends that rarely survive beyond the next season (Rust 1995, 2002), which, of course, means that the time is ripe for (precious) new advice.

The furniture industry has proved especially susceptible to and fertile in such trends. Held in Cologne or Milan, annual innovation trade fairs mutated into lavish shows of fashions and frills. Trend press conferences are staged to put trade and consumers into the right mood. From cocooning to jungle theme living-rooms, from the retro wave to light wood, the new simplicity to nomadic living, organic shapes to furniture on wheels, each year sees new catch phrases launched with the appropriate products, and the furniture design itself wears out even more quickly than its trendy designations.

Declaring all this as “trend research” takes a certain cynical nerve, for research rarely comes into it. Only a few approaches can be called respectable. Economist Franz Liebl links the problem of making decisions on future developments for companies to strategic management (2000) and the question of how to shape the future. In his view, however, the concept of “issues” is of greater import as it allows description of medium-term and long-term processes of change – be they social, technological, or cultural – and the drawing of well-founded conclusions as to future developments on this basis.

OUTLOOK

All these efforts toward developing visions can be traced back to a term that Mihai Nadin revived for the present context: anticipation

(Nadin 2003). Nadin defines anticipation not in terms of probability, but rather as a theory in the mathematical realm of the possible. Possibilities can be described and represented in the form of different scenarios, some of which become realities, while others do not. So the focus is always on the mind anticipating possible events. That “forecasts are difficult, especially when they refer to the future” is proverbial wisdom. Reducing these difficulties is an important function that design is increasingly assuming. Developing and shaping visions and concepts means providing extremely helpful tools for this task.

MICROELECTRONICS AND DESIGN

There are two good reasons for calling the 1980s an epoch-making decade for design. First, the influences of postmodernism triggered a fierce stylistic eclecticism (as promoted, for example, by Memphis and Alchimia), which, however, soon lost its bearings in the fog of what Jürgen Habermas called the “new obscurity” (Habermas 1985). Second, the chip, which was to become the index fossil of the 1990s, opened up completely new horizons (Bürdek 1988). In 1982, for the first time ever, *TIME* magazine’s Man of the Year was not a man at all, but a machine. The computer was seen as the symbol of the new technological age. *TIME*, however, did not give the title to the big, complex mainframe computers used since the 1970s (manufactured by companies like IBM or Bull), but to the desktop personal computer that had only really come into existence after Stephen Wozniak and Steven P. Jobs invented the Apple II in 1979. It was estimated that by the end of the 1980s more than 100 million PCs were in use worldwide (Hahn 1988). Today there are around 575 million PCs and by 2010 it is estimated there will be 1.3 billion (*NZZ*, 18/19 December 2004). Their rapid spread was boosted by their applicability as universal tools for use in nearly all domains of life and work.

According to researchers in cultural studies, the history of Western civilization only includes two real technological revolutions:

1. the invention of movable type by Johannes Gutenberg in the fifteenth century, which paved the way for the triumph of book printing around the world, and



FUTURE STORE - THE COMPLETELY DIGITALIZED
 SUPERMARKET OF THE FUTURE
 SELF-CHECKOUT MACHINE
 INTELLIGENT SCALE
 PERSONAL SHOPPING ADVISER
 INFORMATION TERMINAL

Metro AG, partners: IBM, Wincor Nixdorf,
 SAP, Intel, Cisco (Photos: Metro AG)
 PENTIUM 4 PRESCOTT MICROPROCESSOR, Intel

2. the massive spread of personal computers since the early 1980s.

Both revolutions triggered profound changes in human behavior, communication, centralization and decentralization, education and training, work and leisure, health services and public transportation, and many other domains. The past two decades have affected the life-worlds of wide segments of the population more deeply than ever before in such a short period: the transition from analog to digital technology marked not only a technological, but also a cultural, revolution.

One of the early media theorists, the Canadian Marshall McLuhan, pointed out in his studies on *The Gutenberg Galaxy* (1962) that the invention of the printed book did much to foster individualism: "Just like easel painting emancipated painting from institutions, book printing broke the monopoly of libraries." The analogy in our world today is the computer. It has become a personalized tool, breaking the monopoly of computer centers in companies and administrations, as globally linked networks give most people in industrialized countries access to theoretically unlimited stores of data and processing power.

These days computer literacy is seen as the fourth cultural skill next to reading, writing, and arithmetic. The emerging new illiteracy has its origins in a "digital divide" separating users from non-users. In their thorough discussion of questions relating to artificial intelligence, Roger C. Schank and Peter G. Childers (1986) even compared the acquisition of computer skills with learning Latin, saying that both fostered logical thinking.

MICROELECTRONICS MEETS DESIGN

As the personal computer (PC) spread rapidly throughout the 1980s, the new technology began to draw the attention of designers. Three very different levels were addressed:

1. Microelectronic products were soon recognized as opening up new terrain to design. The practice, frogdesign, that Hartmut Esslinger headed in California is a textbook example with its legendary designs for Apple (Bürdek 1997a; Kunkel 1997).

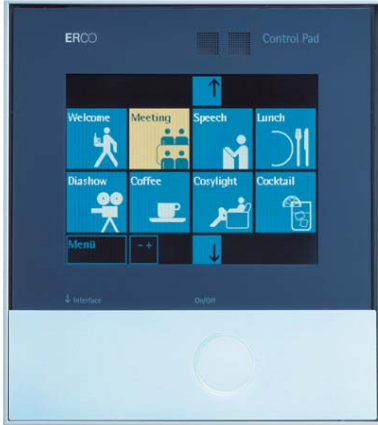

CONTROL PAD TOUCH SCREEN INTERFACE, design, ERCO

2. Rapid progress in the dematerialization of products carried totally new challenges in its wake. Interaction and interface design grew into important fields, especially for product designers (Bürdek 1990b, 1996a).
3. The breakneck speed at which computers' graphic performance improved soon caused great hopes to be placed in CAD (Computer Aided Design). Once considerable teething problems had been overcome, paradigmatic changes in the processes of designing, constructing, and manufacturing followed.

MORE LEEWAY FOR HARDWARE DESIGN

The first overview of digital phenomena in relation to their bearing and impact on design was compiled by Richard Fischer, who had also launched the debate on marking functions at the Offenbach School of Design. Fischer (1988) identified a total of nine areas in microelectronics that are relevant for design:

1. As the use of microprocessors does not allow a product's technology to be revealed, the design of the remaining controls has to achieve a high degree of legibility. The increasing dominance of electronics in many product areas requires more concentrated efforts to be put into marking functions in the remaining areas. It is not only with electronic products that the relationships between user and product are of particular importance, for the "nature" of products is increasingly ephemeral.
2. Miniaturization entails a dematerialization of products in a process that is reflected in increasingly two-dimensional design concepts. Jürgen Hitzler's study of a train tracking terminal conspicuously drew attention to the new design options that microelectronics opened up. Today's tablet PCs and the popular liquid crystal displays are cases in point.
3. The falling prices of microelectronics present regular opportunities to bring products back to a human scale. The costs for realizing appropriate dimensions and sizes are low. The minute calculator watches whose operation required a special stylus illustrate how far developments in this area had veered off course. An equal absurdity is evident when fingernails



CNC MILL CENTER, Offenbach School of Design
(Photos: Wolfgang Seibt)

have to be manicured to a sharp point in order to operate cell phones weighing less than 50g.

4. LCDs, in fact all sorts of displays, and monitors in combination with membrane keyboards have become emblems of progress. Be it in airplanes, automobiles, medical equipment, or machine tools, visual elements are the most important interfaces between person and product.
5. The technology is programmable to a high degree; more and more fully automated products are being developed. The visualization of technical features often makes way for an exaggerated emphasis on ergonomic aspects (hand-shaped casings).
6. Remote controls gain increasing importance as an interface between user and product (Schönhammer 1997). The actual products fulfill their functions in the background while remote controls direct and regulate their operations. Centrally located, freely programmable remote controls direct entire households: TV, stereo and video, domestic appliances, data terminals, front door, garage door, and more.
7. Microelectronics add a new dimension to the modular principle, which opens up endless possibilities for arranging and employing the individual components of a product system.
8. Light-conducting materials come to stand for dematerialization or even symbolize the mystique of products.
9. Product graphics gains increasing importance for electronic products (user interfaces).

This analysis points to the direction that many product areas have already followed. The area of user interfaces developed at a particularly rapid pace, and became an important field of activity for product designers (Bürdek 2002).

User interfaces are the area of innovation that best demonstrates how highly relevant and indispensable the designer's job is.

— GUI BONSIPE, 1991

INTERACTION AND INTERFACE DESIGN

The transition from the mechanical to the electric and then to the electronic world of objects confronted designers and product developers with a host of new challenges and problems. By the late 1980s it was clear just how unwise it was to leave engineers and programmers to deal with the interfaces between digital products

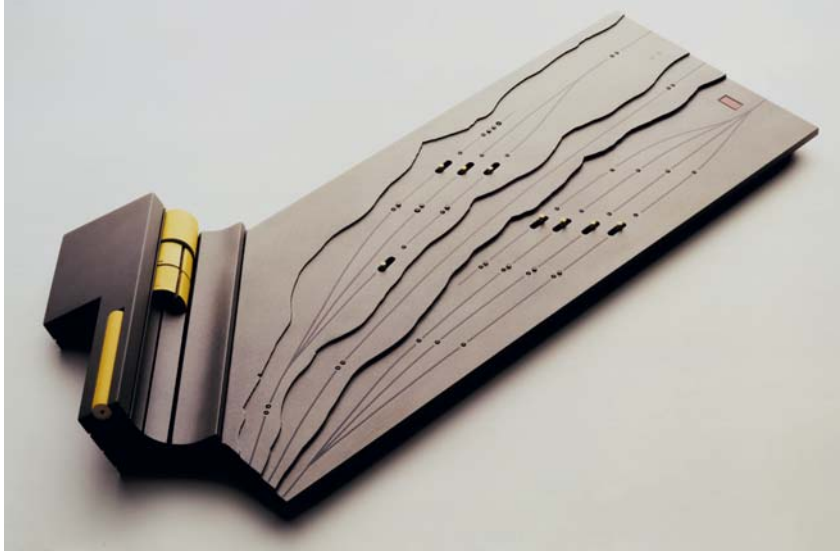

TRACK CONTROL TERMINAL STUDY, design:
 Jürgen Hitzler, Siemens Design, Munich
 W-ONE FURNITURE RANGE, SIDEBOARD, design:
 Daniel Wustlich, Wustlich Design AG
 BLOOD PRESSURE GAUGE, NAIS

and human beings. Mathematics and physics determined the way their minds worked. Made by technical experts for technical users, the solutions they proposed clashed violently with the innocent expectations of lay users. The operating instructions, handbooks, and user manuals that come with digital products tell an obvious tale: to put it in hermeneutical terms, developers and users have widely divergent horizons and act accordingly (Bürdek 1992, 1994, 1996a+b, 1999).

As indicated in our discussion of marking functions, however, experience gathered in analog product design has had an undeniable relevance for the new digital product worlds. One aspect was the transition from matter to language, and the subsequent visualization of that transition. Would it be possible to carry over developments from the 1980s, and bring insights from design theory, for example on product language or communication, to bear on these new challenges? At an early date Stephan Schupbach and Frank Zebner published some fundamental ideas on the topic and designated “language as the most important criterion in design strategy” (Schupbach and Zebner 1990). The digital media play a special role here since, on the one hand, they multiply communication channels and the amount of information communicated, while on the other, they have an almost autopoietic character in that they proliferate and distribute information whose usefulness is rarely challenged.

A CLEAR TERMINOLOGY

Bill Moggridge, co-founder of the global design practice IDEO, and Bill Verplank of Interval Research introduced a clear terminology:

- They defined “interaction design” as relating to the way we handle a digital product (be it hardware or software) and to the behavior patterns that are determined by a specific operating procedure.
- “Interface design” in turn referred to screen layout on the monitor, display, and so on (i.e., the visual representation and user interfaces of hardware and software) (Sprenberg 1994).

This distinction neatly falls in with the above-mentioned possibility of linking up analog and digital product worlds, for communicative



SENSORY, HMI interface study for a haptic interface, Johnson Control
E-PYRUS FLEXIBLE DISPLAY, Siemens

functions are equally relevant to the development and design of non-material products.

The principles of aesthetic form, for example, also apply to user interfaces (i.e., in screen design), including grid formation, regular-irregular, symmetrical-asymmetrical, clear-obscure, all of which resurface on web pages and device displays. Questions related to corporate design play an important role when it comes to designing and harmonizing the visible aspects of a company's operations, from printed materials to websites. This cross-media dimension is highly relevant, in that it is the basis for creating and communicating the identity of companies and institutions.

Terms like "interaction" and "navigation" gain figurative meanings as experiences gathered in the three-dimensional product world are transferred to the handling and use of two-dimensional interfaces. The figurative, however, is firmly rooted in the literal, in the underlying operational structures (interaction), the functionalities, and their visualization. Not every interface is necessarily and immediately self-explanatory. There is, after all, a difference between a public terminal (e.g., for tickets) and a computer game, not least because the amount of time they can reasonably expect users to invest is vastly different. Interfaces open doors to vast stores of information, users crave new discoveries, boredom means failure – at least with game applications. In most other cases, in contrast, users demand efficient, self-explanatory functions. The modernist, functional understanding of design therefore has a considerable explanatory and productive value for this area.

The concept of symbolic function comes into play where interfaces are in immediate contact with their respective user groups: for example, young and hip, professional, or for experts or senior citizens only. Simple software, in particular, allows a plethora of different and even personalized user interfaces.

A GROWING COMPLEXITY

As mentioned above, developers, designers, and users all have very different horizons – just how different became strikingly clear when the early CAD/CAM systems were launched in the mid-1980s. Designers blithely expected to be supplied with handy tools for the designing process. Even the assumption that "CAD" stood for

“computer-aided design,” however, was somewhat optimistic, for what the new tools did, at first, was no more than computer-aided drawing. However, early examples from the CAD working group at the Offenbach School of Design show that the quality of the resulting technical drawings was astonishingly high (Bürdek, Hannes, and Schneider 1988b).

Even at this early stage it was clear that the potential of the new CAD/CAM technologies lay not in image generation, but in the profound changes they would bring to the design and manufacturing processes.

A more serious aspect emerged as rapid growth and falling prices in microelectronics triggered a veritable boom in new functions (“features”). As microprocessors grew ever more powerful and universal, the range of tasks they could fulfill grew ever wider. A concomitant effect was the accelerating complexity of products. Designers were called on to mitigate and restore the products to ready usability, eliminating the need to study operating instructions.

In this context it makes sense to take a look at the operating structures of individual product categories. A high degree of inconsistency is evident here. Some strange predilection results in changes in keyboard configuration from one program version to the next, in the integration of ever new, awkward “features” in hardware (such as cell phones), and an overall tendency to equip each product with “distinctive” operating structures.

Worldwide standardization in the automobile industry, for example, means that while most drivers are able to control just about any vehicle in its basic functionality, they are confused by electronic upgrades like on-board computers, navigation systems, and audio and video systems (Bürdek 1998, 1999). Moreover, the updatability of electronic systems is limited, whereas the lifespan of vehicles extends to ten or more years.

ANTHROPOLOGY AND EVOLUTION

The end of the twentieth century also confronted designers with completely new challenges, namely those related to human development. So rapid was the spread of microelectronics that users could hardly master the new possibilities, much less apply them.

Developers had their sights firmly set on whatever was technically feasible while designers kept their eyes on the user, and suddenly both realized how dire their mistakes were in terms of the history of development. The human ability to learn evolves at a dramatically slower rate than technology, whose continual leaps inexorably increase complexity.

Stephen Jay Gould (1998) argued convincingly that the history of development provides no trace of proof for the alleged need to perpetually increase complexity. In doing so he identified a grave misconception that microelectronics, in general, seems to promote. The basic shape of the human body and brain, Gould says, have not changed at all over the past one hundred thousand years, while technical change hurtled along at breakneck speed – especially in the twentieth century. Though the design of every single artifact should ultimately address this conflict, it has a special significance for interaction and interface design. A collection of essays published by Susan Squires and Bryan Byrne (2002) impressively illustrates that the anthropological perspective has reached design research and practice. It is here to stay.

FROM HARDWARE DESIGN TO SOFTWARE DESIGN

Apart from a considerable reduction in the size of electronic devices, dematerialization also entails a shift to what actually makes these products tick: the programs, otherwise known as software. At the end of the 1970s we described a similar development (Bürdek and Gros 1978), predicting that in the future design quality would no longer rest on constructive achievements, but, to use the words of the followers of Udo Koppelman in Cologne, on its “allusive qualities.” In today’s terminology, this means product language or the communicative functions of products.

Giving a twist to the “linguistic turn” that had exerted such a decisive influence on design theory in the 1970s, talk in the 1980s was of a compelling “visual turn.” Writing and alphabetization had a profound effect on our civilization and culture. The rapid development of digital products and systems, meanwhile, has generated even more visual images, so that today we live in what is basically a “post-alphabetic society.” Our perceptions are increasingly determined by categories of visual representation: photographs,

illustrations, diagrams, pictograms, icons, typography, symbols, and so forth. Literate culture is turning into visual culture, but whether that is a sign of progress is debatable.

With a background in chaos research, Roger Lewin (1992) presented a number of ideas that are very helpful in this context. Order and chaos are the two poles that determine our behavior, with chaos usually meaning coincidence. Lewin referred to studies made at the American Santa Fe Institute, which has been re-searching this field for many years. The Institute's Murray Gell-Mann has a good phrase for it: "Surface complexity arising out of deep simplicity" (Lewin 1993). Translated to interface design this means: "Deep complexity requires surface simplicity" (Bürdek 1999). So the more complex the structures underlying a product are, the less complex its operation has to appear on the surface. This can be regarded as a general maxim for the design of digital products.

DESIGN AND SOFTWARE ERGONOMICS

Ergonomists were just as quick as designers to tackle the challenges arising from the digitalized product world. Though their attention traditionally focused on anthropometrics or workplace physiology, they soon realized that electronics posed totally new problems. American researchers were pioneers in this field, and throughout the 1990s a host of publications appeared; their value for design, however, was extremely limited.

Donald A. Norman's works (1989, 1993, 1998) are an exception. His contributions have reached the status of standard works and have proved highly useful for designers. A psychologist and scholar in cognitive science, Norman not only did research, but also advised well-known IT corporations like Apple and Hewlett-Packard. His interest in users and their habits has yielded many insights that are of special relevance to design processes. Today his ideas about what he calls human-centered development are widely accepted, even if designers and engineers still come up with wildly different interpretations of what he actually meant.

Ben Shneiderman (1992, 1998) produced what is probably the most comprehensive work on the foundations of interface and interaction design. It includes all those scientific insights, tools,

and methods that designers, developers, product managers, and all the various laborers in the field of designing digital products (hardware and software) should have at their fingertips. For example, Shneiderman is in favor of making computer performance disappear from sight, so that a system's intelligence lies not in its user interface but in the system itself. This view largely coincides with the ideas presented above.

In discussing electronic hardware design, Konrad Baumann and Bruce Thomas (2001) address a topic particularly significant for questions of design. Be it in telecommunications, audio and hi-fi systems, medical and measurement products, office communication, home, leisure, transport – nearly all products today are controlled by chips, and microprocessors rule our everyday lives. Baumann and Thomas discuss the fundamentals, covering the wide range of topics from input and output to controlling, evaluation, and usability, from the methodology of interaction design and mental user models to product language, design guidelines, and how to promote the “joy of use” (i.e., the fun to be had with products).

THE CHANGE IN PROCESSES

The rapid and pervasive spread of microelectronics in the 1990s effected a sea change in design, construction, and manufacturing processes. What are known as c-techniques (i.e. computer-aided simulation, digital construction, prototyping, and customized mass production) had a particularly profound impact on work processes in design.

It soon became clear that totally new possibilities were opening up for design. The American economists Michael J. Piore and Charles F. Sabel (1984) predicted at an early date that flow manufacturing would permit made-to-order production on a grand scale. In their view the principle of personalization, now called mass customization, would open up new opportunities for design. These opportunities are exploited today in the most diverse product fields, ranging from customized jeans to shirts, automobiles (Smart, for example, offers more than 10,000 personalized versions), and CNC-machined furniture (Steffen 2003). Computerization has wrought a permanent effect on the form and content of design processes.

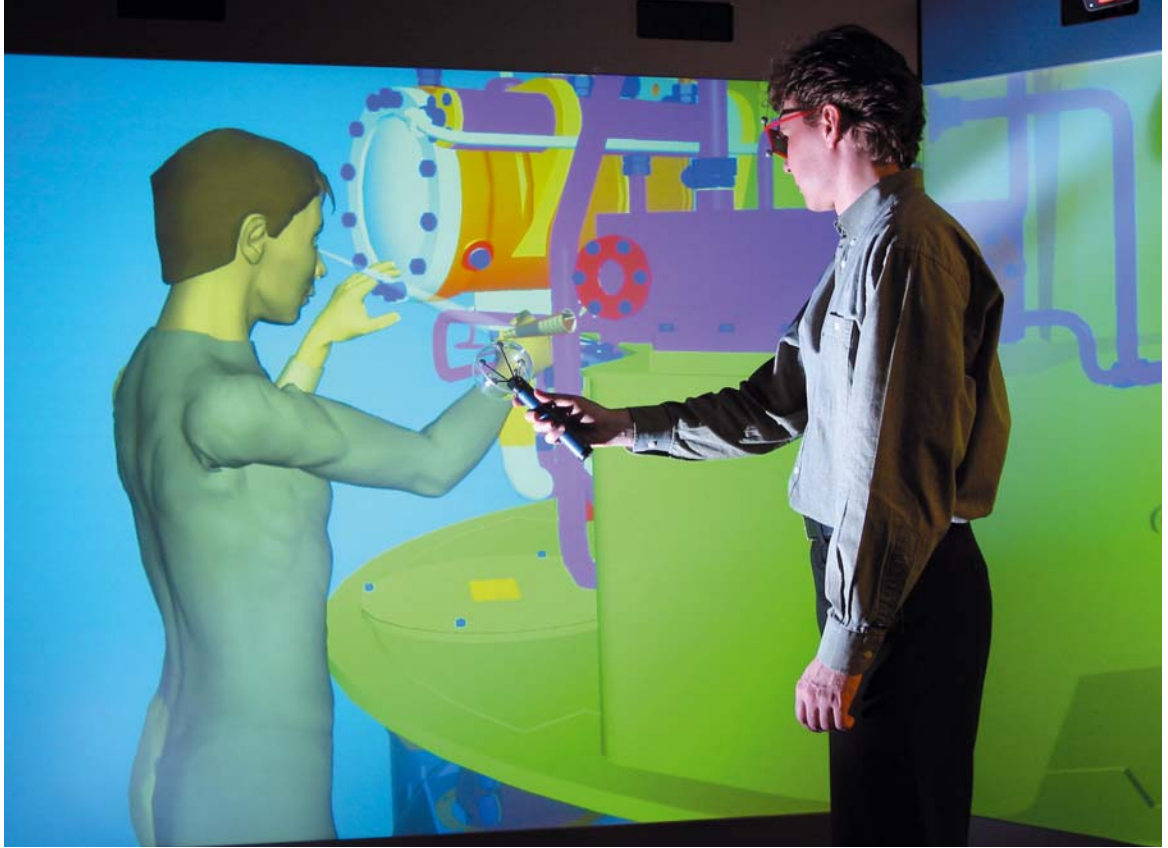

VIRTUAL REALITY, representation simulating the interior of a vehicle, IC:IDO VR productive SINTERCHAIR® INDIVIDUALLY PRODUCED CHAIR, design: Vogt + Weizenegger

The arrival of computer technologies resulted in parallel processes of design, model construction, prototyping, and manufacturing, while since the mid-1990s a growing interconnectedness has offered totally new possibilities for integrating users into the design process. Thus customers today can generate personalized products on the Internet; the data are transmitted to decentralized factories, where the product is built and sent directly to the customer. Stocks are reduced to a minimum and distances are short, adding an ecological dimension to this manufacturing model.

IMAGINEERING

The example of new visualization technologies shows that the “visual turn” that has taken hold in design has also influenced the content of design. Back in the 1990s the term imagineering was coined as a portmanteau word for “image” and “engineering” (Disney and Eisner 1996). What it refers to are “artificial imaginative worlds” (Mutius 2000), which today mainly come into play when new products and systems are presented in new contexts. The aim is to visualize and give shape to the (often nebulous) ideas of the people involved in such processes. Imagineering in this sense is one of the new methods increasingly applied in design management and strategic design.

The automobile industry has perfected this method to an amazing degree. Whether through virtual reality or augmented reality, complex computer applications simulate new vehicle concepts so realistically that even experts have a hard time distinguishing function from fiction. Munich-based Realtime Technology, for example, uses specially developed computer programs that enable it to “realize” applications at top quality. The design agency Unit Design in Frankfurt am Main has even adopted imagineering as its core activity and is continually refining its expertise in this field.

We see more and more pictures. But we do not see more and more pictures because we want to see more and more pictures, and because seeing fewer pictures would leave our need for pictures unsatiated, but rather: more and more pictures compete to be seen by us. The glances do not seek the pictures, but the pictures the glances. The pictures are eye-catchers.

— GERD B. ACHENBACH, 1989

NEW CENTERS FOR THE FUTURE OF THE DIGITAL WORLD

Since the 1980s new centers have sprung up all around the world that were founded – in some cases with massive budgets –



COMPUTER SIMULATION of a DaimlerChrysler SLK automobile "real-time technology" IMAGINEERING, study of the future for new "sunguard" materials, design: Unit Design, Degussa Röhm

to explore and shape the future of digital worlds. Politically advantageous and considered the hip thing to do for towns and regions, investment in the new media was seen to indicate far-sightedness and a secure belief in progress, and so promoted both business and a positive image. The following four examples illustrate this.

The Media Lab

The Media Lab was founded at the Massachusetts Institute of Technology in Cambridge, Massachusetts, in the late 1970s. Its declared aim was to nurture relationships between the converging media of television and film, printing and publishing, and the computer industry. The vision of co-founder Nicholas Negroponte, the prophet of the emerging media age, infected industrial corporations from all over the world, convincing them to commission the Media Lab with pioneering research projects. Synergies from highly diverse projects benefited all involved. Steward Brand (1987) vividly described how the motto “demo or die,” which compelled researchers to demonstrate their idea or forget it, came to bear in multifarious experiments and projects. The Media Lab thus became – and still is – the model for all other media institutes around the world.

Nicholas Negroponte (1995) gave an in-depth analysis of how digitalization had changed and would continue to change all our life-worlds. In a chapter called “Interface” he explains that the user interfaces of digital systems are a classic case for industrial design, a position that has already been discussed in greater detail. As a textbook example for product development he cites Apple’s Knowledge Navigator, which was conceived as a visionary study in the late 1980s and was intended to anticipate the “user interface of the future.” The head of the Media Lab also lets us in on the secret of good interface design: “The interface must disappear” (Negroponte 1995). That refers us to one of the main research fields explored at the Media Lab: TTT – Things That Think. A system’s intelligence, Negroponte says, must lie in the product or system, not on its interface.

In 2000 the Media Lab’s European branch opened in Dublin. It cooperates with a number of European universities and numerous companies (in particular from Asia) in a unique type of collaborative research and development. Research projects focus on subjects

including everyday learning, human connectedness, dynamic interaction, and story networking.

The Center for Art and Media and the State Academy for Design in Karlsruhe

In the 1980s the idea was put forward to continue and update the tradition of Germany's two most important centers of design teaching and research in the twentieth century – the Bauhaus and the Ulm School of Design – by establishing an international center for art and media in Karlsruhe. A driving force behind this initiative was art and architecture historian Heinrich Klotz (see bibliography), who in the 1980s had founded and also directed the German Architecture Museum (DAM) in Frankfurt am Main. Klotz's aim in founding such a center was to provide an environment for research and teaching, basic knowledge and application, so that new uses would emerge under the conflicting influences of traditional arts and digital media technologies. He saw this as a chance to achieve leading-edge excellence by integrating art, design, media, and the sciences, while at the same time making them the object of critical analysis.

To this end a project group consisting of members of diverse institutions and disciplines assembled in the 1980s to work out a concept, called "Konzept 88," which outlined the integration of the various core interests. Peter Zec, who was also involved in the process, used it as a point of departure for his discussion of information design (1988). He identified a number of phenomena that only interface design had addressed in their entire breadth in the 1990s. These included the rapid pace of dematerialization, problems related to complexity, the network idea, and the inflationary increase of information.

One personality Heinrich Klotz convinced as a politically active advocate of this new concept was Lothar Späth, then premier of Baden-Württemberg. Back in 1969 Späth had reported for the budget commission of the parliament of Baden-Württemberg, when it was debating the overhaul or closure of the Ulm School of Design. It has been said that his intense interest in the new media and technologies was not the only reason for his enthusiastic support for the new foundation in Karlsruhe. Perhaps, the implication was, he meant the state government to make up for terminating its funding for the Ulm School of Design in the late 1960s.

In 1988 the Center for Art and Media (ZKM) was officially established as a foundation. Heinrich Klotz was appointed as its first director. In 1992 the new State Academy of Design took up its teaching activities in Karlsruhe. With its departments of product and graphic design, media arts, and scenography (stage design and exhibition design), with a graduate program in fine arts and media theory, as well as foundation courses in painting and multimedia, sculpture and multimedia, architecture, philosophy, and aesthetics, the academy was one of the most important new additions to German higher education at the end of the twentieth century.

When media artist and theorist Peter Weibel (Weibel 1987, 1994, 2001; Decker and Weibel 1990) accepted his appointment as ZKM director in 1999, one of the most important international representatives of the new media was won for Karlsruhe. His critique of art in the age of the information society is a particularly important component for the ZKM, which defines itself as a research and production center in the field of the new media. Its exhibitions and events aim to give impetus to the related discourses. With a Museum for Contemporary Art (MNK), a Media Museum (with a collection of recent experimental and artistic works), an Institute for Visual Media, the Institute for Music and Acoustics, and the new Institutes for Basic Research and Net Development, it can easily hold its own against international rivals like the previously mentioned Media Labs in Cambridge and Dublin.

Collaboration between the ZKM and the artistic director of the ballet company of Frankfurt am Main, William Forsythe, produced an important medium. The "digital academy," an interactive CD-ROM, combines the principles of choreography and model applications of Forsythe's theory of dance with the interactive possibilities of the digital media. Its model character and distinctive interface design made the CD a multimedia highlight. Produced in 1993–1994, it was honored with numerous awards and exhibitions.

The Bauhaus-Universität Weimar

After World War II a School of Architecture and Fine Arts existed in Weimar, the location of the original Bauhaus, which at that time was part of East Germany. In 1954 the school was reorganized into

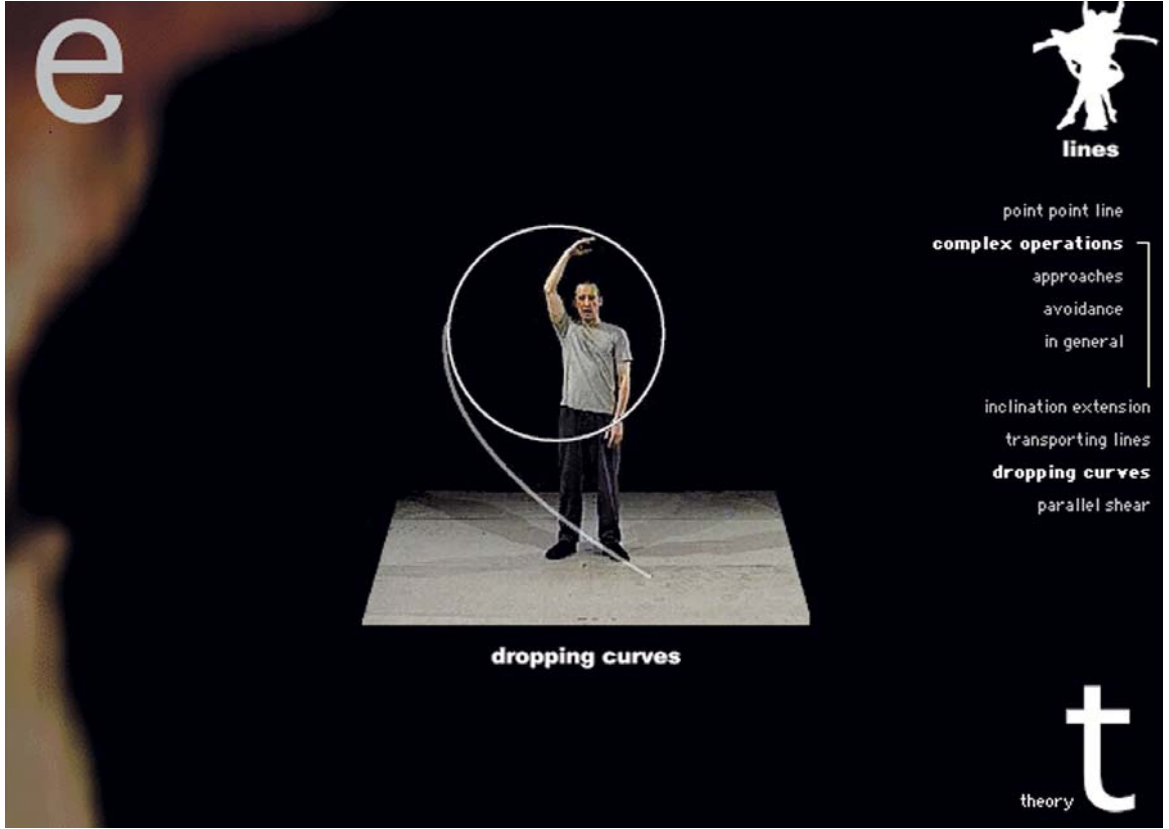

WILLIAM FORSYTHE, *Improvisation Technologies*, CD-Rom, ZKM Karlsruhe and Deutsches Tanzarchiv Cologne (1999), Screendesign: Christian Ziegler

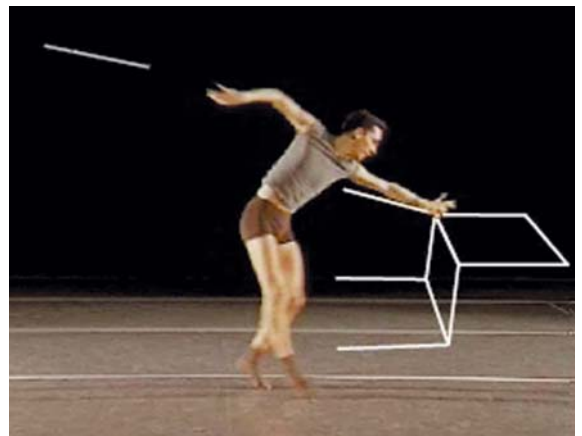
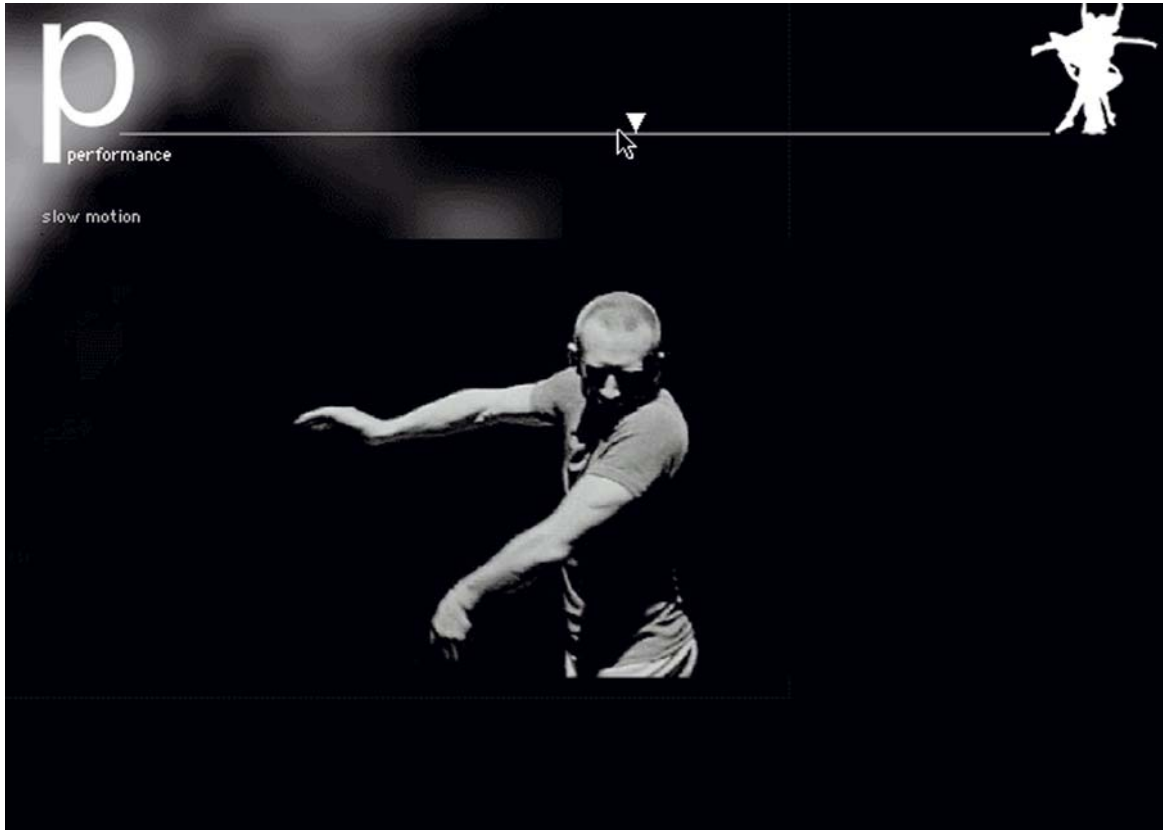

a College of Architecture and Construction. The curriculum did not include separate design courses, which in East Germany were only offered at Halle Burg Giebichenstein and in Berlin-Weissensee. The school in Weimar focused on civil engineering and construction material technology. It also hosted a number of important colloquiums that discussed the functionalist tradition and the meaning of the Bauhaus heritage for product culture.

The two German states were reunified in 1990. Soon the idea gained currency to use the original Bauhaus building by Henry van de Velde in Weimar as a base for bringing back to life the institution that had been considered a pioneer of modernity in art and design all over the world. One of the driving forces was the Swiss sociologist and urban planner Lucius Burkhardt. At the Forum Design Linz 1980 he coined the clairvoyant phrase "Design is invisible" (1980) to predict the transition from materiality to non-materiality in design.

Lorenz Engell played a crucial role when the media section began to cast loose from the mother department in 1994 and raised its flag as a separate department in 1996 (Engell, Fahle, and Neitzel 2000). In 1995 the school changed its name to Bauhaus-Universität Weimar. Its departments are architecture, civil engineering, design (including free arts, art education, product design, visual communication, art in the public domain), and media.

The new media department today offers graduate programs in media design, media culture, and media systems, as well as a program in European media culture conducted in tandem with Lumière University in Lyon. It is today one of the leading protagonists of media design. A systematic orientation on the future is evident in the way it addresses the close interrelationships between classic product design and the new media (Bauer-Wabnegg 1997, 2001), illustrating how the traditional concept of design adapts to new challenges as we move from hardware design to software design and media design.

The Interaction Design Institute in Ivrea

This institute needed very little time to gain an international reputation. Launched in June 2000 as a joint venture of Telecom Italia and Olivetti, its mission was to generate technological and cultural knowledge, impart management skills, and conduct research in the field of interaction and interface design. In addition

to its legendary corporate design activities, Olivetti thus continues its tradition of developing and marketing products while promoting basic research (Olivetti 1983). Early work by Perry A. King and Santiago Miranda on interfaces for the company's products also speak for Olivetti's proactive stance in this field (Kicherer 1990).

Since its opening in 2001, activities at Ivrea have concentrated on the traditions of hardware design – after all, Ivrea is the hometown of Olivetti – while interdisciplinary networks seek to promote the dialog between users and products. At the same time, there is a decided emphasis on cultural and historical contexts. Research also goes into exploring how the new digital products change our perceptions and behaviors. The institute's cultural orientation in particular reflects the long tradition of Italian design, which rests on precisely this understanding.

Among the well-known lecturers who teach in the two-year Masters program for international students are Tony Dunne and Fiona Raby, John Maeda (Media Lab Cambridge), and Ezio Manzini (Politecnico di Milano). The program largely centers around projects, with the dual motto "Design the right thing – design the thing right," reflecting the dichotomy of form and content.

Work at the Design Innovation Research Laboratory addresses broader questions such as how to extend the radius of social action, how to share knowledge with towns and communities, and what new technical and social infrastructures could look like.

The "Applied Dreams" section opens up possibilities (in the sense of utopias and visions) for students and professional designers to collaborate on concepts for the future of interaction design.

FROM THE DIGITAL TO THE BIOLOGICAL AGE

THE END OF DIGITALIZATION

At the dawn of the twenty-first century the end of the digital age seems near: experts forecast that by 2020 the possibilities of miniaturizing silicon technologies will be exhausted. Until that time, however, the performance of digital technologies will continue to improve as chips grow ever more efficient, smaller, and

cheaper. Moore's law (named after Gordon Moore, one of the co-founders of the American chip manufacturer Intel) says that the number of transistors on a silicon chip doubles every eighteen to twenty-four months while the price falls by half (Knop 2003). Since this law will inevitably break down at some point, researchers have started exploring biological computer systems, whose structure may one day resemble human DNA. If they should come to exist, they will shift the emphasis back to analog solutions.

From this perspective, the few decades we call the digital age are no more than a tiny fraction of the history of human development. Nonetheless, nearly all domains of our lives give ample proof that the years of everyday contact with digital products had and still have a profound impact on human behavior.

Some even talk of paradigm shifts, and design in the twentieth century can certainly be said to have changed course several times – just think of the linguistic turn, the semantic turn, and the visual turn. Developments in the twenty-first century promise to be even more spectacular as the focus moves to human beings: a “biological era” is in sight. Peter Sloterdijk, a German philosopher and media theorist who teaches at the State Academy for Design in Karlsruhe, even now speaks of the new anthropotechnologies, for what is at stake is the human organism (2001). Attempts at cloning animals have been successful, and the last barrier began to crumble when the human genome was decoded. Human engineering is the new battleground. The human body is under attack on various fronts, with science leading the charge.

Biological evolution will be replaced by a mental evolution one million times faster.
— HANS MORAVEC, 1996

BODY MODIFICATION

While the influence of postmodernism in the 1980s and 1990s generated a strong orientation on products, the dawn of the twenty-first century brought a new fascination with the human body. Artists like Matthew Barney (Tietenberg 2002), Daniele Buetti, Alba d'Urbano, and designers like James Auger, as well as various studies drawn up at computer companies and design agencies, all take the body as a foil for presenting technological and especially aesthetic innovations.

The latter at least look back on a long tradition. Ethnological studies show that in many traditional cultures, body ornamentation went hand in hand with body modification (Behrens 2002).

WEARABLES

In the 1990s scientists – notably Steve Mann at the Boston Media Lab – began experimenting with ways to bring computers closer to the human body. “Things That Think” was a pioneering research project for such technologies (Gershenfeld 1999). In the 1990s Levi’s and Philips launched a joint project on “wearable electronics,” which showed that electronics really could disappear and become an integral part of clothing. The fact that the user instructions that came with a jacket weighed more than the jacket itself again pointed to the problems related to interaction and interface design.

EMBEDDED SYSTEMS/UBIQUITOUS COMPUTING

Computers can also “disappear” when many small decentralized processors are used for regulation and controlling. Invisible to the user, they work away in the background (without direct user interfaces). In today’s automobiles more than a hundred micro-processors serve the purposes of driving safety, comfort, navigation, communication, and so on. Drivers only feel the effects of these, without usually noticing the processes themselves, a trend they would probably welcome in most products. On the whole, the automobile industry spearheads developments where ease of operation and error prevention are concerned. Software and hardware function perfectly, and their advantages benefit users directly.

Having computer services at one’s fingertips all the time and everywhere is the aim of “ubiquitous computing.” This leading-edge research field has set its sights on developing systems that merge computers and interfaces. Centrally located or decentralized, the service provided by these computers is basically anonymous, in the background. It would be no surprise if the design of devices



WEARABLE COMPUTING

Philips Corporate Design studies

were also to change dramatically. An analysis of the influence computer technologies have had on our behavior so far will play an important role in this context, yielding numerous conclusions for new product concepts.

IMPLANTS

The obvious question after wearables is how to move technology even closer to or into the human body. Continuous miniaturization in microelectronics opens up totally new possibilities, particularly in medicine. Chips and microprocessors will eventually disappear under our skin. Health applications aside, radically new options also emerge in communication. Whereas the headset still placed a technical interface between human being and device, electronics now vanish inside the body. The streets will no longer be inhabited by gesticulating, apparently soliloquizing users of mobile phones, but by people whose brains have a direct link to microcomputers that will seem to read their minds. More than that, all sensory perceptions and expressions will change fundamentally.

CYBORGS

Popularly known as cyborgs, cybernetic organisms are suspended between the natural and the artificial – part human, part machine (Bovenschen 1997). They fulfill humankind's long-cherished dream of altering and extending its limited abilities. The Japanese pop singer Kyoto Date was synthesized on a human model and was regarded as a pop idol in the late 1990s. By using such technologies it might even be possible to bring long-deceased people back to life, and compensate for the genetic deficits of the living.

That cyborgs blur the difference between reality and fiction is an idea that the film industry is especially fond of. Robots are no longer science fiction; they are now a reality. The film industry often points the way for our journeys into the future. Whether it is *Matrix*, *Solaris*, or *Minority Report*, new humanoids are in evidence everywhere.

Things are seething on the body front.

— SILVIA BOVENSCHEN, 1997

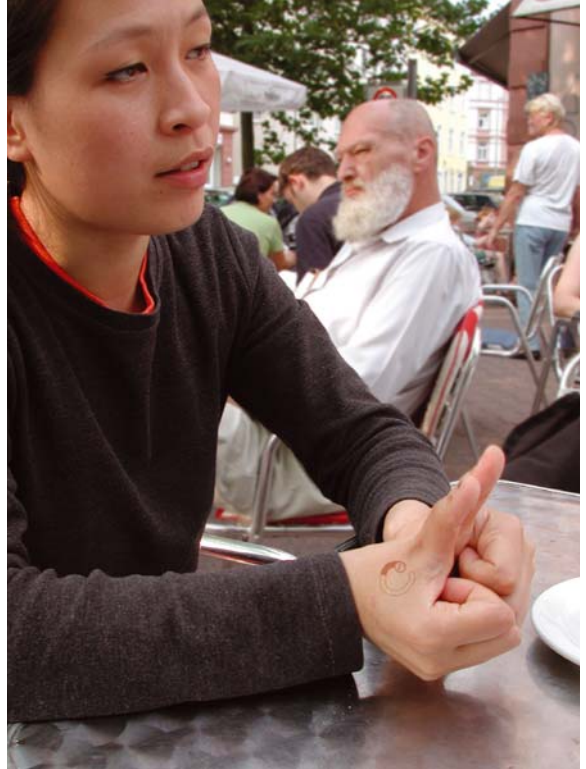
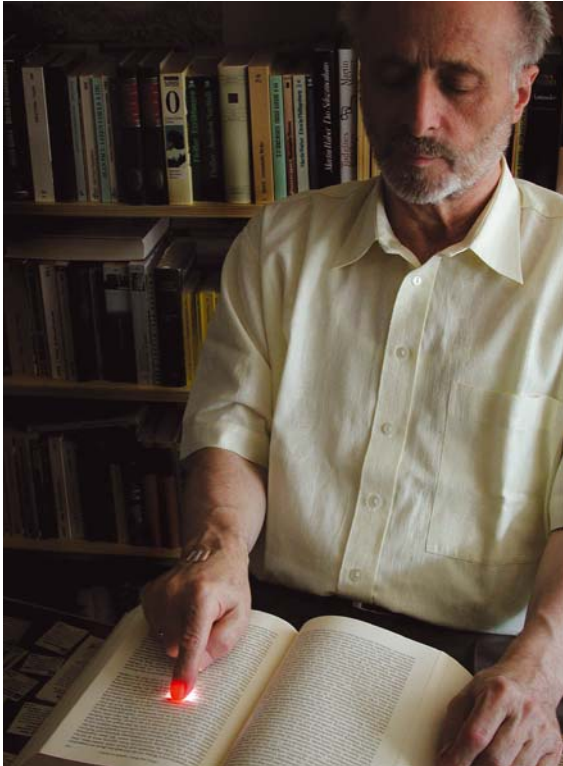
**IMPLANT DESIGN**

SUBCUTANEOUS DISPLAY, concept: Marc Behrens

THE READING FINGER, concept: Marc Behrens

HUMAN DESIGN

What will the twenty-first century bring? Speculation was rife after the decoding of the human genome (DNA) in the year 2000. The industrial age is finally nearing its end and the biotechnical age is at the door (Rifkin 1998). A combination of genetic research and informatics (bioinformatics) will entail totally new challenges for design. The cultivation of human organs will make the human body an object to be designed. Cloning Dolly the sheep in 1997 was only the beginning; in 2003 Italy followed suit with the filly Prometea. Private eugenics will also offer a field of activity for designers, as the themes of "semantic" or "aesthetic" added value are addressed in the brave new future world of human design.

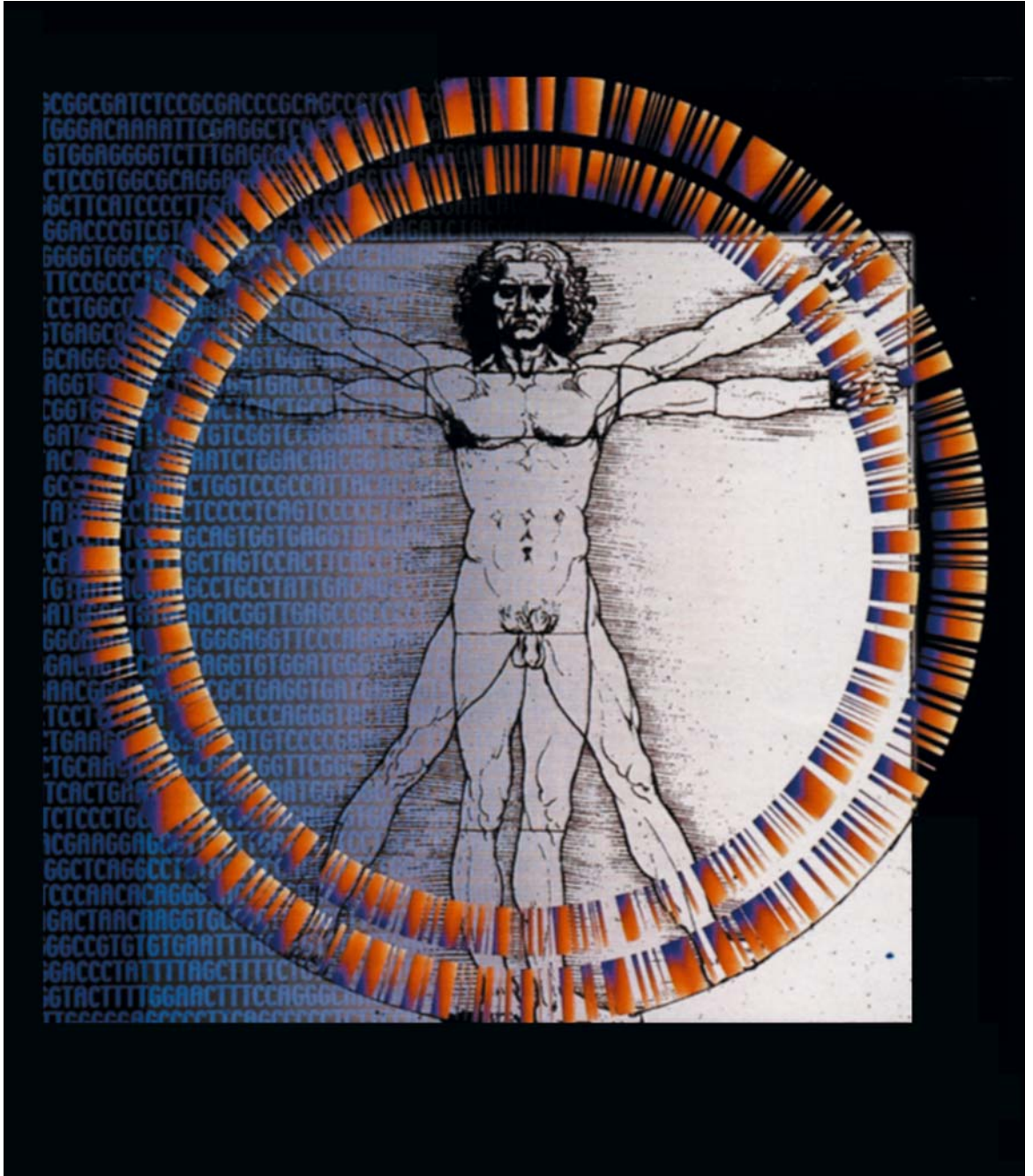

HUMAN GENETIC MATERIAL: THE ORIGIN AND FUTURE
OF DESIGN

© Keystone, Zurich (Photo: James King-Holmes)

BIBLIOGRAPHY

- Adamovich, Michail: "Wer nicht arbeitet, soll auch nicht essen" (1921). Ein Produkt der Staatl. Porzellanmanufaktur. In: Wolter, Bettina-Martine/Schwenk, Bernhart (eds.): *Die große Utopie*.
- Aicher, Otl: *Die Küche zum Kochen. Das Ende einer Architekturdoktrin*. Berlin 1982
- /Kuhn, Robert: *Greifen und Griffe*. Cologne 1987
- Albers, Josef: *Interaction of Color*. New Haven 1963
- : *Interaction of Color. Grundlegung einer Didaktik des Sehens*. Preface by Erich Franz. Cologne 1997
- Albus, Volker/Borngräber, Christian: *Design Bilanz. Neues deutsches Design der 80er Jahre in Objekten, Bildern, Daten und Texten*. Cologne 1992
- Albus, Volker/Feith, Michael/Lecatsa, Rouli et al.: *Gefühlscollagen, Wohnen von Sinnen*. Cologne 1986
- Aldersey-Williams, Hugh: *New American Design. Products and Graphics for a Post-Industrial Age*. New York 1988
- /et al.: *Cranbrook Design. The New Discourse*. New York 1990
- Alessi, Alberto: *The Dream Factory. Alessi since 1921*. Milan 1998
- Alexander, Christopher: *Notes on the Synthesis of Form*. Cambridge/Mass. 1964
- : *The Linz Café. Das Linz Café*. Vienna 1981
- Ambasz, Emilio (ed.): *Italy. The New Domestic Landscape*. New York 1972
- Anceschi, Giovanni (ed.): *Il Progetto delle Interfacce. Oggetti Colloquiali e Protesti Virtuali*. Milan 1992
- Andrews, Edward D./Andrews, Faith: *Shaker Furniture. The Craftsmanship of an American Communal Sect*. First published in 1937. New York 1964
- Antonelli, Paola: Italian Design between Globalism and Affectivity. In: Giampiero Bosoni (ed.): *Italy – Contemporary Domestic Landscapes*. Milan 2001
- A.P.P.C./C.C.I (eds.): *Design français 1960–1990*. Paris 1988
- Architekten Schweger & Partner: *Zentrum für Kunst und Medientechnologie Karlsruhe*. Stuttgart, London 1999
- Armani, Giorgio/Celant, Germano/Koda, Harold: *Giorgio Armani*. Exhibition catalog, Solomon Guggenheim Museum. New York 2001
- Arnheim, Rudolf: *Anschauliches Denken. Zur Einheit von Bild und Begriff*. Cologne 1972
- Baacke, Rolf-Peter/Brandes, Uta/Erlhoff, Michael: *Design als Gegenstand. Der neue Glanz der Dinge*. Berlin 1983

- Bachinger, Richard/Steguweit, Christian: Corporate Identity und Corporate Image der Firma Olivetti. In: Poth, Ludwig, G./Poth, Gudrun S. (eds.): *Marktfaktor Design*. Landsberg/Lech 1986
- Bang, Jens: *Bang & Olufsen. From Vision to Legend*. Skive 2000
- Bangert, Albrecht: *Colani. Das Gesamtwerk*. Exhibition catalog. Schopfheim 2004
- Barley, Nick/British Council: *Lost and Found*. Boston 1999
- Barloewen, Constantin von: Hundert Jahre Einsamkeit. Macht der Mythen: Warum Lateinamerika die Segnungen des nordamerikanischen Fortschritts nicht geheuer sind. In: *Die Zeit* No. 32, 1 August 2002
- Barthes, Roland: *The Fashion System*. Originally published as *Système de la mode* (Paris 1967). New York 1983
- Baudrillard, Jean: *For a Critique of the Political Economy of the Sign*. Originally published as *Pour une critique de l'économie politique du signe* (Paris 1972). St. Louis/Mo. 1981
- : *Fatal Strategies*. London 1990.
- : *Das System der Dinge. Über unser Verhältnis zu den alltäglichen Gegenständen*. Originally published as *Le système des objets* (Paris 1968). First German edition Vienna 1974. Frankfurt/Main 1991.
- Bauer-Wabnegg, Walter: Kleine Welten. Design muß auch in Zukunft Geschichten erzählen können. In: *formdiskurs* 3, 2/1997
- : Logische Tiefen und freundliche Oberflächen. Neue Mythen des Alltags. In: Bürdek, Bernhard E. (ed.): *Der digitale Wahn*
- Baumann, Konrad/Thomas, Bruce: *User Interface Design for Electronic Appliances*. London, New York 2001
- Bayley, Stephen: *Harley Earl and the Dream Machines*. New York 1983
- : *Harley Earl*. New York 1991
- BCD (Barcelona Centro de Diseño): *Diseño Barcelona*. Barcelona 1987
- Behrens, Marc: *Body Modification – Körperdesign*. Diploma thesis, HfG Offenbach, September 2002. Extracts published as "Hautnah vernetzt-Skin-deep Communication" in: *form* 185, September/October 2002
- Bellini, Mario: Italian Style (1984). In: Wichmann, Hans (ed.): *Italien Design 1945 bis heute*. Munich 1988
- Bense, Max: *Aesthetica*. 4 vols. Baden-Baden 1954-1960
- : *Semiotik. Allgemeine Theorie der Zeichen*. Baden-Baden 1967
- : *Einführung in die informationstheoretische Ästhetik*. Hamburg 1969
- : *Zeichen und Design*. Baden-Baden 1971
- Bertsch, Georg: *Alfredo Arribas. Architecture and Design. Arquitectura y diseño. 1986-1992*. Tübingen, Berlin 1993
- Birkigt, Klaus (ed.): *Corporate Identity. Grundlagen – Funktionen – Fallstudien*. 11th ed., Landsberg/Lech 2003
- Bittner, Regina (ed.): *Bauhausstil. Zwischen International Style und Lifestyle*. Berlin 2003
- Blaich, Robert I./Blaich, Janet: *Product Design and Corporate Strategy*. New York 1993
- Blaser, Werner (ed.): *Folding Chairs. Klappstühle*. Basel, Boston 1982
- Bloch, Ernst Werner: Abschied von der Utopie? In: Gekle, Hanna (ed.): *Vorträge*. Frankfurt/Main 1980

- Bocheński, Józef Maria: *Die zeitgenössischen Denkmethode*n. 8th ed., Bern, Munich 1954
- Bochynek, Martin: Das möblierte Museum. In: *Wolkenkratzer Art Journal* 4, 1989
- Bomann, Monica (ed.): *Design Art. Schwedische Alltagsformen zwischen Kunst und Industrie*. Berlin 1988
- Bonsiepe, Gui: Gestammelter Jargon. Industrial Design und Charles Sanders Peirce. In: *ulm* 8/9, 1963
- : *Design im Übergang zum Sozialismus. Ein technisch-politischer Erfahrungsbericht aus dem Chile der Unidad Popular (1971–73)*. Hamburg 1974
- : *Teoria e pratica del disegno industriale. Elementi per una manualistica critica*. Milan 1975
- : *Teoría y práctica del diseño industrial. Elementos para una manualística crítica*. Barcelona 1978
- : *A Tecnologia da Tecnologia*. Sao Paulo 1983
- Boos, Frank/Jarmai, Heinz: Kernkompetenzen – gesucht und gefunden. In: *Harvard business manager*, 4/1994
- Boom, Holger van den: *Betrifft: Design. Unterwegs zur Designwissenschaft in fünf Gedankengängen*. Alfter 1994
- Borchers, Jan: *A Pattern Approach to Interaction Design*. Chichester 2001
- Borisovskij, Georgij: *Form und Uniform. Die Gestaltung der technischen Umwelt in sowjetischer Sicht*. Reinbek/Hamburg 1969
- Bosoni, Giampiero (ed.): *Italy – Contemporary Domestic Landscapes*. Milan 2001
- Bovenschen, Silvia: Soviel Körper war nie. Der Traum ist aus, denn wir sind alle Cyborgs: Die Marginalisierung des Leibes und seine Wiederkehr als Konstrukt der Medien. In: *Die Zeit* no. 47, 14 November 1997
- Bourdieu, Pierre: *Distinction. A Social Critique of the Judgment of Taste*. Translated by Richard Nice. Originally published as *La distinction. Critique sociale du jugement* (Paris 1979). Cambridge/MA 1984
- Bouroullec, Ronan: *Ronan and Erwan Bouroullec*. London 2003
- Brand, Stewart: *The Media Lab. Inventing the Future at MIT*. New York 1987
- Brandes, Uta: Das bedingte Leben. Heubachs Untersuchung der psychologischen Gegenständlichkeit der Dinge. Eine Rezension. In: *Design Report* 6, 1988
- : Die Digitalisierung des Büros. In: Bürdek, Bernhard E.: *Der digitale Wahn*. Frankfurt/Main 2001
- /Steffen, Miriam/Stich, Sonja: Nicht Intentionales Design (NID): Die alltägliche Umgestaltung des Gestalteten im Gebrauch. Forschungsprojekt I+II. Unpublished manuscript. Cologne 1999, 2000
- : Alltäglich und medial: NID – Nicht Intentionales Design. In: Ecker, Gisela/Scholz, Susanne (eds.): *UmOrdnungen der Dinge*. Königstein/Ts. 2000
- Branzi, Andrea: La tecnologia nuda. Interview with Tomás Maldonado and Ettore Sottsass. In: *modo* 76, 1985
- Braun Design*. Edited by Braun GmbH, Peter Schneider. Kronberg, October 2002
- Bremer, Corinna: Wirtschaftliche Wende in Taiwan droht sich zu verzögern. In: *Financial Times Deutschland*, 12 December 2001
- Brenner, Wolfgang/Johannsen, Frank: *Alle lieben Billy. Geschichten, Tips und Reportagen über unser Lieblings-Möbelhaus*. Frankfurt/Main 1998
- Brockhaus Enzyklopädie*. Vol. 4., 19th ed. Mannheim 1987
- Buck, Alex: *Design Management in der Praxis*. Stuttgart 2003

- /Herrmann, Christoph/Lubkowitz, Dirk: *Handbuch Trend Management. Innovation und Ästhetik als Grundlage unternehmerischer Erfolge*. Frankfurt/Main 1998
- Buck, Alex/Vogt, Matthias: *Design Management. Was Produkte wirklich erfolgreich macht*. Frankfurt/Main, Wiesbaden 1996
- (eds.): *Garouste & Bonetti. Designer Monographs 7*. Frankfurt/Main 1996
- Buddensieg, Tilmann: *Industriekultur. Peter Behrens and the AEG 1907-1914*. Translated by Iain Boyd Whyte. Cambridge/MA 1984
- Bürdek, Bernhard E.: *Design-Theorie. Methodische und systematische Verfahren in Industrial Design*. Also published in Italian as *Teoria del Design. Procedimenti di problem-solving. Metodi di pianificazione. Processi di strutturazione* (Milan 1977). Ulm 1971a
- : Modelle für die Praxis. Design-Theorien, Design-Methoden. In: *form* 56, 1971b
- : Keine CI ohne CD. In: *absatzwirtschaft* (special edition). 10/1987
- : Design-Management in der Bundesrepublik Deutschland: Renaissance nach Jahren der Stagnation. In: *FAZ – Blick durch die Wirtschaft*, 25 August 1989, reprinted in: Bachinger, Richard (ed.): *Unternehmenskultur. Ein Beitrag zum Markterfolg*. Frankfurt/Main 1990a
- : Der Chip – Leitfossil der neunziger Jahre? Der Einfluss der Mikroelektronik / Die Rolle des Designs in der individualisierten Massenfertigung. In: *FAZ – Blick durch die Wirtschaft* no. 233, 2 December 1988a, reprinted in: Bachinger, Richard (ed.): *Unternehmenskultur. Ein Beitrag zum Markterfolg*. Frankfurt/Main 1990b
- : Hannes, G./Schneider, H.: Computer im Design. In: *form* 121, 1/1988b
- : Die Benutzeroberflächen rücken in den Blickpunkt der Designer. In: *FAZ – Blick durch die Wirtschaft* no. 105, 1 June 1990c
- : Produkte im Zeitalter der Elektronik. In: Design-Zentrum Nordrhein-Westfalen (ed.): *Design-Innovationen Jahrbuch '92*. Essen 1992
- : Human Interface Design. In: Hahn, Jürgen H. (ed.): *Jahrbuch '94, Technische Dokumentation*, Frankfurt/Main 1994
- : Künstler und Navigator. Der Designer als Führer durch Raum und Zeit. In: *Frankfurter Allgemeine Magazin* no. 850, June 1996a
- : Missing Link with GUI. In: *Design News* 235 (JIDPO/Tokyo), September 1996b
- : Ein Gespräch mit Rolf Fehlbaum. CD-ROM "Design." Cologne 1996b
- : *Der Apple Macintosh*. Frankfurt/Main 1997a
- : Vom Mythos des Funktionalismus. In Franz Schneider Brakel (ed.) *FSB*. Cologne 1997b
- : Form und Kontext. In: *Objekt und Prozess* 17. Design Colloquium at the Academy for Industrial Design in Halle, Burg Giebichenstein, 28-30 November 1996. Halle 1997b
- : Über Sprache, Gegenstände und Design. In: *formdiskurs* 3, 2/1997c
- : Die elektronische Aufrüstung des Autos. In: *form spezial* 2, 1998. Reprinted as "Die Digitalisierung des Autos" in Vegesack, Alexander von/Kries, Mateo (eds): *Automobility – Was uns bewegt*. Vitra Design Museum. Weil/Rhein 1999
- : Design. In: *100 Wörter des Jahrhunderts*. Frankfurt/Main 1999
- : Design: Von der Formgebung zur Sinngebung. In: Zurstiege, Guido/Schmidt, Siegfried J. (eds.) *Werbung, Mode und Design*. Wiesbaden 2001a
- (ed.): *Der digitale Wahn*. Frankfurt/Main 2001b
- : Theorie und Praxis im Design. In: *designreport* 6/02, June 2002

- : Zur Methodologie an der HfG Ulm und deren Folgen. In: *Ulmer Museum/HfG-Archiv ulmer modelle – modelle nach Ulm. Zum 50. Gründungsjubiläum der Ulmer Hochschule für Gestaltung*. Exhibition catalog. Stuttgart 2003
- /FSB – Franz Schneider Brakel (eds.): *Vom Mythos des Funktionalismus*. Cologne 1997d
- /Gros, Jochen: Der Wandel im Design-Verständnis. Interview with representatives of the Cologne-based Koppelman School. In: *form* 81, 1/1978
- /Schubach, Stephan: Klarheit mit Hypermedia. Human Interface Design: Konstruktion von Benutzungsoberflächen. In: *KEM Konstruktion Elektronik Maschinenbau*, no. 7, July 1992
- : Human Interface Design. Über neue Aufgabengebiete des Designs und ein praktisches Beispiel im Zeitalter der Elektronik. In: *form* 142, 2/1993
- : Typographische Gesellschaft (ed.): *Design und Qualität*. Munich 1996b
- Burkhardt, François: Vorwort. In: IDZ Berlin (ed.): *Design als Postulat am Beispiel Italiens*. Berlin 1973
- : Zur Entstehungsgeschichte von Memphis. In: HfG Offenbach (ed.): *Der Fall "Memphis" oder die Neo-Moderne*. Studien und Materialien, vol. 7. Offenbach/Main 1984
- /Franksen, Inez (eds.): *Design: Dieter Rams &*. Berlin 1980
- Burkhardt, Lucius: Design ist unsichtbar. In: Gsöllpointner, Helmuth/Hareiter, Angela/Ortner, Laurids (eds.) *Design ist unsichtbar*.
- : ...in unseren Köpfen. In: *ibid./IDZ Berlin (eds.): Design der Zukunft*. Cologne 1987
- Butenschön, Peter: Norwegian Design. Is There Any Such Thing? In: *ICSIDnews* 1/1998, February 1998
- Buzan, Tony: *The Mind Map Book*. New York 1991
- Byrne, Bryan/Squires, Susan (eds.) *Creating Breakthrough Ideas: The Collaboration of Anthropologists and Designers in the Product Development Industry*. Westport 2002
- Campana, Fernando/ Campana, Humberto: *Campanas*. Sao Paulo 2003
- CETRA (China External Trade Development Council): *Industrial Design in Taiwan 1959–1994*. Taipei 1994
- Cook, Peter: *Archigram*. London, New York 1974
- Couture, Lise Anne/Rashid, Hani: *Asymptote. Flux*. London 2002
- Cross, Nigel: *Developments in Design Methodology*. Chichester 1984
- : *Engineering Design Methods*. Chichester 1989
- : *Design/Science/Research: Developing a Discipline*. Keynote Speech, International Symposium on Design Science, 5th Asian Design Conference, Seoul/Korea. October 2001
- Csikszentmihalyi, Mihaly/Rochberg-Halton, Eugene: *The Meaning of Things. Domestic Symbols and the Self*. Cambridge/MA 1981
- Decker, Edith/Weibel Peter (eds.): *Vom Verschwinden der Ferne. Telekommunikation und Kunst*. Cologne 1990
- Deganello, Paolo: Un Eccesso di Speranza/An Excess of Hope. In: *Anche Gli Ogetti Hanno un'Anima. Paolo Deganello – Opere 1964–2002*. Cantù 2002
- de Kerckhove, Derrick: *The Architecture of Intelligence*. Originally published as *L'architettura dell'intelligenza* (Turin 2001). Basel, Boston, Berlin 2002
- Delacretaz, Helen: *Habitat. Canadian Design Now. Le point sur le design canadien*. Exhibition catalog. Winnipeg 2002

- Design: método e industrialismo*. Exhibition catalog, Mostra Internacional de Design. Rio de Janeiro/Sao Paolo 1998
- Design Forum Finland: *Yrityksen muotoilijayhteydet*. Helsinki 1998
- Design in der UdSSR*. Exhibition catalog. Allunions Research Centre for Technical Aesthetics, with the Landesgewerbeamt Baden-Württemberg and Design Center Stuttgart. Stuttgart 1987
- Design Process Olivetti 1908–1983*. Published by Ing. C. Olivetti e C. Texts by Giovanni Giudici. Milan 1983
- Diebner, Hans/Druckrey, Timothy/Weibel, Peter: *Science of the Interface*. Tübingen 2001
- Dietz, Georg: Begegnung mit einem Monster. In: *Frankfurter Allgemeine Sonntagszeitung*, 10 November 2002
- Disney, Walt/Eisner, Michael D.: *Imagineering: A Behind the Dreams Look at Making the Magic Real by the Imagineers*. New York 1996
- Donaldson, Stephanie: *The Shaker Garden. Beauty through Utility*. North Pomfret/VT 2000
- Dörner, Volkhard: *Die Produktform als Mittel der Anmutungsgestaltung unter besonderer Berücksichtigung der Quantifizierung und Dynamisierung anmutungshafter Formleistung*. Cologne 1976
- Douglas, Mary: *Rules and Meaning*. New York 1973
- : *Purity and Danger. An Analysis of the Concepts of Pollution and Taboo*. New York 1966
- : *Risk and Blame: Essays in Cultural Theory*. London 1992
- Dunas, Peter: *Luigi Colani und die organisch-dynamische Form seit dem Jugendstil*. Munich 1993
- Dunne, Anthony: *Hertzian Tales. Electronic Products, Aesthetic Experience and Critical Design*. Royal College of Art. London 1999
- /Raby, Fiona: *Design Noir: The Secret Life of Electronic Objects*. Basel 2001
- Durkheim, Emile: *The elementary forms of religious life*. Originally published as *Les formes élémentaires de la vie religieuse* (Paris, 1912). Translated by Karen E. Fields. New York, London 1995
- Dyson, James: *Against the odds. An Autobiography*. London 2001
- Eckstein, Hans: *Formgebung des Nützlichen. Marginalien zur Geschichte und Theorie des Design*. Düsseldorf 1985
- Eco, Umberto: *La struttura assente*. Milan 1968
- Egon Eiermann – Die Möbel*. Exhibition catalog, Badisches Landesmuseum. Karlsruhe 1999
- Ehrenfels, Christian von: Über Gestaltqualitäten. In: *Vierteljahresschrift wissenschaftliche Philosophie* 14/1890, p. 249–292
- Eisenman, Peter: *Aura und Exzeß. Zur Überwindung der Metaphysik der Architektur*. Vienna 1995
- Ekuan, Kenji (ed.): *GK Design. 50 Years 1952–2002*. Tokyo 2003
- El Diseño en España. Antecedentes históricos y realidad actual*. Published by the Ministerio de Industria y Energia. Madrid 1985
- Ellinger, Theodor: *Die Informationsfunktion des Produktes*. Special publication of "Produktionstheorie und Produktionsplanung," Festschrift for Karl Hax on the occasion of his 65th birthday. Cologne, Opladen 1966

- Engell, Lorenz/Fahle, Oliver/Neitzel, Britta (eds.): *Kursbuch Medienkultur. Die maßgeblichen Theorien von Brecht bis Baudrillard*. Stuttgart 2000
- Erco Lichtfabrik. *Ein Unternehmen für Lichttechnologie*. Published by Erco Leuchten GmbH. Berlin 1990
- Erlhoff, Michael: Kopfüber zu Füßen. Prolog für Animateure. In: *documenta 8*, vol. 1, Kassel 1987
- /Kunst- und Ausstellungshalle der Bundesrepublik Deutschland: *Design 4:3 – Fünfzig Jahre italienisches und deutsches Design*. Bonn 2000
- Escherle, Hans-Jürgen: *Industrie-Design für ausländische Märkte*. Munich 1986
- Farr, Michael: *Design Management*. London 1966
- Fawcett-Tang, Roger/Owen, William (eds.): *Mapping: An Illustrated Guide to Graphic Navigational System*. Crans/Céligny, Hove 2002
- Fehlbaum, Rolf: Vitra. Eine pluralistische Identität. In: Daldrop, Norbert W. (ed.): *Kompodium Corporate Identity und Corporate Design*. Stuttgart 1997
- Felix, Zdenek: *Konzept-Kunst*. (Kunstmuseum catalog) Basel 1972
- Feuerstein, Günther: Zeichen und Anzeichen. In: *form + zweck 5*, 1981
- Feyerabend, Paul: *Wider den Methodenzwang: Skizze einer anarchistischen Erkenntnistheorie*. Frankfurt/Main, York 1976
- Fiebig, Wilfried: *Zum Begriff der Vernunft*. Lecture in "Theorie der Produktsprache" series, HfG Offenbach, 13 November 1986
- Fiedler, Jeannine/Feierabend, Peter (eds.): *Bauhaus*. Translated by Translate-A-Book. Cologne 2000
- Figal, Günter: *Der Sinn des Verstehens. Beiträge zur hermeneutischen Philosophie*. Stuttgart 1996
- Fischer, Richard: Zur Anzeichenfunktion, In: *Fachbereich Produktgestaltung*, HfG Offenbach (ed.), 1978
- : Mikosch, Gerda: *Anzeichenfunktionen. Grundlagen einer Theorie der Produktsprache*, vol. 3. HfG Offenbach (ed.). Offenbach/Main 1984
- : *Design im Zeitalter der Mikroelektronik*. Lecture at HfG Offenbach, 13 October 1988
- Fischer, Volker: Emotionen in der Digitale. Eine Phänomenologie elektronischer "devices". In: Bürdek, Bernhard E. (ed.): *Der digitale Wahn*.
- : Richard Meier. *The Architect as Designer and Artist*. Translated by Marion McClellan. Stuttgart, London 2003
- (ed.): *Design Now: Industry or Art?* Translated by Hans Brill. New York 1989
- : Produktstrategie als Kulturstrategie. In: *Perspektive* (Vorwerk & Co. Teppichwerke KG magazine) 1, 1988b
- /Gleininger, Andrea: *Stefan Wewerka. Architect, Designer, Object Artist*. Translated by Michael Robinson. Stuttgart, London 1998
- Fischer, Wend: *Die verborgene Vernunft. Funktionale Gestaltung im 19. Jahrhundert*. Exhibition catalog. Munich 1971
- formdiskurs – Zeitschrift für Design und Theorie/Journal of Design and Design Theory* 3, 2/1997 (in-depth discussion of language, objects, and design)
- Frank, Manfred: *What Is Neostructuralism?* Translated by Sabine Wilke and Richard Gray. Minneapolis 1989
- Frenzl, Markus: Interview with Stefan Ytterborn. In: *designreport 2/03*
- Friedländer, Uri: Wir sind in einer Phase der Umorientierung... In: *form 96*, 4/1981/82

- Friedrich-Liebenberg, Andreas: *Anmutungsleistungen von Produkten. Zur Katalogisierung, Strukturierung und Stratifikation anmutungshafter Produktleistungen.* Cologne 1976
- Fritenwalder, Henning: *Kann Design eine Theorie haben?* Diploma thesis, HdK Hamburg, 1999
- FSB-Edition:
- Greifen und Griffe.* With texts by Otl Aicher and Robert Kuhn. Cologne 1987
- Johannes Potente, Brakel. Design der 50er Jahre.* With texts by Otl Aicher, Jürgen W. Braun, Siegfried Gronert, Robert Kuhn, Dieter Rams and Rudolf Schönwandt. Cologne 1989
- Zugänge – Ausgänge.* With poems by Peter Maiwald and texts by Jürgen W. Braun and Marcel Reich-Ranicki. Cologne 1989
- Zugänge – Ausgänge.* Photographs by Timm Rautert, with texts by Otl Aicher, Jürgen Becker and Wolfgang Pehnt. Cologne 1990
- Türdrücker der Moderne. Eine Designgeschichte von Siegfried Gronert.* Cologne 1991
- Annentag in Brakel. Ein deutsches Volksfest.* Photographs by Rudi Meisel, Timm Rautert, Michael Wolf, and text by Bernd Müllender. Cologne 1992
- Übergriff. Brief: Jürgen W. Braun.* Realization: Students of Karlsruhe School of Design under the stewardship of Gunter Rambow. Texts by Peter Sloterdijk, Heinrich Klotz and Jürgen W. Braun. Cologne 1993
- The Doorhandle Disaster. Le chaos de la poignée de porte. Das Türklinken-Chaos.* Story and illustrations by Klaus Imbeck. Cologne 1994
- Visuelle Kommunikation. Bausteine Realisationen.* With texts by Otl Aicher, Sepp Landsbeck and Jürgen W. Braun. Cologne 1995
- Hand und Griff.* Exhibition in Vienna, 1951, organized by Walter Zeischegg and Carl Auböck. Retrospective catalog compiled by Andrea Scholtz. Cologne 1995
- Gesten.* A book by photography students at the College of Graphic Design and Book Craft in Leipzig under the stewardship of Timm Rautert. Cologne 1996
- Vom Mythos des Funktionalismus.* With texts by Bernhard E. Bürdek, Reinhard Kiehl, Florian P. Fischer, Jürgen W. Braun. Drawings by Hans Hollein (Vienna). Cologne 1997
- Das virtuelle Haus.* Workshop with Peter Eisenman, Jaques Herzog, Toyo Ito, Daniel Libeskind, Jean Nouvel, et al. Cologne 1998
- Links – Rechts. Linkshänder in einer rechten Welt.* Ein Buch über Händigkeit von Andrea Scholtz. Cologne 1999
- Les Mains de Le Corbusier.* André Wogenscky. Cologne 2000
- g/df* (Catalog Good Design Festival), Seoul 2001
- Gadamer, Hans-Georg: *Wahrheit und Methode. Grundzüge einer philosophischen Hermeneutik.* 4th ed. Tübingen 1975
- : *Der Mensch als Naturwesen und Kulturträger.* Opening lecture of the “Mensch und Natur” series, Frankfurt/Main 28 August 1988
- Garnich, Rolf: *Konstruktion, Design, Ästhetik.* Esslingen 1968
- Gershenfeld, Neil: *When Things Start to Think.* New York 1999
- Geyer, Erich/Bürdek, Bernhard E.: Designmanagement. In: *form* 51, 3/1970
- /Frerkes, Jupp/Zorn, Manfred: *AW design Kompendium 70,* Stuttgart 1970
- : *Marktgerechte Produktplanung und Produktentwicklung. Teil II: Produkt und Betrieb.* Heidelberg 1972

- Gibson, James J.: *The Senses Considered as Perceptual Systems*. Houghton 1966
- : *The Perception of the Visual World*. Houghton 1950
- : *The Ecological Approach to Visual Perception*. Houghton 1979
- Giedion, Sigfried: *Mechanization Takes Command*. Oxford 1948
- Giralt-Miracle, Daniel/Capella, Juli/Larrea, Quium: *Diseño Industrial en España*. Madrid 1998
- GK Design Group: *GK Design 50 years 1952–2002*. Tokyo 2003
- Glaeser, Willi: *20 Jahre Wogg. Der Werkbericht*. Baden 2003
- Glancey, Jonathan: *Douglas Scott*. London 1988
- Glaser, Hermann: Industriekultur oder die Sache mit den Knopflöchern. In: Sembach, Klaus-Jürgen/Jehle, Manfred/Sonnenberger, Franz (eds.): *Industriekultur. Expeditionen ins Alltägliche*. Published by the Schul- und Kulturreferat der Stadt Nürnberg, Centrum Industriekultur. Nuremberg 1982
- Göbel, Lutz: Den "Integralisten" gehört die Zukunft. In: *VDI nachrichten* no. 13, 1992
- Golde, Chris M./Walker, George: *Overview of the Carnegie Initiative on the Doctorate*. Draft 2.1, Carnegie Mellon University Pittsburgh/PA, 19 August 2001
- Gombrich, Ernst H.: *The Sense of Order*. Oxford 1979
- Gorgs, Claus: Gemeinsamer Nenner. In: *Wirtschaftswoche* no. 3, 9 January 2003
- Gorsen, Peter: *Zur Dialektik des Funktionalismus heute*. English translation in: Habermas, Jürgen (ed.): *Observations on "the Spiritual Situation of the Age." Contemporary German Perspectives*. Translated by Andrew Buchwalter. Cambridge/MA 1984
- Gotlieb, Rachel/Golden, Cora: *Design in Canada. Fifty Years from Teakettles to Task Chairs*. Toronto 2001
- Gould, Stephen Jay: *Full House. The Spread of Excellence from Plato to Darwin*. New York 1996
- Grassi, Alfonso/Pansera, Anty: *Atlante del Design Italiano 1940–1980*. Milan 1980
- Gregotti, Vittorio: *Il disegno del prodotto industriale. Italia 1860–1980*. Milan 1982
- Gros, Jochen: *Dialektik der Gestaltung*. Publication series by the Institut für Umweltpfung of the University of Stuttgart. Ulm 1971
- : *Grundlagen einer Theorie der Produktsprache*, vol 1. HfG Offenbach (ed.). Offenbach/Main 1983
- : *Symbolfunktionen*. in *Grundlagen einer Theorie der Produktsprache*, vol. 4. HfG Offenbach (ed.). Offenbach/Main 1987
- Gsöllpointner, Helmuth/Hareiter, Angela/Ortner, Laurids (eds.): *Design ist unsichtbar*. Vienna 1981
- Gugelot, Hans: *Design als Zeichen*. Lecture, CEAD, Dortmund, 13 October 1962. In: Wichmann, Hans (ed.): *System-Design Bahnbrecher: Hans Gugelot 1920–1965*. Munich 1984
- Guixé, Martí: *Libre de contexte: context-free, kontext-frei*. Basel, Boston, Berlin 2003
- Habermas, Jürgen: *Knowledge and Human Interests*. Translated by Jeremy J. Shapiro. Boston 1971
- : *The Theory of Communicative Action, vol. 1: Reason and the Rationalization of Society*. Translated by Thomas McCarthy. Boston 1984
- : *The Theory of Communicative Action, vol. 2: Lifeworld and System – A Critique of Functionalist Reason*. Translated by Thomas McCarthy. Boston 1987
- : *The New Obscurity: The Crisis of the Welfare State and the Exhaustion of Utopian Energies*. In: *ibid.: The New Conservatism. Cultural Criticism and the*

- Historian's Debate*. Edited and translated by Shierry Weber Nicholsen. Cambridge/MA 1989, pp. 48–70
- Habermas, Tilmann: *Geliebte Objekte. Symbole und Instrumente der Identitätsbildung*. Frankfurt/Main 1999
- Hadwiger, Norbert/Robert, Alexandre: *Produkt ist Kommunikation. Integration von Branding und Usability*. Cologne 2002
- Hahn, Erwin: Amerika Du hast es besser. In: *computer persönlich*. 26, 1988
- Hase, Holger: *Gestaltung von Anmutungscharakteren. Stil und Looks in der marketingorientierten Produktgestaltung*. Cologne 1989
- Hauffe, Thomas: *Fantasie und Härte. Das Neue deutsche Design der achtziger Jahre*. Giessen 1994
- Haug, Wolfgang Fritz: In: IDZ Berlin (ed.): *design? Umwelt wird in Frage gestellt*. Berlin 1970
- : *Critique of Commodity Aesthetics: Appearance, Sexuality and Advertising in Capitalist Society*. Translated by Robert Bock. Minneapolis 1986
- : *Warenästhetik, Sexualität und Herrschaft. Gesammelte Aufsätze*. Frankfurt/Main 1972
- Heidegger, Martin: *Identity and Difference*. Translated by Joan Stambaugh. New York 1969
- : *Vorträge und Aufsätze*. Includes “Das Ding,” “Die Frage nach der Technik,” “Bauen Wohnen Denken.” Pfullingen 1967
- : *Basic writings from Being and Time (1927) to The Task of Thinking (1964)*. Edited by David Farrell Krell. Includes “The Question Concerning Technology” and “Building Dwelling Thinking.” San Francisco 1993
- : *Phänomenologische Analysen zur Kunst der Gegenwart*. The Hague 1968
- Henseler, Wolfgang: Ainterface-Agenten. Der Wandel in der Mensch-Objekt-Kommunikation oder Von benutzungsfreundlichen zu benutzerfreundlichen Systemen. In: Bürdek, Bernhard.E.: *Der digitale Wahn*. Frankfurt/Main 2001
- Heskett, John: *Industrial Design*. First published London 1980. New edition 2000
- Heß, Andreas (Porsche AG): Produktkliniken als Instrument der Marktforschung in der Automobilindustrie. In: Meinig, Wolfgang (ed.): *Auto-Motive 97*. Bamberg 1997
- Heubach, Friedrich W.: *Das bedingte Leben. Entwurf zu einer Theorie der psychologischen Gegenständlichkeit der Dingen*. Munich 1987
- Heufler, Gerhard: *Produkt-Design. Von der Idee zur Serienreife*. Linz 1987
- Hiesinger, Kathryn B./Fischer, Felice: *Japanese Design: A Survey since 1950*. Philadelphia 1994
- Hirdina, Heinz: Voraussetzungen postmodernen Designs. In: Flierl, Bruno/Hirdina, Heinz: *Postmoderne und Funktionalismus*. Sechs Vorträge. Berlin 1995
- : *Gestalten für die Serie. Design in der DDR 1949–1985*. Dresden 1988
- Hitchcock, Henry-Russell/Johnson, Philip: *The International Style*. Originally published as *The International Style: Architecture since 1922* (New York 1932). New York, London 1966
- Hitzler, Jürgen/Siemens Design Studio: *Studie Gleisbildterminal 1986*. English translation in: Fischer, Volker (ed.): *Design Now*
- Höhne, Günter: *Penti, Erika und Bebo Sher. Die Klassiker des DDR-Designs*. Berlin 2001

- Hörisch, Jochen: *Die Wut des Verstehens. Zur Kritik der Hermeneutik*. Frankfurt/Main 1988
- Hosokawa, Shuhei: The Walkman Effect. *Popular music* 4/1984
- HTR (*HighTech Report*). DaimlerChrysler AG (ed.), 1/2003
- Husserl, Edmund: Ideen zur reinen Phänomenologie und phänomenologischen Philosophie (1900/01). In: *Jahrbuch für Philosophie und phänomenologische Forschung*. Halle 1913
- ICSID Daily. Day 4, October 11, 2001. Seoul 2001
- Industrie Forum Design Hannover: *Kriterien einer guten Industrieform* (Herbert Lindinger). Hanover 1990
- Inside Design Now: *National Design Triennial*. New York 2003
- Internationales Design Zentrum Berlin (ed.): *Design als Postulat am Beispiel Italien*. Exhibition catalog. Berlin 1973
- Italia diseño 1946/1986*. Exhibition catalog, Museo Rufino Tamayo. Mexico D. F. 1986
- Jencks, Charles: *The Language of Post-Modern Architecture*. London 1978
- : *Post-Modernism*. London 1987
- Jenkins, David: *on foster – foster on*. Munich 2000.
- Jones, Christopher J.: The State-of-the-Art in Design Methods. In: Broadbent, Geoffrey/Ward, Anthony: *Design Methods in Architecture*. London 1969
- : *Design Methods. Seeds of Human Future*. 9th ed. Chichester 1982
- Jongerius, Hella/Schouwenber, Louise: *Hella Jongerius*. Berlin 2003
- Julier, Guy: *The Culture of Design*. London 2000
- Jun, Cai: Industrial Design in China. In: *ICSID News* 2000/3
- : *Adaptation and Transformation: Design Education in Fast-Changing China*. ICSID Educational Seminar, Seongnam 2001
- Kahn, Hermann: *The Next 200 Years. A Scenario for America and the World*. Boulder 1976
- : *World Economic Development*. Boulder 1979
- Kaku, Michio: *Visions. How Science Will Revolutionize the 21st Century*. New York 1997
- Karmasin, Helene: *Produkte als Botschaften. Was macht Produkte einzigartig und unverwechselbar?* Vienna 1993
- : Cultural Theory und Produktsemantik. Cultural Theory and Product Semantics. In: *formdiskurs – Zeitschrift für Design und Theorie/ Journal of Design and Design Theory* 4, 1/1998
- /Karmasin, Matthias: *Cultural Theory. Ein neuer Ansatz für Kommunikation, Marketing und Management*. Vienna 1997
- Kassner, Jens: *Claus Dietel und Lutz Rudolph. Gestaltung ist Kultur*. Chemnitz 2002
- Katz, David: *Gestalt Psychology: Its Nature and Significance*. Translated by Robert Tyson. Originally published as *Gestaltpsychologi* (Stockholm 1942). Westport/Conn. 1979
- Keine Garantie für gut abgehangene Klassiker. In: *Frankfurter Allgemeine Zeitung* no. 191, 20 August 1987
- Keller, Rudi: Interpretation und Sprachkritik. In: *Sprache und Literatur in Wissenschaft und Unterricht* 17, No. 57, 1986
- Kicherer, Sibylle: *Industriedesign als Leistungsbereich von Unternehmen*. Munich 1987
- : *Olivetti. A Study of the Corporate Management of Design*. New York 1990

- Kiefer, Georg R.: *Zur Semiotisierung der Umwelt*. Ph.D. thesis. Stuttgart 1970
- Kiemle, Manfred: *Ästhetische Probleme der Architektur unter dem Aspekt der Informationsästhetik*. Quickborn 1967
- Kirsch, Karin: *Die Weißenhof-Siedlung*. Werkbund exhibition "Die Wohnung" Stuttgart 1927. Stuttgart 1987
- Klatt, Jo/Jatzke-Wigend, Hartmut (eds.): *Möbel-Systeme von Dieter Rams*. Hamburg 2002
- Kleefisch-Jobst, Ursula/Flagge, Ingeborg (eds.): *Architektur zum Anfassen. FSB Greifen und Griffe*. Frankfurt/Main 2002
- Klein, Naomi: *No Logo*. Toronto 2000
- Klemp, Klaus: *Das USM Haller Möbelbausystem*. Design-Klassiker series, edited by Volker Fischer. Frankfurt/Main 1997
- Klotz, Heinrich: *Geschichte der deutschen Kunst*. 3 vols. Munich 2000
- : *Kunst im 20. Jahrhundert. Moderne – Postmoderne – Zweite Moderne*. Munich 1999
- : *Architektur der Zweiten Moderne. Ein Essay zur Ankündigung des Neuen*. Stuttgart 1999
- : *Contemporary Art. ZKM. Center for Art and Media Karlsruhe*. Translated by Elizabeth Clegg. Munich, New York 1997
- : *Die Zweite Moderne. Eine Diagnose der Kunst der Gegenwart*. Munich 1996
- : *Schriften zur Architektur. Texte zur Geschichte, Theorie und Kritik des Bauens*. Ostfildern 1996
- : *Geschichte der Architektur. Von der Urhütte zum Wolkenkratzer*. Munich 1995
- : *20th Century Architecture*. Exhibition catalog. New York 1989
- : *Moderne und Postmoderne. Architektur der Gegenwart 1960–1980*. 3rd ed. Braunschweig/Wiesbaden 1987
- : *Vision der Moderne. Das Prinzip der Konstruktion*. Munich 1986
- Knop, Carsten: Die Zauberer der schnellen Chips. In: *Frankfurter Allgemeine Zeitung* no. 141, 21 June 2003
- Koenig, Giovanni Klaus: Tertium non datur. In: *Möbel aus Italien. Produktion Technik Modernität*. With an abstract in Italian. Exhibition catalog, Design Center Stuttgart. Stuttgart 1983.
- Kohl, Karl-Heinz: *Die Macht der Dinge. Geschichte und Theorie sakraler Objekte*. Munich 2003
- Köhler, Manfred: Made in Kronberg: Scherköpfe für Schanghai. In: *Frankfurter Allgemeine Zeitung* no. 186, 13 August 2002
- Kölling, Martin: Funkstille In: *Financial Times Deutschland*, 4 June 2002
- Koolhaas, Rem: *Harvard Design School Guide to Shopping*. Cologne 2001
- /OMA/AMO: *Projects for Prada Part 1*. Milan 2001
- Koppelman, Udo: *Grundlagen des Produktmarketing. Zum qualitativen Informationsbedarf von Produktmanagern*. Stuttgart 1978
- Krauch, Helmut: Maieutik. In: Sommerlatte, Tom (ed.): *Angewandte Systemforschung. Ein interdisziplinärer Ansatz*. Wiesbaden 2002
- Krippendorff, Klaus: Die Produktsemantik öffnet die Türen zu einem neuen Bewußtsein im Design. In: *form* 108/109, 1/1985
- : *The Semantic Turn. A New Foundation for Design* (forthcoming)

- : /Butter, Reinhart: *Product Semantics: Exploring the Symbolic Qualities of Form*.
In: *innovation. The Journal of the Industrial Designers Society of America* 3,
No. 2, 1984
- Kristof, Nicholas D./WuDunn, Sheryl: *Thunder from the East: Portrait of a Rising
Asia*. London 2000
- Kruft, Hanno-Walter: *Geschichte der Architekturtheorie*. Munich 1985
- Kuhn, Thomas S.: *The Structure of Scientific Revolutions*. Chicago 1962
- Kümmel, Birgit (ed.): *Made in Arolsen. HEWI und die Kaulbachs; zwischen höfischem
Handwerk und Industriedesign*. Bad Arolsen 1998
- Kunkel, Paul: *Apple Design. The Work of the Apple Industrial Design Group*.
New York 1977
- Kurokawa, Kisho: *The Concept of Metabolism*. Tokyo 1972
- : *Metabolism 1960 – The Proposal for Urbanism*. Tokyo 1960
- Küthe, Erich/Thun, Matteo: *Marketing mit Bildern*. Cologne 1995
- La collection de design du Centre Georges Pompidou*. Musée national d'art moderne
– Centre de création industrielle. Paris 2001
- Lampugnani, Vittorio Magnago: *Architecture and City Planning in the Twentieth Cen-
tury*. New York 1985
- Lamy: *Formen des Erfolgs. Lamy Design 1966–1986*. English edition. Heidelberg
1996
- Lang, Alfred: Preface. In: Csikszentmihalyi, Mihaly/Rochberg-Halton, Eugene: *The
Meaning of Things*.
- Langenmaier, Arnica Verena: *Der Klang der Dinge. Akustik – eine Aufgabe des
Design*. Published by Design Zentrum München. Munich 1993
- Langer, Susanne: *Philosophy in a New Key*. Cambridge/MA 1942
- Lannoch, Helga/Lannoch, Hans-Jürgen: *Metarealistisches Design*. In: *form* 79,
3/1977
- : Überlegungen zu einer neuen Formensprache. In: *form* 104, 4/1983
- : How to Move from Geometric to Semantic Space. In: *innovation. The Journal of
the Industrial Designers Society of America* 3, No. 2, 1984
- : Vom geometrischen zum semantischen Raum. In: *form* 118, 2/1987
- Laurentiev, Alexander/Nasarov, Yuri: *Russian Design. Tradition and Experiment
1920–1990*. London 1995
- Lee, Kun-Pyo: *Culture and Its Effects on Human Interaction with Design. With the
Emphasis on Cross-Cultural Perspectives between Korea and Japan*. Ph.D.
project, University of Tsukuba, Japan 2001
- Lehnhardt, Jana-Maria: *Analyse und Generierung von Designprägnanzen. Designstile
als Determinanten der marketingorientierten Produktgestaltung*. Cologne 1996
- Leithäuser, Thomas/Volmerg, Birgit: *Anleitung zur empirischen Hermeneutik. Psycho-
analytische Textinterpretation als sozialwissenschaftliches Verfahren*.
Frankfurt/Main 1979
- Leitherer, Eugen: *Industrie-Design. Entwicklung – Produktion – Ökonomie*. Stuttgart
1991
- Lenz, Michael: *Gedankensprünge. Zur experimentellen Arbeit der Gruppe Ginbande*.
In: *Design Report* 5, 5/1988
- Lewin, Roger: *Complexity. Life at the Edge of Chaos*. New York 1992.
- Libeskind, Daniel: *Kein Ort an seiner Stelle*. Schriften zur Architektur – Visionen für
Berlin. Dresden, Basel 1995

- Lichtenstein, Claude/Engler, Franz (eds.): *Stromlinienform – Streamline – Aérodynamisme – Aerodinamismo*. Exhibition catalog, Museum für Gestaltung. Zurich 1992
- Liebl, Franz: *Der Schock des Neuen. Entstehung und Management von Issues und Trends*. Munich 2000
- Linn, Carl Eric: *Metaprodukten och det skapande företaget*. Malmö 1985
- Loewy, Raymond: *Never Leave Well Enough Alone*. New York 1949
- : *Industrial Design*. Woodstock/NY 1979
- Lorenzer, Alfred: *Kritik des psychoanalytischen Symbolbegriffs*. Frankfurt/Main 1970
- : *Die Wahrheit der psychoanalytischen Erkenntnis*. Frankfurt/Main 1974
- Lovegrove, Ross/Antonelli, Paola: *Supernatural: The Work of Ross Lovegrove*. London 2004
- Lueg, Gabriele (ed.): *Made in Holland – Design aus den Niederlanden*. Exhibition catalog, Museum für Angewandte Kunst Köln. Tübingen, Berlin 1994
- /Gantenbein, Köbi: *Swiss Made. Aktuelles Design aus der Schweiz*. Exhibition catalog, Museum für Angewandte Kunst Köln. Zurich 2001
- Luhmann, Niklas: *Social Systems*. Translated by John Bednarz, Jr., with Dirk Baecker. Stanford 1995
- Lux, Peter G. C.: Zur Durchführung von Corporate Identity Programmen. In: Birkigt, Klaus (ed.): *Corporate Identity*.
- Lyotard, Jean-François: *Das postmoderne Wissen. Ein Bericht*. Peter Engelmann (ed.). Previously published Bremen 1982. New edition Graz, Vienna 1986
- /et al.: *Immaterialität und Postmoderne*. Berlin 1985
- Maldonado, Tomás: *Critica della ragione informatica*. Milan 1997
- /Bonsiepe, Gui: Wissenschaft und Gestaltung. in: *ulm* 10/11 1964
- Manske, Beate/Scholz, Gudrun: *Täglich in der Hand. Industrieformen von Wilhelm Wagenfeld aus sechs Jahrhunderten*. Worpswede 1987
- Manzini, Ezio/Susani, Marco: *The Solid Side. The Search for a Consistency in a Changing World – Projects and Proposals*. Eindhoven 1995
- Martin, Marijke/Wagenaar, Cor/Welkamp, Annette: *Alessandro & Francesco Mendini! Philippe Starck! Michele de Lucchi! Coop Himmelb(l)au! in Groningen! Dutch and English*. Groninger Museum. Groningen 1995
- Marzano, Stefano: *Creating Value by Design. Thoughts*. London 1998
- Maser, Siegfried: *Numerische Ästhetik. Arbeitsberichte 2*. Institut für Grundlagen der Modernen Architektur (ed.). Stuttgart 1970
- : *Grundlagen der allgemeinen Kommunikationstheorie. Eine Einführung in ihre Grundbegriffe und Methoden (mit Übungen)*. Stuttgart 1971
- : *Einige Bemerkungen zum Problem einer Theorie des Designs* (manuscript). Braunschweig 1972
- : Design und Wissenschaft. Theorie ohne Praxis ist leer, Praxis ohne Theorie ist blind. In: *form* 73, 1/1976
- Mason, George: *Patrick le Quément. Renault Design*. Milan 2000
- Mayr-Keber, Gert M.: Strukturelemente der visuellen Erscheinung von Corporate Identity. In: Birkigt, *Corporate Identity*.
- McCoy, Michael: Defining a New Functionalism in Design. In: *innovations. The Journal of the Industrial Designers Society of America* 3, 2/1984
- Katherine: Design in the Information Age. In: Aldersey-William, Hugh: *New American Design*. New York 1988

- : Interpretive Design. In: Mitchell, C. Thomas: *New Thinking in Design. Conversations on Theory and Practice*. New York 1996
- McLuhan, Marshall: *The Gutenberg Galaxy*. Toronto 1962
- McQuaid, Matilda (ed.): *Visionen und Utopien: Architekturzeichnungen aus dem Museum of Modern Art*. Exhibition catalog Schirn Kunsthalle. Frankfurt/Main 2003
- (ed.): *Envisioning Architecture: Drawings from The Museum of Modern Art*. Exhibition catalog, Royal Academy of Arts, London; Schirn Kunsthalle, Frankfurt; Museu de Arte Contemporanea de Serralves, Porto. New York 2002
- Meadows, Donella: *The Limits to Growth*. New York 1972
- Meier-Kortwig, Hans Jörg: *Design Management als Beratungsangebot*. Frankfurt/Main 1997
- Meinong, Alexius: *Über die Stiftung der Gegenstandstheorie im System der Wissenschaften*. Leipzig 1907
- Meller, James (ed.): *The Buckminster Fuller Reader*. London 1970
- Mendini, Alessandro/Banzi, Andrea/Marzano, Stefano: *Television at the Crossroads*. London 1995
- Metzger, Wolfgang: *Gestalt-Psychologie. Ausgewählte Werke aus den Jahren 1950 bis 1982*. Selected and with an introduction by Michael Stadler and Heinrich Crabus. Paperback edition. Frankfurt/Main 1999
- Miller, R. Craig/Bletter, Rosemarie Haag/et al.: *USDesign 1975–2000*. Exhibition catalog, Denver Art Museum. Munich, London, New York 2001
- Minx, Eckard P.: *Zukunft in Unternehmen – Strategiefindung: Methoden und Beispiele. Lecture for the Leitner Chair of New Economy and New Design*, HfG Offenbach, 13 June 2001
- /Neuhaus, Christian/Steinbrecher, Michael/Waschke, Thomas: Zu Ansatz und Methode im interdisziplinären Forschungsverbund Lebensraum Stadt/Stadt, Mobilität und Kommunikation im Jahre 2020: Zwei Szenarien. In: Forschungsverbund Lebensraum Stadt (ed.): *Mobilität und Kommunikation in den Agglomerationen von Heute und Morgen*. Berlin 1994
- Moles, Abraham A.: Die Krise des Funktionalismus. In: *form* 41, March 1968
- Monö, Rune: *Design for Product Understanding. The Aesthetics of Design from a Semiotic Approach*. Stockholm 1997
- Morris, William: *News from Nowhere or An Epoch of Rest*. First published London 1894. Paperback edition, Oxford 2003
- Morrison, Jasper: *Everything but the Walls*. Baden 2002
- Mukařovský, Jan: *Kapitel aus der Ästhetik*. Frankfurt/Main 1970
- Müller, Lars (ed.): Freitag. *Individual Recycled Freeway Bags*. Baden 2001
- Müller-Krauspe, Gerda: Opas Funktionalismus ist tot. In: *form* 46, 1969
- : Designtheorie aus der Sicht einer zu verändernden Praxis. In: *Designtheorien I*. IDZ Berlin (ed.). Berlin 1978
- Muller, Wim: *Order and Meaning in Design*. Originally published as *Vormgeven ordening en betekenisgeving* (Utrecht 1997). Utrecht 2001
- Mumford, Lewis: *The Myth of the Machine. Vol. 1: Technics and Human Development*. London, New York 1966, 1967. *Vol. 2: The Pentagon of Power*. London, New York 1964, 1970
- Munari, Bruno: Die Methodik des Entwerfens. In: *Kultur und Technologie im italienischen Möbel, 1950–1980*. Cologne 1980

- Muranka, Tony/Rootes, Nick: *“doing a dyson.”* Malmesbury 1996
- Mutius, Bernhard von: *Die Verwandlung der Welt. In Dialog mit der Zukunft.* Stuttgart 2000
- : Gestaltung neu denken. form-interview with Bernhard E. Bürdek. In: *form* 184, July/August 2002
- : *Die andere Intelligenz. Wie wir morgen denken werden.* Stuttgart 2004
- Nadin, Mihai: *Anticipation. The End is Where We Start from.* Baden 2002
- Naisbitt, John: *Megatrends.* New York 1982
- : *Megatrends Asia.* New York 1995
- : *High Tech – High Touch.* New York 1999
- Negroponte, Nicholas: *Being Digital.* New York 1995
- Neumann, Claudia: *Design Lexikon Italien.* Cologne 1999
- Ninaber/Peters/Krouwel (n/p/k) industrial design: *Vision & Precision.* Amsterdam, Leiden 2002
- Nolte, Paul: Unsere Klassengesellschaft. Wie könnten die Deutschen angemessen über ihr Gemeinwesen sprechen? Ein unzeitgemäßer Vorschlag. In: *Die Zeit* no. 2, 4 January 2001
- Norman, Donald A.: *The Psychology of Everyday Things.* New York 1988
- : *Things that make us smart. Defending human attributes in the age of the machine.* Reading/MA 1993
- : *The Invisible Computer. Why good products can fail, the personal computer is so complex, and the information appliances are the solution.* Cambridge/MA, London 1998
- Nouvel, Jean. *Exposition présentée au Centre Georges Pompidou.* Exhibition catalog. Paris 2001
- NZZ (*Neue Züricher Zeitung*). “Zehn kleine Negerlein. Wie viele PC-Hersteller braucht die Welt?” No. 296, 18/19 December 2004, p. 52
- Oehlke, Horst: Zur Funktionsbestimmung der industriellen Formgestaltung. In: *1. Kolloquium zu Fragen der Theorie und Methodik der industriellen Formgestaltung.* Halle 1977
- : Der Funktionsbegriff in der industriellen Formgestaltung. In: *2. Kolloquium zu Fragen der Theorie und Methodik.* Halle 1978
- : *Produkterscheinung/Produktbild/Produktleitbild – ein Beitrag zur Bestimmung des Gegenstandes von industriellem Design.* Ph.D. thesis, Humboldt University Berlin. Berlin 1982
- Ohl, Herbert: Design ist meßbar geworden. In: *form* 78, 2/1977
- Olivetti (ed.): *Ergonomie und Olivetti. Buch 1. Der Mensch im Mittelpunkt: Zusammenfassung des aktuellen Wissenstandes im Bereich der Ergonomie.* Milan 1981
- : *Ergonomie und Olivetti. Buch 2. Olivetti Datensichtgeräte und Arbeitsplätze.* Milan 1981
- : *Design Process Olivetti 1908–1983.* Milan 1983
- Olivetti Corporate Identity Design.* Edited by Richard Bachinger. Published by Ing. C. Olivetti e C., Neue Sammlung Staatliches Museum für Angewandte Kunst. Frankfurt/Main, Munich 1986
- OMA/AMO Rem Koolhaas: *Projects for Prada Part 1.* Milan 2001
- Onck, Andries van: *Design – il senso delle forme die prodotti.* Milan 1994
- Papanek, Victor: *Design for the Real World. Making to Measure.* London 1972
- Peht, Wolfgang: *Karljosef Schattner. Ein Architekt aus Eichstätt.* Stuttgart 1988

- : Der Architektur das Tanzen beigebracht. In: *Frankfurter Allgemeine Zeitung* no. 14, 27 June 1992
- Pevsner, Nikolaus: *Pioneers of Modern Design. From William Morris to Walter Gropius*. First published in 1936 as *Pioneers of the Modern Movement. From William Morris to Walter Gropius*. London 1957
- Philips (ed.): *Vision of the Future*. Eindhoven 1996
- (ed.): *Creating Value by Design: Facts*. London 1998
- Piore, Michael J./Sabel, Charles F.: *The Second Industrial Divide. Possibilities for Prosperity*. New York 1984
- Polster, Bernd (ed.): *West Wind. Die Amerikanisierung Europas*. Cologne 1995
- (ed.): *Design Directory Scandinavia*. New York 1999
- /Elsner, Tim: *Design Lexikon USA*. Cologne 2000
- Prada: *Works in Progress. Stores, Offices, Factories*. Milan 2001
- Aoyama Tokyo: *Herzog & de Meuron*. Milan 2003
- Prahalad, C. K./Hamel, Gary: Nur Kernkompetenzen sichern das Überleben. In: *Harvard business manager* 1/1992
- Racine, Martin: *The Influence of Designer Julien Hébert on the Emergence of the Design Field in Quebec and Canada*. Paper for the 3rd International Conference on Design History and Design Studies, Istanbul 9–12 July, 2002
- Radice, Barbara: *Memphis. Research, Experiences, Results, Failures, and Successes of New Design*. Translated by Paul Blanchard. New York 1984
- Ramakers, Renny: *Less + More. Droog Design in Context*. Rotterdam 2002
- /Bakker, Gijs (eds.): *Droog Design. Spirit of the Nineties*. Rotterdam 1998
- Rashid, Karim: *I Want to Change the World*. New York 2001
- Rat für Formgebung (ed.): *Design Management*. Frankfurt/Main 1990
- Redl, Thomas/Thaler, Andreas: *Beispiele österreichischen Designs. Examples of Austrian Design*. Vienna 2001
- Reinking, Guido: Offroad – Wer ihn braucht und wer ihn kauft. In: *Financial Times Deutschland*, 7 February 2002
- Reinmöller, Patrick: *Produktsprache. Verständlichkeit des Umgangs mit Produkten durch Produktgestaltung*. Fördergesellschaft Produkt-Marketing e.V. Cologne 1995
- Ricard, André: *La aventura creativa. Las raíces del diseño*. Barcelona 2000
- Richard, Birgit: 2001 – odyssee in fashion. Electro-textiles and cargo-mode. In: Aigner, Carl/Marchsteiner, Uli (eds.): *vergangene zukunft. design zwischen utopie und wissenschaft*. Krems 2001
- Rieger, Bodo: Das Januskopfproblem in der CI-Praxis. In: *Markenartikel* (1989); abridged version in: *Frankfurter Allgemeine Zeitung* no. 128, 6 June 1989
- Rifkin, Jeremy. *The Biotech Century. Harnessing the Gene and Remaking the World*. New York 1998
- Rittel, Horst: Bemerkungen zur Systemforschung der "ersten" und "zweiten" Generation. In: *Der Mensch und die Technik. Technisch-wissenschaftliche Blätter der Süddeutschen Zeitung*, No. 221, 27 November 1973
- Roericht, Nick H.: *HfG-Synopse. Die synchron-optische Darstellung der Entstehung, Entwicklung und Auswirkung der Ulmer Hochschule für Gestaltung*. Ulm 1982
- Rogalski, Ulla: Intelligentes Design. Die Züricher Agentur NOSE Design Intelligence ist erfolgreich mit bereichsübergreifender Arbeit. In: *Office Design*, 1/1998

- Ronke, Christiane: Das Abenteuer beginnt gleich um die Ecke. In: *Financial Times Deutschland*, 16 December 2002
- Roozenburg, Norbert F. M./Eekels, Johan: *Product Design. Fundamentals and Methods*. Chichester 1995
- Rossi, Aldo: *The Architecture of the City*. Originally published as *L'Architettura della città* (Padua 1966). Cambridge/MA 1982
- : *A Scientific Autobiography*. Originally published as *Scritti scelti sull'architettura e la città* (Milan 1975). Cambridge/MA 1981
- Rübenach, Bernhard: *Der rechte Winkel von Ulm (1-1958/59)*. Selected and with an introduction by Bernd Meurer. Darmstadt 1987
- Rüegg, Arthur (ed.): *Swiss Furniture and Interiors in the 20th Century*. Translated by Robin Benson. Basel, Boston, Berlin 2002
- Rummel, Carlo: *Designmanagement. Integration theoretischer Konzepte und praktischer Fallbeispiele*. Wiesbaden 1995
- Rusch, Gebhard: Kommunikation und Verstehen. In: Merten, Klaus/Schmidt, Siegfried J./Weischenberg, Siegfried (eds.): *Die Wirklichkeit der Medien*. Opladen 1994
- Rust, Holger: *Trends. Das Geschäft mit der Zukunft*. Vienna 1995
- : *Zurück zur Vernunft. Wenn Gurus, Powertrainer und Trendforscher nicht mehr weiterhelfen*. Wiesbaden 2002
- Sarasin, Wolfgang: Produktdesign, Produktidentität, Corporate Identity. In: Birkigt, *Corporate Identity*
- Sato, Kazuko: *Alchimia. Never-ending Italian Design*. Tokyo 1985
- Schägerl, Christian: Die Scham des Futuristen. William Gibson, Großmeister des Zukunftsromans, kapituliert vor der technischen Entwicklung und beschreibt nur noch die Gegenwart. In: *Frankfurter Allgemeine Sonntagszeitung* no. 50, 15 December 2002
- Schank, Roger C./Schilders, Peter G.: *Zukunft der künstlichen Intelligenz*. Cologne 1986
- Schmidt, Klaus (ed.): *The Quest for Identity. Corporate Identity – Strategies, Methods and Examples*. London 1995
- Schmidt, Siegfried J. (ed.): *Der Diskurs des radikalen Konstruktivismus*. First edition Frankfurt/Main 1987. 7th ed. 1996
- : *Der Diskurs des radikalen Konstruktivismus*. Frankfurt/Main 1987
- : *Kognition und Gesellschaft. Der Diskurs des Radikalen Konstruktivismus 2*. Frankfurt/Main 1992
- Schmidt-Lorenz, Klaus: Verfechter der Serie. In: *Design Report*, 9/1995
- : Clan der Konstrukteure. In: *Design Report*, 9/1995
- Schmitt, Uwe: Muji. Ein Erfolg, der keinen Namen hat. In: *Frankfurter Allgemeine Magazin* 850, 14 June 1996
- Schmitz-Maibauer, Heinz H.: *Der Stoff als Mittel anmutungshafter Produktgestaltung. Grundzüge einer Materialpsychologie*. Cologne 1976
- Schneider, Norbert: *Geschichte der Ästhetik von der Aufklärung bis zur Postmoderne*. Stuttgart 1996
- Schneiderman, Ben: *Designing the User Interface. Strategies for Effective Human-Computer Interaction*. 2nd ed. Reading/MA 1992
- : *Designing the User Interface. Strategies for Effective Human-Computer Interaction*. 3rd ed. Reading/MA 1998

- Schnell, Ralf (ed.): *Metzler Lexikon Kultur der Gegenwart. Themen und Theorien, Formen und Institutionen seit 1945*. Stuttgart, Weimar 2000
- Schönberger, Angela: *Raymond Loewy. Pioneer of American Industrial Design*. With contributions by Stephen Bayley et al. Translations by Ian Robson and Eileen Martin. Munich, New York 1990
- Schöner Wohnen (ed.): *Moderne Klassiker. Möbel, die Geschichte machen*. 16th ed. Hamburg 1994
- Schönhammer, Rainer: *Der "Walkman." Eine phänomenologische Untersuchung*. Munich 1988
- : Zur Anthropologie der Fernbedienung. Zur Wirkungsweise eines magischen Werkzeugs. In: *formdiskurs* 3, 2/1997
- Schulze, Gerhard: *Die Erlebnisgesellschaft. Kultursoziologie der Gegenwart*. Frankfurt/Main, New York 1992
- Schümer, Dirk: Spaghettisiert euch. Alle Welt beklagt den amerikanischen Einfluß, doch die globale Leitkultur kommt aus Italien. In: *Frankfurter Allgemeine Zeitung* no. 226, 28 September 2002
- Schubach, Stephan/Zebner, Frank: Gerätedesign im Computer-Zeitalter. In: *Elektronik* 22, 1990
- Schwarz, Rudolf: *More than Furniture. Wilkhahn, an Enterprise in Its Time*. With contributions by Alex Buck et al. Translations by Katja Steiner, Bruce Almberg, and Jeremy Gaines. Frankfurt/Main 2000.
- Seckendorff, Eva von: *Die Hochschule für Gestaltung in Ulm. Gründung (1949-1953) und Ära Max Bill (1953-1957)*. Ph. D. thesis. Hamburg 1986, Marburg 1989
- Seeling, Hartmut: *Geschichte der Hochschule für Gestaltung Ulm 1953-1968. Ein Beitrag zur Entwicklung ihres Programmes und der Arbeiten im Bereich der visuellen Kommunikation*. Ph.D. thesis. Cologne 1985
- Seiffert, Helmut: *Einführung in die Wissenschaftstheorie*. Vol. 1, 10th ed. Munich 1983. Vol. 2, 8th ed. Munich 1983. Vol. 3, Munich 1985
- Selle, Gert: *Ideologie und Utopie des Design. Zur gesellschaftlichen Theorie der industriellen Formgebung*. Cologne 1973
- : *Die Geschichte des Design in Deutschland von 1870 bis heute*. Previously published Cologne 1978, 1987. New edition Frankfurt/Main, New York 1994
- Sembach, Klaus-Jürgen: Das Jahr 1851 – Fixpunkt des Wandels. In: Fischer, Wend: *Die verborgene Vernunft*.
- S. Siedle & Söhne (eds.): *Von der Glocke zur Gebäudekommunikation. 250 Jahre Siedle*. Furtwangen 2000
- Siemens Nixdorf AG: *Gestaltung von Benutzeroberflächen für Selbstbedienungsanwendungen. Ein Designbuch*. Concept, text and design by Martina Menzel and Frank Zebner. Munich, Paderborn 1993
- : *150 Jahre Siemens. Das Unternehmen von 1847 bis 1997*. Published for the Siemens Forum by Wilfried Feldenkirchen. Munich 1997
- Singapore Design Award 2000*. Published by the Singapore Trade Development Board & Designers Association. Singapore 2000
- Skriver, Poul Erik: *Knud Holscher. Architect and Industrial Designer*. Translated by Courtney D. Coyne. Stuttgart, London 2000
- Sloterdijk, Peter: *Nicht gerettet. Versuche nach Heidegger*. Frankfurt/Main 2001
- Smithson, Peter/Unglaub, Karl: *Flying Furniture*. Cologne 1990

- Soentgen, Jens: *Das Unscheinbare. Phänomenologische Beschreibungen von Stoffen, Dingen und fraktalen Gebilden*. Berlin 1997
- : Die Faszination der Materialien. In: *formdiskurs* 3, 2/1997
- : *Splitter und Scherben. Essays zur Phänomenologie des Unscheinbaren*. Kusterdingen 1998
- Sottsass, Ettore: Für eine neue Ikonographie. In: Gsöllpointner, Helmuth/Hareiter, Angela/Ortner, Laurids (eds.): *Design ist unsichtbar*
- Spalt, Johannes (ed.): *Folding tables. Klapptische*. Basel, Boston, Stuttgart 1987
- Sparke, Penny: *An Introduction to Design and Culture in the Twentieth Century*. New York 1986
- : *Italian Design. 1870 to the Present*. London 1988
- : *Design Directory Great Britain*. New York 2001.
- Spieß, Heinrich: *Integriertes Designmanagement*. Beiträge zum Produktmarketing vol. 23. Cologne 1993
- Spitz, René: *The Ulm School of Design. A View behind the Foreground*. Translated by Ilze Klavina. Stuttgart, London 2001
- SPoKK (ed.): *Kursbuch JugendKultur. Stile, Szenen und Identitäten vor der Jahrtausendwende*. Mannheim 1997
- Sprague, Jonathan: China's Manufacturing Beachhead. In: *Fortune*, 28 October, 2002
- Spreenberg, Peter: Editor's Note in *interact*, ed. by the American Center for Design, vol. 8, no. 1, Chicago 1994
- Stadler, Michael/Crabus, Heinrich (ed.): *Wolfgang Metzger. Gestalt-Psychologie. Ausgewählte Werke aus den Jahren 1950 bis 1982*. Frankfurt/Main 1999
- Stark, Tom: *Less or More – What a Bore. Harley-Davidson: Design im Kontext*. Frankfurt/Main 1999
- Steffen, Dagmar: Zur Theorie der Produktsprache. Perspektiven der hermeneutischen Interpretation von Designobjekten. in: *formdiskurs* 3, 2/1997b
- : Design als Produktsprache. Der "Offenbacher Ansatz in Theorie und Praxis." With contributions by Bernhard E. Bürdek, Volker Fischer and Jochen Gros. Frankfurt/Main 2000
- : *C_Moebel. Digitale Machart und gestalterische Eigenart*. With a text by Jochen Gros. Frankfurt/Main 2003
- Steguweit, Christian: Typologie und Konsequenz einer Corporate Identity. In: Schmidt, Klaus (ed.): *The Quest for Identity*. Frankfurt/Main, New York 1994
- Strassmann, Burkhard: Fühlen Sie mal... In: *Die Zeit* no. 31, 24 July 2003
- Strunk, Peter: *Die AEG. Aufstieg und Niedergang einer Industrielegende*. Berlin 1999
- Sullivan, Louis H. (1896): *Kindergarten Chats and Other Writings*. Revised 1918. Reprint, New York 1955
- : *The Tall Office Building Artistically Considered*. Chicago 1896. Quoted in Fischer, Wend: *Die verborgene Vernunft*
- Swatch & Swatch. *modelli prototipi varianti*. Catalog. Milan 1981
- Tallon, Roger. *Itinéraires d'un designer industriel*. Exhibition catalog, Centre George Pompidou. Paris 1993
- Terragni, Emilia (ed.): *Spoon*. London, New York 2002
- Thackara, John (ed.): *New British Design. Design by Jane Stuart*. London 1986
- Tietenberg, Annette: Der Körper als Möglichkeit/Bodies of Evidence. In: *form* 185, September/October 2002

- Toffler, Alvin: *Future Shock*. New York 1970
- : *The Third Wave*. New York 1980
- : *Powershift*. New York 1990
- Turner, Matthew: *Made in Hong Kong. A History of Export Design in Hong Kong 1900–1960*. Hong Kong 1988
- Tzonis, Alexander: Hütten, Schiffe und Flaschengestelle. Analogischer Entwurf für Architekten und/oder Maschinen. In: *Archithese* 3, 1990
- Ulmer Museum/HfG-Archiv: *ulmer modelle – modelle nach Ulm. Zum 50. Gründungsjubiläum der Ulmer Hochschule für Gestaltung*. Catalog and traveling exhibition. Stuttgart 2003
- Vann, Peter: *Design by Giugiaro 1968–2003*. Stuttgart 2003
- van Hinte, Ed: *Marti Guixé*. Rotterdam 2002
- : *Wim Rietveld. Industrieel Ontwerper*. Rotterdam 1996
- VDI Richtlinie 4500: *Technische Dokumentation – Benutzerinformation*. Düsseldorf 1995
- Venturi, Robert: *Complexity and Contradiction in Architecture*. New York 1966
- Venturi, Robert/ Scott Brown, Denise: Wir sind ja für Unreine. Interview by Hanno Rauterberg. In: *Die Zeit* no. 43, 17 October 2002
- /Izenour, Steven: *Learning from Las Vegas*. Cambridge/MA 1972
- Veraart, Albert/Wimmer, Reiner: Hermeneutik. In: Mittelstraß, Jürgen (ed.): *Enzyklopädie Philosophie und Wissenschaftstheorie*, vol. 2. Mannheim, Vienna, Zurich 1984
- Vershofen, Wilhelm: *Die Marktentnahme als Kernstück der Wirtschaftsordnung*. Berlin, Cologne 1959
- Vihma, Susann: *Products as Representations. A Semiotic and Aesthetic Study of Design Products*. Helsinki 1995
- VNITE *Der sowjetische Designer*. Stuttgart 1976
- von Vegesack, Alexander (ed.): *Citizen Office. Ideen und Notizen zu einer neuen Bürowelt*. Göttingen 1994
- Wagner, Rainer: Warum haben Sie keine Angst vor den Japanern, Herr Wagner? Ein Interview von Benedict Maria Mülder: in: *Frankfurter Allgemeine Magazin* 545, 10 August 1990
- Waldenfels, Bernhard: *In den Netzen der Lebenswelt*. Frankfurt/Main 1985
- Walker, John A.: *Design History and the History of Design*. London 1989
- Walther, Elisabeth: *Zeichen. Aufsätze zur Semiotik*. Weimar 2002
- Wang, Shou Zhi: Chinese Modern Design: A Retrospective. In: Doordan, Dennis P.: *Design History. An Anthology. A Design Issues Reader*. Cambridge/MA 1995
- Wang, Wilfried: *Herzog and de Meuron*. Basel, Boston, Berlin 1998
- Weibel, Peter: *Die Beschleunigung der Bilder in der Chronokratie*. Bern 1987
- (ed.): *Kontext Kunst. Kunst der 90er Jahre*. Cologne 1994
- (ed.): *Vom Tafelbild zum globalen Datenraum. Neue Möglichkeiten der Bildproduktion und bildgebenden Verfahren*. Stuttgart 2001
- Weil, Michelle M./Rosen, Larry F.: *TechnoStress. Coping with Technology @ Work @ Home @ Play*. New York 1997
- Welsch, Wolfgang: *Unsere postmoderne Moderne*. Weinheim 1987
- Wewerka, Stefan: *Tecta 1972–1982. Bericht einer deutschen Unternehmung*. Berlin 1983
- Wichmann, Hans: *Industrial Design, Unikate, Serienerzeugnisse*. Munich 1985

- Wingler, Hans M.: *Das Bauhaus*. 3rd ed. Bramsche, Cologne 1975
- Wolfe, Tom: *From Bauhaus to Our House*. New York 1981
- Wolter, Bettina-Martine/Schwenk, Bernhart (eds.): *Die grosse Utopie. Die Russische Avantgarde 1915–1932*. Exhibition catalog. Frankfurt/Main 1992
- Woodham, Jonathan M.: *Twentieth-Century Design*. Oxford, New York 1997
- : Morris Mini. In: *Icons of Design! The 20th Century*. Edited by Volker Albus, Reyer Kras and Jonathan M. Woodham. Transl. from the German by Elizabeth Schwaiger and Robert Thomas. Transl. from the Dutch by Arthur Payman. Munich, London, New York 2000
- Woolman, Matt: *Digital Information Graphics*. London 2002
- Wünsche, Konrad: *Bauhaus: Versuche, das Leben zu ordnen*. Berlin 1989
- Yingtai, Lung: Erben alter Hochkulturen. Die "asiatischen Werte" – gibt es sie? In: *Der Spiegel*, 24/1999
- Zänker, Jürgen: Utopisches Design oder Utopie des Design. In: Gsöllpointner (ed.), *Design ist unsichtbar*.
- Zec, Peter: *Informationsdesign. Die organisierte Kommunikation*. Zurich, Osnabrück 1988
- Zijl, Ida van: *Droog Design 1991–1996*. Utrecht 1997
- Zumthor, Peter: Schutzbauten des Widerstandes. Interview by Hanno Rauterberg. In: *Die Zeit* no. 45, 31 October 2001

QUOTATION REFERENCES

- 7 Gert Selle: *Siebensachen. Ein Buch über die Dinge*. Frankfurt/New York 1997, page: 205
- 11 Dirk Baecker: *Wozu Systeme?* Berlin 2002, page: 155
- 13 Holger van den Boom: *Betrifft: Design. Unterwegs zur Designwissenschaft in fünf Gedankengängen*. Weimar 1994, page: 30
- 16 Geyer, Matthias/Knaup, Horand/Palmer, Hartmut/Rosenkranz: Gerd Schröders Spiel, in: *Der Spiegel*, Nr. 6/2003, page: 57
- 17 Eduard Beaucamp: Die Avantgarde im Himmel. Endlich: Die Eröffnung der Dritten Pinakothek in München, in: *Frankfurter Allgemeine Zeitung*, Nr. 215, 16.9.2002, page: 35
- 29 Gert Selle: *Siebensachen. Ein Buch über die Dinge*. Frankfurt/New York 1997, page: 169
- 38 Wilhelm Wagenfeld: *Wesen und Gestalt der Dinge um uns*. Worpswede 1990 (Nachdruck der Erstausgabe von 1948), page: 7
- 43 René Spitz: *hfg ulm. Der Blick hinter den Vordergrund*. Stuttgart/London 2001, page: 371
- 46 Gui Bonsiepe: hfg ulm – Modell einer Gestaltungslehre. Podiumsdiskussion an der HfG Offenbach, 1.07.2002
- 49 Angelika Bauer: Maggi-Magie, in: *Die Zeit*, Nr. 23, 27.5. 2004, page: 53
- 51 Gui Bonsiepe: hfg ulm – Modell einer Gestaltungslehre. Podiumsdiskussion an der HfG Offenbach, 1.07.2002
- 54 René Spitz: *hfg ulm. Der Blick hinter den Vordergrund*. Stuttgart/London, 2001, page: 421
- 59 Thomas Wolff: Das Gesicht des deutschen Alltags. Über Dieter Rams. in: *Frankfurter Rundschau Magazin*, 31.3.2001, page: 19
- 57 Ernst Bloch: *Geist der Utopie*. Frankfurt am Main 1985 (1-1918), S.22
- 63 Walter Grasskamp: Das gescheiterte Gesamtkunstwerk. Design zwischen allen Stühlen, in: Michel, Karl Markus/Spengler, Tilman: *Alles Design (Kursbuch 106)*. Berlin 1991, page: 71
- 64 Walter Grasskamp: Das gescheiterte Gesamtkunstwerk. Design zwischen allen Stühlen, in: Michel, Karl Markus/Spengler, Tilman: *Alles Design (Kursbuch 106)*. Berlin 1991, page: 72
- 64 O.V. Design. Knie kaputt, in: *Der Spiegel*, Nr. 22/1988, page: 203
- 67 Uta Brandes: *Design ist keine Kunst. Kulturelle und technologische Implikationen der Formgebung*. Regensburg 1998, page: 9

- 67 Gui Bonsiepe: hfg ulm – Modell einer Gestaltungslehre. Podiumsdiskussion an der HfG Offenbach, 1.07.2002
- 71 Peter Sloterdijk, in: *Wohin führt der globale Wettbewerb? Philosophische Aspekte der Globalisierung*. Berlin 1999, page: 50
- 99 Der Lockruf des großen Geldes. Spiegel-Gespräch mit Porsche-Chef Wendelin Wiedeking, in: *Der Spiegel*, Nr. 21/2002, page: 92
- 104 Martin Kelm (ehemaliger Staatssekretär der DDR), in: *form + zweck*, Nr. 1/1991, S. 60
- 120 Bolz, Norbert/Bosshart, David: *Kult Marketing. Die neuen Götter des Marktes*. Düsseldorf 1995, page: 209
- 122 Beaucamp, Eduard: Bildende Künste: Phyrus-Siege, in: *Frankfurter Allgemeine Zeitung*, Nr. 54, 5.3.1994
- 123 Günther Nenning: Weil es so herrlich bequem ist: Sitze, was sonst?, in: *Frankfurter Allgemeine Magazin*, Nr. 850, 14.6.1996, page: 38
- 151 Albus, Volker/Fischer, Volker: *13 nach Memphis. Eine Einführung. Design zwischen Askese und Sinnlichkeit*. Munich 1995, page: 163
- 153 Thomas Edelmann: Groß in Form, in: *mobil* (Deutsche Bahn AG), Nr. 3/2003, page: 11
- 157 Regis McKenna: Marketing in Echtzeit, in: *Harvard Business Manager*, Nr. 2/1996, Jg. 18, page: 9
- 169 Kristina Maidt-Zinke: Billy auf dem Holzweg. Ikeas Karriere in Deutschland: Ingvar Kamprads Geschichte, in: *Frankfurter Allgemeine Zeitung*, Nr. 87, 15.4.1999, page: 51
- 171 Stefan Ytterborn: im Gespräch mit Markus Frenzl, in: *design report*, Nr. 2/2003, page: 40
- 177 O.V., Kollektion Shaker Authentics. Anzeige in der *Frankfurter Allgemeinen Zeitung* vom 7.12.2000
- 191 Bernd Polster: Garbo in Serie. Karim Rashid ist Amerikas neuer Design-Gott, in: *Financial Times Deutschland*, 9.8.2002, page: 3
- 194 Karim Rashid (Hrsg.): *Das Internationale Design Jahrbuch 2003/04*. Schopfheim 2003, page: 2
- 199 Michael Erlhoff: Deutsche Lebllosigkeit, in: *Kunstzeitung*, Nr. 7/1997, page: 19
- 203 Gersemann, Olaf/Hohensee, Matthias/Köhler, Angela/Schnaas, Dieter/Sieren, Frank: Aus dem Boden gestampft. China wird zur Fabrik für die ganze Welt, in: *Wirtschaftswoche*, Nr. 46/2002, page: 54
- 206 Gersemann, Olaf/Hohensee, Matthias/Köhler, Angela/Schnaas, Dieter/Sieren, Frank: Aus dem Boden gestampft. China wird zur Fabrik für die ganze Welt, in: *Wirtschaftswoche*, Nr. 46/2002, page: 54
- 209 Volker Grassmuck: "Allein, aber nicht einsam" – die Otaku-Generation, in: Bolz, Norbert/Kittler, Friedrich/Tholen, Christoph (Hrsg.): *Computer als Medium*. Munich 1994, page: 281
- 219 Die Preußen Asiens. Samsung wandelt sich zur Premiummarke. Nun wollen die Koreaner Sony stürzen, in: *Wirtschaftswoche*, Nr. 45/2002, page: 64
- 224 Ho Heng-Chun: Die Leute kaufen Design, in: *Wirtschaftswoche*, Nr. 4/2003, page: 60
- 227 Jean Baudrillard: *Cool memoires 1980–1985*. Munich 1989, page: 14
- 229 Mihai Nadin: *Anticipation*. Baden 2003, page: 14

- 229 Holger van den Boom: *Betrifft: Design. Unterwegs zur Designwissenschaft in fünf Gedankengängen*. Weimar 1994, page: 44
- 230 Patrick Bahners: Einer Regel nicht folgen. Verständigung über das Selbstverständliche: Hans-Georg Gadamer und Dieter Henrich, in: *Frankfurter Allgemeine Zeitung*, Nr. 152, 3.7.1996, page: N 5
- 231 Tilmann Habermas: *Geliebte Objekte*. Berlin 1996, pages: 180–181
- 233 Michel Foucault: *Die Ordnung der Dinge. Eine Archäologie der Humanwissenschaften*. Frankfurt am Main 1997 (14. Aufl.), page: 60
- 237 Humberto R. Maturana: Kognition, in: Siegfried J. Schmidt (Hrsg.): *Der Diskurs des Radikalen Konstruktivismus*. Frankfurt am Main 1987, page: 90
- 239 Bernhard von Mutius: *Die Verwandlung der Welt*. Stuttgart 2000, page: 265
- 240 Karin Schulze: Tortenstücke mit Sahnehäubchen, in: *Financial Times Deutschland*, 12.5.2004, page: 35
- 241 Manfred Russo: *Tupperware & Nadelstreif. Geschichten über Alltagsobjekte*. Vienna/Cologne/Weimar 2000, page: 167
- 243 Kraft Wetzell: Vom Zuschauer zum User. Ein televisionäres Szenario, in: *Ästhetik & Kommunikation*, Nr. 88/1995, page: 61
- 245 Ernst von Glasersfeld: *Radikaler Konstruktivismus. Ideen, Ergebnisse, Probleme*. Frankfurt am Main 1996, page: 93
- 249 Gert Selle: Unzeitgemäße Ansichten, in: *Design Bericht 1989–90*. Frankfurt am Main 1990, page: 66
- 249 José R. Méndez-Salgueiro: Beruhigungsgesten des Designs?, in: Hermann Sturm (Hrsg.): *Geste & Gewissen im Design*. Cologne 1998, page: 140
- 257 Barbara Steiner: Notizen zum Verhältnis von Kunst und Architektur, in: Steiner, Barbara/Schmidt-Wulffen, Stephan (Hrsg.): *In Bewegung. Denkmodelle zur Veränderung von Architektur und bildender Kunst*. Hamburg 1994, page: 44
- 258 Gert Selle: *Siebensachen. Ein Buch über die Dinge*. Frankfurt/New York 1997, page: 60
- 267 Uta Brandes: Designing Gender: Thesen zur Konstruktion des Geschlechterverhältnisses, in: *Design ist keine Kunst. Kulturelle und technologische Implikationen der Formgebung*. Regensburg 1998, page: 89
- 277 Siegfried Maser: *Zur Planung gestalterischer Projekte*. Essen 1993, page: 13
- 281 Holger van den Boom: *Betrifft: Design. Unterwegs zur Designwissenschaft in fünf Gedankengängen*. Weimar 1994, page: 11
- 283 Peter Sloterdijk: *Kritik der zynischen Vernunft* (Erster Band). Frankfurt am Main 1983, page: 267
- 287 Gui Bonsiepe: Über Sprache, Design und Software, in: *Design Horizonte*, 8/1991, S.33
- 292 Jochen Gerz: Was die Kunst nicht ändern kann, das soll die Kunst verändern, in: *Frankfurter Allgemeine Zeitung*, Nr. 20, 24.1.1996, page: 31
- 293 Thomas Rempfen: Von der Industriekultur zum Medienkult, in: *form*, Nr. 148/1994, page: 13
- 296 Jürgen Häußler: Schlusswort 5/01, in: *design report*, Nr. 7+8/2001, page: 110
- 296 Regierungserklärung 2002 des deutschen Bundeskanzlers Gerhard Schröder, in: *Wirtschaftswoche*, Nr. 45, 31.10.2002, page: 202
- 297 Herbert H. Schultes: Rat für Formgebung: Designdebatte, Paulskirche Frankfurt am Main, 5. Juni 2003
- 299 Florian Rötzer: *Digitale Weltentwürfe*. Munich/Vienna 1998, page: 104

- 300 Schmidt, Siegfried J./Zurstiege, Guido: *Kommunikationswissenschaft. Was sie kann, was sie will*. Reinbek bei Hamburg 2000, page: 151
- 301 Felicidad Romero-Tejedor: Zeit gestalten. Zur Semiologie Roland Barthes, in: *Öffnungszeiten*, Nr. 17/2003, page: 34
- 302 Bolz, Norbert/Bosshart, David: *Kult Marketing. Die neuen Götter des Marktes*. Düsseldorf 1995, page: 57
- 313 Alex Buck (Hrsg.): *Design Management in der Praxis*. Stuttgart 2003, page: 9
- 320 Steffen Klein: *Differenz und Kohärenz. Gestaltung und Wahrnehmung elektronischer Medien*. Heidelberg 2001, page: 11
- 325 Norbert Bolz: *Die Sinngesellschaft*. Düsseldorf 1997, page: 150
- 327 Koppelman, Udo/Wittorf, Susanne: Zur Sache, Udo Koppelman. Der Marketing-Experte über den Konflikt zwischen Handel und Herstellern, in: *design report*, Nr. 5/1998, page: 66
- 331 Christian Wüst: "Was würde Jesus fahren?" in: *Der Spiegel*, Nr. 3/2003, page: 141
- 333 Gert Selle: *Siebensachen. Ein Buch über die Dinge*. Frankfurt/New York 1997, page: 216
- 337 Barbara Steiner: Notizen zum Verhältnis von Kunst und Architektur, in: Steiner, Barbara/Schmidt-Wulffen, Stephan (Hrsg.): *In Bewegung. Denkmodelle zur Veränderung von Architektur und bildender Kunst*. Hamburg 1994, page: 44
- 339 Jörg Lau: Der Jargon der Uneigentlichkeit, in: Bohrer, Karl Heinz/Scheel, Kurt (Hrsg.): Postmoderne. Eine Bilanz, in: *Merkur*, Nr. 9/10/1998, page: 946-947
- 343 Hans Eckstein: *Formgebung des Nützlichen. Marginalien zur Geschichte und Theorie des Design*. Düsseldorf 1985, page: 78
- 344 Otl Aicher: erscheinungsbild, in: Erco Leuchten (Hrsg.): *Erco Lichtfabrik*, Berlin 1990, page: 189
- 349 Florian Fischer: Corporate Design macht Qualitäten sichtbar, in: Angela Schönberger (Hrsg.): *Deutsche Design Konferenz '96, Corporate Design, Visualisierte Unternehmenskultur*. Berlin 1996, page: 32
- 350 Rolf Fehlbaum: An seiner Selbstverständlichkeit sollt ihr es erkennen. Über Design und Styling und das, was beide unterscheidet, in: *Frankfurter Allgemeine Zeitung* (Beilage Baden-Württemberg), Nr. 82, 7.4.1998, page: B 7
- 358 Walter Bauer-Wabnegg: Die Marke als Medium. Vom digitalen zum virtuellen Unternehmen, in: Norbert W. Daldrop (Hrsg.): *Kompendium Corporate Identity und Corporate Design*. Stuttgart 1997, page: 85
- 359 Norbert Hammer (Hrsg.): *Die Stillen Designer – Manager des Designs*. Essen 1994, page: 8
- 360 Gui Bonsiepe: *Interface. Design neu begreifen*. Mannheim 1996, page: 192
- 361 Helene Karmasin: *Produkte als Botschaften*. Vienna 1993, page: 13
- 364 Alex Buck: Strategic Design Planning – eine Bestandsaufnahme, in: *formdiskurs*, Nr. 4/1998, page: 6
- 367 John Naisbitt: *High Tech – High Touch. Auf der Suche nach Balance zwischen Technologie und Mensch*. Vienna /Hamburg 1999, page: 27
- 370 Bernard Tschumi: Architektur und Ereignis, in: Peter Noever (Hrsg.): *Architektur im Umbruch. Neun Positionen zum Dekonstruktivismus*. Munich 1991, page: 139
- 377 Hans Hollein: *Design. MAN transFORMS. Konzepte einer Ausstellung*. Vienna 1989, page: 110

- 381 Henning Klüver: Marilyn und die Designerträume. Die Mailänder Möbelmesse Salone del Mobile im Zeichen einer neuen Häuslichkeit, in: *Stuttgarter Zeitung*, Nr. 89, 17.4.2002, page: 31
- 384 Schutzbauten des Widerstands. Ein Zeit-Gespräch mit Peter Zumthor, in: *Die Zeit*, Nr. 45, 31.10.2001, page: 47
- 389 Uta Brandes: *Design ist keine Kunst. Kulturelle und technologische Implikationen der Formgebung*. Regensburg 1998, page: 9
- 398 Christoph Böniger: *Zur Lage des Designs*. Hannover 1998 (if Product Design Award), page: XXI
- 407 Gui Bonsiepe: Über Sprache, Design und Software, in: *Design Horizonte* 23/26.8.1991, page: 36
- 417 Gerd B. Achenbach: Der Schein immer neuer, überraschender Dinge, in: *Frankfurter Allgemeine Zeitung*, Nr. 203, 2.9.1989
- 426 Hans Moravec: Geisteskinder. Universelle Roboter: In vierzig Jahren haben sie uns überholt, in: *c't magazin*, Nr. 6/1996, page: 98
- 429 Silvia Bovenschen: Soviel Körper war nie, in: *Die Zeit*, Nr. 47, 14.11.1997, page: 63

LIST OF ILLUSTRATIONS

Abbreviations: l = left, r = right, t = top, b = bottom, m = middle

- Adidas, Herzogenaurach, p. 324
- Alessi (Integra Communication Hamburg), p. 140, 354-355, 382 t.
- AllesWirdGut, Vienna, p. 386 t.
- www.apple.com, p. 187
- Apple Computers, Cupertino CA., (photos: Rick English) p. 394 t.
- Archiv Bürdek, Obertshausen, p. 42, 44, 48, 66 t., 66, 98 t., 144, 200, 216, 262, 323, 382 b., 388 b.
- Archiv Volker Albus, Frankfurt am Main, p. 68
- Archiv Volker Fischer, Frankfurt am Main, p. 78-79, 81, 138 l.b.
- Archiv Fritz Friedl, Frankfurt am Main, p. 110
- Asymptote, New York, p. 372 t.
- Audi, Ingolstadt, p. 72
- Auger, James, London/Dublin, p. 394
- Authentics, Holzgerlingen, p. 76 b.r., 81 t.r., 100 b.
- Bang & Olufsen, Struer, p. 164
- Bauhaus Archiv Berlin, Museum für Gestaltung, (photo: Erich Cosemüller) p. 30
- Bayer, Leverkusen, p. 388
- Bd Ediciones de Diseño, Barcelona, p. 148
- Biegel Schmuckdesign, Frankfurt am Main, p. 248
- BMW, Munich, p. 330, p. 365
- Bose Europe, Nordhorn, p. 190 m.r
- Brandes, Uta, Cologne, p. 270
- Bulo, Mechelen, p. 116
- Bulthaup, Aich, p. 86
- Cambridge Consultants, Cambridge, p. 394 b.
- Cappelini, Arosio, p. 138
- Citroen, Cologne, p. 155
- Claesson Kovisto Rune Architekten, Stockholm, p. 168
- Clivio, Franco, Erlenbach, p. 114
- Coca Cola, Berlin, p. 176
- COR, Theda-Wiedenbrück, p. 40
- Cranbrook Academy, Bloomfield Hills MI, p. 336
- Deganello, Paolo, Milano, p. 143
- Design Center Stuttgart, Stuttgart, p. 36
- Design Continuum, Boston, p. 188
- Design Logic, Chicago, p. 340
- Designwerkstatt Berlin, Berlin, (photos: Idris Kolodziej) p. 65
- Dessauer Geräteindustrie, Dessau, p. 60

- Deutsche Bahn AG, (photo DB AG/Mann) p. 366
- Die Neue Sammlung, Munich, (photo: Tom Vack) p. 8, Katalog "Weltausstellungen im 19. Jahrhundert," Munich 1973, p. 20
- Droog Design, Amsterdam, p. 159
- Duravit, Hornberg, p. 150
- Dyson, Cologne, p. 74
- Edag, Fulda, p. 399
- Enthoven Associates, Antwerp, p. 232.
- Erco, Lüdenscheid, p. 86, 146, 404
- Electrolux, Stockholm, p. 170
- Eschenbach Optik, Nürnberg, p. 314
- Fenzl, Kristian, Linz, p. 110
- Form Finlandia, Helsinki, (photo: Ilmari Kostiainen, Klikki) p. 338
- Galerie Ulrich Fiedler, Cologne, p. 58 t.
- Garnich, Rolf, Esslingen, p. 274
- Globetrotter Ausrüstung, Hamburg, p. 332
- Faber Castell, Stein, p. 314 r.t.
- Fitch International, Worthington OH, p. 190 l.t.
- Flex Development, Delft, p. 159
- Freitag Taschen, Zurich, p. 119
- Friedländer, Uri, London, p. 334
- Häberli, Alfredo, Zurich, p. 118
- Haier Europe, Varese, p. 204 t.l + m.l.
- Hansen, Fritz, Allerød, p. 164
- Harley Davidson Deutschland, Mörfelden, p. 186
- Heufler, Gerhard, Graz, p. 110
- Hewi, Arolsen, p. 89
- hm+p Unternehmensberatung, Frankfurt/Main, p. 268-269
- Holscher Knut Design, Copenhagen, p. 162
- IC:IDO VR productive, Stuttgart, p. 416
- Ideo, London, p. 190 m.l.
- imm (Internationale Möbelmesse), Cologne, p. 197
- www.intel.com, p. 402
- Interlübke, Rheda-Wiedenbrück, p. 89
- IST, Rösraath, p. 166
- iittala, Helsinki, p. 166
- Johnson Control Europe, Burscheid, p. 410 t.
- Junghans, Schramberg, p. 114
- Kahla Thüringen Porzellan, p. 106
- Kartell, Noviglio, p. 142
- Keystone, Zurich, (photo: James King-Holmes) p. 432
- Lada-Welt (c/o Jürgen Dannwolf, Blaubeuren), p. 174
- Lamy, Heidelberg, p. 90
- Lannoch, Linkenheim-Hochstetten, p.334
- Leica, Solms, p. 60 b.
- Lenova Computer, Beijing, p. 204
- LG Electronics, Seoul, p. 220, 397
- Lomographische Gesellschaft, Vienna, (photo: Wolfgang Gastager) p. 174

- Dr. Lossen & Co., Stuttgart, p. 24
- Mabeg GmbH, Soest, p. 80
- Magnat, Pullheim, p. 314 l.t.
- Marchand, Christoph, Zurich, p. 119
- Maurer, Ingo, Munich, p. 100
- Meda, Alberto, Milano, p. 132 m.
- Meier, Richard & Partners, New York, p. 380 t.
- Memphis, Milano, p. 140
- Metro, Düsseldorf, p. 402
- Miller, Herman, Zeeland M.A., p. 186
- Minolta Europe, Langenhagen, p. 214
- Ministerrat der DDR, Amt für industrielle Formgebung - Fotothek - Berlin, (photo:
A. Stirl) p. 32, (photo: M. Brauer) 102
- Minox, Wetzlar, p. 60 m.
- Montana Mobler, Haarby, p. 162
- Moormann Möbelproduktion, Aschau, p. 100, 118 t.
- Motorola Deutschland, Wiesbaden, p. 190 m.t.
- Museum für Angewandte Kunst, Frankfurt/Main, (Donation Bürdek) p. 242
- NAIS, Düsseldorf, p. 408
- Nike International, Möfelden-Walldorf, p. 324
- Nicolai, Markus, Frankfurt am Main, p. 69
- Nokia, Helsinki, p. 166
- nplk industrial design, Leiden, p. 158
- Olivetti, Milano, (photo: Ezio Frea) p. 124 r.t., 126
- OMA Rem Koolhaas, Rotterdam, p. 378
- Philips Design, Eindhoven, p. 160-161, 336, 396, 428
- Pict, Frankfurt am Main, p. 18, 22, 26, 34-35, 36 b., 52-53, 66 b., 82, 114 m., 128-130, 132,
178, 180-181, 184, 210, 232, 306-310, 315-319, 340
- Phoenix Product Design, Stuttgart, p. 15
- Plumbdesign, New York, p. 260 t., 262
- Porsche Design, Zell am See, p. 112
- Puma, Herzogenaurach, (photo: Nicole Weber Communication) p. 362
- Rat für Formgebung, Frankfurt am Main, (photo: C. Meyer Cologne + I. Kurth Frankfurt a.M.),
p. 193
- Realtime Technology, Munich, p. 418 t.
- Renault, Brühl, p. 155
- Richartz + Söhne, Solingen-Ohligs, p. 314
- Riedel, Kufstein, p. 112
- Rimowa, Cologne, p. 94
- Samsung, Seoul, p. 220
- Sawaya & Moroni, Milano, p. 376 t.
- Schimmel Pianofabrik, Braunschweig, p. 304
- sdr+, Cologne, p. 56 b.
- www.segway.com, p. 188
- Sharp, Tokio, (Copyright AXIS magazine), p. 214
- Seibt, Wolfgang, Offenbach am Main, p. 9, 58 b., 106 b., 134, 138 l.t., r.m., 217, 311, 406
- Sieger Design, Sassenberg, p. 96
- Siemens, Munich, p. 348, 408 t.

- Smart, Sindelfingen, p. 366
- Sony Deutschland, Cologne, p. 362
- Sony Europe, Berlin, p. 328
- Sony Japan, Tokyo, p. 214
- www.SonyEricsson.com, p. 170
- Speedo Deutschland, Reutlingen, p. 188
- SSS Siedle, Furtwangen, p. 94
- Sumajin Design, Singapore, p. 220
- Sun (Essential Media Munich), p. 190 l.b.
- Swatch, Biel, p. 119, p. 294
- Swedese Möbler, Vaggeryd, p. 168
- System Design Studio, Beijing, p. 204 r.t.
- T + A Akustik, Herford, p. 56 t.
- TCL, Beijing, p. 204 r.m.
- TechniSat Digital, Daun, p. 98
- Technology Design, Bellevue WA, p. 338.
- Thomson Multimedia, Paris, p. 154 b.
- Thonet, Frankenberg, p. 372 b.
- Üstra, Hannover, p. 80
- Umeda, Massanori, Tokyo, p. 213, 284
- Unit Design, Frankfurt am Main, p. 418 b.
- V.I.A., Paris, p. 152
- Via 4 Design, Nagold, p. 222, 304
- Viessmann, Allendorf, p. 95
- Vignot, Bernard, Paris, p. 154 b.
- Vitra Management, Basel, p. 69, 76 t. and l., (photo: Hans Hansen) 81 b.r.,
140 l.m., (photo: Miro Zagnoli) 154 t., 214 t. (photo: Thomas Dix),
351, 376 (mit Frank O. Gehry, Los Angeles), 380 b., 391
- Vogt + Weizenäcker, Berlin, p. 416
- Volkswagen, Wolfsburg, p. 10, 70
- Volvo Car Germany, Cologne, p. 330
- Vorwerk Teppichwerke, Hameln, p. 39
- Walser, Ludwig Design, Oberrohrdorf, p. 114
- Westefel Werke, Gerolstein, p. 98
- Wilkhahn, Bad Münder, p. 95
- Wogg, Baden/Dättwill, p. 118
- Wüllner Mineralquellen, Bielefeld, p. 98
- Wustlich, Kamp-Lintfort, p. 408 m.
- Yamaha Japan, p. 214
- Yip, Alan, Hong Kong, p. 208
- Zanotta Nova, Milano, (photo: Aldo Ballo) p. 132
- Zanussi (Electrolux), Porcia, p. 143
- ZKM, Karlsruhe, and William Forsythe, p. 422 t., p. 423 t.
- ZKM, Karlsruhe, and Noah D. Gelber, p. 422 b., p. 423 b.

INDEX OF NAMES

- Aalto, Alvar 165
 Adorno, Theodor W. 61f, 276
 Aicher, Otl 45, 87f, 344, 353, 374
 Aisslinger, Werner 101
 Albers, Josef 29, 41, 45
 Albino, Franco 92
 Albus, Volker 121, 36
 Alessi, Alberto 356
 Alessi, Carlo 356
 Alexander, Christopher 108
 Ambasz, Emilio 135
 Ando, Tadao 350, 370
 Arad, Ron 64, 77, 350
 Archimedes 228
 Argan, Guilo Carlo 123
 Aristoteles 228f, 233, 298
 Armani, Giorgio 122
 Arnheim, Rudolf 300ff
 Arribas, Alfredo 371
 Artschwager, Richard 67
 Ashbee, Charles Robert 75
 Ashley, Laura 83
 Askiran, Dmitrii 175
 Asplund, Gunnar 167
 Auböck, Carl 109
 Auger, James 393, 428
 Azúa, Martín 147

 Bader, Markus 392
 Bakker, Gijs 156
 Ballendat, Martin 111
 Ballmer, Walter 125
 Barney, Matthew 425
 Barthes, Roland 137, 291f, 286, 341

 Baudrillard, Jean 137, 151, 235ff, 327, 341, 379
 Bayer, Herbert 179
 Behrens, Marc 427
 Behrens, Peter 25, 27, 85, 343, 344, 358, 367
 Bellini, Mario 125, 135, 368
 Benedito, Ramón 147
 Benevolo, Leonardo 135
 Bense, Max 50, 235, 238, 275, 300
 Bergmiller, Karl Heinz 196
 Bergne, Sebastian 77, 101
 Berkeley, George 298
 Bertoia, Harry 183, 191, 339
 Beuys, Joseph 67
 Bill, Max 43, 45, 113
 Binazzi, Lapo 64
 Bisson, Diane 194
 Black, Misha 77
 Blaich, Robert I. 157, 189, 337
 Blum, Stefan 64
 Bollnow, Otto Friedrich 246
 Bonetti, Mattia 149, 153
 Bonetto, Rodolfo 123, 368
 Bonsiepe, Gui 49, 54, 196, 198, 254
 Borkenhagen, Florian 64
 Bornancini, José Carlos Mário 198
 Bortnik, Sandor 41
 Botta, Mario 115, 353, 371
 Boullée, Etienne-Louis 385
 Bouroullec, Erwan + Ronan 153
 Brancusi, Constantin 67
 Brandes, Uta 271, 272

 Brandolini, Andreas 64
 Branzi, Andrea 123, 133, 137, 139, 156, 390
 Braque, Georges 265
 Braun, Erwin + Artur 55
 Braun, Jürgen W. 353
 Braun, Max 55
 Breuer, Marcel 31, 41, 108
 Brody, Neville 83
 Buck, Alex 360ff
 Buetti, Daniele 427
 Bühler, Karl 288, 291, 300
 Bujons, Anna 147
 Burkhardt, Lucius 424
 Bush, Robin 194

 Calatrava, Santiago 373
 Calder, Alexander 125
 Camp, Freddy van 198
 Campana, Fernando + Humberto 198
 Carson, David 191
 Carvalho, Angela 198
 Cassirer, Ernst 293, 295
 Castelli, Clino 125
 Castiglioni, Achille + Pier 123, 127, 135, 356, 368
 Cerruti, Nino 122
 Chadwick, Donald 189
 Chauvel, Suzi 399
 Chermayeff, Serge 41
 Christen, Andreas 115
 Claret, Curro 147
 Clivio, Franco 117
 Clotet, Lluís 109, 147
 Coates, Nigel 77

- Colani, Luigi 62, 93, 215, 389
 Cole, Henry 19, 21
 Colombo, Joe 111, 135, 389
 Conran, Terence 77
 Cook, Peter 387
 Coray, Hans 113
 Corsbie, Nick 83
 Cortés, Pepe 147
 Coupland, Douglas 399
 Crane, Walter 75
 Cross, Nigel 279
 Czech, Hermann 111
- Dalí, Salvador 67
 Deganello, Paolo 64, 133, 350, 368
 Derrida, Jacques 379
 Descartes, René 228f
 Dewey, John 195, 235
 Dietel, Clauss 104, 107
 Dilthey, Wilhelm 245, 298
 Ditzel, Nanna 163
 Dixon, Tom 77
 Doblin, Jay 183
 Dolce & Gabbana 122
 Dorfles, Gillo 123
 Dörner, Volkhard 289
 Dresser, Christopher 75
 Dreyfuss, Henry 183
 Droysen, Johann Gustav 245
 Duchamp, Marcel 67
 Dunne, Anthony 83, 424
 Durkheim, Emile 326
 Dylan, Bob 137
 Dyson, James 77
- Eames, Charles 183, 191f, 339
 Earl, Harley 183
 Eckart, Peter 322
 Eco, Umberto 137, 236, 291f, 325f
 Ehrenfels, Christian von 299ff
 Eichler, Fritz 55
 Eiermann, Egon 93, 125, 374
 Eisenman, Peter 387
 Ekuan, Kenji 215
 Eldøy, Olav 167
- Ellinger, Theodor 285
 Engels, Friedrich 230
 Erlhoff, Michael 16
 Esslinger, Hartmut 88, 405
- Falange, Fabio 198
 Fehlbaum, Rolf 350
 Feininger, Lyonel 28
 Fenzl, Kristian 111
 Fiebig, Wilfried 229
 Findeli, Alain 280
 Fiorucci, Elio 139
 Fischer, Richard 312
 Fischer, Theodor 25
 Fischer, Uwe 380
 Flatz, Wolfgang 64
 Fleetwood, Roy 77
 Foerster, Heinz von 238
 Fontana, Lucio 123
 Forsythe, William 218, 421f
 Foster, Norman 87, 374
 Frank, Beat 115
 Freitag, Markus + Dani 120
 Freud, Sigmund 131, 295
 Friedländer, Uri 335f
 Friedman, David 191
 Fuller, Richard Buckminster 182, 387
- Gadamer, Hans-Georg 246
 Galilei, Galileo 228
 Gallé, Emile 230
 Gama, Newton 198
 Gammelgaard, Nils 171
 Garnich, Rolf 93, 275
 Garouste, Elizabeth 151
 Gaudí, Antonio 145
 Geddes, Norman Bel 183
 Gehry, Frank O. 87, 145, 191, 350, 375
 Gerken, Gerd 399
 Giedion, Sigfried 15, 113
 Giorgi, Giorgi jr. 198
 Giovannoni, Stefano 356
 Glaser, Milton 125
 Glaserfeld, Ernst von 238
 Graves, Michael 109, 139, 191, 356
- Grcic, Konstantin 101
 Greiman, April 191
 Greutmann, Urs 117
 Greutmann-Bolzern, Carmen 117
 Grimshaw, Nicholas 350
 Gropius, Walter 25, 28, 37, 41, 43, 179, 368
 Grosser, Adam 392
 Gucci 122
 Guerriero, Alessandro 137
 Gugelot, Hans 45, 55, 57, 93, 113, 238, 312
 Guhl, Willy 113
 Guixé, Martí 147, 392
 Gutenberg, Johannes 403
- Habeke, Christian 117
 Häberli, Alfredo 117
 Habermas, Jürgen 250
 Habermas, Tilmann 326, 329
 Hadid, Zaha 350, 375, 387
 Haller, Fritz 115
 Hammerschmied, Herbert 108
 Haug, Wolfgang Fritz 61, 335
 Haussmann, Trix + Robert 115
 Hayek, Nicolas 120
 Hébert, Julien 192f
 Hegel, Georg Wilhelm Friedrich 230, 247
 Heidegger, Martin 241ff, 345, 371
 Heine, Achim 390
 Helmholtz, Hermann 298
 Heufler, Gerhard 111
 Hilfiger, Tommy 191f
 Hilton, Matthew 77, 101
 Hirche, Herbert 57, 93
 Hitchcock, Henry-Russell 368
 Hitzler, Jürgen 408
 Hockney, David 67
 Hoffmann, Josef 25, 108, 111
 Höhler, Gertrud 399
 Höhne, Günter 103
 Hollein, Hans 87, 109, 111, 125, 139, 353, 375, 387
 Holscher, Knud 163
 Horkheimer, Max 61, 276

- Horx, Matthias 399
 Husserl, Edmund 240, 243

 Índio da Costa, Guto 198
 Irvine, James 77
 Isozaki, Arata 139, 212
 Ito, Toyo 377
 Itten, Johannes 28f, 41ff

 Jacobsen, Arne 163
 Jacobsen, Jacob 305
 James, William 195
 Jencks, Charles 237, 369
 Jobs, Steven P. 403
 Johnson, Philip 368
 Jones, Allen 67
 Judd, Donald 67

 Kahn, Hermann 263
 Kahn, Louis I. 125
 Kalman, Tibor 191
 Kalow, Gerd 50
 Kandinsky, Wassily 28
 Kant, Immanuel 229, 240, 282, 333
 Karan, Donna 192
 Karmasin, Helene 289f, 326, 361
 Kastholm, Jørgen 111
 Katz, David 299, 301
 Kelley, Jack 191
 Kelly, David 189
 Kerr, Helen 194
 Kienholz, Edward 67
 King, Perry A. 425
 Kiska, Gerald 112
 Kita, Toshiyuki 215
 Kjaerholm, Poul 163
 Klag, Volker 392
 Klee, Paul 28, 33
 Klein, Calvin 192
 Klein, Naomi 201
 Klier, Hans von 123, 125, 347
 Klotz, Heinrich 420f
 Kluge, Alexander 50
 Knoll, Florence 339
 Koffka, Kurt 300f
 Köhler, Manfred 300ff

 Koolhaas, Rem 67, 377, 387
 Koppelman, Udo 288f
 Koskinen, Harri 165
 Kramer, Friso 156
 Krampen, Martin 47
 Krier, Leon 387
 Krippendorff, Klaus 291, 337
 Krohn, Lisa 339
 Kufus, Axel 101
 Kuramata, Shiro 139, 215
 Kurokawa, Kisho 212

 La Pietra, Ugo 136
 Lagerfeld, Karl 139
 Lamb, Thomas 194
 Lane, Danny 77
 Langer, Susanne 293, 322
 Lannoch, Hans-Jürgen + Helga 335, 336
 Larsson, Lena 169
 Laubersheimer, Wolfgang 101
 Lauren, Ralph 83, 192
 Le Corbusier (Charles-Edouard Jeanneret) 25, 113, 125, 339, 381, 383
 Ledoux, Claude-Nicolas 385
 Lehmann, Andreas 115
 Leibniz, Gottfried Wilhelm 229
 Leitherer, Eugen 287f
 Leitner, Burkhardt 91, 101
 Lepoix, Lucien 149
 Lévi-Strauss, Claude 286, 292
 LeWitt, Sol 389
 Libeskind, Daniel 387
 Lichtenstein, Roy 125
 Lindfors, Stefan 165
 Lindinger, Herbert 93
 Linn, Carl Eric 290
 Lipps, Theodor 298f
 Lissitzky, El 28
 Locke, John 229
 Loewy, Raymond 75, 145, 149, 182, 191
 Loos, Adolf 108, 381
 Lovegrove, Ross 77
 Lucchi, Michele de 137f, 305
 Luhmann, Niklas 226, 239, 296
 Lyotard, Jean-François 151

 Maack, Klaus J. 353
 Mackintosh, Charles Rennie 27, 75
 Maeda, John 424
 Magnussen, Erik 163
 Magritte, René 67
 Maier-Aichen, Hansjerg 101
 Maldonado, Tomás 45f, 123, 195, 237, 292
 Malevitsch, Kasimir 28, 172
 Mankau, Dieter 303
 Mann, Steve 425
 Manzini, Ezio 425
 Manzù, Pio 123
 Marchand, Christophe 117
 Marcks, Gerhard 28
 Marcuse, Herbert 61, 131, 276
 Mari, Enzo 356
 Mariscal, Javier 64, 139, 147
 Marzano, Stefano 264, 395
 Maturana, Humberto 238
 Maurer, Ingo 101
 McCloy, John 45
 McCoy, Katherine + Michael 191, 337ff
 McLuhan, Marshall 194, 403
 Meier, Richard 125, 191, 379
 Meinong, Alexius 299
 Mellone, Oswaldo 198
 Mendini, Alessandro 108, 122f, 135ff, 157, 353, 356, 368, 379, 389, 395
 Menzel, Marianne 109
 Merz, Mario 67
 Meshchaninov, Andrei 175
 Metzger, Wolfgang 300f
 Meyer, Hannes 33, 50
 Mies van der Rohe, Ludwig 25, 29, 33, 41, 57, 115, 145, 179, 367f, 381
 Mikosch, Gerda 312f
 Milani, Francesco 117
 Mill, John Stuart 21, 245
 Miller, Herman 185, 189f
 Mir, Ana 147
 Miranda, Santiago 423
 Missoni 122

- Miyake, Issey 191, 218
 Moggridge, Bill 77, 185, 411
 Moholy-Nagy, László 28f, 33, 37, 41
 Moles, Abraham A. 50
 Møller, Jørgen 163
 Mondrian, Piet C. 27
 Montgomery, Paul 189
 Moore, Charles 109, 135
 Moore, Gordon 424
 Moormann, Nils Holger 101
 Morus, Thomas 385ff
 Morgue, Olivier + Pascal 149
 Morris, Charles William 236, 293
 Morris, William 21f, 27, 75, 85, 387
 Morrison, Jasper 77, 350
 Muche, Georg 28
 Mukařovský, Jan 234f, 295
 Müller, August 117
 Muller, Keith 194
 Müller, Ruedi Alexander 117
 Muller, Wim 292
 Mumford, Lewis 75
 Muthesius, Herman 25
 Mutius, Bernhard von 296f
 MVRDV 387

 Nadin, Mihai 401
 Natalini, Adolfo 123, 133
 Nelson, George 183
 Neumeister, Alexander 93, 198
 Nielsen, Eirik Lund 167
 Nizzoli, Marcello 125
 Noguchi, Isamu 212
 Nonné-Schmidt, Helene 45
 Norman, Donald A. 321, 415
 Nouvel, Jean 153, 379, 380
 Noyes, Eliot 183

 Oehlke, Horst 105, 341
 Olbrich, Josef 25
 Oldenburg, Claes 67
 Olins, Wolf 83
 Olivetti, Adriano 125
 Olivetti, Camillo 123

 Onck, Andries van 291
 Oppenheim, Meret 67
 Ortner, Laurids 108
 Oud, Jacobus Johannes Pieter 25

 Padrós, Emili 147
 Palladio, Andrea 120
 Panton, Verner 163, 389
 Papanek, Victor 185
 Paxton, Joseph 19, 108
 Pei, I. M. 87
 Peirce, Charles Sanders 233ff, 291
 Pensi, Jorge 147
 Pesce, Gaetano 136, 350, 390
 Peterhans, Walter 43, 45
 Petzold, Nelson Ivan 198
 Pevsner, Nikolaus 75
 Pfeiffer, Herbie 189
 Picasso, Pablo 265
 Pinter, Klaus 108
 Piretti, Giancarlo 127
 Piva, Paolo 111
 Platon 227, 233, 244, 312, 385
 Poelzig, Hans 25
 Pohl, Herbert 107
 Popcorn, Faith 399
 Porsche, Ferdinand + Alexander 112
 Prix, Wolf D. 373
 Prouvé, Jean 92
 Putmann, Andrée 151

 Quant, Mary 83, 364
 Quément, Patrick le 153

 Raby, Fiona 83, 395, 426
 Radice, Barbara 109, 137
 Ramakers, Renny 156
 Rams, Dieter 28, 55, 57f, 300, 353, 392
 Rand, Paul 191
 Rashid, Hani 192
 Rashid, Karim 191, 194
 Ratzlaff, Jörg 64
 Reinmöller, Patrick 289

 Reitz, Edgar 50
 Renzi, Guglielmo 64
 Ricard, André 145
 Riemerschmid, Richard 25
 Rietveld, Gerrit T. 27
 Rietveld, Wim 156
 Rittel, Horst 46, 252
 Rodriguez, Sergio 198
 Roericht, Hans 43, 93
 Rogers, Richard 374
 Roozenburg, Norbert F. M.
 Rossi, Aldo 356, 381
 Roth, Gerhard 238
 Roth, Jan 64
 Rübenach, Bernhard 49
 Rudolph, Lutz 104
 Ruskin, John 21, 23, 27, 75

 Saarinen, Eero 183
 Saarinen, Eliel 191, 339
 Samojlowa, Tatjana 175
 Santachiara, Denis 64
 Sapper, Richard 127, 135, 356
 Sarasin, Wolfgang 346
 Saussure, Ferdinand de 234, 288, 326, 339
 Schärer, Paul 115
 Scharoun, Hans 25
 Scheuer, Winfried 335
 Schinkel, Karl Friedrich 383
 Schleiermacher, Friedrich Daniel Ernst 245f
 Schlemmer, Oskar 28, 33
 Schmidt, Siegfried J. 238
 Scholl, Hans + Sophie 45
 Scholl, Inge 45
 Schönhammer, Rainer 241
 Schulze, Gerhard 266, 363
 Schupbach, Stephan 409
 Scott Brown, Denise 191
 Scott, Douglas 75
 Segal, George 67
 Selle, Gert 285f
 Semper, Gottfried 21
 Shneiderman, Ben 415
 Šípek, Bořek 350
 Siza, Alvaro 350

- Skrypalle, Uli 250
 Slany, Hans Erich 93
 Sloterdijk, Peter 427
 Snow, Charles Percy 245
 Sodeau, Michael + Marc 83
 Soentgen, Jens 243
 Sokrates 227
 Soloviev, Yuri 173
 Songe-Møller, Camilla 167
 Sottsass, Ettore 64, 109, 123,
 131, 135ff, 185, 356, 368
 Späth, Lothar 421
 Spencer, Hugh 194
 Spitz, René 43ff
 Spoerri, Daniel 67
 Stam, Mart 15, 25, 156, 368
 Stankowski, Anton 93
 Starck, Philippe 149, 151, 323,
 356, 370
 Stern, Robert A. M. 109
 Steward, Michael 194
 Stieg, Robert M. 108
 Stirling, James 125, 383
 Straub, Christian 50
 Stumpf, William 189
 Sullivan, Louis H. 59
 Swiczinsky, Helmut 373
- Tandberg, Herman 167
 Tallon, Roger 149
 Tange, Kenzo 125, 212
 Tatlin, Vladimir 28, 172
 Taut, Max 25
 Teague, Walter Dorwin 183
 Thallemer, Axel 87
 Thonet, Michael 23, 31, 111,
 117, 374
 Thun, Matteo 111, 120, 137,
 139, 370
 Thut, Walter + Benjamin 101,
 117
 Tigerman, Stanley 191
 Toffler, Alvin 263
 Torres & Torres 147
 Tschumi, Bernhard 387
 Tusquet Blanca, Oscar 64, 109,
 147
- Uecker, Günther 67
 Ulrichs, Timm 67
 Umeda, Masanori 139, 215
 Ungers, Oswald Matthias 384
 d'Urbano, Alba 428
- van de Velde, Henry 23, 25, 28
 van Doesburg, Theo 27
 Varela, Francisco J. 238
 Venturi, Robert 57, 109, 135f,
 191, 368, 369
 Venturini, Guido 356
 Vercelloni, Isa 139
 Verde, Johan 167
 Verplank, Bill 411
 Versace, Gianni 122
 Vershofen, Wilhelm 283, 288
 Viénot, Jacques 149
 Vihma, Susann 291
 Virillo, Paul 379
 Vitruvius 17, 367, 381
 Vogt, Oliver 101
 Vogtherr, Burkhard 111
 Vostell, Wolf 67
 Votteler, Arno 93
- Wagenfeld, Wilhelm 38
 Wagner, Otto 25
 Walser, Ludwig 117
 Walther, Franz Erhard 67
 Watt, James 73
 Wegener, Hans J. 163
 Weibel, Peter 421
 Weil, Daniel 77
 Weizenegger, Hermann 101
 Wenders, Wim 218
 Wendtland, Thomas 64
 Wertheimer, Max 300ff
 Westwood, Vivienne 83
 Wettstein, Hannes 111, 117
 Wewerka, Stefan 63, 92
 Wingler, Hans M. 37
 Wippermann, Peter 399
 Wirkkala, Tapio 165
 Wittgenstein, Ludwig 337, 371
 Wolf, Max 392
 Wozniak, Stephen 403
- Wundt, Wilhelm 298
 Yamamoto, Yohji 218
 Ytterborn, Stefan 171
- Zamp Kelp, Günter 108
 Zanuso, Marco 135, 368
 Zapf, Otto 93
 Zebner, Frank 409
 Zec, Peter 420
 Zegna, Ermenegildo 122
 Zeischegg, Walter 45f, 93
 Zemp, Werner 117
 Zumthor, Peter 241, 384

SUBJECT INDEX

- ability to learn 413
 absent structure 239
 abstraction 302
 acceptance 7, 55, 125, 145, 264ff, 280, 286, 321
 accommodation 21, 29, 33, 45, 49, 113, 211
 Acer 206, 223
 acoustic body 384
 act of creation 225
 action 255, 263f, 283, 295, 327, 357, 425
 adaptation outputs 238
 adaptive design 207
 added value 290, 443
 adidas 167, 326, 360
 advertising 27, 75, 105, 353, 398
 advertising expert 27
 AEG (Allgemeine Elektrizitäts-Gesellschaft) 27, 85, 343, 358
 aesthetic character 254, 264
 aesthetic production 33
 aesthetic synthesis 33
 aesthetics 27, 28, 163, 209, 235f, 273ff, 288, 293ff, 313, 379, 421
 aircraft construction 173, 182, 312
 aircraft industry 192
 Airstream 182
 Alchimia 108, 133, 136f 151, 335, 379, 389, 401
 Alessi 57, 109, 127, 139, 151, 157, 353, 356, 374, 379, 381
 allusive qualities 413
 alphabetization 413
 aluminum 91, 97, 113, 182, 192, 312, 381
 Amat 147
 American way of life 121, 192
 analogy 245, 283, 290, 403
 analysis 29, 37, 49, 51, 85, 172, 203, 228f, 231, 235ff, 259, 295, 326ff, 337, 361, 407, 419f, 429
 anatomy 13
 anthropological turn 413
 anthropology 392
 anthropometric 320
 anticipation 400
 antidesign 131, 133, 137
 antifunctionalism 105
 antithesis 230
 Anzeichenfunktion (marking function) 301, 313, 321ff, 405, 409
 apartment 25, 38, 137, 211, 327
 Apple 185, 360, 392, 401, 403, 414, 419
 application 15, 25, 38, 45ff, 59, 111, 195, 199, 239, 249, 254, 265f, 282, 298, 312, 320, 357, 420
 applied art 15, 51, 75, 163, 203
 Arabia 165, 171
 architectural details 353
 architectural history 113
 architectural idiom 371
 architectural theory 367, 370
 architecture 13, 25, 27, 33, 41, 51, 57ff, 77, 84, 87f, 91f, 108, 111, 115, 120, 131ff, 145f, 167, 172, 183, 192f, 203, 212, 237, 252, 257, 275, 297, 303, 312f, 323, 341ff, 367ff, 381ff, 420ff
 Archizoom Associati 133
 Arno 93, 153
 art and technology 37
 art deco 149, 179
 art education 424
 art house 384
 art nouveau 23
 Artek 165
 Artemide 198, 312
 artifact 413
 artificial intelligence 403
 artisan craftsman 37
 artist 17, 31, 41, 92, 99, 113, 123, 135, 165, 247, 379, 385f, 421
 artistic 13f, 23ff, 45, 50, 63, 67, 85, 125, 131ff, 165, 172, 195, 225, 231, 265, 297, 344, 356, 373, 377, 390, 421
 artistic adviser 27, 85, 344
 Arts and Crafts 21, 23, 28, 55, 63, 75, 192, 203
 Ascom 117
 Asia 71f, 93, 117, 120f, 141, 177, 189, 198f, 219ff, 279, 346, 356, 360ff, 419
 Asko 165
 association 122, 145, 312, 323, 360

- assumption of constancy 301
 Aston Martin 75
 Attac 201
 attention 19, 31, 38, 43, 51,
 55, 75, 93, 99f, 111, 147,
 199, 225, 230, 278, 285, 288,
 321, 341, 359f, 385, 389f,
 403f, 414
 attitude 167, 345, 359, 367f
 attribution of meaning 238,
 292
 Audi 71, 97, 189
 augmented reality 417
 aura 387
 Austria 23, 99, 107, 108, 384
 Authentics 57, 99, 101
 author system 264
 automobile (see car) automomo-
 bile manufacturer 258
 automotive industry 71, 163,
 219, 285, 346, 360, 398, 412,
 417, 427
 autopoietic 238, 296, 409
 avant-garde 38, 46, 77, 83,
 151f, 171f, 195, 264, 287,
 390
 awareness of design 47, 153,
 198, 207

 Bakelite 157, 206
 Banal Design 136
 Bang & Olufsen 157, 165
 basic elements 228f
 basic functionality 412
 basic need 28, 54
 basic shape 305, 413
 Bauhaus 19, 25ff, 84, 91ff,
 104ff, 111, 115, 121, 136,
 156, 165, 172, 179, 254, 280,
 287, 323f, 367, 387, 420ff
 Bauhaus classics 63, 287
 Bauhaus heritage 424
 Bauhaus style 38
 Bauhaus tradition 45, 92, 104,
 115, 136
 B.D. Ediciones de Diseño 147
 beat culture 83
 beauty 17, 43

 Bega 85
 behavior 57, 135, 177, 209,
 226, 235, 243f, 300, 331,
 344f, 357, 398, 403, 409,
 414, 426ff
 behavior of signs 235
 behavior patterns 409
 being at home 384
 bel design 55, 121ff, 145, 287,
 353, 368
 Belux 117
 Biennale 108
 bioinformatics 443
 biological turn 426
 biotechnology 263
 Black & Decker 185
 BMW 97, 189, 285, 290, 331,
 364, 375
 body 97, 122, 218, 255, 278,
 327, 426ff
 body modification 427
 body of knowledge 280, 282,
 289, 293
 body ornamentation 427
 Boeing 185
 Bose 185
 brand 201, 258, 285, 329,
 343ff, 357ff
 brand image 345
 brand loyalty 258
 brand products 329
 brand trends 360
 Braun 27, 54ff, 71, 84ff, 123f,
 145, 163, 211, 344, 350, 359,
 383
 Bree 85
 brutalism 383
 Bulthaup 85
 business culture 87, 125
 business schools 359

 CAD (Computer Aided Design)
 321, 405, 411f
 calculator 211, 405
 Calor 153
 Canada 191ff
 Canon 202ff, 215
 Cappellini 153

 car 11, 15, 71, 75, 83, 97f,
 111, 120, 153, 163ff, 173ff,
 219ff, 235, 258, 266, 285f,
 331, 346, 360ff, 398, 412,
 417, 427
 car brand index 360
 carriers of function 286
 Cartesian 49, 51, 229, 244,
 253ff, 275
 Cassina 38, 141, 215
 cast iron 21
 cell phone 167, 171, 199, 201,
 218, 244, 265, 322, 327ff,
 349, 407, 412
 cement 21
 ceramic design 165
 ceramics 75, 122, 147, 163ff,
 192, 202ff
 chairs of molded plywood or
 cane 373
 changeability 320
 changes of scenery 377
 chaos research 414
 Charter of Athens 113
 checklist 252, 359
 Chicago 27, 38, 41, 183, 189,
 215
 China 71, 199, 202ff, 223f
 chip 401, 426
 CIAM (International Congress
 for Modern Architecture) 113
 circular structure of understand-
 ing 247
 Citroën 153
 civilization 73, 131, 390, 401,
 413
 claim to universality 250
 classics 91, 92, 111f, 127, 241,
 331, 375
 clothing 83, 172, 218, 231,
 326ff, 427
 CNC 375, 415
 cocooning 327, 400
 code of conduct 346
 coffee service 25, 256, 275,
 353, 356, 381
 cognitive 29, 238, 289, 313,
 321, 333, 414

- collage 265
- Cologne School (see Koppelman)
- color 41, 92, 127, 165ff, 191, 299, 381, 387
- comfort 67, 127, 131, 189, 331, 384, 427
- commodity aesthetics 105, 182
- communication 49, 50, 92, 139, 156, 218, 223, 236ff, 264f, 278ff, 297, 325ff, 345ff, 357ff, 403, 409, 427ff
- communicative function 151, 230, 239, 254, 283, 290, 321, 325, 361, 369, 409, 413
- communist 172, 385
- communities of identification 329
- company identity 345
- company philosophy 93, 125
- Compasso d'Oro 122
- complexity 16, 47, 59, 228f, 234, 251ff, 265, 281ff, 296, 299, 300ff, 312, 371ff, 401, 412ff
- composition 253
- computer 185, 194, 198, 201, 267, 272, 339, 356f, 371, 392, 398, 401ff
- computer program 417
- computer scientist 356
- computer technologies 417, 429
- concentration 28, 107, 370
- concept art 135
- concept cars 398
- concept of design 13, 16, 277, 296, 389, 393, 424
- concept of function 17, 31, 85
- concept of functionalism 17
- conceptual art 389
- concrete 16, 131, 151, 212, 241, 253, 277, 296, 302f, 342, 346, 370, 383f, 390
- configurability 320
- connectibility 239, 290ff
- connotation 236, 290, 326, 360
- constants of design 349
- constitution 287, 345
- construct of meaning 290
- construction 19ff, 31, 38, 43, 49, 75, 125, 172, 212, 226, 258, 289, 327, 335, 373ff, 415, 424
- constructive 115, 231, 413
- constructivism 27f
- consubstantiality 345
- consumer 55, 93, 103, 115ff, 194, 286, 357ff, 392, 398
- consumer electronics 194
- consumer goods 103, 115ff, 194
- consumer milieus 361
- consumerism 122, 133, 191
- consumption 16, 27, 173, 266, 329, 331
- contemplation 133, 370, 384
- convention 234, 243, 249, 292ff, 322ff
- core competency 279
- corkscrew 356
- corporate communication 344, 363
- corporate culture 344, 350, 363
- corporate development 358
- corporate identity 107, 117, 171, 205, 285, 343ff, 374
- corporate image 55
- corporate strategy 344
- corporate wording 344
- counterdesign 109, 135ff, 141, 389
- craft revival 192
- craft trades 25, 28, 33
- craft traditions 75, 165
- crafts 27f, 51, 73, 167, 195f, 202, 226, 254
- craftsman 25, 31, 149
- creative attitude 359, 392
- creativity 29, 43, 75, 99, 117, 120, 131ff, 157, 165, 189, 191, 196, 202ff, 212, 225f, 235, 252ff, 265f, 277, 292, 297, 302ff, 323, 331, 337, 350, 356, 359, 364, 374ff, 389ff
- crisis of meaning 227
- critique of functionalism 47, 55, 61, 93, 367
- critique of society 61
- CRM (customer relationship management) 358
- cross-medial dimension 411
- cult brand 218, 326
- cultivation 286, 443
- cultural history 241
- cultural revolution 403
- cultural studies 287, 289, 401
- cultural technique 291
- cultural theory 290
- curriculum reform 54
- curve theory 49
- cutlery 91, 163, 353
- cybernetics 238, 255
- Daewon 219
- Daewoo 219
- Daewoong 219
- DAF 157
- DaimlerChrysler 7, 97, 263, 285, 290, 360
- De Stijl group 27, 156
- death of modernity 369
- decisions on future developments 400
- decoding 325, 443
- decomposition 253
- deconstructivist 373ff
- deduction 228f, 253
- deep simplicity 414
- definition 13ff, 47ff, 59, 123, 227, 279, 287, 331, 342
- dematerialization 350, 389, 405ff, 413, 420
- denotation 236, 249, 326
- department store interiors 182
- deSede 117
- design bible 347
- design boom 147, 153, 185, 198
- design classics 92, 103, 115, 136

- design concept 38, 46, 54,
107, 115, 169ff, 191, 215,
258, 264, 290, 300, 387, 392,
405
- design management 227, 281,
288, 358, 359ff, 417
- design manual 87, 92, 123,
347ff, 357
- design methodology 47, 51,
125, 226f, 251ff, 273, 280,
358, 361
- design noir 83, 393
- design object 105, 286
- design offensive 93, 120f
- design policy 175, 398
- design practice 63, 250, 255ff,
275ff, 329, 363, 409
- design process 62, 225f, 251ff,
271ff, 325, 414ff
- design quality 413
- design research 327, 413
- design strategy 199, 337, 409
- design theory 47, 105, 117,
195, 225ff, 245, 250, 255,
273ff, 291ff, 323ff, 341, 363,
409, 413
- design training 73ff, 113, 157,
203, 256, 280, 337
- des-in 62
- desk lamp 312
- Dessau 29, 33, 41, 156, 172
- Deutsche Lufthansa 87, 344
- Deutsche Telekom 117
- development process 225, 256,
259, 277
- dialectics 313
- differentiation 285ff, 360, 367
- digital age 141, 425f
- digital divide 403
- digitalization 11, 83, 117, 139,
185, 199, 209, 244, 258f,
264, 321, 356ff, 379, 393,
398, 403ff
- dimension 85, 235, 243, 275,
285, 302, 370, 381, 393, 407,
417
- dinks (double income no kids)
364
- discipline 7, 15, 49ff, 67, 73,
121, 182, 209, 225f, 256,
263, 273ff, 323, 327, 333,
359, 370, 398
- disegno 13, 121
- Disform 147
- display 23, 91, 356, 385, 409
- display screens 356
- diversity 16, 123ff, 135, 177,
237, 257, 278
- division of ideas 227
- division of labor 19, 23
- DNA 426, 443
- doctoral education in design
281
- documenta 8 16, 64, 147
- domestic appliances 27, 153,
163, 171, 175, 182ff, 198,
205, 215, 219, 223, 407
- domestic utensils 343
- door handle 353, 370ff
- double coding 281, 369
- draft 13, 263
- drawing 13, 21, 71, 202, 364,
373, 389, 400, 412
- Dresden 11, 104, 258, 373
- Duravit 374
- dymaxion 182
- dynamic interaction 420
- Dyson 77
- ease of operation 427
- East Germany (see German
Democratic Republic)
- eclecticism 63, 369, 401
- ecology 15, 275ff, 286, 374
- economics 45, 73, 277, 288,
358, 374
- economy 103ff, 145, 175,
203ff, 223ff, 278
- education and training 403
- el buen diseño 55
- electric shaver 291
- electrical gadget 206
- electroclimate 393
- Electrolux 85, 171
- electronic 55, 194, 198, 203,
211f, 243, 303, 320, 327,
335ff, 349, 392ff,
- electronic devices 211, 327,
392, 413
- electronics 71, 92, 185, 199,
203, 211, 215, 219, 259, 390,
395, 398, 405, 414, 427, 429
- elemental psychology 299
- emblem 113, 322
- emotionality 47, 62, 117, 172,
226, 231, 247, 271, 285, 346,
364
- empathy 299
- empirical 227ff, 250f, 258, 264,
271, 286, 292, 325
- engine 73
- engineer 17, 117, 123, 182,
285, 296
- engineering sciences 280
- England 19ff, 194, 218, 280,
374
- entertainment electronics 153,
199, 209, 223
- envelopment technique 15
- environment 21, 61, 104, 113,
133, 153, 169, 192, 237,
240ff, 257, 276ff, 303, 322,
364, 371, 385, 420
- environmental concerns 359
- epistemology 225ff, 236
- Erco 87
- ergonomics 15, 45, 57, 67, 85,
131, 171ff, 189, 225, 231,
258, 277, 407
- Ericsson 163, 171, 201
- essence 163, 227ff, 283, 299,
313, 345
- ethics 211, 228, 359
- ethnologists 326
- eugenics 443
- evaluation 235, 256, 271, 287,
358, 395, 415
- event design 7
- exchange value 61
- exhibition concept 194
- exhibition design 156, 203,
207, 395, 421

- exhibition system 50, 87
 existential maximum 121
 existential minimum 121
 experiment 29, 157, 191, 228, 298
 eye of wisdom 371
 fantasy 225
 fashion 11, 15, 51, 62, 75, 83, 105, 120f, 133, 137, 145ff, 171, 183, 191f, 206, 218, 231, 326ff, 377, 392
 fashion designer 192, 218
 feature 238, 343, 349, 373f, 383
 feauritis 303, 322
 Ferrari 122
 Festo 87
 Fiat 122, 173ff
 fiction 389, 417, 429
 film 50f, 145, 218, 263, 395, 419
 film industry 429
 firmitas 17
 Fiskas 165
 Ford 157, 185
 form 7, 16, 21ff, 37ff, 59, 61ff, 84ff, 123ff, 139, 147, 163, 179, 182ff, 191, 218, 233ff, 253ff, 265, 277, 283ff, 323ff, 335ff, 350, 361, 368, 373, 383, 401, 411ff, 425
 form follows function 84, 139, 292, 323
 formal aesthetics 296ff
 formal device 298
 formal element 27, 297
 formal language 77, 84ff, 101, 109, 163, 167, 215, 219
 formal science 253ff, 283
 formalism 21, 27, 77, 84, ff, 101, 109, 163ff, 212ff, 228, 235, 253ff, 283, 296ff, 312f, 320, 383
 formation 127, 182, 300
 Forum Design Linz 57, 84, 108, 136, 147, 424
 foundation course 27ff, 41ff, 421
 France 23, 88, 92, 97, 115, 149ff, 177, 218, 231, 279, 286, 326, 339, 341, 368, 383ff
 Frankfurt School 61, 250, 275
 Fritz Hansen 165
 FSB 87, 344, 350ff, 371ff
 Fujitsu 199
 function 15, 21, 59, 84f, 108, 133, 139, 179, 231ff, 256, 276, 285ff, 312, 322ff, 335, 339, 361, 367ff, 401, 411, 417, 427
 function overload 322
 functional design 88, 91, 104, 111, 156, 215, 342
 functional furniture 31, 167
 functionalism 41, 47, 57, 61ff, 84, 101ff, 125, 236, 254, 273ff, 281, 303, 313, 323, 341, 343
 functionalist design principles 85, 88
 functionality 17, 31, 85, 105, 169, 177, 183, 218, 290, 302, 312, 356
 fundamental design concept 25
 fundamental design skills 29
 furnishings 25, 77, 151, 183, 325, 370ff
 furniture 19, 23ff, 38, 63, 75ff, 88, 93, 99, 101, 107ff, 133ff, 145ff, 163ff, 185, 191ff, 212ff, 231, 325, 343f, 359, 370ff, 384, 390, 392, 400, 415
 furniture classics 63
 furniture design 77, 101, 107, 113ff, 133ff, 141, 147, 151, 156, 169, 171, 194ff, 325, 359, 377ff, 400
 furniture industry 198, 400
 future research 398
 futurism 385
 Gardena 87
 genetic research 443
 German Democratic Republic (GDR) 15, 59, 103ff, 173, 313, 341, 421
 German Werkbund 25
 Germany 23, 33, 43, 51, 55, 59, 61ff, 71, 84, 93, 97, 101ff, 121ff, 139, 157, 169, 185, 201, 209ff, 223, 237, 333, 344, 350, 358ff, 367, 389, 400, 420, 424
 Gesamtkunstwerk 109, 121, 145, 379
 Gestalt laws 49, 301f, 313
 Gestalt psychology 299, 301, 368
 Gestalt quality 299
 Gestalt theory 288, 291, 296, 301f
 Gestetner 182
 Giant 223
 Gira 88
 giving form 296
 glass 19, 31, 73ff, 84, 104, 122, 137, 151, 163ff, 203, 379
 global player 157, 165, 185, 206, 218, 243, 350, 353, 379
 Global Tools 135
 globalization 71, 201, 226, 297, 360
 GM General Motors 183
 goal 25ff, 45ff, 108, 133, 173, 195, 219, 228, 273, 282, 367
 Goldstar 199, 219, 395
 good design 55, 59, 84, 113, 136, 145, 313, 335, 341, 344, 390
 good industrial design 84
 good taste 25
 graphic design 83, 88, 191, 202, 207, 285, 344, 374, 395, 421
 grid formation 411
 Grohe 88
 group 9999 133, 135
 group membership 326
 Grundig 111
 gute Form 55

- Habitat 77
- habits 93, 237, 266, 331, 392, 414
- Hackmann 165, 171
- Haier 205
- handicrafts 203, 219, 254
- handicrafts design 254
- Hansgrohe 88
- haptic design 285
- hardware 7, 16, 83, 88, 185, 189, 258f, 264ff, 296, 322, 339, 343, 353, 357, 390ff, 409ff, 424ff
- Harley-Davidson 185
- harmony 278, 297, 383
- Hasselblad 171, 173
- Haworth 185
- Head 111
- headphones 211, 241
- headset 429
- Helit 374
- Herman Miller 163, 185, 189
- hermeneutic circle 251
- hermeneutics 227, 230, 240ff, 325, 337
- heuristics 228
- Hewi 88
- Hewlett Packard 185
- high culture 136
- high-tech 165, 194, 199, 205, 218, 223, 312, 333, 349, 374ff, 383
- Hilti 117
- hippie movement 131
- history of architecture 383
- history of design 17, 73ff, 221, 350, 370
- history of science 253
- Hitachi 198, 205, 215
- holistic 25ff, 93, 226, 233, 278, 291, 300ff, 320, 358, 361, 373
- home 11, 38, 71ff, 97, 122, 133, 153, 169, 201ff, 231ff, 286f, 356, 373f, 415
- Honda 202, 215
- horizon 240, 247, 265, 333
- household 67, 75, 88, 92, 101, 107, 163ff, 179, 185, 195ff, 215ff, 243, 251, 326ff, 353
- human body 179, 413, 426ff
- human design 393, 443
- humanistic 257
- humanities 227, 230, 239ff, 255, 258, 271, 282f, 313, 325, 335, 369, 392
- Hutchison Whampoa 201
- Hyperbolic Tree 259
- hypothesis 237
- Hyundai Motors 219
- IBM 183ff, 344, 360f, 373, 401
- ICE train 367
- icon 172, 326
- iconography 109, 136
- identification 239, 353, 360
- identity 37, 107, 156, 183, 189, 207ff, 221, 238, 286, 327ff, 343ff, 370, 383, 411
- idle function 320
- Iittala 165
- IKEA 169ff, 287
- illiteracy 403
- illumination 147, 303
- image 50, 75, 83ff, 92f, 107, 123ff, 149ff, 165, 169, 215, 223, 241, 344ff, 360, 364, 412, 417ff
- image transfer 171, 218, 271, 290, 333, 370, 373, 374
- image-bearers for design 151
- imaginary 101, 385
- imagineering 297, 363, 417
- Imax cinema 371
- imitation 201, 205
- imparted by perception 293
- implementation 57, 252, 369
- importance 19, 45, 54, 71, 93, 113, 120, 179, 198, 205, 219, 226ff, 237, 246, 271, 293, 300, 329, 335ff, 343, 349, 357ff, 369, 390, 405ff
- imposing shape 369
- individualism 11, 15, 29, 47, 50, 57, 109, 135, 137, 171ff, 201, 207, 211f, 230ff, 244, 257, 281, 286, 290, 295, 298f, 312, 321ff, 343, 349, 360, 367, 383ff, 403, 407, 412
- individuality 15, 25, 206, 329, 331
- induction 29, 228, 257
- industrial design 11, 15, 17, 21, 27, 46, 73ff, 83, 109, 145, 149, 156, 173, 177, 182, 189, 195, 205, 237, 251ff, 278, 287, 353, 419
- Industrial Revolution 17, 21
- industrialization 21, 73, 75, 125, 195f, 206, 209, 245, 389
- information design 296, 420
- information processing 255
- information theory 50, 275
- innovation 75, 88, 117, 189, 196, 202, 225, 265, 337, 361, 400
- integralist 281
- intellectual 38, 46ff, 59, 85, 111, 115, 121, 131ff, 172, 195, 227ff, 240, 245, 282, 302, 323, 379, 384f, 390
- intention 25, 31, 49, 67, 75, 121, 212, 249, 254, 272
- interaction 127, 191, 215, 238f, 254, 264, 322, 347, 395, 409ff, 424ff
- interaction design 215, 322, 395, 409, 414f, 425
- interactive 218, 259, 264
- interactive possibilities 421
- interconnectedness 417
- interdisciplinarity 51, 147, 183, 263, 277ff, 425
- interface 83, 101, 108, 157, 254, 271, 347, 358, 363, 371, 405ff
- interior 55, 77, 108f, 115ff, 147ff, 165, 198, 207, 212, 218, 285ff, 293, 331, 335, 347, 364, 373ff, 383, 390
- Interlübke 88

- International Style 27, 57, 61,
139, 237, 368f
- Internet 11, 357, 392, 417
- interpretation 62, 85, 97, 136,
165, 175, 183, 215, 231ff,
238ff, 258, 312, 323
- intuition 172, 229, 259, 271,
295, 302
- Italy 11, 38, 54, 63, 103ff,
120ff, 163, 171ff, 215, 223,
279, 287, 291, 344, 347,
353ff, 368, 377ff, 395, 425
- Jaguar 75
- Japan 71, 177, 198ff, 241, 263,
279, 327, 346, 370, 377, 385,
390, 429
- jewelry 327, 375, 392
- John Deere 185
- joy of use 271, 415
- Jugendstil 23, 27
- Kahla 107
- Kantian concept of reason 229
- Kartell 292
- kettle 194, 356
- key competency 297
- KIA 219
- kitchen appliances 55, 165
- kitsch 64, 75, 136
- Knoll International 185, 212,
379
- knowledge 17, 43ff, 227ff, 234,
243ff, 255ff, 273, 277, 280ff,
292ff, 333, 344, 384, 420ff
- knowledge design 296
- knowledge interests 286
- knowledge management 259
- Kodak 185, 205
- Koppelman School 288f
- Korea 177, 198, 201, 219ff,
279, 346, 395
- Koziol 57
- Krups 88, 92, 153
- KTM 109
- Lada 175, 331
- Lamborghini 122
- Lamy 88, 344
- Lancia 122
- language 11, 23ff, 37, 83, 105,
145, 156, 206, 212, 224,
230ff, 244ff, 277, 283ff, 320f,
337, 345, 368f, 409
- language of form 23, 25, 37,
254
- language of things 238
- language theory 300
- laws of design 172
- LCDs (liquid crystal displays)
407
- leather goods 85, 111, 206
- legibility 405
- Lego 165
- Lehni 113
- leisure 11, 103, 113, 125, 211,
266, 403, 415
- leitmotif 329
- Leitner 91, 101
- Lenova 205
- LG Electronics 199, 219, 395
- life expression 293, 299
- life philosophy 246
- lifestyle 71ff, 120f, 131, 139,
153, 179, 189, 194, 218, 258,
329, 331, 349, 353ff
- life-world 196, 212, 240ff,
265f, 283, 403, 419
- lighting 85ff, 113, 117, 165,
198, 215, 257, 359, 370
- lightweight construction techni-
ques 312
- linguistic theory 291
- linguistic turn 250f, 341, 370,
413, 426
- linguistics 233ff, 368f
- list of requirements 256
- logic 228, 234, 253, 322, 337,
370
- logic of semiotics 234
- logo 357
- logotype 347, 349
- Lomo 175
- London 19, 21ff, 64, 75ff, 83,
185, 364, 375, 390, 393
- loss of meaning 297
- Lotus 75
- Love Getties 244
- luxury 7, 50, 93ff, 290, 331
- machine 23, 27, 99, 111, 123,
127, 173, 244, 356, 359,
390ff, 401, 407, 413, 429
- machine tools 173, 407
- Magna Carta of functionalism
61
- man-object relation 293
- man-product interaction 292
- manufacture 19ff, 46, 55, 59,
71, 77, 85, 104, 111, 151,
167, 171ff, 182, 192ff, 219,
223, 231, 258, 277, 337, 350,
381, 405, 412ff
- mapping 259, 393
- mark 11, 17, 293ff, 343, 367
- market analysis 360
- market launch 271, 337, 360
- market niche 290
- market segment 75, 97, 99,
331, 400
- marking function (Anzeichen-
funktion) 301, 313, 321ff,
405, 409
- Maserati 122
- mass communication 50, 286
- mass culture 38, 84, 179, 196,
323ff
- mass market 97, 199
- mass production 23, 31ff, 59,
107, 167, 179, 199ff, 323,
415
- mass products 25, 27, 37, 50,
61, 353, 360
- material 21, 28, 31, 91, 105,
115, 127, 133ff, 191, 230,
245, 271, 278, 285f, 290ff,
347ff, 361, 379, 387, 393,
424
- mathematical 45, 49, 228f,
246, 253f, 282, 401
- Matsushita 198f, 215
- maturity 370
- Mayflower effect 54
- Mazda 189, 202, 215

- MCC 97
- meaning 16, 19, 27, 37, 135ff, 145, 218, 226, 233ff, 245, 249, 272, 281ff, 288ff, 313, 322, 327, 337ff, 356, 360ff, 385, 389, 414, 424
- means 7, 15, 25, 43, 61, 71, 97, 105, 131ff, 165, 171, 177, 218ff, 236, 241ff, 264, 282ff, 322ff, 335, 343ff, 384, 400f, 411ff
- means of communication 57, 327
- means of design 244, 289
- means of transport 206, 231, 327
- measuring device 320
- mechanization 179
- media 7, 77, 93, 117, 120ff, 139, 177, 189, 194, 209, 243, 259, 264, 296, 347, 371, 379, 398, 400ff, 419ff
- media age 419
- media design 121, 392, 424
- medical technology 263, 383
- medicine 16, 233, 429
- medium 88, 122, 303, 350, 357, 398, 400, 421
- Memphis 7, 23, 63, 109, 133ff, 151, 215, 335, 359, 377, 379, 401
- metaphor 290, 335, 384
- metaproduct 290, 291
- method 23, 49f, 105, 167, 226ff, 236ff, 278, 282, 298, 305, 313, 325, 337, 359ff, 383, 393, 417
- methodology 49, 59, 173, 225ff, 238, 251ff, 273, 290, 326, 341, 415
- MG 75
- micro-architecture 109, 381
- microchip 199, 392
- microelectronics 173, 211, 221, 245, 321, 405, 412ff, 429
- Microsoft 185, 360f
- Miele 91
- Milan 117ff, 131ff, 147, 157, 189, 215, 223, 264, 379, 400
- mind mapping 254, 259
- Mini Cooper 75, 364
- Miniaturization 211, 429
- Minolta 202, 215
- Mitsubishi 199
- mobile 182, 212, 244, 395, 429
- model 41ff, 55, 63, 153, 156, 163, 169, 175, 183, 196, 209, 238, 255, 266, 285, 291ff, 312, 337, 357, 361, 368, 417ff
- model construction 417
- modern 16f, 27ff, 37, 47, 75, 92ff, 113, 117, 123ff, 149, 156, 183, 196, 199, 209, 218f, 228f, 243ff, 298, 312, 390
- Modern Style 23
- modernism 17, 51ff, 64, 77, 87f, 91ff, 109ff, 151, 165ff, 195, 212ff, 349, 371ff, 390, 398
- modes of behavior 239, 265, 326
- Molteni 381
- mood charts 265
- Moscow 33, 172ff
- motorcycle 109, 215
- Motorola 185
- Moulinex 153
- mountain bike 189
- movement 7, 21ff, 47, 55, 61ff, 75ff, 109, 125ff, 133ff, 151, 172, 192, 201, 230, 275, 285, 292, 369, 379, 381
- Muji 218
- Munich 7, 25, 61ff, 84, 121, 189, 250, 287, 344, 357, 400, 417
- Munich School 287
- Murano 122
- museum 7, 87, 350, 370f, 377, 381ff
- Mutech 219
- natural science 49, 149, 228, 244f, 258, 283, 322, 392
- nature 37, 43, 59ff, 172ff, 192ff, 212, 218, 228ff, 245, 251, 259, 278, 282, 295ff, 305, 335, 342, 370, 377, 384, 405
- navigation 411f, 427
- navigation systems 412
- NEC 198f, 205, 215
- needs 15, 31ff, 43, 57ff, 85, 104, 117, 177, 205, 230, 236, 259, 322, 331, 345, 374, 389
- net product 297
- New Bauhaus 27, 38
- new obscurity 64, 139, 401
- new simplicity 77, 400
- new technology 403
- New York 7, 67, 120f, 135, 169, 189ff, 368, 377
- NID (Non-Intentional Design) 271
- Niessing 91
- Nike 185, 326, 360
- Nissan 189, 215
- Nokia 163ff, 201, 218, 360
- non-material 241ff, 254, 290, 296f, 327, 349, 356, 361, 379, 411, 424
- non-materiality 379, 424
- notion of function 369
- object design 101, 198
- objective 28f, 37, 43, 62, 104, 172, 228ff, 238ff, 251, 255, 267, 273, 303, 387
- objects of utility 326
- objet-trouvé art 390
- observation 225, 287, 298, 320
- Océ 157
- OEM (Original Equipment Manufacture) 207
- Offenbach School of Design (Hfg Offenbach) 11, 47, 62, 277, 281, 292, 296, 302f, 313, 322, 405, 412
- office chair 93, 189, 231
- office communication 211, 415
- Olivetti 122ff, 139, 185, 292, 344ff, 358, 373, 383, 424f

- Olympus 215
ontic 255
Opel 97
operability 230
operating instructions 409, 412
operating structure 412
operation 16, 236, 271, 302,
320ff, 405, 414
optics 13, 211
order of production 236
organic 62, 93, 108, 183, 215,
219, 364, 371, 387, 400
orientation 93, 105, 173, 207ff,
240ff, 279, 285ff, 303, 313,
320, 357, 361, 424ff
ornamentation 108
overall visual appearance 57
overcoming 59, 63, 323
Oxo 185
- painting 13, 28ff, 45, 63, 104,
136, 149, 172, 183, 202, 403,
421
Palo Alto Products 185
papiers collés 265
paradigm 123, 252ff, 426
Paris 21, 54, 61, 93, 131, 133,
149ff, 370, 379, 398
patent furniture movement 179
Pattern Language 257, 258
perception 16, 49, 229, 238,
245ff, 285ff, 367, 393
perception research 298
perception theory 296
Peugeot 153, 205
phenomena 37, 77, 113, 227,
234, 240ff, 273, 283, 295,
299, 368, 383, 405, 420
phenomenology 230, 240ff,
250
Philadelphia 21
Philips 57, 157, 173, 189, 264,
337, 356ff, 395, 427
philosophy 17, 21, 37, 149,
195, 219, 226ff, 240ff, 288,
322, 329, 345, 353, 370ff,
384, 389, 421
philosophy of life 37, 245
- Piaggio 122
planning 17, 31, 51, 136, 203,
257ff, 263, 358, 367
plastic 99, 113, 151, 163
pluralism 16, 369
polyhedral geometry 49
pop 51, 57, 75, 83, 177, 192,
215, 429
porcelain 73ff, 107, 163, 206
Porsche 99, 109, 219, 331
positivist 385
post-alphabetic society 413
postmodernism 16, 55, 63f, 77,
104, 131, 151, 196, 237, 254,
257, 266, 321ff, 335, 353ff,
368f, 373ff, 381ff, 401, 426
post-structuralism 341
potential for innovation 259
Pott 91
practice 17, 25, 31, 37, 41, 59,
62, 91, 104, 105, 145, 183,
201, 203, 227, 250ff, 266,
276, 279, 283, 291f, 296,
299, 345, 357, 363, 367, 374,
403, 413
Prada 67, 121, 191, 377
pragmatism 195, 233ff, 288,
291, 341
precedents 291f, 313
precision 49, 117, 211, 301,
320
principle of design 313, 373
probability 401
problem of design 258
problem structures 253
problem-solving 182, 228, 256,
259, 281
process 7, 11, 19ff, 63, 73,
117, 131ff, 175, 203ff, 211f,
218, 225f, 235ff, 247ff, 265,
282ff, 293ff, 313, 321ff,
335ff, 346, 358, 360, 370,
395, 403ff, 420
process of communication 239
process of construction 238
process of design 253, 273,
325, 335
process of interpretation 247
- processing power 403
product aesthetics 291
product appearance 313
product clinics 271
product concept 101, 122,
219, 227, 393ff, 429
product culture 57, 84, 99,
103, 113, 153, 163, 171, 179,
192, 207, 239, 424
product development 71, 73,
179, 189, 194ff, 250, 259,
263ff, 277, 290ff, 303, 321,
326, 350, 358ff, 419
product field 265, 395, 415
product function 157, 313, 361
product graphics 303
product group 97, 241
product identity 107
product information 285
product language 16, 47, 87ff,
191, 215, 239, 243, 282ff,
313, 320ff, 341, 409ff
product line 55, 57, 171, 205,
337, 350, 356, 361
product policy 85ff, 167
product sculpture 335
product semantics 103, 191,
291, 337ff, 341
product standardization 25
product system 50, 84, 293,
343, 407
product world 320, 361, 409,
411, 414
production 15ff, 49ff, 59, 67,
71ff, 99, 113, 136, 147, 151,
156, 171ff, 195ff, 203ff,
225ff, 278, 341, 415, 421
professional piracy 370
prognosis 47, 233, 289
prognostic 233, 263
progress 16, 51, 75, 84, 104,
125, 182, 189, 195, 202, 212,
245, 255f, 293ff, 323, 405ff
progression of knowledge 289
project management 358
promotion of design 103, 223
prototype 113, 415ff
PSA 153

- psychology 33, 45, 245, 289,
295ff, 321
- public design 147, 156, 192ff,
293
- public relations 109
- public spaces 85, 392
- Puig 147
- Puma 326, 360
- radical constructivism 238
- radical design 109, 133, 137,
218, 389
- radio 50, 157, 173, 179, 211,
337, 390, 393
- rationalism 21, 41ff, 92, 111,
125, 133, 156, 172ff, 229,
249, 253, 381ff
- rationalization 169, 254
- Ray Ban 185
- ready-made 67, 390
- real sciences 255
- reality 230, 245, 255, 258, 279,
286, 369, 381, 429
- reason 21, 226ff, 237, 245ff,
254, 259, 281, 312, 325ff,
420
- Re-Braun 392
- recognition 92f, 111, 139, 192,
221ff, 247, 250
- recognizability 225
- recycling 16, 62
- recycling design 62
- Red Books 123, 347
- Re-Design 136
- reduction 25, 240, 250, 413
- reference to the human body
320
- referential 234
- reflection 67, 191, 227, 282,
292ff
- reform movement 21, 28
- relation 93, 212, 233ff, 290,
295, 321, 326, 335, 357, 405
- relationship 15, 17, 104, 173,
237, 247, 253f, 285, 292,
296, 320, 337, 358
- remote control 243, 407
- Renaissance 120
- Renault 153
- rendering 256
- repertoire of methods 256
- representation 19, 49, 88, 97,
149, 189, 234, 240, 245, 279,
293ff, 320, 339, 371, 409,
413
- research 11, 38, 46, 173,
202ff, 241ff, 263ff, 292,
298ff, 329, 350, 359, 392ff,
414, 419ff
- retro wave 400
- revolution 73, 172, 385
- revolutionary milestone 323
- rice cooker 219
- Rimowa 91
- Rinnai Korea 219
- Rio de Janeiro 54, 196, 198
- Roca 147
- Rollei 173
- rollerblades 327
- Rosenthal 75, 157, 165
- Röthlisberger 117
- Rover 75, 331
- Rowenta 92, 153
- rule 345, 415
- rules of transformation 236
- Russia 27, 28, 172ff, 266, 385
- Russian Bauhaus 28
- Saab 171
- Sampo 223
- Samsonite 185
- Samsung 111, 199ff, 219
- Sandvik 171
- satisfying needs 290
- Sawaya & Moroni 375
- Scandinavia 103, 125, 163ff,
192, 290
- Scenario 263
- scholarliness 279
- science 13, 17, 29, 37, 45, 51,
203, 226ff, 240ff, 254ff, 266,
277, 280ff, 298ff, 335, 371,
414, 426ff
- science fiction 389, 429
- science of design 29
- science of mental life 298
- science of perception 299, 303
- science theory 277
- scientific 13, 45ff, 61, 104,
173, 195, 226ff, 238, 245ff,
254ff, 271, 277, 280ff, 297f,
325, 373, 387, 414
- scientific community 280
- scissor principle 390
- scooters 327
- Scotland 27
- screen design 361, 411
- screen layout 357, 409
- sculptural 133, 183, 212
- seating furniture 31, 179, 381
- SEB 88, 92, 153
- Secession Style 23
- semantic added value 285ff
- semantic transfer 337
- semantic turn 426
- semantics 105ff, 117, 127ff,
151, 219, 235ff, 249, 265,
285ff, 335ff, 426
- semiology 233
- semiotic terms 297
- semiotics 45, 59, 136, 191,
227ff, 249, 282ff, 313, 326ff,
337ff, 341, 368ff
- semiotics and architecture 236
- semiotization of the environ-
ment 237
- sense 16f, 31, 63, 83, 92, 121,
139, 183, 191, 225, 233ff,
256, 277f, 288, 293ff, 345,
353ff, 383f, 390, 412ff
- sense of space 384
- sensory 84, 229, 241ff, 285ff,
291, 297ff, 379, 429
- sensuality 139, 281ff, 292, 335
- series production 64, 107, 113,
167, 185, 353
- Shaker 179, 343
- shape 59, 83, 169, 172, 192,
257, 277, 287, 293ff, 343ff,
381, 400, 417ff
- Sharp 111, 198, 215
- shop fittings 109, 151, 191
- Siemens 92, 199, 201, 344,
349, 357, 360, 383

- sign 11, 16, 50, 233ff, 288ff,
 298, 322ff, 368, 414
 sign functions 298
 sign management 289
 sign process 237
 sign system 50, 289, 325, 329
 sign user 288
 sign worlds 325
 signal 282, 291
 significance 19, 25, 47, 84, 93,
 107, 135, 185, 313, 343, 360,
 413
 simplicity 27, 107, 165ff, 177,
 218, 371, 414
 simulation 64, 415
 Singer 23, 202
 Slöjdförenigen 25
 Smart 93, 97, 120, 189, 364ff,
 415
 smell 120, 285, 293
 SMH group 97, 117
 sneakers 329, 393
 social sciences 250
 socialization 286, 325
 society 11, 15f, 21ff, 61, 85,
 104f, 122, 135f, 179ff, 236,
 259, 263ff, 276f, 286f, 327,
 385ff, 421
 socio-cultural 71, 77, 135, 206,
 223, 238, 251, 312, 323ff,
 395
 sociology 45, 73, 266, 289,
 326ff, 379
 software 7, 16, 83, 185ff, 201,
 258f, 264ff, 271, 296, 321f,
 339, 343, 356f, 390ff, 409ff,
 424
 software design 357, 390, 424
 Sony 185, 191, 198, 201ff,
 241, 360, 393
 sound design 285
 South America 195
 space 11, 19, 67, 108, 113,
 179, 192, 195, 241, 252, 272,
 279, 335, 370, 375, 377,
 384ff, 390ff
 space travel 11, 192, 387
 spaceship 135
 Spain 11, 145ff, 371ff
 specifications 256
 speech recognition 392
 speechlessness 370
 spirit of invention 115, 177
 sporty 364
 SSS Siedle 92
 stability 31, 91, 320
 stage design 51, 381, 421
 standard 17, 37, 73, 84, 163,
 169, 201, 212, 231, 271, 292,
 299, 301, 349, 414
 standardization 23, 107, 236,
 412
 status 41, 47, 51, 91, 97ff,
 111, 133, 196, 218, 267, 280,
 286f, 291, 346, 367, 371, 414
 status symbol 97, 287, 326
 steel 21, 31, 163, 169, 203ff,
 373
 steel furniture 107, 206
 Steelcase 185
 stewards of the disciplines 281
 stone 384
 story networking 420
 strategic design 171, 296, 344,
 417
 strategic management 400
 strategy 7, 93, 171, 194, 198f,
 205, 221, 227, 241, 249, 296,
 321, 344ff, 356ff, 363ff, 400,
 417
 streamline decade 179, 182,
 183
 streamlined shape 15
 stringency 57, 370, 384
 structuralism 234f, 295, 326,
 341, 368
 structure 19, 41, 91, 145, 224,
 228, 236, 253, 259, 285ff,
 301, 326, 337, 345, 371, 384,
 426
 Strum 133ff, 389
 student protest movements 61,
 131
 Stuttgart 25, 47, 61, 84, 105,
 111, 235ff, 275, 373, 383
 style 19, 23, 57ff, 67, 105,
 115, 125, 137ff, 151, 177,
 191ff, 202, 323, 353, 381ff
 style configuration 361
 style element 57
 style mapping 361
 style principle 254
 styling 15, 177, 182, 183, 192,
 209, 215, 329, 341
 Sun 185, 209
 Sunbeam 185
 Superstudio 131ff, 385, 389
 surface 61, 271, 285, 303, 414
 SUV (Sports Utility Vehicle) 99,
 175, 331, 399
 Suzuki 215
 Swarovski 111
 Swatch 117, 360
 Swatchization 117
 Sweden 85, 157, 167ff, 201
 Swid Powell 379
 Switzerland 25ff, 41, 54, 97,
 111ff, 241, 350, 357, 371,
 384, 424
 symbol 47, 59, 99, 127, 171,
 182, 212, 231, 240f, 285f,
 291ff, 305, 320ff, 361, 379,
 384f, 401, 407, 411
 symbol theory 293, 299
 syntax 235ff, 288, 291, 297
 synthesis 33, 51, 91, 172, 192,
 215, 229, 230, 345
 system 101, 153, 173, 179,
 192ff, 215, 234ff, 250ff, 296,
 321, 343, 371ff, 381, 390,
 415, 419
 system design 46, 85, 87, 88,
 91, 92, 113, 145, 392
 system furniture 115
 systems theory 226, 358
 Taiwan 71, 177, 198, 206,
 223f, 346
 talking furniture 231
 tamagotchi 244
 target 153, 221, 250ff, 266,
 275, 349, 361ff
 target condition 252, 255

- target group 153, 250, 257,
266, 349, 361ff
- taste 182, 285
- Tatung 223
- techné hermeneutiké 244
- technical 13ff, 21, 27, 45, 50,
55, 73, 84f, 91ff, 104, 115ff,
125, 136, 156, 167, 171ff,
182f, 209ff, 230ff, 252, 277,
283, 293, 305, 312, 320, 335,
349, 360, 381, 407ff, 425, 429
- technical aesthetics 27
- technical development 15
- techno scene 329
- technological revolution 401
- technology 16, 28ff, 37f, 45,
50, 57, 73ff, 91, 111, 117,
125, 131, 147, 163, 167, 172f,
182, 189, 194ff, 209ff, 221ff,
231ff, 243ff, 254f, 273ff, 292,
297, 312, 323, 326, 335, 344,
364, 374, 377, 385, 390ff,
400ff, 413, 424ff
- Tecta 63, 92
- teen culture 329
- Tefal 153
- telecommunications 7, 117,
163, 165, 171, 198ff, 209,
238, 393
- telematic systems 285
- television 50, 127, 157, 194,
211, 243, 344, 393ff, 419
- test market 215
- test procedures 256, 271
- textile designer 165
- theoretical 31, 46f, 61ff, 75,
103ff, 141, 172f, 191ff, 226,
234, 240ff, 289, 292ff, 356,
368ff, 381
- theoretical research 131, 300
- theory 17, 29, 41ff, 59, 62ff,
104f, 131, 191, 225ff, 255,
273ff, 313, 325ff, 361, 367,
401, 421
- thesis 230, 238, 289, 296ff
- thing 37, 73, 133, 227, 230ff,
243, 254ff, 293, 313, 345,
364, 419, 425
- things of nature 231
- Think Map 259
- Thomson 153, 185
- Thonet 23, 31, 107, 111, 117,
374
- throne 64, 231, 236
- ticket machine 287, 321
- timber construction 108, 212
- timeless design 335
- tool 59, 87, 113, 173, 182,
264, 321, 359, 403
- Toshiba 199, 215
- totality 16, 73, 115
- Toyota 202, 215
- trade fairs 7, 104, 202, 221,
349, 400
- trademark 38, 343, 349, 360ff
- trademark image 360
- transcendental 240
- trans-classical science 255
- transformation 7, 37, 135f,
206f, 224, 297
- transistor 211
- transmitter 238, 337
- transparent factory 11
- transport 11, 73, 103, 113,
179, 203ff, 251, 287, 321,
364, 403, 415
- trend 19, 49, 59, 202, 361,
395ff, 427
- trend analyst 395
- trend gurus 400
- trend scouts 400
- triadic relation 234, 287
- Triumph 75
- TTT (Things That Think) 419
- tubular steel furniture 31, 59,
107, 113ff, 145, 156, 165
- Tupperware 185
- TV 407
- type furniture 38
- typewriter 103
- typography 50, 111, 392, 414
- typology 235, 295
- Tyrolia 111
- ubiquitous computing 427
- Ulm functionalism 254
- Ulm School of Design (HfG Ulm)
27, 37ff, 84ff, 92f, 113, 122,
145, 191, 195f, 226, 235ff,
251ff, 275f, 280, 291, 312,
335ff, 358, 387, 420
- Ulm style 47
- Umbra 194
- understanding 11, 29, 62, 77,
115, 165, 192, 212, 229ff,
244ff, 282, 320, 325, 363,
387, 411, 425
- Unifor 381
- uniformity 305, 373
- unity 27f, 37, 57, 105, 125,
229, 234, 245, 249ff, 281,
299, 300, 344ff, 374
- universality 195, 234, 245,
250, 291, 401, 412
- urban planning 61, 73, 113ff,
156, 192, 236, 303, 367, 381
- USA 266
- usability 271, 358, 412ff
- use 13, 16, 27, 57, 67, 71, 83,
99, 105, 108, 115, 127,
133ff, 163, 189, 192, 211,
234ff, 264, 271ff, 292, 297,
320ff, 335, 339ff, 357, 360,
367, 370, 377, 383, 401, 405,
411ff, 424
- use value 61
- user 7, 15, 57, 131, 231ff 266,
288, 320ff, 333,ff367, 398,
405, 413, user interface 259,
264, 321f, 350, 357, 390,
407ff, 427
- USM 115
- utensil 237, 251
- utilitarian objects 177
- utilitarianism 21, 25
- utilitas 17
- utility objects 67
- utility value 342
- utopia 387ff
- value 104, 145, 201, 218, 231,
236, 266, 278, 292ff, 343
- value creation 361
- value orientation 266

- vanguardia movement 145
- variability 97, 373
- variety 16, 125, 221, 239, 243, 292, 350ff, 369
- velocity 375
- Venice 108, 157, 381
- video 211, 243, 392ff, 407, 412
- Vienna 21ff, 107ff, 373ff
- Vienna Secession 23
- Viessmann 92, 344
- virtual reality 417
- vision 165, 375, 387ff, 419
- visual communication 41, 117, 235, 303, 344, 424
- visual design 41, 83, 91
- visual turn 413ff, 426
- visualization 23, 41ff, 83ff, 111, 117, 135, 156, 171, 183, 235, 240, 264f, 273, 291, 296ff, 313, 320, 339, 342ff, 357, 361, 374, 407ff, 424ff
- Vitra 117, 141, 153, 350, 360, 370ff
- VKhuTeMas 28, 172
- Volkswagen 11, 97ff, 205, 258, 290, 331, 364
- Volvo 157, 171, 331
- Walkman 185, 212, 241, 393
- way of life 45, 167, 179, 206ff, 264
- wearables 393, 429
- Wedgwood 75
- Weimar 27ff, 37, 105, 172, 421ff
- Werkbund 19, 25, 75, 91, 107, 111, 121, 156, 169
- Werkkunst 226, 254
- Whirlpool 198
- Wilkhahn 93, 156, 344
- Wittmann 111
- Woodnotes 165
- work of art 13, 25, 236, 375, 383
- workplace 231, 373, 383ff, 414
- world of signs 237
- Xerox 185, 347
- Yamaha 111, 205, 215
- Zanotta 117, 141
- Zanussi 292
- Zirkeltraining group 392