

WOODHEAD PUBLISHING IN TEXTILES

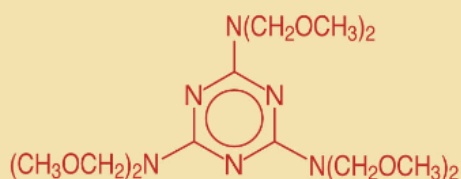

# Chemical finishing of textiles

W. D. Schindler and P. J. Hauser



The Textile Institute

WP

# Chemical finishing of textiles

---

W. D. Schindler and P. J. Hauser



The Textile Institute



CRC Press  
Boca Raton Boston New York Washington, DC

WOODHEAD PUBLISHING LIMITED

Cambridge England

Published by Woodhead Publishing Limited in association with The Textile Institute  
Woodhead Publishing Ltd  
Abington Hall, Abington  
Cambridge CB1 6AH, England  
www.woodhead-publishing.com

Published in North America by CRC Press LLC  
2000 Corporate Blvd, NW  
Boca Raton FL 33431, USA

First published 2004, Woodhead Publishing Ltd and CRC Press LLC

© 2004, Woodhead Publishing Ltd

The authors have asserted their moral rights.

This book contains information obtained from authentic and highly regarded sources. Reprinted material is quoted with permission, and sources are indicated. Reasonable efforts have been made to publish reliable data and information, but the authors and the publishers cannot assume responsibility for the validity of all materials. Neither the authors nor the publishers, nor anyone else associated with this publication, shall be liable for any loss, damage or liability directly or indirectly caused or alleged to be caused by this book.

Neither this book nor any part may be reproduced or transmitted in any form or by any means, electronic or mechanical, including photocopying, microfilming and recording, or by any information storage or retrieval system, without permission in writing from the publishers.

The consent of Woodhead Publishing and CRC Press does not extend to copying for general distribution, for promotion, for creating new works, or for resale. Specific permission must be obtained in writing from Woodhead Publishing or CRC Press for such copying.

Trademark notice: Product or corporate names may be trademarks or registered trademarks, and are used only for identification and explanation, without intent to infringe.

British Library Cataloguing in Publication Data

A catalogue record for this book is available from the British Library.

Library of Congress Cataloging in Publication Data

A catalog record for this book is available from the Library of Congress.

Woodhead Publishing ISBN 1 85573 905 4

CRC Press ISBN 0-8493-2825-X

CRC Press order number: WP2825

The publisher's policy is to use permanent paper from mills that operate a sustainable forestry policy, and which have been manufactured from pulp which is processed using acid-free and elementary chlorine-free practices. Furthermore, the publisher ensures that the text paper and cover board used have met acceptable environmental accreditation standards.

Typeset by Ann Buchan (Typesetters), Shepperton, Middlesex

Printed by TJ International, Padstow, Cornwall, England

# Contents

---

<i>Preface</i>	ix
<b>1 Introduction to chemical finishing</b>	<b>1</b>
1.1 Wet and dry or chemical and mechanical finishing	1
1.2 The challenge and charm of chemical finishing	2
1.3 Importance of chemical finishing	4
References	6
<b>2 Chemical finishing processes</b>	<b>7</b>
2.1 Introduction	7
2.2 Application of chemical finishes	8
2.3 Drying wet textiles	20
2.4 Curing chemical finishes	21
2.5 Coating and laminating	23
References	26
Appendix	27
<b>3 Softening finishes</b>	<b>29</b>
3.1 Introduction	29
3.2 Mechanisms of the softening effect	29
3.3 Typical softened textiles articles	31
3.4 Product types and their chemistry	31
3.5 Schematic comparison of important properties of softeners	36
3.6 Compatibility and combinability	36
3.7 Evaluation and testing methods	38
3.8 Particulars of and troubleshooting for softening finishes	39
References	41
<b>4 Hand building finishes</b>	<b>43</b>
4.1 Introduction	43
4.2 Definitions and terms	43

4.3	The hand building effect	44
4.4	Examples of textiles with hand building finishes	44
4.5	Typical hand builder chemistry	44
4.6	Evaluation methods	48
4.7	Troubleshooting for hand building finishes	50
	References	50
<b>5</b>	<b>Easy-care and durable press finishes of cellulose</b>	<b>51</b>
5.1	Introduction	51
5.2	Mechanisms of easy-care and durable press finishing	52
5.3	Examples of textiles with easy-care and durable press finishes	54
5.4	Chemistry of easy-care and durable press finishes	55
5.5	Application methods	64
5.6	Compatibility with other finishes	67
5.7	Evaluation methods	67
5.8	Troubleshooting and practical problems	69
	References	72
<b>6</b>	<b>Repellent finishes</b>	<b>74</b>
6.1	Introduction	74
6.2	Mechanisms of repellency	75
6.3	Repellent chemistry	76
6.4	Evaluation of textiles treated with repellent finishes	84
6.5	Troubleshooting for repellent finishes and particularities	84
	References	85
<b>7</b>	<b>Soil-release finishes</b>	<b>87</b>
7.1	Introduction	87
7.2	Mechanisms of soil release	87
7.3	Soil-release chemistry	91
7.4	Evaluation of soil release	95
7.5	Troubleshooting for soil-release finishes	96
	References	97
<b>8</b>	<b>Flame-retardant finishes</b>	<b>98</b>
8.1	Introduction	98
8.2	Mechanisms of flame retardancy	98
8.3	Flame-retardant chemistry	102
8.4	Flame retardants for cellulose	103
8.5	Flame retardants for wool	108
8.6	Flame retardants for polyester	109
8.7	Flame retardants for nylon	110
8.8	Flame retardants for other fibres	111

8.9	Flame-retarding fibre blends	111
8.10	Novel approach to flame retardancy: intumescent	112
8.11	Evaluation of flame retardants	112
8.12	Troubleshooting for flame-retardant finishes and particularities	115
	References	116
<b>9</b>	<b>Non-slip finishes</b>	<b>117</b>
9.1	Introduction	117
9.2	Mechanisms of non-slip finishes	118
9.3	Chemistry of non-slip finishes	118
9.4	Application methods and combinability	118
9.5	Evaluation of non-slip finishes	119
9.6	Troubleshooting for non-slip finishes	120
	References	120
<b>10</b>	<b>Antistatic finishes</b>	<b>121</b>
10.1	Introduction	121
10.2	Mechanisms of antistatic finishes	123
10.3	Chemistry of antistatic finishes	123
10.4	Conductive fibres	125
10.5	Evaluation of antistatic finishes	126
10.6	Troubleshooting for antistatic finishes and particularities	127
	References	128
<b>11</b>	<b>Anti-pilling finishes</b>	<b>129</b>
11.1	Introduction	129
11.2	Pilling mechanism	129
11.3	Mechanisms and chemistry of anti-pilling finishes	132
11.4	Evaluation of anti-pilling finishes	133
11.5	Troubleshooting for anti-pilling finishes and compatibility	134
	References	136
<b>12</b>	<b>Elastomeric finishes</b>	<b>138</b>
12.1	Introduction	138
12.2	Elastomeric mechanism	139
12.3	Chemistry of elastomeric finishes	139
12.4	Evaluation of elastomeric finishes	141
12.5	Troubleshooting for elastomeric finishes and particularities	142
	References	142
<b>13</b>	<b>Finishes to improve colour fastness</b>	<b>144</b>
13.1	Introduction	144
13.2	Improved wet fastness	144

13.3	Improved light fastness	149
13.4	Improved crocking and rubbing fastness	153
	References	155
<b>14</b>	<b>Ultraviolet protection finishes</b>	<b>157</b>
14.1	Introduction	157
14.2	Mechanism of UV protection	158
14.3	Chemistry of UV protection finishes	160
14.4	Evaluation of UV protection finishes	162
14.5	Troubleshooting for UV protection finishes and combinability	163
	References	163
<b>15</b>	<b>Antimicrobial finishes</b>	<b>165</b>
15.1	Introduction	165
15.2	Properties of an effective antimicrobial finish	166
15.3	Mechanisms of antimicrobial finishes	166
15.4	Chemistry of antimicrobial finishes	167
15.5	Evaluation of antimicrobial finishes	171
15.6	Troubleshooting for antimicrobial finishes	172
	References	174
<b>16</b>	<b>Insect resist and mite protection finishes</b>	<b>175</b>
16.1	Introduction	175
16.2	Mechanisms of insect resist finishes	175
16.3	Chemistry of insect resist finishes	177
16.4	Application of insect resist finishes	178
16.5	Evaluation of insect resist finishes	178
16.6	Troubleshooting for insect resist finishes	178
16.7	Finishes for protection from dust mites	179
	References	179
<b>17</b>	<b>Finishing with enzymes: bio-finishes for cellulose</b>	<b>181</b>
17.1	Introduction	181
17.2	Action of cellulase enzymes on cellulose	183
17.3	Chemistry of enzyme finishing	184
17.4	Evaluation of bio-finishing	186
17.5	Troubleshooting for bio-finishing	186
	References	187
<b>18</b>	<b>Novel finishes</b>	<b>189</b>
18.1	Introduction	189
18.2	Anti-odour and fragrance finishes	189

18.3	Fibre surface modifying finishes using plasma and radiation technologies	193
18.4	Fibre surface modification by sol–gel finishes with inorganic oxide films	194
	References	197
<b>19</b>	<b>Actual and future trends in chemical finishing</b>	<b>198</b>
19.1	Introduction	198
19.2	Cost reduction and greater efficiency	198
19.3	New kinds of effects	198
19.4	Fewer undesirable side effects	200
19.5	Easier application	200
19.6	Microencapsulation, a new trend for storage and release of active finishing products	200
19.7	Greater permanence in washing and chemical cleaning	201
19.8	Easier care of the finished textiles	202
19.9	Better ecology	202
19.10	Using fewer chemicals	203
19.11	Smart textiles by chemical finishing	204
19.12	Summary and outlook	205
	References	206
	<i>Index</i>	207

In grateful appreciation of their unwavering support and many sacrifices,  
we dedicate this book to our wives, Helga and Helen.

## Preface

---

In final chemical finishing, with its great range of desired and undesired effects, the task of a textile finisher can become demanding. He or she has to consider the compatibility of the different types of finishing products and treatments, in particular their mutual influence on the desired effects. With about 20 different types of chemical finishes and several thousand finishing agents, most of which are combined to give one-bath multipurpose finishes, chemical finishing needs a solid basis of textile chemical knowledge and technical understanding as well as some practical experience. This book aims to fulfil some of these requirements.

It is anticipated that this book on the chemical finishing of textiles will appeal particularly to finishing plant management, process engineers, technologists, qualified practitioners and foremen; representatives and co-workers of the textile chemical industry, textile research and testing institutes, quality inspectors, textile machinery makers; chemist colourists, clothing manufacturers, textile designers, dry cleaners, buyers, sales personnel, wholesalers and last but not least students, lecturers and teaching staff of textile chemistry and finishing as well as of related subjects. The presentation of this compact description of all important types of chemical finishing might be especially useful for advanced undergraduates. This book stresses fundamentals rather than specific recipe and procedure proposals, which are often provided by the finish producers. The interplay between chemical structures and the effects of finishing products is a central concern of this book. Readers without a deeper chemical interest may especially profit from the discussions of typical advantages and disadvantages, application conditions, compatibility and combinability, testing methods and practical tips about every important type of chemical finish.

The idea for this book started with a comprehensive lecture script on chemical finishing from the University of Applied Sciences Hof/Münchberg, that was translated into English during the stay of Professor Schindler as a guest at the College of Textiles of the North Carolina State University. There the authors met and planned to fill a gap in the market with an actual, compact and clearly understandable survey on chemical finishing of textiles in the form of a small

textbook focusing on the interaction of the underlying chemistry and technology with the textile fabric.

The authors want to thank their colleague Professor Gary N. Mock for constant support and encouragement and Woodhead Publishing Limited, especially Ms Emma Starr, for very friendly and inspiring cooperation. We also thank the *International Textile Bulletin*, for leaving us the copyright for two corresponding publications on softening and hand building finishes in issues 2 and 4 in 2003.

We welcome suggestions and comments and hope that this book might be useful for all those who enjoy the charm and the demanding challenge of chemical finishing for textiles.

*Prof. Wolfgang D. Schindler*  
*University of Applied Sciences Hof*  
*Department Münchberg, Germany*

*Prof. Peter J. Hauser*  
*North Carolina State University*  
*Raleigh, North Carolina, USA*

## 1.1 Wet and dry or chemical and mechanical finishing

Textile wet processing can be thought of having three stages, pretreatment (or preparation), coloration (dyeing or printing) and finishing. Finishing in the narrow sense is the final step in the fabric manufacturing process, the last chance to provide the properties that customers will value. Finishing completes the fabric's performance and gives it special functional properties including the final 'touch'.

But the term finishing is also used in its broad sense: 'Any operation for improving the appearance or usefulness of a fabric after it leaves the loom or knitting machine can be considered a finishing step'.<sup>1</sup> This broad definition includes pretreatments such as washing, bleaching and coloration. In this book the term finishing is used in the narrow definition to include all those processes that usually follow coloration and that add useful qualities to the fabric, ranging from interesting appearance and fashion aspects to high performance properties for industrial needs. This definition may be applied to similar finishing processes for grey fabrics (without coloration). Bleaching and carbonisation are chemical treatments that also improve the quality of fabrics. They are not treated in this book because they belong typically in pretreatment, although there are rare exceptions.

Most finishes are applied to fabrics such as wovens, knitwear or nonwovens. But there are also other finishing processes, such as yarn finishing, for example sewing yarn with silicones and garment finishing (see Chapter 2.2.5). Textile finishing can be subdivided into two distinctly different areas, chemical finishing and mechanical finishing. Chemical finishing or 'wet finishing' involves the addition of chemicals to textiles to achieve a desired result (see Chapter 2). Physical properties such as dimensional stability and chemical properties such as flame retardancy can both be improved with chemical finishing. Typically, the appearance of the textile is unchanged after chemical finishing. Mechanical finishing or 'dry finishing' uses mainly physical (especially mechanical) means to change fabric properties and usually alters the fabric appearance as well. Mechanical finishing also encompasses thermal processes such as heat setting (thermal finishing). Typical

mechanical finishes include calendering, emerising, compressive shrinkage, raising, brushing and shearing or cropping, and especially for wool fabrics milling, pressing and setting with crabbing and decatizing. A summary of mechanical finishing has recently appeared.<sup>2</sup>

Often mechanical and chemical finishing overlap. Some mechanical finishes need chemicals, for example milling agents for the fulling process or reductive and fixation agents for the decatizing of wool fabrics. On the other hand chemical finishing is impossible without mechanical assistance, such as fabric transport and product application. The assignment to mechanical or chemical finishing depends on the circumstance, if the major component of the fabric's improvement step is more mechanical- or chemical-based.

This book will focus on the chemical finishing of textiles, the application of relatively minor amounts of chemicals (often  $< 5 \text{ g m}^{-2}$ ) to, in most cases, both sides of the fabric. Subsequent chapters will discuss the importance of each specific finish, the chemical mechanism for the effect, the chemicals used to provide the desired properties, the application and fixation procedures, the relevant evaluation methods and trouble shooting tips. Processes that employ high levels of chemical application ( $15\text{--}50 \text{ g m}^{-2}$  and more), primarily as one-sided treatments, such as coating are addressed only briefly in Chapter 2.

## 1.2 The challenge and charm of chemical finishing

The proper formulation of chemical finishes requires consideration of several important factors: the type of textile being treated (fibre and construction); the performance requirements of the finish (extent of effect and durability); the cost to benefit ratio; restrictions imposed on the process by availability of machinery, procedure requirements, environmental considerations; and compatibility of different formula components as well as the interaction of the finishing effects.

To bring all these parameters to an acceptable compromise is not easy, even for a single purpose finish. But usually several types of finishes are combined for economical reasons mostly in one bath (only one application and drying process). This is often the hardest challenge of chemical finishing. First, all components of the finish bath must be compatible. Precipitations of anionic with cationic products have to be avoided. The emulsion stability of different products may be reduced by product interactions. More difficult is often the second hurdle, the compatibility of the primary and secondary effects of the different types of finishes that are being combined:

- Some effects are similar or assist each other, for example silicone elastomers cause water repellency, softeners bring about antistatic effects and antistatic finishes can be softening.
- Some effects are obviously contradictory, for example hydrophobic finishes and hydrophilic antistatic finishes, or stiffening and elastomeric finishes, or stiffening and softening finishes.

Table 1.1 General requirements of chemical finishes

---

Primary effects of finishes	<ul style="list-style-type: none"> <li>• High effect level at low cost for products and application</li> <li>• Possible effect design, adaptation to customer wishes, article demands and favoured use</li> </ul>
Desired secondary effects	<ul style="list-style-type: none"> <li>• Usable for all kind of fibres and all textile forms, as yarn, woven or knit fabric, garment, nonwovens</li> <li>• High permanence for washing and dry cleaning for garments and most household textiles</li> <li>• No loss of important textile qualities such as tear strength and abrasion resistance, comfort, appearance, hand</li> <li>• No yellowing of undyed fabrics, no shade change of coloured ones, no reduced colour fastness</li> <li>• Easy and safe handling, non-flammable</li> <li>• Simple application, preferably with several standard methods and equipment at low cost</li> <li>• High stability under storage and application conditions (temperature, pH, mechanical stress)</li> <li>• Even distribution, either on the fibre or fabric surface or inside the fabric</li> <li>• Compatibility with other finishes</li> <li>• Synergistic effects, no reduction of effect of other finishes</li> <li>• Easy correction of finishing faults such as removal of finish or stains</li> <li>• No environmental problems, non-toxic, biodegradable, no volatile organic compounds</li> </ul>

---

- Other types of finishes typically reduce the main effect of a finish type, for example the flame retardant effect is decreased by nearly all other types of chemical finishes as they add flammable components to the fabric.
- Fortunately true antagonistic effects are rare, but true synergistic effects are also rare, where the resulting effect of a combination is greater than the sum of the single effects of the combined products. Examples of both cases are different types of flame retardants.

Thus the finisher is glad when the combined products do not interfere, neither in the finishing bath nor on the fabric, with all their different effects, but this usually is the exception rather than the rule.

This discussion of the interaction of the primary effects of the combined products can be expanded to their secondary effects, the desired and the undesired ones. Obviously this task quickly approaches confusion. It is not surprising that successful chemical finishing is sometimes thought of as being nearly magical. As Rouette wrote in *Fundamentals of Textile Finishing*:

Nowhere in textile finishing does the formulation of recipes need such a

special knowledge, almost comparable to a secret science, than in chemical finishing.<sup>3</sup>

Table 1.1 gives some of the general requirements expected of a chemical finish. As can be seen, they can be quite daunting. One future challenge for chemical finishing is the ever increasing concern over environmental and ecological issues. Traditional chemistries and manufacturing methods must be changed and modified to meet the new realities of our modern world.

Thus it is not surprising that an expert system was developed (TEXPERTO from Clariant), where the experience of many finishing experts is combined in a software program that enables less experienced finishers to create successful finishing recipes interactively with a computer. This computer-aided generation of recipes starts with detailed questions about the textile article to be finished, followed by a profile of requirements for the chemical finish. Included are questions concerning restrictions, for example cost limits, available machinery, process steps and environmental limitations. This expert system incorporates most of the different requirements and factors that have to be considered when formulating a demanding finishing recipe.

This recipe formulation is not only a challenge but also a charming task. For those finishers who have the knowledge and some experience, chemical finishing is an inspiring and fascinating job, where the interaction of chemical understanding, technical grasp, textile feeling and an instinct for market trends leads to considerable success and increased value (both in the worth of the finished fabric and in the esteem of the finish designer).

### 1.3 Importance of chemical finishing

Chemical finishing has always been an important component of textile processing, but in recent years the trend to 'high tech' products has increased the interest and use of chemical finishes. As the use of high performance textiles has grown, the need for chemical finishes to provide the fabric properties required in these special applications has grown accordingly.

The amount of textile chemical auxiliaries sold and used globally in one year is estimated to be about one-tenth of the world's fibre production. With fibre production currently at 60 million tonnes, about 6 million tonnes of chemical auxiliaries are consumed. The percentage of market share of textile auxiliaries is shown in Fig. 1.1. About 40 % of textile auxiliaries are used in finishing, the largest percentage usage of all textile chemicals, followed by dyeing and printing auxiliaries and pretreatment chemicals. Within the textile finishing group, the product breakdown, based on TEGEWA,<sup>4</sup> is given as a survey in Fig. 1.2 and given in more detail in Table 1.2. Softeners are clearly the most important individual product group. In terms of value, the repellent group is the leader with the highest ratio of cost per amount. This reflects the relatively high cost of the fluorochemical subgroup of repellents.

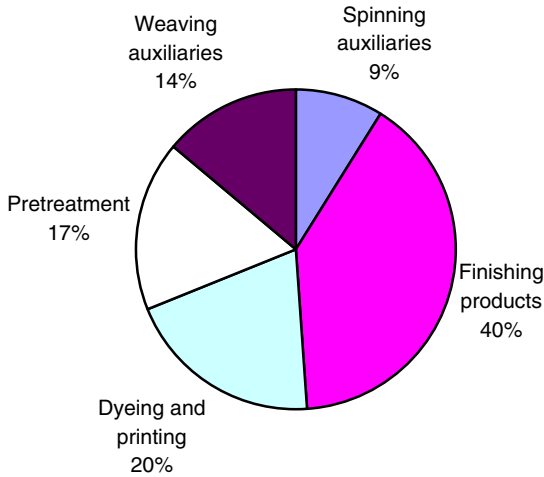

1.1 Distribution of textile auxiliaries by market share.

Table 1.2 Importance of the finishing product groups in order

Value importance	Finishing product group	Value (%)	Amount (%)	Euro/kg
1	Soft handle products based on: silicones, including elastomers	19.9	22.1	2.10
	cationics	8.9	5.4	3.80
	non-ionics, without silicones	5.3	8.0	1.50
	anionics	5.0	8.1	1.40
		0.7	0.7	2.10
2	Repellents based on: fluorocarbons	15.2	4.1	8.50
	paraffins	13.8	2.4	13.00
	silicones	1.1	1.6	1.60
		0.4	0.1	6.30
3	Flame retardants	13.9	13.9	2.30
4	Products for coating, laminating, fibre and thread bonding	13.8	18.4	1.70
5	Products for easy-care and permanent press finishes	7.9	13.5	1.30
6	Hand builders	7.0	10.0	1.60
7	Antimicrobial products, including protection from insects	1.9	0.3	14.20
8	Antistatic agents, including carpet finishing	1.8	2.3	1.80
9	Non-slip agents	1.2	1.4	2.00
10	Products for soil-release/anti-soiling (without fluorocarbons)	0.04	0.01	6.70
	Remainder, including brighteners, products for sewing thread preparation, anti-felting of wool, carpet back-coating, hydrophilation, delustering and brightening, foaming of finishes	17.4	14.0	

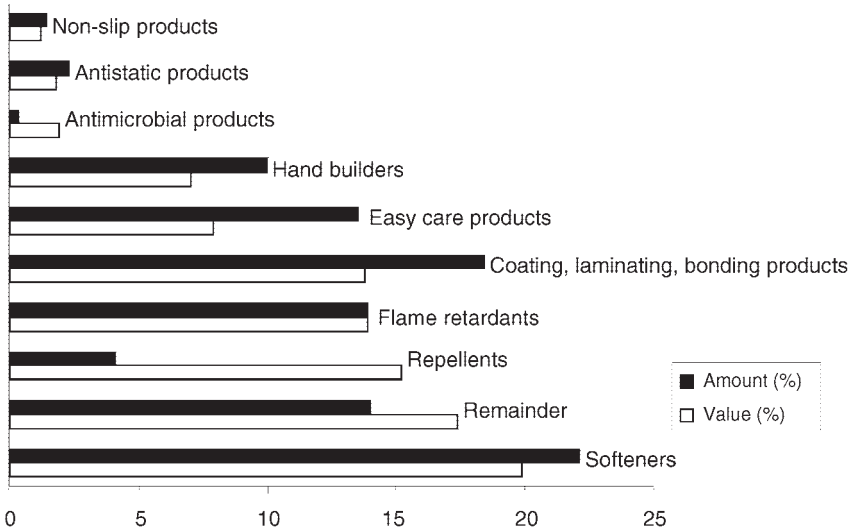

1.2 Distribution of finishing product groups by amount and value.

The textile chemical sector is serviced by a multitude of suppliers. A 2003 buyers' guide,<sup>5</sup> lists over 100 companies offering textile chemicals. The *International Textile Auxiliaries Buyers' Guide*<sup>6</sup> contains over 7000 trade names, of which about 40 % are finishing products.

## References

- 1 Tomasino C, *Chemistry and Technology of Fabric Preparation and Finishing*, Raleigh NC, North Carolina State University, College of Textiles, 1992.
- 2 Lockett A P, 'Mechanical finishing – traditional and modern', in *Textile Finishing*, Heywood D (ed.), Bradford, Society of Dyers and Colourists, 2003, 114–134.
- 3 Rouette H-K, *Grundlagen der Textilveredlung*, Frankfurt/Main, Deutscher Fachverlag, 1989.
- 4 *TEGEWA statistics for 2001*. TEGEWA = Verband der Textilhilfsmittel-, Lederhilfsmittel-, Gerbstoff- und Waschrohstoff-Industrie, Frankfurt/Main, Germany (Association of German Textile Auxiliary Producers).
- 5 Anonymous, 'Buyers guide', *AATCC Review*, 2003, **3**(7), 17–143.
- 6 *International Textile Auxiliaries Buyers' Guide, 2000*, Melliand and TEGEWA, Frankfurt/Main, Deutscher Fachverlag, 2000.

## 2.1 Introduction

Chemical finishing can be defined as the use of chemicals to achieve a desired fabric property. Chemical finishing, also referred to as 'wet' finishing, includes processes that change the chemical composition of the fabrics that they are applied to. In other words, an elemental analysis of a fabric treated with a chemical finish will be different from the same analysis done prior to the finishing.

Typically chemical finishing takes place after coloration (dyeing or printing) but before fabrics are made into garments or other textile articles. However, many chemical finishes can also be successfully applied to yarns or garments.

Chemical finishes can be durable, i.e. undergo repeated launderings or dry cleanings without losing effectiveness, or non-durable, i.e. intended when only temporary properties are needed or when the finished textile typically is not washed or dry cleaned, for example some technical textiles. In nearly all cases, the chemical finish is a solution or emulsion of the active chemical in water. Use of organic solvents to apply chemical finishes is restricted to special applications owing to the expense and the real or possible toxicity and flammability of the solvents employed.

The actual method of finish application depends on the particular chemicals and fabrics involved and the machinery available. Chemicals that have strong affinities for fibre surfaces can be applied in batch processes by exhaustion in dyeing machines, usually after the dyeing process has been completed. Examples of these exhaust applied finishes include softeners, ultraviolet protection agents and some soil-release finishes. Chemicals that do not have an affinity for fibres are applied by a variety of continuous processes that involve either immersing the textile in a solution of the finishing chemical or applying the finishing solution to the fabric by some mechanical means.

After application of the chemical finish, the fabric must be dried and if necessary, the finish must be fixed to the fibre surface, usually by additional heating in a 'curing' step. A schematic diagram of a pad-dry-cure process is



of finishing solution applied, the concentration of the supplied chemical in the finishing solution or emulsion and the solids or active compound concentration of the supplied chemical. The amount of finishing solution or emulsion applied is referred to as the 'wet pickup' (wpu) of the fabric and is usually expressed as a percentage on the weight of the dry untreated fabric (Equation 2.2):

$$\% \text{ wpu} = \frac{\text{wt of solution applied} \times 100}{\text{wt of dry fabric}} \quad [2.2]$$

To determine the amount of supplied chemical added to the fabric, the '% add-on' is given by Equation 2.3:

$$\% \text{ add-on} = \frac{\% \text{ conc in solution (wt/wt)} \times \% \text{ wpu}}{100} \quad [2.3]$$

where % conc is the concentration of the finishing chemical in the applied solution or emulsion expressed as percentage by weight. Since most finishing formulas are given in terms of grams per litre ( $\text{g l}^{-1}$ ), Equation 2.4 can be used to convert the  $\text{g l}^{-1}$  concentration to weight percent:

$$\% \text{ conc in solution (wt/wt)} = \frac{\text{conc in g l}^{-1}}{10 \times \text{density (g ml}^{-1}\text{)}} \quad [2.4]$$

where the density is the applied solution or emulsion density.

When the actual solids level added to the fabric is desired, the percentage of solids add-on can be found from Equation 2.5.

$$\% \text{ solids add-on} = \frac{\% \text{ solids of chemical} \times \% \text{ conc in solution} \times \% \text{ wpu}}{100 \times 100} \quad [2.5]$$

## 2.2.2 Pad application of chemicals to dry fabric

Chemical finishes are often pad applied to dyed or printed fabrics after a drying step. In this situation, dry fabric is passed through the chemical finish solution and the process is called a 'wet on dry' process. The wet pickup of a chemical solution in a pad mangle is influenced by many factors such as fabric characteristics, machine settings and solution or emulsion properties.<sup>1</sup> Table 2.1 summarises some of these factors.

In order to obtain consistent chemical application, the nip pressure should be uniform across the fabric width, the solution level and temperature in the pad should be constant and the fabric speed should not vary throughout the application process.<sup>2</sup>

Table 2.1 Factors affecting fabric wet pickup

Factor	Effect on wet pickup
Fibre type	Higher wet pickup with hydrophilic fibres
Yarn construction	Higher wet pickup with low twist and/or open end yarns
Fabric construction	Higher wet pickup with loose constructions (knit vs. woven)
Wettability	Higher wet pickup with more easily wetted fabrics
Pressure of squeeze rolls	Higher pressures lead to lower wet pickups
Nature and hardness of squeeze roll coverings	Harder coverings lead to lower wet pickups
Length of immersion time	Higher wet pickup with longer immersion time
Viscosity of solution or emulsion	Higher wet pickup with higher viscosity
Surface tension of solution or emulsion	Higher wet pickups with faster wetting solutions
Temperature of solution or emulsion	Viscosity and surface tension change with temperature, changing wet pickups
Concentration of solution	Viscosity and surface tension change with component concentrations, changing wet pickups

Equation 2.3 can be rearranged as Equation 2.6

$$\% \text{ conc (wt/wt)} = \frac{\% \text{ add-on} \times \% \text{ wpu}}{100} \quad [2.6]$$

to calculate the necessary chemical concentration from a given percentage add-on and wet pickup.

Equation 2.7 can be used to determine the necessary solution feed rate to maintain a constant liquid level in the pad:

$$\text{solution flow rate (l min}^{-1}\text{)} = \frac{\text{fabric mass flow (kg min}^{-1}\text{)} \times \% \text{ wpu}}{\text{solution density} \times 100} \quad [2.7]$$

where fabric mass flow is defined as:

$$\text{fabric mass flow} = \text{fabric speed (m min}^{-1}\text{)} \times \text{fabric linear density (kg m}^{-1}\text{)}$$

In practice, however, it is more common to maintain a constant level in a wet on dry pad application with a float valve controlling the liquid level.

### 2.2.3 Pad application of chemicals to wet fabric

To avoid the costs of a drying step after dyeing, chemical finishes are often pad applied to wet fabric in a process called 'wet-on-wet'. In this case, the wet pickup

of the fabric exiting the pad must be maintained at a higher level than that of the incoming fabric, usually at least 15–20 % higher. An additional complication is the fact that water entering the pad on the incoming fabric can interchange with the finishing solution, in effect diluting the concentration of the components and causing tailing of the finish effect. Therefore, a chemical feed more concentrated than the pad solution must be employed. Several authors have addressed this problem and have derived equations to allow the calculation of the required parameters.<sup>2-4</sup> The following is a simplified summary of the necessary equations.

In most cases a defined chemical add-on is desired. In order to determine the pad solution or emulsion concentration of the finishing chemicals, an effective percentage wet pickup,  $wpu_{\text{eff}}$  is calculated from Equation 2.8:

$$wpu_{\text{eff}} = (wpu_0 - wpu_i) + wpu_i \times f \quad [2.8]$$

where  $wpu_0$  is the percentage wet pickup of the fabric exiting the pad,  $wpu_i$  is the percentage wet pickup of the fabric entering the pad and  $f$  is the interchange factor, a measure of interaction between incoming water and the pad solution, that can vary from 0 to 1 depending on fabric and machine parameters. Typically  $f$  is between 0.7 and 0.8. An initial interchange factor is assumed and then corrected, if necessary based on analysis of the treated fabric.

The pad solution concentration is found from Equation 2.9 using the desired percentage add-on:

$$\text{pad conc (g l}^{-1}\text{)} = \frac{\% \text{ add-on} \times 1000 \times \text{solution density}}{wpu_{\text{eff}}} \quad [2.9]$$

The concentration of the chemical feed solution must be higher than the pad concentration since the pad bath is being diluted by the water on the incoming wet fabric. The feed concentration needed to maintain the pad concentration is calculated from Equation 2.10:

$$\text{feed conc (g l}^{-1}\text{)} = \frac{\text{pad conc} \times wpu_{\text{eff}}}{wpu_0 - wpu_i} \quad [2.10]$$

The feed flow rate is found from Equation 2.11:

$$\text{feed flow rate (l min}^{-1}\text{)} = \frac{\text{fabric mass flow (kg min}^{-1}\text{)} \times (wpu_0 - wpu_i)}{\text{feed solution density (g ml}^{-1}\text{)} \times 100} \quad [2.11]$$

Examples of these calculations are given in the Appendix.

## 2.2.4 Low wet pickup methods

Typically, pad applications of chemical finishes yield wet pickups in the 70–100 %

range. These high pickups necessarily require the removal of large amounts of water during drying. The evaporation of this water can lead to uneven finish distribution in the dried textile owing to migration of the finish to the fabric surface during drying.<sup>5</sup> The high rate of evaporation at the fabric surface leads to movement of the finish solution from the wet fabric interior to the drier fabric exterior resulting in a higher concentration of the finish at the fabric surfaces with a corresponding lower concentration in the fabric interior regions. This migration is reduced as the finish solution becomes more and more concentrated and viscous as drying progresses. Therefore, reducing the amount of water initially applied will tend to reduce finish migration.

However, too low a wet pickup can be equally problematic and also lead to uneven finish distribution if the liquid phase is discontinuous.<sup>6</sup> The concept of a 'critical application value' (CAV) is useful when discussing optimal wet pickups.<sup>7</sup> The CAV is defined as the minimum amount of durable press finish liquid that can be applied to a given cotton fabric without producing a non-uniform distribution of crosslinks after drying and curing. Dye staining tests can be used to determine these distributions. For non-cellulosic fibres, other methods of finish distribution analysis can be used.

The CAV for a particular process is dependent on fibre type and fabric construction and absorbency. A finish application below the CAV may result in a non-uniform speckled treatment, while an application above the CAV could lead to finish migration. Cellulosic fibres, because of their inherent hydrophilicity, have CAVs in the range of 35–40 % wet pickup. Hydrophobic fibres like polyester can have CAVs of less than 5 %, allowing much lower wet pickups than hydrophilic fibres.

In order to minimise finish migration during drying and reduce the energy costs associated with drying large amounts of water, various techniques have been developed to reduce the amount of water used in finish applications. An additional benefit is that some applications will allow precise placement of chemicals, leading to the possibility of fabrics with different finishes on their face and back. Another advantage is the recovery and reuse of the finish liquor removed by some of these techniques. To reduce the danger of uneven finish distribution on the fabric, caused by low wet pickup, a thorough preparation is necessary by any method that provides a very good and uniform absorbency.

There are two main types of low wet pickup applicators. The first is the saturation–removal type where the fabric is completely saturated with the finish liquid and then the excess liquid is removed mechanically or with a vacuum before drying. With the second type, a precise amount of finish liquid is uniformly applied to the fabric using transfer roll, spray or foam techniques. Table 2.2 gives a survey on low wet pickup finishing application methods, some of which will now be discussed in more detail.

One of the simplest approaches to the saturation–removal has been to place a vacuum extraction device after the application pad and prior to dryer entry. By

Table 2.2 Low wet pickup finish application methods (adapted from Greenwood and Holme)<sup>4</sup>

Type of method	Examples
Saturation–removal	Vacuum extraction Porous bowl techniques Air-jet ejectors Transfer padding (squeeze–suck technique)
Topical application	Kiss-roll Loop transfer system Engraved roll Nip padding system Spray system Foam application

pulling a vacuum through the wet fabric and returning the extracted liquid to the pad, an effective lower pickup can be achieved, usually in the order of 40 %. Figure 2.2 shows a typical vacuum extraction installation.

Another relatively simple method of reducing wet pickup is the use of the Machnozzle system, Fig. 2.3,<sup>8,9</sup> a machine similar in principle to air-jet ejectors. In this device, high pressure steam is used to push excess liquid out of the fabric, leading to very low wet pickups, especially for synthetic fabrics.

In the area of topical application, several methods have been used to apply chemical finishes using transfer rolls.<sup>1</sup> The kiss roll, Fig. 2.4, picks up the chemical finish and transfers it by direct contact to the fabric. The amount of finish picked up is dependent upon how well the finish wets the roll, the absorbency of the fabric, and to a lesser extent, the surface speed of the roll relative to the fabric speed.

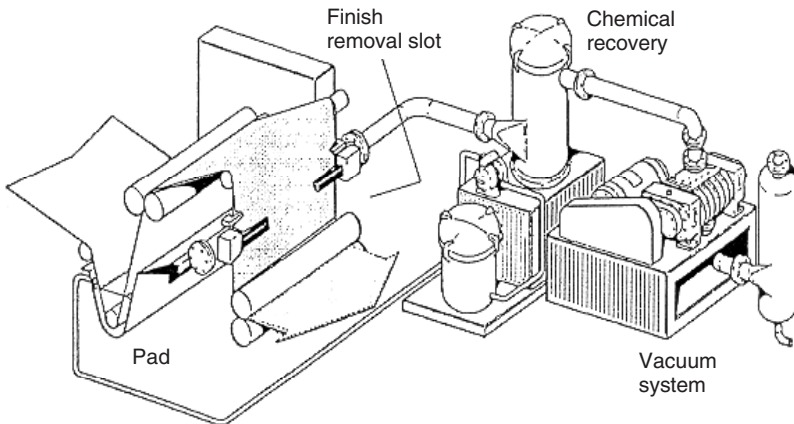

2.2 Vacuum extraction system. Reproduced from *Cotton Dyeing and Finishing: a technical guide*, 1997, p 157, courtesy of Cotton Incorporated, Cary, NC.

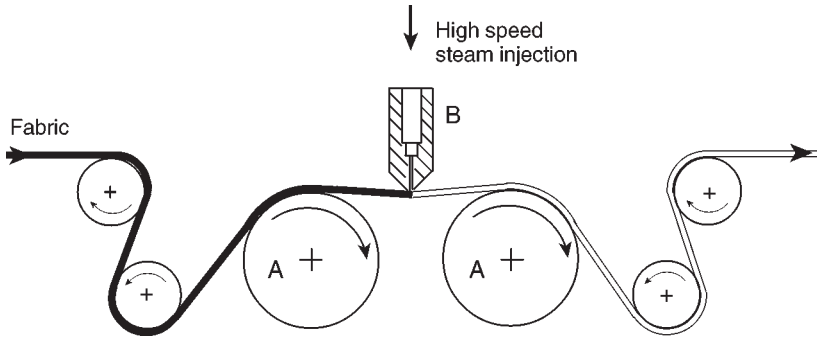

2.3 Machnozzle system. Reprinted from *Textiles Sciences and Technology 11: Textile processing and properties: preparation, dyeing, finishing and performance*, T.L. Vigo (ed.), 1997, Chap 4, p 275, with permission from Elsevier.

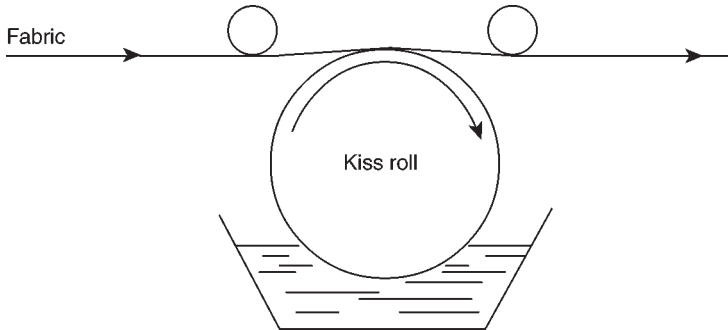

2.4 Kiss roll applicator. Reproduced from *Cotton Dyeing and Finishing: a technical guide*, 1997, p 153, courtesy of Cotton Incorporated, Cary, NC.

Another version of finish application with transfer rolls is the loop transfer system, Fig. 2.5.<sup>4,9</sup> A loop of fabric is immersed in finish liquid and then squeezed with the fabric to be treated between squeeze rollers. The finish is transferred to the fabric at a much lower wet pickup than possible by direct immersion. These roll transfer techniques are especially useful for the backside application of finishes, for example hand builders and flame retardants, to pile fabrics (without crushing the pile).

One interesting modification of the kiss roll applicator is the Triatex MA machine which uses on-line monitoring to control wet pickup. Figure 2.6 shows a schematic of the system. As the fabric passes through the system, two  $\beta$ -gauges are used to determine the fabric weight difference before and after the fabric has passed over a kiss roll. The  $\beta$ -gauges measure mass per unit area based on the

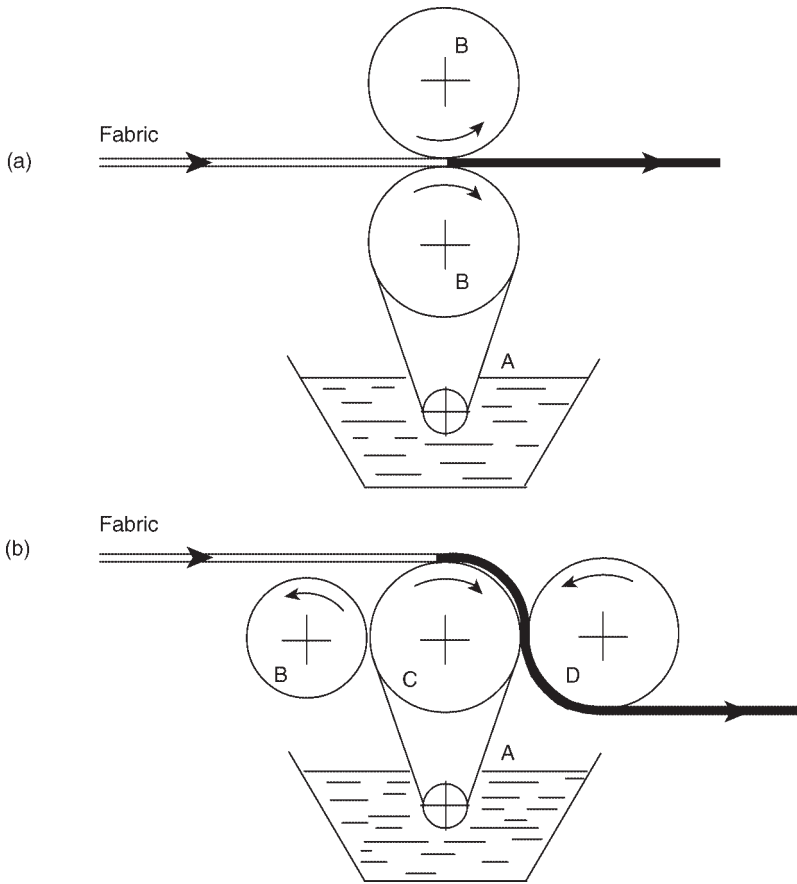

2.5 Loop transfer applicators. Reproduced from *Textile Finishing*, D. Heywood (ed.). Bradford, SDC, 2003, by permission of The Society of Dyers and Colourists.

intensity of electrons that pass through the fabric. The kiss roll rotational speed is then automatically adjusted relative to the fabric speed to maintain the desired wet pickup.

An engraved roll (Fig. 2.7)<sup>4,9</sup> can transfer precise amounts of chemical finish to fabrics since the engravings can be made in various depths and designs. A doctor blade removes any excess liquid from the roll surface before fabric contact insuring that only the liquid in the engraved areas is transferred to the fabric. A disadvantage of engraved rolls is that a roll will deliver the same amount of finish, regardless of the fabric being treated. Therefore multiple rolls are needed if different fabrics are to be treated to the same wet pickup.

Chemical finishes can also be applied by spraying (Fig. 2.8). By controlling the flow rate through the spray bars, the amount of applied finish can be set to the

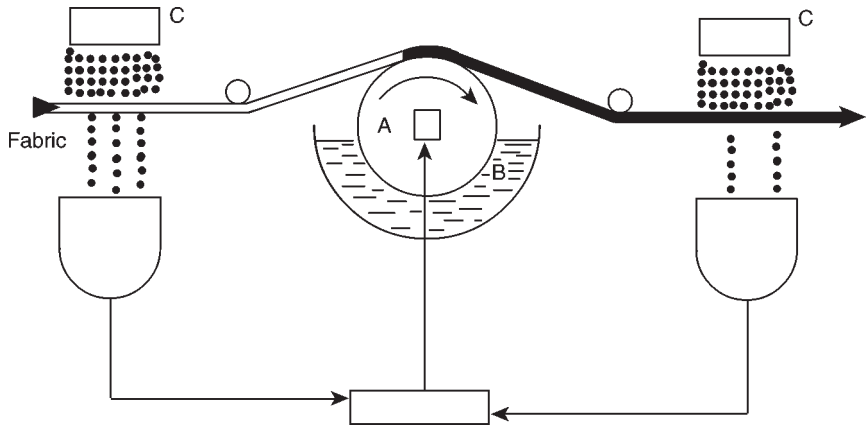

2.6 Triatex MA (minimum application) system. Reproduced from *Textile Finishing*, D. Heywood (ed.). Bradford, SDC, 2003, by permission of The Society of Dyers and Colourists.

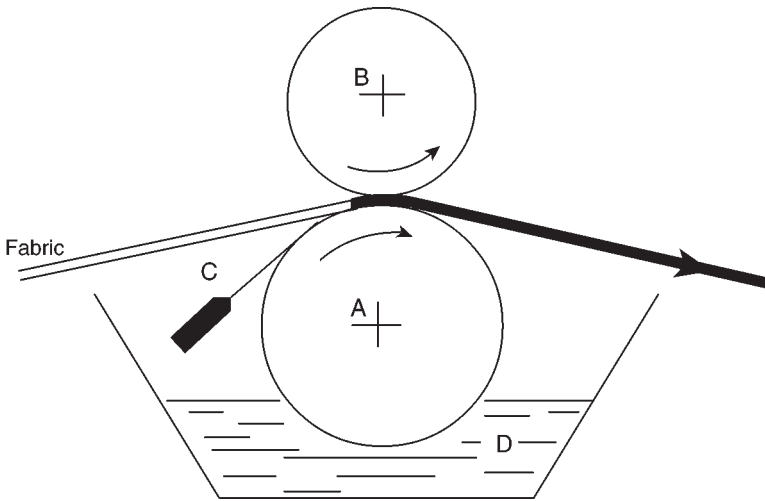

2.7 Engraved roll applicator. Reproduced from *Textile Finishing*, D. Heywood (ed.). Bradford, SDC, 2003, by permission of The Society of Dyers and Colourists.

desired add-on. Care must be taken to avoid overlapping spray patterns that could lead to an unacceptable uneven finish distribution. Special care is needed with aerosols from fluorocarbon sprays (inhalation, followed by repellency of the inside of the lungs is a deadly danger).

One important application method for chemical finishes is the use of foam to apply the finish to the fabric. By replacing part of the water in the chemical

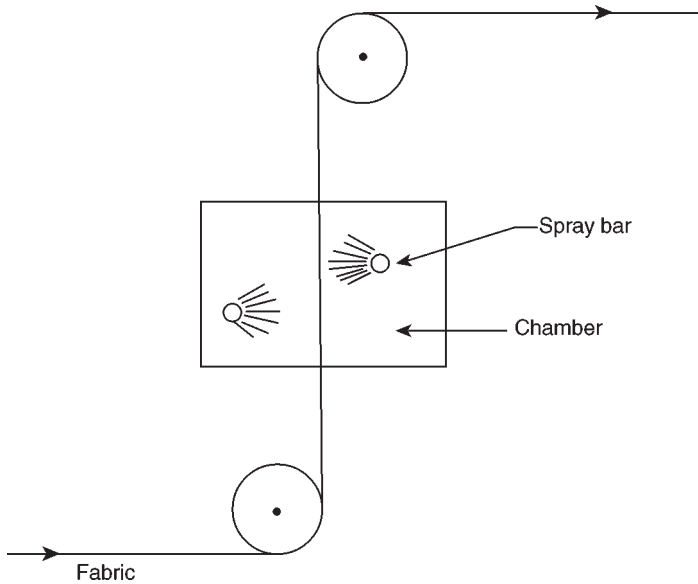

2.8 Spray applicator. Reproduced from *Cotton Dyeing and Finishing: a technical guide*, 1997, p 156, courtesy of Cotton Incorporated, Cary, NC.

formulation with air, the amount of water added to the fabric can be significantly reduced. In addition, surfactants are included in the formulation to be foamed. Even if they are carefully selected, they may cause effect reduction of repellent finishes. The chemical formulation is mixed with air in a foam generator producing high volumes of foam that can be applied to fabrics in a number of ways. The ratio of liquid to air in a foam is referred to as the 'blow ratio', conveniently determined by Equation 2.12:

$$\text{blow ratio} = \frac{1}{\text{foam density}} \quad [2.12]$$

Foam densities in the order of  $0.1 \text{ g cm}^{-3}$  are routinely used. The stability of the foam is influenced by the components of the chemical system, the viscosity of the foam and the method of foam preparation. The half-life of a foam is the time in which 50 % of the liquid in a given foam volume has been drained from the foam. Foams for textile applications can have half-lives from a few seconds to several hours.

Some of the foam application methods are shown in Fig. 2.9 and Fig. 2.10. The one side applicators apply foam to only one side of the fabric, leaving open the possibility of two different finishes on different sides of the same fabric. The two side applicators, on the other hand, apply the same foam to both sides of the treated

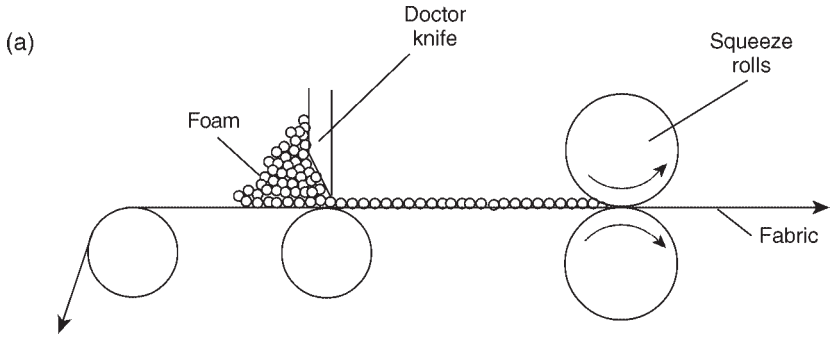

Doctor blade coater

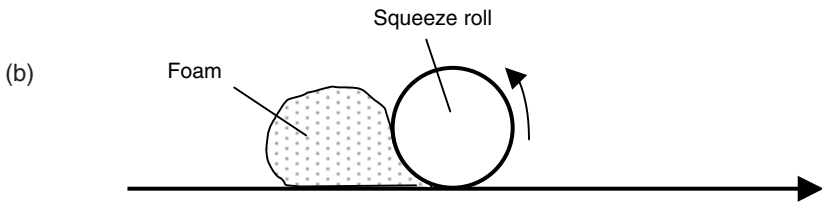

Roller coater

2.9 One side foam applicators. (a) Reproduced from *Cotton Dyeing and Finishing: a technical guide*, 1997, p 155, courtesy of Cotton Incorporated, Cary, NC.

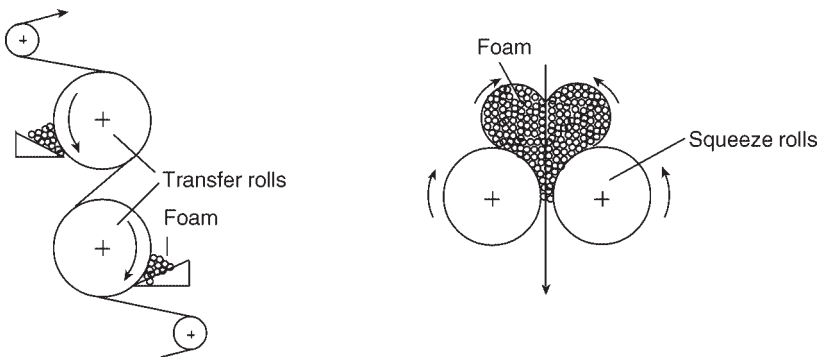

2.10 Two side foam applicators. G.H.J. van der Walt and N.J.J. van Rensburg from *Textile Progress*, 1986, **14**(2), 16–17. Reproduced by permission of The Textile Institute, UK.

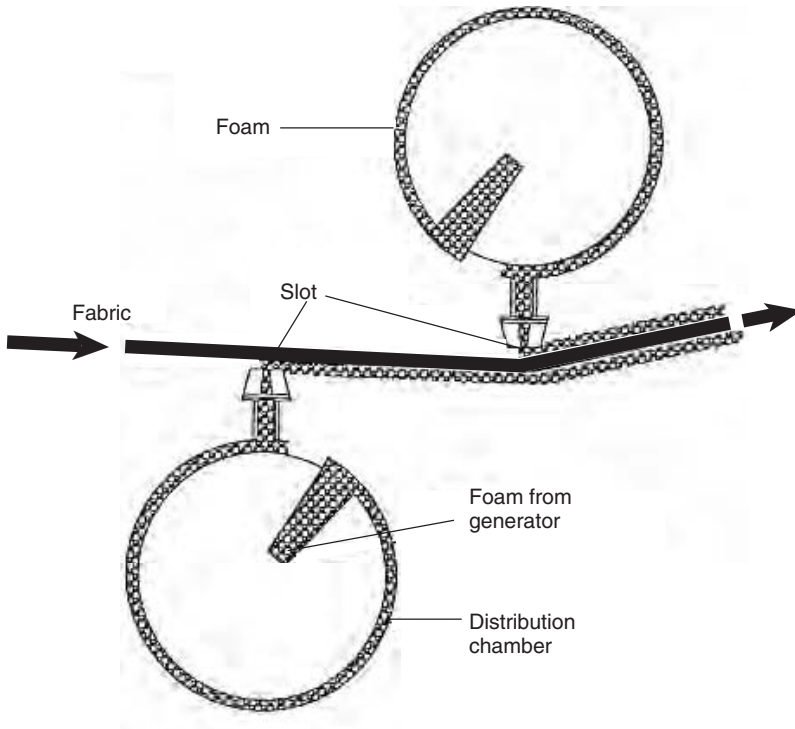

2.11 Foam slot applicator. Reproduced from *Cotton Dyeing and Finishing: a technical guide*, 1997, p 155, courtesy of Cotton Incorporated, Cary, NC.

fabric. Another two side foam application method is illustrated in Fig. 2.11. This applicator employs two slots to apply the foam to the fabric. Two distinctly different finishes can be applied to different sides of the same fabric simultaneously. Foam application on fabrics with large open spaces or non-uniform porosity often causes uneven finish distribution. Foam application systems also include horizontal pad mangles, kiss coating systems, knife-over-roller or knife-on-air systems, screen printing, and slot applicators. A more detailed overview on finish application methods is given by Greenwood and Holme.<sup>4</sup>

In all these application methods, proper fabric preparation is required in order to achieve uniform finish distributions. A well-absorbent fabric is the best guarantee of a proper finish application.

In order to maintain the same chemical add-on with lower wet pickups, the concentrations of the finish bath components must be increased according to Equation 2.13:

$$\text{conc}_2 = \text{conc}_1 \times \frac{\text{density}_2}{\text{density}_1} \times \frac{\text{wpu}_1}{\text{wpu}_2} \quad [2.13]$$

where  $\text{conc}_2$  is the component concentration at the lower wet pickup,  $\text{conc}_1$  is the original concentration,  $\text{density}_2$  and  $\text{density}_1$  are the densities of the modified and original solutions, respectively, and  $\text{wpu}_2$  and  $\text{wpu}_1$  are the lower and the original wet pickups, respectively. Since the density of the more concentrated solution cannot be determined until after the solution has been made, an initial estimate of  $\text{density}_2$  is used in Equation 2.13 to calculate an approximate  $\text{conc}_2$ . Through successive iterations, more accurate values of  $\text{density}_2$  and  $\text{conc}_2$  can be obtained if necessary.

### 2.2.5 Application of finishes to garments

Applying chemical finishes to garments is usually accomplished using exhaustible finishes (softeners, antimicrobials, ultra violet (UV) absorbers, and so on), which are added to the bath of the garment processing machine after all other garment wet processing steps have been completed. However, occasionally, a non-exhaustible finish such as an easy care finish is desired. Special procedures have been developed for this situation. One approach is to extract as much water as possible from the garments and then immerse them into the finish solution, either in a separate trough or in the garment machine itself, followed by further extraction, drying and curing. A second approach is to spray a precise amount of finish solution into the garment processing machine after water extraction. Even distribution of finish is accomplished by rotating the garments long enough to allow the finish to migrate throughout the garment. Drying and curing complete the process. Both methods have been demonstrated commercially, but the spray procedure requires fitting existing garment machines with the precision spraying attachment, while the immersion procedure involves less capital investment, but consumes more chemical finish.

## 2.3 Drying wet textiles

Water in a wet textile resides in three different areas. The most loosely bound water is on the fabric surface and interstices. Much of this water can be taken out by mechanical means such as squeezing, centrifugation or vacuum extraction. The remaining water, the water held in the yarn capillaries and the water absorbed internally by the fibre, must be removed through vaporisation by thermal means.

There are three heat transfer mechanisms used to dry textiles. Conduction methods involve direct contact of the wet textile with heated surfaces. These are the most efficient heat transfer methods, but do not allow for control of fabric width during drying. Steam heated cylinders are examples of conduction drying methods



2.12 Steam heated drying cylinders.

(Fig. 2.12). High pressure steam inside the cylinders provides the energy necessary to dry the fabric.

Convection methods involve contact of the wet textile with hot air and are the most common method used in textiles since they combine high process speeds with control of fabric dimensions during drying. Examples include tenter frames (Fig. 2.13). Air is heated to the desired temperature by gas- or oil-fired burners or steam heat exchangers and passed over the fabric by high velocity blowers. Fabric tensions are adjusted in both the width and length directions, allowing for complete control of final fabric dimensions.

The third heat transfer mechanism is radiation, examples of which are infrared and radio frequency dryers. Radiant heaters are often used as predryers, removing much of the moisture from wet fabric prior to entering the actual drying process (Fig. 2.14). Use of predryers minimises finish migration and increases dryer productivity since less water must be removed in the dryer. A more detailed description of drying methods and machines is given by Miles.<sup>10</sup>

## 2.4 Curing chemical finishes

The same heating equipment used to dry wet textiles can also be used to heat the fabric and finish to the temperatures desired for optimal curing. For all equipment, it must be remembered that the temperature of the fabric cannot exceed 100 °C

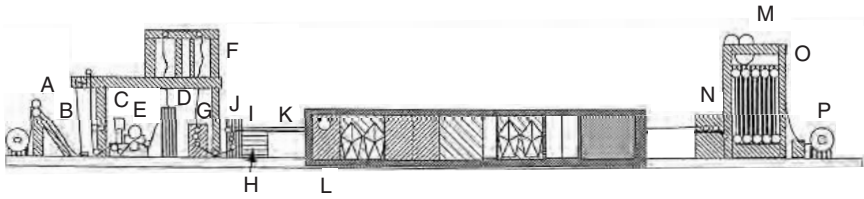

2.13 Tenter frame. Reproduced from *Cotton Dyeing and Finishing: a technical guide*, 1997, p 166, courtesy of Cotton Incorporated, Cary, NC.

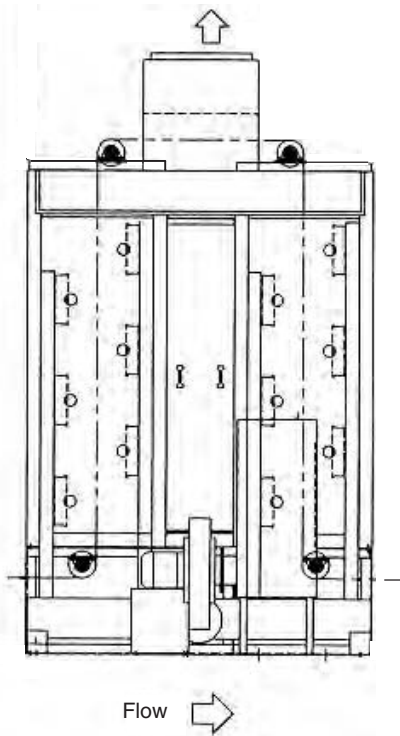

2.14 Predryer. Reproduced by permission of Aztec Machinery Company, USA.

until all of the water has been removed. Figure 2.15 demonstrates this effect. The fabric temperature does not rise to the set temperature until after all the water has gone.

When drying and curing are done separately in two steps, the curing time can be controlled easily. As speed is defined by distance divided by time, the curing time can be calculated by Equation 2.14:

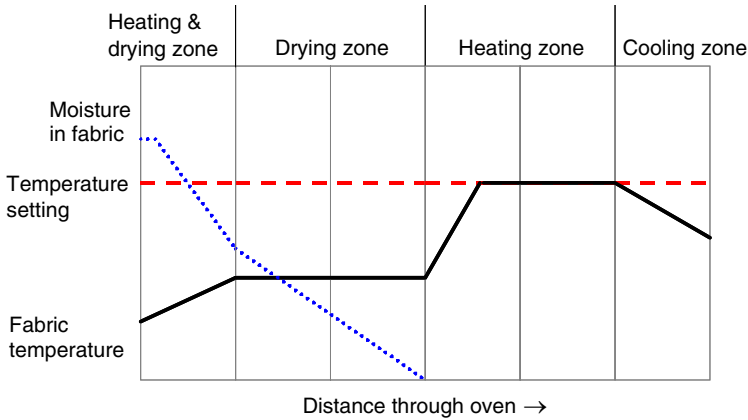

2.15 Temperature and moisture profiles in the tenter.

$$\text{curing time} = \frac{\text{amount of fabric in machine}}{\text{speed of the fabric through the machine}} \quad [2.14]$$

For example, if the fabric content of the machine is 20 m and the fabric speed is  $40 \text{ m min}^{-1}$ , then the curing time is 0.5 min.

Often drying and curing are combined in one process, for example the so-called shock-condensation or shock-curing processes. As the end of the drying phase is not easy to determine, there is a risk of over- or under-curing with many disadvantages (see Table 5.8 in Chapter 5 on easy-care and durable press finishes). The best available solution for this problem is curing controlled by the temperature of the fabric. As shown in Fig. 2.15 only when all the water is evaporated, will the temperature of the fabric rise from the wet-bulb temperature to the temperature of the surroundings and the curing process can start. With radiation pyrometers the surface temperature of the fabric is exactly measured free of contact. Thereby the end of the drying step and the time of the curing step can be determined and monitored. As radiation pyrometers are relatively expensive, often not all the sections of long tenters are completely monitored by pyrometers; they are concentrated in and most important in the tenter section where drying ends and curing starts.

## 2.5 Coating and laminating

A short survey on coating might be of interest, because there is a smooth transition between chemical finishing with one-side application of greater amounts of products, for example stiffeners or flame retardants, and fine or thin coating. Fine coating is characterised by adds-on of about  $4\text{--}50 \text{ g m}^{-2}$ , mostly  $15\text{--}20 \text{ g m}^{-2}$ . Also

some application techniques are similar for one-side finishing and for coating, for example those using doctor knives, rolls, rotary screens, foam or spray applications.

The chemical finishing processes discussed in the following chapters have the goal, for the most part, of producing a finish uniformly distributed throughout the textile material. Except for specific performance properties, the treated fabric is nearly indistinguishable from untreated fabric since the physical appearance of the textile is seldom changed by conventional chemical finishing. However, other forms of chemical finishing are practiced where the goal is to produce a textile with a layer of chemical finish on, in or in between substrates leading to non-homogeneous structures. Coating and laminating are two such processes. With coating, the intent is to add the chemical finish to a substrate, while with laminating, the purpose is to join two textiles into one structure with the chemical acting as the adhesive.

A variety of useful products are produced by coating and laminating. Coating and lamination technology provides products for automotive air bags, footwear, interlinings, upholstery, hats, labels, umbrellas, adhesive tapes, rainwear, protective clothing, artificial leather articles, window blinds, tents, sleeping bags, curtains, floor coverings, luggage, sails, mattress ticking, flexible fuel tanks, abrasive products, awnings, filter fabrics, geotextiles, hoses and many others.<sup>11,12</sup> The entire market sector of technical textiles benefits from coated and laminated products.

Both coating and laminating require a textile substrate to be treated. The substrate plays a major role in establishing the final properties of the finished article.<sup>12</sup> In addition to the chemical and physical properties of fibres themselves, yarn construction and fabric formation are significant factors. Yarns made from staple fibres provide rough surfaces that enhance adhesion to chemical coatings. Filament yarns generally must be pretreated with chemicals to generate a more reactive surface prior to coating or laminating. Fabric structure determines the extent of textile-finish interbonding as well as influencing the final mechanical properties of the treated material. Knitted and non-woven structures are especially useful for coating and laminating but when strength and dimension stability are required, wovens are preferred.

The chemicals used for coating and laminating are polymeric materials, either naturally occurring or produced synthetically. These include natural and synthetic rubbers, polyvinyl chloride, polyvinyl alcohol, acrylic, phenolic resins, polyurethanes, silicones, fluorochemicals, epoxy resins and polyesters.<sup>11</sup> Coating formulations typically include auxiliaries such as plasticizers, adhesion promoters, viscosity regulators, pigments, fillers, flame retardants, catalysts and the like.<sup>13</sup>

The combination of the textile fabric and the polymer matrix on it results in interesting new properties. Thus coated textiles can be both flexible (similar to fabrics) and water- and air-tight (similar to films). Generally, the textile component provides strength and/or flexibility, the polymer coating delivers thermal

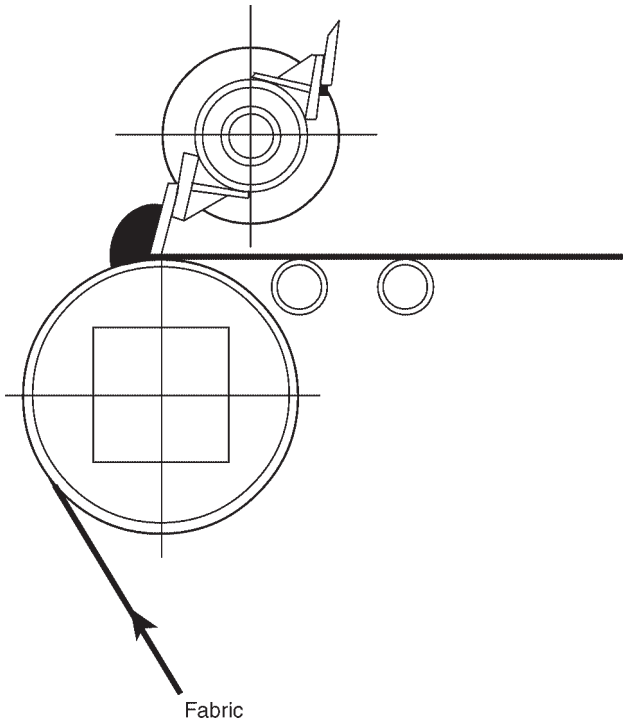

2.16 Knife over roll coater. Reproduced from *Textile Finishing*, D. Heywood (ed.). Bradford, SDC, 2003, by permission of The Society of Dyers and Colourists.

insulation and barrier functions against liquids, gases and light. Both components contribute to various aesthetic requirements.

The most common coating application method is the knife over roll system (Fig. 2.16). The shape and angle of the coating blade, the gap between the blade and the fabric and the viscosity of the coating all affect the amount of coating applied and the penetration into the fabric.

Usually a direct coating consists of two or three layers. The first base or tie coat delivers adhesion to the fabric, the main layer (top or cover coat) consists of the dominating type of polymer with all the additives necessary for the required properties, and often there is a final or finish coat for protective and aesthetic demands. Reverse or transfer coating follows a contrasting order of the layers. It is used when the textile component does not have enough dimensional stability or has a structure which is too open for the direct coating process. Therefore a support foil, called release paper is used, first coated with the finish layer, then with the main layer, followed by the tie coat and at last the textile, for example, a knit-wear or a thin non-woven. Every coat step needs a short pregelation. After the final heating and end-gelation the release paper is separated. After the coating is

applied, the fabric can be heated to evaporate water and other solvents and cured if required by the polymer system. Some coated fabrics are embossed or printed, depending on the fabrics intended end use.

The laminating process involves applying an adhesive coating to the surface of the primary substrate, bringing the second substrate together with the adhesive layer, thereby making a three component composite, and finally with heat and pressure forming the final laminate. The adhesive can be applied by a variety of techniques including the knife over roll method mentioned earlier. Other application methods include scatter coating of thermoplastic polymers and rotary screen printing of adhesive emulsions or solutions.

According to the immense market importance of coatings and related fibre-composite products, there are many special processes and products, including front-, back- and double-side coatings, water vapour permeable coating (incorrectly called breath-active), foam and spray coating, flame laminating, bonding, flocking, hot-melt and paste-dot coating for fusible interlinings, prepregs and other textile composite materials for wide technical usage.

## References

- 1 Perkins W S, *Textile Coloration and Finishing*, Durham, North Carolina, Carolina, Academic Press, 1996, 224–225.
- 2 Anonymous, *A Bleacher's Handbook*, Solvay Interox.
- 3 Yang Y and Hensley S A, 'Bath concentration and add-on control in wet-on-wet padding', *Textile Research Journal*, 2001, **71**(9), 822–803.
- 4 Greenwood P and Holme I, in *Textile Finishing*, Heywood D (ed.), Bradford, Society of Dyers and Colourists, 2003, 61–100.
- 5 Preston J M and Bennett A, 'Some aspects of the drying and heating of textiles V – migration in relation to moisture content', *Journal Society Dyers Colourists*, 1951, **67**, 101.
- 6 Shippee F B and Garliardi D D, 'Differential distribution of cross-linking agents in cotton fabrics', *Textile Research Journal*, 1966, **36**, 177.
- 7 Heap S A, 'Consideration of the critical add-on and the uniformity of crosslinking', *Textile Research Journal*, 1979, **49**, 150.
- 8 van der Linden H J L J and Groot-Wassink J, 'Cross flow drying of textiles on porous rollers. II. Model description, verification and process design', *American Dyestuff Reporter*, 1983, **72**(5), 16.
- 9 van der Walt G H J and van Rensburg N J J, 'Low-liquor dyeing and finishing', *Textile Progress*, 1986, **14**(2), 1–60.
- 10 Miles L, in *Textile Finishing*, Heywood D (ed.), Bradford, Society of Dyers and Colourists, 2003, 34–60.
- 11 Woodruff F A, in *Textile Finishing*, Heywood D (ed.), Bradford, Society of Dyers and Colourists, 2003, 447–525.
- 12 Fung W, *Coated and Laminated Textiles*, Cambridge, UK.
- 13 Wypych J, *Polymer Modified Textile Materials*, New York, John Wiley and Sons, 1988, 50–58.

## Appendix: sample calculations

A cotton fabric is to be treated with 5.0 % on weight of fabric (owf) with a chemical finish in a wet on dry padding process. If the wet pickup is 90 %, what concentration of chemical is needed?

From Equation 2.6:

$$\% \text{ conc (wt/wt)} = \frac{\% \text{ add-on} \times \% \text{ wpu}}{100}$$

$$\% \text{ conc (wt/wt)} = \frac{5.0 \times 90}{100} = 4.5 \% \text{ (wt/wt)}$$

If the solution density is 1.05 g ml<sup>-1</sup>, what is the required concentration in g l<sup>-1</sup>?

From Equation 2.4:

$$\text{conc in g l}^{-1} = 10 \times \text{density (g ml}^{-1}) \times \% \text{ conc in solution (wt/wt)}$$

$$\text{conc in g l}^{-1} = 10 \times 1.05 \times 4.5 = 47.2 \text{ g l}^{-1}$$

If the fabric has a linear density of 0.250 kg m<sup>-1</sup> and a speed of 80 m min<sup>-1</sup>, with linear density of 0.250 kg m<sup>-1</sup>, what is the flow rate of solution necessary to maintain a constant level in the pad?

From Equation 2.7:

$$\text{solution flow rate (l min}^{-1}) = \frac{\text{fabric mass flow (kg min}^{-1}) \times \% \text{ wpu}}{\text{solution density} \times 100}$$

where

$$\text{fabric mass flow} = \text{fabric speed (m min}^{-1}) \times \text{fabric linear density (kg m}^{-1})$$

$$\text{fabric mass flow} = 80 \times 0.250 = 20 \text{ kg min}^{-1}$$

therefore

$$\text{solution flow rate (l min}^{-1}) = \frac{20 \times 90}{1.05 \times 100} = 17.1 \text{ l min}^{-1}$$

This same fabric is to be treated with 5 % owf of the same chemical finish in a wet on wet pad application with entry wet pickup of 75 %, exit wet pickup of 90 % and interchange factor of 0.7. What are the effective wet pickup and the necessary pad concentration?

From Equation 2.8:

$$\text{wpu}_{\text{eff}} = (\text{wpu}_0 - \text{wpu}_i) + \text{wpu}_i \times f = (90 - 75) + 75 \times 0.7 = 67.5 \%$$

From Equation 2.9:

$$\text{pad conc (g l}^{-1}\text{)} = \frac{\% \text{ add-on} \times 1000 \times \text{solution density}}{\text{wpu}_{\text{eff}}}$$

$$\text{pad conc (g l}^{-1}\text{)} = \frac{5.0 \times 1000 \times 1.05}{67.5} = 77.8 \text{ g l}^{-1}$$

What are the necessary feed solution concentration and flow rate?

From Equation 2.10:

$$\text{feed conc (g l}^{-1}\text{)} = \frac{\text{pad conc} \times \text{wpu}_{\text{eff}}}{\text{wpu}_0 - \text{wpu}_i}$$

$$\text{feed conc (g l}^{-1}\text{)} = \frac{77.8 \times 67.5}{90 - 75} = 350 \text{ g l}^{-1}$$

From Equation 2.11:

$$\text{feed flow rate (l min}^{-1}\text{)} = \frac{\text{fabric mass flow (kg min}^{-1}\text{)} \times (\text{wpu}_0 - \text{wpu}_i)}{\text{feed solution density (gml}^{-1}\text{)} \times 100}$$

$$\text{feed flow rate (l min}^{-1}\text{)} = \frac{20 \times (90 - 75)}{1.05 \times 100} = 2.8 \text{ l min}^{-1}$$

### 3.1 Introduction

Softening finishes are among the most important of textile chemical after treatments. With chemical softeners, textiles can achieve an agreeable, soft hand (supple, pliant, sleek and fluffy), some smoothness, more flexibility and better drape and pliability. The hand of a fabric is a subjective sensation felt by the skin when a textile fabric is touched with the finger tips and gently compressed. The perceived softness of a textile is the combination of several measurable physical phenomena such as elasticity, compressibility and smoothness.<sup>1-3</sup> During preparation, textiles can become embrittled because natural oils and waxes or fibre preparations are removed. Finishing with softeners can overcome this deficiency and even improve on the original suppleness. Other properties improved by softeners include the feeling of added fullness, antistatic properties and sewability. Disadvantages sometimes seen with chemical softeners include reduced crockfastness, yellowing of white goods, changes in hue of dyed goods and fabric structure slippage.

### 3.2 Mechanisms of the softening effect

Softeners provide their main effects on the surface of the fibres. Small softener molecules, in addition, penetrate the fibre and provide an internal plasticisation of the fibre forming polymer by reducing of the glass transition temperature  $T_g$ . The physical arrangement of the usual softener molecules on the fibre surface is important and shown in Fig. 3.1. It depends on the ionic nature of the softener molecule and the relative hydrophobicity of the fibre surface. Cationic softeners orient themselves with their positively charged ends toward the partially negatively charged fibre (zeta potential), creating a new surface of hydrophobic carbon chains that provide the characteristic excellent softening and lubricity seen with cationic softeners. Anionic softeners, on the other hand, orient themselves with their negatively charged ends repelled away from the negatively charged fibre surface. This leads to higher hydrophilicity, but less softening than with cationic

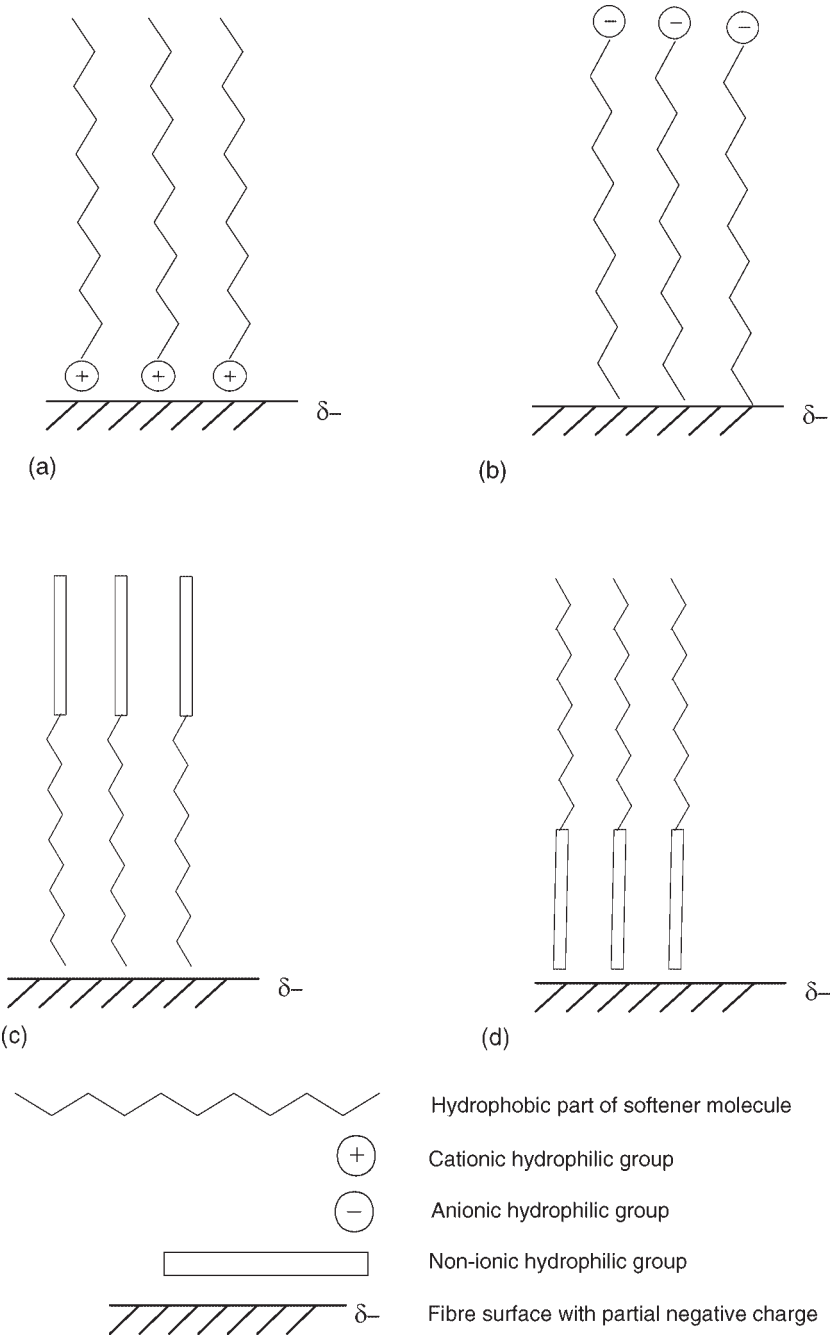

3.1 Schematic orientation of softeners on fibre surfaces. (a) Cationic softener and (b) anionic softener at fibre surface. Non-ionic softener at (c) hydro-phobic and (d) hydrophilic fibre surface.

softeners. The orientation of non-ionic softeners depends on the nature of the fibre surface, with the hydrophilic portion of the softener being attracted to hydrophilic surfaces and the hydrophobic portion being attracted to hydrophobic surfaces.

### 3.3 Typical softened textiles articles

Almost all apparel and home furnishing textiles are treated with softeners, because the hand of a textile is a very important quality for most buyers and users. Nearly everyone who examines a textile automatically touches it with their fingers to get an impression of the hand. Only a few speciality fabrics do not receive a softener finish, consequently, it is easier to state which fabrics are not softened. These include wall coverings, carpeting and most industrial textiles.

### 3.4 Product types and their chemistry

Most softeners consist of molecules with both a hydrophobic and a hydrophilic part. Therefore, they can be classified as surfactants (surface active agents) and are to be found concentrated at the fibre surfaces. Most softeners have a low water solubility. Therefore softening products are usually sold as oil in water emulsions containing 20–30 % solids. The softener molecules typically contain a long alkyl group, sometimes branched, of more than 16 and up to 22 carbon atoms, but most have 18 corresponding to the stearyl residue. Exceptions to this molecular structure are the special categories of silicones, paraffins and polyethylene softeners. About one-third of the softeners used in the textile industry are silicone based.

#### 3.4.1 Cationic softeners

Figure 3.2 shows typical cationic softener structures, for example, *N,N*-distearyl-*N,N*-dimethyl ammonium chloride (DSDMAC). Cationic softeners have the best softness and are reasonably durable to laundering. They can be applied by exhaustion to all fibres from a high liquor to goods ratio bath and they provide a hydrophobic surface and poor rewetting properties, because their hydrophobic groups are oriented away from the fibre surface.<sup>4,5</sup> They are usually not compatible with anionic products (precipitation of insoluble adducts).

Cationic softeners attract soil, may cause yellowing upon exposure to high temperatures and may adversely affect the lightfastness of direct and reactive dyes. Inherent ecological disadvantages of many conventional (unmodified) quaternary ammonium compounds (quatarnaries) are fish toxicity and poor biodegradability. But they are easily removed from waste water by adsorption and by precipitation with anionic compounds. Quaternaries with ester groups, for example triethanol amine esters, are biodegradable, through the hydrolysis of the ester group.<sup>6</sup> The example of an ester quaternary in Fig. 3.2 is synthesised from triethanolamine,

## Quaternary ammonium salts

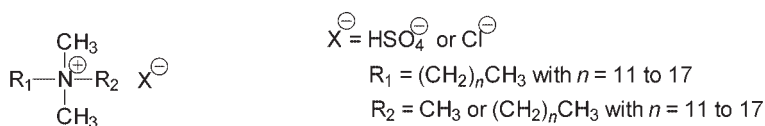

## Amine salts

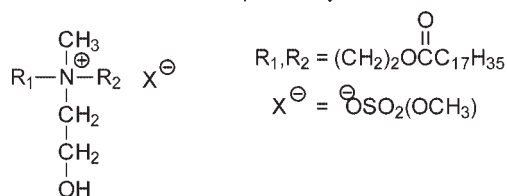

## Imidazolines

Di-(stearylcarboxylethyl)-hydroxyethylmethylammonium methylsulfate  
A triethanolamine ester quaternary

## 3.2 Chemical structures of typical cationic softeners.

esterified with a double molar amount of stearic acid and then quaternarised with dimethylsulfate. More examples, as well as other structure types, are described by Mooney.<sup>7</sup> Compared to the amine salt type which can be deprotonated, quaternary modified cationic softeners show a high stability under alkaline application conditions up to pH 11.<sup>8</sup>

## 3.4.2 Anionic softeners

Anionic softeners are heat stable at normal textile processing temperatures and compatible with other components of dye and bleach baths. They can easily be washed off and provide strong antistatic effects and good rewetting properties because their anionic groups are oriented outward<sup>4,9</sup> and are surrounded by a thick hydration layer. Sulfonates are, in contrast to sulfates, resistant to hydrolysis (Fig. 3.3). They are often used for special applications, such as medical textiles, or in combination with anionic fluorescent brightening agents.



### 3.3 Chemical structures of typical anionic softeners.

#### 3.4.3 Amphoteric softeners

Typical properties are good softening effects, low permanence to washing and high antistatic effects (because of their strong ionic character). They have fewer ecological problems than similar cationic products. Examples of the betaine and the amine oxide type are shown in Fig. 3.4.

#### 3.4.4 Non-ionic softeners based on paraffin and polyethylene

Polyethylene (Fig. 3.5) can be modified by air oxidation in the melt at high pressure<sup>6</sup> to add hydrophilic character (mainly carboxylic acid groups). Emulsification in the presence of alkali will provide higher quality, more stable products. They show high lubricity (reduced surface friction) that is not durable to dry cleaning, they are stable to extreme pH conditions and heat at normal textile processing conditions, and are reasonably priced and compatible with most textile chemicals.

##### Alkyldimethylamine oxide softener

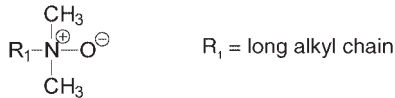

##### Betaine softeners

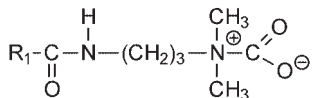
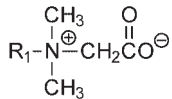
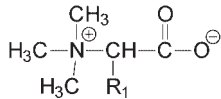

### 3.4 Chemical structures of typical amphoteric softeners.

## 34 Chemical finishing of textiles

Polyethylene



Ethoxylated fatty alcohol

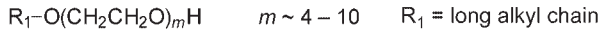

Ethoxylated fatty acid

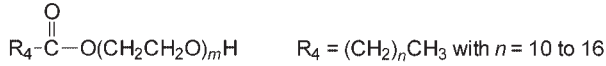

Ethoxylated fatty amide

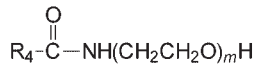

Ethoxylated fatty amine (cationic at pH < 7)

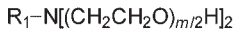

Castor oil ethoxylate, an important triglycerol ester

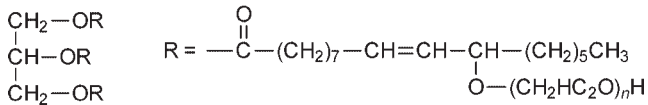

### 3.5 Chemical structures of typical non-ionic softeners.

#### 3.4.5 Ethoxylated non-ionic softeners

These polyglycol ethers are synthesised by the addition of ethylene oxide to fatty alcohols, carboxylic acids, esters, amides or amines (Fig. 3.5). They are surfactants and often used as antistatic agents and as components of fibre spin finishes. Their main characteristics are relatively high substantivity and hydrophilicity, non-yellowing and sometimes a low softening effect and lubricity, and a potential for foaming during processing.

#### 3.4.6 Silicone softeners

Non-ionic and cationic examples of silicone softeners are shown in Fig. 3.6. They provide very high softness, special unique hand, high lubricity, good sewability,



elastic resilience, crease recovery, abrasion resistance and tear strength. They show good temperature stability and durability, with a high degree of permanence for those products that form crosslinked films and a range of properties from hydrophobic to hydrophilic.<sup>10,11</sup> More detailed general and textile-related silicone properties are described by Mooney.<sup>7</sup>

Depending on their method of synthesis, silicone softeners can contain variable amounts of volatile siloxane oligomers. Together with volatile emulsifiers these oligomers can cause pollution problems in the waste air from tenter frames.<sup>12</sup> In textile finishing, silicones are also used as water repellents, elastomeric finishes, coatings and as defoamers.

According to Bereck *et al.*<sup>13</sup> the high molecular flexibility of the silicone chain is the reason for the very low glass transition temperature (about  $-100\text{ }^{\circ}\text{C}$ ) and for their special softness. They postulate that to a great extent the methyl groups of the  $\text{OSi}(\text{CH}_3)_2$ -structure shield the oxygen atoms from outside contact. Therefore the surface of fibres finished with polydimethylsiloxane is mostly non-polar and hydrophobic. In the case of cellulose, wool, silk and polyamide fibres, there are strong hydrogen bonds between the hydroxyl or amino groups of the fibres and the amino groups of the modified silicones (Fig. 3.7, upper figure). These bonds act as an anchor for the silicone, which forms an evenly distributed film on the fibre surface. Good water repellency and very soft hand are the result. With an optimal content of amino side groups, the polysiloxane segments between the anchor sites are long enough to maintain their high flexibility. This is the main reason for the softness and the lubricating effect of amino functional silicones on polar fibres.

In the case of relatively non-polar fibres such as polyester, the hydrophobic segments of the silicone chains interact strongly with the hydrophobic fibre surface (Fig. 3.7, lower figure). The positively charged amino side groups of the silicone chains repel each other and give rise to enhanced flexibility of the silicone chain loops. This again is the reason for the specially soft hand of amino functional silicones on non-polar fibres. The rate of amino modification of silicone softeners as shown in Fig. 3.6 is low:  $y + z$  is 1–20 compared to  $x$  of about 100 (50–200).<sup>14</sup> Quaternary modified groups provide high alkaline and shear stability.<sup>8</sup>

### 3.5 Schematic comparison of important properties of softeners

An overview of the generic properties of the different chemical softener types is given in Table 3.1. Naturally, non-ionic softeners have the best compatibility with other finishing compounds.

### 3.6 Compatibility and combinability

Softener finishes are often combined with easy care and antistatic treatments. As a rule of thumb, hydrophobic softeners cause an extra soft hand whereas

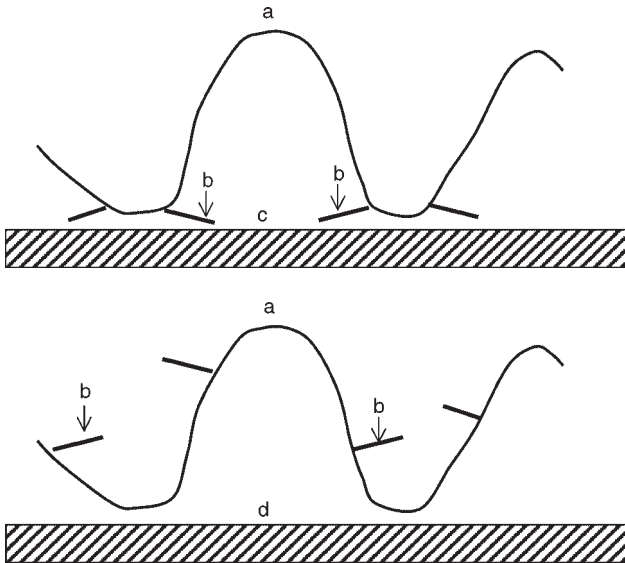

3.7 Schematic arrangement of amino-modified silicone softeners on the fibre surface as suggested by Bereck *et al.*<sup>13</sup> a = loops of the polydimethylsiloxane chain, b = partially cationic aminoethyl-aminopropyl side groups (about half of them are positively charged), c = fibre surface with partially negative charge, for example cotton and wool, d = hydrophobic attraction of unmodified silicone chain segments and fibre surface, for example polyester.

hydrophilic softeners bring about some fullness. In combination with fluorocarbons, most softeners reduce oil repellency. Some ionic, surface active and silicone free softeners are not compatible with water repellents. Since softeners are usually also excellent fibre lubricants, softening finishes often give poor anti-pilling and slippage properties.

Table 3.1 Important softener characteristics

Chemical type	Softness	Lubricity	Hydrophilicity	Substantivity	Stability to yellowing	Non-foaming
Anionic	+	++	++	-	++	-
Cationic	+++	-	-	+++	-	+
Amphoteric	++	-	+++	+	-	-
Non-ionic						
Ethoxylates	+	++	++	++	+	-
Polyethylene	+	+++	-	-	+	++
Silicones	+++	+++	- to +	+++	+++ to +	++

+, characteristic present; -, characteristic absent.

### 3.7 Evaluation and testing methods

Fabric hand is defined as the estimated quality of a fabric, evaluated as reaction of the sense of touch, which is integrated in our brain to a total value.<sup>5,15</sup> Important components of the sensory perception are the smoothness, compressibility and elasticity of the textile sample. As the hand of fabrics is primarily a subjective feeling – similar to the impression of colour – there have been many efforts to find methods for objective evaluation of the fabric hand. While instrumental colour measurement is very common in textile quality control, the automated measurement of fabric hand is still a topic of discussion and subjective manual hand evaluation is still the most important method. Simple methods to measure some aspects of fabric hand were described by Dawes and Owen.<sup>16</sup> Many factors such as the colour of the textile, the light and the surroundings, influence the manual evaluation of fabric hand.<sup>17</sup> The American Association of Textile Chemists and Colorists has published guidelines for subjective hand evaluation.<sup>18</sup>

In some textile production laboratories single reference standards or a simple set of hand standards with different hand values is used. This set of standards is produced from the same fabric as the one being evaluated by applying the same softener at incremental concentrations. If the softener is used in combination with other finishes, the concentration of the other finishes must be held constant. Relatively simple methods to evaluate only the bending properties of fabric (flex rigidity) are the cantilever method and a similar device called Softometer, which are described in Chapter 4 on hand building.

The Handle-O-Meter<sup>3</sup> is another method in which different kinds of deformation have a simultaneous effect on the sample, resulting in a total value for the hand. A rectangular sample of maximum 20 cm or 8 inches width is pushed by a blade into a variable slit. The maximum resistance force on the blade is registered, giving a value that depends on the flex rigidity of the sample and the frictional resistance on the corner of the slit. Thus both the surface smoothness and the compressibility are included in the measurement. The mean values of both sides of the fabric in lengthwise and crosswise directions are determined and recorded. In other relatively simple methods the resistance is measured, when a textile sample is drawn through a ring aperture<sup>19</sup> or a nozzle.<sup>20</sup> The measured resistance force consists of components of the flexural rigidity, the surface friction, the shear rigidity and the compressibility.

The most comprehensive but most expensive method of objective hand evaluation was developed by Kawabata and co-workers<sup>21–23</sup> and is called KES-F (Kawabata Evaluation System-Fabrics). It consists of several different measuring instruments, for example for tensile and shear properties (KES-F1), bending properties (KES-F2), compressibility (KES-F3), surface (KES-F4) and thermal (KES-F7) properties. The measured parameters and the area weight are normalised and correlated to the subjective handle scores. From this correlation, for every hand evaluation a transformation equation is developed, resulting in a primary

hand value between 0 and 10. From these primary hand values a total hand value can be calculated, ranging from 0 (not acceptable) to 5 (excellent). For every fabric type new correlation equations have to be developed. Therefore many users of the KES-F equipment correlate only selected properties with the subjective assessments of their interest, for example the shear hysteresis with softness. Kawabata parameters can also be measured, with some restrictions, with the usual testing machines (such as Instron) at low stress settings.<sup>7</sup>

FAST (Fabric Assurance by Simple Testing) is another well known system.<sup>24</sup> It was developed for quality assessment in the wool garment industry. FAST is less expensive and much quicker than the KES-F because it measures only some aspects of the fabric hand such as compression, bending, extension and dimensional stability at a few given points in a simplified form. The first three parameters correlate fairly well with the perceived softness but no quantitative hand values are calculated. For the evaluation of yarn softness, there are several other devices in use, for example the  $\mu$ -Meter (Zweigle), a frictional balance (Reibwertwaage from Schlafhorst) and the F-meter.

As can be seen, there are numerous instruments available to make objective, but incomplete, measurements of those physical properties that determine fabric hand. It is fair to say, however, that the best of these very expensive tools is, in general, not any better for making real time production decisions than an experienced finisher who knows what his or her customer expects.

### 3.8 Particulars of and troubleshooting for softening finishes

Microemulsions of softeners, mainly amino-modified silicones, give special softening effects. Their main advantage is high emulsion stability. This is important for applications with high shear, as in jet or package dyeing machines. Emulsions that do not have excellent shear stability can actually breakdown and deposit softener particles on equipment and fabric that are either very difficult or impossible to remove. In Table 3.2, some characteristics of normal and microemulsions are compared.

**Emulsion stability:** When the stability of a normal (not micro-) emulsion is very high in an exhaust treatment, then the softening effect decreases. An emulsion of moderate stability gives the best results, probably because small drops of the emulsified softener can exhaust to the fibre surface. Poor emulsion stability causes stains.

**Reactive softeners:** Some softeners have functional groups that can react with the corresponding groups of some fibres, for example *N*-methylolated amines with the hydroxyl groups of cellulose (compare the mechanism of the crease resistance finish). The result is a very durable finish, combined with the typical advantages and disadvantages of this crosslinking chemistry, as discussed in Chapter 5.

**Softeners and thermomigration of dyes:** Many hydrophobic softeners are

Table 3.2 Emulsion properties

	Normal emulsion	Micro emulsion
Size of the drops (nm)	150–300	10–20 See also Holzdörfer <sup>25</sup> : no droplets, only micelles
Appearance	Milky cloudy, scattering of light of wavelength of 400 nm and more	Clear as water, because the droplets are much smaller than the wavelength of visible light
Emulsifier content	Normal (~3 % on weight of the softener solids)	Very high (can be equal to softener solids)
Distribution after application	On the fibre surface	More inside the fibre bundle
Handle	Soft to greasy	Very soft, not greasy
Stability to mechanical forces	Moderate	High
Substantivity	Good	Less good
Effect on crockfastness	None	Sometimes negative (because of the high emulsifier content)

solvents for disperse dyes. Therefore they increase thermomigration of the dyes and the staining of adjacent yarns (bleeding). The crockfastness and washfastness of the fabric decrease as the dyes migrate to the fibre surface.

**Volatility:** Some softeners are volatile or contain volatile components. During drying, heatsetting or curing these volatile components can condense on cooler areas of the ovens and then drop back onto the fabric, causing spots. Heating the top of the ovens can help prevent this problem.

**Yellowing:** This problem arises especially with undyed fabrics. It can be caused by the oxidation of cationic softeners or amino-modified silicones or by the ionogen attraction of cationic softeners and anionic fluorescent brighteners (extinguishing the fluorescence by salt formation).<sup>6</sup> Dispersing agents and product selection are then helpful.

**Mechanical softening:** Softening effects can be gained on some fabrics without chemicals, only by mechanical treatment, for example washing or in a tumbler or with high pressure water jets. This hydroentanglement of the fibres is similar to the spunlace technique for nonwovens, with the advantage of an additional cleaning effect and the disadvantage of drying and machinery costs. The degree of softness is normally increased in the following order: going from mechanical treatments to fabric construction (for example with micro fibres) to chemical softening, in other words chemical softening has the greatest effect.

**Deeper colour, darker black:** Finishes with silicone softeners or elastomerics

generate deeper colour impressions, similar to wet textiles. This is caused by a lower light reflection, especially by a low refractive index (silicone 1.43 and water 1.33). A middle refractive index is typical for cotton (1.56) and nylon (1.57). But the high refractive index of polyester (1.63) causes such a high light reflection that a deep black on polyester fibres needs relatively high amounts of dyestuff. This becomes more critical with micro fibres. Their large surface (about double that of normal fibres) causes even more reflection. With silicone finishes, preferably with amino-modified macroemulsions, a deep black or other deep colour on polyester micro fibres is achievable, combined with a very soft handle. A disadvantage is the increased thermomigration, leading to lower wet and crocking fastness. This can be reduced by avoiding over-dosing and drying temperatures over 120 °C.<sup>26</sup>

## References

- 1 Evans W P, 'Cationic fabric softeners', *Chemistry and Industry* 1969, 893–903.
- 2 Vaughan E A and Kim C J, 'Definition and assessment of fabric hand', *AATCC Book of Papers: 1975 National Technical Conference*, 1975, 66–77.
- 3 Kim C J and Vaughan E A, 'Physical properties associated with fabric hand', *AATCC Book of Papers: 1975 National Technical Conference*, 1975, 78–95.
- 4 Wakelyn P J and Johnson R F, 'Orientation of antistatic agents at the surface of acrylic fibres', *Journal Society Dyers Colourists*, 1972, **88**, 150.
- 5 *Textile Terms and Definitions*, 10th edn, Manchester, Textile Institute, 1995.
- 6 Hausch F, 'Textilweichmacher', *Textilveredlung*, 2001, **36**, 23–28.
- 7 Mooney W, 'Chemical softening', in *Textile Finishing*, Heywood D (ed.), Bradford, Society of Dyers and Colourists, 2003, 251–307.
- 8 Thumm S, 'Prozessoptimierte Siliconweichgriffmittel', *International Textile Bulletin*, 2001, **47**(4), 88.
- 9 Flath H-J, 'Aktuelle Probleme der Weichgriffausrüstung', *Textiltechnik*, 1987, **37**, 255–258.
- 10 Habereeder P, 'Silicon-Weichmacher: Struktur-Wirkungsbeziehungen', *Melliand Textilberichte*, 2002, **83**, 336–338.
- 11 Thoss H, Hesse A, Höcker H, Wagner R and Lange H, 'Aufziehverhalten von ammoniummodifizierten Silikonweichmachern auf CO-Gewebe', *Melliand Textilberichte*, 2003, **84**, 314–318.
- 12 Habereeder P, 'Textilsilicone und Umwelt – für den Praktiker in Zahlen', *Melliand Textilberichte*, 1997, **78**, 352–354.
- 13 Bereck A, Weber B, Riegel D, Bindl J, Habereeder P, Huhn K G, Lautenschlager H-J and Preiner G, 'Einfluss von Siliconweichmachern auf Griff und mechanische Eigenschaften von textilen Flächengebilden, Teil 4', *Textilveredlung*, 1997, **32**, 138–141.
- 14 Sand C, Brückmann R and Zyschka R, 'Modische Akzente in der textilen Ausrüstung', *Melliand Textilberichte*, 2000, **81**(11/12), 992–997.
- 15 Ellis B C and Garnsworthy R, 'A review of techniques for the assessment of hand', *Textile Research Journal*, 1980, **50**, 231.
- 16 Livesy R J and Owen J D, 'Cloth stiffness and hysteresis in bending', *Journal Textile Institute*, 1964, **55**, T516.
- 17 Bishop D P, 'Fabrics: sensory and mechanical properties', *Textile Topics*, Manchester, Textile Institute 1996, (see also *Textile Progress*, **26**(3)).

- 18 AATCC Evaluation Procedure 5, *AATCC Technical Manual 1999*, Research Triangle Park.
- 19 Ehrler P, Mavely J, Weisse F, Augenadel A and Blankenburg G, 'Description and control of tactile properties by the Kawabata and alternative test systems', *DWI Reports*, 1993, **111**, 495–508.
- 20 Behery H M, *Textile Research Journal*, 1986, **56**, 227.
- 21 Kawabata, S, *The Standardization and Analysis of Hand Evaluation*, Vol. 2, Osaka, Textile Machinery Society Japan, 1980.
- 22 Kawabata S and Niva M, *Proceedings 5th International Wool Textiles Research Conference*, Aachen 1975, Vol. V, 1976, 413.
- 23 Finimore E, 'Objektive Griffbeurteilung nach dem KES-F System', *Chemiefasern/ Textilindustrie*, 1982, **32/84**, 826.
- 24 Allen C F, Shaw T, de Boos A G and Ly N G, 'Verbesserung der Qualität von Wollgeweben durch Anwendung des FAST-Systems', *Melliand Textilberichte*, 1990, **71**, 614.
- 25 Holzdörfer U D, 'Hydrophile Weichmacher auf Basis von Silikonem', *Textilveredlung*, 2001, **36**, 5.
- 26 Poppenwimmer K and Schmidt J, 'Ausrüsten von Synthesefaserstoffen – Teil 2', *Textilveredlung*, 1999, **34**(7/8), 6.

## 4.1 Introduction

The hand building finish is not only one of the oldest but also one of the most important kind of finishes. Very different natural and synthetic polymers are used for an astonishing variety of hand effects. The main effects of fullness and stiffness enable a very interesting hand design, often in combination with other finishes. Softness and hardness or stiffness are incompatible contrasts, but there are – especially with the filling finish – many fluent transitions. Filling products can be combined as well with softeners as with stiffening products.

Finishes that add firmness to fabric hand are often called hand builders. Fabric hand was discussed in detail in Chapter 3 on softening finishes. Large quantities of hand builders are used today to improve the hand of fabrics that are too flimsy, limp or raggy for either the customer, as point-of-sale finishes, or subsequent processing, such as sewing or automated materials handling. These finishes are also used to increase the weight of fabrics that are below weight specifications. With increased bulk, stiffness or weight, the processability and marketability of these fabrics is increased. When a permanent finish is not required, non-durable products can be used to provide a ‘counter finish’ for increased sale appeal. Hand builders durable to repeated laundering and dry cleaning are employed for permanent effects.

## 4.2 Definitions and terms

Hand builders can be roughly divided into two groups depending on the major effect on fabric hand. One group adds fullness, which is a feeling of increased bulk or weight. The second group provides stiffness or a resistance to bending. However, it is not always possible to make clear distinctions because some stiffening products also yield a fuller hand and many products that add fullness also provide stiffening effects, especially at high concentrations.

### 4.3 The hand building effect

High molecular weight and especially the crosslinked hand builders tend to provide mostly stiffness with some added fullness. This is due to their attachment at the fabric surface and accumulation in spaces between yarns. Individual fibres and yarns are bound together, which accounts for the stiffness observed. Smaller macromolecules penetrate more easily between individual fibres of the yarn bundle, binding the fibres with a minimum of yarn-to-yarn connections and resulting in both fullness without a high degree of stiffness. Crosslinkable products can provide both fabric fullness and stiffness that is durable to laundering and dry cleaning.

### 4.4 Examples of textiles with hand building finishes

Stiffening with starch is often used after laundering shirts, blouses and table linens. An increased fullness is frequently important for fabrics with low warp and fill densities, such as some lining, suit and costume fabrics, overcoat poplin and also for pile fabrics, for example corduroy. Some stiffness and fullness effects are necessary for laces and knitted dress fabrics. Even greater stiffness is usual for selected denim articles, work clothes and industrial uniforms, such as some jeans, overalls, aprons and lab coats. A full and stiff hand is demanded for mattress duck, tapestries and awning fabrics. Fabrics for window treatments like blinds and curtains require a measure of stiffness. Many textiles receive a non-durable stiffening finish for ease in cutting and processing. Some durable hand builders are also used as pigment binders, binders for non-wovens, finishes for carpet backings, coatings for glass fibre fabrics and as additives (for example adhesives) for other speciality finishes.

### 4.5 Typical hand builder chemistry

#### 4.5.1 Non-durable hand building finishes

Hand building finishes that lose their effect after one or two launderings are considered non-durable. The two major product types of non-durable hand builders are starch derivatives and polyvinyl alcohol. Natural starch is produced commercially from potatoes, corn, wheat, rice and tapioca. Its two main components are polymers of  $\alpha$ -glucose, amylopectin and amylose, shown in Fig. 4.1. The thickening effect of starch is mainly due to the long and branched amylopectin chains.

Polyvinyl alcohol (PVA) is a water-soluble polymer with a glass transition temperature,  $T_g$ , of 80 °C. Although its name implies a homopolymer structure, the structure of commercial PVA is a copolymer of vinyl alcohol and vinyl acetate as seen in Fig. 4.2. PVA is made by the incomplete hydrolysis of polyvinyl acetate

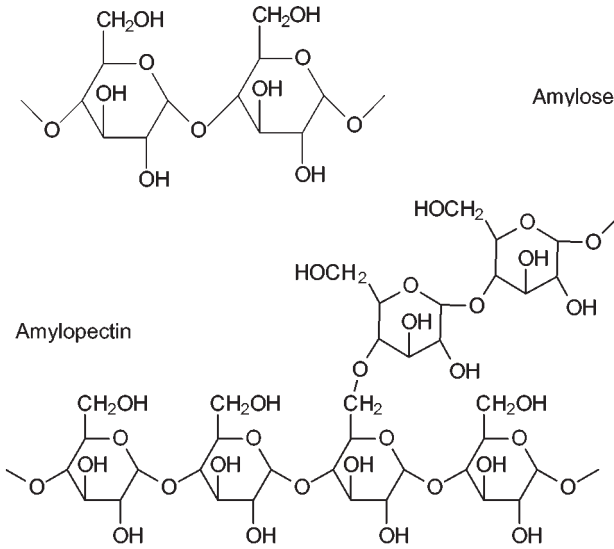

4.1 Structures of starch components.

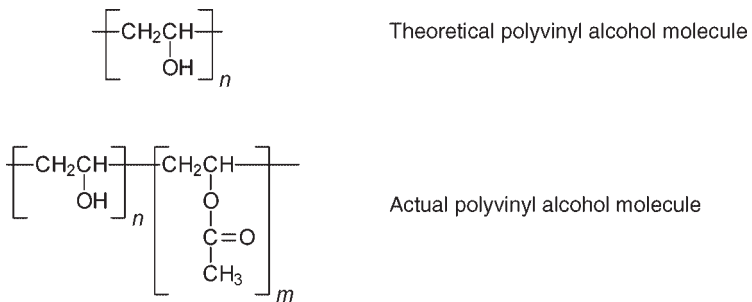

4.2 Polyvinyl alcohol structures.

and several grades with varying degrees of hydrolysis are available. Incorporating *N*-methylol crosslinking agents into PVA and starch formulations can increase the laundering durability of their hand building effects. In addition to their use as hand builders, starch and polyvinyl alcohol are important warp sizes.

#### 4.5.2 Durable hand building finishes

Hand building finishes that retain their stiffening and fullness effects after repeated launderings are considered to be durable. These products are usually aqueous emulsions of polymers that form water-insoluble films on the fibre surface when dried. The three main types of products are vinyl acetate-containing polymers, acrylic copolymers and thermosetting polymers.

Vinyl acetate-containing polymers include both polyvinyl acetate and ethylene-vinyl acetate copolymers (EVA), as shown in Fig. 4.3. Polyvinyl acetate has a glass transition temperature of 30 °C and provides a stiff hand to treated fabrics. EVA copolymers can yield a variety of hand effects depending on the relative amounts of ethylene and vinyl acetate in the copolymer. Increasing the amount of ethylene ( $T_g$  of polyethylene = -70 °C) in the copolymer will give products with increasingly softer hand effects. Another vinyl polymer used for hand building is polyvinyl methyl ether (PVME) as shown in Fig. 4.4. PVME has a low  $T_g$ , less than -20 °C and provides a very full hand. It is particularly useful with rayon lining fabric.

The largest and most versatile group of hand builders is based on polyacrylate and polymethacrylate chemistry. The general structures of acrylate and methacrylate polymers are given in Fig. 4.5. Some of the more important individual polymers are listed in Table 4.1. From this table, several trends concerning  $T_g$  are evident. Methacrylates have higher  $T_g$  values than the corresponding acrylates, and the longer the alcohol group, the lower the  $T_g$  of the polymers. Fischer has shown that a high  $T_g$  of polymers leads to a firm, stiff hand when they are applied to fabric and that a low  $T_g$  leads to a softer, more flexible effect.<sup>1</sup> The same relationship between  $T_g$  and stiffness is applicable to acrylic emulsions used as print paste

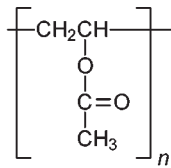

Polyvinyl acetate

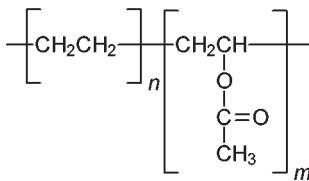

Ethylene-vinyl acetate copolymer

#### 4.3 Polyvinyl acetate structures.

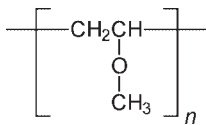

#### 4.4 Polyvinyl methyl ether structure.

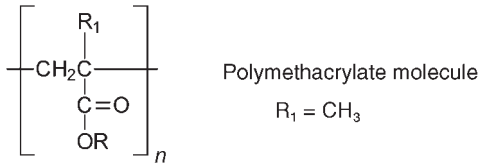
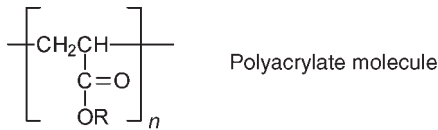

#### 4.5 Polyacrylate and polymethacrylate structures.

binders.<sup>2</sup> Products with a low  $T_g$  value can be used to build up fabric weight and fullness without causing the fabrics to become excessively stiff, while high  $T_g$  products can add fabric stiffness with only slight weight gain. Indeed, the extremely high  $T_g$  (105 °C) of polymethylmethacrylate leads to its use as an acrylic glass.

Typically, polymers of these acrylic and methacrylic esters are produced as copolymers with other acrylic and vinyl monomers. For example, acrylonitrile is often added to impart additional water and solvent resistance. Other features that can be improved include abrasion resistance, adhesion, elasticity, flexibility and film hardness. Enhanced durability to laundering can be achieved by incorporating reactive, especially crosslinking, monomers such as *N*-methylol acrylamide, hydroxyethyl acrylate, acrylamide, acrylic and methacrylic acid. Optimisation of polymer properties with the large variety of available monomers leads to near endless combinations of copolymers<sup>3</sup> that are limited only by the imagination of the chemist and by the reality of the cost–efficiency ratio.

Another category of durable hand builders are formaldehyde-containing thermosetting polymers. These products are usually supplied as dispersions or aqueous solutions of precondensates of urea or melamine with formaldehyde, for example di-methylol urea or di- to hexa-methylol melamine and their methyl ethers. The thermosetting polymers are comparatively inexpensive and provide fabrics with stiffness and resilience. However, they have a tendency to reduce abrasion resistance, yellow after exposure to heat, and release formaldehyde. Melamine-based hand builders are more highly crosslinked than urea-based products and are accordingly more durable. Butylated urea condensates are especially useful for rayon fabrics (see also Chapter 5: Easy-care and durable press finishes of cellulose).

Modified polyurethanes as shown in Fig. 4.6 are used for valuable hand variations and as additives for cellulose crosslinkers. Their flexible and elastic films on the fibre surface improve elastic resilience, which is, for example, important for pile fabrics.<sup>4</sup> The principle of their elasticity is, as in elastan fibres, the molecular combination of so-called weak and hard segments. The large weak

Table 4.1  $T_g$  values for important polyacrylates and polymethacrylates

Polymer	R in Fig. 4.5	Glass transition temperature ( $T_g$ )
Polymethylacrylate	$\text{CH}_3$	ca. 6 °C
Polyethylacrylate	$\text{CH}_2\text{CH}_3$	ca. -18 °C
Poly- <i>n</i> -butylacrylate	$\text{CH}_2\text{CH}_2\text{CH}_2\text{CH}_3$	ca. -45 °C
Polymethylmethacrylate	$\text{CH}_3$	105 °C
Polyethylmethacrylate	$\text{CH}_2\text{CH}_3$	ca. 63 °C
Poly- <i>n</i> -butylmethacrylate	$\text{CH}_2\text{CH}_2\text{CH}_2\text{CH}_3$	ca. 23 °C

macrodiol segments with low intermolecular attraction enable elongation and flexibility. The smaller rest of the molecule, called hard segments because of the strong intermolecular bonding, mainly hydrogen bridges, causes local fixation and finally the effect of the retaining forces in the soft segments after elongation, thereby generating elasticity.

## 4.6 Evaluation methods

The same subjective and objective methods for determining the effects of softeners discussed in Chapter 3 can be applied to the assessment of hand builders. Process control of fullness is most easily accomplished by monitoring the percentage weight increase of the fabric in finishing. Standard-sized samples are cut from the fabric before and after the finish is applied. The gain in weight ( $\text{g m}^{-2}$  or  $\text{oz yd}^{-2}$ ) on

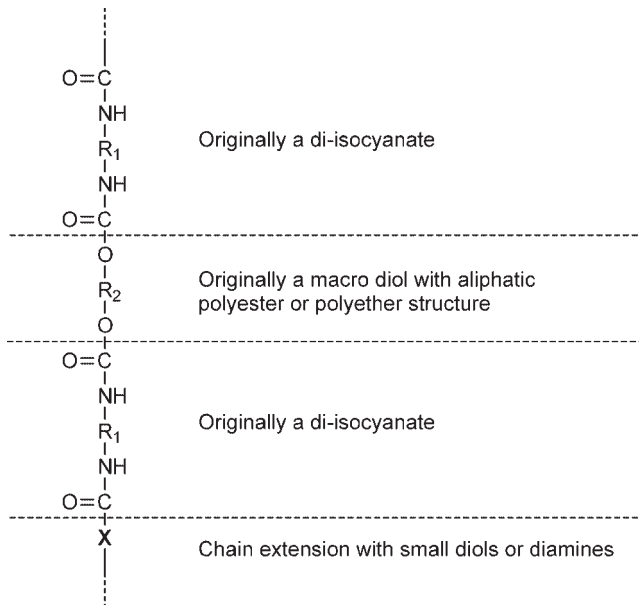

4.6 Structure of modified polyurethanes.

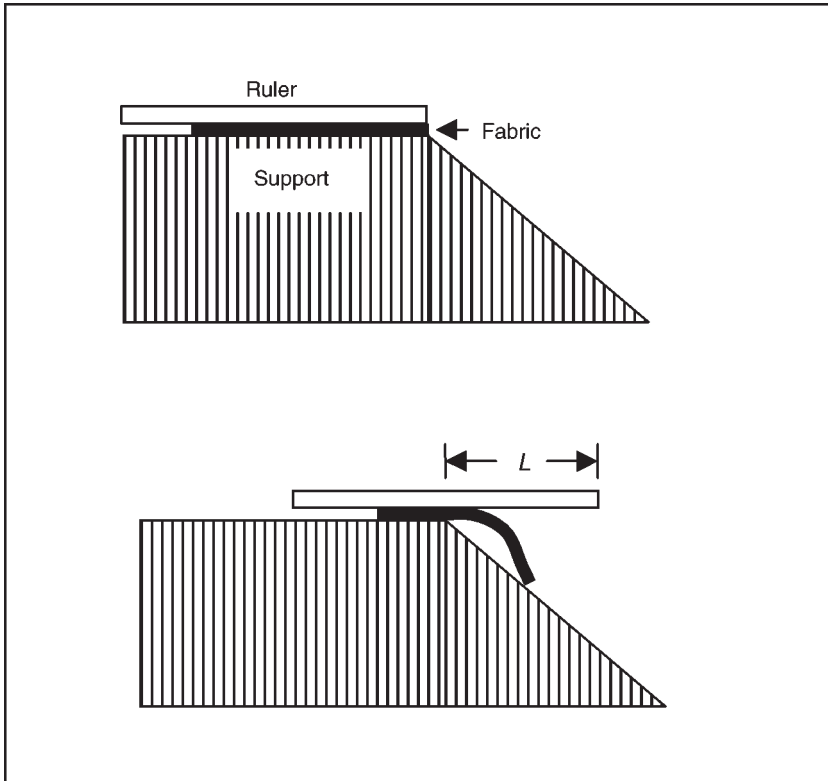

4.7 Device for the cantilever test method with  $L$  = sagged length.

finishing divided by the weight before the finish application, times 100, is the weight increase in percent that is due to the finish. This is sometimes referred to as the percent relative weight increase. Continuous measurements of fabric weight can be made using  $\beta$ -radiation with the aptly named 'beta gauges'. These on-line measurements allow for corrective action to be taken immediately, for example variation of the roller pressure of the padder, to maintain fabric weight within specified limits.

Fabric stiffness and drape qualities can be easily quantified by the cantilever method.<sup>5,6</sup> As shown in Fig. 4.7, a sample of specified width and length is placed on the top of the test device and covered with a ruler, preferably a transparent one. The fabric edge, the zero mark of the ruler and the upper edge of the inclined plane are aligned (inclination angle  $41.5^\circ$ ). The fabric sample and the ruler are moved together over the horizontal plane towards the inclined plane until the sagging edge of the fabric sample touches the inclined plane. The length indicated on the ruler at that point is recorded as the bending length. An average of 10 measurements is determined. The flexural rigidity,  $G$ , can be expressed by:

$$G = (1/8) \times W \times L^3 \quad [4.1]$$

where  $W$  is the fabric weight in  $\text{g cm}^{-2}$  and  $L$  is the average sagged length of the sample in cm. The flexural rigidity depends mainly on the internal friction between the fibres and the fabric construction. In other test methods the bending of the fabric sample is not caused by its own weight but by several load weights thereby being better adaptable to different degrees of stiffness degrees.<sup>7,8</sup> By the way, most permanent hand builders decrease the water absorbency, which can easily be proved by the drop test.<sup>9</sup>

## 4.7 Troubleshooting for hand building finishes

Some potential difficulties with hand builders include:

- increased soiling and staining of the finished fabrics
- increased fabric flammability and
- mark-off, a special finishing fault that exists when fabrics show chalk-like marks when scratched.

All of these problems are more severe at high hand builder concentrations. Selection criteria for products that add stiffness and/or fullness include cost, ease of application, compatibility with other chemicals present in the finishing bath and, of course, the properties of the resulting finished fabrics and their degree of permanence. Hand builders provide antislip effects and can be used for antipilling.<sup>4</sup> Obviously the stiffening effect is not compatible with an elastomeric finish.

## References

- 1 Fischer K, 'Modern trends in the use of Appretan brands for the finishing, binding and coating of textiles', *Melliand Textilberichte*, 1990, **71**, 290–303, E 131-E136.
- 2 Patel D C, 'Synthetic Binders for Pigment Printing', in *Pigment Printing Handbook*, AATCC, Research Triangle Park, 1995.
- 3 Wilhelm H, 'Reaktionsfähige Hochpolymere für die Textilveredlung', *Textilveredlung*, 1988, **23**(part 1), 96–100, (part 2), 178–181, (part 3), 25–230, (part 4), 307–312.
- 4 Sand C, Brückmann R and Zyschka R, 'Modische Akzente in der textilen Ausrüstung', *Melliand Textilberichte*, 2000, **81**(11/12), 992–997.
- 5 Pierce F T, 'Cantilever method, corresponding to BS 3356-1961 and to ASTM 1388-55 T', *Journal Textile Institute*, 1930, **21**, T377.
- 6 Mooney W, in *Textile Finishing*, Heywood D (ed.), Bradford, Society of Dyers and Colourists, 2003, 251–307.
- 7 DIN 53 864, *Determination of the bending strength, method according to Schlenker*. Deutsches Institut für Normung.
- 8 ASTM D 1388, *Standard Test Method for Stiffness of Fabrics*. American Society for Testing and Materials.
- 9 Wurster P, Schmidt G *et al.*, 'Der TEGEWA-Tropftest, eine Methode zur schnellen Bestimmung der Saugfähigkeit an textilen Flächengebilden', *Melliand Textilberichte*, 1987, **68**(8), 581–583.

## 5.1 Introduction

Cellulose fibres and especially cotton are still the most important kind of fibres, because of their numerous advantages. One of their main disadvantages, wrinkling after washing is overcome by a very important and special kind of finish. It is difficult to find the one best term to describe this class of finishes. Some of the words and phrases that have been used in the past include easy-care, minimum care, easy-to-iron, no-iron, wash and wear, crease resistant, durable press, permanent press, shrink proof, wrinkle resistant and wrinkle free. Table 5.1 shows the main positive effects of cellulosic finishes. Writing advertising copy for these products has been an ad-man/woman's dream come true. In actual fact, all of these terms do describe some important performance features of these multi-talented finishes. The most technically correct description would be 'cellulosic anti-swelling' or 'cellulosic crosslinking' finishes, but these terms probably wouldn't be of much value for increasing retail sales. In this chapter, the terms 'easy-care' and 'durable press' will be used preferably.

Easy-care and durable press finishes are generally applied to cellulose and cellulose blend fabrics, but other fibres can benefit from these finishes also. In addition to the dimensional stability properties mentioned above, the sheen of calendered fabrics (permanent chintz) and the stand and hand of pile fabrics are generally improved by durable press finishes. The primary effects of the easy-care and durable press finish on cellulosic fibres are reduction in swelling and shrinkage, improved wet and dry wrinkle recovery, smoothness of appearance after drying, and retention of intentional creases and pleats. The total crease recovery angle (CRA), that is the sum of the crease recovery angles of the warp and the fill directions of the fabric, increases from about 150° to about 300°. A fabric shrinkage of less than 5 % can usually be achieved.

An unavoidable side effect of the cellulosic crosslinking finishes is a reduction in the elasticity and flexibility of the cellulose fibres. This produces a considerable decrease in abrasion resistance and tear and tensile strengths on natural cellulose

*Table 5.1* Positive effects of cellulosic crosslinking finishes and corresponding textiles

Primary effect	Corresponding textile
<b>Easy-care and wrinkle resistance</b> , a smooth wrinkle-free appearance after washing without ironing	Mainly for woven fabrics
<b>Dimension stability</b> , shrink resistance after washing	Mainly for knitwear
<b>Durable press</b> , retention of intentional creases	Formal and leisure wear with some demands, plis�ee/pleated goods
<b>Pile resilience</b> , improved stand of pile by better elastic resilience	Pile fabrics
<b>Sheen and wash permanence of chintz</b>	Calendered (chintzed) fabrics
<b>Permanent knitter (hand knitted) look</b> , retention of irregular creases and wrinkles	Crushed fabrics, a fashion trend similar to the used look
<b>Antipilling</b> by better abrasion of the pills, a turn around of the disadvantage of strength loss	Most important for knitwear from 100 % cellulose
<b>Fixation of other finishes</b> , for example stiffening with water-soluble hand builders	Fabrics with low warp and fill densities, knitted dress fabrics, denim articles, mattress duck, awning fabrics
<b>Fixation of dyestuffs and pigments</b> by incorporation in the crosslinked cellulose and in the finish network, also providing better wet fastness for conventional dyeings and printings	Cellulosics mainly with direct and acid dyes, <sup>1</sup> cotton/polyester blends with reactive dyes, <sup>2</sup> preparation for dry heat transfer printing of cellulosics <sup>3</sup>

fibres. A rule of thumb states that an increase in the wrinkle recovery angle of 10° corresponds to a loss in abrasion and tear strength of about 7 %. The dry tear strength of regenerated cellulose fibres decreases only slightly with a crosslinking finish, but the wet tear strength actually increases because of the strongly reduced swelling. Table 5.2 gives an overview of the disadvantages of the cellulosic crosslinking finishes and the possible corresponding remedies.

## 5.2 Mechanisms of easy-care and durable press finishing

The primary cause of the shrinkage of cellulosic fibres is the fact that these fibres can readily absorb moisture. This absorbed moisture facilitates internal polymer chain movements in the amorphous fibre areas by lubrication. It disrupts the

*Table 5.2* Disadvantages of cellulosic crosslinking finishes and possible remedies

	Possibilities for remedy
<b>General disadvantages:</b>	
Loss of abrasion, tear and ripping strength	Wet condensation, liquid ammonia treatment, addition of silicones and other auxiliaries for example polyvinyl acetate, polyurethane
Hard handle	Combination with softeners
Greying during washing	Combination with soil-release finishes
Less dilatible and elastic	Combination with silicones, for example elastomeric
<b>Case-wise disadvantages:</b>	
Release of larger amounts of formaldehyde	Formaldehyde-free or low formaldehyde finishes, selection of products and condensation conditions (better than formaldehyde scavengers and cheaper than washing with new drying)
Reduction of light fastness and shade changes of coloured fabrics	Selection of products as dyestuffs, crosslinkers, catalysts
Yellowing, especially when not dyed and/or fluorescent brightened	Selection of catalysts, fluorescent brighteners and application conditions
Objectionable odours, sometimes fish smell	Selection of catalysts (no ammonium products), crosslinkers, if necessary washing
Chlorine retention, causing marked yellowing and strength loss	Selection of crosslinking agents, use of chlorine free washing products

internal hydrogen bonding between these polymer chains. When a moisture laden cellulosic fibre is stressed, the internal polymer chains of the amorphous areas are free to move to relieve that stress. Hydrogen bonds can reform between the polymer chains in their shifted positions, in effect locking in the new configuration. With no restoring forces available, a newly formed wrinkle or crease will remain until additional processes (ironing for example) apply adequate moisture and mechanical forces to overcome the internal forces.

The swelling of cellulosic fibres by moisture can be reduced by the application of self crosslinking urea or melamine products as well as by products that mainly crosslink with cellulose molecules. Without such a crosslinking finish, cellulose fibres can take up more than 10 % of their weight in water. As the fibres swell, the fabric must crease and shrink to relieve the internal stresses caused by the swelling.

The new arrangement of the cellulose molecules in the swollen form of the fibre is fixed by newly formed hydrogen bonds between adjacent cellulose molecules, mostly in the amorphous fibre area. Therefore the uneven and wrinkled appearance of the cellulose fabric remains after drying, in contrast to fabrics made of non-swelling synthetic fibres.

Two different chemical approaches have been used commercially to produce non-swelling or durable press cellulose fabrics. The original approach is the incorporation of a polymerised finish in the pores of the fibres, so that water molecules cannot easily penetrate the fibre. The newer approach is the reaction of multifunctional crosslinking agents with the hydroxyl groups of adjacent cellulose molecules that hinder the swelling of the cellulose fibre.

### 5.3 Examples of textiles with easy-care and durable press finishes

Easy-care and durable press finishes are applied to cellulose fabrics and fabric blends with high cellulose content that are laundered and which should maintain a smooth, 'just ironed' appearance through the lifetime of the article. These include shirts, blouses, trousers, work clothes, lining fabrics, suits, formal wear and overcoats. A novel fashion trend is the used and knitter (hand knitted) look. Here the marked creases of the crushed articles are irregular and fixed by permanent press finishes. Although wrinkles and creases are not as severe a problem with knitted fabrics (the loops of knitwear have a greater freedom of yarn movement when they are swelling, reducing the internal fibre stresses), easy-care finishes are also useful in providing dimensional stability to knitted fabrics (see Table 5.3). Pile fabric for clothes and upholstery can achieve a better appearance and resilience of the pile, in addition to the shrink and creaseproof effects. This easy-care finish is also used for table and bed linen because the wrinkling of linen after washing is very marked. One special use of the cellulose crosslinking finishes are wash permanent chintz articles, produced by the heat and high pressure of calendering the impregnated fabrics.

*Table 5.3* Importance of the requirements of easy-care finishes depending on the type of fabric<sup>4</sup>

Importance	Wovens	Knitwear
1	No-iron or easy-to-iron	Extra soft handle
2	Durable press performance	High dimension stability
3	Dimension stability	Elasticity and resilience
4	Soft and pleasant handle	Very good sewability
5	High abrasion stability	Hydrophilicity
6	Tear strength	High degree of whiteness

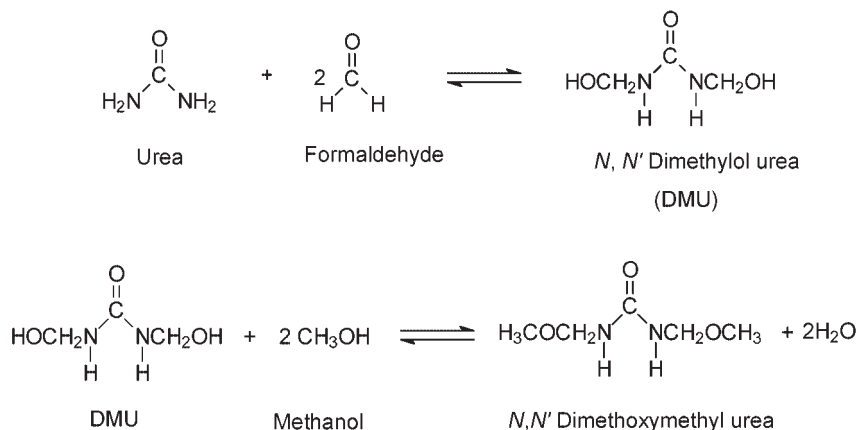

5.1 Dimethylol urea reactions.

## 5.4 Chemistry of easy-care and durable press finishes<sup>5,6</sup>

The end of the 1920s saw the introduction of formaldehyde condensation products for the durable press finishing of fabrics made of viscose, linen or cotton. Initially mainly urea–formaldehyde products were used, soon followed by melamine–formaldehyde compounds. In 1947 dimethylolethylene urea products began to appear. Easy-care finishing of cotton has been a major market success since the middle of the 1950s. During the 1960s and 1970s, concern about formaldehyde encouraged development of cellulose crosslinking finishes with low free formaldehyde levels. Continued research has provided products with very low free formaldehyde content as well as products that are completely formaldehyde free.

### 5.4.1 Formaldehyde-containing products

Urea–formaldehyde (U/F) products are readily synthesised from water solutions of urea and formaldehyde at pH 7.5–9. The resulting *N,N'*-dimethylol urea (DMU) is often modified by further reaction at pH 8–9 with methanol to the more stable and liquid dimethylether of DMU (dimethoxymethyl urea) as shown in Fig. 5.1. These reactions are equilibrium reactions with significant concentrations of the starting compounds. These equilibria are the reasons for the high content of free and easily released formaldehyde found with U/F products. Because of their high reactivity, unmodified U/F finish baths must be used within a few hours. The high stiffness and firmness of the U/F finish can be important for rayon fabrics which often are considered too limp when compared with cotton. The U/F finish gives the best elastic resilience.<sup>7</sup>

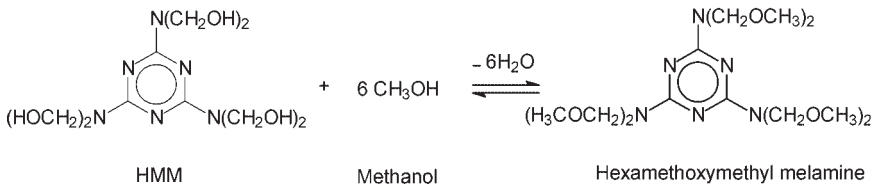
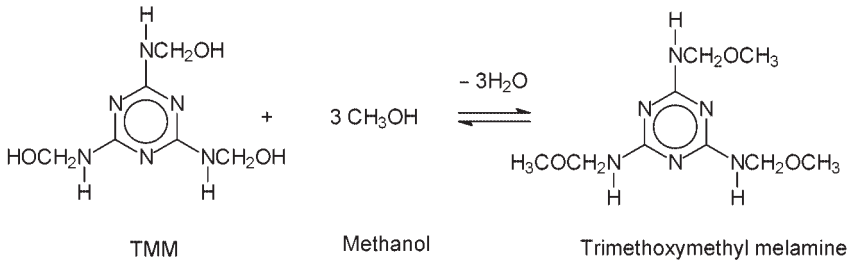
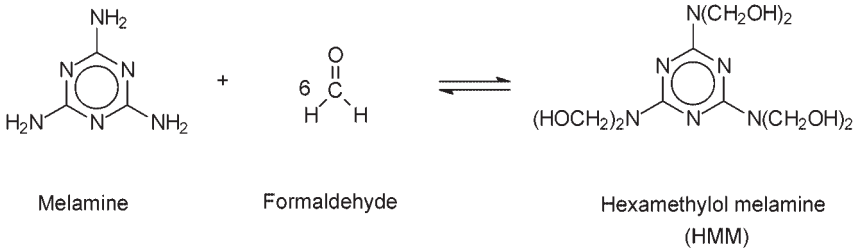
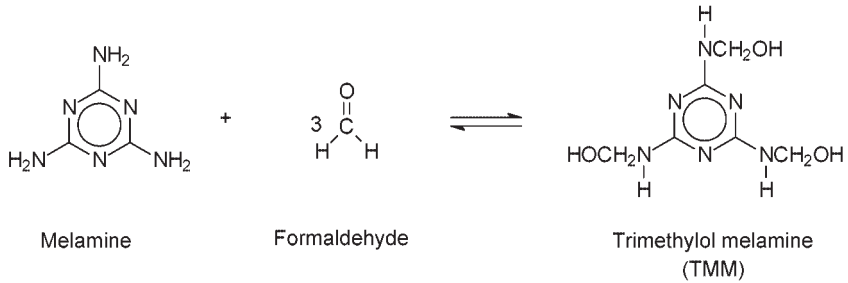

### 5.2 Melamine–formaldehyde reactions.

The main properties of U/F products are:

- DMU is highly reactive; finish baths have to be used in a few hours
- Low stability to hydrolysis, low durability to laundering
- High chlorine retention

- High content and release of formaldehyde
- Very high elastic resilience.

Melamine–formaldehyde (M/F) products have mostly three to six reactive *N*-methylol groups connected to one melamine ring. This leads to a higher crosslinking and an easy-care finish with better wash fastnesses. Their synthesis is similar to the U/F products, providing tri- to hexamethylol melamine (TMM, HMM) and their methyl ethers (tri- or hexamethoxymethyl melamine) as shown in Fig. 5.2. TMM is preferred for the easy-care finish, often only as a component of a product mixture to give a better permanence of the effects. It is also used for permanent chintz (glazing, embossing, Schreinerung) of cellulose. HMM finds additional uses in pigment binders and Basofil® fibres.<sup>8,9</sup>

The main properties of M/F products are:

- Better stability to hydrolysis and better washing durability than U/F products
- Relatively high formaldehyde content and release
- Fewer problems with chlorine retention than U/F products
- More dimensional stability and stiffness (also for nylon and polyester).

The predominant reaction of U/F and M/F products is their self condensation to three-dimensional resin structures (Fig. 5.3). These structures impart a very stiff, firm handle to fabrics treated with U/F and M/F products. The self condensation is caused by the active hydrogen atom attached to the nitrogen of the *N*-methylol group. If this active hydrogen atom is substituted by a carbon atom in a ring structure, as in ethylene urea, the reaction with the hydroxyl groups of cellulose becomes dominant. Crosslinking of neighbouring cellulose molecules is then the main reaction, especially activated by inductive effects of the hydroxyl groups in the dihydroxyethylene urea heterocycle (DHEU).

*N,N'*-Dimethylol-4,5-dihydroxyethylene urea (DMDHEU) is the chemical basis of about 90 % of the easy-care and durable press finish products on the market. DMDHEU is synthesised from urea, glyoxal and formaldehyde as shown in Fig. 5.4.

It is less reactive than DMU and TMM and therefore requires more active catalysts. However, finish baths containing DMDHEU are more stable than finish baths with DMU or TMM. The reactivity of DMDHEU can be further reduced by reaction with methanol or diethylene glycol, leading to ether-modified DMDHEU products. These alcohols are also formaldehyde scavengers and are often added to commercial finish products for that purpose. Diethylene glycol has the additional advantage of a high boiling temperature of 254 °C (490 °F). Therefore a significant portion can remain in the cured fabric and reduce the free formaldehyde content via acetal formation. Addition of diethylene glycol also improves the chlorine fastness and the degree of whiteness.

A typical DMDHEU commercial product is made from about 45 % DMDHEU, 9 % diethylene glycol and 2 % methanol. This product could contain less than

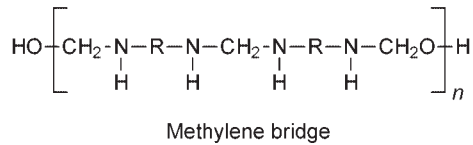
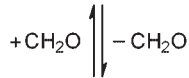
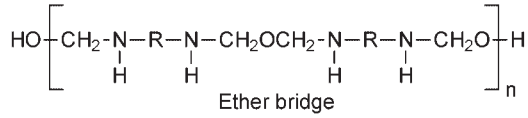
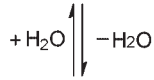
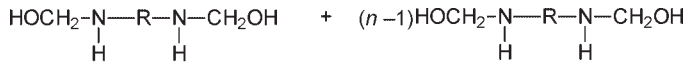

5.3 Self condensation reactions of U/F and M/F products.

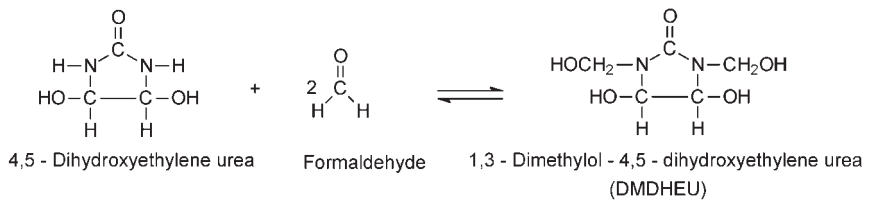
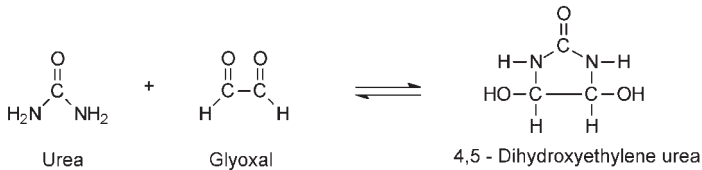

5.4 Synthesis of DMDHEU.

Table 5.4 Effects of the ether modification of DMDHEU<sup>10</sup>

Crosslinker	Formaldehyde release in ppm (AATCC 112-1983)	DP rating
Unmodified DMDHEU	750–1000	4
Partially methylated DMDHEU	300–500	3.0
Fully methylated (tetra-substitution) DMDHEU	< 300	3.0
DMDHEU + diethylene glycol (ULF product)	< 50	3.25

DP = degree of polymerisation.

0.3 % free formaldehyde. As indicated there are two ways to incorporate diethylene glycol into these products. One version is a simple mixture of the glycol and DMDHEU. The other involves reacting the glycol with DMDHEU to form a glycolated product. Both products perform similarly and both types are available in the market place and are referred to as ‘ultra low formaldehyde’ (ULF) with less than 50 ppm released formaldehyde in the AATCC Testing Method 112-1983 (Table 5.4)

The principal reaction of DMDHEU products is the crosslinking of adjacent cellulose molecules, as shown in Fig. 5.5. This crosslinking prevents the movement of the fibre molecules during stress and hinders shrinkage and wrinkle formation. This lack of molecular movement also leads to the fabric tensile strength and tear strength loss associated with durable press finishes because without crosslinking, the tear stresses can be distributed over many molecules which can slightly shift sharing the external forces.

The main properties of DMDHEU-based products are:

- Low to very low reactivity (when ether modified)
- Excellent durability to laundering
- Low chlorine retention
- Medium to very low formaldehyde release (Table 5.4)
- The most commonly used durable press products.

#### 5.4.2 Formaldehyde considerations

There are several aspects to the ‘formaldehyde problem’. Formaldehyde is not only a very useful and inexpensive chemical compound but also a natural product. Traces of formaldehyde are present in air, fruits, vegetables, wood, and in blood. Every incomplete burning process, including cigarette smoking, produces formaldehyde. Formaldehyde does not build up in the environment because oxygen in the air reacts with it to form formic acid. More than 1 ppm of formaldehyde in the air causes a pungent odour (the threshold detection level by smell is 0.5 ppm). Formaldehyde irritates mucous membranes, causes teary eyes, induces cough, and

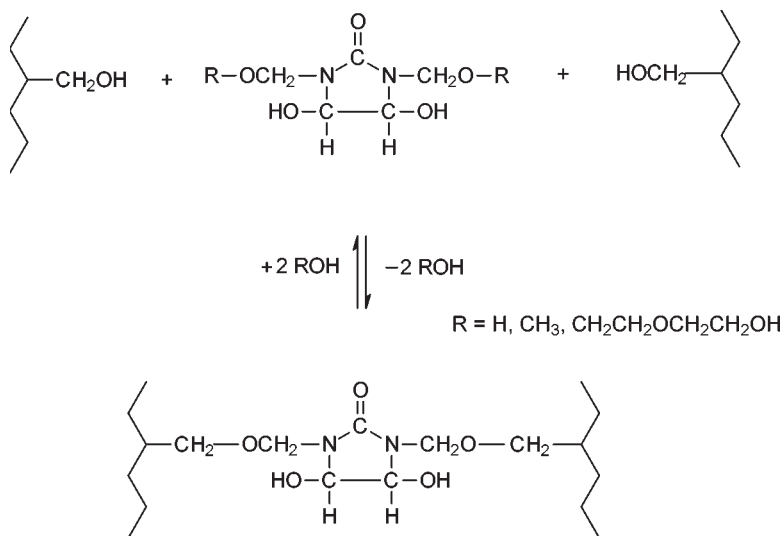

### 5.5 Crosslinking of cellulose with DMDHEU products.

can lead to difficulties in breathing and headaches. Skin contact with aqueous solutions of formaldehyde or with textiles that contain a high level of formaldehyde can give rise to eczema and occasional allergic reactions. In addition, formaldehyde is a suspected human carcinogen.

The most severe problems with formaldehyde and textiles occurred in the cut and sew industries before the introduction of DMDHEU. In normal usage, when clothing is periodically laundered, there are no formaldehyde-related problems. However, it is advisable to wash durable press treated textiles before their first use. Several countries have enacted laws designating concentration limits for formaldehyde in the workplace (0.75 ppm in the USA and 0.5 ppm in Germany). There are also governmental restrictions (for example European Community, Japan), company requirements (for example Levi Strauss, Marks and Spencer) and several labels (for example Öko-Tex Standard 100) that set limits for free or easily freed formaldehyde in textiles. These limits are always specified by a particular test method for formaldehyde because there are significant differences in results between the various formaldehyde test methods. For example, finished fabrics for adult clothing and other skin contact textiles may be labelled and called low formaldehyde finished according to Öko-Tex Standard 100 when their free formaldehyde content is lower than 75 ppm according to the Japan Law 112 method.

### 5.4.3 Non-formaldehyde containing products

*N,N*-Dimethyl-4,5-dihydroxyethylene urea (DMeDHEU) should not be confused with DMDHEU. DMeDHEU does not contain formaldehyde. It is synthesised



This poor cost performance ratio is one reason for the relatively small market penetration by this formaldehyde-free finish. Another reason is that a completely formaldehyde-free finish is not as commercially important since the advent of the ultra low formaldehyde products. However, a 1:1 mixture of DMDHEU and DMeDHEU is popular because of its reduced formaldehyde levels with only slightly inferior physical properties at an acceptable cost.

The main properties of DMeDHEU products are:

- Formaldehyde free
- Very low reactivity
- Very low chlorine retention
- Limited durability to laundering
- Yellowing effect when not ether modified
- Price/effect ratio nearly 4:1 compared with DMDHEU
- Development of unpleasant odours, depending on the product formulation.

1,2,3,4-Butanetetracarboxylic acid (BTCA) and similar polycarboxylic acids provide an alternative possibility for a formaldehyde-free crease resistant finish.<sup>14,15</sup> The activation mechanism of BTCA and the reaction with cellulose are shown in Fig. 5.8. BTCA gives rise to good crease recovery but with limited laundering durability owing to hydrolysis of the ester bonds to cellulose. These polycarboxylic acids are relatively expensive, comparable in cost to DMeDHEU. In addition, the reactions of these acids with cellulose require large amounts of sodium hypophosphite as a catalyst. Not only is sodium hypophosphite expensive, but it is also a reducing agent that discolours certain dyestuffs, especially some reactive and sulfur dyes. Recently, polyacrylic acid-based products, for example maleic acid anhydride copolymers,<sup>16</sup> have been introduced that provide similar properties to BTCA finishes but at a more economical price.<sup>17</sup>

Novel cellulosic crosslinking agents with interesting properties are gained by molecular incorporation of the phosphorus catalyst in the BTCA structure. These formaldehyde-free phosphono- and phosphinocarboxylic acids (APCM, modified polycarboxylic acids) show good crosslinking properties with minimal strength losses, no shade changes and good durability for up to 20 washing cycles. The APCM products are liquid, water soluble and neither toxic nor skin irritating.<sup>18</sup>

#### 5.4.4 Miscellaneous crosslinking agents

Other chemical crosslinking agents that have been used to provide durable press properties to cellulose include dimethylol ethylene or propylene urea, diglyoxal urea, triazons, urons, carbamates, diepoxides and diisocyanates. However, owing to either high cost or limited technical advantages, very few are actually used commercially, sometimes as minor components of mixtures for special effects.

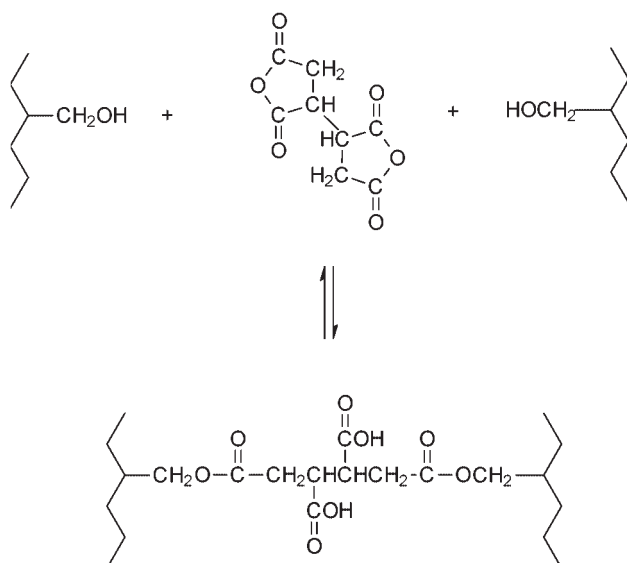
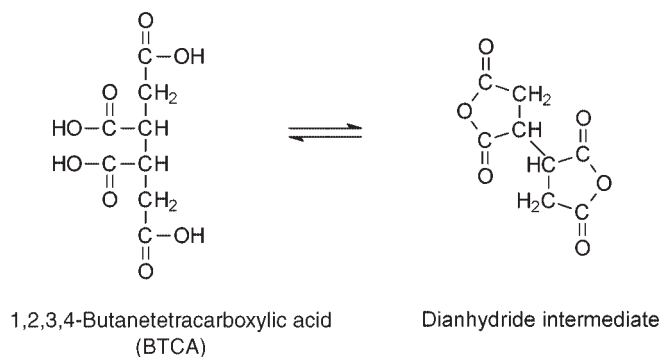

5.8 Crosslinking of cellulose with BTCA.

#### 5.4.5 Catalysts for easy-care and durable press finishes

The reaction of *N*-methylol reactants such as DMDHEU with cellulose requires an acid catalyst for acceptable yields under conditions suitable for textile processing, for example, 150 °C (300 °F) to 170 °C (340 °F) for 0.5 to 3 min:

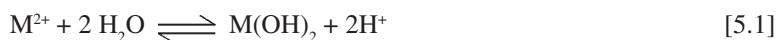

The catalysed crosslinking follows the Arrhenius equation, so that as a rule of thumb a temperature change of 10 °C causes a factor of 2 change in the condensation time as shown in Table 5.5. The most common catalysts are Lewis acid salts

Table 5.5 Examples for the relation between curing temperature and time

Curing temperature (°C)	140	150	160	170
Curing time (min)	8	4	2	1
	6	3	1.5	0.75
	4	2	1	0.5

such as magnesium chloride and zinc nitrate that generate acidic conditions during the curing process, thus providing neutral liquors and thereby good finish bath stability.

Brönsted acids such as sulfuric and hydrochloric acids and their ammonium salts, while serving as excellent catalysts, also lead to undesirable fibre degradation and unstable finish baths. Often citric acid is combined with a Lewis acid to provide an additional boost to the reaction, especially for the short shock condensation. A particularly powerful co-catalyst for ether modified DMDHEU products is sodium borotetrafluoride  $\text{Na}(\text{BF}_4)$ . But this flash catalyst may cause cellulose depolymerisation leading to high strength loss.

The proposed reaction scheme for the acid catalysed reaction of *N*-methylol compounds is given in Fig. 5.9. Under acid conditions, *N*-methylol compounds can react either through nitrogen protonation or oxygen protonation. Nitrogen protonation leads to the formation of amines and formaldehyde. This mode often occurs with U/F and M/F products, which accounts for their larger amount of free formaldehyde. The DMDHEU products are more likely to proceed via oxygen protonation because of steric hindrance from the ethylene bridge interfering with nitrogen protonation. Oxygen protonation yields carbonium ions that are stabilised by resonance with their immonium forms. With DMDHEU, the electron-donating effects of the hydroxyl groups in the 4 and 5 positions add to the stability of these ions. The carbonium ions can then react with hydroxyl groups from either cellulose or the original *N*-methylol material. U/F and M/F products will react primarily by self condensation, while DMDHEU products will yield the reaction with cellulose.

## 5.5 Application methods

The most common application method for easy-care and durable press finishes is a pad-dry-cure procedure. In this process, the crosslinking reactant, catalyst, softener, and other components are dried on the fabric prior to the crosslinking reaction that takes place during the curing step. If the finish is cured immediately after drying, while the fabric is still in an open width configuration, the finish is referred to as a 'pre-cure' finish, the finish is cured *prior* to garment manufacture. Textiles with a pre-cure finish are most suited for fabrics and apparel that require wrinkle resistance, such as sheeting, shirting and casual trousers.

For fabrics that require crease retention, such as trousers and pleated skirts, the

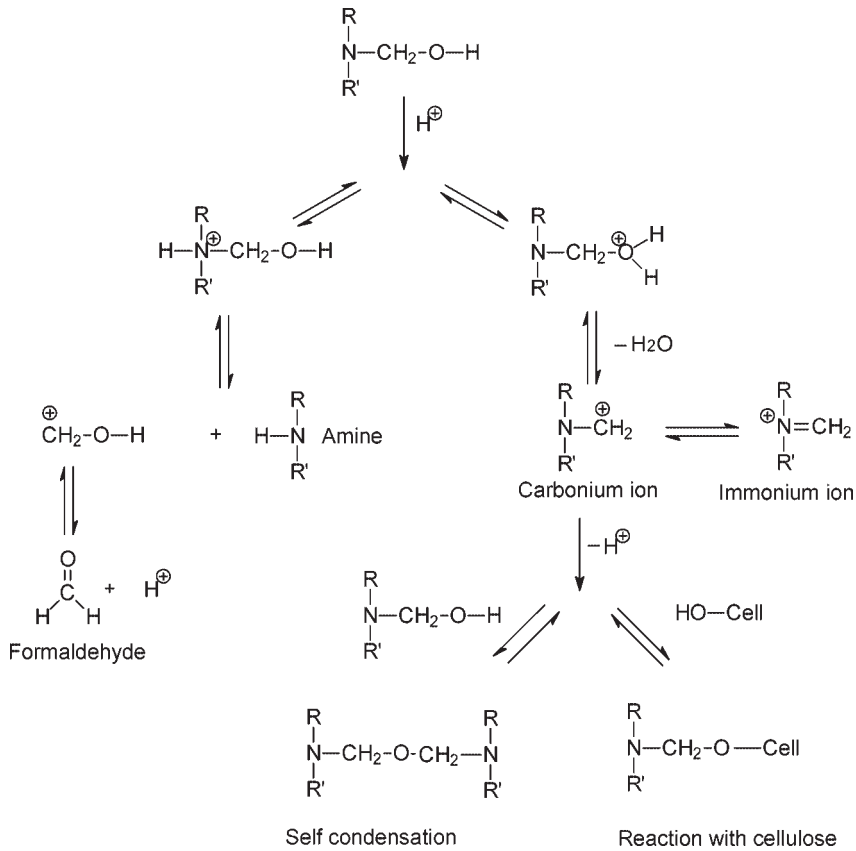

5.9 N-Methylol reaction scheme.

durable press finish is only dried by the fabric manufacturer and cured after the garment has been made and creased appropriately. This finish is referred to a 'post-cure' finish or 'delay cure' finish, the finish is cured *after* the garment has been manufactured.

In the special cases where entire garments are to be treated with a durable press finish, the finishing chemicals can be sprayed in exact doses onto the garments before the final shape is formed and then cured.<sup>19</sup> Also impregnation by dipping (garment dipping) or in a tumbler, followed by centrifugation, drying and pressing or ironing is common. The made-up garments are finally suspended on hangers in a curing oven. Some advantages and disadvantages of these application methods are summarised in Table 5.6.

Several variations on the conventional pre-cure process have been explored, including short one-step flash-dry-curing (shock condensation) of cellulosic fabrics with the risk of crosslinker migration during the quick drying. The

*Table 5.6* Comparison of finish application methods

Application method	Advantages	Disadvantages
Pre-cure	High process productivity	Poor crease retention
Post-cure	Excellent crease retention	Curing equipment needed by garment manufacturer
Garment	Softest handle	Application and curing equipment needed by garment processor

*Table 5.7* Effects of different curing conditions on fabric properties

'Dry' curing, short times at high temperatures	'Wet' curing, long times at low temperatures
Loss of tear strength and abrasion resistance	Good tear strength and abrasion resistance
High dry crease recovery angle	Lower dry crease recovery angle
Lower wet crease recovery angle	High wet crease recovery angle

traditional pad–dry–cure method is a 'dry' curing process, i.e. all of the water has been removed from the fabric prior to the actual crosslinking reaction. It is also possible to crosslink cellulose in a 'wet' process. Fabric padded at ~ 80 % wet pickup with the finishing chemicals is wrapped in plastic film and batched at room temperature for about 24 hours before washing and drying. The water content of the cellulose fibres during the crosslinking step greatly affects the final fabric properties as is seen in Table 5.7.

Normally a high dry crease recovery angle is preferred because the appearance of the dry textile is more important than that of the wet one. Between these two extremes is the 'moist' cure, a 5–20 hour room temperature reaction with ~ 6 % above normal moisture regain. The fabric properties of the 'moist' cure are a good compromise between the extremes of the 'dry' and 'wet' processes. The 'moist' cure is preferred when high tear strength of the finished fabric is required, but controlling the critical moisture level can be very difficult.

These difficulties with moisture control are overcome in a continuous process using a hot flue. There the residual moisture of the fabric is easily regulated by the content of steam in the air at 6–10 %, where the best compromise of the easy-care factor (ECF) and the strength loss factor (SLF) is realised. ECF includes dry and wet crease recovery angles and the Monsanto values. SLF is a combination of

abrasion (Accelerator), tear and ripping strength loss values. A disadvantage of this process is the lack of fabric width control in the hot flue. A widthwise tentering device between paddler and hot flue is helpful.<sup>20</sup>

## 5.6 Compatibility with other finishes

Textile chemical auxiliary suppliers will provide suggested recipes in their product information. These recipes will contain recommendations for the appropriate catalyst and other additives that improve the performance characteristics of the easy-care and durable press finishes, such as softeners to improve the fabric handle and products to improve tear strength (for example polyvinyl acetate, amino-modified or epoxy-functional silicones). Less decrease in degree of polymerisation (DP) rating and abrasion resistance is provided by adding water-based polyurethane emulsions of self crosslinking silicone elastomers.

In commercial use, easy-care and durable press finishes are frequently combined with other finishes to provide additional properties such as water and oil repellency, flame retardancy, soil release and the like. Often the combination of another finish with the cellulose crosslinking finish will result in a more durable effect from the first finish. Combination with pigment printing is very common because of similar chemistry to cellulose crosslinking agents and binders and the similar application conditions.

## 5.7 Evaluation methods

### 5.7.1 Fabric properties

A variety of test methods are used to evaluate the performance characteristics of fabrics treated with easy-care and durable press finishes. Some of the more common ones are summarised in Table 5.8.

### 5.7.2 Evaluation methods for formaldehyde<sup>21</sup>

Some of the more useful formaldehyde tests are summarised below.

**Qualitative test for the presence of formaldehyde in fabrics:** Add a small piece of fabric to 2–3 ml of a solution of 10 mg chromotropic acid per 100 ml of 72 % sulfuric acid. Warm the solution carefully to not more than 100 °C for 1 min. A red to violet colour in the solution indicates the presence of formaldehyde.

**Quantitative test for formaldehyde in air:** This is most conveniently done with testing tubes designed for this purpose (Dräger tubes from Drägerwerk AG, Lübeck, Germany, are an example). A colour change to a certain mark after a specified amount of air is drawn through the tube gives the formaldehyde concentration.

Table 5.8 Test methods for finished fabric properties

Test method	Title	Comments
AATCC test method 124 <sup>22</sup>	Appearance of fabric after repeated home launderings	Fabrics are washed and dried with specified procedures. The fabric appearance is compared to standards on a 1–5 scale. Aim is a DP rating of > 3.5.
AATCC test method 128	Wrinkle recovery of fabrics: appearance method	Fabrics are wrinkled on a specified apparatus and their appearance compared to standards on a 1–5 scale.
AATCC test method 66	Wrinkle recovery of woven fabrics: recovery angle	Flat fabrics are creased in a specified apparatus either in dry or in wet state. The final dry or wet crease recovery angle is measured.
AATCC test method 88C	Retention of creases in fabrics after repeated home laundering	Fabrics with set-in creases are washed and dried by specified procedures. The crease appearance is compared to standards on a 1–5 scale.
DIN 53861	Vaulting and bursting test	Fabric strength, tear, and burst tests
AATCC test method 93	Abrasion resistance of fabrics: accelerator method	Fabrics are abraded on a specified apparatus. Fabric weight loss due to the abrasion is determined.
DIN 53814	Determination of water retention power of fibres and yarn cuttings	‘Swelling value’: wetting, water-extraction with a centrifuge, weighing. Very sensitive to curing conditions.
AATCC test methods 92 and 114	Chlorine, retained, tensile loss: single and multiple samples	Fabrics are treated with a standard hypochlorite solution and exposed to high temperatures. Strength loss due to retained chlorine is determined.

Table 5.8 cont'd

Test method	Title	Comments
Monsanto wash and wear standards	Standard samples or photographs for wash and wear performance (standard one is worst and five is best smoothness)	A fabric is finished, washed, dried in a standard manner and compared subjectively for appearance with a series of five standard samples, using a panel for the test sample with illumination at an angle of indication with the plane of fabric of 10–15°.
ISO 2313	Determination of the wrinkle recovery	Fabric sample with horizontal fold edge.

**Quantitative tests for formaldehyde in fabrics:** There are two types of test for formaldehyde content of fabric. The first type is designed to imitate dry skin contact with the fabric and especially for the release of formaldehyde during storage and transportation in closed containers. During the test the fabric sample is held above water in a sealed jar. Free and easily released formaldehyde dissolves in the water during the test and can be determined by specific analytical methods.

The second type of test is intended to simulate extraction of formaldehyde by perspiration. This test determines mainly the free formaldehyde that is dissolved in the test liquid during a direct extraction. The test liquid can be water only or water with specific additives like wetting agents or buffer salts. Some of the more important formaldehyde analysis methods are given in Table 5.9.

The pH of the fabric and the solution affects the amount of formaldehyde extracted. A neutral pH minimises the amount determined. Higher extraction temperatures and longer extraction times increase the amount of formaldehyde extracted owing to hydrolysis of the crosslinker bond to cellulose (Fig. 5.4 and Fig. 5.5). In many cases the usual order of these formaldehyde content values related to the determination method is Shirley I > AATCC 112 > Japan Law 112 > DIN 54 260.

## 5.8 Troubleshooting and practical problems

Proper preparation is critical to achieving the optimal performance from durable press finishes. Residual alkali will deactivate the catalyst. Non-uniform wetting will cause uneven finish pickup and result in unlevel finish effects. Since the durable press effect depends on chemical reactions taking place in the fibre during curing, all parameters that may affect the reaction (concentrations of all finish components, temperature and time of curing) must be carefully controlled. Excessive curing leads to increased losses of strength and abrasion resistance.

Table 5.9 Methods for the determination of free and released formaldehyde

Method	Type 1	Type 2	Type 2	Type 2
Name	AATCC 112-1993	Japan Law 112 <sup>23</sup>	Shirley I <sup>24</sup> BS 6806 part 2	DIN 54 260 (2/1988)
Reagent	Acetyl acetone	Acetyl acetone	Chromotropic acid/H <sub>2</sub> SO <sub>4</sub>	1N Na <sub>2</sub> SO <sub>3</sub> + 0.05N iodine
Sample preparation	Over water in vapour atmosphere	In water	In water with wetting agent	In buffer solution at pH 9.4
Temperature	49±1 °C (120±2 °F)	40 °C (104 °F)	25 °C, room temp. (77 °F)	0–2 °C(32– 35.5 °F)
Time	20 hours	1 hour	20 min	10 min
Covering				
=N-CH <sub>2</sub> OCH <sub>3</sub>	–	–	+	–
=N-CH <sub>2</sub> OH	+	+	+	–
CH <sub>2</sub> O, HO(CH <sub>2</sub> O) <sub>n</sub> H, HOCH <sub>2</sub> OR	+	+	+	+

Type 1: sample in the air above the water, type 2: sample in the water, EN ISO 14 184 part 1 = Japan Law 112, part 2 = AATCC 112. BS 6806 part 3 is a slight modification of AATCC 112. BS 6806 part 2 is called a free formaldehyde test method, but it also covers released formaldehyde, caused by elevated reaction temperature and the use of concentrated sulfuric acid for the colour development before colorimetric determination.

The effects of a durable press finish are different with regenerated cellulosic fibres. Their lower crystallinity, their higher actual content of amorphous areas, requires higher concentrations of crosslinking agents than does cotton. Cotton is about 30 % and regenerated cellulose is up to 60 % amorphous. With regenerated cellulose, dimensional stability and firm handle are the principal advantages obtained from durable press finishes. Tear strength is not appreciably lowered and loss of abrasion resistance is similar to cotton.<sup>7</sup>

Chlorine retention is a special problem with amine and amide-containing finishes. When fabrics treated with these finishes are laundered with chlorine bleach, unsubstituted nitrogen atoms can react to form chloramines (Fig. 5.10). Chloramines hydrolyse to form hypochlorous acid that can decompose to materials that will degrade cellulose by significant strength loss and marked yellowing. DMDHEU products show less chlorine retention than do TMM or DMU products. Chlorine retention of *N*-methylol-based finishes is used for antimicrobial effects (Chapter 15.4 and Fig. 15.3 and 15.4).

Cellulose fabrics can be treated with liquid ammonia to produce fabrics with

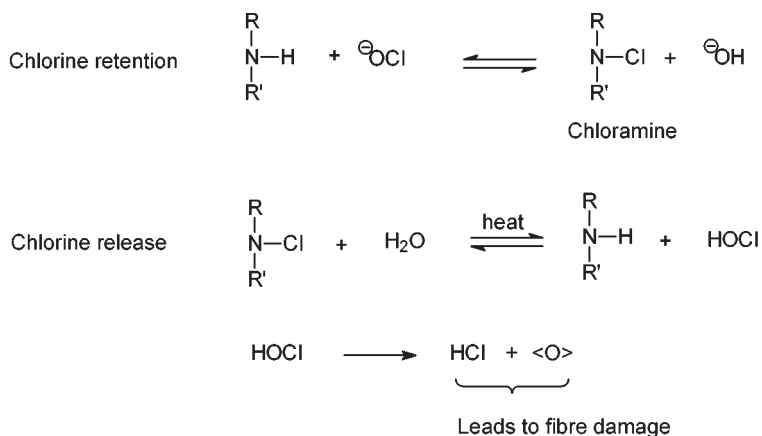

#### 5.10 Chlorine retention reactions.

improved properties. Ammonia, a liquid below  $-30^\circ\text{C}$  or  $-33^\circ\text{F}$ , causes cellulose fibres to swell, bringing about some effects similar to mercerisation. Commercial treatment with anhydrous liquid ammonia is called a Sanforset® treatment. Fabrics so treated have reduced shrinkage and smooth drying properties without large losses in strength and abrasion resistance. Best results are achieved by combining the ammonia treatment with a low level of a DMDHEU finish. This finish is used for high quality fabrics where the relatively expensive ammonia treatment can be justified.

In order to minimise the free formaldehyde levels in the final finished fabric, the correct choice of crosslinking agent (ether modified DMDHEU is preferred), catalyst, and processing conditions must be made. Formaldehyde scavengers such as urea, ethylene urea and diethylene glycol can be added to durable press finish baths to lower the formaldehyde levels of the final fabric even further. The disadvantages of this approach include lower durable press performance, higher chlorine retention and lower light fastness. The durability of the easy-care and durable press finishes to repeated launderings decreases from DMDHEU over TMM to DMU products.

Disposal of the remainders of finish baths should be done in compliance with local regulations. Some catalysts used with these finishes contain zinc or other metals whose presence in waste water may be restricted. One side benefit of cellulose crosslinking finishes, especially the formaldehyde-containing ones, is increased resistance of the fabric to microbial attack. The effects of wrong condensation conditions for the common dry crosslinking process and steps to their optimisation are listed in Table 5.10.<sup>4</sup>

Table 5.10 Optimisation of the dry crosslinking process<sup>4</sup>

- Condensation control by the temperature of the fabric
- Adjusted crosslinker type and concentration
- Adequate condensation time and temperature.

**Consequences of over-condensation:**

- Loss of tear and abrasion strength
- Yellowing
- Harsher handle
- Damage of elastan fibres
- Expensive.

**Consequences of under-condensation:**

- Effect level too low
- Formaldehyde content too high
- Danger of offensive odour development.

---

## References

- 1 Nechwatal A and Nicolai M, 'Möglichkeiten zur gleichzeitigen Anfärbung und Ausrüstung von Baumwollgeweben', *Melliand Textilberichte*, 1999, **80**(3), 185–191.
  - 2 Schindler W, Tauwald E and Krüger R, 'Are reactive dyes fixed with covalent bonds after one-bath dyeing and low-swell finishing of PES/cotton?', *Melliand Textilberichte*, 1990, **71**(5), 388–392, E176–E178.
  - 3 Haupt-Stephan R, 'New developments for the transfer printing on cotton', *International Textile Bulletin*, 2002, **48**(5), 73–78.
  - 4 Jakob B, Ciba Speciality Chemicals, private communication.
  - 5 Levin M, *Handbook of Fiber Science and Technology: Vol. II. Chemical Processing of Fibers and Fabrics. Functional Finishes: Part A*, Chapters 1 (Cross-linking of cellulose) and 2 (Cross-linking with formaldehyde-containing reactants), New York, Marcel Dekker, 1983.
  - 6 Sharpe G and Mallinson P, 'Easy care finishing of cellulose', in *Textile Finishing*, Heywood D (ed.), Bradford, Society of Dyers and Colourists, 2003, 337–350.
  - 7 Geubtner M, 'Fortschritte bei der Hochveredlung von Viskose- und Modalfaserartikeln', *Melliand Textilberichte*, 1990, **71**, 214–218.
  - 8 Berbner H, 'Eine neue Faser für Schutzkleidung gegen Hitze und Feuer auf Basis Melaminharz', *Chemiefasern/Textilindustrie*, 1990, **40/92**, T 154–157.
  - 9 Widler G, Nahr U, Eichhorn H and Schindler W, 'Dyeing and printing of Basofil fabrics', *Technische Textilien*, 1997, **40**, 104–105, E26.
  - 10 Tomasino C, *Chemistry and Technology of Fabric Preparation and Finishing*, NC State University Coursebook, Raleigh, 1996.
  - 11 Reinert F, 'Neue Entwicklungen in der Ausrüstung', *Textilveredlung*, 1989, **24**, 223–228.
  - 12 Volz W, 'Formaldehydfreie Hochveredlung', *Taschenbuch der Textilindustrie*, Berlin, Schiele & Schön, 1990, 429–437.
  - 13 Geubtner M, 'Modern formaldehyde-free easy-care finishing for a handle in line with modern trends', *Melliand Textilberichte*, 1990, **71**, 394–397, E180–E182.
-

- 14 Welch C M, 'Formaldehyde-free durable-press finishes', *Review Progress Coloration*, 1992, **22**, 32–41.
- 15 Turner J D, 'Knitterfreiausrüstung von Baumwolltextilien', *International Textile Bulletin/Finishing*, 1994, **40**, 50–58.
- 16 Weber S and Schindler W, 'Formaldehydfreie Pflegeleichtausrüstung mit anhydridbildenden Copolymeren', 42. Deutscher Färbertag, Juni 2000, Mönchengladbach.
- 17 Shank D, 'Nonformaldehyde wrinkle-free finishing: a commercial update', *AATCC Review*, 2002, **2**(3), 29–32.
- 18 Gelabert A and Kyriazis J, 'APCM – a new type of formaldehyde-free crosslinking agents for wash-and-wear finishes', *Melliand International*, 1999, **5**(2), 181–184 and (in German) *Melliand Textilberichte*, 1999, **80**(1/2), 50–53.
- 19 Worsham J B III, 'Cotton quality and the metered addition process for wrinkle-resistant products', *International Textile Bulletin*, 1998, **44**(2), 22–28.
- 20 Wersch K van, 'Hochveredlung von Baumwolle', *Melliand Textilberichte*, 2002, **83**(7/8), 538–542.
- 21 Weaver J W (ed.), *Analytical Methods for a Textile Laboratory*, 3rd edn, AATCC, Research Triangle Park, North Carolina, 1984.
- 22 *Technical Manual of the American Association of Textile Chemists and Colorists*, Vol. 74, 1998.
- 23 Ministry of International Trade and Industry (MITI), *Japanese Industrial Standards – 1041; Law of Control of Household Goods Containing Harmful Substances; Law No. 112 of 1973*, Welfare Ministry Ordinance, Japan No.34–1974.
- 24 Lund G, 'Formaldehyde odour problems in resin-finished materials', *Shirley Institute Bulletin*, 1975, **48**, 17–21.

## 6.1 Introduction

Finishes that repel water, oil and dry dirt are important in all parts of the textile market – for clothing, home and technical textiles. Water repellency is achieved using different product groups, but oil repellency is attained only with fluorocarbon polymers. They are modified to have a wide range of properties to fit the different demands of the users and the intended purpose. This is one of the most interesting new developments of chemical finishing.

The oldest repellent finish is to repel water. The purpose of this finish is self evident. Drops of water should not spread on the surface of the textile and should not wet the fabric. The drops should stay on the surface and easily drip off.<sup>1-3</sup> Similarly, oil repellent finishes should prevent oily fluids from wetting treated textiles. In a similar manner, soil-repellent finishes should protect textiles from both dry and wet soils. In all cases, the air permeability of the finished fabric should not be significantly reduced.<sup>4</sup> Waterproofing treatments will not be covered in depth. A waterproof textile should withstand the hydrostatic pressure exerted by a column of water from at least a 1 m height before the first drops of water penetrate through the fabric.<sup>5,6</sup> In practice this is mostly achieved with coatings which have the disadvantages of stiff handle, lack of air and vapour permeability and consequently poor wear comfort.

In addition to the desired repellency effects, other undesirable fabric properties are often found with repellent finishes. These include problems with static electricity, poor soil removal in aqueous laundering, stiffer fabric hand, greying (soil redeposition) during aqueous laundering and increased flammability. Some fabric properties that are often improved by repellent finishes include better durable press properties, more rapid drying and ironing, and increased resistance to acids, bases and other chemicals. Table 6.1 shows typical textile applications for repellent fabrics and their requirements.

Table 6.1 Typical textiles and their requirements for repellency finishes according to Lämmermann.<sup>10</sup>

Kind of textile	OR	WR	DS	SR	CF	AS	H	P
Sport wear, leisure wear	+	+++	0	+	+	+	+++	++
Uniforms, workwear	+++	+++	++	+++	+	+	++	+++
Upholstery and automotive fabrics	+++	++	+++	++	+++	+++	+	+
Awnings, sunblinds, curtain fabrics	+	+++	+++	0	0	0	0	+
Table and bed linen	+++	++	++	+++	+	0	+	+++
Carpets	++	++	+++	0	++	++	0	+

Oil repellency = OR, water repellency = WR, dry soil = DS, soil release = SR, crocking fastness = CF, antistatic = AS, handle = H, permanence = P.

## 6.2 Mechanisms of repellency

Repellent finishes achieve their properties by reducing the free energy at fibre surfaces. If the adhesive interactions between a fibre and a drop of liquid placed on the fibre are greater than the internal cohesive interactions within the liquid, the drop will spread. If the adhesive interactions between the fibre and the liquid are less than the internal cohesive interactions within the liquid, the drop will not spread. Surfaces that exhibit low interactions with liquids are referred to as low energy surfaces. Their critical surface energy or surface tension  $\gamma_c$  must be lower than the surface tension of the liquid  $\gamma_L$  (the internal cohesive interaction) that is repelled.  $\gamma_L$  of water, at  $73 \text{ mN m}^{-1}$ , is two to three times greater than  $\gamma_L$  of oils ( $20\text{--}35 \text{ mN m}^{-1}$ ). Therefore, oil repellency finishes with fluorocarbons ( $\gamma_c = 10\text{--}20 \text{ mN m}^{-1}$ ) always achieve water repellency, but fluorine-free products, for example silicones ( $\gamma_c = 24\text{--}30 \text{ mN m}^{-1}$ ) will not repel oil.<sup>7</sup> Low energy surfaces also provide a measure of dry soil repellency by preventing soil particles from strongly adhering to fibre surfaces. This low interaction allows the soil particles to be easily dislodged and removed by mechanical action.

There are different ways that low energy surfaces can be applied to textiles. The first way is mechanical incorporation of the water-repellent products in or on the fibre and fabric surface, in the fibre pores and in the spacing between the fibres and the yarns. Examples of these are paraffin emulsions. Another approach is the chemical reaction of the repellent material with the fibre surface. Examples of these are fatty acid resins. Yet another method is the formation of a repellent film on the fibre surface. Examples of these are silicone and fluorocarbon products. The final approach is to use special fabric constructions<sup>6,8</sup> like stretched polytetrafluoroethylene films (Goretex), films of hydrophilic polyester (Sympatex) and microporous coatings (hydrophilic modified polyurethanes).

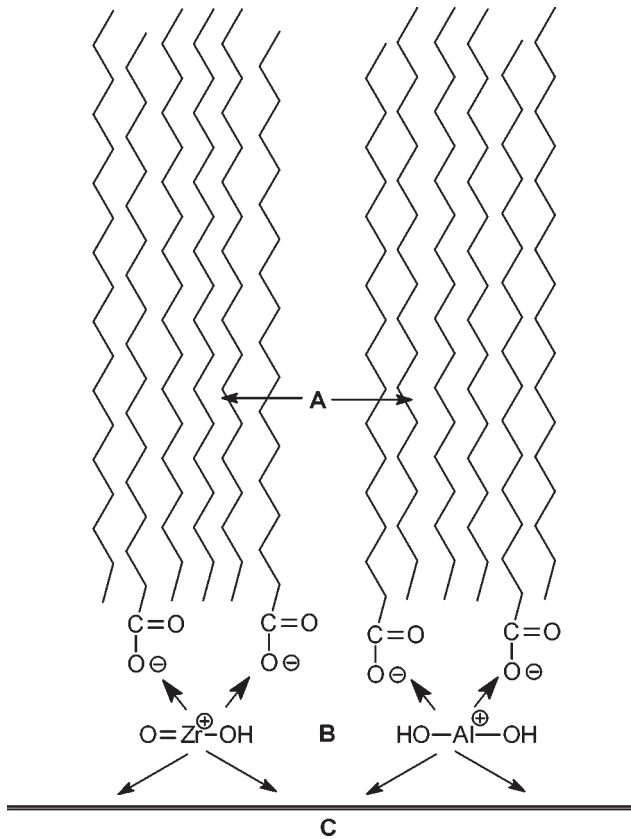

6.1 Fatty acid metal salts. A, hydrophobic interactions; B, polar interactions; C, fibre surface.

## 6.3 Repellent chemistry

### 6.3.1 Paraffin repellents

These were one of the earliest water repellents used, but do not repel oil. Typically the products are emulsions that contain aluminium or zirconium salts of fatty acids (usually stearic acid). These materials increase the finish's adhesion to polar fibre surfaces by forming polar–non-polar junctions as shown in Fig. 6.1. The paraffinic portion of the repellent mixture is attracted to the hydrophobic regions, while the polar ends of the fatty acid are attracted to the metal salts at the fibre surface. These finishes can be applied by both exhaustion and padding. They are compatible with most kinds of finishes but they increase flammability. Although they are available at relatively low cost and generate uniform waterproof effects, the lack of durability to laundering and dry cleaning and their low air and vapour permeability limits the use of paraffin-based repellents.

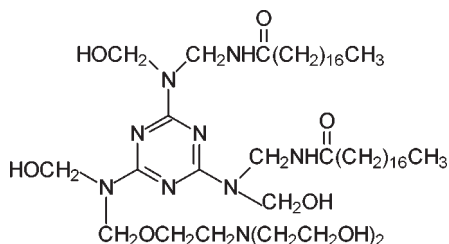

6.2 Stearic acid–melamine derivative.

### 6.3.2 Stearic acid–melamine repellents

Compounds formed by reacting stearic acid and formaldehyde with melamine constitute another class of water-repellent materials. An example is shown in Fig. 6.2. The hydrophobic character of the stearic acid groups provide the water repellency, while the remaining *N*-methylol groups can react with cellulose or with each other (crosslinking) to generate permanent effects. Advantages of the stearic acid–melamine repellents include increased durability to laundering and a full hand imparted to treated fabrics. Some products of this type can be effectively applied by exhaustion procedures. Their use as extenders for fluorocarbon repellents is now increasingly replaced by boosters<sup>7</sup> as described in Section 6.3.4. Disadvantages of stearic acid–melamine repellents include problems similar to durable press finishes (a tendency to exhibit finish mark-off, decreased fabric tear strength and abrasion resistance, changes in shade of dyed fabric, and release of formaldehyde).

### 6.3.3 Silicone water repellents

Polydimethylsiloxane products that are useful as water repellents can form a hydrophobic layer around fibres (Fig. 6.3). The unique structure of the polydimethylsiloxanes provides the ability to form hydrogen bonds with fibres as well as display a hydrophobic outer surface.<sup>9</sup> In order to gain some measure of durability, silicones designed as water-repellent treatments usually consist of three components, a silanol, a silane and a catalyst such as tin octoate (Fig. 6.4). The catalyst enables not only moderate condensation conditions but also promotes the orientation of the silicone film on the fibre surface. The outward oriented methyl groups generate the water repellency. During the drying step after pad application, the silanol and silane components can react (Fig. 6.5) to form a three-dimensional crosslinked sheath around the fibre. This reaction is often completed after storage of about one day, then providing full repellency. The Si–H groups of the silane are the reactive links in the silicone chain, generating crosslinks or being oxidised by air or hydrolysed by water to hydroxyl groups. These hydroxyl groups may cause further crosslinking, but if too many of them stay unreacted, their hydrophilicity will decrease the repellency.

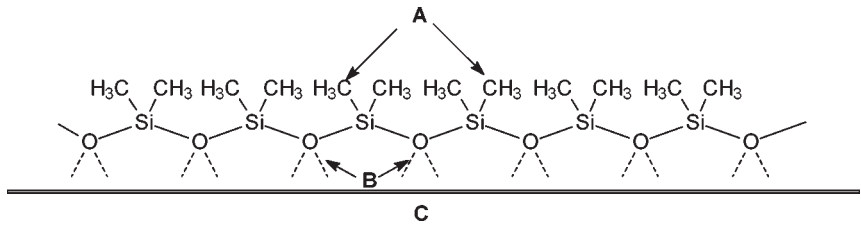

6.3 Polydimethylsiloxane on a fibre surface. A, hydrophobic surface; B, hydrogen bonds to polar surface; C, fibre surface.

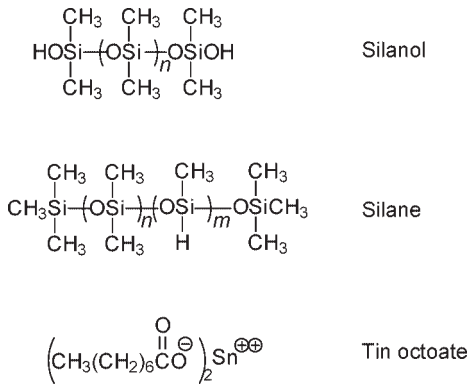

6.4 Components of a silicone water repellent.

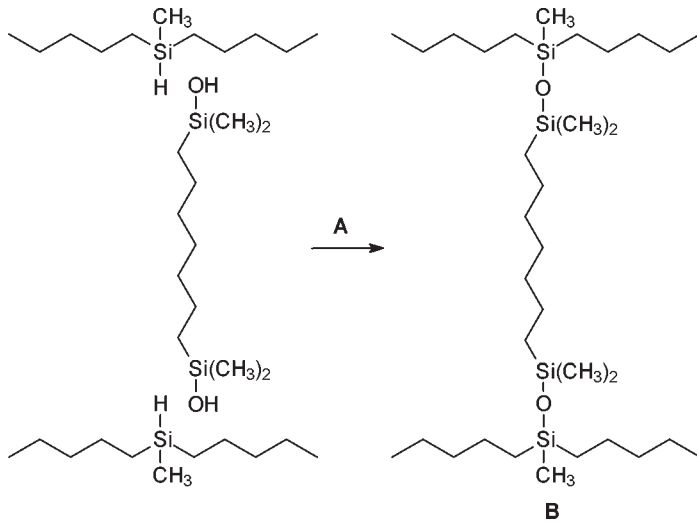

6.5 Silanol-silane reaction. A is removal of  $\text{H}_2$ ; B is Si-O-Si crosslinked polymer; tin octoate is the catalyst.

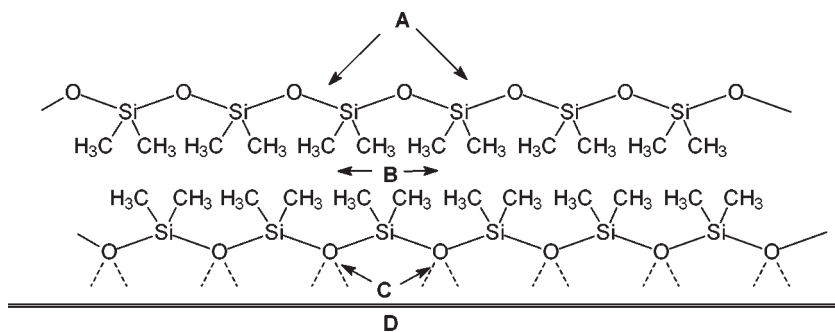

6.6 Silicone double layer on the fibre. A, polar surface; B, hydrophobic attraction of the methyl groups; C, hydrogen bonds to polar fibre surface; D, fibre surface.

Advantages of silicone water repellents include a high degree of water repellency at relatively low (0.5–1 % owf) on weight of fabric concentrations, very soft fabric hand, improved sewability and shape retention, and improved appearance and feel of pile fabrics. Some modified silicone repellents can be exhaust applied (to pressure-sensitive fabrics).

The disadvantages of silicone repellents include increased pilling and seam slippage, reduced repellency if excessive amounts are applied (for example silicone double layer with polar outside, Fig. 6.6), only moderate durability to laundering (through hydrolysis of siloxane and rupture of the film by strong cellulose fibre swelling) and dry cleaning (adsorption of surfactants), and no oil and soil repellency. The silicone finish may enhance the attraction of hydrophobic dirt. In addition, the waste water, especially the residual baths, from these finish application processes are toxic to fish.

### 6.3.4 Fluorocarbon-based repellents

Fluorocarbons (FC) provide fibre surfaces with the lowest surface energies of all the repellent finishes in use. Both oil and water repellency can be achieved. FC repellents are synthesised by incorporating perfluoro alkyl groups into acrylic or urethane monomers that can then be polymerised to form fabric finishes (Fig. 6.7). Originally, the perfluoro alkyl groups were produced by electrochemical fluorination, but today they are produced by telomerisation (Fig. 6.8). The final polymer, when applied to a fibre, should form a structure that presents a dense  $\text{CF}_3$  outer surface for maximum repellency. A typical structure is shown in Fig. 6.9. The length of the perfluorinated side chains should be about 8–10 carbons. The small spacer group, mostly ethylene, can be modified to improve emulsification and solubility of the polymer.<sup>10</sup> Comonomers (X, Y, for example stearyl- or lauryl-methacrylate, butylacrylate, methylol- or epoxy-functional acrylates and block copolymers from  $\alpha,\omega$ -dihydroxydimethylpolysiloxane) affect fabric hand, film

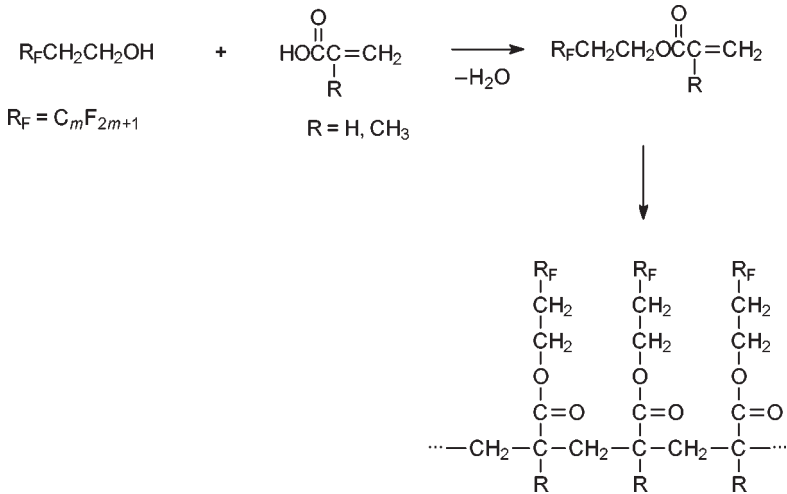

6.7 Preparation of perfluoro containing acrylic polymers.

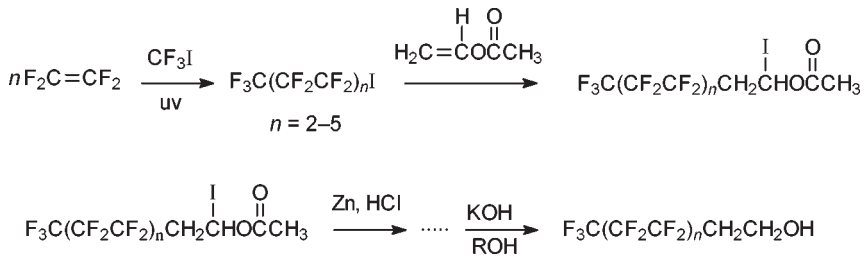

6.8 Telomerisation process for preparing fluoroalkyls.

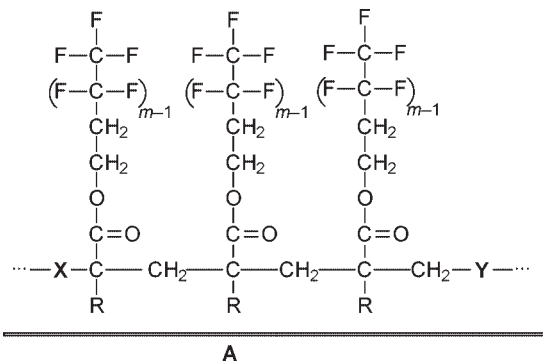

6.9 Fluorocarbon repellent on fibre surface.  $m = 8-10$ . X and Y are comonomers, mainly stearylacrylates.  $R = H$  or  $CH_3$  (polyacrylic or polymethacrylic acid esters). A is the fibre surface.

Table 6.2 Effects of blocked isocyanates as FC boosters

Effect	Caused by
Higher repellency	Better film formation and orientation of the perfluorinated side chains
Higher permanence to washing, dry cleaning and rubbing	Crosslinking with functional groups on the fibre surface and by incorporation in the network of the reaction products of multifunctional isocyanates
Lower curing temperature	Catalytic effects, activation of the crosslinking and crystallisation
LAD (laundry-air-dry), lower temperature of the repellency regeneration after washing	Better and easier orientation of the perfluorinated side chains
Less VOC (volatile organic compounds)	Higher fluorocarbon efficiency (less FC polymer for equal repellency)
Softer hand	Less FC polymer caused by higher fluorocarbon efficiency

formation and durability. In this way and by adding appropriate emulsifiers, FC products can be widely modified for many special performance profiles (see Table 6.1). A more detailed overview of this interesting area of textile chemical engineering is given by Grottenmüller<sup>11</sup> and Holme.<sup>8</sup>

Most FC products are padded, dried and cured. Heat treatment causes an orientation of the perfluoro side chains to almost crystalline structures. This is crucial for optimal repellency. Washing and dry cleaning disturb this orientation and reduce finish performance. The orientation must be regenerated by a new heat treatment (ironing, pressing or tumble drying). But with some new FC products, drying in air is sufficient (laundry-air-dry or LAD products). Tailored FCs and blocked isocyanates, the so-called boosters, are used for this effect. Depending on the kind of blocking group, the isocyanate is activated at different temperatures and then reacts with the functional groups of the FC, the fibre or with itself (crosslinking). This fixation on the fibre surface provides durability to washing, dry cleaning and rubbing as a second important effect. Boosters also cause better film formation and thereby higher repellency effects.<sup>12</sup> Useful effects of boosters are listed in Table 6.2. However, high amounts of boosters adversely affect fabric hand.

General advantages of fluorocarbon-repellent finishes include low active additions (< 1 % owf) and more rapid drying of treated fabrics. Special FCs allow improved soil release during household laundering or stain resistance on nylon, which is especially useful for carpets.<sup>13</sup> Disadvantages of fluorocarbon repellents include high cost, greying during laundering, potentially hazardous aerosols, the

need for special treatment of waste water from application processes and the fact that they usually cannot be applied effectively by exhaustion (but there are some new FC products that are exceptions to this rule).

Low-curing FCs are another new development. They get their repellency without heat, only after drying at room temperature. This is of interest for the impregnation of garments, upholstery and carpets. An inevitable disadvantage is their low durability because of the lack of fixation by crosslinking.

A novel FC development is inspired by nature and therefore called bionic finishes.<sup>14</sup> Fluorocarbon polymers are applied together with dendrimers, causing self organisation where the fluorocarbon chains are enriched on the surface and co-crystallise with the dendrimers. Dendrimers are highly branched oligomers with non-polar chains forming a starbrush structure. They force the polar parts of the FC polymers to form the surface structure mentioned at the beginning of this section.<sup>7</sup> The resulting polar and non-polar sandwich arrangements are highly ordered, causing equal or better repellency effects with lower amounts of fluorocarbon compared to dendrimer-free FC finishes. Other advantages include low condensation temperature (80–130 °C), high abrasion resistance, good wash permanence and soft hand. A hypothetical structure of a dendrimer is shown in Fig. 6.10.

An overview on the importance of FC finishes in the three market segments of clothing, household and technical textiles is presented by Otto.<sup>15</sup> An important group of water-repellent textiles are microfibre fabrics finished with fluorocarbon polymers. Emerising creates further effects that are of interest for leisure wear. Problems and their solutions that arise from this finish combination are discussed by Nassl *et al.*<sup>16</sup> A group of FC finished articles with special importance are ballistic fabrics, providing protection against bullets, splinters and cutting.<sup>17</sup> They consist of several layers of para-aramide wovens, thoroughly finished with fluorocarbon polymers. Without this water repellency they would lose their protective action when wetted (gliding effect of water).

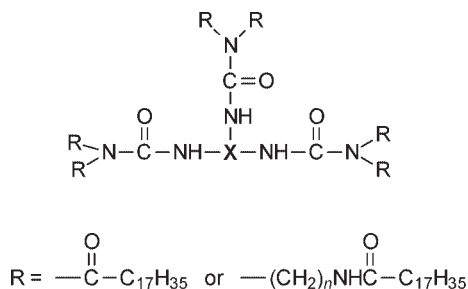

6.10 Hypothetical structure of a dendrimer synthesised from three distearyl-amines or -amides and a trifunctional isocyanate  $\text{X}(\text{N}=\text{C}=\text{O})_3$ .

Table 6.3 Test methods for fabrics with repellent finishes

Test method	Procedure summary
AATCC TM 22 – Water repellency: spray test	Treated fabric is stretched taut, held at a 45° angle and sprayed with 250 ml of water from above. The resulting wetting pattern, if any, is rated using photographic standards. This is a simple, rapid method suitable for the plant floor.
AATCC TM 42 – Water resistance: impact penetration test	Similar to AATCC TM 22, but a weighed piece of blotter paper is placed under the fabric. The weight gain of the paper after 500 ml of water has been sprayed on the fabric is recorded.
AATCC TM 35 – Water resistance: rain test	The treated fabric, backed by a weighed piece of blotter paper, is sprayed with water under constant hydrostatic pressure for 5 min. The weight gain of the paper after the test is recorded. This test requires a special apparatus.
ISO 9865 (DIN 53 888) Bundesmann rain-shower test	Four samples of treated fabric are subjected to simulated rain for 10 min. The fabrics (placed on inclined cups and sealed at the edges) are in constant motion and the side of the fabric not exposed to the rain is subjected to a rubbing action. The repellency of the fabric is determined by the appearance of the wetted side, the amount of water absorbed by the fabric and the amount of water passing through the fabric. This test requires an elaborate special apparatus.
AATCC TM 127 and ISO 811 or EN 20 811 – Water resistance: hydrostatic pressure test (former DIN 53886, Schopper- or Schmerber test)	One surface of the treated fabric is subjected to a constantly increasing hydrostatic pressure until three points of leakage appear on the opposite surface. The pressure at the third point of leakage is recorded in centimetres or metres on a water gauge. A static pressure variation of this test determines the time until the named leakage occurs at a given pressure. This test requires a special apparatus.
AATCC TM 118 – Oil repellency: hydrocarbon resistance test, equivalent to ISO 14 419	Drops of eight standard fluids, consisting of a selected series of eight hydrocarbons with decreasing surface tensions, are placed on the treated fabric and observed for wetting, wicking and contact angle. The highest numbered fluid that does not wet the fabric is recorded as the oil repellency rating with grade numbers from 0 to 8. This method is a simple, rapid test suitable for the plant floor but it is a static test involving no mechanical stress that is often common in real life.
DuPont water repellency test	Similar to AATCC TM 118, but with 8 water-propan-2-ol mixtures with increasing alcohol content.
3M Dry soil resistance test	Samples of treated fabric are shaken in a sealed container with a standard dry soil. Loose soil is removed with compressed air and the appearance of the fabrics is compared to photographic standards.

## 6.4 Evaluation of textiles treated with repellent finishes

Rapid and simple tests for water repellency are the water drop test (method standardised by TEGEWA)<sup>18</sup> and the spray test. If there is insufficient differentiation, even with a higher distance between sample and nozzle, the water resistance with the hydrostatic pressure test should be checked. Some of the most important quantitative test methods are given in Table 6.3. For fabrics that require durable repellency performance, the test methods in Table 6.3 can be applied to fabrics that have been laundered or dry cleaned by standard methods (as AATCC TM 124 and TM 86) in order to determine the durability of the repellency properties. Three groups of corresponding test methods may be distinguished, static drop tests, spray tests and hydrostatic pressure tests.

## 6.5 Troubleshooting for repellent finishes and particularities

Conditions for high repellency of finished fabrics include a close-packed textile structure with small inter-yarn spaces (therefore better woven than knitted) with fine yarns (preferably microfibrils or microfilaments) and a uniform distribution of the repellent finish. This last condition is enhanced by the removal of protruding surface fibres by singeing or shearing.

Any residual sizing agents or surfactants present on the fabric can defeat the repellency properties. All fabrics destined for repellent finishes should be well prepared prior to finishing.<sup>19</sup> Non-rewetting, thermally degradable or volatile surfactants such as isopropanol should be used in the repellent finish bath to maximise the final properties.

Repellent finishes are usually compatible with easy-care and durable press finishes and many softeners. However, most silicone products interfere with the oil repellency of fluorocarbon finishes and should generally be avoided in an oil-repellent formulation. This is a remarkable contrast to the incorporation of silicone segments in the backbone chain of fluoropolymers, which generates a special soft handle.

The combination of FC and antistatic finishes, achieved with selected products<sup>2</sup> is important for synthetic microfibre textiles. Other common finish combinations include hand builders, flame retardant and antimicrobial agents, which generate valuable and useful multifunctional finishes.

FC finishes alone do not sufficiently prevent coffee, tea and other foodstuffs from 'dyeing' nylon and wool carpets with coloured spots, especially when these liquids are not quickly removed. Stain blocking for these carpets is achieved by the combination of FC products with syntans. The latter are also used for wet fastness improvement of acid dyed nylon (see Chapter 13). Stain repellency is promoted by hydrophobic finishes, mostly fluorocarbons, but with decreasing costs also by

silicones, fatty acid-modified melamine products and by paraffin waxes fixed with zirconium salts.

Naturally, water repellency impedes the access of the washing liquor during laundering. Therefore, so-called dual-action fluorocarbon block copolymers were developed, which combine repellency in the dry state and soil-release effects in an aqueous environment (see Chapter 7 on soil-release finishes). Dual active fluorocarbons enable a better removal of oily stains and dirt in domestic washing or laundering. With conventional FC products, the wash water is hindered from wetting and penetrating the fabric. Dual action fluorocarbons are called hybrid fluorochemicals because they are block copolymers containing hydrophobic (like the usual FCs) and highly hydrophilic segments. In air the perfluorinated side chains are, as usual, outwardly oriented and develop high repellency, but in water the double face surface structure flips and the hydrophilic segments turn outwards to promote the wash effect as an oily soil release finish. During heat drying or ironing the sandwich-like surface flips again to generate water, oil and soil repellency.

Traditional commercial FC products consist of 15–30 % fluorocarbon polymer, 1–3 % emulsifier, 8–25 % organic solvents and water. The exhaust air of the drying and curing processes of fluorocarbon finishes therefore often contains high amounts of volatile organic compounds (VOC), like glycols and other organic solvents and a lower content of residual monomers. Cellulosic fibres retain most of the glycols. The exhaust air problem is greater with FC finishes on synthetic fibres. VOCs can be reduced by more than 90 % by the addition of corresponding boosters, providing equal effects with lower quantities of finish products.<sup>7</sup>

Long-life by-products of the fluorocarbon synthesis by electrochemical fluorination are the perfluorooctansulfonic acid and their corresponding salts (perfluorooctyl sulfonate, PFOS). These environmentally critical products (with concerns about persistence, bioaccumulation and potential toxicity) are avoided by synthesis via telomerisation.

Silicones and fluorocarbon polymers cannot easily be stripped off, especially when they are crosslinked. As it is the nature of repellent finishes to reduce adhesion, there are problems with backcoating and laminating of fabrics finished by padding fluorochemicals. One solution is the one side application of the repellents by nip-padding, spray, foam or squeegee techniques.

## References

- 1 Kissa E, *Handbook of Fiber Science and Technology, Vol. II, Chemical Processing of Fibers and Fabrics. Functional Finishes, Part B*, Levin M and Sello S B (eds), New York, Marcel Dekker, 1984, 159–172.
- 2 Sahin B, 'Fluorochemicals in textile finishing', *International Textile Bulletin – Dyeing/Printing/Finishing*, 1996, **42**(3), 26–30.
- 3 Singh O P, 'Stain removal characteristics of fabrics and stain-resistance/release finishing', *Textile Dyer & Printer*, 1987, **20**(25), 24–27.

- 4 Friedrich S and Schindler W, 'Influence of water- and oil repellent finishing on the permeability to air of a woven cotton fabric', *Melliand Textilberichte*, 1990, **71**, 211 – 213, E67–E68.
- 5 Croskell R, 'Burden of (Water)proof', *Apparel International*, 1994, **25**, 9.
- 6 *Funktionelle Sporttextilien*, Internationales Sportmodeinstitut, München, 1989.
- 7 Duschek G, 'Emissionsarme und APEO-freie Fluorcarbon-Ausrüstung', *Melliand Textilberichte*, 2001, **82**(7/8), 604–608.
- 8 Holme I, 'Water repellency and waterproofing', in *Textile Finishing*, Heywood D (ed.), Bradford, Society of Dyers and Colourists, 2003, 135–213.
- 9 Kurz E, 'Ausrüstung aus organischen Lösungsmitteln', *Textilveredlung*, 1969, **4**, 773–786.
- 10 Lämmermann D, 'Fluorocarbons in textile finishing', *Melliand Textilberichte*, 1991, **72**, 949–954, E 380.
- 11 Grottenmüller R, 'Fluorocarbons – an innovative auxiliary for the finish of textile surfaces', *Melliand Textilberichte*, 1998, **79**(10), 743–746, E 195.
- 12 Thumm S, 'LAD-fluorocarbon technology for high-tech sports-wear', *International Textile Bulletin*, 2000, **46**(1), 56–61.
- 13 Buck R C, 'Neue Fleckenschutz-Chemie für Nylon', *Textilveredlung*, 1998, **33**, 57–61.
- 14 Anonymous short report in *Melliand Textilberichte*, 2003, **84**(7/8), 604; Rudolf-Info 8/2003, Rudolf GmbH, Geretsried, Germany.
- 15 Otto P, 'Novel fluoropolymers for textile finishing', *Melliand Textilberichte*, 1991, **72**(5), 378–380, E 155–156.
- 16 Nassl W, Sahin B and Schuirer M, 'Functional finishing of sports and leisure wear', *Chemiefasern/Textilindustrie*, 1992, **42/94**, 137–142.
- 17 Wallitzer T, 'Scotchgard Faserschutz', *Textilveredlung*, 1998, **33**, 4–13.
- 18 Wurster P, Schmidt G, *et al.*, 'TEGEWA- Tropftest', *Melliand Textilberichte*, 1987, **68**, 581.
- 19 Küster B, Fiebig D and Herlinger H, 'Beeinflussung von wasserabweisenden Ausrüstungen durch oberflächenaktive Textilhilfsmittel', *Textil Praxis International*, 1984, **39**, 162–166.

## 7.1 Introduction

The easy-care attributes of garments made from durable press finished cotton and synthetic fibres led to their ready acceptance by consumers in the 1960s. However, it quickly became apparent that these garments were more difficult to clean than garments made from natural fibres. A great deal of research in the textile industry was focused on the problem of soil release and many products were introduced to the market to overcome this performance deficiency.<sup>1-3</sup> Soil-release finishes on textiles facilitate the removal of soils during laundering under common household conditions. The main factors affecting soil release are listed in Table 7.1.

Fabrics treated with soil-release finishes are particularly suited to active wear and leisure wear, markets that are continuing to grow in importance. Industrial uniforms and napery are other market areas where soil release is a desirable product feature.<sup>4</sup> Recent work has shown that soil release can even be incorporated into yarn finishes.<sup>5</sup>

Other fabric properties that are enhanced by soil-release finishes include protection from soil redeposition during laundering and absorbency or transport of liquid water. Fabrics with increased absorbency provide garments that feel more comfortable under hot, humid conditions, thus leading the name 'comfort finish' that has often been applied to fabrics treated with soil-release agents.

## 7.2 Mechanisms of soil release

Removal of soils from fabrics has been attributed to several mechanisms.<sup>1,2</sup> These are:

- 1 Adsorption of detergent and absorption of water leading to:
  - Rollup of oily soil
  - Penetration of soil–fibre interface by wash liquid
  - Solubilisation and emulsification of soils.

Table 7.1 Main factors affecting soil release

Factor	Explanation
Nature of the soil	Oily soil or particulate soil, hydrophobic or hydrophilic, liquid or solid
Kind of fibres	Type of fibre, hydrophilic or hydrophobic, smooth or porous fibre surface
Nature of textile	Textile construction; yarn (staple or filament), fabric (knit, woven or nonwoven)
Effects of preparation	Residual waxes, warp sizes, or other hydrophobic materials
Effects of dyeing and printing	Difference in binder films, residual hydrophobic dyeing auxiliaries
Effects of other finishes	Compatible with antistatic finishes, easy-care finishes and other finishes not harmed by a hydrophilic surface. Not compatible with conventional repellent finishes and other finishes where hydrophilicity is detrimental to finish performance
Washing conditions	Detergents, hydrodynamic flow in the washing machine

## 2 Mechanical work leading to:

- Hydrodynamic flow carrying away the removed soil
- Fibre flexing to force soil from between fibres
- Surface abrasion to remove soil physically
- Swelling of finish to reduce inter-fibre spacing.

Of these mechanisms, solubilisation and emulsification of soils are controlled by detergent composition, hydrodynamic flow is controlled by washing machine design and fibre flexing is controlled by fabric construction. The textile chemist can only influence the mechanisms that involve the fibre surface, i.e. rollup of oily soil, penetration of soil–fibre interface, surface abrasion and finish swelling. Finishes have been developed that provide soil release performance by taking advantage of all of these mechanisms.

Particulate soil is removed from fibres by a two-step process.<sup>1</sup> First, a thin layer of wash liquid penetrates between the particle and the fibre surface, enabling surfactants to adsorb onto the particle surface (Fig. 7.1). Then, the particle becomes solvated and is transported away from the fibre and into the bulk of the wash liquid by mechanical action. Finishes that are hydrophilic (enhancing penetration of the fibre–soil interface) with low adhesion to soil under washing conditions should improve particulate soil release. Ablative or sacrificial finishes

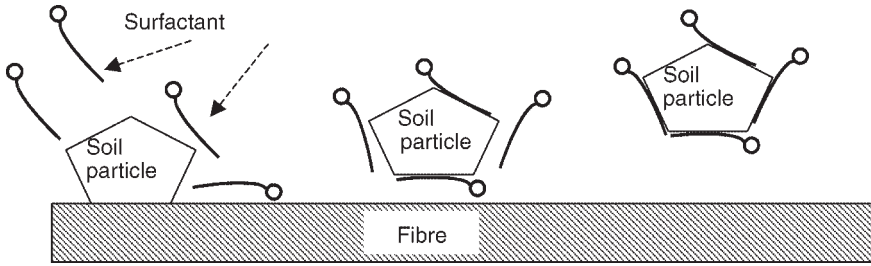

7.1 Release of particulate soil.

that leave the fibre surface during washing and take the soil particles along with them can also benefit particulate soil release.<sup>2</sup> For the most part however, the removal of particulate soils is determined by detergent composition and mechanical action.

Oily soils that are liquids at wash temperatures are released by a 'roll up' mechanism (Fig. 7.2), if the surface free energies of the fibre and oil have the relationship indicated by:

$$R = \gamma_{FO} - \gamma_{FW} + \gamma_{OW} \cos\Theta > 0 \quad [7.1]$$

where  $R$  is the resultant force of the interfacial energies between the fibre and the oil,  $\gamma_{FO}$ ; the fibre and the wash liquid,  $\gamma_{FW}$ ; and the oil and the wash liquid,  $\gamma_{OW}$ .<sup>1</sup> The angle  $\Theta$  is the angle formed at the intersection of the fibre–oil–water interface (Fig. 7.3). For  $R$  to be greater than 0, the contact angle  $\Theta$  must be  $180^\circ$  ( $\cos\Theta = -1$ ). This leads to:

$$\gamma_{FO} - \gamma_{FW} > \gamma_{OW} \quad [7.2]$$

indicating that the difference between the two fibre liquid interactions must be greater than the interfacial tension of the oil with the wash liquid. Analysis of this inequality leads to the following conclusions:

- A low fibre–wash liquid interfacial energy is desired, that is a *hydrophilic* finish is preferred for spontaneous oil roll up.
- A high fibre–oil interfacial energy is desired, that is the finish should also be *oleophobic*.
- A low interfacial tension between the oil and the wash liquid will favour oily soil release.

Additional finish characteristics that should facilitate oily soil release include the ability of the finish to swell during the washing process and flexibility under mechanical action. As in particulate soil release, sacrificial finishes are expected to benefit oily soil release.

The effects of fabric and yarn construction on soil release must be considered. Tightly woven fabrics will be more difficult to clean than loosely knit fabrics and

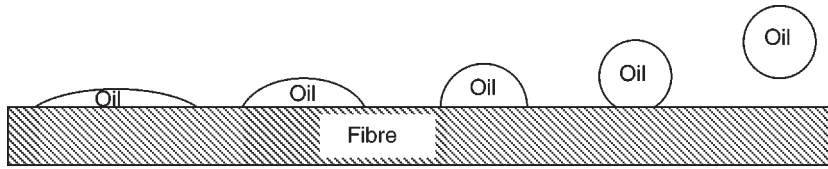

7.2 Roll up of oily soil.

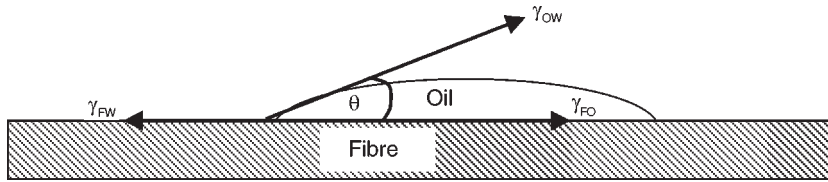

7.3 Fibre-oil-water interface.

yarns made from spun fibres will be more difficult to clean than yarns made from textured filament fibres because the tighter structures will have less ability to flex from mechanical action during laundering.

The colour of the treated and stained fabric cannot be ignored. Very dark fabrics and very light fabrics can appear to have less soil simply from optical effects.<sup>6</sup> Table 7.2 gives an overview on the chemical mechanisms of soil-release finishing.

Table 7.2 Chemical mechanisms of soil-release finishes

Chemical mechanism	Examples of structure types involved
Increasing hydrophilicity, swelling of fibre and finish	PVA, CMC, caprolactam oligomers, ethoxylated products, sulfonates, polyacrylic acid or adipic acid copolymers
Some hydrophobicity, (HLB value about 15)	Hybrid fluorocarbons (dual action block copolymers), or polyacrylic acid esters or polyethylene terephthalate block copolymers
Electrostatic repulsion	Anionic polymers such as polyacrylates and CMC in alkaline washing liquors or sulfonates repulse partly negatively charged soil particles or micelles, including dispersed soil particles
Protective coating with ablative or sacrificial finishes	PVA, CMC, starch
Alkali treatment of polyester	New carboxylic and hydroxyl groups on the fibre surface by hydrolysis of ester structures
Plasma treatment	New carboxylic and hydroxyl groups on the fibre surface by carbon radical formation and oxidation

HLB is the hydrophilic-lipophilic balance; PVA, polyvinyl alcohol; CMC, carboxymethyl cellulose.

### 7.3 Soil-release chemistry

Finishes providing soil release can be classified in numerous ways, by method of application, by fibre type used with them, by chemical structure, electrical charge and so on. Here, chemical structure will be used.

#### 7.3.1 Carboxy-based finishes

Some of the earliest carboxy-based finishes were developed to be used in conjunction with durable press finishes on cotton and cotton blend fabrics. The first patent appeared in 1969.<sup>7</sup> The composition of these finishes is based on acrylic and methacrylic acid and ester copolymers (Fig. 7.4). An ester to acid ratio of ~70:30 is typical. This ratio seems to provide the proper blend of hydrophilicity and oleophobicity (hydrophilic-lipophilic balance, HLB) required for a soil-release finish. The HLB scale<sup>8</sup> is often used for the preselection of surfactants and ranges from about 0 (very hydrophobic) to nearly 20 (very hydrophilic). For good soil-release performance, HLB values of about 15 are favoured. But this is only a rough orientation, because the important copolymer block arrangements are not expressed by these HLB values. Greater hydrophilicity would strongly reduce durability to laundering. These products are usually pad applied in combination with DMDHEU crosslinkers (as described in Chapter 5) and provide soil release by a finish swelling mechanism (Fig. 7.5). The ease of incorporating different acrylic monomers into copolymers has led to a wide variety of available finishes. Often a monomer such as *N*-methylol acrylamide that can react easily with DMDHEU during the finish curing step is added for increased laundering durability. For these finishes to be effective, about 2.5 % solids add-on of the soil-release polymer is necessary. Other carboxy polymers that have been used as soil-release finishes include styrene-maleic anhydride copolymers and sodium carboxymethyl cellulose (Na-CMC).<sup>9</sup>

#### 7.3.2 Hydroxy-based finishes

One of the earliest soil-release materials was starch, which functioned as a sacrificial treatment. Other starch- and cellulose-based products that have been

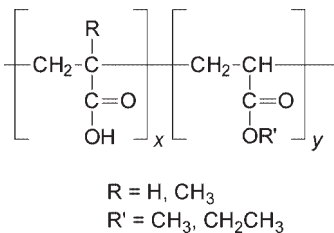

#### 7.4 Acrylic copolymer soil-release finishes.

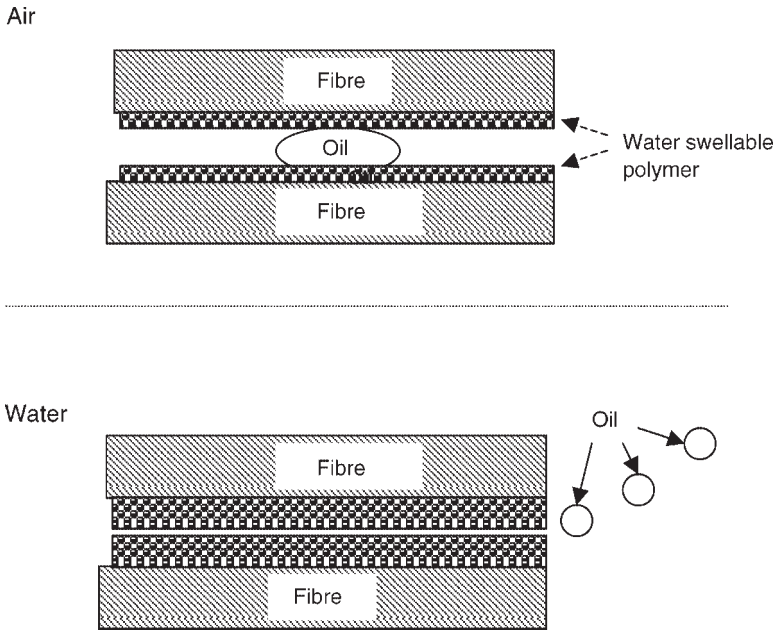

7.5 Mechanism of soil release with acrylic copolymers.

used as soil-release agents include methyl cellulose, ethyl cellulose, hydroxypropyl starch, hydroxyethyl cellulose, hydroxypropylmethyl cellulose and hydrolysed cellulose acetates.<sup>1</sup> With some exceptions,<sup>10</sup> these finishes lack the laundering durability desired in a finish expected to last the life of a garment and must be applied in combination with a binder or crosslinking agent.

### 7.3.3 Ethoxy-based finishes

A great variety of materials containing oxyethylene groups have been offered as soil-release finishes. These products may contain actual polyethylene blocks or ethylene oxide reaction products with acids, alcohols, amines, phenols, etc. Binding agents may or may not be required, depending on the durability of the finish. One important group of soil-release agents for polyester fibres is based on condensation copolymers of terephthalic acid with ethylene glycol and polyethylene glycol (Fig. 7.6).<sup>11</sup> The structure of this polyester–ether copolymer contains blocks of polyethylene terephthalate and polyoxyethylene terephthalate that provide a structure that has regions of hydrophilicity interspersed with hydrophobic regions that have a strong attraction for the polyester surface (Fig. 7.7). These products can provide extremely durable soil-release properties for polyester fabrics by either exhaust or pad applications with about 0.5 % solids add-on. It is possible to exhaust apply these products during the dyeing process.

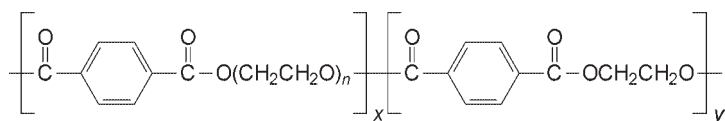

7.6 Polyester-ether condensation copolymer.

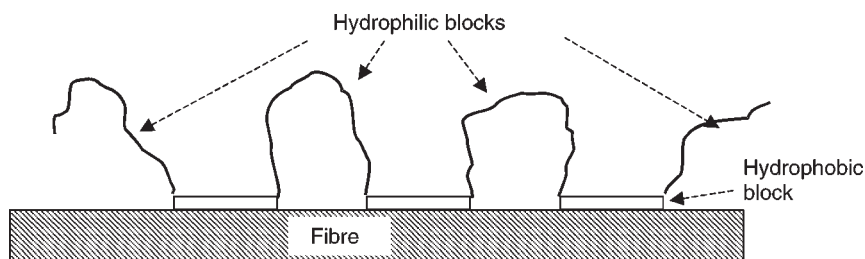

7.7 Copolymer with hydrophilic and hydrophobic blocks on hydrophobic fibre.

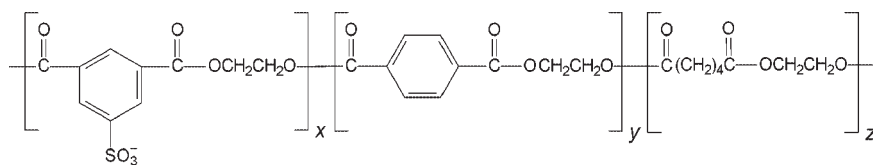

7.8 Modified polyester condensation copolymer.

A modification of the condensation copolymer compounds involves incorporating anionic character into the polymer chain by use of sulfonated monomers.<sup>12</sup> The necessary hydrophilicity is provided by the sulfonated blocks (Fig. 7.8). Like the other polyester condensation polymers, these anionic products can be applied by exhaust or padding. The exhaustion efficiency can be significantly improved by adding small amounts of magnesium chloride to the application bath.

High soil-release performance, excellent softness and combinability with fluorocarbon finishes may be achieved by special silicone/polyalkylene oxide copolymers.<sup>13,14</sup> The silicone segments contain hydrophobic dimethylsiloxane structures and hydrophilic silicone modifications with ethoxylated or amino group-containing side groups. The different hydrophilic-lipophilic balance (HLB) of the polyalkylene blocks is adjusted by the ratio of hydrophobic (polypropylene oxide) and hydrophilic (polyethylene oxide) components.



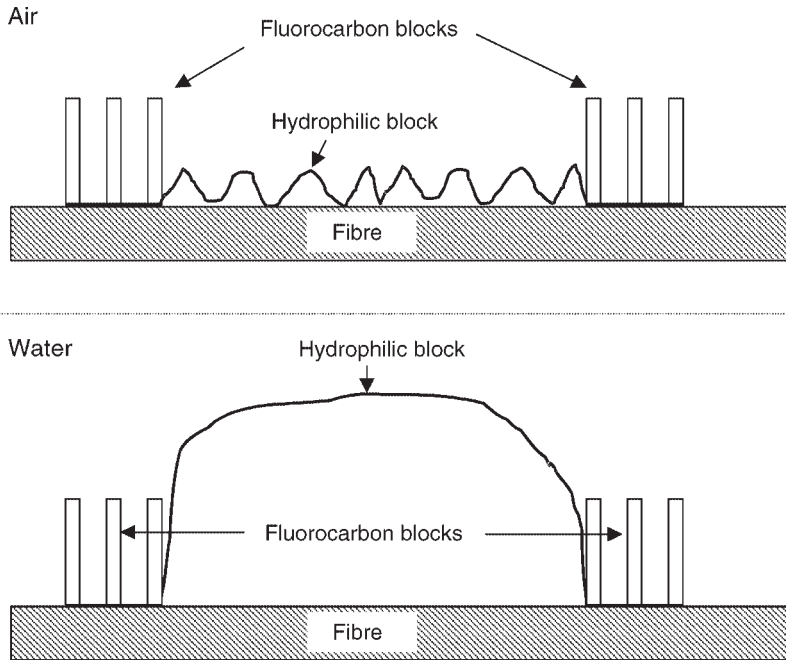

7.10 'Dual action' fluorocarbon in air and water.

## 7.4 Evaluation of soil release

The ideal evaluation method for a soil-release finish would be to stain the fabric with the same material that will soil consumers' clothes and then to wash the fabric with the same detergents in the same washing machines at the same water temperatures that consumers will use. This is not practical in real life so compromises must be made. The American Association of Textile Chemists and Colorists (AATCC) has developed standardised procedures for evaluating soil-release finishes that provide a strong indication of the actual finish performance in the real world. When used by fabric manufacturers and their customers, these procedures are helpful guides in product development and resolution of finish quality issues. However, reliance on these tests alone may be misleading. Good finish development procedures should always include some testing with the actual soils and detergents likely to be encountered by the consumer.

Evaluation of soil-release effects after washing is mostly visually done by comparison with photographic standards, but also by reflectance measurements and other instrumental techniques, including microscopy. Reflectance data using the Kubelka–Munk equation correlate fairly with the oily soil content but not with residual particulate soil (which is probably partly buried within the fabric and shielded from the light path).<sup>1</sup>

### 7.4.1 Oily soil-release testing

AATCC Test Method 130<sup>16</sup> specifies all the parameters that strongly influence soil release of oily soils. A measured amount of corn oil is placed on the fabric to be tested and pressed into the fabric with a specified force. The soiled fabric is washed with a standardised detergent under specific conditions of water temperature and time in a specified washing machine. After tumble drying and equilibration, the stained fabric is compared to photographic standards and rated accordingly. For durability testing, the fabrics are washed prior to staining in accordance with AATCC Test Method 124.<sup>17</sup>

### 7.4.2 Soil reposition

AATCC Test Method 151<sup>18</sup> can be used to estimate the degree of soil redeposition likely to occur during laundering. The fabrics to be tested are exposed to a soiling medium (two dry soils and fabric swatches pretreated with a standard oily soil) during a laundering simulation with a standard detergent. The change in reflectance of the fabric before and after the testing is an indication of the redeposition potential of the fabric.

### 7.4.3 Moisture transport

The procedure given in AATCC Test Method 79<sup>19</sup> can also be used to determine the degree of absorbency of fabrics finished with soil-release agents. Typically, near instantaneous wetting of the fabric with water ( $< 1$  s) is expected from non-fluorine-containing soil-release finishes.

## 7.5 Troubleshooting for soil-release finishes

The performance of a soil-release finish depends upon its ability to provide a hydrophilic surface during the laundering process. Therefore any material deposited on the fibre surface that would reduce this necessary hydrophilicity should be avoided. Softeners, lubricants and other products that modify surface properties should be carefully investigated in laboratory trials before being used with fabrics treated with soil-release finishes.

The relative amounts of the binders and crosslinkers applied in conjunction with acrylic copolymer soil-release compounds must be carefully determined. Too little crosslinking and the soil-release finish is not durable to multiple launderings; too much crosslinking and the finish cannot swell as much as is needed for adequate soil release.

## References

- 1 Kissa E, *Handbook of Fiber Science and Technology, Vol. II, Chemical Processing of Fibers and Fabrics. Functional Finishes, Part B*, Levin M and Sello SB (eds), New York, Marcel Dekker, 1984, 211–289.
- 2 Cooke T F, ‘Soil release finishes for fibres and fabrics’, *Textile Chemist and Colorist*, 1987, **19**(1), 31–41.
- 3 Pailthroe M and David S K, ‘Antistatic and soil release finishes’, in *Textile Finishing*, Heywood D (ed.), Bradford, Society of Dyers and Colourists, 2003, 330.
- 4 Holme I, ‘New development in the chemical finishing of textiles’, *Journal Textile Institute*, 1993, **84**(4), 520–533.
- 5 Schuette R L, DeMott P, Taylor D and Lee A, ‘Method and apparatus for preparing nitride products’, European Patent 0793746, assigned to Milliken Research Corp., 1997.
- 6 Hinks D, North Carolina State University, private communication, 1999.
- 7 Marco F W, ‘Soil release of polyester containing textiles through treatment with aminoplast resins in conjunction with acrylic emulsion polymers containing at least 20 % acid calculated as acrylic acid’, US Patent 3,377,249, assigned to Deering Milliken Inc., 1969.
- 8 Griffin W C, ‘Classification of surface-active agents by HLB’, *Journal Society Cosmetic Chemists*, 1950, **1**, 311.
- 9 Moyse J A, ‘Finishing processes for synthetic and blended fibre textiles to confer soil release and related effects’, *Textilveredlung*, 1970, **5**, 377–385.
- 10 Hauser P J and Marco F W, ‘Textile materials having durable soil release and moisture transport characteristics and process for producing same’, US Patent 4,164,392, assigned to Deering Milliken Inc., 1979.
- 11 McIntyre J E and Robertson M M, ‘Surface modifying treatment of shaped articles made from polyesters’, US Patent 3,416,952, assigned to ICI, 1968.
- 12 Larson W K, Lynn M M and McAllister E S, ‘Process for modifying the surfaces of polyester fibers’ US Patent 4,330,588, assigned to 3M, 1982.
- 13 Holme I, ‘Water repellency and waterproofing’, in *Textile Finishing*, Heywood D (ed.), Bradford, Society of Dyers and Colourists, 2003, 185–186.
- 14 Czech A M, Pavlenyi J and Sabia A J, *Textile Chemist Colorist*, 1997, **29**(9), 29.
- 15 Sherman P O, Smith S and Johannessen B, ‘Textile characteristics affecting the release of soil during laundering. Part II Fluorochemical soil release textile finishes’, *Textile Research Journal*, 1969, **39**, 449.
- 16 AATCC Test Method 130 Soil release: oily soil method, *AATCC Technical Manual*, American Association of Textile Chemists and Colorists, Research Triangle Park, NC, 1999, 217–219.
- 17 AATCC Test Method 124 Appearance of fabrics after repeated home laundering, *AATCC Technical Manual*, American Association of Textile Chemists and Colorists, Research Triangle Park, NC, 1999, 205–208.
- 18 AATCC Test Method 151 Soil redeposition, resistance to: launder-ometer method, *AATCC Technical Manual*, American Association of Textile Chemists and Colorists, Research Triangle Park, NC, 1999, 267–268.
- 19 AATCC Test Method 79 Absorbency of bleached fabrics, *AATCC Technical Manual*, American Association of Textile Chemists and Colorists, Research Triangle Park, NC, 1999, 102.

## 8.1 Introduction

Flame-retardant finishes provide textiles with an important performance characteristic. Protection of consumers from unsafe apparel is only one area where flame retardancy is needed. Firefighters and emergency personnel require protection from flames as they go about their duties. Floor coverings, upholstery and drapery also need protection, especially when used in public buildings. The military and the airline industry have multiple needs for flame-retardant textiles.

The requirements for a commercially successful flame-retardant textile product have been given<sup>1</sup> as meeting flammability requirements: having little or no adverse effect on the textile's physical properties; retaining the textile's aesthetics and physiological properties; being produced by a simple process with conventional equipment and inexpensive chemicals; and being durable to repeated home launderings, tumble dryings and dry cleaning. It has been possible to meet these requirements for many textile products since before 1983<sup>1</sup> and our society enjoys a safer environment as a result. Progress is continuing in this field and recent reviews have highlighted advances in the understanding and chemistry of flame retardants,<sup>2,3</sup> but progress has been relatively slow and the advances quite minor and specialised. Two excellent reviews have appeared<sup>1,4</sup> and should be required reading for those wishing to have a comprehensive understanding of treatment with flame-retardant finishes. This chapter will cover the same ground in a much more general way.

## 8.2 Mechanisms of flame retardancy

In order to understand the mechanisms of effective flame retardants better, the mechanism of combustion should first be clarified. Combustion is an exothermic process that requires three components, heat, oxygen and a suitable fuel. When left unchecked, combustion becomes self catalysing and will continue until the oxygen, the fuel supply or the excess heat is depleted. A diagram of the current model of combustion of textile fibres is given in Fig. 8.1.<sup>2</sup>

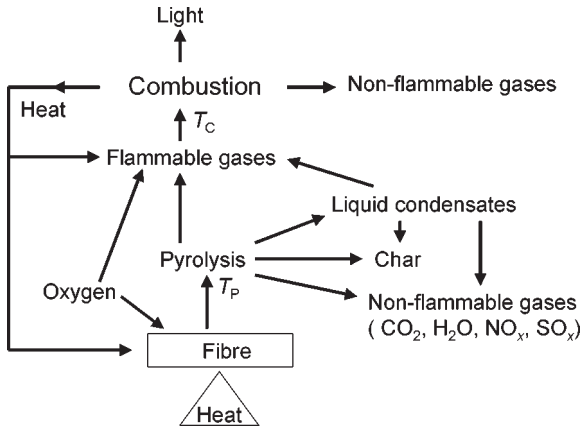

8.1 Combustion cycle for fibres.

When heat is applied, the fibre's temperature increases until the pyrolysis temperature,  $T_p$ , is reached. At this temperature, the fibre undergoes irreversible chemical changes, producing non-flammable gases (carbon dioxide, water vapour and the higher oxides of nitrogen and sulfur), carbonaceous char, tars (liquid condensates) and flammable gases (carbon monoxide, hydrogen and many oxidisable organic molecules). As the temperature continues to rise, the tars also pyrolyse, producing more non-flammable gases, char and flammable gases. Eventually, the combustion temperature,  $T_c$ , is achieved. At this point, the flammable gases combine with oxygen in the process called combustion, which is a series of gas phase free radical reactions (Fig. 8.2). These reactions are highly exothermic and produce large amounts of heat and light. The heat generated by the combustion process provides the additional thermal energy needed to continue the pyrolysis of the fibre, thereby supplying more flammable gases for combustion and perpetuating the reaction. The burning behaviour of textiles is determined more by the speed or rate of heat release than by the amount of this heat.

Attempts to disrupt this cycle for textile substrates have focused on several approaches. One method is to provide a heat sink on or in the fibre by use of materials that thermally decompose through strongly endothermic reactions. If enough heat can be absorbed by these reactions, the pyrolysis temperature of the

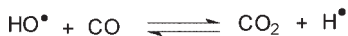
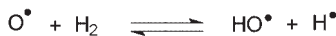
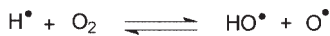

8.2 Some free radical combustion reactions.

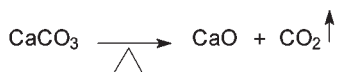

### 8.3 Endothermic decomposition reactions.

fibre is not reached and no combustion takes place. Examples of this method are the use of aluminium hydroxide or 'alumina trihydrate' and calcium carbonate as fillers in polymers and coatings (Fig. 8.3).

Another approach is to apply a material that forms an insulating layer around the fibre at temperatures below the fibre pyrolysis temperature. Boric acid and its hydrated salts function in this capacity (Fig. 8.4). When heated, these low melting compounds release water vapour and produce a foamed glassy surface on the fibre, insulating the fibre from the applied heat and oxygen.

A third way to achieve flame retardancy is to influence the pyrolysis reaction to produce less flammable volatiles and more residual char. This 'condensed phase' mechanism can be seen in the action of phosphorous-containing flame retardants which, after having produced phosphoric acid through thermal decomposition, crosslink with hydroxyl-containing polymers thereby altering the pyrolysis to yield less flammable by-products (Fig. 8.5). But there are also other explanations for the first steps of this dehydration, including single esterification without crosslinking, for example, of the primary hydroxyl group in the C-6 position of the cellulose units. These phosphorous esters catalyse the dehydration (Fig. 8.6) and prevent the formation of undesired levoglucosan (Fig. 8.7), the precursor of flammable volatiles.<sup>5</sup>

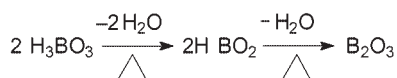

### 8.4 Formation of foamed glass.

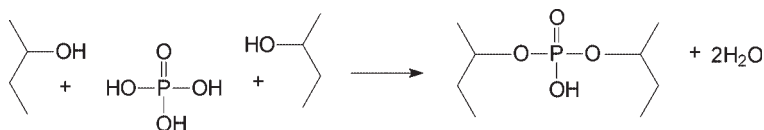

### 8.5 Crosslinking with phosphoric acid.

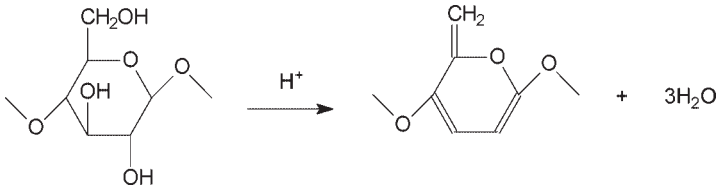

8.6 Dehydration of cellulose by strong acids.

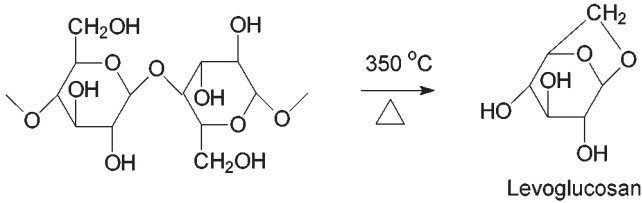

8.7 Thermal degradation of cellulose.

Table 8.1 Comparison of two important flame-retardant mechanisms

Type of mechanism	Condensed phase	Gas phase
Type of chemistry involved	Pyrolysis chemistry	Flame chemistry
Typical type of synergism	P/N	Sb/Br or Sb/Cl
Effective for fibre type	Mainly cellulose, also wool, catalysing their dehydration to char	All kinds of fibres, because their flame chemistry is similar (radical transfer reactions)
Particularities	Very effective because dehydration and carbonisation decrease the formation of burnable volatiles	Fixation with binder changes textile properties such as handle and drape, preferably for back coating, for example of furnishing fabrics and carpets
Application process	If for durable flame retardancy then demanding multi-step processes	Relatively simple, standard methods of coating, but viscosity control is important
Environment, toxicity	With durable flame retardancy, formaldehyde emission during curing and after finishing, phosphorous compounds in the waste water	Antimony oxide and organic halogen donors (DBDPO and HCBC) are discussed as problems (for example possibility of generating polyhalogenated dioxins and furanes)

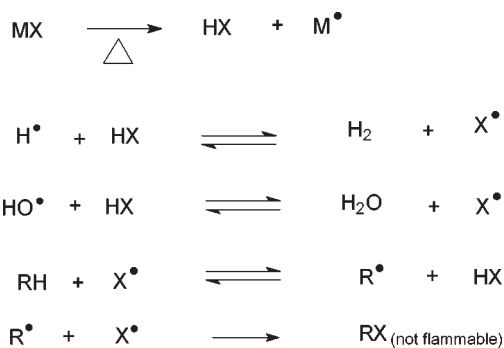

8.8 Competing free radical reactions during combustion of halogen (X)-containing material (M). R is the organic residue.

The ‘condensed phase’ strategy includes the described mechanism of removal of heat and the enhancement of the decomposition temperature as in heat resistant fibres. In Table 8.1 the ‘condensed phase’ and the ‘gas phase’ mechanisms are compared.

A fourth approach to preventing combustion is to interfere with the free radical reactions (flame chemistry, Fig. 8.2) that provide the heat needed for the process to continue. Materials that act in this ‘gas phase’ mechanism include halogen-containing compounds which, during combustion, yield hydrogen halides that form relatively long lived, less reactive free radicals, effectively reducing the heat available for perpetuating the combustion cycle, and which decrease the oxygen content by flame gas dilution (Fig. 8.8).

### 8.3 Flame-retardant chemistry

The most important commercial flame retardants can be classified into three broad categories.<sup>1</sup> Primary flame retardants based on phosphorous (condensed phase mechanism) and halogens (gas phase mechanism); synergistic retardancy enhancers that have only small flame retarding effects by themselves, but greatly enhance the flame retardancy of primary flame retardants (nitrogen with phosphorous and antimony with halogens); and adjunctive flame retardants that exhibit their activity through physical effects (borates, alumina trihydrate, calcium carbonate and intumescent, explained in Section 8.10).

Organic nitrogen is thought to help control the pH during the crosslinking reactions of phosphoric acid. The nitrogen can become protonated, reducing the amount of acid available. If the pH is too low, cellulose will undergo acid hydrolysis rather than crosslinking. If the pH is too high, the acid catalysed crosslinking cannot take place. Organic nitrogen may be converted to phosphorous acid amides that also catalyse the dehydration and carbonisation of cellulose. The synergistic effect of antimony comes from the volatility of antimony trihalides and

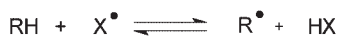
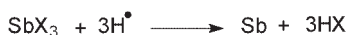
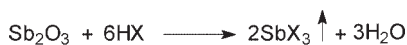

### 8.9 Gas phase free radical reactions with antimony.

Table 8.2 Synergistic combinations of flame retardants<sup>6</sup>

Synergistic combination	Suitable for	Generated primary active compounds
P/N Halogen (X)/Sb <sub>2</sub> O <sub>3</sub>	Cellulose Synthetic fibres, especially PAN, PP, PA	H <sub>3</sub> PO <sub>4</sub> , P-amides SbOX → SbX <sub>3</sub>
P/halogen (X) Halogen/radical generator	PP, (PET, PAN, PA) Synthetic fibres, especially PET, CT, CA	POX <sub>3</sub> , PX <sub>3</sub> Halogenated polymers

PP = polypropylene, PET = polyethylene tetrachloride, PAN = polyacrylonitrile, PA = polyamide, CT = cellulose triacetate, CA = cellulose acetate.

the effectiveness of antimony compounds in scavenging free radicals (Fig. 8.9) over a broad temperature range (for example 245–565 °C).<sup>6</sup> Table 8.2 shows common synergistic combinations of flame retardants.

## 8.4 Flame retardants for cellulose

One important thermal degradation mechanism of cellulose fibres (cotton, rayon, linen, etc.) is the formation of the small depolymerisation product levoglucosan (Fig. 8.7). Levoglucosan and its volatile pyrolysis products are extremely flammable materials and are the main contributors to cellulose combustion. Compounds that are able to hinder levoglucosan formation are expected to function as flame retardants for cellulose. The crosslinking and the single type of esterification of

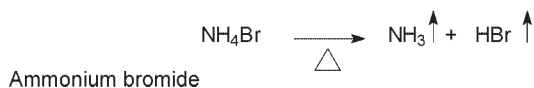
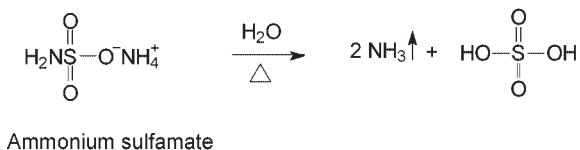
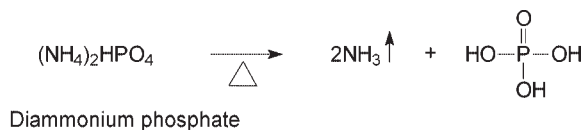

### 8.10 Thermal decomposition of ammonium salts.

cellulose polymer chains by phosphoric acid reduces levoglucosan generation, catalyses dehydration and carbonisation, and thus functions as an effective flame-retardant mechanism. This carbonisation of cellulose is similar to the well known carbonisation process of wool with sulfuric acid, removing plant dirt and other cellulose. In an idealised equation, flame-retardant finished cellulose ( $\text{C}_6\text{H}_{10}\text{O}_5$ )<sub>n</sub> would be decomposed to  $6n \text{ C}$  and  $5n \text{ H}_2\text{O}$ . The first step of this reaction is shown in Fig. 8.6. The resulting char is much less flammable than the volatile organic pyrolysis products of untreated cellulose.

Chemicals that can yield phosphoric acid during the early stages of fibre pyrolysis form the majority of successful flame retardants for cellulose. However, it is not sufficient to supply just phosphoric acid precursors. The presence of nitrogen has been found to provide a synergistic effect with phosphorous. Minimum levels of added phosphorous and nitrogen for effective flame retardancy have been estimated at  $\sim 2\% \text{ P}$  and  $\sim 1\% \text{ N}$ . However, these minimum levels can vary greatly depending on fabric construction and test requirements.

#### 8.4.1 Non-durable flame retardants for cellulose

Inorganic salts have long been known to provide flame retardancy on cellulosic material that will not be exposed to water, rain or perspiration. The French chemist Gay-Lussac proposed a borax and ammonium sulfate treatment as a flame retardant for cotton in 1820. Today, a mixture of boric acid and borax is still an effective flame retardant for cotton at  $\sim 10\% \text{ solids add-on}$ . Ammonium salts of strong acids, especially phosphoric acid (P/N synergism) are particularly useful as non-durable flame retardants for cellulose. Three commercially important products are diammonium phosphate, ammonium sulfamate and ammonium bromide. These salts readily form the corresponding strong acids upon heating (Fig. 8.10).

Diammonium phosphate and ammonium sulfamate are used at ~ 15 % solids add-on and function as condensed phase flame retardants, not only by crosslinking but also by dehydrating cellulose to polymeric char with reduced formation of flammable by-products (Fig. 8.6). The water insoluble ammonium polyphosphate is an effective flame retardant and is added to coatings and binder systems, for example for pigment printing. Ammonium bromide is applied at ~ 10 % solids add-on and is effective in the gas phase.

#### 8.4.2 Durable flame retardants for cellulose

Although inorganic salts can provide excellent flame-retardant properties for cellulose, reasonable laundering durability must be incorporated into any finish destined for apparel use. The most successful durable flame retardants for cellulose are based on phosphorous- and nitrogen-containing chemical systems that can react with the fibre or form crosslinked structures on the fibre. The key ingredient of one of these finishes is tetrakis(hydroxymethyl)phosphonium chloride (THPC), made from phosphine, formaldehyde and hydrochloric acid (Fig. 8.11).<sup>1</sup> THPC reacts with urea to form an insoluble structure on cellulose in a pad-dry-cure process (Fig. 8.12).

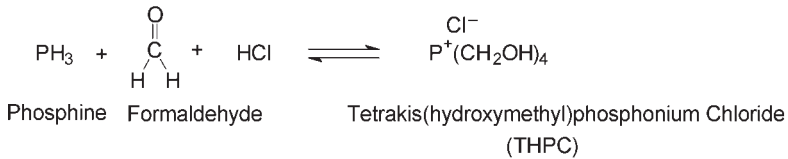

8.11 Synthesis of THPC.

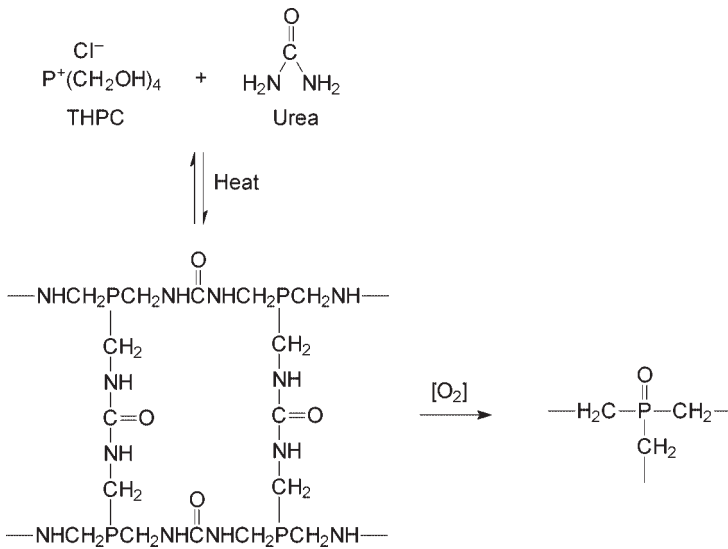

8.12 Reaction of THPC with urea.

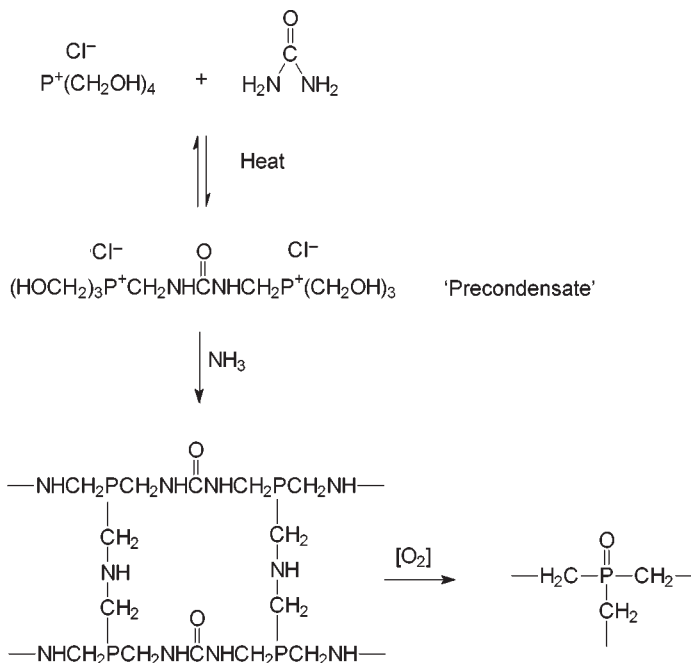

8.13 THPC-urea-ammonia reaction.

Some reaction with cellulose also occurs. Treating the cured finish with hydrogen peroxide to convert the phosphorous atoms to their highest oxidation state results in cellulosic goods with very durable flame retardancy. Applying 25 % THPC with 15 % urea yields a final phosphorous add-on of 3.5–4 %, which is adequate for most fabrics. Although the THPC-urea system can give highly effective and durable flame retardancy to cellulose, treated fabrics are stiff and have significantly impaired tensile and tear strengths as well as releasing formaldehyde during processing. Typically, carefully chosen softeners and mechanical finishing techniques are used to provide commercially acceptable fabrics. Variations on THPC-based systems have been the use of the sulfate or hydroxy salts; THP-S to eliminate the possible formation of highly toxic bis(chloromethyl) ether during processing, and THP-OH to reduce acidic tendering of the goods.

A variation on the THPC-urea system was developed to produce finishes with less stiffness and fibre damage (Proban process). A precondensate is prepared by the careful reaction of THPC with urea. This precondensate is padded onto the fabric and the fabric is dried to a specific moisture content (~ 15 %). The fabric is then exposed to ammonia vapours in a special reaction chamber, followed by oxidation with hydrogen peroxide (Fig. 8.13). The polymer that forms is primarily located in the lumen of the cotton fibre. The final finish provides durable flame retardancy to cotton with much improved fabric properties.<sup>1</sup> It is important to note

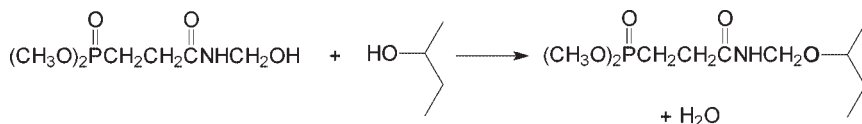

8.14 Reaction of *N*-methylol dimethylphosphonopropionamide with cellulose.

that very few direct or fibre reactive dyes can withstand exposure to THP-based finishes. Almost all cellulosic goods that are to be flame retardant treated with a THP finish should be dyed with vat dyes.

Another successful commercial approach to durable phosphorous-containing finishes is the use of *N*-methylol dimethylphosphonopropionamide (Fig. 8.14) in combination with trimethylol melamine and phosphoric acid as catalyst in a pad-dry-cure process.<sup>1</sup> The required add-on is 20–30 % depending on the weight of the fabric. In this process, washing after curing is necessary to remove the phosphoric acid, leading to higher costs associated with the second drying step. In addition, the finish may give rise to an unpleasant odour during the curing step. Novel developments include higher product purity, decrease in formaldehyde emission during curing<sup>5</sup> and by the finished textile, and also higher fixation rates enabled by moderate condensation conditions (accompanied by less fibre damage). Table 8.3 shows a comparison of these two important permanent flame-retardant finishes for cellulotics. Both processes are justified by the common finishing practice.

Table 8.3 Comparison of two permanent flame-retardant finishes for cellulotics

Modified THPC-urea finish ('Proban' type)	<i>N</i> -methylol phosphonopropionamide finish ('Pyrocatex CP new' type)
Demanding process, including moisture control, ammonia vapour treatment and oxidation	Extra washing after curing including drying costs
Smaller wash shrinkage	Softer handle
Better stability to hydrolysis	Fewer dyestuff restrictions, including brilliant shades
Somewhat better ripping strength	Much less free formaldehyde development
Less odour bothering	Shorter after-burning time
Also for fibre blends with small cellulose content	Less smoke development
Preferably for large production runs, to minimise the process costs including machinery requirements	No licence required, including corresponding restrictions and costs

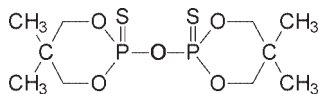

8.15 Viscose spinning bath additive for flame-retardant rayon.

### 8.4.3 Flame retardants for rayon

Although in principle rayon can be flame retarded by the same processes developed for cotton, the majority of research efforts have focused on additives to the viscose spinning bath. One successful additive, based on an alkyl dioxaphosphorinane disulfide (Fig. 8.15), is used at ~ 20 % for effective flame retardancy.<sup>1</sup>

## 8.5 Flame retardants for wool

Despite the fact that wool fibres are inherently less flammable than most other fibres, some flame-retardant treatment is usually necessary in order to meet specific flammability tests. One well known process (Zirpro, developed by Benisek for the IWS) is based on hexafluoro zirconate and titanate salts.<sup>1,5</sup> These products can be applied by exhaustion and pad processes under acid conditions (at pH < 3). The heavy metal complex anions form ionic and perhaps other polar bonds with the wool fibre, similar to dyestuff anions. The flame-retardancy mechanism is thought to take place in the condensed phase through zirconium ions or zirconium compounds that enhance or catalyse the char formation.<sup>5</sup> Zirconium levels of ~ 2 % are needed for effective flame retardancy. The hexafluoro titanium salt is more effective and cheaper, but a yellow shade is imparted to the treated wool, which is increased by exposure to light. The finish is durable to dry cleaning and water washing up to 40 °C at pH < 6. At higher pH values ineffective zirconium oxide is formed.<sup>7</sup> This finish can be combined with dyeing at pH < 3 (levelling acid or 1:1 metal complex dyes). It is compatible with shrink-resist and insect-resist finishes. Repellent finishes should be applied after the Zirpro process.<sup>8</sup> This finish was modified for wool used for thermal insulation material, especially with skin contact,<sup>9</sup> enabling less strength loss after heating and high flame retardancy (limiting oxygen index, LOI up to 35, see Section 8.11).

Another flame-retardant treatment for wool based on exhaustion of an anionic species is the use of tetrabromophthalic anhydride, TBPA (Fig. 8.16), which hydrolyses to the carboxylic form during application. Use of TBPA at ~ 10 % on weight of fabric under acid conditions provides effective flame retardancy that is durable to dry cleaning and mild laundering conditions (cold water washing at neutral pH).<sup>1</sup> But TBPA is suspected to generate polybrominated dioxins under burning conditions.

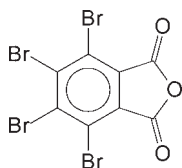

8.16 Tetrabromophthalic anhydride (TBPA).

## 8.6 Flame retardants for polyester

The three possible approaches to flame-retardant polyester – additives to the polymer melt, flame-retardant copolymers and topical finishes – have all been used commercially to produce flame-retardant polyester textiles.<sup>1</sup> All the methods employ phosphorous- or bromine-containing compounds as the active flame retardant.

One of the most useful flame-retardant finishes for polyester was a bromine-containing phosphate ester, trisdibromopropylphosphate, commonly known as ‘Tris’ (Fig. 8.17). Most simple phosphate triesters could also have been given the name of ‘tris’ for simplicity but the best known is the dibromopropyl product. ‘Tris’ was an extremely versatile and effective product, being applied by both padding and exhaustion processes (even though the substantivity and exhaustion yields were low) and provided excellent flame retardancy at reasonable add-ons. However, ‘tris’ was shown to be a potential carcinogen and was eventually removed from the marketplace by legislation.<sup>1</sup> At the time, in the mind of the general public, anything that could be named ‘tris’ was considered to be a dangerous carcinogen!

One current commercial flame retardant for polyester is a mixture of cyclic phosphate/phosphonates used in a pad-dry-heat set process (Fig. 8.18).<sup>10</sup> Heat set conditions of 190–210°C for 0.5–2 min are adequate. This product when applied at ~ 3–4 % add-on can provide durable flame retardancy to a wide variety of polyester textiles.

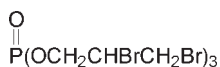

8.17 Tris(2,3-dibromopropyl) phosphate.

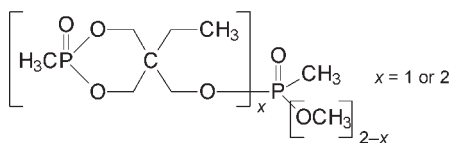

8.18 Cyclic phosphate/phosphonate flame retardant.

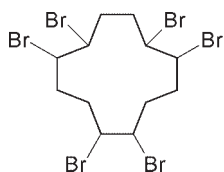

8.19 Hexabromocyclododecane (HBCD).

Another approach to durable flame retardant finishes for polyester is the use of highly brominated chemicals as topical finishes. One particularly useful material is hexabromocyclododecane (HBCD, Fig. 8.19). To achieve durable flame retardancy, fabric padded with ~ 8% of a dispersion of this water insoluble material must be heated above 190 °C or 375 °F to form a film of the flame retardant on the fibre surface.<sup>11</sup>

Polyester fabrics when burned exhibit a melt-drip behaviour. Since the fabric melts away from the flame, some polyester fabric constructions can actually pass vertical flame tests without any flame-retardant treatment. The waiving of melt-drip specifications for children's sleepwear has allowed untreated polyester garments to be sold into that market.

## 8.7 Flame retardants for nylon

Although there are several possible methods of incorporating flame retardants into nylon, only additives to the polymer melt and topical finishes have been commercialised. Phosphorous- and bromine-containing compounds are the most common melt additives.<sup>12</sup> The topical flame-retardant finishes for nylon that are of special interest are the treatments based on the condensation product of thiourea with formaldehyde and urea. The flame-retardancy effect of these products is attributed to the lowering of the melting point of nylon by 40 °C and allowing the fibre to drip away from the ignition source.<sup>1</sup> Common practice in nylon flame retardancy, especially for nylon carpets, is back-coating with antimony trioxide combined with bromine donors and a binder as shown in Fig. 8.20.

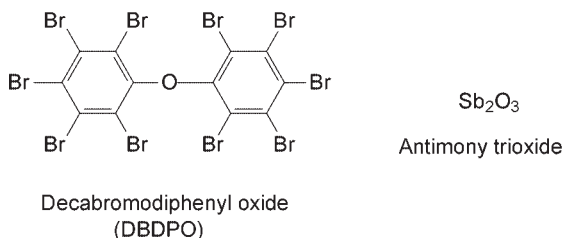

8.20 Flame-retardant system for fibre blends.

## 8.8 Flame retardants for other fibres

The most successful approach for flame-retarding acrylic fibres is to copolymerise halogen-containing monomers into the fibre. These modacrylic fibres have excellent permanent flame retardancy and acceptable fibre properties.<sup>1</sup> Some problems including reproducibility of dyeing gave rise to their substitution by flame-retardant modified polyester, for example for curtain fabrics and other decorative textiles.

Polypropylene fibres can be flame retarded with bromine- and phosphorous-containing additives to the polymer melt. However, very high add-ons are necessary and fibre properties are adversely affected. When polypropylene is used in carpets, flame retardancy can be achieved by incorporating halogen-containing compounds and antimony trioxide into the latex backing.<sup>1</sup>

Although *m*-aramid fibres (for example Nomex®) have an inherent flame retardancy, caused by their high decomposition temperature, this retardancy can be enhanced by the use of certain halogen/phosphorous compounds during exhaust dyeing.<sup>13</sup> Along with Nomex®, other inherently flame-resistant fibres such as Kevlar® (p-aramid), PBI (polybenzimidazole), Basofil® or Kynol® (melamine or phenol formaldehyde condensates), and flame-retardant modified polyester and regenerated cellulose find uses in protective clothing and other textiles that require flame resistance.

Inorganic fibres such as ceramic and glass may be incorporated into, or used entirely for, textile products where appropriate to take advantage of their inherent non-flammability. Product examples are curtains, textile tapestries and fireblockers in airplane, automotive and military textiles.

## 8.9 Flame-retarding fibre blends

Providing flame retardancy for fibre blends has proved to be a difficult task. Fibre blends, especially blends of natural fibres with synthetic fibres, usually exhibit a flammability that is worse than that of either component alone. Natural fibres develop a great deal of char during pyrolysis, whereas synthetic fibres often melt and drip when heated. This combination of thermal properties in a fabric made from a fibre blend results in a situation where the melted synthetic material is held in the contact with the heat source by the charred natural fibre. The natural fibre char acts as a candle wick for the molten synthetic material, allowing it to burn readily. This can be demonstrated by the LOI values of cotton (18–19), polyester (20–21) and a 50/50 blend of both (LOI 18), indicating a higher flammability of the blend as described later (Section 8.11). But a rare case of the opposite behaviour is also known (modacrylic fibres with LOI 33 and cotton in blends from 40–60 % can raise the LOI to 35).

Even an antagonistic behaviour is reported for wool/polyester blends.<sup>8,14</sup> Both Zirpro finished wool and Trevira CS, which is inherently flame retardant modified

by copolymerisation with methylpropionylphosphinic acid, are excellent flame protectors. But their blends burn easily.

In order to flame retard natural/synthetic fibre blends, high levels of flame retardants are often required. One approach to this dilemma is to add the necessary amounts of retardant as a fabric coating. By using decabromodiphenyl oxide (DBDPO) in combination with antimony trioxide (Fig. 8.20), a cotton/polyester blend fabric has been produced that exhibits durable flame retardancy.<sup>1</sup> Unfortunately, the finish required 37 % add-on of the retardants in addition to a latex binder and softener. The colour and hand of the finished fabric are significantly altered and chemical costs are high. However, if all of the coating is on the back of the fabric, the fabric face can be left essentially unaltered. The rubber-like hand of the fabric back can be minimised if the coating is applied discontinuously. Despite these drawbacks, advances in application technology and careful fabric design have led to the commercialisation of flame-retardant blends of cotton/polyester<sup>15</sup> and cotton/nylon<sup>16</sup> using precise combinations of phosphorous and bromine flame retardants and formulations that capitalise on a narrow window of effectiveness.

## **8.10 Novel approach to flame retardancy: intumescent**

Prevention from burning as early as possible is an accepted aim. Engineering the first steps of the burning process seems to be better than managing the last ones. In this context it might be preferable to moderate first the pyrolysis and then the flame chemistry. The concentration of research and development (R&D) work on the catalysis of the pyrolysis step gave rise to a new and promising approach, called intumescent.<sup>5</sup> This is the generation of expanded, foamed char formed by heat and special additives, such as char formers (for example starch), catalysts that yield inorganic acids at about 150 °C, generators that provide non-flammable gases for the foam and binders for fixation to the fabric. This system provides a foamed insulation layer on the fabric surface, similar to the formation of char by cellulose, wool and especially by Basofil fibres. This porous char layer seems to fulfil many flame retardancy requirements, such as preventing or retarding further ignition by thermal and chemical insulation, creating a flame barrier, including reduction of material exchange (volatiles, oxygen). Additionally smoke and toxic gas development is decreased. This double barrier function (for heat and material exchange) is very effective and avoids some ecological disadvantages of common flame retardants. A more detailed and competent overview is given by Horrocks.<sup>5</sup>

## **8.11 Evaluation of flame retardants**

Many factors influence the flammability of textiles, including the fibre type, the fabric weight and construction, the method of ignition, the extent of heat and material exchange, and the presence or absence of flame retardants. Differing

Table 8.4 Common flammability tests

Test method	Sponsoring organisation	Comments
16 CFR 1610	Consumer Product Safety Commission (CPSC)	Fabric at 45° angle to flame for 1 s. For general apparel.
16 CFR 1615/1616	CPSC	Fabric held vertical to flame for 3 s. For children's sleepwear.
NFPA 1971	National Firefighters Protection Association (NFPA)	Fabric held vertical to flame for 12 s. For protective clothing.
NFPA 701	NFPA	Fabric held vertical to flame for 45 s to 2 min. For drapery.
ASTM D-2863 Limiting oxygen index (LOI)	ASTM	Fabric is held vertical in atmosphere of different oxygen/nitrogen ratios and ignited from top. Determines minimum oxygen level to support combustion.
BS 5852 Part 1 and 2, for ignition sources 'cigarette' and 'match' equivalent also EN 1021 and EN 597	British Standards Institution	Burning behaviour of upholstered furniture fabrics (also for private use) against smoker-materials like cigarettes and matches. Finished fabric must be soaking resistant at 40 °C according to BS 5651, then horizontally and vertically fixed on a mini chair on a support of foamed PU, by seven ignition methods.
ISO 6940/6941	International Standards Organisation	Vertically held specimens, determination of the ease of ignition/the flame spread properties.
DIN 54333 T1	Deutsches Institut für Normung	Horizontally held specimens, because of the heat distribution less severe than vertical tests

performance requirements and government regulations have led to the development of numerous test methods for evaluating the flame retardancy of textiles.<sup>17</sup> According to the great variety of textile usage there are numerous test methods with vertical, horizontal or diagonal arrangement of the samples, methods with and without air ventilation, and many special tests, for example for carpets and fire protection clothing. Some of the more commonly encountered tests are given in Table 8.4. In the case of military fabrics, each fabric will have to fulfil the requirements and procedures listed in the MIL specification.

Table 8.5 Limiting oxygen index (LOI) values of different types of fibres

Flammability in air	LOI	Fibre type
Easy ignition, rapid burning	18.2	Acrylic
	18.4	Cotton
	18.6	Viscose
	19	Polypropylene
Normal ignition and burning behaviour	20–21	Polyester PET
	20–21.5	Nylon 6 and 6.6
Almost ignition resistant	25	Wool
Flame retardant with LOI > 26	29–30	Modacrylic
	28–31	Meta-aramide
	29–31	Para-aramide
Flame retardant under severe conditions, for example with heavy air ventilation, LOI about > 30	30–34	Phenol-formaldehyde type (Kynol)
	32	Melamine-formaldehyde type (Basofil®)
	32	Poly(aramide-imide) (Kermel)
	34	Polyphenylenesulfide (PPS)
	35	Polyetheretherketone (PEEK)
	36–38	Polyimide (PI, P84)
	>41	Polybenzimidazole (PBI)
	44–45	Polyetherimide (PEI)
	45–55	Partially oxidised PAN (Preox, Panox)
	60	Poly(vinylidene/vinylchloride) PVDC
68	Polybenzoxazole (PBO, Zylon)	
98	Polytetrafluoroethylene (PTFE)	
Not burning, even in pure oxygen (LOI 100), only melting		Glass and ceramic fibres, inorganic compounds on their highest oxidation level

A measure that enables an obvious assessment of flame protection properties is the limiting oxygen index (LOI), determined according to ASTM D-2863. The LOI is defined as the content of oxygen in an oxygen/nitrogen mixture that keeps the sample at the limit of burning:

$$\text{LOI} = 100 \times \text{O}_2 : (\text{O}_2 + \text{N}_2) \quad [8.1]$$

As the oxygen content of air is 20 % corresponding to LOI = 20 all textiles with lower LOI values will burn quite easily in air and those with LOI values much higher than 20 will not burn. Table 8.5 illustrates this readily imaginable measure for the flammability and burnability of different types of fibres.

For all methods, strict adherence to the testing protocol is crucial to obtaining reliable and repeatable results. However, it is important to recognise that if a fabric passes a particular test, it just means that the fabric passed this particular test. There are no other performance guarantees. More detailed information on actual flame retardancy test methods and an outlook on their development have been published.<sup>4,5,18</sup>

## 8.12 Troubleshooting for flame-retardant finishes and particularities

The legal implications of selling a flame-retardant fabric require a very thorough testing programme to guarantee that all areas of the fabric, side to side, end to end, and piece to piece meet the necessary performance requirements. Uniform application of flame retardants is the key to meeting these requirements. For pad applied finishes, all the factors that influence uniformity must be identified and controlled. These include pad roll pressures, finish bath concentrations and uniformity of drying and heat setting. Both exhaust and pad applied finishes are also susceptible to adverse flammability interactions from softeners, lubricants and other finish components. Laboratory evaluations of all new components must be completed before introducing any new finish into a production environment.

There are also serious side effects to fabric physical properties from flame-retardant finishing that must be recognised, often caused by the high application levels of the flame retardants. Harsh hand, loss of tensile strength and colour effects (fabric yellowing and dye shade changes) are common problems with durable flame-retardant finishes for cotton. The combination with other finishes, such as softeners, easy-care and repellent finishes, must be carefully tested. The flame retardancy of the multi-purpose finish is more often reduced than it is acceptable.

The toxicity of some flame-retardant components and of their combustion gases is a particular concern for flame-retardant finishes, especially if based on halogens and several heavy metals. Therefore, aircraft textile equipment has to fulfil special requirements, for example, smoke density and toxicity tests. Toxicity problems include:

- halogenated compounds, especially aromatics, are capable of generating polyhalogenated dioxins and furans,
- whether or not the hexa- or the penta-bromium compounds (HBCD or DBDPO) are more dangerous,
- dust that contains antimony oxide,
- phosphorous, antimony and zirconium compounds in the waste water,
- halogenated organic flame retardants, especially aromatic ones, get into the waste water (often they are only slowly biodegradable and cause high AOX (halogenated adsorbable organics) values) and
- formaldehyde release during curing of the permanent flame retardant finishes of cellulose and free formaldehyde of finished fabrics (storage, transport).

Most flame-retardant finished textiles are excluded from the Öko-Tex Standard 100 label. In all cases, the durability of the finish is often a problem. It is the responsibility of the fabric finisher to address these issues if commercial flame-retardant fabrics are to be produced. An alternative for the fabric designer without most of the named problems is the use of flame-resistant modified fibres, but

unfortunately these give rise to other problems. Combination with other finishes mostly enhances the flammability if they include flammable organic compounds. With silicone-containing finishes the silicate residue, formed during burning, may prevent thermoplastic fibres from melting away from the flame, thus increasing the burning. Similar effects are reported for fluorocarbon finishes on polyester.

## References

- 1 Levin M, *Handbook of Fiber Science and Technology, Vol. II, Chemical Processing of Fibers and Fabrics. Functional Finishes, Part B*, Levin M and Sello S B (eds), New York, Marcel Dekker, 1984, 1–141.
- 2 Horrocks A R, 'Flame retardant finishing of textiles', *Review Progress Coloration*, 1986, **16**, 62–101.
- 3 Holmes I, 'Recent advances in chemical processing', *Colourage*, 1998, **45**(annual), 41–56.
- 4 Horrocks A R, 'Textiles', in *Fire Retardant Materials*, Horrocks A R and Price D, (eds), Cambridge, Woodhead Publishing, 2001, Chap 4, 128–181.
- 5 Horrocks A R, in *Textile Finishing*, Heywood D (ed.), Bradford, Society of Dyers and Colourists, 2003, 214–250.
- 6 Einsele U, 'Wirkungsweise und synergistische Effekte bei Flammenschutzmitteln für Chemiefasern', *Melliand Textilberichte*, 1976, **57**, 64–72.
- 7 Benisek L, private communication.
- 8 Heiz H, 'Flammhemmende Ausrüstung von Wolle', *Textilveredlung*, 1981, **16**(2), 53–58.
- 9 Schindler W and Korndörfer C, 'Modifizierung von Wolle zur Verbesserung ihrer Thermostabilität und Flammresistenz', *Chemiefasern/Textilindustrie*, 1988, **38/89**(7/8), T82–T83.
- 10 (a) Anderson J J, Camacho V G and Kinney R E, 'Cyclic phosphonate esters and their preparation', US Patent 3,789,091, 1974; (b) Anderson J J, Camacho V G and Kinney R E, 'Fire retardant polymers containing thermally stable phosphonate esters', US Patent 3,849,368, 1974; both patents assigned to Albright & Wilson Inc.
- 11 Johnson J R, *Functional Finishes and High Performance Textiles*, AATCC Symposium, Charlotte, NC, January 27–28, 2000.
- 12 Pearce E M, Shalaby S W and Barker R H, 'Retardation of combustion of amides', *Flame Retardant Polymeric Materials, Vol. 1*, Lewin M, Atlas S M and Pearce E M (eds), New York, Plenum Press, 1975, Chap 6, 239–290.
- 13 Riggins P H and Hauser P J, 'Exhaust process for simultaneously dyeing and improving the flame resistance of aramid fibers', US Patent 4,898,596, 1990, assigned to Burlington Industries.
- 14 Benisek L, 'Antagonism and flame retardancy', *Textile Research Journal*, 1981, **51**, 369.
- 15 Johnson J R and Sujarit C, 'Flame resistant polyester/cotton fabric and process for its production', US Patent 4,748,705, 1988, assigned to Burlington Industries.
- 16 Hauser P J, Triplett B L and Sujarit C, 'Flame-resistant cotton blend fabrics', US Patent 4,732,789, 1988, assigned to Burlington Industries.
- 17 Standard D-4723, American Society of Testing Materials, 1999.
- 18 Wakelyn P J, Rearick W and Turner J, 'Cotton and flammability – overview of new developments', *American Dyestuff Reporter*, 1998, **87**(2), 13–21.

## 9.1 Introduction

Non-slip finishes are easy to understand. Their practical importance is much greater than one might suppose from first looking at these few pages. Since the main effect of non-slip finishes is to increase the adhesion between fibres and yarns regardless of fabric construction, the generic term for these finishes would be fibre and yarn bonding finishes. Other terms that can be used include anti-slip, non-shift and slip-proofing finishes.

Adhesion between yarns is especially important in woven fabrics at the seams and in highly stretched areas like the elbows of shirts, blouses and jackets. Slippage of warp and fill yarns can also be a problem during preparation, dyeing, printing and finishing. This shifting generates an unequal appearance of woven fabrics, but the yarns are not damaged as in similar knitwear defects. Fabric elongation, moiré and crack marks can be caused by a too low yarn density, under-constructed fabrics and by very smooth fibres.

Smooth fibres, such as filaments of synthetic yarn, can cause similar problems in knitted fabrics. Runs, dropped stitches and snags are fabric defects that can be attributed to lack of fibre adhesion. Common terms for these interrelated problems are picking and snagging. The chemical products that reduce or eliminate these defects (anti-picking and anti-snagging finishes) are quite similar to non-slip finishes. Among the factors that can affect yarn slippage are fibre type, yarn size, fabric weave, yarn count (ends and picks per square inch or centimeter), fabric weight and type of finishing process.<sup>1</sup>

Non-slip finishes are often used with under-constructed fabrics to compensate for the reduced yarn count and to achieve acceptable physical properties. Lining and pocketing fabrics made with smooth synthetic filaments are finished with friction enhancers combined with durable press agents, water repellents or hand modifiers to prevent seam slippage. Umbrella fabrics made from nylon or polyester filament yarns are treated with friction enhancers and water repellents. The properties of any woven fabric with long floats can usually be improved with non-slip finishes. In particular, Jacquard upholstery fabrics with long floats are

stabilised by backcoating with film-forming polymers. A special variation of the non-slip finishes, often combined with the incorporation of metal filaments, is the stab- and stitch-resistant finish, used for protective clothing and furniture, for example in trains and buses.

## 9.2 Mechanisms of non-slip finishes

The primary mechanism for the effectiveness of non-slip finishes is increased adhesion between fibres, filaments and yarns. This increased adhesion is accomplished by two approaches. The first is the addition of inorganic solids to the surface of the fibres to increase frictional forces. The second is to use film-forming polymers to hold the yarns physically in place.<sup>2</sup> Often commercial non-slip products contain both friction enhancers and film formers.

## 9.3 Chemistry of non-slip finishes

The most common friction enhancing agents are based on dispersions of silicic acid called 'sols' (Fig. 9.1). About two-thirds of the commercial non-slip finishing products, listed in the *International Textile Auxiliary Buyers' Guide*,<sup>3</sup> are based on silicic acid sols; only a few are aluminium oxide dispersions. These products can be formed in a variety of particle sizes from 5 to 150  $\mu\text{m}$  and yield dispersions that range from clear to milky white. When the sols are deposited on the fibre surface, the surface becomes much rougher and frictional forces between fibres become much larger.

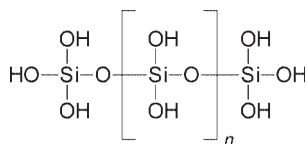

9.1 Silicic acid structure.

The polymeric film formers used as non-slip finishes are typically copolymers of vinyl, acrylic and methacrylic monomers. These materials are similar in structure to the copolymers used as hand builders (see Chapter 4, Fig. 4.3 and Fig. 4.5).

## 9.4 Application methods and combinability

Non-slip finishes are mostly applied by the pad-dry process, combined as needed with hand builders, repellents or cellulose crosslinkers (easy-care finish). The combination of silicic acid sols with softeners or silicone-based water repellents is crucial – their effects are contrasting.

Table 9.1 Test methods for non-slip finished woven fabrics

Test method	Examples and comment
1. Resistance to yarn slippage within the fabric system	Determination of the sliding resistance of woven fabrics to displacement, for example DIN 53934
2. Resistance to yarn slippage near a seam	AATCC Test Method 88B
2.1 Determination of the extent of slippage after the effect of a defined force	Low priced small devices for rough orientation, for example Hårdi device, Hårdi AG, CH-5036 Oberentfelden, Switzerland
2.2 Determination of the force that is necessary for a defined seam opening	Need for an expensive tear strength tester with registration of tear strength/length alternation, for example ASTM D 434, DIN 53868, Marks & Spencer TM P12

Performance problems can occur when non-slip finishes are combined with repellent finishes. Polymeric non-slip products, more than silicic acid sols, can reduce repellency performance. One solution is to apply the non-slip finish, dry the fabric, then apply the repellent finish. Enhanced performance of anti-pilling and handbuilding finishes can be seen when these are combined with a non-slip finish.

Furniture fabrics are back-coated with non-slip finishes, often with polymer-based ones. The formulation may include thickeners and flame retardants. Back-coating is mostly achieved by nip-padding or using a doctor (squeegee) or by foam application or spray techniques (for a lower add-on). Another one-side application is rotary printing (screens with regular perforation).

## 9.5 Evaluation of non-slip finishes

Generally the slipping of woven fabrics is tested by two different methods, those that imitate yarn shifting within the fabric system and those that cover yarn shifting near a seam sewn into the treated fabric (Table 9.1). The latter are more important in the textile industry.<sup>4</sup>

Seam slippage tests register the force that is necessary for a defined seam opening or they record the yarn shifting after the effect of a defined force. The last type of test provides a rough differentiation of fabrics according to their usage. The AATCC Test Method 88B provides a qualitative rating based on seam appearance after laundering and photographic standards, while ASTM D 434 yields more quantitative results.

## 9.6 Troubleshooting for non-slip finishes

Some potential difficulties with non-slip finishes include less flexibility and a harsher fabric hand (sometimes dry or fatty), dusting during cutting and sewing and delustering of fibres.

### References

- 1 McIntyre J E and Daniels P N, *Textile Terms and Definitions*, Manchester, UK, The Textile Institute, 1995.
- 2 Chwala A and Anger V, (eds) *Handbuch der Textilhilfsmittel*, Weinheim, Verlag Chemie, 1977, 727–734 and 895–910.
- 3 *International Textile Auxiliaries Buyers' Guide, 2000*, Melliand and TEGEWA, Frankfurt / Main, Deutscher Fachverlag, 2000.
- 4 Schrobsdorf B, 'Prüfung der Schiebefestigkeit im Nahtbereich', *Chemiefasern/ Textilindustrie*, 1990, **40/92**, 1002–1006.

## 10.1 Introduction

Static electricity can cause many processing problems for textile materials, especially those made from hydrophobic synthetic fibres. In most dry textile processes, fibres and fabrics move at high speeds over various surfaces which can generate electrostatic charging from frictional forces. This electrical charge can cause fibres and yarns to repel each other, leading to ballooning. Fabrics and non-wovens are also affected by static charges, causing materials handling problems. Consumers are well aware of the clinging of garments and the small electrical shocks caused by walking on carpets in low humidity conditions. Computers and other electronic equipment can be damaged by static discharges. Safety requirements for many textiles include antistatic limits at a defined relative humidity (mostly ranging from 65 to 25 %).

Most textile fibres do not conduct electricity efficiently and can be classified as dielectric materials, demonstrating insulating properties when dry. Whenever two surfaces come into contact, electrons can flow from one to the other. Conducting materials allow this electron flow to be equalised instantly when the surfaces are separated. Insulating materials, on the other hand, can retain the electrical charge difference for some time. Rubbing is not necessary for this charge difference to occur, but it usually increases the amount of charge produced significantly. Triboelectrification is the term used for electrical charges generated by frictional forces. Fibres can be ordered in a 'triboelectric' series such that each fibre type becomes positively charged when rubbed with fibres below it in the series. A typical series is given in Table 10.1.

If polyester and wool fibres touch and then separate, the polyester fibres become negatively charged and the wool fibres positively charged. If, however, polyester and polyethylene fibres touch and separate, the polyester fibres become positively charged and the polyethylene fibres negatively charged. The greater the separation of two fibres in the series, the greater the charge generated by their contact. When the charge difference between the two fibres reaches the electrical discharge

Table 10.1 Triboelectric series of textile fibres

	Fibre type
Positive end of series	Glass
	Wool
	Nylon 6
	Nylon 6.6
	Rayon
	Cotton
	Acetate
	Hemp
	Silk
	Polyester
	Acrylic, modacrylic
	Polyethylene, polypropylene
	Negative end of series

potential of air ( $\sim 3 \times 10^6 \text{ V m}^{-1}$ ), the charge is released by an electrical discharge accompanied by light and sound. The crackling noise heard when an acrylic sweater is pulled over a cotton shirt and the spark seen when touching a metal door knob after walking across a carpet are examples of these discharges. The electrical charging of fibres by friction is affected by the nature of the mechanical contact, the ranking of the fibres in the triboelectric series, the humidity of the environment, and the presence or absence of moisture on the fibres. Electric charging and discharging behaviour is crucial for electrostatic spinning processes and for flocking for example flock printing.<sup>1</sup>

All synthetic fibres are treated with a finish very shortly after their exit from the spinnerets. This 'spin finish' contains lubricating oils and other components, including antistatic agents. The high speeds of modern fibre processing would not be possible without these finishes. Chemical processing aids in yarn making, knitting, weaving and nonwoven manufacture also contain antistatic agents. Having accomplished their purpose, these processing aids are usually removed during fabric preparation. Non-durable antistats are also applied to technical textiles that are neither washed nor shampooed, for example textile filters, conveyor belts, transport bands and driving cords.

Although antistatic finishes applied after dyeing or printing are more common with hydrophobic fibres, fabrics made from cotton, rayon and wool may also be antistatic treated depending on the intended use. Examples of textiles that are treated with antistatic finishes include carpets for computer rooms, upholstery fabrics and airbags for automobiles, conveyor belts, filtration fabrics, airmail bags, parachutes, fabrics for hospital operating rooms, and protective clothing for work with flammable gases, liquids and powdered solids.

## 10.2 Mechanisms of antistatic finishes

The principal mechanisms of antistatic finishes are increasing the conductivity of the fibre surface (equivalent to lowering the surface resistivity) and reducing frictional forces through lubrication. The surface resistivity is defined (AATCC TM 76) as a 'material property of a substance whose numerical value is equal to the ratio of the voltage gradient to the current density'. The resistivity is in effect the resistance of the fibre to electrical flow. Increasing conductivity produces a lower charge buildup and a more rapid dissipation while increased lubricity decreases the initial charge buildup.

Antistatic agents that increase fibre surface conductivity form an intermediate layer on the surface. This layer is typically hygroscopic. The increased moisture content leads to higher conductivity. The presence of mobile ions on the surface is very important for increased conductivity. The effectiveness of hygroscopic antistatic finishes depends greatly on the humidity of the surrounding air during actual use; lower humidity leads to lower conductivity (higher resistance) and greater problems with static electricity.

Most non-polymeric antistatic finishes are also surfactants that can orient themselves in specific ways at fibre surfaces. The hydrophobic structure parts of the molecule act as lubricants to reduce charge buildup. This is particularly true with cationic antistatic surfactants that align with the hydrophobic group away from the fibre surface, similar to cationic softeners (see Chapter 3, Fig. 3.1). The main antistatic effect from anionic and non-ionic surfactants is increased conductivity from mobile ions and the hydration layer that surrounds the hydrophilic portion of the molecule since the surface orientation for these materials places the hydrated layer at the air interface.

## 10.3 Chemistry of antistatic finishes

### 10.3.1 Non-durable finishes

Both durable and non-durable effects are possible with antistatic finishes. Non-durable antistatic agents are preferred for fibre and yarn processing finishes since ease of removal is important. Other important requirements of spin finish and fibre lubricants are heat resistance and oil solubility. This group of mostly hygroscopic materials includes surfactants, organic salts, glycols, polyethylene glycols, polyelectrolytes, quaternary ammonium salts with fatty alkyl chains, polyethylene oxide compounds and esters of salts of alkylphosphonium acids. The general requirements for non-durable antistats are low volatility, low flammability, non-yellowing (heat stable), and non-corrosive. Low foaming properties are also desirable.

Esters of phosphoric acid form the largest group of non-durable antistats (Fig. 10.1). The alkyl groups are usually derived from fatty acids. Ethoxylated fatty

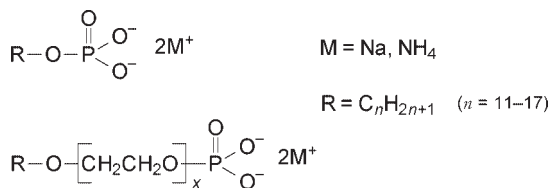

### 10.1 Phosphoric ester antistats.

alcohols are also used to form the esters. The durability of these phosphoric acid esters increases with molecular size.

Quaternary ammonium compounds are the next largest group of non-durable antistats. The most widely used are ditallowdimethylammonium chloride and dihydrogenated tallowdimethylammonium chloride (Fig. 10.2). These are common ingredients in laundry and dryer applied consumer softeners. Like many other cationic materials, cationic antistats have an affinity for textile fibres and can be applied by exhaustion processes.

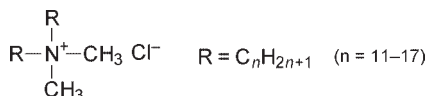

### 10.2 Quaternary ammonium antistats.

The last group of non-durable antistats is composed of non-ionic compounds such as ethoxylated fatty esters, alcohols and alkylamines (Fig. 10.3). Mixtures of cationic and non-ionic surfactants demonstrate synergistic antistatic properties. The non-ionic materials provide increased moisture absorption and the cationic products provide the mobile counterions.

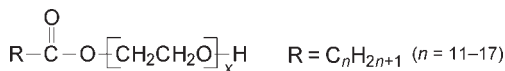

### 10.3 Non-ionic antistats.

#### 10.3.2 Durable antistats

Obtaining antistatic properties that are durable to repeated launderings from a single finish application is difficult to achieve. The basic principle is to form a crosslinked polymer network containing hydrophilic groups. Typically, polyamines are reacted with polyglycols to make such structures. These polymers can be formed prior to application to fabrics, or they can be formed *in situ* on the fibre surface after pad application. A variety of crosslinking approaches can be used, one based on polyepoxides is shown in Fig. 10.4. The amount of hydrophilic character in the final polymer can be varied to meet individual requirements. The

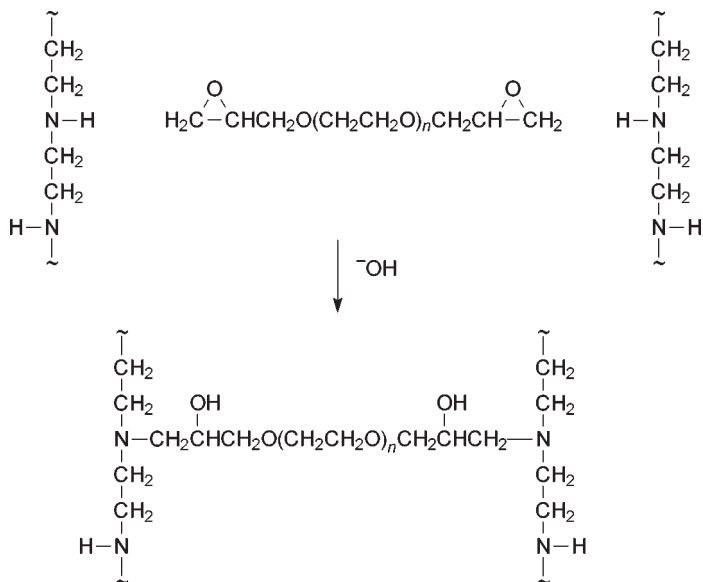

10.4 Crosslinking of polyamines to form durable antistats.

larger the hydrophilic portion, the more moisture is absorbed and the greater the antistatic effect obtained. However, at high levels of absorbed moisture, the polymer surface film softens and is more easily removed by abrasion during laundering. Higher degrees of crosslinking will reduce the moisture absorption and subsequent swelling, but the antistatic effectiveness decreases. Additional difficulties with crosslinked hydrophilic polymers include interferences with soil release and soil-redeposition properties. Owing to the difficulties in achieving the perfect balance of desired properties, the use of durable antistatic finishes is limited. Other wash-fast antistatic agents are described in the literature, including polyhydroxypolyamines (PHPA, by Sello and Steven)<sup>2</sup> or polyalkylene and polyacrylic copolymers (by Pailthorpe and David).<sup>3</sup>

## 10.4 Conductive fibres

Electrically conductive fibres have been produced by several methods: dispersing carbon particles or other antistatic agents in polymer melts prior to extrusion, depositing carbon (epitropic fibres) or metallic (for example nano-silver) coatings onto fibre surfaces (for example Ni, CuS), incorporating hydrophilic comonomers, and by fabricating fibres from stainless steel, aluminium or other metals. Although excellent durable control of static electricity is achieved by incorporating these fibres into fabrics during spinning, knitting or weaving, these conductive fibres are always black or metallic in appearance and can be easily seen in most textiles, even

at low levels of use (mostly 0.2–2 % wt/wt). This drawback limits conductive fibres to industrial fabrics and very specialised apparel and carpeting.

## 10.5 Evaluation of antistatic finishes

All laboratory evaluations of antistatic finishes should be conducted in an environment where the temperature and especially the relative humidity are thoroughly controlled. The relative humidity has a great effect on the antistatic effect since the resistivity of the fibre depends on its moisture content. The higher the relative humidity, the higher the moisture content and the lower the resistivity. The large variety of electrostatic test methods can be divided in three main groups, measuring the cling time, the electrical resistance or the electrostatic voltage or charge, often as half-life time.

Perhaps the simplest test method for the evaluation of antistatic finishes is the ash test. A piece of the fabric to be evaluated is rubbed briskly on a piece of plastic or rubber (the vinyl covered arms of a chair, for example). The fabric is then placed over an ashtray containing cigarette ash. The amount of ash transferred to the fabric is an indication of the amount of static charge imparted to the fabric. Owing to the difficulty in quantifying the results, this test is mainly used as a qualitative tool to distinguish between antistatic-treated and untreated fabrics.

More quantitative results based on the same principle of charge build-up can be obtained with AATCC Test Method 115: 'Electrostatic clinging of fabrics: Fabric to metal test', also known as the 'cling' test. A fabric that has been electrically charged in a repeatable manner by rubbing is placed next to a grounded inclined metal plate. Any residual electrical charge causes the fabric to cling to the plate. The time required for the fabric to be released from the plate is measured. The shorter the cling time, the better the antistatic properties. However, fabric-to-metal cling times are not directly related to fabric-to-body cling times.<sup>4</sup>

AATCC Test Method 76 : 'Electrical resistivity of fabrics' is used to measure the surface resistivity of fabrics (units are ohm/square). The voltage drop across a ring electrode system is used to determine the fabric's resistivity. A resistivity value of  $10^{11}$  ohm/square or lower is considered to be indicative of a fabric with negligible static propensity. The National Fire Protection Association (NFPA) has specified a resistivity of  $10^{11}$  ohm/square for textiles intended for use in operating rooms with flammable anaesthetic gases. Table 10.2 shows a common assignment of surface resistivity values to practical usage of the finished textiles at 65 % relative humidity (corresponding to DIN 54 345-1: 'determination of electrical resistance').

The surface resistivity is easy and relatively reproducible to determine with the ring electrode but it is limited for various reasons,<sup>2</sup> for example it is based on a static test with no information about the important charging and discharging behaviour of the textiles. Therefore, combination with a charge dissipation test is favoured.

**Table 10.2** Surface resistivity and practical use of antistatic finished textiles<sup>7</sup>

Surface resistivity range ( $\Omega$ ) <sup>a</sup>	Assessment
$1 \times 10^6 - 1 \times 10^8$	Very good
$1 \times 10^8 - 1 \times 10^9$	Good
$1 \times 10^9 - 1 \times 10^{10}$	Satisfactory
$1 \times 10^{10} - 5 \times 10^{10}$	Limit of sufficiency <sup>b</sup>
$> 5 \times 10^{10}$	Insufficient

<sup>a</sup>Normal climate with 65 % relative air humidity.

<sup>b</sup>Need for more control and detailed specification.

**Table 10.3** Field intensity half-life time and practical use of antistatic finished textiles<sup>7</sup>

Field intensity half-life time (s) <sup>a</sup>	Assessment
0–0.3	Very good
0.3–1	Good
1–2	Satisfactory
2–3	Sufficient <sup>b</sup>
> 3	Insufficient <sup>c</sup>

<sup>a</sup>Normal climate with 65 % relative air humidity.

<sup>b</sup>Need for more control and detailed specification.

<sup>c</sup>Absolute times for change of charge are an additional helpful criterion for the selection of antistats.

A charge dissipation test is performed with the Static Voltmeter (Rothschild, Zürich, Switzerland). The fabric sample is fixed vertically and charged with direct voltage or by rubbing with a glass rod. The Static Voltmeter measures the maximum charge generated as well as the charge decay. The time necessary for the charge to fall to one half its maximum value is recorded (field intensity half-life time). The shorter this half-life, the better the antistatic properties, as shown in Table 10.3.

A charge generation test for carpets is given in AATCC Test Method 134: ‘Electrostatic propensity of carpets’. The body voltage of a person wearing shoes with standard neoprene or leather soles is measured as they walk across a carpet. The maximum voltage after 30–60 s is recorded. Again, the lower the voltage, the better the antistatic properties. A more detailed overview on antistatic test methods is presented by Pailthorpe and David<sup>3</sup> and by Ehrler and Schmeer-Lioe.<sup>1</sup>

## 10.6 Troubleshooting for antistatic finishes and particularities

The performance of most antistatic finishes depends on the kind of fibre and sometimes also on the kind of fabric (anisotropic behaviour, for example, different

in warp and weft directions). Although wool is a hydrophilic fibre, wool fabrics often are highly charged, caused by the strong friction between the wool scales.

When applying antistatic finishes to fabrics, uniform fabric penetration is important for optimal performance. The use of wetting agents in the finish formulation is recommended. Pad, spray and kiss-roll applications are favoured. Cationic antistats are suitable for exhaust processes. Spray and foam applications are enabled by the low add-on values (mostly about one or a few percent on weight of fibre). With identical adds-on, padding leads to lesser effects than does foam application.<sup>5</sup> This is probably caused by the higher concentrations of antistatic agents on the fibre surface by the foam application. On the other hand, the durability of the padded finish might be greater.

Some of the potential side effects of the use of antistatic finishes include wear comfort (no clinging and a pleasant skin contact caused by hydrophilicity), soil-release properties, increased soiling with dry soil, yellowing after exposure to heat and impaired crockfastness of textiles dyed or printed with disperse dyes. The permanence of antistatic finishing effects to repeated washings, even at only 40 °C, is limited, as the mechanical stress of the washing process decreases the antistatic performance significantly. So the washing and the abrasion resistances of antistatic finishes are crucial.

Permanent antistatic finishes, based on crosslinked polyamines and polyglycols, need an alkaline catalyst. Therefore the one-bath combination with finishes, which need acid catalysis, is difficult but not impossible.<sup>6</sup> Examples of acid-catalysed finishes are the easy-care and durable press finishes, durable hydrophilic silicone softeners and elastomeric finishes, also fluorocarbon-based repellency and some flame-retardant finishes. High finish effects result from a two-bath application with of the easy-care finish first followed by the surface-related antistatic finish.

## References

- 1 Ehrler P and Schmeer-Lioe G, 'Das elektrostatische Verhalten als funktionale Eigenschaft und als Qualitätsmerkmal textiler Flächengebilde', *Textil Praxis International*, 1991, **46**(10), 1100–1109.
- 2 Sello S B and Stevens C V, *Handbook of Fiber Science and Technology, Vol. II, Chemical Processing of Fibers and Fabrics. Functional Finishes, Part B*, M Levin and S B Sello (eds), Marcel Dekker, New York, 1984, 291–315.
- 3 Pailthorpe M and David S K, 'Antistatic and soil release finishes,' in *Textile Finishing*, D Heywood (ed.), Bradford, Society of Dyers and Colourists, 2003, 308–336.
- 4 *AATCC Technical Manual*, American Association of Textile Chemists and Colorists, Research Triangle Park, NC, 1999.
- 5 Elbadawi A M, 'Foam application: the future of textile wet processing?', *International Textile Bulletin*, 2000, **46**(2), 70–74.
- 6 Mahall K, 'Die permanente antistatische Ausrüstung heute', *Deutscher Färberkalender*, 1972, **76**, 332–351.
- 7 Goebel I, Cognis/Henkel, private communication, 1989 and 2003.

## 11.1 Introduction

Pilling is a phenomenon exhibited by fabrics formed from spun yarns (yarns made from staple fibres). Pills are masses of tangled fibres that appear on fabric surfaces during wear or laundering. Fabrics with pills have an unsightly appearance and an unpleasant handle. Loose fibres are pulled from yarns and are formed into spherical balls by the frictional forces of abrasion. These balls of tangled fibres are held to the fabric surface by longer fibres called anchor fibres. Fabrics made from cotton, wool or rayon do not usually display pilling problems since the anchor fibres are easily broken and pills fall from the fabric soon after they are formed. When fabrics are made from polyester or nylon spun yarns, however, the stronger anchor fibres are not easily broken and the pills that are formed are not released quickly from the fabric, leading to appearance problems. In the case of fibre blends, such as cotton and polyester, the pilling can be particularly severe with the weaker cotton fibres easily entangled with and then held to the fabric surface by the stronger polyester fibres. The same is true for blends of synthetic fibres with wool. Pills on one fabric can contain fibres from other fabrics that were involved in the abrasion, for example, pills on pajamas may contain fibres from the bed sheets.

Fabric and yarn construction play a major role in pilling. Tighter constructions (woven versus knit, high twist versus low twist) show less problems than do looser constructions. Although pilling affects only the fabric aesthetics and does not cause any functional problems, it is important to minimise or prevent pilling in order to maintain customer satisfaction.

## 11.2 Pilling mechanism

The number of pills on a fabric surface at any time is the result of a dynamic equilibrium between two opposing effects, pill formation and pill wear off.<sup>1,2</sup> Figure 11.1 shows the process schematically. Through abrasion, loose fibres are pulled to the fibre surface and form a layer of 'fuzz'. The loose fibres are then

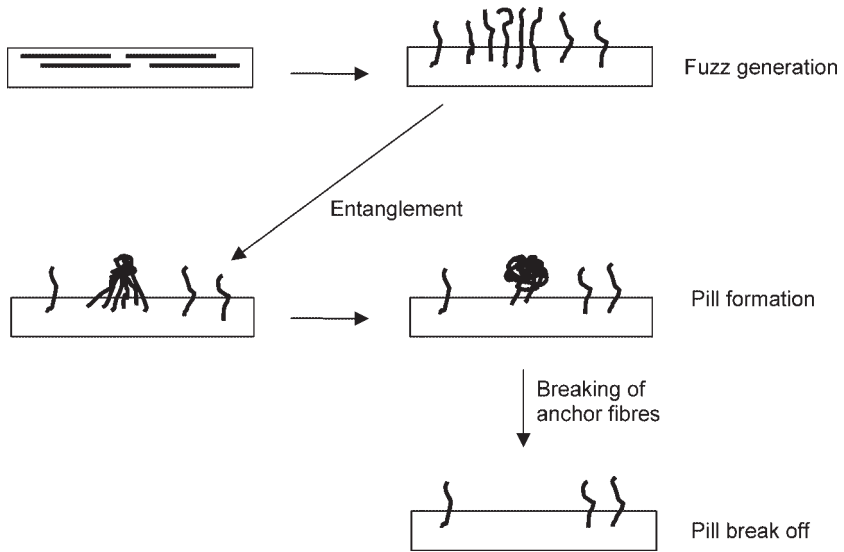

11.1 Pilling mechanism.

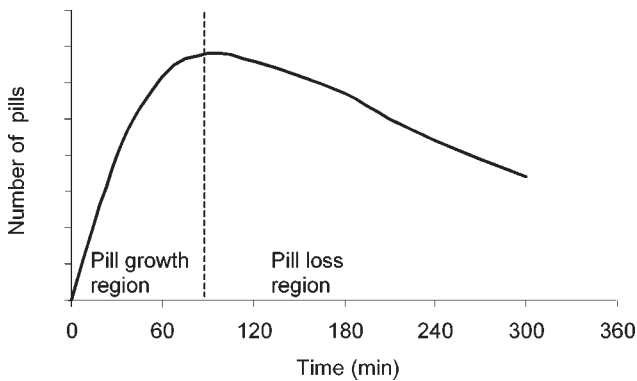

11.2 Pill curve.

entangled by the applied abrasion to form pills. As the abrasion continues, the anchor fibres are eventually broken and the pills break off. When the rate of pill formation and the rate of pill break off are equal, an equilibrium state exists. When the abrasion lasts long enough, the source of loose fibres becomes exhausted, the rate of pill formation decreases and the total number of pills decreases. This is illustrated by pill curves (Fig. 11.2) that show the number of pills as a function of time. Every point on this curve is the result of the rate of pill formation and the rate of pill break off at a given time. As can be seen, after an initial period of pill growth, the total number of pills is maximised and then decreased as pill loss increases.

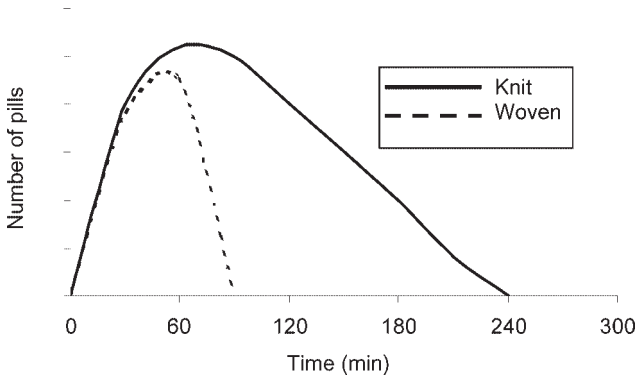

11.3 Pill curves for knit and woven fabrics.

The key fibre property that determines pill loss is the flex life of the anchor fibres. The higher the flex life, the longer the pill remains on the fabric surface. The specific details of these curves depend on fabric and yarn characteristics as well as on the particular mechanical forces acting on the fabric. The pill curves for a knit and a woven fabric made from the same polyester yarns are shown in Fig. 11.3.

The knit fabric curve demonstrates the adverse effect of looser constructions on pilling. Other factors that can increase pilling tendency include short staple length, fine yarn count, round fibre cross-section, open-end spun yarn, loose yarn and fabric construction, yarn hairiness, long wet processing times and napping. Factors that can reduce pilling tendency include yarn crimp, high yarn twist, ring spun yarn, rough yarn surface, singeing, heat setting, steaming and shearing. Table 11.1 shows a correlation of fibre properties to the three pilling steps.

Table 11.1 Pilling behaviour and fibre properties

Pill step	Involved fibre property
1. Fuzz formation	Surface roughness, structured profile Flexing resistance, rigidity, stiffness Tear strength Abrasion resistance Staple length Crimp
2. Entanglement	Count (denier) Stiffness, rigidity Elongation Recovery power Surface roughness, structured profile Crimp
3. Pill break off	Flexing and bending break resistance Tear strength Staple length Crimp

The influence of chemical finishing on pilling is relatively small. In the first pilling step anti-pilling finishing may increase the fibre and yarn attraction and in the last pilling step reduction of the abrasion and tear strength of some kinds of fibres is an additional possibility. All the other pilling parameters depend on fibre, yarn and fabric construction. Therefore, the best recipe for anti-pilling might be an intense co-operation of fabric designers, producers and finishers.

### 11.3 Mechanisms and chemistry of anti-pilling finishes

For all kinds of finishes, special product groups are known and listed in catalogues. There is, however, no group of anti-pilling products in the *International Textile Auxiliaries Buyers' Guide*.<sup>3</sup> The reason is not that this finish is not important enough. This astonishing fact may be explained by:

- the large variety of parameters that influence the pilling behaviour,
- the corresponding variety of approaches to anti-pilling finishes,
- the circumstance that textile auxiliary producers mostly recommend products that are primarily used for other purposes for anti-pilling finishes,
- there are only a few general recipes for anti-pilling finishes,
- the need for specific solutions for every type of article, including all other finishing components.

Several chemical finishing approaches have been taken to prevent pills from accumulating on fabric surfaces.<sup>4,5</sup> The first approach is to prevent loose fibres from forming the initial 'fuzz' by applying polymeric coatings that bind the fibres into the fabric surface. These finishes typically include friction reducing lubricants to minimise abrasion damage. The most useful polymers are acrylic copolymers since they can be easily modified to yield tough, flexible films with good adhesion to fibre surfaces.

The second chemical finish approach to reduce pilling is to cause the pills to fall off the fabric as soon as they are formed. This can be accomplished by reducing fibre strength. For synthetic fibres, changes in the polymer structure can be made prior to extrusion. Figure 11.4 gives pill curves for two identical fabrics made from different polyester yarns. One yarn was made with normal polyester staple fibres, the second was made with polyester fibres that had been modified to have lower strength. The fabric made from the lower strength fibres had significantly less pilling, illustrating the positive effect of weaker fibres on pilling. The use of these lower strength polyester fibres in polyester/cotton blend fabrics will greatly reduce pilling. Modified fibres are called pilling-poor if the pills are scrubbed off within two hours in the random tumble pilling test and if the maximum of the pill curve is lower than rating 6 of the 'Reutlinger Pillgrad' as shown by the horizontal broken line in Fig. 11.4. With 100 % cotton fabrics, treatment with durable press agents will, in addition to providing durable press properties, reduce the fibre strength sufficiently to improve pilling performance.

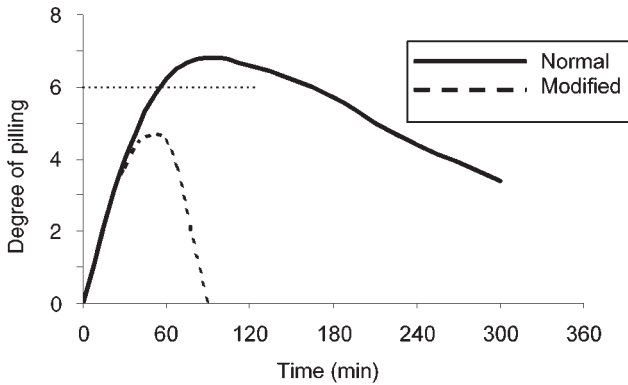

11.4 Pill curves for fabrics with normal and modified polyester fibres.

A third approach to reducing pilling tendency is applicable to 100 % cotton fabrics. As described in Chapter 17 on enzymatic finishes the use of cellulase enzymes during wet processing can remove enough of the loose fibres in the yarns so that pilling is greatly reduced.

## 11.4 Evaluation of anti-pilling finishes

The exact nature of the abrasive forces that cause textiles to pill varies significantly among individual consumers. Physical characteristics, personal habits and wearing environment can all affect fabric pilling. In order to estimate the pilling propensity of fabrics accurately, standardised testing methods are used. Even then, results from these tests must be interpreted with caution. The correlation of laboratory pilling tests with wear tests is discussed quite differently.<sup>6-8</sup> Wegener and Wulforst describe an overview on the pill literature and on 21 pilling tests. They compare 12 of them using 11 different woven and knitted fabrics.<sup>9</sup> Sometimes real wear tests, which take a long time, are preferred to laboratory pilling tests, which cannot perfectly imitate the pill behaviour of fabrics during usage in a short testing time. On the other hand, short laboratory pill tests are indispensable for the prediction of unproblematic fabric pilling behaviour, thus reducing expensive customer complaints.

A useful pilling test method is ASTM D-3512: 'Standard test method for pilling resistance and other related surface changes of textile fabrics: Random tumble pilling tester'. The test apparatus, developed from the well known accelerotor abrasion tester, is a cylinder with an inner cork lining and two propellers rotating around a central axis. A square sample of fabric is placed in the cylinder and the rotation started. Short cotton fibres may be added to aid in pill formation. The sample is abraded against the cork lining and is tumbled by the propellers. The cut edges of the sample must be glued prior to testing to avoid unravelling or deknitting. This tester should not be left unattended during testing, however. The

sample often becomes stuck against the walls and not moved by the propellers. If this occurs, the tester is stopped, the fabric freed and the testing begun again. At selected time intervals (5, 10, 20, 30, 40, 50, and 60 min) the pilled sample is removed, compared to photographic standards or actual abraded fabric standards and rated accordingly. In the United States, the ratings are from 1 to 5, with 1 being severely pilled and 5 showing no pills. The POS (pilling ordinal scale) (DIN 53867) ranges from 1 (worst ranging) to 9 (best rating). The 'Reutlinger Pillgrad' used in Europe has, by contrast, 8 ratings with 1 being pill free and 8 being severely pilled.

The Nu-Martindale Pilling Tester<sup>10</sup> is a modification of the well known Martindale Abrasion Tester. The size of the round pill test samples is much larger and fabric-to-fabric friction conditions are milder than the abrasion conditions, but the principle of the Lissajous movement is the same. Usually three similar samples are tested with 125, 500, 2000 and eventually 5000 rotations. For the assessment of the pills, photographic standards (from the testing organisation EMPA (EMPA Test Materials Ltd, St Gallen, Switzerland) with rating 5 best and rating 1 worst pilling) and a special observation chamber are needed.

The shake box was developed by ICI as a pill box (BS 5811-1979: 'Method of Test for Determination of the Resistance to Pilling of Woven Fabrics') and later modified, for example, by Hoechst.<sup>7,11,12</sup> Two samples of the fabric are cut to 7 × 7 cm and sewed to a sandwich with a soft rubber or plastic plate of 6 × 6 cm in-between. One outside of the sandwich has to be the face side of the fabric, the other one the back side. Two short rubber wire pieces are added to one sample in each test chamber. All their inner sides are lined with cork. The four side by side connected cubic boxes (test chambers) rotate about their common edge at 60 rotations per minute for 4, 8, 12 or 16 hours. The testing time has to be adjusted to the type of sample.

The assessment of the pill tests is done by photographic standards and by correlation with literal descriptions of pill ratings, relating to the number and to the performance of the pills. Assessments at short time intervals enable pilling curves that provide a better insight of the pilling behaviour than single pill ratings.

Table 11.2 shows a comparison of common pill test methods. The best correlation between test method and actual wear is found when a variety of mechanical forces act upon the fabric during testing. For anti-pilling tests of a new article with strange pilling behaviour, the combination of at least two different methods is recommended. They should be based on different principles, for example a friction test (e.g. Martindale) and a shock or impact dominated test as RTPT or the shake box test.<sup>6</sup>

## 11.5 Troubleshooting for anti-pilling finishes and compatibility

As a general rule, finishes that can lubricate fibres increase pilling by reducing the frictional forces needed to pull loose fibres from yarns. Therefore care must be

Table 11.2 Comparison of common pilling test methods

Pilling test	Martindale pilling tester	Random tumble pilling tester (RTPT, Du Pont)	Shake box (Pillbox ICI/Hoechst)
Standards involved	ASTM D 4970 EN ISO 12 945-2 IWS TM 196	ASTM D 3512 DIN 53 867	EN ISO 12 945-1 BS 5811
Device producer	J H Heal & Co, Halifax, UK	Atlas Devices Company, Chicago, USA	Zweigle, Reutlingen, Germany
Main principle and effecting forces	Fixed samples with controlled movement (Lissajous figures, 47.5 rpm), fabric-to-fabric friction and abrasion	Free tumbling movement of the samples, stroked by propellers with 1200 rpm, friction and abrasion with cork lining and other fabric samples	Free tumbling movement by gravity in a rotating box with 60 rpm, strokes from rubber rope pieces, friction and abrasion with cork lining
Intensity of effecting forces	Medium to strong	Strong	Medium to low
Usual testing time	Short (about 40–60 min)	Short (30–60 min, casewise up to 120 min)	Long (1–16 hours)
Number of samples for one testing cycle	1–6	3–18	1–4
Variability, except testing time	Adaptable pressure (higher for woven than for knitted fabrics)	Addition of cotton lintens	
Mainly imitated pill formation mechanism	Friction and abrasion, e.g. caused by moving arms and legs, sitting movements on furniture fabrics, socks moving in shoes	Heavy strokes combined with softer friction and abrasion, faint similar to usual wearing stress on sports wear or working clothes	Slight strokes combined with soft friction and abrasion, similar to wear stress of sports wear, working clothes, bed linen and clothes, socks in sport shoes
Main problems	Without stroke forces, imitation of real pilling in too short a time for the pill equilibrium	Too hard strokes, imitation of real pilling in too short a time for the pill equilibrium	Long testing time, otherwise perhaps too unequal stress and pill distribution on the fabric surface

**Table 11.3** Effects of other finishes on the pilling behaviour and combinability

Effects and combinability	Type of finish
Usable for anti-pilling	Hand building finishes, for cellulose easy-care Durable press finishes Cellulase finishes
Supporting anti-pilling	Non-slip finishes Fluorocarbon finishes, if not too smooth (they may concentrate the anti-pilling products near the fibre surface) Flame retardants (large amounts are often stiffening, crosslinkers reduce the tear and abrasion strength)
Almost no effect	Soil-release finishes Antistatics, if not softening and smoothing Finishes to improve colour fastness Finishes for protection from UV or insects Antimicrobial finishes
Unsuitable (increased pilling)	Most softeners, especially silicones Silicone elastomers and repellents Paraffin water repellents Antistats, if softening

taken when using softeners and silicone elastomers. Combinations of softeners and polymeric coatings can be used to achieve both a soft hand and pilling control. Table 11.3 gives an overview on the effects of the different kinds of finishes on the pilling behaviour.

If a customer complains about a pilled textile, the only way to repair it is by using an electrical shaver, preferably with rotating knives and large slots. Special pill shavers are available for purchase.

## References

- 1 Gintis D and Mead E J, 'The mechanism of pilling', *Textile Research Journal*, 1959, **29**, 578–585.
- 2 Conti W and Tassinari E, 'Simplified kinetic model for the mechanism of pilling', *Journal Textile Institute*, 1974, **65**, 119–125.
- 3 *International Textile Auxiliaries Buyers' Guide 2000*, Melliand and TEGEWA, Frankfurt/Main, Deutscher Fachverlag, 2000.
- 4 Shank D M, Vulcan Performance Chemicals, Columbus, GA, private communication, 2000.
- 5 Patel D C, Consultant, Charlotte, NC, private communication, 2000.
- 6 Cooke W D and Goksoy M, 'Problematik der Vorhersage des Pillingverhaltens anhand von Labortestmethoden', *Melliand Textilberichte*, 1988, **69**, 250–254.

- 7 Hoechst Trevira GmbH & Co. KG, 'Vergleich von Pilling-Prüfverfahren und Vorschlag für ihre künftige Durchführung', Taschenbuch für die Textilindustrie, Berlin, Schiele & Schön, 1997, 422–429.
- 8 Anonymous, 'Random tumble pilling test beats Martindale method', *Melliand International*, 1999, **5**(1), 88.
- 9 Wegener E H and Wulfhorst B, 'Pilling an textilen Flächengebilden', *Textil-Betrieb*, 1985, **103**, 39–51.
- 10 Martindale J G, 'Method of Test for Abrasion Resistance of Fabrics', BS 5690, 1979.
- 11 Wiime W, 'Prüfung von Bezugsstoffen aller Art', *Textil Praxis International*, 1985, **40**, 724–726, 839–843.
- 12 Grünewald K H, 'Zur Problematik der Prüfung textiler Flächengebilde auf Pillneigung', *Chemiefasern/Textil Industrie*, 1968, **18/70**, 862–867 and 933–943.

## 12.1 Introduction

Elastomeric finishes are also referred to as stretch or elastic finishes and are particularly important for knitwear. These finishes are currently achieved only with silicone-based products. The main effect is durable elasticity, because not only must extensibility be enhanced, but recovery from deformation is of crucial importance. After all stresses and disturbing forces have been released, the fabric should return to its original shape.

An alternative approach to providing fabrics with elastomeric finishes is to incorporate a few percent of elastic fibres (mostly segmented polyurethanes) into the yarn making process prior to fabric manufacture. Depending on the content of elastic fibres the resulting elasticity of the fibre blend can be much greater (e.g. power stretch) than with elastomeric finishes. But these finishes avoid the typical problems correlated to weaving or knitting, dyeing or printing of fabrics from elastic fibre blends. Elastomeric finishes are preferred when a lesser degree of elasticity, combined with other useful performances, as shown in Table 12.1, is desired. For this reason, even the combination of elastomeric finishes and elastic fibre blends is common.<sup>1</sup>

Elastomeric finishes are frequently used with swimwear, lingerie, foundation garments, athletic wear, hosiery and normal clothing. Some performance

*Table 12.1* Assessment of the main effects of elastomeric finishes on woven and knitted fabrics<sup>2</sup>

	Wovens	Knitwear
Elasticity	#	###
Crease recovery	##	#
Handle	###	##
Sewability	#	###

# = Important, ## = very important, ### = greatest importance.

enhancements provided by elastomeric finishes include very soft handle, improved crease recovery, better sewability, higher abrasion resistance and some stain-repellency. Table 12.1 shows the importance of the main effects of elastomeric finishes on woven and knitted fabrics.<sup>2</sup> Silicone products, including elastomers, are used for the preparation of wool, creating shrink resistance and soft handle,<sup>3</sup> often in combination with polyurethane prepolymers (e.g. blocked isocyanates).<sup>4</sup> In the textile-related silicone market elastomers are very important. The order of decreasing share, related to value, is elastomers > softeners >> repellents > coatings, and related to amount is softeners >> elastomers > repellents > coatings.<sup>5</sup>

## 12.2 Elastomeric mechanism

The individual fibres of an elastomeric fabric must be completely covered with a thin film of an elastic material without any fibre-to-fibre bonding. The film causes a high degree of recovery from deformations owing to its particular structure of widely spaced crosslinks.

## 12.3 Chemistry of elastomeric finishes

The mesh structure responsible for elasticity is achieved by the condensation of a mixture of silicone prepolymers on the fabric surface. This mixture may often consist of a terminal silanol ( $\alpha,\omega$ -dihydroxy polydimethylsiloxane), methyl hydrogen silane and a metal salt catalyst (Fig. 12.1). The crosslinking reaction that forms the elastic structure is shown in Fig. 12.2. Some hydrosilane groups can be oxidised by air to silanol groups. Condensation of the silanol groups of neighbouring molecules generates crosslinked structures that are necessary for elasticity.

The incorporation of a small content of tri- or tetra-functional silanols, hydroxysilanes, acyloxy or ester derivatives is another approach that yields wide-

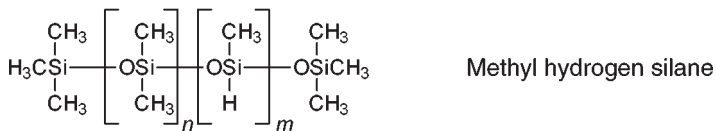
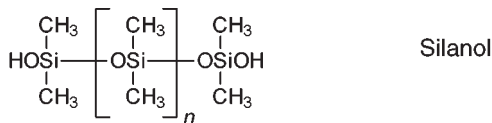

12.1 Elastomeric finish components.

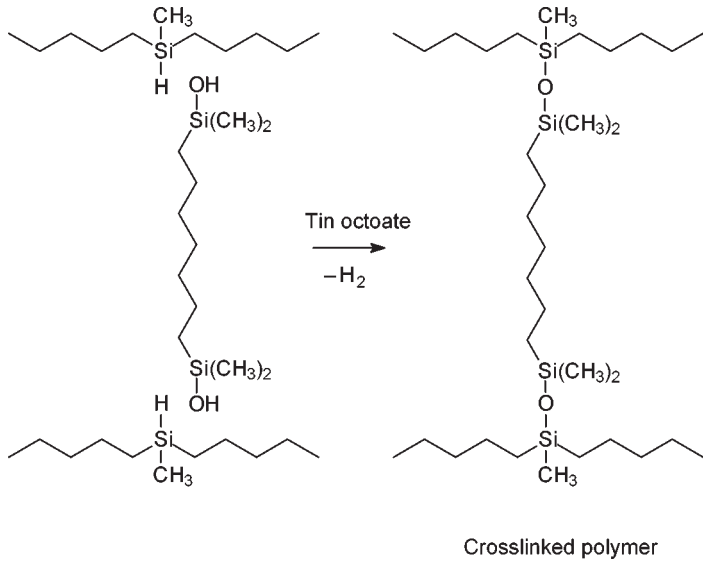

12.2 Reaction of a silane and a silanol to form an elastomeric finish.

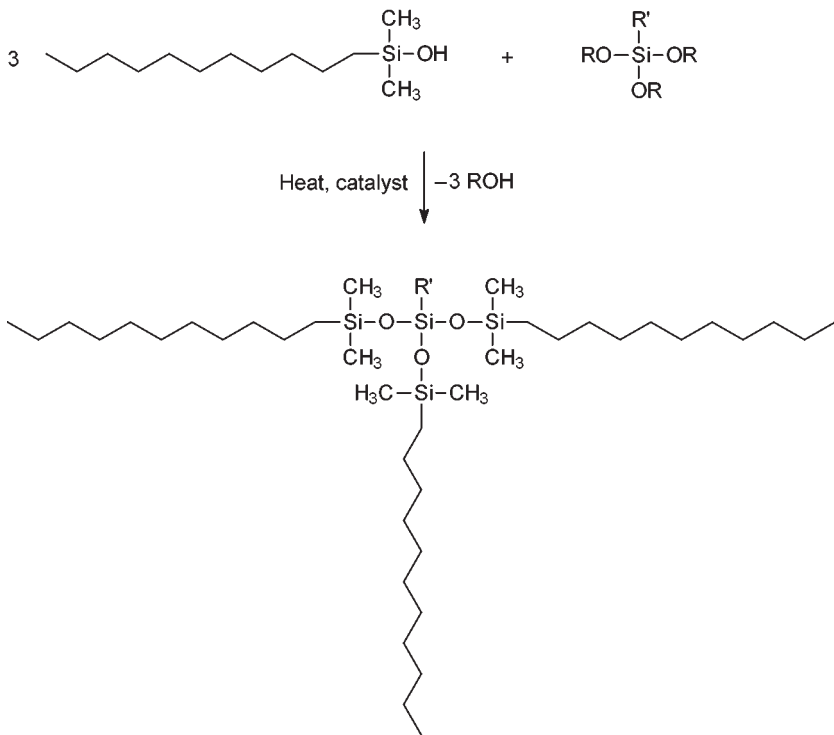

12.3 Tri-functional silicone crosslinkers.

Table 12.2 Test methods for elastomeric finishes

Standard	Title
ASTM D 4964	Standard Test Method for Tension and Elongation of Elastic Fabrics (Constant-Rate-of-Extension Type Tensile Testing Machine)
ASTM D 2594a	Standard Test Method for Stretch Properties of Knitted Fabrics Having Low Power
ASTM D 3107	Standard Test Methods for Stretch Properties of Fabrics Woven from Stretch Yarns
ASTM D 6614	Standard Test Method for Stretch Properties of Textile Fabrics – CRE Method
SAE J 855	Test Method of Stretch and Set of Textiles and Plastics
Draft DIN EN 14704-1	Determination of the elasticity of fabrics, part 1: Test of strips (August 2003)

meshed networks with high permanence.<sup>6</sup> The typical reaction mechanism is shown in Fig. 12.3. The molar ratio of terminal silanols and crosslinking multi-functional compounds determines how widely spaced the resulting silicone film and the corresponding elasticity will be.

The permanence of these silicone films on hydrophilic fibres, such as cellulosics, is restricted by mechanical stress caused by repeated laundering and related swelling.<sup>6</sup> Therefore reactive fixation of epoxy-modified silicones was developed. The epoxy groups react with the hydroxyl groups of cellulose or the amino groups of wool and silk generating stable ether or amino bonds between the silicone film and the fibre surface. In addition to their high wash permanence these epoxy-modified silicone finishes have low yellowing properties, but their softness is less than that of the amino silicones.<sup>6</sup> As with all highly reactive compounds, the handling of epoxides needs special care. They are potentially physiologically dangerous. Non-ionic elastomeric silicones are best applied by padding, while cationically modified silicone products may also be applied by exhaustion techniques.

## 12.4 Evaluation of elastomeric finishes

The simplest, but not necessarily the best, way of evaluating elastomeric finishes is the ‘template’ method. The fabric is stretched by hand with, it is to be hoped, constant force in both warp and fill or weft and wale directions. The residual elongation is determined by the fabric’s dimensional change. This method suffers from difficulties in repeatability owing to the variable stretching forces.

A more reliable extension tester is produced by Hepatex AG, Wattwil, Switzerland. This machine (the Dehnungsprüfgerät DP-5) has hydraulic damping and constant tension controls to provide reproducible stretching forces to the fabric. Fabrics can be tested in the wet or dry states. The degree of elasticity,  $E$ , can be calculated by:

$$E = \frac{\text{extension after 10 s} - \text{final extension}}{\text{extension after 10 s}} \times 100\% \quad [12.1]$$

Another suitable method for evaluating elastomeric finishes is ASTM D 4964-96: 'Standard Test Method for Tension and Elongation of Elastic Fabrics (Constant-Rate-of-Extension Type Tensile Testing Machine)'. Fabric samples are formed into loops and are placed through several extension–recovery cycles under controlled conditions. Table 12.2 shows an overview of test methods for elastomeric finishes.

## 12.5 Troubleshooting for elastomeric finishes and particularities

Elastomeric finishes that have been completely reacted cannot be easily removed, so reworking of fabric seconds can be a problem. Other potential difficulties with elastomeric finishes include increased pilling and flammability (the silicate residue prevents thermoplastic fibres from melting away from the flame). Silicone elastomers can attract dirt. The fabric shade after treatment with elastomeric finishes may be significantly altered from the original shade, therefore good communications between the dyeing and finishing departments are necessary.

Elastomeric finishes are often combined with easy-care and durable press finishes. The silicones reduce abrasion, increase tearing strength (Elmendorf testing apparatus – ASTM D1424), and crease recovery. For equal crease resistance and durable press performance the amount of cellulose crosslinking agents can be markedly reduced in these combinations.<sup>5</sup>

Silicone films have a relatively low light reflectance and therefore cause more depth of colour (similar to the appearance of wet fabrics). In contrast the high reflectance of polyester, especially of polyester micro fibres, impedes their dyeing and printing to deep shades. Here silicone finishes are used as 'black improvers'.<sup>7</sup> But silicones increase the thermomigration of disperse dyes, causing lower wash and crocking fastness. This disadvantage is especially marked with microemulsions of silicone softeners, containing high concentrations of emulsifiers which also increase dyestuff migration.

## References

- 1 Hardt P, 'Silicon-Textilhilfsmittel', *Textilveredlung*, 1984, **19**(5), 143–146.
- 2 Gysin H P, 'Moderne Textilausrüstung mit Silikonelastomeren', *Textilveredlung*, 1981, **16**(12), 475–479.
- 3 Guise B and Jones F W, 'Shrink-resisting wool with silicones', *Textile Chemist Colorist*, 1977, **9**(3), 65–69.

- 4 Geubtner M and Hannemann K, 'Waschbare Wolle durch moderne Pflegeleichtausrüstung', *Melliand Textilberichte*, 2001, **82**(7/8), 598–602.
- 5 Liebiger M, 'Silikone zum Ausrüsten von Textilien', *Deutscher Färberkalender*, 1989, **93**, 132–151.
- 6 Mooney W, 'Chemical softening', in *Textile Finishing*, D Heywood (ed.), Bradford, Society of Dyers and Colourists, 2003, 283–291.
- 7 Poppenwimmer K and Schmidt J, 'Ausrüstung von Synthefaserstoffen, Teil 2', *Textilveredlung*, 1999, **34**(7/8), 4–8.

### 13.1 Introduction

Chemical finishing is defined as and includes all processes after coloration that provide better properties and that enable the qualified use of the treated textiles. But dyers and printers are often responsible for finishes that improve colour fastness. Nowadays coloured textiles have to fulfil many requirements. Therefore improvement in the colour fastness is a type of chemical finishing of particular practical interest and importance.

Properties provided by these finishes are mostly improved wet fastness, for example washing, water, perspiration and ironing fastness, then better light fastness and only to a small extent improved crocking and rubbing fastness. For other kinds of colour fastness, for example dry ironing, chlorine, peroxide and carbonisation, there are no known possibilities for improvement by an after treatment. The market importance of these finishes is based on customer preferences and economic production demands. For a better understanding, each of these three quite different fastness improvements will be dealt with separately.

### 13.2 Improved wet fastness

#### 13.2.1 Definitions and terms

Colour fastness is the resistance of a material to change in any of its colour characteristics, to the transfer of its colourants to adjacent materials or both. Fading means that the colour changes and lightens. Bleeding is the transfer of colour to a secondary, accompanying fibre material. This is often expressed as soiling or staining meaning that the accompanying material gets soiled or stained.

Generally fastness properties are expressed in ratings of fastness. Normally they range from rating 5, which means unchanged to rating 1, which means major changes. Only the light fastness ratings range up to eight for the best behaviour. They are mostly evaluated on the so-called blue scales. These contain stripes of standard dyeings on wool with eight blue dyestuffs that have different light

fastness. The other fastness ratings are normally evaluated by the grey scales for bleeding and for fading. They consist of five different grey colour gradations and are compared with the tested textile and its prescribed adjacent material.

### 13.2.2 Basis of the effect

The physical and chemical principles involved in the performance of the fastness improving finishes concern either the interaction with the dyestuff or with the fibre or both. The simplest after treatment to achieve better wet fastness can be an intensive washing process. Thus wool dyeings are washed under mild alkaline conditions with ammonia, soda or sodium hydrogen carbonate. Cellulose fabrics dyed or printed with reactive dyestuffs are washed at high temperature often with special auxiliaries that have dispersing, sequestering and dissolving (hydration, increased solubility) properties. Compounds with a high affinity for reactive dyes, or more precisely for their hydrolysates are helpful, the so-called colour transfer inhibitors, for example polyacrylic acid derivatives.

Another approach for removing reactive dye hydrolysates from the fibre and from the wash water (decolourised waste water) is the use of peroxidases (oxidative active enzymes such as Baylase RP). This multipurpose enzymatic rinse process saves time, energy and water but it is restricted mainly to jet applications. The question of the potential toxicity of the resulting aromatic nitro-compounds (cleavage products of the reactive azoic dyes) has to be resolved.

When polyester textiles are deeply dyed they need an after treatment with reductive agents to remove and destroy the unfixed or only weakly fixed disperse dyestuffs on the fibre surface (reductive decomposition). With these after washings or after cleanings the colour fastness can be elevated up about one rating. The widespread principle that enables the wet fastness of dyeings to be improved with anionic dyestuffs (such as reactive, direct and acid dyes) is their molecule enlargement. It causes reduced water solubility, generated by dye–salt formation of the anionic dyestuffs in the fibre with the cationic products applied after dyeing (Fig. 13.1). For lesser requirements, enclosure of the dyestuffs in cellulose fibres with formaldehyde condensation products is a low cost alternative.<sup>1,2</sup>

Another solution to the problem is the reactant fixation of the dyestuffs to the fibre with highly reactive uncoloured chemicals. Their main problem is their essential high reactivity, which causes cancer or mutagenicity when they come into contact with the finish workers. The end user is not involved because after the fixation reaction these chemicals lose their risk to health.

### 13.2.3 Applied chemistry<sup>3</sup>

An older method of improving the wet fastness of selected direct dyeings is their diazotisation on the fibre, followed by the reaction with so-called developers

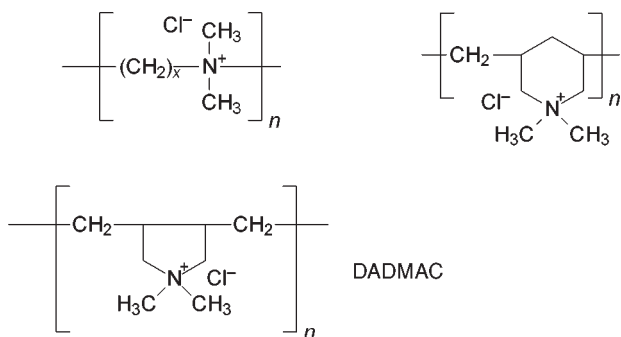

**13.1** Quaternary ammonium polymers improve wet fastness with anionic dyes.

(coupling compounds). The great effort and handling problems involved have made this method unattractive.

**Cationic products**,<sup>4,5</sup> for example polyammonium compounds, the so-called polyquats are shown in Fig. 13.1. Many successful products are based on quaternary polyheterocycles such as polydiallyldimethyl ammonium chloride (DADMAC). They are mostly used for direct and reactive dyed cellulose and improve the wet fastness for about one to, at most, two ratings. The washing fastness is usually more improved than the contact fastness (water or perspiration fastness). Quaternary ammonium polymers are often used to shorten the long washing processes (soaping at the boil) of reactive dyes on cellulose, thus providing relatively good wet fastness. Their high affinity for cellulose enables exhaust application. But cationic products can cause several problems:

- Insufficient permanence of the effects of repeated washings, caused by salt formation with anionic surfactants and release of the immobilised dyestuff
- Variation of the degree of wet fastness improvement, depending on the specific dyestuff interaction
- Reduced light fastness and colour changes, which are also dyestuff specific
- Competition with cationic soft handle products (blocking their uptake)
- Greying and increased soiling when applied in large amounts (cationised cotton)
- Stripping off is only possible with large amounts of anionic surfactants
- Fish toxicity, almost no biodegradation but high rate of elimination in the waste water.<sup>4</sup>

**Formaldehyde condensation products** from urea and/or melamine are shown in Fig. 13.2. They are comparable to the corresponding products for permanent press and easy-care finishes (Chapter 5). They have the same advantages and disadvantages and they often improve the perspiration more than the washing fastness. Therefore they are mostly used for lining fabrics, where their price advantage is especially important.

Some possible disadvantages are:

- Harsher handle (requiring combination with softeners)
- Decreased light fastness up to two ratings (a problem more for reactive dyed fabrics than for direct dyed ones, the latter often provide greater light fastness)
- Colour changes (the dyer has to take these into consideration during the dye recipe formulation)
- Formaldehyde release.

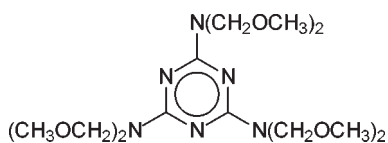

13.2 Precursor of the formaldehyde condensation polymer that improves wet fastness on cellulosic fabrics.

**The condensation products of aromatic sulfonic acids** are used for dyeing and printings on nylon fibres, especially for the after treatment of carpets, to improve their wet fastness by up to about two ratings. Their common name is syntan, derived from 'synthetic tannin'. Figure 13.3 shows typical structures of syntans

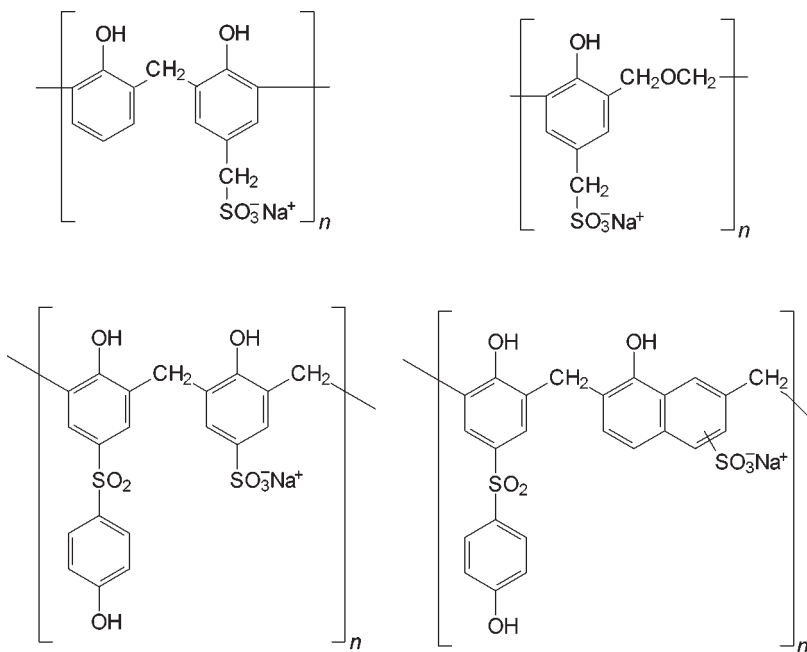

13.3 Reaction products of formaldehyde and aromatic sulfonic acids (syntans) improve wet fastness on nylon.

(partly from Brennich and Engelhardt).<sup>6</sup> These formaldehyde condensation products of sulfonated phenols and naphthalenes are also used as reservation agents for dyeing fibre blends and as stain blockers.

Formaldehyde connects the aromatic rings in the form of relatively stable methylene bridges. Therefore release of formaldehyde from these finishes is very low. The preferred application of anionic syntans to nylon is by exhaustion at 70–80 °C and pH 3.5–5. They form a barrier near the fibre surface to the anionic dyes in the fibre, mainly caused by anionic repulsion. Another theory favours the aromatic attraction of dyestuff and syntan, thus hindering the dyestuff molecules from migrating out of the fibre. The disadvantages of classical syntans are reduced bath stability and decreased efficiency caused by pseudocationic surfactants, for example, levelling agents based on fatty amine ethoxylates. Newly developed syntans have decreased these problems and can be used in the exhausted dye bath instead of fresh finishing solutions.<sup>6,7</sup>

Epoxy derivatives with cationic structures (Fig. 13.4) have been and are still used as **reactive fixation compounds**. Under alkaline application conditions the epichlorohydrin groups generate very reactive epoxy ring structures that provide stable ether bondings to the hydroxyl groups of the cellulose fibre (Fig. 13.5). Thus the cationic groups are permanently fixed and attract the anionic dyestuff very effectively with astonishingly high fastness ratings for selected direct dyestuffs of up to 4–5 for washing at 95 °C.<sup>8</sup> If lower wet fastness is accepted, reduced amounts of fixation agents enable controlled fastness ratings. Apart from the health problems already mentioned during handling and application, there are other disadvantages.

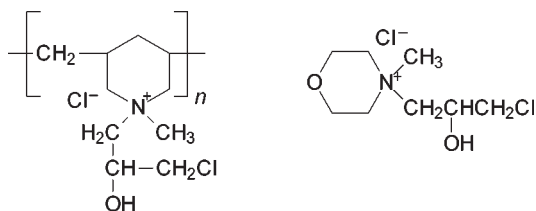

13.4 Reactive fixatives for anionic dyes on cellulose.

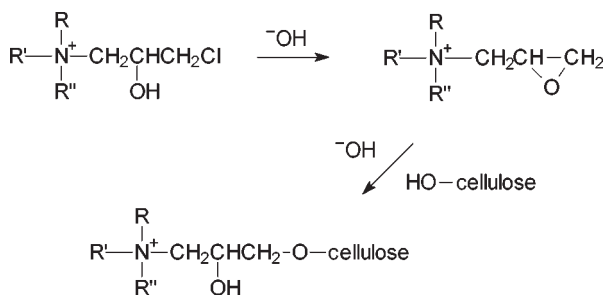

13.5 Reactions of cellulose reactive fixatives.

The fixation agent can only be applied by padding and the high permanence causes problems with the correction of the shade after imperfect dyeing.

### 13.2.4 Evaluation methods

Standard procedures for colour fastness and especially wet fastness evaluations (for example ISO, AATCC, ASTM, BS, DIN, FTMS, Marks & Spencer) are used to evaluate the treated and accompanying fabrics.

### 13.2.5 Troubleshooting finishes that improve wet fastness

Some potential problems with finishes designed to improve wet fastness include:

- Levelness when applied on packages (crosswound bobbins)
- Less absorbency caused by some products
- Low durability of the effects in use, for example after several washings, especially with formaldehyde condensation or non-fibre reactive cationic products (salt exchange processes with anionic surfactants).

## 13.3 Improved light fastness

### 13.3.1 Definitions and terms

The light fastness is the resistance of dyestuffs to the influence of light energy, especially the ultraviolet (UV) part of the electromagnetic spectrum. It is subdivided into UVA (320–400 nm), UVB (280–320 nm) and UVC (100–280 nm). The shorter the wavelength,  $\lambda$ , the higher is the energy  $E$  and the dyestuff damage. (Einstein's rule:  $E = h \times \nu = h \times c/\lambda$ ). Fortunately, UVC is absorbed by ozone in the higher atmosphere, the usual content of UVB in the total radiation intensity ( $\text{W m}^{-2}$ ) is less than 1 % and the content of UVA is about 5.6 % (see Table 14.1 in Chapter 14 on UV protection finishes).

Fading, fastness ratings, blue and grey scales were described in the first part of this chapter. So-called fading in tone is important if there is not enough light protection. It only constitutes a brightening and is generally less severe than the more usual fading out of tone.

The light protection of the applied dyestuffs is connected to the light protection of the fibre. Fibre damage also accelerates dyestuff decomposition. Fading by light is generally promoted by moisture, heat (heat–light fastness is especially important for automotive textiles), oxygen in the air (photo-oxidation, triplet and singlet oxygen  $^3\text{O}_2 \leftrightarrow ^1\text{O}_2$ ) and other factors shown in Table 13.1. The interactions of these influencing factors, including photosensitisers, radical scavengers, singlet oxygen quenchers and possible chemical reactions are quite complex.

Table 13.1 Factors influencing light fastness (LF)

Factors influencing LF	Examples and comment
Type of light (energy content including exposure time, rhythm of change from light to dark)	Strictly regulated by LF test methods
Dyestuff or pigment: type, concentration and distribution	Better LF with higher concentration and lower specific surface (pigment particles have better LF than molecular distributed dyes). Equal dye distribution over the fibre cross-section has better LF than ring dyeing with dyes concentrated near the fibre surface.
Dyestuff combination	Catalytic fading (another dye catalyses photodegradation), rarely also LF protection
Fibre type	Identical disperse dyes on PES show better LF than on PA. Basic dyes on PAN have better LF than on meta aramide (for example Nomex).
Moisture	Better LF with lower water content. Defined humidity for LF testing
Heat	Less LF with higher temperature (for example heat LF for automotive fabrics), defined by LF testing
Accompanying substances	Mostly lower LF, e.g. with the delustering agent titanium dioxide (even though it is a strong UV absorber), residual size, thickeners, auxiliaries such as cationic wet fastness improvers, formaldehyde condensation products, oxidising or reducing agents. Exception from this rule: LF improvers

### 13.3.2 Basis of the effect

The protecting products show either interaction with the light or with the dyestuff. Examples of the first category are the UV-absorber or UV-screener, which have light filter effects (UV-cutting). Examples of the interaction with dyestuffs are the after treatment with copper salts (formation of copper complexes with high light fastness) and the application of radical traps, so-called anti-oxidants, which are mostly sterically hindered phenols and amines. Other involved mechanisms are the decomposition of intermediate peroxides and singlet-oxygen quenching. From this survey of the different possibilities for interference, it is obvious that they can be easily combined, resulting in an increased protection effect.

### 13.3.3 Applied chemistry

Ultraviolet light absorbers are colourless organic compounds, mostly with aromatic

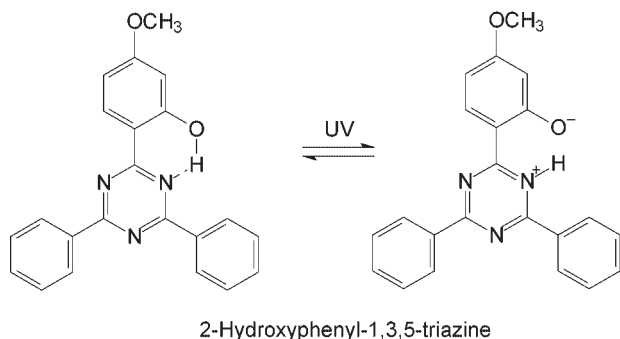
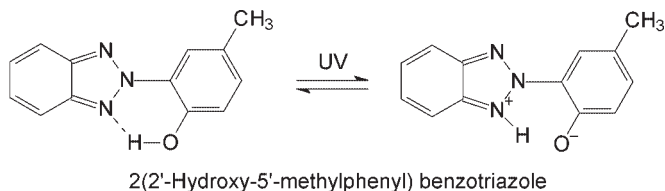

### 13.6 Ultraviolet light absorbers from the hydroxy phenyl class.

structures, for example benzophenone, benzotriazole, phenyl triazine and  $\alpha$ -cyanoacrylic acid derivatives. Titanium dioxide, the common delustering agent in all synthetic fibres, also strongly absorbs UV light. This paragraph focuses on UV absorbers that primarily protect dyes and secondary fibres. The same or similar UV absorbers are used for finishes that protect the human skin, as described in Chapter 14.

These products have to transform the absorbed UV energy into heat energy (Fig. 13.6, compare also Fig. 14.3 and 14.4 with UV absorbers for finishes on synthetic and natural fibres). In the first step they have to absorb the high UV energy and to transform it almost quantitatively into vibration energy of the absorber molecules without cleavage of bonds (photodegradation). In the next step the vibration energy is transferred to the surrounding material as heat, again with the requirement of no fibre or dyestuff damage. Useful further effects of the UV absorber may be deactivation of excited dye chromophores and scavenging of radicals. It is interesting to compare differences and similarities to fluorescent brighteners (whitening agents) that produce heat and visible light from the absorbed UV energy.

The main disadvantages of the UV absorbers are their relatively high price and the relatively high concentration (0.5–2 % of the weight of the fibre) that is needed for sufficient protection. Therefore they are often used in combination with other light fastness improving products.<sup>9–12</sup>

The formation of a copper complex with the dyestuff requires special structures to be present in the dyestuff. Therefore, copper salt after treatments work only with

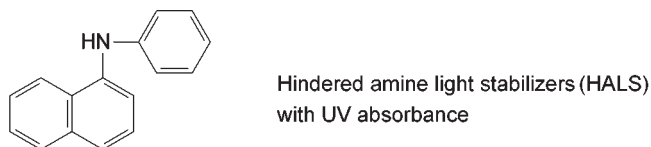
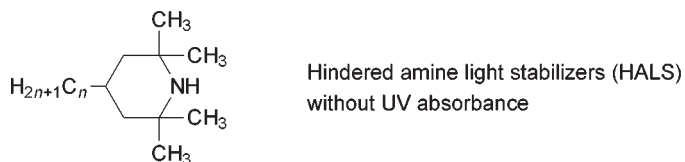

### 13.7 Anti-oxidants that enhance light fastness.

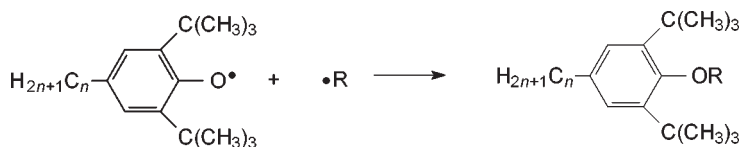

### 13.8 Anti-oxidant free radical trapping mechanism.

selected dyes. But some efficient light protection products consist of colourless copper complexes. They show fibre affinity similar to dyestuffs, destroy peroxides, stop radical reactions and are also UV absorbers. A content of 40–60 ppm ( $\mu\text{g g}^{-1}$ ) copper in the finished textile is sufficient for good light protection.<sup>13</sup> In former times direct dyeings and printings were after treated with copper sulfate solutions. Nowadays this is mostly forbidden because of the high residual concentration of copper in the waste water. For basic dyes sodium phosphorous molybdenum tungstenate is also known as a light protective after treatment.

Two groups of anti-oxidants are of practical importance: hindered phenol light stabilisers (HPLS) and hindered amine light stabilisers (HALS). Examples are shown in Fig. 13.7 and the mechanism of the radical trapping reaction is shown in Fig. 13.8. They are often combined with UV absorbers (for partly synergistic effects) and mostly used for the fibre protection.

### 13.3.4 Application and evaluation methods

- UV absorbers can be combined with dyeing or after treatment with exhaustion or pad-dry techniques.

- Useful evaluation methods include ISO 105 B01–B06, AATCC Test Methods, FAKRA tests and SAE J1885 for automotive textiles.

### 13.3.5 Troubleshooting finishes that improve light fastness

Most auxiliary chemicals, except fibre and dyestuff, decrease light fastness (Table 13.1). Therefore, it is important to wash out carefully all residues of sizing agents and all auxiliaries used for pretreatment and in dyeing or printing (e.g. thickeners). Sometimes combination of light protecting agents with pH buffers or protecting agents against over-oxidation (with reducing agents such as glucose, dextrin or  $\text{NaNO}_2$ ) or over-reduction (with oxidation agents such as *meta*-nitrobenzolsulfonic acid) is useful.

Vat dyestuff selection: some vat dyestuffs are called fibre protectors, others are fibre damagers. The fibre protectors mostly contain nitrogen atoms in their chromophores. These vat dyestuffs have good light fastness and compensate for the influence of the damagers. The latter and/or their light decomposition products catalyse the fibre damage by photolysis.

## 13.4 Improved crocking and rubbing fastness

Everybody who has sat with blue jeans on a pale sofa or an upholstery chair knows about the importance of the crocking fastness. Of course, indigo-dyed clothing is famous for poor crocking and rubbing fastness. This disadvantage is a desirable quality in other cultures: the Tuareg and other nomads in Africa like to colour their skin and hair by rubbing it with dark dyed indigo fabrics.<sup>14</sup>

### 13.4.1 Definitions and terms

Rubbing fastness means a change in colour of the rubbed textile (by bleeding and fading). Crocking fastness is the migration of colour from the dyed surface to another surface by intense contact, for example by rubbing (soiling/staining). Depending on the kind of fibre, especially its tensile strength, small abraded coloured fibre particles cause the staining effect on the partner textile.<sup>15,16</sup> Coarse fibre particles are not taken into consideration by the determination of the crocking fastness rating. If the dyestuff involved is water soluble and not sufficiently fixed on the fibre, this can also be the reason for staining. But even dyeings with the best wet properties, for example vat dyeings, have limited/restricted wet crocking fastness because of cellulose fibre abrasion.<sup>15</sup>

Fastness ratings, according to the grey scales for staining, range from 1 (poor rating) to 5 (best rating). Parameters of influence include:

- Kind and concentration of dyestuff
- Dyeing or printing procedure, degree of fixation, ring dyeing

- After treatment with softeners, silicones, crosslinking agents
- Type of fibre (tensile strength, wet abrasion)
- Type of textile in contact: shade, surface, kind of fibre and fabric
- Intensity of the contact: pressure, time, moisture and temperature.

The influence of the moisture is taken into account in the test methods (dry or wet crocking tests). Wet cellulosic fibres may be partly destroyed by rubbing, leading to additional staining. The rubbing force for the wet testing procedure is about double the rubbing force for dry rubbing.<sup>17</sup> Therefore the wet rubbing ratings of the same sample are always poorer than the dry ones (up to two ratings difference).

### 13.4.2 Basis for improvement in rubbing fastness

Rubbing fastness is improved by formation of films coating the fibres, reduced rubbing of the smoothed surface and by hydrophobation. The finish products can behave similarly to lubricants in reducing the rubbing forces. Generally also finishes that reduce the swelling of hydrophilic fibres cause an effect (durable press and easy-care finishes with crosslinking agents for cellulose fibres). Less migration of dyestuff but poorer tensile strength of the cellulose fibre cause more abrasion.

### 13.4.3 Applied chemistries

Improved rubbing fastness can be achieved with partially hydrolysed polyvinylacetate (PVAc/PVA) or polyvinylether and the application of pigment binders, mostly based on acrylic copolymers similar to those used as hand builders (Chapter 4). Application methods mostly use pad-dry techniques.

### 13.4.4 Evaluation methods

- ISO 105-X12 and AATCC Crockmeter Method, Test method 8: Color fastness to crocking.
- For small fabric samples and for printed samples AATCC developed the Rotary Vertical Crockmeter Method (AATCC Test method 116).
- For testing loosened fibre material, for example flock, tuft, loose stock, the method and device according to Ruf is recommended. The tested material is pressed with a rubber membrane and then rubbed.<sup>18</sup>

### 13.4.5 Troubleshooting and special problems

Possible problems with finishes used to improve rubbing fastness include the following.

- There may often be only small effects.

- Although silicones give very smooth films around any kind of fibre, silicone finishes (soft handle, water repellency, stretch) may reduce the crocking fastness.
- Softeners on dyed polyester often cause more disperse dye migration (especially thermomigration) and cause reduced crocking fastness. This is similar to softeners on the basis of fatty acids and azoic dyeings.
- Deeply dyed polyester needs an after treatment, mostly with reducing agents that destroy the low or unfixed disperse dyes, to obtain acceptable crocking and wet fastness properties.<sup>19</sup>

## References

### References concerning finishes that improve wet fastness

- 1 Schindler W, Tauwald E and Krüger R, 'Are reactive dyes fixed with covalent bonds after one-bath dyeing and low-swell finishing of PES/cotton?', *Melliand Textilberichte*, 1990, **71**(5), 388–392, E176–E178.
- 2 Nechwatal A and Nicolai M, 'Möglichkeiten zur gleichzeitigen Anfärbung und Ausrüstung von Baumwollgeweben', *Melliand Textilberichte*, 1999, **80**(3), 185–191.
- 3 *Ullmann's Encyclopedia of Industrial Chemistry*, 5th edn, Weinheim, VCH, 1995, Vol. A26, 287–288.
- 4 Fischer H, 'Theoretische, praktische und ökologische Aspekte der kationischen Nachbehandlung', *Textilveredlung*, 1990, **25**(2), 54–61.
- 5 Robinson T, 'Neue Trends in der kationischen Vor- und Nachbehandlung von Färbungen mit Reaktivfarbstoffen', *Melliand Textilberichte*, 1987, **68**, 137–141.
- 6 Brennich Wand Engelhardt B, 'Neue Wege bei der Nachbehandlung von PA-Färbungen', *Melliand Textilberichte*, 2003, **84**(1/2), 64–67.
- 7 Kittler K, 'Neue Effekte von Polyamid-Nachbehandlungen', *Melliand Textilberichte*, 2000, **81**(1/2), 49–53.
- 8 Provisional information V:I. 212 on Levogen RS, Bayer, Leverkusen, Germany, 1978.

### References concerning finishes that improve light fastness

- 9 Chwala A and Anger V (eds), *Handbuch der Textilhilfsmittel*, Weinheim/New York, Verlag Chemie, 1977, 926–932.
- 10 Herrmann M, Hilfiker R, 'Beeinflussen photochemische Abhängigkeiten durch Faserparameter bei PES die Heiss-Licht-Alterung?', *Melliand Textilberichte*, 1999, **80**(4), 274–277.
- 11 Schäfer K and Gröger B, 'Lichtschutzausrüstung von Wolle', *Melliand Textilberichte*, 1991, **72**(8), 664–671.
- 12 Reinert G, Schmidt E and Hilfiker R, 'Facts about the application of UV absorbers on textiles', *Melliand Textilberichte*, 1994, **75**(7/8), 606–614, E151–E153.
- 13 Reinert G and Thommen F, 'Photodegradation und Photostabilisierung der Polyamid-Faser', *Textilveredlung*, 1989, **24**(5), 182–187.

## References concerning finishes that improve crocking and rubbing fastness

- 14 Heid C, 'Reib(un)echtheit von Textilien – ein vielseitiges Problem', *Melliand Textilberichte*, 1986, **67**, 345–353.
- 15 Herlinger H and Schulz G, 'Ursachen ungenügender Nassreibechtheiten bei textilen Färbungen', *Melliand Textilberichte*, 1990, **71**(2), 126–129.
- 16 Bredereck K and Strauss E, 'Aspekte der Reibechtheit reaktiv gefärbter Cellulose Textilien', *Melliand Textilberichte*, 2001, **82**(10), 831–836.
- 17 Bigler N, 'Untersuchungen über die Reibechtheit von Färbungen', *Textilveredlung*, 1969, **4**, 166–181.
- 18 Ruf F, 'Gerät zur Prüfung der Reibechtheit an Flocke, Garn und Gewebe', *Melliand Textilberichte*, 1955, **36**, 755.
- 19 Anders S and Schindler W, 'Comparison of reducing agents in reduction clearing of polyester dyeings and prints', *Melliand Textilberichte*, 1997, **78**, 85–87, E21–E22.

## 14.1 Introduction

This chapter tackles the prevention from harmful effects of solar ultraviolet (UV) radiation on human skin. These effects were recognised in the early 1990s. Long-term exposure to UV light can result in acceleration of skin ageing, photodermatosis (acne), phototoxic reactions to drugs, erythema (skin reddening), sunburn, increased risk of melanoma (skin cancer), eye damage (opacification of the cornea) and DNA damage.<sup>1</sup> Numerous publications have appeared concerning the use of textiles to protect the wearer from these harmful effects; a selection are quoted.<sup>1-4</sup>

Solar radiation striking the earth's surface is composed of light waves with wavelengths ranging from the infrared to the UV. Table 14.1 gives the wavelengths, relative intensities and average photon energies of this radiation.

Although the intensity of UV radiation is much less than visible or infrared radiation, the energy per photon is significantly higher. The very high energy of the UV-C photons is mostly absorbed by ozone in the higher regions of the atmosphere decreasing their relative intensity on the earth surface to almost zero. But the energies of UV-A and UV-B photons that reach the earth surface exceed the carbon-carbon single bond energy of  $335 \text{ kJ mol}^{-1}$ , which is why UV radiation can be used to initiate chemical reactions. The actual damage to human skin from UV radiation is a function of the wavelength of the incident radiation, with the most damage done by radiation less than 300 nm. If this erythemal effect is multiplied by the intensity of the incident solar light, as a function of wavelength, the wavelengths of maximum danger to skin are 305–310 nm.<sup>1,4</sup> Therefore, to be useful in protecting the wearer from solar UV radiation, textiles must demonstrate effectiveness in the 300–320 nm range.

To quantify the protective effect of textiles, the solar protection factor (SPF) is determined. The SPF is the ratio of the potential erythemal effect to the actual erythemal effect transmitted through the fabric by the radiation and can be calculated from spectroscopic measurements.<sup>3</sup> The larger the SPF, the more protective the fabric is to UV radiation. In Europe and Australia, the SPF is referred

Table 14.1 Characteristics of solar radiation striking the earth's surface

Classification	Wavelength (nm)	Relative intensity (%)	Average photon energy (kJ mol <sup>-1</sup> )
UV-B radiation	280–320	0.5	400
UV-A <sub>1</sub> radiation	320–360	2.4	350
UV-A <sub>2</sub> radiation	360–400	3.2	315
Visible radiation	400–800	51.8	200
Infrared radiation	800–3000	42.1	63

to as the ultraviolet protection factor (UPF). The SPF is also used with so-called 'sun blocking' skin creams, giving a relative measure of how much longer a person can be exposed to sunlight before skin damage occurs.<sup>4</sup> Typically, a fabric with an SPF of > 40 is considered to provide excellent protection against UV radiation (according to AS/NZS 4399: *Sun protective clothing – Evaluation and classification*, Standards Australia, Sydney). It is possible to realise about 80 % of the theoretical maximum of SPF 200.

Since the most probable time for long-term solar exposure is in the summer, the most likely candidates for UV protective finishes are lightweight woven and knitted fabrics intended for producing shirts, blouses, T-shirts, swimwear, beachwear, sportswear, and the like. Industrial fabrics designed for awnings, canopies, tents and blinds may also benefit from a UV-protective treatment.

## 14.2 Mechanism of UV protection

When radiation strikes a fibre surface, it can be reflected, absorbed, transmitted through the fibre or pass between fibres (Fig. 14.1). The relative amounts of

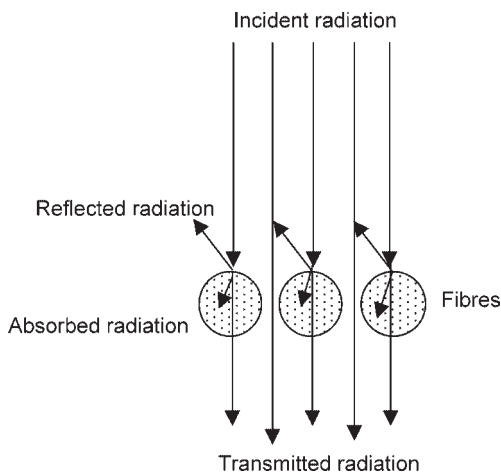

14.1 Radiation in contact with a textile surface.

*Table 14.2* Solar protection factors (SPF) of undyed fabrics<sup>1</sup>

Fabric description	Approximate SPF
Cotton tricot	4
Wool tricot	45
Silk twill	7
Polyester tricot	26
Nylon/elastomer 80/20 tricot	12

radiation reflected, absorbed or transmitted depend on many factors, including the fibre type, the fibre surface smoothness, the fabric cover factor (the fraction of the surface area of the fabric covered by yarns) and the presence or absence of fibre delustrants, dyes and UV absorbers.

The effect of fibre type on the SPF of undyed fabrics of similar construction is demonstrated in Table 14.2. Cotton and silk fibres offer little protection to UV radiation since the radiation can pass through without being markedly absorbed. Wool and polyester, on the other hand, have significant higher SPF's since these fibres will absorb UV radiation. Nylon falls in between these extremes. One factor influencing nylon and polyester absorbance is the presence of the delustrant  $\text{TiO}_2$ , a material that strongly absorbs UV radiation.

If the fibres absorb all of the incident radiation, then the only source of transmitted rays is from the spacing between the yarns. By definition, the theoretical maximum SPF is the reciprocal of 1 minus the cover factor.

$$\text{SPF}_{\text{max}} = \frac{1}{1 - \text{cover factor}} \quad [14.1]$$

Figure 14.2 illustrates the relationship between the maximum SPF and the cover factor. Using a SPF value of 50 as the goal, a fabric with a cover factor of 0.98 and composed of fibres that absorb all of the non-reflected UV radiation will provide its wearer with excellent protection against solar UV radiation.

Of course, tight micro-fibre fabrics provide a better UV protection than fabrics made from normal sized fibres with the same specific weight and type of construction. Many dyes absorb UV radiation as well as visible light. A cotton fabric dyed to a deep shade can achieve SPF values of 50 or higher just from the presence of the dye.<sup>1,4</sup> Since fashion and comfort often dictate the use of lightly coloured fabrics for summer apparel, the need arose for UV absorbing materials that could be applied to fibres to provide the desired SPF values in light shades. Dyestuff and auxiliary manufacturers have responded by developing a variety of materials suitable for use as UV protection finishes.

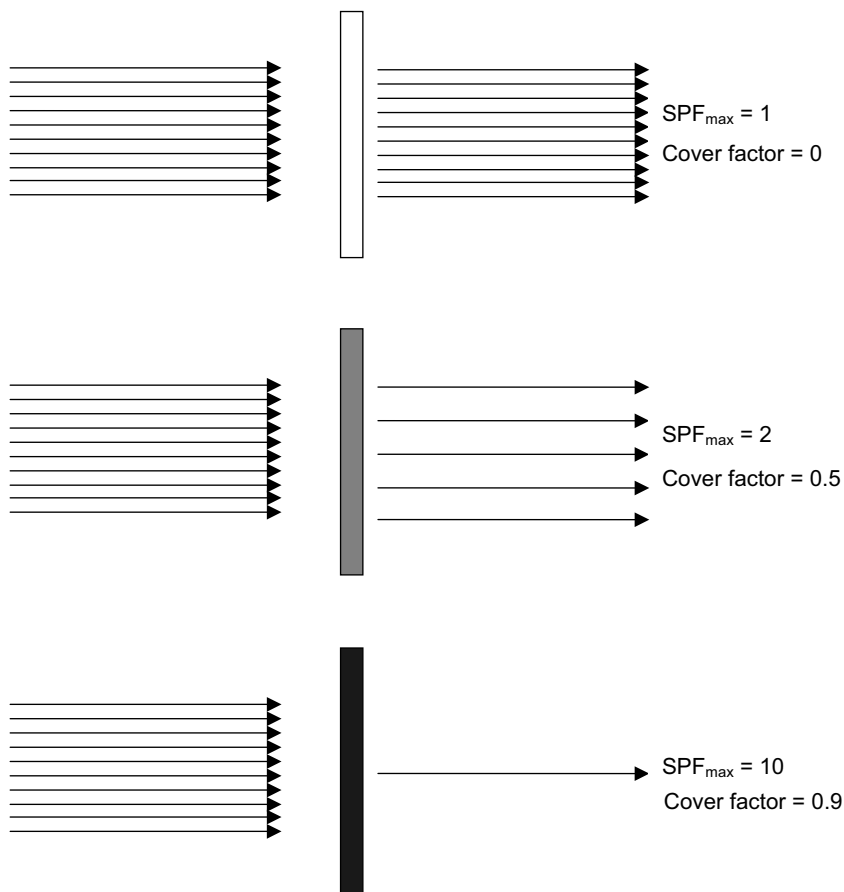

14.2 Interaction of radiation with fabrics of varying cover factors.

### 14.3 Chemistry of UV protection finishes

The requirements for a material to be effective as a UV protection finish include efficient absorption of UV radiation at 300–320 nm, quick transformation of the high UV energy into the vibration energy in the absorber molecules and then into heat energy in the surroundings without photodegradation. Further requirements are convenient application to textile fibres and lack of added colour for the treated fibre. Some typical chemical structures useful for UV protection are shown in Fig. 14.3 and Fig. 14.4.<sup>5–7</sup> The reversible chemical reaction, induced by UV absorption of hydroxyphenyl structures of UV absorbers, is shown in Chapter 13 (Fig. 13.6). By careful choice of substituents, molecules can be formed that have the required absorbance of UV radiation, lack of added colour and the necessary affinity to fibres and fastness. In most cases, the UV absorber is applied with the dyes during

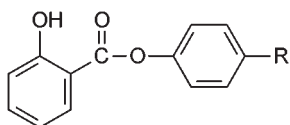

Phenyl salicylates

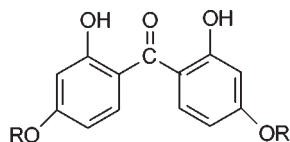

Benzophenones

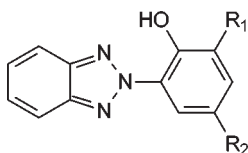

Benzotriazoles

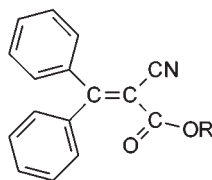

Cyanoacrylates

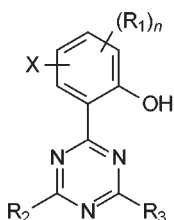

Phenyltriazines

 $R_1 = \text{alkyl, alkoxy, halide, sulfoalkoxy}$ 
 $n = 0, 1, 2$ 
 $X = \text{H, SO}_3^-$ 
 $R_2 = \text{hydroxy, alkoxy, alkylthio, substituted alkyl, substituted phenyl, } o\text{-hydroxyphenyl}$ 
 $R_3 = R_2 \text{ (identical or different)}$ 

### 14.3 Structures of UV absorbers for synthetic fibres.

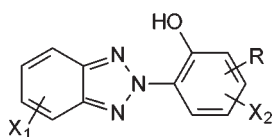

Benzotriazole derivatives

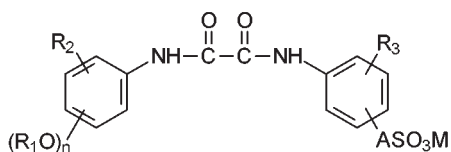
 $R = \text{alkyl, alkoxy, sulfonate}$ 
 $X_1 = \text{H, sulfonate, halide, sulfonated arylalkyl}$ 
 $X_2 = X_1$ 

Oxalic acid dianilide derivatives

 $R_1 = \text{substituted or unsubstituted alkylbenzyl}$ 
 $n = 0, 1, 2$ 
 $R_2 = \text{H, halide, alkyl, phenylalkyl}$ 
 $R_3 = R_2 \text{ (identical or different)}$ 
 $A = \text{direct bond or alkylene linkage}$ 
 $M = \text{H or alkali metal}$ 

### 14.4 Structures of UV absorbers for natural fibres.

*Table 14.3* Standards for UV protection finished fabrics

Organisation	Standard	Title
Standards Australia/ New Zealand (AS/NZS)	AS/NZS 4399	Sun protective clothing – evaluation and classification
Comité European de Normalisation	Proposed CEN	Classification and marking of UV protective apparel
British Standards Institution	BS 7949	Children’s clothing; requirements for protection against erythemally weighted solar UV radiation
American Society for Testing and Materials	Proposed ASTM	Standard guide for labeling of UV-protective textiles
Commission Internationale de l’Eclairage	CIE TC 6-29	Proposed UV protective index for clothing
International Test Association for Applied UV Protection	UV standard 801	UV standard 801

the dyeing process. Several possible application methods are described by Haerri and Haenzi.<sup>8</sup>

#### 14.4 Evaluation of UV protection finishes

Several organisations around the world have developed or have proposed performance standards for UV protection fabrics. These organisations and their standards are summarised in Table 14.3.<sup>9</sup>

Although there are multiple standards for UV protective fabrics, there are significant differences between the various organisations. The particular standard for the intended market area should be consulted during fabric development. Before the development of instrumental methods, SPF values of fabrics were determined by irradiating human subjects and measuring the critical amount of radiation necessary to cause skin reddening at a particular wavelength with and without wearing the fabrics. Fortunately, several methods (Table 14.4) are now

*Table 14.4* Test methods for UV protective fabrics

Test method	Title
AATCC TM 183	Transmittance or blocking of erythemally weighted UV radiation through fabrics
BS 7914	Method of test for penetration of erythemally weighted solar UV radiation through clothing fabrics
CEN/TC 248/WG 14	Apparel fabrics; solar UV protective properties, method of test

available that do not result in a sunburned participant. These methods all determine the transmittance of UV radiation through fabrics and calculate the SPF value using standard charts for the solar spectrum and the erythral effect.<sup>3</sup> UV Standard 801 considers in addition the effects of usage of the finished textiles that normally reduce the UV protection.<sup>10,11</sup>

## 14.5 Troubleshooting for UV protection finishes and combinability

UV absorbers have the same need for wash fastness and light fastness as dyestuffs. Laundering trials should be carried out with all new formulations to confirm that the claimed UV protection is actually active during the life of the garment.

One concern is specific to the use of UV absorbers in combination with optical brightening agents (OBA). These brightening agents function by absorbing UV radiation and re-emitting visible light. If a UV absorber is also present in the fibre, the brightening effect from the OBA can be greatly diminished or even absent. Proper choice of an appropriate OBA can minimise this problem.

In most other cases combination with other finishes does not reduce the UV protection. A two-step application is necessary if the pH values of the UV protection finish bath and that of the other finishes are very different. The UV protection finish should be applied first. Problems may arise from limited bath uptake after a repellent finish or after calendering.<sup>12</sup>

## References

- 1 Reinert G, Fuso F, Hilfiker R and Schmidt E, 'UV-protecting properties of textile fabrics and their improvement', *Textile Chemist and Colorist*, 1997, **29**(12), 36–43.
- 2 *Textiles and Sun Protection Conference*, University of New South Wales, Sydney, May 1993.
- 3 Hilfiker R, Kaufmann W, Reinert G and Schmidt E, 'Improving sun protection factors of fabrics by applying UV-absorbers', *Textile Research Journal*, 1996, **66**(2), 61–70.
- 4 Reinert G, Hilfiker R, Schmidt E and Fuso F, 'Sonnenschutzigenschaften textiler Flächen und deren Verbesserung', *Textilveredlung*, 1996, **31**(11/12), 227–234.
- 5 Communication from Meisei Chemical Works, Ltd, Japan, *UV Absorbers & Applications*, June 1998.
- 6 Reinert G and Fuso F, 'Stabilization of textile fibres against ageing', *Review Progress Coloration Related Topics*, 1997, **27**, 33–34.
- 7 Reinert G, Schmidt E and Hilfiker R, 'Facts about the application of UV absorbers on textiles', *Melliand Textilberichte*, 1994, **75**(7/8), 606–614, E151–E153.
- 8 Haerri H P, Haenzi D, 'UV absorbers for woven cotton fabrics', *International Textile Bulletin*, 2002, **48**(5), 65–68.
- 9 Hatch K L, Standards for UV-protective textiles, from *High Performance and Functional Finishes*, an AATCC Symposium, Charlotte, NC, January 2000.
- 10 Rieker J, Guschlbauer T and Rasmich S, 'Wissenschaftliche und praktische Bewertung des UV-Schutzes', *Melliand Textilberichte*, 2001, **82**(7/8), 617–619.

- 11 Rieker J and Guschlbauer T, 'UV Standard 801', *Textilveredlung*, 1999, **34**(11/12), 4–11.
- 12 Teichmann R, Fuchs H, Körber W and Matt W, 'UV-Cutting-Effekt: Welchen Einfluss haben andere Ausrüstungen?', *Textilveredlung*, 2002, **37**(5/6), 5–9.

## 15.1 Introduction

Two different aspects of antimicrobial protection provided by chemical finishes can be distinguished.<sup>1,2</sup> The first is the protection of the textile user against pathogenic or odour causing microorganisms (hygiene finishes). The second aspect is the protection of the textile itself from damage caused by mould, mildew or rot producing microorganisms. Both aspects will be discussed in this chapter. Protection of textiles from damage caused by insects is covered in Chapter 16.

The growth of microorganisms on textiles can lead to functional, hygienic and aesthetic difficulties (for example staining). The most trouble-causing organisms are fungi and bacteria. Under very moist conditions, algae can also grow on textiles but are troublesome only because they act as nutrient sources for fungi and bacteria. Fungi cause multiple problems to textiles including discoloration, coloured stains, and fibre damage. Bacteria are not as damaging to fibres, but can produce some fibre damage, unpleasant odours and a slick, slimy feel. Often, fungi and bacteria are both present on the fabric in a symbiotic relationship.

Substances added to fibres, such as lubricants, antistats, natural-based auxiliaries (for example size, thickener and hand modifiers) and dirt provide a food source for microorganisms. Synthetic fibres are not totally immune to microorganisms, for example polyurethane fibres and coatings can be damaged.<sup>3</sup> Of course, because of evolution, natural fibres are more easily attacked. Wool is more likely to suffer bacterial attack than cotton, and cotton is more likely than wool to be attacked by fungi.

Antimicrobial finishes are particularly important for industrial fabrics that are exposed to weather. Fabrics used for awnings, screens, tents, tarpaulins, ropes, and the like, need protection from rotting and mildew. Home furnishings such as carpeting, shower curtains, mattress ticking and upholstery also frequently receive antimicrobial finishes. Fabrics and protective clothing used in areas where there might be danger of infection from pathogens can benefit from antimicrobial finishing. These include hospitals, nursing homes, schools, hotels, and crowded public areas. Textiles in museums are often treated with antimicrobial finishes for

preservation reasons. Sized fabrics that are to be stored or shipped under conditions of high temperature (~40 °C or 100 °F) and humidity require an antimicrobial finish to retard or prevent microbial growth fuelled by the presence of warp size. Textiles left wet between processing steps for an extended time often also need an antimicrobial treatment.

The use of antimicrobial finishes to prevent unpleasant odours on intimate apparel, underwear, socks and athletic wear is an important market need. The odours are produced by the bacterial decomposition of sweat and other body fluids, and controlling bacterial growth by hygiene finishes reduces or eliminates the problem. An alternative approach is described in Chapter 18 on novel anti-odour finishes.

## 15.2 Properties of an effective antimicrobial finish<sup>4</sup>

The growth rate of microbes can be astoundingly rapid. The bacteria population, for example, will double every 20 to 30 min under ideal conditions (36–40 °C or 77–98 °F, pH 5–9). At this rate, one single bacteria cell can increase to 1 048 576 cells in just 7 hours. Therefore, antimicrobial finishes must be quick acting to be effective.

In addition to being fast acting, a number of other important criteria can be listed for antimicrobial finishes. The antimicrobial must kill or stop the growth of microbes and must maintain this property through multiple cleaning cycles or outdoor exposure. The antimicrobial must be safe for the manufacturer to apply and the consumer to wear. The finish must meet strict government regulations and have a minimal environmental impact. The antimicrobial finish must be easily applied at the textile mill, should be compatible with other finishing agents, have little if any adverse effects on other fabric properties including wear comfort, and should be of low cost.

## 15.3 Mechanisms of antimicrobial finishes

Despite the long list of requirements, a variety of chemical finishes have been used to produce textiles with demonstrable antimicrobial properties. These products can be divided into two types based on the mode of attack on microbes. One type consists of chemicals that can be considered to operate by a controlled-release mechanism. The antimicrobial is slowly released from a reservoir either on the fabric surface or in the interior of the fibre. This 'leaching' type of antimicrobial can be very effective against microbes on the fibre surface or in the surrounding environment. However, eventually the reservoir will be depleted and the finish will no longer be effective. In addition, the antimicrobial that is released to the environment may interfere with other desirable microbes, such as those present in waste treatment facilities.

The second type of antimicrobial finish consists of molecules that are chemically

bound to fibre surfaces. These products can control only those microbes that are present on the fibre surface, not in the surrounding environment. 'Bound' antimicrobials, because of their attachment to the fibre, can potentially be abraded away or become deactivated and lose long term durability.

Antimicrobial finishes that control the growth and spread of microbes are more properly called biostats, i.e. bacteriostats, fungistats. Products that actually kill microbes are biocides, i.e. bacteriocides, fungicides. This distinction is important when dealing with governmental regulations, since biocides are strongly controlled. Textiles with biostatic properties, however, are subject to fewer regulations.

The actual mechanisms by which antimicrobial finishes control microbial growth are extremely varied, ranging from preventing cell reproduction, blocking of enzymes, reaction with the cell membrane (for example with silver ions) to the destruction of the cell walls and poisoning the cell from within.<sup>3</sup> An understanding of these mechanisms, although important for microbiologists, is not really a requirement for the textile chemist who applies and evaluates the effectiveness of antimicrobial finishes.

## 15.4 Chemistry of antimicrobial finishes<sup>5-9</sup>

### 15.4.1 Antimicrobials for controlled release

Many antimicrobial products that were formerly used with textiles are now strictly regulated because of their toxicity and potential for environmental damage. Products such as copper naphthenate, copper-8-quinolate, and numerous organo mercury compounds fall into this category. Other materials that still have limited use in specialised areas include tributyl tin oxide (deleted in many countries, Fig. 15.1a), dichlorophene (Fig. 15.1b) and 3-iodopropynylbutyl carbamate (Fig. 15.1c). These products typically show a very broad spectrum of activity against bacteria and fungi, but suffer from application and durability problems.

Some more useful products of this same general type include benzimidazol derivatives, salicylanilides and alkylolamide salts of undecylenic acid (particularly effective against fungi). Application of these materials with resin precondensates can improve durability to laundering, but also deactivation by reaction with the resin may occur.

A widely used biocide and preservation product is formaldehyde. Solutions of formaldehyde in water, called formalin, were used for disinfection and conservation, for example, of biological samples for display. Bound formaldehyde is released in small amounts from common easy-care and durable press finishes (Chapter 5). Therefore these finishes include – at least until they are washed – a small antimicrobial side effect. This can also be true for some quaternary compounds, for example wet fastness improvers and softeners. But for more effective requirements specific antimicrobial finishes are necessary.

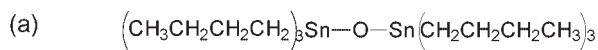

Tributyl tin oxide (TBTO)

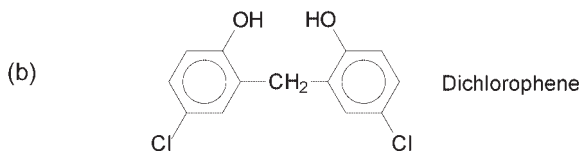

2,2'-Dihydroxy-5,5'-dichlorodiphenyl methane

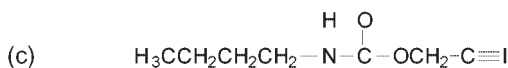

3-Iodopropynylbutyl carbamate

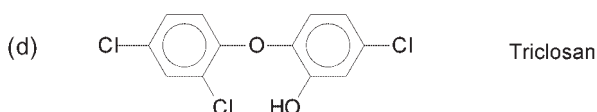

2,4,4'-Trichloro-2'-hydroxydiphenyl ether

### 15.1 Controlled-release antimicrobials.

One of the most widely used antimicrobial products today is 2,4,4'-trichloro-2'-hydroxydiphenyl ether, known more commonly as 'triclosan' (Fig. 15.1d). Triclosan finds extensive use in mouthwashes, toothpastes, liquid hand soaps, deodorant products, and the like. Although it is effective against most bacteria, it has poor antifungal properties. Triclosan is also important as a textile finish, but since its water solubility is very low, aqueous application requires use of dispersing agents and binders.

Quaternary ammonium salts have been found to be effective antibacterial agents in cleaning products and for disinfecting swimming pools and hot tubs. However, their high degree of water solubility limits their use as textile finishes.

Research into controlled-release antimicrobials continues with organo-silver compounds and silver zeolites, which are promising candidates for textile finishes. Silver ions, for example, incorporated in glass ceramic, have a very low toxicity profile and excellent heat stability.<sup>3</sup> These principles are also used for fibre modification, an alternative to the antimicrobial finishes with high permanence.<sup>10</sup> In recent years a variety of antimicrobial modified fibres have been developed, including polyester, nylon, polypropylene and acrylic types. An example of these fibre modifications is the incorporation of 0.5–2% of organic nitro compounds

(for example based on 5-nitrofurfural) before primary wet or dry spinning. Regenerated cellulose can be modified with carboxylic or sulfonic acid groups, followed by immersing in a solution of cationic antimicrobials which are then fixed to the cellulose by salt bonds. A novel approach to the controlled release of antimicrobials is microencapsulation. These capsules are incorporated either in the fibre during primary spinning or in coatings on the fabric surface.

#### 15.4.2 Bound antimicrobials

Several antimicrobial finishes that function at fibre surfaces have been commercialised. One popular product is based on octadecylaminodimethyltrimethoxysilylpropylammonium chloride (Fig. 15.2a). This material can be applied by either exhaust or continuous methods. After application, a curing step is required to form a siloxane polymer coating on the fibre surface. This coating immobilises the antimicrobial part of the molecule (the quaternary nitrogen) and provides the necessary durability to laundering. Another bound finish has been developed with PHMB, polyhexamethylene biguanide (Fig. 15.2b). PHMB can also be either pad or exhaust applied. This chemical has the proper molecular structure to bind tightly to fibre surfaces, yet still be an effective antimicrobial. The antimicrobial effect of cationically charged materials is thought to involve interaction of the cationic molecule with anionic phospholipids in the microbe's cell walls. This interaction is believed to increase the permeability of the cell walls to the point of cell death.

A new and novel approach to bound antimicrobials was recently introduced. Cotton reacted with methylol-5,5-dimethylhydantoin is then treated with hypochlorite to form chloramines in the fibre (Fig. 15.3). These chloramine sites have antibacterial activity and can function as renewable antimicrobial agents by continued treatment with hypochlorite through household bleaching and washing

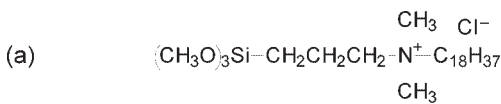

Octadecylaminodimethyltrimethoxysilylpropylammonium chloride

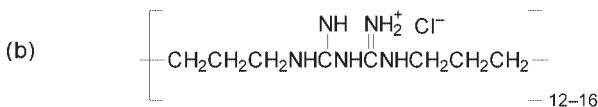

Polyhexamethylene biguanide

#### 15.2 Bound antimicrobials.

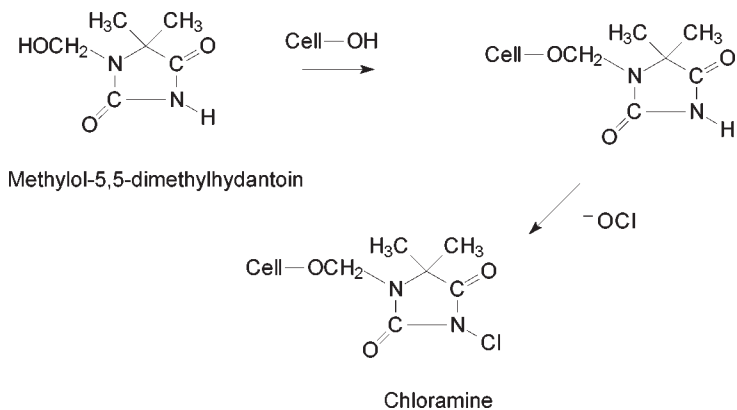

### 15.3 Formation of chloramines on cellulose.

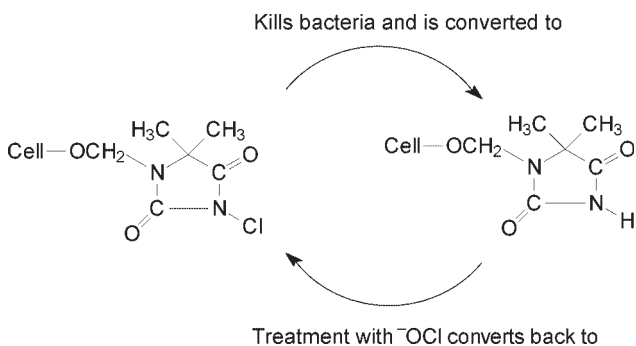

### 15.4 Renewable bound antimicrobial.

after reacting with bacteria (Fig. 15.4). Problems with using higher concentrations of chloramines include yellowing with heat (for example ironing) and cellulose fibre damage especially significant strength loss, caused by oxy- and hydrocellulose (generated by hypochlorous acid, see Chapter 5.8 and Fig. 5.10).

Another novel approach is the application of chitosan. This modified biopolymer is manufactured from inexpensive natural waste. Chitin from crustacean shells (e.g. from crabs) is converted to chitosan by alkaline treatment. Chitin is an analogue of cellulose with *N*-acetyl groups instead of hydroxy groups in position 2 (Fig. 15.5). Alkali splits most of them (75–95 %), generating free amino groups that provide fungistatic and bacterostatic effects. This mild antimicrobial activity may be amplified by methylation of the amino groups to quaternary trimethylammonium structures. Chitosan can be applied by microencapsulation or by reactive bonding to cellulose and by crosslinking of chitosan. The advantages of the antimicrobial finish with chitosan include high absorbency properties, moisture control, promotion of wound healing, non-allergenic, non-toxic and biodegradable properties.<sup>11</sup>

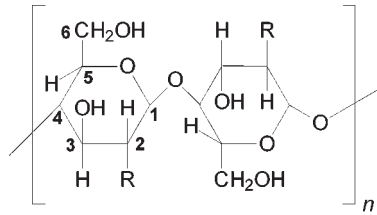

Cellulose if R = —OH

Chitin if R = —NH— $\overset{\text{O}}{\parallel}$ —C—CH<sub>3</sub>

Chitosan if R = —NH— $\overset{\text{O}}{\parallel}$ —C—CH<sub>3</sub> and —NH<sub>2</sub>

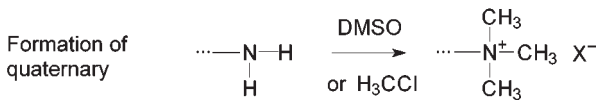
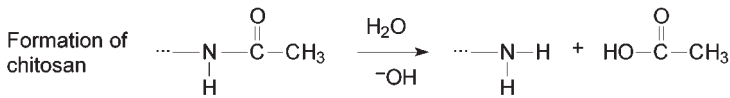

15.5 Chitosan from chitin.

## 15.5 Evaluation of antimicrobial finishes

The AATCC Technical Manual<sup>12</sup> has a number of test methods that are useful for evaluating antimicrobial finishes on textiles. These tests are summarised in Table 15.1. Two types of antimicrobial tests are dominant, the agar-based zone of inhibition tests and the bacteria counting tests. The relatively new ISO/DIS 20645 and the corresponding EN ISO 20645 are based on the agar diffusion test and ISO 11721 is a burial test (part 1 for the determination of an antimicrobial finish and part 2 for the determination of the long-term resistance). A detailed survey and a comparison of the main test methods for evaluating antimicrobial finishes is given by Dring<sup>3</sup> and summarised in Table 15.2. The main difficulties of these tests are mostly poor reproducibility of the test results and often insufficient correlation between laboratory results and actual conditions in the field. Careful attention to detail and trained laboratory personnel are essential for accurate and repeatable results from these methods.

A more rapid test method, developed by the British Textile Technology Group in the late 1980s, is based on adenosine triphosphate (ATP) luminescence. The growth of microorganisms is assessed by firefly bioluminescent detection and ATP analysis.<sup>3</sup>

Table 15.1 Antimicrobial test methods used with textiles

AATCC test method	Comments
Antibacterial activity of textile materials: parallel streak method; test method 147 (agar plate test)	Rapid qualitative method for determining antibacterial activity of treated textile materials against both Gram-positive and Gram-negative bacteria. Treated material is placed in nutrient agar that is streaked with test bacteria. Bacterial growth is determined visually after incubation. Antibacterial activity is demonstrated by zones of inhibition on and around the textile.
Antibacterial finishes on textile materials, assessment of: test method 100	Quantitative method for determining the degree of antimicrobial activity of treated textiles. The amount of bacterial growth in inoculated and incubated textiles is determined through serial dilutions and subsequent inoculations of sterile agar. Gram-positive and Gram-negative bacteria are used.
Antifungal activity, assessment on textile materials: mildew and rot resistance of textiles; test method 30	Four methods for determining the antifungal properties of treated textiles. One method involves testing fabric properties after burial in soil that contains fungi. In a second method, cellulose fabric is exposed to <i>Chaetomium globosum</i> in an agar plate and the subsequent growth visually determined. The third method exposes textiles to <i>Aspergillus niger</i> in an agar plate and visually determines any fungal growth. The fourth method uses a humidity jar to expose textiles to mixture of fungi spores. Any growth on the textile is visually determined.
Antimicrobial activity assessment of carpets; test method 174	Methods are given for the qualitative and quantitative determination of antibacterial activity and the qualitative evaluation of antifungal properties of carpet samples using procedures and materials similar to those in the above test methods.

## 15.6 Troubleshooting for antimicrobial finishes

Difficulties arise in several areas with antimicrobial finishes. The use of binders and resins with controlled-release finishes can lead to stiff hand and fabric strength loss. Colour changes after finishing can also occur. Some consumers may develop dermatitis from prolonged skin contact with antimicrobial finishes. Therefore antimicrobial finishes are excluded from the Öko-Tex Standard 100 label. If residual finish is improperly disposed of at the finishing plant, the desirable and necessary microbes in the waste treatment facility can be destroyed, causing serious ecological problems. Another area of concern is whether the long term use of antimicrobial products in our society will lead to the eventual development of resistant microbes with perhaps deadly consequences.

A general problem of antimicrobial finishes is their selective effect. Some are

Table 15.2 Comparison of main antimicrobial test methods according to Dring<sup>3</sup>

	Agar plate test	Soil burial test	Saturated atmosphere test	Count test
Procedure	Similar to AATCC TM 147 (Table 15.1) and ISO 20645. Agar may contain a nutrient or be nutrient-free to test if samples are a viable carbon source.	Samples are buried up to 28 days, longer for coatings and plastics.	Samples are sprayed with a mixed spore suspension (fungi) and held over water. Organism must obtain its carbon from material under test.	Inoculated samples are left in contact for 0–24 hour. Organisms are then extracted and counted.
Evaluation	Visual, growth of contact and halo	Loss of tensile strength or weight. Control samples must rot in about 7 days.	Visual assessment (including a microscope)	Number of colony forming units (cfu)
Advantages	Quick test for bacteria and fungi, variability of test conditions	The most severe test	Especially suitable for testing fungi or yeasts	Relatively quick, distinguishes between biocide and biostat
Disadvantages	Size of halo indicates high diffusion or efficiency of the biocide	Long term and expensive	Long time of incubation	Only for bacteria. Time consuming and expensive
Accuracy (at average sample number)	Good (4 samples)	± 10 % (10 samples)	± 10 %	± 30–40 % (6 samples)

efficient against fungi, others against Gram-positive or Gram-negative bacteria. Therefore commercial biocide formulations are often composed of a mixture of several substances with different activities. Another general problem is to find the balance between high biocide activity and the requirements of safe handling, including non-toxicity to humans at usual concentrations and environmental demands. Consumers and their organisations have become more aware of toxicological and environmental problems, such as skin irritation, sensitising and allergic potential, biodegradability and bioaccumulation. In response to these concerns, legislation increasingly restricts commerce, handling, use and disposal of dangerous and potentially dangerous substances.

## References

- 1 Vigo T L, *Handbook of Fiber Science and Technology, Vol. II, Chemical Processing of Fibers and Fabrics, Functional Finishes, Part A*, M Lewin M and S B Sello (eds), New York, Marcel Dekker, 1983, 367–427.
- 2 Vigo T L, *Textile Science and Technology II, Textile Processing and Properties*, Amsterdam, Elsevier, 1994, 252–262.
- 3 Dring I, 'Antimicrobial, rotproofing and hygiene finishes', in *Textile Finishing*, D Heywood (ed.) Bradford, Society of Dyers and Colourists, 2003, 351–371.
- 4 Rajan J, *Antimicrobial Finishes for Textiles*, presented at the Chemical Principles of Textile Finishing Short Course, North Carolina State University, Raleigh, NC, March 1999.
- 5 Nomiya K, Takahashi, S and Noguchi R, 'Synthesis of crystal structure of three silver (I) complexes with (s)-(+)-5-ixi-2-tetrahydrofurancarboxylic acid (S-Hothf) and its isomeric forms (R-Hothf and R, S-Hothf) showing wide spectra of effective antibacterial and antifungal activities. Chiral helical polymers in the solid state formed by self-assembly of the dimeric Ag(othef)<sub>2</sub> cores', *Journal of The Chemical Society – Dalton Transactions*, 2000, issue 8, 1343–1348.
- 6 <http://web.archive.org/web/20001205204100/http://www.dupont.com/powders/ampoverv.html>
- 7 Gettings, R L and Triplett B L, *Book of Papers, AATCC International Conference & Exhibition*, 1978, Anaheim, California, 259–261.
- 8 Payne J D and Kudner D W, 'A durable anti-odor finish for cotton textiles', *Textile Chemist and Colorist*, 1996, **28**(5), 28–30.
- 9 Sun G and Xu X, 'Durable and regenerable anti-bacterial finishing of fabrics: biocidal properties', *Textile Chemist and Colorist*, 1998, **30**(6), 26–30.
- 10 Kawata T, 'First permanently antibacterial and deodorant fibres', *Chemical Fibres International*, 1998, **48**(2), 38–43.
- 11 Knittel D and Schollmeyer E, 'Chitosan und seine Derivate für die Textilveredlung', part 1 *Textilveredlung*, 1988, **33**(3/4), 67–71 and part 4 *Melliand Textilberichte*, 2002, **83**(1/2), 58–61.
- 12 *Technical Manual of the American Association of Textile Chemists and Colorists*, American Association of Textile Chemists and Colorists, Research Triangle Park, NC, 1999.

## 16.1 Introduction

Protection against biological attack includes antimicrobial finishes, discussed in Chapter 15, and insect resist finishes, including protection against dust mites. Insect resist finishes are chemical treatments that protect wool and other animal fibres from attack by the larvae of certain moths and beetles. Only keratin-containing fibres are damaged by these insects. Dust mites cause health problems, such as allergy, asthma and neurodermitis. Mites are not insects, they belong to the spider group of animals. Finishes that protect from dust mites are covered in Section 16.7.

Keratin-digesting pests include the clothes moth (*Tineola bissiella*), brown house moth (*Hofmannophila pseudoprettella*), carpet beetle (*Anthrenus flavipes*) and fur beetle (*Attagenus pelli*). Moth populations can increase dramatically in a relatively short time. Each female moth lays about 150 eggs and four to five generations per year can be produced. Various chemicals have been used to control damage from larval attack on wool,<sup>1-7</sup> but environmental concerns have limited the use of some of the more effective products. Annually, about 2 million pounds weight (about 900 000 kg) of insect resist finishes are used with wool products.

The most important market for insect resist finishes is the carpet industry. More than two-thirds of these finishes are used with floor coverings and wall hangings. Other significant markets include home furnishing and upholstery fabrics, blankets, uniforms, apparel and furs.

## 16.2 Mechanisms of insect resist finishes

Insect resist finishes fall into two types, poisons that interfere with the keratin-digesting process of the larvae and nerve poisons that have been specifically formulated from agricultural pesticides for textile applications. Of the two types, digestion-affecting poisons are more species specific, killing the feeding larvae by blocking enzymes needed for digestion. Nerve poisons are more general control agents, affecting a broader range of insects. Both types are considered to enter

through the larvae's digestive tract because insect resist treated wool only kills insects that ingest the fibre.<sup>1</sup>

Each category has distinct advantages and disadvantages. Digestive poisons present a lower environmental hazard than nerve poisons, but are not as effective against some pests such as the brown house moth. Nerve poisons are usually more rapidly biodegraded than digestive poisons, but also exhibit less durability.

The usual application level of insect resist finishes varies from 0.1 to 1.5 % on

(a) Chlorinated triphenylmethane

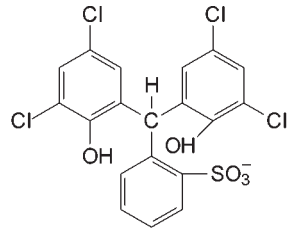

(b) Chlorophenylids

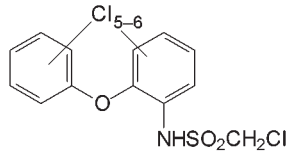
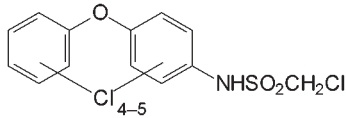

(c) Sulcofenuron

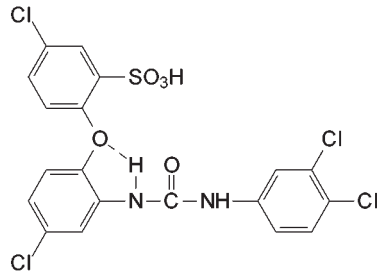

(d) Flucofenuron

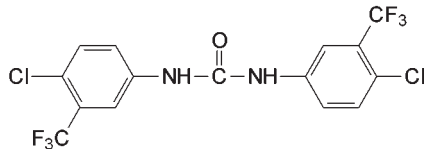

16.1 Digestive poisons used as insect resist finishes.

weight of goods depending on the final product, the specific finish and the performance requirements.

### 16.3 Chemistry of insect resist finishes

Digestive poisons were the first durable insect resist finishes to be commercialised. Early products were based on chlorinated triphenylmethanes (Fig. 16.1a) and chlorophenylids (Fig. 16.1b). Later, sulcofenurons (Fig. 16.1c) and flucofenurons (Fig. 16.1d) were introduced. These compounds could, for the most part, exhaust to wool under acidic conditions and have reasonable fastness properties.

Agricultural pesticides were found to be effective insect resist agents when applied in emulsion form to wool dyebaths.<sup>7</sup> Dieldrin (Fig. 16.2a), one of the original nerve poisons, is also highly toxic to mammals and aquatic life and its use has been banned in most countries. Products based on permethrin (Fig. 16.2b), a synthetic pyrethroid, are very effective against moth larvae, but have less effect on *Anthrenus* beetles. To overcome this disadvantage, combination products of permethrin and hexahydropyrimidine derivatives (Fig. 16.2c) have been introduced.

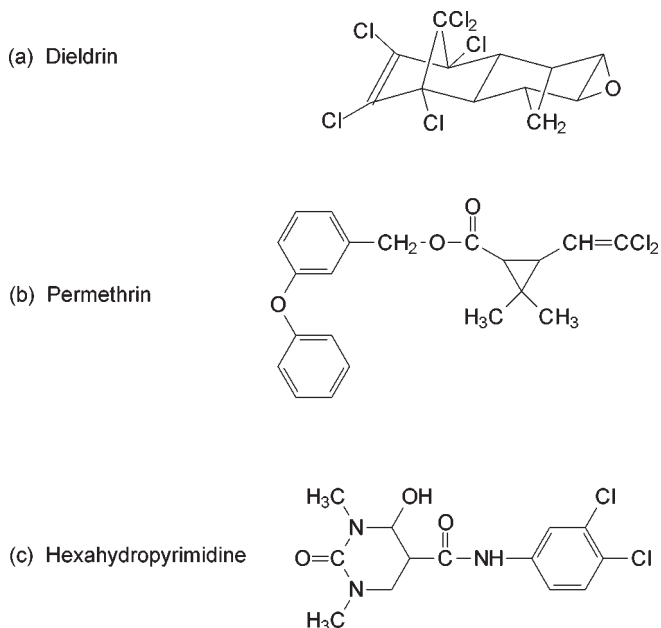

16.2 Nerve poisons used as insect resist finishes.

## 16.4 Application of insect resist finishes

Insect resist finishes are most commonly applied during dyeing. The best light fastness and wet fastness properties are obtained when the finish is able to fully penetrate the fibres. When applying insect resist finishes to wool/nylon blends, care must be taken in the choice of the particular finish used. Chlorphenylid derivatives exhaust preferentially to nylon, leaving the wool fibres unprotected, whereas permethrin-based products distribute themselves more uniformly between the two fibre types.

Application of insect resist finishes during scouring is also possible when wool yarns for carpets are scoured in hank form or when fabrics for blankets, apparel and upholstery are prepared as piece goods. Finishes applied during scouring do not completely penetrate the fibres owing to the lower temperatures and shorter treatment times in the scouring process, so fastness properties are not as durable as with finishes applied during dyeing.

A third approach to the application of insect resist finishes is to combine the finish with spinning lubricants and then to apply the combination to loose wool prior to spinning. This method of finish application produces yarns with only a superficial treatment with much lower fastness than applications made during dyeing or scouring.

Chemical cleaning of wool textiles as smaller carpets, wall hangings, upholstery fabrics, furs or uniforms can easily be combined with the application of insect resist finishes. Dip and cautious spray application is used for the protection of wool and silk textile exhibits in museums.

## 16.5 Evaluation of insect resist finishes

The efficiency of insect resist finishes can be determined by tests that measure the weight loss of the treated fabrics and/or the weight of insect excrement after exposure to insects under controlled conditions. The direct examination of exposed fabrics by microscopic methods to observe fibre damage is also useful. The typical half round bite traces of the moth larvae are observable. Standard methods for evaluating fabrics with insect resist finishes are given in AATCC Test Method 24.<sup>8</sup> Procedures for cultivating the test insects are included in this method.

## 16.6 Troubleshooting for insect resist finishes

Exposure to light as well as mild washing, dry cleaning and shampooing can reduce the effectiveness of insect resist finishes significantly. The durability requirements of the final product must be carefully considered during product development.

Finish baths that are not completely depleted of insect resist finishes must be disposed of in accordance with local, state and federal regulations. Special care

must be taken to prevent accidental release of these insect poisons to the environment.

## 16.7 Finishes for protection from dust mites

In contrast to insects with three pairs of legs, mites have four pairs. Mites (lat. *Acari*) are a group of spiders, characterised by the fusion of the chest with the lower body. Dust mites live and proliferate in house textiles such as bedding, mattresses, quilts and also, but to a lesser extent in carpets, upholstery and pillows. Their main nutrients are skin scales which are produced and scraped off by the regeneration of the human skin. Comfortable temperature and moisture conditions that are found in modern houses are not only agreeable for human inhabitants but also for dust mites and microorganisms. Bedding and mattresses especially are a paradise for dust mites, providing ideal living conditions.

Human problems arise from the faeces of these mites. They contain the allergen DER P1, which is regarded as responsible for the symptoms of about one-half of all asthma sufferers. Additionally about 5 % of the western population are allergic to mildew.<sup>9</sup>

Simple protection from these problems is achieved by repeated airing (reduced moisture), lower room temperature, washing and cleaning. Allergic persons store their bedding for several hours in a freezer or vacuum them with a vacuum cleaner. An easier solution is provided by mite- and skin-scale-tight fabrics for sheeting, bed covers and similar textiles. With these tight woven fabrics, often made from microfibrils, the mites are separated from their nutrients.

There are several chemical approaches to solving the dust mite problem in addition to this mechanical solution. Mite-specific biocides and biostats are applied following the strategies described in Chapter 15 on antimicrobial finishes. They are either durably bonded to the fibre or control released. Microencapsulation is another interesting possibility for application. Direct chemical protection with specific products against dust mites is available (e.g. Ultra Fresh from Thompson Research Associates (TRA), Canada and Actigard from Sanitized AG, Switzerland<sup>9</sup>) and may be combined with mite-tight textiles. Fungicides and bactericides help by the way of a side effect. Fungi grow on the skin scales, prepare them as pre-digester and provide additional nutrients for the mites. TRA found out that common mould fungi and bacteria are important in the mite's food chain. Their reduction by antimicrobial finishes helps to control the mite population.

## References

- 1 Lewis DL, *Wool Dyeing*, Manchester, Society of Dyers and Colourists, 1992, 126–132.
- 2 Haas J and Fuss A, 'Mottenschutzrüstung mit Eulan Produkten – ein aktuelles Problem', *Deutscher Färber-Kalender*, 1978, **82**, 408–424.

- 3 Vigo T L, *Handbook of Fiber Science and Technology, Vol. II, Chemical Processing of Fibers and Fabrics, Functional Finishes, Part A and B*, M Lewin and S B Sello (eds), New York, Marcel Dekker, 1983 and 1984.
- 4 Vigo T L, *Textile Science and Technology II, Textile Processing and Properties*, Amsterdam, Elsevier, 1994, 257–258.
- 5 Shaw T and White M A, *Handbook of Fiber Science and Technology, Vol. II, Chemical Processing of Fibers and Fabrics, Functional Finishes, Part B*, M Lewin and S B Sello (eds), New York, Marcel Dekker, 1984, 318–396.
- 6 Mayfield R J, ‘Mothproofing: a critical appreciation of recent developments’, *Textile Progress*, Manchester, The Textile Institute, 1982, **11**(4), 1–11.
- 7 Lipson M and Hope R J, *Proceedings 1st International Wool Textile Research Conference*, 1955, E, 523.
- 8 *Technical Manual of the American Association of Textile Chemists and Colorists*, American Association of Textile Chemists and Colorists, Research Triangle Park, NC, 1999.
- 9 Dring I, in *Textile Finishing*, D Heywood (ed.), Bradford, Society of Dyers and Colourists, 2003, 356.

## 17.1 Introduction

Bio-finishing, also called bio-polishing, is a finishing process applied to cellulosic textiles that produces permanent effects by the use of enzymes. Bio-finishing removes protruding fibres and slubs from fabrics, significantly reduces pilling, softens fabric hand and provides a smooth fabric appearance, especially for knitwear and as a pretreatment for printing. Second rate articles can obtain the high value eye appeal of first rate ones. In denim processing, bio-finishing can reduce or eliminate abrasive stones and the aggressive chlorine chemistry, achieving the desired 'worn' looks. Bio-finishing is not only useful for cotton but also for regenerated cellulose fabrics, especially for lyocell and microfibre articles.<sup>1</sup> By incorporating enzymes into detergents to remove protruding surface fibres, improved colour retention is achieved after multiple launderings. The disadvantages of bio-polishing are the formation of fibre dust, which has to be removed thoroughly, the reproducibility of the effect (which is dependent upon many parameters) and in the worst case, loss of tear strength.

Enzymes are high molecular weight proteins produced by living organisms to catalyse the chemical reactions essential for the organism's survival. They have complex three-dimensional structures composed of long chains of amino acids (Fig. 17.1) with molecular weights ranging from 10 000 to about 150 000 and occasionally to more than 1 000 000. These naturally occurring molecules provide a high degree of catalytic specificity unmatched by man-made catalysts. The enzyme and substrate form a 'lock and key' complex that requires the enzyme to have a specific molecular alignment in order to act as a catalyst. The lock and key theory of Emil Fischer was broadened by Koshland Jr to the induced-fit theory of the enzyme–substrate–complex. Chemical reactions catalysed by enzymes can typically be carried out – as is most usual in nature – under mild aqueous conditions without the need for high temperatures, extreme pH values or chemical solvents. What a dream for every chemist!

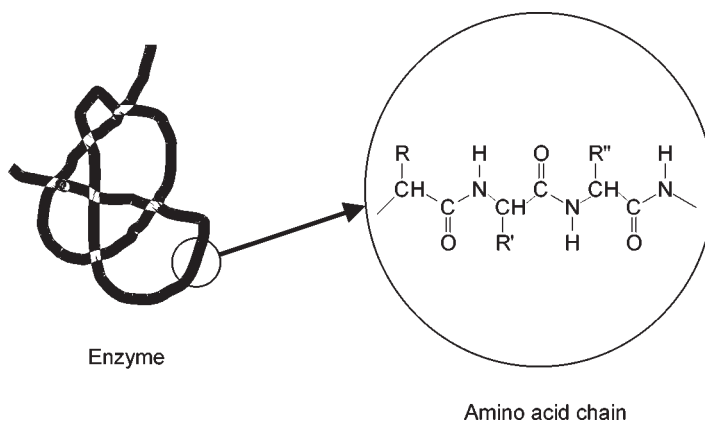

## 17.1 Enzyme structure.

Table 17.1 Enzyme treatments of textiles

Type of enzyme	Textile use and effects
Cellulases	Bio-finishing, bio-polishing, anti-pilling, softness, smoothness, lustre improvement and stone-washed effects on denim
Amylases	Standard procedure for the removal of starch warp size
Proteases	In household washing agents better removal of protein containing soil or stains. Anti-felting of wool, accompanied by high loss of weight, tear strength and of the typical handle, <sup>2,3</sup> degumming of silk with the problem of silk fibroin damage
Lipases	In detergents for the hydrolysis of lipids
Pectinases	Hydrolysis of pectins, for example in cotton preparation <sup>4</sup> and retting of flax and hemp
Catalases	Catalyse the decomposition of hydrogen peroxide, important before reactive dyeing or printing of peroxide bleached fabrics and yarn
Peroxidases	Used as an enzymatic rinse process after reactive dyeing, oxidative splitting of hydrolysed reactive dyes on the fibre and in the liquor, providing better wet fastness, decolourised waste water and potentially toxic decomposition compounds (aromatic nitro-compounds)
Ligninases	Removal of burrs and other plant compounds from raw wool
Collagenases	Removal of residual skin parts in wool
Esterases	In development: polyester finish, removal of oligomers
Nitrilases	In development: polyacrylonitrile preparation for better coloration

Enzymes find commercial use in detergents, leather processing, baking, brewing, cheese manufacture, fruit juice processing, dairy production, animal feed, wine making and textiles. A wide variety of different enzymes finds use in textile areas as shown in Table 17.1. This chapter will focus on cellulases, which are enzymes that catalyse the hydrolysis of the cellulose polymer. Except for the peroxidases, which are used to improve colour fastness and are described in Chapter 13, all the other types of enzymes are used for preparation processes and therefore not included in this discussion.

The names of the examples of textile-relevant enzymes follow the nomenclature of Duclaux from 1898, characterising an enzyme by the end-syllable 'ase', added to the name of the substrate that is split, synthesised or otherwise catalysed. As with all catalysts, enzymes reduce the activation energy of a specific reaction. The discovery of large quantities of new enzyme systems afforded a more differentiated nomenclature, realised in 1964 by the International Union of Pure and Applied Chemistry (IUPAC) and the International Union for Biochemistry (IUB). In the new enzyme classification (EC) the first number refers to one of the six main groups and the following numbers to subgroups, for example EC 3.4.5.6, where 3 stands for hydrolases.<sup>5</sup>

## 17.2 Action of cellulase enzymes on cellulose

Enzymes that hydrolyse cellulose are found in nature in both *Trichoderma* and *Humicola* fungi.<sup>6</sup> The  $\beta(1-4)$  linkages between adjacent repeat units in the cellulose polymer chain are the sites that are vulnerable to catalytic hydrolysis by cellulases (Fig. 17.2). These enzymes are thus able to provide a food source for the organisms by producing glucose from cellulose. Industrial production of cellulases involves large scale growth of fungal populations, followed by extraction of the enzyme. The extracted enzymes contain multiple components that work together to yield glucose from a cellulose polymer chain.<sup>7</sup> At least four components have been identified as being important in providing efficient glucose production. Endo-glucanases hydrolyse cellulose at random locations along the polymer

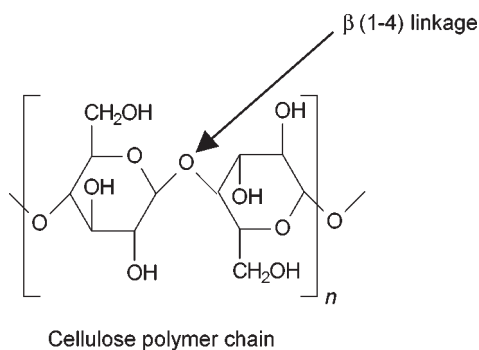

17.2 Cellulase hydrolysis site.

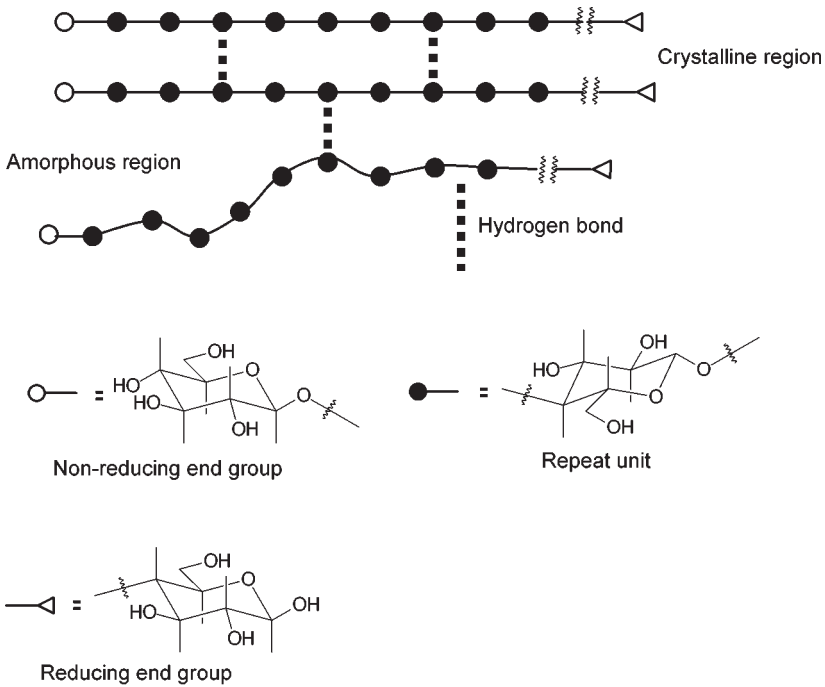

17.3 Schematic representation of cellulose fibre internal structure.

chain. Beta-glucanases hydrolyse cellulose polymers from the non-reducing end producing glucose and leaving a polymer chain with one less repeat unit. Cellobiohydrolases produce cellobiose (the glucose dimer) from polymer chains, and cellobiases convert cellobiose into glucose. These components and their points of attack on cellulose polymer chains are shown schematically in Fig. 17.3 and Fig. 17.4.

Numerous studies of the mechanism of cellulase interactions with cellulose have been reported.<sup>8-13</sup> The generally accepted mechanism is adsorption of the endo-glucanase, beta-glucanase or cellobiohydrolase components onto the fibre surface followed by complex formation with the cellulose polymer chain and water. After hydrolysis of the  $\beta(1-4)$  bond, the enzyme desorbs and is available for further adsorption and reaction. Endo-glucanase effectively opens up more of the fibre structure to attack by beta-glucanase and cellobiohydrolase. These two components in turn produce water-soluble fragments from the exposed area. This synergistic action allows for rapid reduction in fibre strength.

### 17.3 Chemistry of enzyme finishing

More than with other chemical reactions, the enzyme catalysed hydrolysis of cellulose is strongly influenced by factors such as pH, temperature, time and

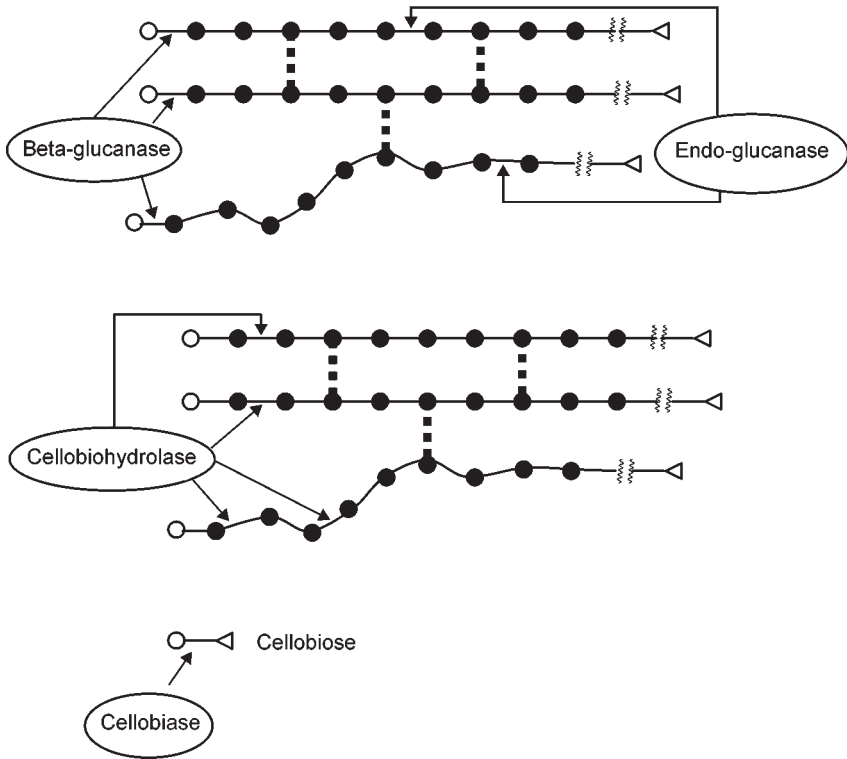

17.4 Action of cellulase components on cellulose.

agitation. The optimal pH for a particular cellulase depends upon its origin. *Trichoderma*-based products (sometimes called ‘acid cellulases’) work best at pH 4.5–6, whereas cellulases from *Humicola* (often called ‘neutral cellulases’) are more effective at pH 6–6.5.<sup>6</sup> The reaction temperature is also critical since at low temperatures, the reaction rate is slower than desired, but very high temperatures can deactivate the enzyme by providing enough energy to alter its molecular alignments and thereby destroy its catalytic ability. Since enzymes are true catalysts and are not consumed during the chemical reaction, the hydrolysis reaction will continue until either the reaction conditions change or the cellulose is physically removed from the reaction mixture. Mechanical agitation is important in order for the hydrolysis reaction to proceed efficiently. Recent work has demonstrated that the kinetics of the reaction are controlled by mass transfer effects.<sup>10</sup> The adsorption–desorption mechanism of enzyme action depends on agitation to remove hydrolysis by-products and expose new fibre areas to attack.

Because the enzyme’s catalytic action is not reduced during the reaction, an effective method of ending the hydrolysis must be employed to prevent excessive fibre loss. Since the molecule’s physical alignments are crucial to its catalytic ability, procedures that alter the cellulase molecule’s internal structure can be used

to deactivate the catalysis and halt the hydrolysis. High temperatures ( $> 70\text{ }^{\circ}\text{C}$  or  $160\text{ }^{\circ}\text{F}$  for at least 20 min or short drying at  $120\text{ }^{\circ}\text{C}$  or  $248\text{ }^{\circ}\text{F}$ ), high pH ( $>10$ ) and high electrolyte content as well as enzyme poisons can serve to terminate the reaction by distorting the enzyme's molecular shape.

Recent developments in enzyme manufacturing have led to commercial products that contain a preponderance of one cellulase component.<sup>6</sup> These 'mono-component' enzymes are produced from modified *Humicola* strains and are primarily endo-glucanases active at pH 7–7.5 and are referred to as 'alkaline cellulases'.

## 17.4 Evaluation of bio-finishing

The removal of cellulosic fibres to improve pilling performance, soften hand, and create an abraded appearance requires not only enzymatic hydrolysis but also mechanical action to carry away reaction by-products physically. The final results from the hydrolysis with respect to appearance and hand are affected just as much by the mechanical components of the process as by the chemical components. Therefore, laboratory evaluations of bio-finished goods can only produce relative rather than absolute results.

Enzyme suppliers determine the activity of their products by measuring the extent of the catalysed reaction under carefully controlled conditions. A standard test exists for amylases (AATCC Test Method 103)<sup>14</sup>, but the evaluation of cellulases is more complex and can vary from supplier to supplier. One common method is to measure the degradation of carboxymethylcellulose solutions. Another is to determine the weight or strength loss of standard cotton fabrics under laboratory conditions where there is a correlation problem, because the mechanical conditions of the technical application are different to the laboratory ones. For example, the hydrolysis degree, HD, is determined by  $\text{HD} = (m_0 - m)/m_0$  where  $m_0$  and  $m$  are the weight of the test material before and after bio-finishing.

## 17.5 Troubleshooting for bio-finishing

As mechanical agitation is important to effect the bio-finishing, only selected processes and machines can be used, for example tubular fabric preferably cut to open width and treated in open width washers. In the rope form the loosened fibre particles are filtered out by the fabric and cannot easily be removed. The pad-batch process, jig or package dyeing machines are not effective in bio-finishing.

Not all cellulase enzymes give identical results, even with similar fabrics in similar equipment. Cellulases derived from *Trichoderma* typically are the most aggressive in their action, whereas mono-component endo-glucanases often require the most mechanical action to achieve the desired effects. Slow deactivation of the cellulases during transport and storage can adversely affect the reproducibility of the resulting effects. If cotton is not washed carefully before bio-finishing,

secondary fibre compounds as residual biocides can deactivate the cellulases. The same is true for natural or synthetic tannic acids, and resist or fastness improving agents for wool or nylon in cellulose fibre blends.

Deactivation of cellulases after the desired effects have been achieved is very important. If the enzyme is not completely removed from the fabric, or is not effectively deactivated, the hydrolysis reaction will continue, although at a slower rate. As very large molecules, cellulases cannot diffuse into the crystalline parts of the cellulose fibres. They react on the fibre surface, so fibre damage takes time. But eventually enough hydrolysis will have taken place to weaken the affected fabrics or garments, leading to customer complaints and returns.

Undesirable deactivation may be caused by high temperature and time, for example, caused by transport and storage and also by enzyme poisons such as certain surfactants (especially cationic ones), formaldehyde-containing products or heavy metal ions. An activation effect on cellulases was reported by Nicolai and co-workers.<sup>15,16</sup> Alkaline pretreatment, low concentrations of selected non-ionic surfactants, polycarboxylic acids and polyvinyl pyrrolidone can enhance the bio-finishing of celluloses.

The use of pH buffers during the hydrolysis reaction is strongly recommended, especially when abrading denim fabrics. Cellulase enzymes have very narrow pH ranges of effectiveness and denim fabrics can have significant quantities of residual alkali from the indigo dyeing process. Buffers are required to maintain the appropriate reaction conditions for maximum enzyme effectiveness.

Because the effect of processing auxiliaries on cellulase catalysis is difficult to predict, it is important to evaluate any changes in processing formulas carefully by conducting small scale trials before making significant changes in production procedures.

## References

- 1 Hohberg T and Thumm S, 'Finishing of lyocell – part 3', *Melliand International*, 1999, **5**(1), 83–85.
- 2 Breier R, 'Rein enzymatische Antifilzausrüstung von Wolle nach dem Lanazym-Verfahren', *Melliand Textilberichte*, 2000, **81**(4), 298–302.
- 3 Stöhr R, 'Enzyme–Biokatalysatoren in der Textilveredlung', *Melliand Textilberichte*, 1995, **76**(11), 1010–1013.
- 4 Etters, J N, Annis P A, *American Dyestuff Reporter*, 1998 **87**(5) 18–23.
- 5 *Enzyme Nomenclature*, Amsterdam–London–New York, Elsevier, 1973.
- 6 Stewart C W, *Book of Papers, 1996 AATCC International Technical Conference & Exhibition*, Nashville, TN, AATCC, Research Triangle Park, NC, 1996, 212–217.
- 7 *Novo's Handbook of Practical Biotechnology*, Boyce C O L (ed.), Bagsvaerd, Denmark, Novo Industries A/S, 1982, 77–81.
- 8 Lee Y and Fan L T, *Biotechnology and Bioengineering*, 1982, **24**(11), 2383–2406.
- 9 Buschle-Biller G and Traore M K, *Textile Research Journal*, 1998, **68**(3), 185–192.
- 10 Sarker A and Etters J N, *AATCC Review*, 2001, **1**(3), 48–52.

- 11 Cavaco-Paulo A, Almedia L and Bishop D, *Textile Research Journal*, 1996, **66**(5), 287–294.
- 12 Li Y and Hardin I, *Textile Chemist and Colorist*, 1998, **30**(9), 23–29.
- 13 Ueda M, Koo H and Wakida T, *extile Research Journal*, 1994, **64**(10), 616–618.
- 14 *Technical Manual of the American Association of Textile Chemists and Colorists*, American Association of Textile Chemists and Colorists, Research Triangle Park, NC, 1999.
- 15 Nicolai M and Nechwatal A, 'Einflussfaktoren beim Biofinish-Prozess', *International Textile Bulletin*, 2002, **48**(6), 52.
- 16 Nicolai M, Nechwatal A and Miek K-P, 'Biofinish-Prozesse in der Textilveredlung', *Textilveredlung*, 1999, **34**(5/6), 19–22.

## 18.1 Introduction

The term 'novel finishes' is used in the sense of new types of finishes. This should mean more than new research and development (R&D) ideas or patents. First, new products should be available or be in the industrial test phase. On the other hand, if a novel finish is successful and accepted by the market, it is no longer really new and should therefore be discussed in a chapter of its own. So, although the content of this chapter might be outdated in a relatively short time, it still deserves some interest.

## 18.2 Anti-odour and fragrance finishes

The human sense of smell registers not only the quality of different odours but also combines it automatically and often unconsciously with feelings ranging from agreeable to unpleasant. This connection is used in many ways. Perfumed people and merchandise become more attractive and stink bombs are used to the opposite effect. Textiles have a very large specific surface (for example 0.1 to 1 m<sup>2</sup> g<sup>-1</sup>). Therefore they attract, adsorb and store various gaseous or volatile substances from their surroundings. This high adsorption capacity can become a problem with unpleasant smelling substances under desorption conditions. Desorption is accelerated by temperature, time and the possibility of gaseous exchange, for example airing.

### 18.2.1 Anti-odour finishes

Because unpleasant odours have a negative impact on textiles and their comfort properties, there is a need for anti-odour finishing. Malodour is an increasing problem with textiles packed, shipped and stored over a long period of time, especially for the mail-order business. The simplest ways of removing such malodours are by airing and washing. There are also consumer products available which can be sprayed onto textiles to prevent or reduce odours. Mostly they cover only the unpleasant odours with better ones and they are not resistant to

Table 18.1 Possibilities for deodorising textiles

Principle	Method	Advantages and disadvantages
Covering	Mostly by spraying of perfumes	Easy handling but not free from odour, short-acting, not permanent
Removal	Airing	Simple and free of applied chemistry but needs a long time and has restricted efficiency, difficulty of handling large amounts
Removal	Washing out odorous substances	Conventional technique with mostly good effects, side effect cleaning but high costs of drying
Removal	Adsorption of odorous substances, e.g. in cyclodextrins or on active carbon	Permanent to washing and dry cleaning but limited uptake and saturation, requires regeneration, for example by washing with the costs of drying
Decomposition	Ozonisation	Very effective, side effect disinfection but need of special equipment, probability of damaging dyestuffs, fluorescent brighteners and sensitive fibres like nylon
Decomposition	Catalytic oxidation with air at room temperature	Permanent with respect to usual cleaning, no saturation and regeneration but need of large surfaces, restricted to indoor applications like carpets and roller blinds
Prevention	Antimicrobial finishes or fibre modifications hinder the decomposition of sweat	Permanent with respect to washing and dry cleaning, especially in the case of fibre modification, restricted to smells from sweat decomposition, therefore only for clothing with skin contact.

washing. There remains a need for a permanent anti-odour finish. Table 18.1 shows an overview on the possibilities of deodorisation of textiles.

One way to prevent the development of unpleasant odours that originate from the decomposition of sweat are antimicrobial finishes or bacteriostatic modified fibres. They prevent the decomposition of perspiration by bacteria to bad smelling products as described in Chapter 15.

Another principle of anti-odour finishes is the hindrance and delay of adsorption and desorption of unpleasant smelling substances by the textiles. This odour

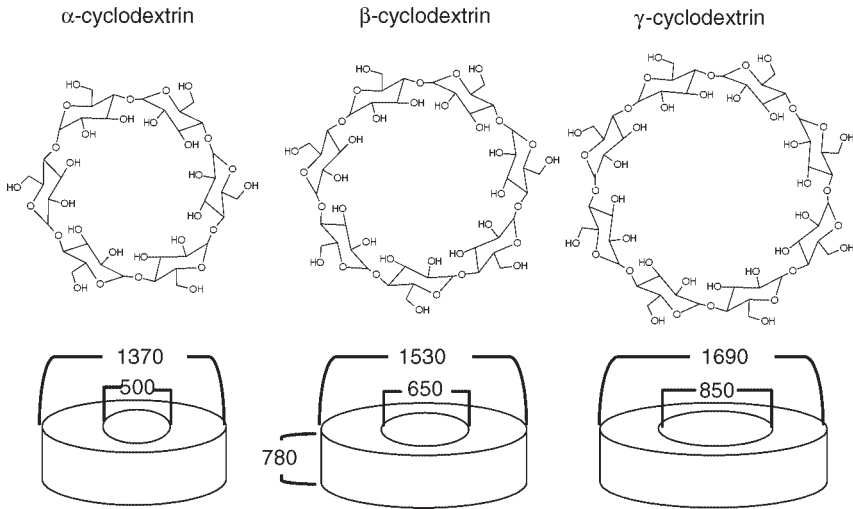

**18.1** Structures and dimensions of cyclodextrins. The  $\alpha$ -form has six, the  $\beta$ -form has seven and the  $\gamma$ -form has eight, 1,4-connected D-glucose units; dimensions are in pm according to Buschmann *et al.*<sup>1</sup>

control is often based on cyclodextrins. They are polysaccharides built from six to eight D-glucose units as shown in Fig. 18.1.<sup>1,2</sup> They are formed by enzymatic degradation of starch and are non-toxic and not skin sensitising. Cyclodextrins are decomposed by starch desizing agents and conditions such as high temperature, acid, oxidising agents and amylases, but these conditions can be avoided during finishing and normal usage.

Cyclodextrins are torus-shaped molecules with hydrophobic cavities between 0.5 and 0.85 nm. They can store other molecules that fit into these cavities depending on their shape and intermolecular attraction. The empty cavities can be filled with organic molecules from sweat so that their microbiological decomposition and the formation of malodours are prevented. On the other hand, the malodorous decomposition products can also be stored if they can fit into the cavities. These bound molecules can then be removed by normal washing.

For an effective anti-odour finish the cyclodextrins must be resistant to normal washing. Their fixation to the textile fibre is managed by chemical binding, depending on the kind of fibre. Cyclodextrin derivatives with reactive groups, similar to fibre reactive dyestuffs, are used for cellulose, for example monochlorotriazinyl anchors. Cyclodextrin derivatives with sulfonic acid groups form ionic bonds with the amino groups of polyamide fibres, wool and silk. Fixation to wool is also achieved with reactive polyurethanes, as used for anti-felting.<sup>3</sup> Normally, however, wool and silk do not need anti-odour finishing. These natural fibres are known for their ability to store perspiration without the development of malodours. On polyester fibres the fixation of cyclodextrins can be accomplished by hydrophobic attractions, based on a cyclodextrin modification

with long alkyl chains or other hydrophobic groups. Another means of fixation is nearly independent of fibre type and uses binders similar to those used for pigment printing. The binder is applied by padding and fixed by heat in such a way that most of the adsorption products are not completely coated by the binder film. Cyclodextrins can also be fixed on cellulose by combination with an easy-care finish such as the usual *N*-methylol compounds without losing their capability to attract and store organic molecules like butyric acid, which is representative of the malodorous sweat decomposition products.<sup>1</sup>

Another interesting approach to anti-odour finishes is the incorporation of specific catalytic materials into a thin surface coating. These catalysts, for example a mixture of organic nitrogen compounds and metal salts, enable oxidation of unpleasant or harmful components in the air of interior rooms at room temperature. Good effects are reported for formaldehyde, nicotine, acetaldehyde, acetic acid, ammonia, trimethylamine, hydrogen sulfide and methyl mercaptan. These compounds are oxidised to harmless products like water and carbon dioxide.<sup>4</sup> Another advantage of this catalytic reaction compared to odour adsorbers like the cyclodextrins is that there is no saturation level and no need for regeneration. This finish is restricted to household textiles in mainly closed rooms and therefore is applied to carpets and indoor light and sun protection roller blinds and vertical lamella.

Special protective clothing is available commercially to provide protection against harmful or toxic gases. This often has a finish consisting of activated carbon particles fixed by a binder film to the textile surface. This principle is also used in odour active filters, for example air freshener for cars and also for the adsorption of emission gases from internal combustion engines. The very high specific surface of the porous activated carbon (500–2000 m<sup>2</sup> g<sup>-1</sup>) provides the high adsorption capacity of these protective textiles. Other adsorption agents incorporated in textile filters are aluminium oxide, zeolite and organic bonopore with particle sizes of 0.4–9 μm.<sup>5</sup>

Recently, several new anti-odour finishing products have become available that correspond to the principles described above. Some of these products are also recommended and used for fragrance finishes.

### 18.2.2 Fragrance finishes

Cyclodextrins can be filled not only with perspiration compounds but also with perfume oils. If the vapour pressure of the oils is high enough but not too high, the perfume will evaporate over an extended time in low concentrations delivering a pleasant scent to the finished textile. This finish is not permanent to washing or chemical cleaning but regeneration by the user is possible.<sup>1</sup> This seems to be more a finish that aims to stimulate the buyer of these textiles. The purpose is similar to the application of perfumes in household washing agents or in new cars, with the difference that the cyclodextrins enable comparatively long fragrance release and

can be regenerated. This release can be adjusted mainly to the wearing of the textiles, for example the body moisture and temperature, and perhaps to movement, causing air circulation. Additionally, cyclodextrins can be filled with pharmaceutically active substances or cosmetic products which are of interest for medical textiles or for textiles designed to provide skin care.

These additives can also be placed into microcapsules with a thin polymer skin. For example, they are filled with natural aromas and applied to the textile from a water dispersion in combination with a polyurethane or silicone binder. The ratio of micro bubbles to binder determines the efficiency and permanence of the finish. Good results after 4–12 washing cycles are reported. The encapsulated materials are released during wearing as the micro bubbles burst from rubbing caused by body movement or by diffusion through the thin layer of the capsules.<sup>6,7</sup> A market available encapsulation in micro bubbles, built from chitosan, is described by Hampe.<sup>8</sup> The incorporation and controlled release of fragrance compounds is also provided by the sol–gel nano-technique described in Section 18.4.

### 18.2.3 Test methods

Similar to the subjective evaluation of the hand of textiles by the sense of the touch, odour changing finishes were traditionally only checked by the human nose. Now an interesting objective method to measure the odour properties of textile finishes has been reported.<sup>9</sup> The systematic measurement of odour gradation, SMOG, was developed by EMPA St Gallen, Switzerland in cooperation with Ciba Speciality Chemicals Inc. This automated quantitative analytical measurement is based on gas chromatography and imitates the real life odour cycle of textiles. Adsorption and desorption of treated and untreated textiles are compared with the relative odour index (ROI) value. The ROI can be calculated for model substances representing human sweat, cigarette smoke and perfumes. Additional parameters of importance are the type of textile and its finish, temperature, exposure time and humidity. A recent publication describes simpler and subjective test methods.<sup>3</sup> The complex interaction of factors brings to mind the problematic evaluation of the quality of perfumes and wines and the old question of whether the human senses or highly developed analytical measurements are the best sensors for smell and taste.

## 18.3 Fibre surface modifying finishes using plasma and radiation technologies

This fibre and fabric modification is based on photophysical and photochemical processes induced by exposure to plasma gases. Reactive gases are used to create chemical fibre surface modifications such as repellency of water, oil and soil and higher fibre resistance against aggressive chemicals. These modifications are mainly restricted to the fibre surface to avoid damaging the fibre bulk, for example

loss of strength. Other possible disadvantages are the limited effectiveness and durability of plasma treatments of textiles at normal pressures (corona discharging) and the technical effort required to use plasma technology at low pressures.<sup>10</sup>

Fewer disadvantages are reported<sup>2,11</sup> for the photo-induced activation reactions with excimer–ultraviolet (UV) light sources. They combine simple textile processing with the high efficiency of pulsed monochromatic UV light. These reactions are accomplished with either non-absorbing gases and UV absorbing fibres like polyester and aramid or with UV absorbing gases and UV transparent fibres such as polyethylene.

The UV radiation absorbed by the fibre causes cleavage of chemical bonds mainly on the fibre surface, for example the ester groups of polyethylene terephthalate, and the formation of radicals. These radicals form new bonds with the reactive gases in the atmosphere. For example, 1,5-hexadiene creates a hydrophobic hydrocarbon fibre surface and unsaturated fluorinated gases (such as hexafluoroethylene) form oleophobic surfaces. Photo-oxidation in air atmosphere yields mainly carboxyl groups that create a hydrophilic fibre surface. Polyethylene does not absorb UV radiation at, for example 222 nm wavelength, in contrast to various acrylic monomers. This system leads to polyacryl-grafted polyethylene fabrics with interesting new properties like hydrophilicity, dyeability or printability.

Pretreatment with excimer lasers can create super-repellent effects on polyester or aliphatic polyamide fibres. Radiation changes their originally smooth surface to a rather regular roll-like surface structure perpendicular to the fibre axis caused by regular relaxation.<sup>12</sup> This structuring, combined with grafting processes leads to high repellency effects.<sup>13</sup> On the other hand, adsorption and deposition of very small particles (in the micrometre range) in the roll structures is possible, creating special filter effects.

A useful side effect of the radiation and especially the plasma treatments is the cleaning of the fibre surface. Fibre lubricants, sizing agents, soil and other residuals are burned off. This provides, combined with the creation of reactive radicals on the fibre surface, better wetting properties and a higher adhesion of coatings and laminations. Anti-felting finishes for wool are also achievable with plasma treatments.

## **18.4 Fibre surface modification by sol–gel finishes with inorganic oxide films**

For many applications, especially technical applications, textiles should be protected against physical or chemical assault, for example abrasion, damage by UV radiation and aggressive chemicals. This can be achieved by thin crosslinked layers of inorganic or mixed inorganic–organic polymers on the fibre surface<sup>2,14,15</sup> These special finishes are carried out with common techniques at moderate processing temperatures that do not exceed 150 °C and result in very thin polymer films on the fibre surface.

Precursors that create a crosslinked polymer based on an inorganic network after hydroxylation and polycondensation are mostly silica compounds with three or four alkoxy groups, preferably methoxy groups. The hydrolysis of the alkoxy groups creates so-called nano-sols. They are applied as relatively stable dispersions with a metal oxide content of about 3–20 % by weight. The oxide particles are originally smaller than 10 nm, leading to the name nano-sol. During application onto the textiles, a gel is formed. After drying the gel forms a thin porous layer on the fibre surface, called a xerogel film.

In the case of mixed inorganic–organic hybriide polymers, also called ormocers (organically modified ceramics), the fourth bond partner at some silicon atoms can be a hydrocarbon group, often functionalised, for example by a glycidil, chlorine or methacrylic reactive end group. These end groups can react with each other or with corresponding groups of fibres, for example hydroxyl groups of cellulose or amino groups of polyamide, creating a highly durable finish. Other organic groups connected to the silicon atoms can be fluoroalkyl, bioactive or dyestuff groups. Even without fibre-reactive organic groups these porous oxide films have a high affinity to the fibre surface.

Another advantage of the silicon oxide network is that it can be modified in various ways as shown in Fig. 18.2. One way is co-condensation of the most used tetramethylol silanes with other kinds of metal oxides. Another way is co-hydrolysis and co-polycondensation with substituted trimethoxy silanes where this substituent is, for example, a long alkyl chain for hydrophobation, an organic portion with polar structures for antistatic effects, a fluorocarbon for the release of water, oil and soil or a bioactive group. The easiest method of modification is the physical one, the simple addition of the desired chemicals. They are then incorporated in the porous network of the metal oxides and are released in a more or less controlled way.

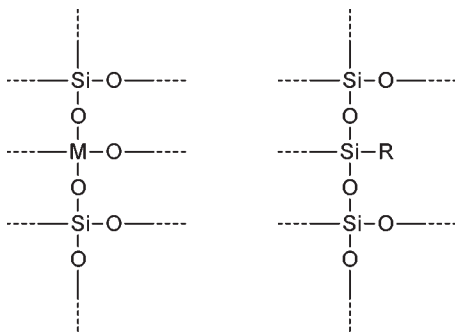

18.2 Schematic representation of the chemical modifications of the silicon oxide network. Inorganic modification with M = Al, Ti, Zr and others, organic modification with R = alkyl, aryl, both without and with additional functional groups, for example fluoroalkyl, or R = bioactive or dyestuff group.

**Table 18.2** Possibilities for storing and releasing effect chemicals by finishing of textiles

Principles of storage, fixation and release	Advantages and disadvantages
<b>Enclosure by complex formation with cage compounds like cyclodextrins</b> , fixed with primary or secondary valence forces to the fibre surface, release by evaporation or displacement	Biodegradable and harmless, but restricted to molecules of fitting shape and polarity (hydrophobicity); only for small amounts (saturation); need of regeneration
<b>Enclosure in micro bubbles</b> from polyurethane or silicone, binder fixation to the fibre surface, release by burst of the bubbles through rubbing	Suitable for all aggregate states, fewer restrictions on the amount and polarity, but the binder film with the micro bubbles changes textile properties like softness, wetting, air and vapour permeability
<b>Adsorption in porous metal oxide films</b> , fixed as a polymer network on the fibre surface, release by evaporation or transfer in liquid form by wetting	High capacity for storage of preferably liquid effect chemicals; only few restrictions on their molecular size or polarity but the oxide film changes textile qualities like softness; causes a harder hand and problems during sewing (needle abrasion)

The inorganic part of these polymers gives rise to greater hardness and heat resistance and to some measure of flame resistance, especially if filled with inorganic nano-particles like aluminium oxide or hydroxyde pigments. Incorporation of zinc oxide pigments causes high UV absorption which protects the fabric as well as the human skin. Special advantages of this inorganic UV absorber are the transparency of the finish (in contrast to titanium dioxide), resistance to ageing (in contrast to organic UV absorbers) and the fact that zinc oxide is not harmful. This material is also used in the cosmetic industry. Additionally, this finish can greatly improve the wear resistance of fibreglass fabrics.

Organic coated micro bubbles and inorganic silicon networks have been discussed. Another remarkable finish is similar to these products: evacuated micro bubbles from silicon compounds, fixed with an acrylate binder on the fibre surface provide new insulation textiles. The high insulation value of the vacuum and the reflectance of the ceramic bubbles of this so-called liquid ceramic finish protects very effectively from heat and cold.<sup>16</sup>

Textile finishes that release fragrances, cosmetics and pharmaceutical substances are sometimes called wellness finishes with corresponding terms for the finished textiles as attractive buying incentives. Possibilities for storing and releasing such effect chemicals by the chemical finishing of textiles are listed in Table 18.2.

## References

- 1 Buschmann H-J, Knittel D and Schollmeyer E, 'Wie funktionieren Textilien mit fixierten Cyclodextrinen?', *Melliand Textilberichte*, 2003, **84**(11/12), 988–989 and the older papers by the same authors quoted here.
- 2 Schollmeyer E, Textor T and Bahnert T, 'Functionalisation of textile material by surface modification, 3. *Texchem*, Dvur Kralove, Czech Republic, 2003.
- 3 Volz W, 'Anti-Smell-Ausrüstungen in der Textilveredlung', *Textilveredlung*, 2003, **38**(11/12), 17–21.
- 4 Anonymous report on BakaSave, *Melliand Textilberichte*, 2002, **83**(1/2), 12.
- 5 Böttcher P, 'Textile filters', *Industrial Fabrics Bulletin*, 2002, (3), 34–36.
- 6 Anonymous report on Bayscent, *Textilveredlung*, 2003, **38**(1/2), 40.
- 7 Mathis R, 'Textilien mit kosmetischen Substanzen', *Melliand Textilberichte*, 2002, **83**(5), 339–340.
- 8 Hampe M, 'Die nächste Generation: Textilien mit Zusatznutzen', *Textilveredlung*, 2003, **38**(11/12), 14–16.
- 9 Reifler F A, Ritter A, Ellmann J and Niederstadt R, 'SMOG – eine Methode zur Erfassung der Antismell-Wirksamkeit', *Textilveredlung*, 2002, **37**(11/12), 5–9 and patent PCT/EP 02/14029.
- 10 Leinte K, Schmalz R, 'Koronabehandlung von Polyestergeweben', *Melliand Textilberichte*, 2003 **84**(7/8) 636.
- 11 Prashak D, Bahnert T, Bossmann A and Schollmeyer E, 'Oberflächenmodifizierung von PES durch Bestrahlung mit Eximer-Lampen'. *Melliand Textilberichte*, 1997, **78**(7/8), 531–532.
- 12 Schollmeyer E and Bahnert T, 'Oberflächenveränderungen von Fasern durch Laserbehandlung', *Melliand Textilberichte*, 1990, **71**(4), 251–256.
- 13 Bahnert T, Schollmeyer E, Prashak D, 'Schaffung superabweisender Eigenschaften mittels photonischer Techniken', *Melliand Textilberichte*, 2001, **82**(7/8), 613–614.
- 14 Böttcher H, 'Sol-Gel-Beschichtung auf Textilien – Möglichkeiten und Probleme', *Textilveredlung*, 2001, **36**(3/4), 16–21.
- 15 Textor T, Bahnert T and Schollmeyer E, 'Funktionelle (adaptive) Schichtsysteme für Bautextilien', *Technical Textiles/Technische Textilien*, 2001, **44**(4), 304–306 and *Melliand Textilberichte*, 1999, **80**, 847–848.
- 16 Fuchs H and Hardtke G, 'Keramikbeschichtung für funktionelle Bekleidung', *Textilveredlung*, 2001, **36**(3/4), 13–15.

### 19.1 Introduction

New developments in the different types of chemical finishing have been described in the relevant chapters and new kinds of finishing are the subject of the chapter on novel finishes. In this chapter tendencies in the development of chemical finishing, including technical, economical and ecological trends, will be pointed out. On this basis, and as far as it is possible to predict, an extrapolation to the future will be attempted. Table 19.1 gives an overview of these trends.

### 19.2 Cost reduction and greater efficiency

The most important trend in chemical finishing is characterised by the key term 'better cost-efficiency relation'. The general aims are lower costs for the finishing processes and final products, preferably combined with improved main effects and less undesirable side effects of the finish. This is easy to state and hard to realise. But in the different chapters of this book several examples for this main trend are given. The best known ones are probably those with the silicones and fluorocarbon products. Their costs are relatively high. Naturally there have been many efforts to reduce these. In the past extenders have been used, currently boosters give rise to a higher fluorocarbon efficiency and other advantages. Better effects with less fluorocarbon polymers are also reached with additional dendrimers as described in Sections 6.3.4 and 19.10.1.

### 19.3 New kinds of effects

Demanding and sophisticated customers as well as fashion designers are looking for new effects. Some of them have been discussed in the chapter on novel finishes, for example anti-odour and protective finishes, wellness finishes that release fragrances or cosmetics and medical finishes that deliver drugs. Additionally, cellulase finishing, especially on microviscose or lyocell fibres, enables novel

Table 19.1 Overview of trends in chemical finishing of textiles

Trends	Examples
Cost reduction and higher efficiency	Boosters and dendrimers for fluorocarbon finishes (FC)
New types of effects	Bio-polishing and anti-pilling with cellulases, odour and anti-odour, wellness to wear or medical finishes
Fewer undesired side effects	Less strength loss by moisture controlled fixation of easy-care finishes
Easier application	Low curing of FC finishes
Higher permanence in laundering and chemical cleaning	Crosslinking of silicones, new catalysts for the fixation of flame retardants
Easier care of finished textiles	Laundry-air-dry of FC finishes (LAD)
Better ecology	Well-tolerated by the skin, no problems with waste water, air pollution, recycling of textiles
Using less chemicals	Soft hand through treatment in a tumbler or with enzymes and bionic finishes, with fluorocarbon polymers and dendrimers causing high fluorine efficiency by self organised layered structures
Smart textiles from chemical finishing	Temperature protection by coating with phase change materials (PCMs) foam, quicker healing/recovery of wounds by moisture regulation, release of drugs on demand by signals from the skin

effects such as peach skin and chamois surfaces. The metallisation of textiles with a thin film of, for example, Au, Ag, Cu and Zn, by high vacuum vaporisation provides new optical and electric effects, such as radiation protection, conductivity with antistatic properties and electric heating. These can be used for curtains and tapestries as well as for filters and heatable seats.

Another interesting new finish effect is self cleaning of a solid surface by special microstructures, similar to the lotus flower (see Section 19.10.1 for more about the lotus effect). This self cleaning is therefore called the lotus effect. It is based on the interaction of three components in different aggregate states, the solid, for example the finished nano-structured textile, a liquid such as water or soils and a gaseous component, usually air. If the last one is missing, as in permanent wetted systems, the lotus effect is impossible. This self cleaning finish has been achieved for exterior wall colours and for tiles. The application to textiles, for example sunblinds and other outdoor textiles, is a challenging subject of research and development.

## 19.4 Fewer undesirable side effects

Focusing on the desired main effects of the chemical finish can lead to the disadvantages and the negative side effects being overlooked. But where there is light, there is also shadow. So every kind of finishing has disadvantages and generates problems. Skilled finishers are aware of these problems and try to minimise them. A good example of such problems is the loss of strength associated with the crosslinking of cellulose during easy-care finishing. With dry crosslinking, the most commonly used procedure, a rule of thumb is that ten degrees of better crease recovery angle correspond to a 7 % loss of strength. The new continuous damp crosslinking process with controlled humidity does not follow this rule. It creates acceptable main effects and minimises the disadvantages.

## 19.5 Easier application

The demand for easy, almost simple, application of finishes has many roots: cost reduction by shorter production times and less complicated machinery, less energy and water consumption, easier or less expensive process control and automation, fewer possibilities to make mistakes and less skilled personnel. Examples of better application include new low curing fluorocarbon finishes based on special boosters with fixation temperatures near the normal drying temperature. These save not only energy, but are important for heat sensitive fibres like polypropylene. High fixation temperatures can cause dyestuff migration, colour changes or yellowing. Low fixation temperatures are also necessary and useful for after treating and garment finishing.

New catalysts that enable the fixation of finishes, for example flame retardants or easy-care finishes, in a broader range of parameters – like temperature, time and pH value – help to avoid mistakes and textile damage. A simple method of reducing the possibilities of production mistakes is the incorporation of catalysts and other compounds in the main product, with the positive side effect for the finish producer that no competitive products are used.

## 19.6 Microencapsulation, a new trend for storage and release of active finishing products

An interesting actual and probable future trend for finishing, characterised by a long lasting, slow continuous release and transfer of products to the human skin is filling microcapsules with active agents and fixing them on the surface of the fabric. A great variety of water- or oil-soluble compounds, such as fragrances, cosmetics, vitamins, and drugs are encapsulated in the biopolymer chitosan (see Fig. 15.5)<sup>1</sup>. Finishes are available with many different capsule ingredients, including products for wellness to wear, for example moisturising, relaxing and anti-cellulite or capsules filled with a hair growth inhibitor or a sun-tan inducer.

These finishes are applied in pad-dry or exhaust processes to almost all kinds of fibres, especially synthetics. Favoured articles include underwear, towels and bath mats that dispense body lotion, pantyhose that reduce cellulite, pyjamas and bed linen that ease neurodermitis, and shirts and other clothing that repel mosquitoes. The fixed chitosan capsules are described to be permanent for several cycles of hand or machine washing.

Microcapsules filled with phase change materials (PCMs) and incorporated in fibres during primary spinning or in foam coatings need a capsule that has a relatively stable and thick coat. But capsules that are engineered to release their ingredients have to fulfil a narrow compromise between stability to the application process, durability in domestic washing and the defined release. The active compounds are mainly delivered by friction of the finished textile against the skin. In the case of chitosan capsules there is already an additional release by biodegradation by natural skin enzymes and by change of the pH value. Chitosan membranes are insoluble at pH 6–7 but are slowly dissolved at the normal pH 4–5 of the skin.<sup>1</sup>

## 19.7 Greater permanence in washing and chemical cleaning

Many kinds of finishing compete in the marketplace with modified fibres, for example antistatic finishes and antistatic-modified fibres, flame-retardant finishes and fibres, antimicrobial finishes and fibres, soil-release finishes and fibres, anti-pilling finishes and fibres, soft hand finishes and silicone-modified fibres or microfibrils. The main advantage of these modified fibres compared to the corresponding finishes is their very high permanence in laundering, chemical cleaning and even mechanical stress. This permanence is the result of the incorporation of the finish chemicals during fibre production, mostly before primary spinning, so that they are equally distributed over the fibre cross-section. Exceptions are the anti-pilling-modified fibres that have less tear strength caused by structural loosening with comonomers and the silicone modifications that consist of a silicone film on the fibre surface similar to that achieved by fabric finishing with traditional silicone finishes.

Finish producers are aware of this advantage for the fibre makers. So permanence in laundering and chemical cleaning of many finishes has been improved in the last few years, mostly by chemical reaction with functional groups of the fibres, by crosslinking of the effect chemicals and by the formation of insoluble films on the fibre surface. Another principle is the solvation of the effect chemicals in the fibre, for example thermosolvation of flame retardants in polyester fibres. Even with this progress there remains in many but not in all cases a disadvantage with respect to permanence for the finished textiles compared to the modified fibres. Of course, there are also products where no or only little permanence is wanted, for example technical textiles that need no cleaning.

A principal advantage of finishing compared to the corresponding fibre modification is greater flexibility. Often only a part of a batch has to be finished according to the special wishes of the customers, other parts receive another or no finish. This meets the trend for lower cost production in a shorter time.

## 19.8 Easier care of the finished textiles

The interests of the consumer are becoming more and more important. Finished textiles with high performance should need no special care during their usage. Standard cleaning methods should be sufficient and these textiles should not be very sensitive to heat, light, sweat, soil, rubbing or ageing.

The first and best known example is the easy-care or permanent press finish that reduces ironing after the washing of cellulose textiles. Another established example is the soil-release finish that provides easier soil removal. A newer development is the laundry or line air dry fluorocarbon finish (LAD-FC). Special boosters enable high repellent effects after washing without ironing. This property is also important for water, oil- and soil-repellent finishes for special articles like bath and sport clothing, bags and luggage textiles.

## 19.9 Better ecology

Ecological demands vary greatly, depending on the region of the world, the corresponding awareness of the consumer and the financial and technical possibilities. But there is a general trend for the growing importance of ecological and economical demands and for their combination.

The three sectors of ecological importance to textiles are textile production, textile use and their disposal. In developed countries many regulations exist – from the viewpoint of producers there are often too many of them – for the safety of textile production and the corresponding products. The correct handling of finishing products is usually not a general problem. There is no need to use highly toxic chemicals, and problems related to these chemicals, especially with some early flame retardant and antimicrobial finishes, belong to the past. Ecological improvements are reached by using more careful synthetic routes to finishing products and by less energy consumption.

The second sector, the use of finished textiles, especially those in contact with human skin, has developed greatly with the advent of eco labels. Well known examples are limiting values for concentrations of free formaldehyde and the corresponding test methods in connection with easy-care finished textiles. Meanwhile, low formaldehyde finishes are standard and guaranteed by most producers. Novel and new developments include formaldehyde-free, easy-care finishes. Another example is provided by newer flame retardants for synthetic fibres, which do not contain antimony and halogen. The narrow path between high performance and safe ecology with antimicrobial finishes shows interesting results.

The third ecological sector, the disposal of textiles after their use, is probably the least developed. However, there are almost no problems caused by finishing, comparable to the other sectors. The ecologically best solution for used textiles and the textile waste from production is typically recycling. This depends on the fibre type and the chemical homogeneity of the textile. The content of finishing products in textiles that are to be disposed of is mostly as little as the amount of soil picked up during use. If the fibre recycling is based on a first hydrolysis step, as with polyester or polyamide, the purification steps for the recovered monomers are not affected by most finishing products. If the recycling is based on remelting and new melt spinning, as is the case with polypropylene, purification is more difficult or perhaps even impossible. The addition of larger amounts of fresh polymer helps maintain the quality level of the recycled fibre material. Textile waste from natural fibres can be composted. Most finishing products have only a small influence on this process, except cellulose that has been crosslinked with formaldehyde-containing finishes. Disposal by modern waste combustion plants is not adversely affected by finishes. Even the decomposition products of fluorocarbon polymers, mainly hydrogen fluoride, can be washed or filtered out.

## 19.10 Using fewer chemicals

Fewer chemicals are discussed here in the sense of smaller amounts of finishing products, combined with higher efficiency. Often large amounts of chemicals are necessary for sufficient effect, for example in flame retardants. This is then not only a cost problem for the product, but also a quality problem for the finished textile. Important textile properties such as hand, drape, as well as air and vapour permeability can be unfavourably changed by large amounts of finishing chemicals. Other problems include dusting and the development of chalky marks when scratched. The need for large amounts of finishing products can also lead to solubility problems in chemical baths and to non-uniform or insufficient liquor uptake, especially with hydrophobic synthetic fibres.

Therefore, finish producers are searching for products with greater efficiency so that high-performance effects can be achieved with smaller amounts of finishing products while leaving the textile character almost unchanged. This approach is true for water repellency finishes based on small amounts of fluorocarbons or silicones. Older repellents based on paraffins and modified melamines changed the textile character more. The use of a small amount of enzymes is another possibility to reduce the amounts of conventional chemicals, for example, for the anti-pilling finish.

### 19.10.1 Bionic finishes

Bionic finishes are a special way of using fewer chemicals for greater effects. As mentioned in Section 6.3.4 bionic means using examples from nature as an impetus

for a new technical design. It is the systematic transformation and use of successful biological constructions, processes and developments. The term biomimetics includes this technical mimicry of biological principles.

A good example to explain this impetus is the shark skin effect. The scales of predatory fishes have fine longitudinal grooves that cause less cross-flow in the displaced water. This principle has been adapted to aeroplane surfaces to help to reduce fuel consumption by 1 %. Similar shark skin swimsuit surfaces allow competitive swimmers to enjoy the advantages of lower resistance to movement through the water.

Another popular example of bionic finishes is the lotus effect. On the surface of the leaf of the lotus plant, fine knobs of wax are arranged in a nano structure providing self cleaning in combination with water drops and air.<sup>2</sup> This natural construction has been successfully adapted for the surfaces of walls, roof tiles and road signs. Current R & D (research and development) activities are being directed to applying this principle to textiles and resolving the issues of permanence versus handle. If these nano structures are created with soft waxes, they can be removed by mechanical stresses. If the structures are made harder, for example by pigments in a polymer film, the handle of the textile is changed. If these difficulties can be overcome with reasonably priced technical solutions, the textile adaptation of the lotus effect would combine super-repellency with self cleaning. Generation of these new special surface effects could be a good example for a future trend in textile finishing. An actual example of the use of bionic finishes is the repellent finish made with fluorocarbon polymers combined with dendrimers, as described in Section 6.3.4.<sup>3</sup>

The common principle of these examples and in general for all bionic finishes is a successful and almost intelligent construction of sophisticated structures, for example like the special surfaces or poly-layers in spider hair, insect wings, butterfly scales or porous bone material. This principle is that material, which is often self organised, is used in small amounts for great efficiency in specific regions and not used where it is less important.

Even though it is not the subject of finishing but of coloration, it is remarkable in this context that the beautifully coloured wings of butterflies inspired Japanese fibre chemists to produce multilayer bicomponent fibres with different interference colours without the use of any dyestuff or pigment.<sup>4</sup>

## 19.11 Smart textiles by chemical finishing

Smart textiles is an exaggerated but often used term. Can textiles really be smart or intelligent? Only in the sense that they react to changing conditions, for example temperature, light or moisture. This provides a greater effect than the well known protection function of textiles that leads to the term functional textiles.

Textiles that cool down when the ambient temperature rises or warm when the temperature drops are an interesting new development. This temperature buffer is

provided by incorporating phase change materials (PCM) into the textile. These are mostly paraffins with a melting point in the temperature range of interest, for example 20–30 °C. When the temperature of the surroundings rises above the range, the crystalline paraffins melt and their large heat of fusion cools the textile and its user temporarily. Conversely, when the temperature of the surroundings drops from above the range to below the range, the liquid paraffins crystallise and give up their high heat of crystallisation to warm the textile. The paraffins are placed into micro bubbles and then incorporated either into the fibres, mostly acrylic, or into a foam coating on the textile. The last solution has the advantage of higher thermal buffer capacity since more PCM can be incorporated and the insulation effects are greater and longer lasting.<sup>5</sup> This example is a good illustration of smart textiles or clothing, but foam coating is not a typical finish, even though there are some similarities. Adaptive camouflage with chameleon effects is also not a typical finish but is a matter of photochromic dyestuffs or pigments.

Reaction that is dependent on the changing moisture level of the surroundings is better suited to the subject of chemical finishes. Textile fibres have a wide range of moisture uptake, natural fibres such as cotton or wool have high moisture uptake, while synthetic fibres such as polyester or polypropylene have a very low uptake. Hydrophobic and hydrophilic finishes can change or enhance this behaviour. This is of interest for medical textiles that supply a moisture buffer for wounds. If the wounds become too dry, the finished textiles spend moisture, and in case of too much wound excretion, the textile absorbs it and the healing process is also shortened. A more sophisticated example is a medical textile with a sensor for moisture or temperature, that dispenses the medication on demand to the skin. The drugs are incorporated into micro bubbles or in a porous network formed by silicon dioxide nano particles through a sol–gel finishing or coating. Fixation of these drugs on to the textile surface and their release are challenging finish problems, since they involve the incorporation of chemicals into a thin film on the fibre surface that can respond to delivery signals over an extended period of time.

## 19.12 Summary and outlook

About 20 different types of chemical finishing have been described in this book. Most of them were developed to solve problems with unfinished textiles or to expand their usefulness. Examples of such problems are insufficient fabric hand, inadequate appearance after washing without ironing, high absorbency of water, oil and soil, flammability, and pilling, slipping or static problems during production and usage. It has been shown how these problems and restrictions can be solved and overcome with chemical finishing. New ideas and stimulation from finish producers result in the development of finishes that enable high performance and meet new challenges. Examples are odour changing finishes and smart textiles.

Finish producers and finish users meet two main challenges, first the stepwise

evolution of existing finishes (mainly cost reduction and greater efficiency) and then the search for new finishes, providing new usages – technical, functional and fashionable. Both the improved and the newly developed finishes are valuable tools that can project an enhanced image of the finish producers, demonstrating their R & D competence and creating a more competitive position, for themselves as well as for their customers, in the difficult world textile market.

## References

- 1 Hampe M, 'Die nächste Generation: Textilien mit Zusatznutzen', *Textilveredlung*, 2003, **38**(11/12), 14–16.
- 2 Barthlott W and Neinhuis C, 'Der Lotus-Effekt: Selbstreinigende Oberflächen nach dem Vorbild der Natur', *International Textile Bulletin*, 2001, **47**(1), 8–12.
- 3 Anonymous, *Melliand Textilberichte*, 2003, **84**(7/8), 604 and Rudolf-Info 8/2003 on Rucostar E<sup>3</sup>, Rudolf Chemie Geretsried/Germany.
- 4 Dempsey E, 'The third millennium: collaborative strategy will gain in influence', *International Textile Bulletin*, 1999, **45**(6), 12–18.
- 5 Rupp J, Boehringer A and Yonenaga A, 'High performance textiles or smart textiles? There's money in know-how', *International Textile Bulletin*, 2001, **47**(3), 6–24.

- 
- AATCC Testing Method 59, 68  
acid cellulases 185  
acrylic fibres 111  
algae 165  
alkali treatments 94  
ammonia treatments 70–1, 104–5, 146, 168  
amphoteric softeners 33  
anchor fibres 129  
    flex life 131  
anionic softeners 29, 32–3  
anti-odour finishes 189–92  
anti-oxidants 152  
anti-pilling finishes 52, 129–36  
    chemistry 132–3  
    mechanisms 132–3  
    testing and evaluation 133–4  
    troubleshooting 134–6  
antimicrobial finishes 165–74  
    biostats 167  
    bound antimicrobials 167, 169–71  
    chemistry 167–71  
    chitosan 170  
    chloramines 169–70  
    controlled release products 166, 167–9  
    fabrics treated 165–6  
    formaldehyde 167  
    mechanisms 166–7  
    PHMB 169  
    properties 166  
    testing and evaluation 171–2, 173  
    triclosan 168  
    troubleshooting 172–4  
antistatic finishes 121–8  
    chemistry 123–5  
    conductive fibres 125–6  
    durable finishes 124–5, 128  
    mechanisms 123  
    non-durable finishes 123–4  
    side effects 128  
    testing and evaluation 126–7  
    textiles treated 122  
    troubleshooting 127–8  
    wetting agents 128  
application methods 8–20, 200  
    easy-care and durable press finishes 64–7  
    insect resist finishes 178  
    non-slip finishes 118–19  
    to garments 20  
aromatic sulfonic acids 147–8  
Arrhenius equation 63  
ash test 126  
ATP (adenosine triphosphate) analysis 171  
  
bacteria 165  
batch processes 8  
bath remainder disposal 71  
beta gauges 49  
bio-finishes 181–7  
    cellulase enzyme action 183–4  
    chemistry 184–6  
    deactivation of cellulases 187  
    mechanical agitation 185, 186  
    pH buffers 187  
    testing and evaluation 186  
    troubleshooting 186–7  
bionic finishes 82, 203–4  
biostats 167  
black improvers 142  
bleaching 1  
bleeding 144  
blocked isocyanates 81  
blow ratio 17  
blue scales 144–5

- bound antimicrobials 167, 169–71
- Brønsted acids 64
- BTCA 62
- cantilever method 49
- carbonisation 1
- carboxy-based finishes 91
- carpets, charge generation test 127
- catalysts 63–4
- cationic products
  - colour fastness 146
  - softeners 29, 31–2
- cellulose 51–4
  - ammonia treatments 70–1
  - cellulase enzyme action 183–4, 187
  - colour fastness 145
  - flame-retardant finishes 103–7
  - regenerated cellulose 70
  - see also* bio-finishes; easy-care and durable press finishes
- ceramic fibres 111
- charge dissipation test 127
- charge generation test 127
- chemical cleaning 201–2
- chintz fabrics 51, 52
- chitosan 170
- chloramines 169–70
- chlorine retention 70
- chlorophenylid 178
- coating 23–6
- colour of fabrics 40–1, 90
- colour fastness 144–55
  - aromatic sulfonic acids 147–8
  - cationic products 146
  - cellulose fabrics 145
  - crocking fastness 153–5
  - formaldehyde concentration products 146–7
  - light fastness 144, 149–53
  - reactive fixation compounds 148–9
  - rubbing fastness 153–5
  - testing and evaluation 149, 152–3, 154
  - troubleshooting 149, 153, 154–5
  - wet fastness 144–9
  - see also* dyes
- combustion of textile fibres 98–9
- compatibility and combinability 2–3
  - easy-care and durable press finishes 67
  - flame-retardant finishes 116
  - non-slip finishes 118–19
  - repellent finishes 84
  - softening finishes 36–7
  - UV protection finishes 163
- concentration relationships 8–9, 27–8
- condensed phase strategy 100, 101, 102
- conduction drying methods 20–1
- conductive fibres 125–6
- continuous processes 8–9, 66–7
- controlled release antimicrobial products 166, 167–9
- convection drying methods 21
- cost-efficiency relationship 198
- counter finish 43
- crease recovery angle (CRA) 51, 53, 66
- critical application value (CAV) 12
- crocking fastness 153–5
- crosslinked hand builders 44
- crosslinking agents 62–3, 72
- curing 7–8, 21–3
- cyclodextrins 191–3
- deactivation of cellulases 187
- deeper colour impressions 40–1
- delay cure finishes 65
- denim processing 181
- deodorising textiles 189–92
- DHEU 57
- dieldrin 177
- digestive poisons 175–6, 177
- DMDHEU 57–9, 60, 64, 71, 91
- DMeDHEU 60–2
- dry finishing 1–2
- drying wet textiles 20–1
- dual-action fluorocarbons 85
- durable finishes 7
  - antistatic 124–5, 128
  - flame-retardant 105–7, 115
  - hand building 45–8
  - see also* easy-care and durable press finishes
- dust mites 175, 179
- dyes
  - fixation 52
  - reactive dye hydrolysates 145
  - softeners and thermomigration of 39–40
  - vat dyestuffs 153
  - see also* colour fastness

- easy-care and durable press finishes 51–72, 202
  - application methods 64–7
  - catalysts 63–4
  - compatibility 67
  - crosslinking agents 62–3, 72
  - fabrics treated 54
  - formaldehyde products 55–60, 67–8
  - non-formaldehyde products 60–2
  - testing and evaluation 67–9
  - troubleshooting 69–72
- ecological demands 202–3
- efficiency-cost relationship 198
- elastomeric finishes 138–42
  - chemistry 139–41
  - mechanism 139
  - testing and evaluation 141–2
  - textiles treated 138–9
  - troubleshooting 142
- electrical discharge 121–2
- electrical resistivity of fabrics 126
- emulsion stability 2, 39
- energy, low energy surfaces 75
- engraved rolls 15
- enzyme treatments *see* bio finishes
- ethoxy based finishes 92–3
- ethoxylated softeners 34
- evaluation *see* testing and evaluation
- exhaust applied finishes 7, 20
  
- fabric and yarn construction 89–90
- fading *see* light fastness
- FAST (Fabric Assurance by Simple Testing) system 39
- fastness *see* colour fastness
- fibre production 4
- fibre surface modifying finishes 193–6
- finishing product groups 4–6
- firmness 43
- flame-retardant finishes 98–116
  - for acrylic fibres 111
  - for cellulose 103–7
  - for ceramic fibres 111
  - chemistry 102–3
  - combustion of textile fibres 98–9
  - compatibility and combinability 116
  - condensed phase strategy 100, 101, 102
  - durable 105–7, 115
  - fabrics treated 98
  - for fibre blends 111–12
  - gas phase strategy 101, 102
  - for glass fibres 111
  - heat sinks 99–100
  - insulation of fibres 100
  - intumescents 112
  - for *m*-aramid fibres 111
  - mechanisms 98–102
  - non-durable 104–5
  - for nylon 110
  - for polyester 109–10
  - for polypropylene 111
  - pyrolysis reaction 100
  - for rayon 108
  - requirements 98
  - side effects 115
  - testing and evaluation 112–14
  - toxicity of components 115
  - troubleshooting 115–16
  - for wool 108
- flex life 131
- fluorine-based finishes 94
- fluorocarbons
  - dual-action 85
  - repellent finishes 75, 79–83, 85
- foam application methods 16–19
- formaldehyde products
  - antimicrobial finishes 167
  - colour fastness 146–7
  - easy-care and durable press finishes 55–60, 67–8
  - melamine-formaldehyde (M/F) 57, 64
  - urea-formaldehyde (U/F) 55–7, 64
- fragrance finishes 192–3
- friction 122
- fullness 43, 44
- fungi 165, 183
  
- gas phase strategy 101, 102
- glass fibres 111
- glucose production 183
  
- hand building finishes 43–50
  - crosslinked hand builders 44
  - durable 45–8
  - evaluation and testing 48–50
  - fabrics treated 44
  - non-durable 44–5

- troubleshooting 50
- hand of fabrics 38–9
- hand knitted look 52
- Handle-O-Meter 38
- HBCD 110
- heat sinks 99–100
- heat transfer mechanisms 20–1
- hindered amine light stabilisers (HALS) 152
- hindered phenol light stabilisers (HPLS) 152
- HLB (hydrophilic-lipophilic balance) 91
- hot flue 66
- hydroxy-based finishes 91–2
- hygroscopic antistatic finishes 123
  
- induced-fit theory 181
- inorganic oxide films 194–6
- insect resist finishes 175–9
  - application 178
  - chemistry 177
  - dust mites 179
  - mechanisms 175–7
  - poisons 175–6, 177
  - testing and evaluation 178
  - troubleshooting 178–9
- insulation of fibres 100
- intumescants 112
  
- Jacquard fabrics 117–18
  
- keratin-digesting pests 175
- KES-F (Kawabata Evaluation System-Fabrics) 38–9
- kiss rolls 13, 14–15
- knife over roll system 25
  
- laminating 23–6
- levoglucosan 103–4
- Lewis acid salts 63–4
- light fastness 144, 149–53
- limiting oxygen index (LOI) 114
- line air dry fluorocarbon finish (LADFC) 202
- lock and key theory 181
- loop transfer system 14
- lotus effect 199, 204
- low energy surfaces 75
- low wet pickup methods 11–20
  
- m*-aramid fibres 111
- Machnozzle systems 13
- Martindale Pilling Tester 134, 135
- mechanical agitation 185, 186
- mechanical finishing 1–2
- medical textiles 205
- melamine–formaldehyde (M/F) products 57, 64
- metallisation of textiles 199
- microbes *see* antimicrobial finishes
- microencapsulation 200–1
- mite protection *see* insect resist finishes
- modified polyurethanes 47–8
- moisture buffer 205
- moisture control 66
- moisture transport testing 96
- moths 175
  
- nerve poisons 175–6, 177
- nitrogen, organic nitrogen 102–3
- non-durable finishes
  - antistatic 123–4
  - flame-retardant 104–5
  - hand building 44–5
- non-ionic softeners 31, 33–4
- non-polymer soil release treatments 94
- non-slip finishes 117–20
  - application methods 118–19
  - chemistry 118
  - combinability 118–19
  - mechanisms 118
  - testing and evaluation 119
  - troubleshooting 120
- novel finishes 189
- Nu-Martindale Pilling Tester 134, 135
- nylon 110
  
- odour *see* anti-odour finishes
- oil repellent finishes *see* repellent finishes
- oily soils 89
  - release testing 96
- optical brightening agents (OBA) 163
- organic nitrogen 102–3
- oxide films 194–6
  
- pad applications 9–11, 64–7
  - dry fabric 9–10
  - wet fabric 10–11

- paraffin repellents 76
- paraffin softeners 33–4
- permanence in washing 201
- permethrin 177
- pH buffers 187
- phase change materials (PCMs) 201, 205
- PHMB 169
- pigments 52
- pile resilience 52
- pilling 129–32
  - see also* anti-pilling finishes
- plasma treatments 94, 193–4
- poisons 175–6, 177
- polyammonium compounds 146
- polydimethylsiloxane products 77
- polyester
  - electrical discharge 121–2
  - flame-retardant finishes 109–10
- polyethylene softeners 33–4
- polypropylene fibres 111
- polyvinyl alcohol (PVA) 44–5
- post cure finishes 65
- predrying 21
- primary effects of finishes 3
- Proban process 106
- processes 7–2
  - application of finishes 8–20, 64–7
  - batch processes 8
  - coating 23–6
  - concentration relationships 8–9, 27–8
  - continuous processes 8–9, 66–7
  - curing 7–8, 21–3
  - drying wet textiles 20–1
  - laminating 23–6
  - low wet pickup methods 11–20
  - pad applications 9–11, 64–7
  - wet-on-dry processes 9–10
  - wet-on-wet processes 10–11
- pyrolysis reaction 100
  
- quaternary ammonium compounds 146, 168
  
- radiant heaters 21
- radiation pyrometers 23
- radiation technologies 193–4
- random tumble pilling tester 133–4, 135
- rayon 108
- reactive dye hydrolysates 145
- reactive fixation compounds 148–9
- reactive softeners 39
- recipe formulation 4
  - see also* compatibility and combinability
- recycling 203
- regenerated cellulose 70
- relative odour index (ROI) 193
- repellent finishes 74–85
  - compatibility and combinability 84
  - fluorocarbon-based repellents 79–83, 85
  - mechanisms 75
  - paraffin repellents 76
  - silicone water repellents 77
  - stearic acid-melamine repellents 77
  - testing and evaluation 83, 84
  - textiles treated 74–5
  - troubleshooting 84–5
- roll transfer techniques *see* transfer rolls
- rubbing fastness 153–5
  
- secondary effects of finishes 3
- self-cleaning 199
- shake box 134, 135
- shark skin effect 204
- shock-condensation processes 23, 65
- shrink resistance 52
- side effects 200
  - antistatic finishes 128
  - flame-retardant finishes 115
- silicon oxide network 195
- silicone softeners 34–6
- silicone water repellents 77
- slip-proofing *see* non-slip finishes
- slow continuous release products 200–1
- smart textiles 204–5
- SMOG 193
- softening finishes 4, 29–41
  - amphoteric 33
  - anionic 29, 32–3
  - cationic 29, 31–2
  - comparison of 36, 37
  - compatibility and combinability 36–7
  - deeper colour impressions 40–1
  - ethoxylated 34
  - fabrics treated 31
  - mechanical softening 40
  - mechanisms of 29–31

- molecular structure 31
- non-ionic 31, 33–4
- reactive 39
- silicone 34–6
- testing and evaluation 38–9
- troubleshooting 39–41
- volatile components 40
- software programs 4
- soil reposition testing 96
- soil-release finishes 87–96
  - carboxy-based 91
  - colour of fabrics 90
  - ethoxy-based 92–3
  - fabric and yarn construction 89–90
  - fabrics treated 87
  - fluorine-based 94
  - hydroxy-based 91–2
  - mechanisms 87–90
  - non-polymer 94
  - oily soils 89
  - testing and evaluation 95–6
  - troubleshooting 96
- sol-gel finishes 194–6
- solar protection factor 157–9
- solar radiation 157
- sols 118
- spin finishes 122
- spray test 84
- spraying 15–16
- stain repellency 84–5
- static electricity *see* antistatic finishes
- Static Voltmeter 127
- stearic acid-melamine repellents 77
- stiffness 43, 44, 49
- strength loss factors (SLF) 66–7
- sulfonates 32
- surface modifying finishes 193–6
- surface resistivity of fabrics 126
- syntans 147–8
  
- TBPA 108
- temperature buffer 204–5
- testing and evaluation
  - AATCC Testing Method 59, 68
  - anti-odour finishes 193
  - anti-pilling finishes 133–4
  - antimicrobial finishes 171–2, 173
  - antistatic finishes 126–7
  - ash test 126
  - bio-finishes 186
  - charge dissipation test 127
  - charge generation test 127
  - crocking fastness 154
  - easy-care and durable press finishes 67–9
  - elastomeric finishes 141–2
  - electrical resistivity of fabrics 126
  - flame-retardant finishes 112–14
  - fragrance finishes 193
  - hand building finishes 48–50
  - insect resist finishes 178
  - light fastness 152–3
  - moisture transport testing 96
  - non-slip finishes 119
  - oily soil-release testing 96
  - repellent finishes 83, 84
  - rubbing fastness 154
  - softening finishes 38–9
  - soil reposition testing 96
  - soil-release finishes 95–6
  - spray test 84
  - surface resistivity of fabrics 126
  - UV protection finishes 162–3
  - water drop test 84
  - wet fastness 149
- TEXPERTO 4
- thermosetting polymers 47
- THP-based finishes 105–6
- toxicity 115
- transfer rolls 13–15
- Triatex MA machine 14–15
- triboelectrification 121
- triclosan 168
- Tris products 109
- troubleshooting
  - anti-pilling finishes 134–6
  - antimicrobial finishes 172–4
  - antistatic finishes 127–8
  - bio-finishes 186–7
  - crocking fastness 154–5
  - easy-care and durable press finishes 69–72
  - elastomeric finishes 142
  - flame-retardant finishes 115–16
  - hand building finishes 50
  - insect resist finishes 178–9
  - light fastness 153
  - non-slip finishes 120

- repellent finishes 84–5
- rubbing fastness 154–5
- softening finishes 39–41
- soil-release finishes 96
- UV protection finishes 163
- wet fastness 149
  
- umbrella fabrics 117
- urea–formaldehyde (U/F) products 55–7, 64
- UV protection finishes 157–63, 194
  - chemistry 160–2
  - combinability 163
  - fabrics treated 158
  - mechanism 158–60
  - solar protection factor 157–9
  - testing and evaluation 162–3
  - troubleshooting 163
  - UV radiation skin damage 157
  - see also* light fastness
  
- vacuum extraction systems 12–13
- vat dyestuffs 153
- vinyl acetate-containing polymers 46
  
- volatile components 40
  
- washing permanence 201
- water drop test 84
- water use 12
- waterproofing *see* repellent finishes
- wellness finishes 196, 198
- wet fastness 144–9
- wet finishing 1–2, 7
- wet pickup 9–10
  - low wet pickup methods 11–20
- wet-on-dry processes 9–10
- wet-on-wet processes 10–11
- wetting agents 128
- wool
  - electrical discharge 121–2
  - flame-retardant finishes 108
- wrinkle resistance 52–3
  
- yarns 24, 89–90
- yellowing 40
  
- zirconium compounds 108
- Zirpo process 108