

Training and Further Education in Automotive Engineering

Practical Automotive Laboratory
Instruction and Diagnostics

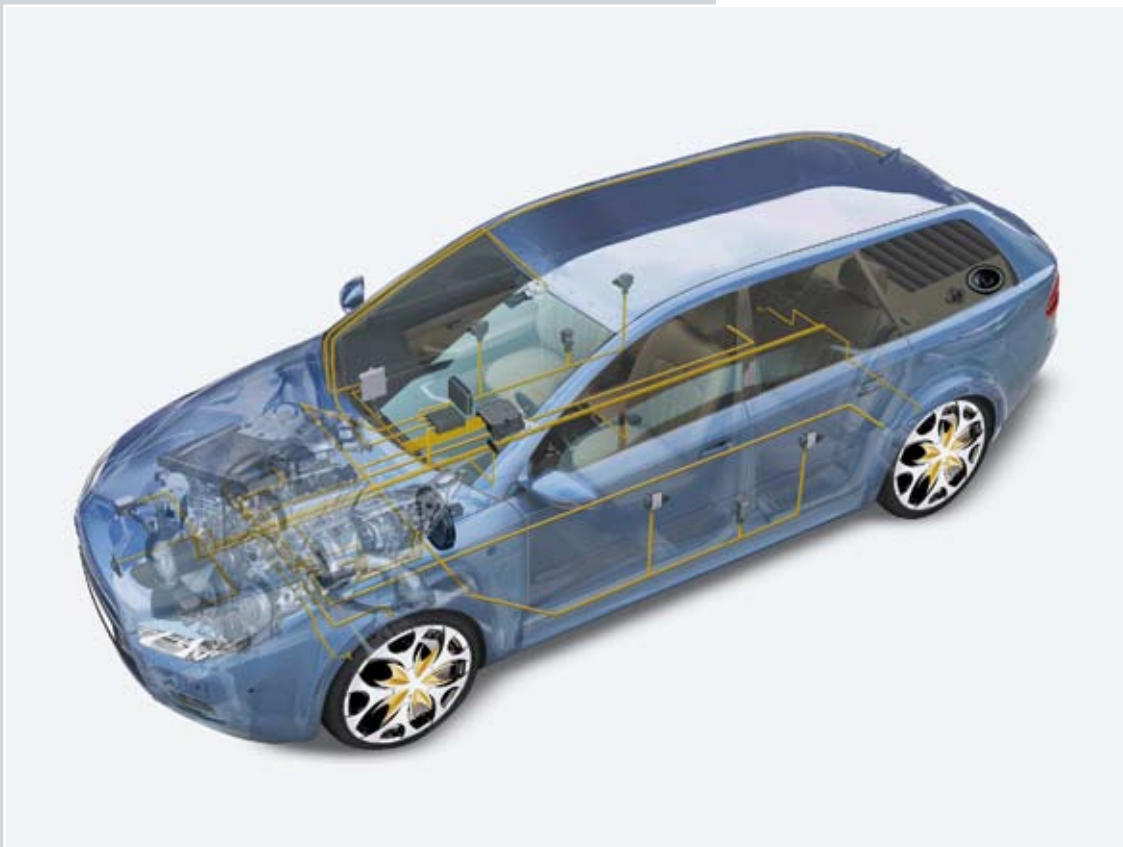

2nd Edition

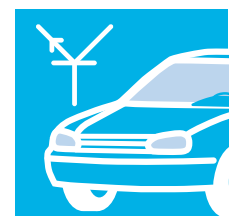

Contents

Qualifications Through Quality	
Training Systems for Automotive Engineering	4
Different Systems to Suit Different Needs	
UniTrain-I	6
Connect®	8
Plug-in System	10
Compact System	12
Training Panel Systems	13
Training Vehicles	14
The Entire Program at a Glance	16
More than a Training System	
A Complete System Comprising a Diagnostic Workshop Lab for Automotive Engineering	18
Animated Presentation of Complex Training Contents	
Project-oriented Training Media – Adaptable to any Training System	20



Contents

Electrics / Electronics	22-33
DC and AC Technology in Motor Vehicles	
Three-phase Generator	
Pulse-width Modulated Signals	
Sensors and Actuators	34-39
Automotive Sensors	
Engine Management Sensors	
Vehicle Lighting	40-49
Lighting and Signalling Systems	
CAN Bus Extension	
Dashboard Training Model Incorporating CAN and LIN Buses	
Comfort Systems	50-57
GPS Navigation	
Alarm System and Immobilizer	
Air-conditioning and Climate Control	
Alternative Drives	58-65
Hybrid Automotive Drive	
Fuel Cells	
Photovoltaics	
Engine Management	66-83
Ignition Systems	
Diesel Engine Management Systems	
Spark-ignition Engine Management Systems	
Vehicle Diagnosis	84-97
On-board Diagnosis II	
Auto Diagnosis Trainer Software	
Automobile Diagnosis Units	
Chassis and Driving Safety	98-111
Brake Power Control ABS/ASR/ESP	
Hydraulic Brake System	
Airbag and Seat-belt Tensioner	
Networked Systems	112-119
LIN Bus	
CAN Bus	
MOST Bus	
Practical Automotive Workshop Lab	120-133
Exhaust Gas Analysis and EOBD Data Readout	
Axle Measurement	
Tool Kits	
Topics	

Qualifications Through Quality

Training Systems for Automotive Engineering

Advances in technology ...

Unusual concepts and rapid innovations in the development of automotive systems – these are the challenges of today. Unique driving culture afforded by a blend of excellent comfort and superior agility place the highest demands on industry and trade. Automotive electronics in general has turned into one of the most innovative areas here.



... are having a huge impact on training and education.

A host of patents and new technologies viewed as milestones in automotive technology make new training systems necessary. Advances in safety optimization, intelligent drive systems and integration of mobile communications are just a few examples of the changes occurring in this profession. The enormous demands placed on automotive trainees today involve correspondingly modern and practical hands-on systems of instruction. One of the most important training objectives is to enable students to work independently in a professional manner.

Practical competence is a key qualification

Greater work satisfaction and independence acquired early on during the training phase are not just coincidences, but the results of purposeful instruction using Lucas-Nülle's training and educational systems. All training topics are fully covered, from the fundamentals of automotive electrics through lighting and comfort systems to vehicle diagnosis and automotive experiments in the practical automotive workshop laboratory. Our modular and scalable training systems provide an innovative and future-proof platform for first-rate, in-depth theoretical and practical training in automotive engineering.

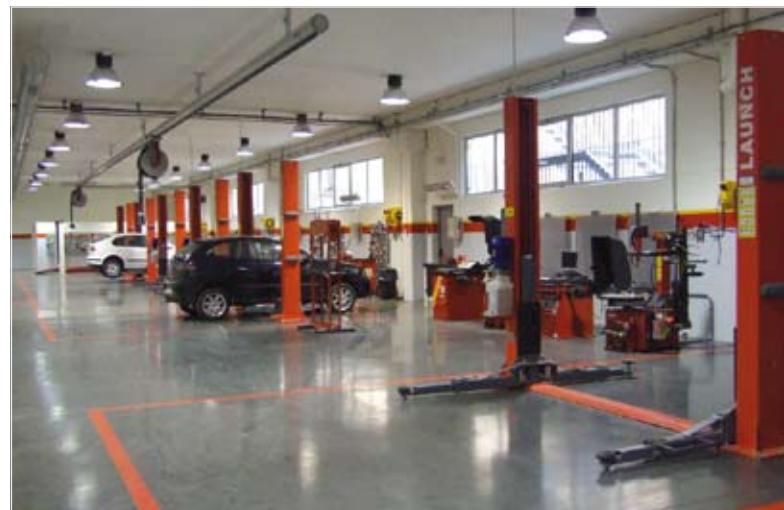

Different Systems to Suit Different Needs

UniTrain-I – a Multimedia Laboratory with over 100 Courses

With the UniTrain-I multimedia experiment and training system, students are guided through the experiments by means of clearly structured course software including texts, graphics, animations and knowledge tests. In addition to the training software, each course comes with an experiment card for performing practical exercises. Courses such as those on the fundamentals of electrical engineering, automotive sensors and ignition systems convey the knowledge and skills needed to understand, connect, diagnose and operate modern automotive systems. Animations and numerous experiments on authentic systems found in the various courses impart the fundamentals, principles and attributes of electrical, safety, lighting and engine-management equipment.



Your benefits

- Theory and practice all in one
- PC and new media for high levels of student motivation
- Quick success through structured courses
- Animated theory for quick understanding
- Practical competence through independent experimentation
- Constant feedback through quizzes and knowledge tests
- Guided trouble shooting with an integrated fault simulator
- Protection of low voltages ensuring safe operation
- Large selection of courses (covering more than 100 subjects)
- Sample solutions for teachers and students



UniTrain-I system

- Comprehensive, portable laboratory
- Multimedia courses
- High-tech measurement and control interface
- Theory and practice all in one package



UniTrain-I interface with USB

- Oscilloscope with 2 analogue differential inputs
- Sampling rate of 40 Msamples/s
- 9 measuring ranges from 100 mV - 50 V
- 22 time ranges from 1 μ s - 10 s
- 16 digital inputs / outputs
- Function generator for frequencies up to 1 MHz
- 8 relays for fault simulation



UniTrain-I experimenter

- Holds experiment cards
- Experiment power supply of ± 15 V, 400 mA
- Experiment power supply of 5 V, 1 A
- Variable direct or three-phase current, 0 - 20 V, 1 A
- IrDa interface for multimeters
- Serial interface for additional experiment cards



Integrated measuring equipment and power supplies

- Multimeters, ammeters, voltmeters
- Dual-channel storage oscilloscope
- Function and waveform generator
- Three-fold DC power supply
- Three-phase power supply
- ... and many other instruments

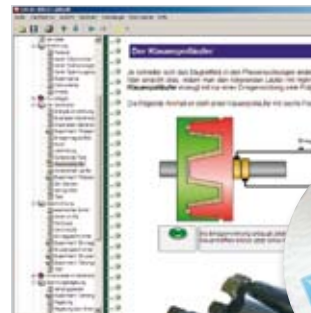

LabSoft training and experiment software

- Large selection of courses
- Comprehensive theory
- Animations
- Interactive experiments with instructions
- Free navigation
- Documentation of measurement results
- Knowledge test

Different Systems to Suit Different Needs

Connect® Multimedia Training System with Original Components

The Connect® system consists of a series of A4-format panels with original components from corresponding engine management systems. A multimedia program provides helpful information on the individual components and overall systems. All components are described in detail in the software. Functions are elucidated by videos and animations. Due to the equipment's modular nature, a variety of injection systems can be realized simply by interchanging individual components.

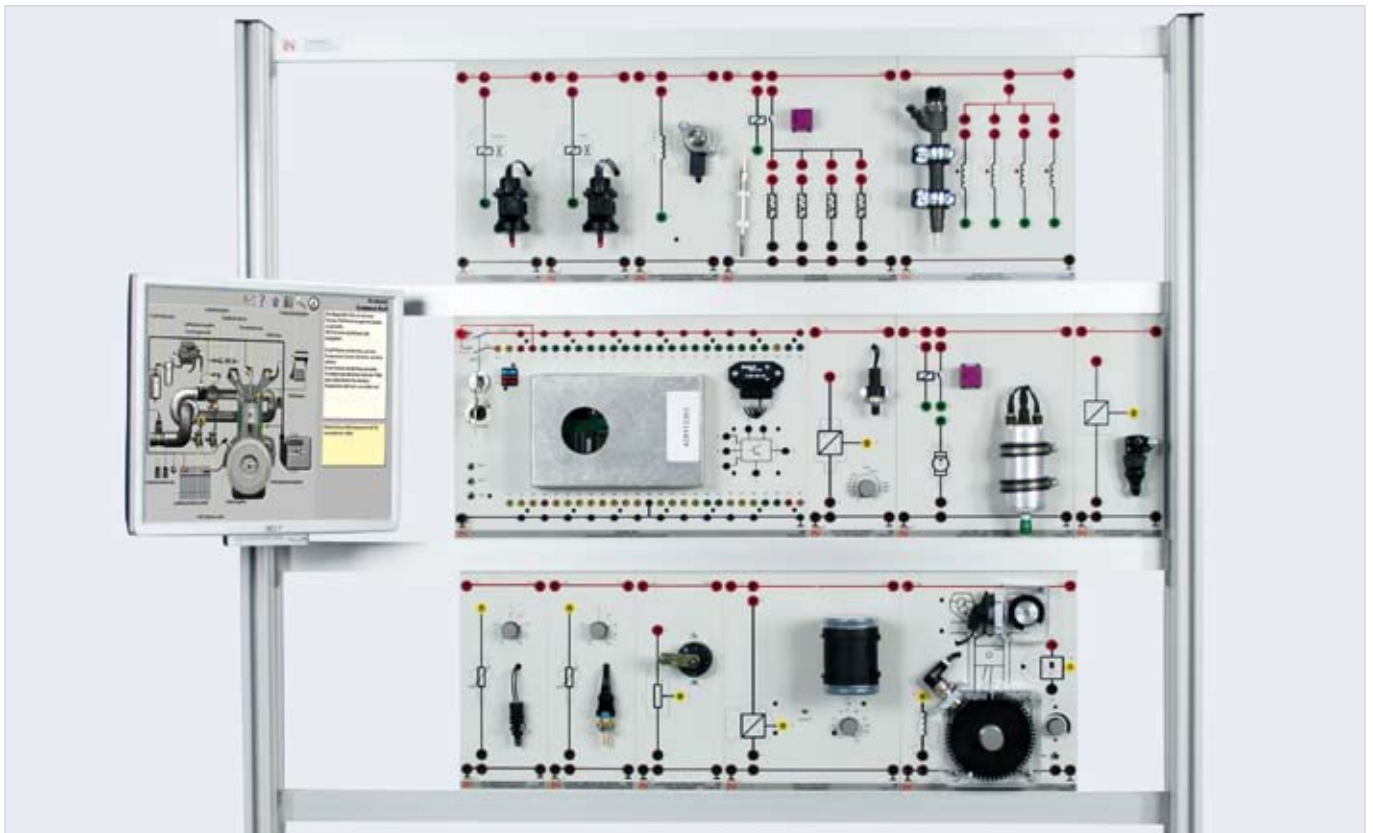

Your benefits

- Original automotive components provide an ideal blend of theory and practice
- Easy to use

Suitable for basic as well as specialized training:

- Storage of solutions, option of transferring solutions to other Connect® systems
- Universal use in workshops and classrooms
- Quick checks of acquired skills
- Maximum operational safety
- Future-oriented learning

CBT software features

- Instructions for use
- Detailed representations
- Result monitoring and analysis for the trainer
- Hardware layout and wiring diagrams
- Problems and questions for trainees
- Technical documentation
- Videos
- Animations

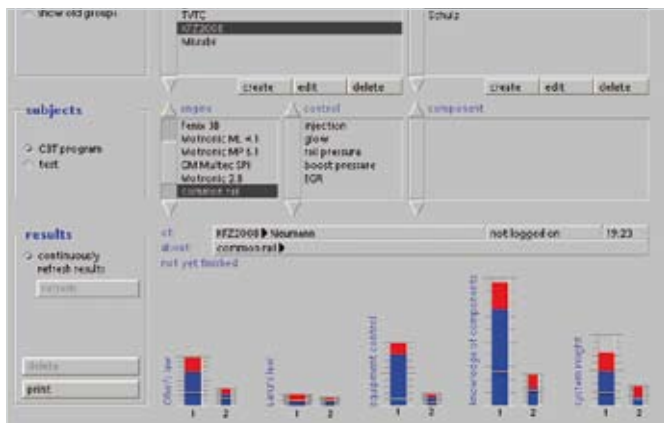

Connect® is suitable for:

- Demonstrations
- Practical laboratory work
- Independent studies
- Group work



Topics

- Fundamentals
- Special skills
- Measurement of electrical variables
- Sensors and actuators
- Engine management systems
- Ignition systems
- Conversion from mechanical to electrical variables

Multimedia support

- Multimedia presentations of component functionality
- Efficient independent learning
- Self-explanatory user interface
- Simple program resumption after interruption

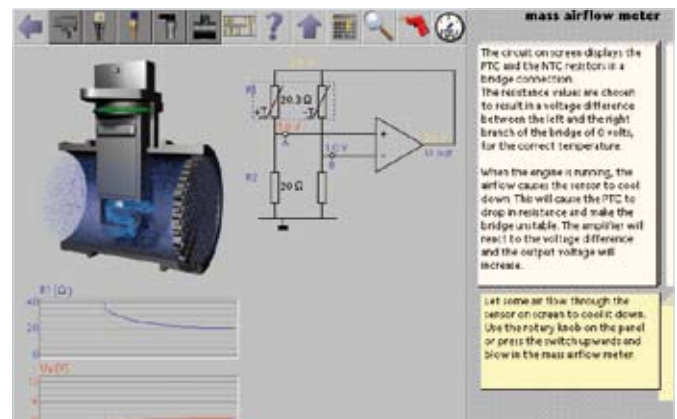
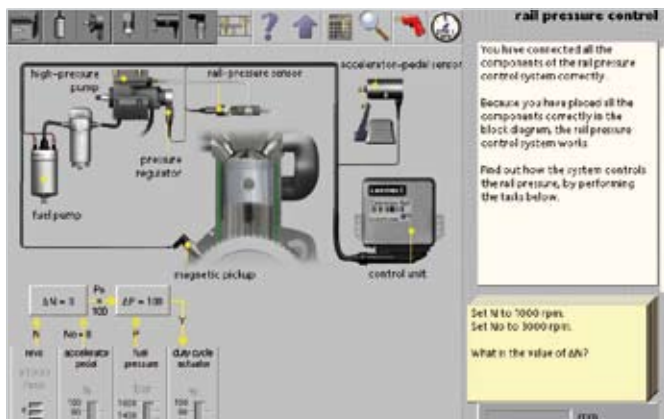

Different Systems to Suit Different Needs

Plug-in System – a Classic for Students' Exercises

Sound training in the fundamentals of electrical engineering is a prerequisite for understanding the complex relationships between various automotive applications. Our classic, modular plug-in system is meant for thorough and practical training in electrical engineering and electronics. Particularly suitable for students' exercises, experimentation and familiarization, this robust system permits a true reproduction of circuit diagrams in experiment configurations.



Your benefits

- Gold-plated contacts
- Extremely practical approach
- Students' exercises tailored specially to automotive engineering
- 1:1 mapping of circuit diagrams on the rastered plug-in board
- Exploring complex relationships through experimentation
- Universal applications
- Robust components
- High degree of transparency

Universal power supply

- A single device for all experiments
- Direct and alternating voltage
- Three-phase current source and function generator
- Voltages are adjustable, controllable and short-circuit proof

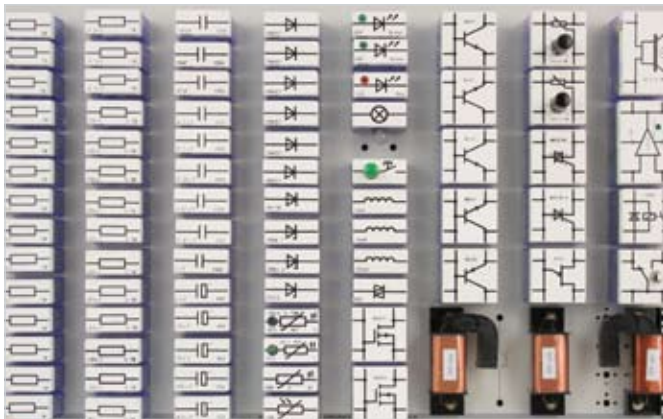

Compact and fast

- Versatile deployment
- Integrated power supply
- Integrated function generator and DC/AC source
- Plug-in components can be stored securely in the lid



Versatility

The same board can be used in the following variants:

- Desktop device
- Portable device in a component storage case
- Experiment panel mounting frame for demonstration purposes

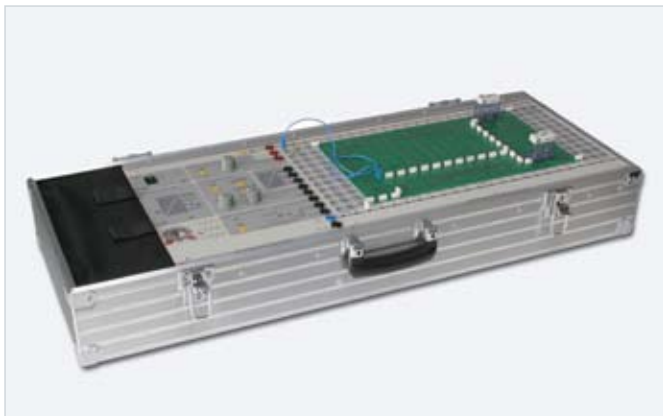

Experiments with overlay masks

- Experiments tailored specially to automotive applications
- Simple approach to teaching fundamentals using practical hands-on experiments
- Integrated automotive-type ground connection via the chassis

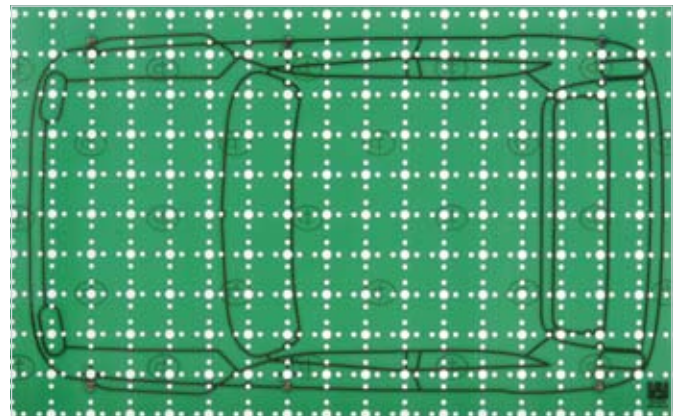

Different Systems to Suit Different Needs

Compact – Ready for Immediate Use

The compact system provides function groups comprising all relevant components configured for the purpose of instruction. All components needed to operate the system are clearly arranged on a large housing panel. The components are original vehicle parts prepared in such a way that they can be put to use quickly and easily.



Your benefits

- Practical, hands-on training using original vehicle parts
- All components are fully functional
- Complex systems are clearly depicted
- All necessary components have been configured for the purpose of instruction
- Easy and quick to set up and put into operation

Training Panel Systems – a Modular System

Whether for conventional classroom instruction or practical experiments, this system of panels permits a variety of teaching methods to be implemented. The experiment panels have an identical height of 297 mm (A4 format). Each panel's front indicates the symbol associated with that particular device or circuit according to latest DIN specifications. Wherever possible and appropriate, the print on the front side is complemented by colour graphics or photos. For a better educational overview, the voltage supply bus is highlighted at the panel's top and bottom edges in colour according to DIN72551.

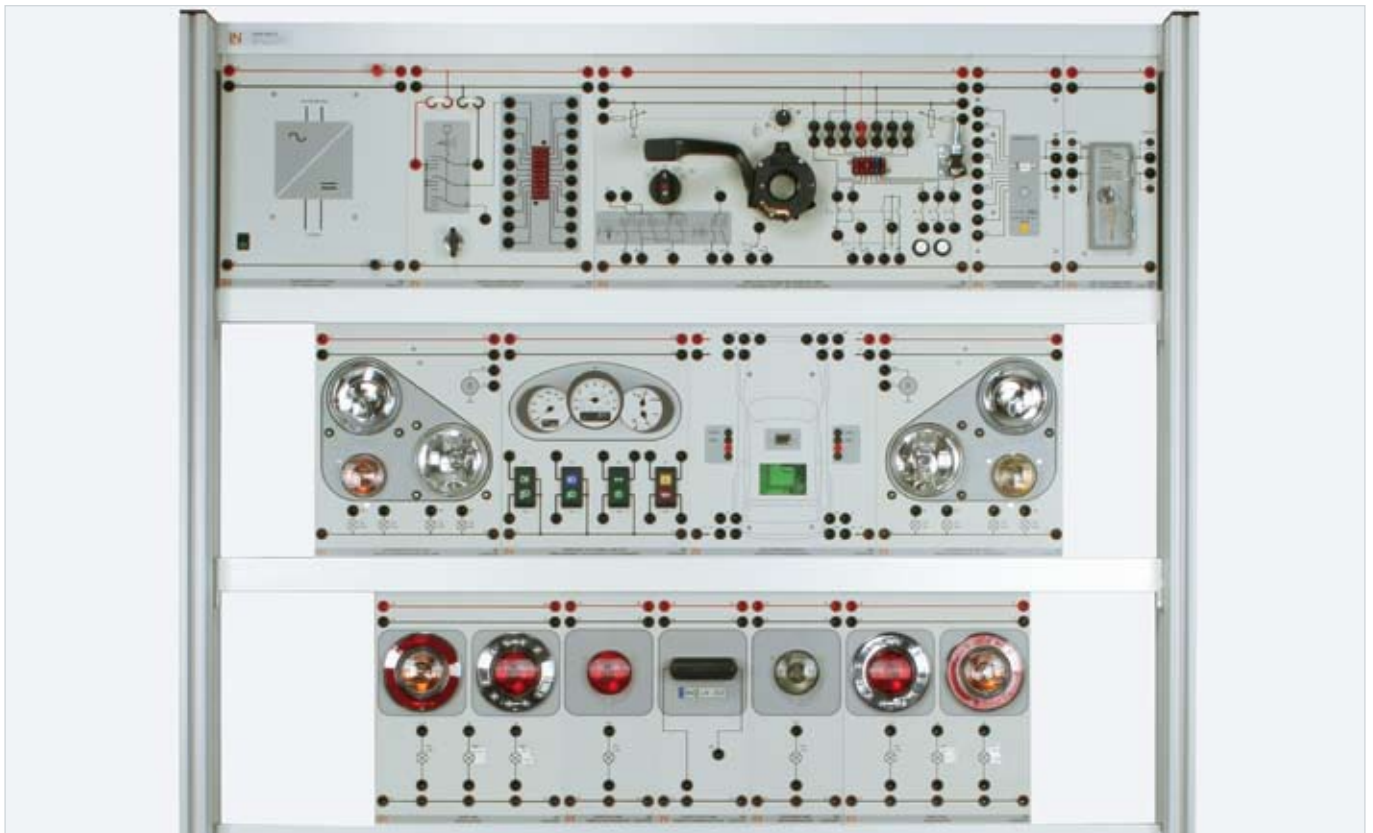

Your benefits

- Modular design for versatility and flexibility
- Suitable for students' exercises and demonstrations
- Safety through dual insulation (safety sockets and leads)
- Practical training using original vehicle parts
- Clear layout with the help of high-contrast, scratch-proof print on the front panel
- Modern measurement technology with PC interface
- Experiment and technical handbooks in colour
- Students' worksheets and sample solutions

Different Systems to Suit Different Needs

Training Vehicles – a Practical Form of Education

To make training as practical as possible, LN training vehicles are modified specifically for educational purposes. Accordingly, all major components are made accessible to allow direct measurements of sensor and actuator signals. To emulate typical workshop situations, malfunctions can be activated via a hidden fault simulation box.



Your benefits

- Practical, hands-on training using original vehicle parts
- All components fully functional
- Self-diagnosis and acquisition of operational data
- Fault simulation
- Direct measurements without a need to dismantle the vehicle
- Measurements of all systems possible while the engine runs
- Investigation of electrical and mechanical components

The Entire System at a Glance

Solutions for Automotive Training

Electrics / Electronics

UniTrain-I

- Basics of electrical engineering
- Basics of electronics and digital technology
- Pulse-width modulated signals
- Three-phase generator

Plug-in system

- Basics of electrical engineering
- Automotive electrics and electronics
- Semiconductor components

Sensors and Actuators

UniTrain-I

- Automotive sensors

Compact system

- Sensor technology in engine management

Vehicle Lighting

Panel system

- Headlights with range adjustment
- Auxiliary lights
- Trailer lights
- Acoustic signals
- Static cornering light

Compact system

- Dashboard training stand

Comfort Systems

Panel system

- Alarm system and immobilizer
- Check control

Compact system

- "Climatronic" air-conditioning
- GPS

Alternative Drives

UniTrain-I

- Hybrid automotive drive
- Photovoltaics
- Fuel cells

Compact system

- Hybrid sectional model (Toyota Prius)



Chassis and Driving Safety

UniTrain-I

- Airbag and belt tensioner
- Brake systems
- Transmission system technology
- Chassis technology
- Steering systems

Compact system

- SRS airbag and seat-belt tensioner
- Hydraulic brake systems
- ABS
- ABS and ASR

Networked Systems

UniTrain-I

- LIN bus
- CAN bus
- Waveguides / MOST bus

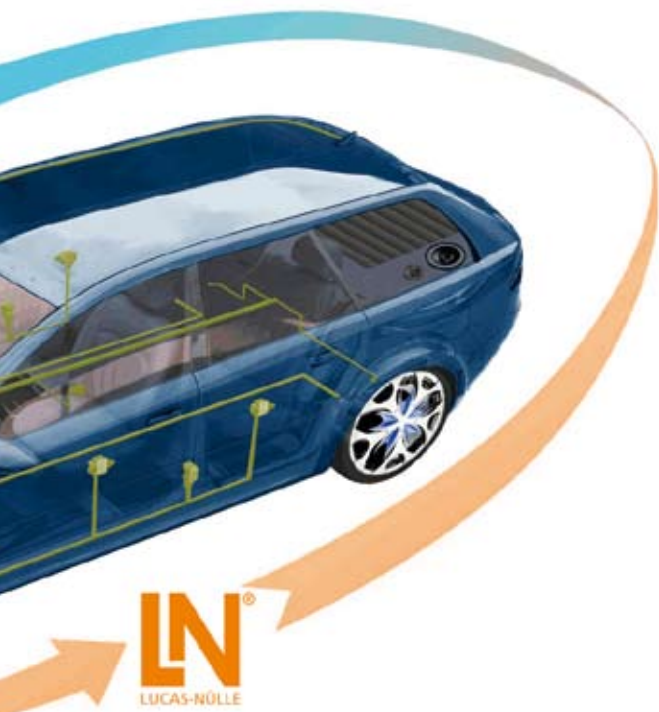

Vehicle Diagnosis

Panel system

- On-board diagnosis II

Software

- Automobile diagnosis trainer

Compact system

- On-board diagnosis II – data recorder
- Automobile diagnosis case
- Diagnosis unit with an oscilloscope
- Common rail diagnosis set

Practical Lab

Compact system

- Exhaust gas analysis and EOBD data readout
- Tyre fitting machine
- Balancing machine
- Axle measurement
- Hydraulic lifting platform
- Fully automatic air-conditioning service unit
- Motor vehicle tool kit

Engine Management

UniTrain-I

- Automotive ignition systems
- Common rail

Connect®

- Motronic 2.8
- Common rail
- Direct petrol injection
- Performance tuning at an engine test bench

Compact system

- Common rail
- Electronic diesel control (EDC)
- Motronic ML 4.1
- L-Jetronic
- D-Jetronic
- KE-Jetronic

Functional engine

- Fuel injection engine
- Pump injector (TDI)
- Common rail

More than a Training System

A Complete System Comprising a Diagnostic Workshop Lab for Automotive Engineering

Lucid presentations of complex concepts with modern educational media

Complete solutions for modern engine management, brake, climate control and airbag systems

Multimedia-based knowledge transfer using the UniTrain-I and panel systems

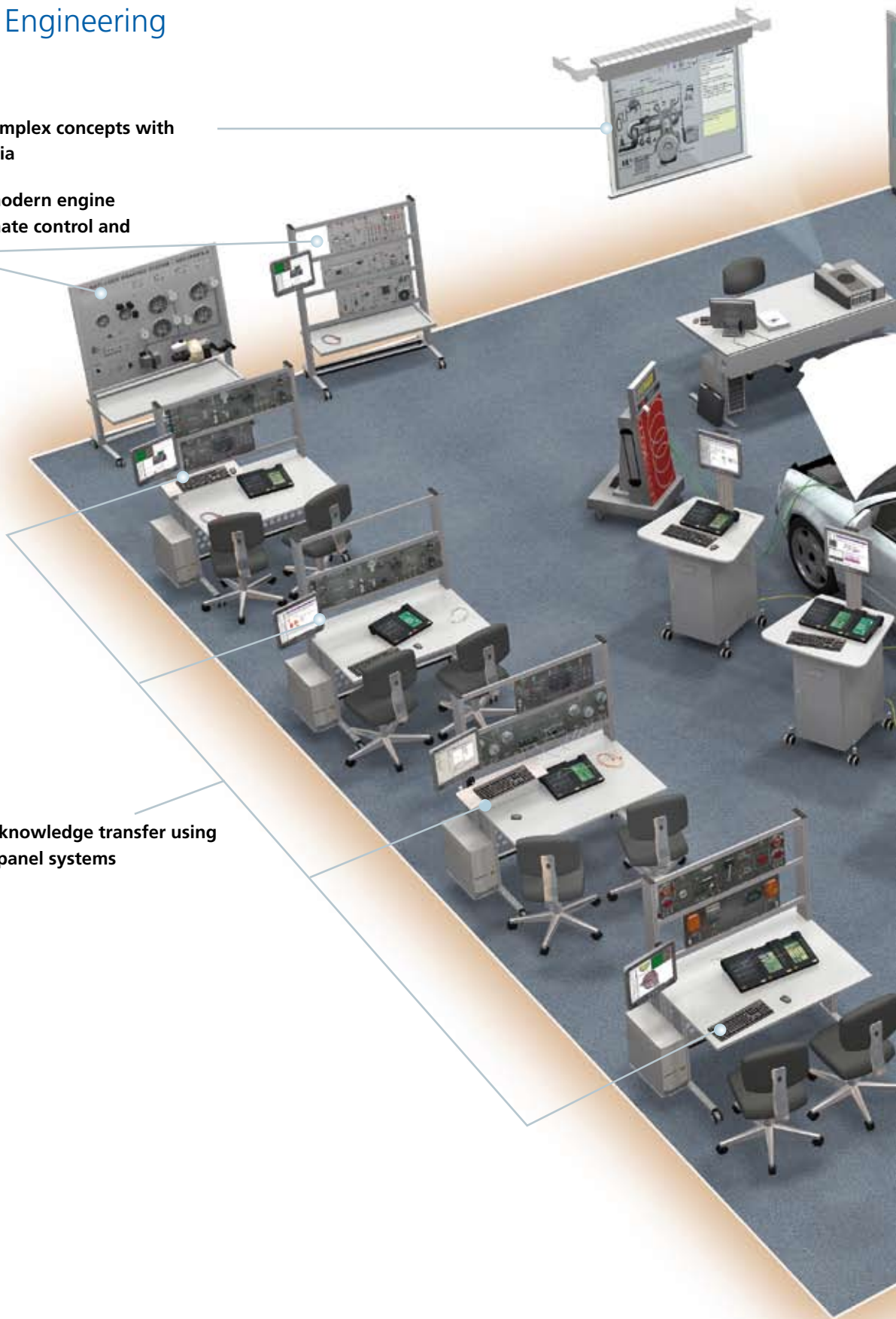

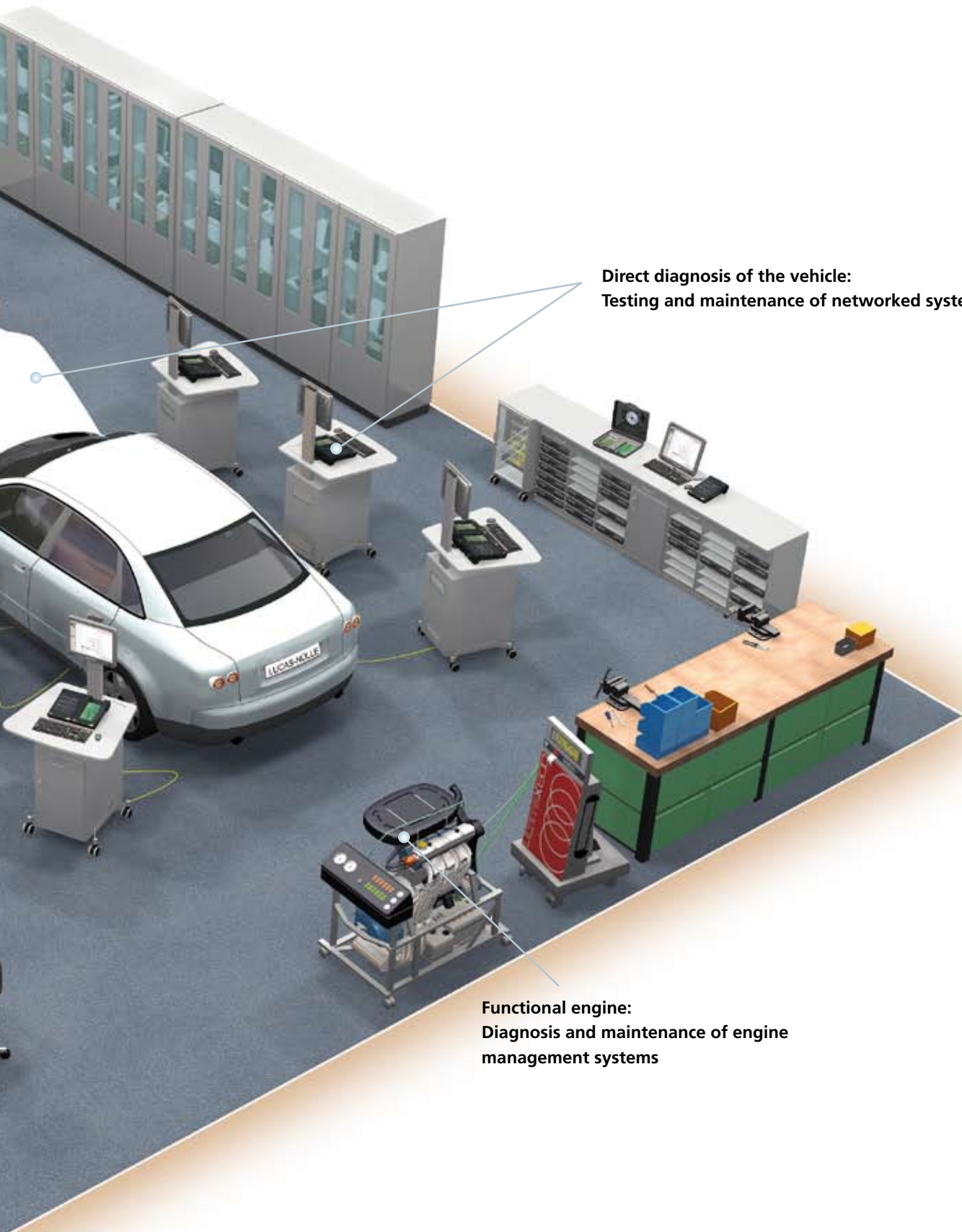

Direct diagnosis of the vehicle:
Testing and maintenance of networked systems

Functional engine:
Diagnosis and maintenance of engine management systems

Animated Presentation of Complex Training Contents

Project-oriented Training Media – Adaptable to any Training System

Manuals

Providing detailed descriptions of how to put training systems into operation, these handbooks also contain numerous exercises, experiments and projects.

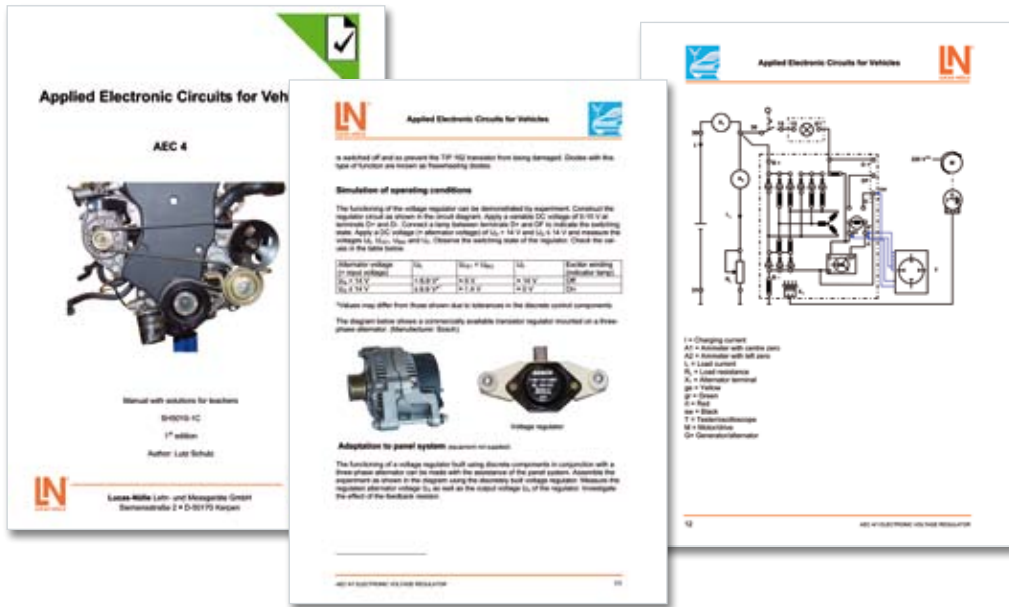

Multimedia courses

Available as multimedia courses, many of the manuals include features familiar from the UniTrain-I courses, e.g.:

- Tests
- Interactive experiment set-ups
- Navigation bars
- Animations

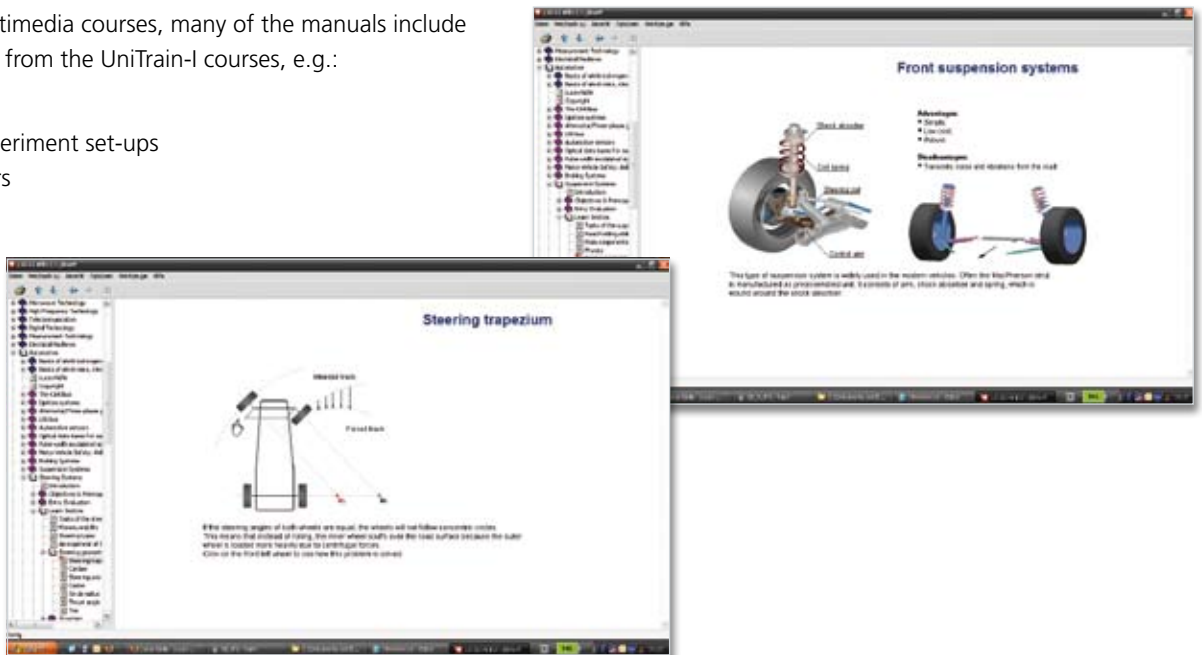

QuickCharts

These provide a quick overview of certain topics. The steps to be taken, the work processes and the technical relationships are explained briefly and vividly.

Presentation slides

Slides on CD can provide support for your lessons, e.g. supplying background information, block circuit diagrams, physical fundamentals, specific standard characteristics, special modifications and application examples. The slides come in PowerPoint format on a CD.



Electrics / Electronics

DC and AC Technology in Motor Vehicles	26
Electronic and Digital Technology in Motor Vehicles	27
Three-phase Generator	28
Pulse-width Modulated Signals (PWM)	29
Three-phase Generator with a Multi-function Controller	30
Three-phase Generator with a Hybrid Controller	31
Fundamentals of Automotive Electrics and Electronics	32

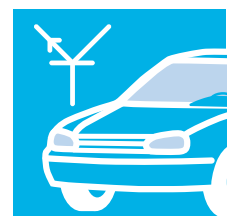

Electrics / Electronics

Practical Elementary Knowledge

Sound training in the fundamentals of automotive electrics is a prerequisite for understanding the complex relationships between various electrical and electronic applications in automobiles. Our training systems are geared specially to education in the area of automotive engineering. Electrical and electronic fundamentals are presented clearly by means of numerous examples, descriptions and practical exercises.



Analogue technology

In electrical engineering, an analogue system is one where physical variables continuously vary in value and time. The LN case system imparts the related fundamentals in a practical manner.



Digital technology

This topic deals with the processing of discrete-value and discrete-time numerical sequences as well as digital signals. Our basic courses are made up of typical automotive examples and exercises intended to provide the most practical training possible.

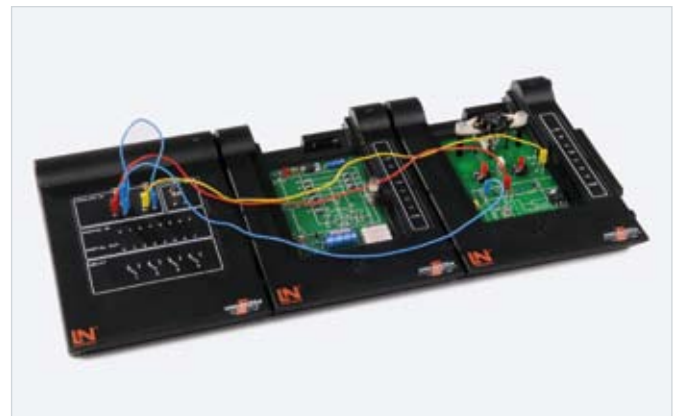

Training systems

Our training systems cover the following topics:

- Electrical fundamentals
- Basics of automotive electronics
- Semiconductor components
- Basic electronic circuits
- Applied electronic circuits
- Basic and applied digital circuits



Electrics / Electronics

DC and AC Technology in Motor Vehicles

The growing significance of electric and electronic components in motor vehicles necessitates practical training in the fundamentals of electronics.



UniTrain
SYSTEM

Training contents

- Introduction to the basic concepts of current, voltage and resistance
- Usage of voltage sources and measuring devices
- Experiment-based demonstration of Ohm's and Kirchhoff's laws
- Measurements of series / parallel connections, voltage dividers and mixed circuits
- Recording the characteristics of variable resistors (LDR, NTC, PTC, VDR)
- Trouble shooting

Electronic and Digital Technology in Motor Vehicles

A knowledge of the characteristics and functionality of electronic components forms the basis for understanding and analyzing such components and their circuits in motor vehicles.



UniTrain
SYSTEM

Training contents

- Determining a diode's valve and rectifier action
- Recording diode characteristics
- Basic transistor circuits
- Setting the operating point of a basic transistor circuit
- Gain, emitter and collector circuits
- Design of basic logic circuits
- Boolean functions and laws
- Static and dynamic switching characteristics of JK flip-flops
- Design of a counter circuit

Electrics / Electronics

Three-phase Generator

Nearly all modern motor vehicles possess a three-phase generator for supplying the necessary electrical energy.



UniTrain
SYSTEM

Training contents

- Generator principle
- Three-phase current
- Diode and rectifier circuits
- Functionality of an unregulated three-phase generator
- Discrete and integrated voltage controllers
- Regulated three-phase generator
- Fault diagnosis

Pulse-width Modulated Signals (PWM)

Many actuator systems in motor vehicles require variable power levels for the devices being controlled. Actuators which need to assume intermediate values between the ON and OFF limits are controlled by means of pulse-width modulated signals.



UniTrain
SYSTEM

Training contents

- Principle of pulse-width modulation
- Automotive applications of pulse-width modulation
- Adjusting the power of electrical loads with PWM
- Measuring a PWM signal's characteristics: frequency, amplitude, mark-to-space ratio
- Pulse width, edges and signal shapes
- Control and operating-current circuits
- Diagnosis of PWM-controlled components

Electrics / Electronics

Three-phase Generator with a Multi-function Controller

This training system is used to examine how energy is generated on modern motor vehicles. Today's compact generators make use of a monolithic controller. This kind of multifunction controller has now largely replaced hybrid controllers. A progressive sequence of experiments gradually introduces students to the subject of electricity generation on automobiles.

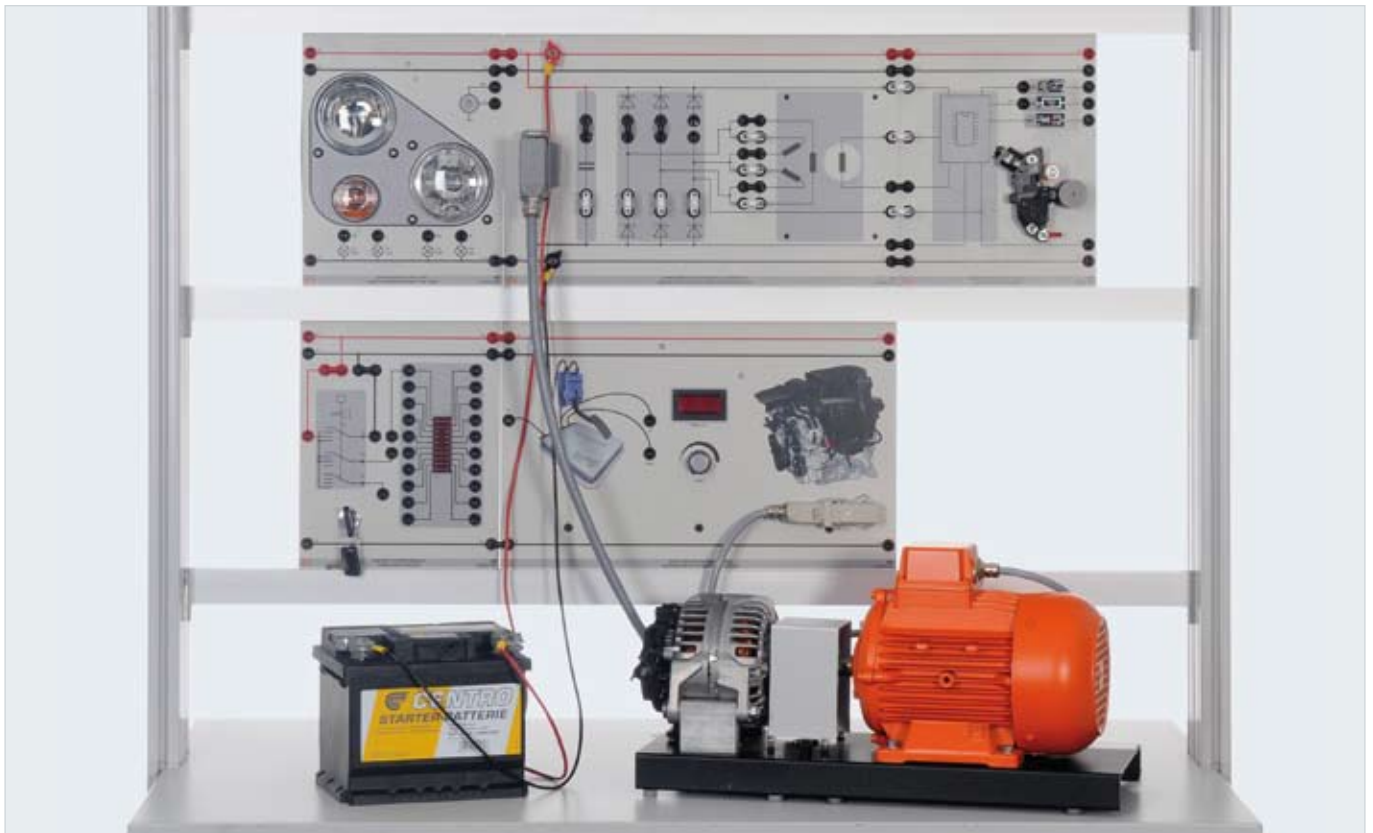

Training contents

- Principle of three-phase current generation
- Generation of 3-phase alternating voltage in vehicles
- Rectification and protection by power Z-diodes
- Characteristics of a multi-function controller
- Battery monitoring (sensing)
- Controlled pre-excitation (pulse-width modulation)
- Fault diagnosis

Three-phase Generator with a Hybrid Controller

The hybrid controller is meant to maintain the generator voltage at a certain level, regardless of speed and load. The average excitation current is adjusted by varying the power-on and power-off times. This accordingly changes the magnetic field in the excitation winding and the induction of the stator winding.

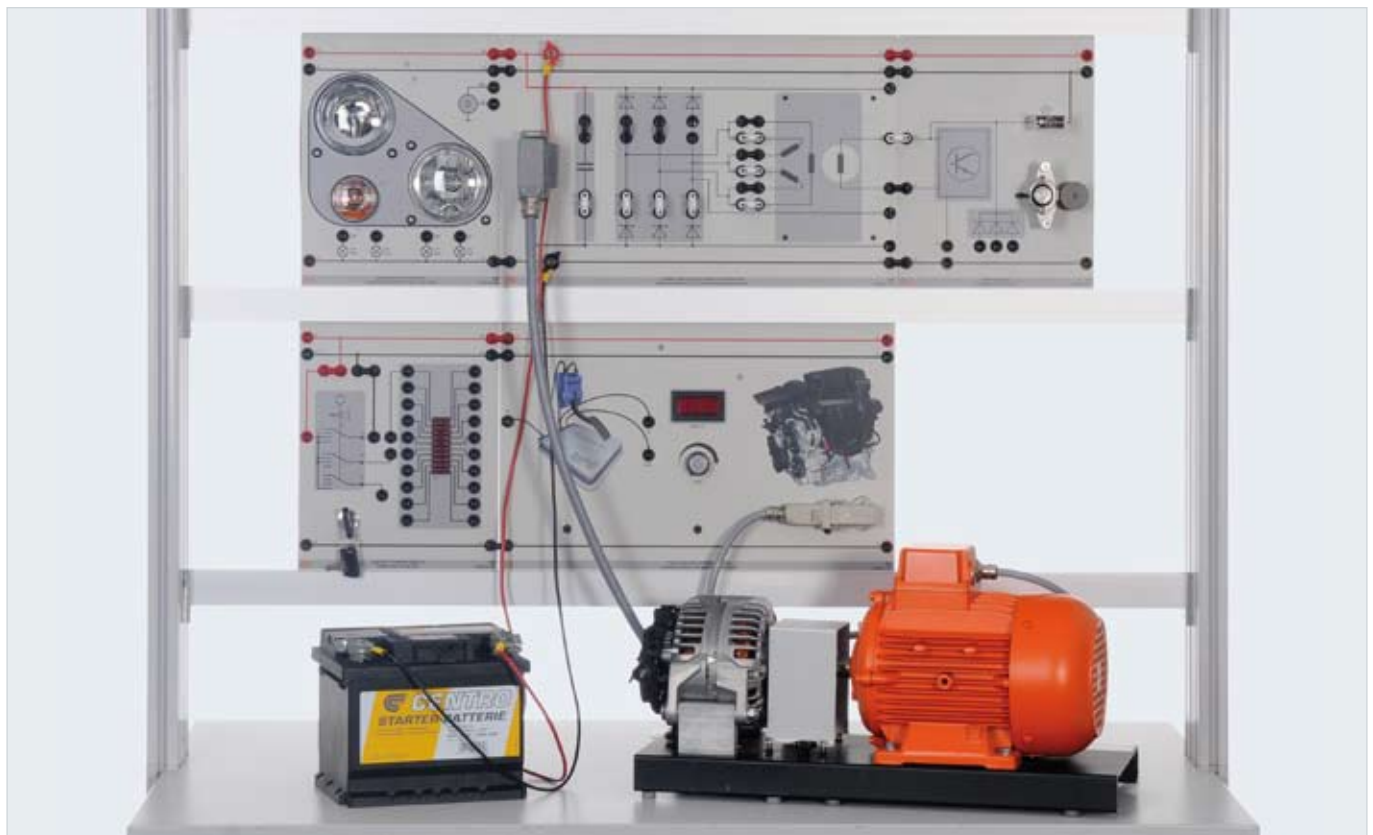

Training contents

- Principle of three-phase current generation and voltage control
- How 3-phase alternating voltage is produced in vehicles
- Characteristics of a hybrid controller
- Necessity for exciter diodes
- Investigation of exciter current
- Diagnosis of system faults

Electrics / Electronics

Fundamentals of Automotive Electrics and Electronics

This system's standard patch panels can be used to configure a wide variety of circuits. The electric and electronic components available to the student can be easily plugged into the patch panel.



Training contents

- Introduction to electric and electronic components
 - Resistors
 - Capacitors
 - Coils
 - Semiconductor elements
- Configuring basic electric and electronic circuits in motor vehicles
- Experiment-based determination of characteristics
- Working with electric measuring devices
- Design and functionality of analogue and digital automotive circuits

Training / experiment topics

Fundamentals of automotive electronics

- Connection of measuring devices, voltage, current and resistance measurement
- Ohm's law
- Resistor circuits
- Series connection
- Parallel connection
- Mixed circuits
- Voltage divider under load and no-load
- Photoresistor
- Bridge circuits
- Capacitor circuits
- Diodes
- Light-emitting diodes
- Z-diode
- Transistor
- Thyristor
- Field-effect transistor

► PS4200-2A equipment set

Electronic and digital circuits

- Rectifier circuits
- Transistor and thyristor as switches
- Voltage stabilization
- Schmitt trigger
- Flip-flops
- Electronic voltage controller
- Electronic rpm counter
- Bistable flip-flop
- Overvoltage protection for three-phase generators
- Logic gates (AND, OR, NAND, XOR)
- Half-adder / full-adder
- RS flip-flop
- Binary and decimal counters
- Shift register

► PS4200-2B equipment set, supplementary set for PS4200-2A





Sensors and Actuators

Automotive Sensors	38
Engine Management Sensors	39

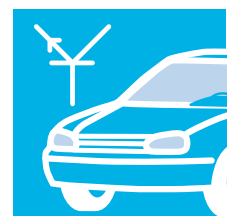

Sensors and Actuators

Process Control with Sensors and Actuators

A motor vehicle uses sensors to monitor rpm, speed, acceleration, gas concentrations, temperature and other input variables. Such signals have become indispensable for many process control functions of management systems, e.g. for the engine, chassis, safety and comfort. Typical automotive components integrated into training systems are used to demonstrate the functions and applications of sensors and actuators.



Maximum learning efficiency

A multimedia training platform ensures fast learning, even during independent studies. Integrated, virtual measuring devices make for an efficient work environment.



Hands-on

For the most practical possible instruction, all sensors in our training and educational systems have features found typically on automotive components. The compact system's exercise stands are especially well suited for demonstrations.



Training systems

Our training systems cover the following topics:

- Sensors on automobile body and chassis
- Sensors in the engine management system

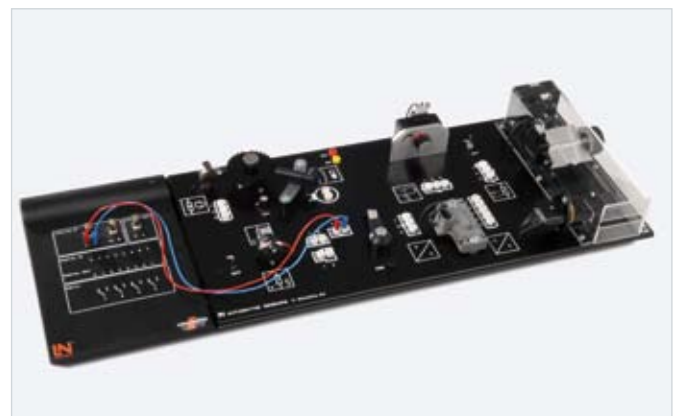

Sensors and Actuators

Automotive Sensors

An increasing number of components on modern motor vehicles are being electronically controlled and monitored. Sensors are designed to register physical data and convert it into electrical signals which can be processed by the relevant control units.



UniTrain
SYSTEM

Training contents

- Physical principles of sensors: induction, Hall effect, piezo effect
- Sensor functions as part of engine control
- Inductive and Hall speed sensors
- Throttle valve position measurement: throttle valve switch and potentiometer
- Air-flow measurement with hot-wire and hot-film sensors
- Pressure measurement in intake manifold
- Detection of shock waves with the knock sensor
- Temperature measurement with NTC and PTC sensors

Engine Management Sensors

This training system from the "Compact" family allows hands-on experimentation and demonstrations using various engine-management and chassis sensors. The system's practical design makes for highly realistic training.

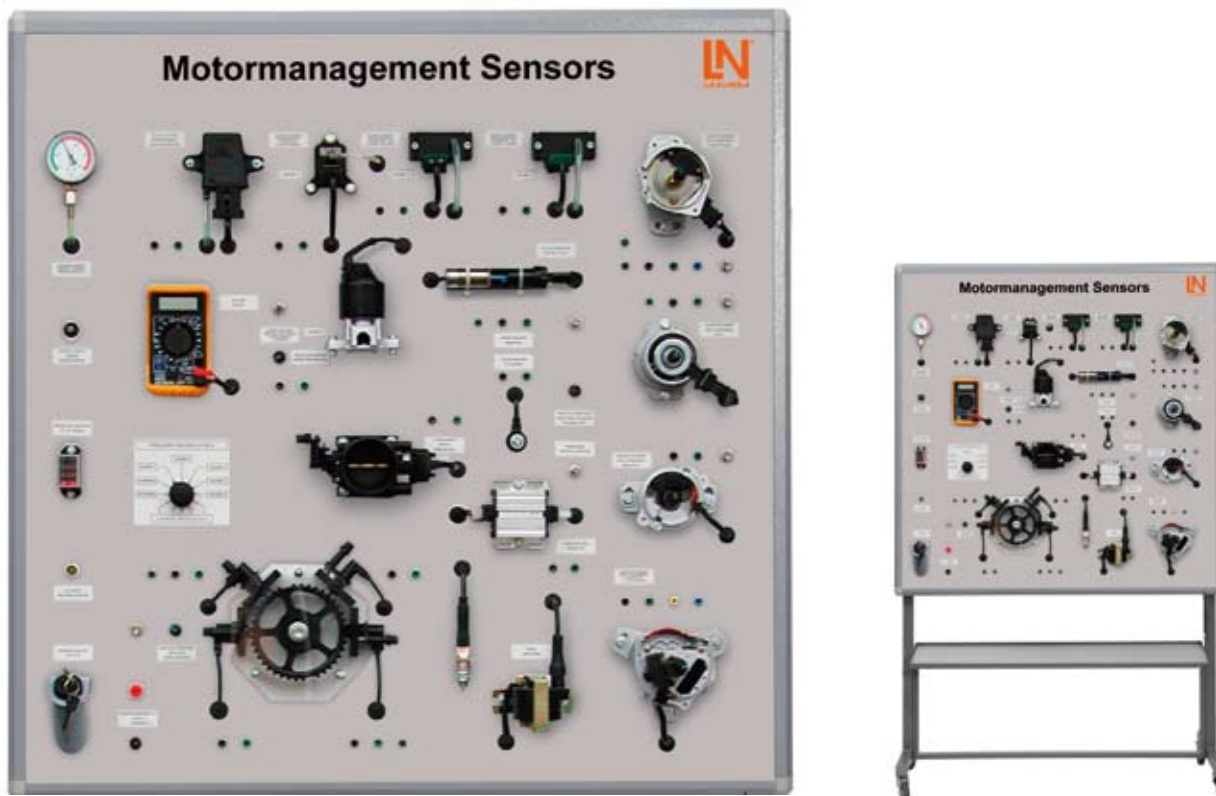

Training contents

- Clarifying the functionality of common sensors
- Conducting typical electrical measurements on various engine management sensors
- Interpreting and using circuit diagrams
- Building up diagnostic skills
- Planning and implementing typical diagnostic strategies
- Conducting typical electrical measurements on various chassis sensors



Vehicle Lighting

Motor Vehicle Main Lights	44
Auxiliary Lighting and Signalling Systems	45
Trailer Lights	46
Static Cornering Light	47
CAN Bus Extension	48
Dashboard Training Model Incorporating CAN and LIN Buses .	49

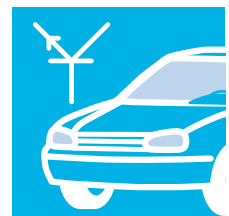

Vehicle Lighting

From Metal Filament Lamps to Adaptive Headlight Systems

Increasingly complex lighting systems place growing demands on trainees in the automotive field. Our modular training systems provide students with step-by-step introductions to the various systems involved here.



Active safety provided by lighting systems

Vehicle lighting components are among those contributing to active safety. A vehicle's lighting components form part of its electric system. Innovations integrated into state-of-the-art headlight systems are explored and explained here in a clear and practical manner.



Source: Hella

Static cornering lights

This feature involves control of the headlights via the indicator unit, yaw rate and travelling speed so as to perfectly illuminate the road ahead, even on curves. This ensures a high level of convenience and safety when cornering. The LN training system "Static cornering lights" can be integrated as an expansion kit into the existing lighting system.



Source: Hella

Training systems

Our training systems cover the following topics:

- Static cornering lights
- Headlights with range adjustment
- Auxiliary lights
- Trailer lights



Vehicle Lighting

Motor Vehicle Main Lights

The lighting system including all supplementary equipment is comprised of original automotive components. Besides conventional bulbs, LEDs have also been built into the tail-lights. The headlights are furnished with range adjustment as a standard feature.



Training contents

- Differences between control and load circuits
- Use of multi-function switches
- Circuit protection
- Use of an electronic relay
- Optical and acoustic signalling units
- Manual headlight range adjustment mechanism
- Recording of measurement values, fault localization

Auxiliary Lighting and Signalling Systems

Driving safety can be enhanced through the use of auxiliary headlights and fog lamps. There are diverse means of controlling such components. Furthermore, every vehicle must possess a signalling system by law. Circuits of practical relevance providing various means of controlling components serve as a bridge between theory and practice.

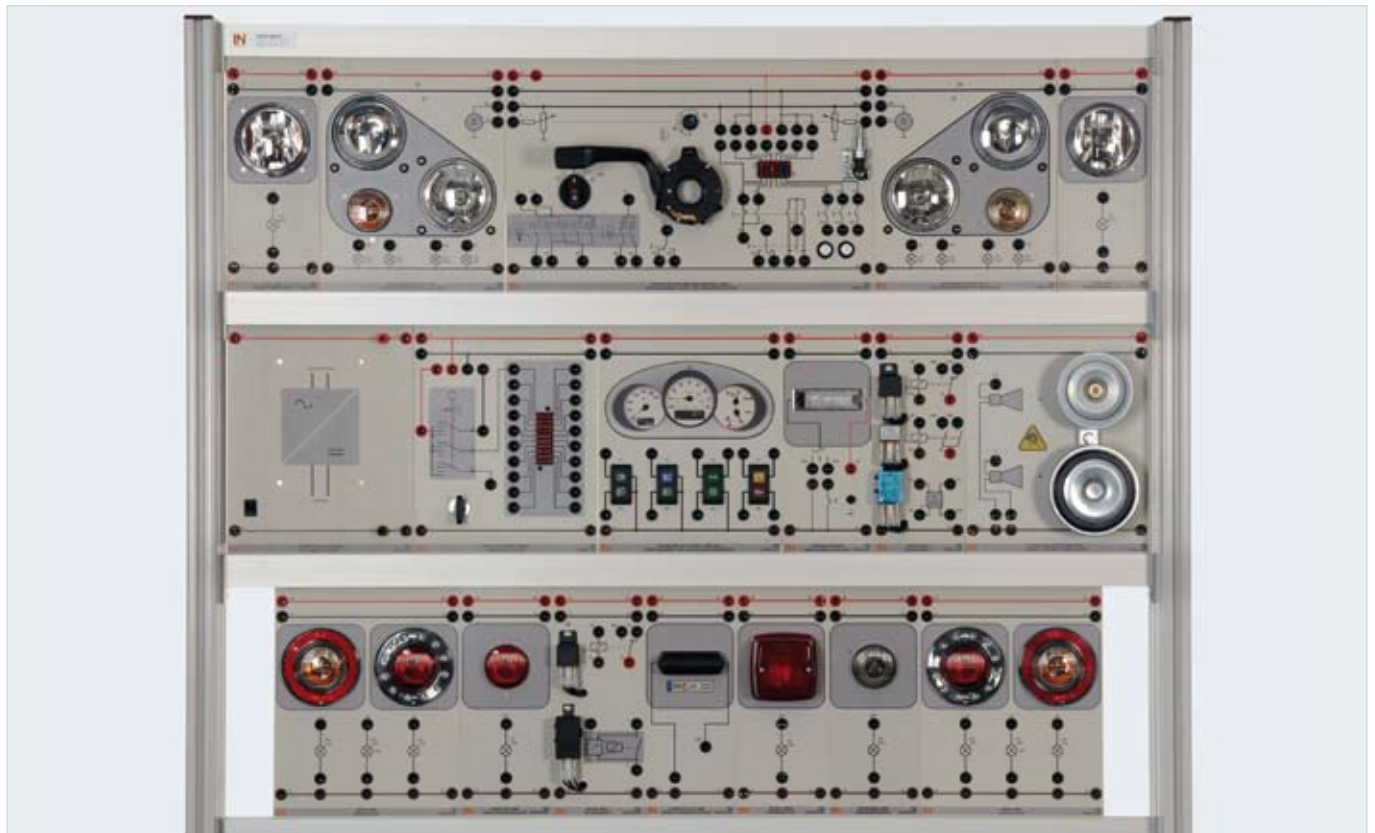

Training contents

- Fog lights with relay
- Fog lights system including rear fog light and 2 relays
- Halogen lights for enhanced road illumination
- Reversing lights
- 3rd brake light
- Interior lights
- Delayed switching of interior lights
- Horn unit
- Standard-tone / loud-tone horn unit with relay

Vehicle Lighting

Trailer Lights

A trailer's electrical system becomes notably more complex if converted from 7-pole to 13-pole assignment. Furthermore, the towing vehicle's electrical system must be protected against overload, and the trailer control functions must comply with statutory regulations.



Training contents

- Upgrading of lighting systems on motor vehicles
- Differences between control and load circuits
- Circuit protection
- Optical and acoustic signalling units
- Trailer lighting systems
- Recording of measurement values, fault localization
- Overload protection for the towing vehicle
- Trailer's plug and socket assignments

Static Cornering Lights

Thanks to a control unit mounted on a movable bearing, the curve or cornering light is activated without delay on operation of the indicator if the low beam is on, or automatically while cornering at speeds of up to 40 km/h. An auxiliary right-hand or left-hand headlight can be employed as required, and the fog lamp function switched separately as needed. The headlight can serve as a cornering light or fog lamp.

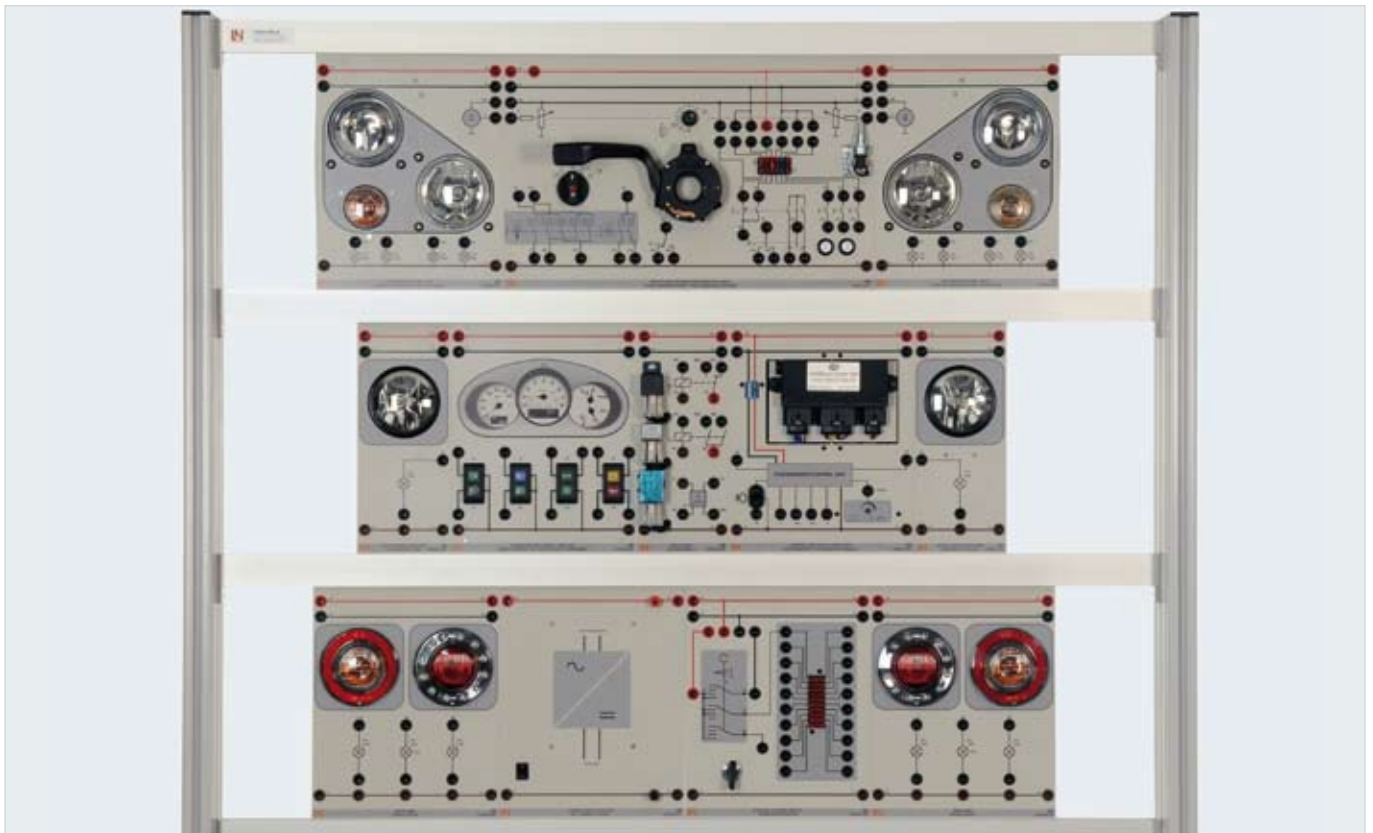

Training contents

- Safety aspects on the road
- Electric circuit diagrams for static cornering light accessory set
- Cornering acceleration of a vehicle as measured by a yaw-rate sensor
- Design of turning light systems in conjunction with dipped headlights
- Differences between turning lights and cornering lights
- How turning lights work
- Upgrading of lighting systems on a vehicle
- Calibration of vehicle components

Vehicle Lighting

CAN Bus Extension

Expand any existing automotive lighting display by one completely diagnostic-capable CAN bus node. This novel concept permits operation in low-speed mode and, with just the push of a button, in high-speed mode, too. As a result, even with a CAN bus drive you can explore the basics of the different transmission speeds and the voltage levels associated with them. With the fault simulator you only have to activate a switch to feed various ISO standard fault codes onto the CAN bus.



Training contents

- Design of a steering column control unit
- Data transmission via a CAN bus
 - Data protocol for low-speed CAN (class B)
 - Data protocol for high-speed CAN (class C)
 - Fault patterns on a high-speed CAN bus
 - Fault patterns on a low-speed CAN bus
 - CAN bus diagnosis
- Baud rate analysis
- Short-circuit test of the power output stage

Dashboard Training Model Incorporating CAN and LIN Buses

This model comprises an original dashboard (VW Golf V) with an instrument panel, driver's and front passenger's airbags, as well as the entire lighting system including instrument lighting. The model includes a fault simulation circuit. Also present are diagnostic plugs for measurements on control units, e.g. for the airbag or illumination.



Training contents

- CAN bus for light control/central locking/comfort window winder
- LIN bus for wiper and mirror control
- Circuit comprising headlights and range adjustment mechanism
- Headlight settings
- Indicator
- Hazard warning system
- Horn
- Fan, ventilation, circulating-air mode (open to allow observation)
- Instrument lighting
- Optional: xenon headlights



Comfort Systems

GPS Navigation	54
Alarm System and Immobilizer	55
Air-conditioning and Climate Control	56

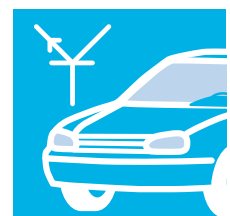

Comfort Systems

Interior Ventilation and Climate Control

Comfort systems increase general safety and comfort levels for the driver and passengers. On the basis of job orders and fault descriptions, students plan their measures for diagnosis, tests of individual components and repairs of comfort systems comprising original vehicle parts.



Air-conditioning

A person's ability to perform and concentrate is influenced strongly by the temperature and condition of the surrounding air. Consequently, all efforts must be made to supply the passenger compartment with fresh, filtered air whose temperature can be raised or lowered depending on the exterior temperature.

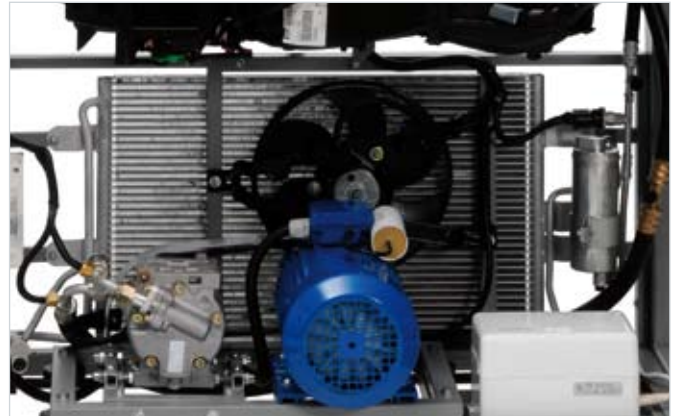

Immobilizer and alarm system

The training system introduces students to the design and functionality of an alarm system including an immobilizer and remote control. The system demonstrates how vehicles can be safeguarded in actual practice.

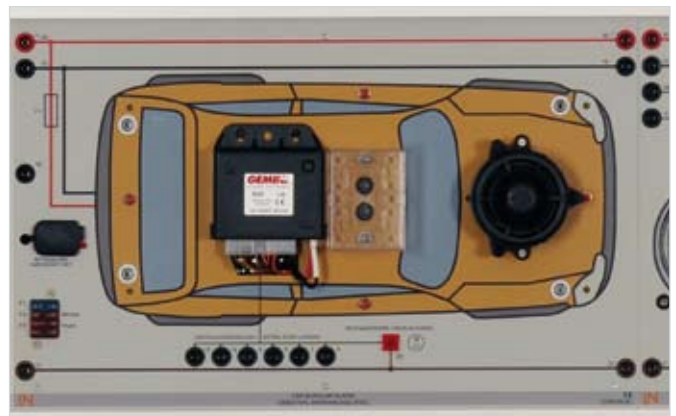

Training systems

Our training systems cover the following topics:

- "Climatronic" air-conditioning
- Alarm system and immobilizer
- GPS navigation



Comfort Systems

GPS Navigation

To simulate navigation, this GPS system can be set to simulation mode by means of a special software. This is extremely useful for learning and understanding the various functions involved. The navigation system is housed securely in a robust yet light storage case providing protection against damage.



Your benefits

- Simulation mode for navigation routes
- 3D map display
- Traffic lane guidance system
- Automatic route calculation
- Active route search function
- Real-time language guidance
- Highway information display
- Integrated RDS-TMC receiver
- Operable via remote control and touchscreen
- Integrated gyroscope and speedometer
- Switchable between DVD and navigation mode
- Includes a connection and switch for a reversing camera

Alarm System and Immobilizer

The alarm system issues optical and acoustic signals in the event of attempted intrusion. Arranged compactly on a panel for training purposes, this fully functional alarm system permits clear demonstrations of functionality.

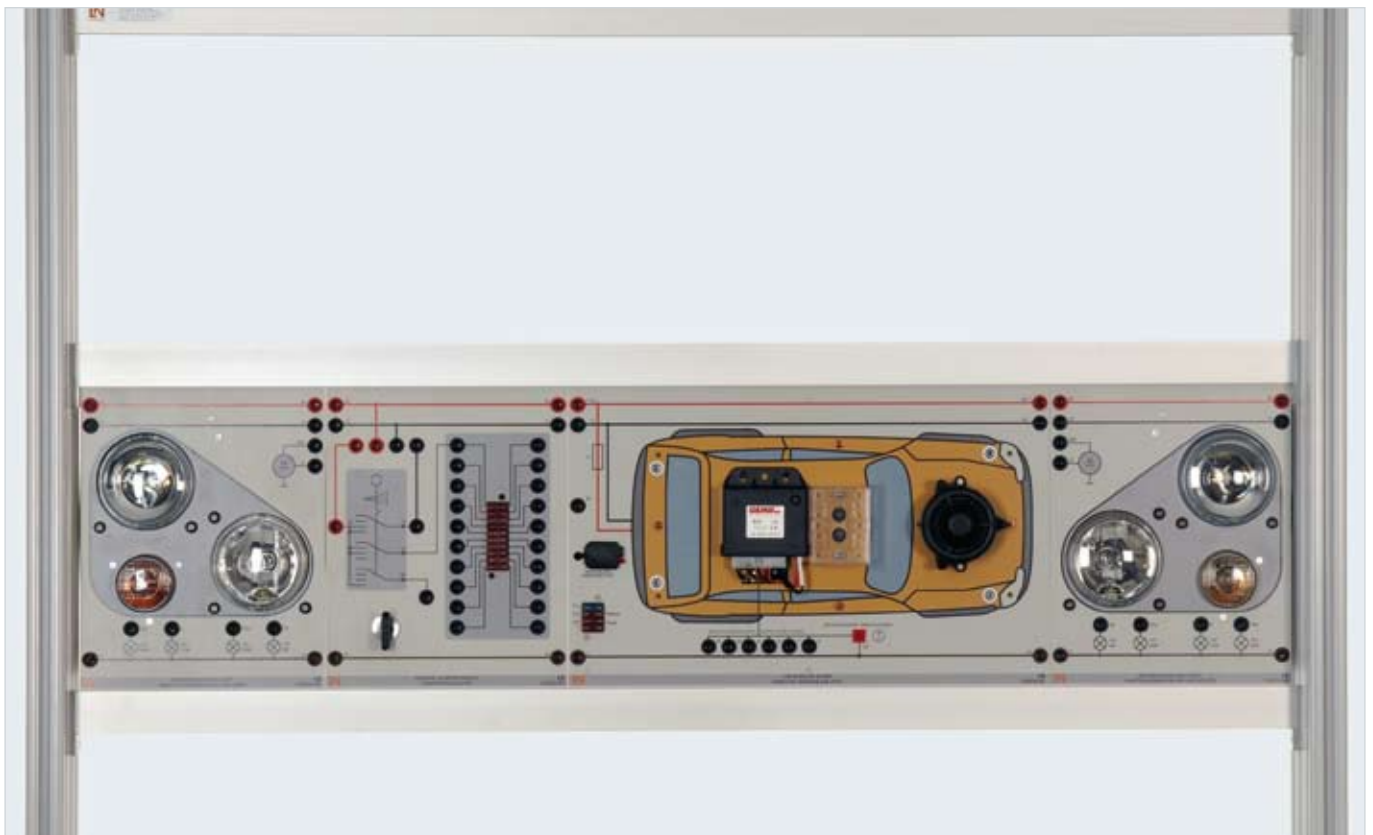

Sample experiment: "Alarm system and immobilizer"

Training contents

- Explaining the design and operation of an alarm system and immobilizer
- Setting and checking the theft-warning unit and immobilizer
- Country-specific programming of the alarm system
- Interaction of the alarm system with other vehicle components
- Trouble shooting

Comfort Systems

Air-conditioning and Climate Control

This training system permits practical experimentation and demonstration with a "Climatronic" automotive air-conditioning unit with climate control. The system's very realistic design makes for equally realistic training.



Training contents

- Setup and initial operation of an air-conditioning unit
- Enhancement of automotive comfort and safety through air-conditioning
- Fundamentals of refrigeration
- Air-conditioning system's operating principle
- Description of air-conditioning components
- Handling of refrigerants and relevant statutory regulations
- Open-/closed-loop control of the vehicle's interior temperature
- Diagnosis of air-conditioning units
- Maintenance of air-conditioning units
- Repairs
- Trouble shooting

Fully Automatic Air-conditioning Service Unit

This easily operable air-conditioning service unit incorporates several functions such as leakage detection, recycling, cleaning, evacuation and replenishment.



Your benefits

- **Recycling**
Recycling of residual refrigerant
- **Cleaning**
Cleaning of refrigerant through drying, filtration and separation of oil as well as liquids according to the SAE standard
- **Replenishment**
Refilling of the air-conditioning cycle
- **Leakage detection**
Checks of the cooling system for leakages
- **Oil separation**
Replacement of old oil with a fresh batch to lengthen the compressor's life cycle
- **Evacuation**
Emptying of hoses and system parts to ensure that exactly the required quantity of refrigerant is refilled
- **Weighing**
Measurement of the filling quantity



Alternative Drives

Hybrid Automotive Drive	62
Hybrid Sectional Model (Toyota Prius)	63
Fuel Cells	64
Photovoltaics	65

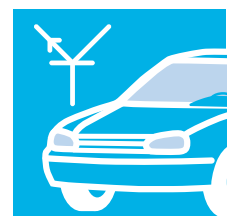

Alternative Drives

Hybrid Drives

Low fuel consumption, low emissions and maximum driving pleasure: these requirements need to be met in increasing measure by modern motor vehicles. Besides optimization of conventional drive concepts, the course also pursues new approaches to meeting demands for dependable mobility.



Generator operation

In generator mode, the power output of the combustion engine is higher than that needed for moving the vehicle. The remaining power is fed to the generator, where it is converted into electrical energy and stored.

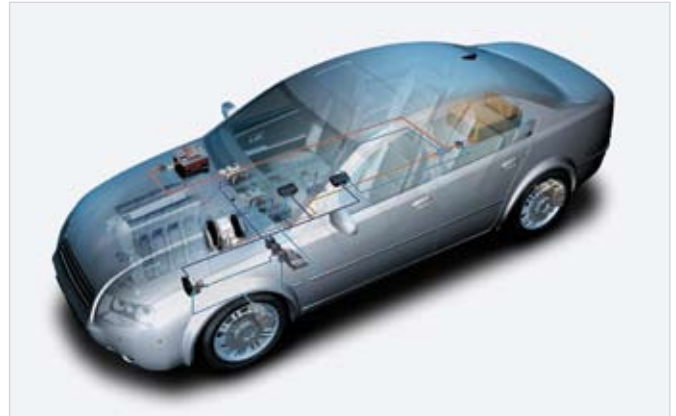

Source: Bosch

Regenerative braking

In this mode, the vehicle is braked entirely or partly without the service brake's frictional torque, which is replaced by the braking moment generated by the electric motor. In this process, the vehicle's kinetic energy is converted into electrical energy and stored.



Source: Bosch

Training systems

Our training systems cover the following topics:

- UniTrain-I hybrid drives
- Hybrid sectional model (Toyota Prius)
- Photovoltaics
- Fuel cells

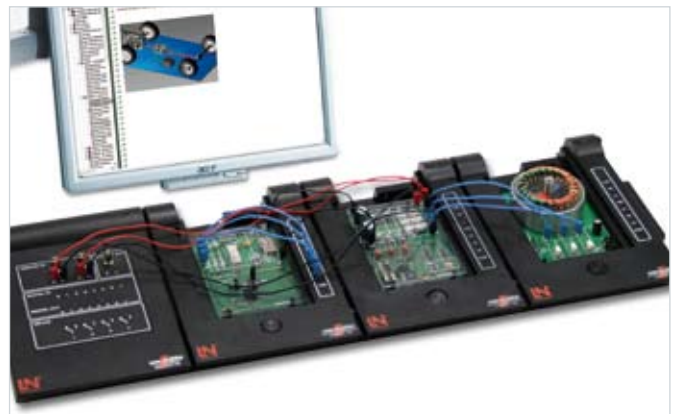

Alternative Drives

Hybrid Automotive Drive

Hybrid drives are essentially meant to meet three objectives: save fuel, reduce emissions, increase torque / power. Different hybrid concepts can be employed depending on the required application.



UniTrain
SYSTEM

Training contents

- Advantages of hybrid systems
- Serial hybrid system
- Parallel hybrid system
- Combinations of hybrid drives
- Design of electrical machines
 - Asynchronous machine
 - Synchronous machine
- Fundamentals of inverters
 - Three-phase rectifiers
- Fundamentals of frequency converters
- Three-phase voltage supply
- Measurements of:
 - Direct voltage
 - Alternating voltage
 - Three-phase alternating voltage
- Investigations of energy and power flows
- On-board networks for hybrid vehicles

Hybrid Sectional Model (Toyota Prius)

This sectional model reveals a hybrid drive's design. The model is cut so as to display the components and demonstrate their functionality. The engine, generator, gearbox and drive train can be observed while in operation.



Training contents

- Design of a hybrid drive
- Introduction to operating states such as starting, regular operation, maximum load, braking and acceleration
- Investigation of drives comprising a fuel-operated engine or electric motor

Equipment

- Original components of the Toyota Prius
- The model is mounted on a rack with rollers
- 230 V electric motor
- Functions are controlled via a switch on the front side

Alternative Drives

Fuel Cells

Motorized vehicles (cars, trucks) produce large quantities of CO_2 . Despite considerable advancements, the internal combustion engine still has very high CO_2 emission levels. It is therefore no surprise that engineers are seeking alternative drive concepts here. One such concept involves a use of electric motors in conjunction with fuel cells.



Training contents

- Use of fuel cells in motor vehicles
- Operating principles of fuel cells
- Design of fuel cells
- Fundamentals of the chemical process
- Fuel cell characteristics
- Recording the characteristics
- Efficiency of a fuel cell

Photovoltaics

The term photovoltaics stands for a direct conversion of sunlight into electrical energy by means of solar cells. The energy obtained in this manner can be supplied to ancillary consumers to enhance driving comfort, e.g. to additionally cool a vehicle's interior in extremely bright sunshine.



Training contents

- Use of a photovoltaic system on a motor vehicle
- Design of a photovoltaic cell
- Open-circuit voltage
- Short-circuit current
- V-I characteristic
- Power of a photovoltaic cell
- Series-connected photovoltaic cells
- Parallel-connected photovoltaic cells
- Direct operation
- Storage operation



Engine Management

Ignition Systems	70
Common Rail Diesel Injection System	71
Connect® Common Rail	72
Common Rail	73
Electronic Diesel Control (EDC)	74
Connect® Motronic 2.8 (Multi-point)	75
Connect® Direct Fuel Injection	76
Motronic ML 4.1 (Multi-point)	77
KE-Jetronic (Multi-point)	78
L-Jetronic (Multi-point)	79
D-Jetronic (Mono-point)	80
Connect® FIRE – Chip Tuning	81
Functional Engine	82

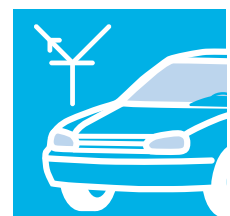

Engine Management

Networked Systems in an Engine Compartment

Increasingly complex engine management systems place growing demands on trainees in the automotive field. Our modular training systems provide students with step-by-step introductions to the various systems involved here.



Fuel mixture preparation

Lucas-Nülle's training systems provide students with a fully comprehensive introduction to the subject of fuel mixture preparation. The steps needed for optimizing fuel mixtures, registering and processing operational data, and outputting the data as actuator signals can be directly observed here. Practical exercises consolidate the acquired technical knowledge. Worksheets and exercise sheets are used for regular knowledge tests.



Source: Bosch

Chip tuning

All modern vehicles have an engine controlled by a central processor which also monitors operating states. The Connect® FIRE training system permits chip tuning on a single-cylinder, four-stroke engine.



Training systems

Our training systems cover the following topics:

- Ignition systems
- Engine management systems (spark-ignition and diesel)
- Functional engines
- Chip tuning



Engine Management

Ignition Systems

A petrol-operated engine requires a system for igniting the fuel mixture. In the course of developments, ignition systems have become increasingly complex and precise, thereby ensuring adherence to emission standards and the achievement of the extremely high performance levels required of modern spark-ignition engines.



UniTrain
SYSTEM

Training contents

- Generation of the ignition spark
- Ignition timing (mechanical and map-based)
- Conventional ignition system
- Dual-spark ignition systems
- Transistorized ignition systems with Hall and inductive sensors
- Electronic ignition system
- Recording and evaluating ignition oscillograms
- Static and rotary high-voltage distribution

Common Rail Diesel Injection System

Mechanically controlled injection systems are no longer able to meet ever stricter requirements for minimizing fuel consumption, exhaust emissions and diesel engine noise. For this purpose, the injection systems need to achieve very high pressures, exact sequences and precisely dosed quantities.

Piezo-technology with up to seven injection cycles



UniTrain
SYSTEM

Training contents

- Requirements to be met by diesel injection systems
- Introduction to various designs
- Design and functionality of a common rail system
- Fault localization on a common rail system
- Injection characteristics of common rail systems
- Injection characteristics of piezo-injectors (with up to seven injection cycles)
- Investigation of the fuel system
- Distinction between low- and high-pressure circuits
- Component layouts and functions
- Electrical tests of injectors
- Examination of a common rail system's hydraulics

Engine Management

Connect® Common Rail

Designed for direct injection of diesel at high pressure, the common rail system differs from conventional diesel injection systems in terms of its operating principle. As opposed to systems with directly driven injection pumps, the common rail injection system decouples pressure-generation from injection-control functions.

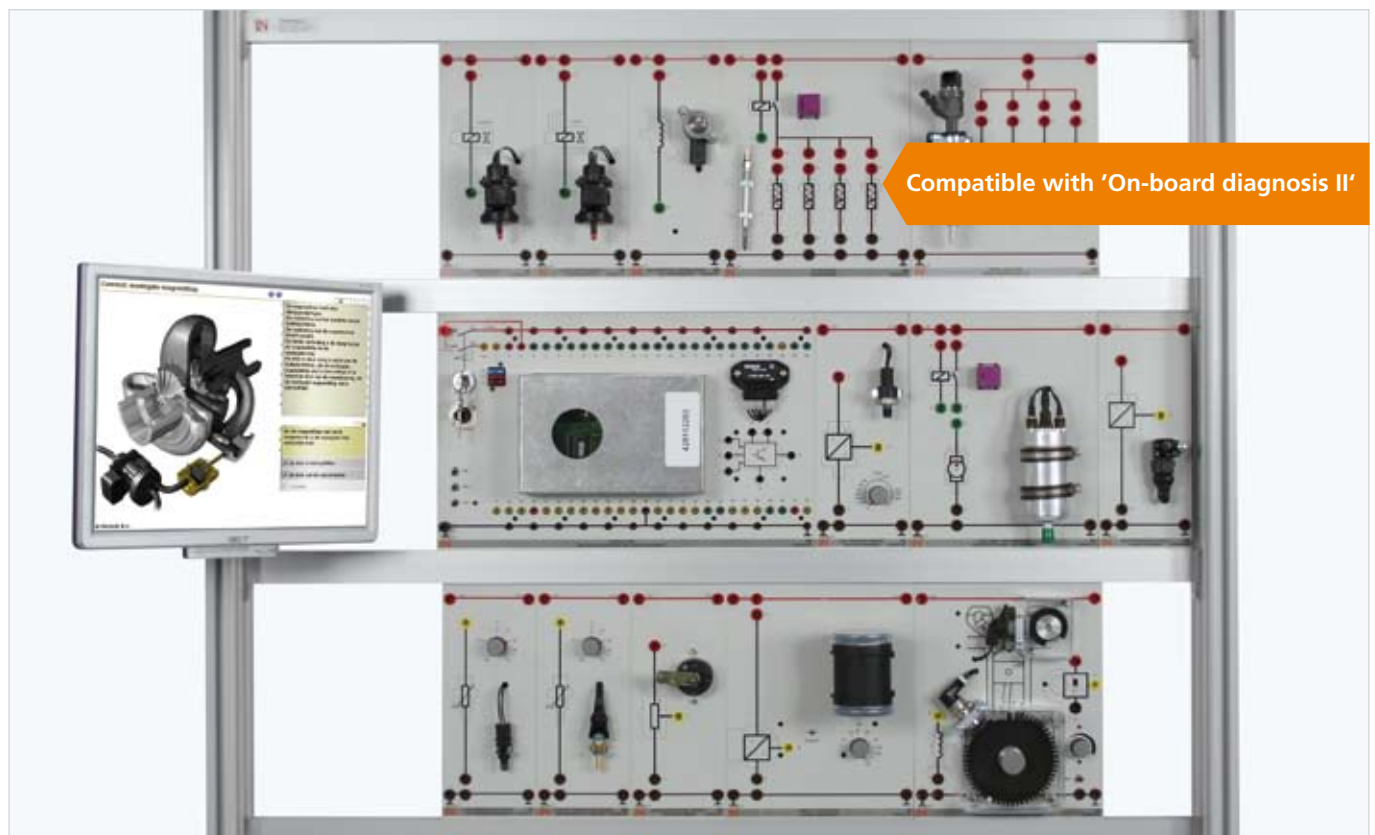

Sample experiment: "Common rail"

Training contents

- Combustion process
- Pollutant emissions
- Reduction in pollutant emissions
- Block diagrams, circuit diagrams, function diagrams, graphs
- Signal, material and energy flows
- Diagnostic, testing and measuring devices
- Test and measuring methods
- Sensors and actuators
- Open-loop and closed-loop control
- Engine management sub-systems
- Assembly groups and systems for fuel mixture preparation in diesel engines
- Adaptive systems
- Interfaces to other systems
- Fuels

Common Rail

Common rail is an injection system for self-igniting combustion engines. Map-controlled injectors can be operated and diagnosed here just like on a real engine.



Training contents

- Combustion process
- Pollutant emissions
- Reduction in pollutant emissions
- Block diagrams, circuit diagrams, function diagrams, graphs
- Signal, material and energy flows
- Diagnostic, testing and measuring devices
- Test and measuring methods
- Sensors and actuators
- Open-loop and closed-loop control
- Engine management sub-systems
- Assembly groups and systems for air-fuel mixture preparation in diesel engines
- Adaptive systems
- Interfaces to other systems
- Fuels

Engine Management

Electronic Diesel Control (EDC)

Electronic diesel control is an electronic management system for diesel engines. EDC embodies all open- and closed-loop control functions in one electronic engine control unit connected to a large number of sensors and actuators.



Training contents

- Combustion process
- Pollutant emissions
- Reduction in pollutant emissions
- Block diagrams, circuit diagrams, function diagrams, graphs
- Signal, material and energy flows
- Diagnostic, testing and measuring devices
- Test and measuring methods
- Sensors and actuators
- Open-loop and closed-loop control
- Engine management sub-systems
- Assembly groups and systems for mixture preparation in diesel engines
- Adaptive systems
- Interfaces to other systems
- Fuels

Connect® Motronic 2.8 (Multi-point)

Motronic 2.8 is a multi-point injection system in which each cylinder has its own injection valve. The actuators forming part of this training system are controlled as a function of corresponding sensor signals.

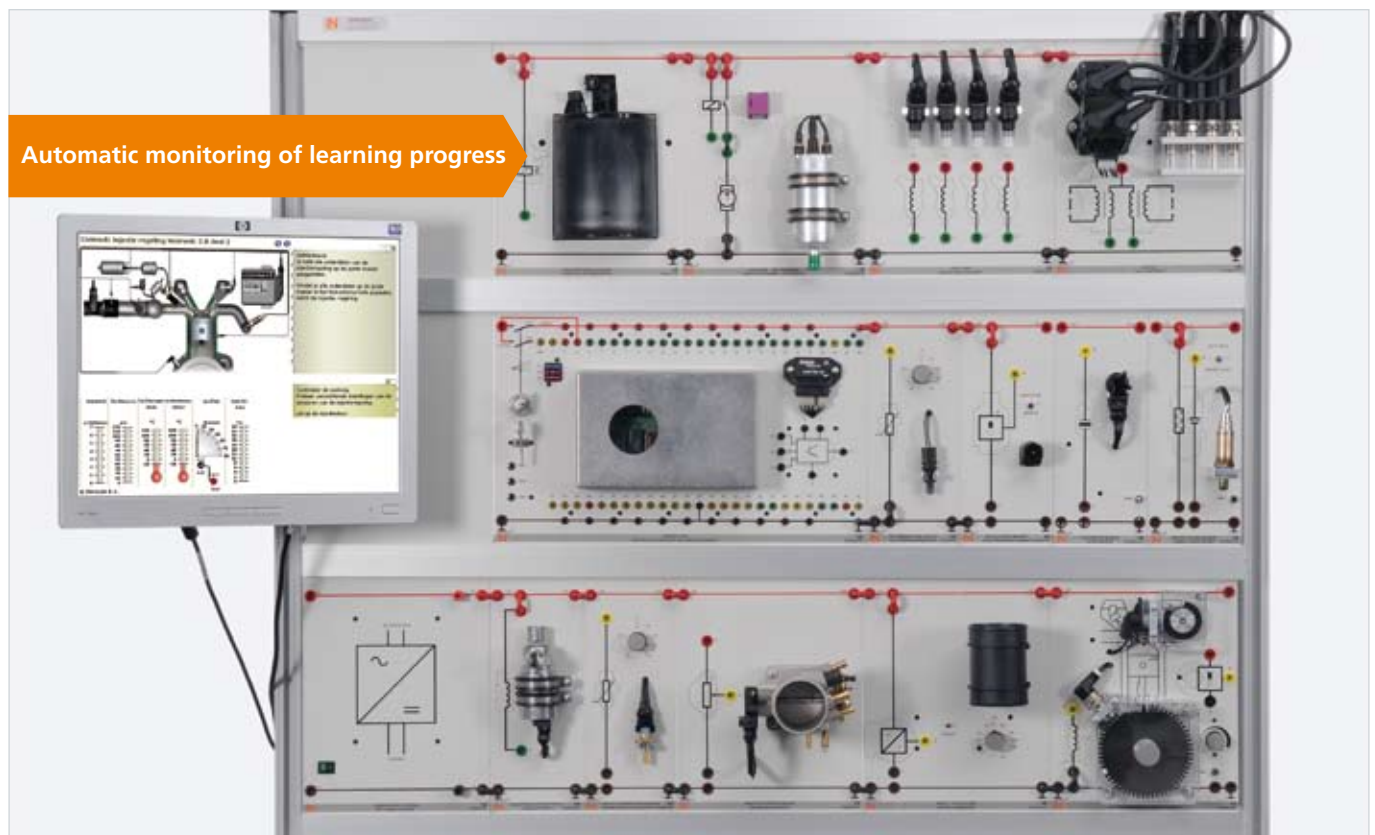

Sample experiment: "Motronic 2.8"

Training contents

- Combustion process
- Pollutant emissions
- Reduction in pollutant emissions
- Block diagrams, circuit diagrams, function diagrams, graphs
- Signal, material and energy flows
- Diagnostic, testing and measuring devices
- Test and measuring methods
- Sensors and actuators
- Open-loop and closed-loop control
- Engine management sub-systems
- Assembly groups and systems for air-fuel mixture preparation in combustion engines
- Adaptive systems
- Interfaces to other systems
- Fuels

Engine Management

Connect® Direct Fuel Injection

This system comprises a blend of hardware and software with training and educational purposes in mind. The experiment hardware consists of real automotive components mounted on experiment panels. Electrical connections are established via safety sockets. This permits every component to be operated and measured under realistic conditions.

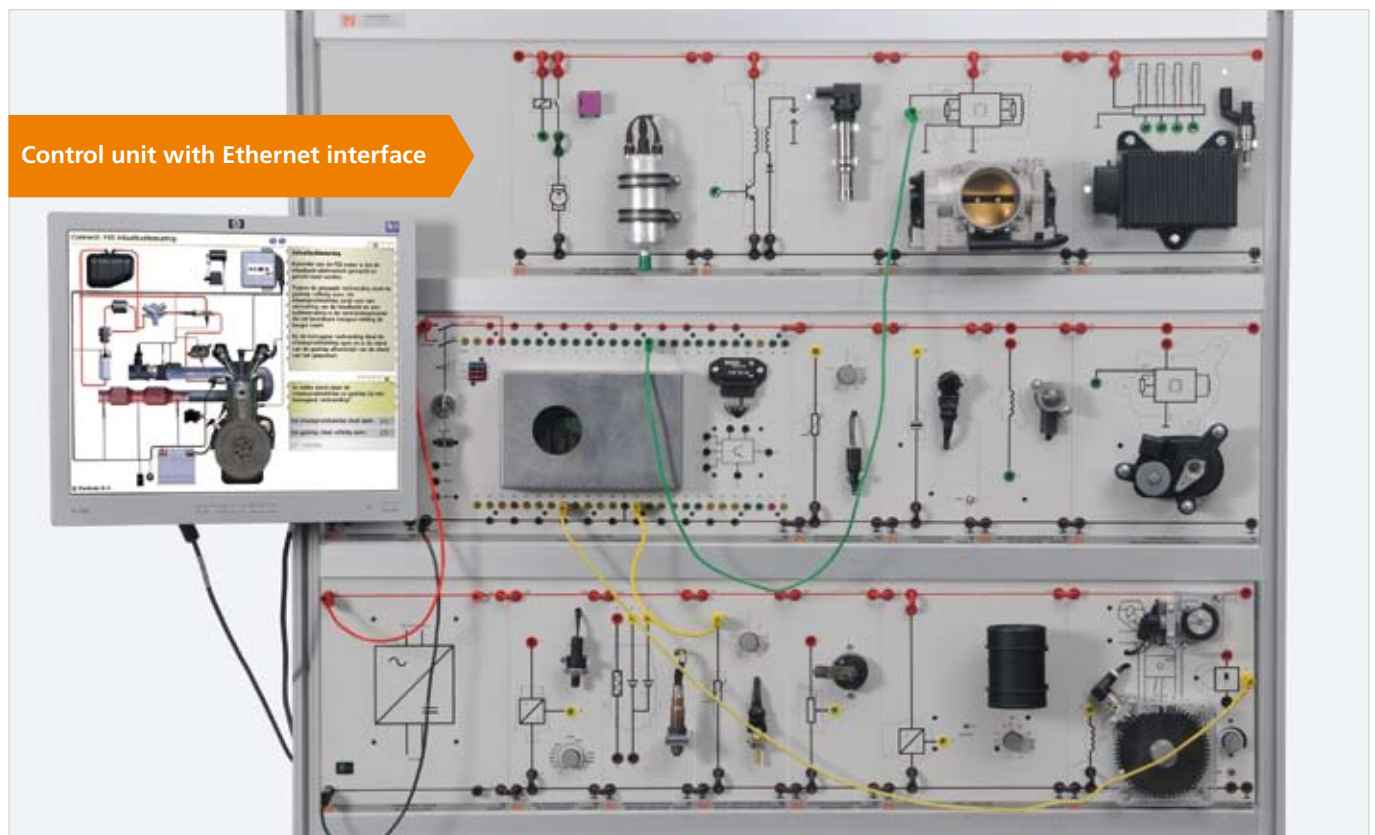

Sample experiment: "Direct fuel injection"

Training contents

- Exploring sensor and actuator designs and operating principles
- Interpreting and using circuit diagrams
- Building up diagnostic skills
- Conducting practical measurements on an ignition system's components
- Combustion process
- Diagrams and function charts
- Diagnostic, testing and measuring devices
- Test and measuring methods
- Sensors and actuators
- Open-loop and closed-loop control
- Engine management sub-systems
- Assembly groups and systems for mixture preparation in direct fuel injection engines
- Adaptive systems
- Interfaces to other systems

Motronic ML 4.1 (Multi-point)

Motronic is a digital control system for spark-ignition combustion engines. Introduced in 1979, Motronic (an abridgement of "motor electronics") for the first time combined air-fuel mixture preparation and ignition systems in a single, electronic engine control unit, in contrast to the predecessor, Jetronic, which was a pure fuel injection module with a separate ignition system.



Training contents

- Combustion process
- Block diagrams, circuit diagrams, function diagrams, graph
- Signal, material and energy flows
- Diagnostic, testing and measuring devices
- Test and measuring methods
- Sensors and actuators
- Open-loop and closed-loop control
- Engine management sub-systems
- Assembly groups and systems for air-fuel mixture preparation in petrol engines

Engine Management

KE-Jetronic (Multi-point)

Introduced in 1973, KE-Jetronic is an electronically / mechanically / hydraulically controlled fuel injection system in which the fuel is injected continuously into the intake manifold. The fuel is dosed only as a function of the intake air quantity, irrespective of the intake valve setting.



Training contents

- Understanding engine management functionality
- Understanding the functions of the involved control circuits
- Conducting typical electrical measurements on various engine management components
- Interpreting and using circuit diagrams
- Building up diagnostic skills
- Planning and implementing typical diagnostic strategies
- Pressure measurements on the fuel distributor
- Design and function of sensors and actuators

L-Jetronic 4.1 (Multi-point)

L-Jetronic is an electronically controlled fuel injection system where the fuel is injected intermittently into the intake manifold. The fuel is dosed as a function of the intake air quantity which is electrically measured.

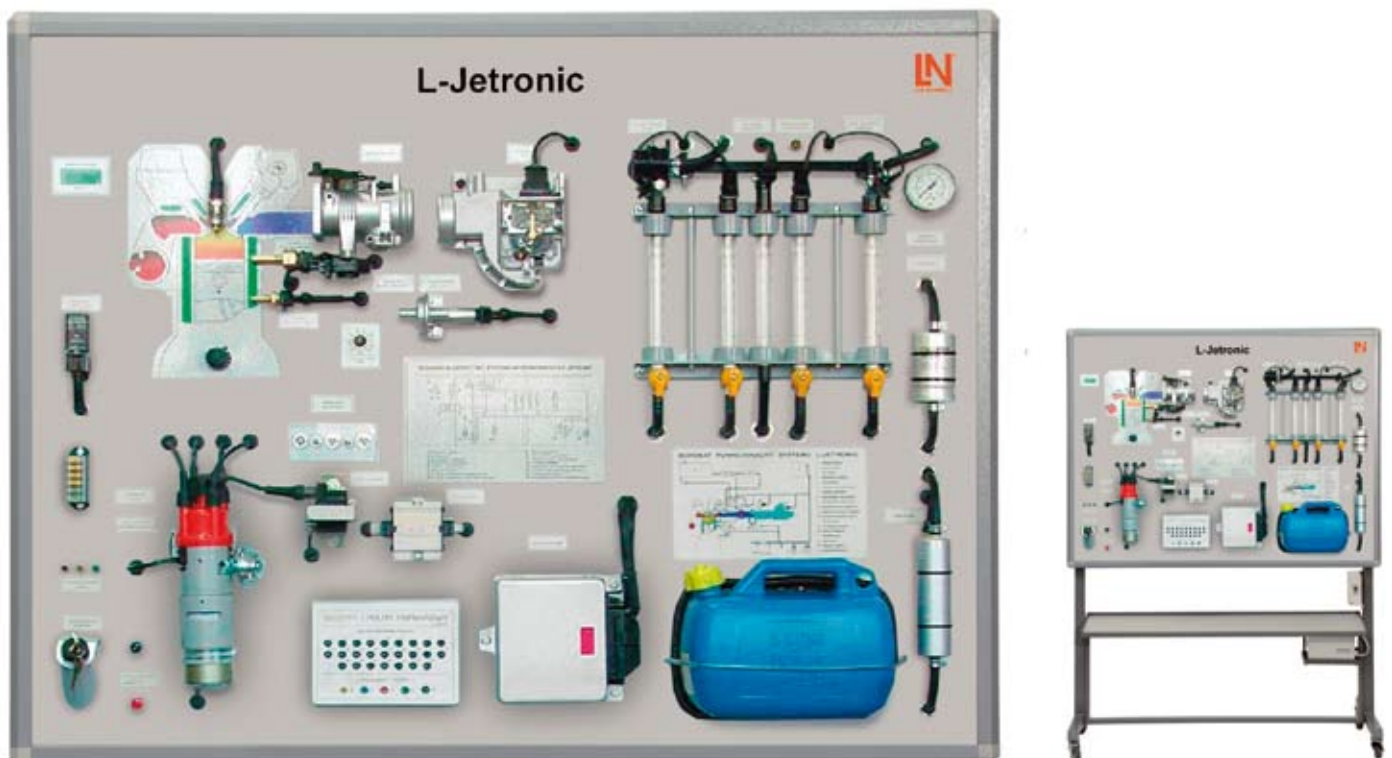

Training contents

- Understanding engine management functionality
- Understanding the functions of the involved control circuits
- Conducting typical electrical measurements on various engine management components
- Interpreting and using circuit diagrams
- Building up diagnostic skills
- Planning and implementing typical diagnostic strategies
- Sensors and actuators
- Open-loop and closed-loop control
- Assembly groups and systems for air-fuel mixture preparation in petrol engines

Engine Management

D-Jetronic (Mono-point)

D-Jetronic was the first electronic, pressure-controlled fuel system, introduced in 1967 by Bosch. The main constituent of D-Jetronic is its intake manifold pressure sensor (MAP sensor).



Training contents

- Understanding engine management functionality
- Understanding the functions of the involved control loops
- Conducting typical electrical measurements on various engine management components
- Interpreting and using circuit diagrams
- Building up diagnostic skills
- Planning and implementing typical diagnostic strategies

Connect® FIRE Software-based Performance Tuning at an Engine Test Bench

Connect® FIRE is a supplement to the internationally unique, interactive, multimedia engine management system Connect®. A special feature of Connect® FIRE is its miniature fuel injection engine with electronically controlled loading unit, control unit, interface and intelligent teachware / software.

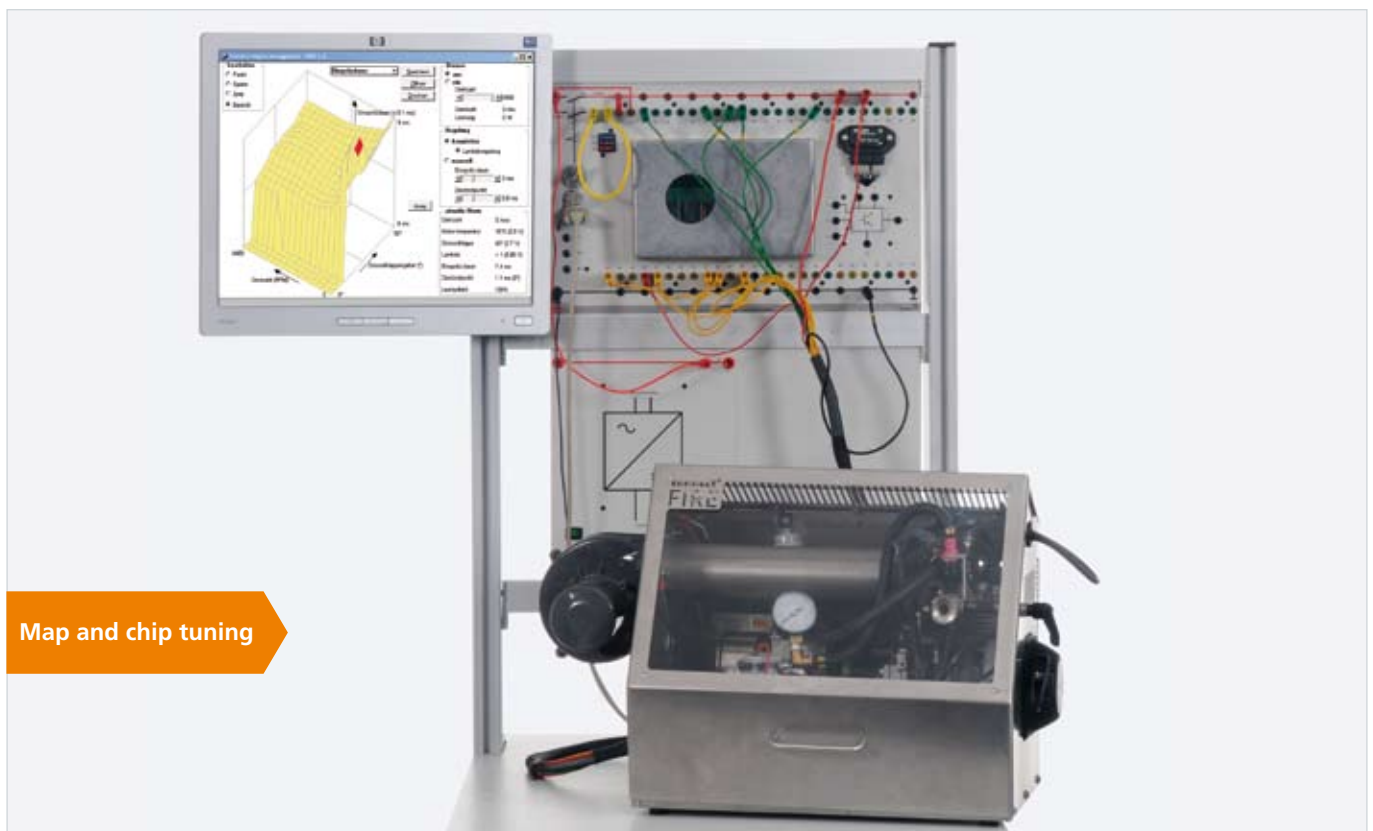

Map and chip tuning

Experiment: Performance tuning at an engine test bench

Training contents

- Conducting measurements on various engine management components
- Observing the engine's response to changes in timing
- Editing and optimizing maps for idling, ignition and injection
- Recording performance and torque characteristics
- Optimizing performance and torque (chip tuning)
- Investigating emission characteristics

Engine Management

Functional Engine

Standard commercial diagnostics testers can be used to read out the functional engine's error memory via the OBD terminal in order to perform typical automotive diagnoses. As in real life, all signals can be tapped from the cable harness or the plug connectors. A switch can be used to easily simulate typical electrical faults on the engine.



Example: 1.9-litre common rail

Training contents

- Learning typical assembly and dismantling tasks
- Identifying components and getting acquainted with their operating characteristics / parameters
- Learning and implementing genuine diagnostic strategies
- Interpreting technical documentation
- Reading circuit diagrams
- Conducting typical measurements and interpreting their results
- Using computer-aided diagnostic devices

Equipment

Engine models

- Diesel (pump injector)
- Diesel (common rail)
- Spark-ignition (direct injection)
- Further models available on request



Safety

- Guards are installed to prevent inadvertent contact with any hot or rotating part
- Noise levels have been lowered by slightly modifying the exhaust system



Diagnosis

- The error memory can be read out via the OBD terminal
- Sensor signals can be tapped via the cable harness or the plug connectors, as in real life
- Signals can also be tapped easily via a breakout box
- An error box can be used to realistically simulate malfunctions and faults



Your benefits

- Documents tailored to training and educational purposes
- Practical training
- Exercises ranging from simple oil change to sophisticated engine diagnosis

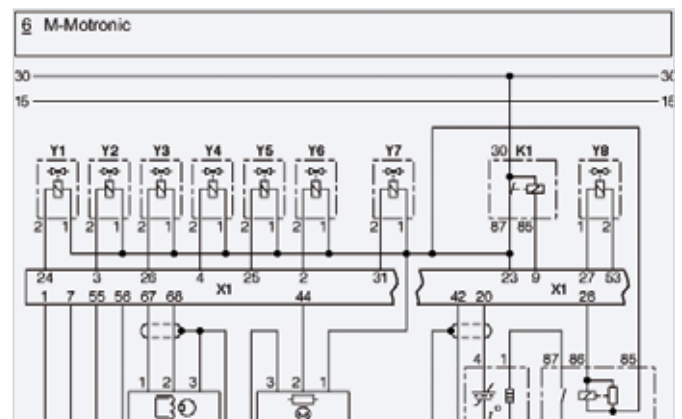



Vehicle Diagnosis

On-board Diagnosis II	88
On-board Diagnosis II Data Recorder	89
Auto Diagnosis Trainer Software	90
Automobile Diagnosis Case	91
Automobile Diagnosis Unit with an Oscilloscope	92
PDA Vehicle Diagnosis Unit	94
LIN/CAN Monitor	95
Common Rail Diagnosis Set – High-pressure	96
Common Rail Diagnosis Set – Low-pressure	97

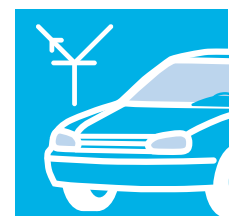

Vehicle Diagnosis

Developing of Diagnostic Strategies

Trouble shooting methods and strategies are used as part of systematic vehicle diagnosis. Manufacturer-specific diagnosis concepts also need to be considered in this process. Maintenance strategies are planned on the basis of customer information, visual checks and the results of independent diagnosis.



On-board diagnosis II

This is used by students to perform diagnoses in the area of engine management. Students identify the engine management system with the help of electronic information systems and vehicle-specific documents, and perform system analyses. A standard interface provides access to the engine control unit.



Engine tester

The engine tester is an indispensable aid for diagnosis, maintenance and repair of all important automotive systems. It can be used to read vehicle-specific data, errors and parameters out of the control units.



Training systems

Our training systems cover the following topics:

- On-board diagnosis II
- Vehicle diagnosis and trouble shooting methods
- Diagnoses of petrol and diesel



Vehicle Diagnosis

On-board Diagnosis II

This course demonstrates how to read out emission data with the help of the on-board diagnosis unit (OBD II or EOBD), interpret the data and use the results as a basis for eliminating systemic faults.



Training contents

- Diagnoses of systems of emission-relevant systems
- Systematic development of trouble shooting and diagnostic strategies
- Working with test devices
- Planning fault localization and repair measures
- Evaluating and documenting test results

On-board Diagnosis II – Data Recorder

This remote diagnosis unit can be used to record automotive data while the vehicle is moving. Recorded data can be transferred to software programs for the purpose of evaluation in tabular or graphic form.

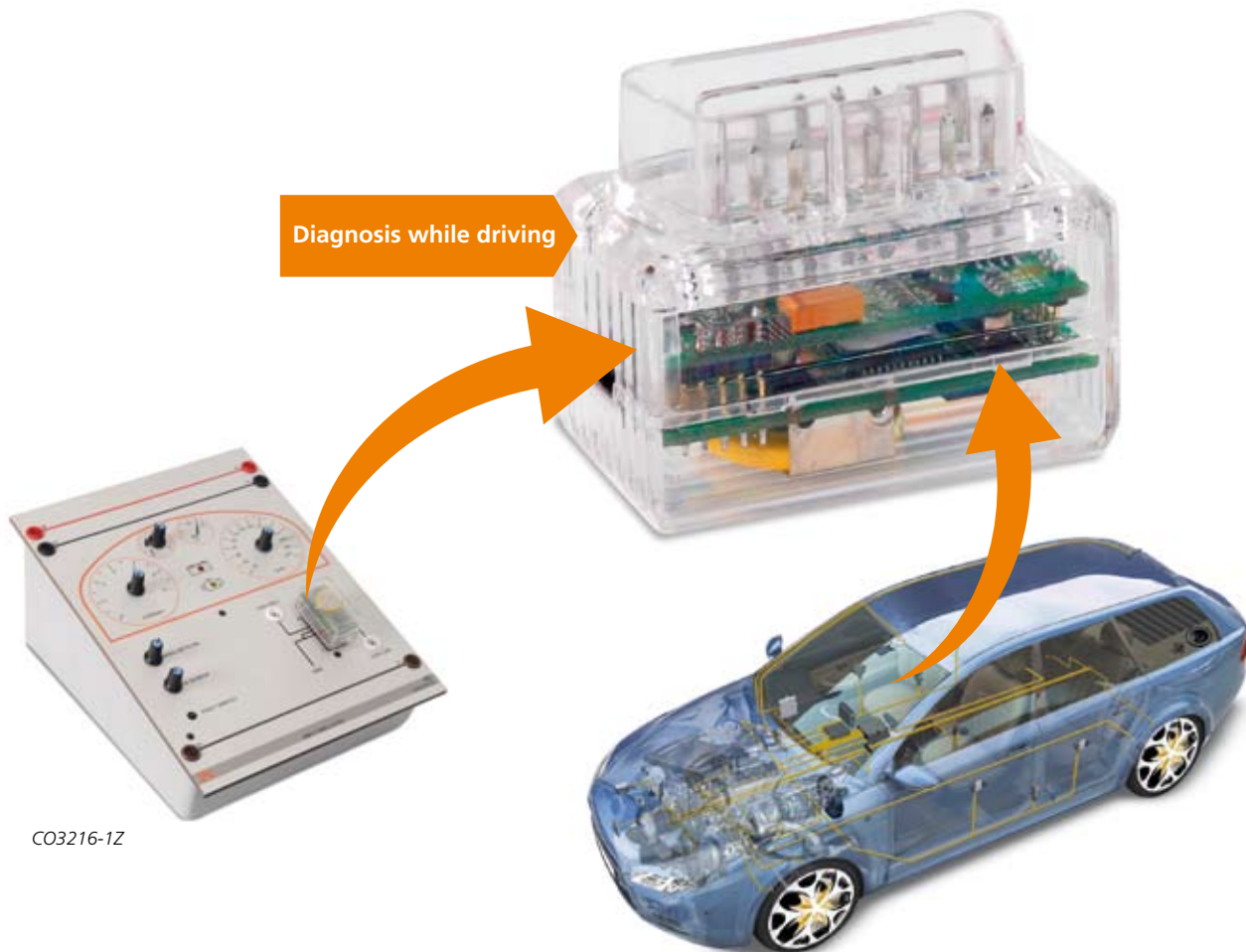

CO3216-1Z

Your benefits

- Compact plug-and-play device
- Automatic recording of all data specific to OBD II (24 hours)
- Evaluation by means of diagnostic software
- User-friendly menu guidance and data display
- Supported protocols
 - OBD II: ISO9141, SAE J1850VPW, SAE J1850 PWM
 - EOBD: ISO14230KPW
 - CAN Bus: ISO15765

Vehicle Diagnosis

Auto Diagnosis Trainer Software

Lucas-Nülle's new automobile diagnosis trainer (ADT) software is meant for students to develop and consolidate strategies for successful automotive diagnosis and trouble shooting using a training program before moving on to real vehicles.

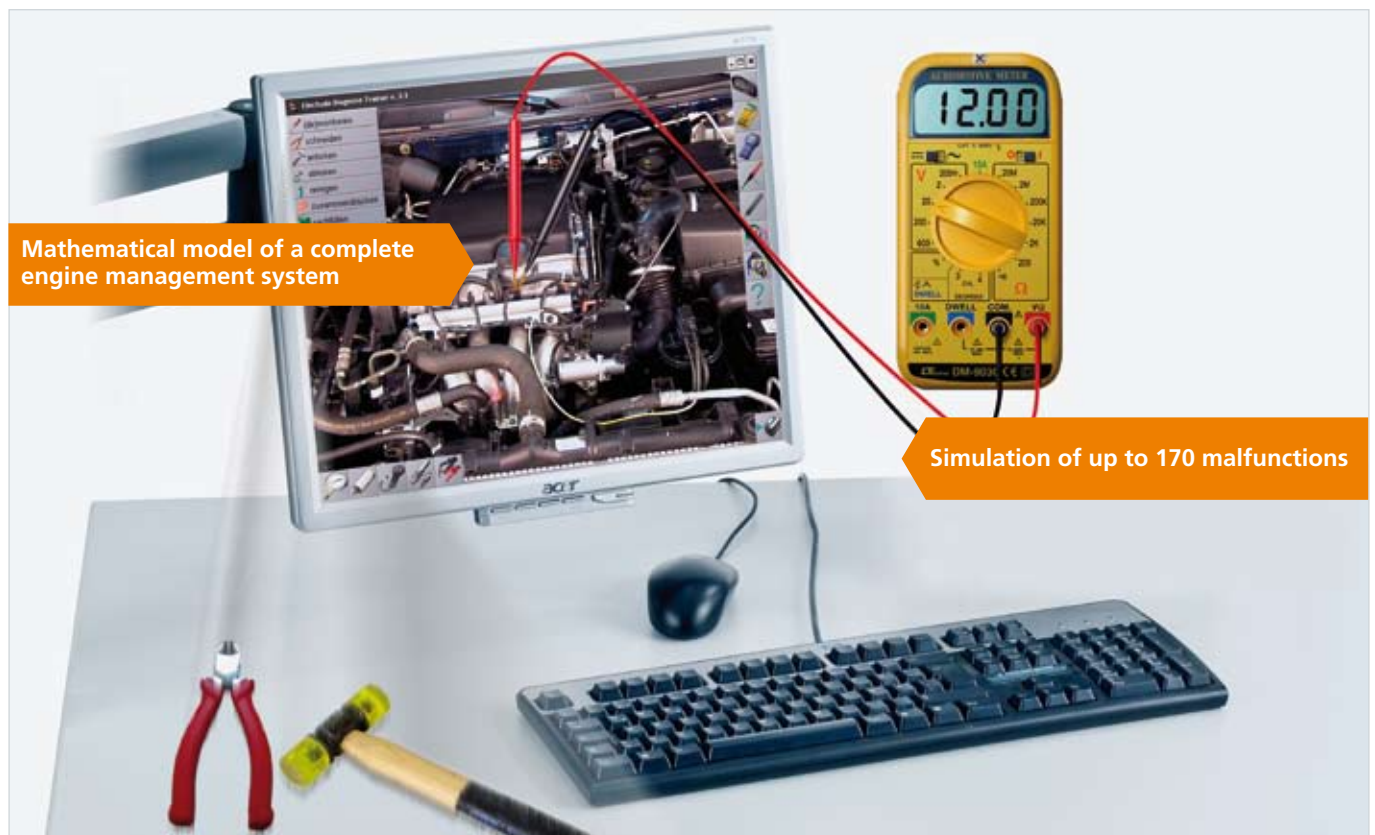

Training contents

- Diagnosis and maintenance in the area of engine management
- Developing diagnostic strategies
- Planning fault localization and repair measures
- Documenting, monitoring and assessing implemented measures
- Working with block, circuit and function diagrams
- Working with measurement devices and diagnostic tools

Automobile Diagnosis Case

The diagnosis case was developed to meet the demands of automobile manufacturers and workshops as well as service and training centres. It serves as a universal means of contacting all connectors present on a motor vehicle. Secure contacting as part of diagnosis and trouble shooting on motor vehicles helps to quickly obtain the best possible measurement and test results.



Your benefits

- High-quality, comprehensive service case for automotive diagnosis and trouble shooting
- Integrated, universal, laboratory multimeter
- Secure contacting of connectors most commonly found on motor vehicles
- Flexible, temperature-resistant adapter leads
- Needle-shaped, miniature probe tips made of spring steel and especially suited to contacting enclosed connectors

Vehicle Diagnosis

Automobile Diagnosis Unit with an Oscilloscope

This versatile diagnosis unit incorporates the functions of an engine tester, oscilloscope, sensor tester, multimeter and vehicle database. The database contains technical information for vehicle service personnel, including comments on error codes, setpoint data, circuit diagrams and setpoint curves. Bluetooth technology allows vehicles to be tested within a radius of up to 20 m.

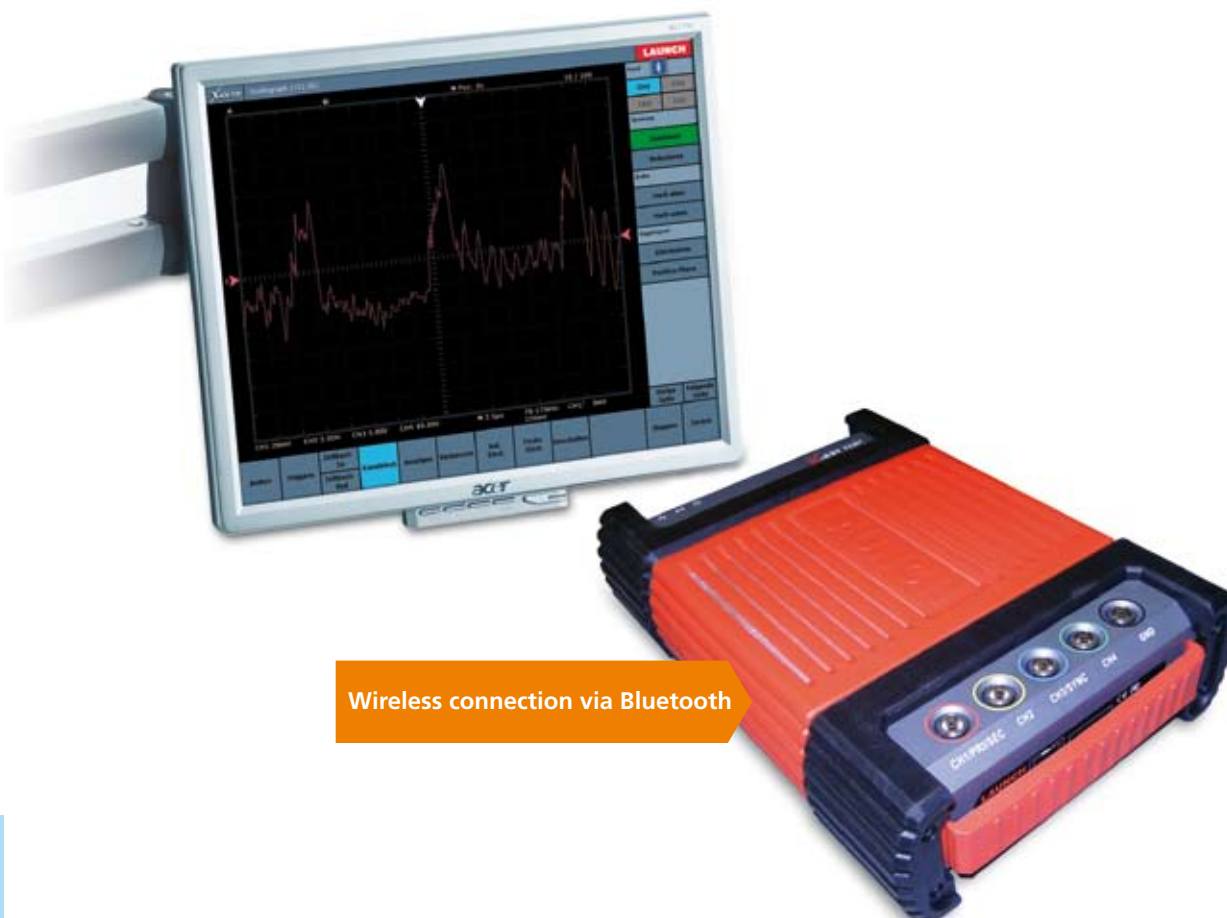

Wireless connection via Bluetooth

Your benefits

- Wireless diagnosis of electronic control units via Bluetooth
- Up to 148 systems per vehicle type (all common models)
- Recording of current data
- Display of primary and secondary ignition curves
- Various possibilities of automotive sensor simulation
- Integrated 4-channel oscilloscope, battery tester and multimeter
- Vehicle database with technical data, service information on error codes and circuit diagrams
- Measuring adapters and diagnosis lines for all common vehicles included

Includes

- Diagnostic unit
- Adapter for all common motor vehicles
- Diverse measurement leads
- Manual



Engine analysis

- Display of primary and secondary ignition curves
- DIS ignition curve
- Power analysis (in kW)
- Test and analysis of starter current
- Charging voltage and sensor signals

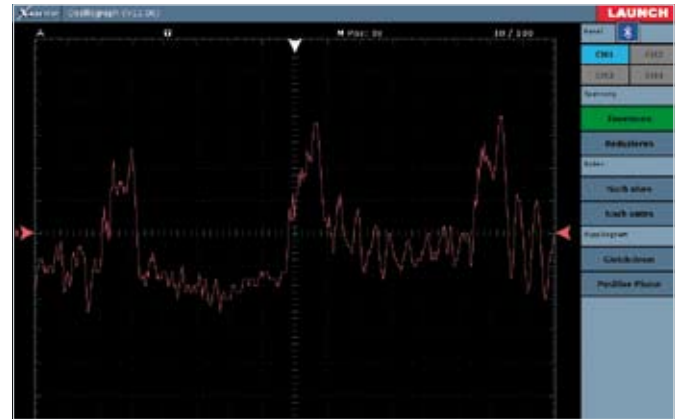

Sensor simulation

- Simulation of DC signals, pulse signals, standard curve shapes and manually traced curves
- Output voltage: -12 V to +12 V
- Output current: max. 40 mA

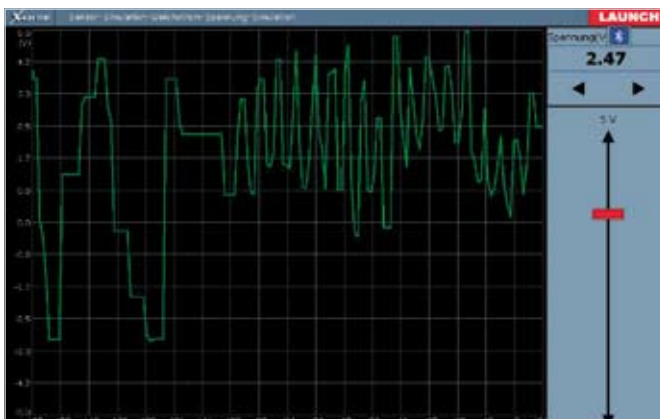

Vehicle database

- Technical data for vehicle servicing
- Service information on error codes
- Setpoint reference data and curves
- Circuit diagrams
- Recording of current data



Vehicle Diagnosis

PDA Vehicle Diagnosis Unit

A handy vehicle diagnostic unit incorporating state-of-the-art technology in PDA format. Its impressive features include fast response and ease of use. The device furthermore possesses the unique capability of diagnosing two vehicles simultaneously: If data are lacking, a second vehicle can be used as a reference for direct comparison with actual data.



Your benefits

- Small and handy to use
- Portability
- Wireless communication via Bluetooth at up to 25 m
- Large memory card, allowing for large quantities of vehicle data to be stored
- Read-out/deletion of fault codes
- Engine scan and many other functions, including gearbox, airbags, ABS tests, etc.
- Live data transfer
- Capability of accessing daily updates via internet download
- PC interfaces via Bluetooth and USB
- Printer interface via Bluetooth and USB

LIN/CAN Monitor

The LIN/CAN monitor allows bus protocols on a LIN bus, CAN bus or any serial bus to be recorded and investigated.

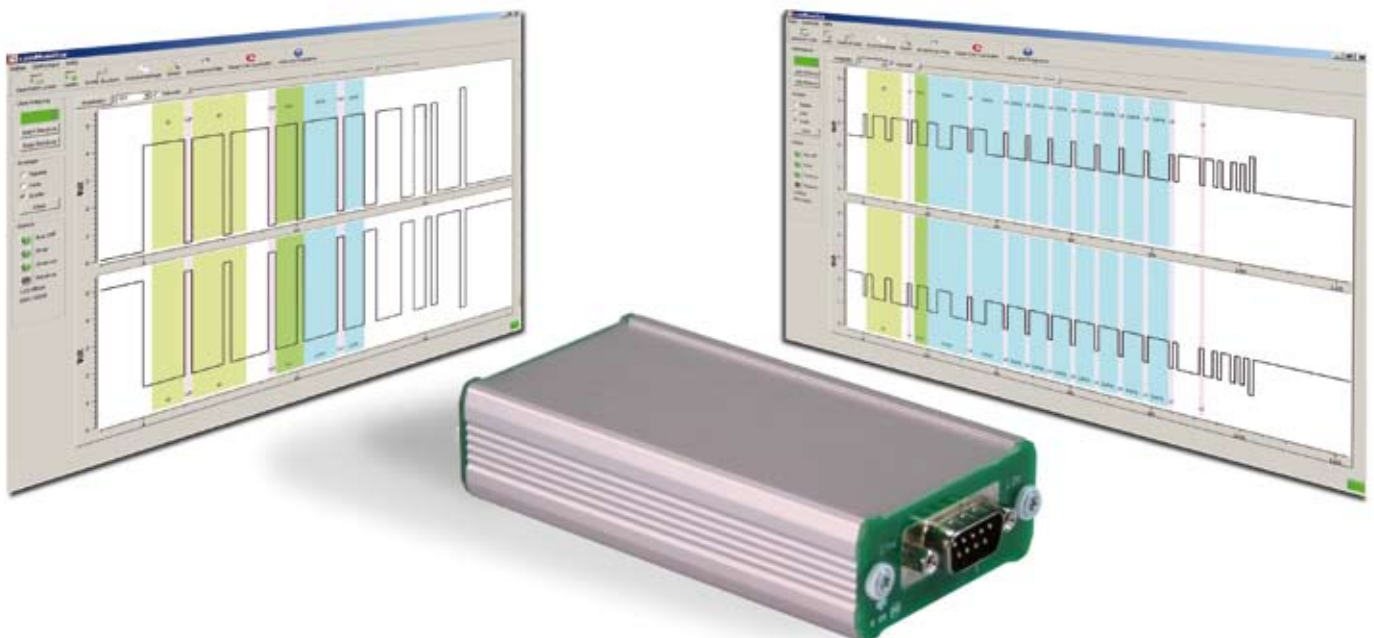

Your benefits

- Visual display of bus protocol structure
- Option for displaying in binary or hexadecimal code format
- Recording of bus packets
- Transmission of bus packets
- Suitable for student experiments and demonstrations
- Simple to put into operation
- Displays 'identifier - data length - period'
- User-configurable graphic interface

Vehicle Diagnosis

Common Rail Diagnosis Set – High-pressure Injectors in Circulation Method

This portable diagnosis set can be used to test common rail high-pressure injectors with the engine running. All familiar common rail systems can be linked to the diagnosis set via original connecting elements. During diagnosis, the fuel's reflux rate, pressure and return temperature can be measured continuously.



Training contents

- Understanding the functions of common rail technology
- Testing high-pressure injectors in circulation method
- Diagnosis and maintenance of engine management systems
- Building up diagnostic skills
- Conducting measurements on common rail systems
- Principles of rail-pressure regulation

Common Rail Diagnosis Set – Low-pressure Circuit Tests

The pressures in the feed and return lines of the various systems here must adhere to manufacturer specifications. Low-pressure circuits are tested to permit fault localization and ensure trouble-free operation. Such tests make it possible, for instance, to detect air bubbles and impurities in the fuel system.



Training contents

- Introduction to the common rail low-pressure system
- Understanding the functions of common rail technology
- Diagnosis and maintenance of engine management systems
- Building up diagnostic skills
- Principles of rail-pressure regulation
- Conducting measurements on common rail systems

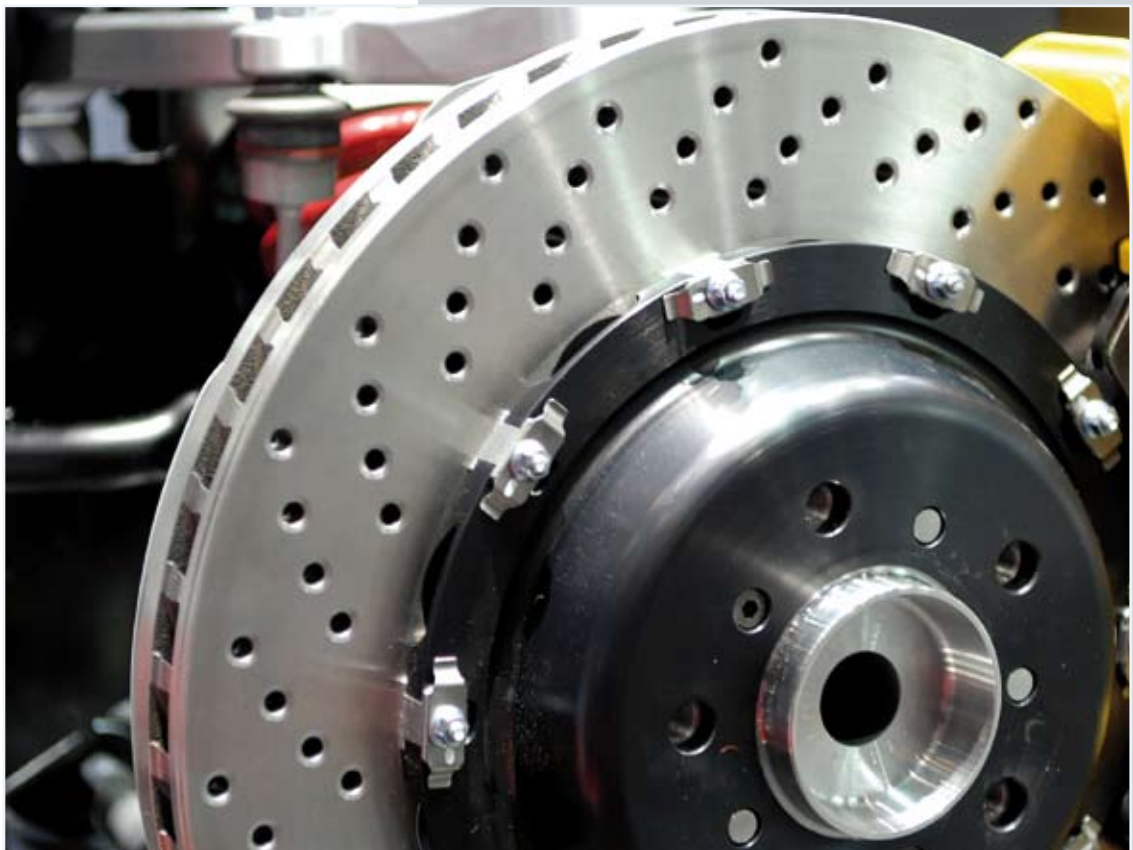

Chassis and Driving Safety

Electromechanical Parking Brake	102
Electromechanical Power Steering	103
Brake Systems – ABS, ESP, ASR and Brake Assistant	104
Brake Power Control with ABS and ASR	105
Anti-lock Brake System ABS	106
Hydraulic Brake System	107
Airbag, Seat-belt Tensioner and Crash Behaviour	108
SRS Airbag and Seat-belt Tensioner	109
Suspension, Springs and Shock Absorbers	110
Gearbox and Drive	111
Steering Systems	111

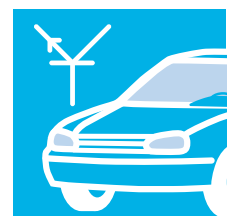

Chassis and Driving Safety

Active and Passive Safety

The sensors and actuators of the systems involved here perform important functions for active and passive safety, comfort as well as engine management in motor vehicles. Driving safety and impact protection features are especially significant to the safety of a vehicle's occupants. Work on such safety components requires sound qualifications acquired through first-rate training and education systems. Students are introduced to the complex subjects by a combination of e-learning courses and real-life compact systems, and are able to apply acquired skills on true replicas of original components.



ABS

ABS measures a wheel's circumferential speed. During braking, the wheel's slip is calculated automatically and the brake pressure regulated accordingly. This prevents the wheel from blocking. Our true replica of an original ABS system allows students to examine these functions and perform related measurements.

**Airbag**

The airbag training environment from our family of panel systems allows practical experiments and demonstrations using an SRS airbag and seat-belt tensioner. This UniTrain-I airbag course includes a steering wheel with a fully functional, re-usable airbag.

**Training systems**

Our training systems cover the following topics:

- Airbag and belt tensioner
- ABS and ASR
- Chassis technology
- Steering systems
- Transmission technology



Chassis and Driving Safety

Electromechanical Parking Brake with AUTO-HOLD Function

An electromechanical parking brake replaces the conventional handbrake with a simple switch on the dashboard so that there is no need for a handbrake lever. On uphill starts, sensors determine how steep the slope is. If the driver stops the vehicle, the brake engages automatically until the car is started again.



Training contents

- How rear-wheel brake actuators work
- Sensors and actuators in an electromechanical parking brake
- How an electromechanical parking brake works
- Parking brake function
- Dynamic pull away assistant
- Dynamic emergency brake function
- AUTO-HOLD function
- Gauging of brake discs
- Understanding how brake boosters and hydraulic brakes work
- Interpretation and use of technical documentation
- Experimental investigation of the various functions for improved understanding
- Assembly, configuration and testing of mechanical components
- Design and function of disc brakes

Electromechanical Power Steering

Electromechanical power steering has many advantages over hydraulic steering. It assists the driver not just in purely physical terms, but also intelligently by responding only when the driver explicitly requests it. Steering assistance is provided as a function of vehicle speed as well as steering moment and angle.

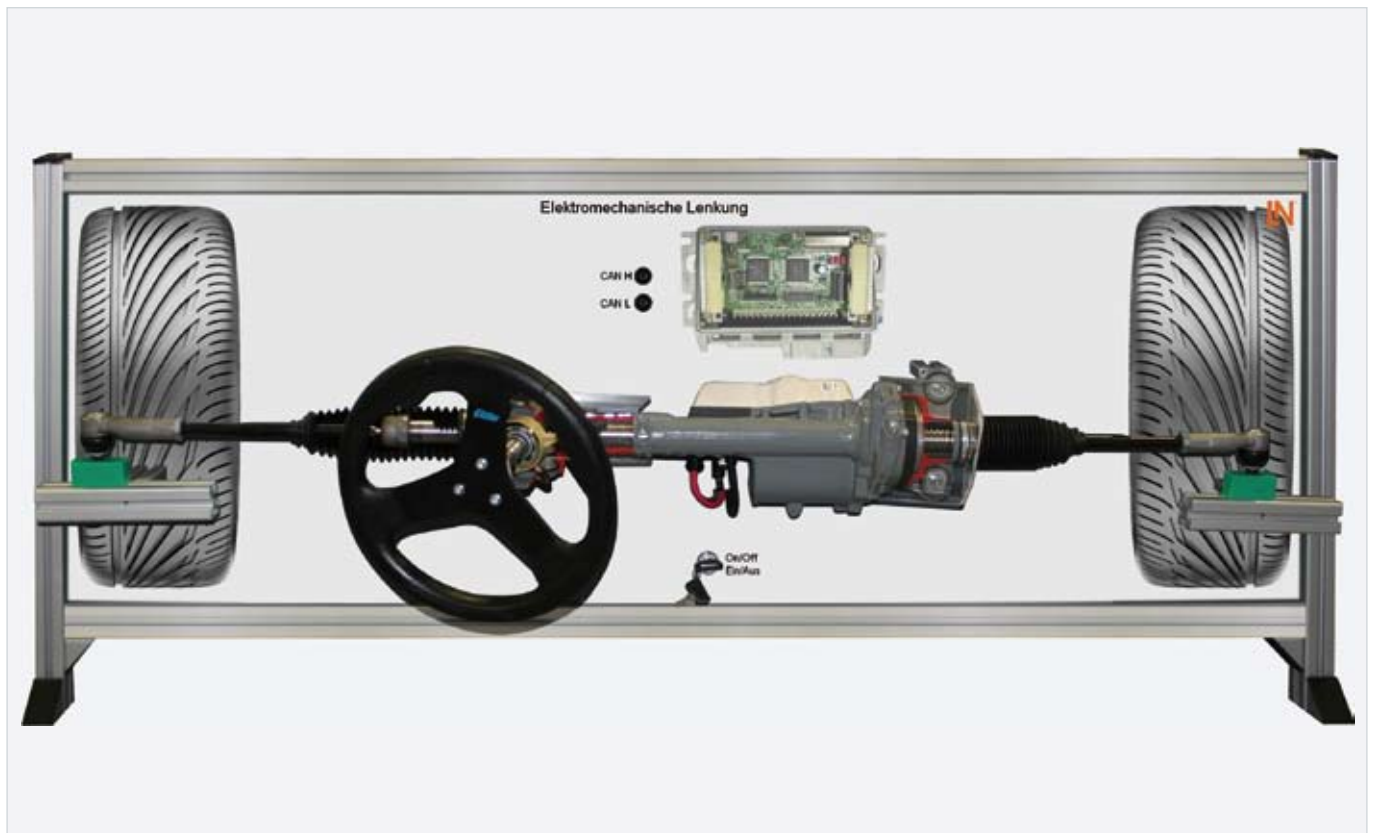

Training contents

- Design of an electromechanical power steering
- Function of the individual assembly groups
- Steering geometry
- Inverter control
- CAN bus control
- Vehicle speed sensor
- Steering angle sensor
- Steering moment sensor

Chassis and Driving Safety

Brake Systems – ABS, ESP, ASR and Brake Assistant

Brake systems of modern motor vehicles are becoming increasingly complex. Electronic aids such as ABS, ASR and ESP are now standard features in such systems. Electronic brakes ("brake-by-wire") currently still in the experimental phase are to be introduced to the market soon.

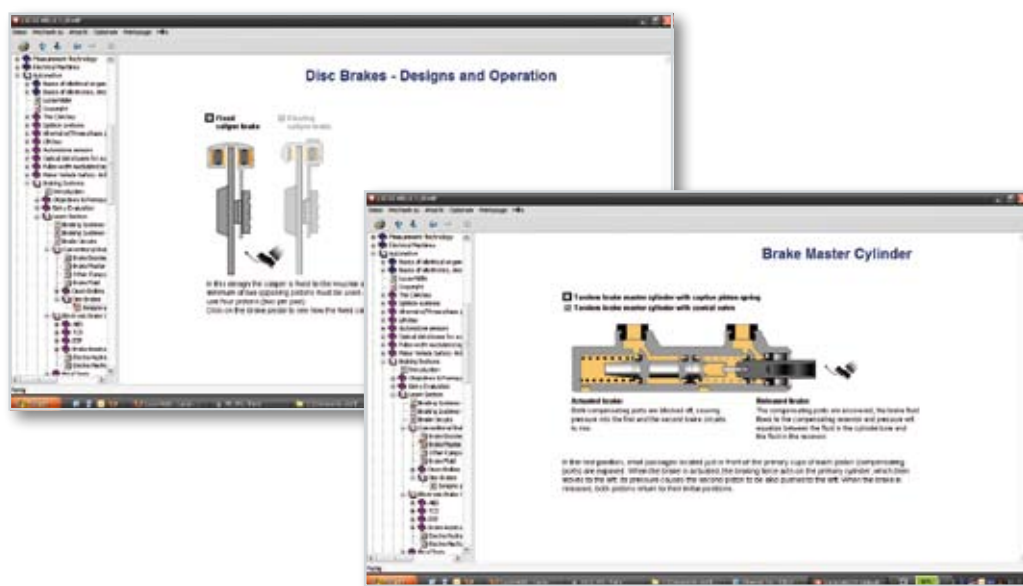

Training contents

- Design of a brake system
- Main brake cylinder
- Brake booster
- Drum and disc brakes
- ABS
- Traction control (ASR)
- Electronic stability program (ESP)
- Brake assistant

Brake Power Control with ABS and ASR

This training system permits practical experimentation and demonstrations by means of an electronically controlled ABS/ASR brake system (Bosch 5.3). All important electrical signals can be tapped centrally via 4-mm sockets.



Training contents

- Understanding the functionality of a typical brake system incorporating ABS and ASR
- Understanding the functionality of brake boosters and hydraulic brakes
- Identifying the effects of typical malfunctions on brake systems incorporating ABS and ASR
- Conducting various electrical measurements
- Interpreting and employing technical documentation
- Building up diagnostic skills
- Planning and implementing typical diagnostic strategies

Chassis and Driving Safety

Anti-lock Brake System ABS

The ABS system possesses four original wheel brake cylinders controlled hydraulically via authentic brake lines. The system's very realistic design makes for equally realistic training.

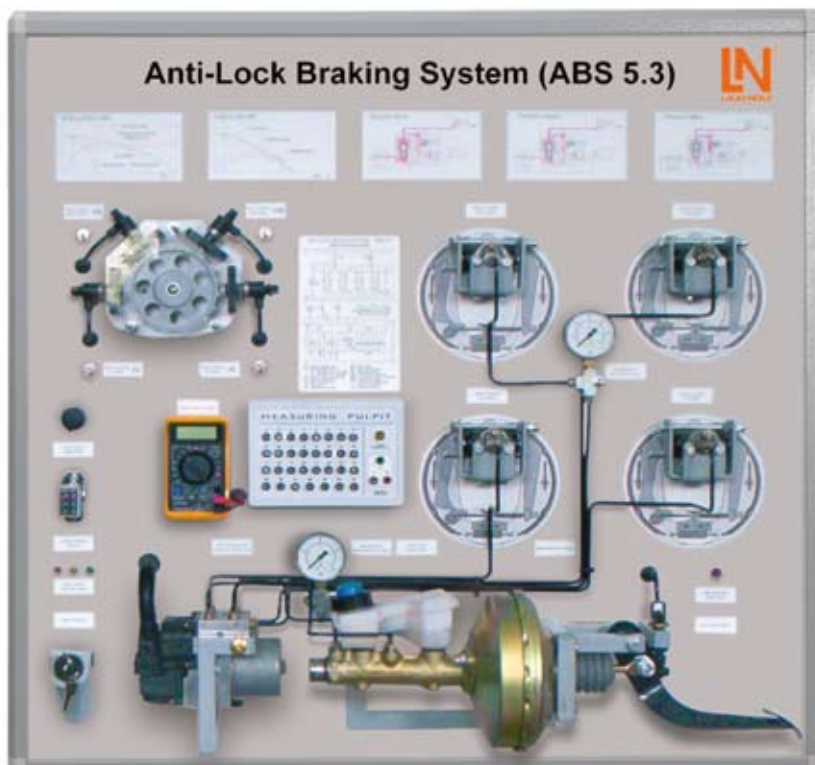

Training contents

- Understanding the functionality of a typical ABS brake system
- Understanding the functionality of brake boosters and hydraulic brakes
- Identifying the effects of typical malfunctions on ABS brake systems
- Conducting various electrical measurements
- Interpreting and employing technical documentation
- Building up diagnostic skills
- Planning and implementing typical diagnostic strategies

Hydraulic Brake System

This training system contains all the relevant electrical, mechanical and hydraulic components forming part of a typical brake system in a passenger car.

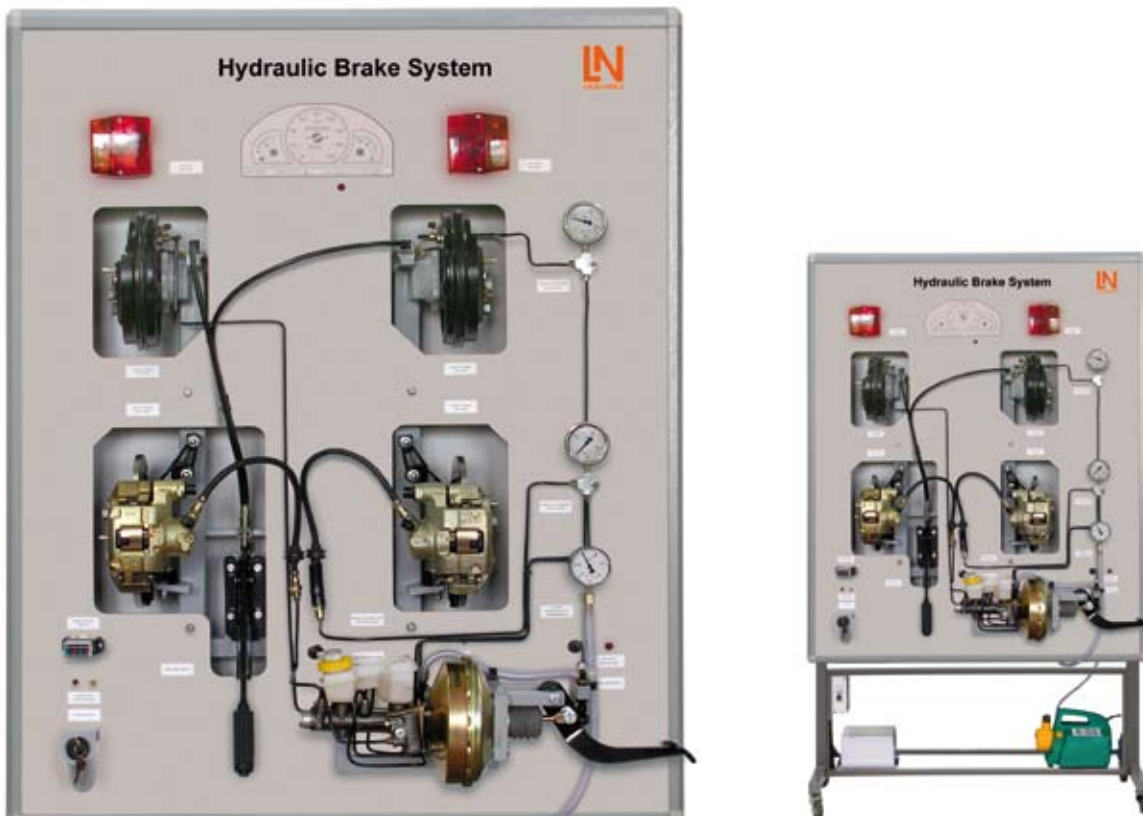

Training contents

- Understanding the functionality of a typical brake system in a passenger car
- Understanding the functionality of brake boosters and hydraulic brakes
- Examining the effects of typical malfunctions on a brake system
- Conducting pressure measurements on various brake circuits
- Performing typical settings and maintenance tasks on brake components
- Interpreting and employing technical documentation
- Building up diagnostic skills
- Planning and implementing typical diagnostic strategies

Chassis and Driving Safety

Airbag, Seat-belt Tensioner and Crash Behaviour

Active safety systems like airbags and seat-belt tensioners have been standard features in all vehicle classes for years. Regular inspections of these features are needed to ensure that they operate properly.



Optional: SO3219-1P

UniTrain
SYSTEM

Training contents

- Active and passive safety in motor vehicles
- Operating principles of airbags and seat-belt tensioners
- Safety switch and ignition cap
- Operating principle of pressure and acceleration sensors
- Measurement of acceleration
- Typical crash situations
- Trigger times and sequences
- Fault management for airbag systems
- Trouble shooting

SRS Airbag and Seat-belt Tensioner

This training environment from our family of "Compact" systems allows practical experimentation and demonstrations using an SRS airbag and seat-belt tensioner. The system's very realistic design makes for equally realistic training.



Training contents

- Understanding the functionality of an SRS system
- Understanding the operating principles of pyrotechnic actuators (airbag and seat-belt tensioner)
- Identifying the effects of typical faults on SRS systems
- Conducting various electrical measurements
- Interpreting and employing technical documentation
- Building up diagnostic skills
- Planning and implementing typical diagnostic strategies

Chassis and Driving Safety

Suspension, Springs and Shock Absorbers

The chassis and suspension need to perform diverse functions. For safe and comfortable driving, they must ensure a high level of traction while absorbing jolts from bumps in the road.

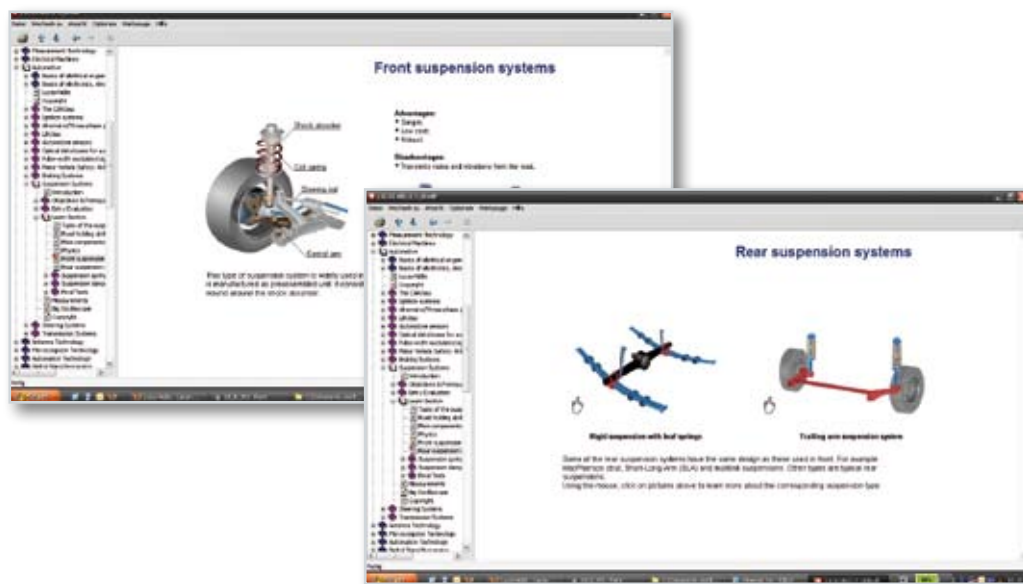

Training contents

- Introduction to chassis functions
- Suspension design and components
- Front-axle suspension systems
- Rear-axle suspension systems
- Leaf springs
- Helical springs
- Torsion bar suspension
- Air suspension
- Rubber suspension
- Hydro-pneumatic suspension
- Stabilizer
- Hydraulic shock absorber
- Telescopic shock absorber

Gearbox and Drive

The gearbox is used to convert and transmit engine torques and speeds. Different gearwheel pairs are used to raise or lower gear ratios and reverse directions of rotation. In conjunction with the clutch, this makes it possible to control the transmission of power.

Training contents

- Design and components of the drive train
- Clutches
- Manual and automatic gearboxes
- Planetary gear and torque converter
- Infinitely variable gear
- Sequential gear
- Differential gear
- Drive shafts
- Front, rear and 4-wheel drive

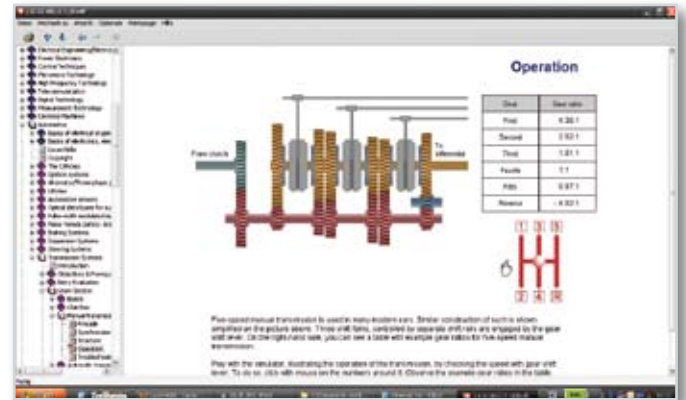

UniTrain
SYSTEM

Steering Systems

The steering is used to turn the vehicle's wheels. Special design features make it possible to realize a variety of turning angles. Power steering components boost the manual torque applied to a steering wheel.

Training contents

- Steering design and components
- Steering geometry: track, pitch, trailing
- Spread
- Steering gear and linkage
- Measuring and setting the steering on the chassis
- Diagnosis



UniTrain
SYSTEM



Networked Systems

CAN Bus	116
CAN Lighting Technology	117
CAN Comfort Technology	117
LIN Bus	118
Optical Waveguides	119

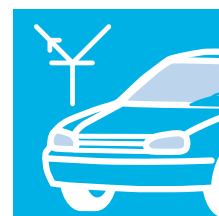

Networked Systems

Data Buses

A modern automobile's on-board networks are similar in magnitude to a medium-sized enterprise's IT network, where 70 to 90 control units are linked via different data buses for the extensive exchange of information. More than two-thirds of all automotive innovations are now software-based. LN training systems cover all the educational requirements pertaining to all common bus systems.



Optical data bus systems

Large quantities of data can be transmitted with the help of light waves. The UniTrain-I course on optical waveguides contains practical examples demonstrating how to handle such waveguides.

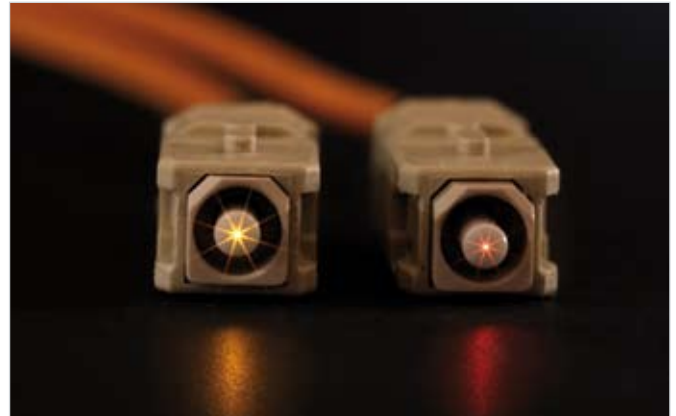

Networks

An automobile can be divided into various data communication zones, each one being assigned particular duties which place corresponding demands on the network. For this reason, the automobile is organized into a number of sub-networks. The various possibilities of doing this are described in our courses on bus systems.

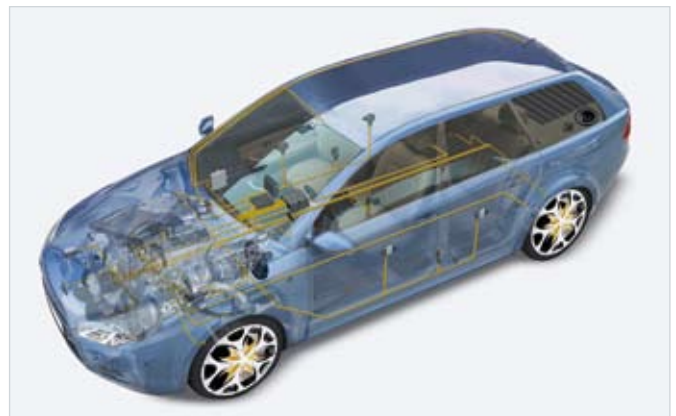

Training systems

Our training systems cover the following topics:

- CAN bus
- LIN bus
- MOST bus



Networked Systems

CAN Bus

Modern motor vehicles incorporate numerous electronic control units which communicate with each other continually via digital bus systems. Widely used for this purpose in passenger cars as well as commercial vehicles are CAN buses, especially when it comes to comfort, engine management and diagnostic applications.

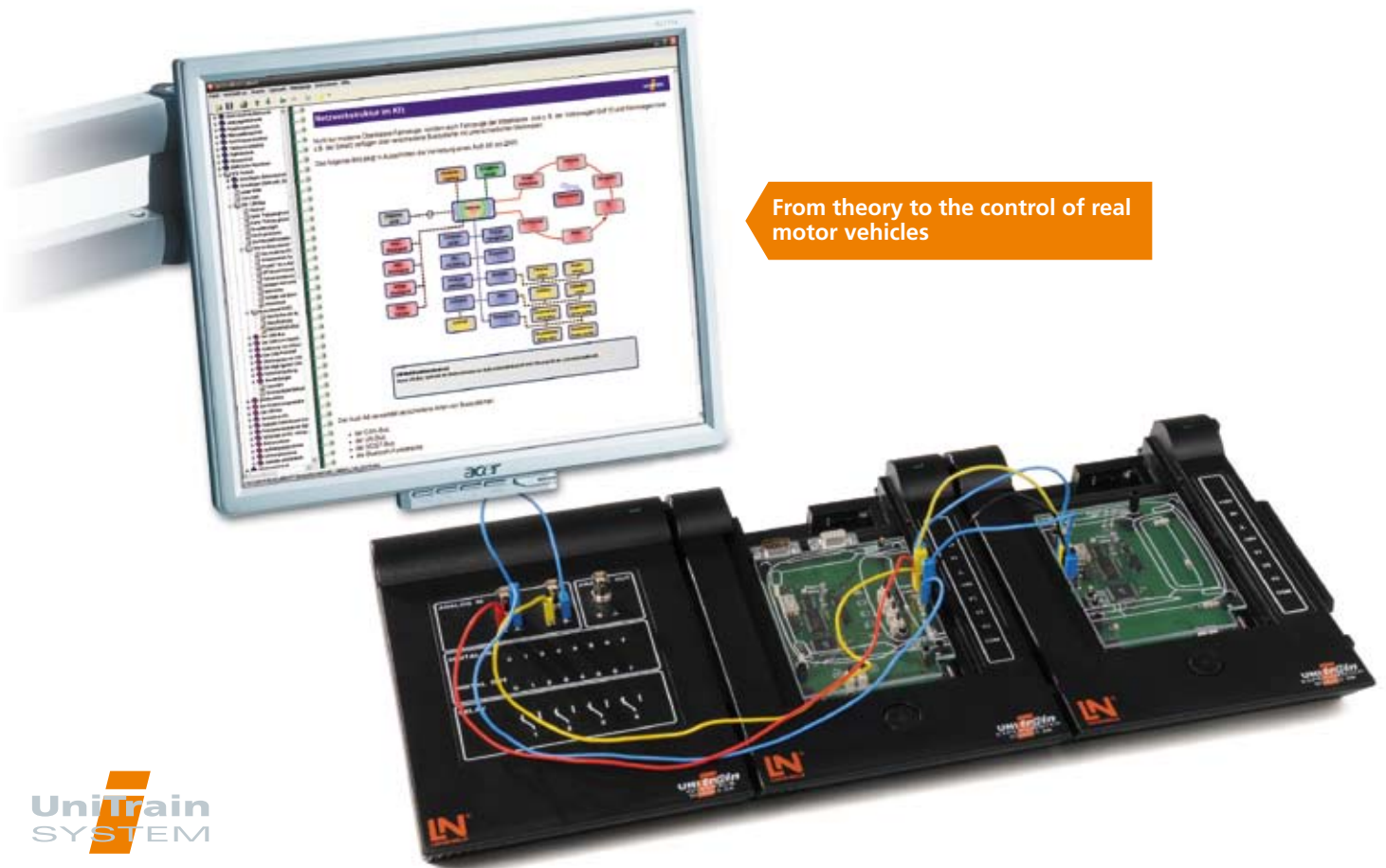

From theory to the control of real motor vehicles

UniTrain
SYSTEM

Training contents

- Reasons for using bus systems in motor vehicles
- Topology and components of a CAN bus system in a motor vehicle
- Differences between low-speed and high-speed CAN
- Electrical properties of a CAN bus
- Data rate, identifier, addressing and arbitration (low-speed and high-speed CAN)
- Design of a CAN message's frame
- Analyzing CAN messages with a CAN monitor and oscilloscope
- Editing and sending CAN messages via PC
- Trouble shooting

Training Projects Involving a CAN Bus

CAN Lighting Technology, Programming and Diagnosis

The "Lighting technology" training project supplements the CAN bus course with an additional control unit. The "Lighting technology" interface makes it possible to control any conventional lighting system. Such systems can be controlled via the switches and buttons on the UniTrain-I cards forming part of the "CAN bus" course.



Experiment: "Vehicle lighting control via CAN bus" with a SO3216-2Z interface and additional components

CAN Comfort Technology, Programming and Diagnosis

The "Car door" training project integrates an original car door into the experimentation system. This allows the door's essential functions (e.g. electric window winder and electrically adjustable external mirror) to be controlled by means of real CAN messages. The resultant data traffic on the CAN bus can be analyzed using the applications forming part of the LabSoft course.



Experiment: "Car door control via CAN bus", SO3216-2Y equipment set

Networked Systems

LIN Bus

In addition to the CAN bus, the somewhat simpler LIN bus is also used. This bus is employed mainly for comfort systems which are not crucial to safety.



UniTrain
SYSTEM

Training contents

- Development of bus systems in motor vehicles
- Topology and components of a LIN bus system
- Electrical properties of a LIN bus
- Addressing of a LIN bus
- Master / slave principle
- Measurement tests of data fields
- Message frame structure
- Analysis of LIN messages
- Editing and sending LIN messages
- Trouble shooting

Optical Waveguides

At present, optical bus systems are used mainly to achieve high data transmission rates in luxury automobiles. However, optical buses are likely to find broader use in view of the increase in data volumes that generally require processing in automobiles.



Training contents

- Data networks in motor vehicles
- Reasons for using optical waveguides in automotive applications
- Fundamentals of the MOST bus
- MOST protocol and control units
- Ring breakage diagnosis
- Design of optical waveguides in motor vehicles
- Optical bus systems in motor vehicles
- Fundamentals of ray optics (refraction, reflection)
- Attenuation by optical waveguides
- Data transmission and optical measurements on optical waveguides



Practical Automotive Workshop Lab

Exhaust Gas Analysis and EOBD Data Readout	124
Tyre Fitting Machine	125
Balancing Machine	126
Axle Measurement	127
Two-column Hydraulic Lifting Platform	128
Four-column Hydraulic Lifting Platform	129
Fully Automatic Air-conditioning Service Unit	130
Vehicle Tool Kit – 77 Pieces	131
Set of Socket Spanners – 94 Pieces	132
Trolley with 64-piece Tool Kit	133

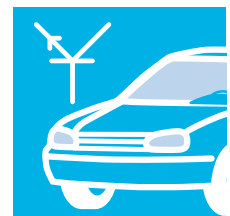

Practical Automotive Workshop Lab

Complete Solution – a Practical Lab for Assembly, Dismantling and Diagnosis of Vehicles and Automotive Assembly Groups

Diagnosis and maintenance of engine management systems

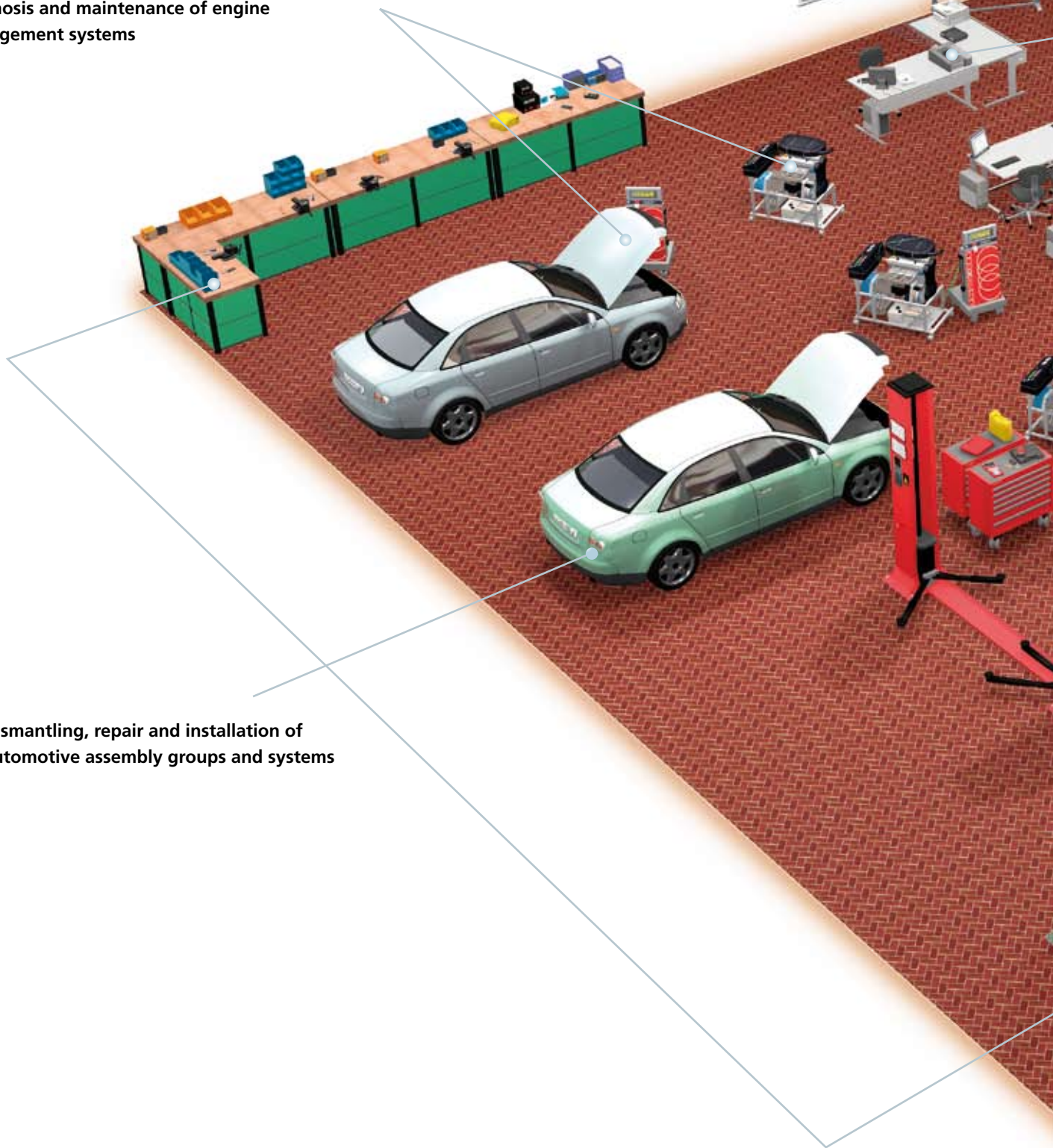

Dismantling, repair and installation of automotive assembly groups and systems

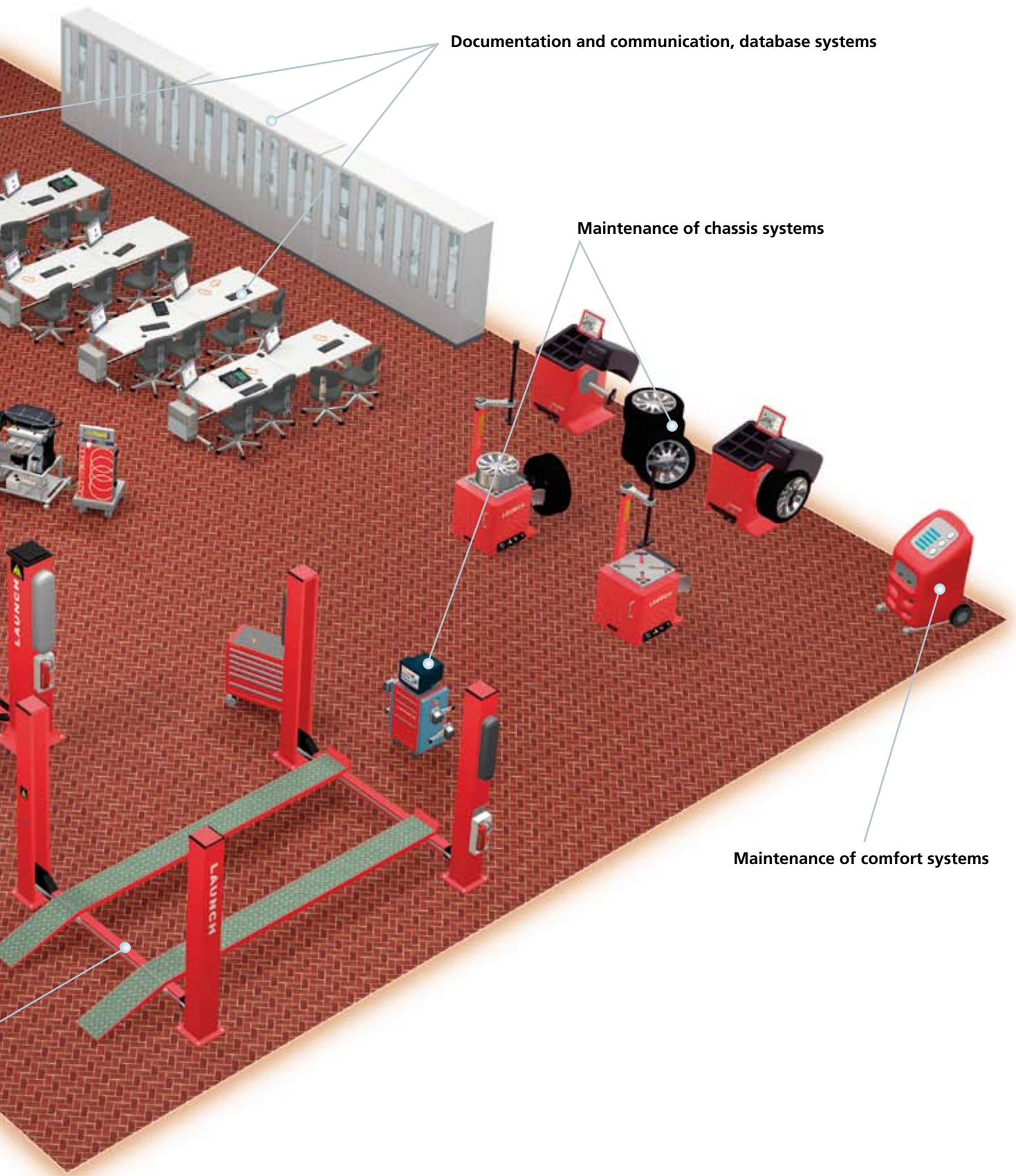

Documentation and communication, database systems

Maintenance of chassis systems

Maintenance of comfort systems

Practical Automotive Workshop Lab

Exhaust Gas Analysis and EOBD Data Readout

Analyses of exhaust gases from combustion engines provide information on the composition of such gases. The concentrations of individual constituents in exhaust gases depend on a variety of factors, including the type of fuel, combustion process and engine model.



Your benefits

- Emission tests of vehicles with a spark-ignition or diesel engine
- Emission tests of EOBD vehicles with a spark-ignition or diesel engine
- Large LCD display for indicating results
- Integrated vehicle database
- Storage of customer-specific data
- Interface for export to the "AU-Plus" emission test module
- Infrared remote control
- Rollers for device mobility
- Simple operation by means of arrow keys and keypad
- Menu guidance and emission test log printout

Tyre Fitting Machine

The tyre fitting machine covers all workshop requirements for modern tyre fitting technology. Stable, safe and fast, the machine complies with international specifications.



Your benefits

- Ability to fit a wide range of tyres
- Pneumatic locking of the fitting arm and release of the fitting head
- Pneumatic, backward-tilting mounting column
- Powerful drive motor
- Compliant with UL / CE international specifications
- Quiet operation
- Metal / plastic fitting head compatible with various wheel types

Practical Automotive Workshop Lab

Balancing Machine

Increasingly complex chassis components on modern motor vehicles entail increasingly precise wheel balancing techniques. Balancing is performed with the aid of small weights fastened to the rim using a variety of methods.



Your benefits

- Three programs for aluminium rims
- Program for hiding weights behind rim spokes
- Manual entry of wheel data
- Simple switchover between grams and ounces
- Quick wheel locking and release
- High dependability to the nearest gram
- Universal tightening nut
- Exact indication of the imbalance position
- Including:
 - 4 cones
 - 2 adapter rings
 - Quick-clamping nut
 - Measurement aid
 - Weight pliers
 - Calibration weight (100 g)

Axle Measurement

Axle measurement and adjustment are required if the vehicle drifts left or right instead of travelling straight ahead. One indicator of a possible need for axle measurement is one-sided or uneven wear of tyre tread.



Your benefits

- Standard measurement
- Quick measurement
- Supplementary measurement
- Program for low-chassis vehicles
- Customer-specific vehicle database
- Robust measuring heads
- System protection against water spray
- Standard batteries
- Standard PC
- Self-centring clamp holder
- Adapter for aluminium rims (optional)

Practical Automotive Workshop Lab

Two-column Hydraulic Lifting Platform

The lifting platform is an essential feature at any automotive workshop - a prerequisite for repairs requiring free access to the motor vehicle's underbody or full removal of load from the wheels.



Your benefits

- Two-column hydraulic lifting platform with a floor-level cable receptacle
- Electromagnetic release of the safety mechanism
- 4-t load-bearing capacity
- Manufactured according to international standards, e.g. CE standard
- Concealed cables and hoses
- Two hydraulic cylinders each
- Chain guard for protecting operators
- Electromechanical height limitation
- Levelling of both lifting carriages via cable control
- Quiet operation

Four-column Hydraulic Lifting Platform

This lifting platform is especially suited to axle measurement. All necessary components such as the axle jack, sliding plates and rotary disc for axle measurement are included.



Your benefits

- Variable distance between the rails (1445 mm or 1595 mm, centre-to-centre)
- Axle jack, sliding plates and rotary disk for axle measurement included
- 4-t load-bearing capacity
- Manufactured according to international standards, e.g. CE standard
- Concealed cables and hoses
- Two hydraulic cylinders each
- Chain guard for protecting operators
- Electromechanical height limitation
- Levelling of both lifting carriages via cable control
- Quiet operation

Practical Automotive Workshop Lab

Fully Automatic Air-conditioning Service Unit

This easily operable air-conditioning service unit incorporates several functions such as leakage detection, recycling, cleaning, evacuation and replenishment.



Your benefits

- **Recycling**
Recycling of residual refrigerant
- **Cleaning**
Cleaning of refrigerant through drying, filtration and separation of oil as well as liquids according to the SAE standard
- **Replenishment**
Refilling of the air-conditioning cycle
- **Leakage detection**
Checks of the cooling system for leakages
- **Oil separation**
Replacement of old oil with a fresh batch to lengthen the compressor's life cycle
- **Evacuation**
Emptying of hoses and system parts to ensure that exactly the required quantity of refrigerant is refilled
- **Weighing**
Measurement of the filling quantity

Vehicle Tool Kit – 77 Pieces

This specially composed vehicle tool kit contains all the tools necessary for carrying out professional repairs. Made of high-quality alloys, the entire assortment of tools complies with DIN as well as ANSI standards.



Your benefits

- Professional, high-quality tool kit
- Compliant with DIN and ANSI standards
- Contains all tools needed for professional repairs
- Tools are stored in a practical, hard-shell case

Practical Automotive Workshop Lab

Set of Socket Spanners – 94 Pieces

This specially composed vehicle tool kit contains all the socket spanners necessary for carrying out professional repairs. Made of high-quality alloys, the entire assortment of tools complies with DIN as well as ANSI standards.



Your benefits

- Professional, high-quality tool kit
- Compliant with DIN and ANSI standards
- Contains all socket spanners needed for professional repairs
- Tools are stored in a practical, hard-shell case

Trolley with 64-piece Tool Kit

Configured specially for training purposes, this indispensable tool-kit trolley meets all relevant DIN und ANSI standards.



Your benefits

- Tool kit trolley with seven drawers
- The uppermost two drawers contain a professional, high-quality tool kit
- Borne on heavy-duty rollers with ball bearings
- Large, stable work plate with corrugated PVC surface
- Compliant with DIN and ANSI standards

Essential Product Benefits

... Ensure Long-term Customer Satisfaction



Bernd Klein, instructor at the Nikolaus-August-Otto vocational school, regularly uses Lucas-Nülle's automotive training systems in his lessons.

Having worked with Lucas-Nülle for many years now, we are satisfied with their self-learning concepts. Our trainees are especially keen to use software-based training systems.

I particularly like the new Connect® program which can be used to clearly explain engine management systems.

Also very popular with instructors here are the robust lighting and signalling units.

In general, Lucas-Nülle's training systems make instruction at vocational schools much more practical and hands-on.

The Whole is Greater than the Sum of its Parts

Individual Consultation with Lucas-Nülle

Do you require detailed advice or a specific quotation?

You can contact us as follows:

Phone: +49 2273 567-0

Fax: +49 2273 567-39

Lucas-Nülle is a byword for customized vocational training systems in the following areas:



Installation Engineering



Electropneumatics, Hydraulics



Electrical Power Engineering



Instrumentation



Power Electronics, Electrical Machines,
Drive Technology



Microcontrollers



Electrical and Electronic Circuits



Automation Technology



Communications Technology



Automotive Engineering



Process Control



Lab Systems

**Ask for detailed information via any of the contact methods mentioned above.
Our employees will be happy to advise you.**

Lucas-Nülle training systems meet the highest safety and quality standards. Changes in areas like environmental protection, customer benefits, design and construction entail corresponding advancements to systems or components. This can lead to discrepancies between product details and relevant items in the scope of delivery.

Further information on our products can also be found at:

www.lucas-nuelle.com

Topics

Topics		Fundamentals of DC and AC technology	Fundamentals of electronic/digital technology	Three-phase generator	Pulse-width modulated signals	Three-phase generator	Fundamentals of automotive electrics/electronics	Engine management sensors	Vehicle lighting	CAN bus for vehicle lighting	Instrument panel with CAN and LIN	GPS navigation	Alarm system and immobilizer	Air-conditioning and climate control	Hybrid drives
		p. 26	p. 27	p. 28	p. 29	p. 30, 31	p. 32	p. 38, 39	p. 44-47	p. 48	p. 49	p. 54	p. 55	p. 56	p. 62, 63
1	Maintenance / care of vehicles and automotive systems														
2	Dismantling, repair and installation of automotive assembly groups and systems										X				
3	Testing / maintenance of electrical and electronic systems	X	X		X	X	X	X	X	X	X		X	X	X
4	Testing / maintenance of open-loop and closed-loop control systems		X	X	X	X		X		X	X	X	X	X	X
5	Testing / maintenance of power supply and starting systems	X	X	X	X	X									X
6	Testing / maintenance of engine mechanics														
7	Diagnosis and maintenance of engine management systems							X							
8	Servicing and maintenance of exhaust systems														
9	Maintenance of power transmission systems														
10	Maintenance of chassis and brake systems														
11	Retrofitting and commissioning of auxiliary systems									X		X	X		
12	Testing and maintenance of networked systems				X						X				
13	Diagnosis and maintenance of body, comfort and safety systems												X	X	
14	Servicing and maintenance for statutory inspections								X		X				

Lucas-Nülle Lehr- und Meßgeräte GmbH

Siemensstrasse 2 · D-50170 Kerpen-Sindorf
Phone: +49 2273 567-0 · Fax: +49 2273 567-39
www.lucas-nuelle.com

